

CA047 NEUTRON ACER TENDL-2019 LIBRARY; T=293.16K
Principal cross sections

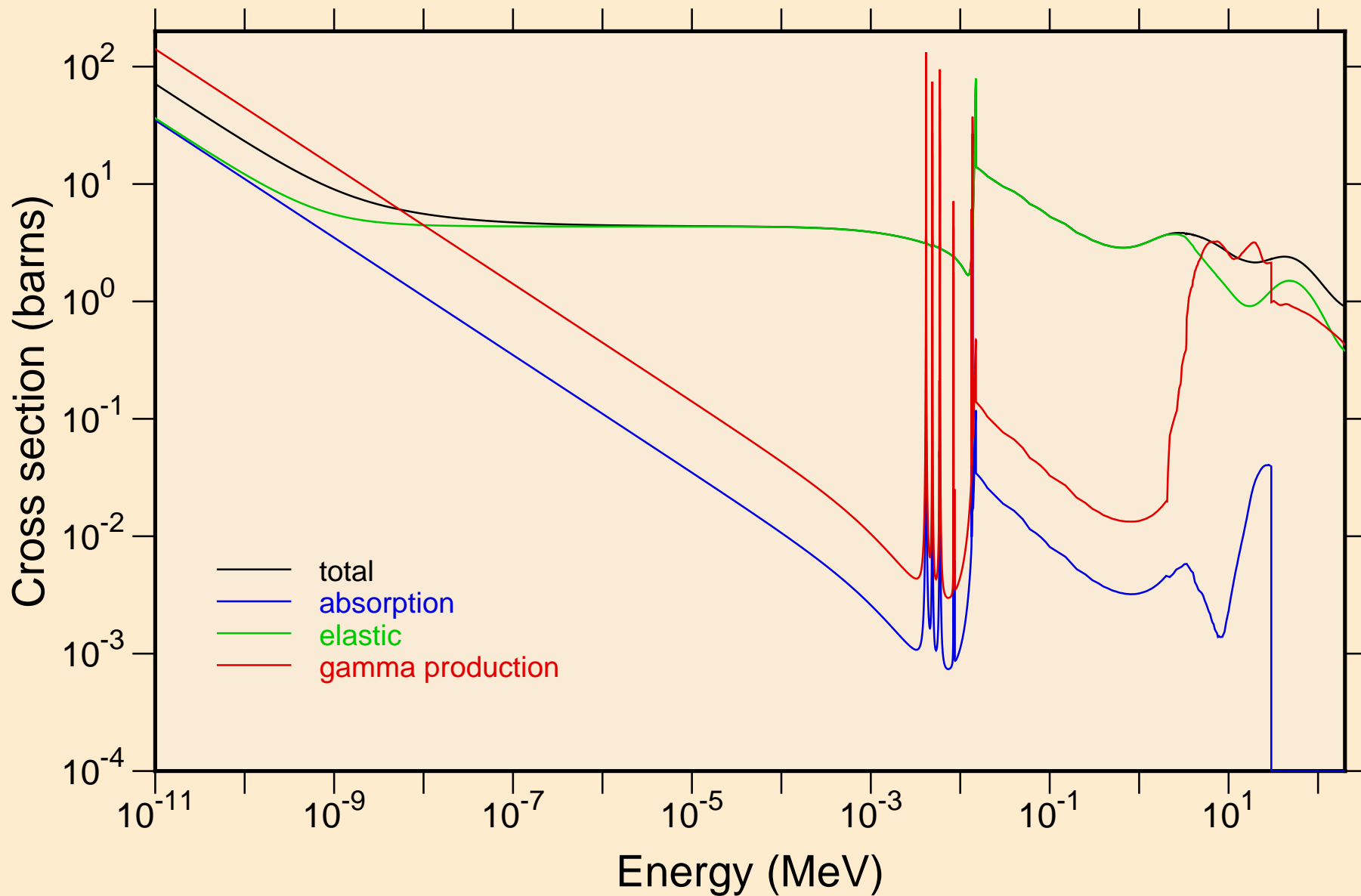

CA047 NEUTRON ACER TENDL-2019 LIBRARY; T=293.16K
resonance total cross section

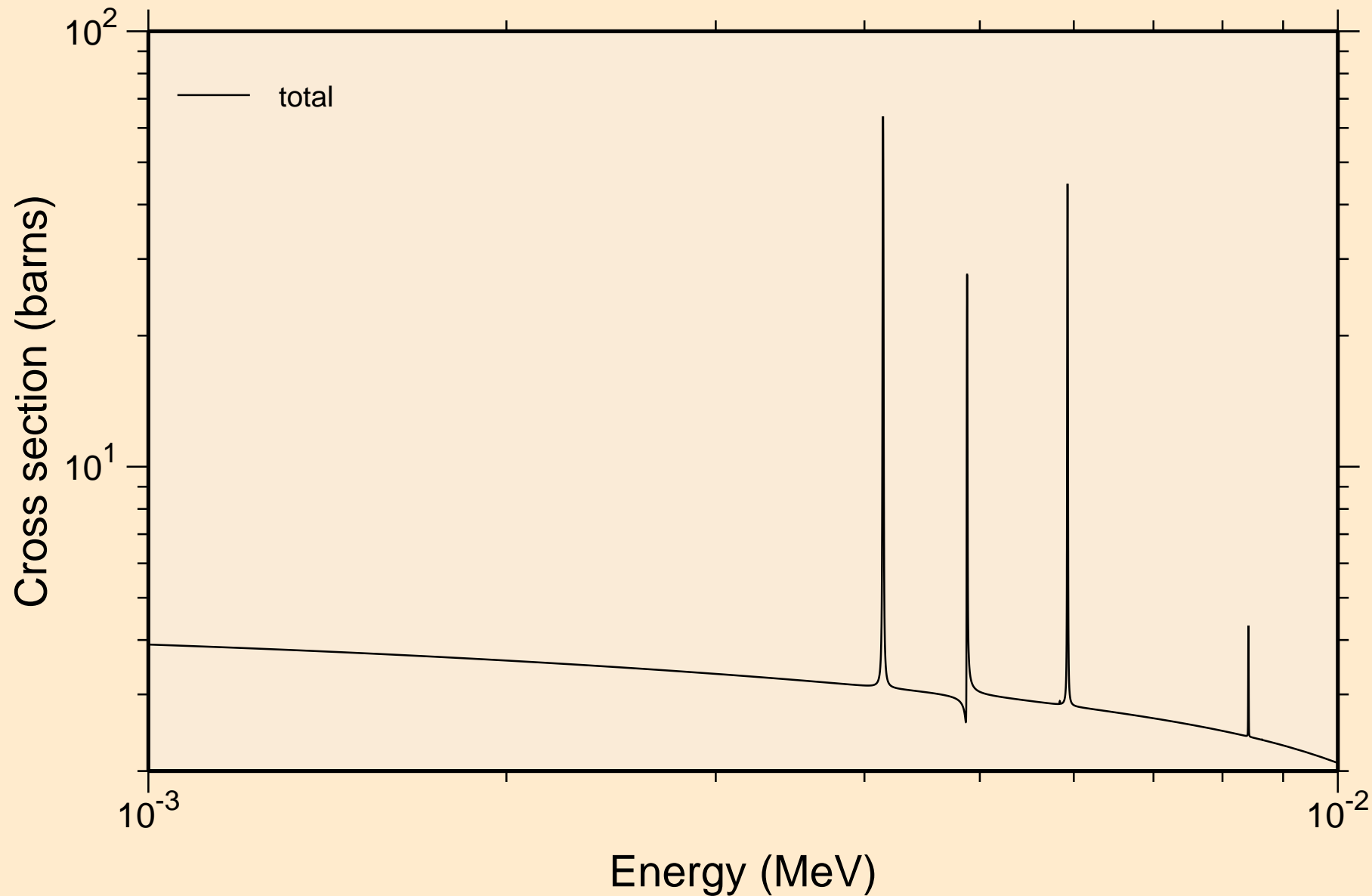

CA047 NEUTRON ACER TENDL-2019 LIBRARY; T=293.16K
resonance total cross section

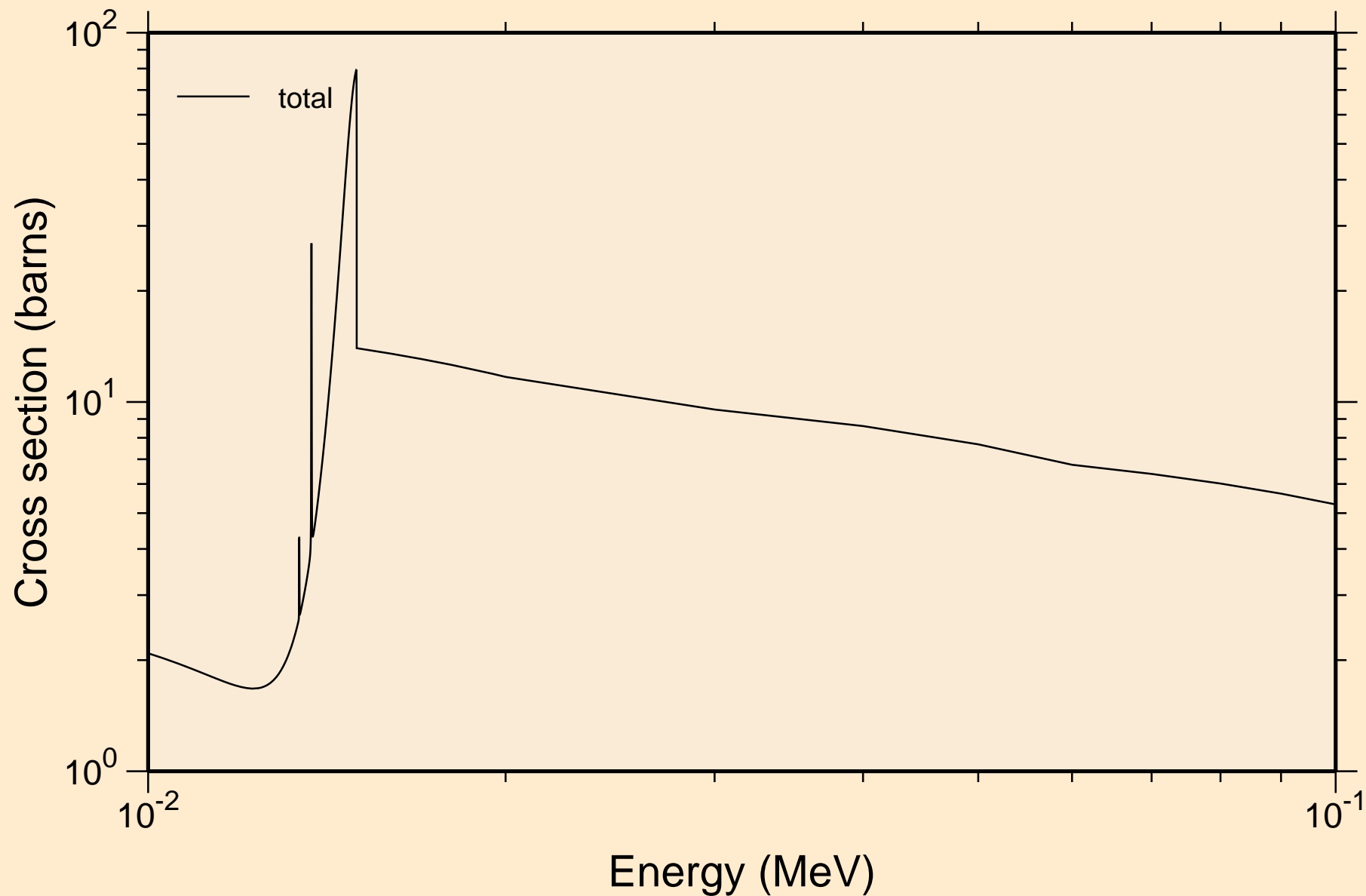

C̄A047 NEUTRON ACER TENDL-2019 LIBRARY; T=293.16K
resonance total cross section

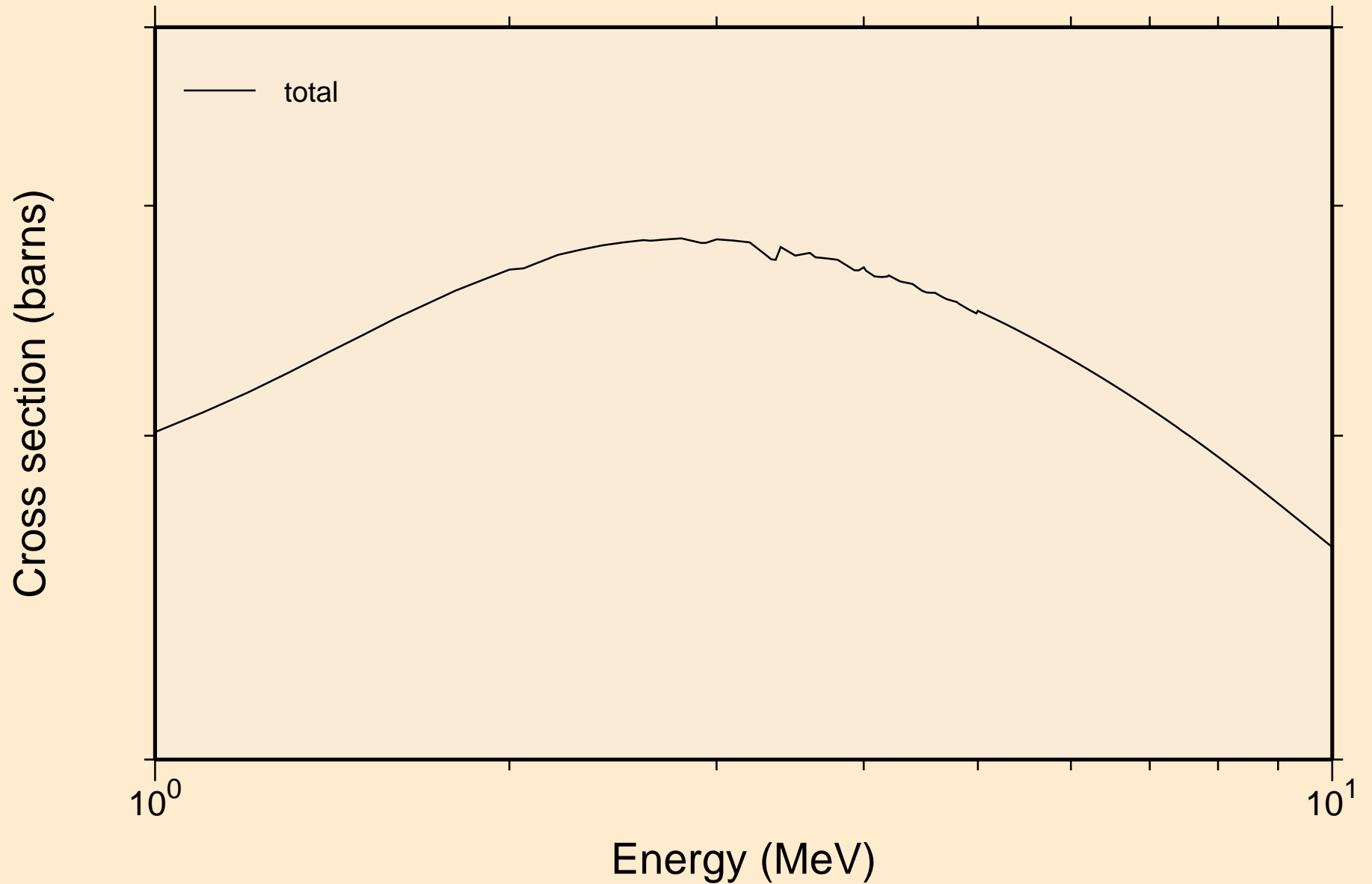

CA047 NEUTRON ACER TENDL-2019 LIBRARY; T=293.16K
resonance absorption cross sections

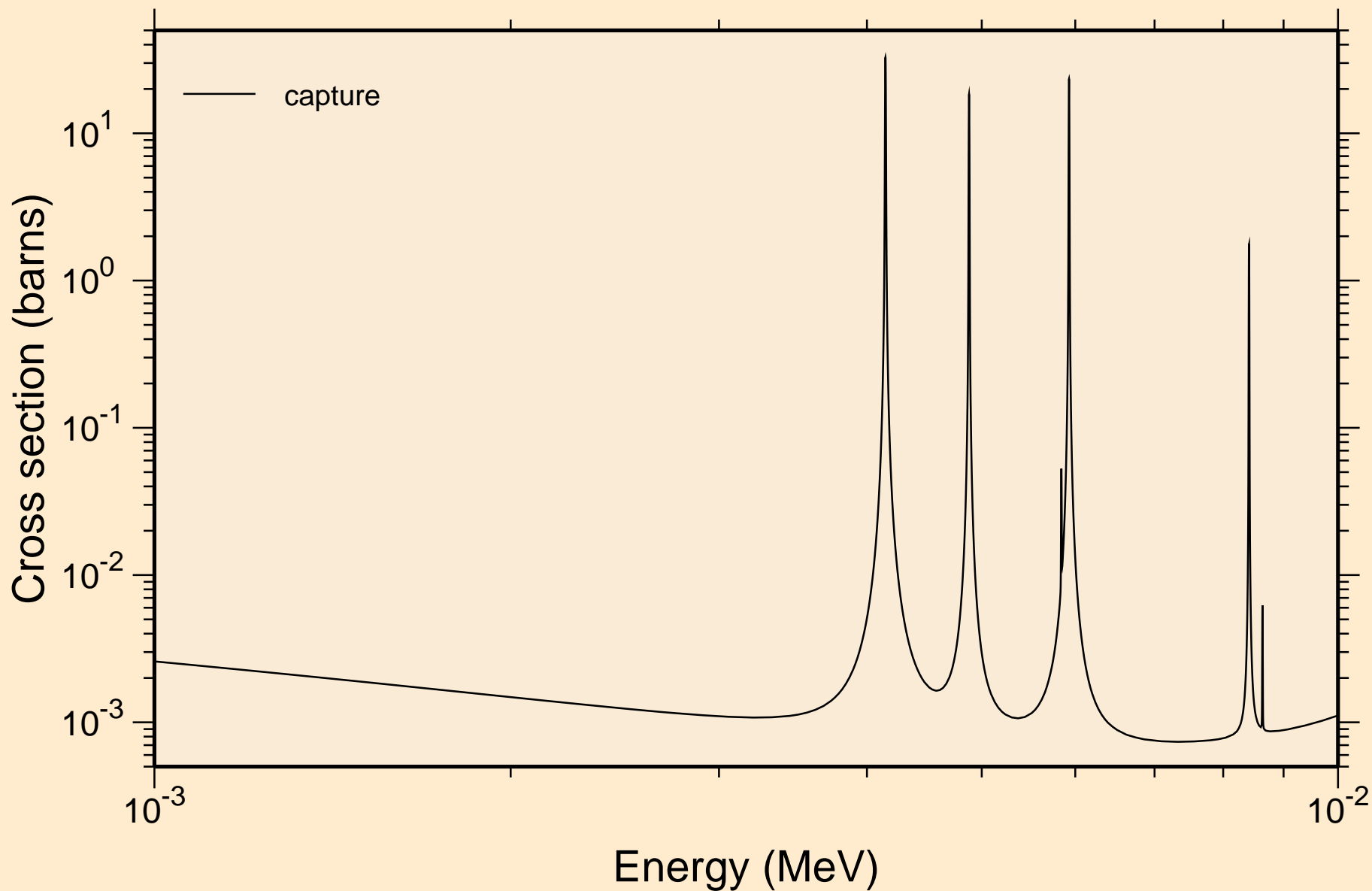

CA047 NEUTRON ACER TENDL-2019 LIBRARY; T=293.16K
resonance absorption cross sections

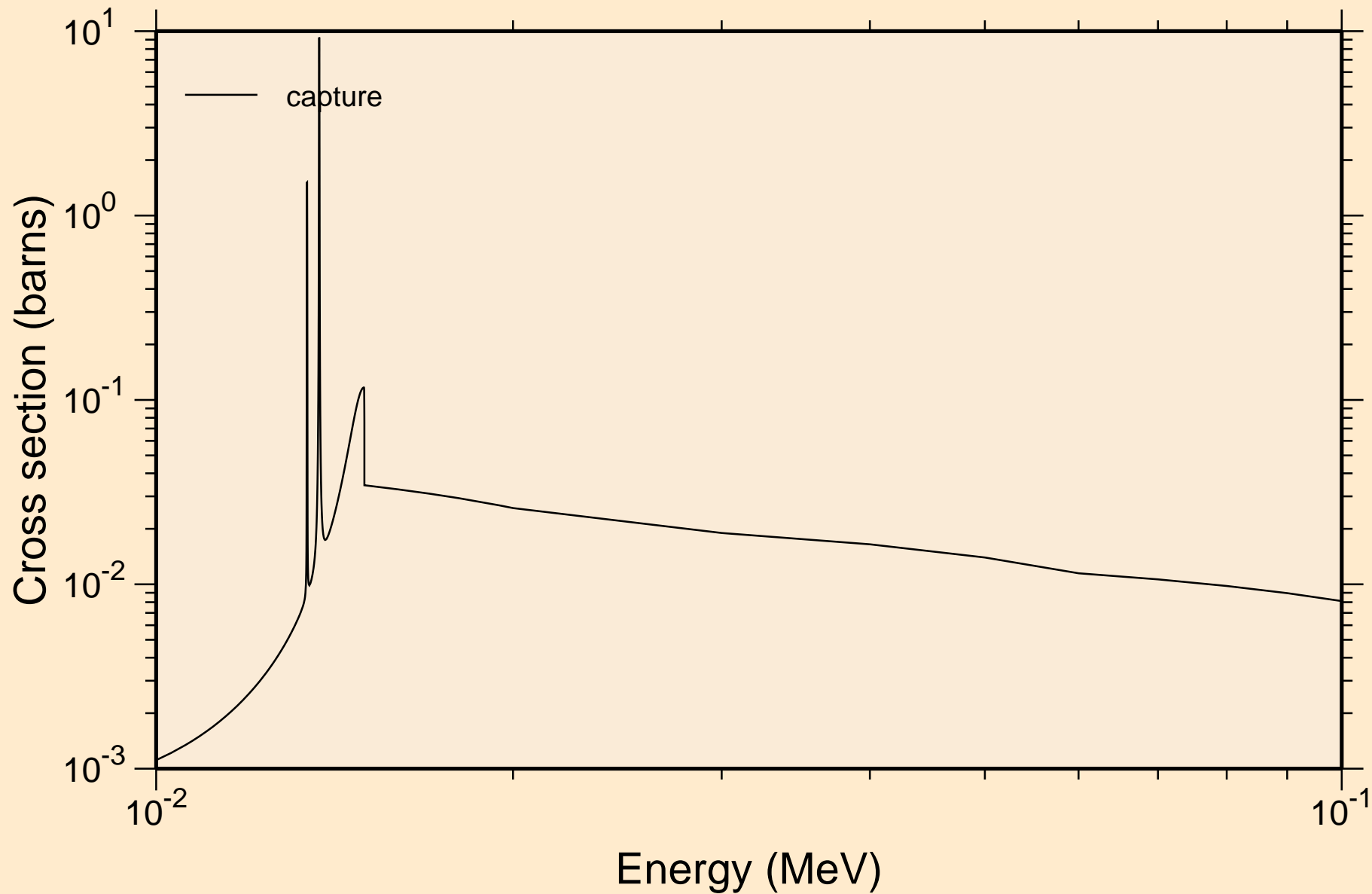

CA047 NEUTRON ACER TENDL-2019 LIBRARY; T=293.16K
resonance absorption cross sections

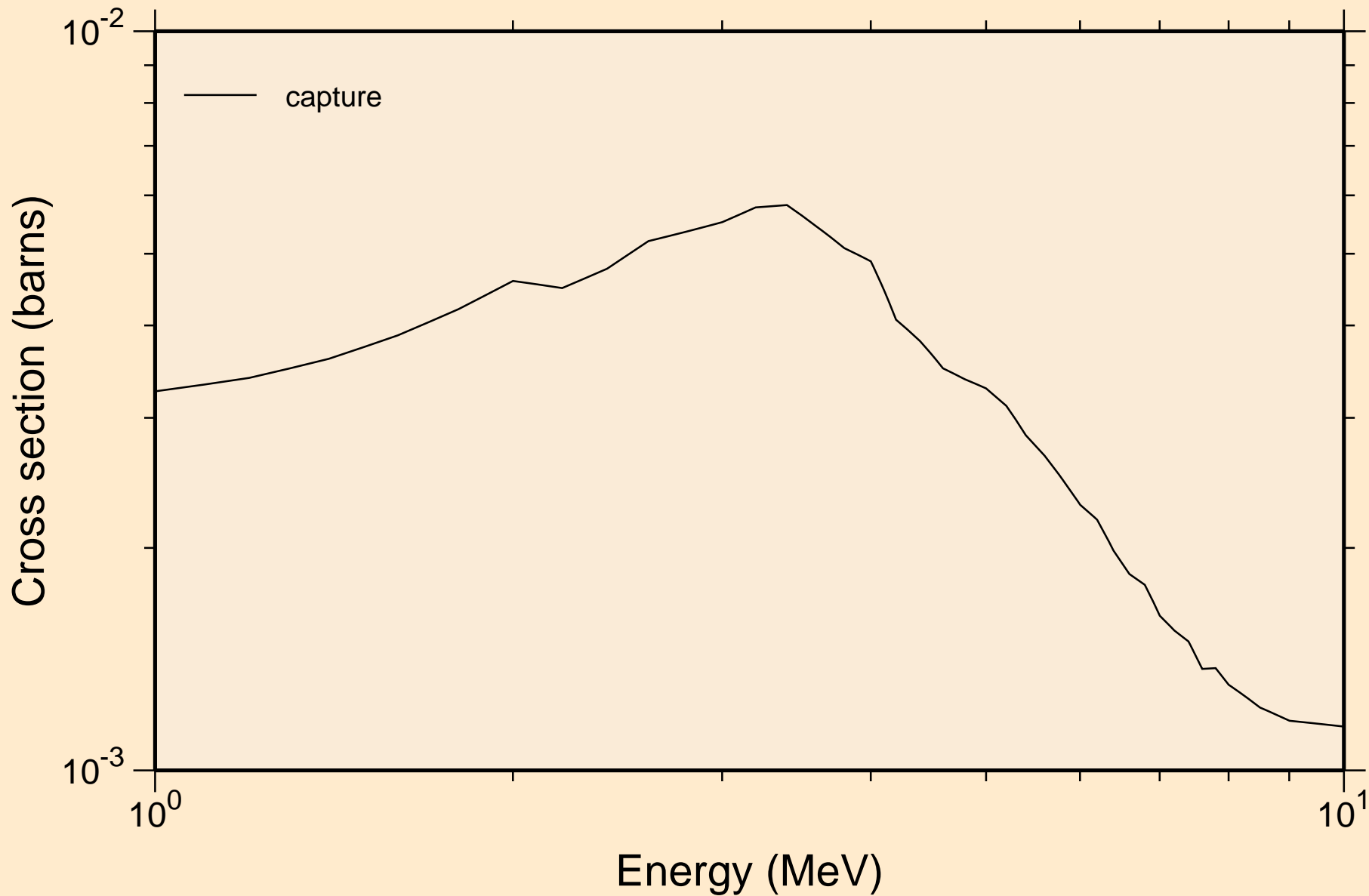

CA047 NEUTRON ACER TENDL-2019 LIBRARY; T=293.16K
Heating

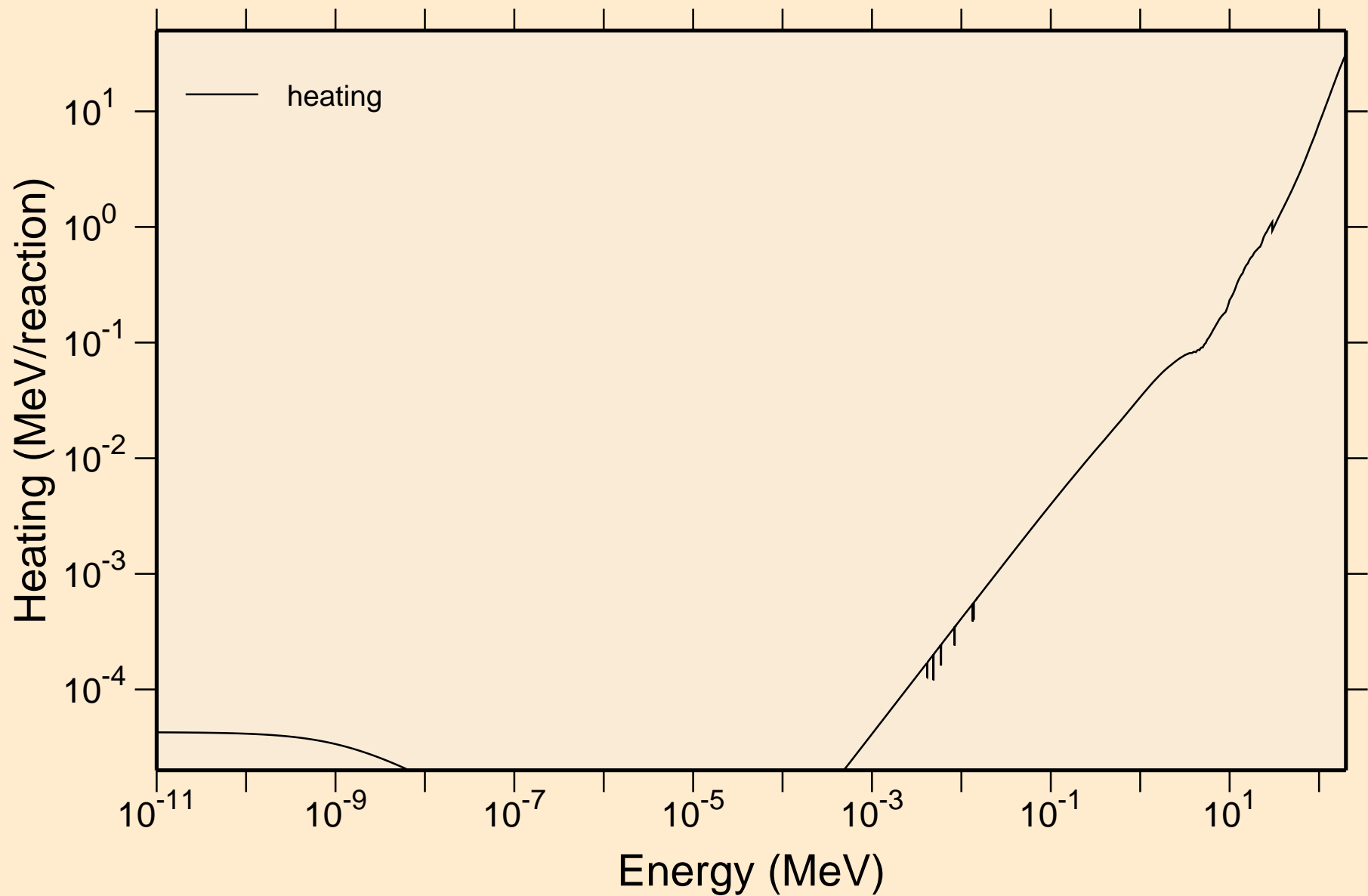

CA047 NEUTRON ACER TENDL-2019 LIBRARY; T=293.16K
Damage

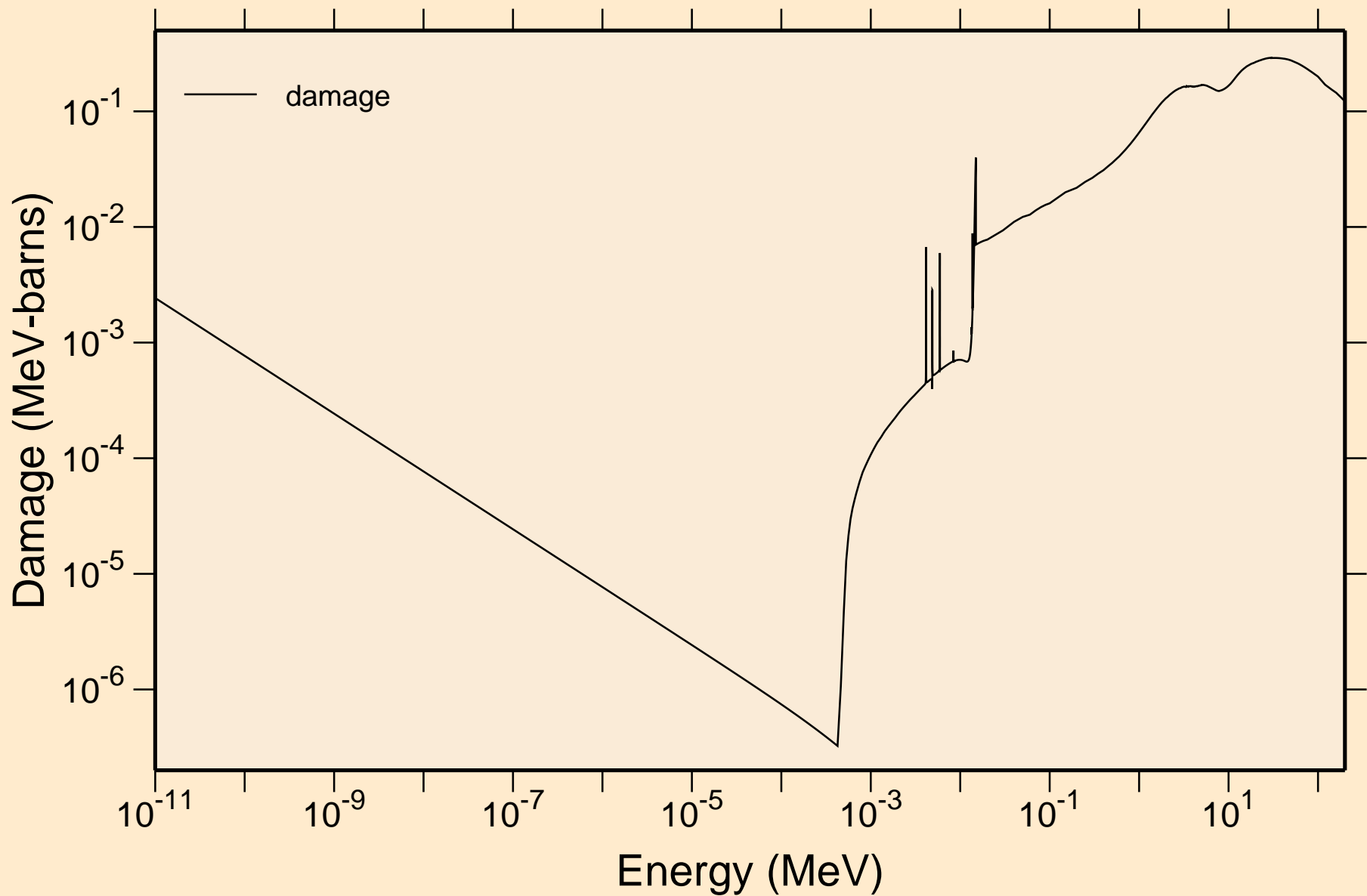

CA047 NEUTRON ACER TENDL-2019 LIBRARY; T=293.16K
Non-threshold reactions

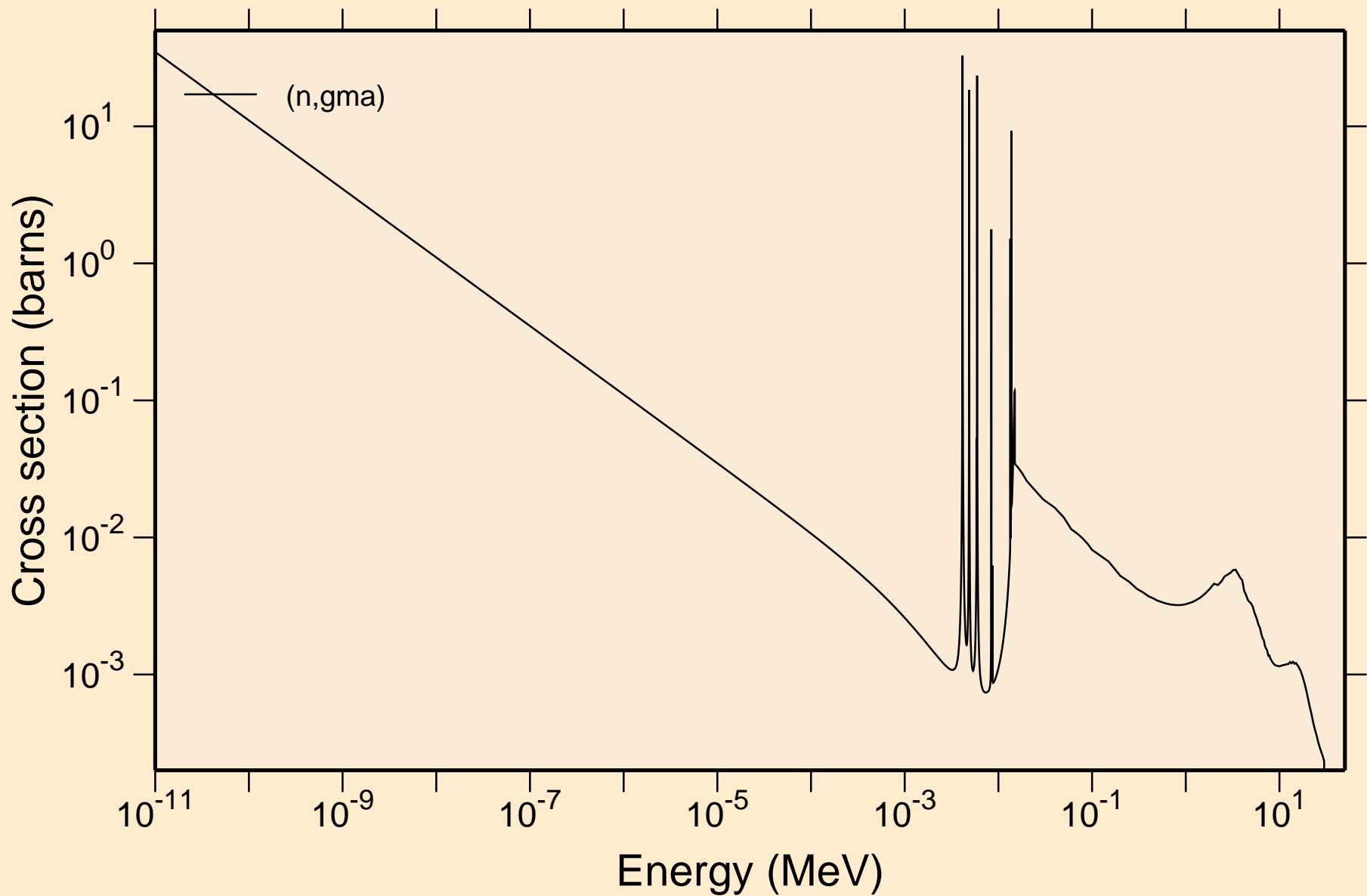

CA047 NEUTRON ACER TENDL-2019 LIBRARY; T=293.16K

Principal cross sections

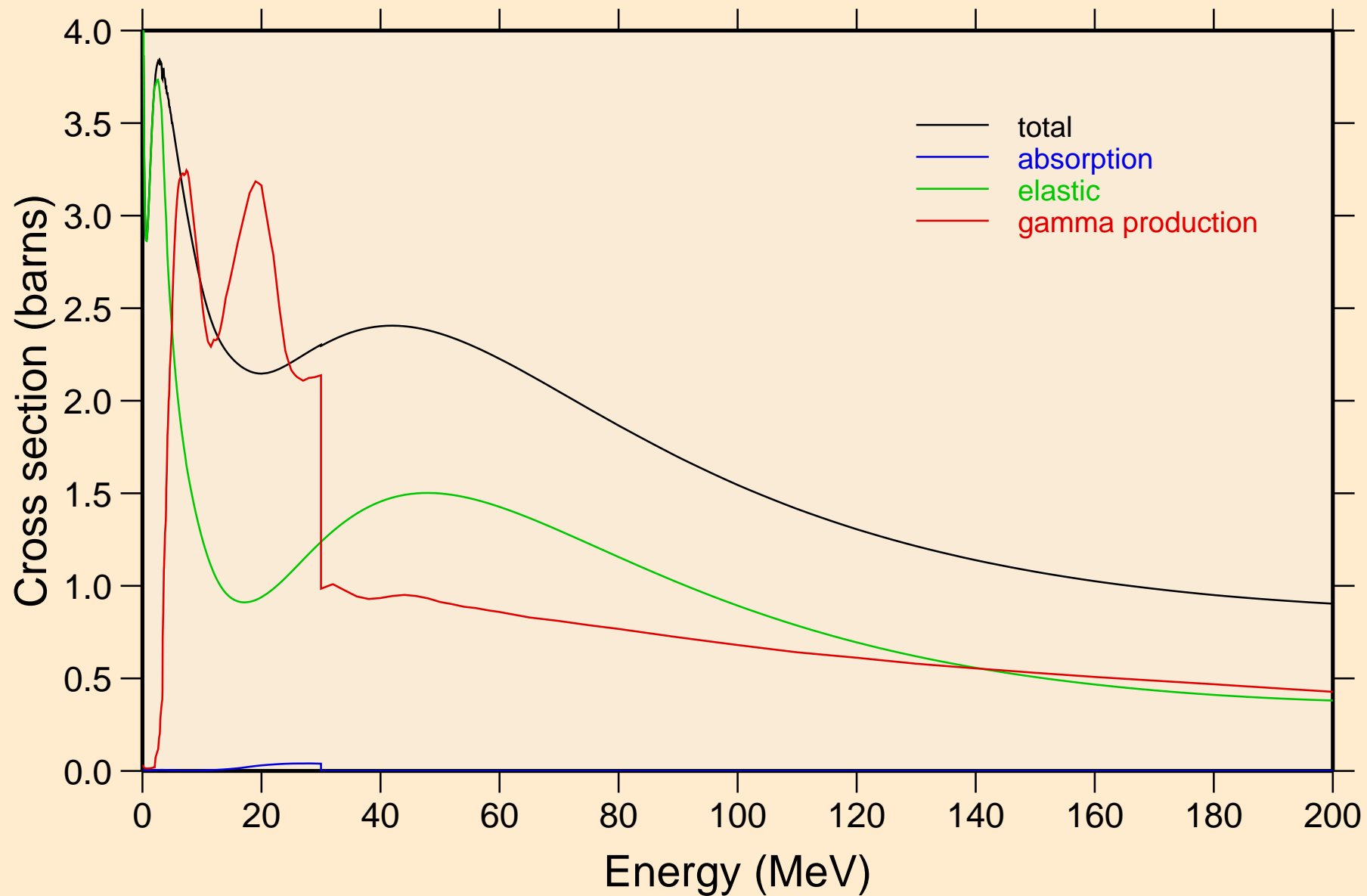

CA047 NEUTRON ACER TENDL-2019 LIBRARY; T=293.16K
Heating

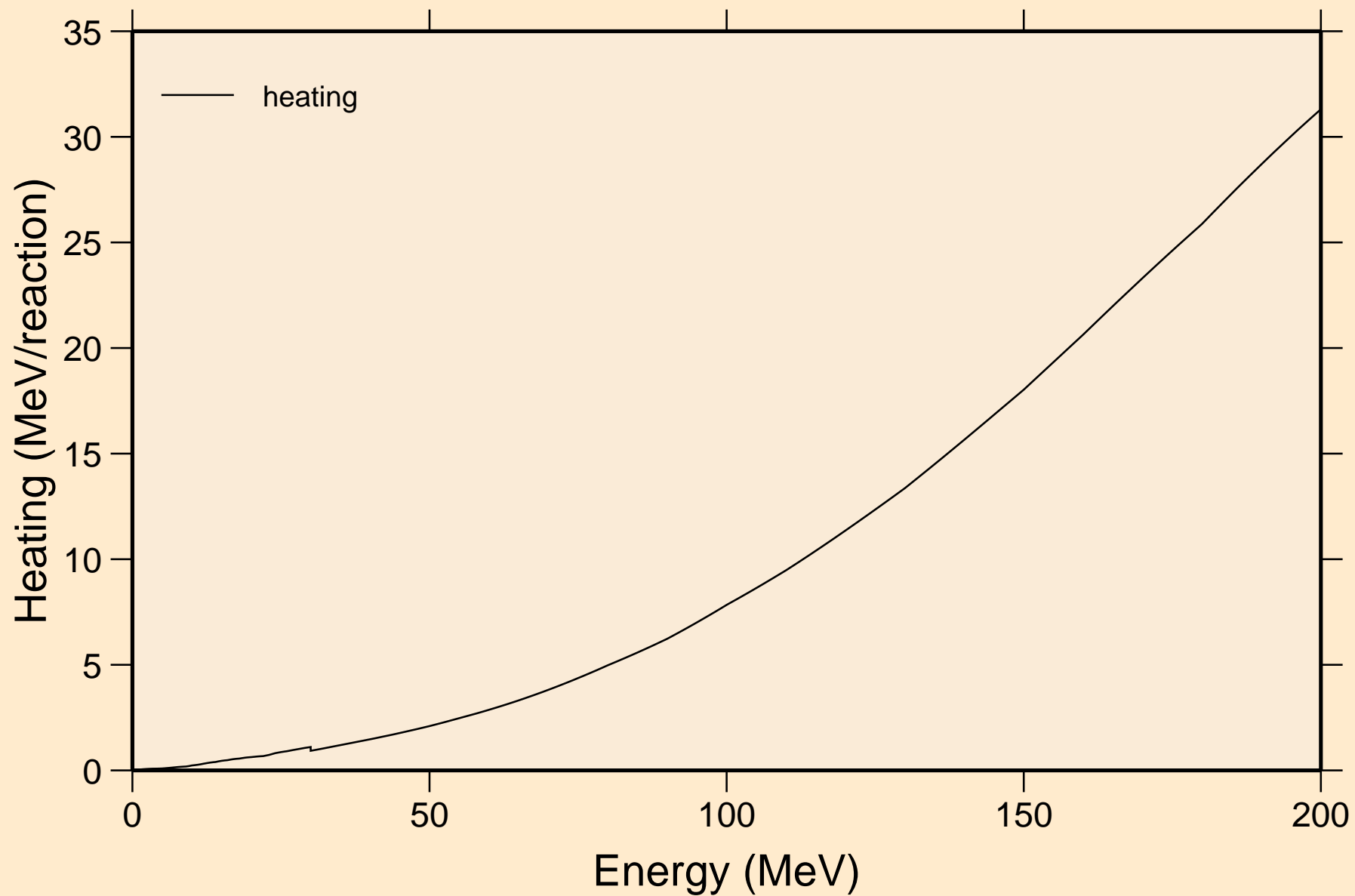

CA047 NEUTRON ACER TENDL-2019 LIBRARY; T=293.16K
Damage

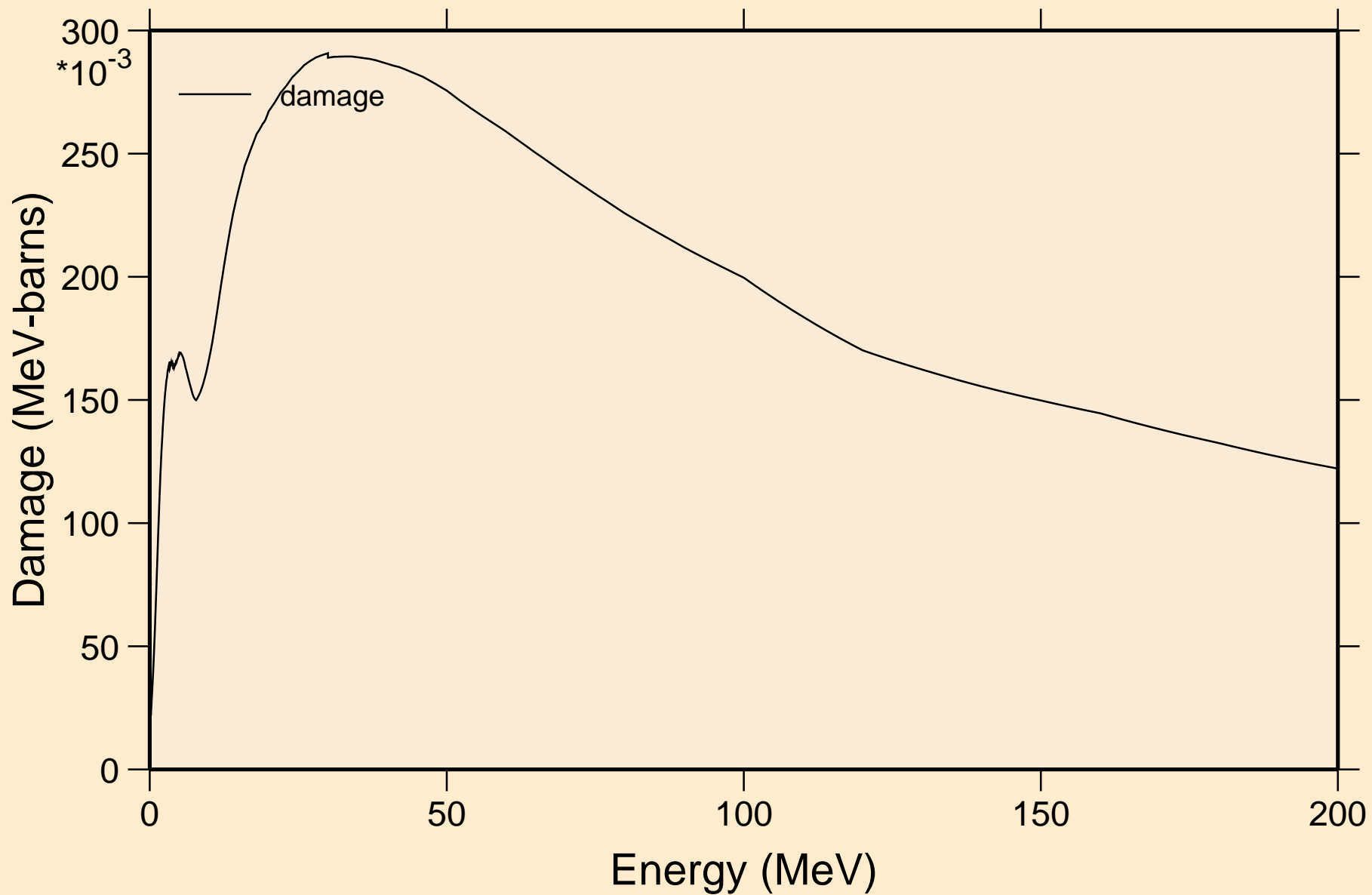

CA047 NEUTRON ACER TENDL-2019 LIBRARY; T=293.16K
Non-threshold reactions

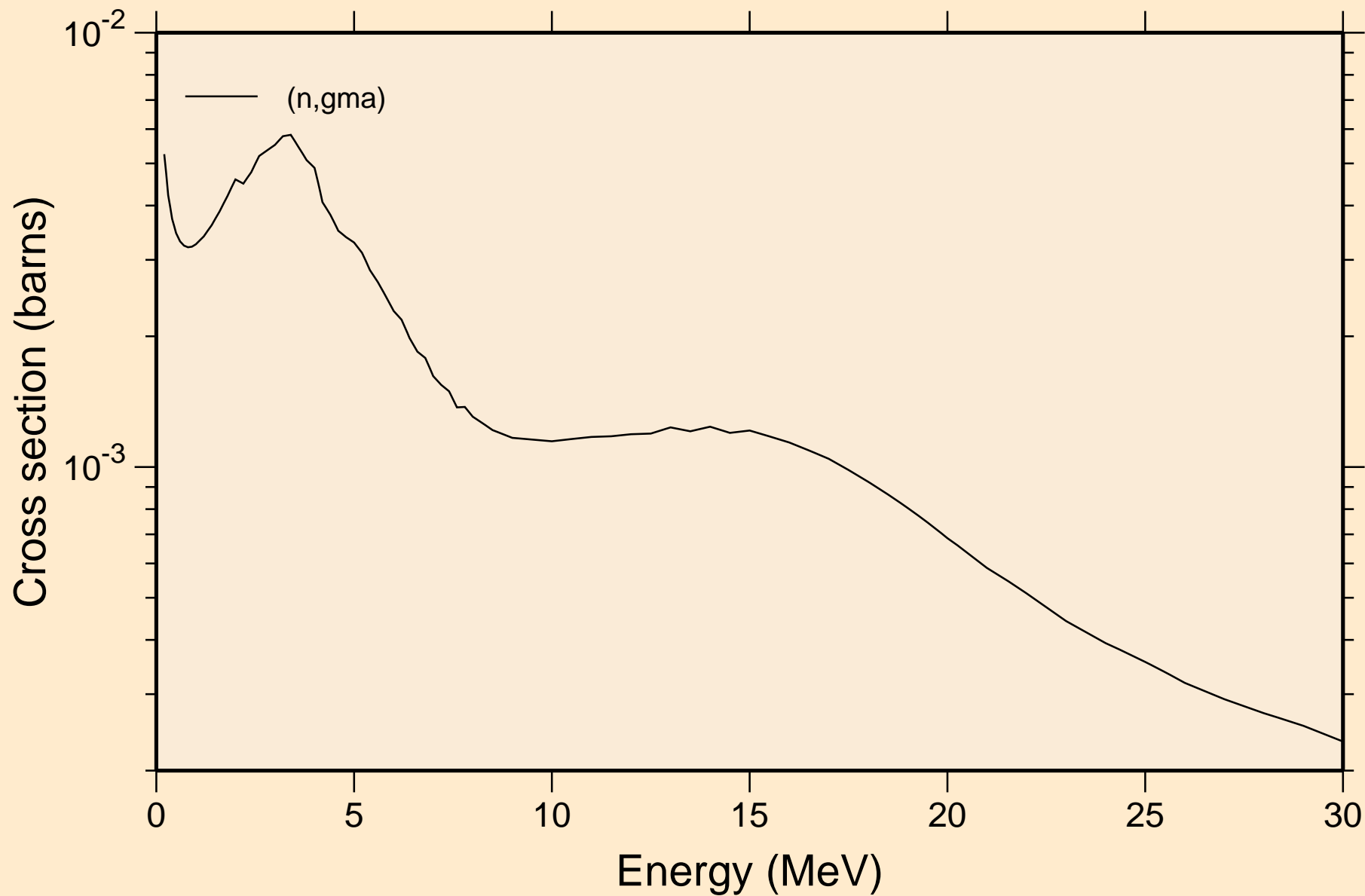

CA047 NEUTRON ACER TENDL-2019 LIBRARY; T=293.16K
Inelastic levels

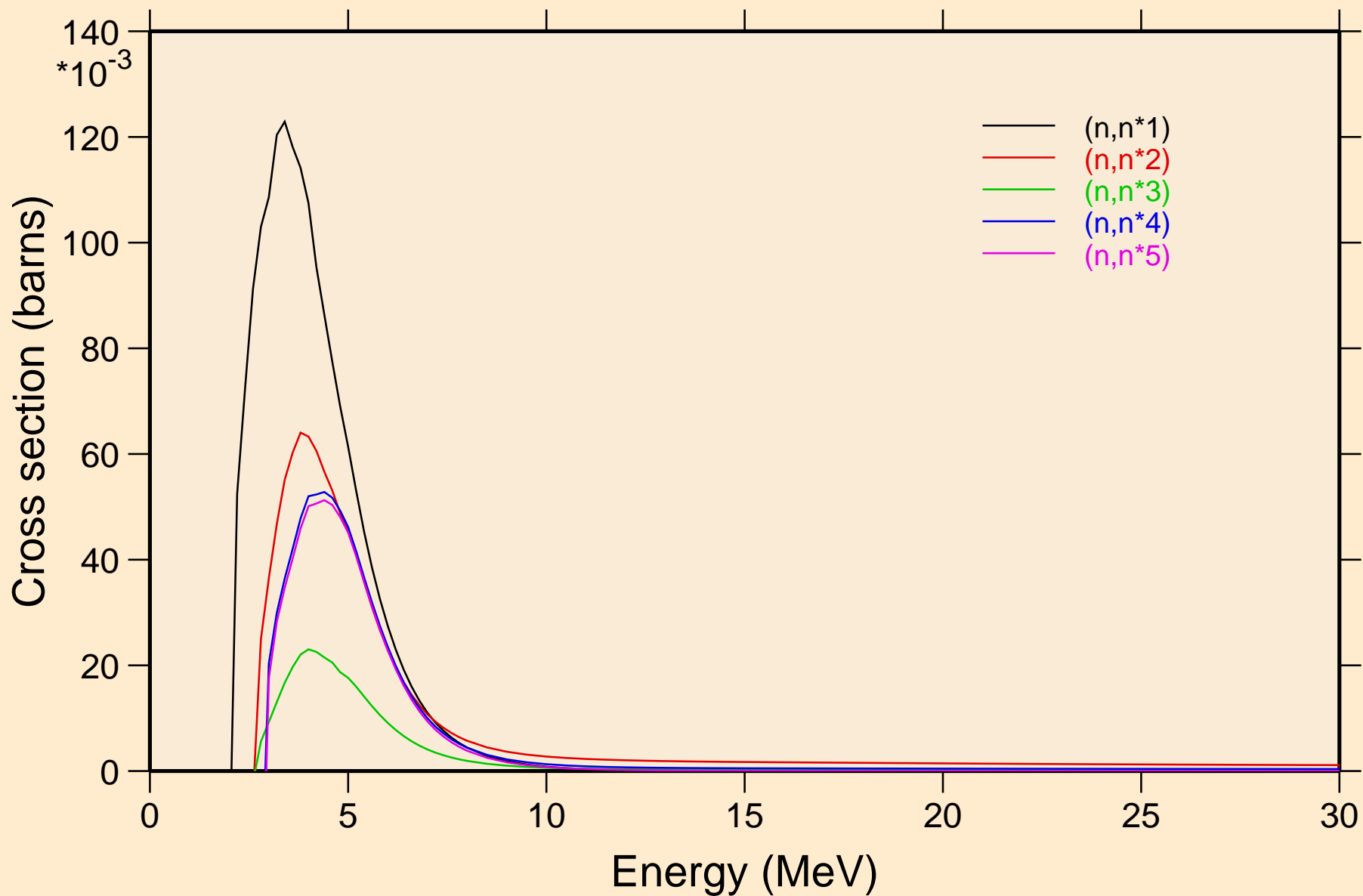

CA047 NEUTRON ACER TENDL-2019 LIBRARY; T=293.16K
Inelastic levels

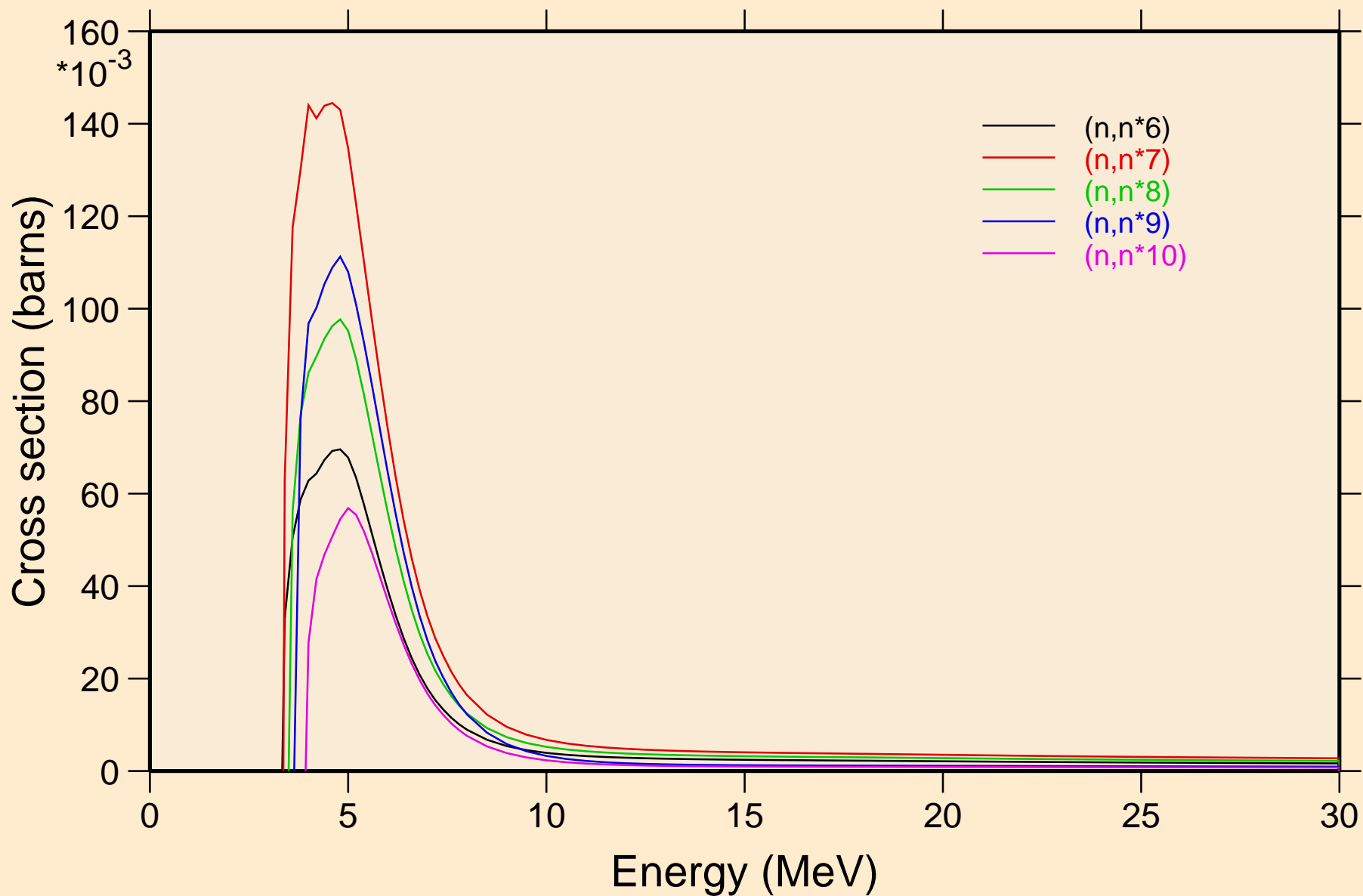

CA047 NEUTRON ACER TENDL-2019 LIBRARY; T=293.16K
Inelastic levels

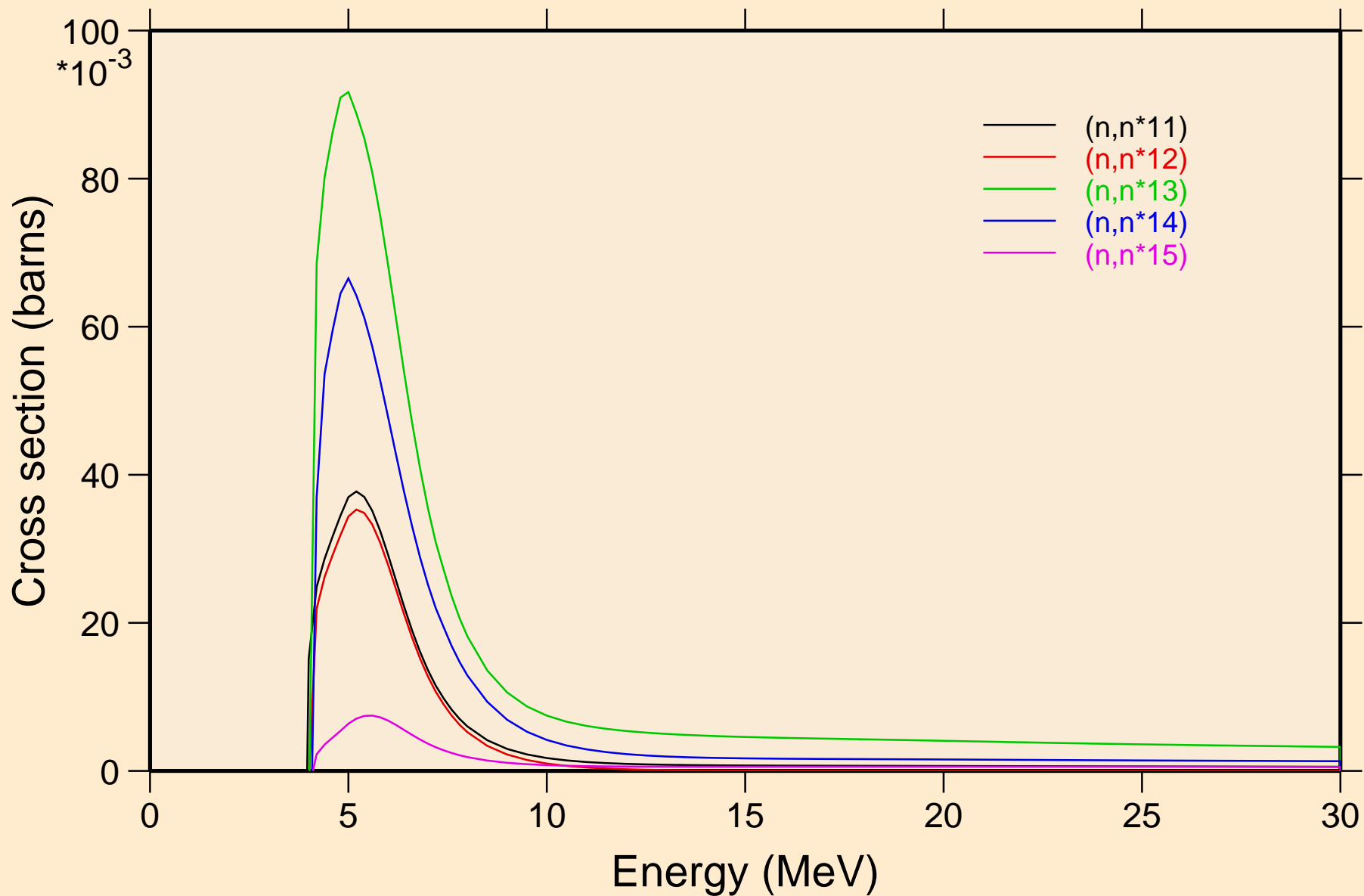

CA047 NEUTRON ACER TENDL-2019 LIBRARY; T=293.16K
Inelastic levels

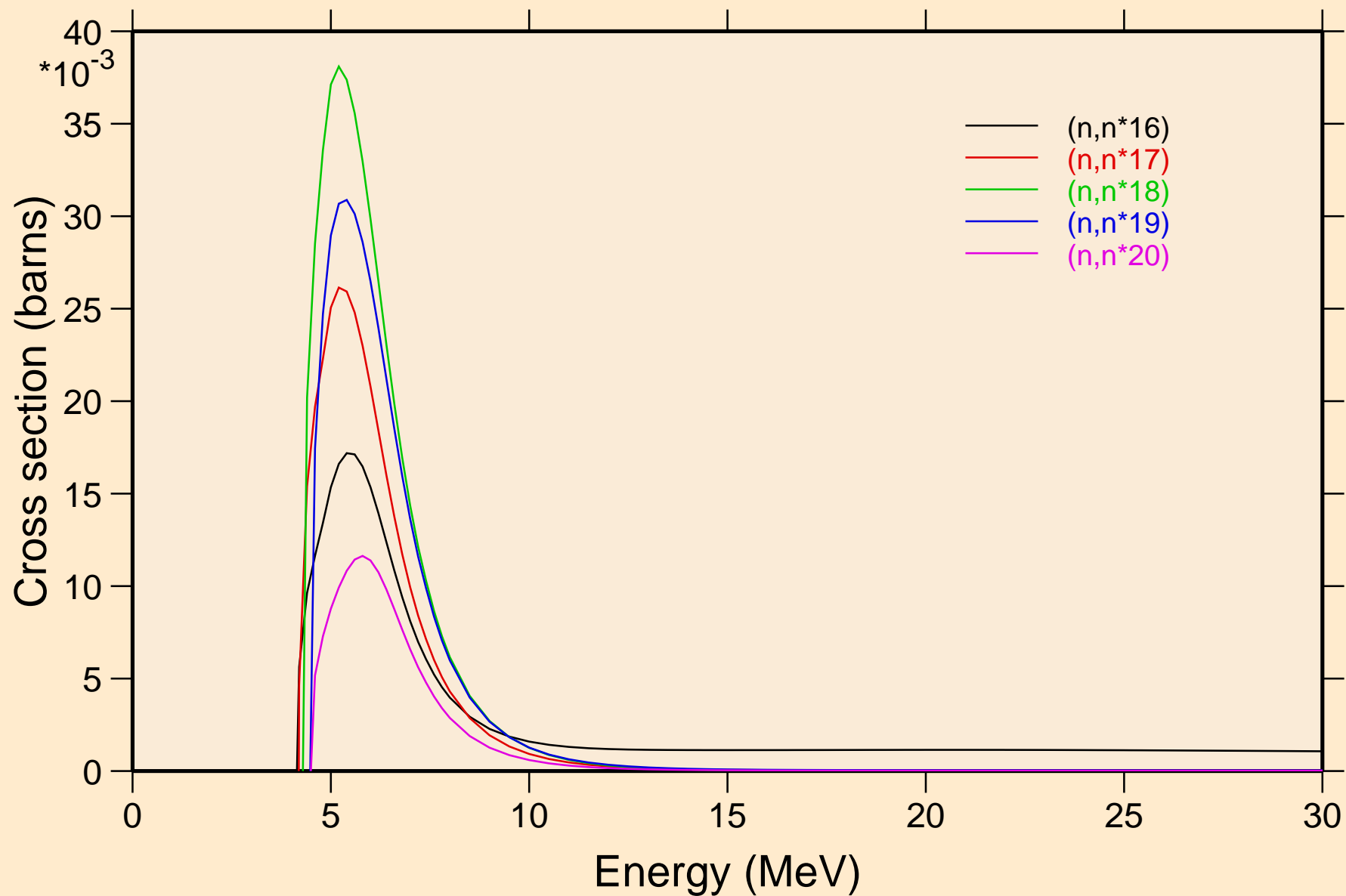

CA047 NEUTRON ACER TENDL-2019 LIBRARY; T=293.16K
Inelastic levels

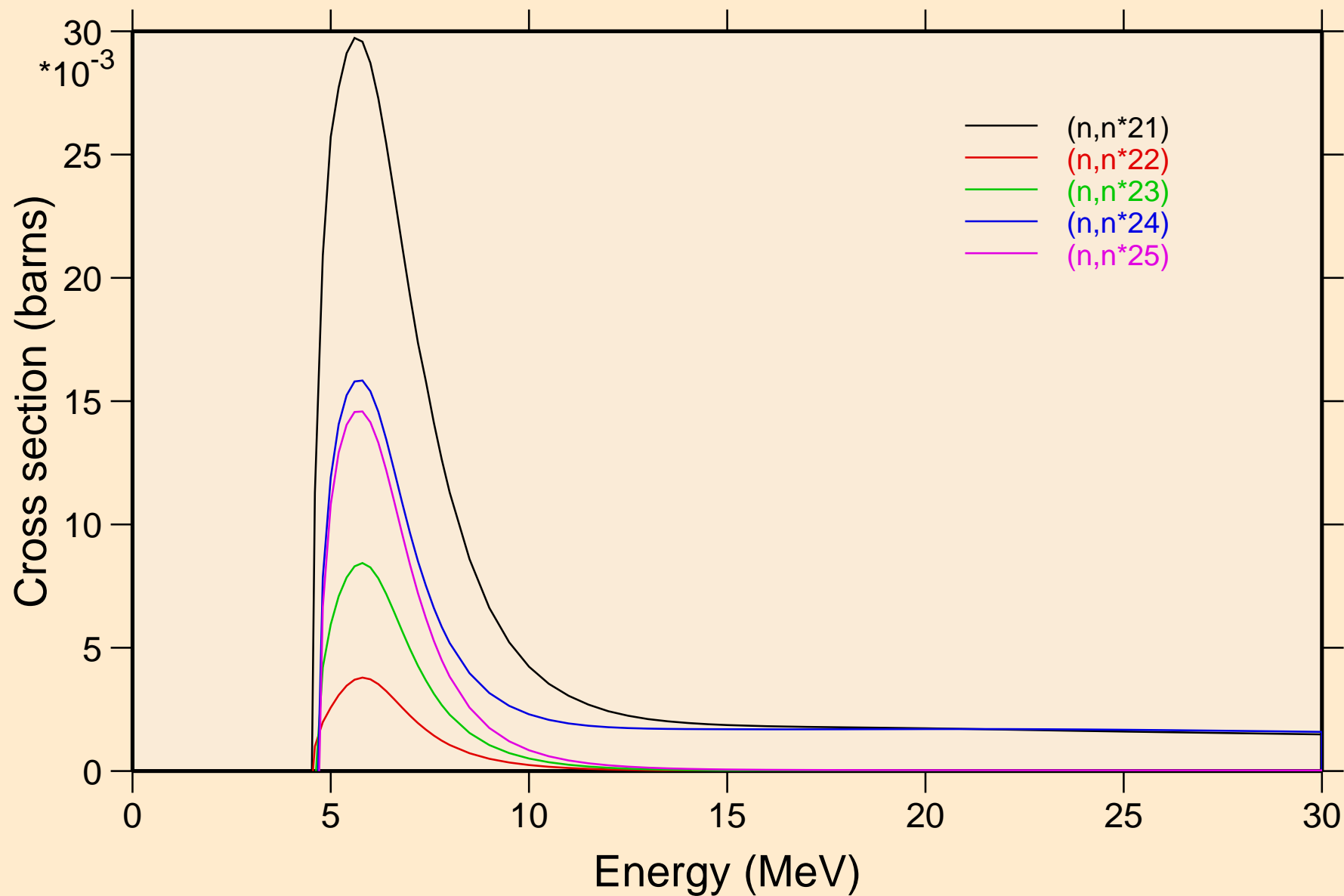

CA047 NEUTRON ACER TENDL-2019 LIBRARY; T=293.16K
Inelastic levels

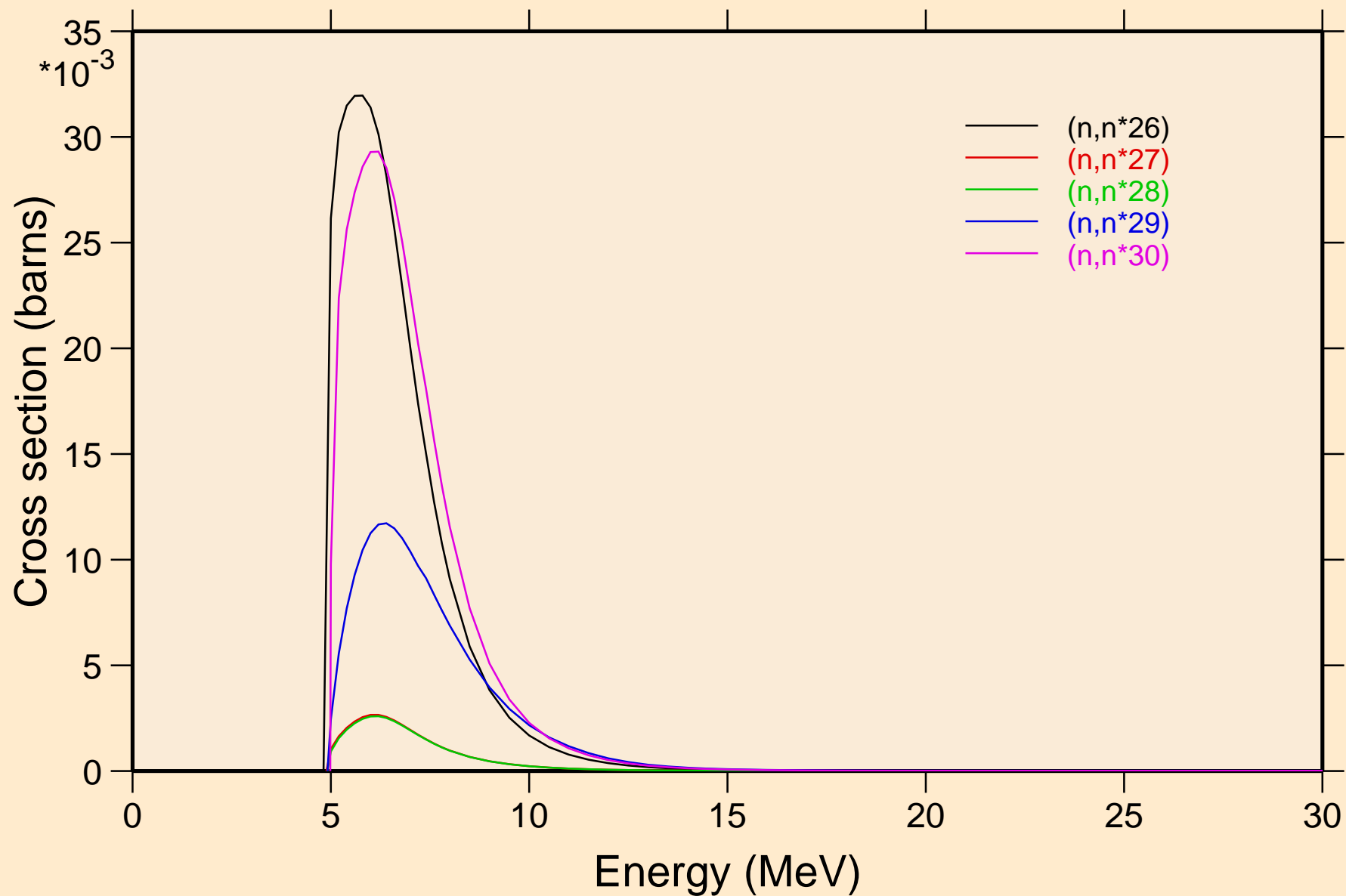

CA047 NEUTRON ACER TENDL-2019 LIBRARY; T=293.16K
Threshold reactions

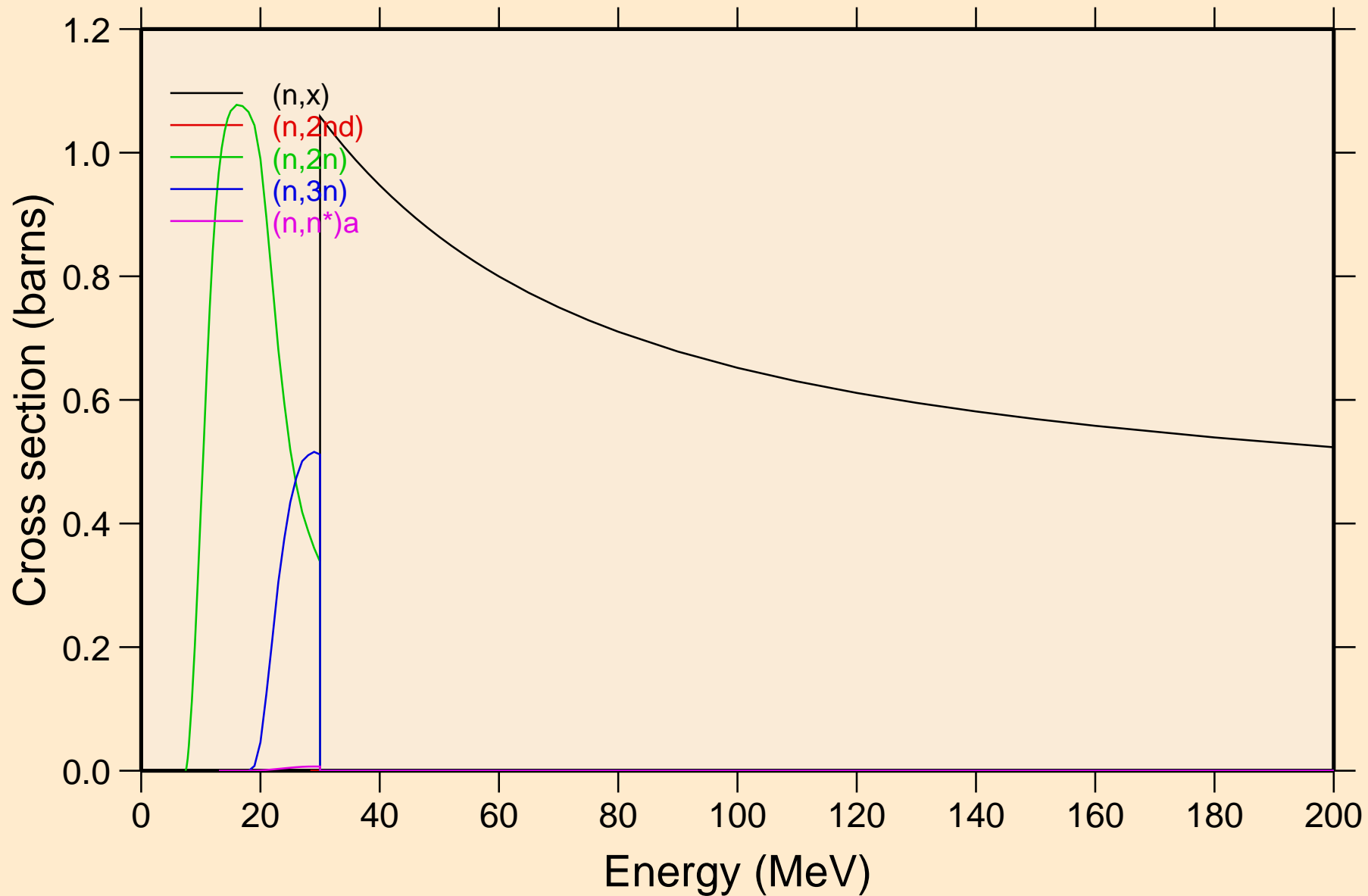

CA047 NEUTRON ACER TENDL-2019 LIBRARY; T=293.16K
Threshold reactions

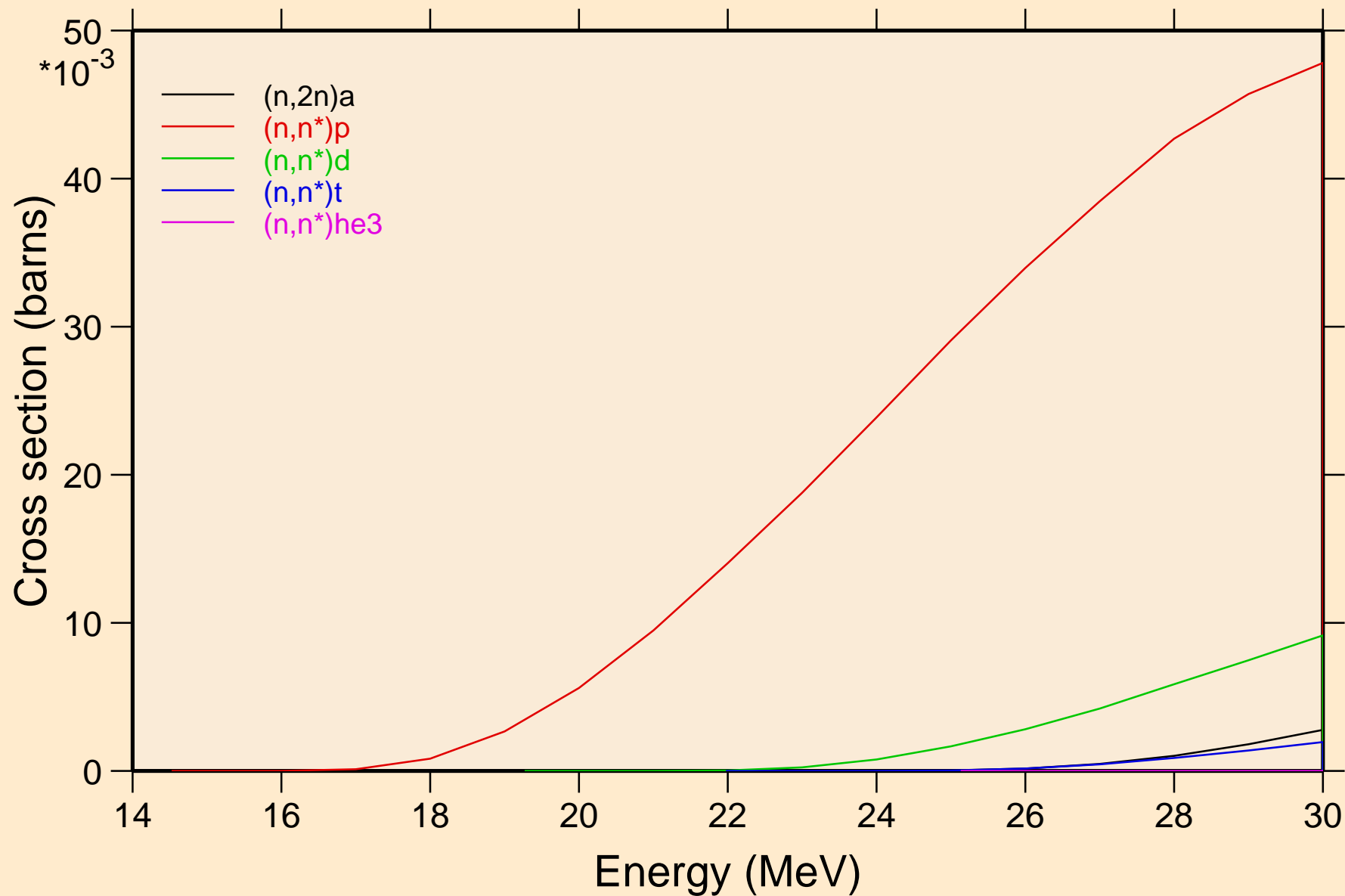

CA047 NEUTRON ACER TENDL-2019 LIBRARY; T=293.16K
Threshold reactions

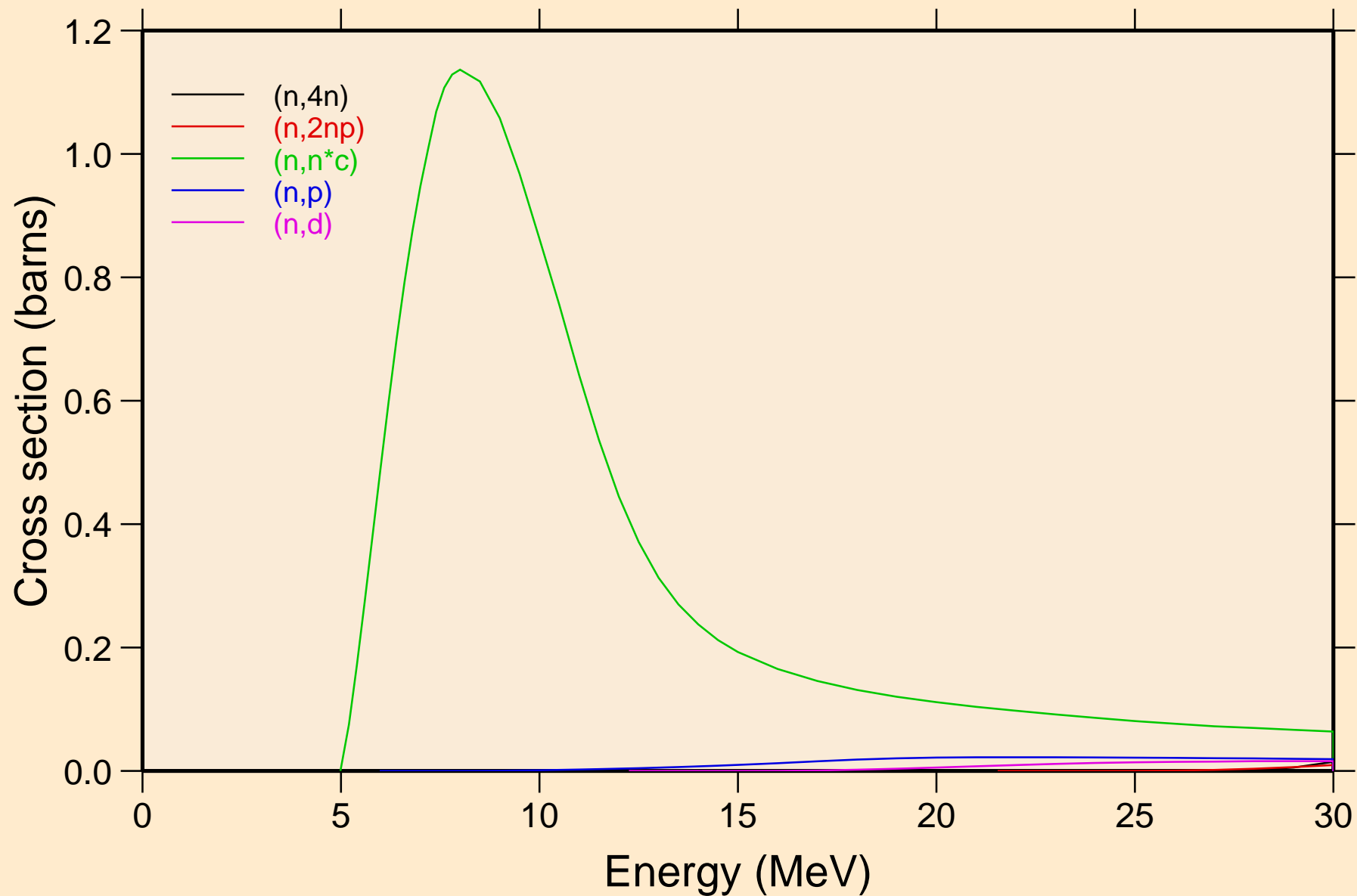

CA047 NEUTRON ACER TENDL-2019 LIBRARY; T=293.16K
Threshold reactions

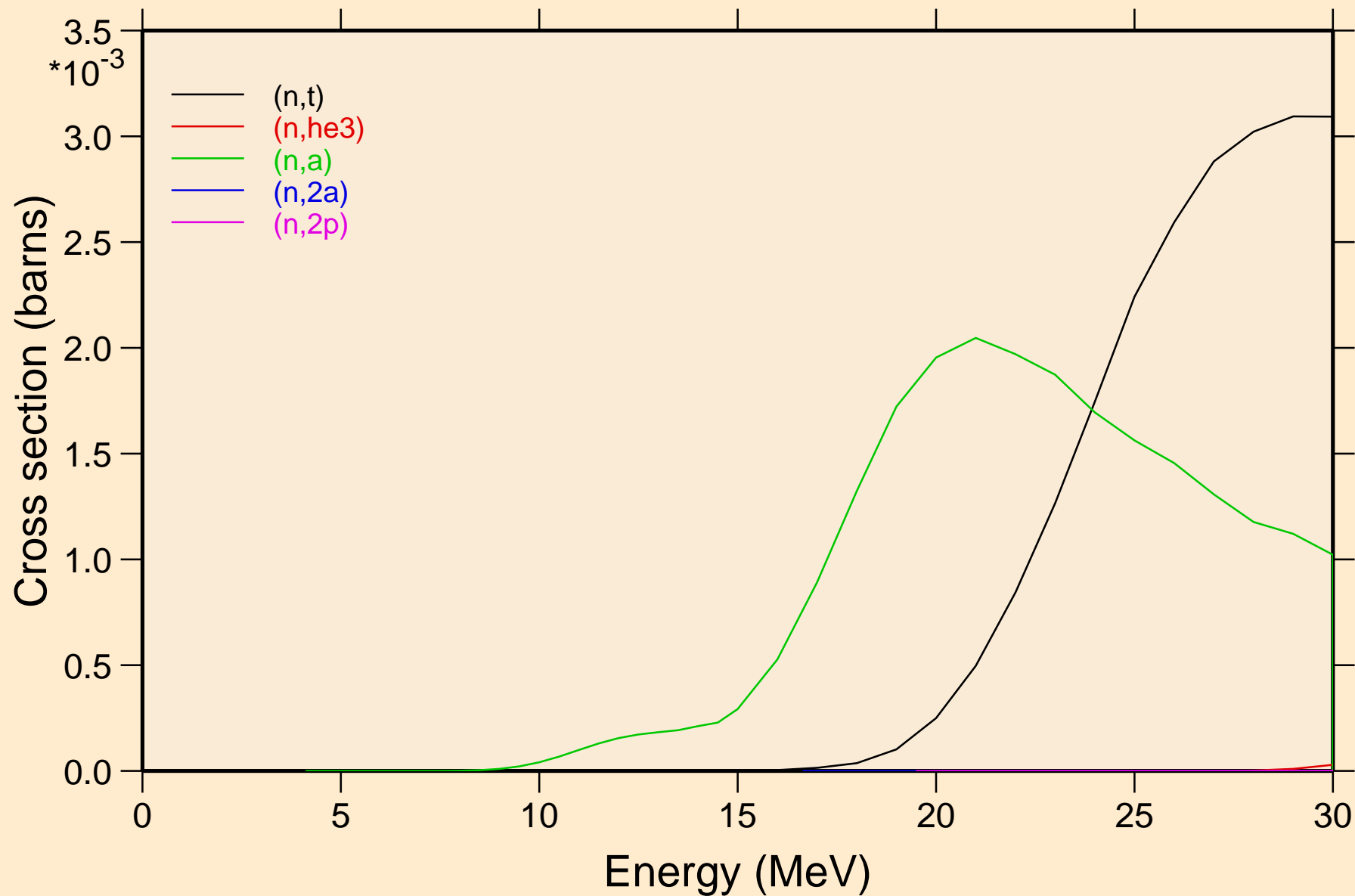

CA047 NEUTRON ACER TENDL-2019 LIBRARY; T=293.16K
Threshold reactions

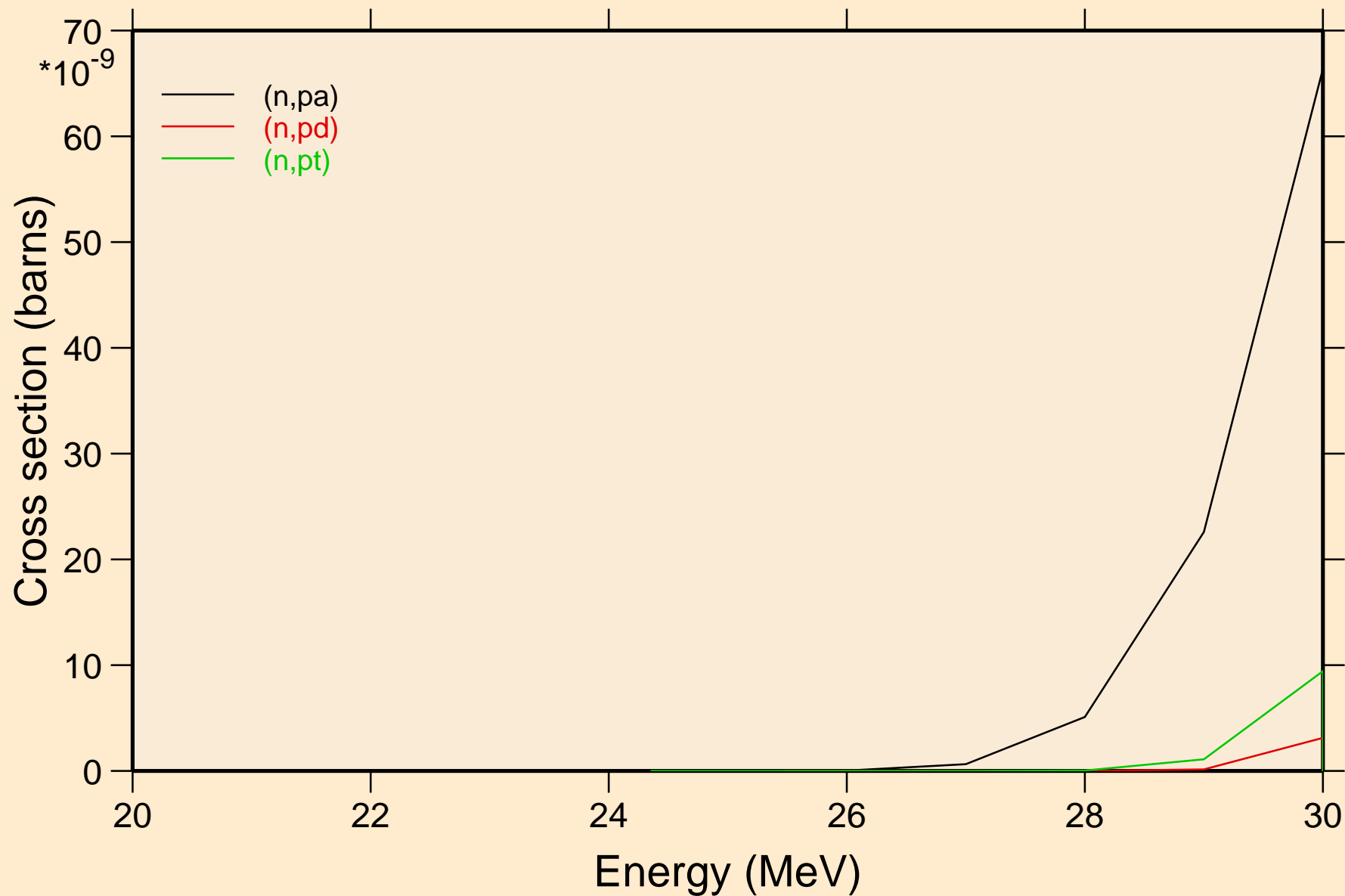

CA047 NEUTRON ACER TENDL-2019 LIBRARY; T=293.16K
Threshold reactions

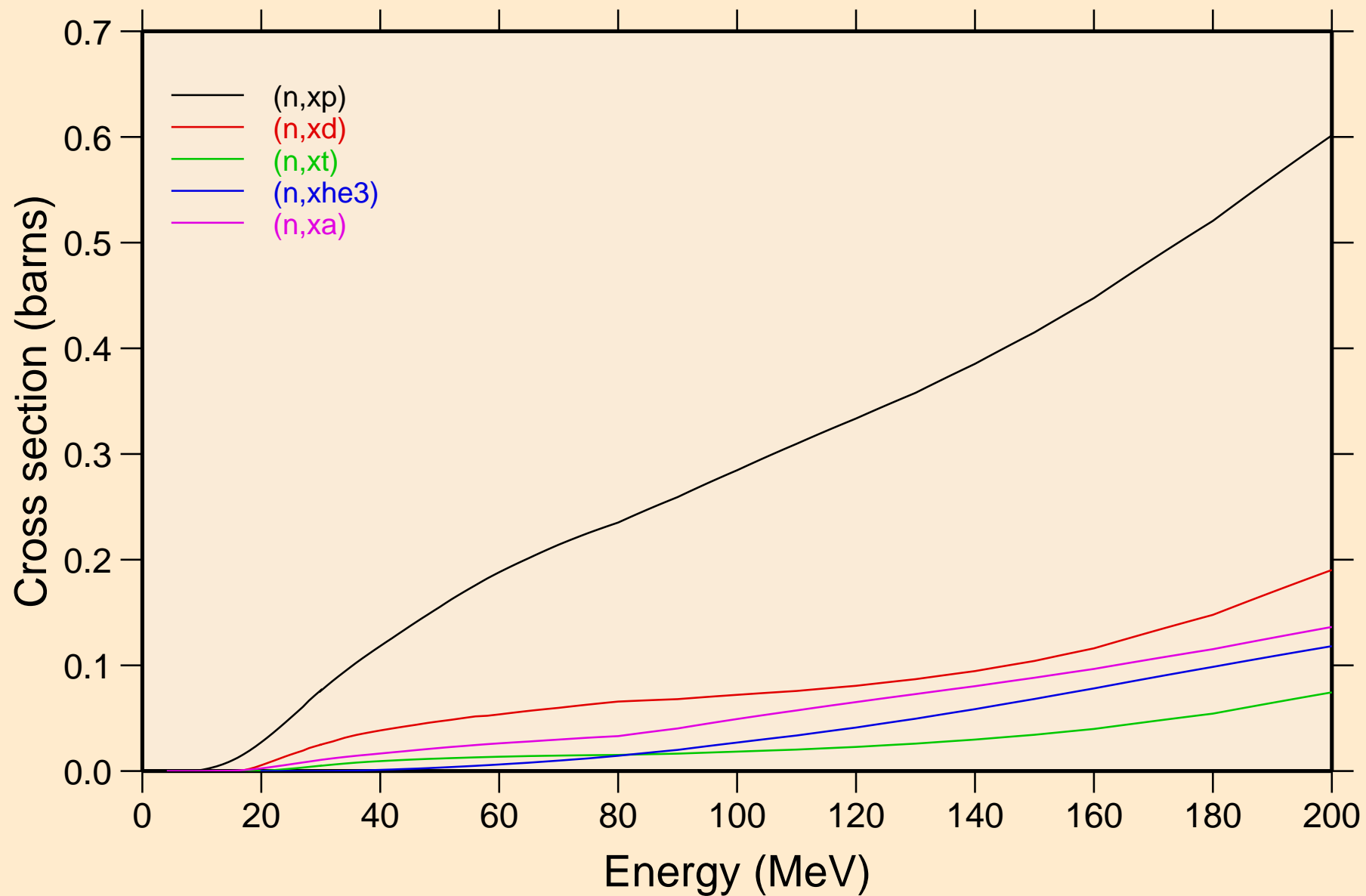

CA047 NEUTRON ACER TENDL-2019 LIBRARY; T=293.16K
angular distribution for elastic

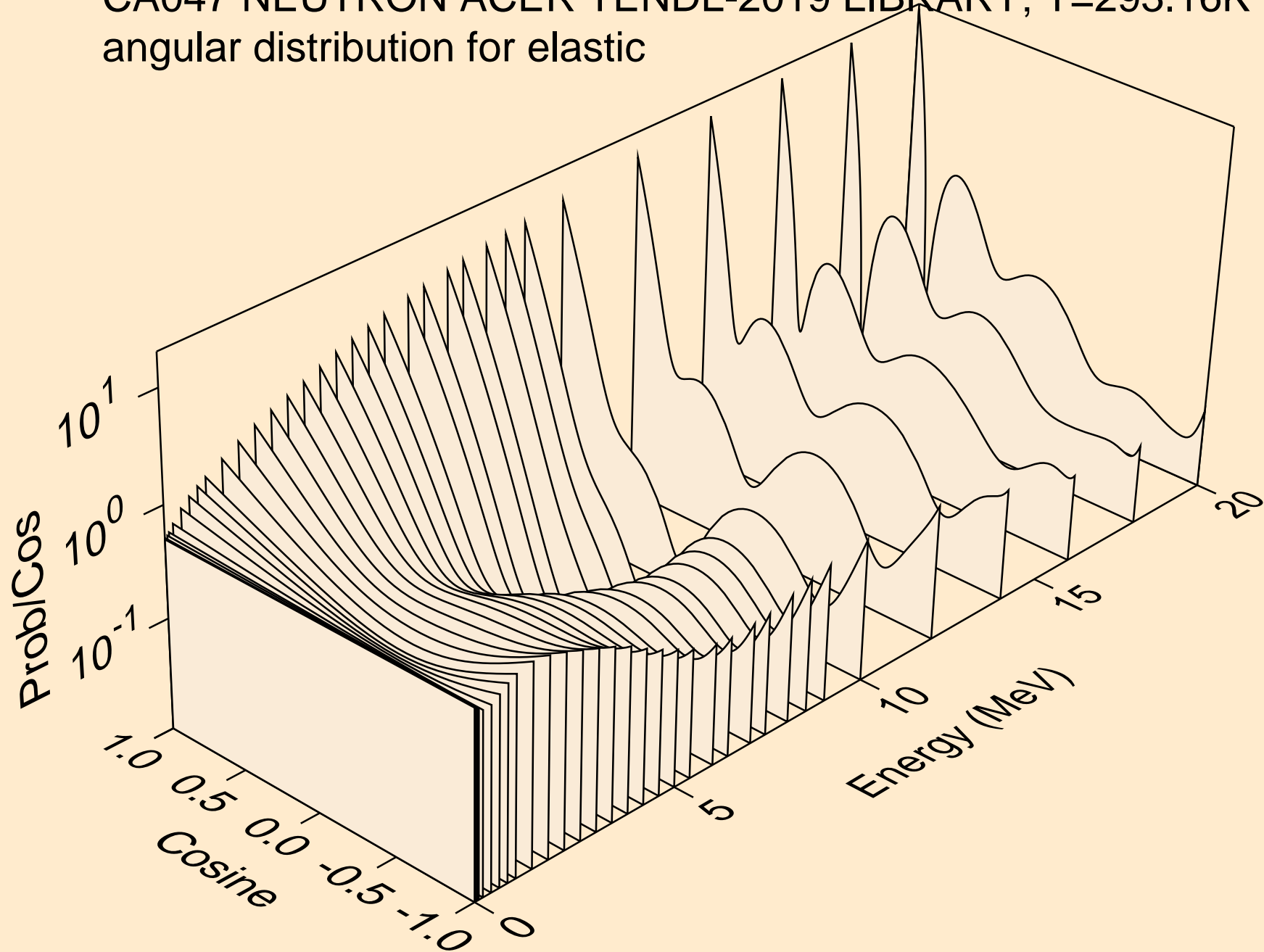

CA047 NEUTRON ACER TENDL-2019 LIBRARY; T=293.16K
angular distribution for elastic

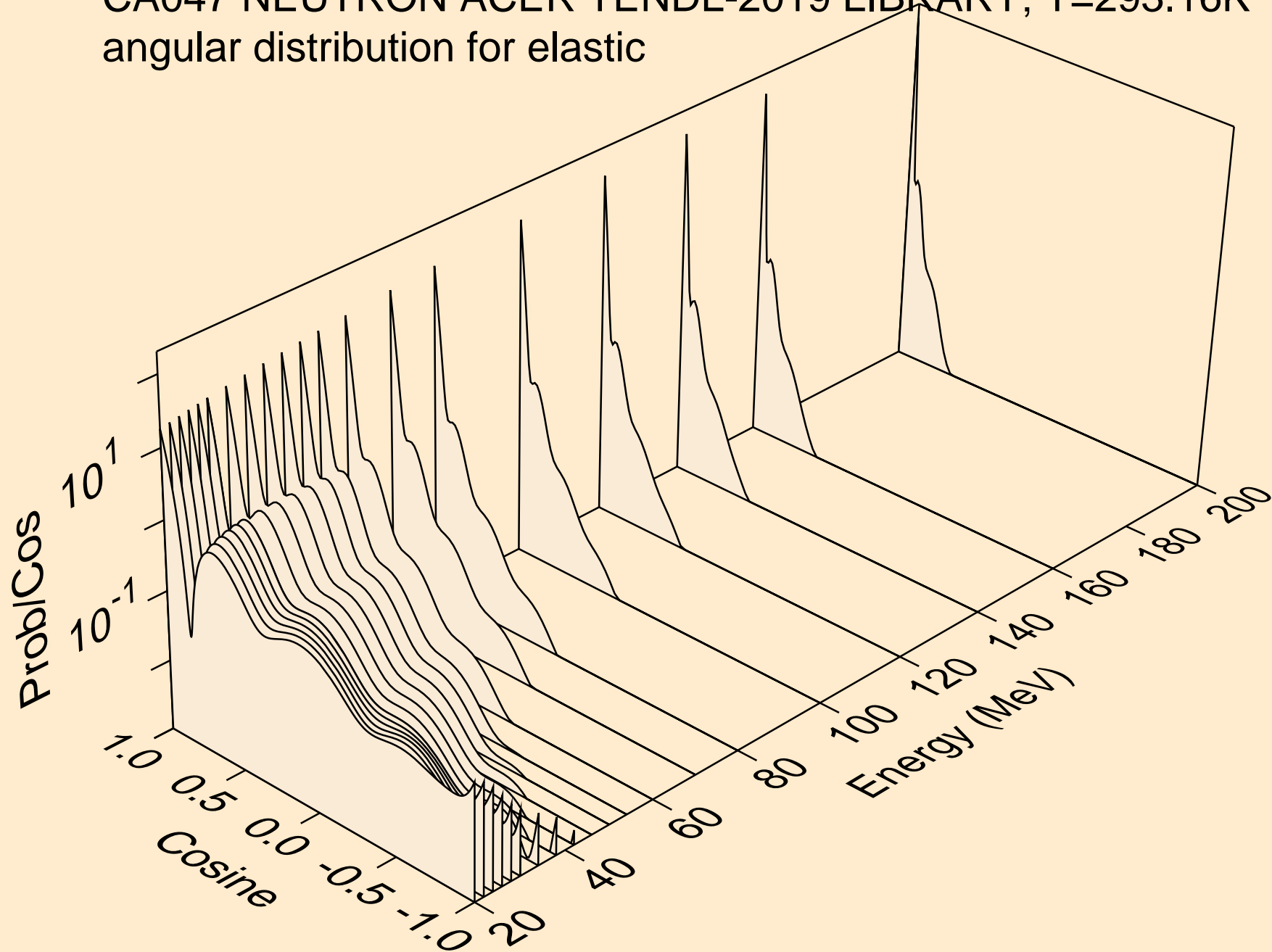

CA047 NEUTRON ACER TENDL-2019 LIBRARY; T=293.16K
angular distribution for (n,n*1)

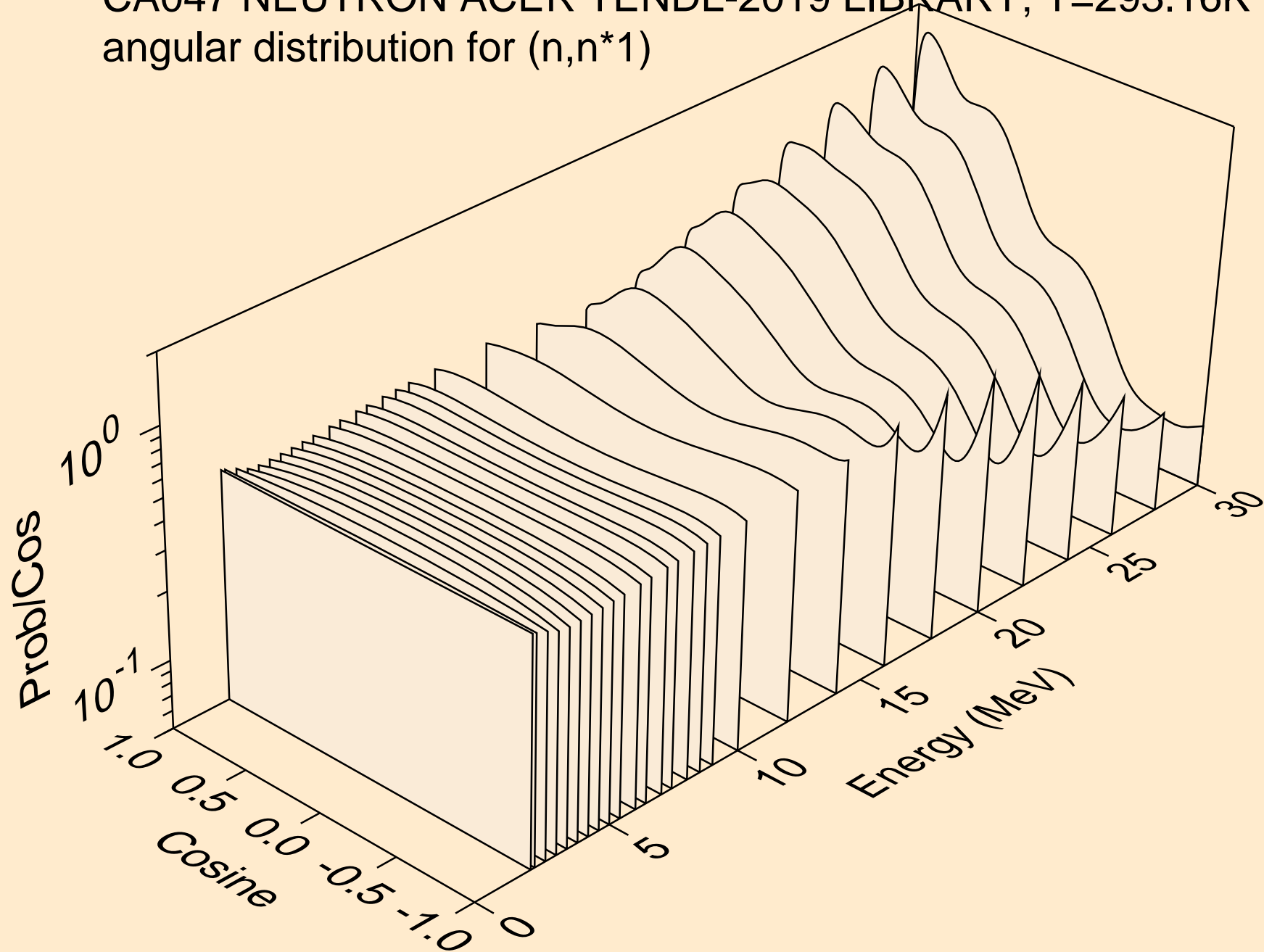

CA047 NEUTRON ACER TENDL-2019 LIBRARY; T=293.16K
angular distribution for (n,n*2)

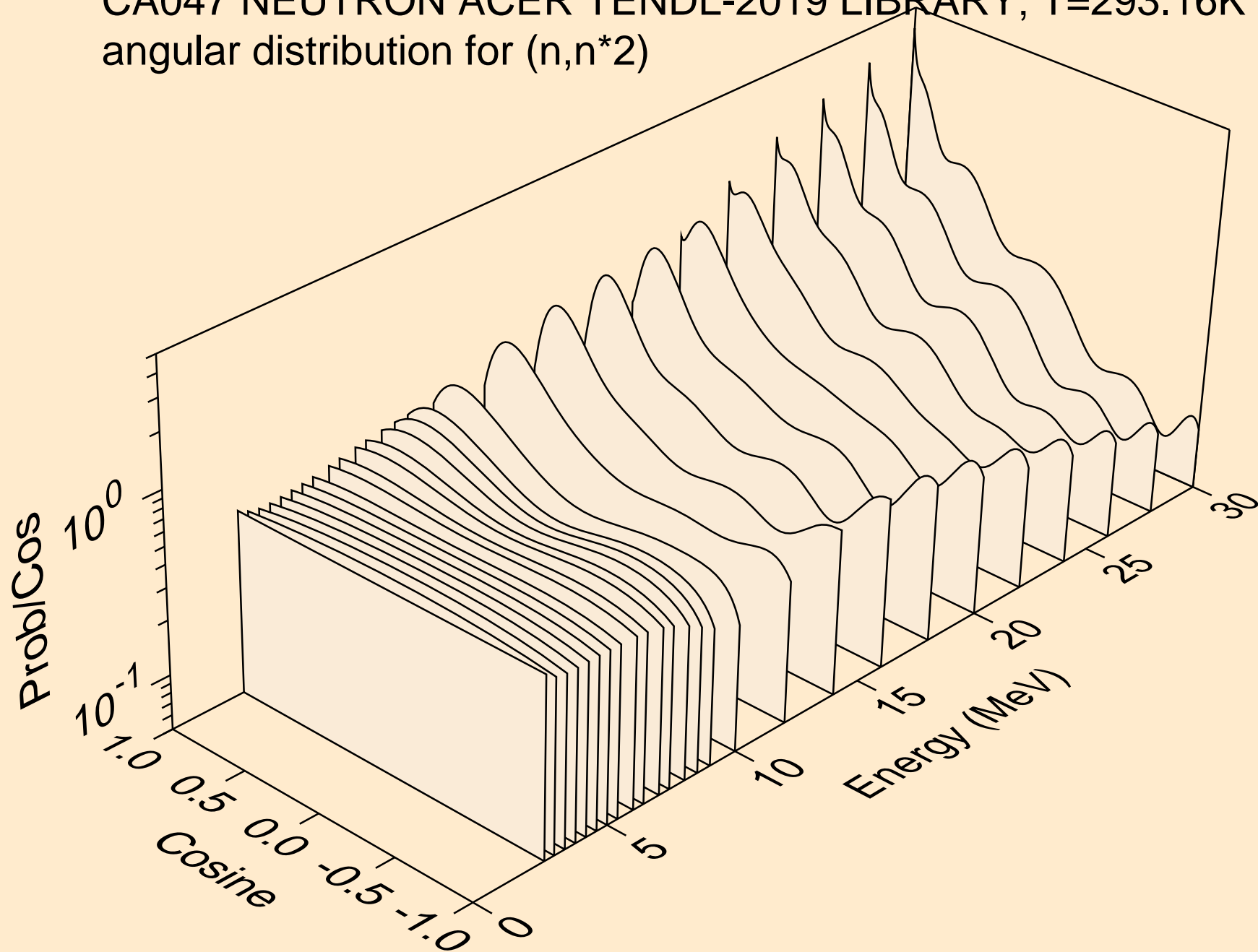

CA047 NEUTRON ACER TENDL-2019 LIBRARY; T=293.16K
angular distribution for (n,n*3)

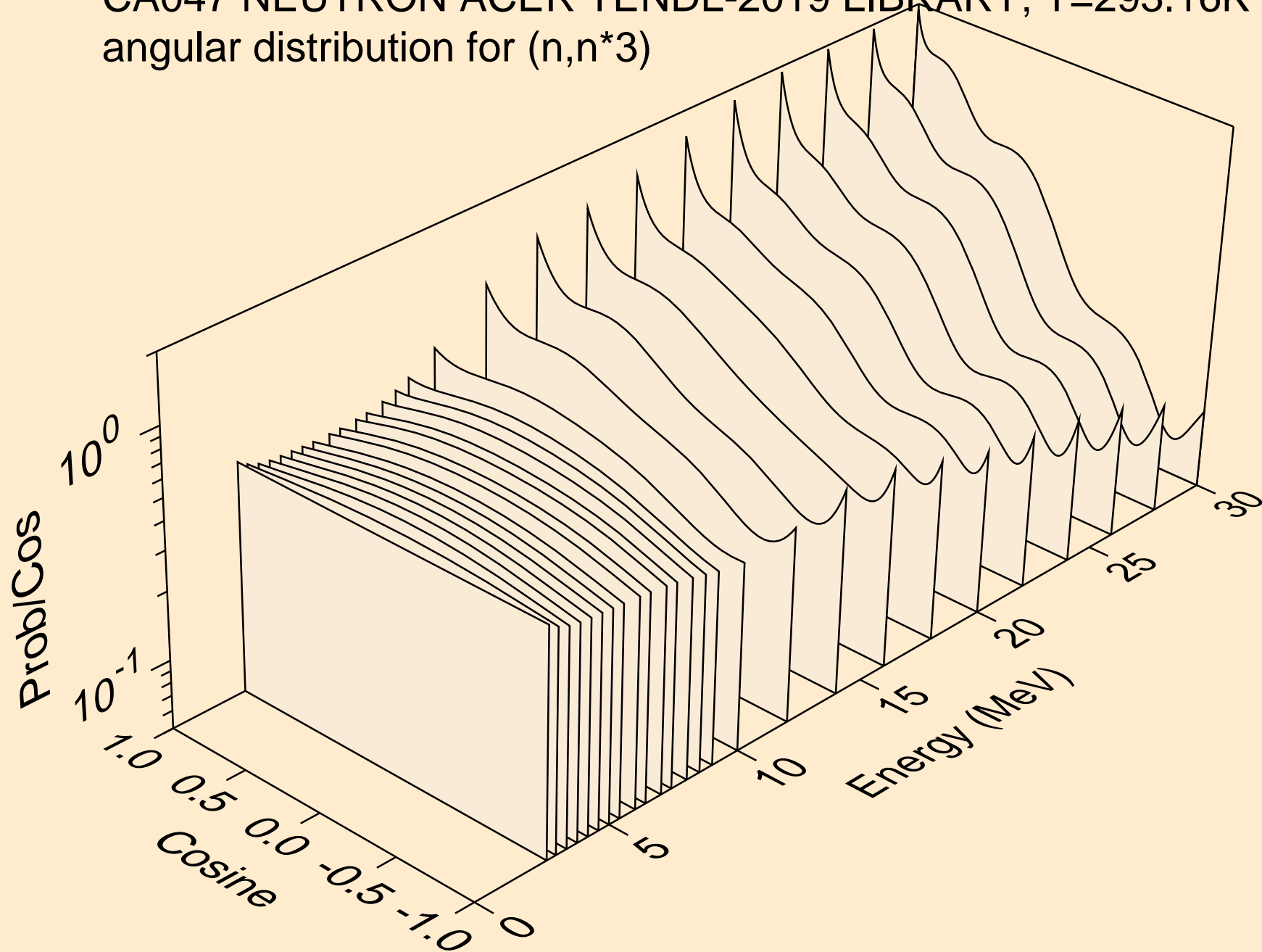

CA047 NEUTRON ACER TENDL-2019 LIBRARY; T=293.16K
angular distribution for (n,n*4)

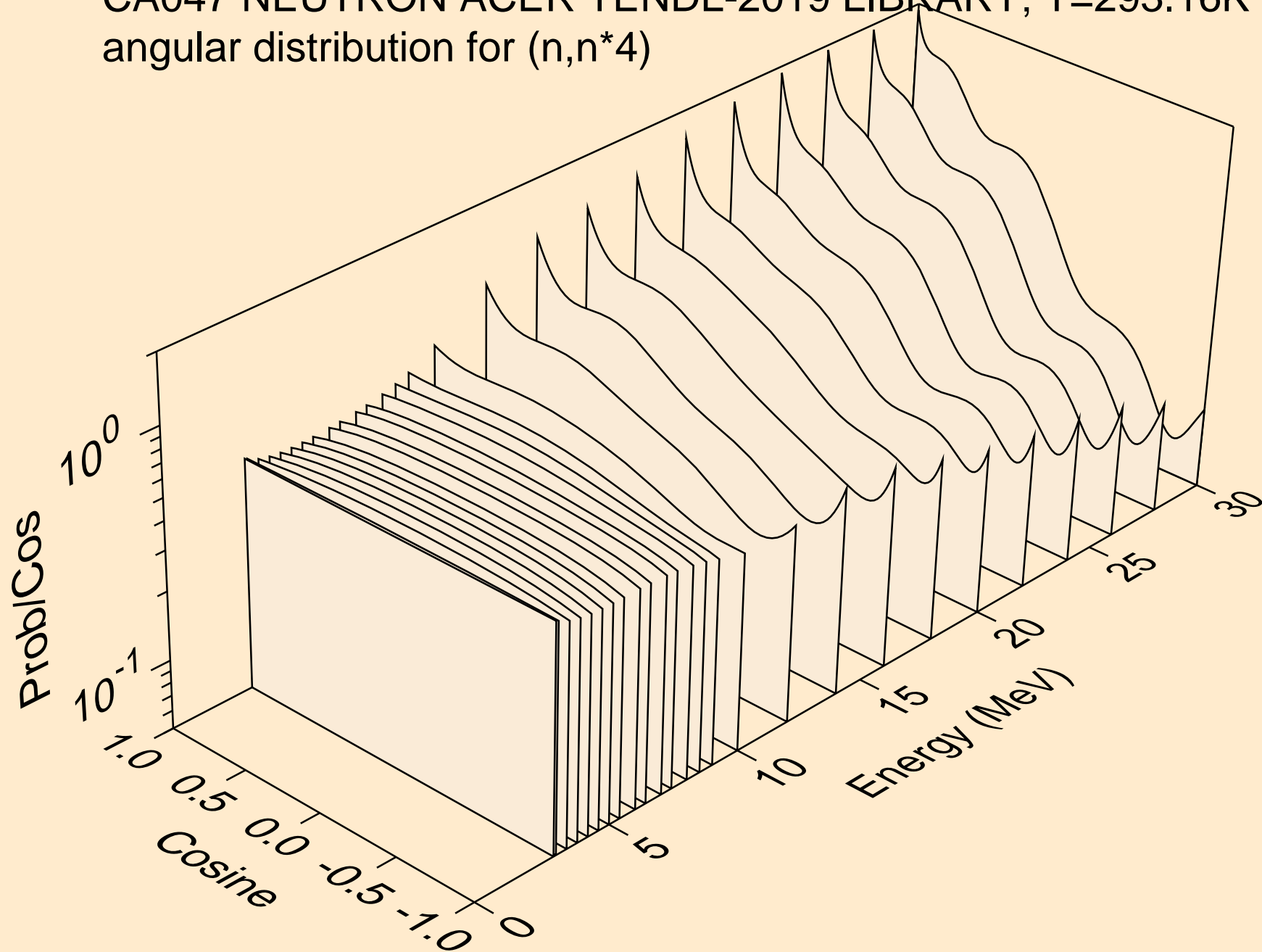

CA047 NEUTRON ACER TENDL-2019 LIBRARY; T=293.16K
angular distribution for (n,n*5)

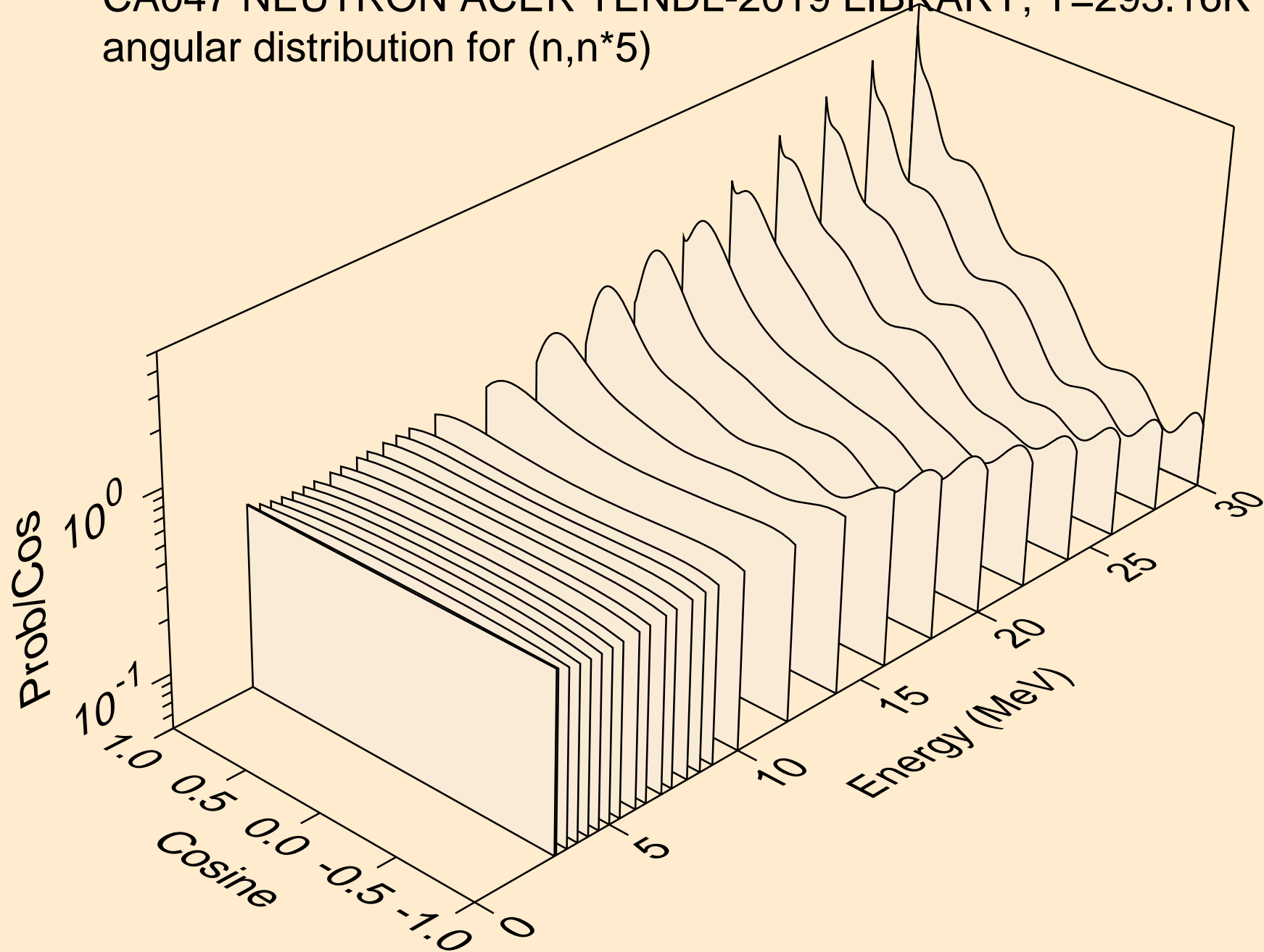

CA047 NEUTRON ACER TENDL-2019 LIBRARY; T=293.16K
angular distribution for (n,n*6)

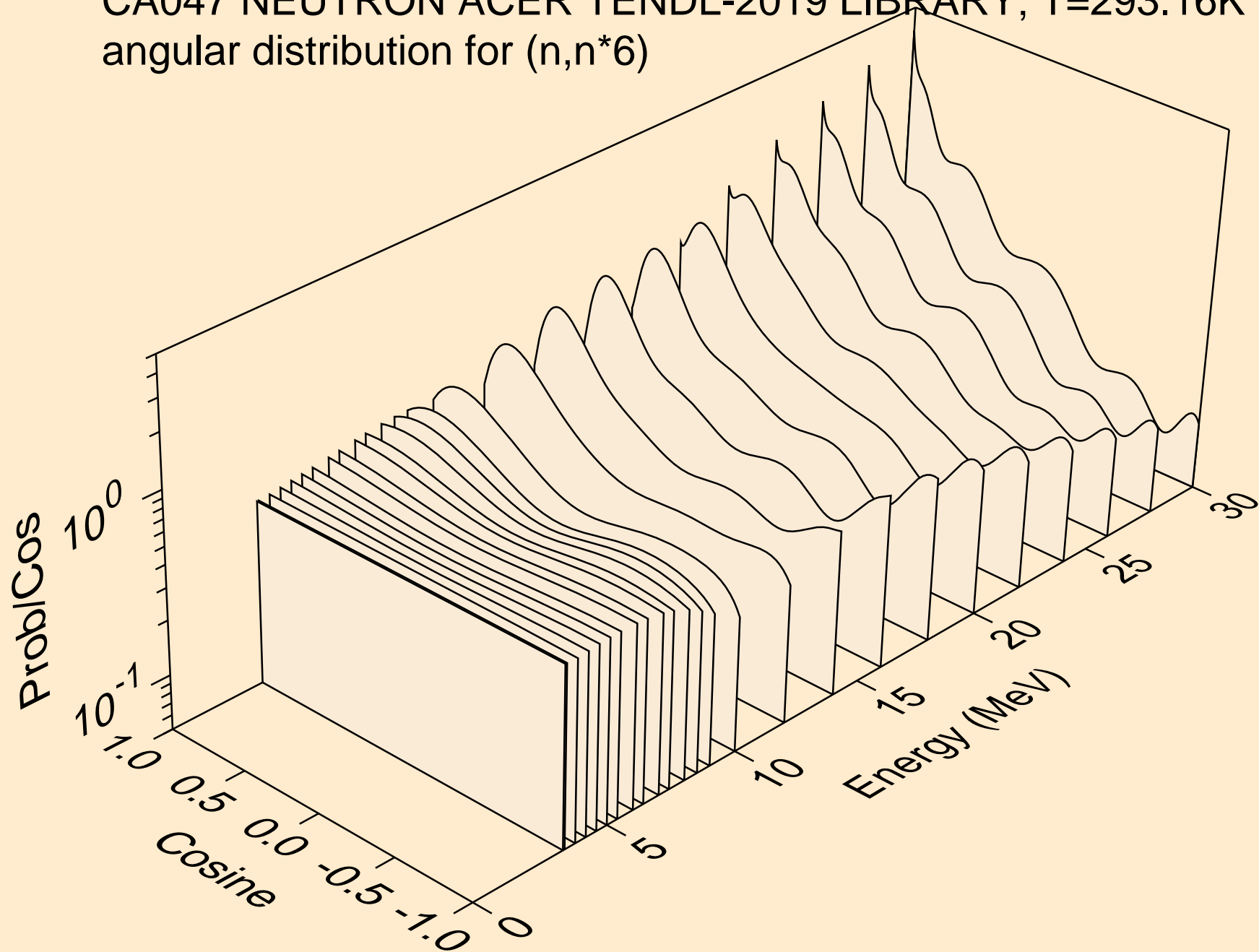

CA047 NEUTRON ACER TENDL-2019 LIBRARY; T=293.16K
angular distribution for (n,n*7)

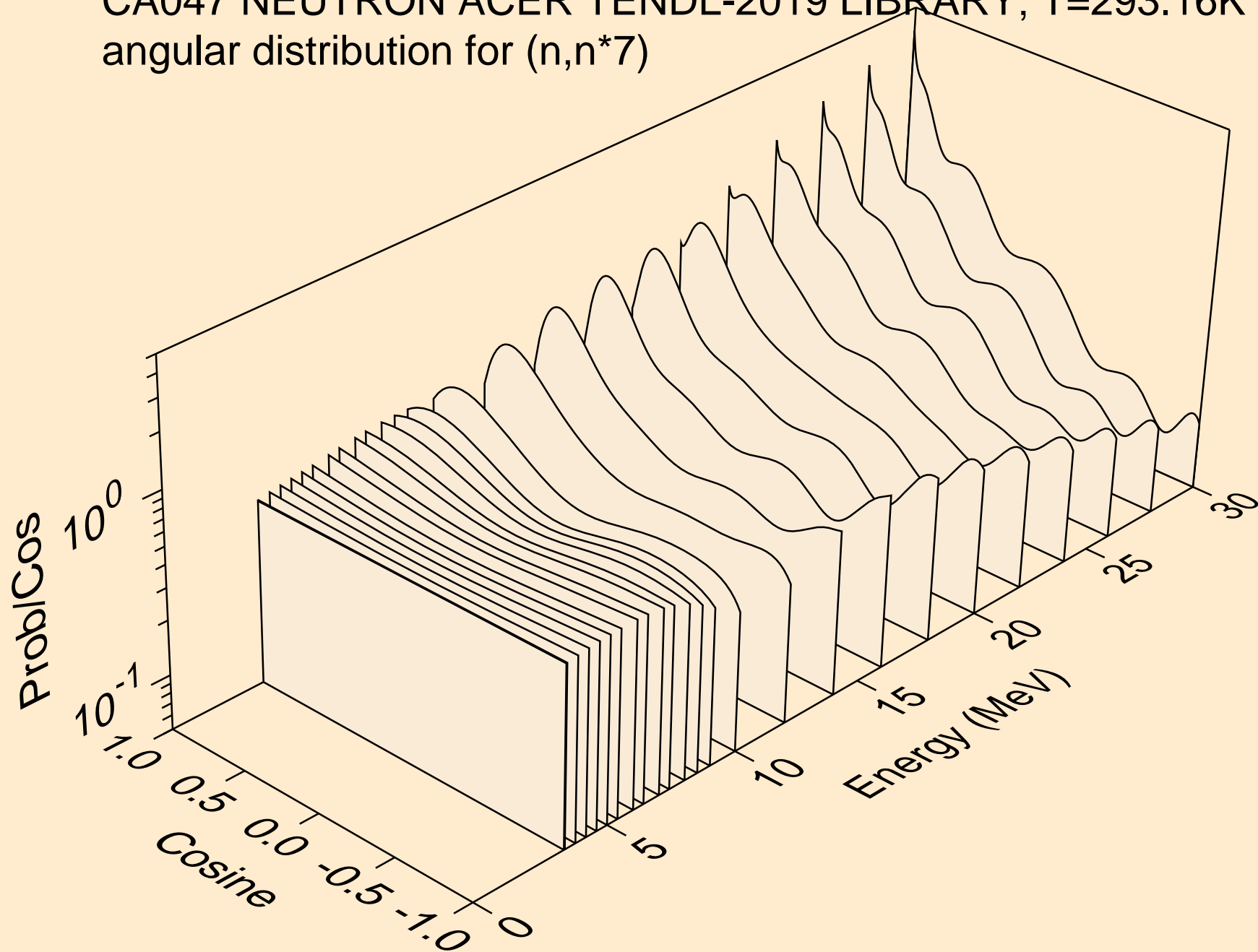

CA047 NEUTRON ACER TENDL-2019 LIBRARY; T=293.16K
angular distribution for (n,n*8)

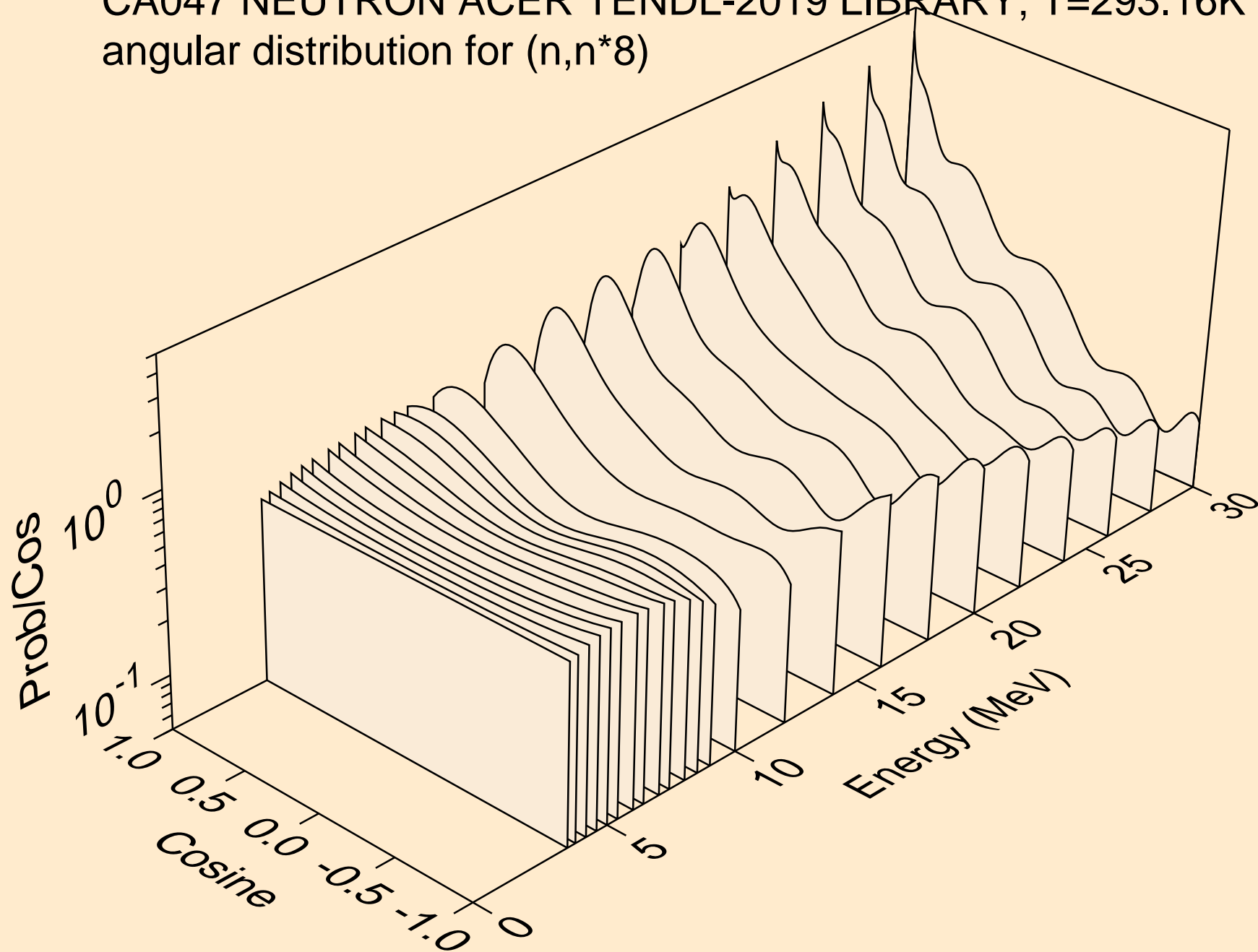

CA047 NEUTRON ACER TENDL-2019 LIBRARY; T=293.16K
angular distribution for (n,n*9)

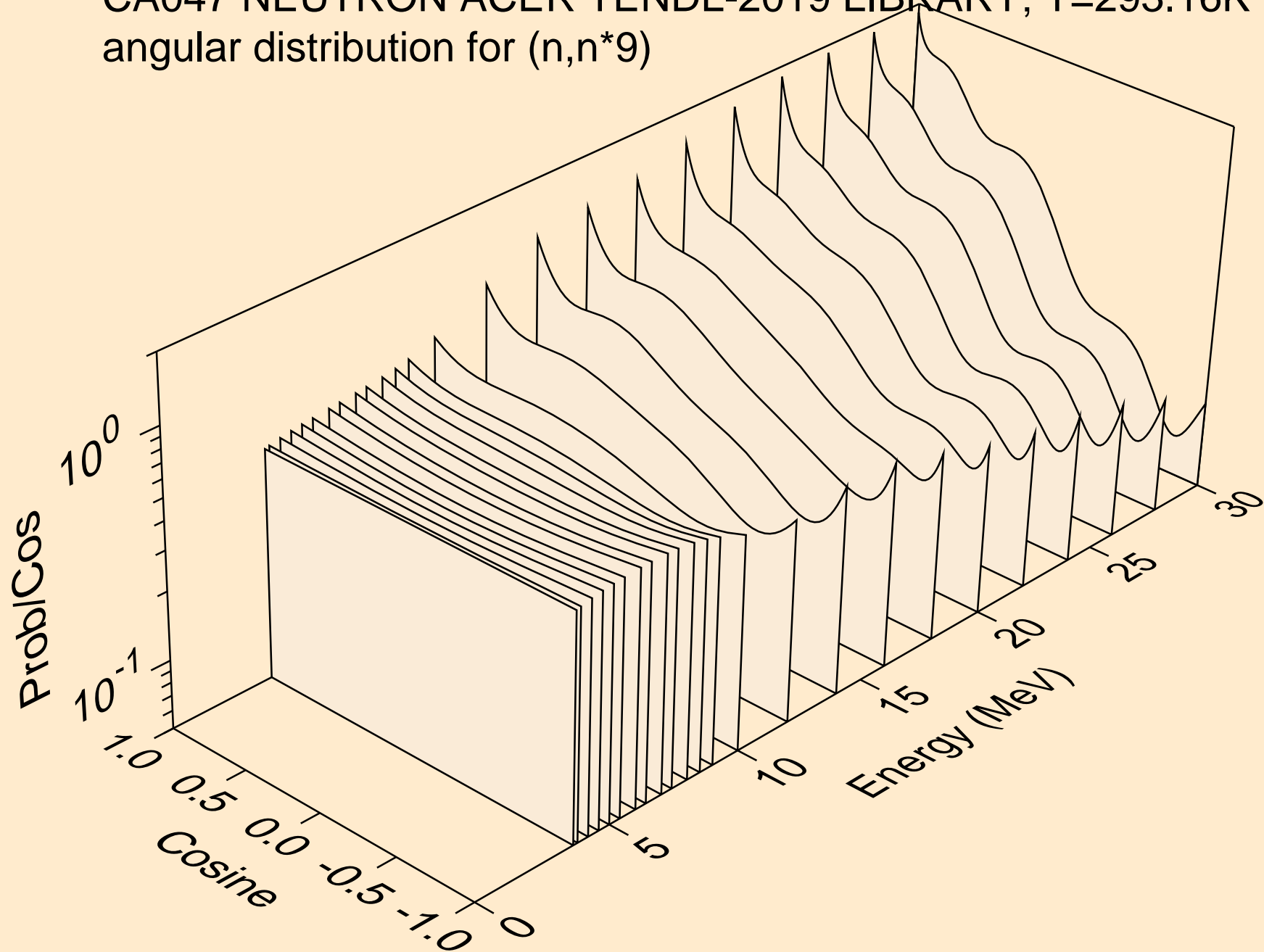

CA047 NEUTRON ACER TENDL-2019 LIBRARY; T=293.16K
angular distribution for (n,n*10)

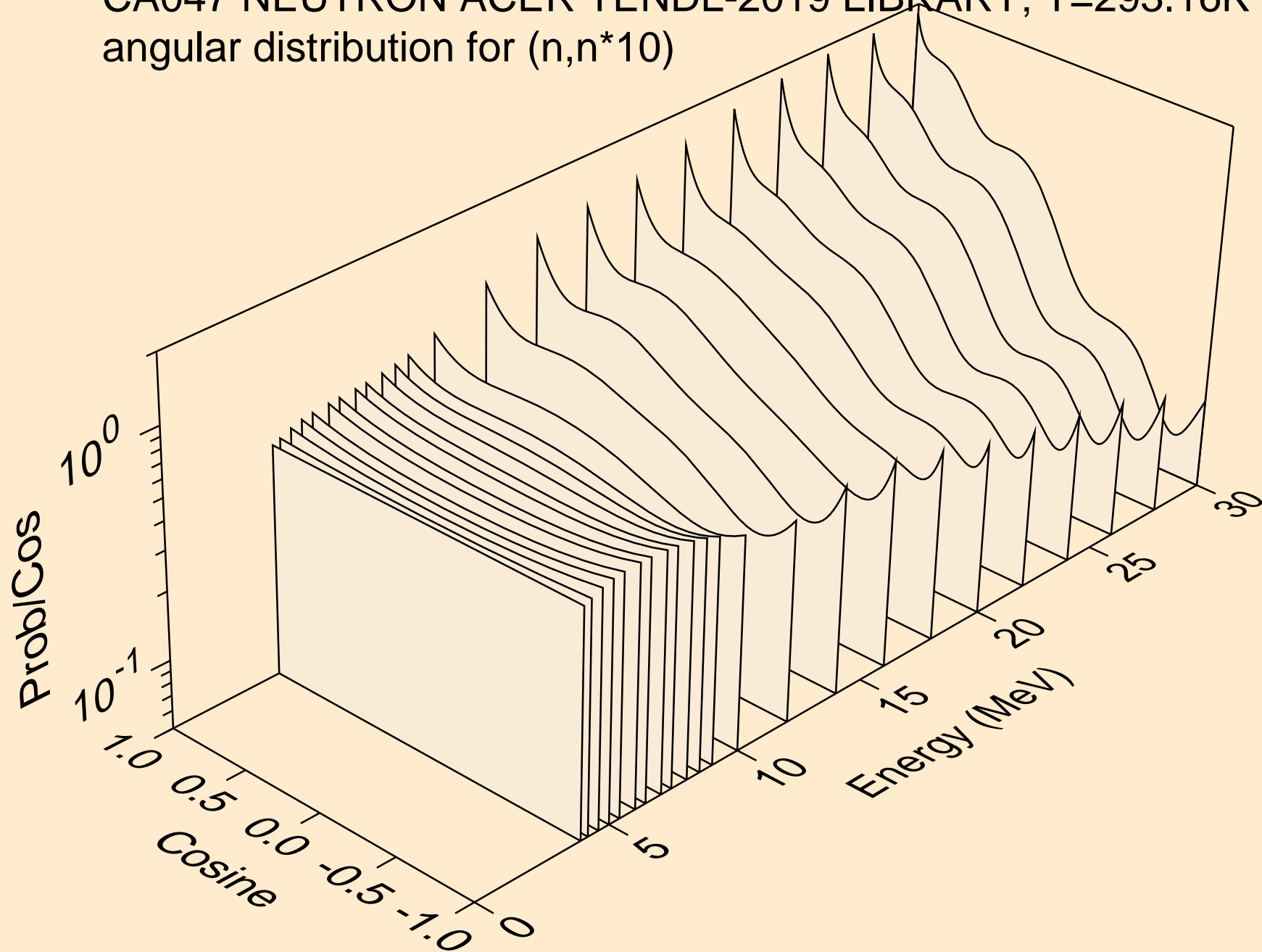

CA047 NEUTRON ACER TENDL-2019 LIBRARY; T=293.16K
angular distribution for (n,n*11)

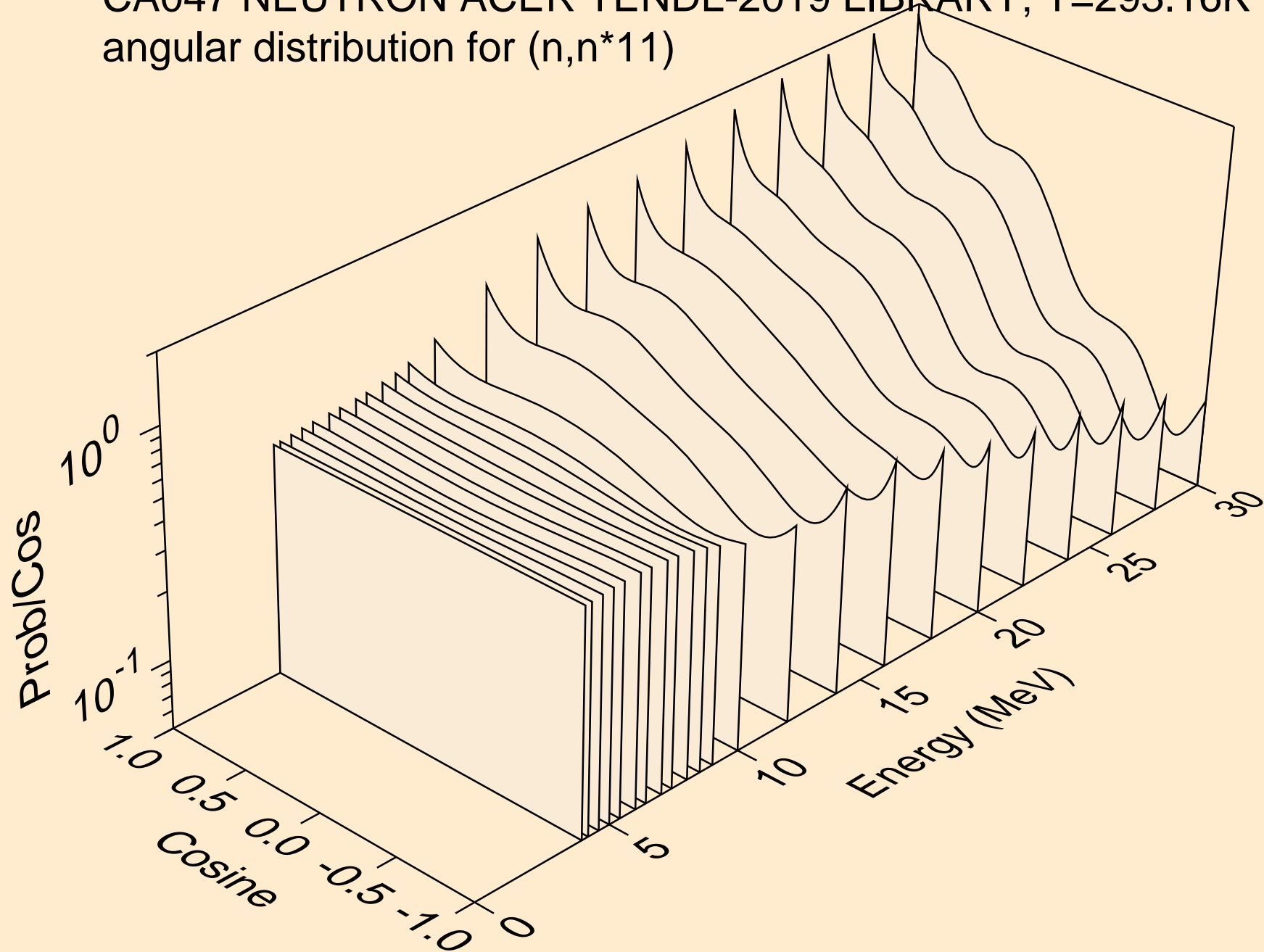

CA047 NEUTRON ACER TENDL-2019 LIBRARY; T=293.16K
angular distribution for (n,n*12)

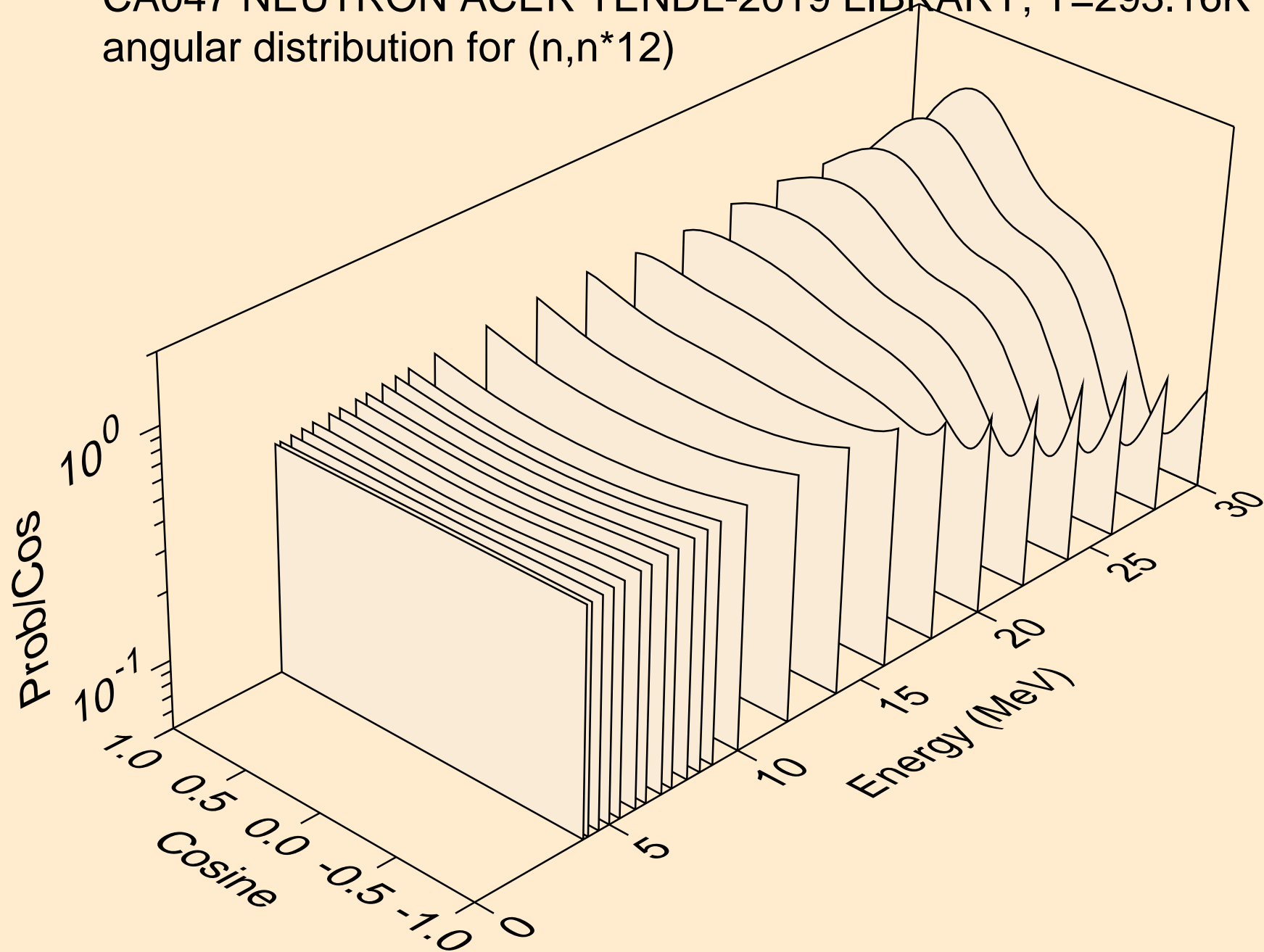

CA047 NEUTRON ACER TENDL-2019 LIBRARY; T=293.16K
angular distribution for (n,n*13)

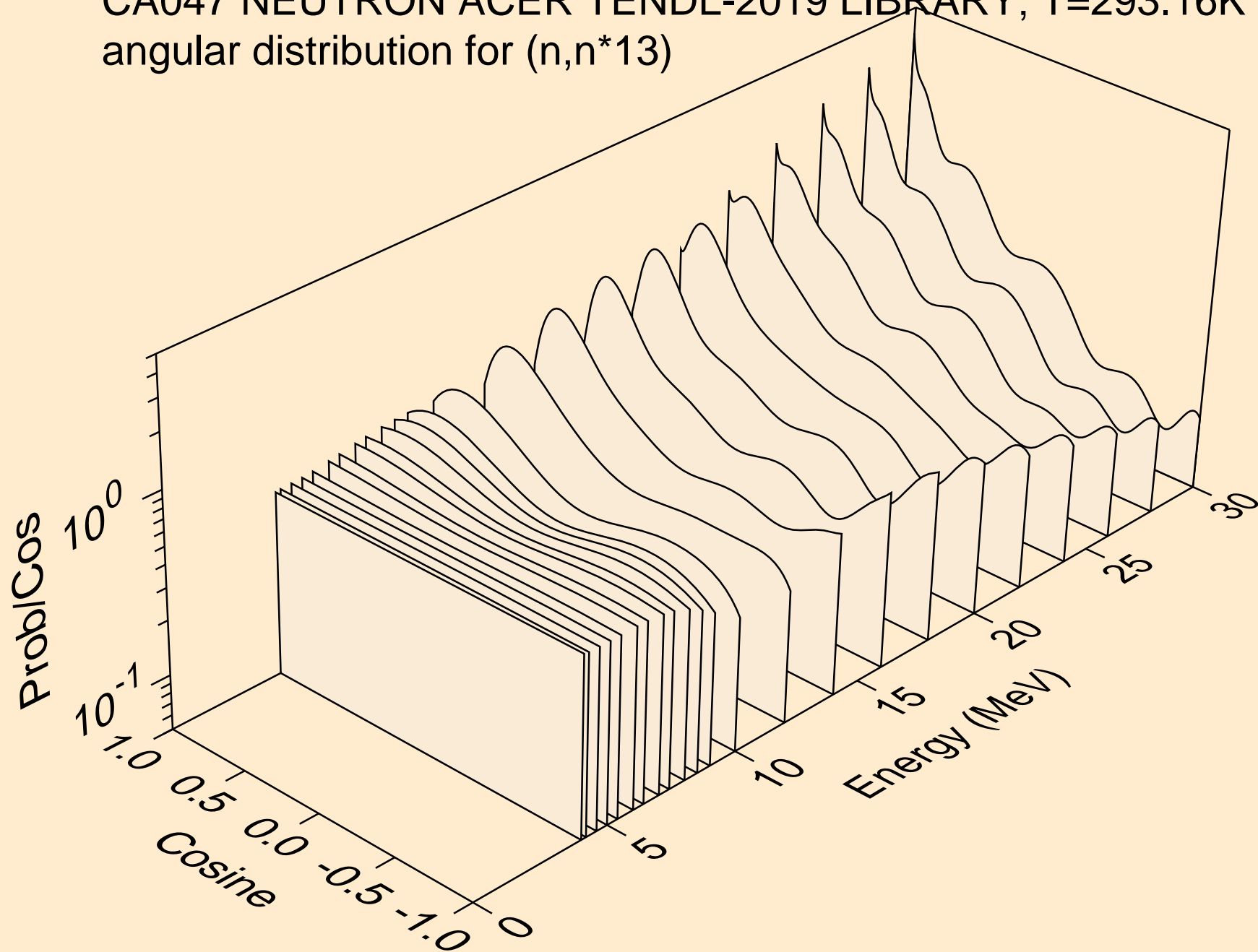

CA047 NEUTRON ACER TENDL-2019 LIBRARY; T=293.16K
angular distribution for (n,n*14)

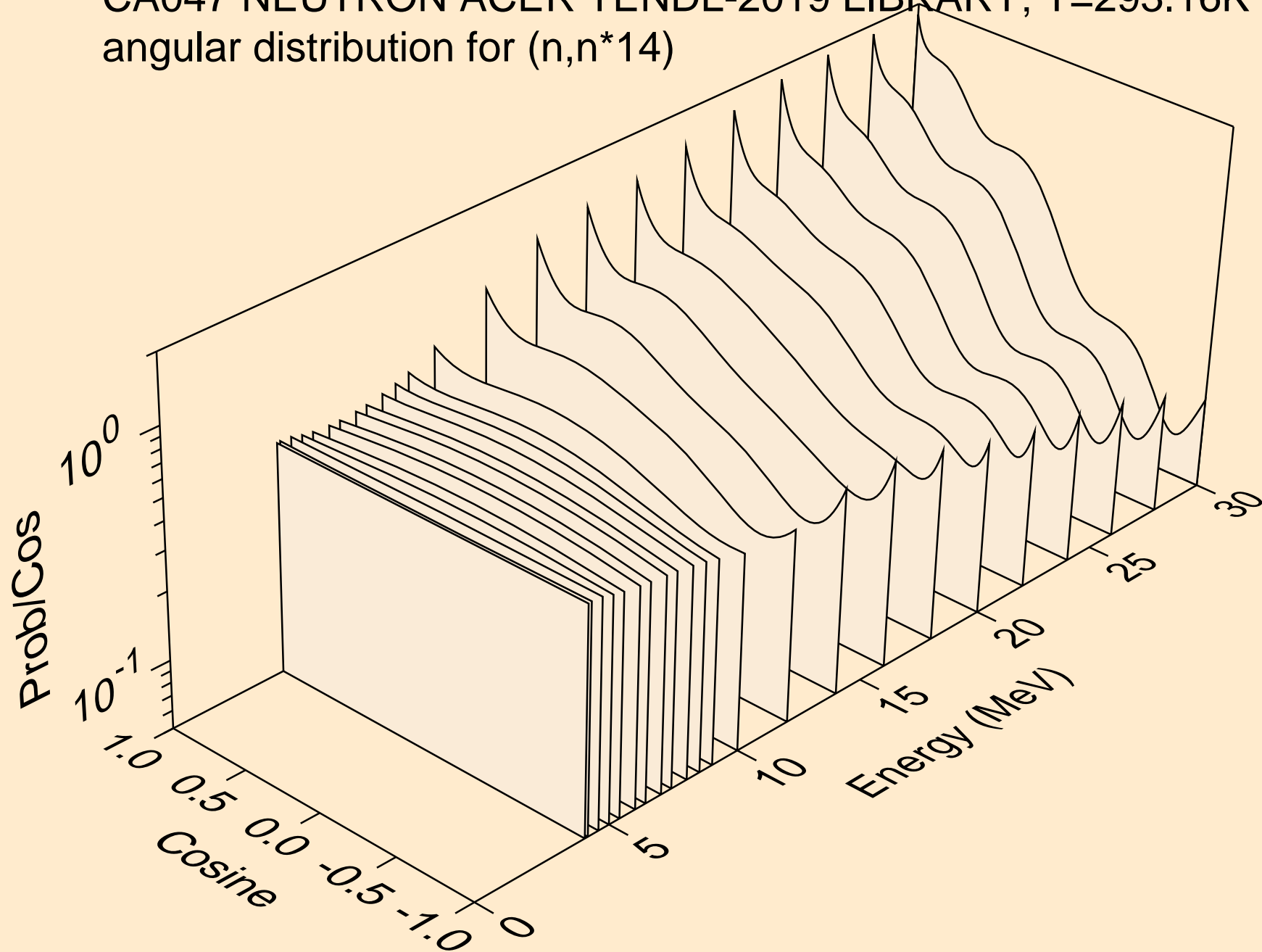

CA047 NEUTRON ACER TENDL-2019 LIBRARY; T=293.16K
angular distribution for (n,n*15)

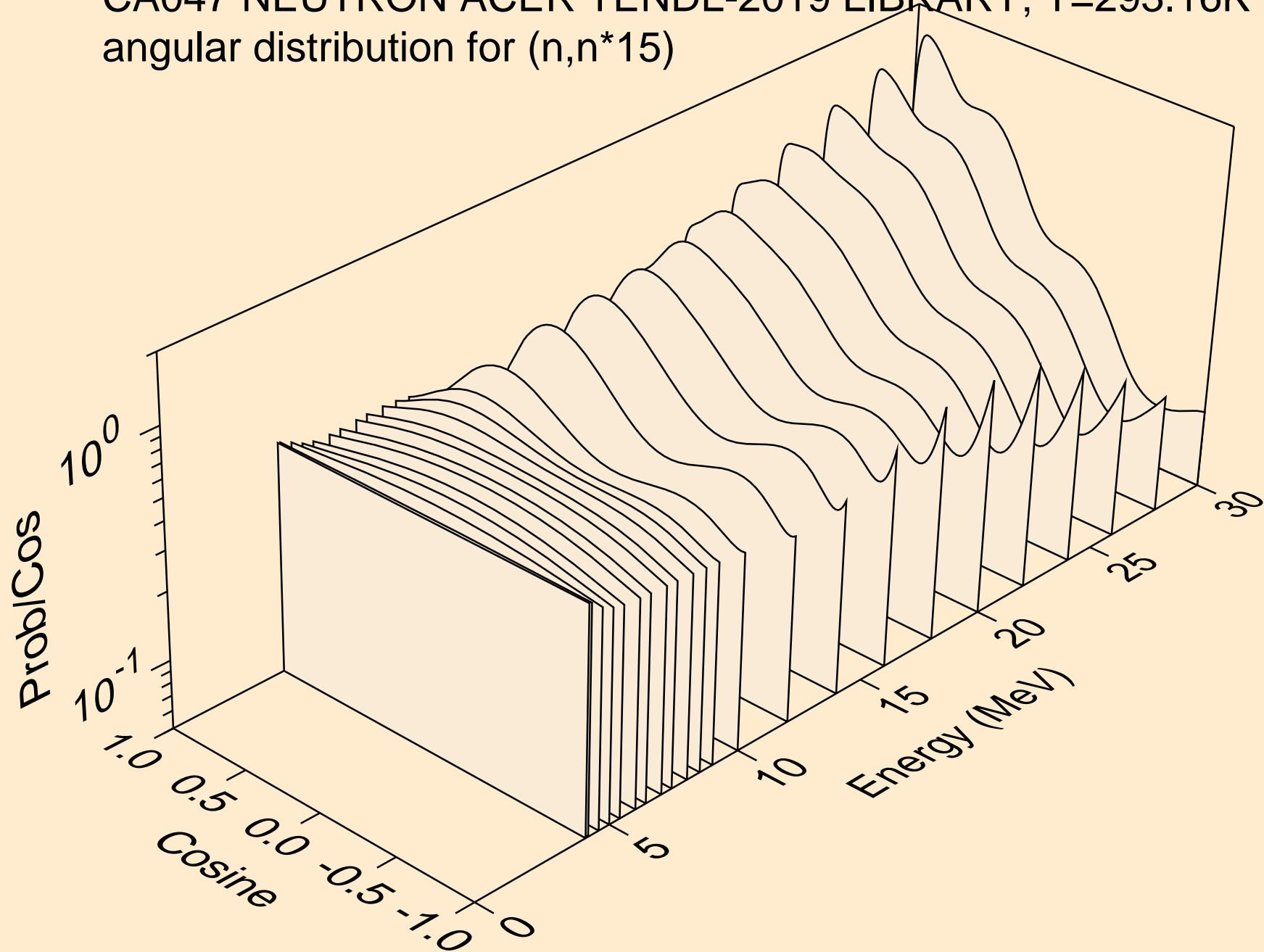

CA047 NEUTRON ACER TENDL-2019 LIBRARY; T=293.16K
angular distribution for (n,n*16)

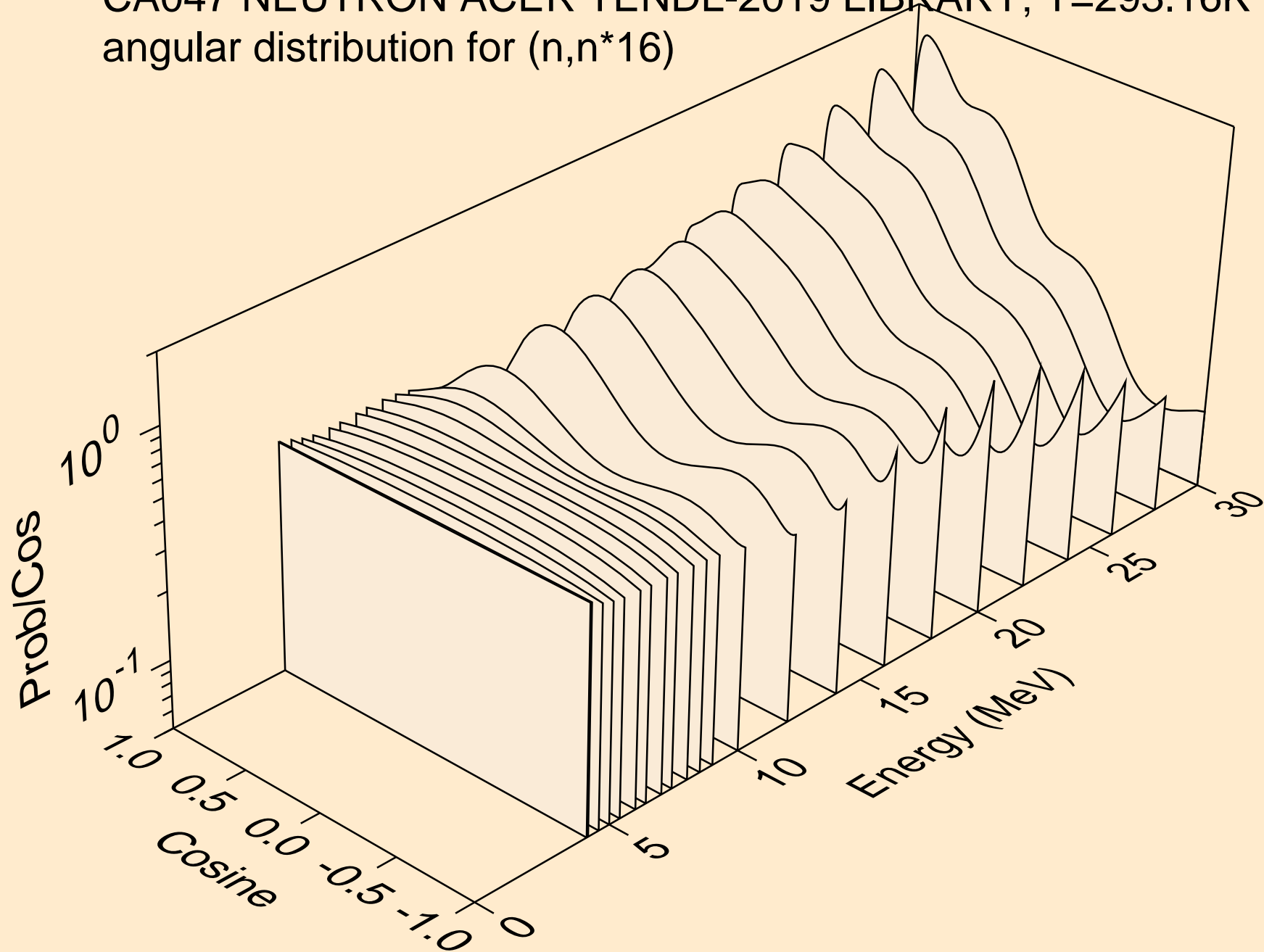

CA047 NEUTRON ACER TENDL-2019 LIBRARY; T=293.16K
angular distribution for (n,n*17)

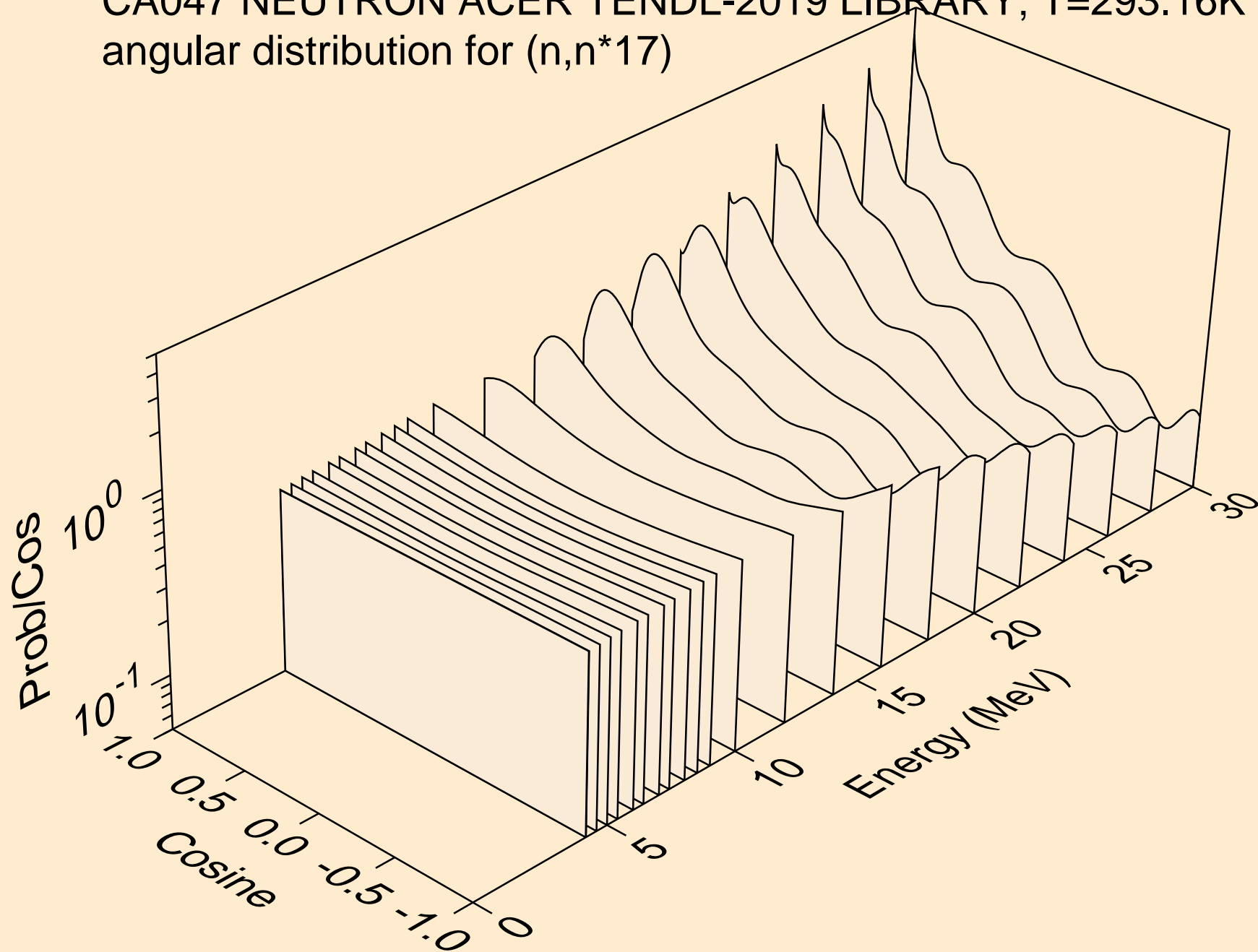

CA047 NEUTRON ACER TENDL-2019 LIBRARY; T=293.16K
angular distribution for (n,n*18)

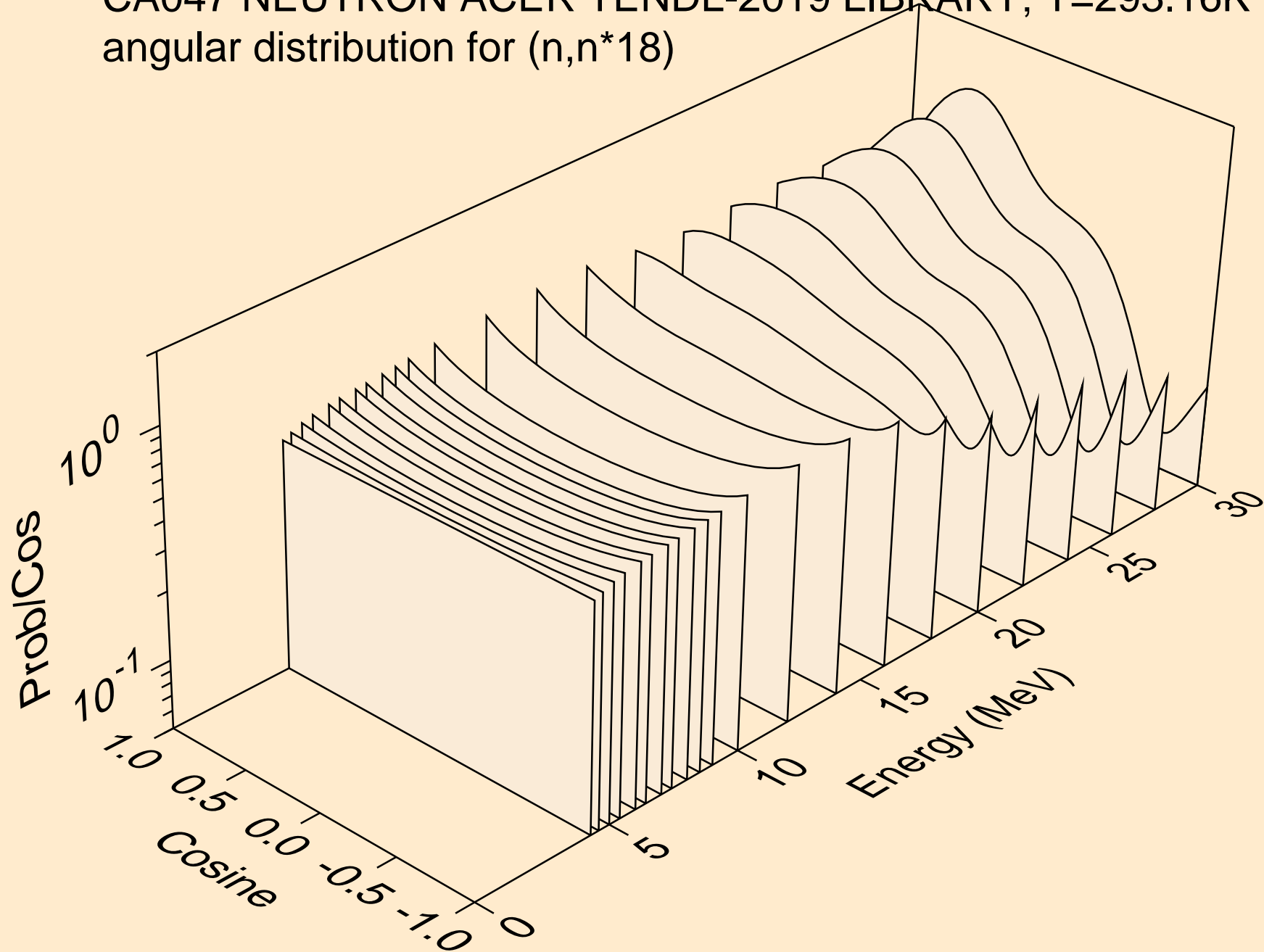

CA047 NEUTRON ACER TENDL-2019 LIBRARY; T=293.16K
angular distribution for (n,n*19)

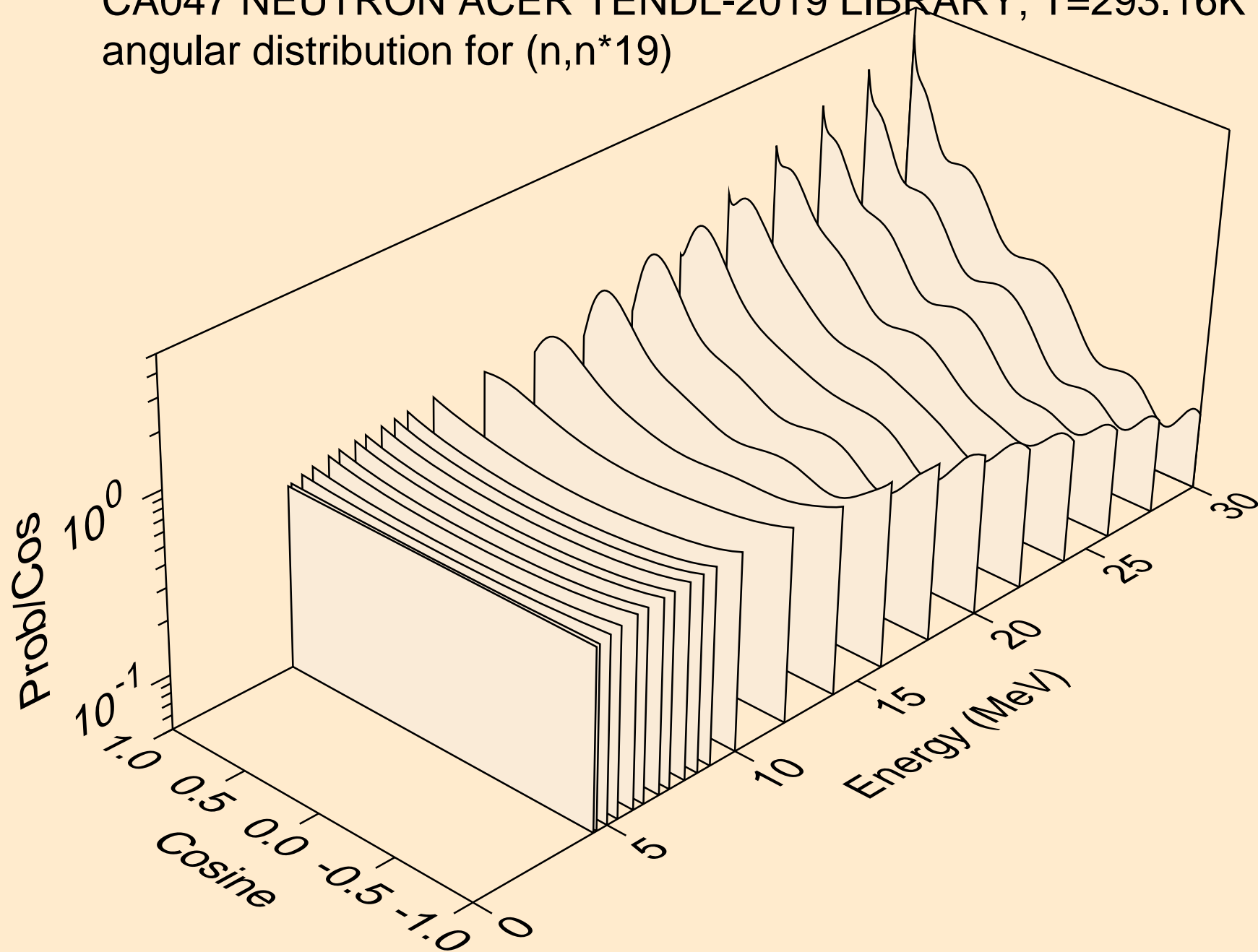

CA047 NEUTRON ACER TENDL-2019 LIBRARY; T=293.16K
angular distribution for (n,n*20)

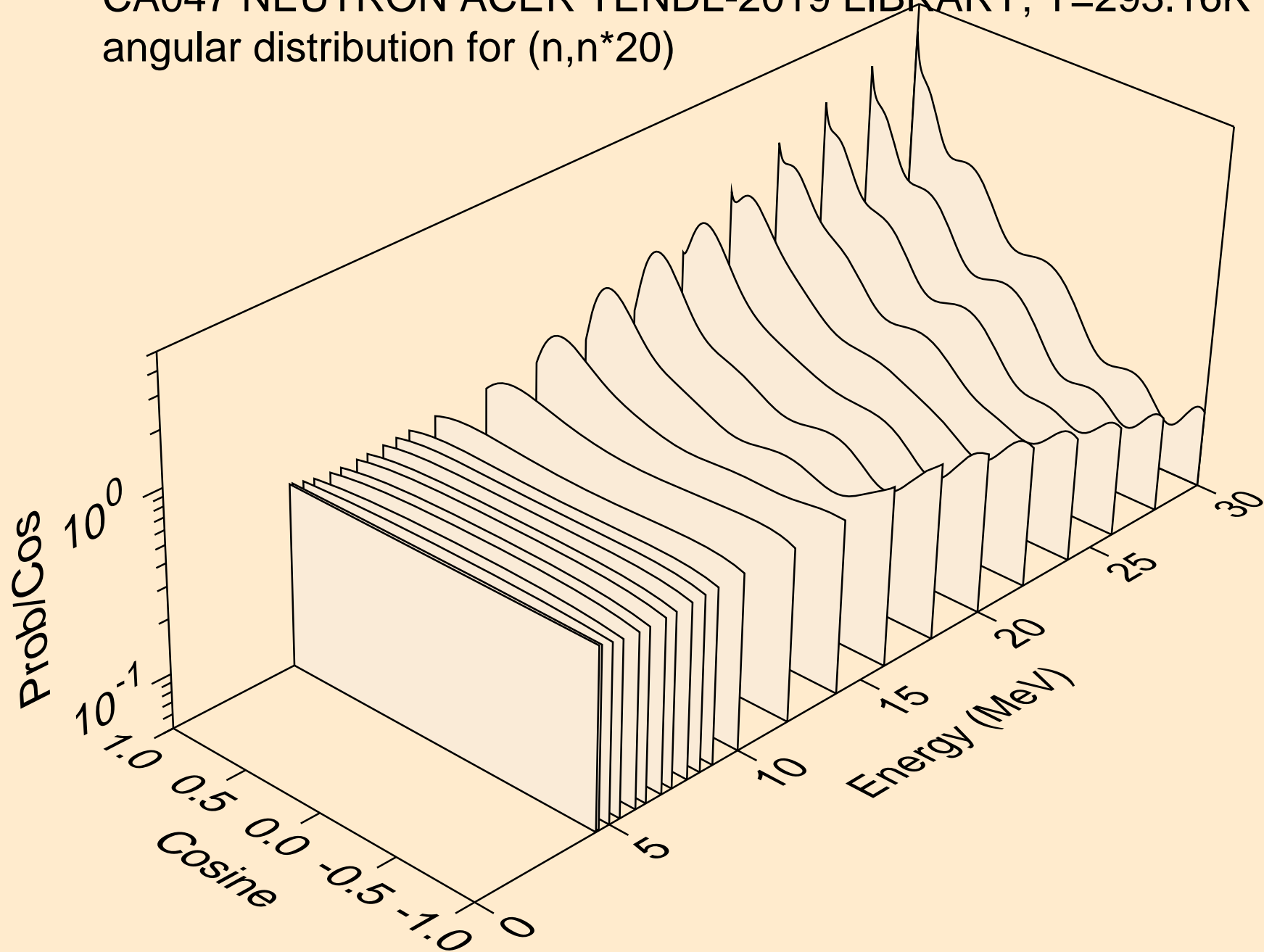

CA047 NEUTRON ACER TENDL-2019 LIBRARY; T=293.16K
angular distribution for (n,n*21)

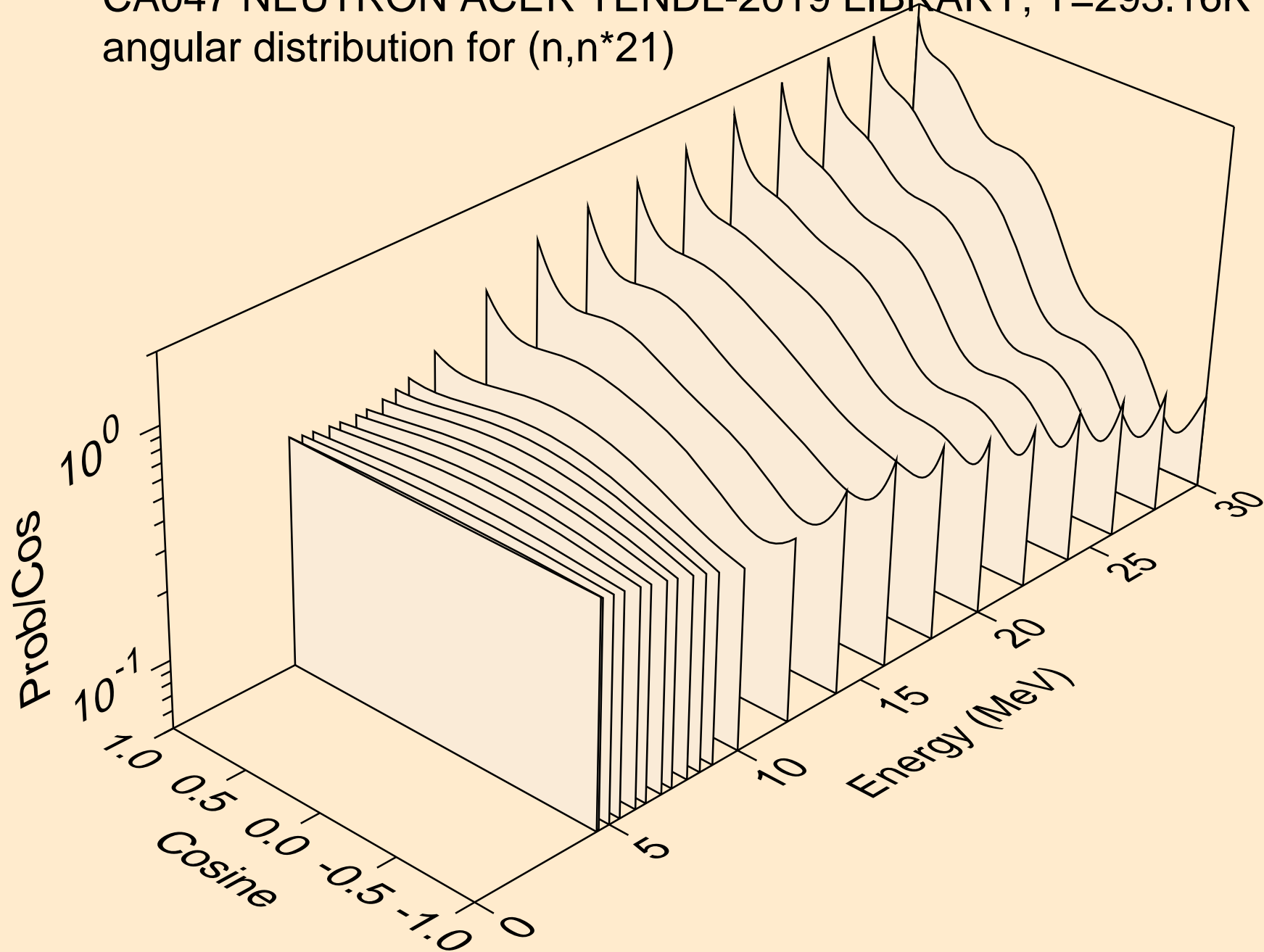

CA047 NEUTRON ACER TENDL-2019 LIBRARY; T=293.16K
angular distribution for (n,n*22)

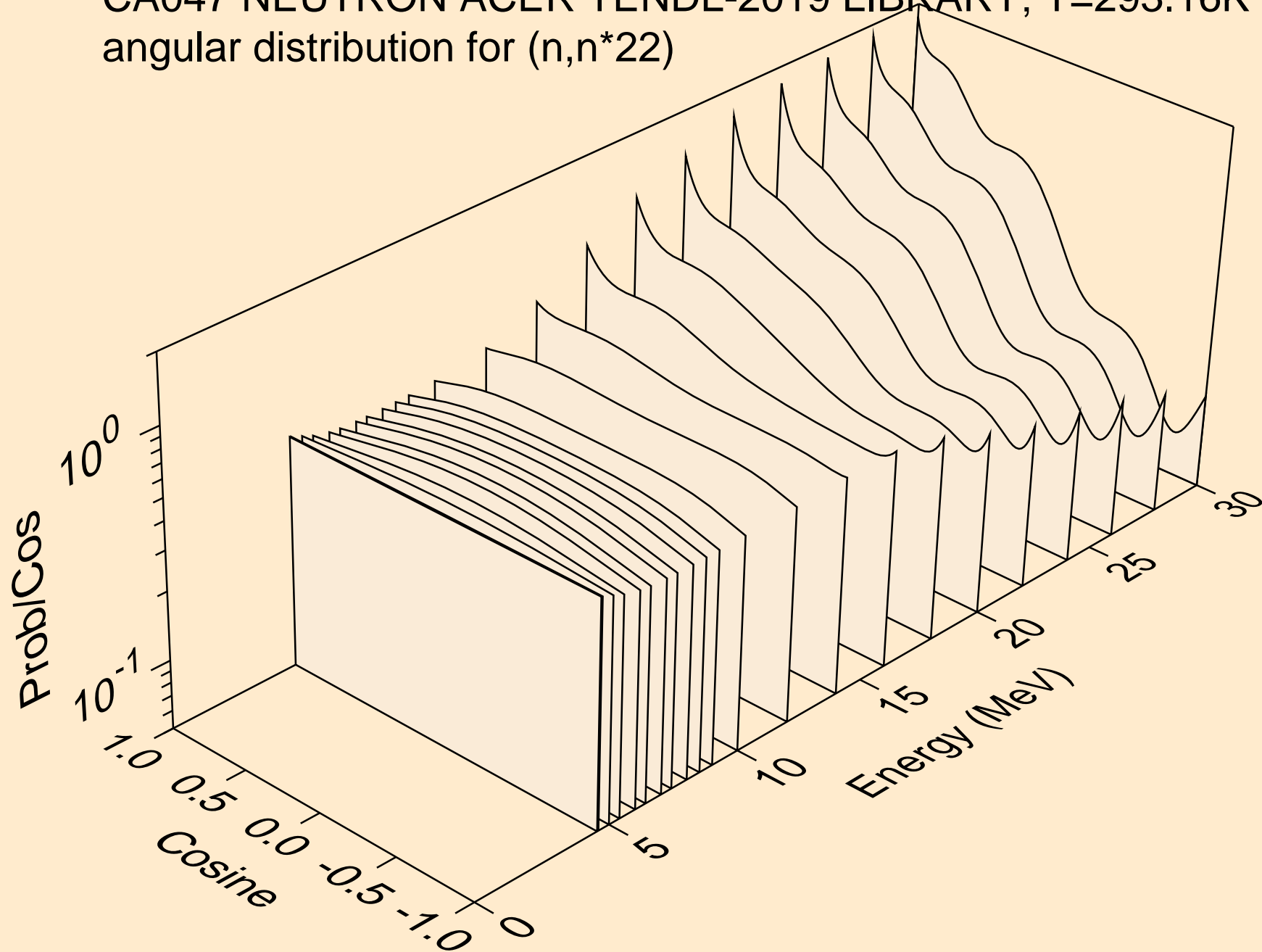

CA047 NEUTRON ACER TENDL-2019 LIBRARY; T=293.16K
angular distribution for (n,n*23)

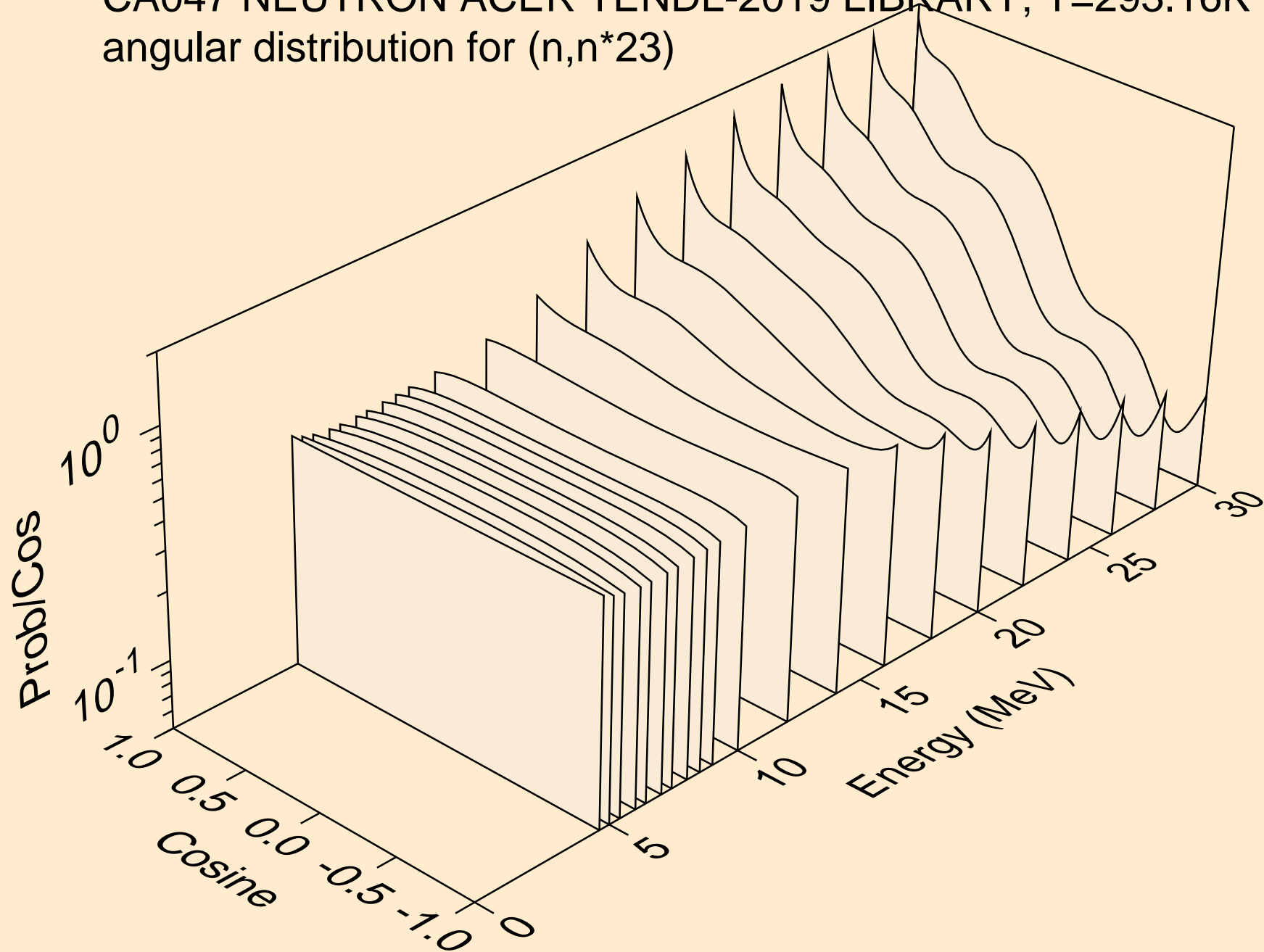

CA047 NEUTRON ACER TENDL-2019 LIBRARY; T=293.16K
angular distribution for (n,n*24)

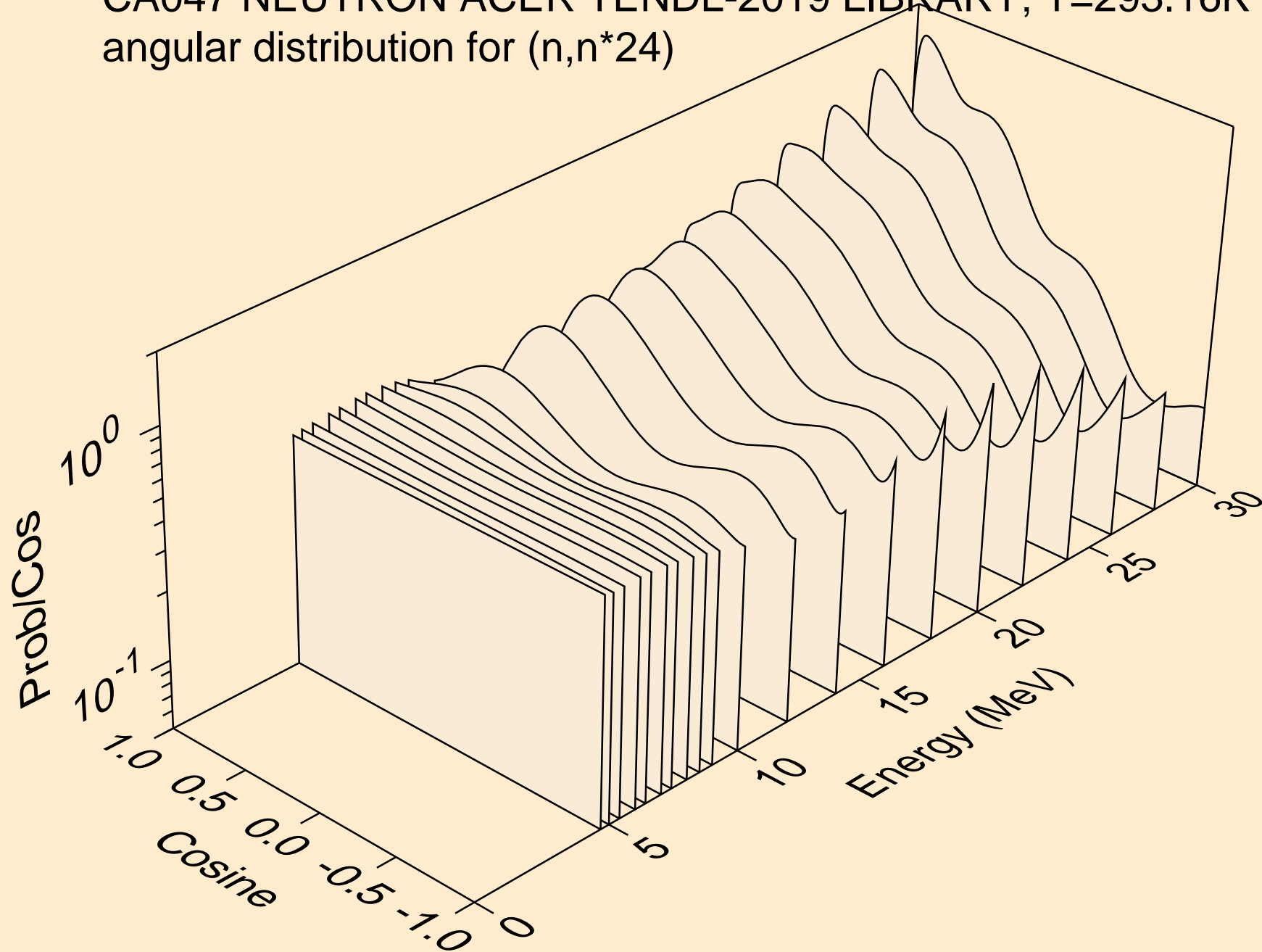

CA047 NEUTRON ACER TENDL-2019 LIBRARY; T=293.16K
angular distribution for (n,n*25)

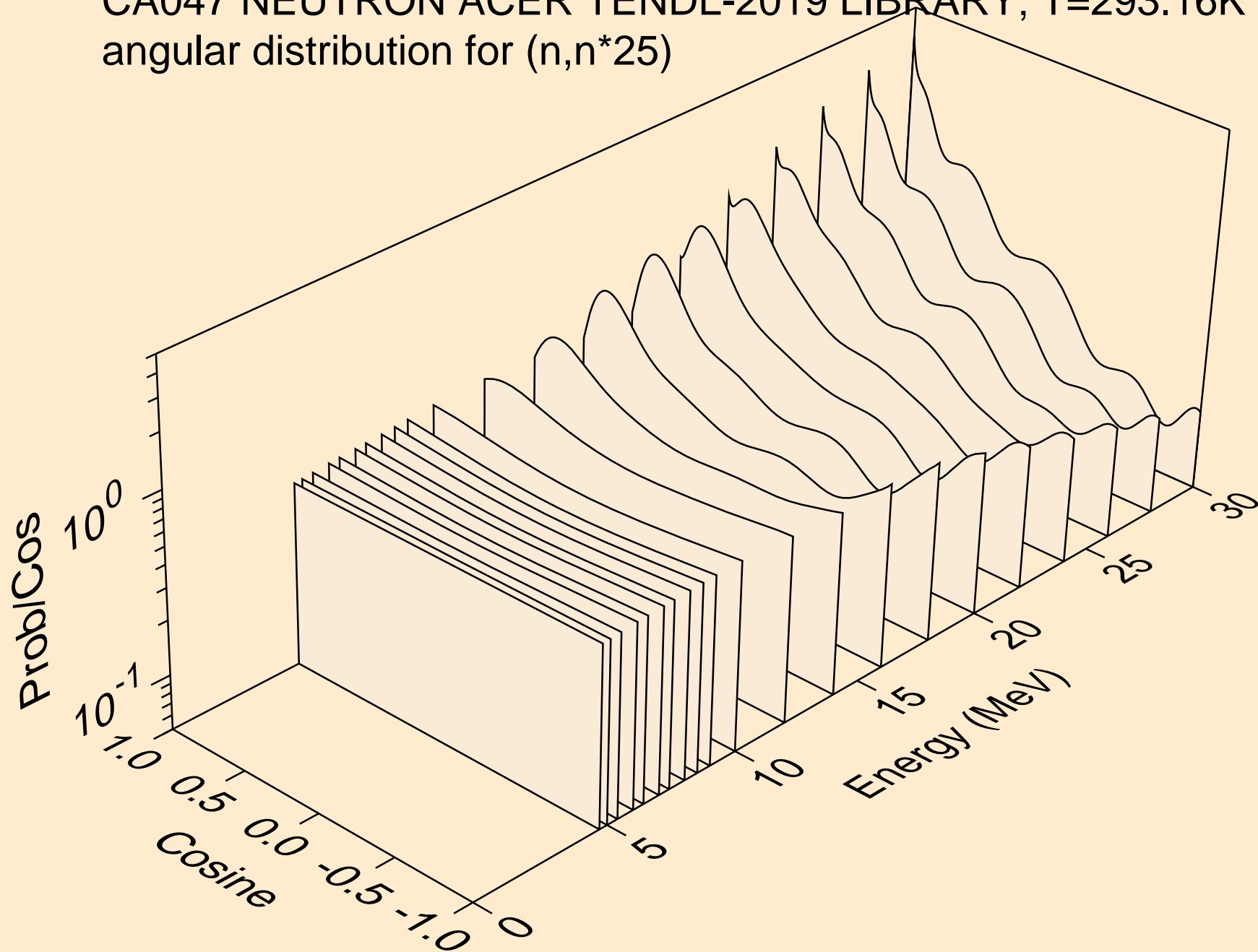

CA047 NEUTRON ACER TENDL-2019 LIBRARY; T=293.16K
angular distribution for (n,n*26)

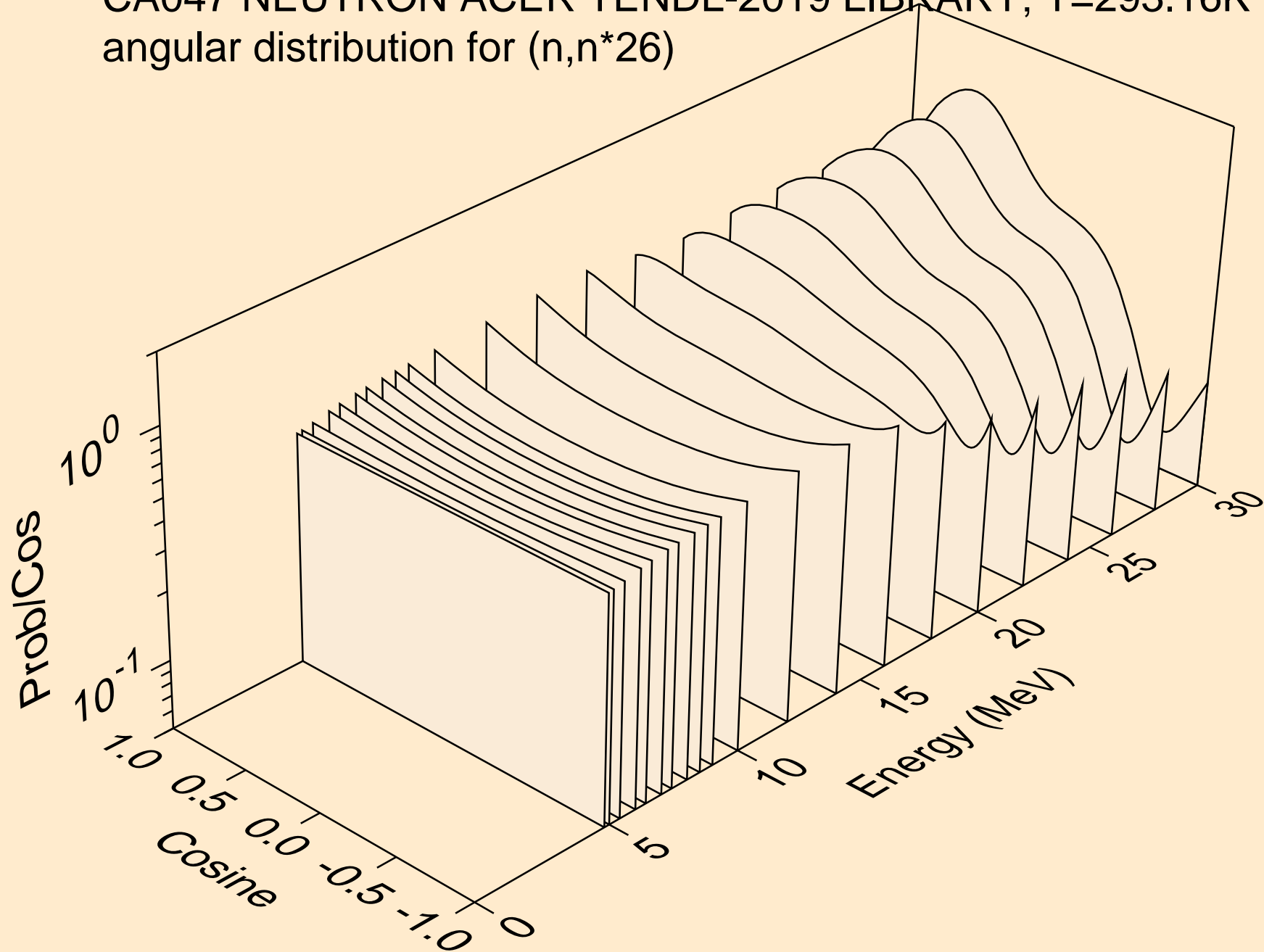

CA047 NEUTRON ACER TENDL-2019 LIBRARY; T=293.16K
angular distribution for (n,n*27)

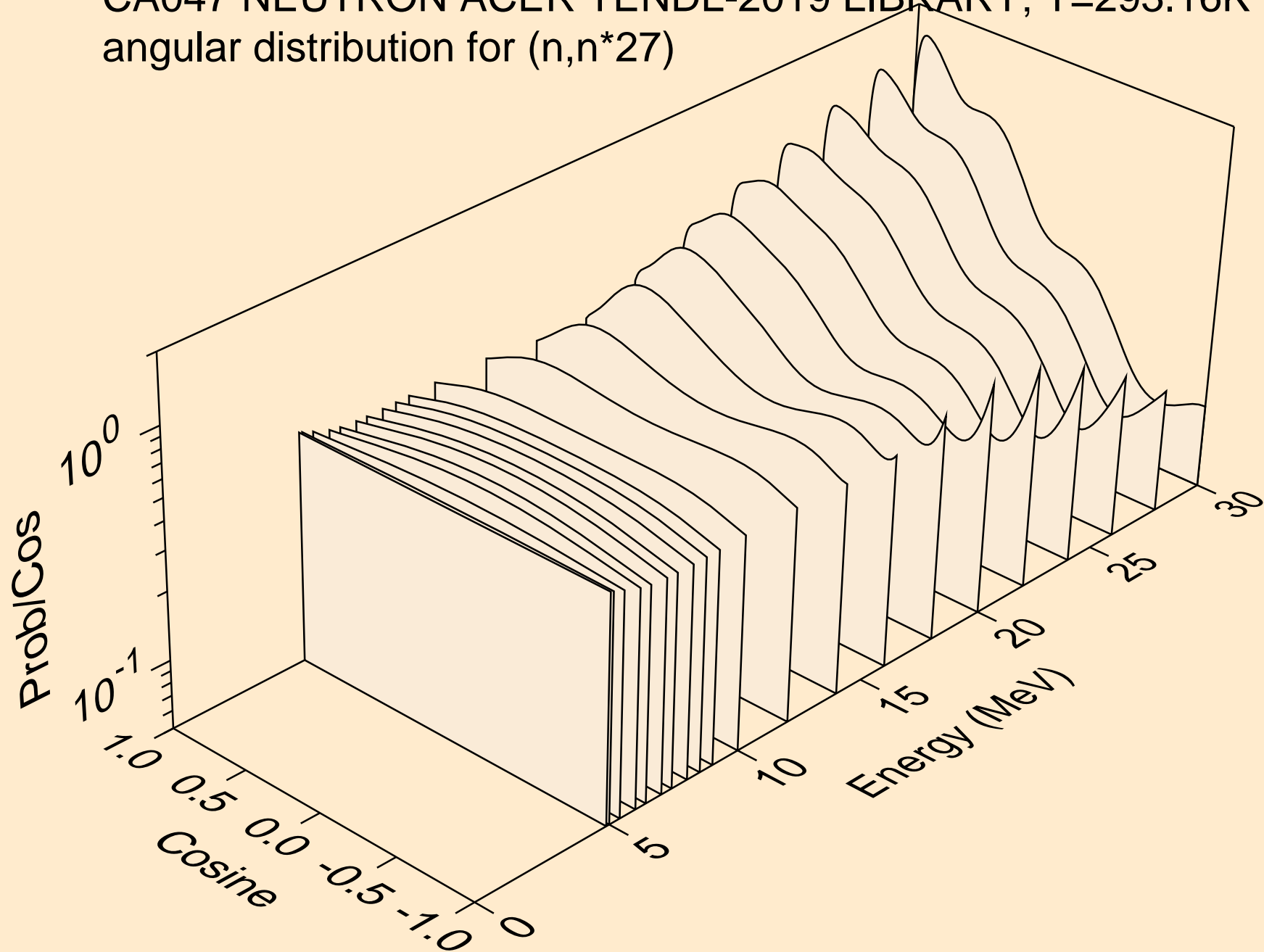

CA047 NEUTRON ACER TENDL-2019 LIBRARY; T=293.16K
angular distribution for (n,n*28)

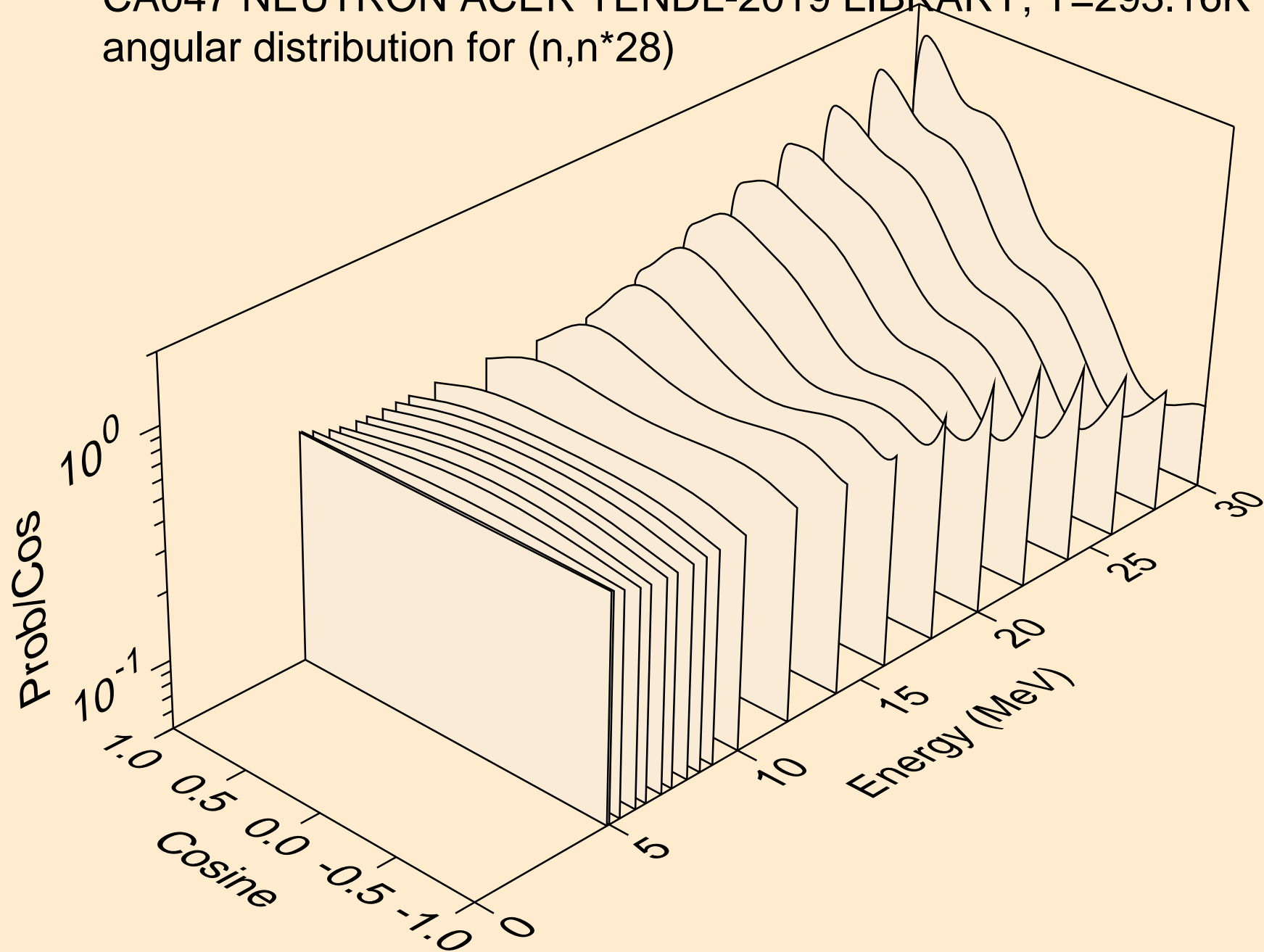

CA047 NEUTRON ACER TENDL-2019 LIBRARY; T=293.16K
angular distribution for (n,n*29)

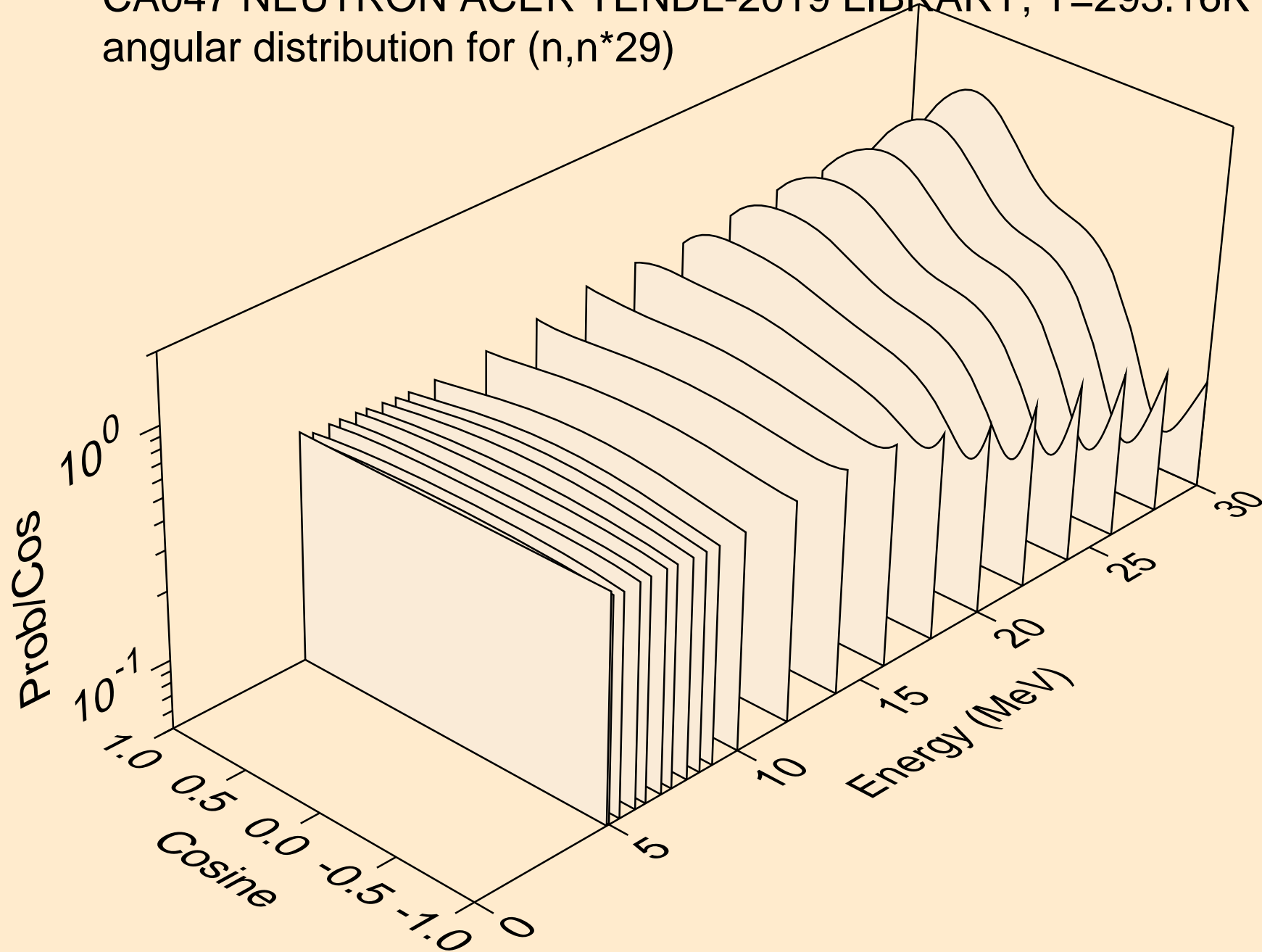

CA047 NEUTRON ACER TENDL-2019 LIBRARY; T=293.16K
angular distribution for (n,n*30)

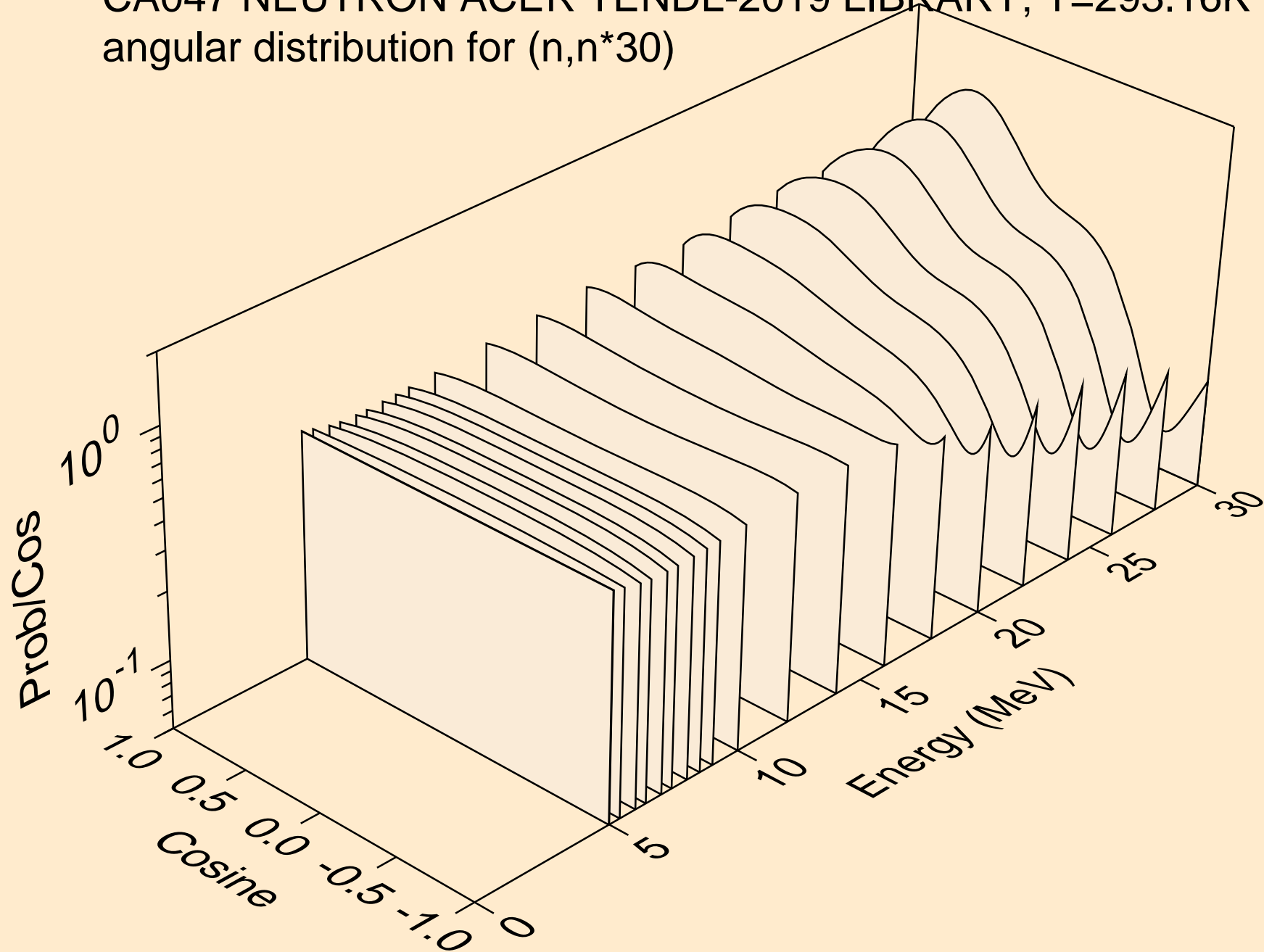

CA047 NEUTRON ACER TENDL-2019 LIBRARY; T=293.16K
Neutron emission for (n,x)

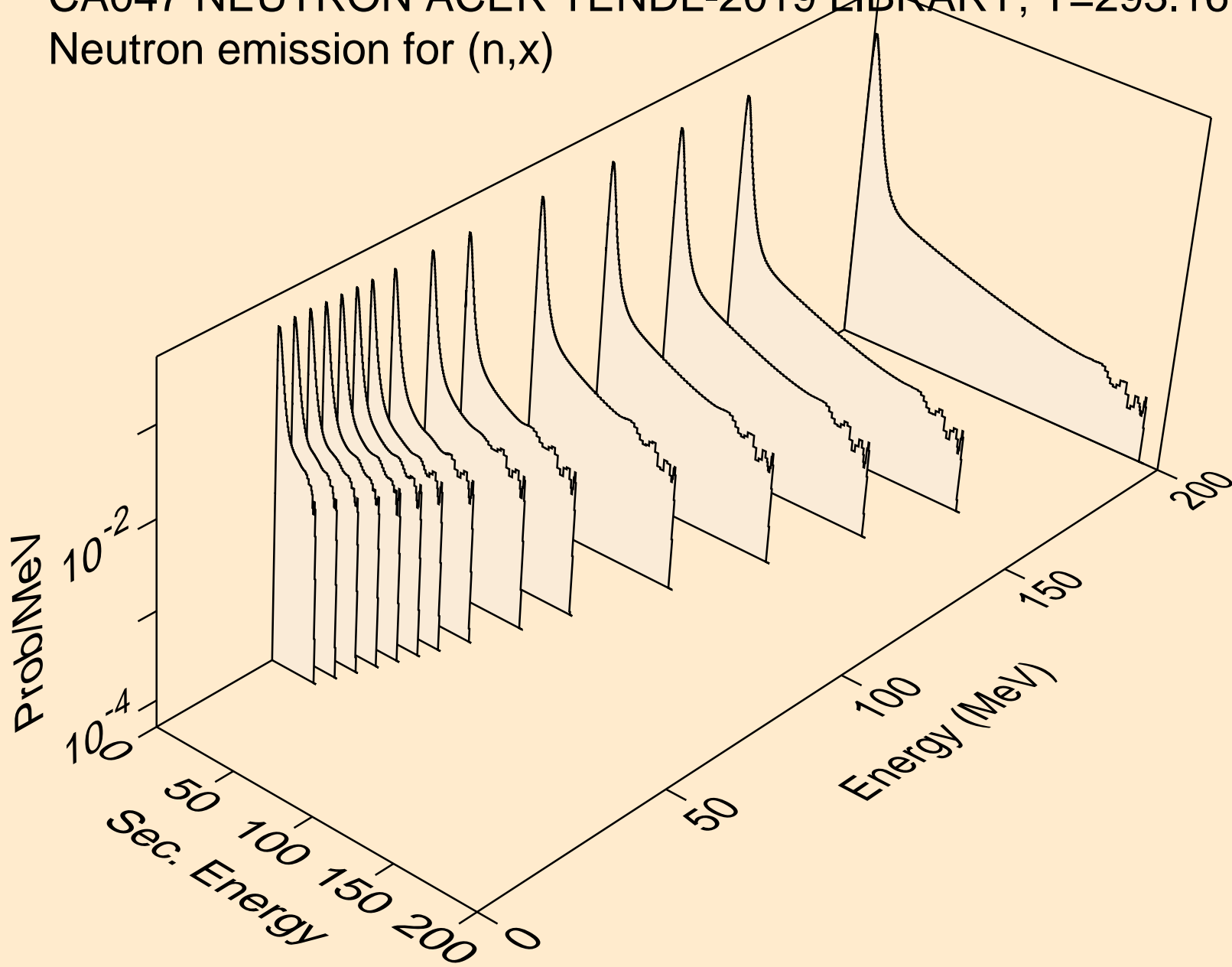

CA047 NEUTRON ACER TENDL-2019 LIBRARY; T=293.16K
Neutron emission for (n,2nd)

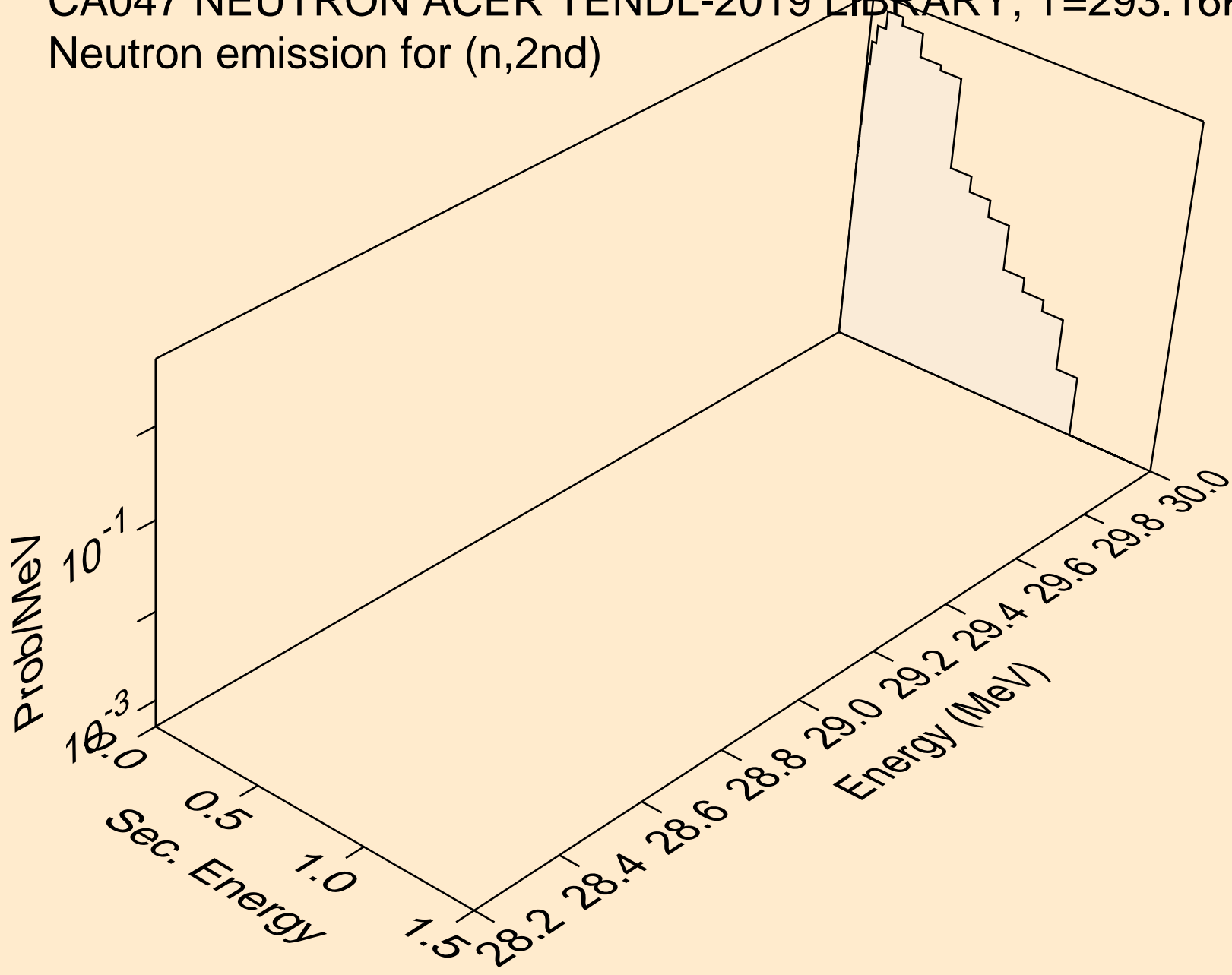

CA047 NEUTRON ACER TENDL-2019 LIBRARY; T=293.16K
Neutron emission for (n,2n)

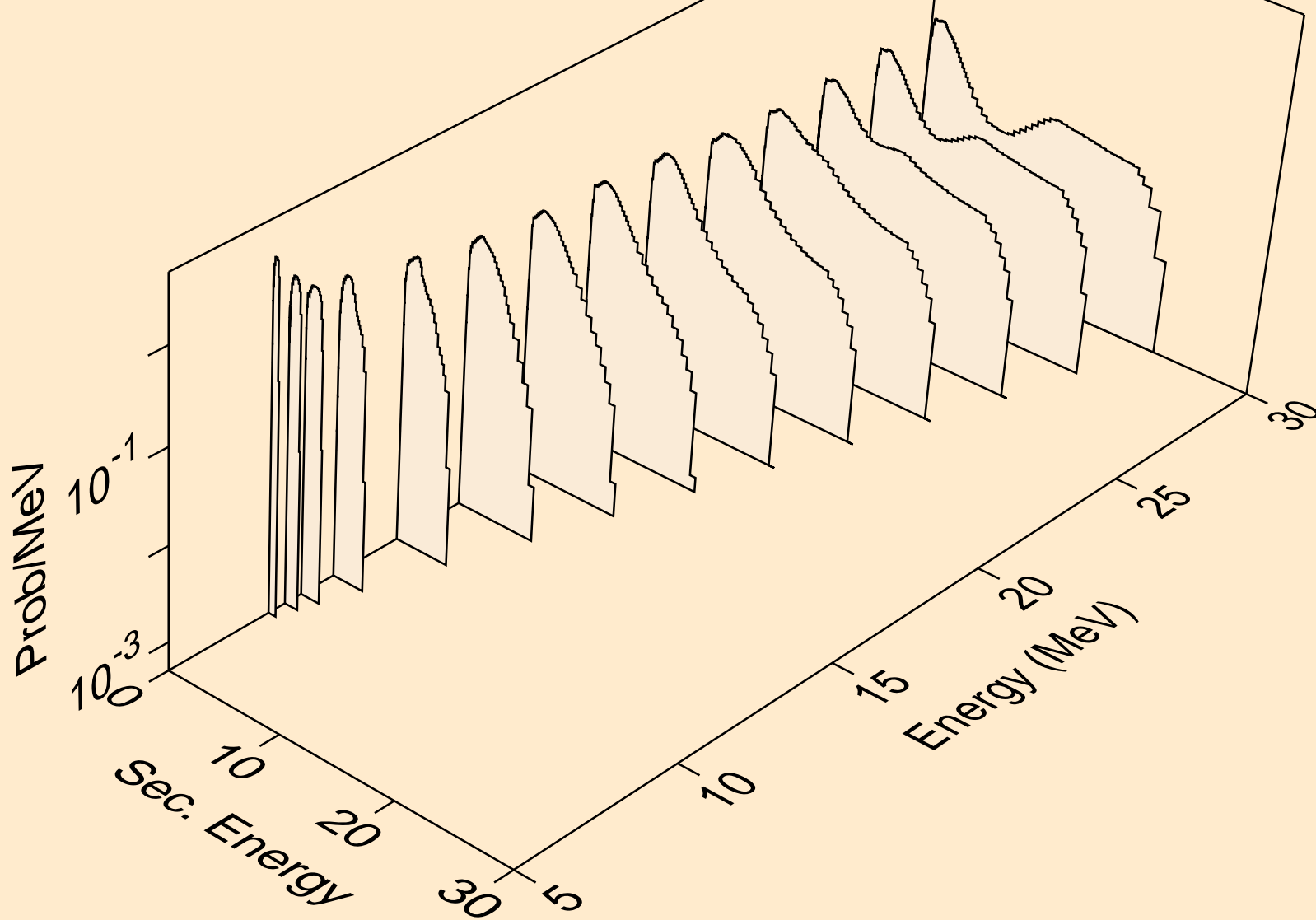

CA047 NEUTRON ACER TENDL-2019 LIBRARY; T=293.16K
Neutron emission for (n,3n)

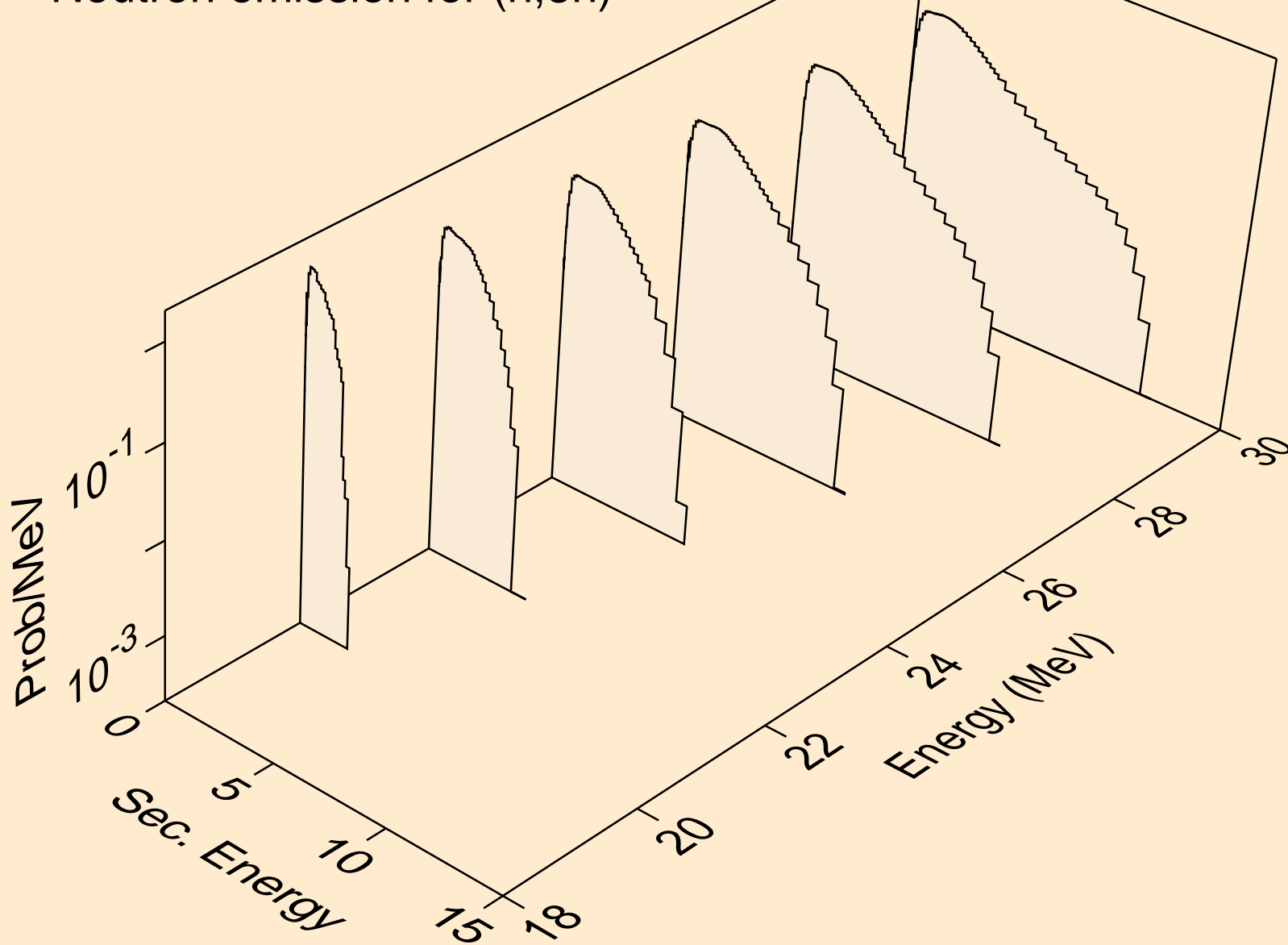

CA047 NEUTRON ACER TENDL-2019 LIBRARY; T=293.16K
Neutron emission for (n,n*)a

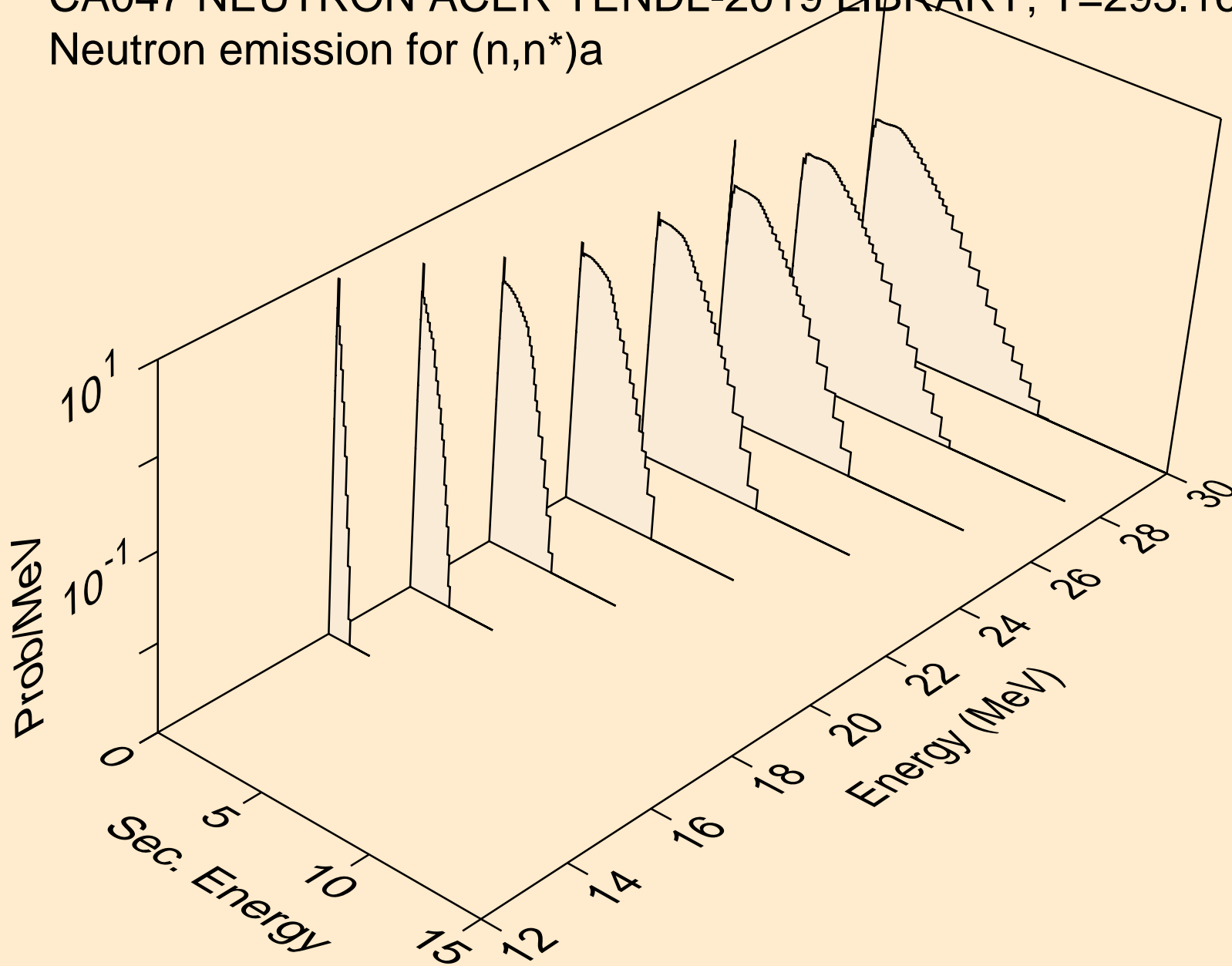

CA047 NEUTRON ACER TENDL-2019 LIBRARY; T=293.16K
Neutron emission for (n,2n)a

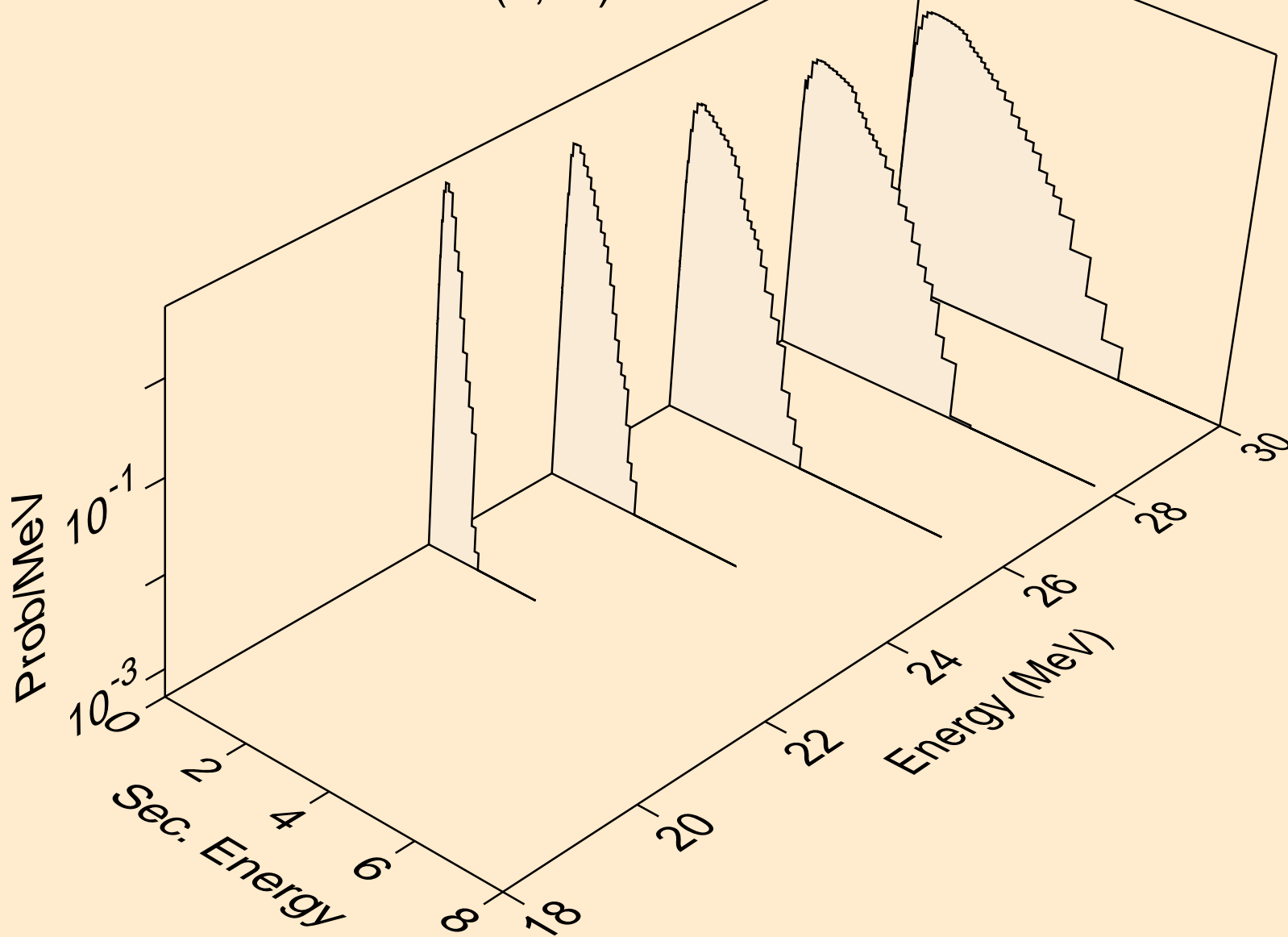

CA047 NEUTRON ACER TENDL-2019 LIBRARY; T=293.16K
Neutron emission for (n,n*)p

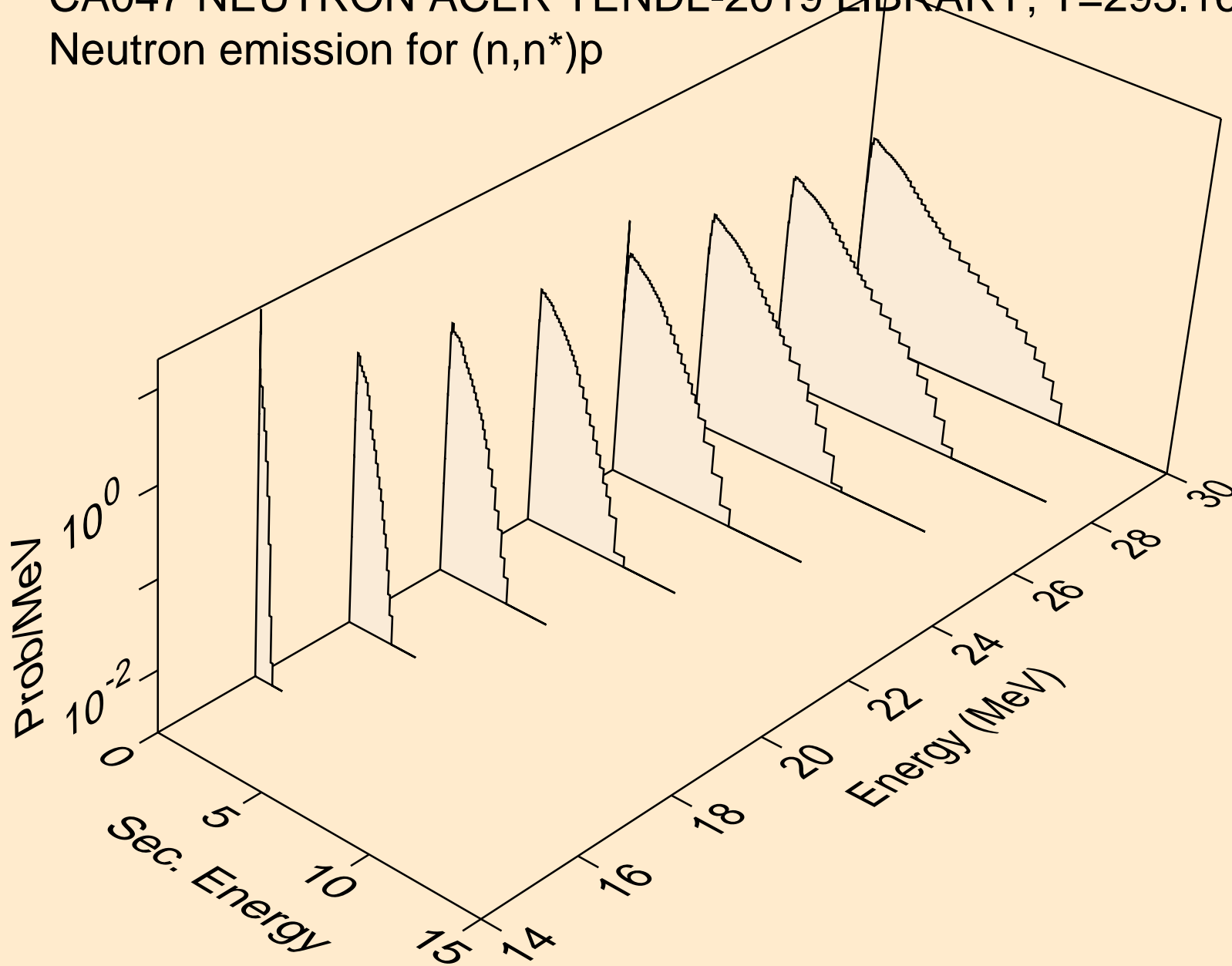

CA047 NEUTRON ACER TENDL-2019 LIBRARY; T=293.16K
Neutron emission for (n,n*)d

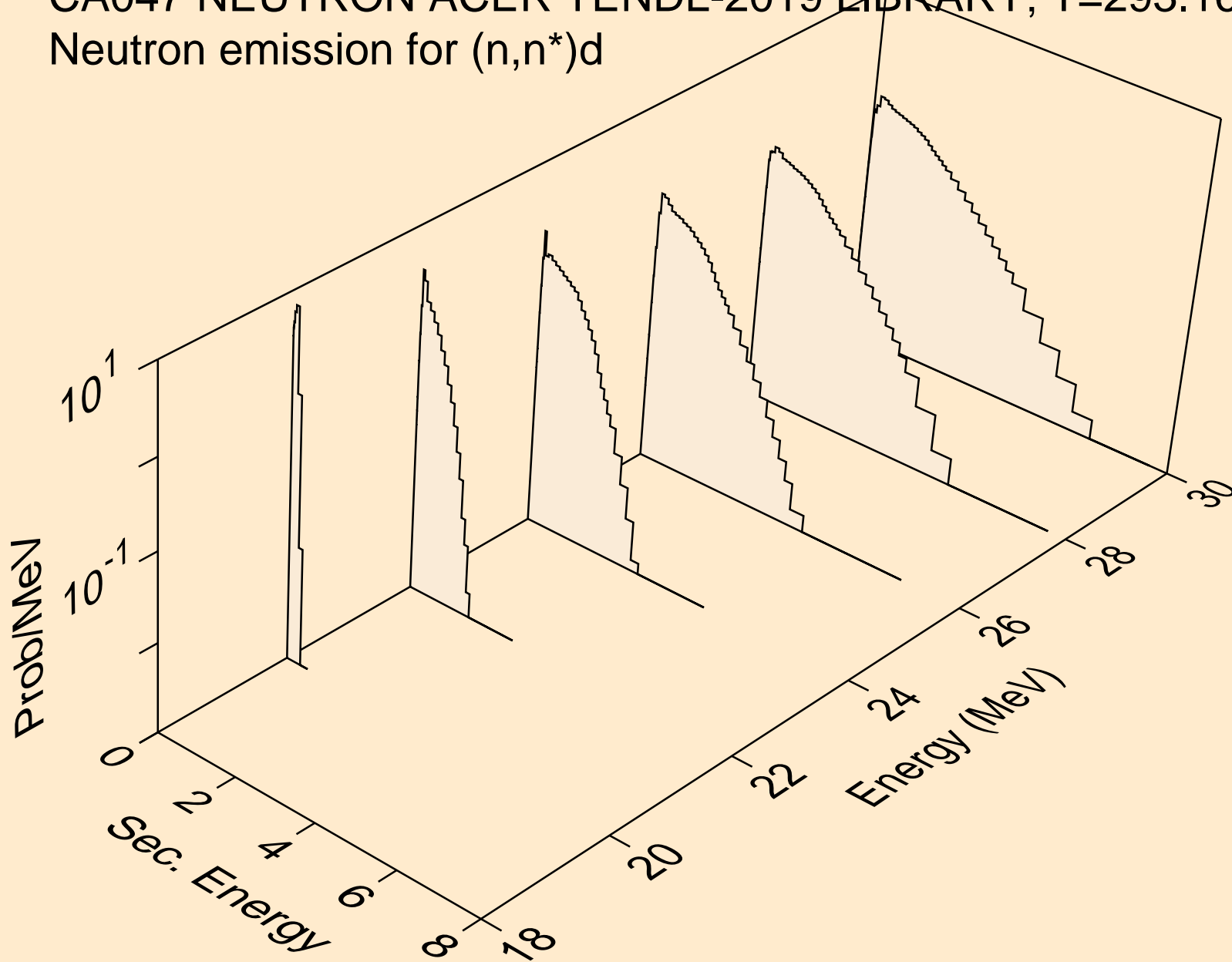

CA047 NEUTRON ACER TENDL-2019 LIBRARY; T=293.16K
Neutron emission for (n,n*)t

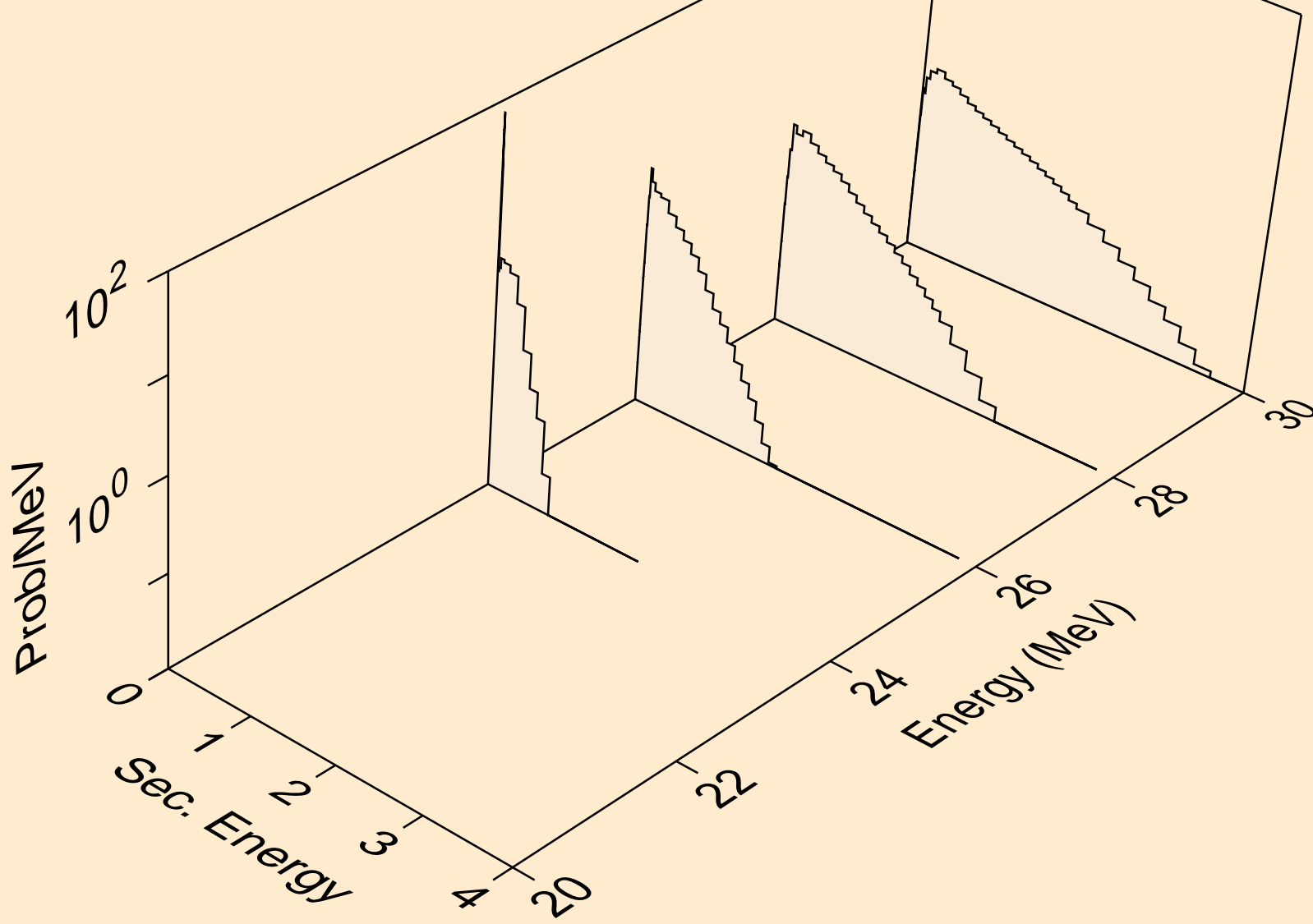

CA047 NEUTRON ACER TENDL-2019 LIBRARY; T=293.16K
Neutron emission for (n,n*)he3

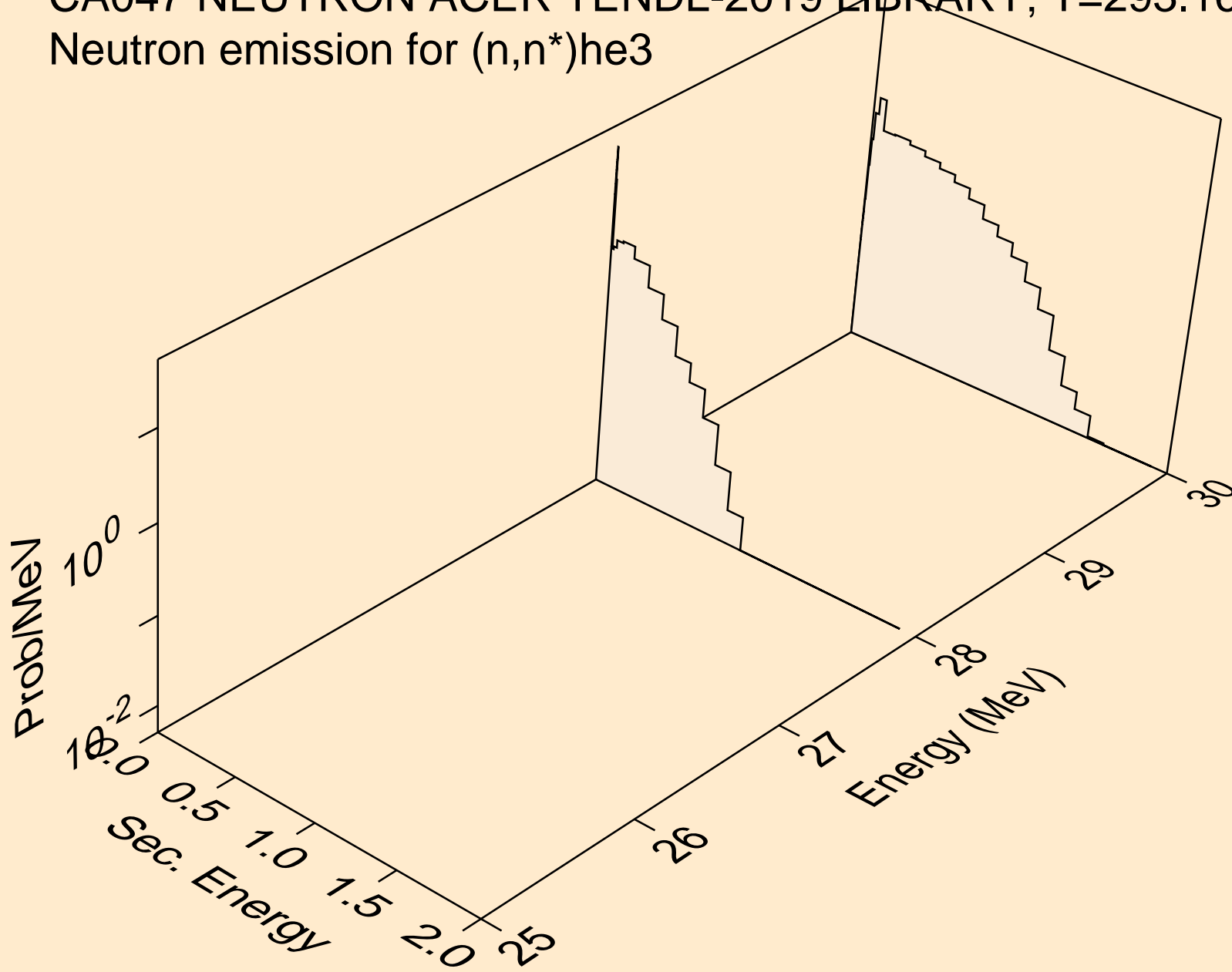

CA047 NEUTRON ACER TENDL-2019 LIBRARY; T=293.16K
Neutron emission for (n,4n)

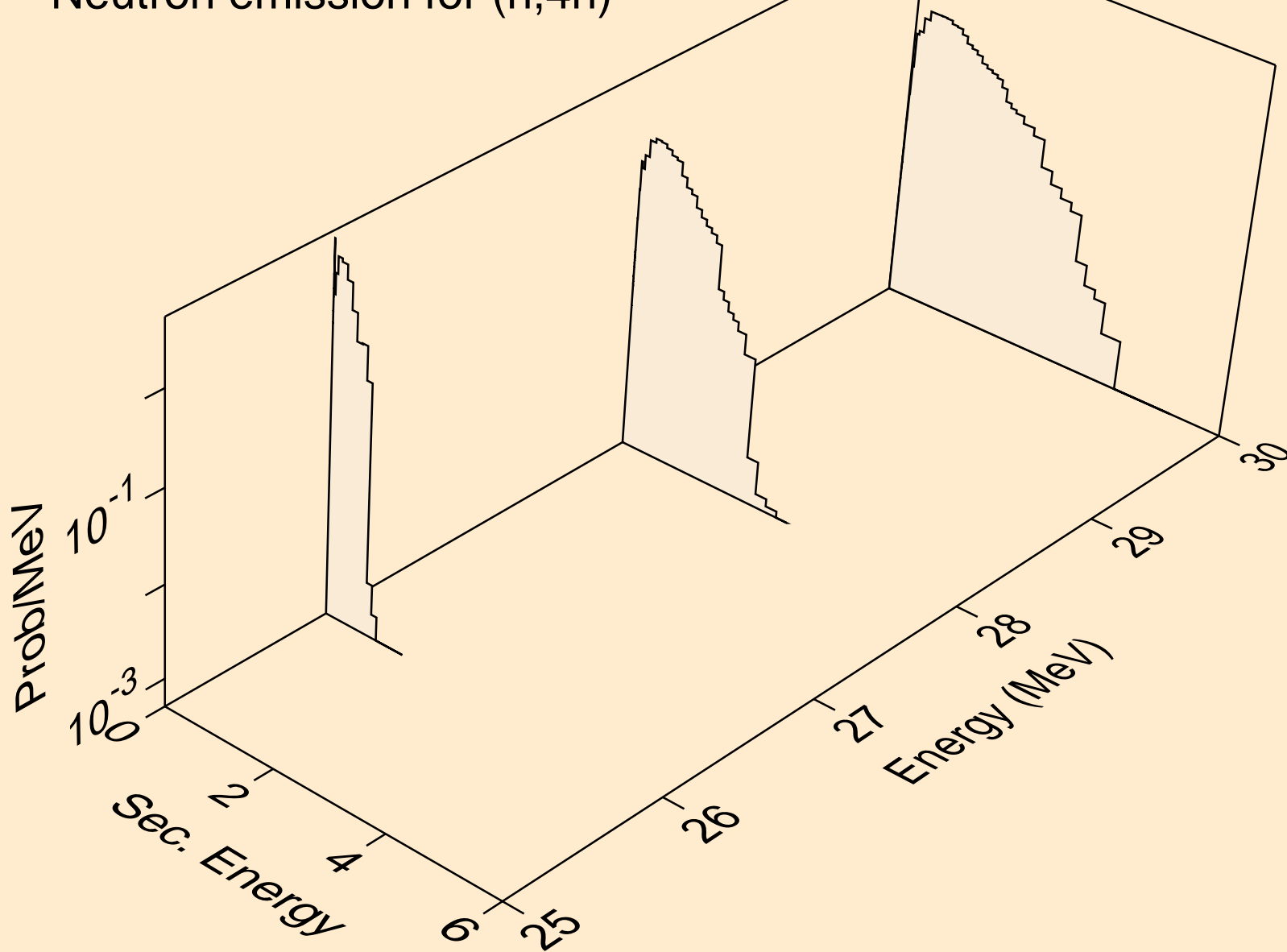

CA047 NEUTRON ACER TENDL-2019 LIBRARY; T=293.16K
Neutron emission for (n,2np)

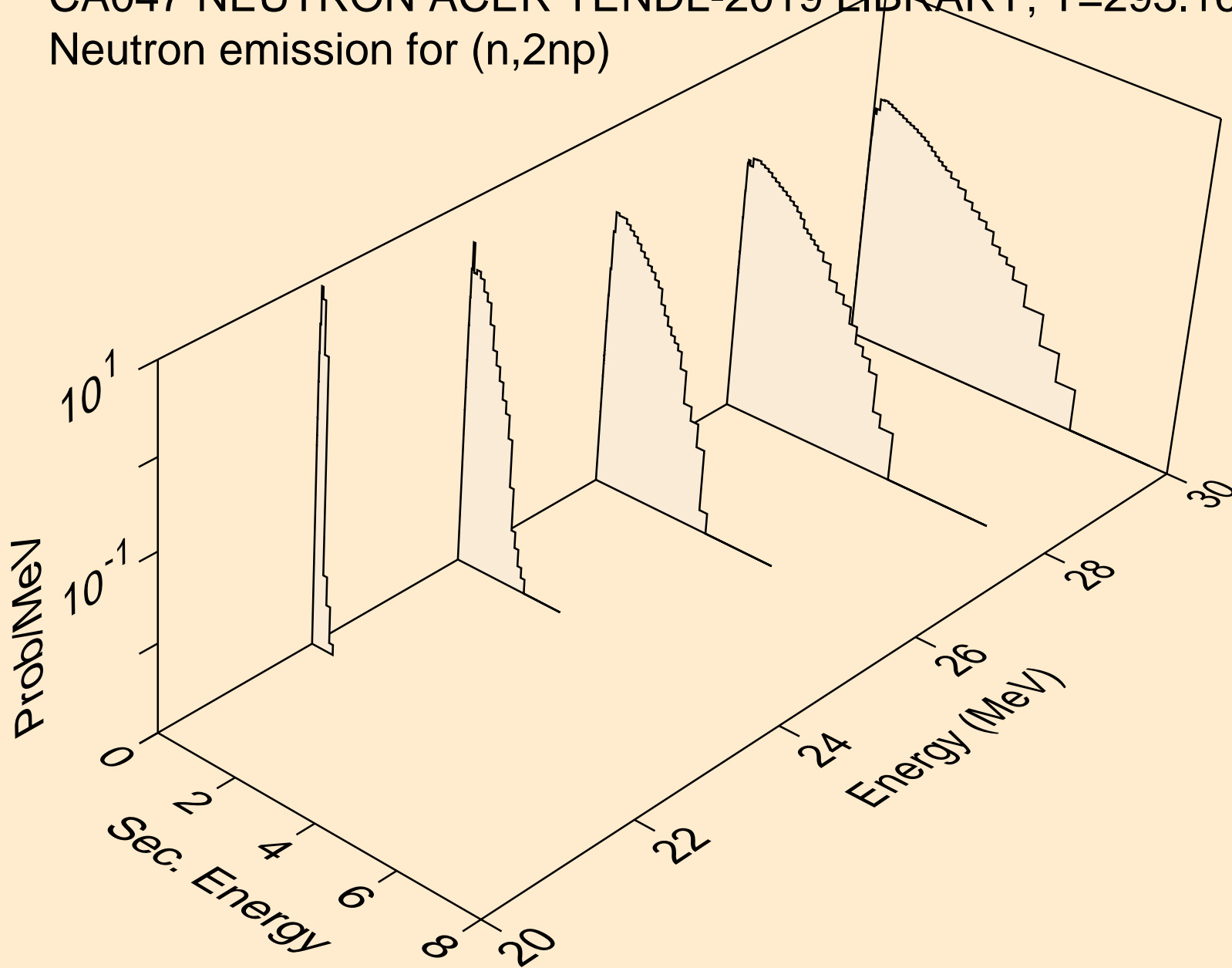

CA047 NEUTRON ACER TENDL-2019 LIBRARY; T=293.16K
Neutron emission for (n,n*c)

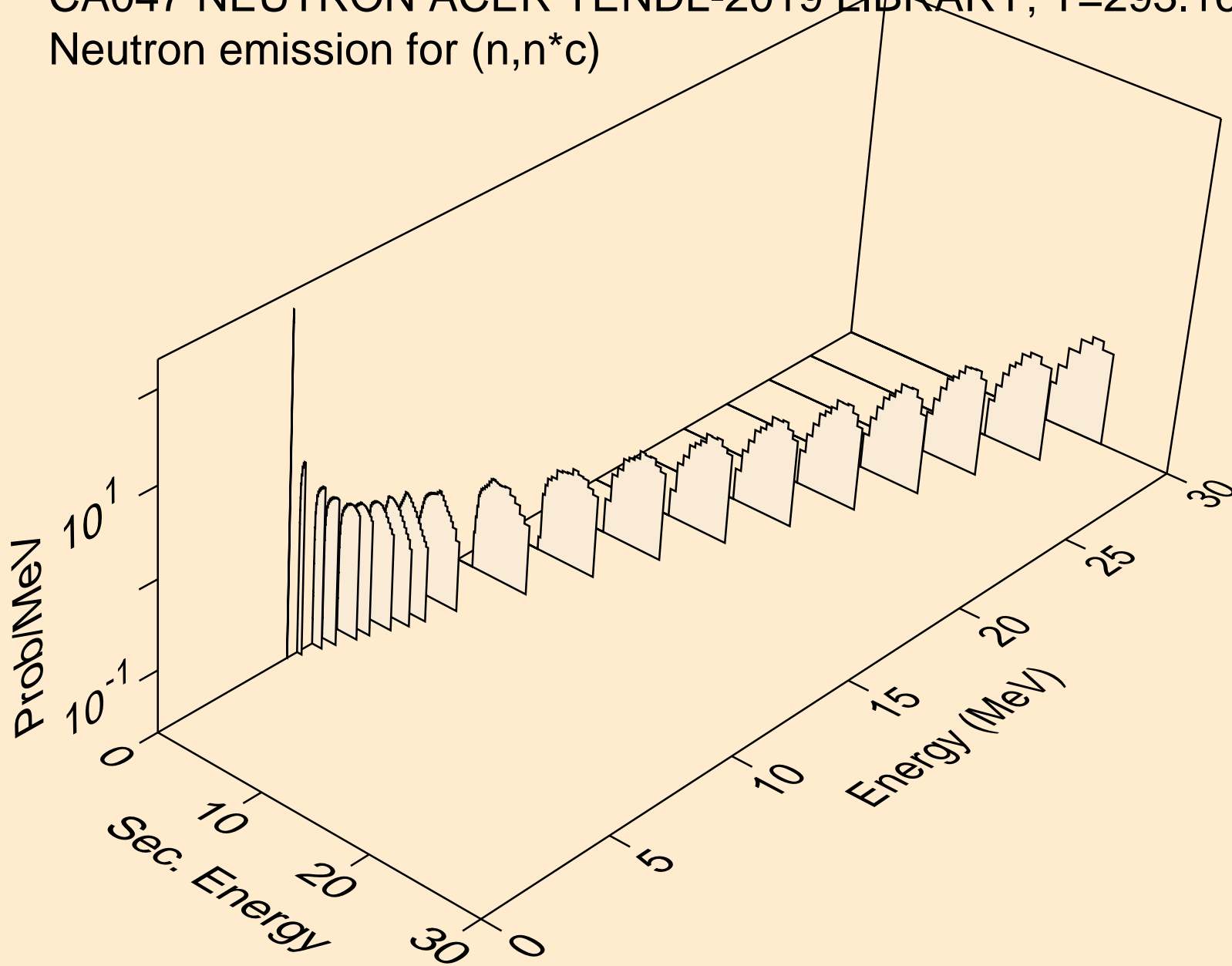

CA047 NEUTRON ACER TENDL-2019 LIBRARY; T=293.16K
Photon emission for (n,x)

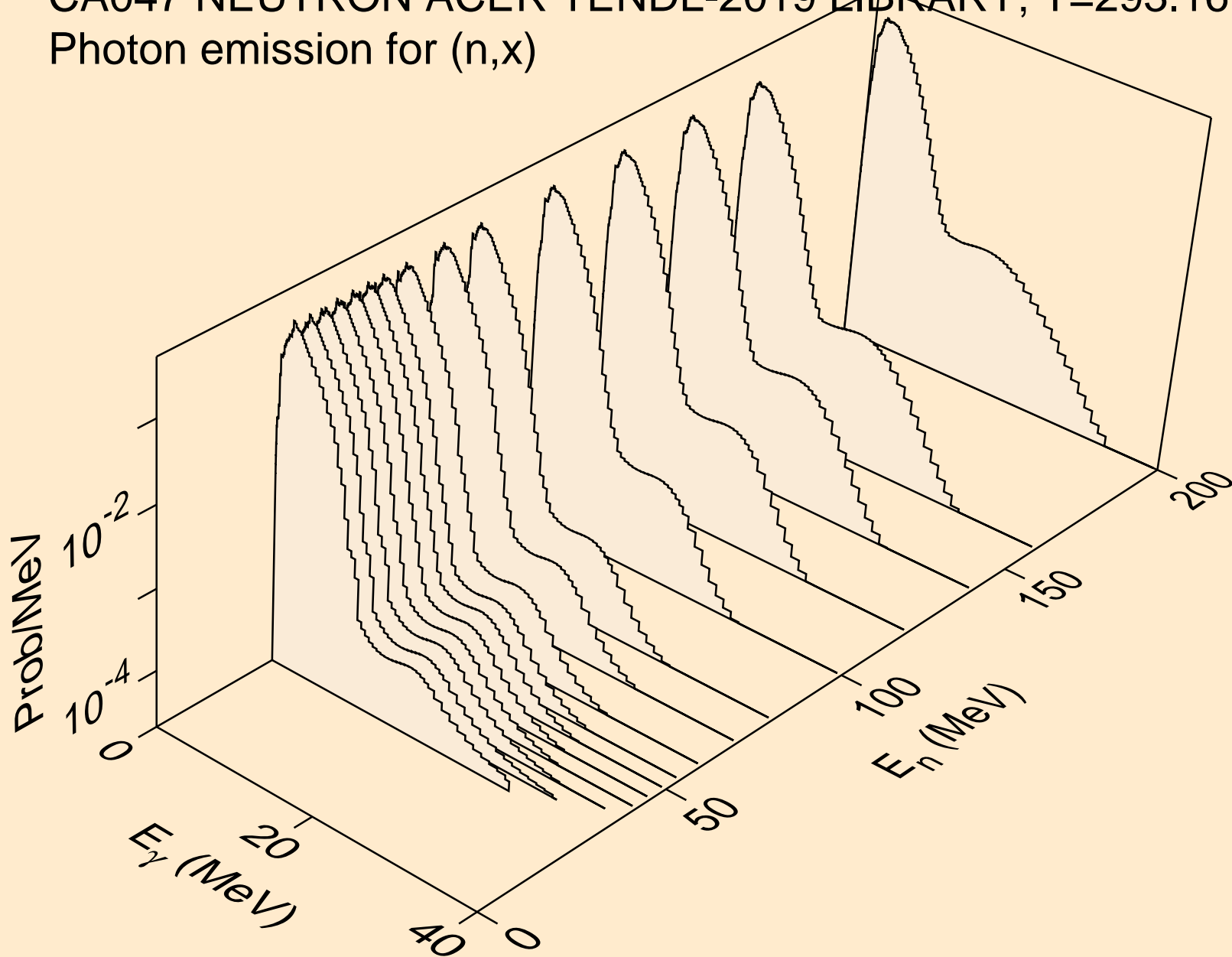

CA047 NEUTRON ACER TENDL-2019 LIBRARY; T=293.16K
Photon emission for (n,2nd)

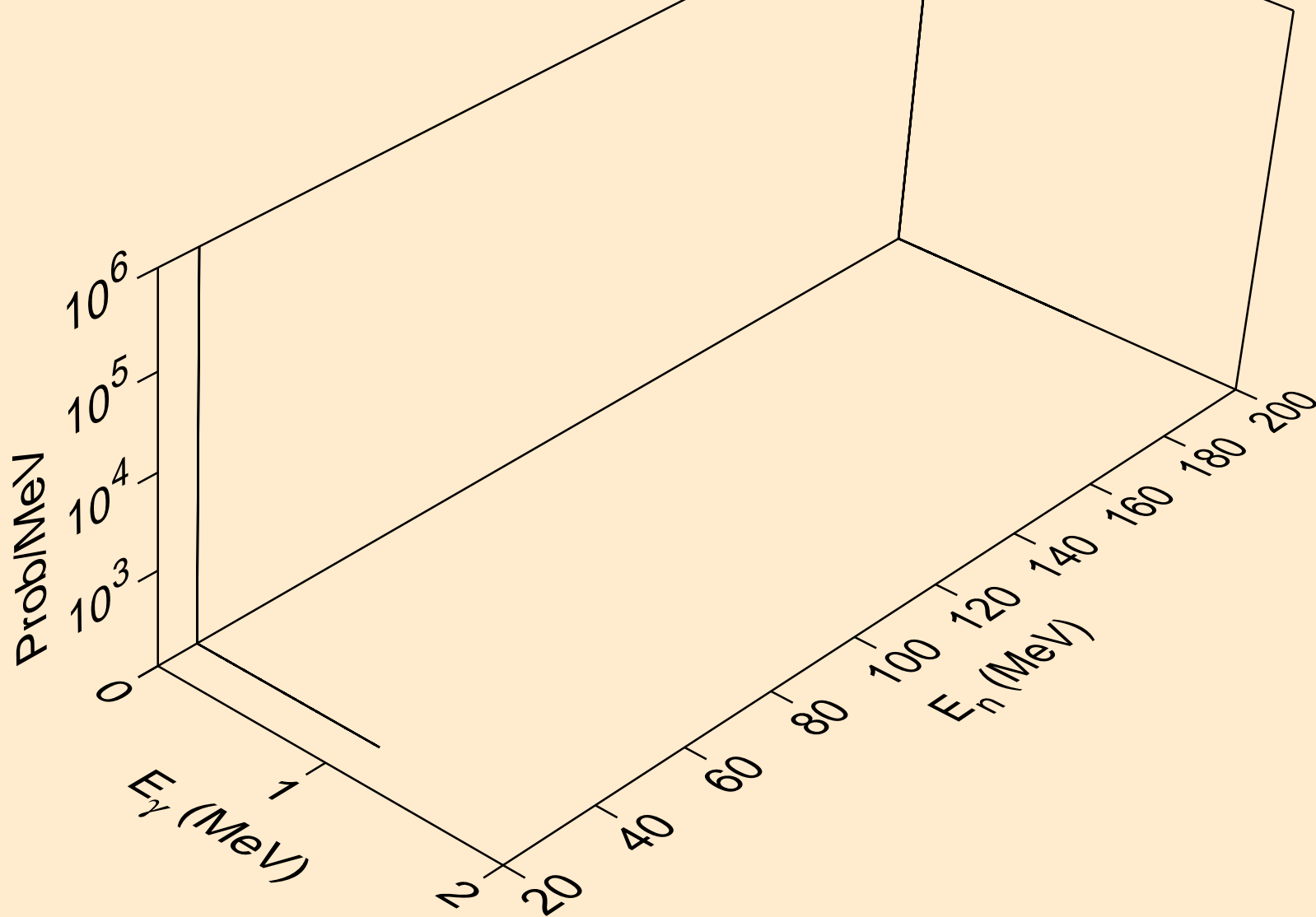

CA047 NEUTRON ACER TENDL-2019 LIBRARY; T=293.16K
Photon emission for (n,2n)

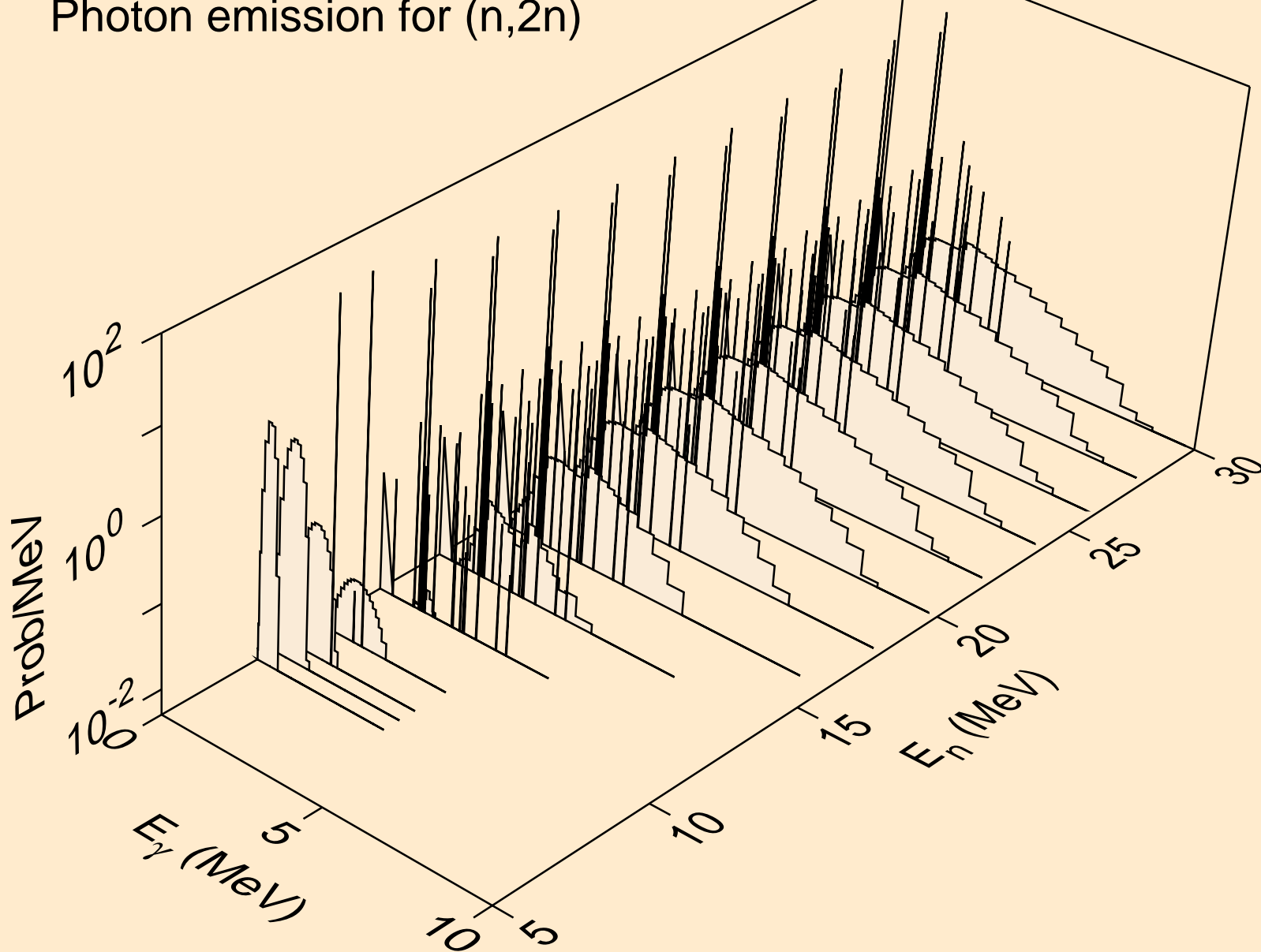

CA047 NEUTRON ACER TENDL-2019 LIBRARY; T=293.16K
Photon emission for (n,3n)

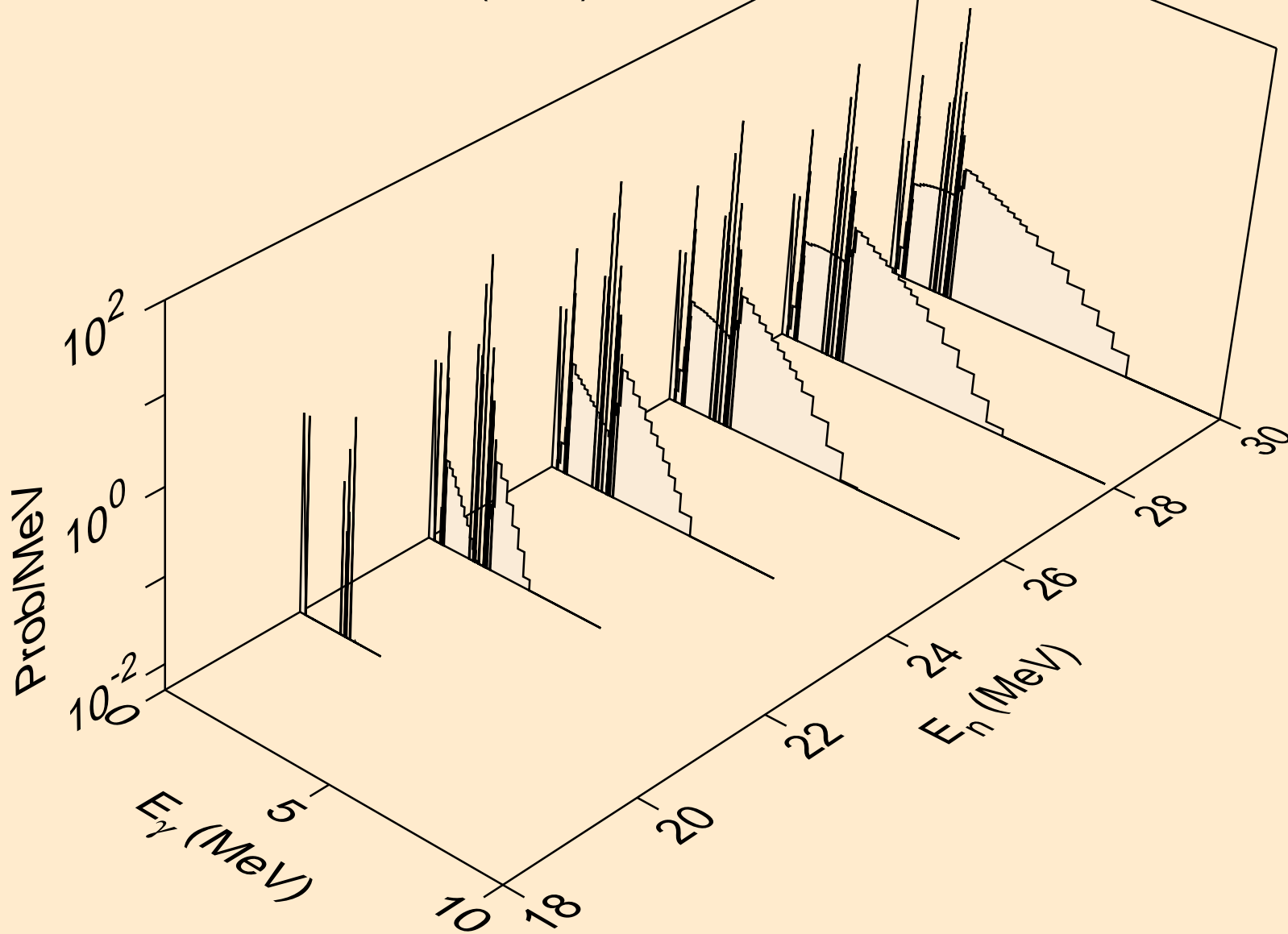

CA047 NEUTRON ACER TENDL-2019 LIBRARY; T=293.16K
Photon emission for (n,n*)a

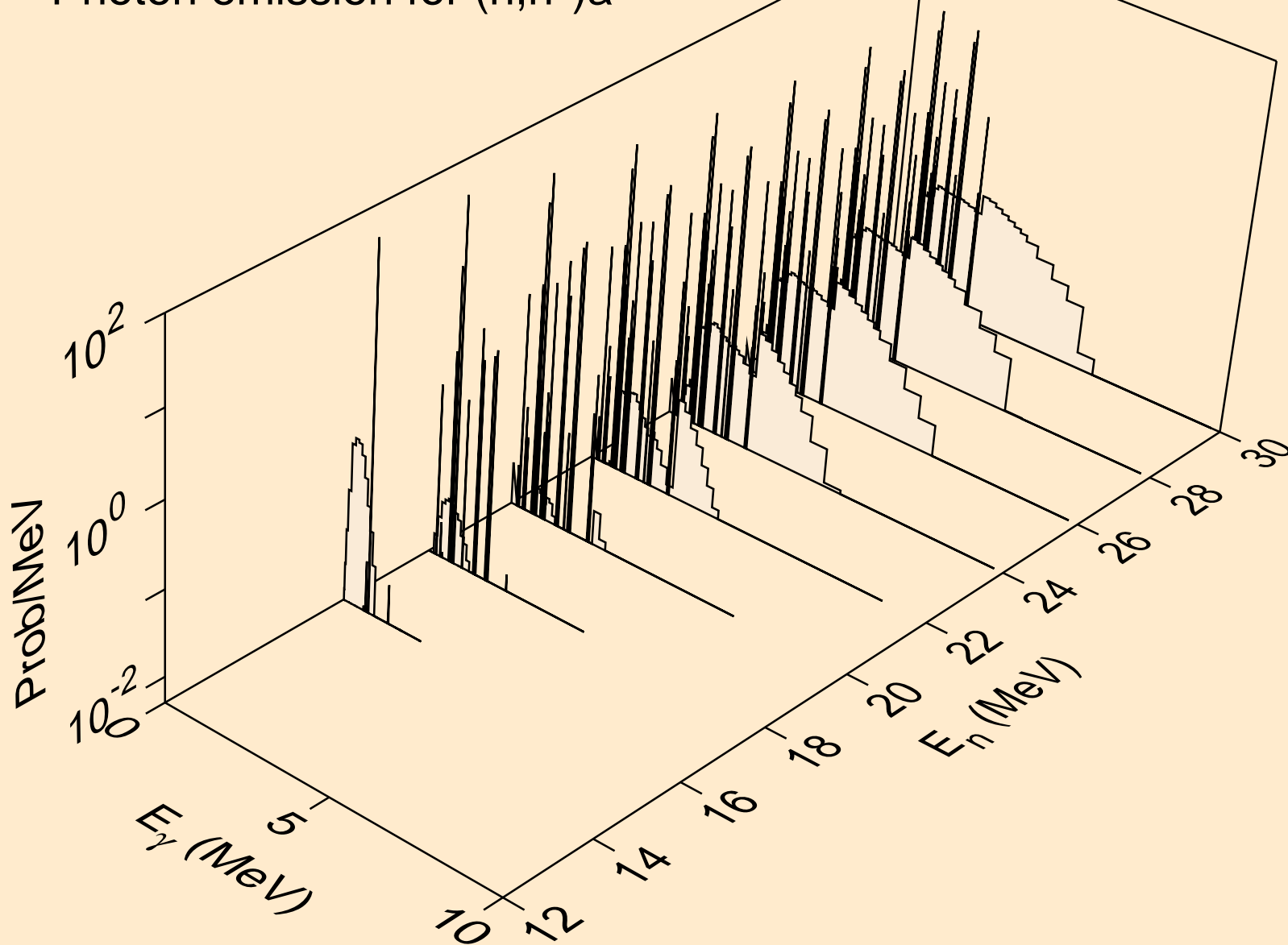

CA047 NEUTRON ACER TENDL-2019 LIBRARY; T=293.16K
Photon emission for (n,2n)a

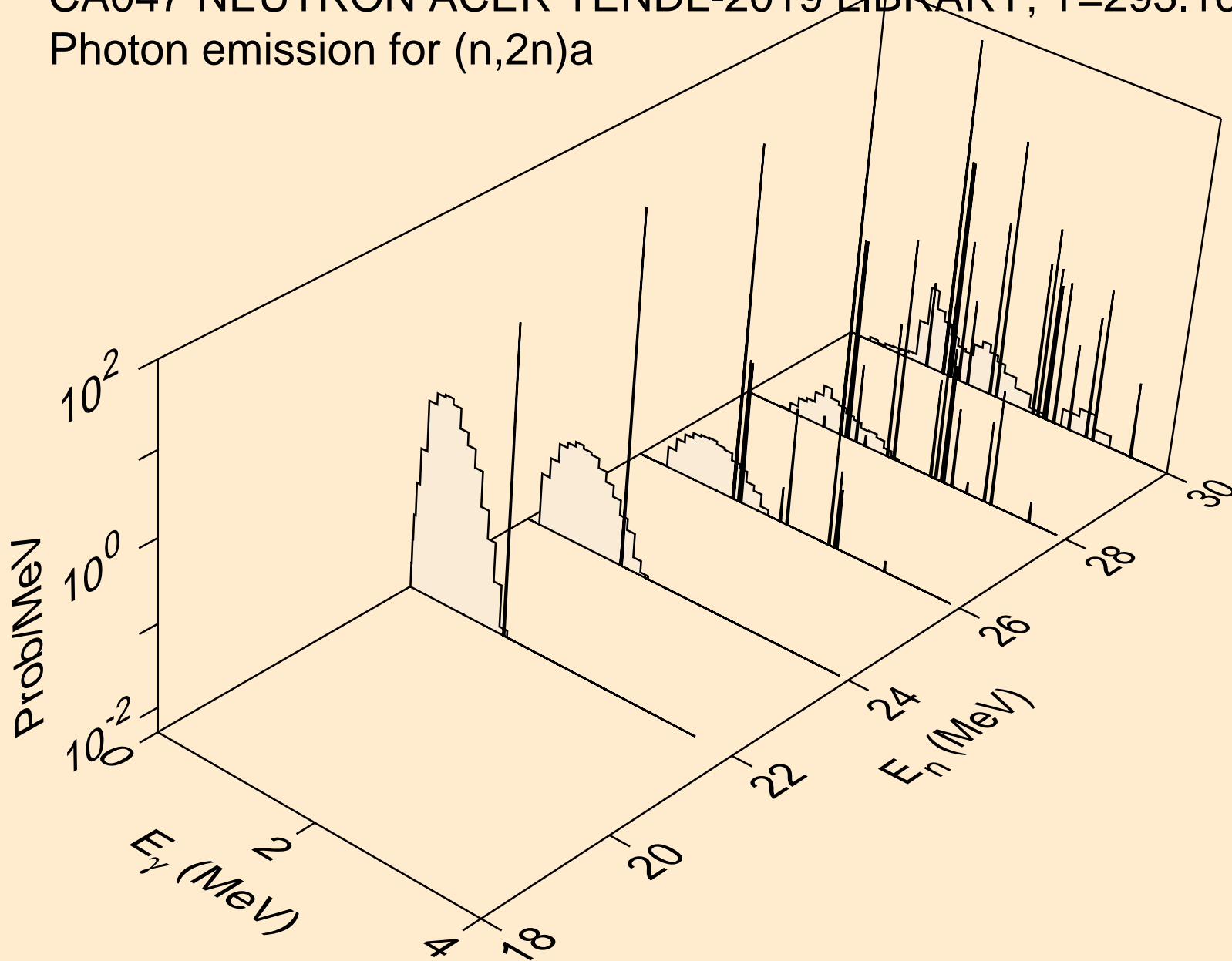

CA047 NEUTRON ACER TENDL-2019 LIBRARY; T=293.16K
Photon emission for (n,n*)p

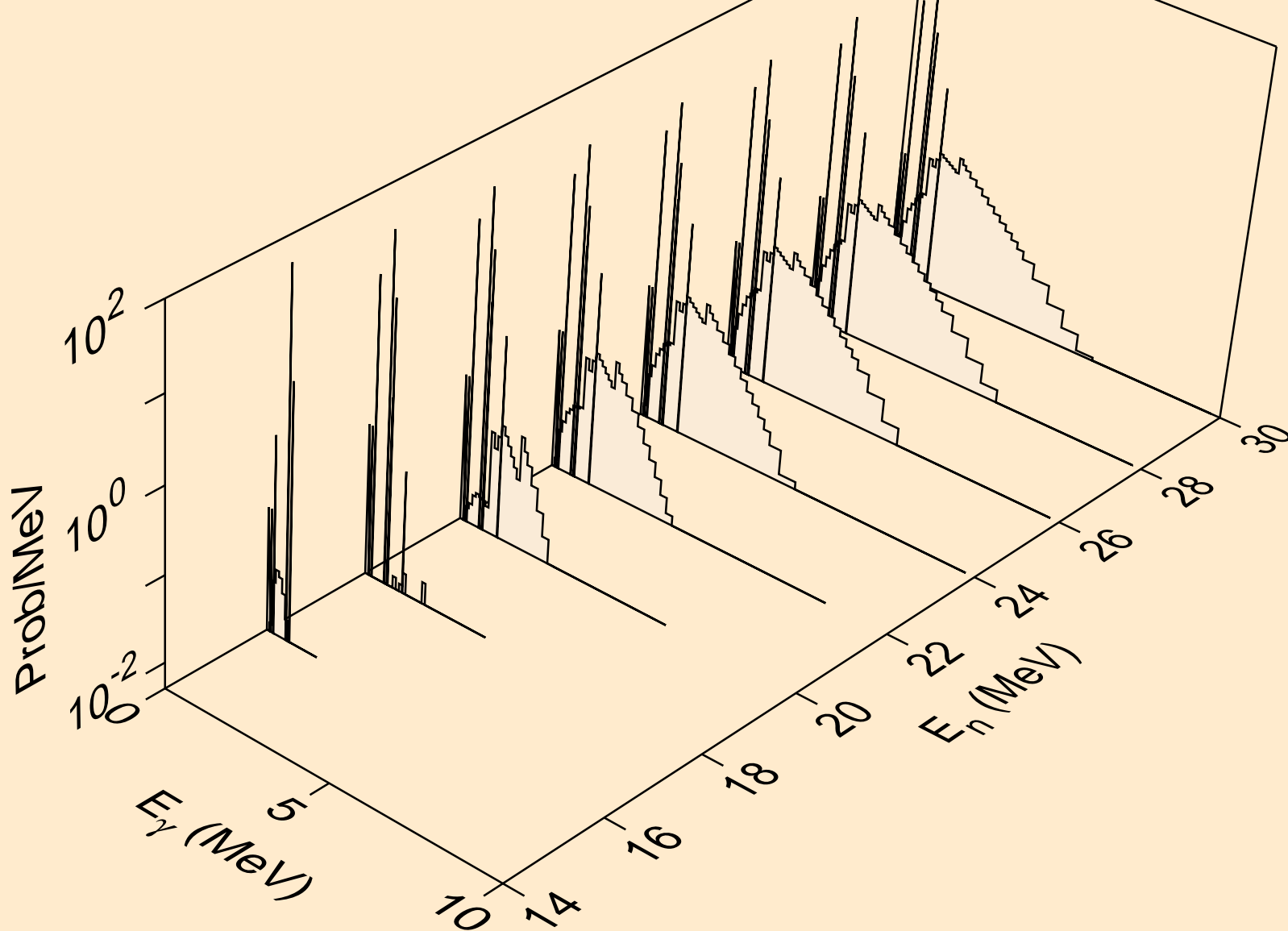

CA047 NEUTRON ACER TENDL-2019 LIBRARY; T=293.16K
Photon emission for (n,n*)d

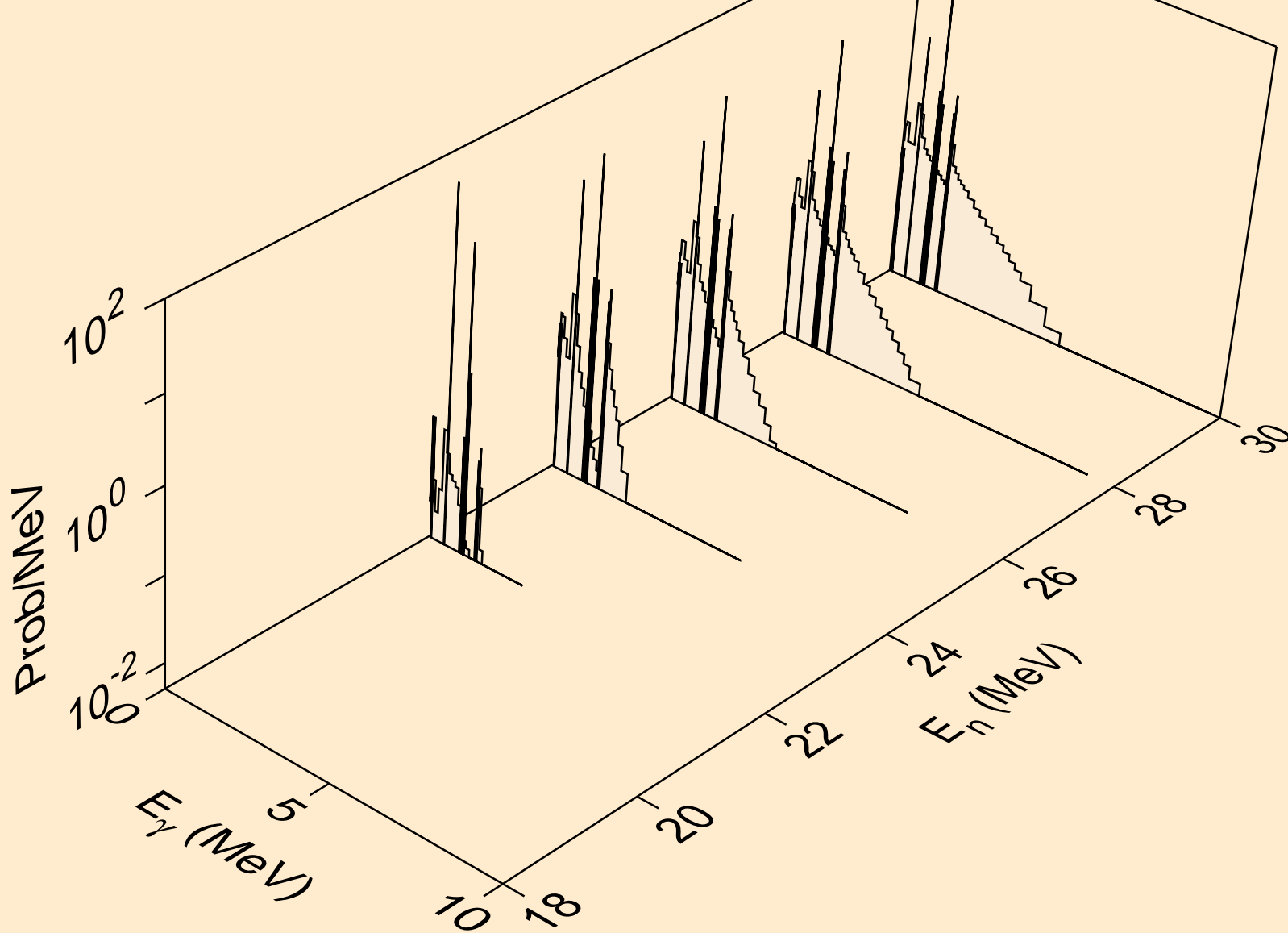

CA047 NEUTRON ACER TENDL-2019 LIBRARY; T=293.16K
Photon emission for (n,n*)t

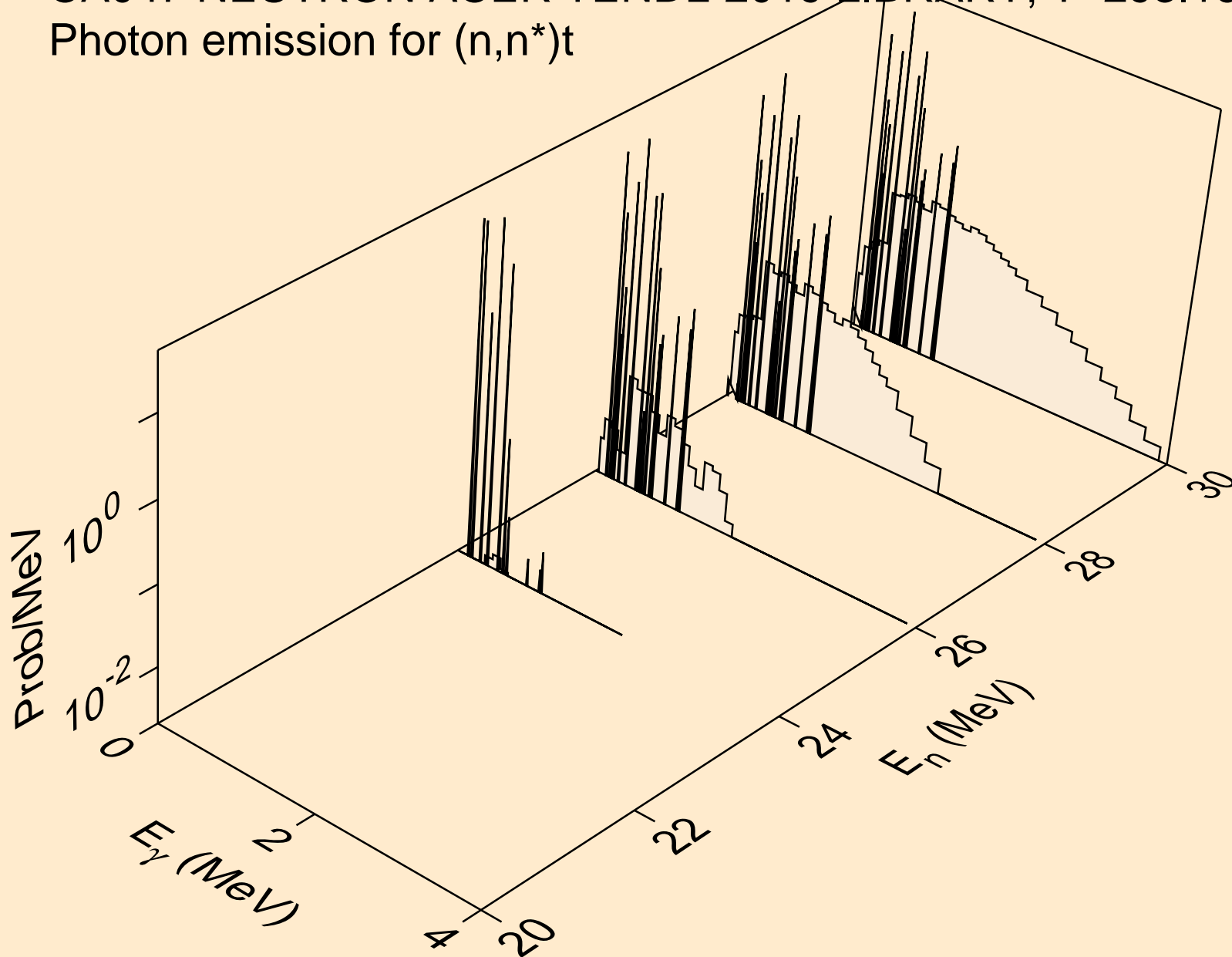

CA047 NEUTRON ACER TENDL-2019 LIBRARY; T=293.16K
Photon emission for (n,n*)he3

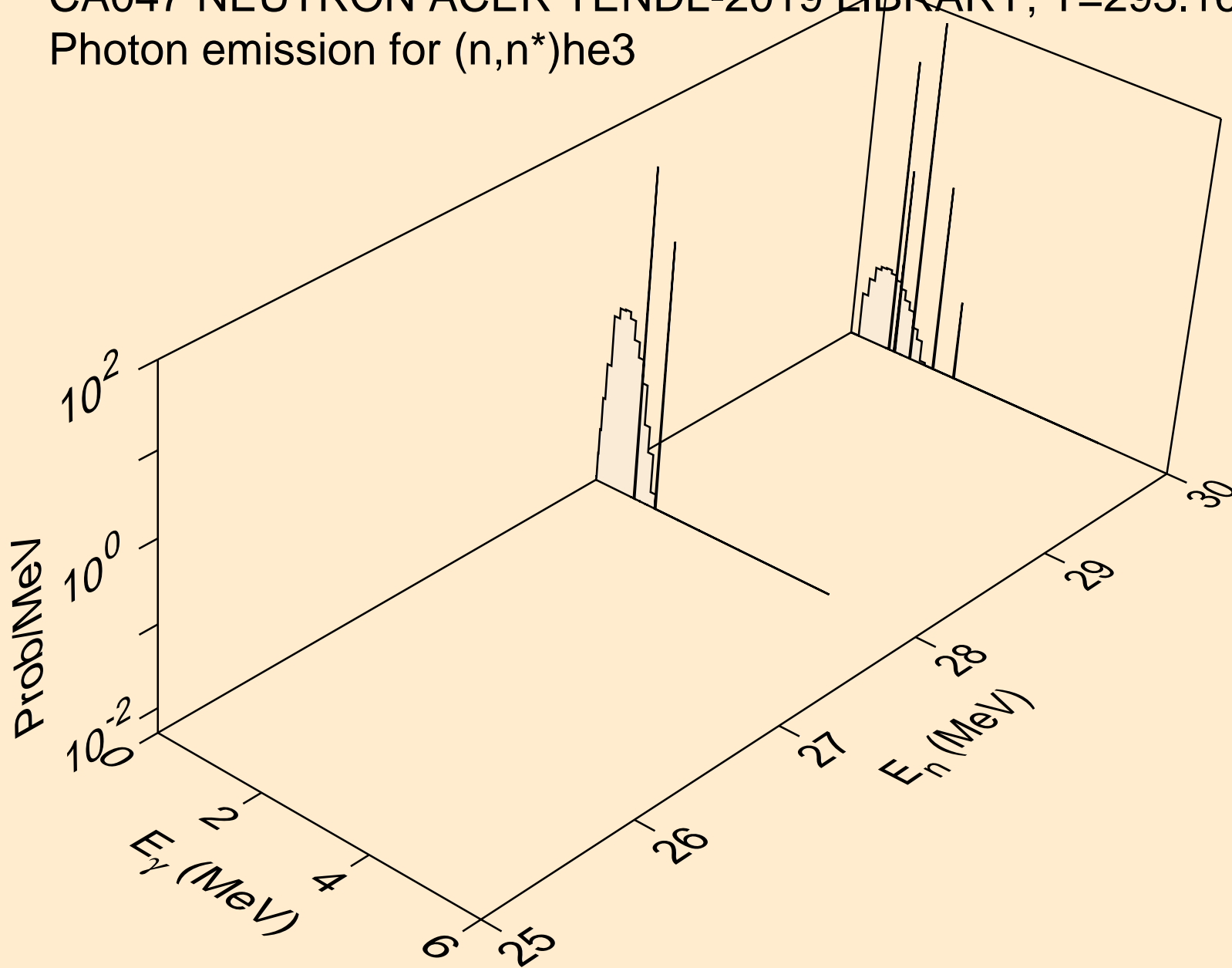

CA047 NEUTRON ACER TENDL-2019 LIBRARY; T=293.16K
Photon emission for (n,4n)

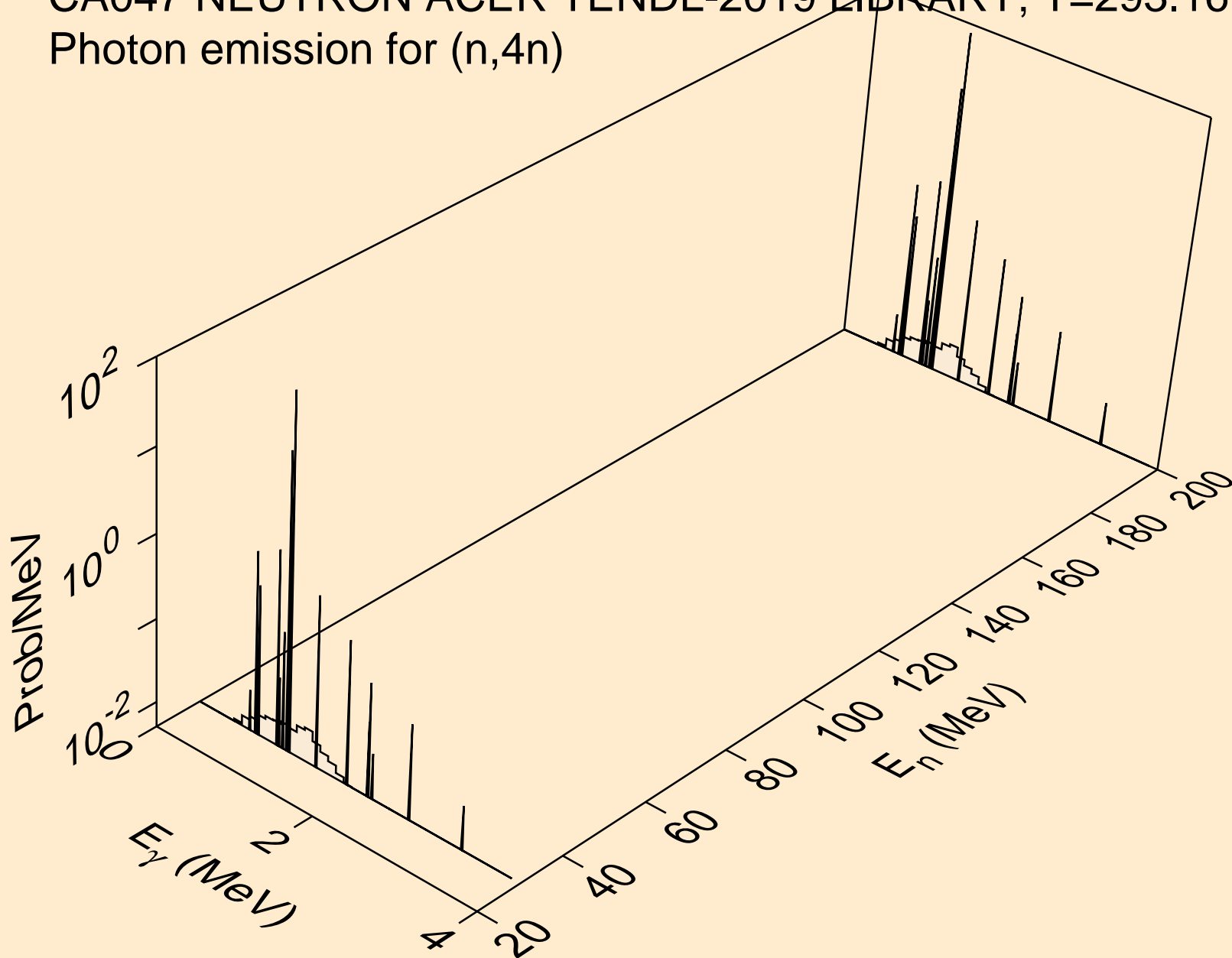

CA047 NEUTRON ACER TENDL-2019 LIBRARY; T=293.16K
Photon emission for (n,2np)

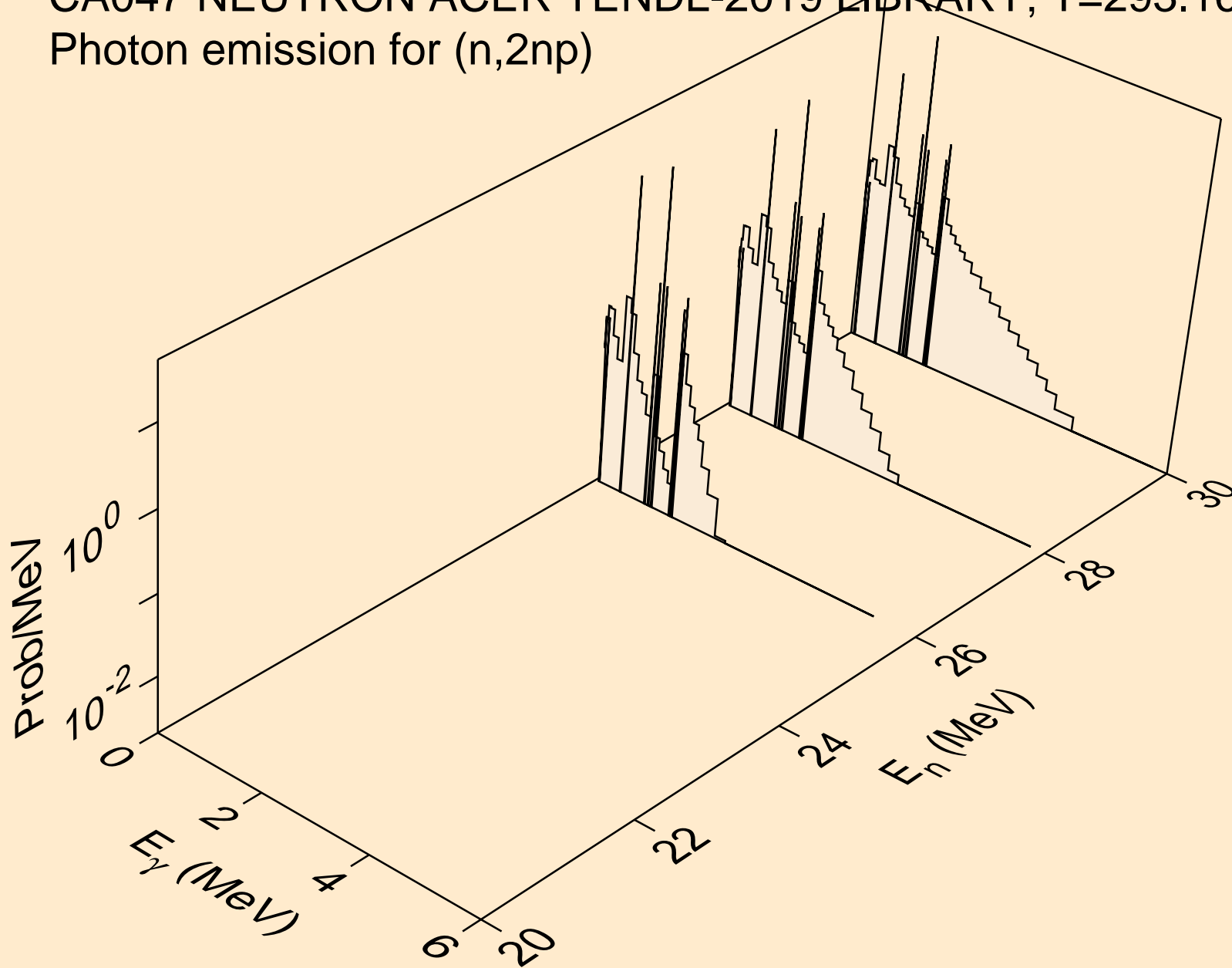

CA047 NEUTRON ACER TENDL-2019 LIBRARY; T=293.16K
Photon emission for (n,n*c)

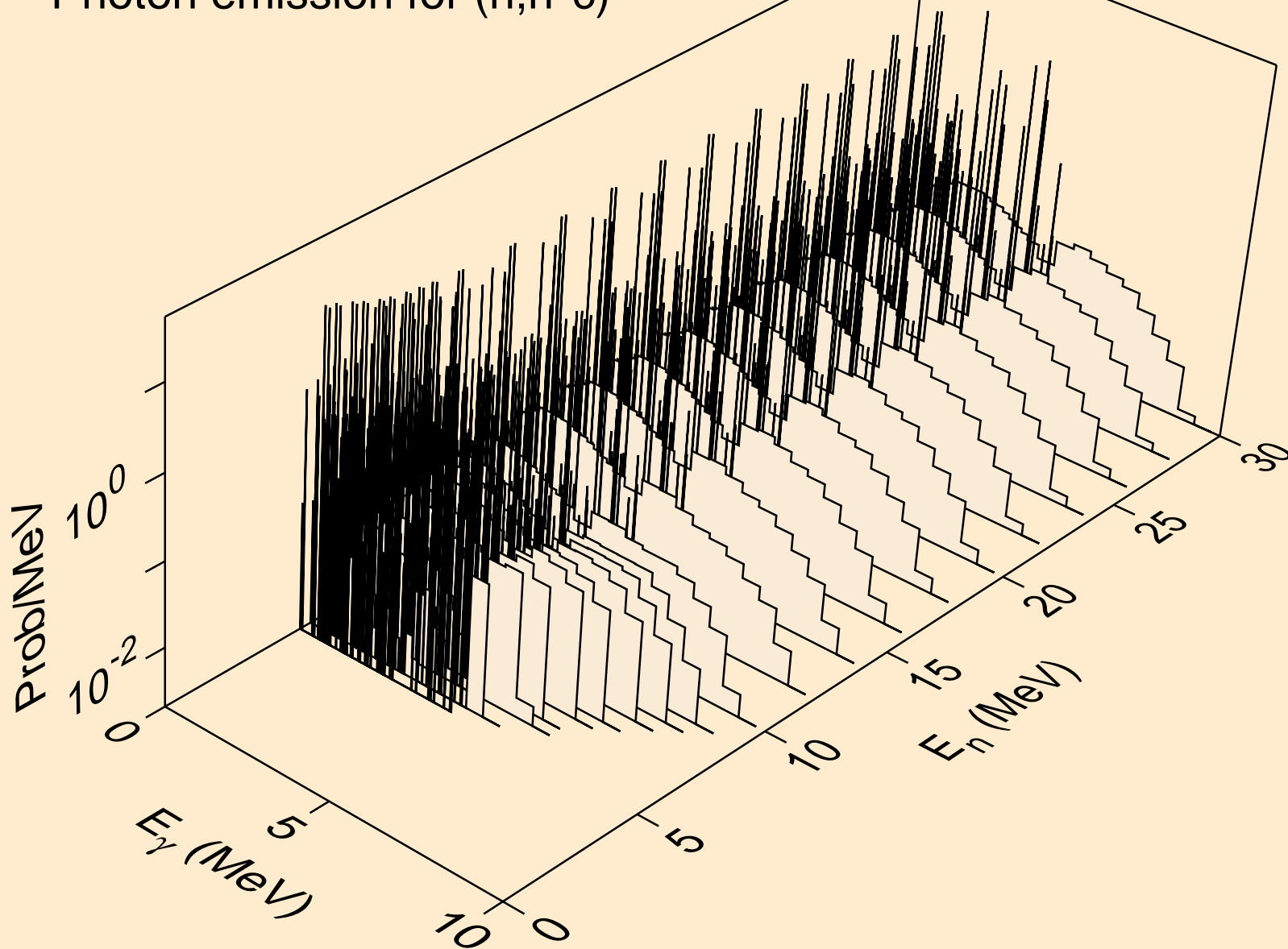

CA047 NEUTRON ACER TENDL-2019 LIBRARY; T=293.16K
Photon emission for (n,gma)

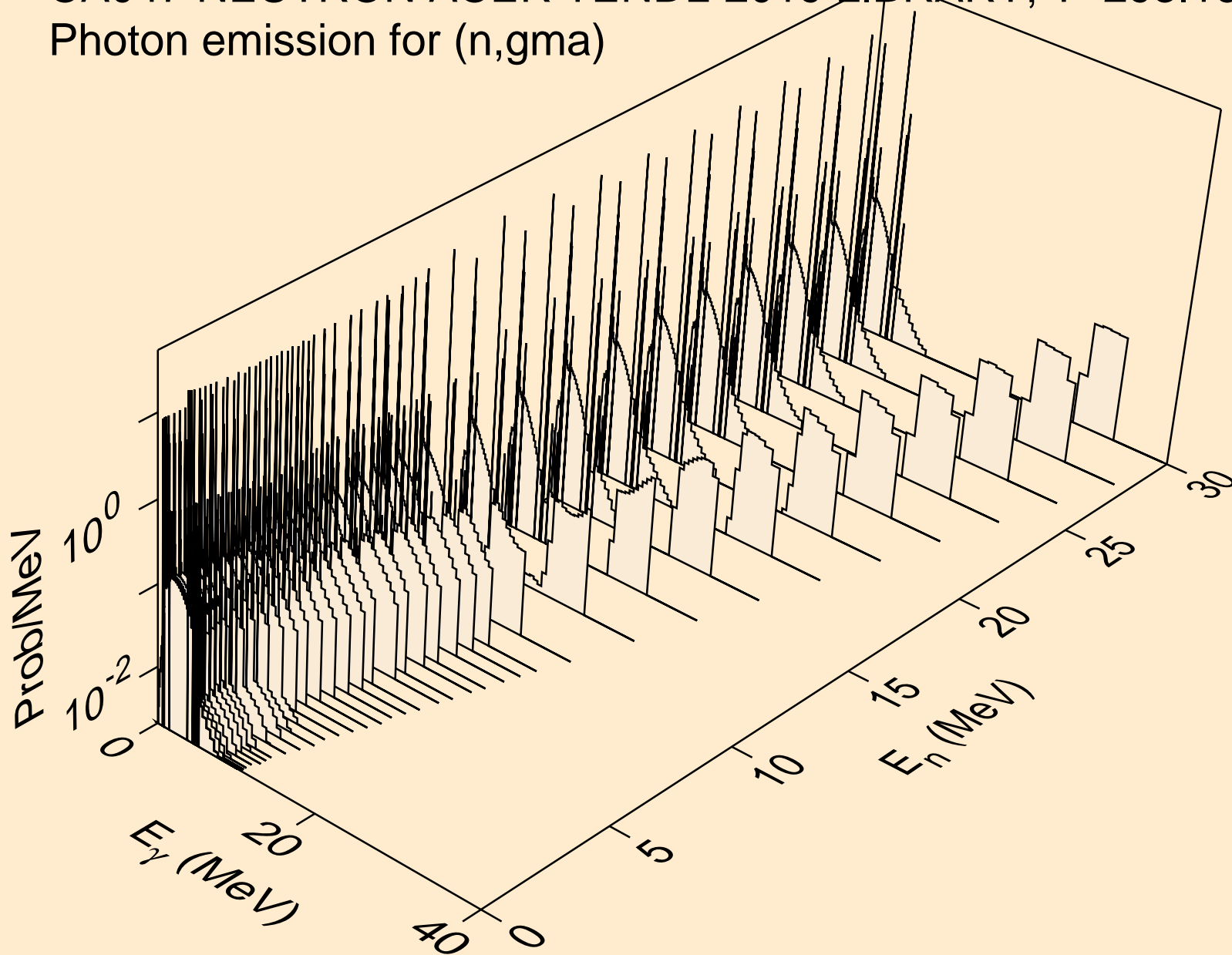

CA047 NEUTRON ACER TENDL-2019 LIBRARY; T=293.16K
Photon emission for (n,p)

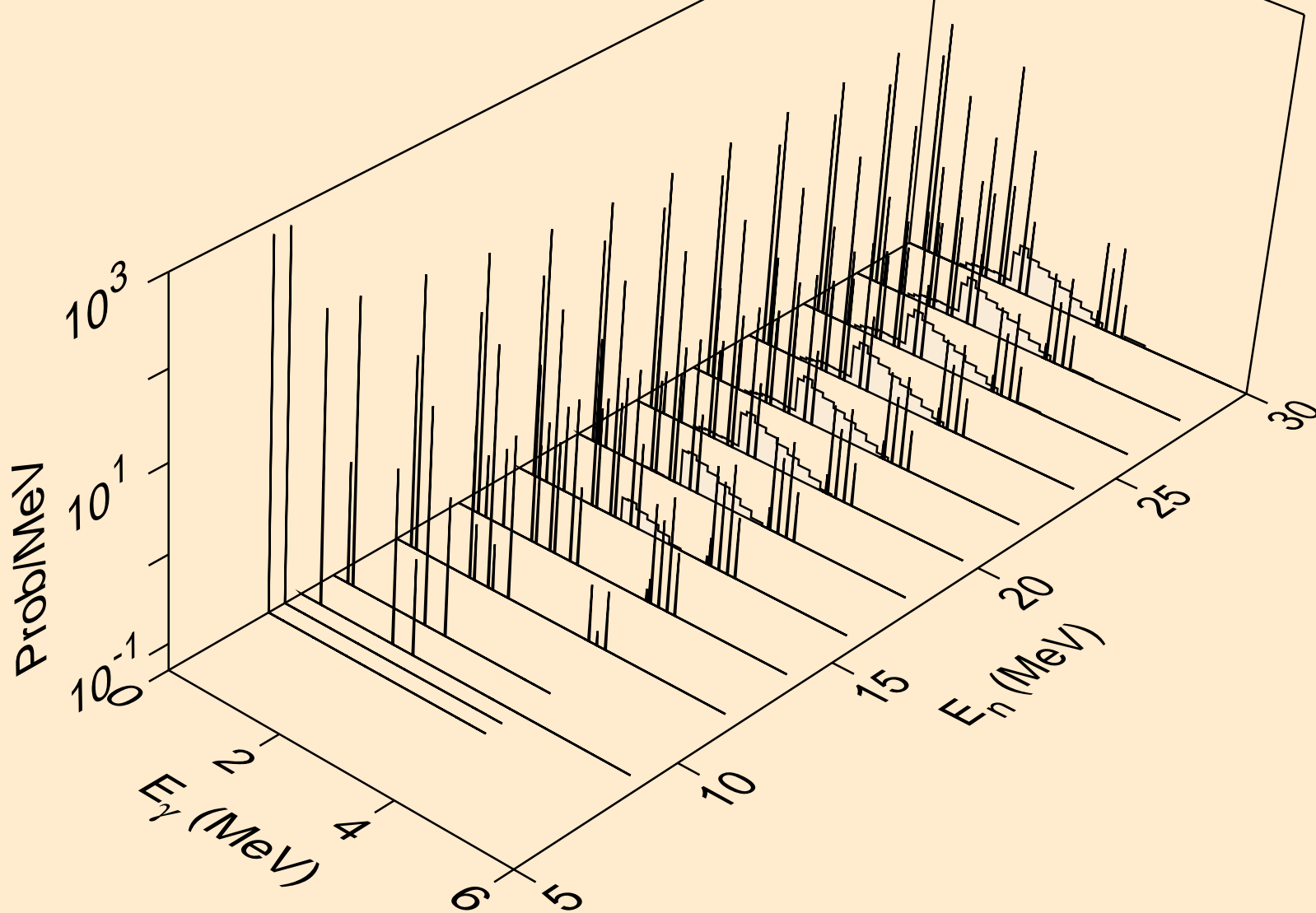

CA047 NEUTRON ACER TENDL-2019 LIBRARY; T=293.16K
Photon emission for (n,d)

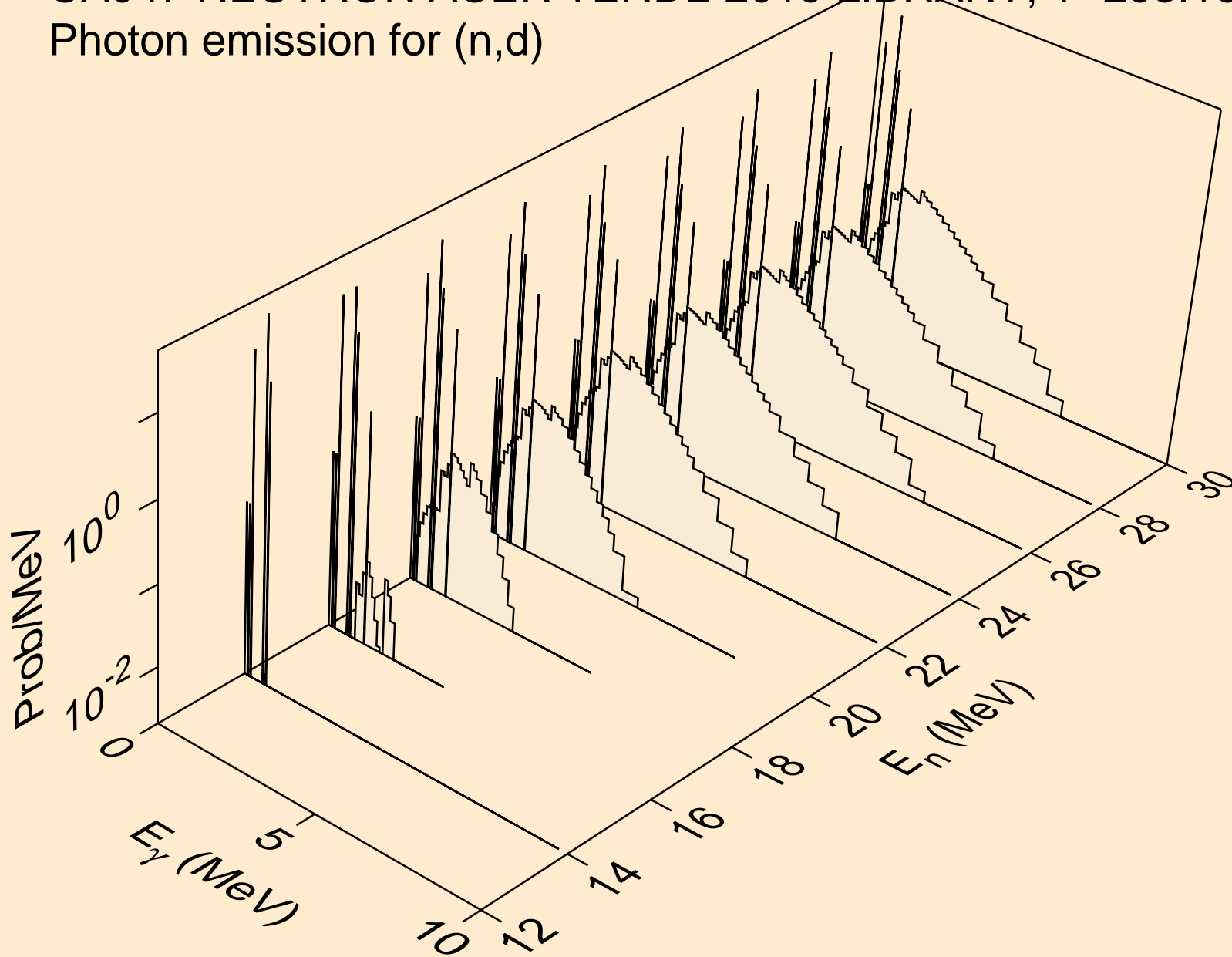

CA047 NEUTRON ACER TENDL-2019 LIBRARY; T=293.16K
Photon emission for (n,t)

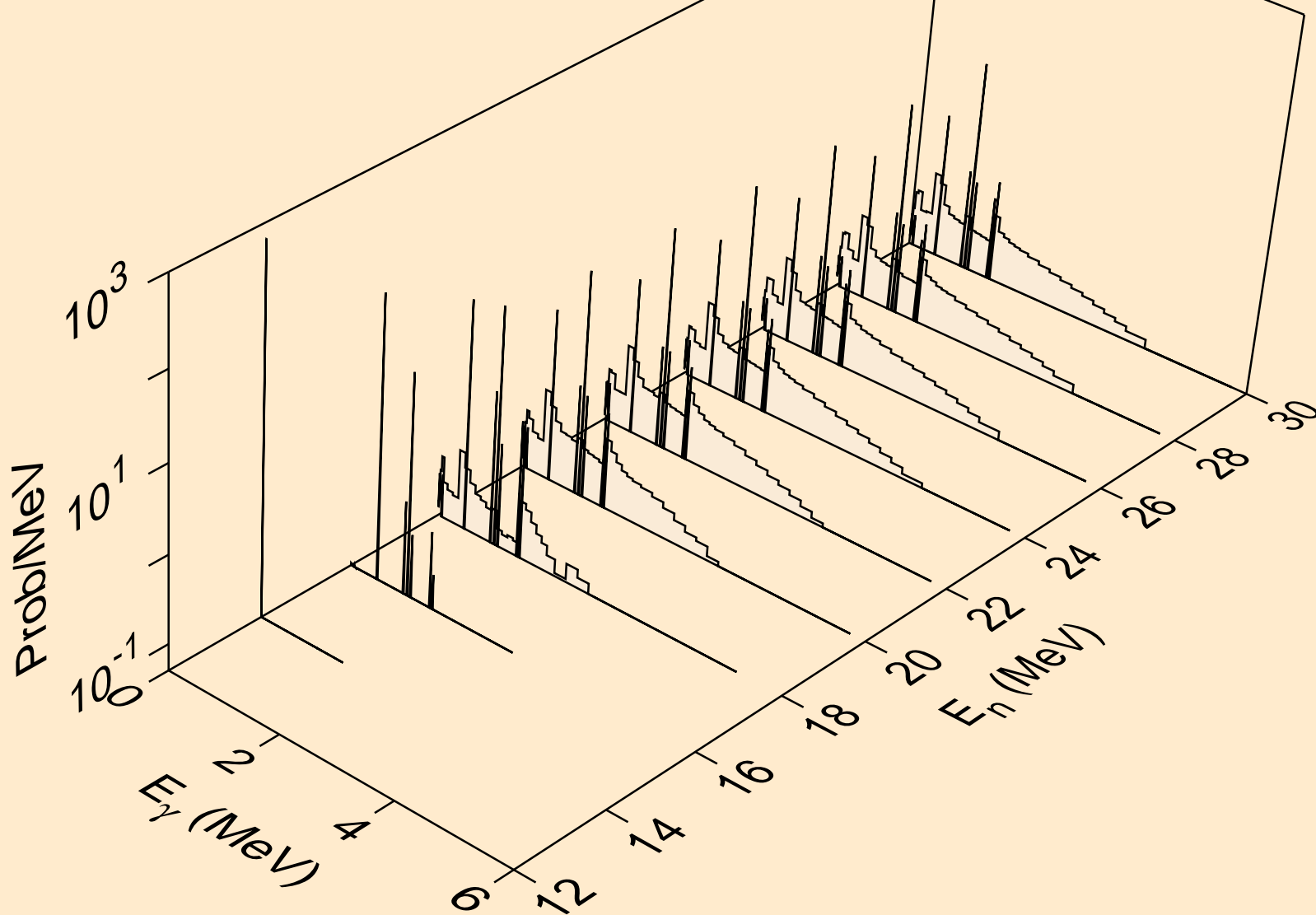

CA047 NEUTRON ACER TENDL-2019 LIBRARY; T=293.16K
Photon emission for (n,he3)

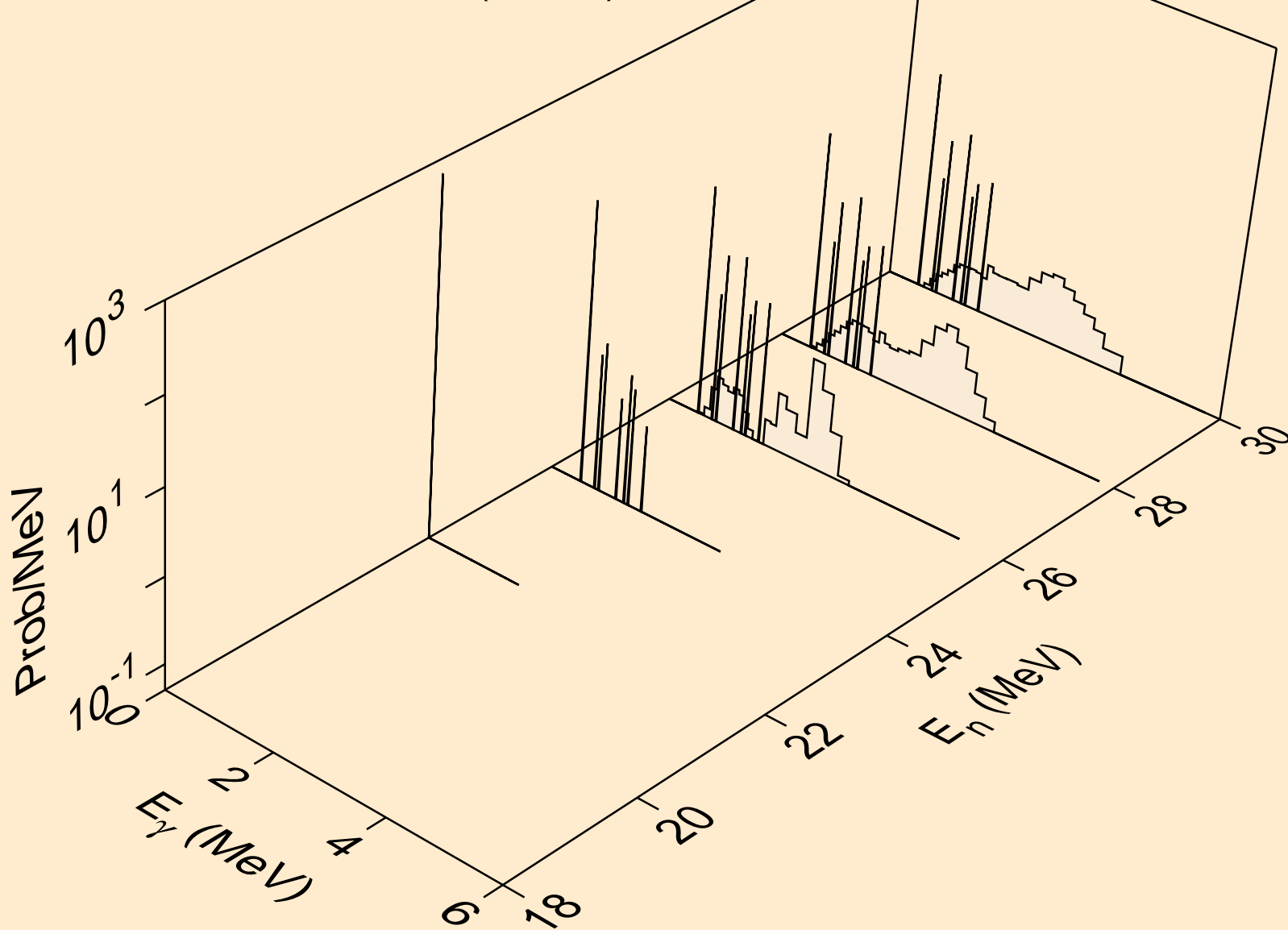

CA047 NEUTRON ACER TENDL-2019 LIBRARY; T=293.16K
Photon emission for (n,a)

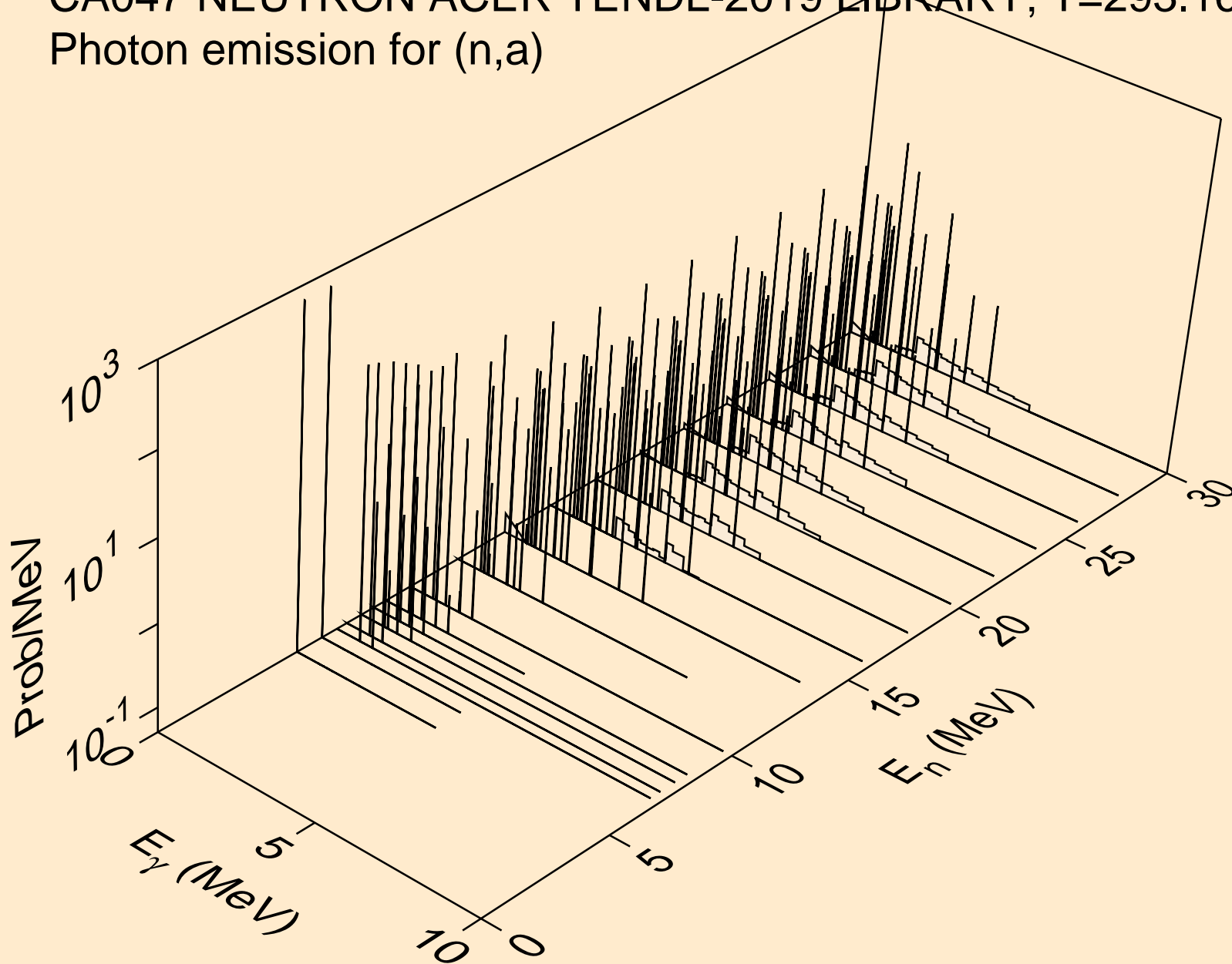

CA047 NEUTRON ACER TENDL-2019 LIBRARY; T=293.16K
Photon emission for (n,2a)

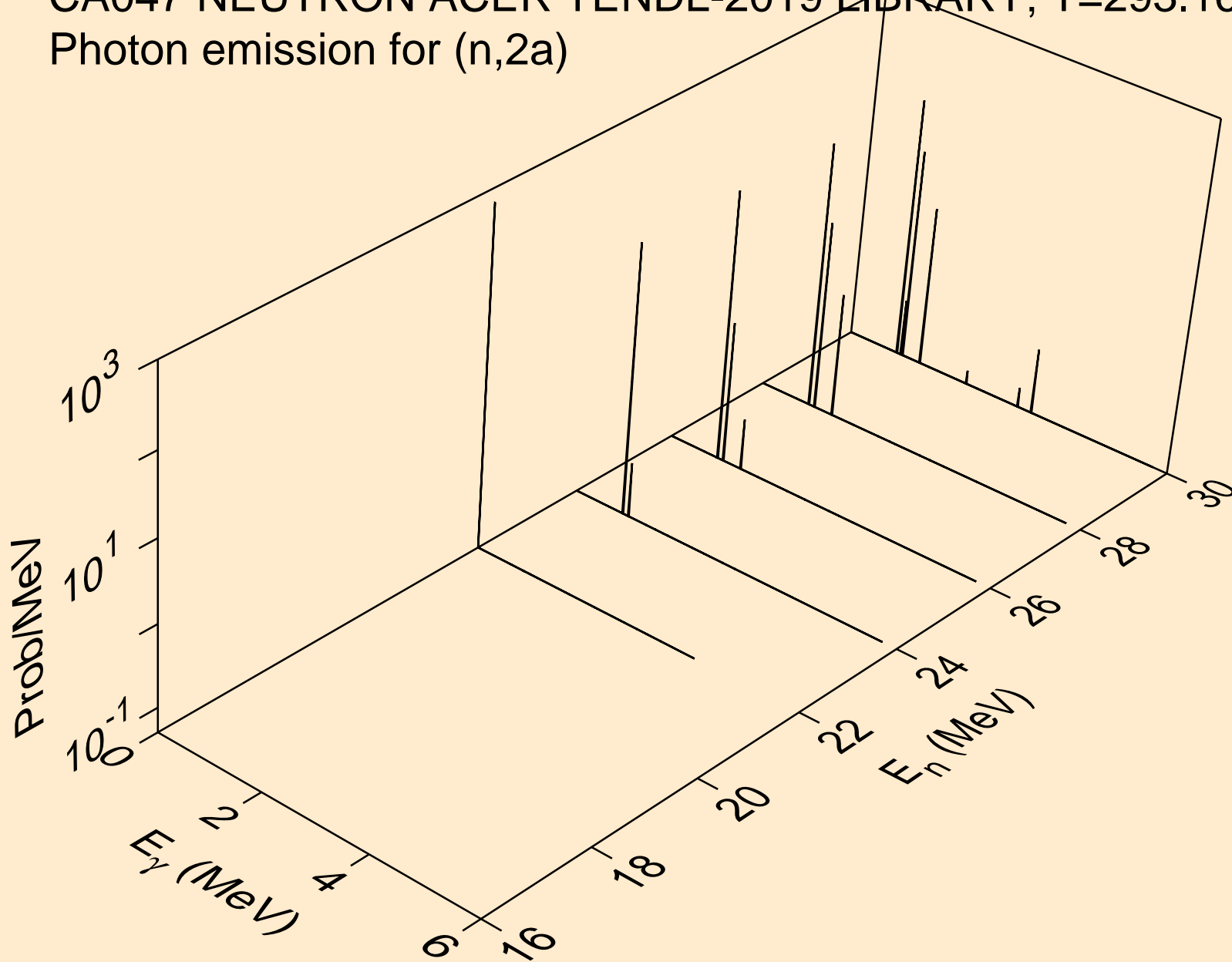

CA047 NEUTRON ACER TENDL-2019 LIBRARY; T=293.16K
Photon emission for (n,2p)

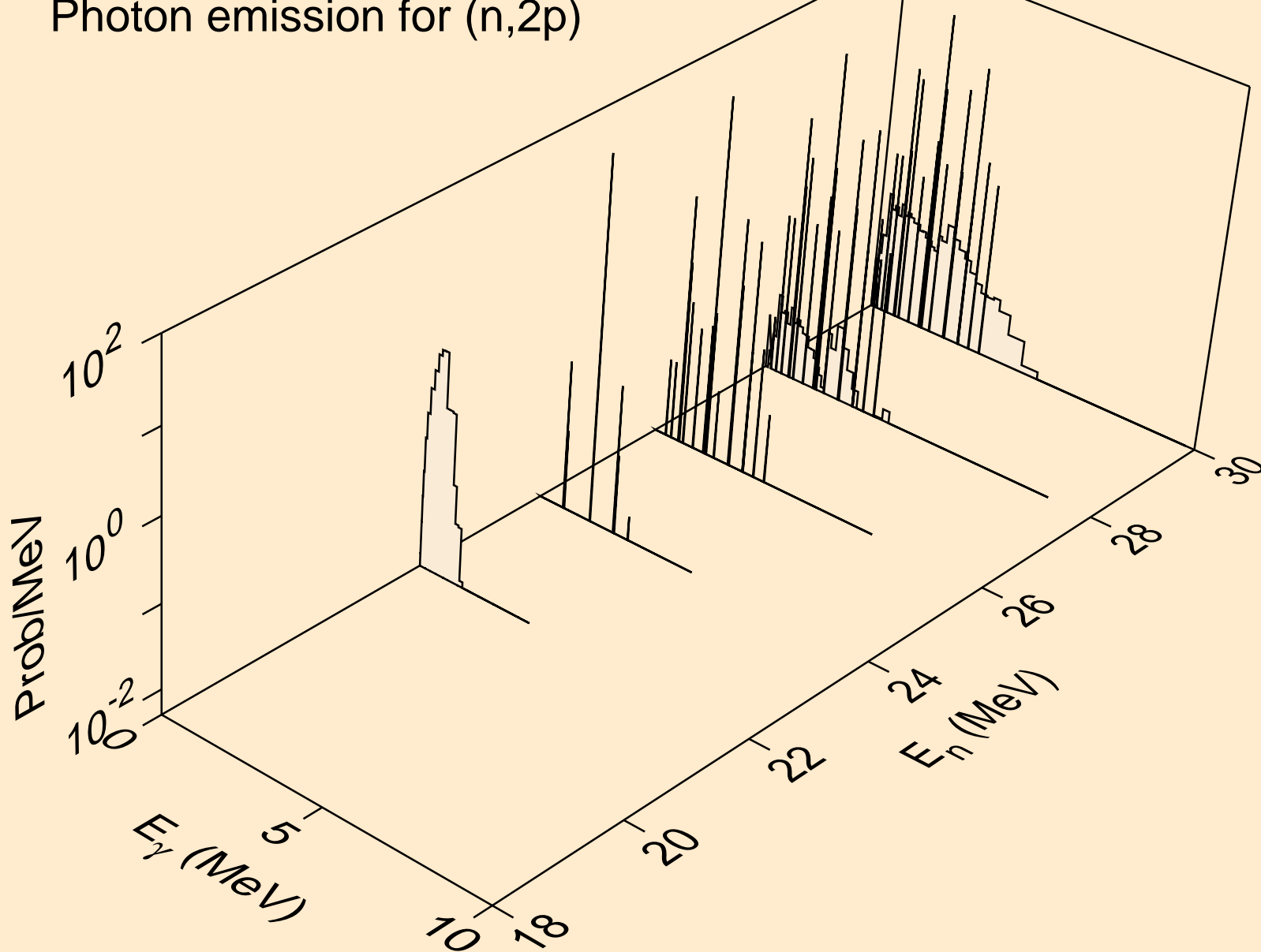

CA047 NEUTRON ACER TENDL-2019 LIBRARY; T=293.16K
Photon emission for (n,p α)

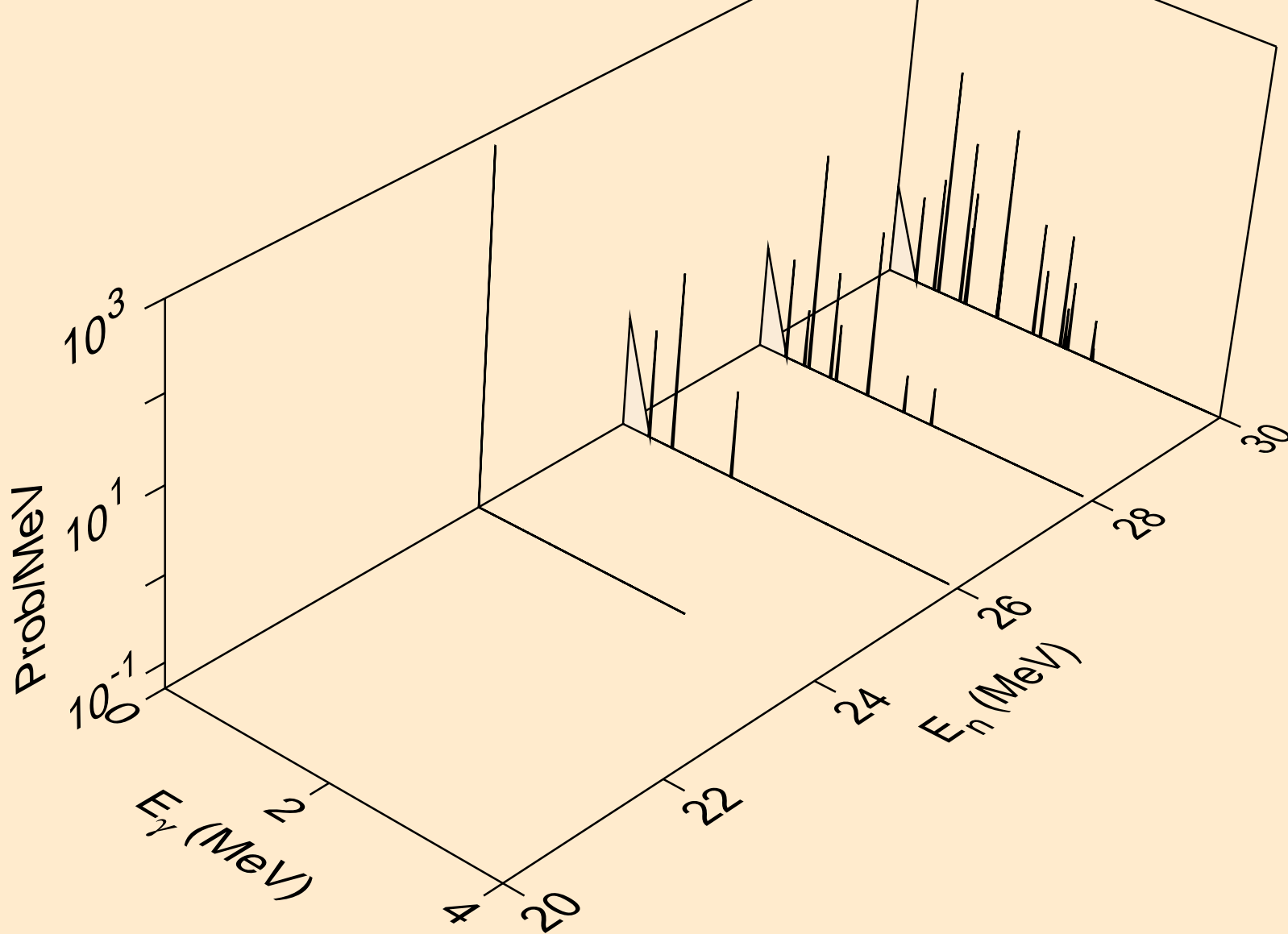

CA047 NEUTRON ACER TENDL-2019 LIBRARY; T=293.16K
Photon emission for (n,pd)

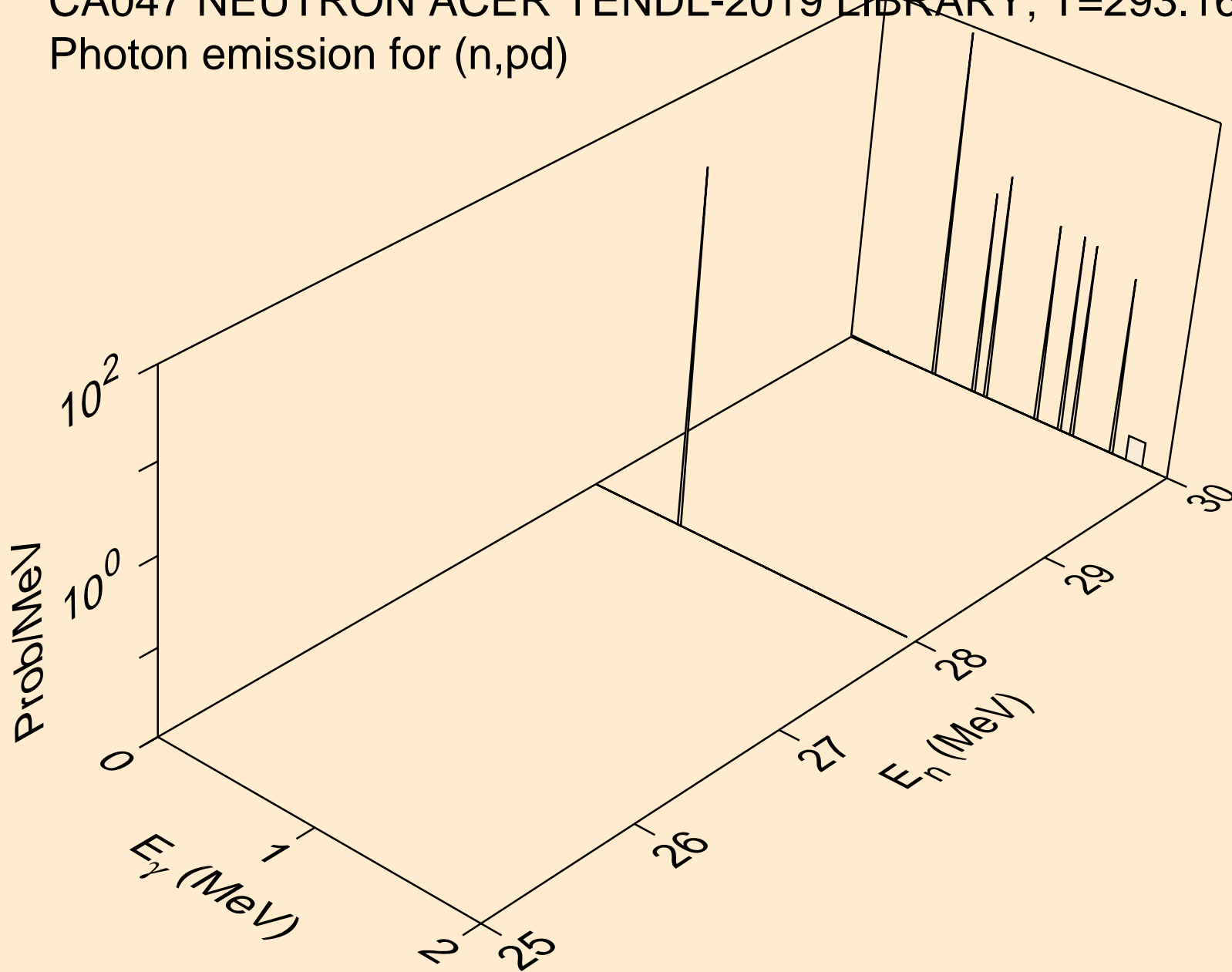

CA047 NEUTRON ACER TENDL-2019 LIBRARY; T=293.16K
Photon emission for (n,pt)

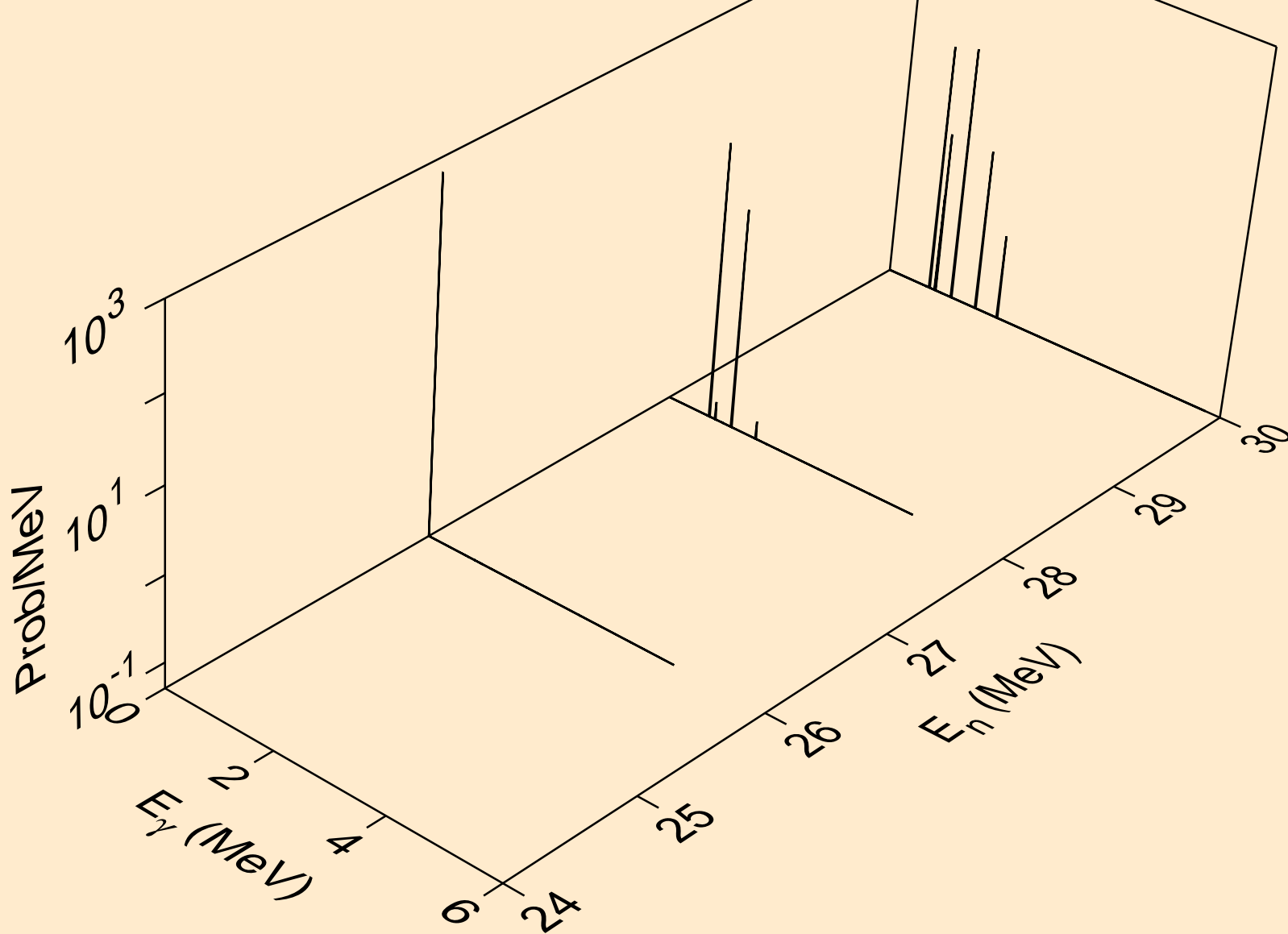

CA047 NEUTRON ACER TENDL-2019 LIBRARY; T=293.16K
thermal capture photon spectrum

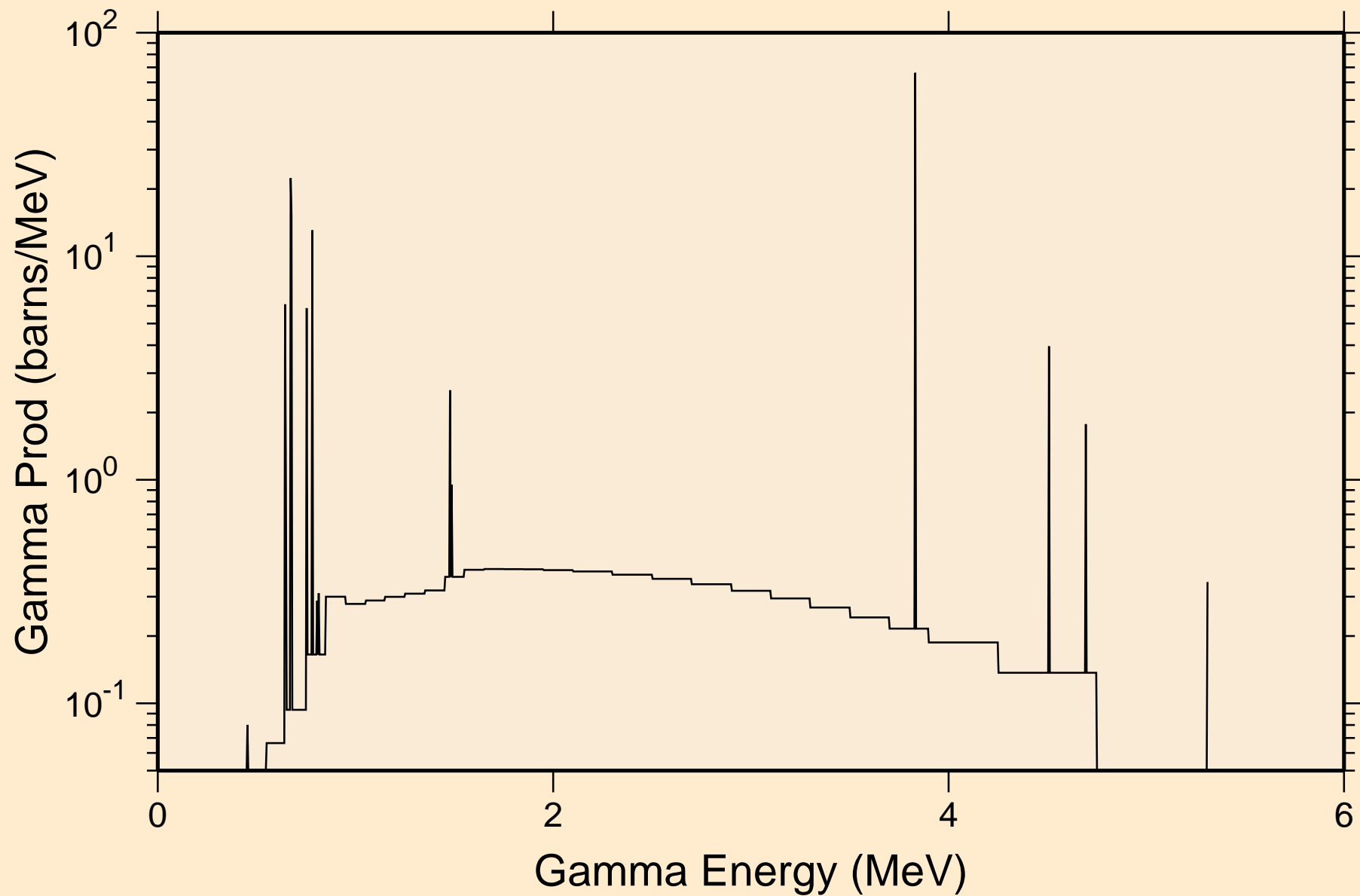

CA047 NEUTRON ACER TENDL-2019 LIBRARY; T=293.16K
14 MeV photon spectrum

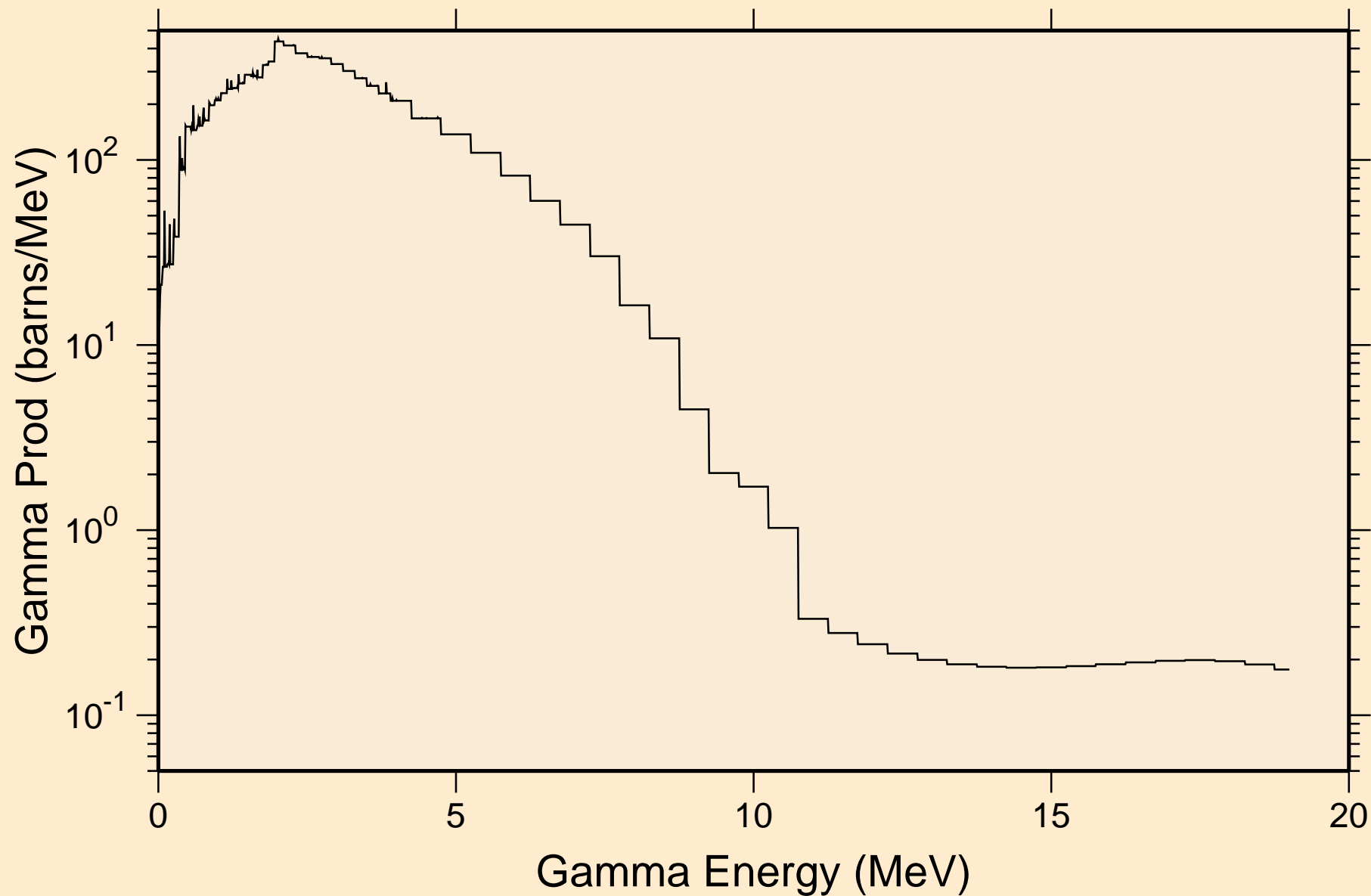

CA047 NEUTRON ACER TENDL-2019 LIBRARY; T=293.16K
Particle heating contributions

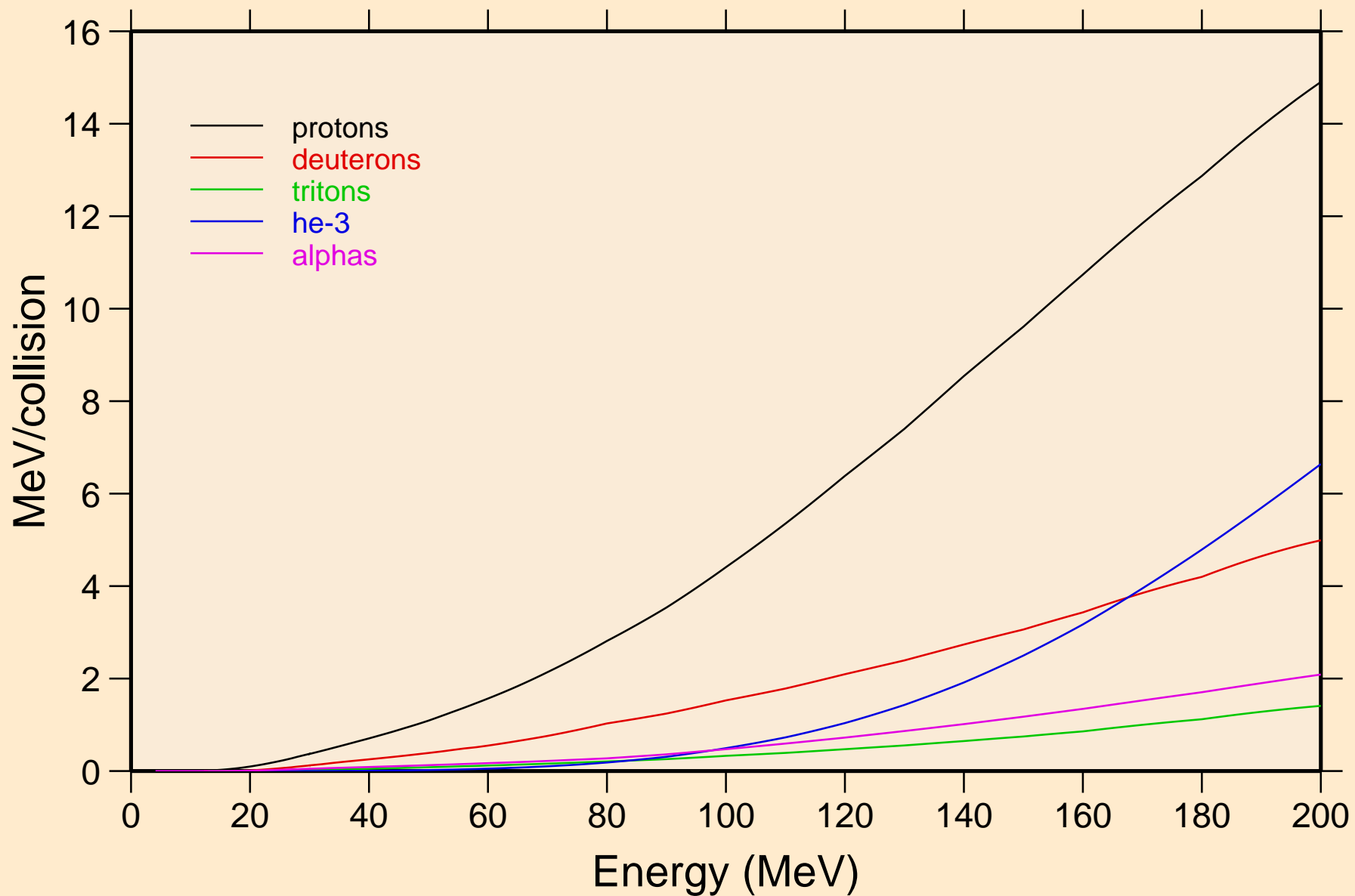

CA047 NEUTRON ACER TENDL-2019 LIBRARY; T=293.16K
Recoil Heating

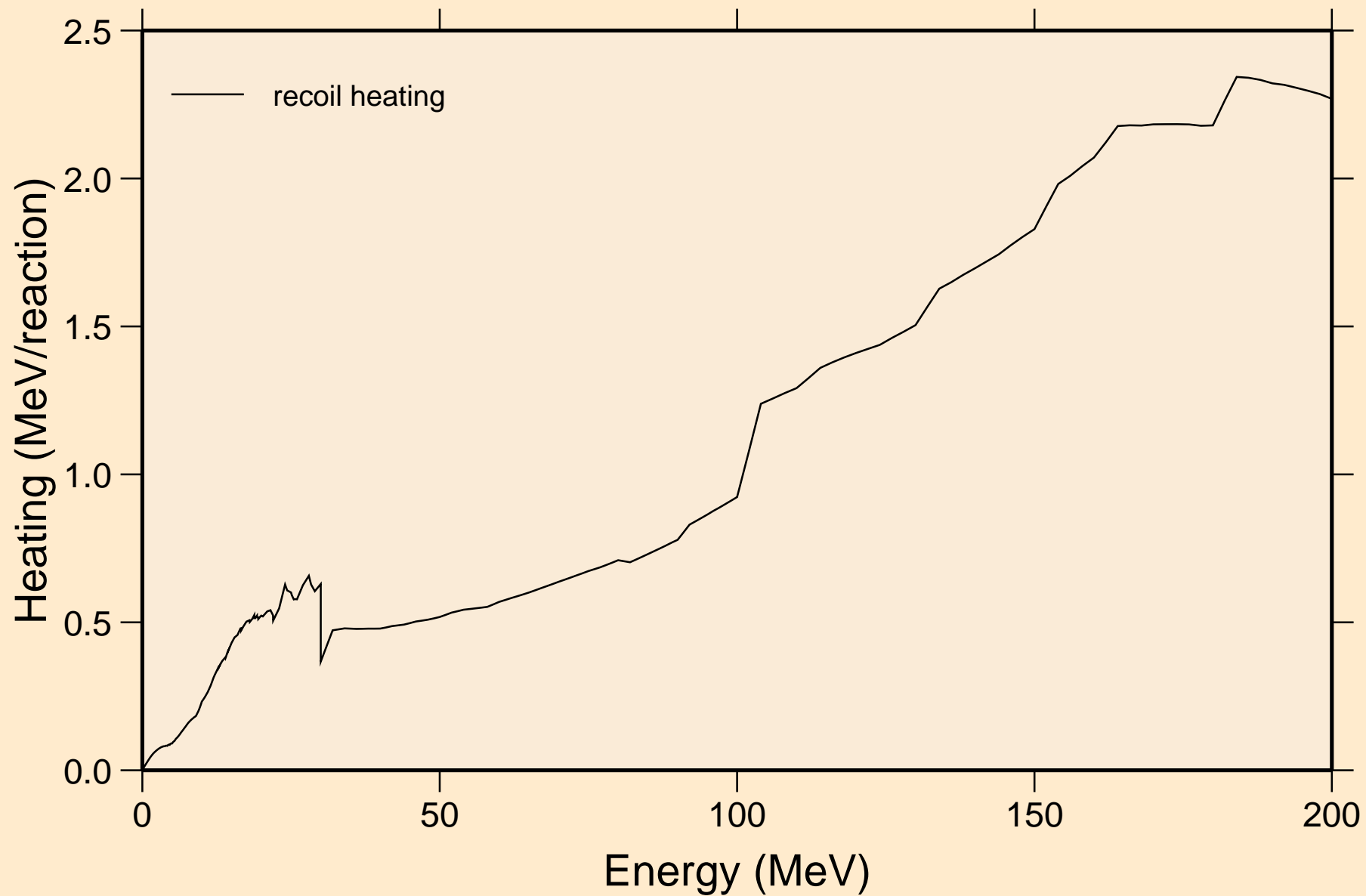

CA047 NEUTRON ACER TENDL-2019 LIBRARY; T=293.16K
Particle production cross sections

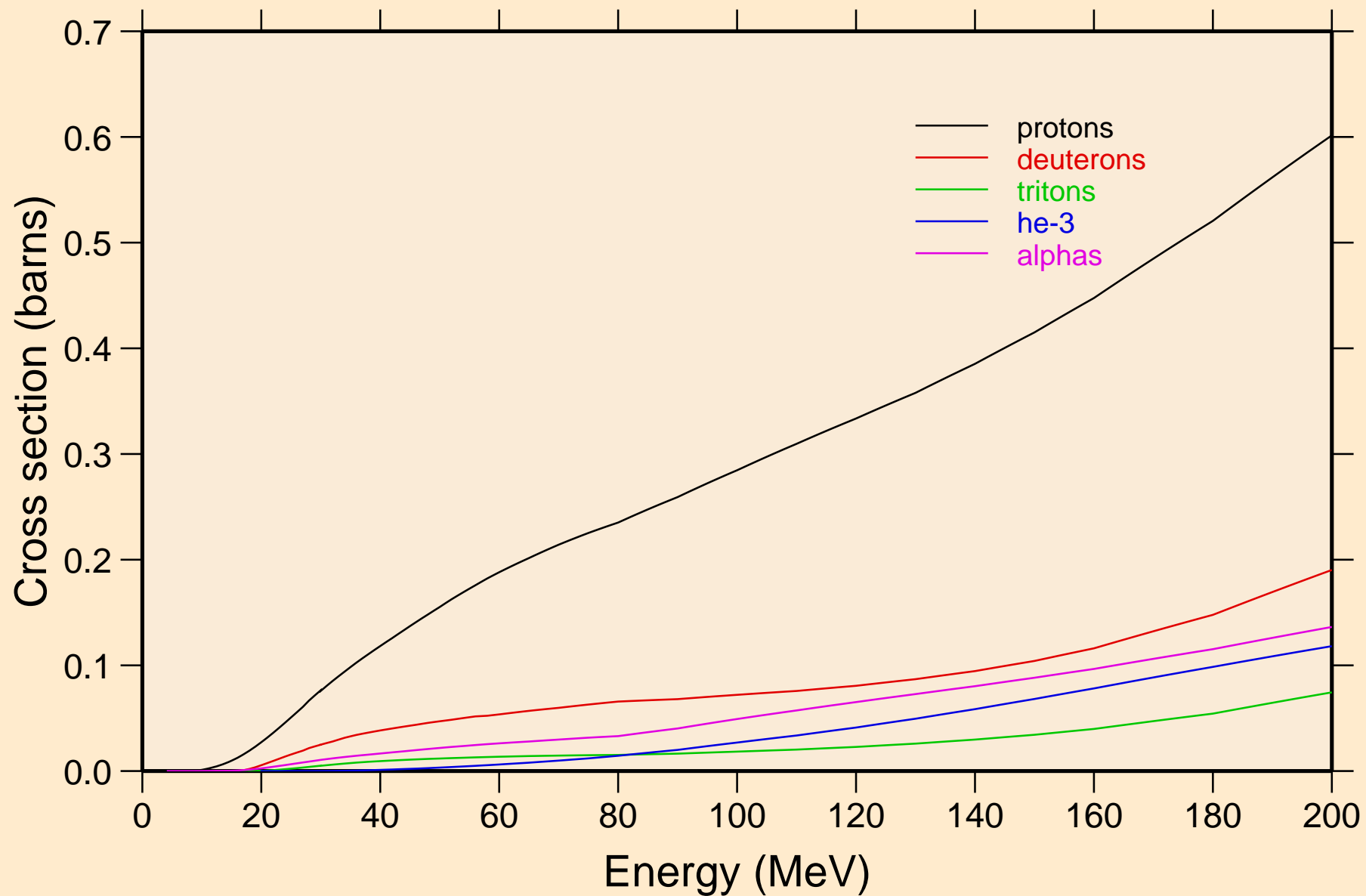

CA047 NEUTRON ACER TENDL-2019 LIBRARY; T=293.16K
protons from (n,x)

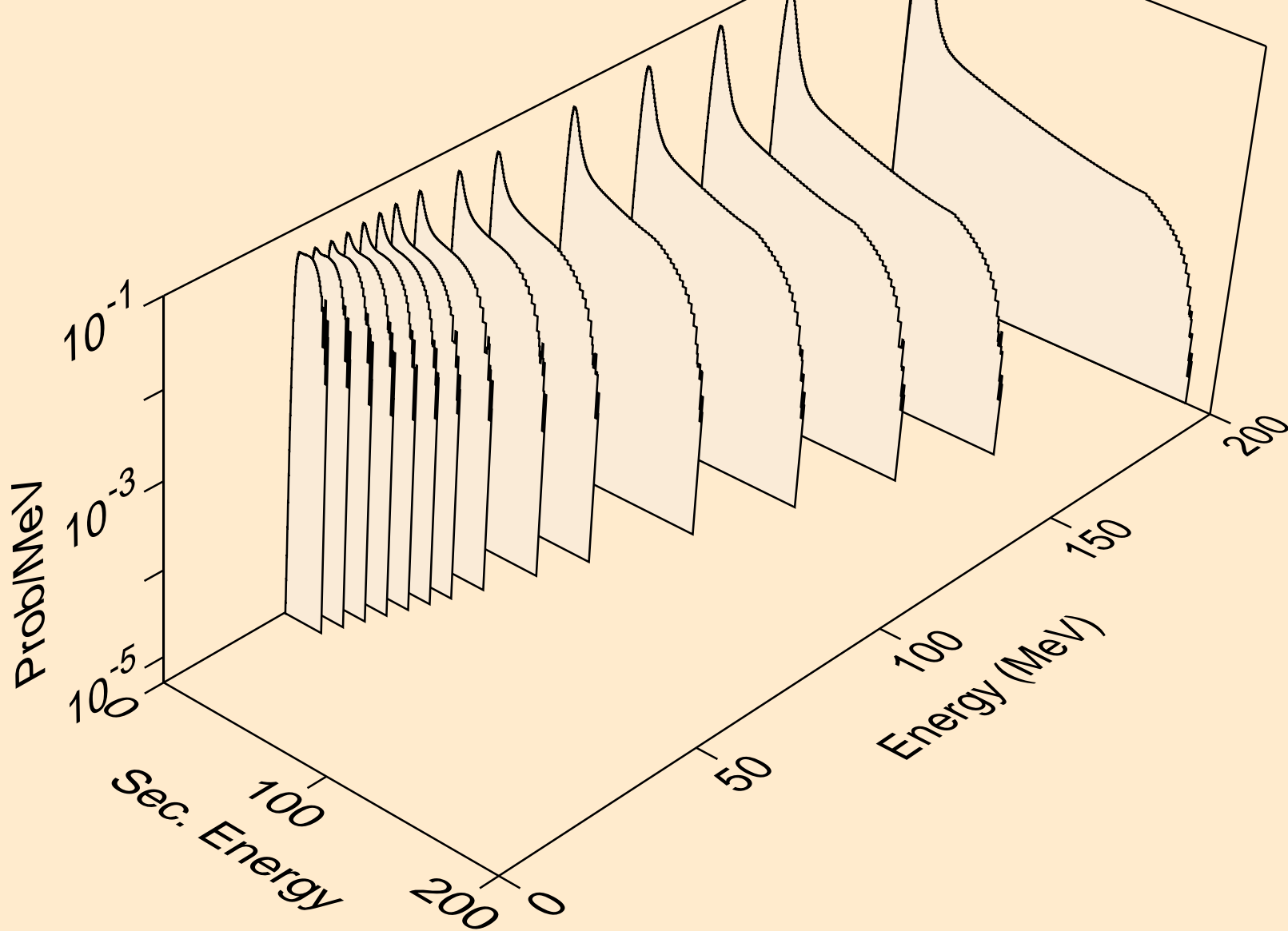

CA047 NEUTRON ACER TENDL-2019 LIBRARY; T=293.16K
protons from (n,n*)p

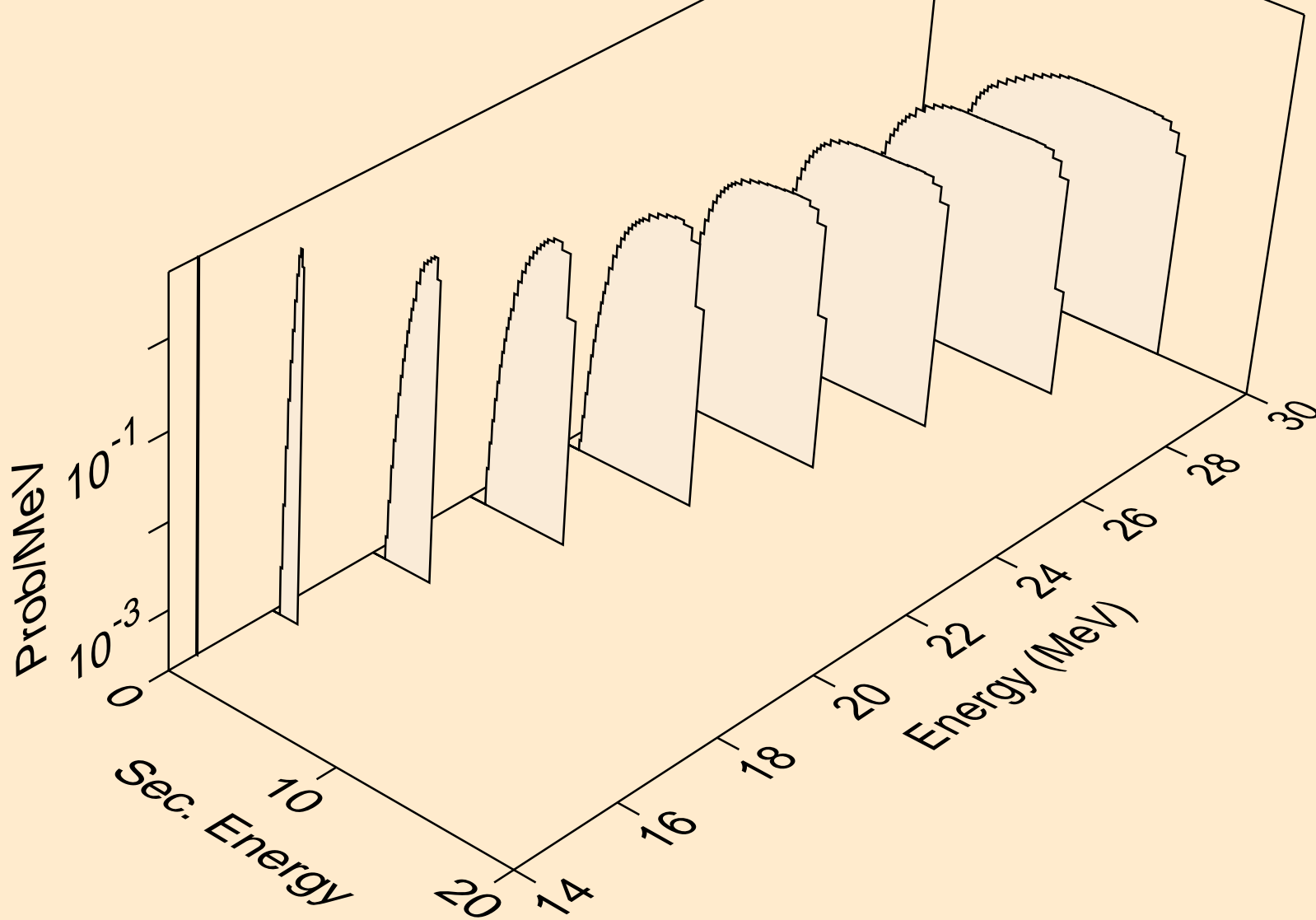

CA047 NEUTRON ACER TENDL-2019 LIBRARY; T=293.16K
protons from (n,2np)

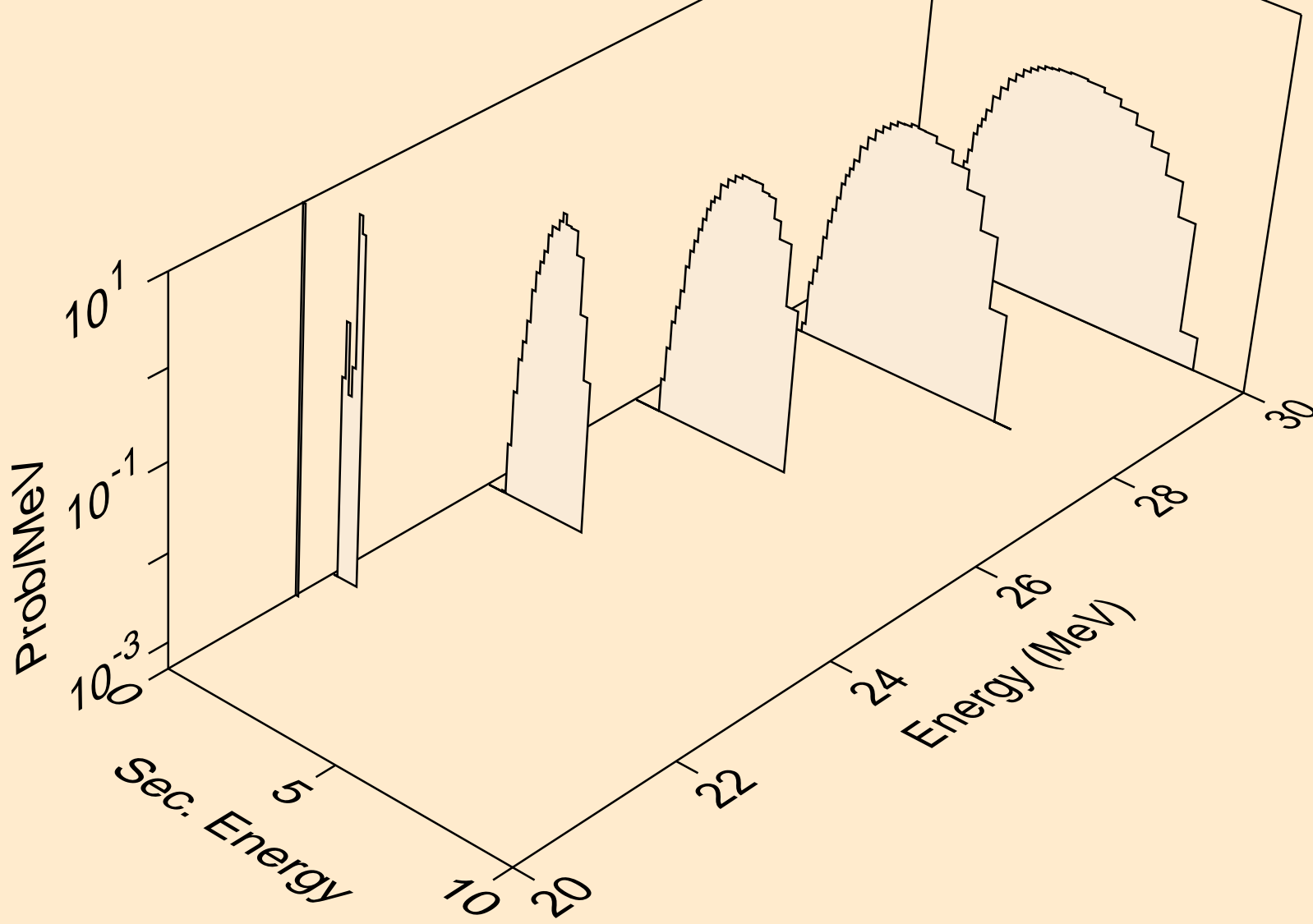

CA047 NEUTRON ACER TENDL-2019 LIBRARY; T=293.16K
protons from (n,p)

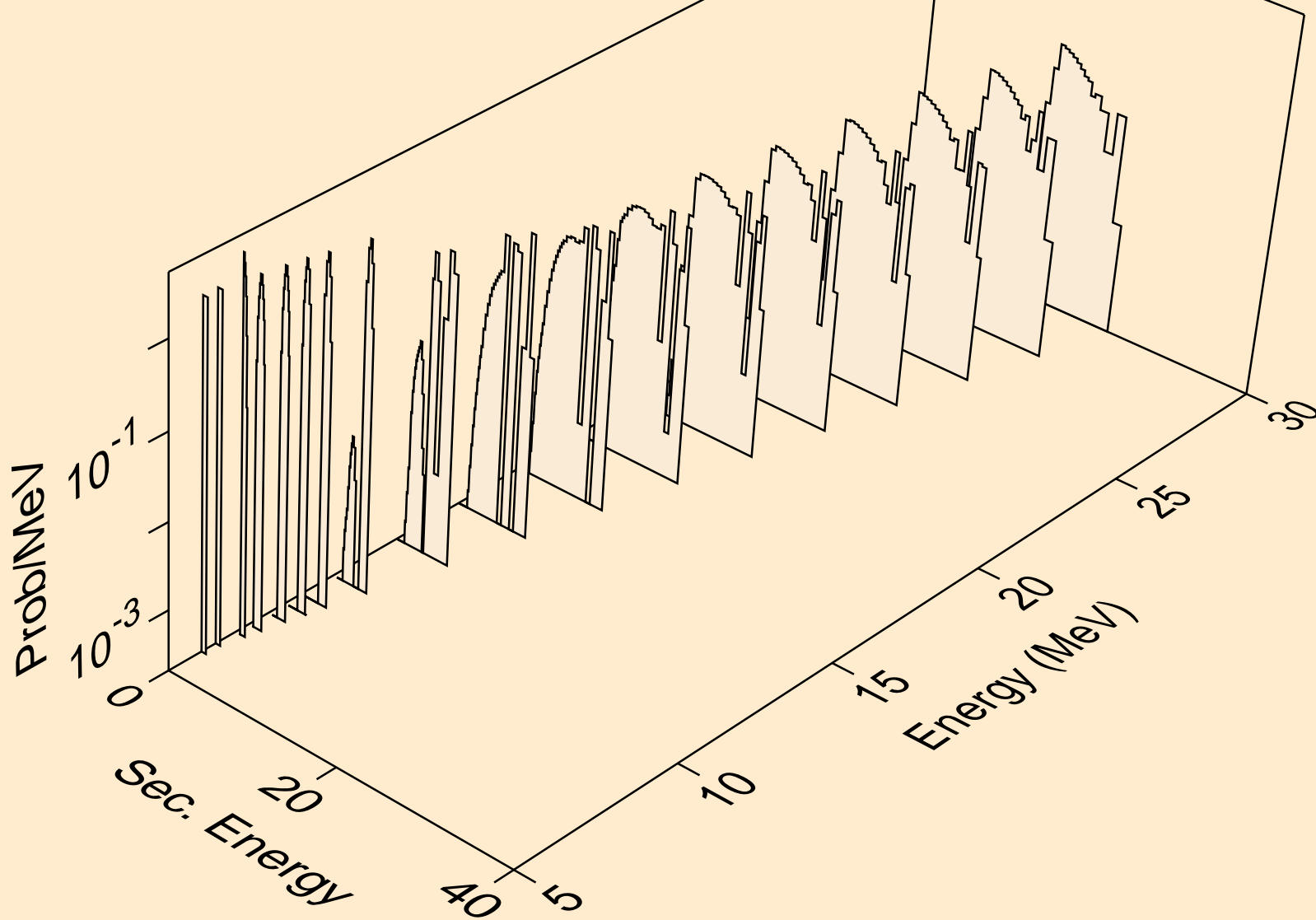

CA047 NEUTRON ACER TENDL-2019 LIBRARY; T=293.16K
protons from (n,2p)

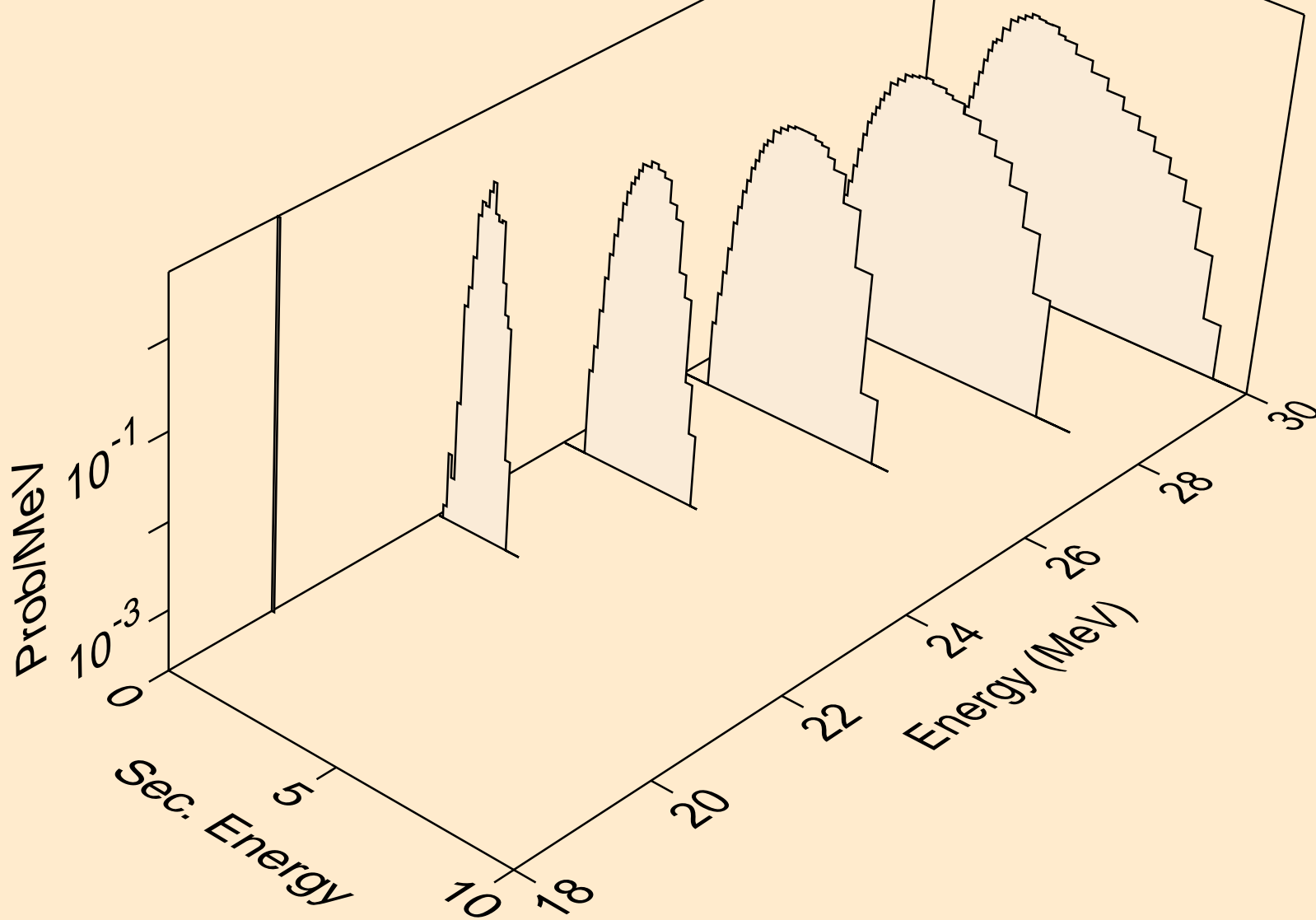

CA047 NEUTRON ACER TENDL-2019 LIBRARY; T=293.16K
protons from (n,p)

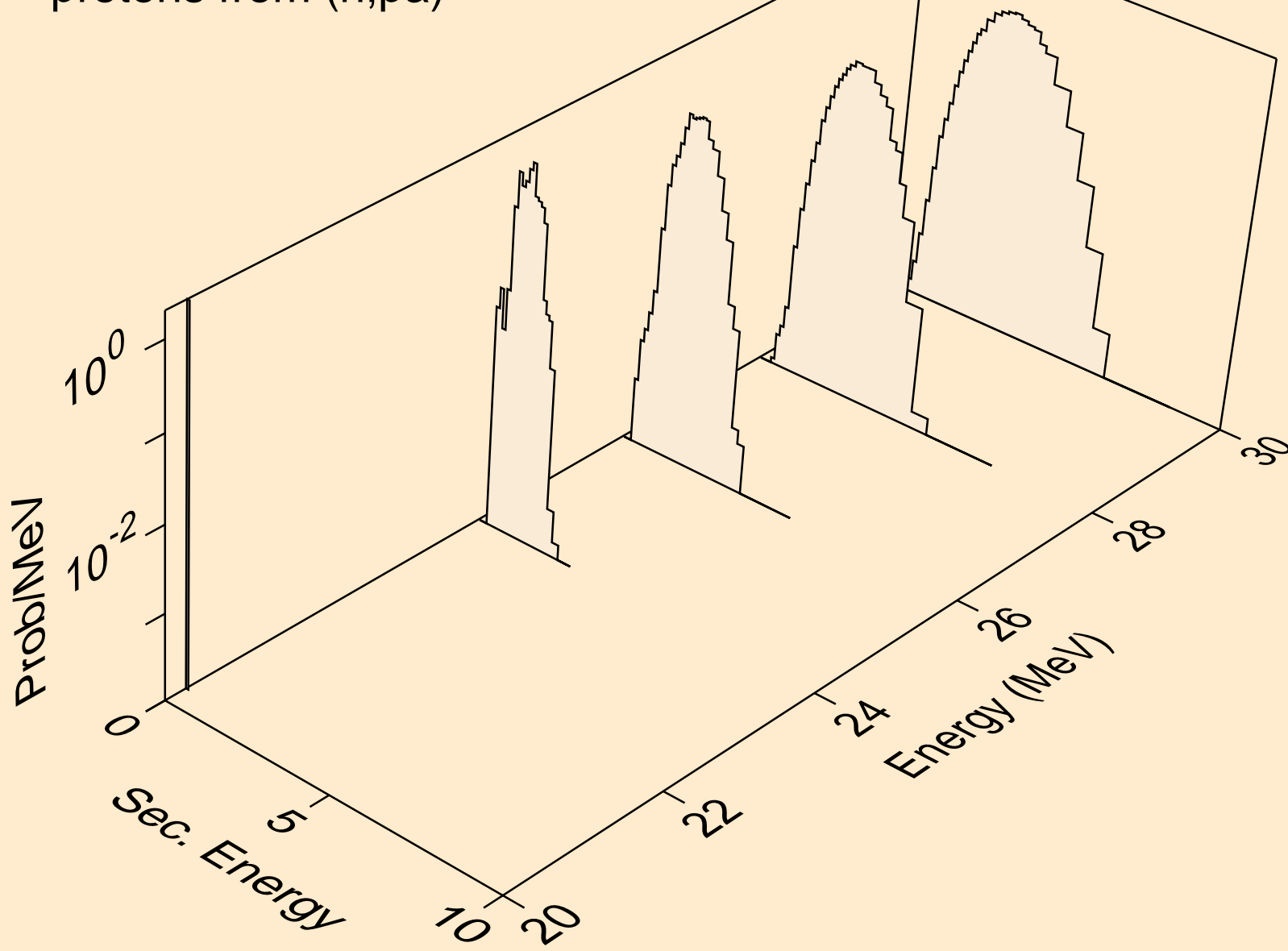

CA047 NEUTRON ACER TENDL-2019 LIBRARY; T=293.16K
protons from (n,pd)

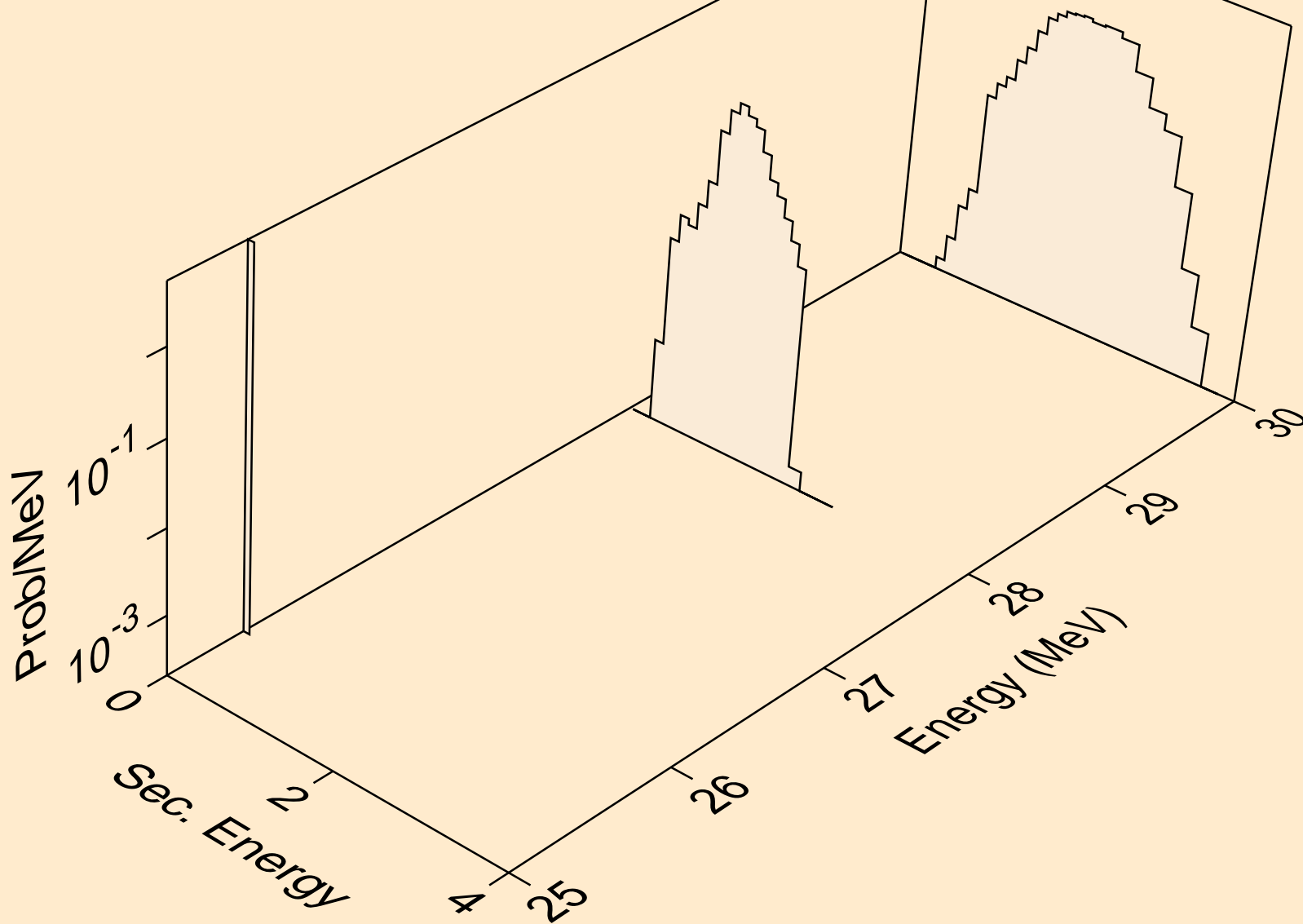

CA047 NEUTRON ACER TENDL-2019 LIBRARY; T=293.16K
protons from (n,pt)

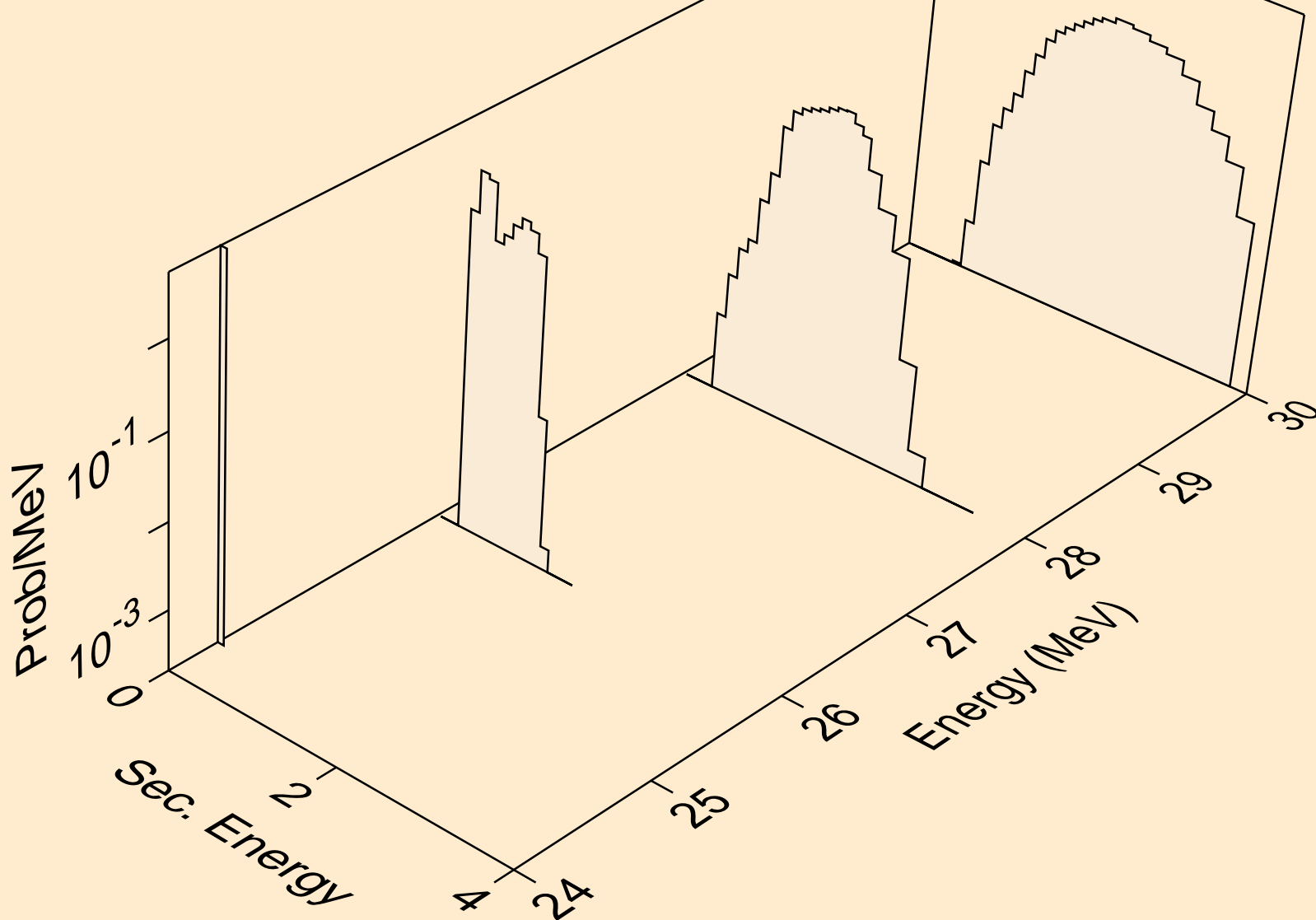

CA047 NEUTRON ACER TENDL-2019 LIBRARY; T=293.16K
deuterons from (n,x)

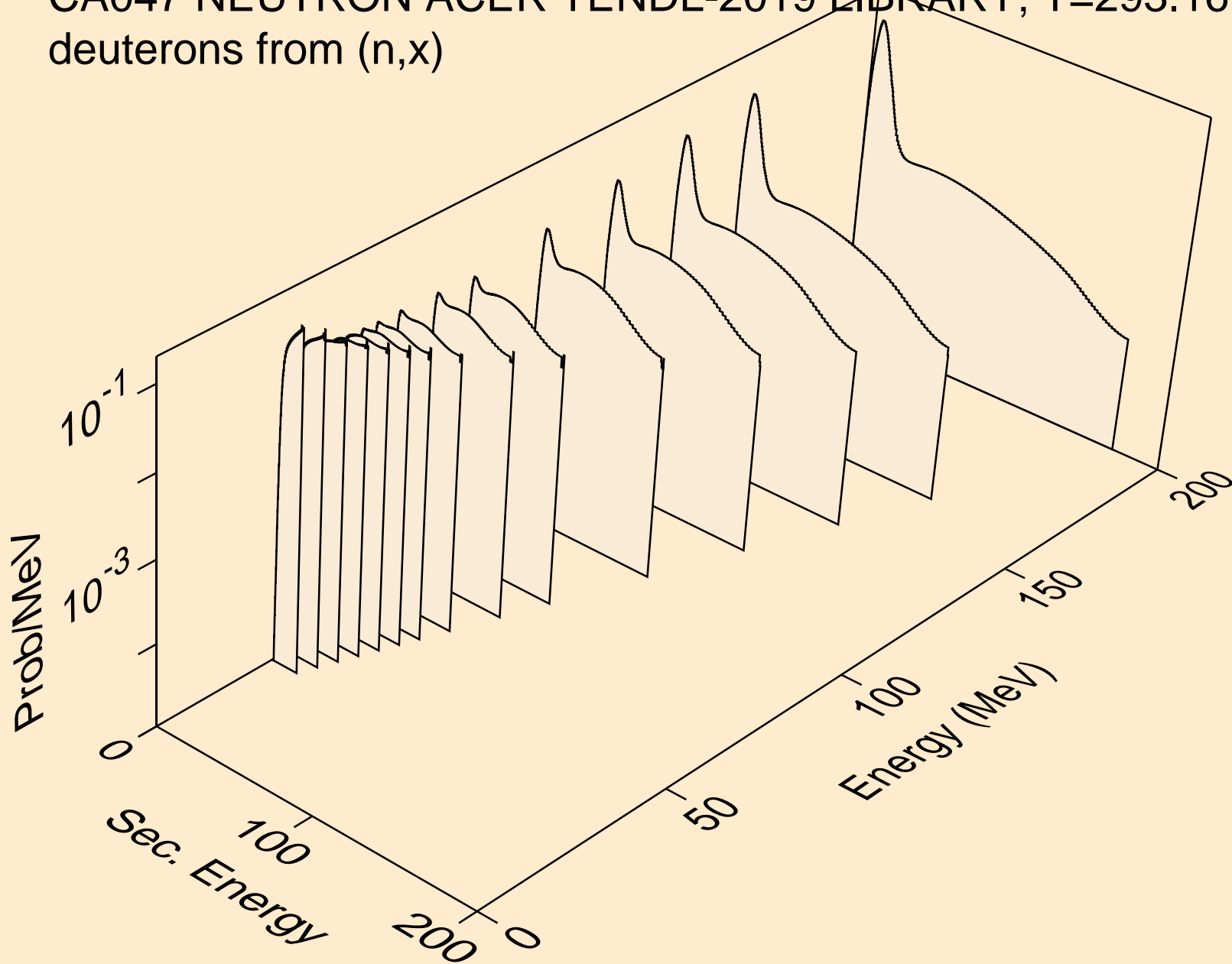

CA047 NEUTRON ACER TENDL-2019 LIBRARY; T=293.16K
deuterons from (n,2nd)

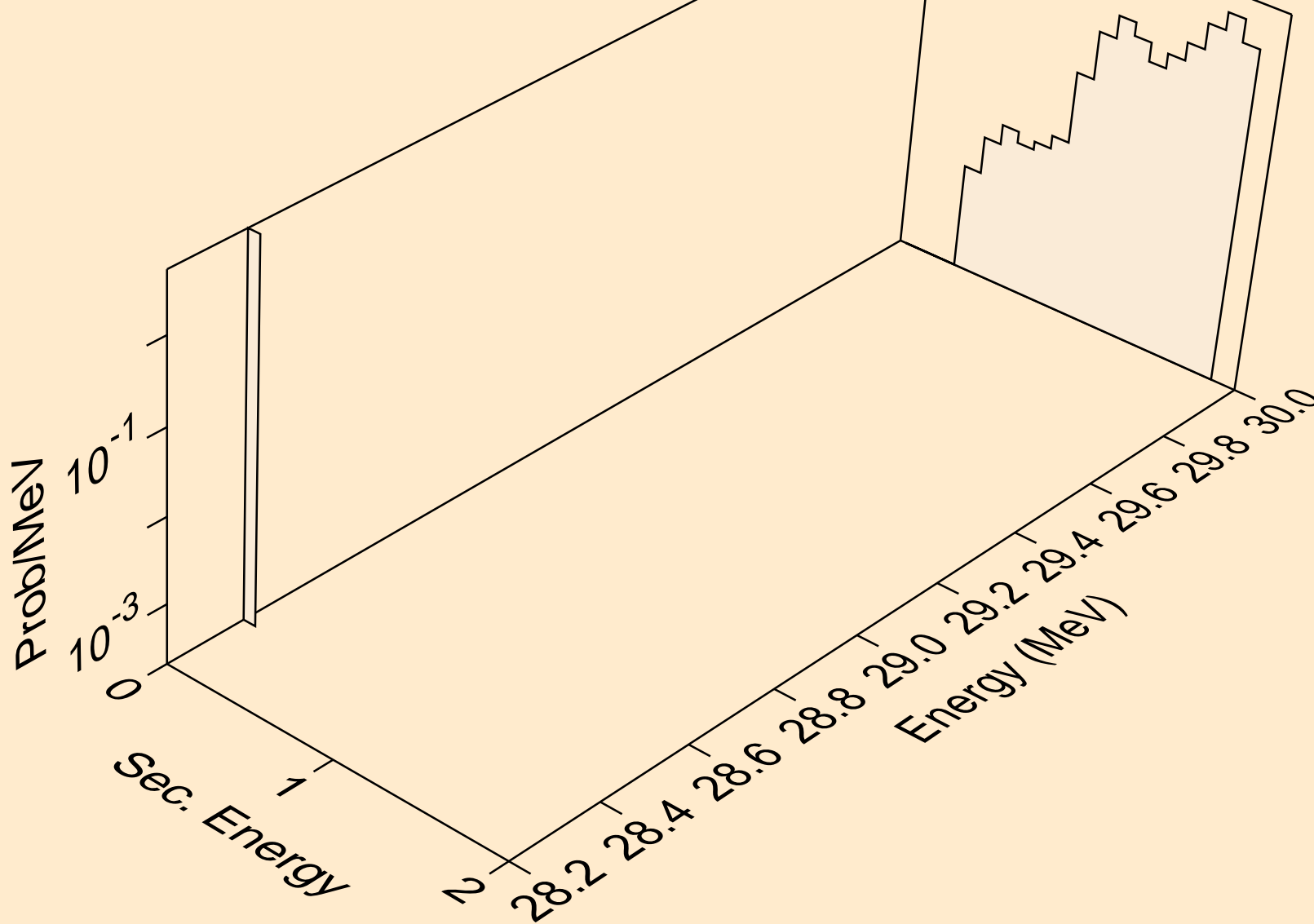

CA047 NEUTRON ACER TENDL-2019 LIBRARY; T=293.16K
deuterons from (n,n*)d

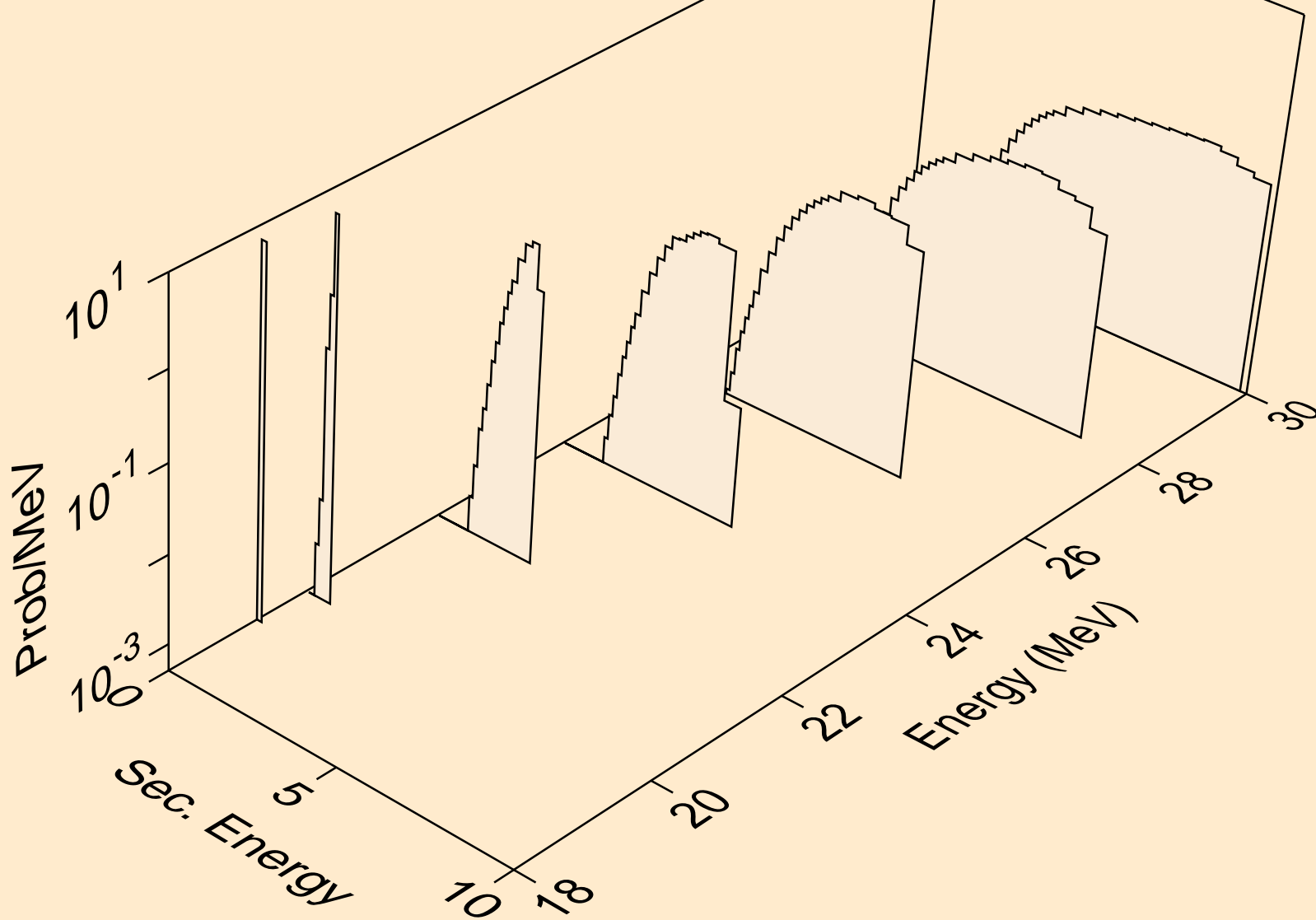

CA047 NEUTRON ACER TENDL-2019 LIBRARY; T=293.16K
deuterons from (n,d)

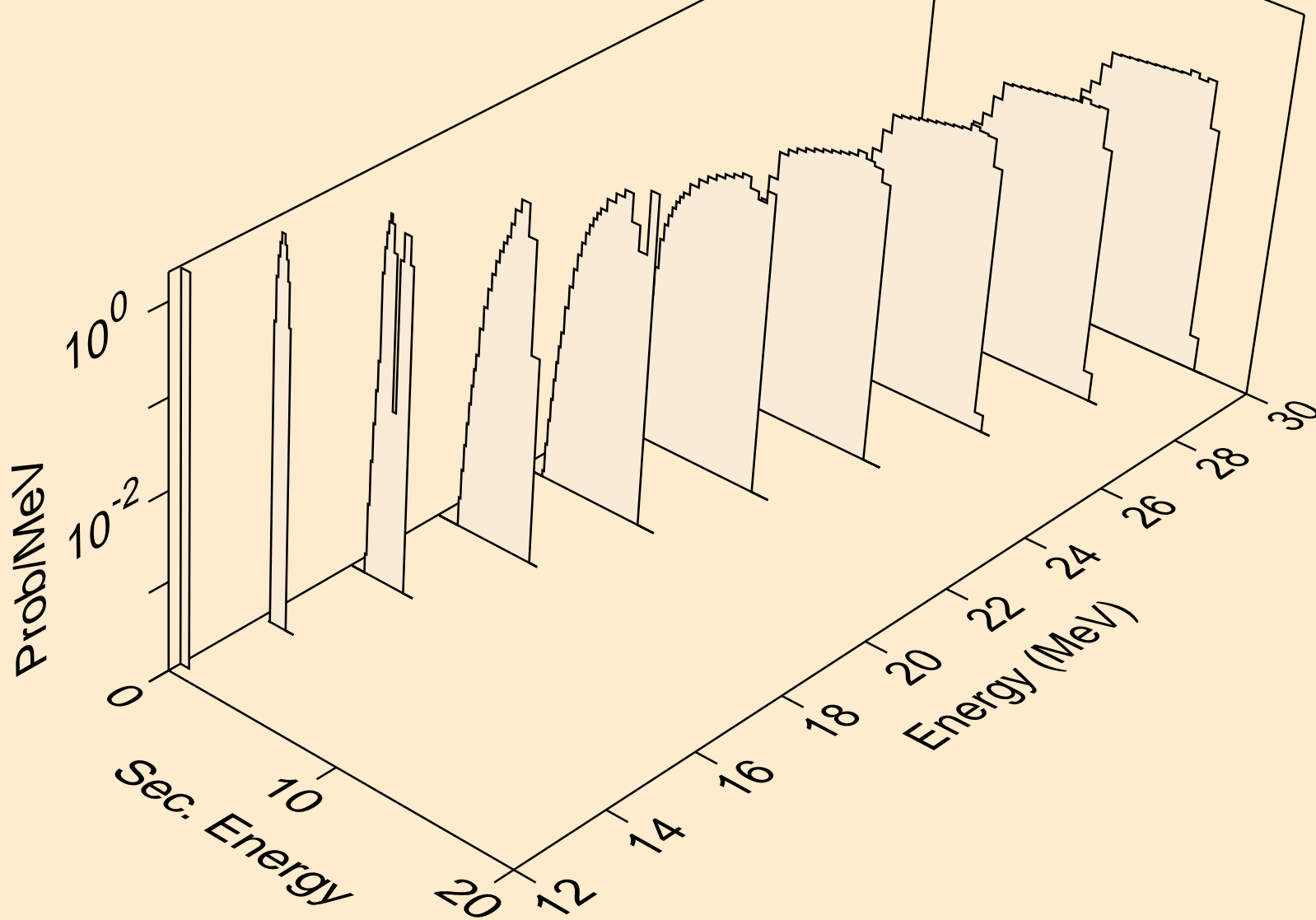

CA047 NEUTRON ACER TENDL-2019 LIBRARY; T=293.16K
deuterons from (n,pd)

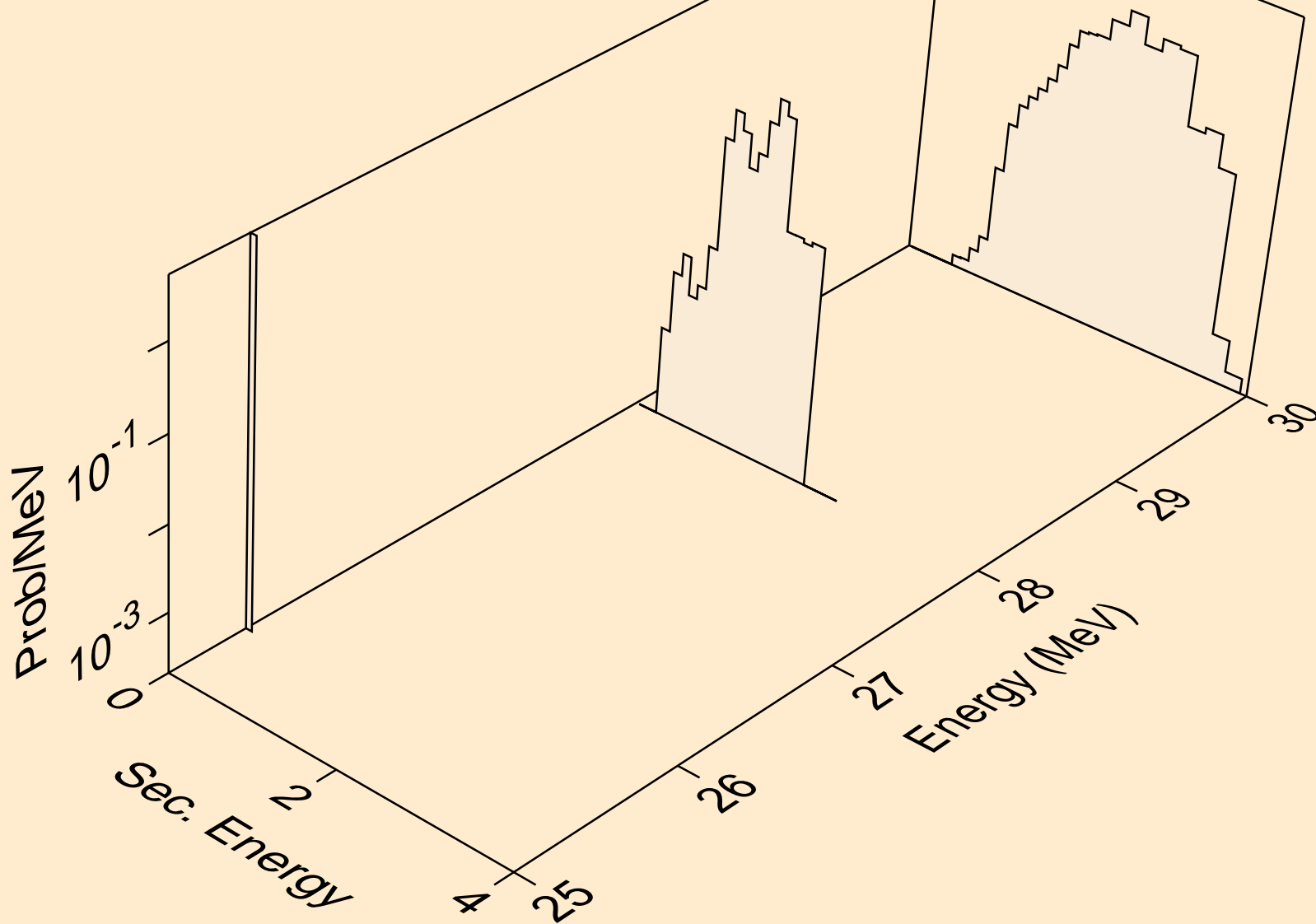

CA047 NEUTRON ACER TENDL-2019 LIBRARY; T=293.16K
tritons from (n,x)

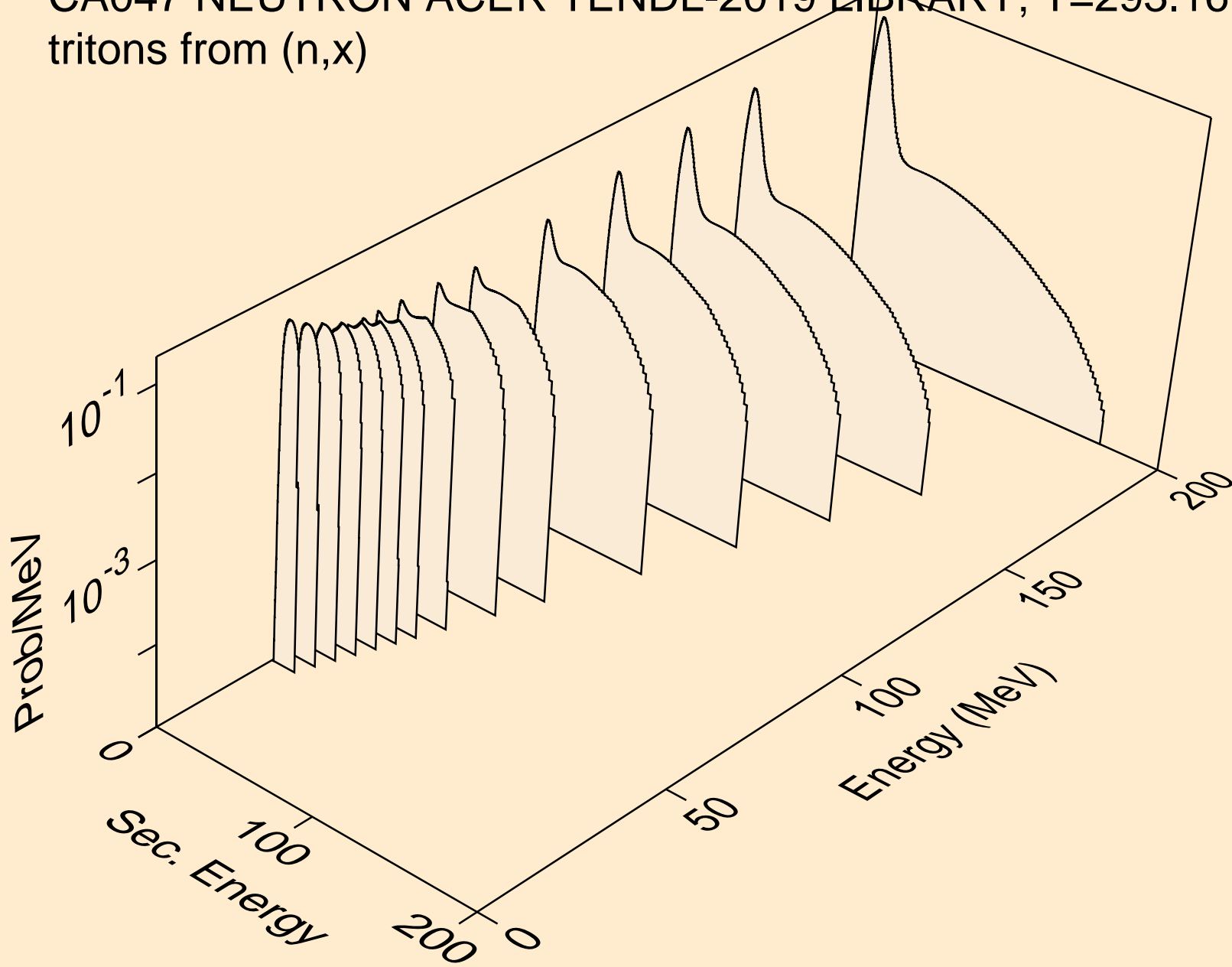

CA047 NEUTRON ACER TENDL-2019 LIBRARY; T=293.16K
tritons from (n,n*)t

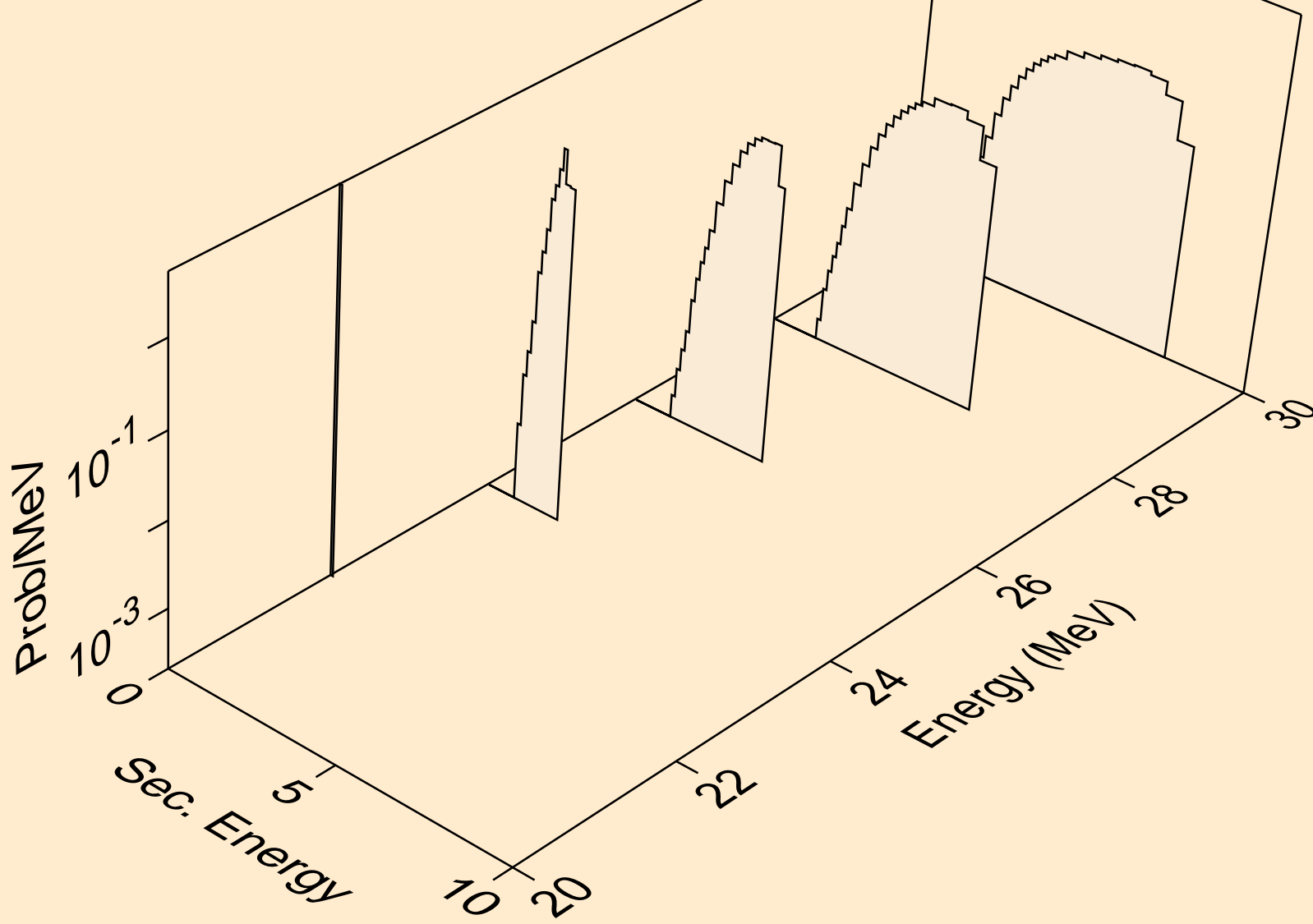

CA047 NEUTRON ACER TENDL-2019 LIBRARY; T=293.16K
tritons from (n,t)

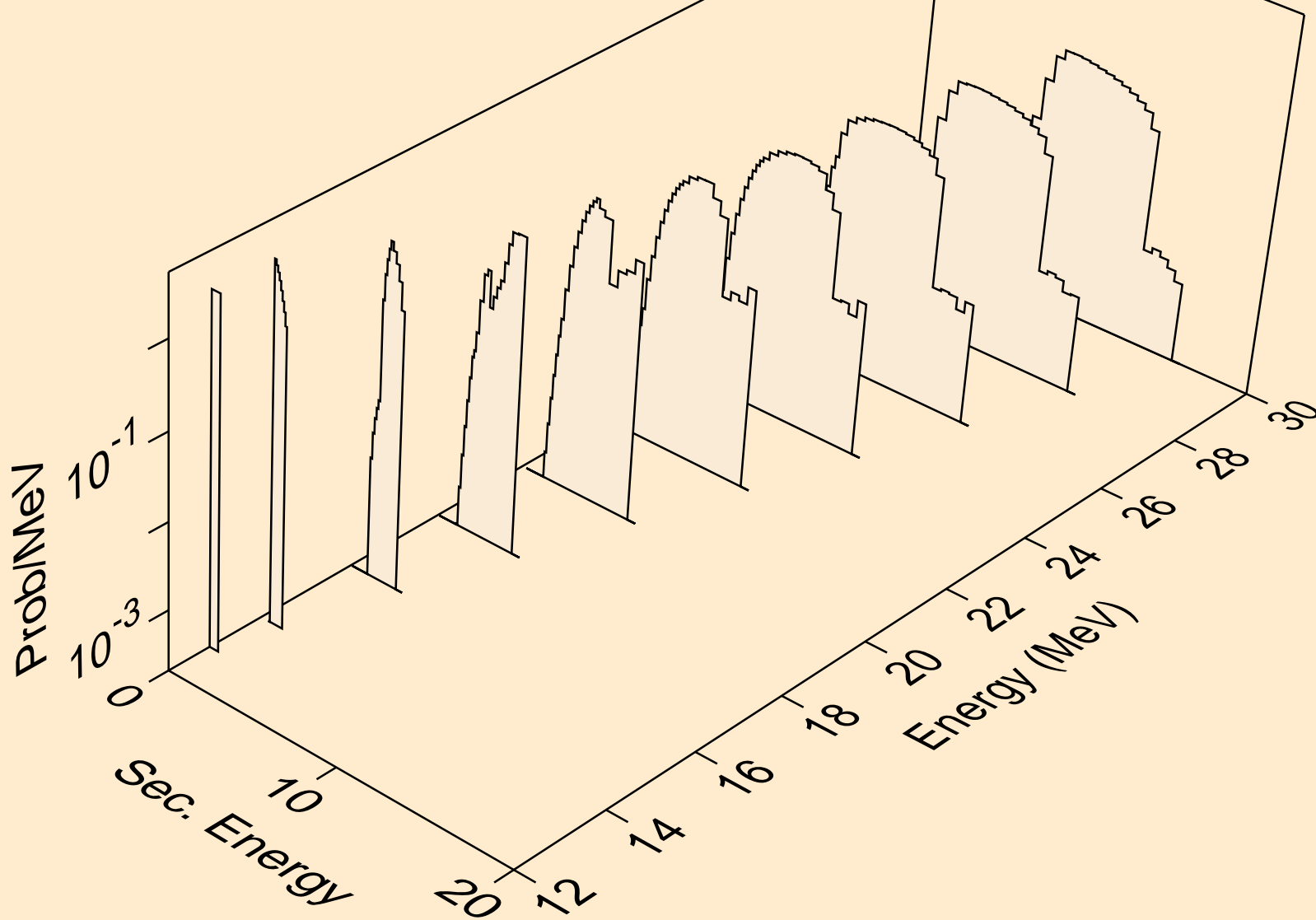

CA047 NEUTRON ACER TENDL-2019 LIBRARY; T=293.16K
tritons from (n,pt)

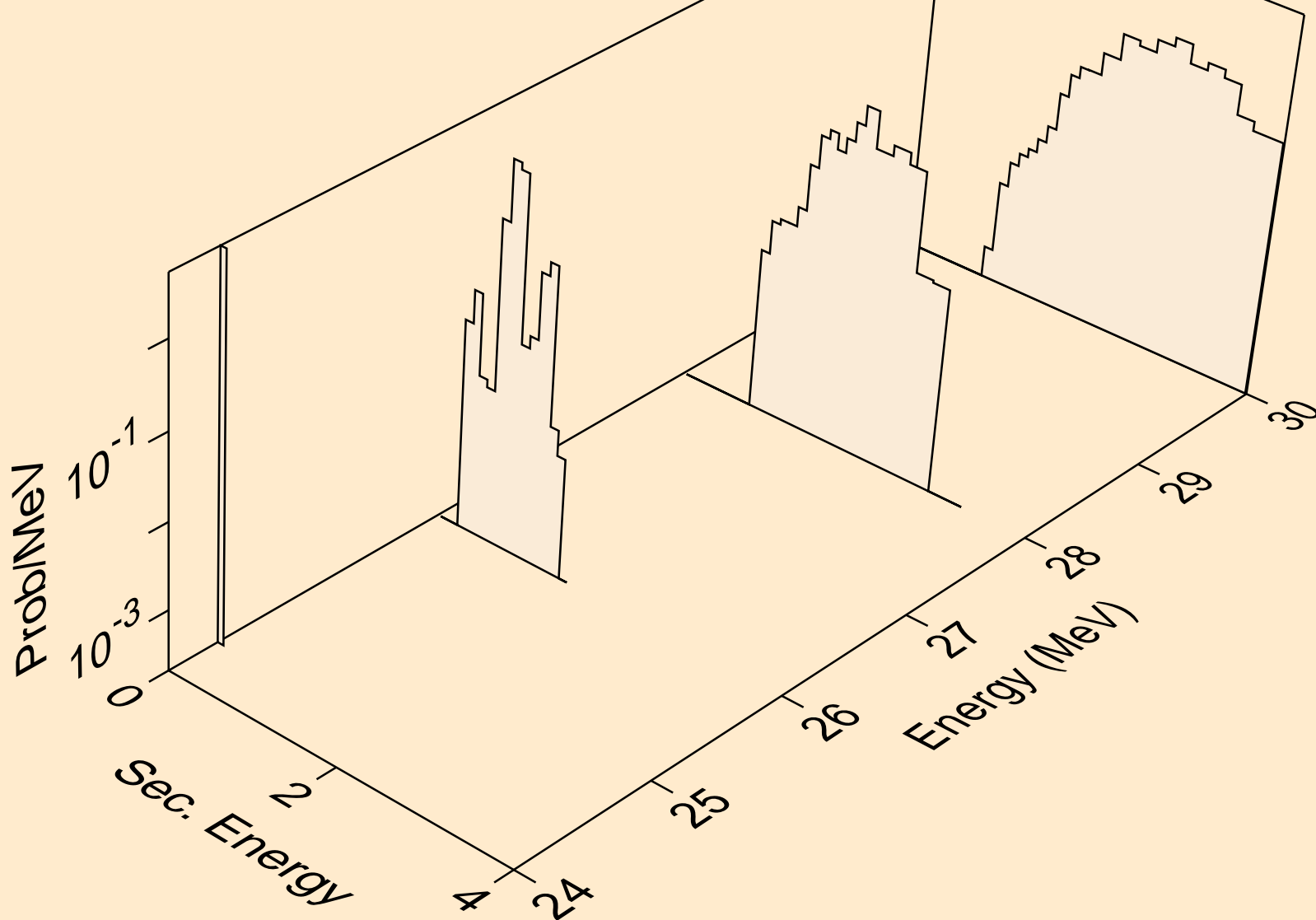

CA047 NEUTRON ACER TENDL-2019 LIBRARY; T=293.16K
he3s from (n,x)

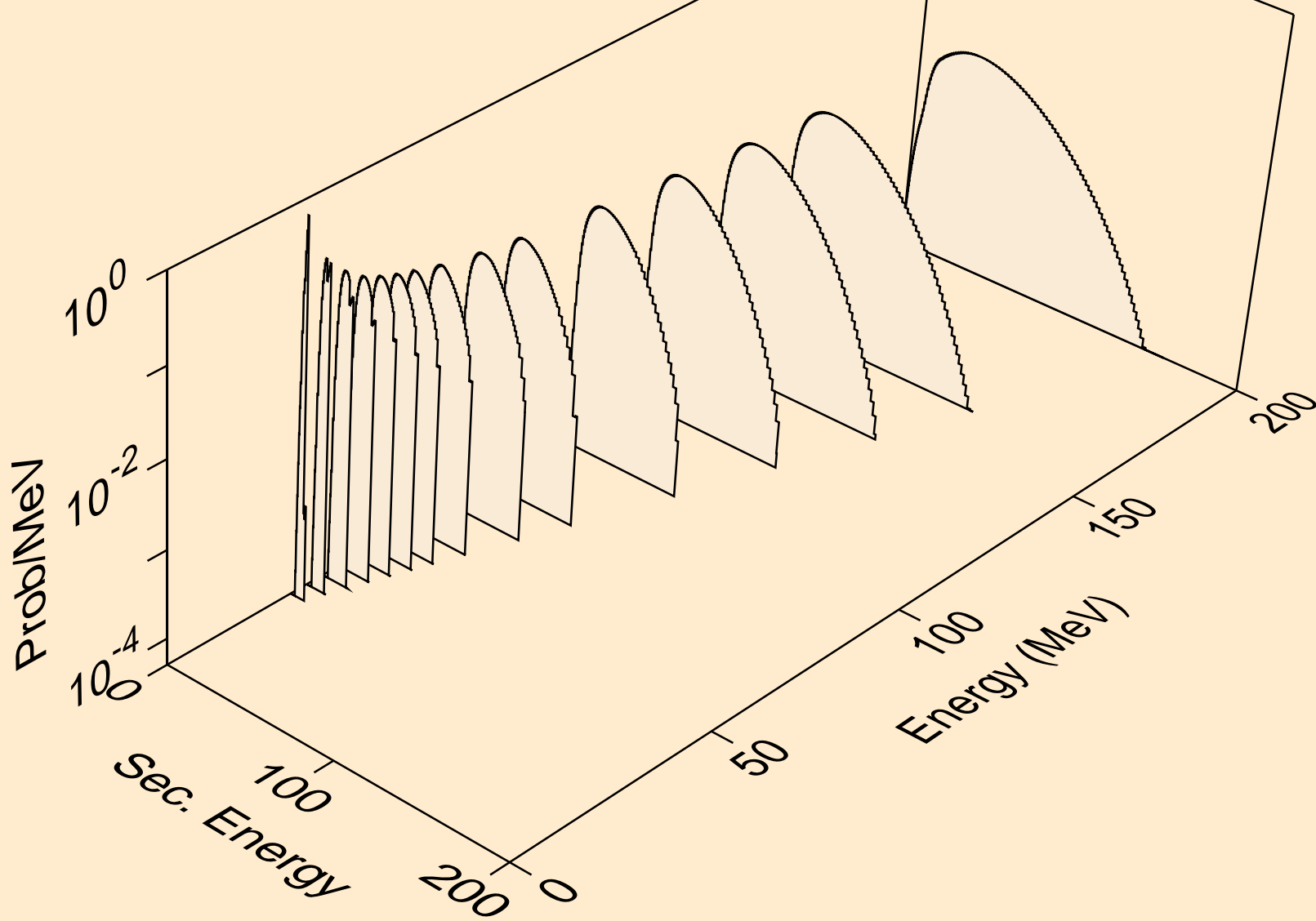

CA047 NEUTRON ACER TENDL-2019 LIBRARY; T=293.16K
he3s from (n,n*)he3

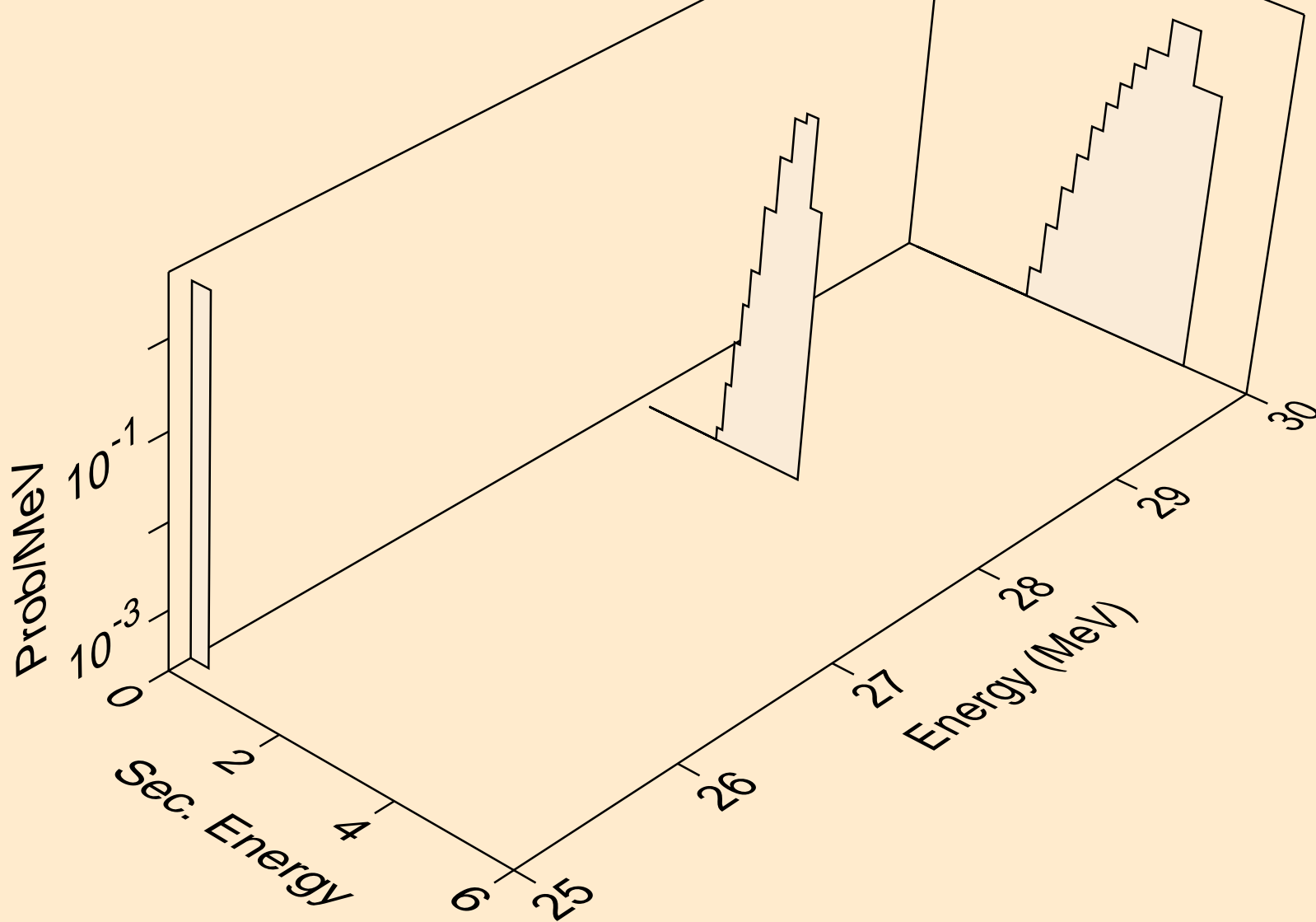

CA047 NEUTRON ACER TENDL-2019 LIBRARY; T=293.16K
he3s from (n,he3)

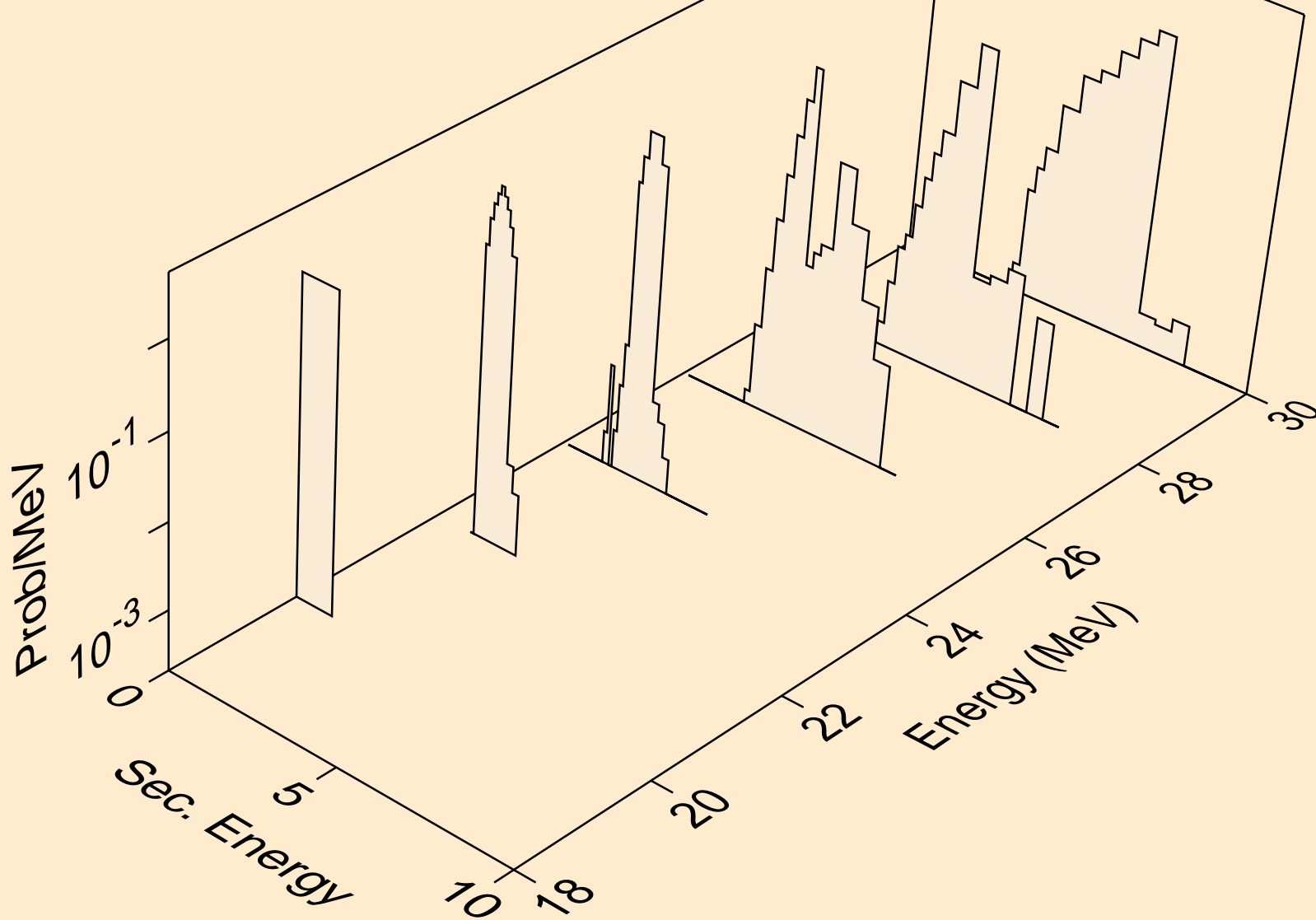

CA047 NEUTRON ACER TENDL-2019 LIBRARY; T=293.16K
alphas from (n,x)

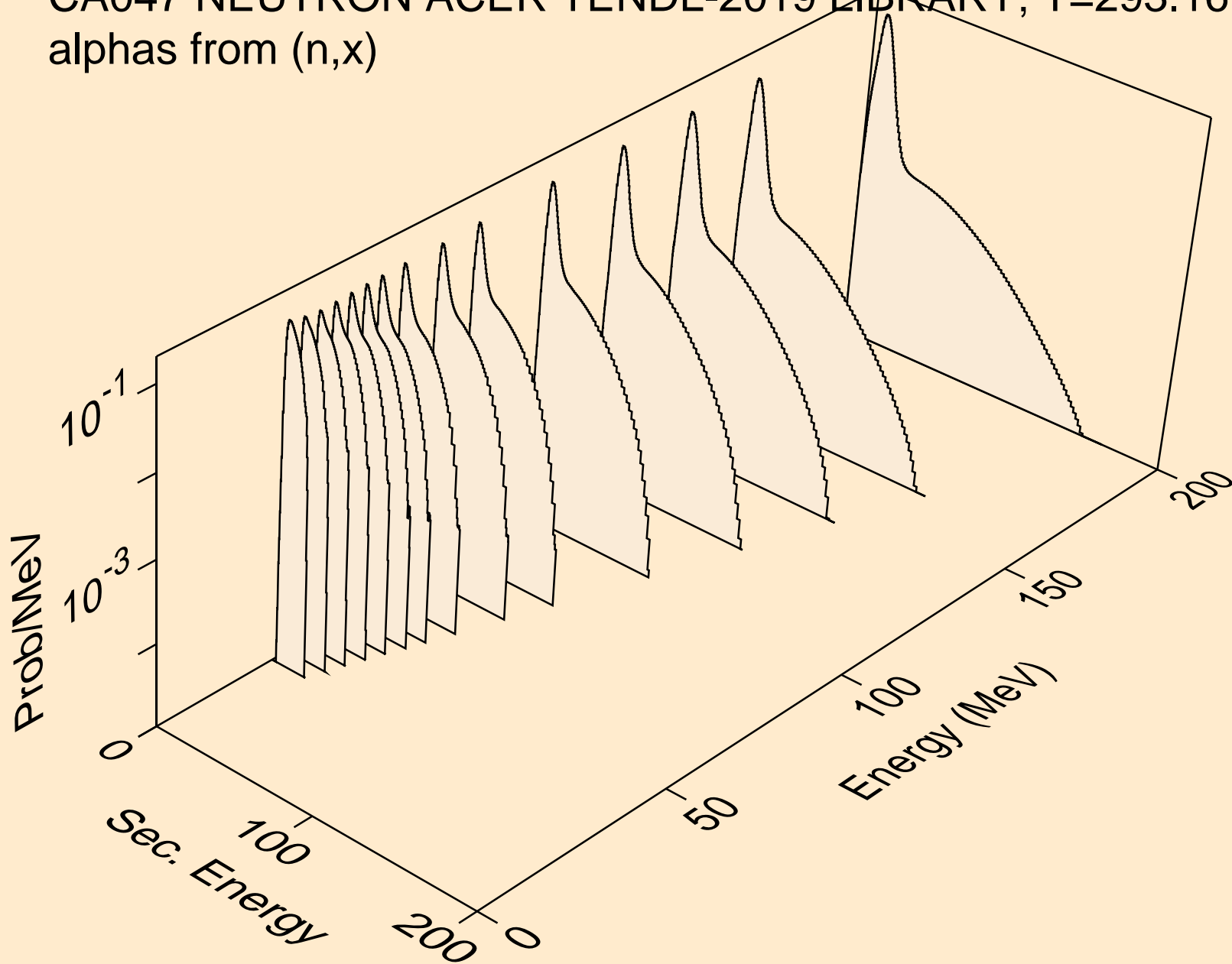

CA047 NEUTRON ACER TENDL-2019 LIBRARY; T=293.16K
alphas from (n,n*)a

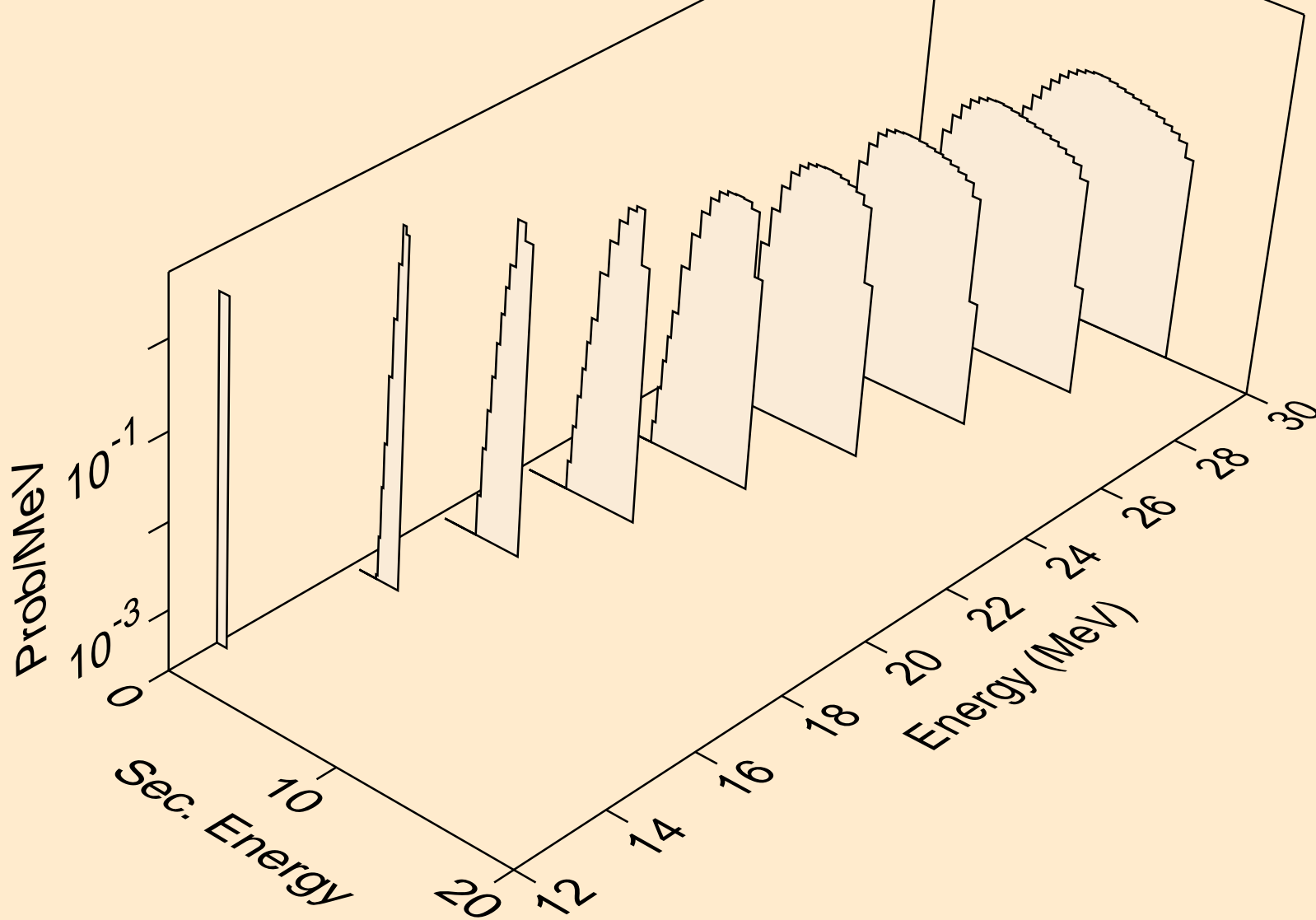

CA047 NEUTRON ACER TENDL-2019 LIBRARY; T=293.16K
alphas from (n,2n)a

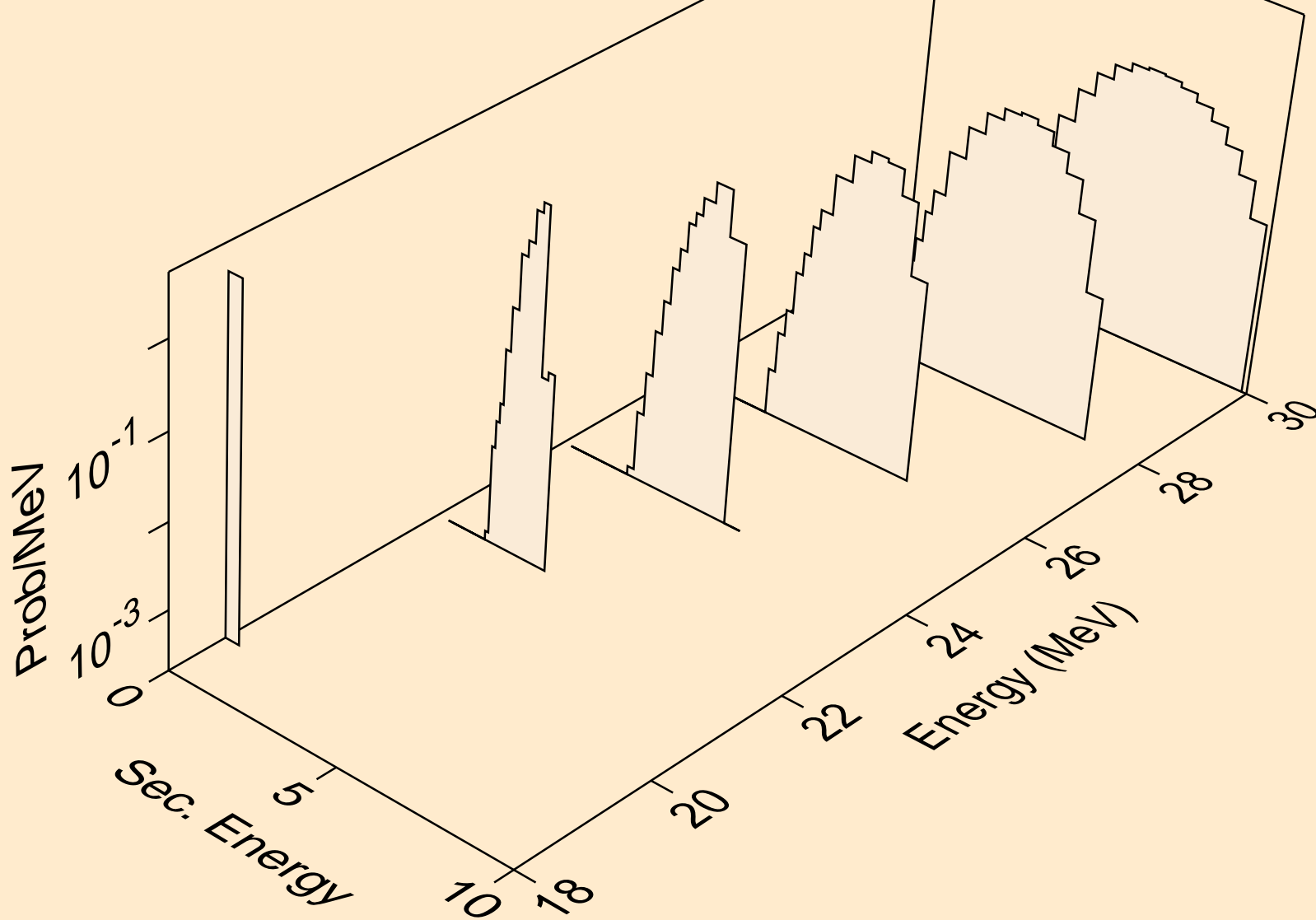

CA047 NEUTRON ACER TENDL-2019 LIBRARY; T=293.16K
alphas from (n,a)

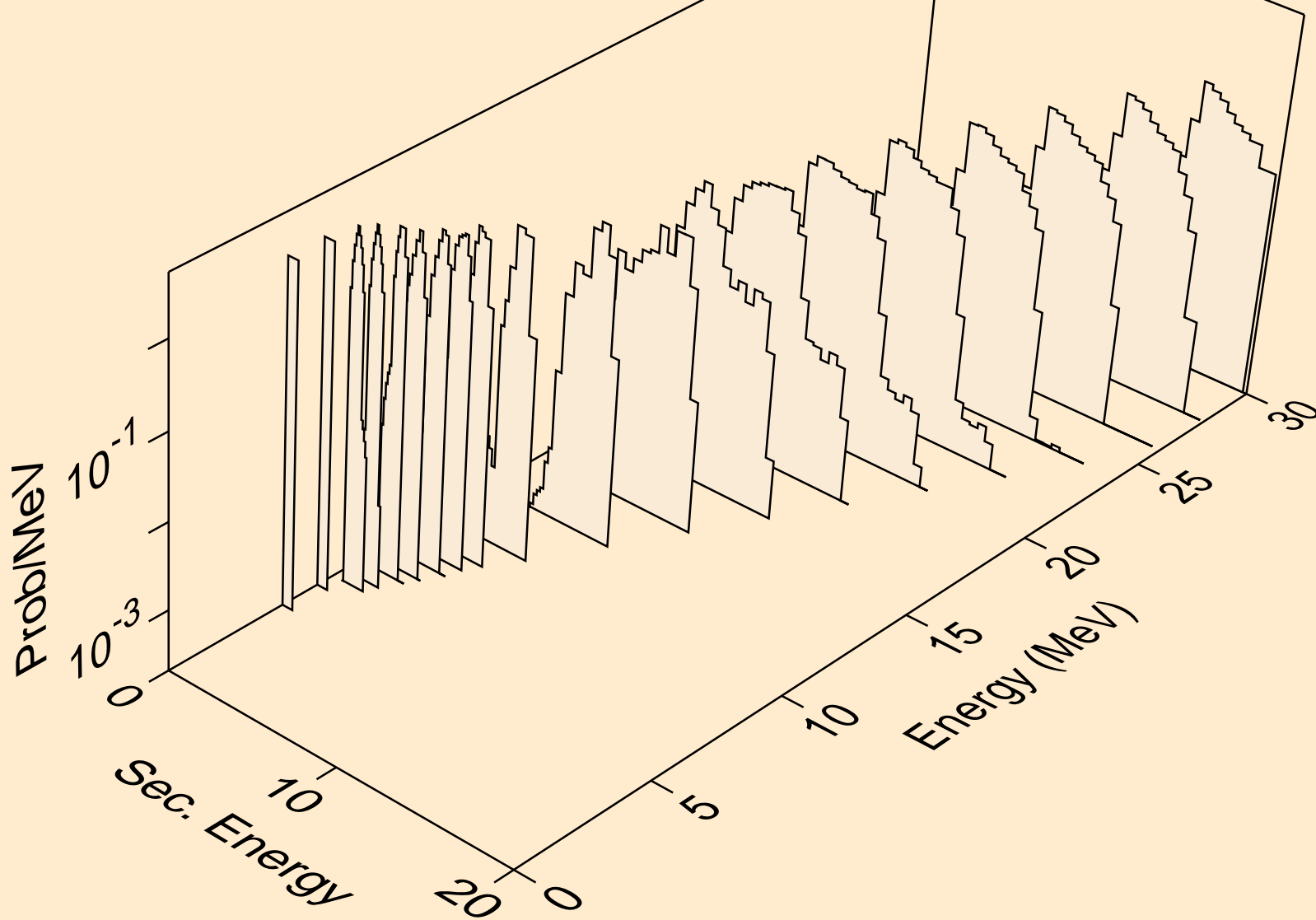

CA047 NEUTRON ACER TENDL-2019 LIBRARY; T=293.16K
alphas from (n,2a)

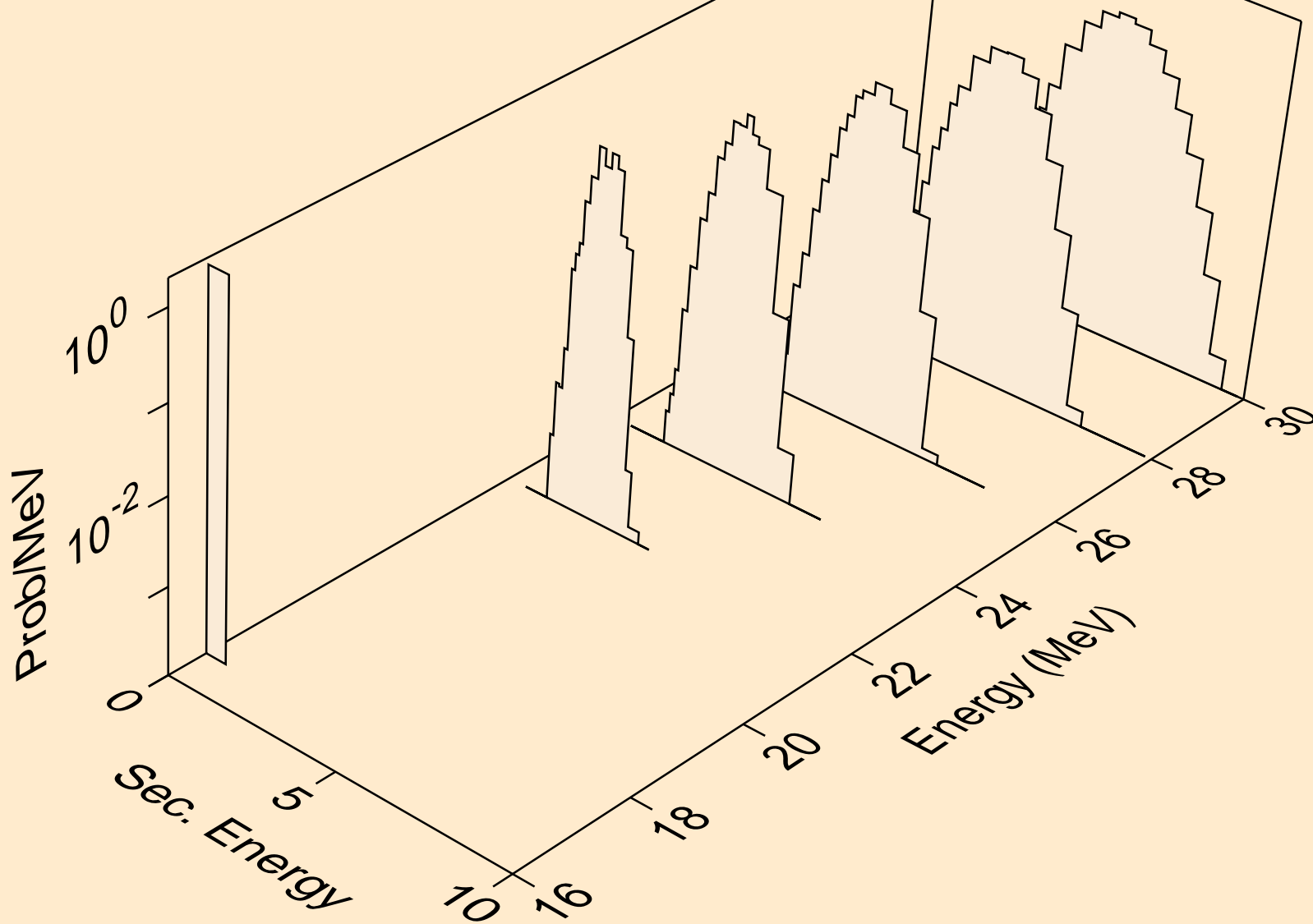

CA047 NEUTRON ACER TENDL-2019 LIBRARY; T=293.16K
alphas from (n,pa)

