

CN283 NEUTRON ACER TENDL-2019 LIBRARY; T=293.16K
Principal cross sections

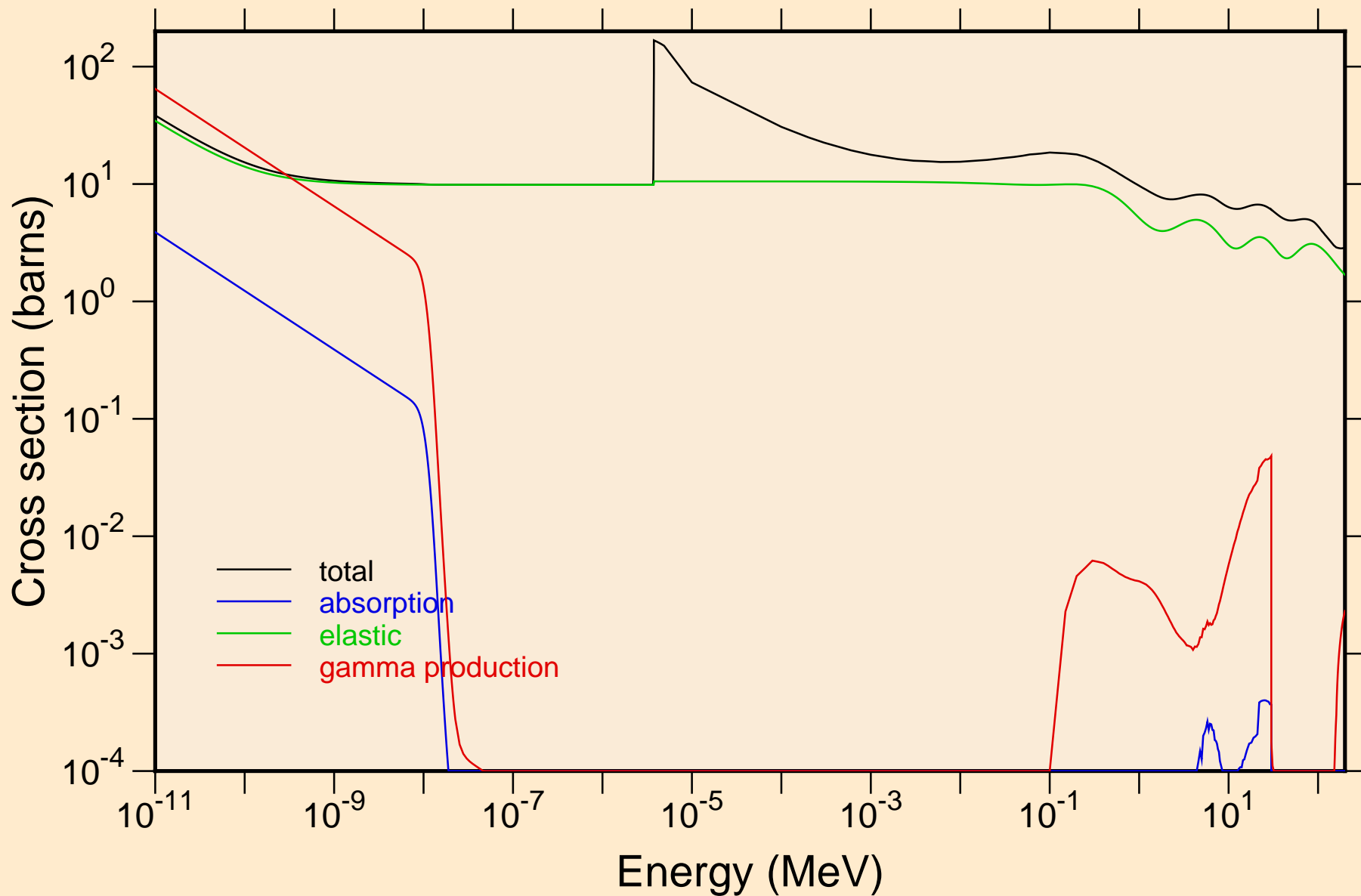

CN283 NEUTRON ACER TENDL-2019 LIBRARY; T=293.16K
Heating

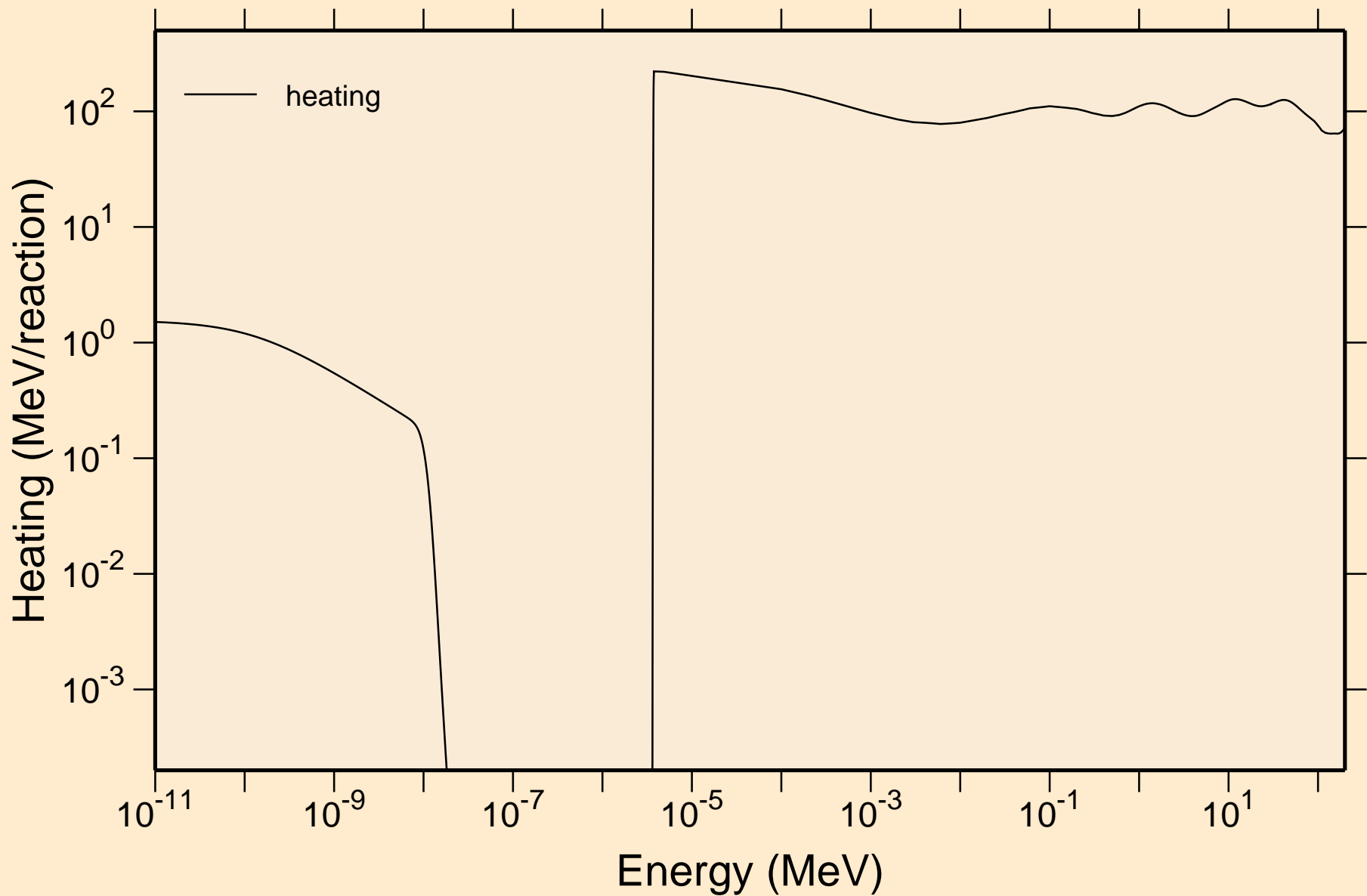

CN283 NEUTRON ACER TENDL-2019 LIBRARY; T=293.16K
Damage

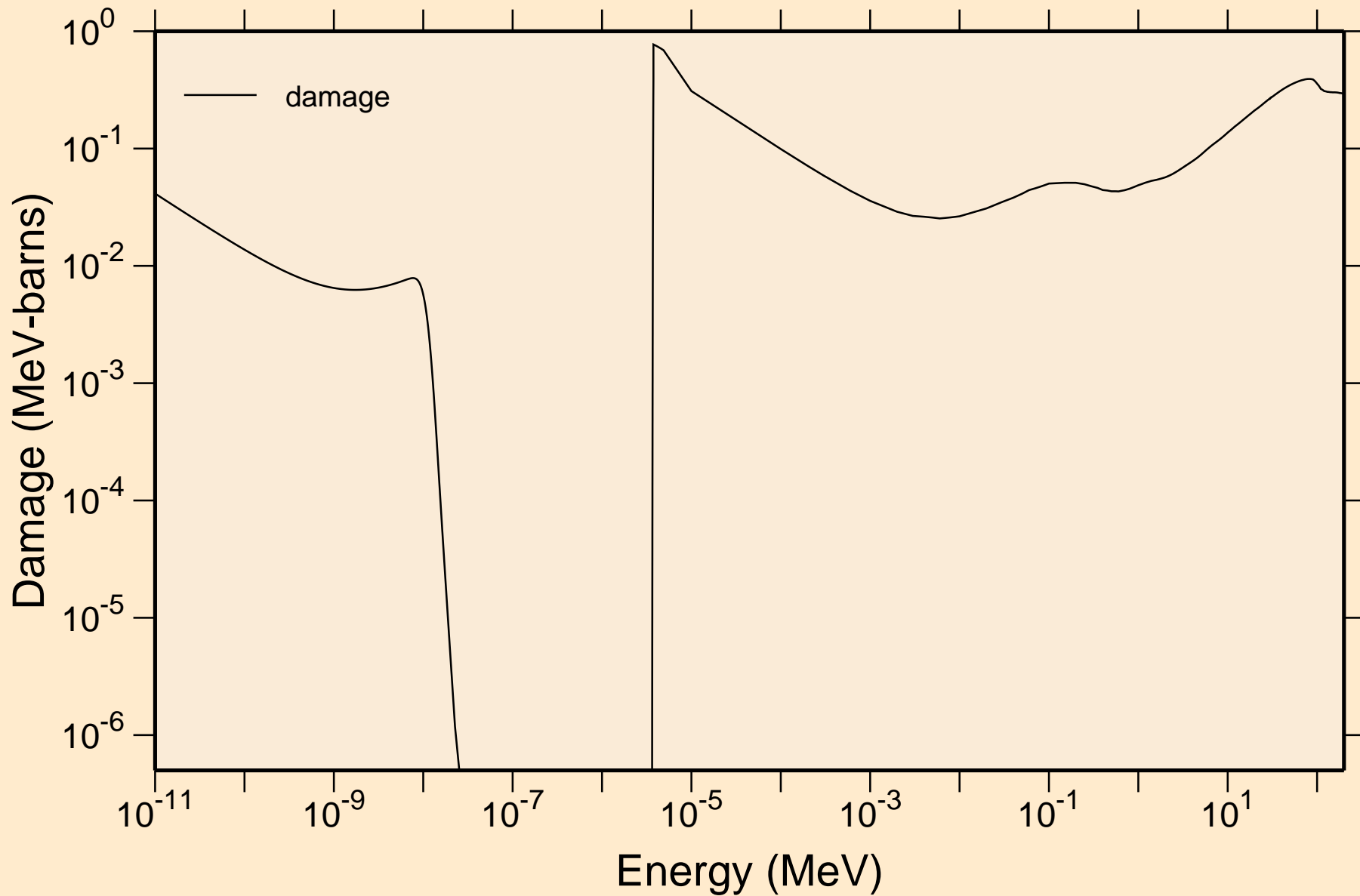

CN283 NEUTRON ACER TENDL-2019 LIBRARY; T=293.16K
Non-threshold reactions

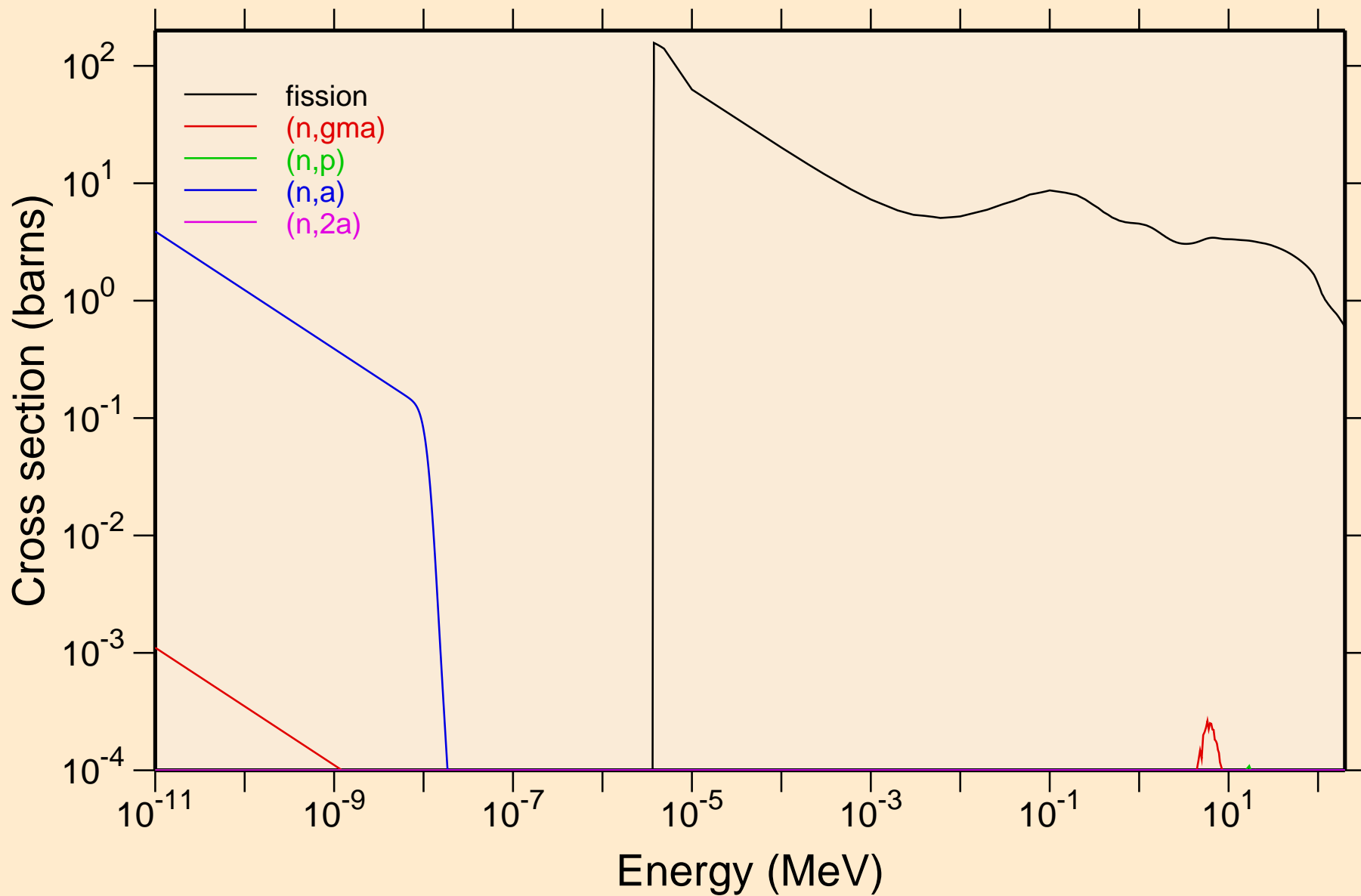

CN283 NEUTRON ACER TENDL-2019 LIBRARY; T=293.16K
Non-threshold reactions

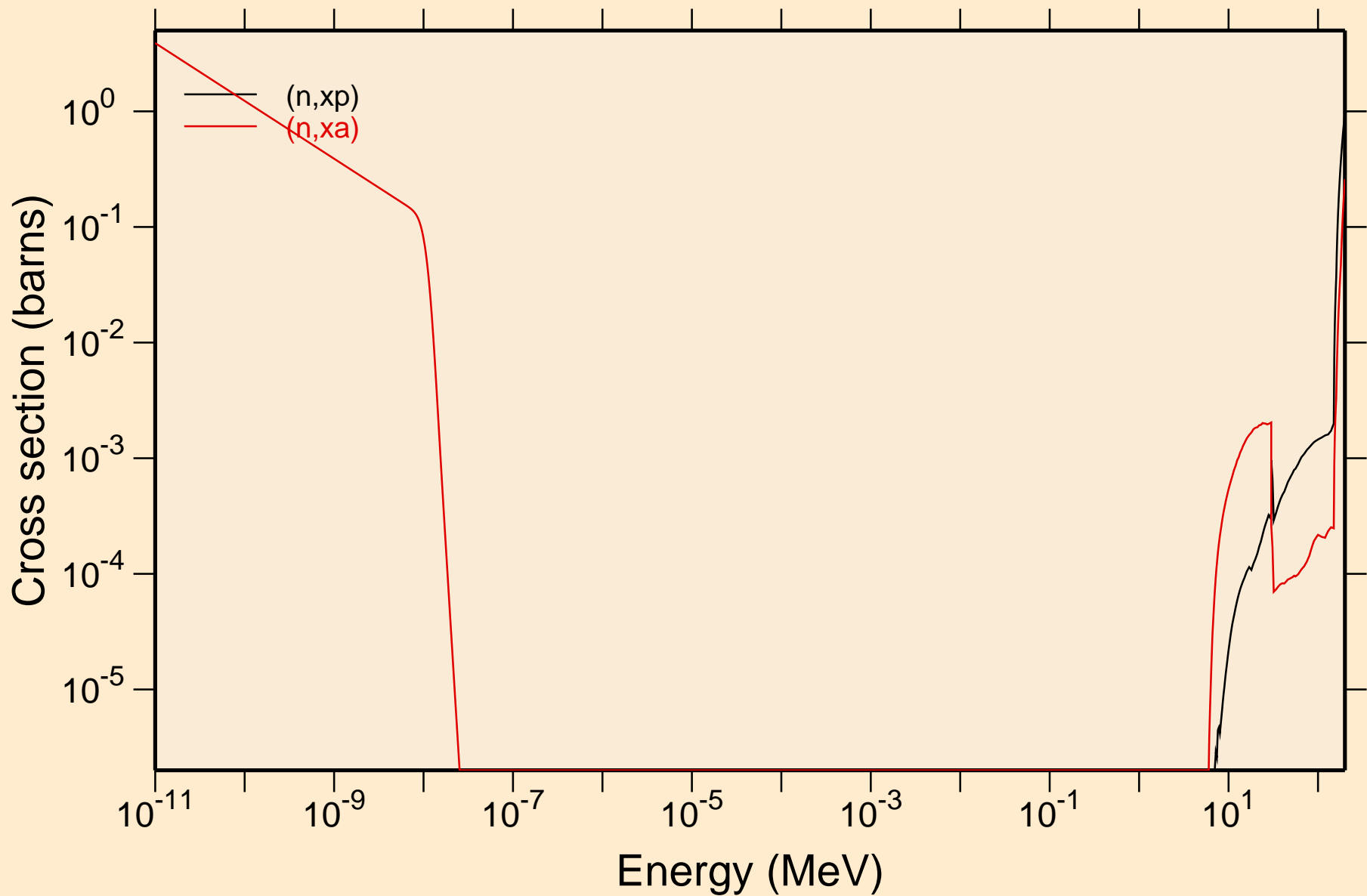

CN283 NEUTRON ACER TENDL-2019 LIBRARY; T=293.16K
Principal cross sections

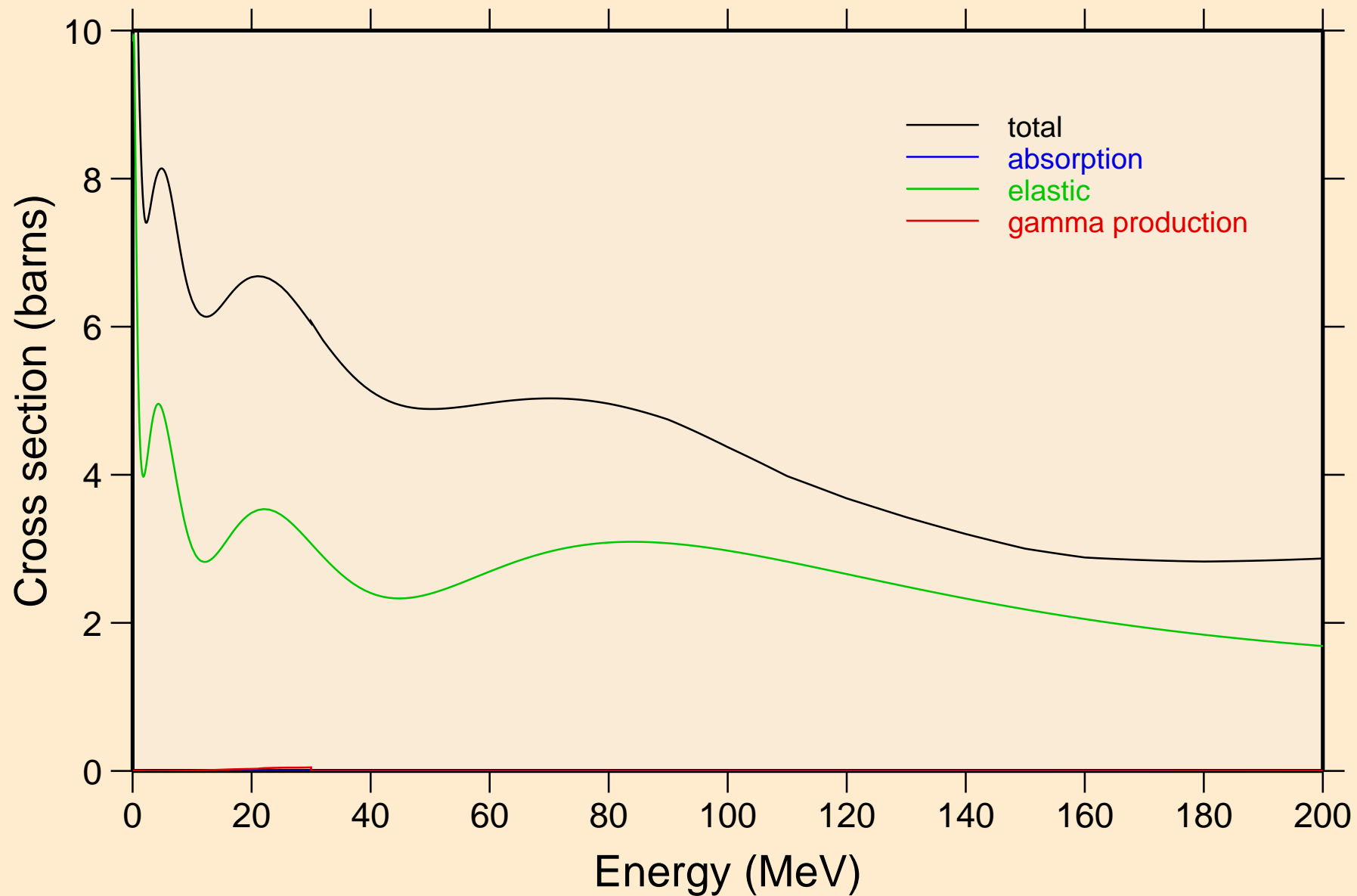

CN283 NEUTRON ACER TENDL-2019 LIBRARY; T=293.16K
Heating

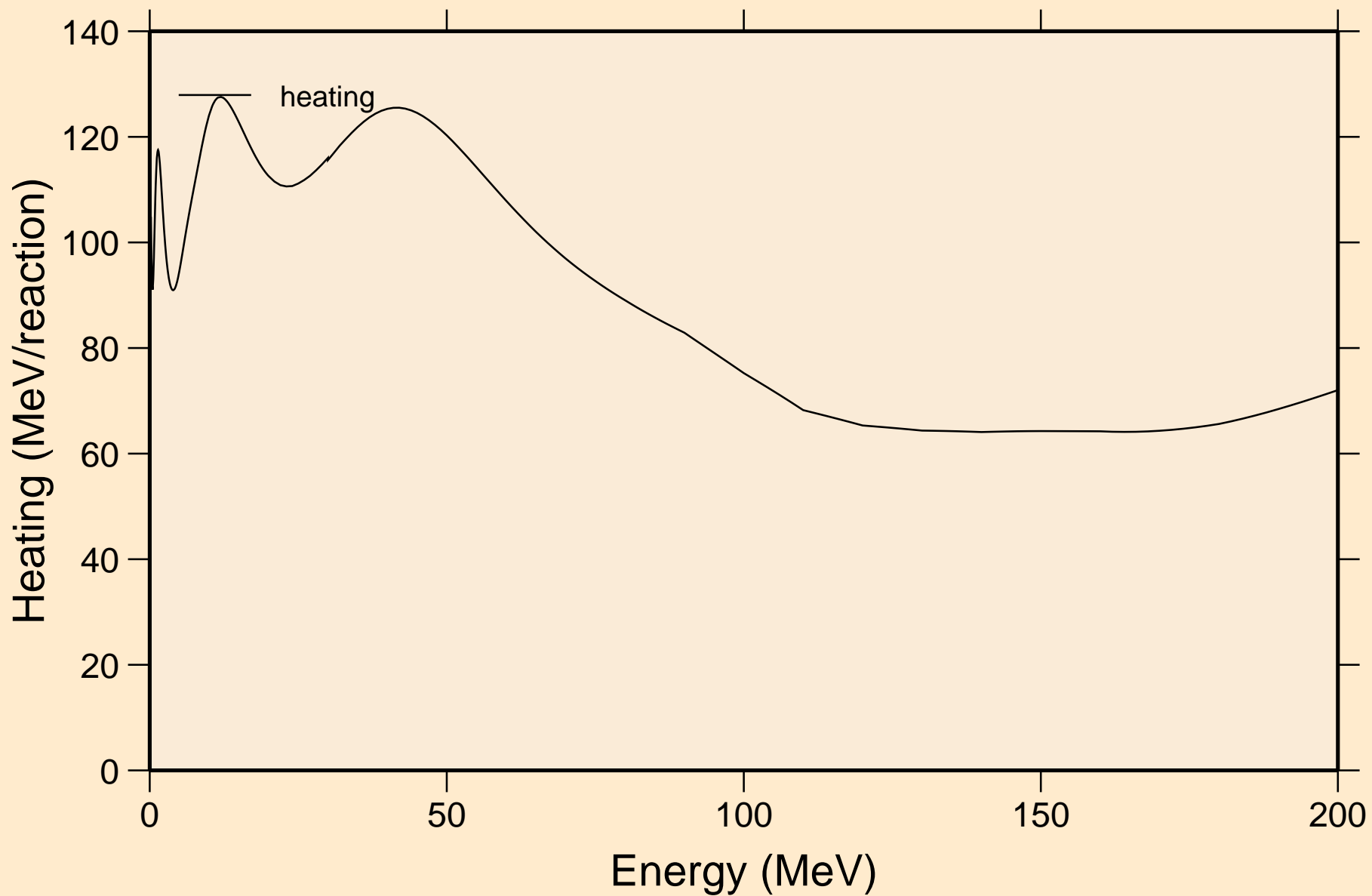

CN283 NEUTRON ACER TENDL-2019 LIBRARY; T=293.16K
Damage

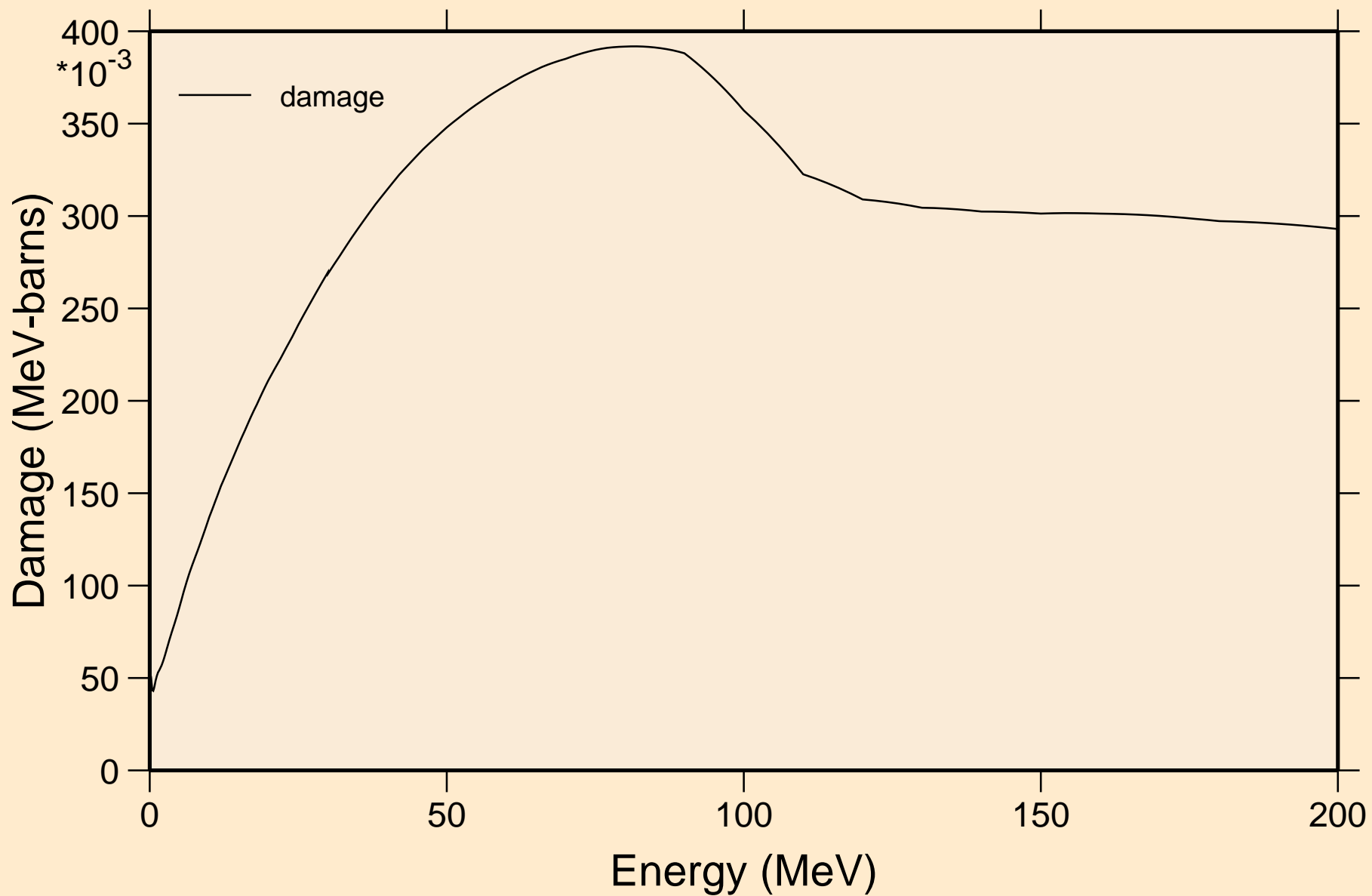

CN283 NEUTRON ACER TENDL-2019 LIBRARY; T=293.16K
Non-threshold reactions

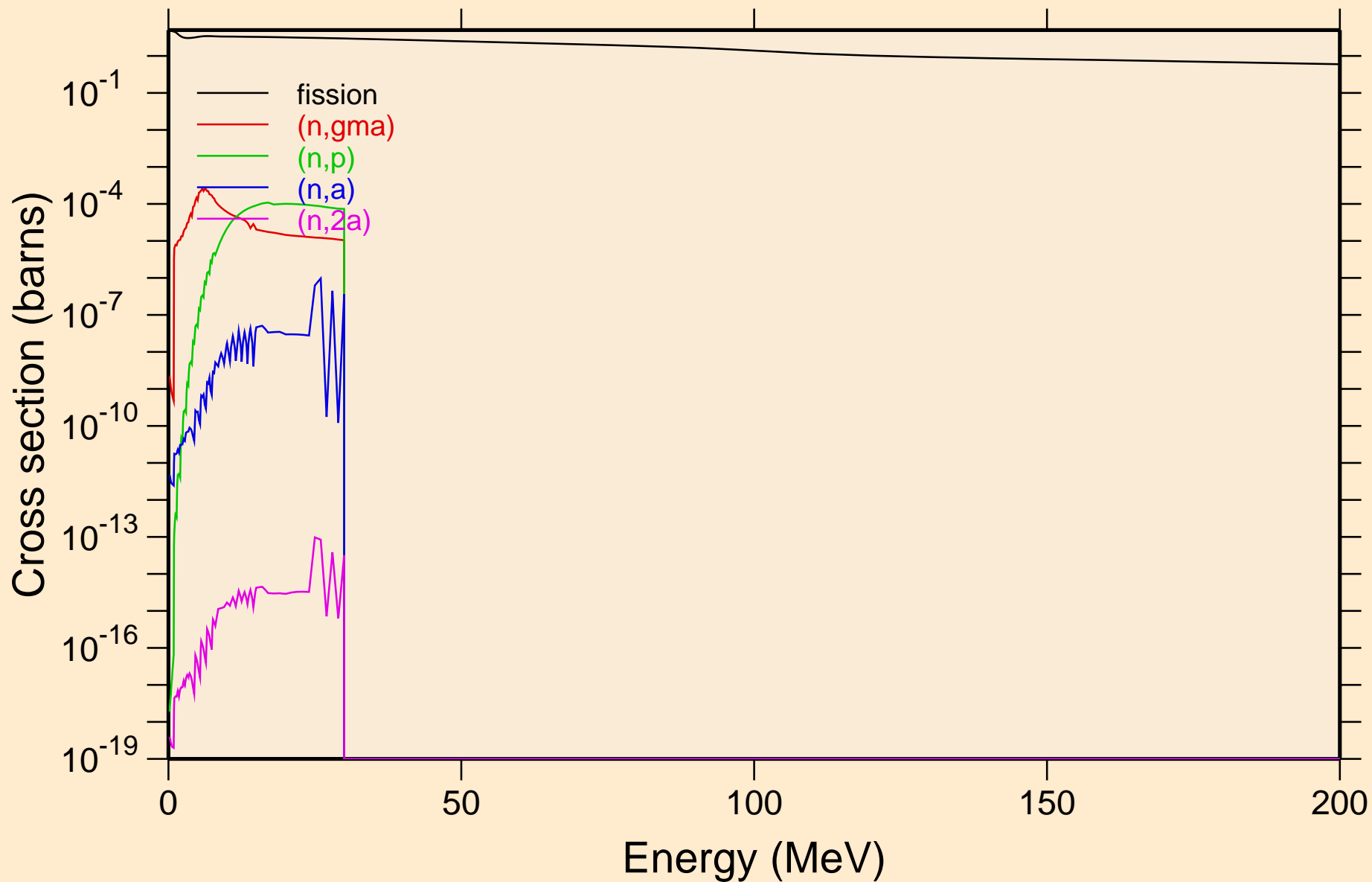

CN283 NEUTRON ACER TENDL-2019 LIBRARY; T=293.16K
Non-threshold reactions

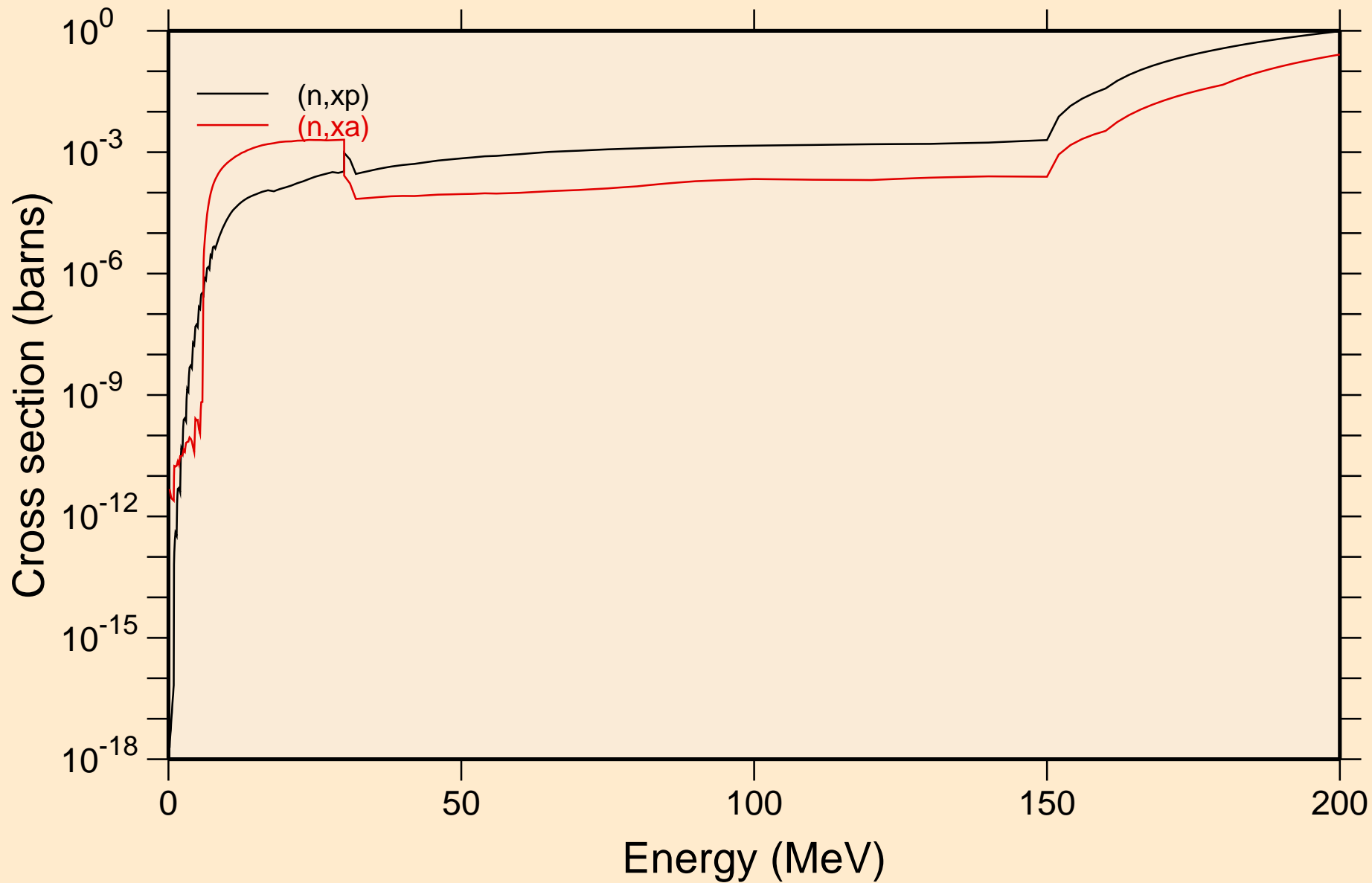

CN283 NEUTRON ACER TENDL-2019 LIBRARY; T=293.16K
Inelastic levels

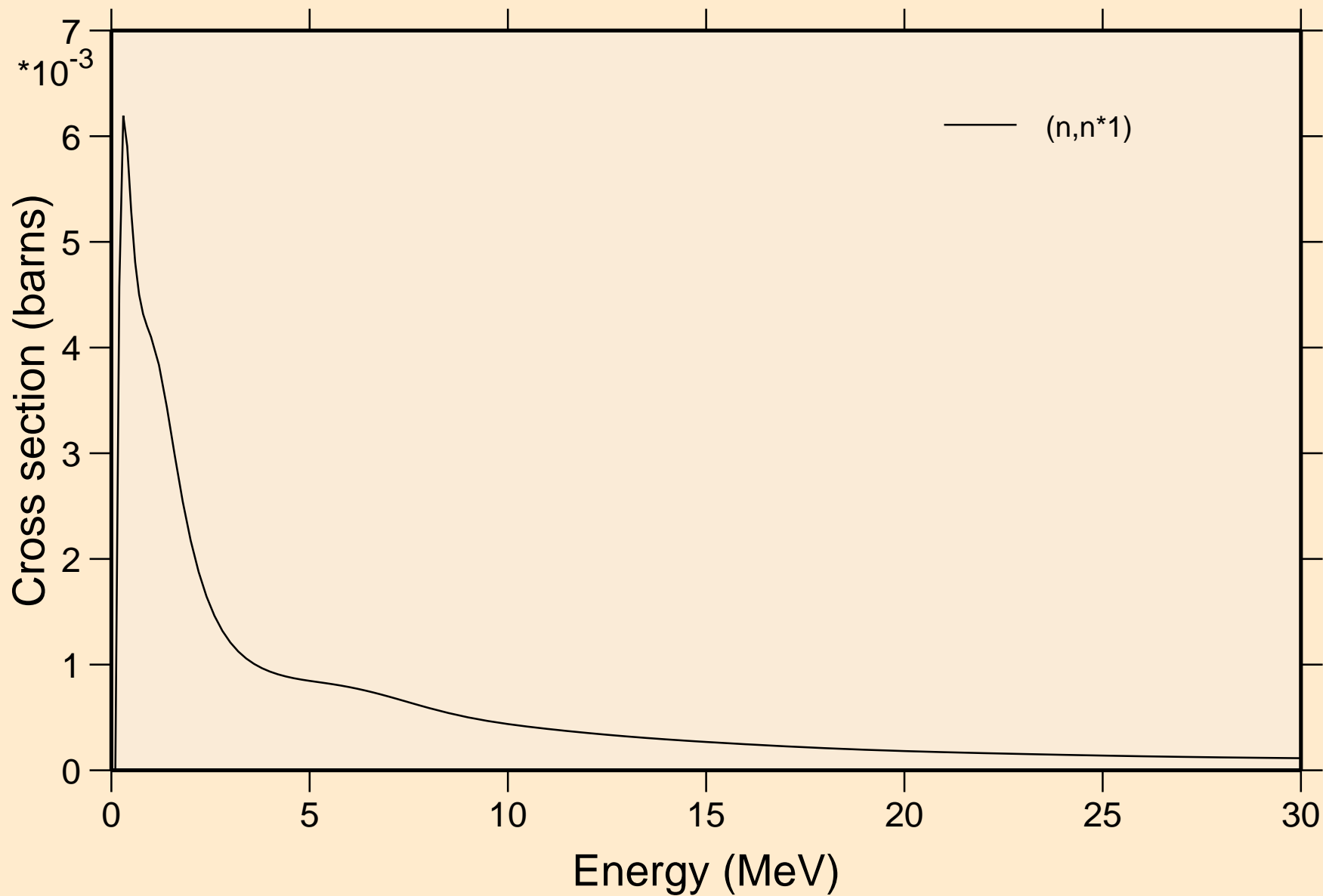

CN283 NEUTRON ACER TENDL-2019 LIBRARY; T=293.16K
Threshold reactions

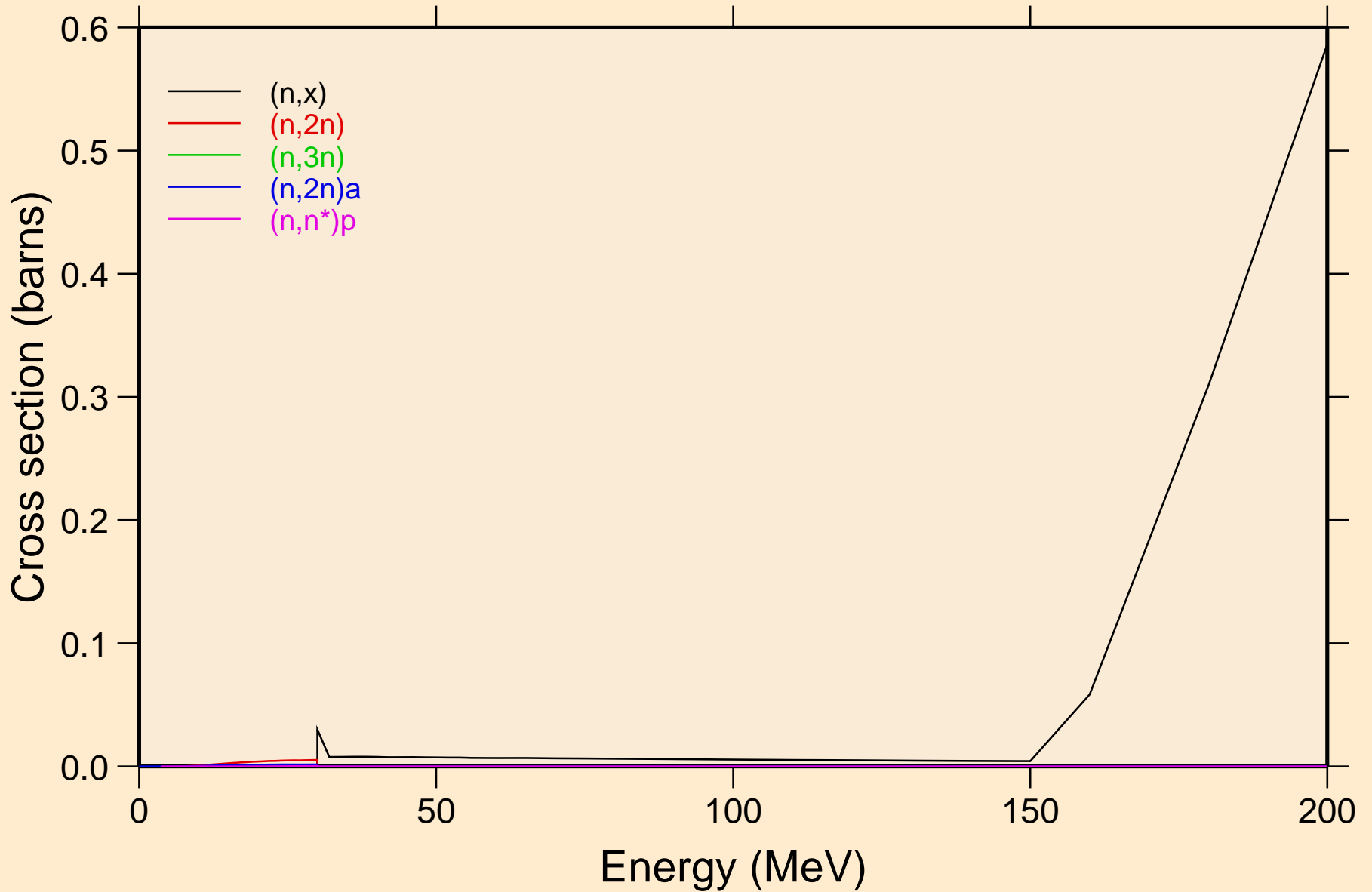

CN283 NEUTRON ACER TENDL-2019 LIBRARY; T=293.16K

Threshold reactions

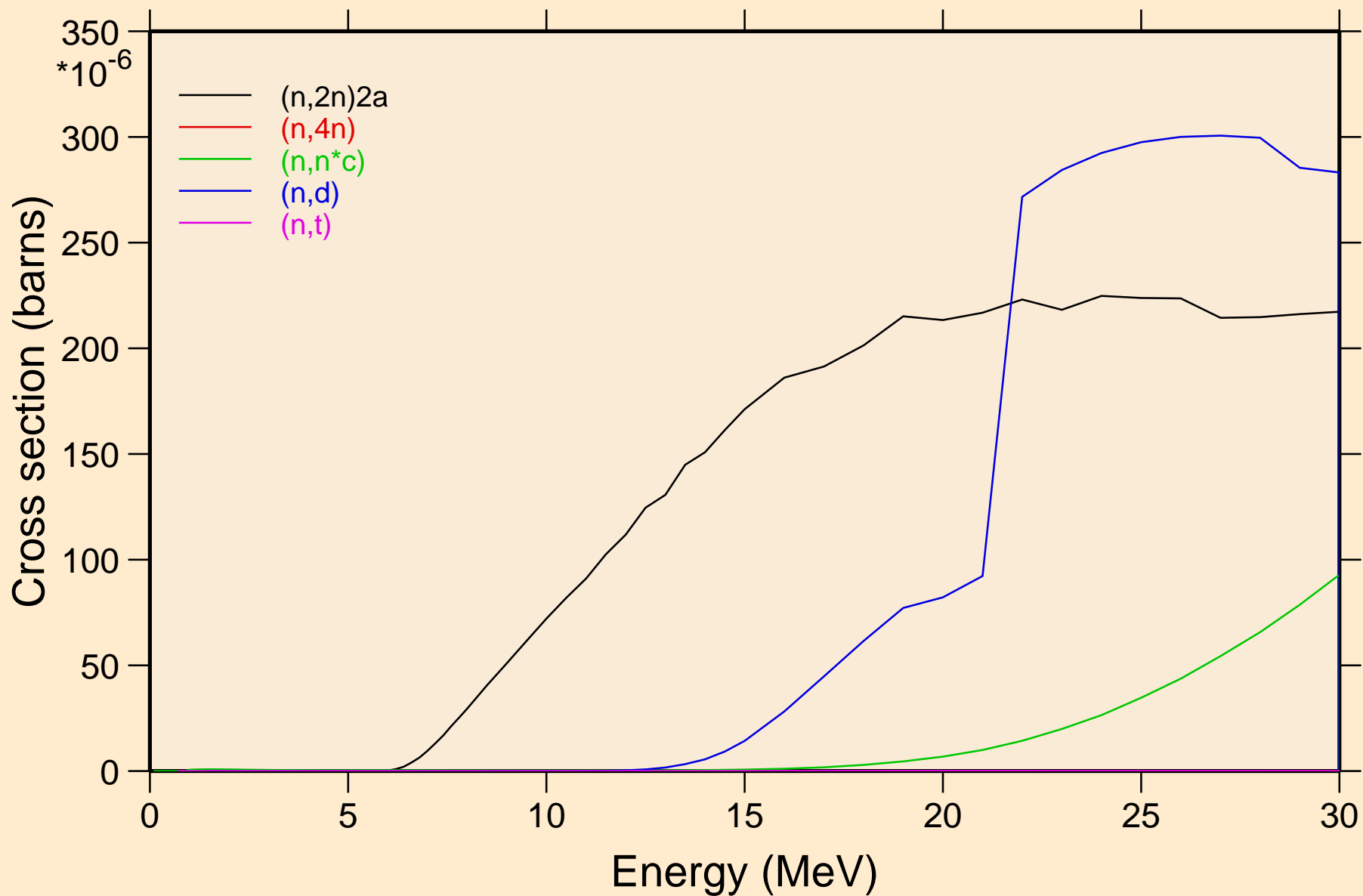

CN283 NEUTRON ACER TENDL-2019 LIBRARY; T=293.16K
Threshold reactions

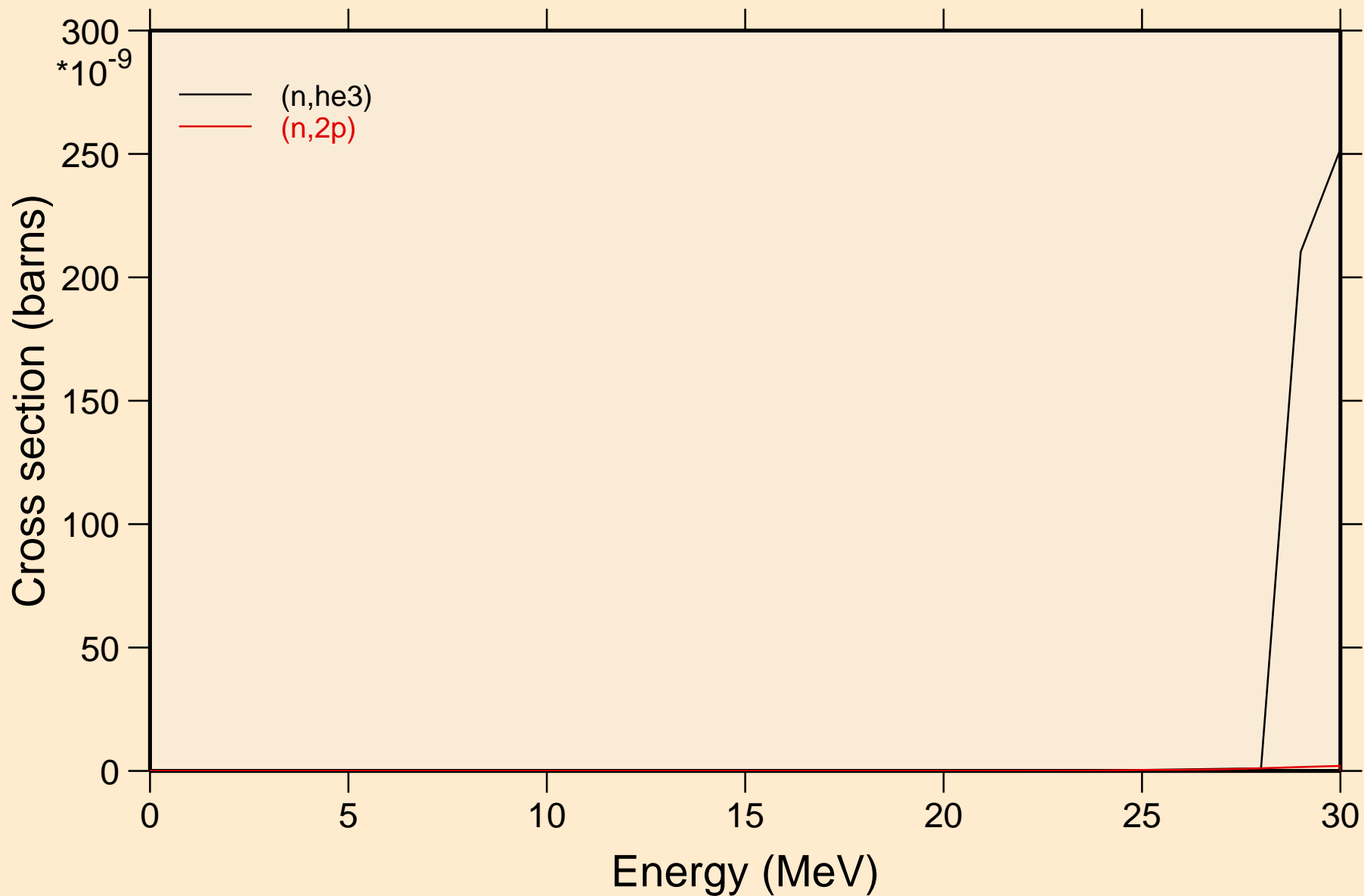

CN283 NEUTRON ACER TENDL-2019 LIBRARY; T=293.16K
Threshold reactions

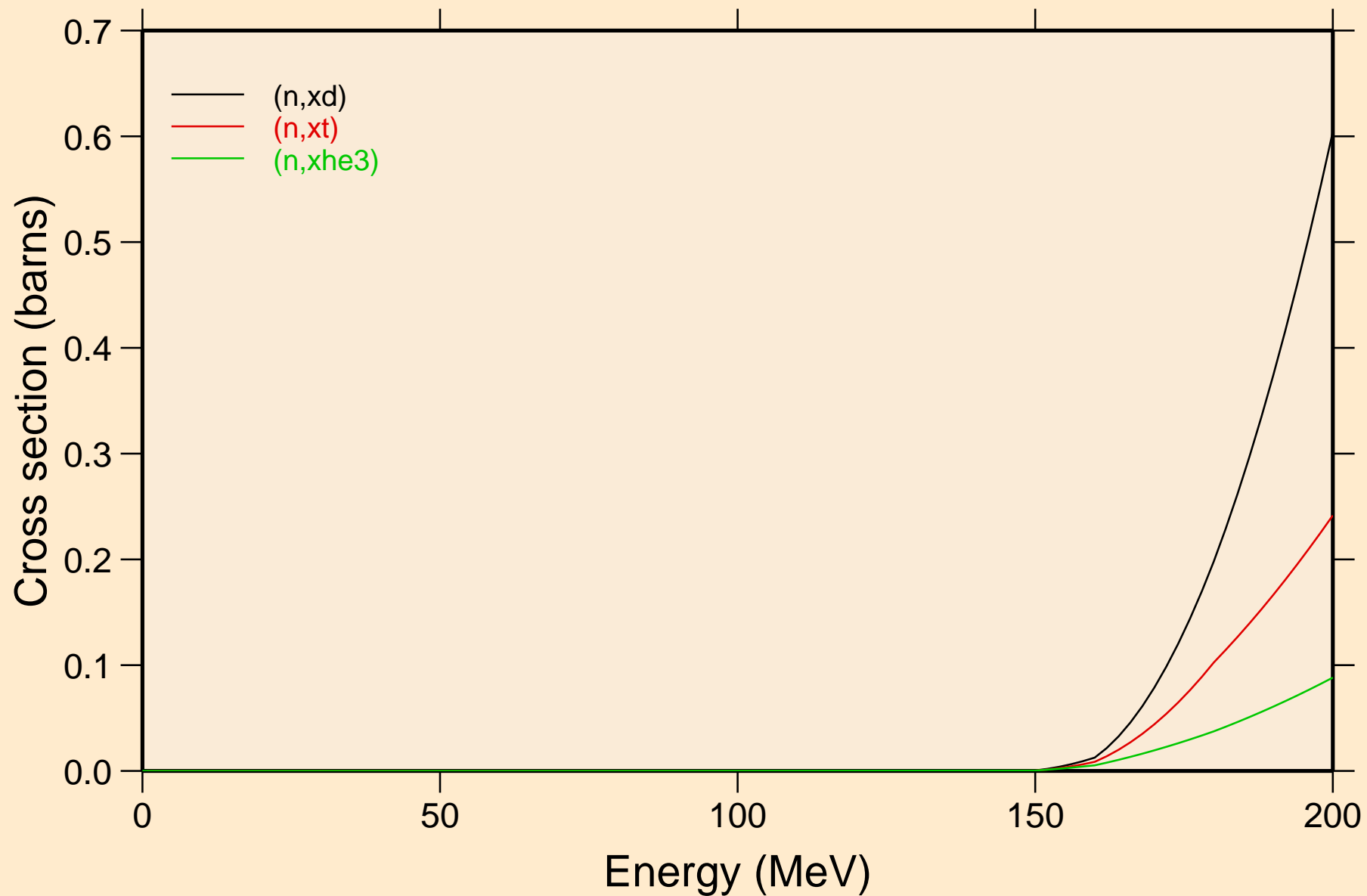

CN283 NEUTRON ACER TENDL-2019 LIBRARY; T=293.16K
angular distribution for elastic

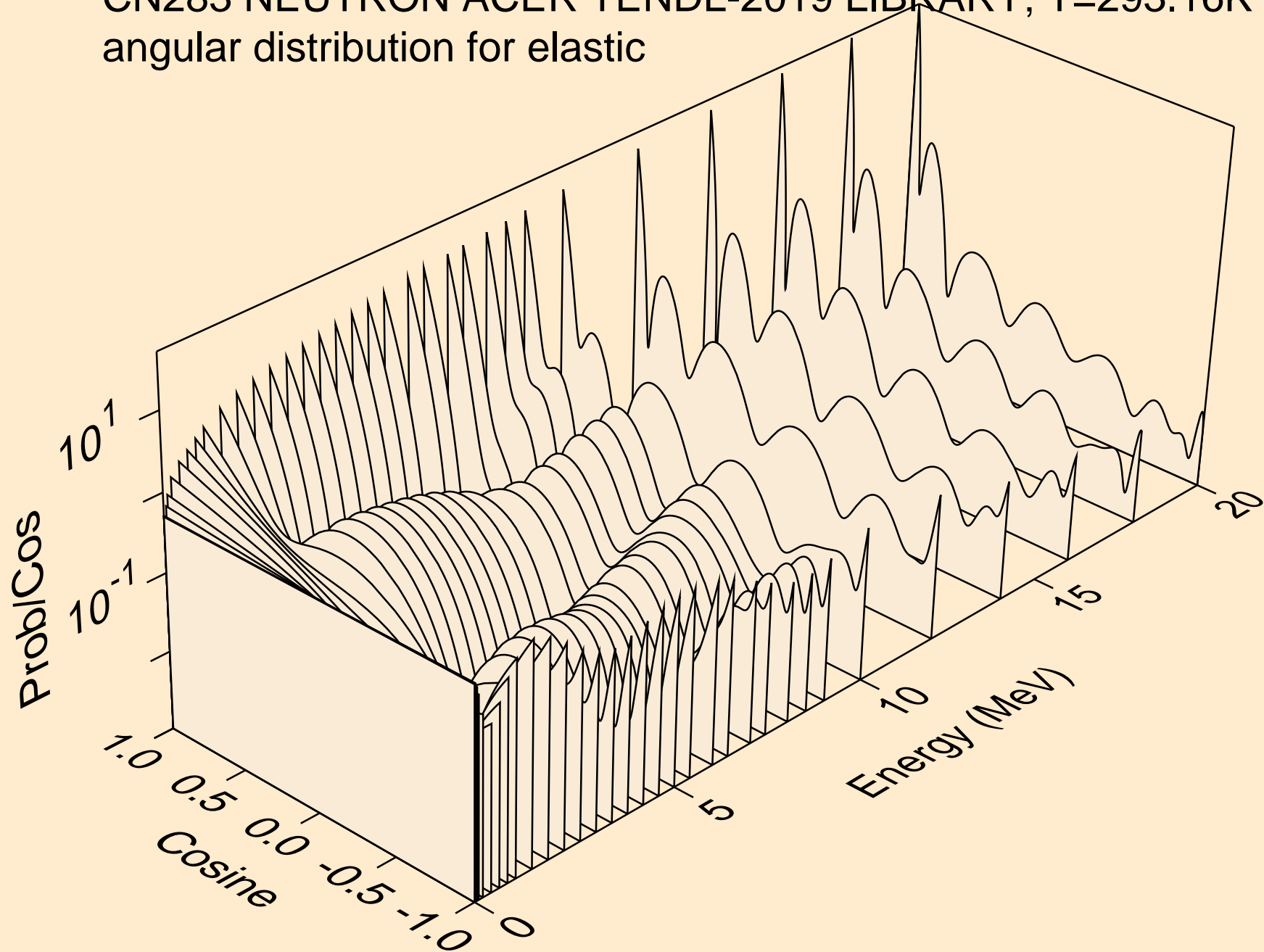

CN283 NEUTRON ACER TENDL-2019 LIBRARY; T=293.16K
angular distribution for elastic

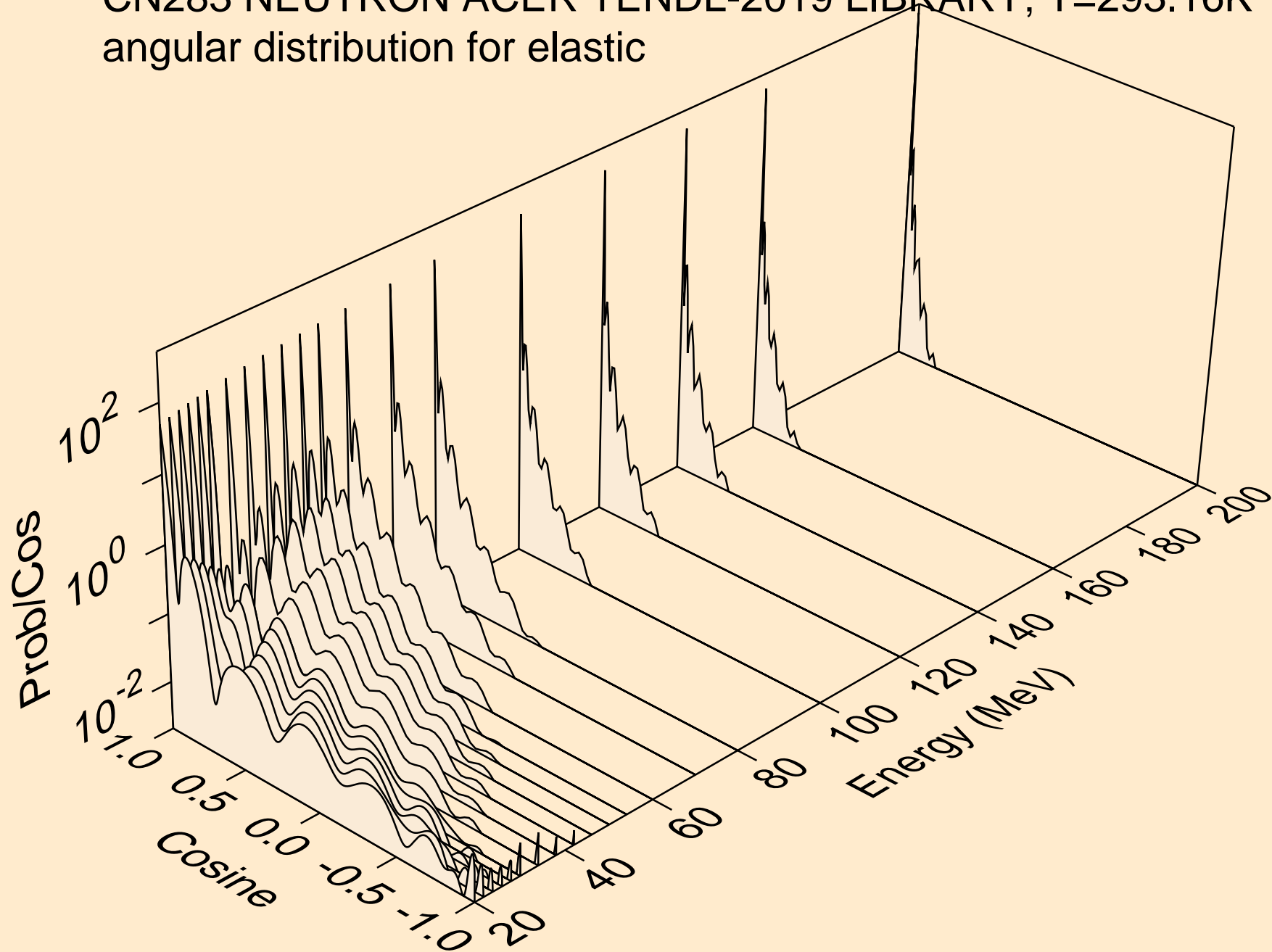

CN283 NEUTRON ACER TENDL-2019 LIBRARY; T=293.16K
angular distribution for (n,n*1)

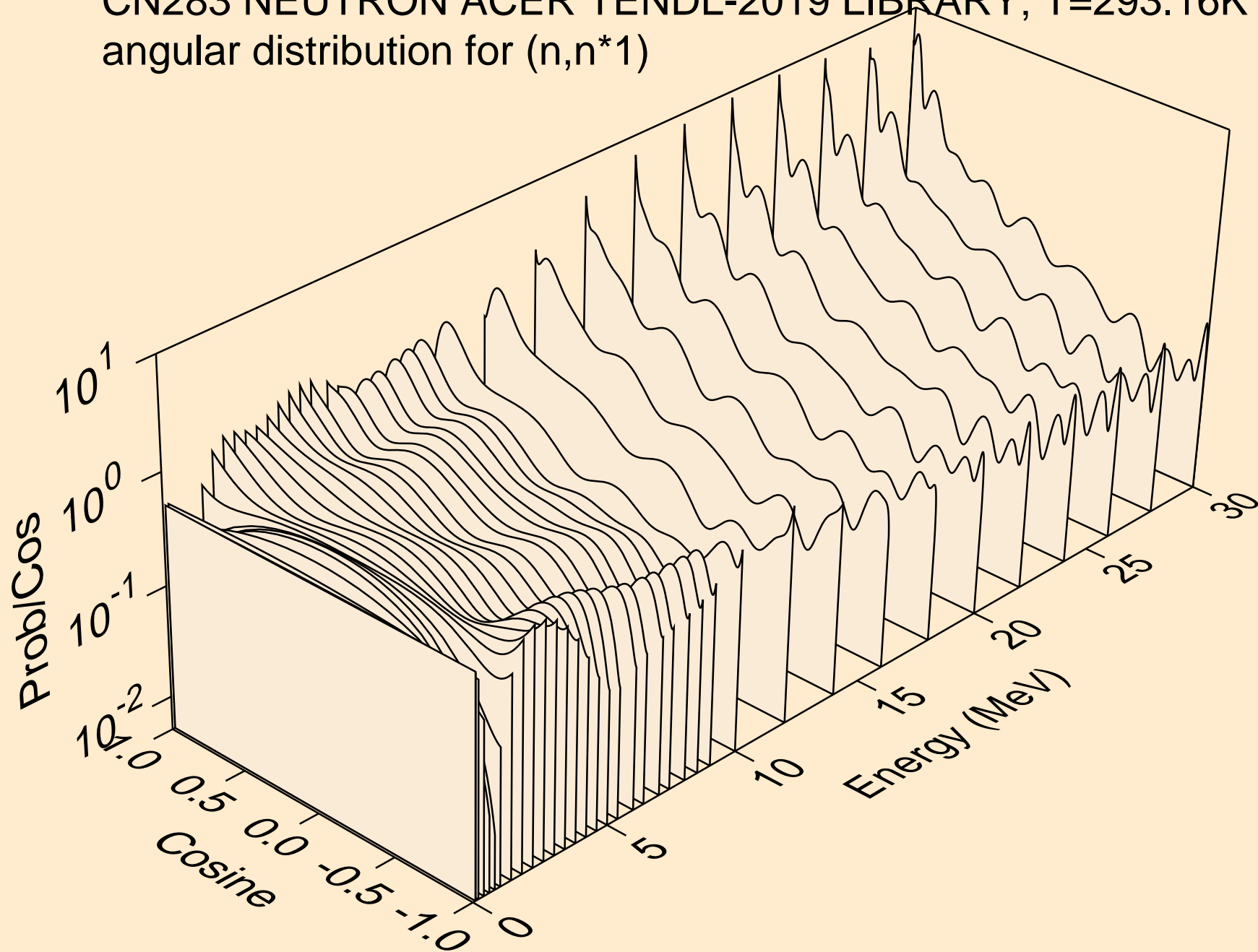

CN283 NEUTRON ACER TENDL-2019 LIBRARY; T=293.16K
Total fission nubar

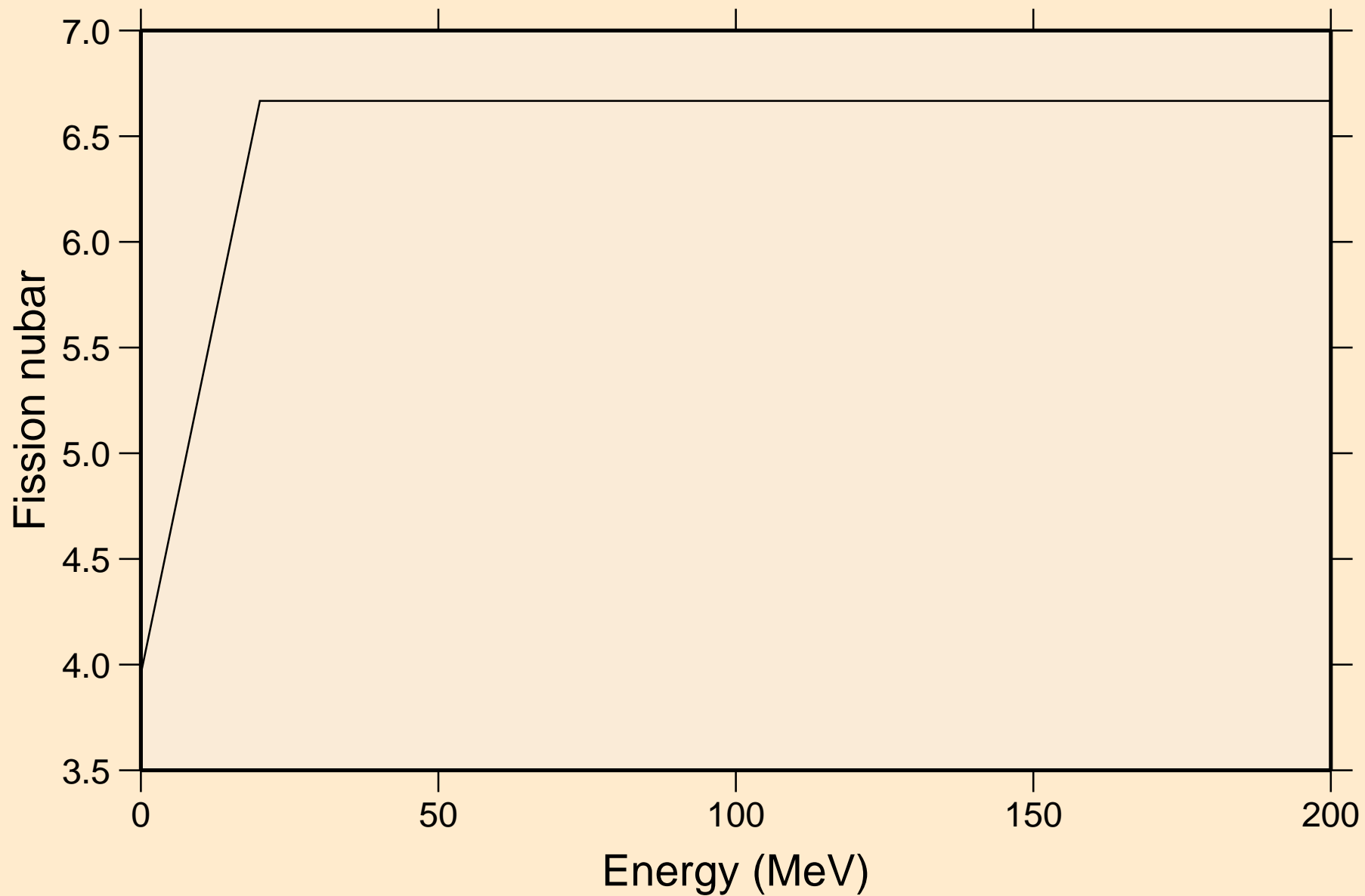

CN283 NEUTRON ACER TENDL-2019 LIBRARY; T=293.16K
Neutron emission for (n,x)

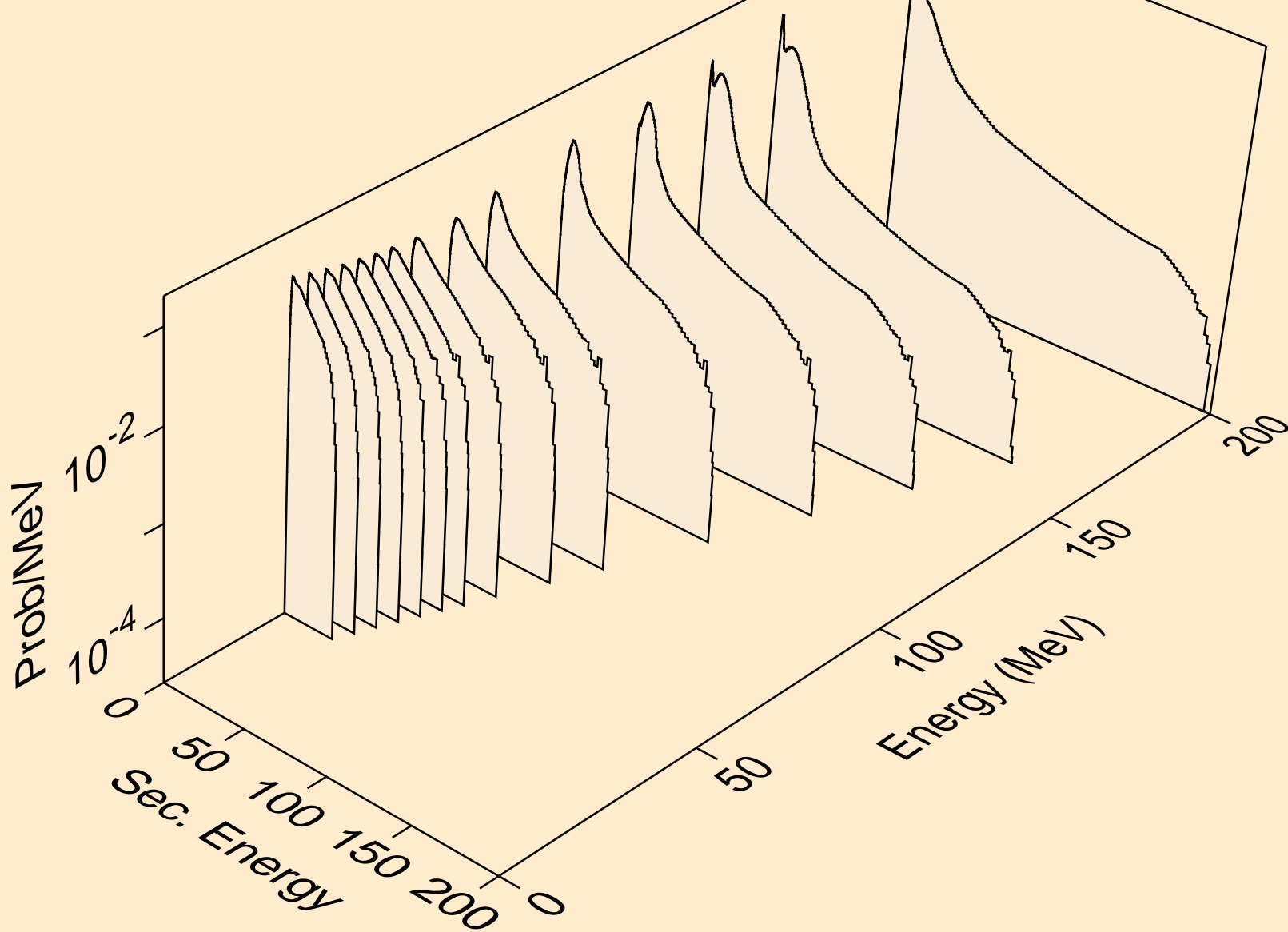

CN283 NEUTRON ACER TENDL-2019 LIBRARY; T=293.16K
Neutron emission for (n,2n)

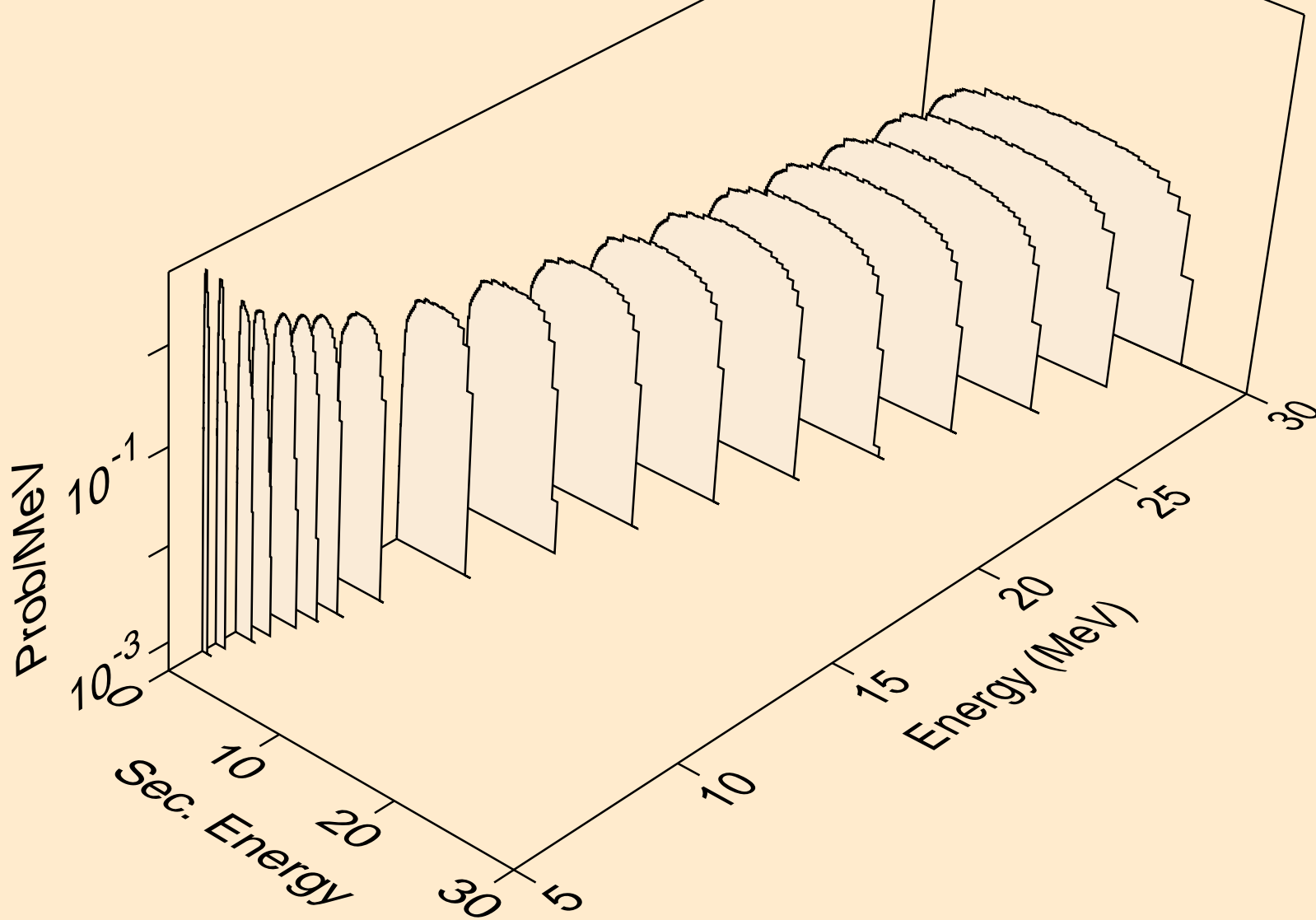

CN283 NEUTRON ACER TENDL-2019 LIBRARY; T=293.16K
Neutron emission for (n,3n)

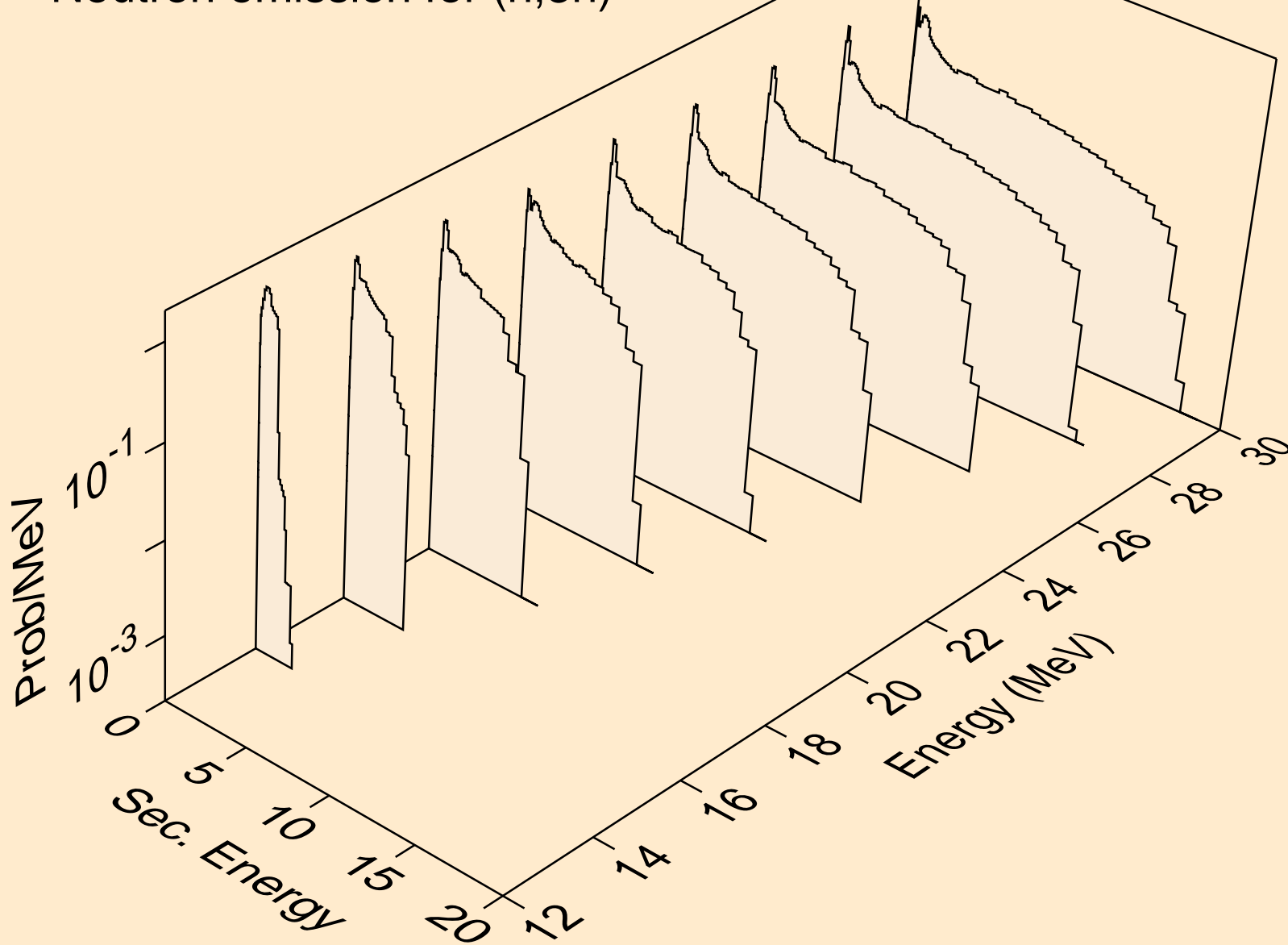

CN283 NEUTRON ACER TENDL-2019 LIBRARY; T=293.16K
Neutron emission for fission

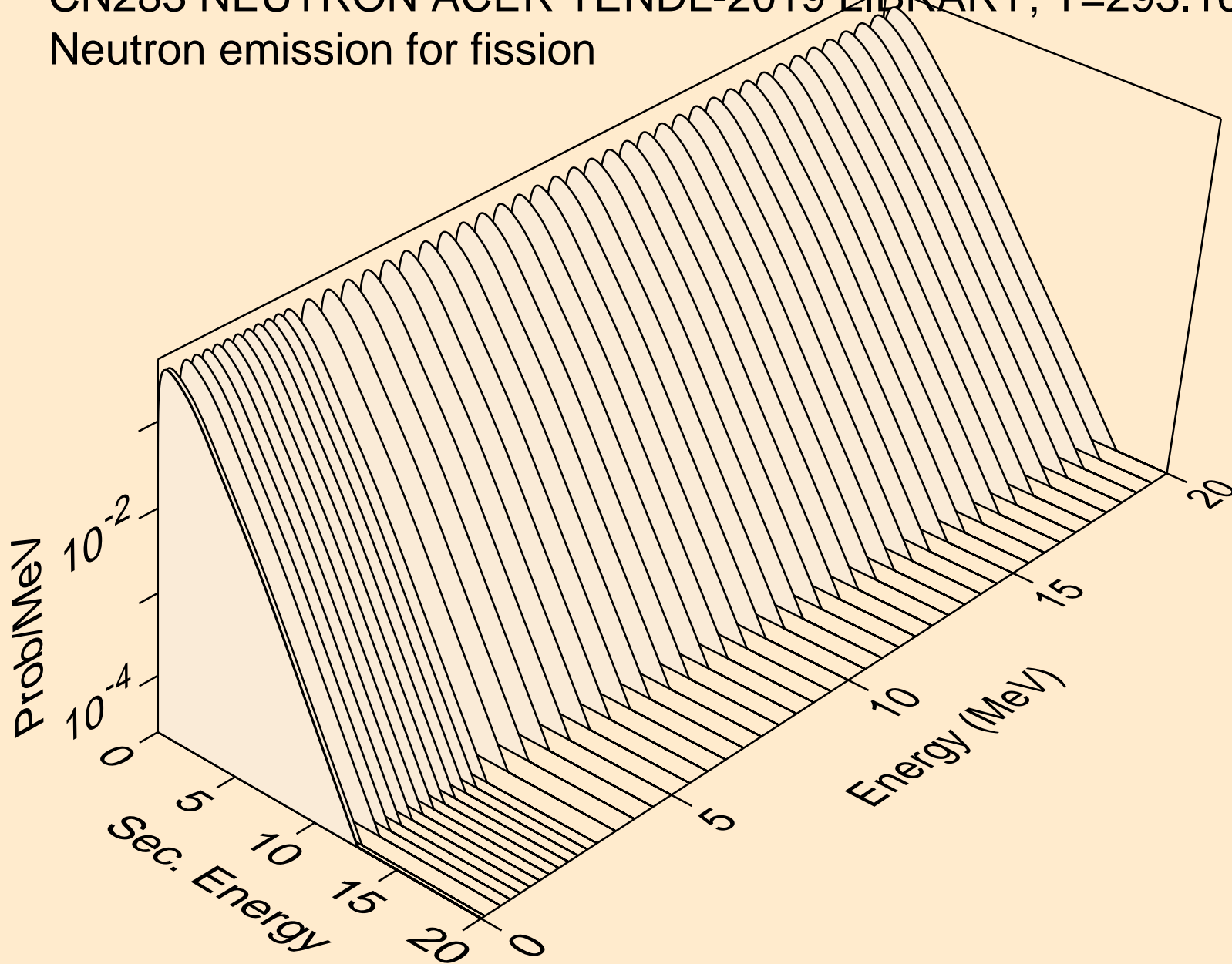

CN283 NEUTRON ACER TENDL-2019 LIBRARY; T=293.16K
Neutron emission for (n,2n)a

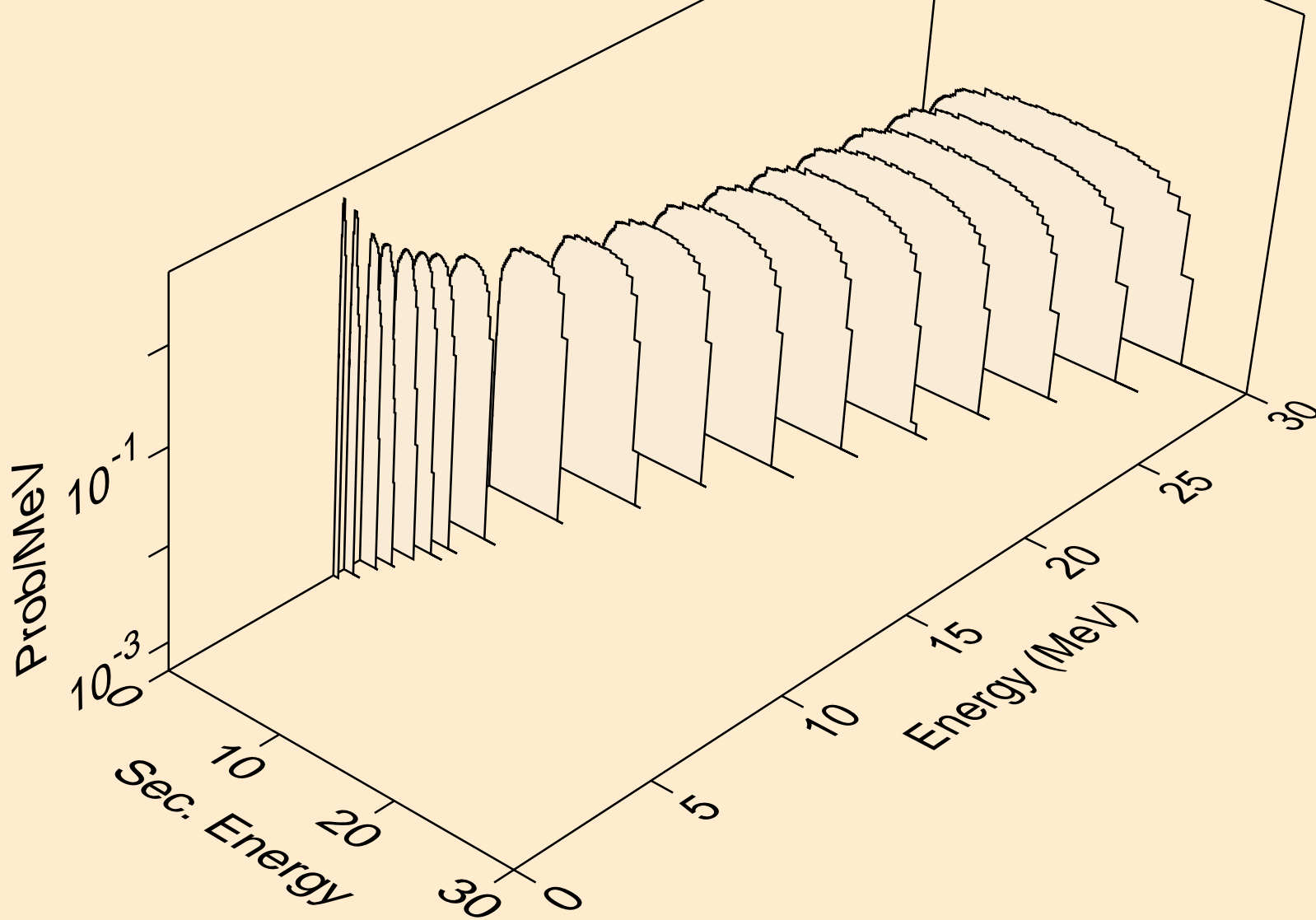

CN283 NEUTRON ACER TENDL-2019 LIBRARY; T=293.16K
Neutron emission for (n,n*)p

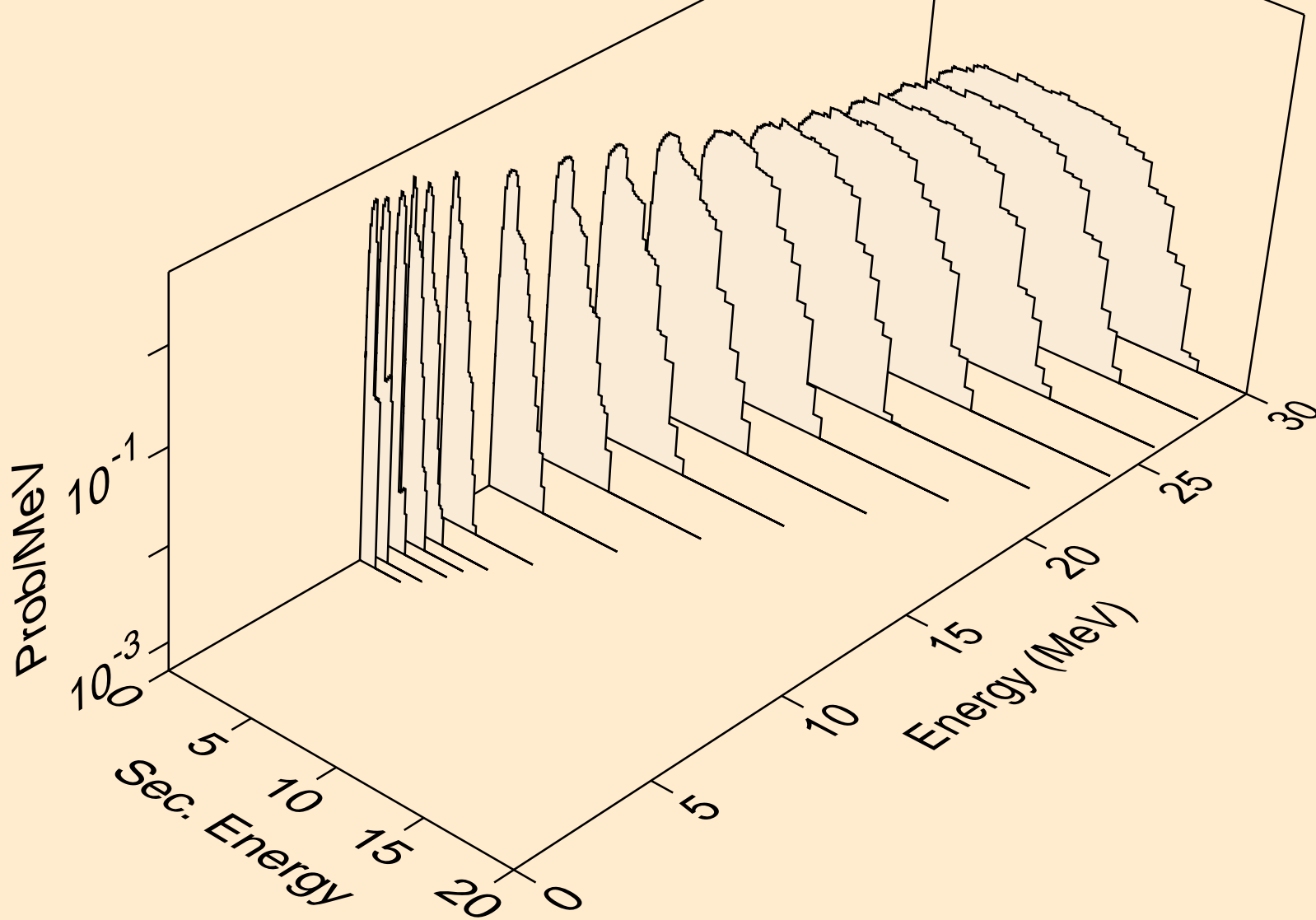

CN283 NEUTRON ACER TENDL-2019 LIBRARY; T=293.16K
Neutron emission for (n,2n)2a

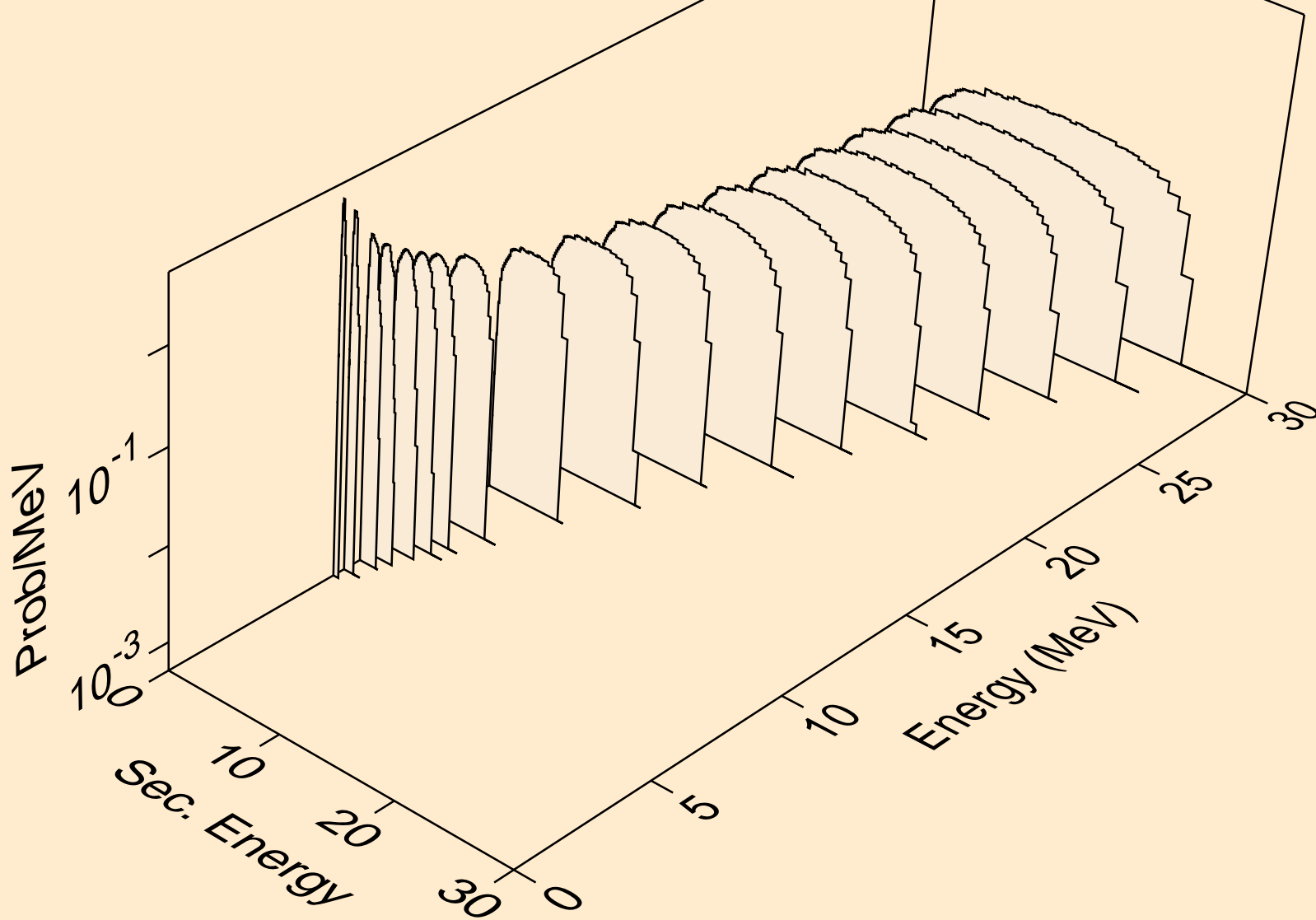

CN283 NEUTRON ACER TENDL-2019 LIBRARY; T=293.16K
Neutron emission for (n,4n)

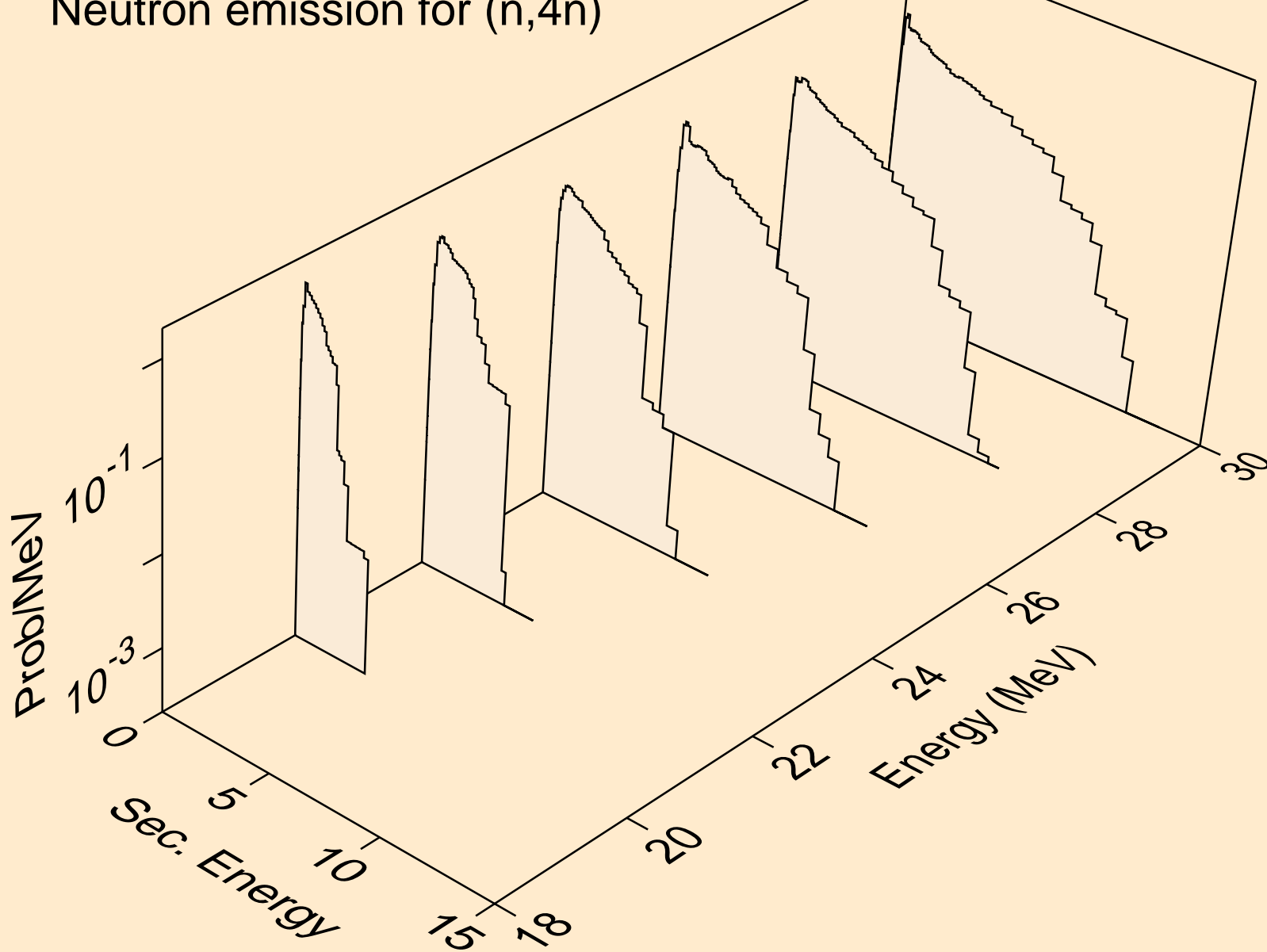

CN283 NEUTRON ACER TENDL-2019 LIBRARY; T=293.16K
Neutron emission for (n,n*c)

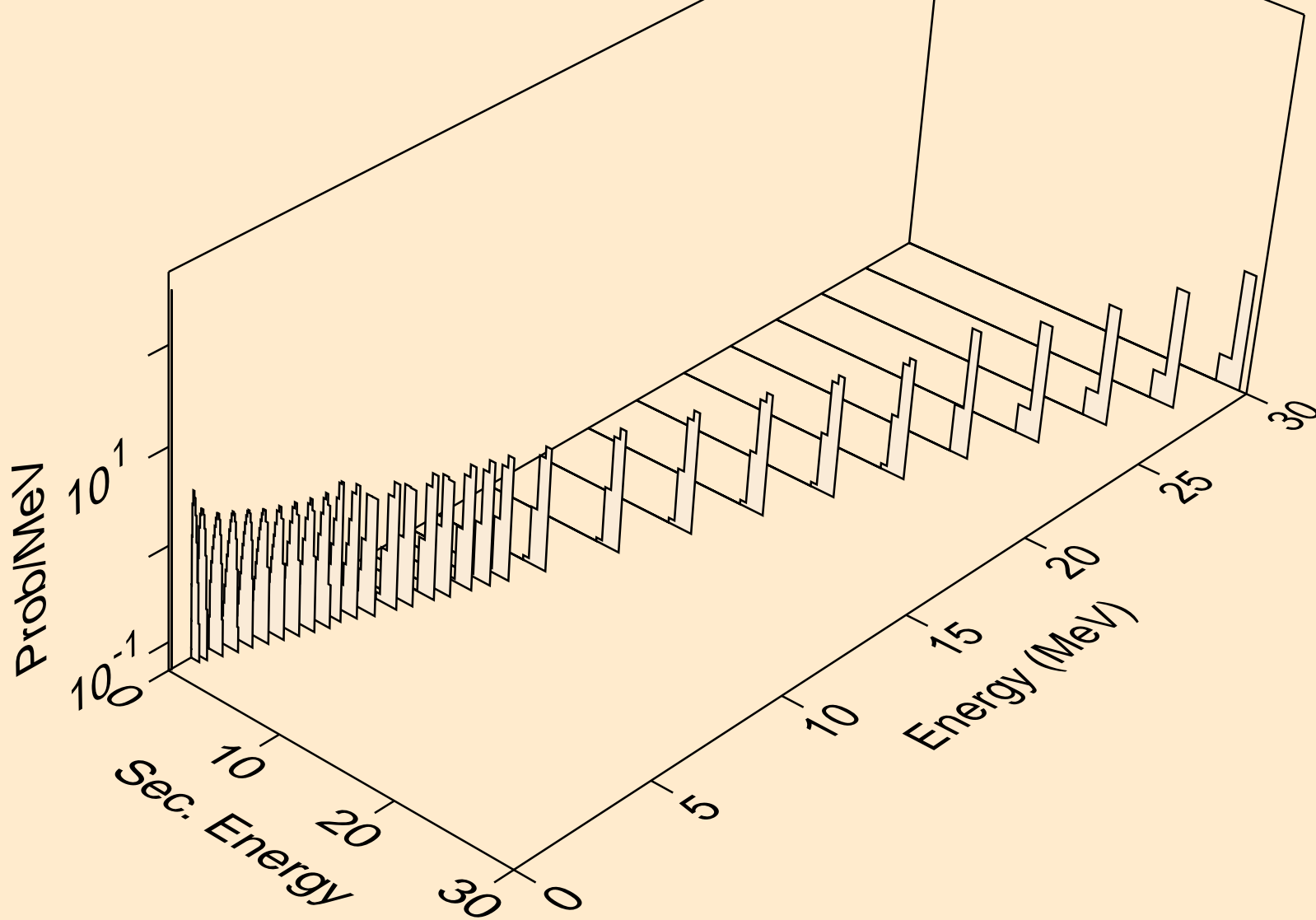

CN283 NEUTRON ACER TENDL-2019 LIBRARY; T=293.16K

Delayed nubar

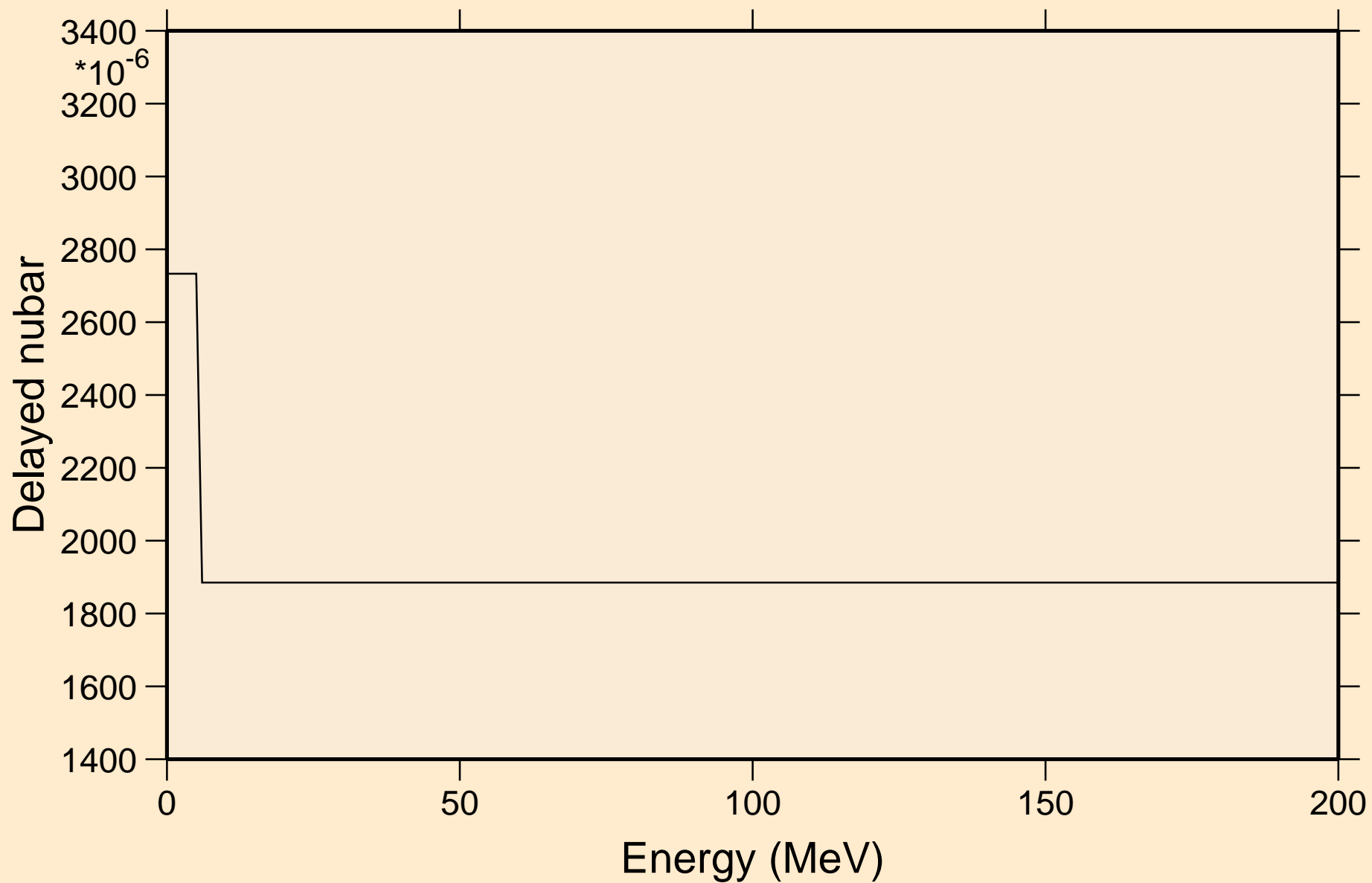

CN283 NEUTRON ACER TENDL-2019 LIBRARY; T=293.16K

Delayed neutron spectra

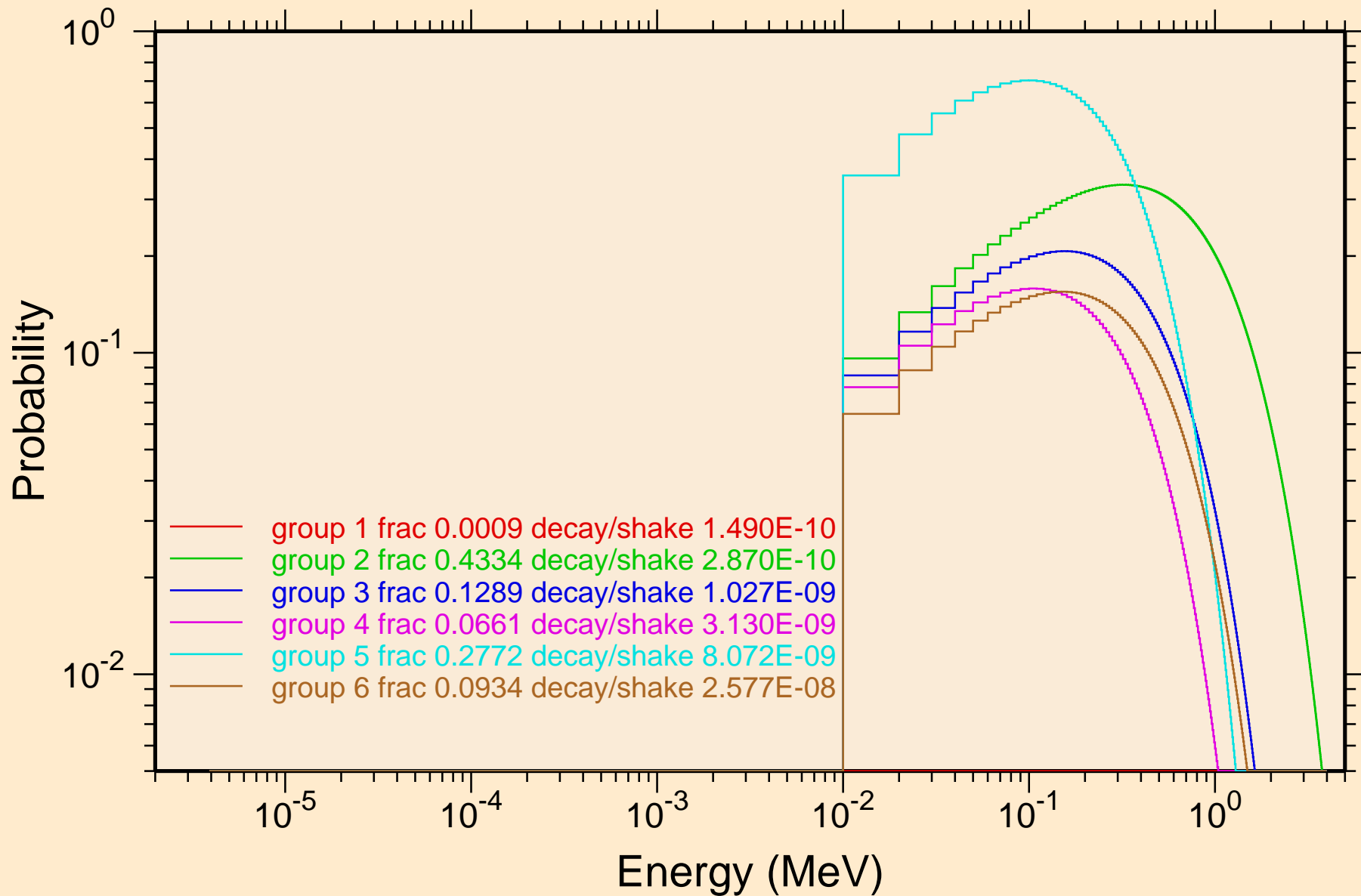

CN283 NEUTRON ACER TENDL-2019 LIBRARY; T=293.16K
Photon emission for (n,x)

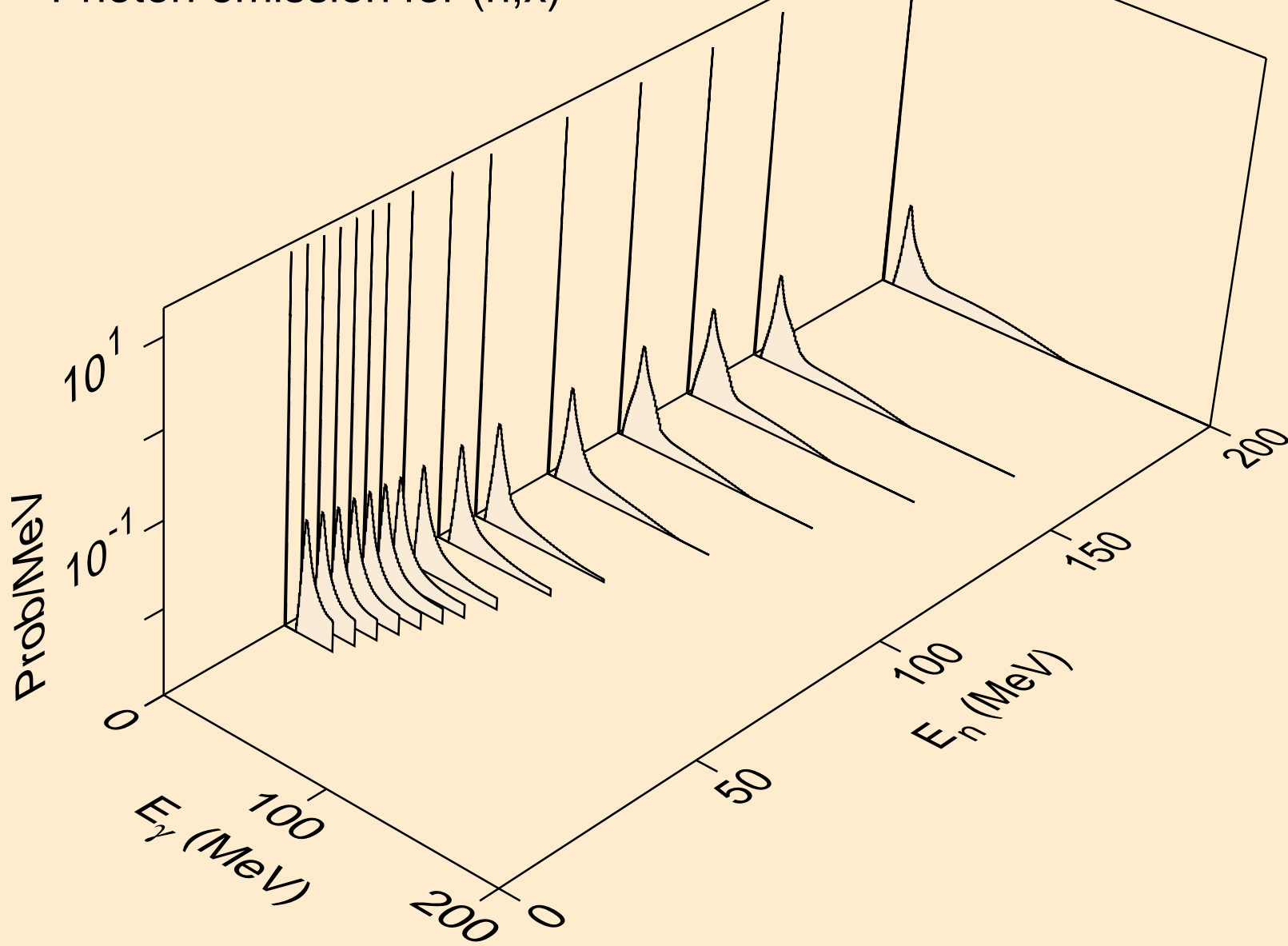

CN283 NEUTRON ACER TENDL-2019 LIBRARY; T=293.16K
Photon emission for (n,2n)

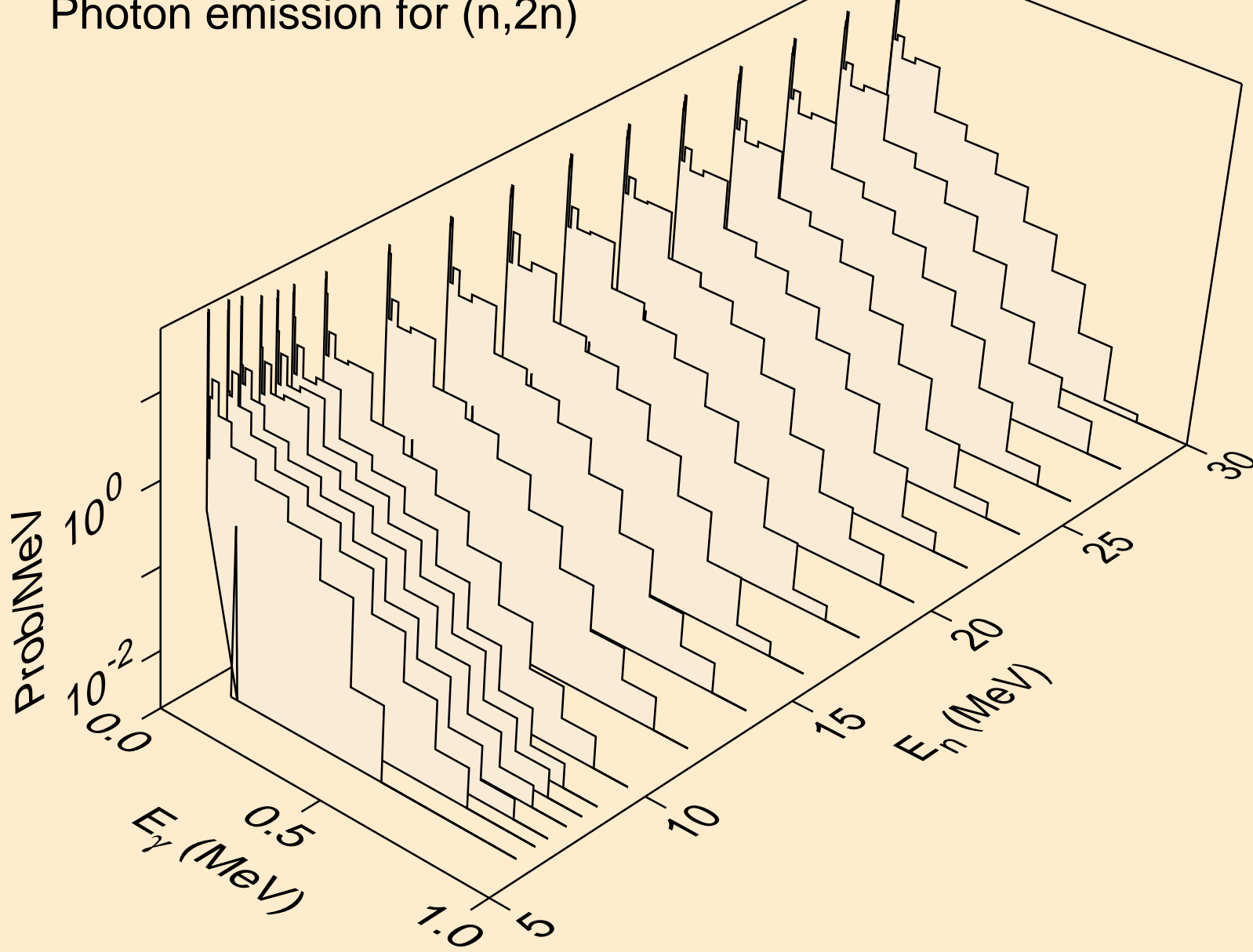

CN283 NEUTRON ACER TENDL-2019 LIBRARY; T=293.16K
Photon emission for (n,3n)

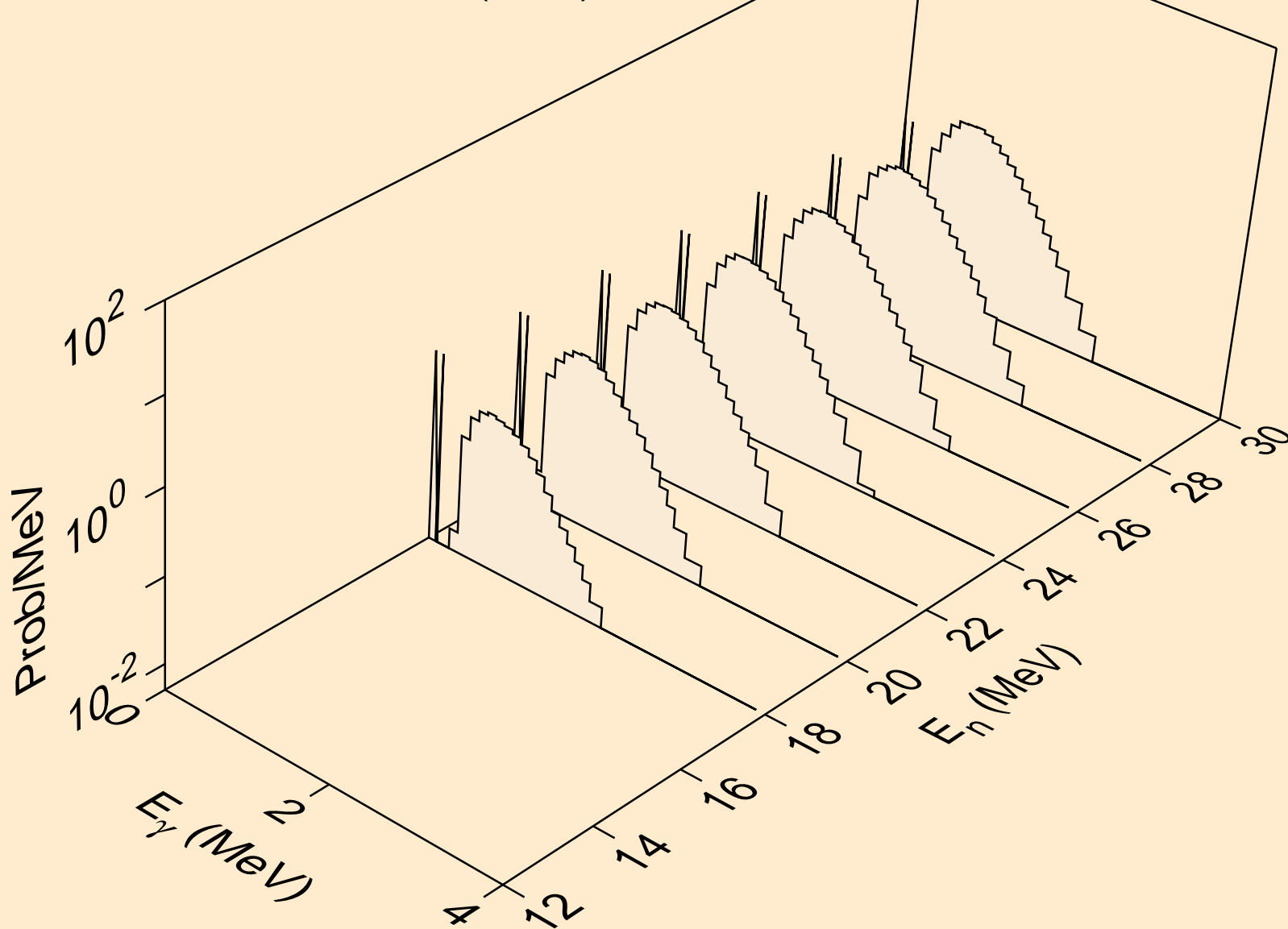

CN283 NEUTRON ACER TENDL-2019 LIBRARY; T=293.16K
Photon emission for (n,2n)a

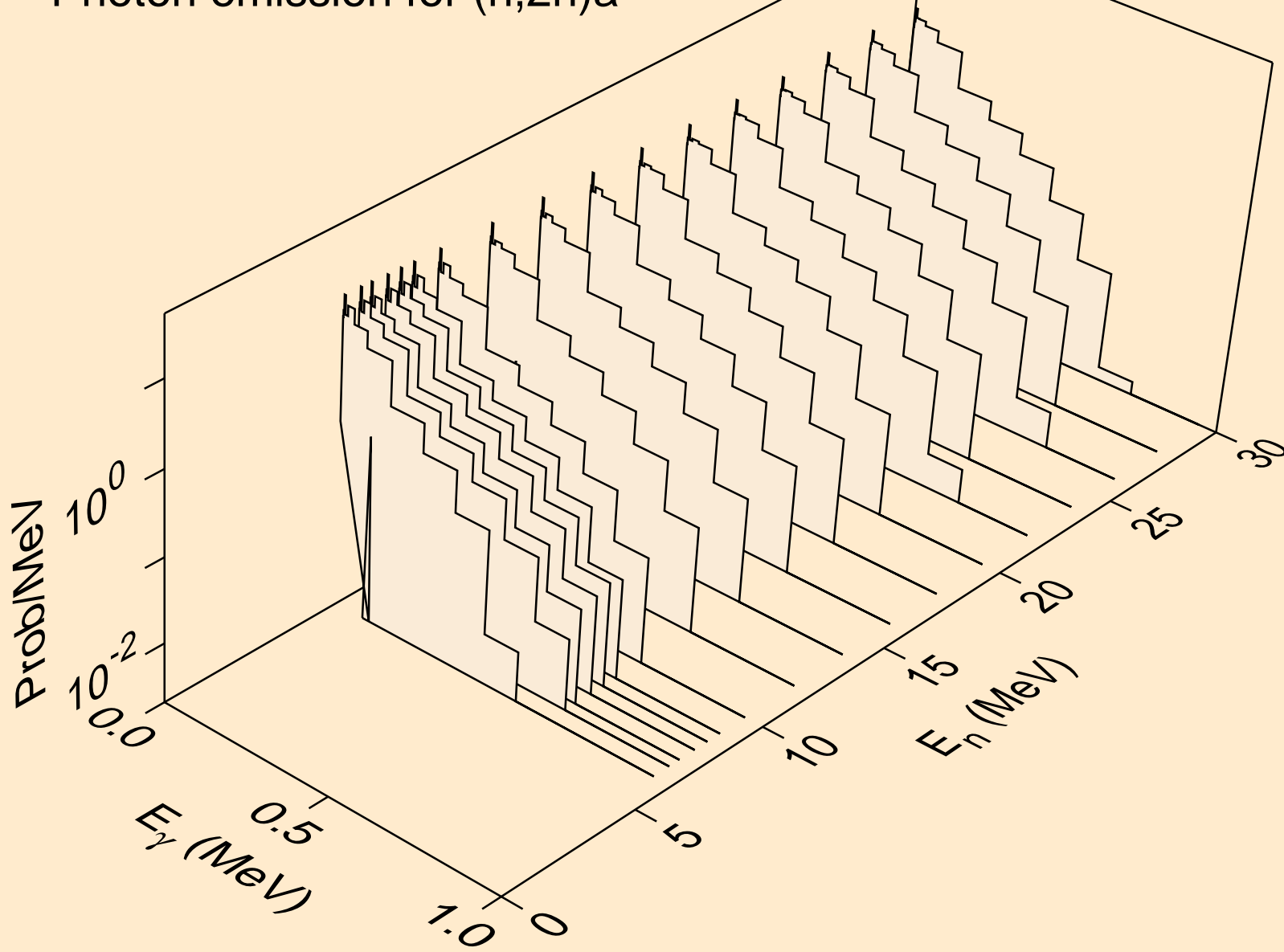

CN283 NEUTRON ACER TENDL-2019 LIBRARY; T=293.16K
Photon emission for (n,n*)p

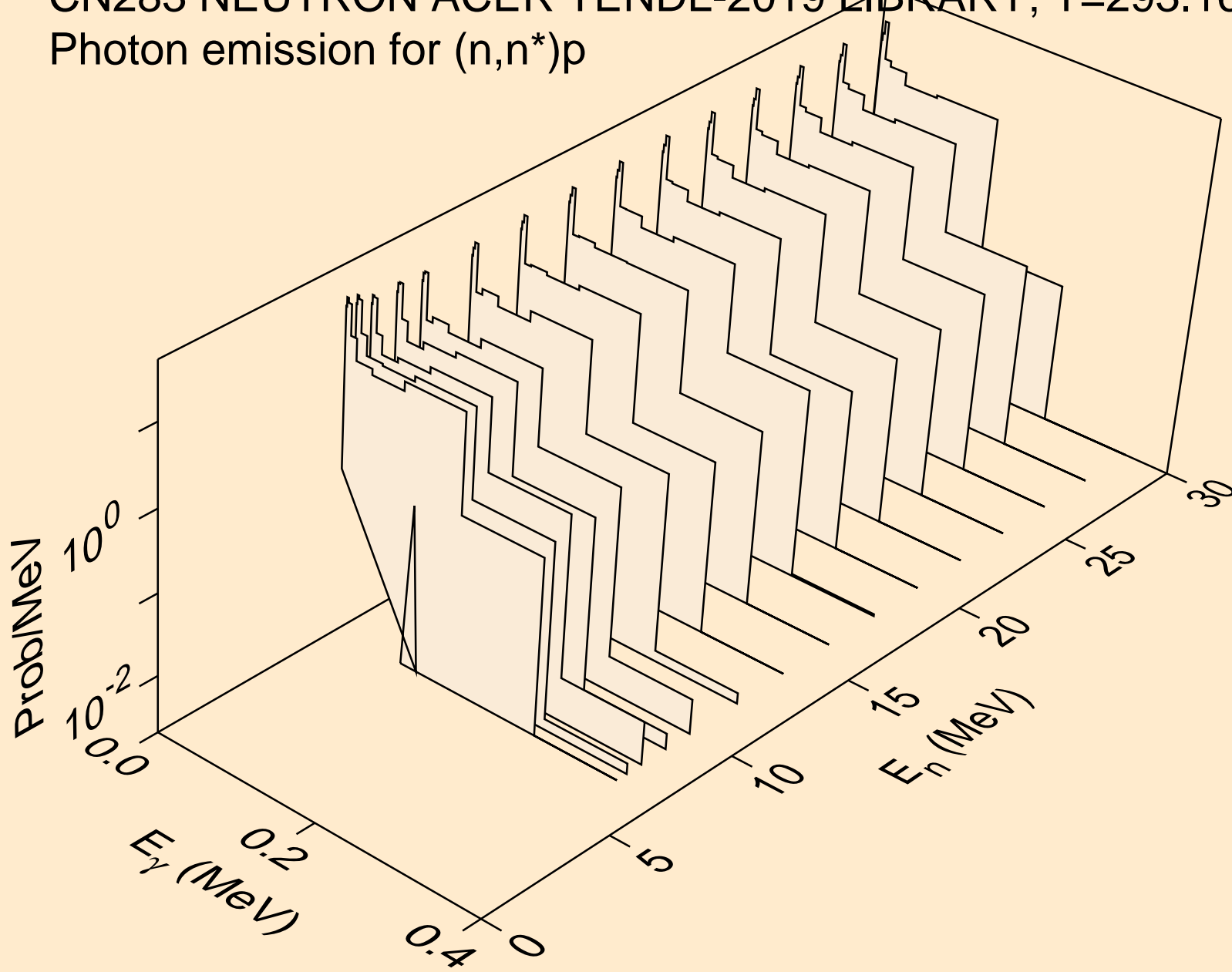

CN283 NEUTRON ACER TENDL-2019 LIBRARY; T=293.16K
Photon emission for (n,2n)2a

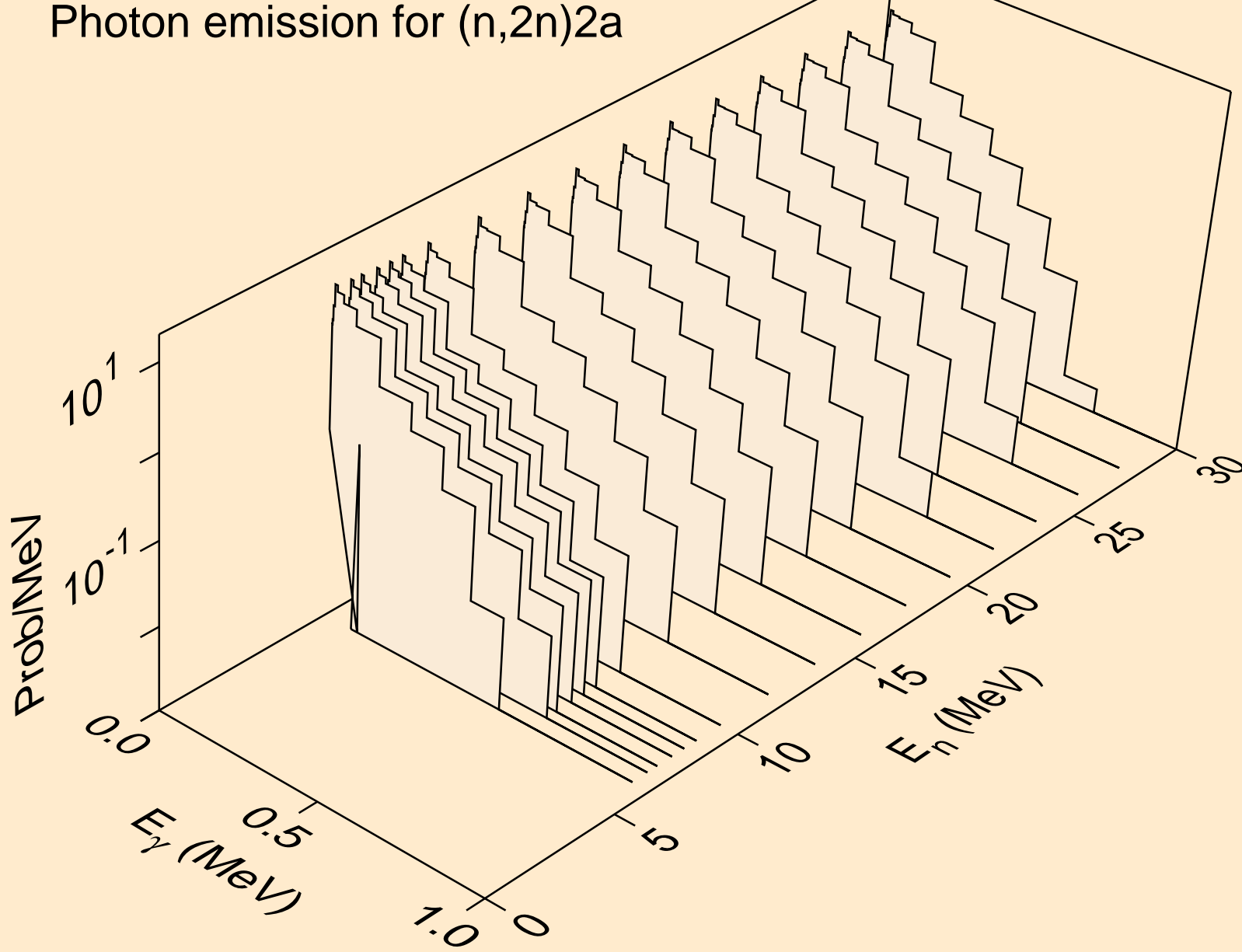

CN283 NEUTRON ACER TENDL-2019 LIBRARY; T=293.16K
Photon emission for (n,4n)

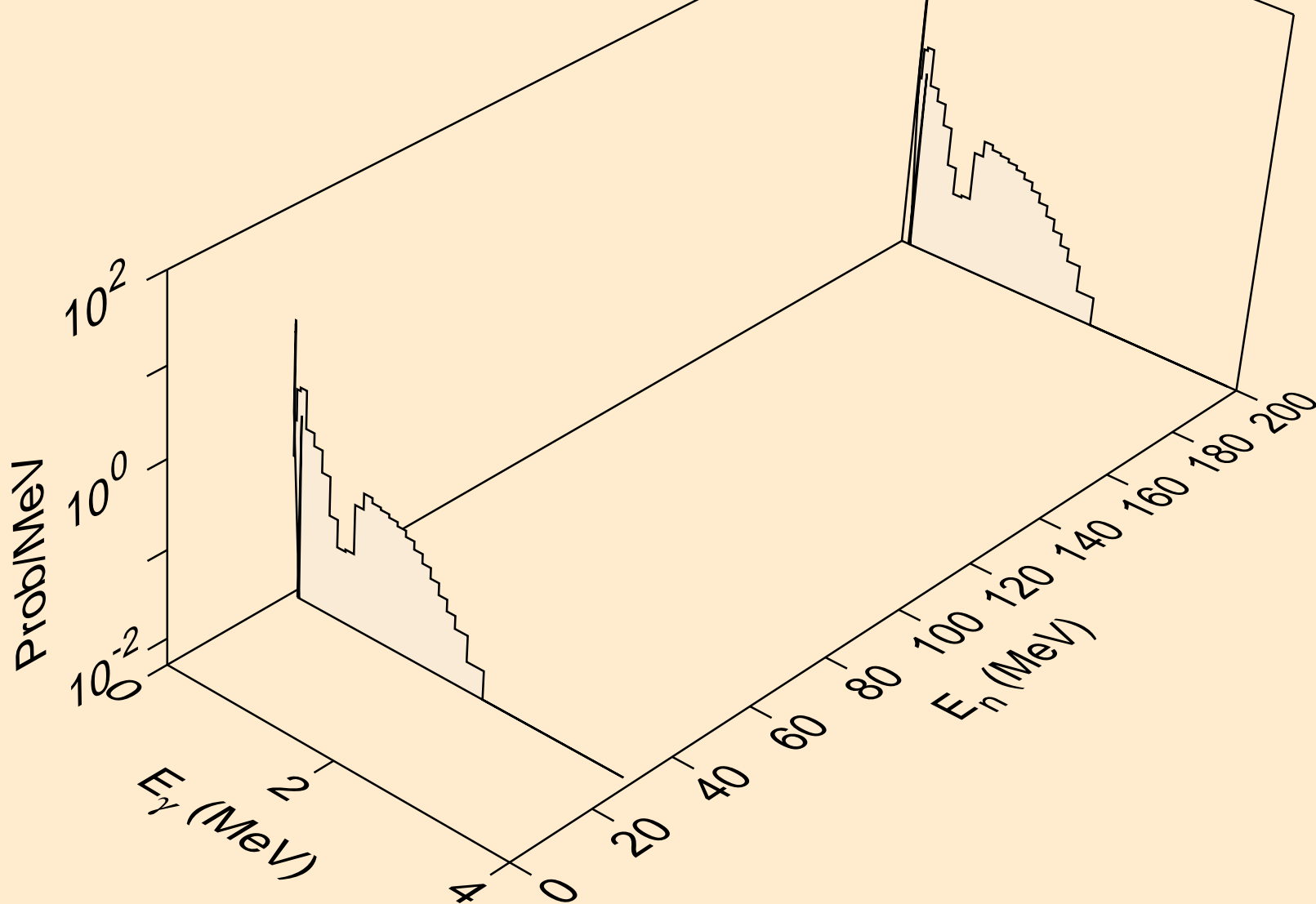

CN283 NEUTRON ACER TENDL-2019 LIBRARY; T=293.16K
Photon emission for (n,n*c)

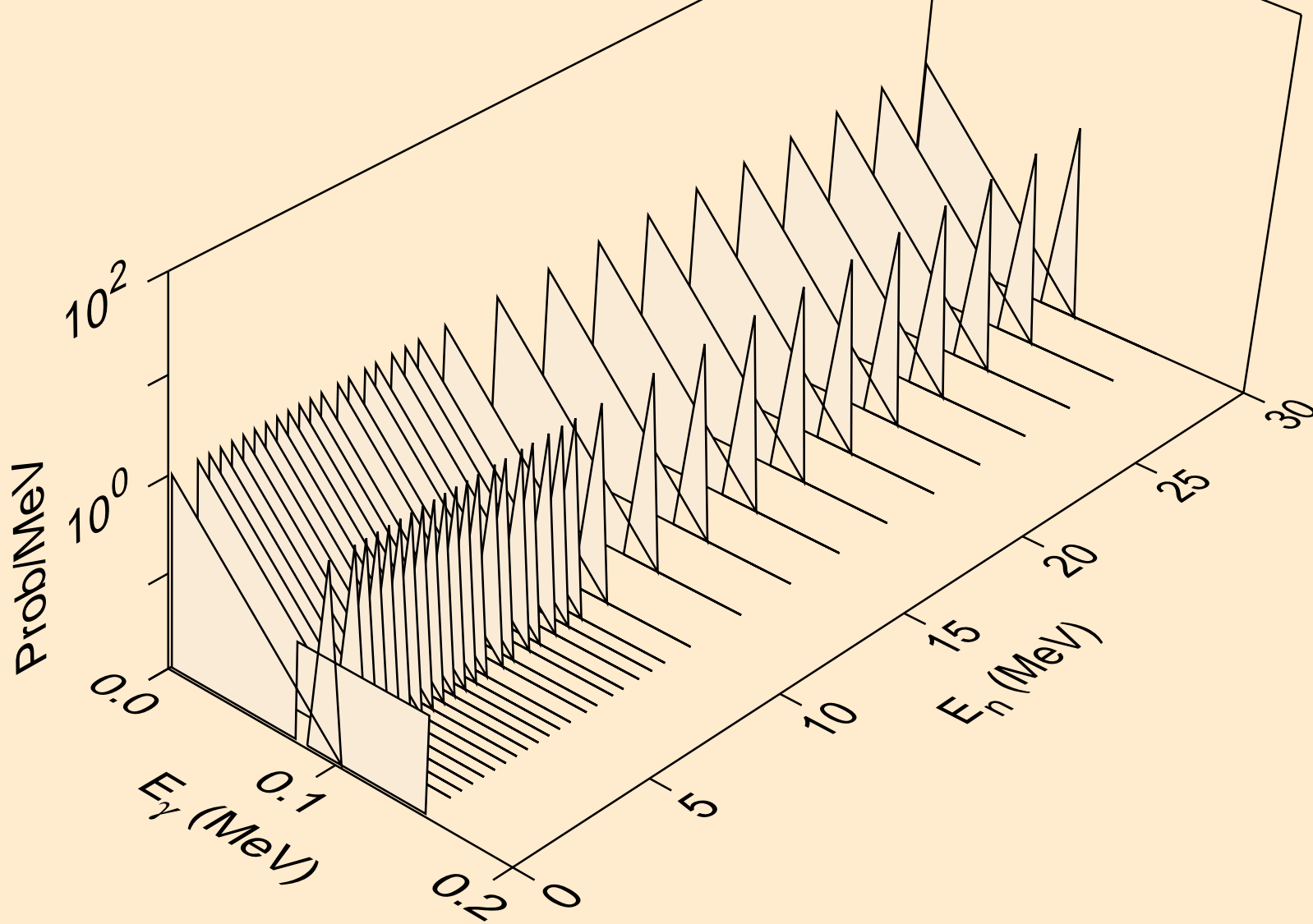

CN283 NEUTRON ACER TENDL-2019 LIBRARY; T=293.16K
Photon emission for (n,gma)

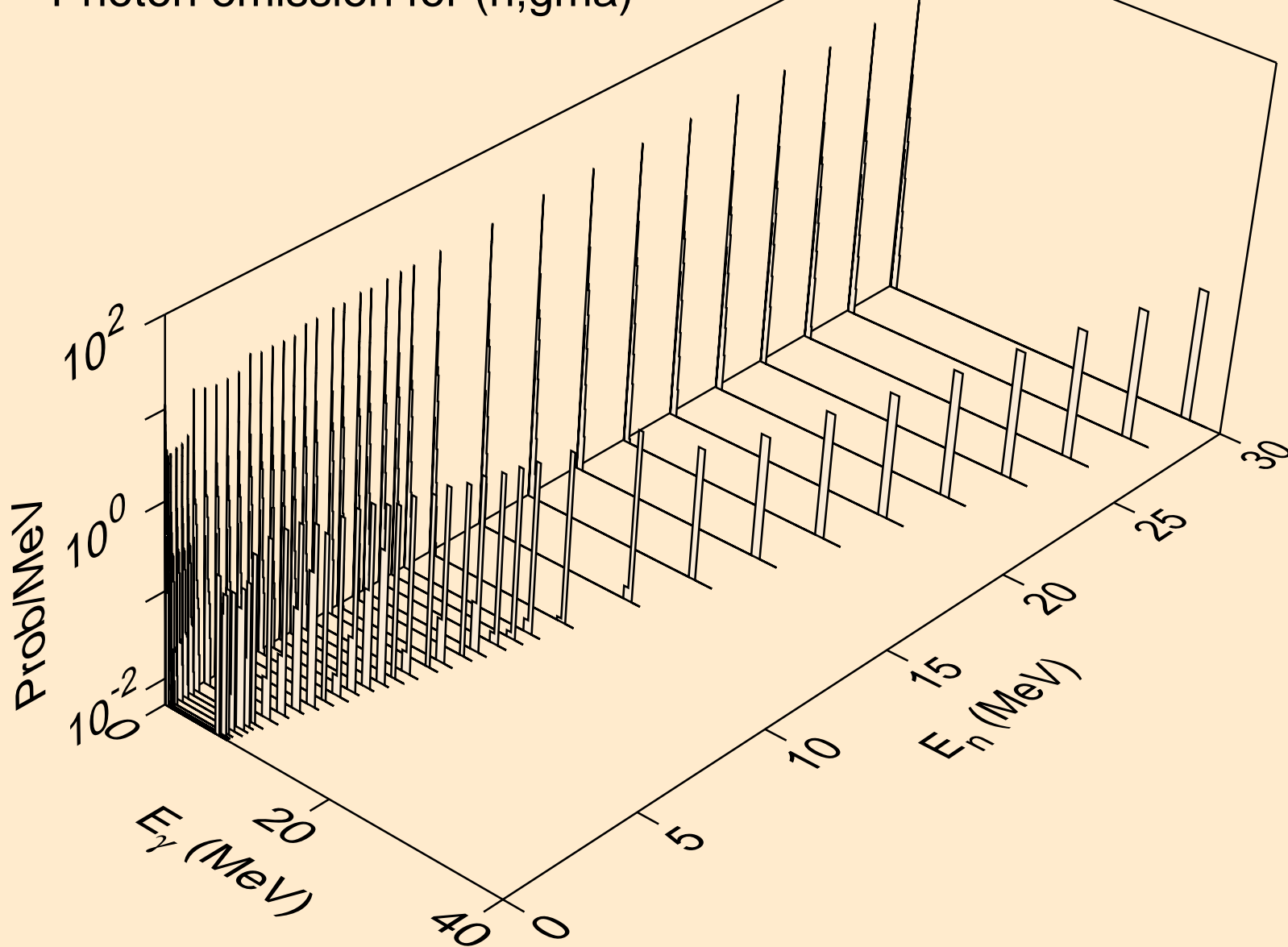

CN283 NEUTRON ACER TENDL-2019 LIBRARY; T=293.16K
Photon emission for (n,p)

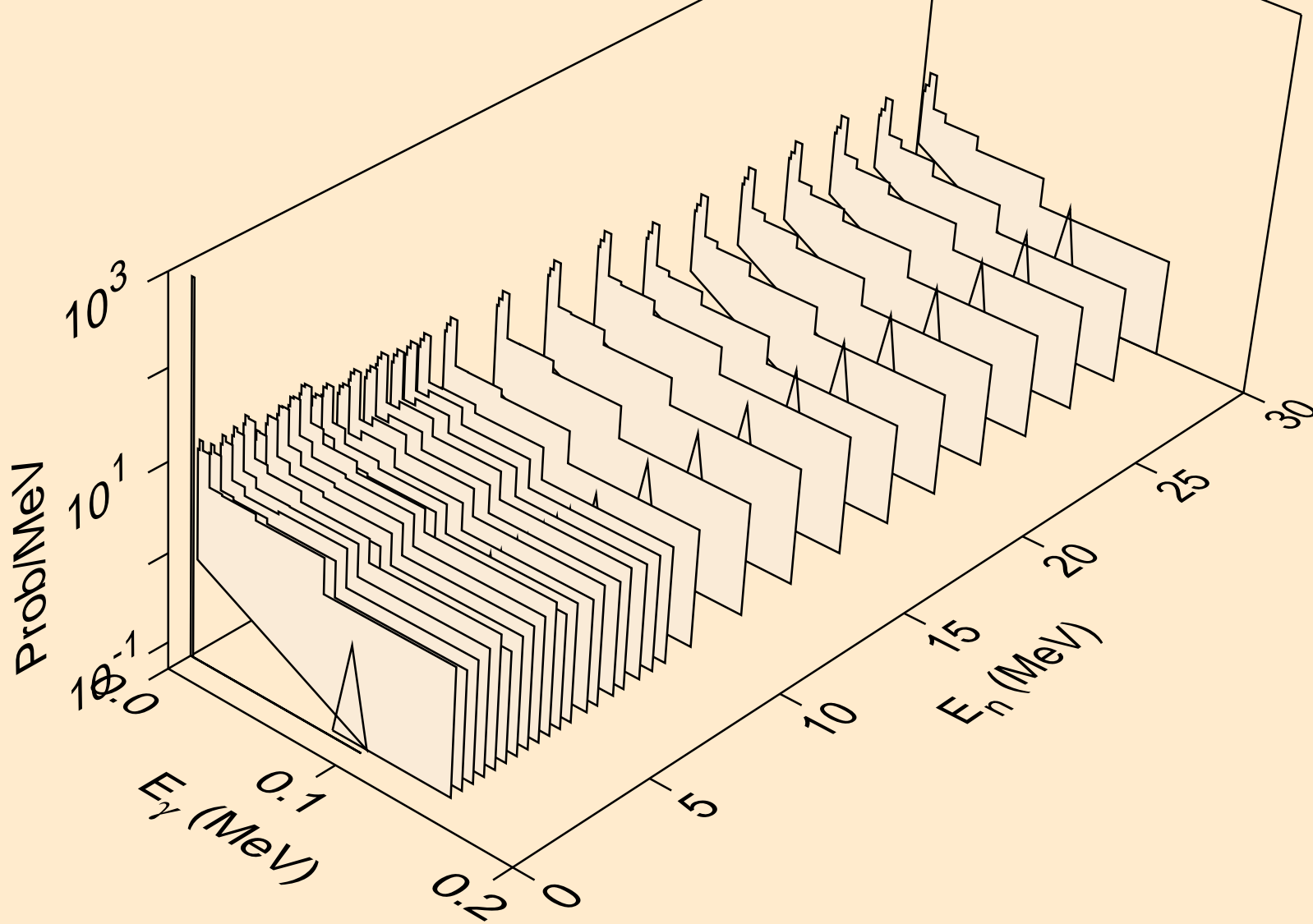

CN283 NEUTRON ACER TENDL-2019 LIBRARY; T=293.16K
Photon emission for (n,d)

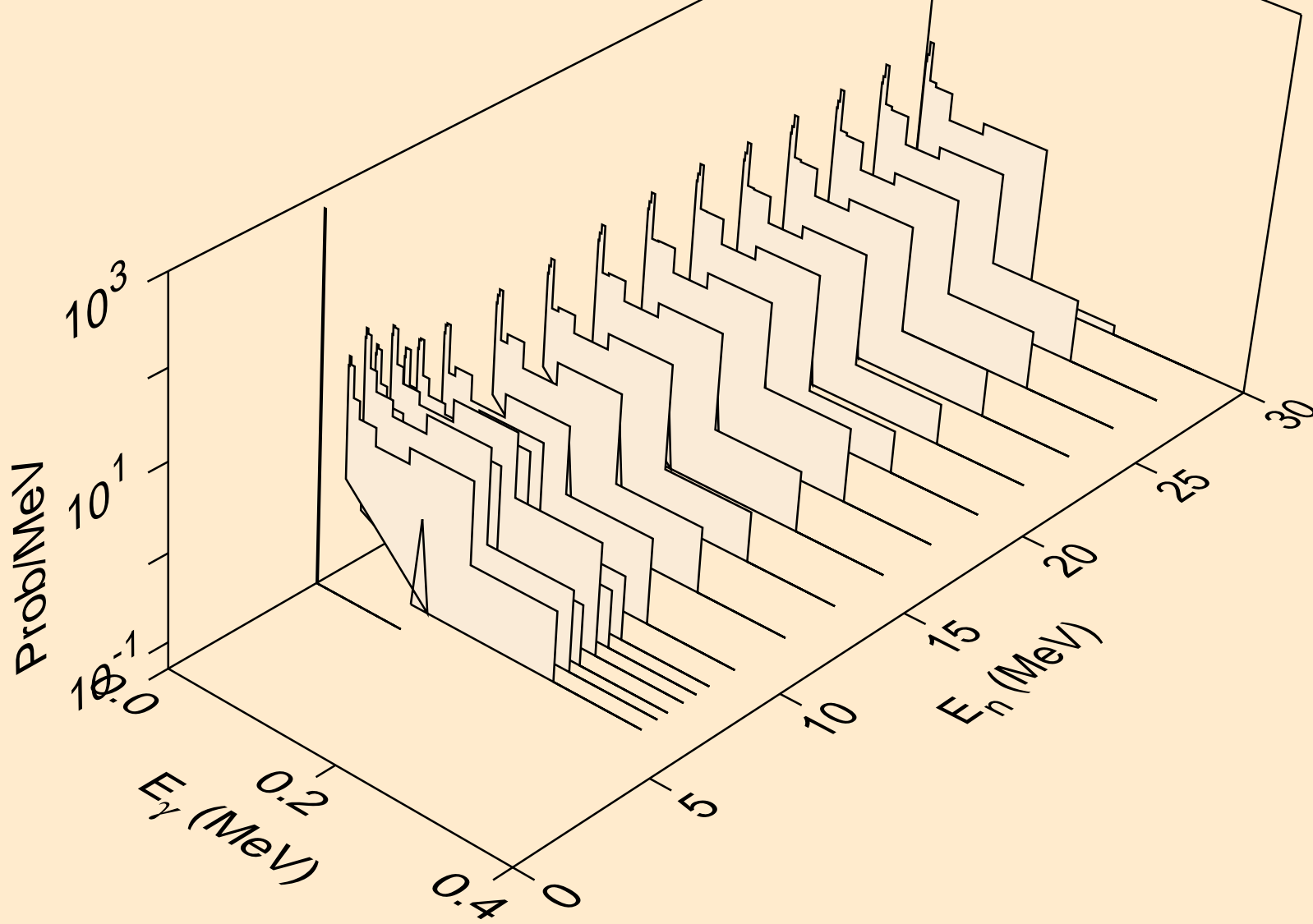

CN283 NEUTRON ACER TENDL-2019 LIBRARY; T=293.16K
Photon emission for (n,t)

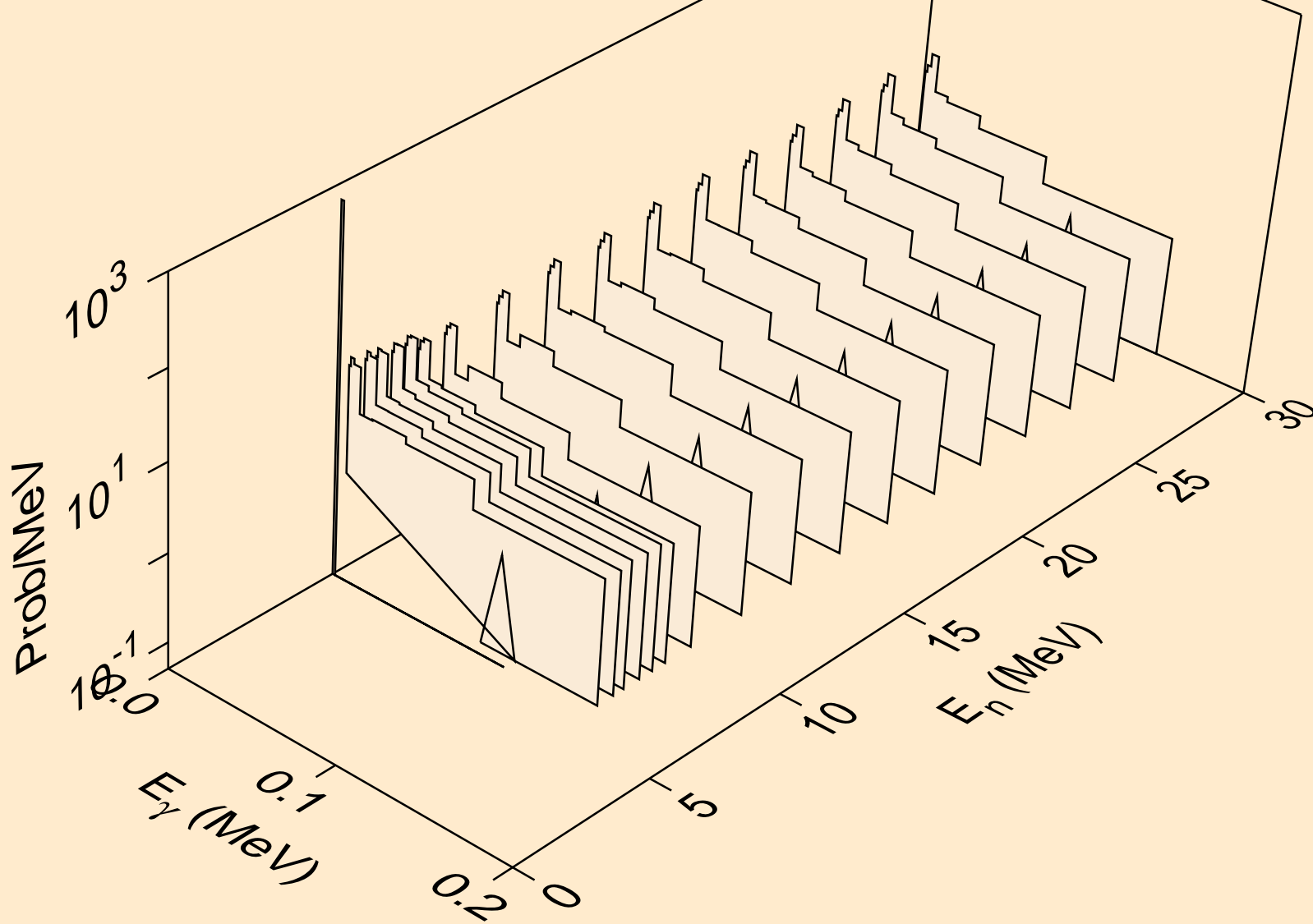

CN283 NEUTRON ACER TENDL-2019 LIBRARY; T=293.16K
Photon emission for (n,he3)

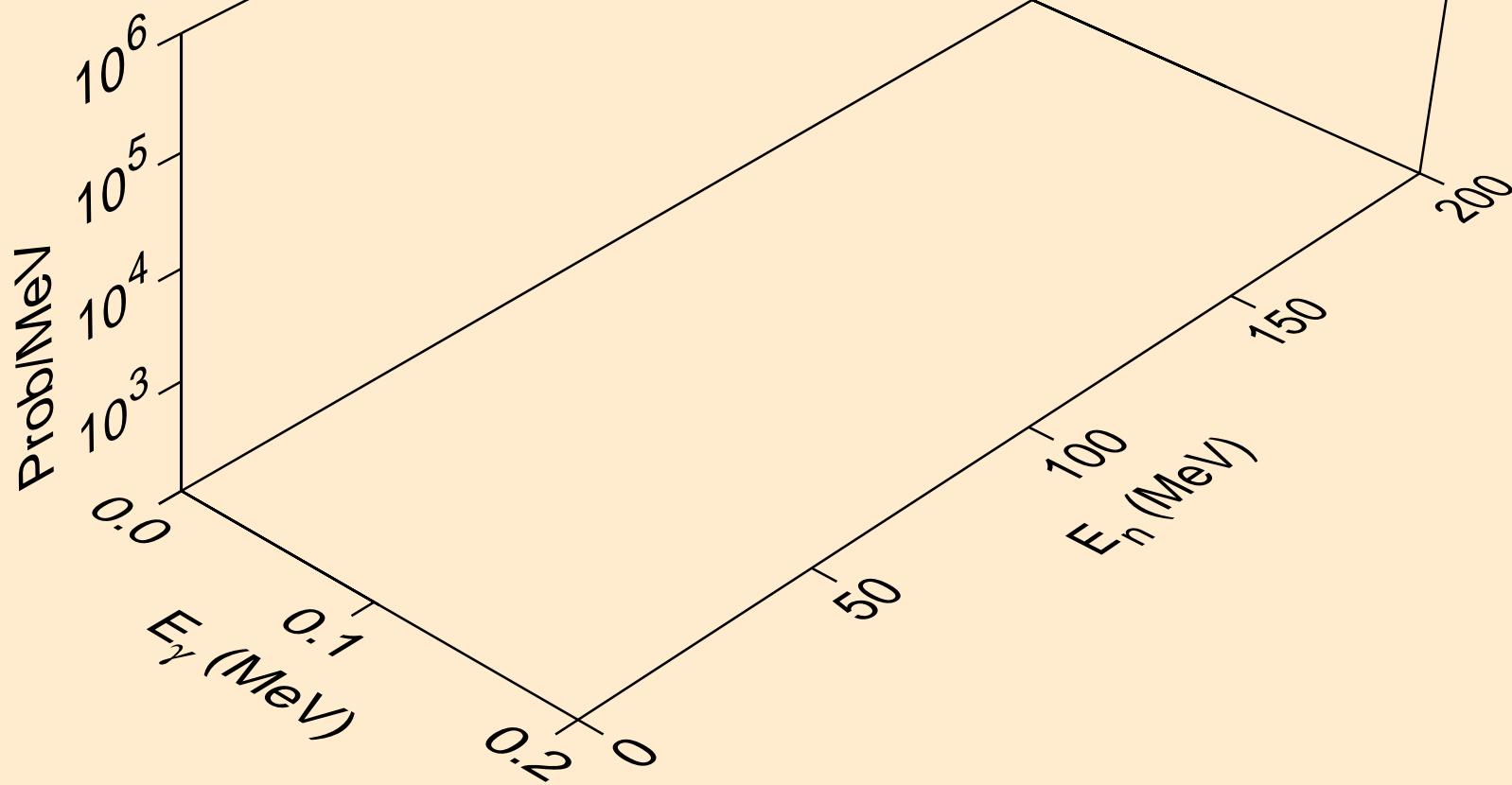

CN283 NEUTRON ACER TENDL-2019 LIBRARY; T=293.16K
Photon emission for (n,a)

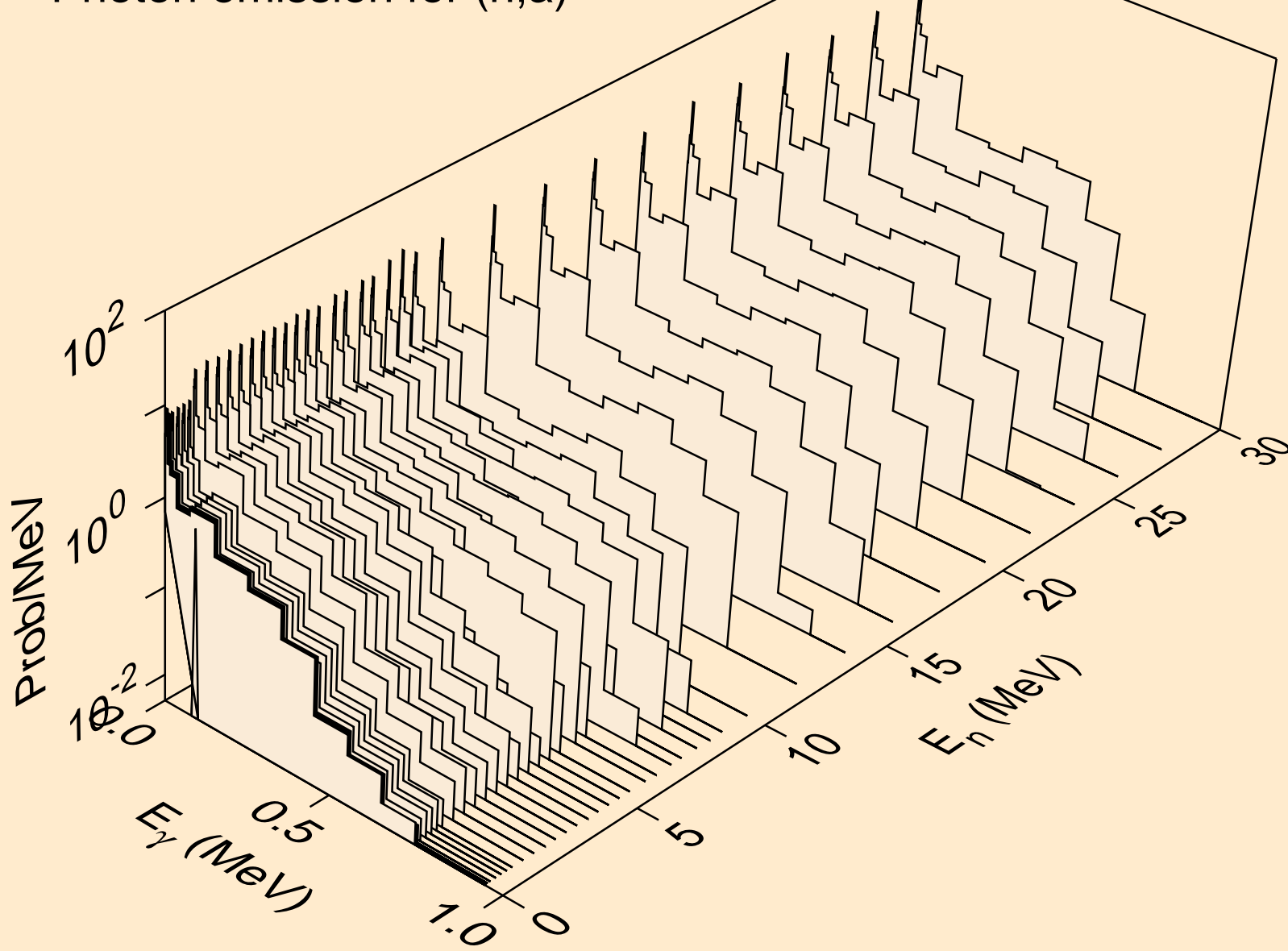

CN283 NEUTRON ACER TENDL-2019 LIBRARY; T=293.16K
Photon emission for (n,2a)

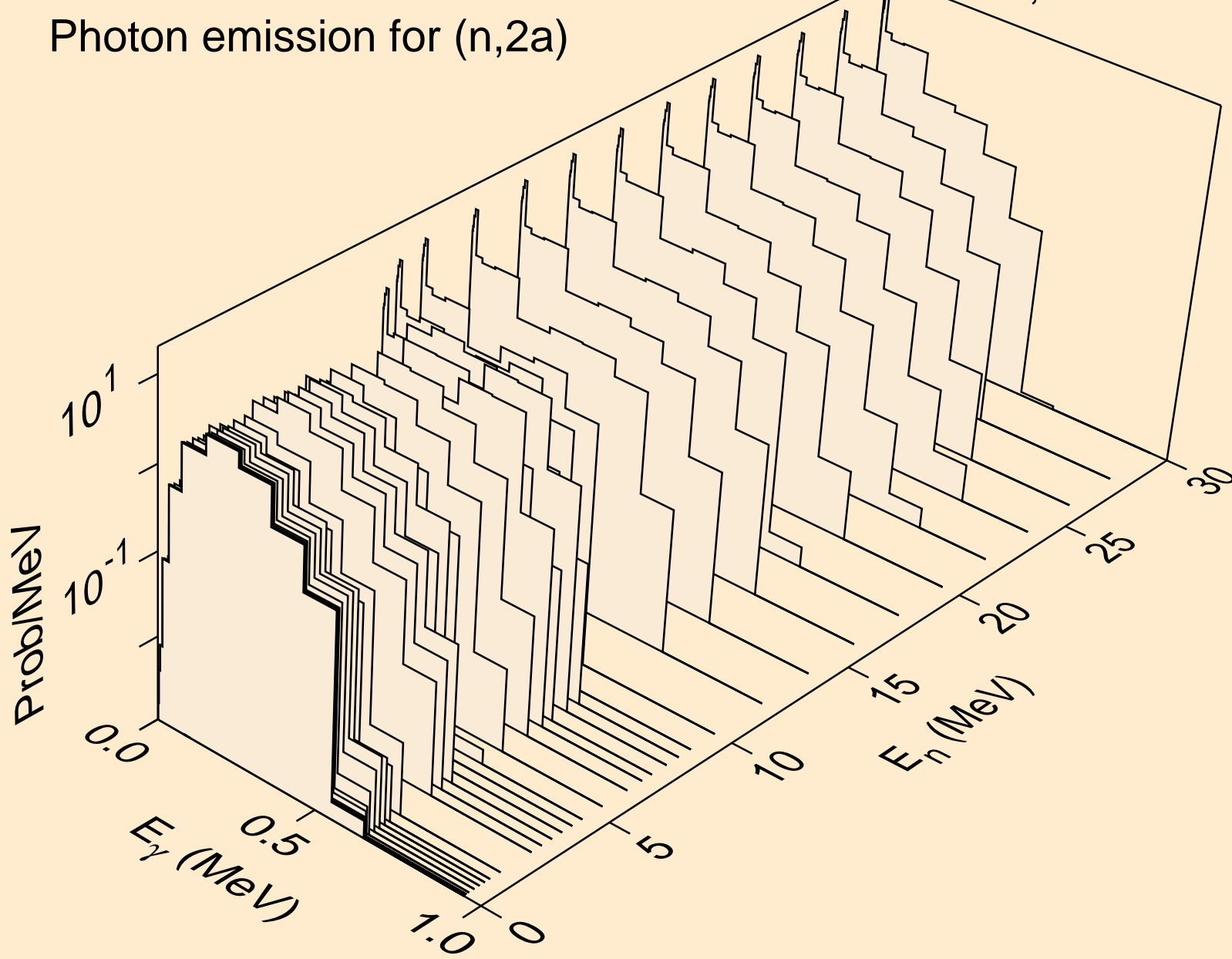

CN283 NEUTRON ACER TENDL-2019 LIBRARY; T=293.16K
Photon emission for (n,2p)

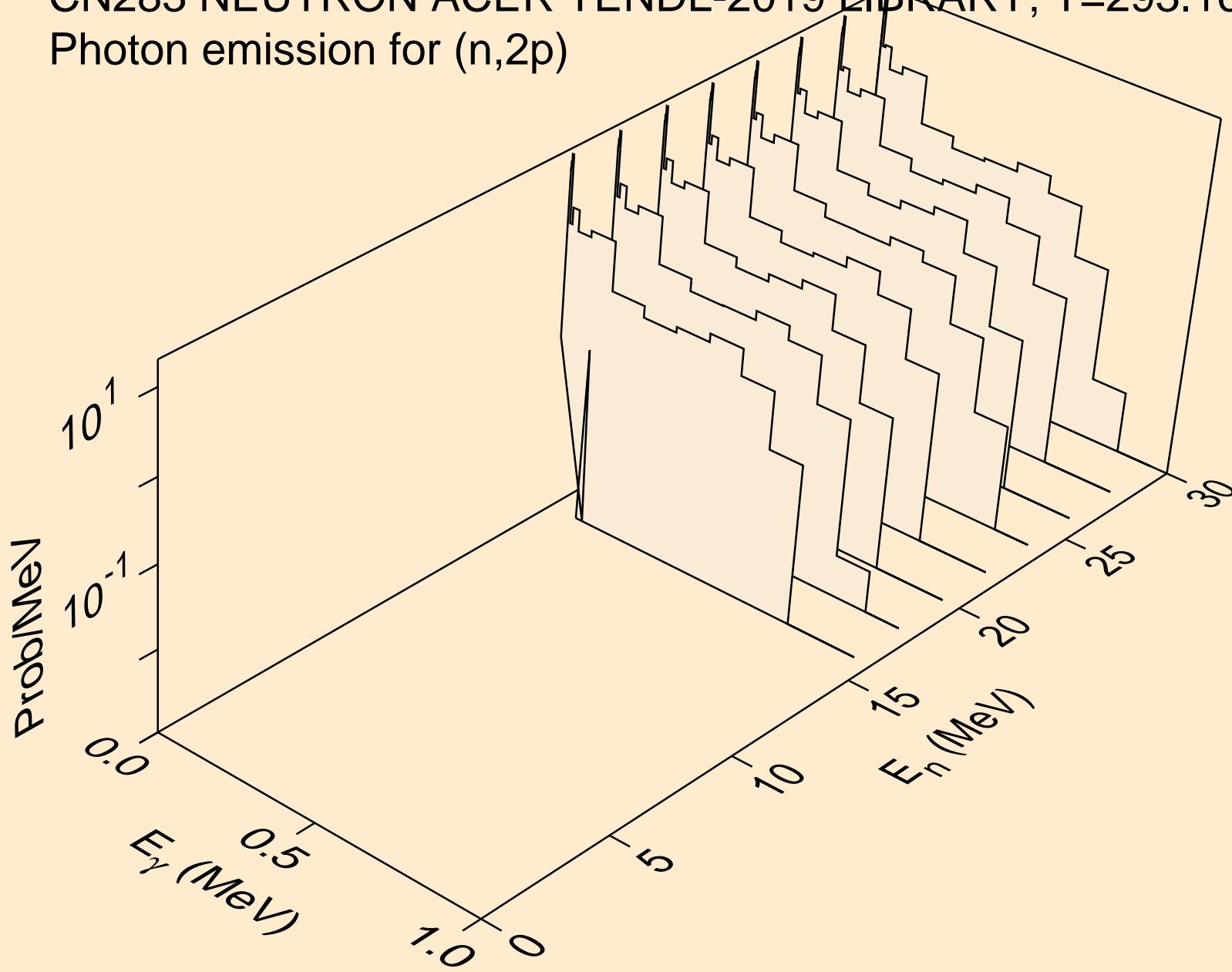

CN283 NEUTRON ACER TENDL-2019 LIBRARY; T=293.16K
thermal capture photon spectrum

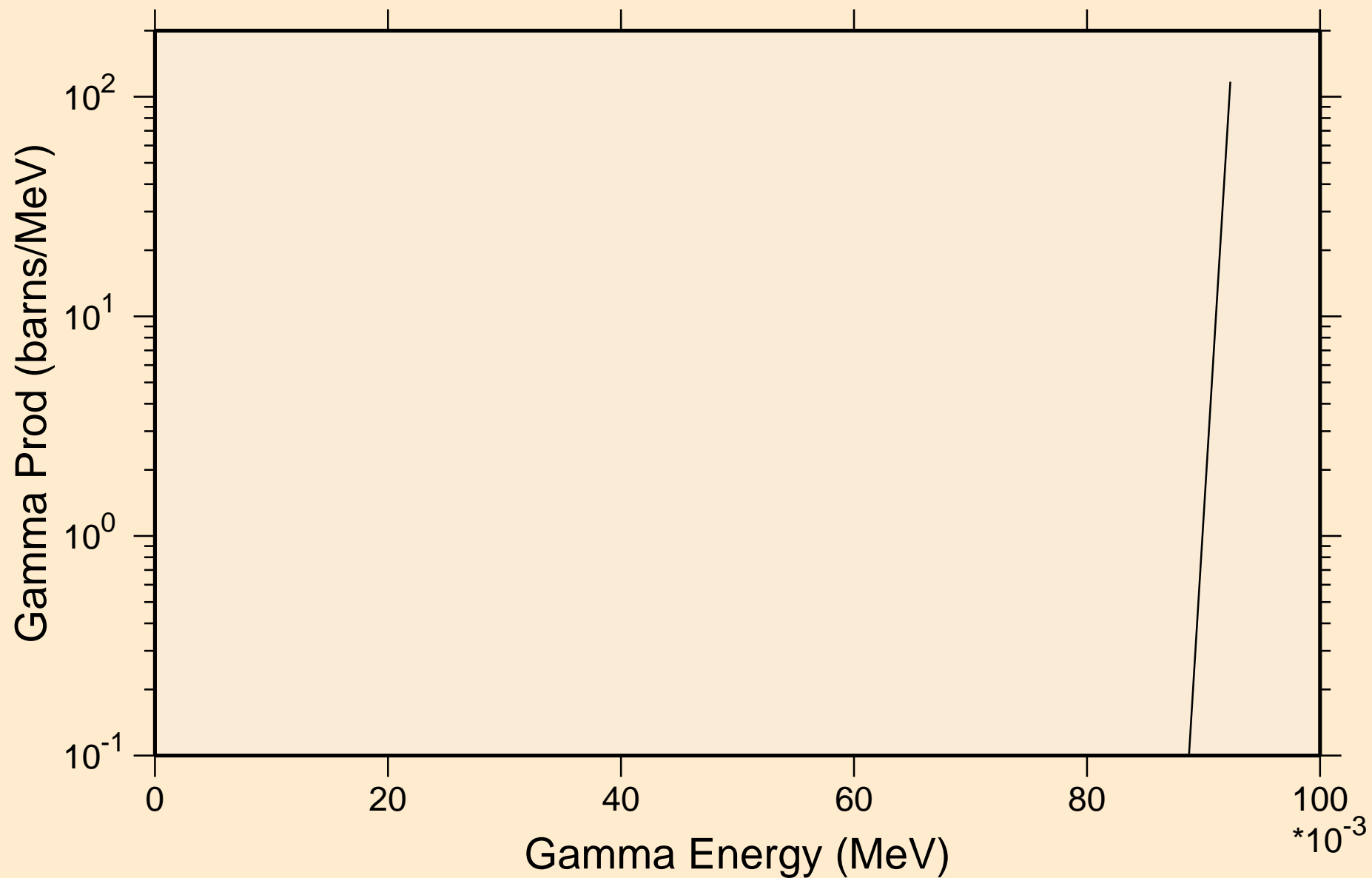

CN283 NEUTRON ACER TENDL-2019 LIBRARY; T=293.16K
14 MeV photon spectrum

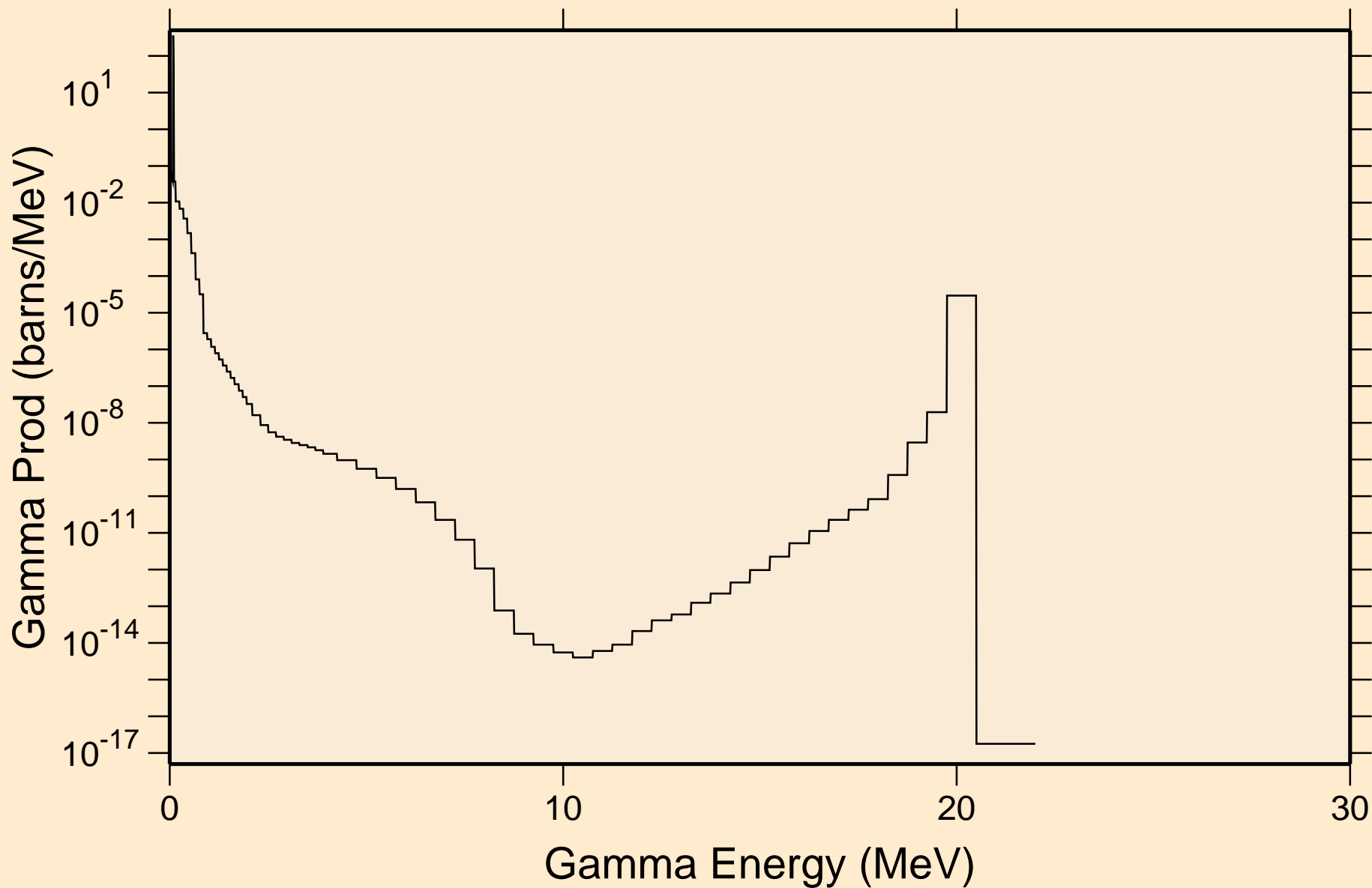

CN283 NEUTRON ACER TENDL-2019 LIBRARY; T=293.16K

Particle heating contributions

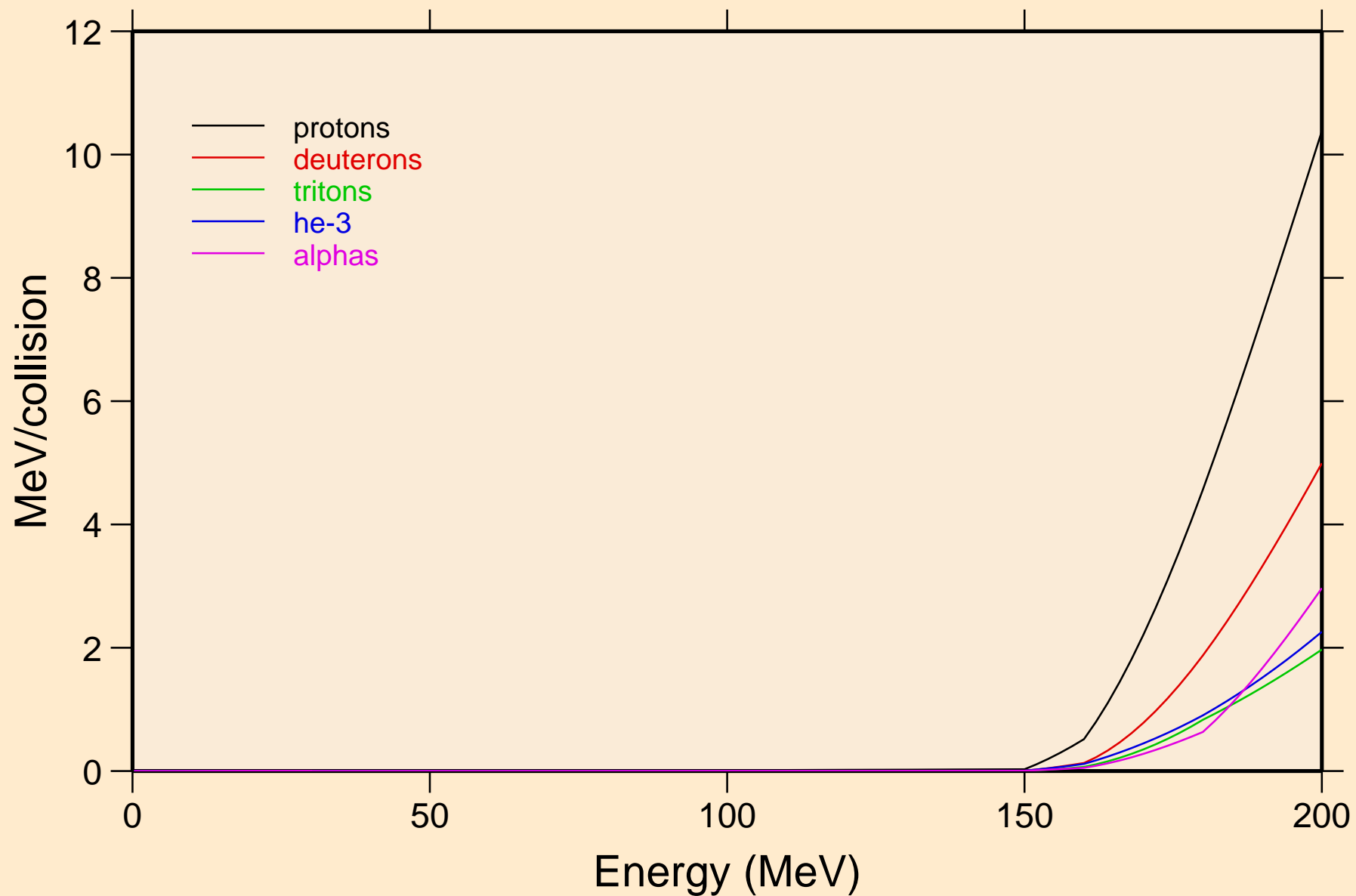

CN283 NEUTRON ACER TENDL-2019 LIBRARY; T=293.16K
Recoil Heating

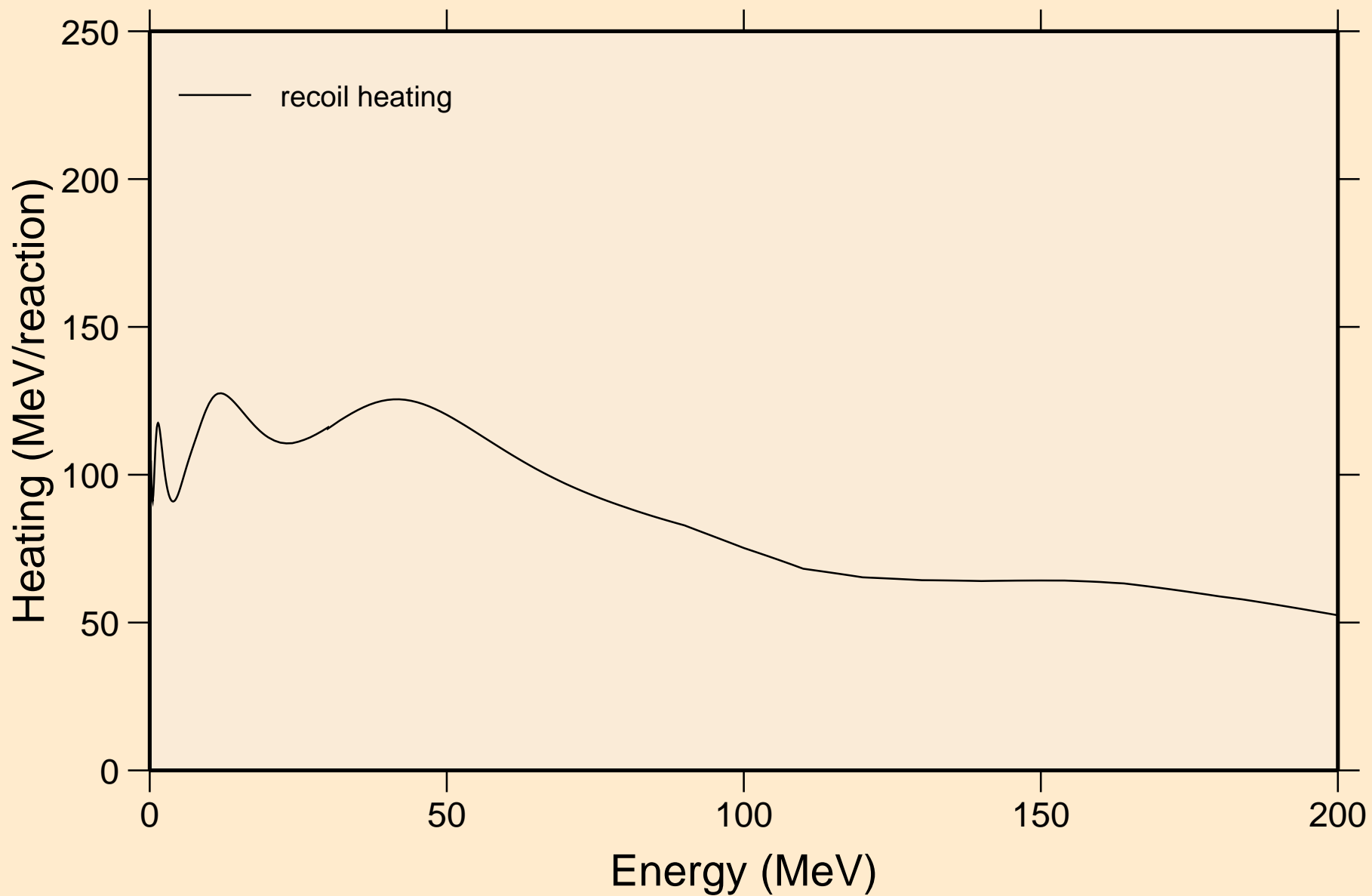

CN283 NEUTRON ACER TENDL-2019 LIBRARY; T=293.16K

Particle production cross sections

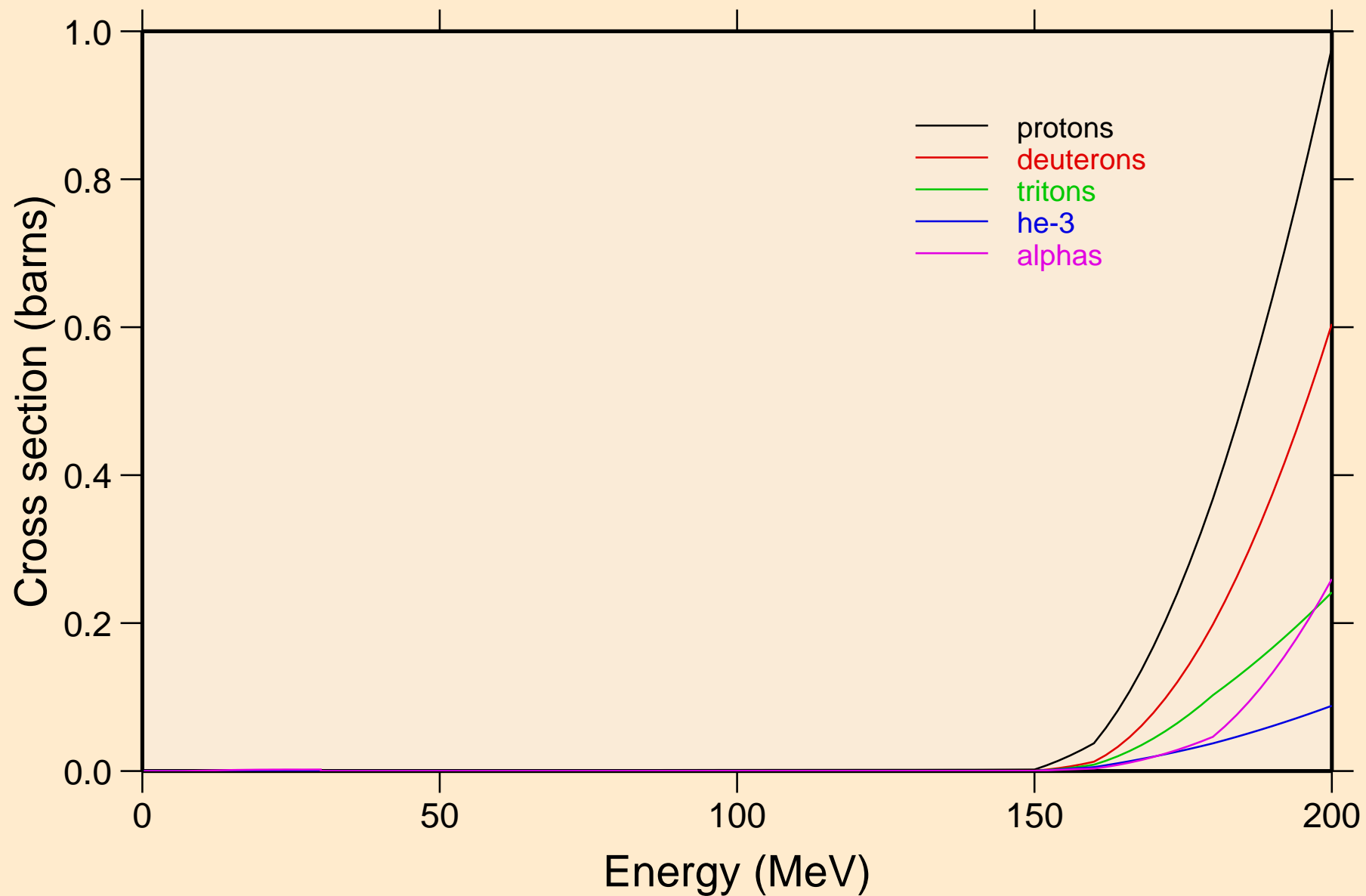

CN283 NEUTRON ACER TENDL-2019 LIBRARY; T=293.16K
protons from (n,x)

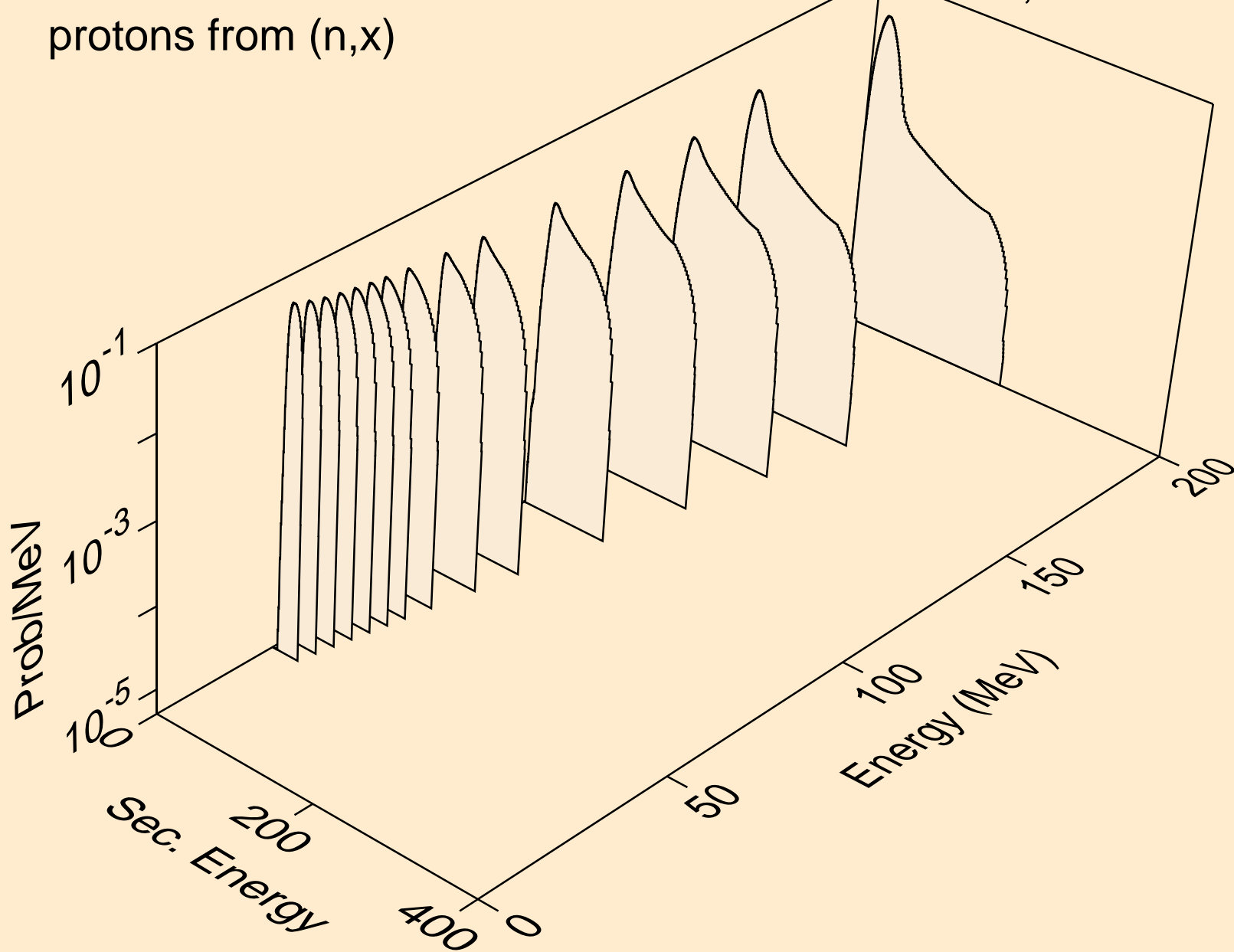

CN283 NEUTRON ACER TENDL-2019 LIBRARY; T=293.16K
protons from (n,n*)p

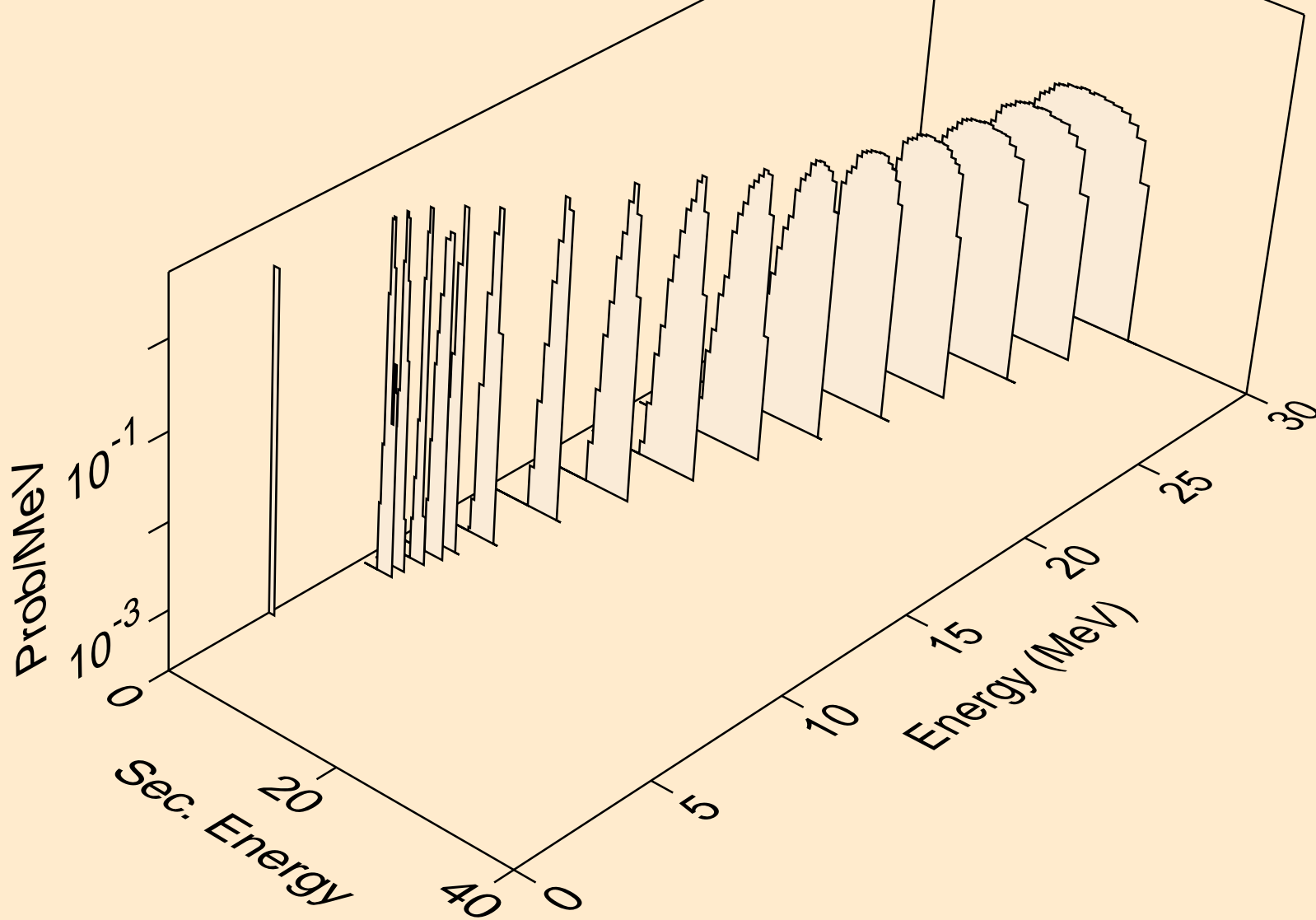

CN283 NEUTRON ACER TENDL-2019 LIBRARY; T=293.16K
protons from (n,p)

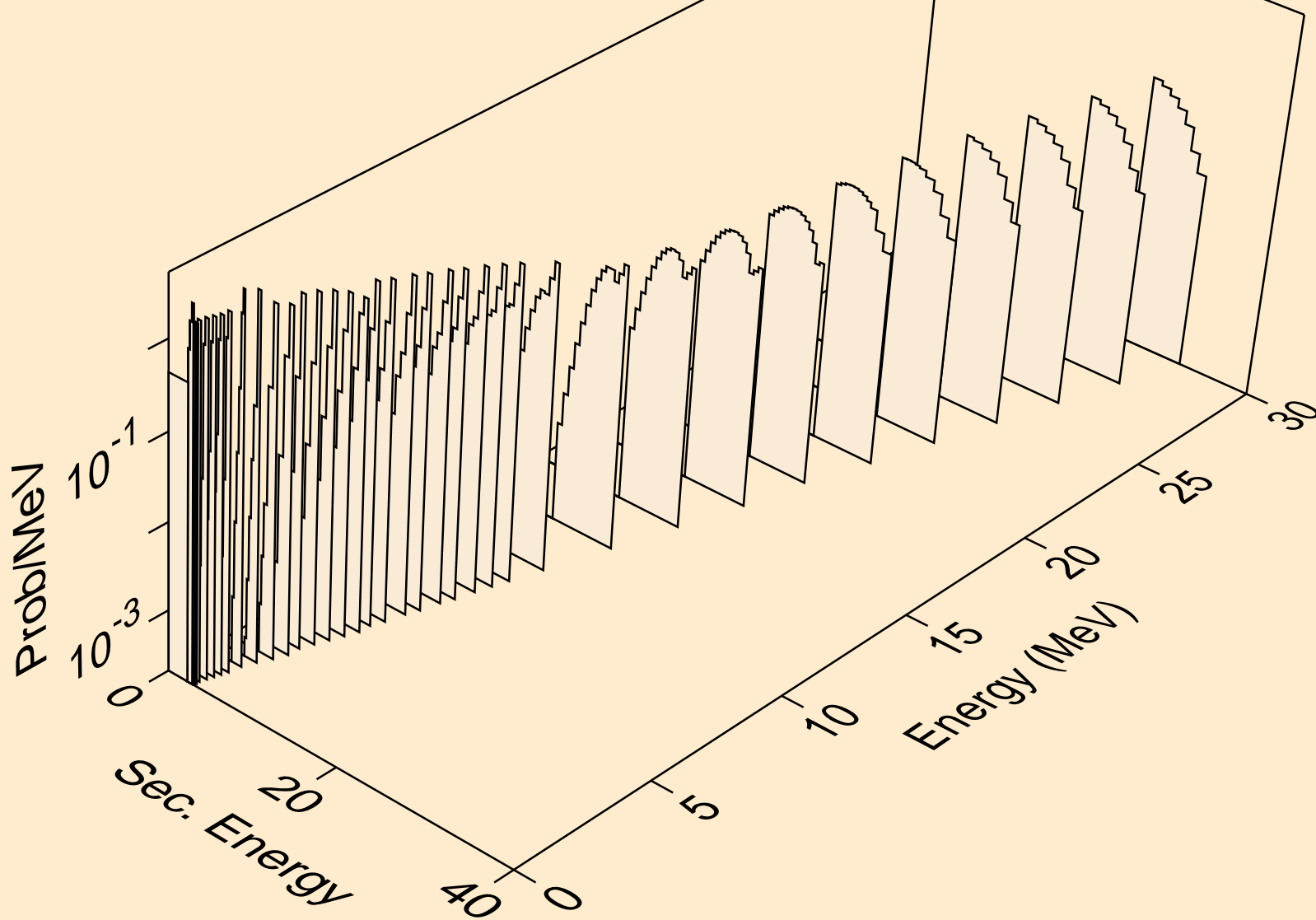

CN283 NEUTRON ACER TENDL-2019 LIBRARY; T=293.16K
protons from (n,2p)

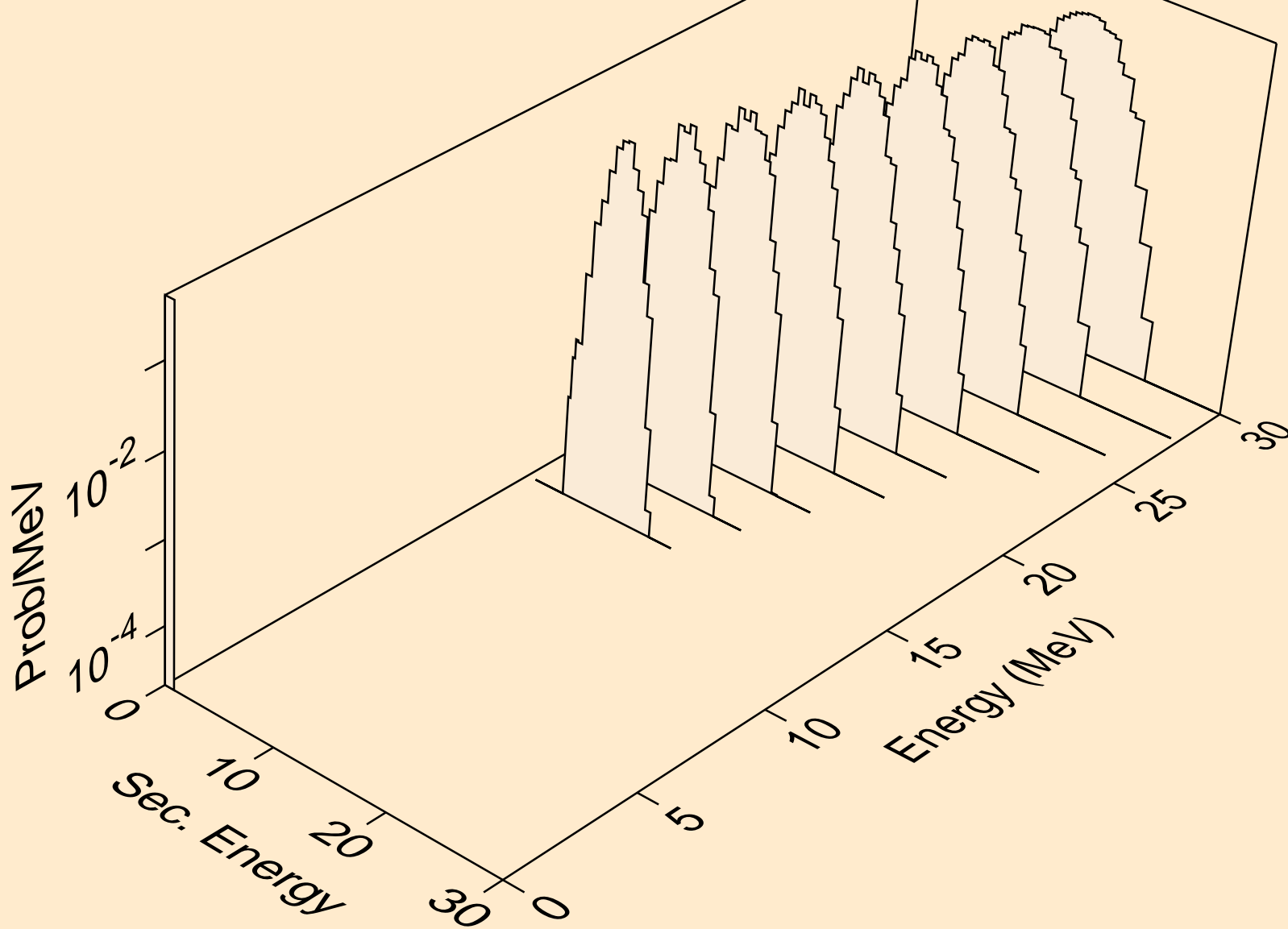

CN283 NEUTRON ACER TENDL-2019 LIBRARY; T=293.16K
deuterons from (n,x)

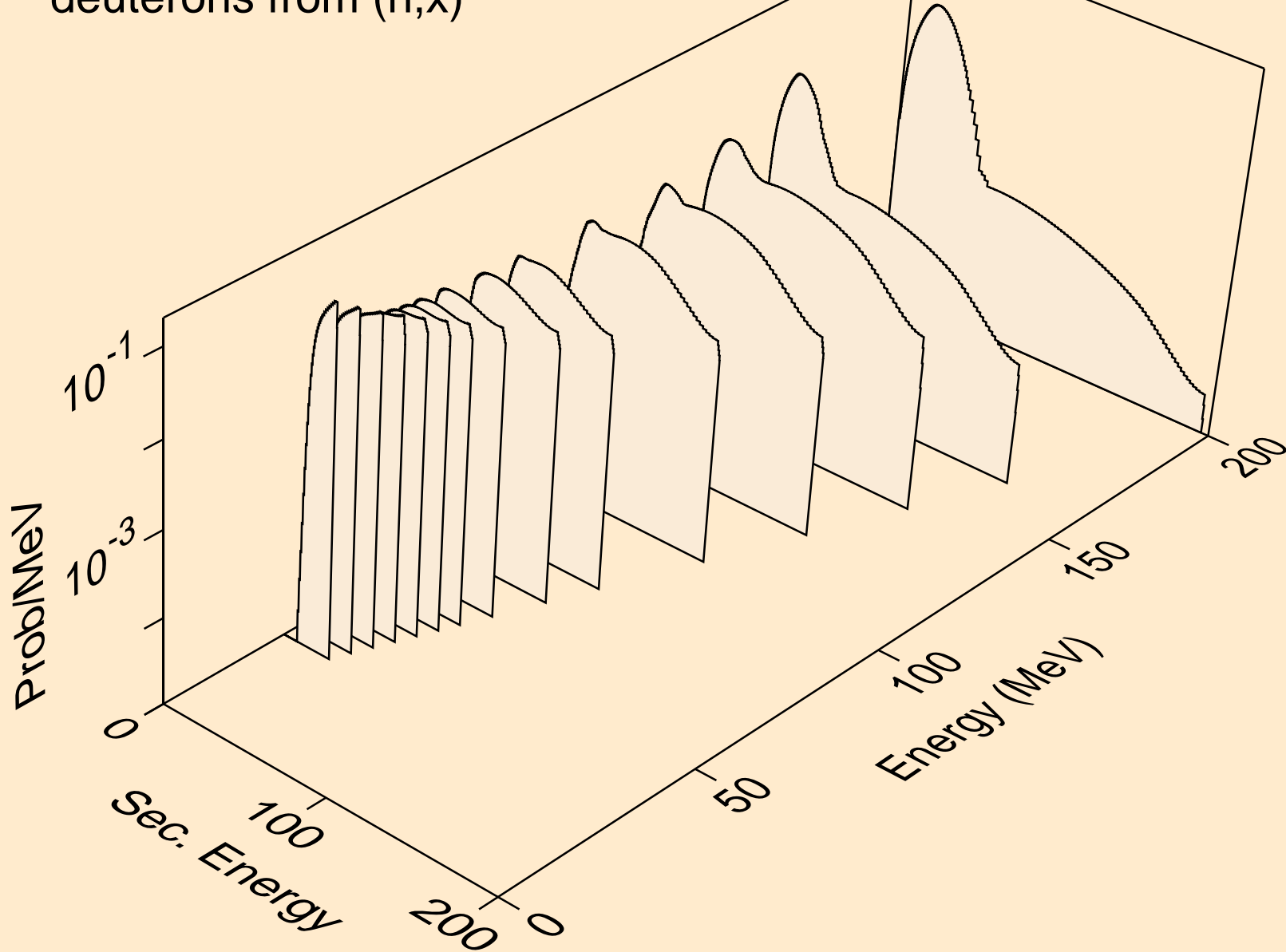

CN283 NEUTRON ACER TENDL-2019 LIBRARY; T=293.16K
deuterons from (n,d)

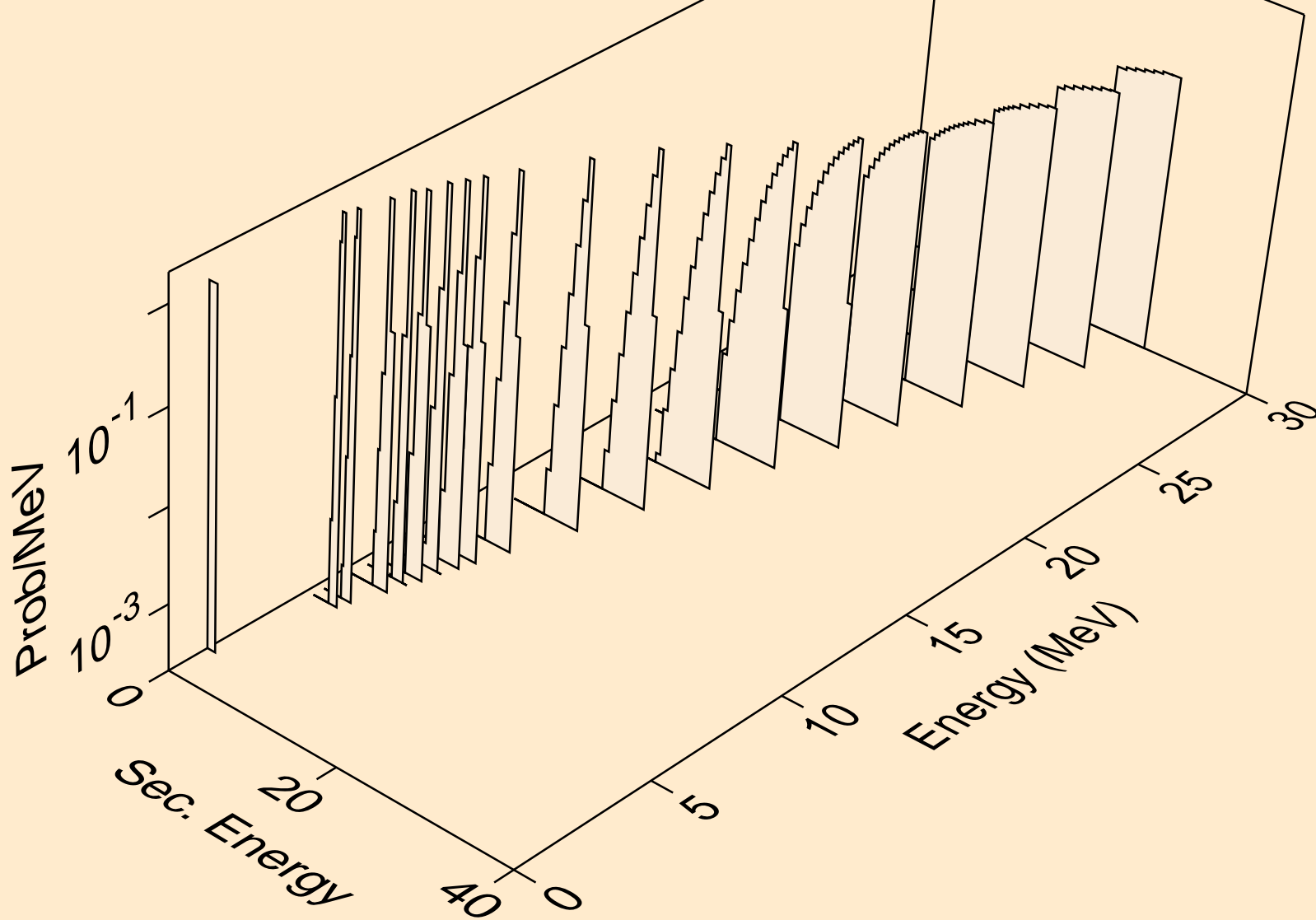

CN283 NEUTRON ACER TENDL-2019 LIBRARY; T=293.16K
tritons from (n,x)

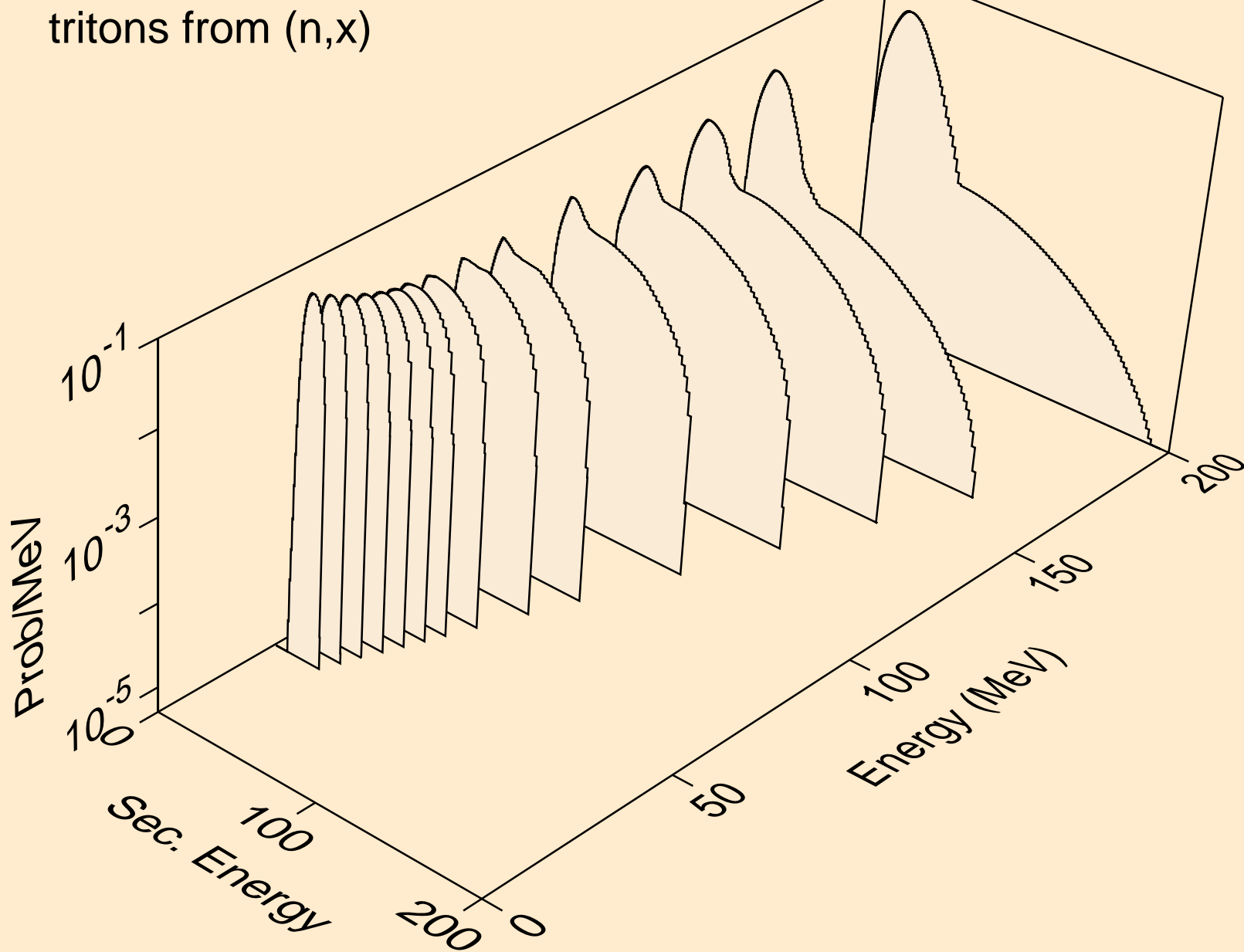

CN283 NEUTRON ACER TENDL-2019 LIBRARY; T=293.16K
tritons from (n,t)

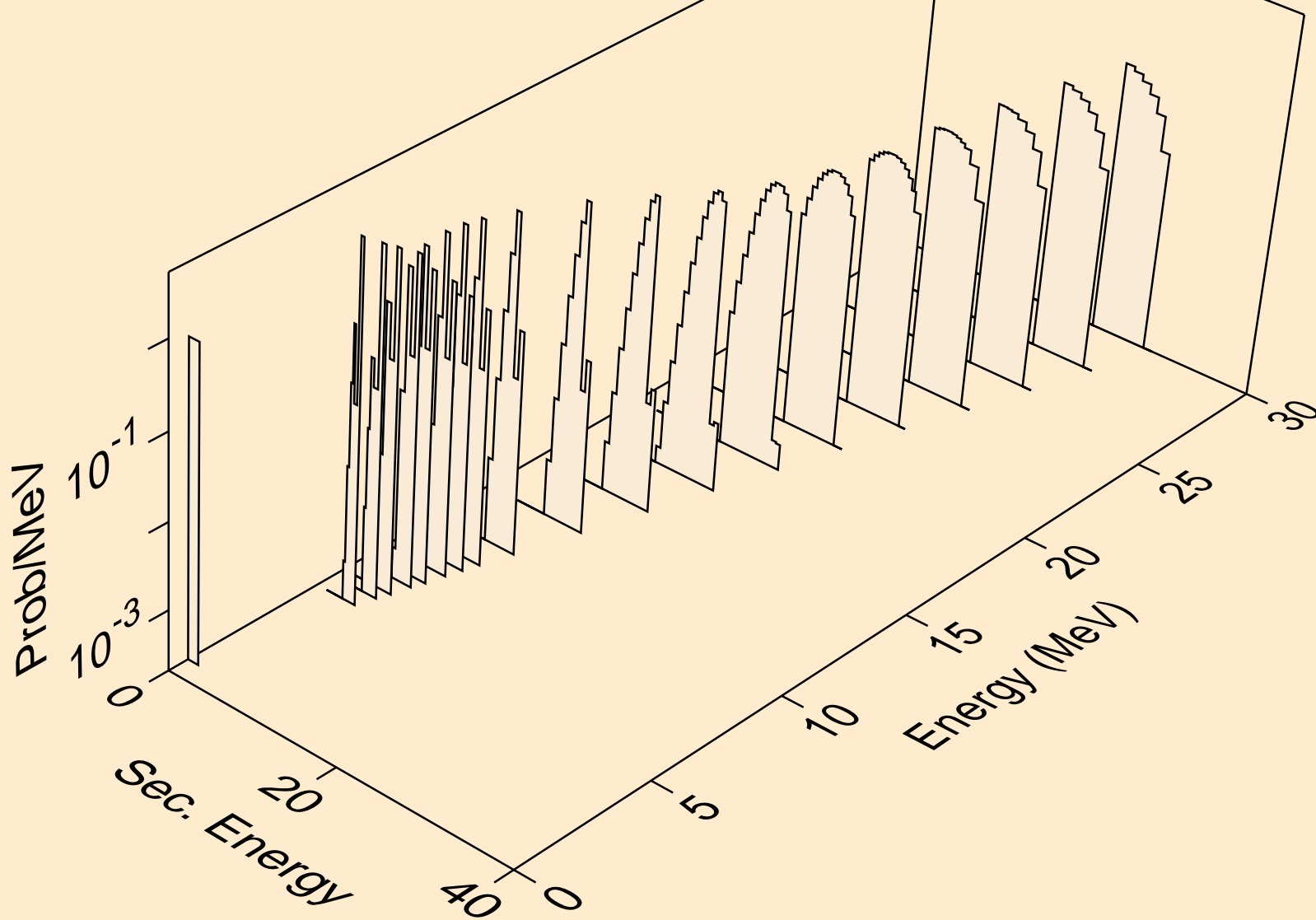

CN283 NEUTRON ACER TENDL-2019 LIBRARY; T=293.16K
he3s from (n,x)

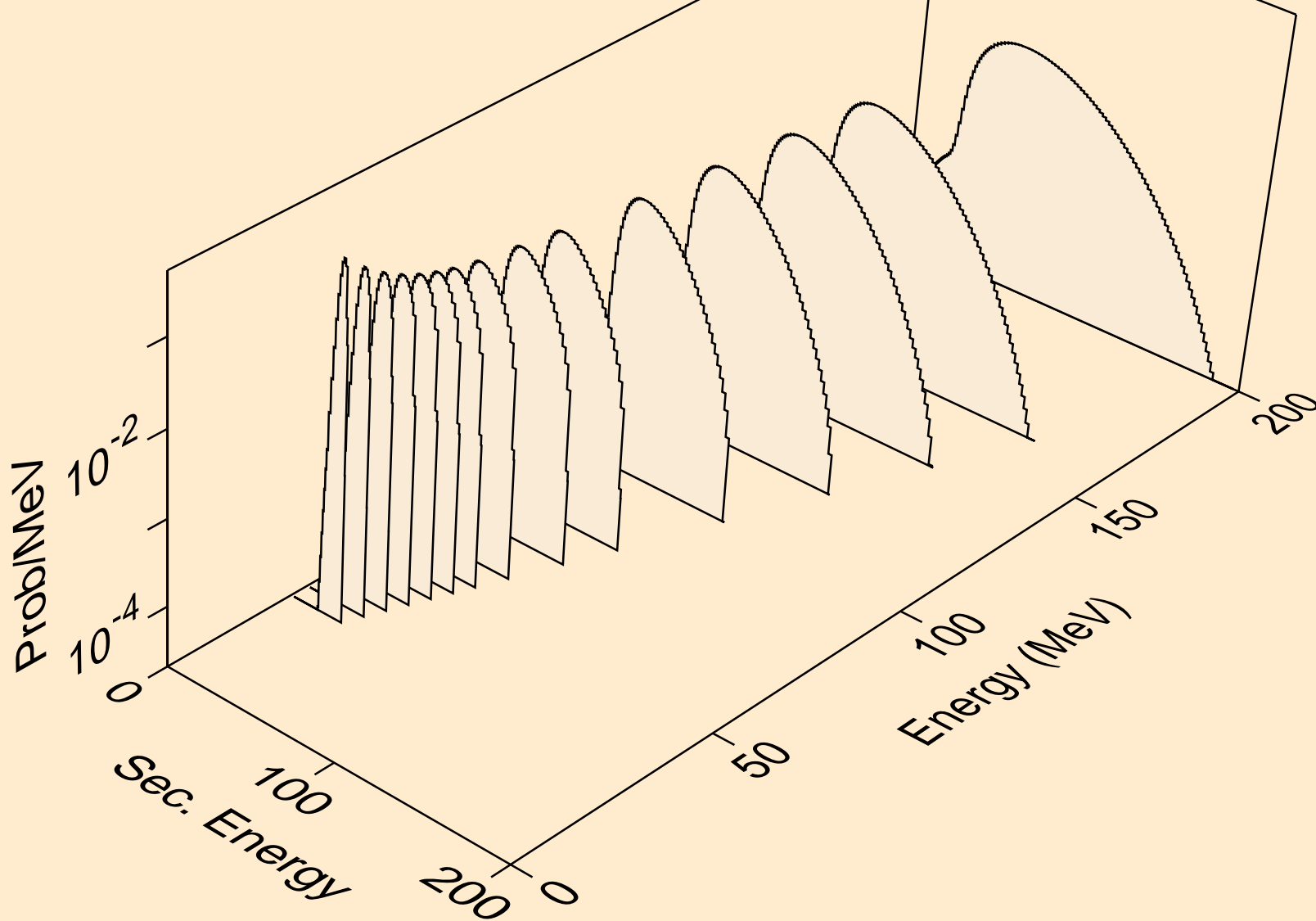

CN283 NEUTRON ACER TENDL-2019 LIBRARY; T=293.16K
he3s from (n,he3)

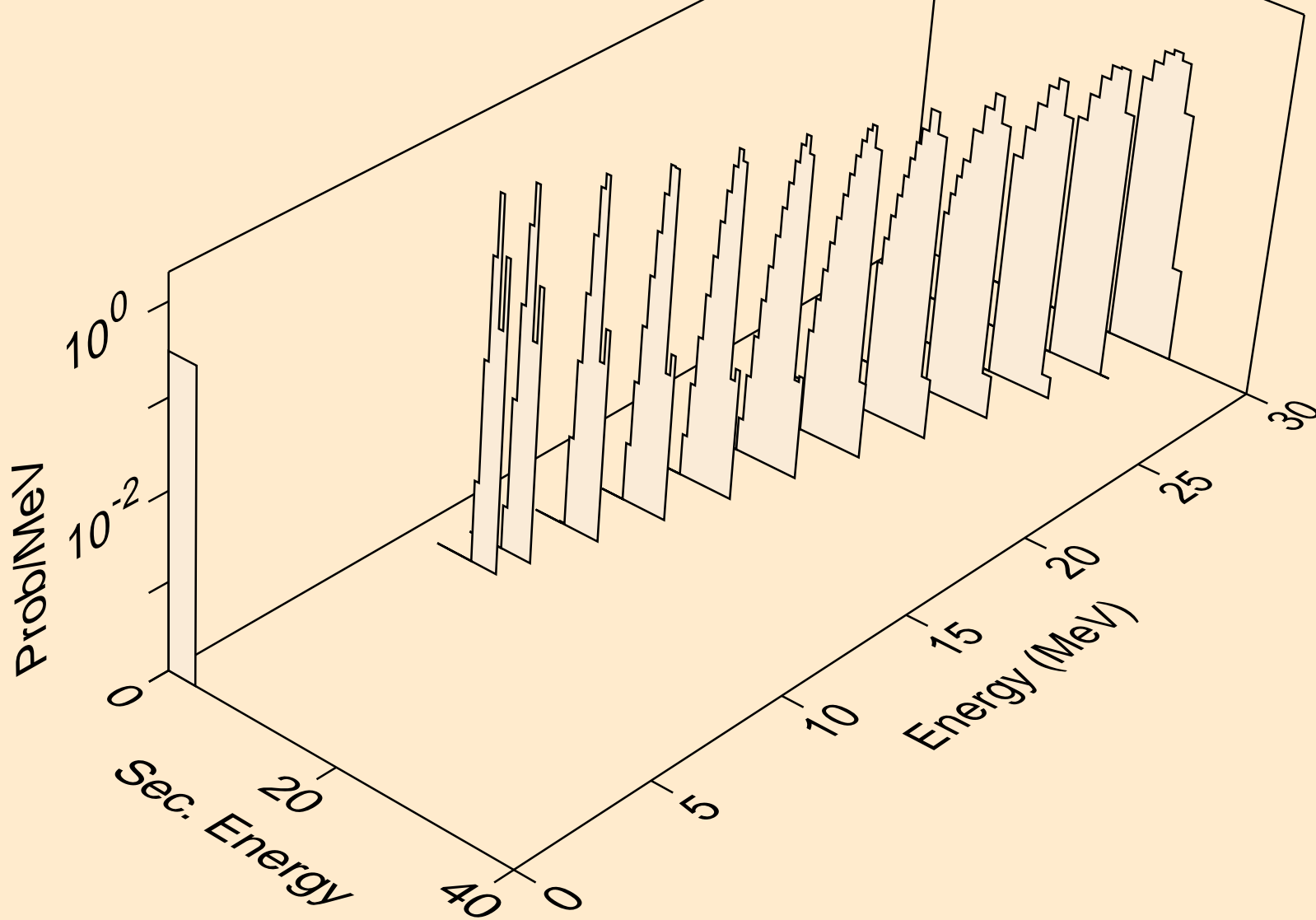

CN283 NEUTRON ACER TENDL-2019 LIBRARY; T=293.16K
alphas from (n,x)

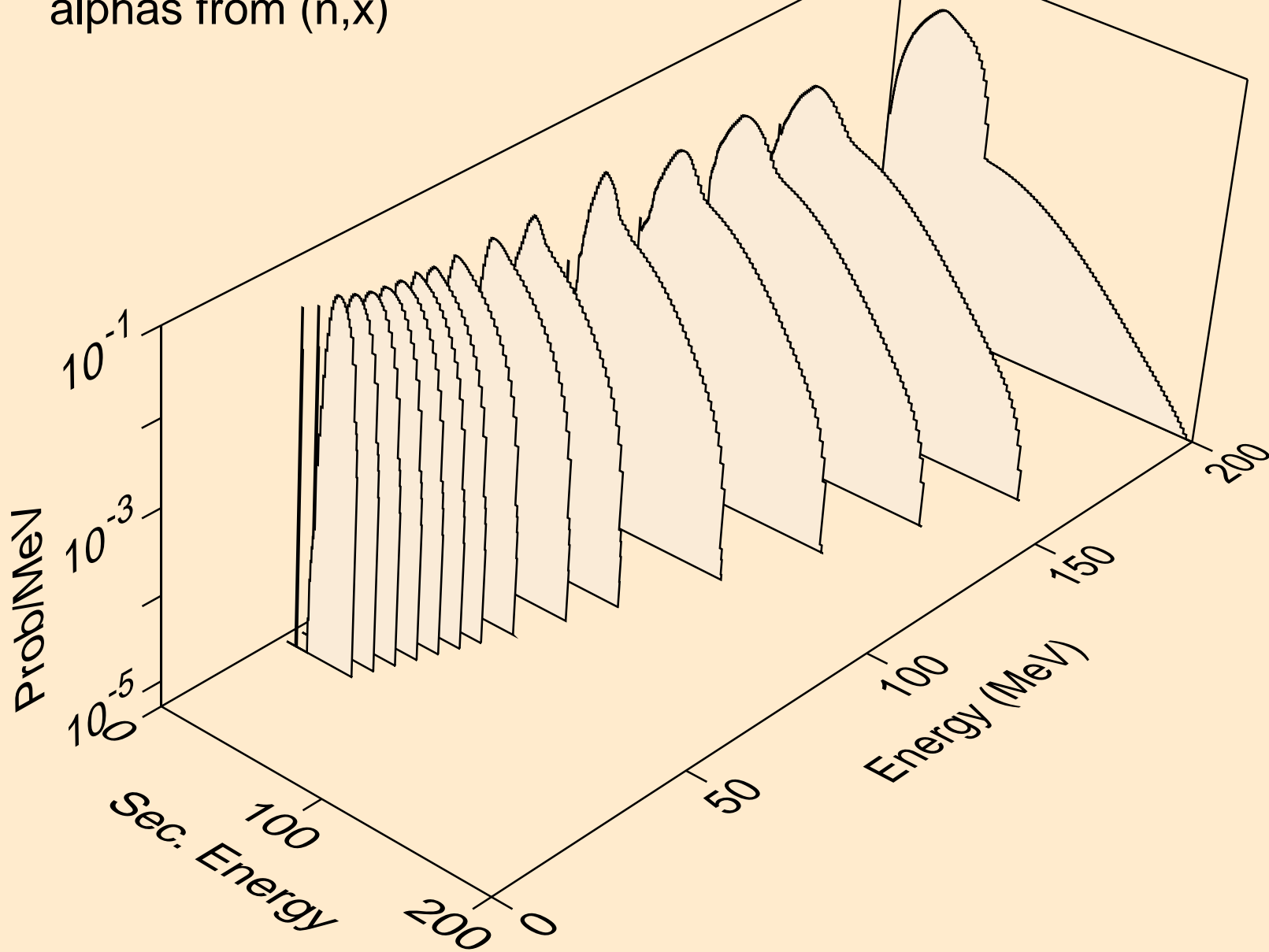

CN283 NEUTRON ACER TENDL-2019 LIBRARY; T=293.16K
alphas from (n,2n)a

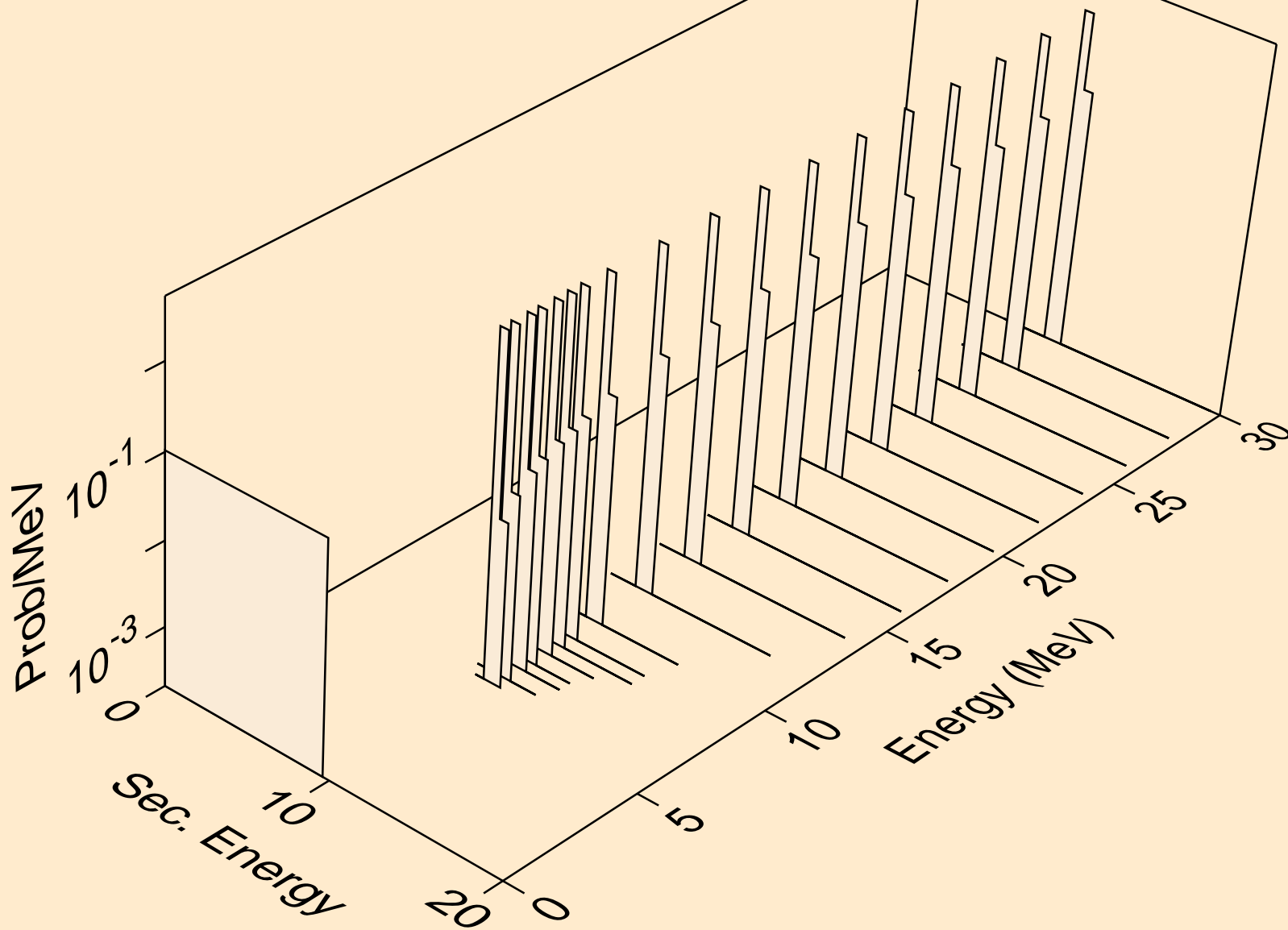

CN283 NEUTRON ACER TENDL-2019 LIBRARY; T=293.16K
alphas from (n,2n)2a

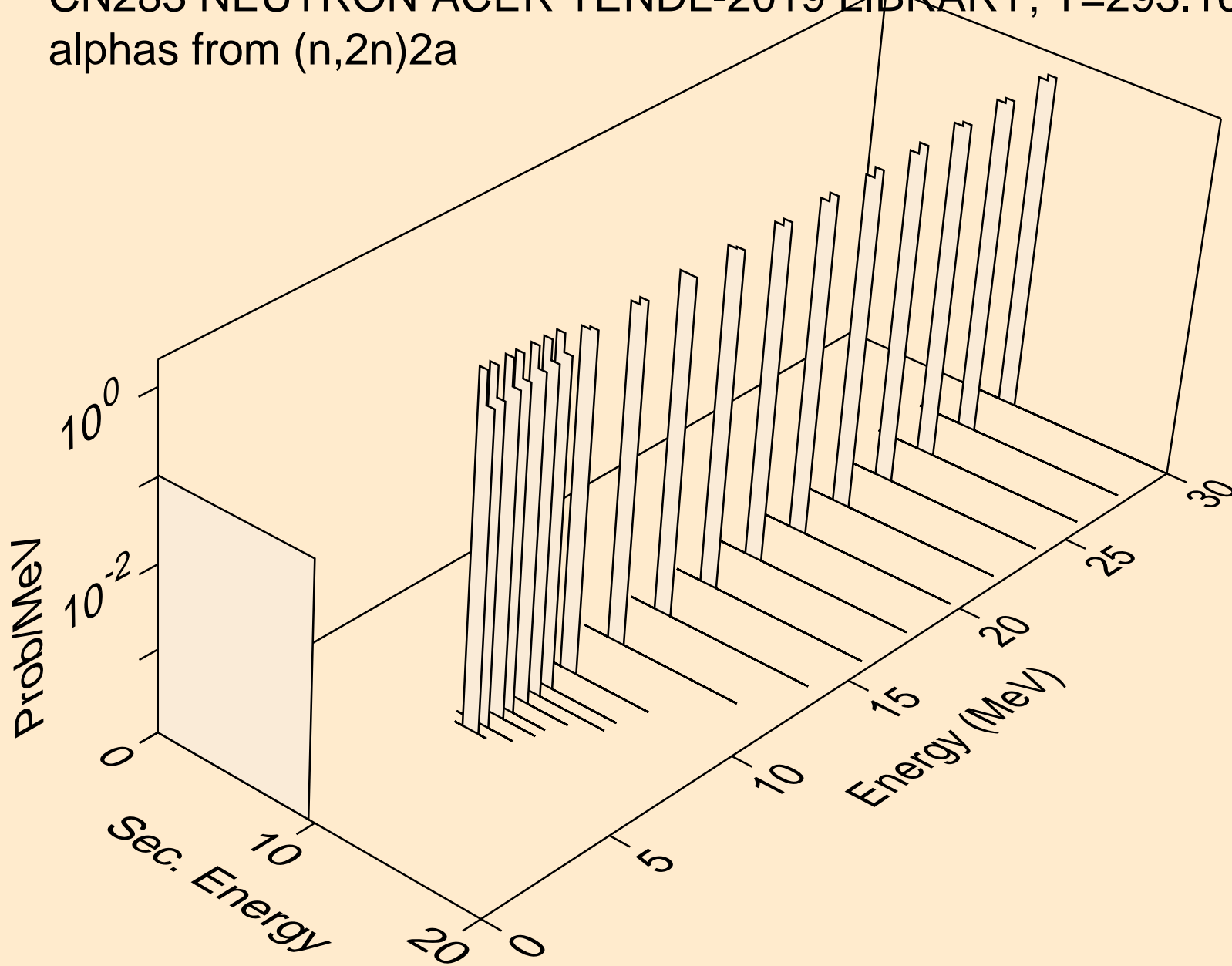

CN283 NEUTRON ACER TENDL-2019 LIBRARY; T=293.16K
alphas from (n,a)

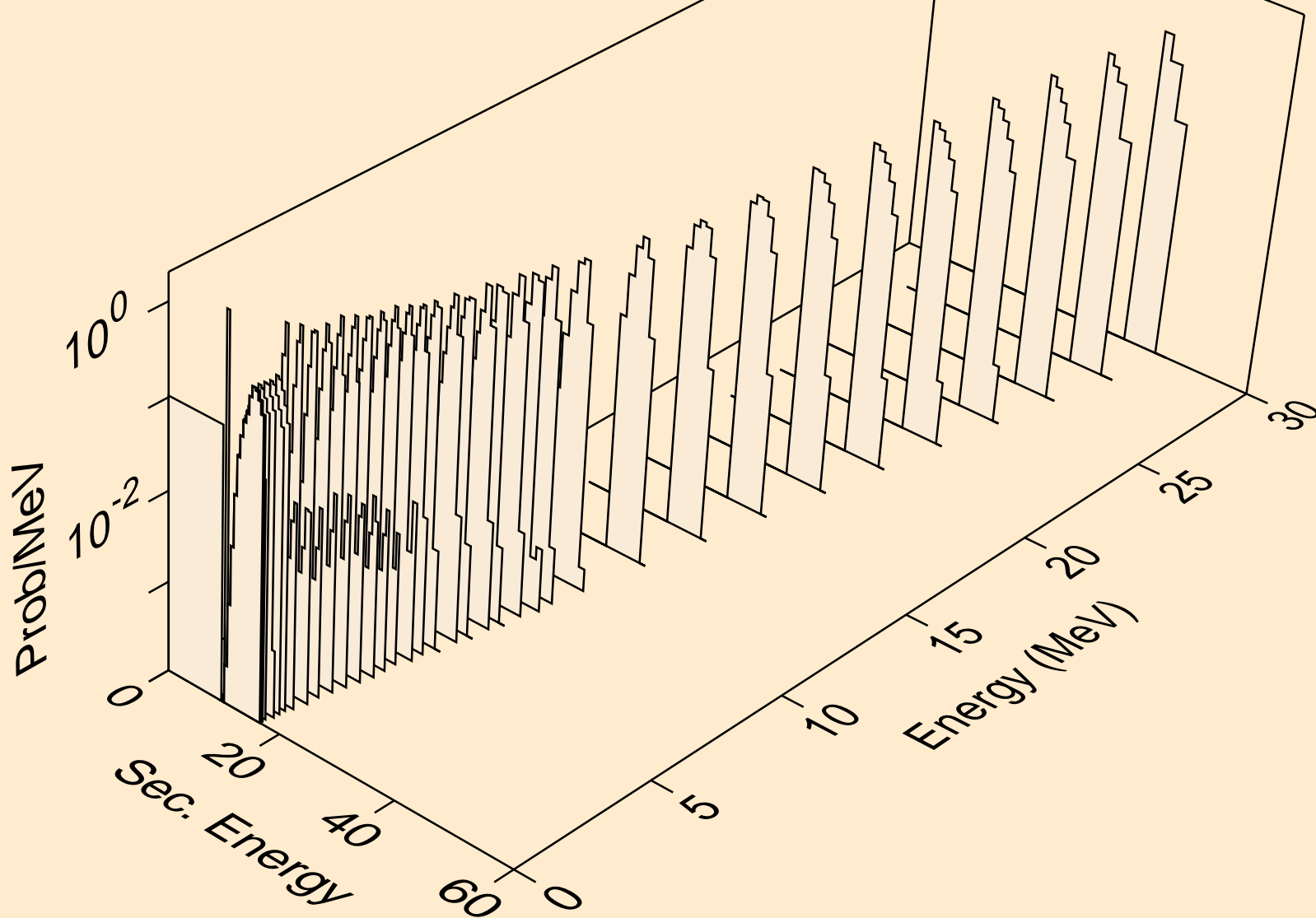

CN283 NEUTRON ACER TENDL-2019 LIBRARY; T=293.16K
alphas from (n,2a)

