

DB261 NEUTRON ACER TENDL-2019 LIBRARY; T=293.16K  
Principal cross sections

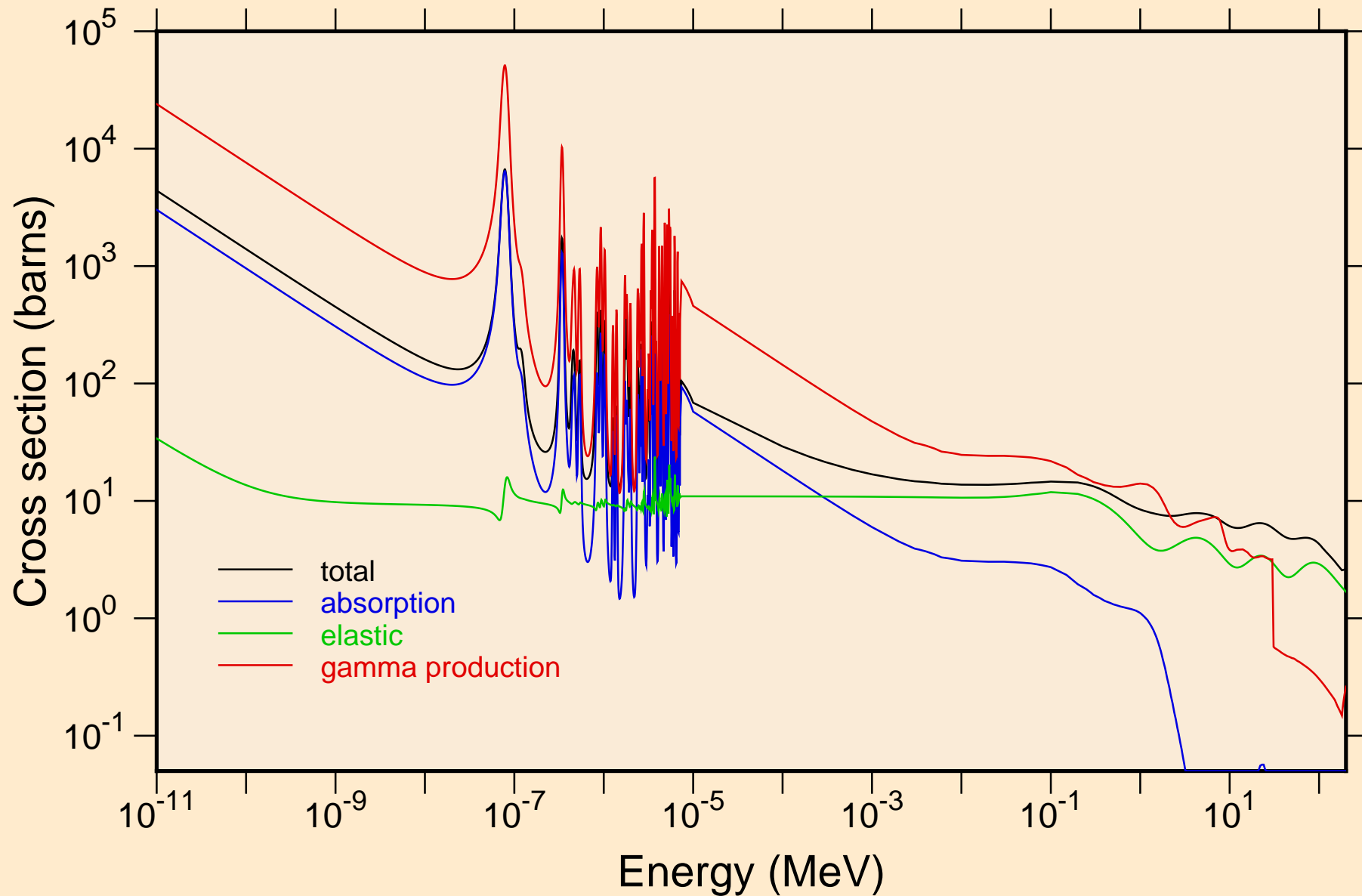

DB261 NEUTRON ACER TENDL-2019 LIBRARY; T=293.16K  
resonance total cross section

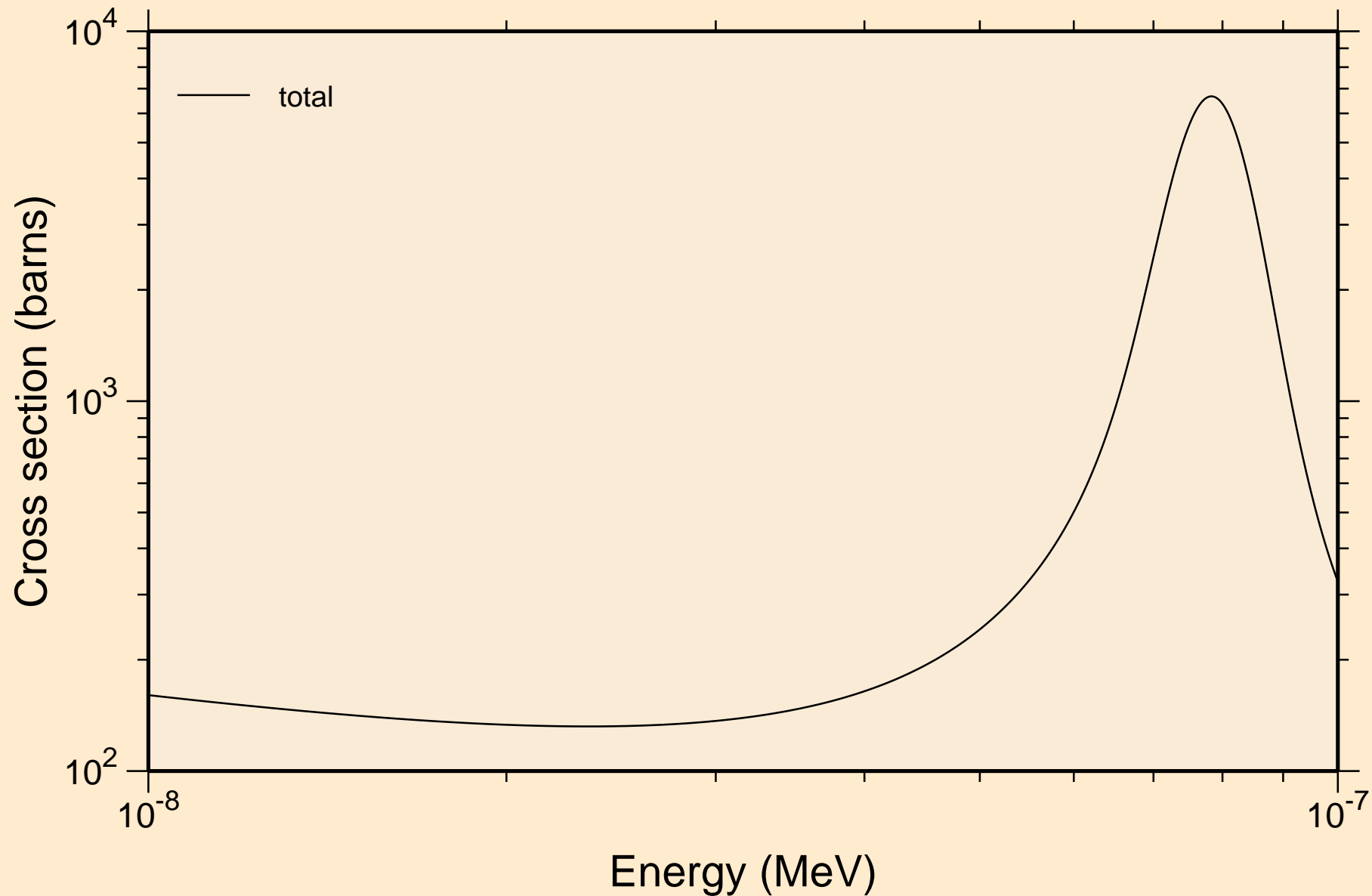

DB261 NEUTRON ACER TENDL-2019 LIBRARY; T=293.16K  
resonance total cross section

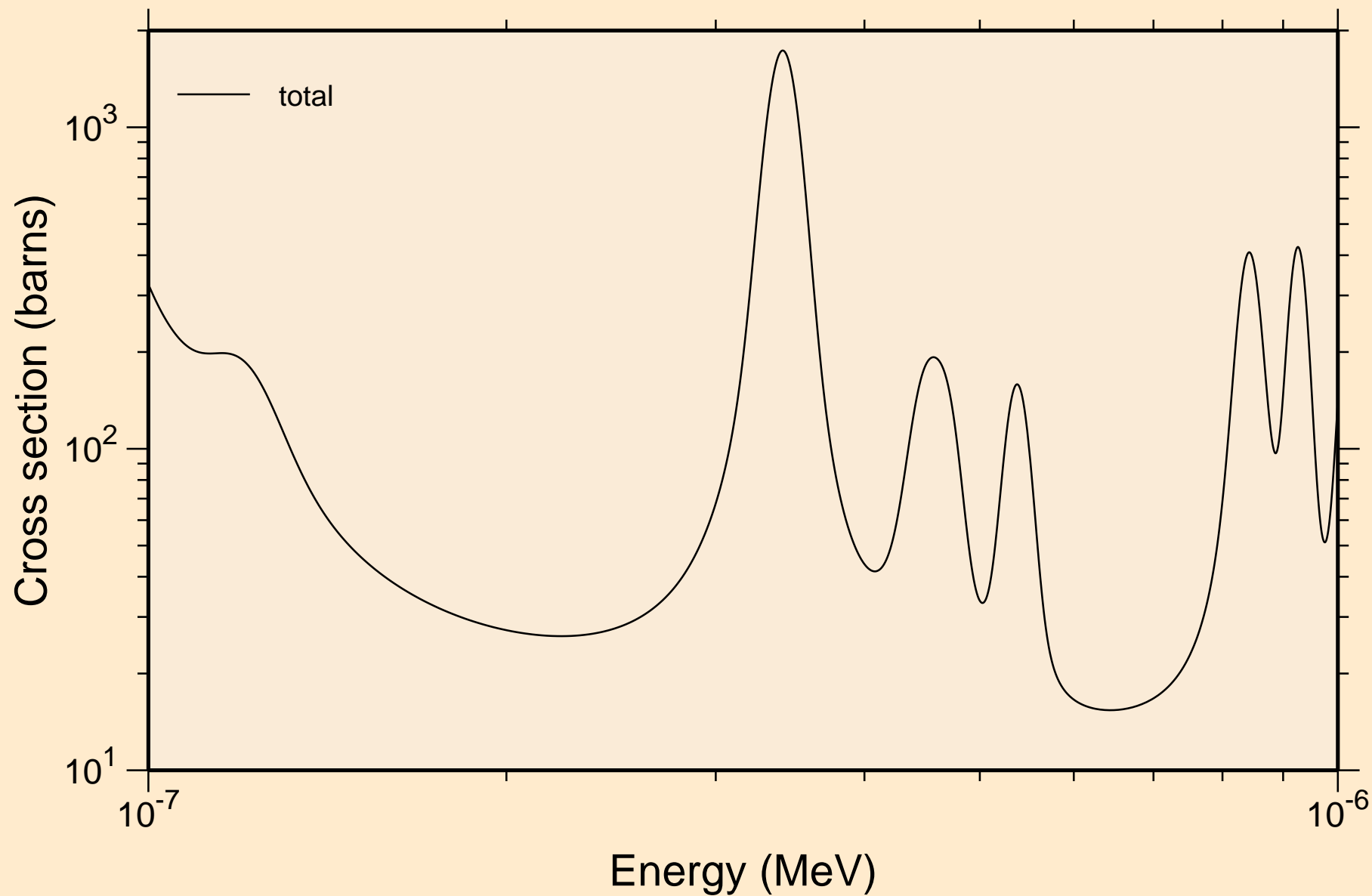

DB261 NEUTRON ACER TENDL-2019 LIBRARY; T=293.16K  
resonance total cross section

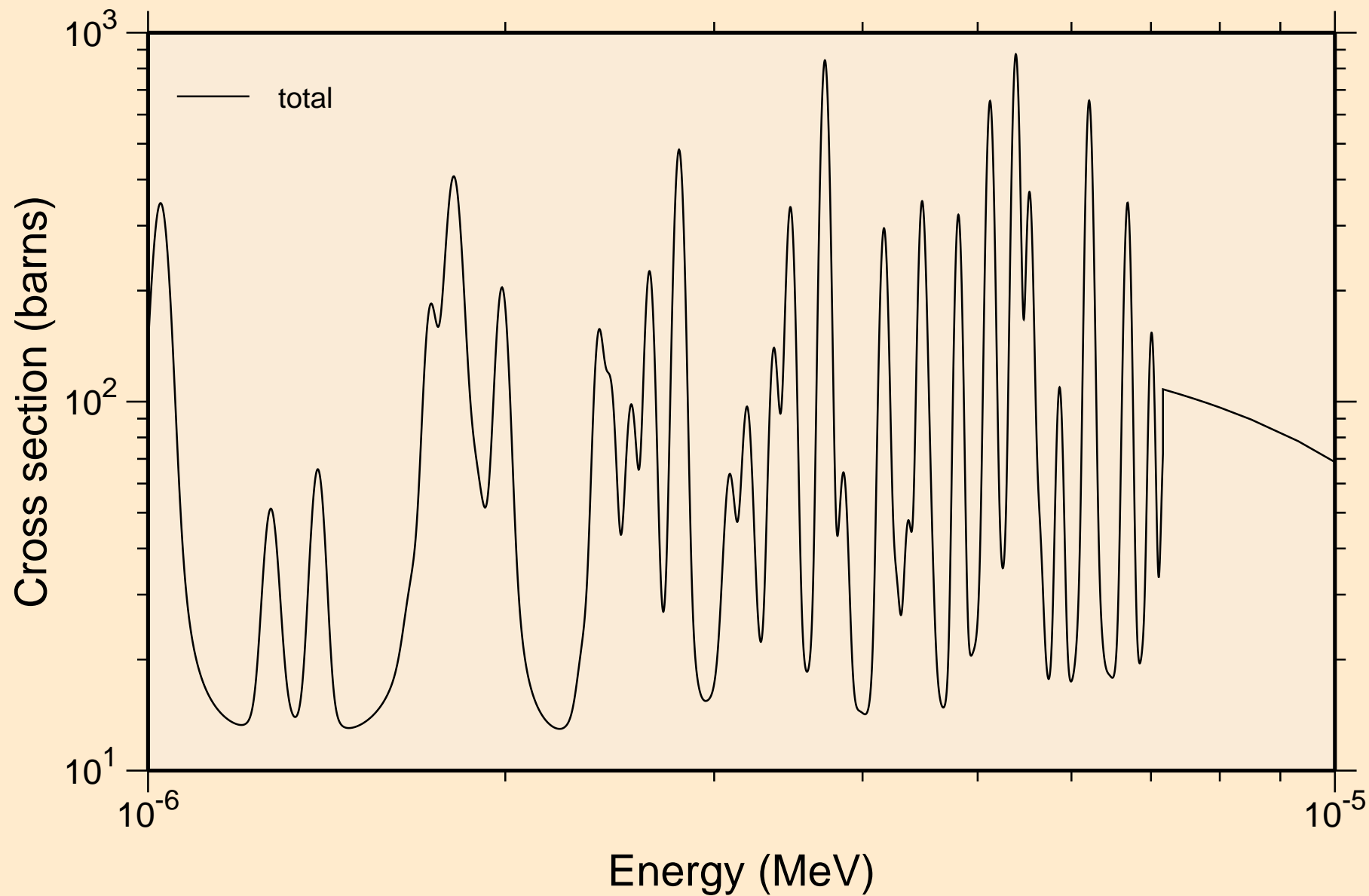

DB261 NEUTRON ACER TENDL-2019 LIBRARY; T=293.16K  
resonance total cross section

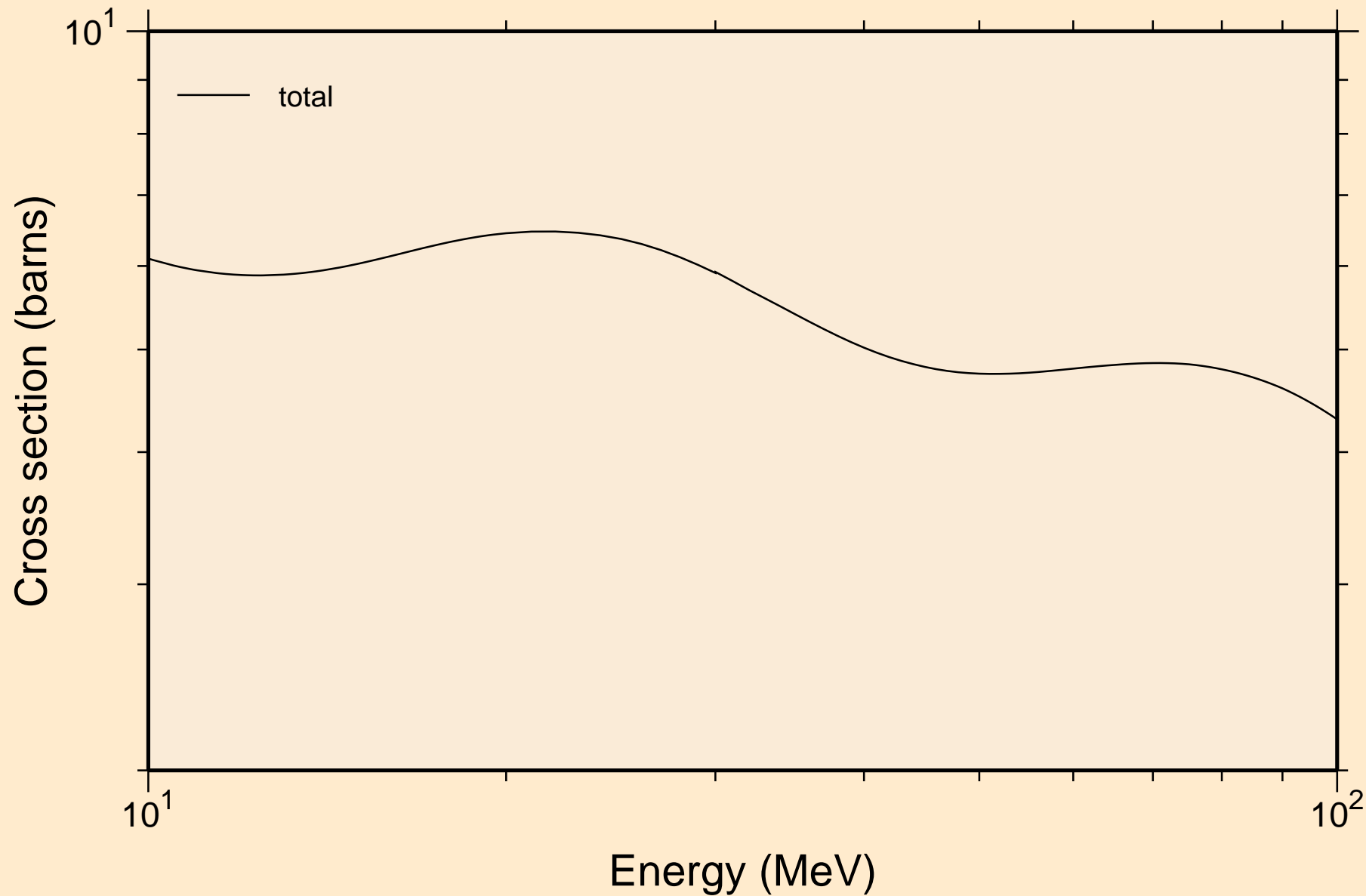

DB261 NEUTRON ACER TENDL-2019 LIBRARY; T=293.16K  
resonance absorption cross sections

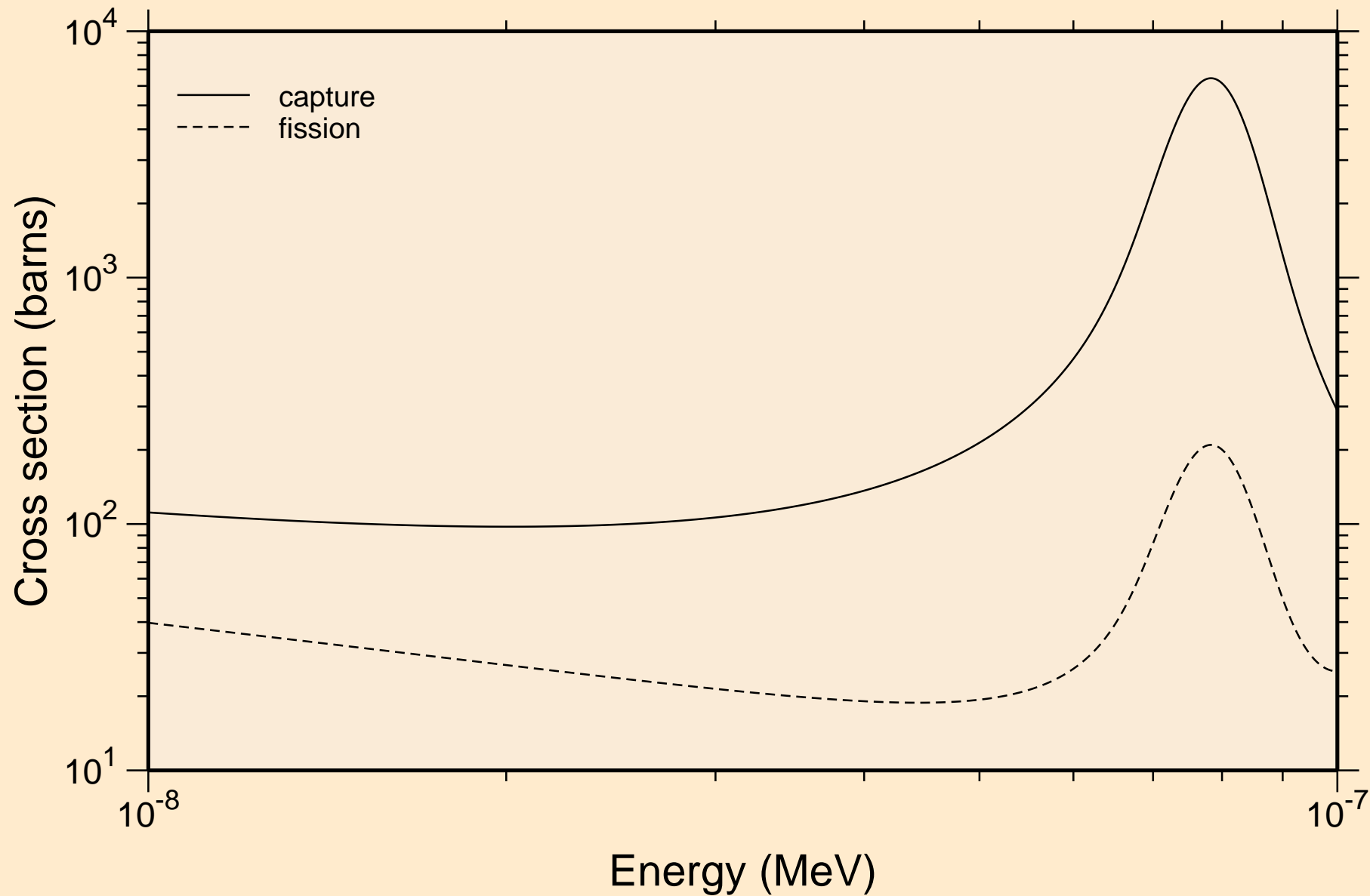

DB261 NEUTRON ACER TENDL-2019 LIBRARY; T=293.16K  
resonance absorption cross sections

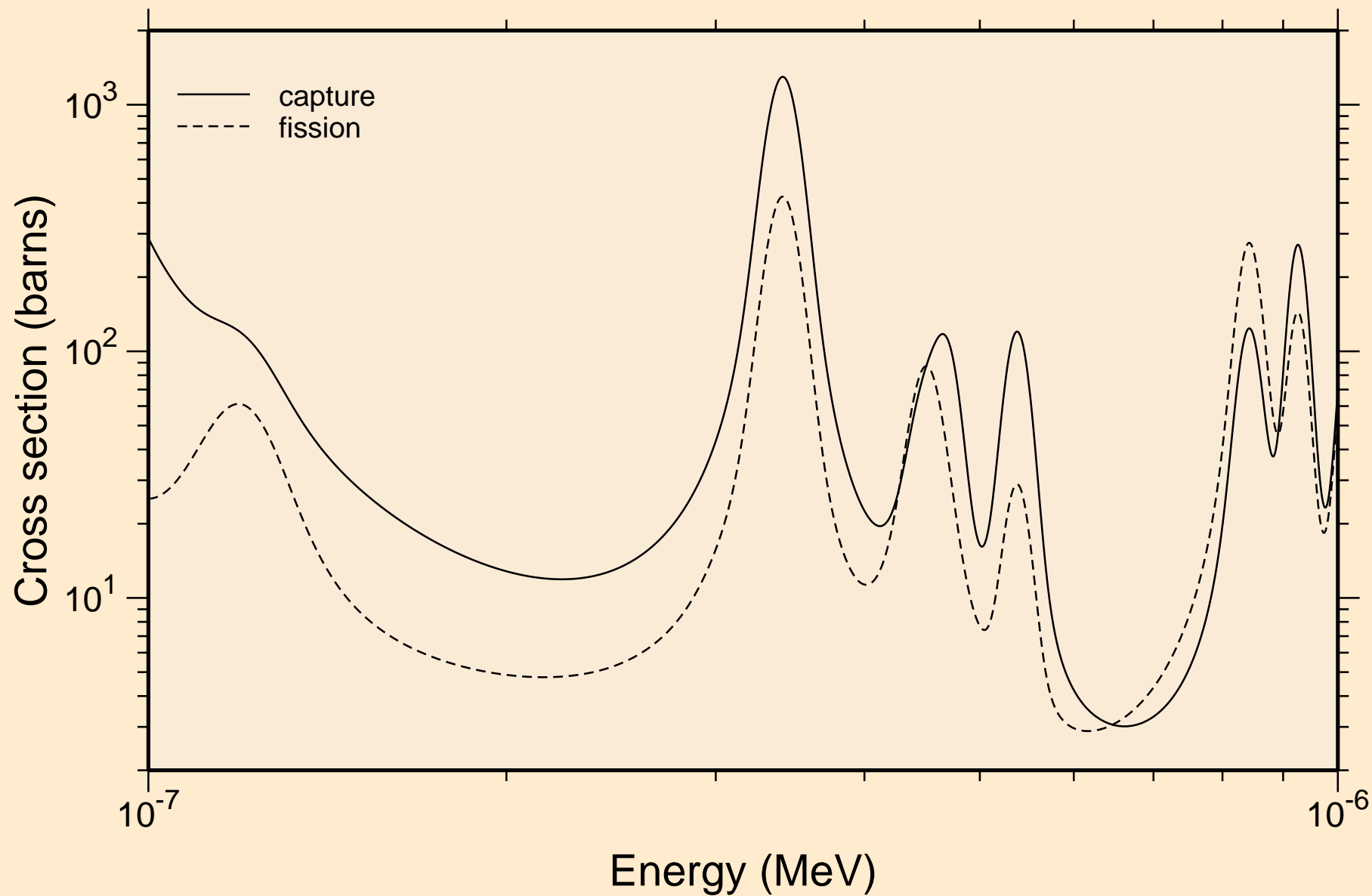

DB261 NEUTRON ACER TENDL-2019 LIBRARY; T=293.16K  
resonance absorption cross sections

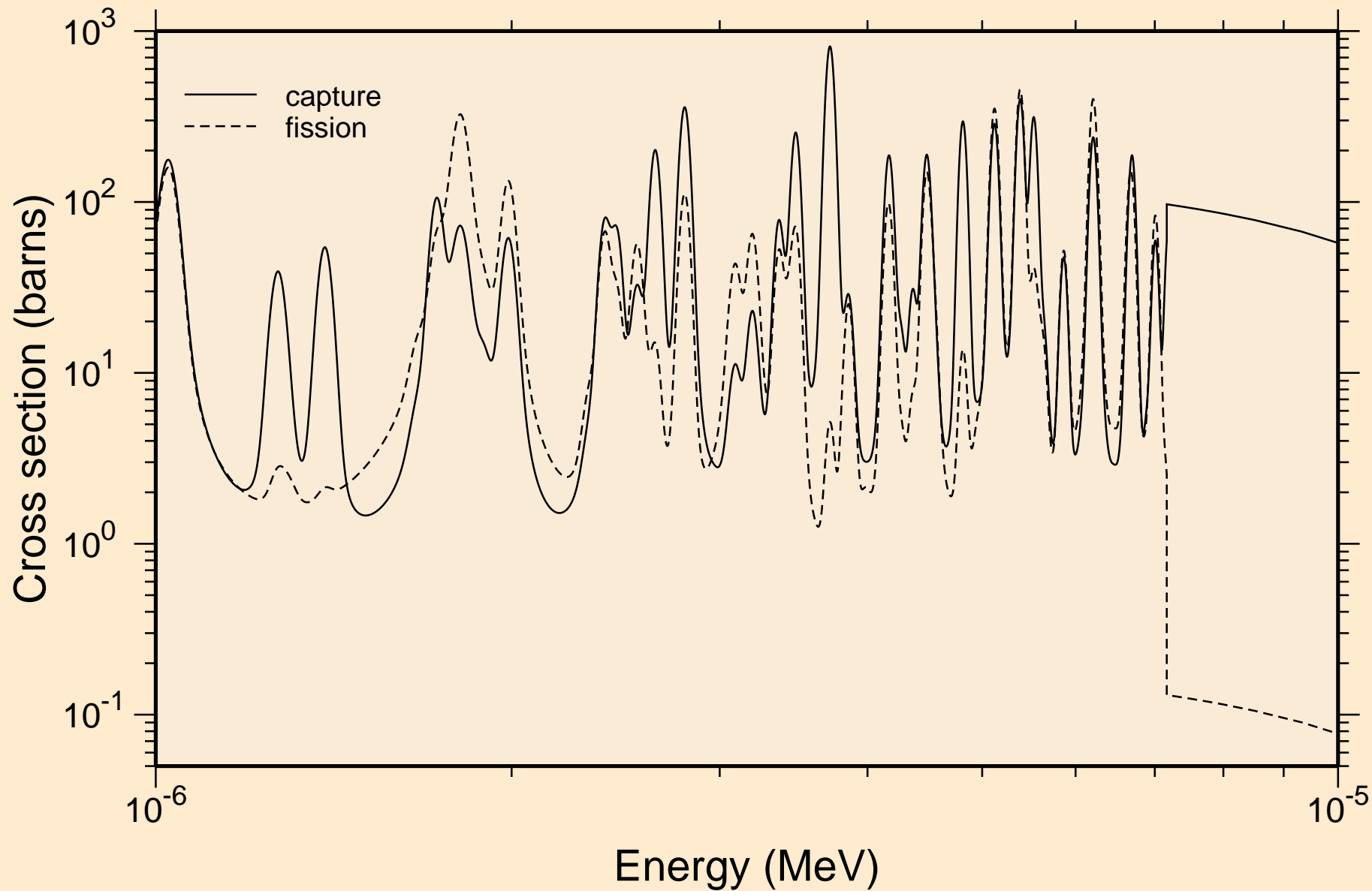

DB261 NEUTRON ACER TENDL-2019 LIBRARY; T=293.16K  
resonance absorption cross sections

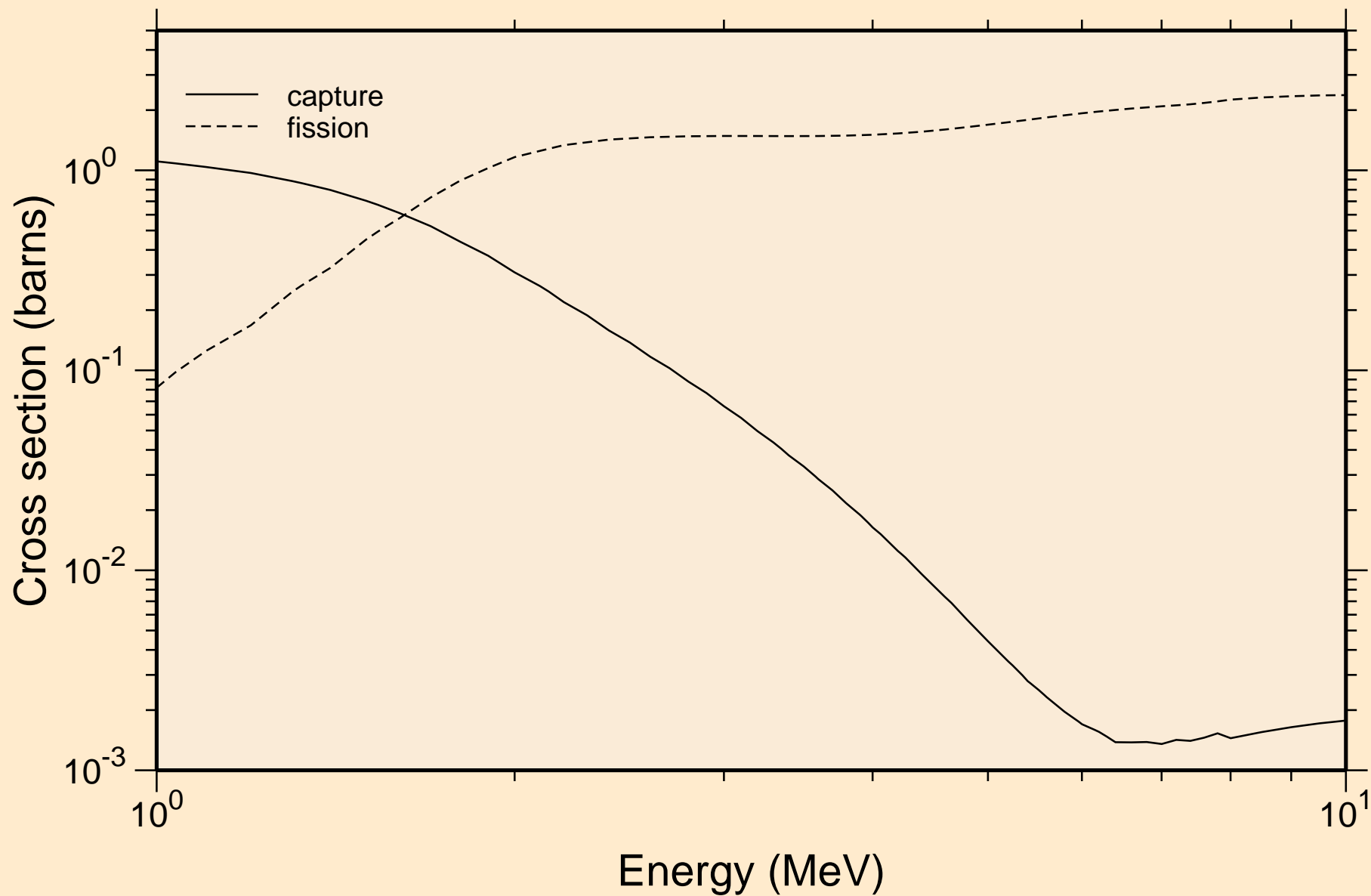

DB261 NEUTRON ACER TENDL-2019 LIBRARY; T=293.16K  
Heating

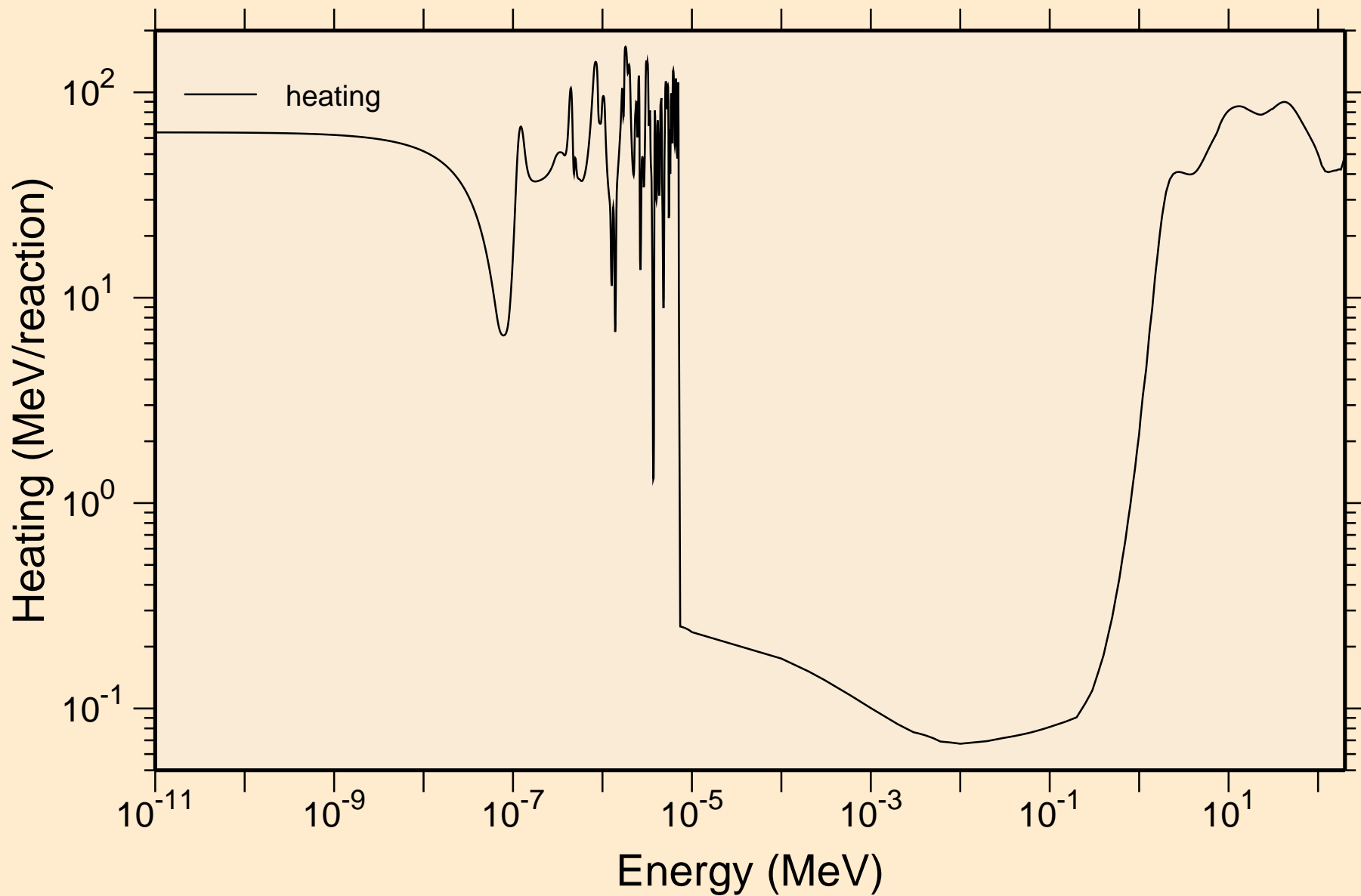

DB261 NEUTRON ACER TENDL-2019 LIBRARY; T=293.16K  
Damage

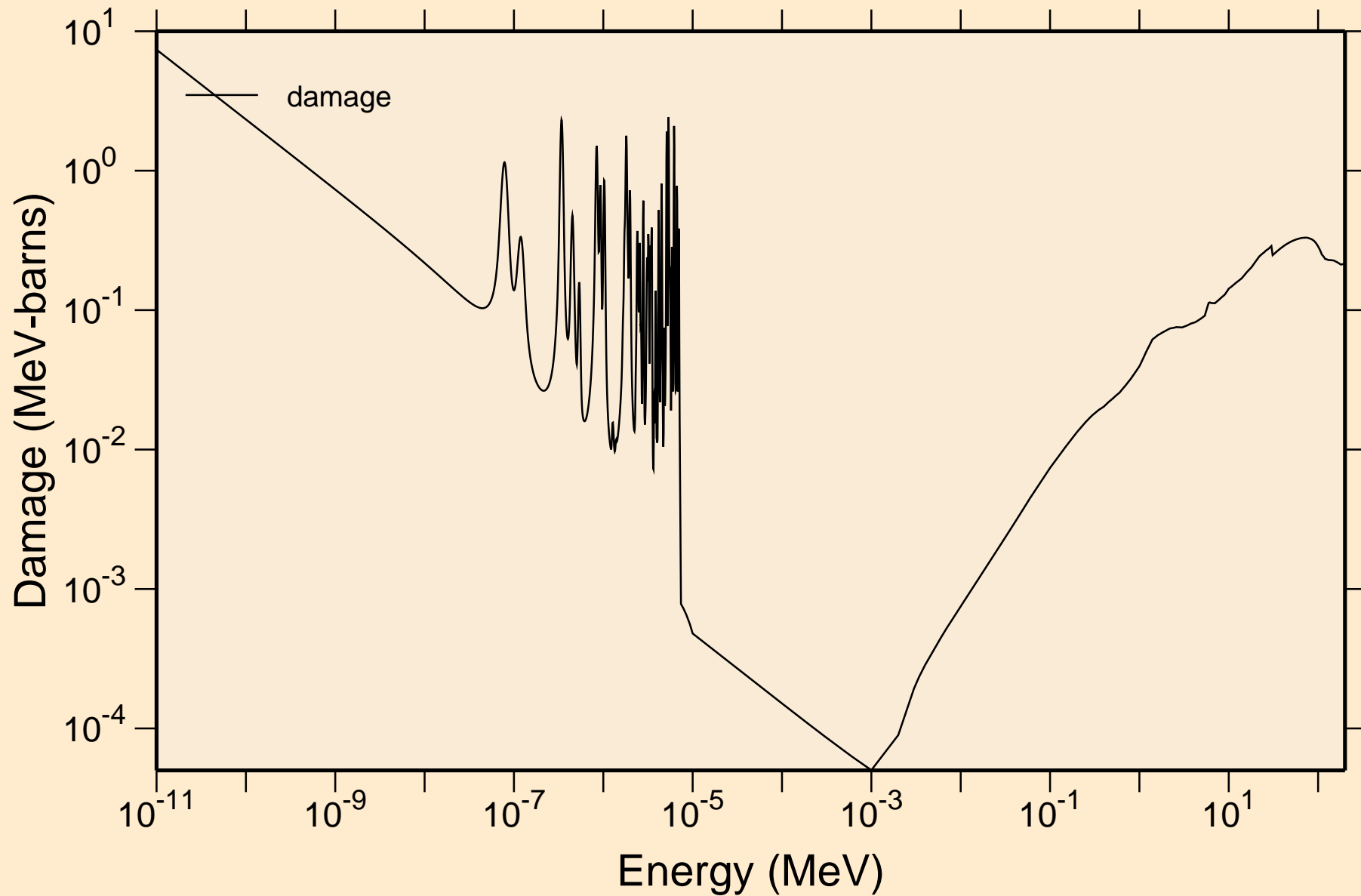

DB261 NEUTRON ACER TENDL-2019 LIBRARY; T=293.16K  
Non-threshold reactions

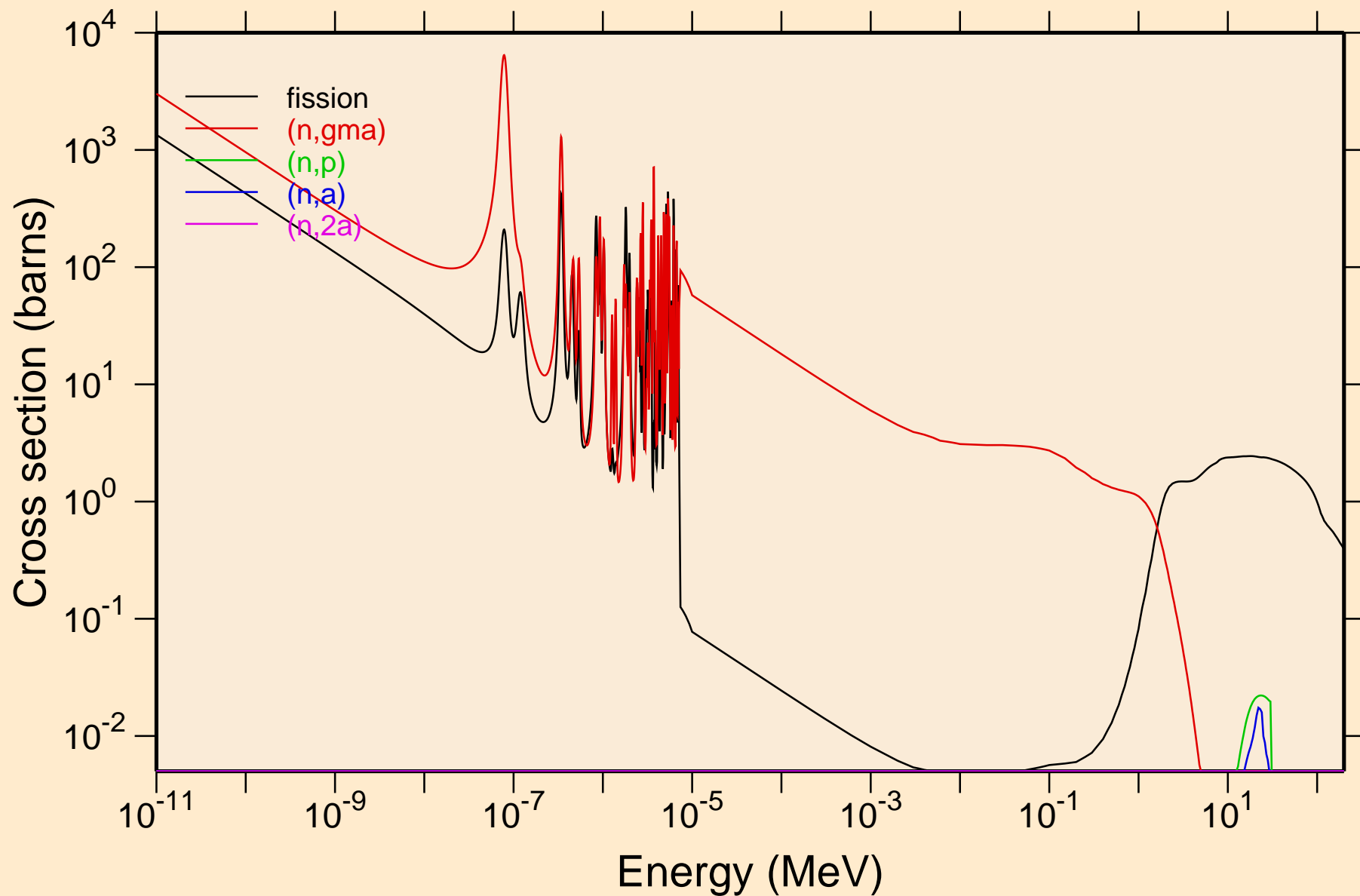

DB261 NEUTRON ACER TENDL-2019 LIBRARY; T=293.16K  
Non-threshold reactions

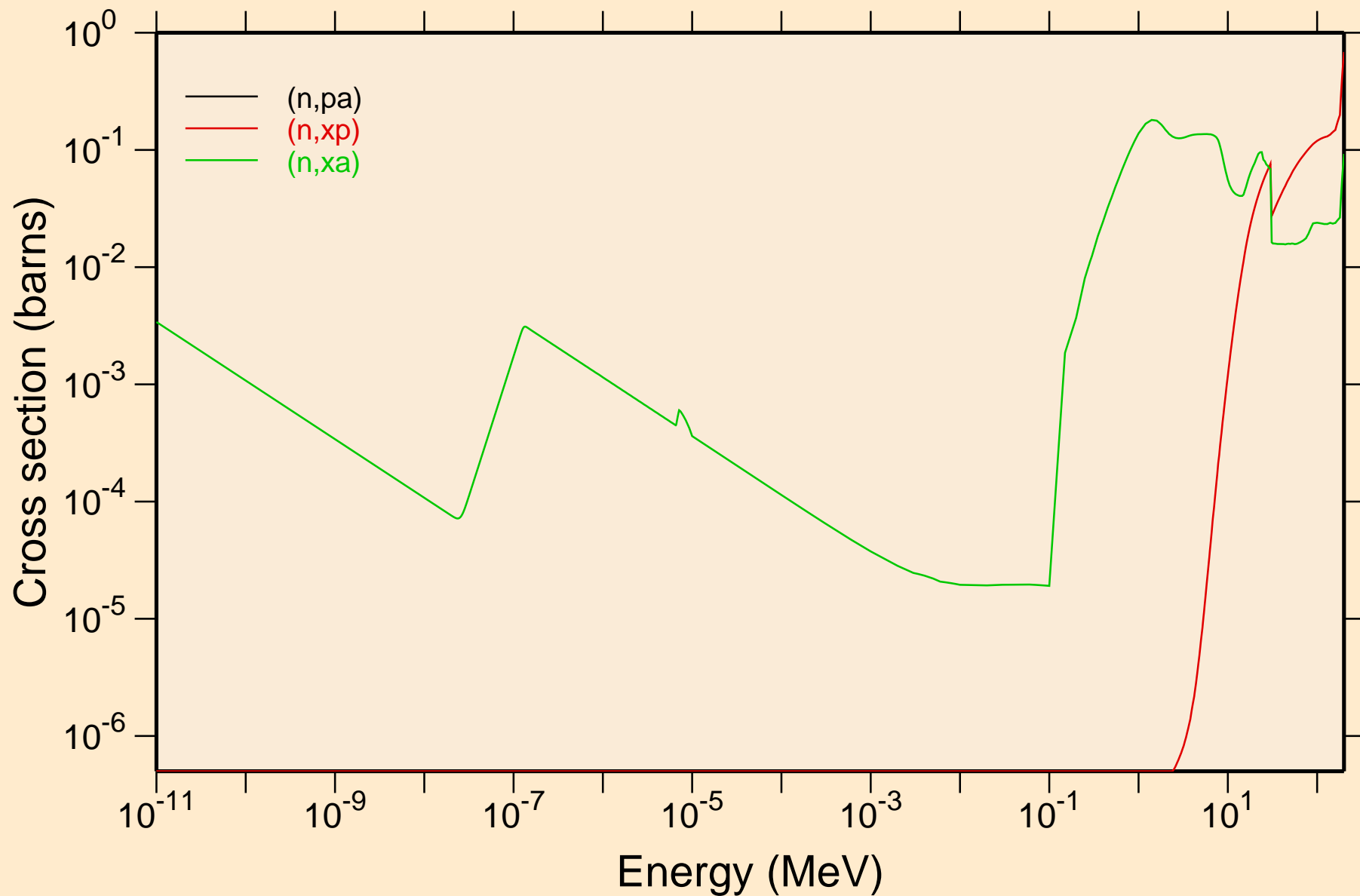

DB261 NEUTRON ACER TENDL-2019 LIBRARY; T=293.16K  
Principal cross sections

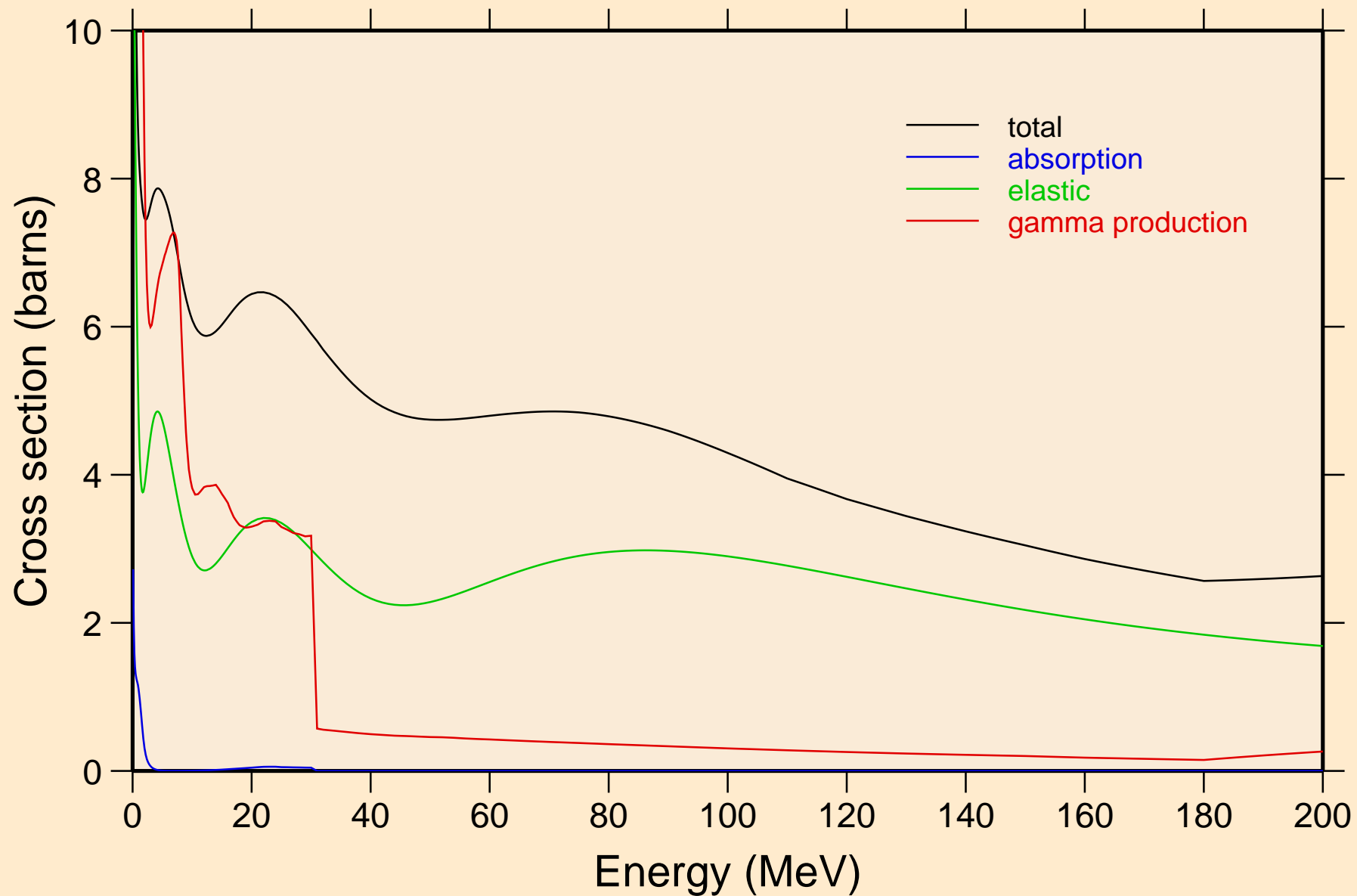

DB261 NEUTRON ACER TENDL-2019 LIBRARY; T=293.16K  
Heating

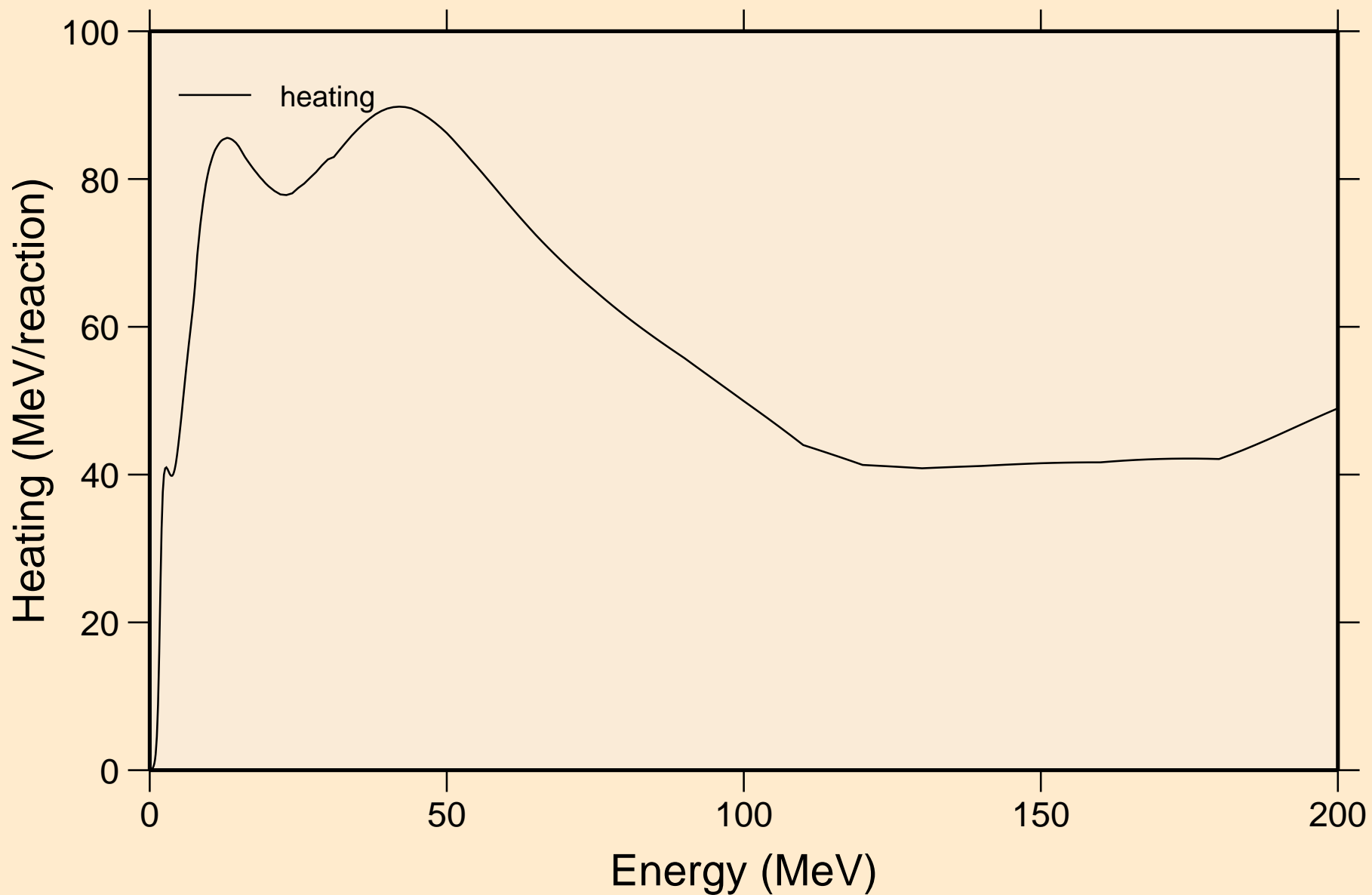

DB261 NEUTRON ACER TENDL-2019 LIBRARY; T=293.16K  
Damage

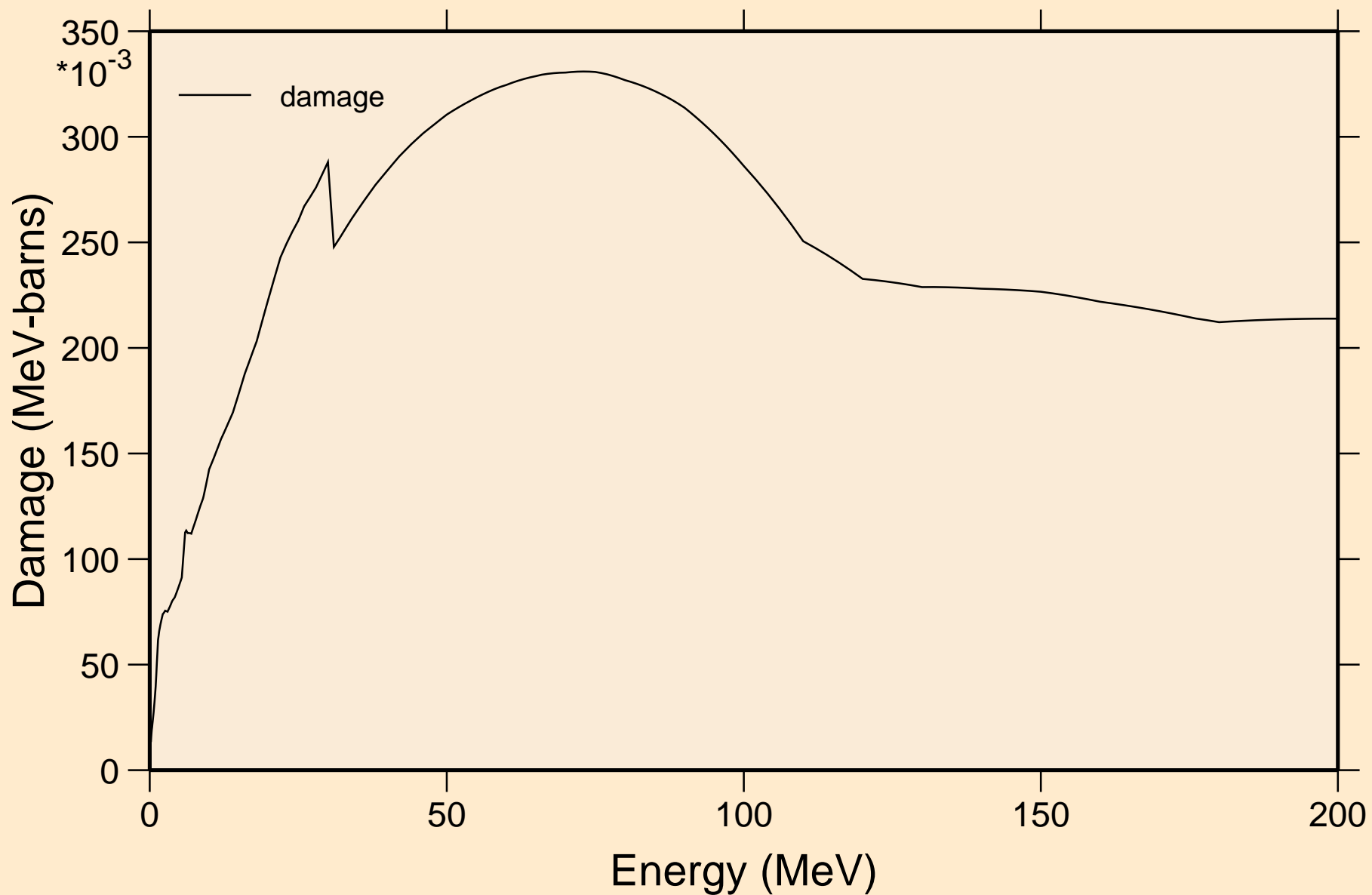

DB261 NEUTRON ACER TENDL-2019 LIBRARY; T=293.16K  
Non-threshold reactions

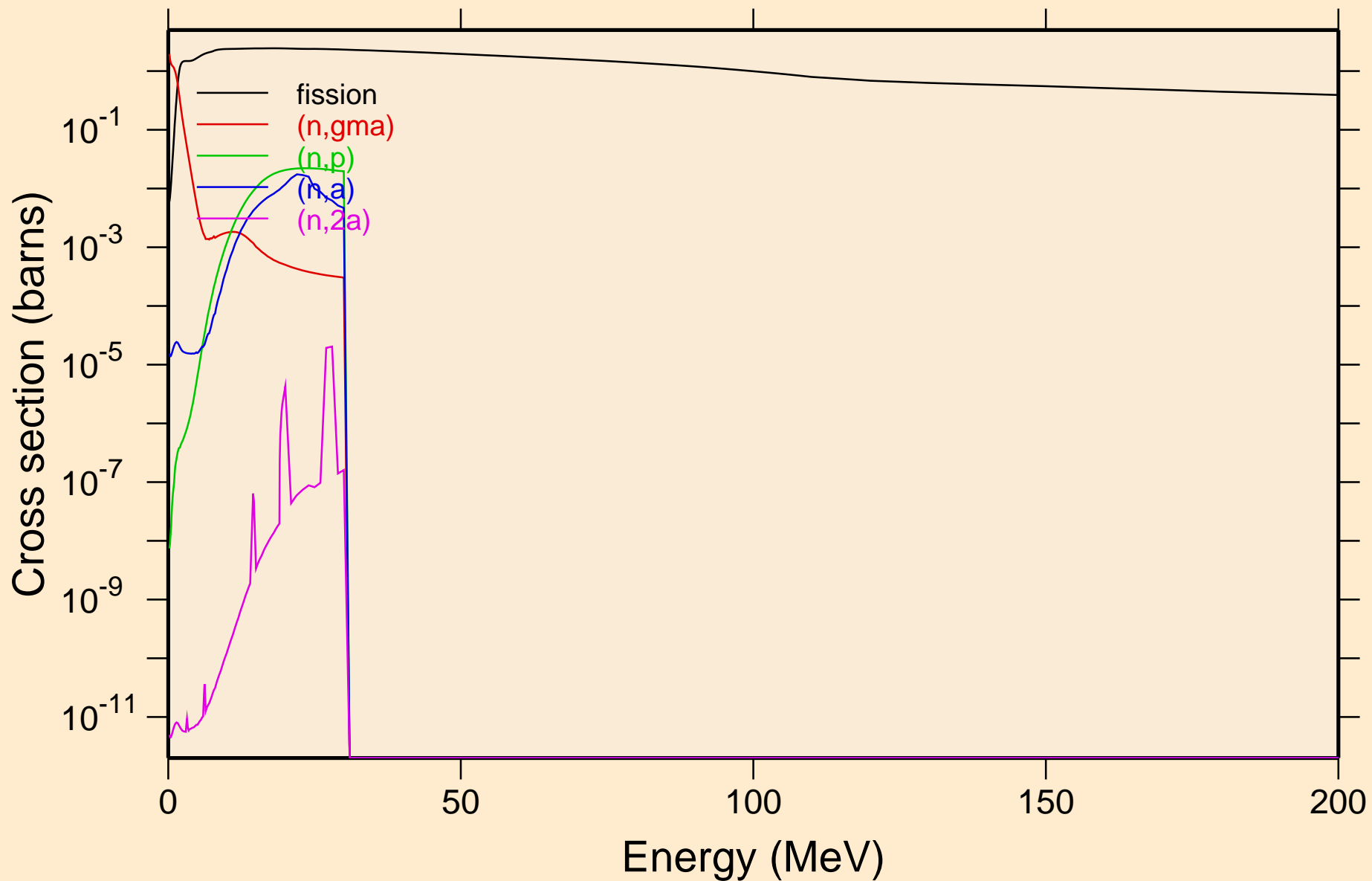

DB261 NEUTRON ACER TENDL-2019 LIBRARY; T=293.16K  
Non-threshold reactions

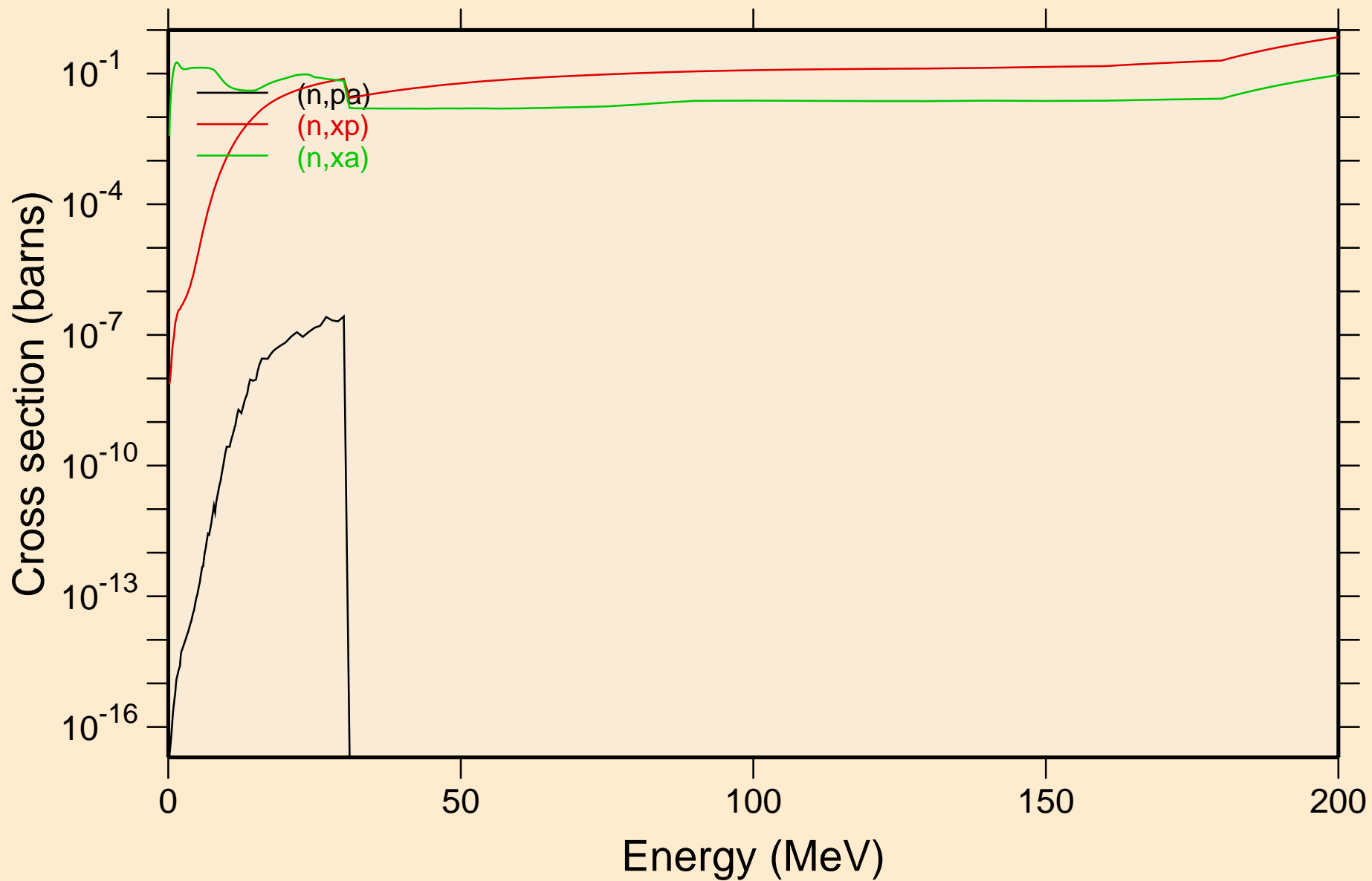

DB261 NEUTRON ACER TENDL-2019 LIBRARY; T=293.16K  
Inelastic levels

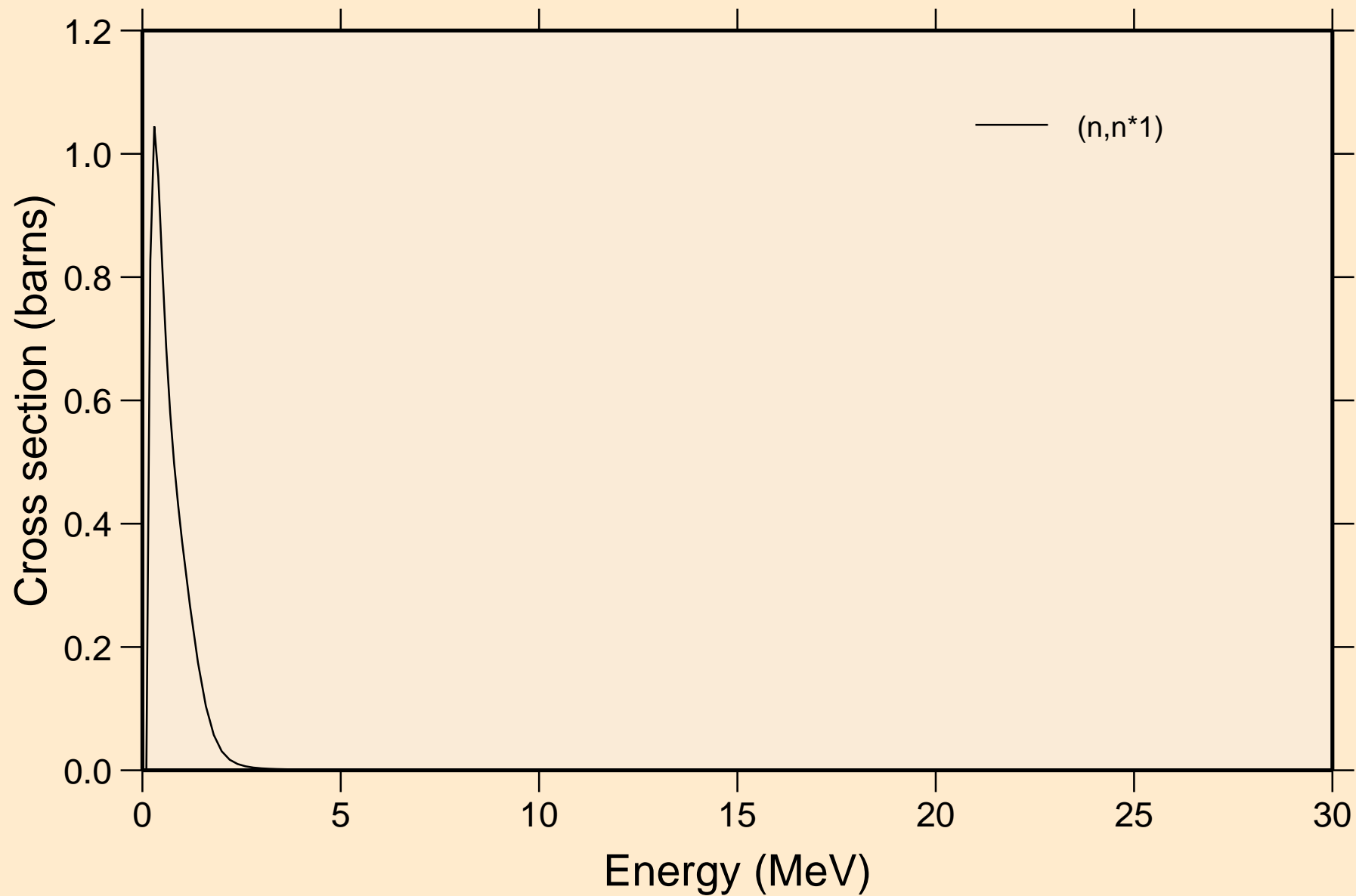

DB261 NEUTRON ACER TENDL-2019 LIBRARY; T=293.16K  
Threshold reactions

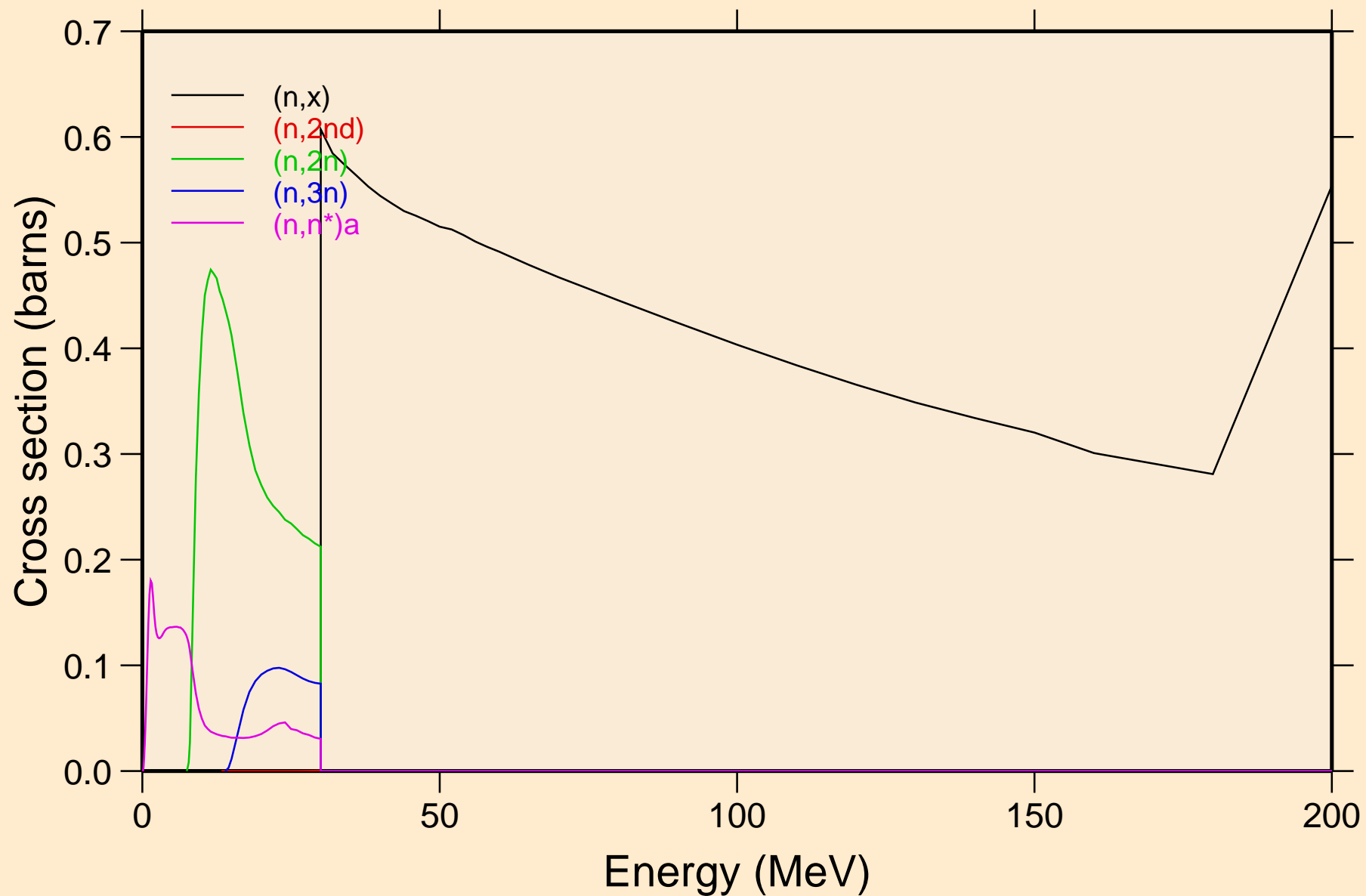

DB261 NEUTRON ACER TENDL-2019 LIBRARY; T=293.16K  
Threshold reactions

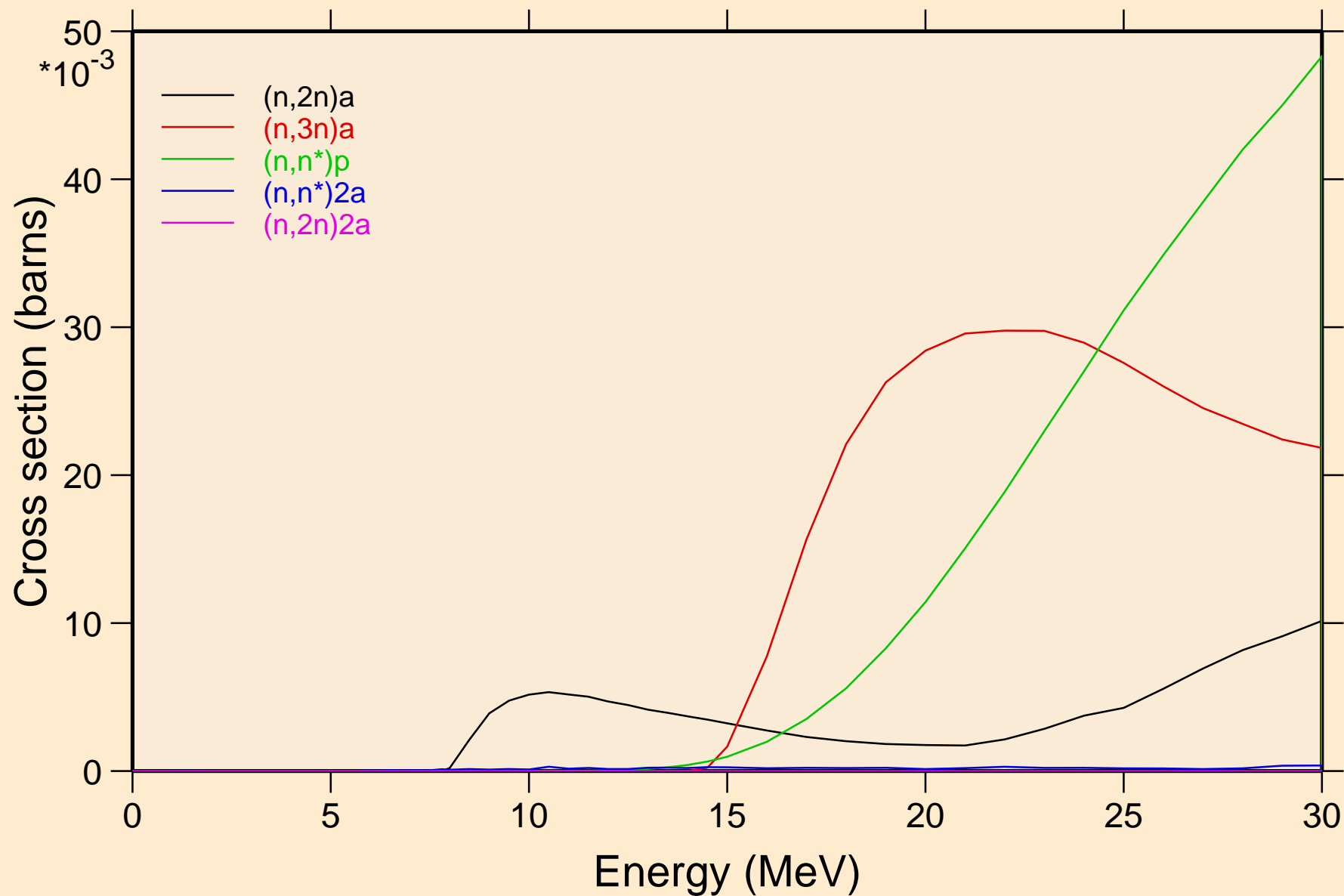

DB261 NEUTRON ACER TENDL-2019 LIBRARY; T=293.16K  
Threshold reactions

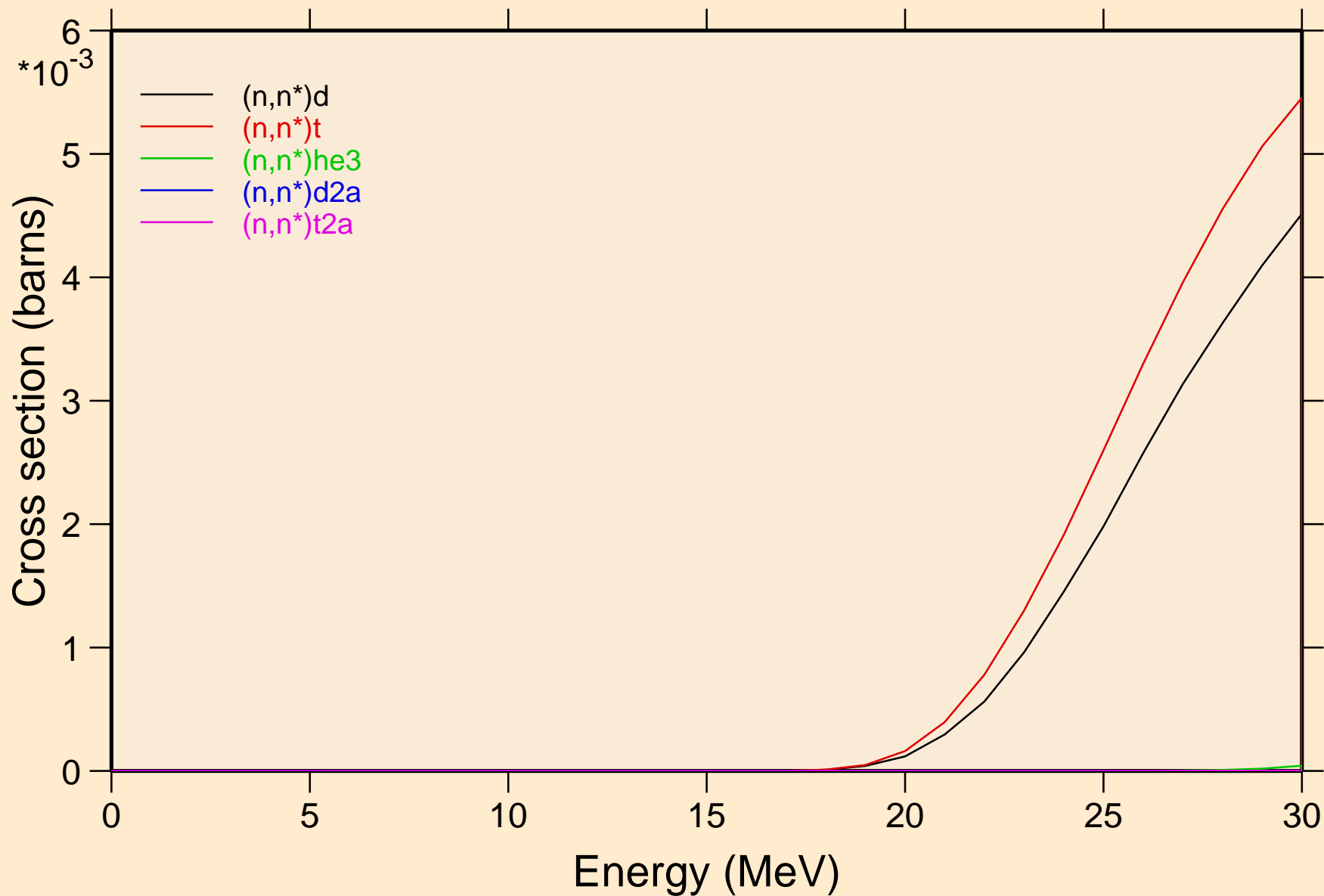

DB261 NEUTRON ACER TENDL-2019 LIBRARY; T=293.16K  
Threshold reactions

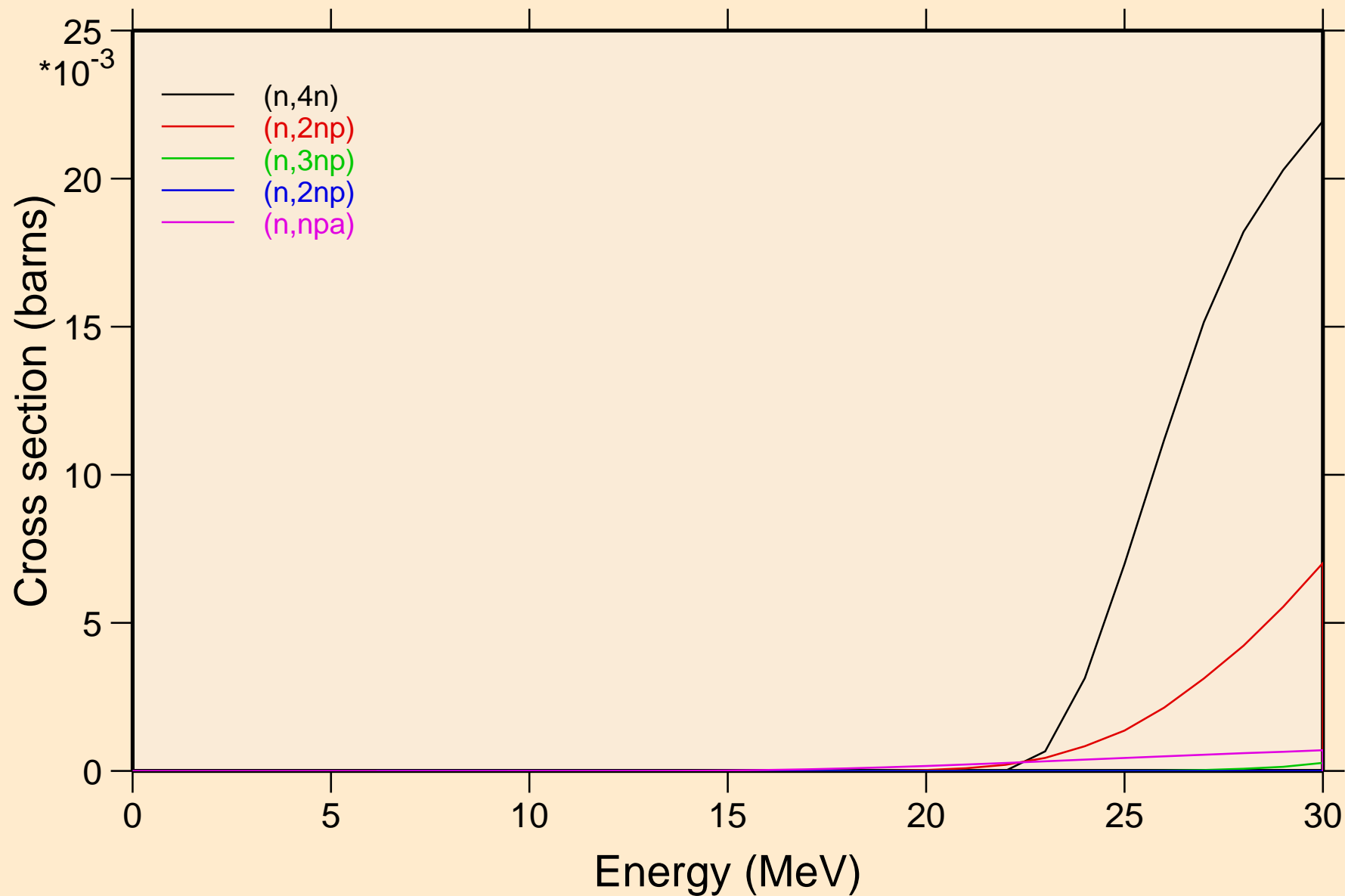

DB261 NEUTRON ACER TENDL-2019 LIBRARY; T=293.16K  
Threshold reactions

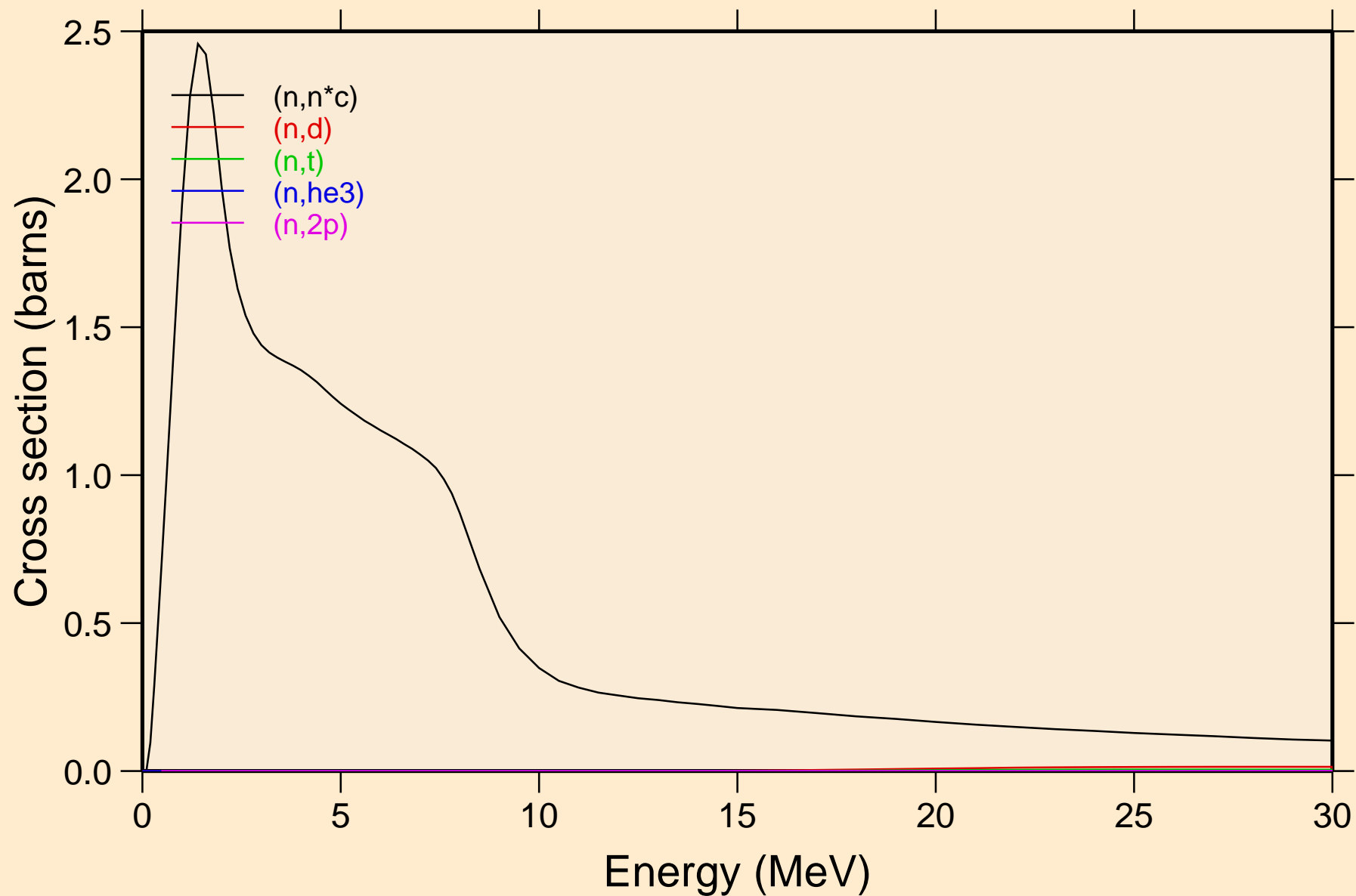

DB261 NEUTRON ACER TENDL-2019 LIBRARY; T=293.16K  
Threshold reactions

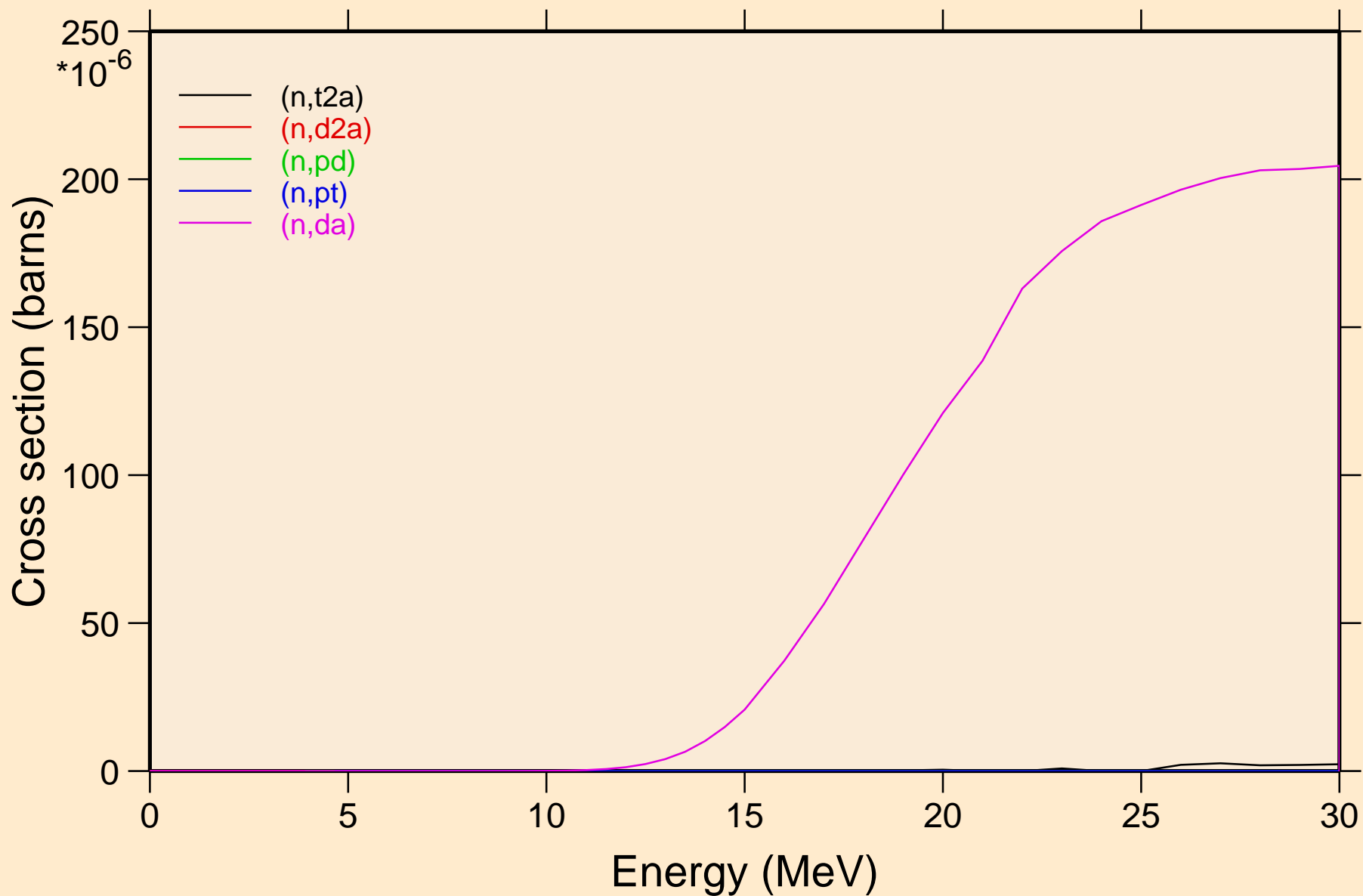

DB261 NEUTRON ACER TENDL-2019 LIBRARY; T=293.16K  
Threshold reactions

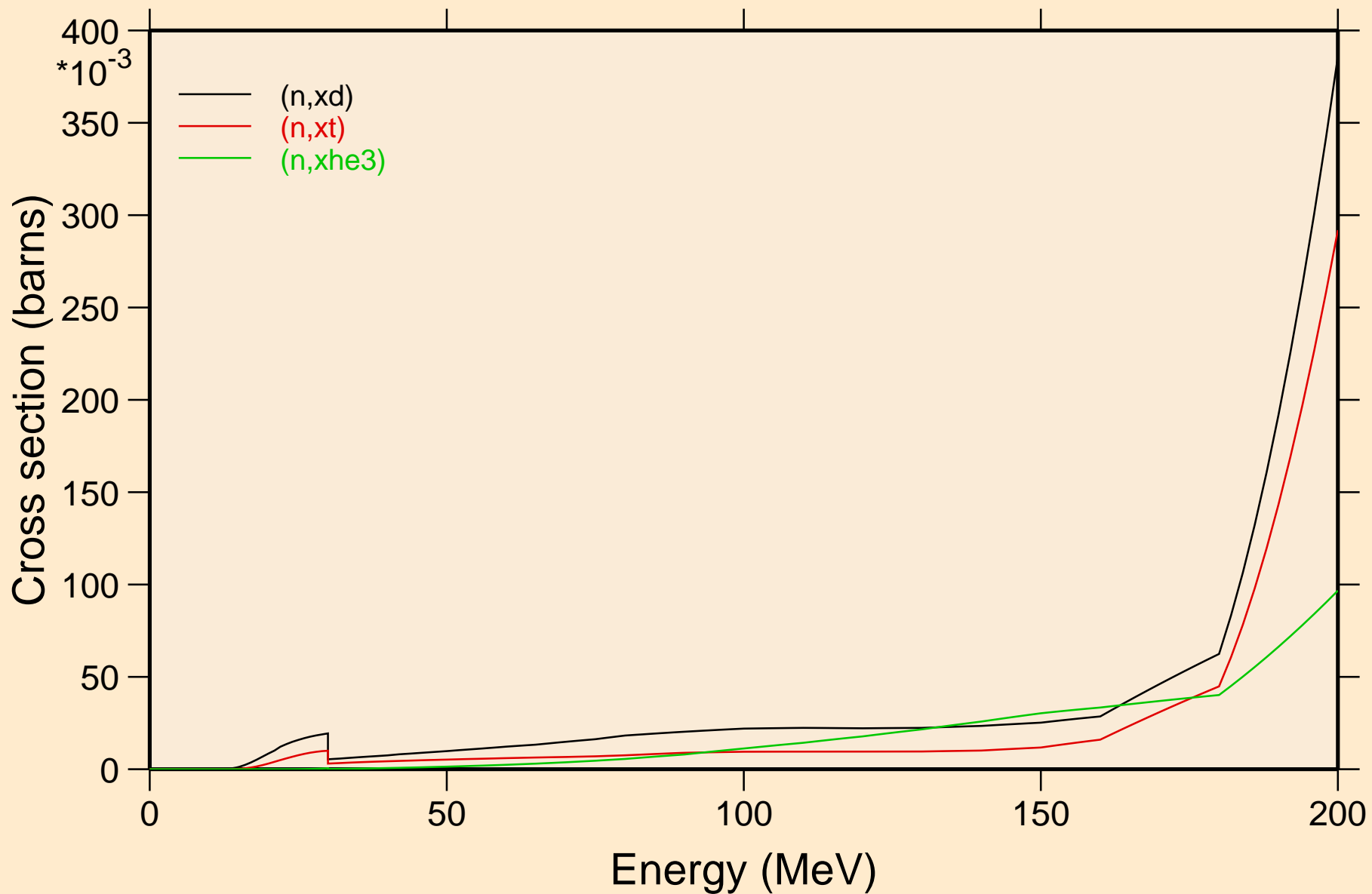

DB261 NEUTRON ACER TENDL-2019 LIBRARY; T=293.16K  
angular distribution for elastic

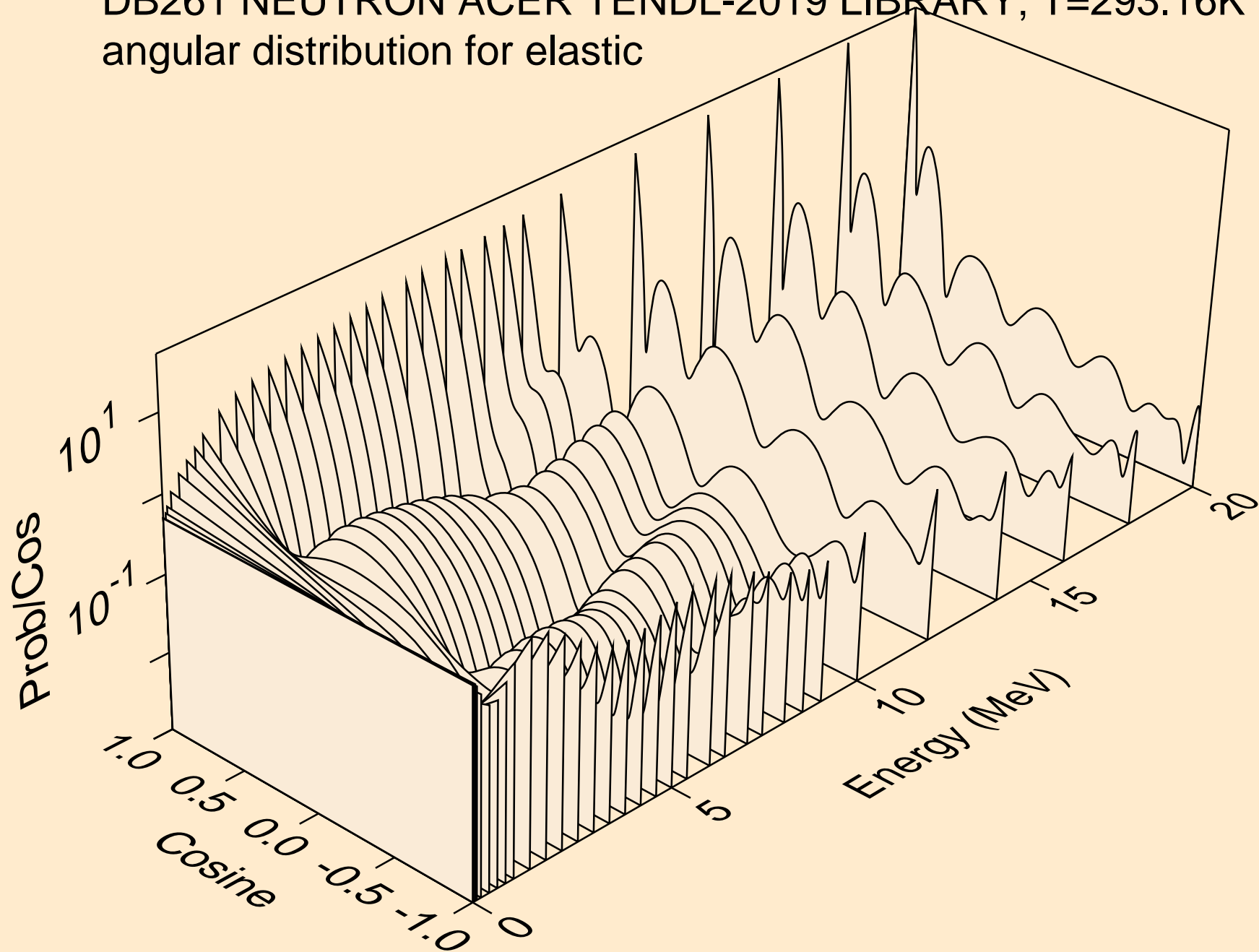

DB261 NEUTRON ACER TENDL-2019 LIBRARY; T=293.16K  
angular distribution for elastic

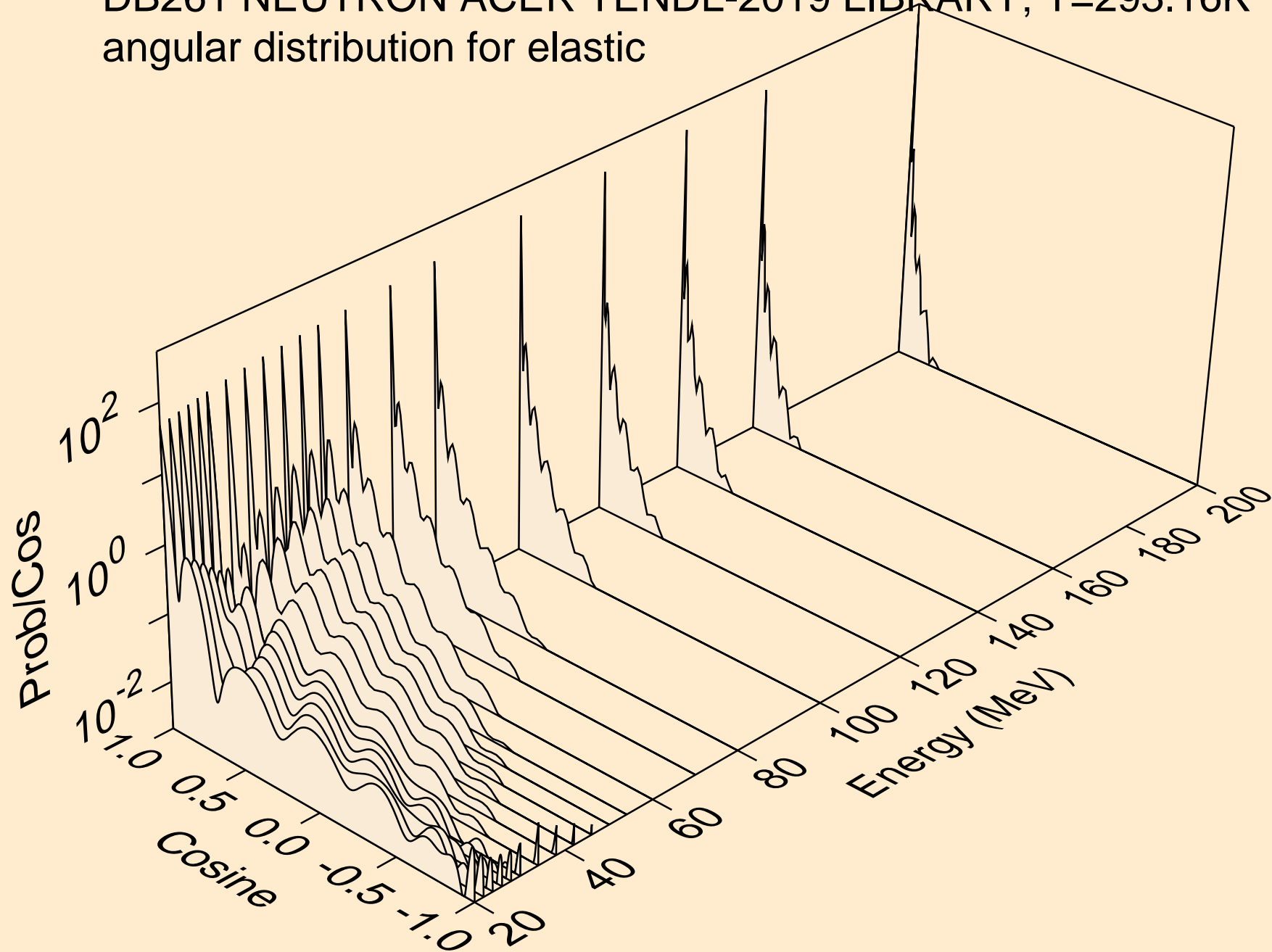

DB261 NEUTRON ACER TENDL-2019 LIBRARY; T=293.16K  
angular distribution for (n,n\*1)

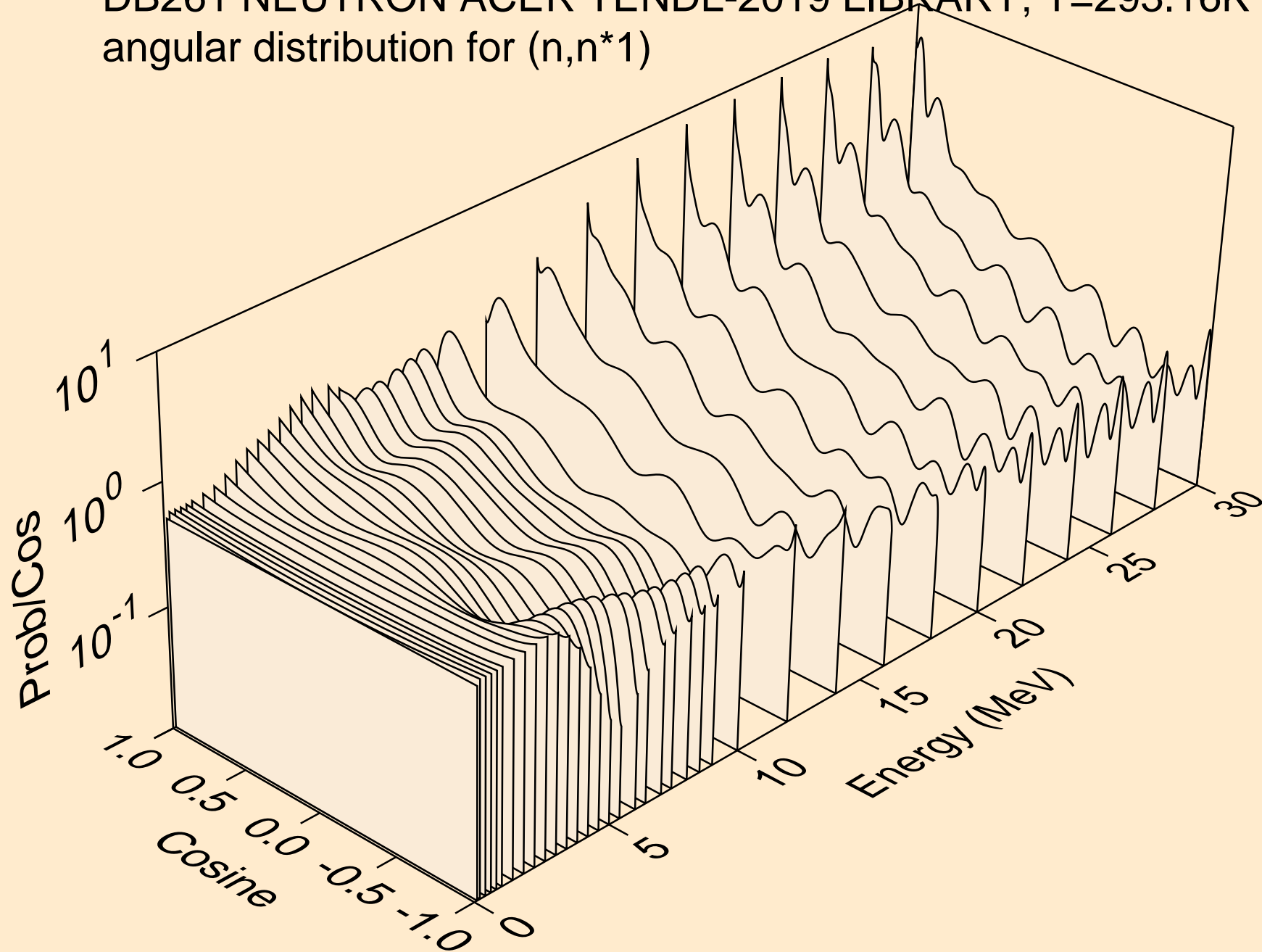

DB261 NEUTRON ACER TENDL-2019 LIBRARY; T=293.16K  
Total fission nubar

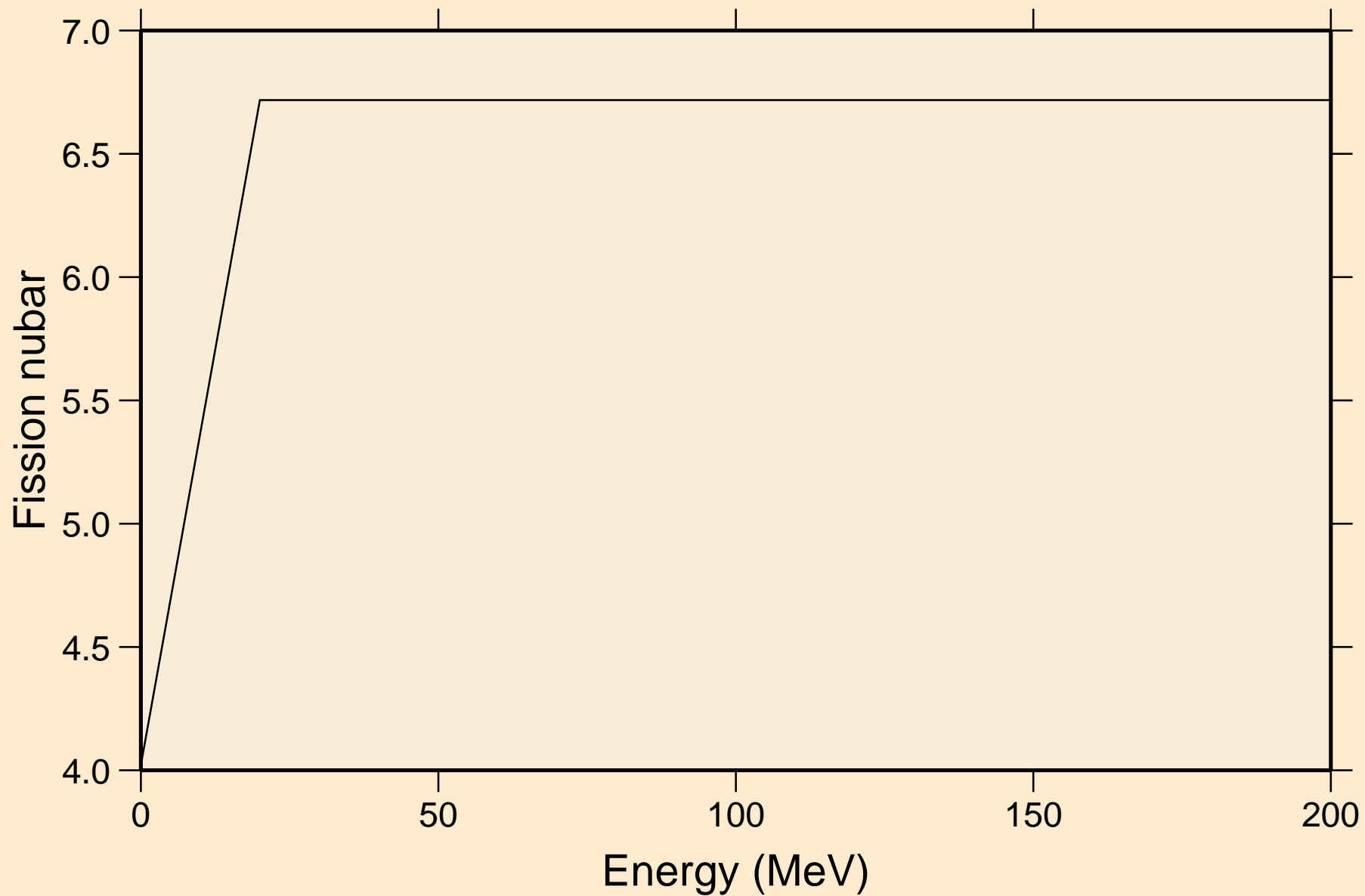

DB261 NEUTRON ACER TENDL-2019 LIBRARY; T=293.16K  
Neutron emission for (n,x)

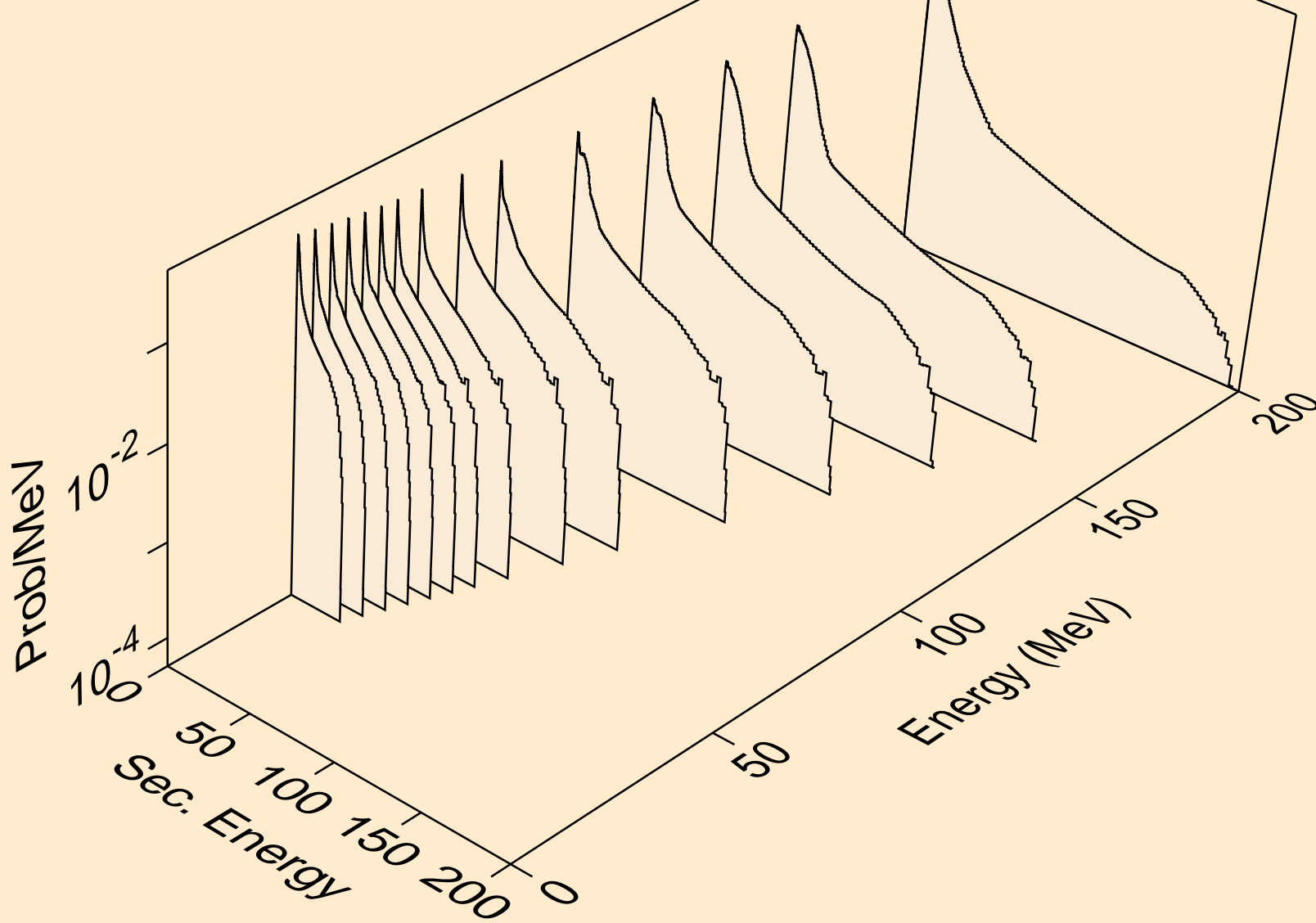

DB261 NEUTRON ACER TENDL-2019 LIBRARY; T=293.16K  
Neutron emission for (n,2nd)

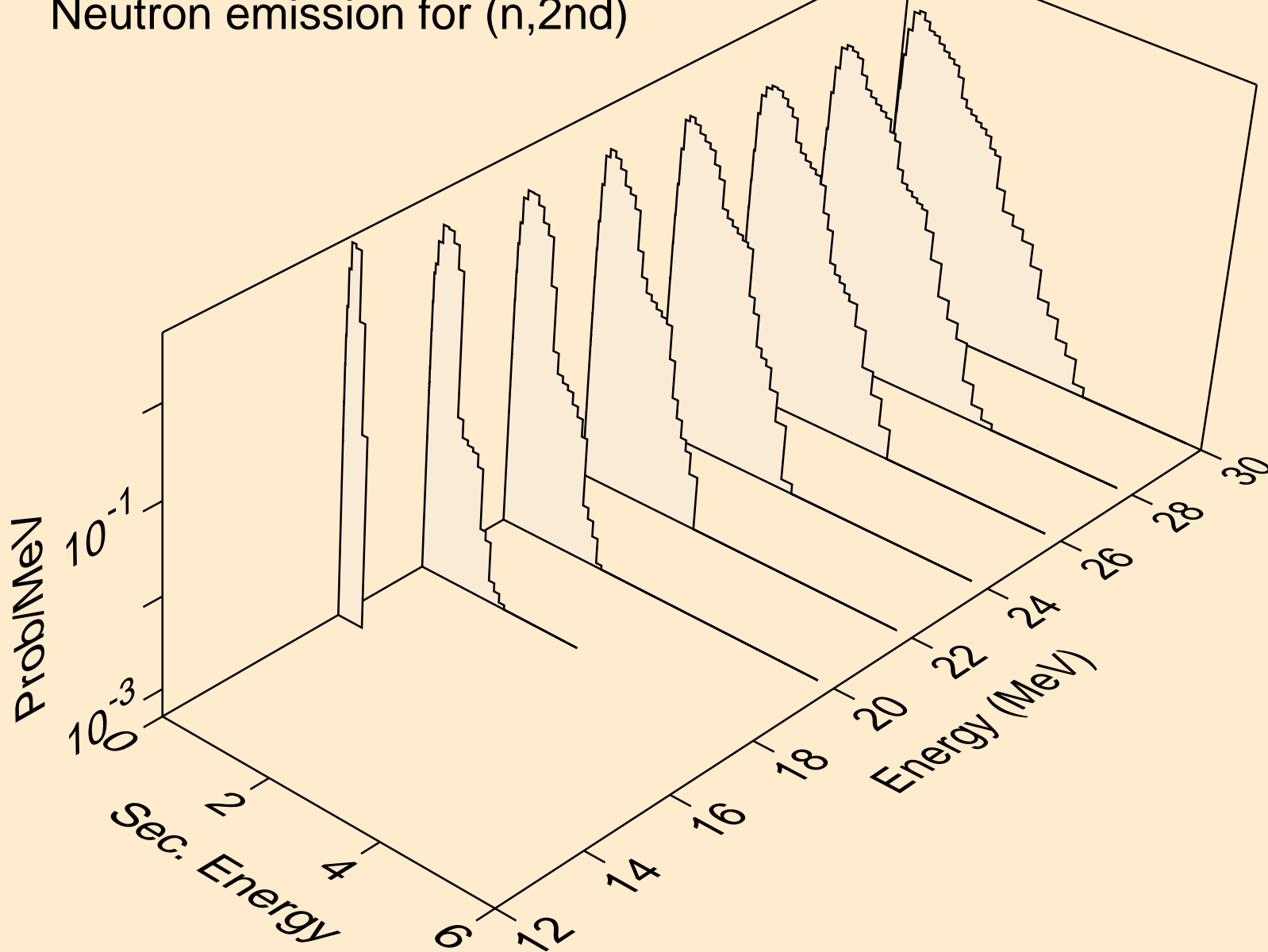

DB261 NEUTRON ACER TENDL-2019 LIBRARY; T=293.16K  
Neutron emission for (n,2n)

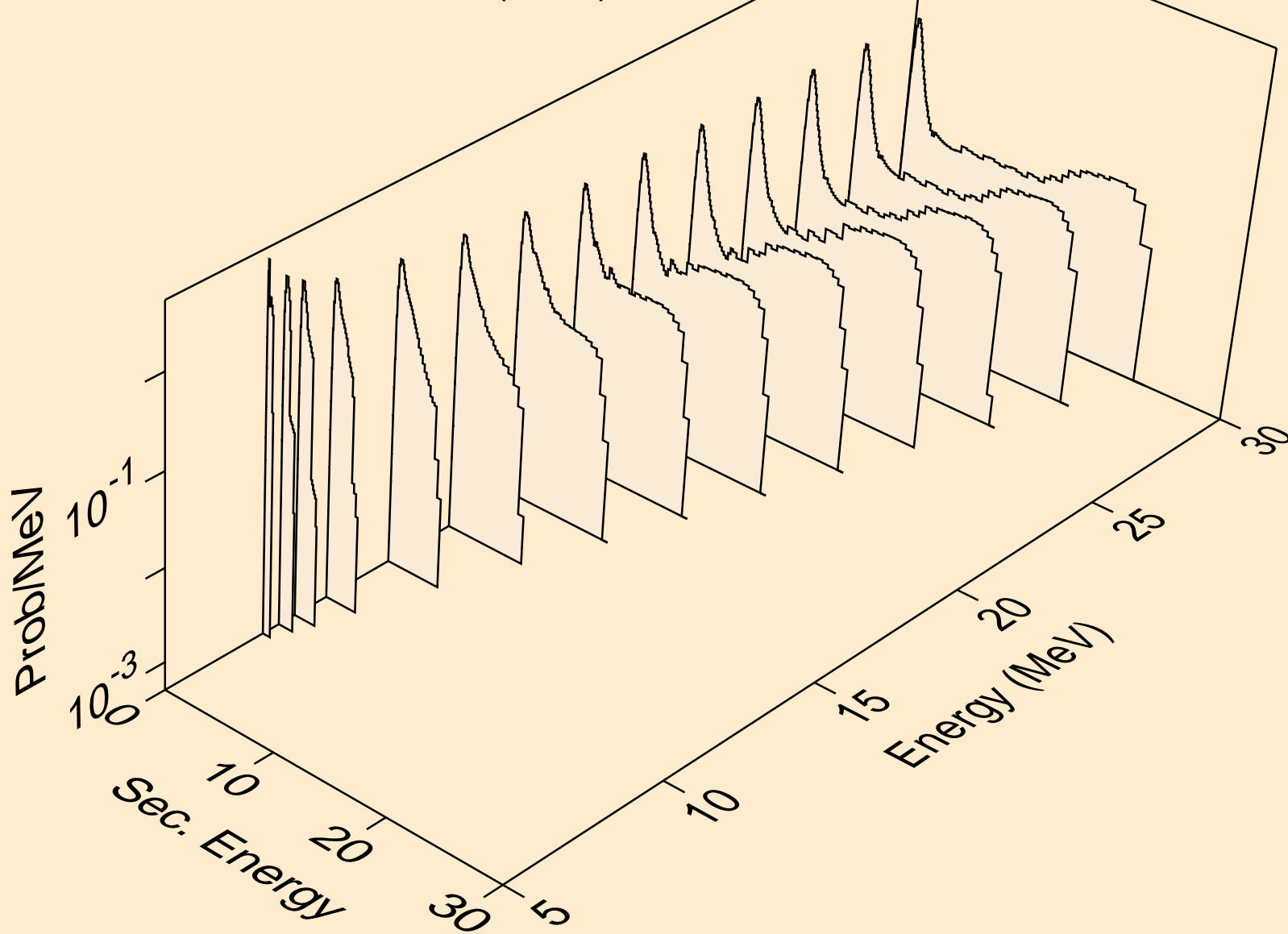

DB261 NEUTRON ACER TENDL-2019 LIBRARY; T=293.16K  
Neutron emission for (n,3n)

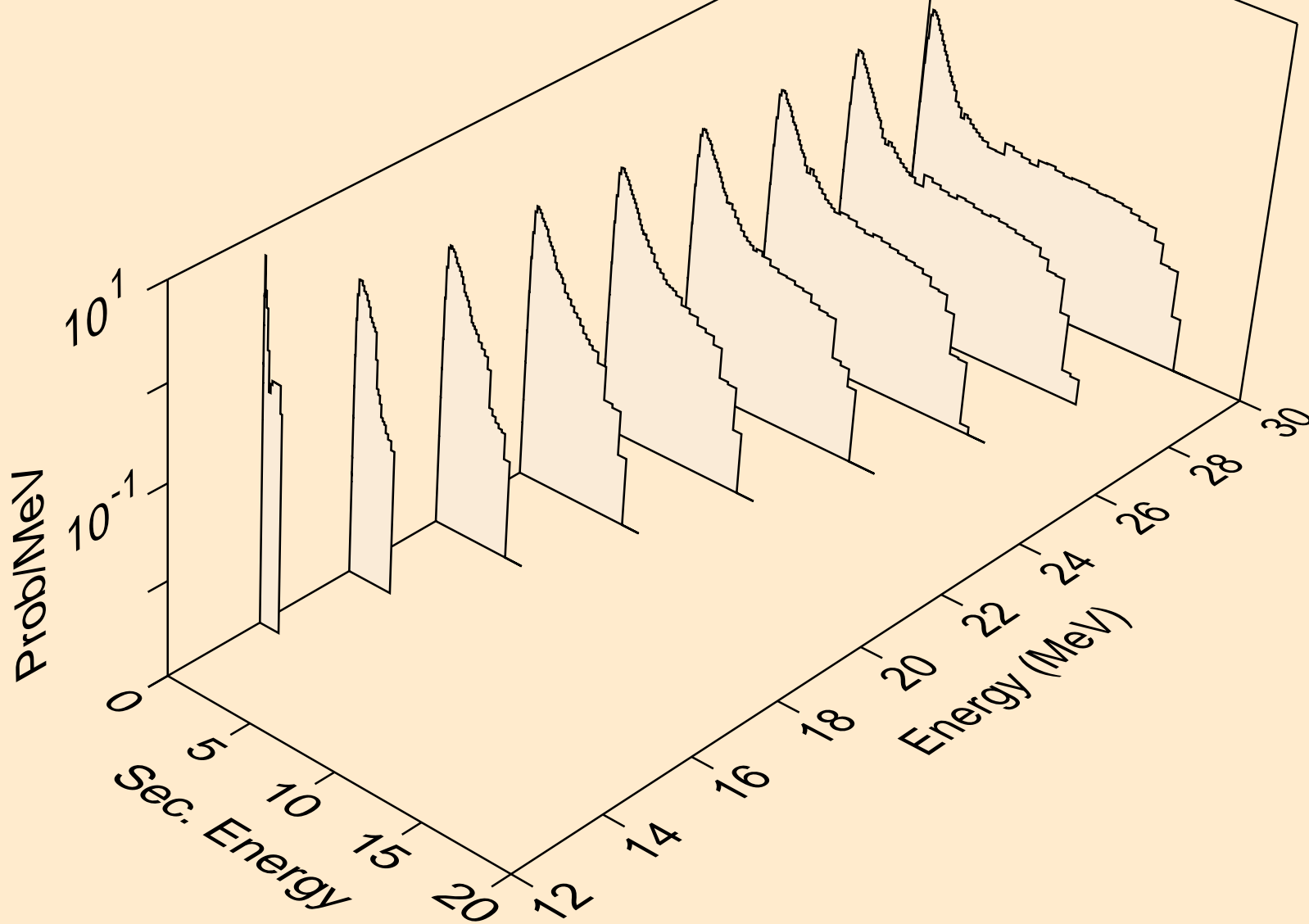

DB261 NEUTRON ACER TENDL-2019 LIBRARY; T=293.16K  
Neutron emission for fission

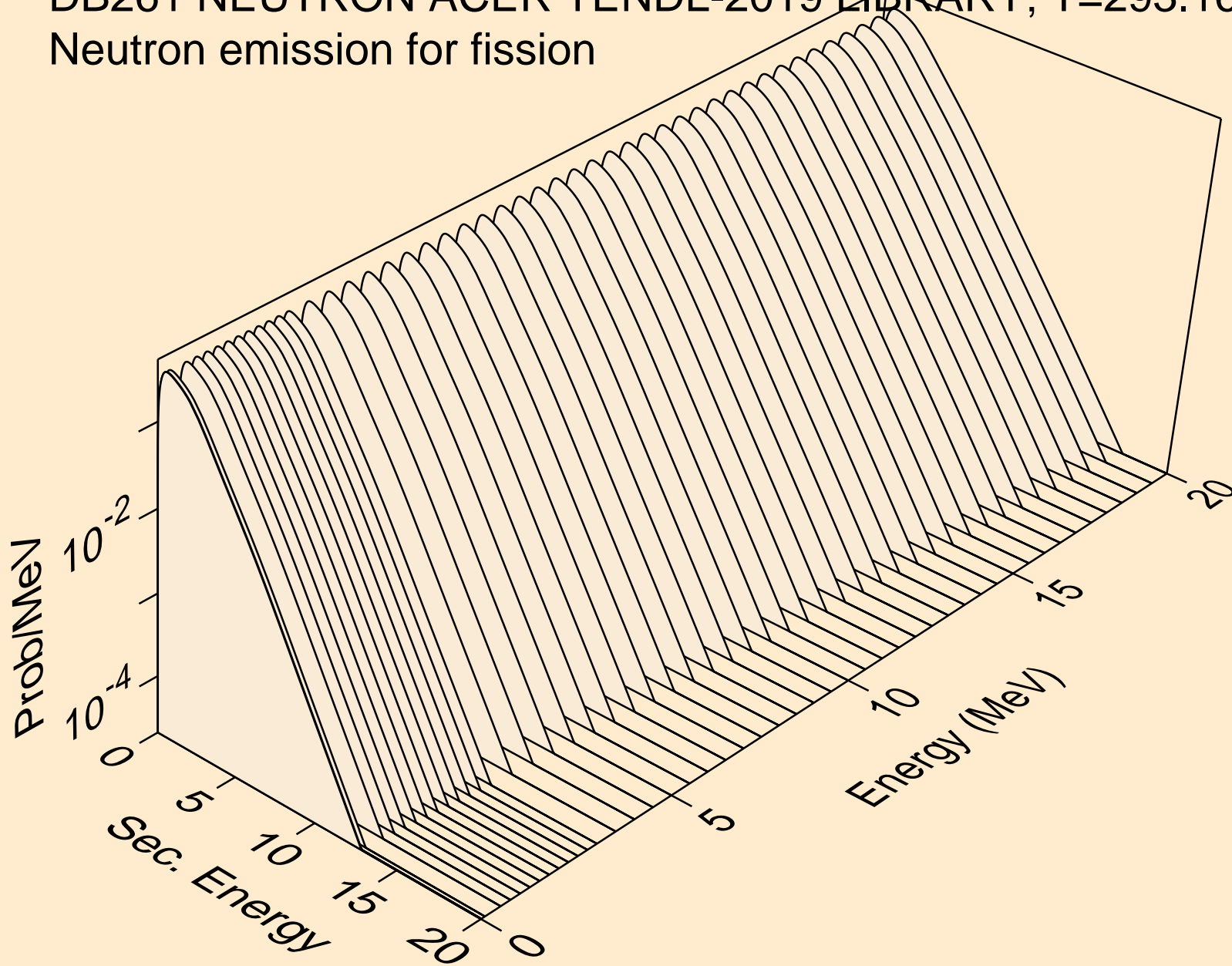

DB261 NEUTRON ACER TENDL-2019 LIBRARY; T=293.16K  
Neutron emission for (n,n\*)a

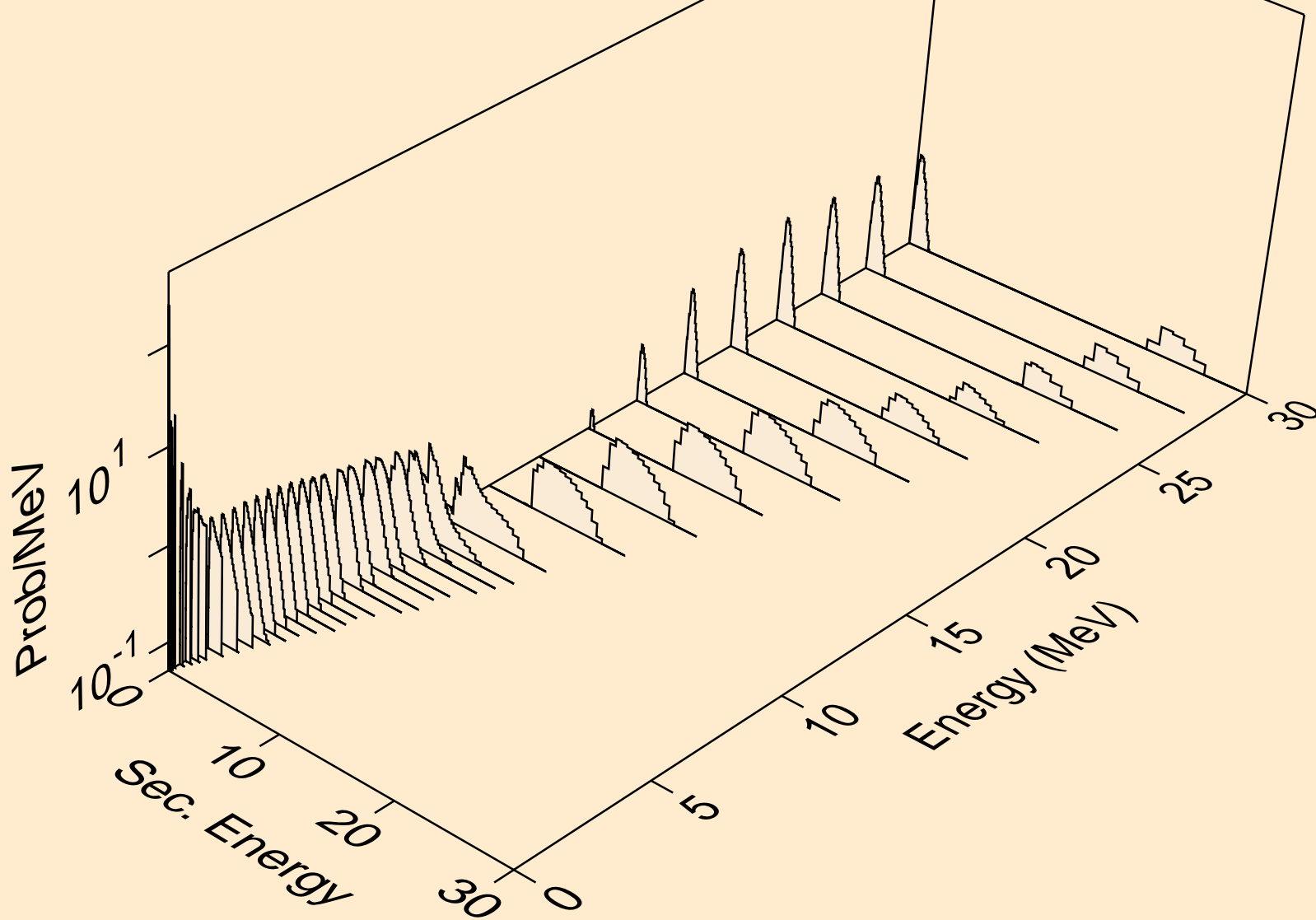

DB261 NEUTRON ACER TENDL-2019 LIBRARY; T=293.16K  
Neutron emission for (n,2n)a

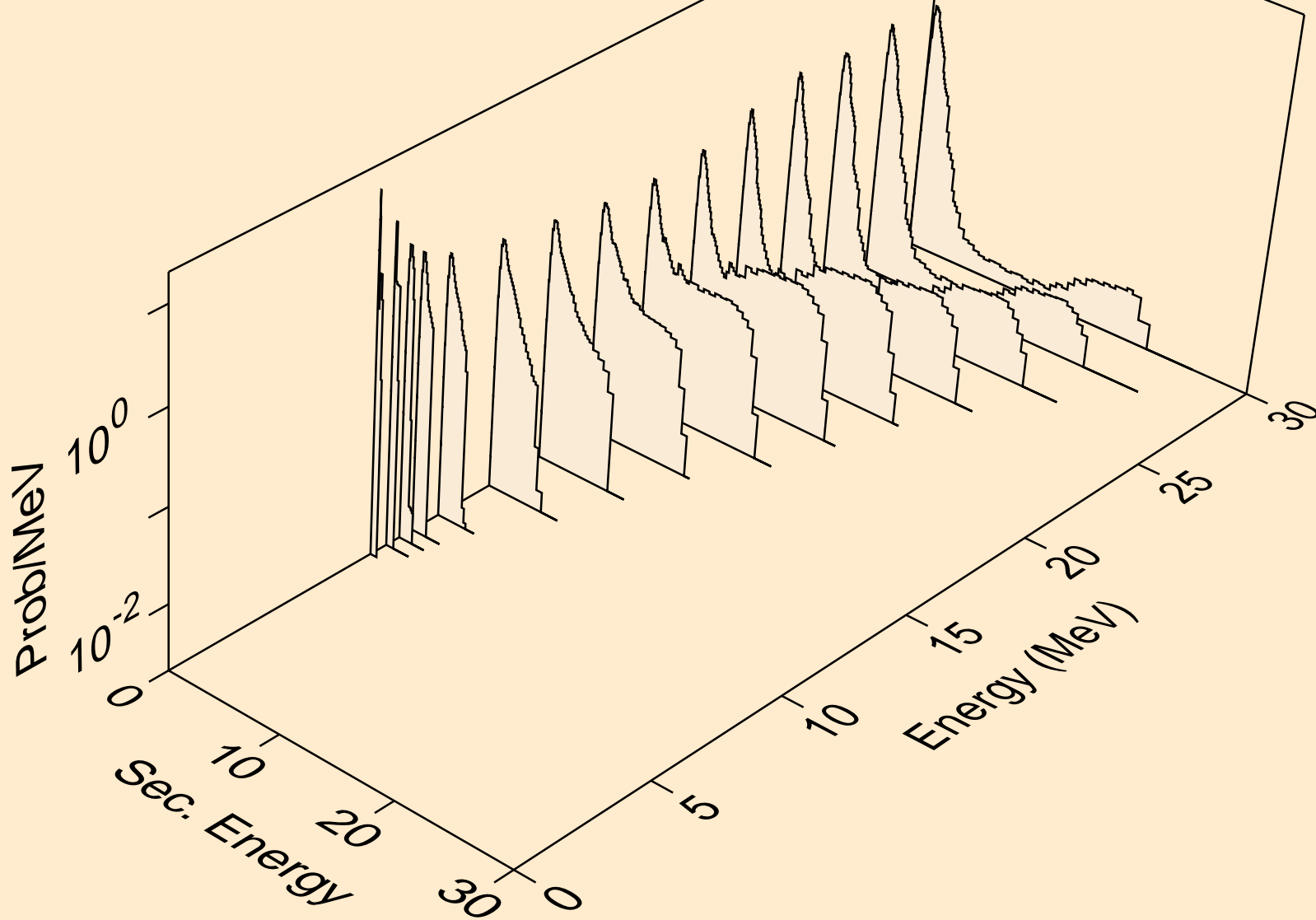

DB261 NEUTRON ACER TENDL-2019 LIBRARY; T=293.16K  
Neutron emission for (n,3n)a

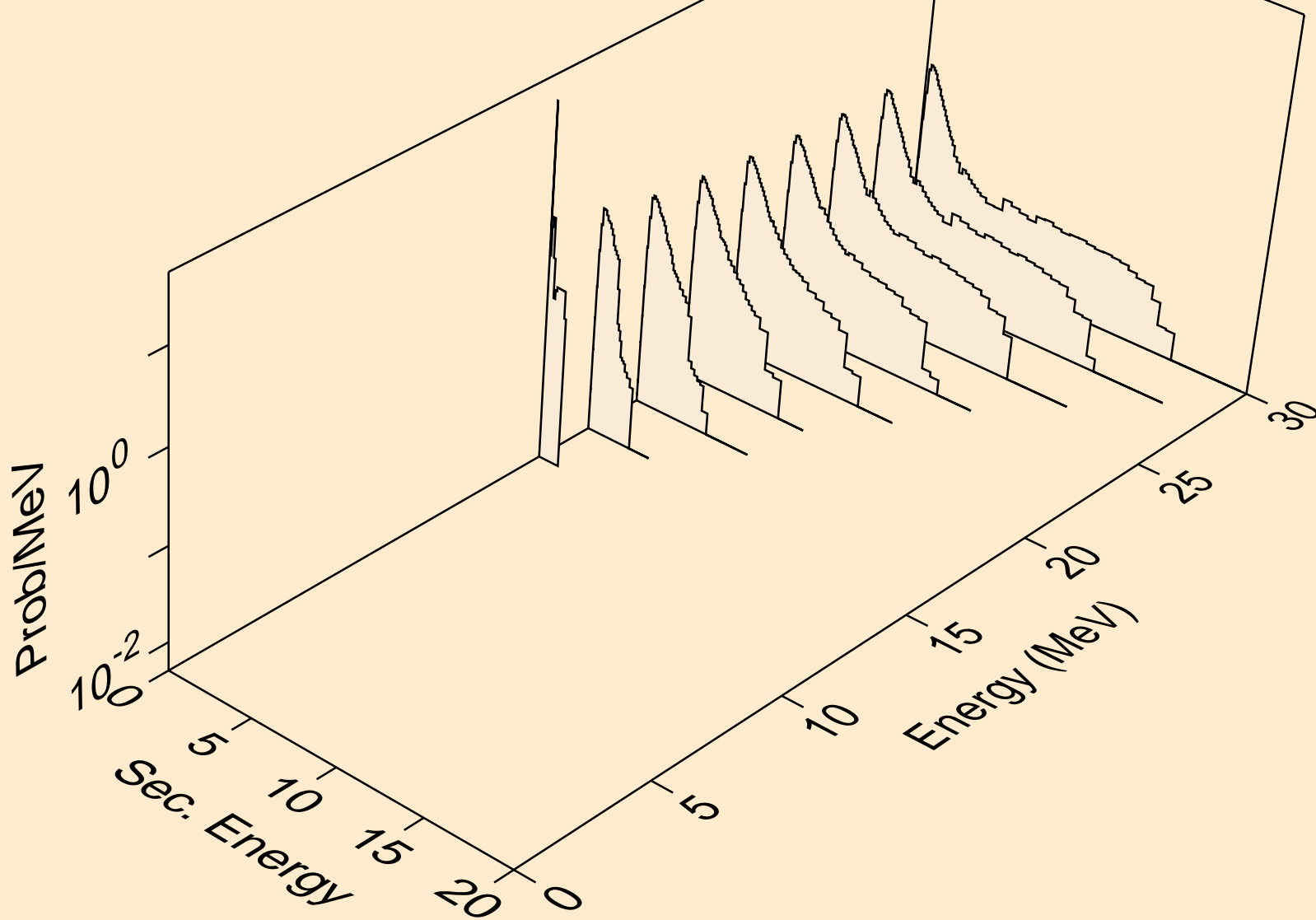

DB261 NEUTRON ACER TENDL-2019 LIBRARY; T=293.16K  
Neutron emission for (n,n\*)p

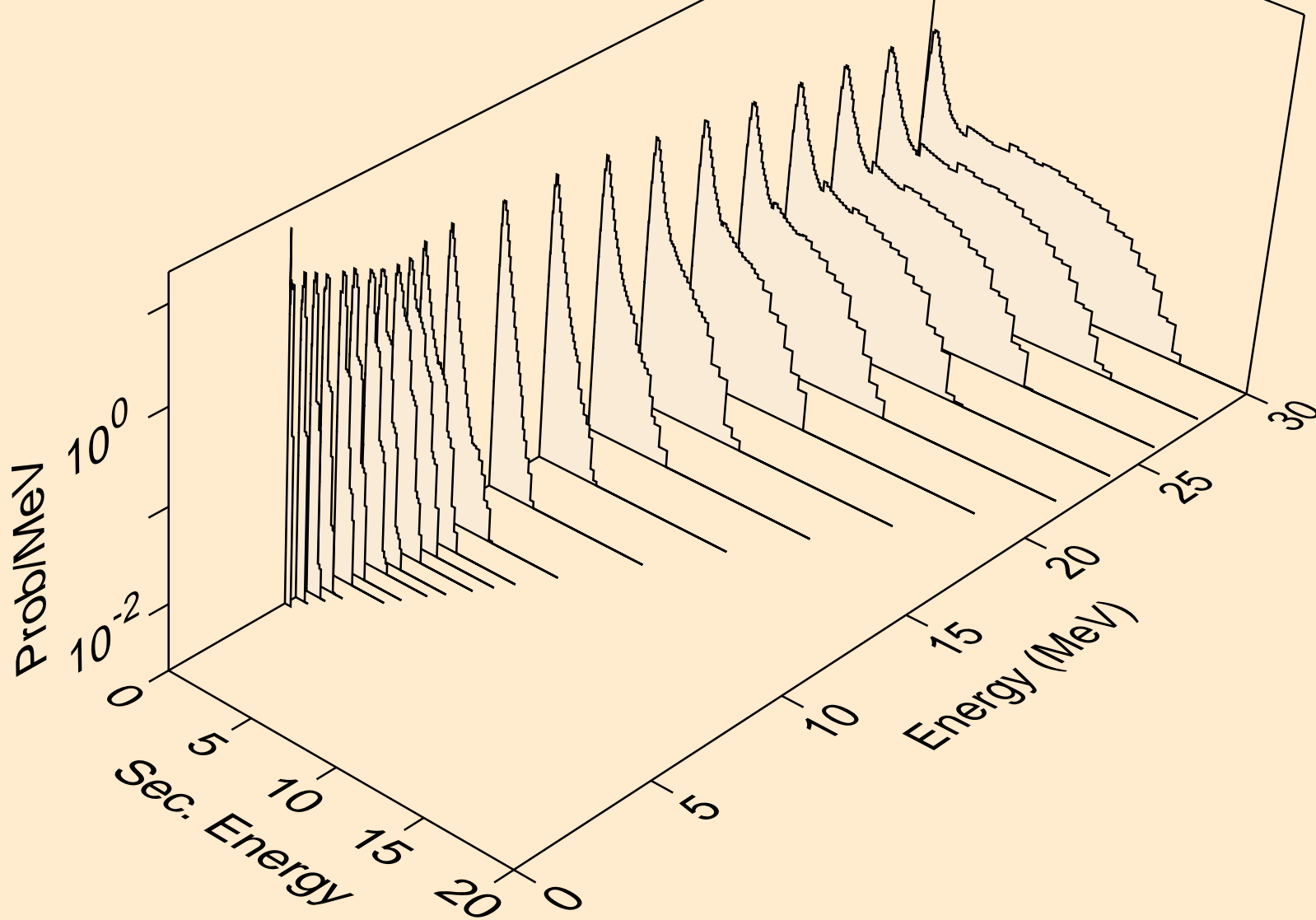

DB261 NEUTRON ACER TENDL-2019 LIBRARY; T=293.16K  
Neutron emission for (n,n\*)2a

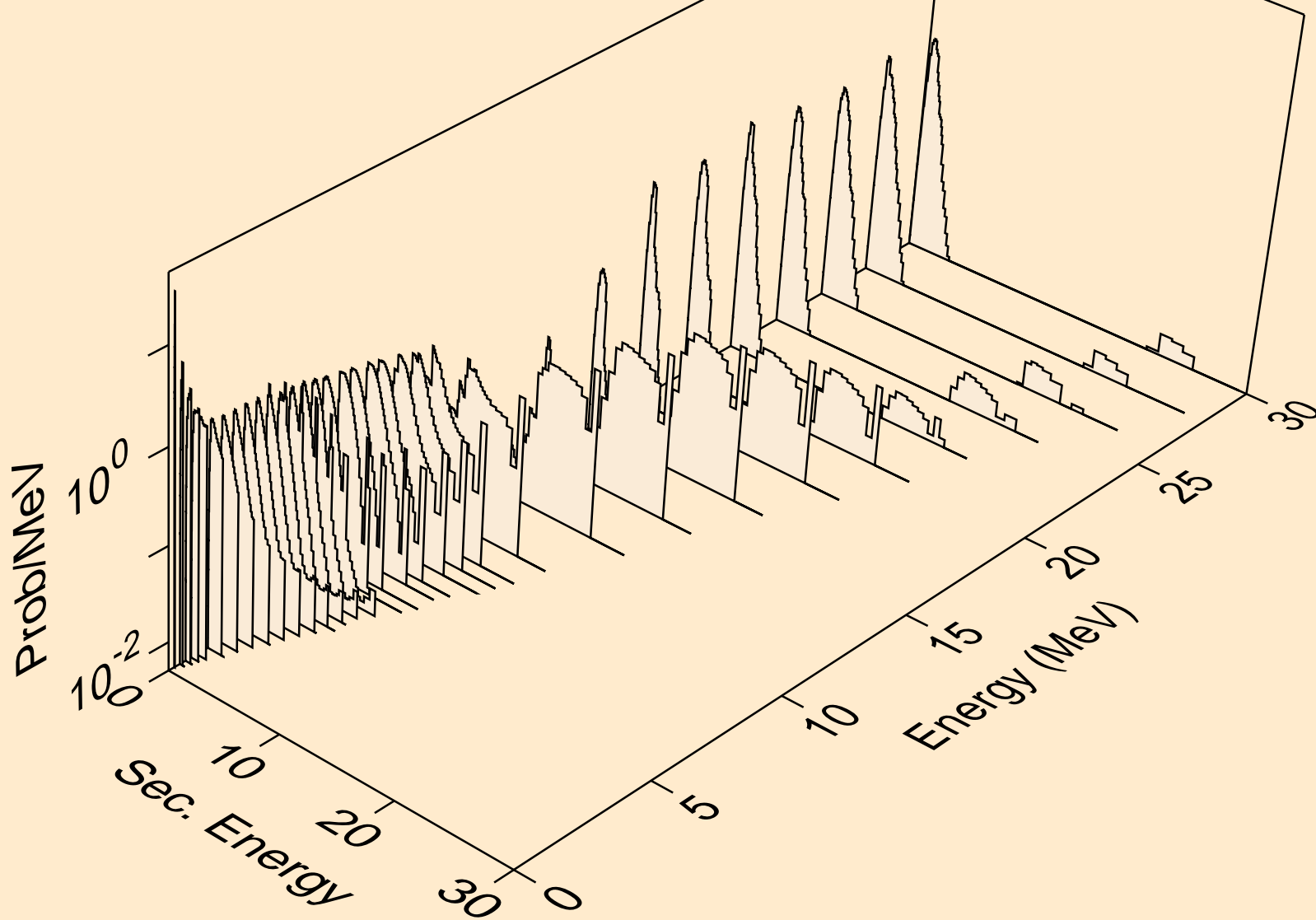

DB261 NEUTRON ACER TENDL-2019 LIBRARY; T=293.16K  
Neutron emission for (n,2n)2a

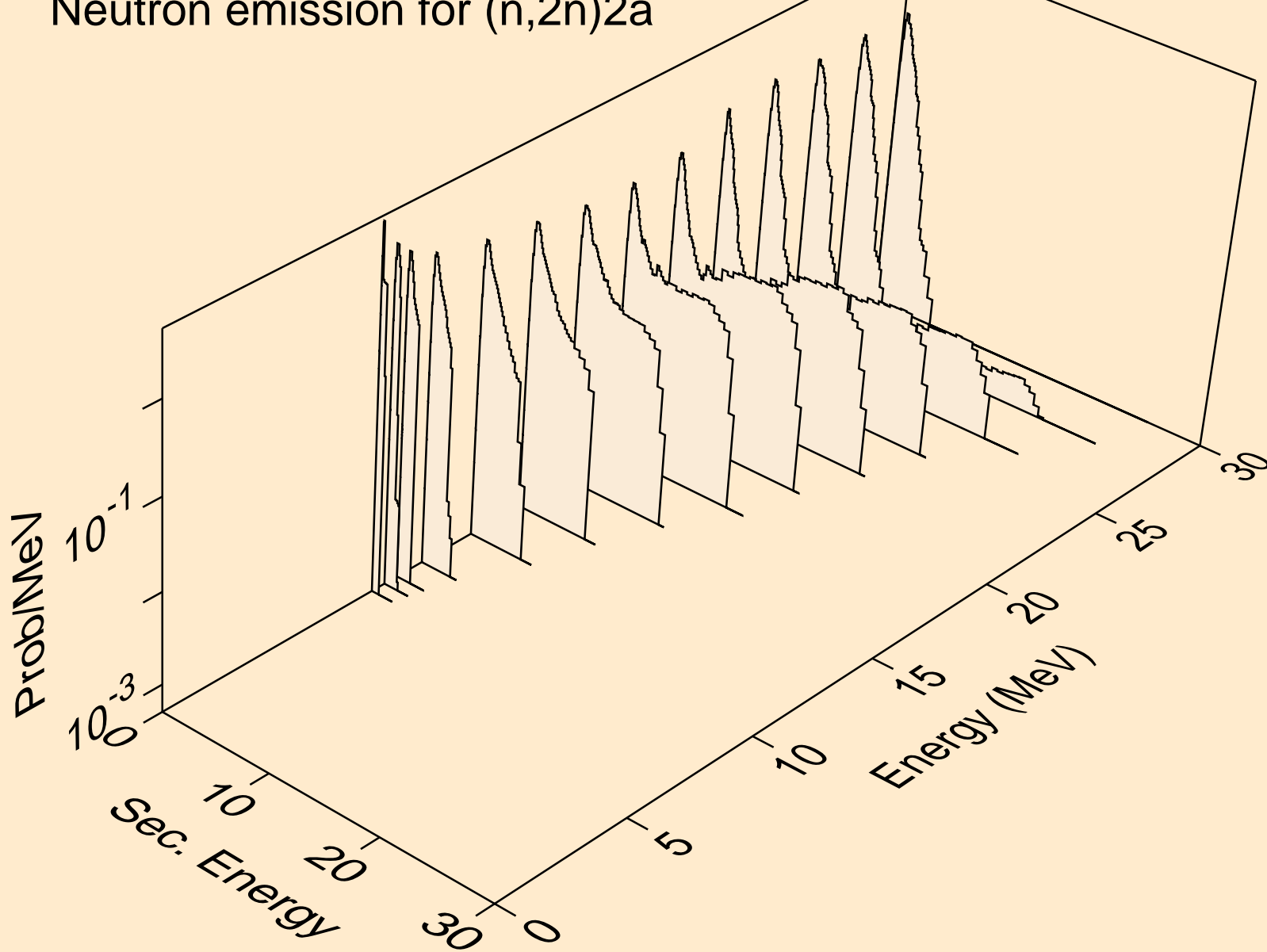

DB261 NEUTRON ACER TENDL-2019 LIBRARY; T=293.16K  
Neutron emission for (n,n\*)d

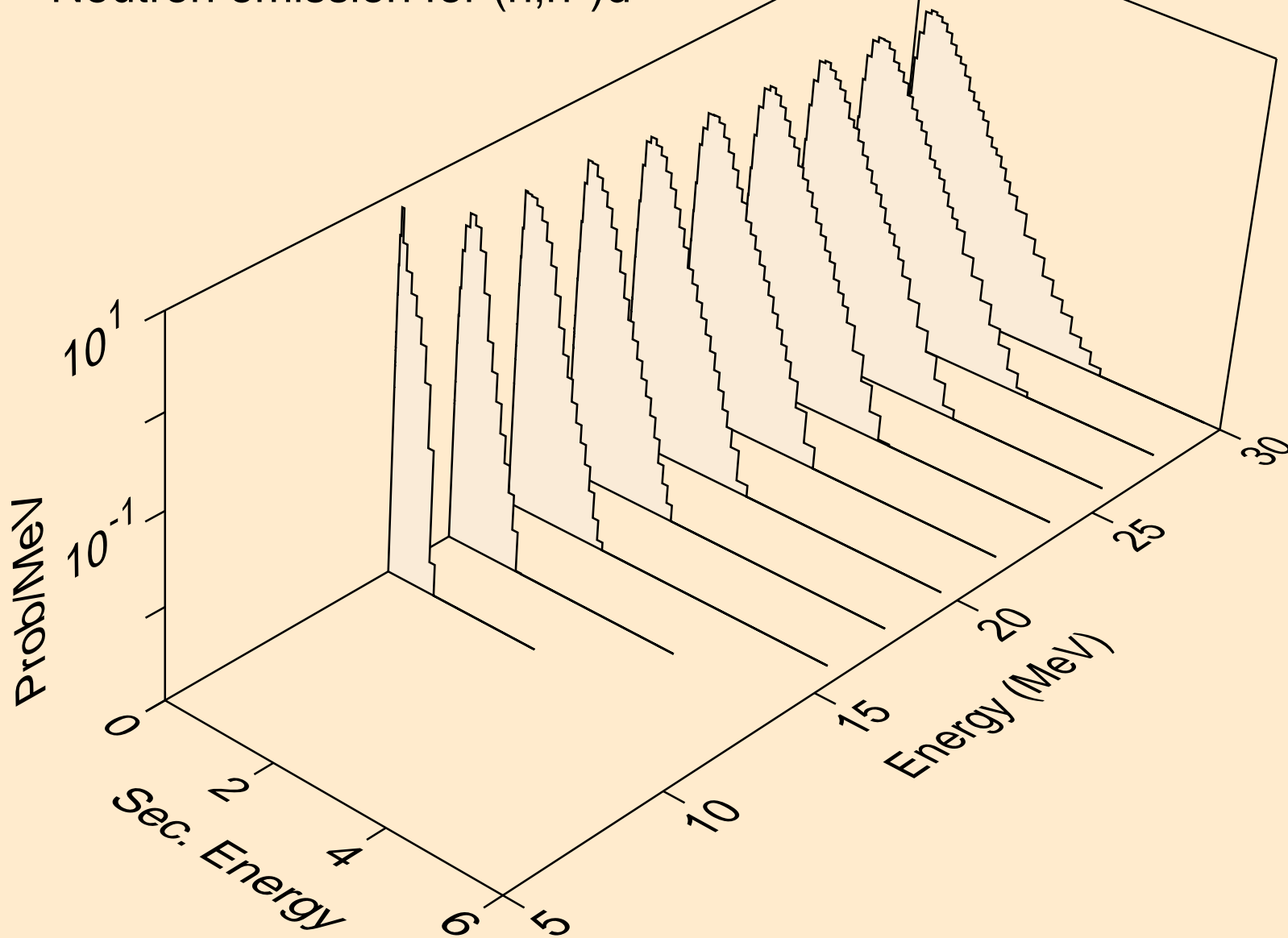

DB261 NEUTRON ACER TENDL-2019 LIBRARY; T=293.16K  
Neutron emission for (n,n\*)t

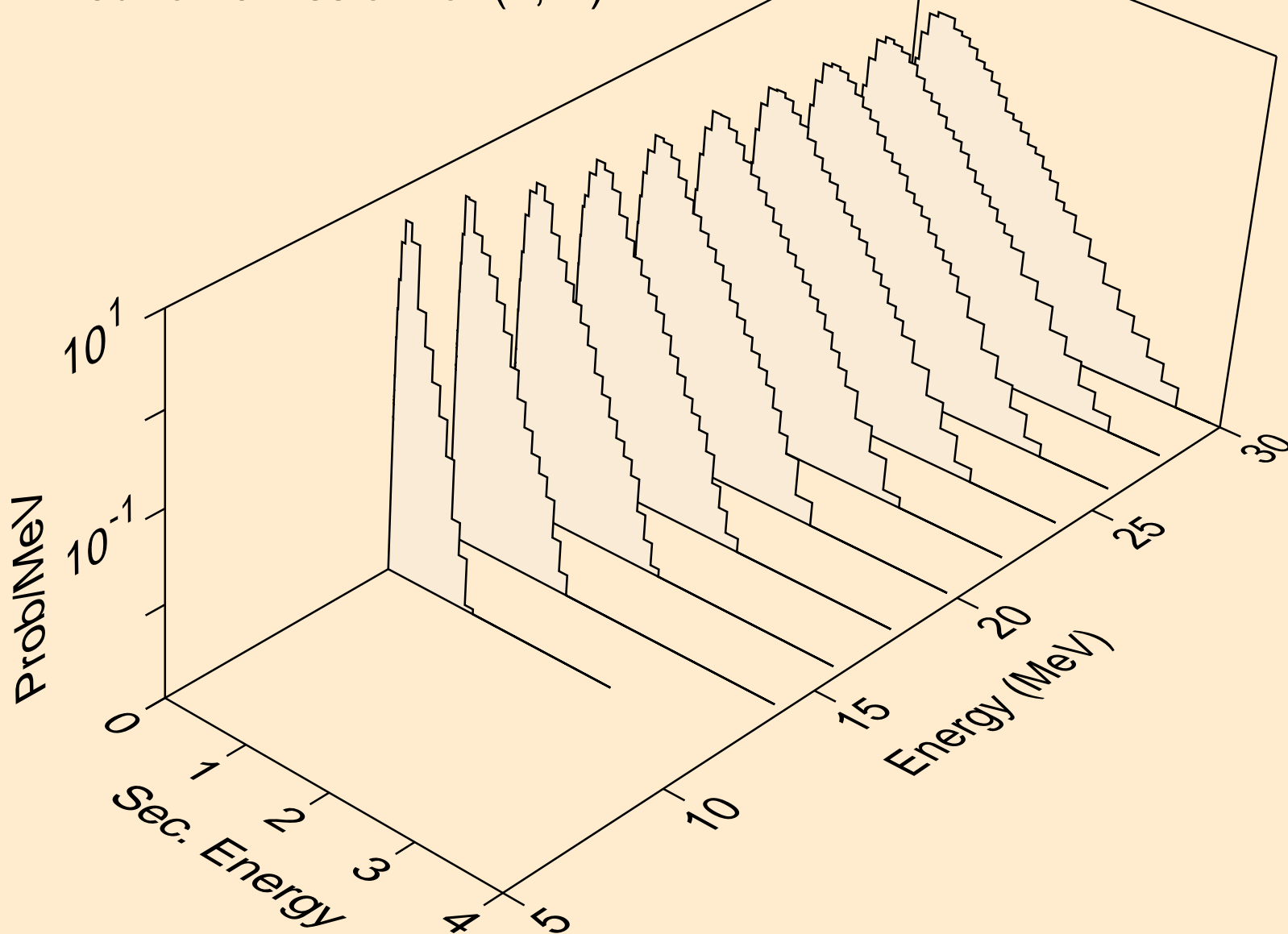

DB261 NEUTRON ACER TENDL-2019 LIBRARY; T=293.16K  
Neutron emission for (n,n\*)he3

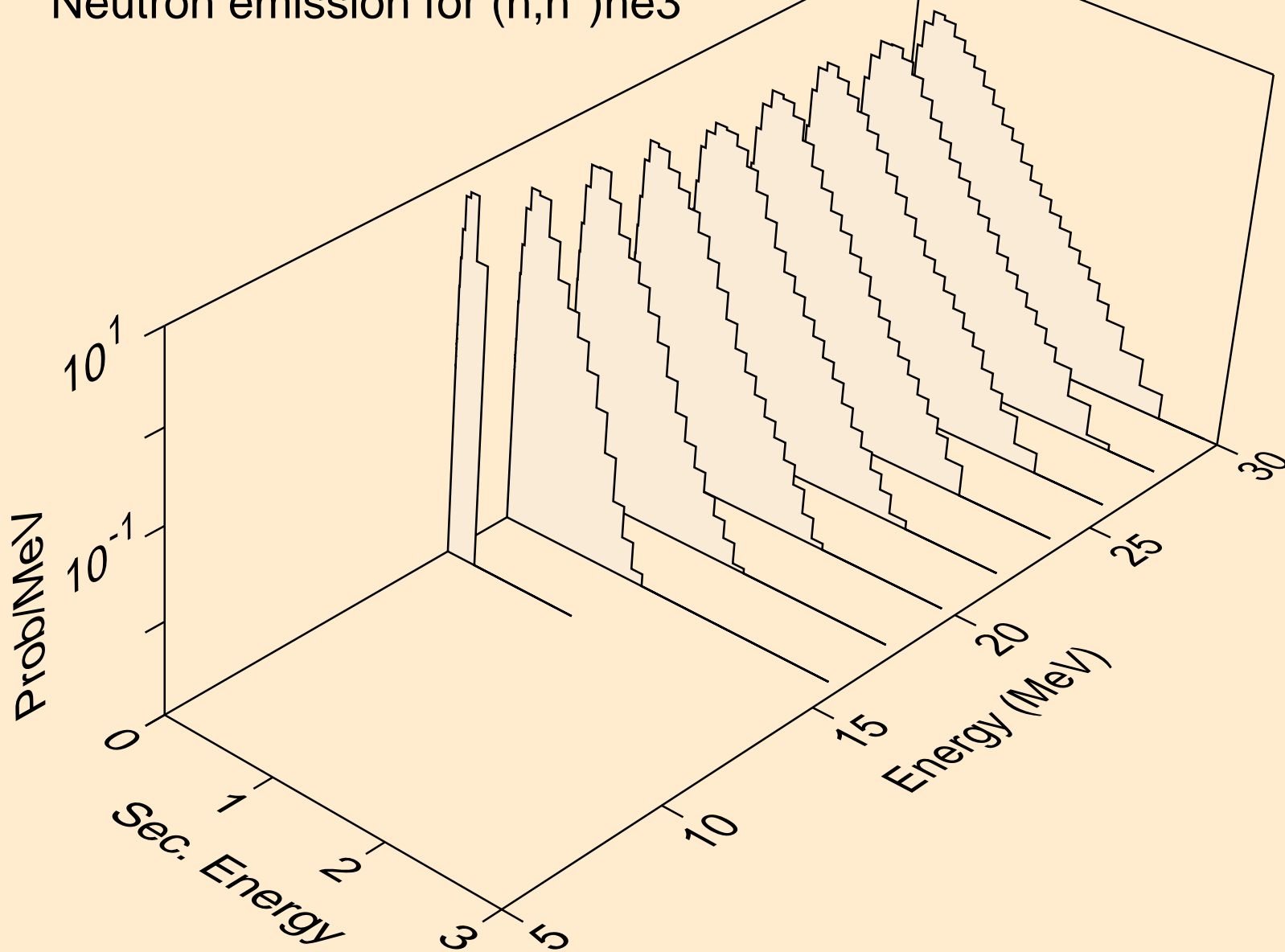

DB261 NEUTRON ACER TENDL-2019 LIBRARY; T=293.16K  
Neutron emission for (n,n\*)d2a

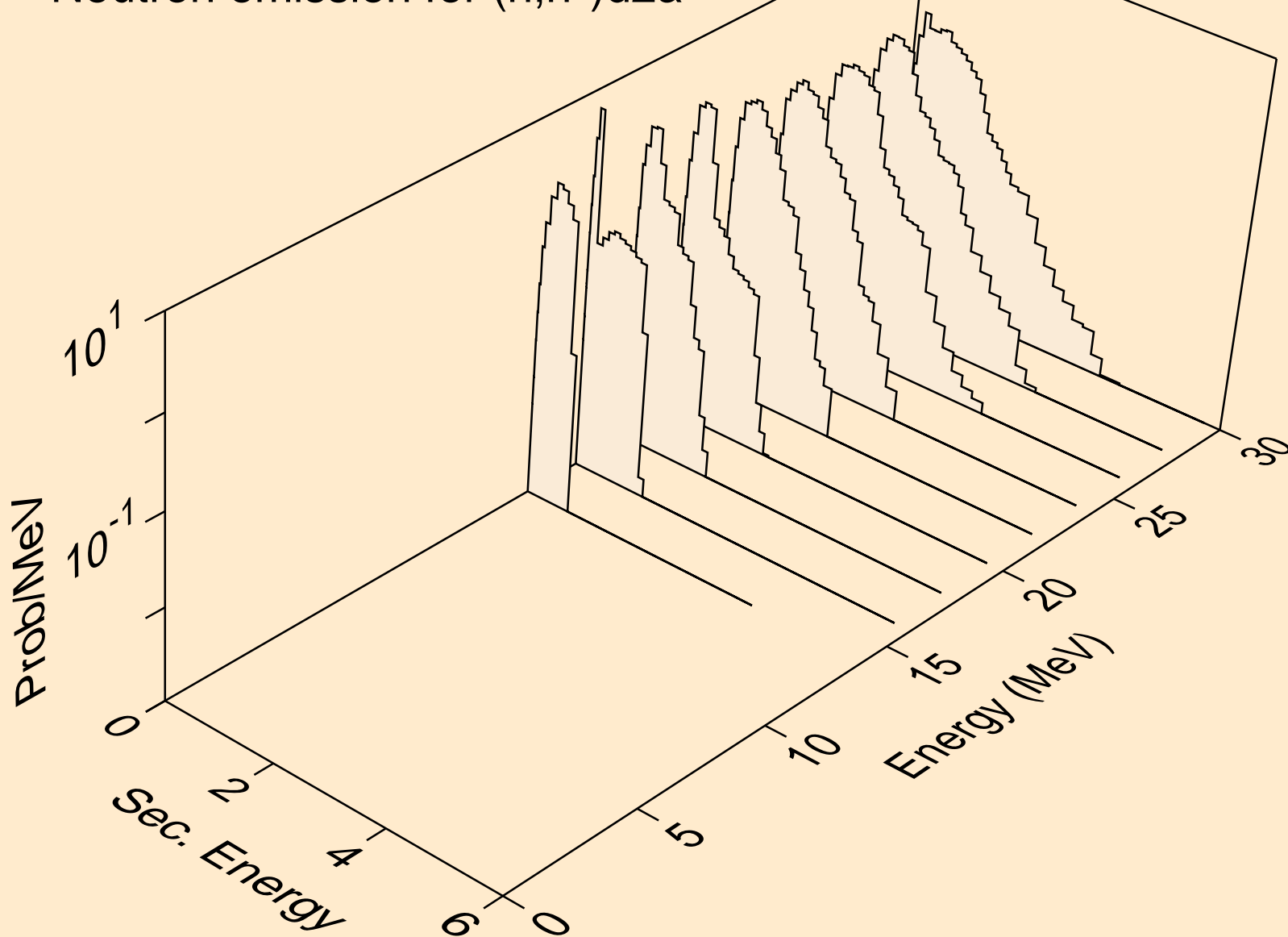

DB261 NEUTRON ACER TENDL-2019 LIBRARY; T=293.16K  
Neutron emission for (n,n\*)t2a

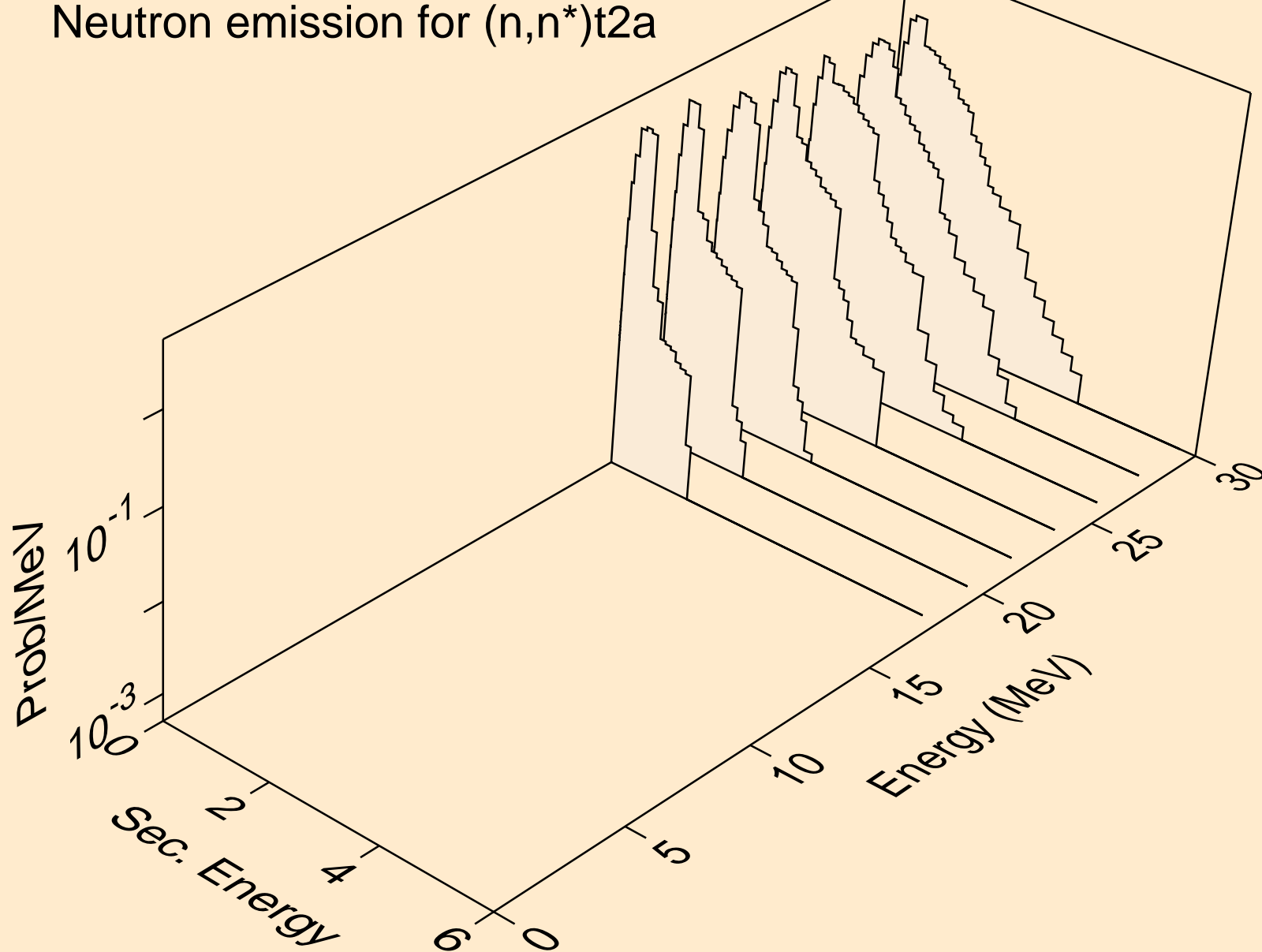

DB261 NEUTRON ACER TENDL-2019 LIBRARY; T=293.16K  
Neutron emission for (n,4n)

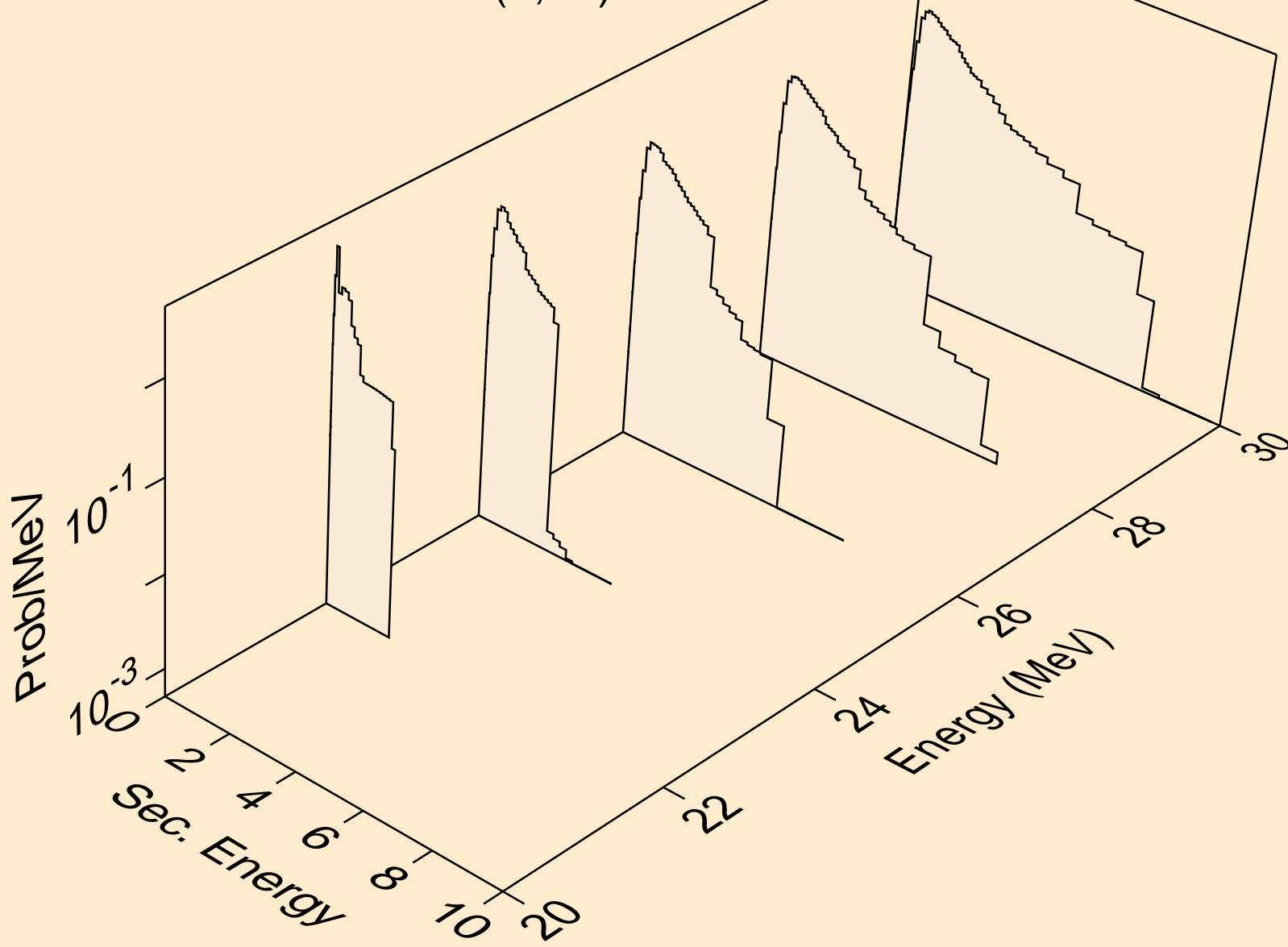

DB261 NEUTRON ACER TENDL-2019 LIBRARY; T=293.16K  
Neutron emission for (n,2np)

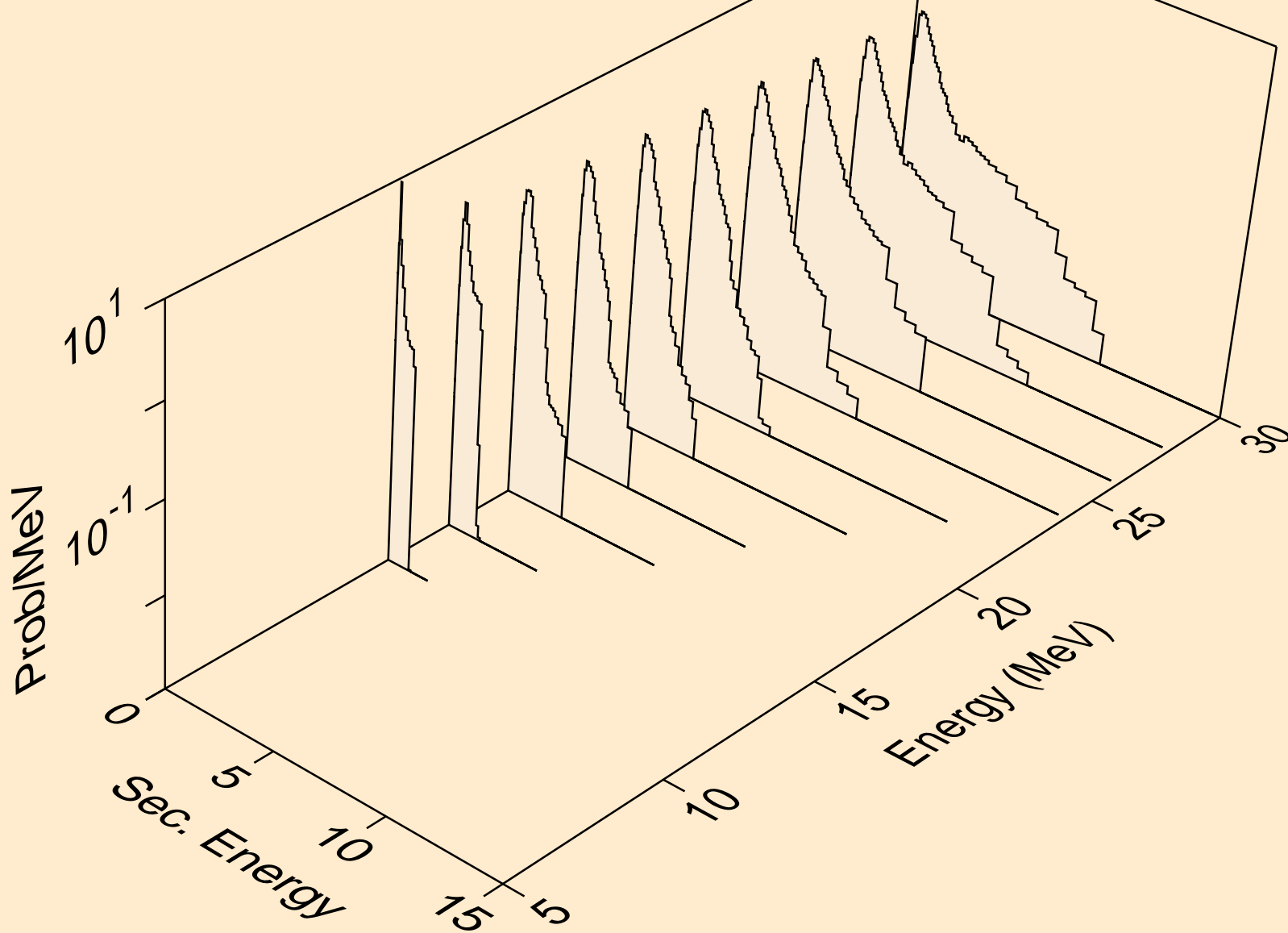

DB261 NEUTRON ACER TENDL-2019 LIBRARY; T=293.16K  
Neutron emission for (n,3np)

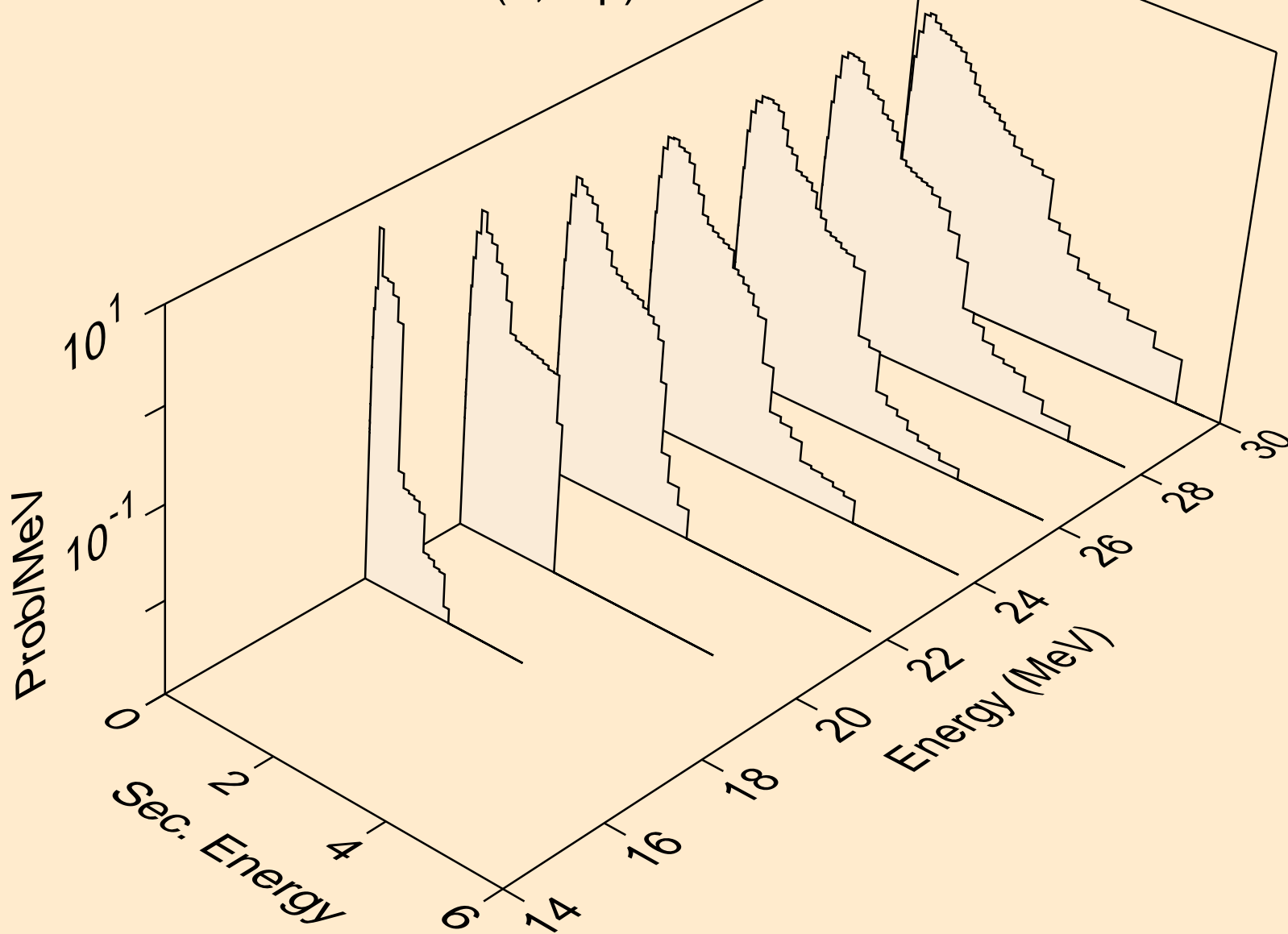

DB261 NEUTRON ACER TENDL-2019 LIBRARY; T=293.16K  
Neutron emission for (n,2np)

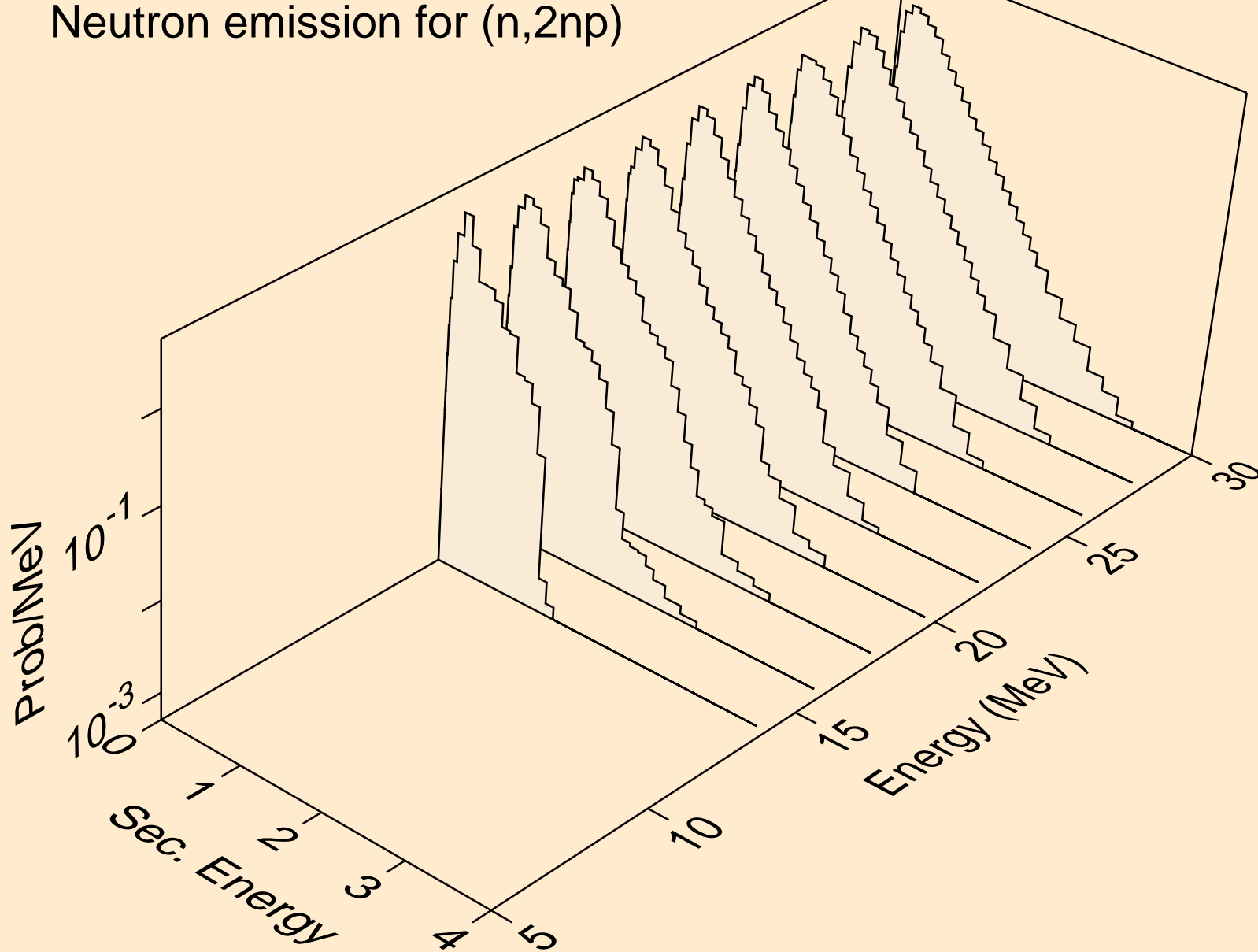

DB261 NEUTRON ACER TENDL-2019 LIBRARY; T=293.16K  
Neutron emission for (n,npa)

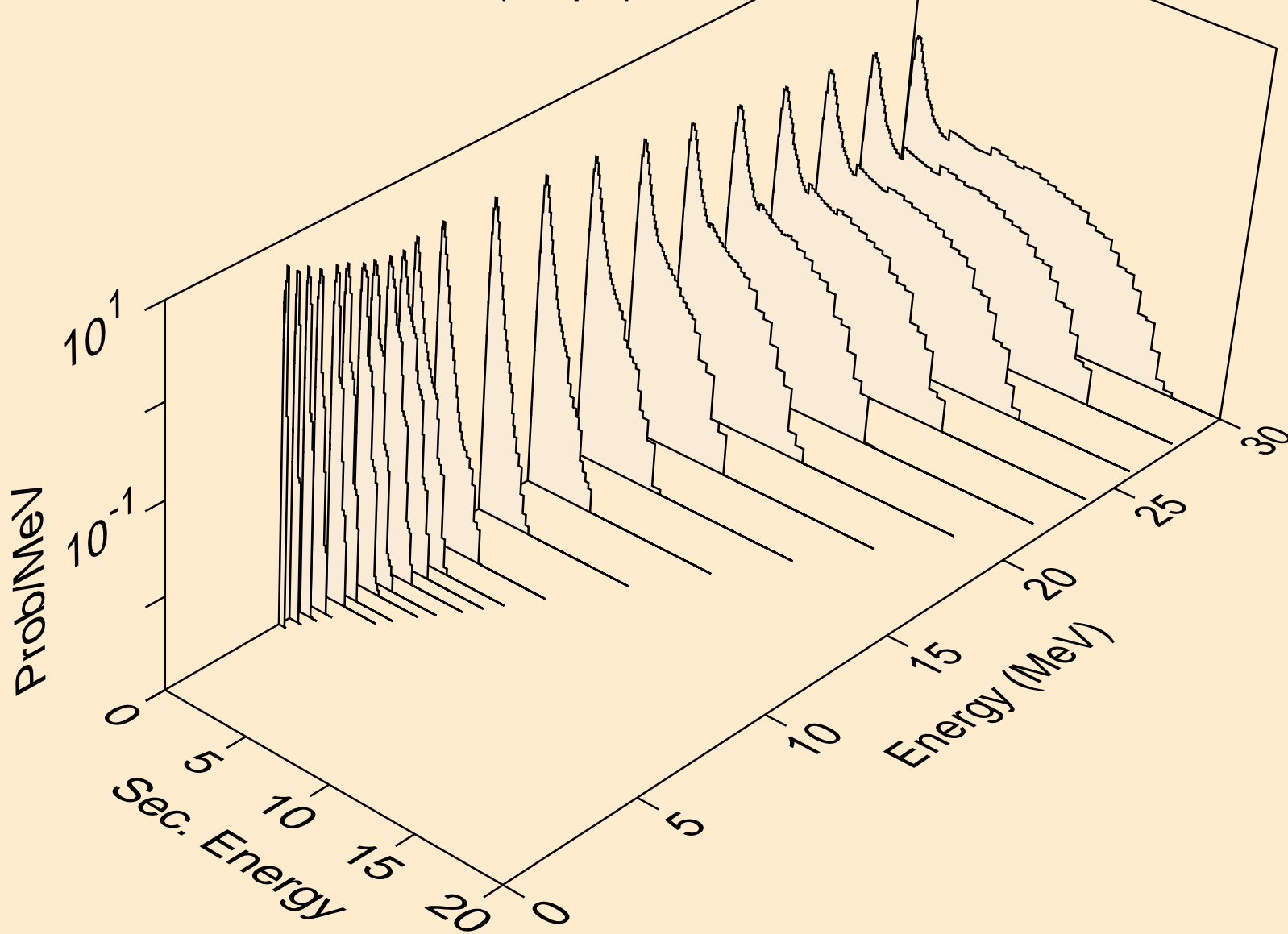

DB261 NEUTRON ACER TENDL-2019 LIBRARY; T=293.16K  
Neutron emission for (n,n\*c)

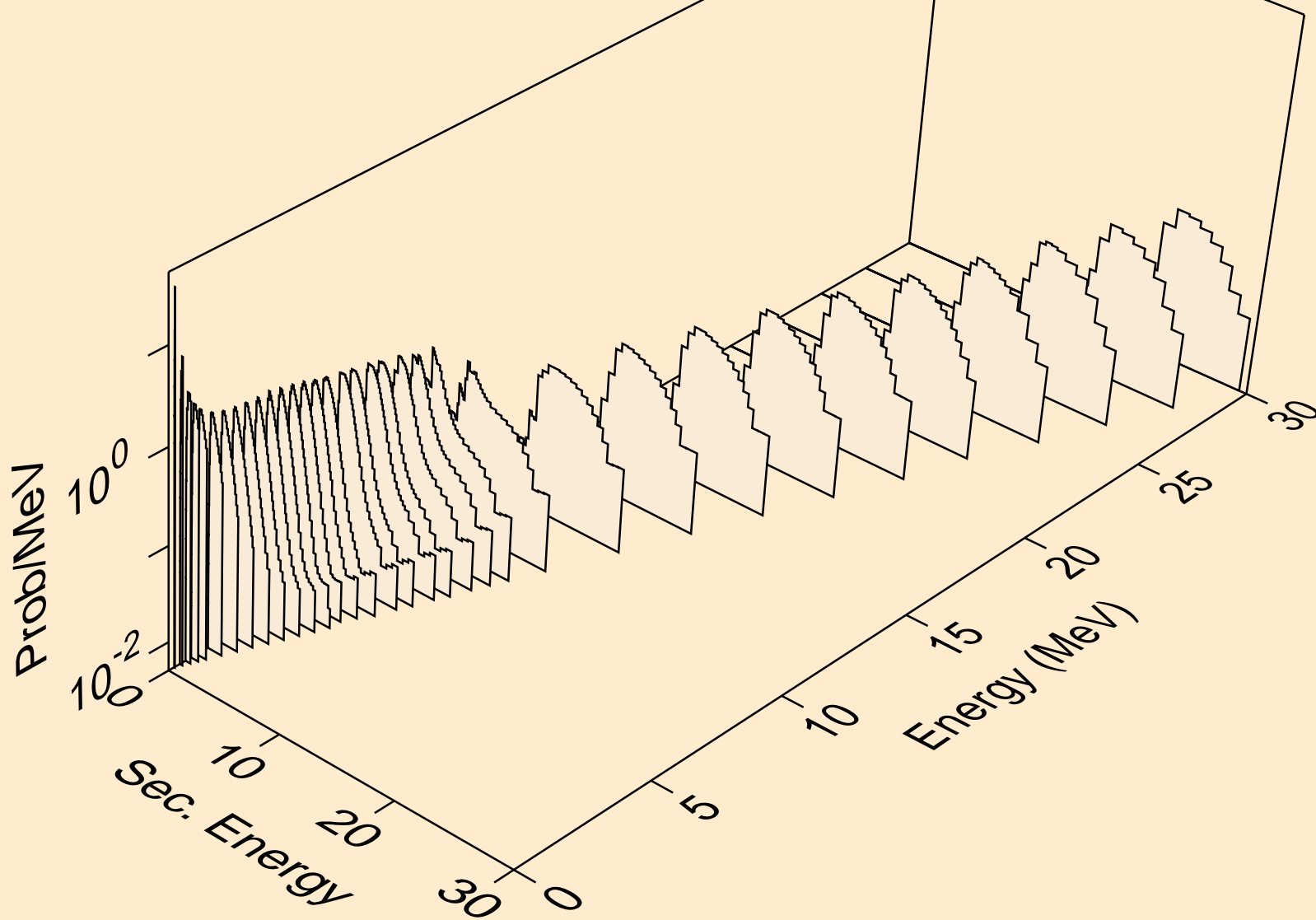

DB261 NEUTRON ACER TENDL-2019 LIBRARY; T=293.16K

Delayed nubar

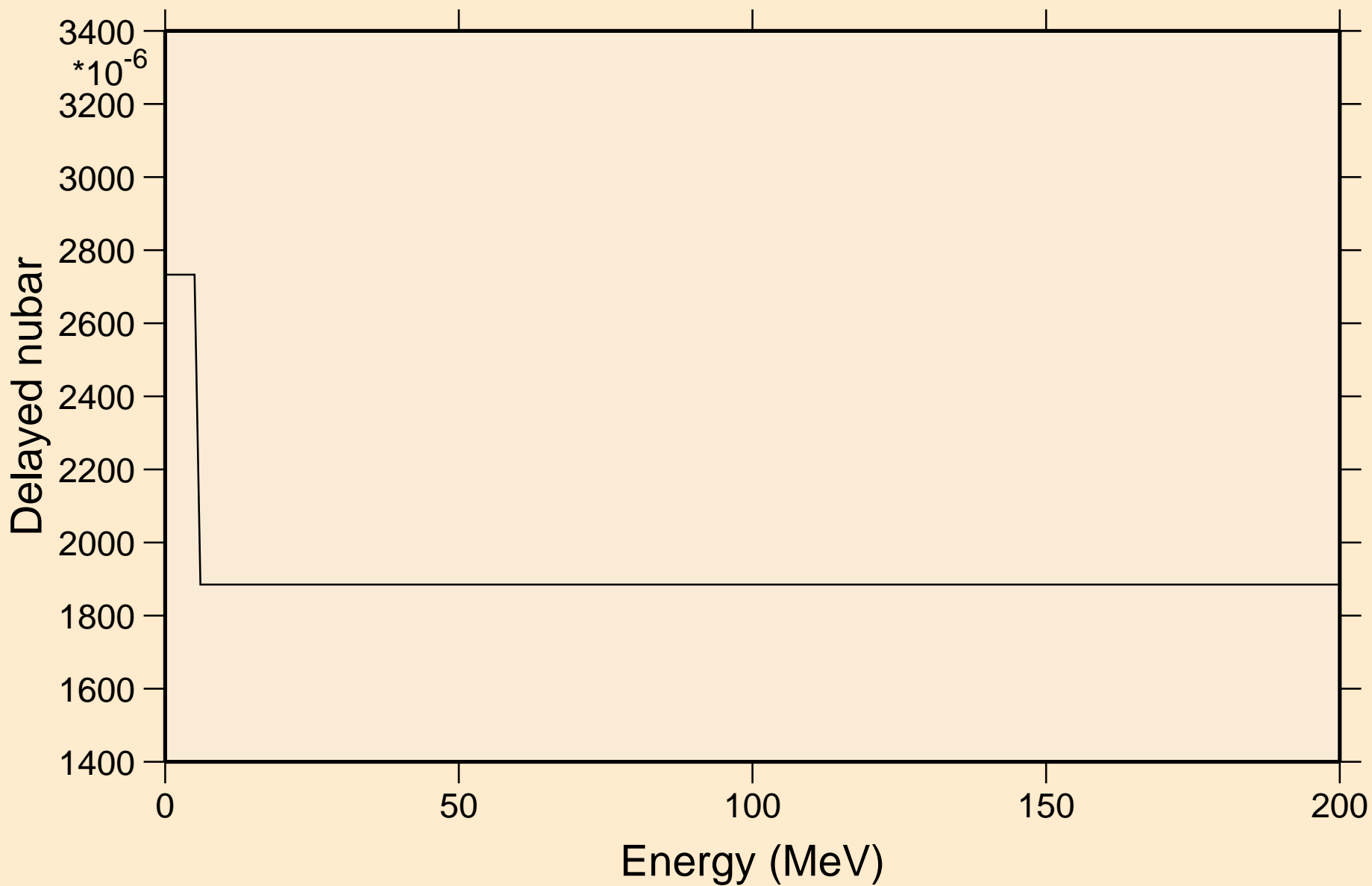

DB261 NEUTRON ACER TENDL-2019 LIBRARY; T=293.16K  
Delayed neutron spectra

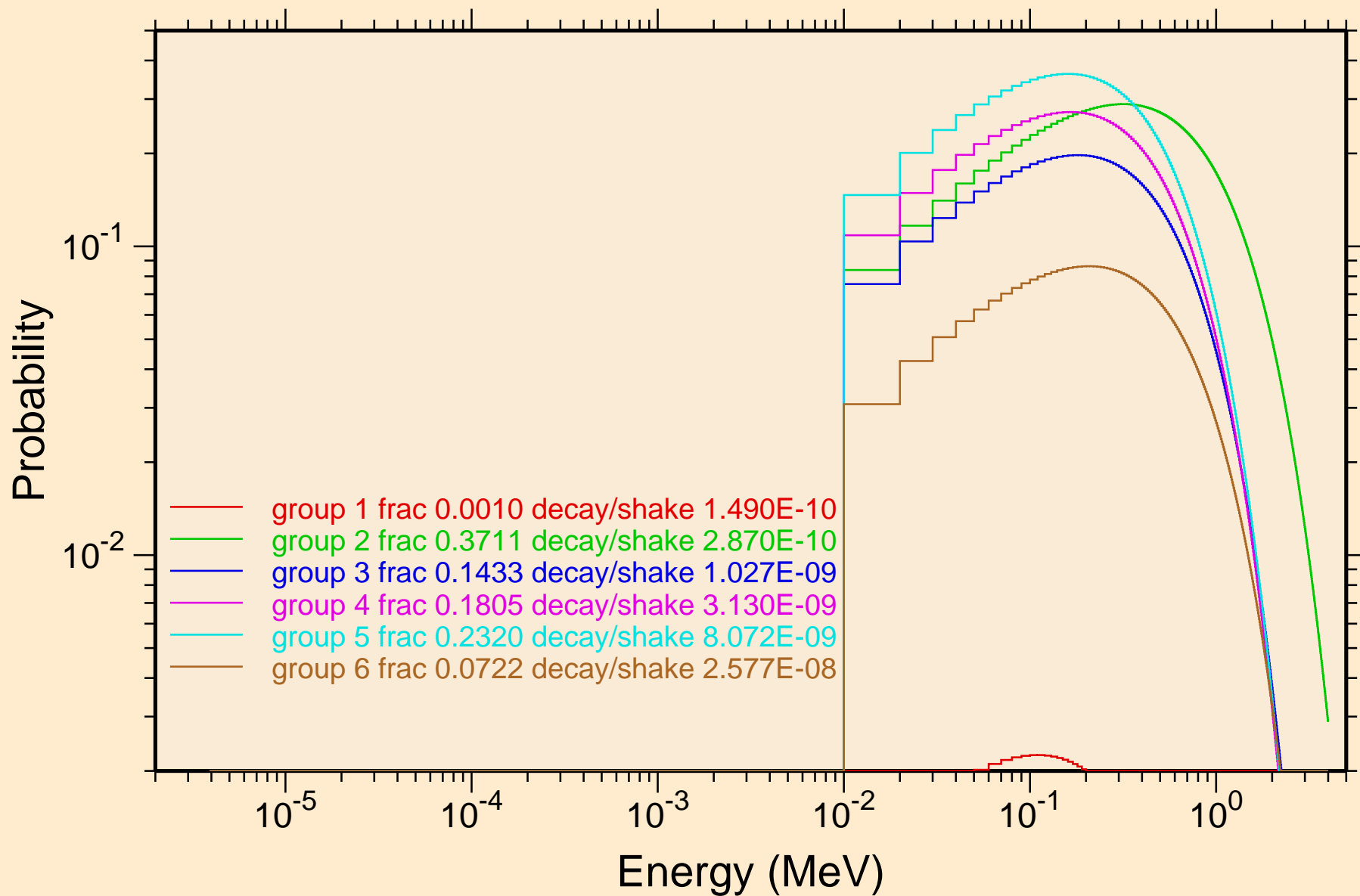

DB261 NEUTRON ACER TENDL-2019 LIBRARY; T=293.16K  
Photon emission for (n,x)

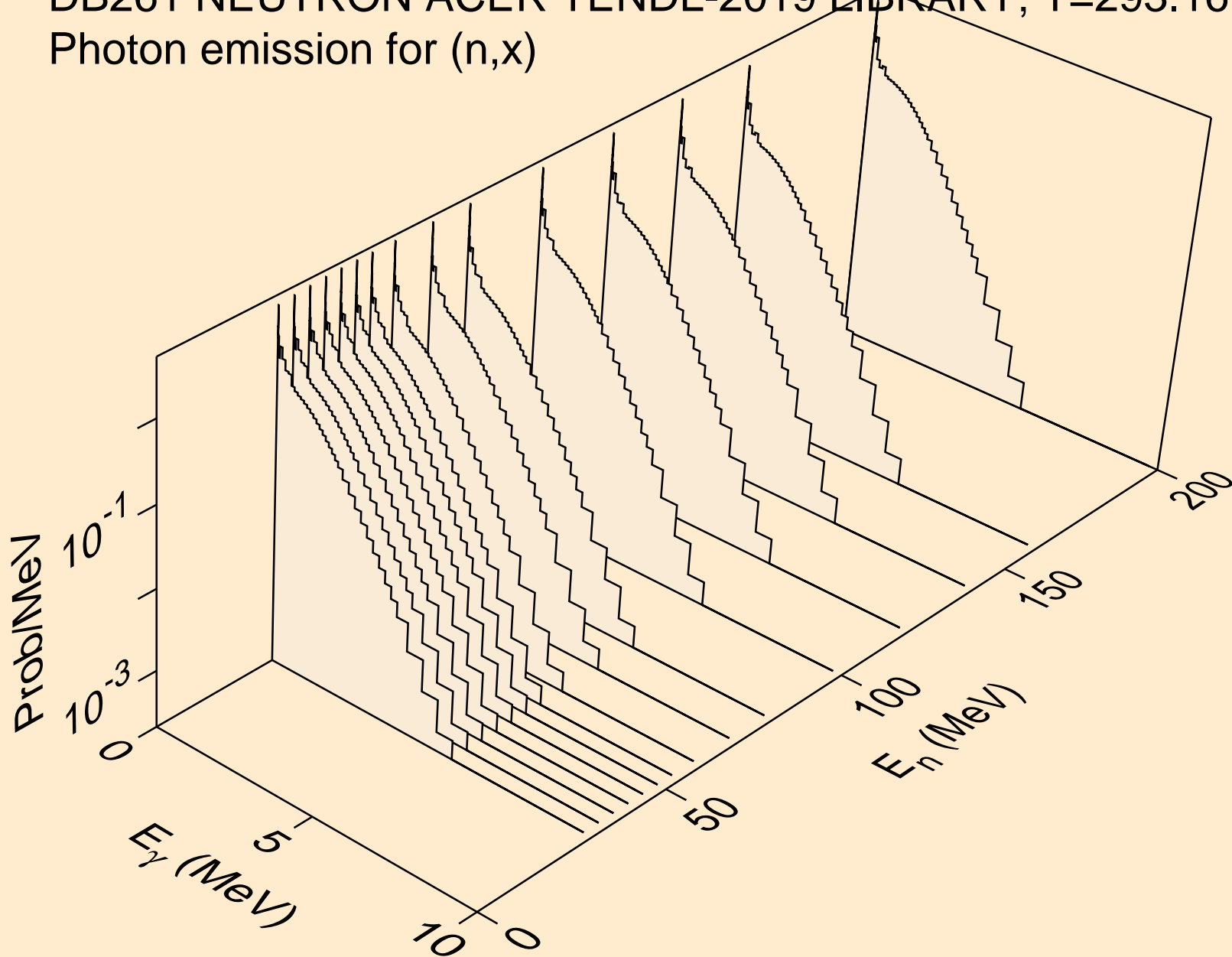

DB261 NEUTRON ACER TENDL-2019 LIBRARY; T=293.16K  
Photon emission for (n,2nd)

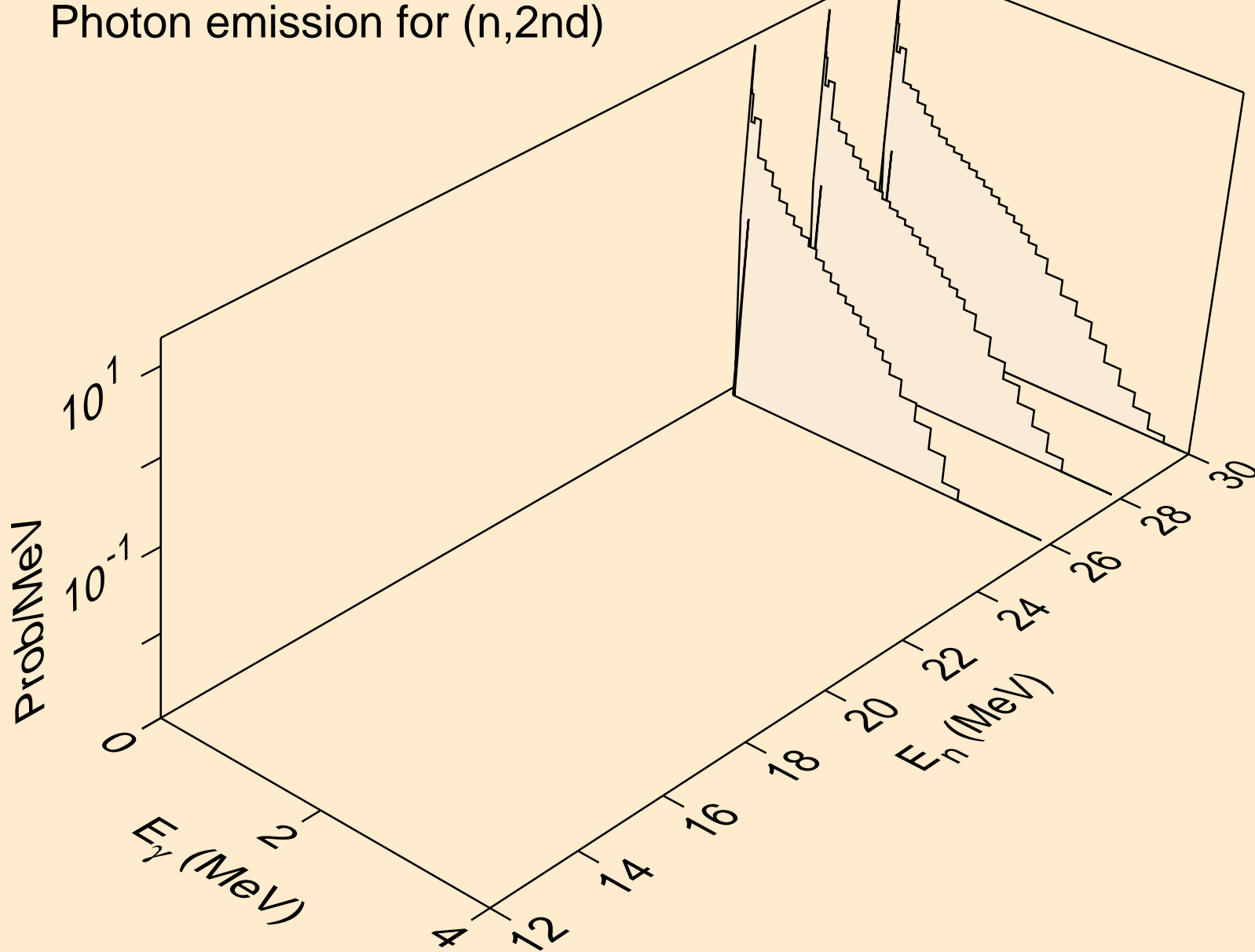

DB261 NEUTRON ACER TENDL-2019 LIBRARY; T=293.16K  
Photon emission for (n,2n)

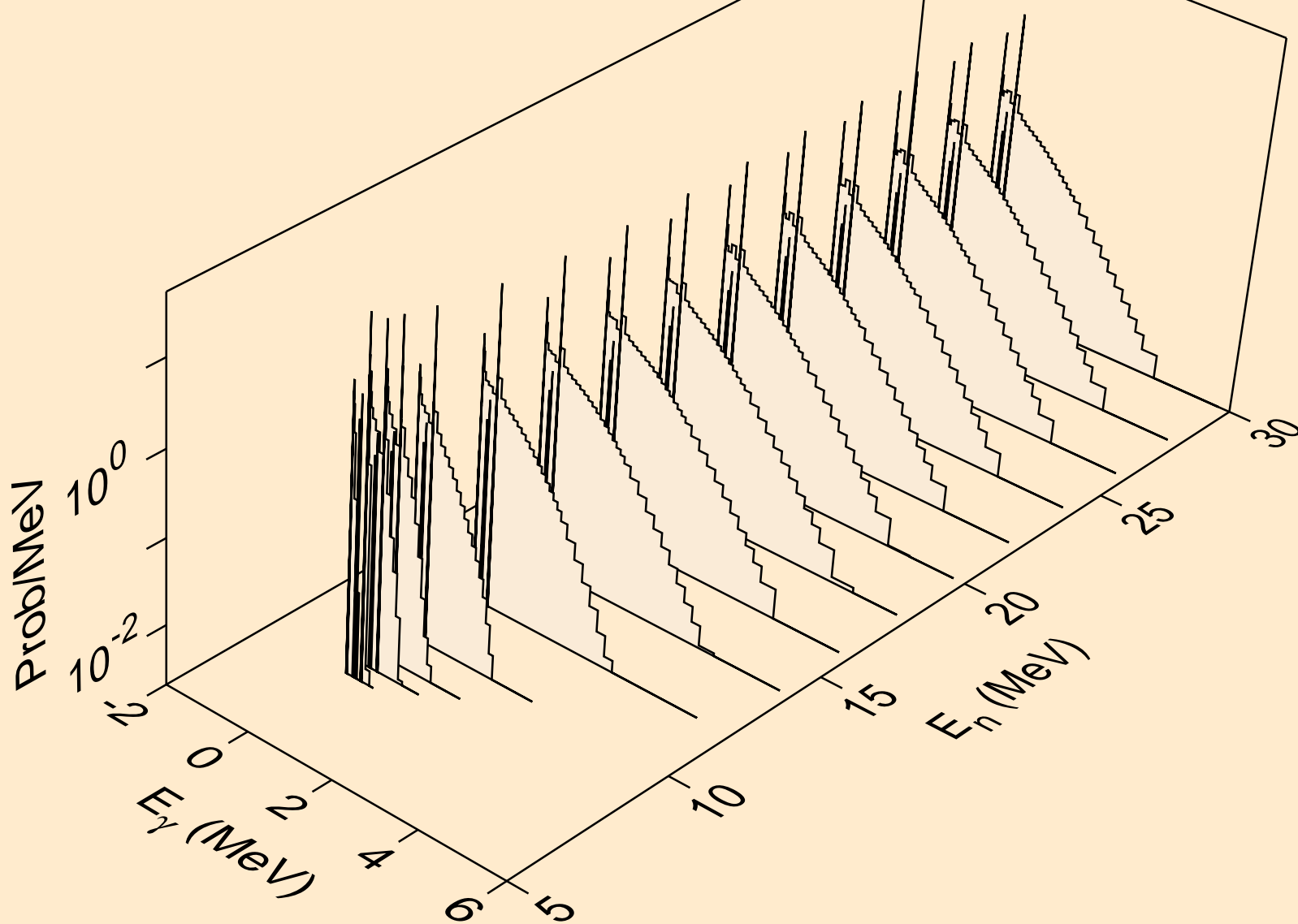

DB261 NEUTRON ACER TENDL-2019 LIBRARY; T=293.16K  
Photon emission for (n,3n)

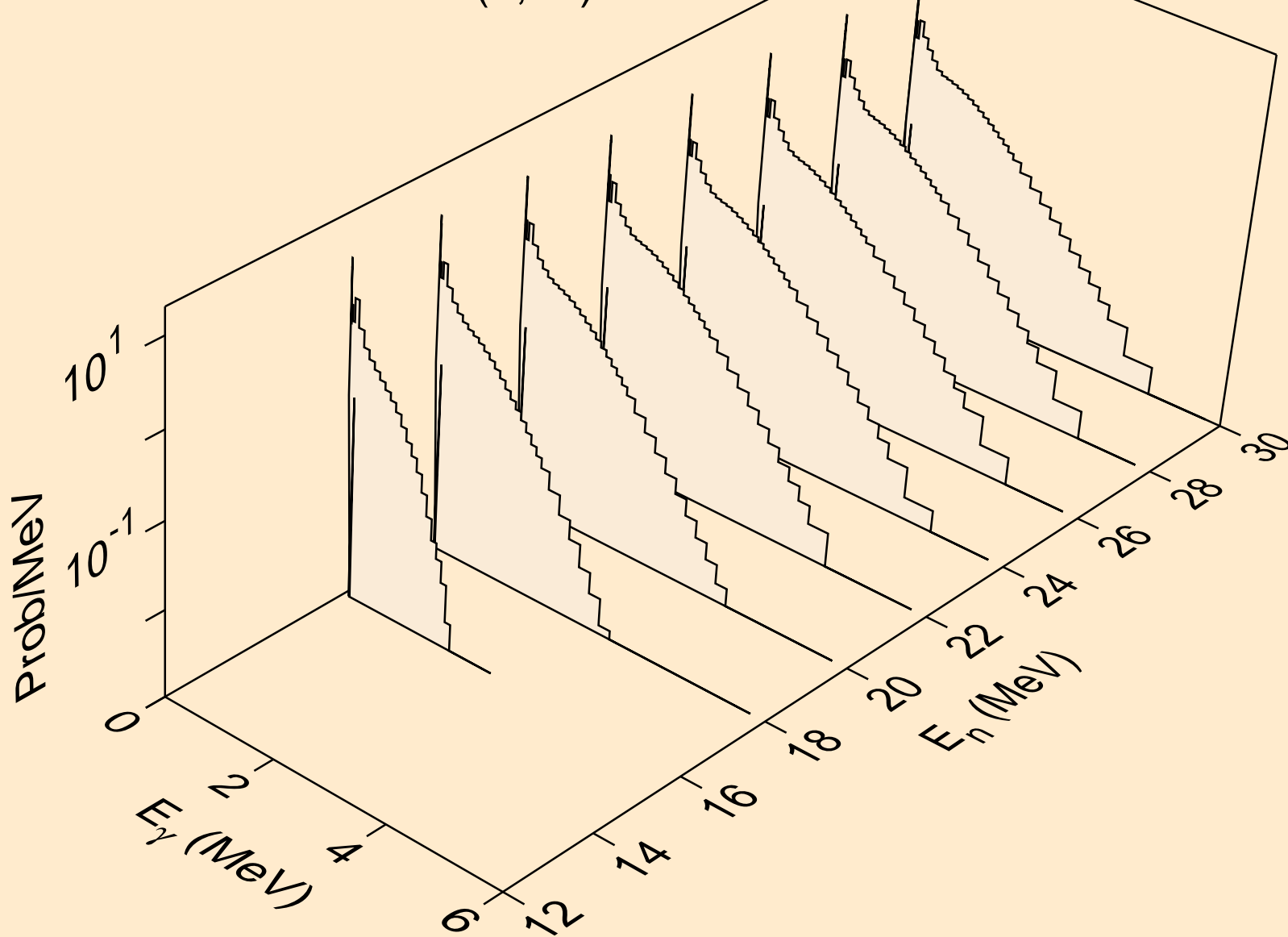

DB261 NEUTRON ACER TENDL-2019 LIBRARY; T=293.16K  
Photon emission for (n,n\*)a

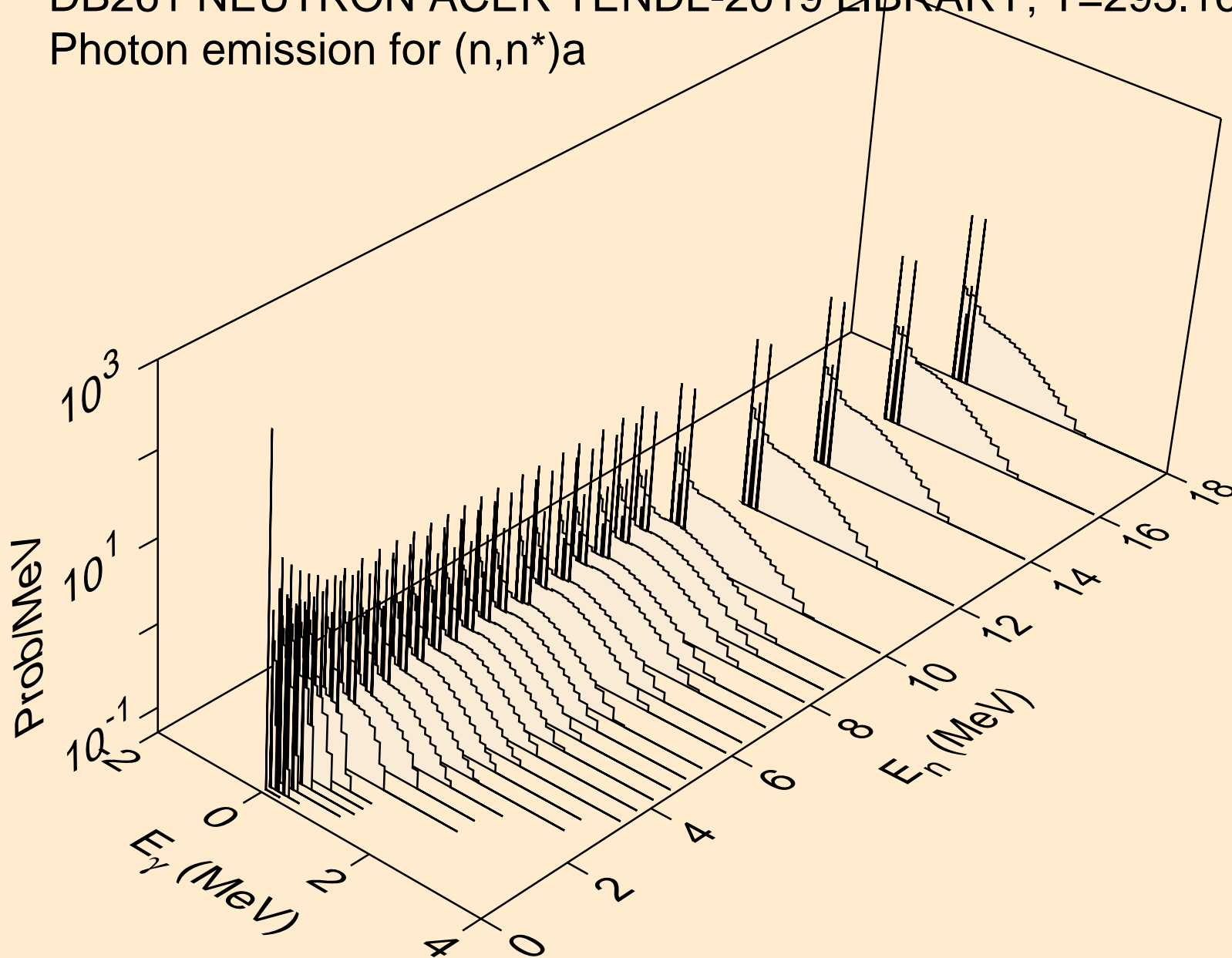

DB261 NEUTRON ACER TENDL-2019 LIBRARY; T=293.16K  
Photon emission for (n,2n)<sub>a</sub>

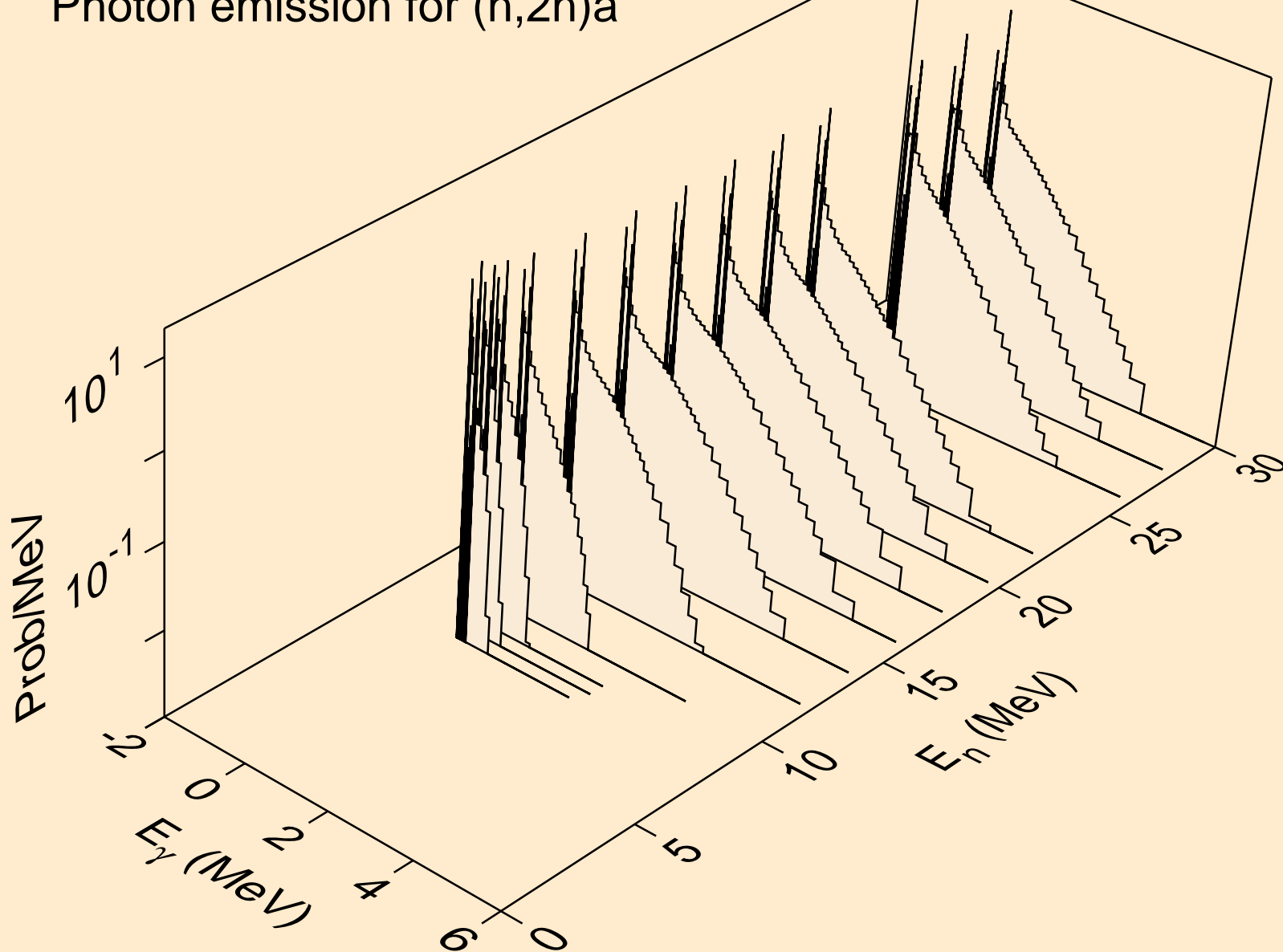

DB261 NEUTRON ACER TENDL-2019 LIBRARY; T=293.16K  
Photon emission for (n,3n)a

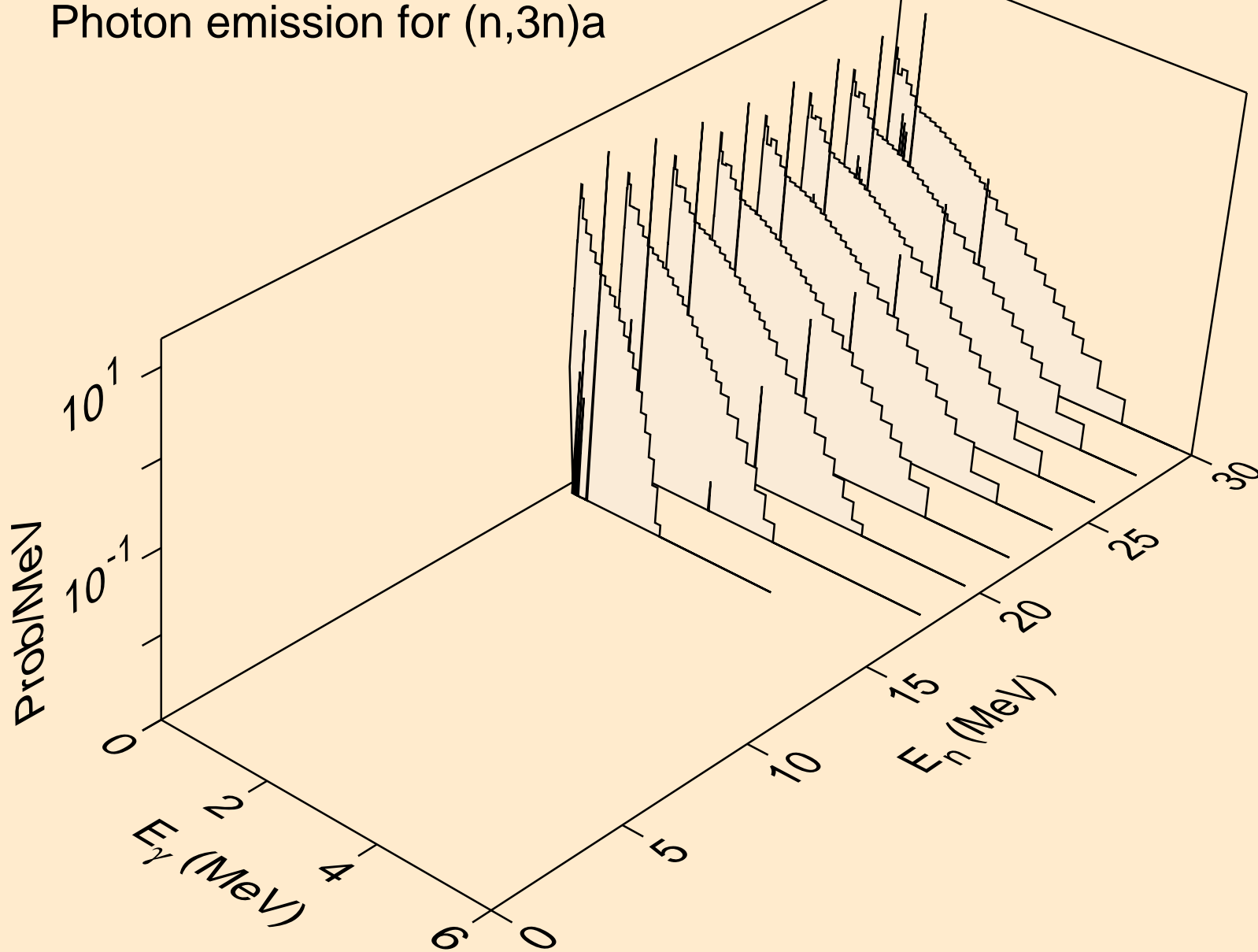

DB261 NEUTRON ACER TENDL-2019 LIBRARY; T=293.16K  
Photon emission for (n,n\*)p

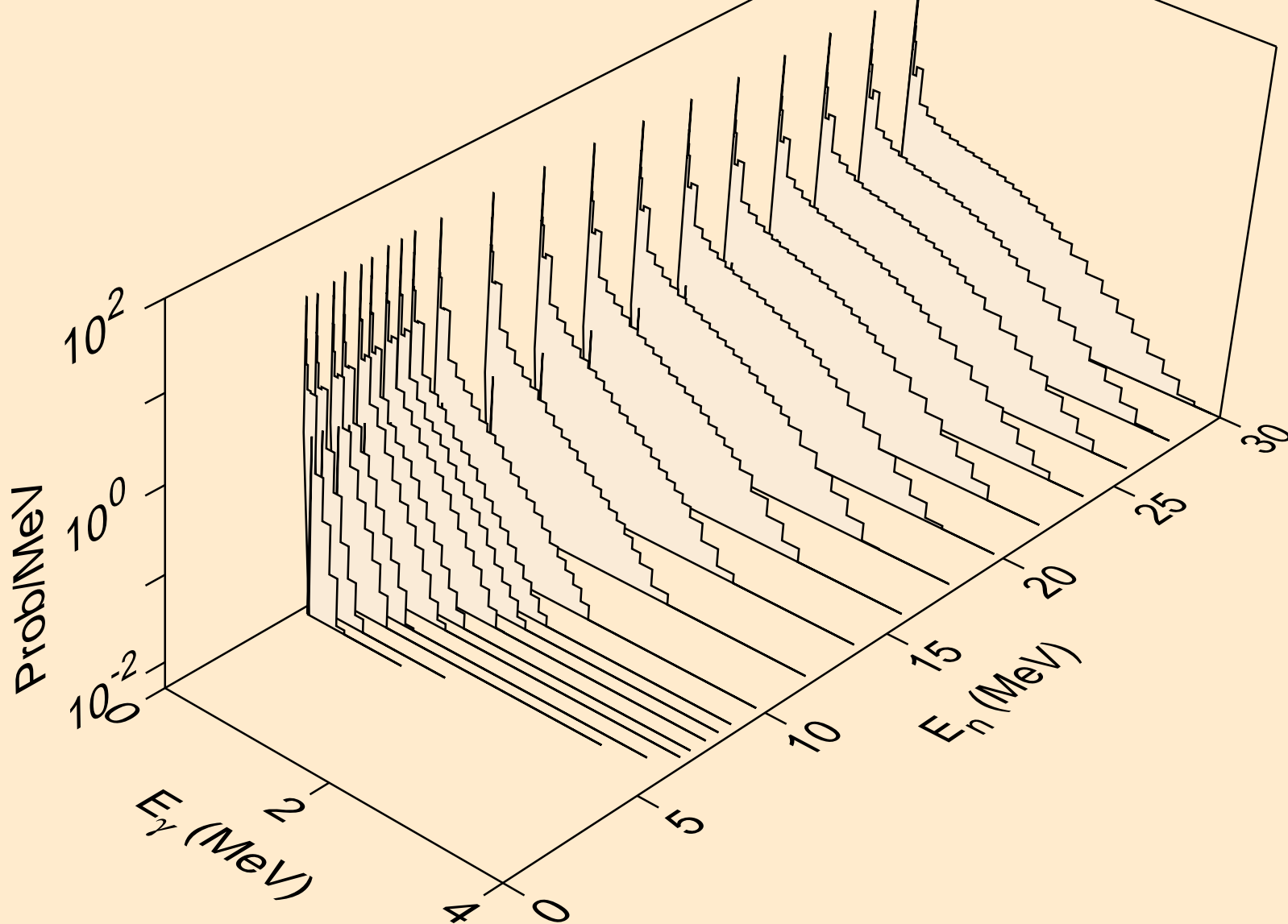

DB261 NEUTRON ACER TENDL-2019 LIBRARY; T=293.16K  
Photon emission for (n,n\*)2a

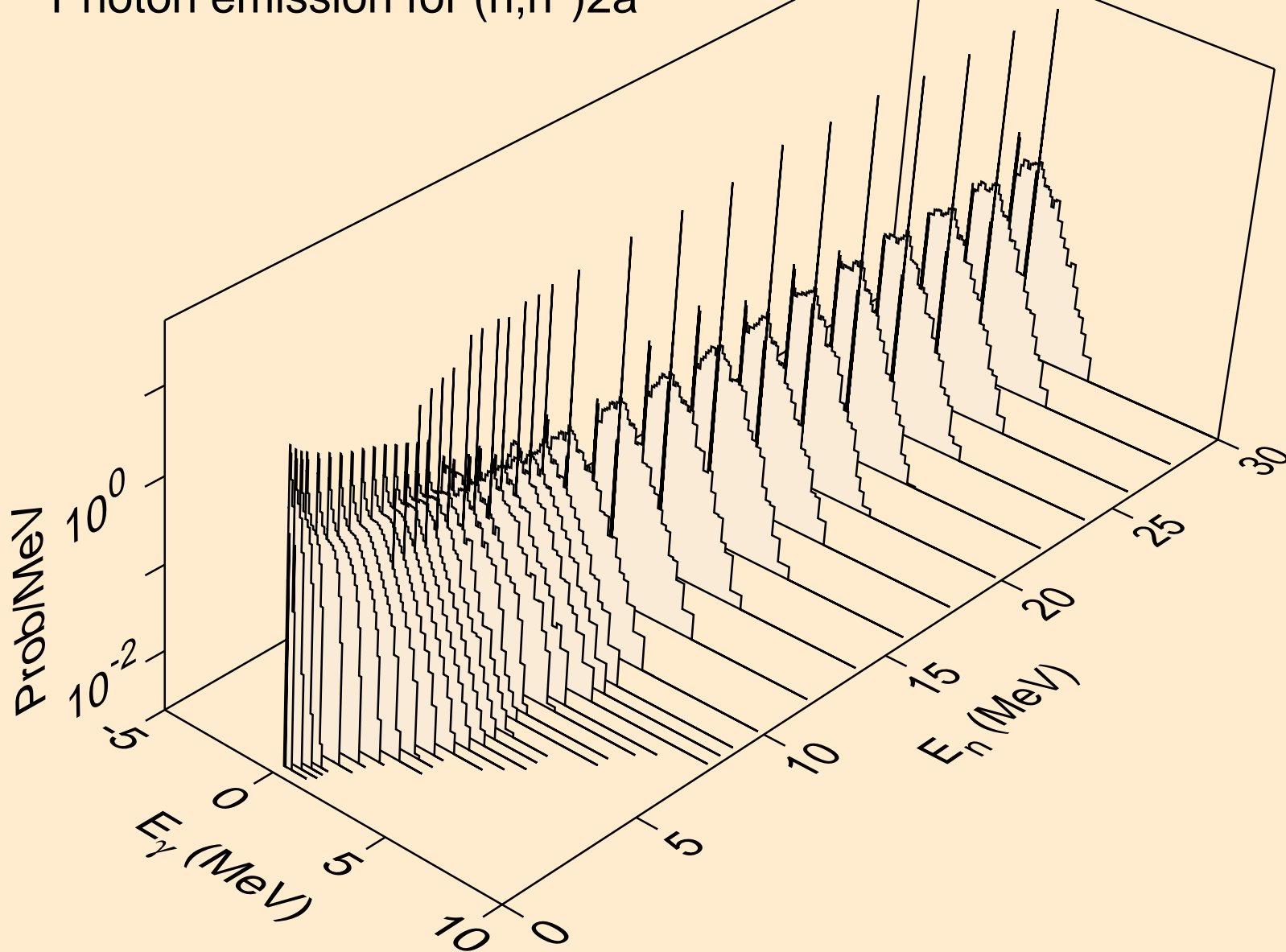

DB261 NEUTRON ACER TENDL-2019 LIBRARY; T=293.16K  
Photon emission for (n,2n)2a

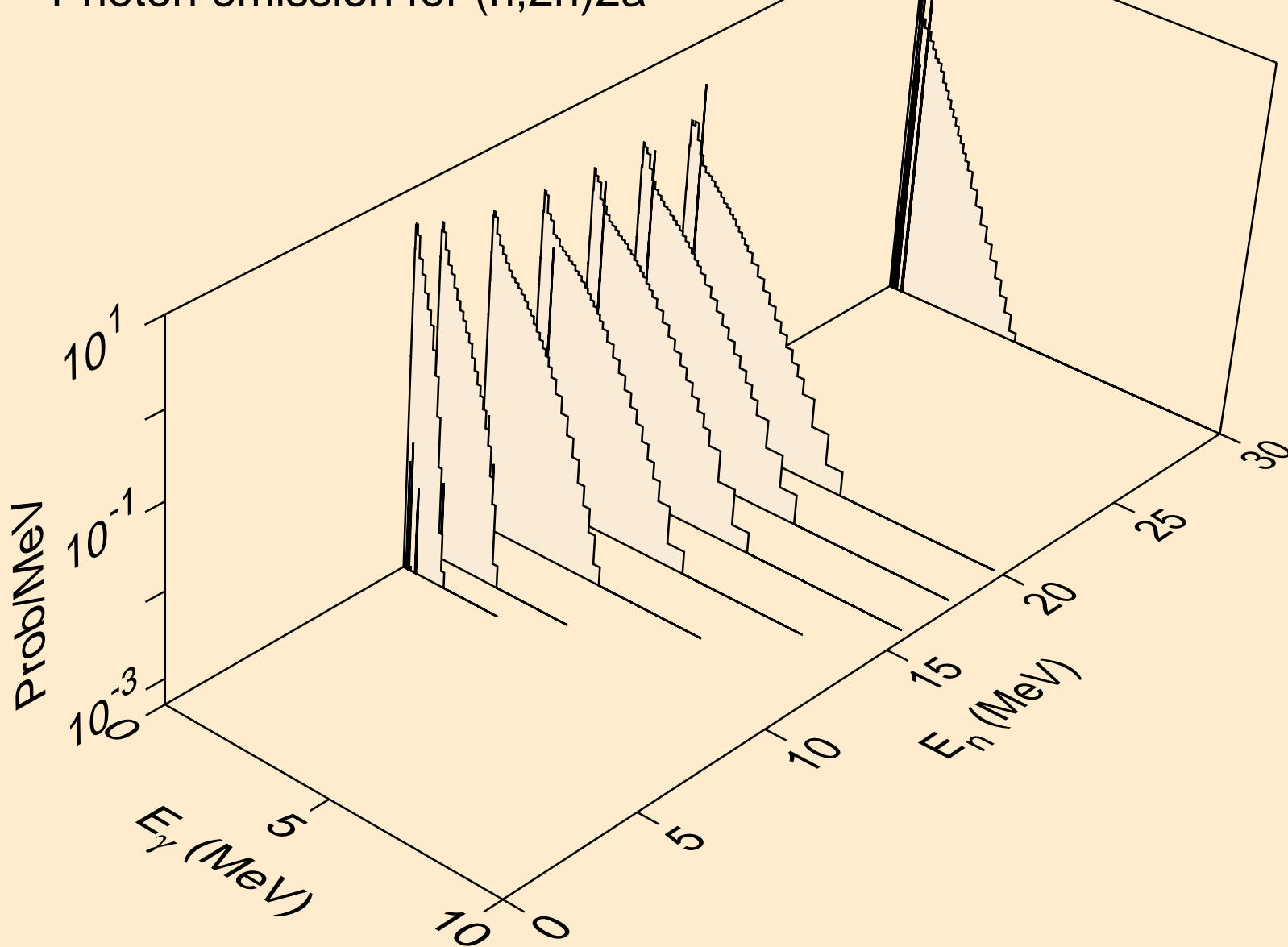

DB261 NEUTRON ACER TENDL-2019 LIBRARY; T=293.16K  
Photon emission for (n,n\*)d

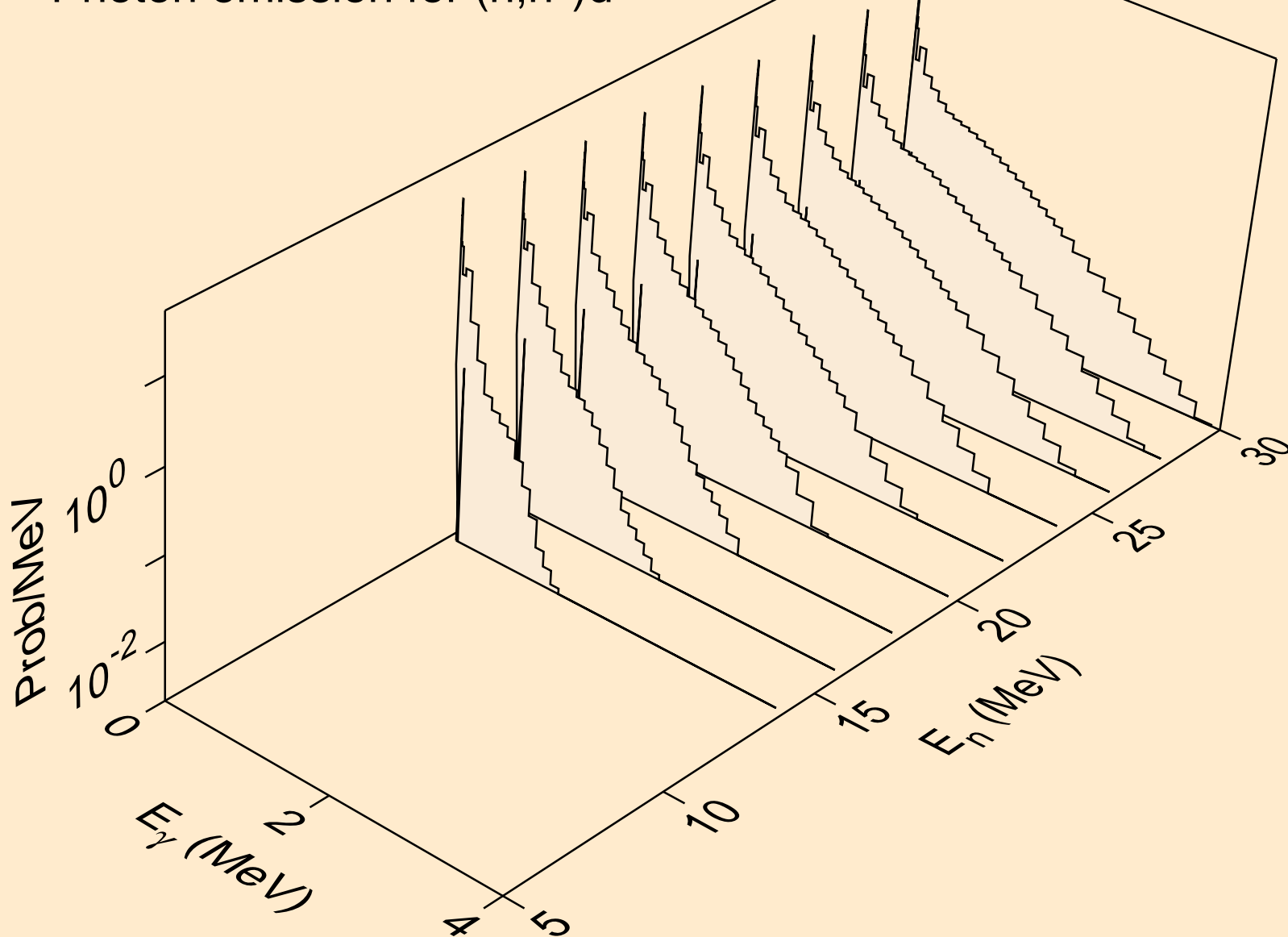

DB261 NEUTRON ACER TENDL-2019 LIBRARY; T=293.16K  
Photon emission for (n,n\*)t

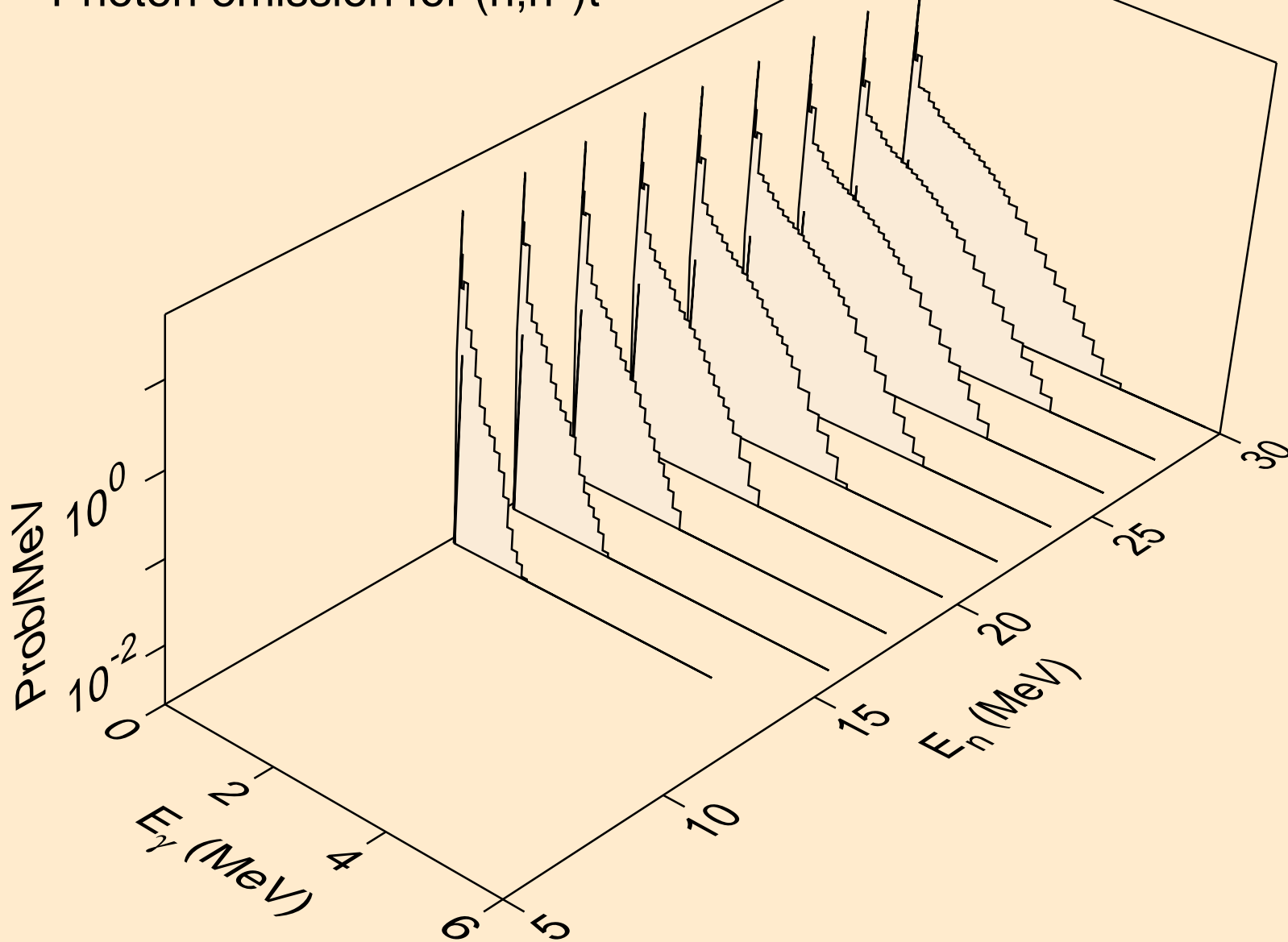

DB261 NEUTRON ACER TENDL-2019 LIBRARY; T=293.16K  
Photon emission for (n,n\*)he3

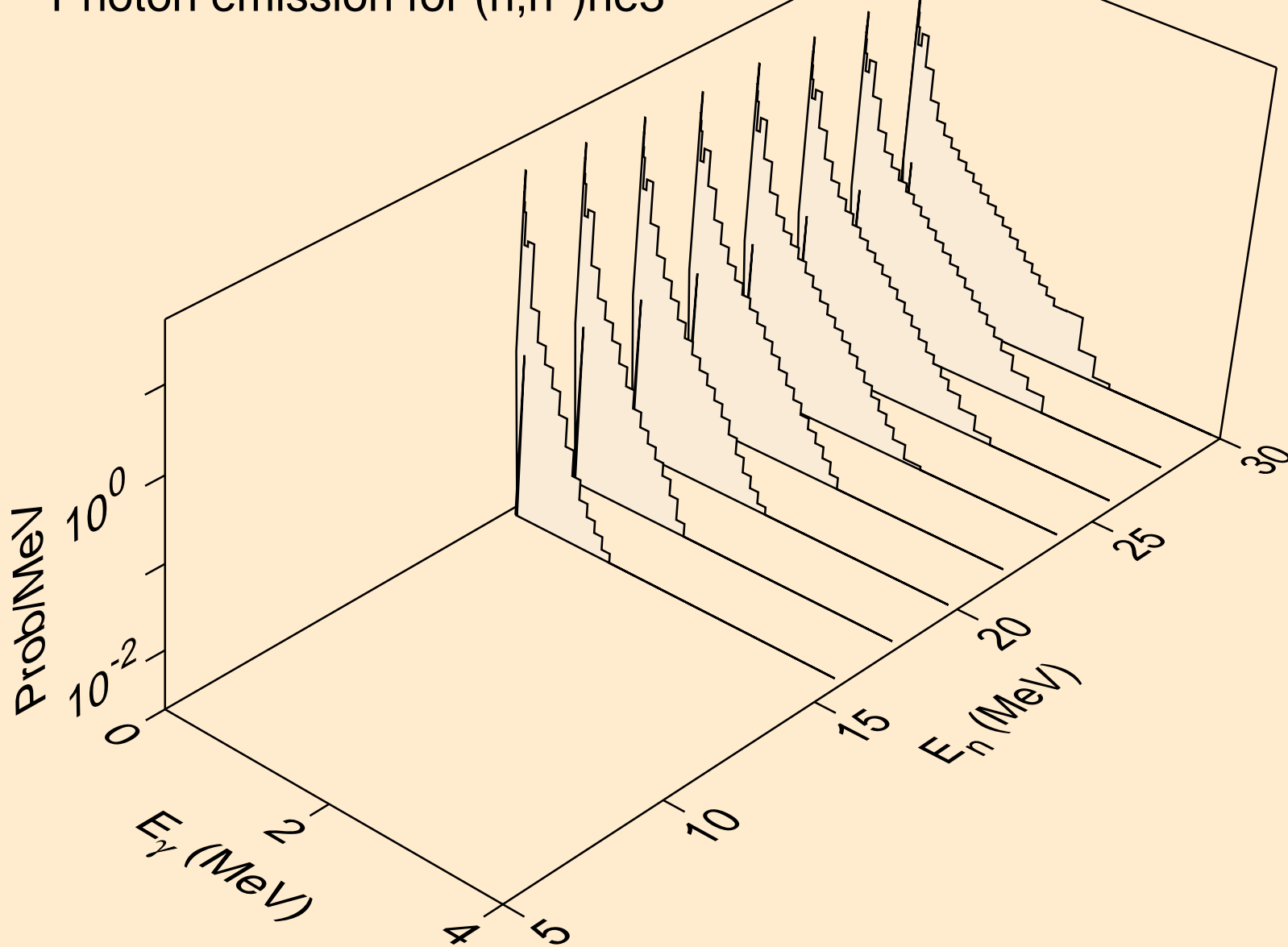

DB261 NEUTRON ACER TENDL-2019 LIBRARY; T=293.16K  
Photon emission for (n,n\*)d2a

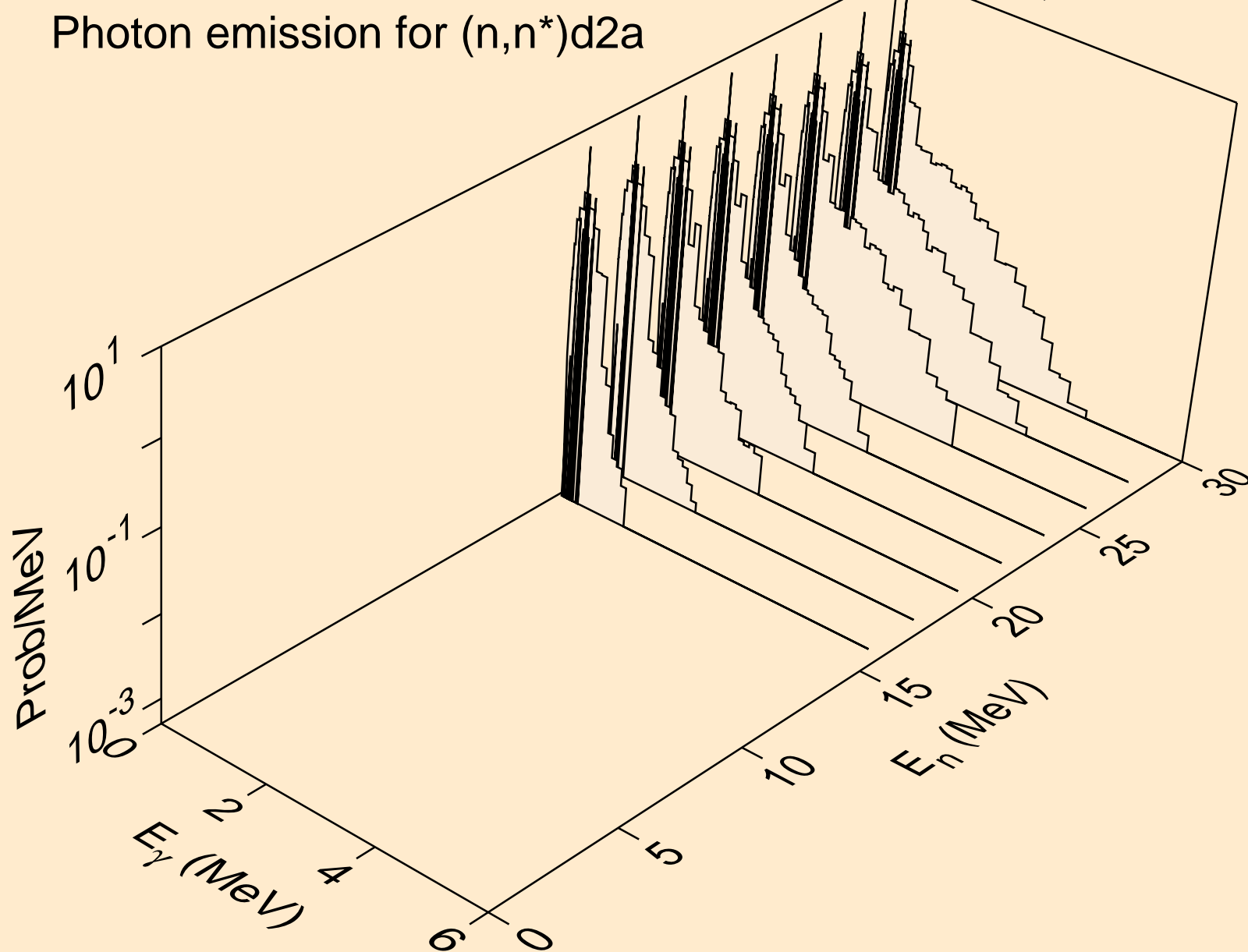

DB261 NEUTRON ACER TENDL-2019 LIBRARY; T=293.16K  
Photon emission for (n,n\*)t2a

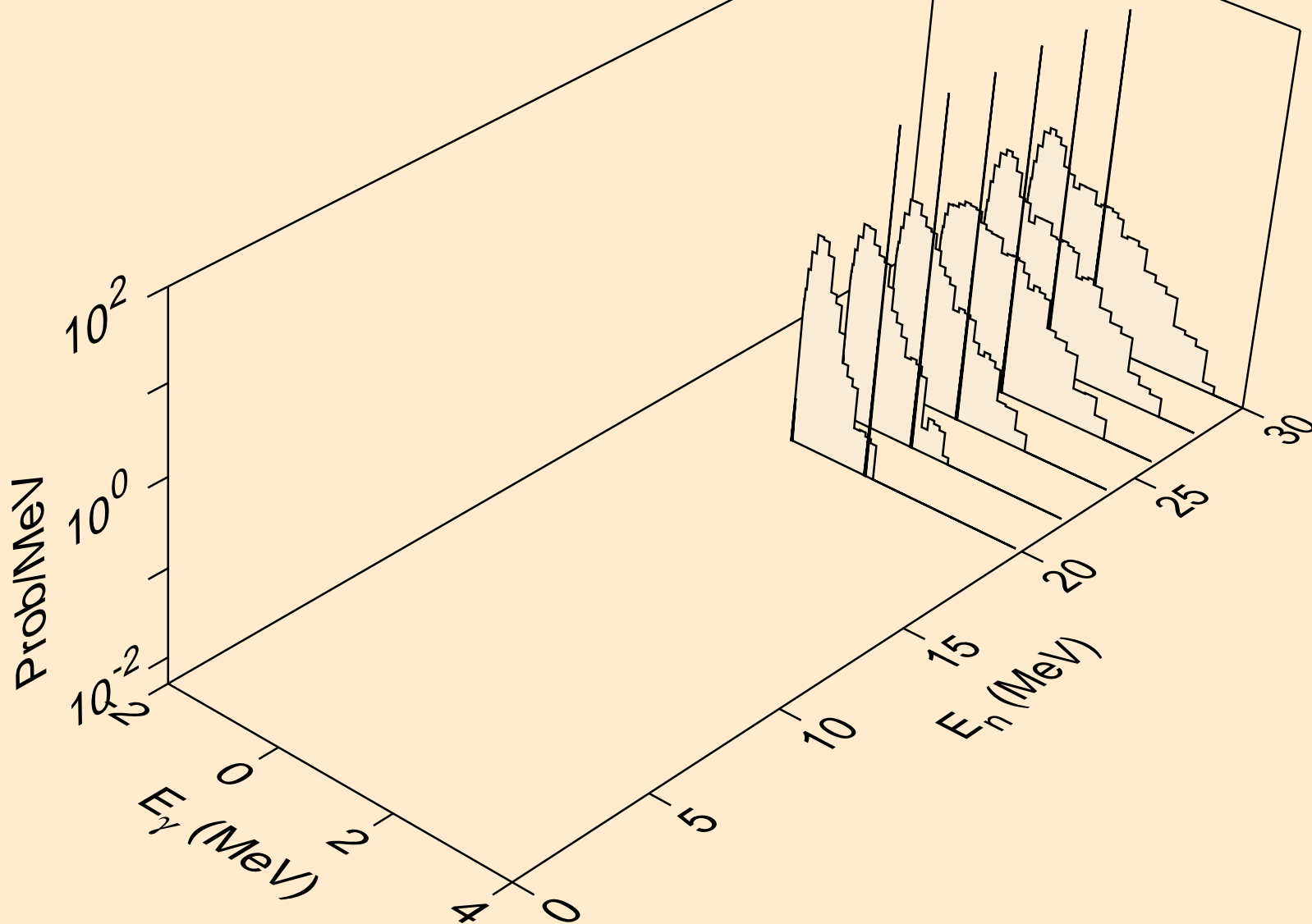

DB261 NEUTRON ACER TENDL-2019 LIBRARY; T=293.16K  
Photon emission for (n,4n)

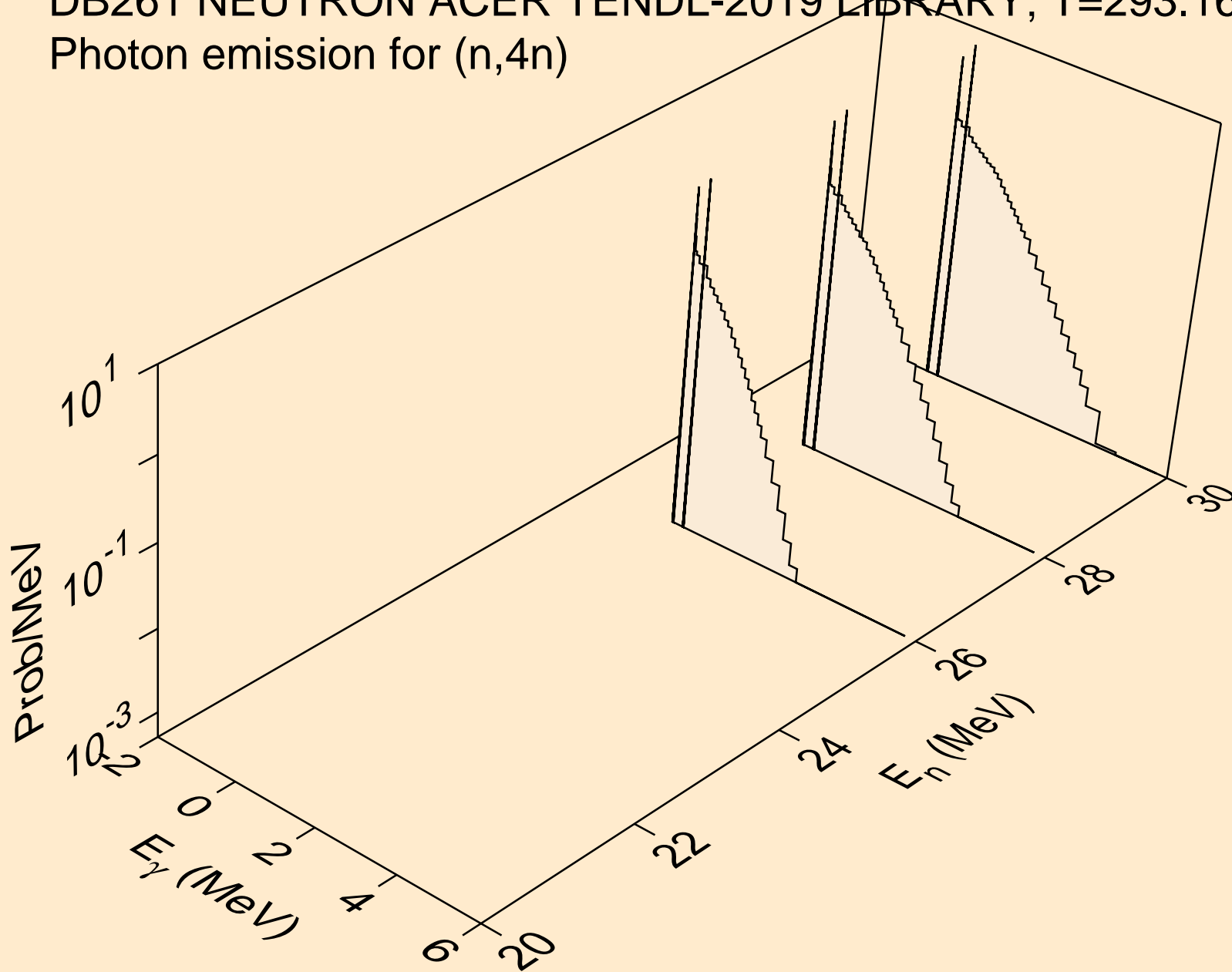

DB261 NEUTRON ACER TENDL-2019 LIBRARY; T=293.16K  
Photon emission for (n,2np)

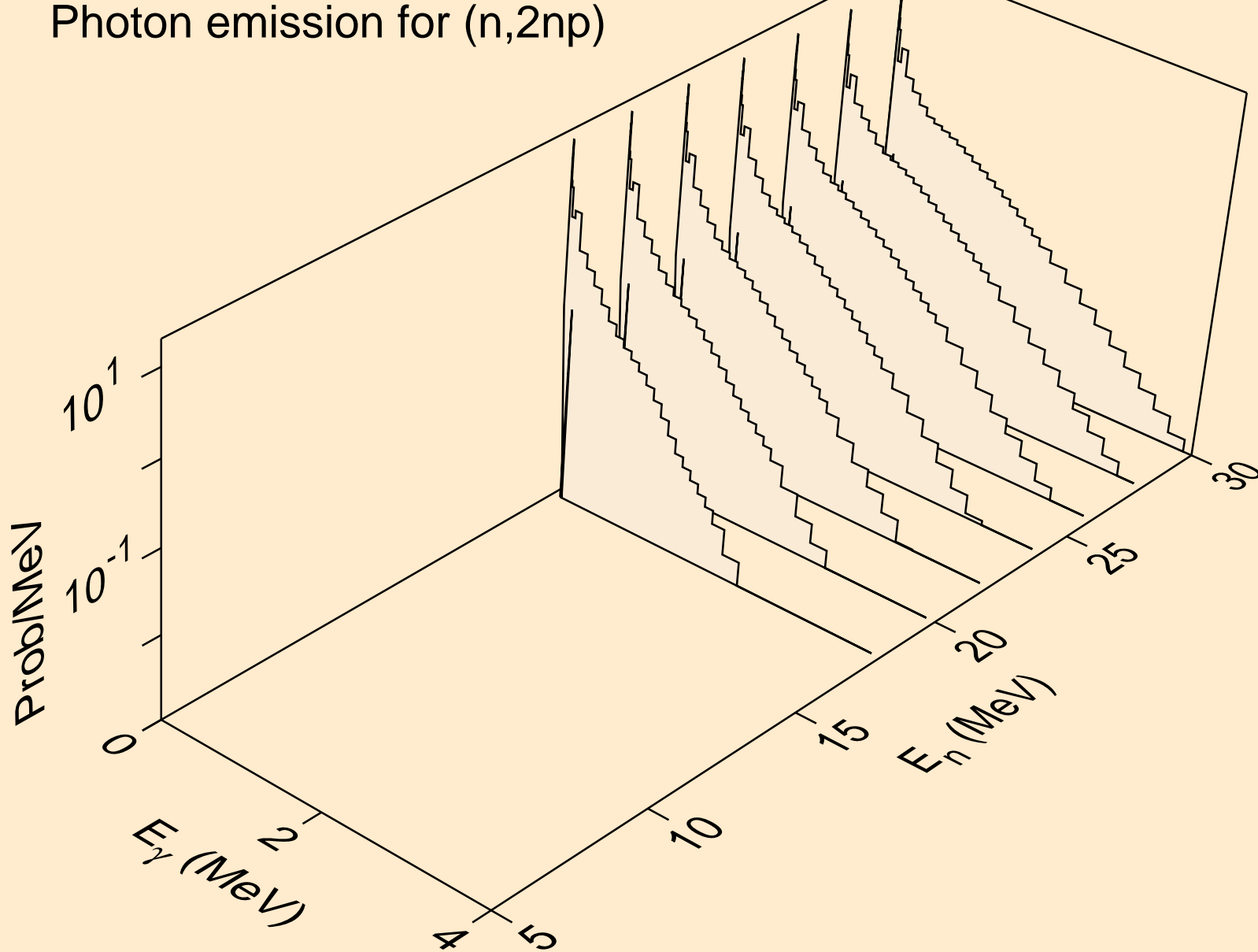

DB261 NEUTRON ACER TENDL-2019 LIBRARY; T=293.16K  
Photon emission for (n,3np)

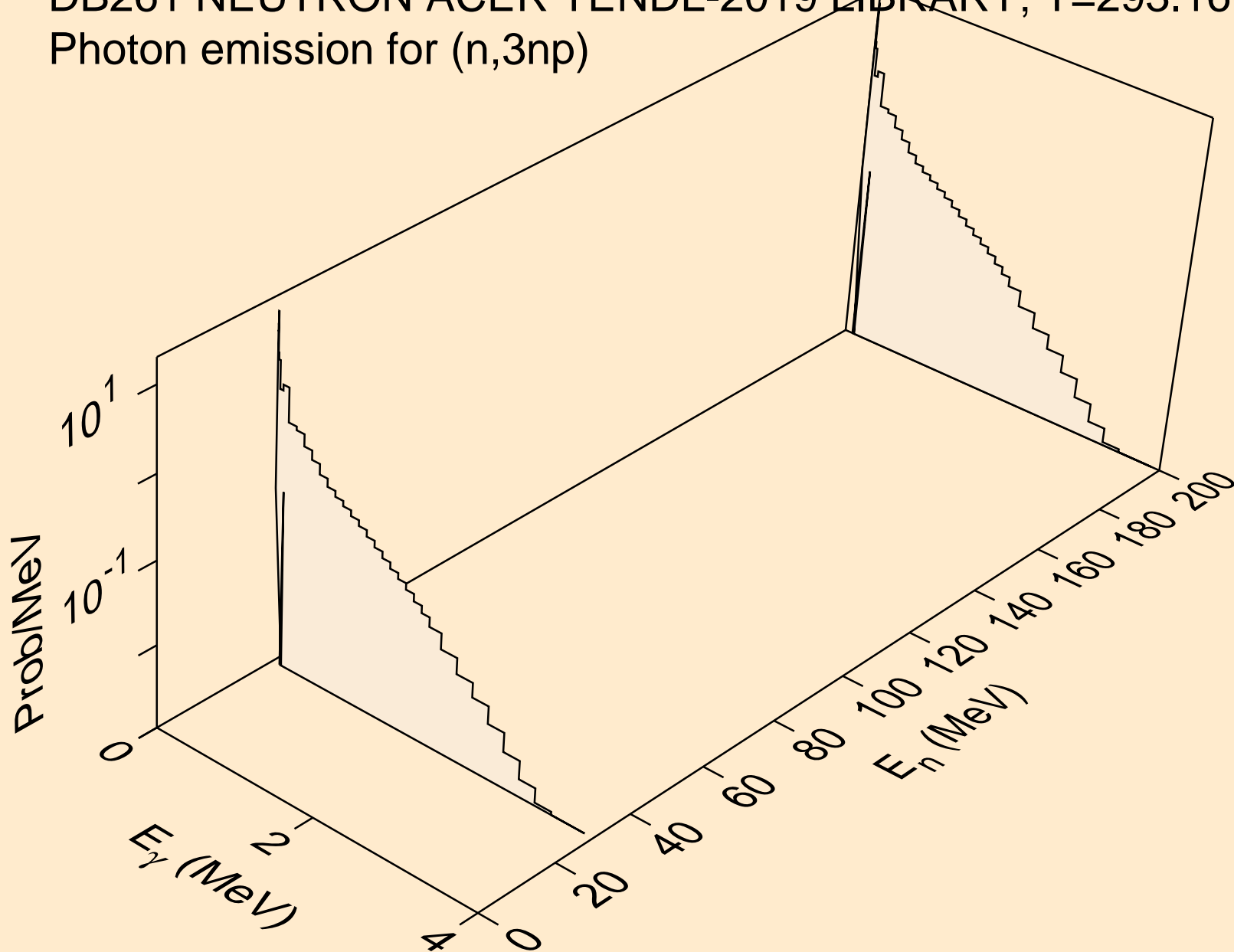

DB261 NEUTRON ACER TENDL-2019 LIBRARY; T=293.16K  
Photon emission for (n,2np)

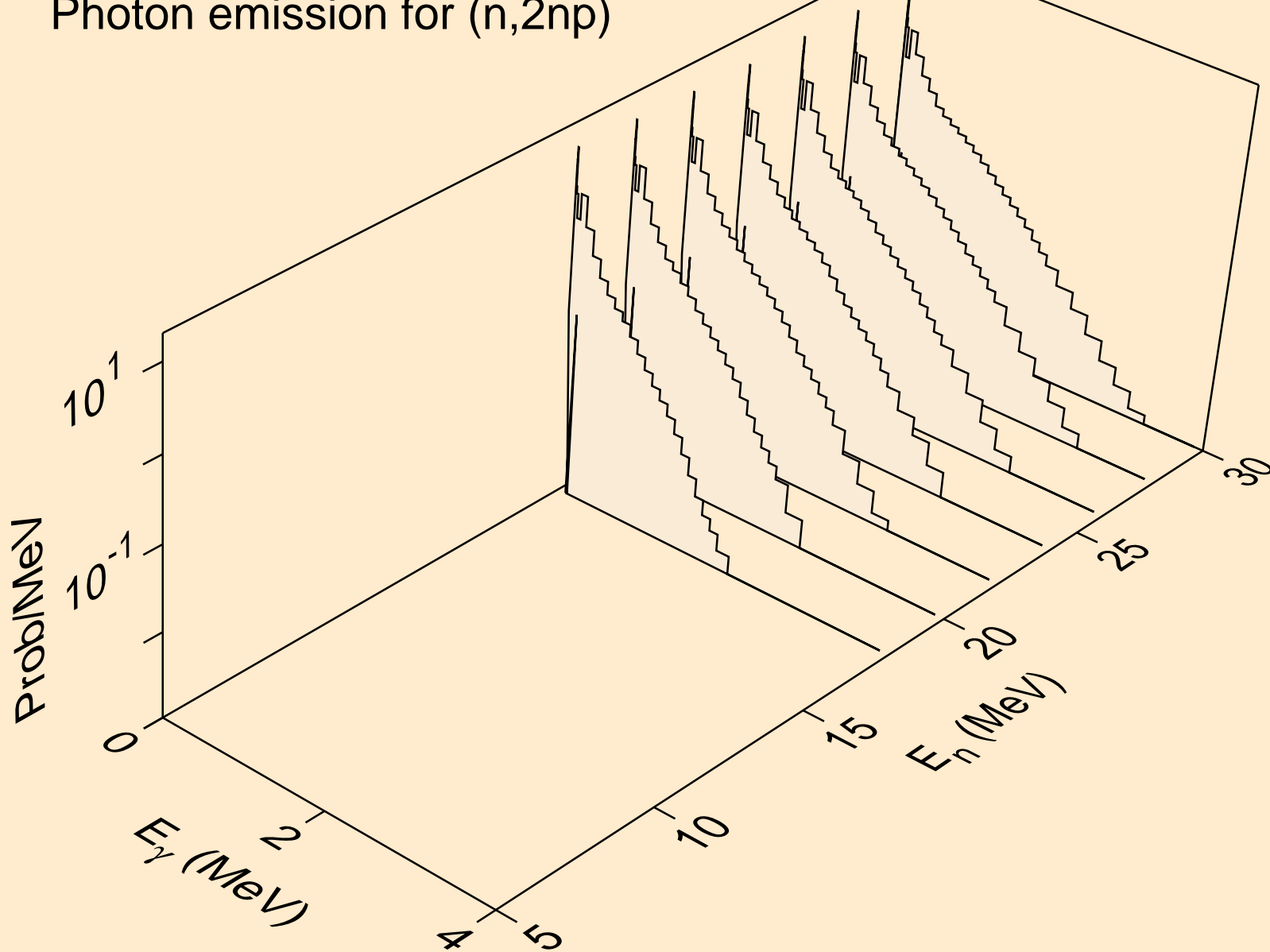

DB261 NEUTRON ACER TENDL-2019 LIBRARY; T=293.16K  
Photon emission for (n,npa)

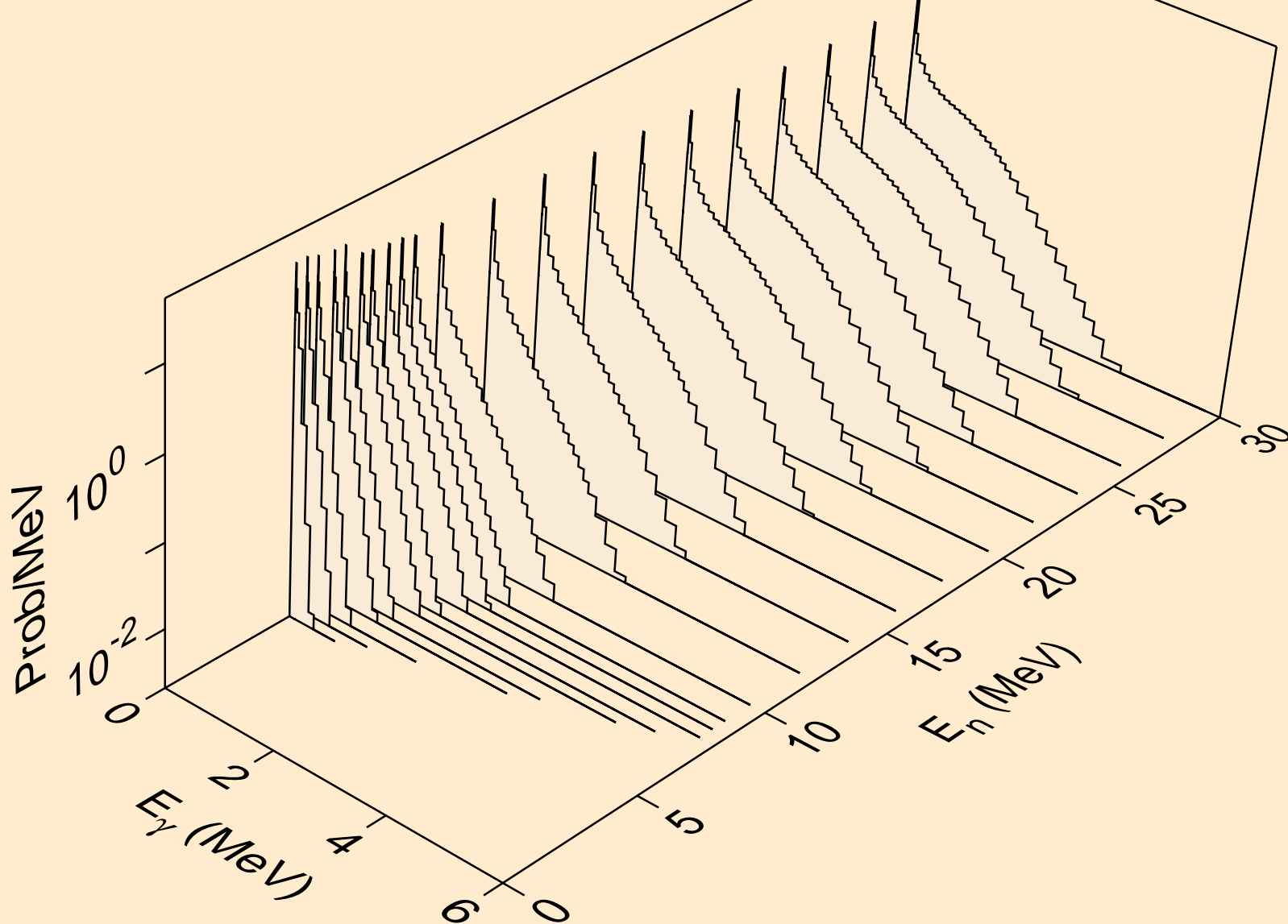

DB261 NEUTRON ACER TENDL-2019 LIBRARY; T=293.16K  
Photon emission for (n,n\*c)

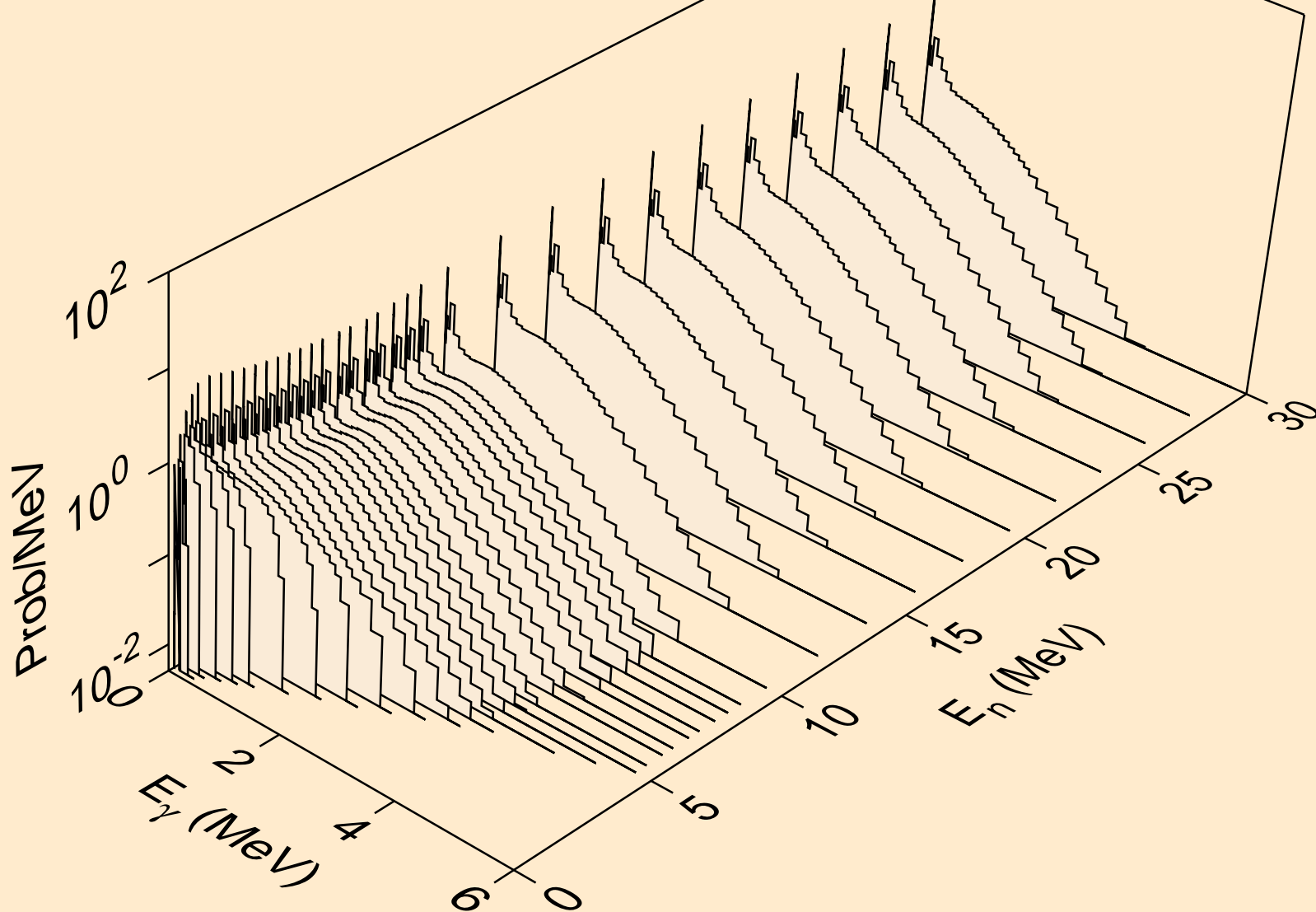

DB261 NEUTRON ACER TENDL-2019 LIBRARY; T=293.16K  
Photon emission for (n,gma)

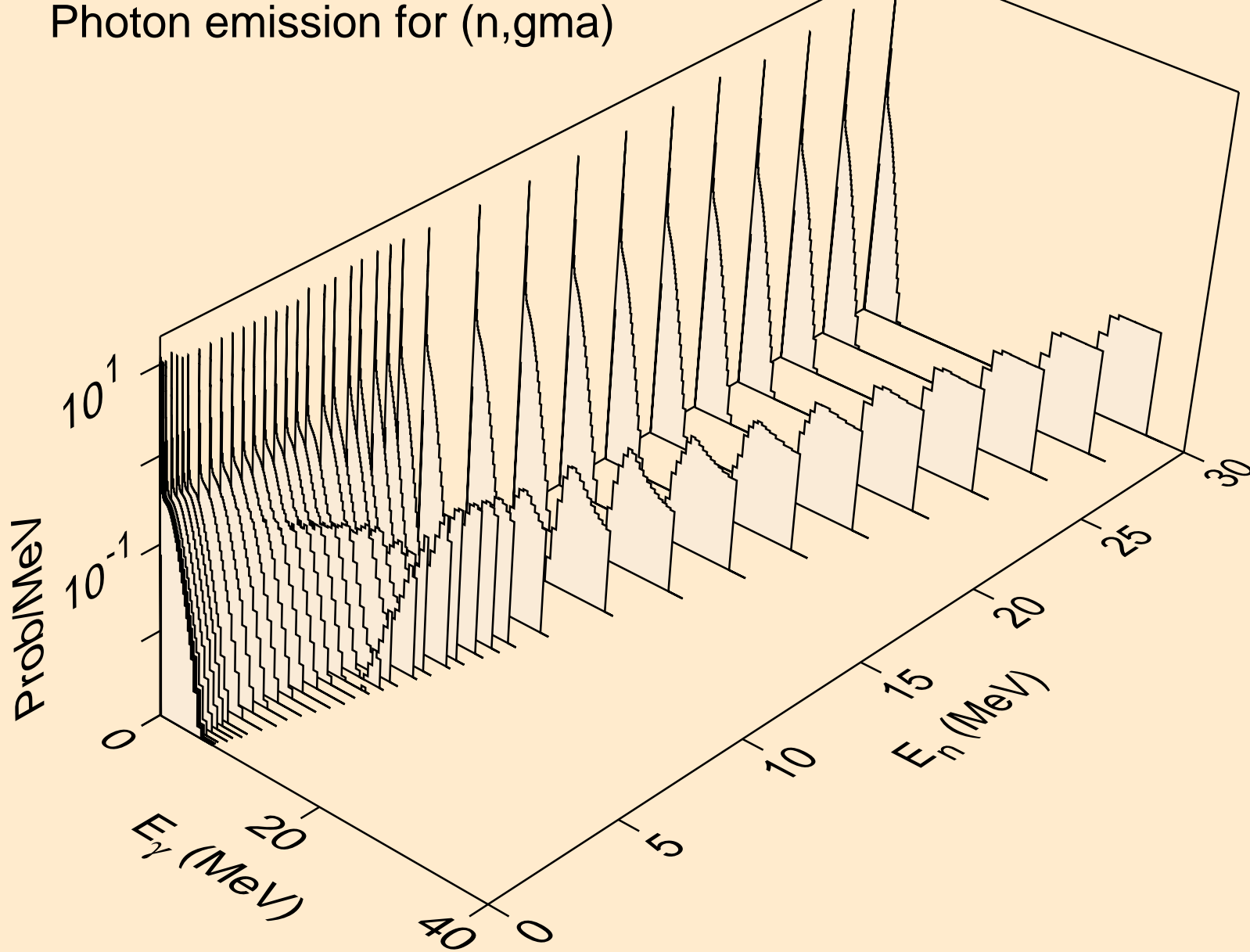

DB261 NEUTRON ACER TENDL-2019 LIBRARY; T=293.16K  
Photon emission for (n,p)

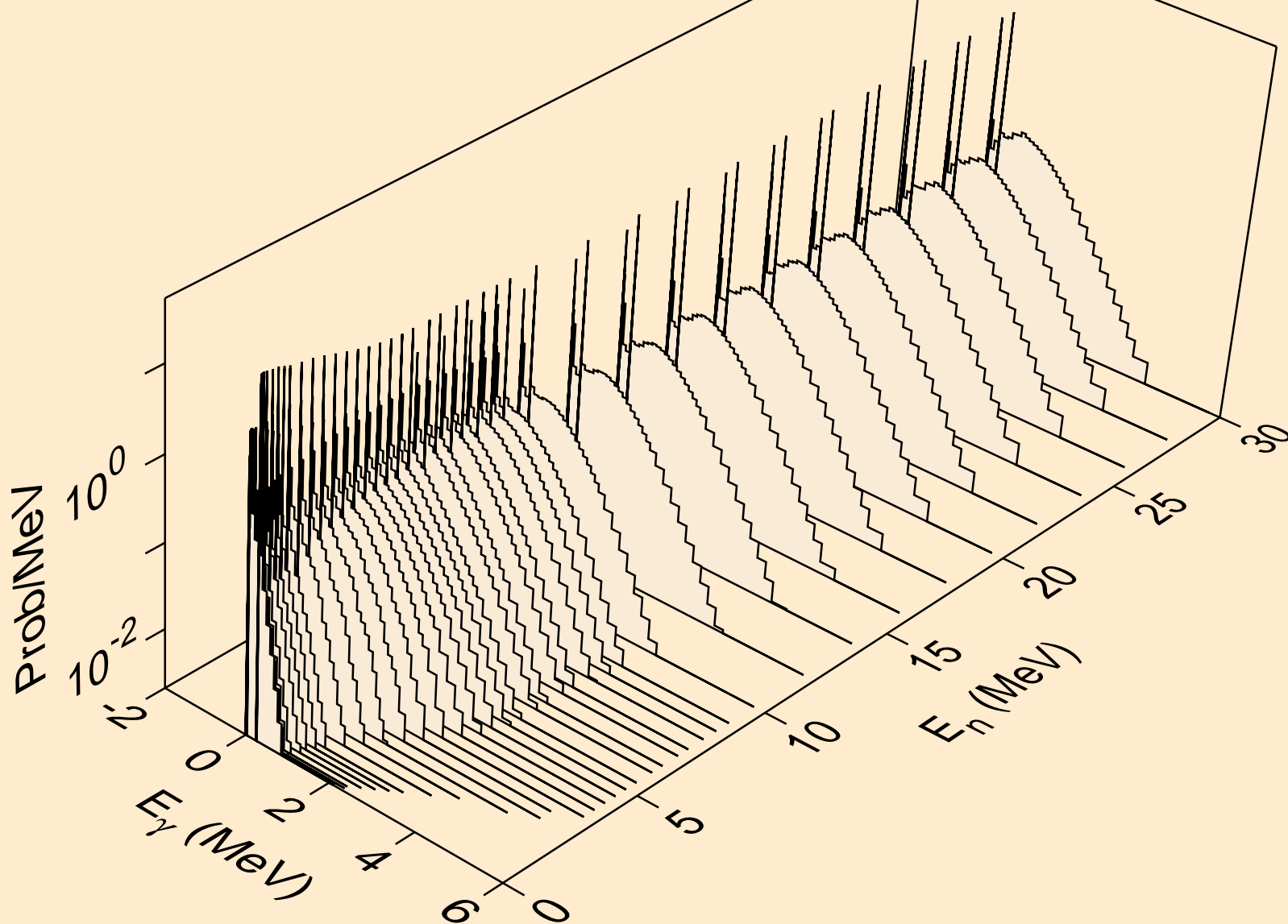

DB261 NEUTRON ACER TENDL-2019 LIBRARY; T=293.16K  
Photon emission for (n,d)

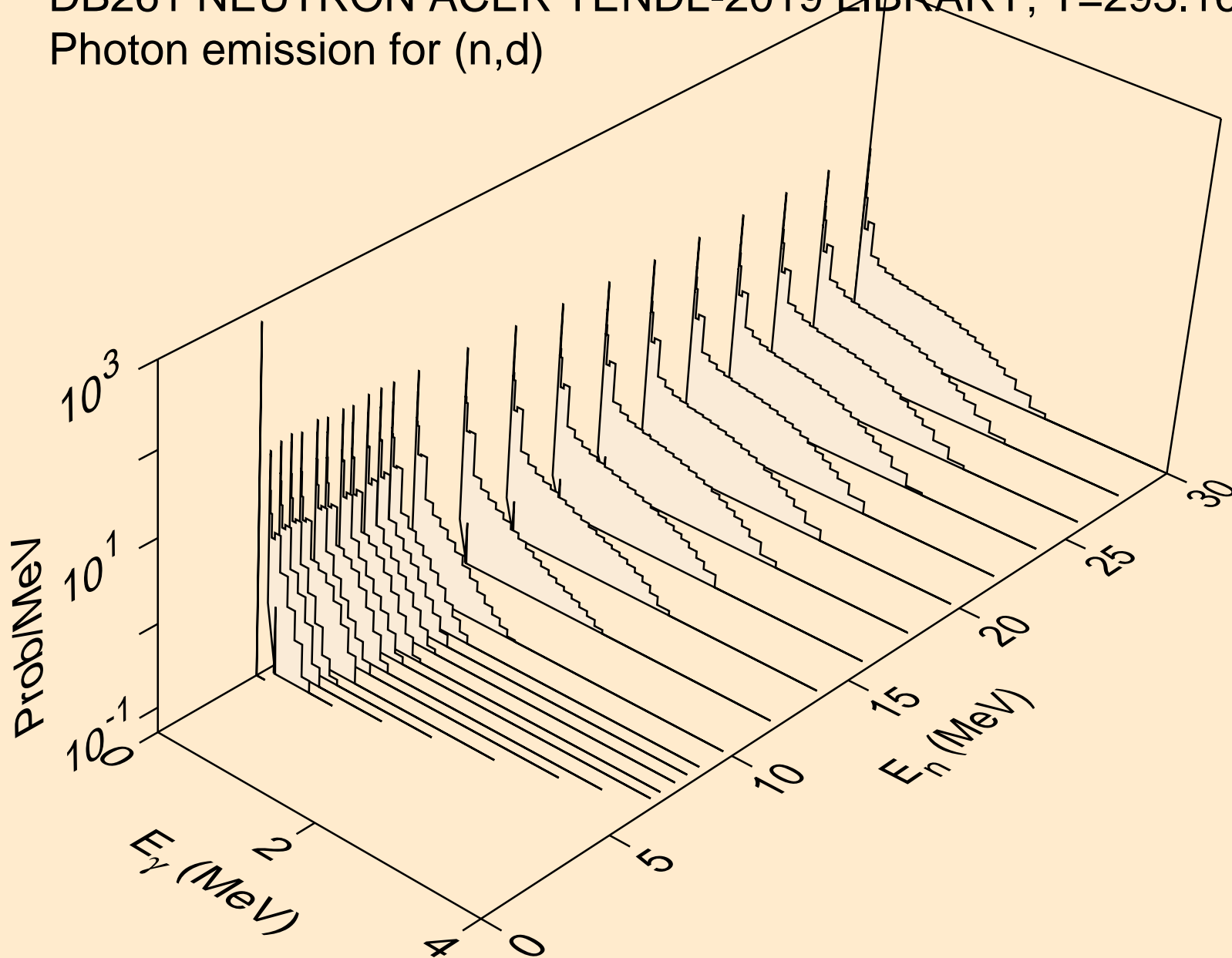

DB261 NEUTRON ACER TENDL-2019 LIBRARY; T=293.16K  
Photon emission for (n,t)

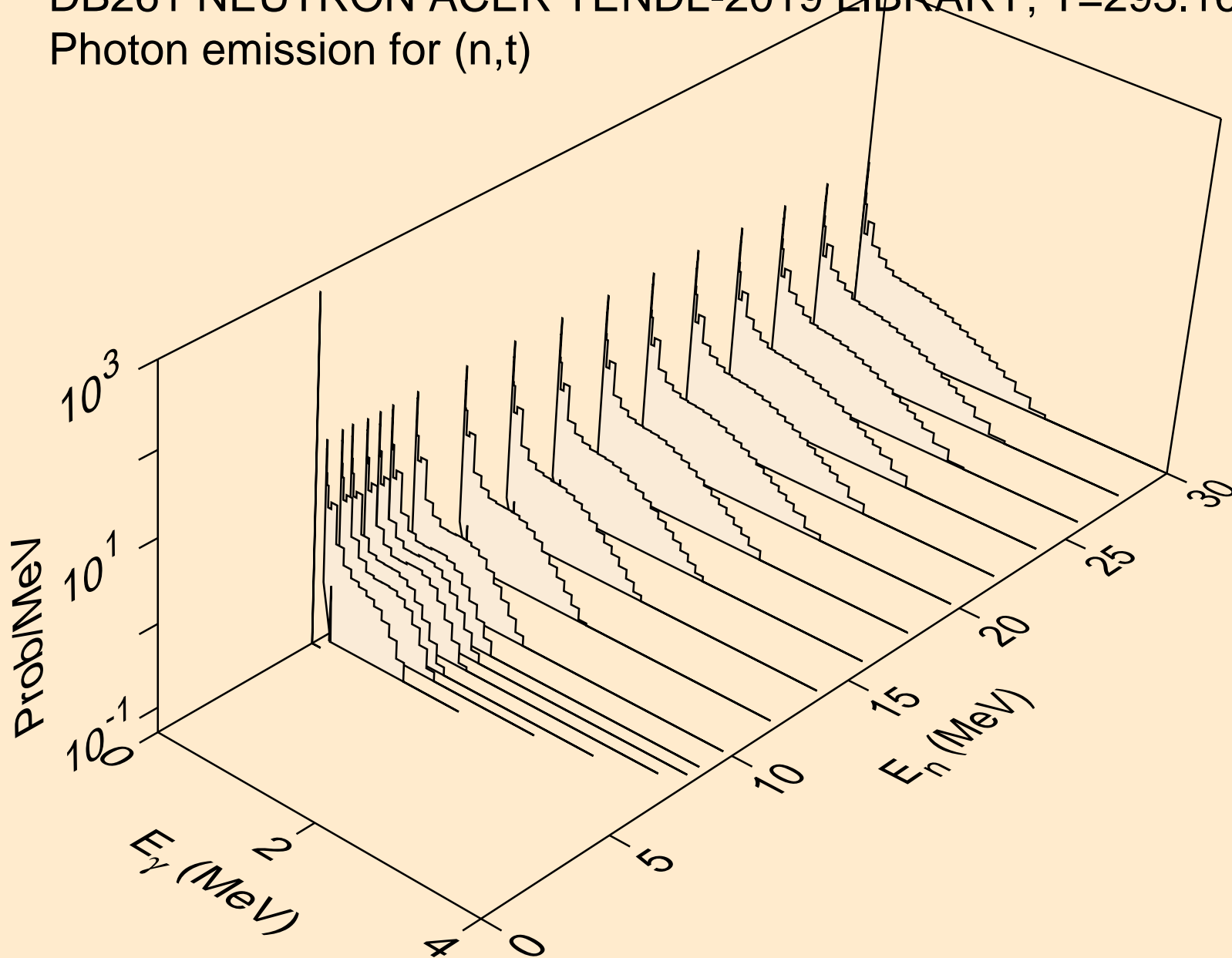

DB261 NEUTRON ACER TENDL-2019 LIBRARY; T=293.16K  
Photon emission for (n,he3)

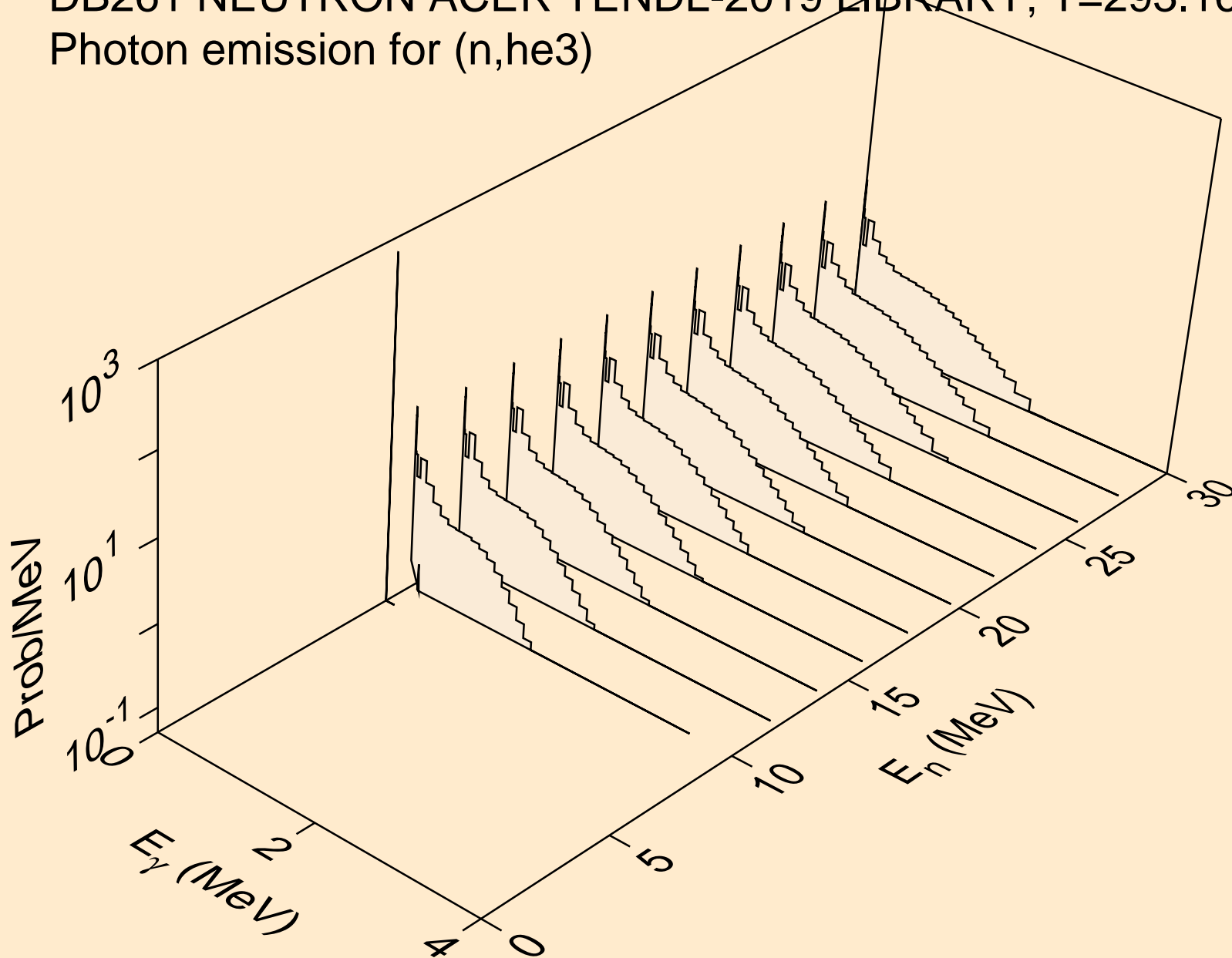

DB261 NEUTRON ACER TENDL-2019 LIBRARY; T=293.16K  
Photon emission for (n,a)

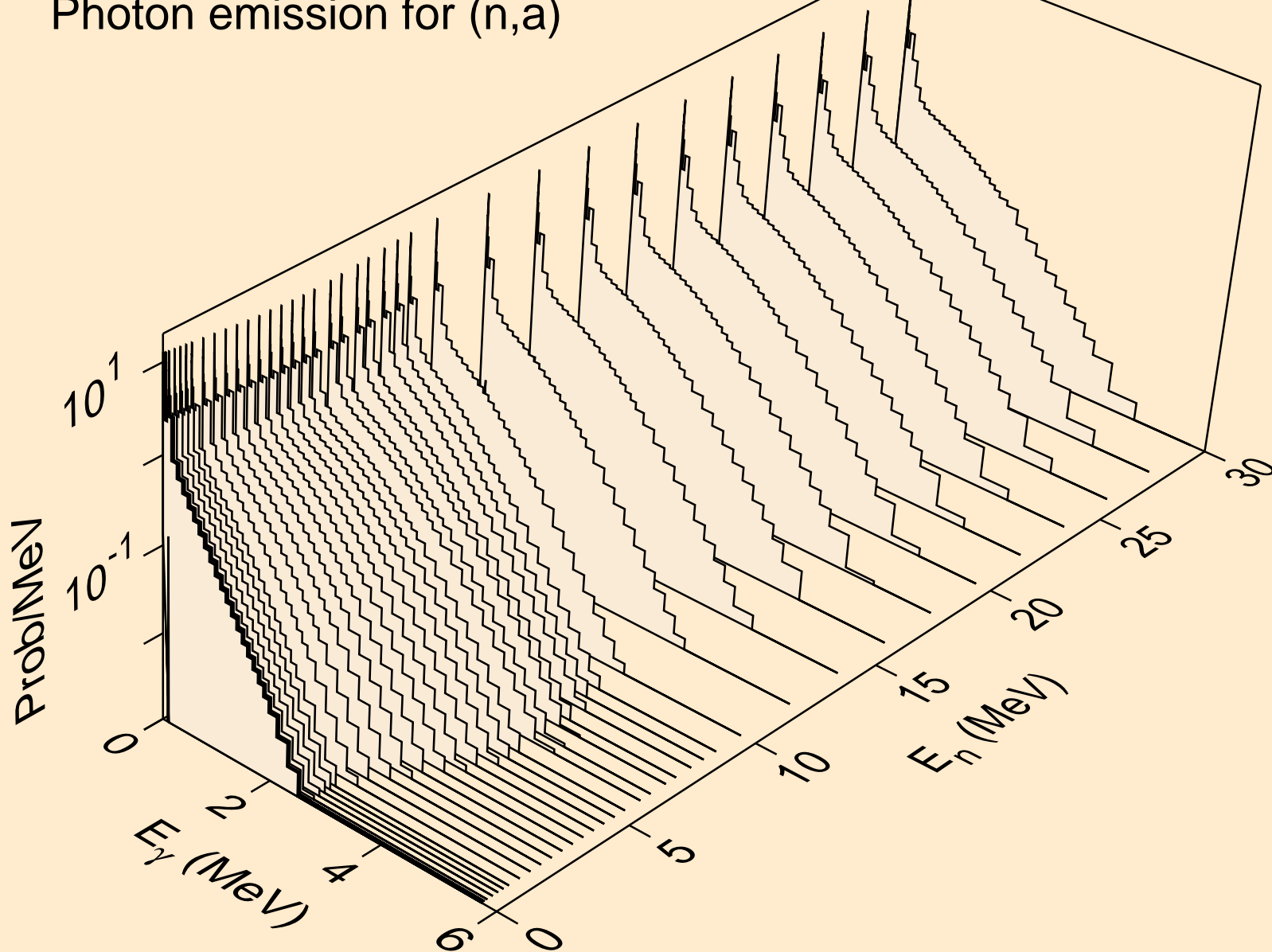

DB261 NEUTRON ACER TENDL-2019 LIBRARY; T=293.16K  
Photon emission for (n,2a)

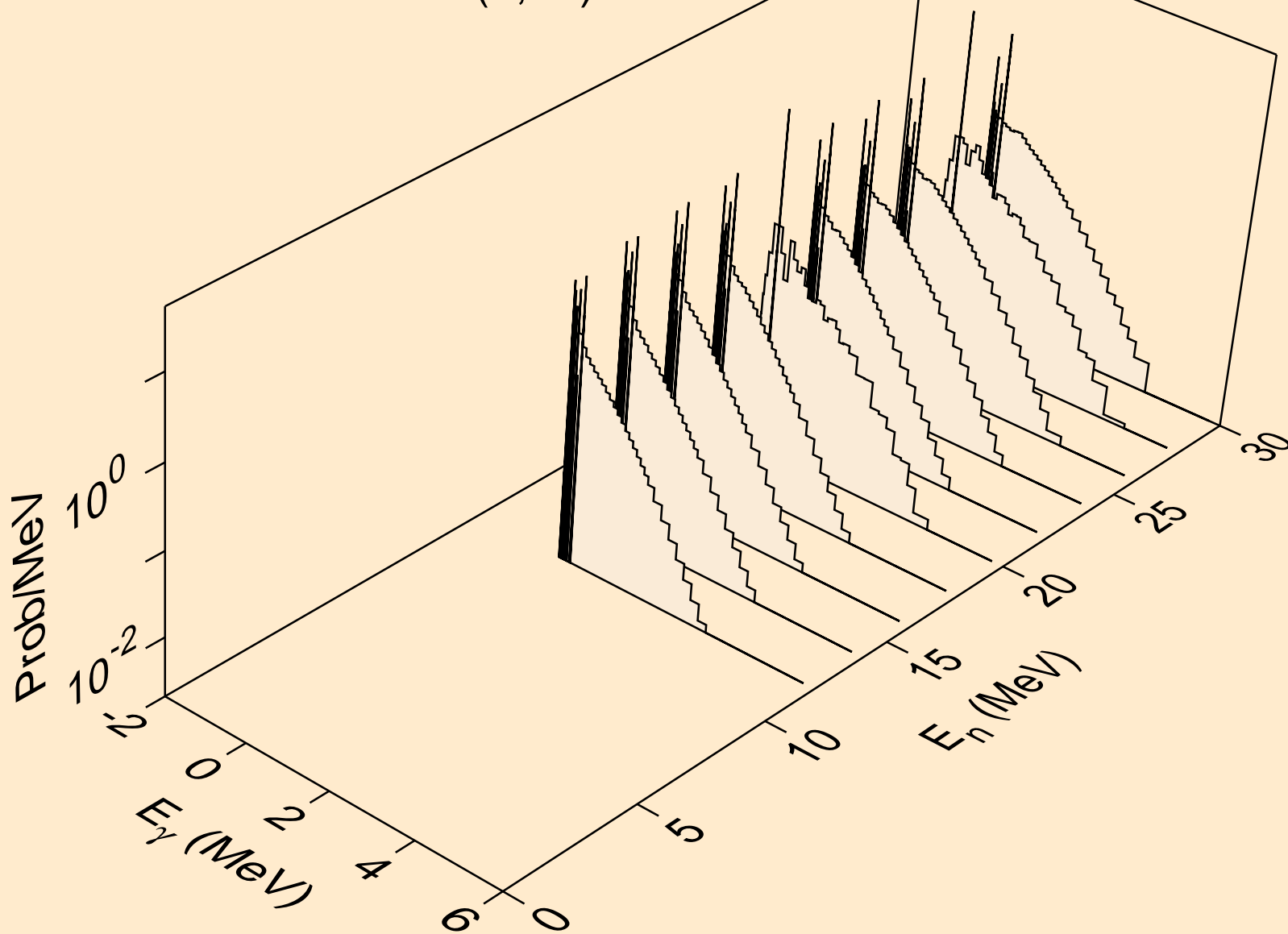

DB261 NEUTRON ACER TENDL-2019 LIBRARY; T=293.16K  
Photon emission for (n,2p)

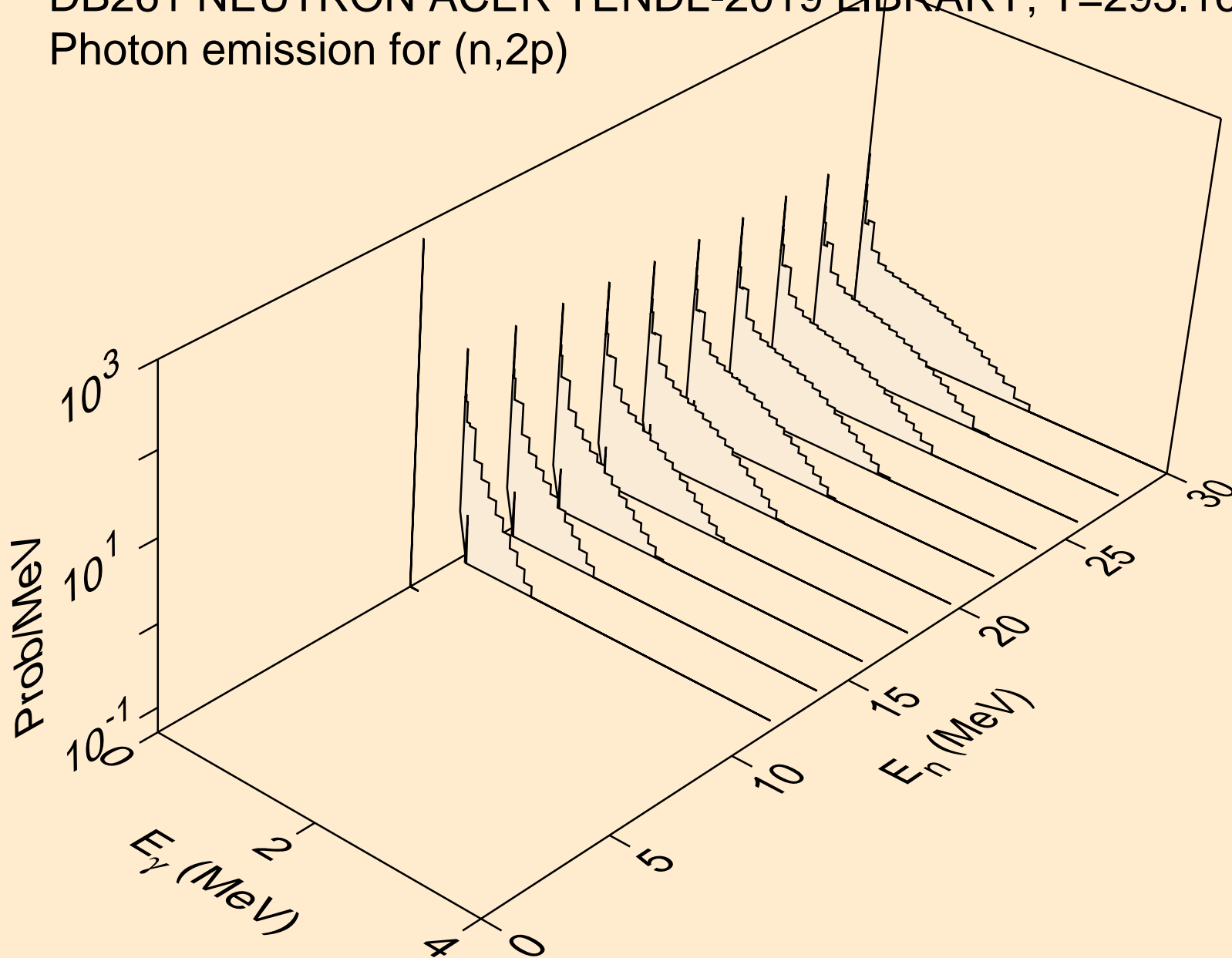

DB261 NEUTRON ACER TENDL-2019 LIBRARY; T=293.16K  
Photon emission for (n,p $\alpha$ )

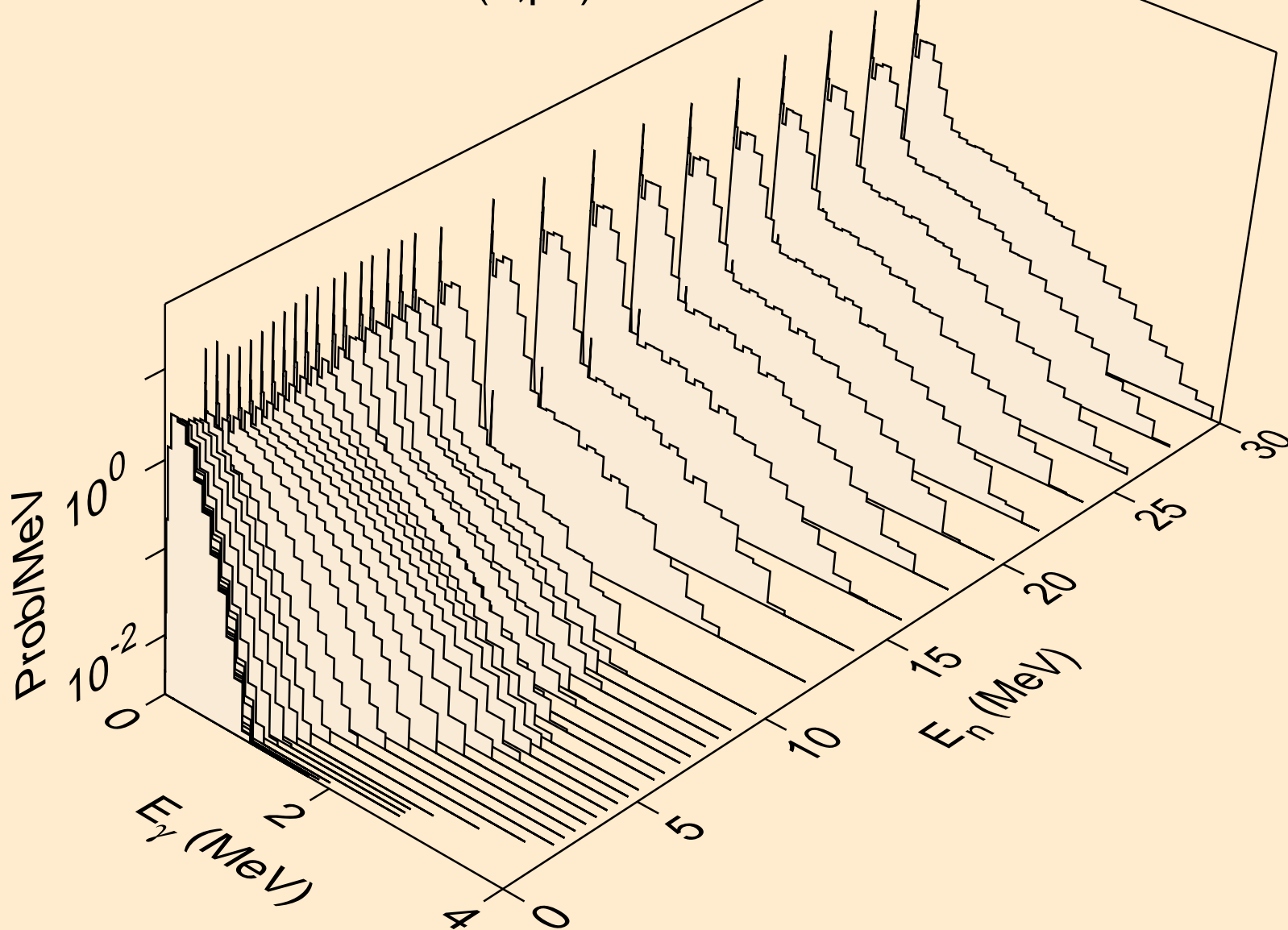

DB261 NEUTRON ACER TENDL-2019 LIBRARY; T=293.16K  
Photon emission for (n,t2a)

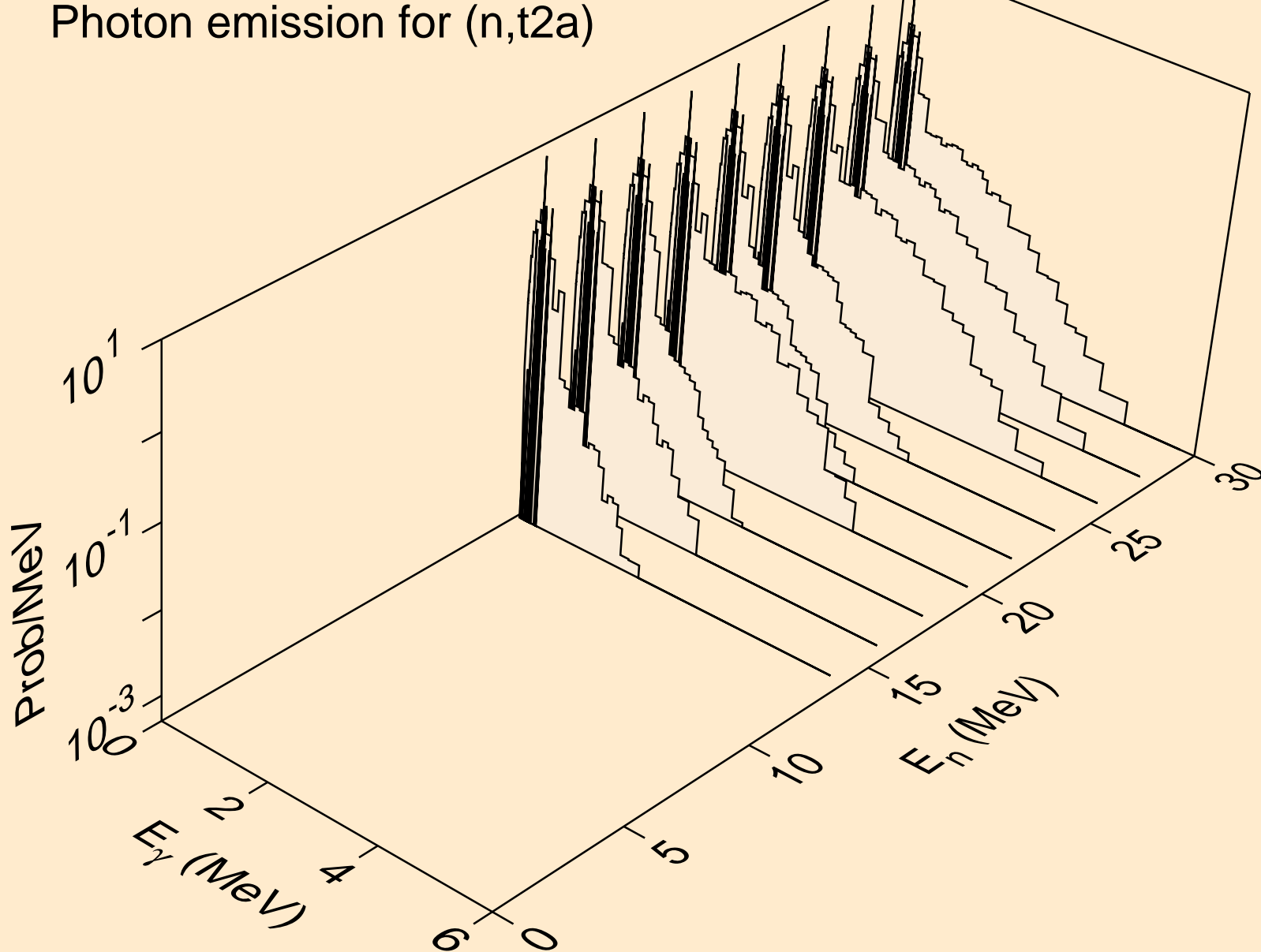

DB261 NEUTRON ACER TENDL-2019 LIBRARY; T=293.16K  
Photon emission for (n,d2a)

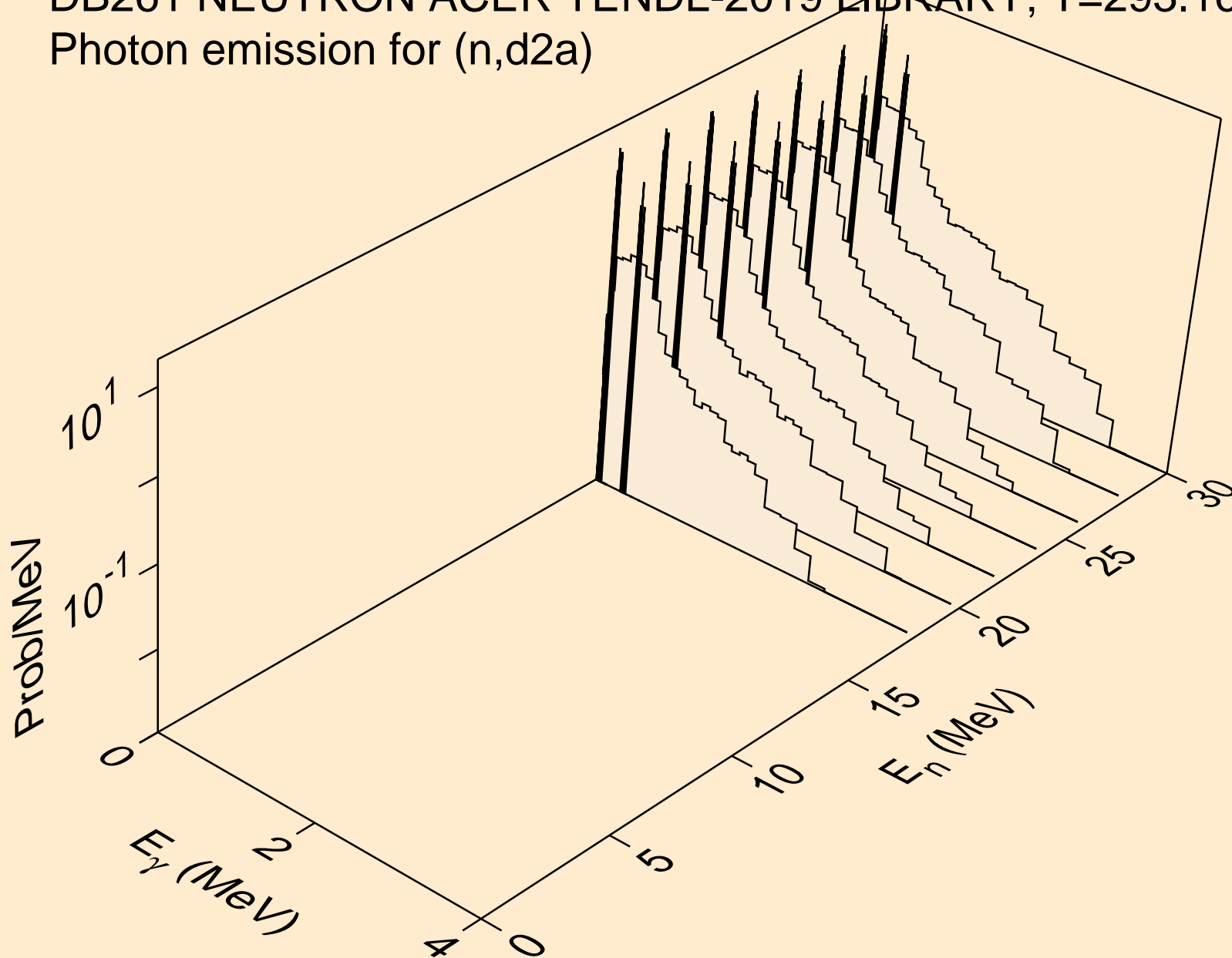

DB261 NEUTRON ACER TENDL-2019 LIBRARY; T=293.16K  
Photon emission for (n,pd)

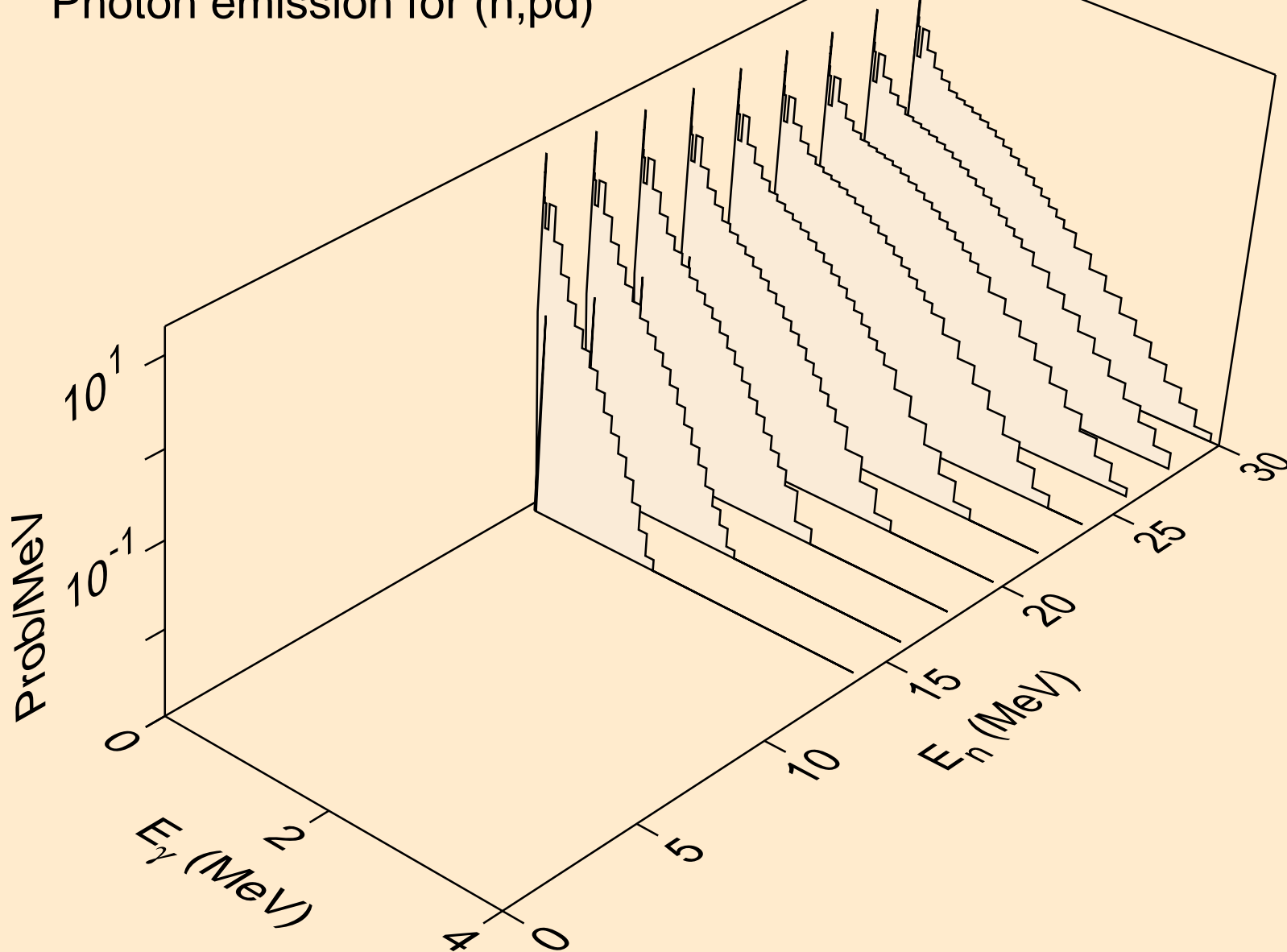

DB261 NEUTRON ACER TENDL-2019 LIBRARY; T=293.16K  
Photon emission for (n,pt)

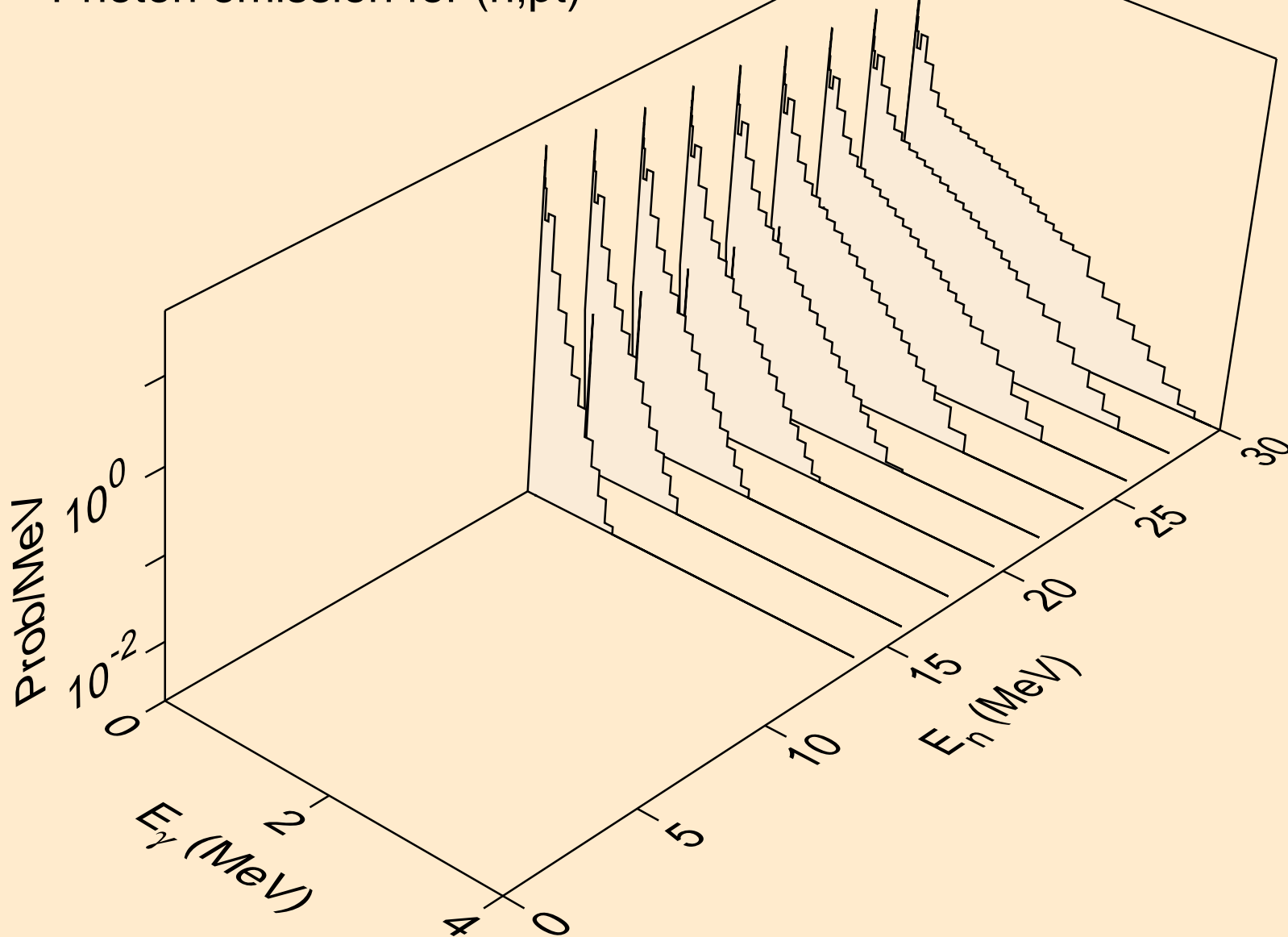

DB261 NEUTRON ACER TENDL-2019 LIBRARY; T=293.16K  
Photon emission for (n,da)

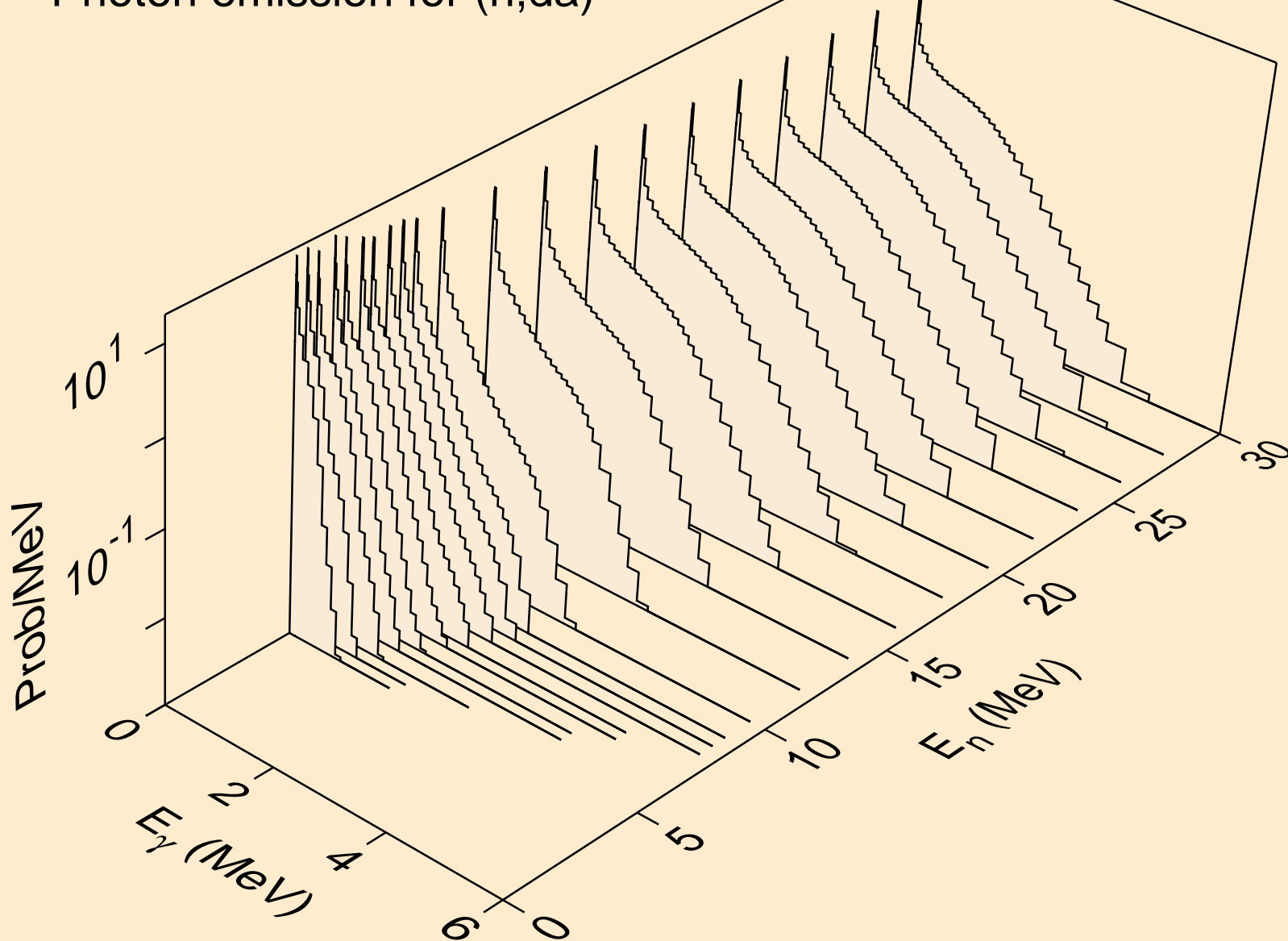

DB261 NEUTRON ACER TENDL-2019 LIBRARY; T=293.16K  
thermal capture photon spectrum

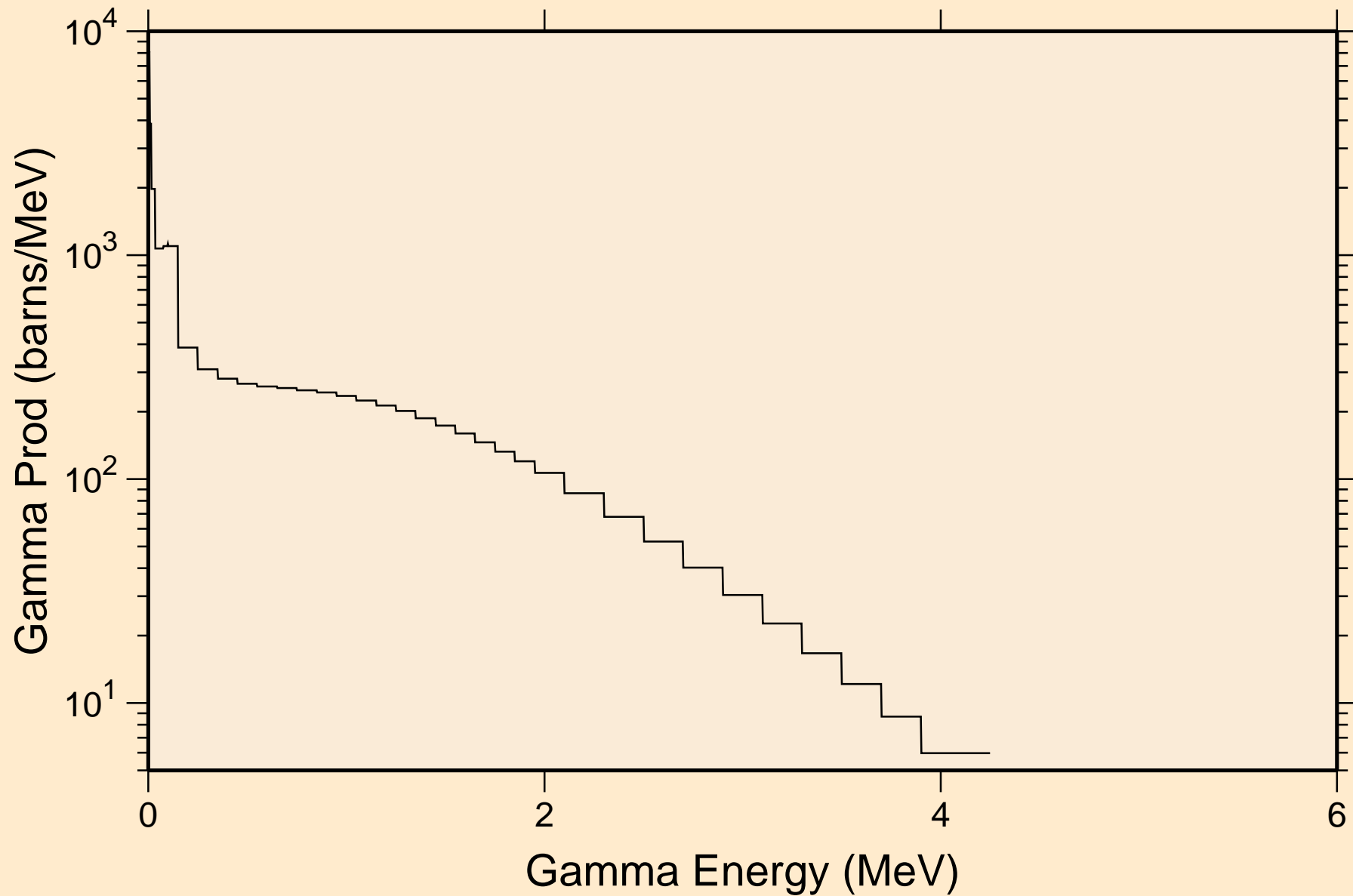

DB261 NEUTRON ACER TENDL-2019 LIBRARY; T=293.16K  
14 MeV photon spectrum

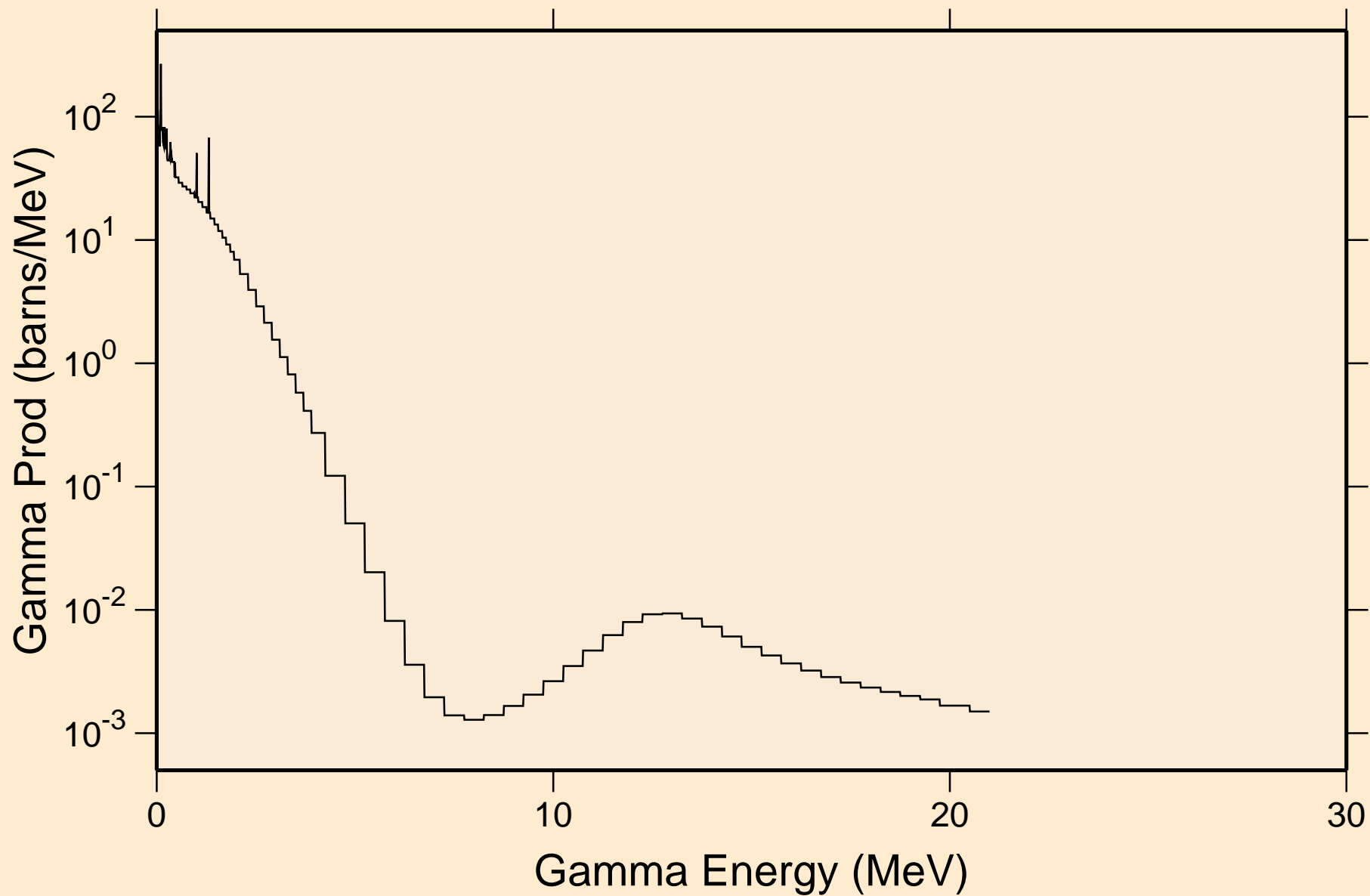

DB261 NEUTRON ACER TENDL-2019 LIBRARY; T=293.16K  
Particle heating contributions

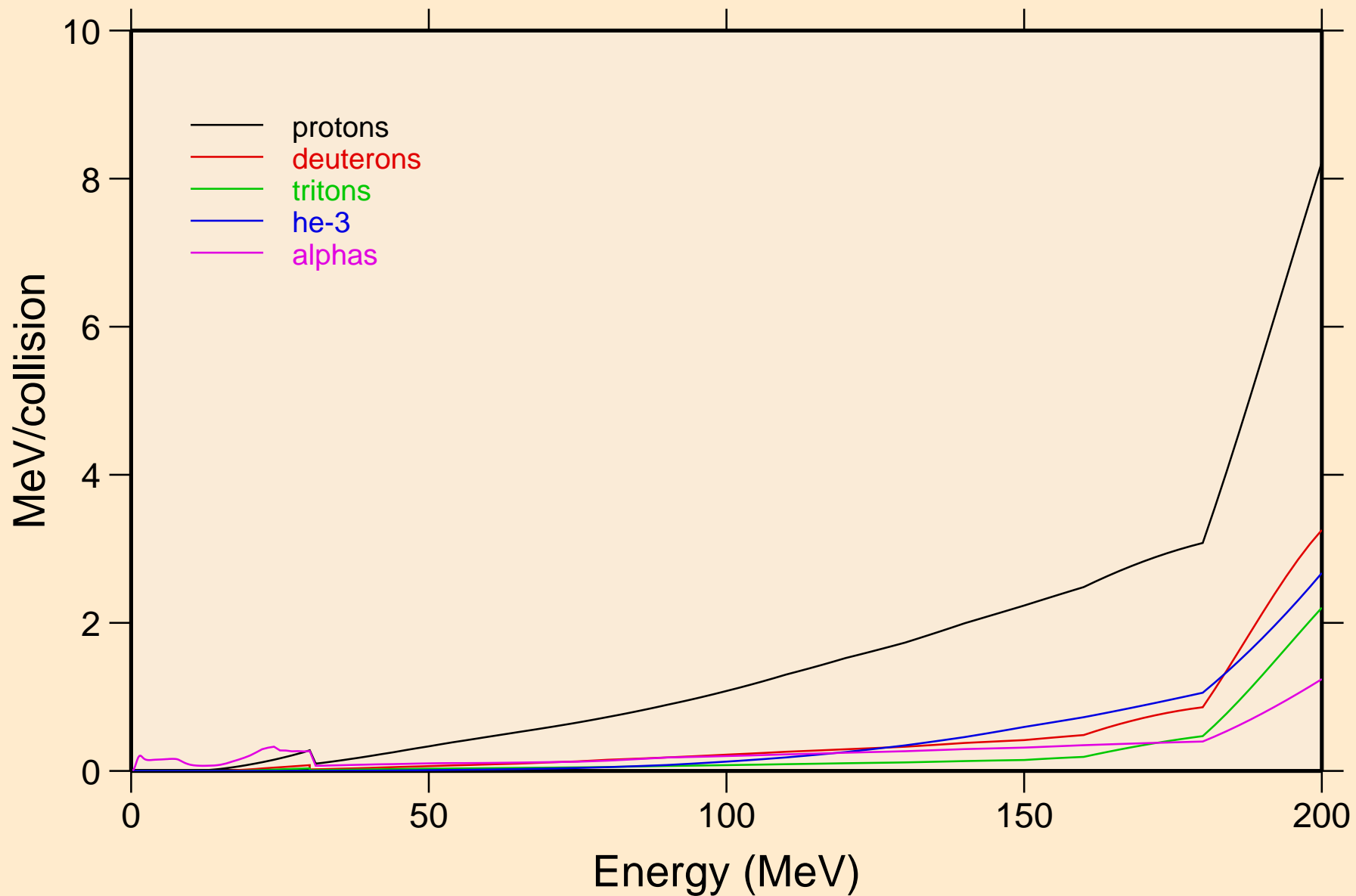

DB261 NEUTRON ACER TENDL-2019 LIBRARY; T=293.16K  
Recoil Heating

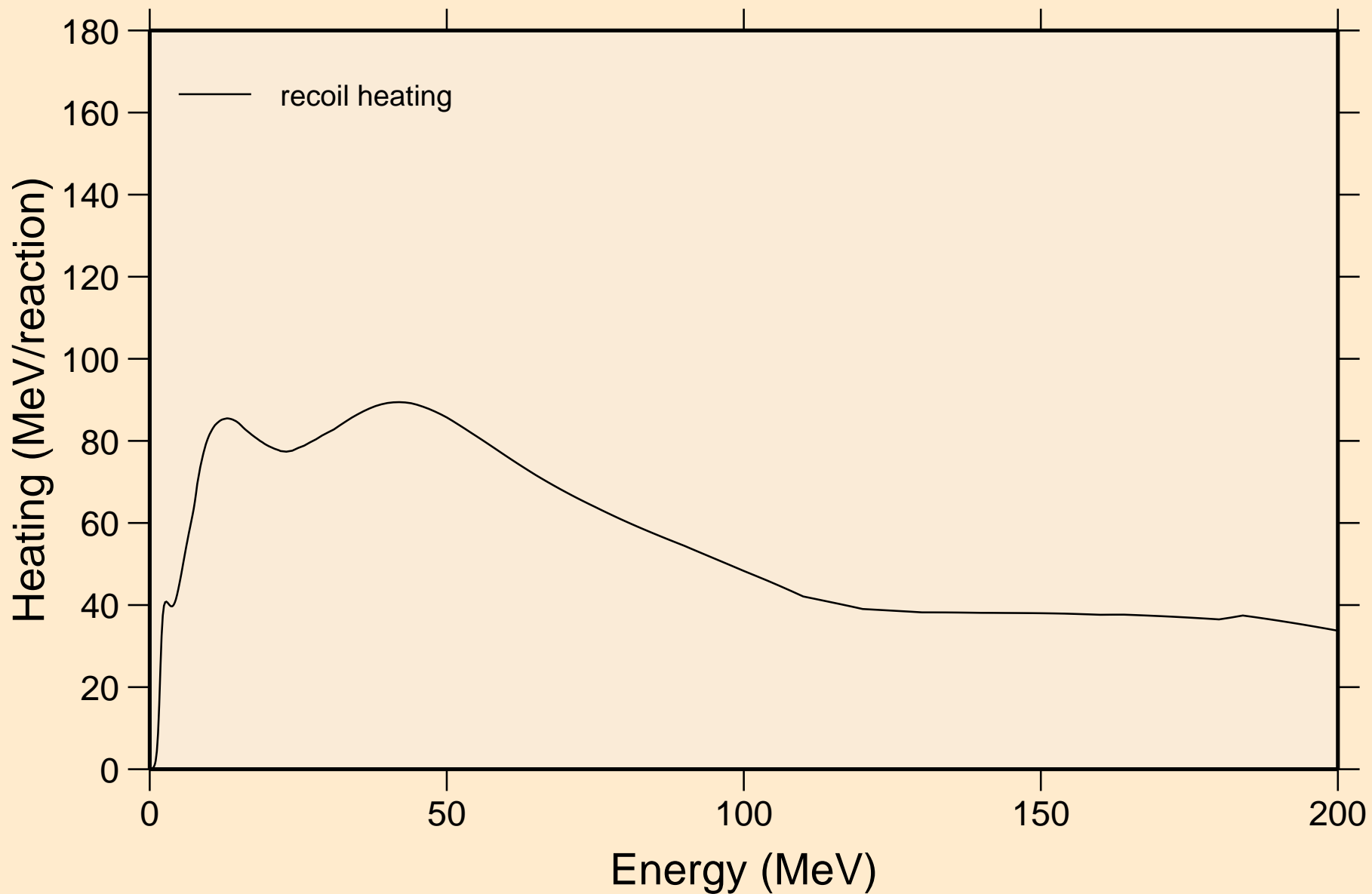

DB261 NEUTRON ACER TENDL-2019 LIBRARY; T=293.16K  
Particle production cross sections

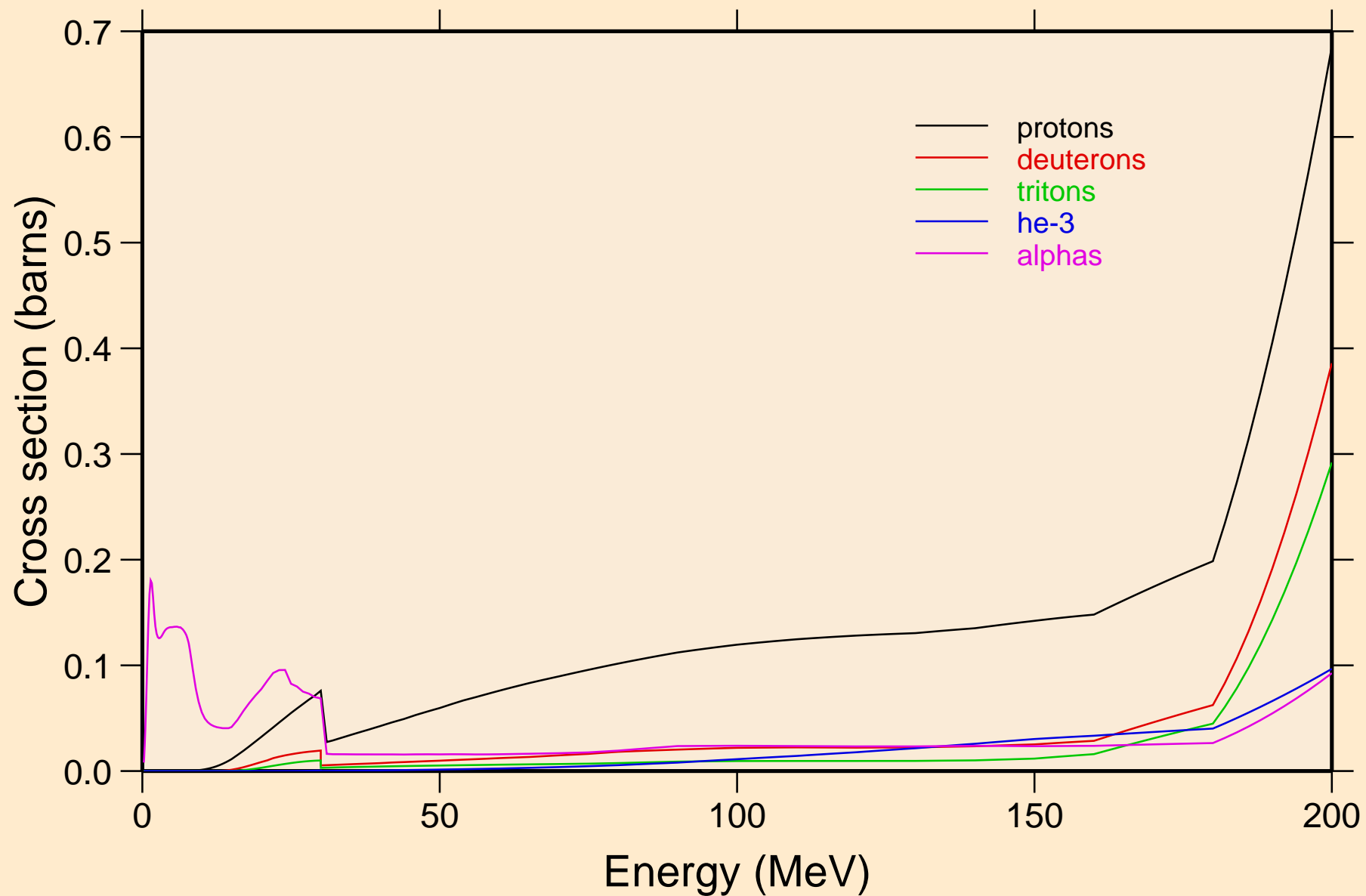

DB261 NEUTRON ACER TENDL-2019 LIBRARY; T=293.16K  
protons from (n,x)

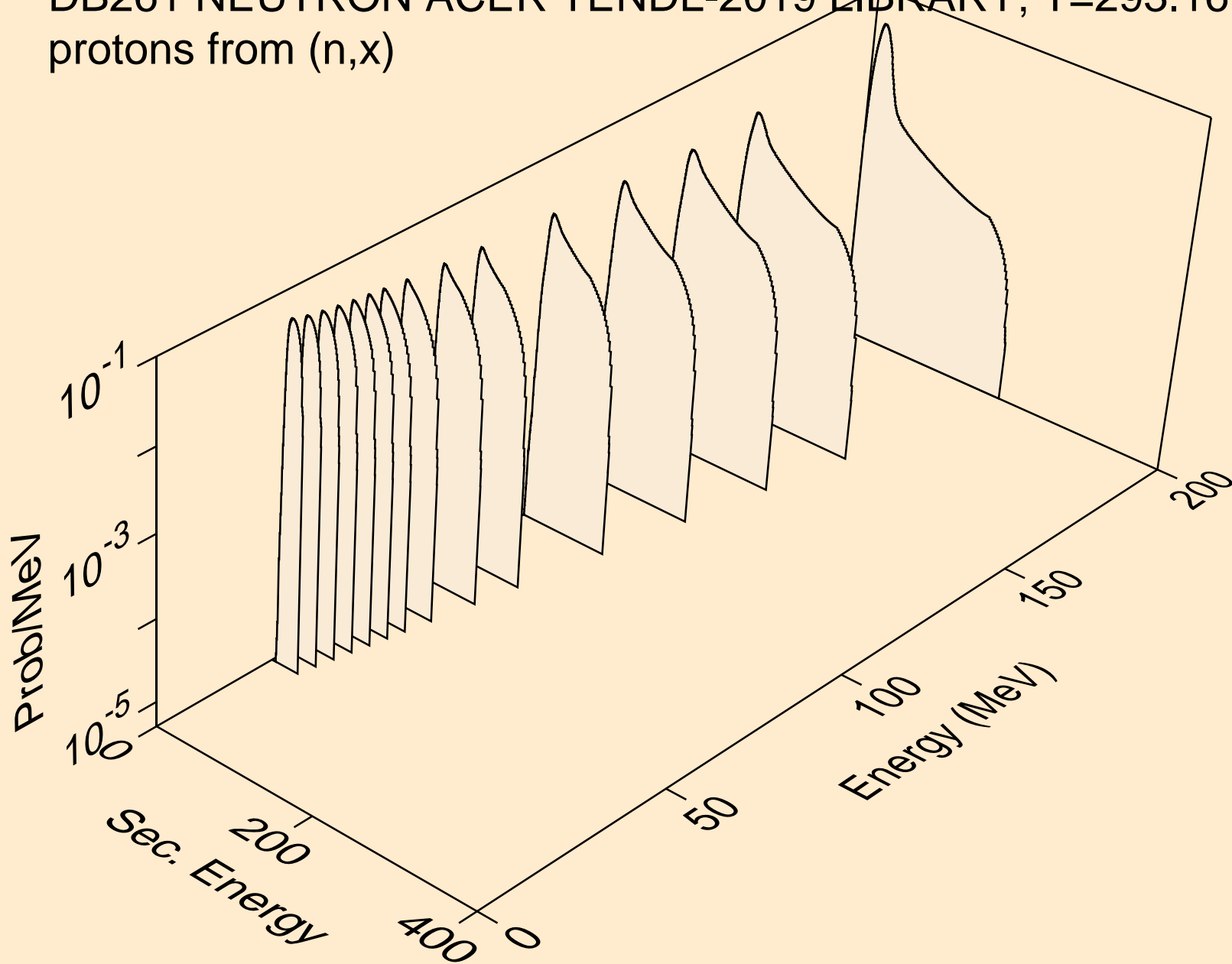

DB261 NEUTRON ACER TENDL-2019 LIBRARY; T=293.16K  
protons from (n,n\*)p

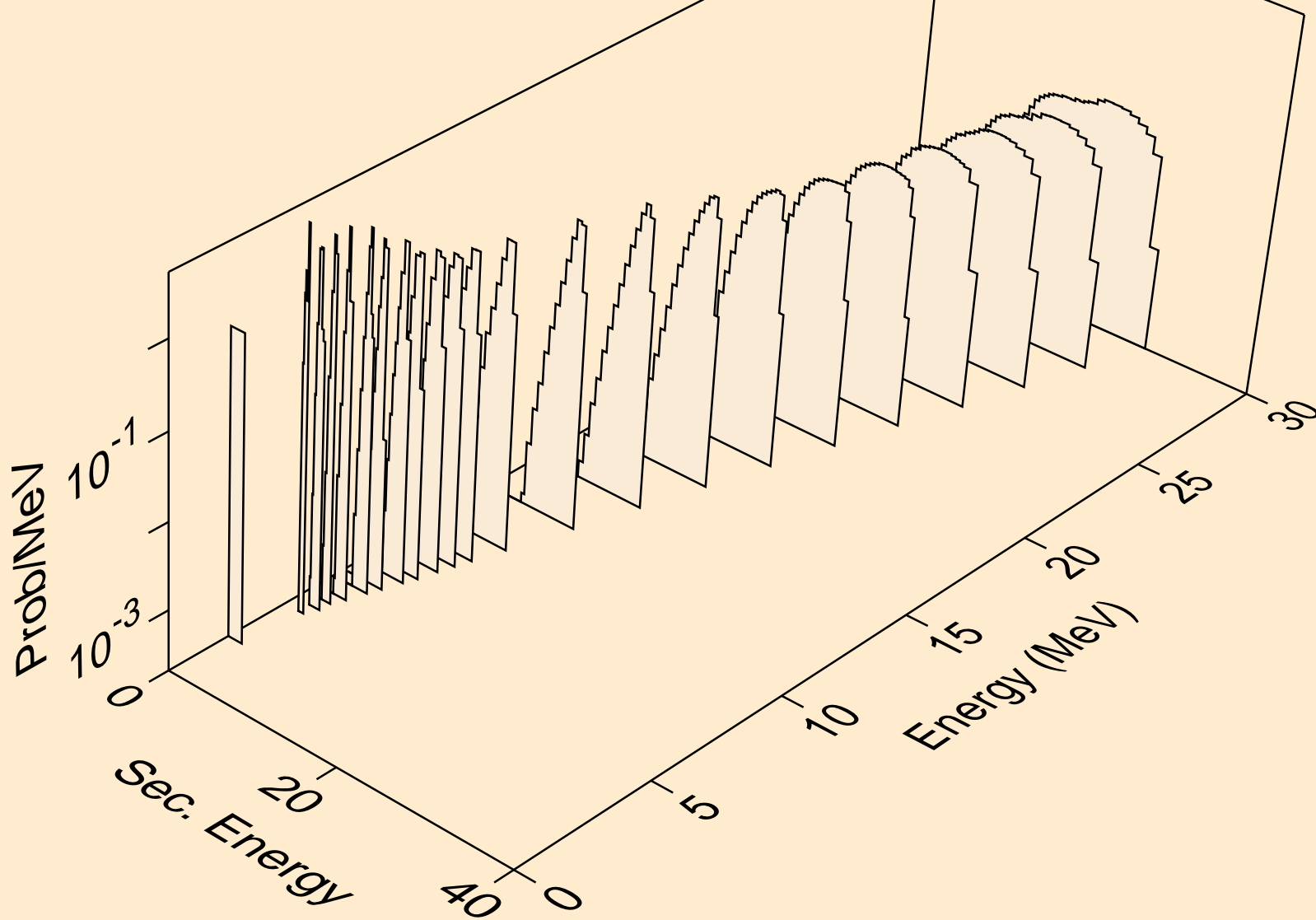

DB261 NEUTRON ACER TENDL-2019 LIBRARY; T=293.16K  
protons from (n,2np)

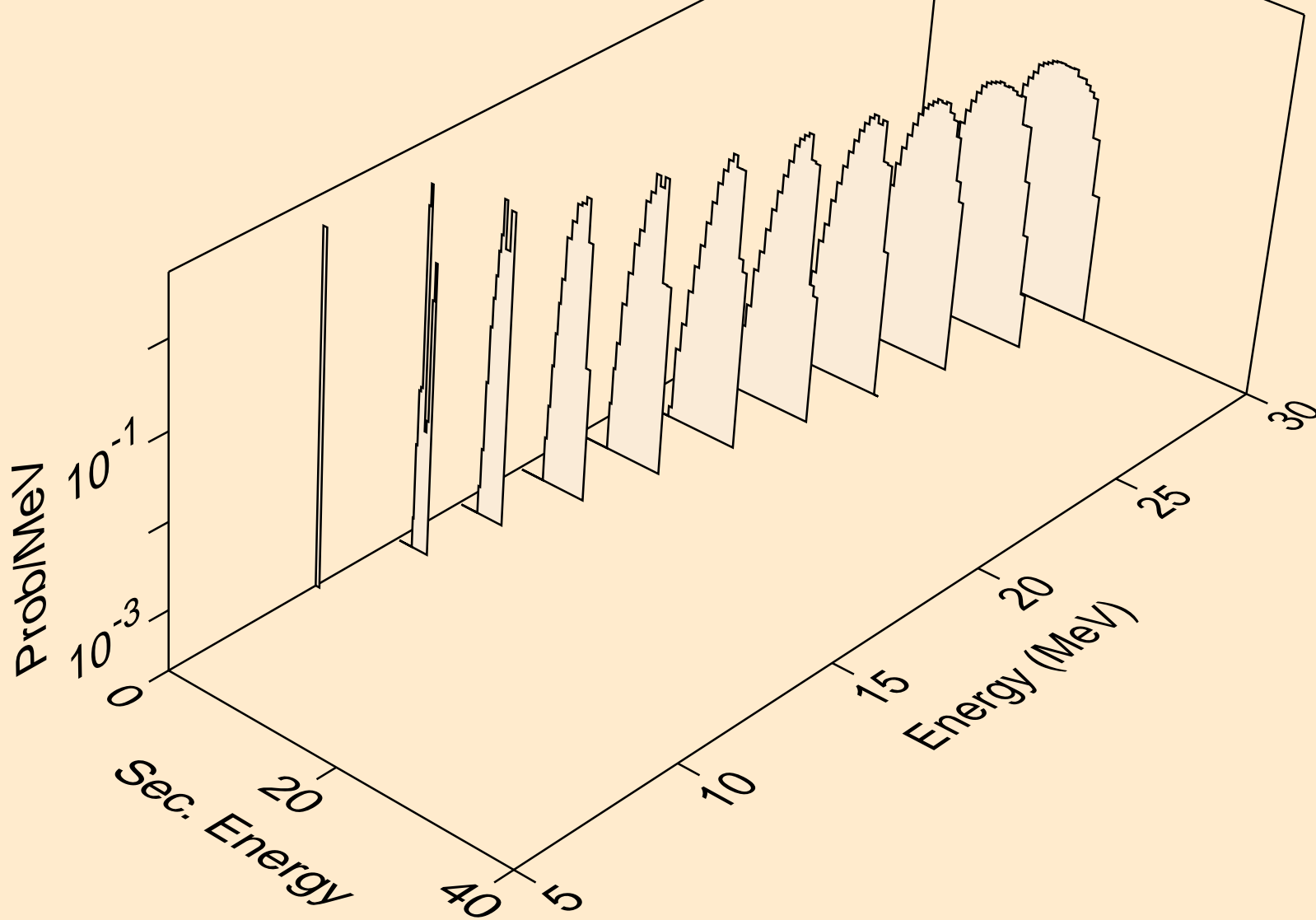

DB261 NEUTRON ACER TENDL-2019 LIBRARY; T=293.16K  
protons from (n,3np)

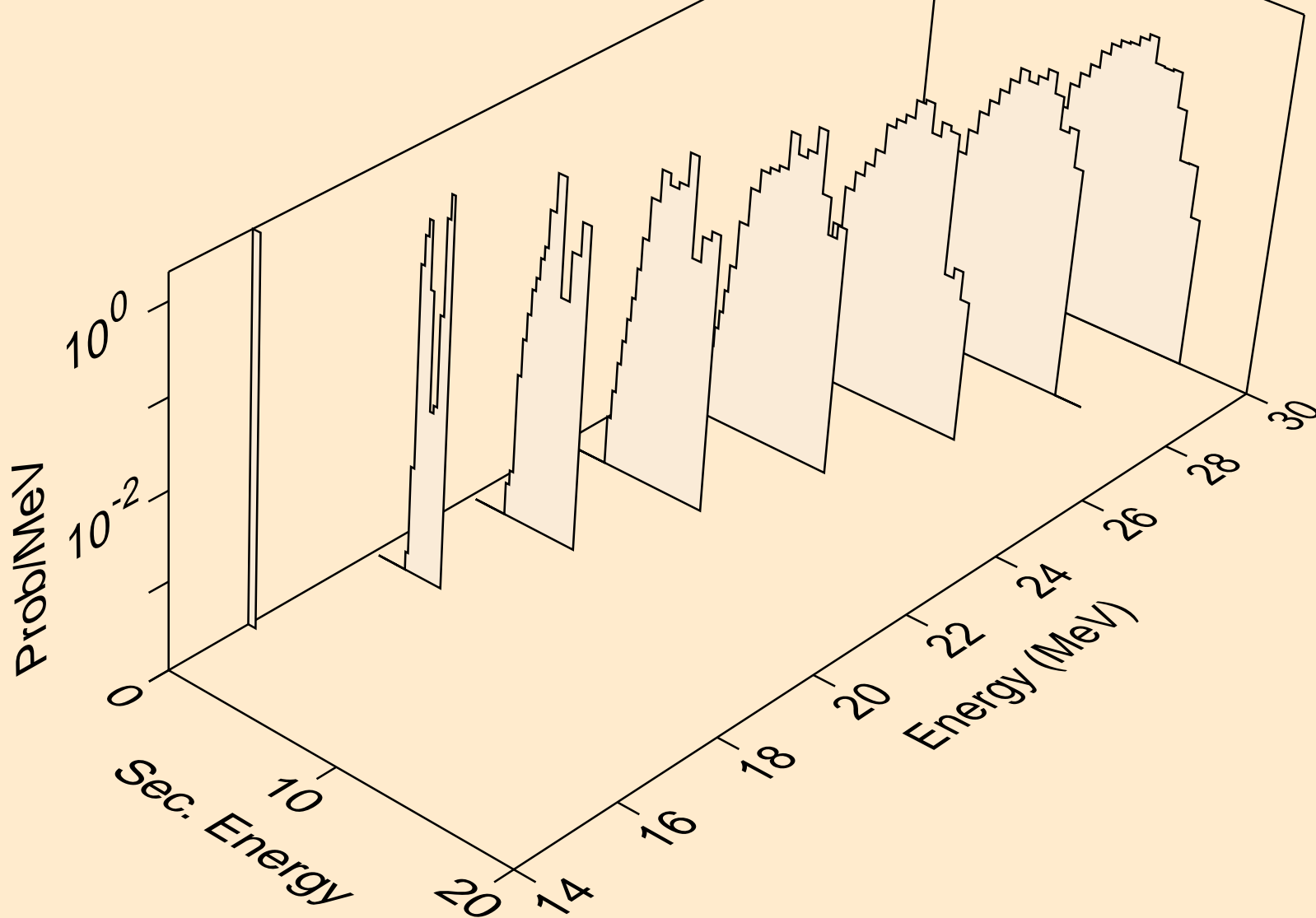

DB261 NEUTRON ACER TENDL-2019 LIBRARY; T=293.16K  
protons from (n,2np)

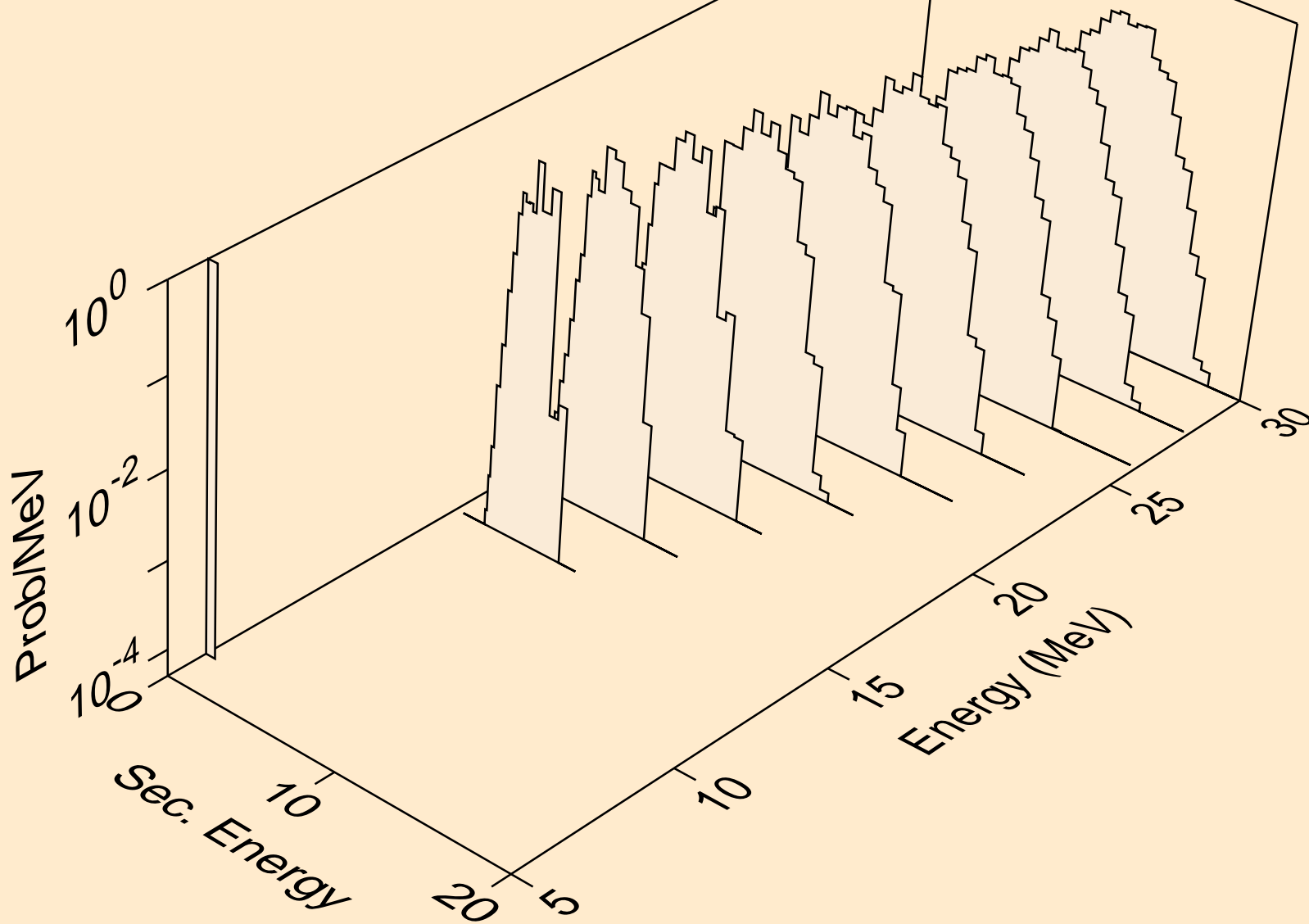

DB261 NEUTRON ACER TENDL-2019 LIBRARY; T=293.16K  
protons from (n,npa)

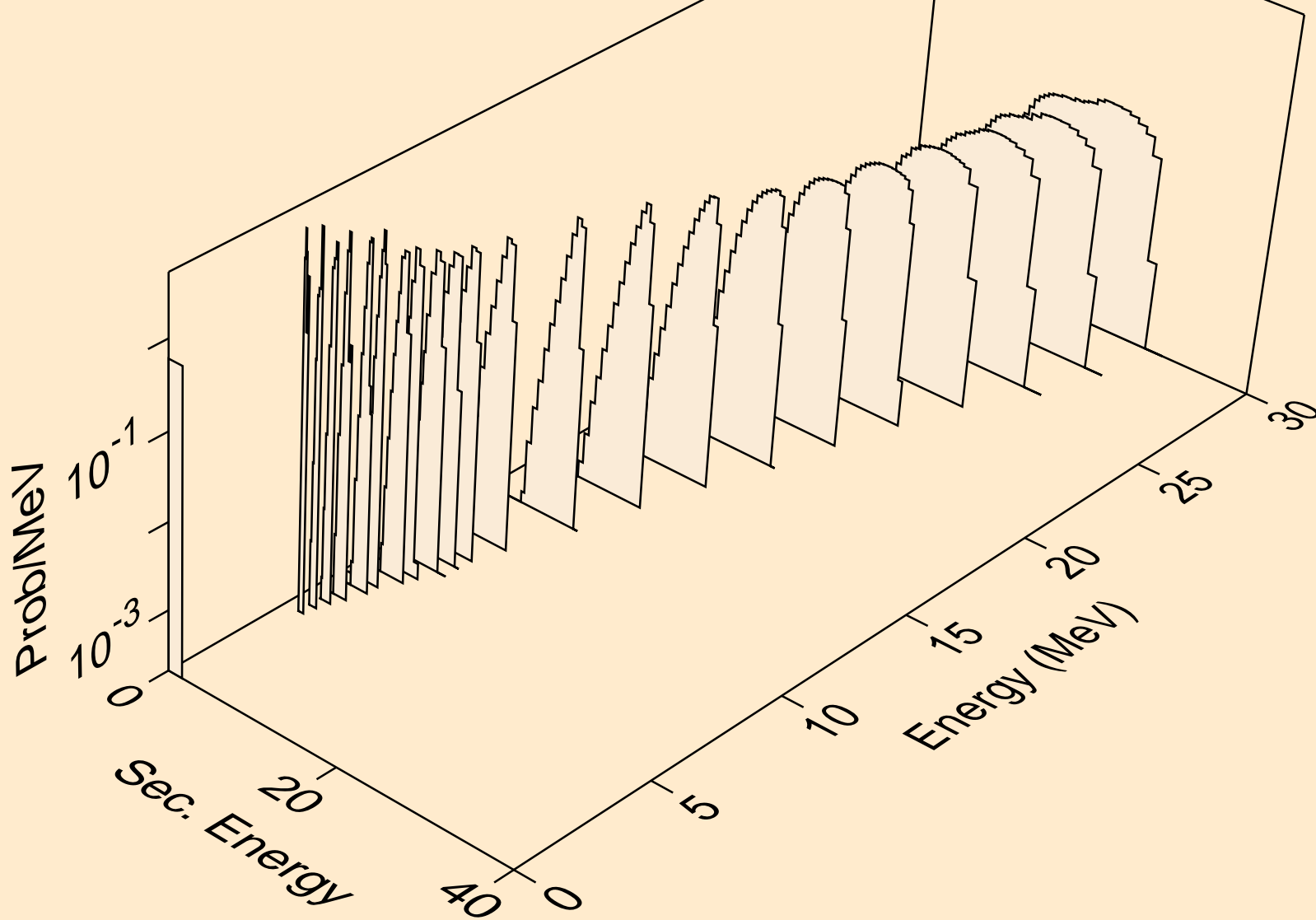

DB261 NEUTRON ACER TENDL-2019 LIBRARY; T=293.16K  
protons from (n,p)

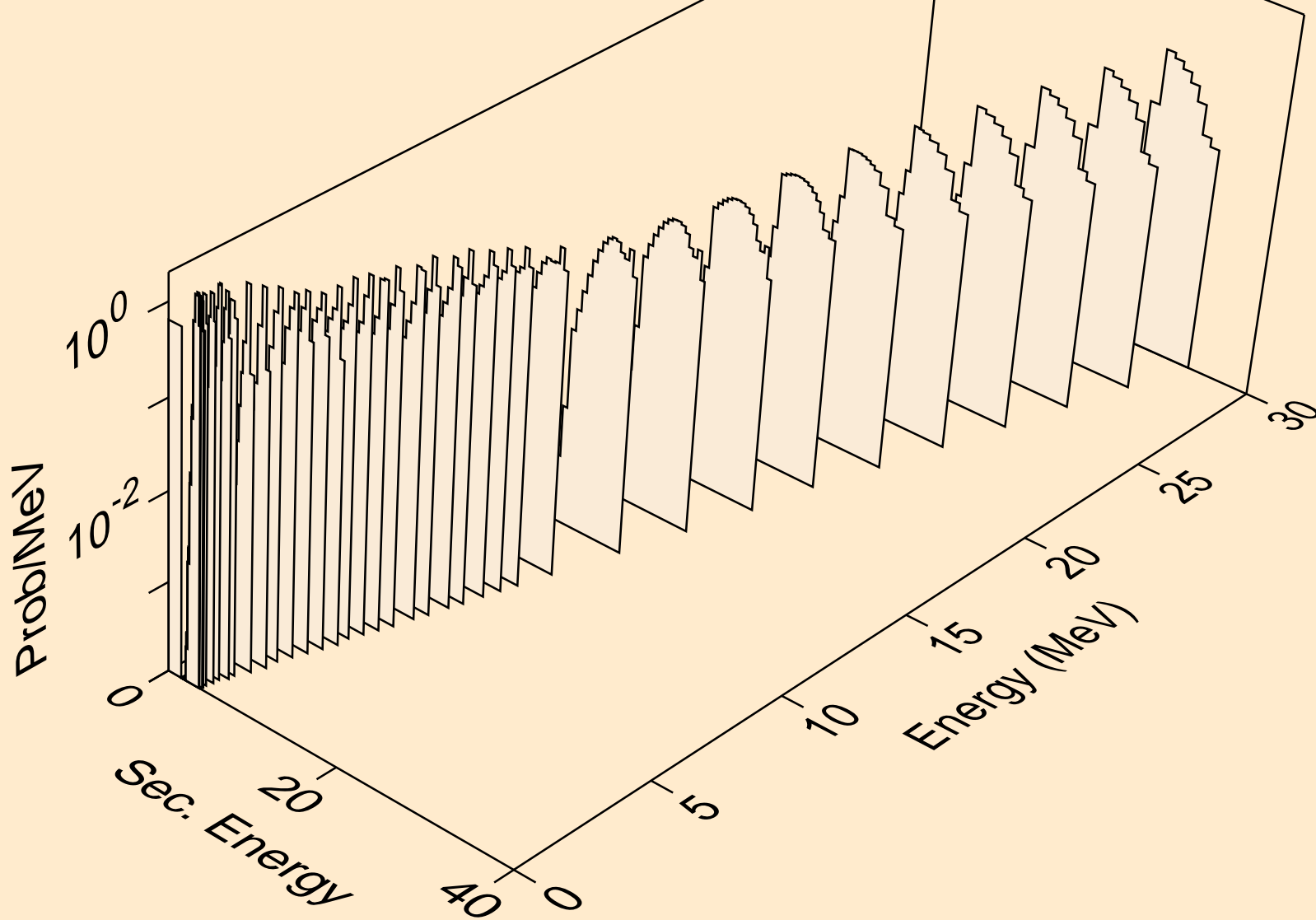

DB261 NEUTRON ACER TENDL-2019 LIBRARY; T=293.16K  
protons from (n,2p)

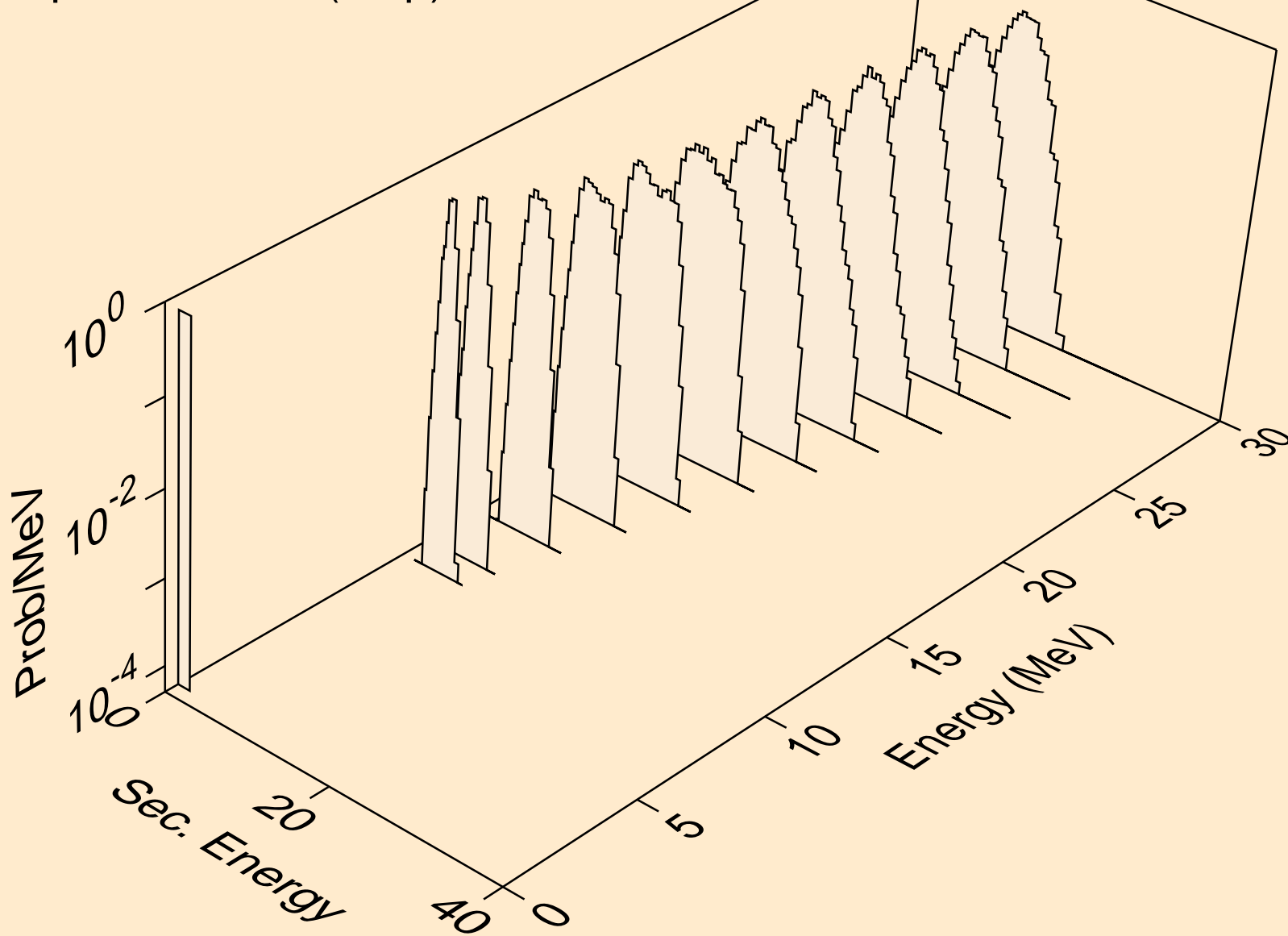

DB261 NEUTRON ACER TENDL-2019 LIBRARY; T=293.16K  
protons from (n,p)

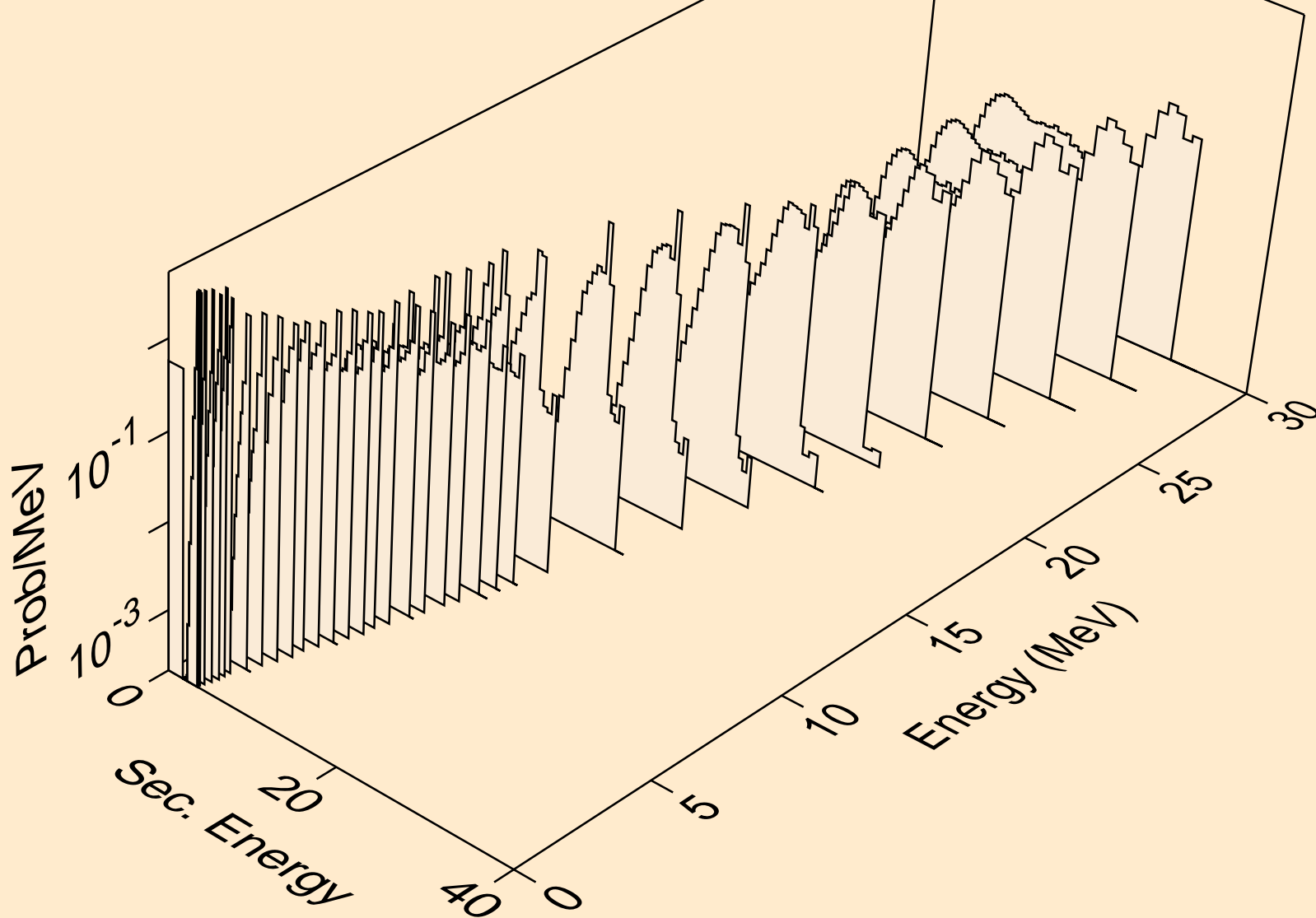

DB261 NEUTRON ACER TENDL-2019 LIBRARY; T=293.16K  
protons from (n,pd)

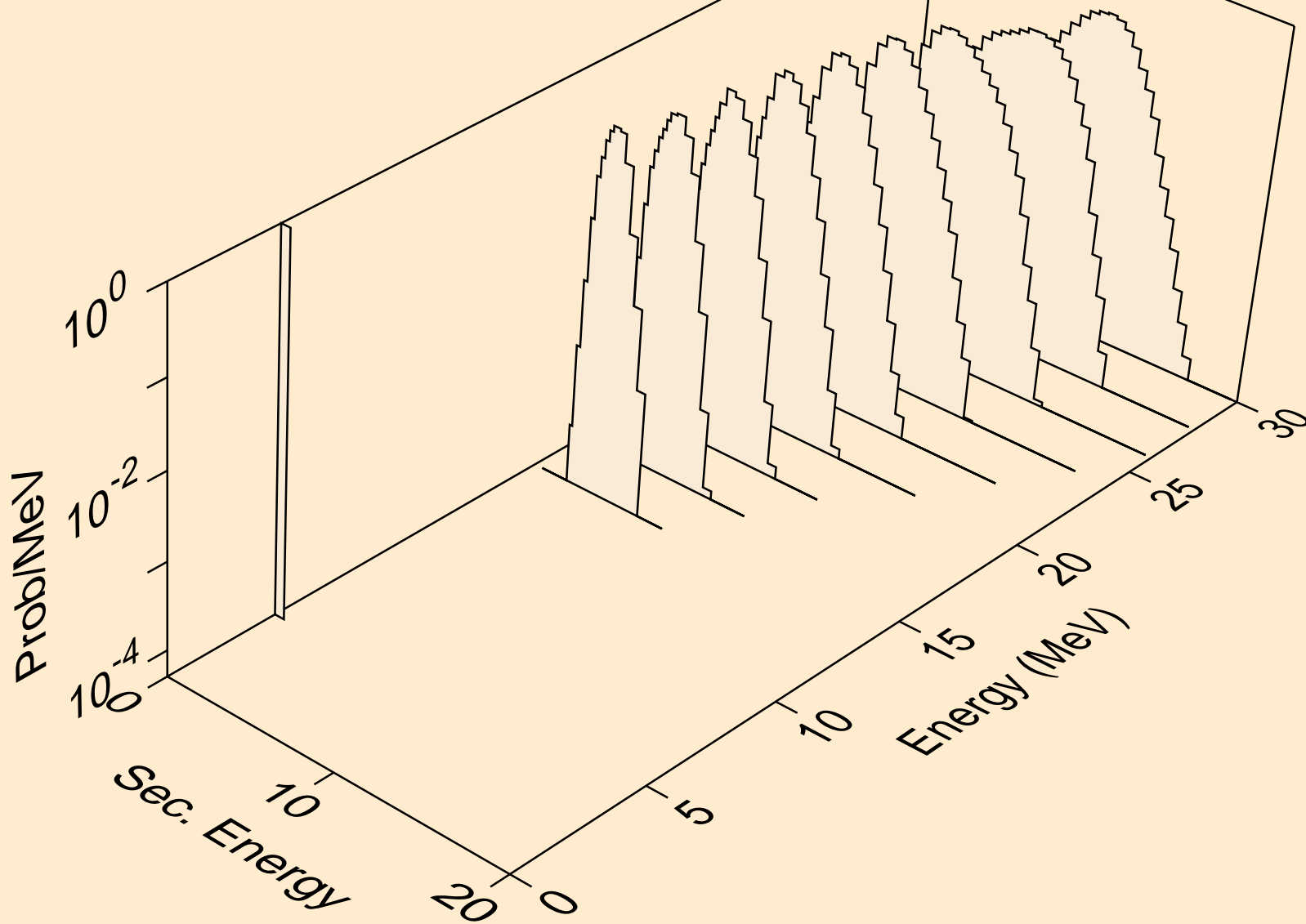

DB261 NEUTRON ACER TENDL-2019 LIBRARY; T=293.16K  
protons from (n,pt)

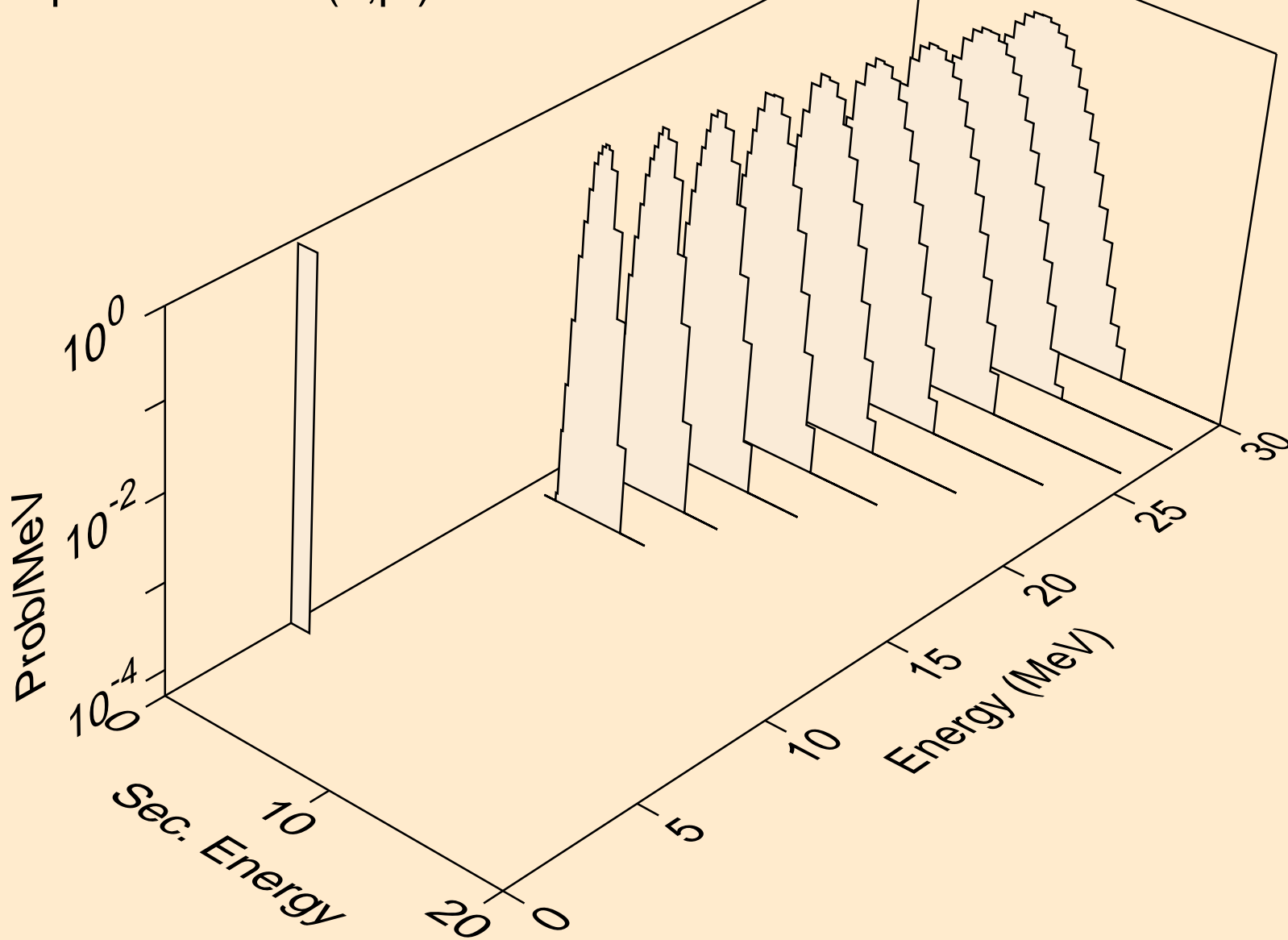

DB261 NEUTRON ACER TENDL-2019 LIBRARY; T=293.16K  
deuterons from (n,x)

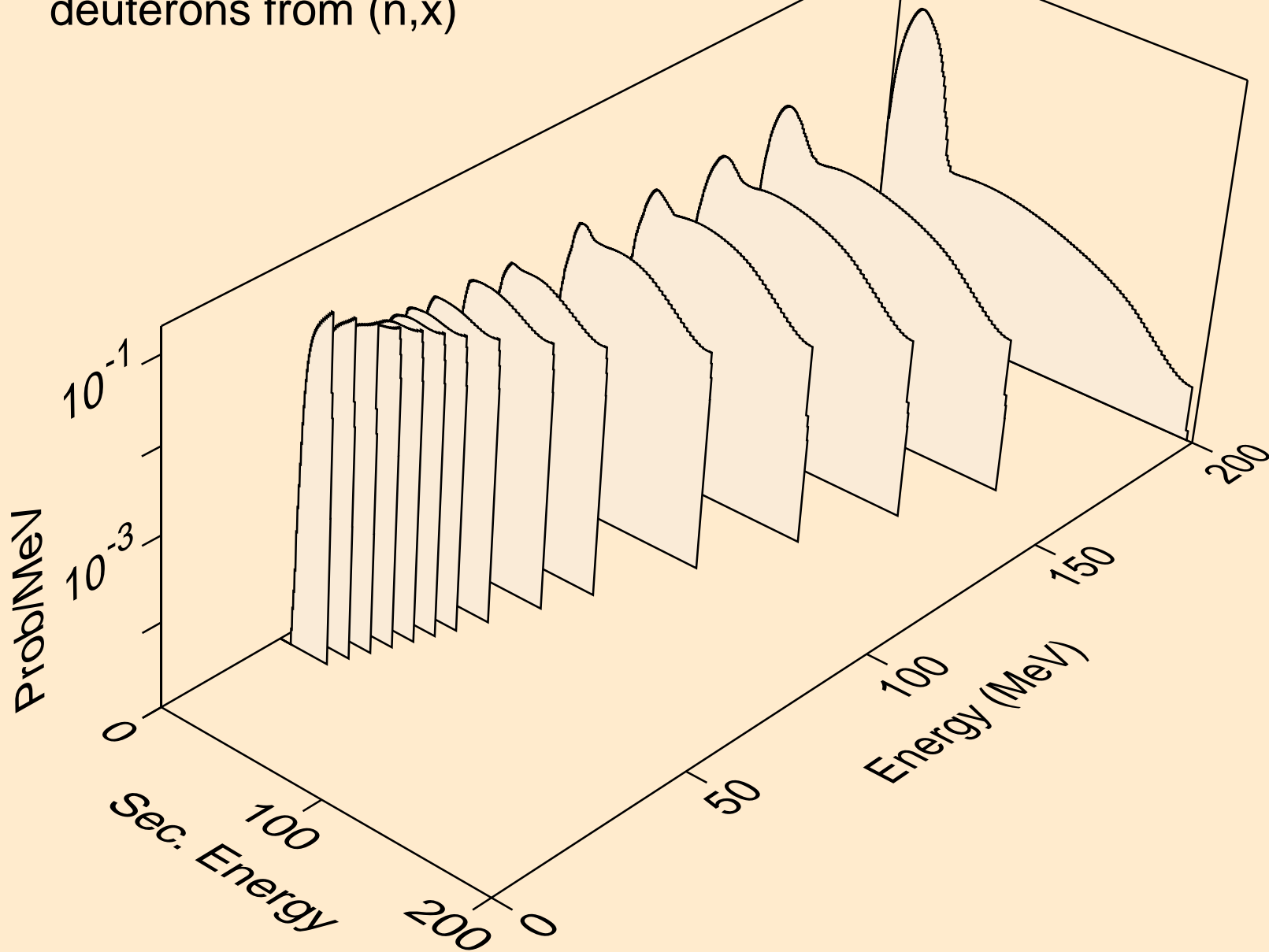

DB261 NEUTRON ACER TENDL-2019 LIBRARY; T=293.16K  
deuterons from (n,2nd)

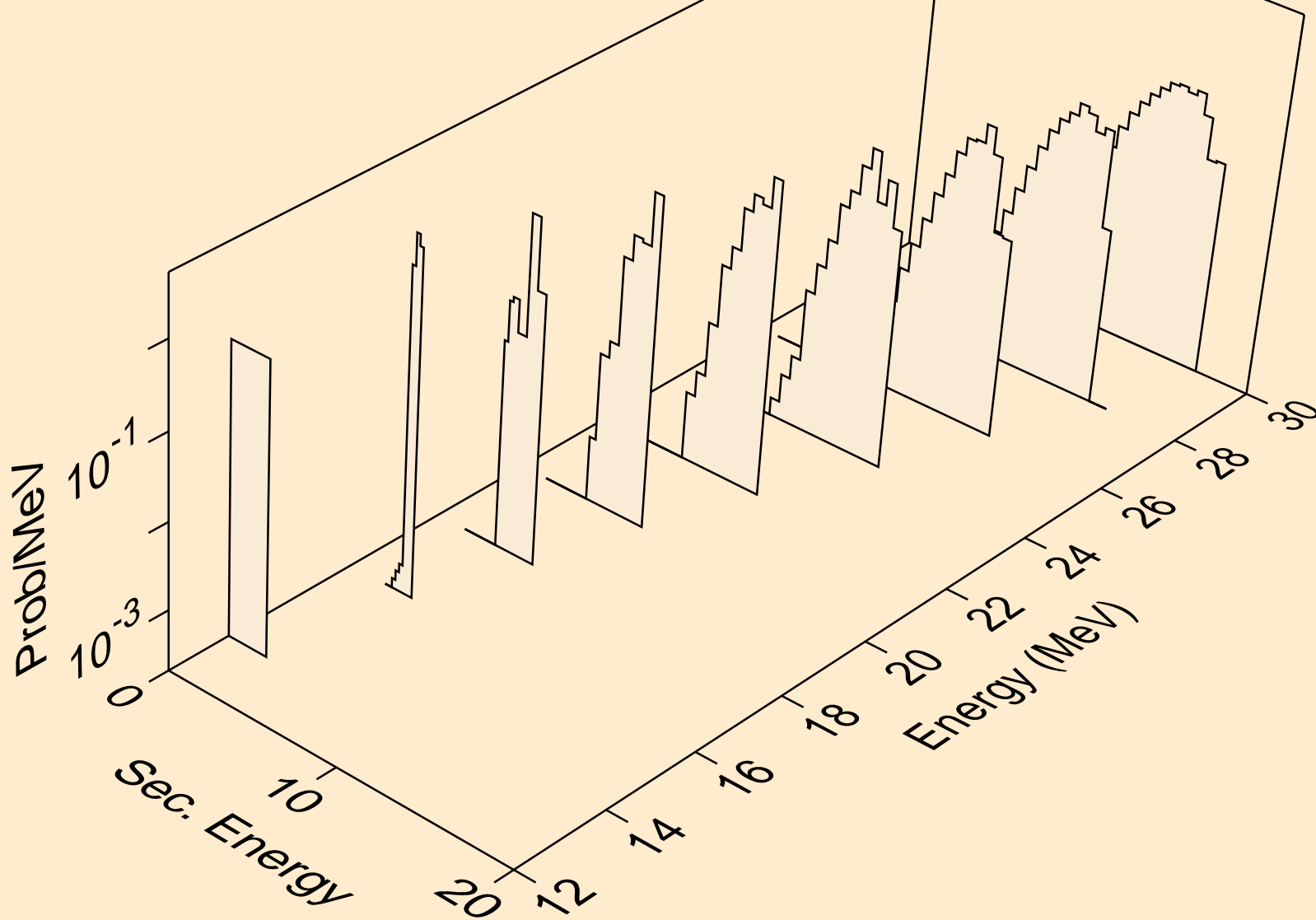

DB261 NEUTRON ACER TENDL-2019 LIBRARY; T=293.16K  
deuterons from (n,n\*)d

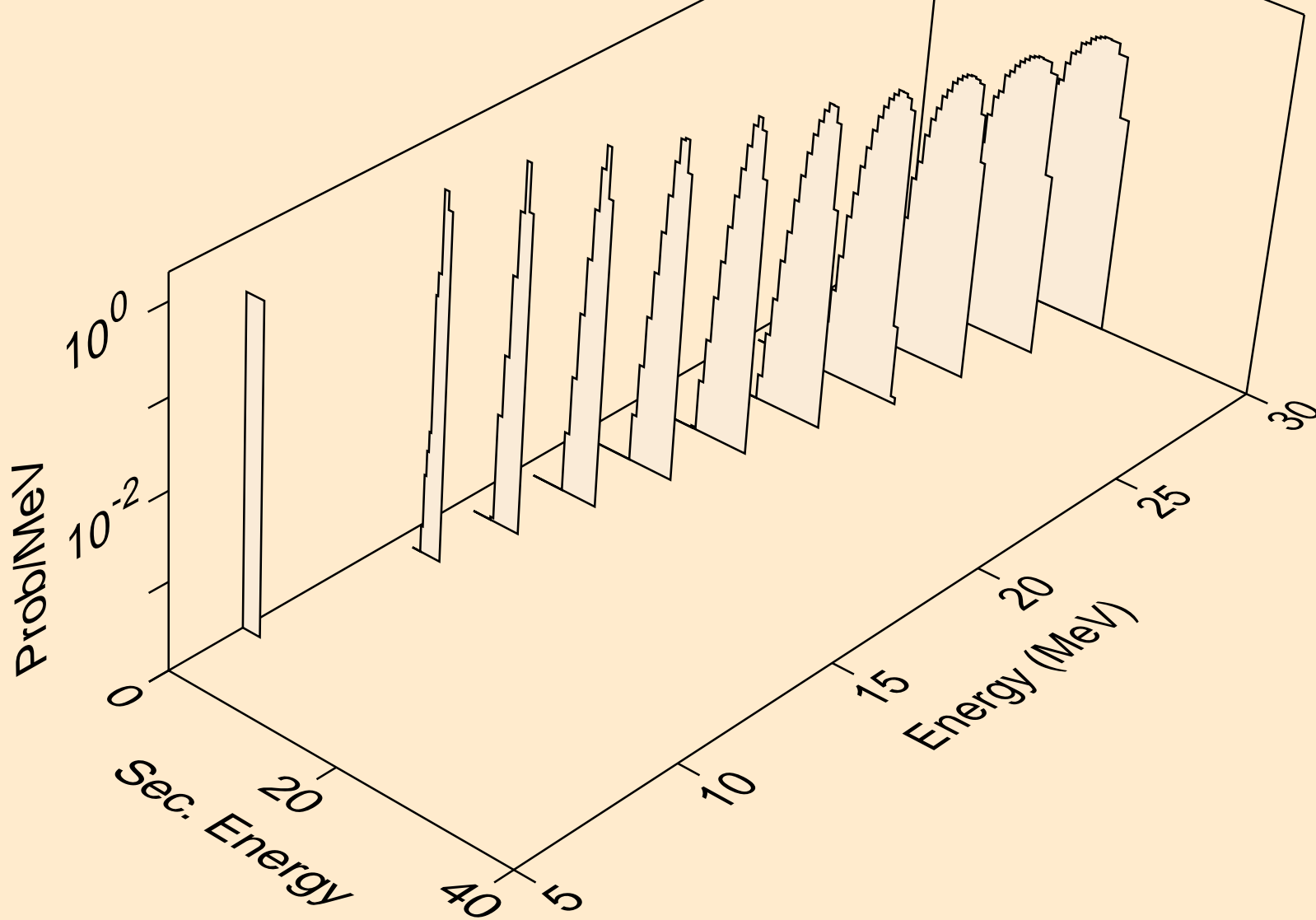

DB261 NEUTRON ACER TENDL-2019 LIBRARY; T=293.16K  
deuterons from (n,n\*)d2a

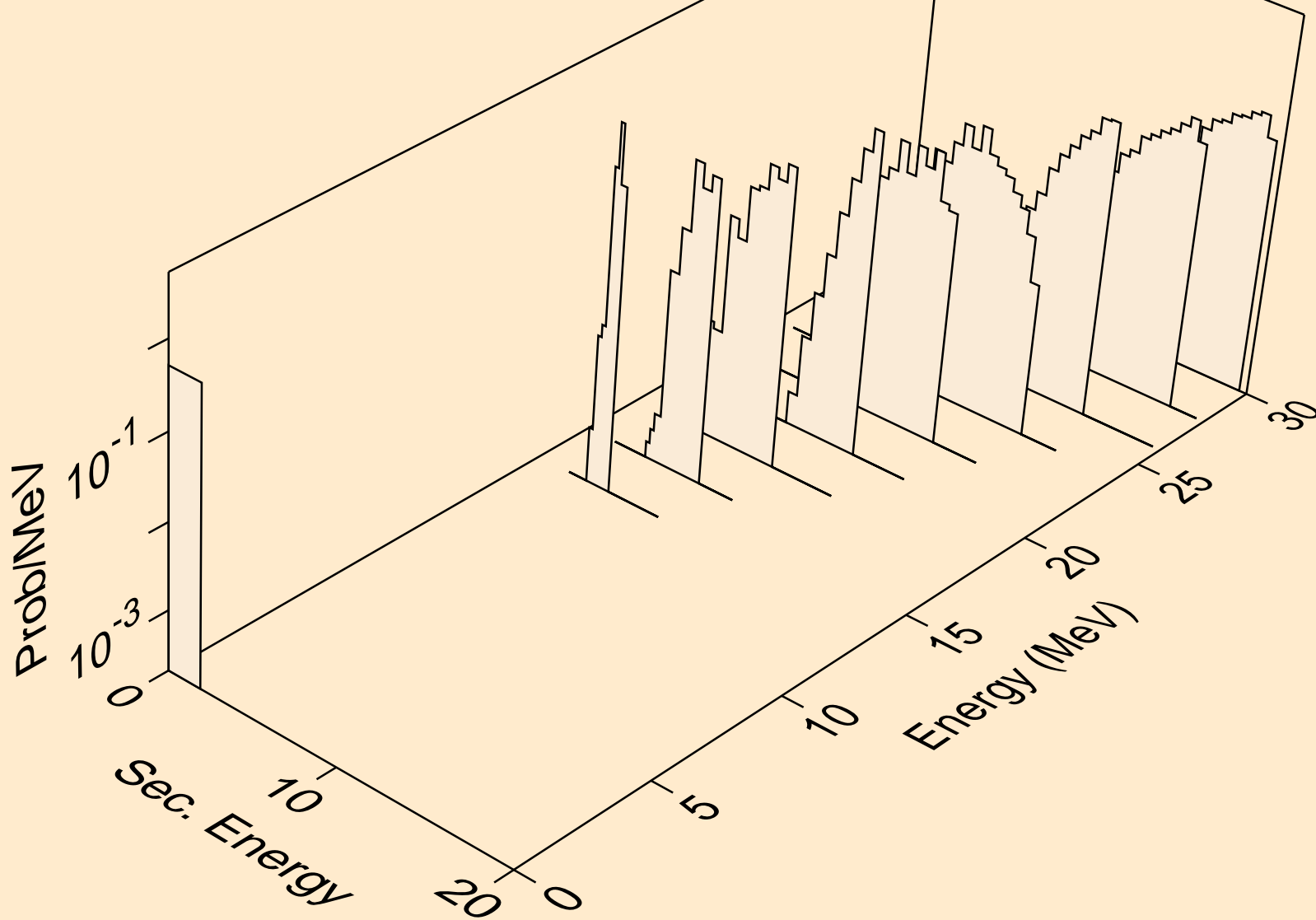

DB261 NEUTRON ACER TENDL-2019 LIBRARY; T=293.16K  
deuterons from (n,d)

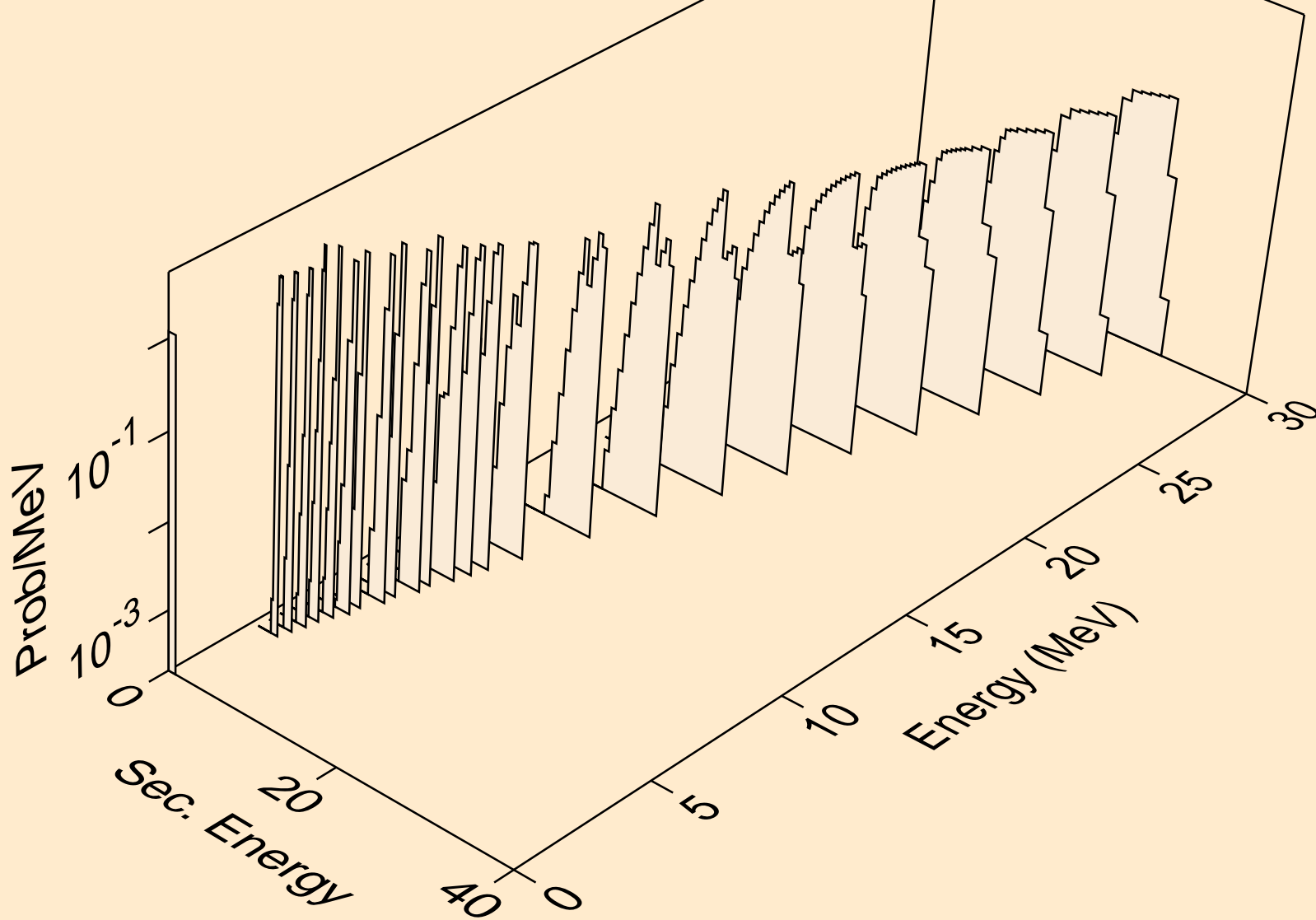

DB261 NEUTRON ACER TENDL-2019 LIBRARY; T=293.16K  
deuterons from (n,d2a)

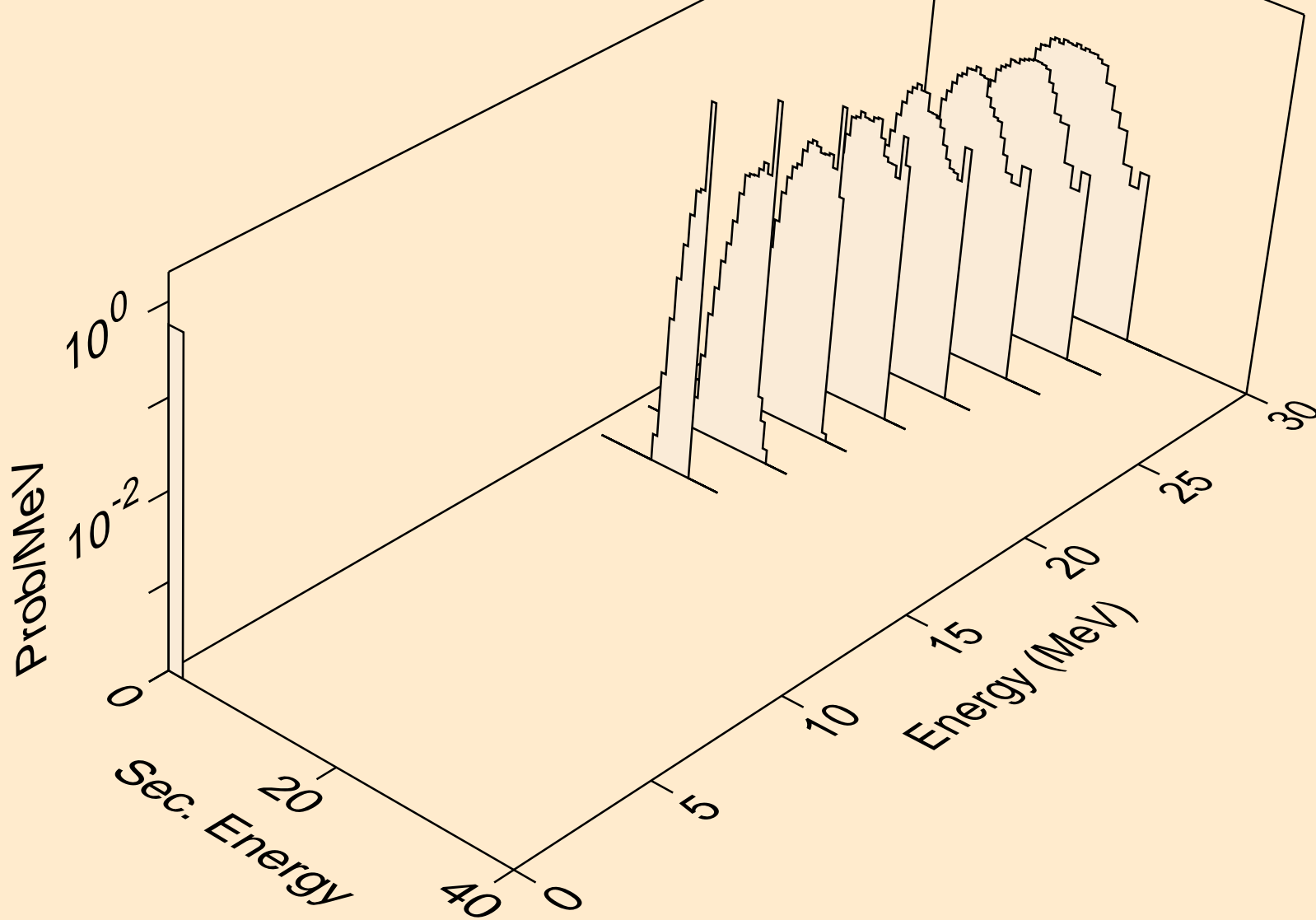

DB261 NEUTRON ACER TENDL-2019 LIBRARY; T=293.16K  
deuterons from (n,pd)

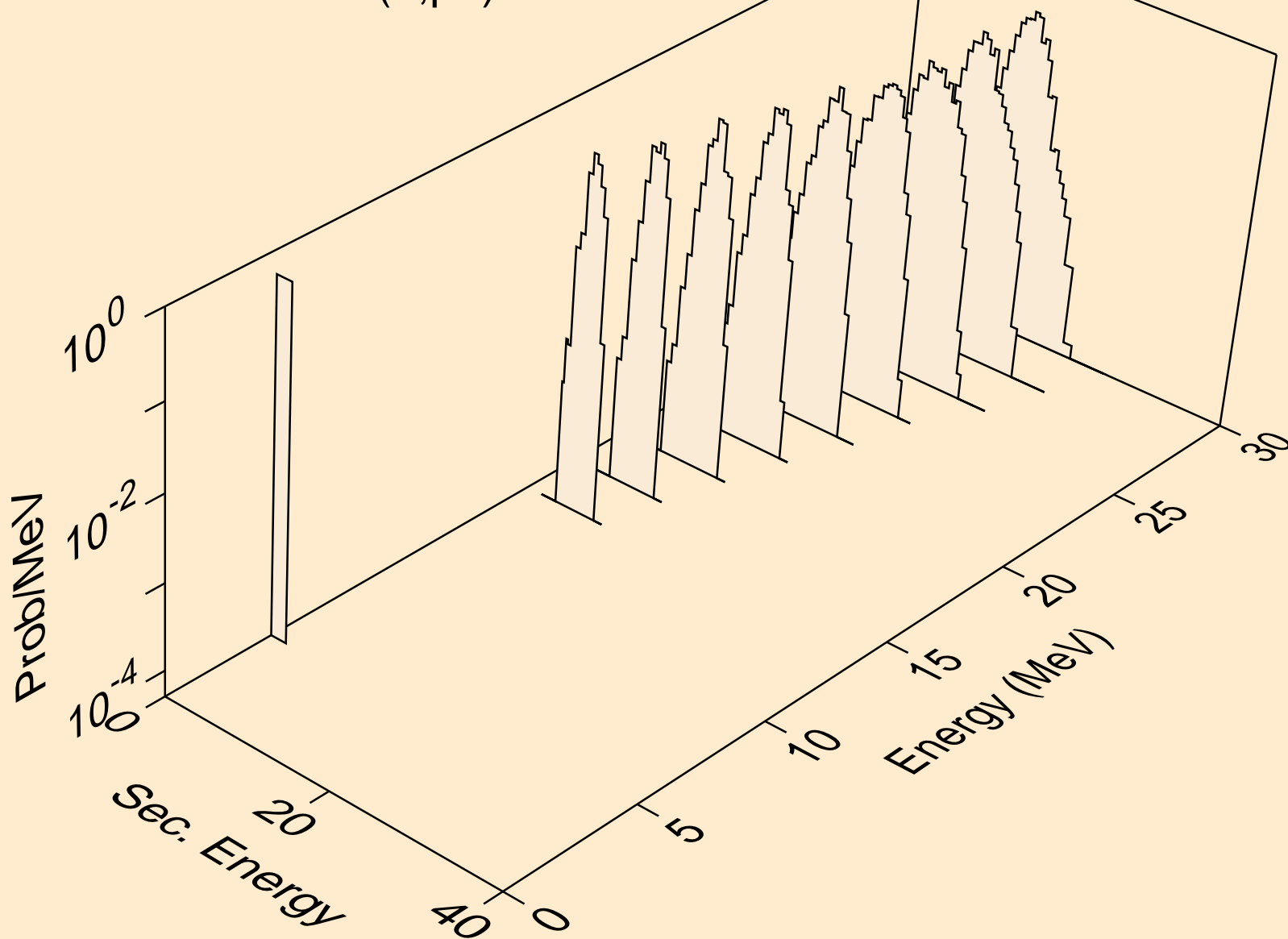

DB261 NEUTRON ACER TENDL-2019 LIBRARY; T=293.16K  
deuterons from (n,da)

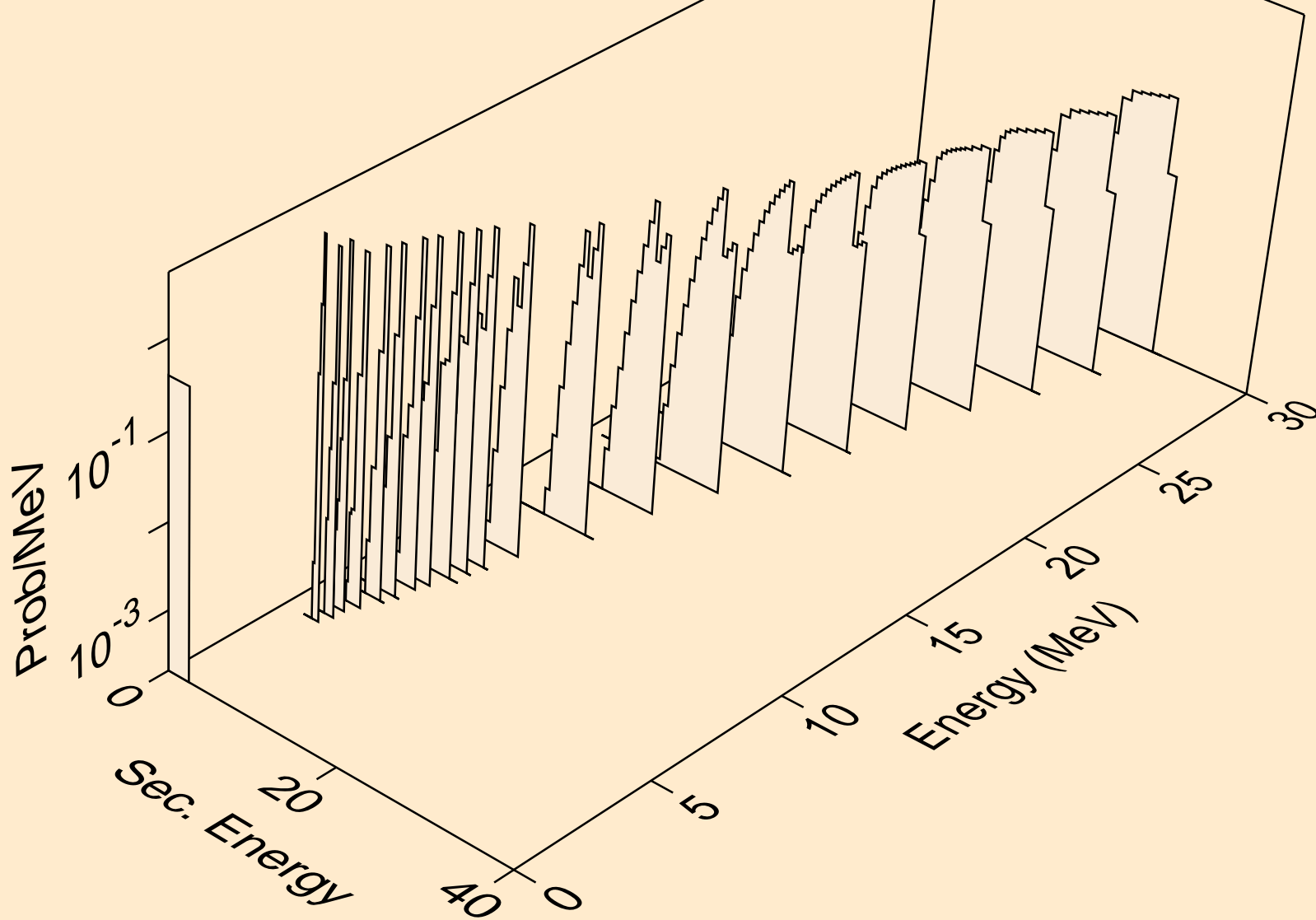

DB261 NEUTRON ACER TENDL-2019 LIBRARY; T=293.16K  
tritons from (n,x)

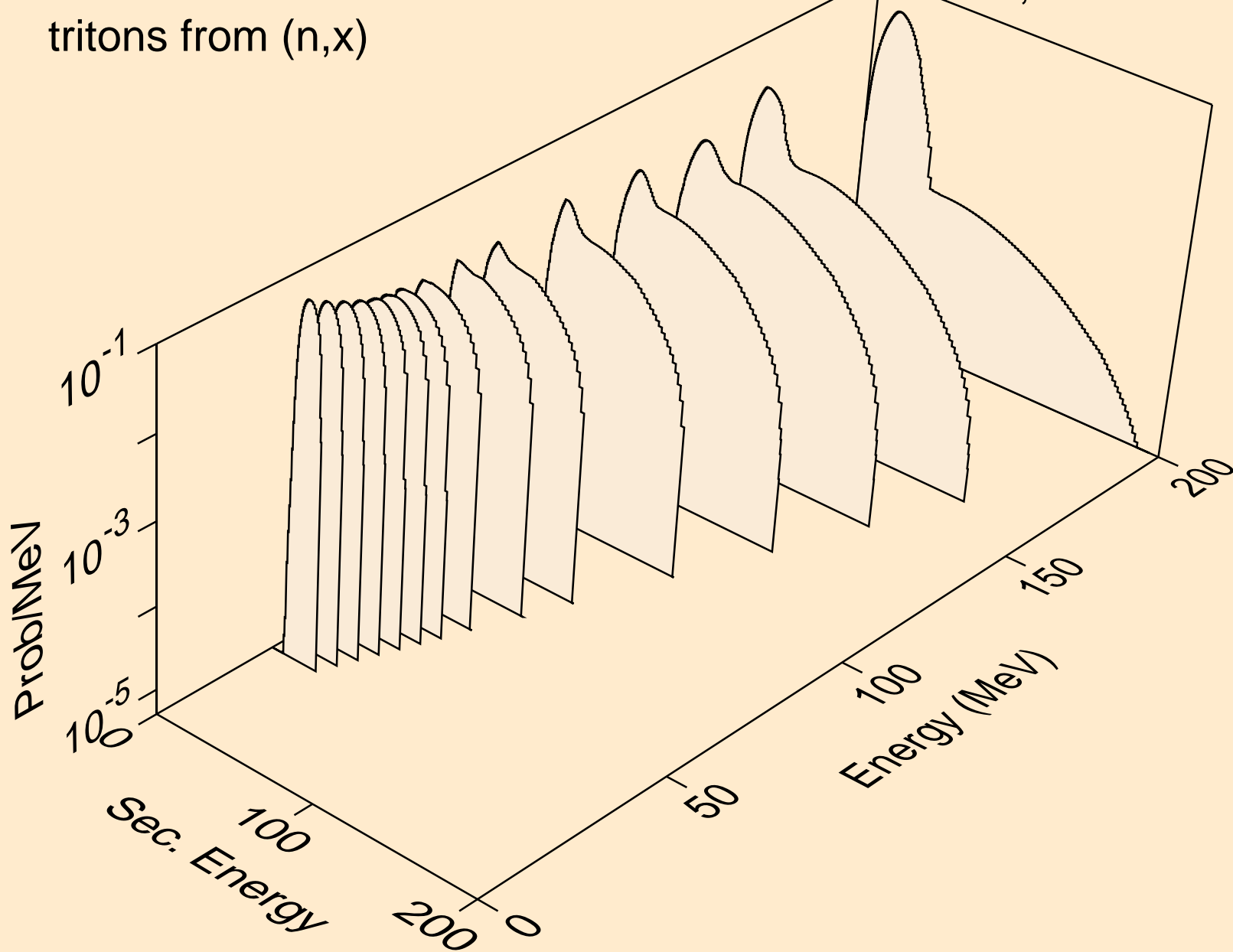

DB261 NEUTRON ACER TENDL-2019 LIBRARY; T=293.16K  
tritons from (n,n\*)t

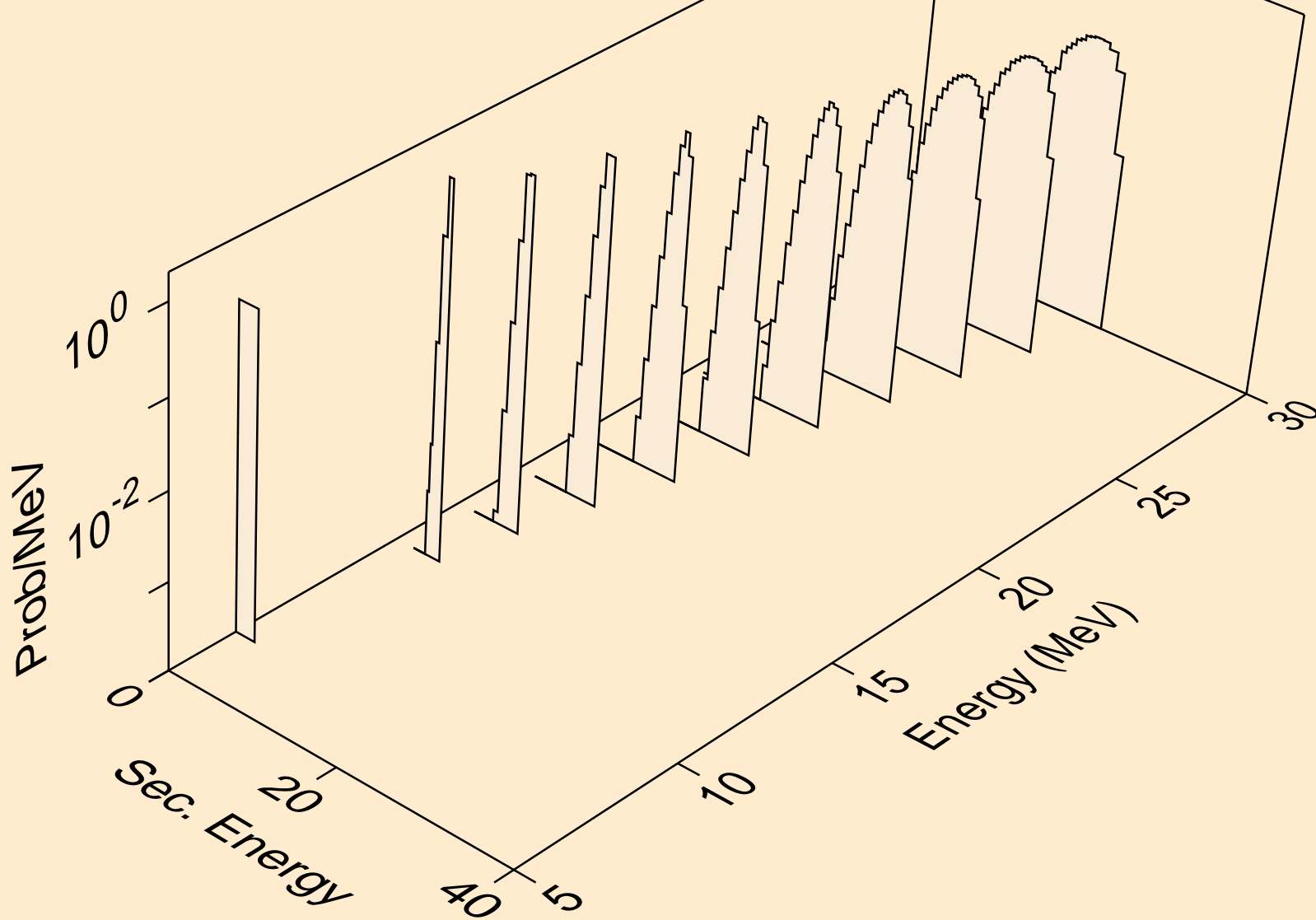

DB261 NEUTRON ACER TENDL-2019 LIBRARY; T=293.16K  
tritons from (n,n\*)t2a

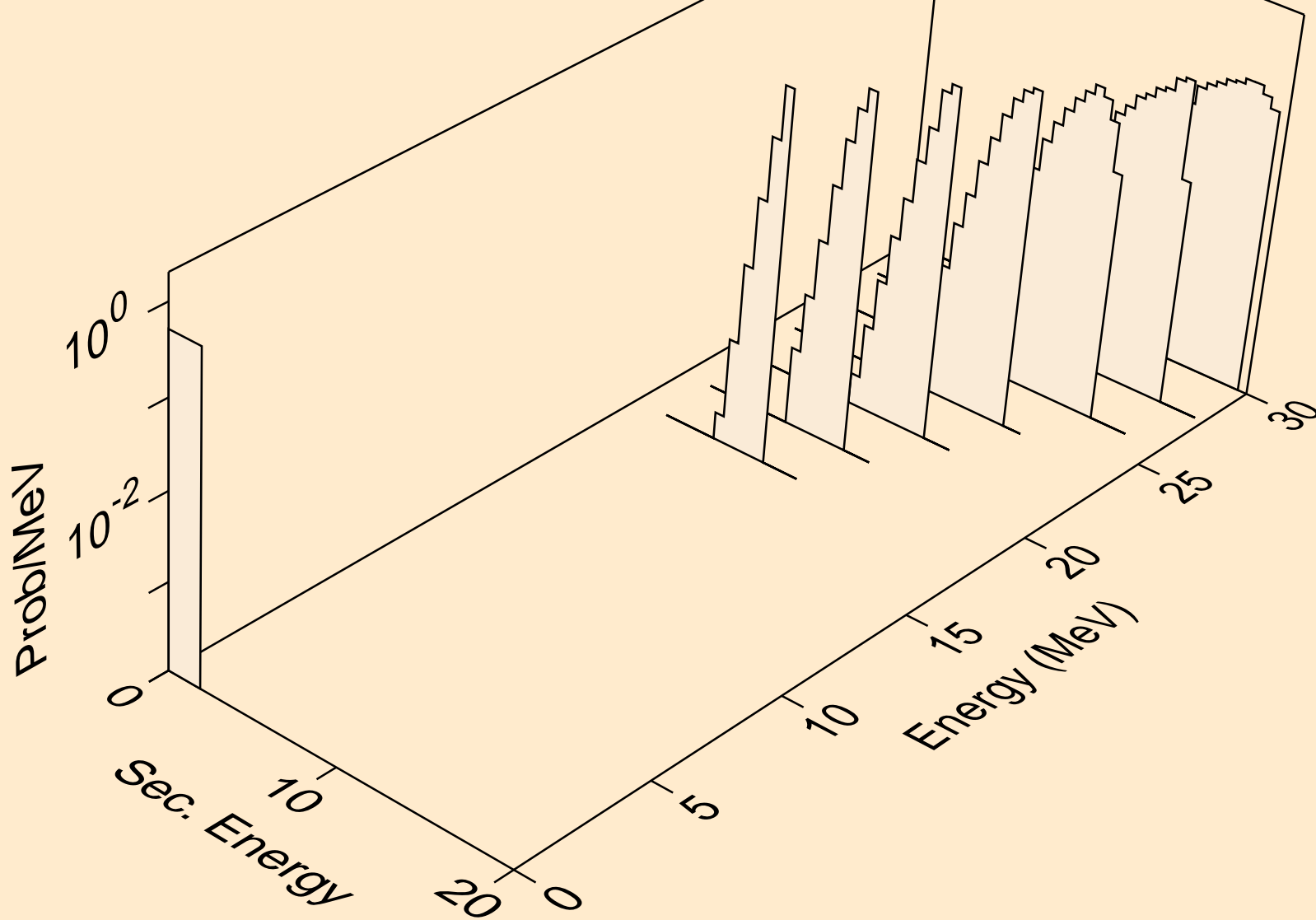

DB261 NEUTRON ACER TENDL-2019 LIBRARY; T=293.16K  
tritons from (n,t)

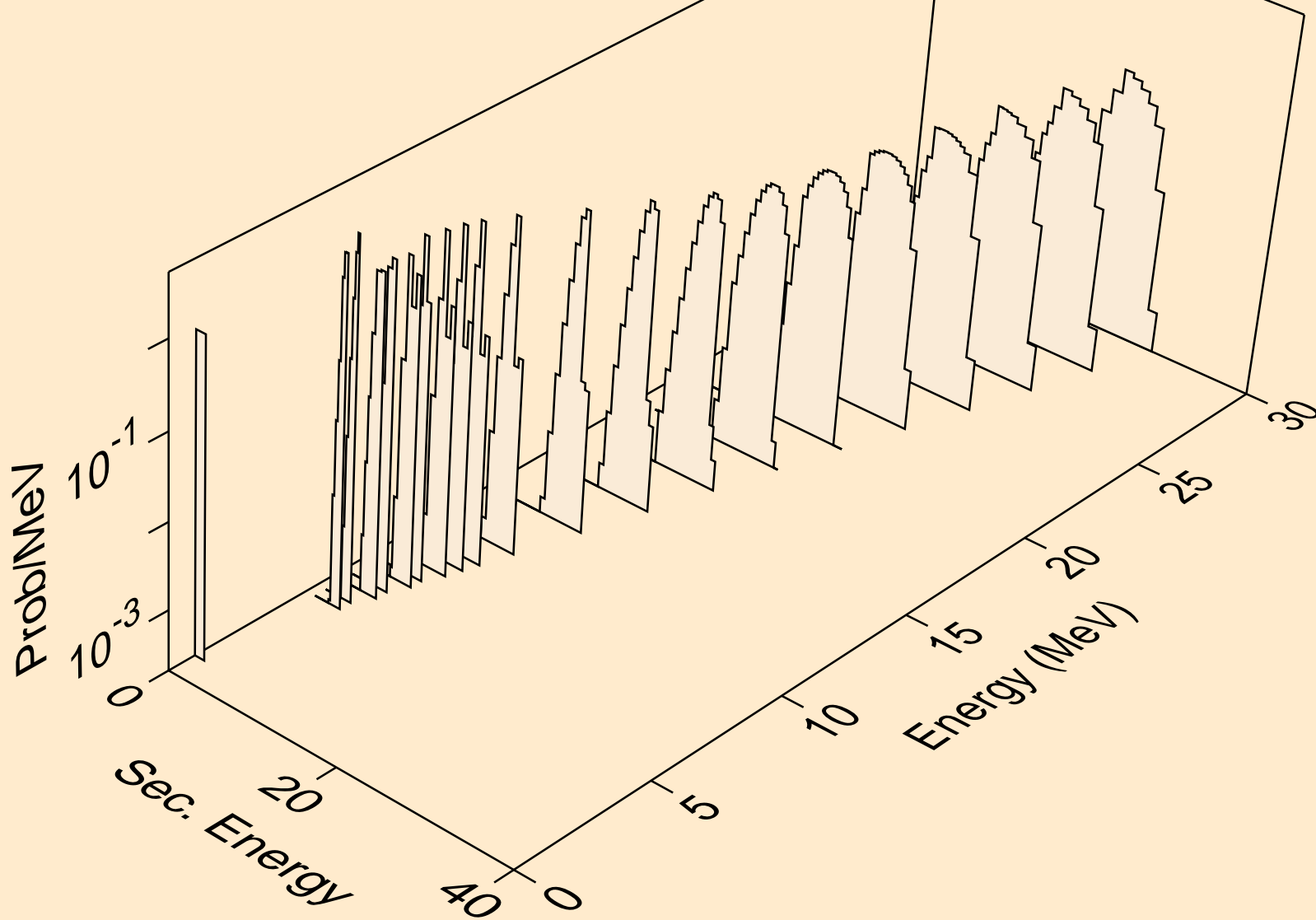

DB261 NEUTRON ACER TENDL-2019 LIBRARY; T=293.16K  
tritons from (n,t2a)

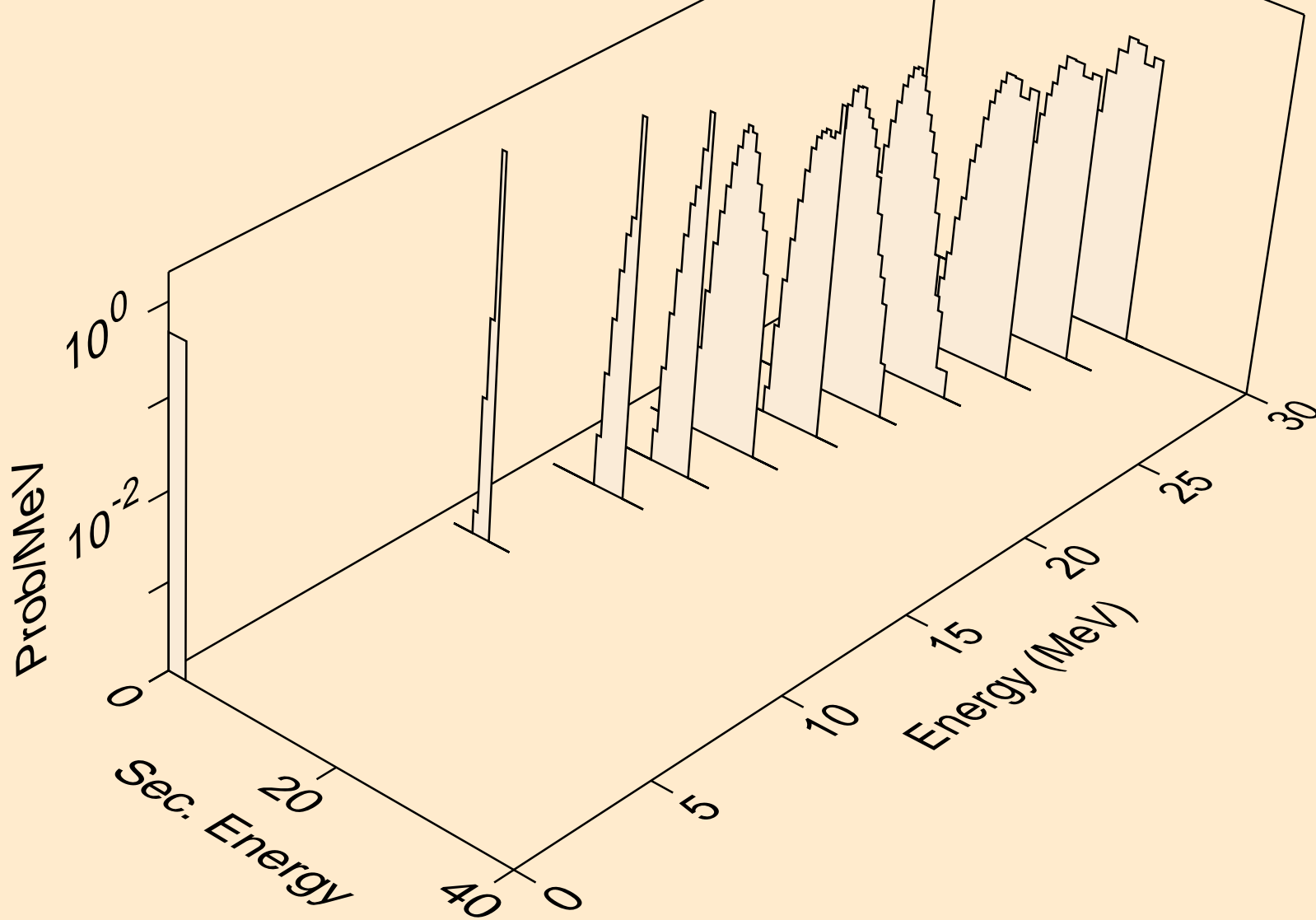

DB261 NEUTRON ACER TENDL-2019 LIBRARY; T=293.16K  
tritons from (n,pt)

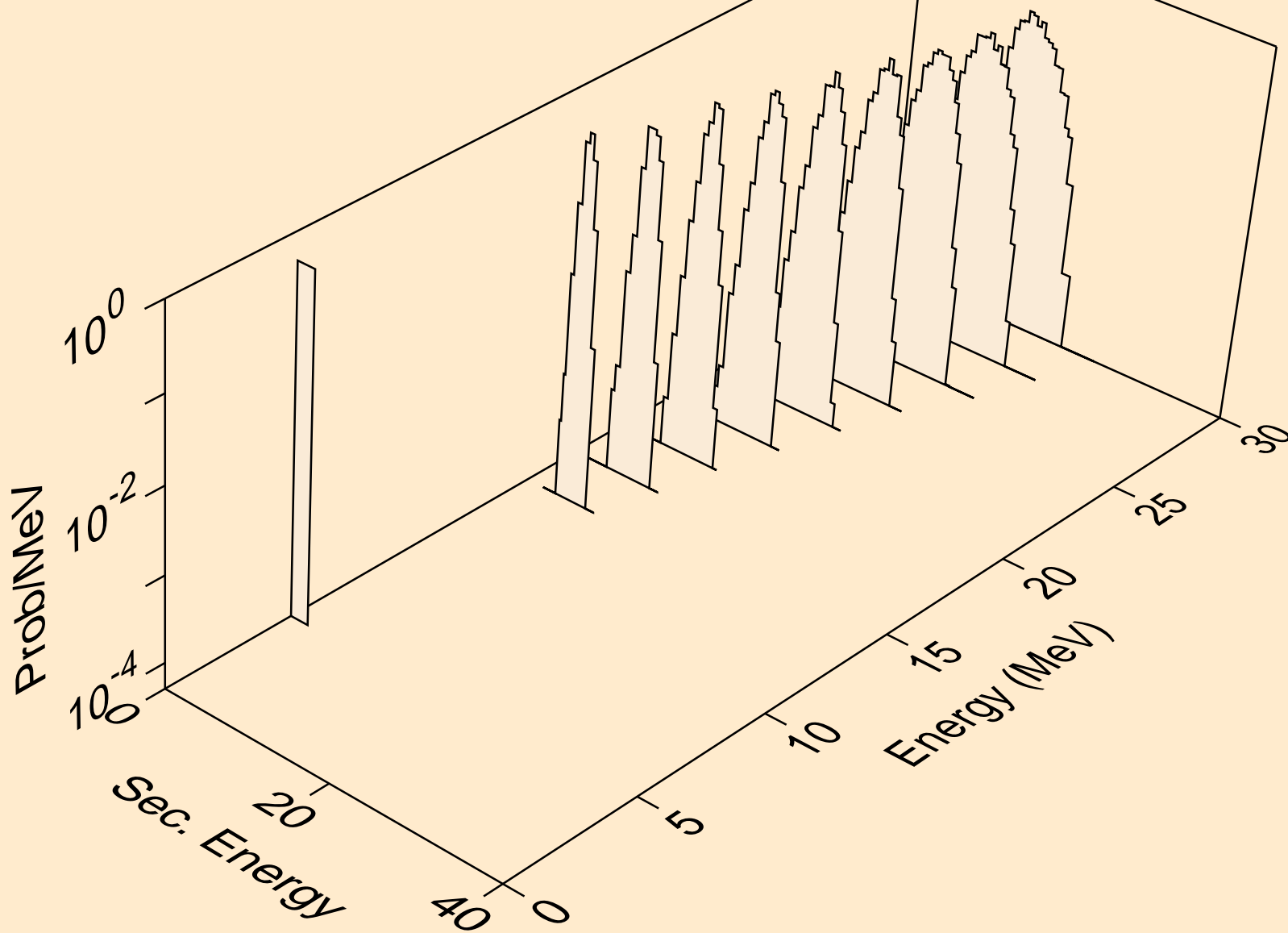

DB261 NEUTRON ACER TENDL-2019 LIBRARY; T=293.16K  
he3s from (n,x)

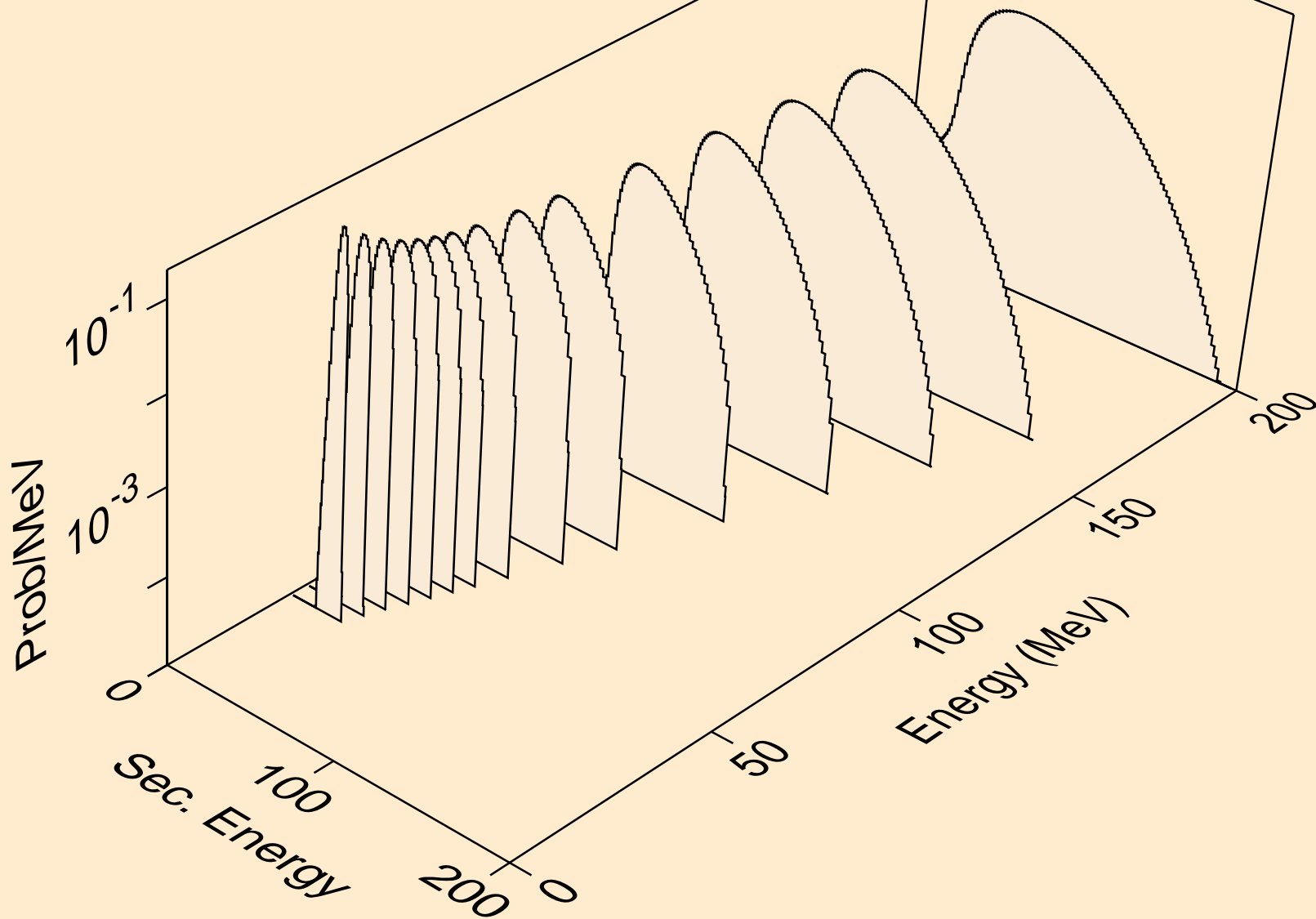

DB261 NEUTRON ACER TENDL-2019 LIBRARY; T=293.16K  
he3s from (n,n\*)he3

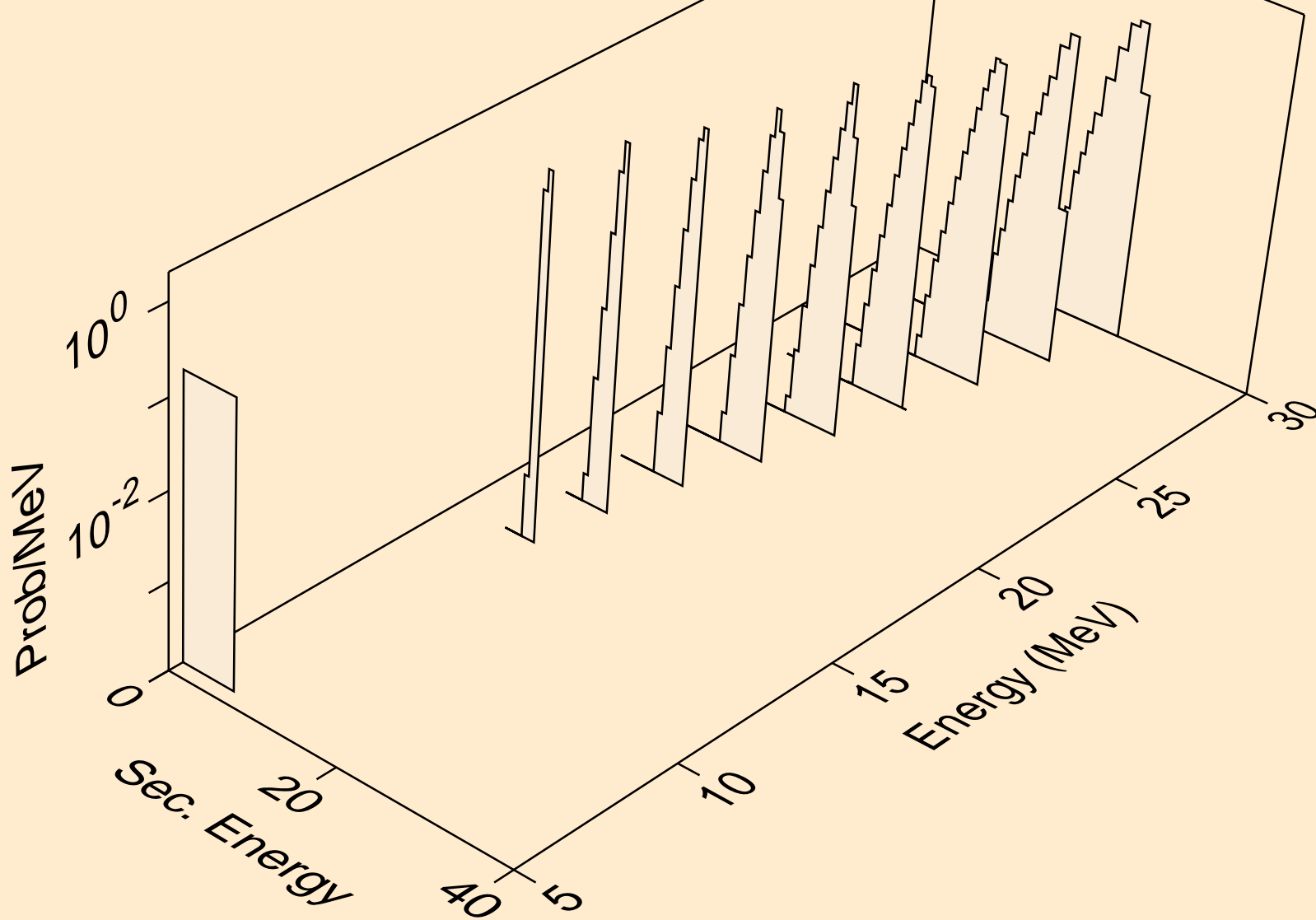

DB261 NEUTRON ACER TENDL-2019 LIBRARY; T=293.16K  
he3s from (n,he3)

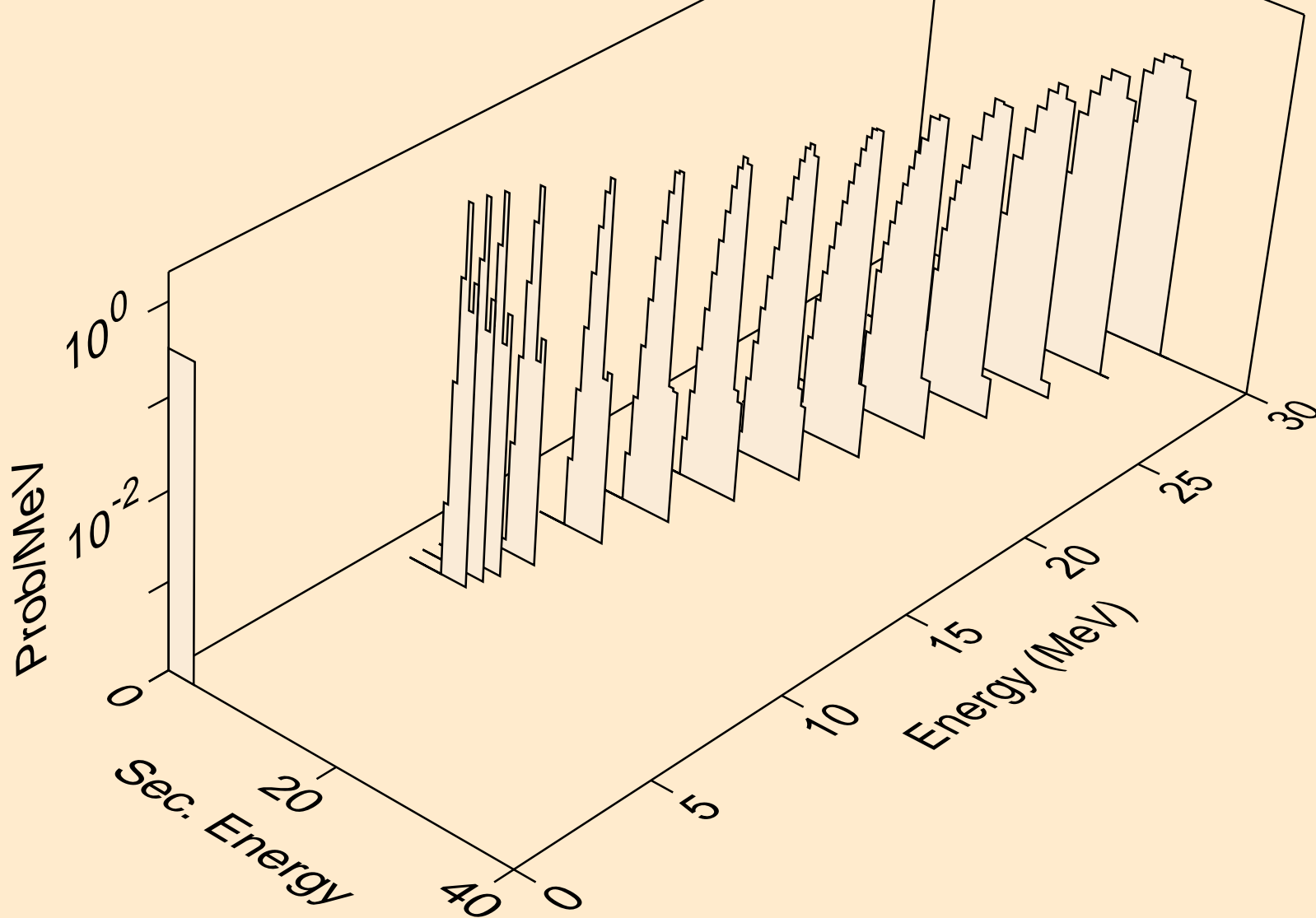

DB261 NEUTRON ACER TENDL-2019 LIBRARY; T=293.16K  
alphas from (n,x)

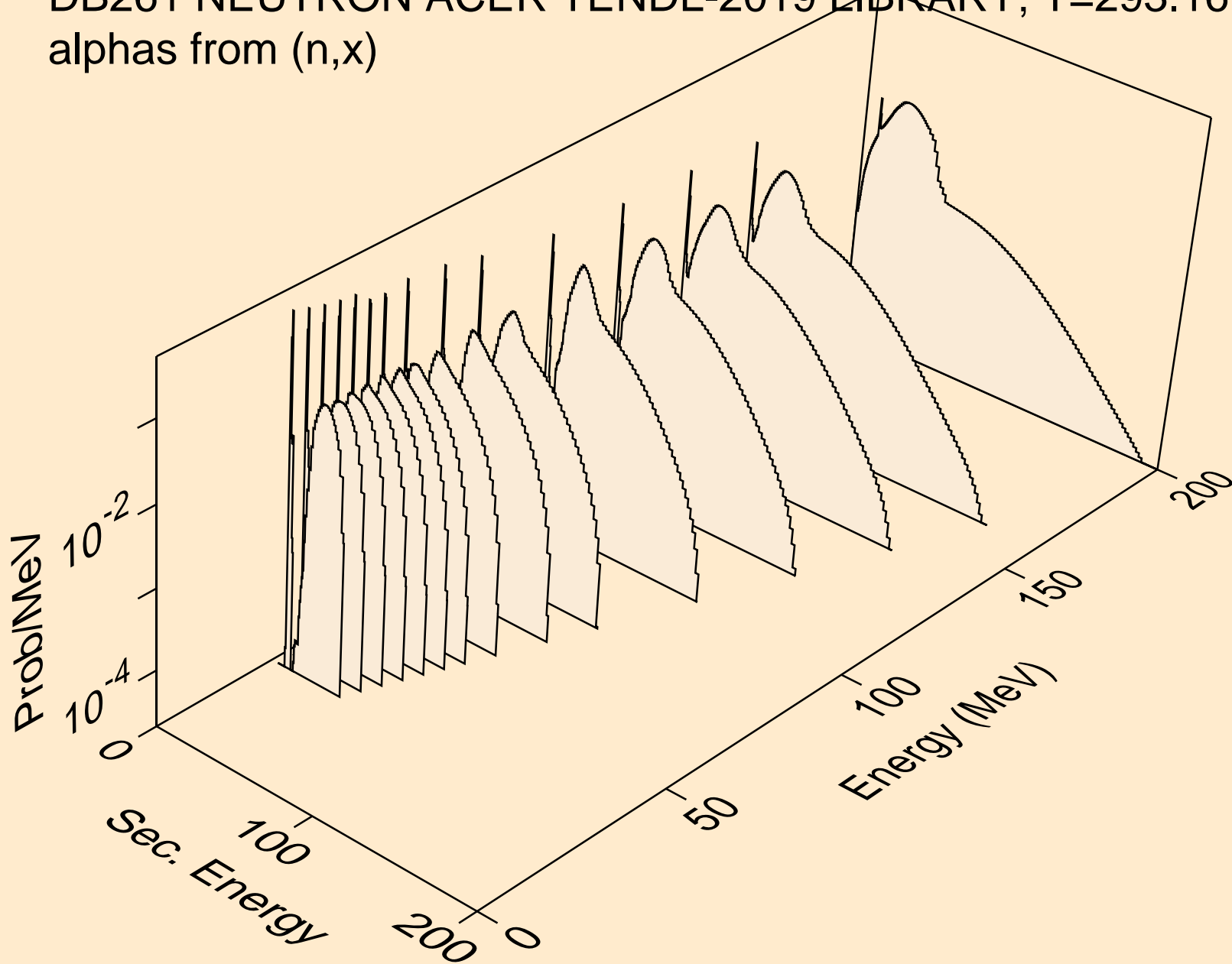

DB261 NEUTRON ACER TENDL-2019 LIBRARY; T=293.16K  
alphas from (n,n\*)a

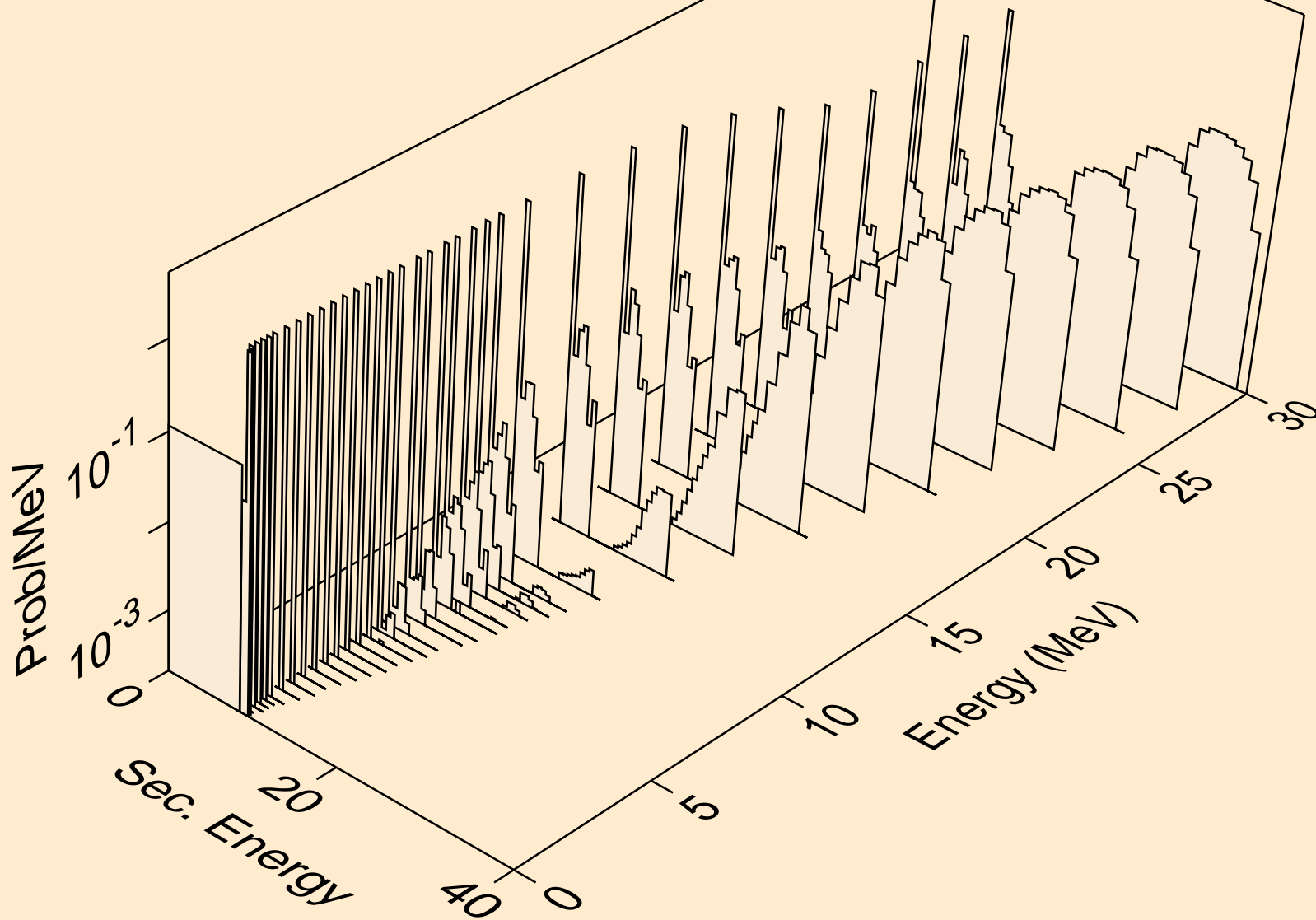

DB261 NEUTRON ACER TENDL-2019 LIBRARY; T=293.16K  
alphas from (n,2n)a

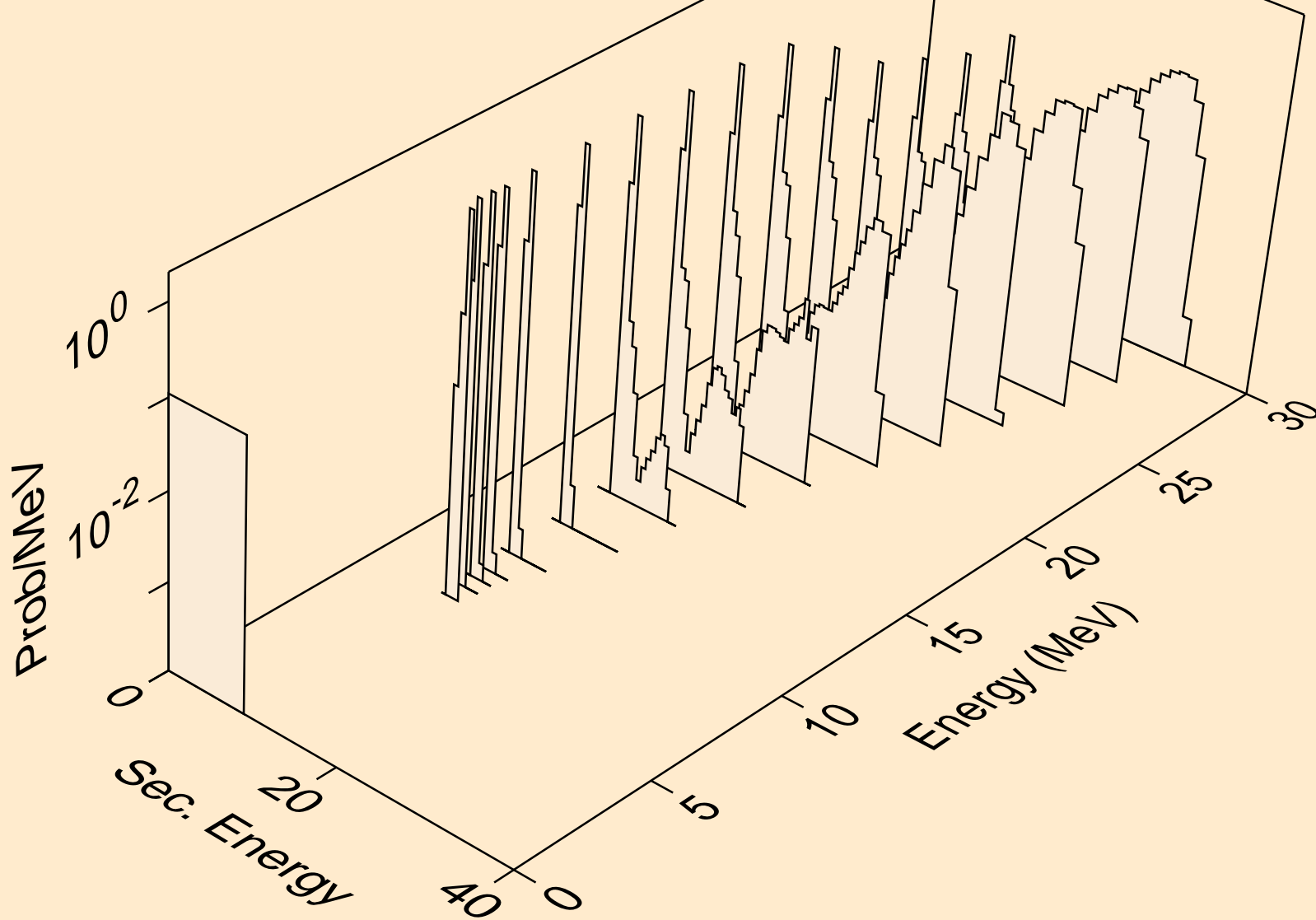

DB261 NEUTRON ACER TENDL-2019 LIBRARY; T=293.16K  
alphas from (n,3n)a

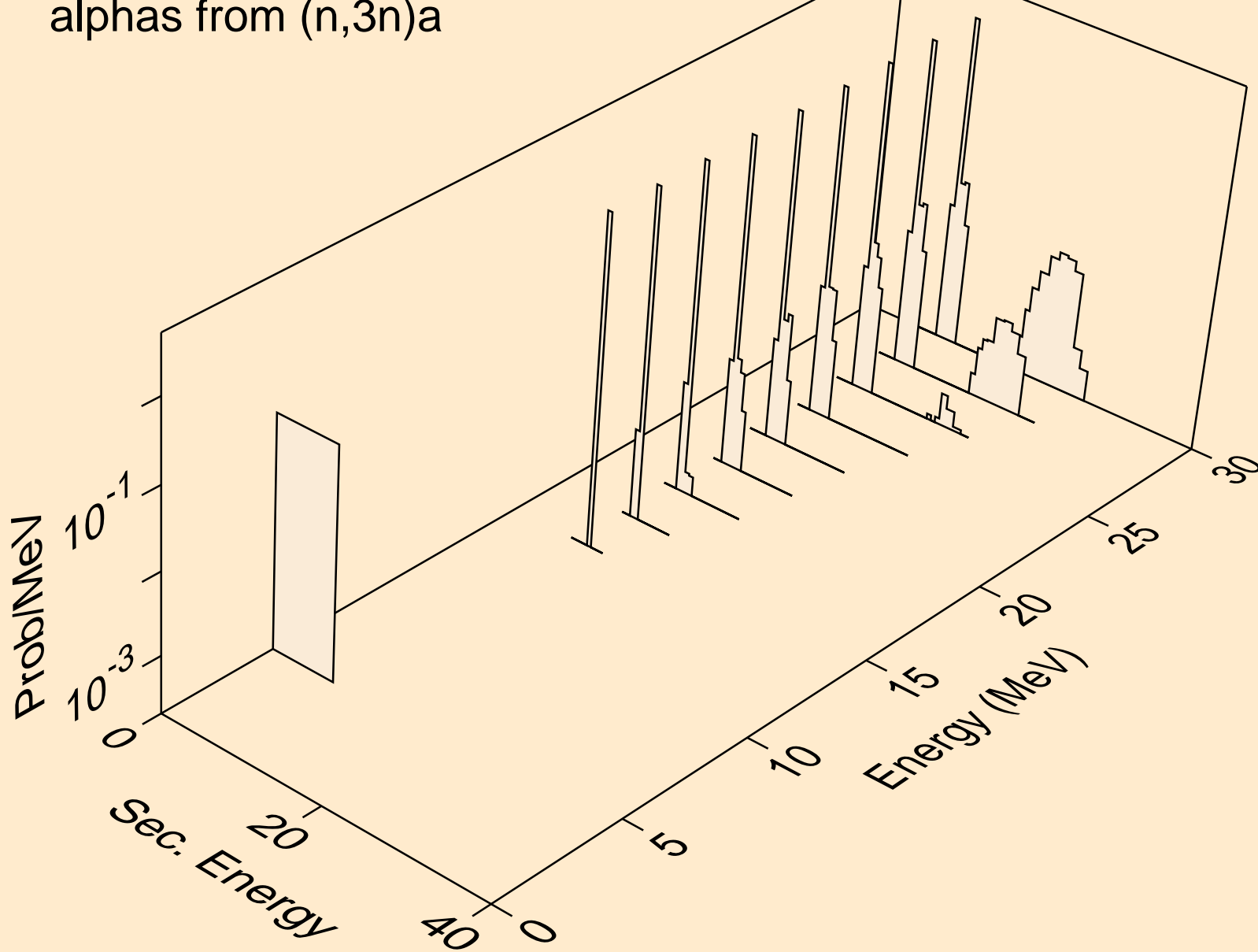

DB261 NEUTRON ACER TENDL-2019 LIBRARY; T=293.16K  
alphas from (n,n\*)2a

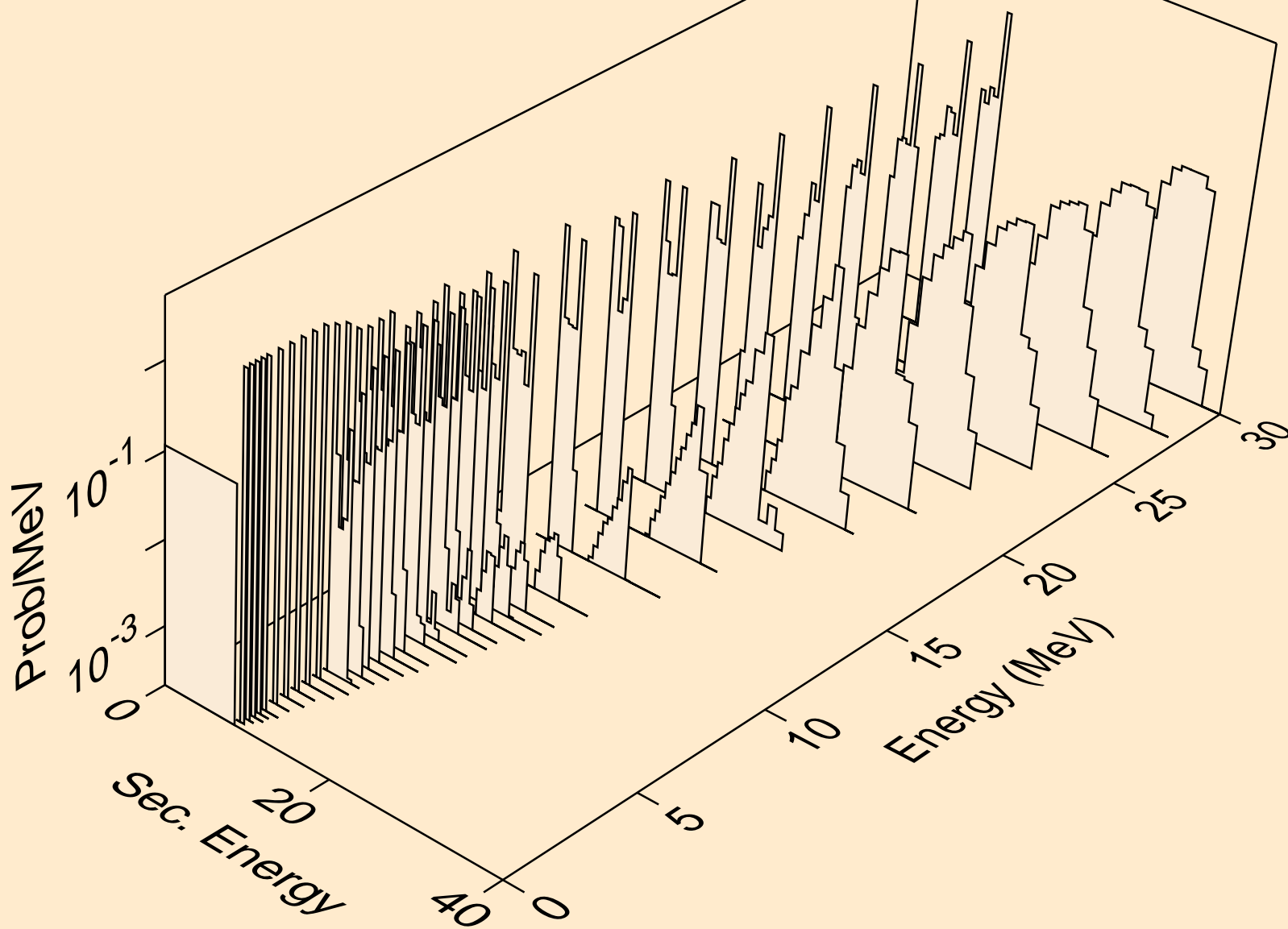

DB261 NEUTRON ACER TENDL-2019 LIBRARY; T=293.16K  
alphas from (n,2n)2a

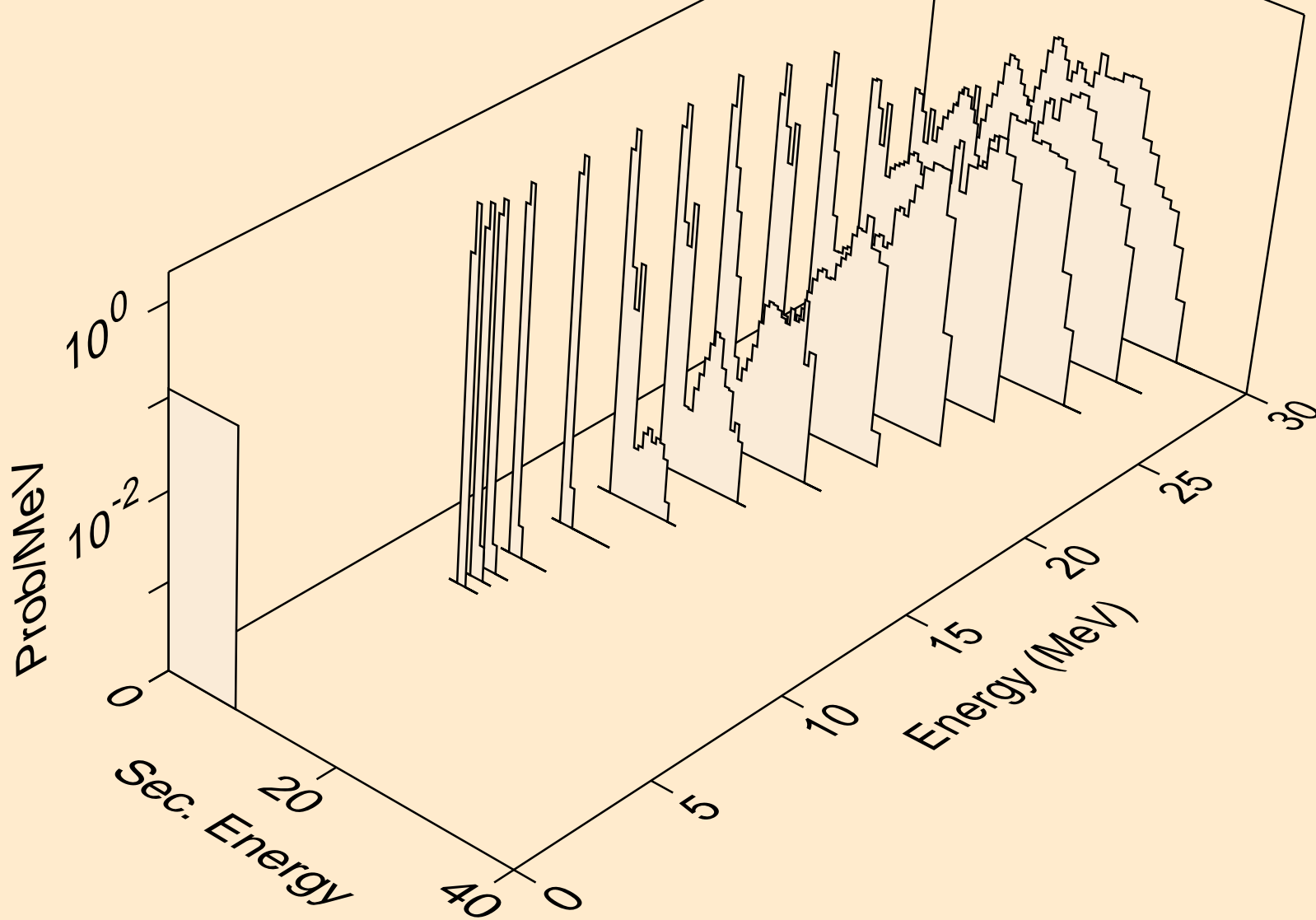

DB261 NEUTRON ACER TENDL-2019 LIBRARY; T=293.16K  
alphas from (n,n\*)d2a

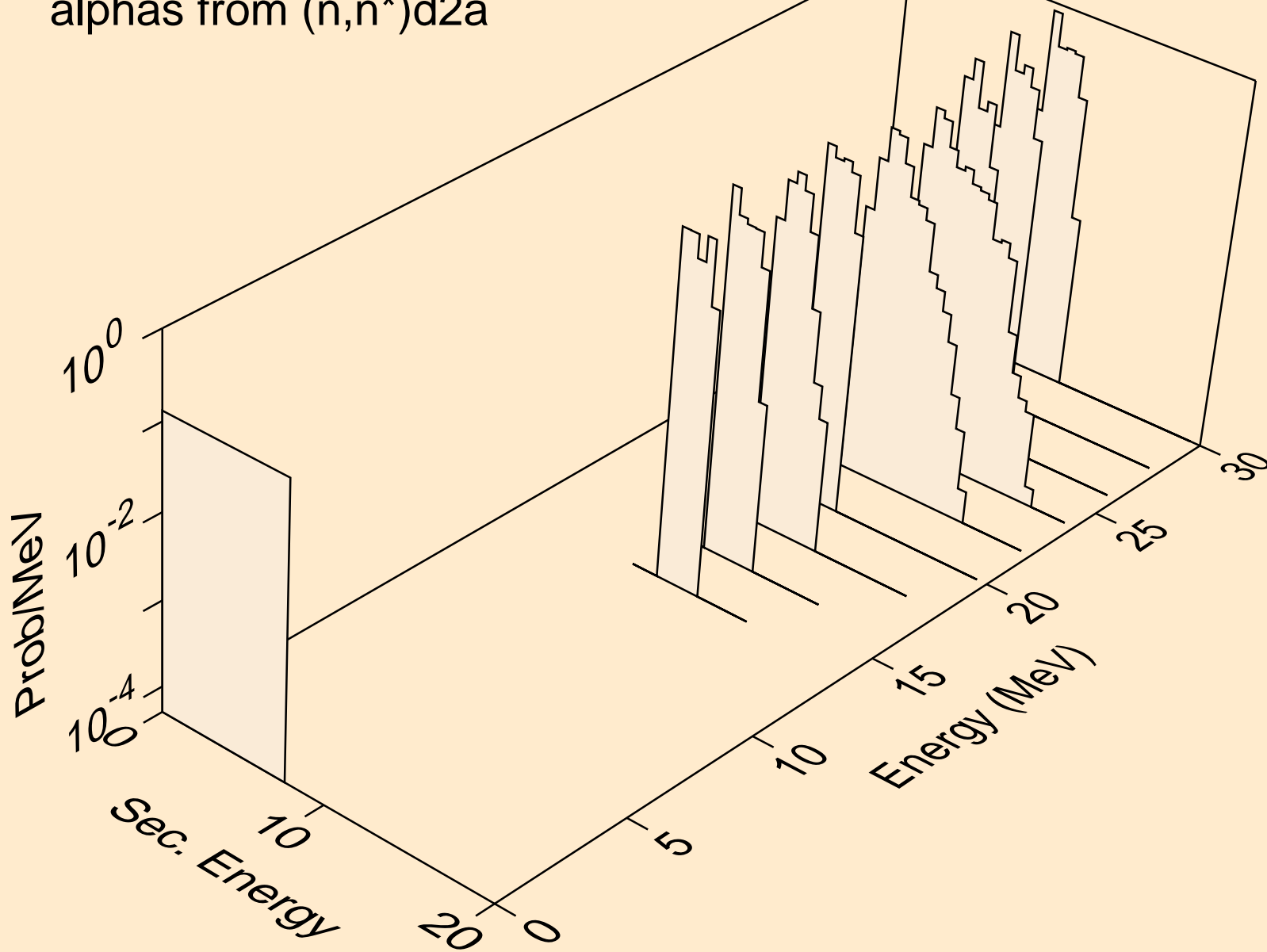

DB261 NEUTRON ACER TENDL-2019 LIBRARY; T=293.16K  
alphas from (n,n\*)t2a

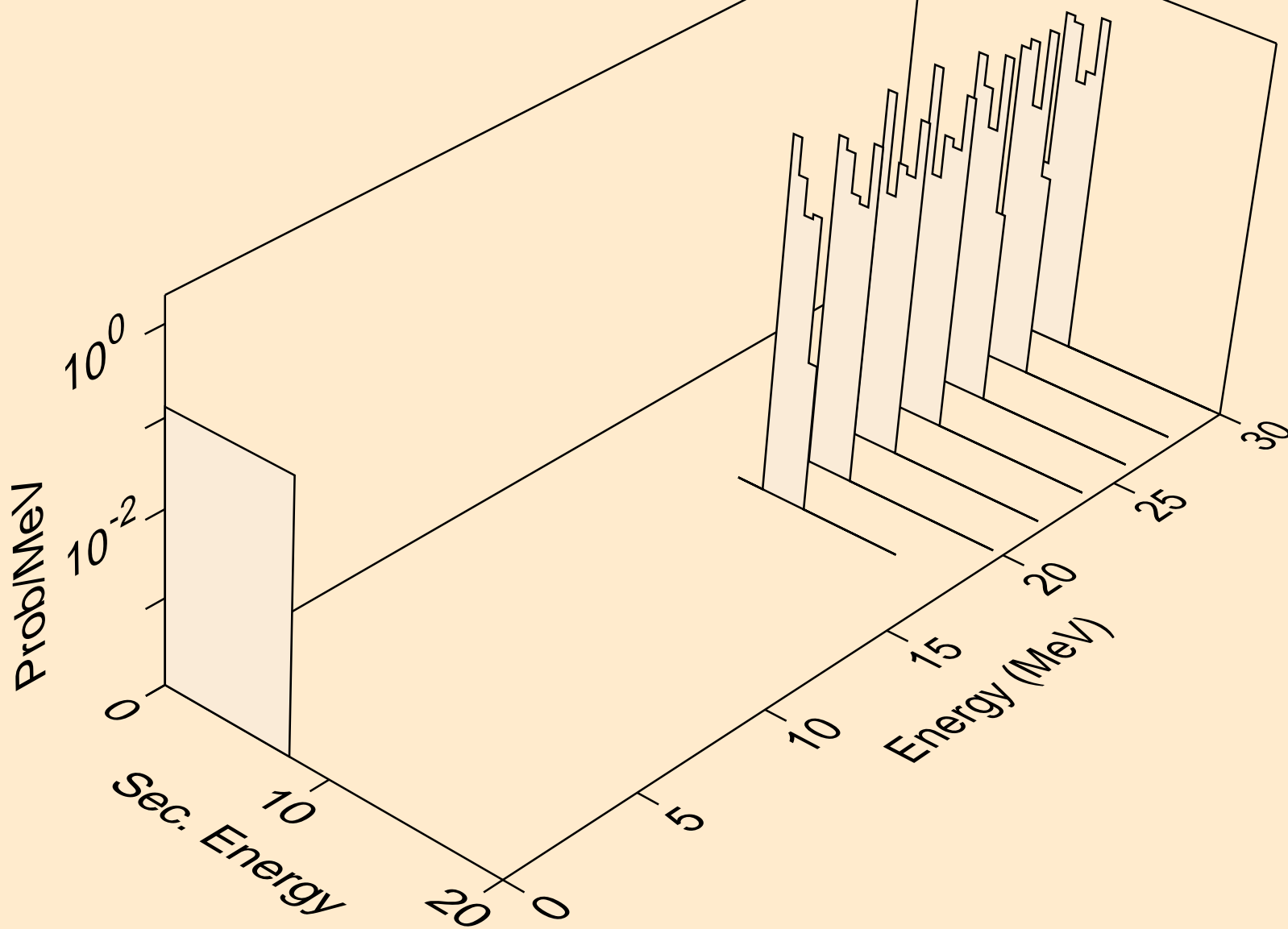

DB261 NEUTRON ACER TENDL-2019 LIBRARY; T=293.16K  
alphas from (n,npa)

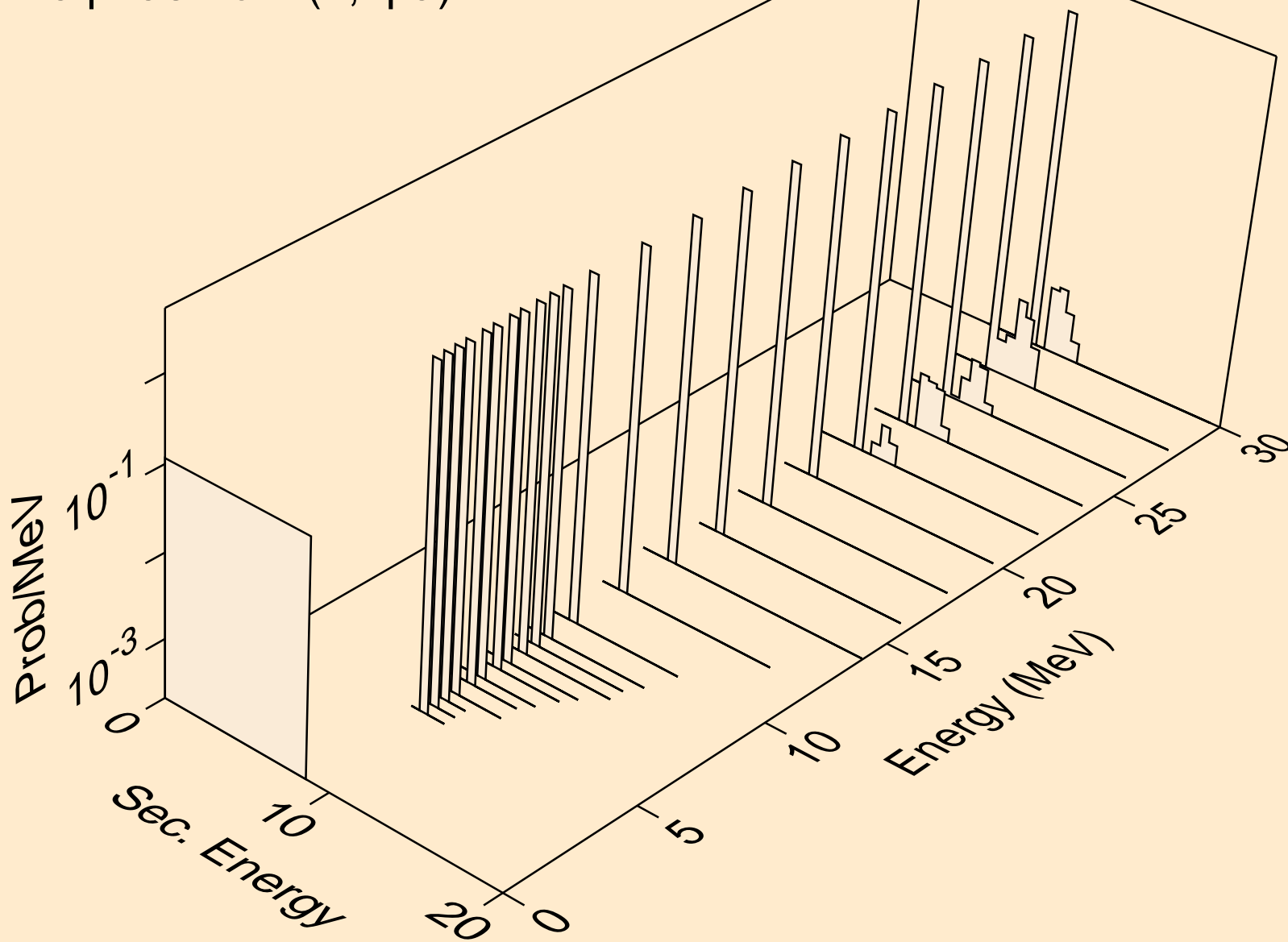

DB261 NEUTRON ACER TENDL-2019 LIBRARY; T=293.16K  
alphas from (n,a)

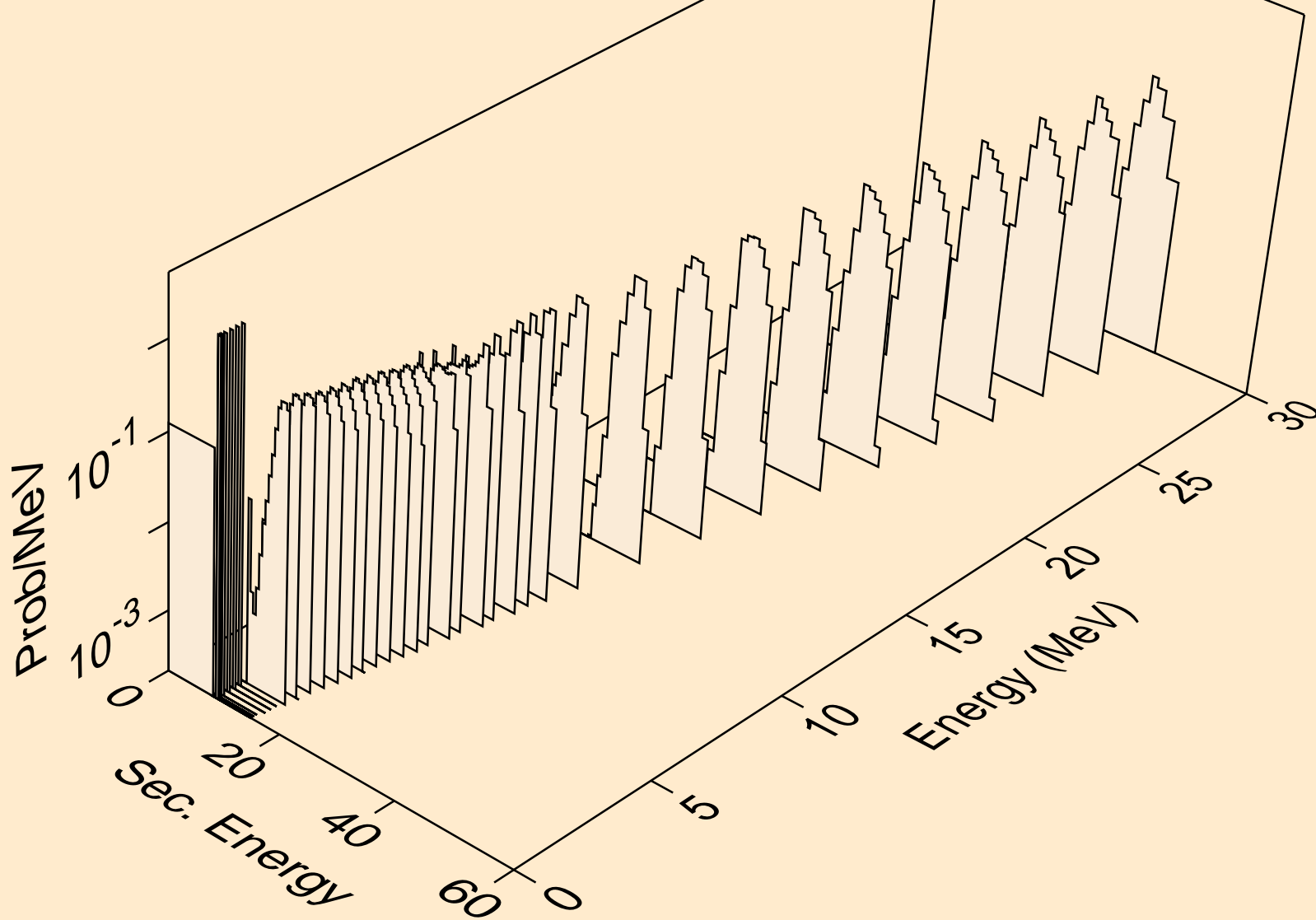

DB261 NEUTRON ACER TENDL-2019 LIBRARY; T=293.16K  
alphas from (n,2a)

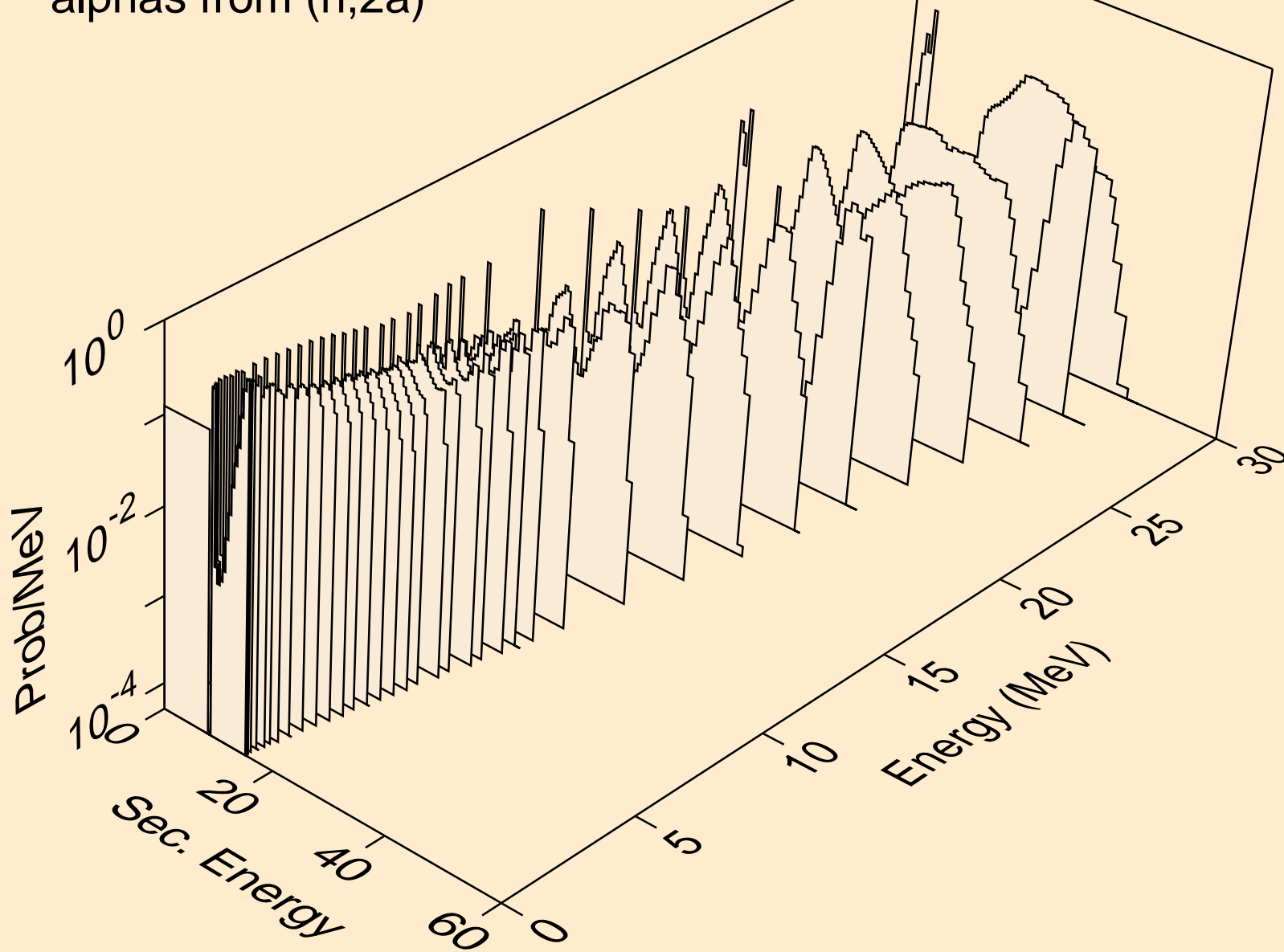

DB261 NEUTRON ACER TENDL-2019 LIBRARY; T=293.16K  
alphas from (n,pa)

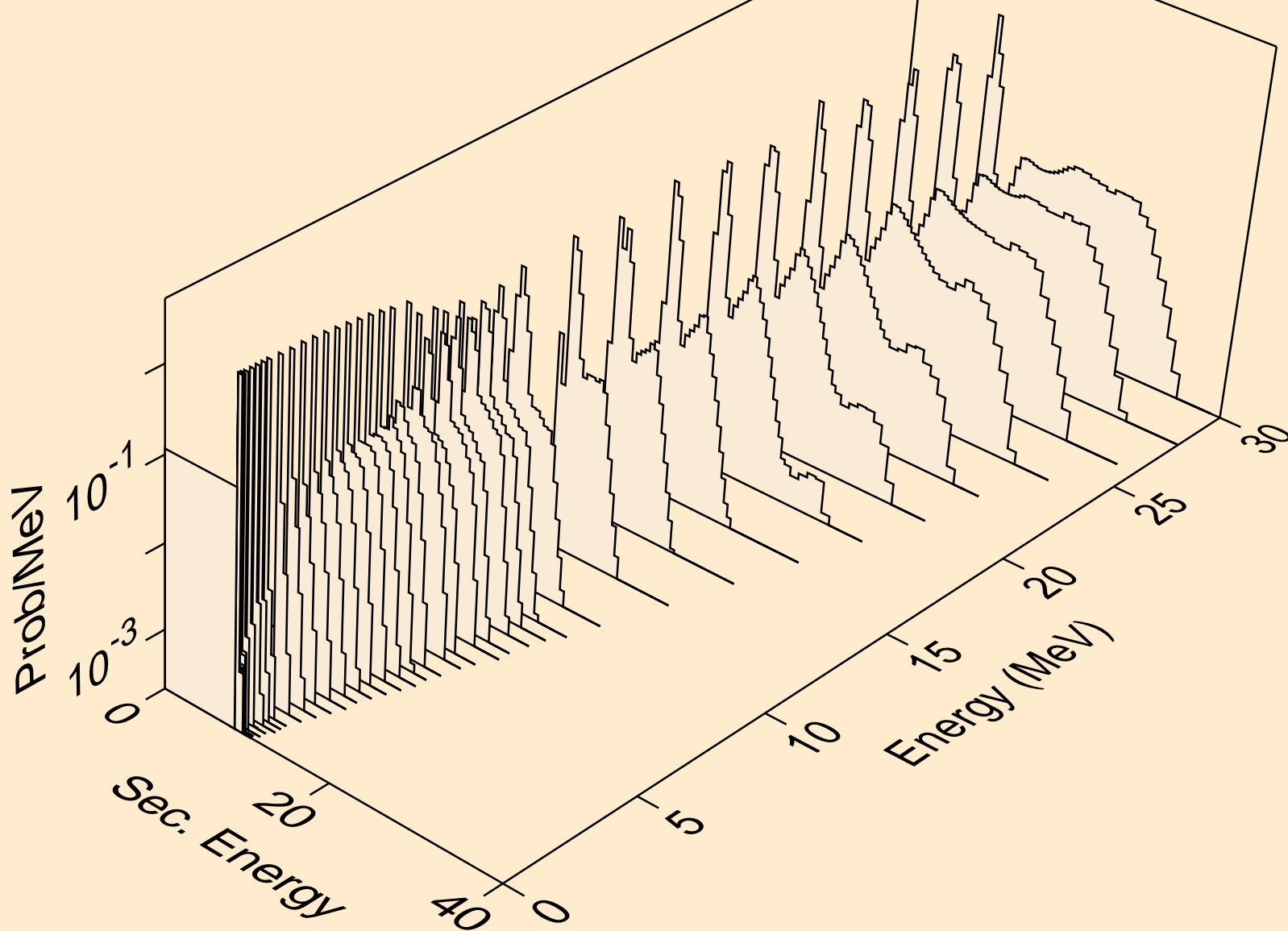

DB261 NEUTRON ACER TENDL-2019 LIBRARY; T=293.16K  
alphas from (n,t2a)

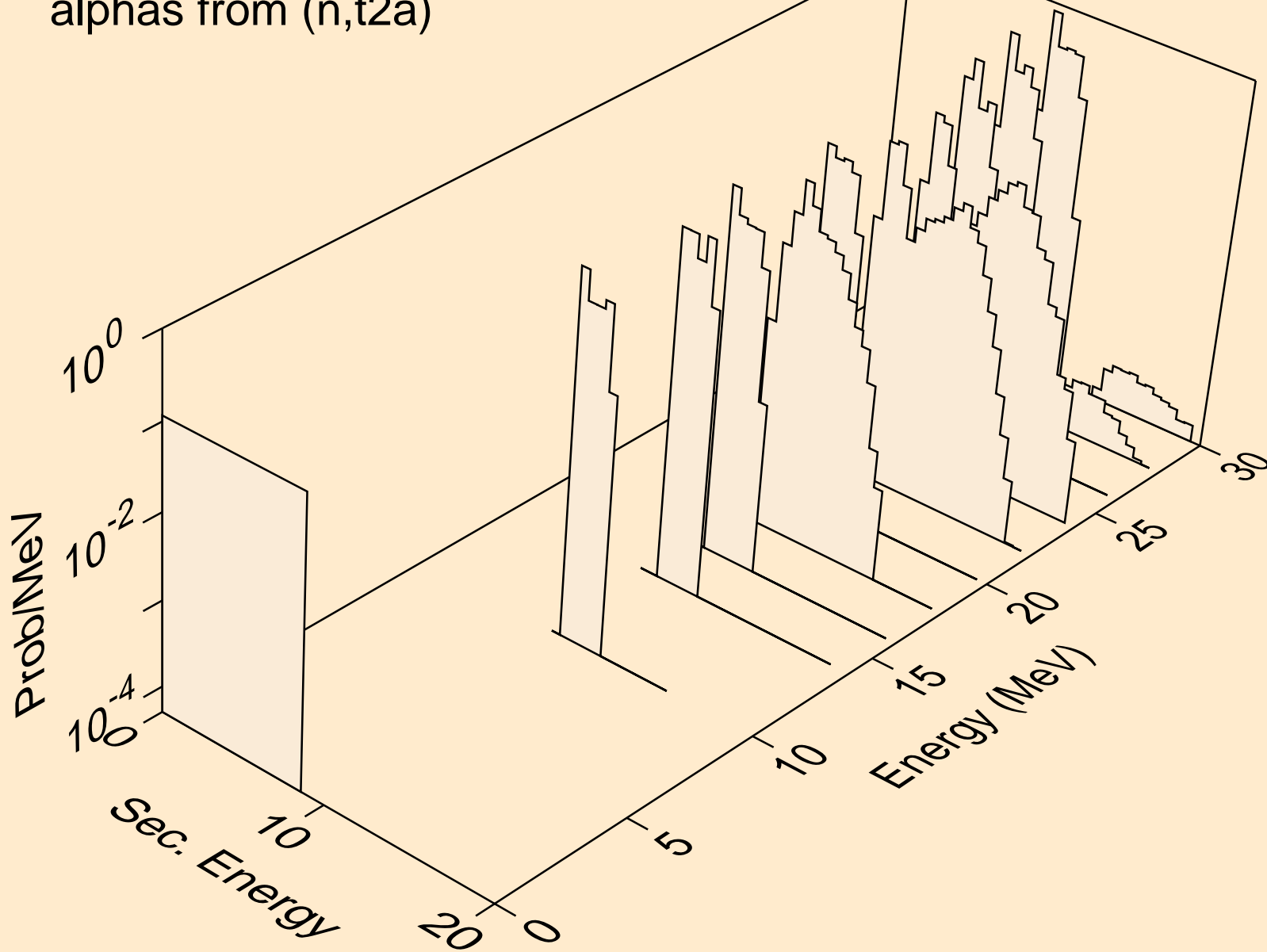

DB261 NEUTRON ACER TENDL-2019 LIBRARY; T=293.16K  
alphas from (n,d2a)

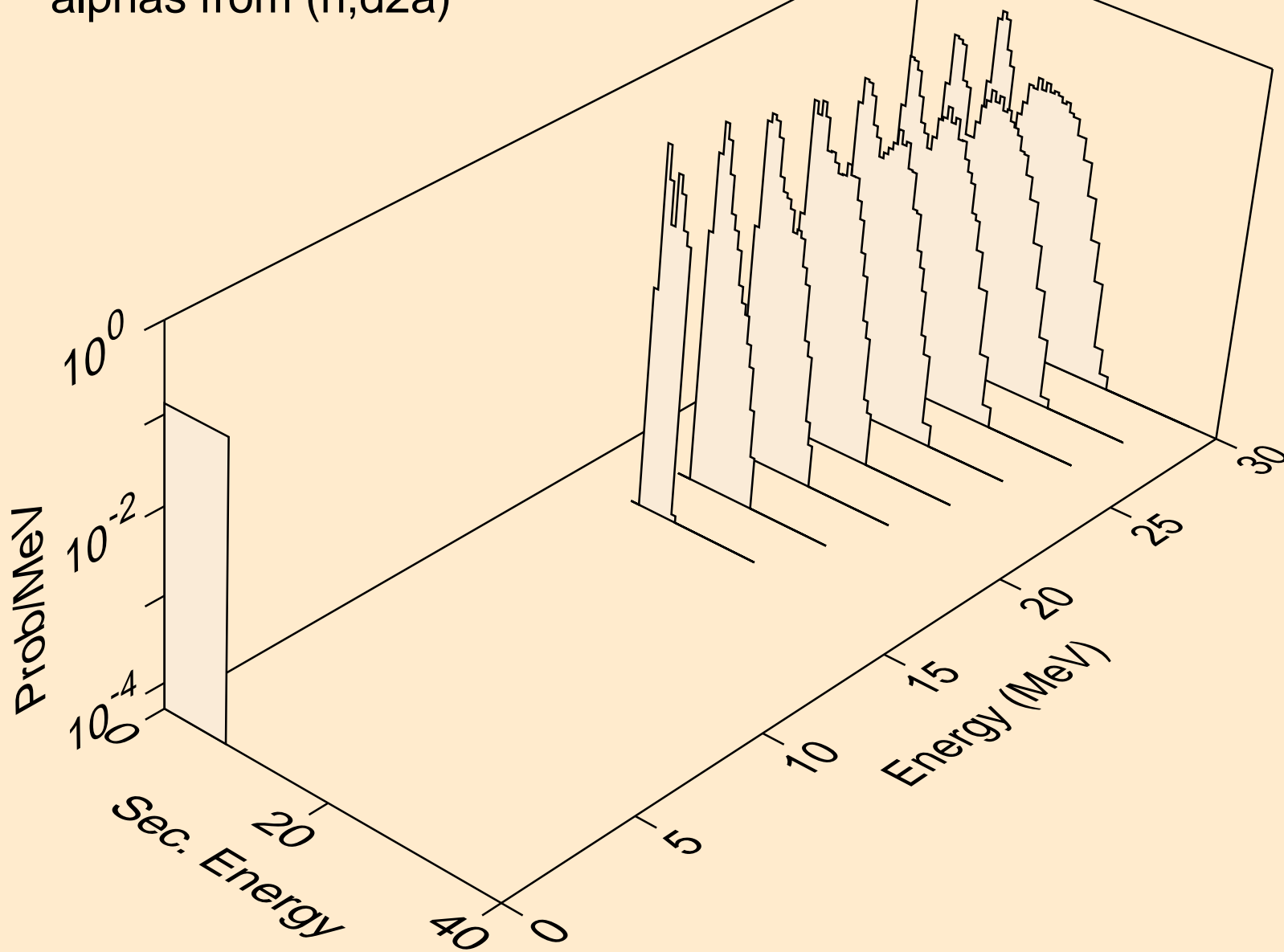

DB261 NEUTRON ACER TENDL-2019 LIBRARY; T=293.16K  
alphas from (n,da)

