

LR262 NEUTRON ACER TENDL-2019 LIBRARY; T=293.16K  
Principal cross sections

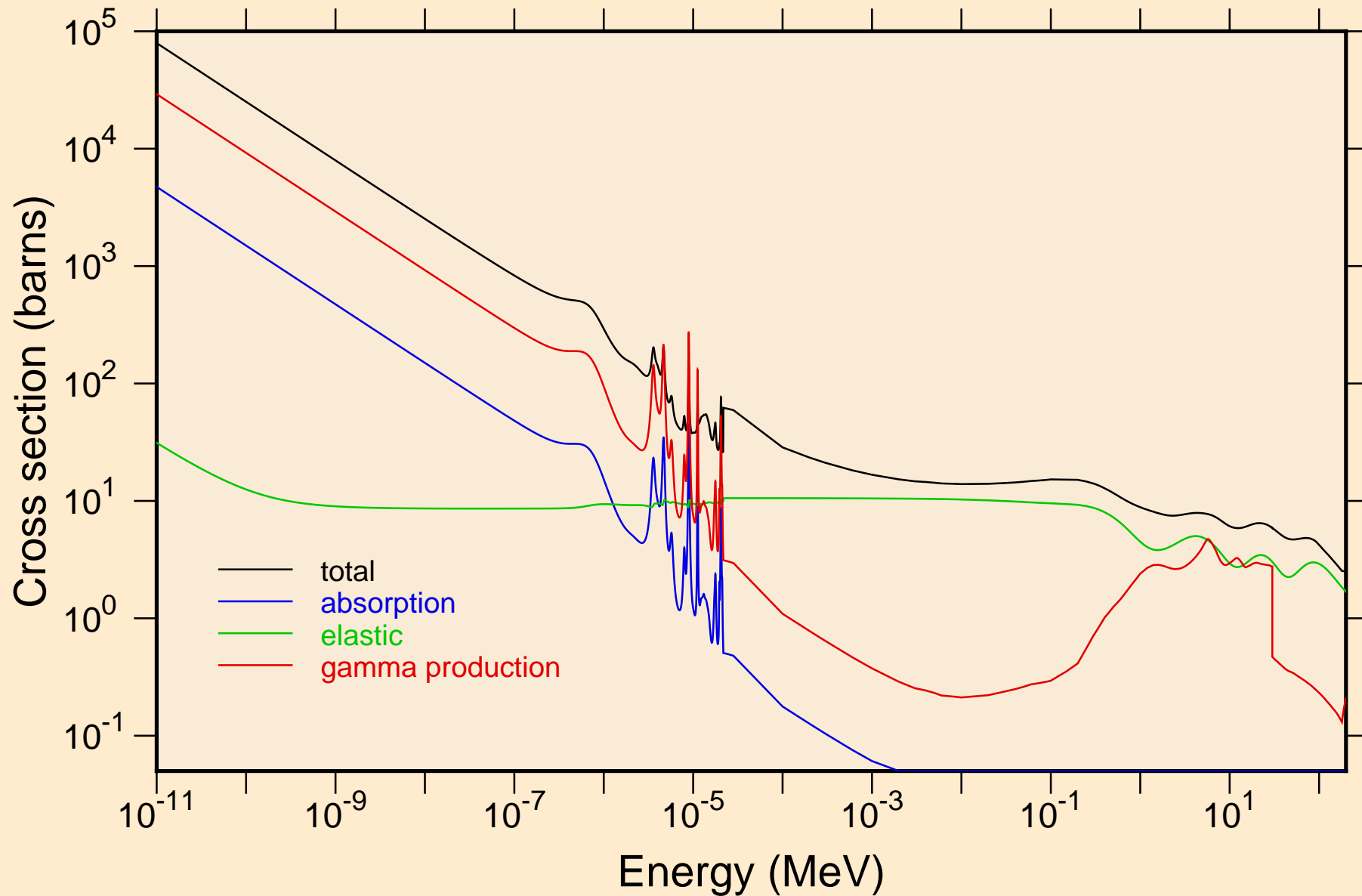

LR262 NEUTRON ACER TENDL-2019 LIBRARY; T=293.16K  
resonance total cross section

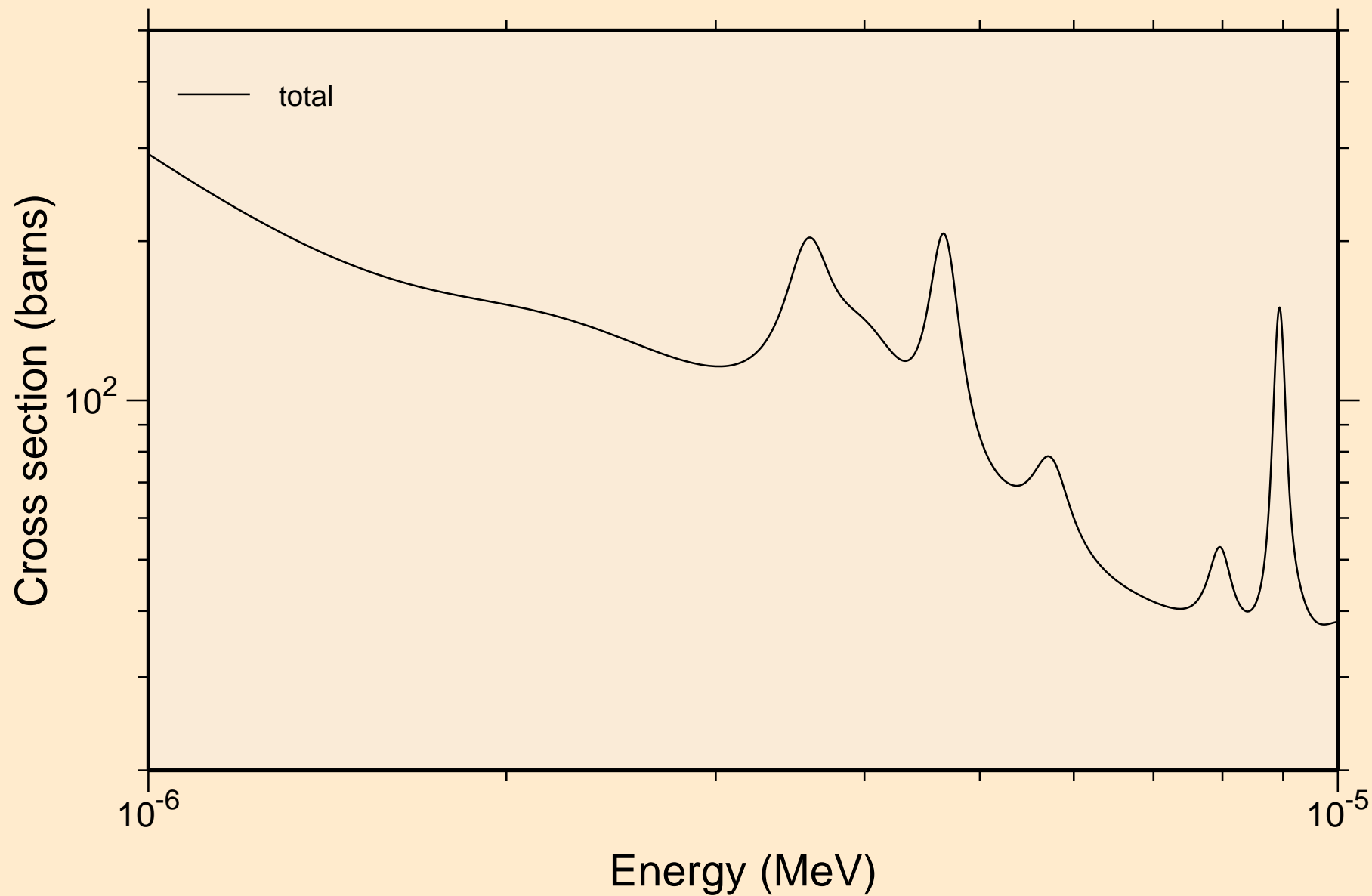

LR262 NEUTRON ACER TENDL-2019 LIBRARY; T=293.16K  
resonance total cross section

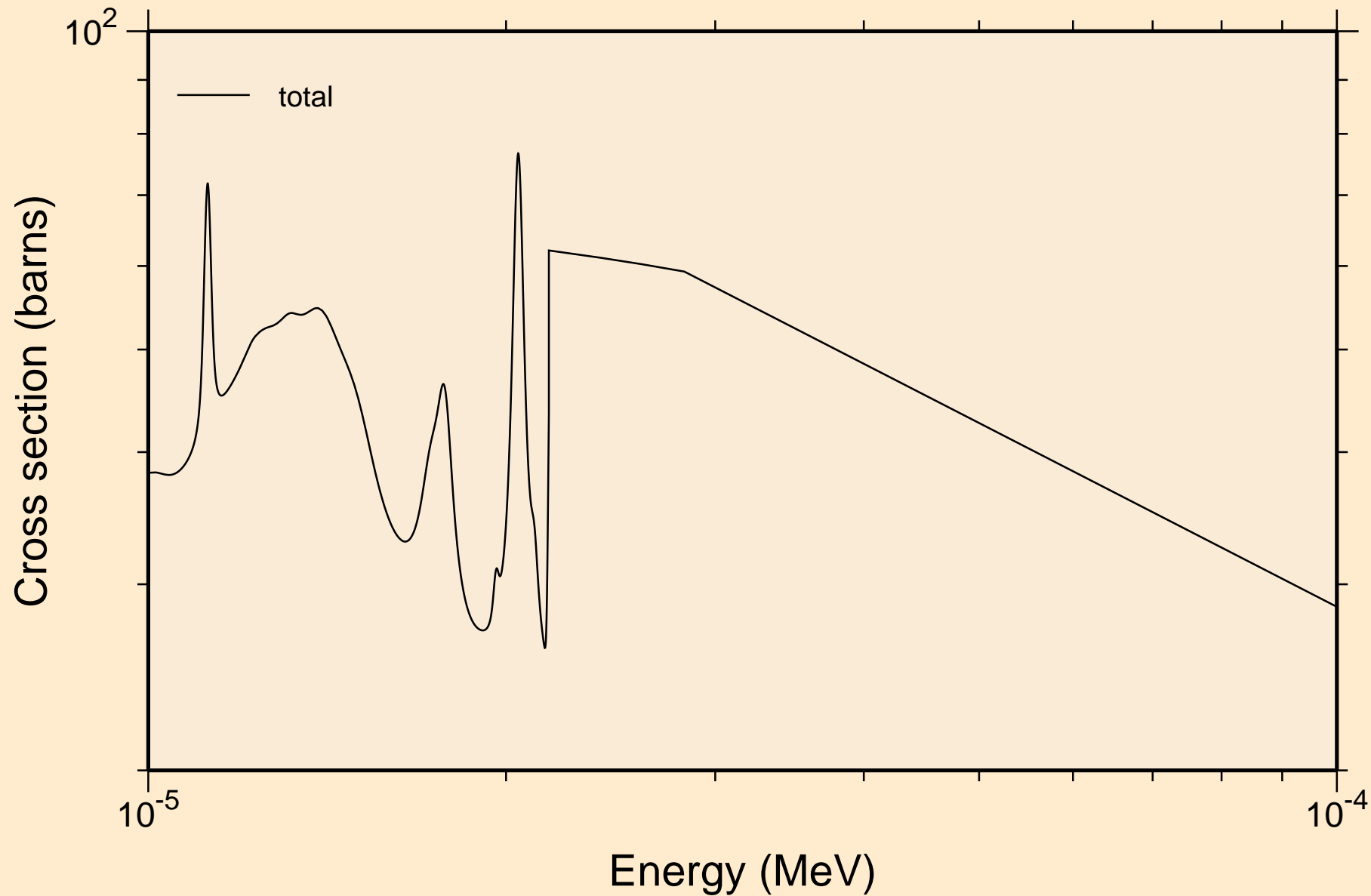

LR262 NEUTRON ACER TENDL-2019 LIBRARY; T=293.16K  
resonance total cross section

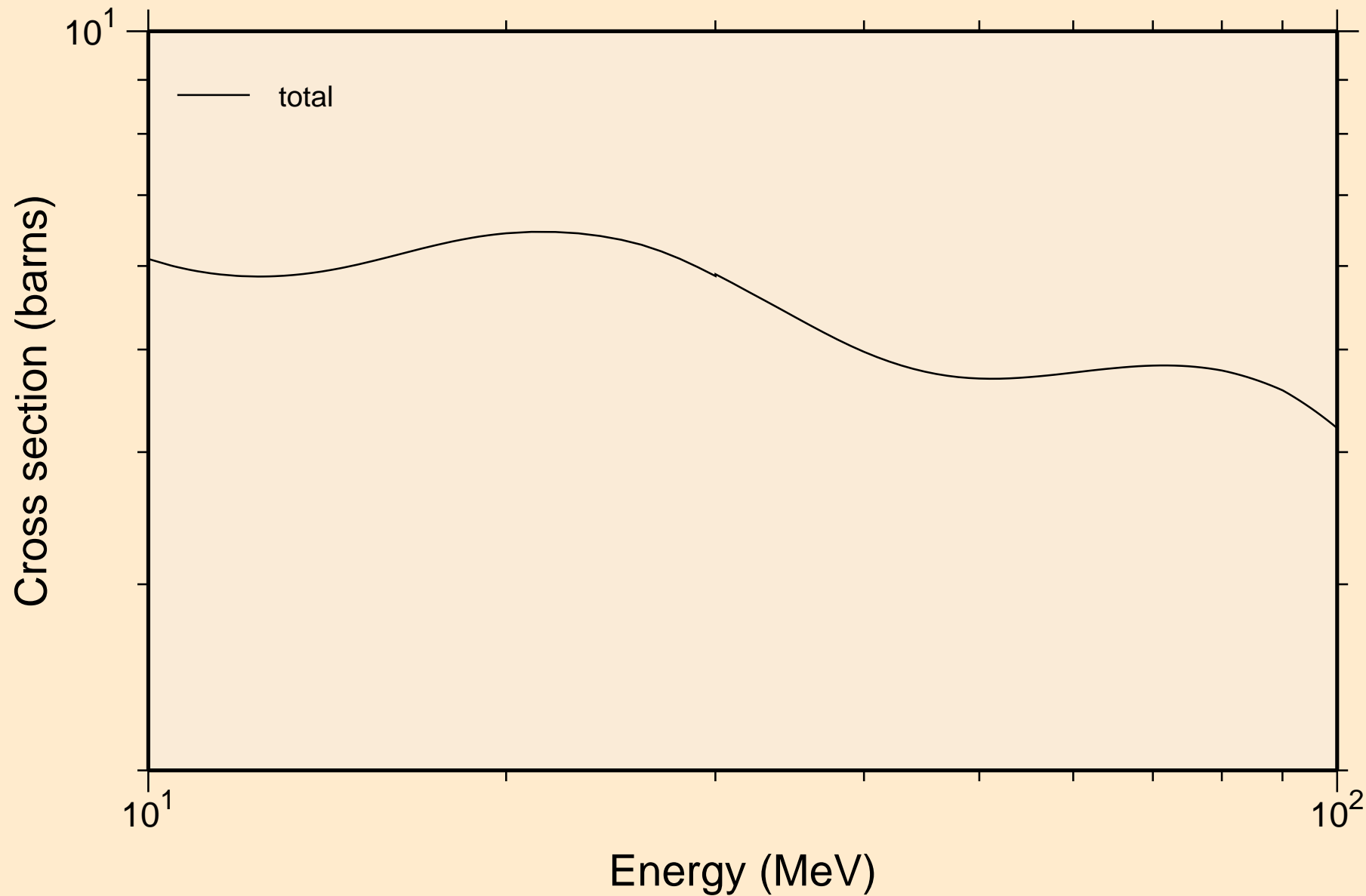

LR262 NEUTRON ACER TENDL-2019 LIBRARY; T=293.16K  
resonance absorption cross sections

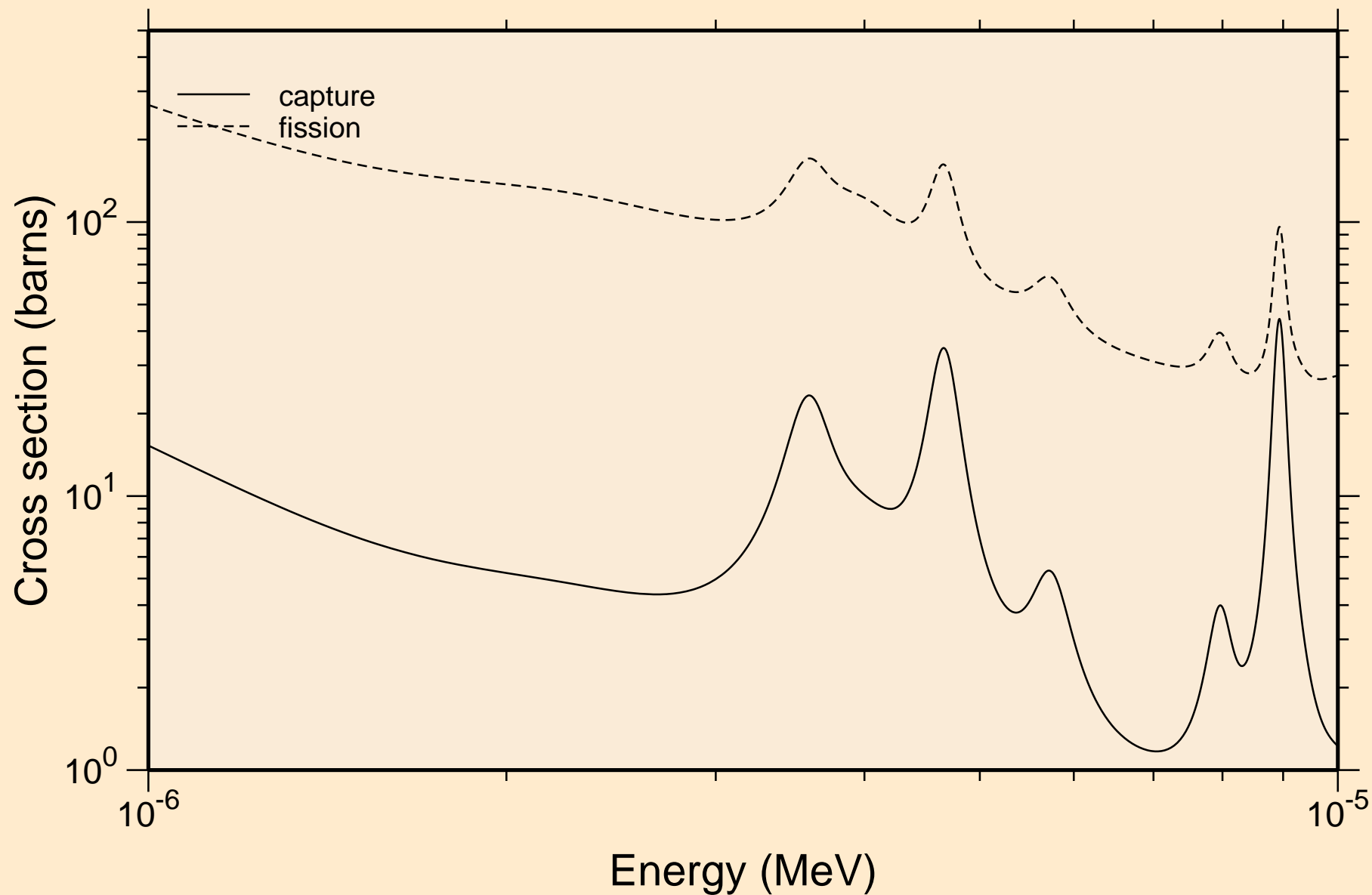

LR262 NEUTRON ACER TENDL-2019 LIBRARY; T=293.16K  
resonance absorption cross sections

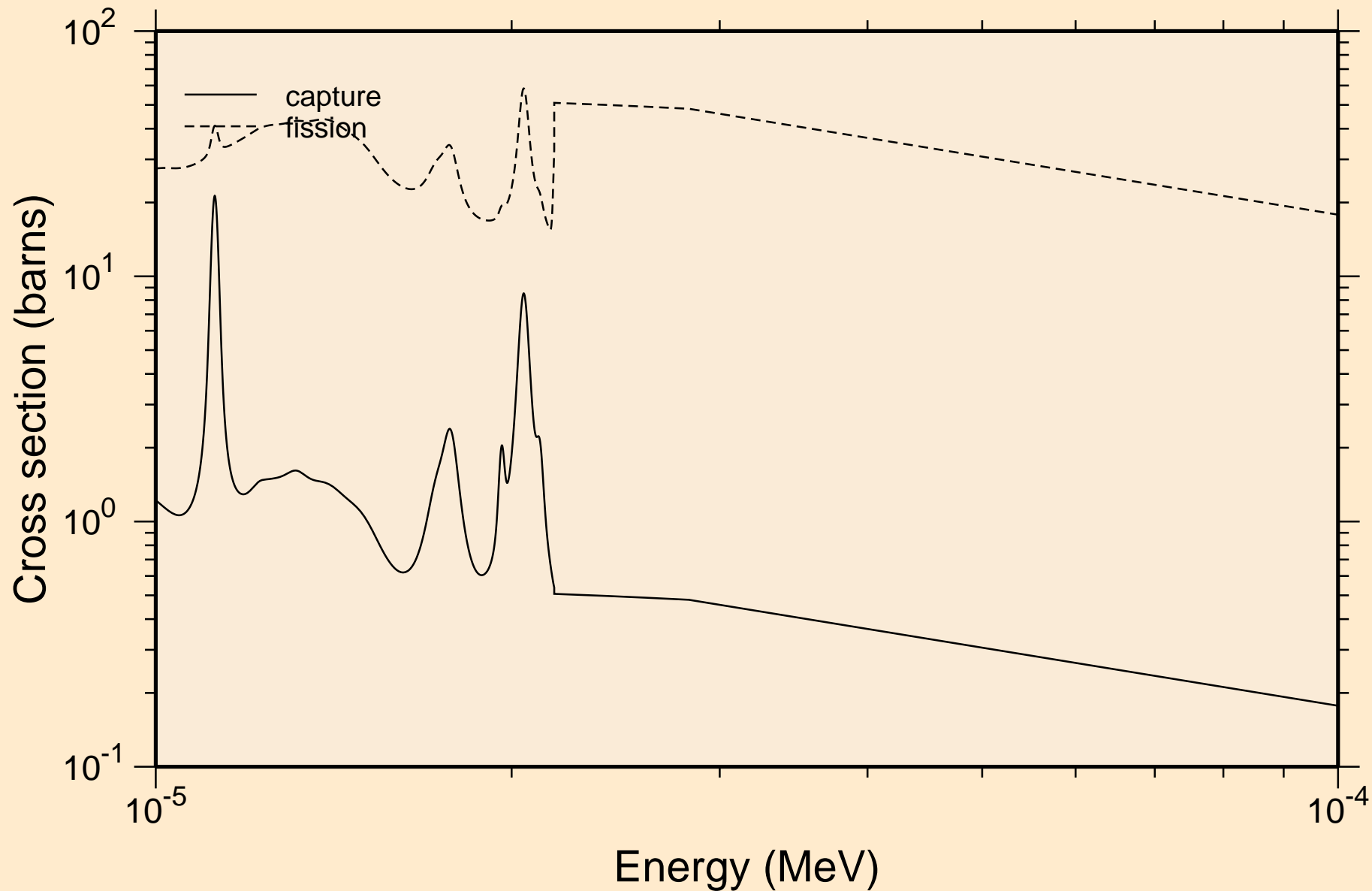

LR262 NEUTRON ACER TENDL-2019 LIBRARY; T=293.16K  
resonance absorption cross sections

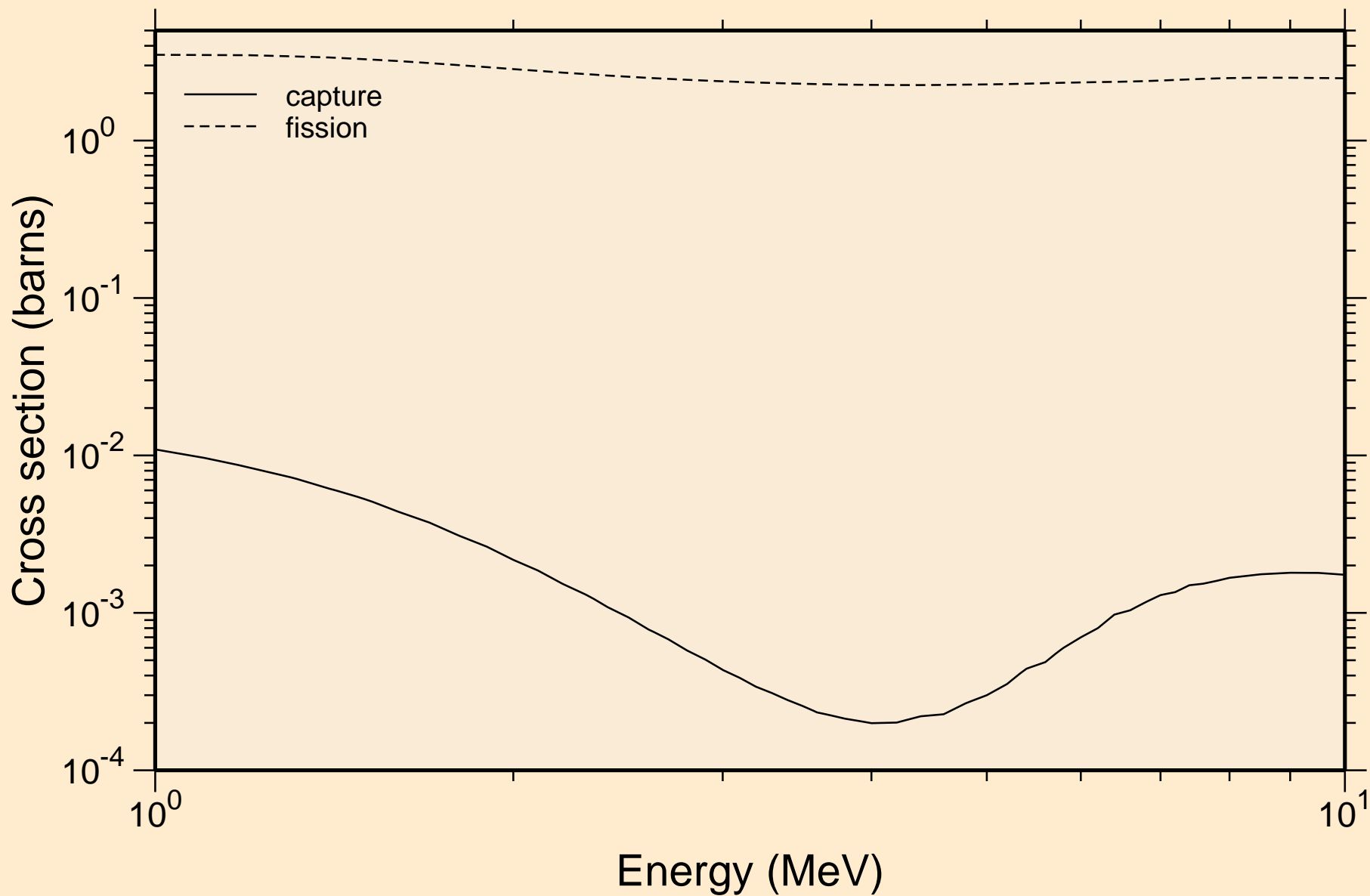

LR262 NEUTRON ACER TENDL-2019 LIBRARY; T=293.16K  
Heating

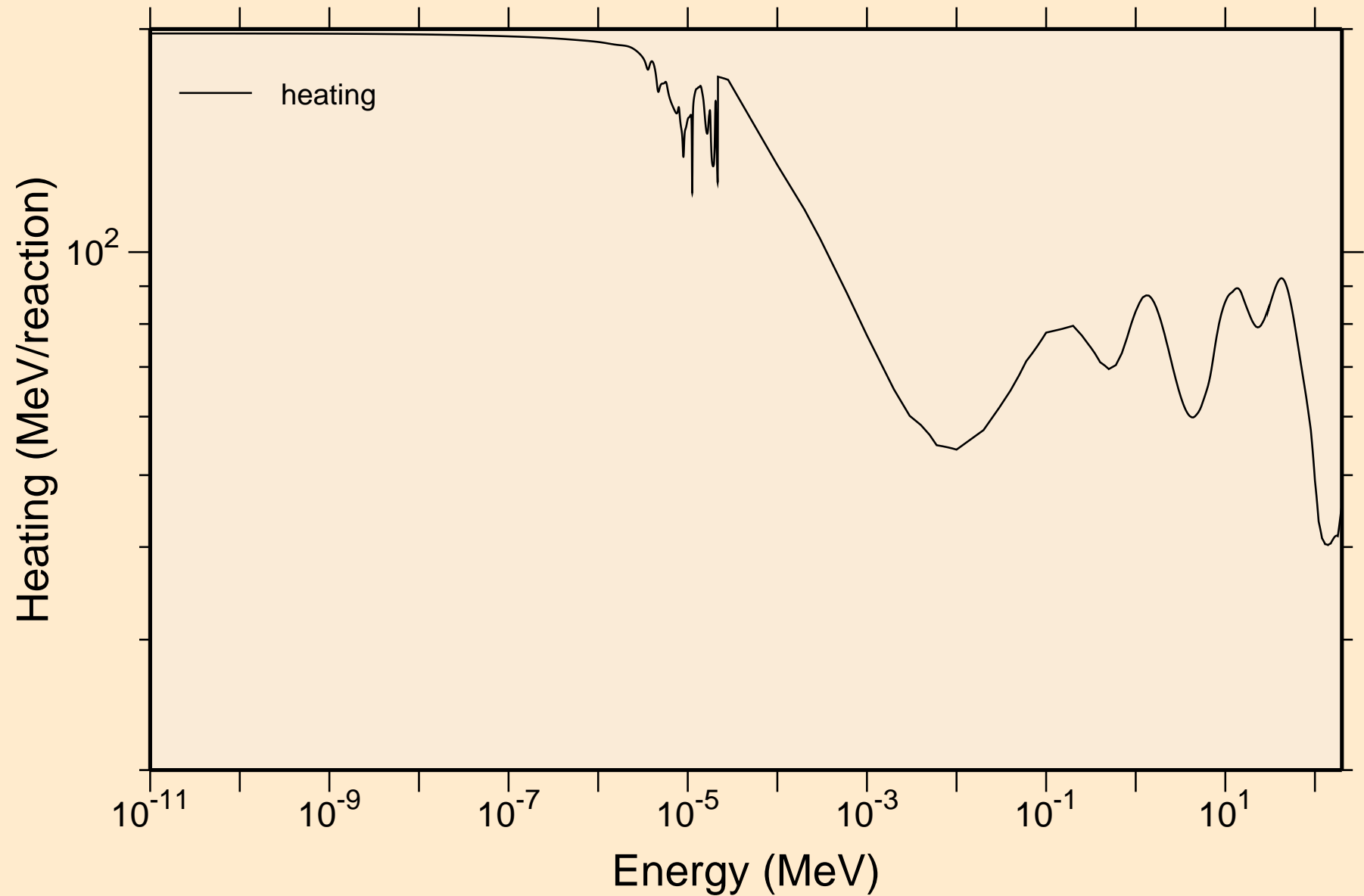

LR262 NEUTRON ACER TENDL-2019 LIBRARY; T=293.16K  
Damage

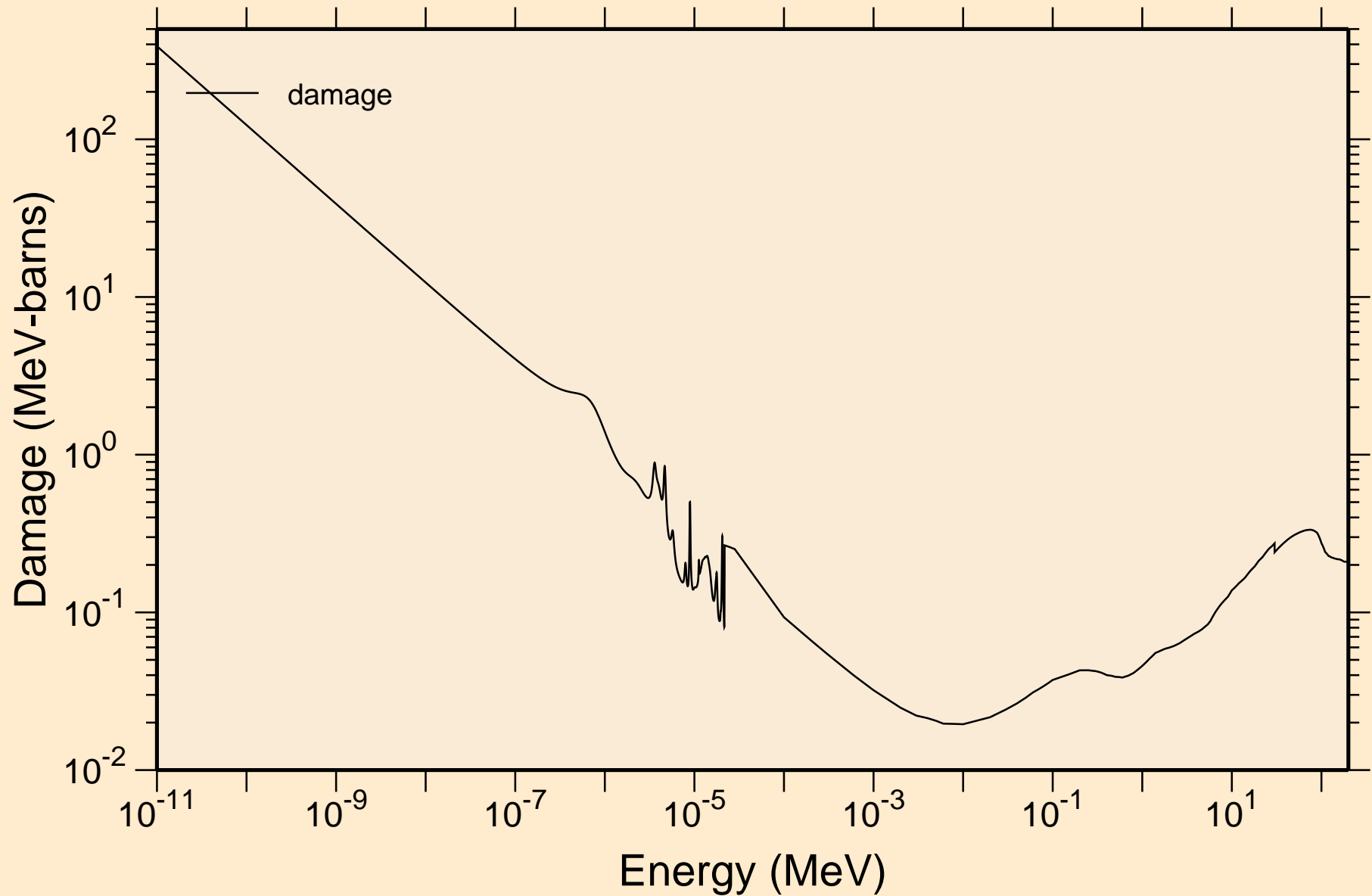

LR262 NEUTRON ACER TENDL-2019 LIBRARY; T=293.16K  
Non-threshold reactions

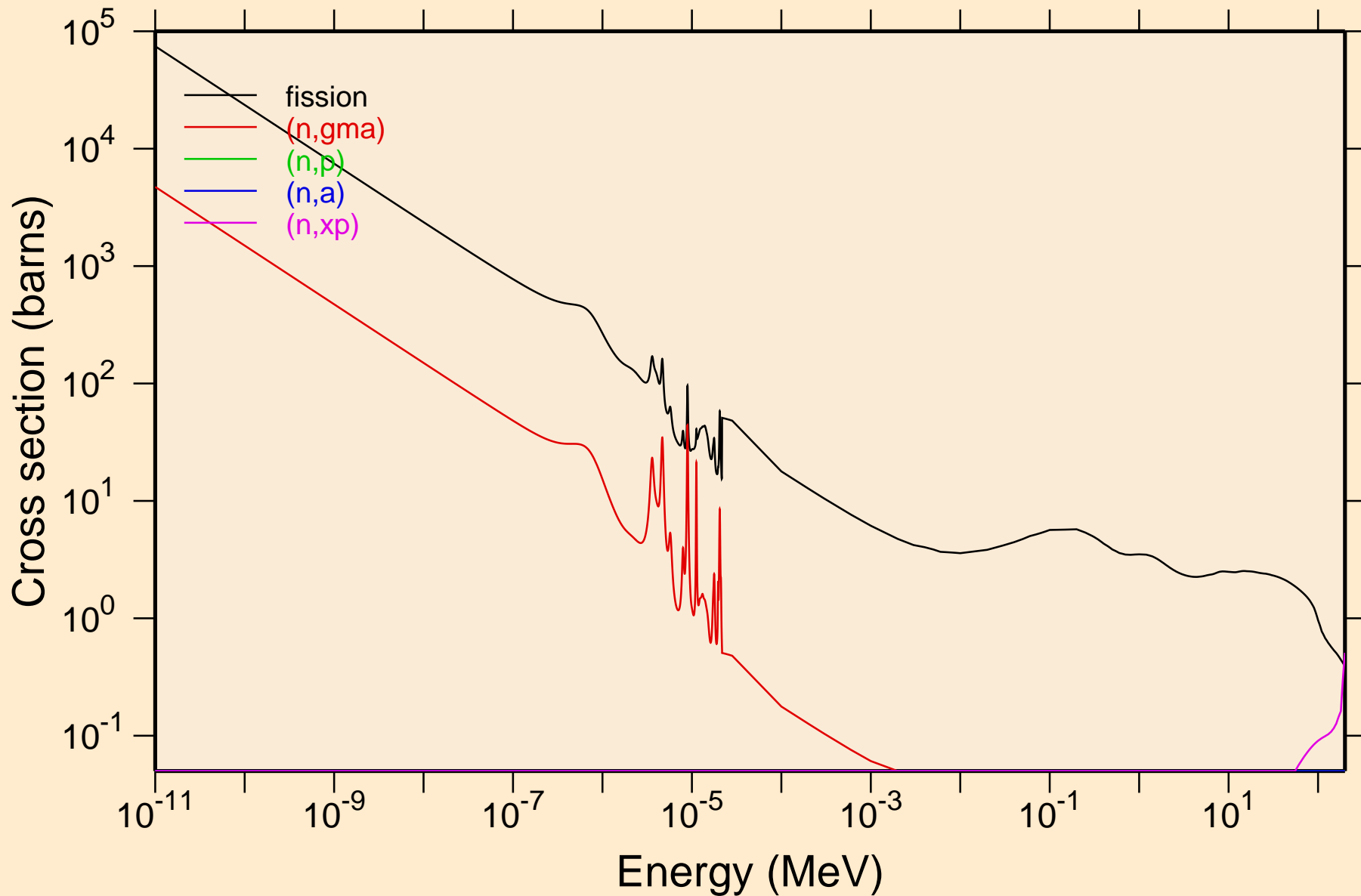

LR262 NEUTRON ACER TENDL-2019 LIBRARY; T=293.16K  
Non-threshold reactions

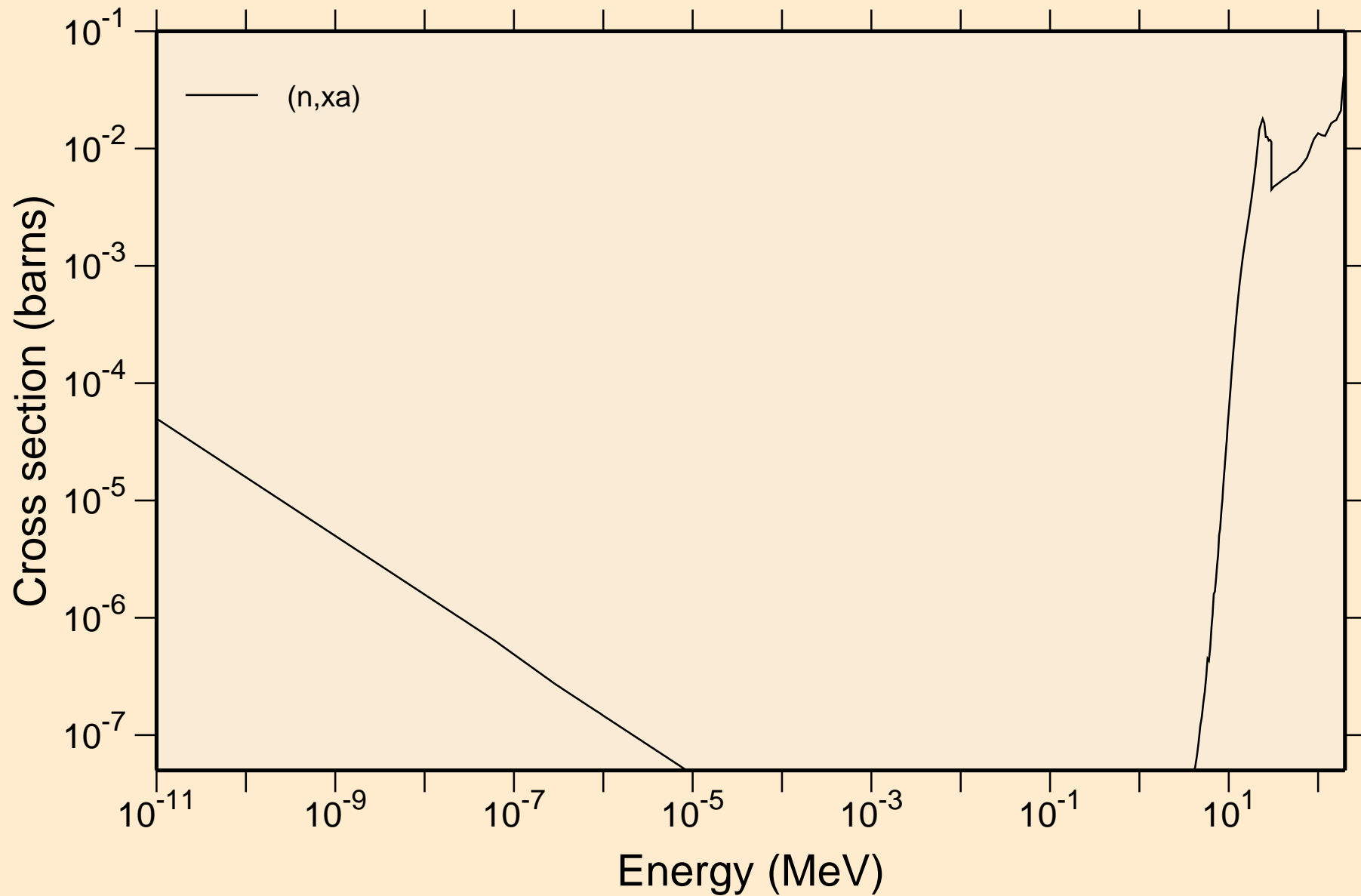

LR262 NEUTRON ACER TENDL-2019 LIBRARY; T=293.16K  
Principal cross sections

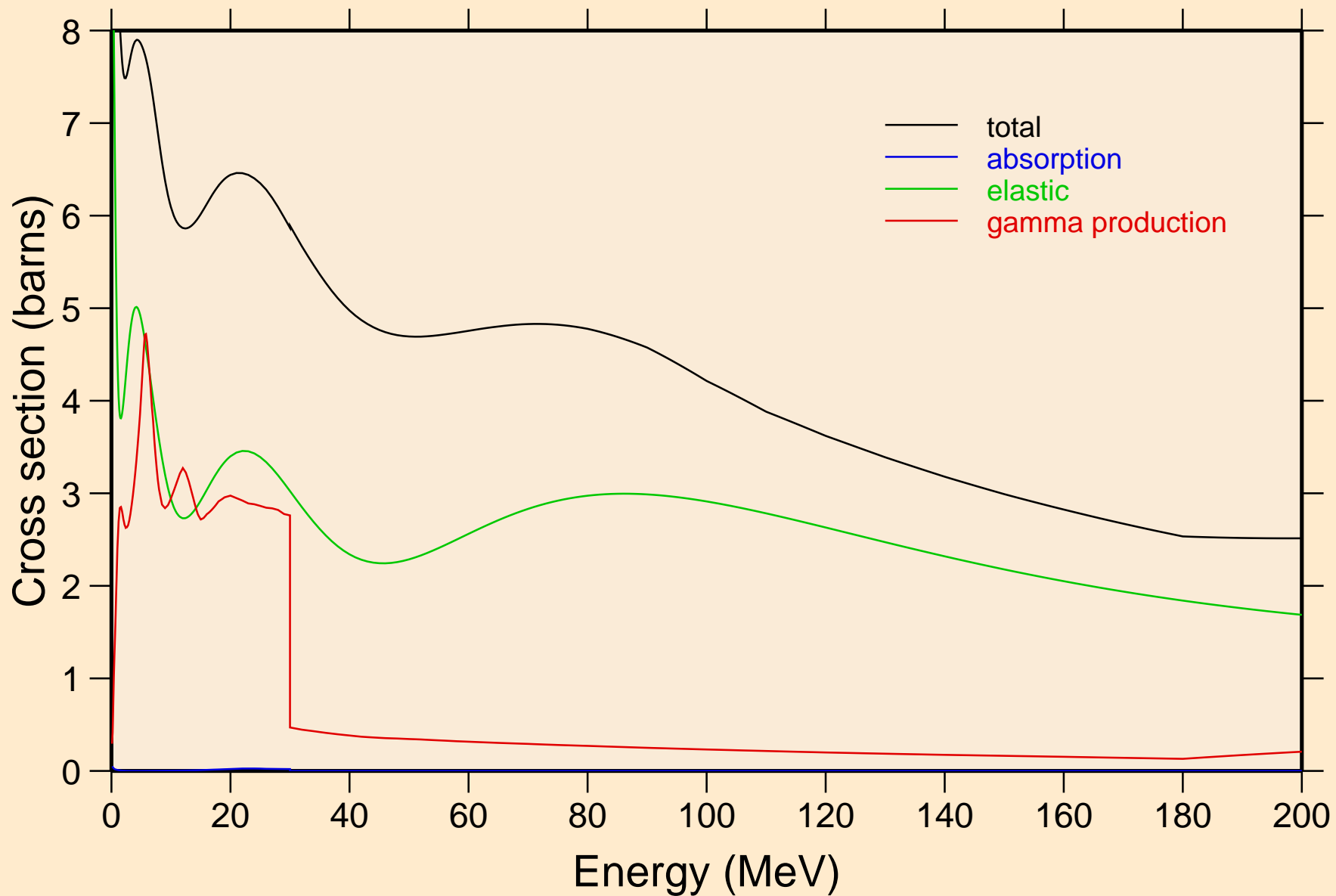

LR262 NEUTRON ACER TENDL-2019 LIBRARY; T=293.16K  
Heating

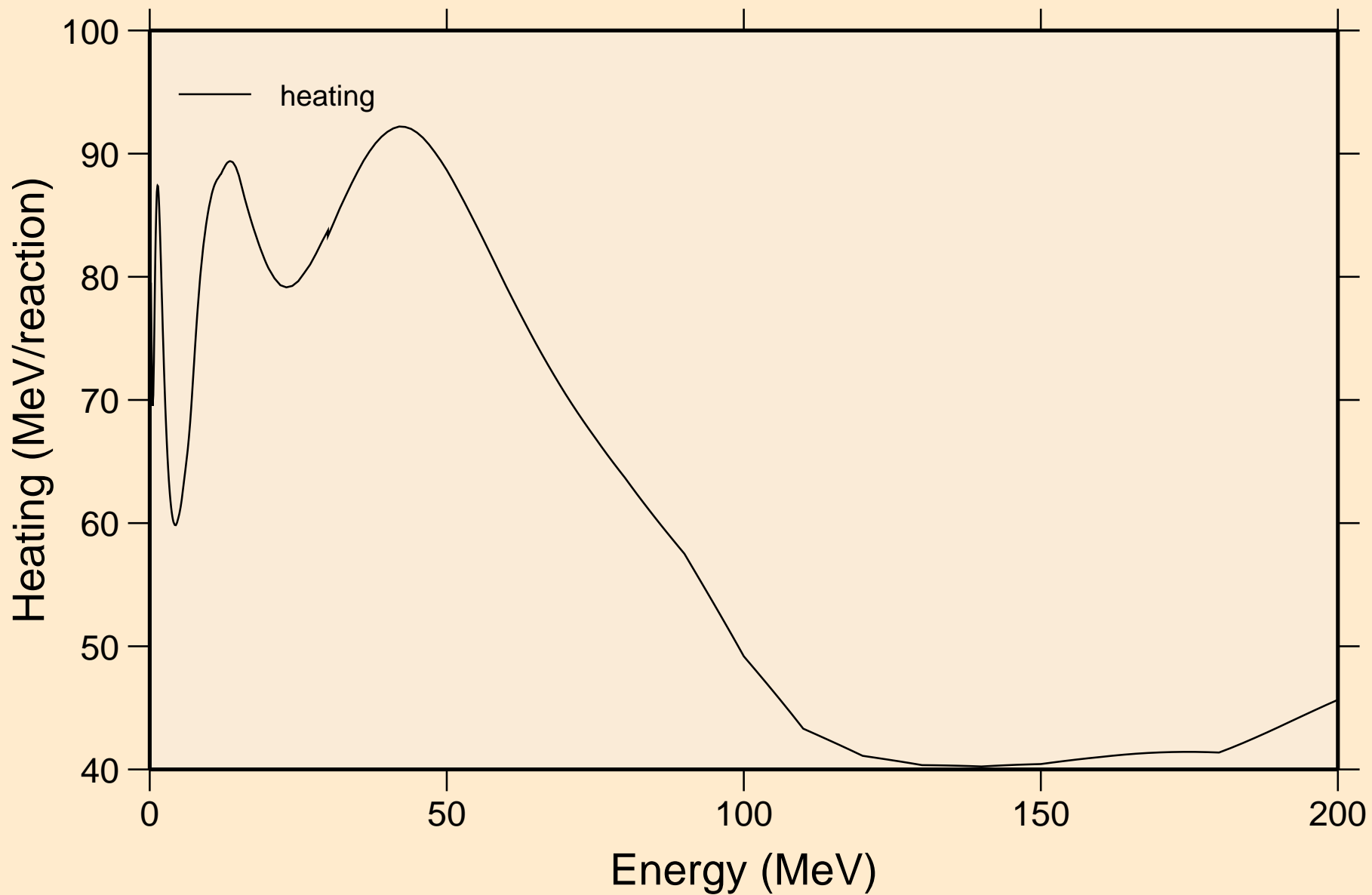

LR262 NEUTRON ACER TENDL-2019 LIBRARY; T=293.16K  
Damage

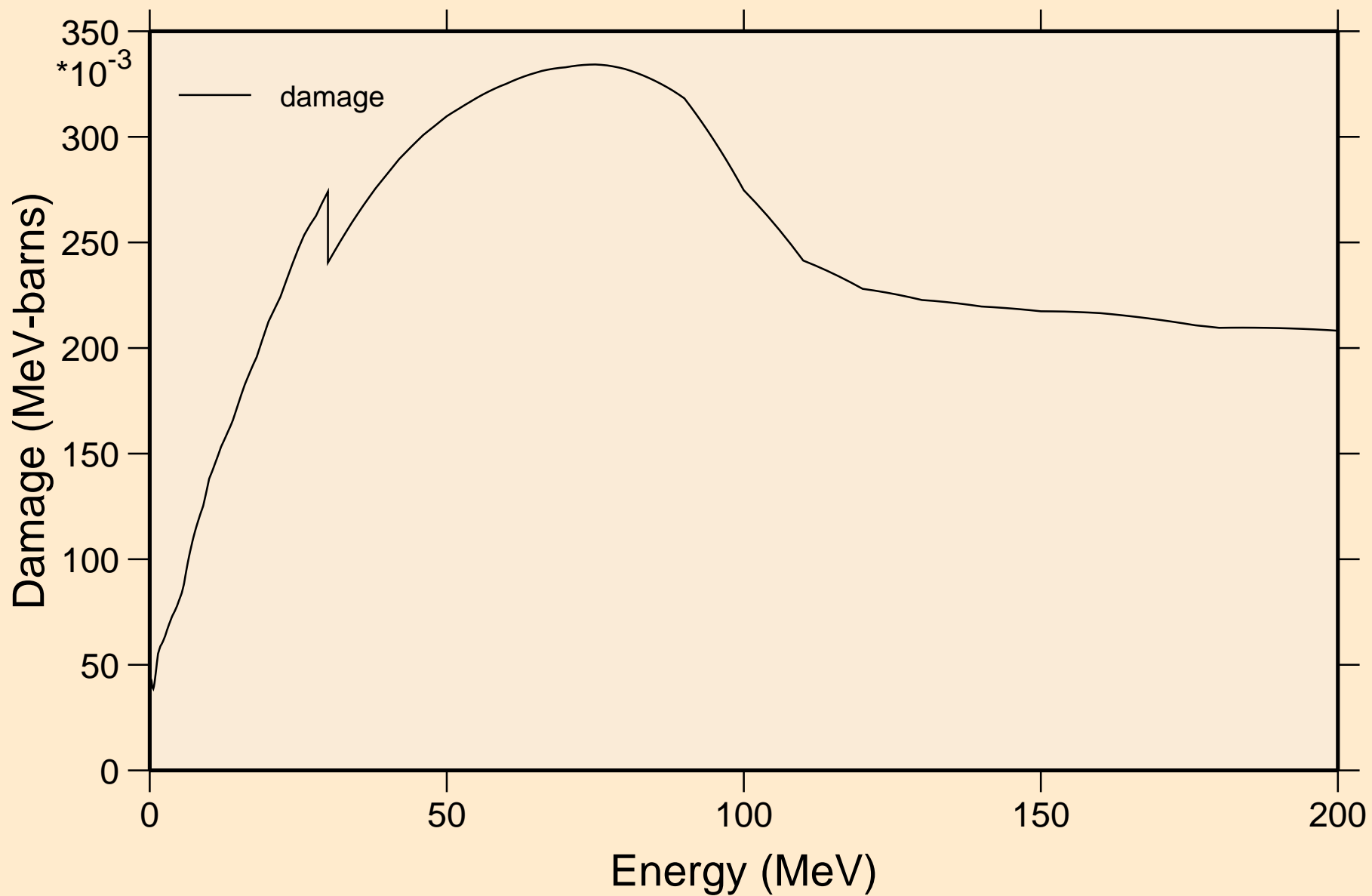

LR262 NEUTRON ACER TENDL-2019 LIBRARY; T=293.16K  
Non-threshold reactions

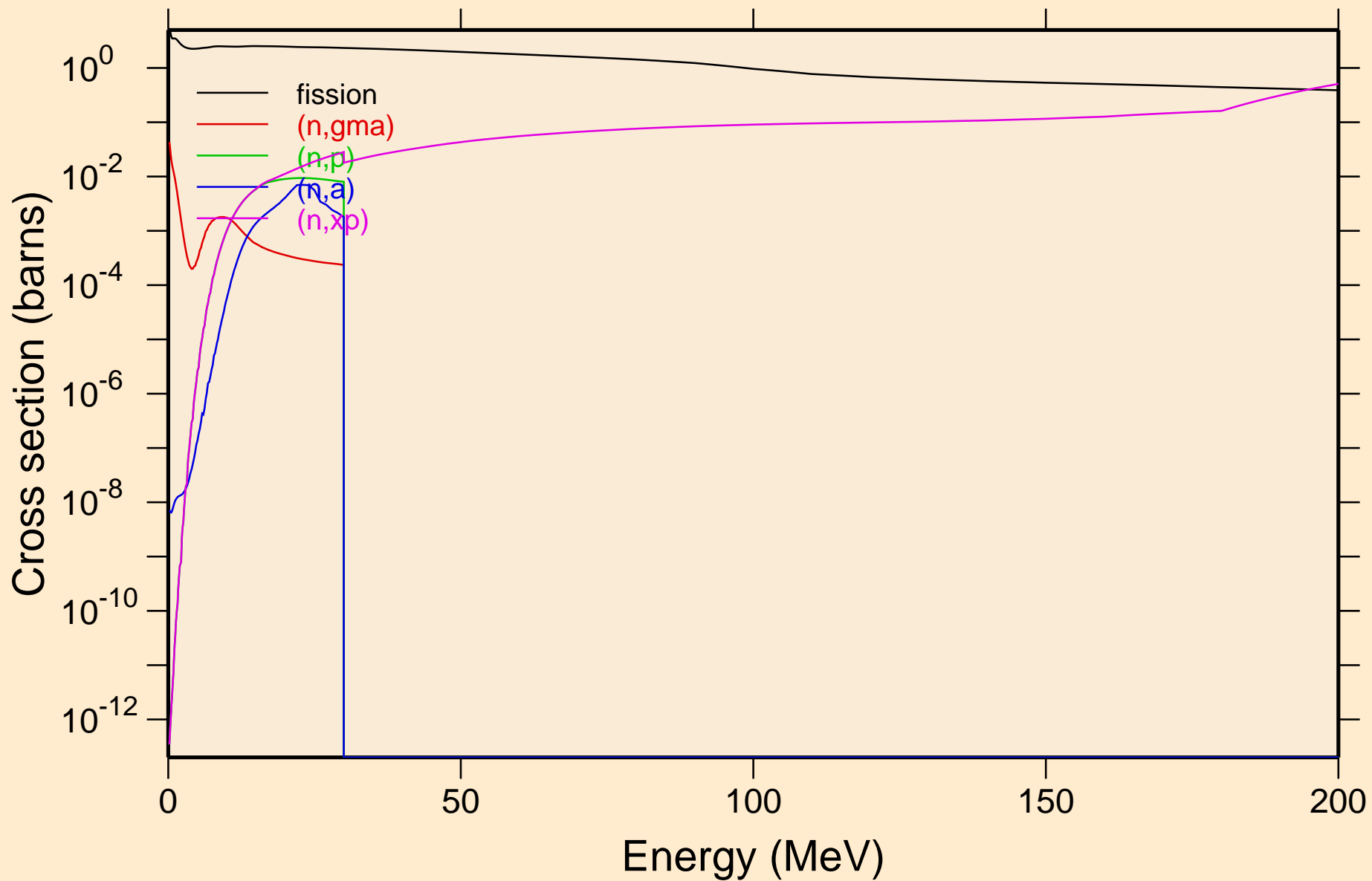

LR262 NEUTRON ACER TENDL-2019 LIBRARY; T=293.16K  
Non-threshold reactions

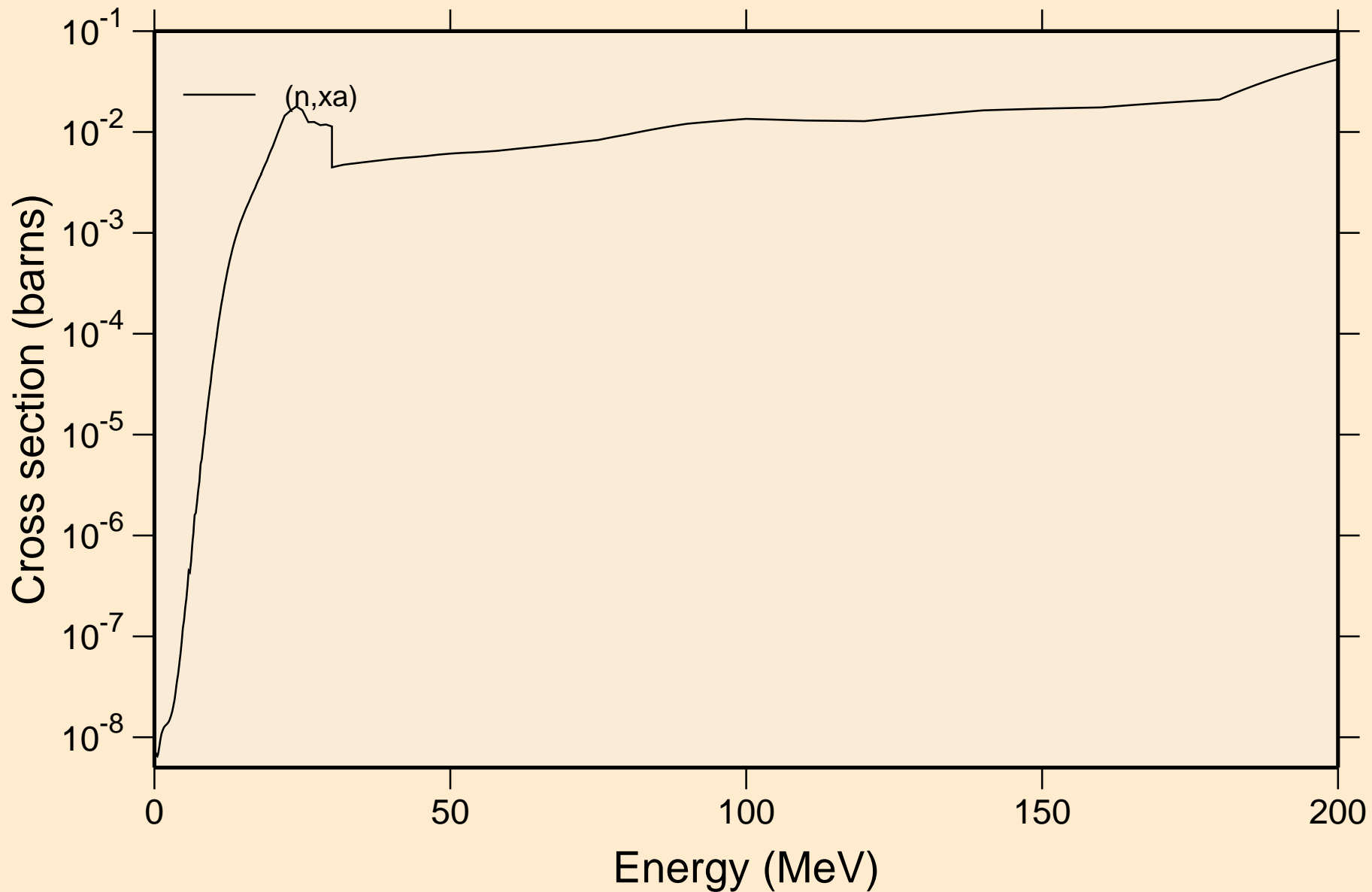

LR262 NEUTRON ACER TENDL-2019 LIBRARY; T=293.16K  
Inelastic levels

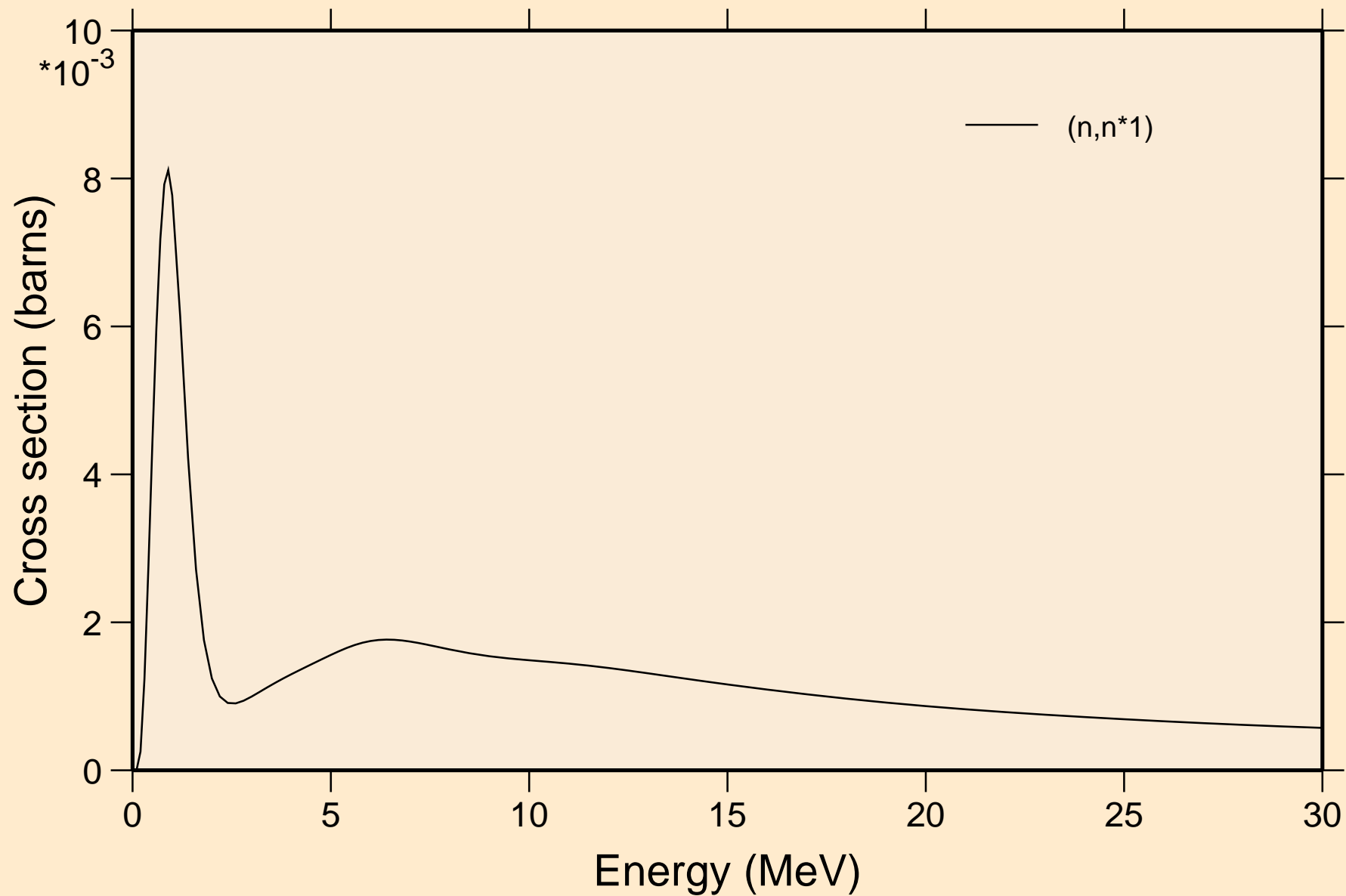

LR262 NEUTRON ACER TENDL-2019 LIBRARY; T=293.16K  
Threshold reactions

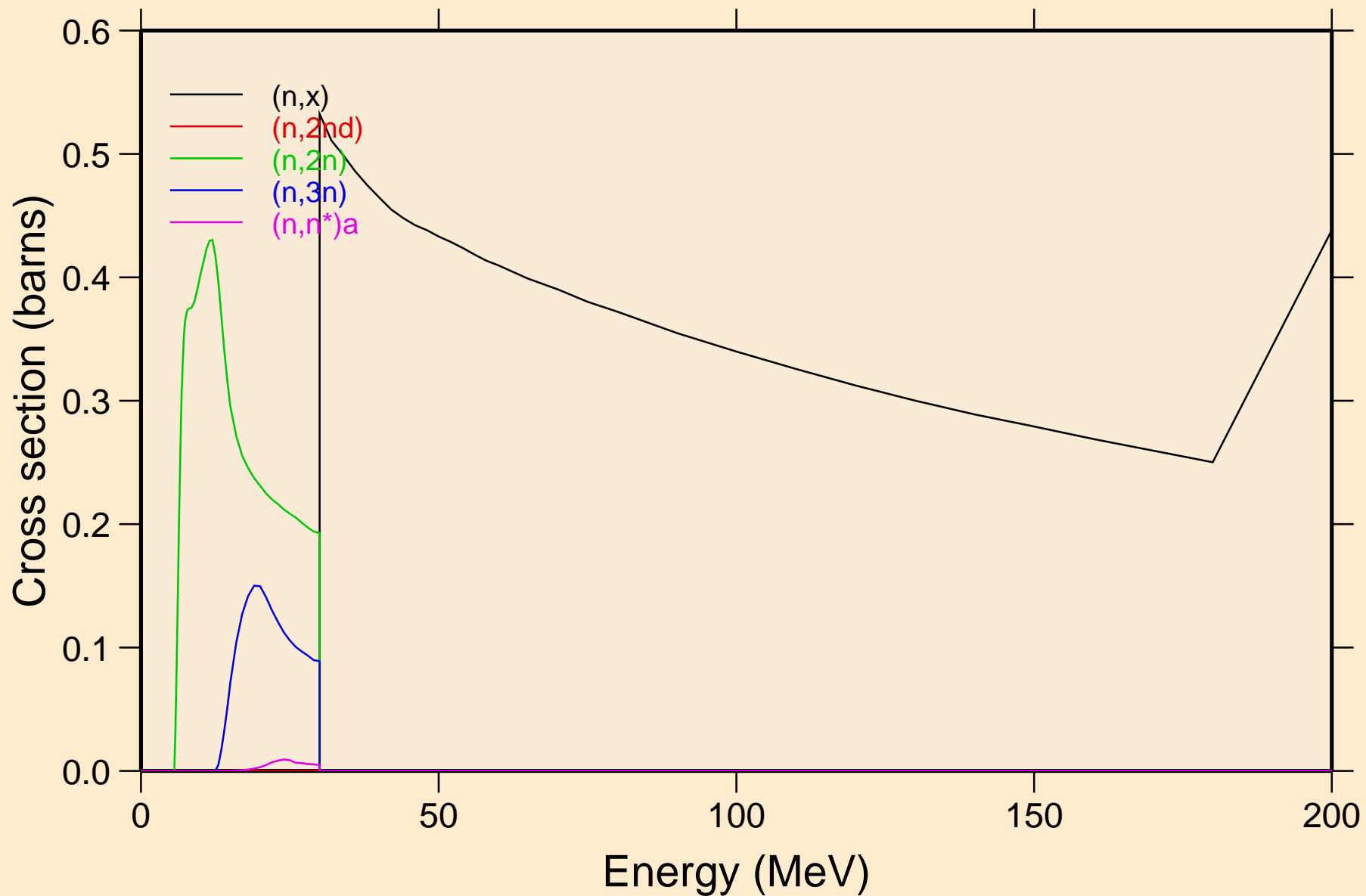

LR262 NEUTRON ACER TENDL-2019 LIBRARY; T=293.16K  
Threshold reactions

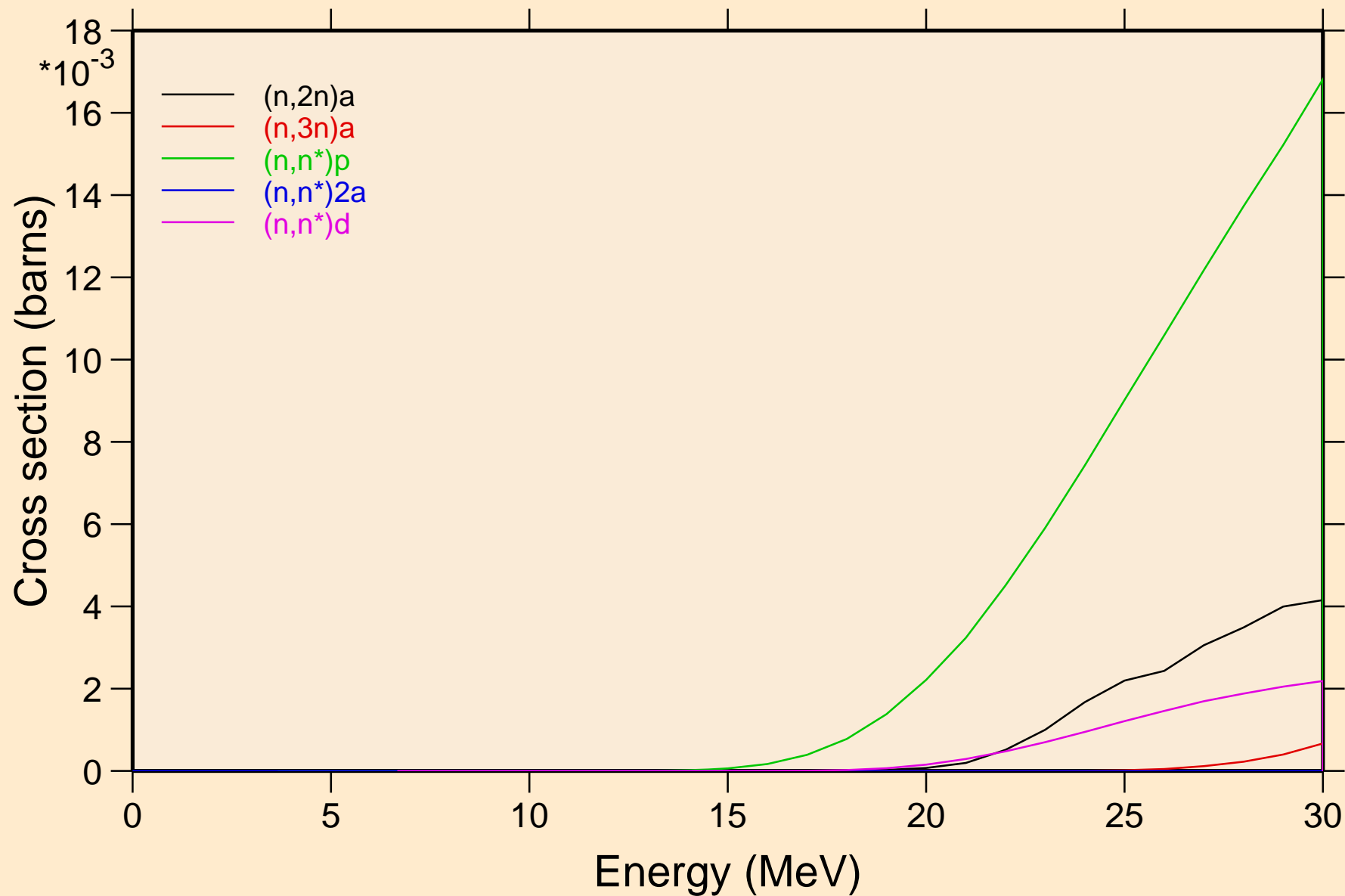

LR262 NEUTRON ACER TENDL-2019 LIBRARY; T=293.16K  
Threshold reactions

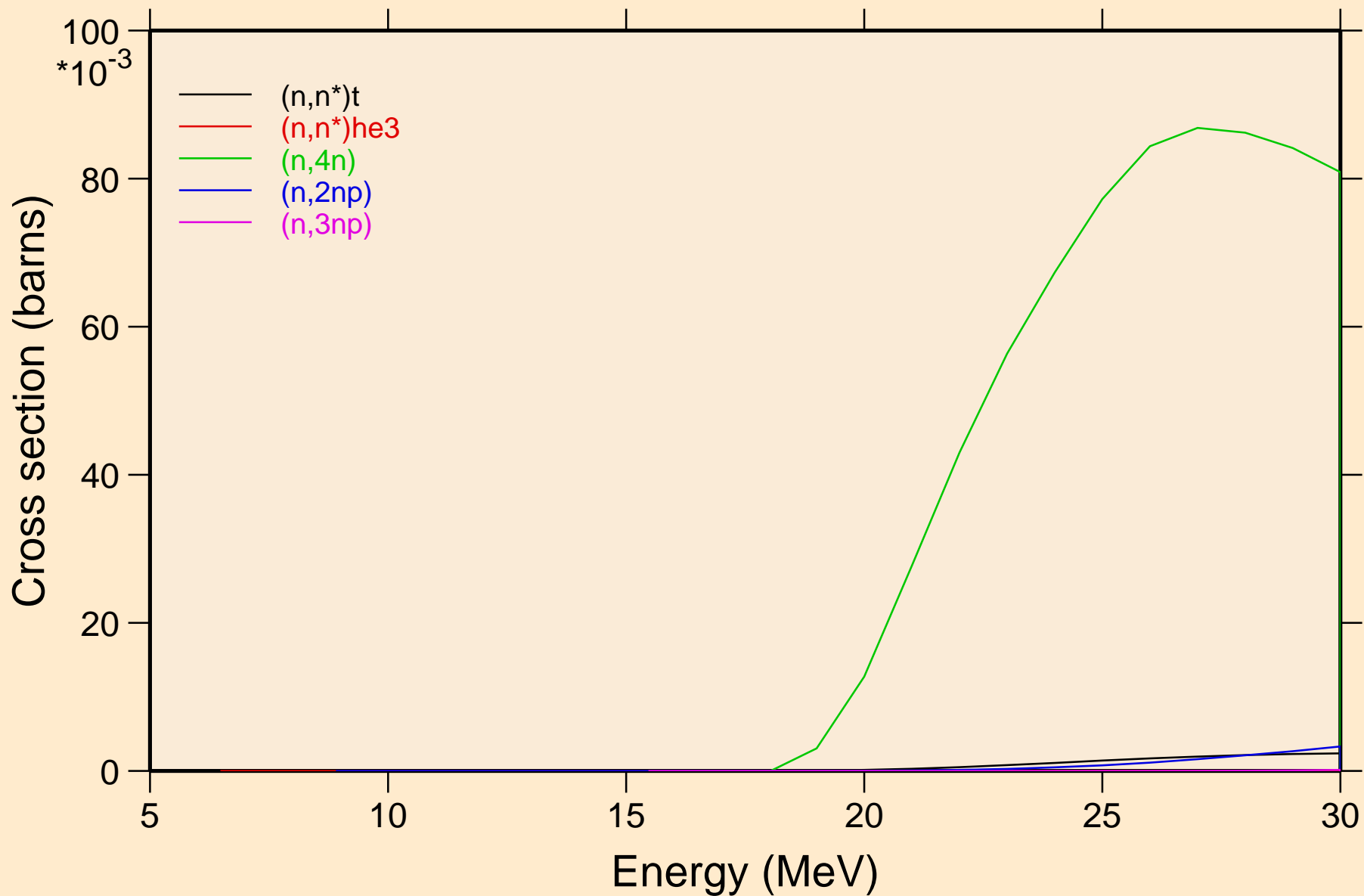

LR262 NEUTRON ACER TENDL-2019 LIBRARY; T=293.16K  
Threshold reactions

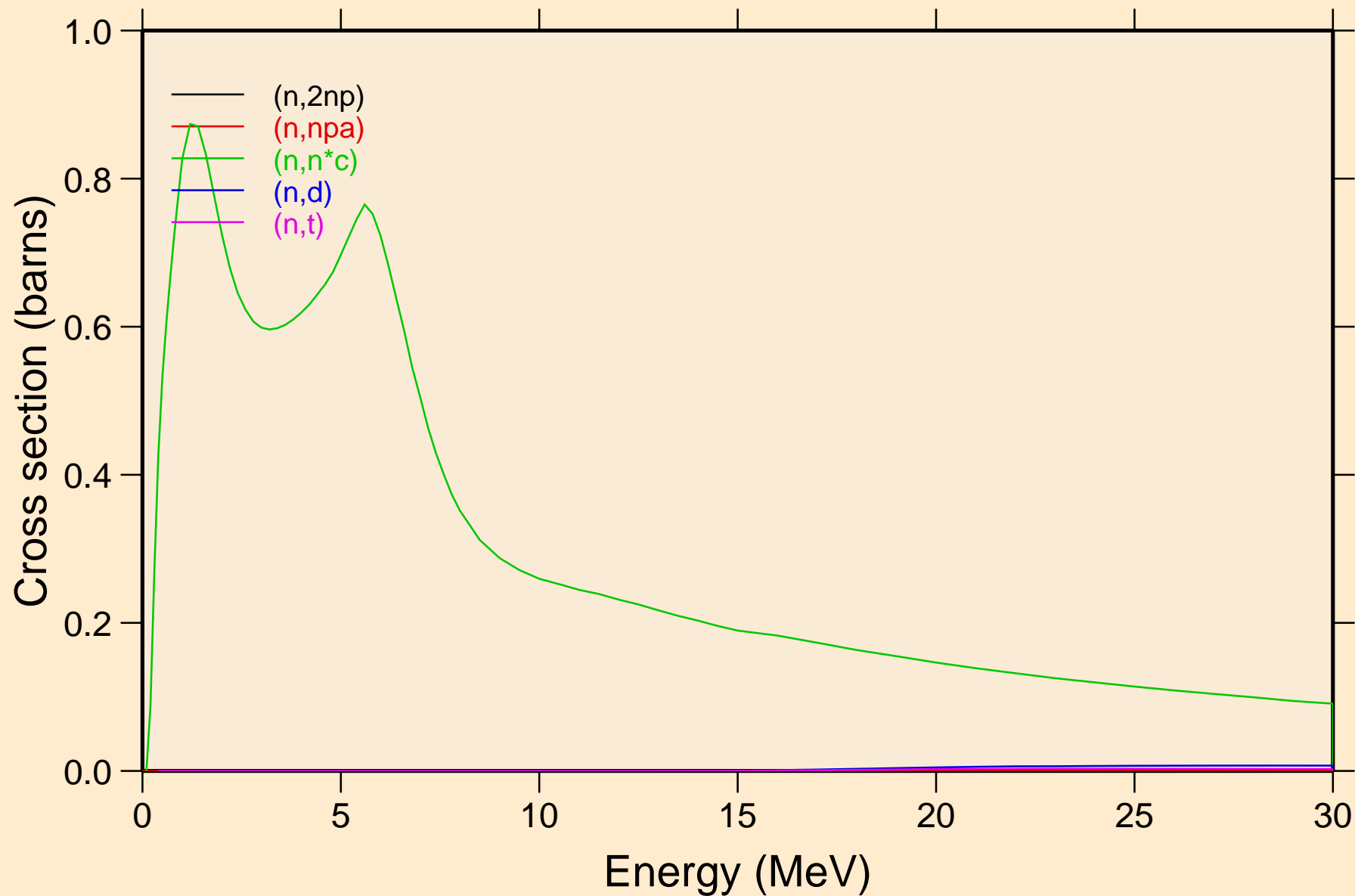

LR262 NEUTRON ACER TENDL-2019 LIBRARY; T=293.16K  
Threshold reactions

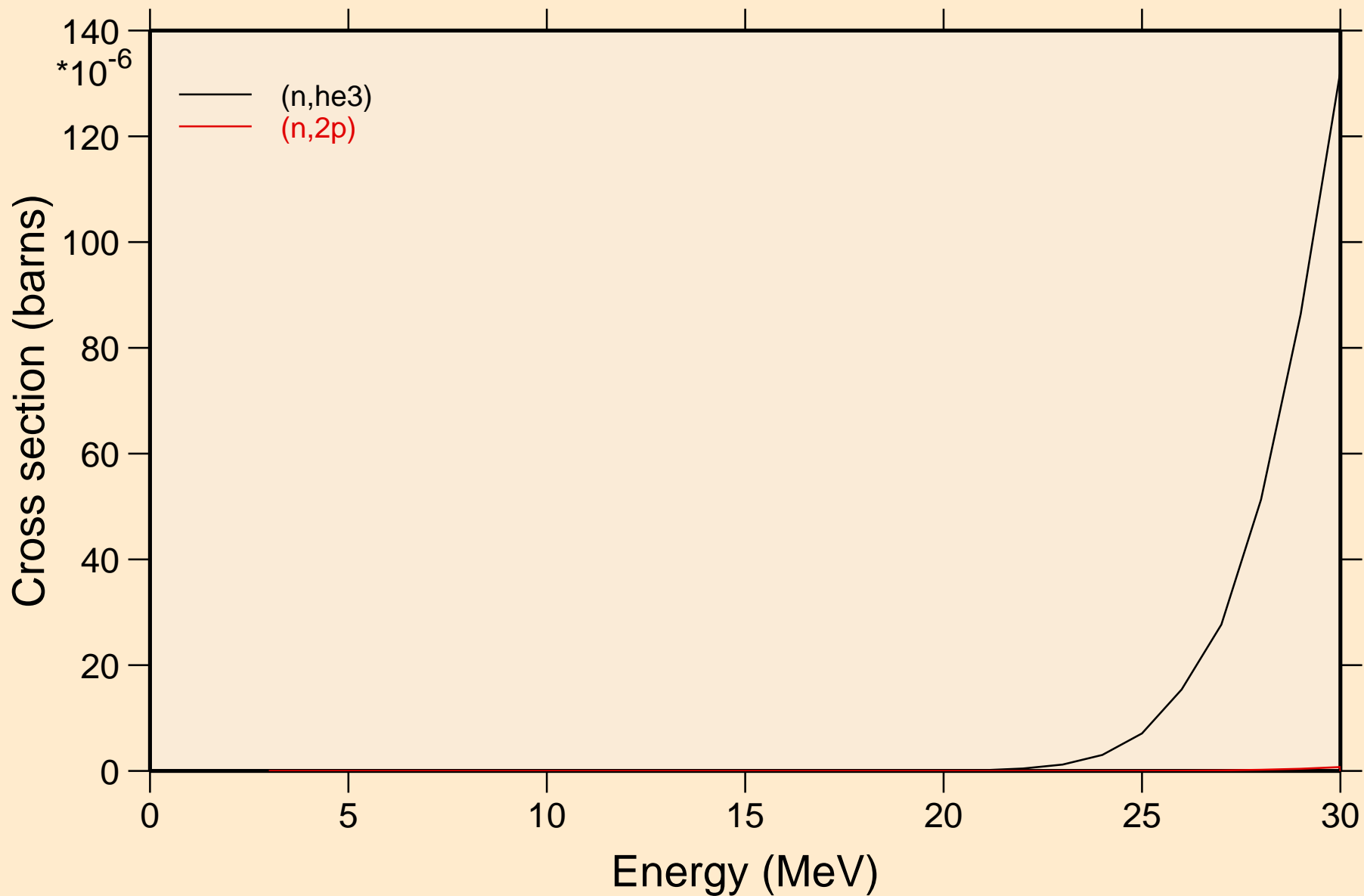

LR262 NEUTRON ACER TENDL-2019 LIBRARY; T=293.16K  
Threshold reactions

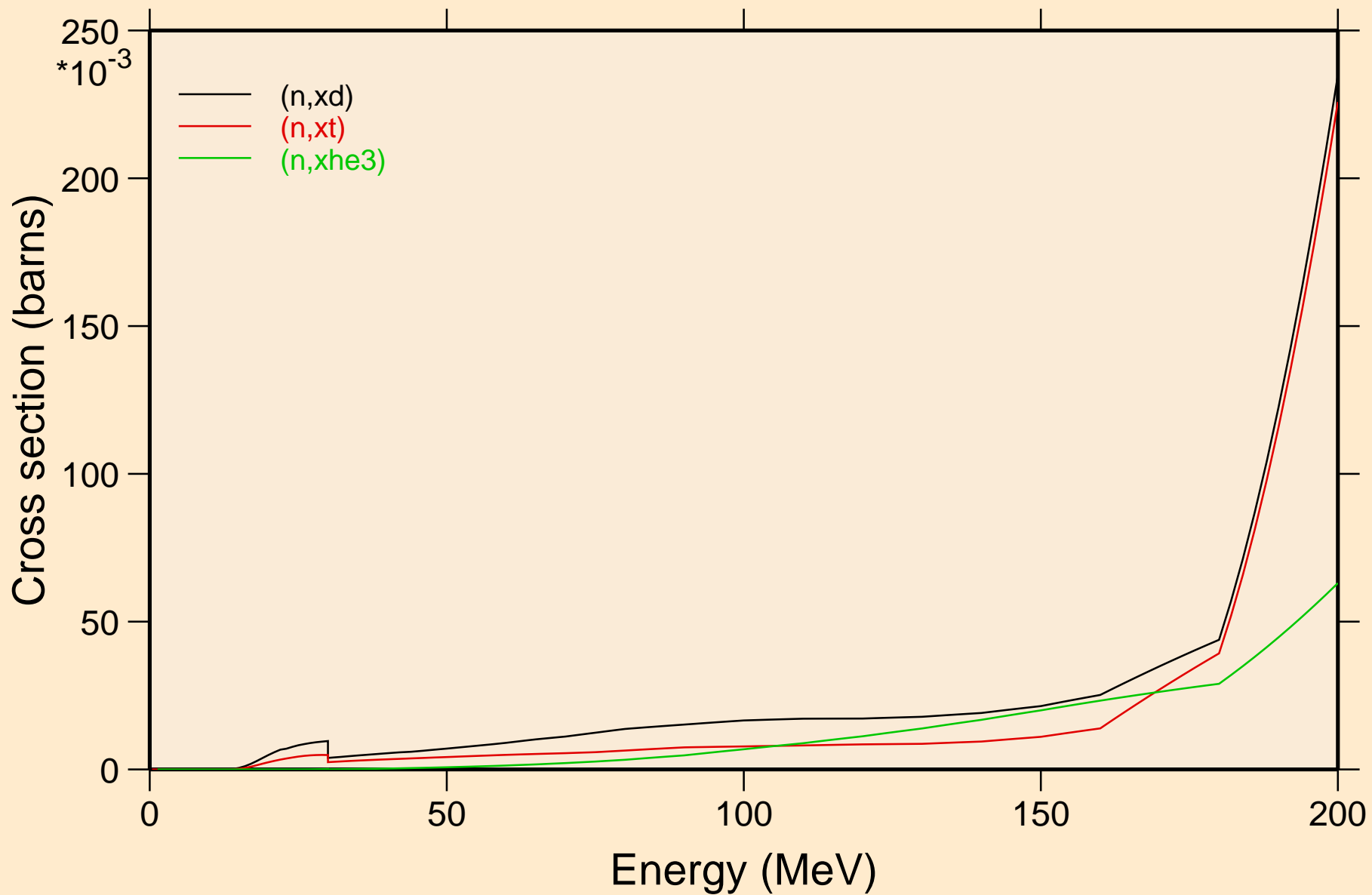

LR262 NEUTRON ACER TENDL-2019 LIBRARY; T=293.16K  
angular distribution for elastic

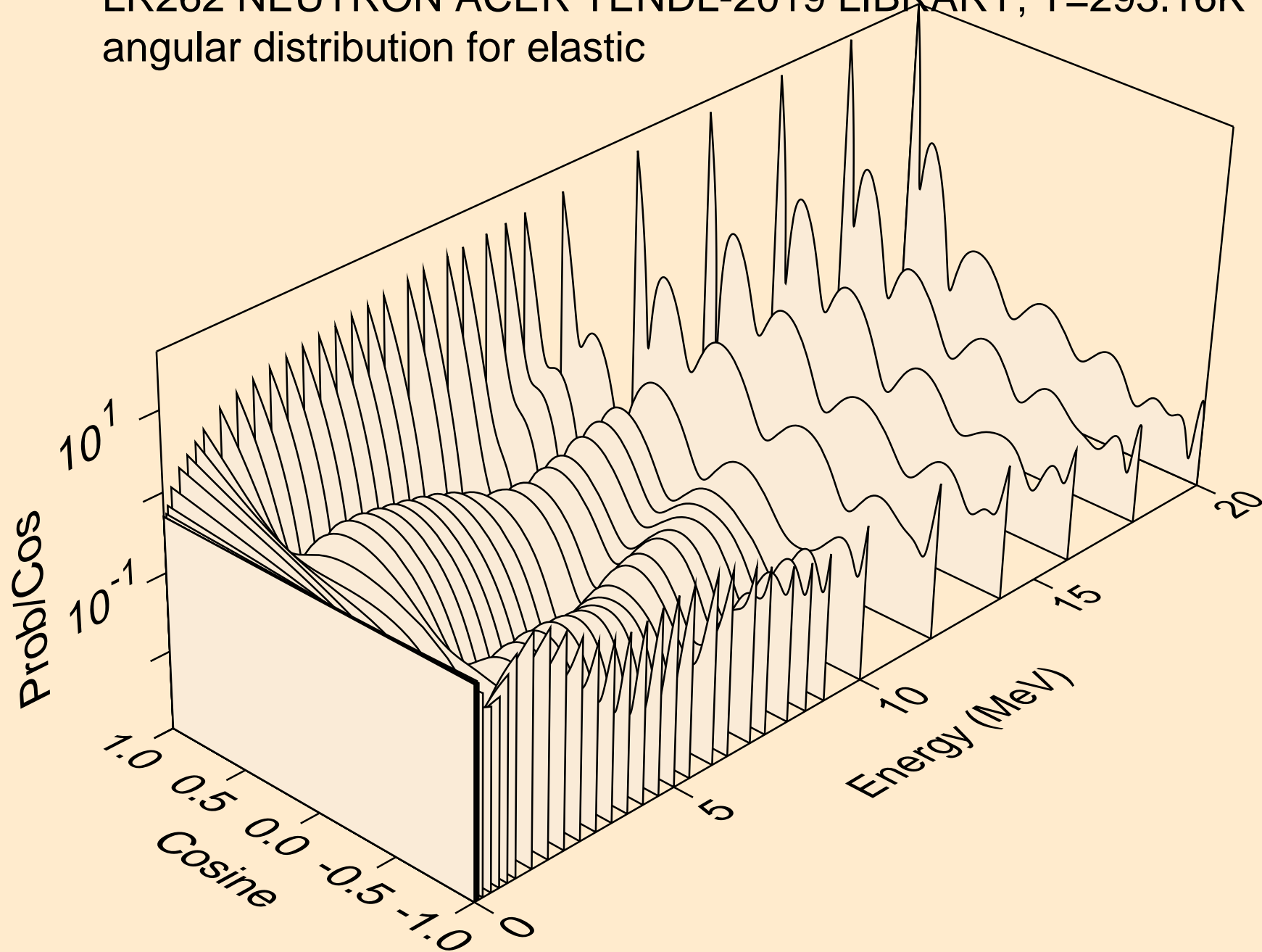

LR262 NEUTRON ACER TENDL-2019 LIBRARY; T=293.16K  
angular distribution for elastic

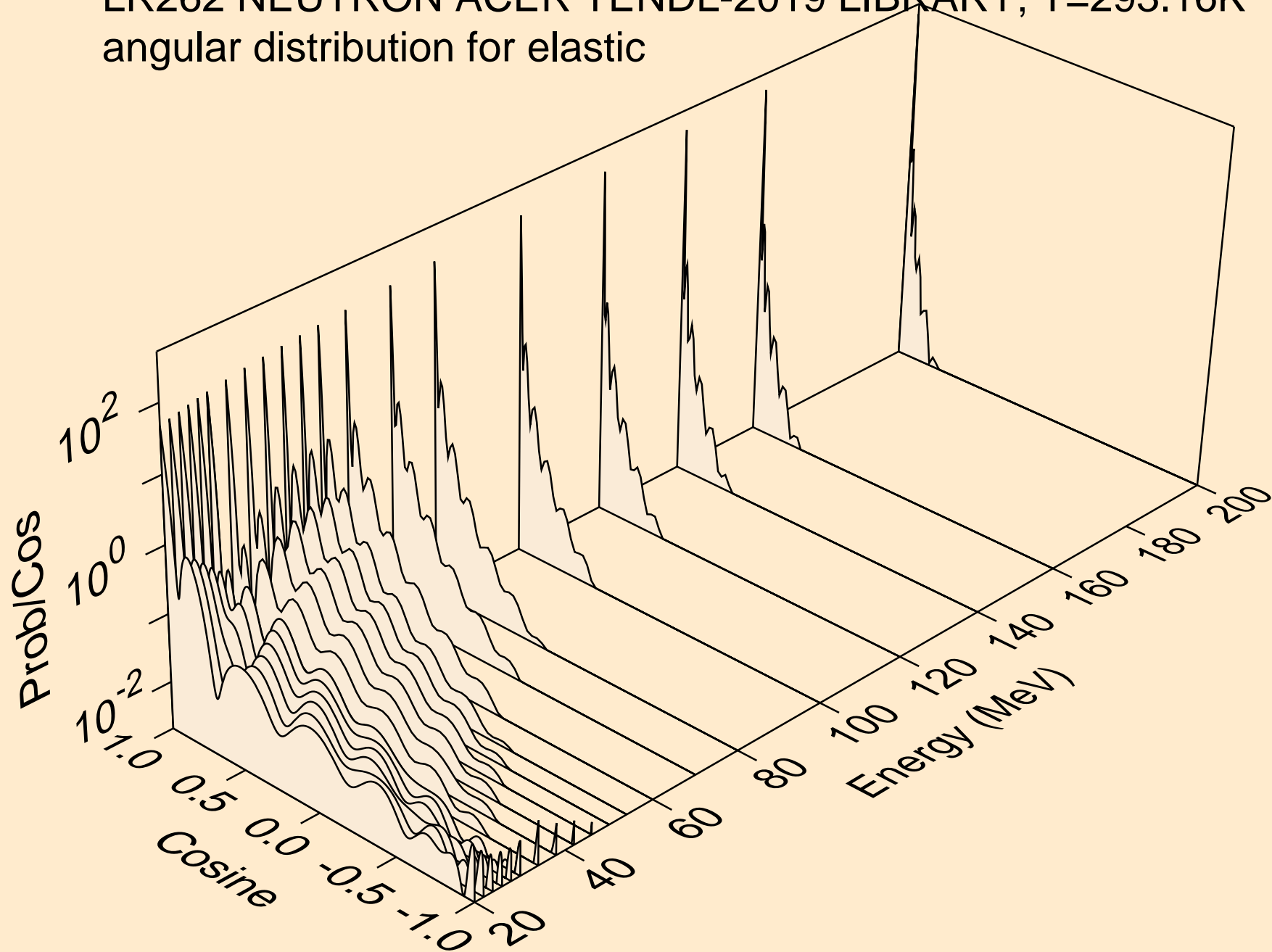

LR262 NEUTRON ACER TENDL-2019 LIBRARY; T=293.16K  
angular distribution for (n,n\*1)

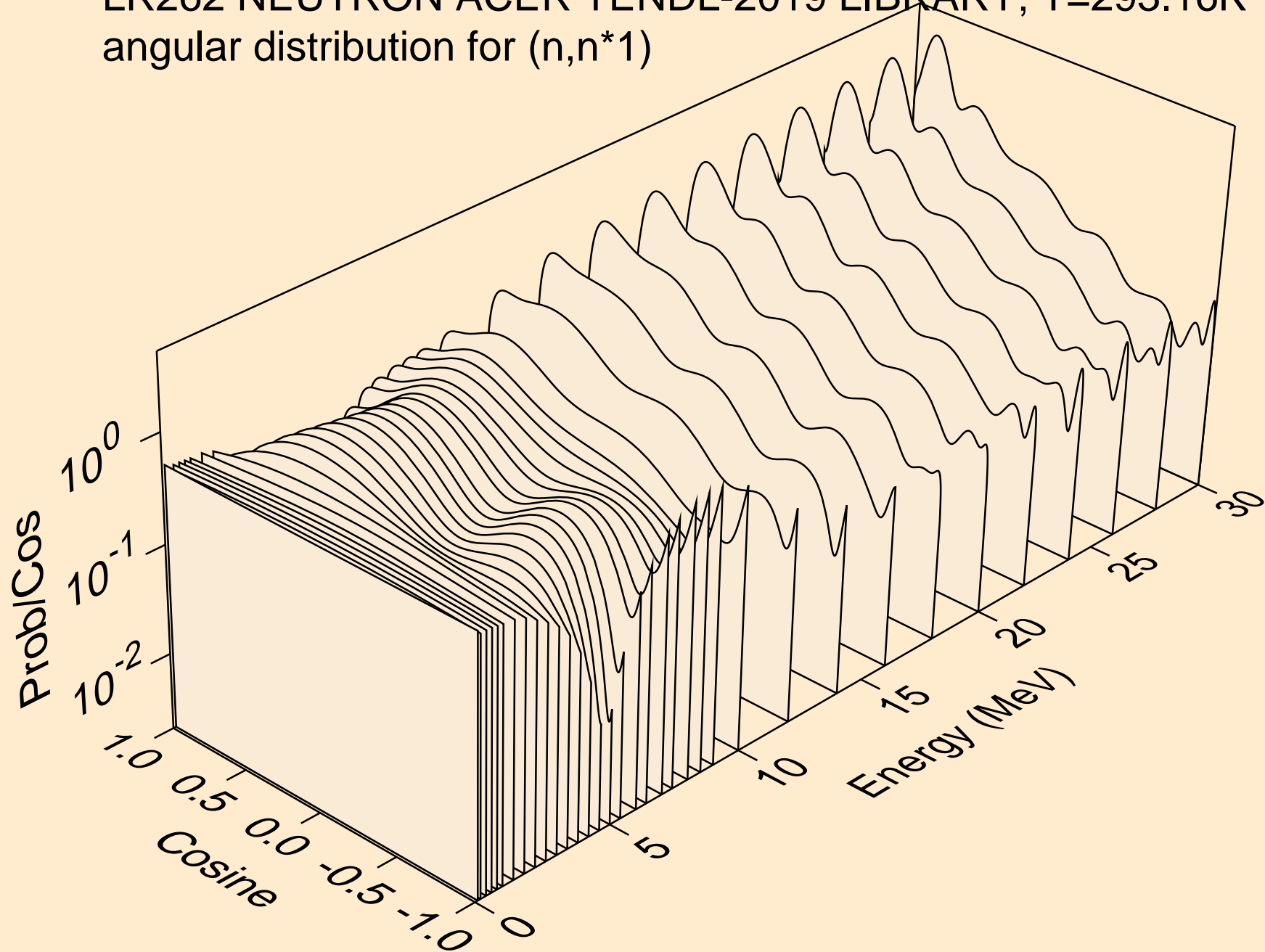

LR262 NEUTRON ACER TENDL-2019 LIBRARY; T=293.16K  
Total fission nubar

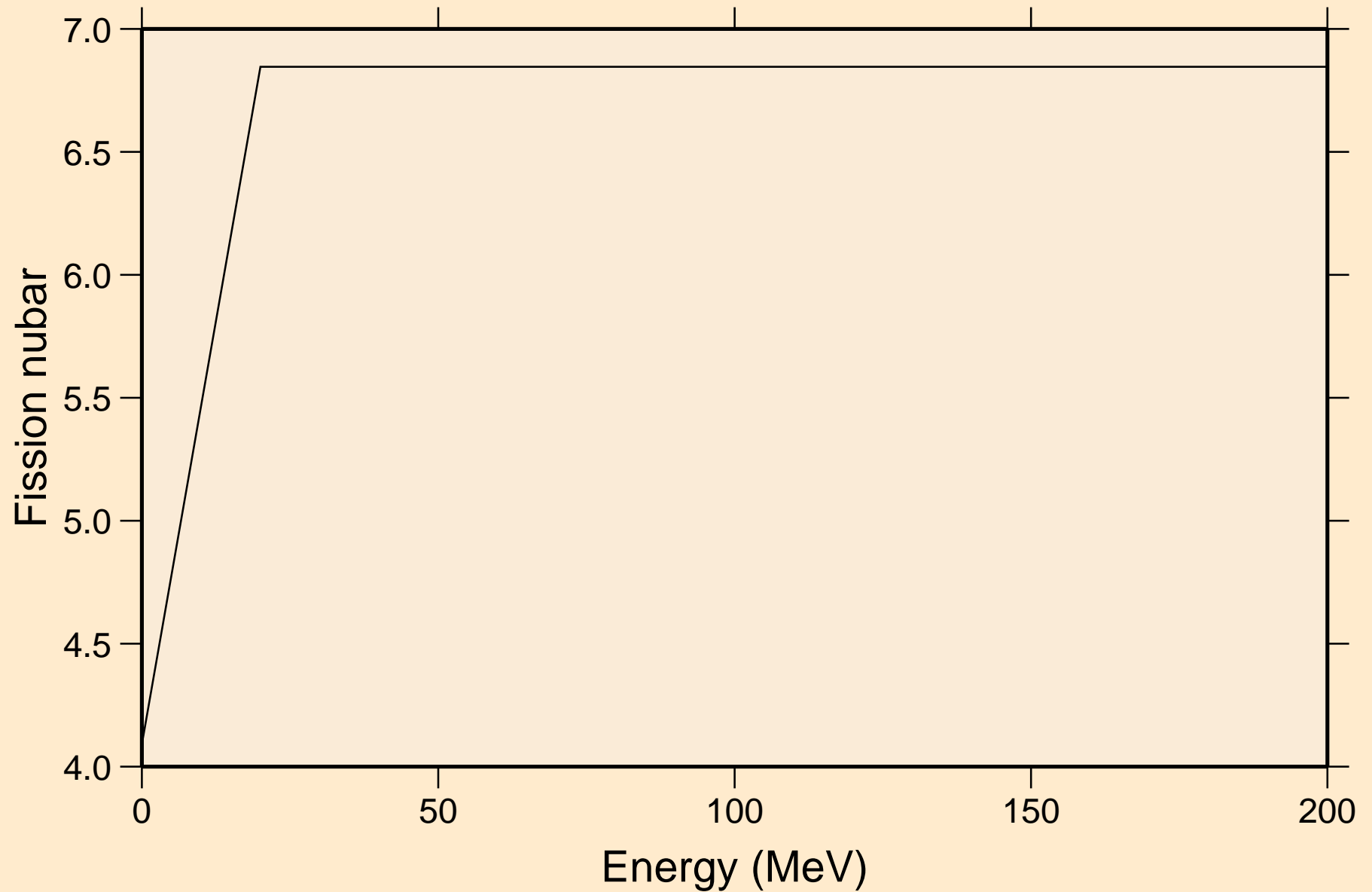

LR262 NEUTRON ACER TENDL-2019 LIBRARY; T=293.16K  
Neutron emission for (n,x)

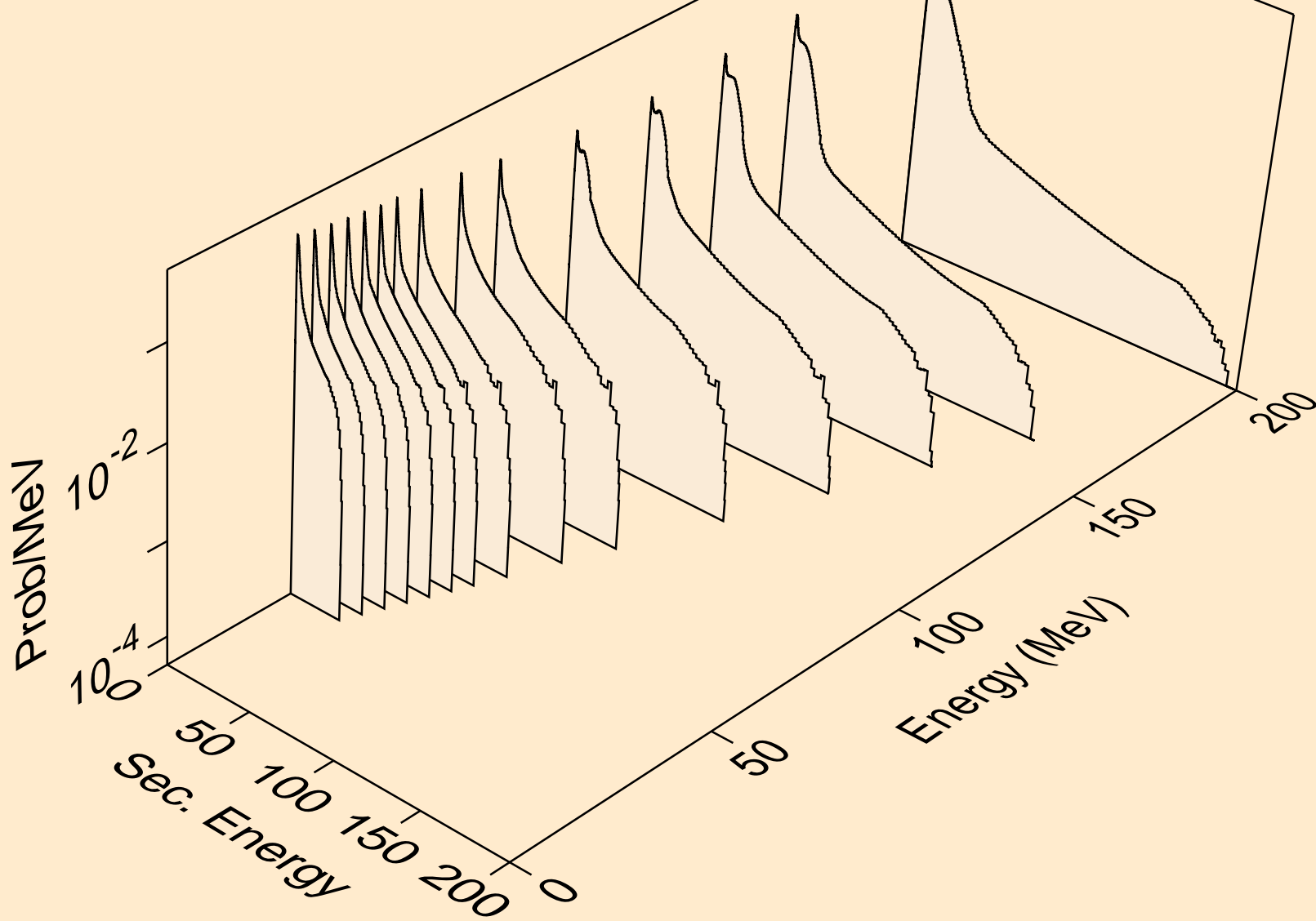

LR262 NEUTRON ACER TENDL-2019 LIBRARY; T=293.16K  
Neutron emission for (n,2nd)

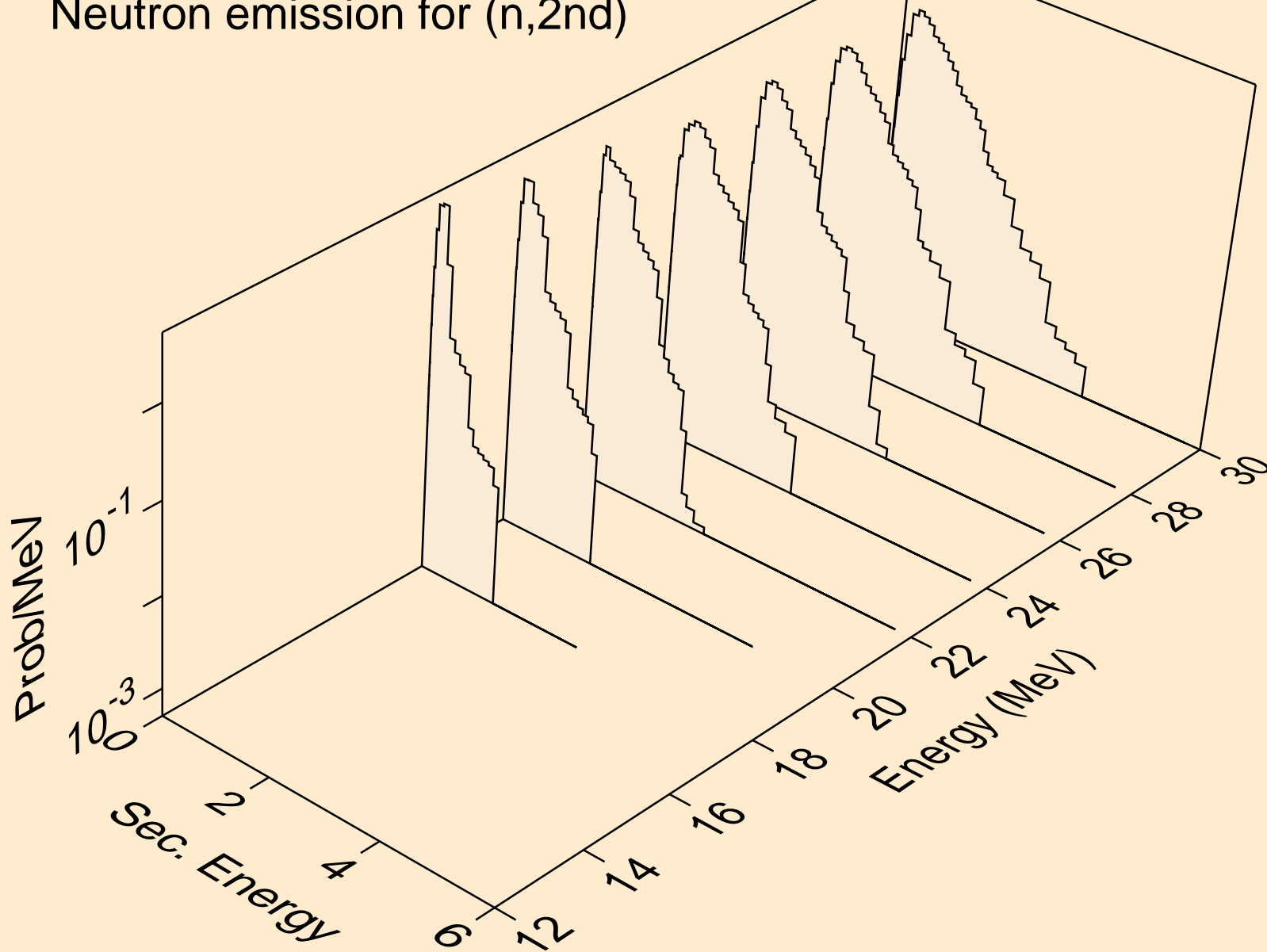

LR262 NEUTRON ACER TENDL-2019 LIBRARY; T=293.16K  
Neutron emission for (n,2n)

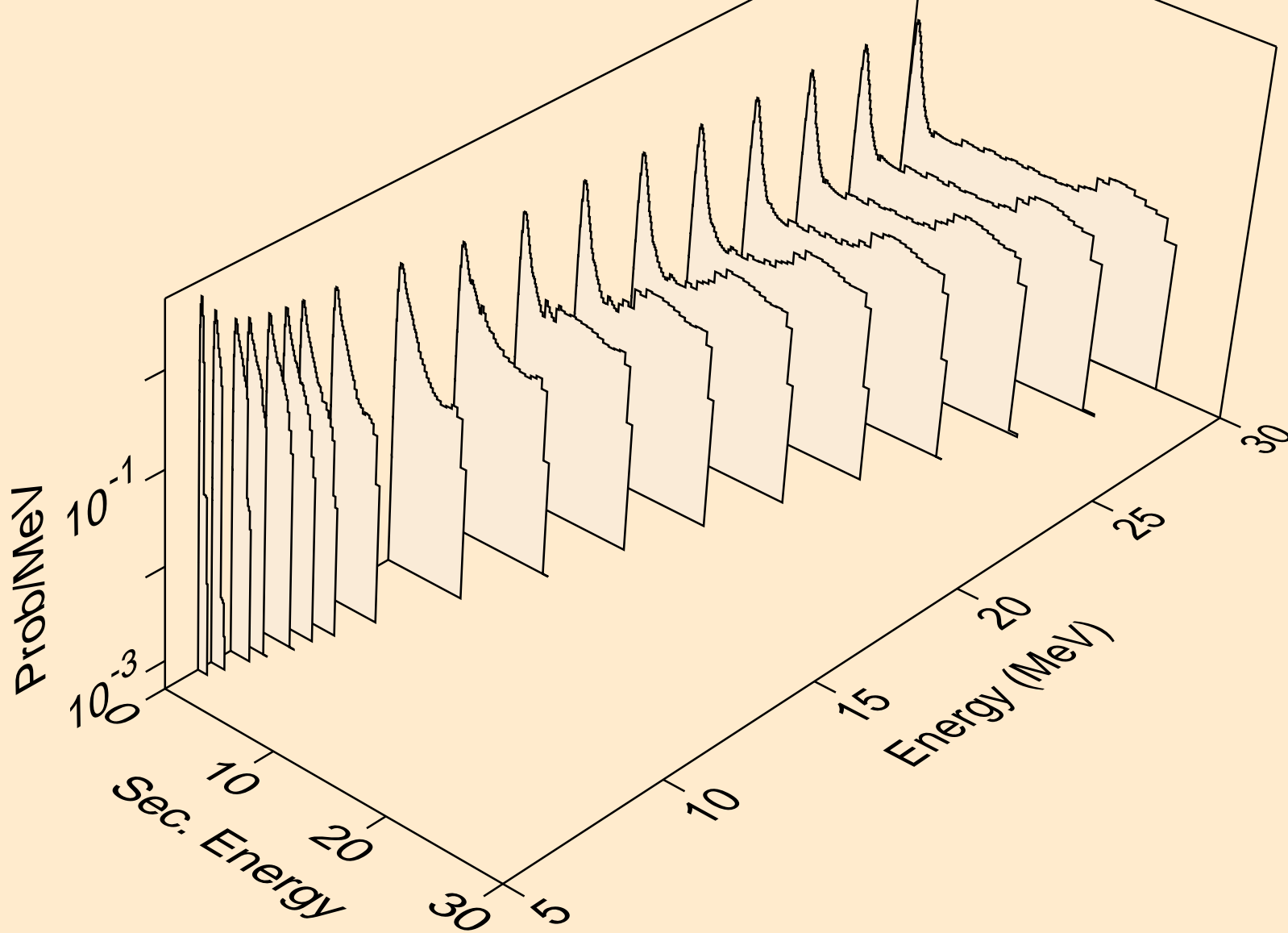

LR262 NEUTRON ACER TENDL-2019 LIBRARY; T=293.16K  
Neutron emission for (n,3n)

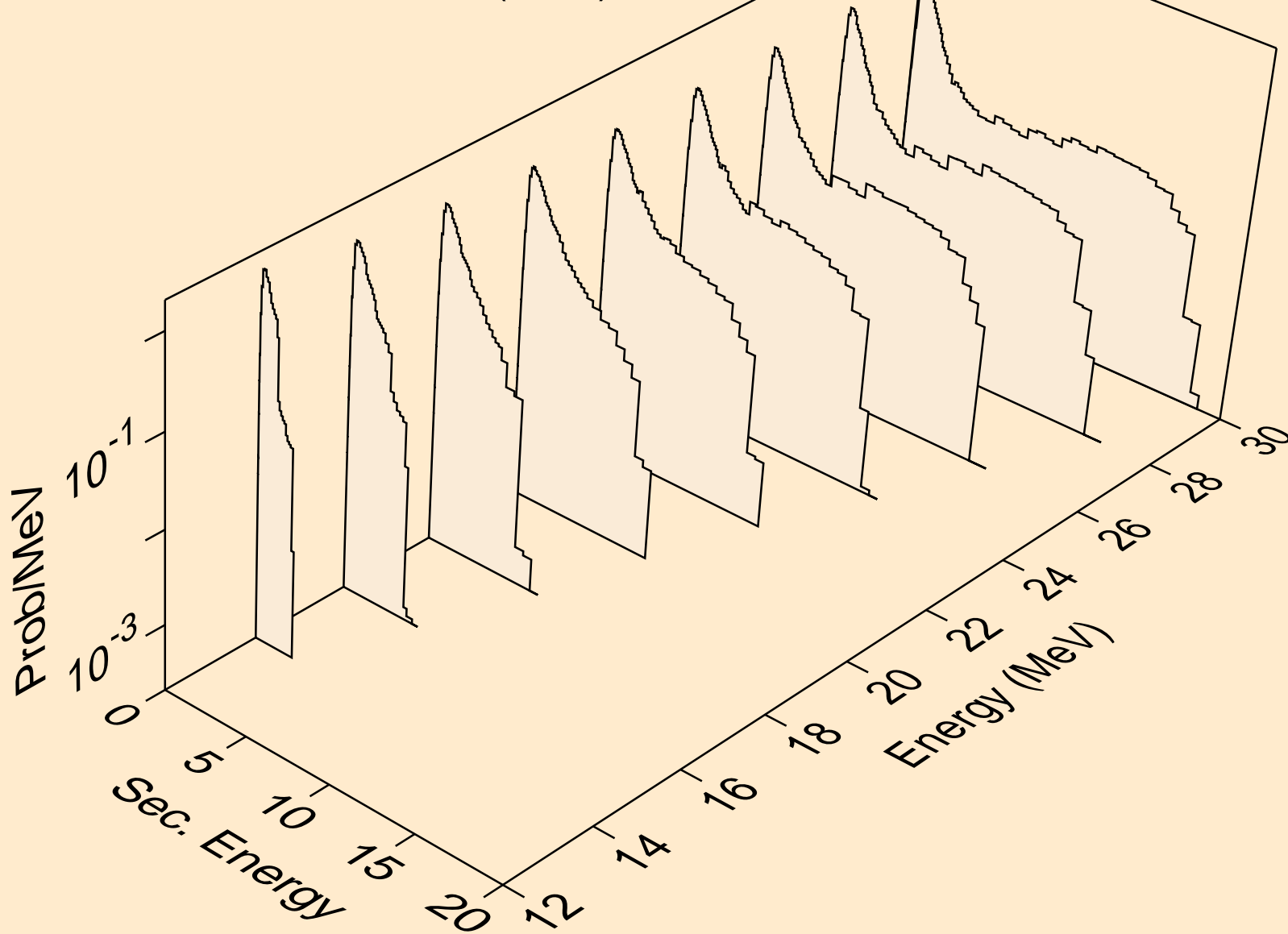

LR262 NEUTRON ACER TENDL-2019 LIBRARY; T=293.16K  
Neutron emission for fission

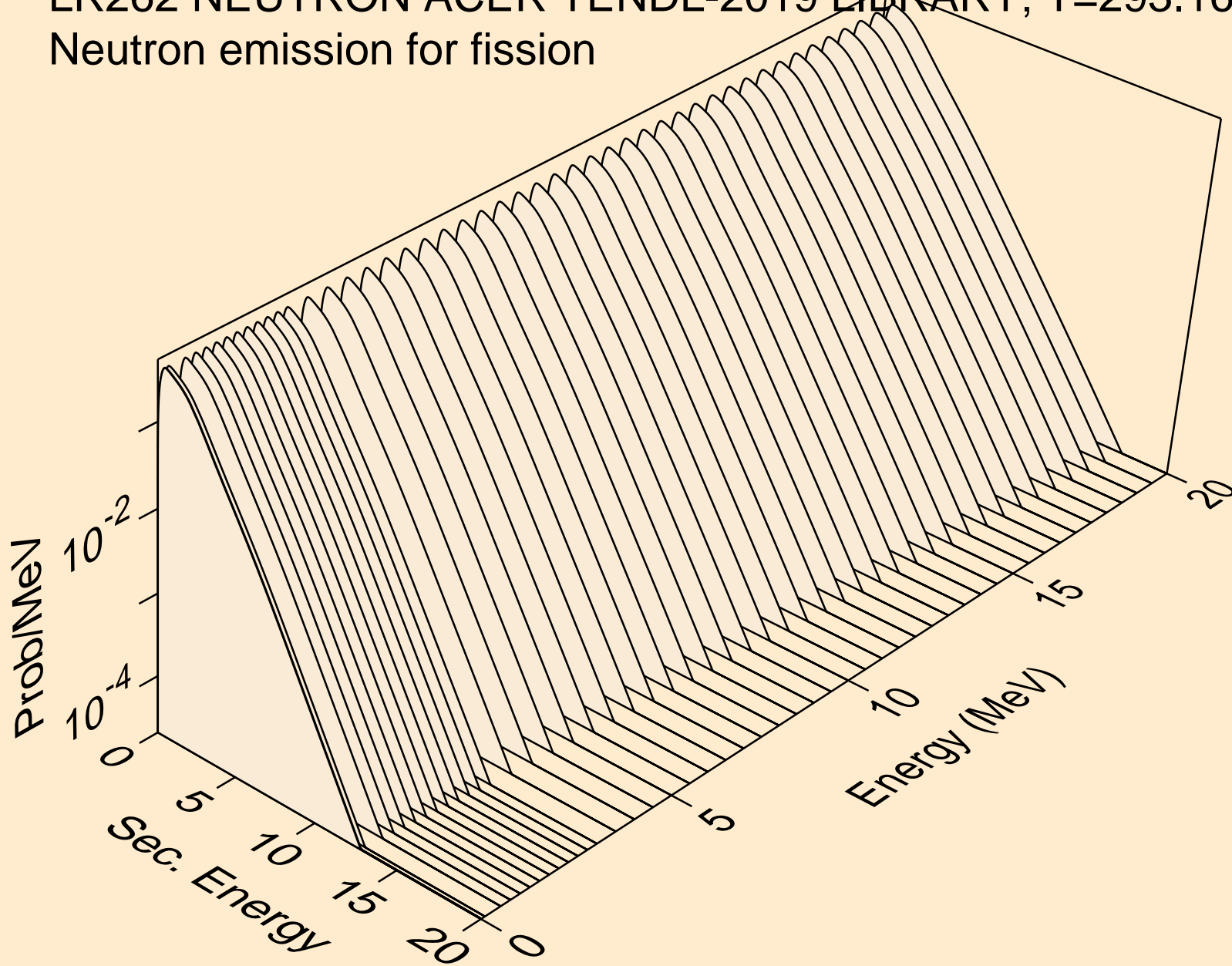

LR262 NEUTRON ACER TENDL-2019 LIBRARY; T=293.16K  
Neutron emission for (n,n\*)a

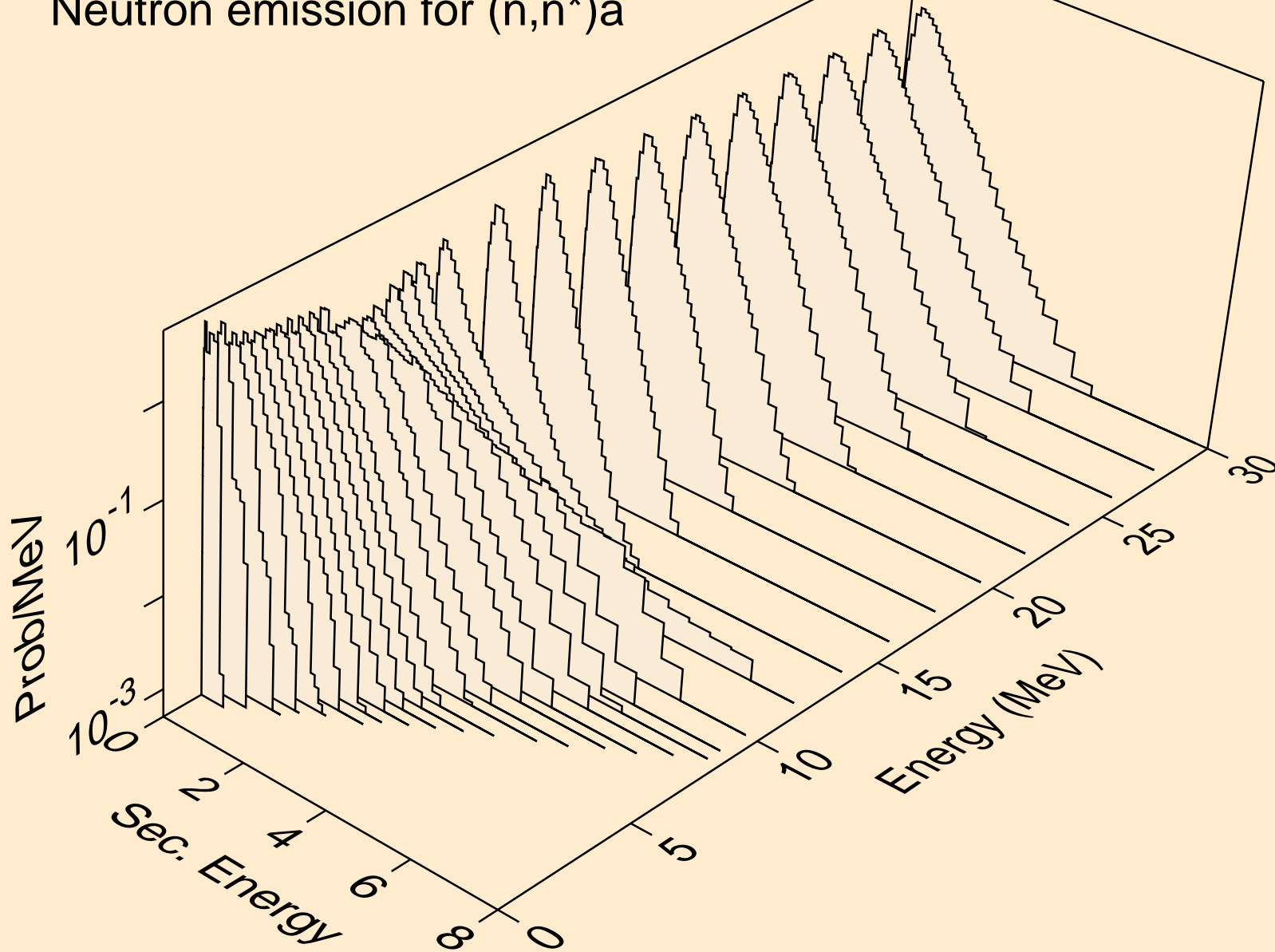

LR262 NEUTRON ACER TENDL-2019 LIBRARY; T=293.16K  
Neutron emission for (n,2n)a

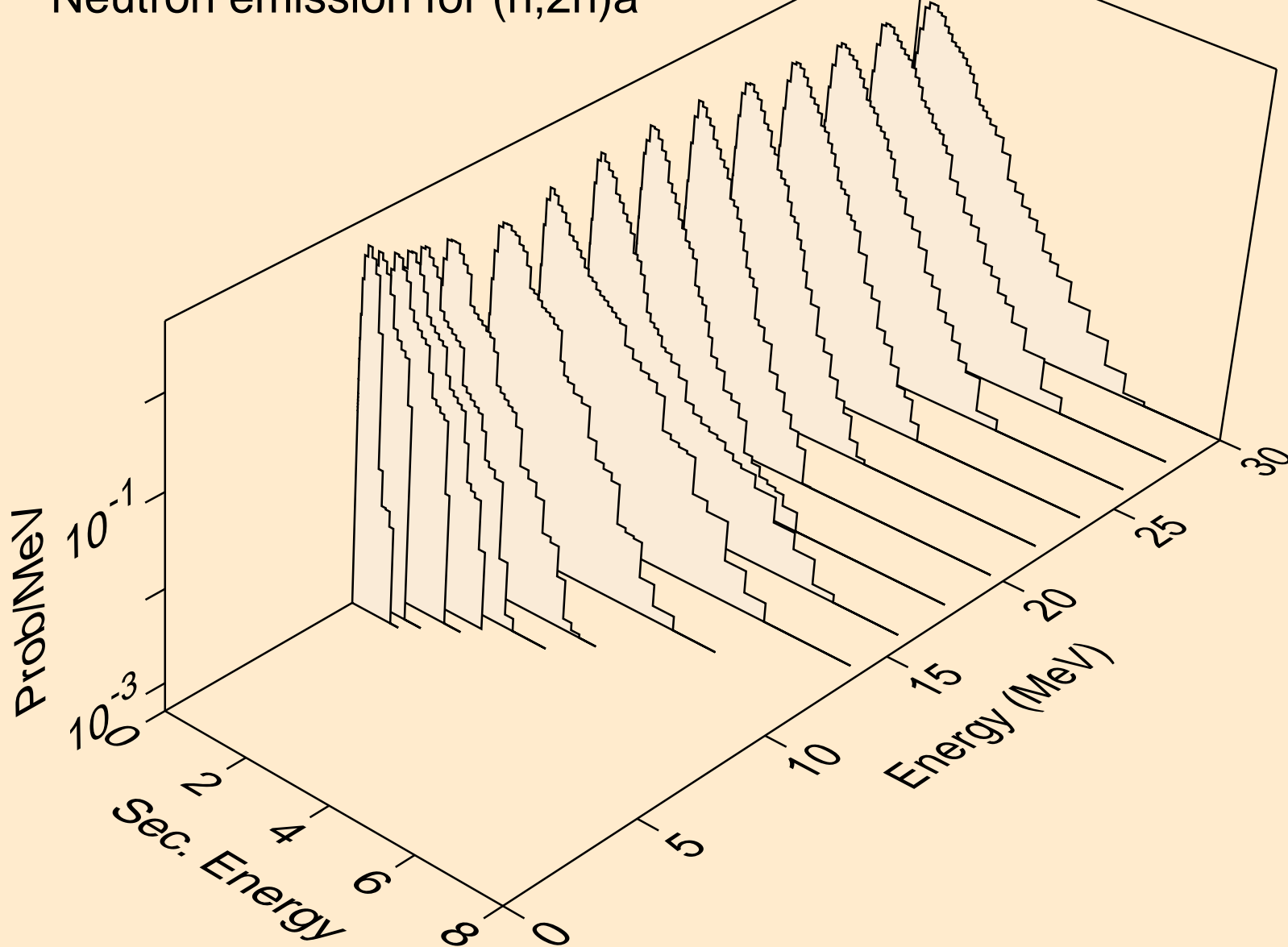

LR262 NEUTRON ACER TENDL-2019 LIBRARY; T=293.16K  
Neutron emission for (n,3n)a

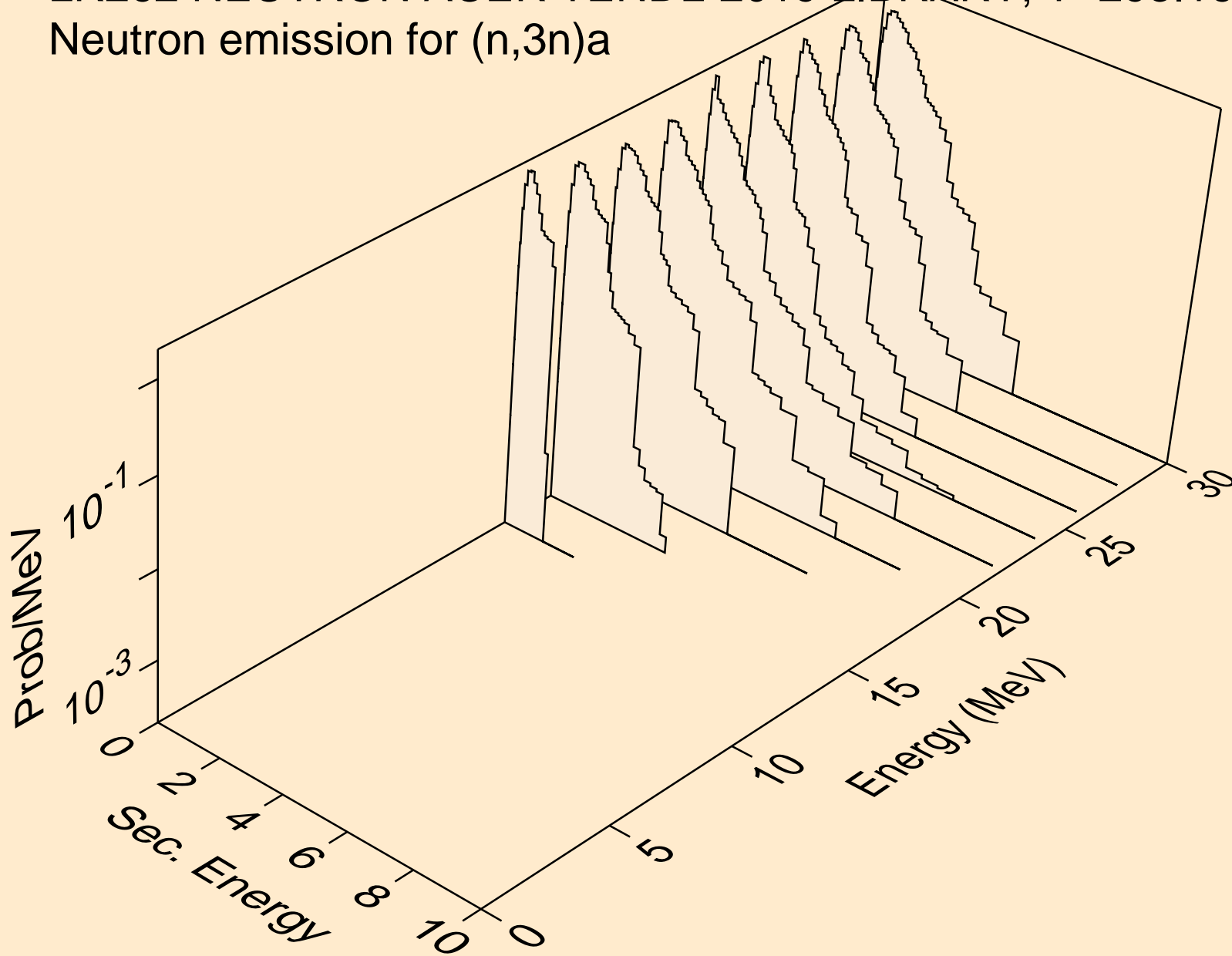

LR262 NEUTRON ACER TENDL-2019 LIBRARY; T=293.16K  
Neutron emission for (n,n\*)p

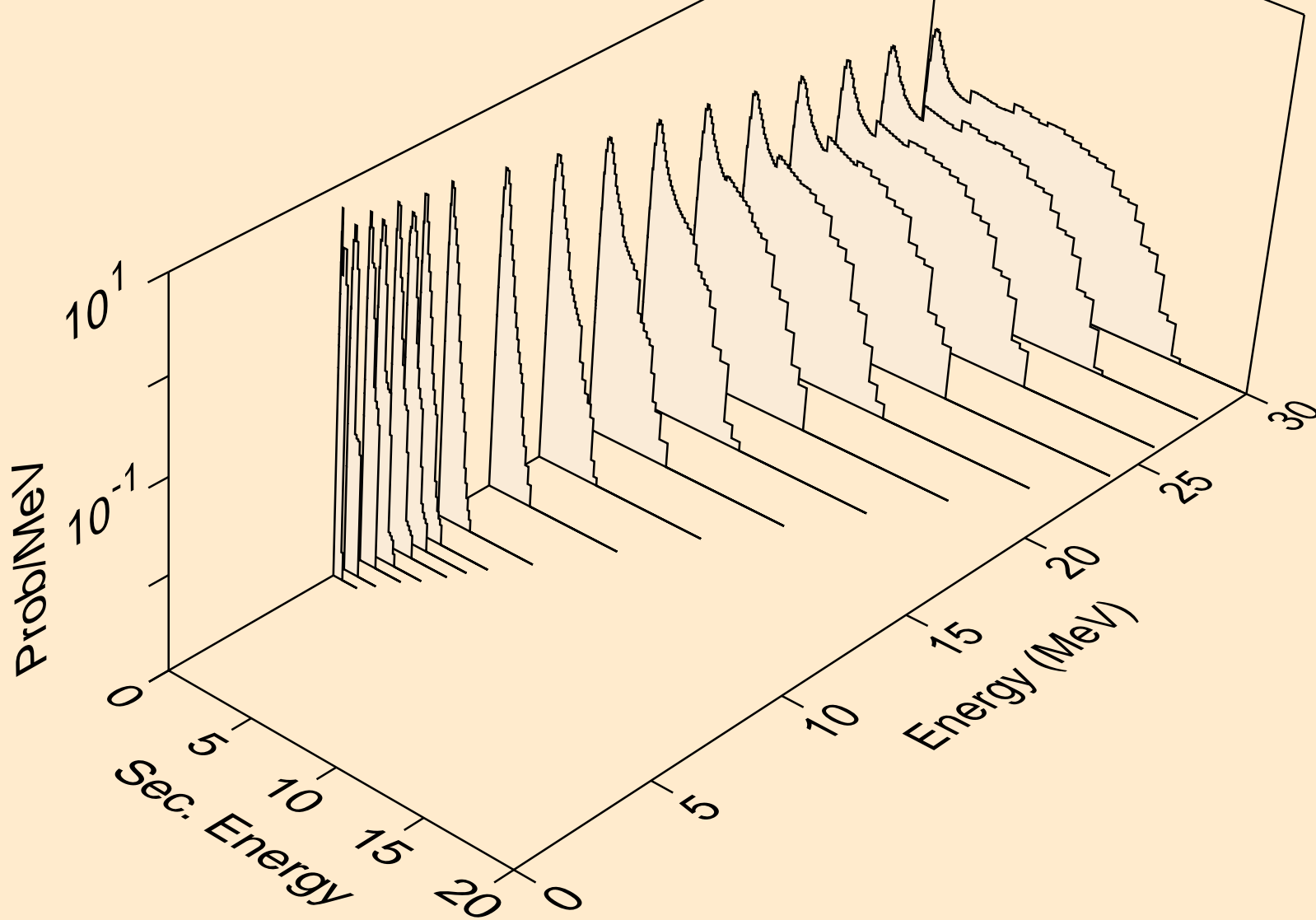

LR262 NEUTRON ACER TENDL-2019 LIBRARY; T=293.16K  
Neutron emission for (n,n\*)2a

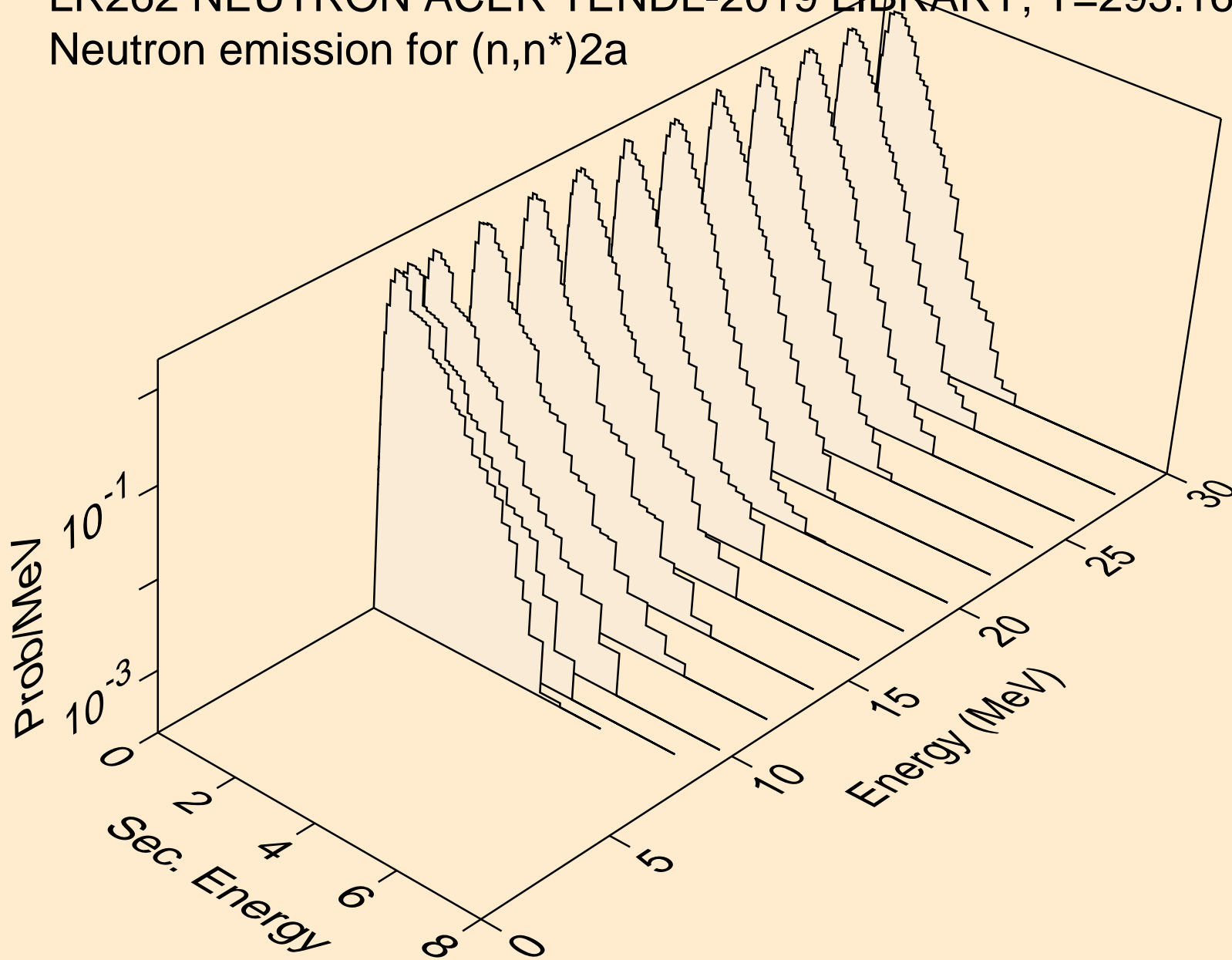

LR262 NEUTRON ACER TENDL-2019 LIBRARY; T=293.16K  
Neutron emission for (n,n\*)d

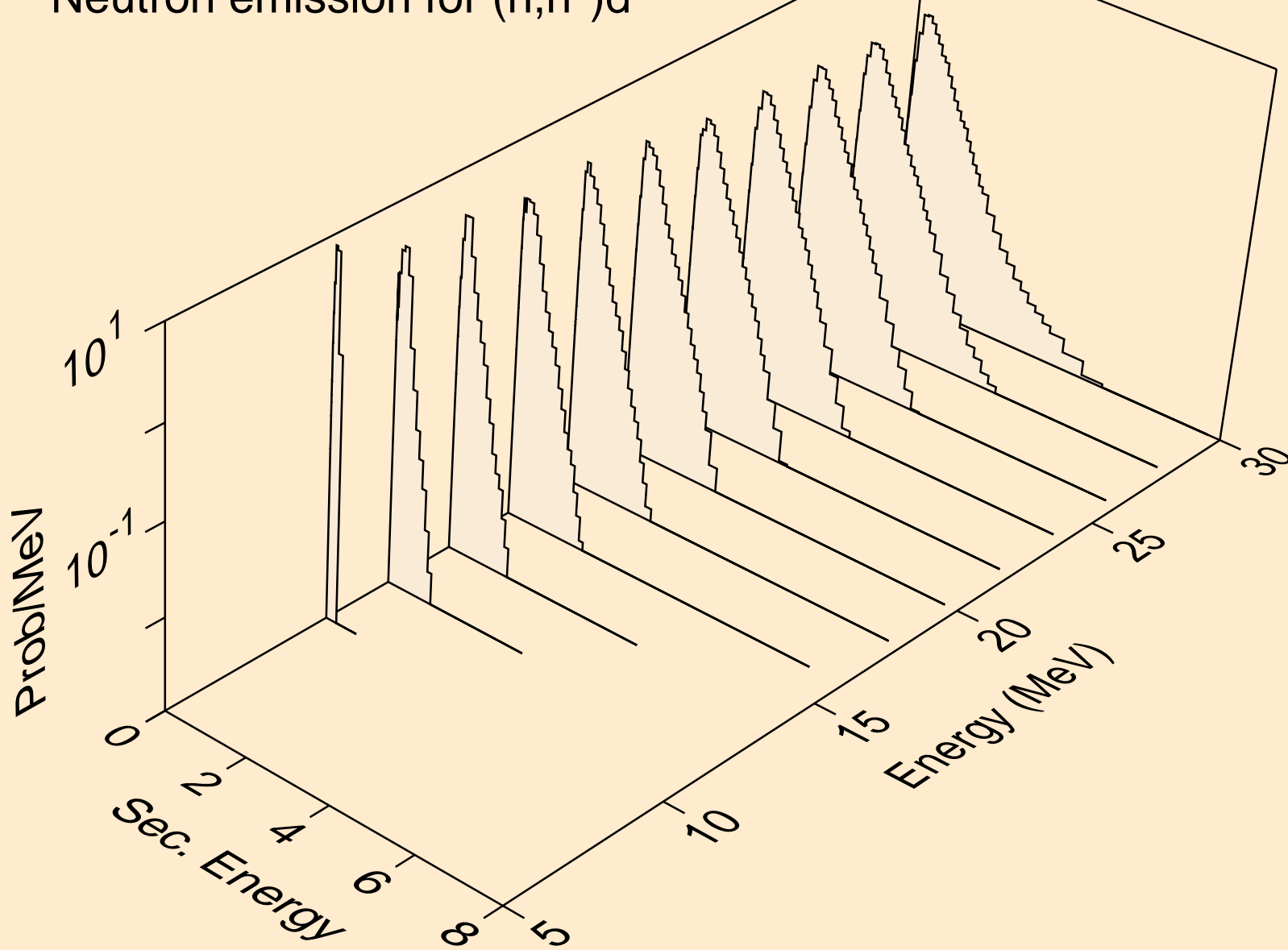

LR262 NEUTRON ACER TENDL-2019 LIBRARY; T=293.16K  
Neutron emission for (n,n\*)t

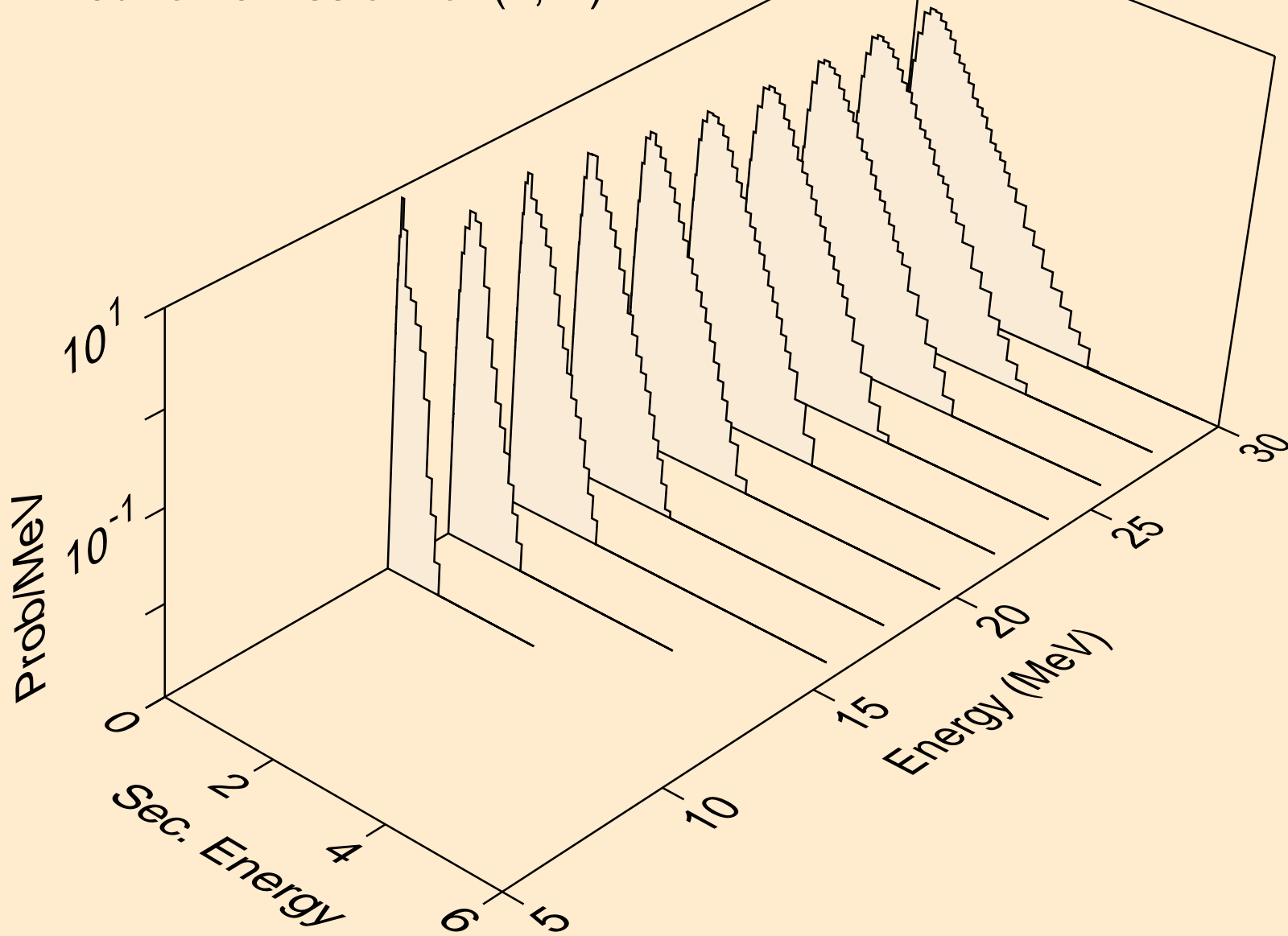

LR262 NEUTRON ACER TENDL-2019 LIBRARY; T=293.16K  
Neutron emission for (n,n\*)he3

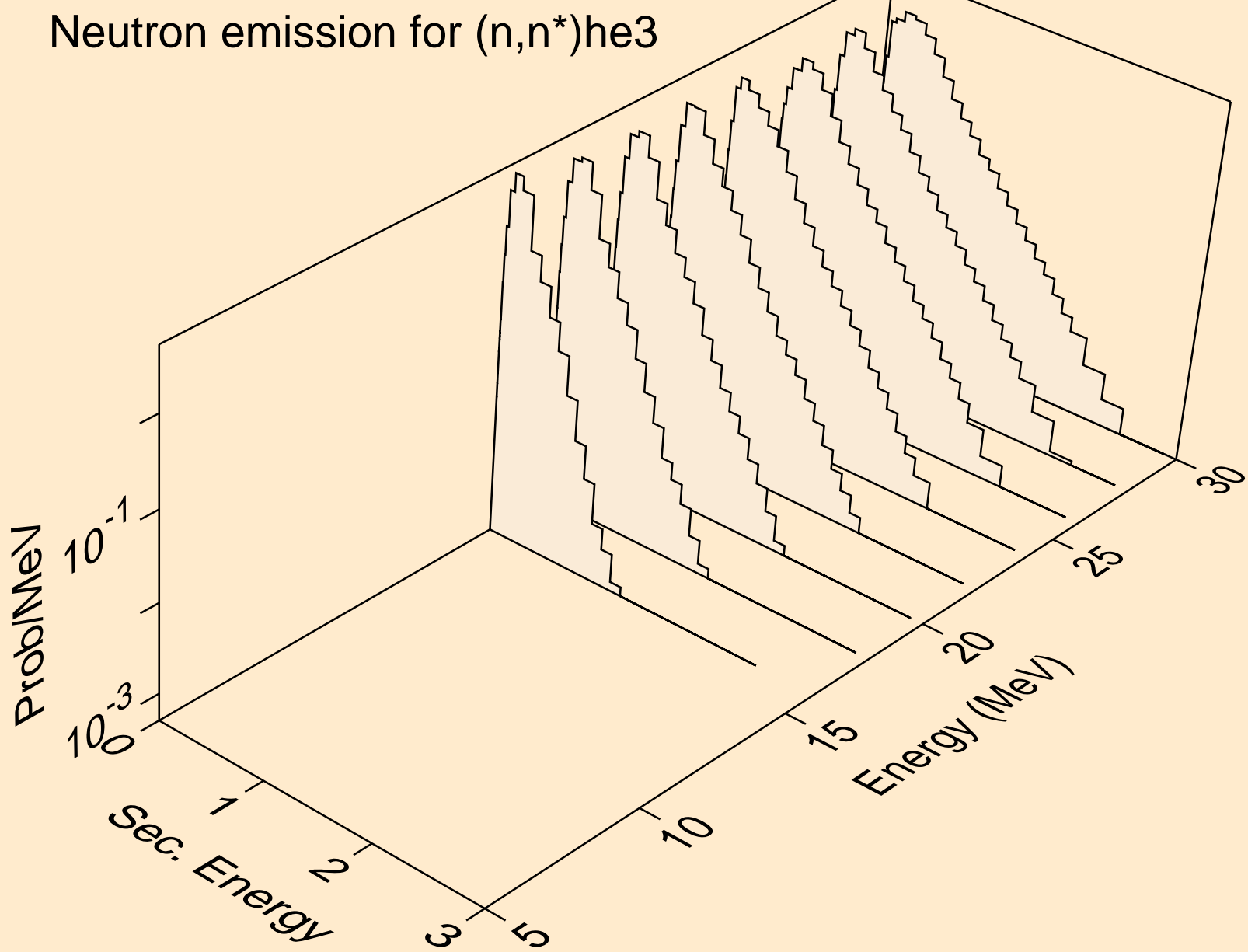

LR262 NEUTRON ACER TENDL-2019 LIBRARY; T=293.16K  
Neutron emission for (n,4n)

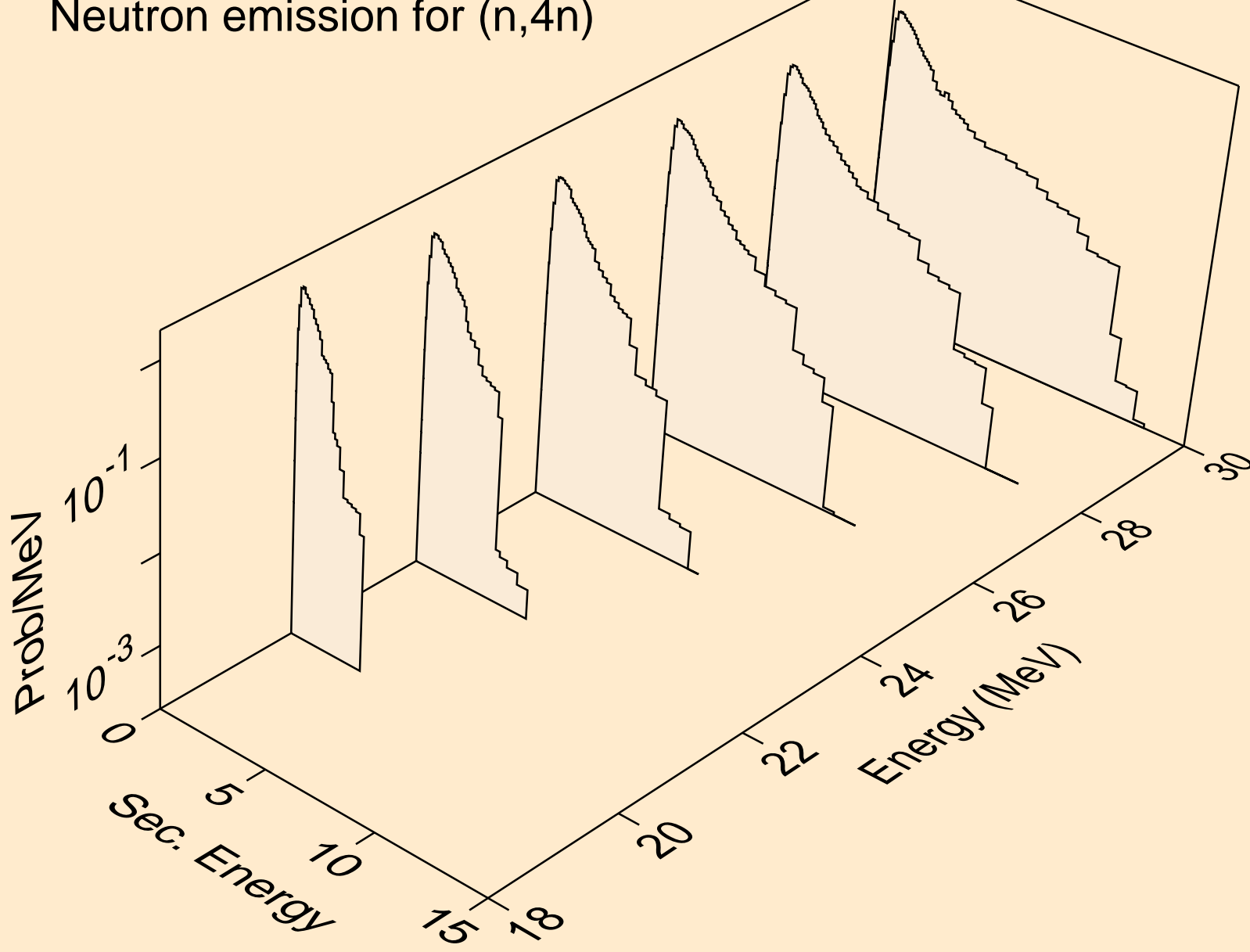

LR262 NEUTRON ACER TENDL-2019 LIBRARY; T=293.16K  
Neutron emission for (n,2np)

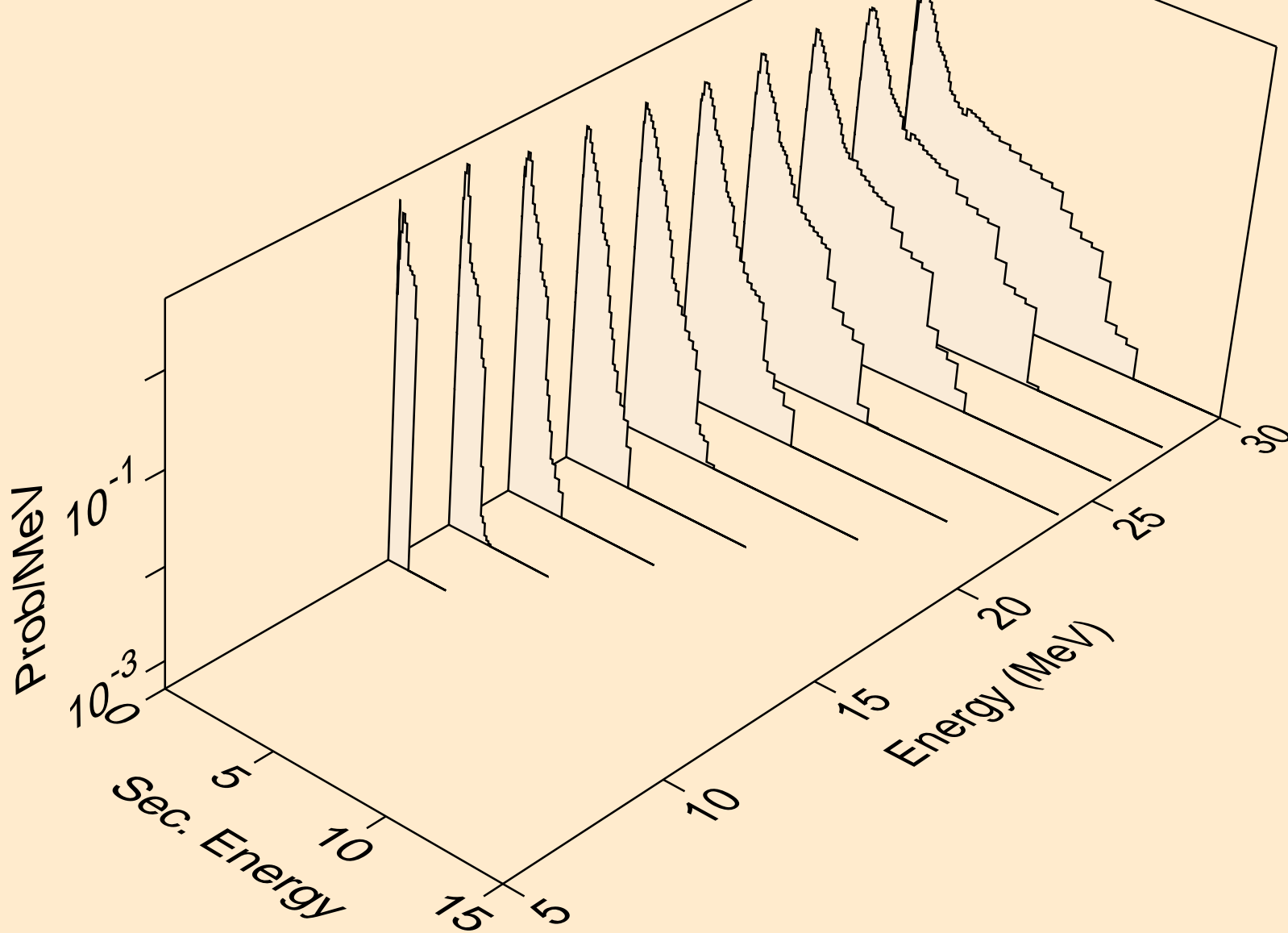

LR262 NEUTRON ACER TENDL-2019 LIBRARY; T=293.16K  
Neutron emission for (n,3np)

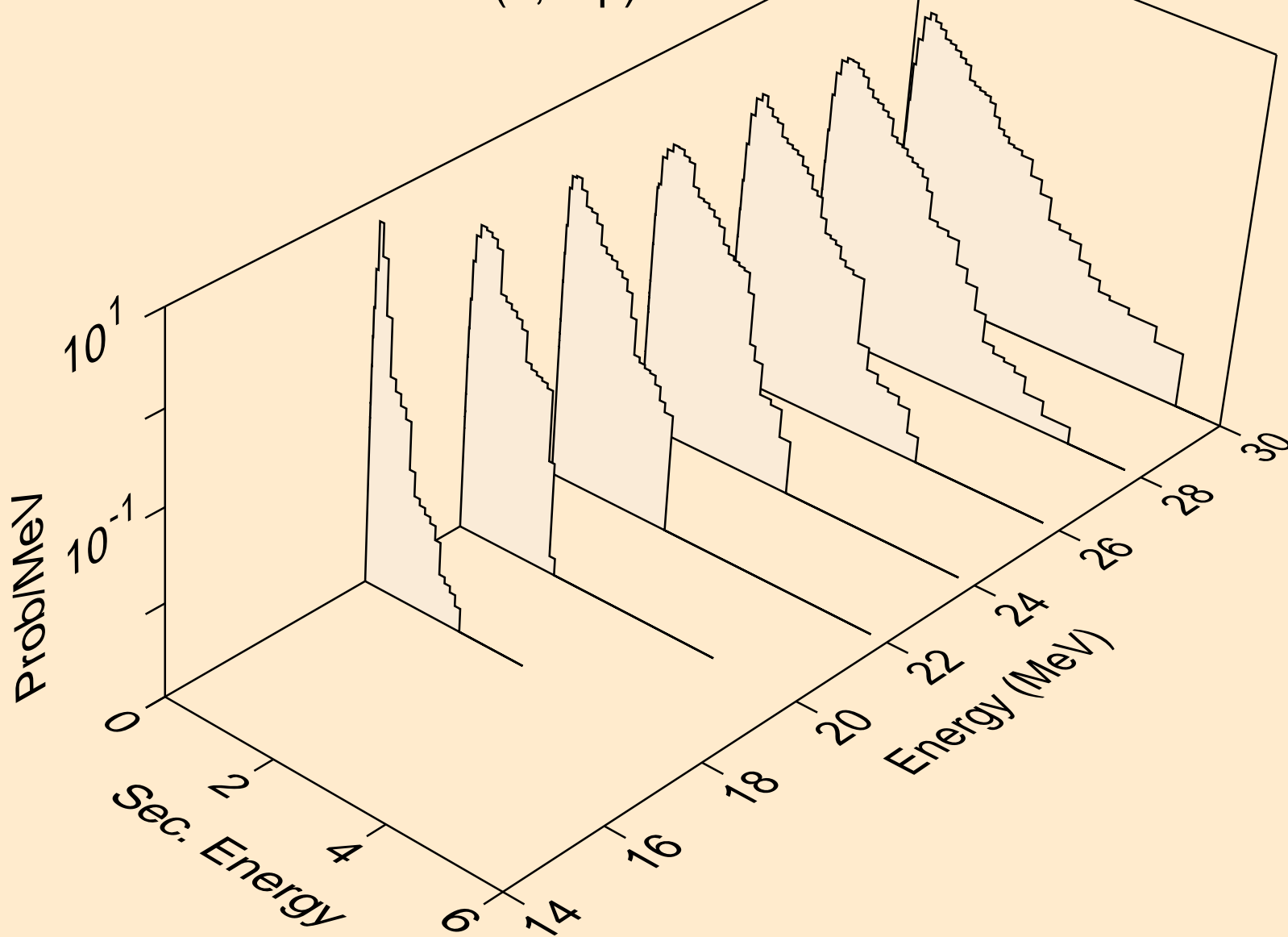

LR262 NEUTRON ACER TENDL-2019 LIBRARY; T=293.16K  
Neutron emission for (n,2np)

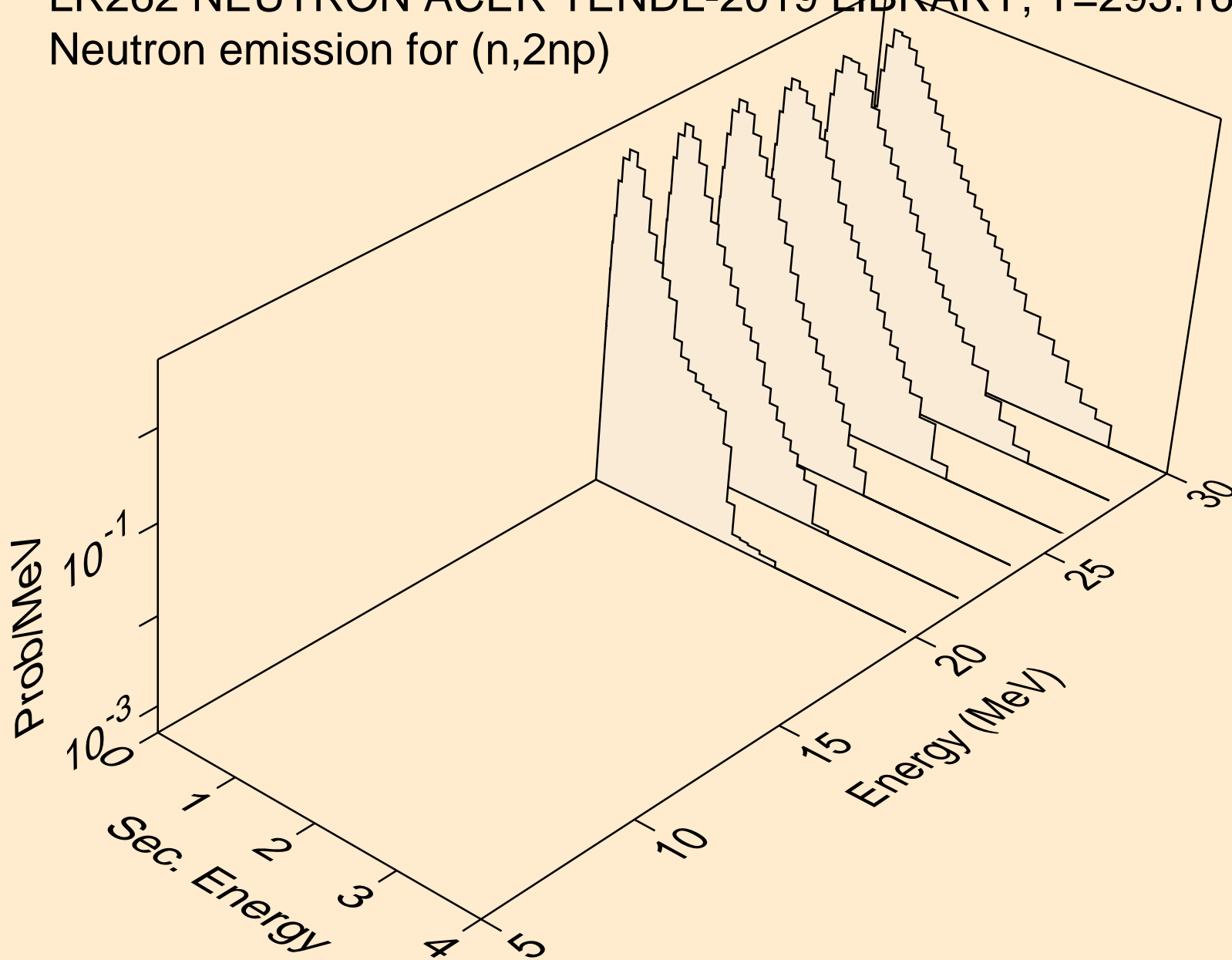

LR262 NEUTRON ACER TENDL-2019 LIBRARY; T=293.16K  
Neutron emission for (n,npa)

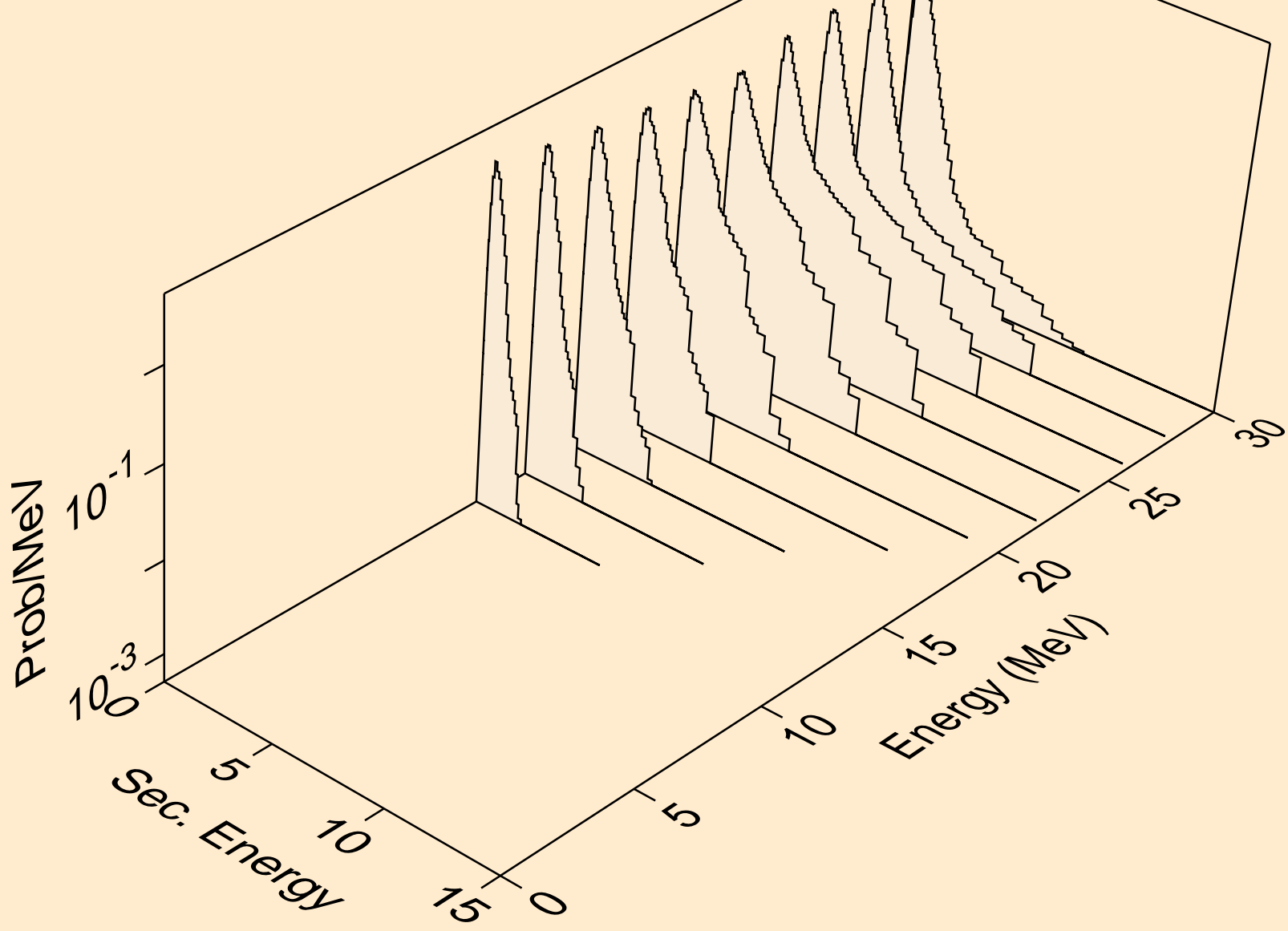

LR262 NEUTRON ACER TENDL-2019 LIBRARY; T=293.16K  
Neutron emission for (n,n\*c)

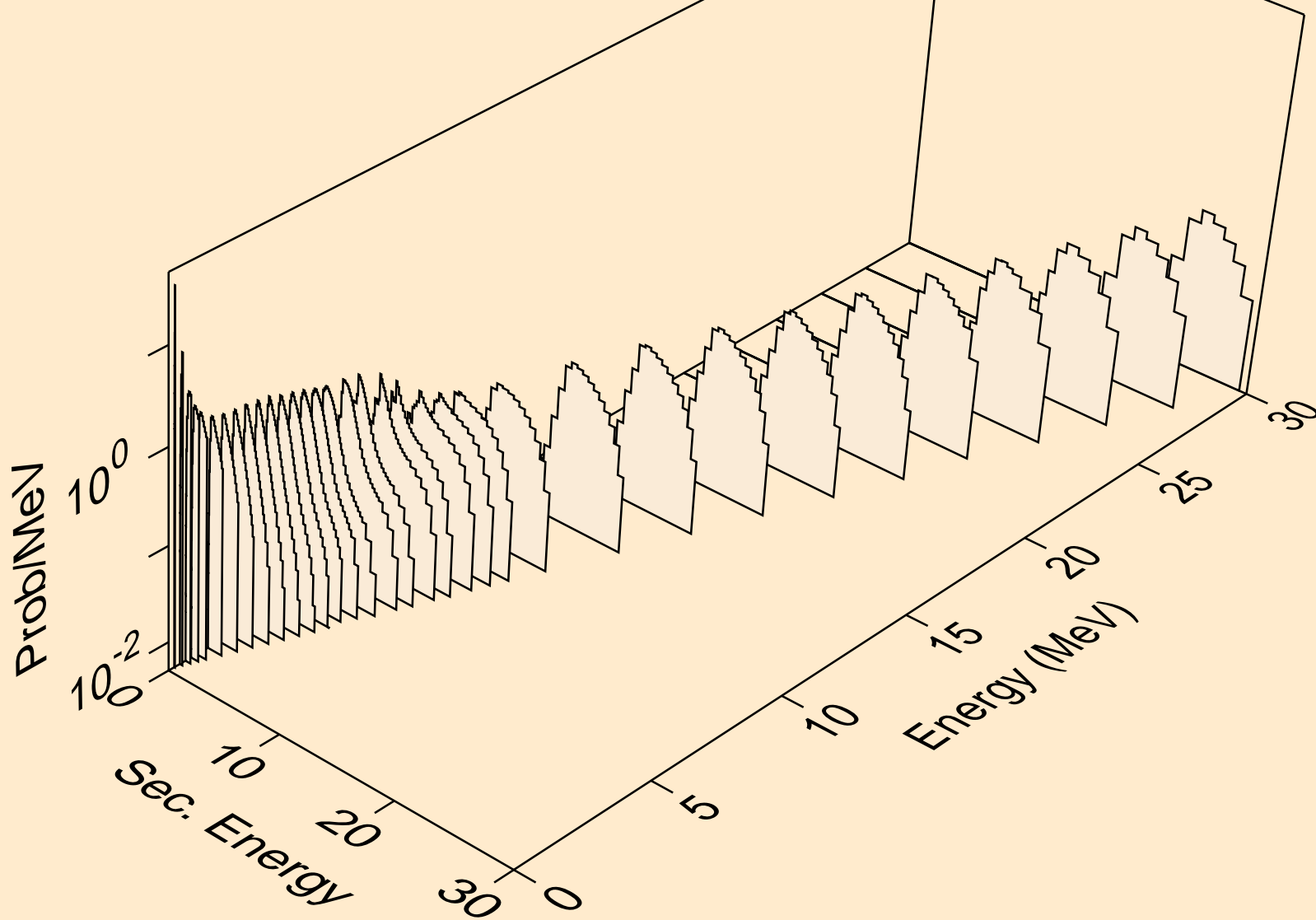

LR262 NEUTRON ACER TENDL-2019 LIBRARY; T=293.16K

Delayed nubar

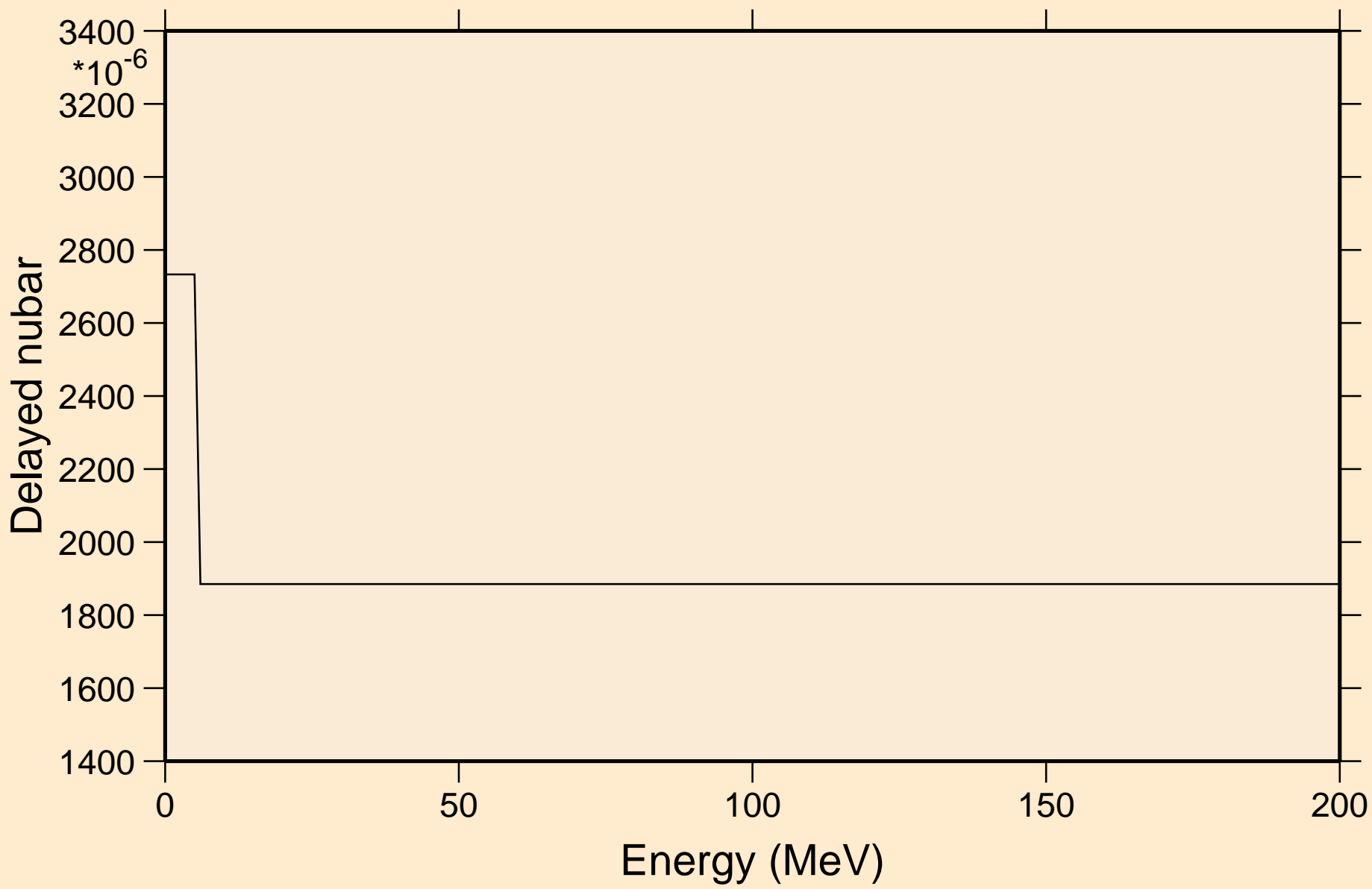

# LR262 NEUTRON ACER TENDL-2019 LIBRARY; T=293.16K

## Delayed neutron spectra

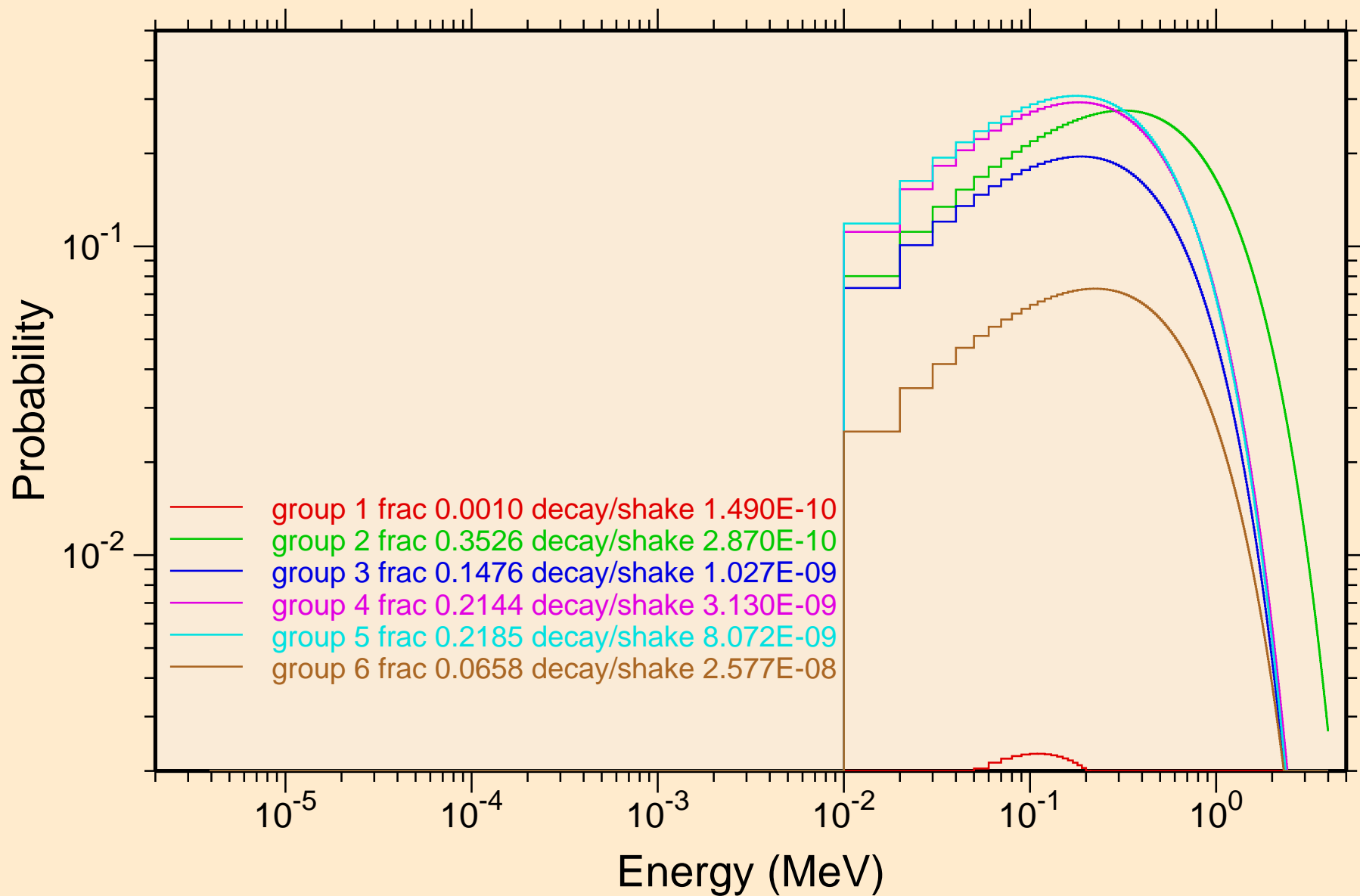

LR262 NEUTRON ACER TENDL-2019 LIBRARY; T=293.16K  
Photon emission for (n,x)

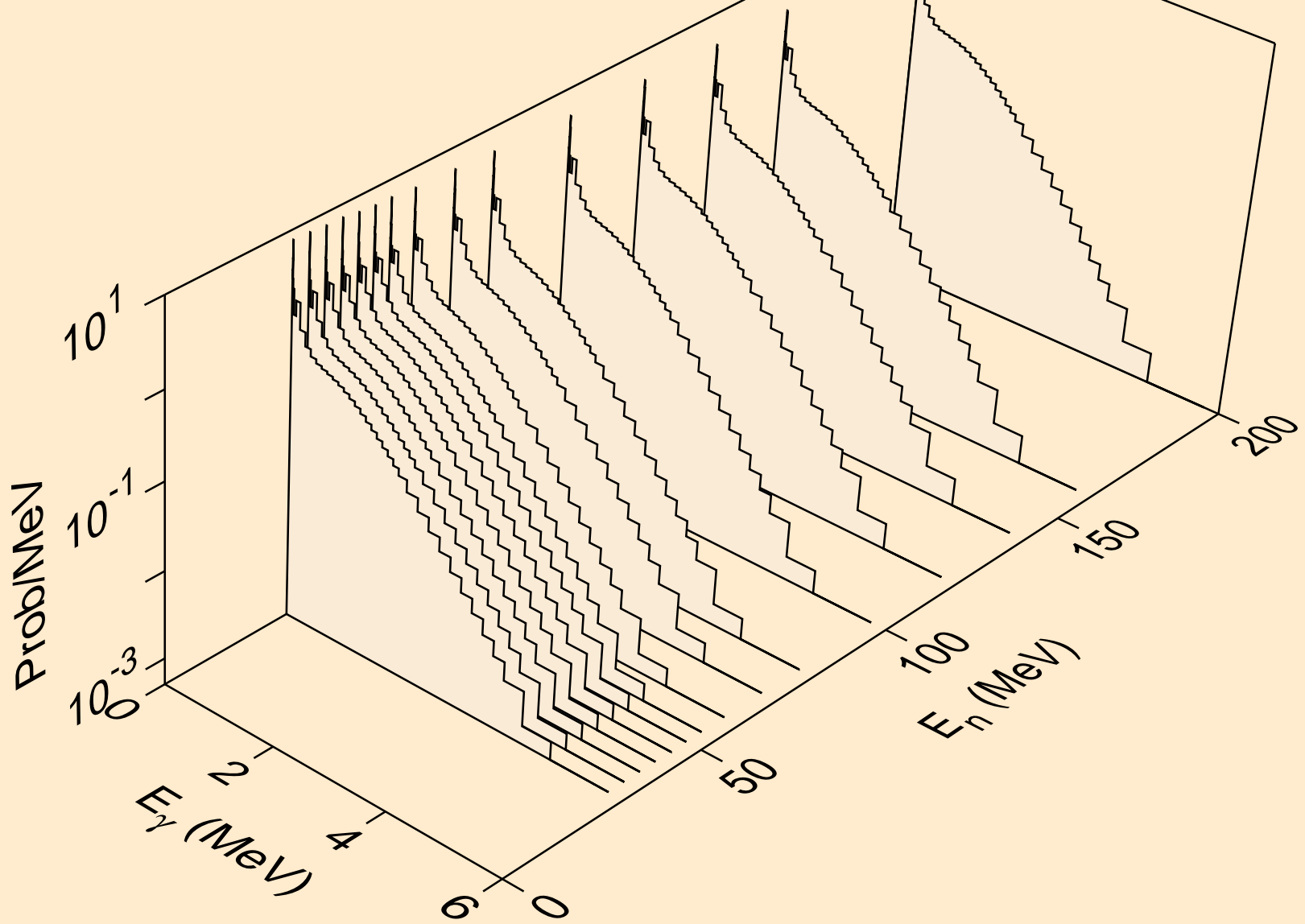

LR262 NEUTRON ACER TENDL-2019 LIBRARY; T=293.16K  
Photon emission for (n,2nd)

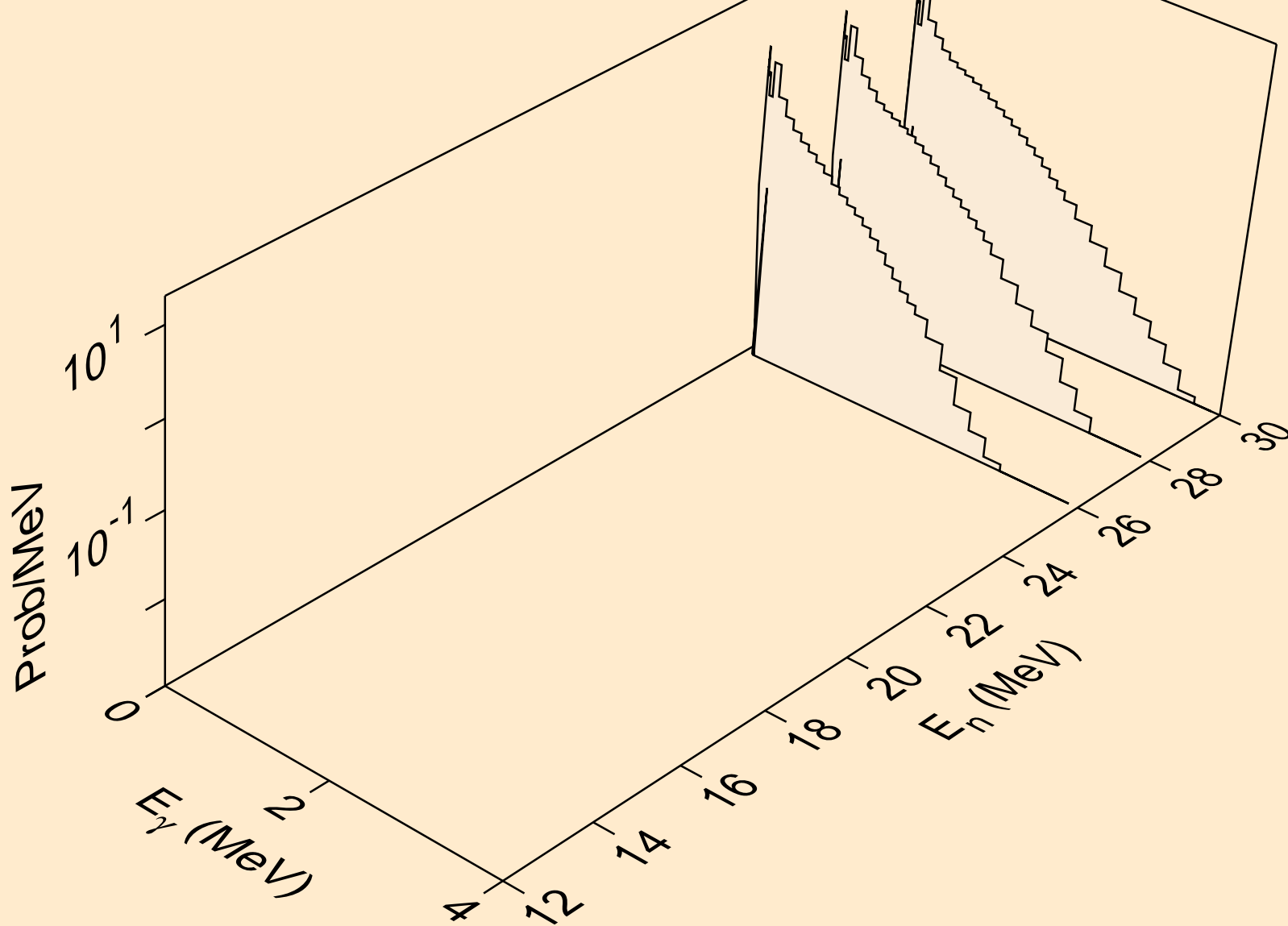

LR262 NEUTRON ACER TENDL-2019 LIBRARY; T=293.16K  
Photon emission for (n,2n)

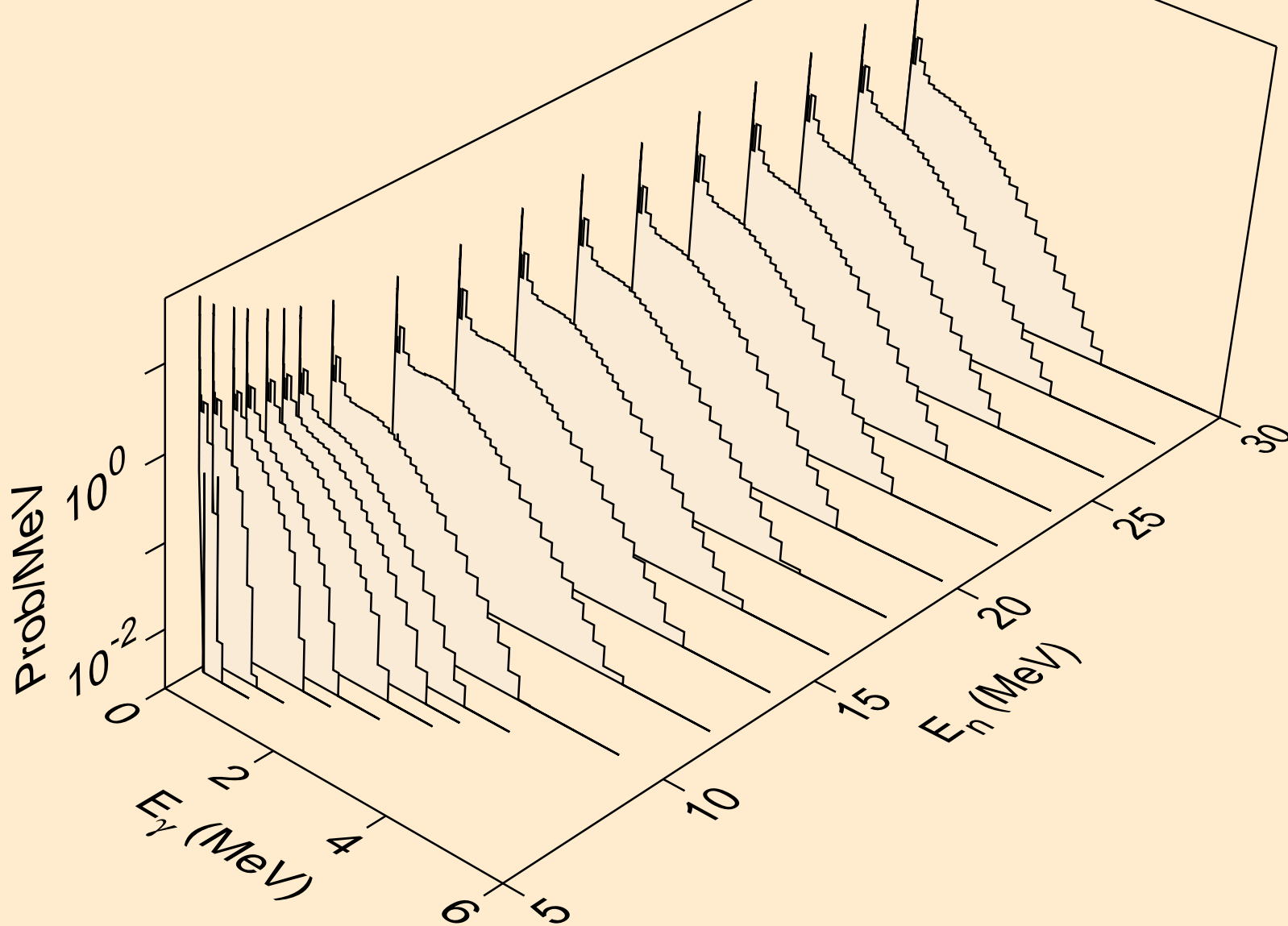

LR262 NEUTRON ACER TENDL-2019 LIBRARY; T=293.16K  
Photon emission for (n,3n)

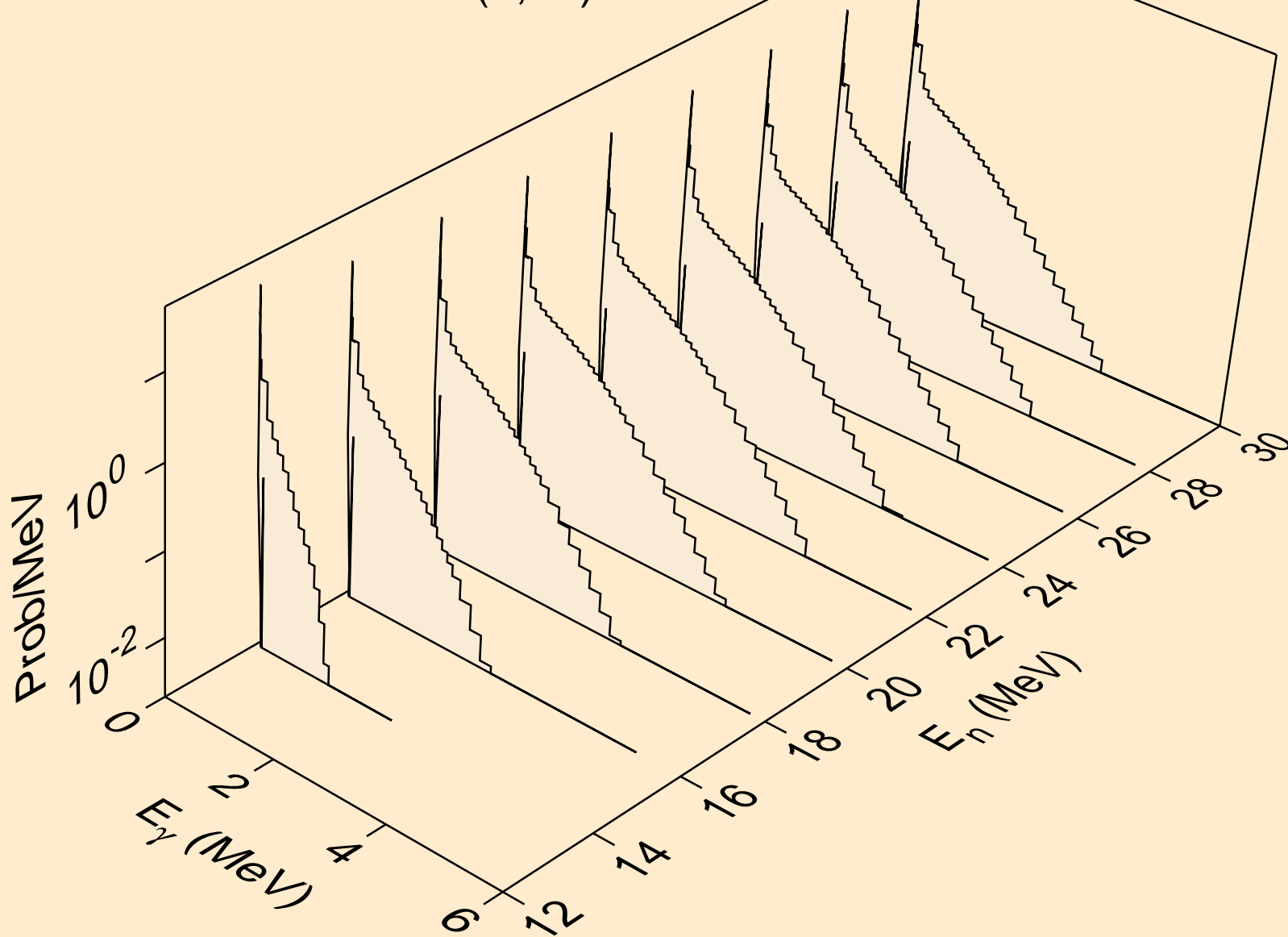

LR262 NEUTRON ACER TENDL-2019 LIBRARY; T=293.16K  
Photon emission for (n,n\*)a

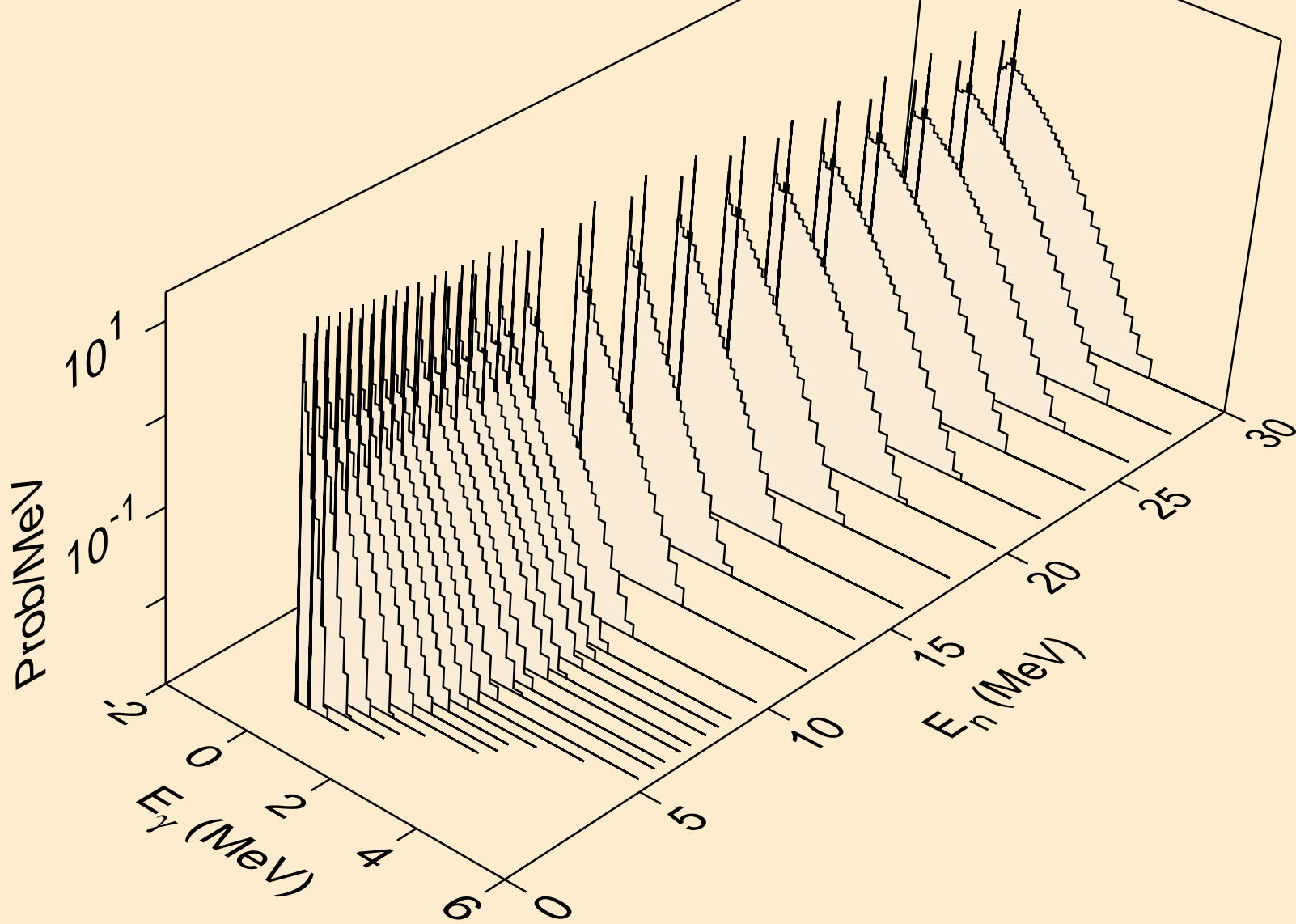

LR262 NEUTRON ACER TENDL-2019 LIBRARY; T=293.16K  
Photon emission for (n,2n)a

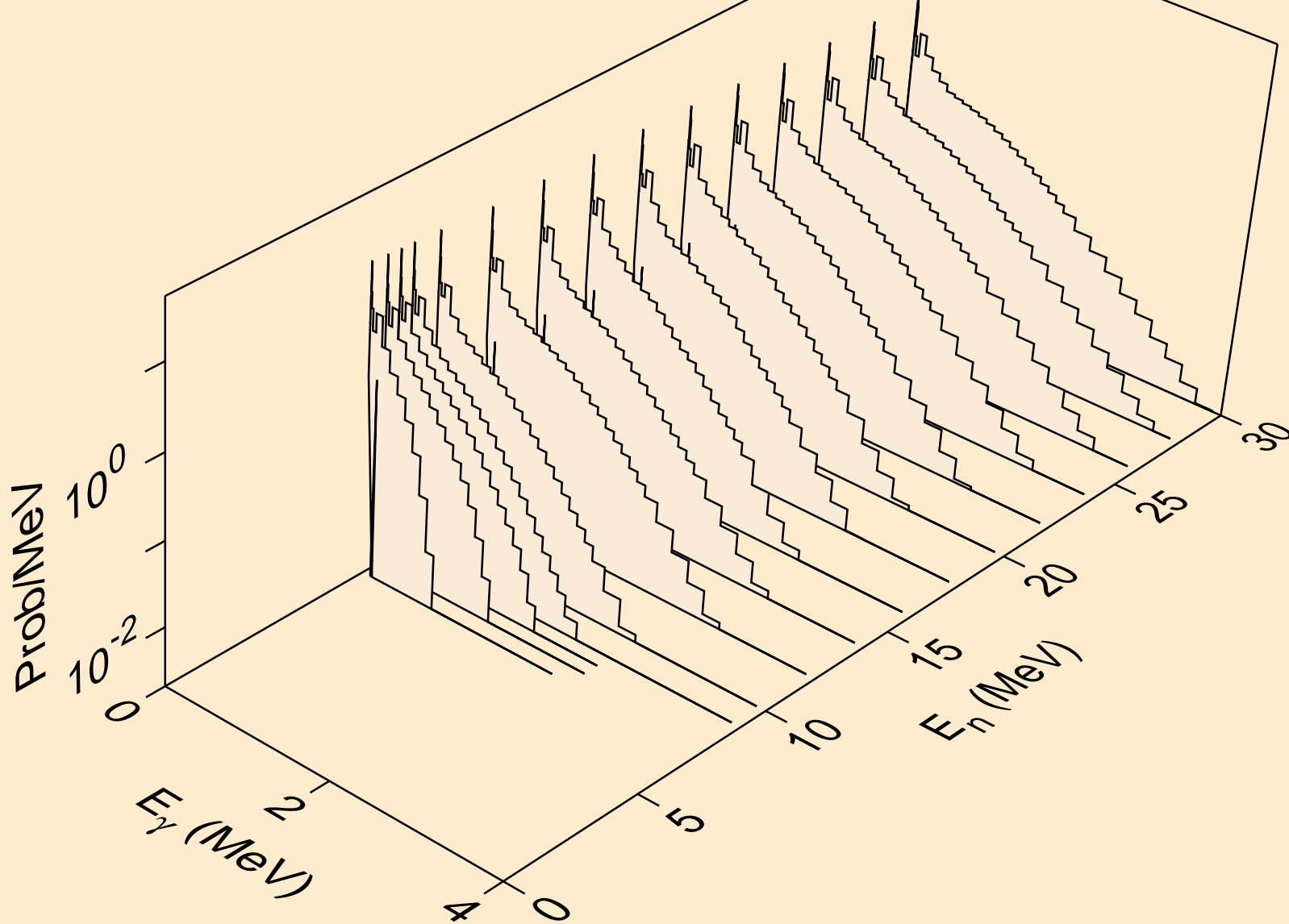

LR262 NEUTRON ACER TENDL-2019 LIBRARY; T=293.16K  
Photon emission for (n,3n)a

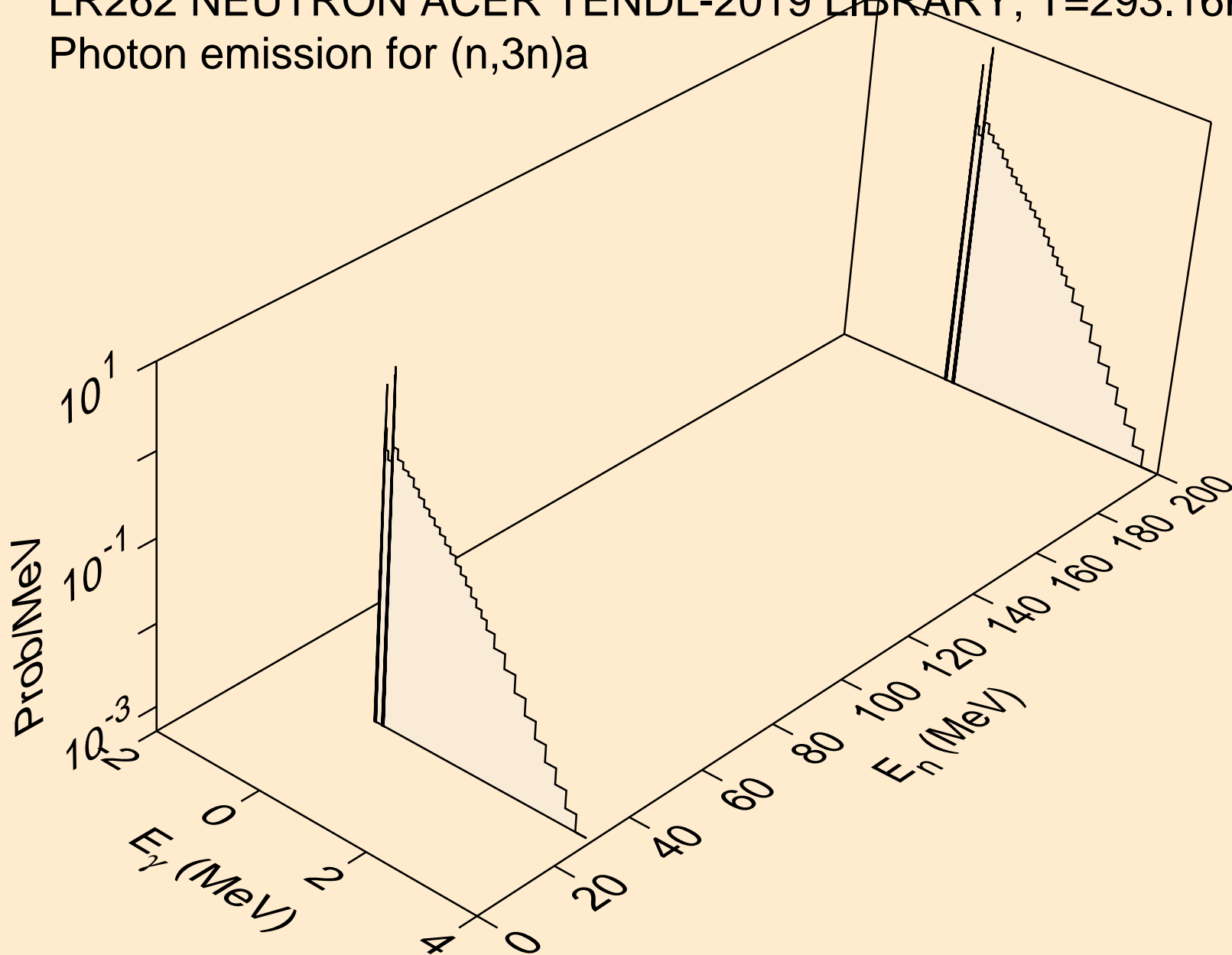

LR262 NEUTRON ACER TENDL-2019 LIBRARY; T=293.16K  
Photon emission for (n,n\*)p

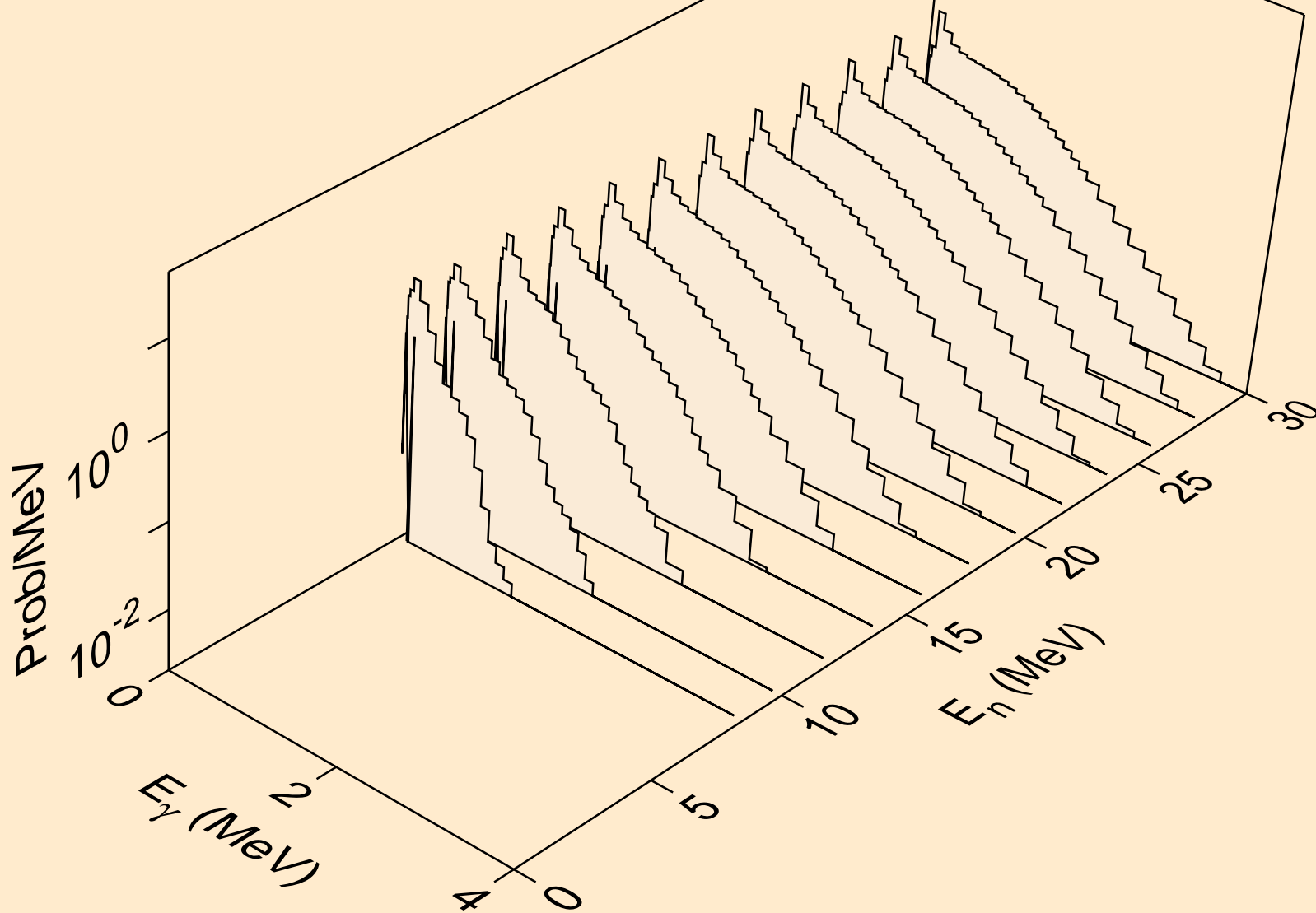

LR262 NEUTRON ACER TENDL-2019 LIBRARY; T=293.16K  
Photon emission for (n,n\*)2a

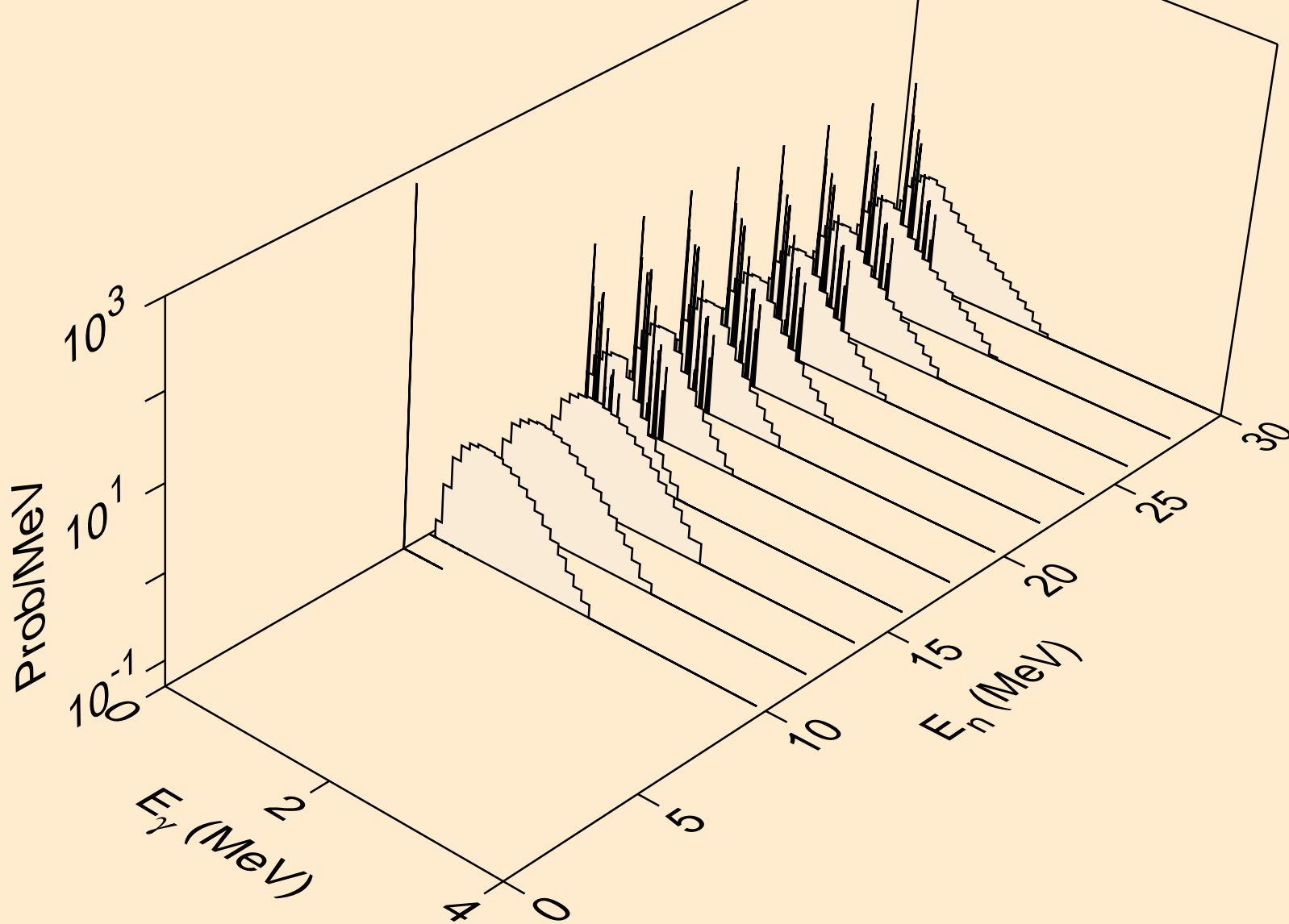

LR262 NEUTRON ACER TENDL-2019 LIBRARY; T=293.16K  
Photon emission for (n,n\*)d

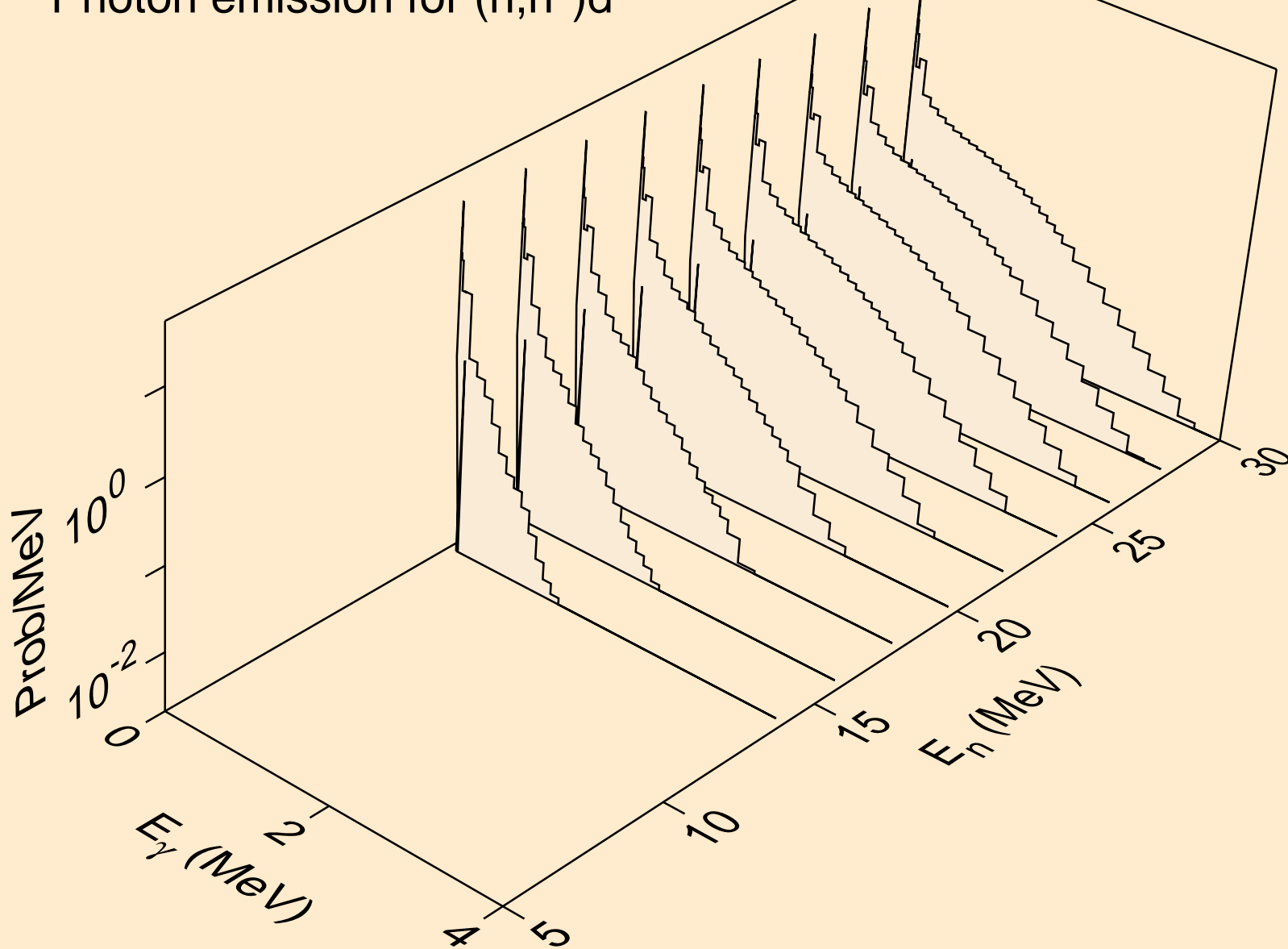

LR262 NEUTRON ACER TENDL-2019 LIBRARY; T=293.16K  
Photon emission for (n,n\*)t

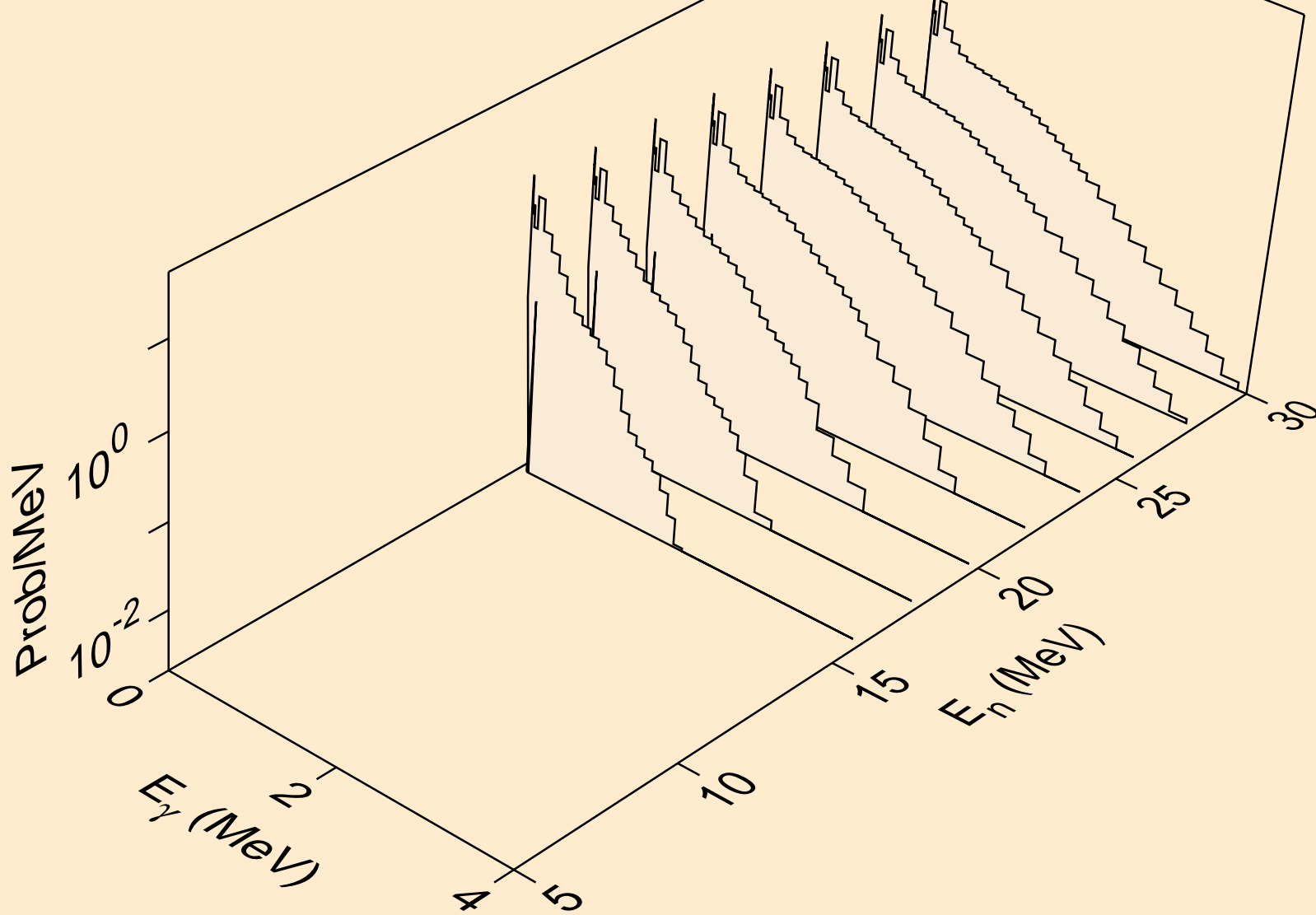

LR262 NEUTRON ACER TENDL-2019 LIBRARY; T=293.16K  
Photon emission for (n,n\*)he3

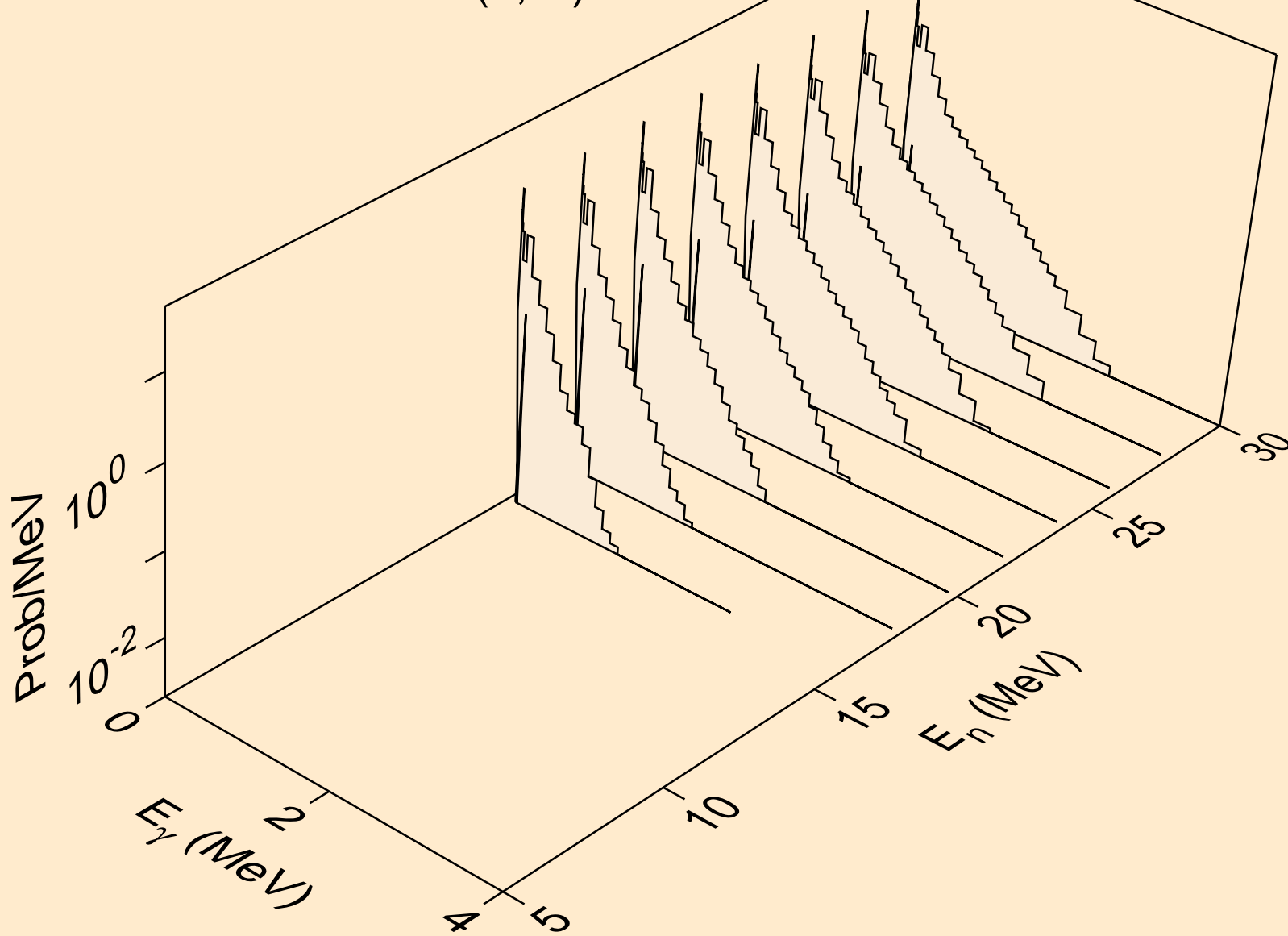

LR262 NEUTRON ACER TENDL-2019 LIBRARY; T=293.16K  
Photon emission for (n,4n)

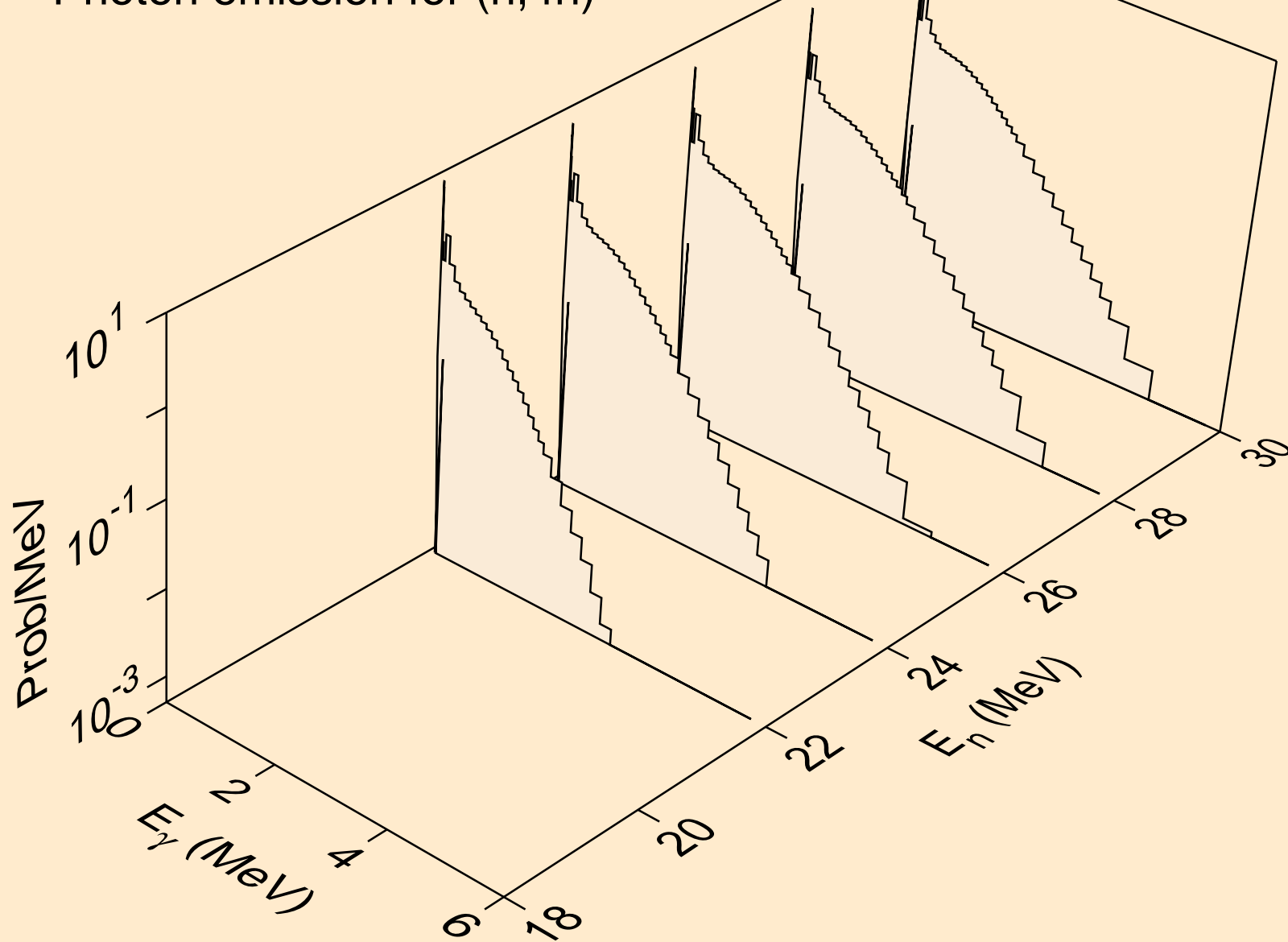

LR262 NEUTRON ACER TENDL-2019 LIBRARY; T=293.16K  
Photon emission for (n,2np)

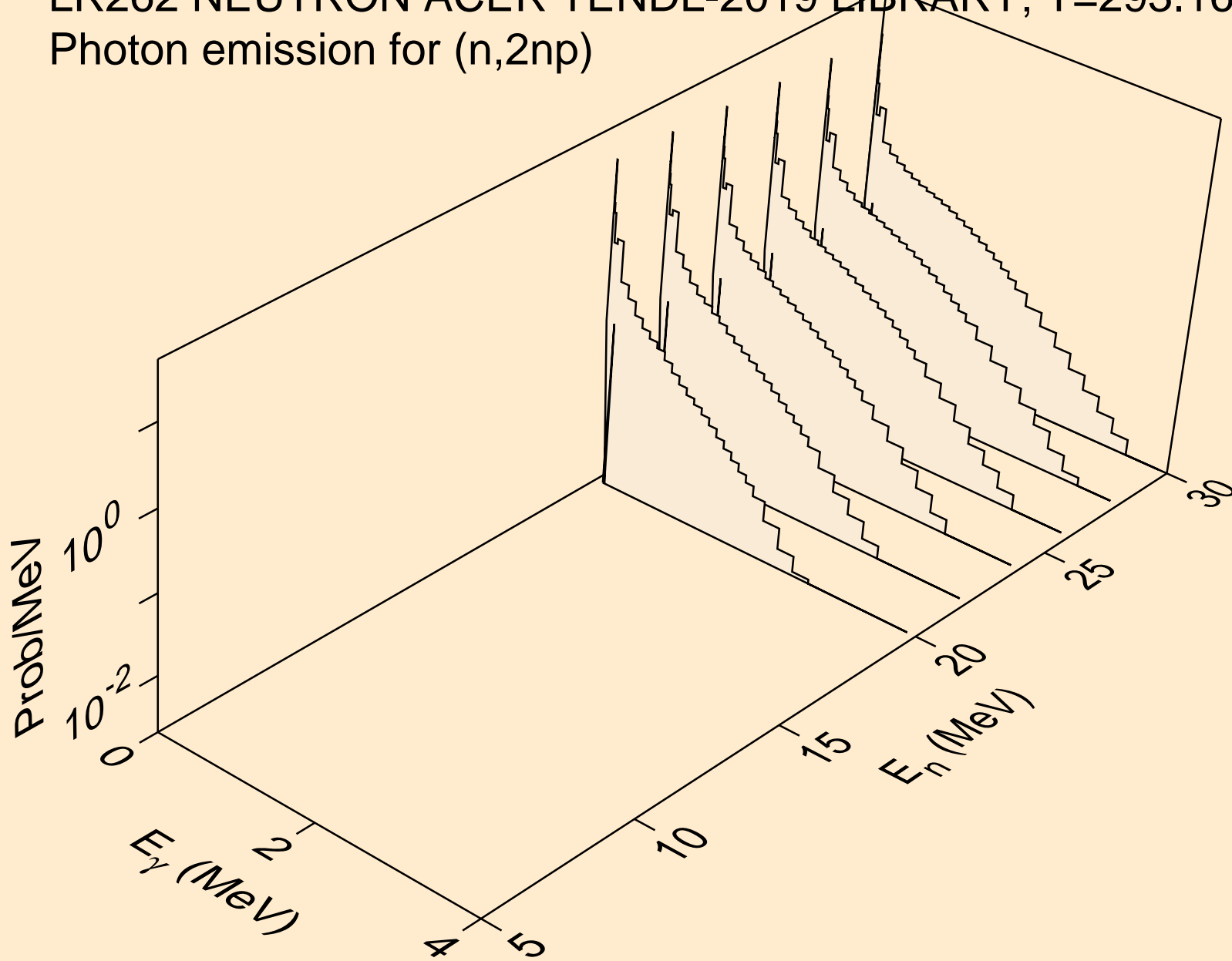

LR262 NEUTRON ACER TENDL-2019 LIBRARY; T=293.16K  
Photon emission for (n,3np)

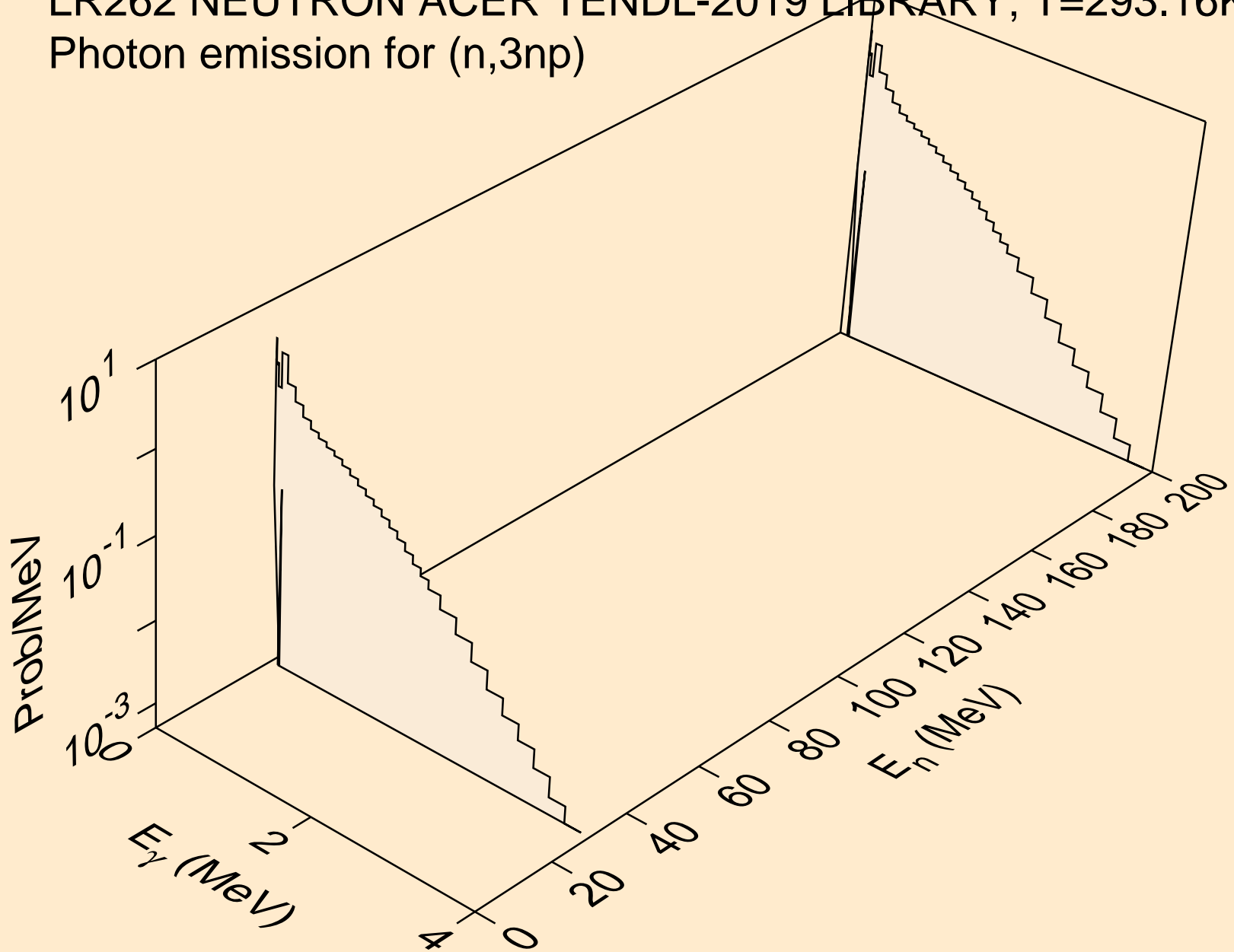

LR262 NEUTRON ACER TENDL-2019 LIBRARY; T=293.16K  
Photon emission for (n,2np)

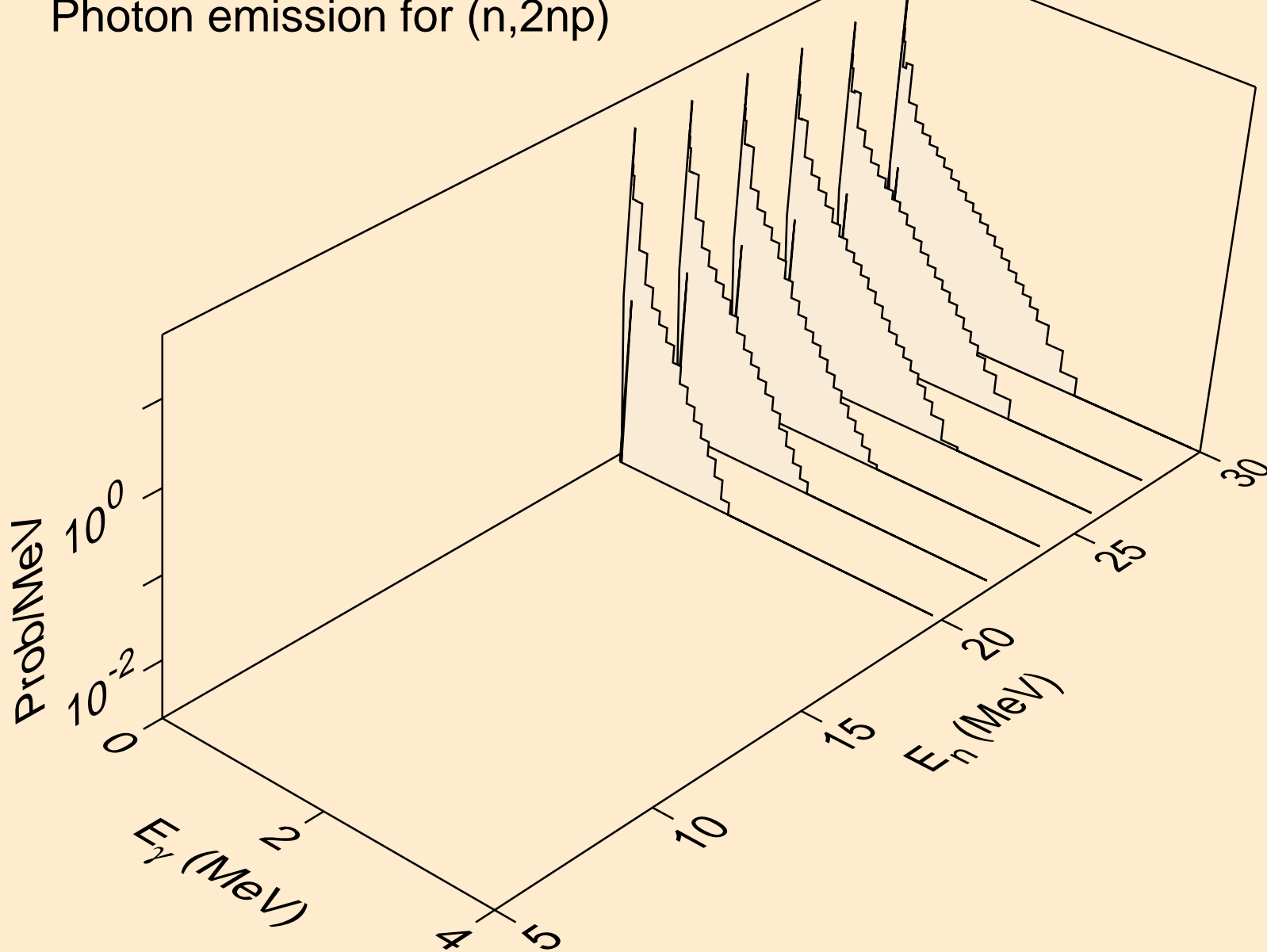

LR262 NEUTRON ACER TENDL-2019 LIBRARY; T=293.16K  
Photon emission for (n,npa)

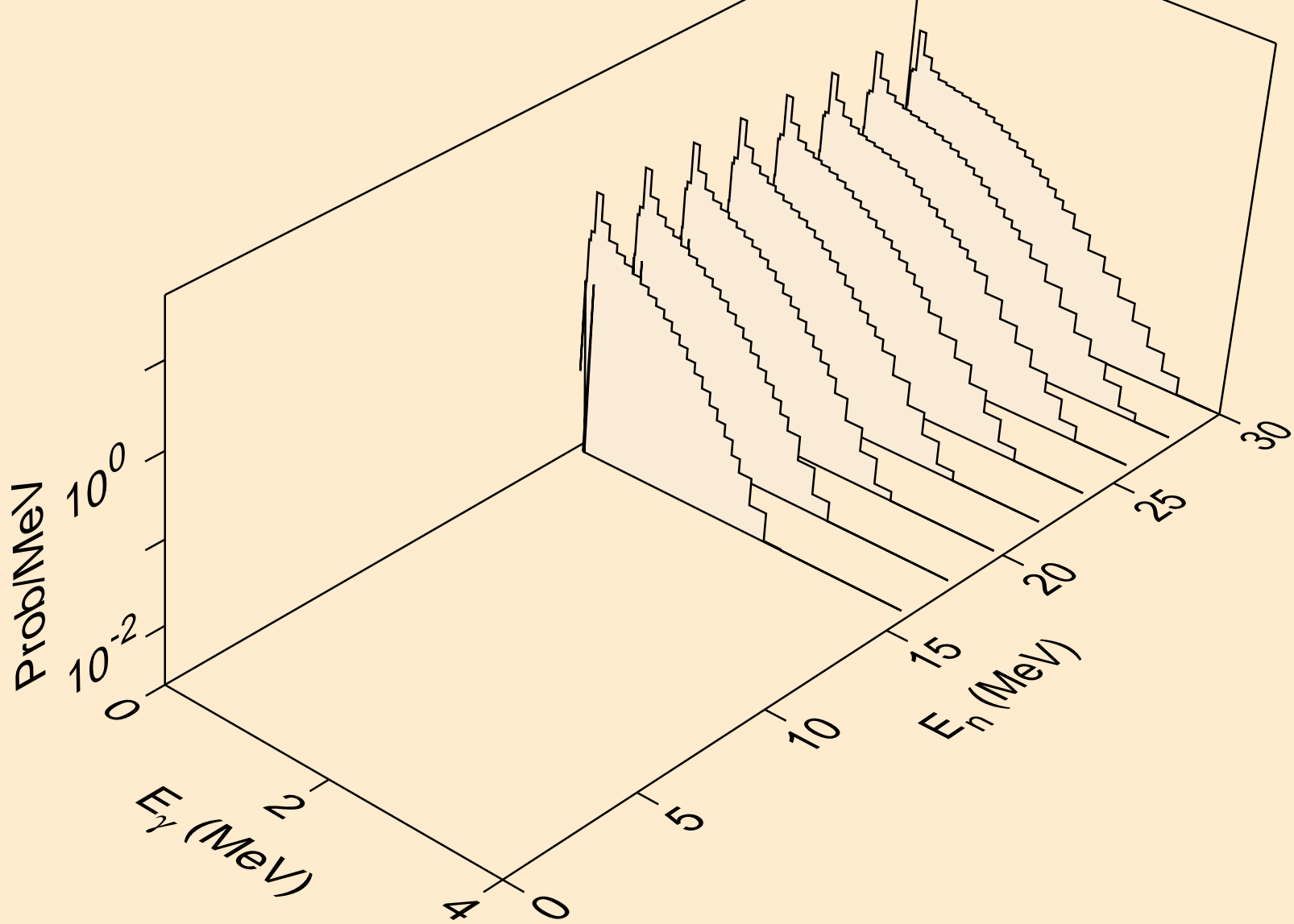

LR262 NEUTRON ACER TENDL-2019 LIBRARY; T=293.16K  
Photon emission for (n,n\*c)

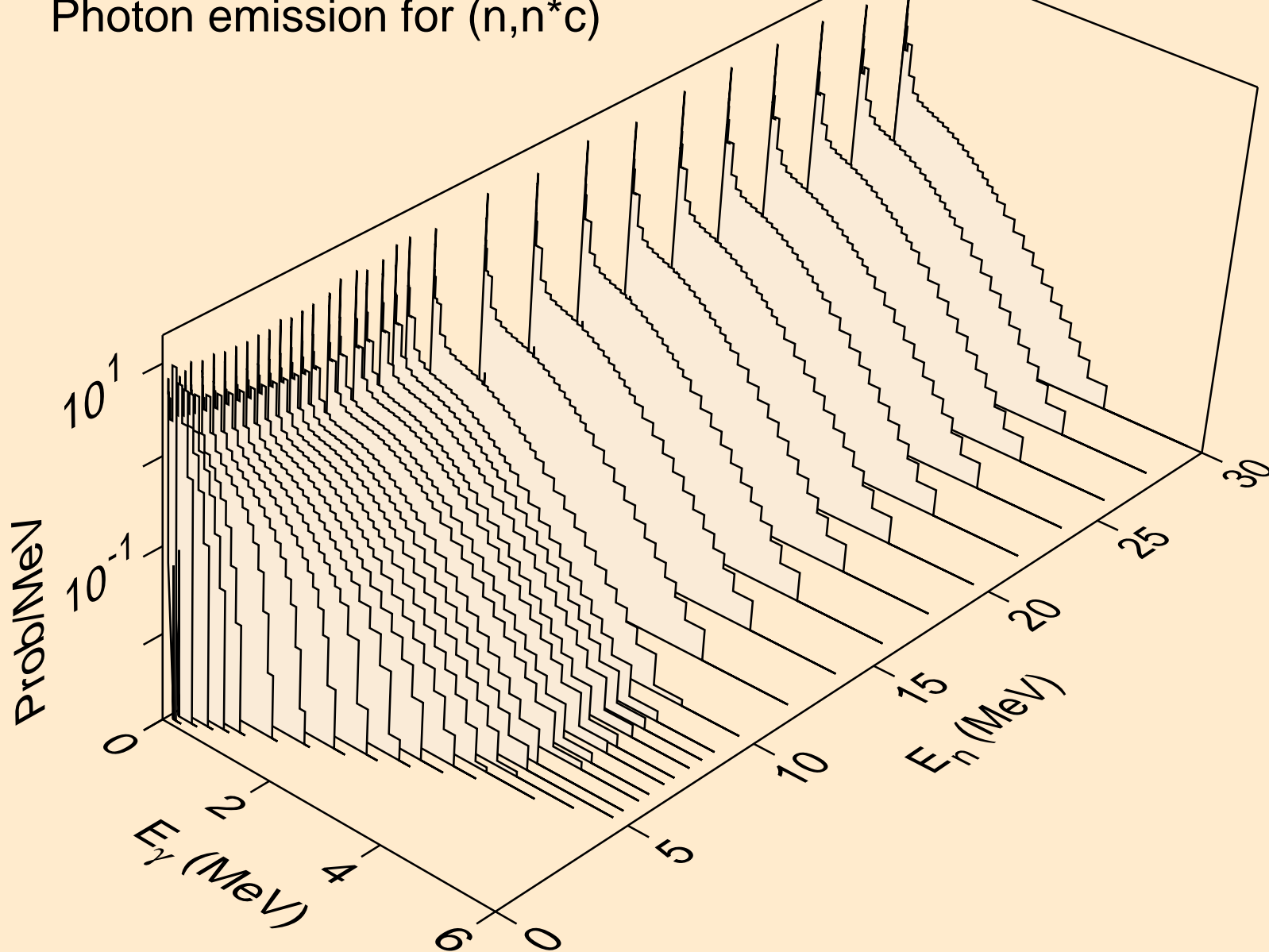

LR262 NEUTRON ACER TENDL-2019 LIBRARY; T=293.16K  
Photon emission for (n,gma)

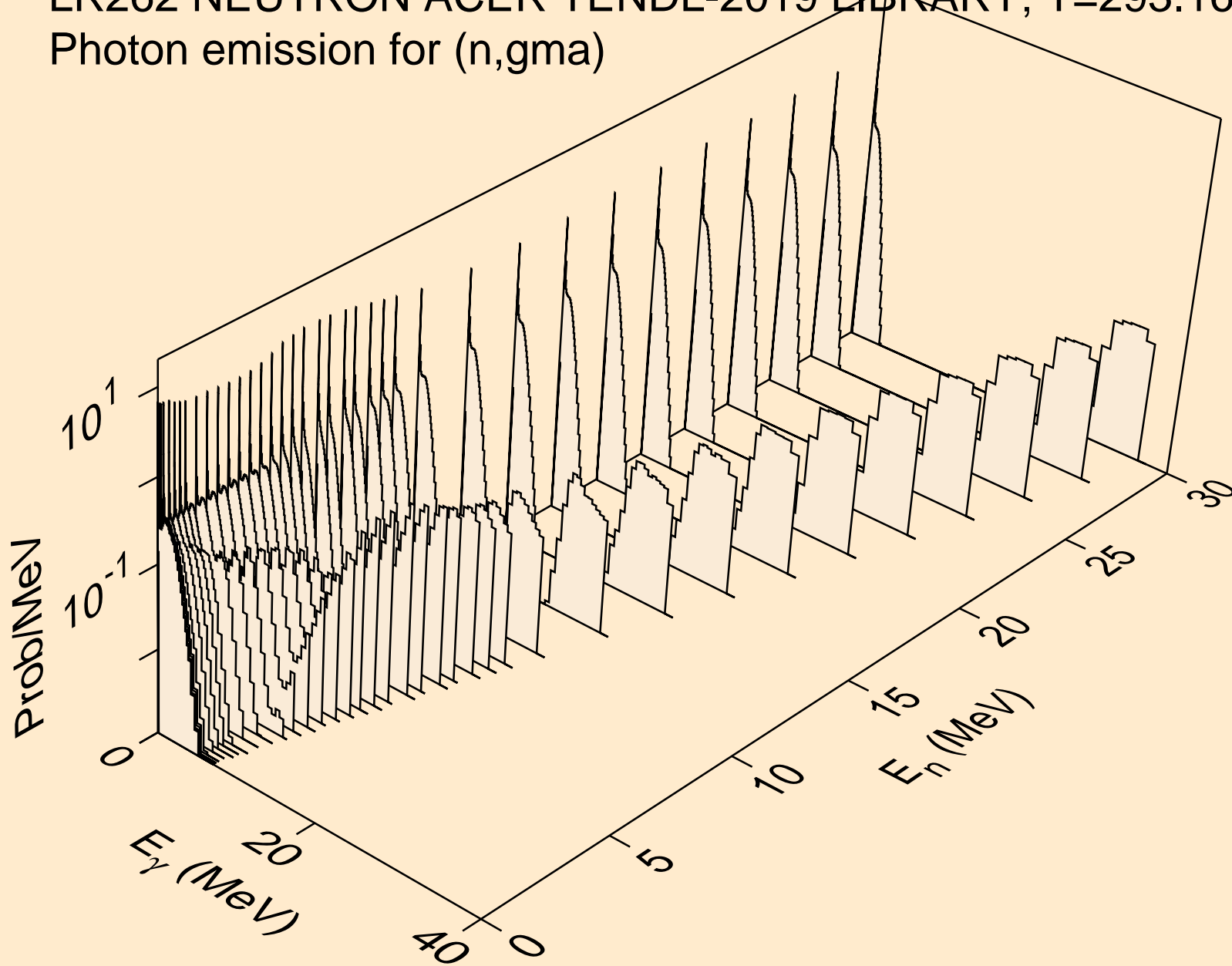

LR262 NEUTRON ACER TENDL-2019 LIBRARY; T=293.16K  
Photon emission for (n,p)

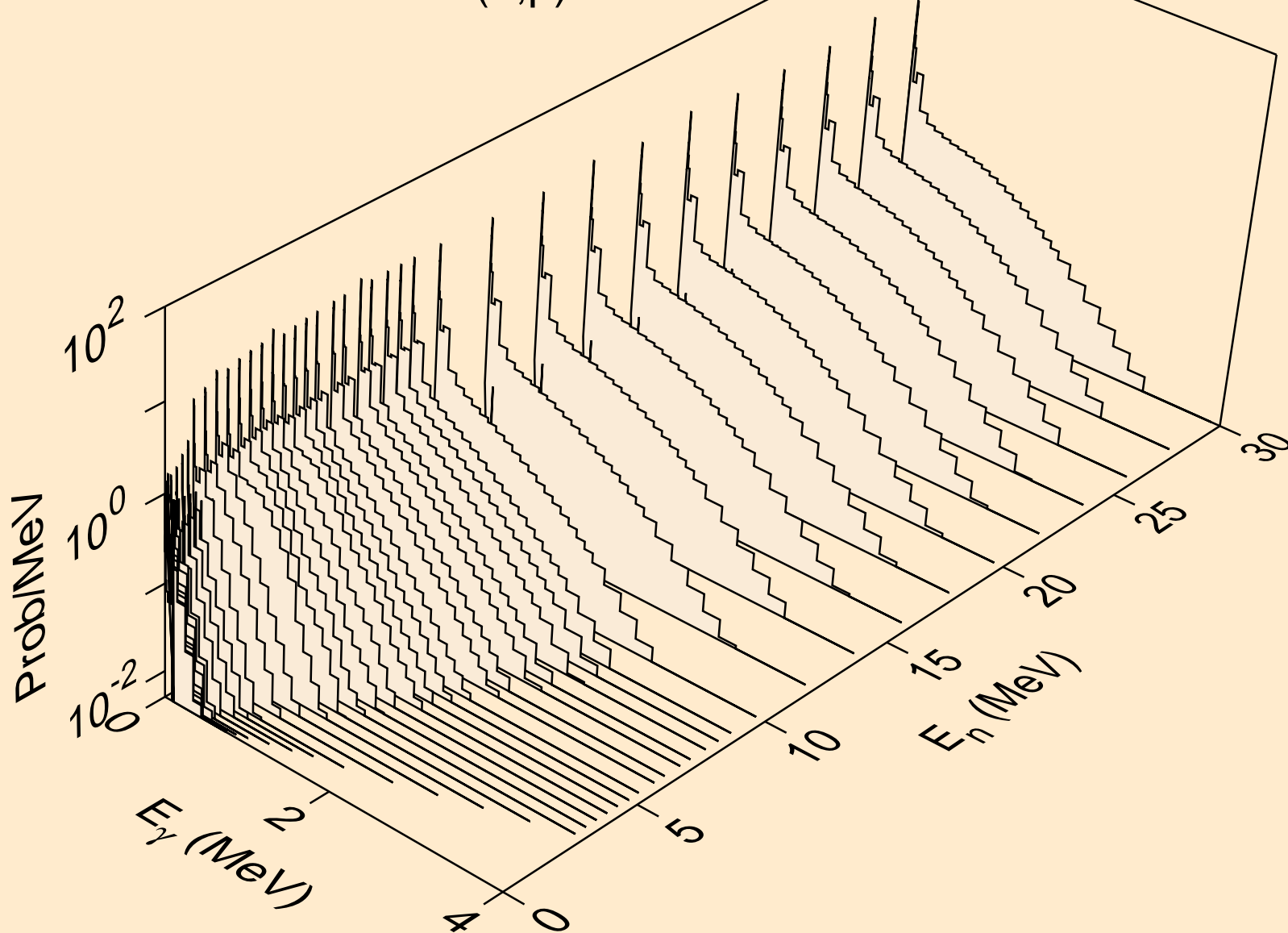

LR262 NEUTRON ACER TENDL-2019 LIBRARY; T=293.16K  
Photon emission for (n,d)

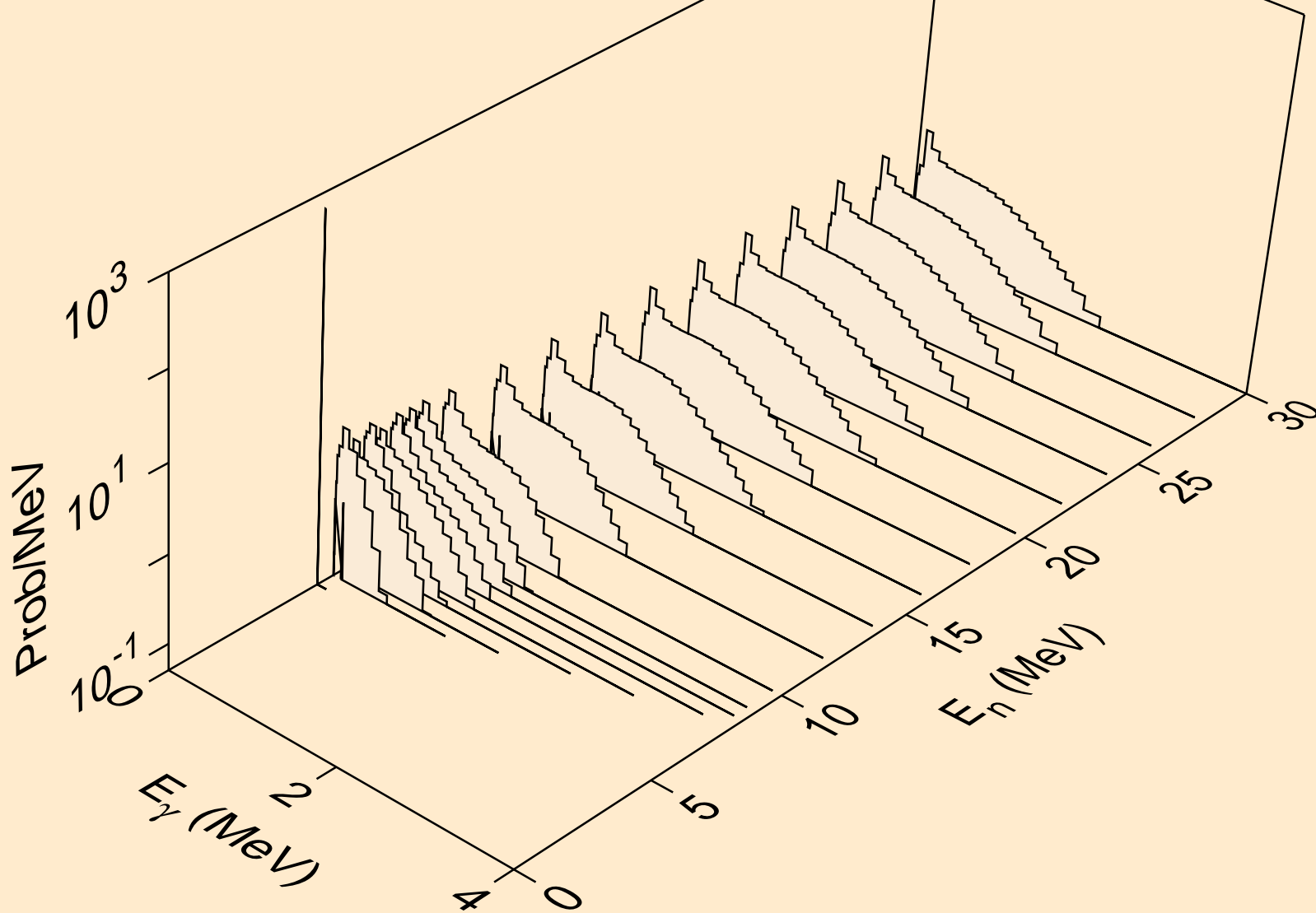

LR262 NEUTRON ACER TENDL-2019 LIBRARY; T=293.16K  
Photon emission for (n,t)

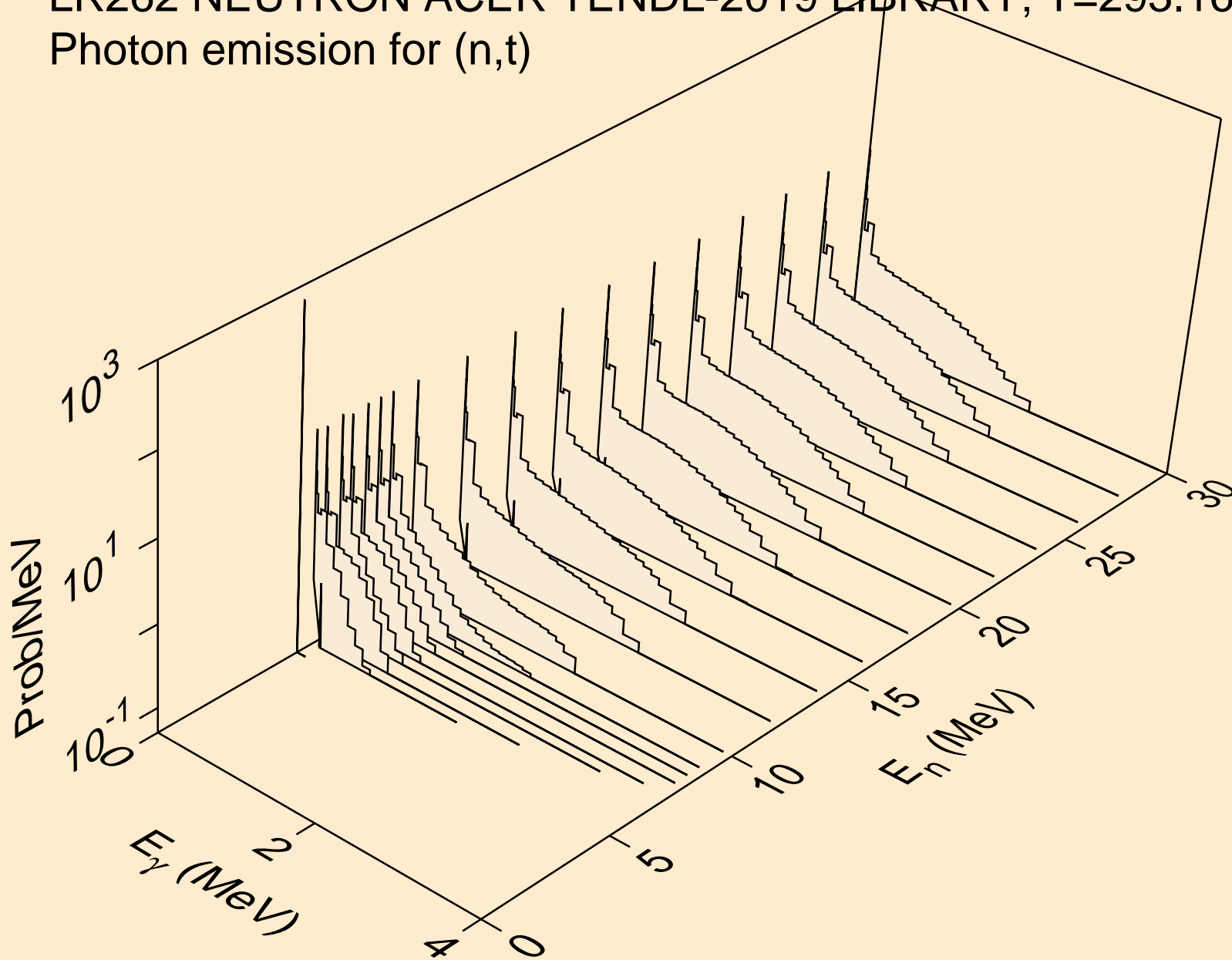

LR262 NEUTRON ACER TENDL-2019 LIBRARY; T=293.16K  
Photon emission for (n,he3)

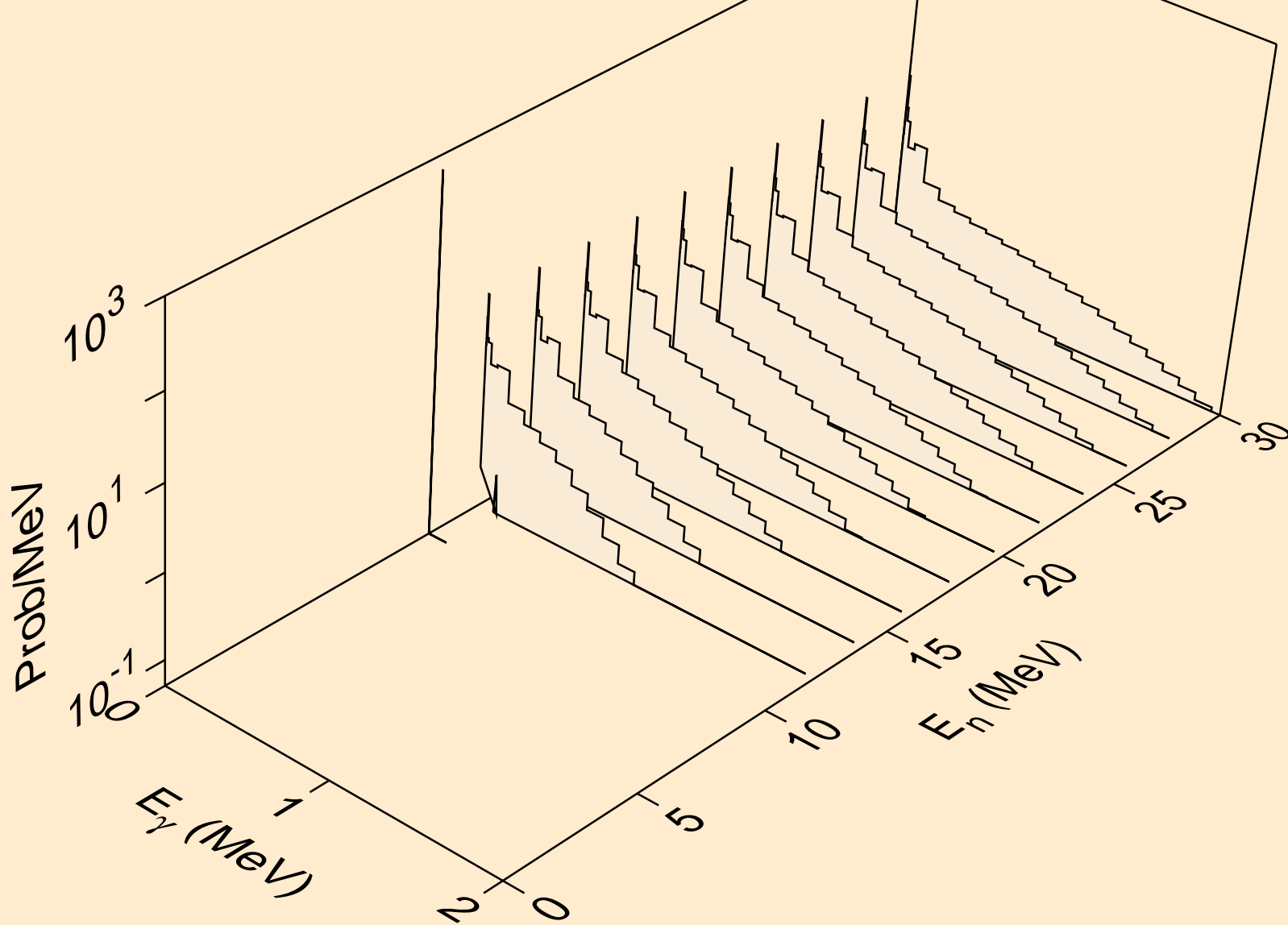

LR262 NEUTRON ACER TENDL-2019 LIBRARY; T=293.16K  
Photon emission for (n,a)

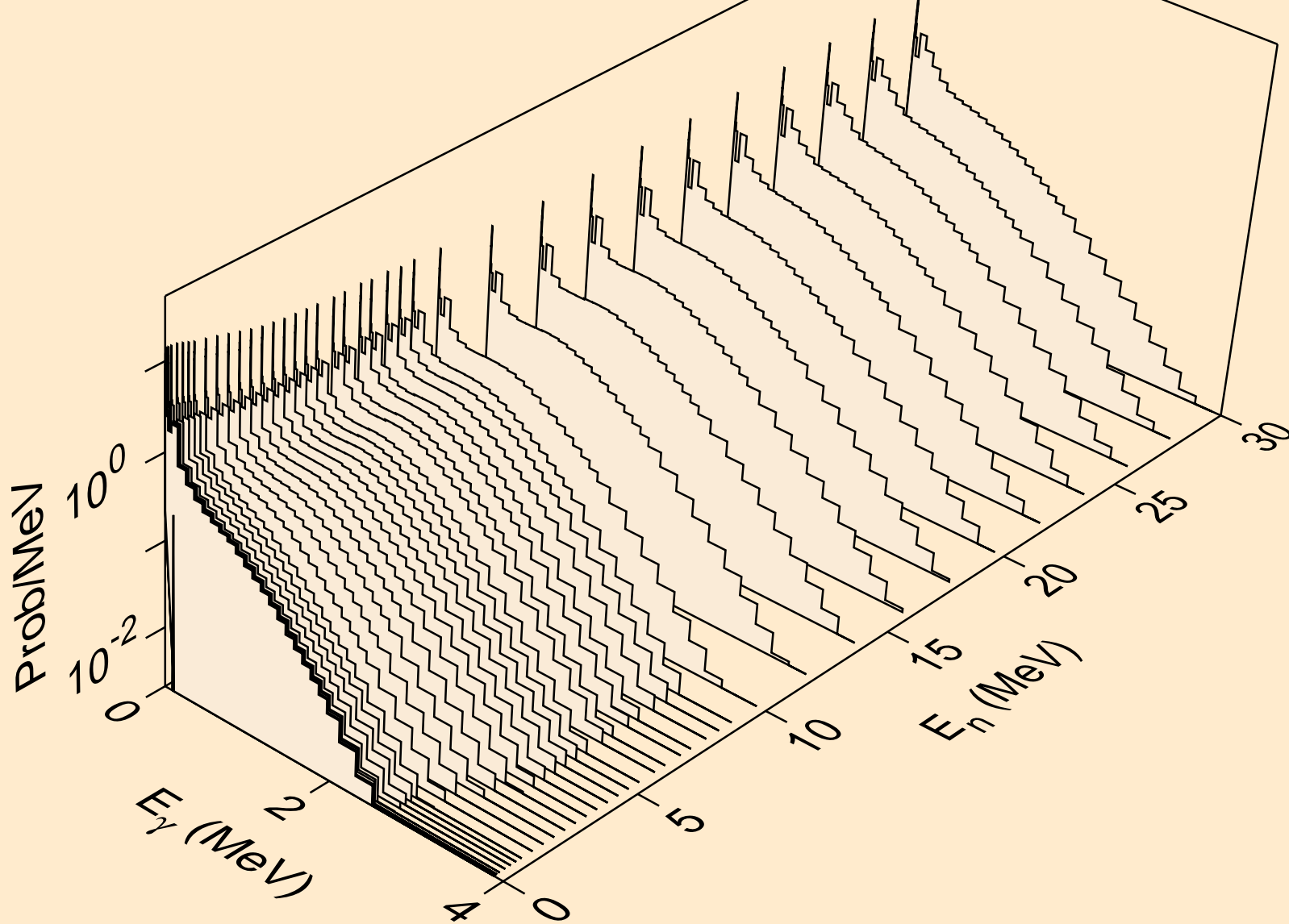

LR262 NEUTRON ACER TENDL-2019 LIBRARY; T=293.16K  
Photon emission for (n,2p)

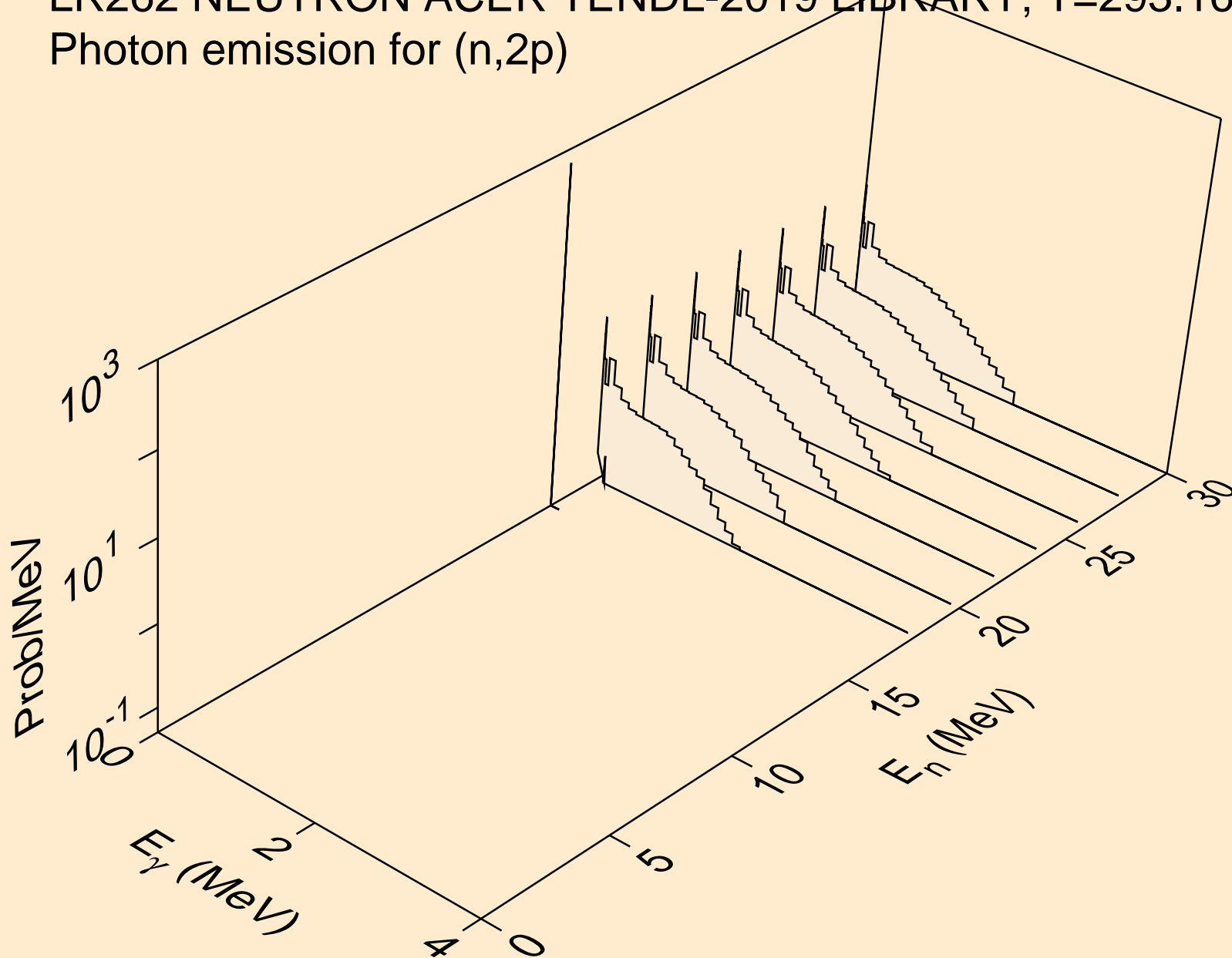

LR262 NEUTRON ACER TENDL-2019 LIBRARY; T=293.16K  
thermal capture photon spectrum

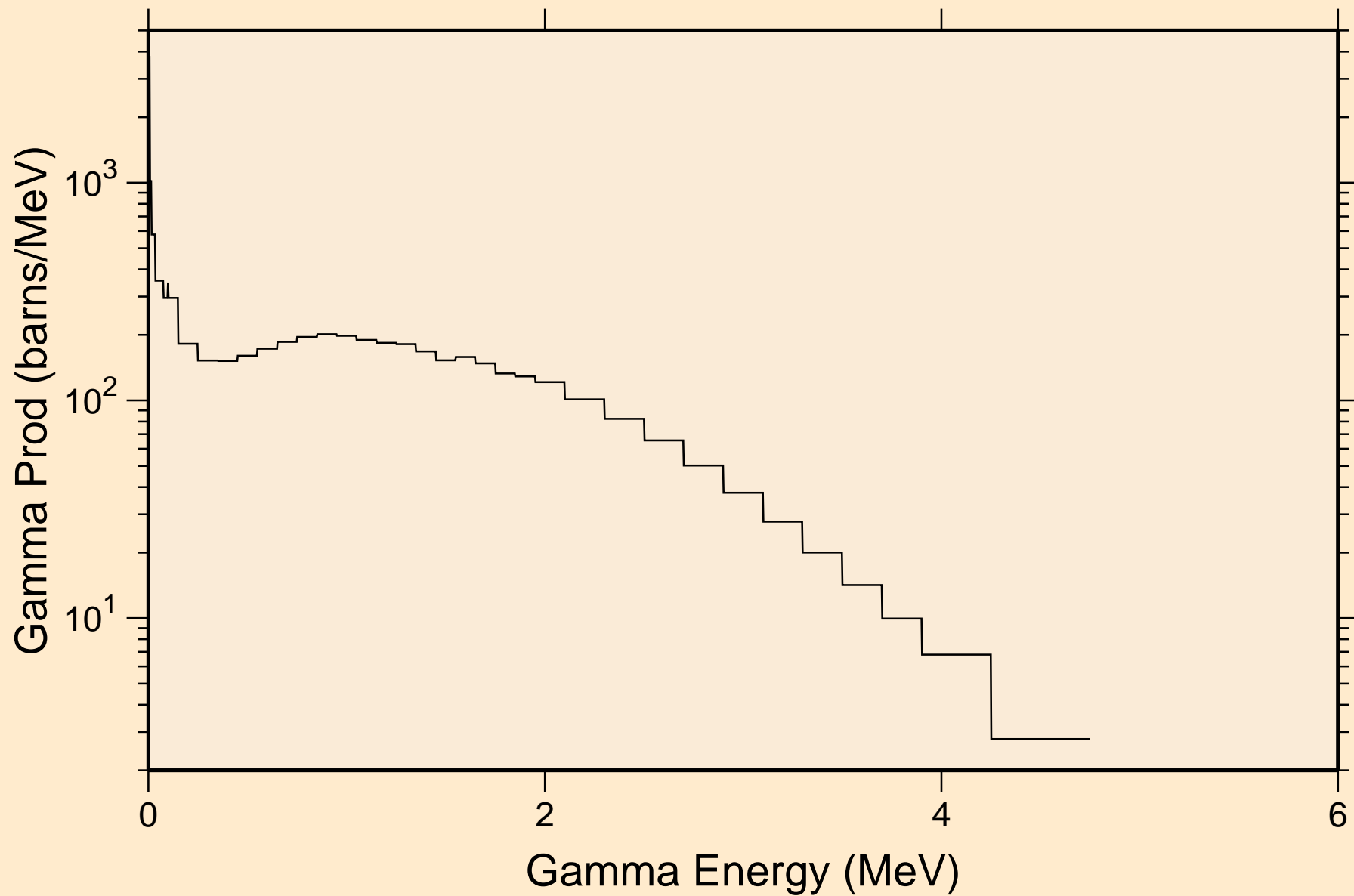

LR262 NEUTRON ACER TENDL-2019 LIBRARY; T=293.16K  
14 MeV photon spectrum

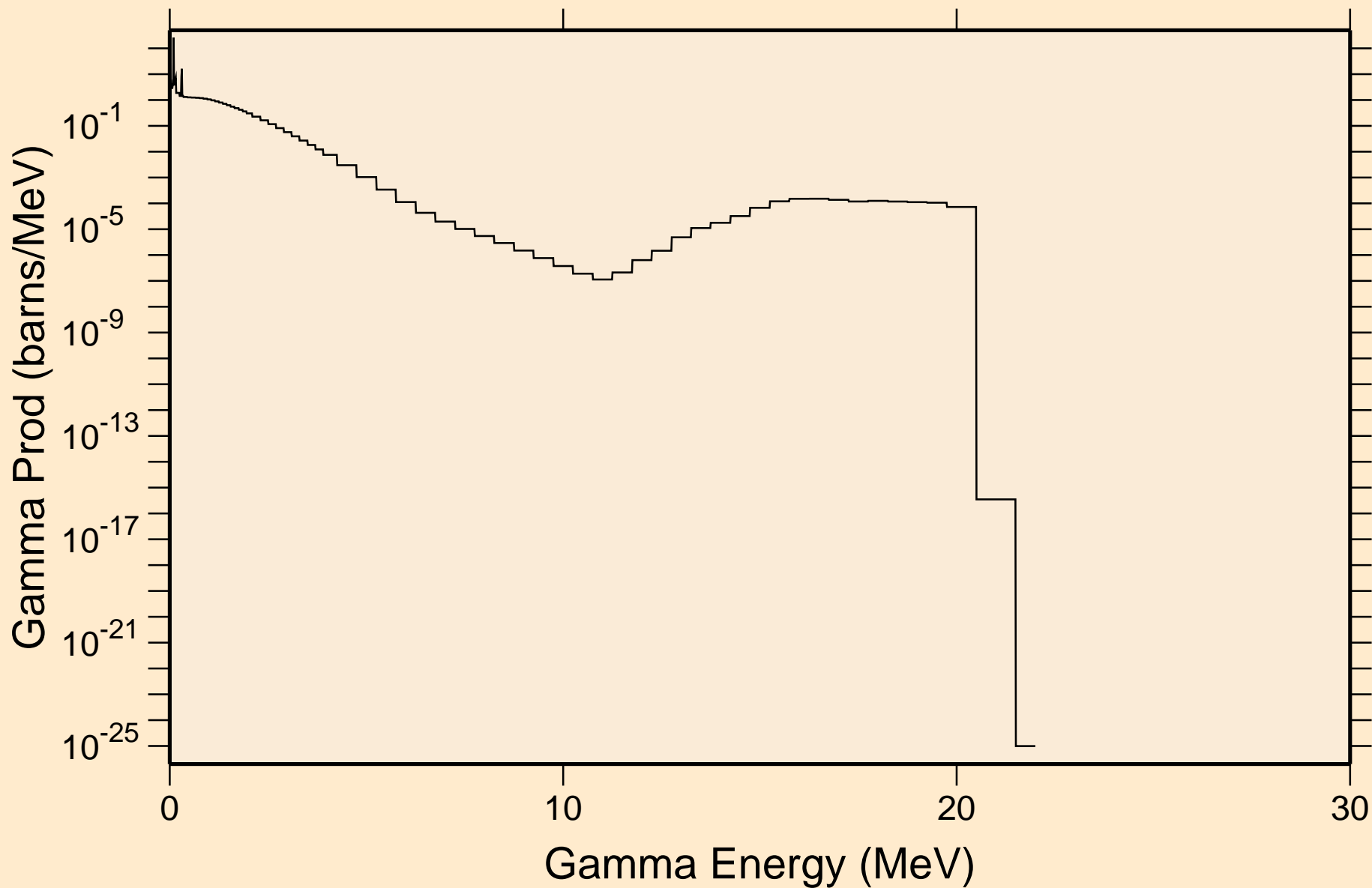

LR262 NEUTRON ACER TENDL-2019 LIBRARY; T=293.16K  
Particle heating contributions

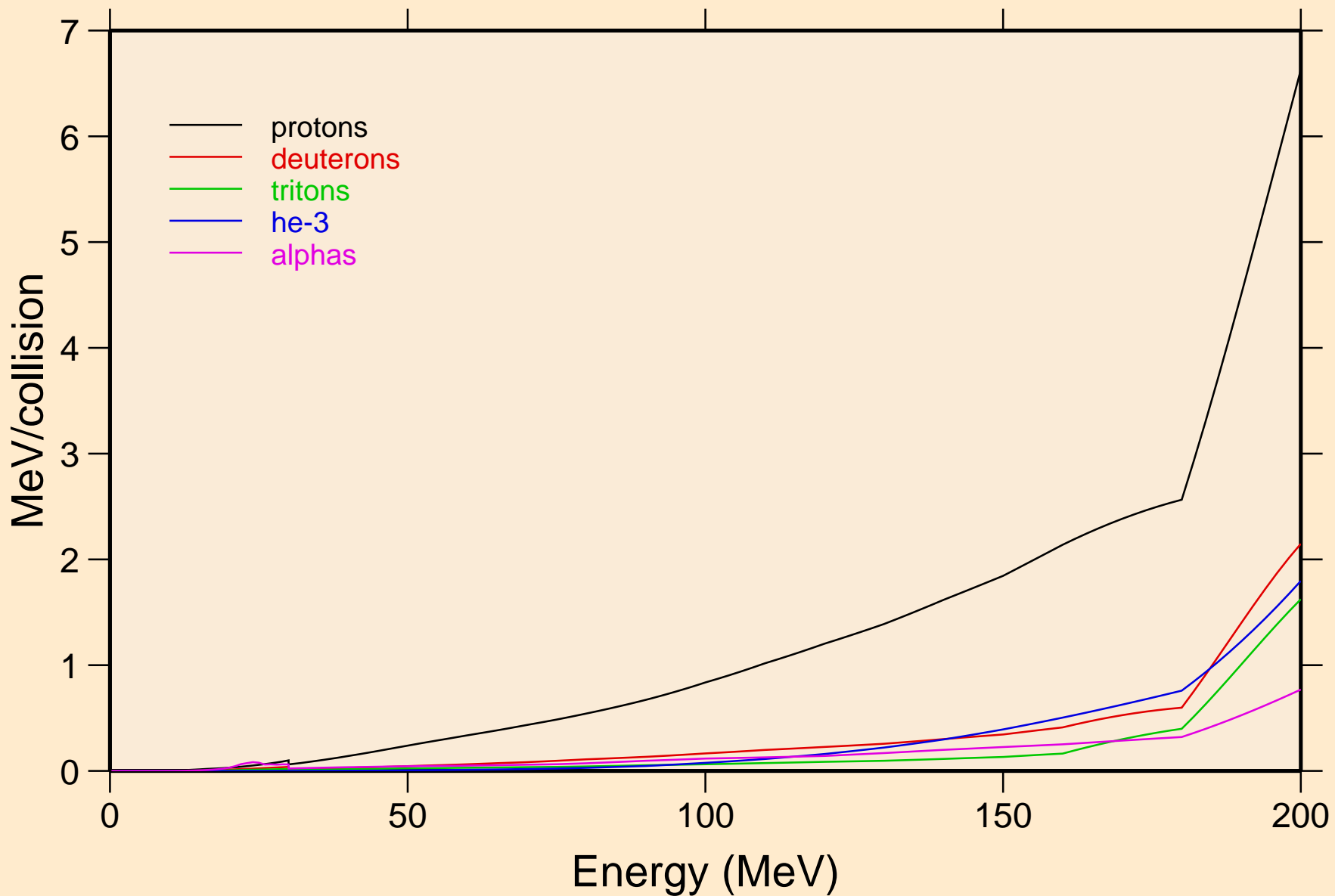

LR262 NEUTRON ACER TENDL-2019 LIBRARY; T=293.16K  
Recoil Heating

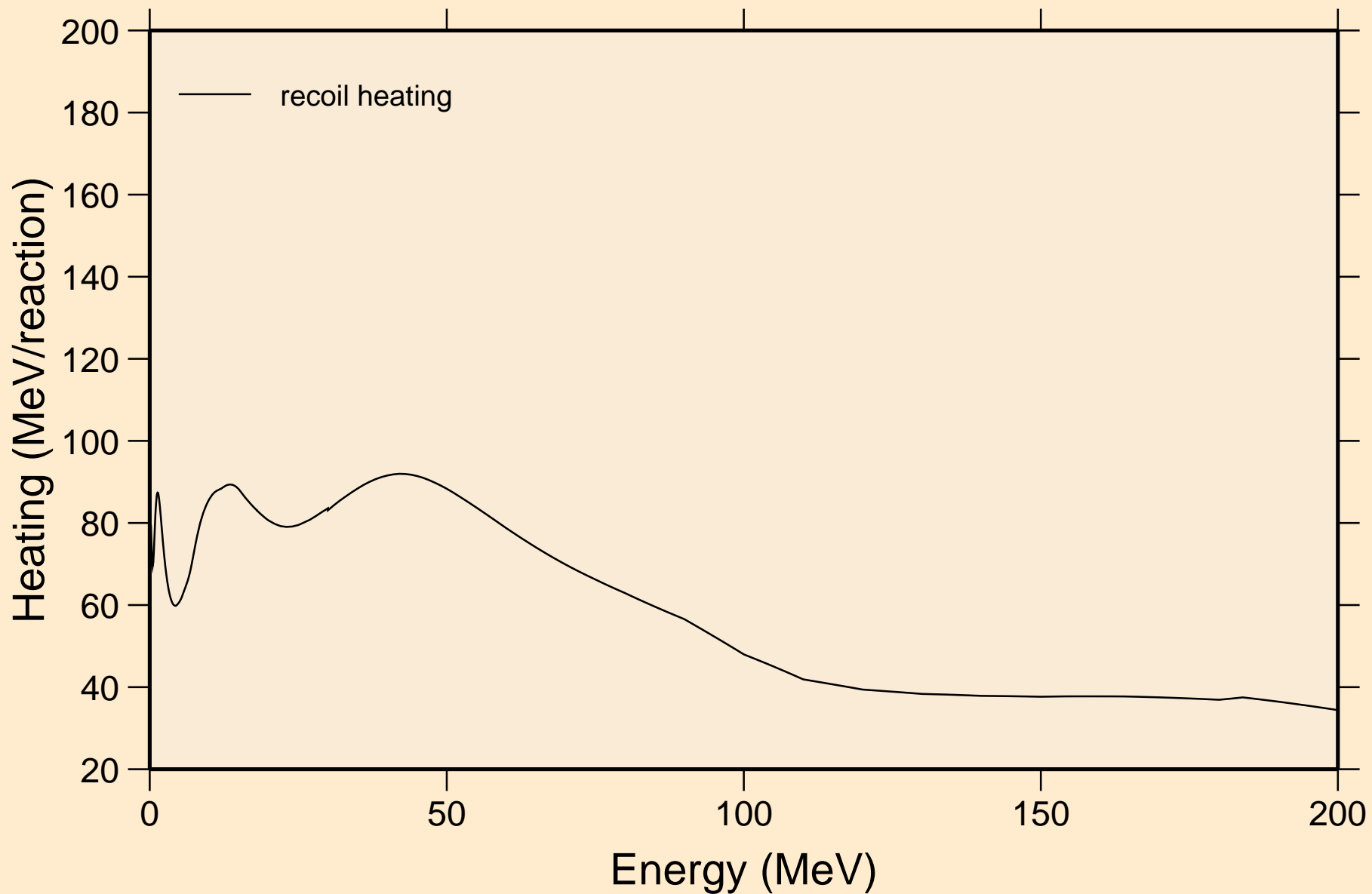

LR262 NEUTRON ACER TENDL-2019 LIBRARY; T=293.16K  
Particle production cross sections

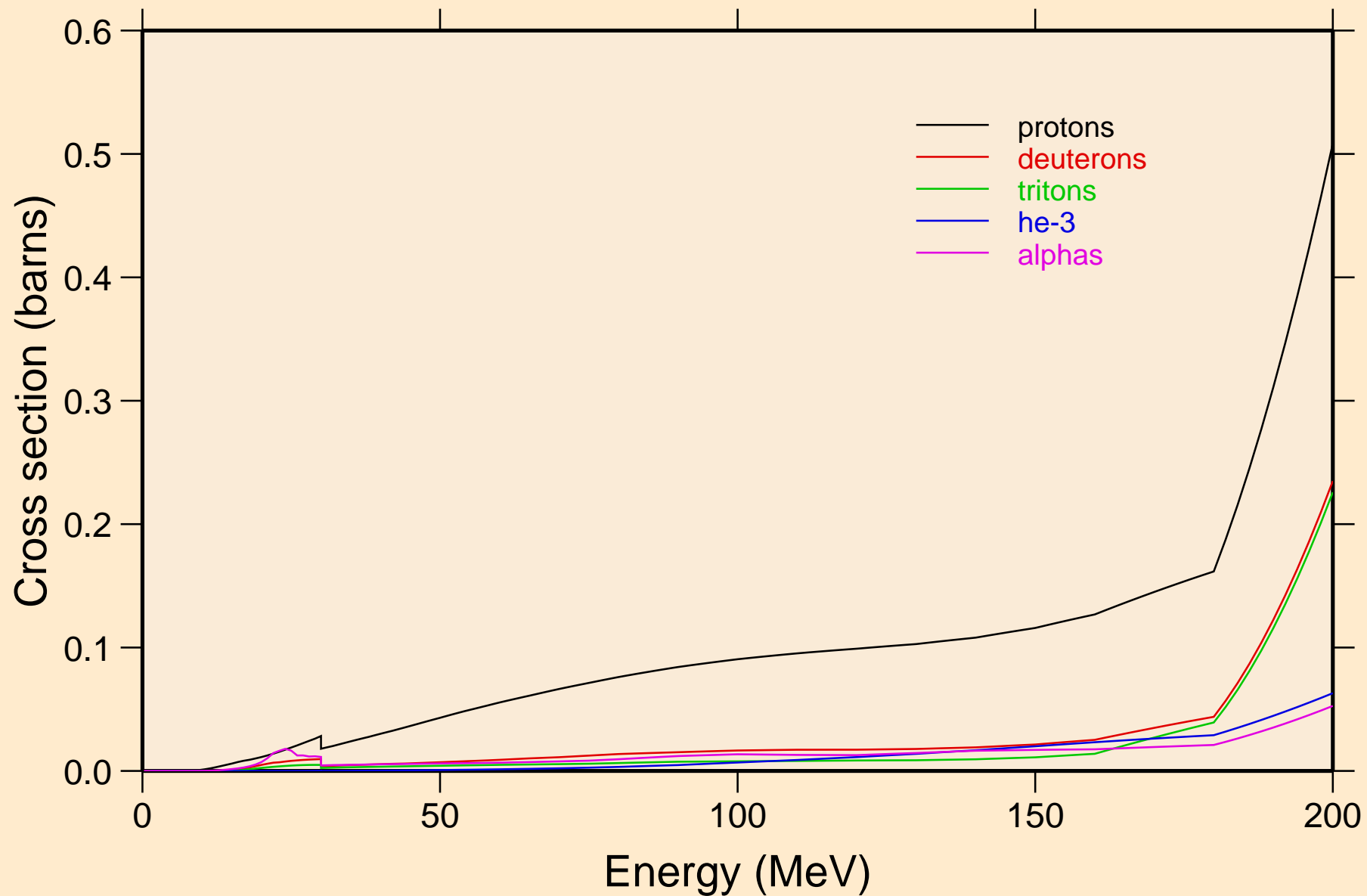

LR262 NEUTRON ACER TENDL-2019 LIBRARY; T=293.16K  
protons from (n,x)

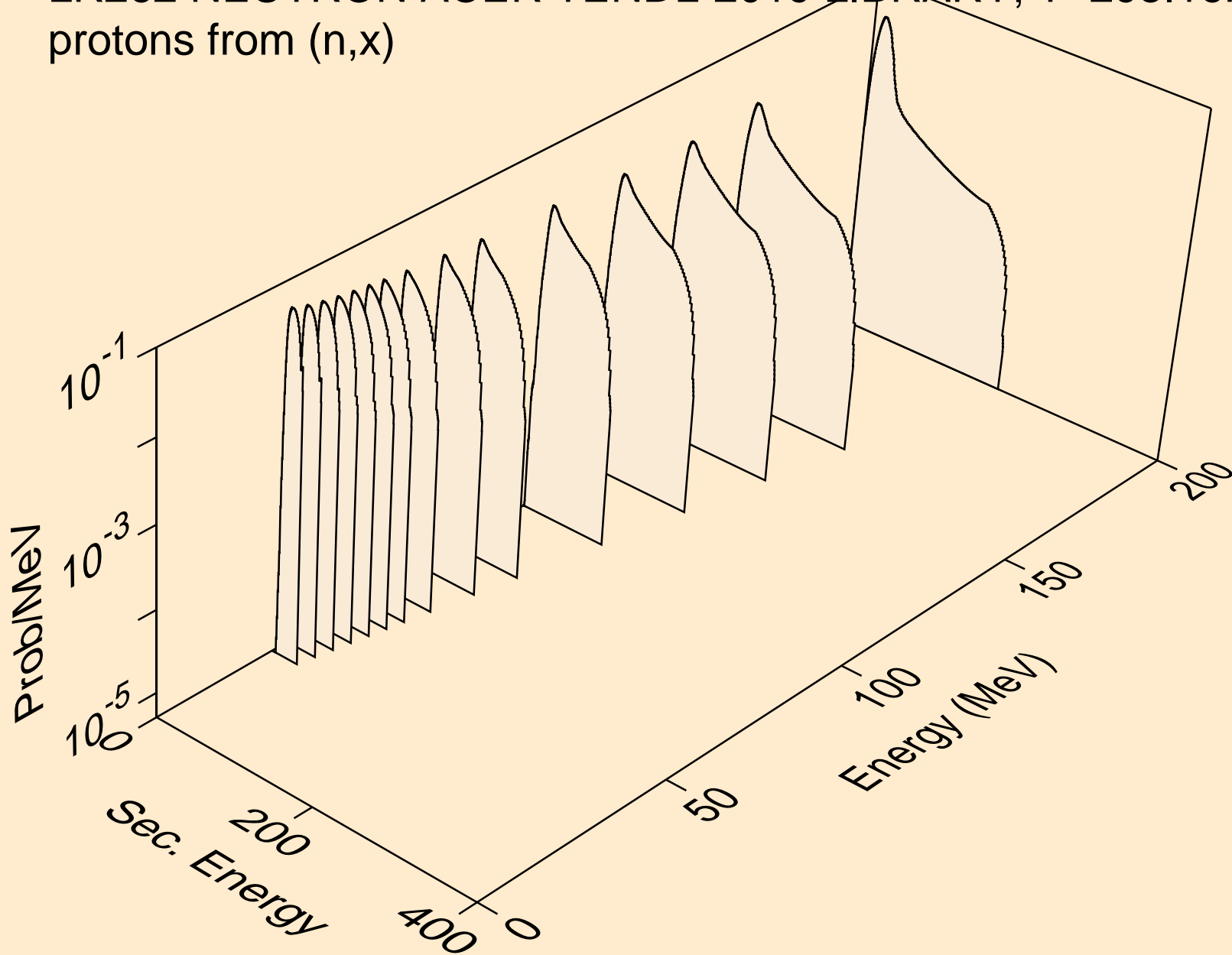

LR262 NEUTRON ACER TENDL-2019 LIBRARY; T=293.16K  
protons from (n,n\*)p

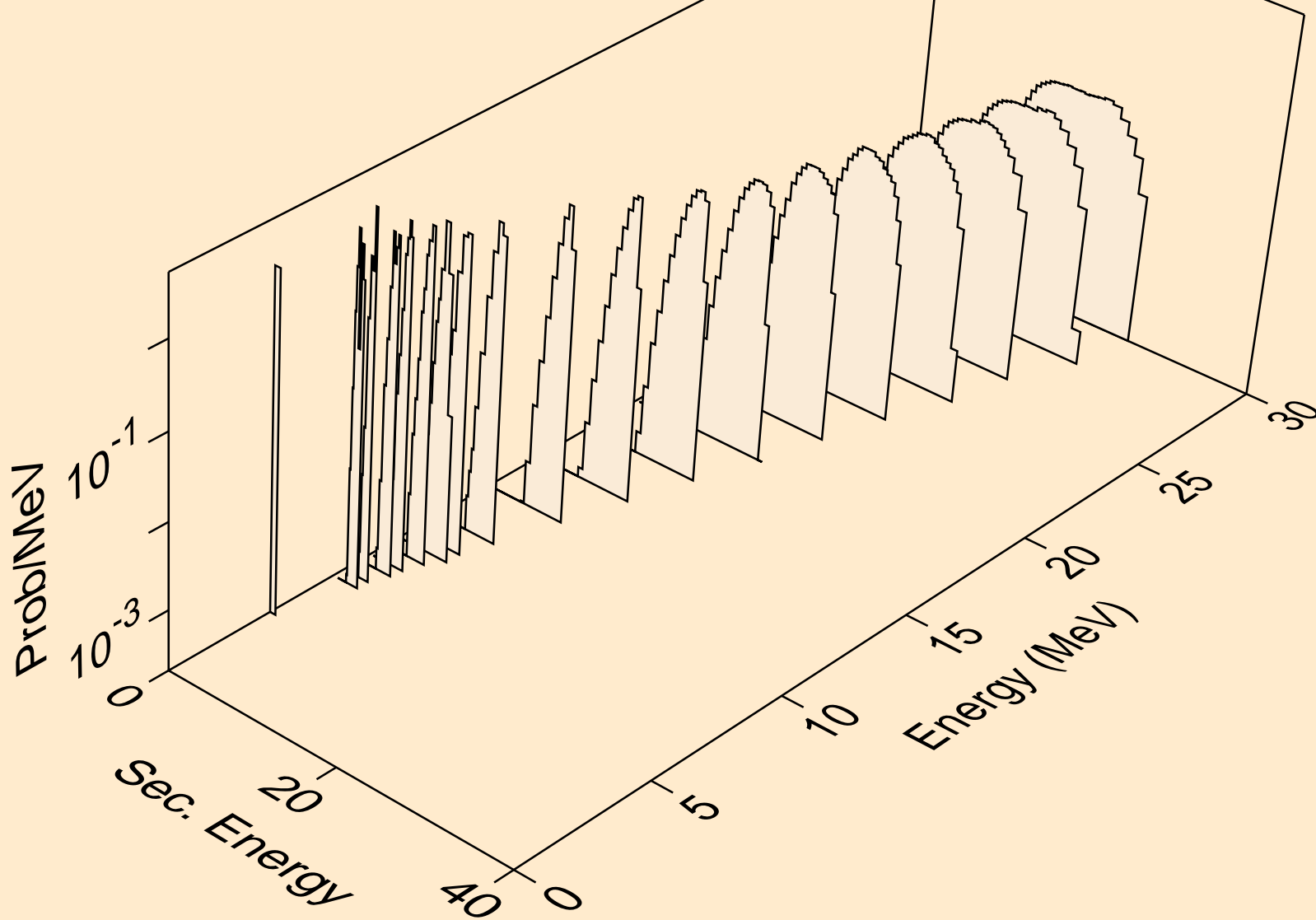

LR262 NEUTRON ACER TENDL-2019 LIBRARY; T=293.16K  
protons from (n,2np)

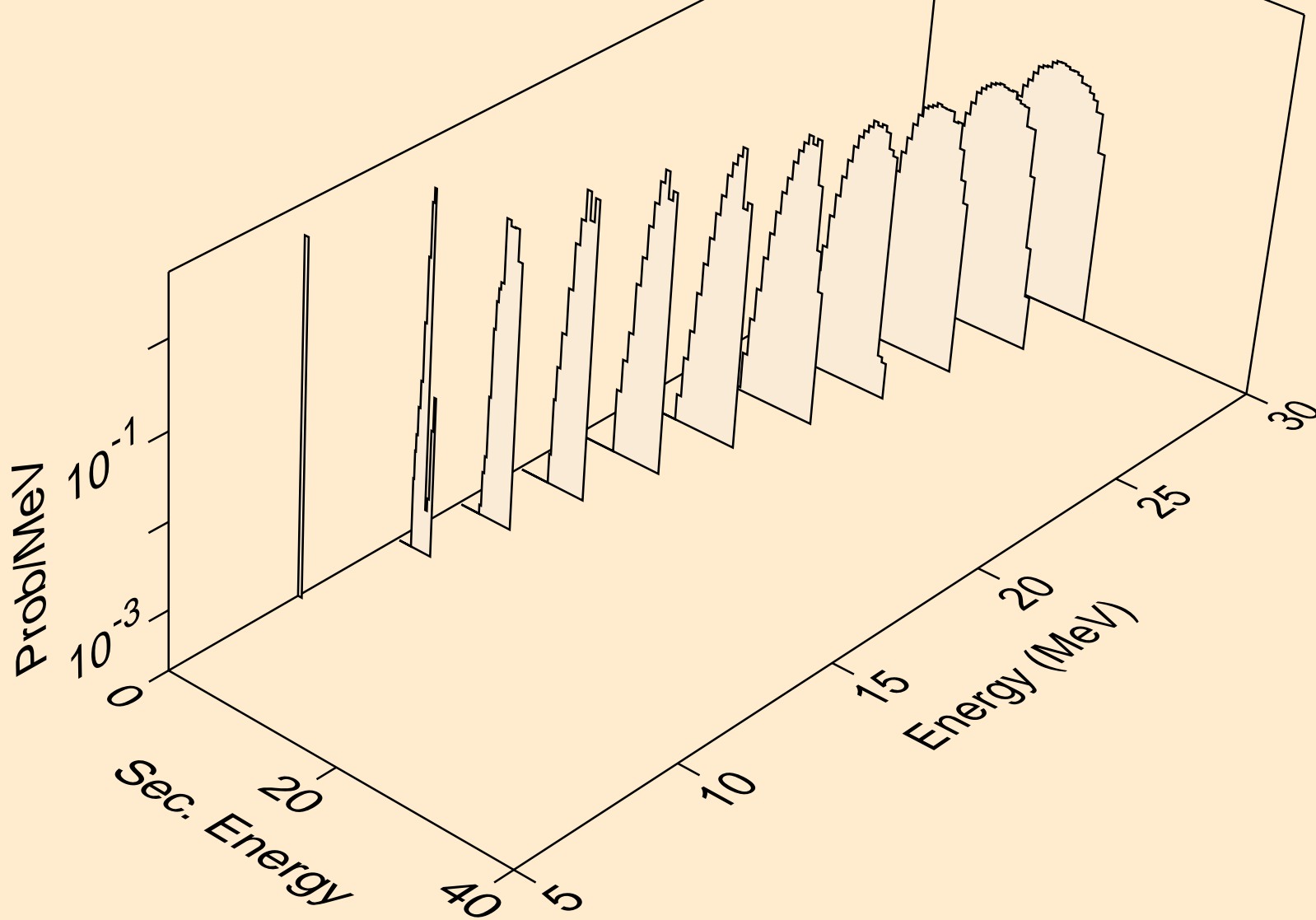

LR262 NEUTRON ACER TENDL-2019 LIBRARY; T=293.16K  
protons from (n,3np)

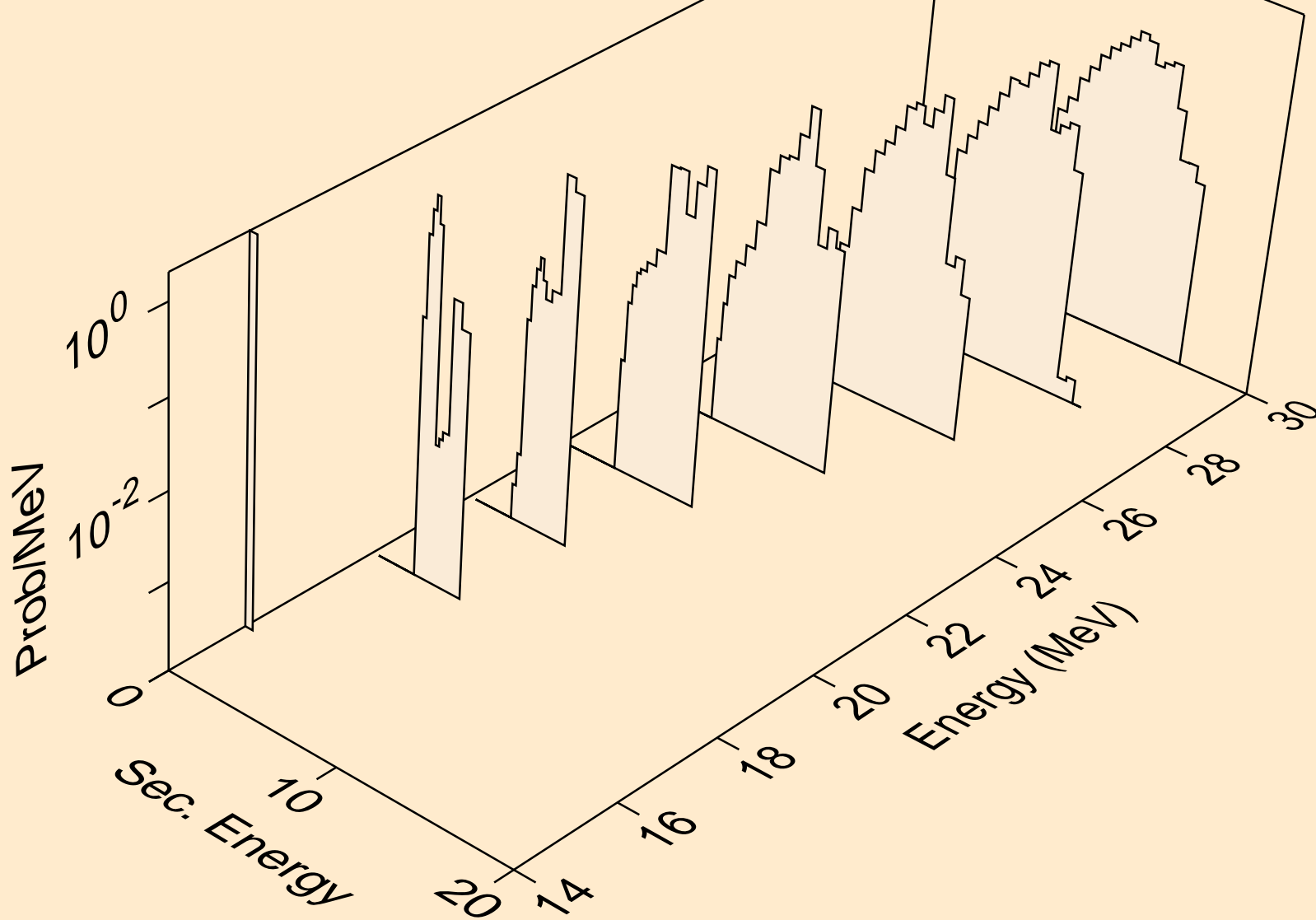

LR262 NEUTRON ACER TENDL-2019 LIBRARY; T=293.16K  
protons from (n,2np)

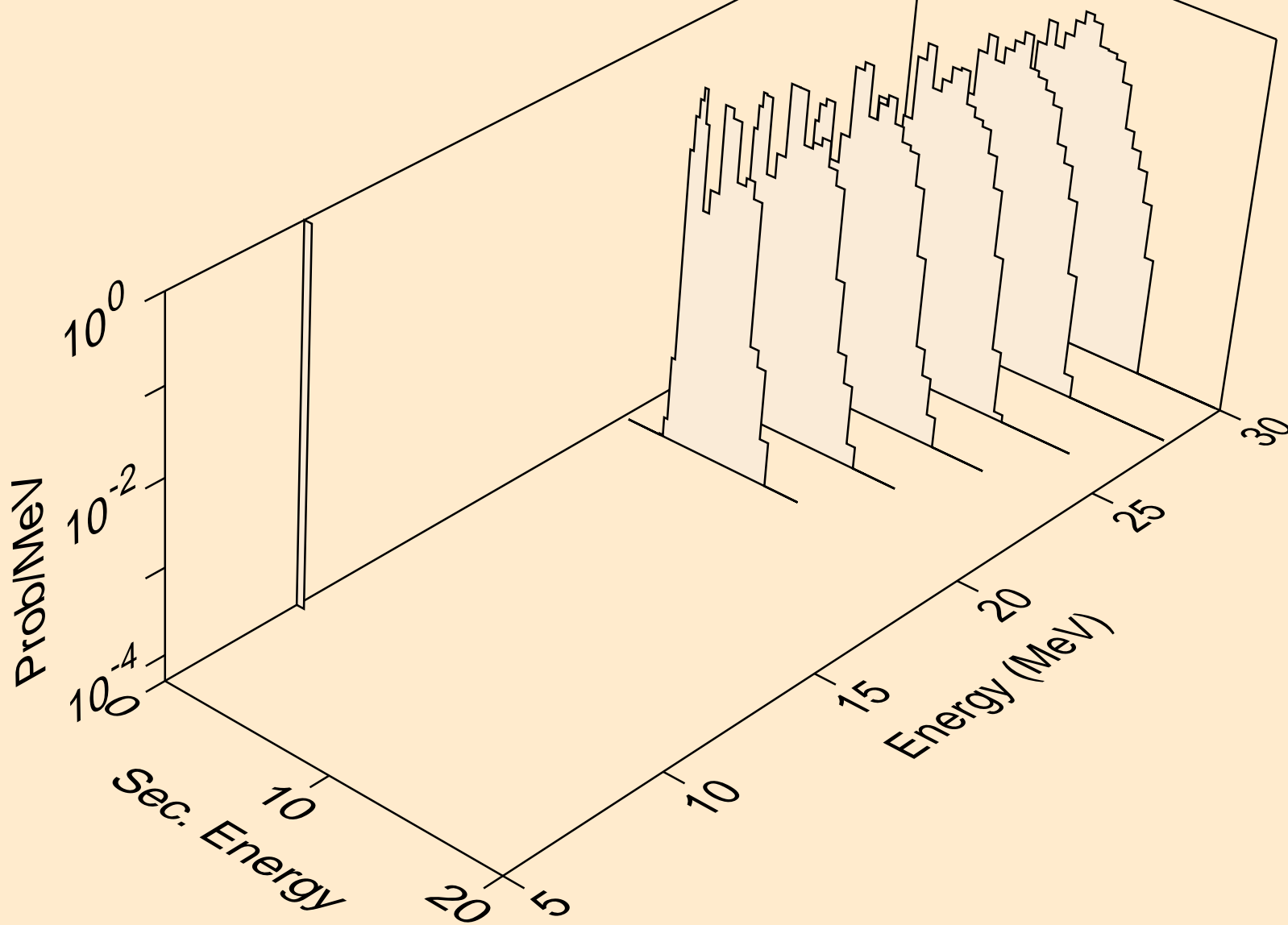

LR262 NEUTRON ACER TENDL-2019 LIBRARY; T=293.16K  
protons from (n,npa)

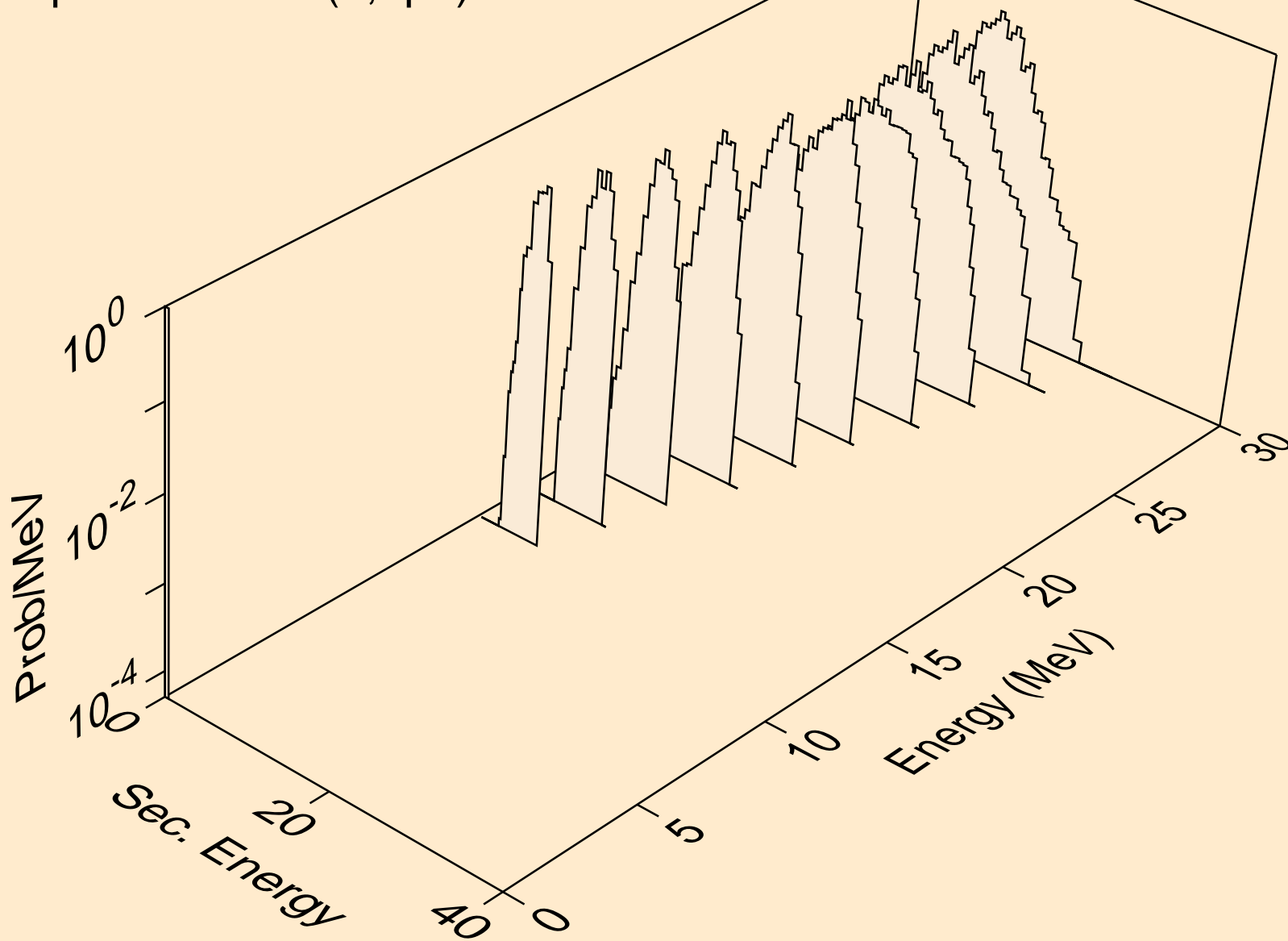

LR262 NEUTRON ACER TENDL-2019 LIBRARY; T=293.16K  
protons from (n,p)

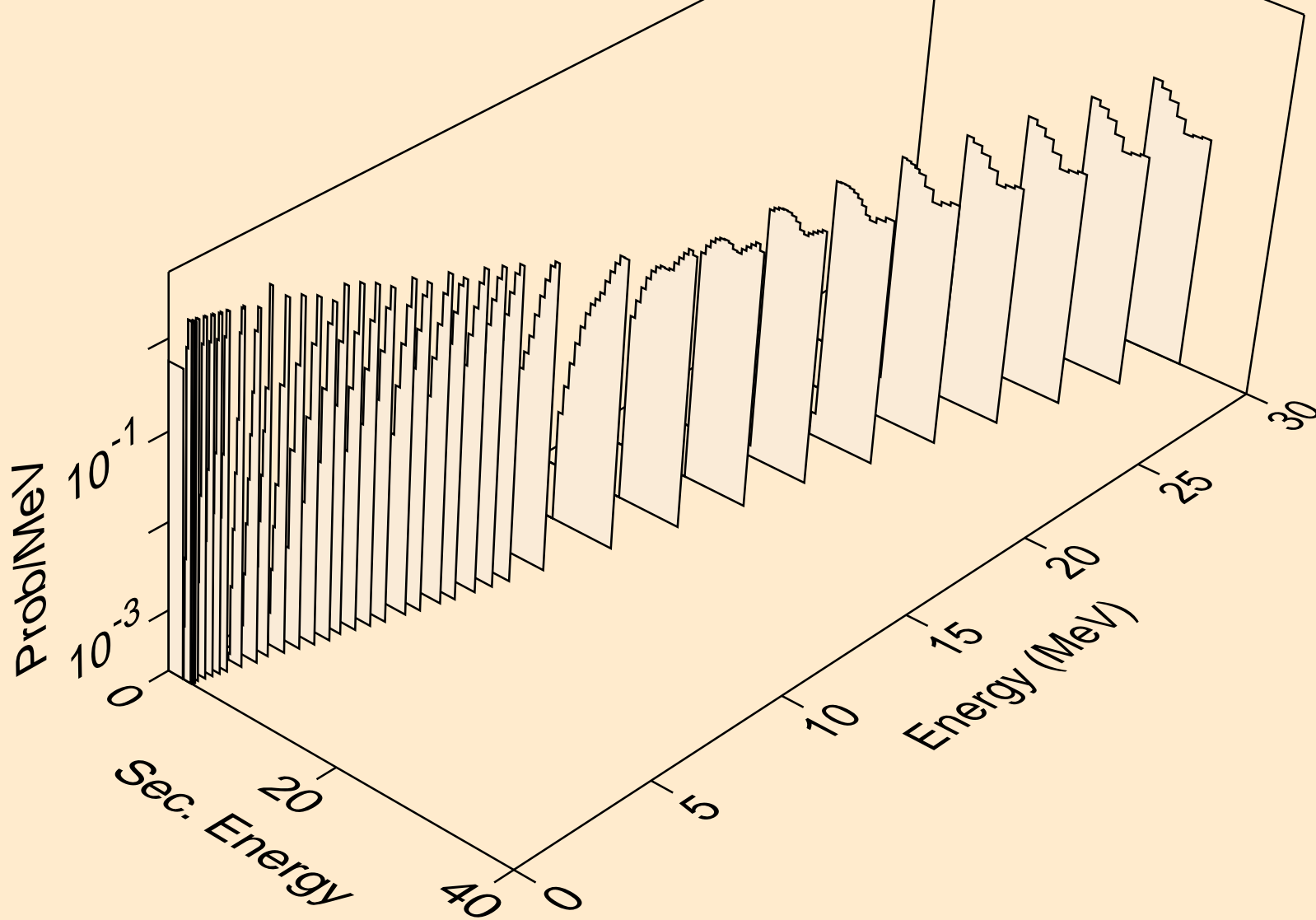

LR262 NEUTRON ACER TENDL-2019 LIBRARY; T=293.16K  
protons from (n,2p)

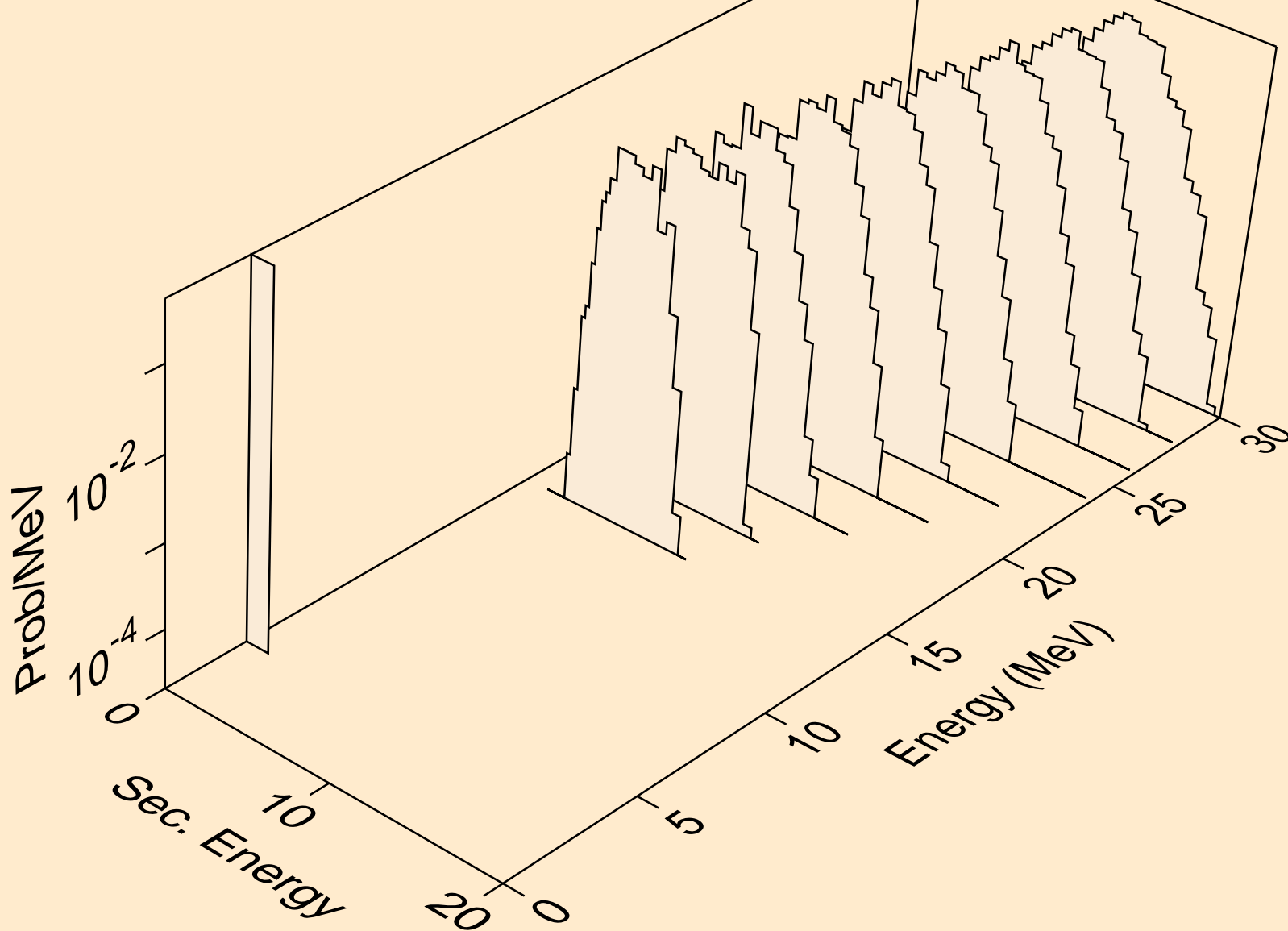

LR262 NEUTRON ACER TENDL-2019 LIBRARY; T=293.16K  
deuterons from (n,x)

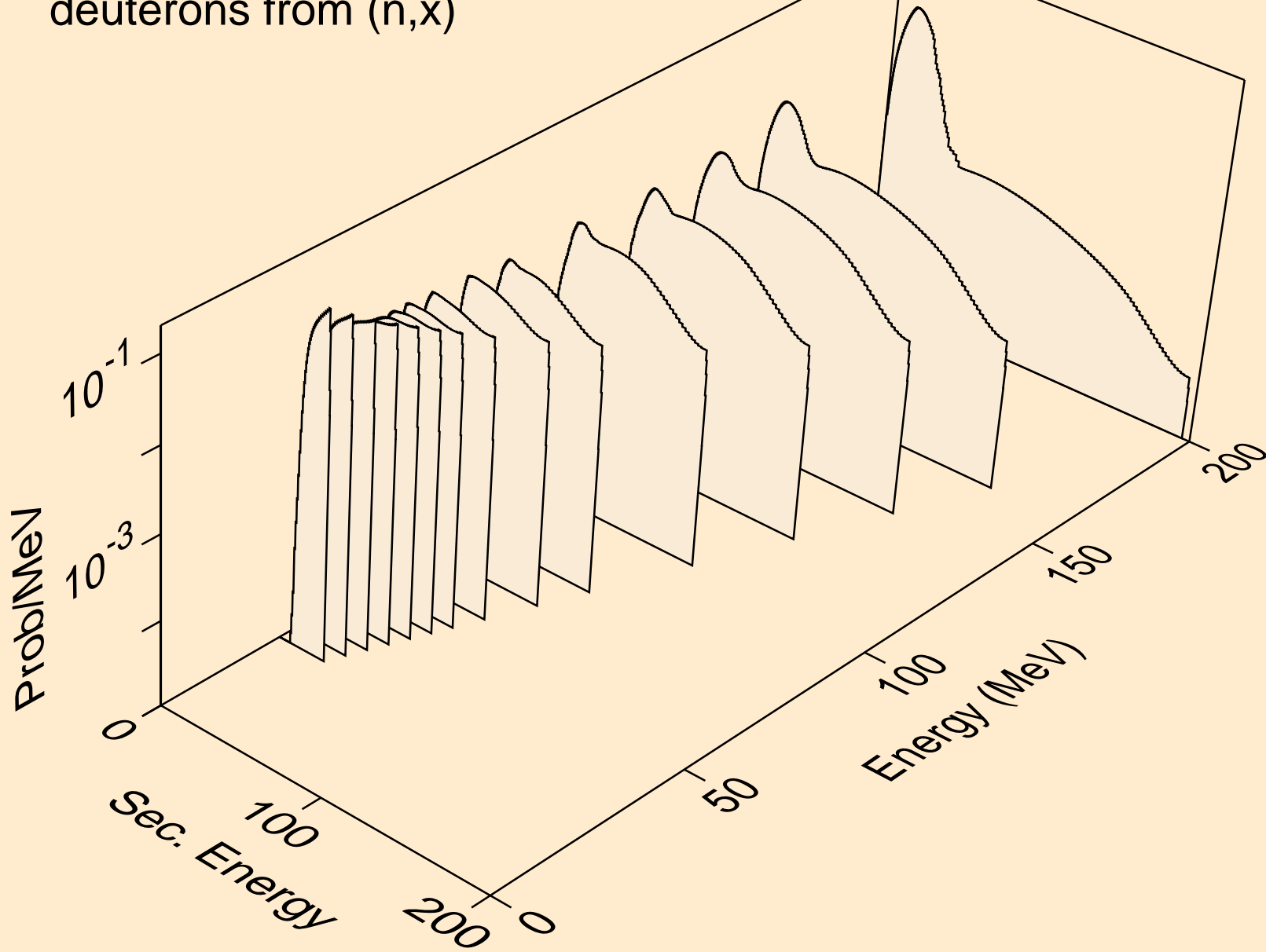

LR262 NEUTRON ACER TENDL-2019 LIBRARY; T=293.16K  
deuterons from (n,2nd)

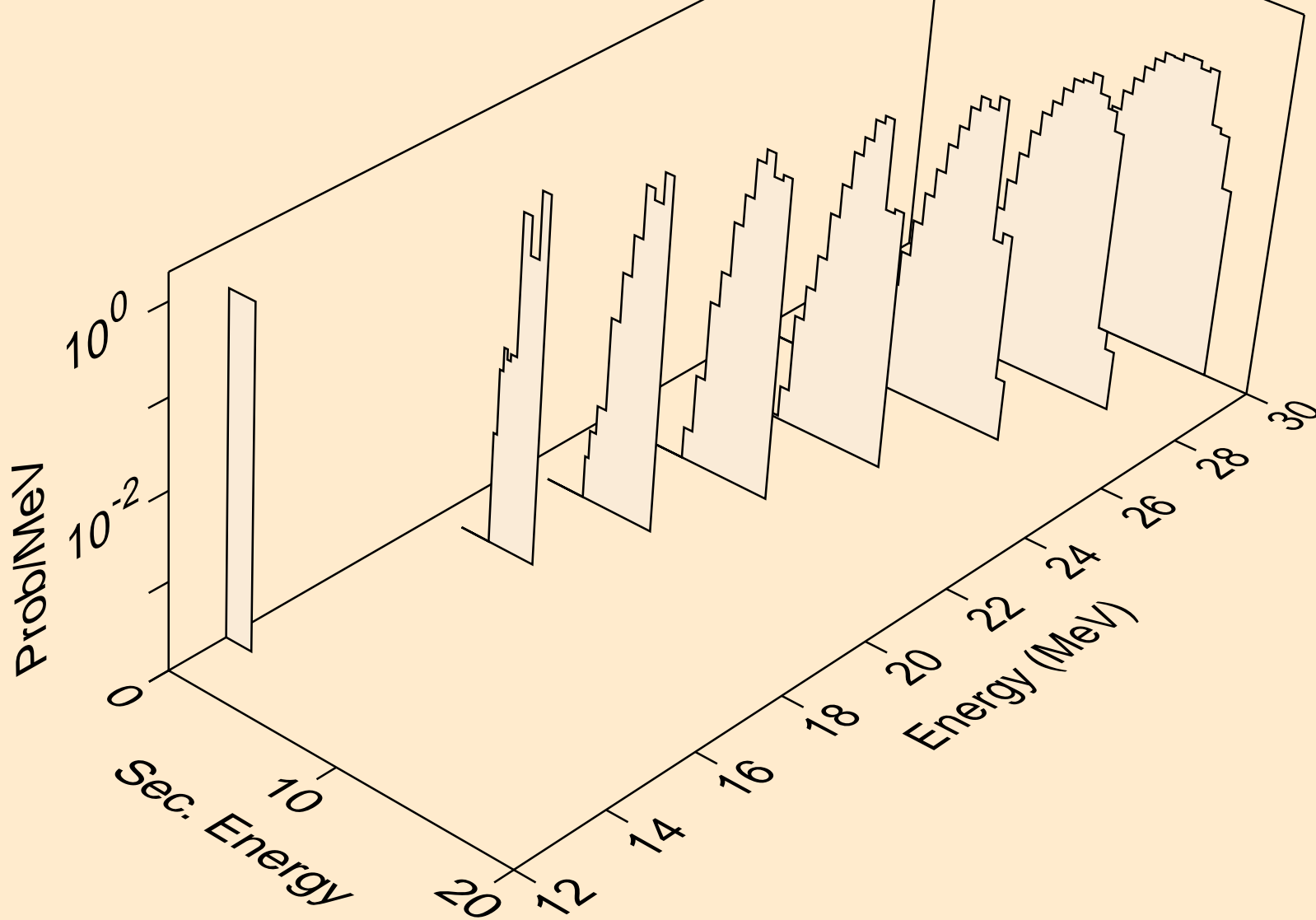

LR262 NEUTRON ACER TENDL-2019 LIBRARY; T=293.16K  
deuterons from (n,n\*)d

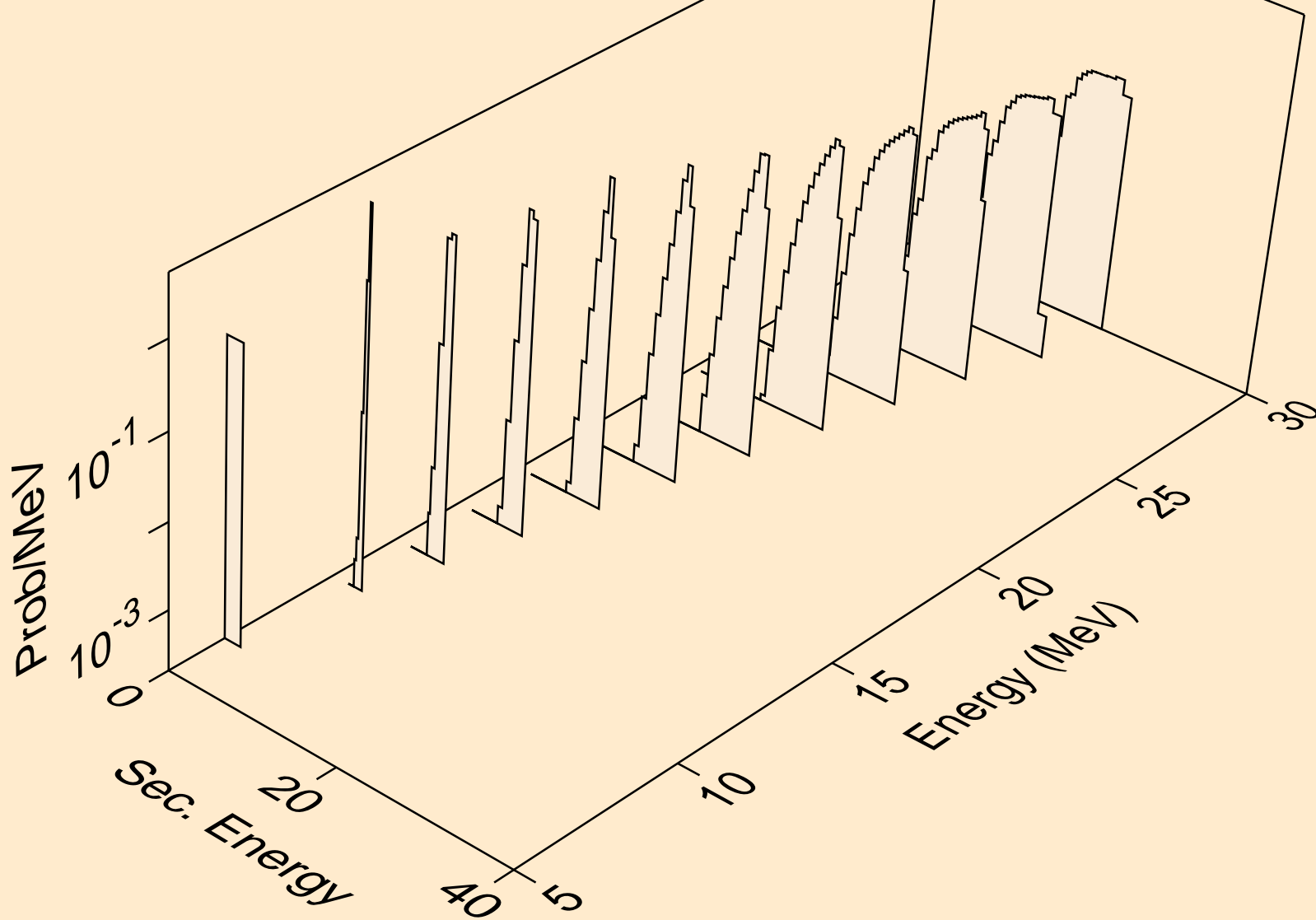

LR262 NEUTRON ACER TENDL-2019 LIBRARY; T=293.16K  
deuterons from (n,d)

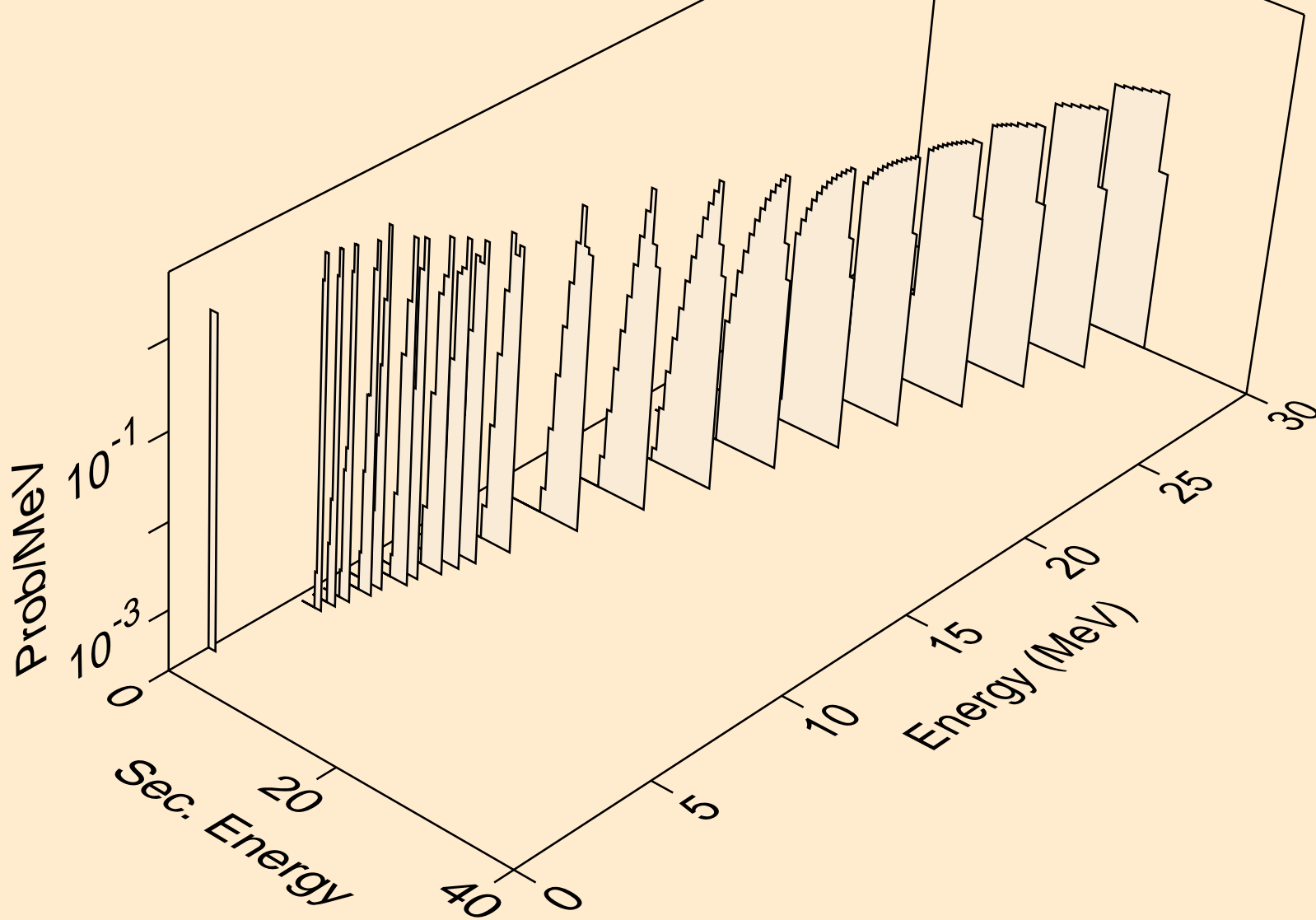

LR262 NEUTRON ACER TENDL-2019 LIBRARY; T=293.16K  
tritons from (n,x)

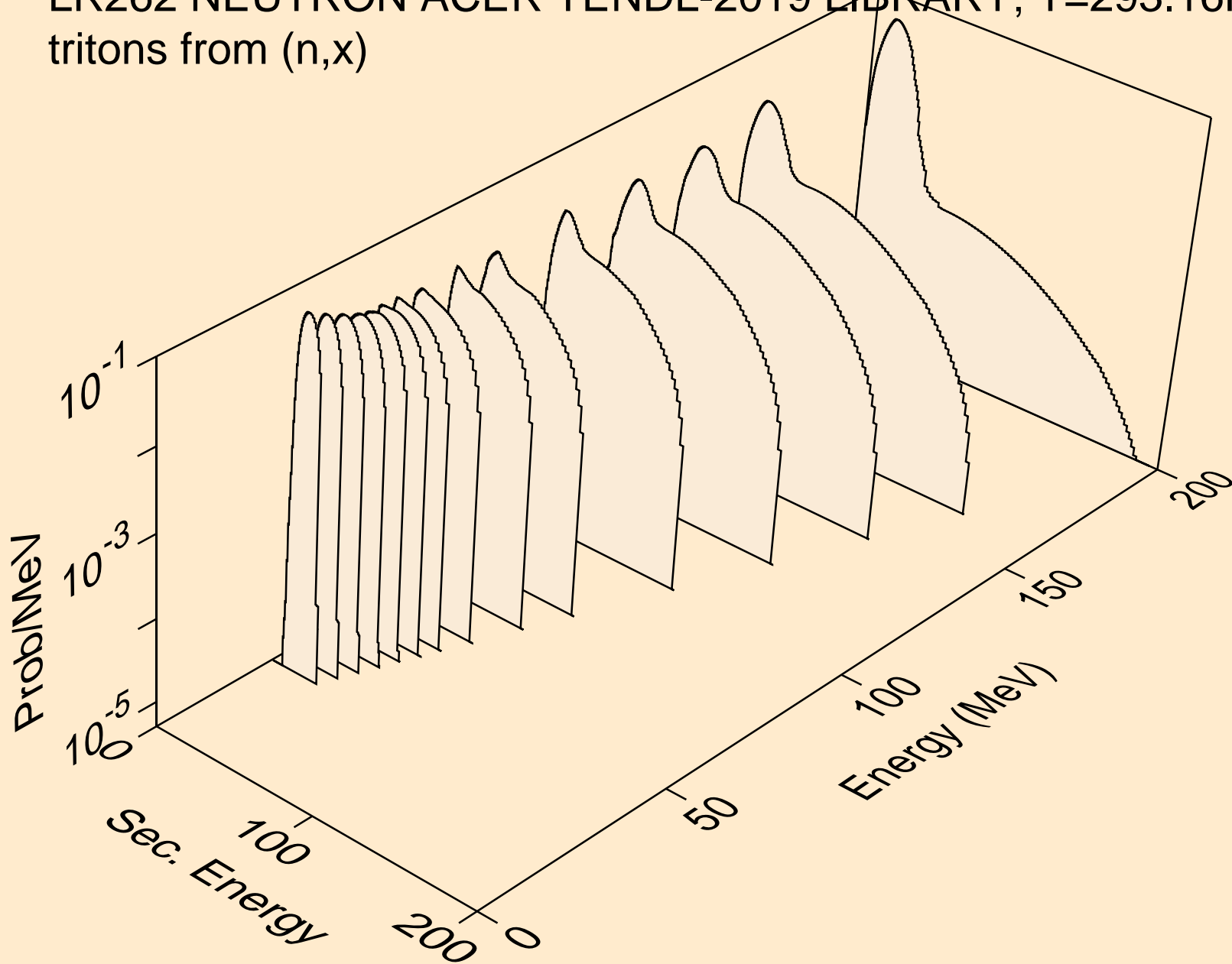

LR262 NEUTRON ACER TENDL-2019 LIBRARY; T=293.16K  
tritons from (n,n\*)t

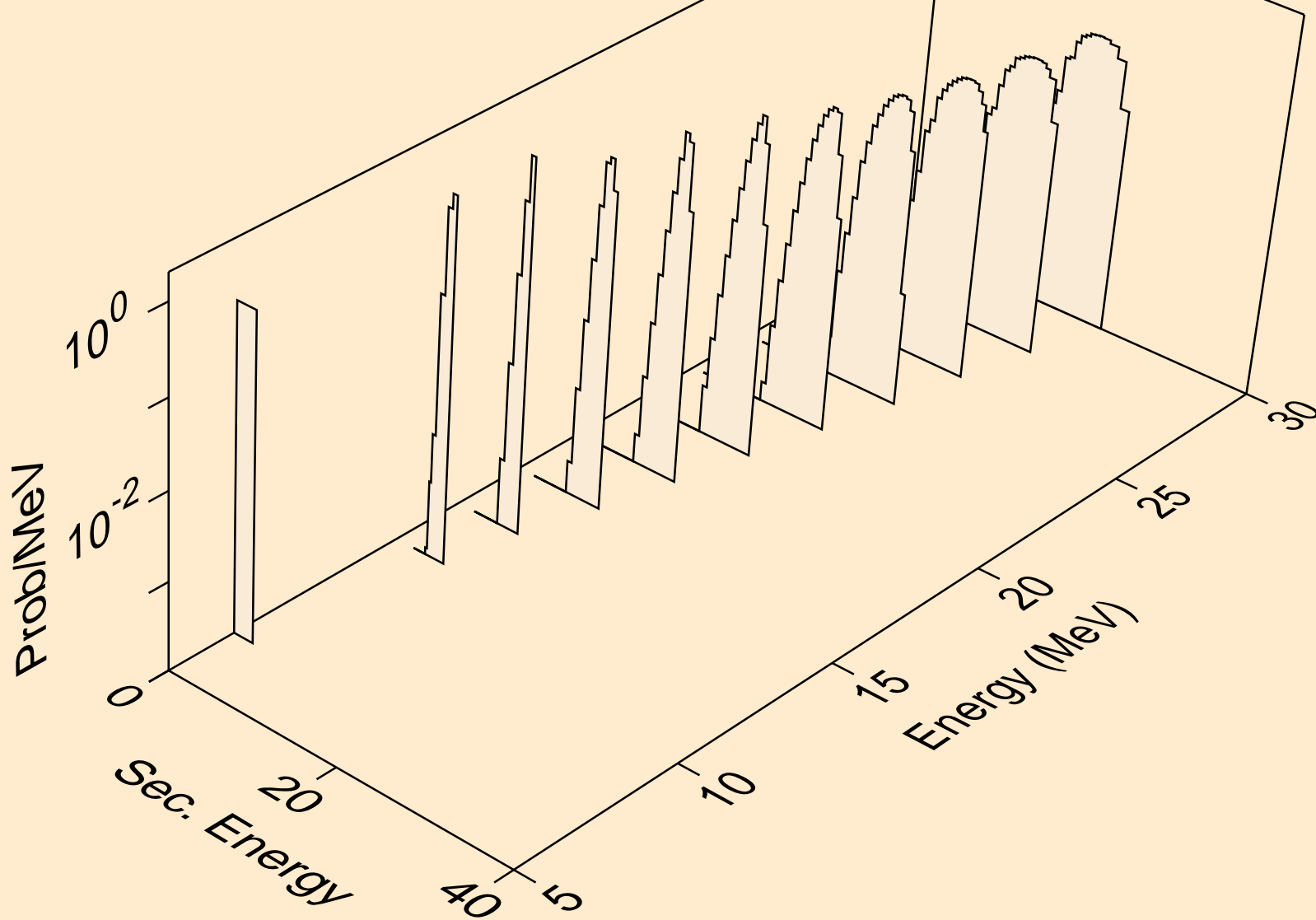

LR262 NEUTRON ACER TENDL-2019 LIBRARY; T=293.16K  
tritons from (n,t)

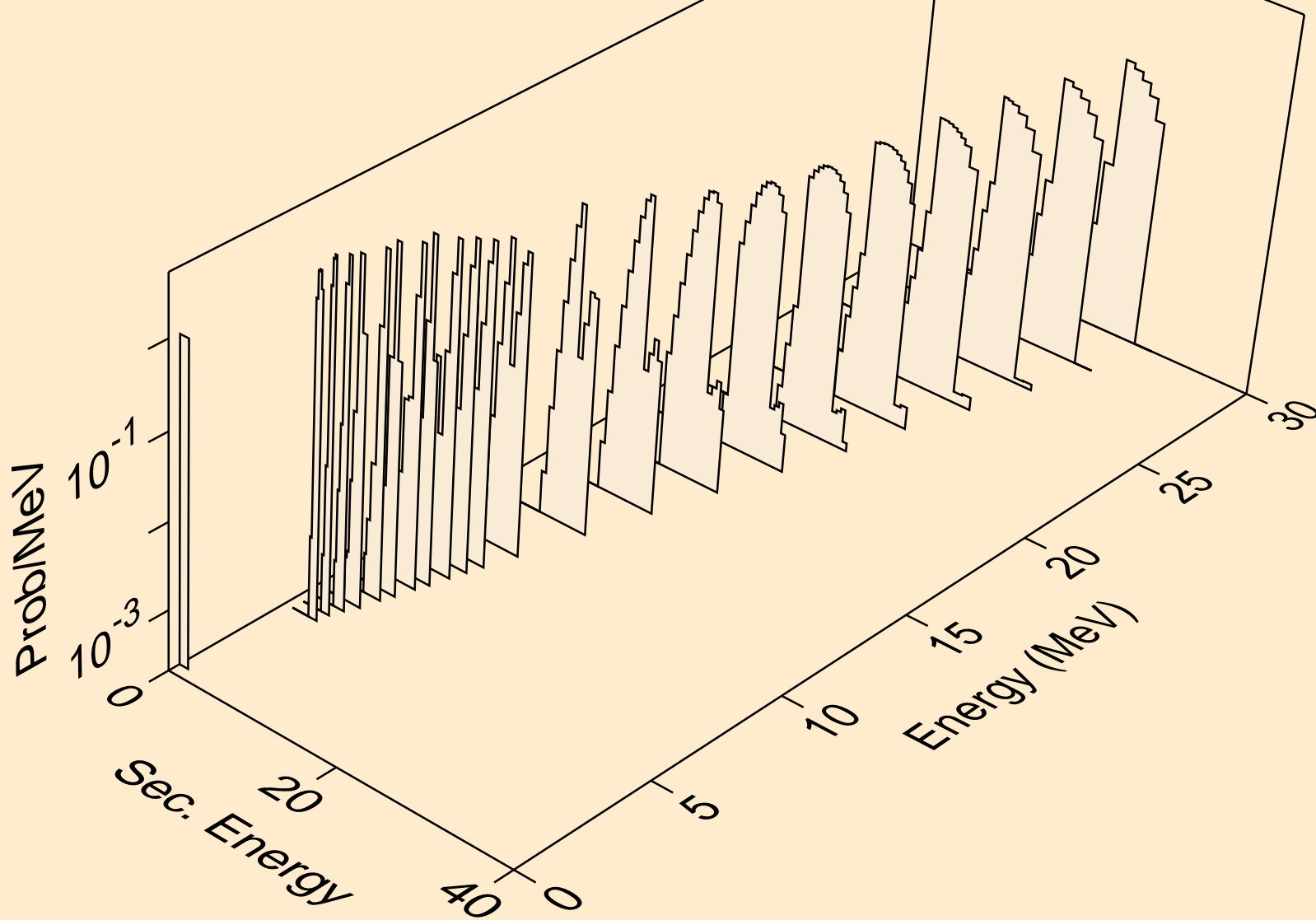

LR262 NEUTRON ACER TENDL-2019 LIBRARY; T=293.16K  
he3s from (n,x)

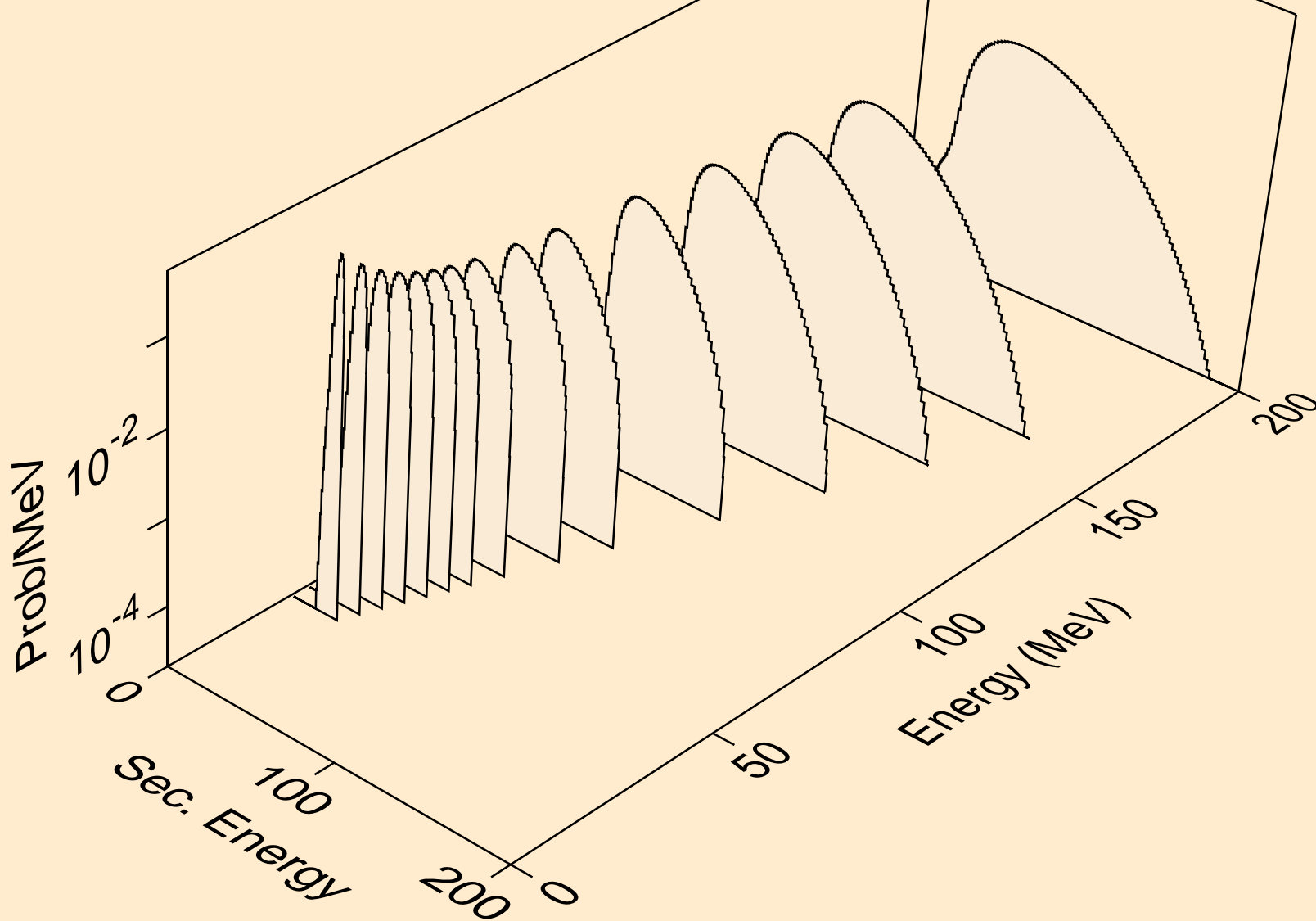

LR262 NEUTRON ACER TENDL-2019 LIBRARY; T=293.16K  
he3s from (n,n\*)he3

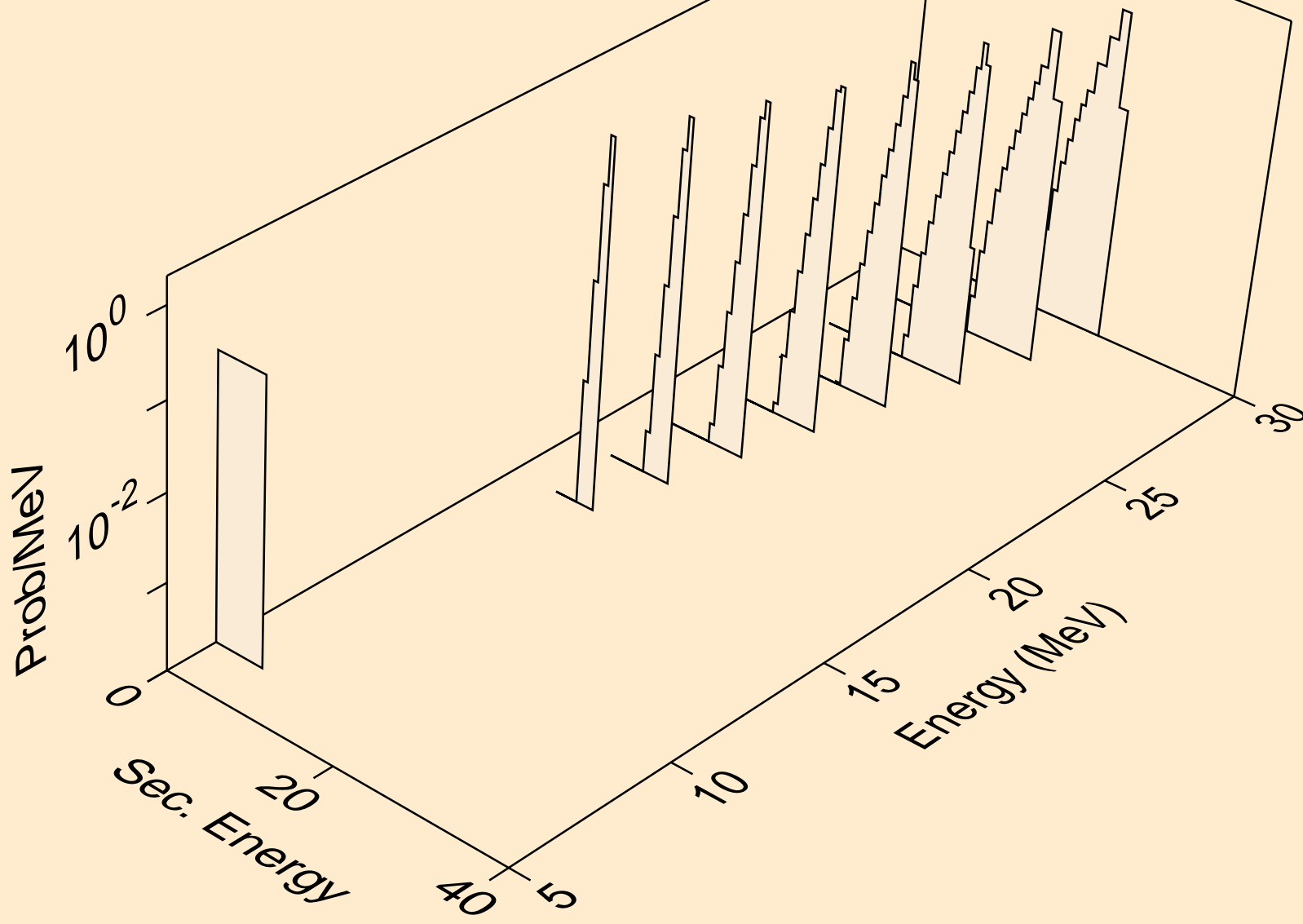

LR262 NEUTRON ACER TENDL-2019 LIBRARY; T=293.16K  
he3s from (n,he3)

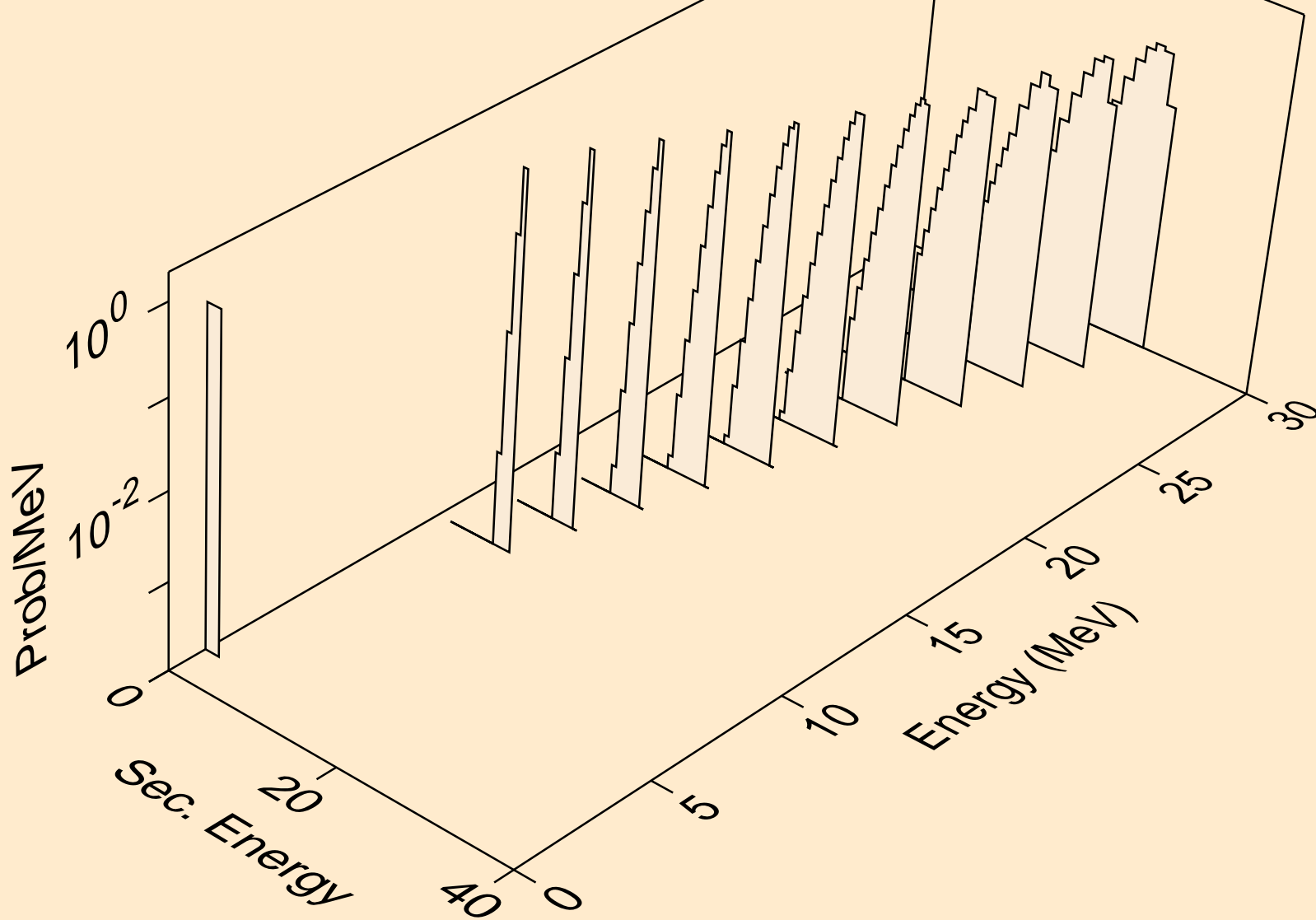

LR262 NEUTRON ACER TENDL-2019 LIBRARY; T=293.16K  
alphas from (n,x)

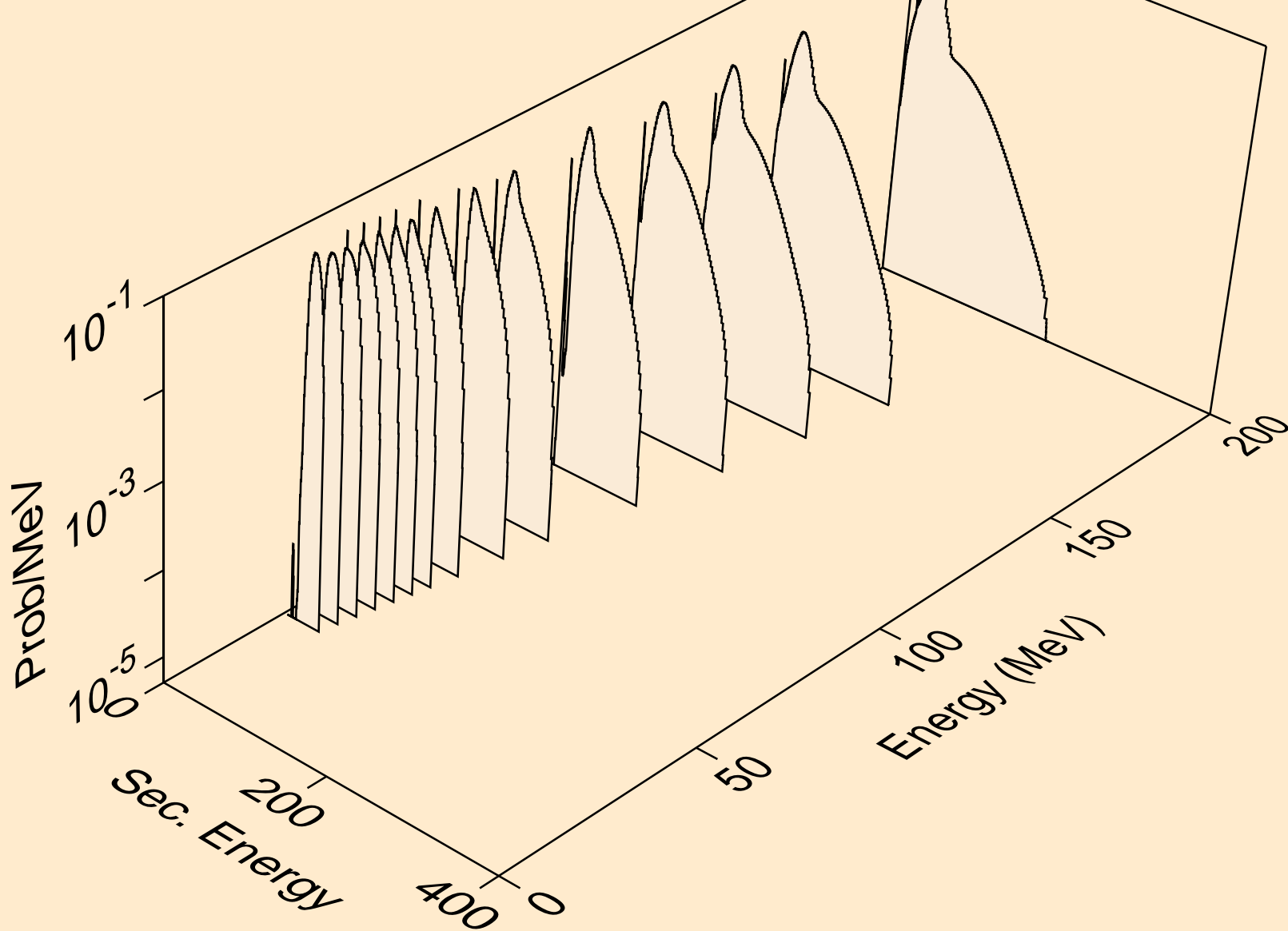

LR262 NEUTRON ACER TENDL-2019 LIBRARY; T=293.16K  
alphas from (n,n\*)a

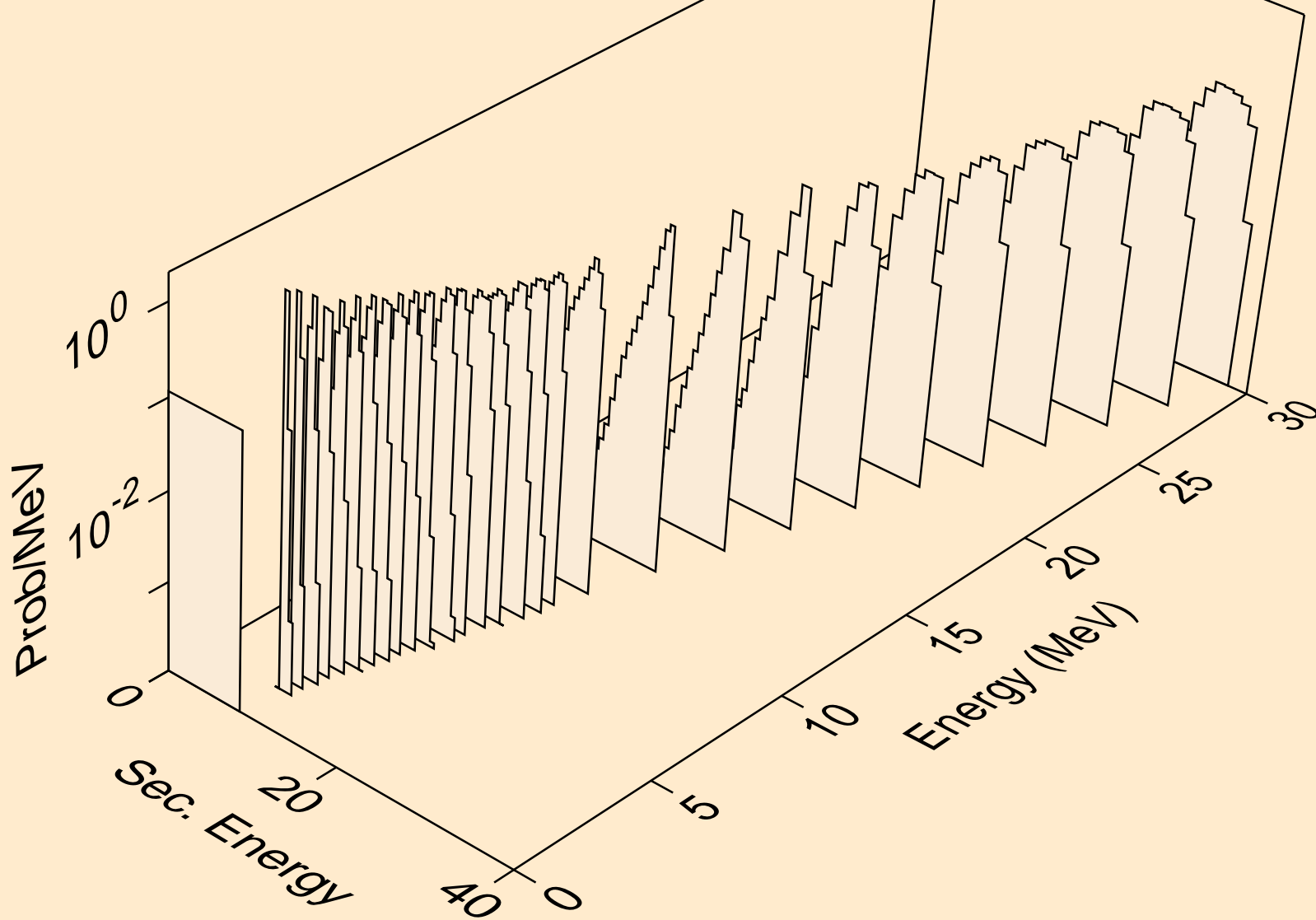

LR262 NEUTRON ACER TENDL-2019 LIBRARY; T=293.16K  
alphas from (n,2n)a

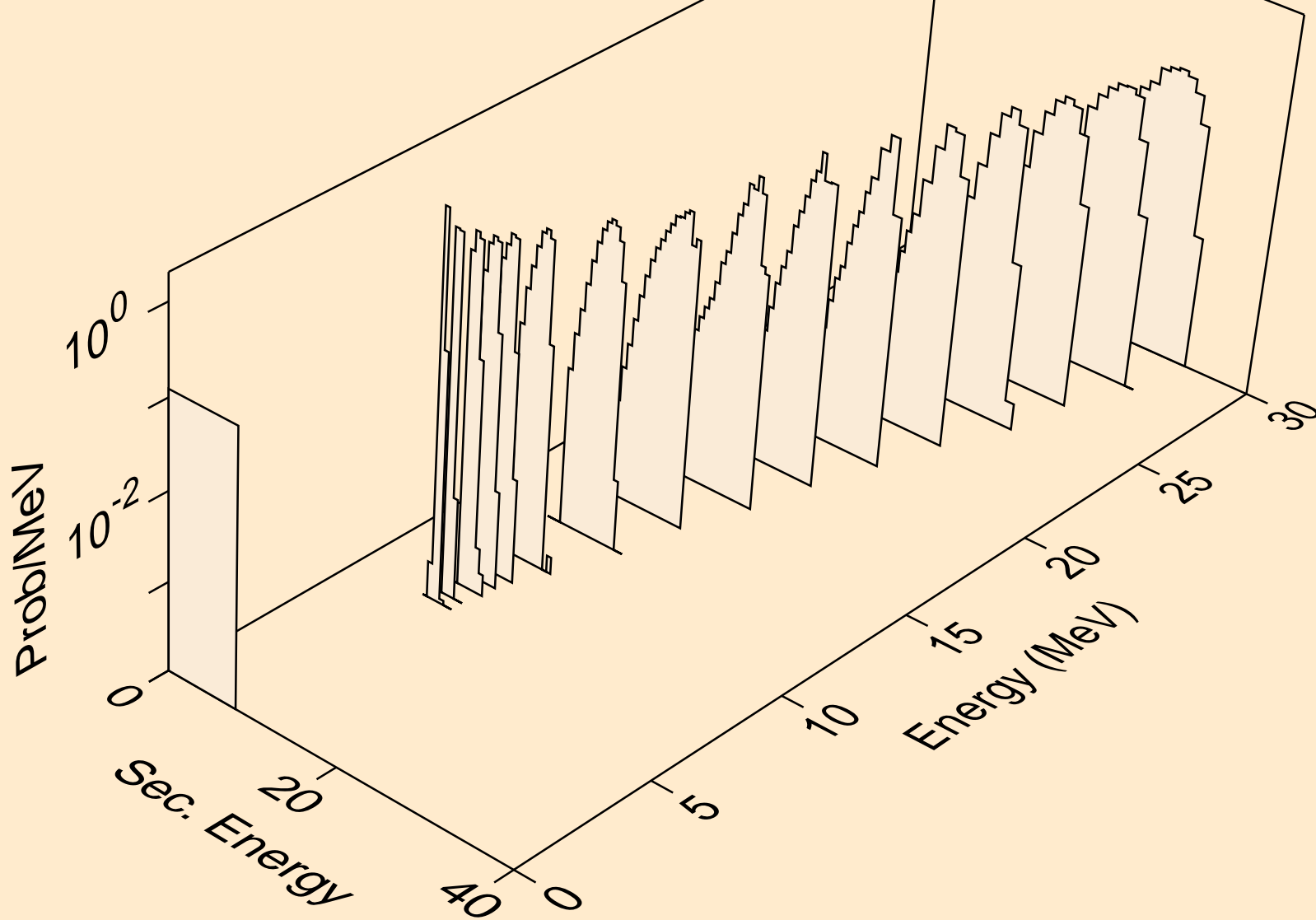

LR262 NEUTRON ACER TENDL-2019 LIBRARY; T=293.16K  
alphas from (n,3n)a

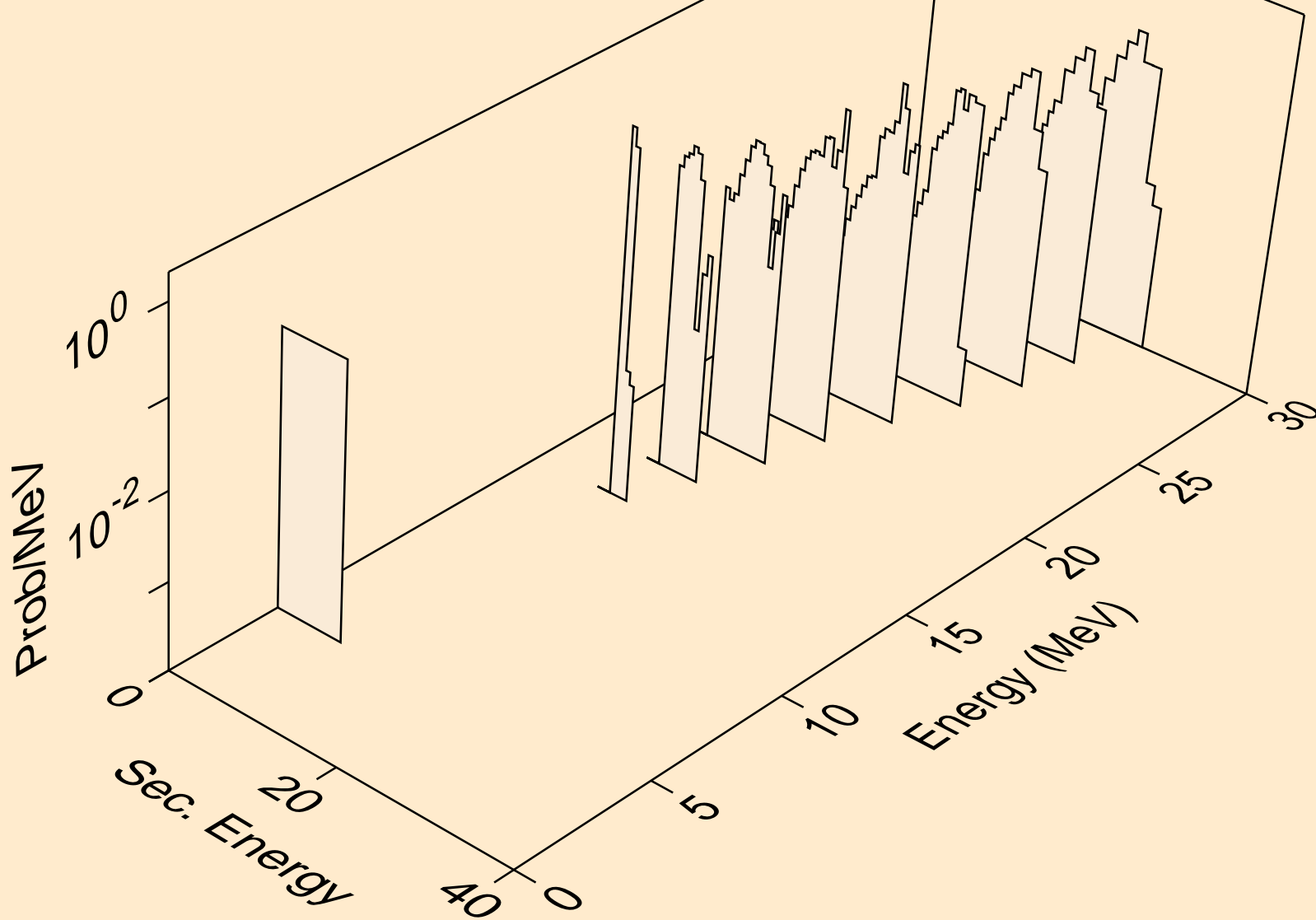

LR262 NEUTRON ACER TENDL-2019 LIBRARY; T=293.16K  
alphas from (n,n\*)2a

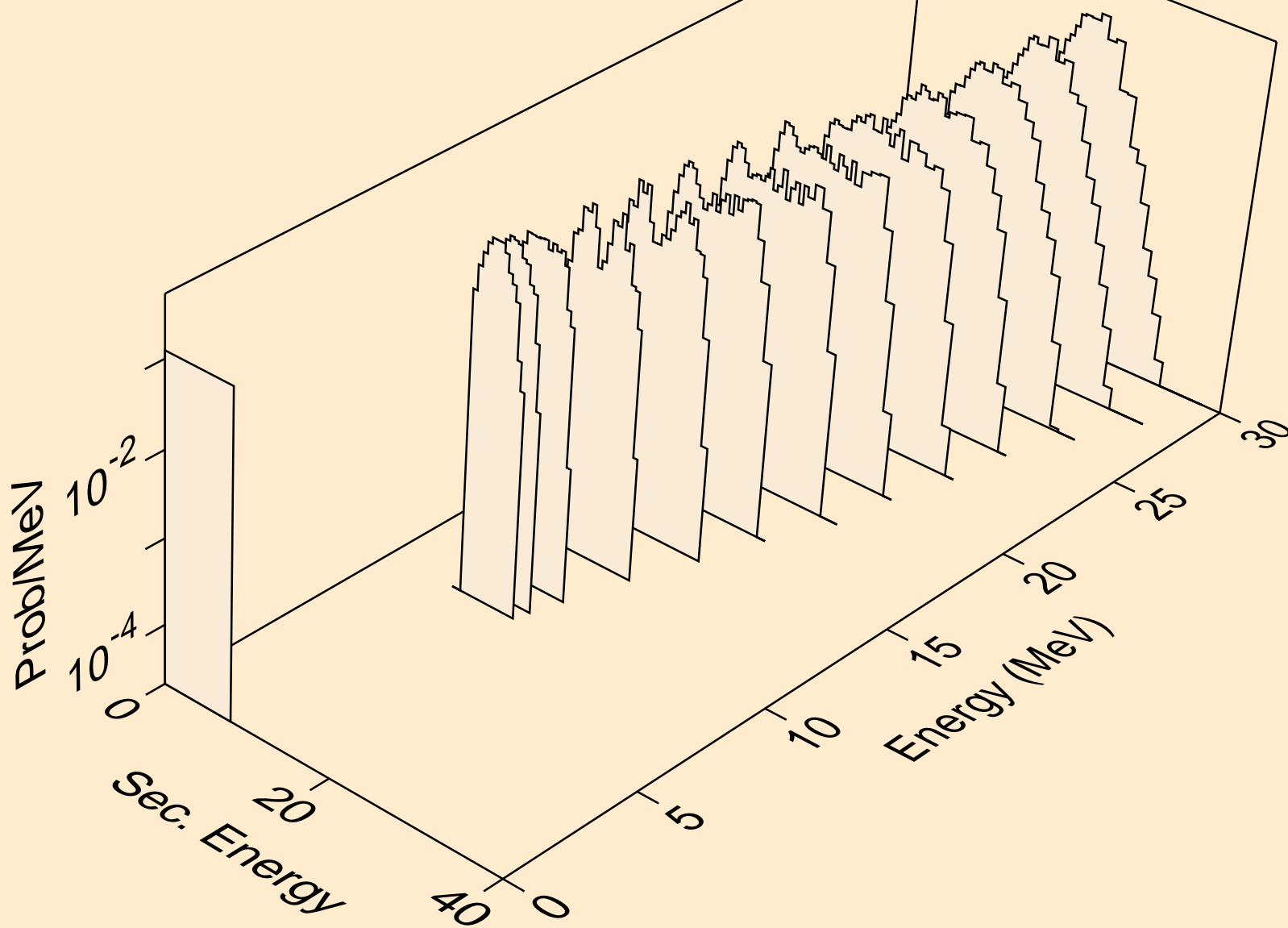

LR262 NEUTRON ACER TENDL-2019 LIBRARY; T=293.16K  
alphas from (n,npa)

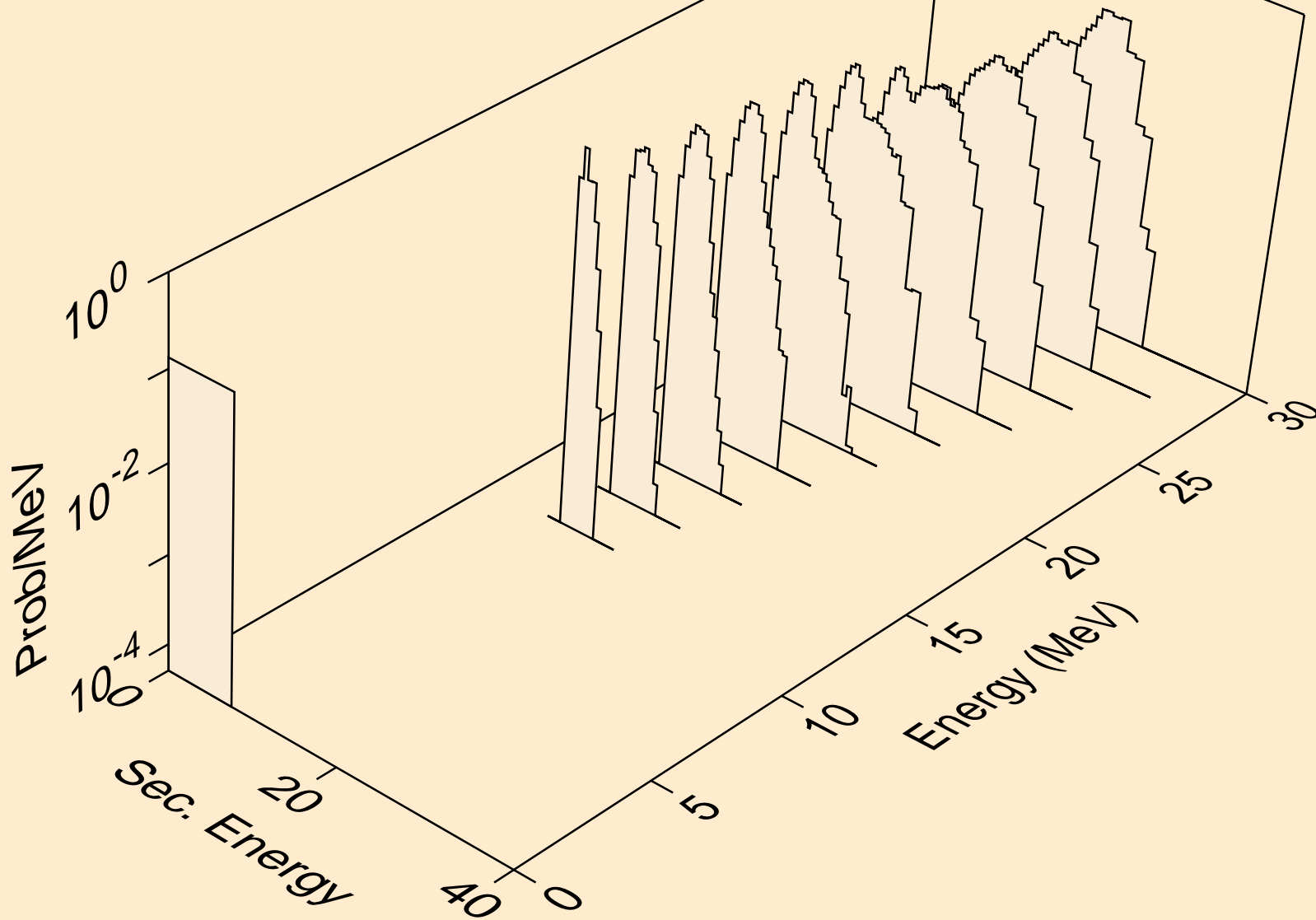

LR262 NEUTRON ACER TENDL-2019 LIBRARY; T=293.16K  
alphas from (n,a)

