

TH225 ALPHA ACER TENDL-2021 LIBRARY; T=0.K
Principal cross sections

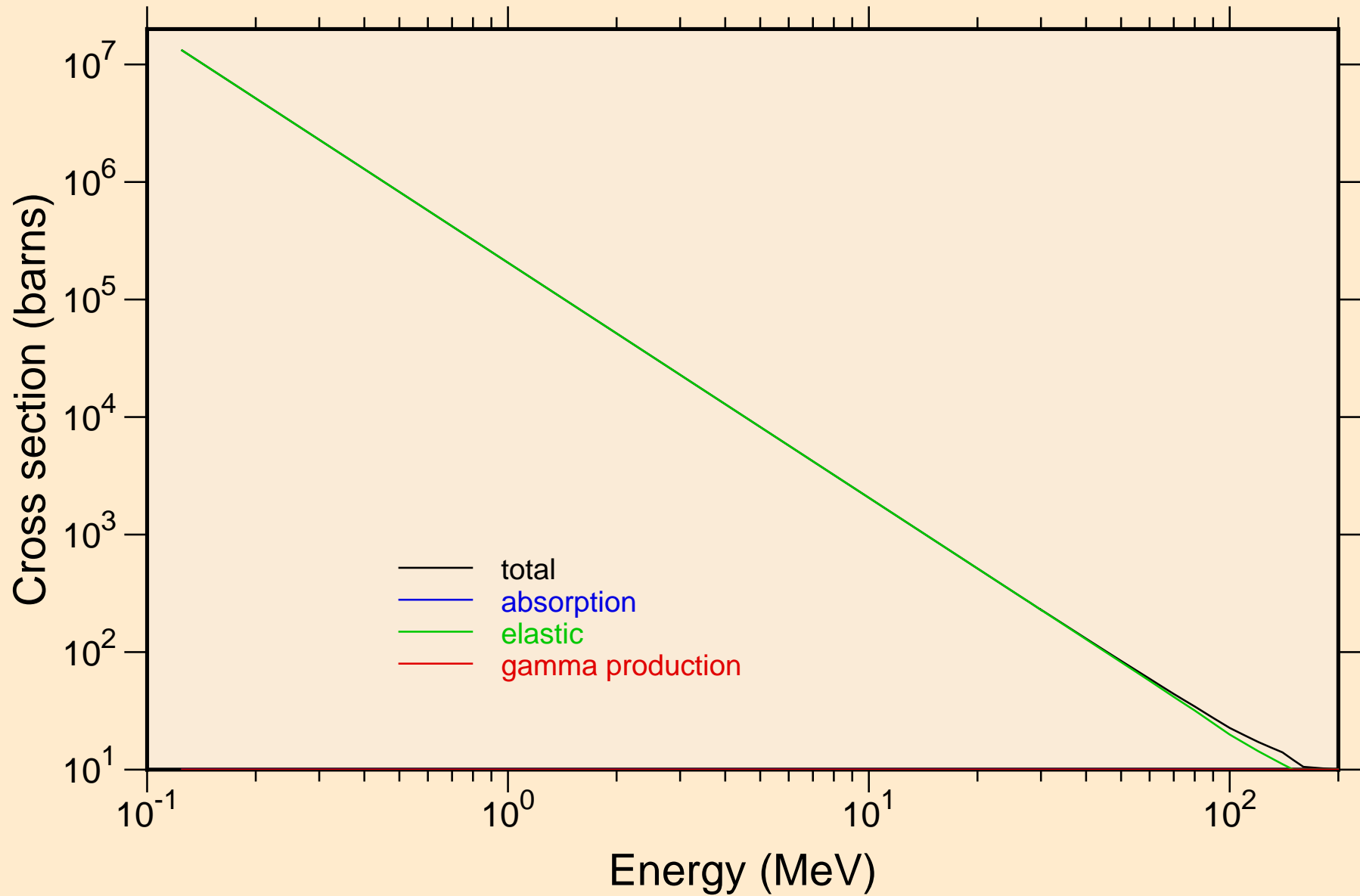

TH225 ALPHA ACER TENDL-2021 LIBRARY; T=0.K

Heating

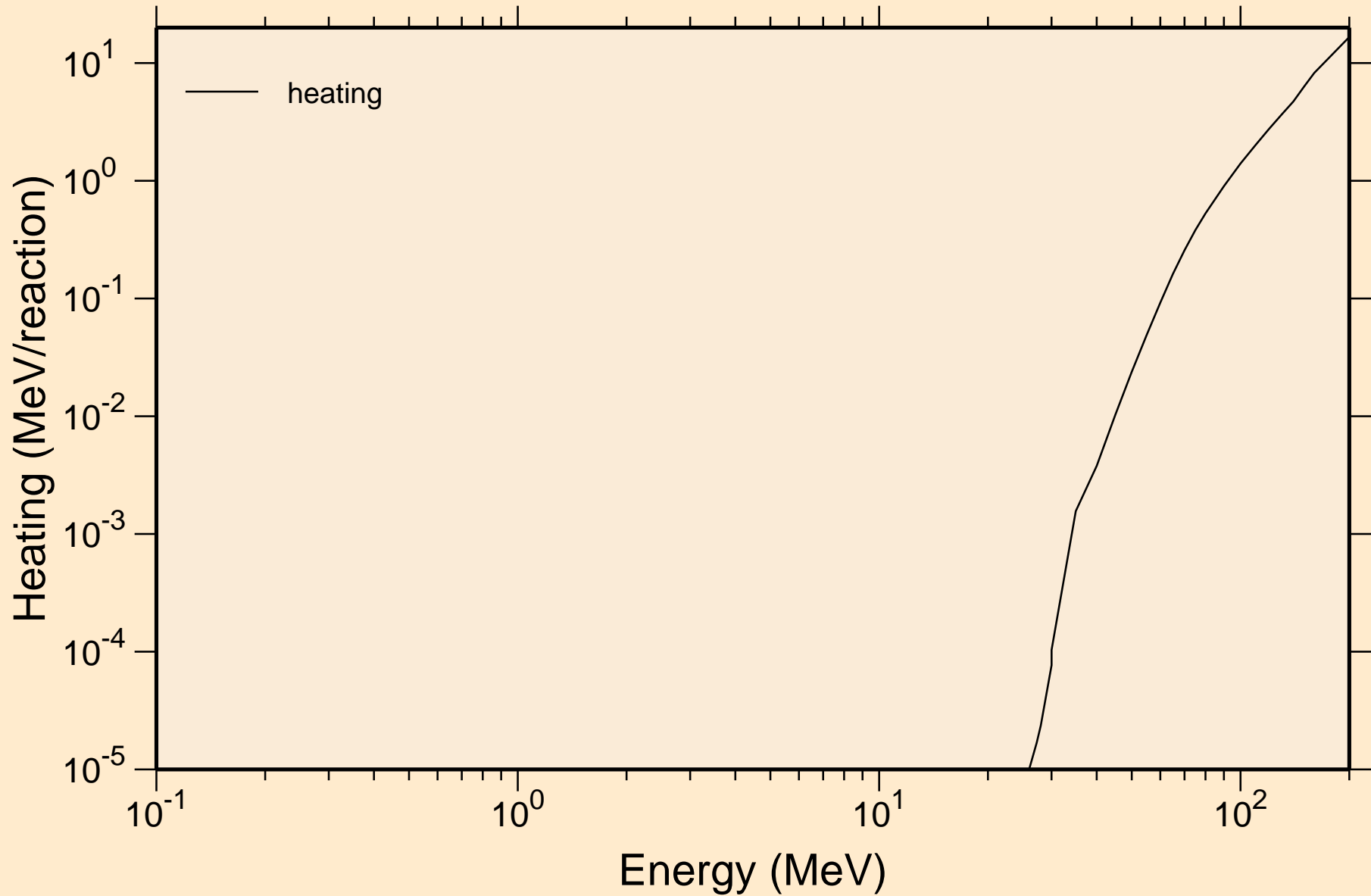

TH225 ALPHA ACER TENDL-2021 LIBRARY; T=0.K

Principal cross sections

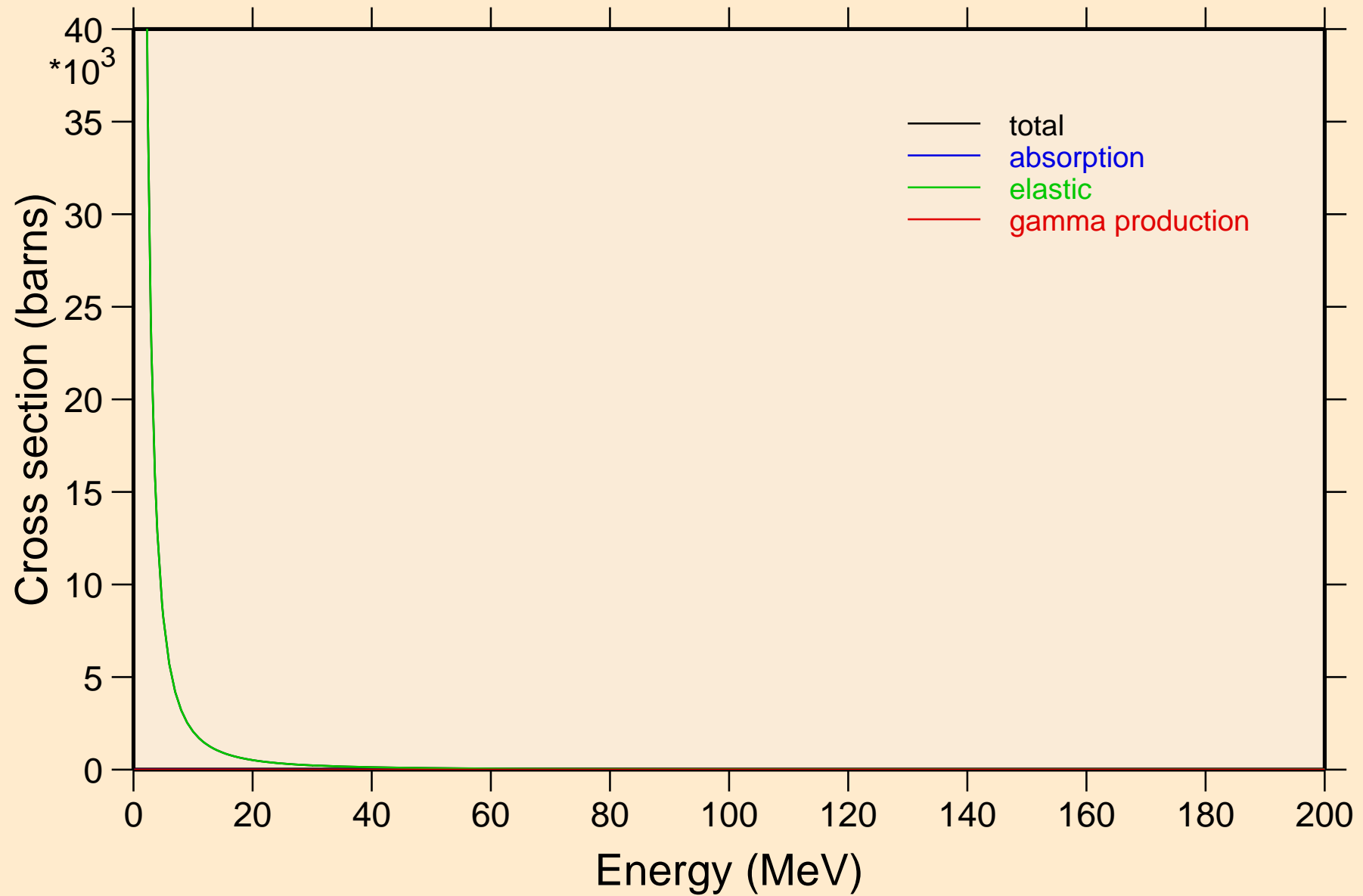

TH225 ALPHA ACER TENDL-2021 LIBRARY; T=0.K

Heating

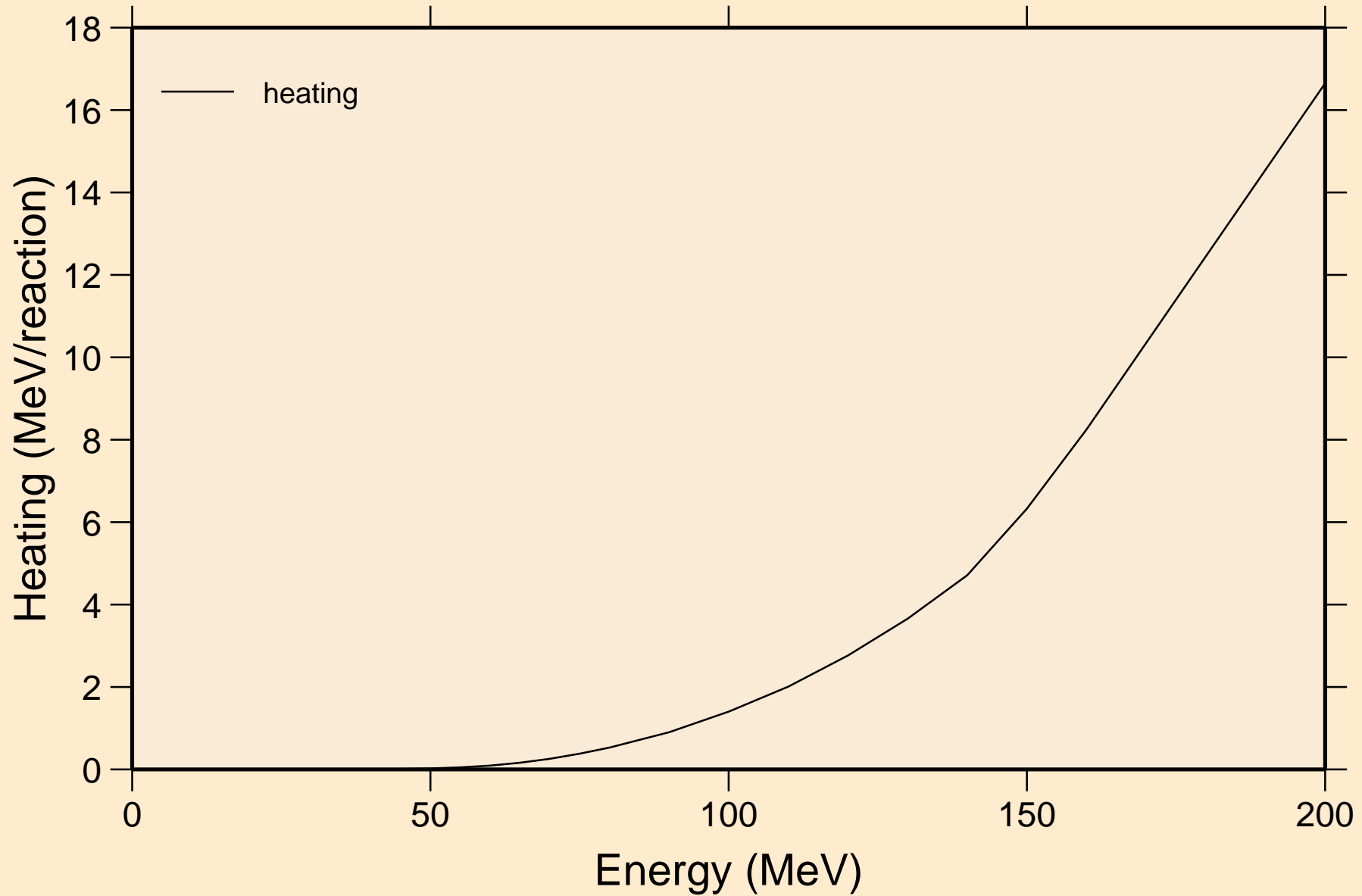

TH225 ALPHA ACER TENDL-2021 LIBRARY; T=0.K
Threshold reactions

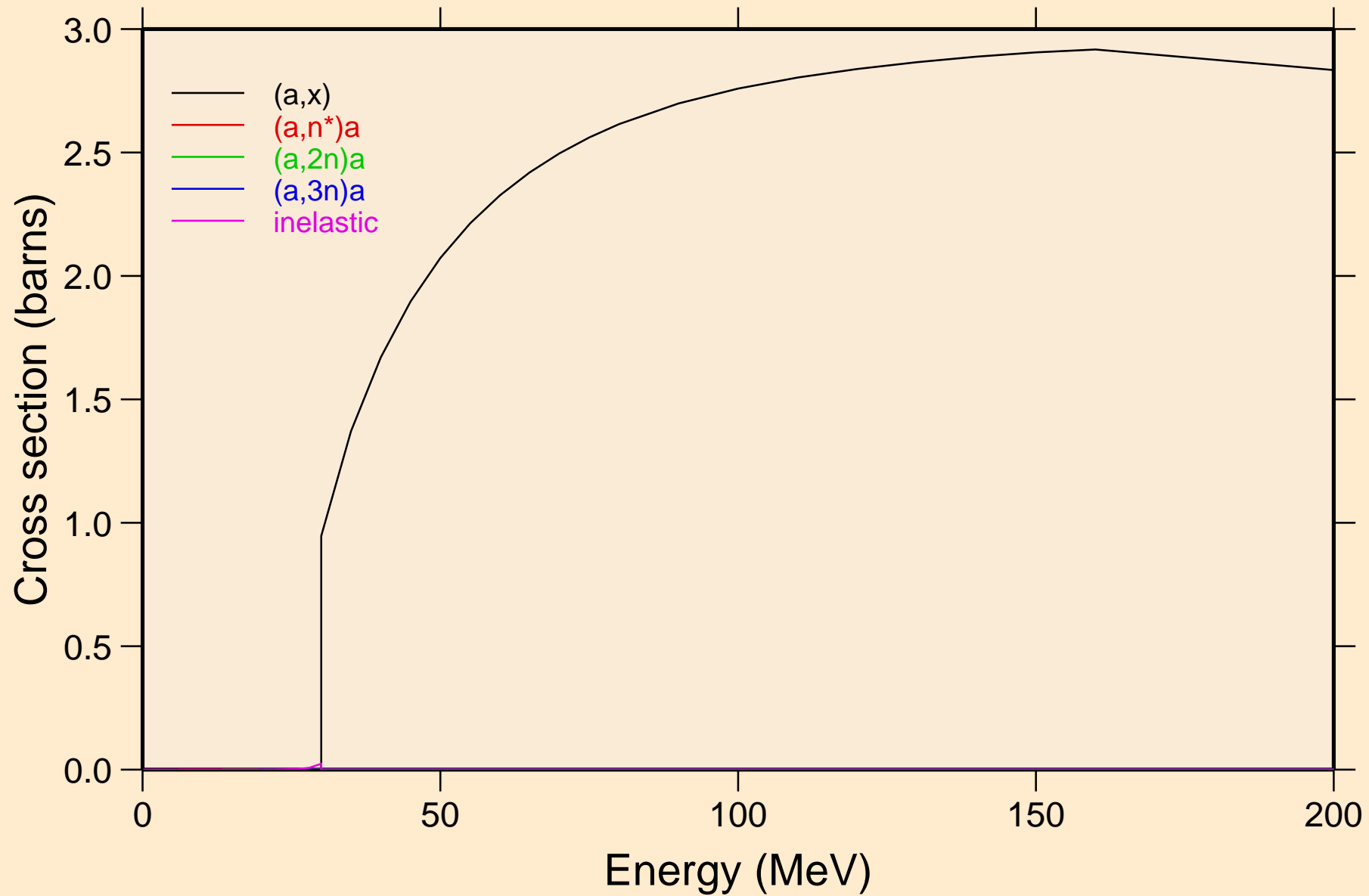

TH225 ALPHA ACER TENDL-2021 LIBRARY; T=0.K
Threshold reactions

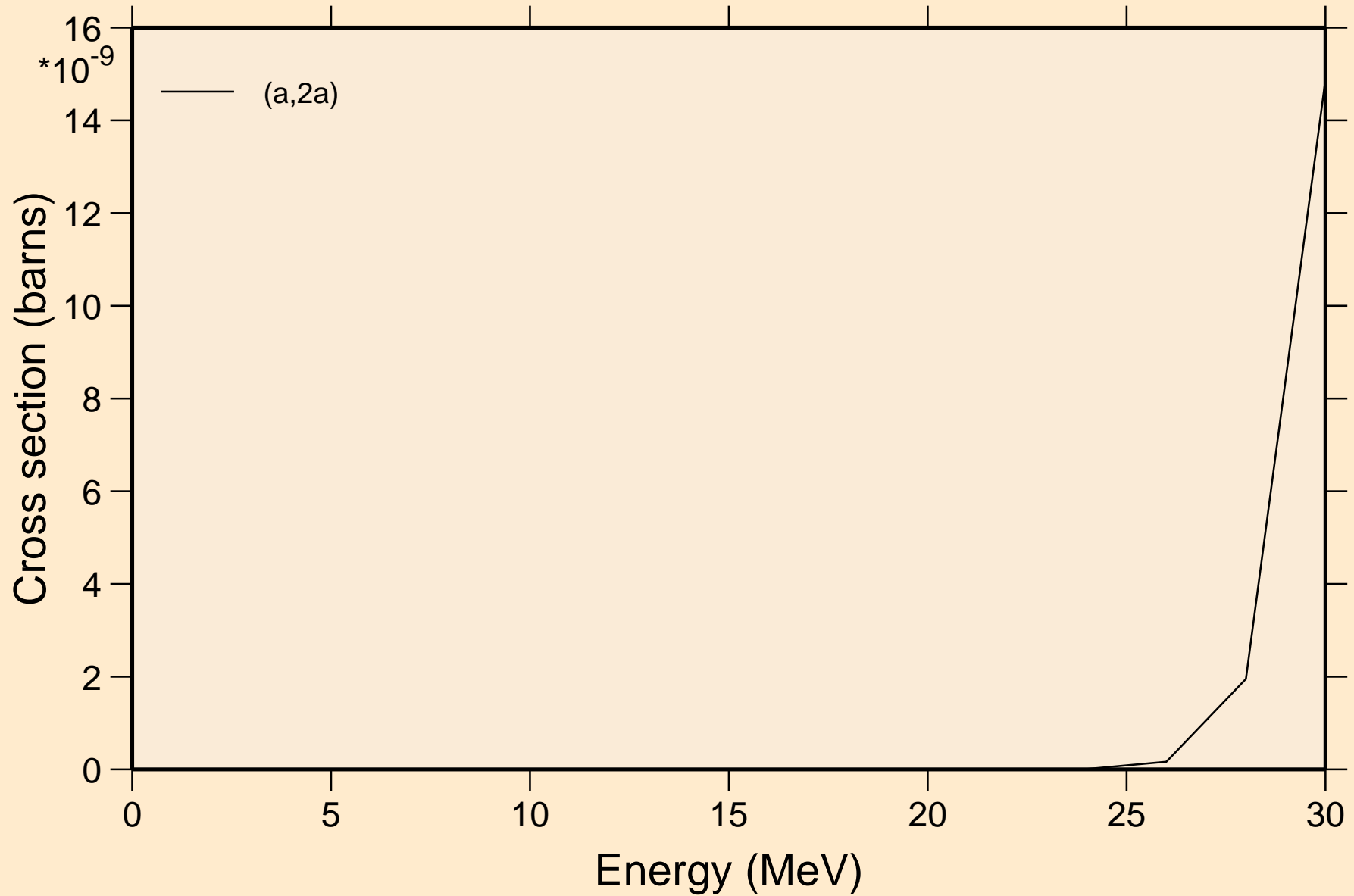

TH225 ALPHA ACER TENDL-2021 LIBRARY; T=0.K
angular distribution for elastic

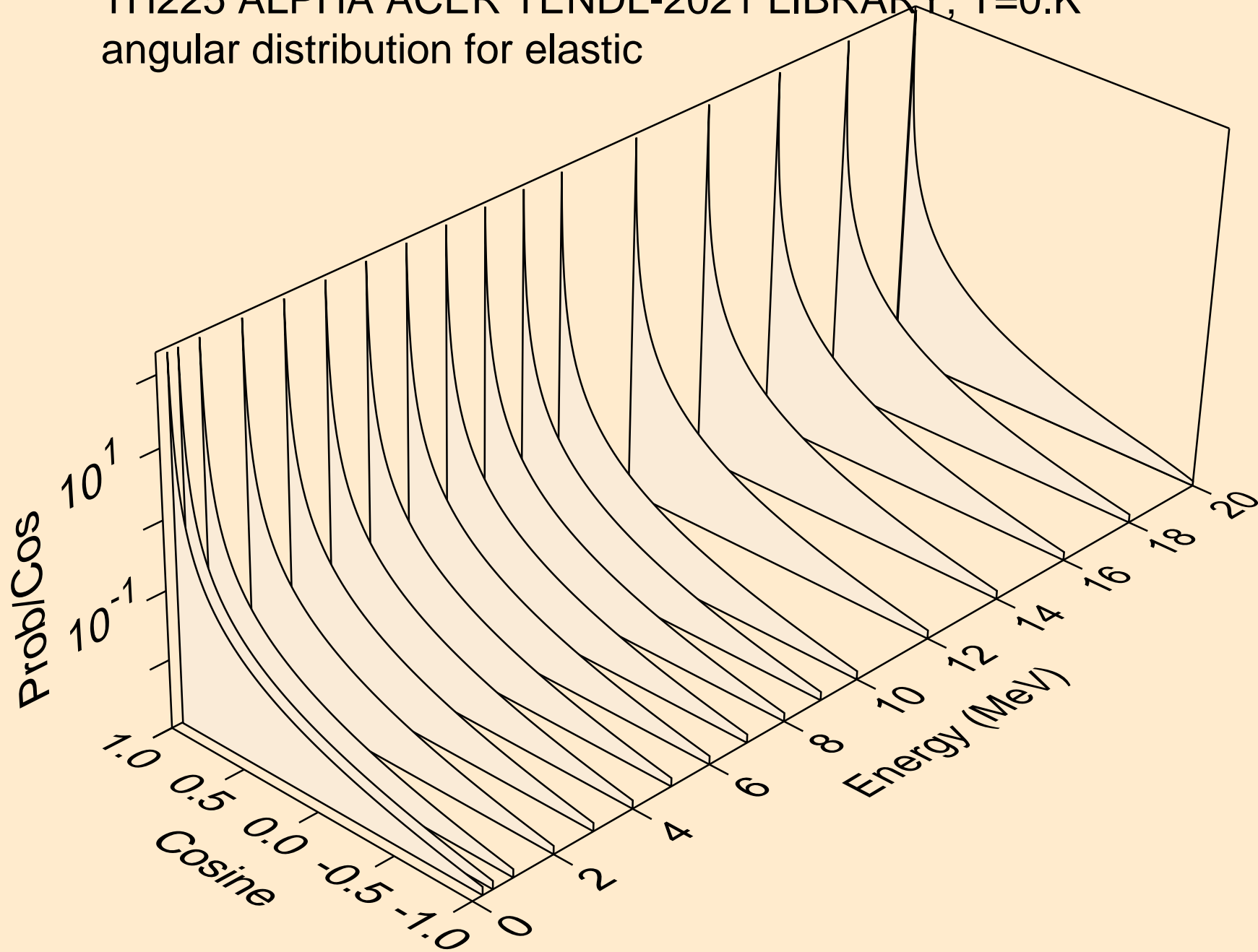

TH225 ALPHA ACER TENDL-2021 LIBRARY; T=0.K
angular distribution for elastic

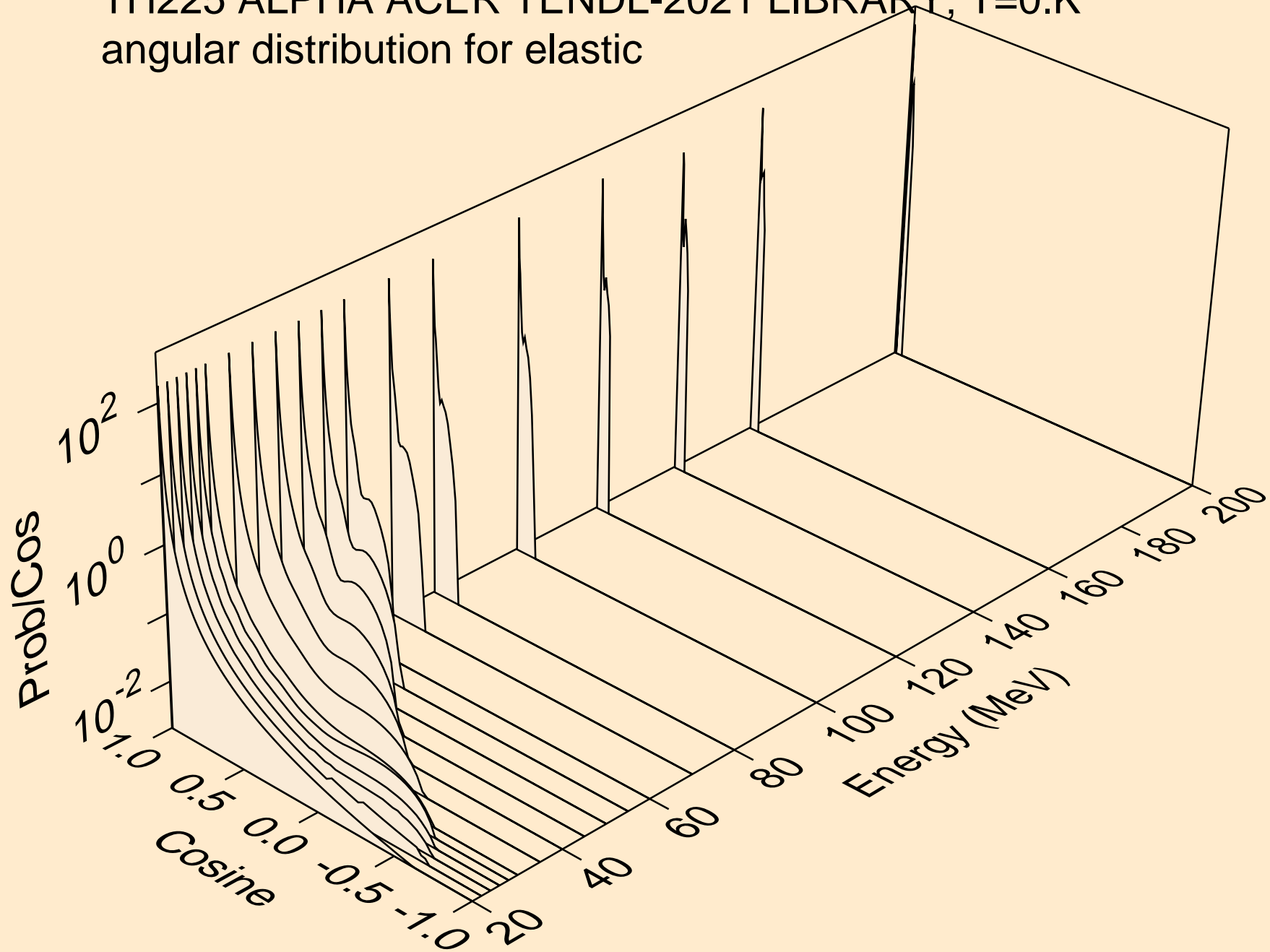

TH225 ALPHA ACER TENDL-2021 LIBRARY; T=0.K
Alpha emission for (a,x)

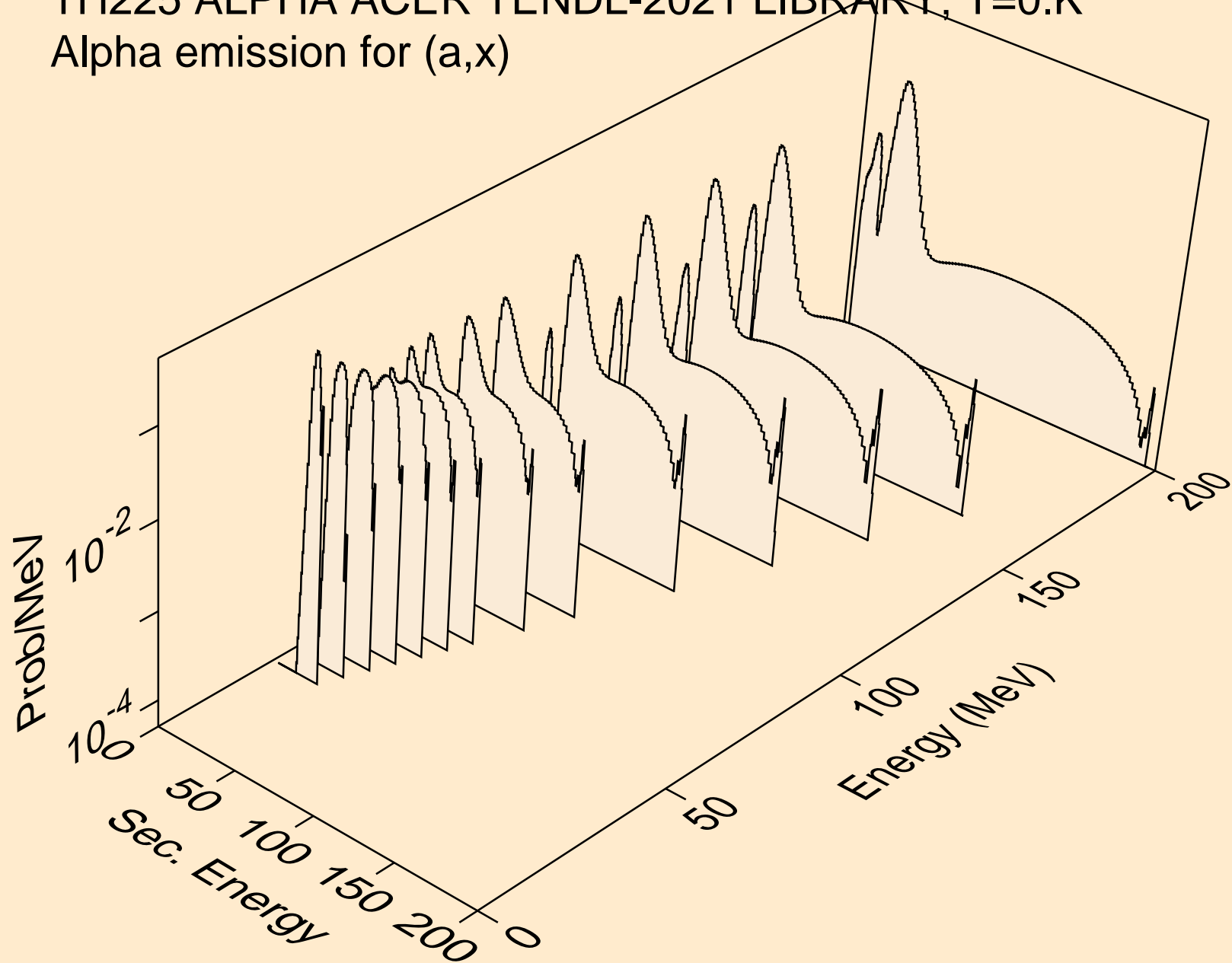

TH225 ALPHA ACER TENDL-2021 LIBRARY; T=0.K
Alpha emission for (a,n*)a

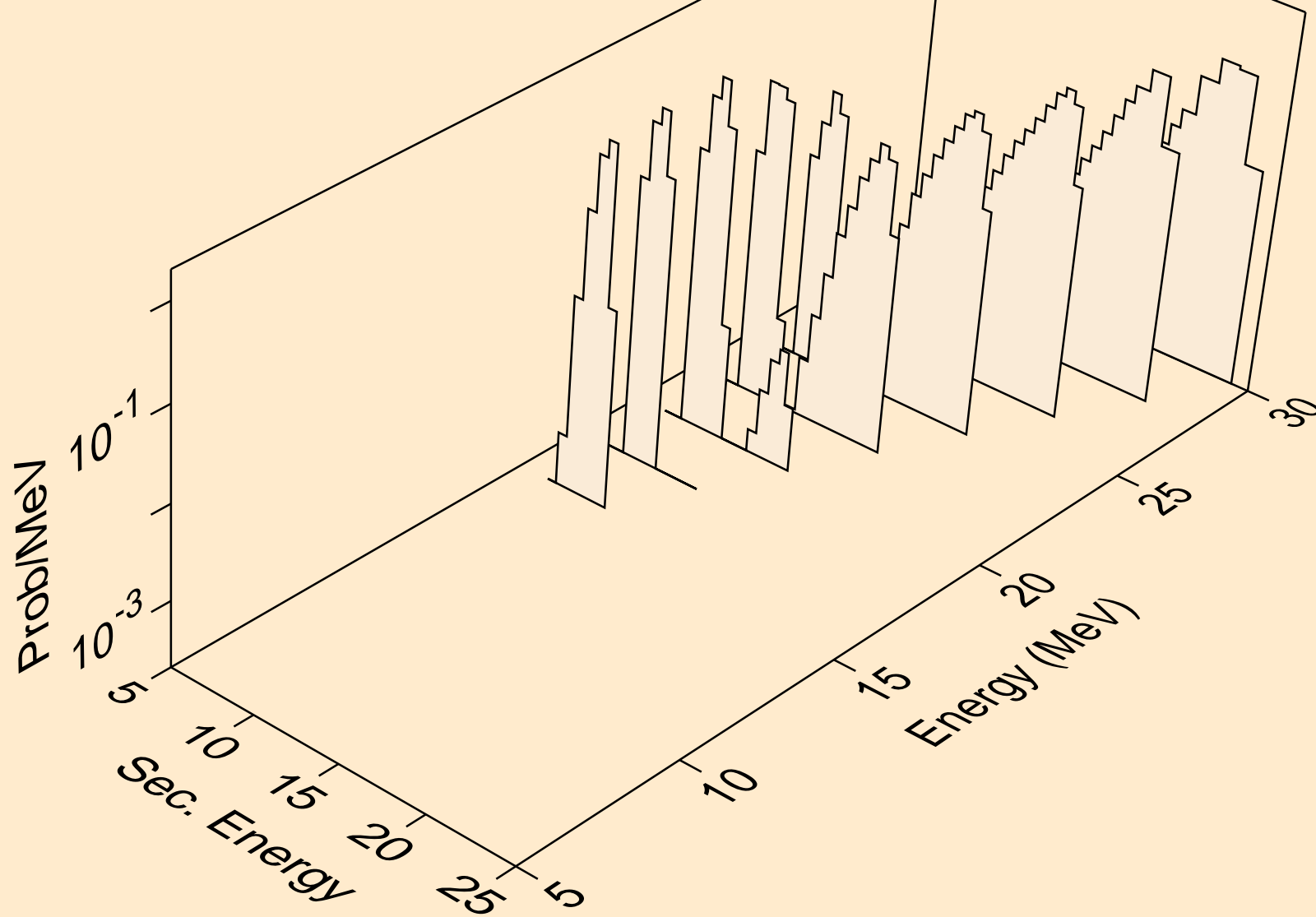

TH225 ALPHA ACER TENDL-2021 LIBRARY; T=0.K

Alpha emission for (a,2n)a

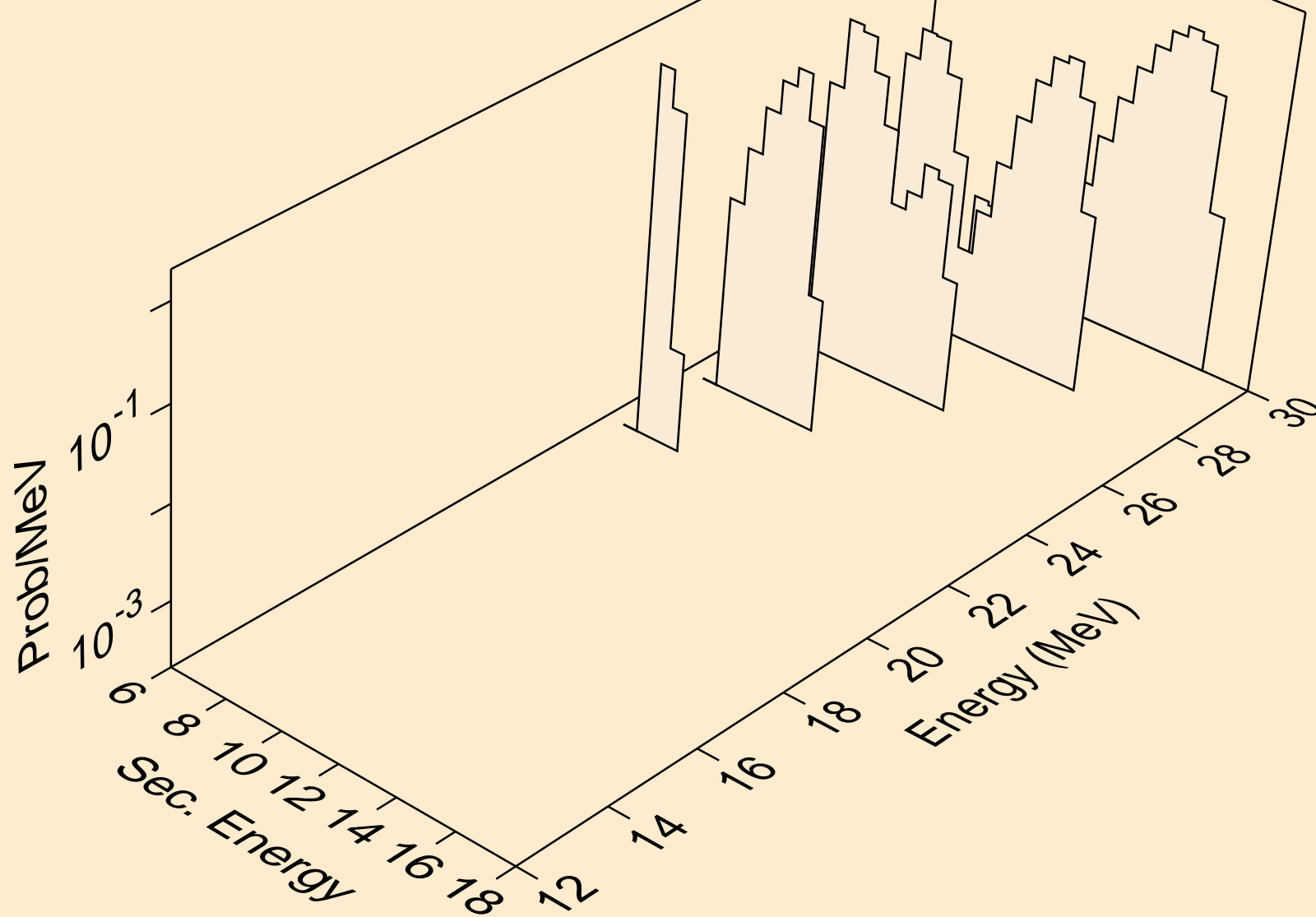

TH225 ALPHA ACER TENDL-2021 LIBRARY; T=0.K
Alpha emission for (a,3n)a

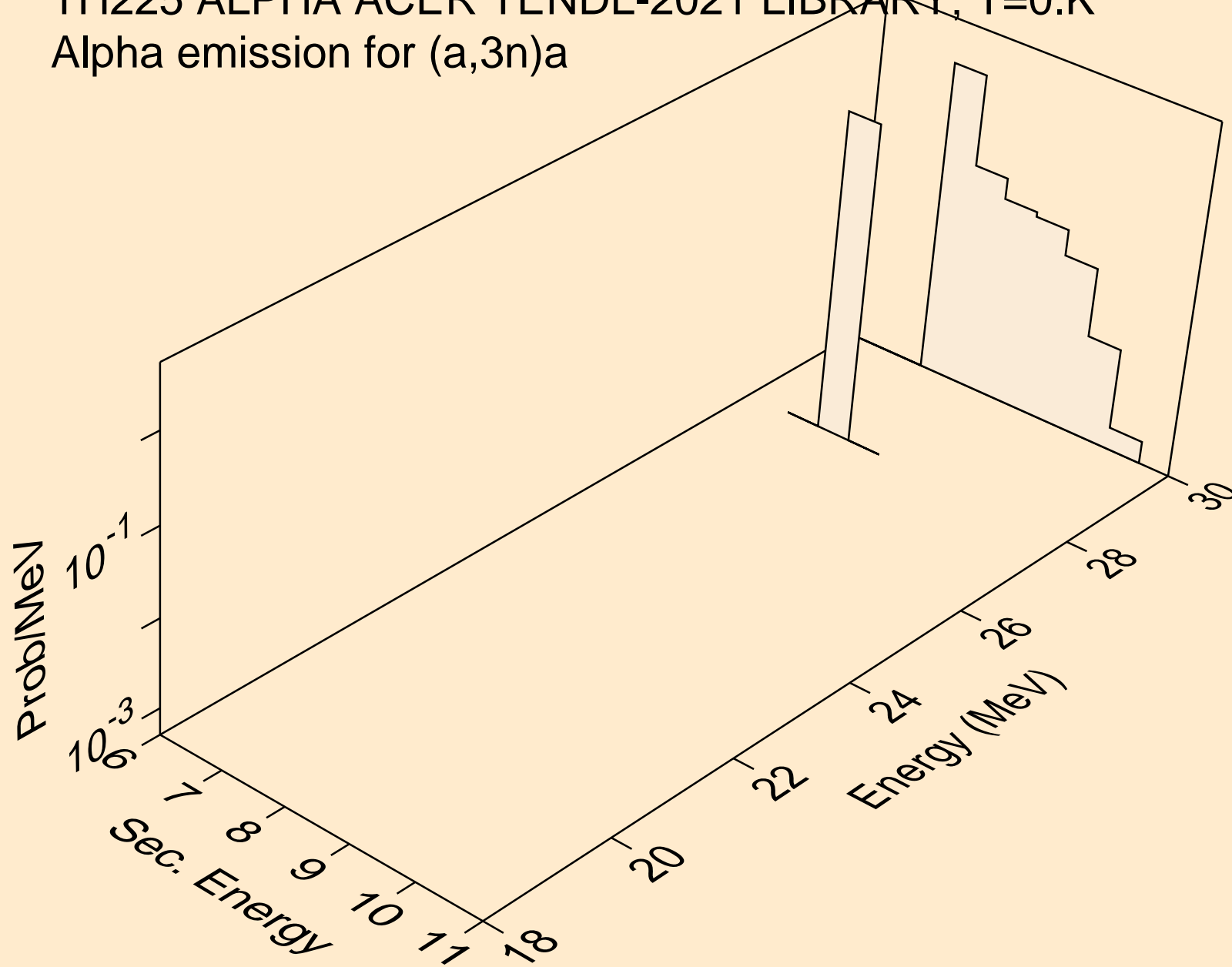

TH225 ALPHA ACER TENDL-2021 LIBRARY; T=0.K
Alpha emission for inelastic

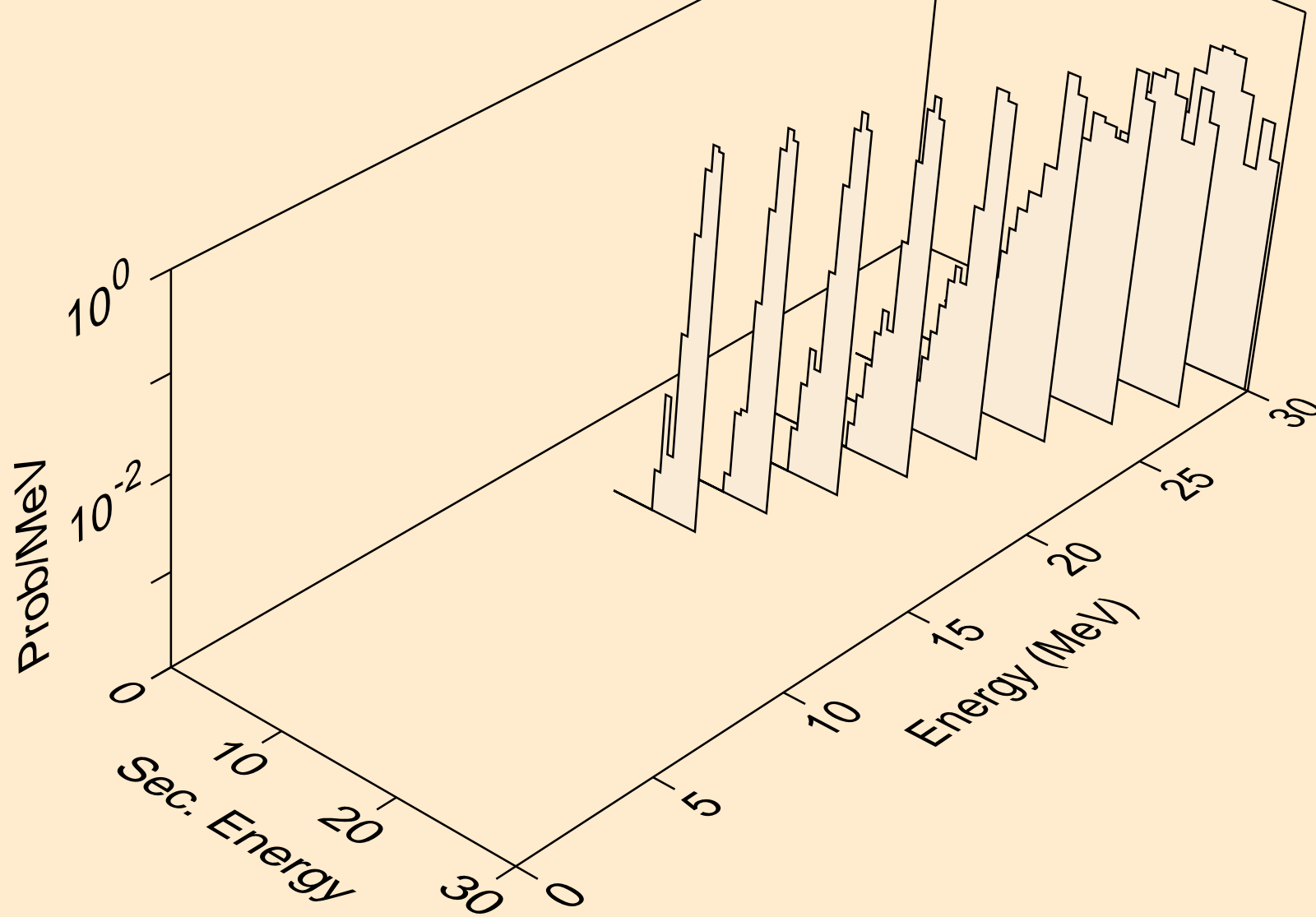

TH225 ALPHA ACER TENDL-2021 LIBRARY; T=0.K
Alpha emission for (a,2a)

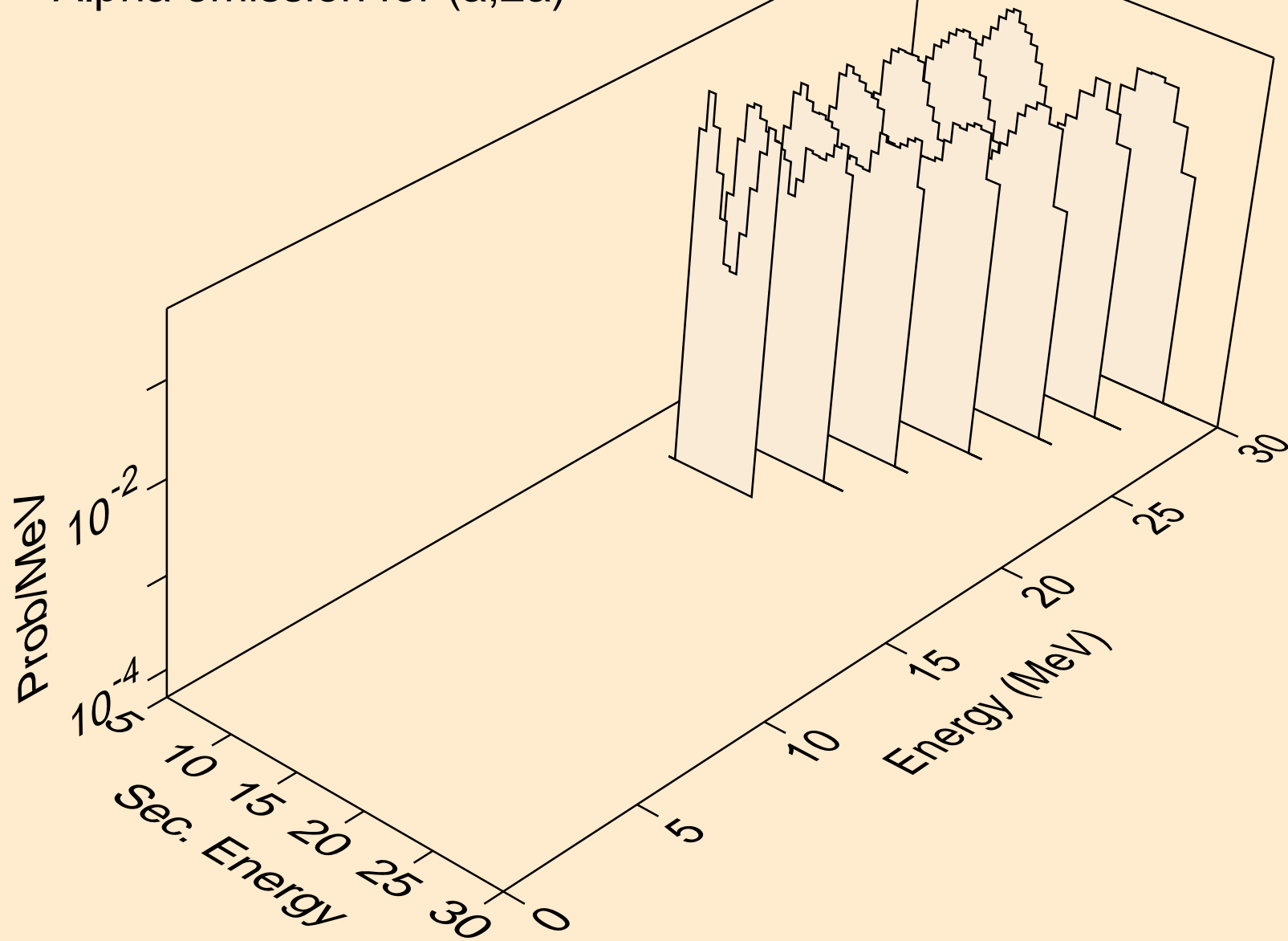

TH225 ALPHA ACER TENDL-2021 LIBRARY; T=0.K
Photon emission for (z,n)

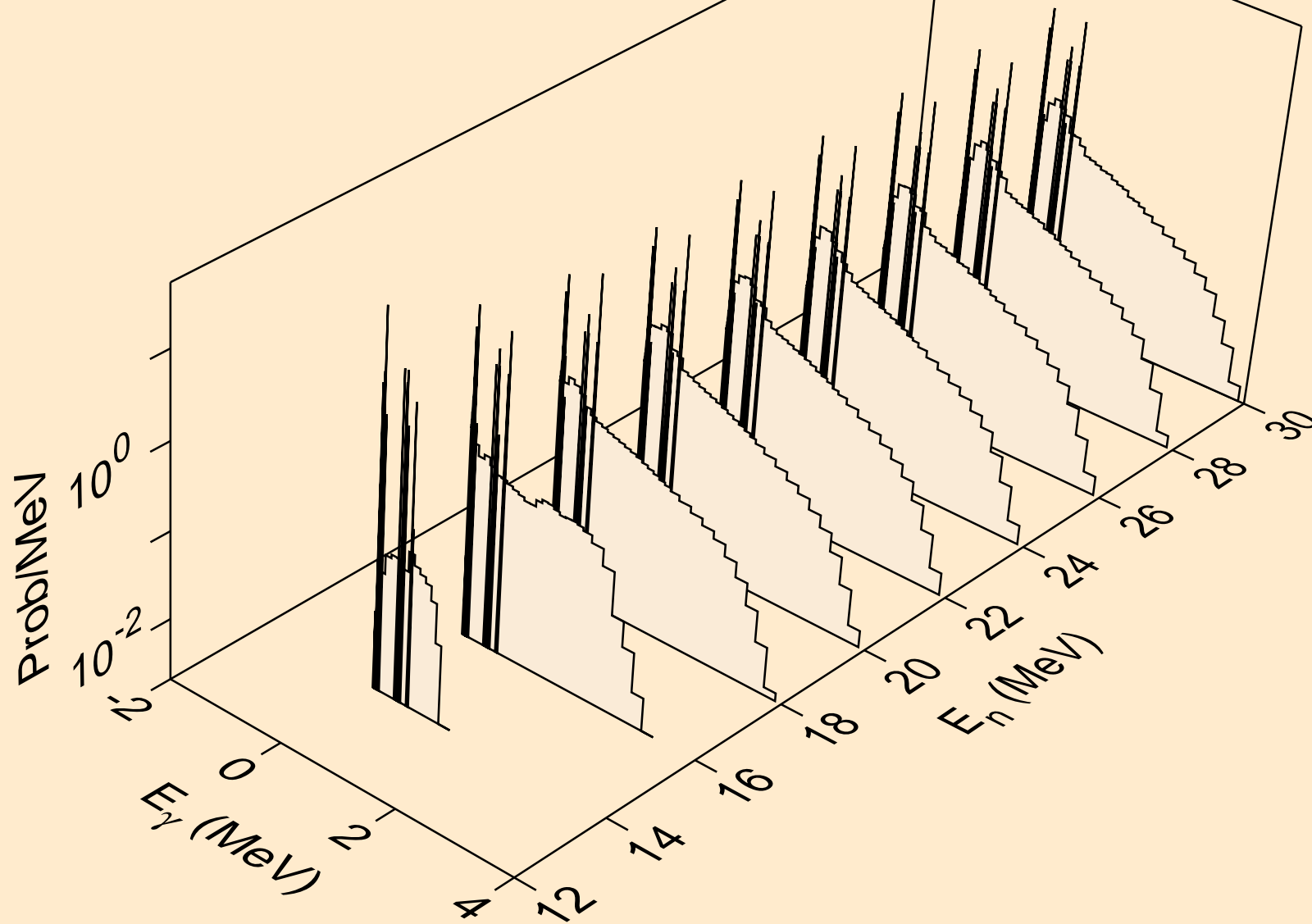

TH225 ALPHA ACER TENDL-2021 LIBRARY; T=0.K
Photon emission for (n,x)

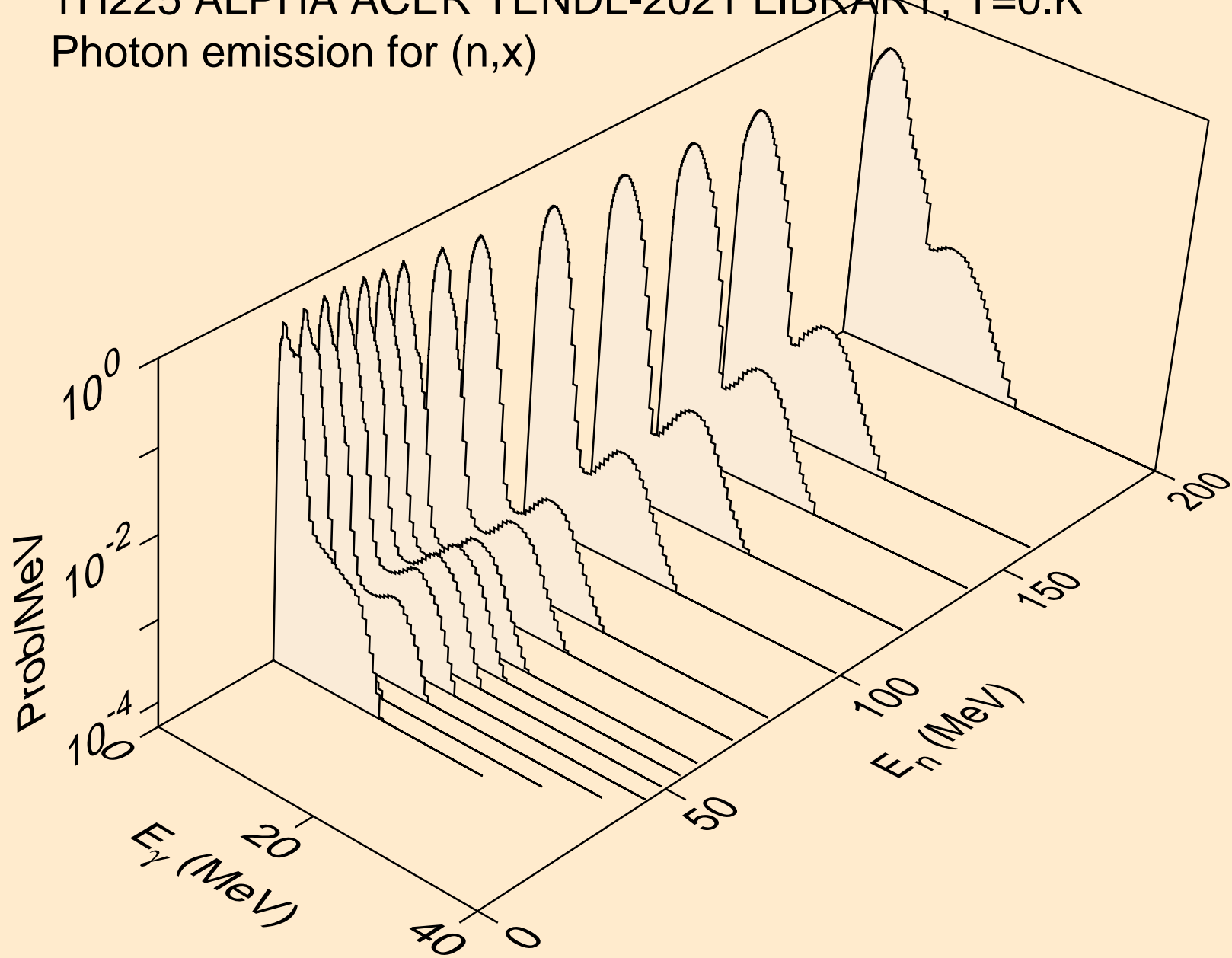

TH225 ALPHA ACER TENDL-2021 LIBRARY; T=0.K
Photon emission for (n,2n)

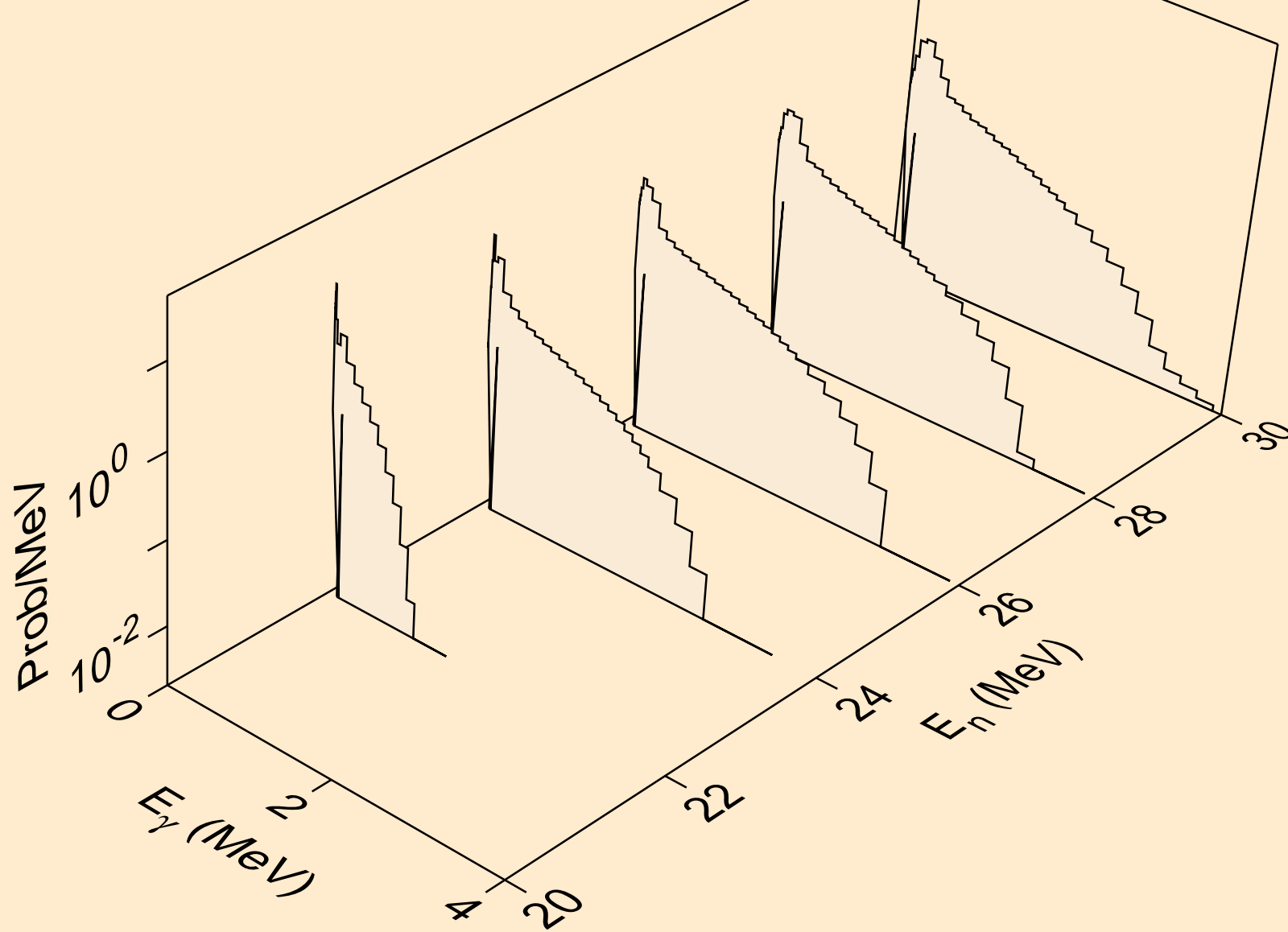

TH225 ALPHA ACER TENDL-2021 LIBRARY; T=0.K
Photon emission for (n,3n)

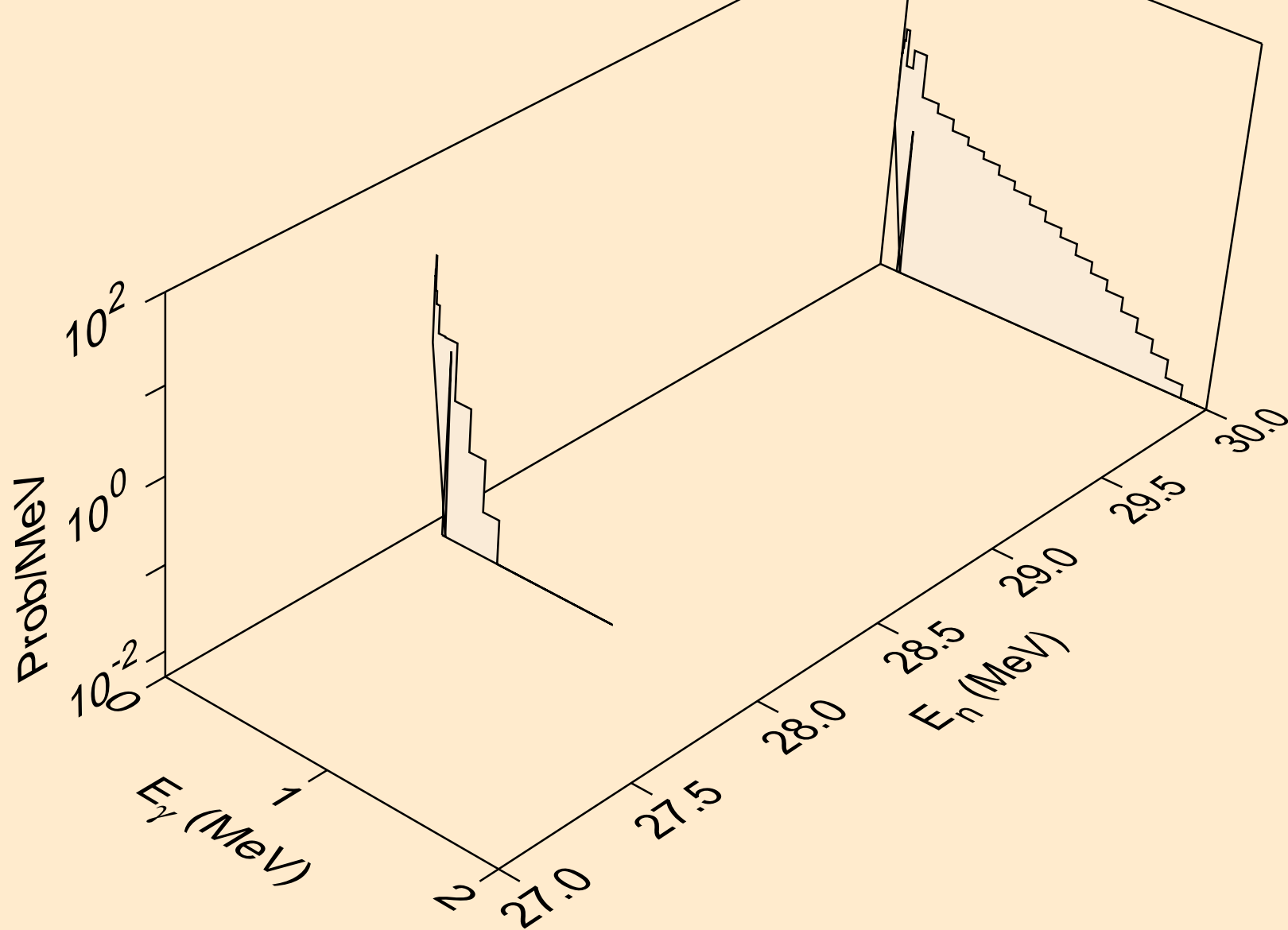

TH225 ALPHA ACER TENDL-2021 LIBRARY; T=0.K
Photon emission for (n,n*)a

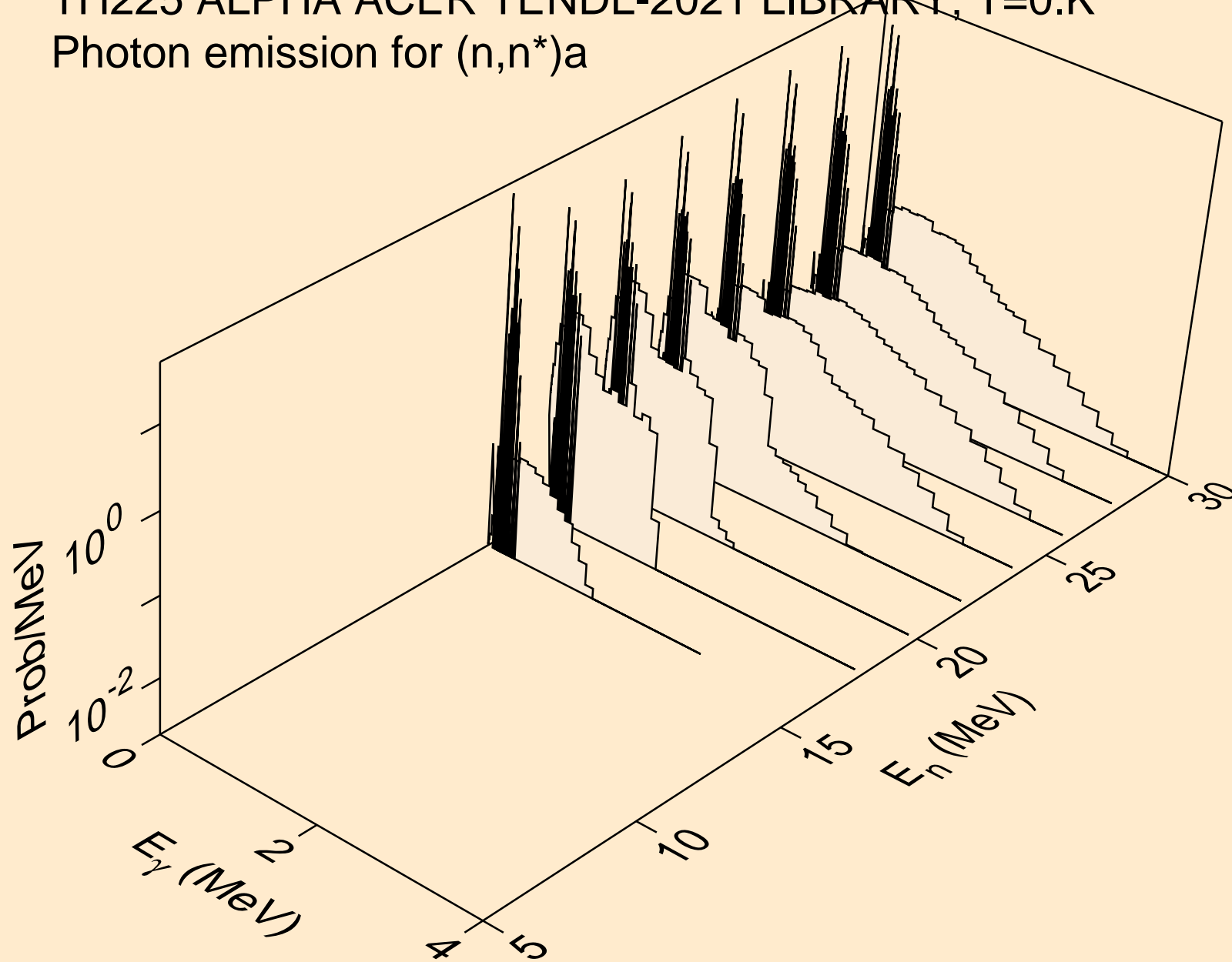

TH225 ALPHA ACER TENDL-2021 LIBRARY; T=0.K
Photon emission for (n,2n)a

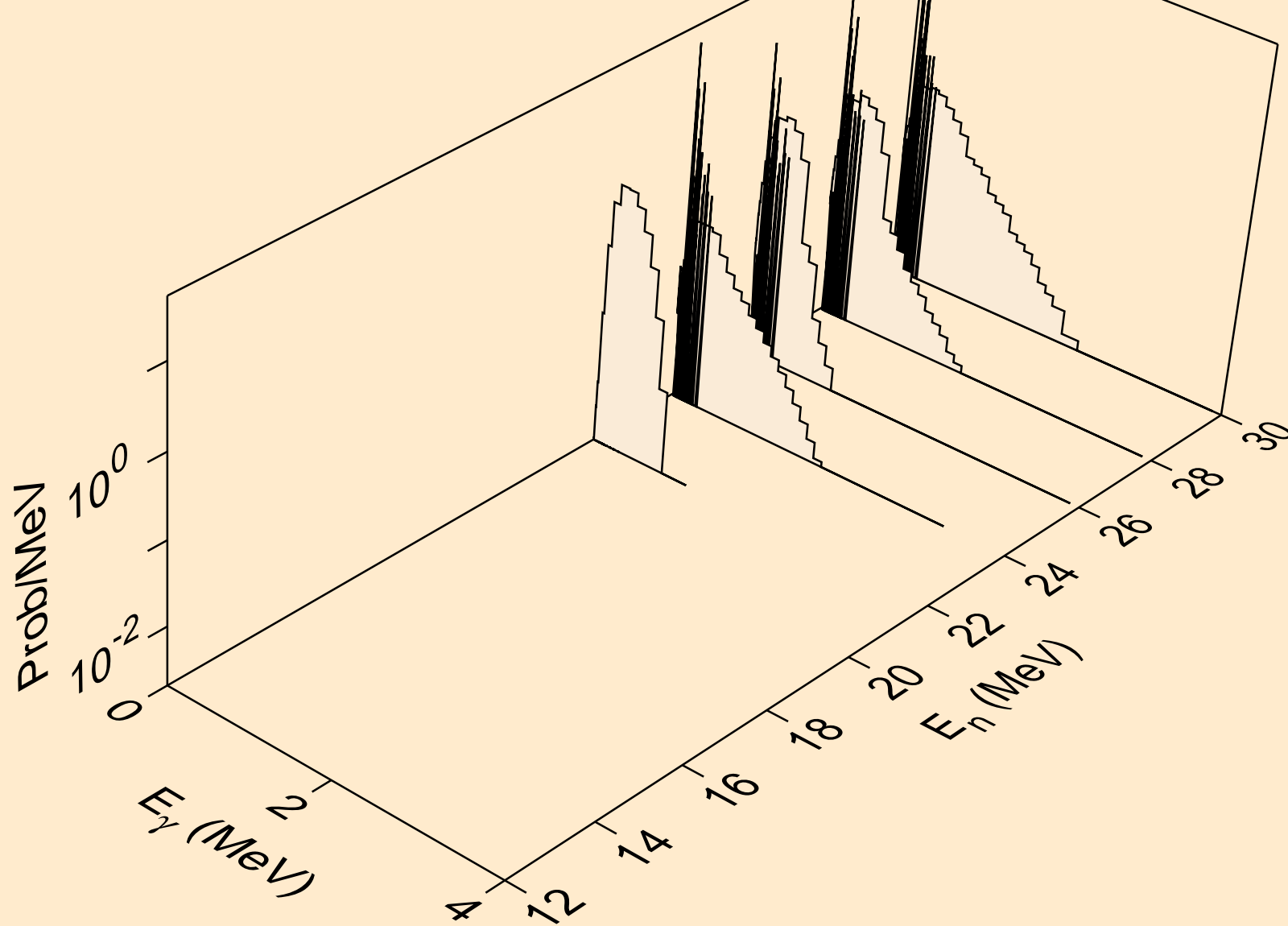

TH225 ALPHA ACER TENDL-2021 LIBRARY; T=0.K

Photon emission for (n,3n) α

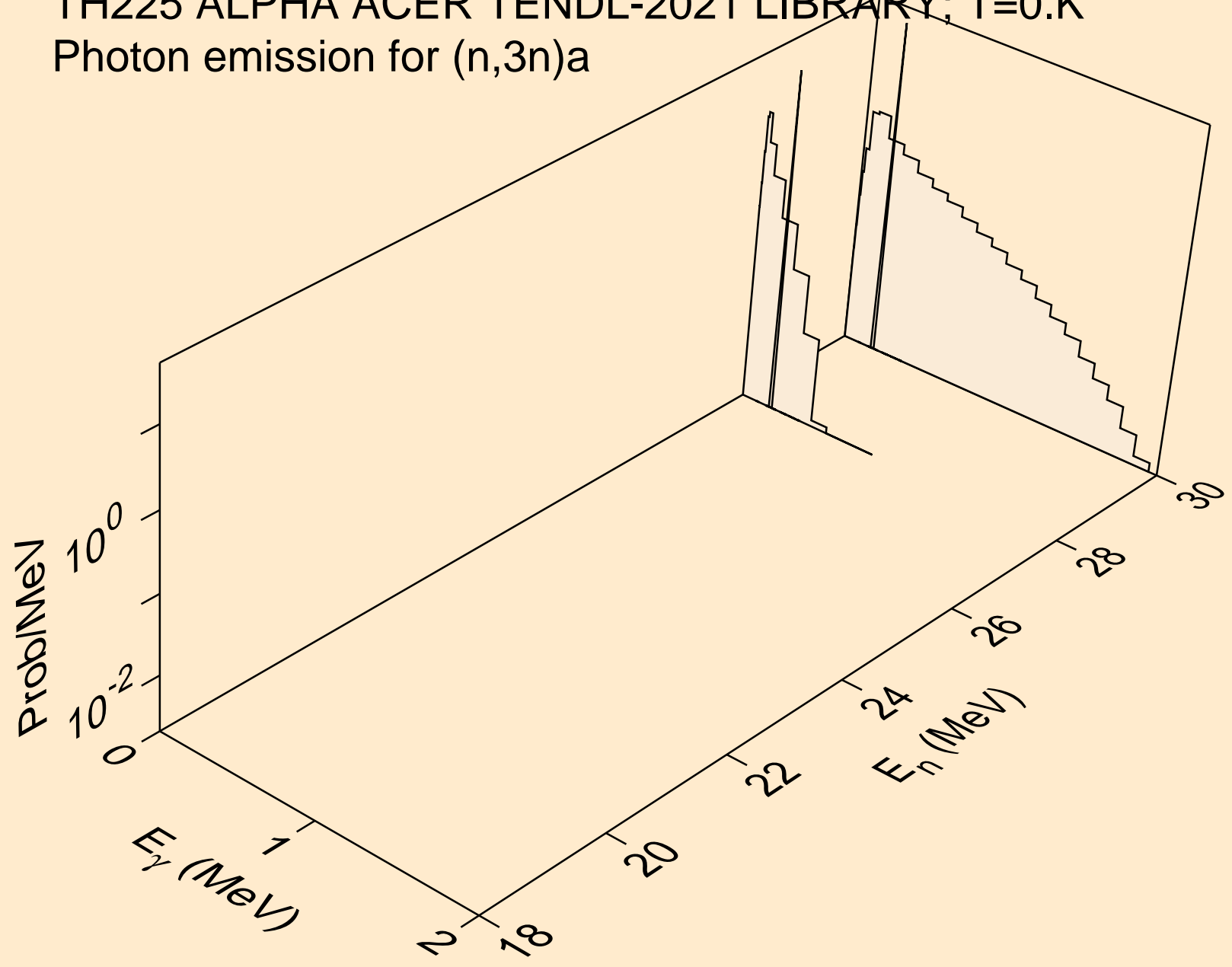

TH225 ALPHA ACER TENDL-2021 LIBRARY; T=0.K
Photon emission for (n,n*)p

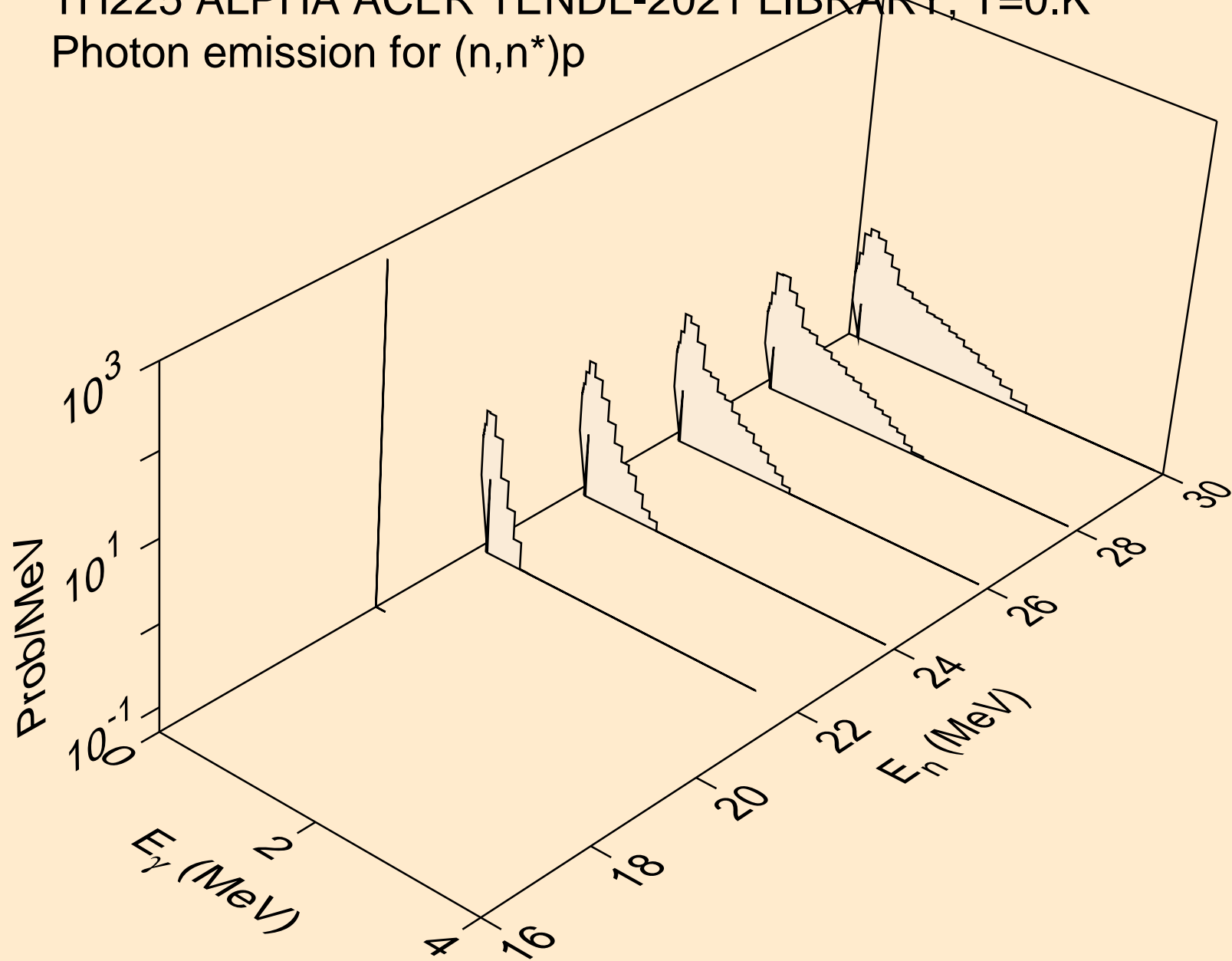

TH225 ALPHA ACER TENDL-2021 LIBRARY; T=0.K
Photon emission for (n,gma)

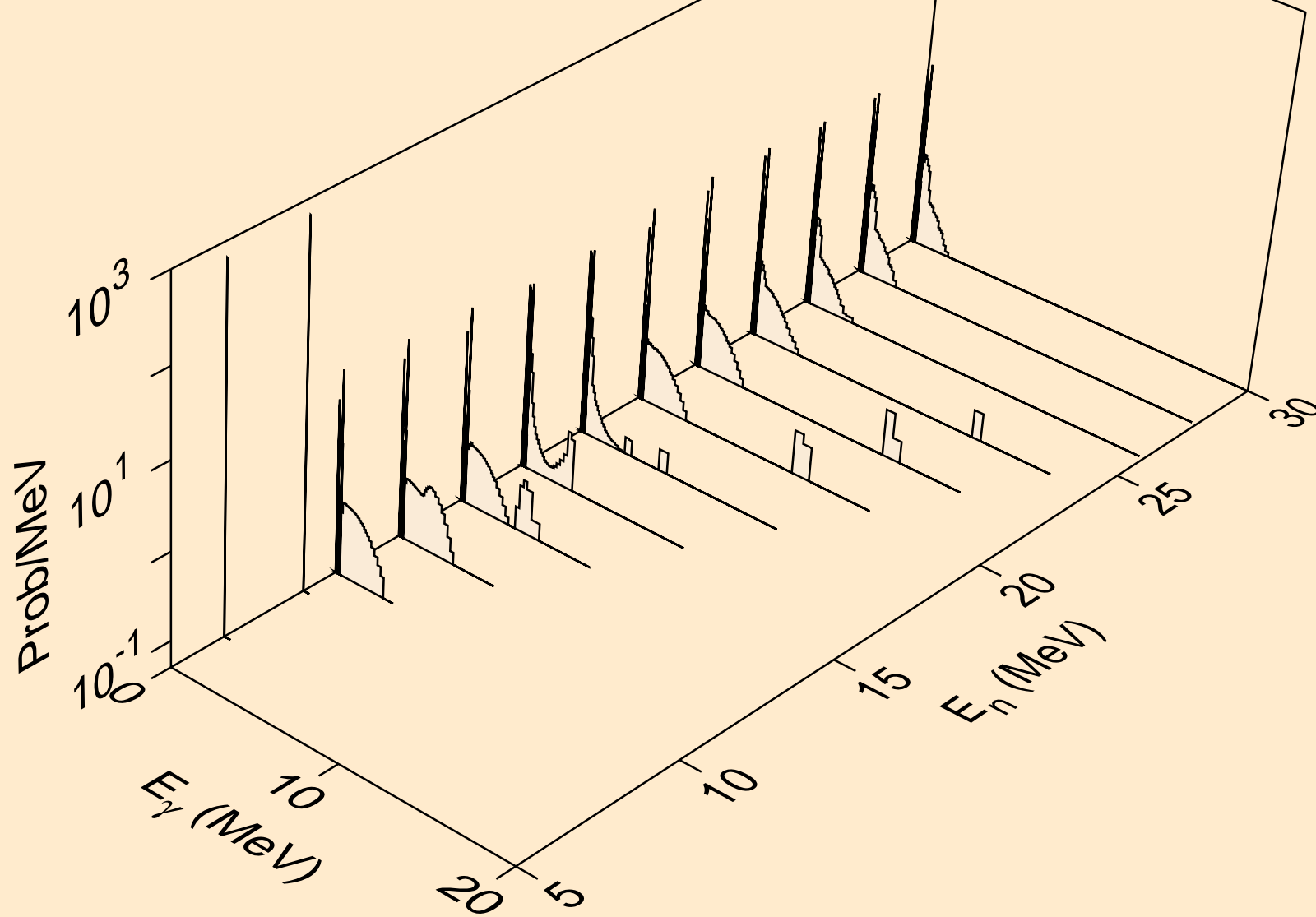

TH225 ALPHA ACER TENDL-2021 LIBRARY; T=0.K
Photon emission for (n,p)

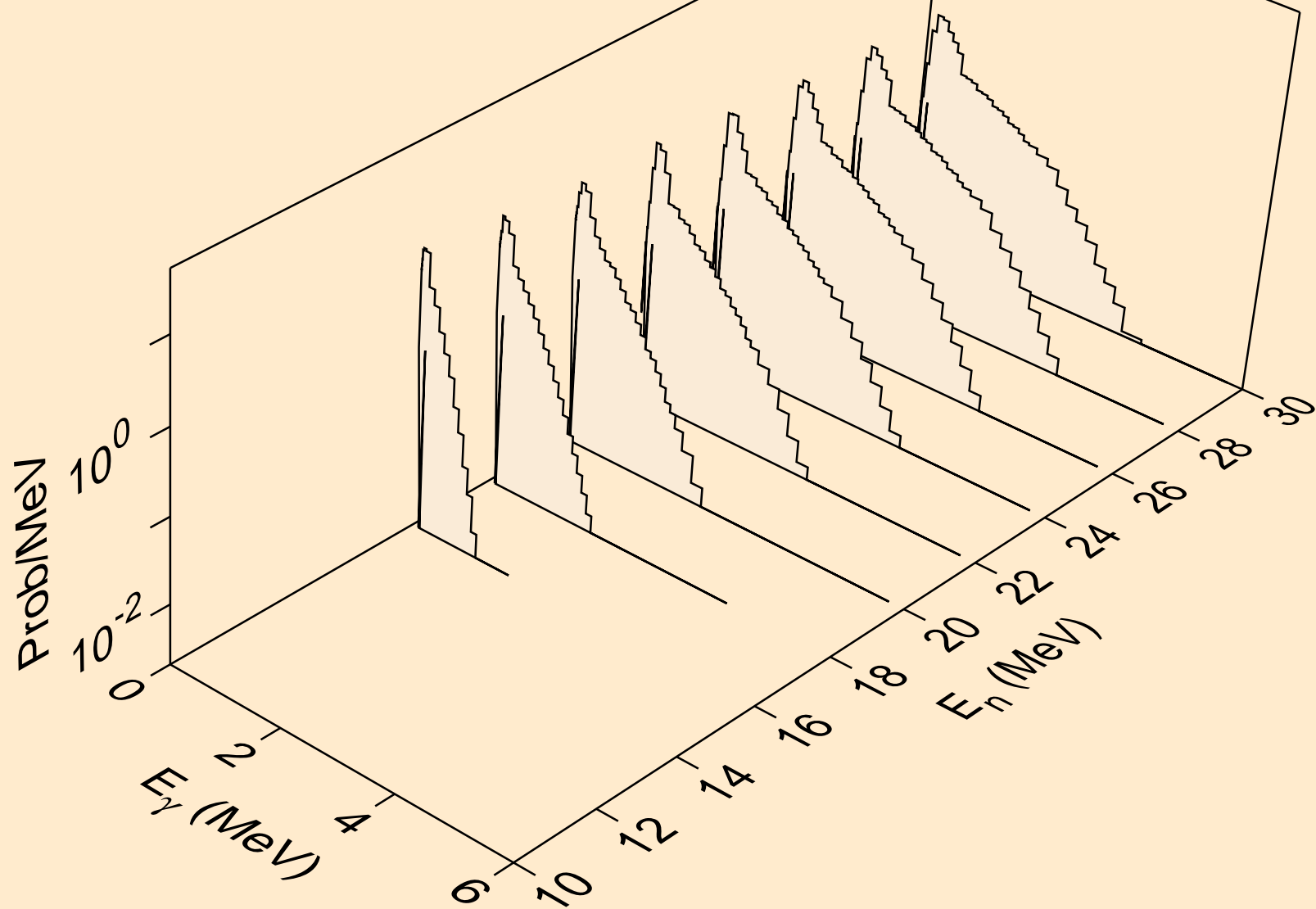

TH225 ALPHA ACER TENDL-2021 LIBRARY; T=0.K
Photon emission for (n,d)

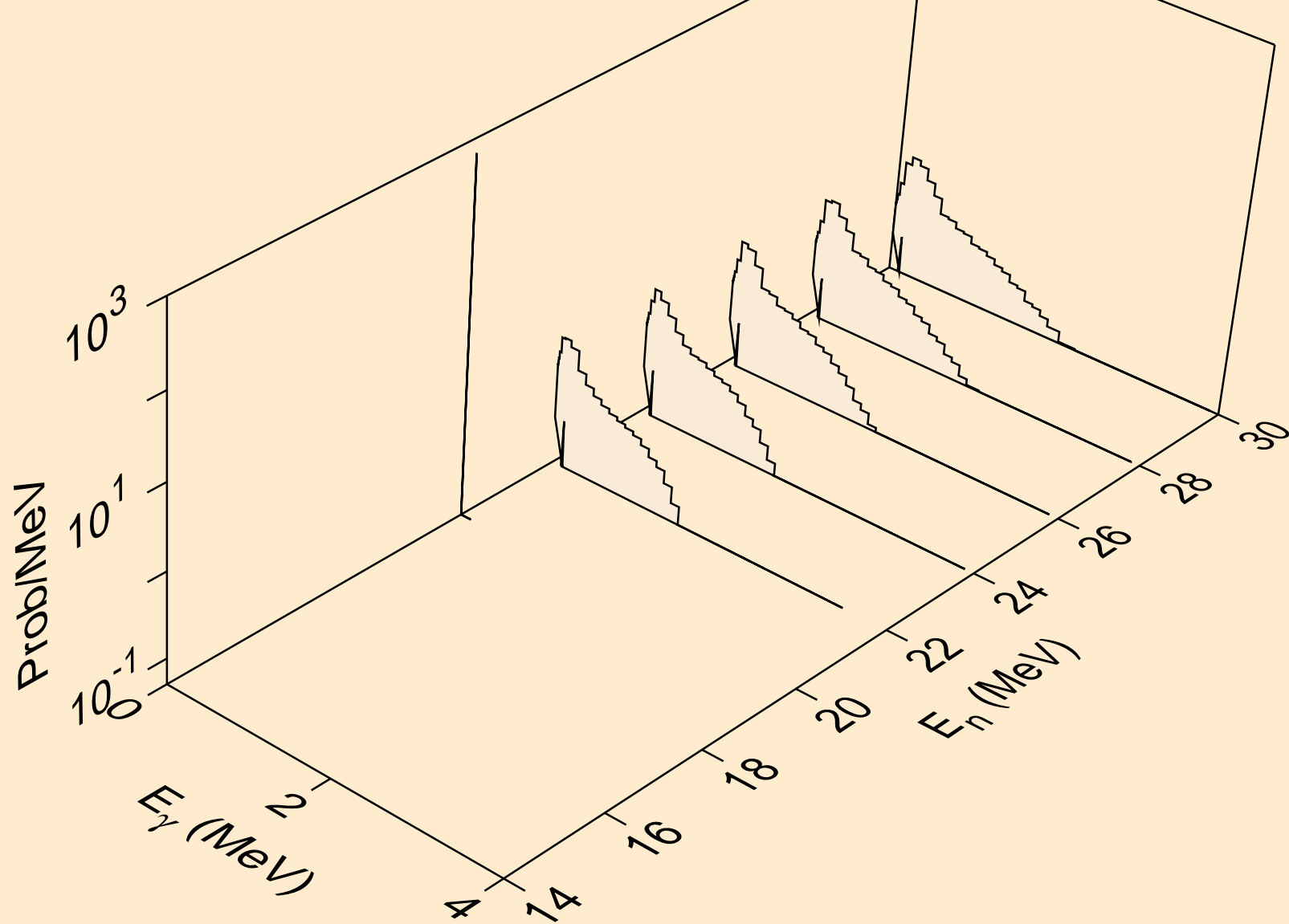

TH225 ALPHA ACER TENDL-2021 LIBRARY; T=0.K
Photon emission for (n,t)

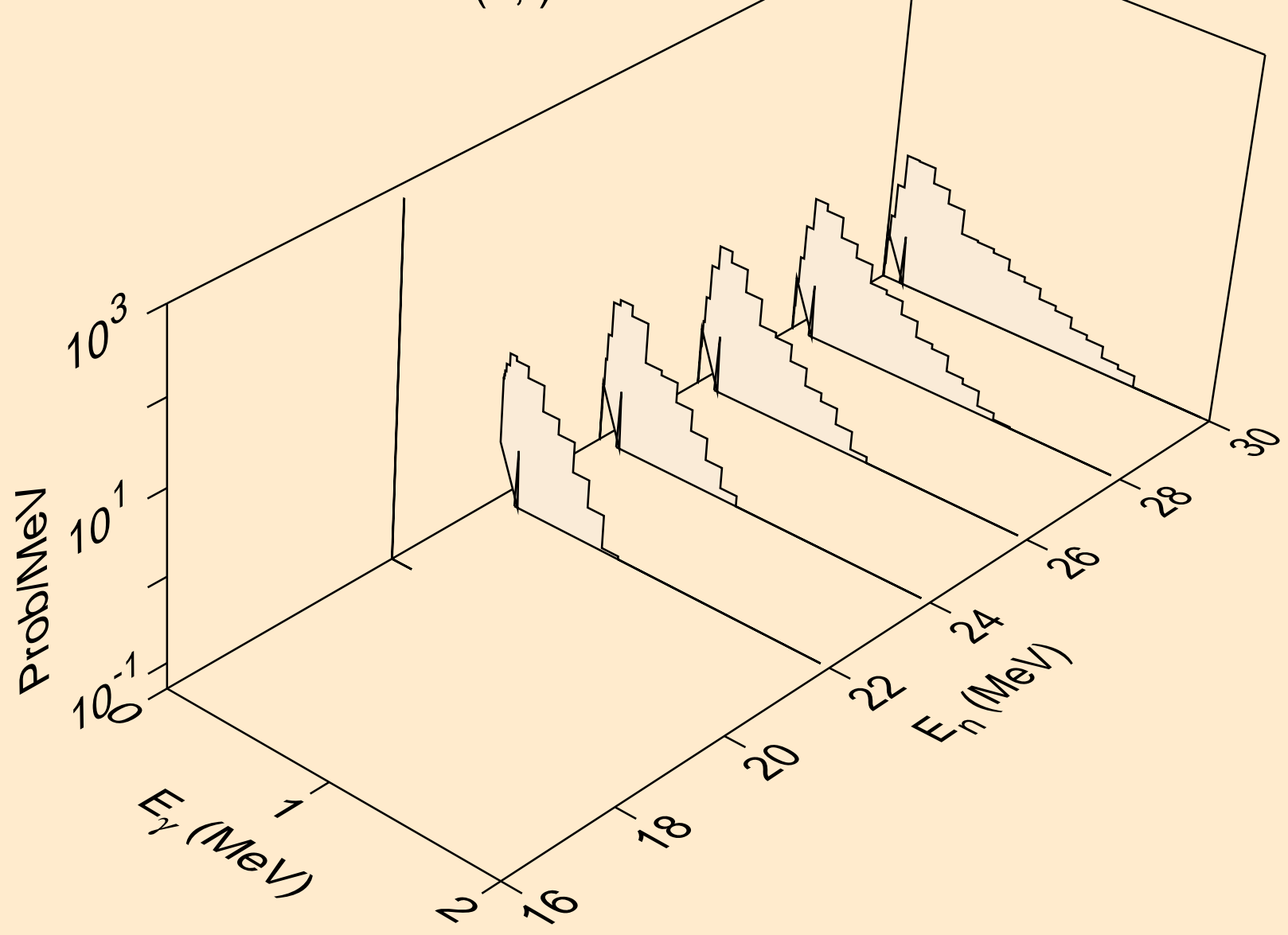

TH225 ALPHA ACER TENDL-2021 LIBRARY; T=0.K
Photon emission for (n,he3)

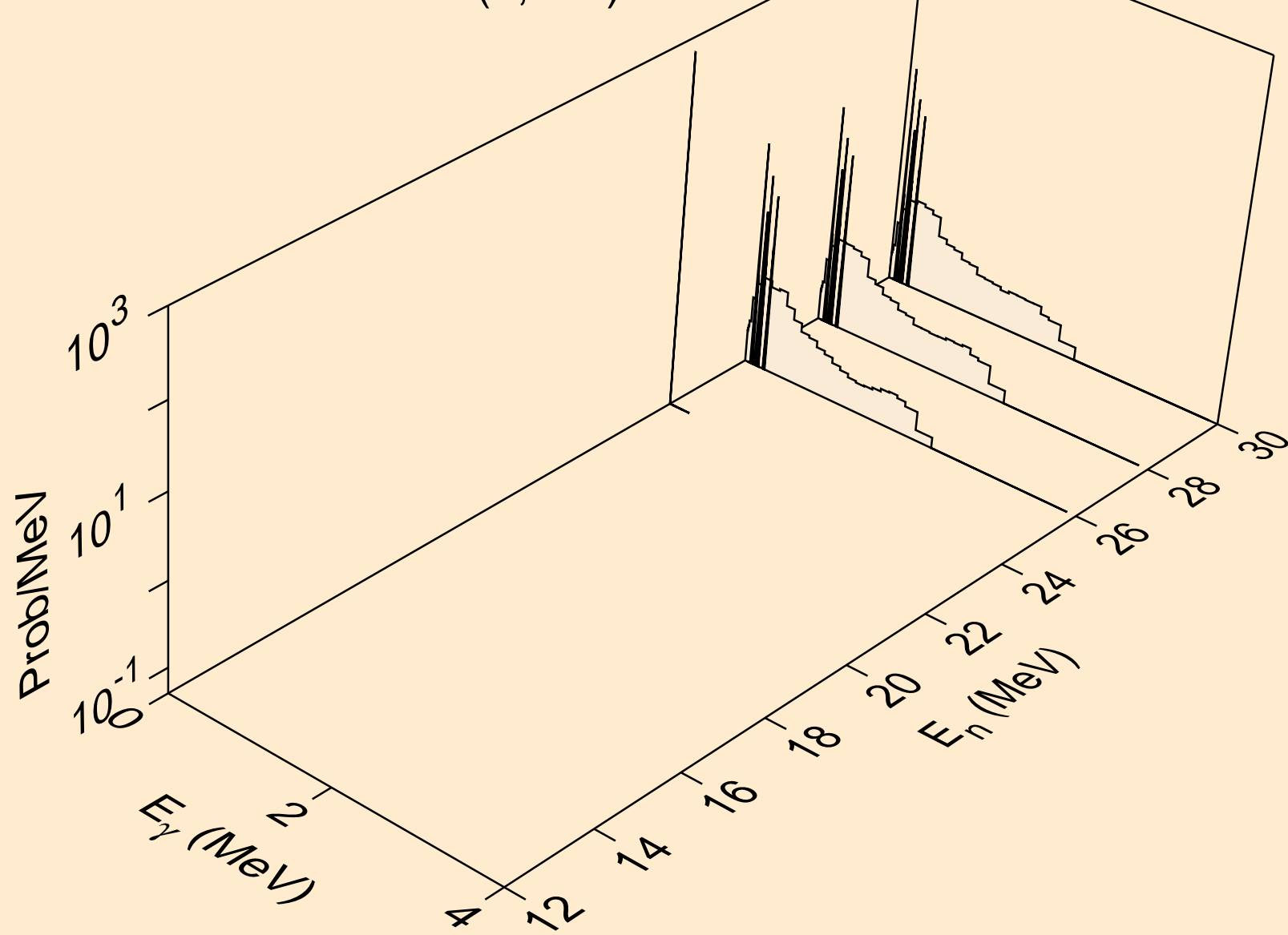

TH225 ALPHA ACER TENDL-2021 LIBRARY; T=0.K
Photon emission for inelastic

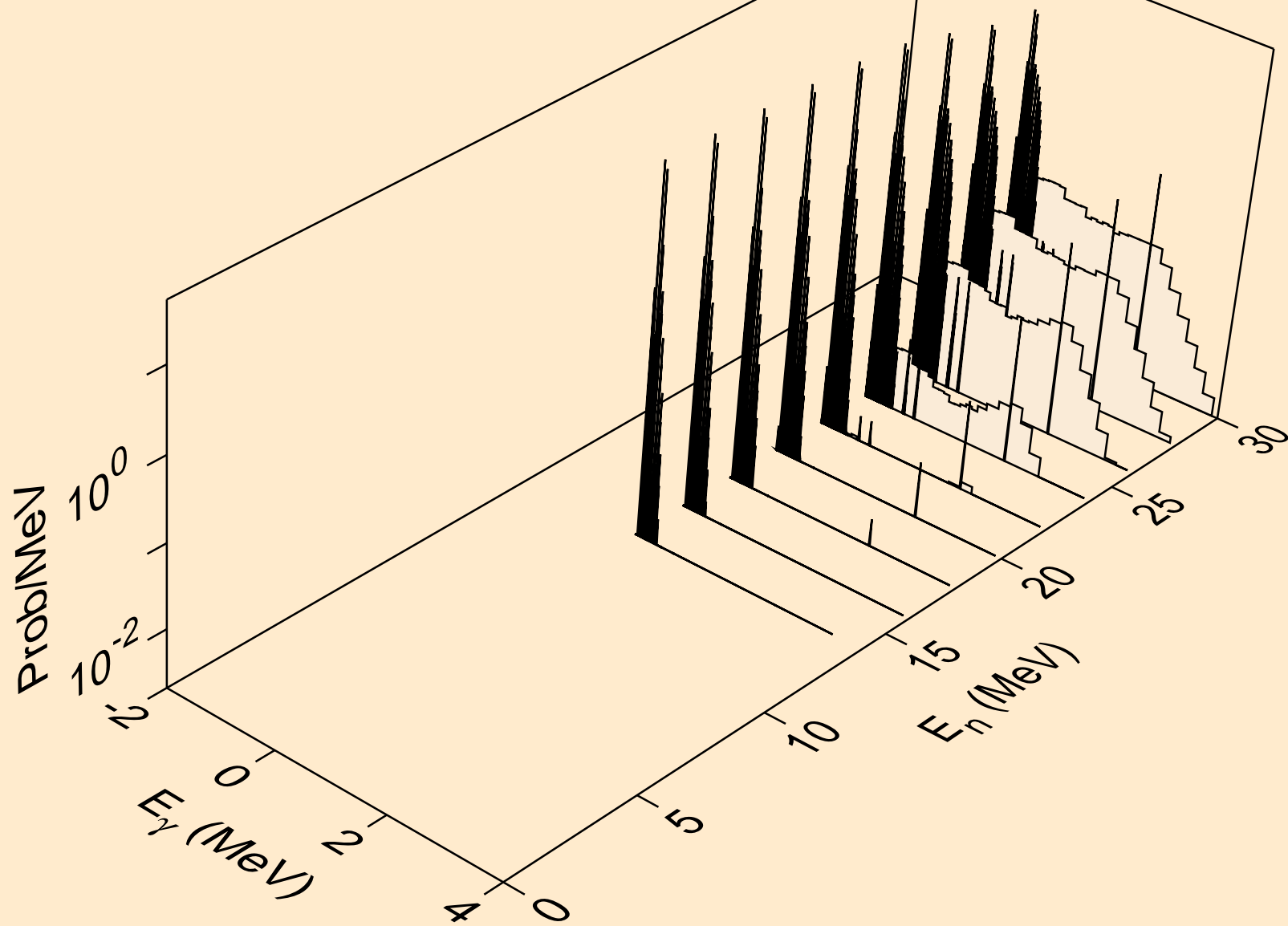

TH225 ALPHA ACER TENDL-2021 LIBRARY; T=0.K
Photon emission for (n,2a)

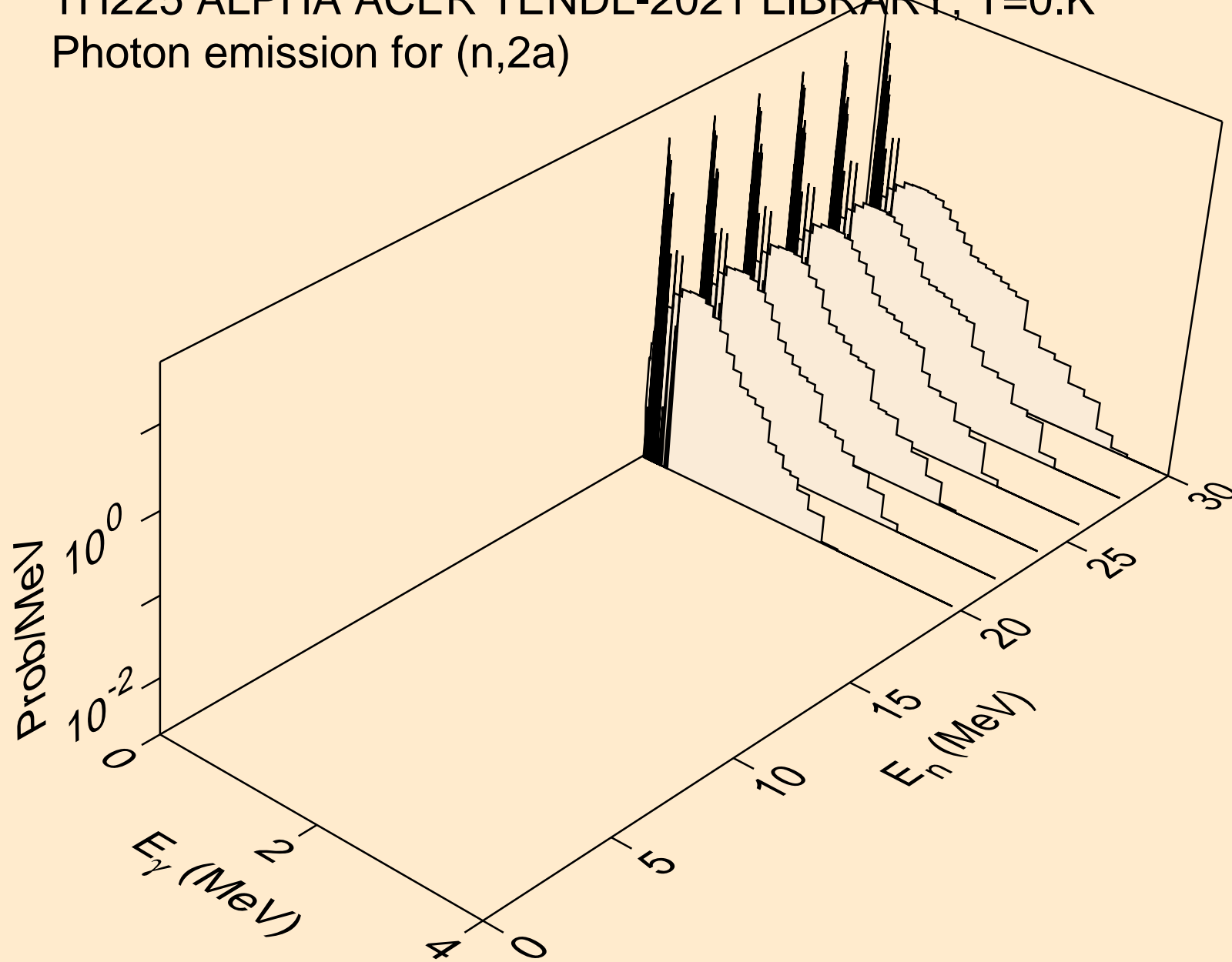

TH225 ALPHA ACER TENDL-2021 LIBRARY; T=0.K
Particle heating contributions

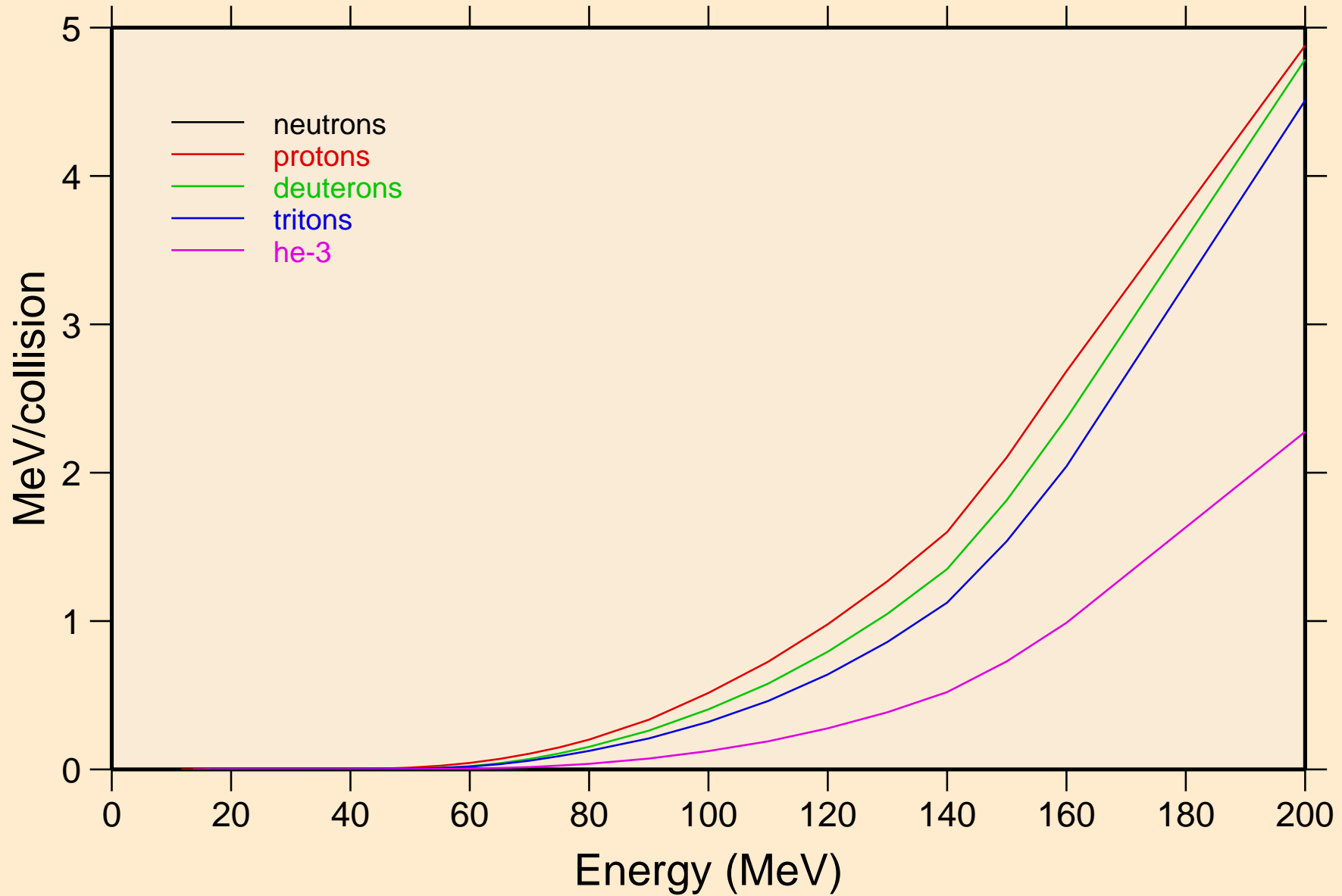

TH225 ALPHA ACER TENDL-2021 LIBRARY; T=0.K
Recoil Heating

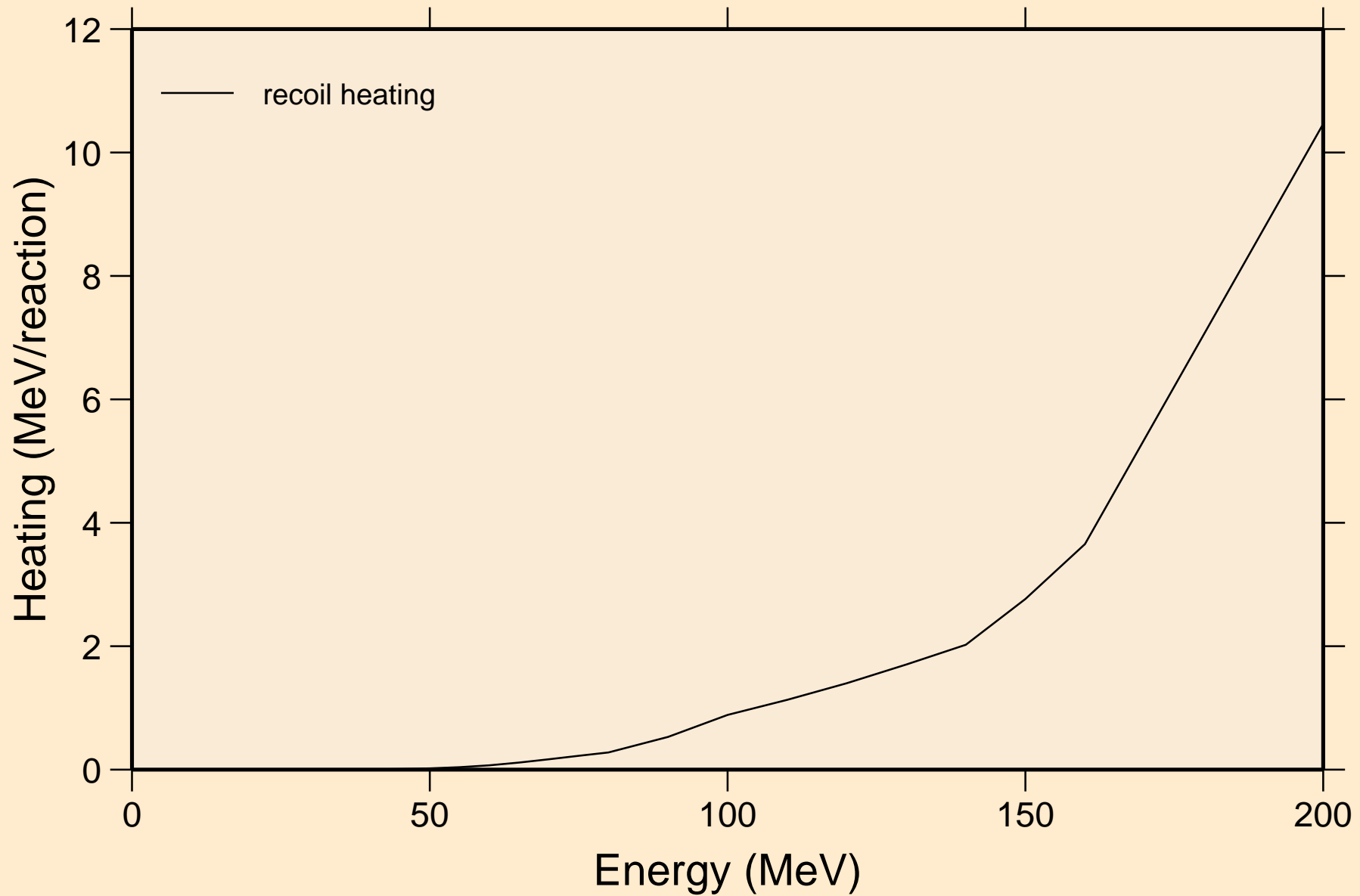

TH225 ALPHA ACER TENDL-2021 LIBRARY; T=0.K
Particle production cross sections

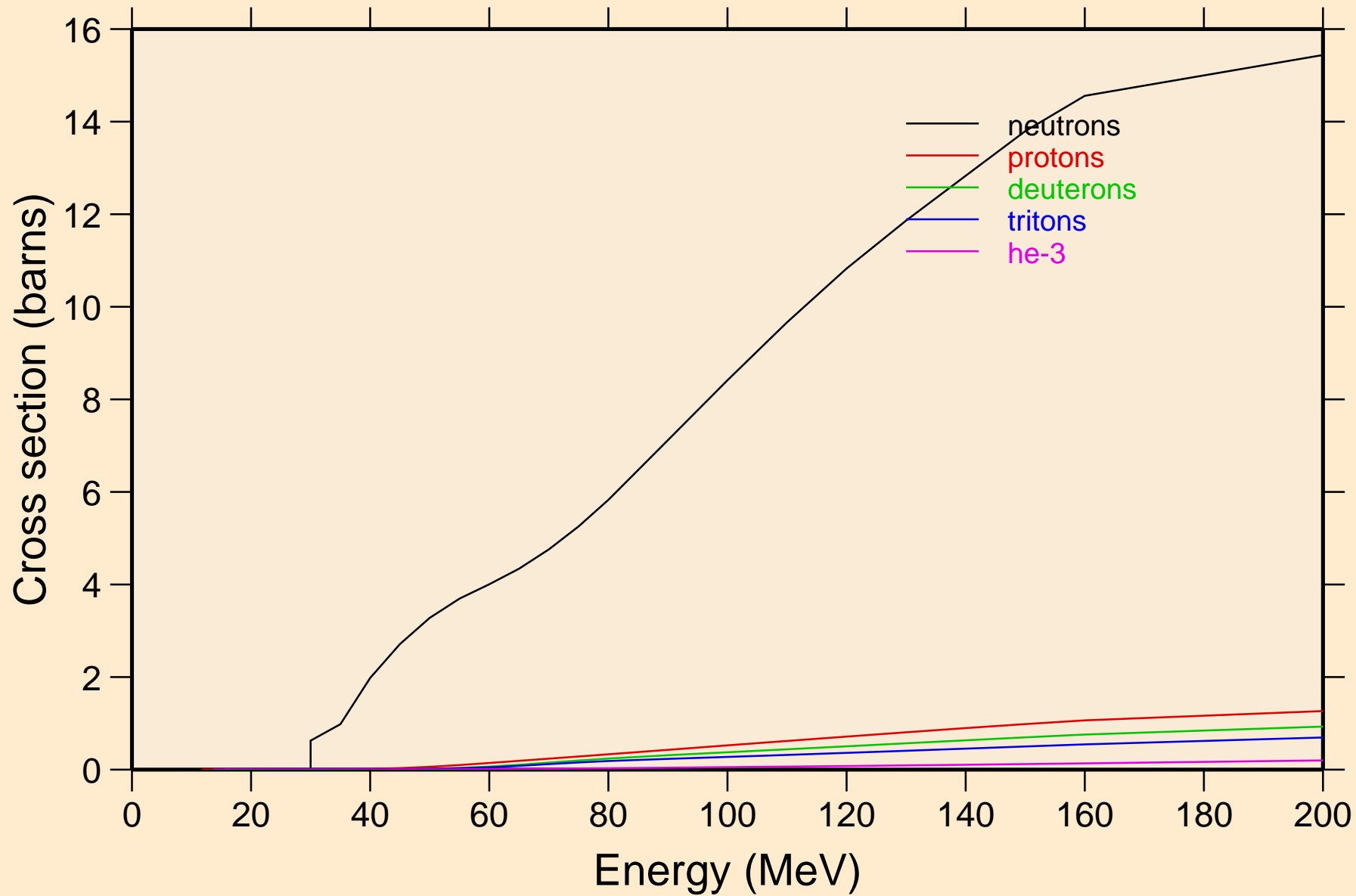

TH225 ALPHA ACER TENDL-2021 LIBRARY; T=0.K
neutrons from (a,n)

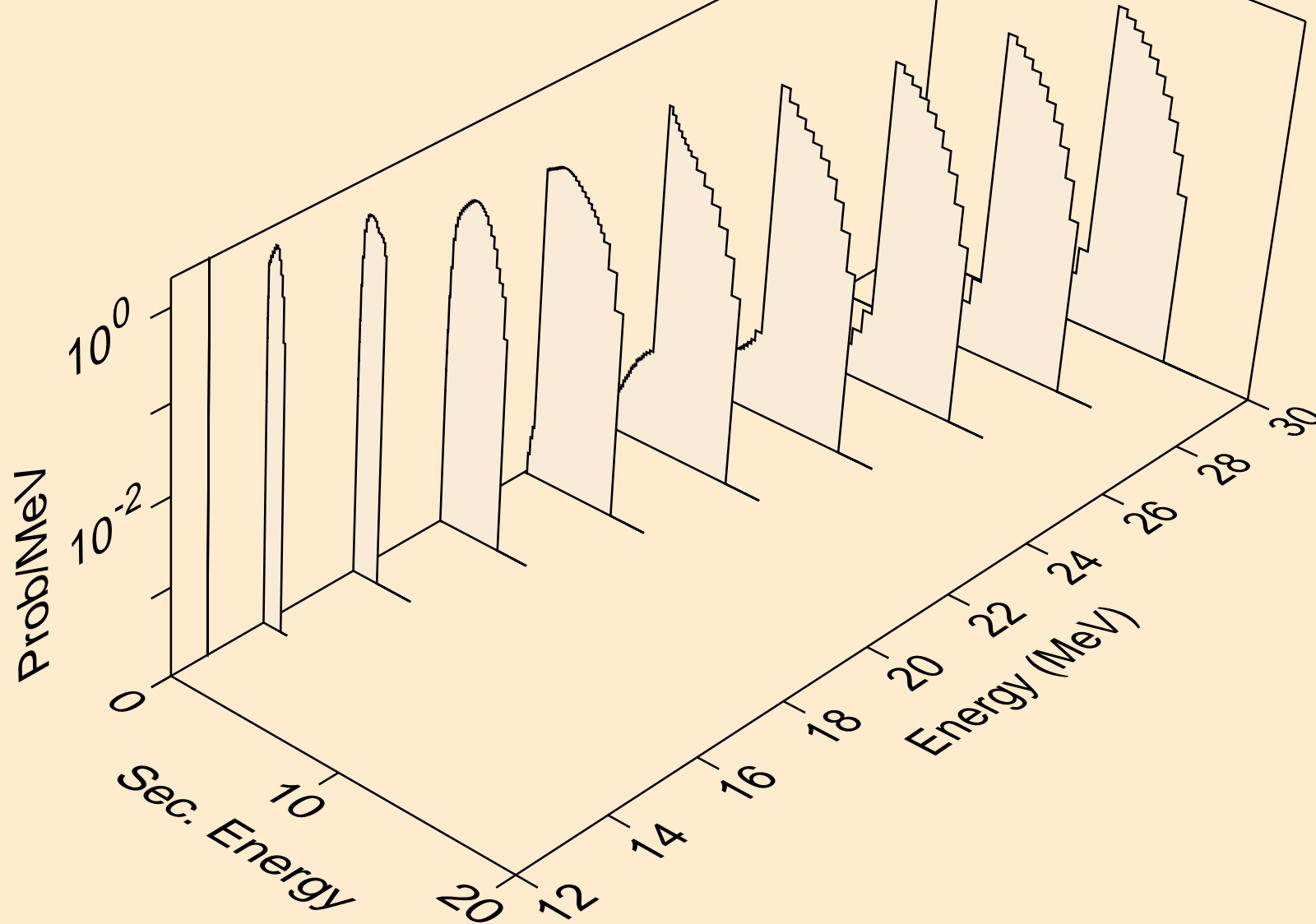

TH225 ALPHA ACER TENDL-2021 LIBRARY; T=0.K
neutrons from (a,x)

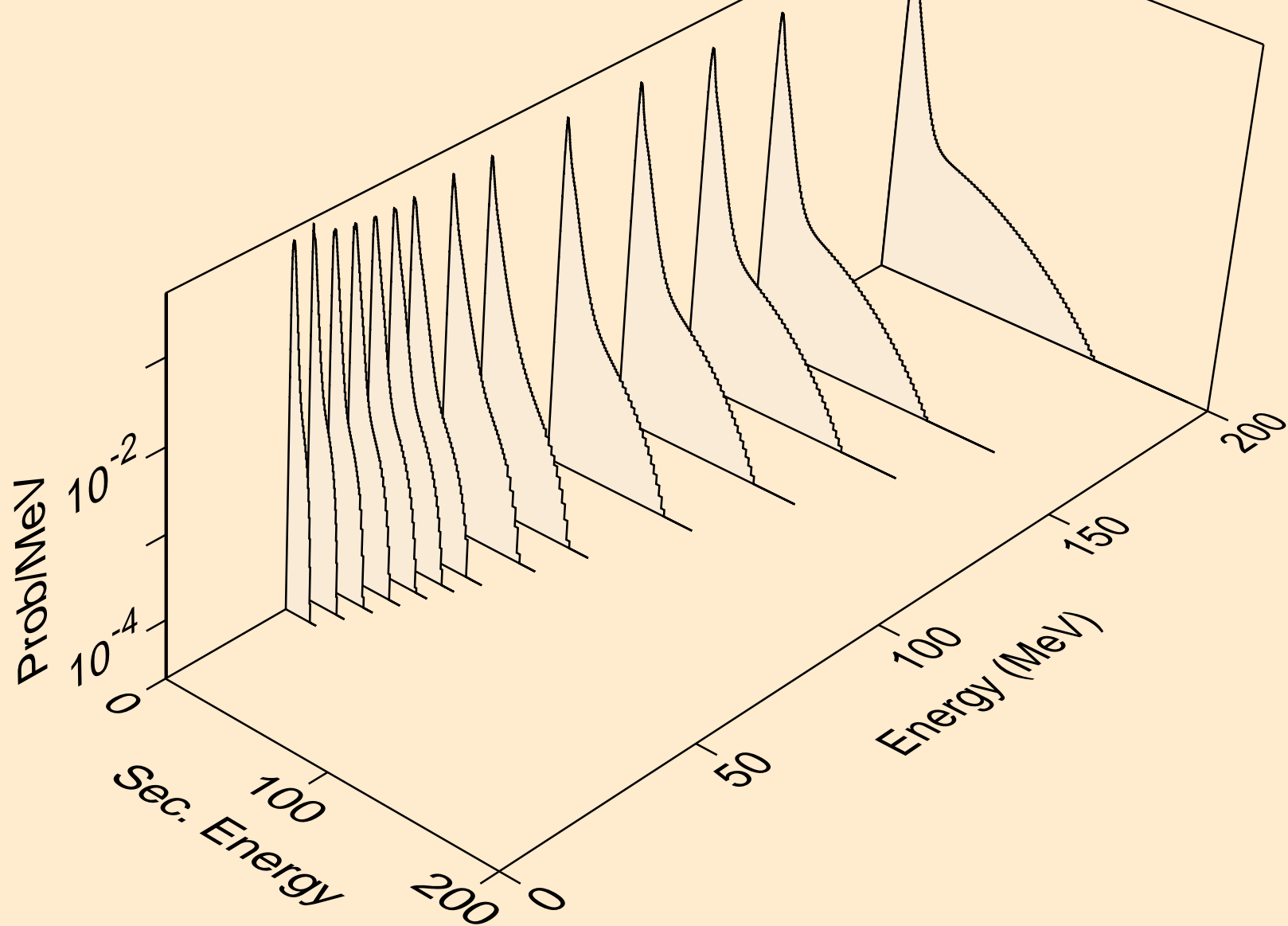

TH225 ALPHA ACER TENDL-2021 LIBRARY; T=0.K
neutrons from (a,2n)

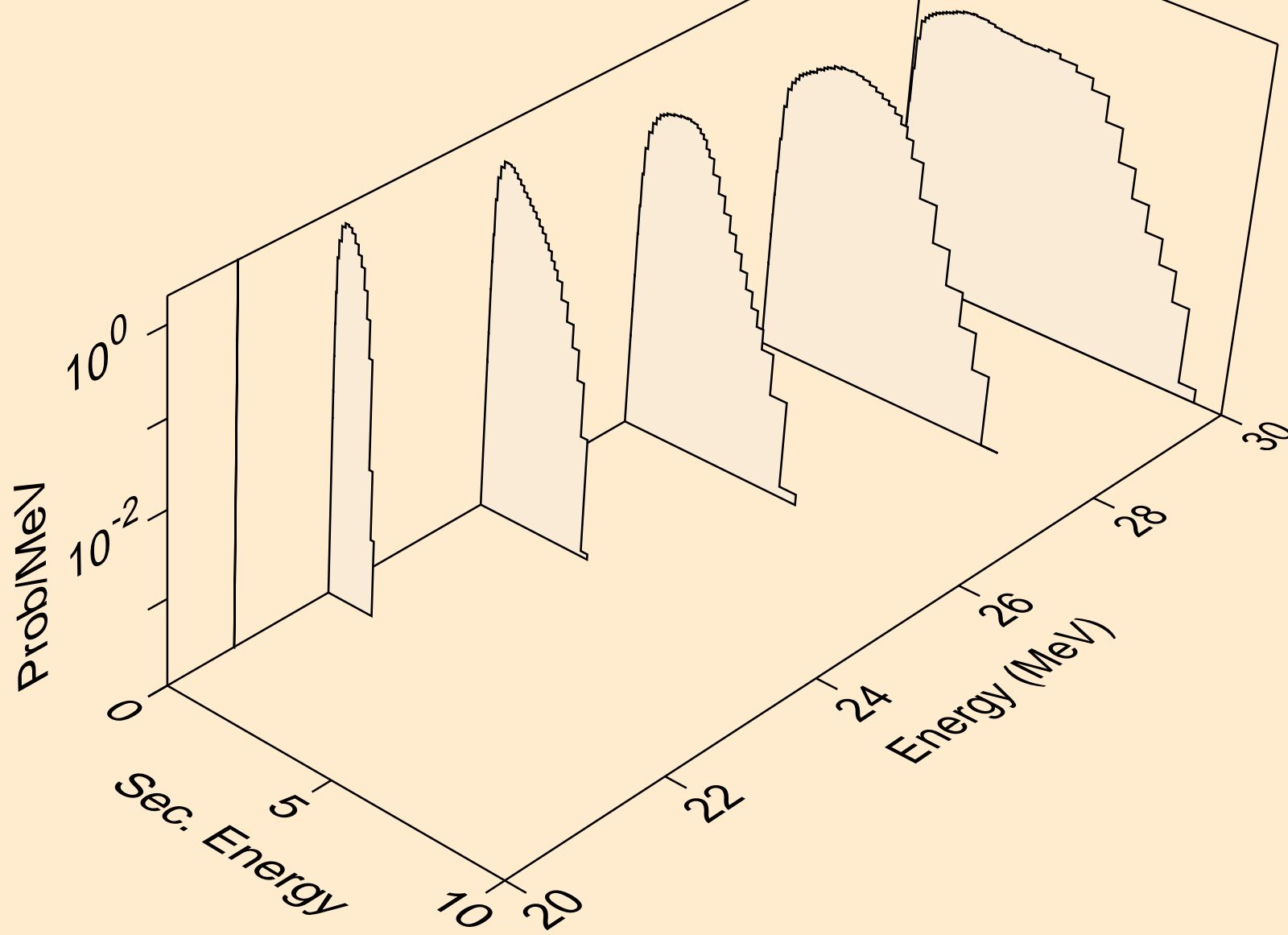

TH225 ALPHA ACER TENDL-2021 LIBRARY; T=0.K
neutrons from (a,3n)

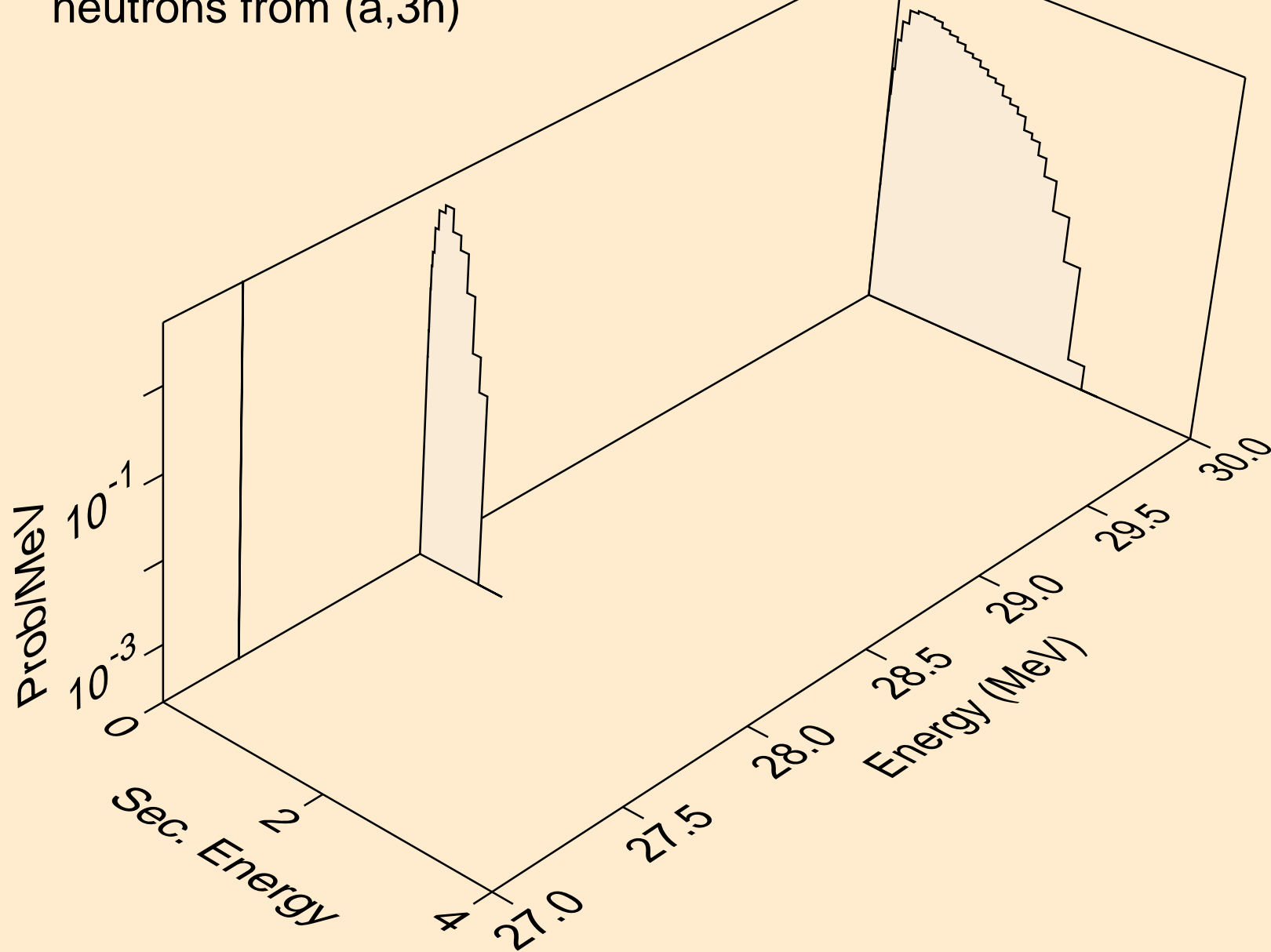

TH225 ALPHA ACER TENDL-2021 LIBRARY; T=0.K
neutrons from (a,n*)a

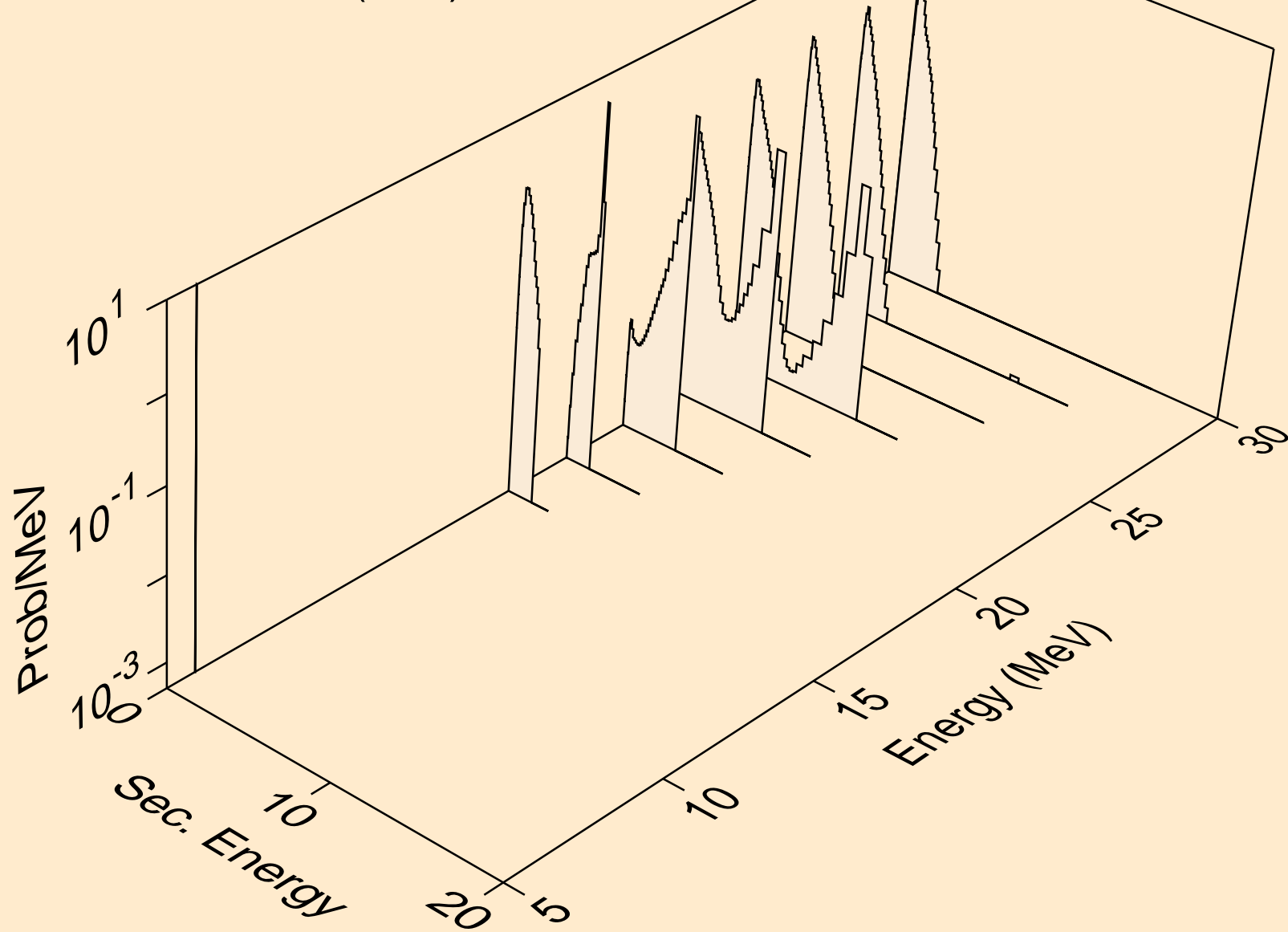

TH225 ALPHA ACER TENDL-2021 LIBRARY; T=0.K
neutrons from (a,2n)a

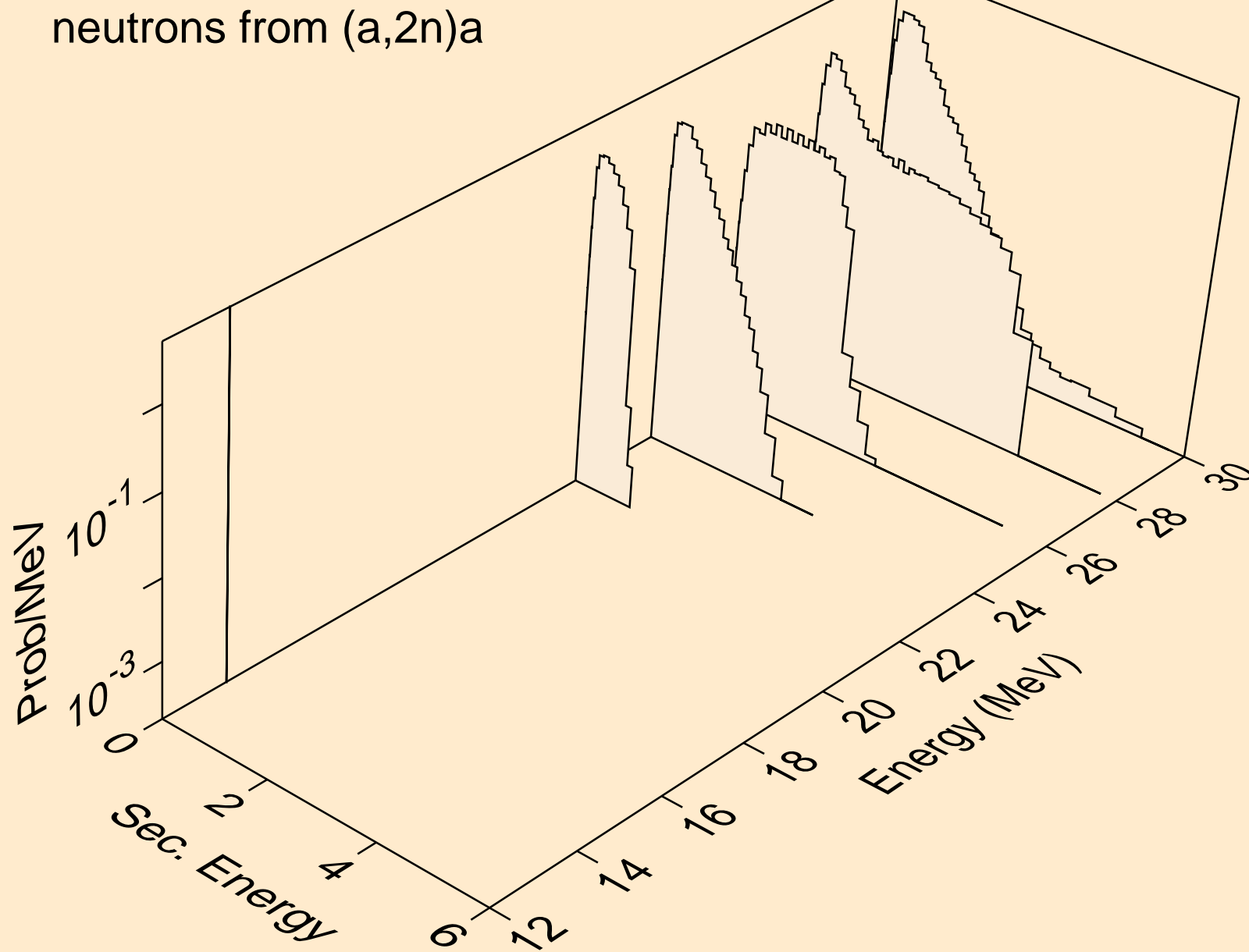

TH225 ALPHA ACER TENDL-2021 LIBRARY; T=0.K
neutrons from (a,3n)a

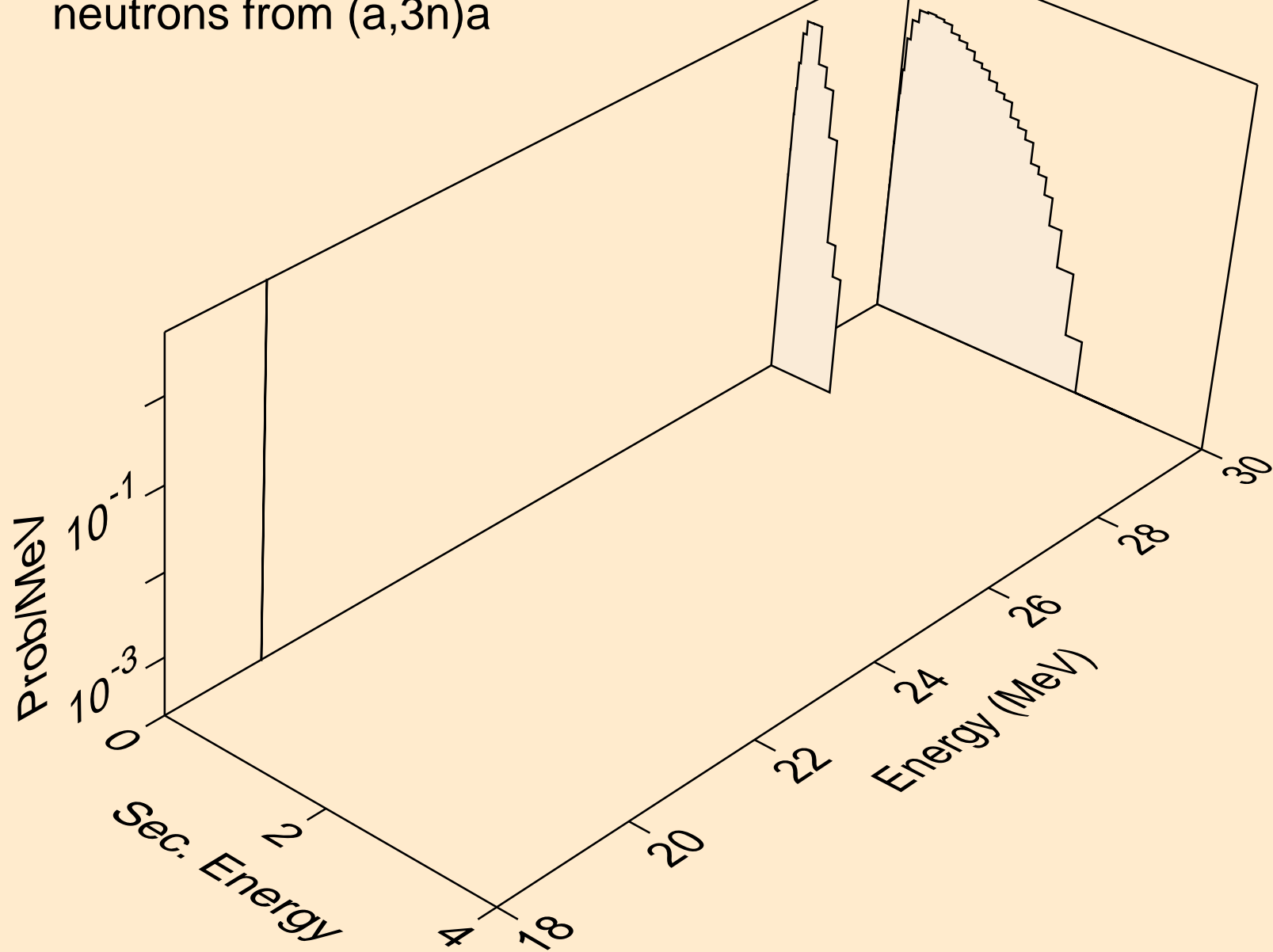

TH225 ALPHA ACER TENDL-2021 LIBRARY; T=0.K
neutrons from (a,n*)p

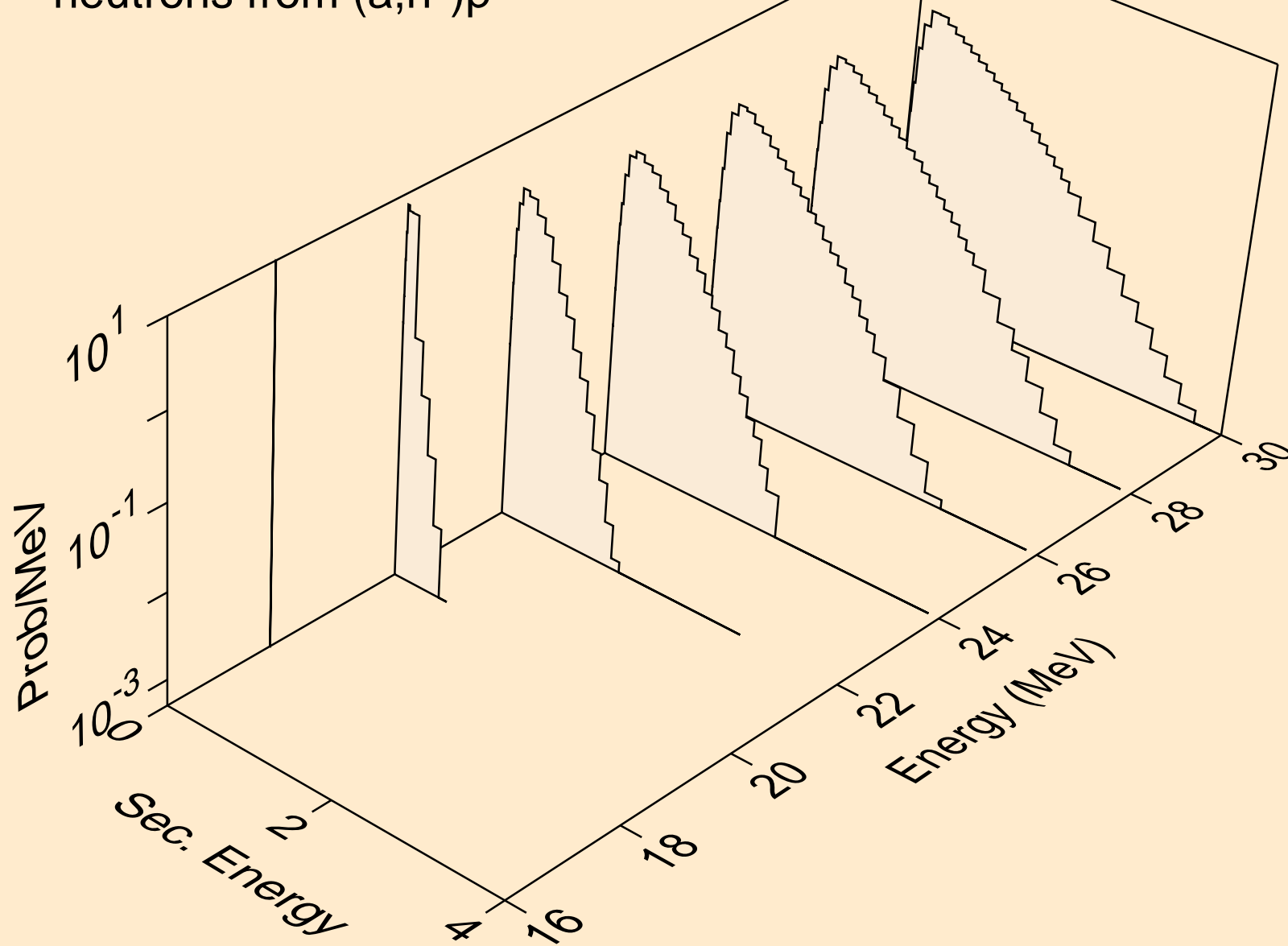

TH225 ALPHA ACER TENDL-2021 LIBRARY; T=0.K
protons from (a,x)

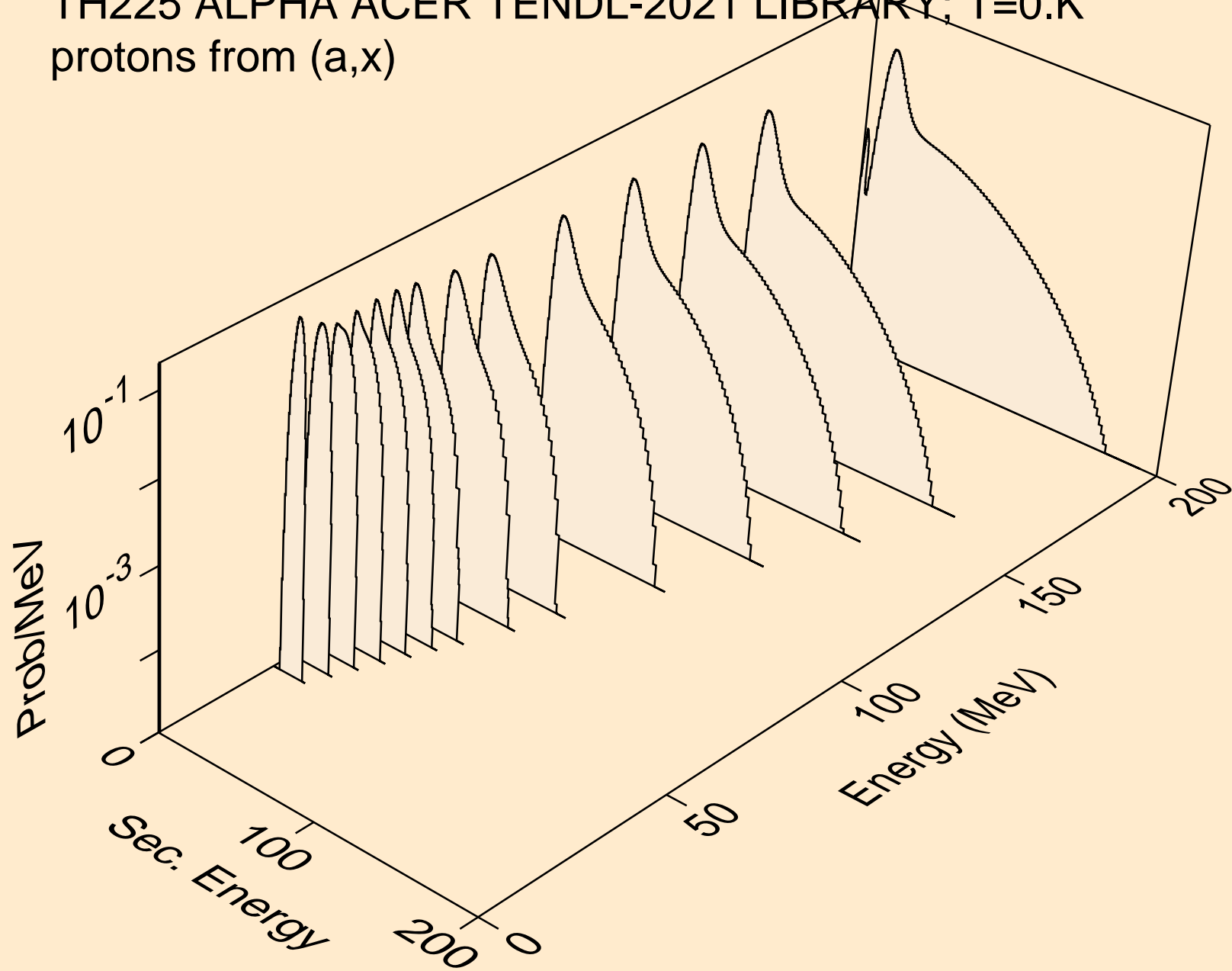

TH225 ALPHA ACER TENDL-2021 LIBRARY; T=0.K
protons from (a,n*)p

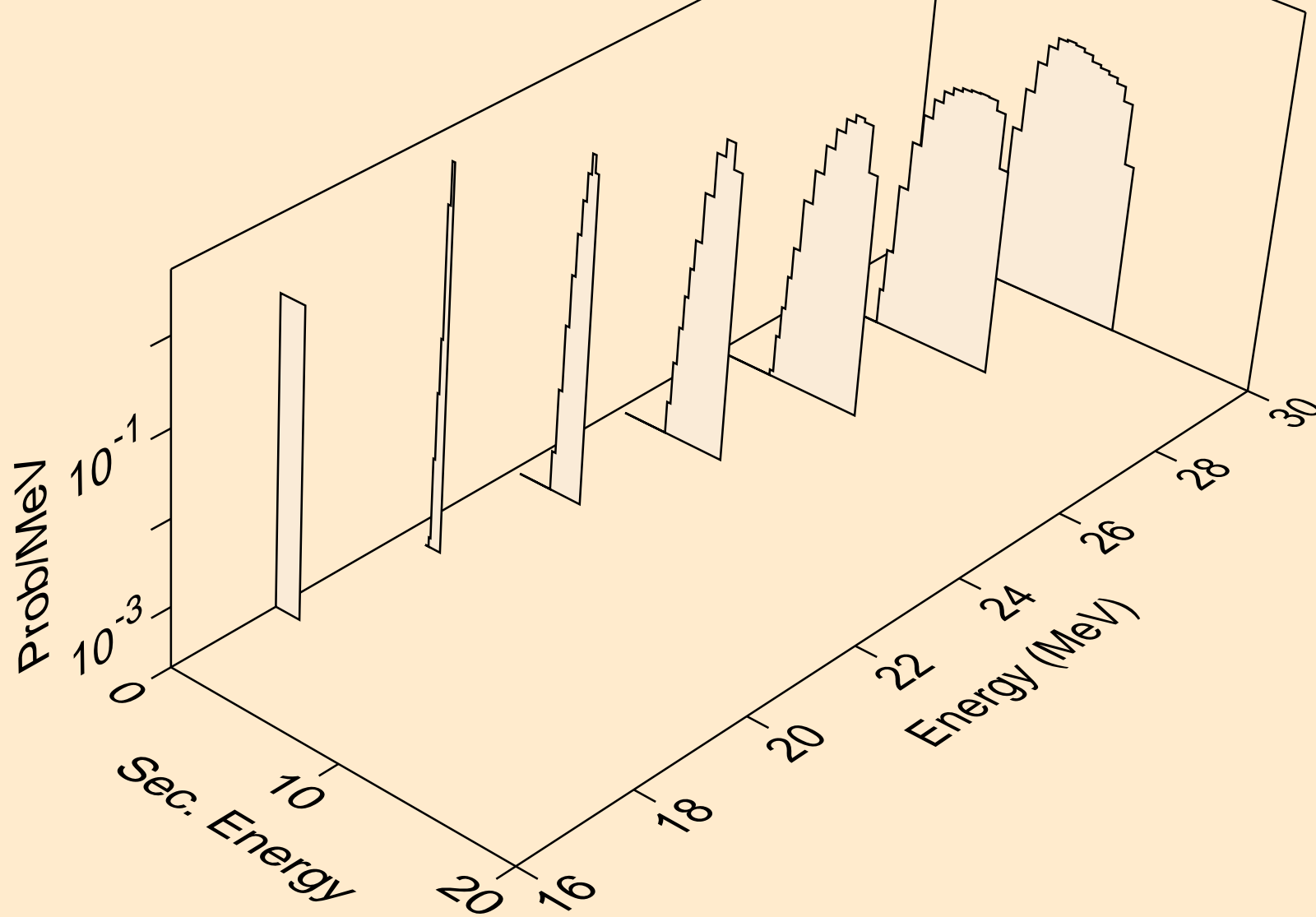

TH225 ALPHA ACER TENDL-2021 LIBRARY; T=0.K
protons from (a,p)

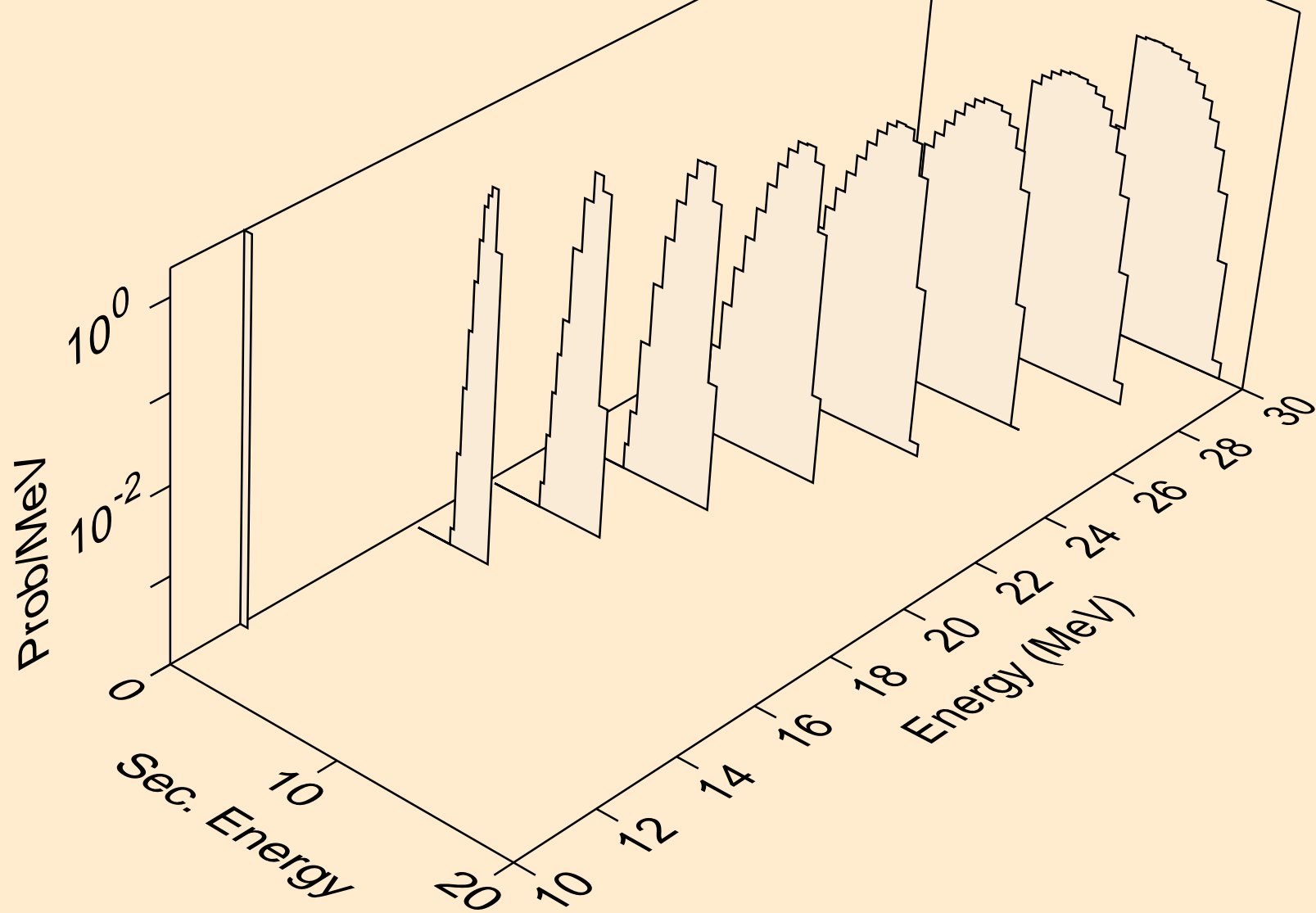

TH225 ALPHA ACER TENDL-2021 LIBRARY; T=0.K
deuterons from (a,x)

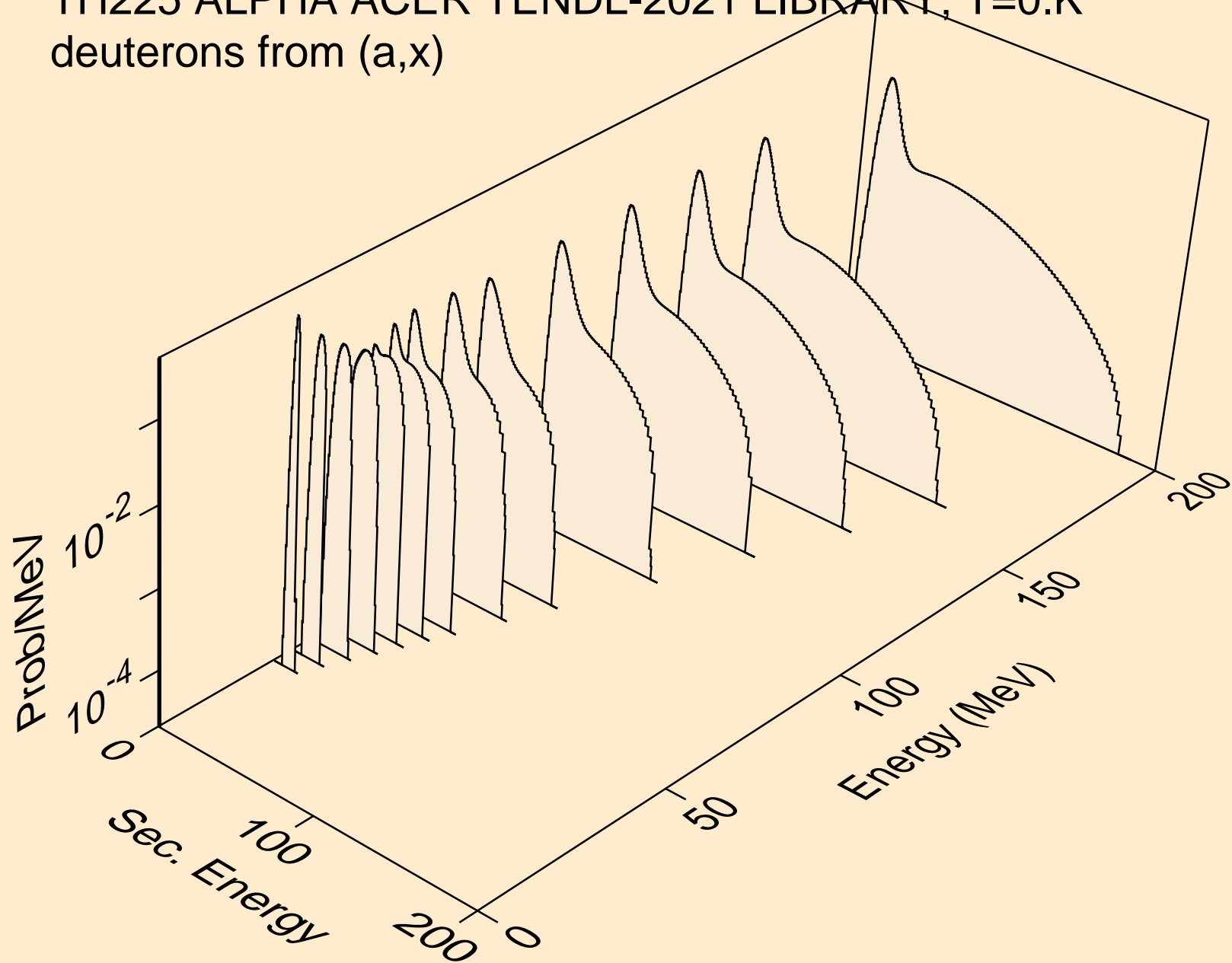

TH225 ALPHA ACER TENDL-2021 LIBRARY; T=0.K
deuterons from (a,d)

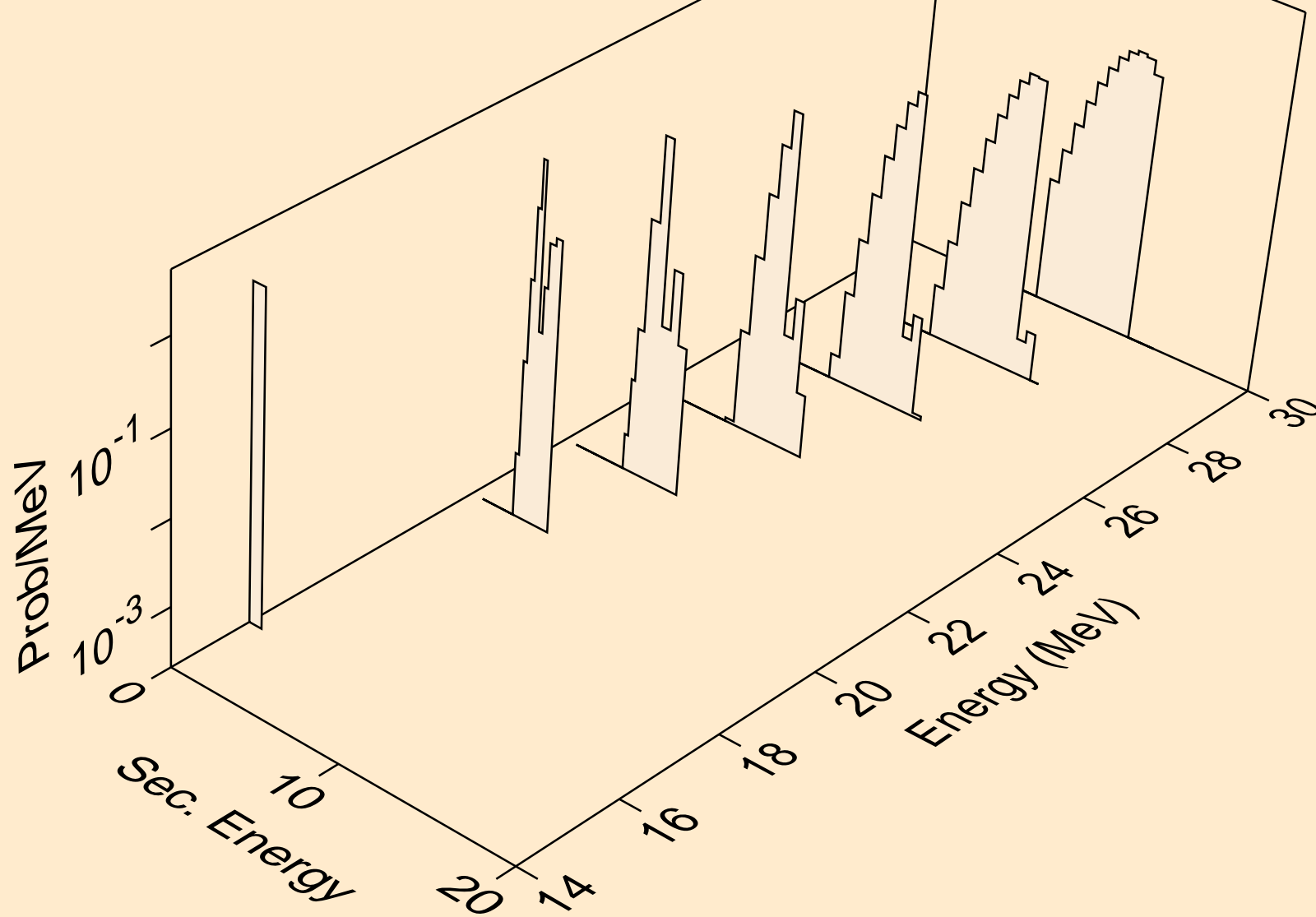

TH225 ALPHA ACER TENDL-2021 LIBRARY; T=0.K
tritons from (a,x)

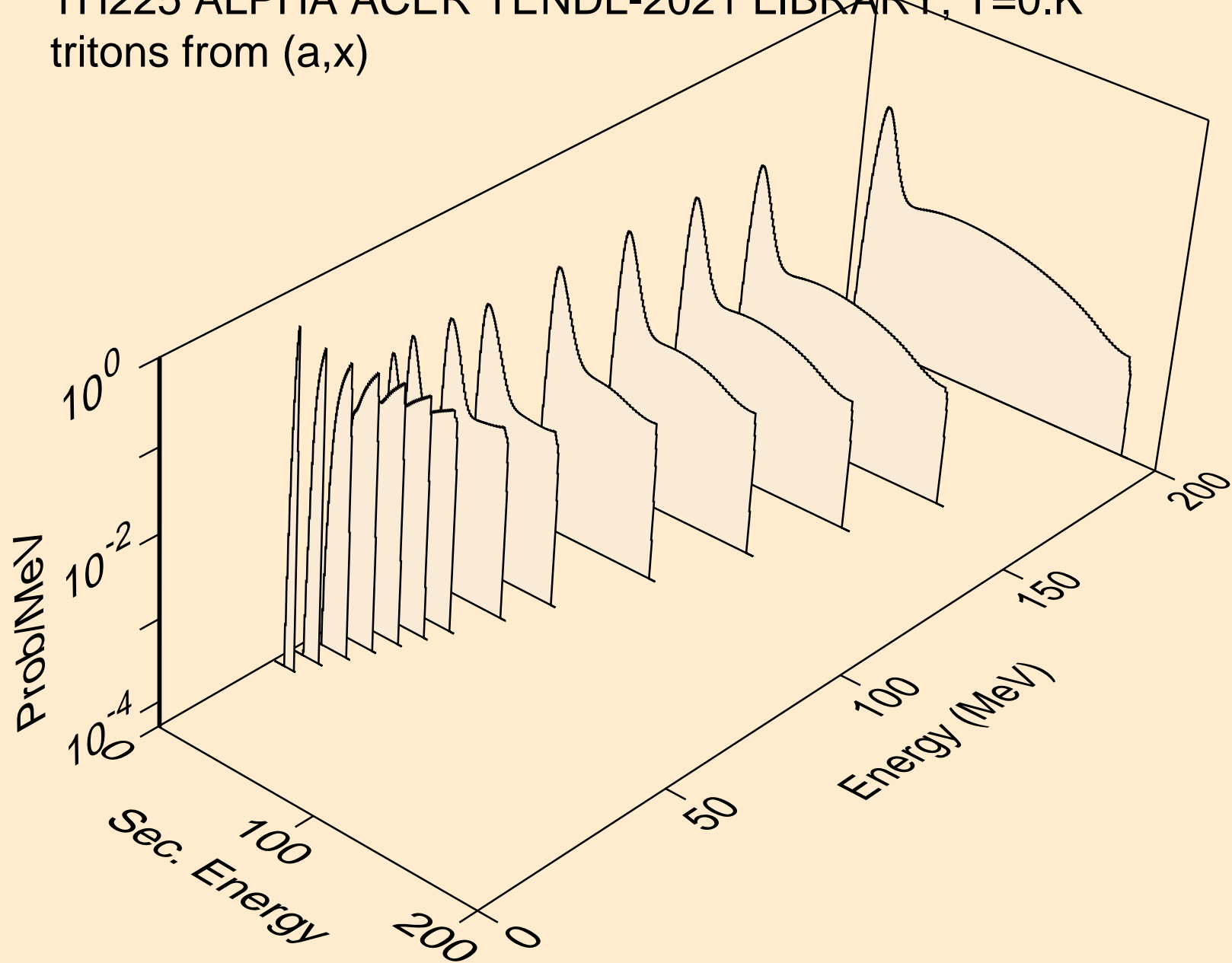

TH225 ALPHA ACER TENDL-2021 LIBRARY; T=0.K
tritons from (a,t)

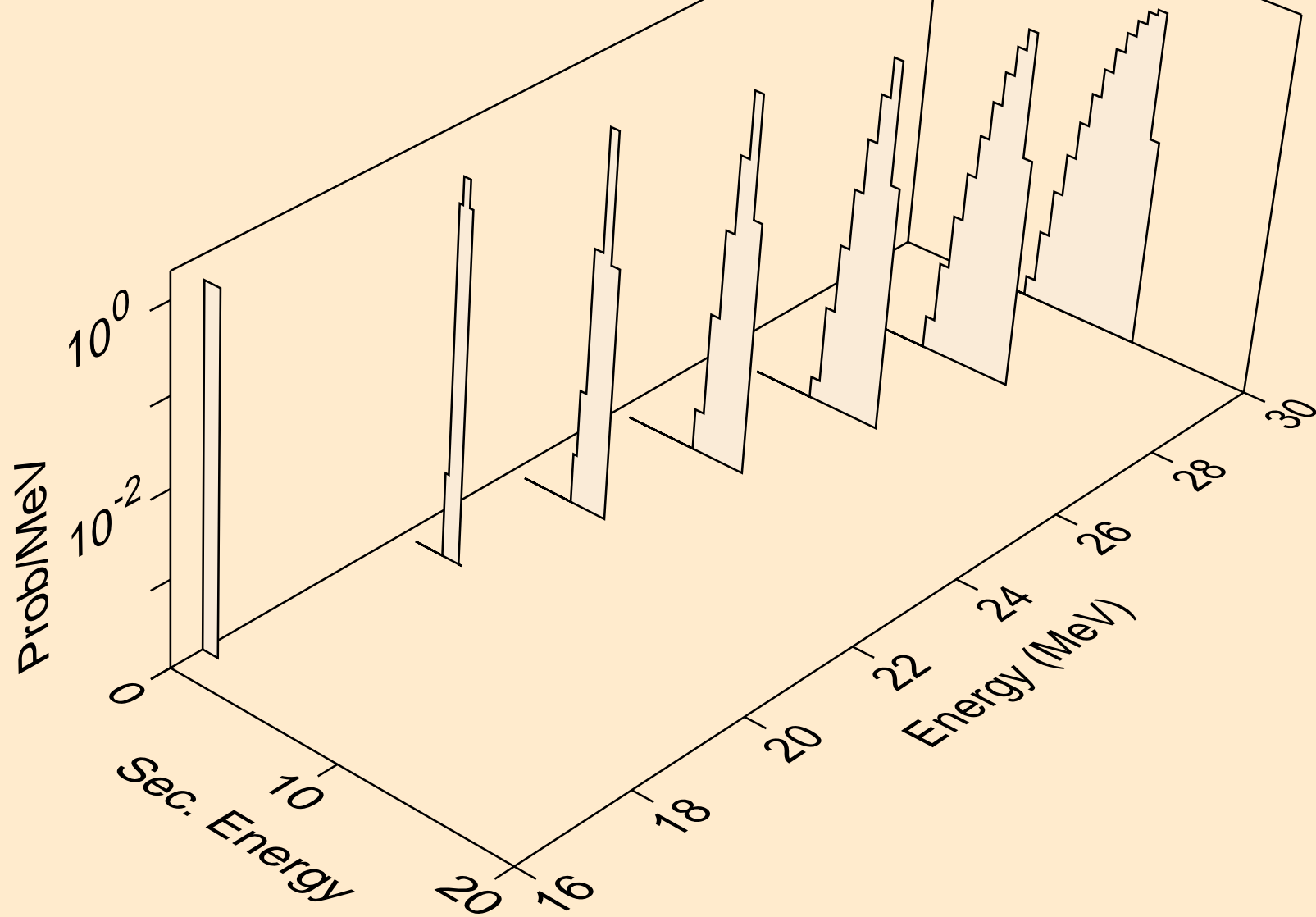

TH225 ALPHA ACER TENDL-2021 LIBRARY; T=0.K
he3s from (a,x)

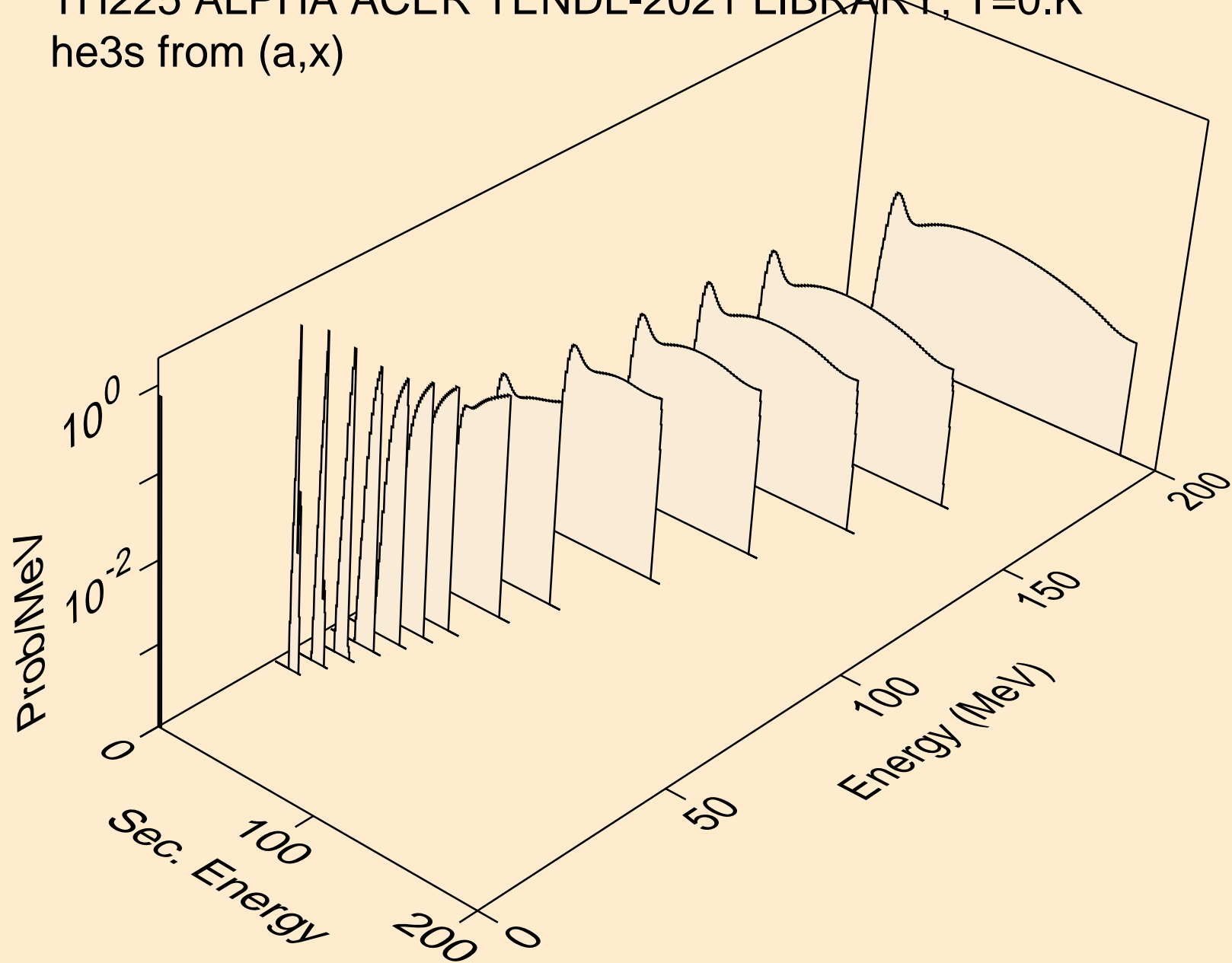

TH225 ALPHA ACER TENDL-2021 LIBRARY; T=0.K
he3s from (a,he3)

