

# N014 DEUTERON ACER TENDL-2021 LIBRARY; T=0.K

## Principal cross sections

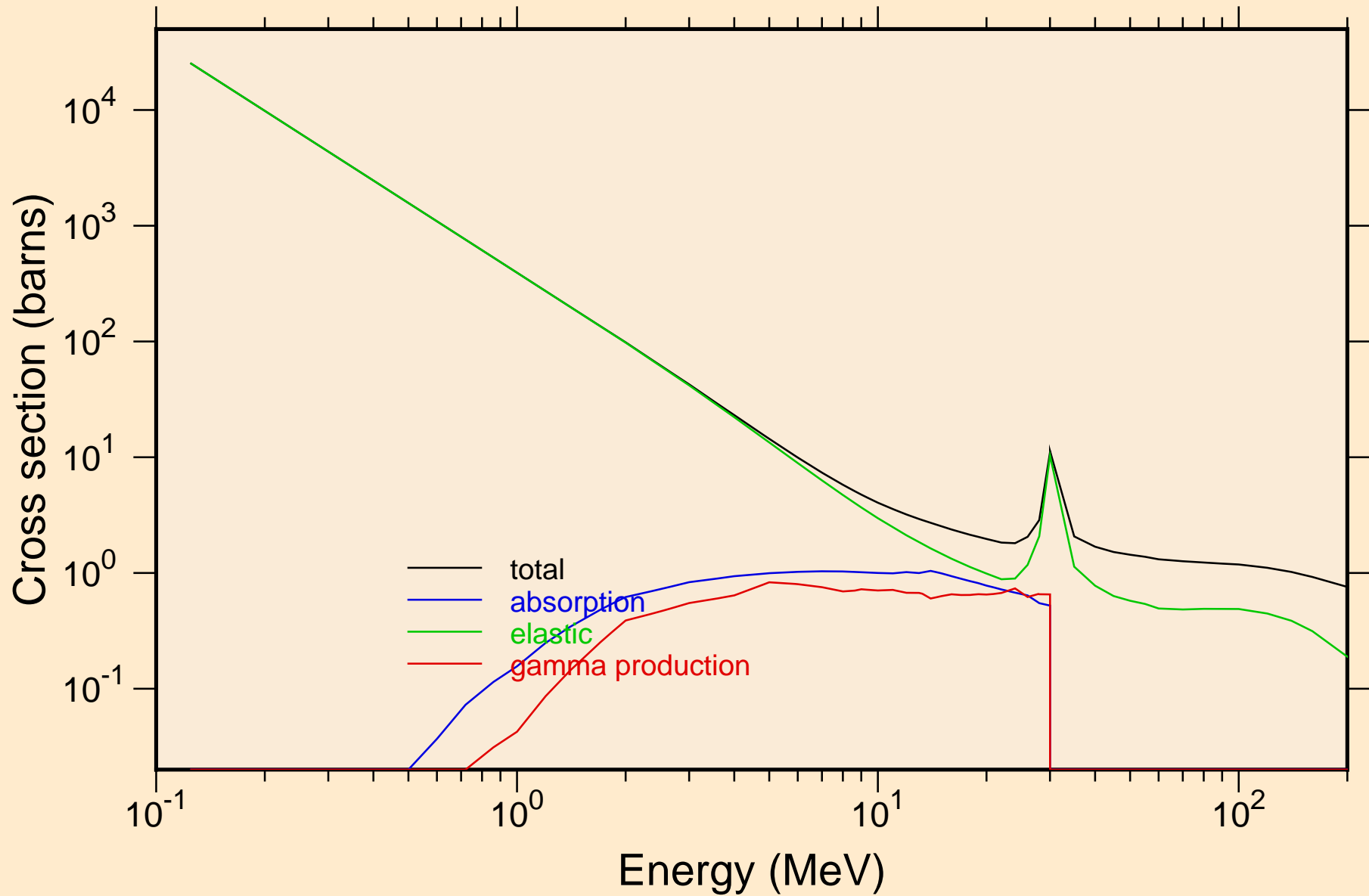

# N014 DEUTERON ACER TENDL-2021 LIBRARY; T=0.K

## Heating

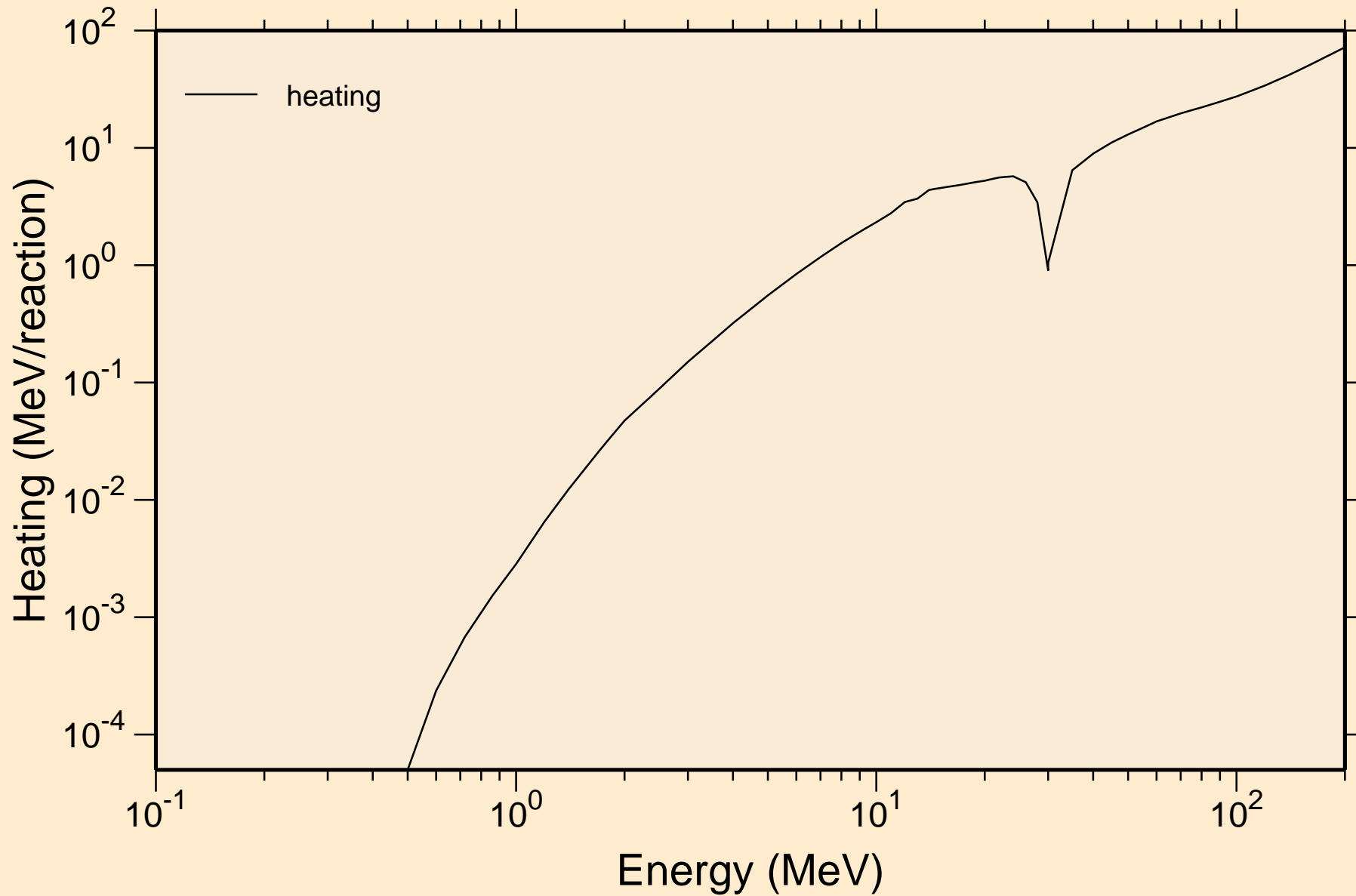

# N014 DEUTERON ACER TENDL-2021 LIBRARY; T=0.K

## Principal cross sections

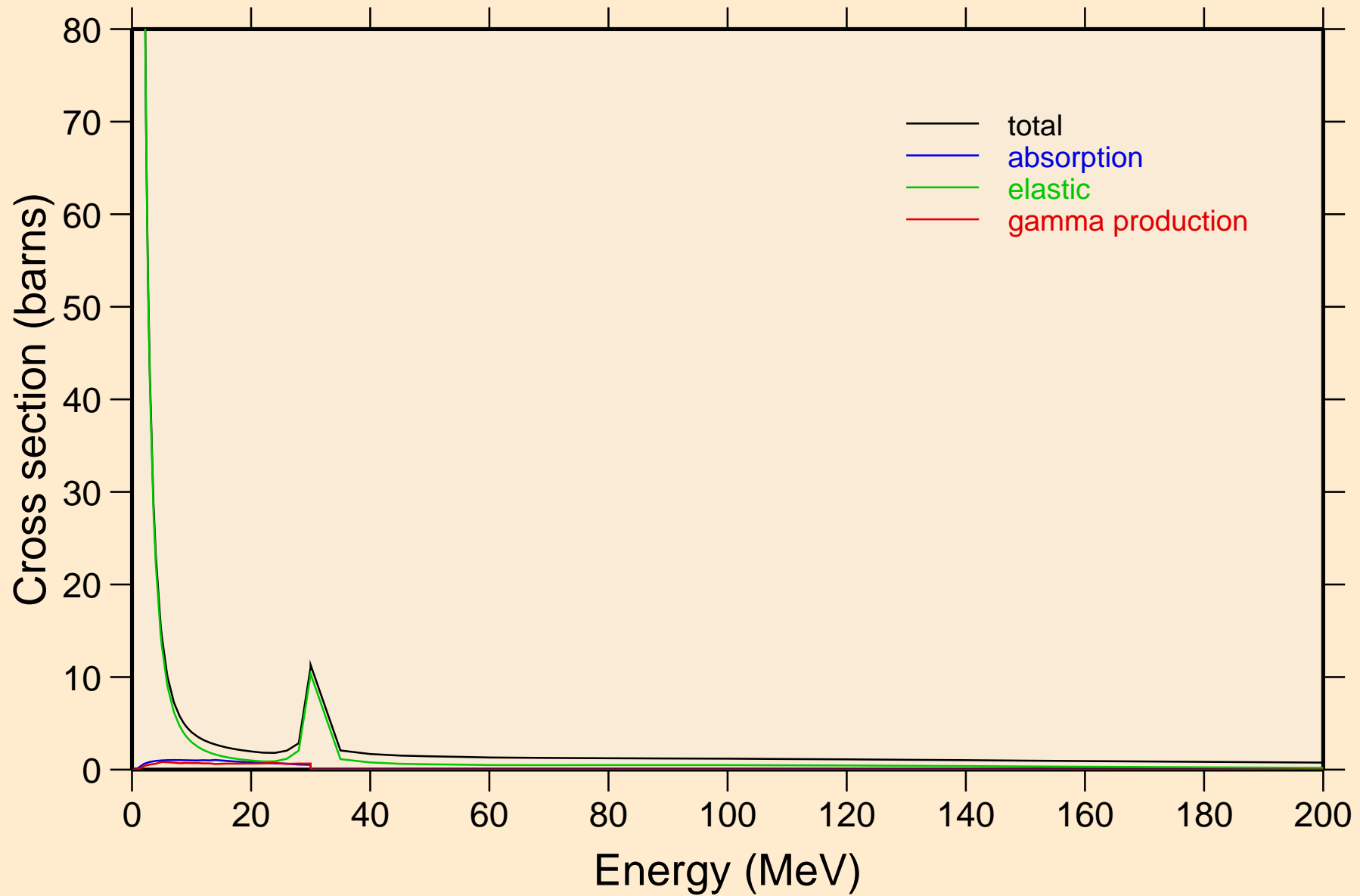

# N014 DEUTERON ACER TENDL-2021 LIBRARY; T=0.K

## Heating

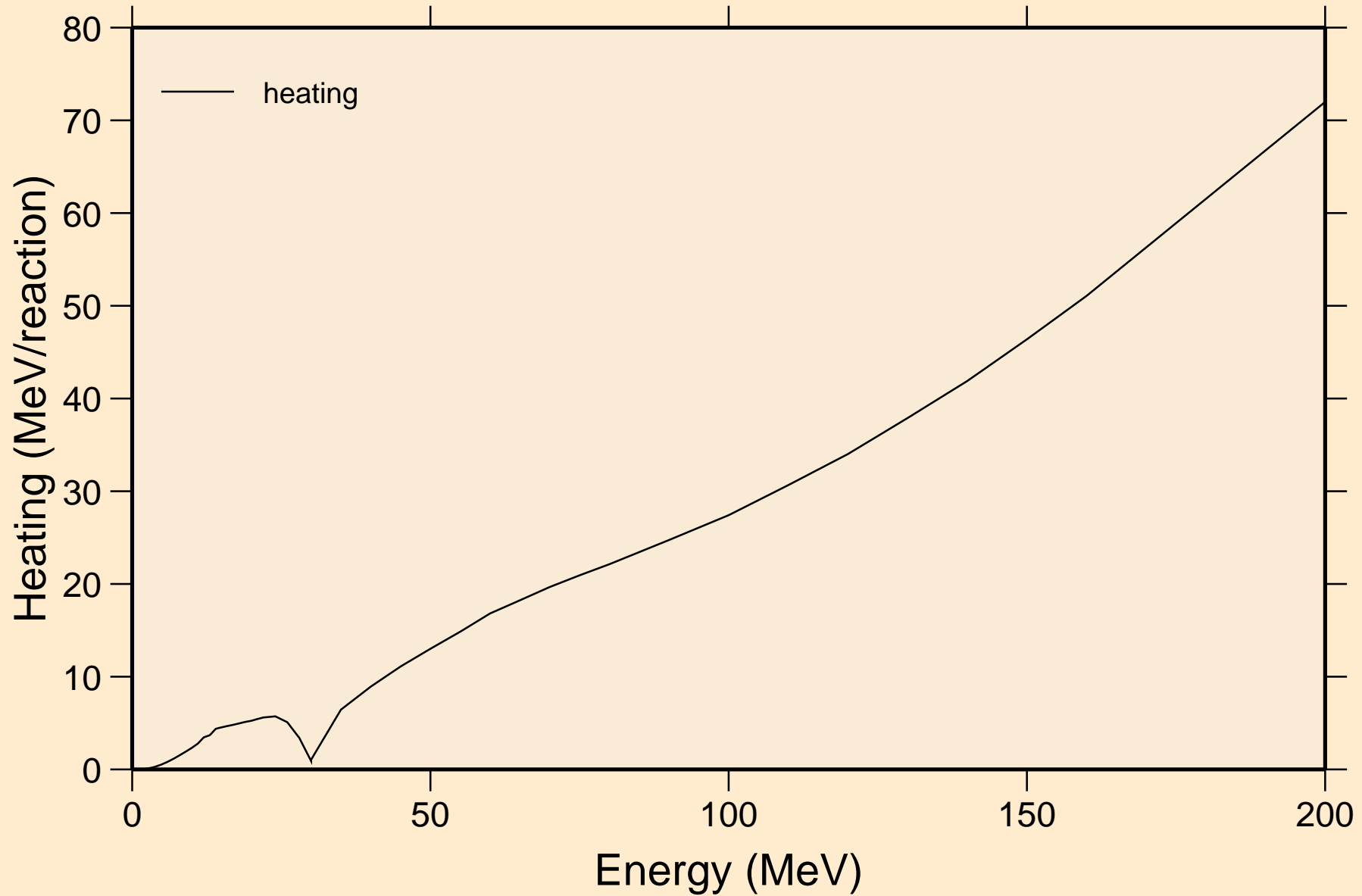

N014 DEUTERON ACER TENDL-2021 LIBRARY; T=0.K  
Threshold reactions

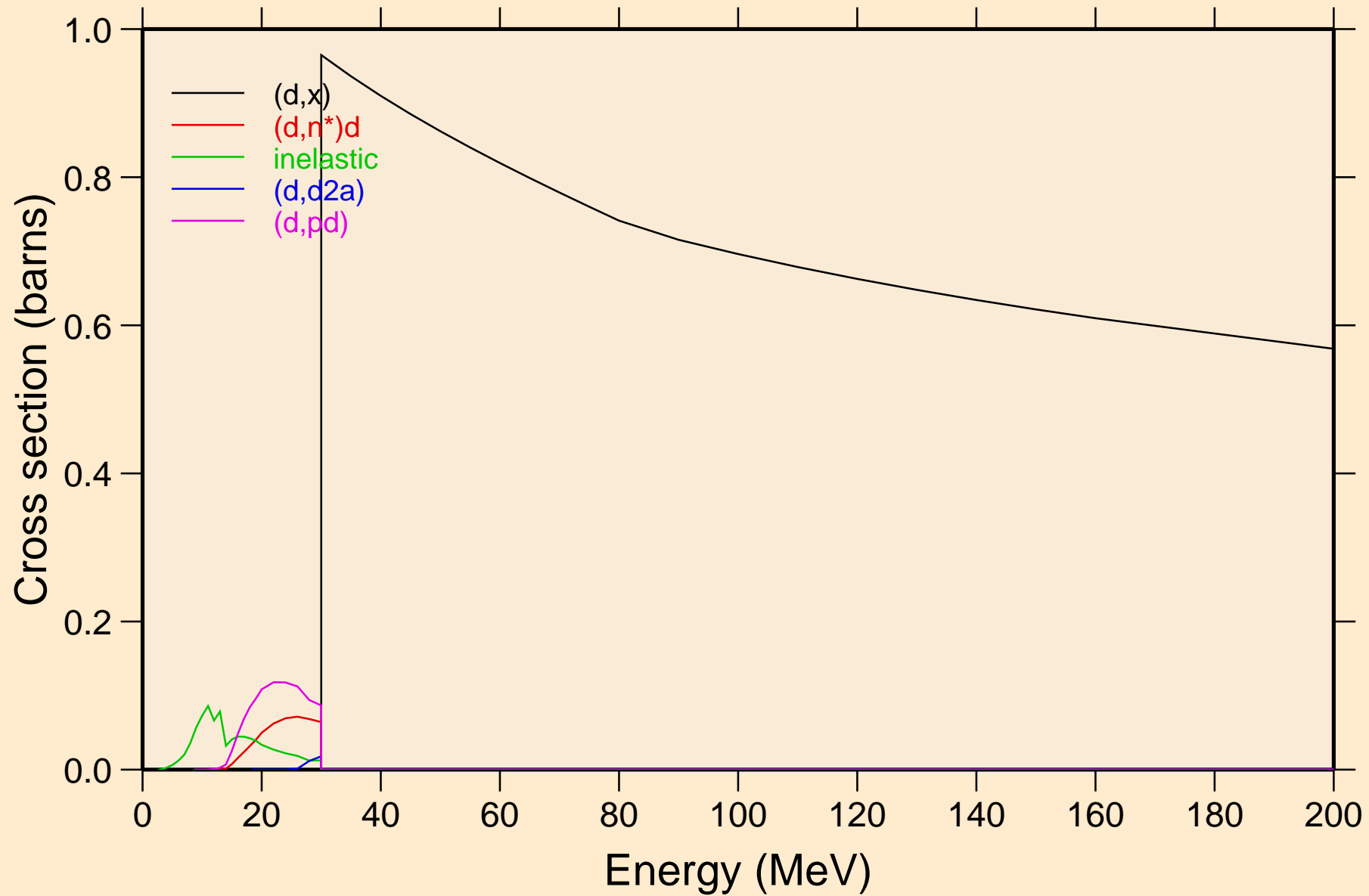

N014 DEUTERON ACER TENDL-2021 LIBRARY; T=0.K  
Threshold reactions

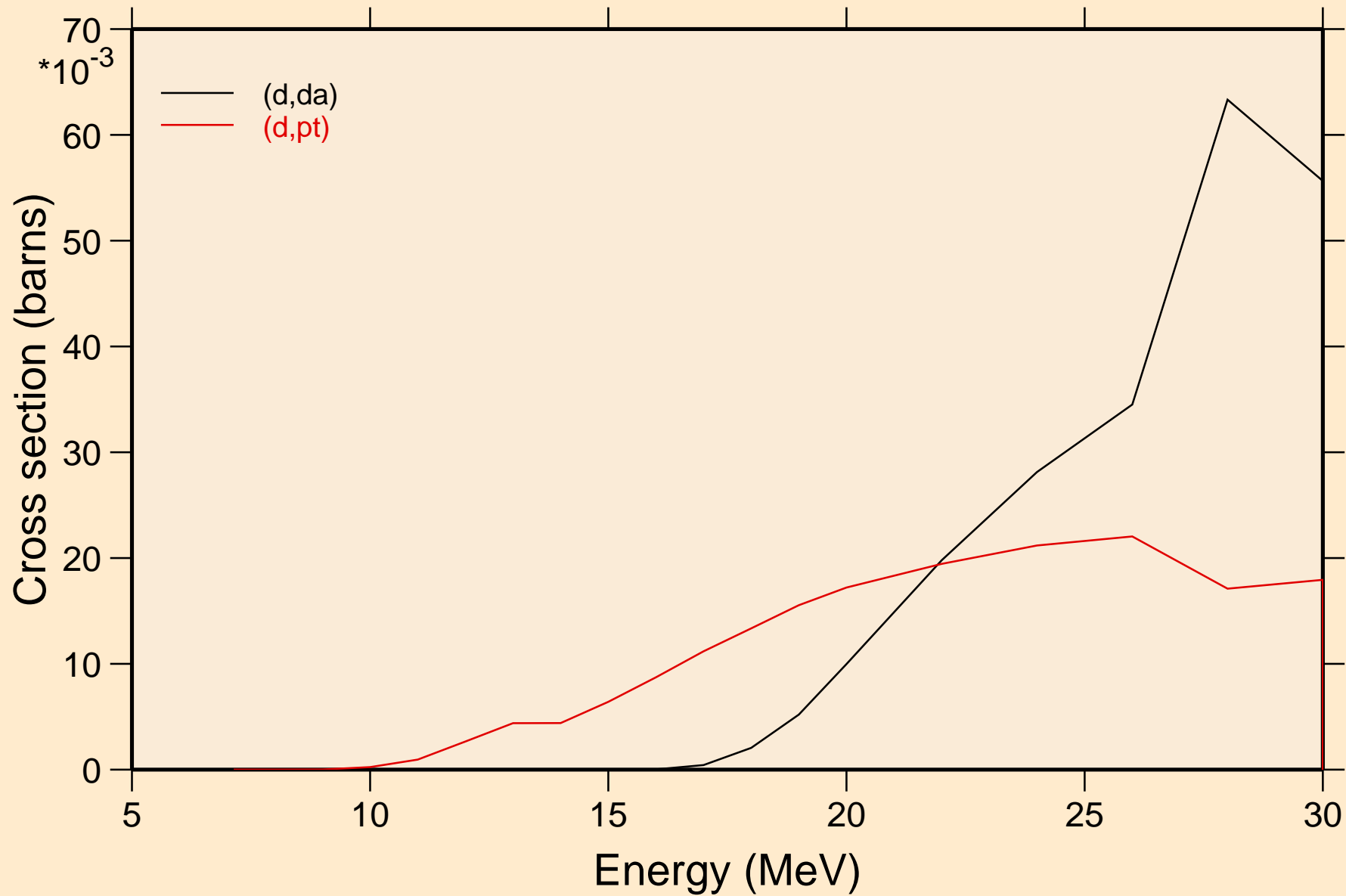

N014 DEUTERON ACER TENDL-2021 LIBRARY; T=0.K  
Threshold reactions

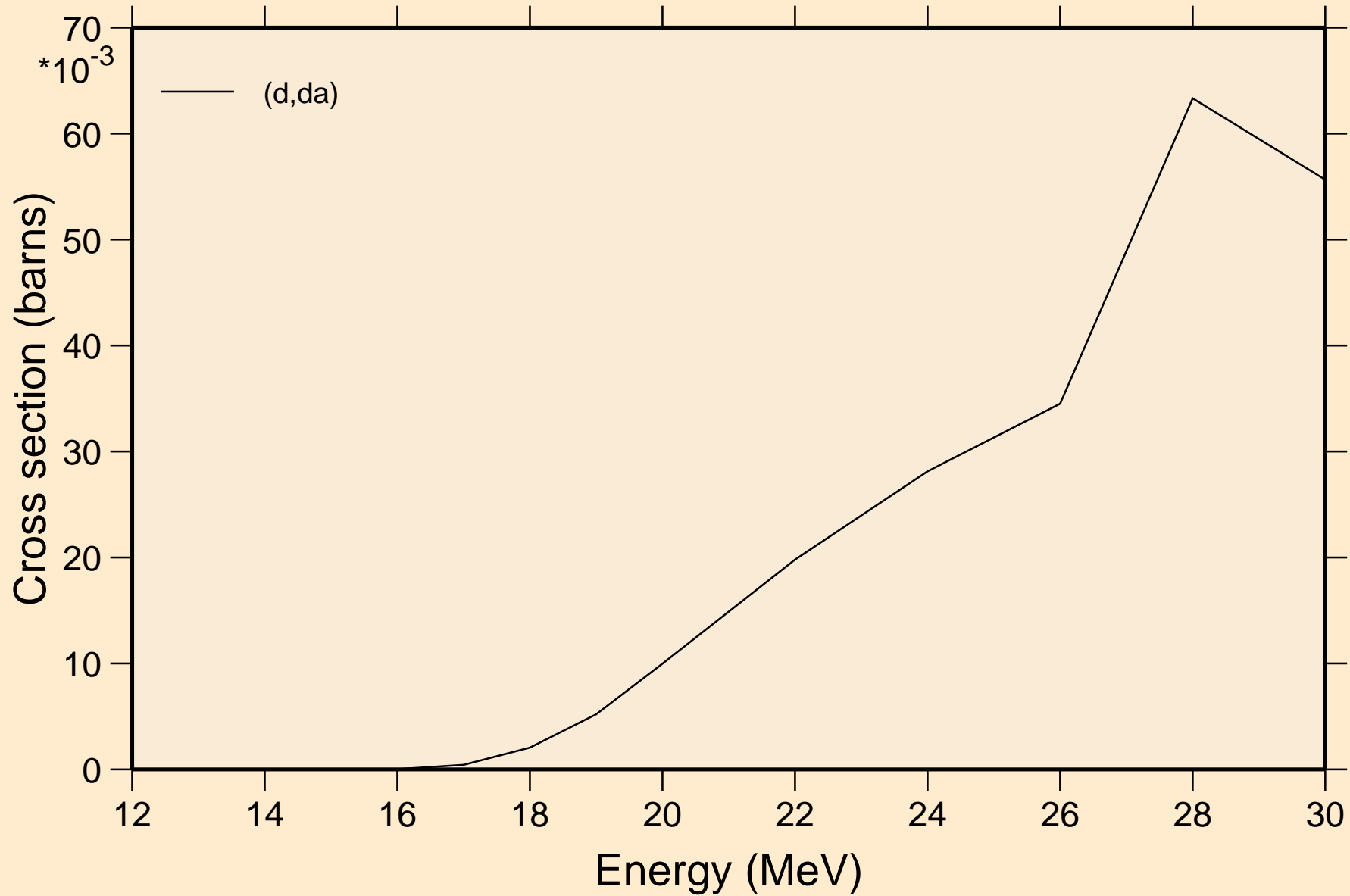

N014 DEUTERON ACER TENDL-2021 LIBRARY; T=0.K  
angular distribution for elastic

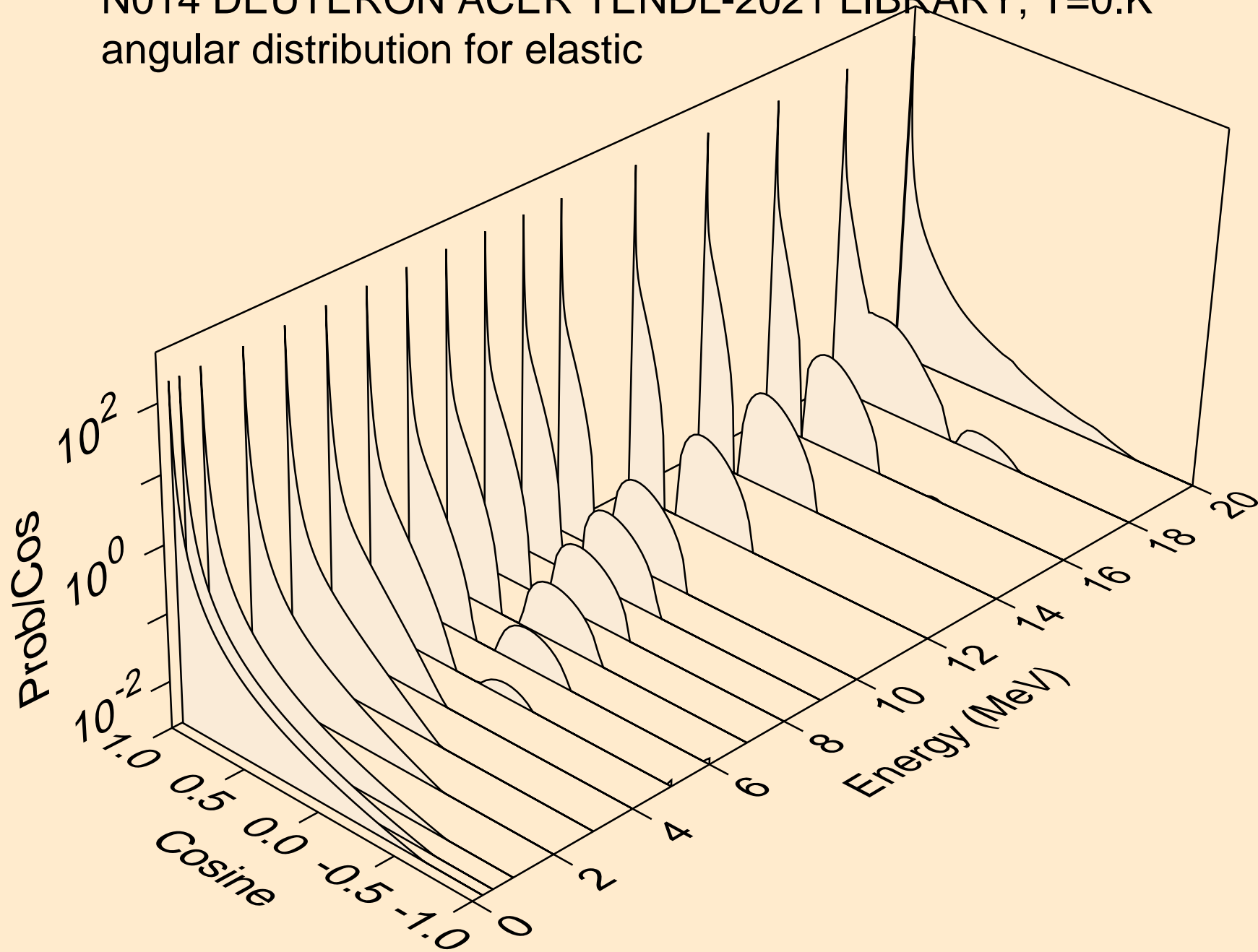

N014 DEUTERON ACER TENDL-2021 LIBRARY; T=0.K  
angular distribution for elastic

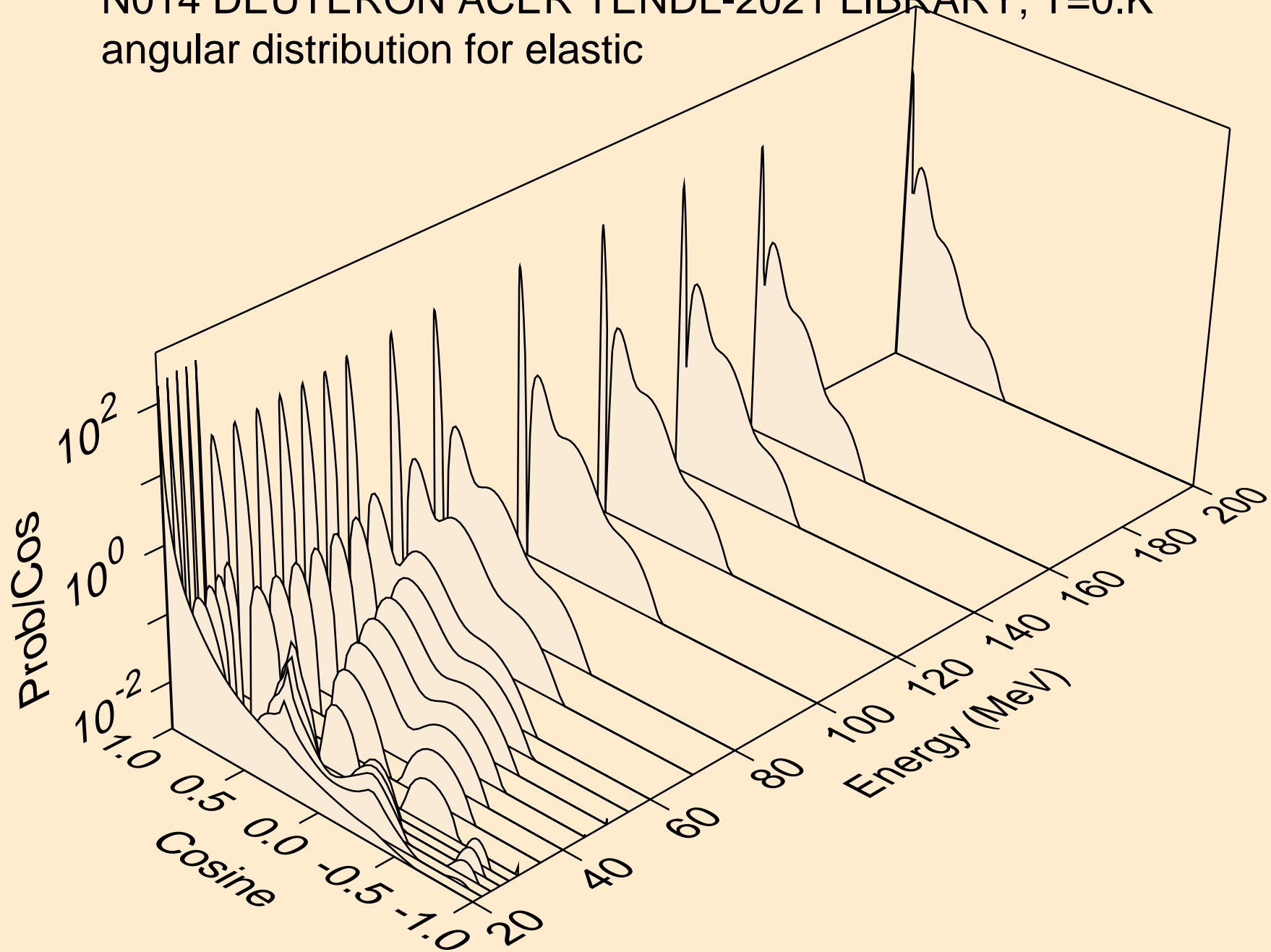

N014 DEUTERON ACER TENDL-2021 LIBRARY; T=0.K  
Deuteron emission for (d,x)

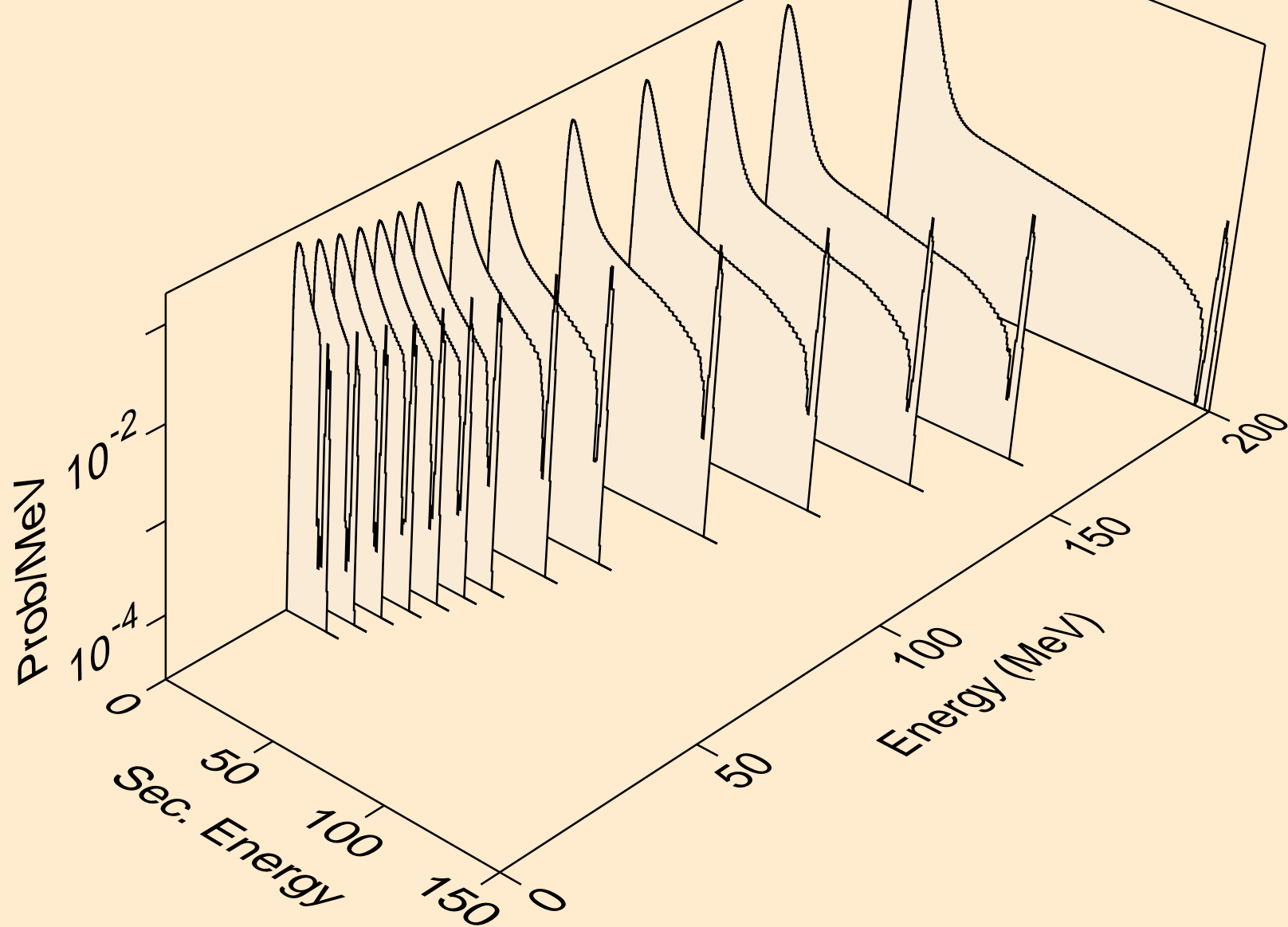

N014 DEUTERON ACER TENDL-2021 LIBRARY; T=0.K  
Deuteron emission for (d,n\*)d

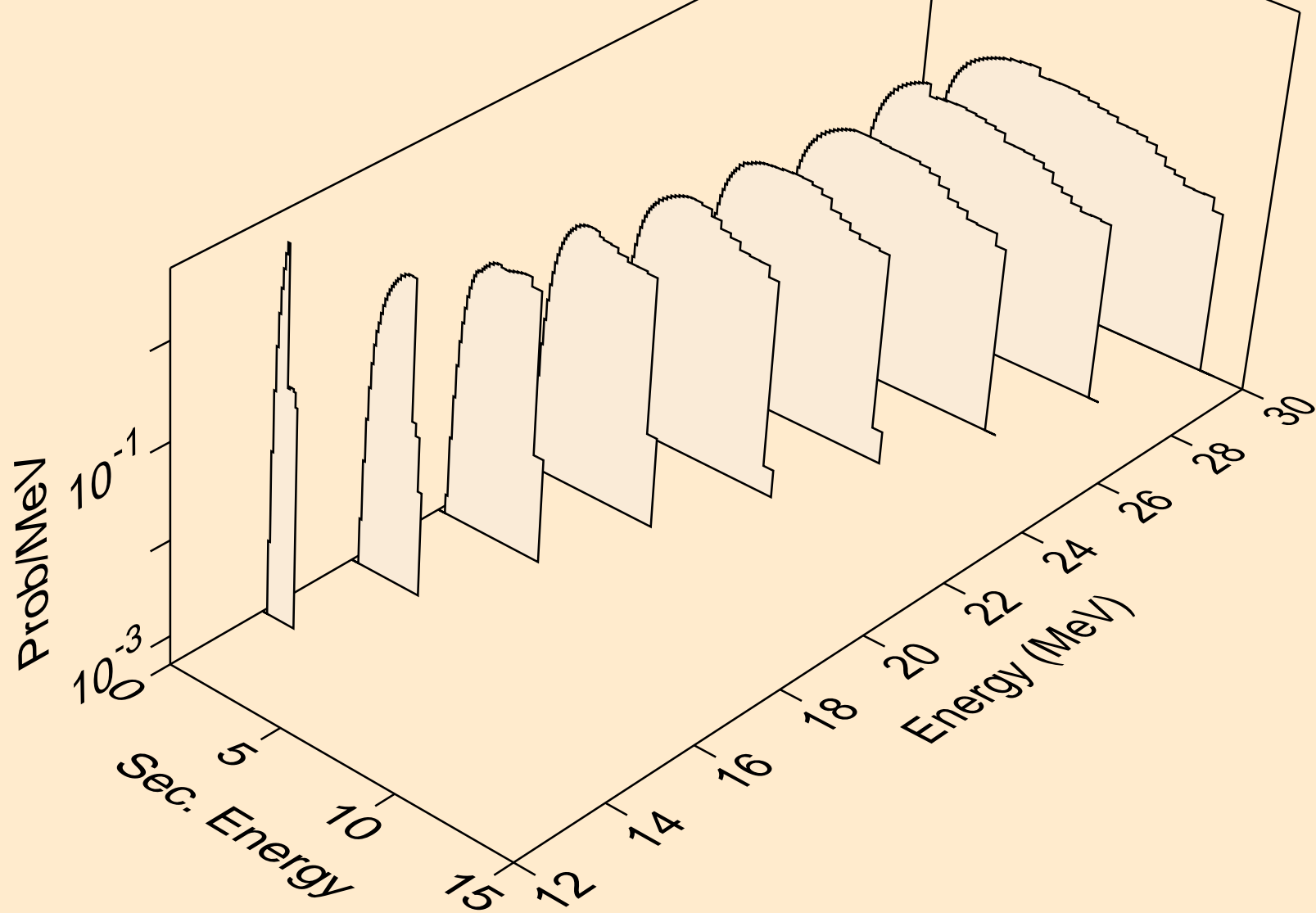

N014 DEUTERON ACER TENDL-2021 LIBRARY; T=0.K  
Deuteron emission for inelastic

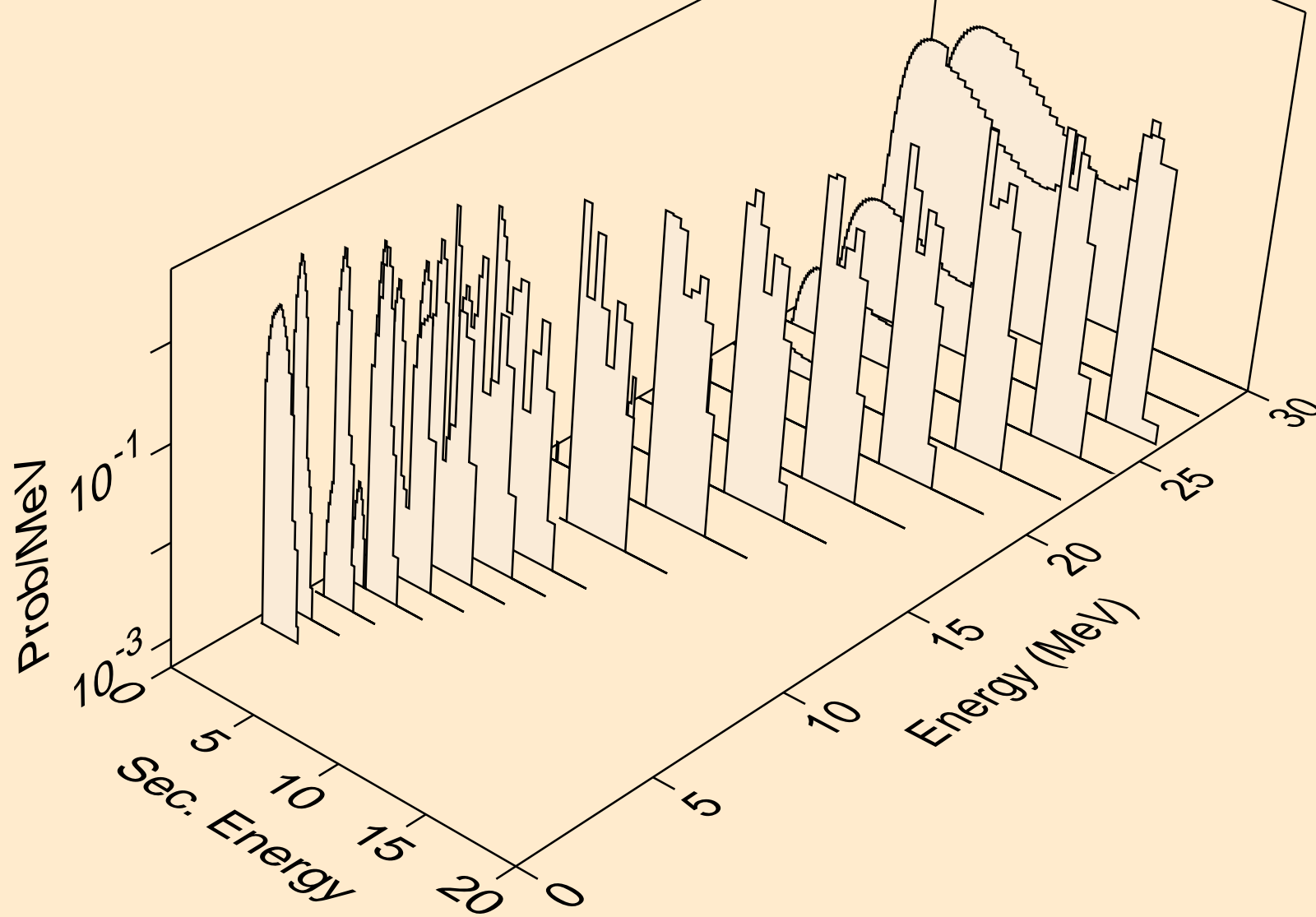

N014 DEUTERON ACER TENDL-2021 LIBRARY; T=0.K  
Deuteron emission for (d,d2a)

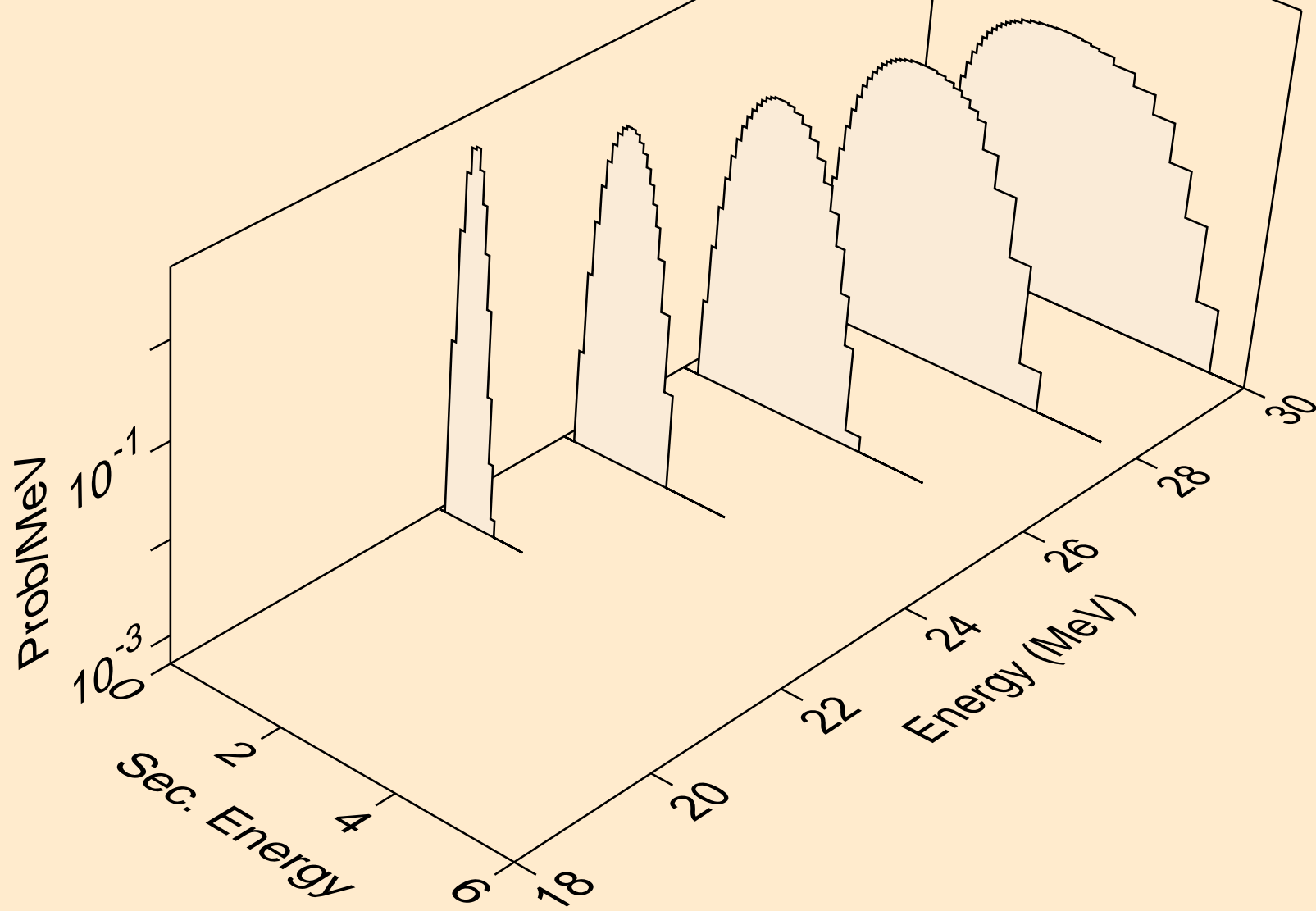

N014 DEUTERON ACER TENDL-2021 LIBRARY; T=0.K  
Deuteron emission for (d,pd)

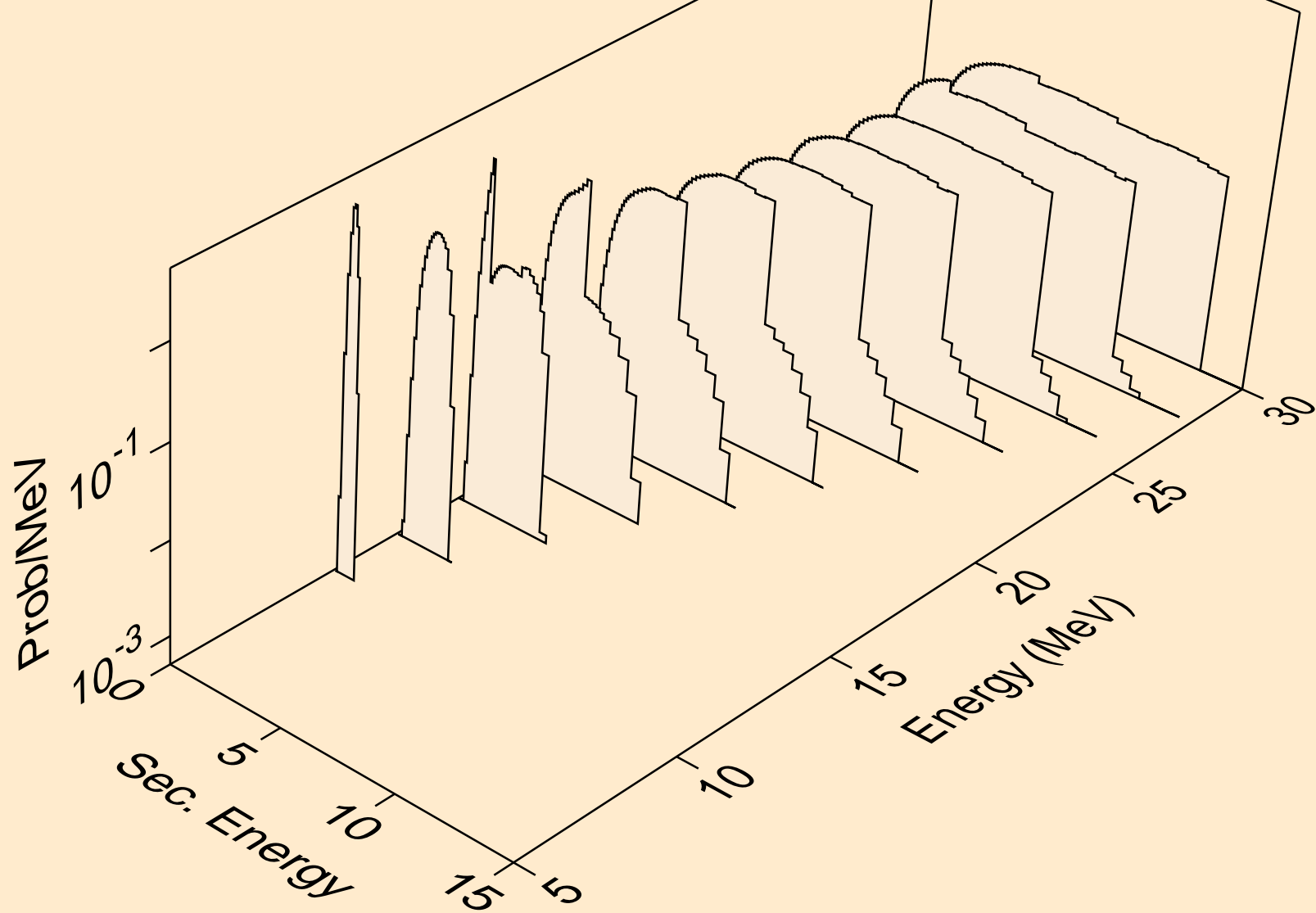

N014 DEUTERON ACER TENDL-2021 LIBRARY; T=0.K  
Deuteron emission for (d,da)

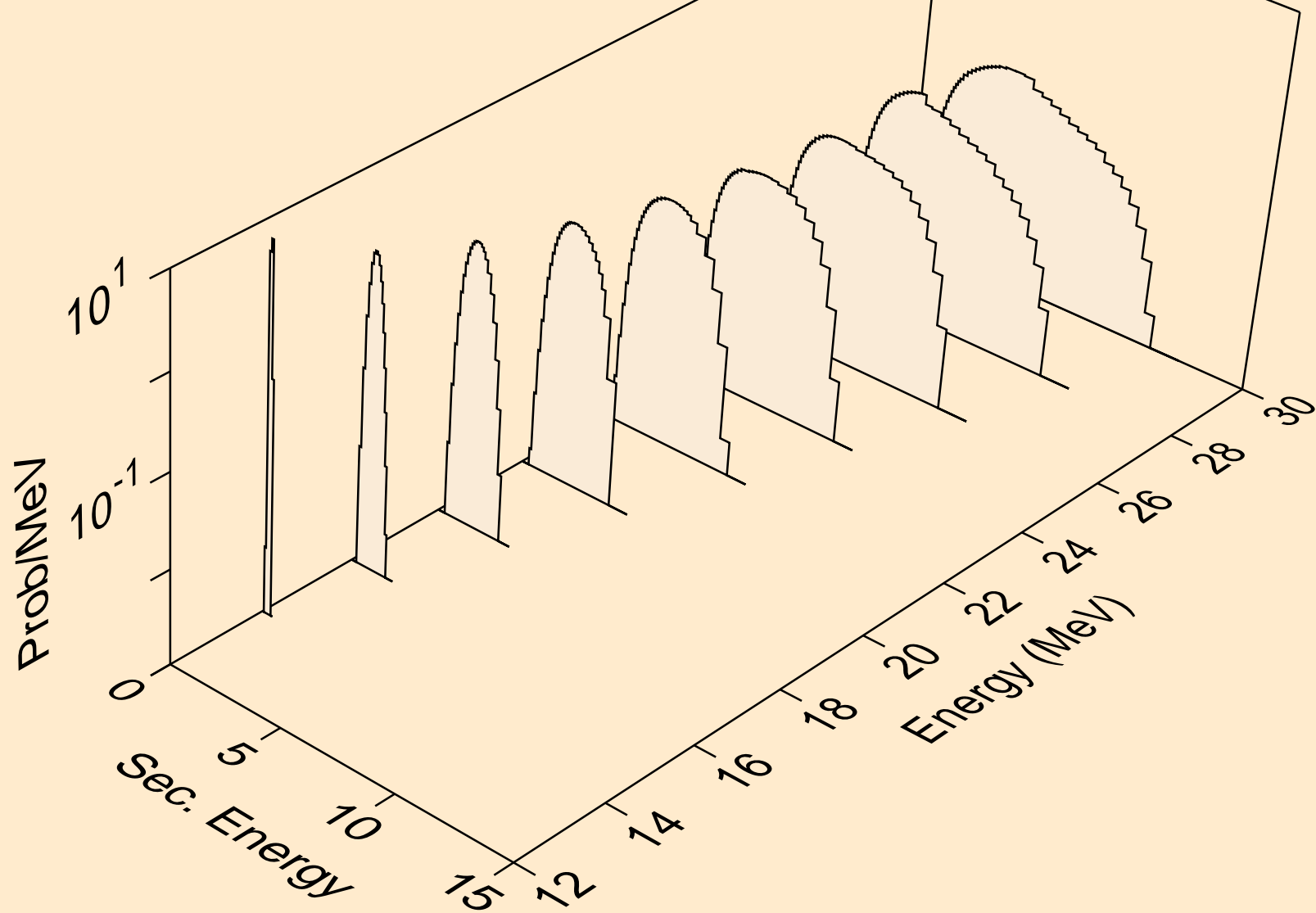

N014 DEUTERON ACER TENDL-2021 LIBRARY; T=0.K  
Photon emission for (z,n)

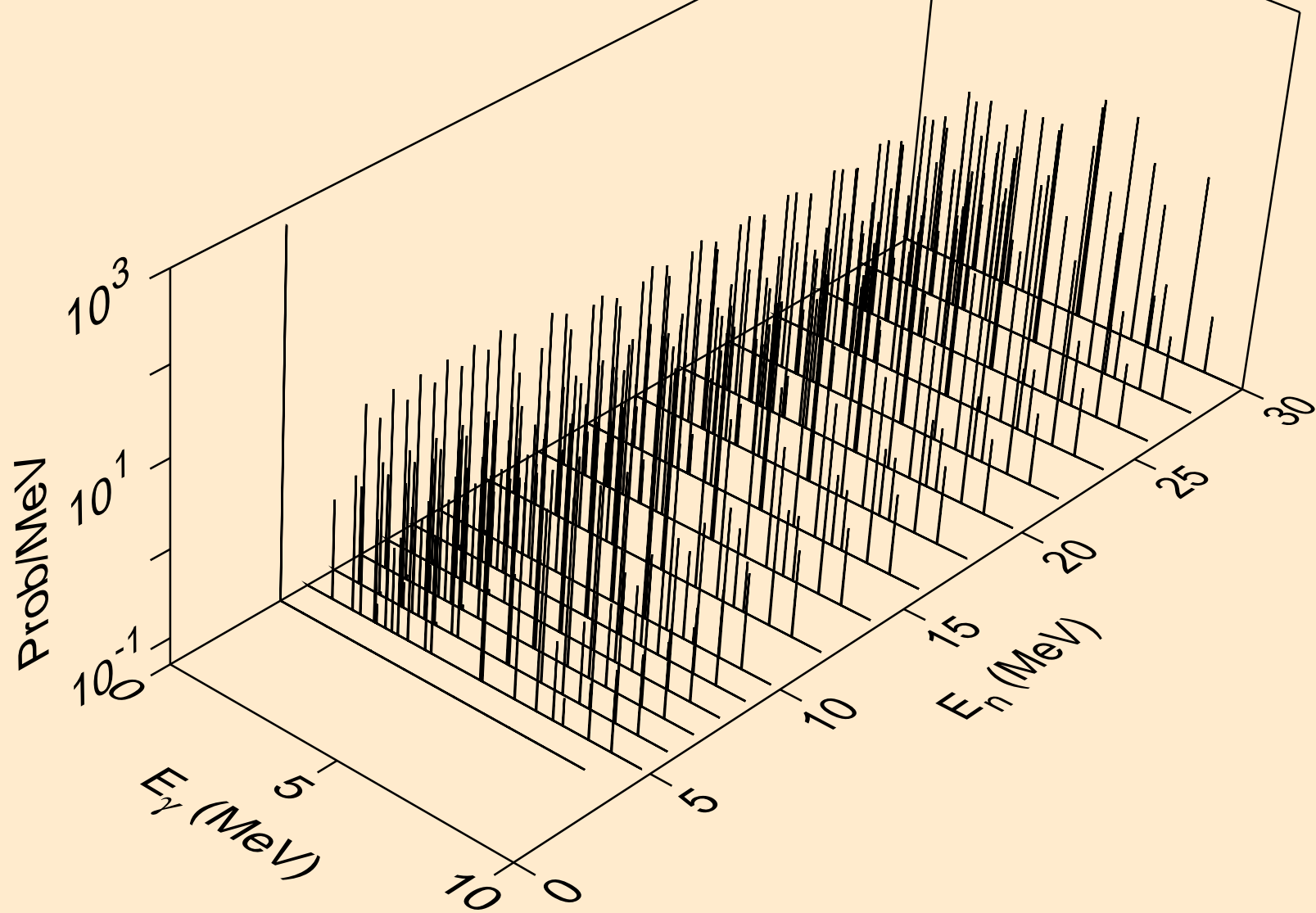

N014 DEUTERON ACER TENDL-2021 LIBRARY; T=0.K  
Photon emission for (n,x)

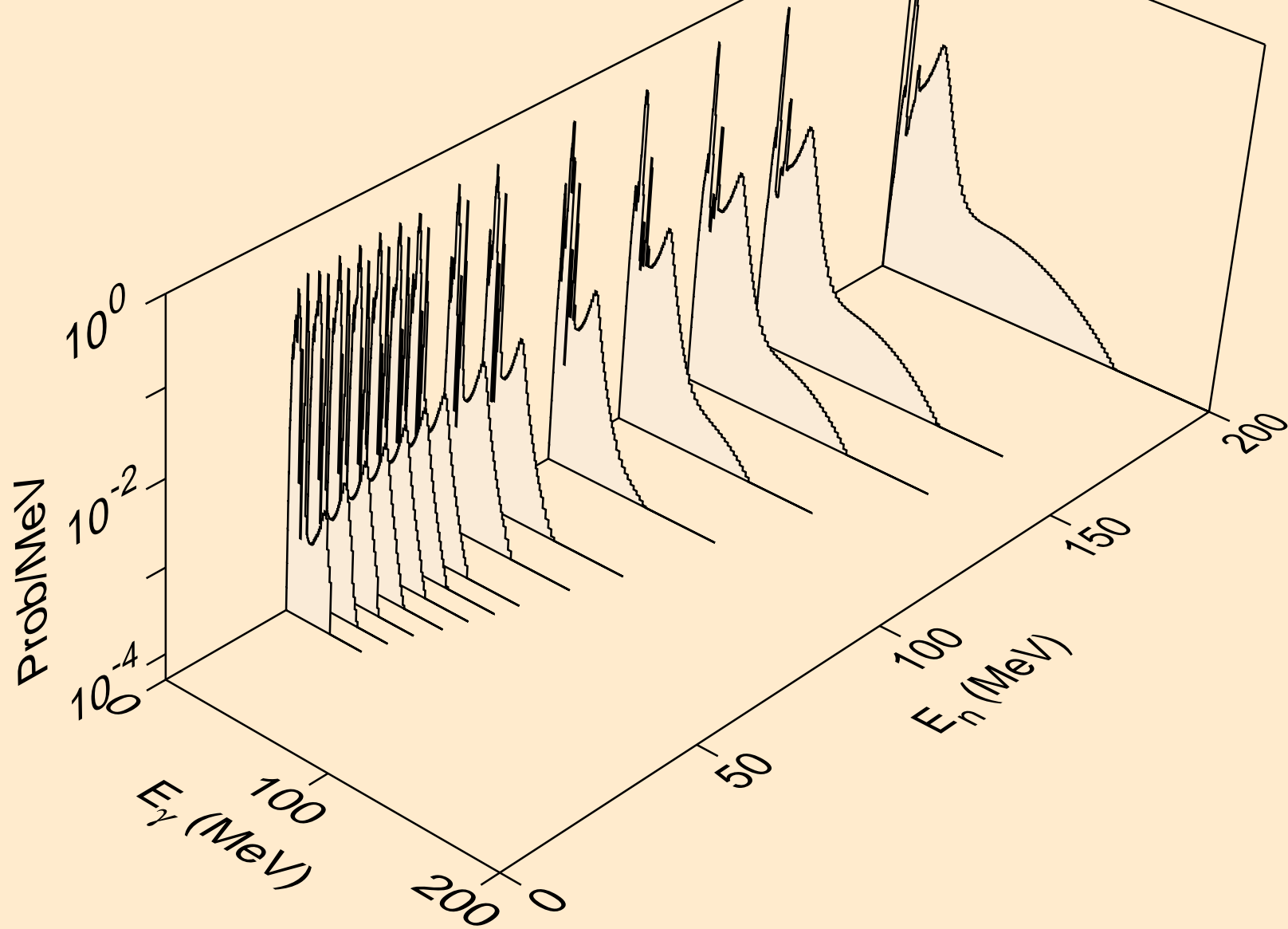

N014 DEUTERON ACER TENDL-2021 LIBRARY; T=0.K  
Photon emission for (n,2n)

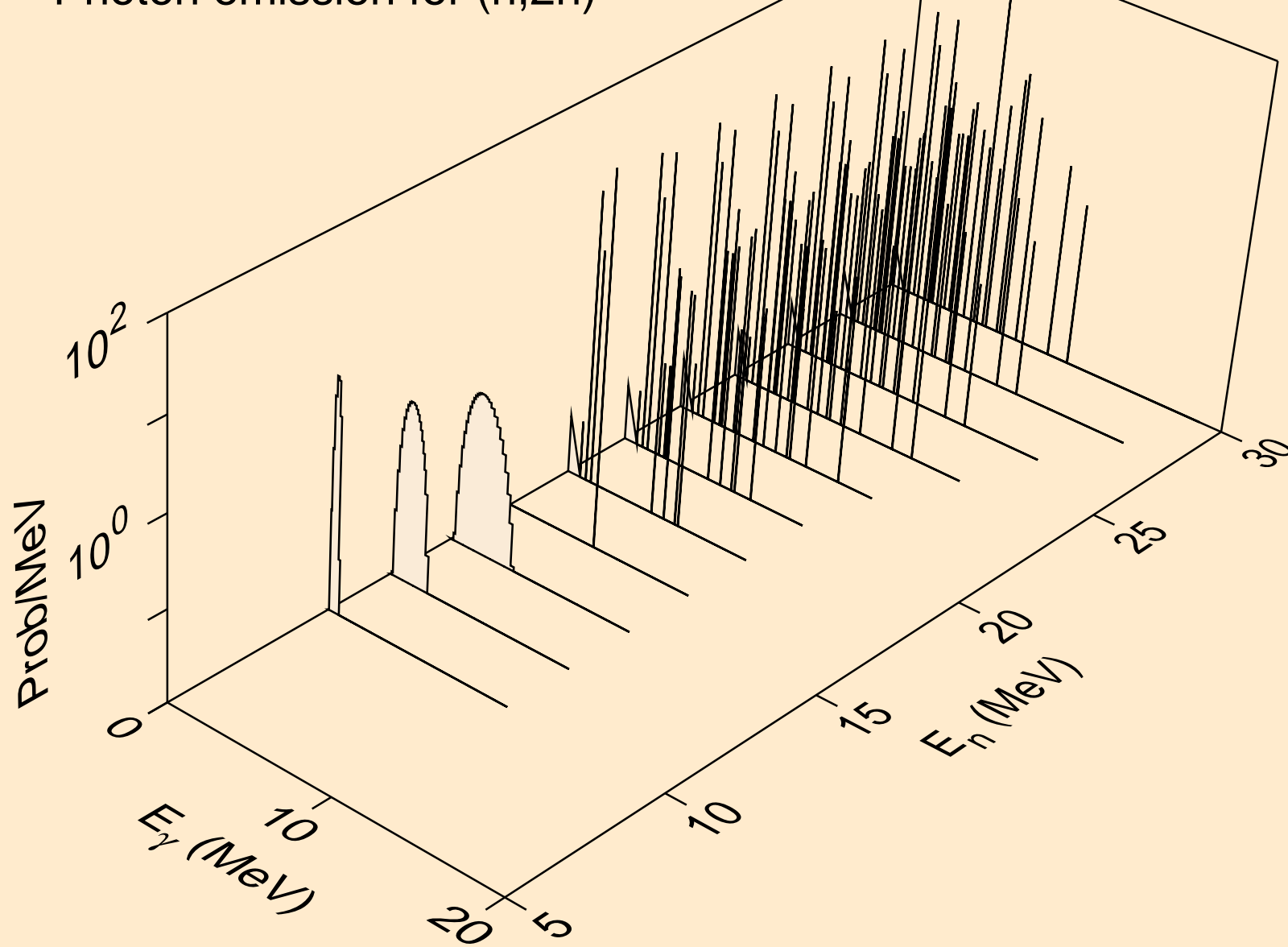

N014 DEUTERON ACER TENDL-2021 LIBRARY; T=0.K  
Photon emission for (n,n\*)a

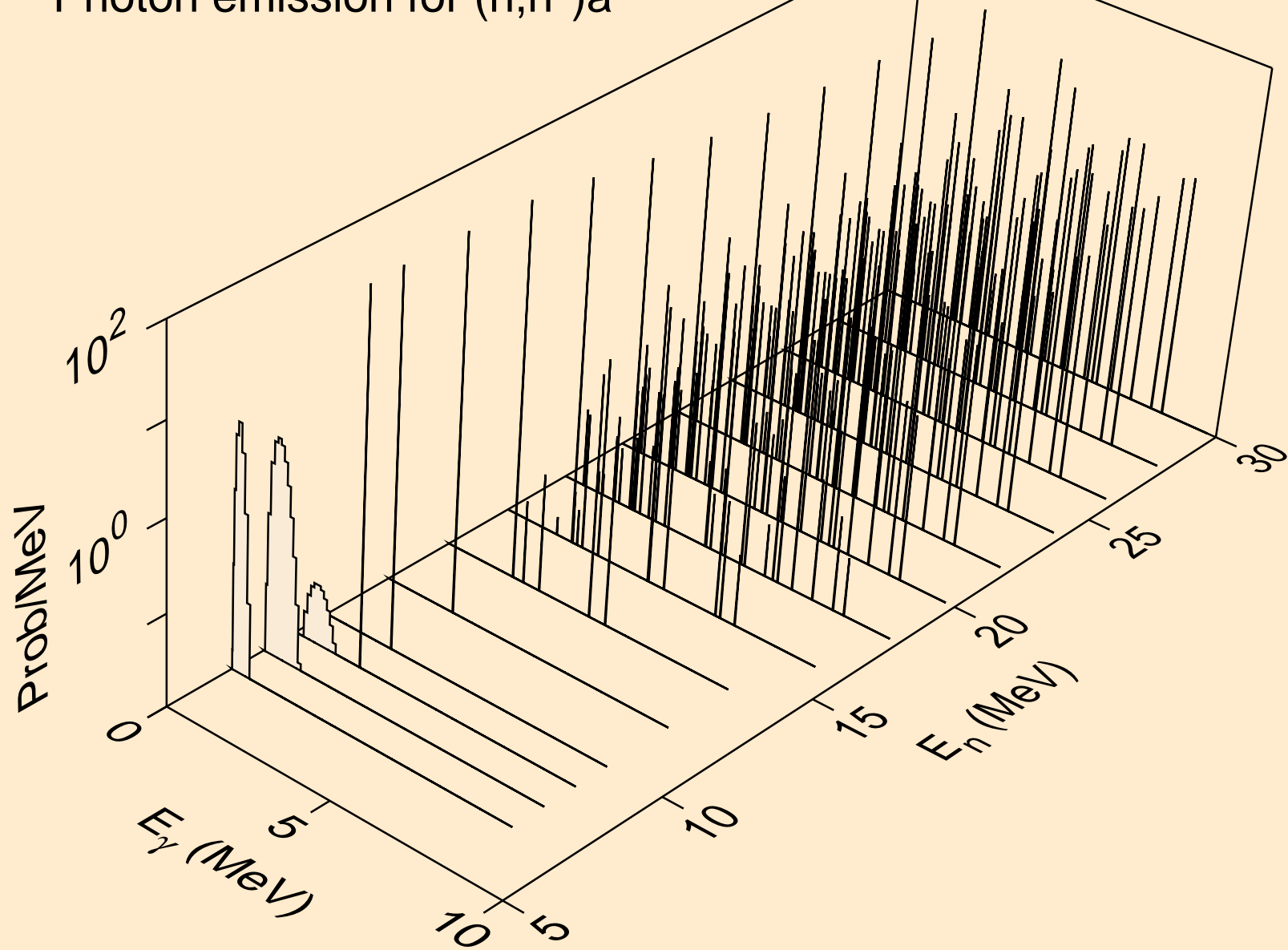

N014 DEUTERON ACER TENDL-2021 LIBRARY; T=0.K  
Photon emission for (n,2n)a

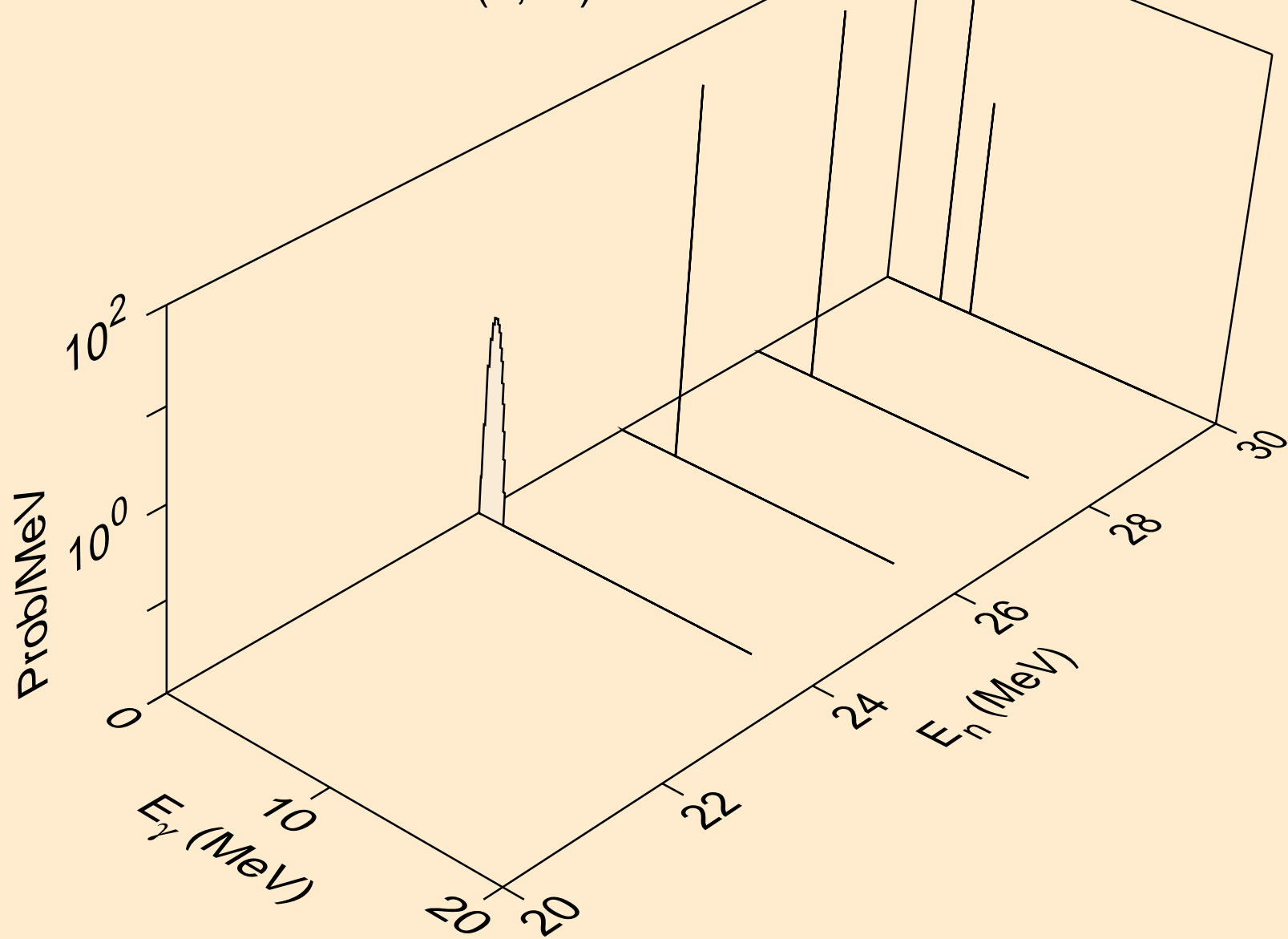

N014 DEUTERON ACER TENDL-2021 LIBRARY; T=0.K  
Photon emission for (n,n\*)p

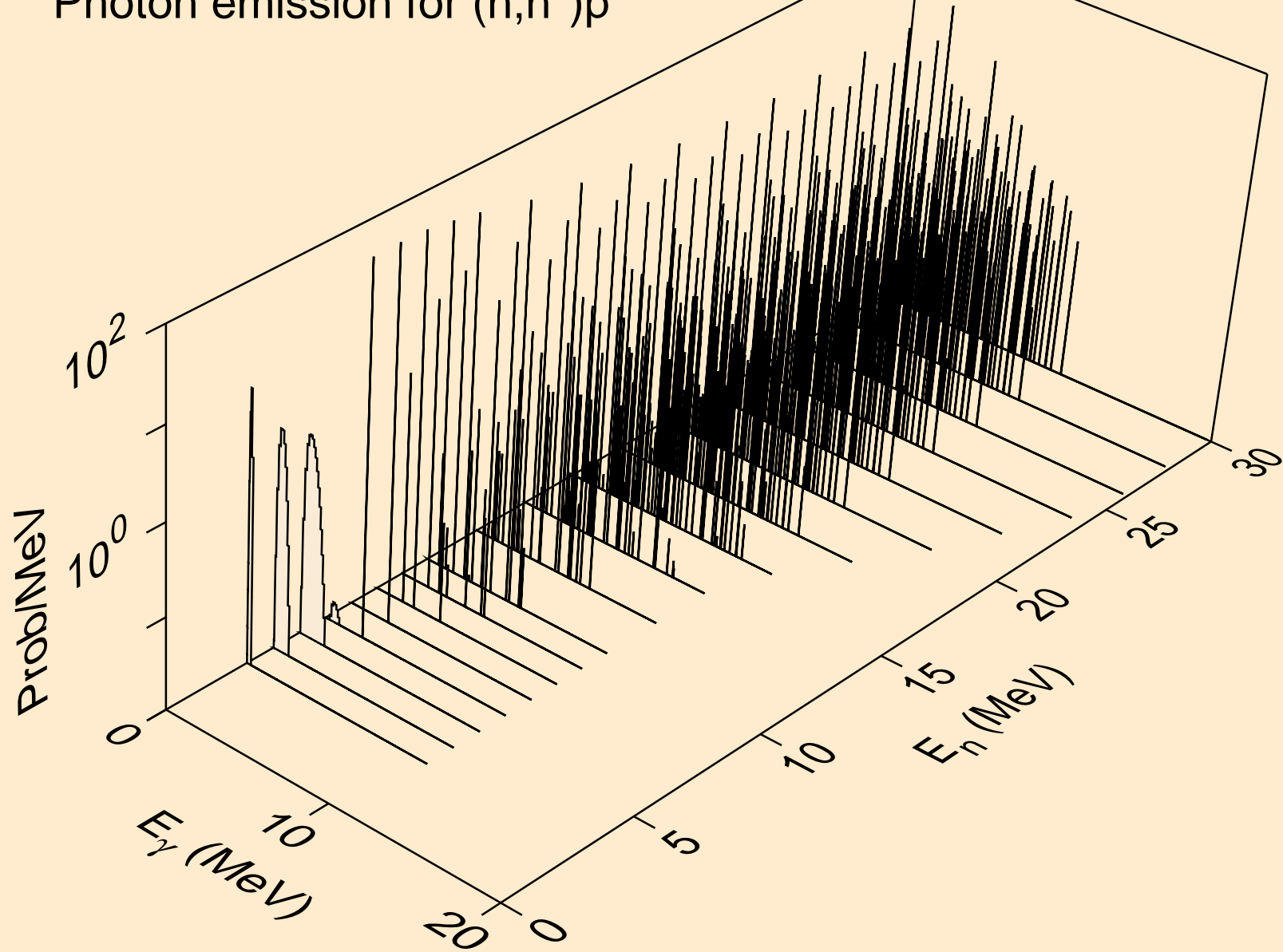

N014 DEUTERON ACER TENDL-2021 LIBRARY; T=0.K  
Photon emission for (n,n\*)2a

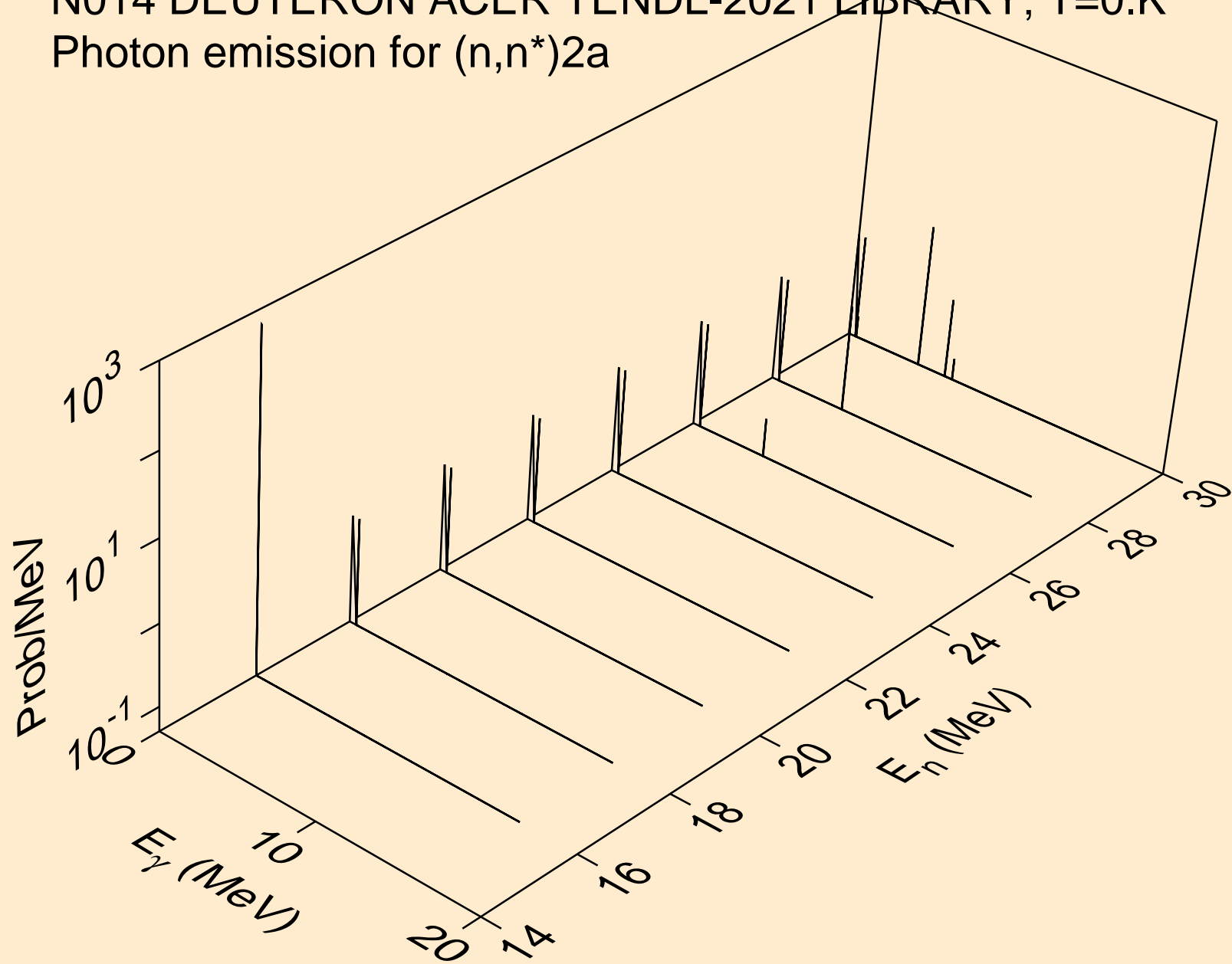

N014 DEUTERON ACER TENDL-2021 LIBRARY; T=0.K  
Photon emission for (n,n\*)d

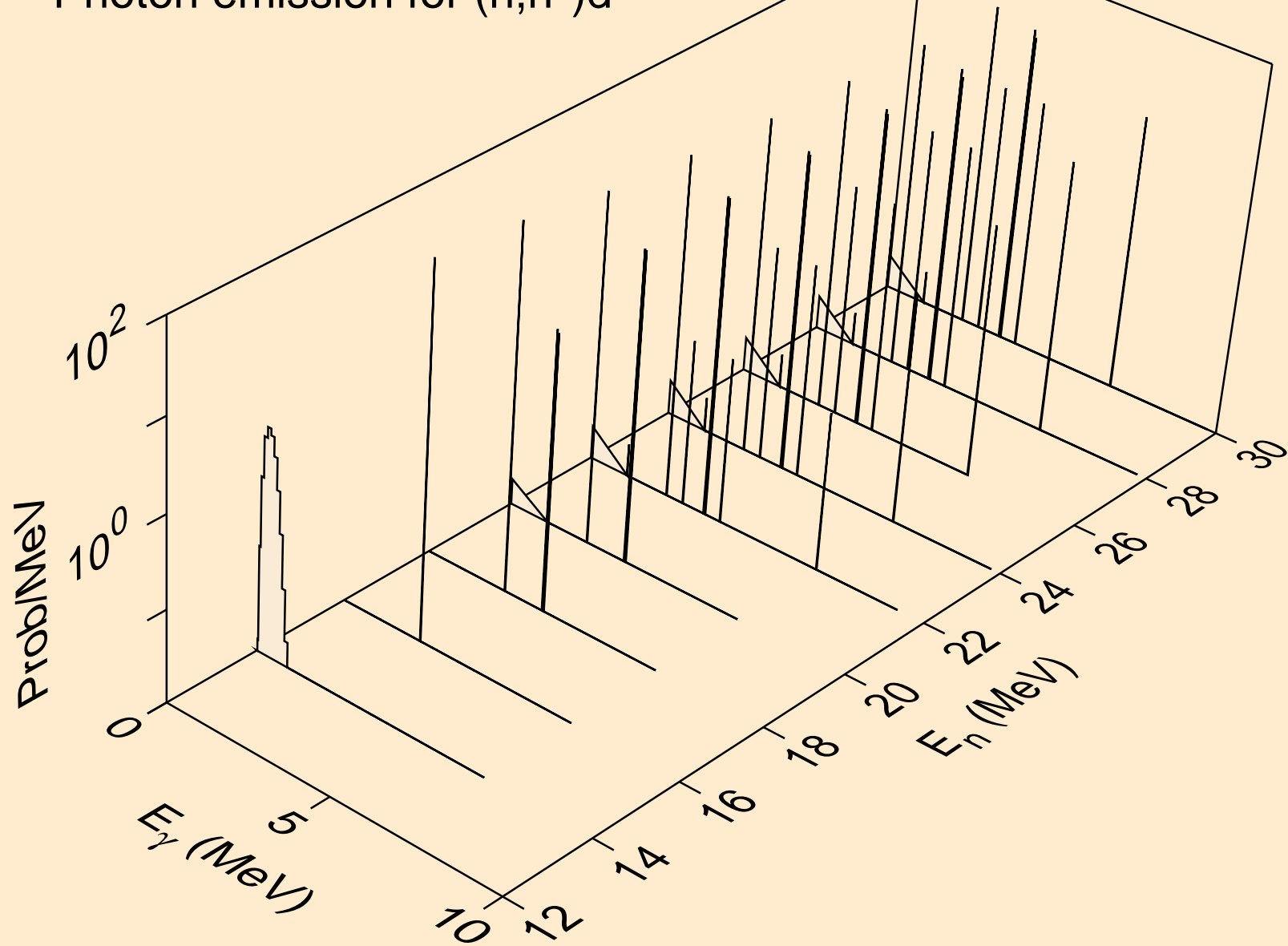

N014 DEUTERON ACER TENDL-2021 LIBRARY; T=0.K  
Photon emission for (n,n\*)t

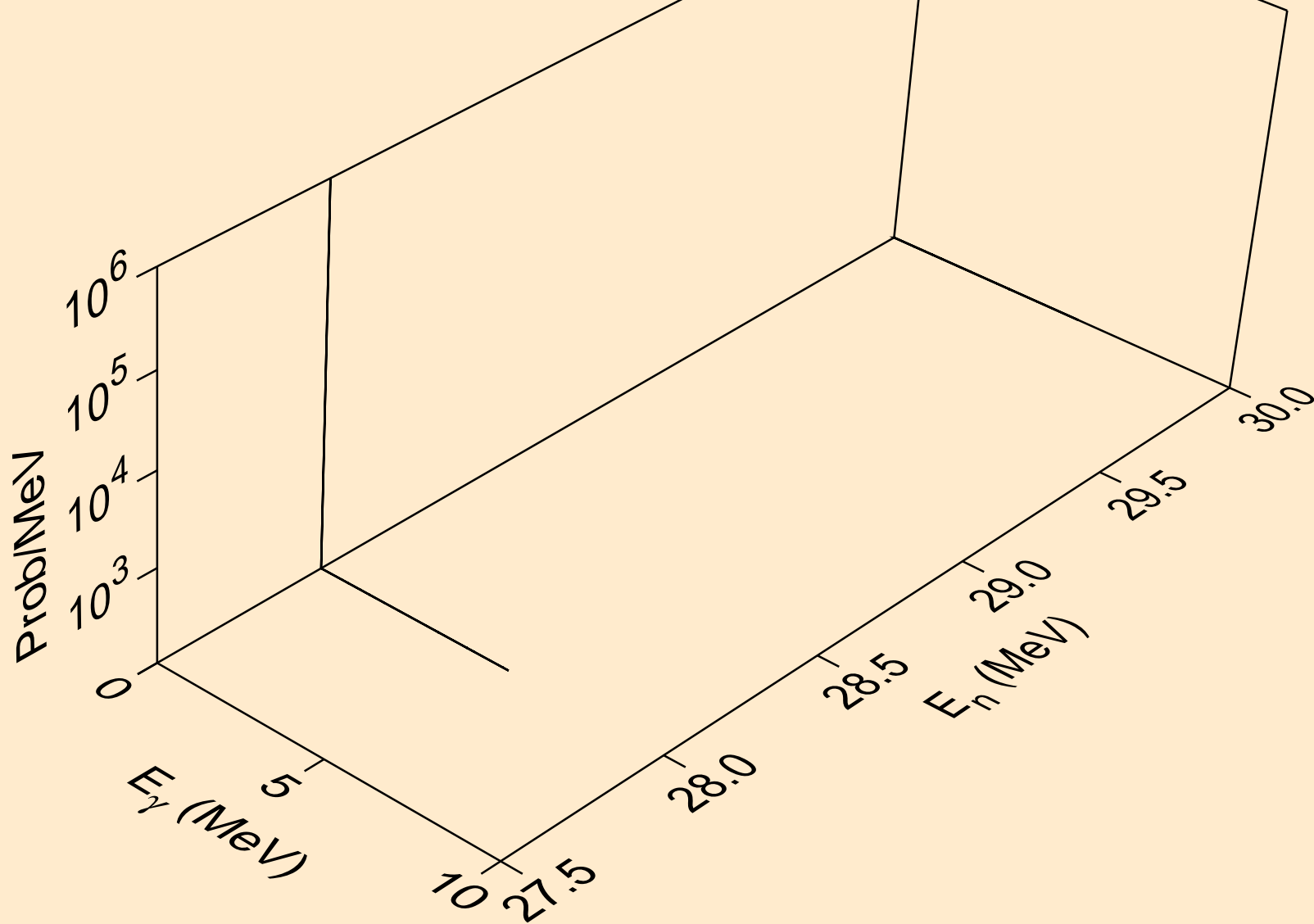

N014 DEUTERON ACER TENDL-2021 LIBRARY; T=0.K  
Photon emission for (n,n\*)he3

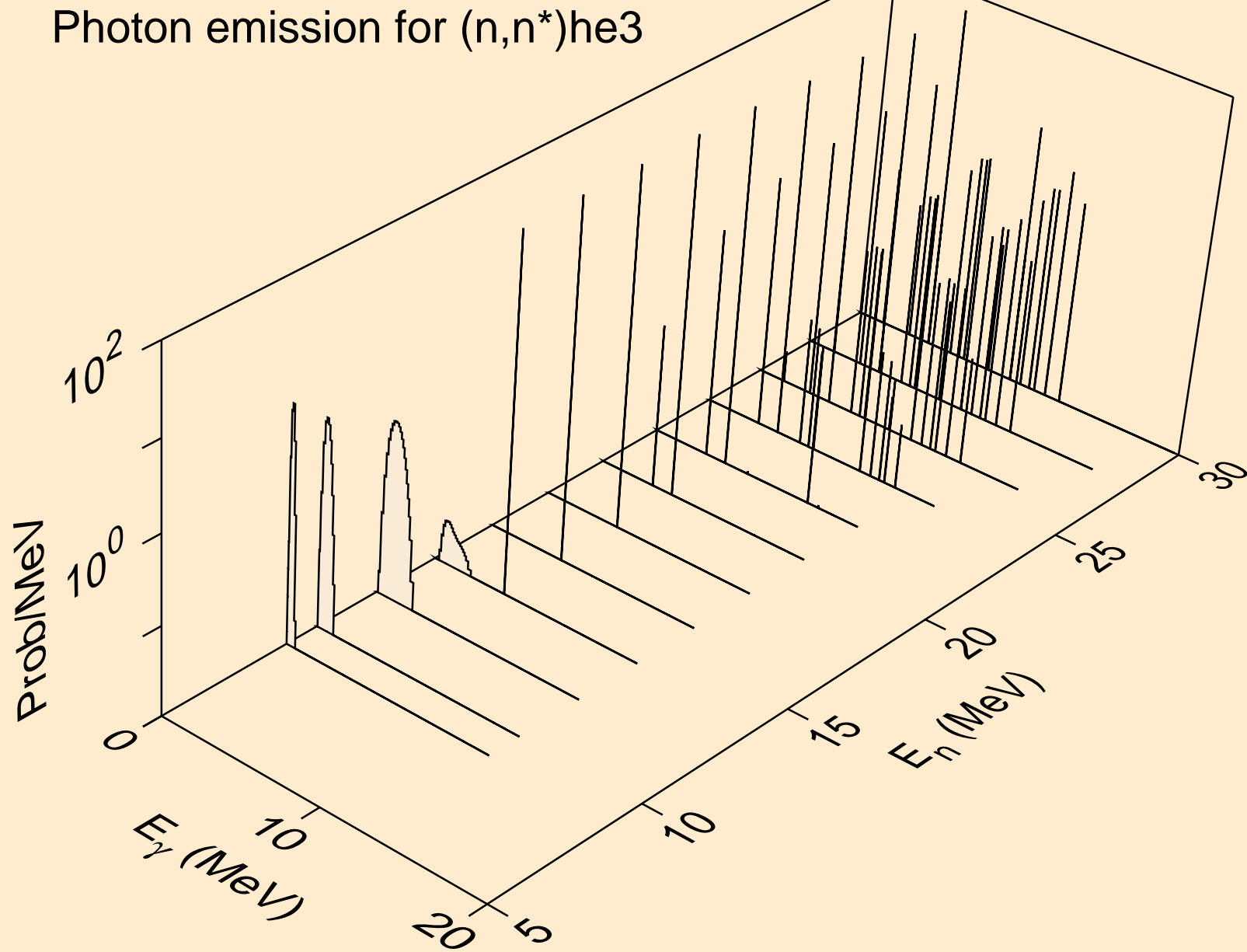

N014 DEUTERON ACER TENDL-2021 LIBRARY; T=0.K  
Photon emission for (n,2np)

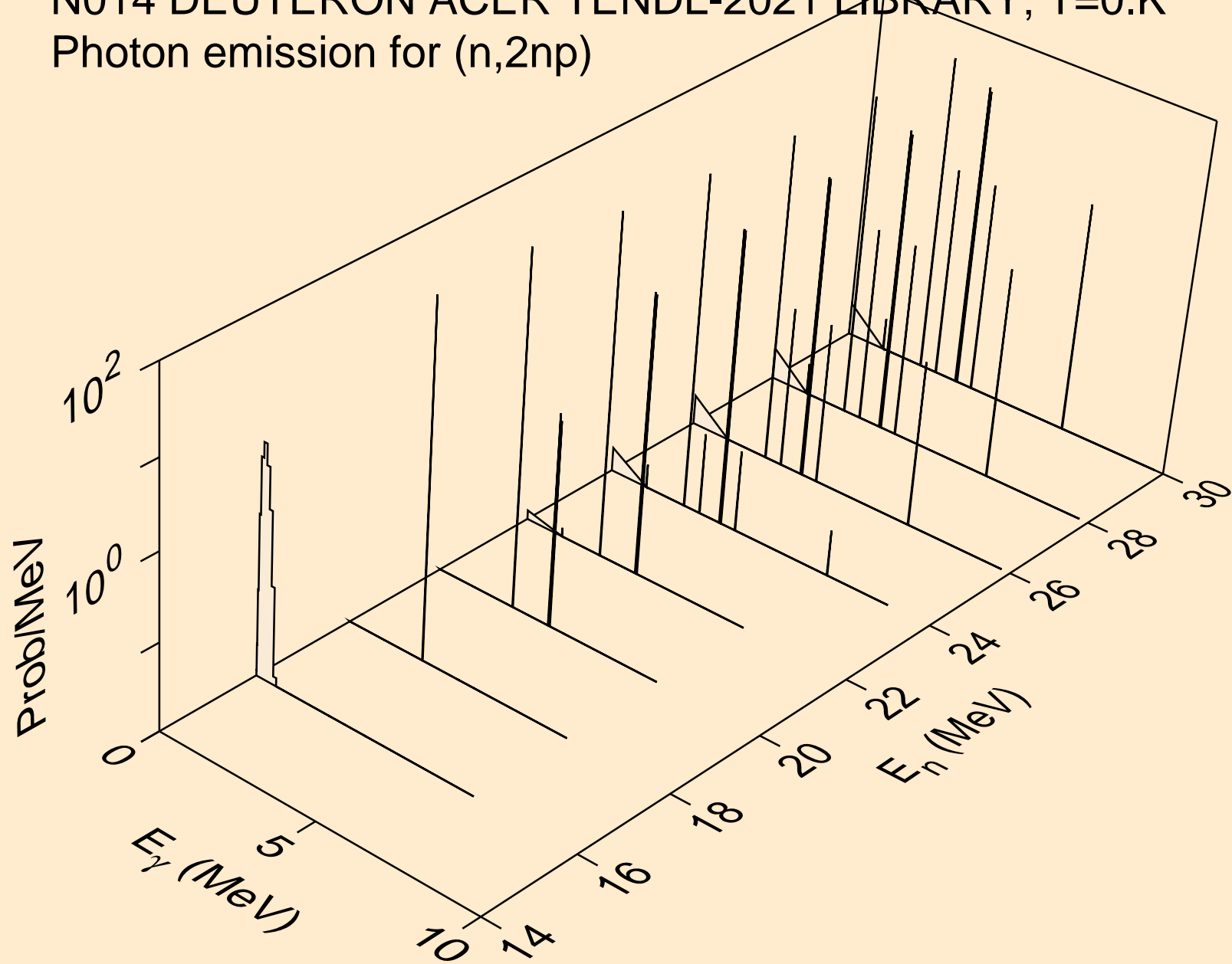

N014 DEUTERON ACER TENDL-2021 LIBRARY; T=0.K  
Photon emission for (n,2np)

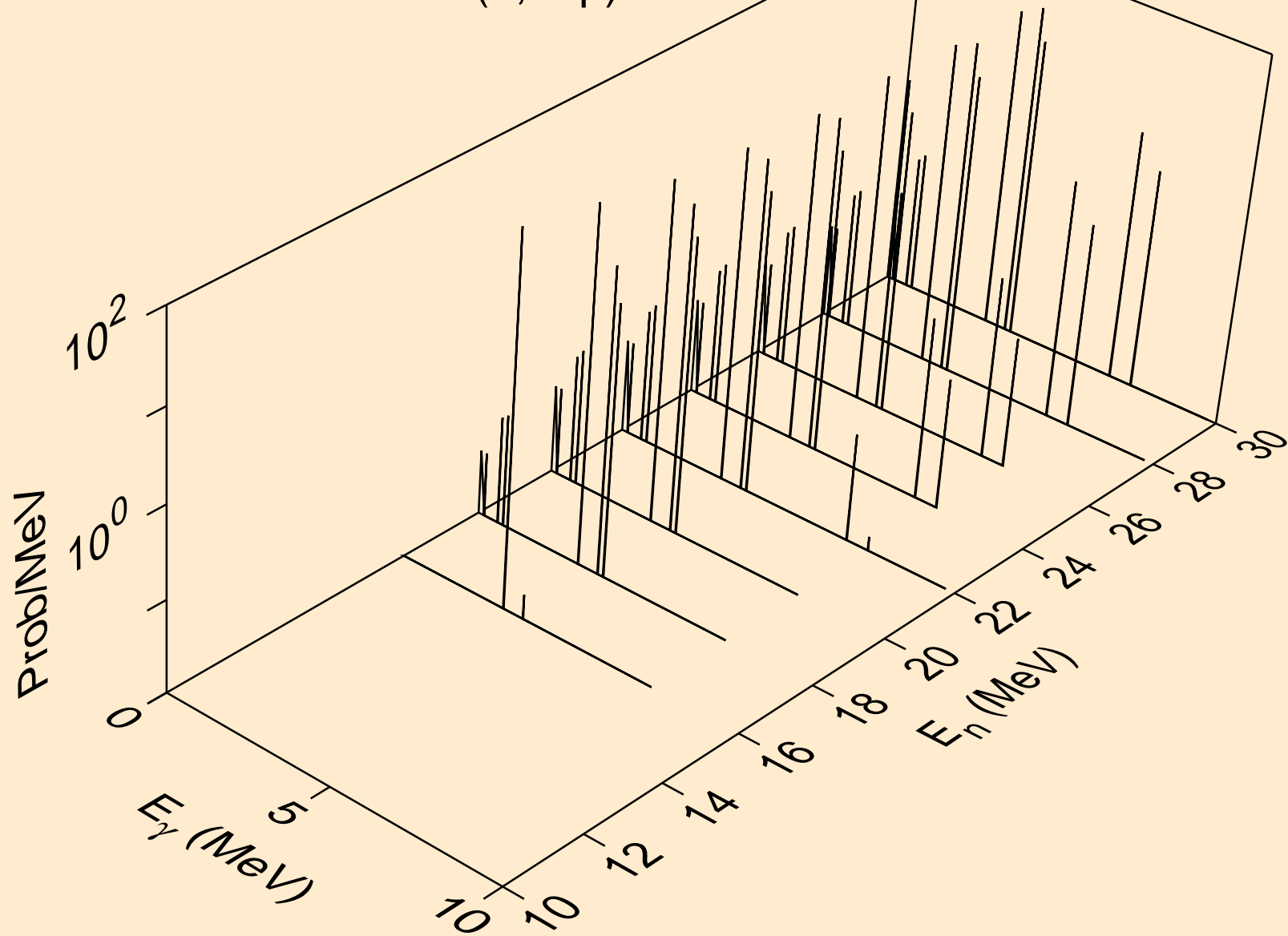

N014 DEUTERON ACER TENDL-2021 LIBRARY; T=0.K  
Photon emission for (n,npa)

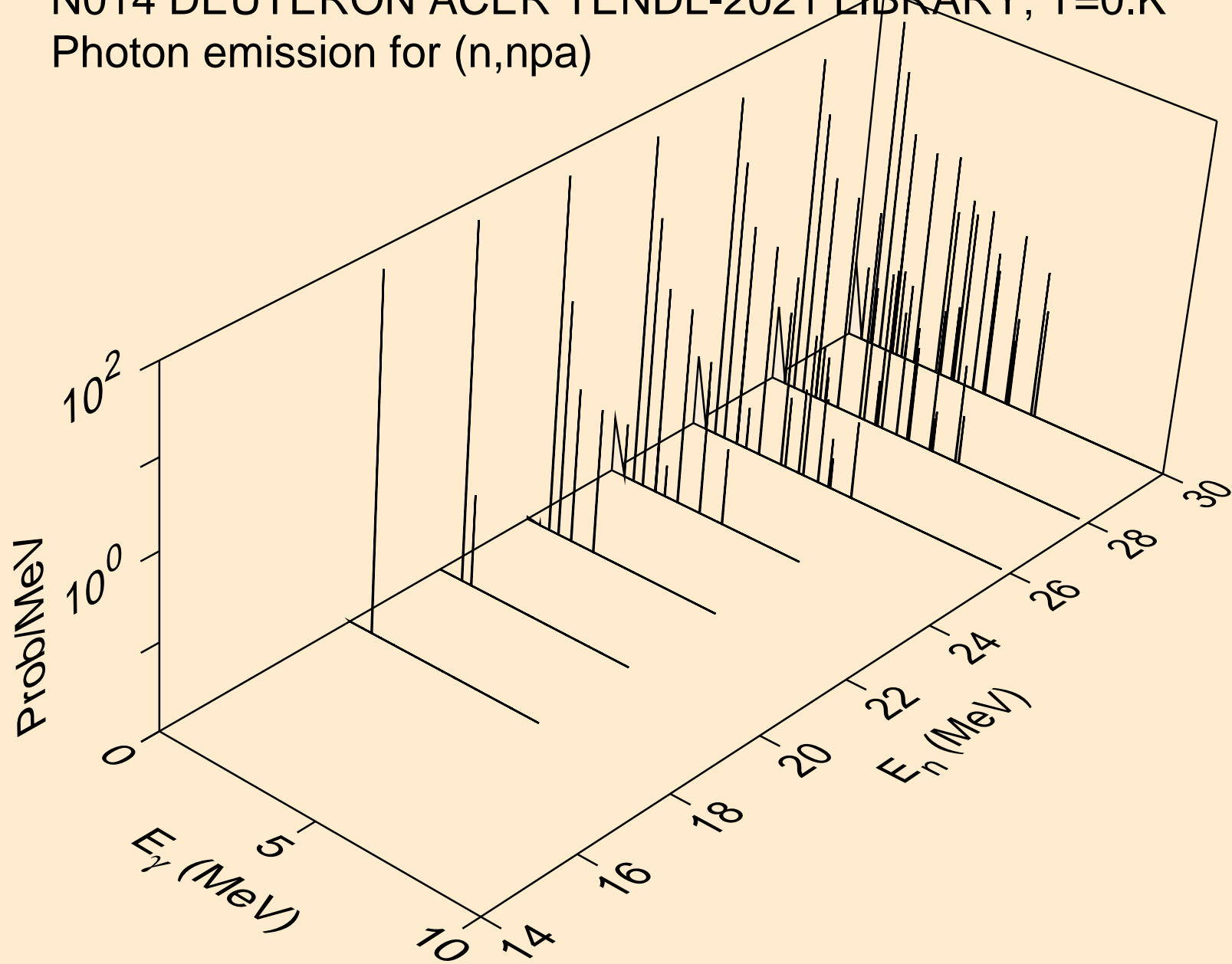

N014 DEUTERON ACER TENDL-2021 LIBRARY; T=0.K  
Photon emission for (n,gma)

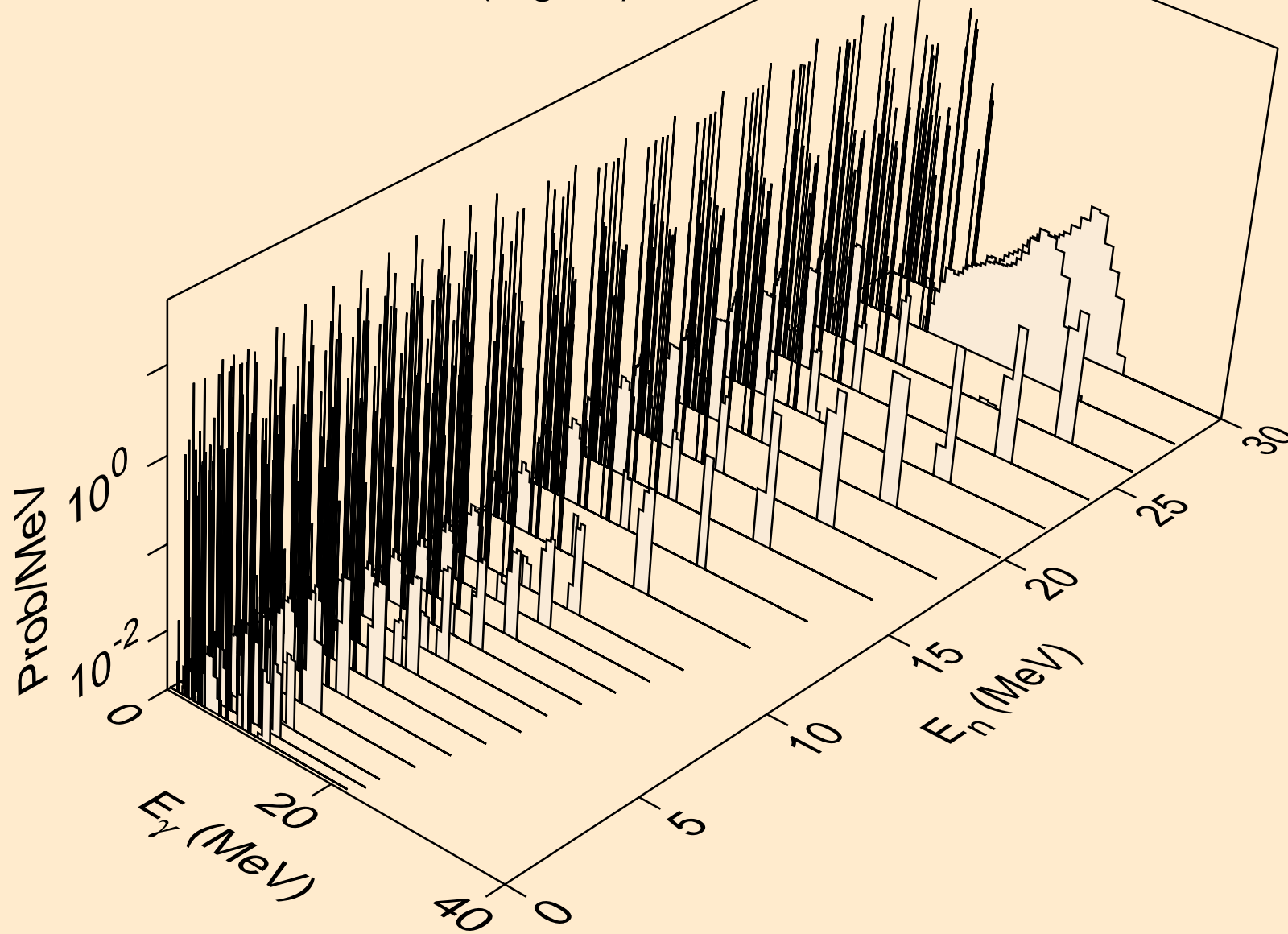

N014 DEUTERON ACER TENDL-2021 LIBRARY; T=0.K  
Photon emission for (n,p)

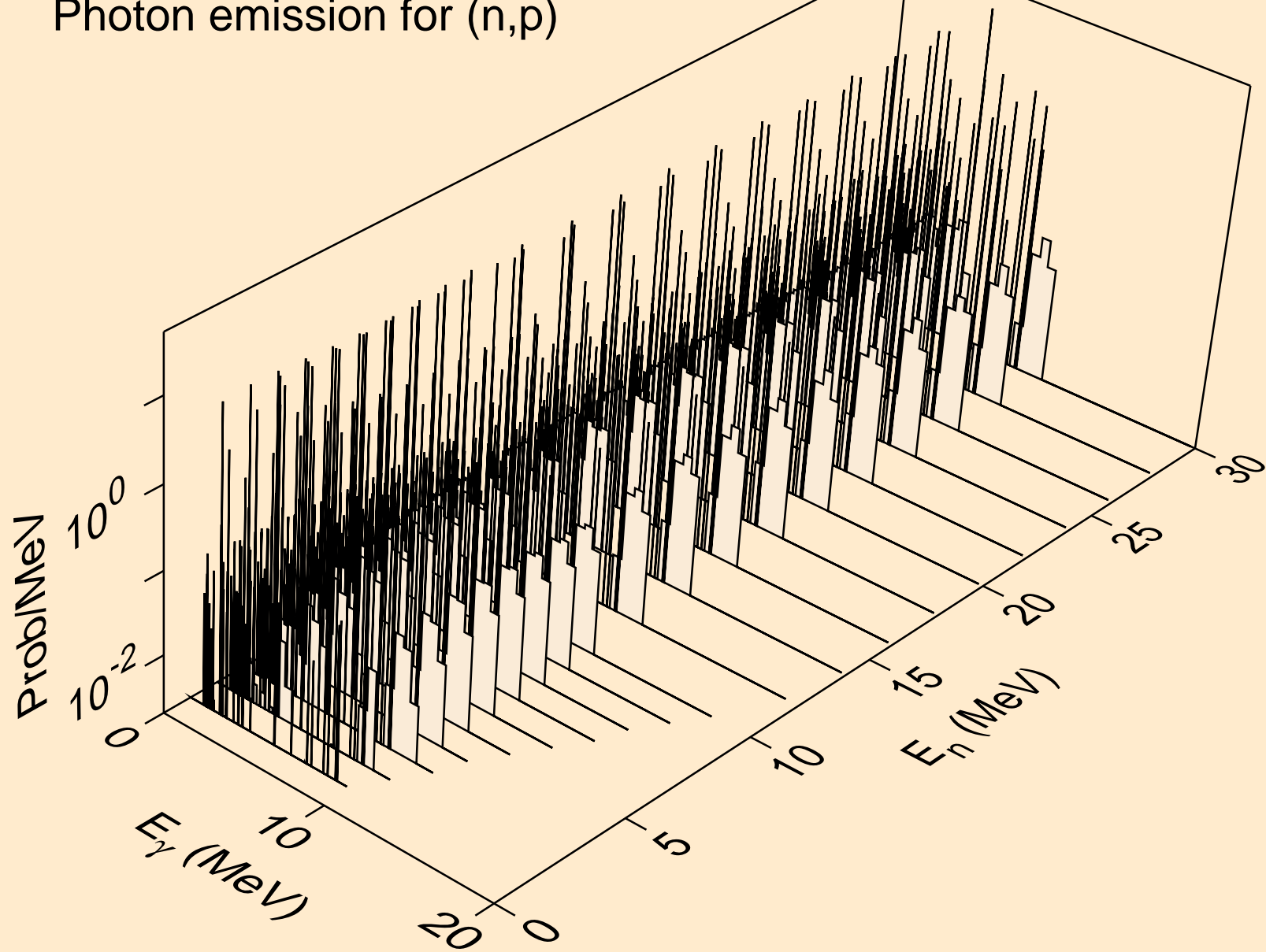

N014 DEUTERON ACER TENDL-2021 LIBRARY; T=0.K  
Photon emission for inelastic

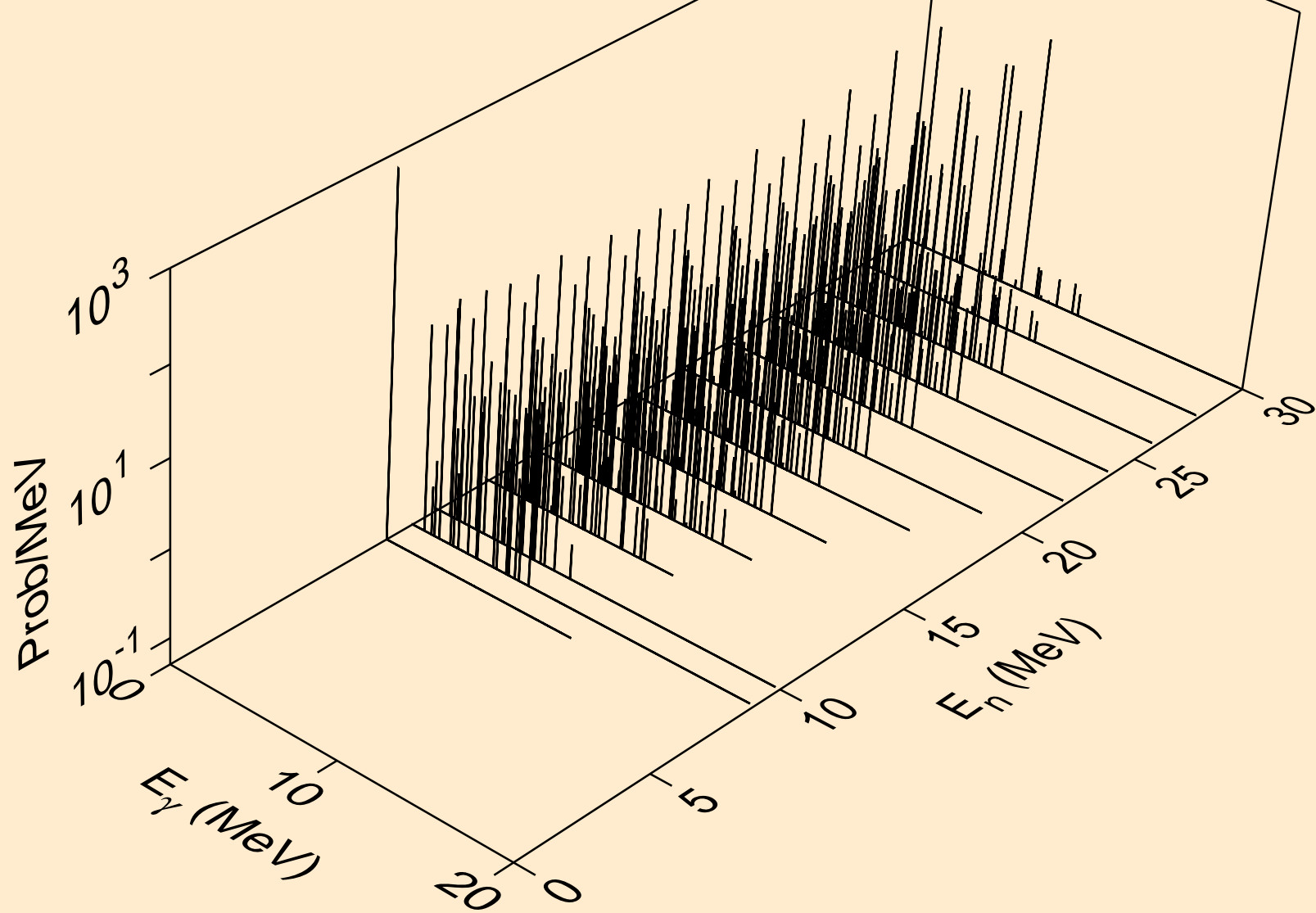

N014 DEUTERON ACER TENDL-2021 LIBRARY; T=0.K  
Photon emission for (n,t)

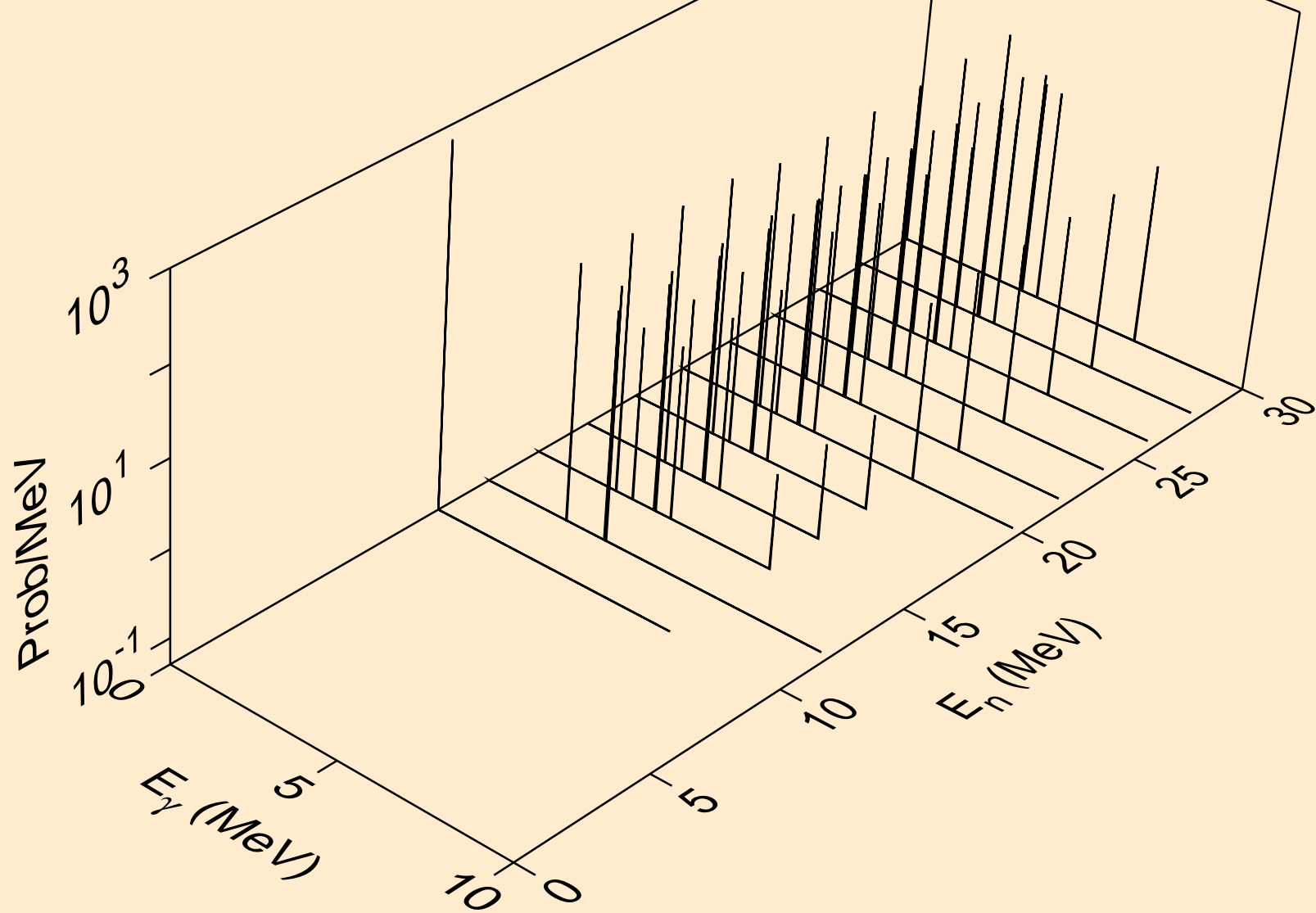

N014 DEUTERON ACER TENDL-2021 LIBRARY; T=0.K  
Photon emission for (n,he3)

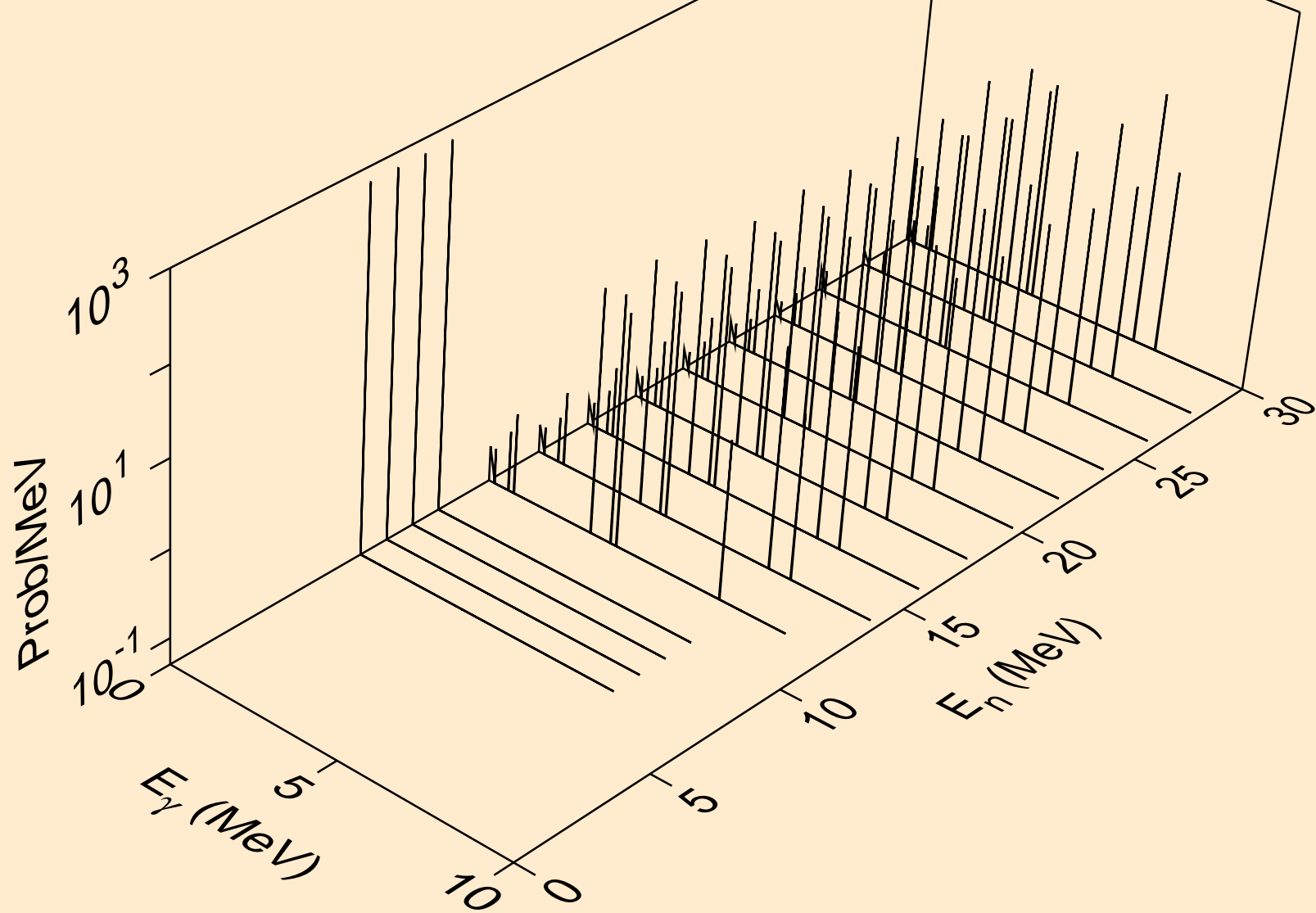

N014 DEUTERON ACER TENDL-2021 LIBRARY; T=0.K  
Photon emission for (n,a)

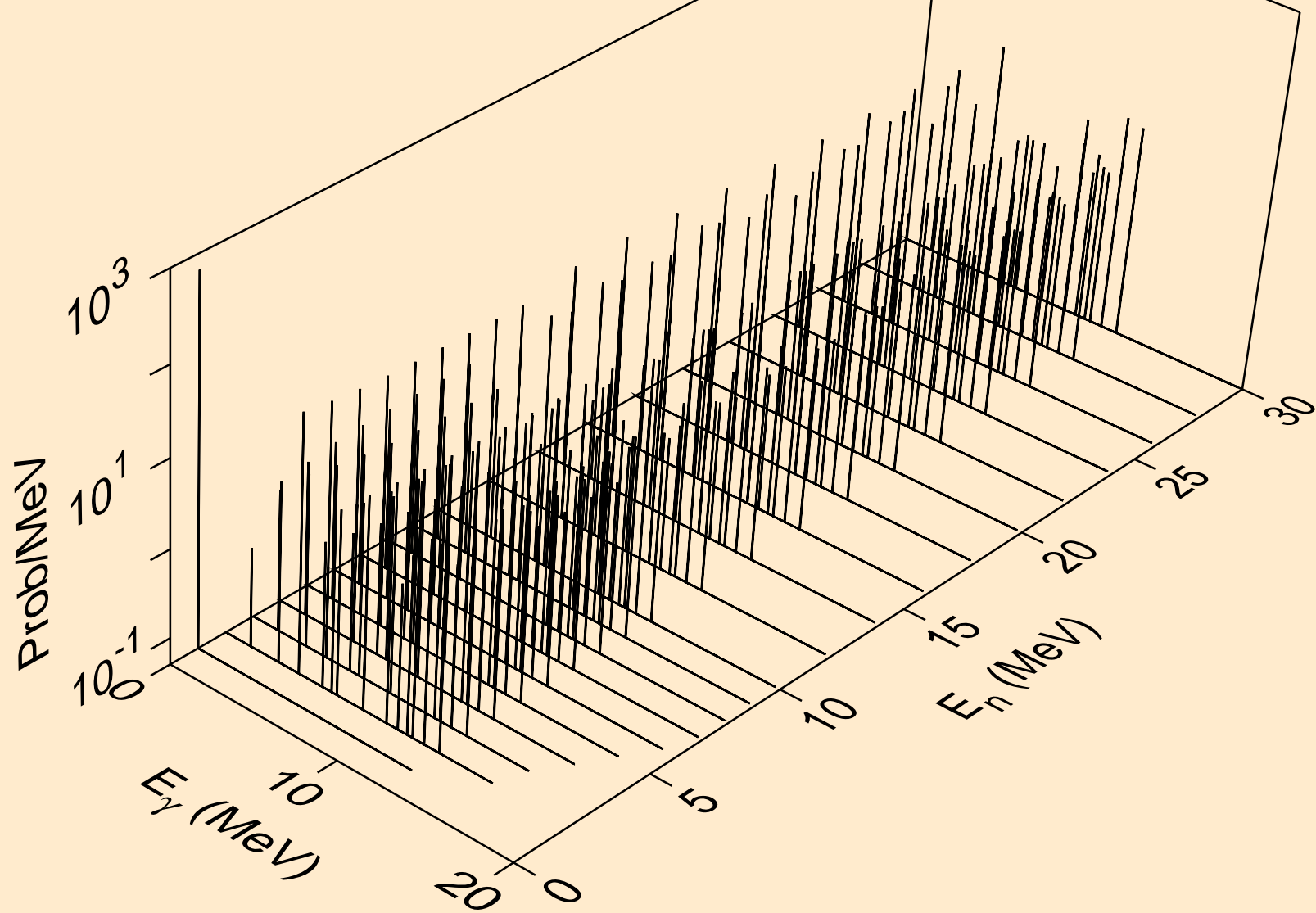

N014 DEUTERON ACER TENDL-2021 LIBRARY; T=0.K  
Photon emission for (n,2a)

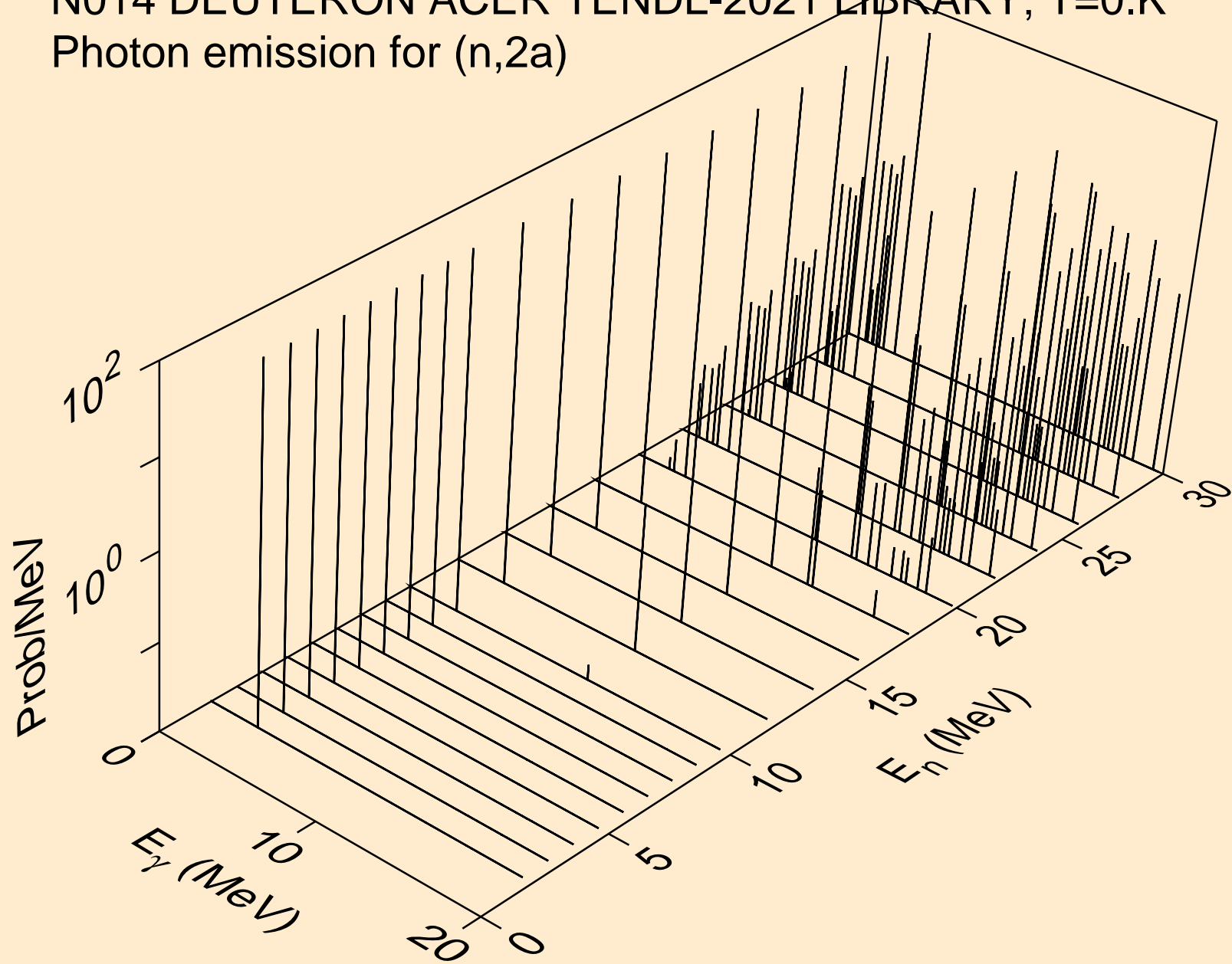

N014 DEUTERON ACER TENDL-2021 LIBRARY; T=0.K  
Photon emission for (n,2p)

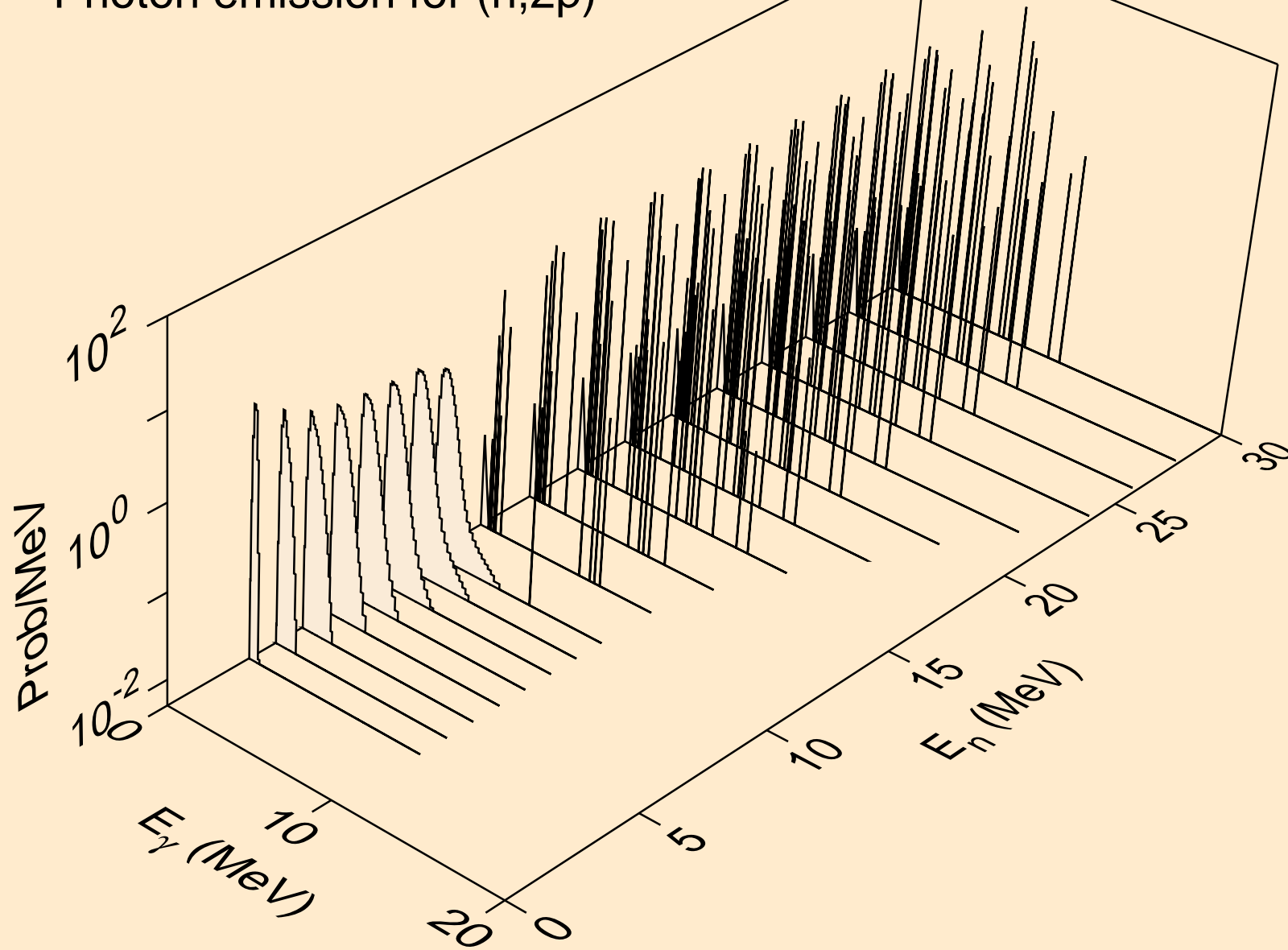

N014 DEUTERON ACER TENDL-2021 LIBRARY; T=0.K  
Photon emission for (n,p)

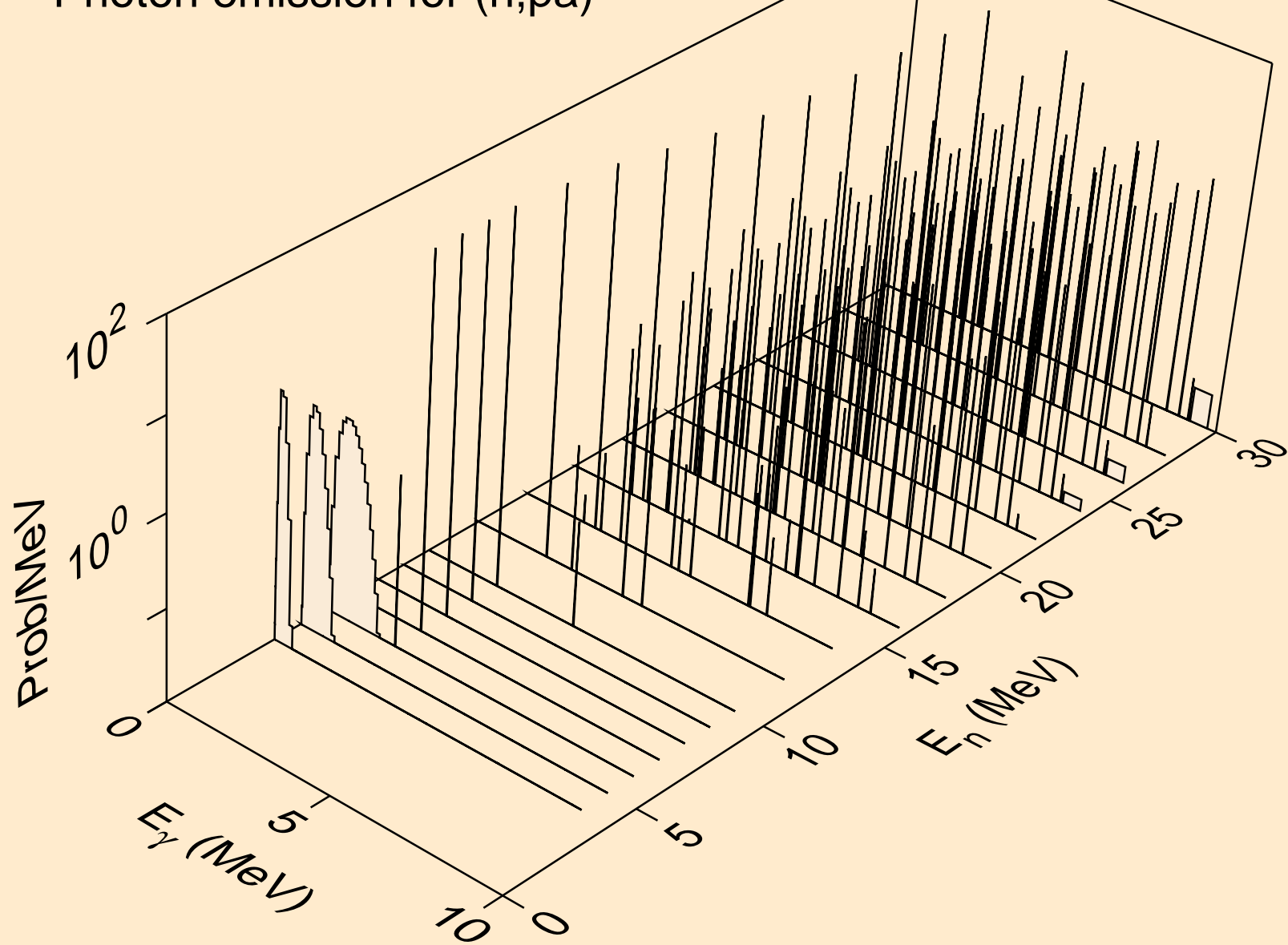

N014 DEUTERON ACER TENDL-2021 LIBRARY; T=0.K  
Photon emission for (n,d2a)

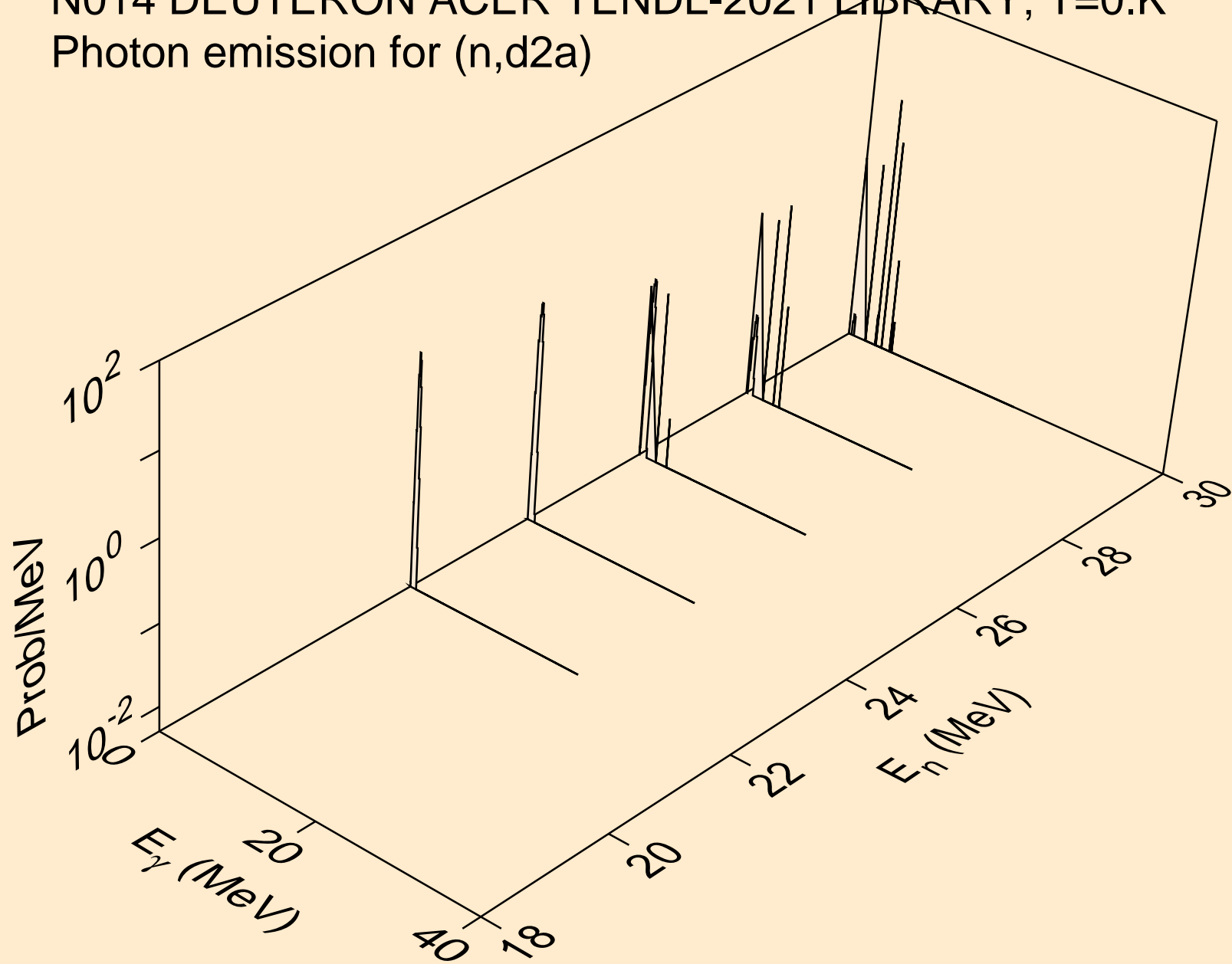

N014 DEUTERON ACER TENDL-2021 LIBRARY; T=0.K  
Photon emission for (n,pd)

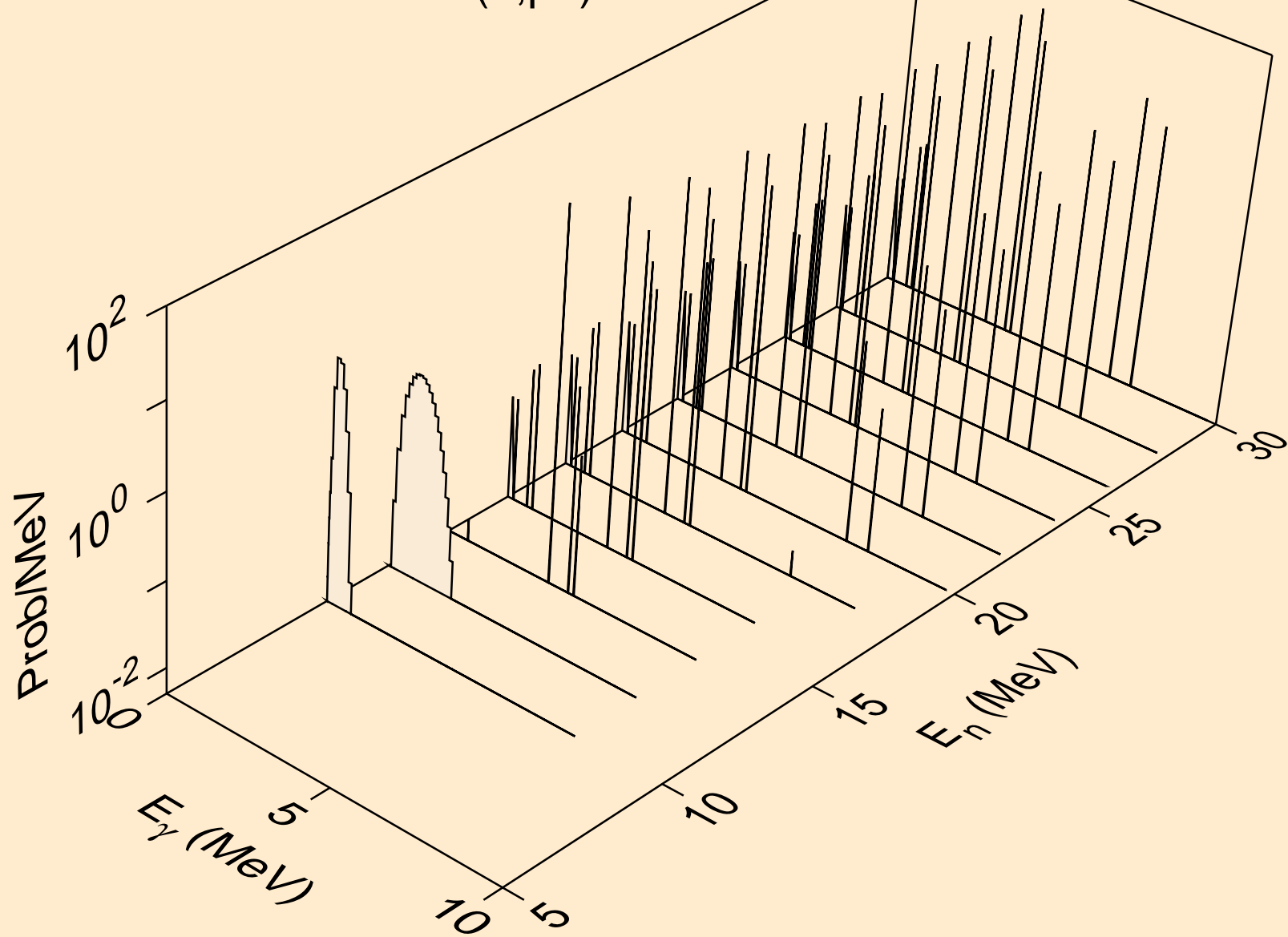

N014 DEUTERON ACER TENDL-2021 LIBRARY; T=0.K  
Photon emission for (n,pt)

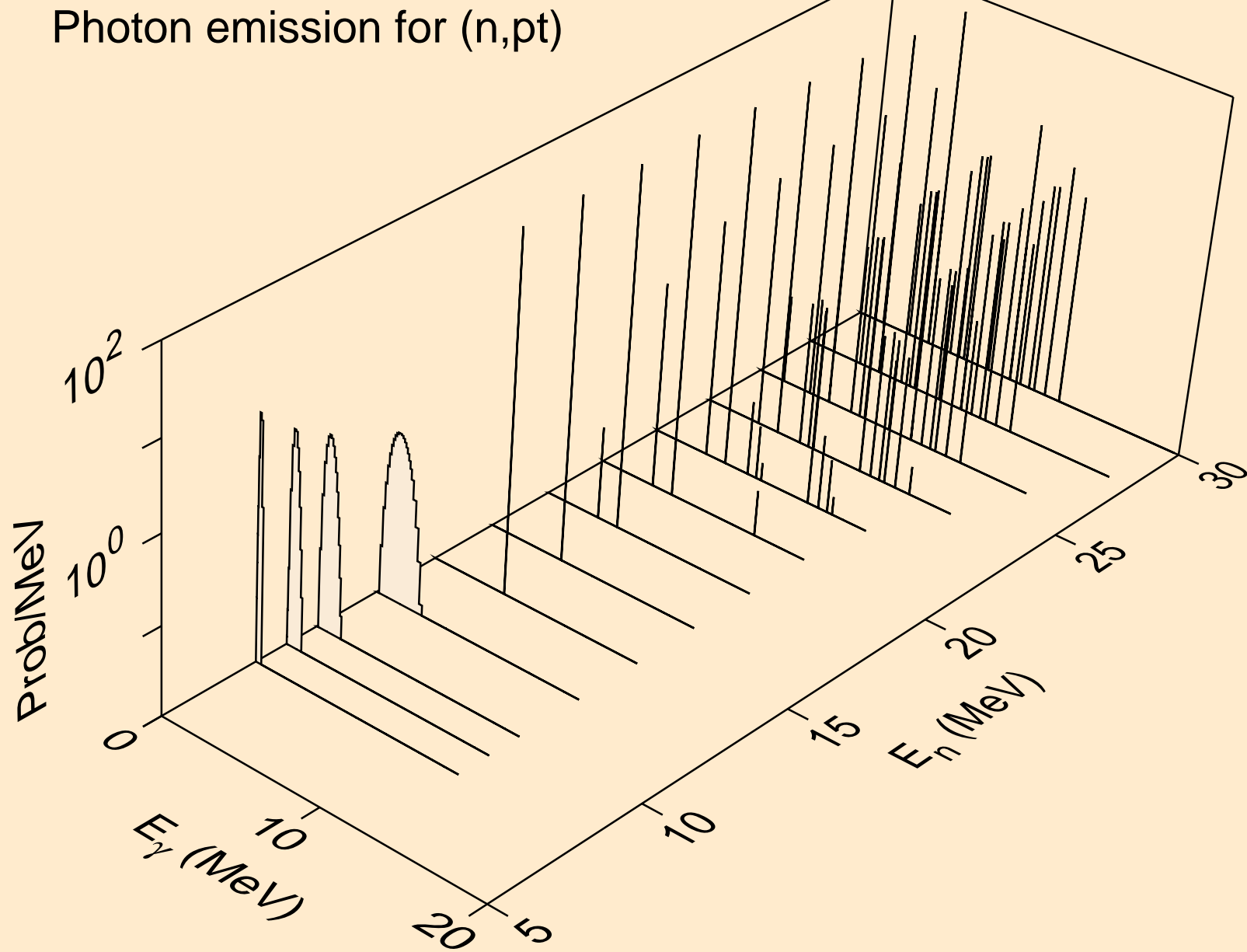

N014 DEUTERON ACER TENDL-2021 LIBRARY; T=0.K  
Photon emission for (n,da)

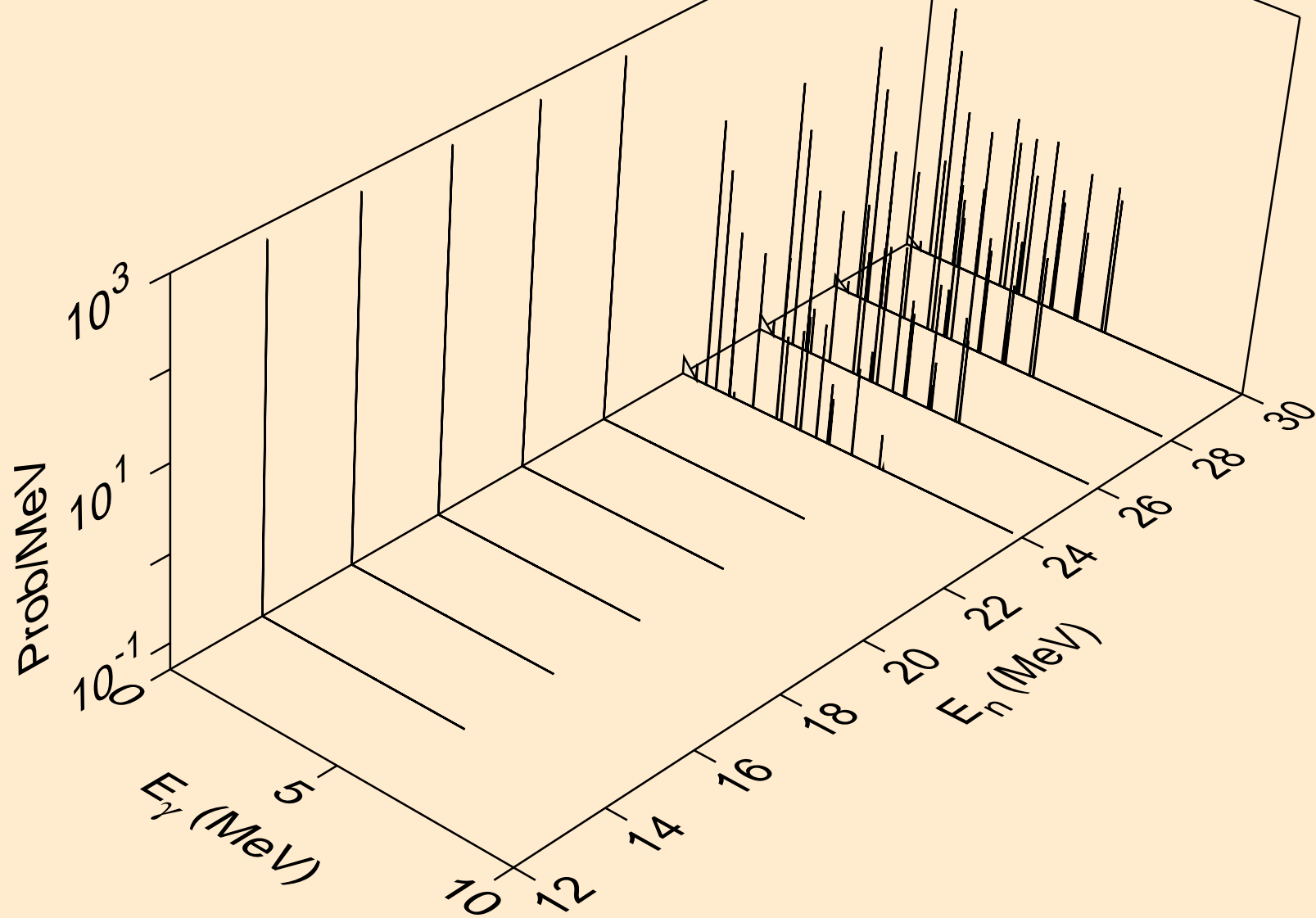

# N014 DEUTERON ACER TENDL-2021 LIBRARY; T=0.K

## Particle heating contributions

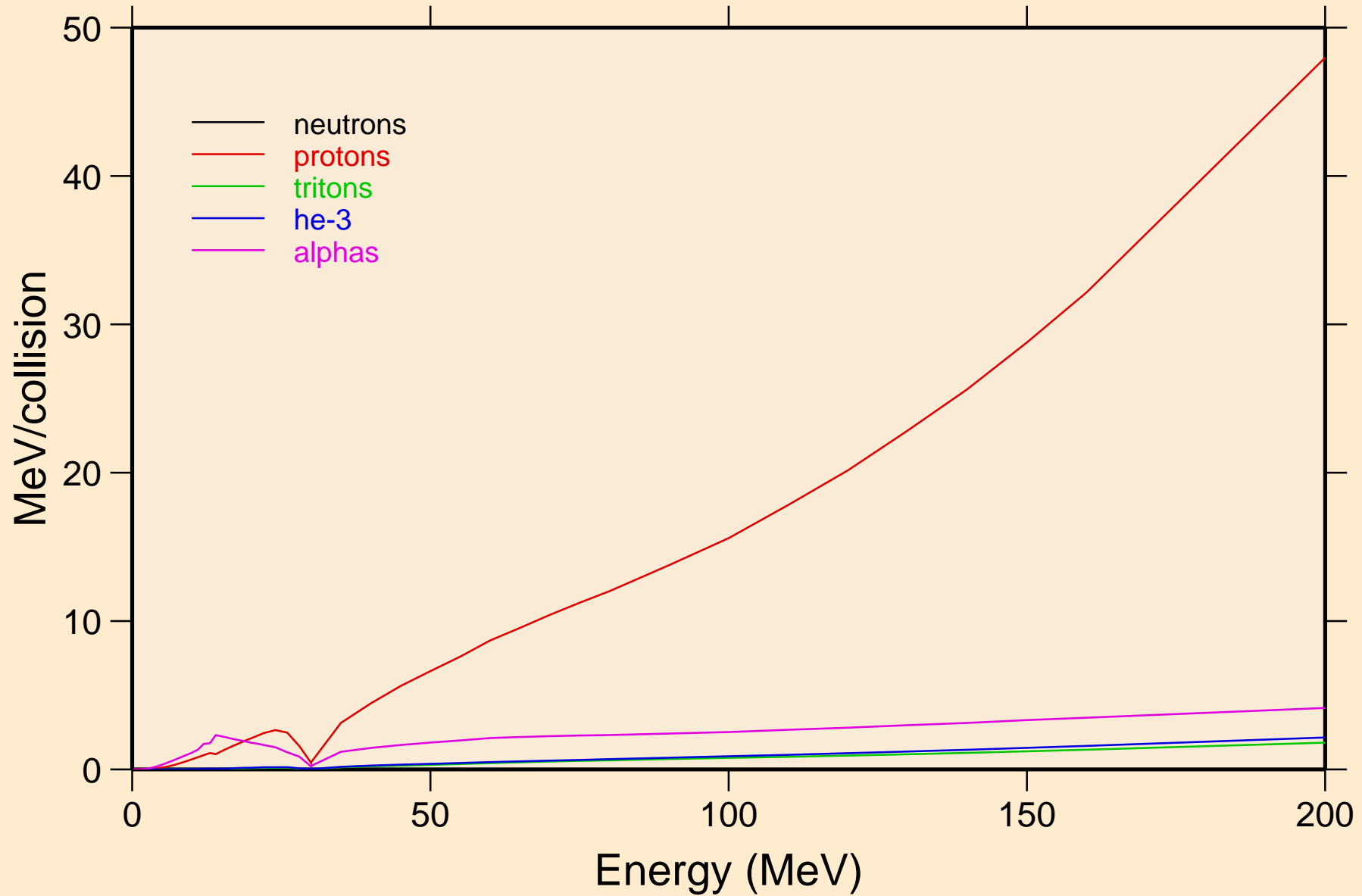

# N014 DEUTERON ACER TENDL-2021 LIBRARY; T=0.K

## Recoil Heating

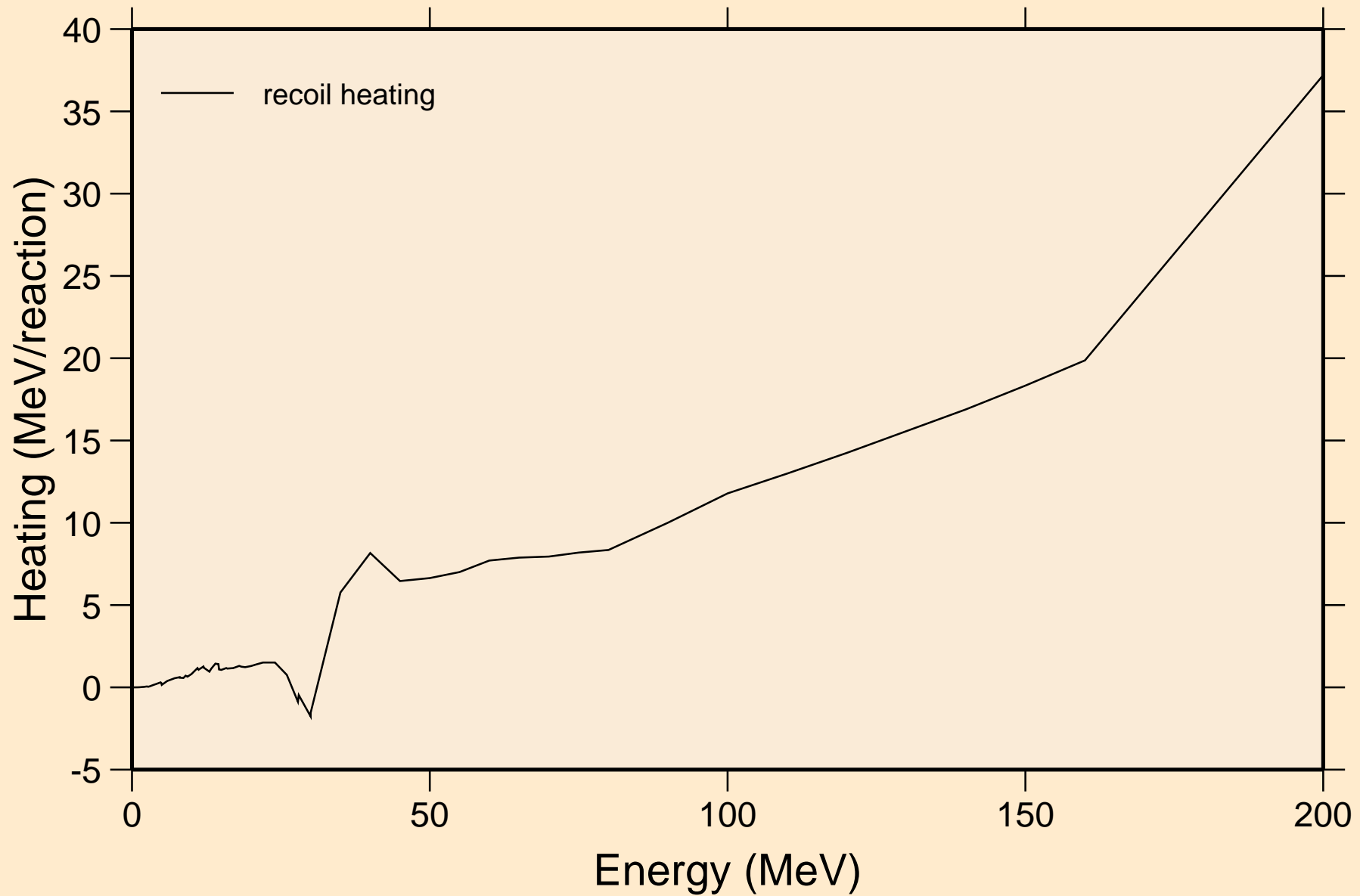

# N014 DEUTERON ACER TENDL-2021 LIBRARY; T=0.K

## Particle production cross sections

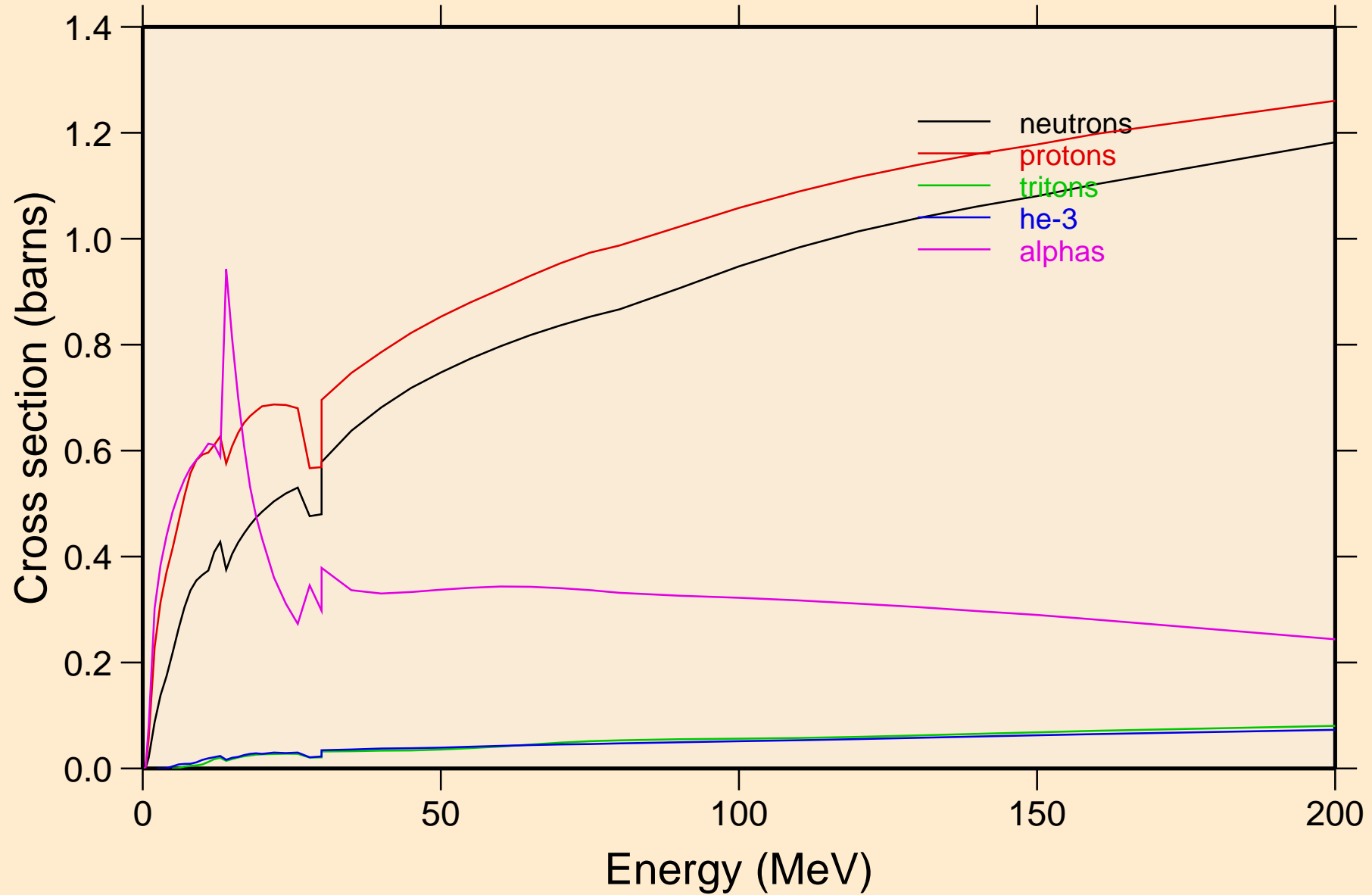

N014 DEUTERON ACER TENDL-2021 LIBRARY; T=0.K  
neutrons from (d,n)

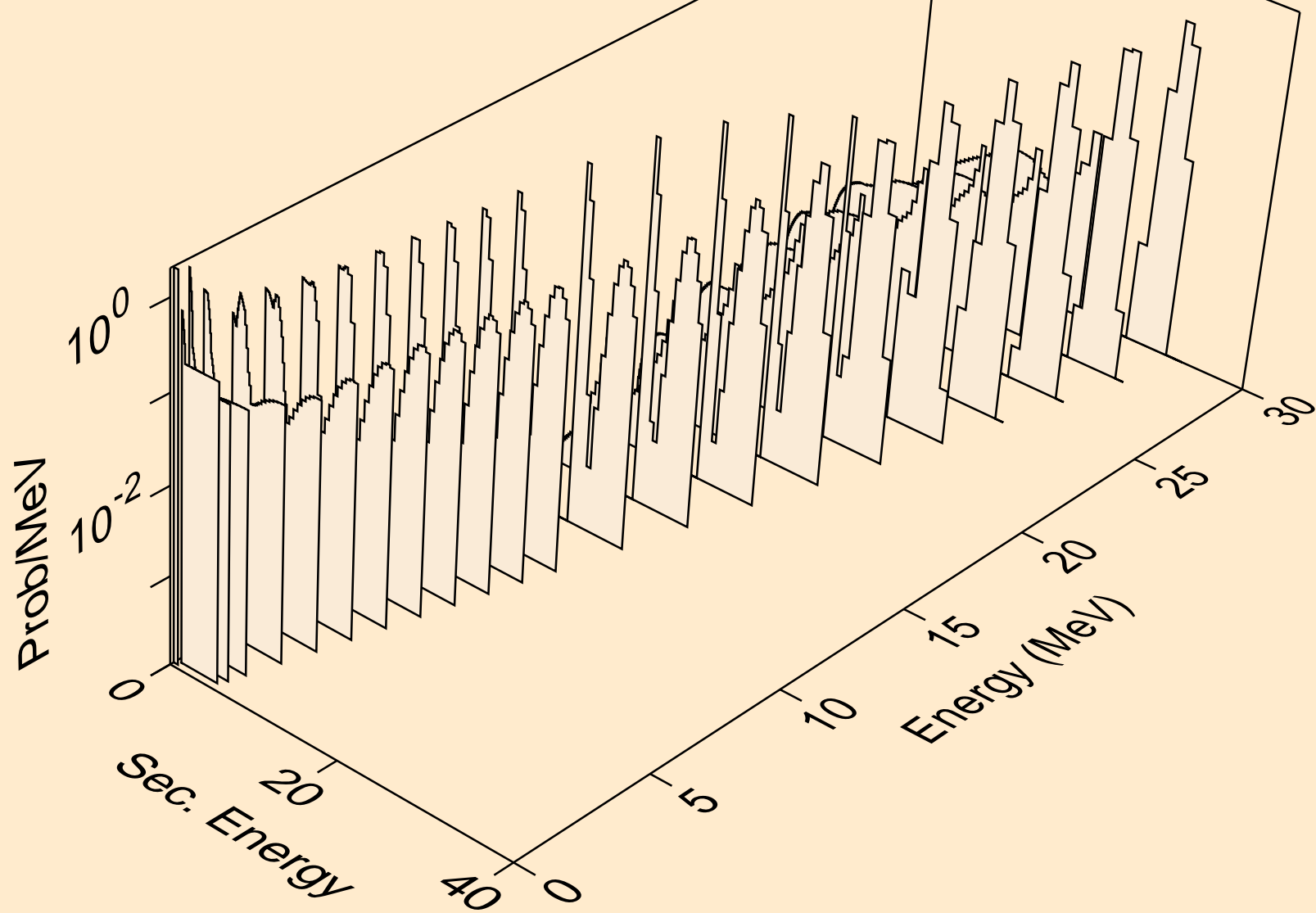

N014 DEUTERON ACER TENDL-2021 LIBRARY; T=0.K  
neutrons from (d,x)

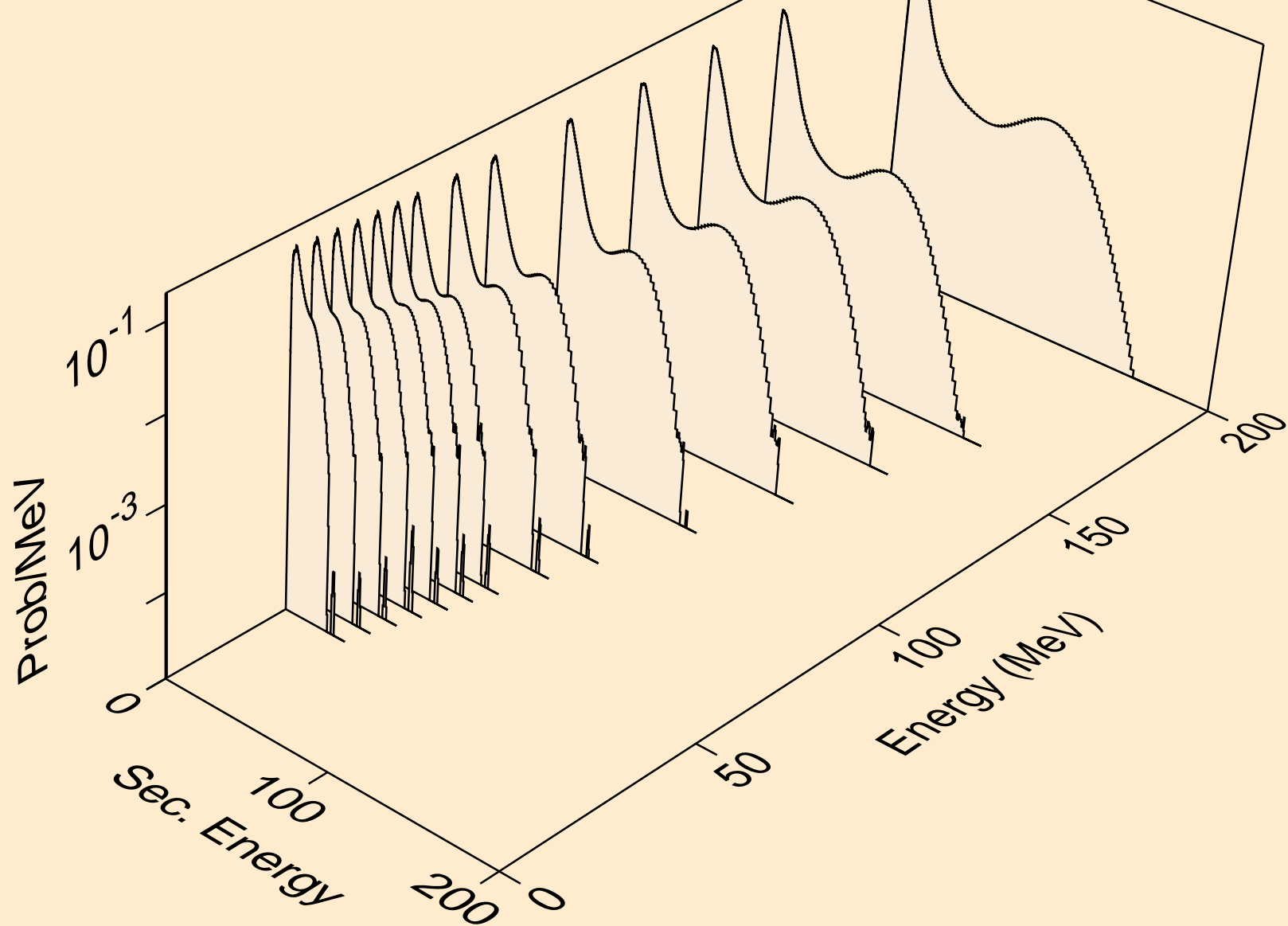

N014 DEUTERON ACER TENDL-2021 LIBRARY; T=0.K  
neutrons from (d,2n)

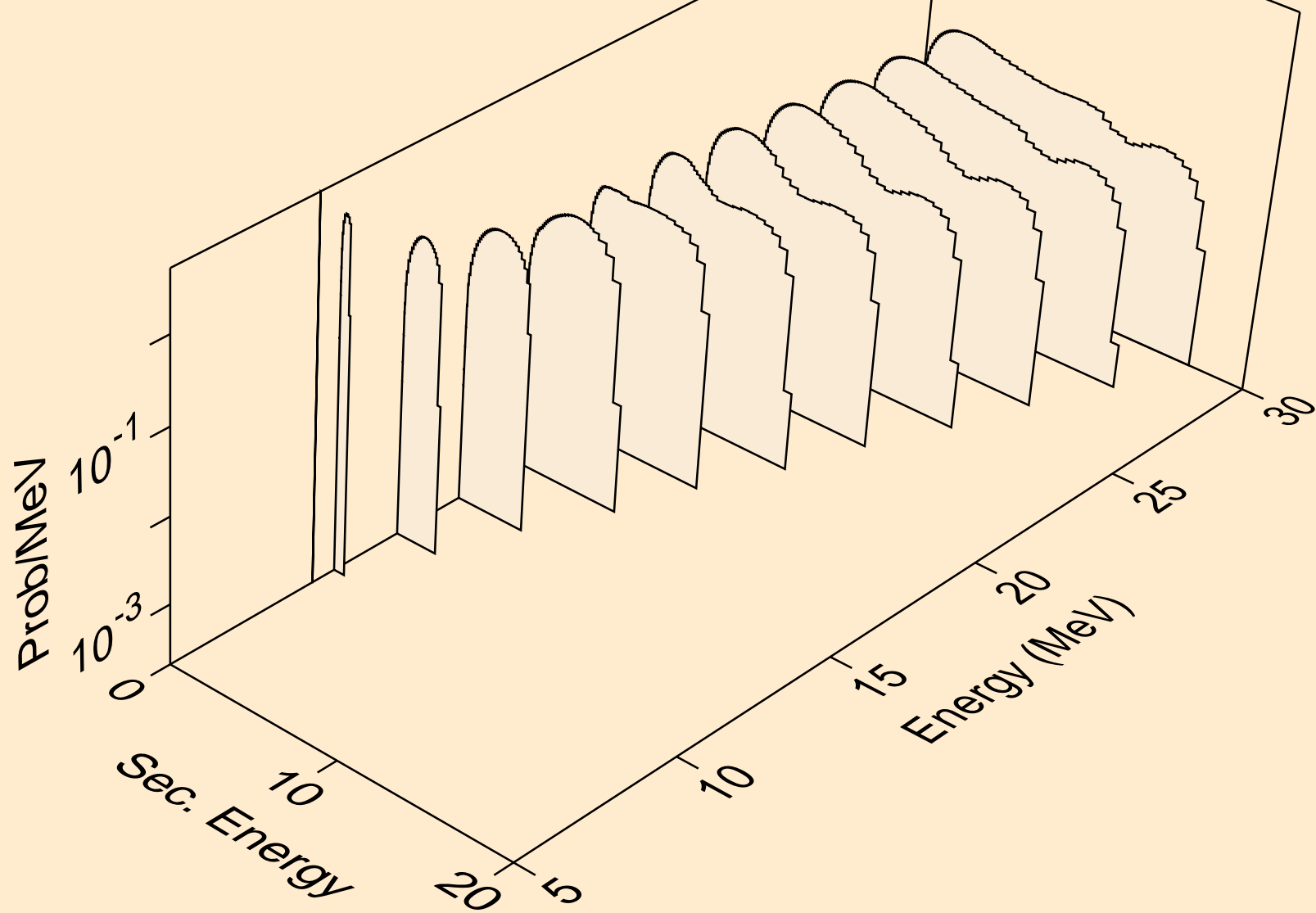

N014 DEUTERON ACER TENDL-2021 LIBRARY; T=0.K  
neutrons from (d,n\*)a

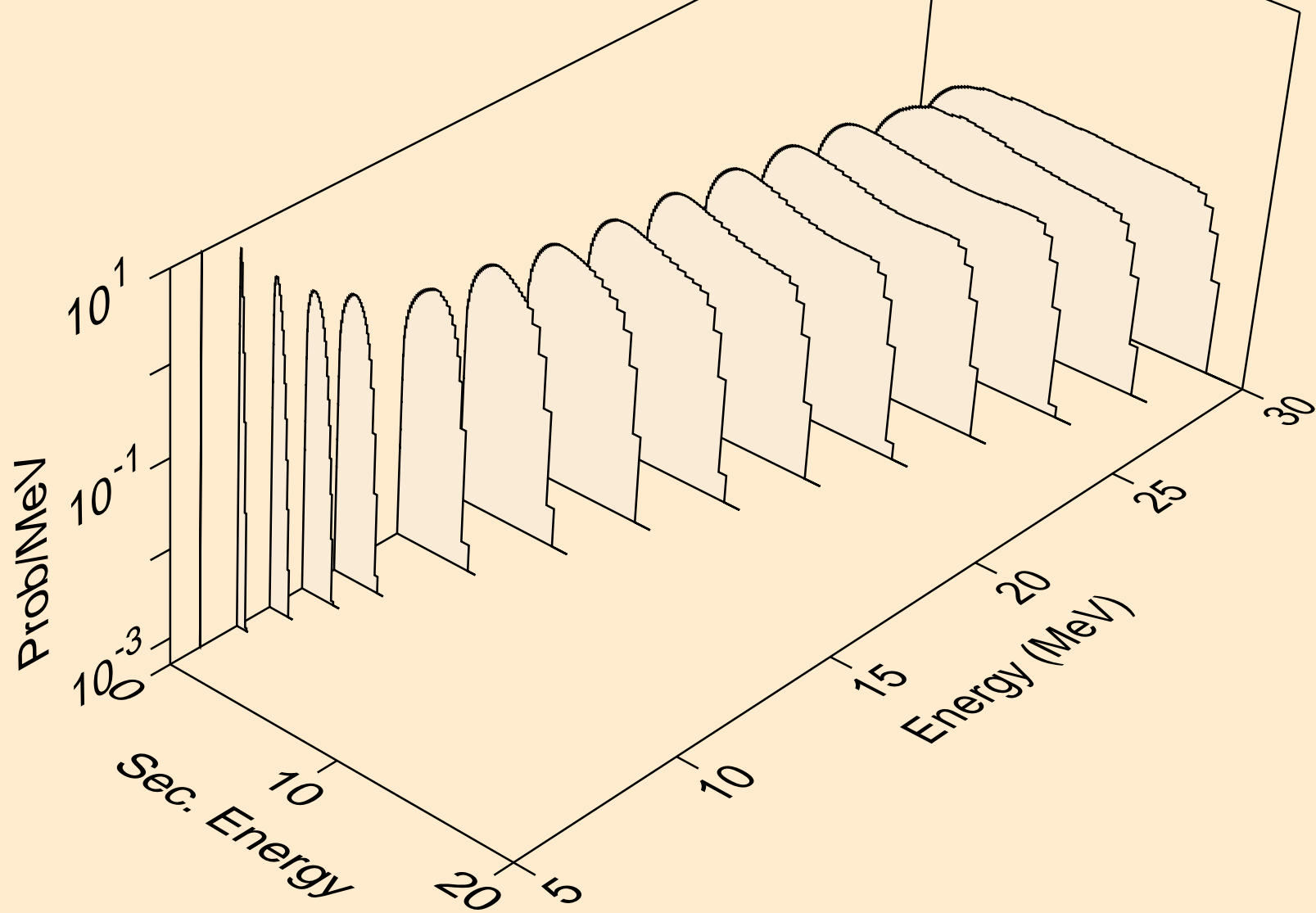

N014 DEUTERON ACER TENDL-2021 LIBRARY; T=0.K  
neutrons from (d,2n)a

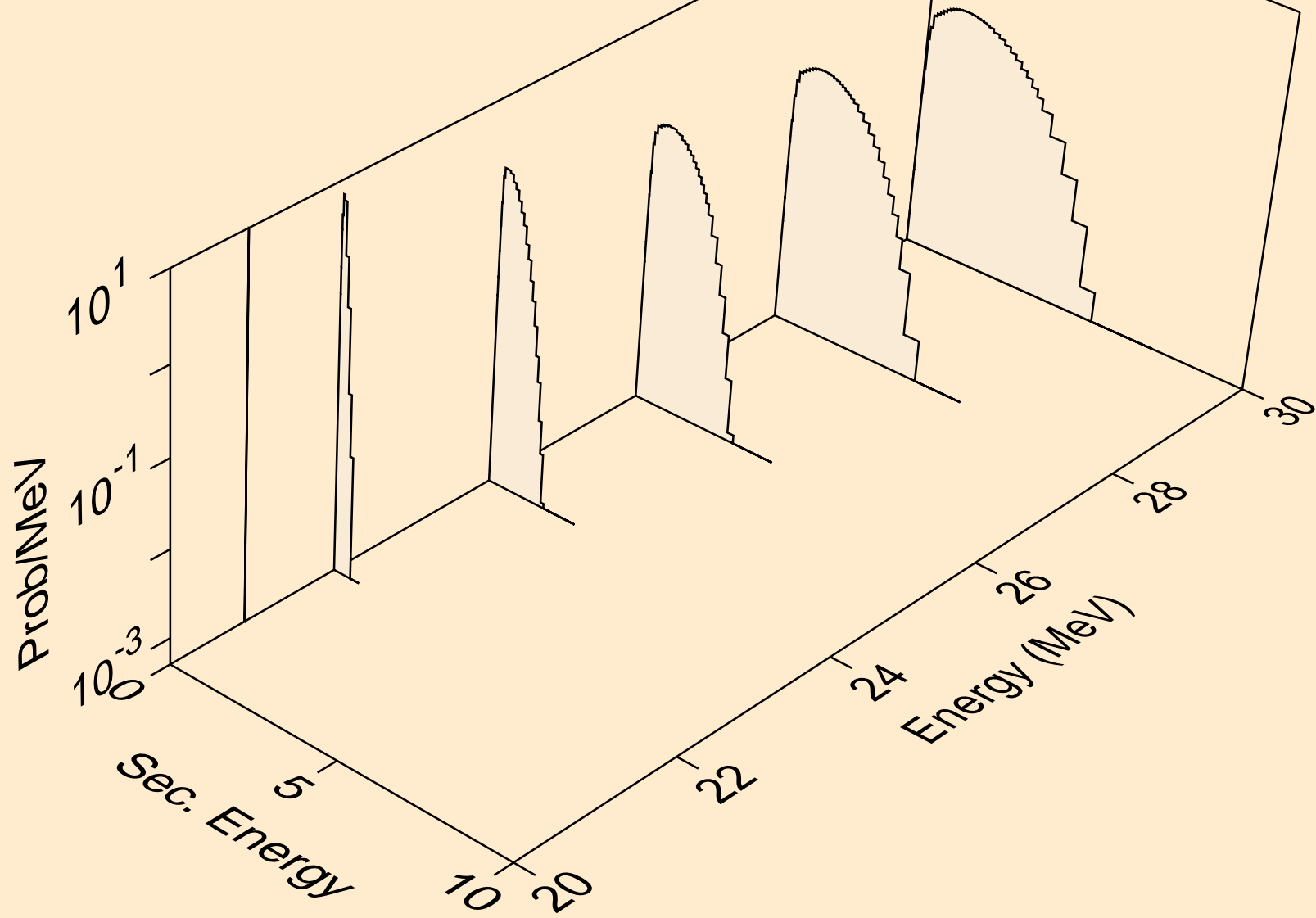

N014 DEUTERON ACER TENDL-2021 LIBRARY; T=0.K  
neutrons from (d,n\*)p

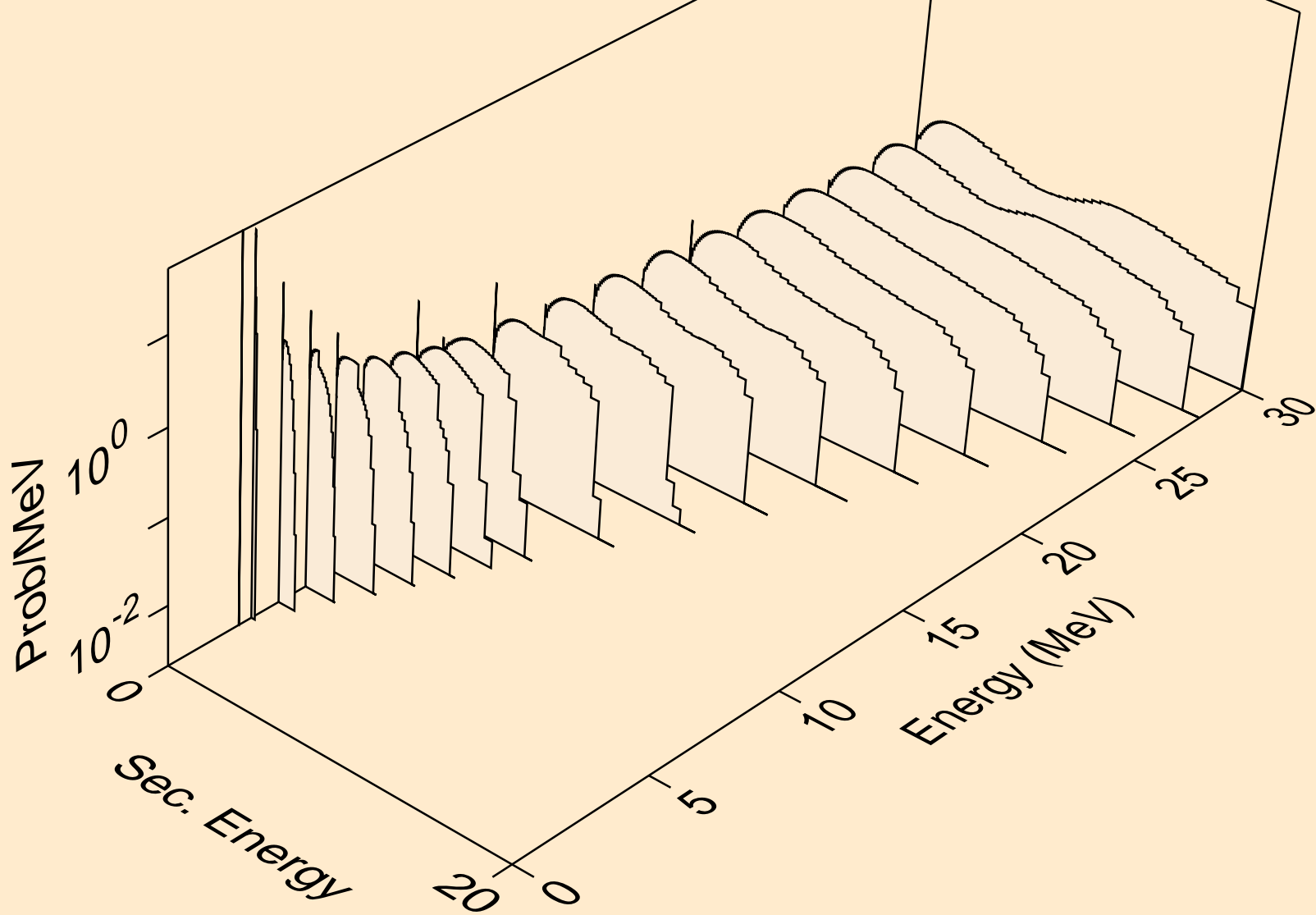

N014 DEUTERON ACER TENDL-2021 LIBRARY; T=0.K  
neutrons from (d,n\*)2a

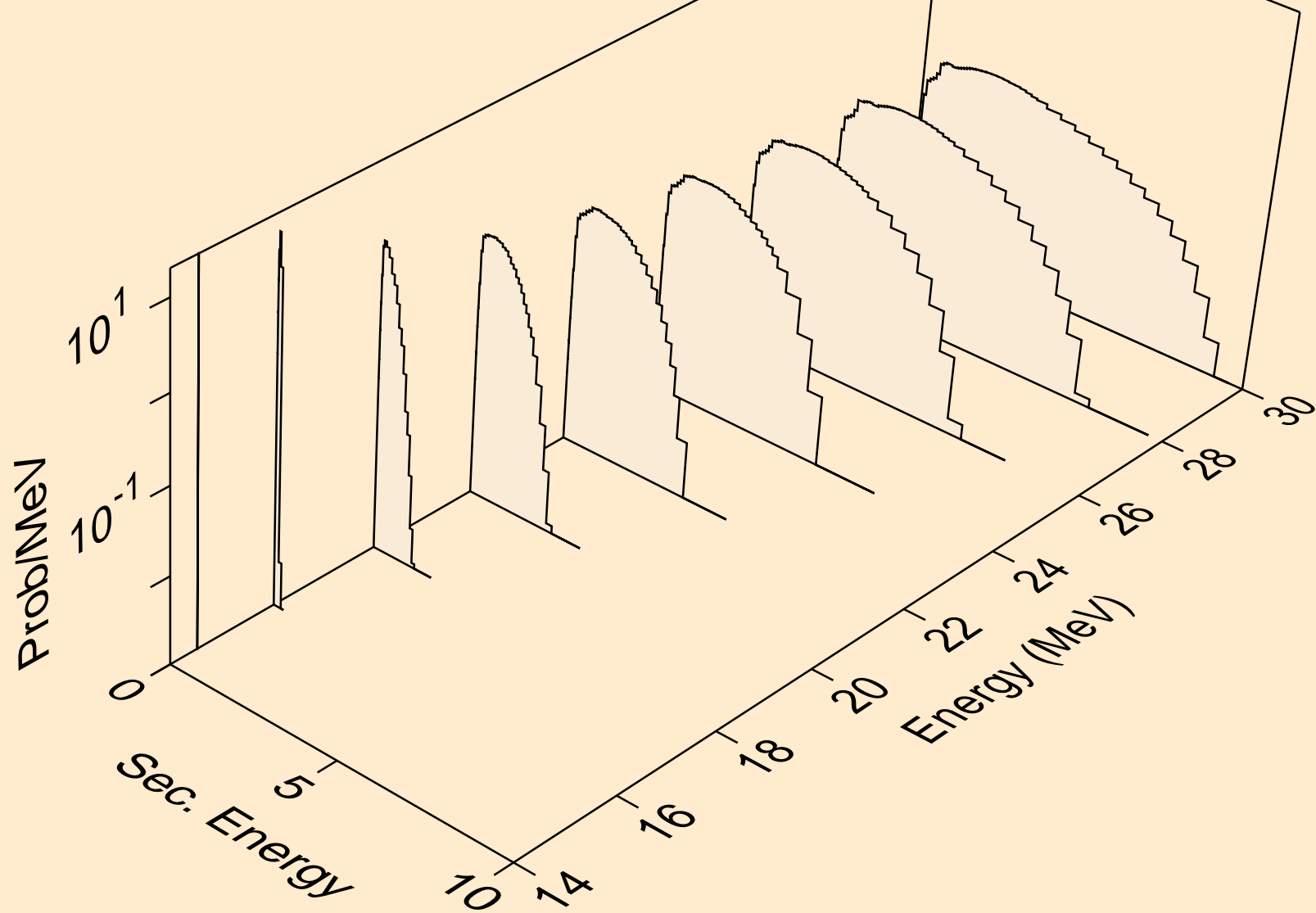

N014 DEUTERON ACER TENDL-2021 LIBRARY; T=0.K  
neutrons from (d,n\*)d

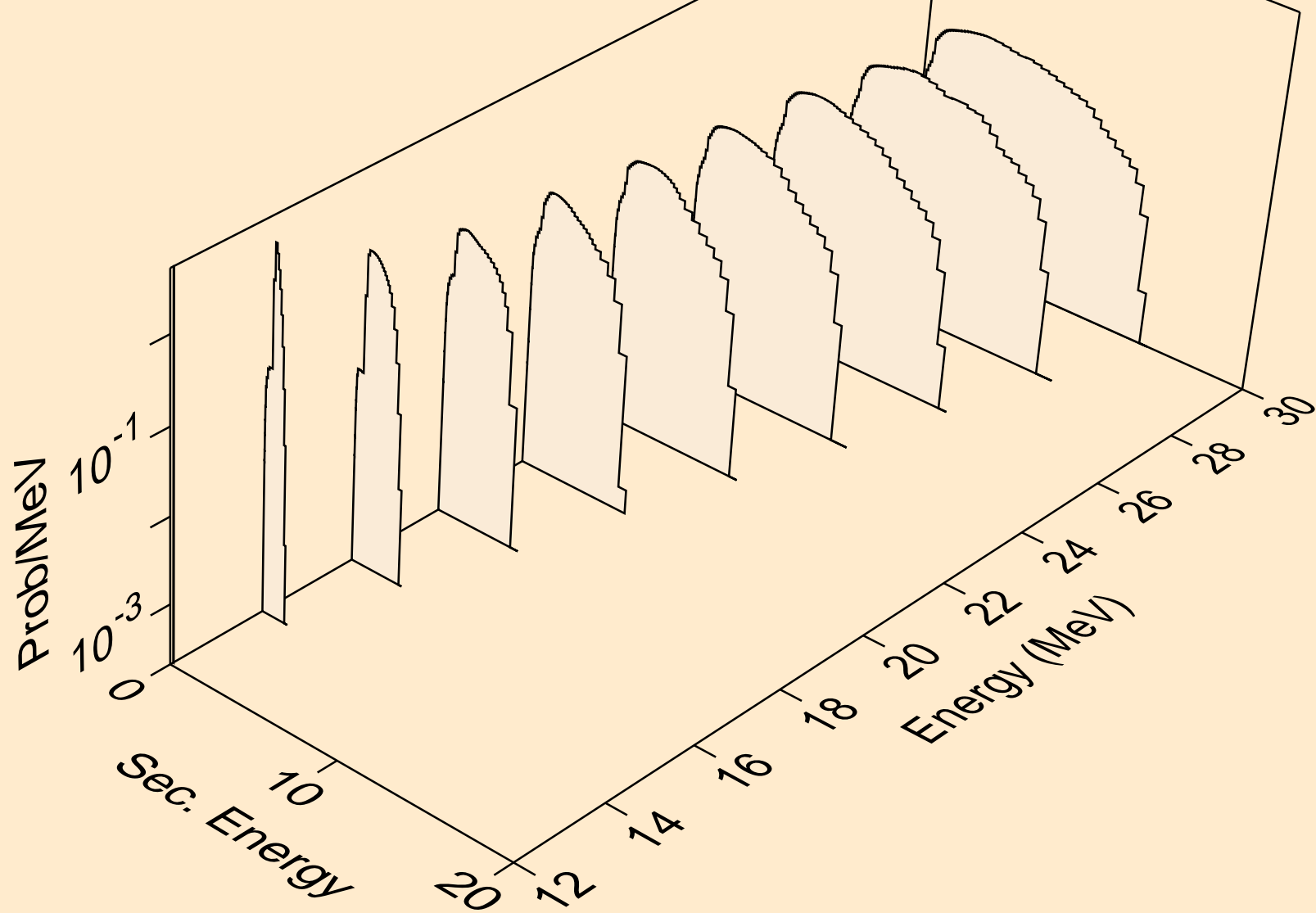

N014 DEUTERON ACER TENDL-2021 LIBRARY; T=0.K  
neutrons from (d,n\*)t

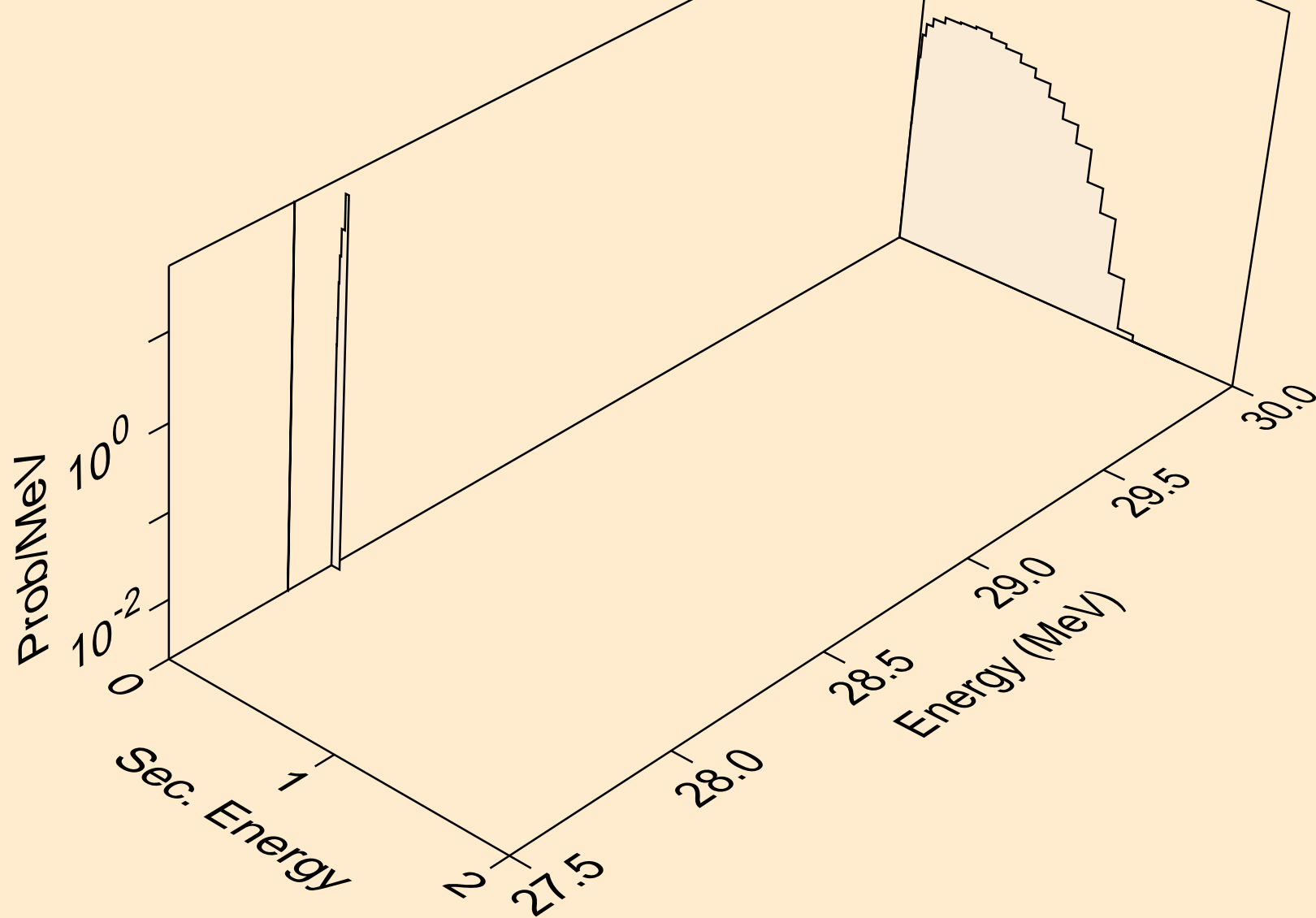

N014 DEUTERON ACER TENDL-2021 LIBRARY; T=0.K  
neutrons from (d,n\*)he3

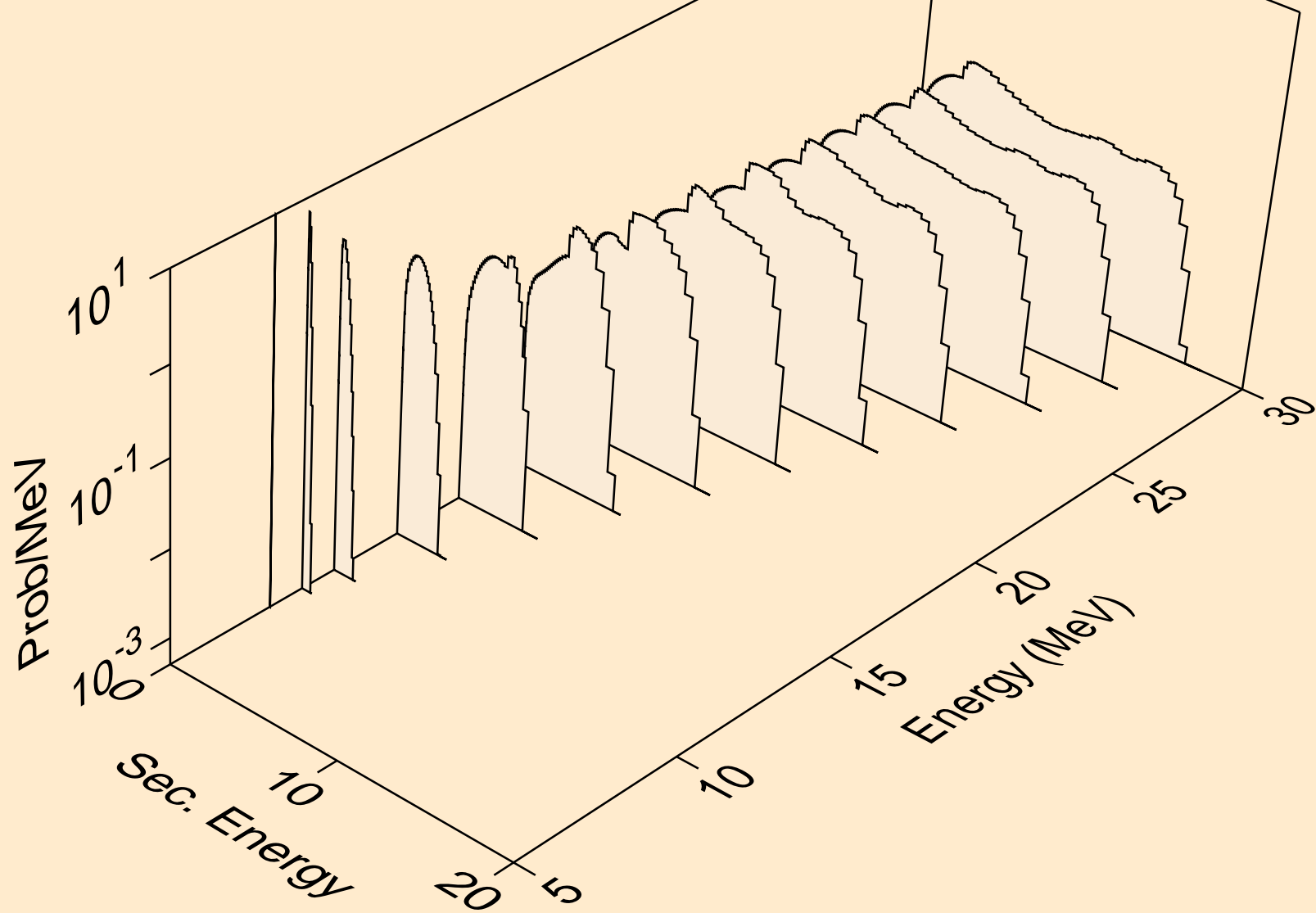

N014 DEUTERON ACER TENDL-2021 LIBRARY; T=0.K  
neutrons from (d,2np)

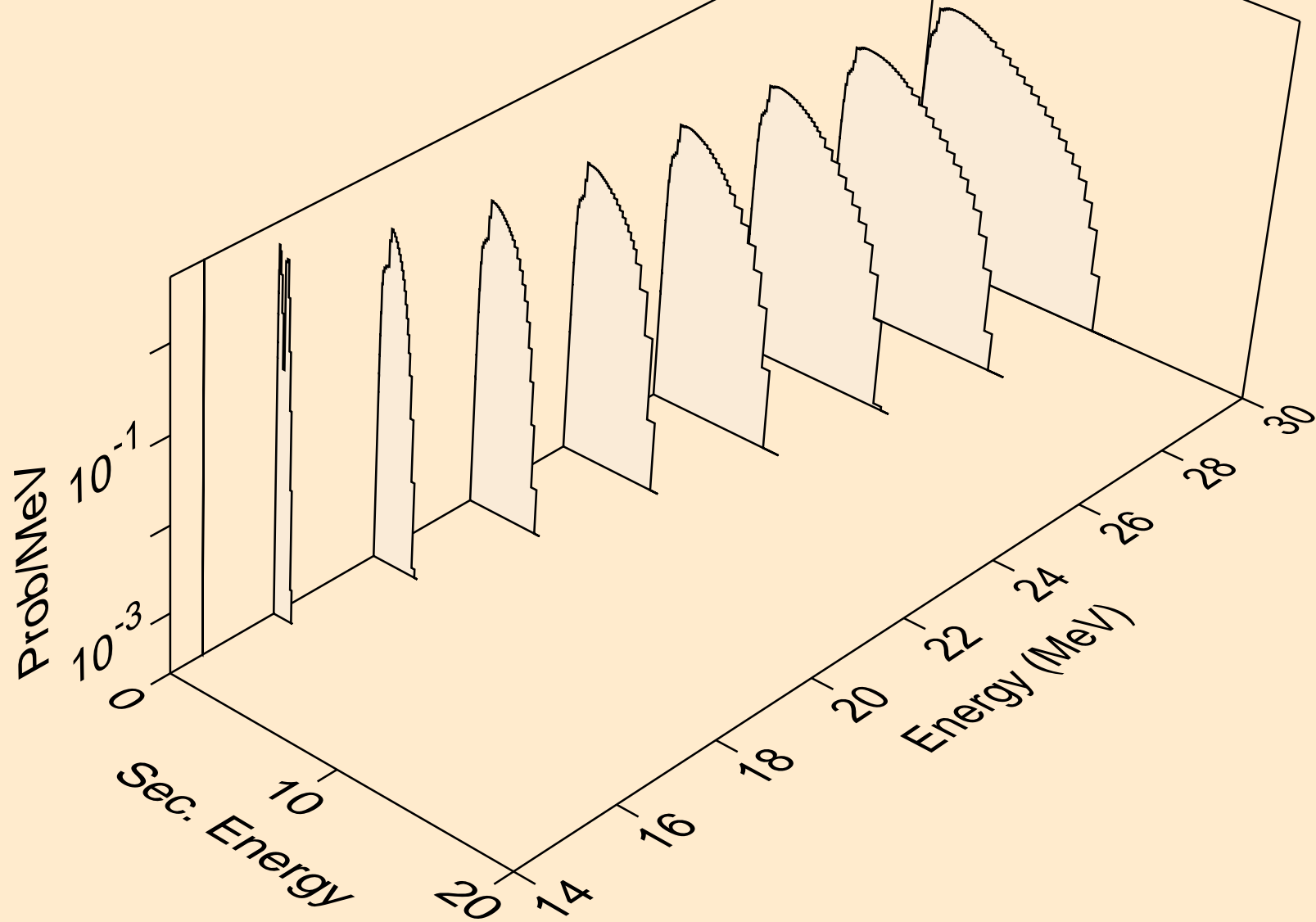

N014 DEUTERON ACER TENDL-2021 LIBRARY; T=0.K  
neutrons from (d,2np)

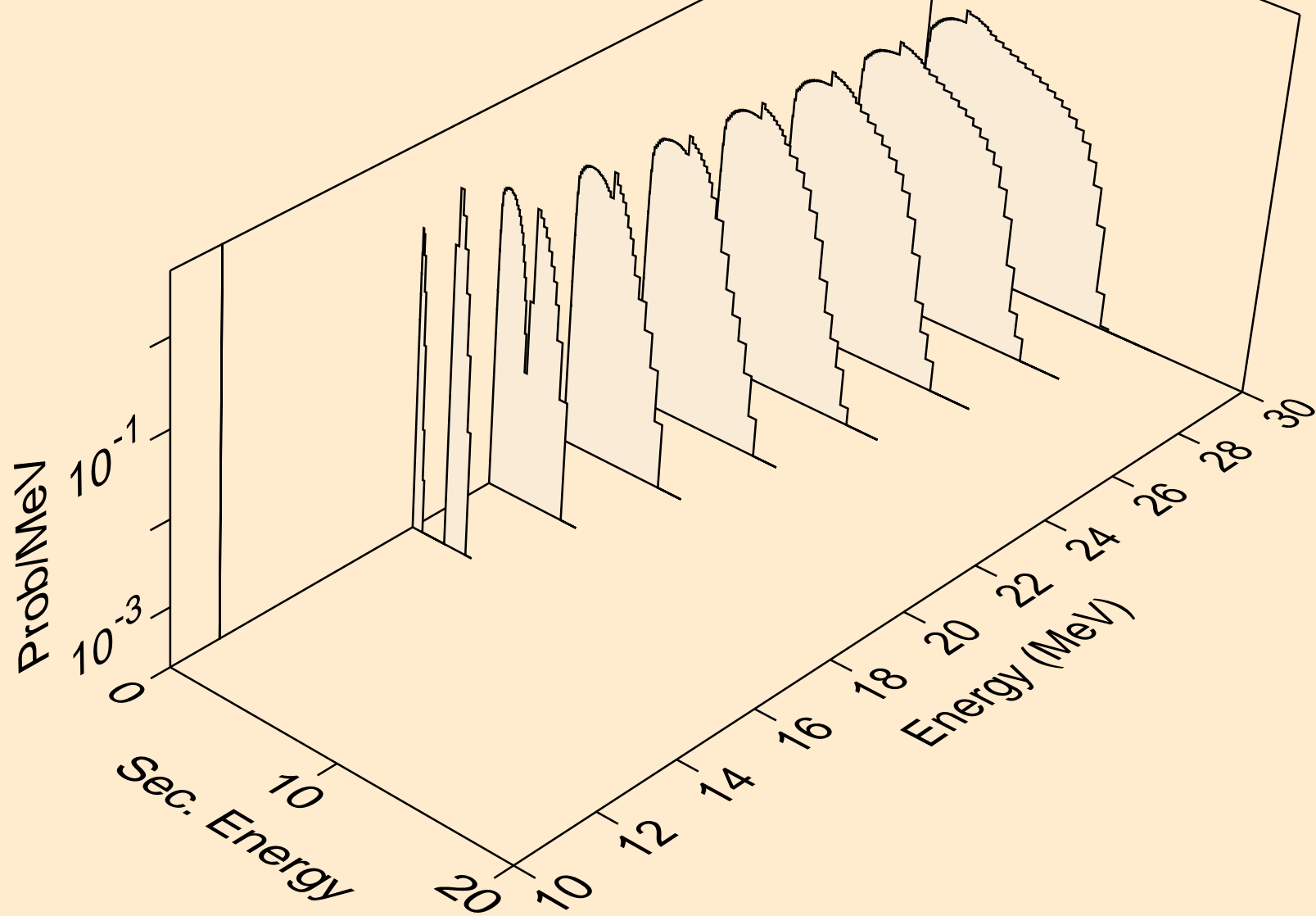

N014 DEUTERON ACER TENDL-2021 LIBRARY; T=0.K  
neutrons from (d,npa)

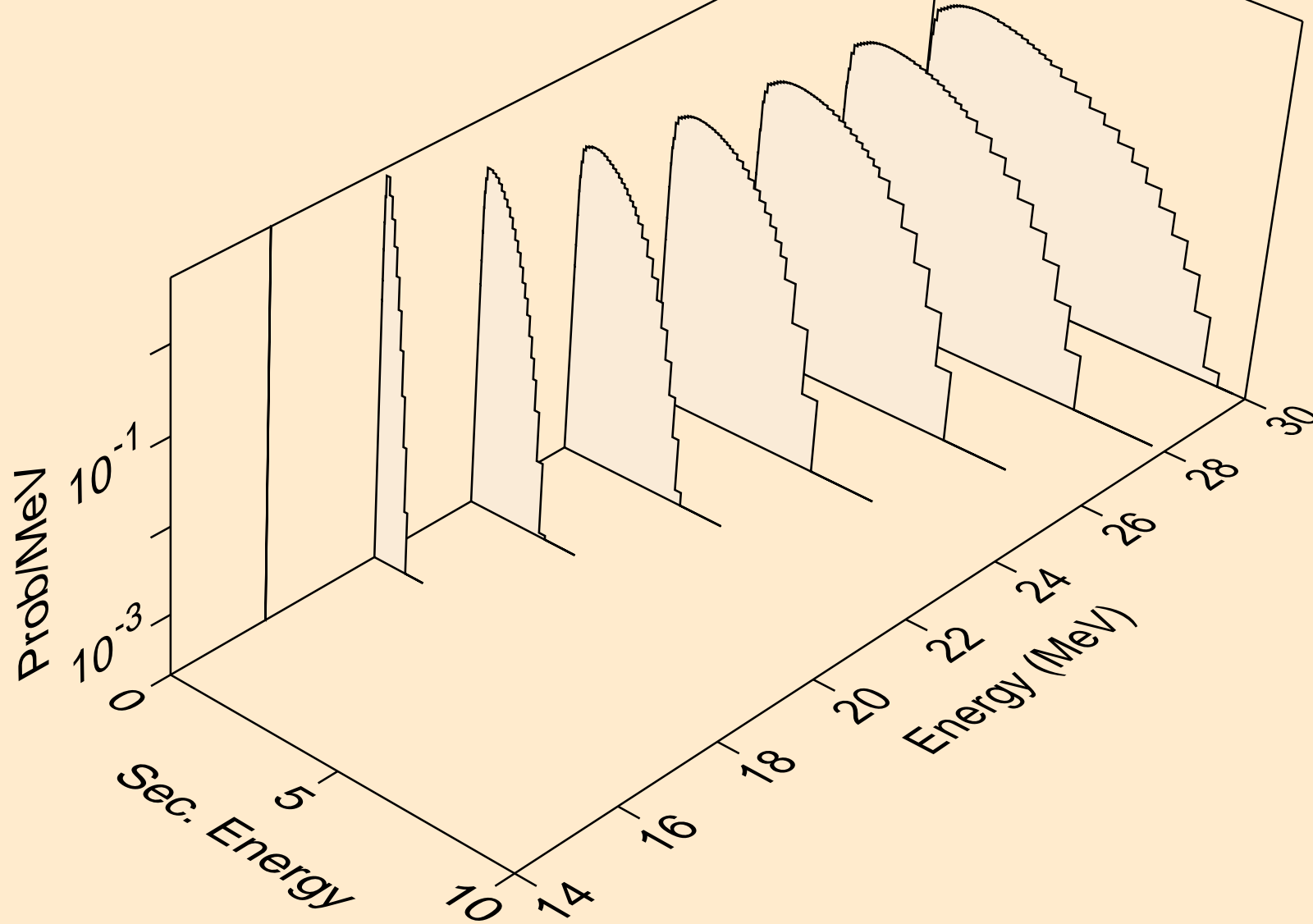

N014 DEUTERON ACER TENDL-2021 LIBRARY; T=0.K  
protons from (d,x)

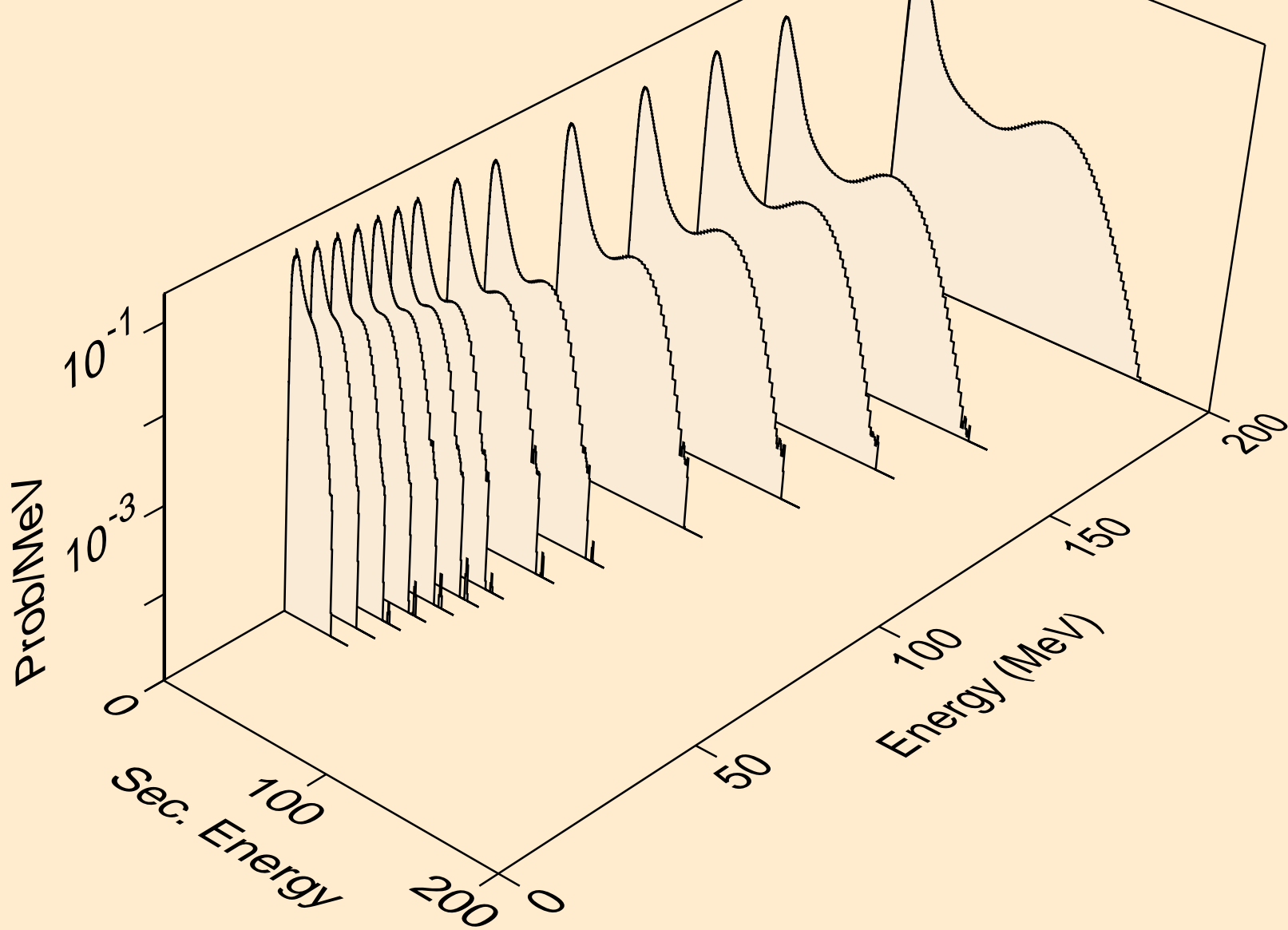

N014 DEUTERON ACER TENDL-2021 LIBRARY; T=0.K  
protons from (d,n\*)p

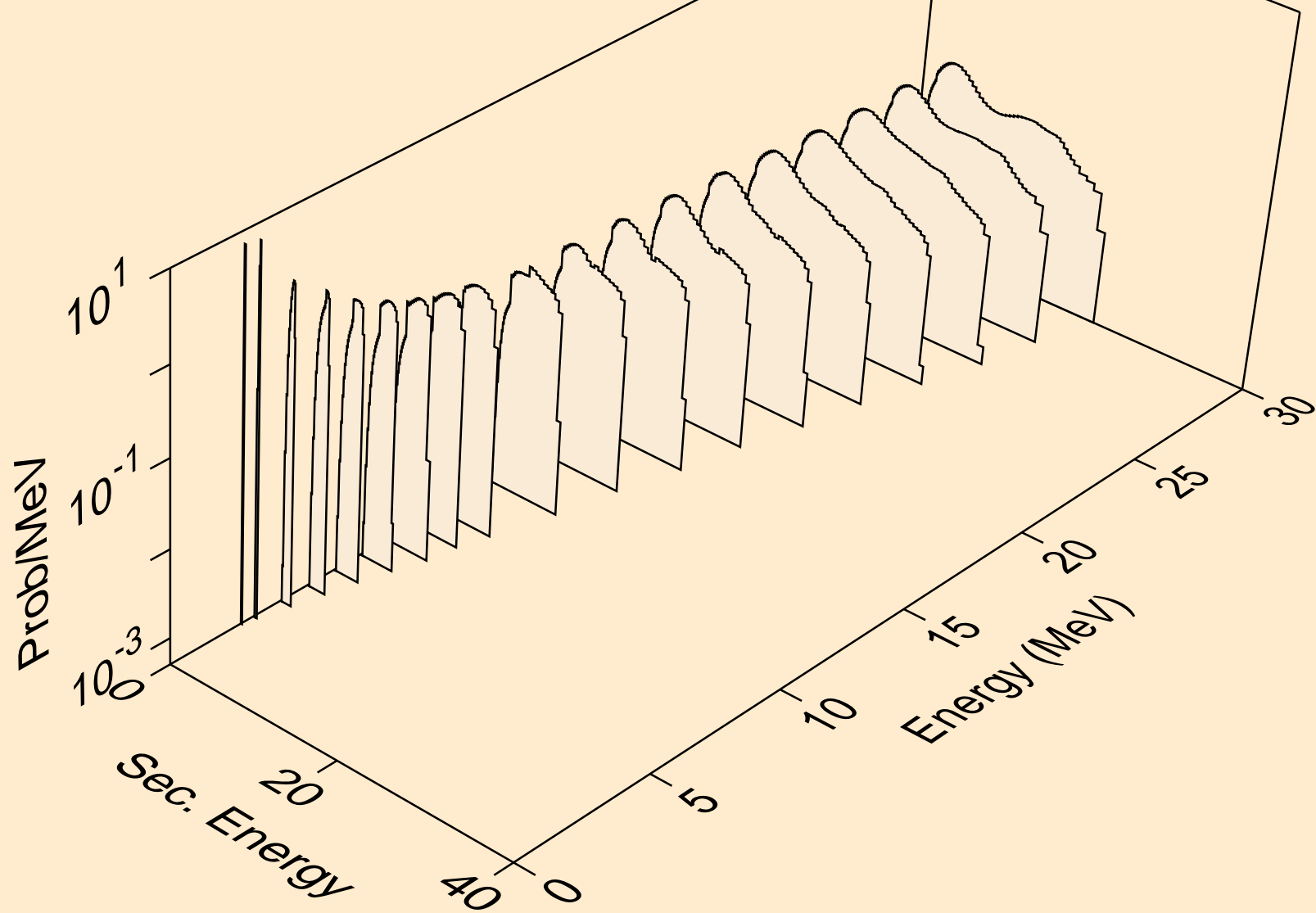

N014 DEUTERON ACER TENDL-2021 LIBRARY; T=0.K  
protons from (d,2np)

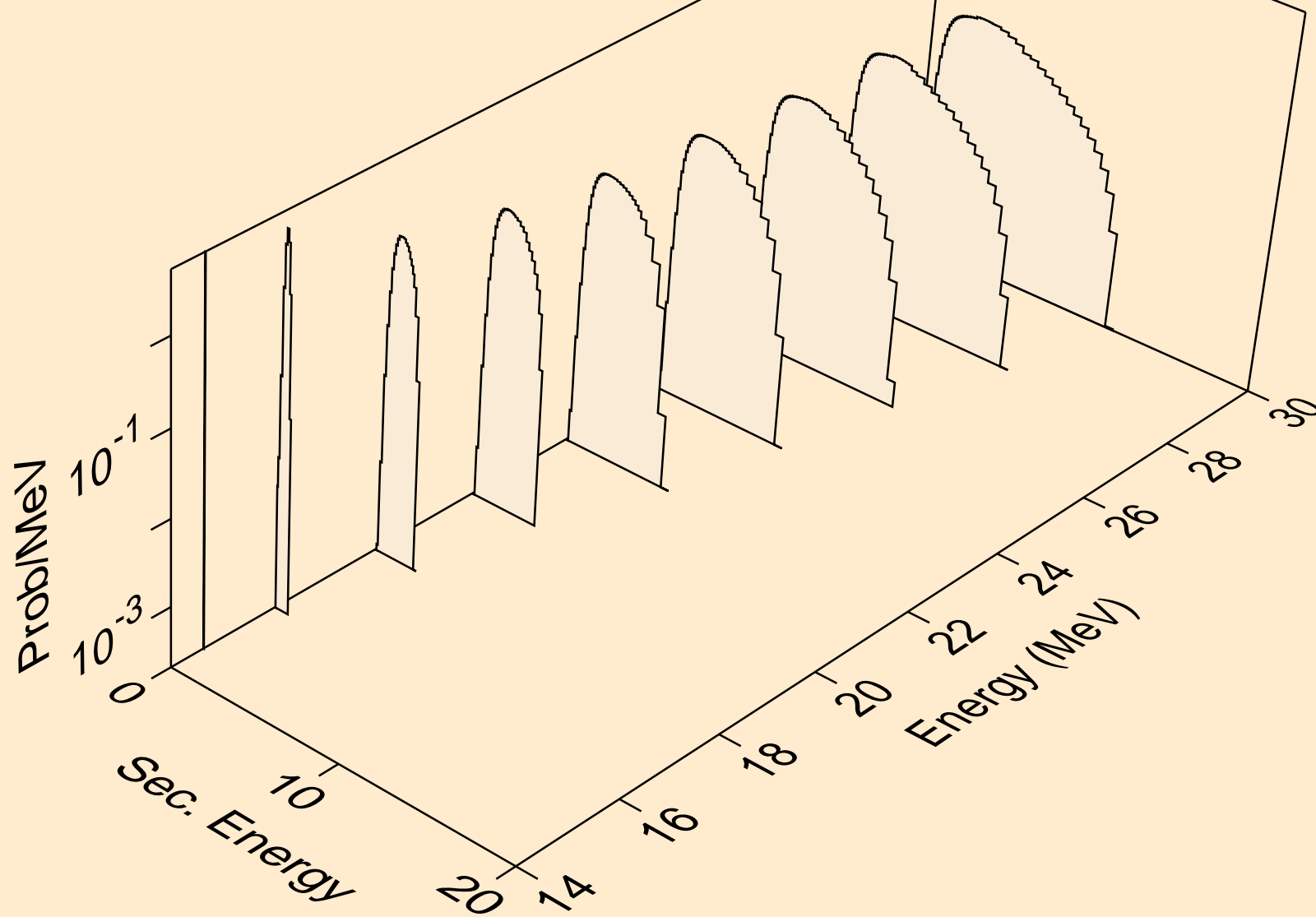

N014 DEUTERON ACER TENDL-2021 LIBRARY; T=0.K  
protons from (d,2np)

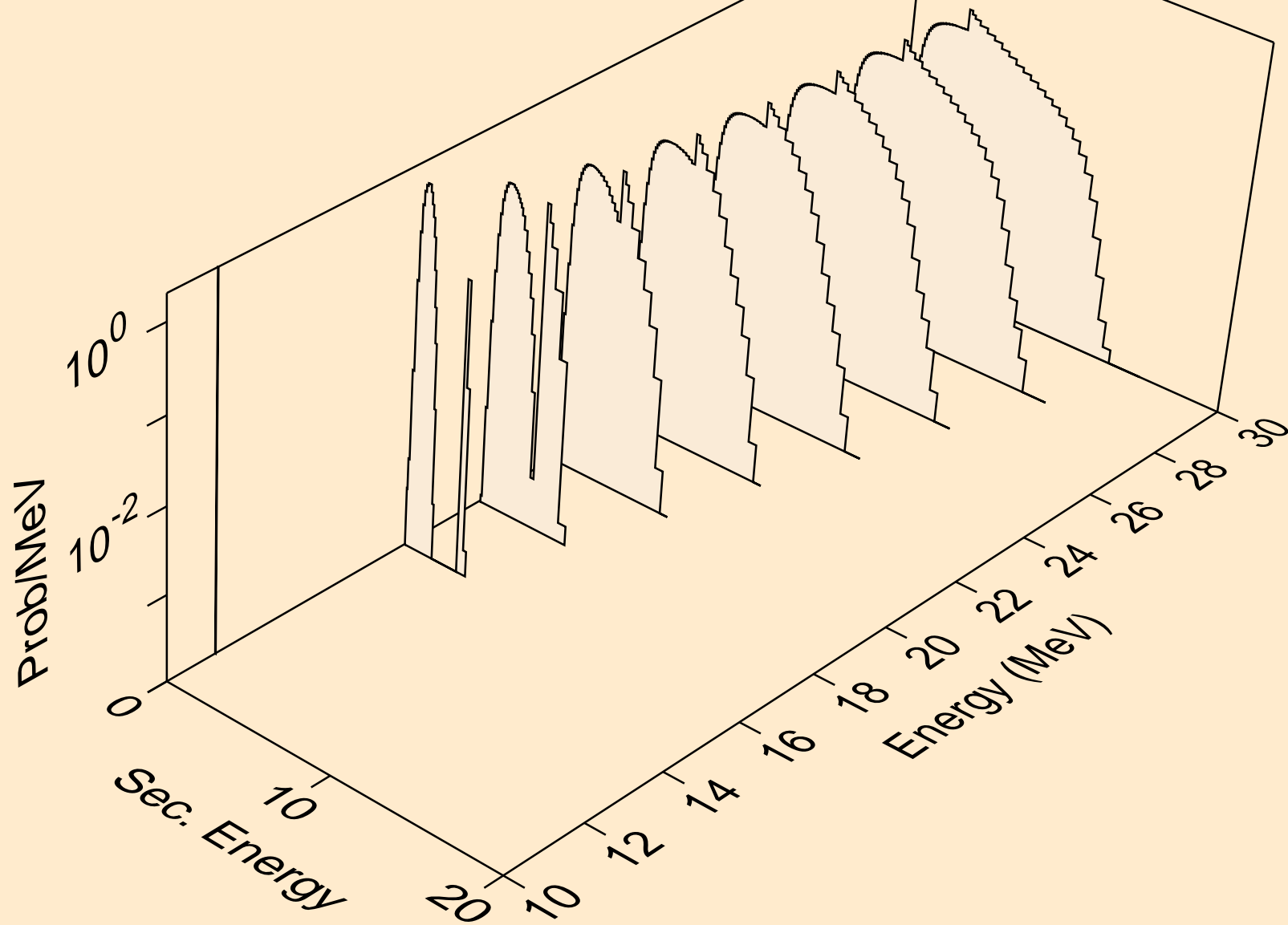

N014 DEUTERON ACER TENDL-2021 LIBRARY; T=0.K  
protons from (d,npa)

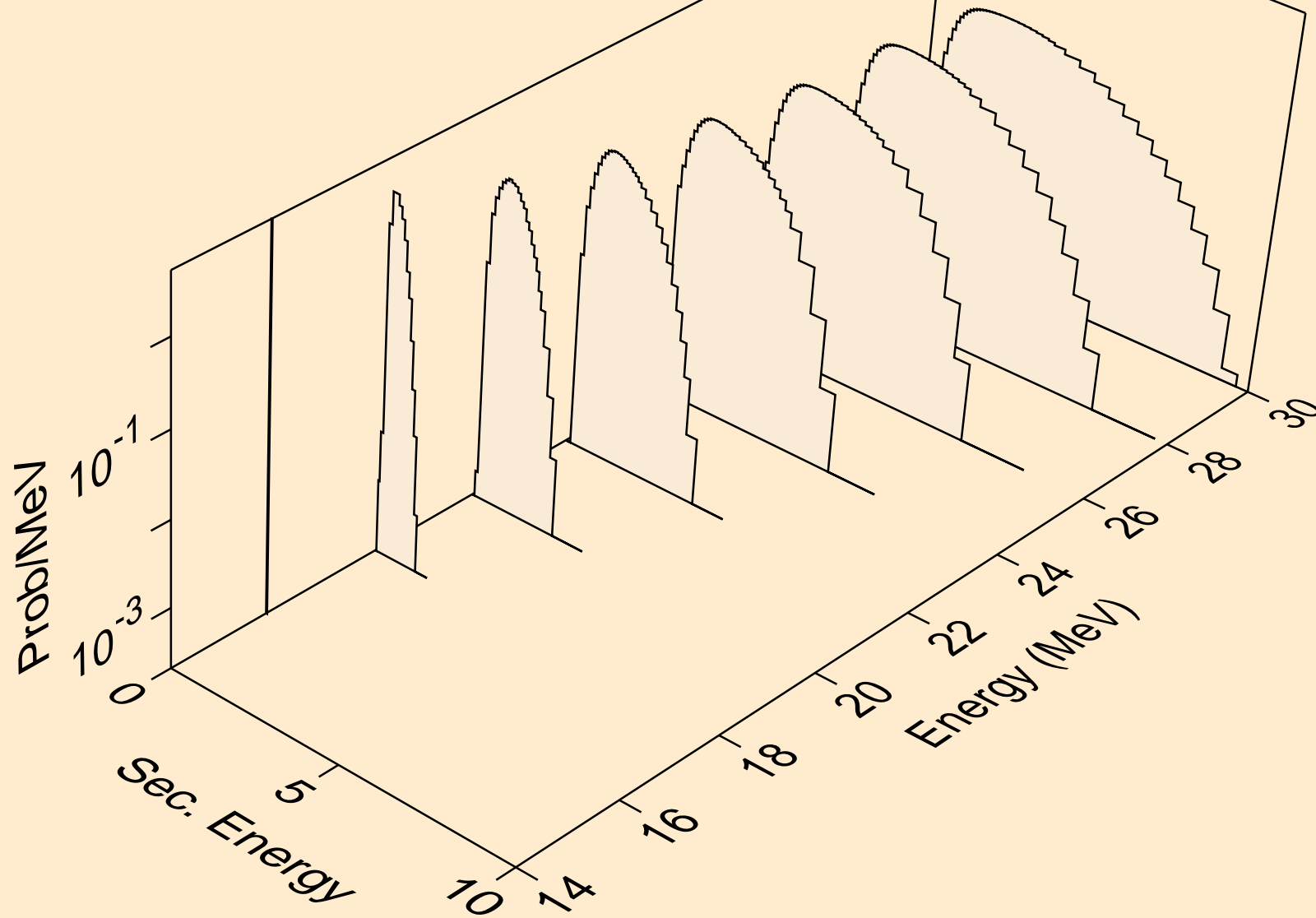

N014 DEUTERON ACER TENDL-2021 LIBRARY; T=0.K  
protons from (d,p)

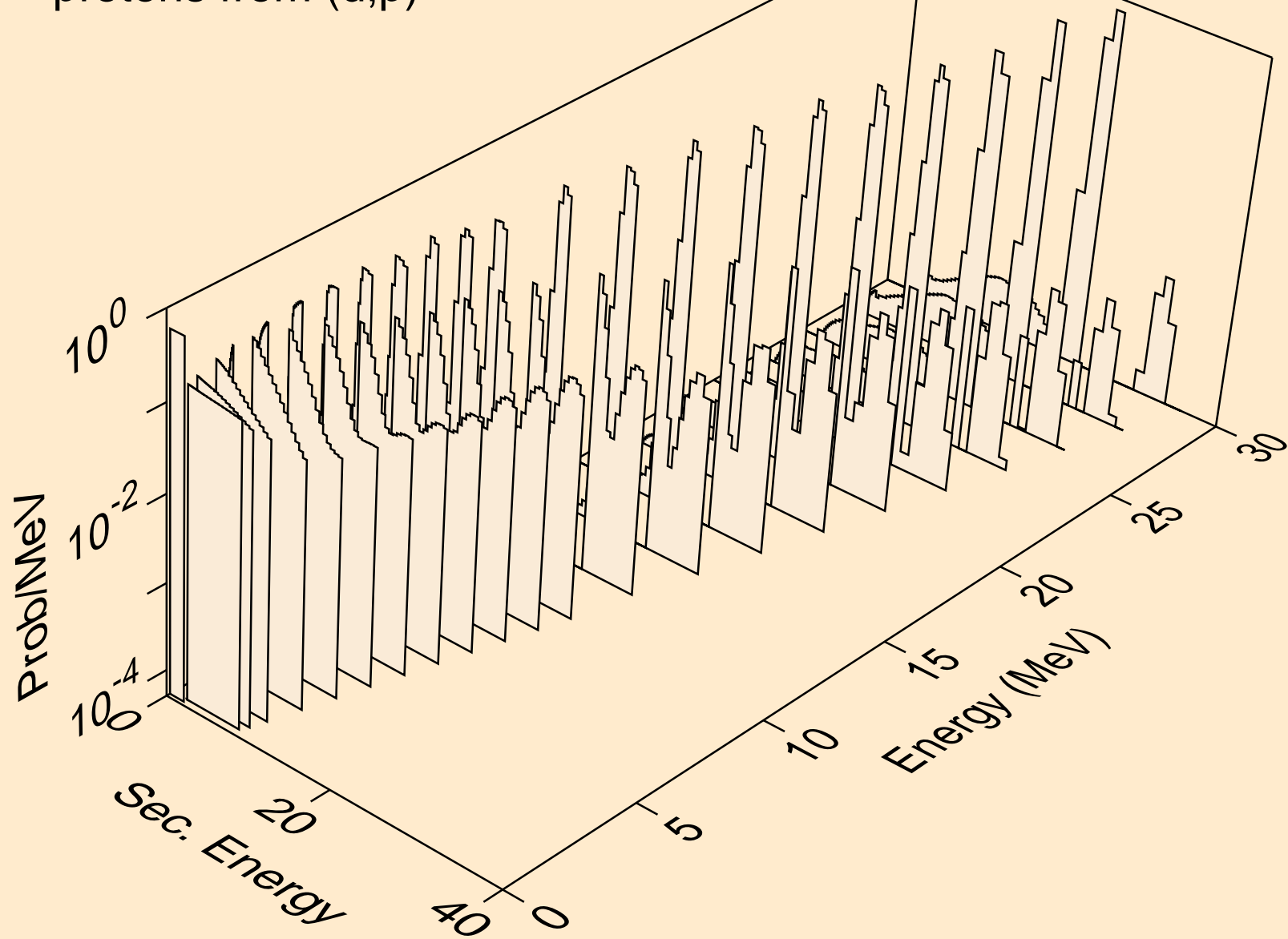

N014 DEUTERON ACER TENDL-2021 LIBRARY; T=0.K  
protons from (d,2p)

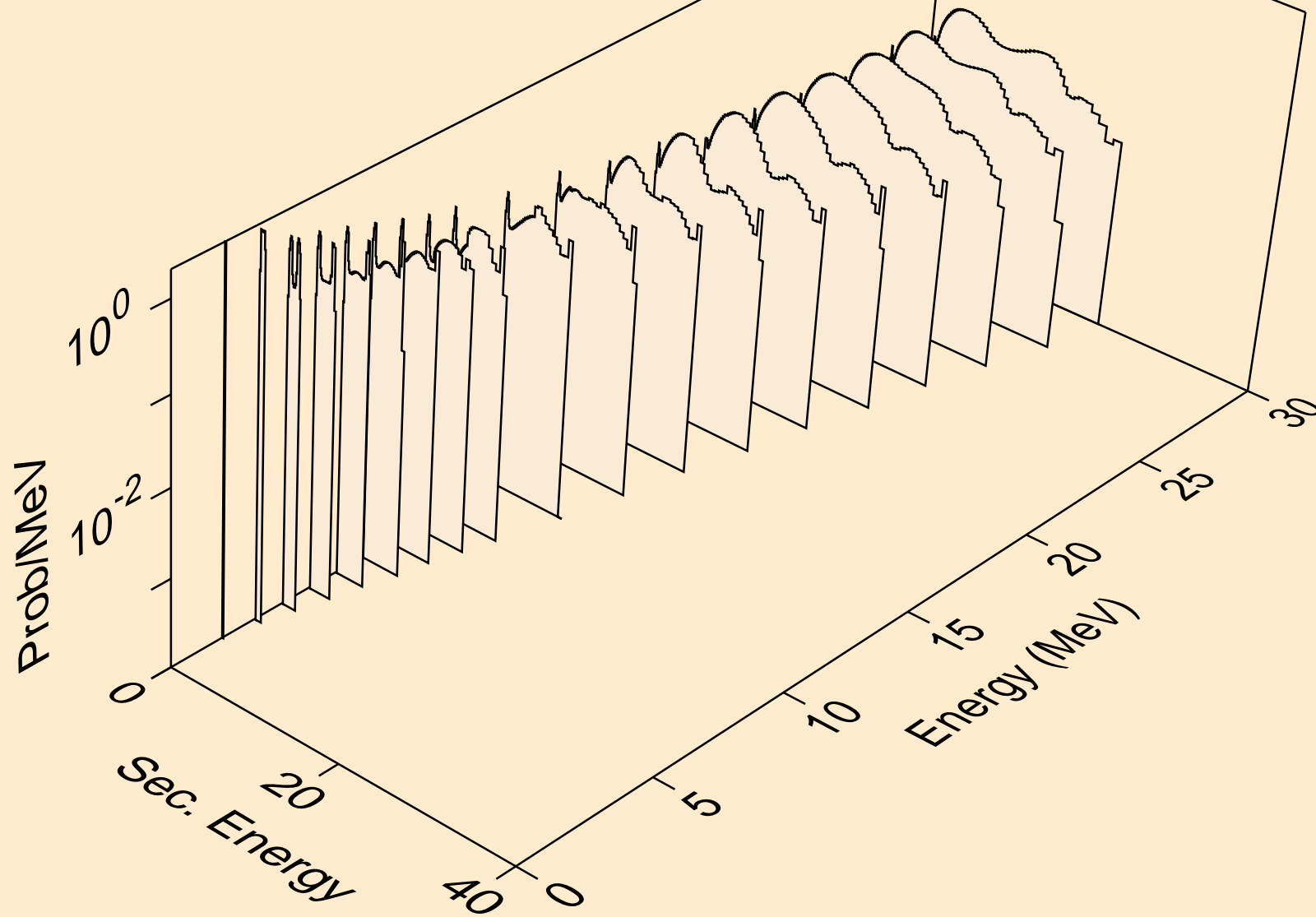

N014 DEUTERON ACER TENDL-2021 LIBRARY; T=0.K  
protons from (d,pa)

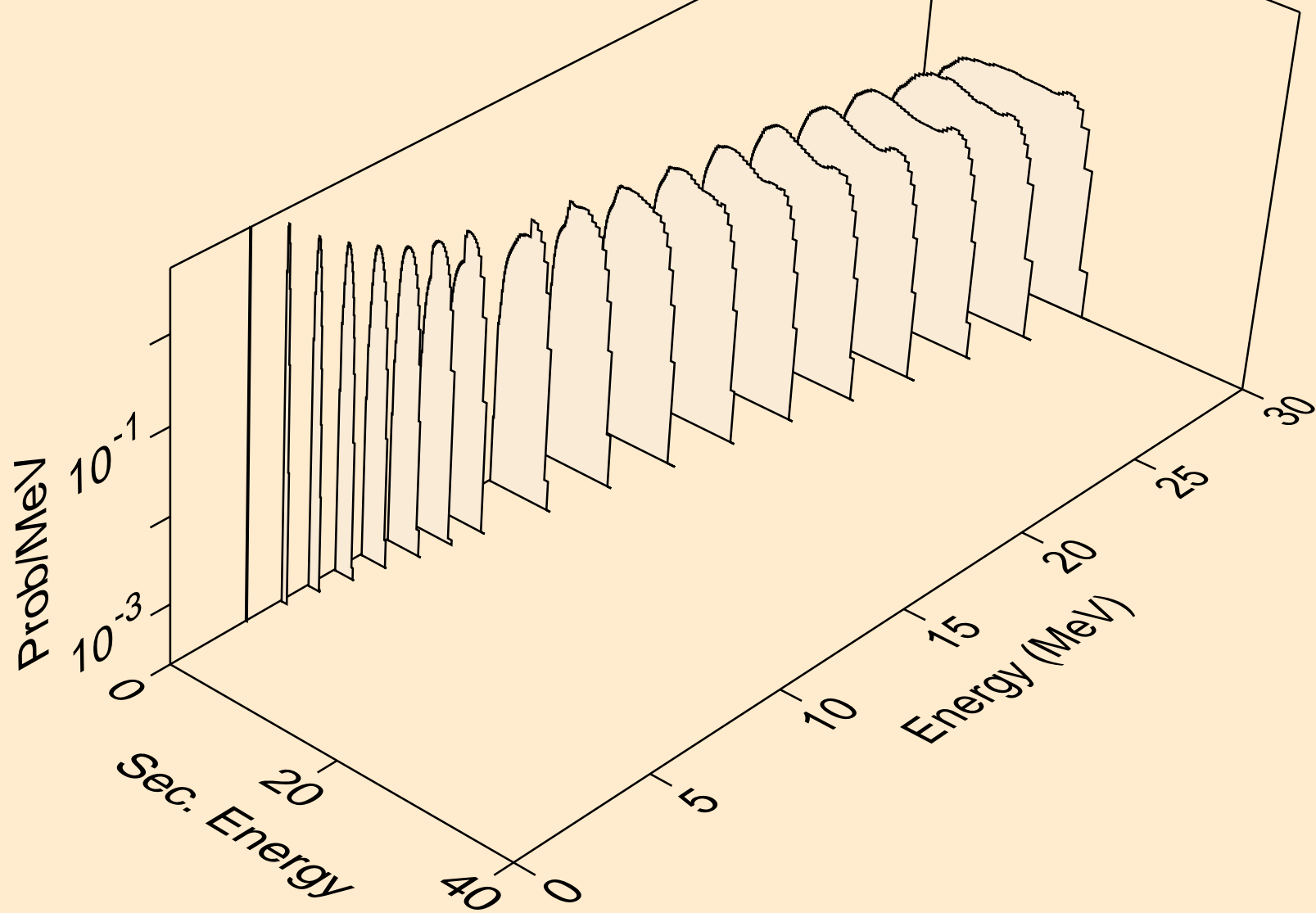

N014 DEUTERON ACER TENDL-2021 LIBRARY; T=0.K  
protons from (d,pd)

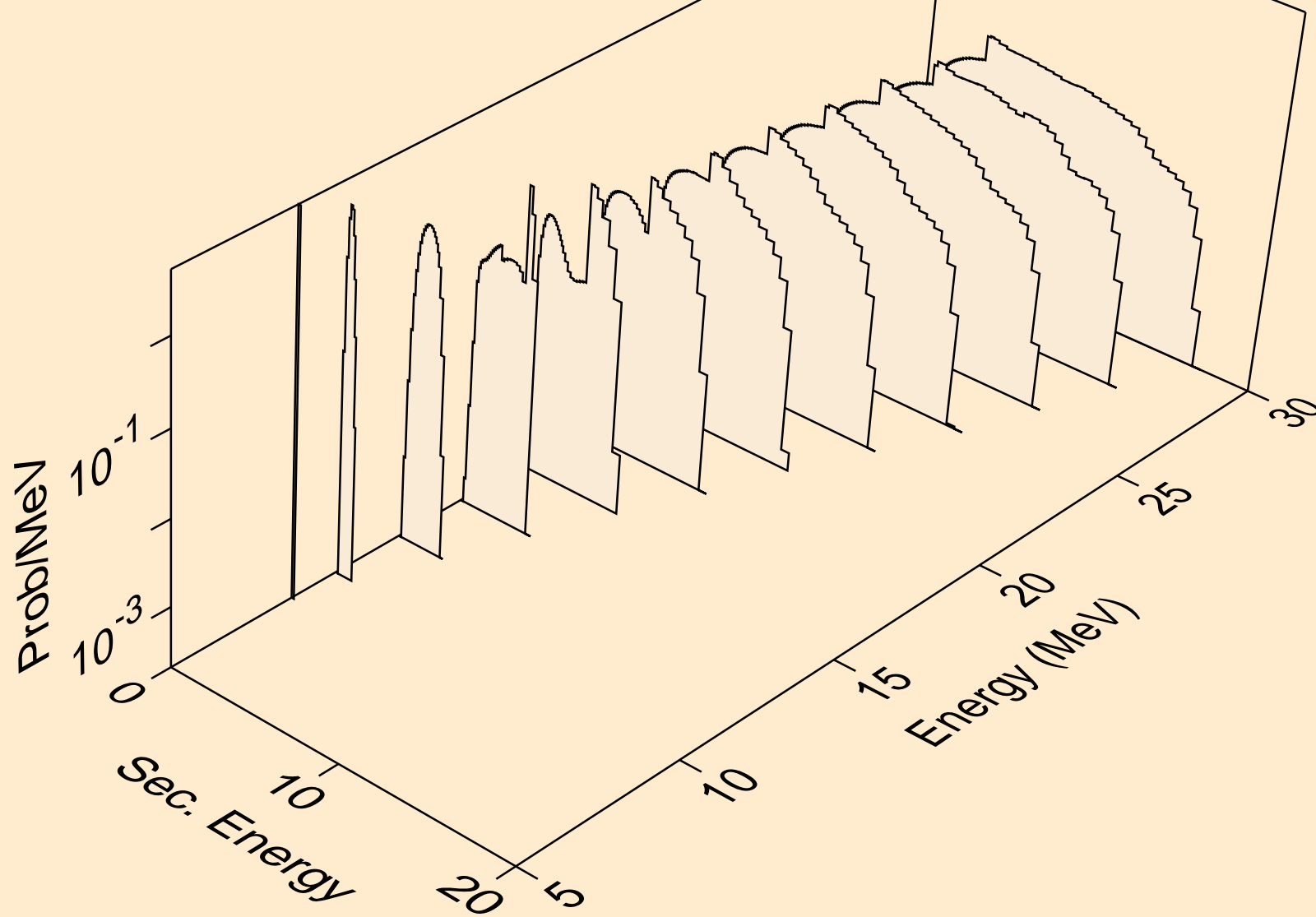

N014 DEUTERON ACER TENDL-2021 LIBRARY; T=0.K  
protons from (d,pt)

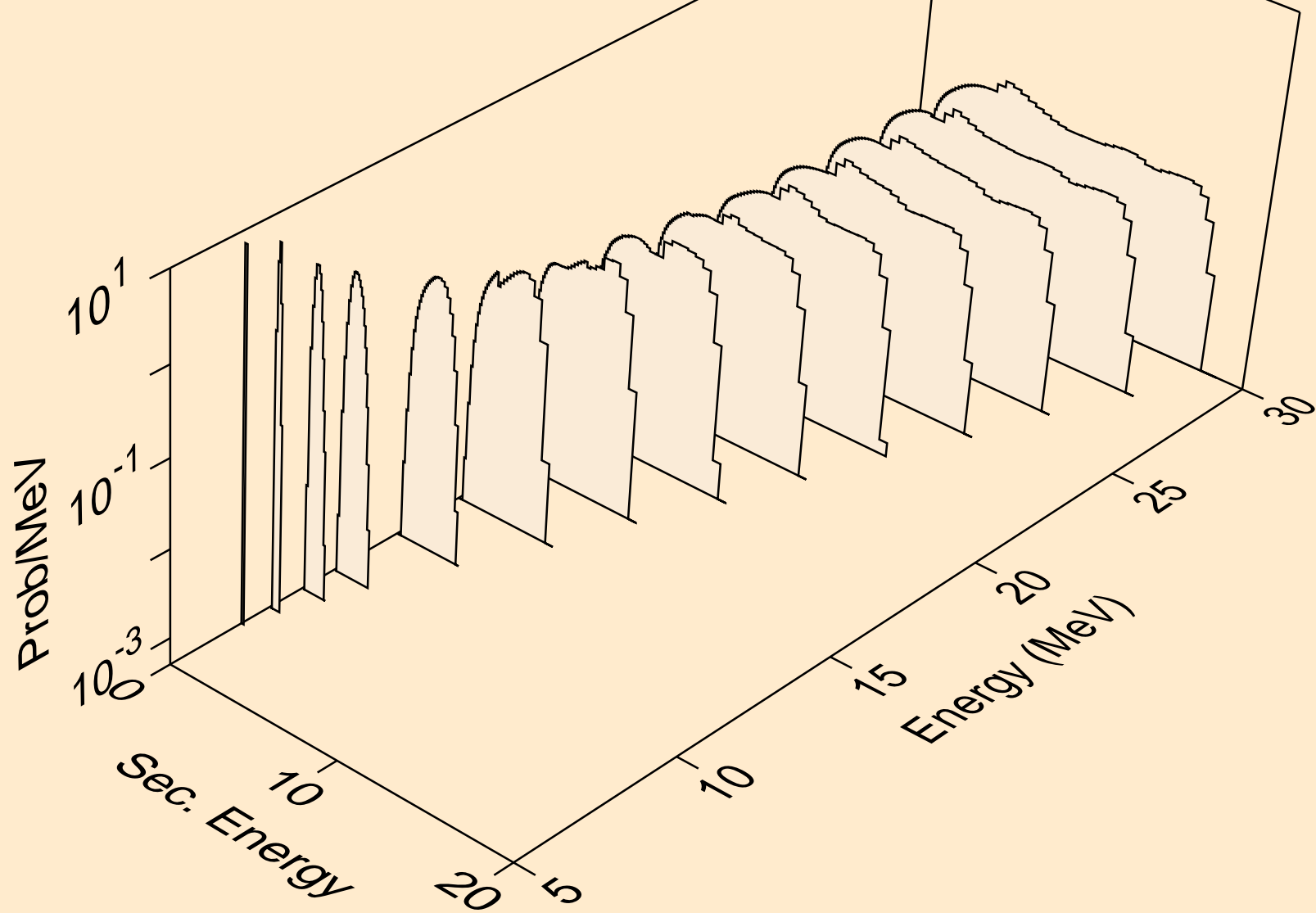

N014 DEUTERON ACER TENDL-2021 LIBRARY; T=0.K  
tritons from (d,x)

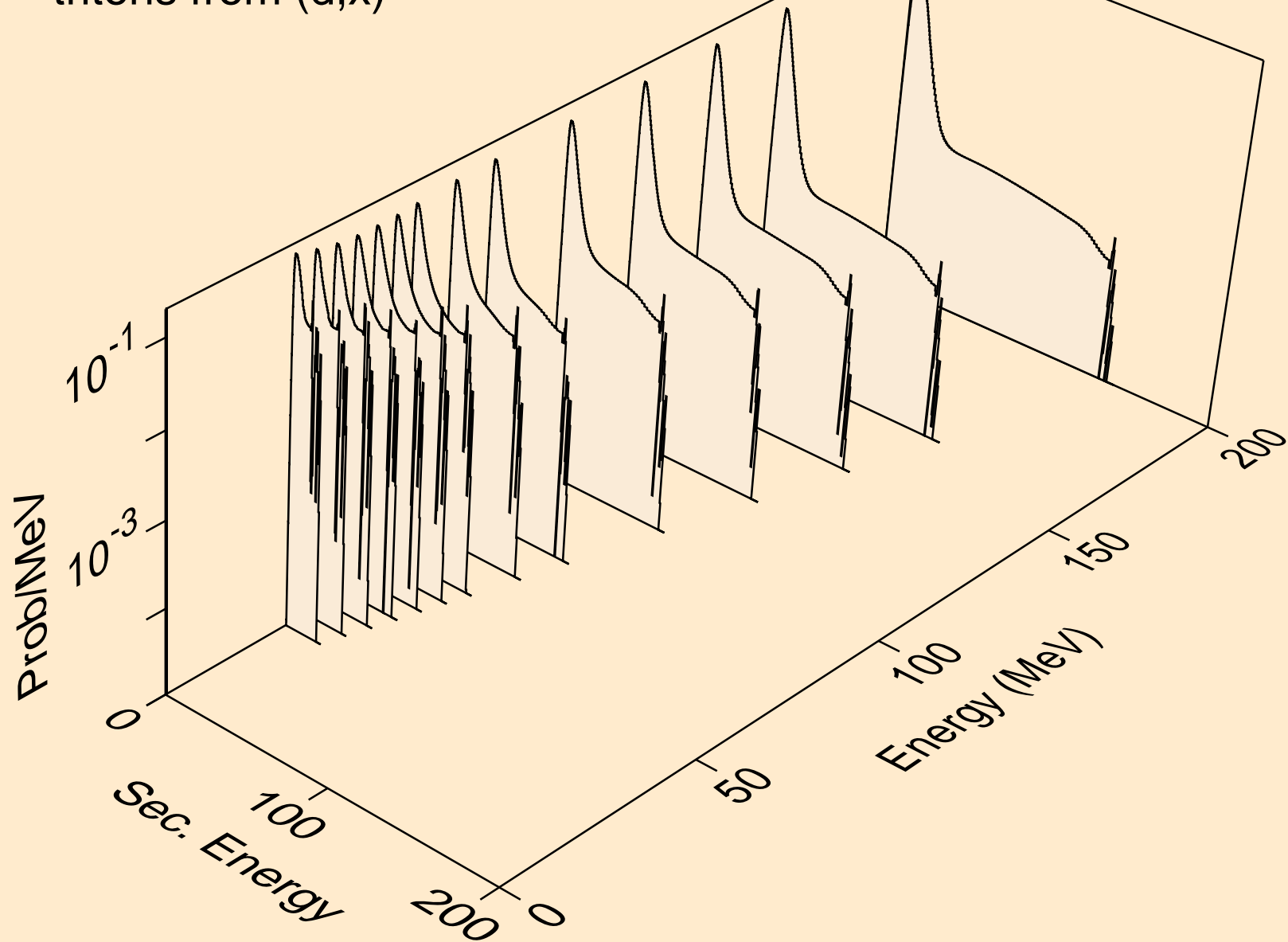

N014 DEUTERON ACER TENDL-2021 LIBRARY; T=0.K  
tritons from (d,n\*)t

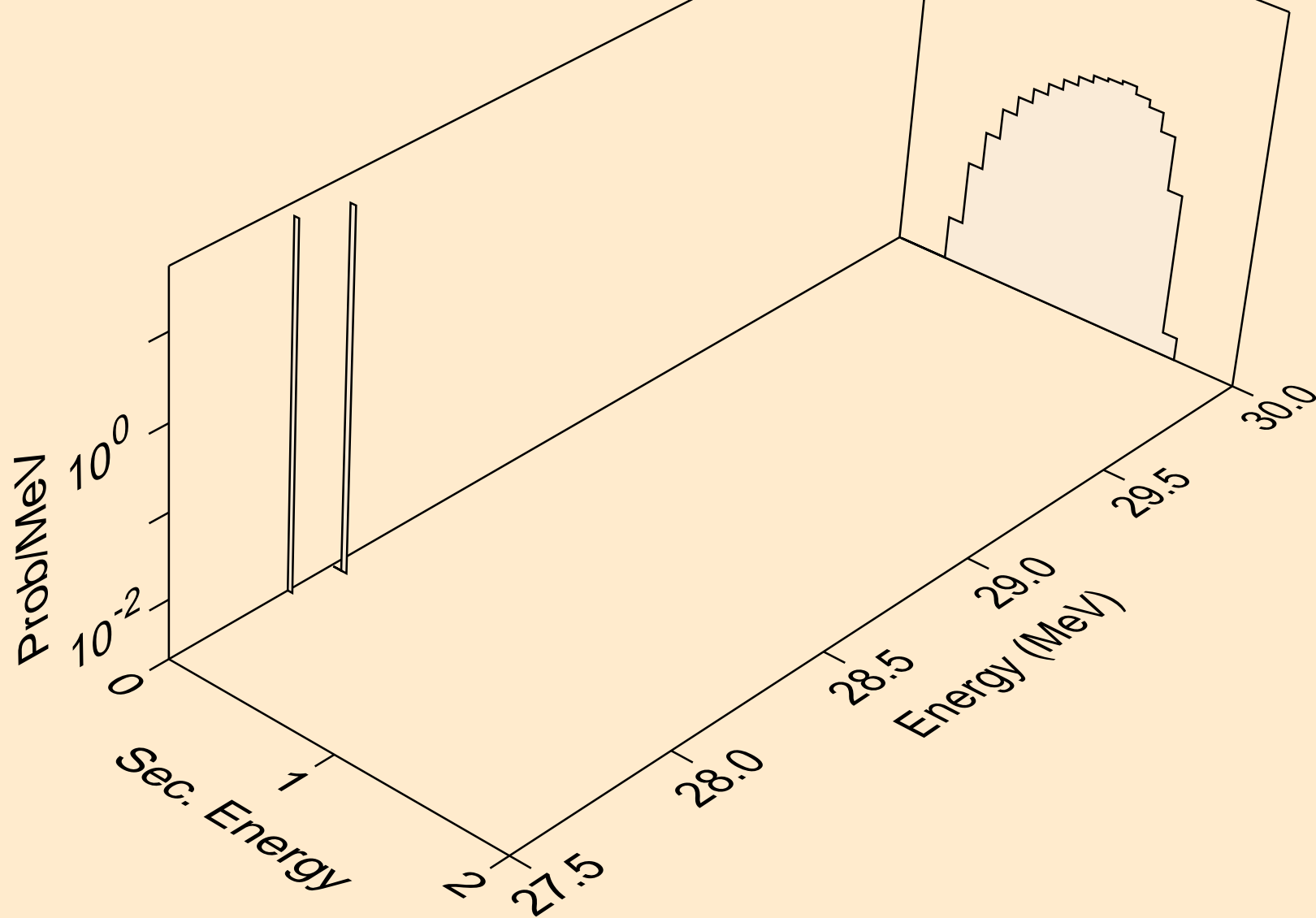

N014 DEUTERON ACER TENDL-2021 LIBRARY; T=0.K  
tritons from (d,t)

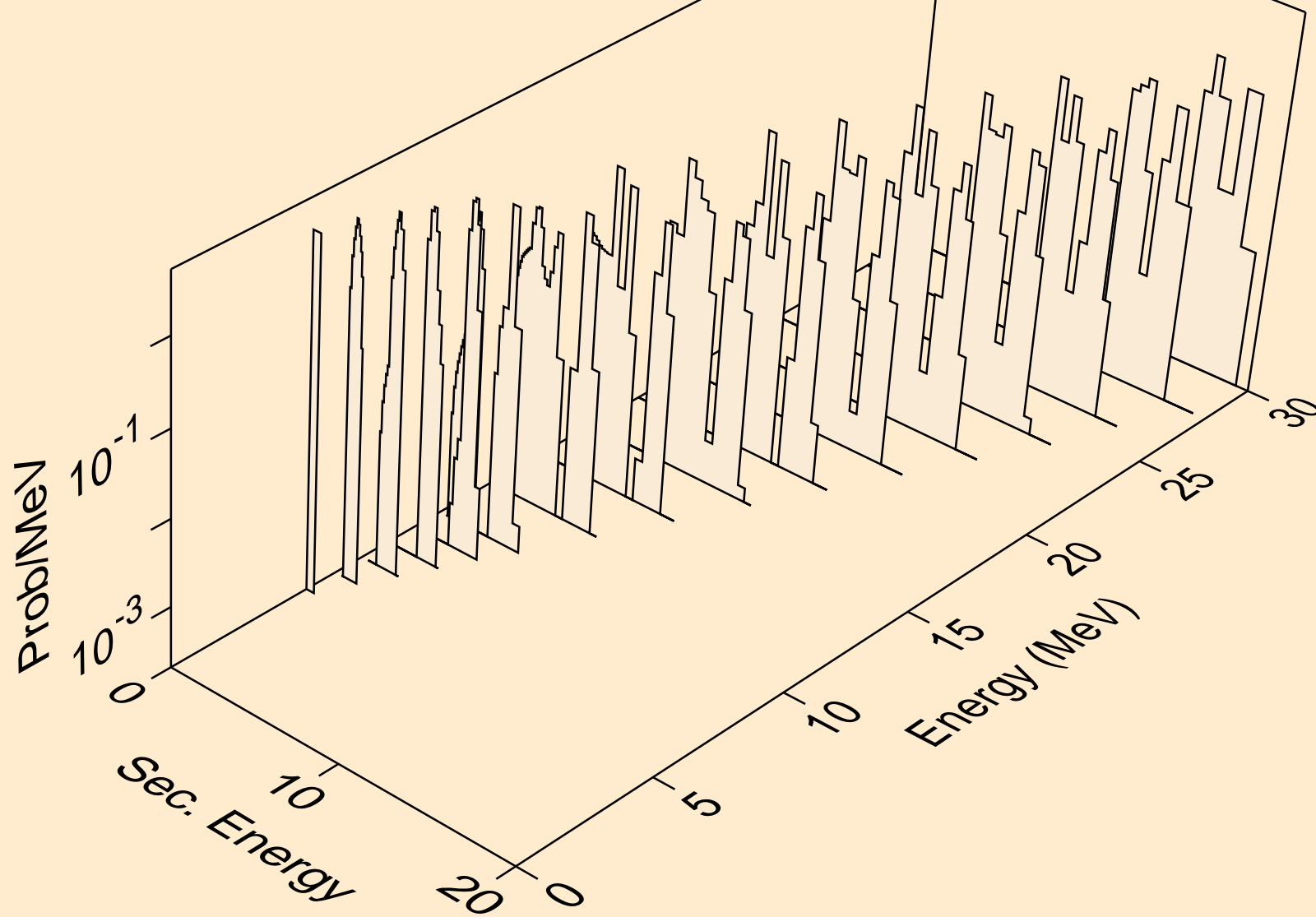

N014 DEUTERON ACER TENDL-2021 LIBRARY; T=0.K  
tritons from (d,pt)

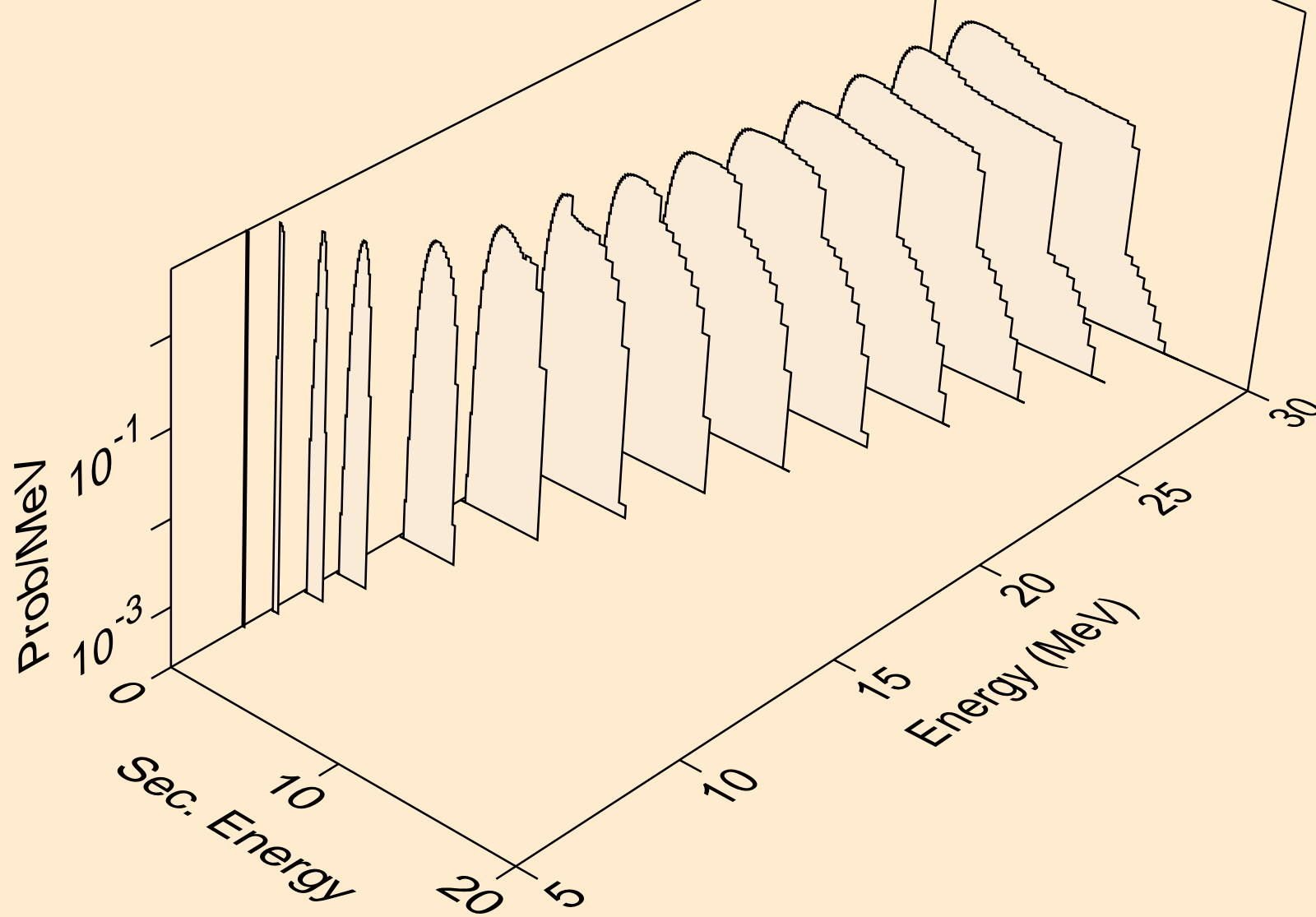

N014 DEUTERON ACER TENDL-2021 LIBRARY; T=0.K  
he3s from (d,x)

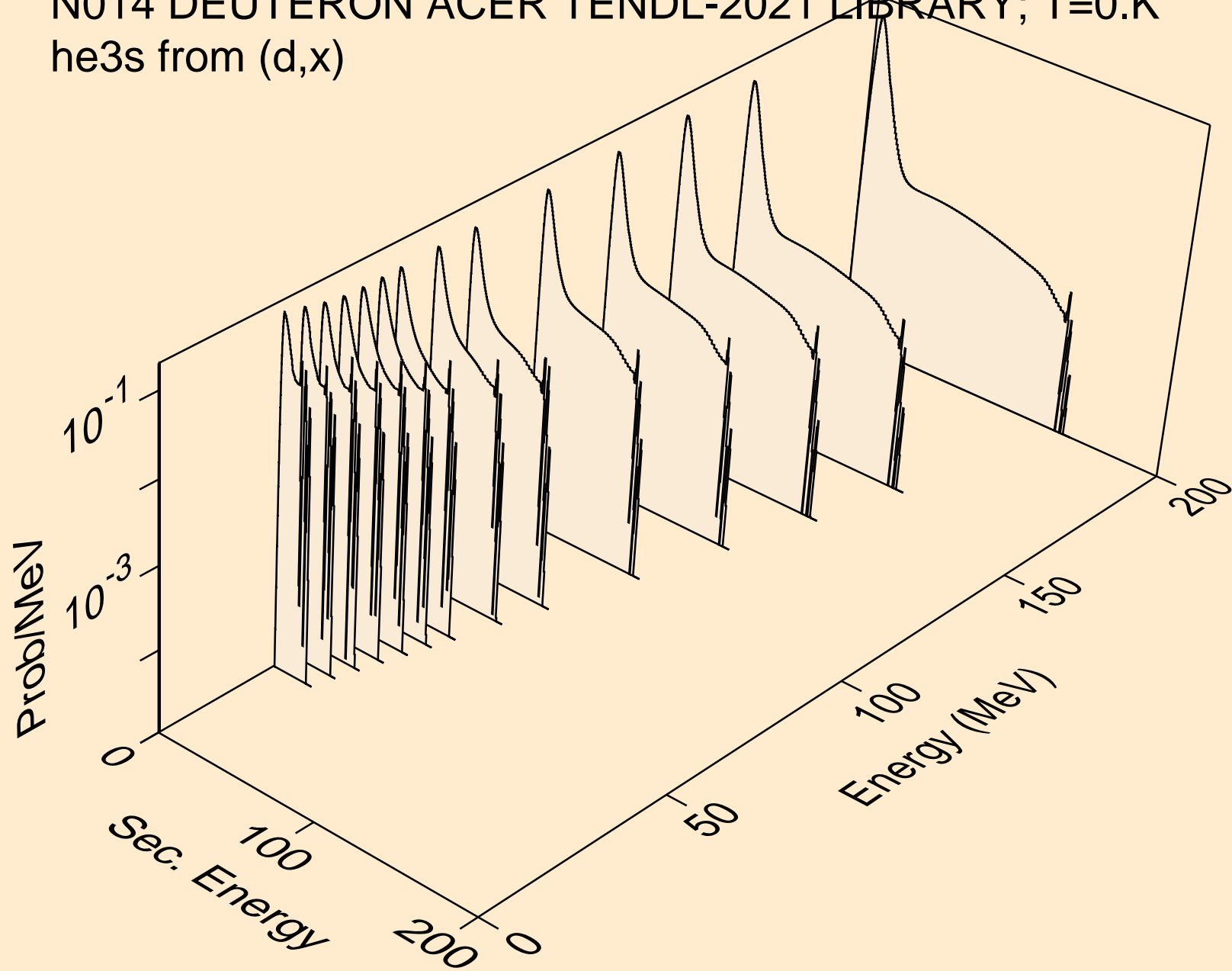

N014 DEUTERON ACER TENDL-2021 LIBRARY; T=0.K  
he3s from (d,n\*)he3

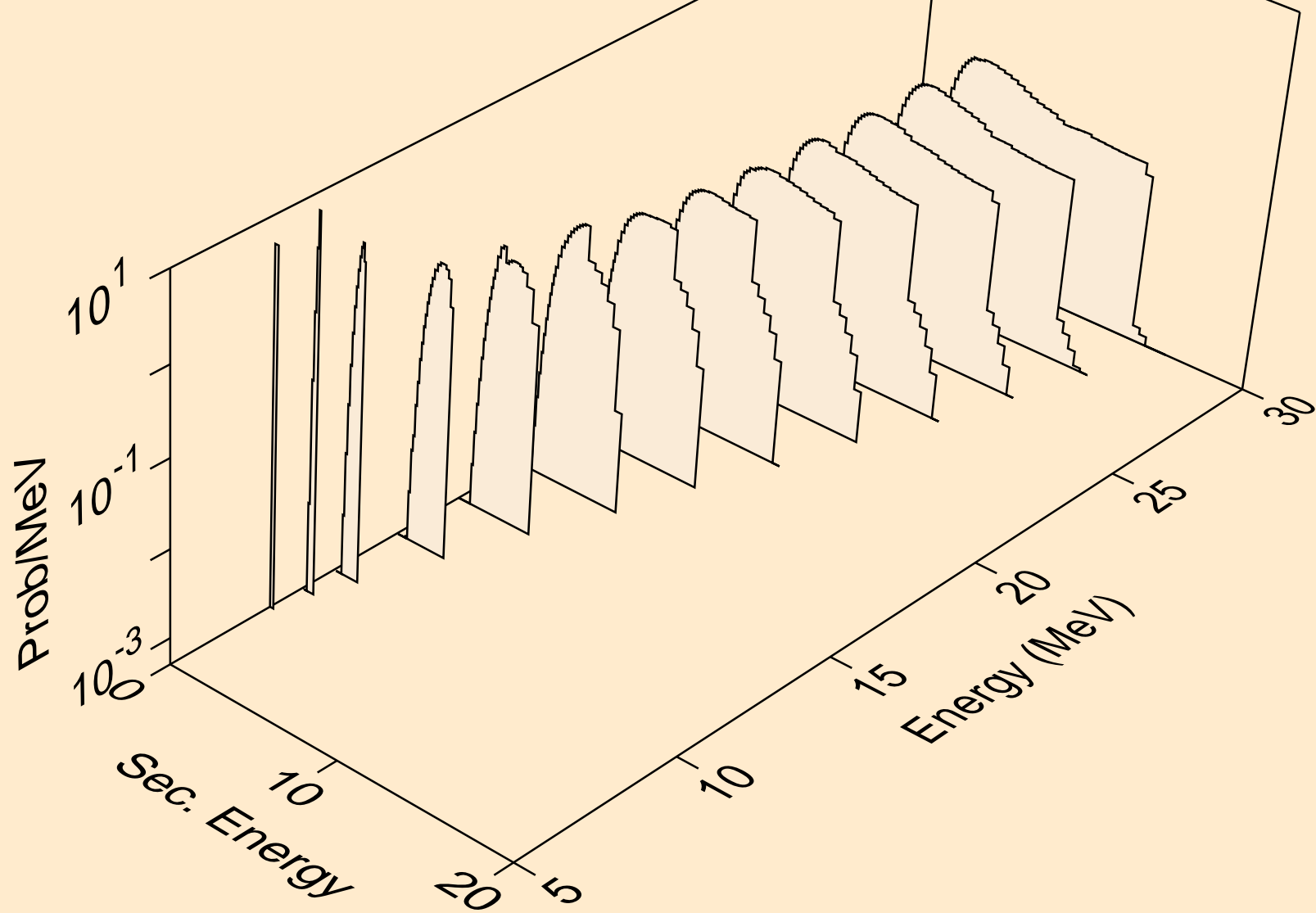

N014 DEUTERON ACER TENDL-2021 LIBRARY; T=0.K  
he3s from (d,he3)

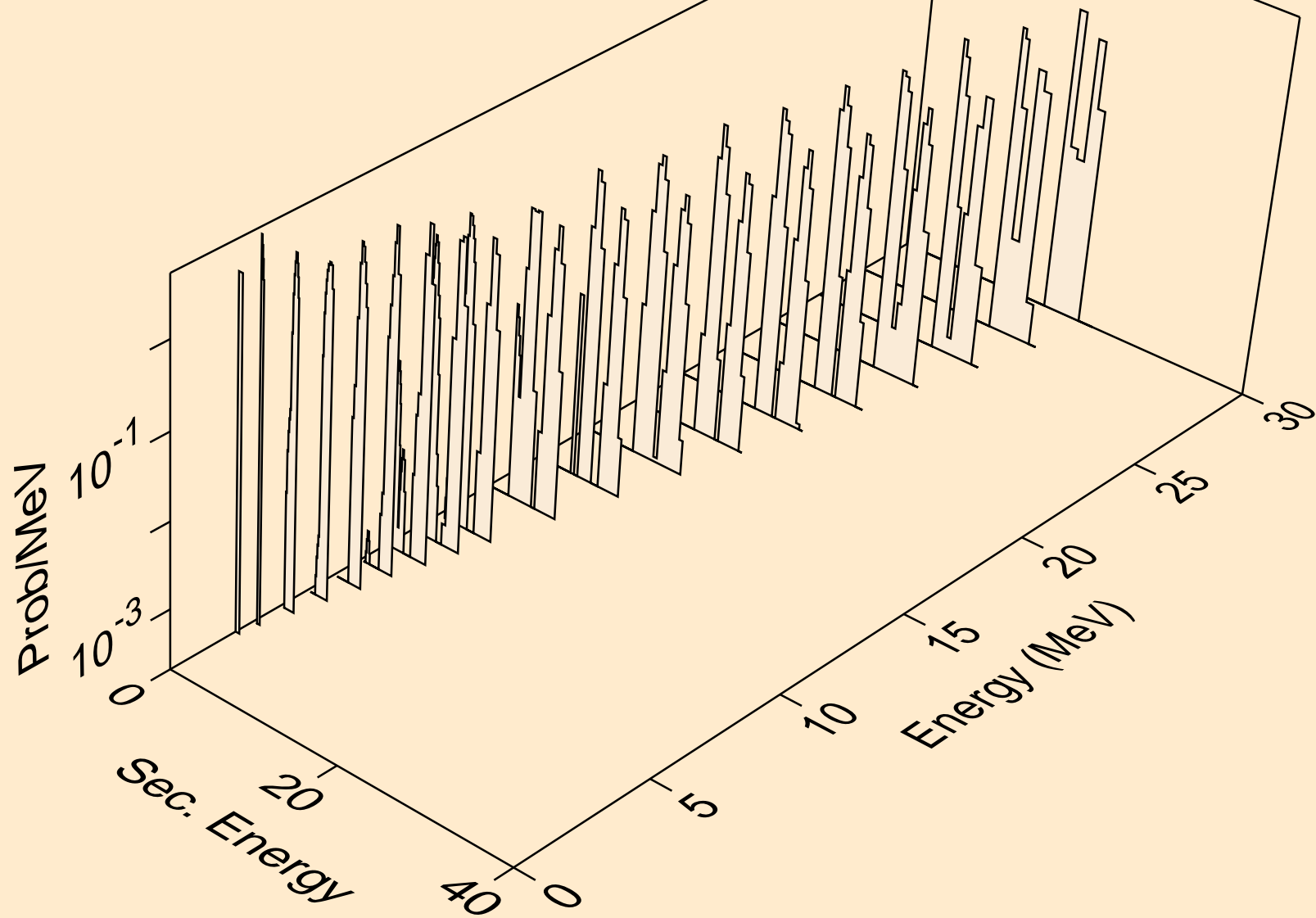

N014 DEUTERON ACER TENDL-2021 LIBRARY; T=0.K  
alphas from (d,x)

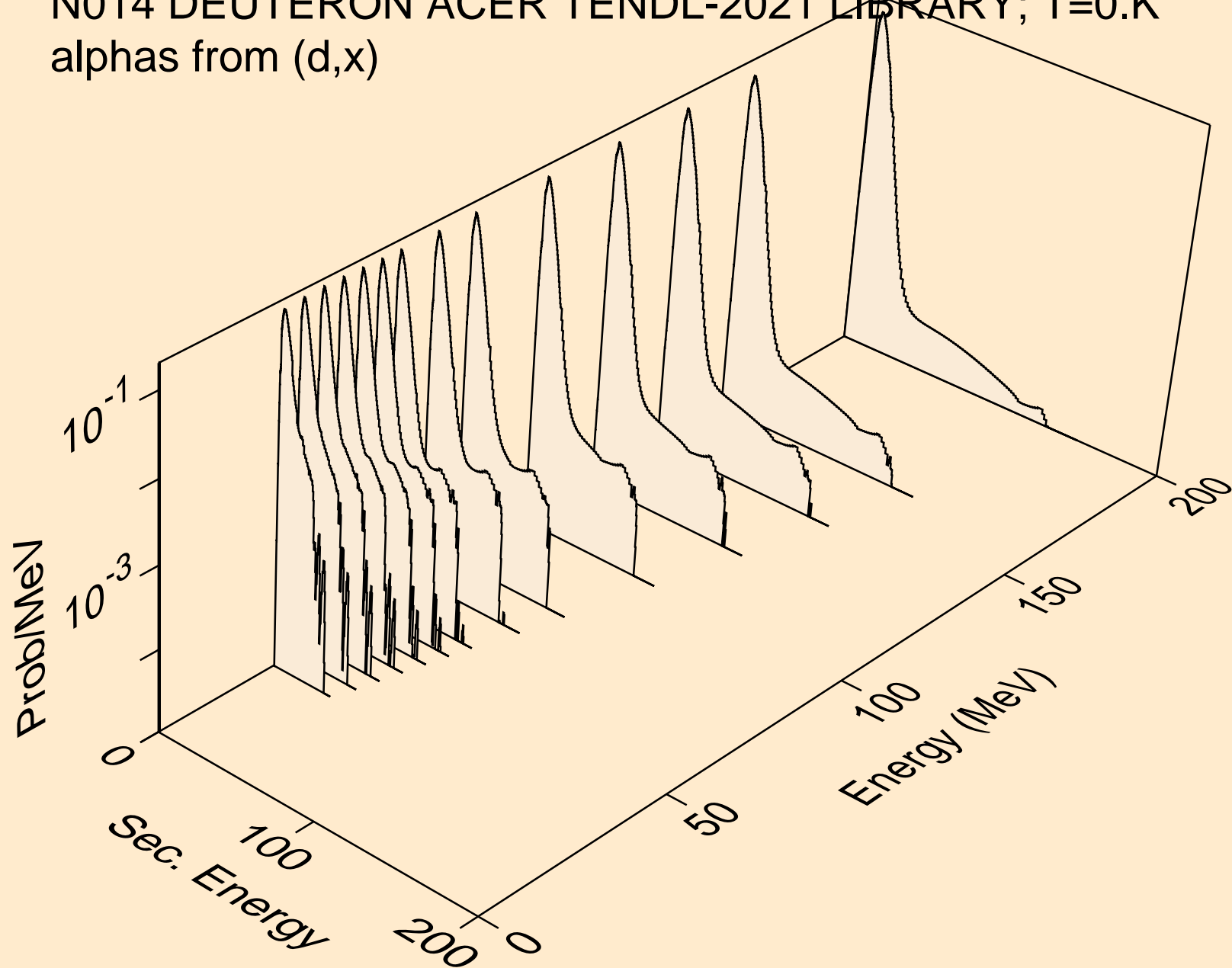

N014 DEUTERON ACER TENDL-2021 LIBRARY; T=0.K  
alphas from (d,n\*)a

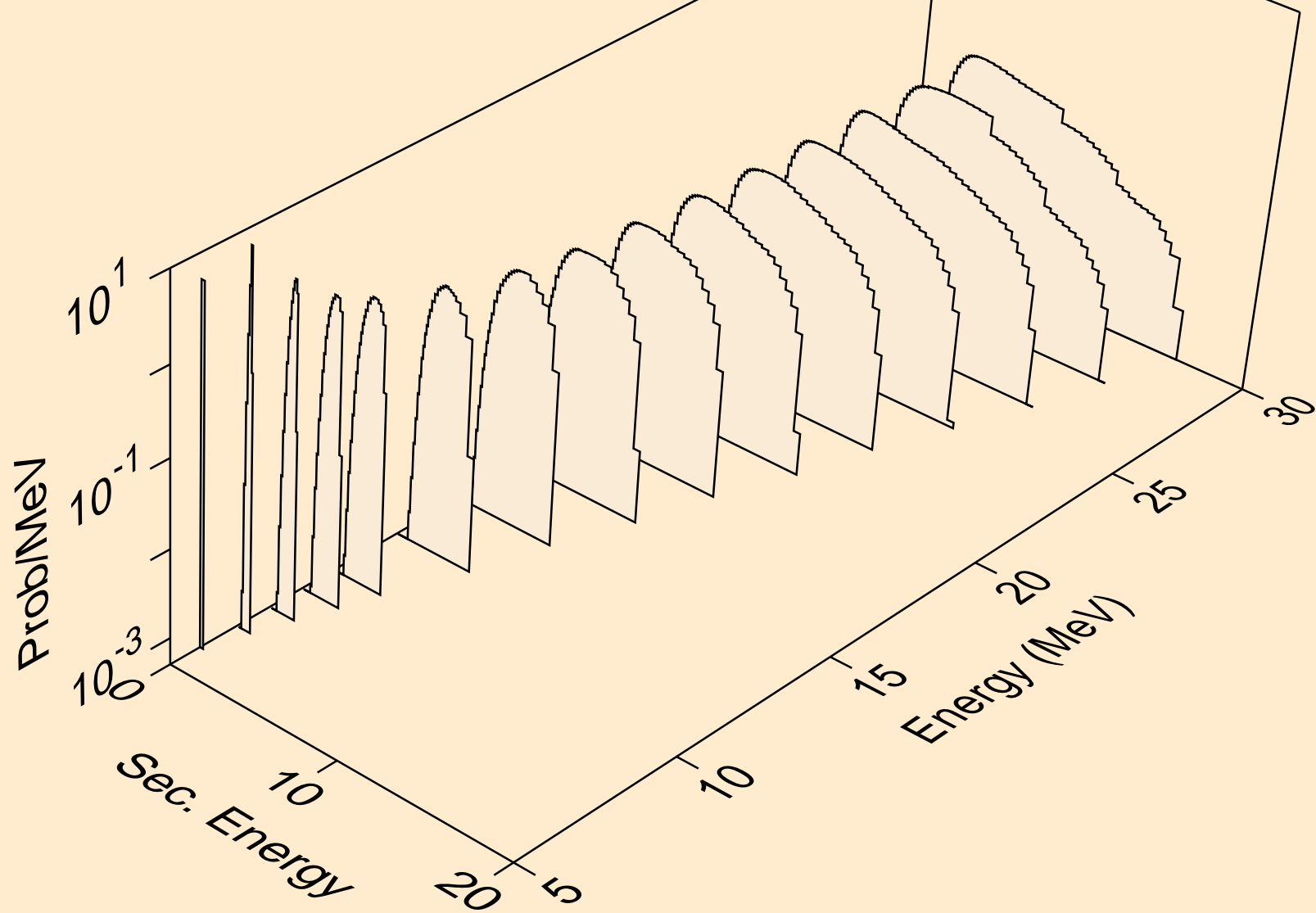

N014 DEUTERON ACER TENDL-2021 LIBRARY; T=0.K  
alphas from (d,2n)a

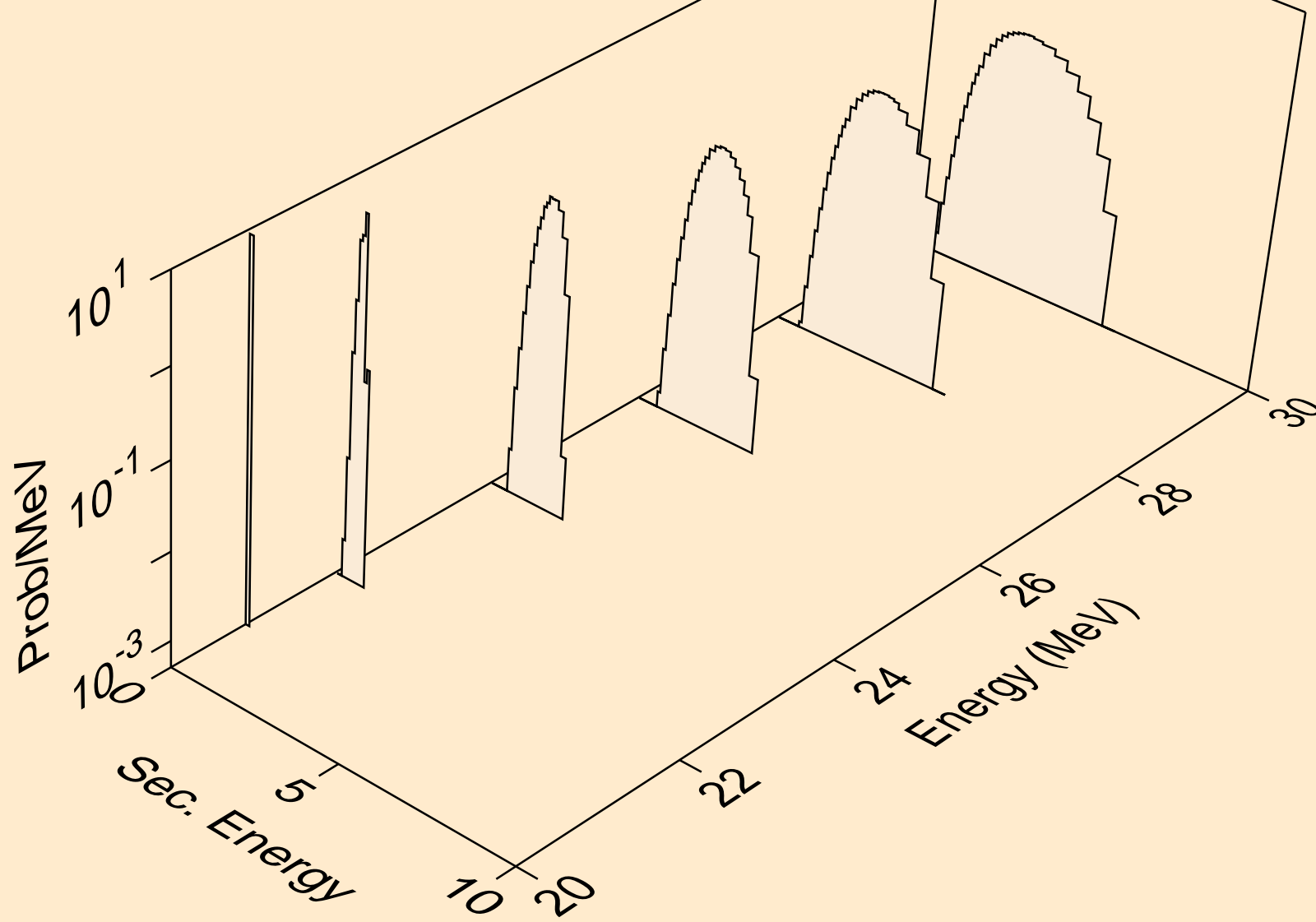

N014 DEUTERON ACER TENDL-2021 LIBRARY; T=0.K  
alphas from (d,n\*)2a

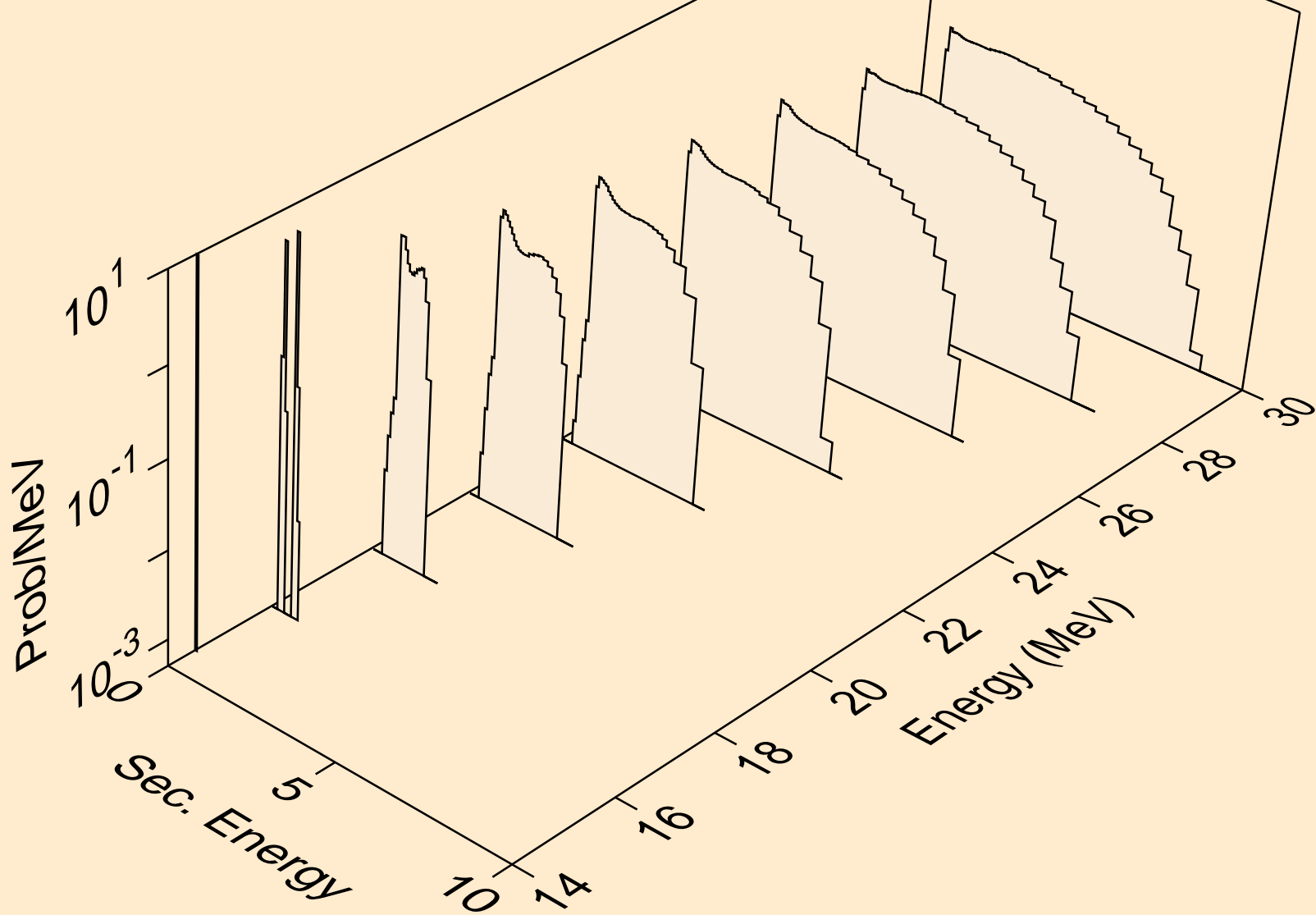

N014 DEUTERON ACER TENDL-2021 LIBRARY; T=0.K  
alphas from (d,npa)

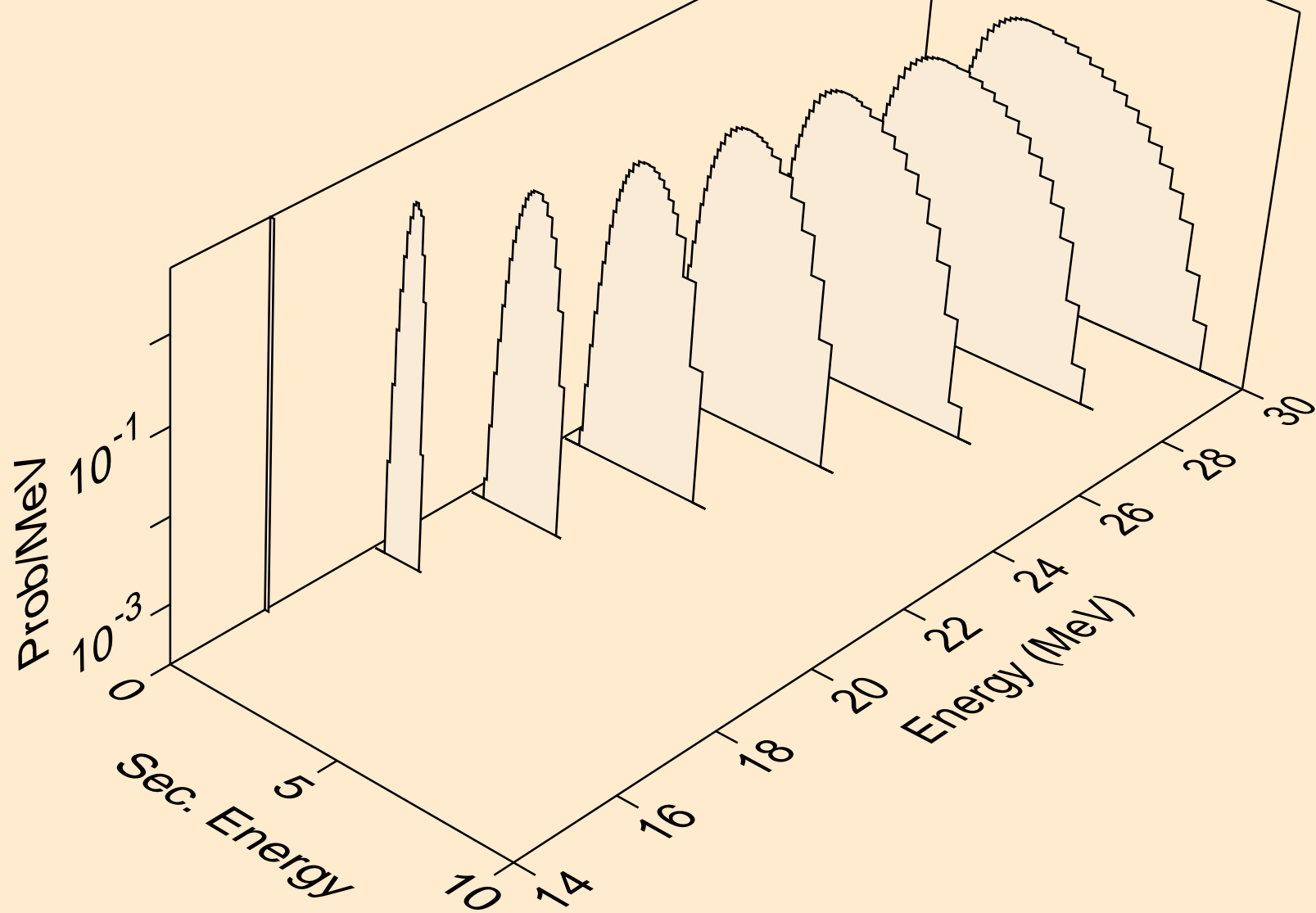

N014 DEUTERON ACER TENDL-2021 LIBRARY; T=0.K  
alphas from (d,a)

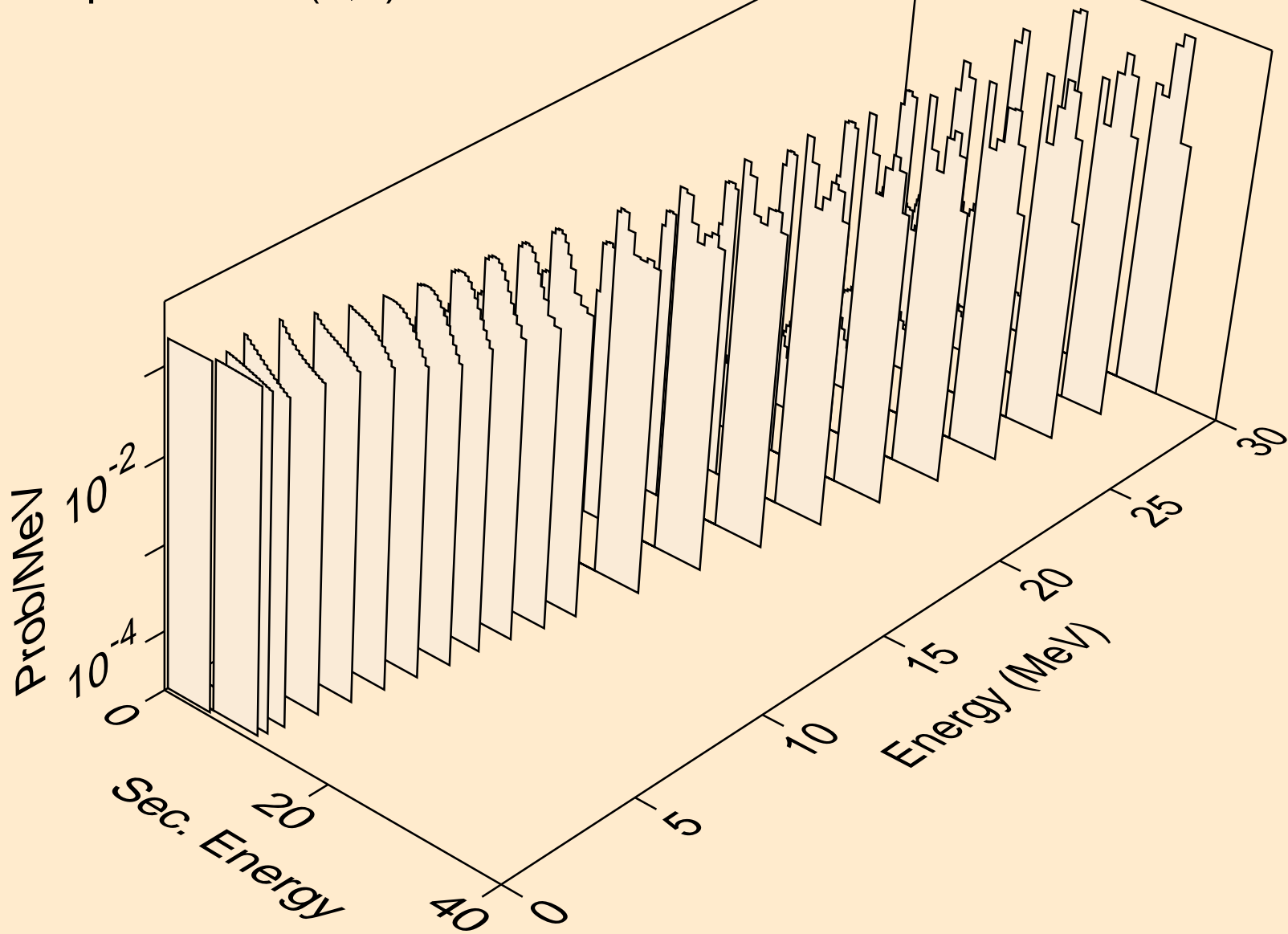

N014 DEUTERON ACER TENDL-2021 LIBRARY; T=0.K  
alphas from (d,2a)

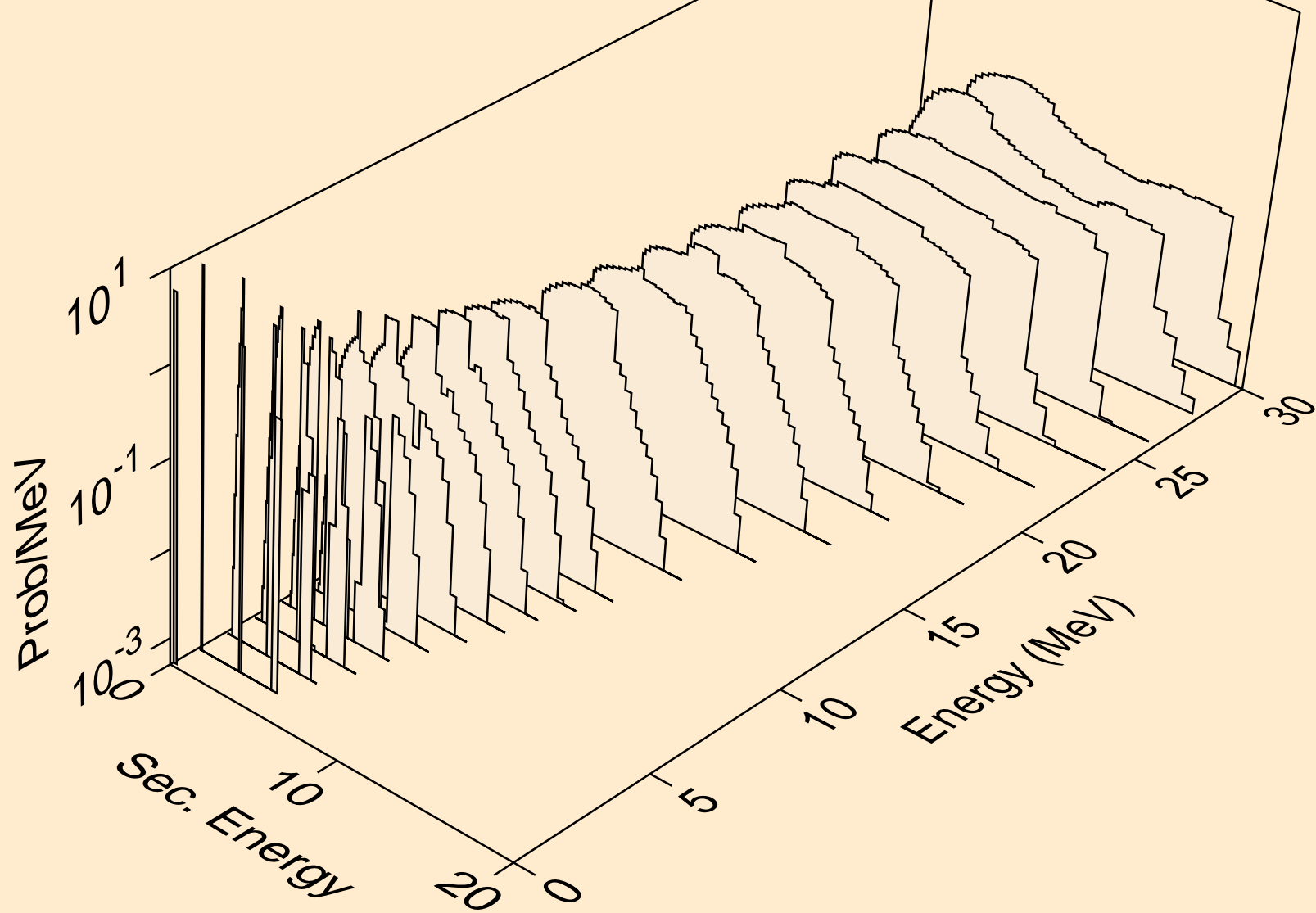

N014 DEUTERON ACER TENDL-2021 LIBRARY; T=0.K  
alphas from (d,pa)

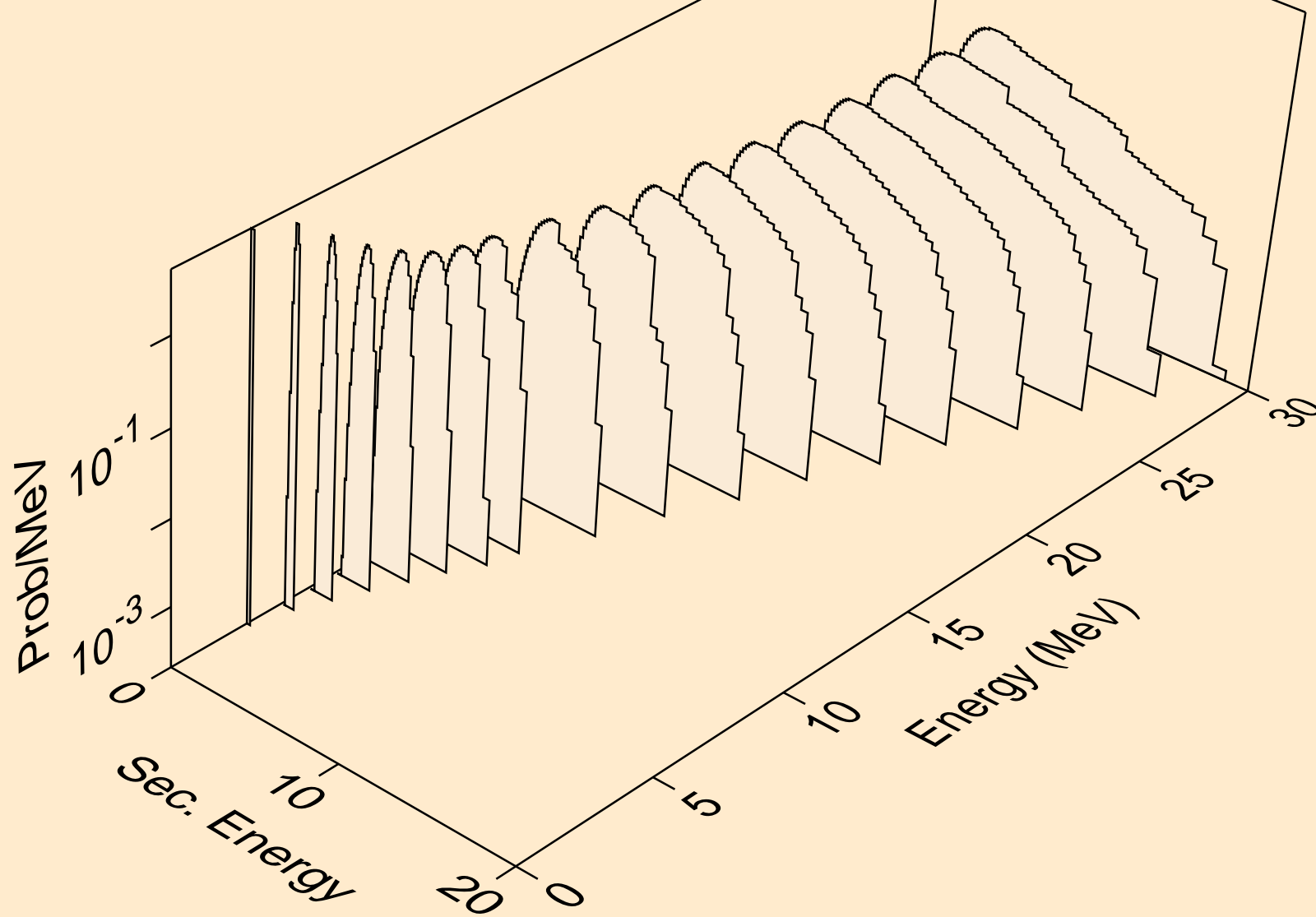

N014 DEUTERON ACER TENDL-2021 LIBRARY; T=0.K  
alphas from (d,d2a)

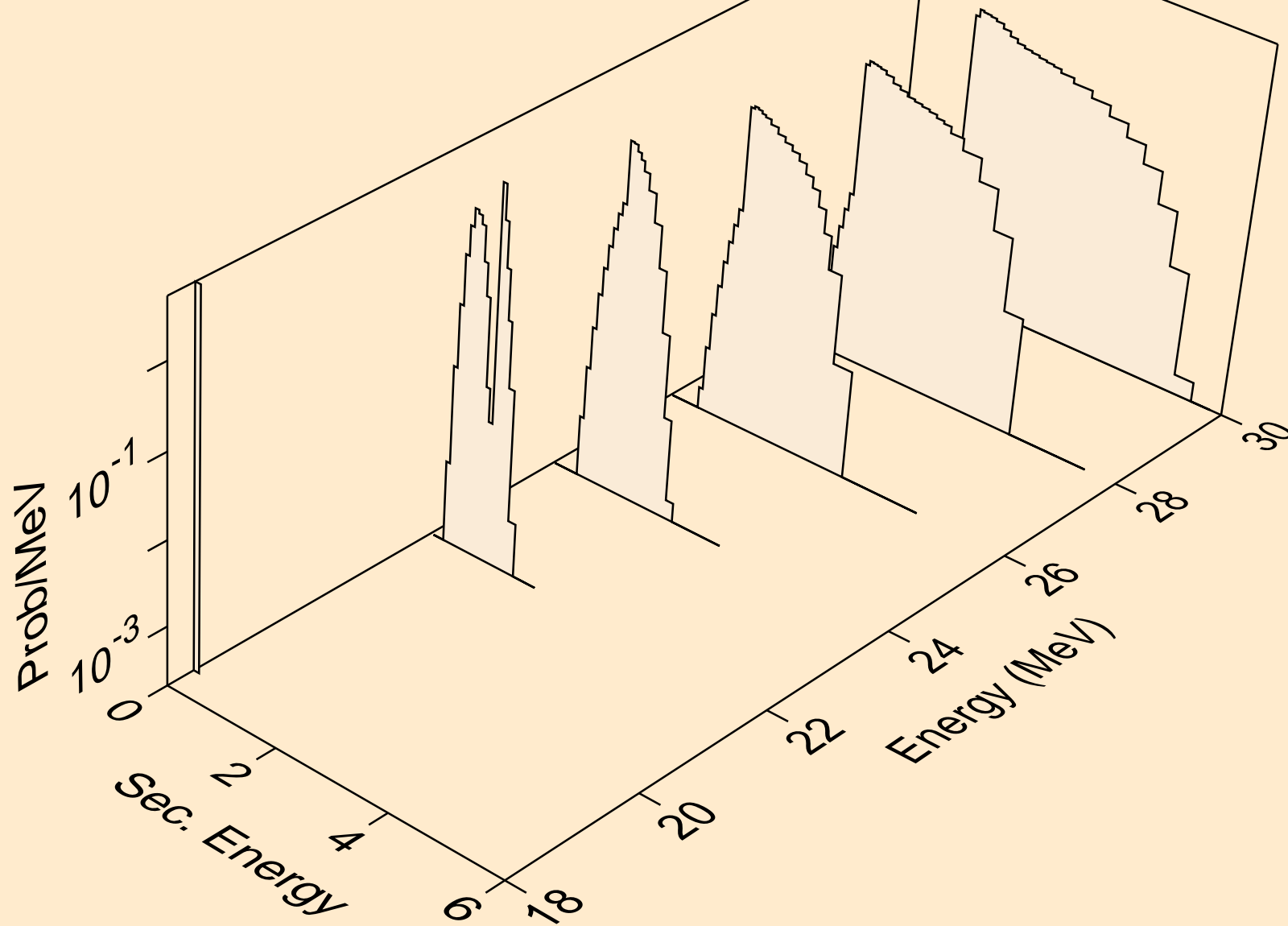

N014 DEUTERON ACER TENDL-2021 LIBRARY; T=0.K  
alphas from (d,da)

