

PU228 DEUTERON ACER TENDL-2021 LIBRARY; T=0.K  
Principal cross sections

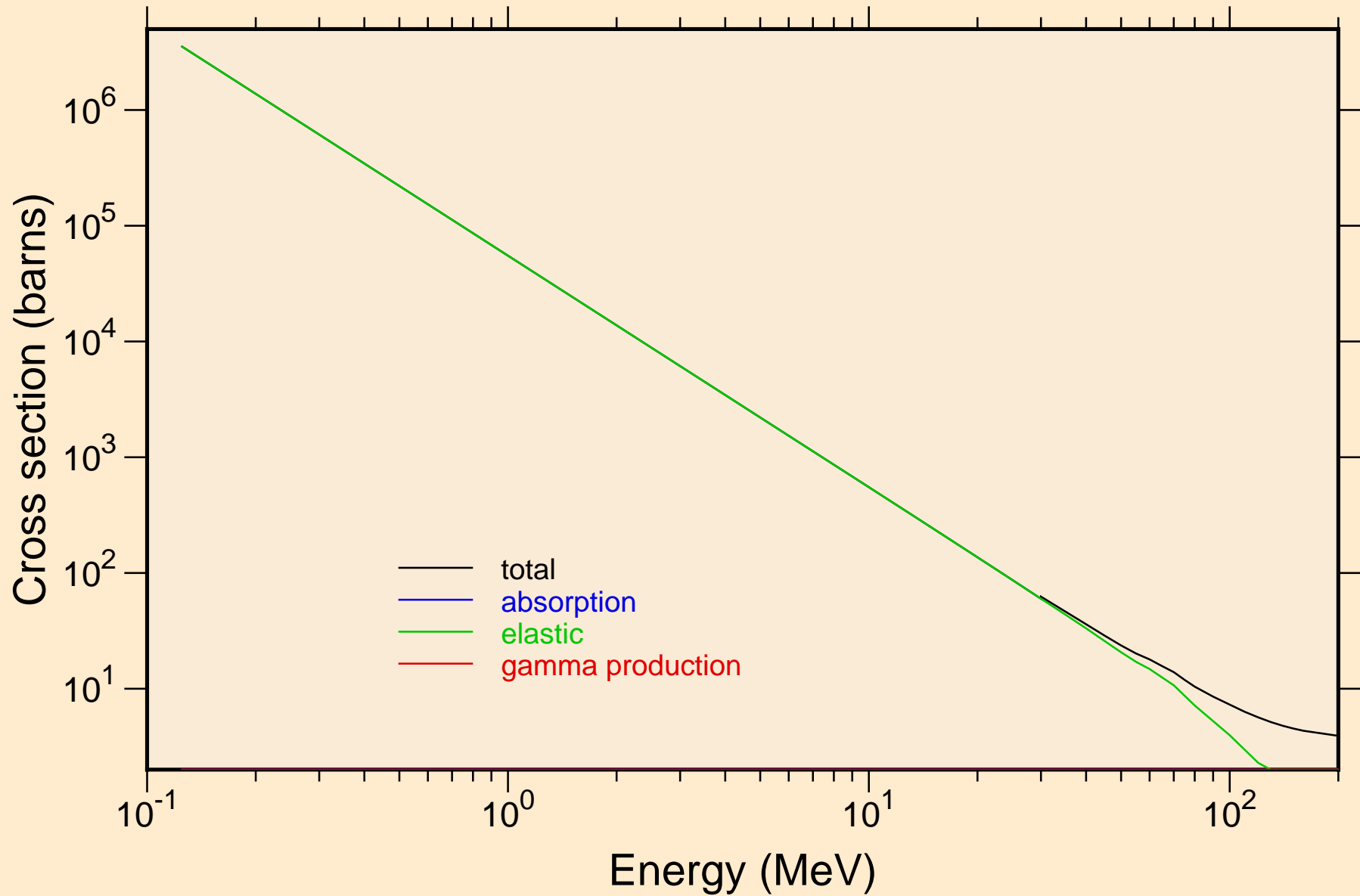

PU228 DEUTERON ACER TENDL-2021 LIBRARY; T=0.K  
Heating

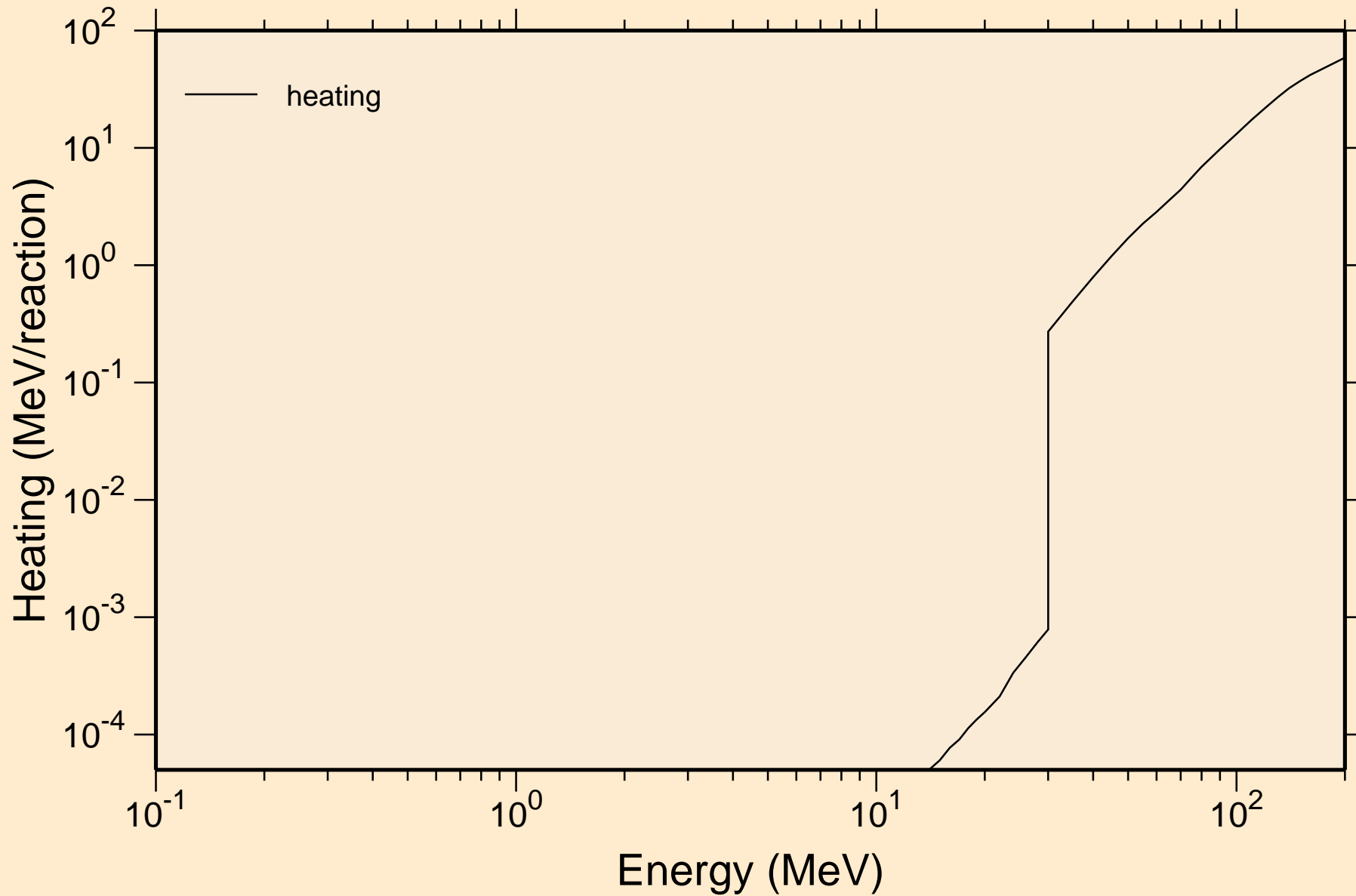

PU228 DEUTERON ACER TENDL-2021 LIBRARY; T=0.K  
Principal cross sections

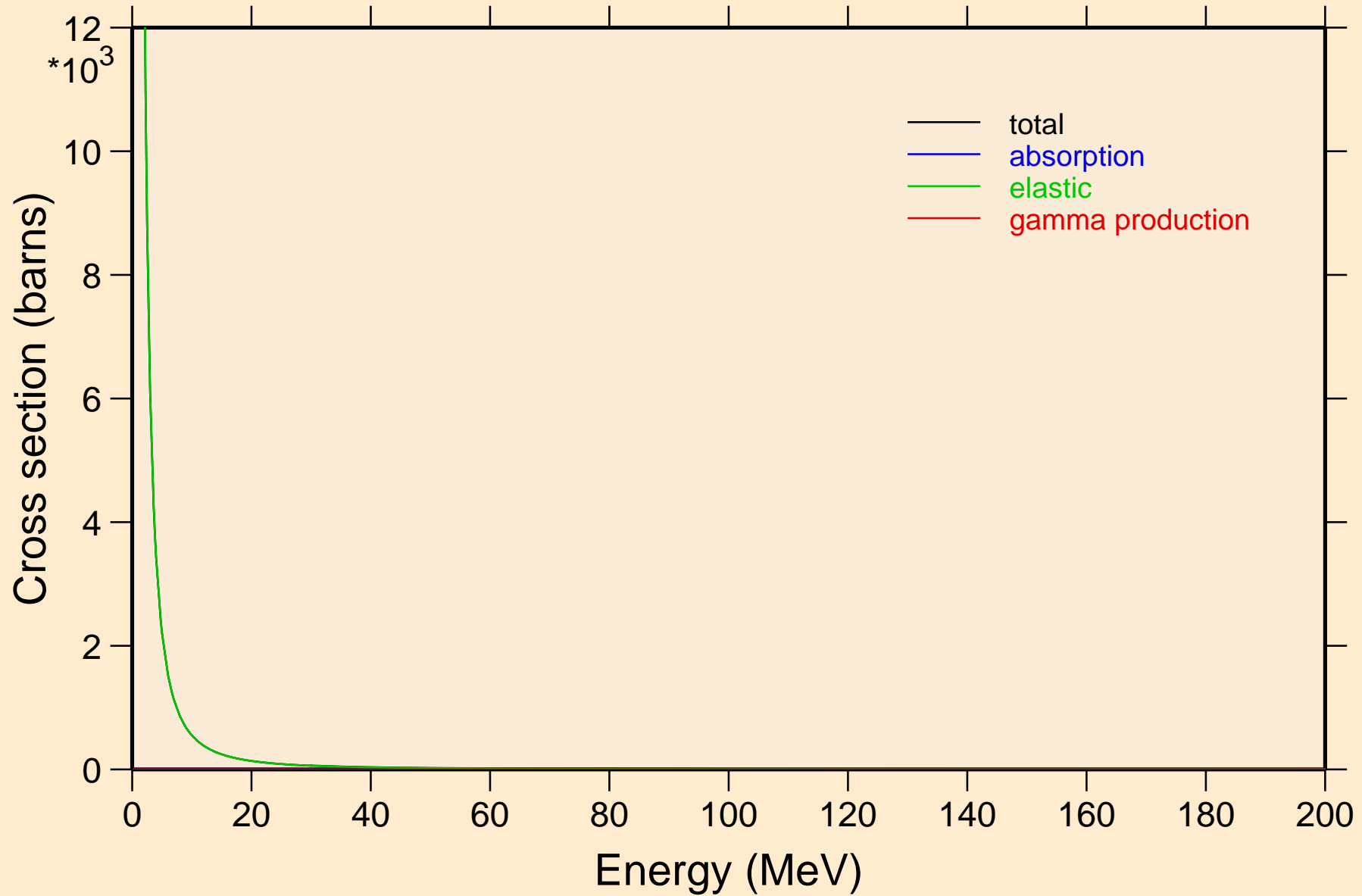

PU228 DEUTERON ACER TENDL-2021 LIBRARY; T=0.K  
Heating

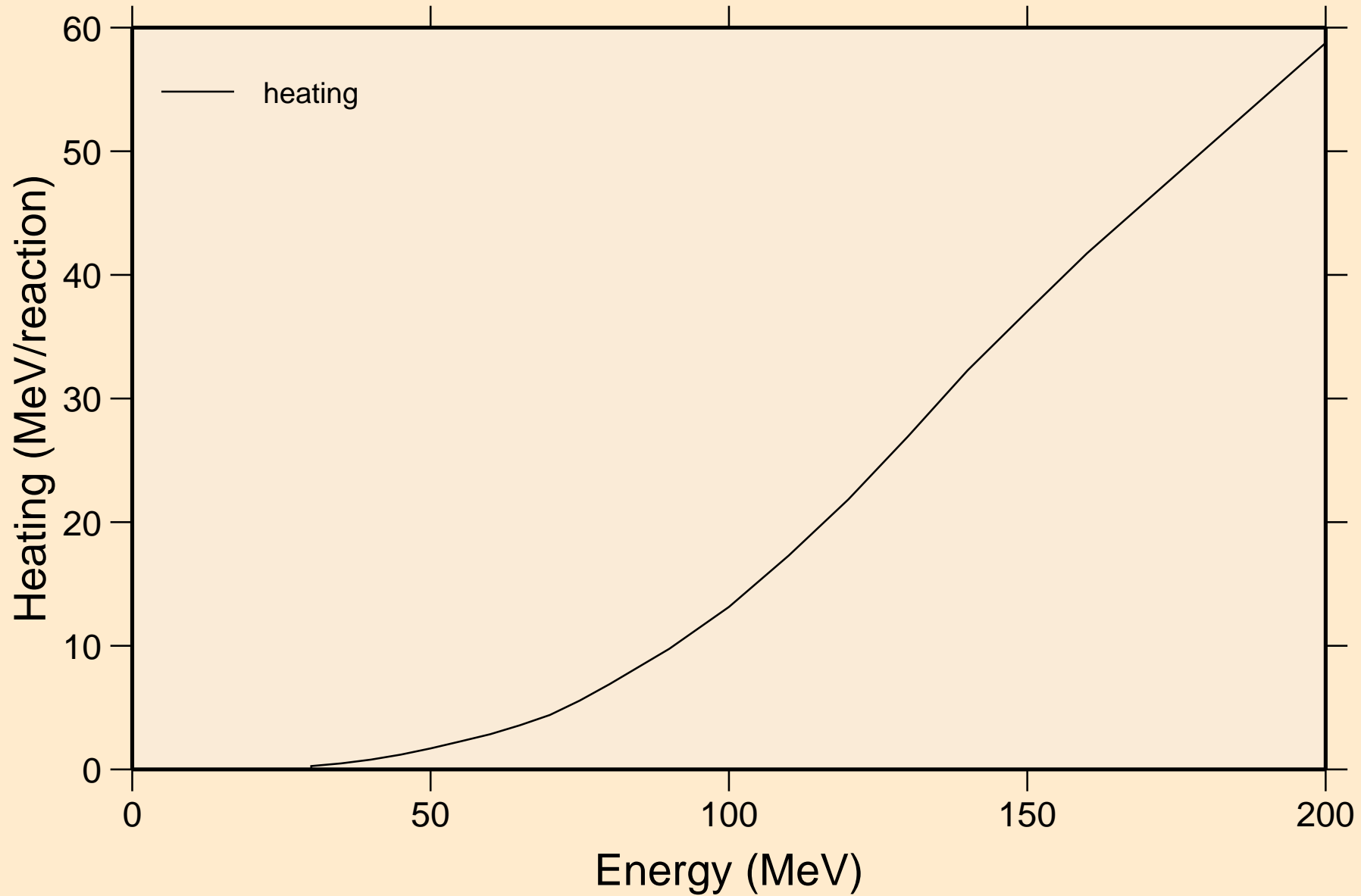

PU228 DEUTERON ACER TENDL-2021 LIBRARY; T=0.K  
Threshold reactions

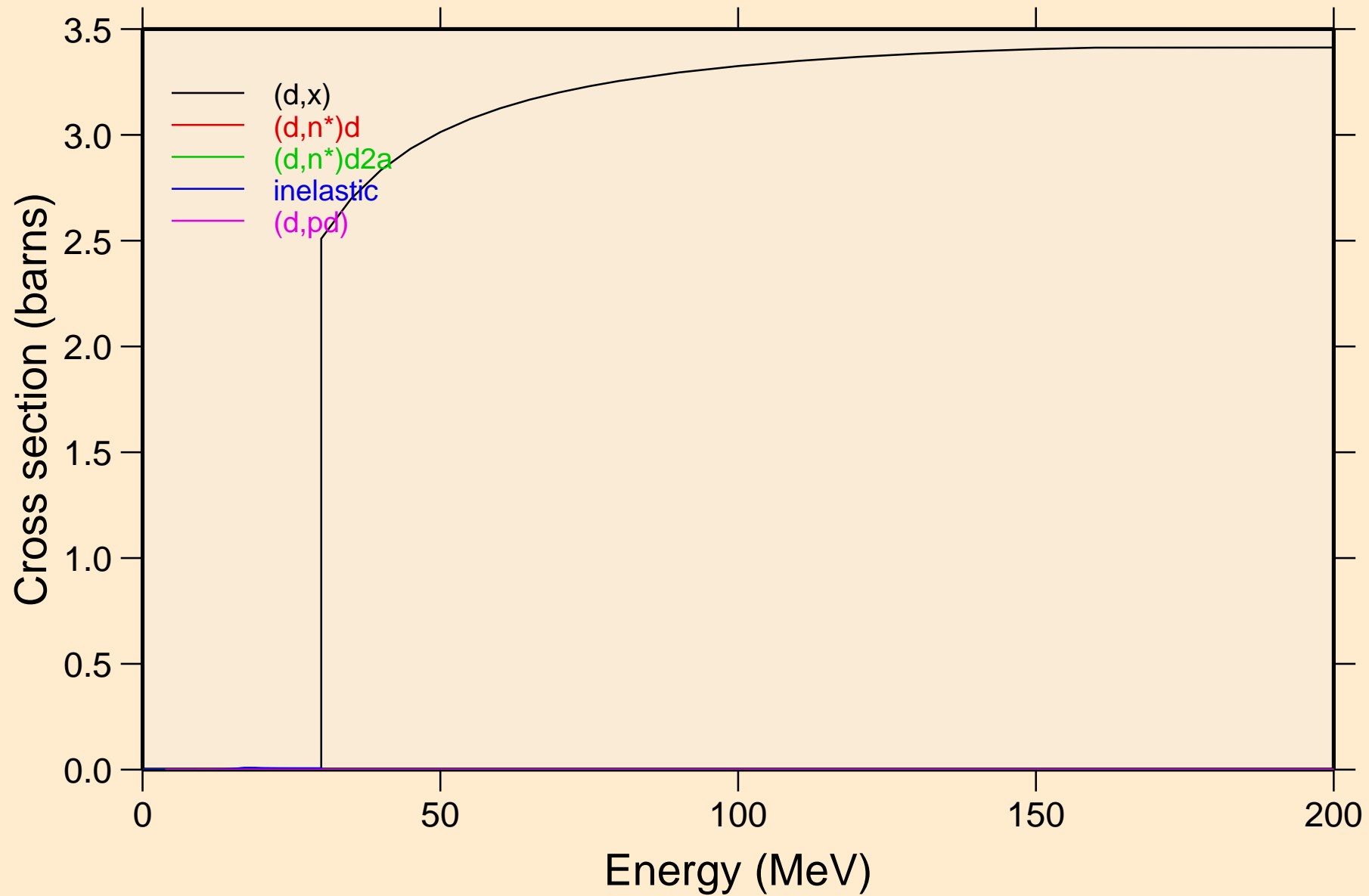

PU228 DEUTERON ACER TENDL-2021 LIBRARY; T=0.K  
Threshold reactions

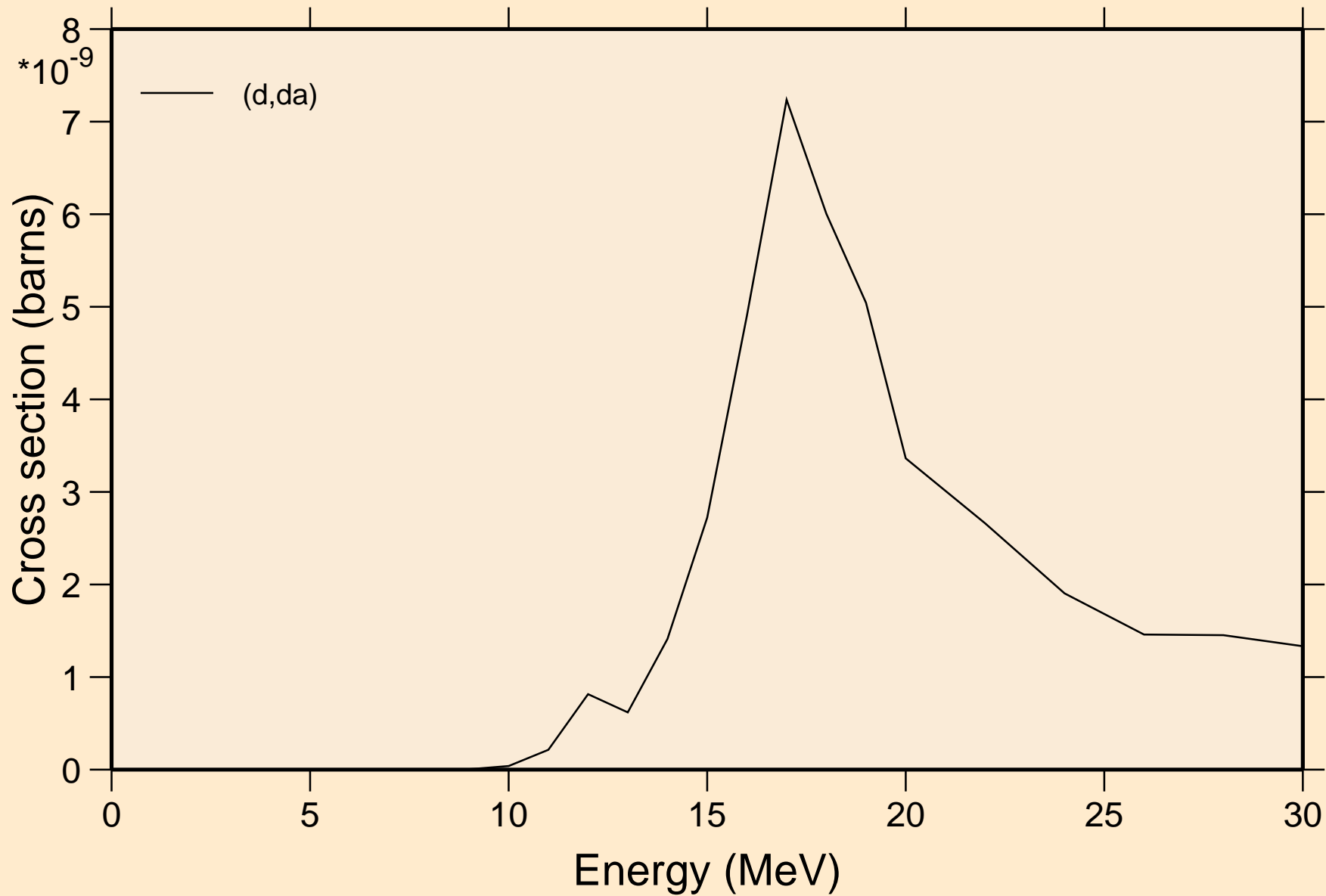

PU228 DEUTERON ACER TENDL-2021 LIBRARY; T=0.K  
angular distribution for elastic

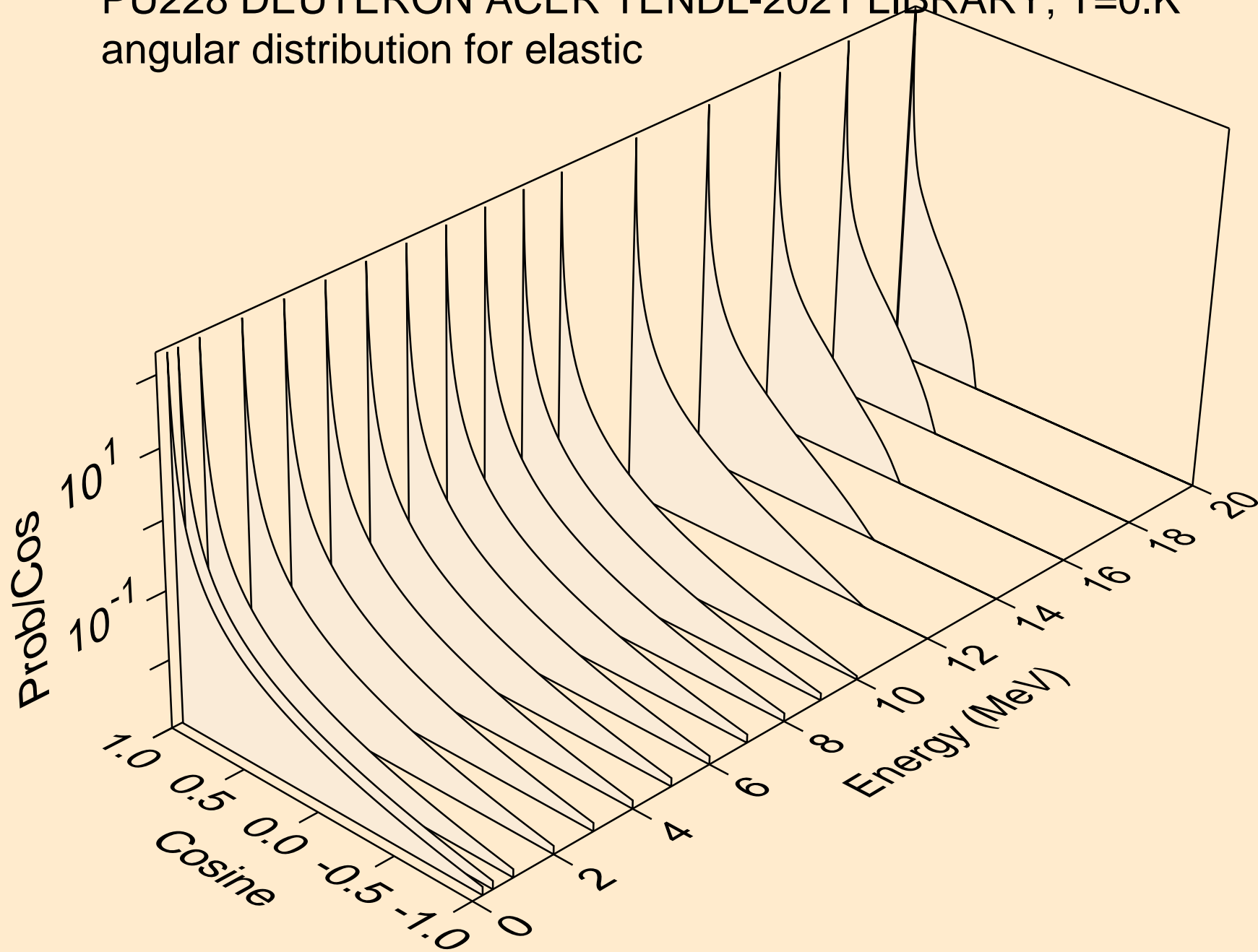

PU228 DEUTERON ACER TENDL-2021 LIBRARY; T=0.K  
angular distribution for elastic

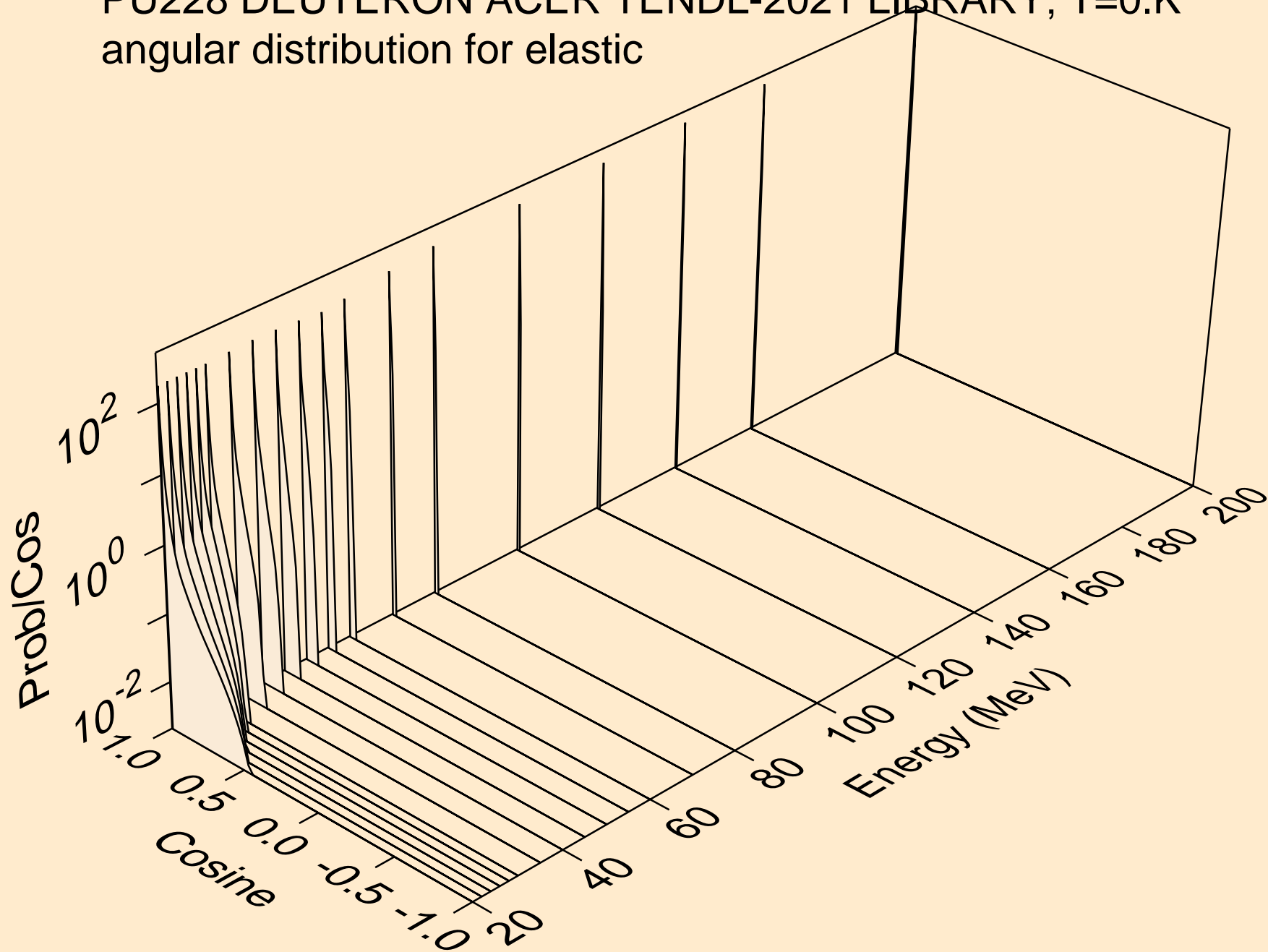

PU228 DEUTERON ACER TENDL-2021 LIBRARY; T=0.K  
Deuteron emission for (d,x)

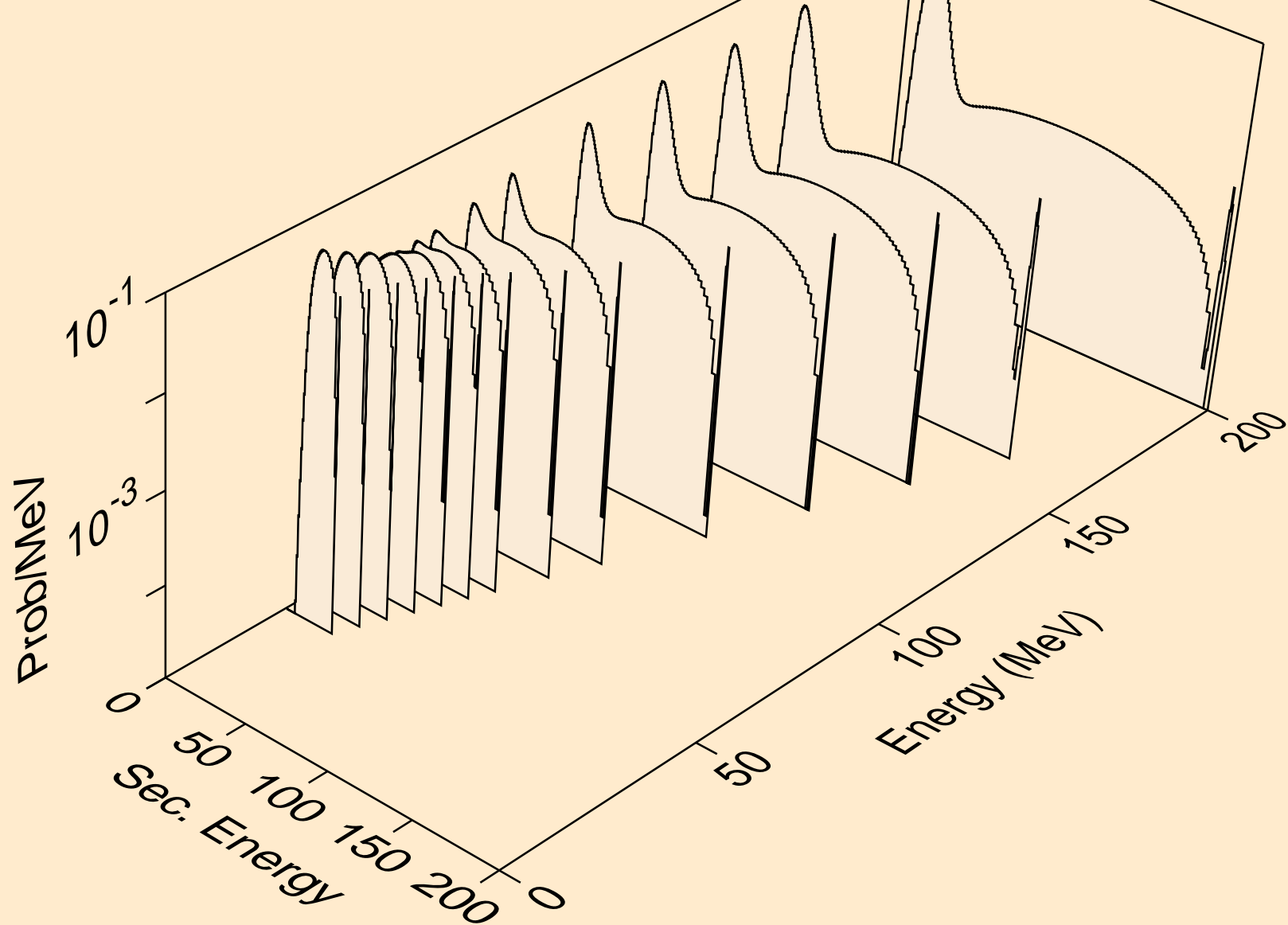

PU228 DEUTERON ACER TENDL-2021 LIBRARY; T=0.K  
Deuteron emission for (d,n\*)d

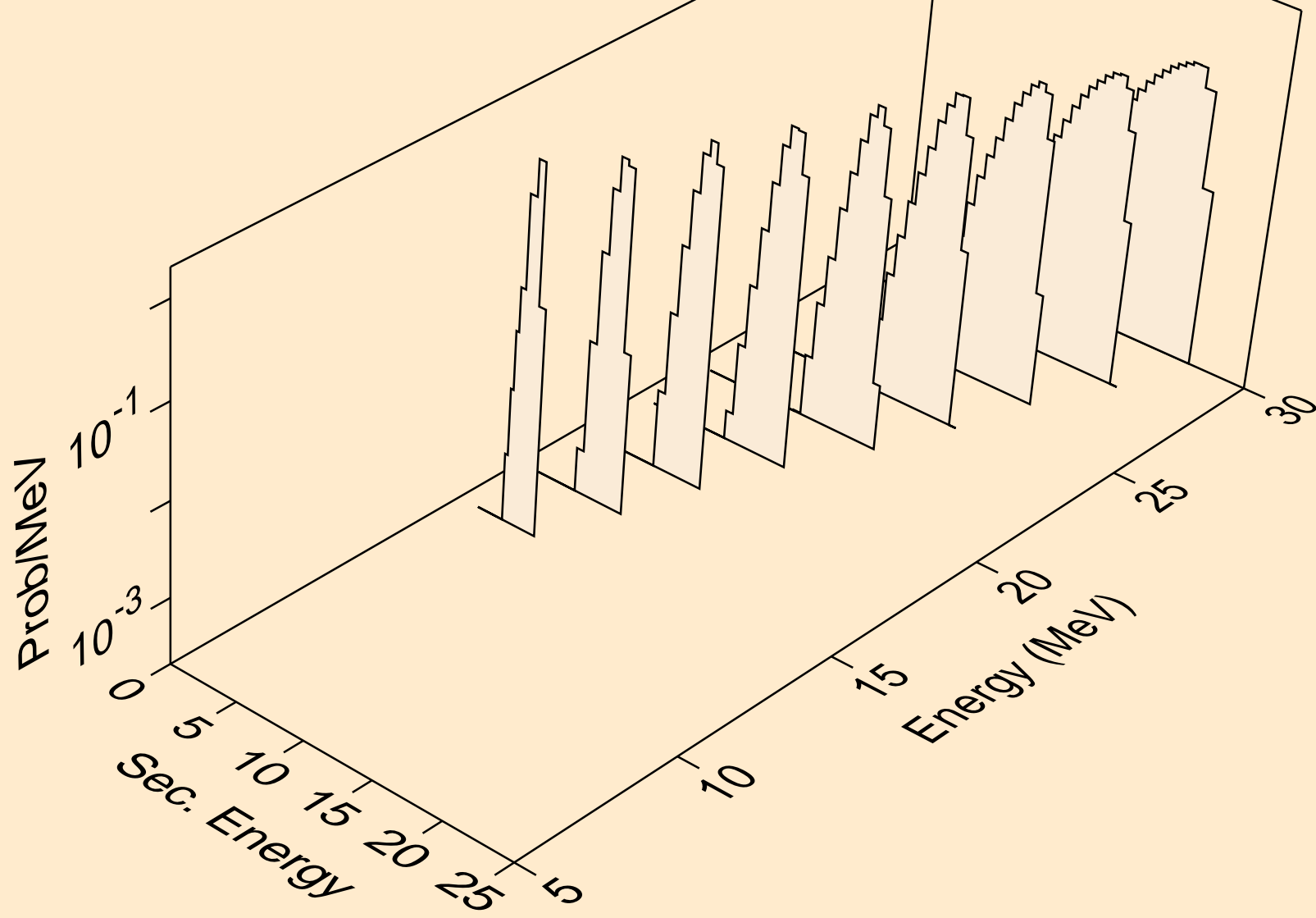

PU228 DEUTERON ACER TENDL-2021 LIBRARY; T=0.K  
Deuteron emission for (d,n\*)d2a

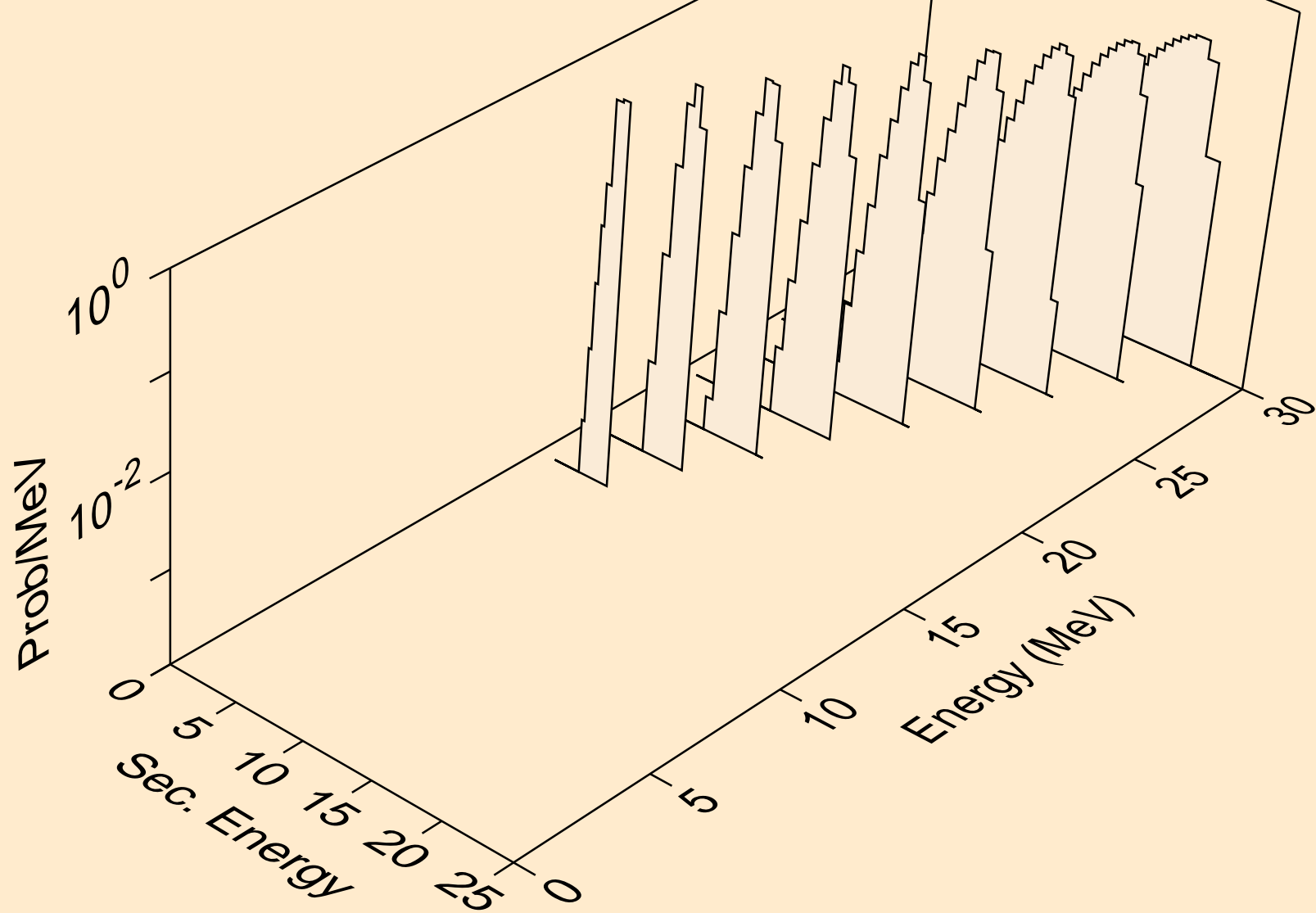

PU228 DEUTERON ACER TENDL-2021 LIBRARY; T=0.K  
Deuteron emission for inelastic

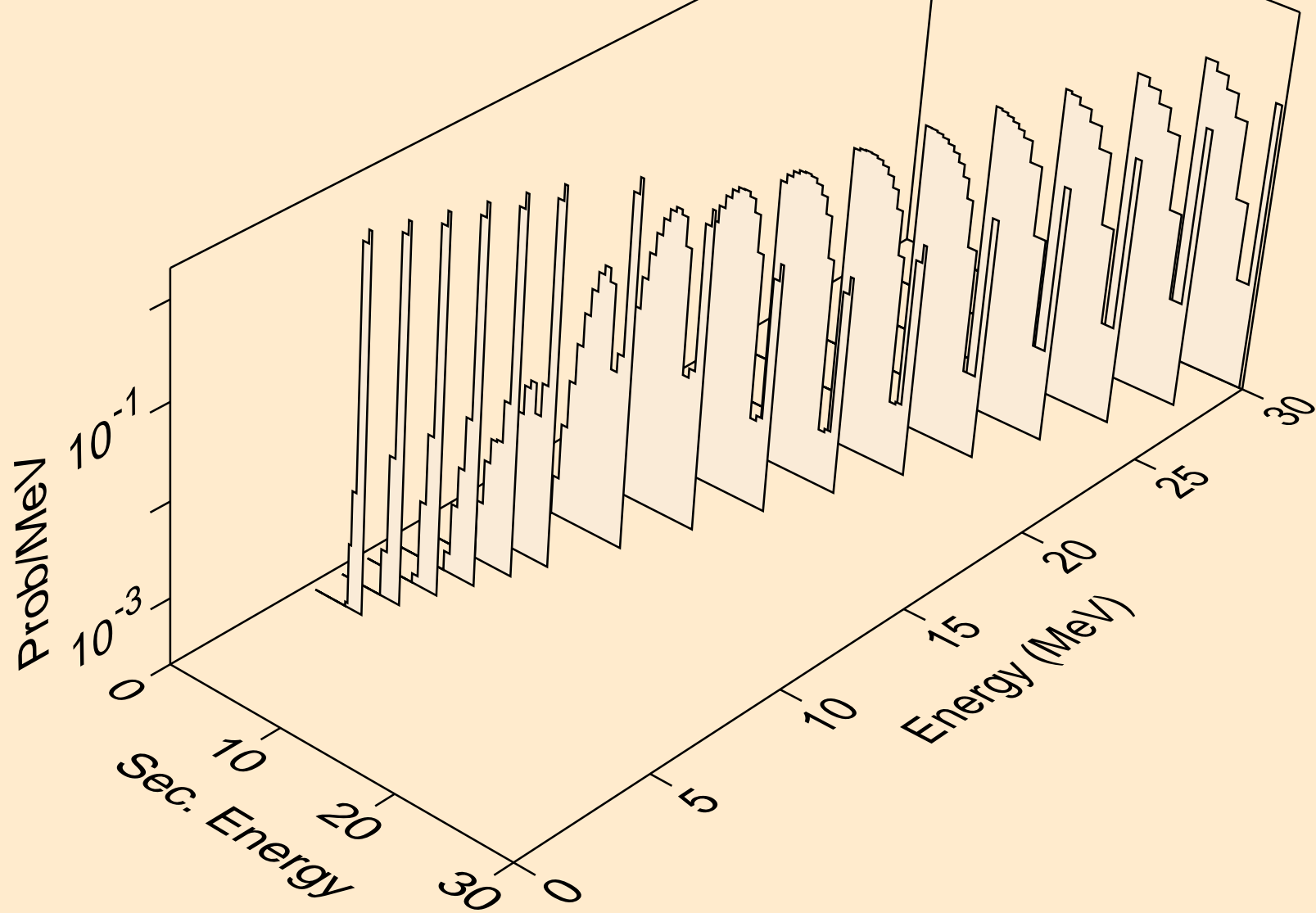

PU228 DEUTERON ACER TENDL-2021 LIBRARY; T=0.K  
Deuteron emission for (d,pd)

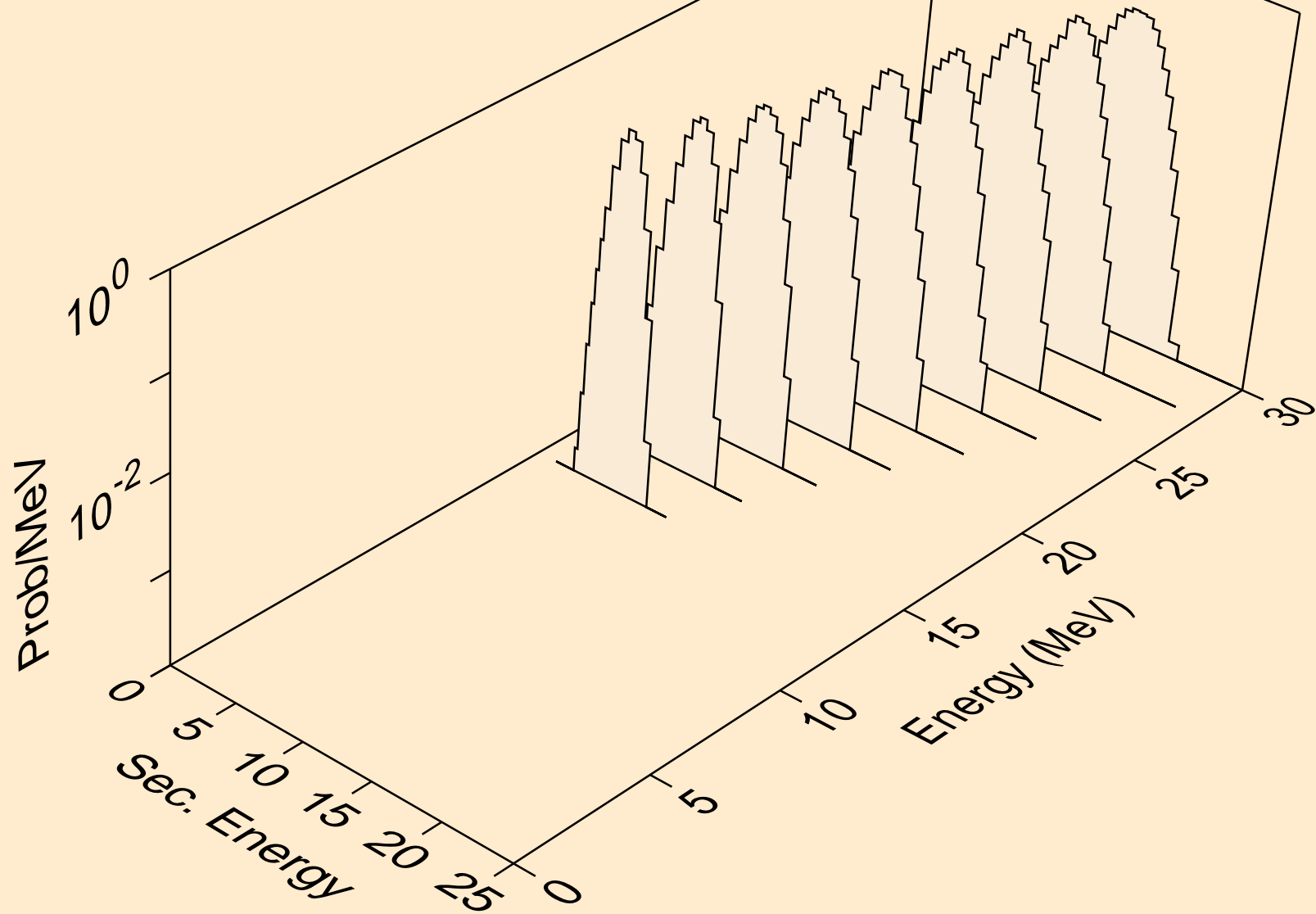

PU228 DEUTERON ACER TENDL-2021 LIBRARY; T=0.K  
Deuteron emission for (d,da)

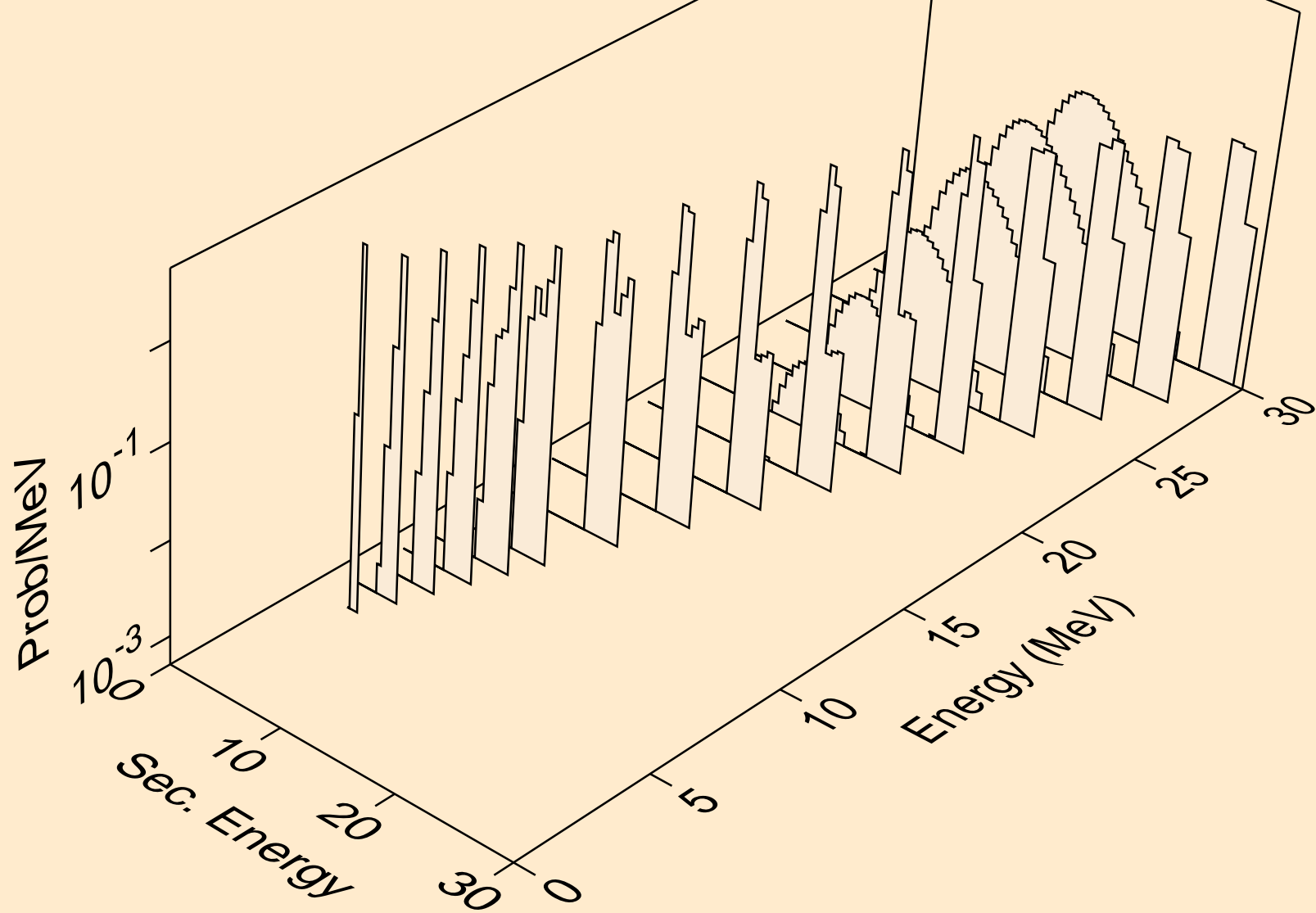

PU228 DEUTERON ACER TENDL-2021 LIBRARY; T=0.K  
Photon emission for (z,n)

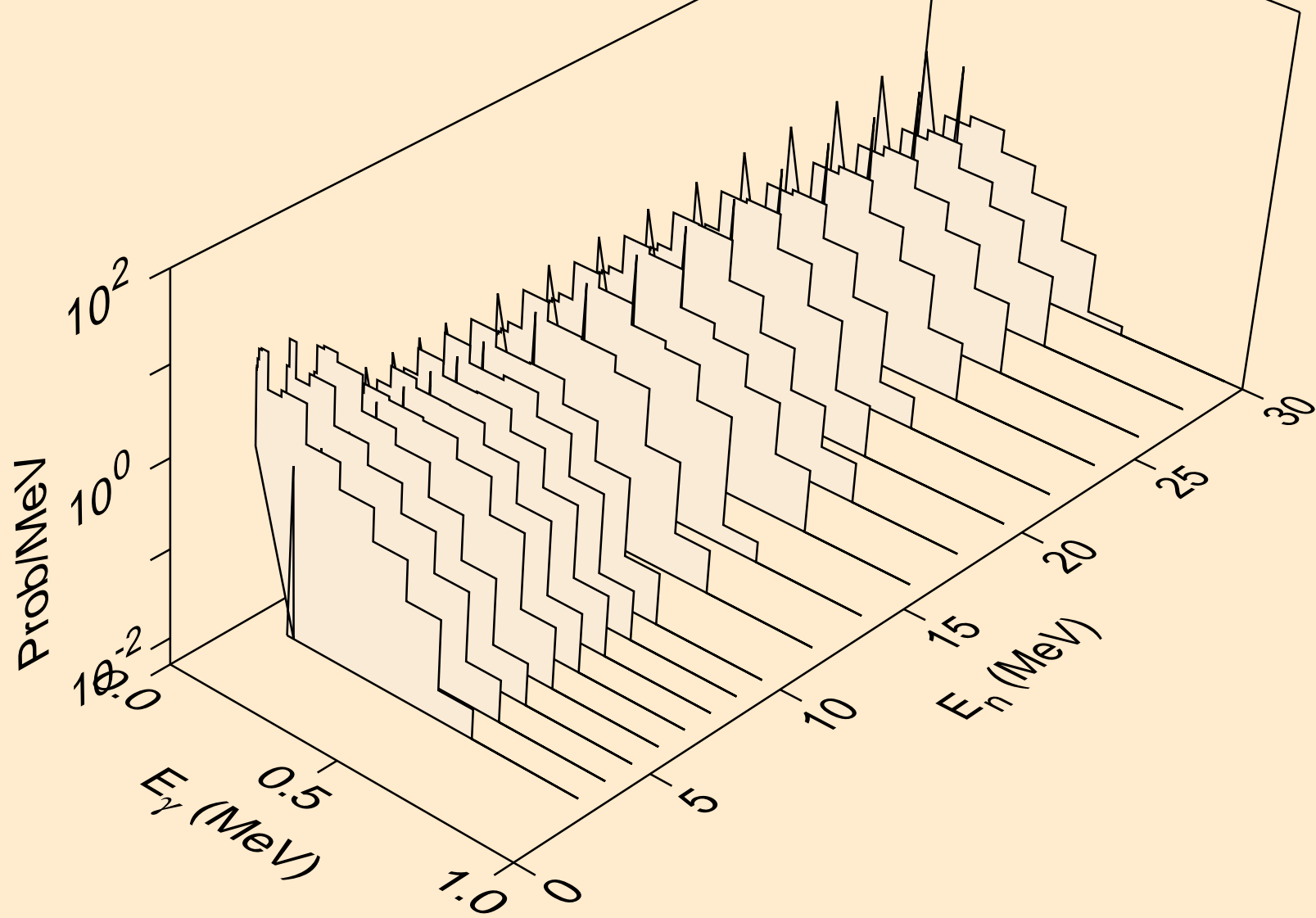

PU228 DEUTERON ACER TENDL-2021 LIBRARY; T=0.K  
Photon emission for (n,x)

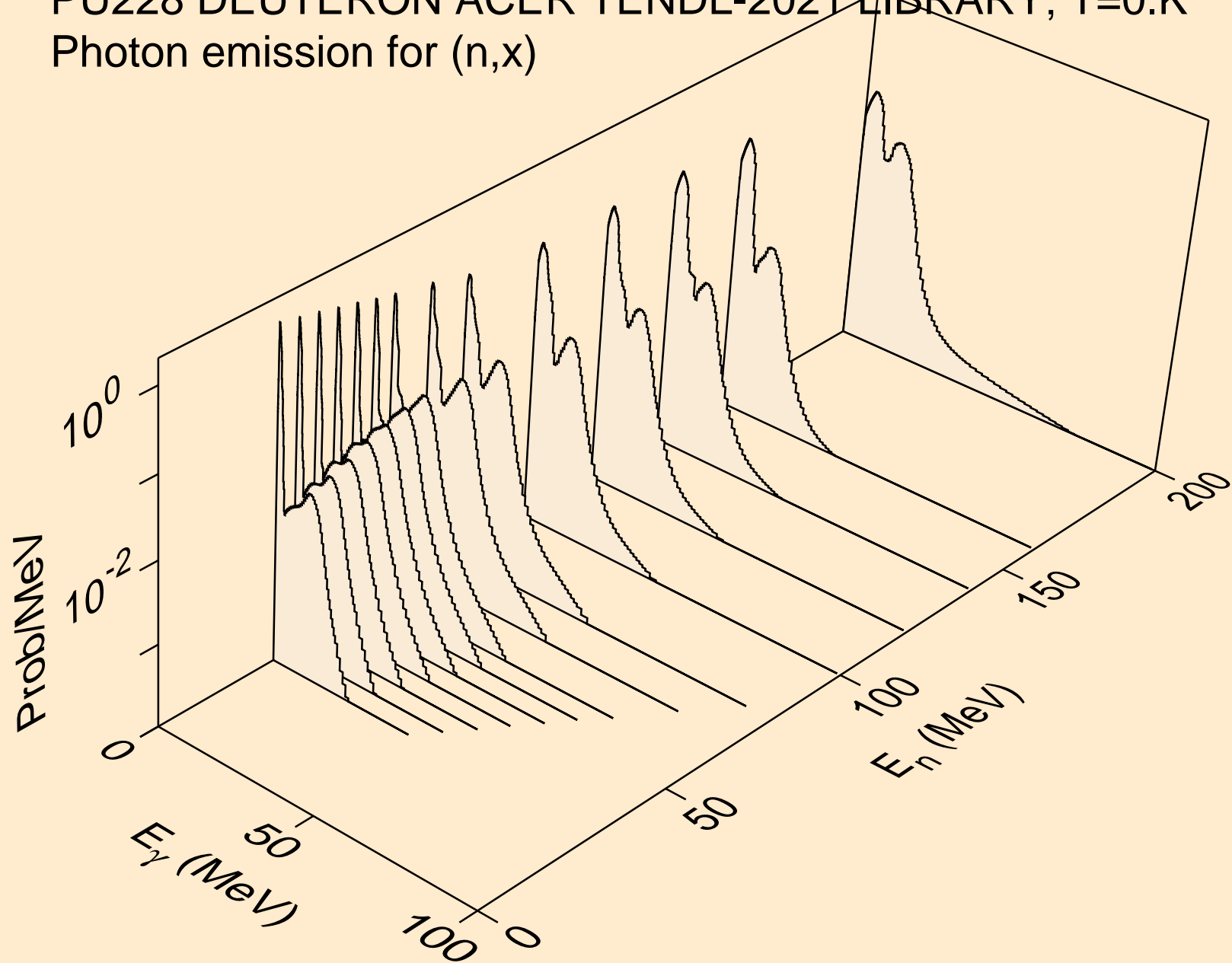

PU228 DEUTERON ACER TENDL-2021 LIBRARY; T=0.K  
Photon emission for (n,2n)

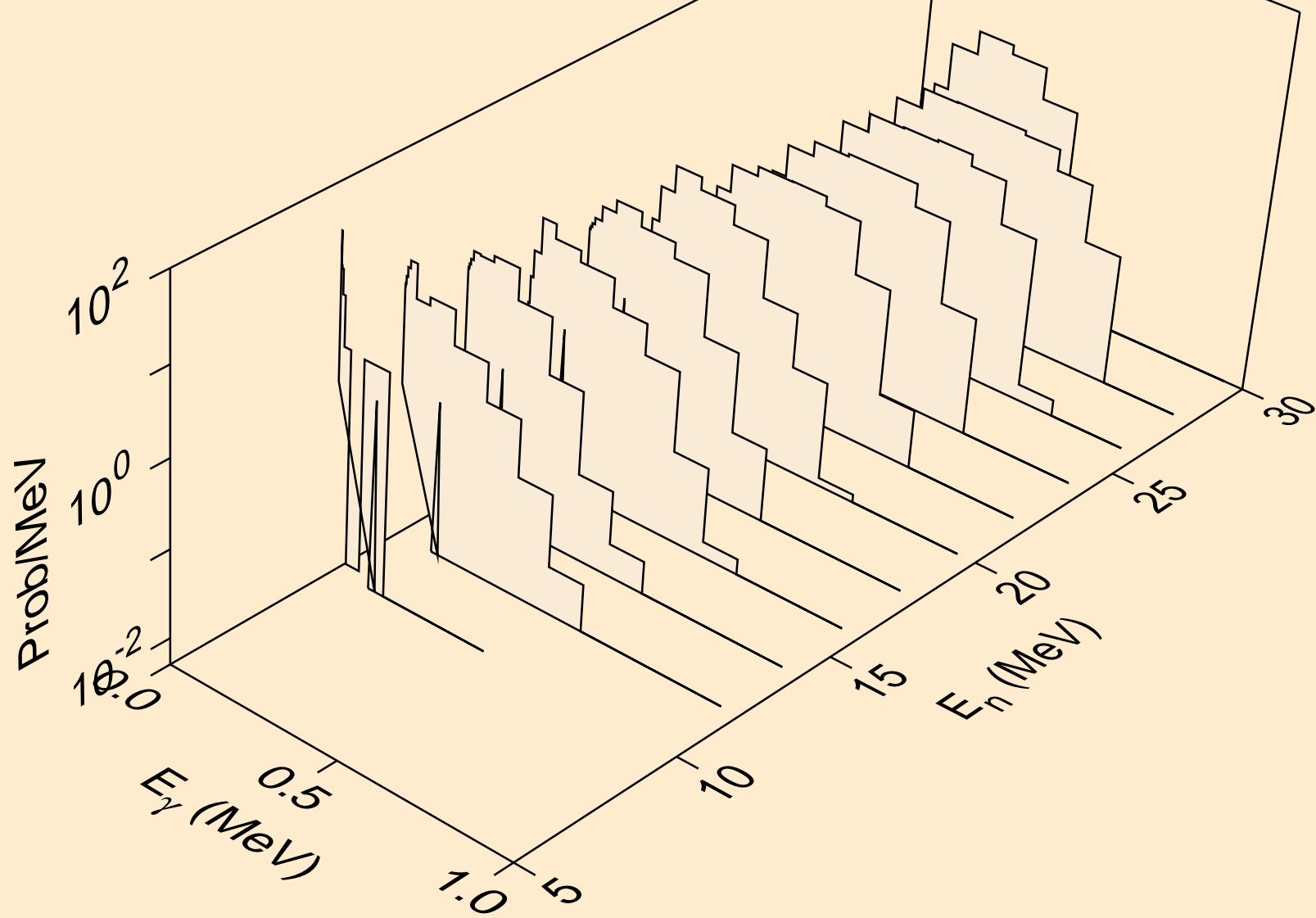

PU228 DEUTERON ACER TENDL-2021 LIBRARY; T=0.K  
Photon emission for (n,n\*)a

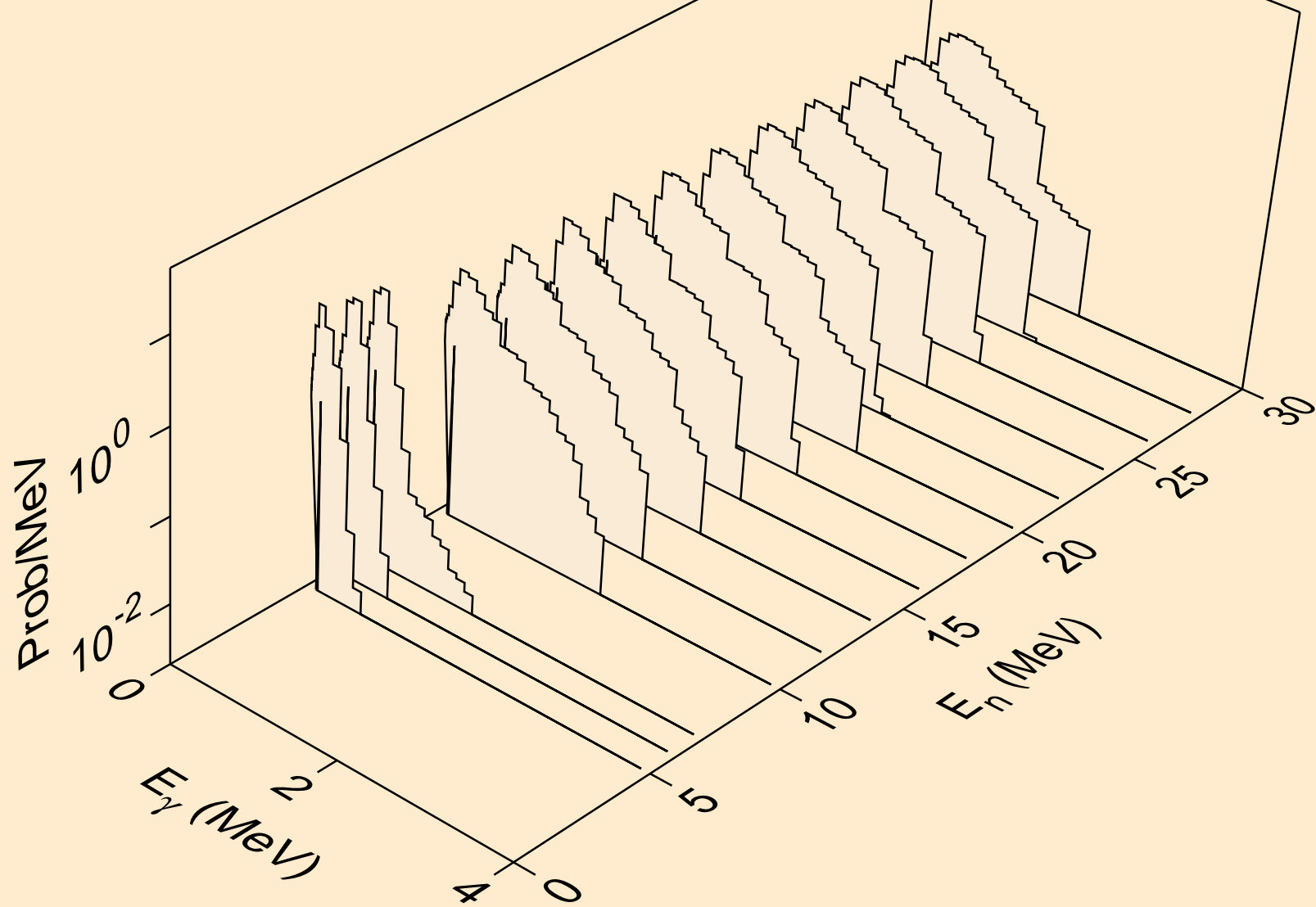

PU228 DEUTERON ACER TENDL-2021 LIBRARY; T=0.K  
Photon emission for (n,n\*)3a

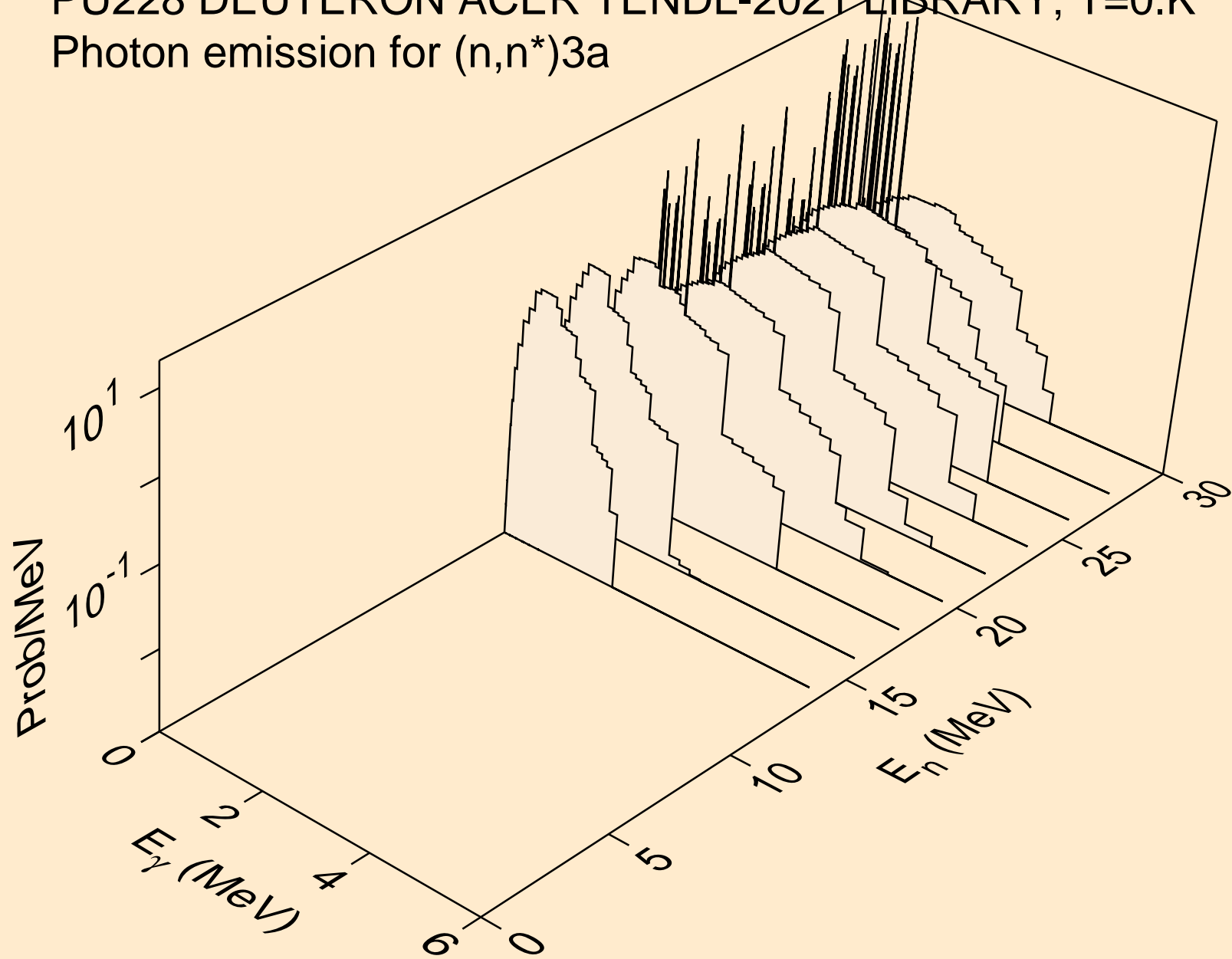

PU228 DEUTERON ACER TENDL-2021 LIBRARY; T=0.K  
Photon emission for (n,2n)a

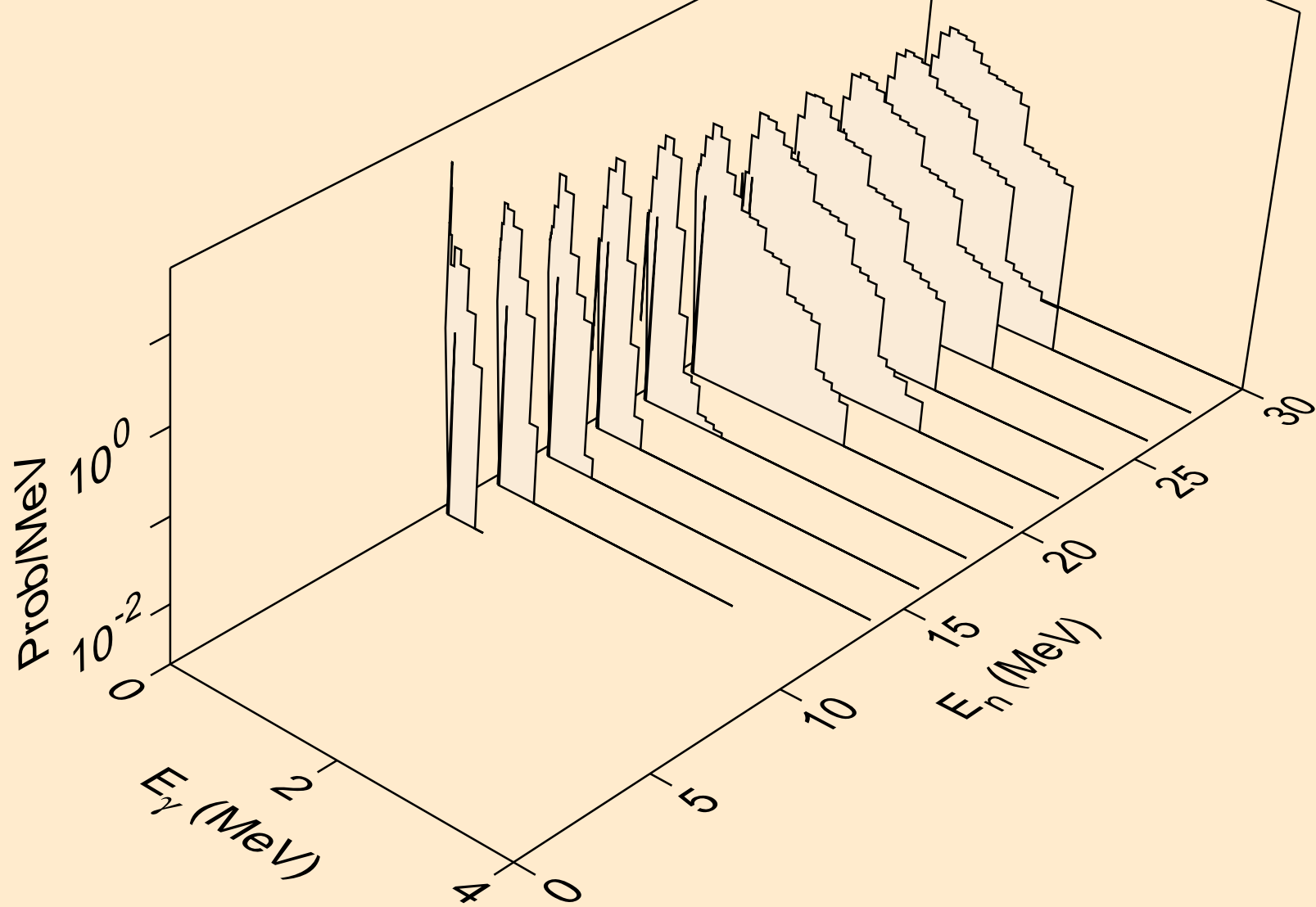

PU228 DEUTERON ACER TENDL-2021 LIBRARY; T=0.K  
Photon emission for (n,n\*)p

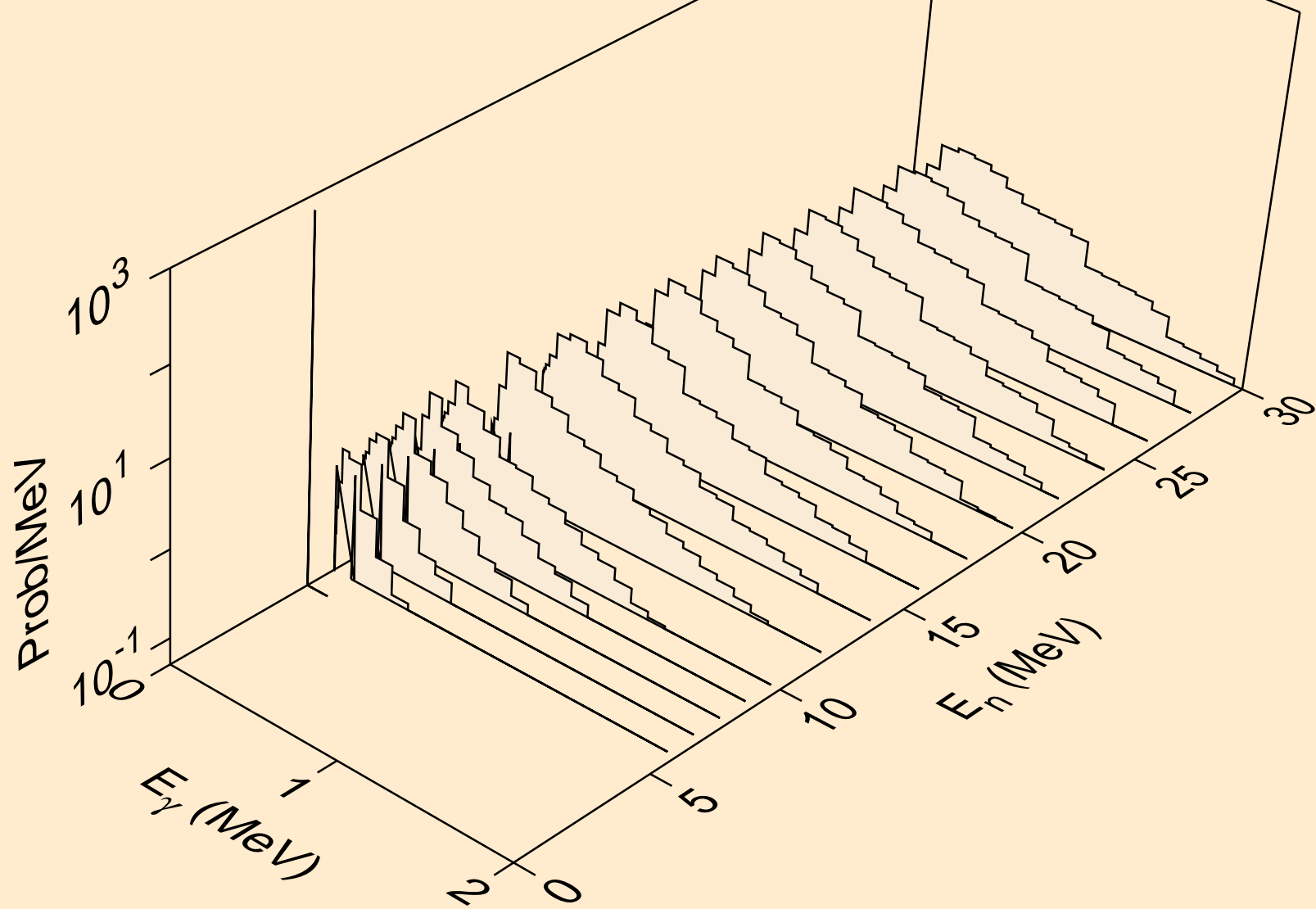

PU228 DEUTERON ACER TENDL-2021 LIBRARY; T=0.K  
Photon emission for (n,n\*)2a

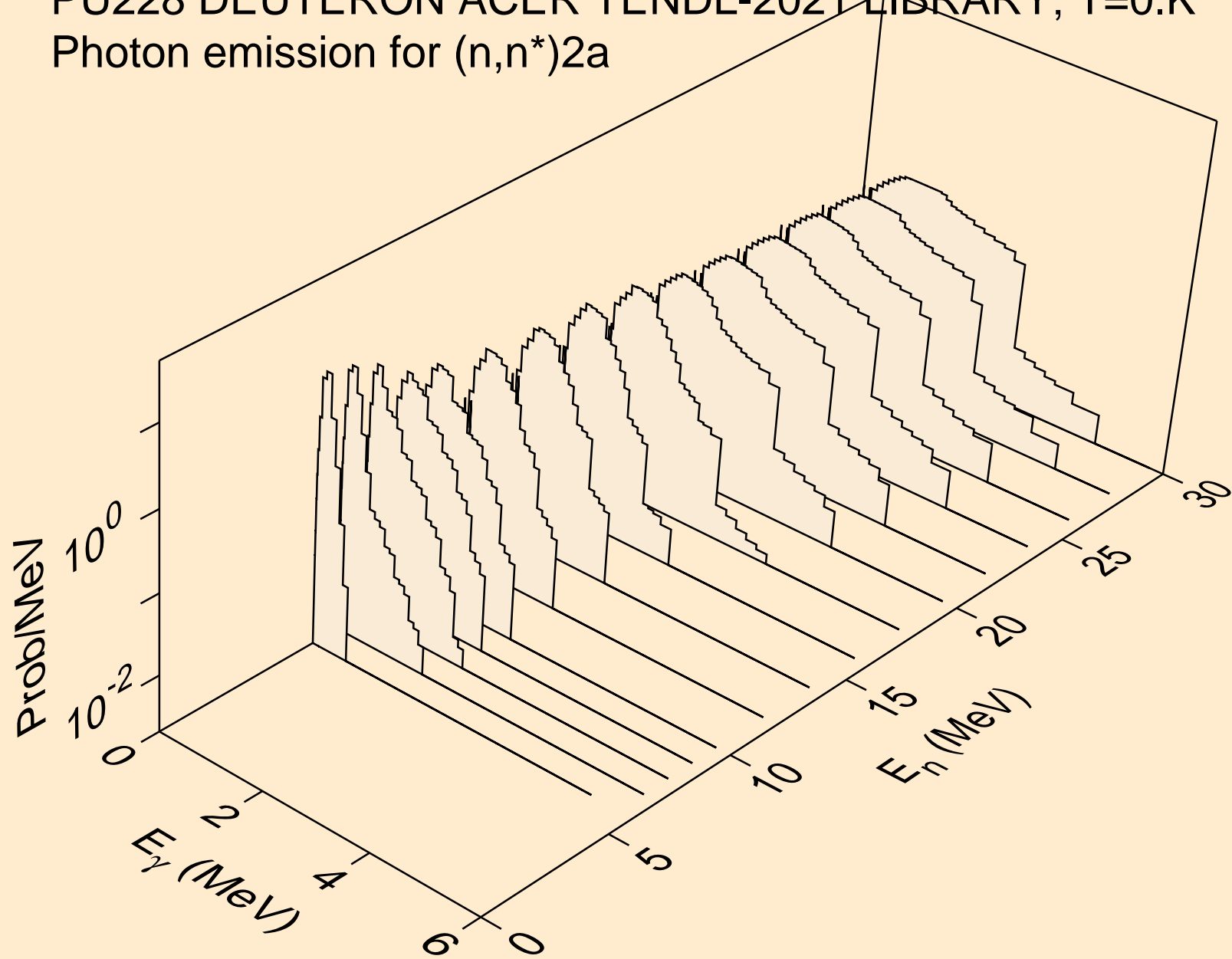

PU228 DEUTERON ACER TENDL-2021 LIBRARY; T=0.K  
Photon emission for (n,2n)2a

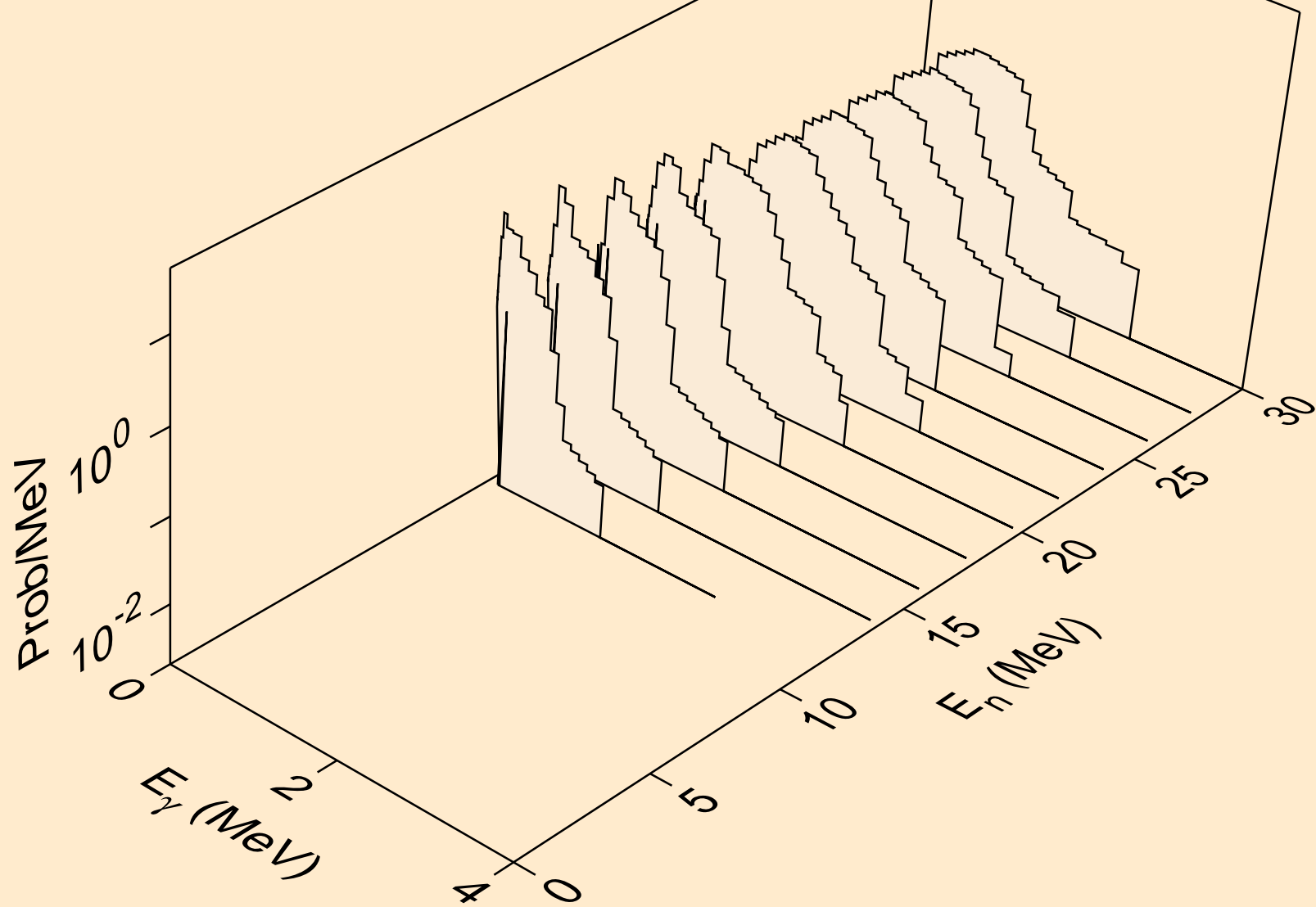

PU228 DEUTERON ACER TENDL-2021 LIBRARY; T=0.K  
Photon emission for (n,n\*)d

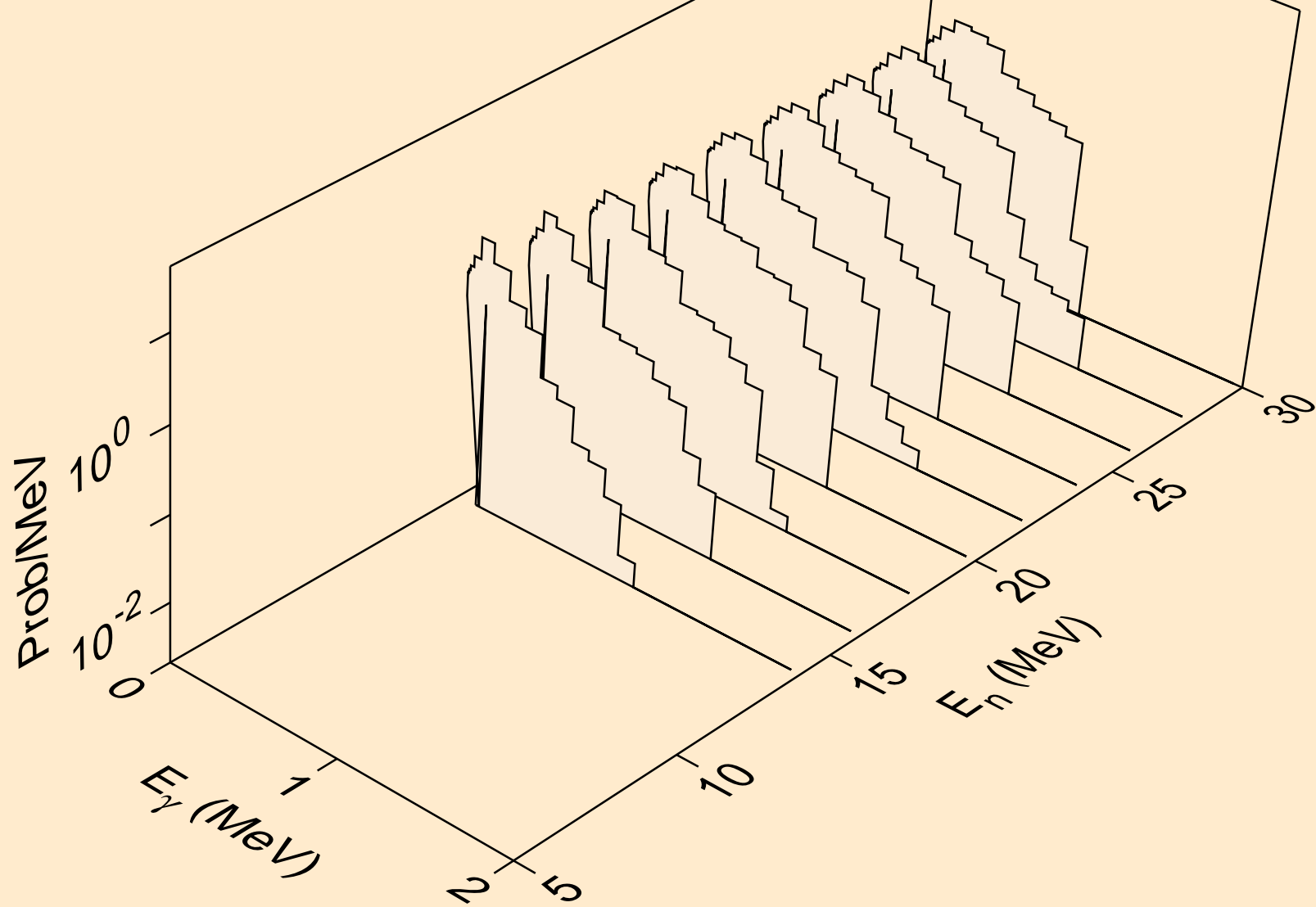

PU228 DEUTERON ACER TENDL-2021 LIBRARY; T=0.K  
Photon emission for (n,n\*)t

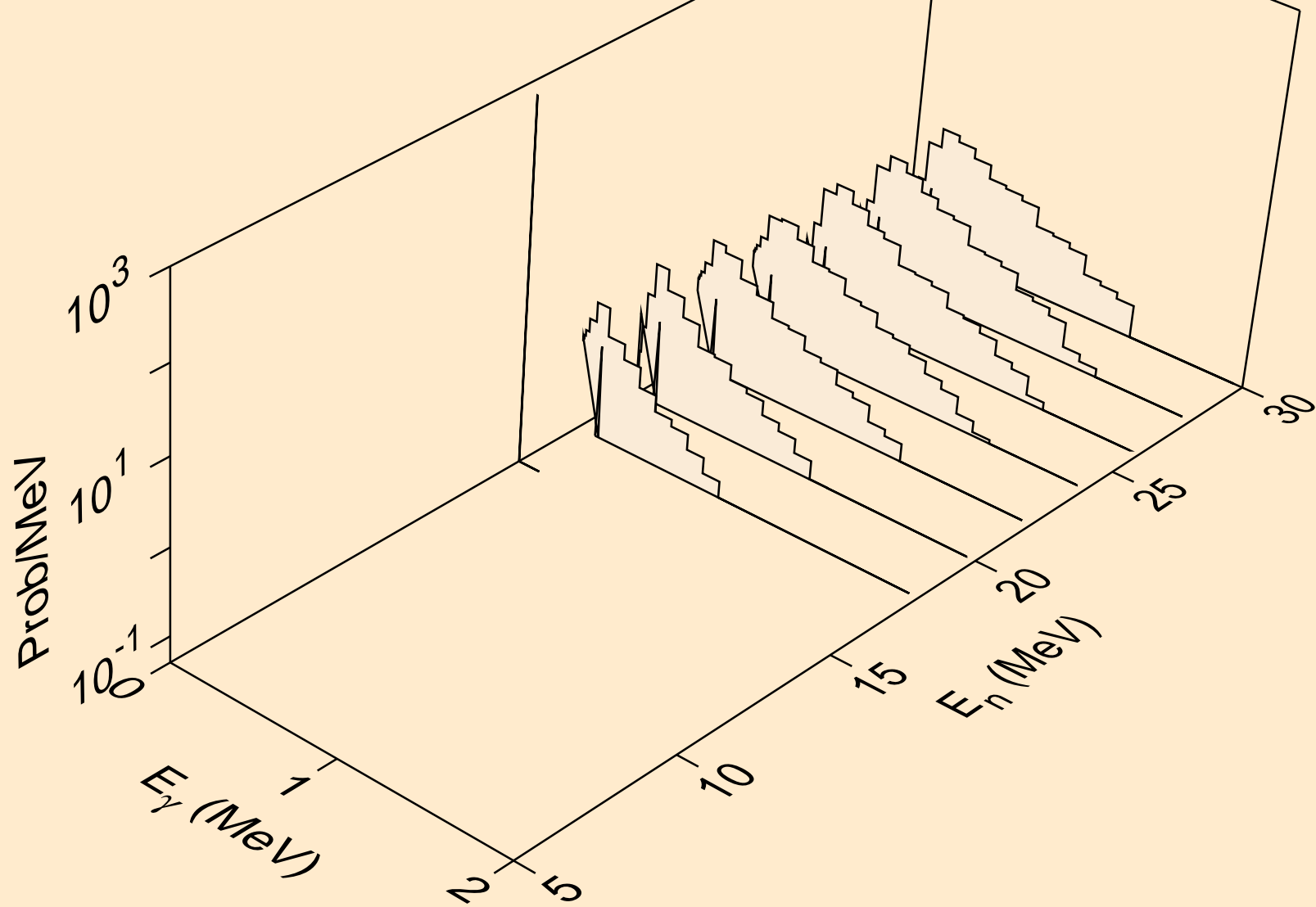

PU228 DEUTERON ACER TENDL-2021 LIBRARY; T=0.K  
Photon emission for (n,n\*)he3

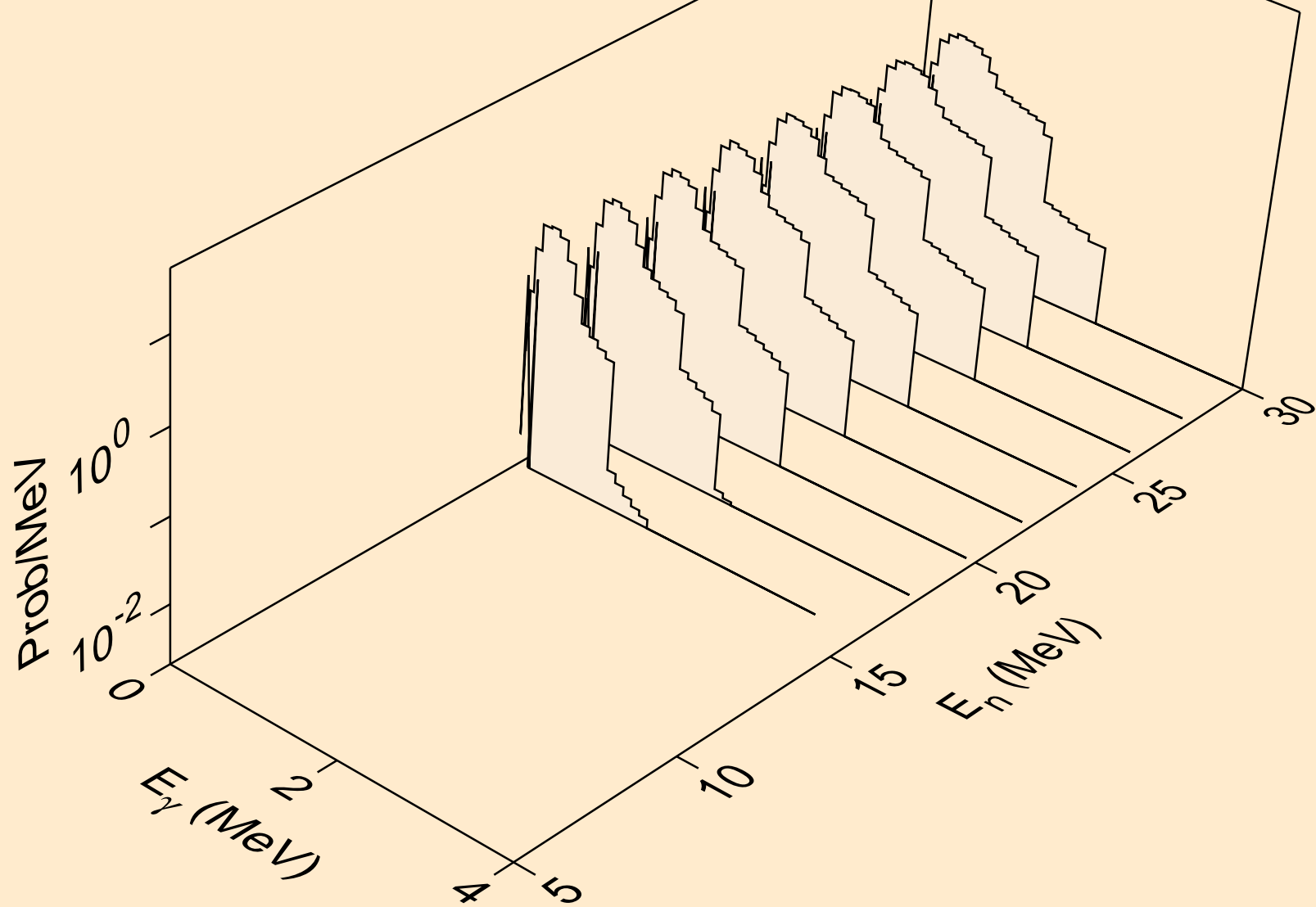

PU228 DEUTERON ACER TENDL-2021 LIBRARY; T=0.K  
Photon emission for (n,n\*)d2a

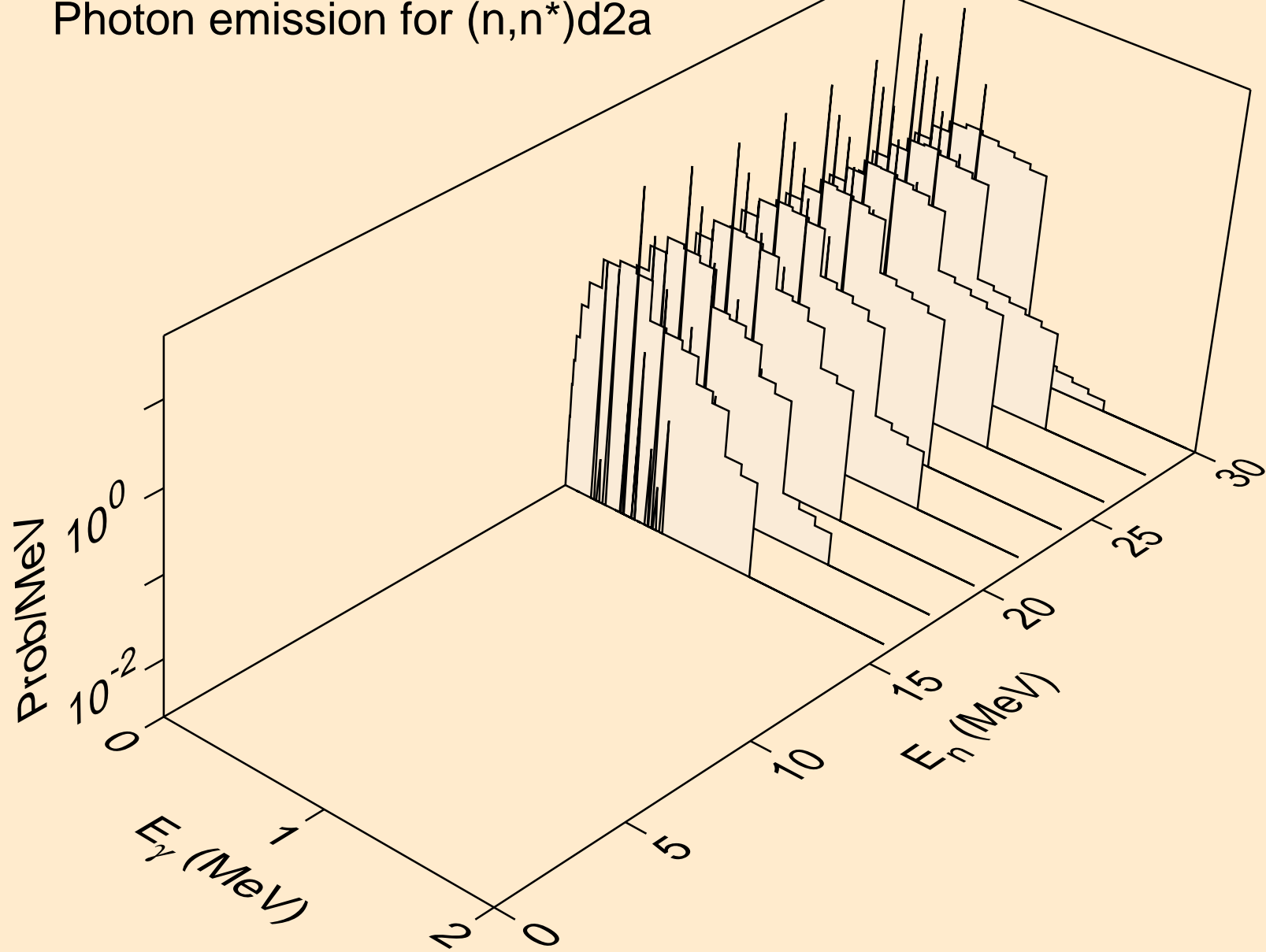

PU228 DEUTERON ACER TENDL-2021 LIBRARY; T=0.K  
Photon emission for (n,2np)

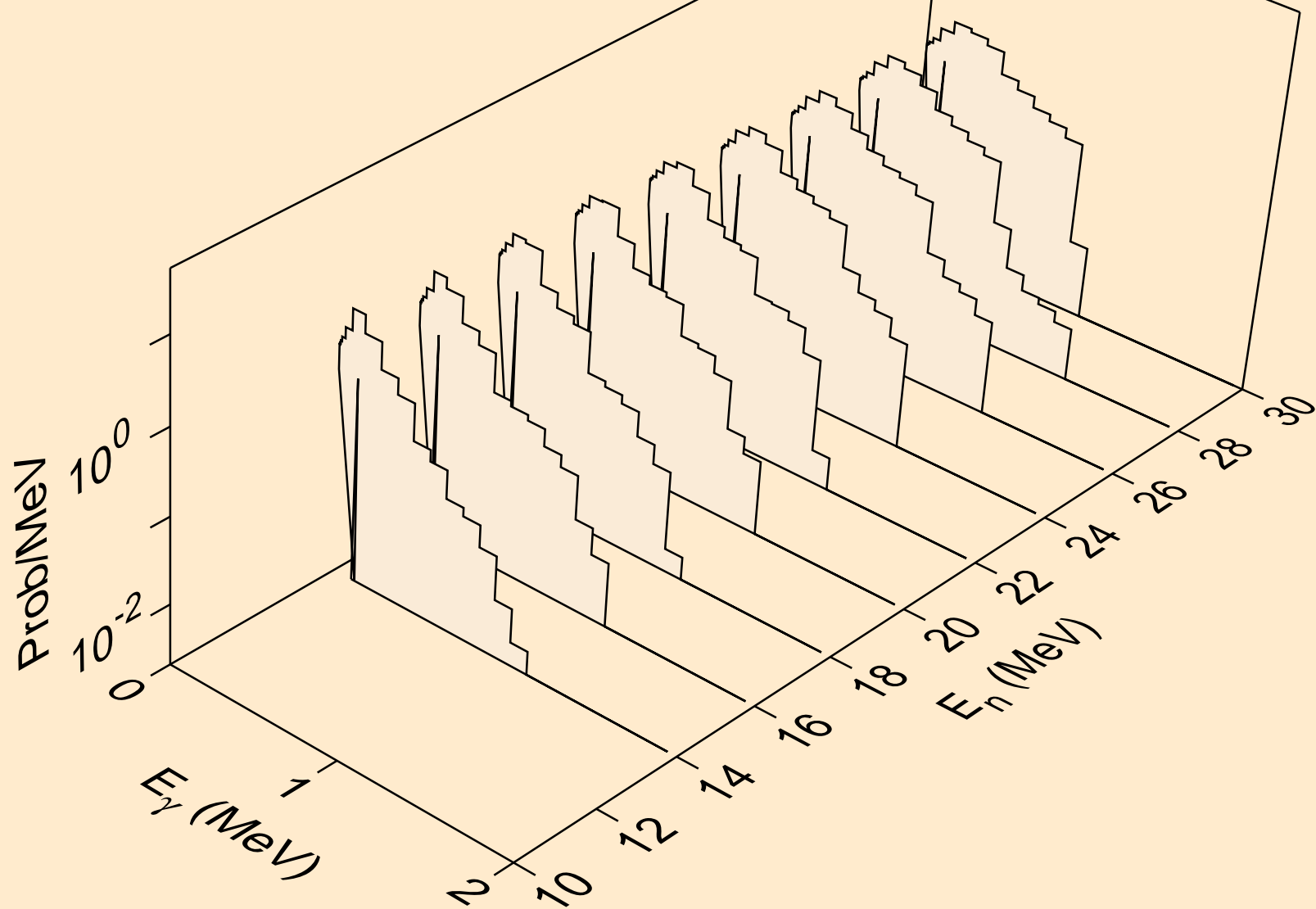

PU228 DEUTERON ACER TENDL-2021 LIBRARY; T=0.K  
Photon emission for (n,2np)

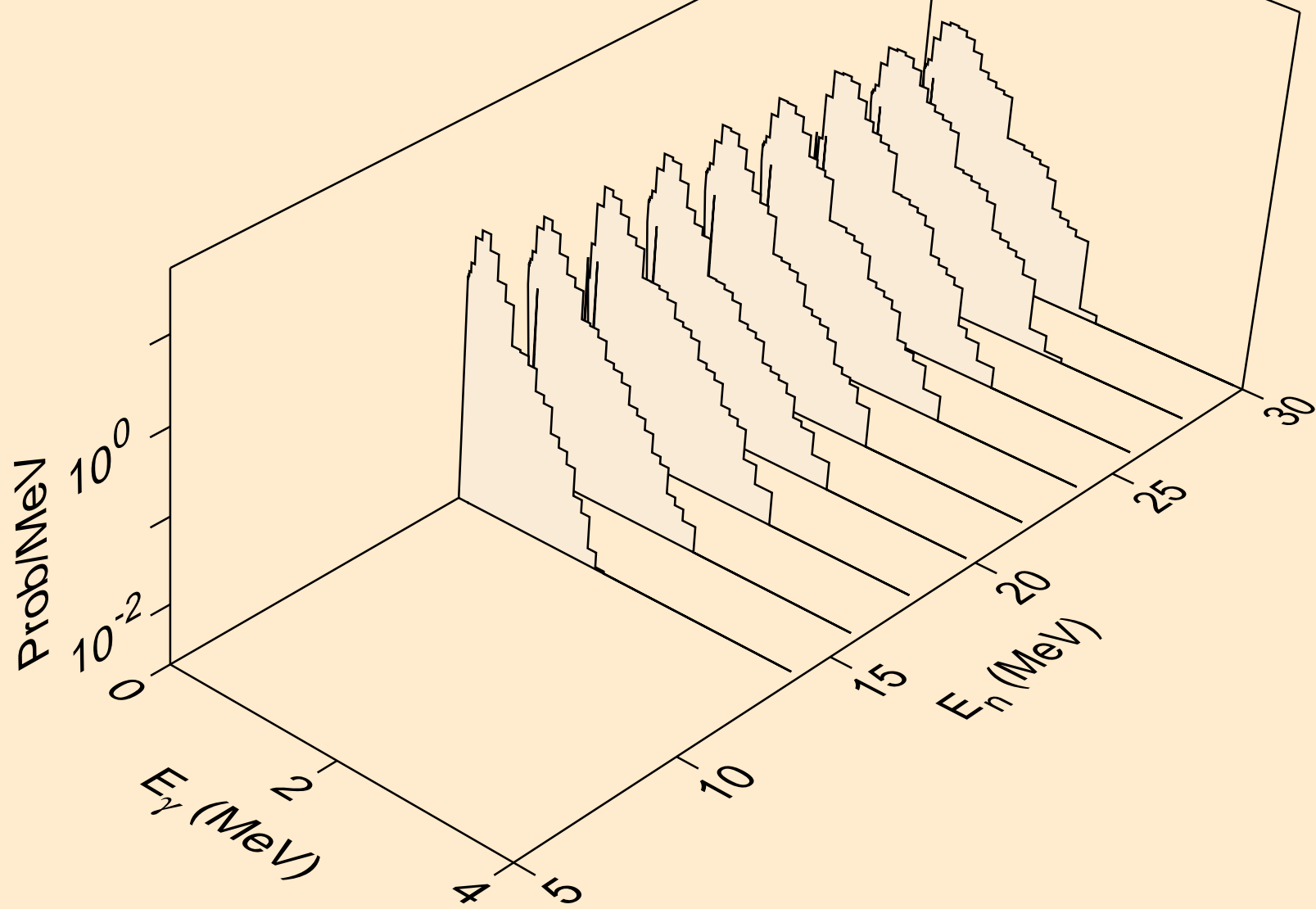

PU228 DEUTERON ACER TENDL-2021 LIBRARY; T=0.K  
Photon emission for (n,npa)

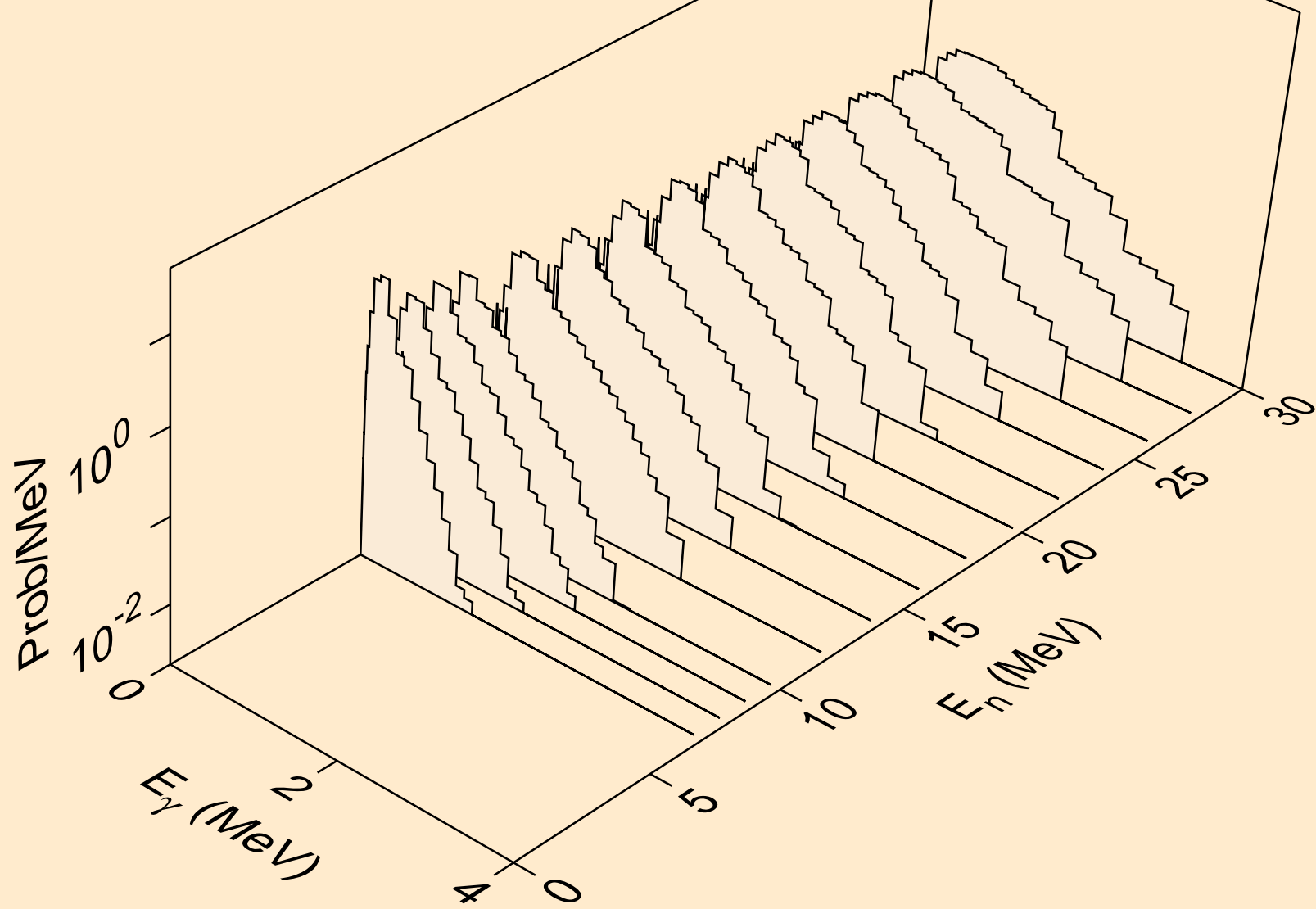

PU228 DEUTERON ACER TENDL-2021 LIBRARY; T=0.K  
Photon emission for (n,p)

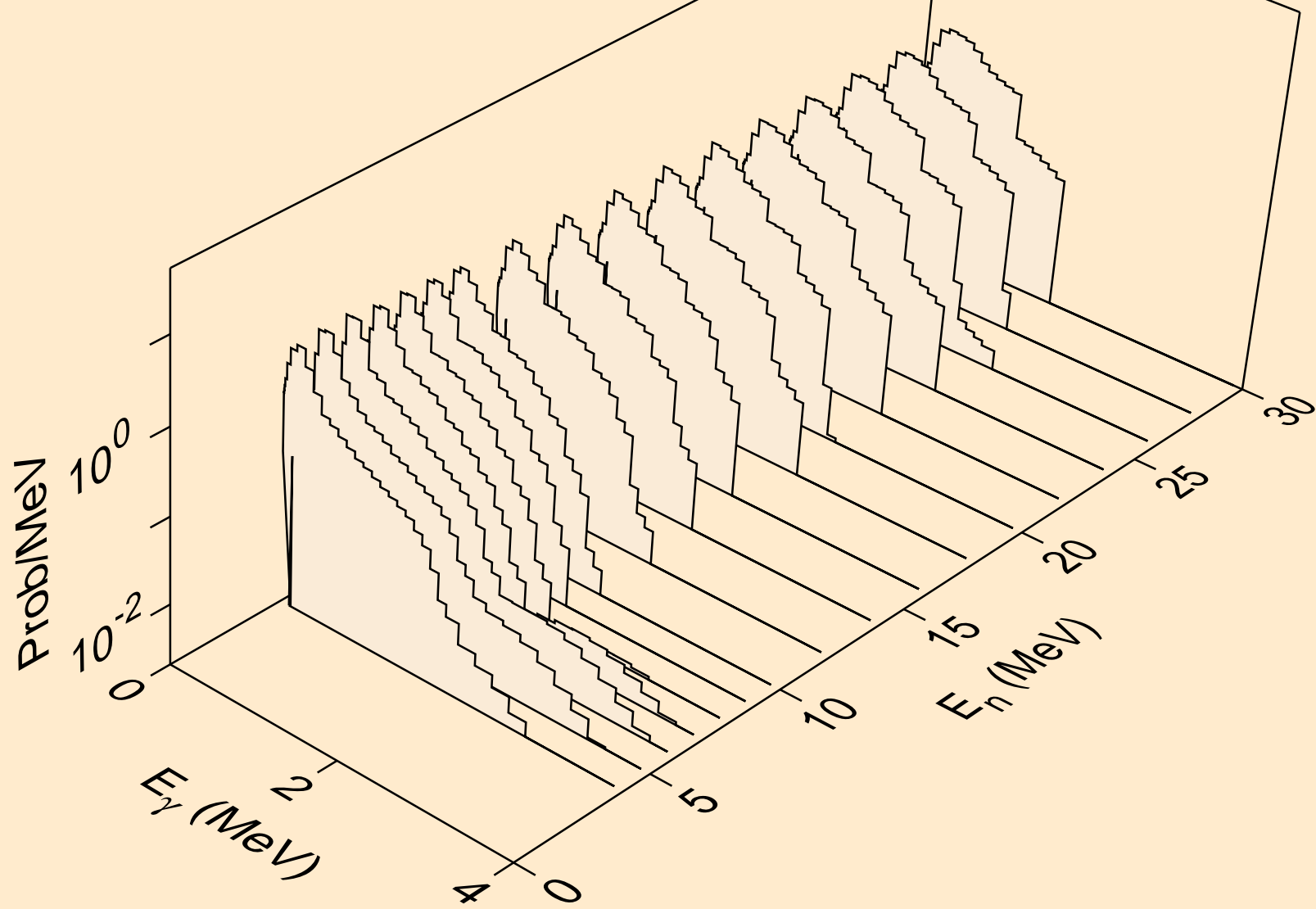

PU228 DEUTERON ACER TENDL-2021 LIBRARY; T=0.K  
Photon emission for inelastic

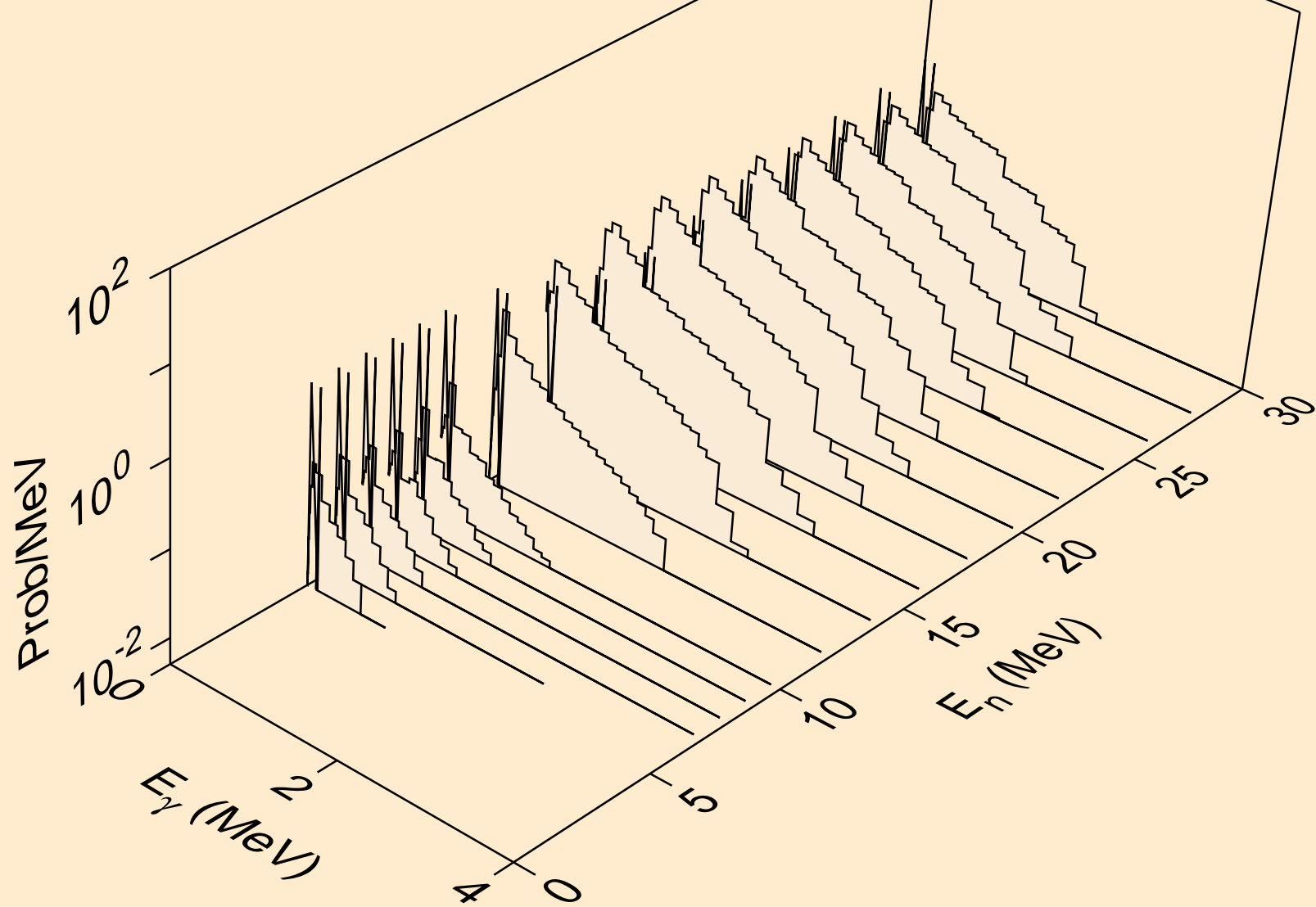

PU228 DEUTERON ACER TENDL-2021 LIBRARY; T=0.K  
Photon emission for (n,t)

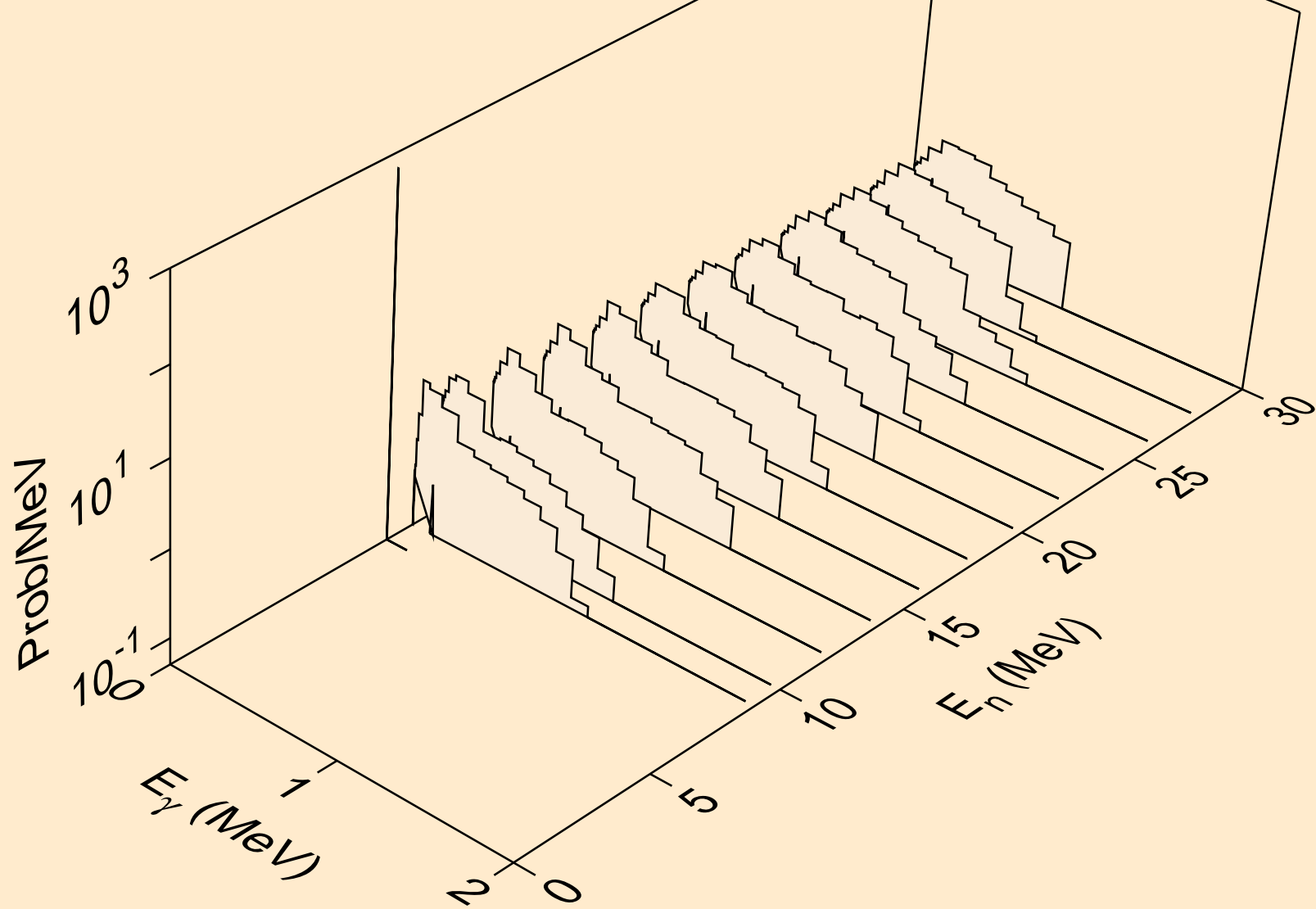

PU228 DEUTERON ACER TENDL-2021 LIBRARY; T=0.K  
Photon emission for (n,he3)

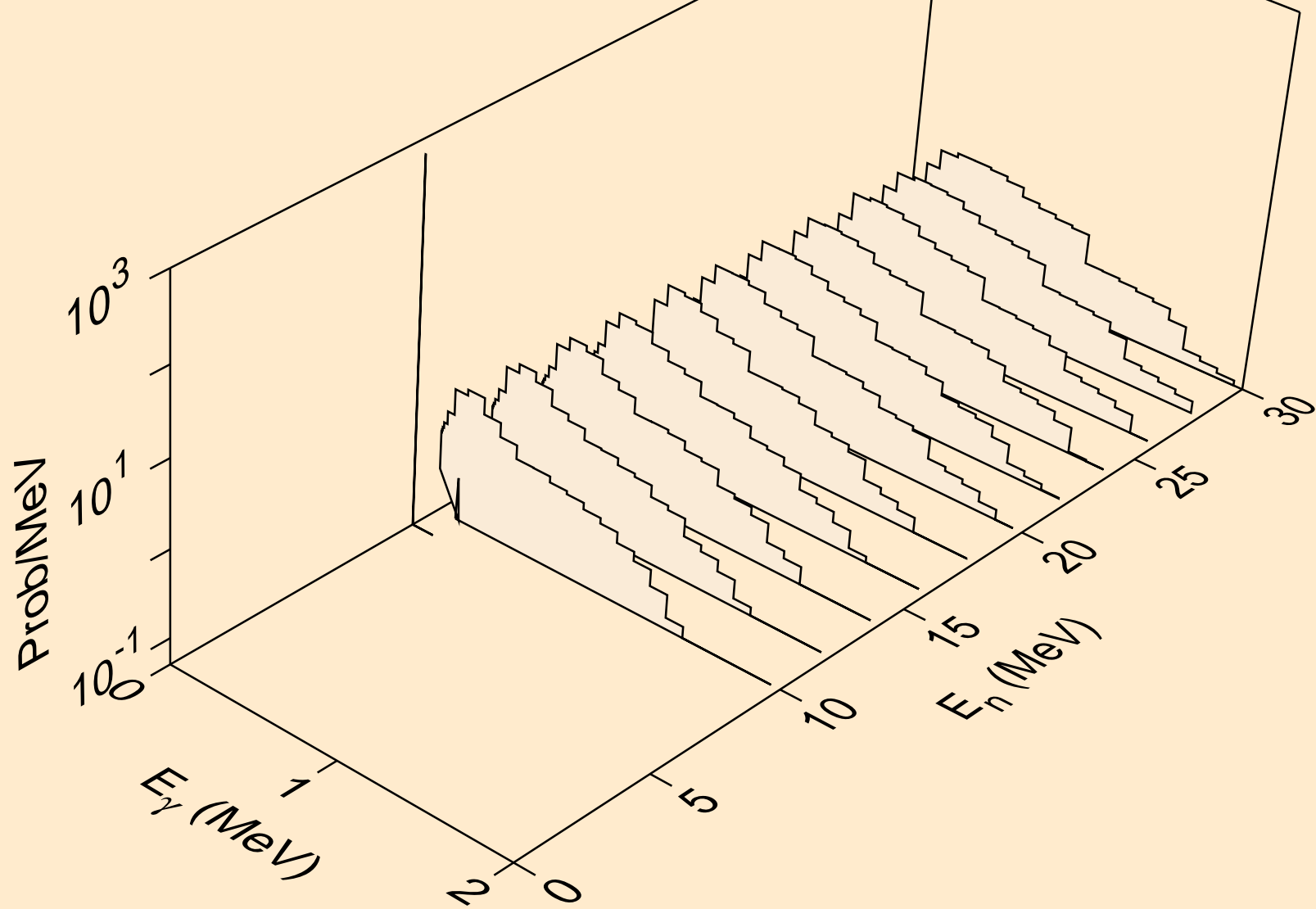

PU228 DEUTERON ACER TENDL-2021 LIBRARY; T=0.K  
Photon emission for (n,a)

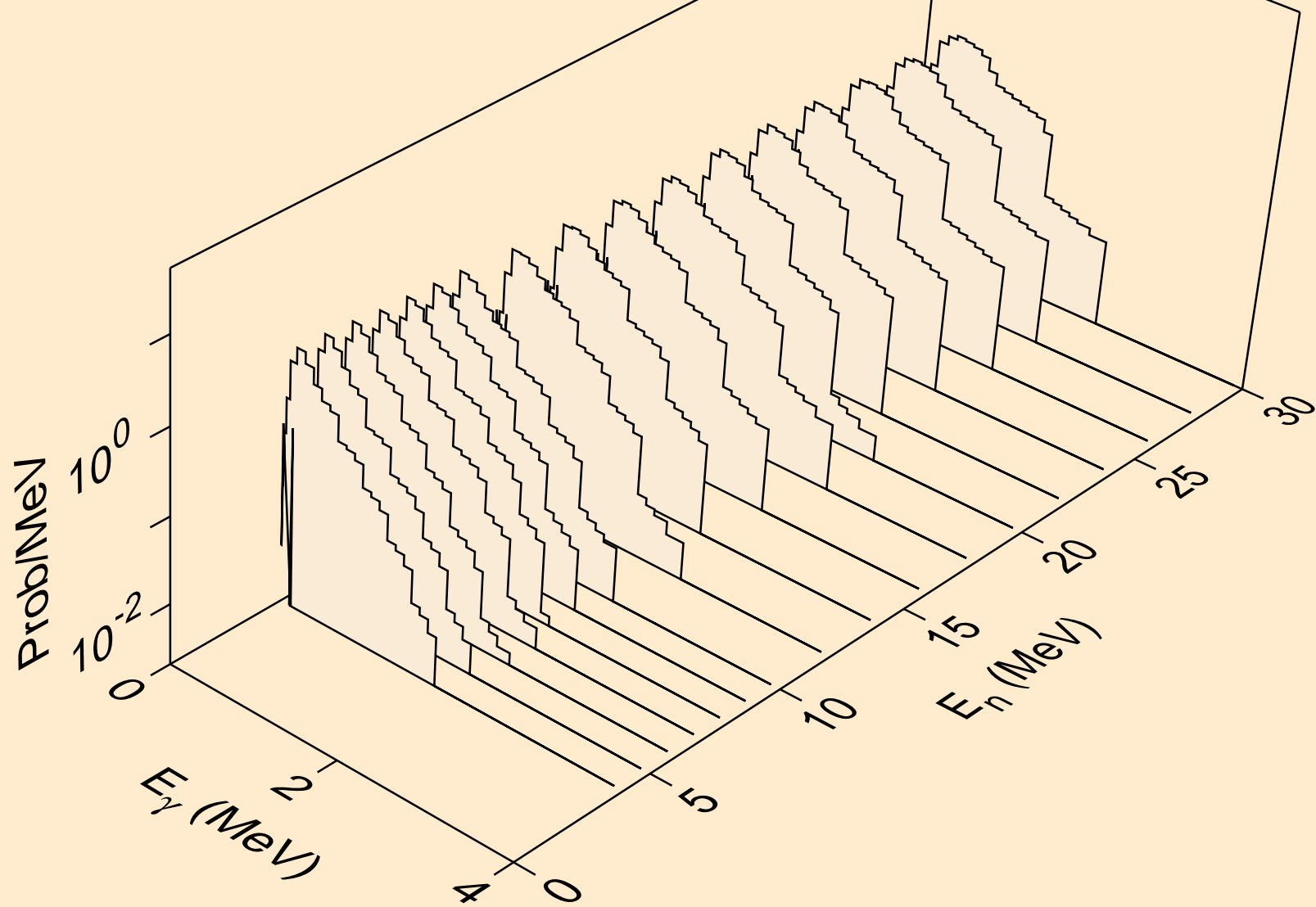

PU228 DEUTERON ACER TENDL-2021 LIBRARY; T=0.K  
Photon emission for (n,2a)

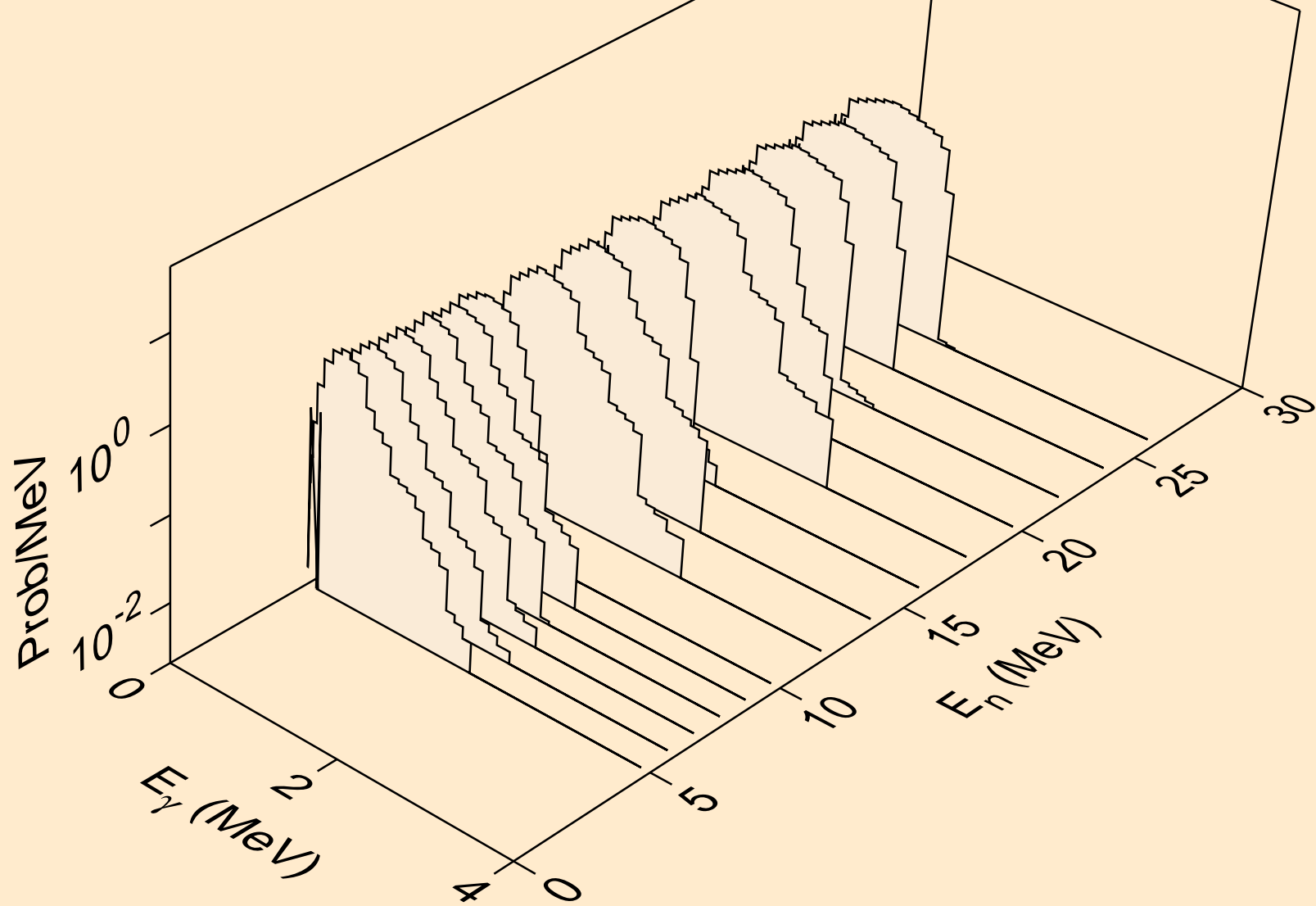

PU228 DEUTERON ACER TENDL-2021 LIBRARY; T=0.K  
Photon emission for (n,2p)

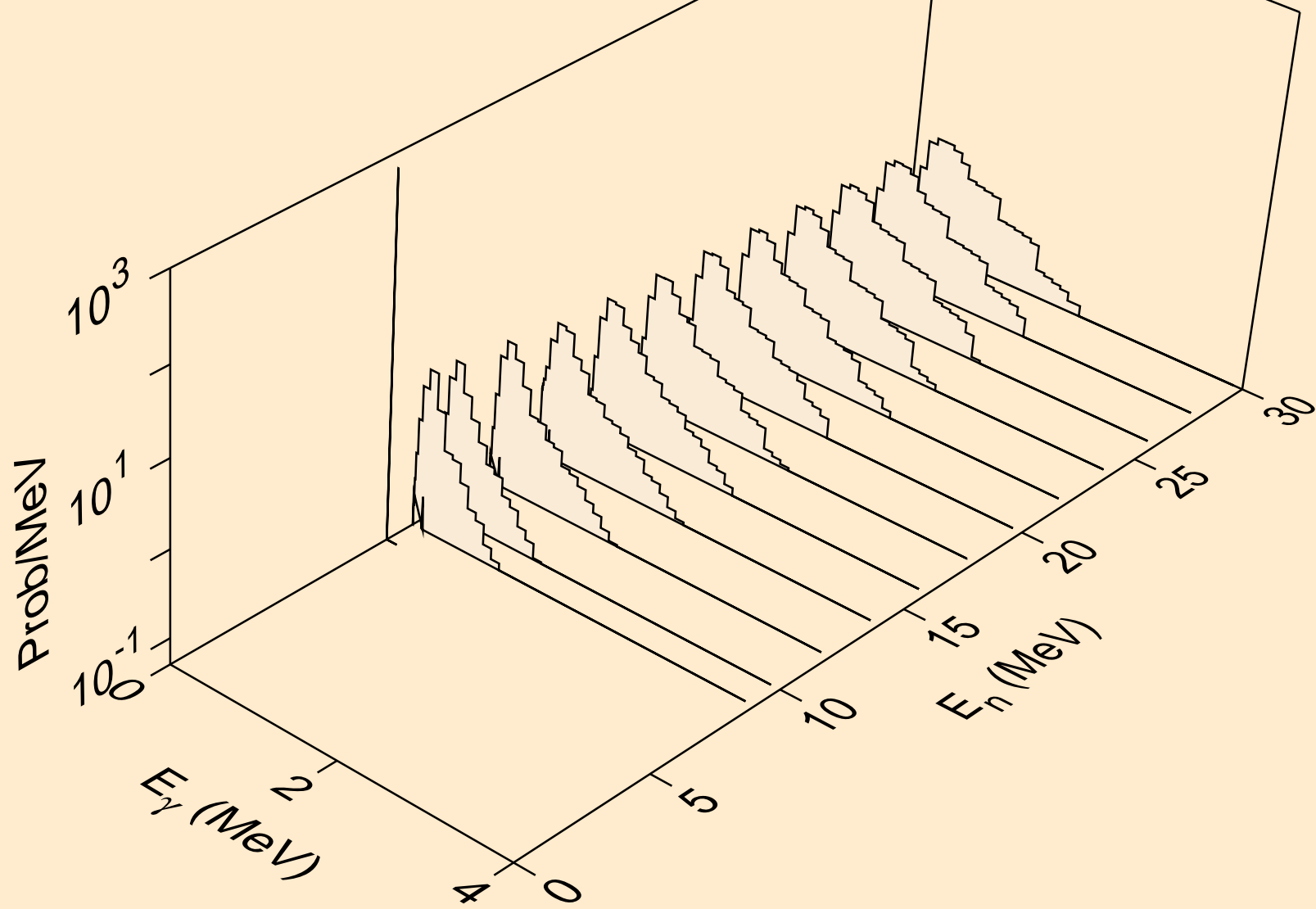

PU228 DEUTERON ACER TENDL-2021 LIBRARY; T=0.K  
Photon emission for (n,p)

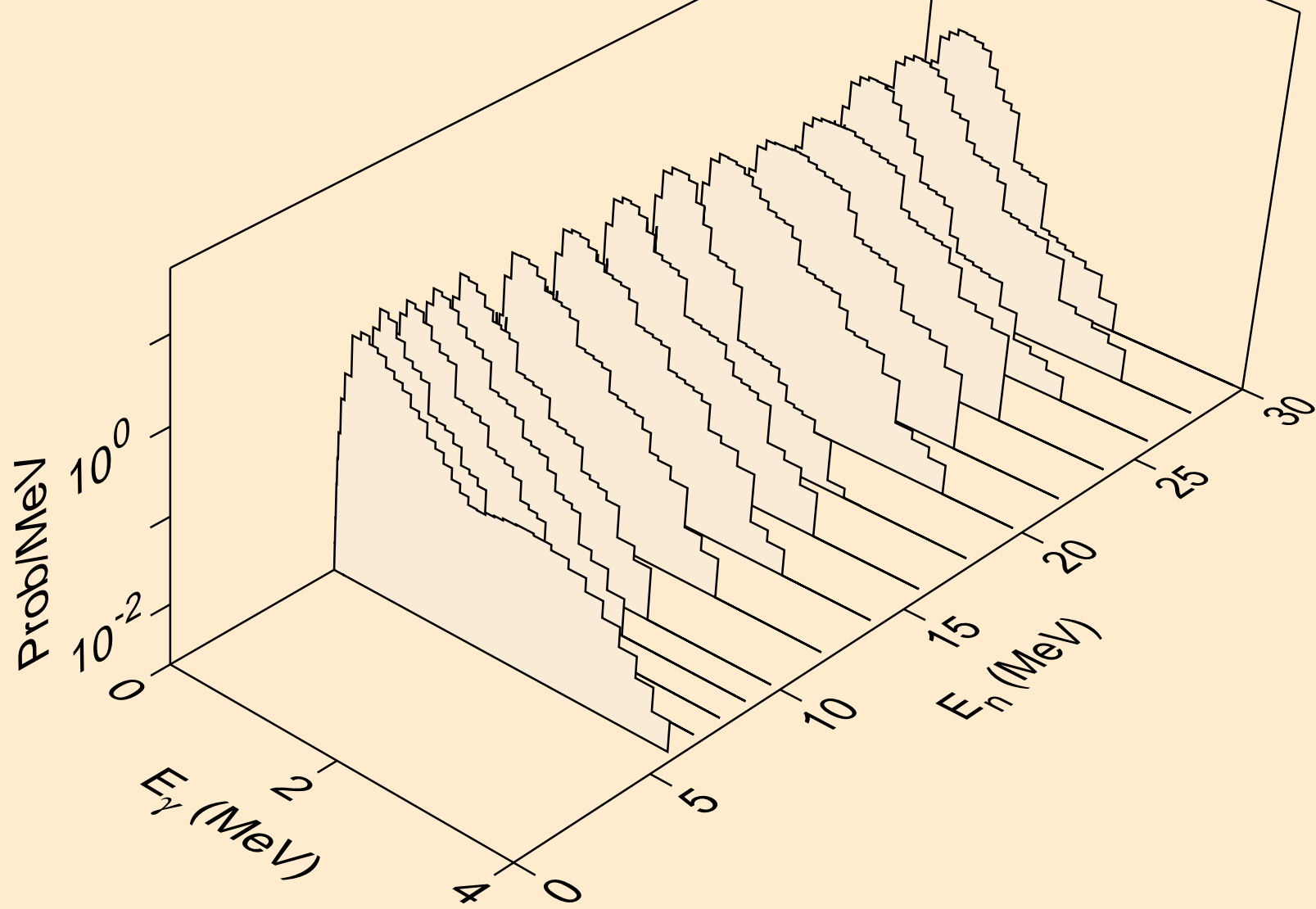

PU228 DEUTERON ACER TENDL-2021 LIBRARY; T=0.K  
Photon emission for (n,t2a)

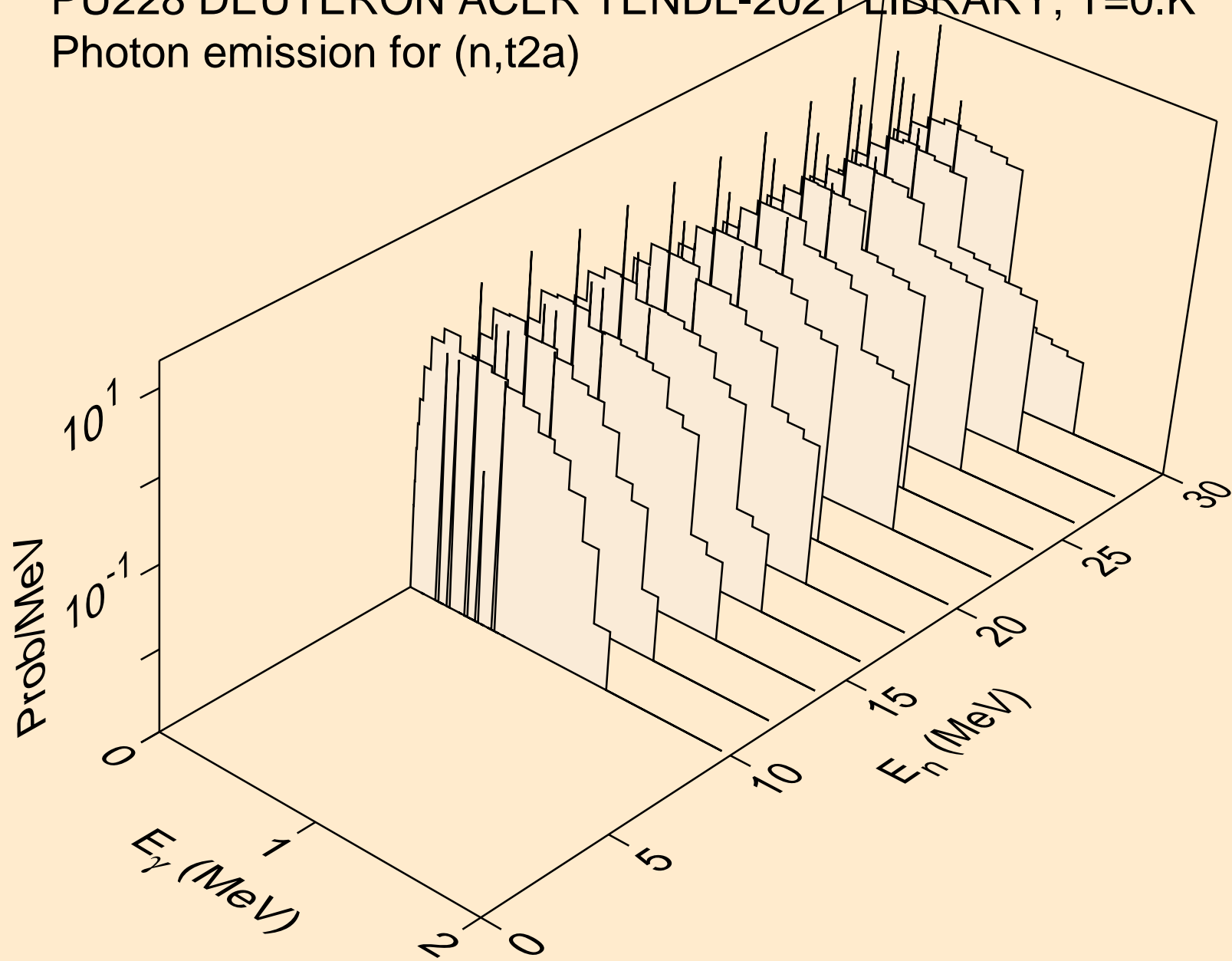

PU228 DEUTERON ACER TENDL-2021 LIBRARY; T=0.K  
Photon emission for (n,pd)

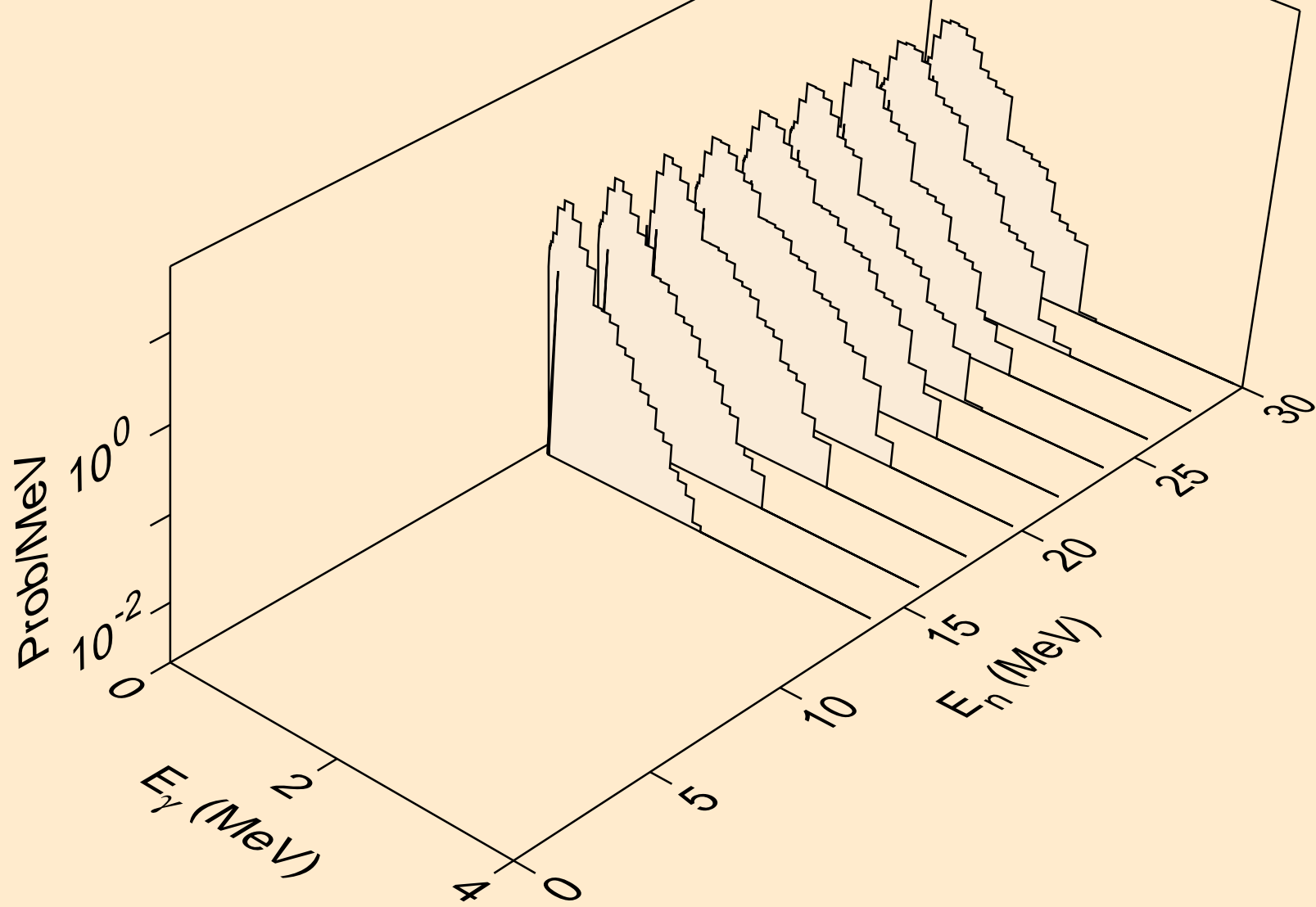

PU228 DEUTERON ACER TENDL-2021 LIBRARY; T=0.K  
Photon emission for (n,da)

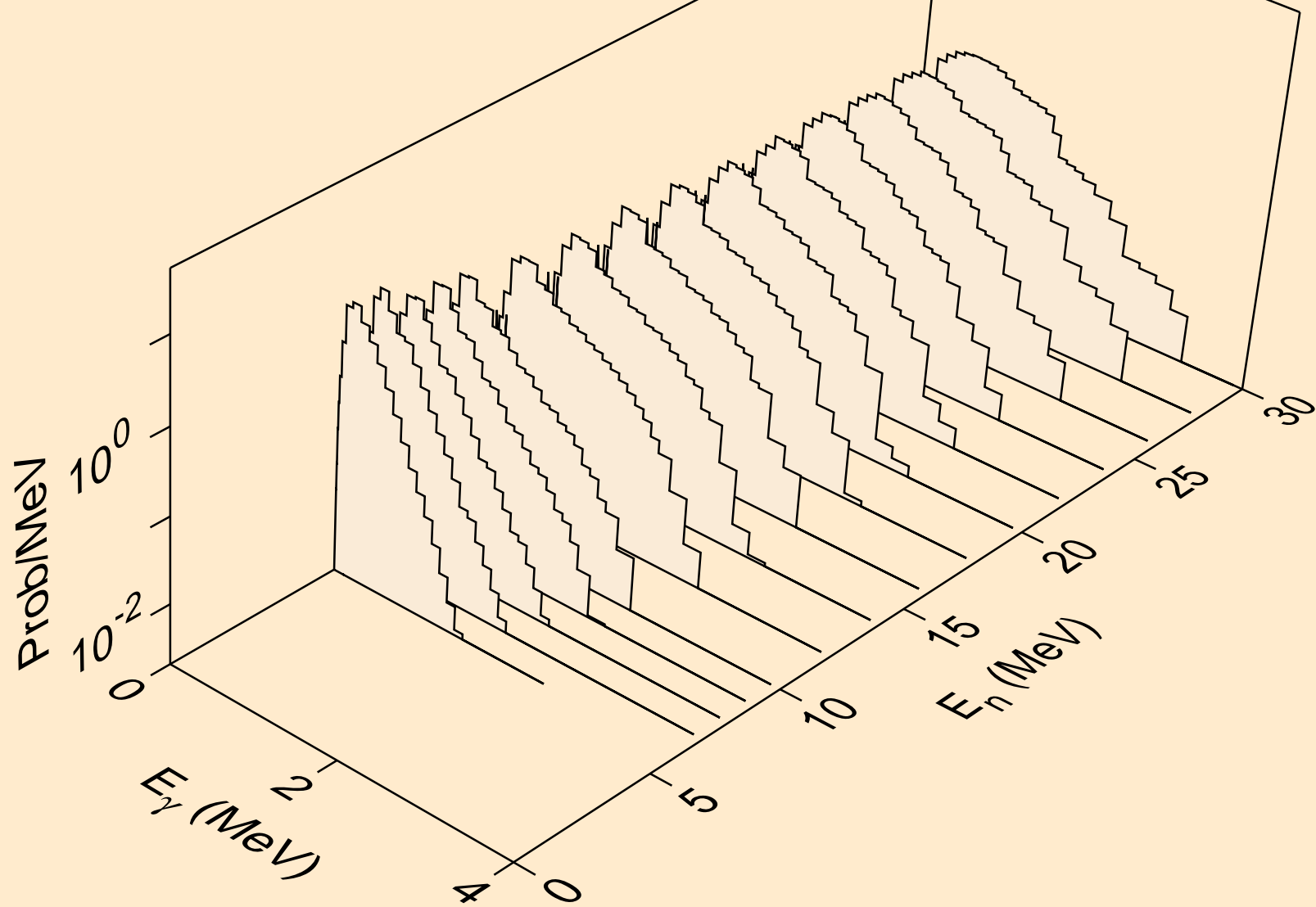

PU228 DEUTERON ACER TENDL-2021 LIBRARY; T=0.K  
Particle heating contributions

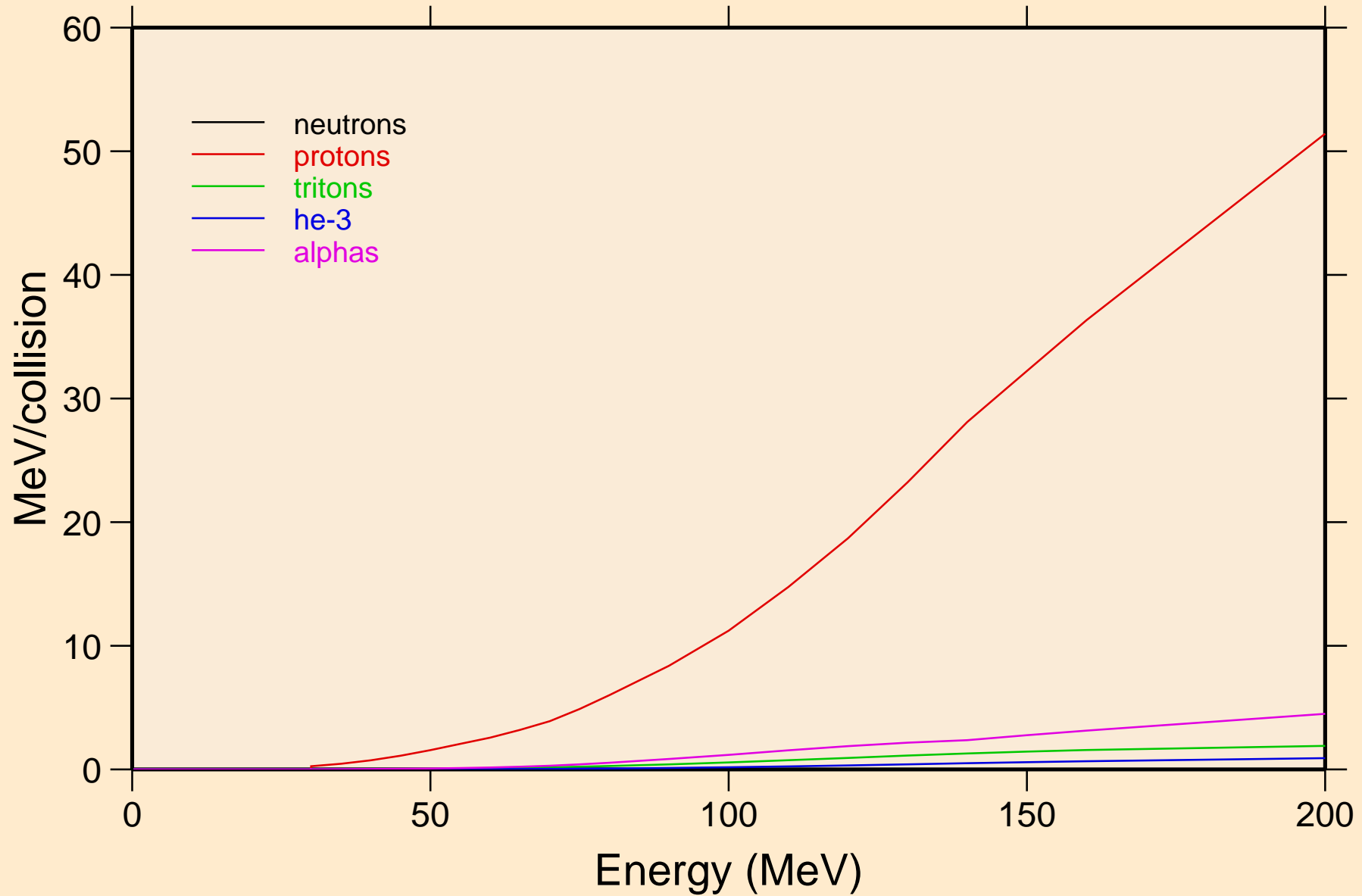

PU228 DEUTERON ACER TENDL-2021 LIBRARY; T=0.K  
Recoil Heating

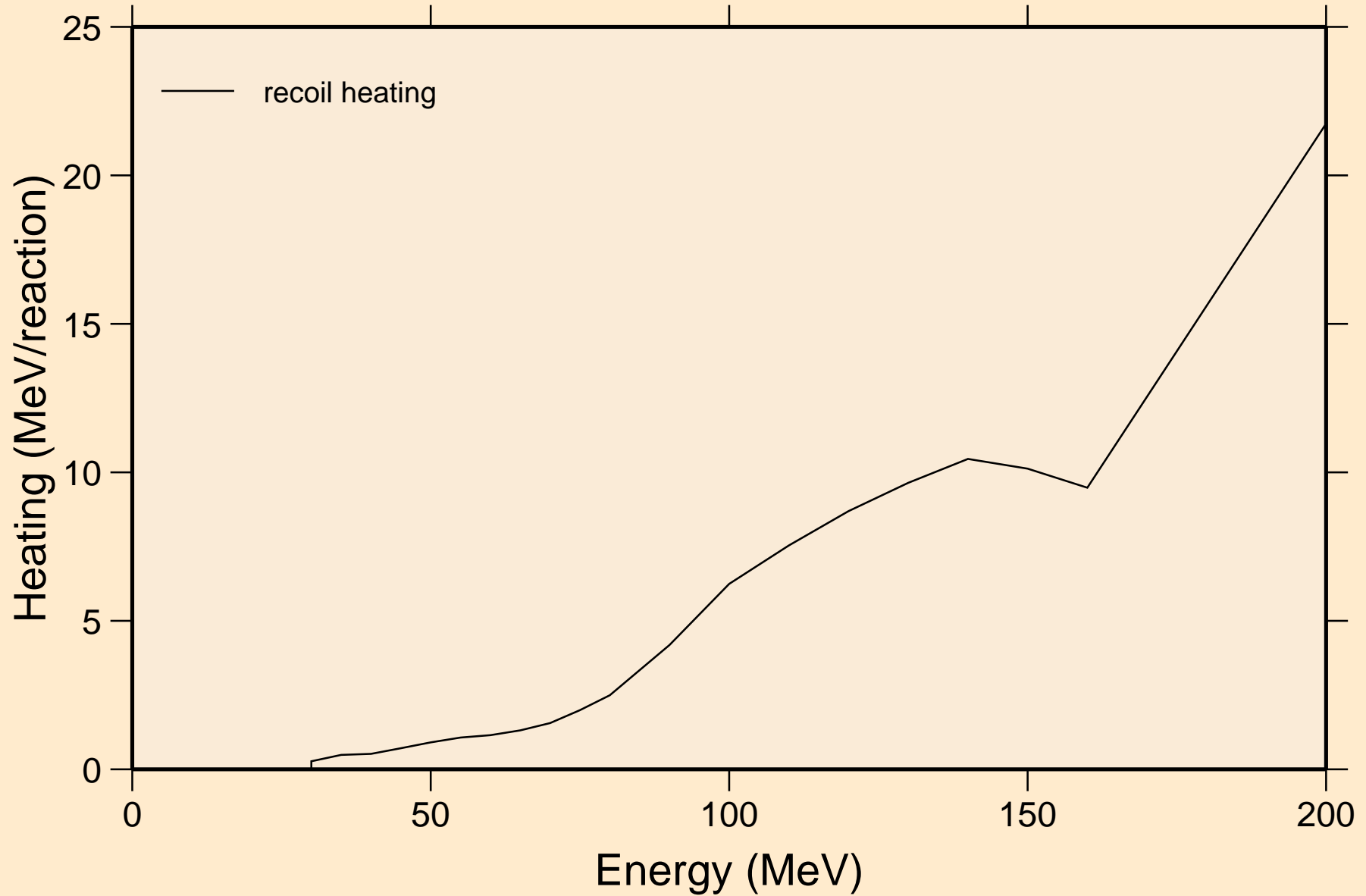

PU228 DEUTERON ACER TENDL-2021 LIBRARY; T=0.K  
Particle production cross sections

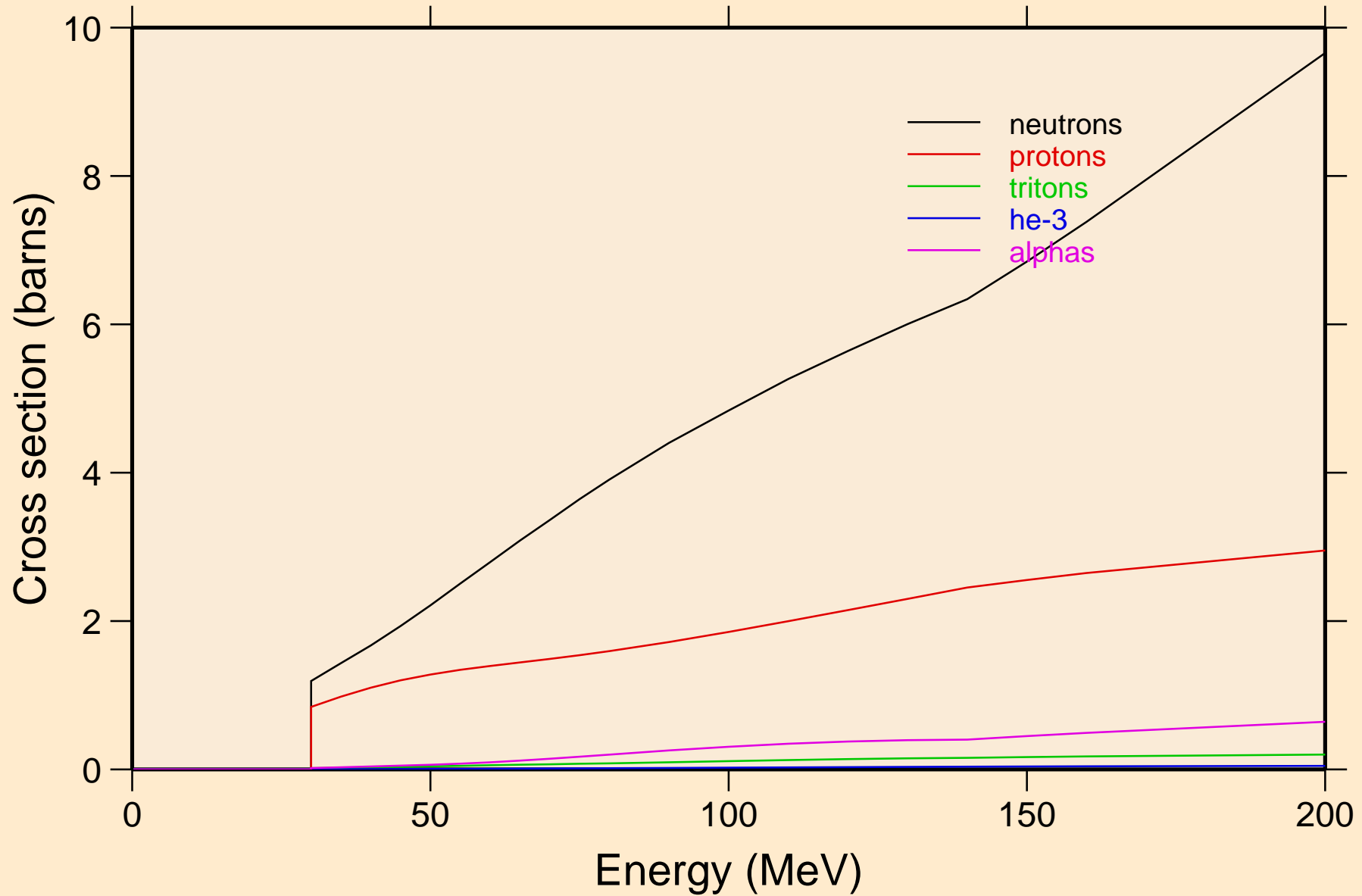

PU228 DEUTERON ACER TENDL-2021 LIBRARY; T=0.K  
neutrons from (d,n)

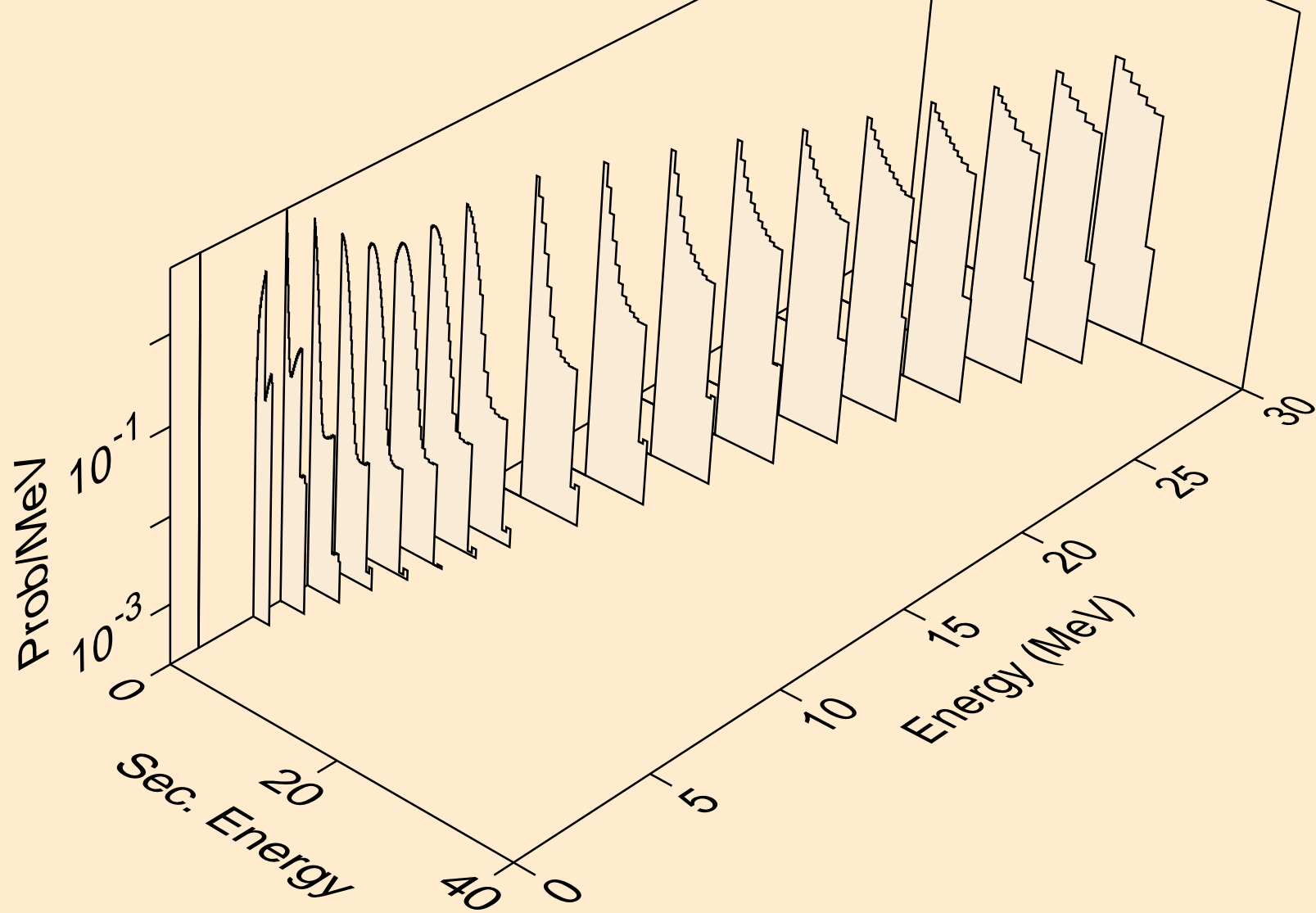

PU228 DEUTERON ACER TENDL-2021 LIBRARY; T=0.K  
neutrons from (d,x)

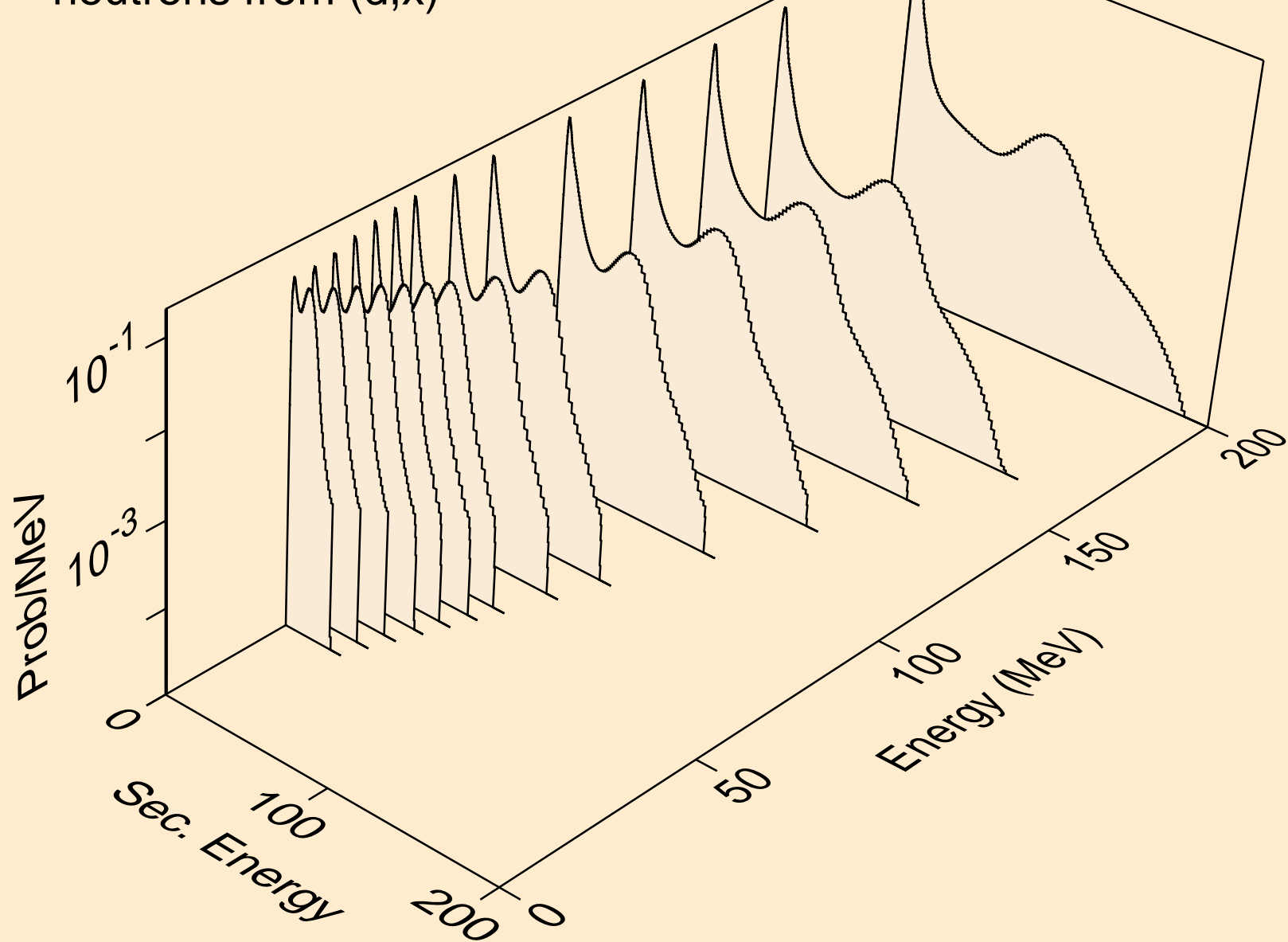

PU228 DEUTERON ACER TENDL-2021 LIBRARY; T=0.K  
neutrons from (d,2n)

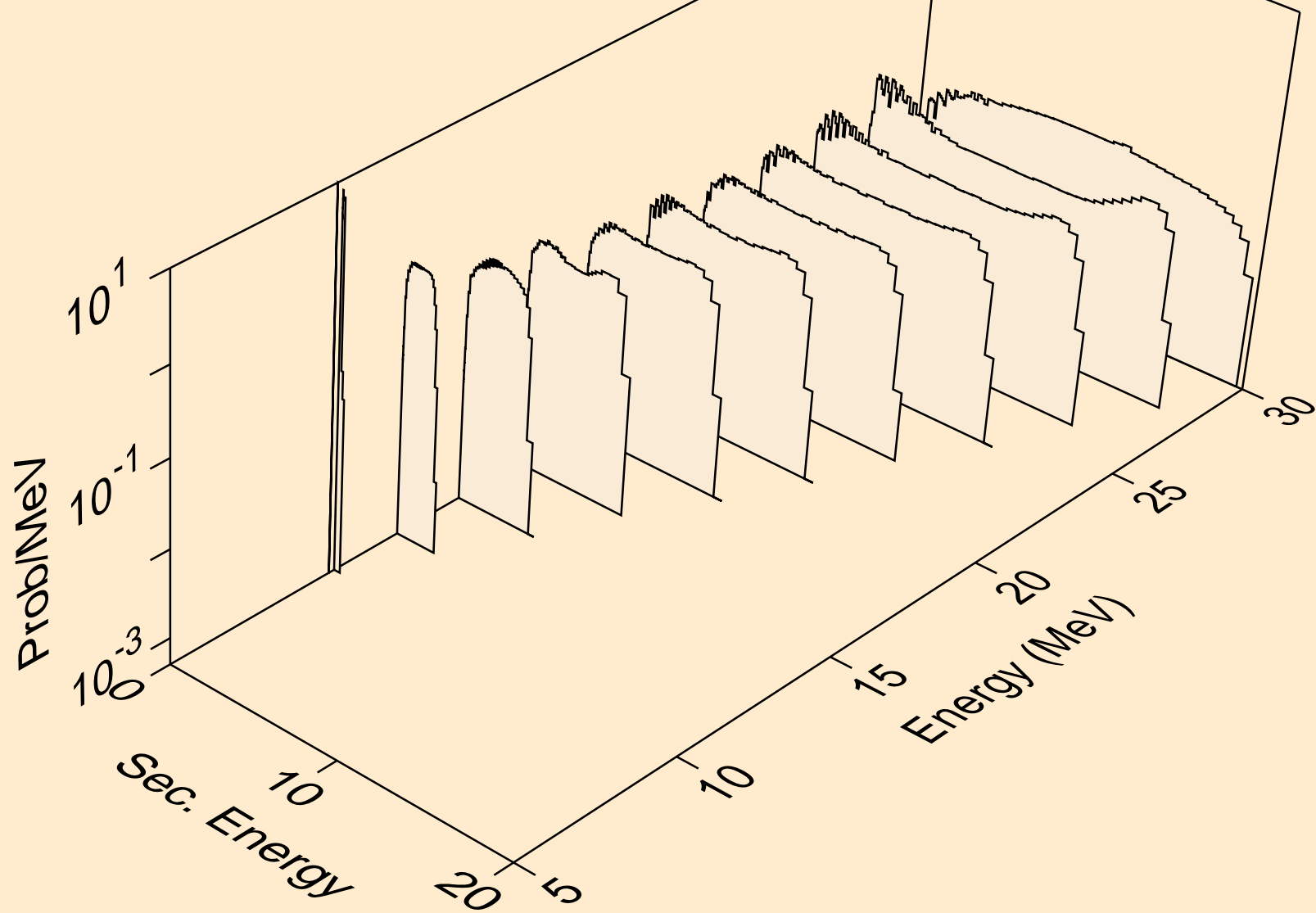

PU228 DEUTERON ACER TENDL-2021 LIBRARY; T=0.K  
neutrons from (d,n\*)a

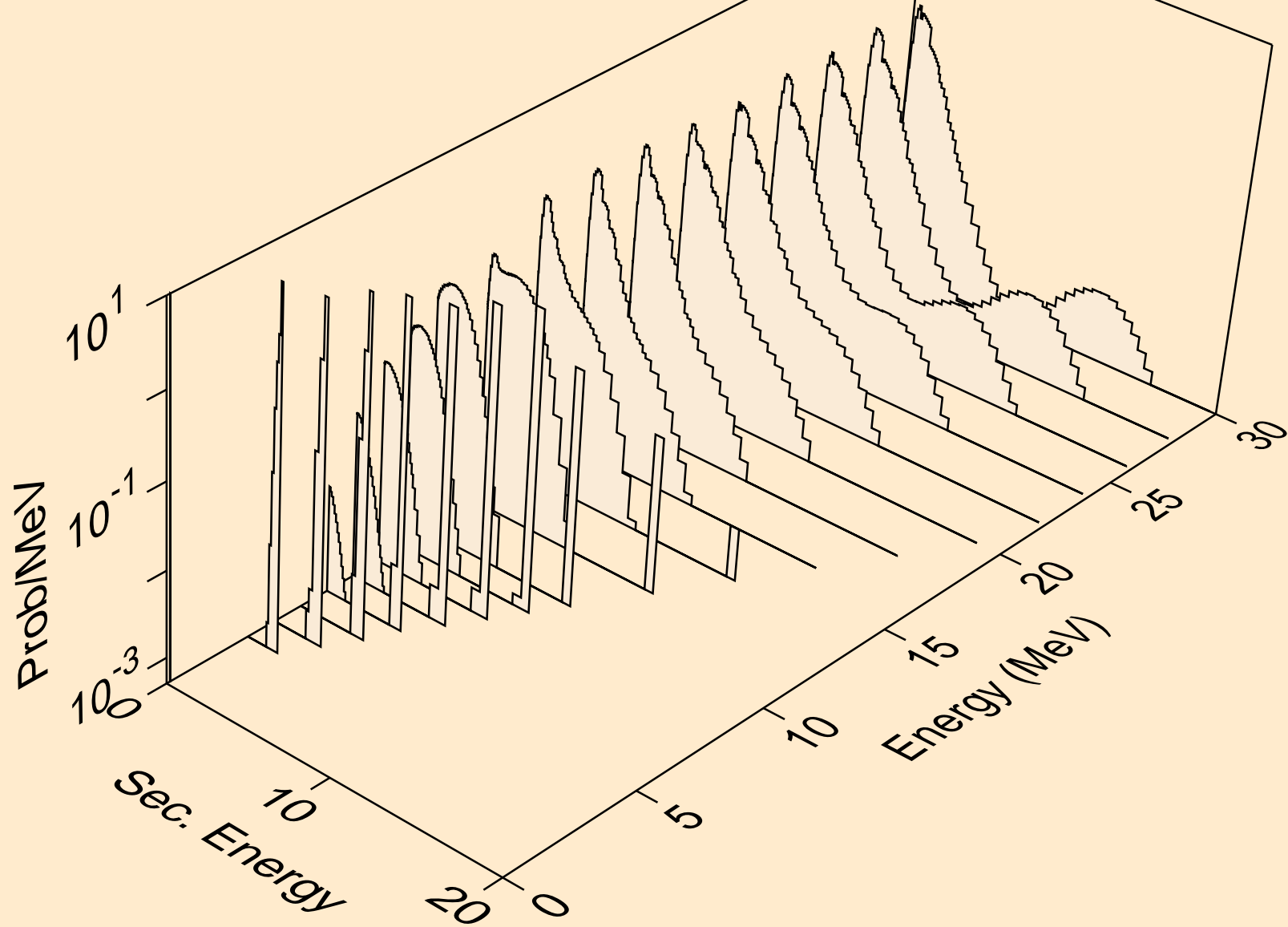

PU228 DEUTERON ACER TENDL-2021 LIBRARY; T=0.K  
neutrons from (d,n\*)3a

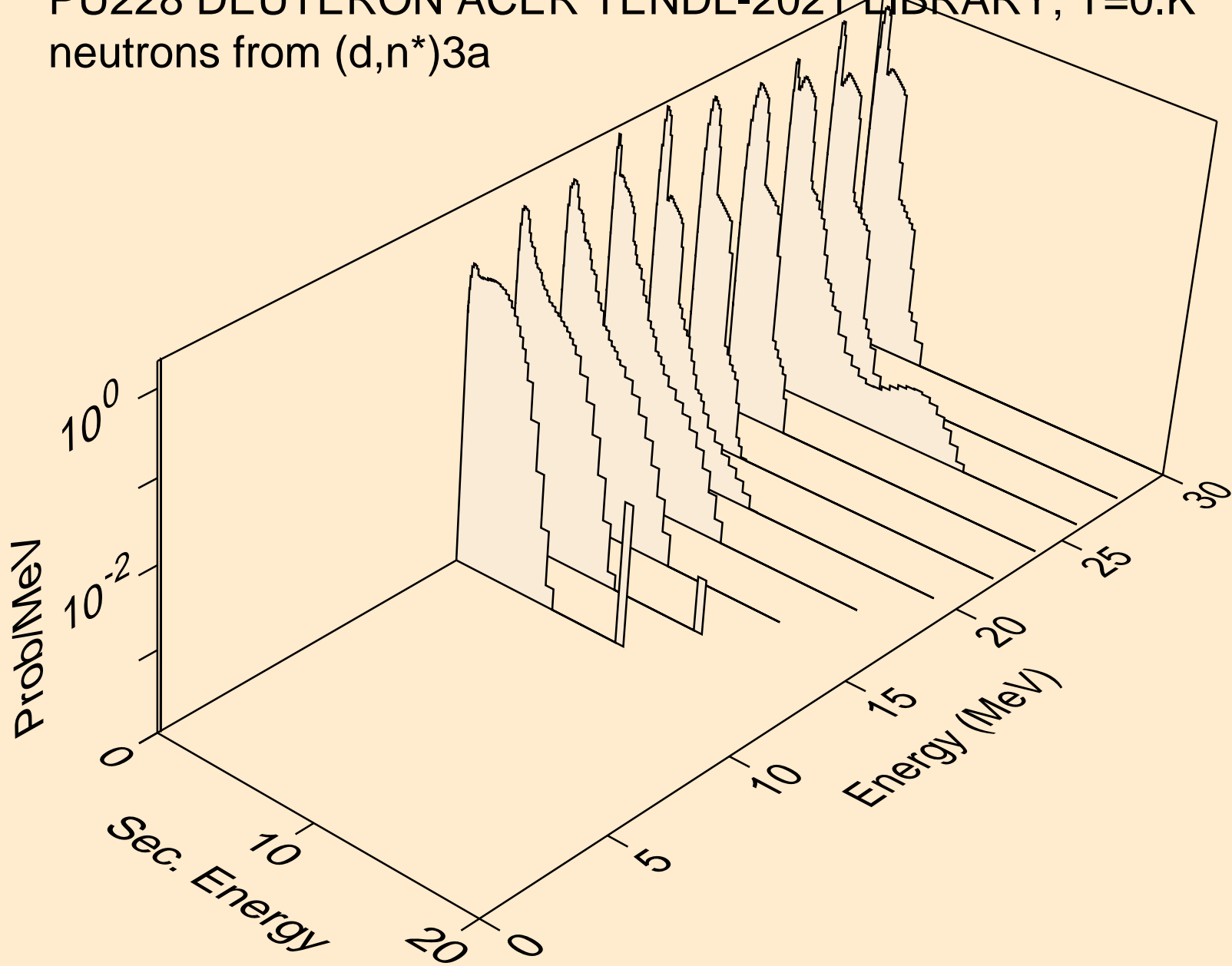

PU228 DEUTERON ACER TENDL-2021 LIBRARY; T=0.K  
neutrons from (d,2n)a

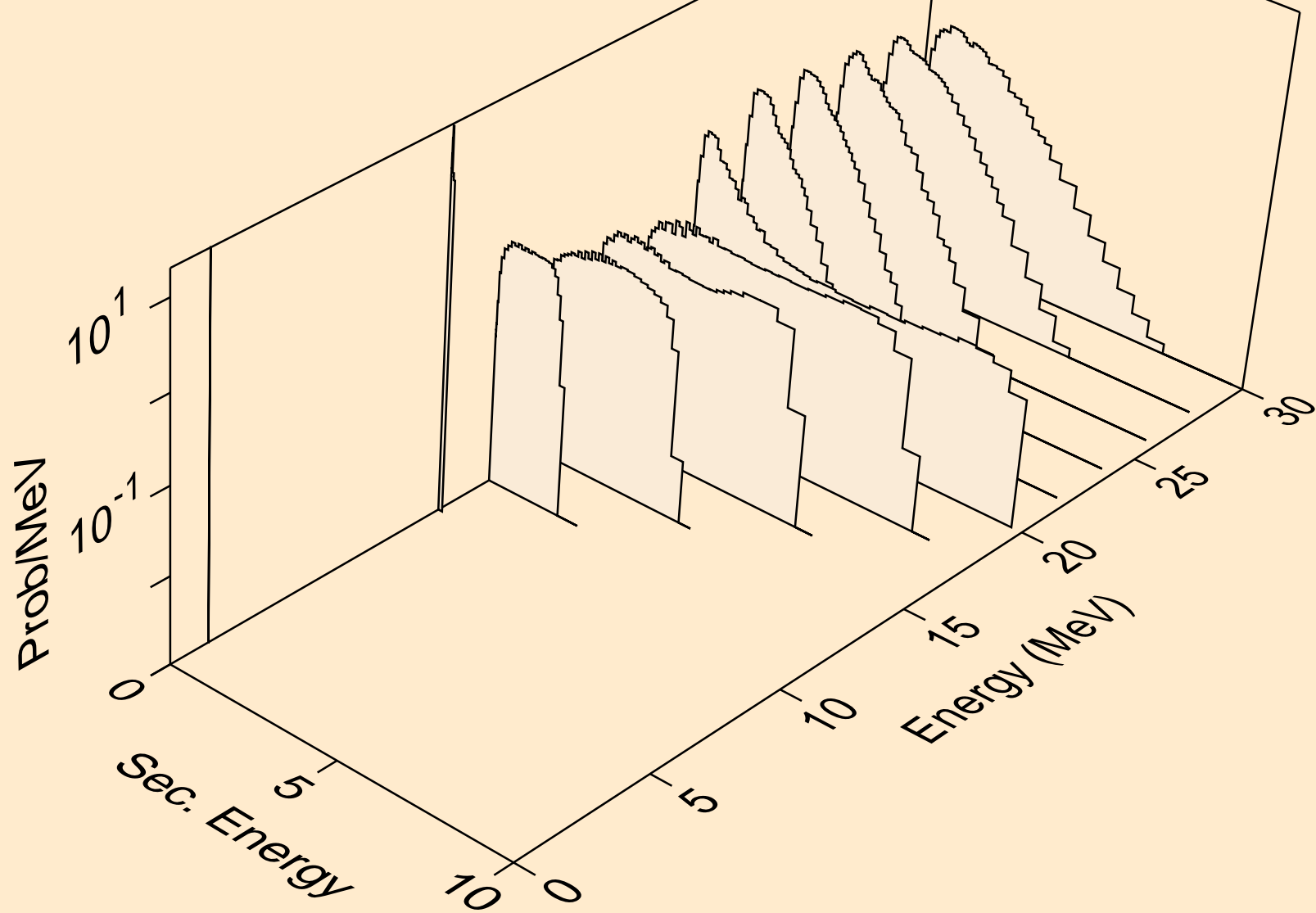

PU228 DEUTERON ACER TENDL-2021 LIBRARY; T=0.K  
neutrons from (d,n\*)p

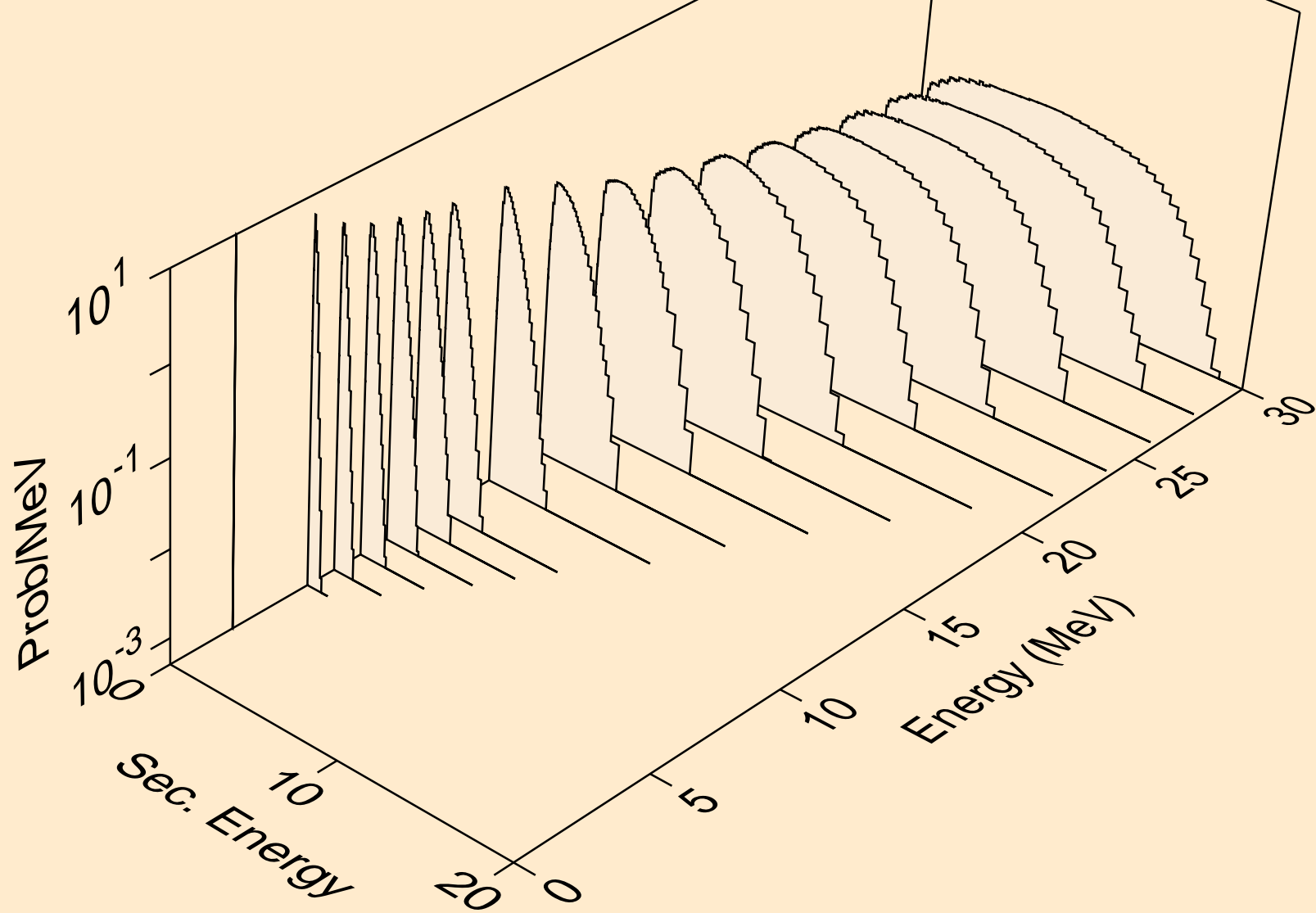

PU228 DEUTERON ACER TENDL-2021 LIBRARY; T=0.K  
neutrons from (d,n\*)2a

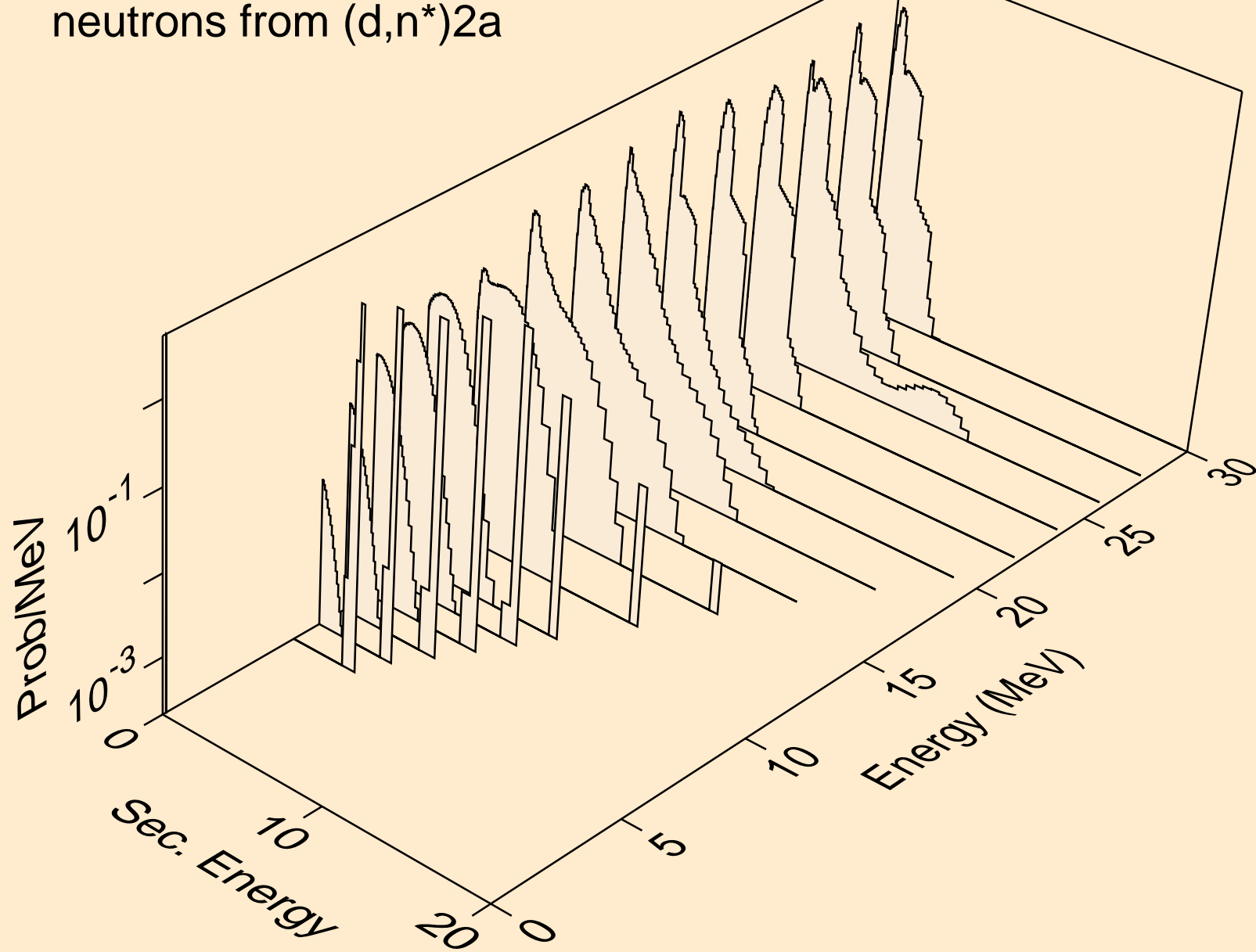

PU228 DEUTERON ACER TENDL-2021 LIBRARY; T=0.K  
neutrons from (d,2n)2a

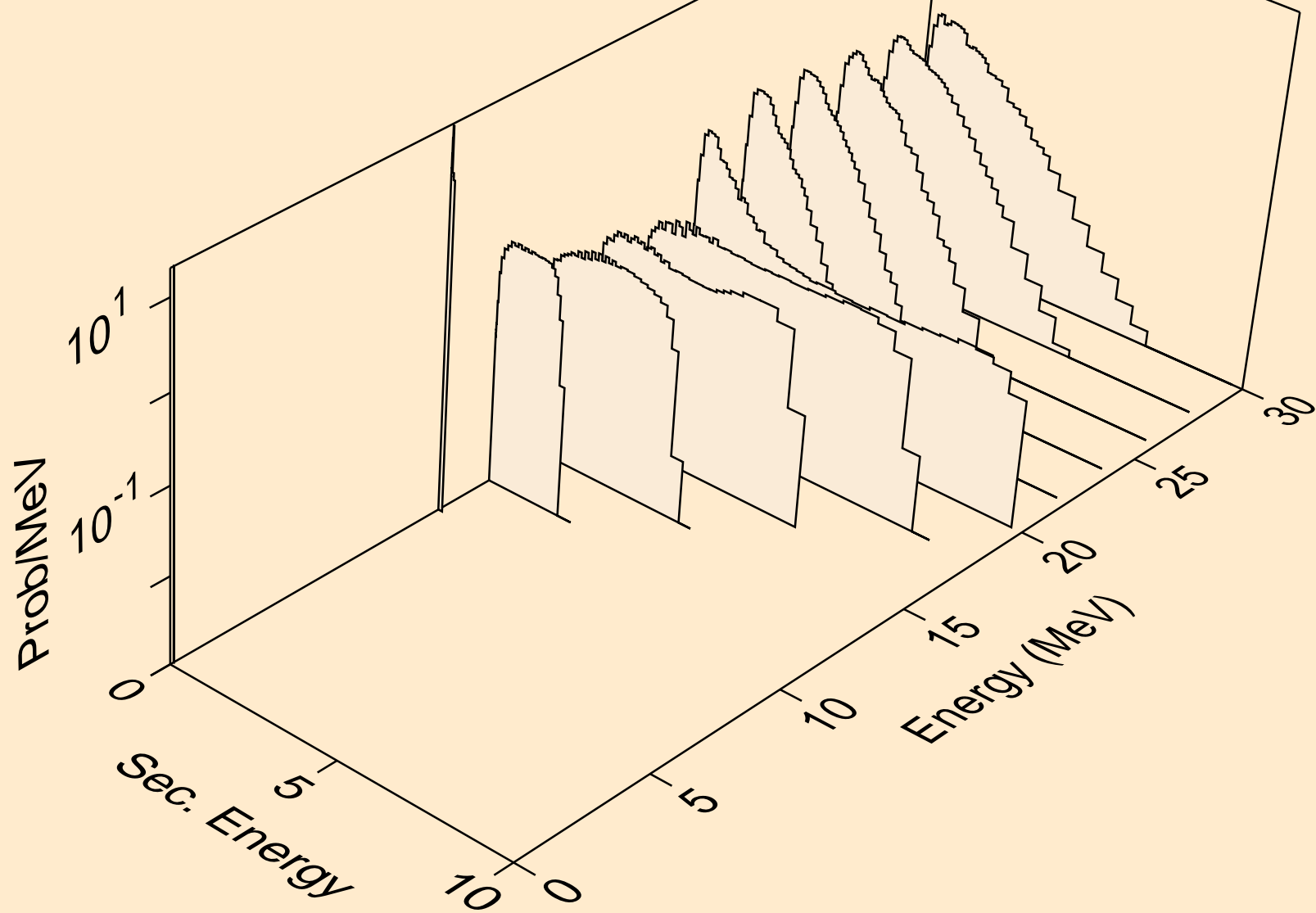

PU228 DEUTERON ACER TENDL-2021 LIBRARY; T=0.K  
neutrons from (d,n\*)d

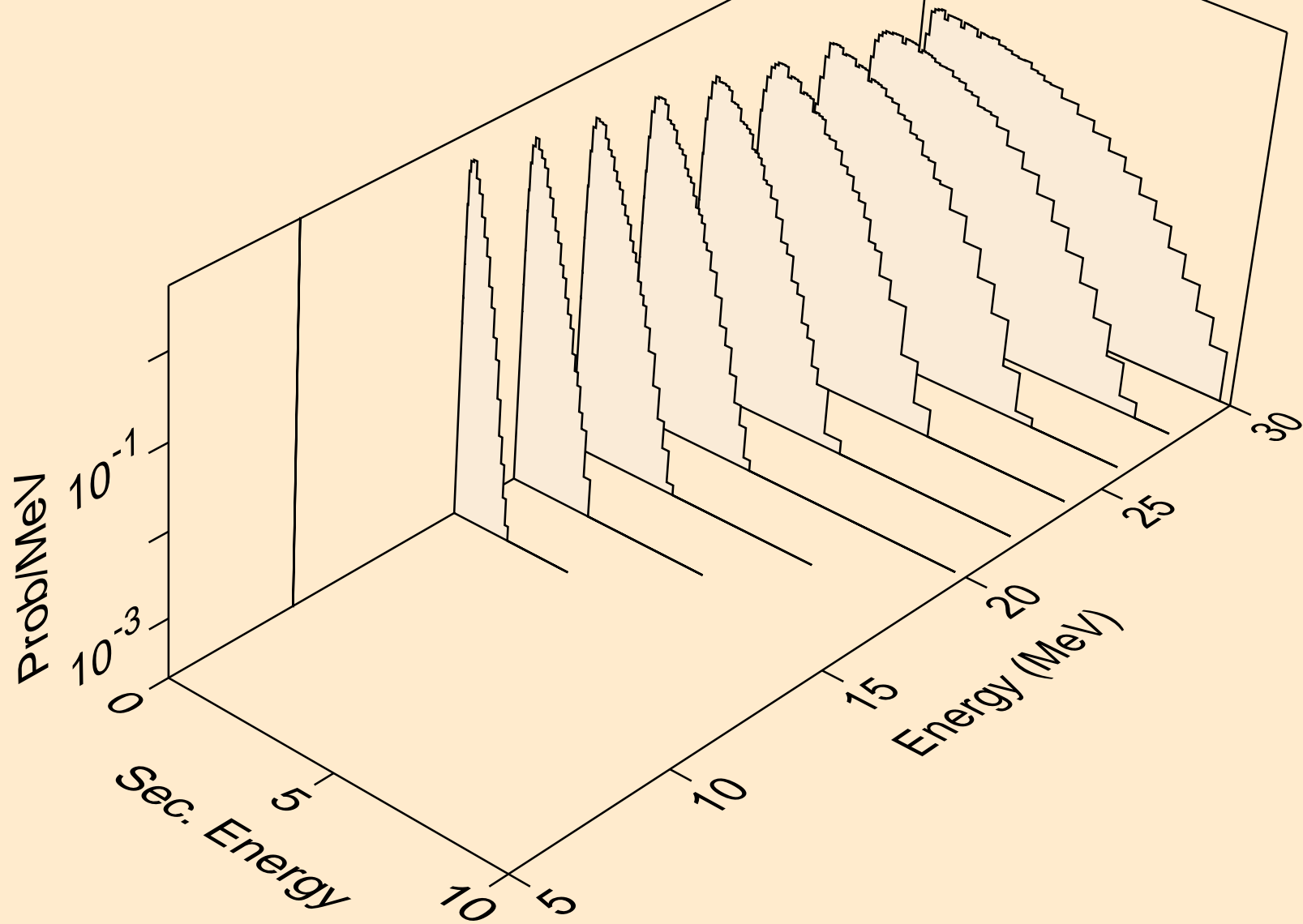

PU228 DEUTERON ACER TENDL-2021 LIBRARY; T=0.K  
neutrons from (d,n\*)t

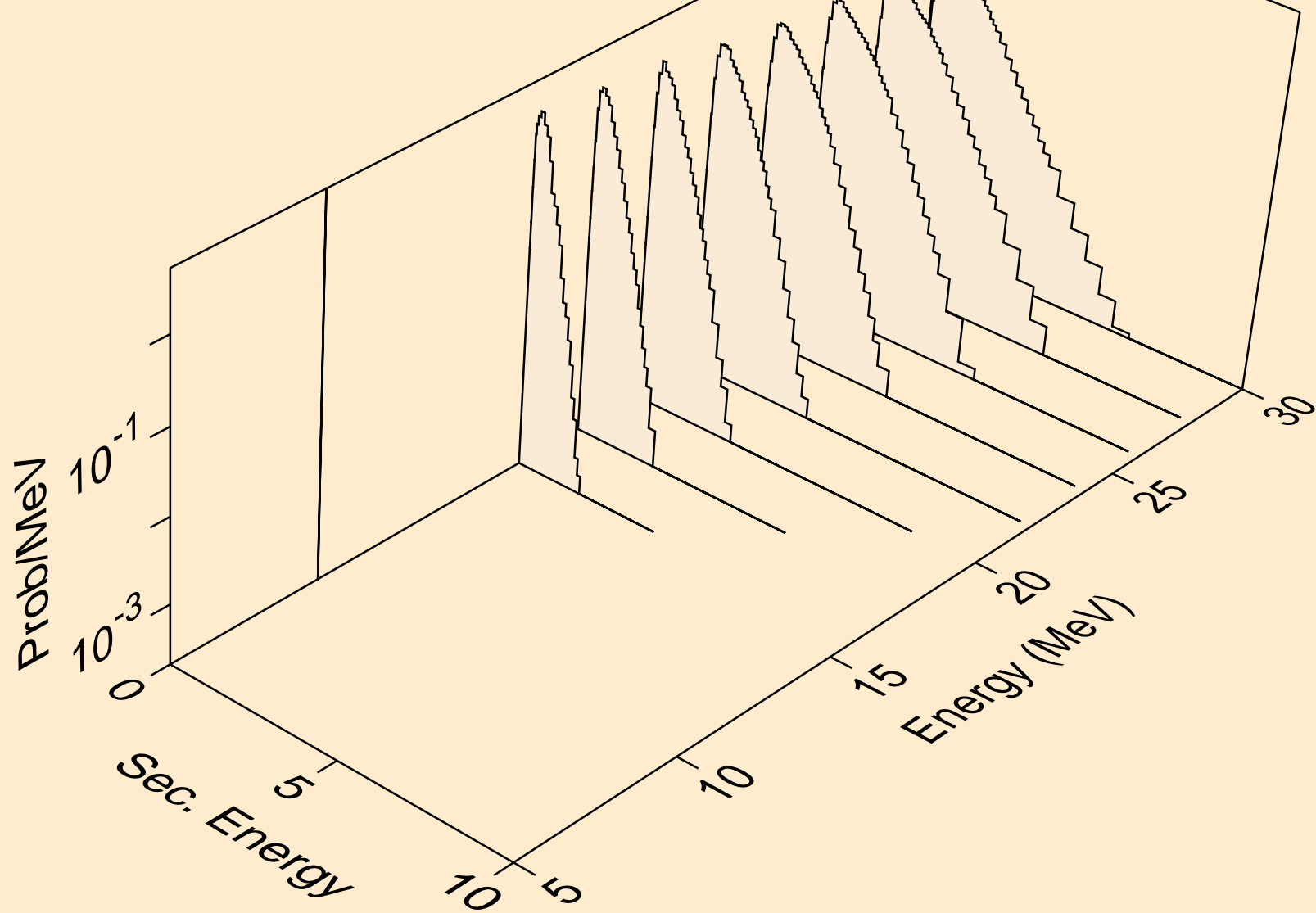

PU228 DEUTERON ACER TENDL-2021 LIBRARY; T=0.K  
neutrons from (d,n\*)he3

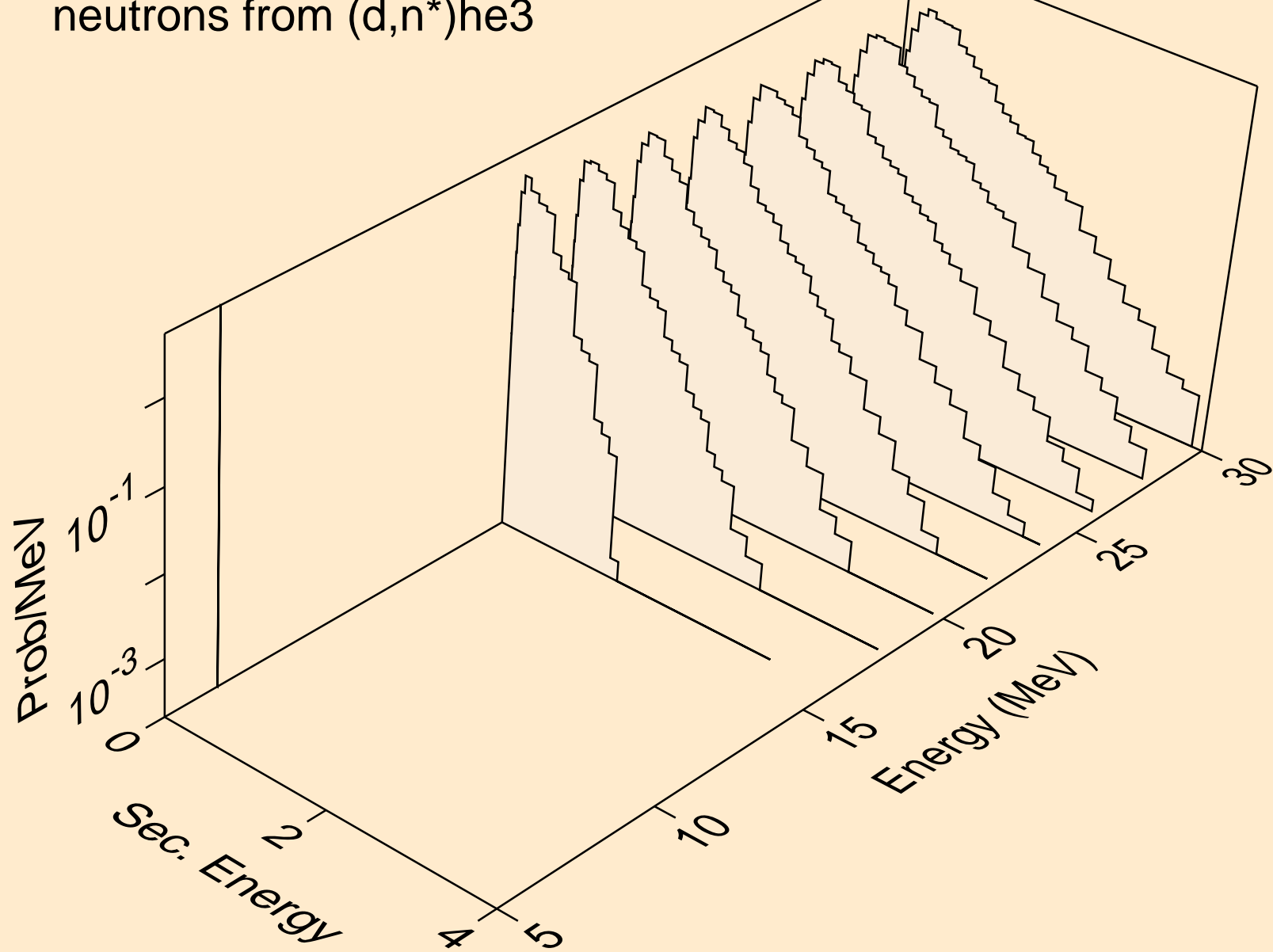

PU228 DEUTERON ACER TENDL-2021 LIBRARY; T=0.K  
neutrons from (d,n\*)d2a

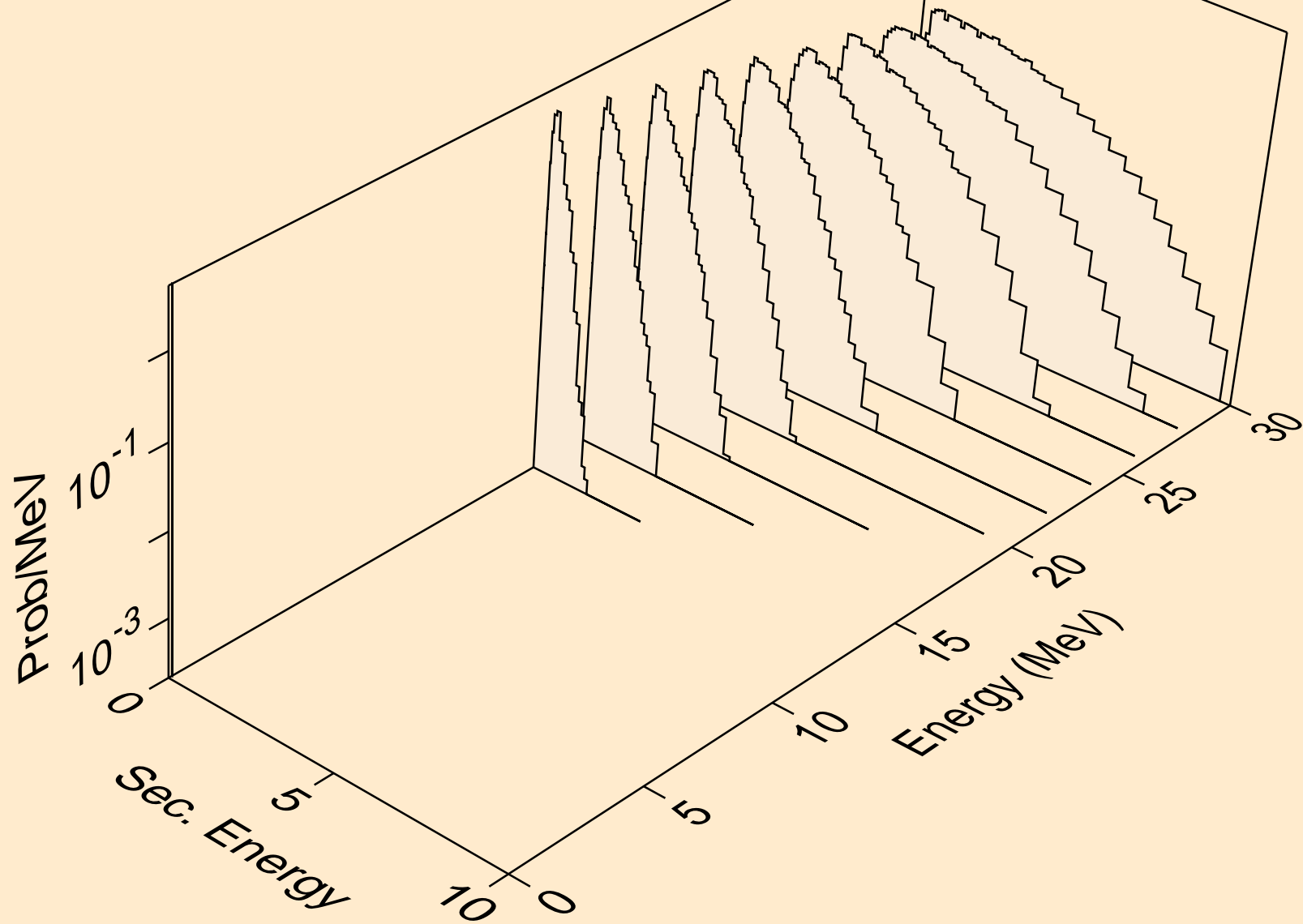

PU228 DEUTERON ACER TENDL-2021 LIBRARY; T=0.K  
neutrons from (d,2np)

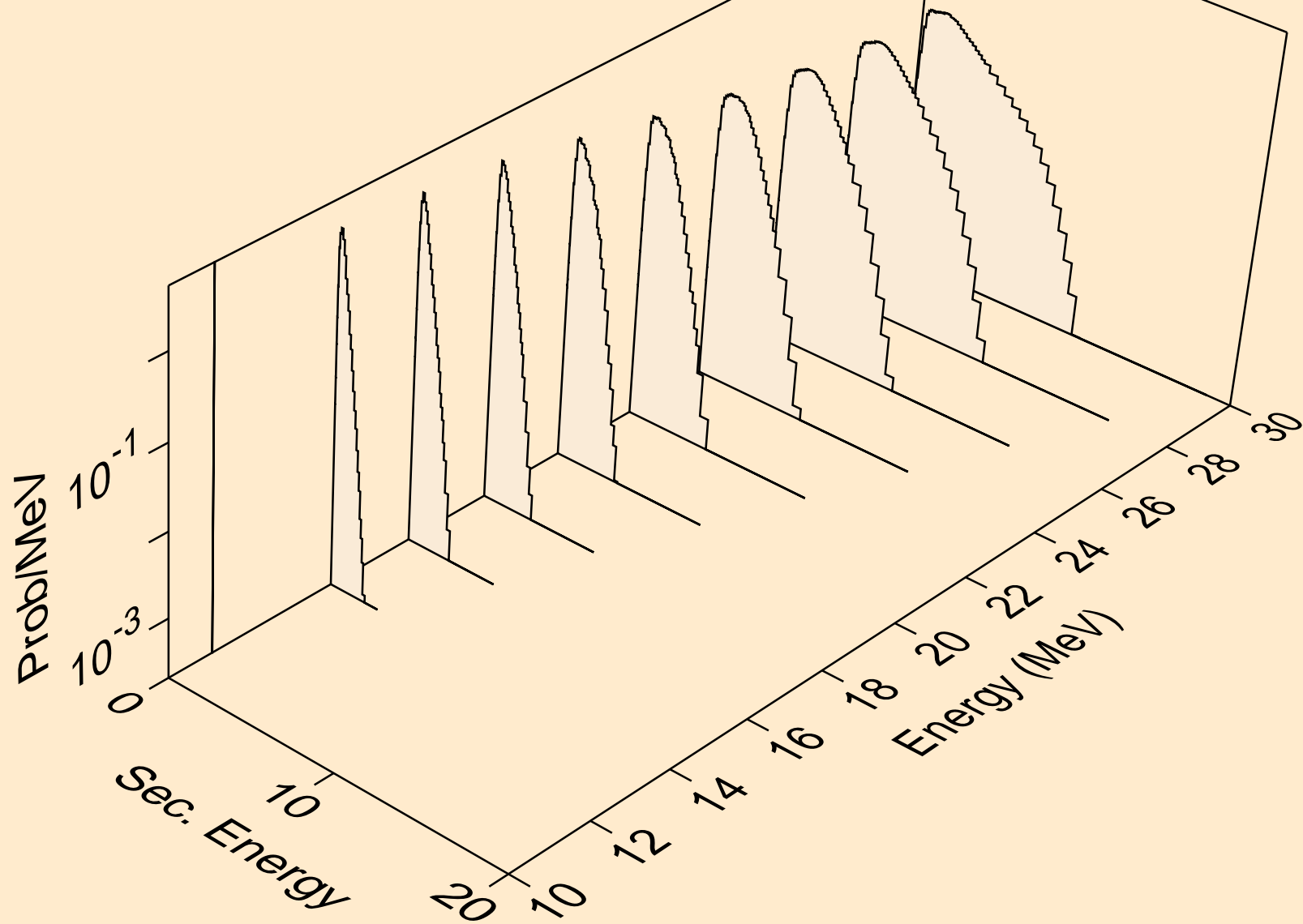

PU228 DEUTERON ACER TENDL-2021 LIBRARY; T=0.K  
neutrons from (d,2np)

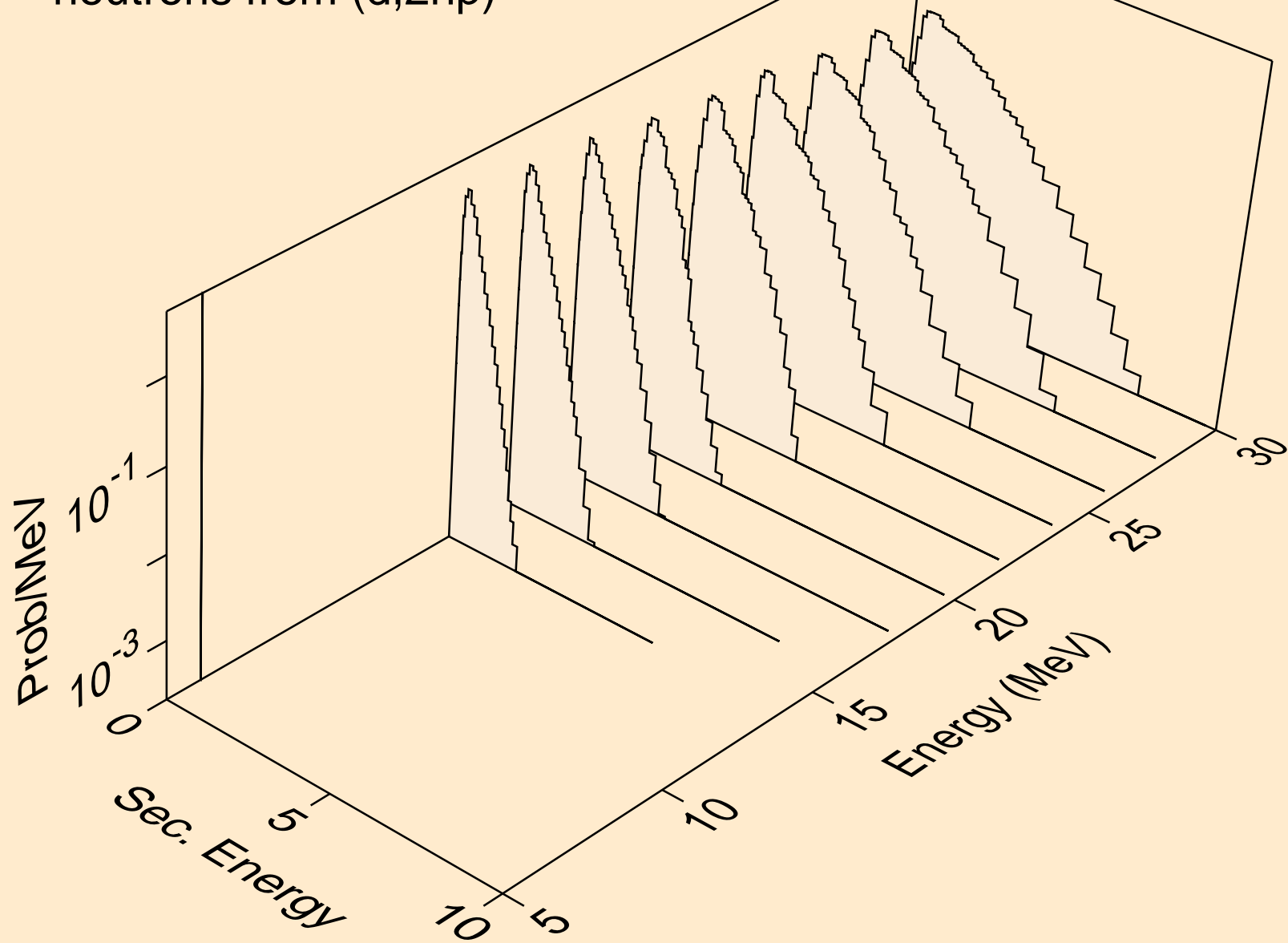

PU228 DEUTERON ACER TENDL-2021 LIBRARY; T=0.K  
neutrons from (d,npa)

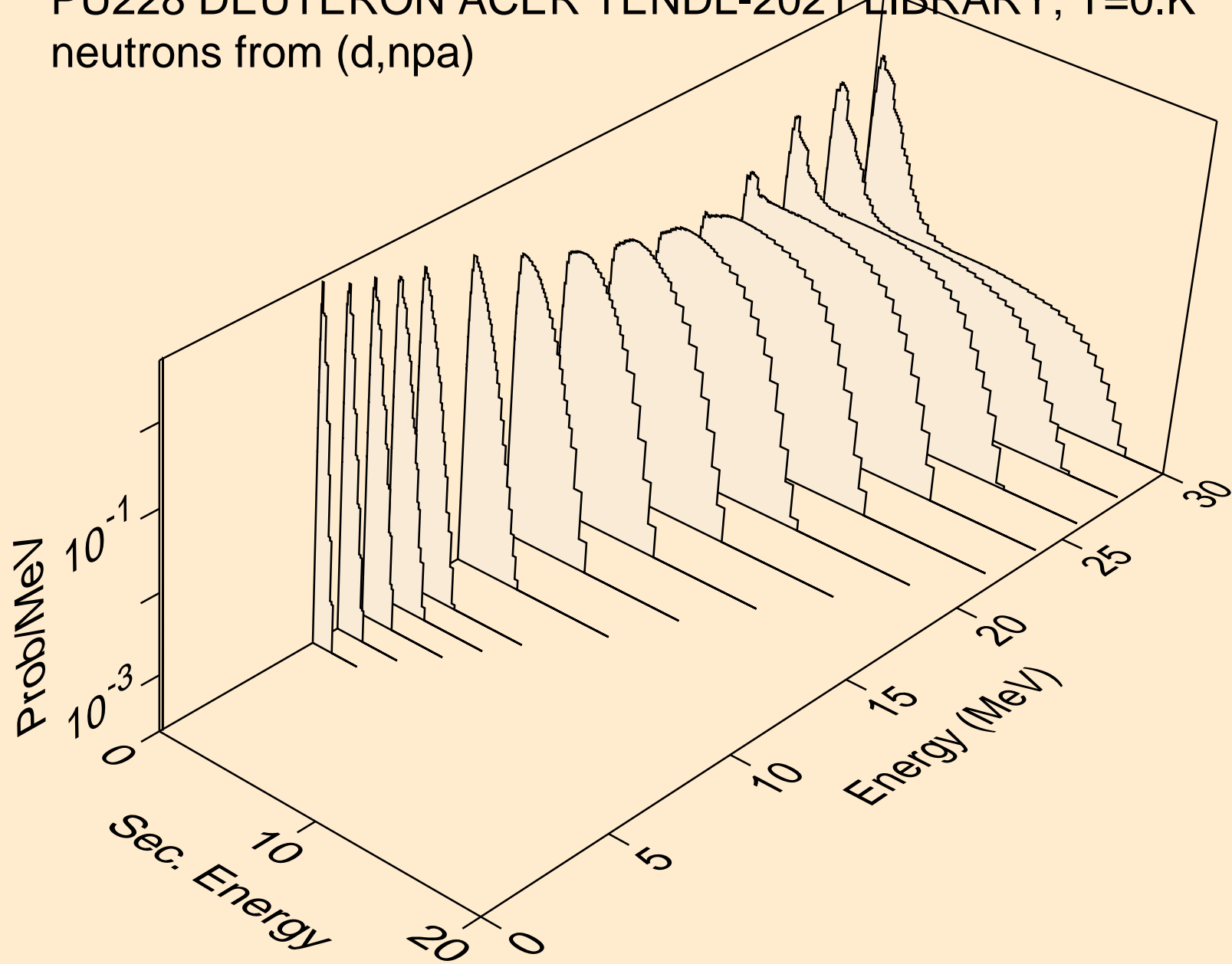

PU228 DEUTERON ACER TENDL-2021 LIBRARY; T=0.K  
protons from (d,x)

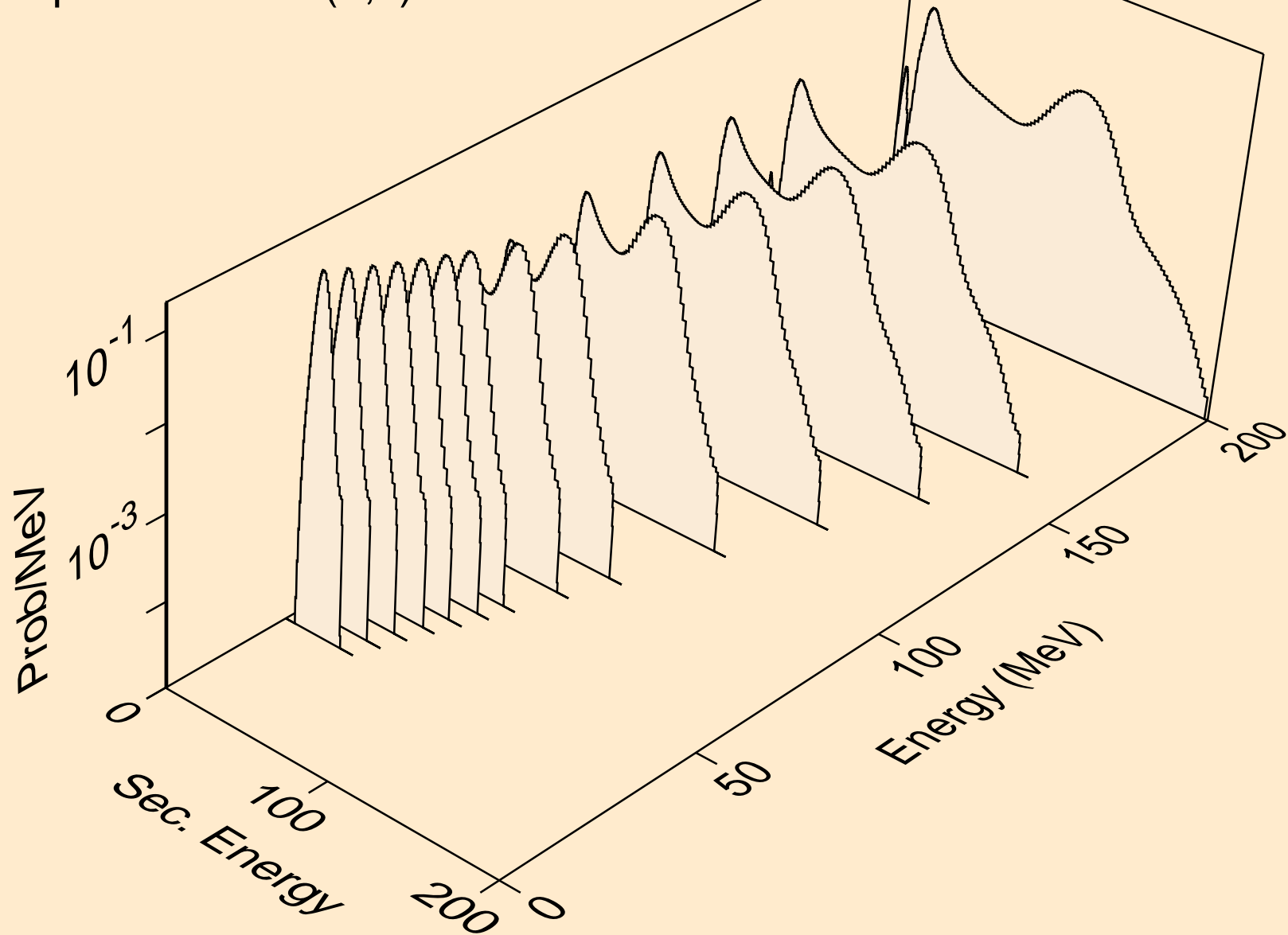

PU228 DEUTERON ACER TENDL-2021 LIBRARY; T=0.K  
protons from (d,n\*)p

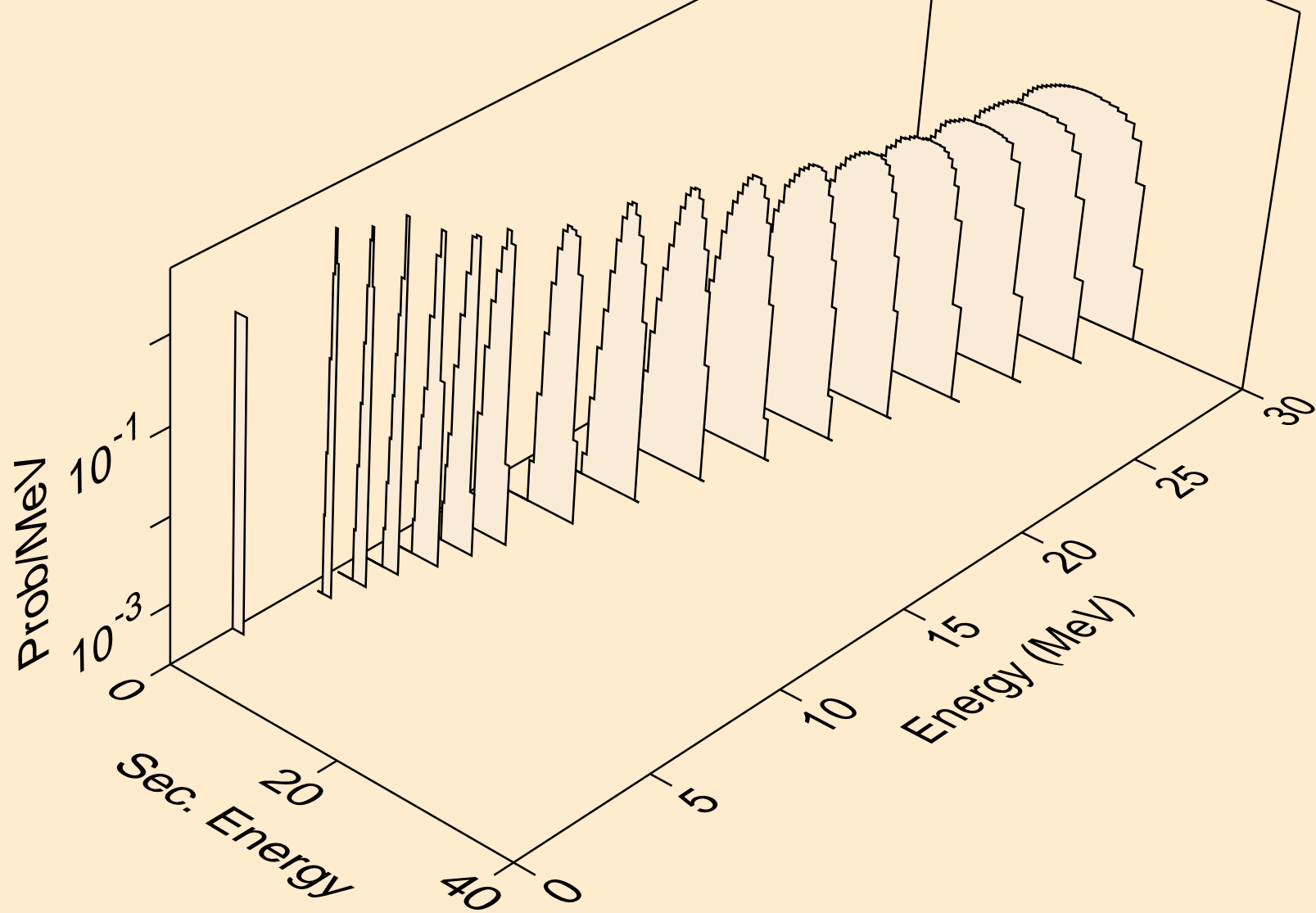

PU228 DEUTERON ACER TENDL-2021 LIBRARY; T=0.K  
protons from (d,2np)

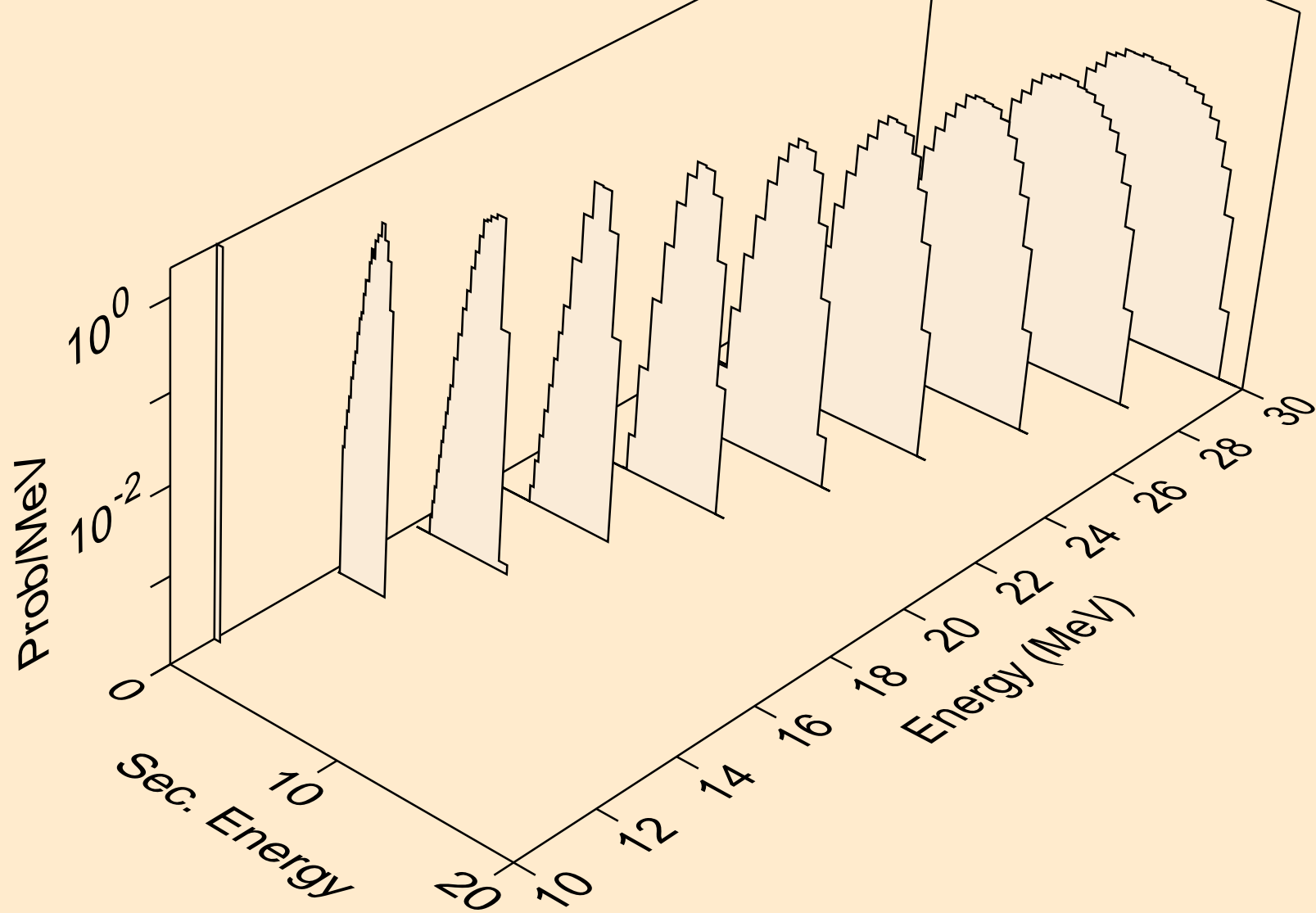

PU228 DEUTERON ACER TENDL-2021 LIBRARY; T=0.K  
protons from (d,2np)

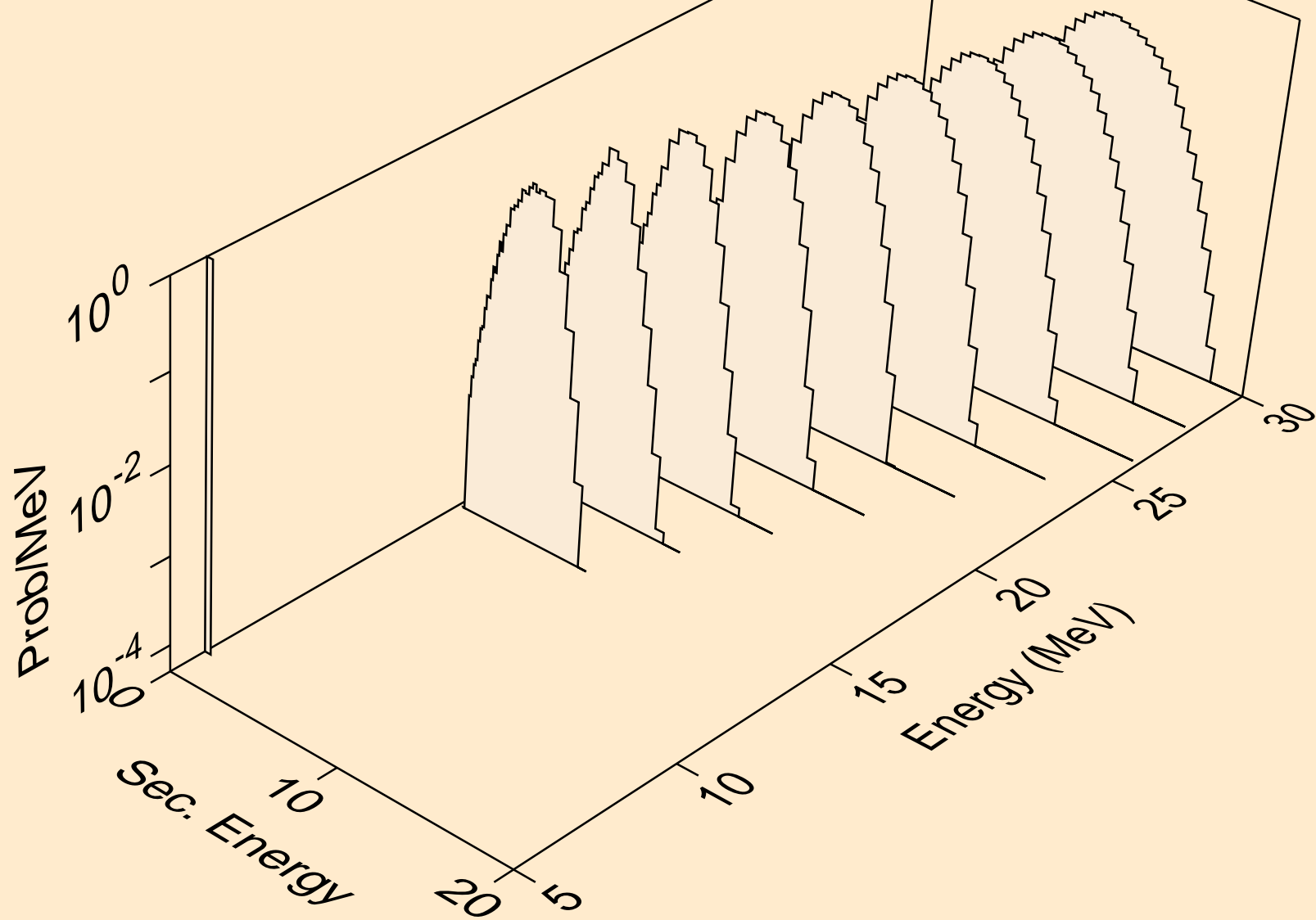

PU228 DEUTERON ACER TENDL-2021 LIBRARY; T=0.K  
protons from (d,npa)

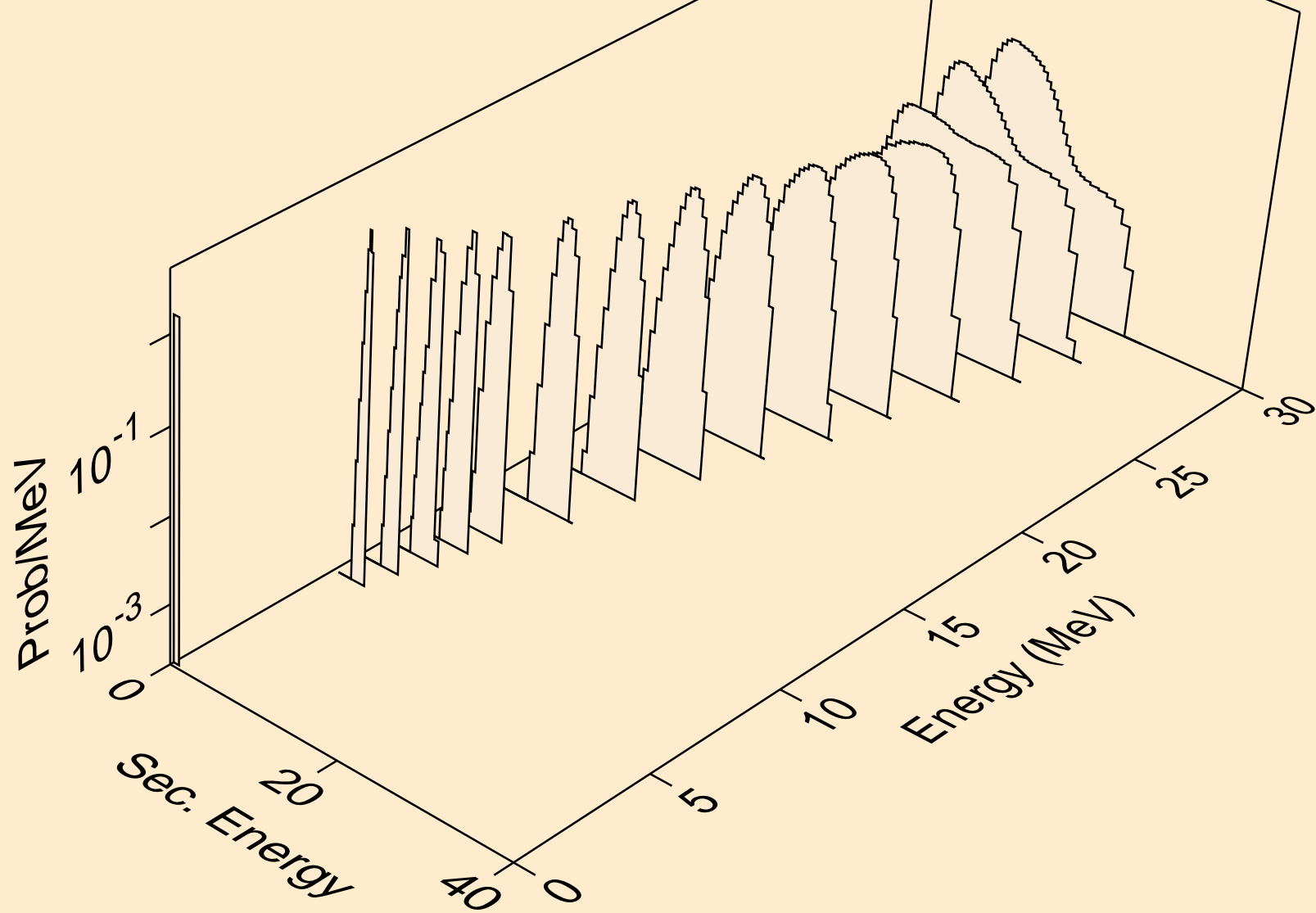

PU228 DEUTERON ACER TENDL-2021 LIBRARY; T=0.K  
protons from (d,p)

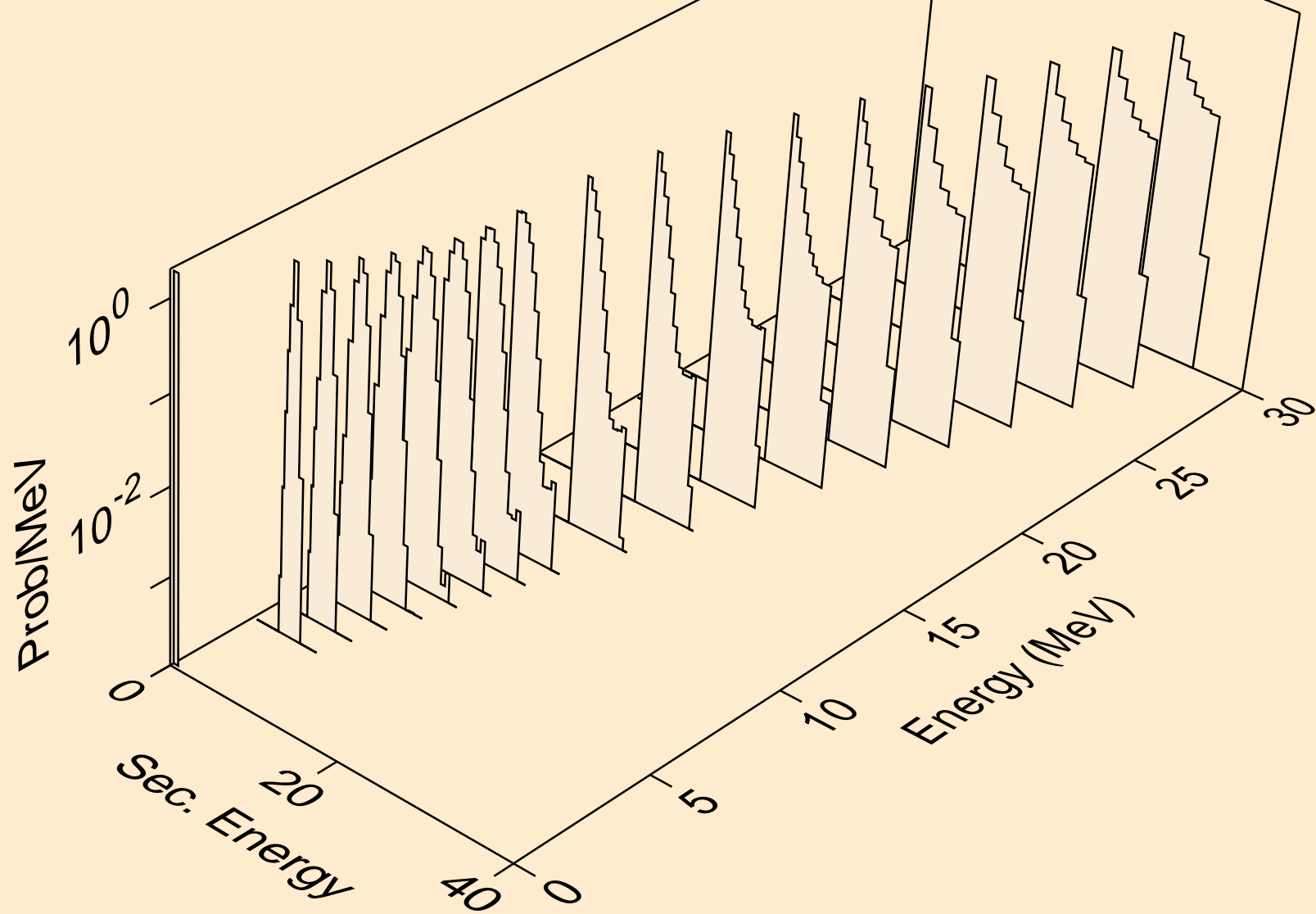

PU228 DEUTERON ACER TENDL-2021 LIBRARY; T=0.K  
protons from (d,2p)

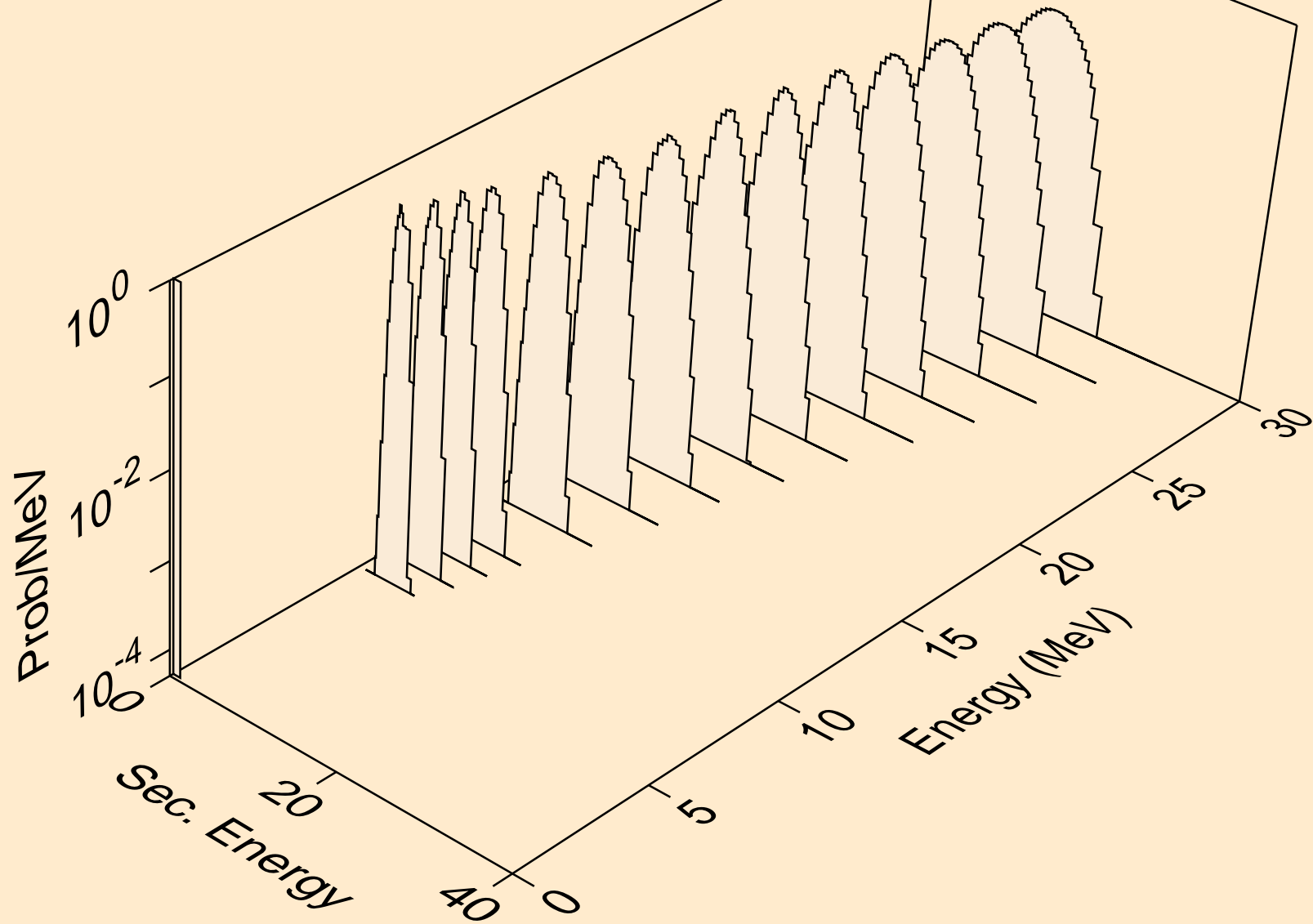

PU228 DEUTERON ACER TENDL-2021 LIBRARY; T=0.K  
protons from (d,pa)

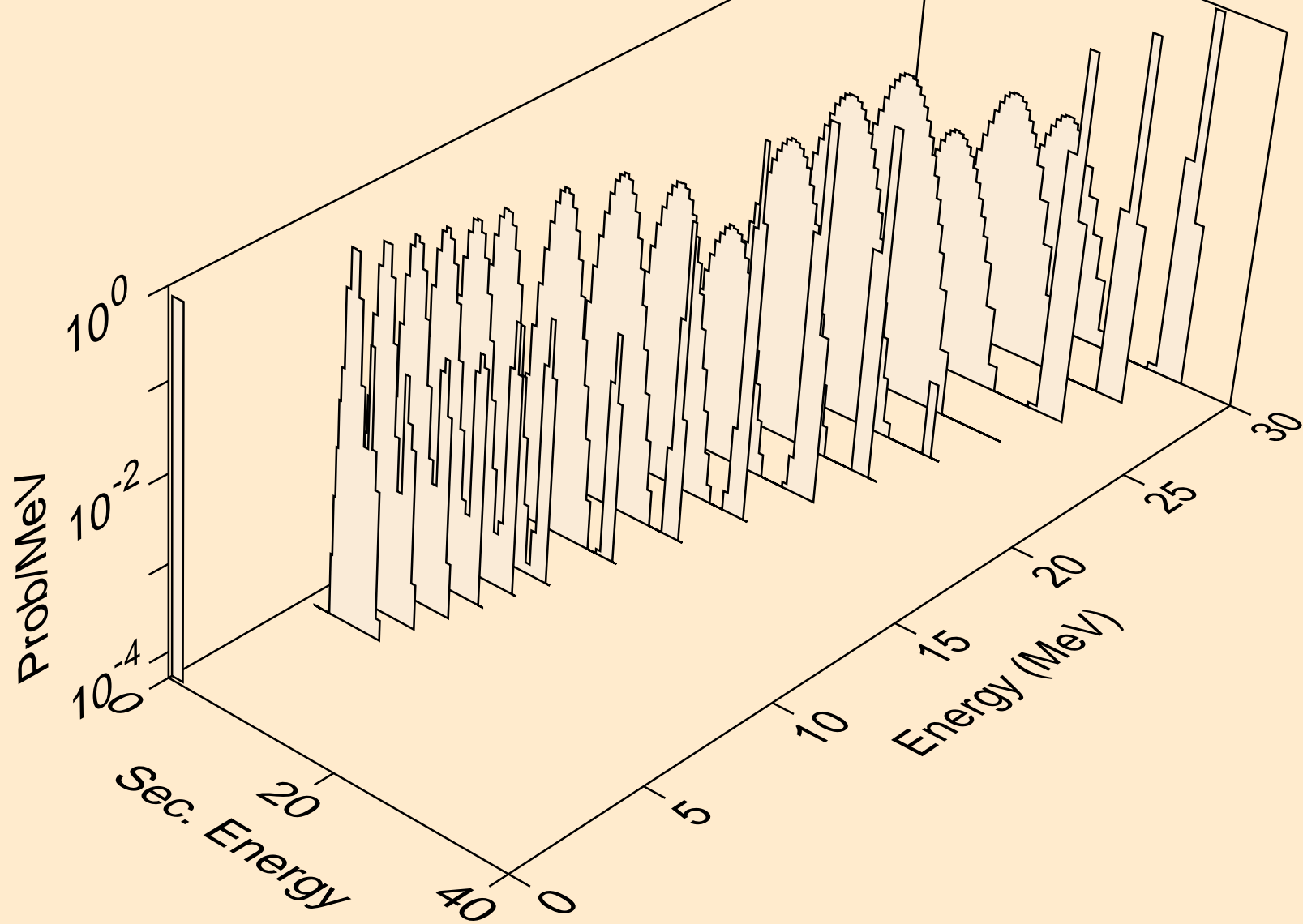

PU228 DEUTERON ACER TENDL-2021 LIBRARY; T=0.K  
protons from (d,pd)

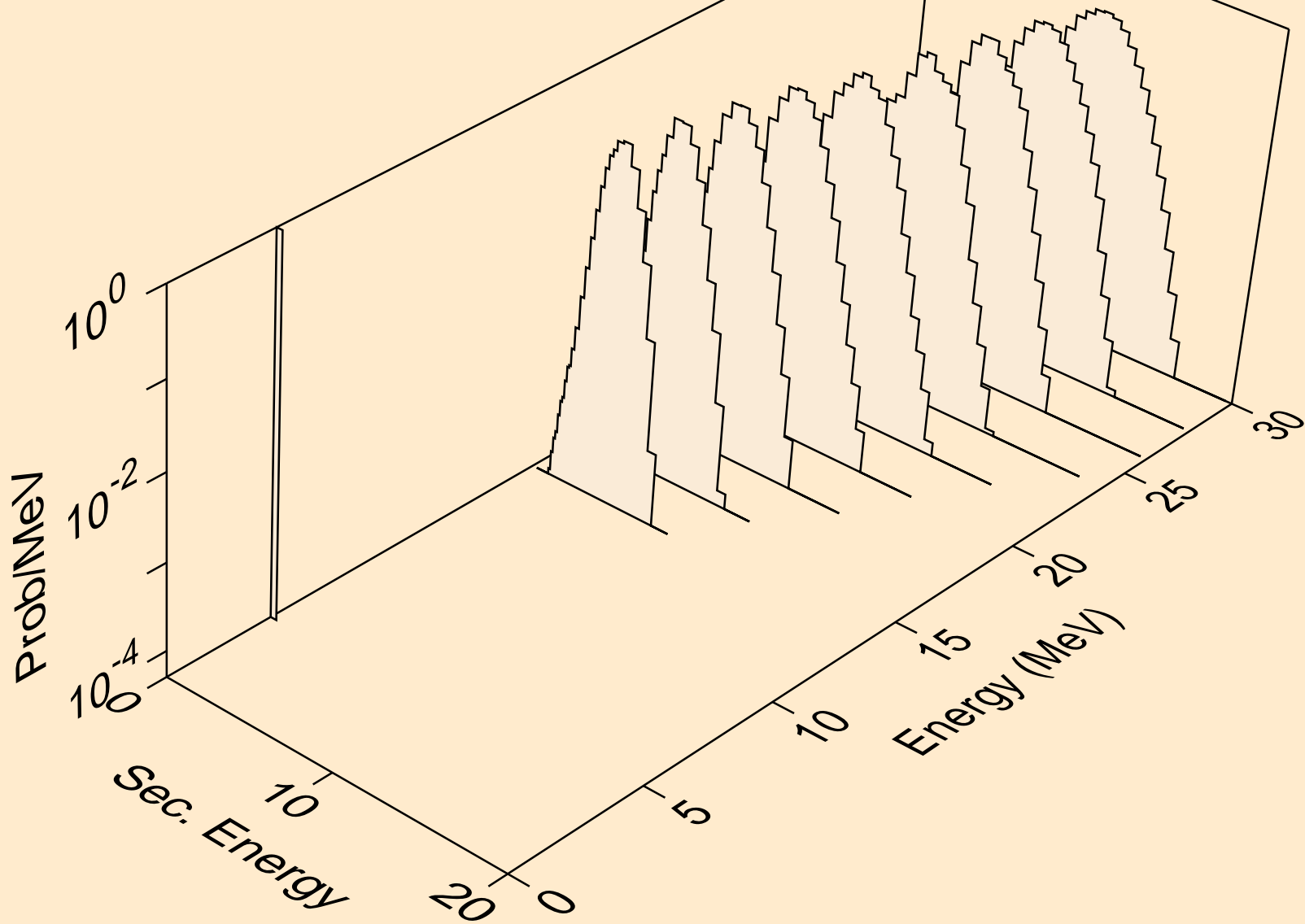

PU228 DEUTERON ACER TENDL-2021 LIBRARY; T=0.K  
tritons from (d,x)

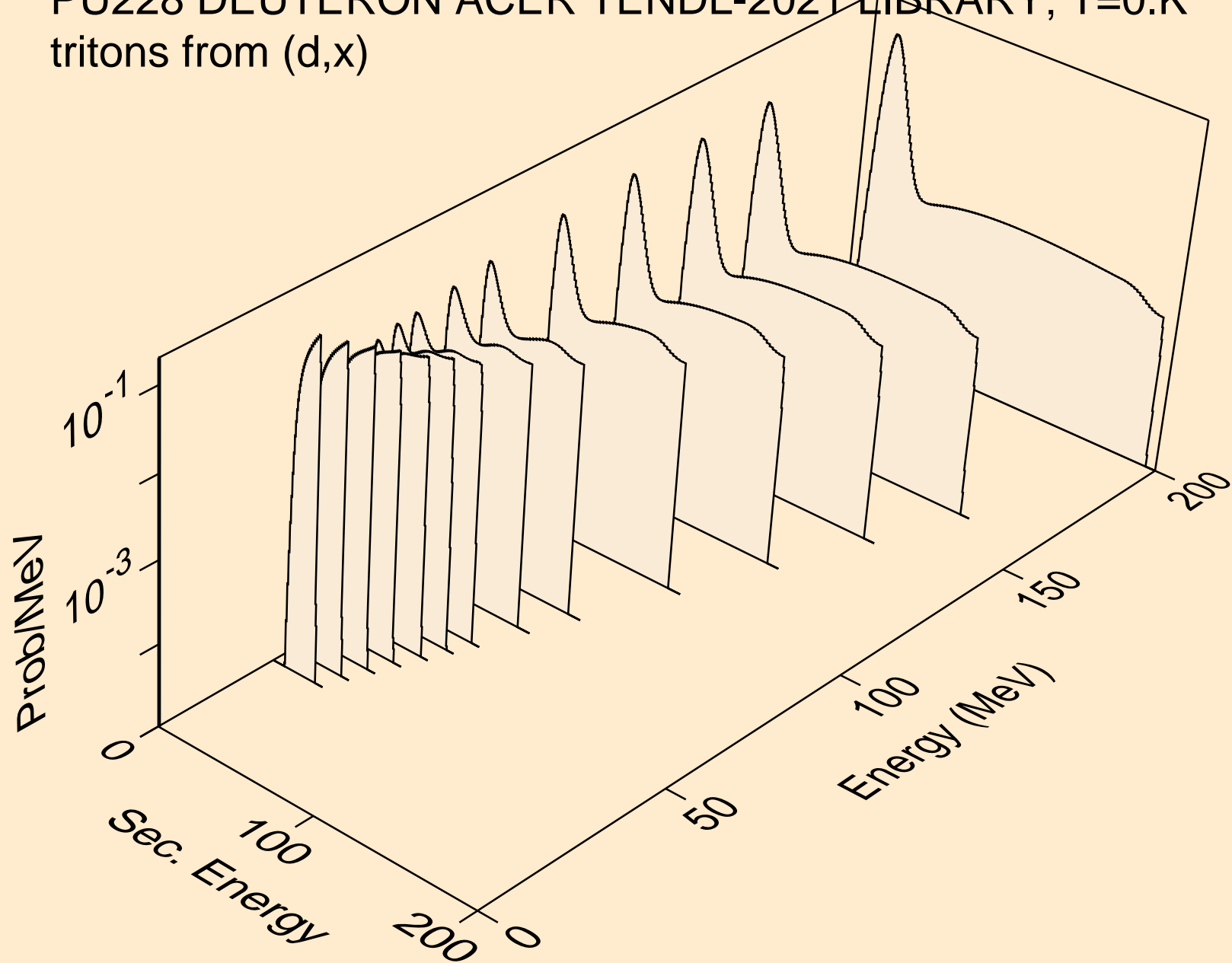

PU228 DEUTERON ACER TENDL-2021 LIBRARY; T=0.K  
tritons from (d,n\*)t

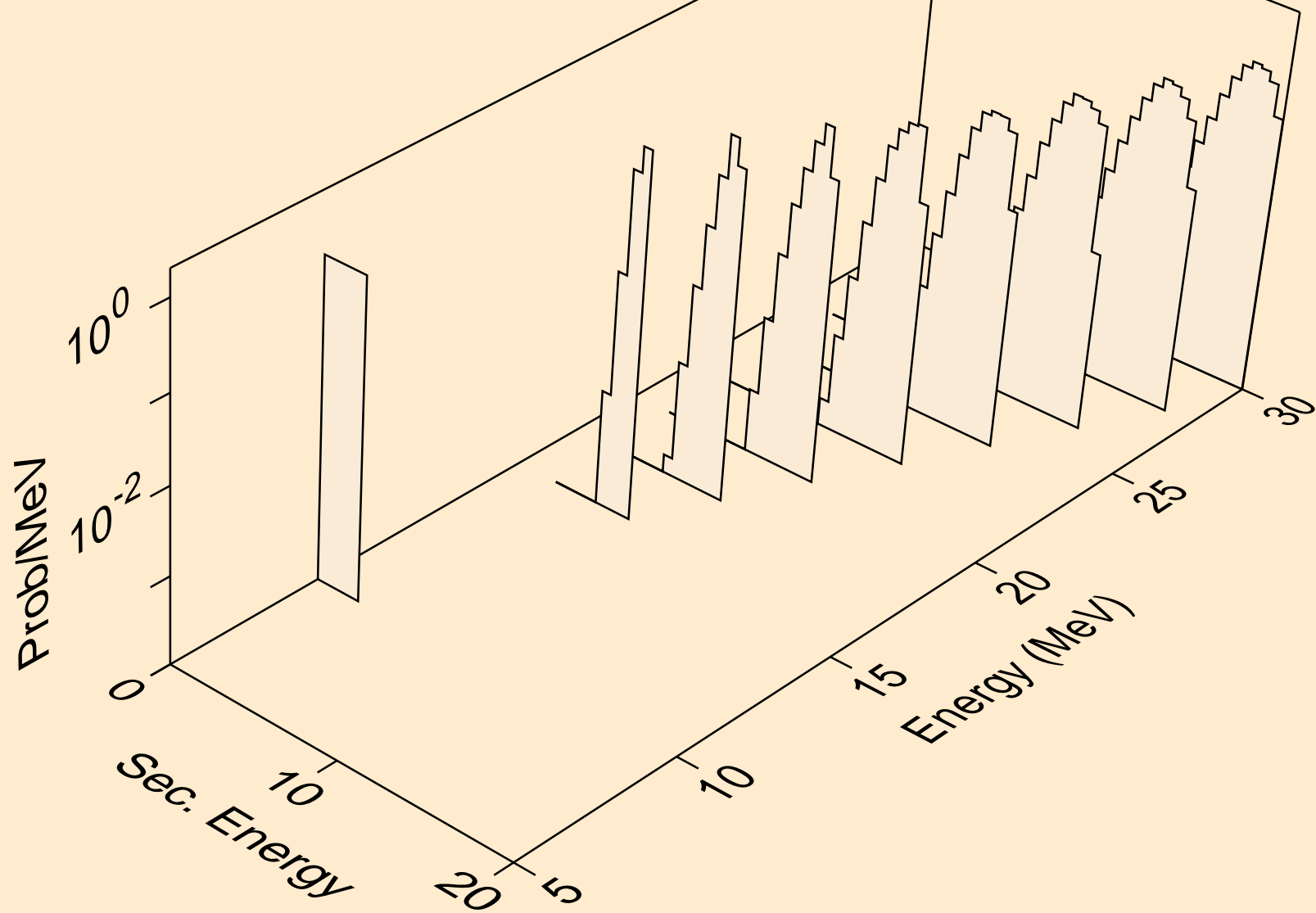

PU228 DEUTERON ACER TENDL-2021 LIBRARY; T=0.K  
tritons from (d,t)

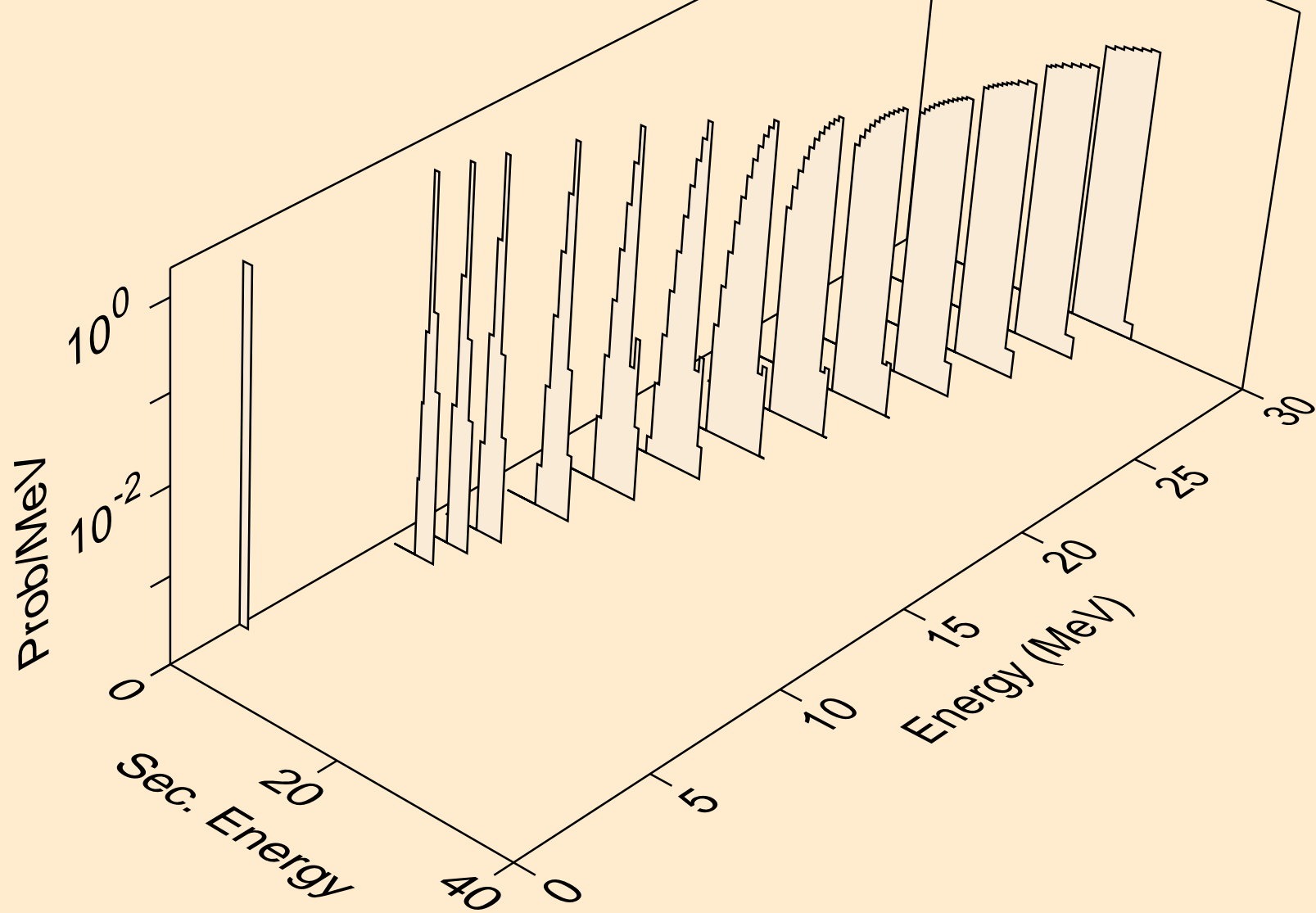

PU228 DEUTERON ACER TENDL-2021 LIBRARY; T=0.K  
tritons from (d,t2a)

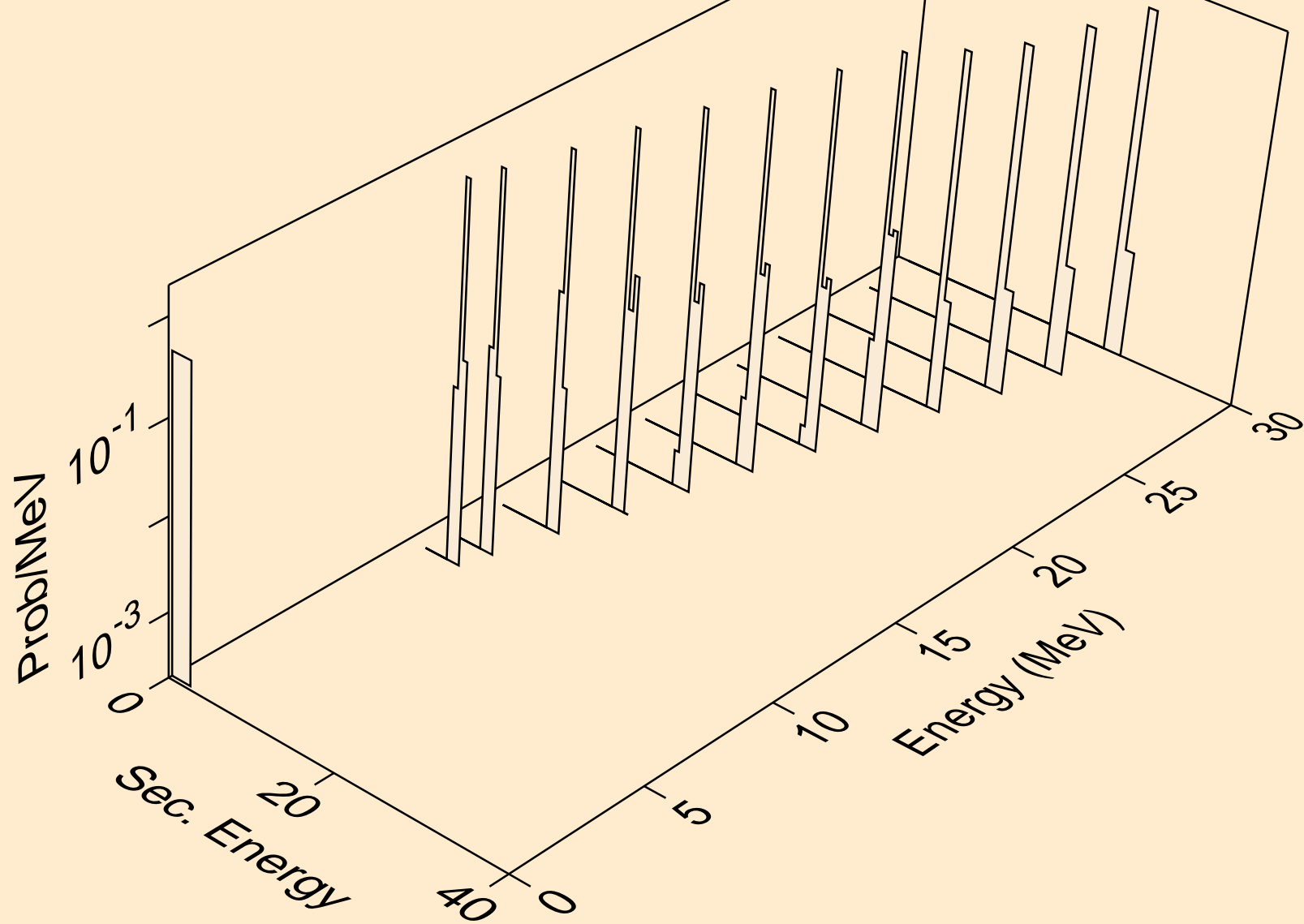

PU228 DEUTERON ACER TENDL-2021 LIBRARY; T=0.K  
he3s from (d,x)

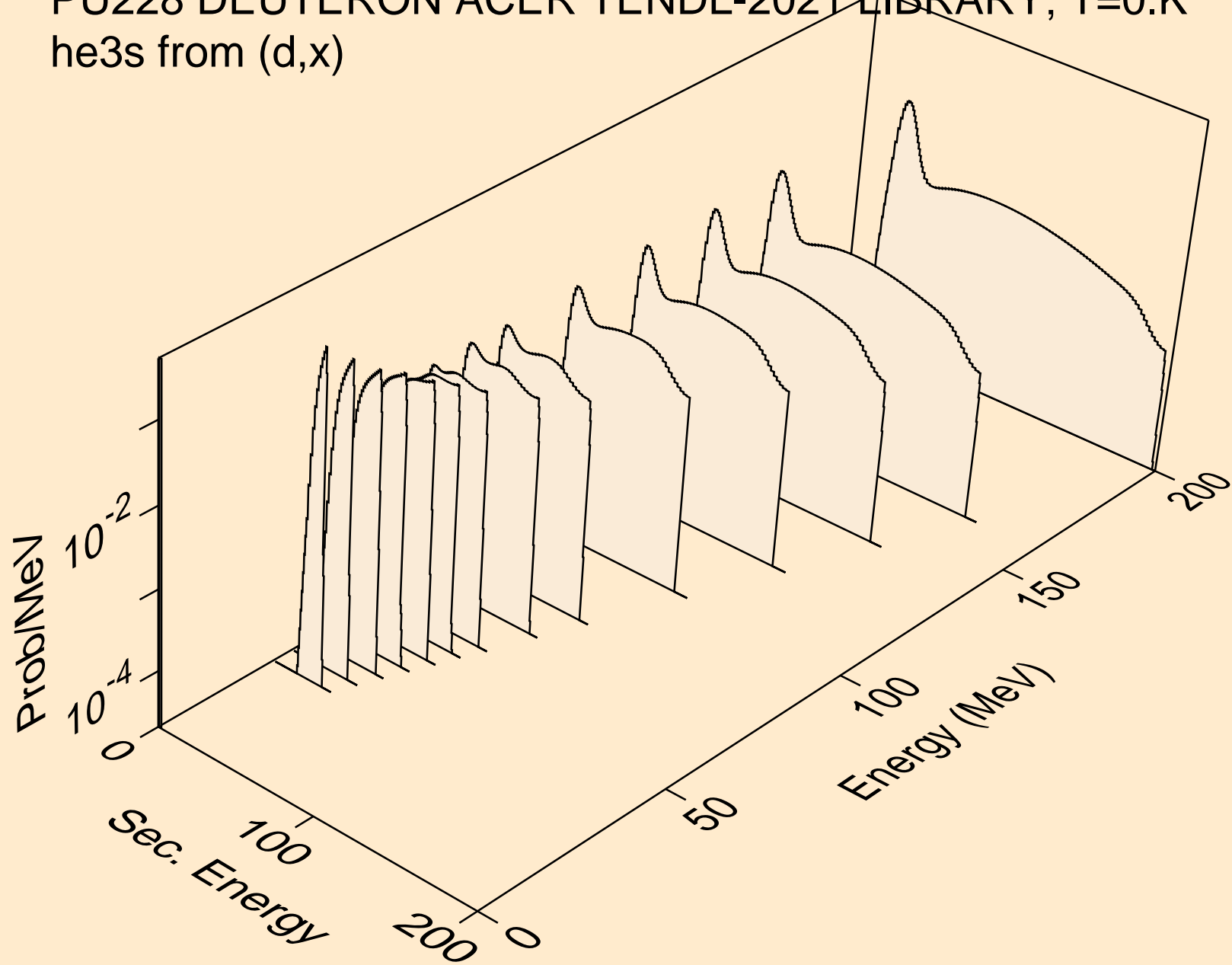

PU228 DEUTERON ACER TENDL-2021 LIBRARY; T=0.K  
he3s from (d,n\*)he3

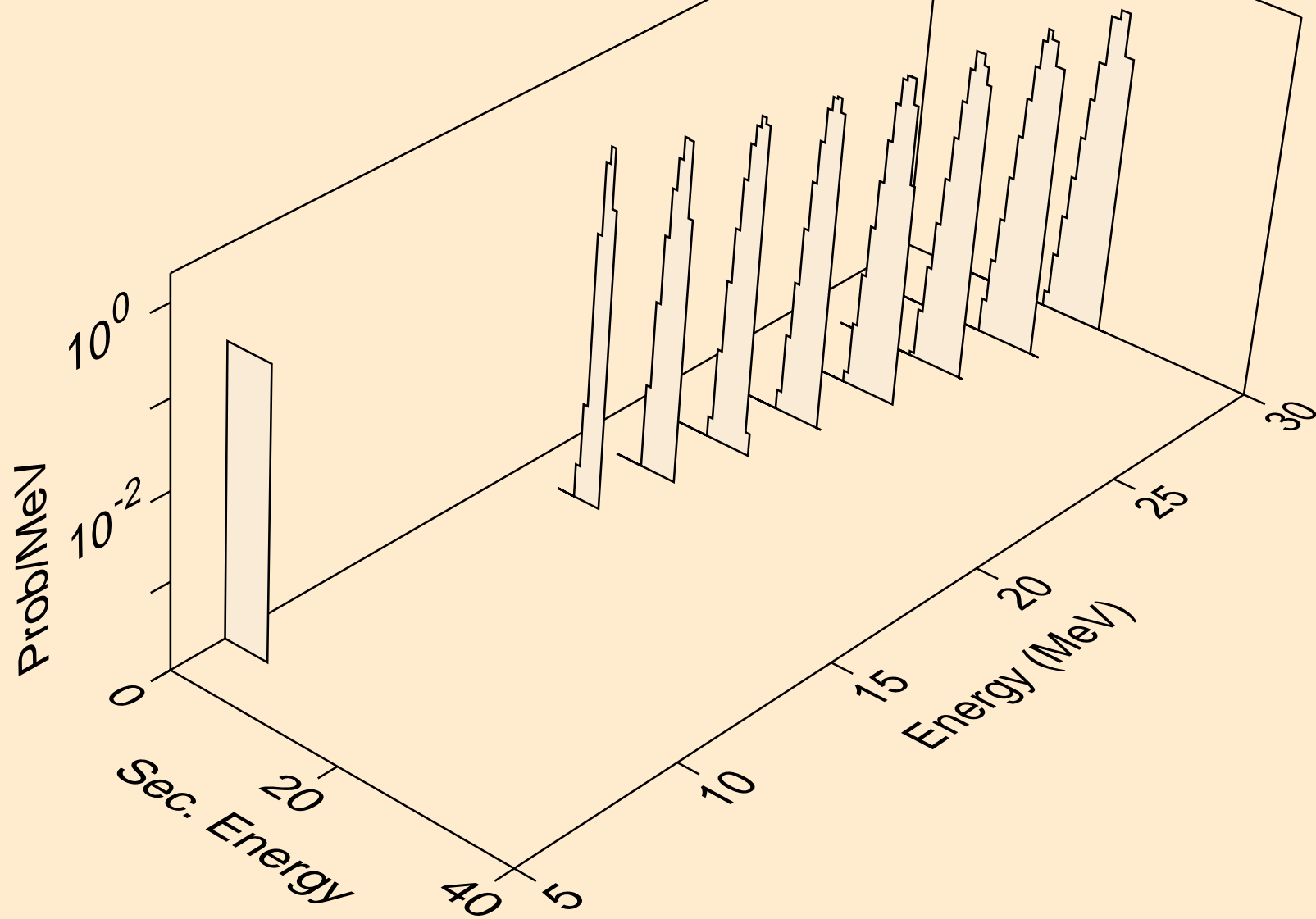

PU228 DEUTERON ACER TENDL-2021 LIBRARY; T=0.K  
he3s from (d,he3)

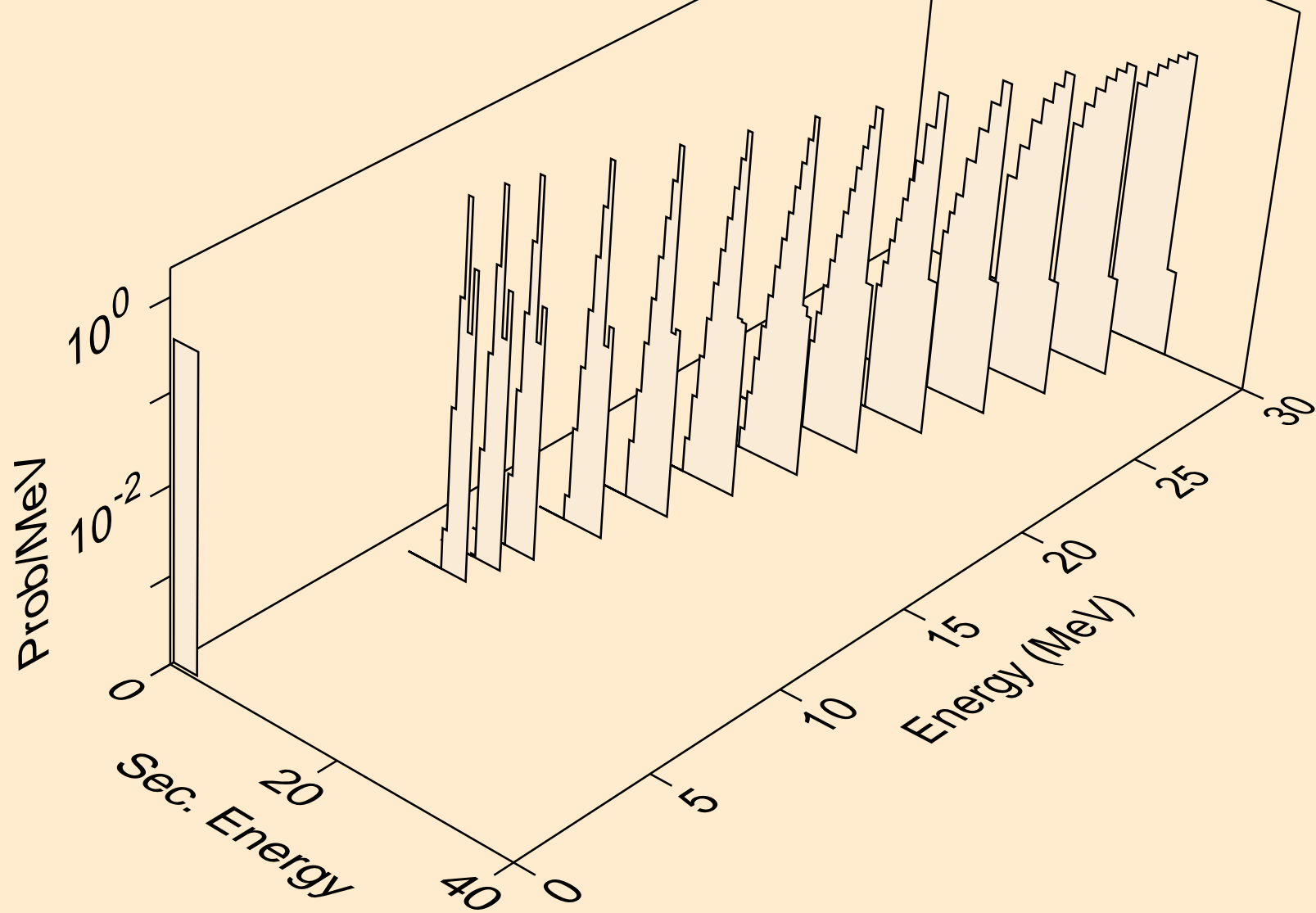

PU228 DEUTERON ACER TENDL-2021 LIBRARY; T=0.K  
alphas from (d,x)

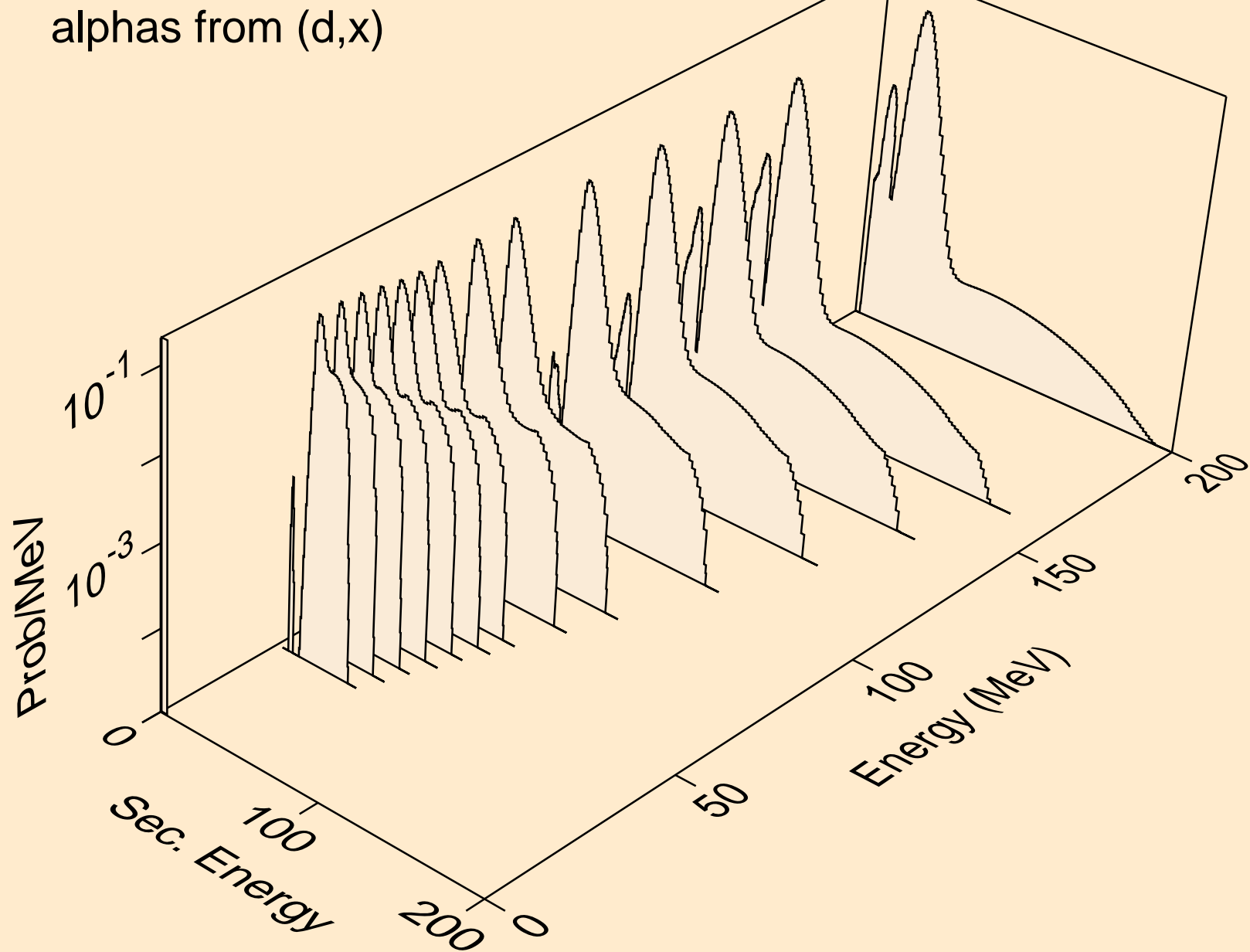

PU228 DEUTERON ACER TENDL-2021 LIBRARY; T=0.K  
alphas from (d,n\*)a

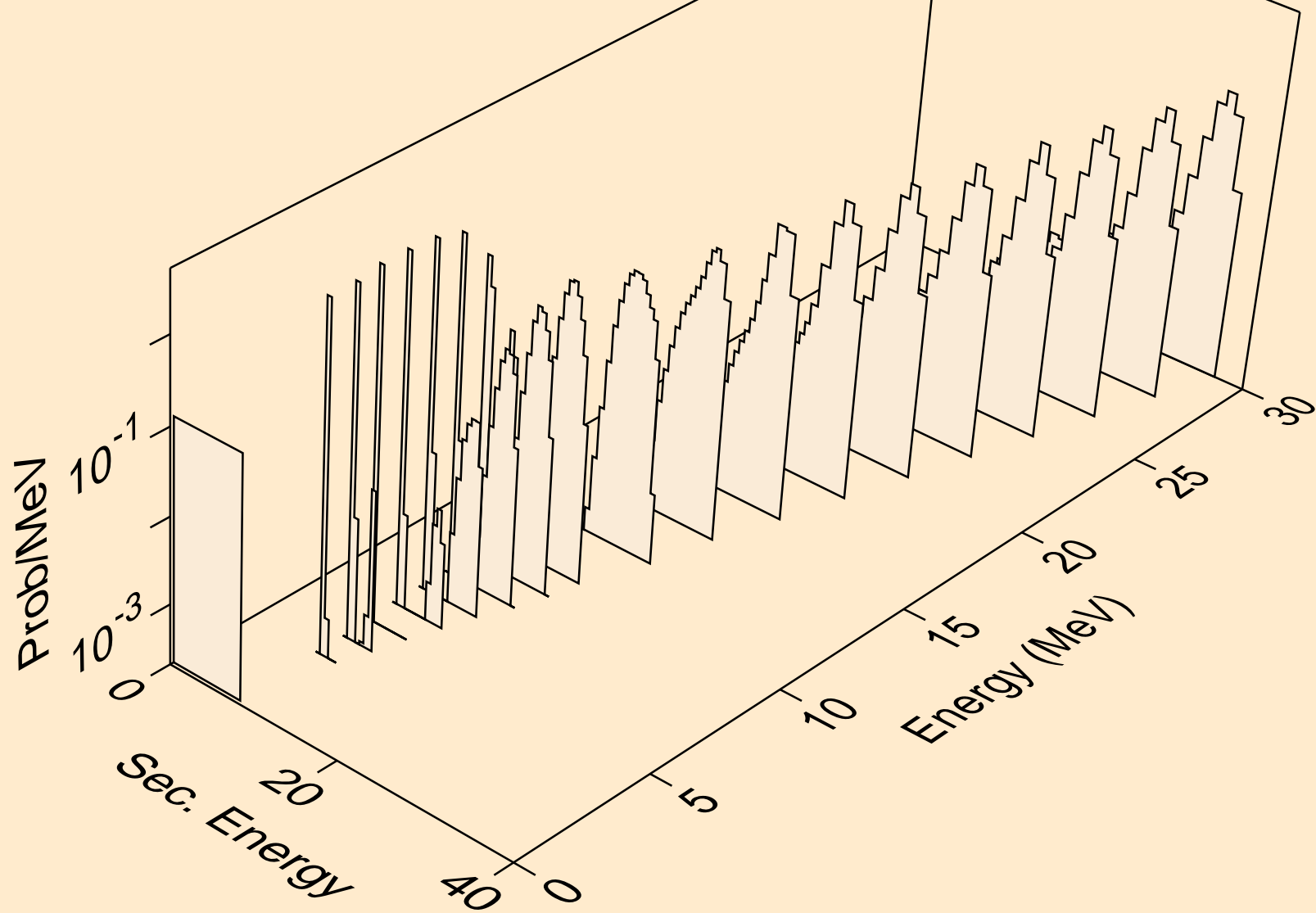

PU228 DEUTERON ACER TENDL-2021 LIBRARY; T=0.K  
alphas from (d,n\*)3a

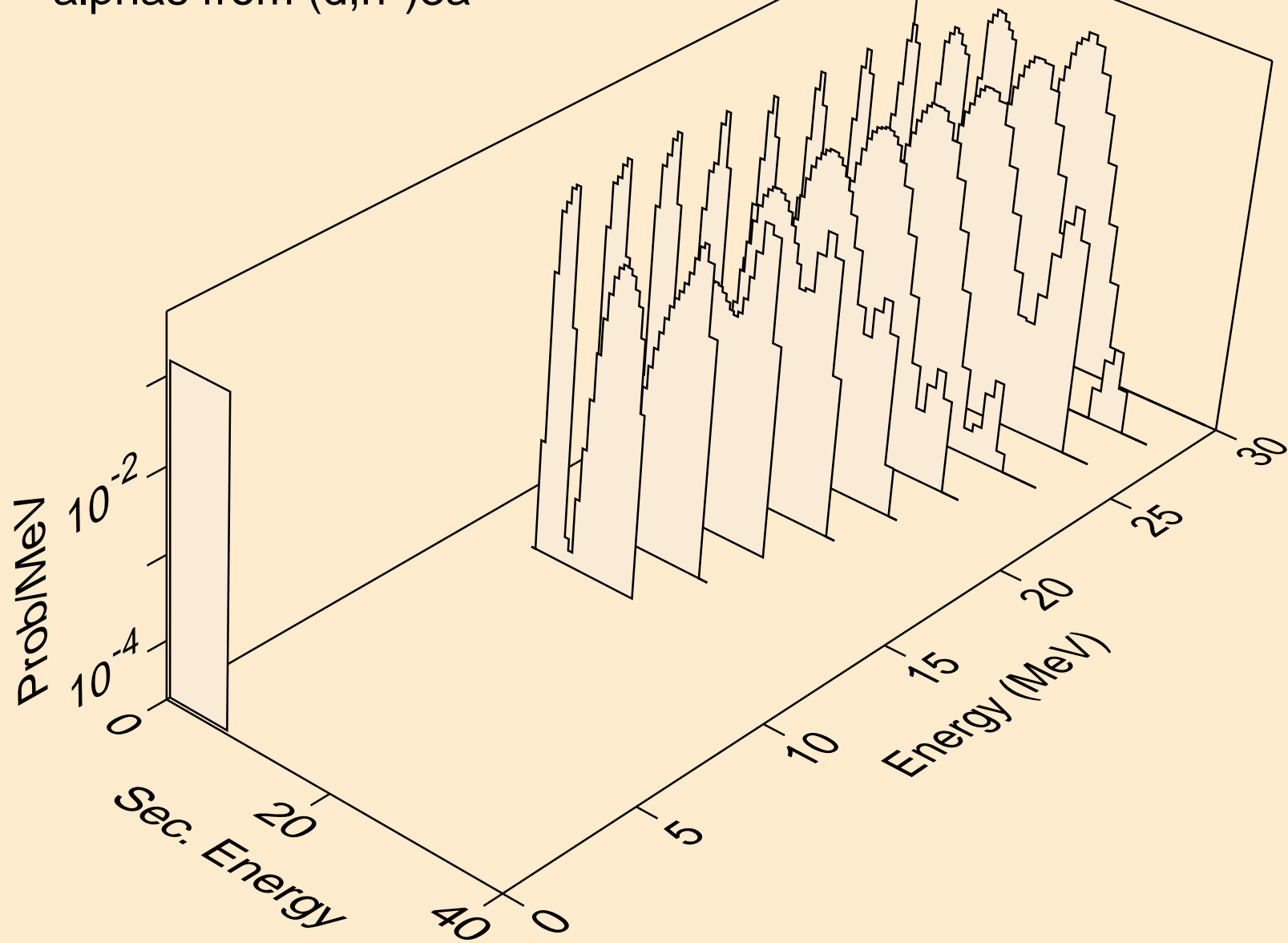

PU228 DEUTERON ACER TENDL-2021 LIBRARY; T=0.K  
alphas from (d,2n)a

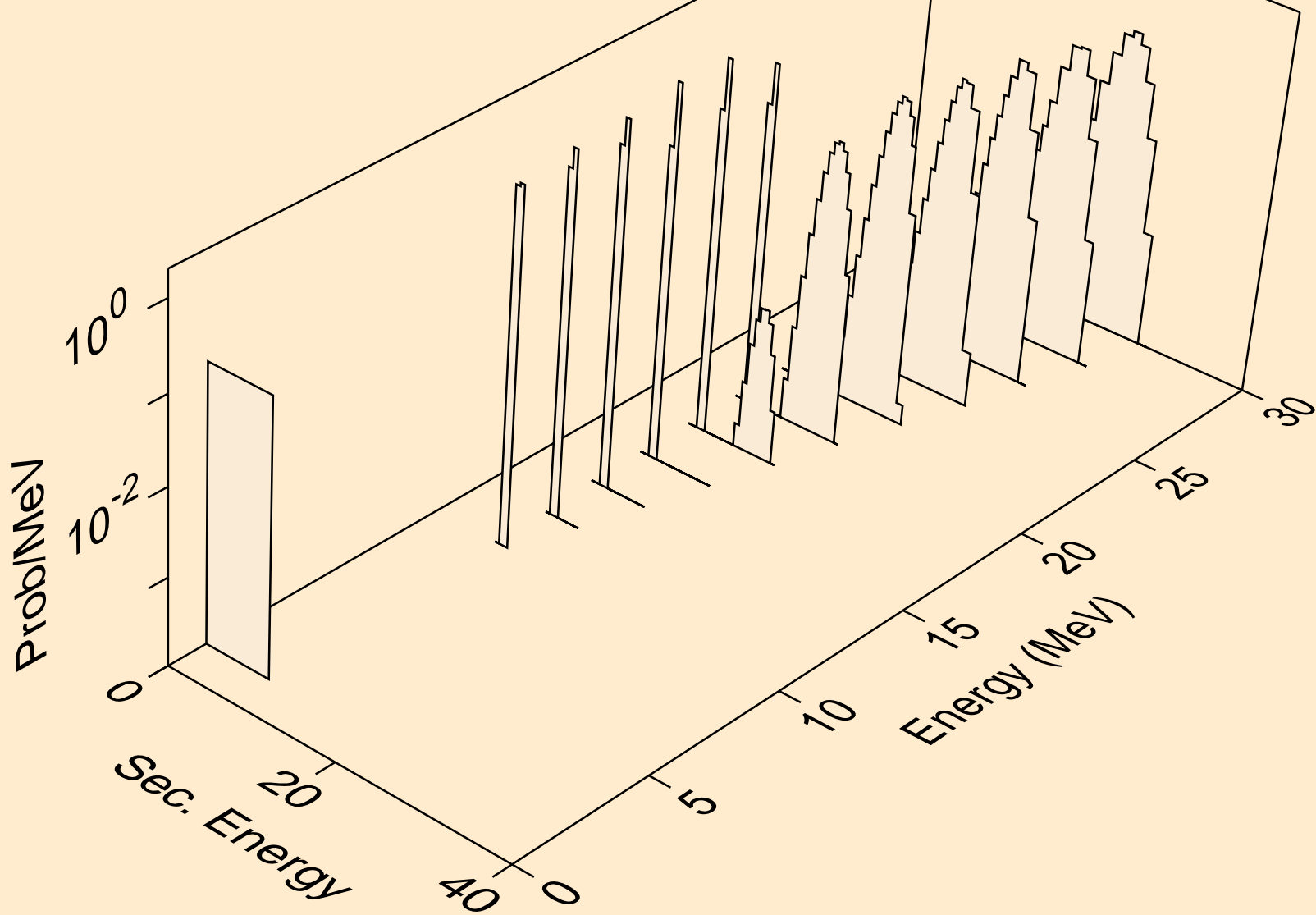

PU228 DEUTERON ACER TENDL-2021 LIBRARY; T=0.K  
alphas from (d,n\*)2a

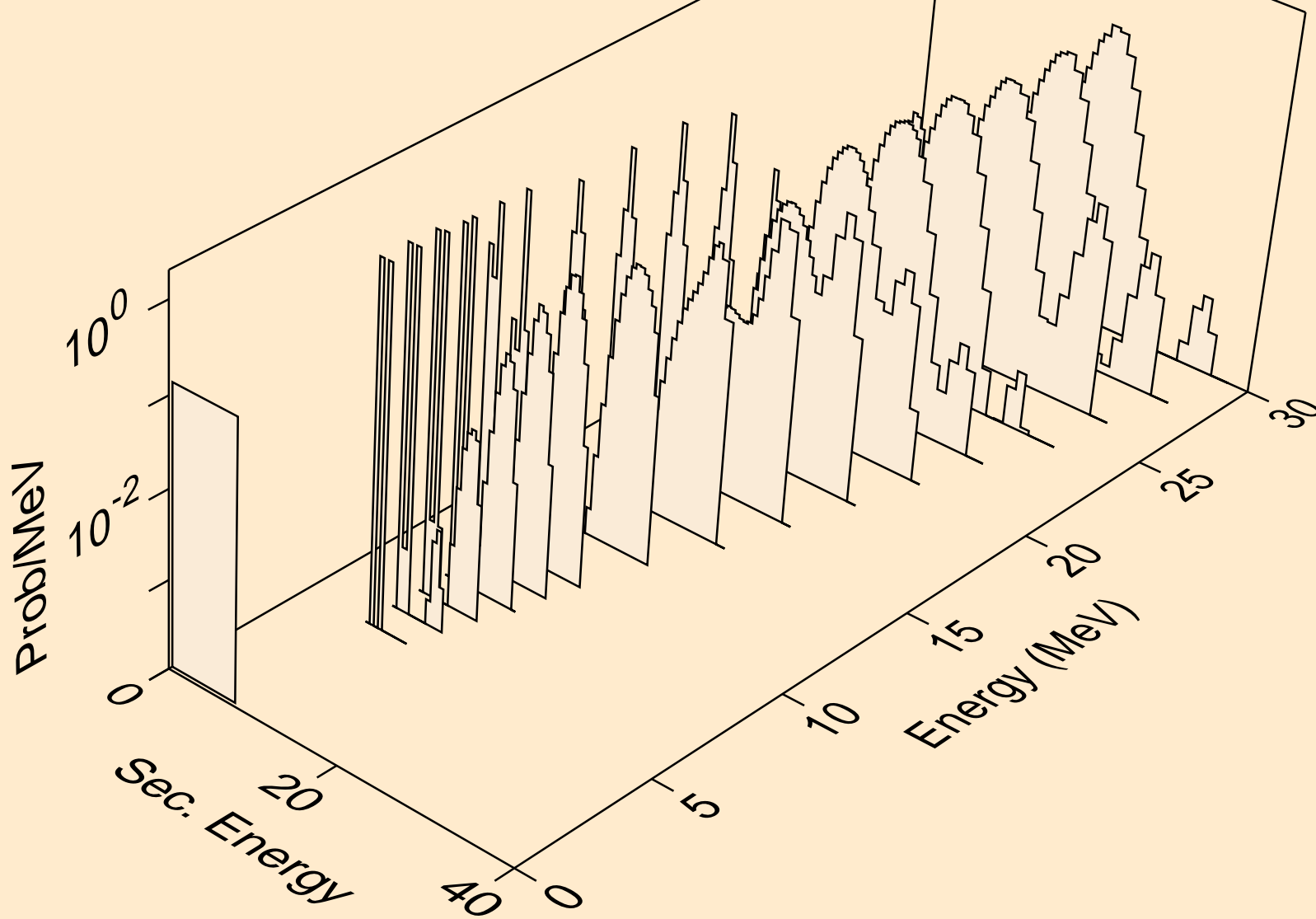

PU228 DEUTERON ACER TENDL-2021 LIBRARY; T=0.K  
alphas from (d,2n)2a

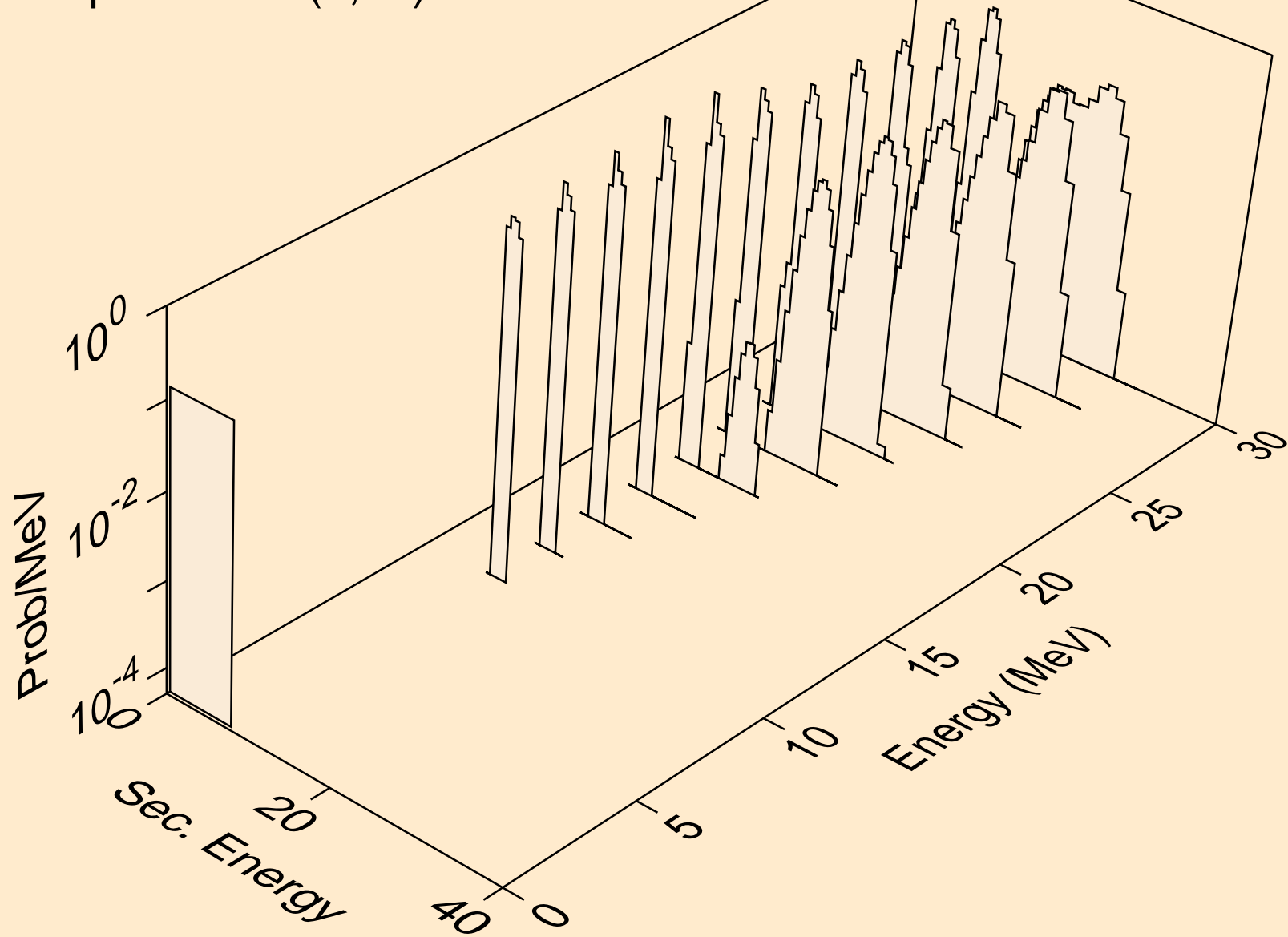

PU228 DEUTERON ACER TENDL-2021 LIBRARY; T=0.K  
alphas from (d,n\*)d2a

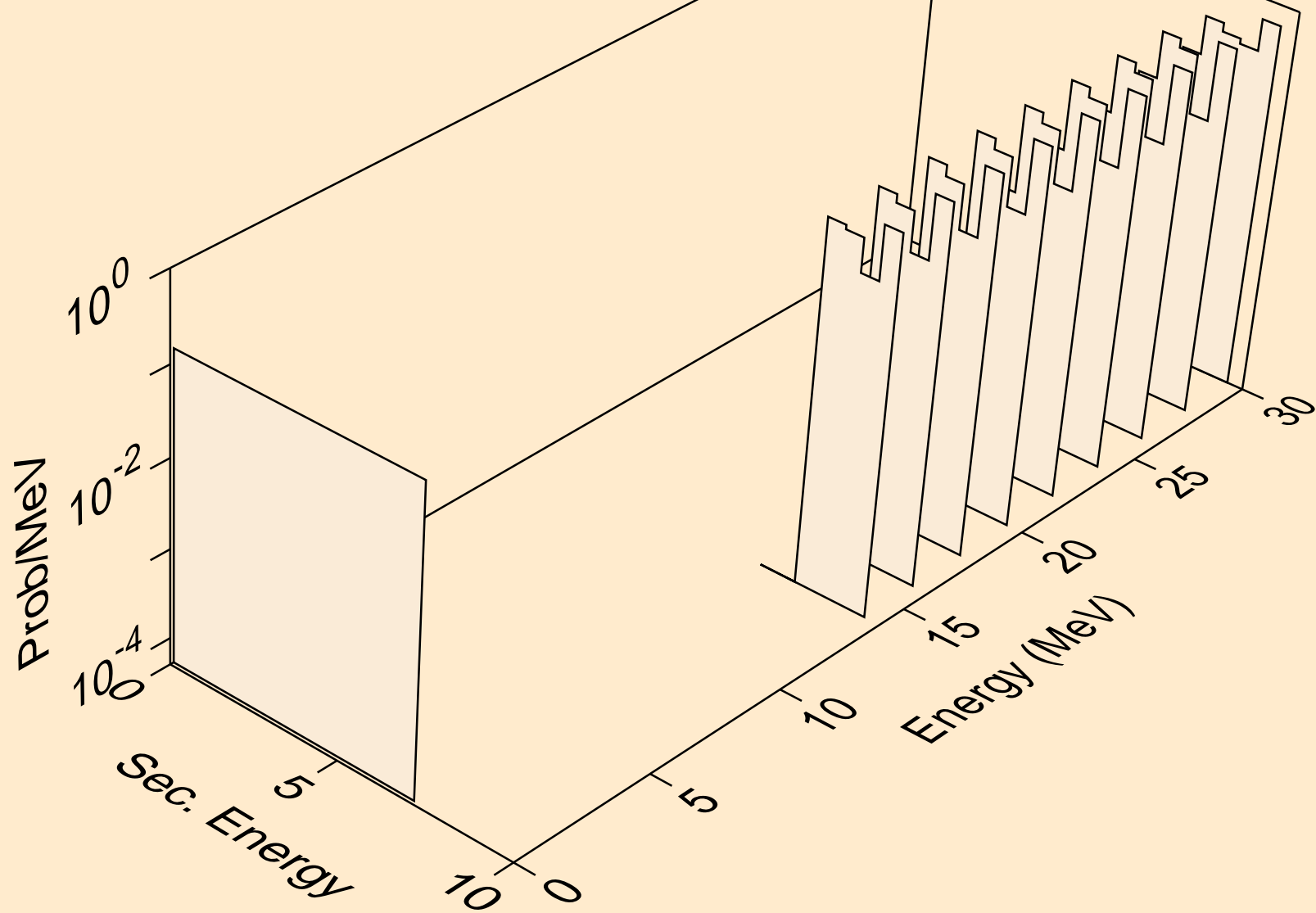

PU228 DEUTERON ACER TENDL-2021 LIBRARY; T=0.K  
alphas from (d,npa)

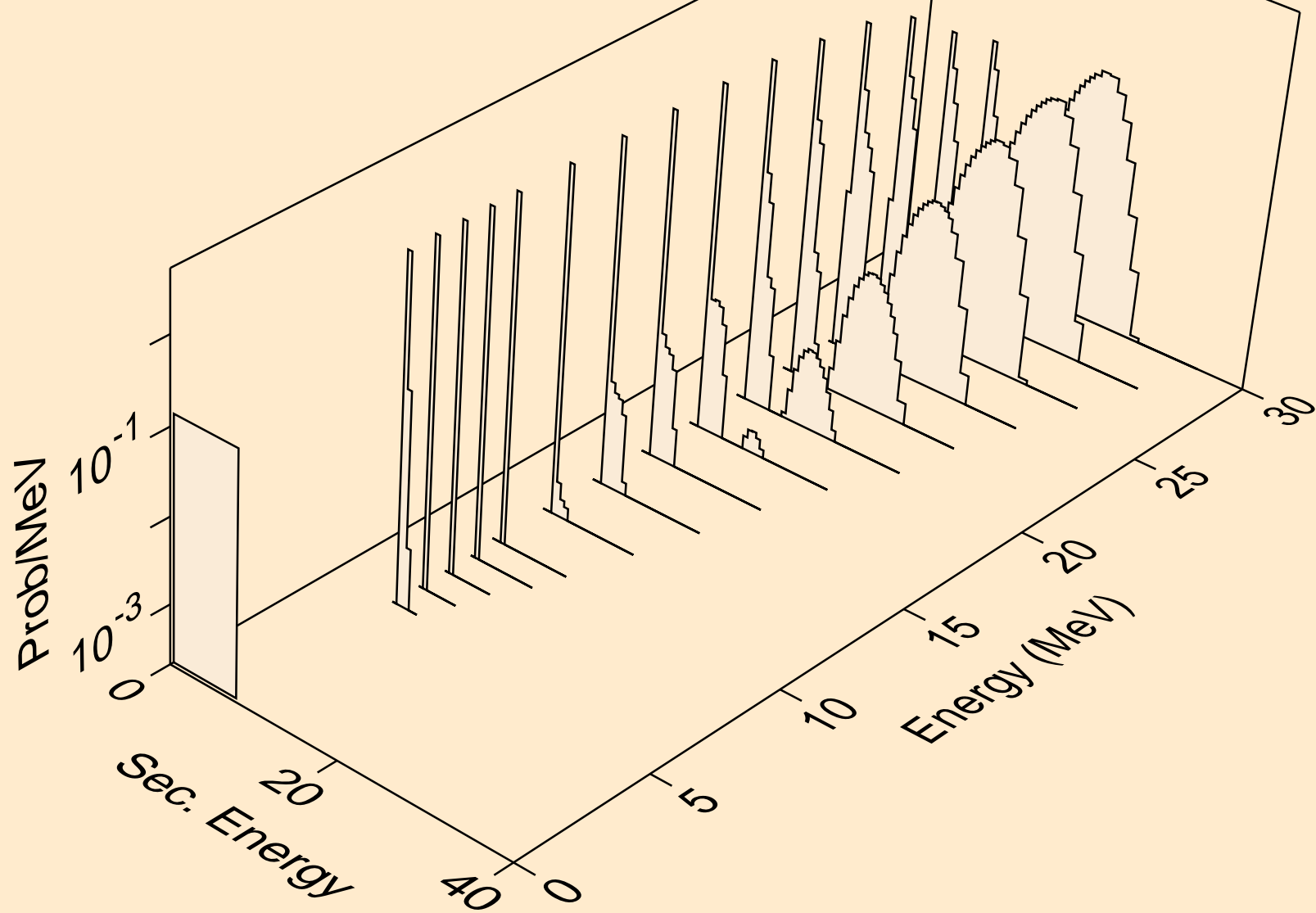

PU228 DEUTERON ACER TENDL-2021 LIBRARY; T=0.K  
alphas from (d,a)

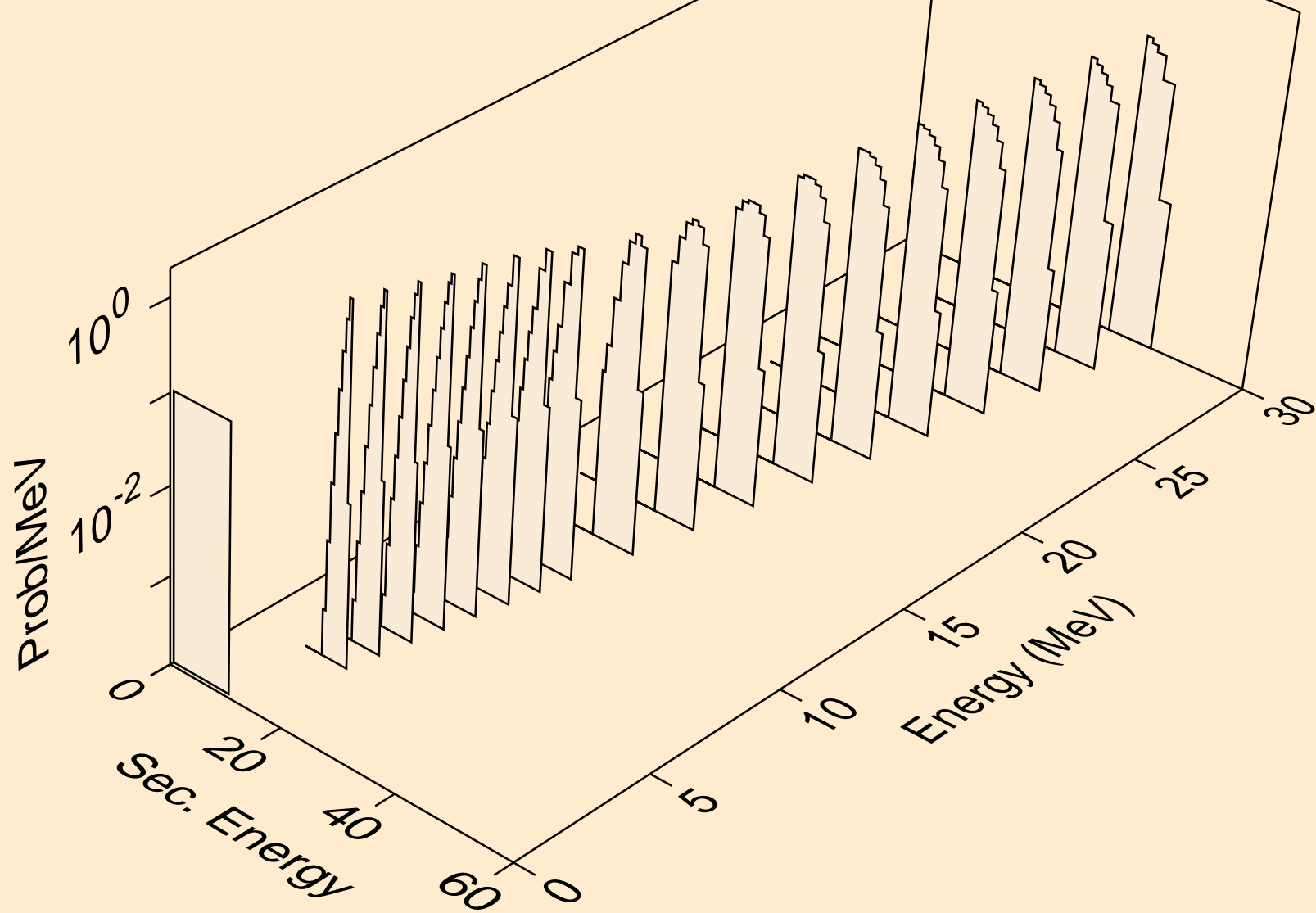

PU228 DEUTERON ACER TENDL-2021 LIBRARY; T=0.K  
alphas from (d,2a)

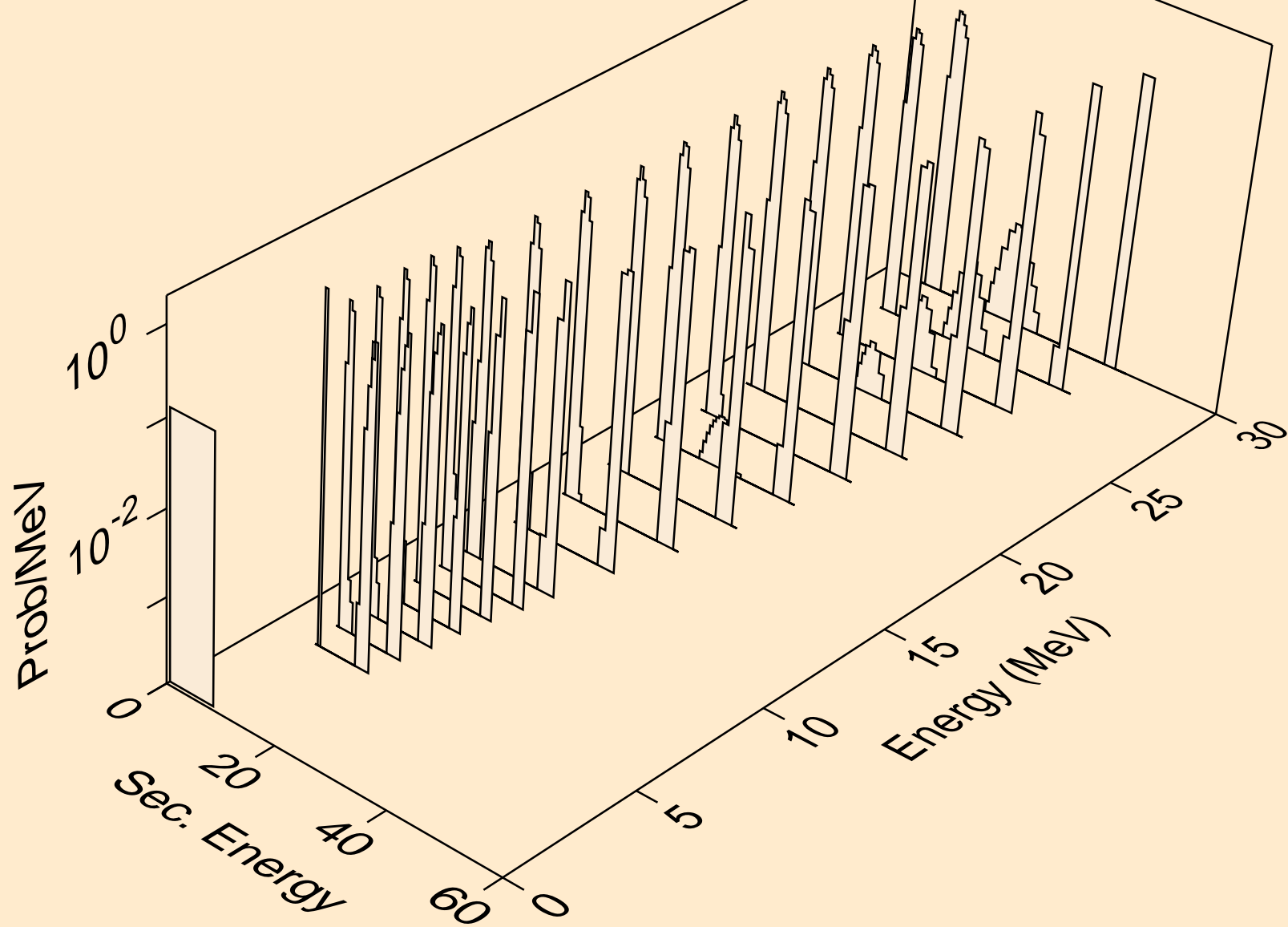

PU228 DEUTERON ACER TENDL-2021 LIBRARY; T=0.K  
alphas from (d,pa)

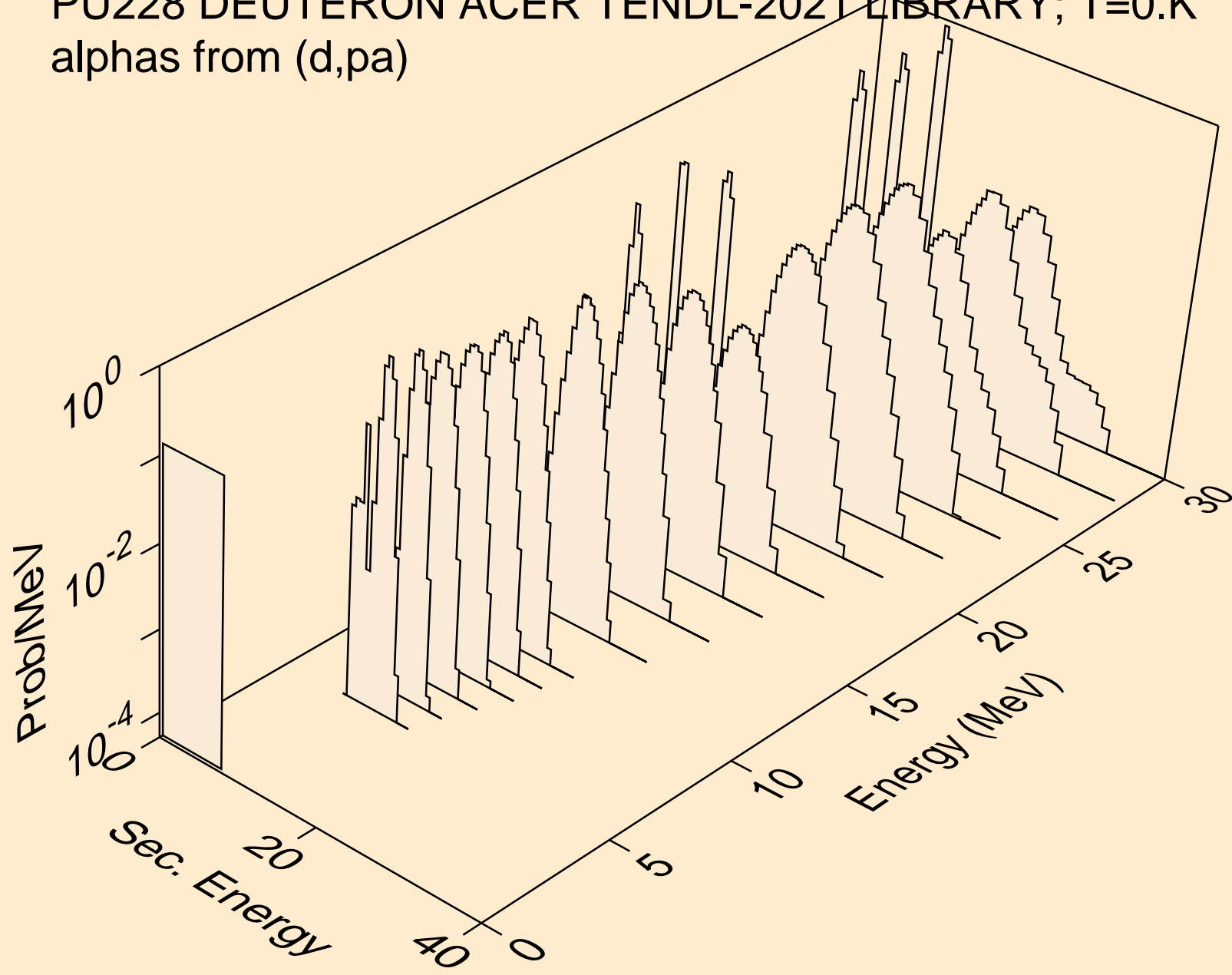

PU228 DEUTERON ACER TENDL-2021 LIBRARY; T=0.K  
alphas from (d,t2a)

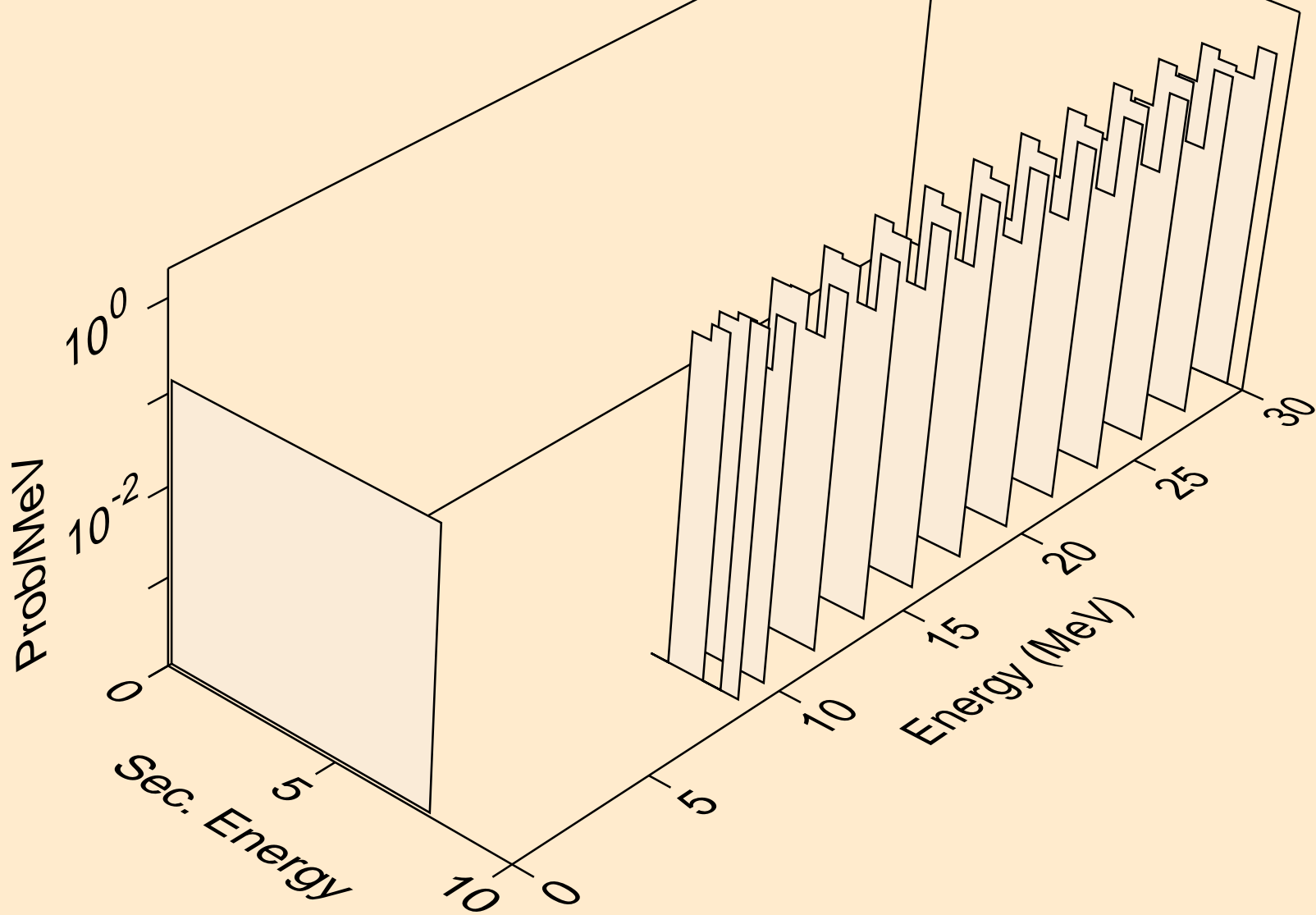

PU228 DEUTERON ACER TENDL-2021 LIBRARY; T=0.K  
alphas from (d,da)

