

# K039 PHOTON ACER TENDL-2021 LIBRARY; T=0.K

## Principal cross sections

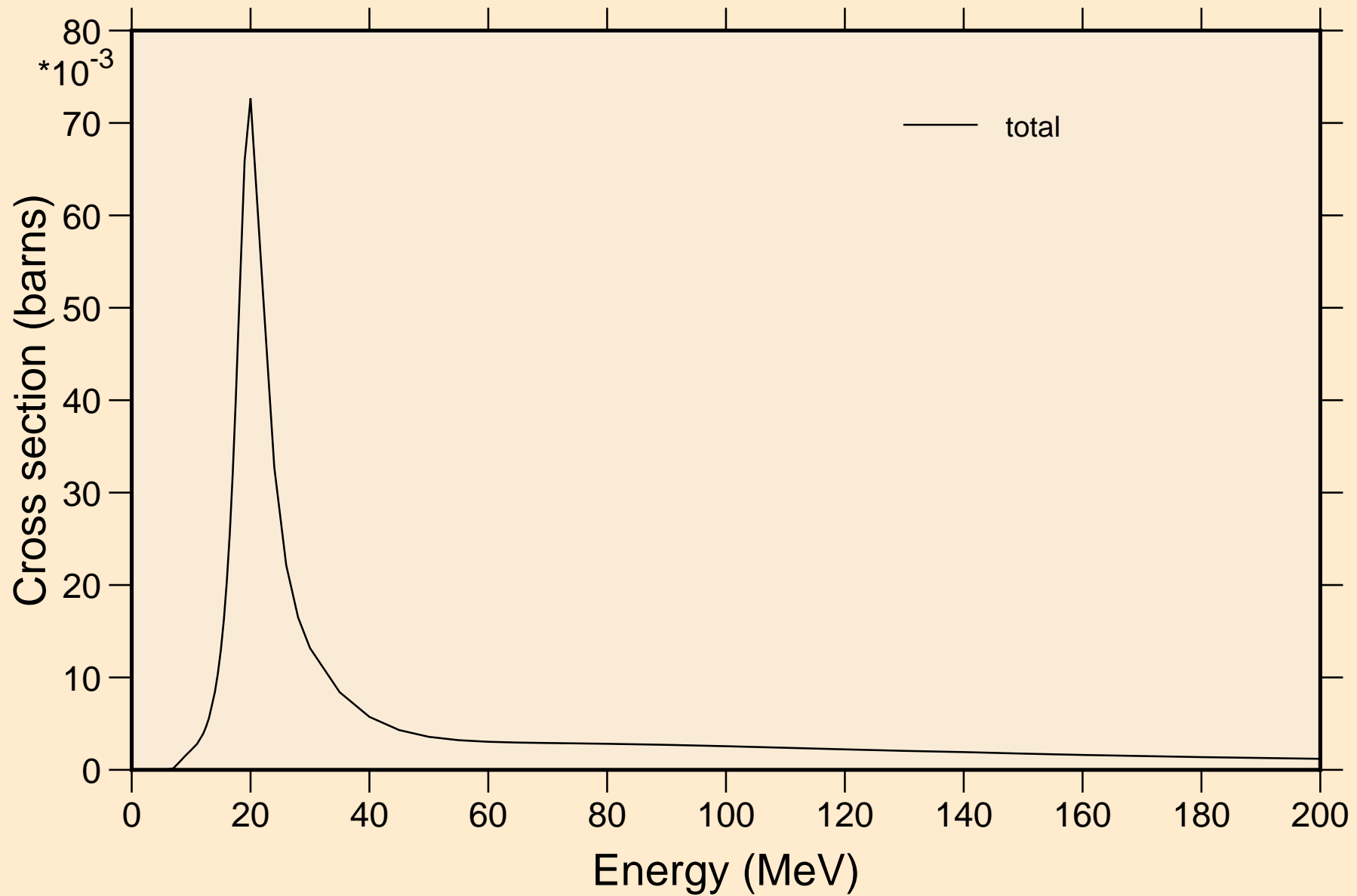

# K039 PHOTON ACER TENDL-2021 LIBRARY; T=0.K

## Partial cross sections

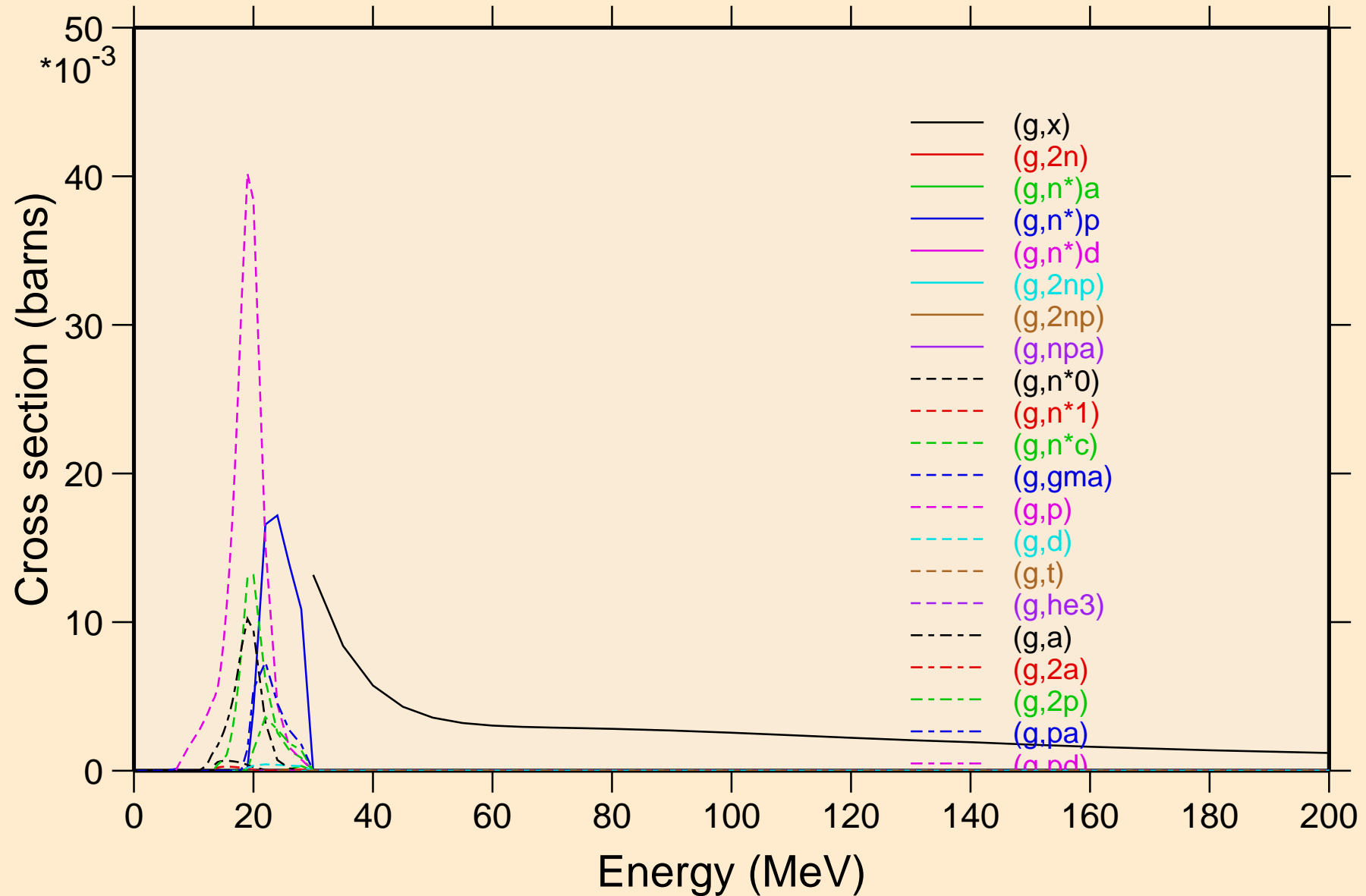

# K039 PHOTON ACER TENDL-2021 LIBRARY; T=0.K

## Heating

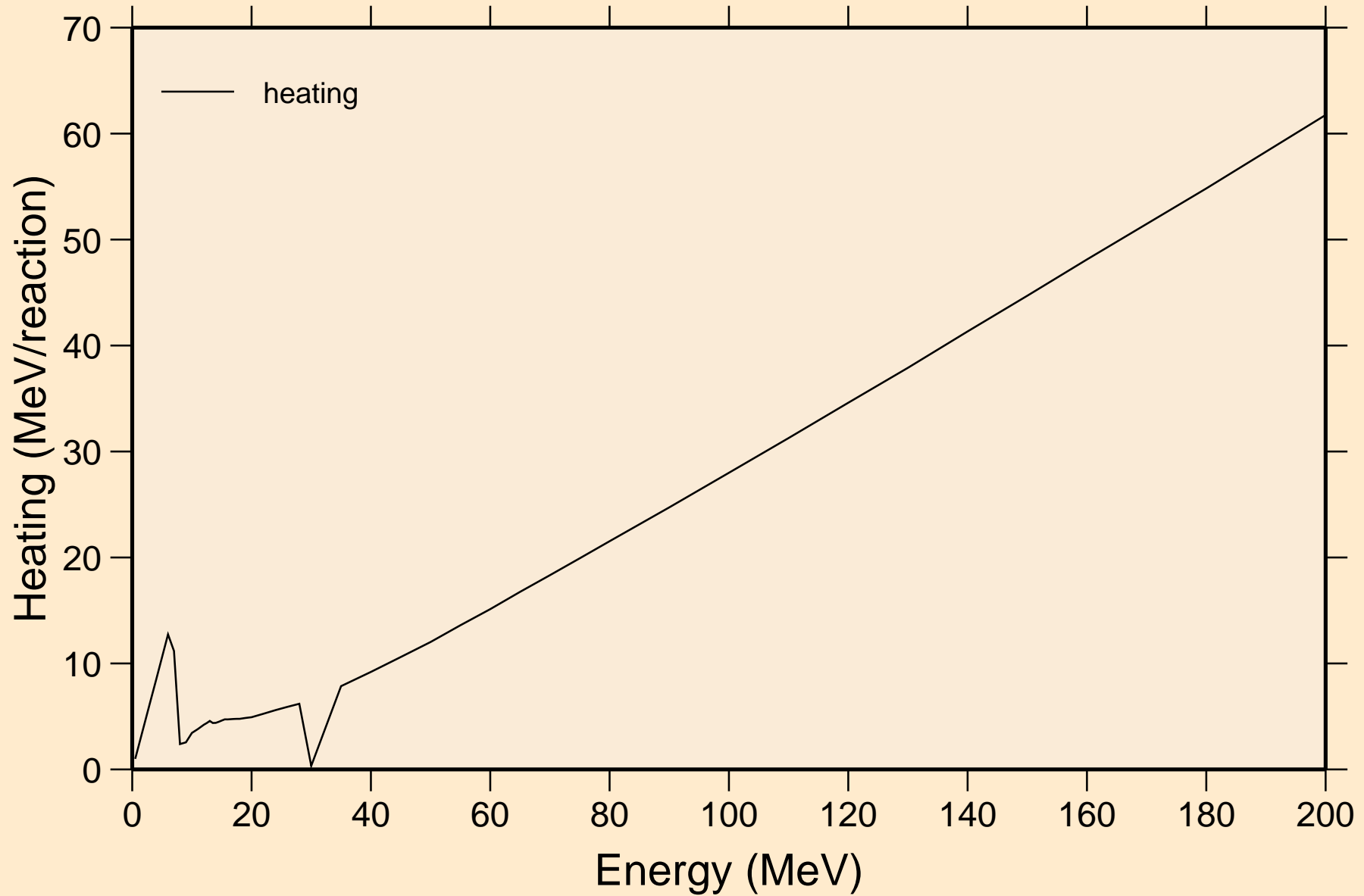

# K039 PHOTON ACER TENDL-2021 LIBRARY; T=0.K

## Particle heating contributions

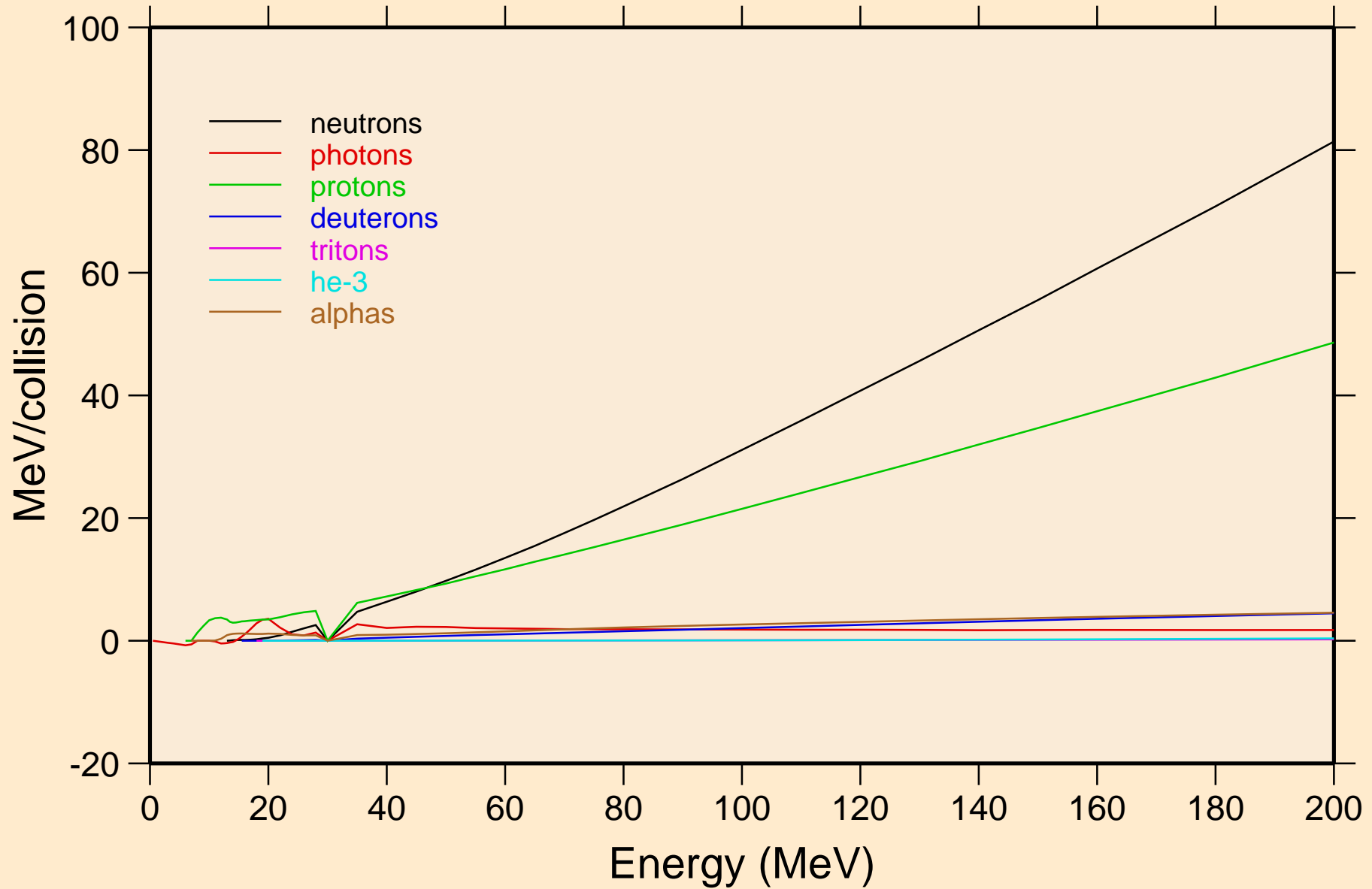

K039 PHOTON ACER TENDL-2021 LIBRARY; T=0.K  
Particle production cross sections

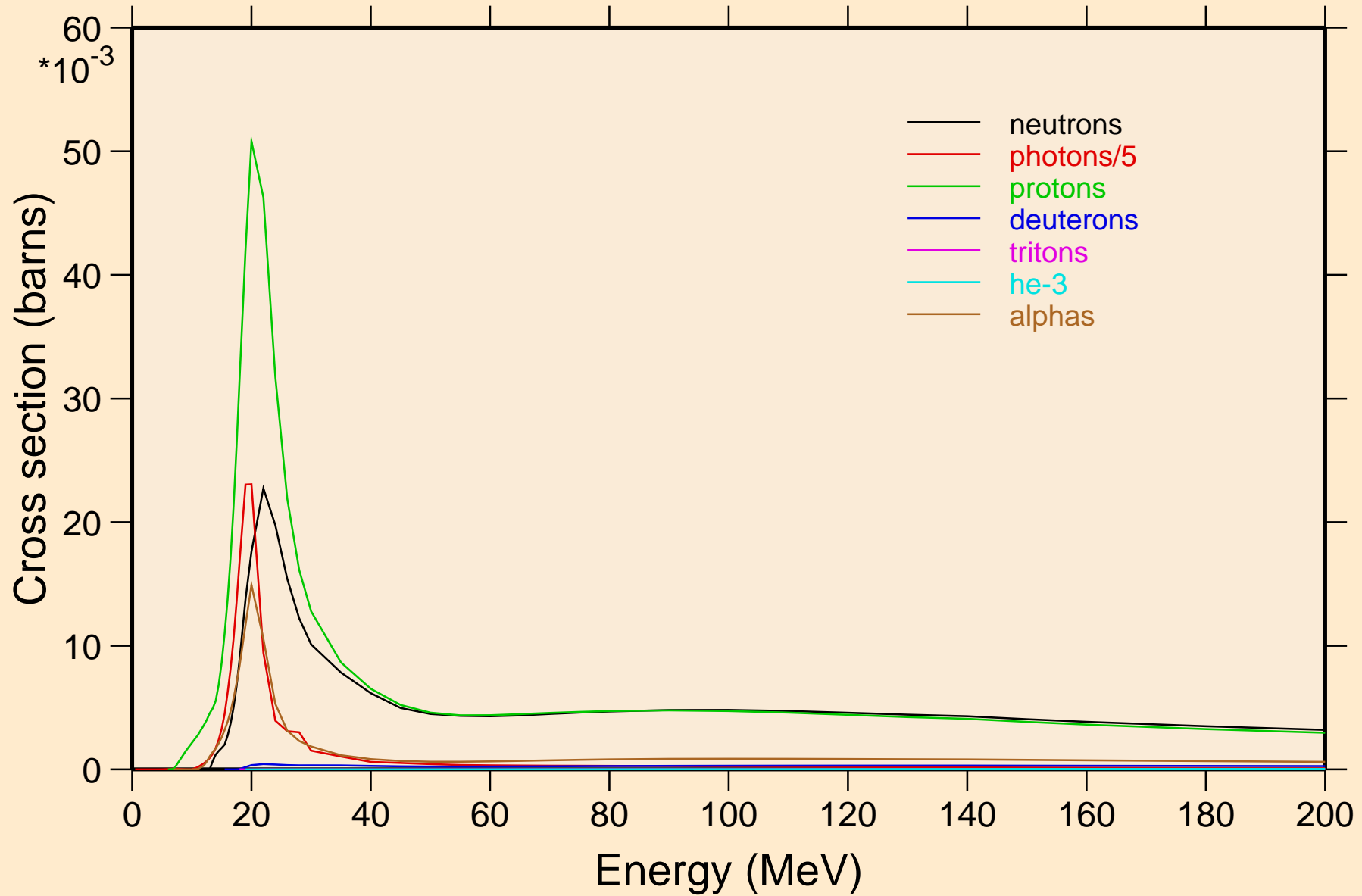

K039 PHOTON ACER TENDL-2021 LIBRARY; T=0.K  
neutrons from (g,x)

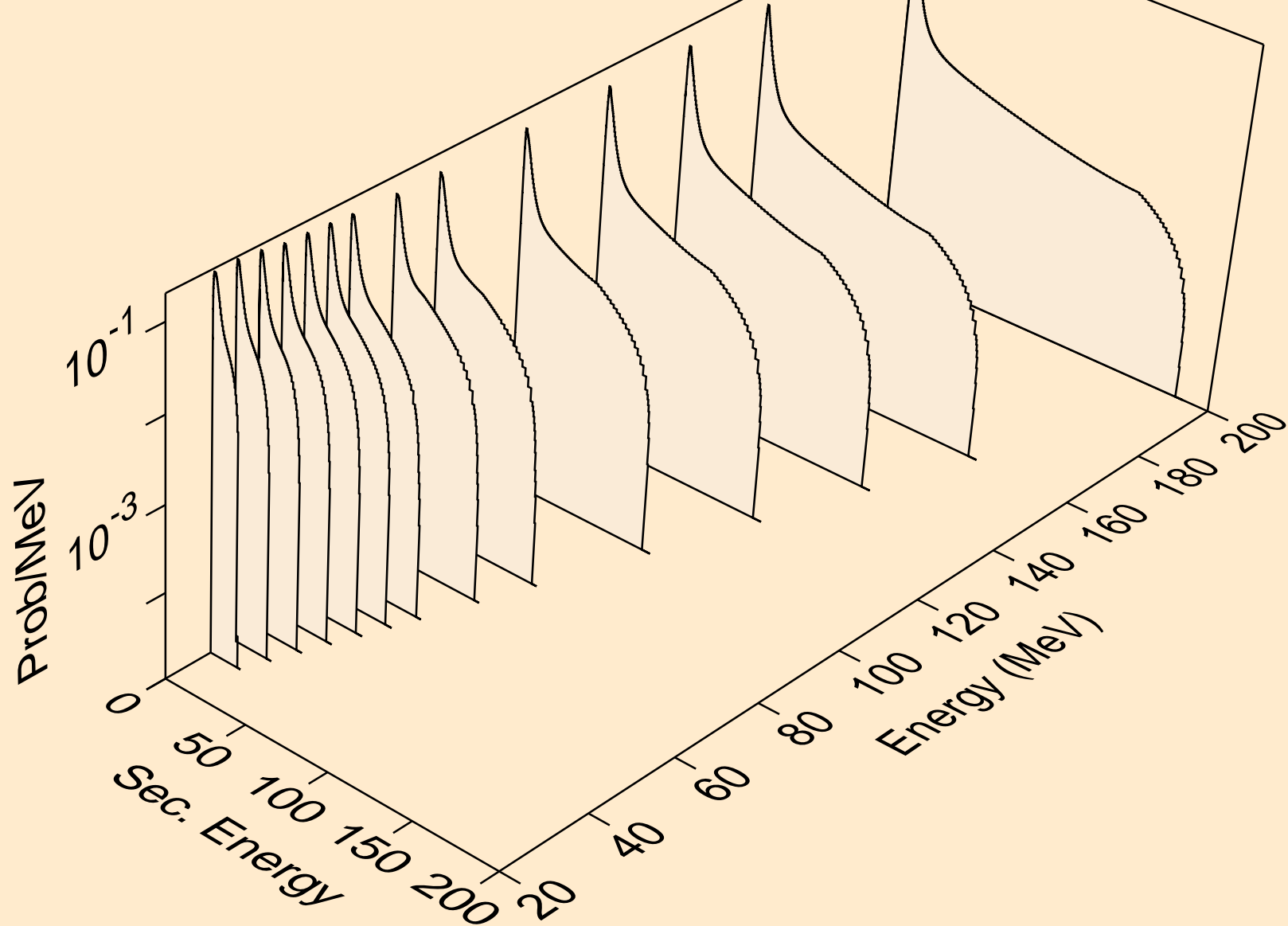

K039 PHOTON ACER TENDL-2021 LIBRARY; T=0.K  
neutrons from (g,2n)

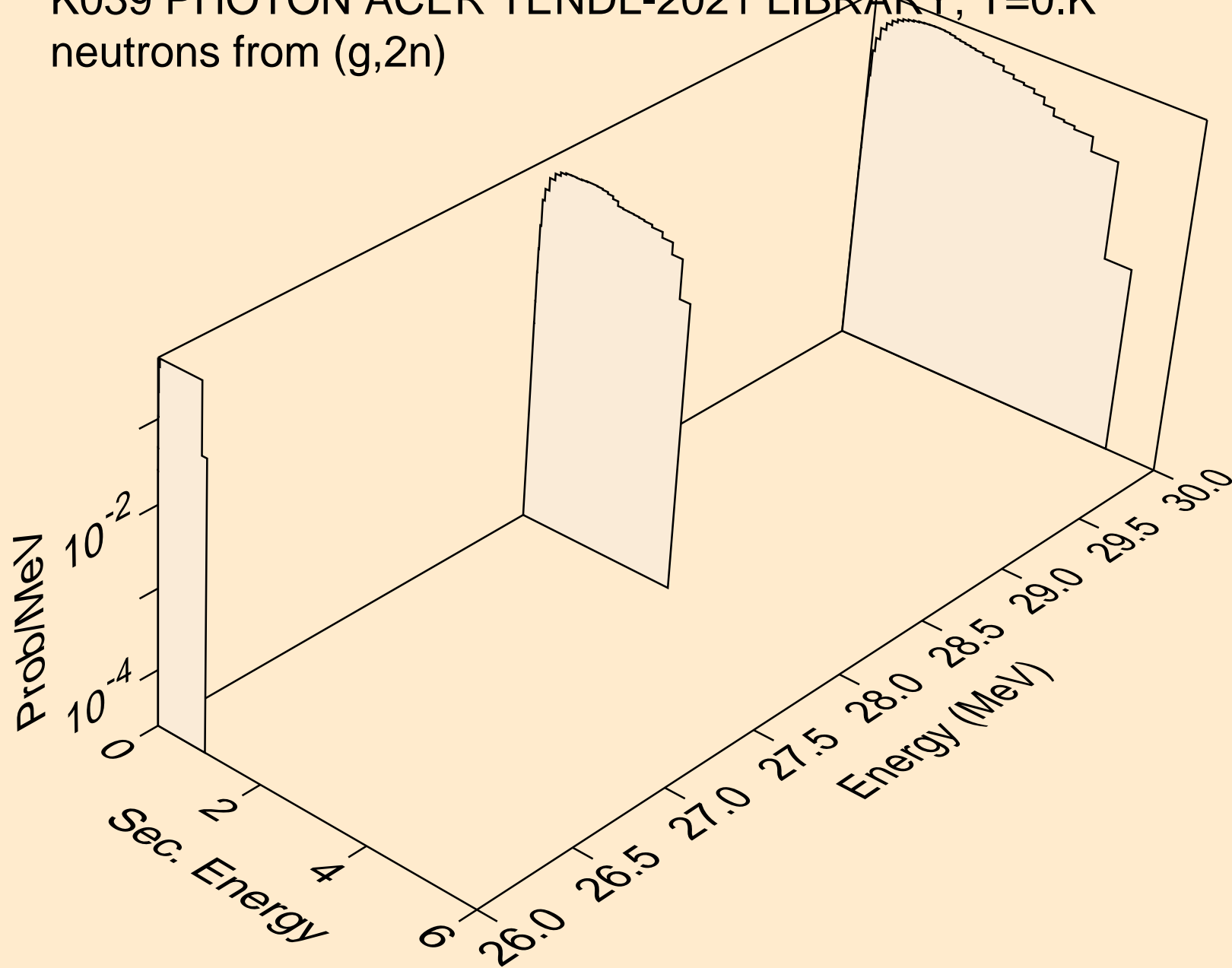

K039 PHOTON ACER TENDL-2021 LIBRARY; T=0.K  
neutrons from (g,n\*)a

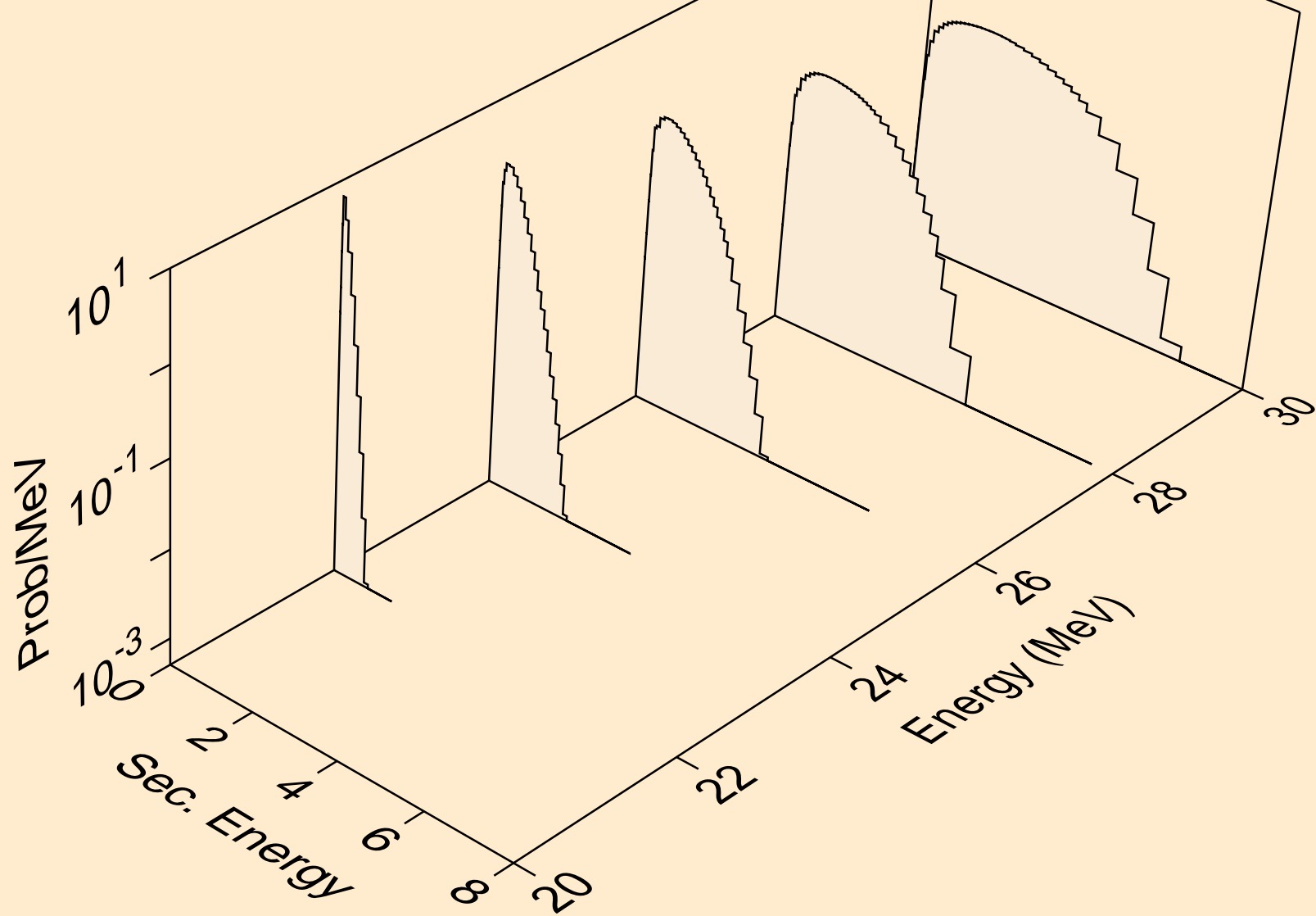

K039 PHOTON ACER TENDL-2021 LIBRARY; T=0.K  
neutrons from (g,n\*)p

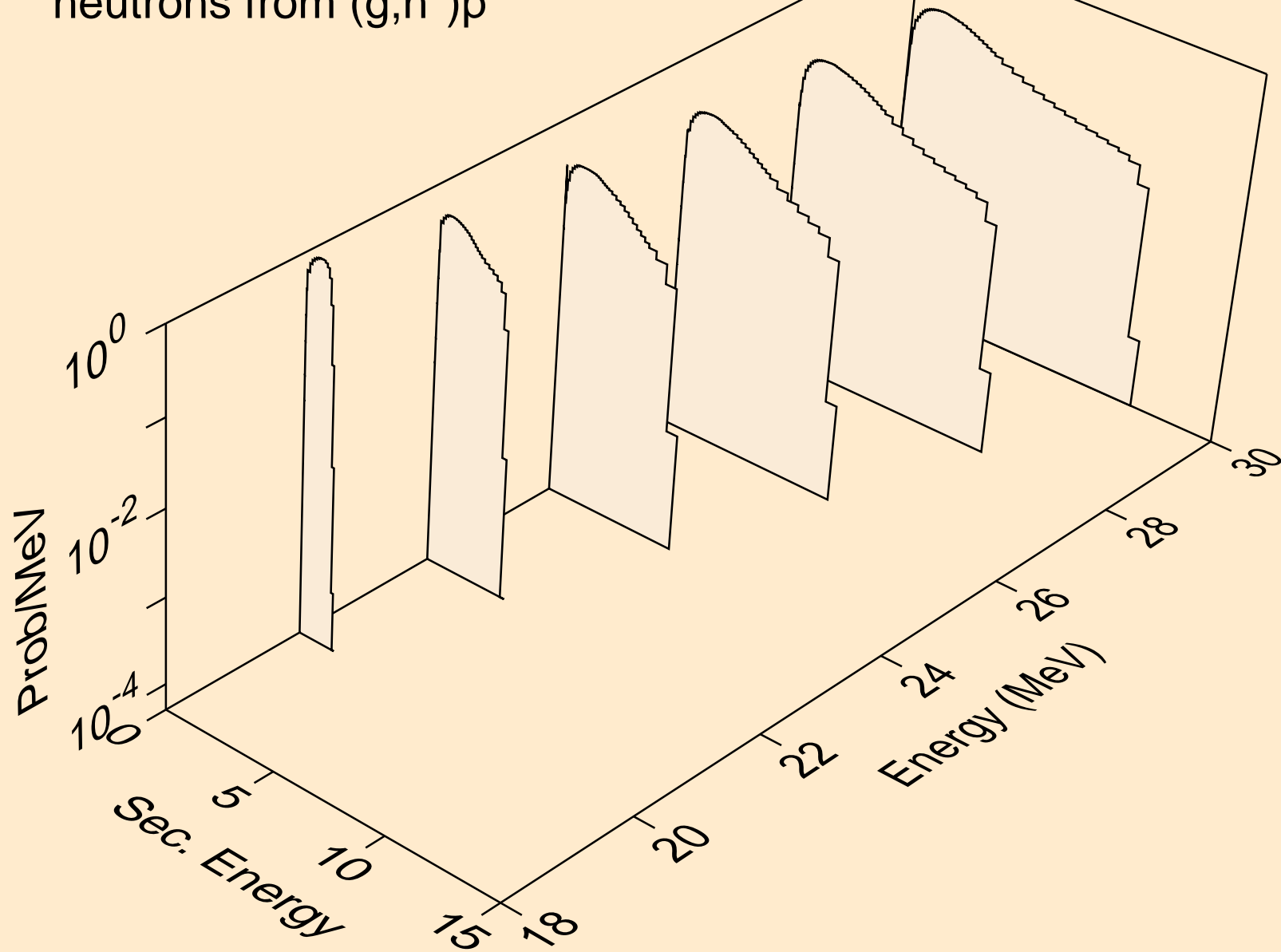

K039 PHOTON ACER TENDL-2021 LIBRARY; T=0.K  
neutrons from (g,n\*)d

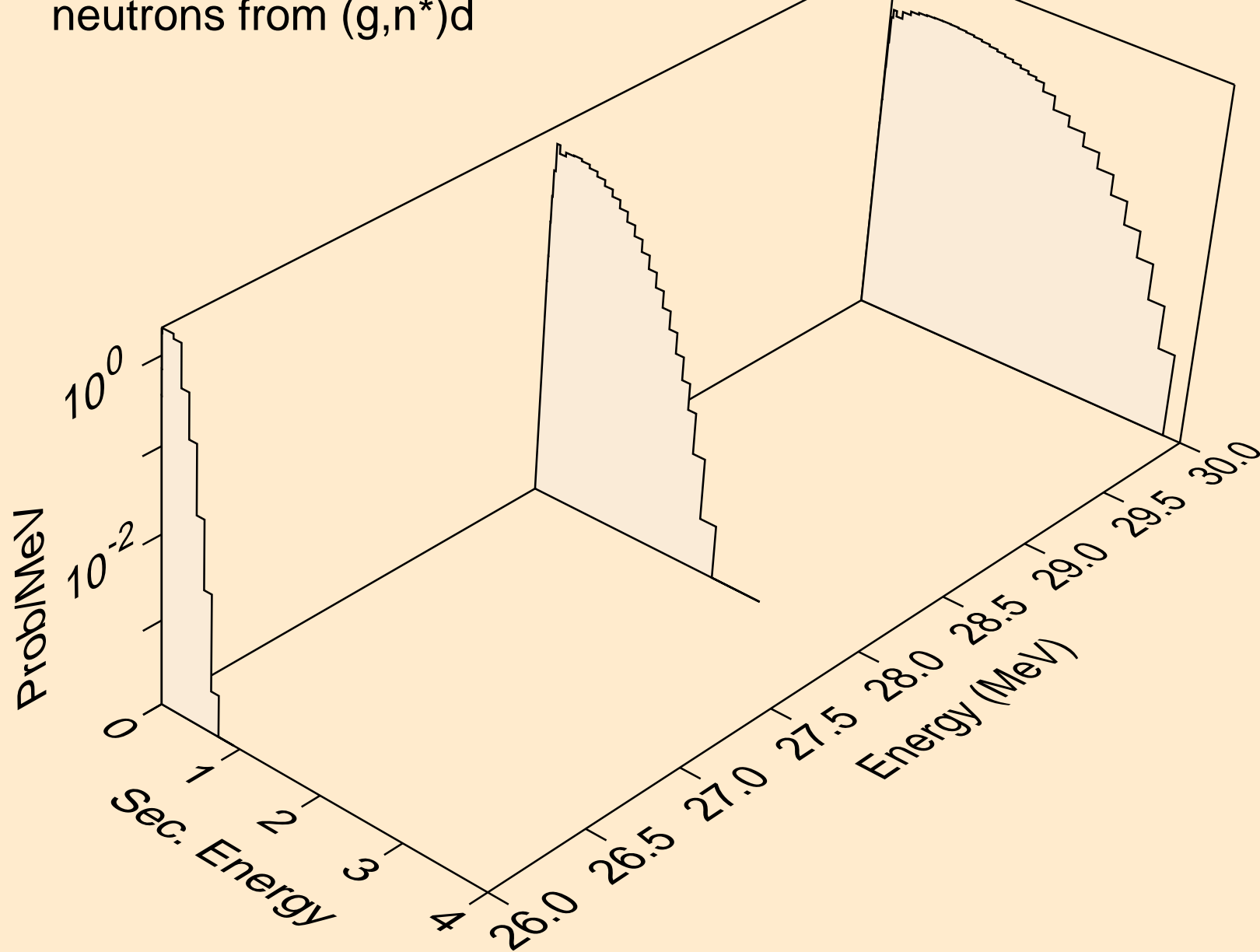

K039 PHOTON ACER TENDL-2021 LIBRARY; T=0.K  
neutrons from (g,2np)

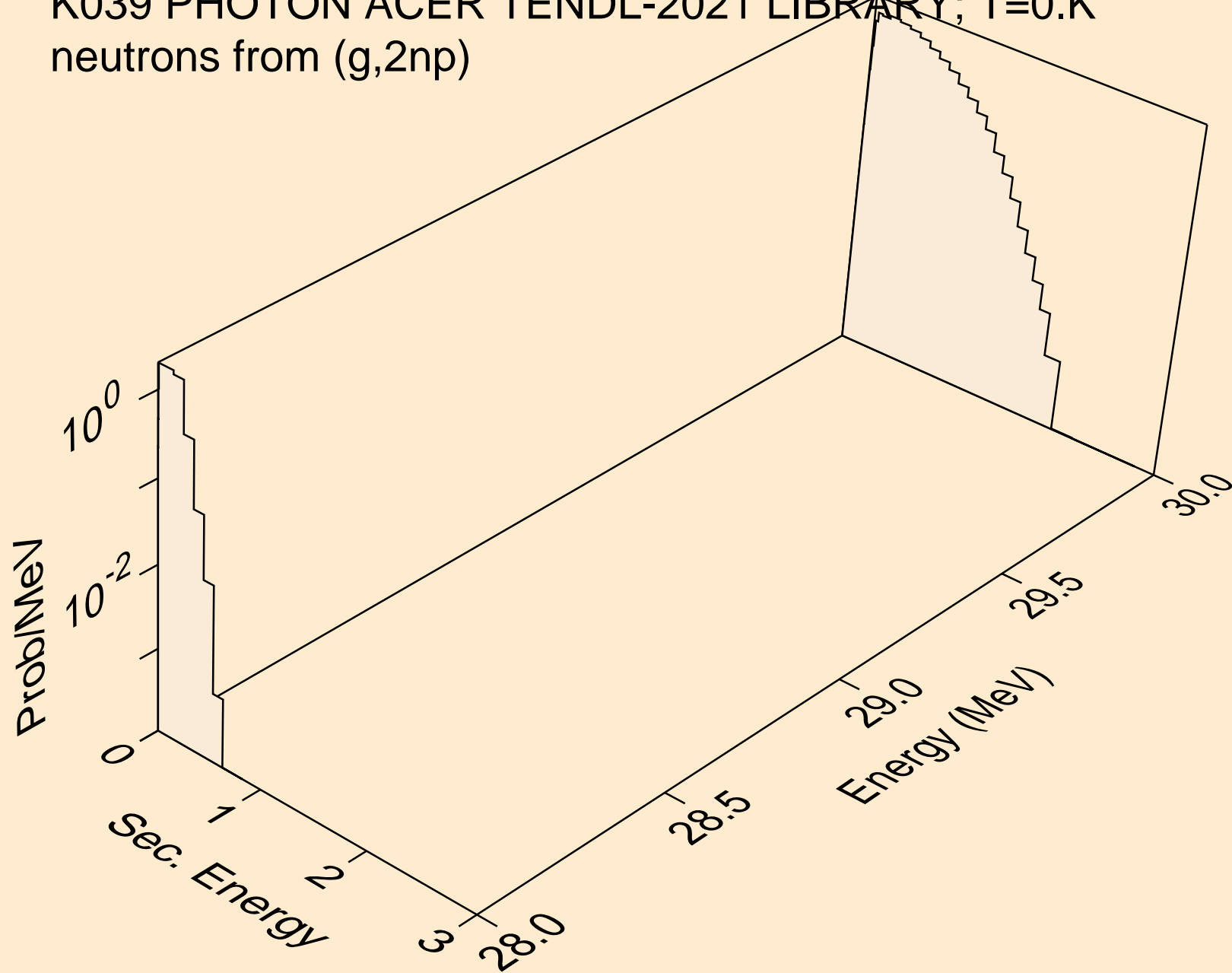

K039 PHOTON ACER TENDL-2021 LIBRARY; T=0.K  
neutrons from (g,2np)

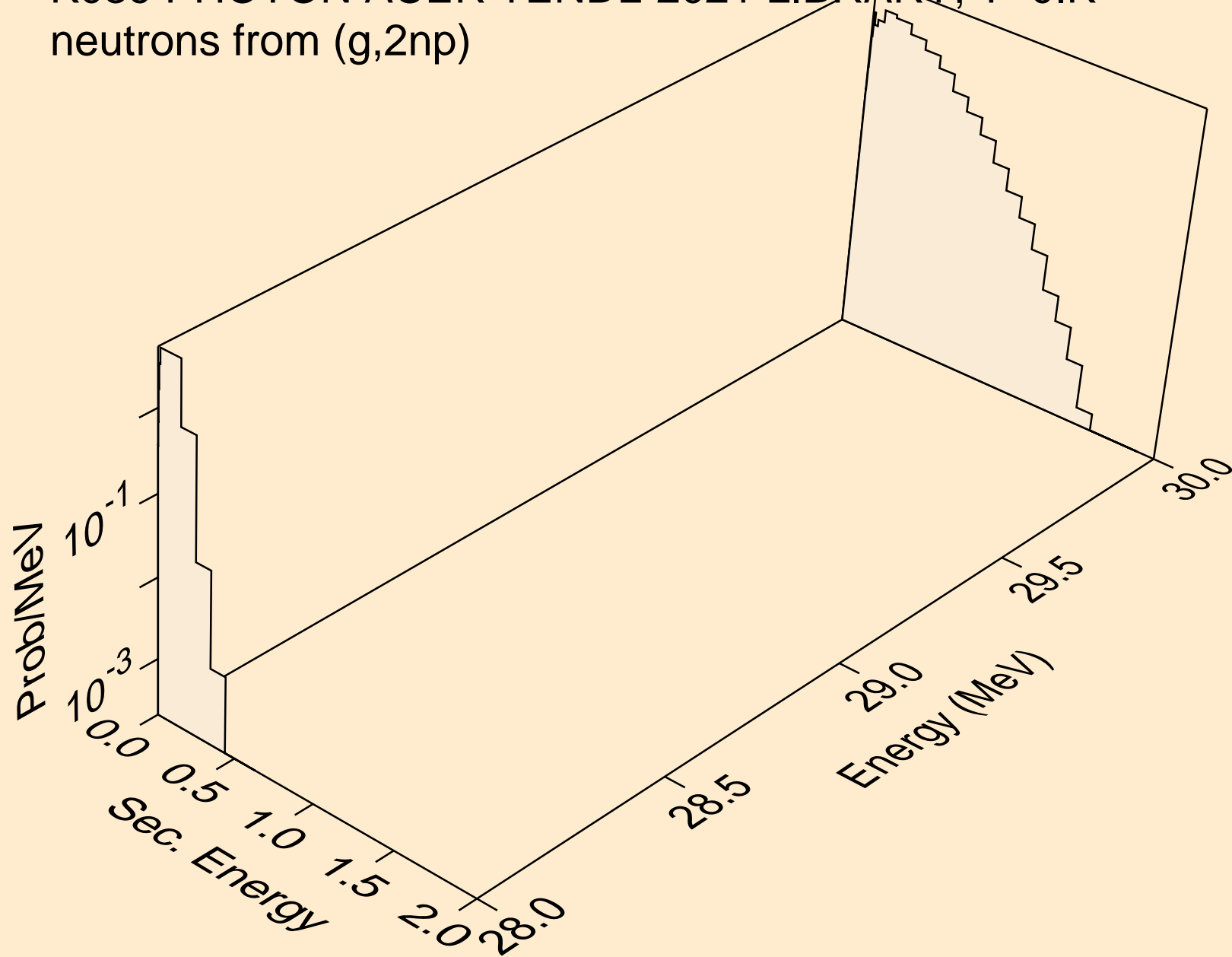

K039 PHOTON ACER TENDL-2021 LIBRARY; T=0.K  
neutrons from (g,npa)

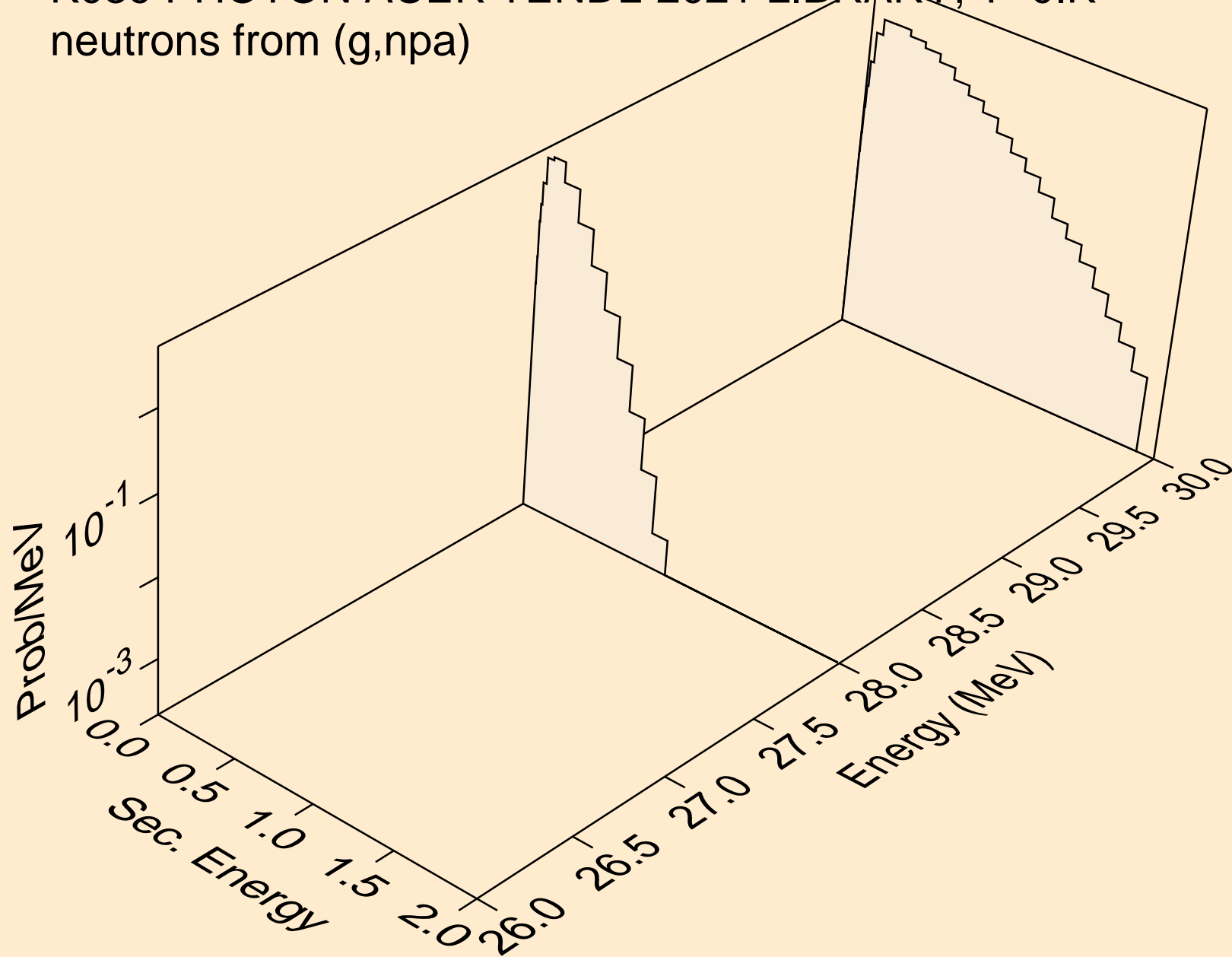

K039 PHOTON ACER TENDL-2021 LIBRARY; T=0.K  
angular distribution for (g,n\*0) neutron

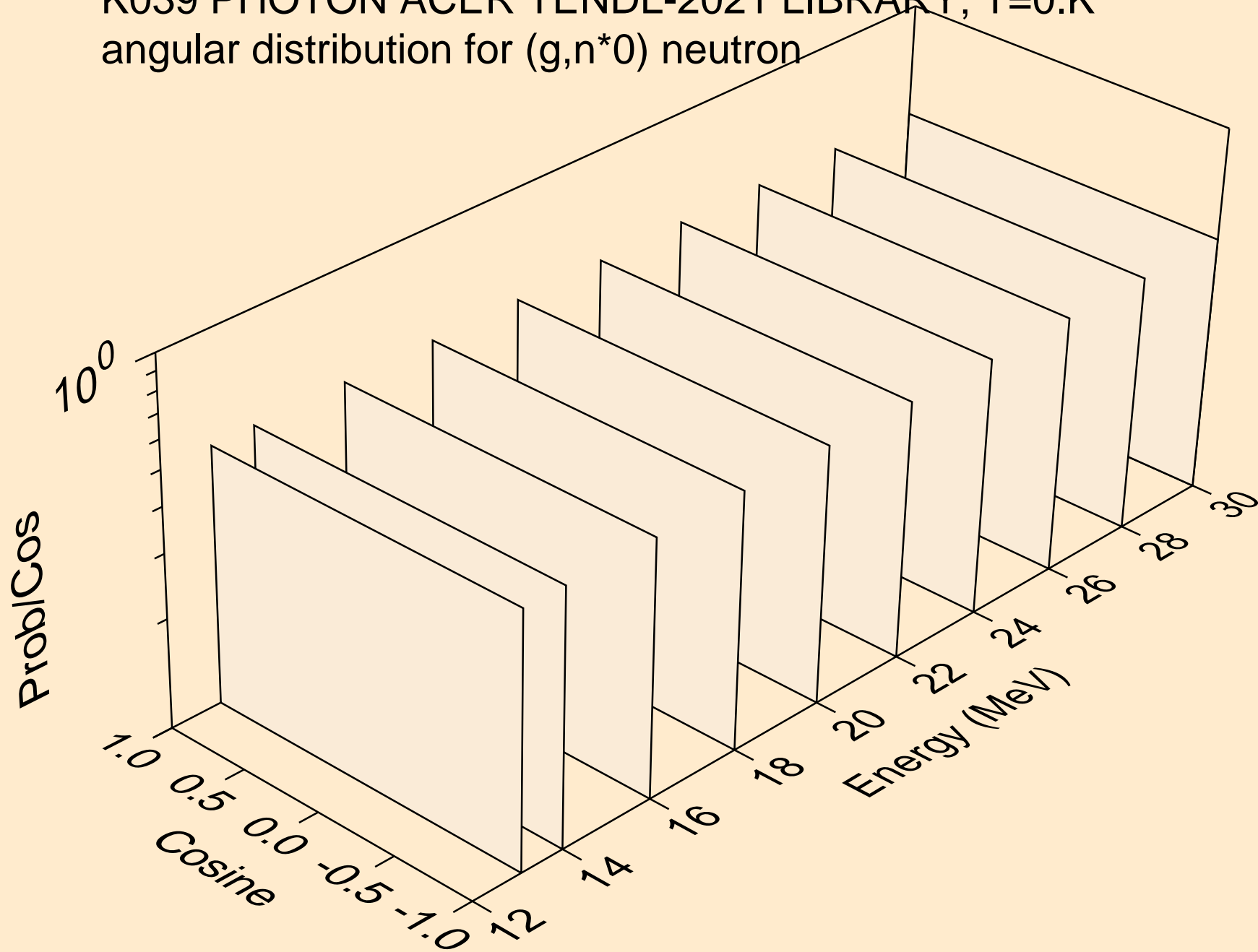

K039 PHOTON ACER TENDL-2021 LIBRARY; T=0.K  
angular distribution for (g,n\*1) neutron

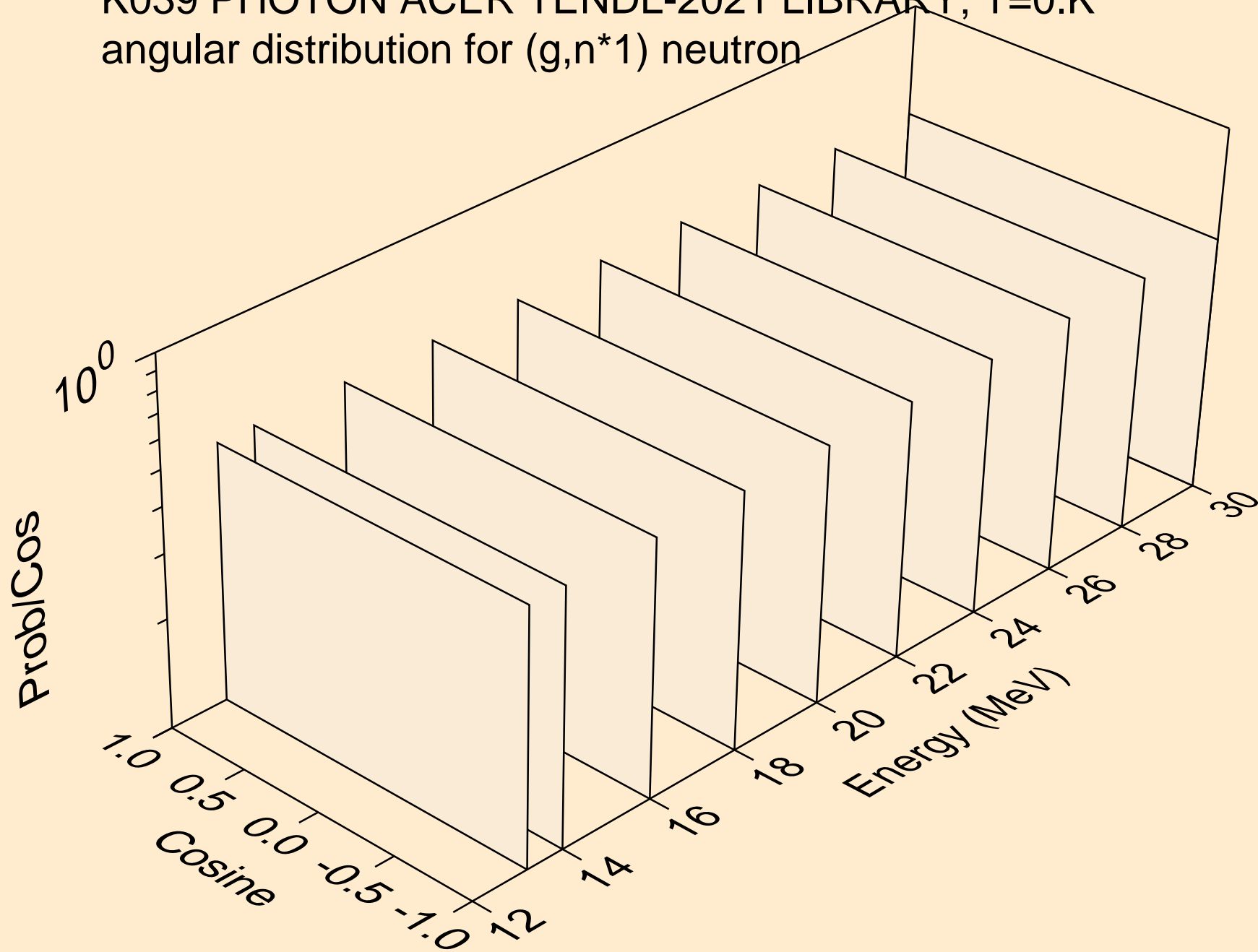

K039 PHOTON ACER TENDL-2021 LIBRARY; T=0.K  
neutrons from (g,n\*c)

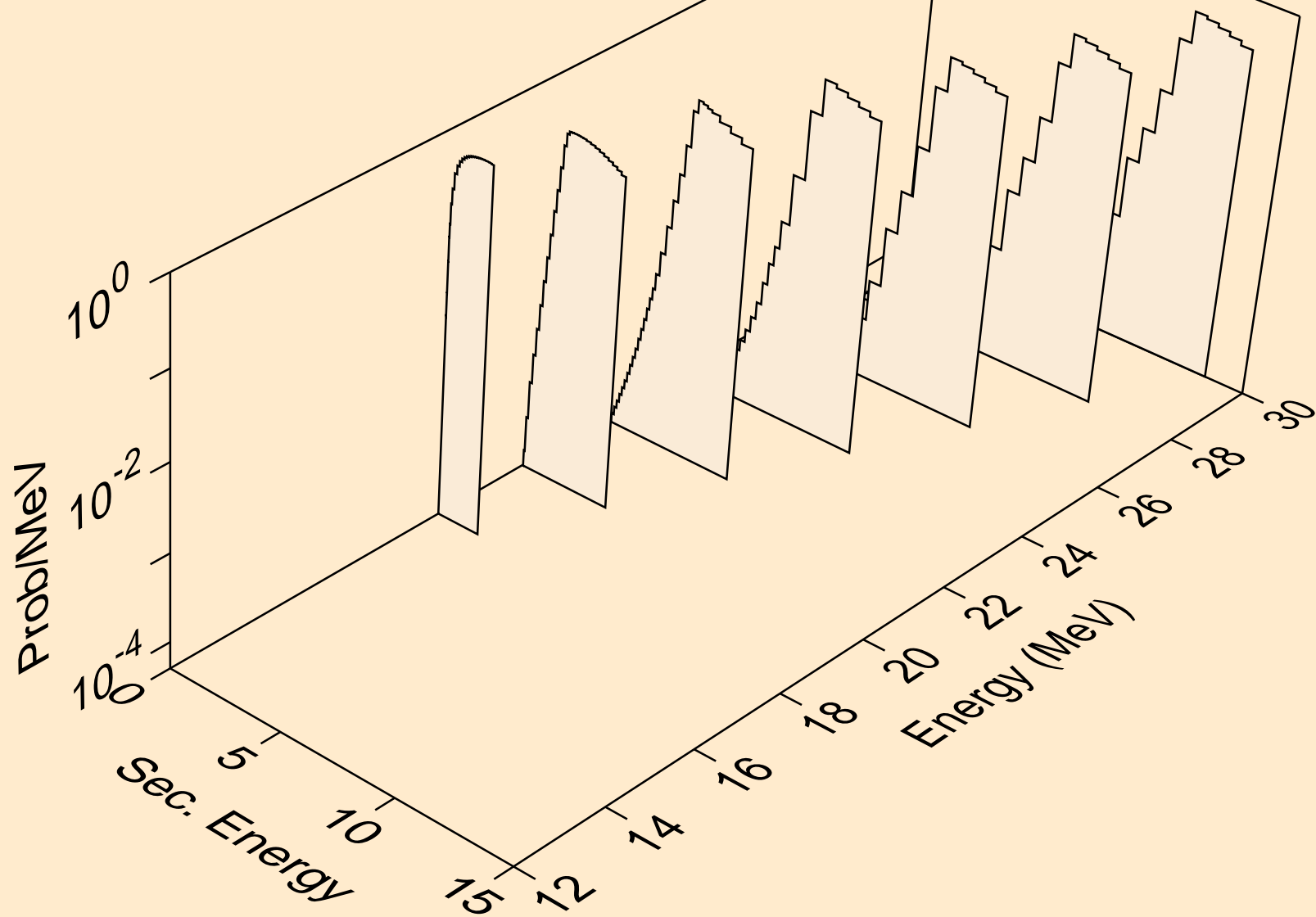

K039 PHOTON ACER TENDL-2021 LIBRARY; T=0.K  
photons from (g,x)

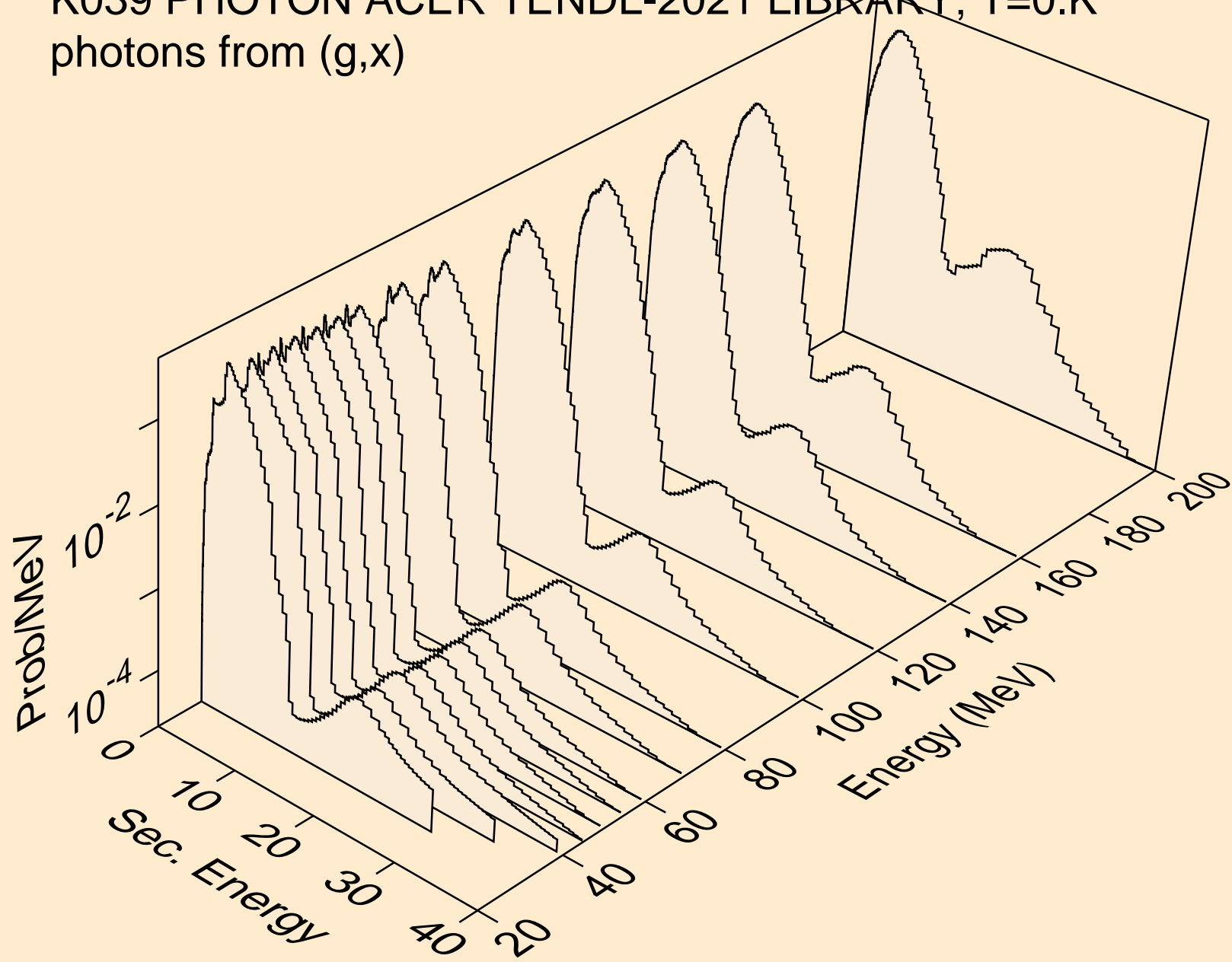

K039 PHOTON ACER TENDL-2021 LIBRARY; T=0.K  
photons from (g,2n)

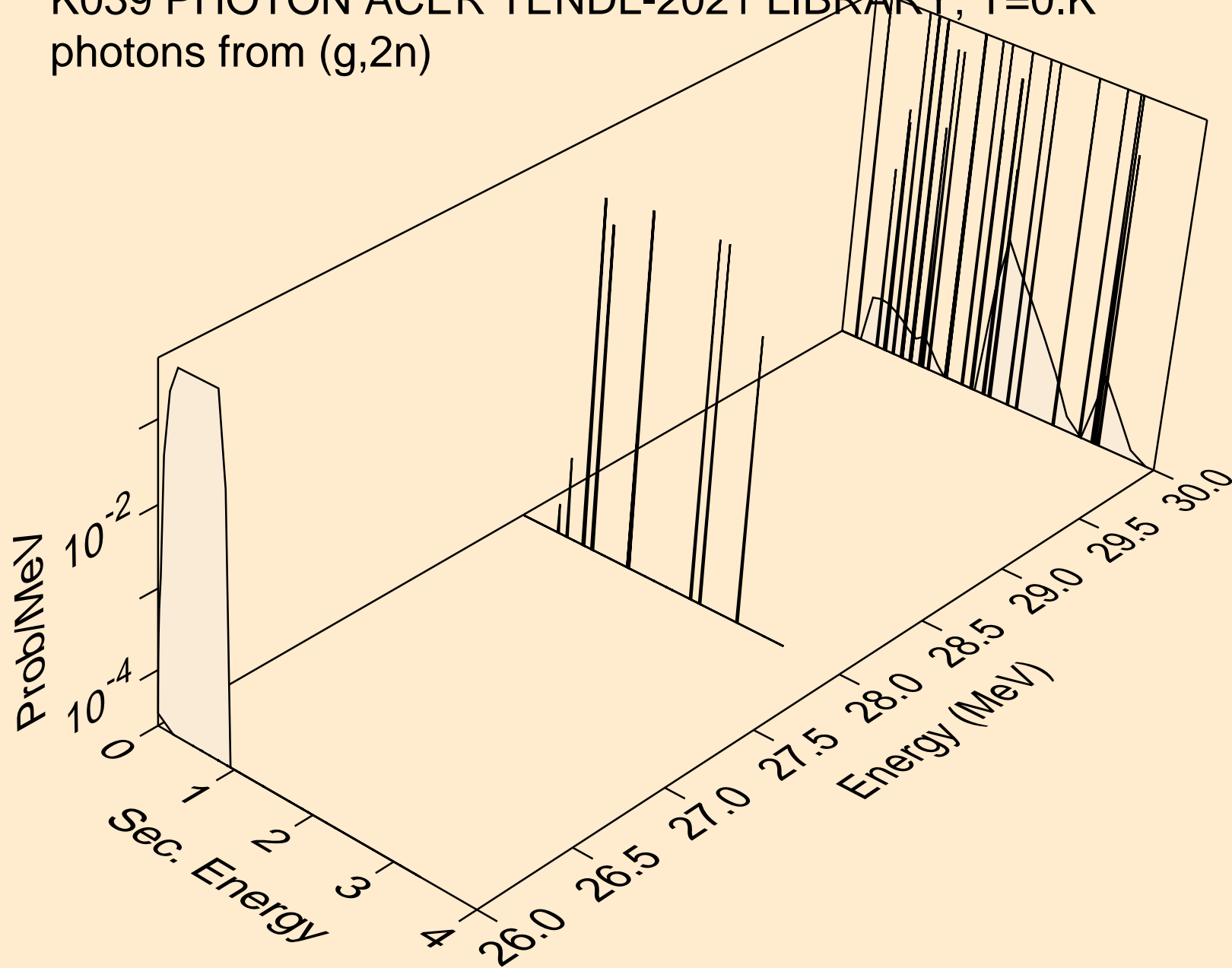

K039 PHOTON ACER TENDL-2021 LIBRARY; T=0.K  
photons from (g,n\*)a

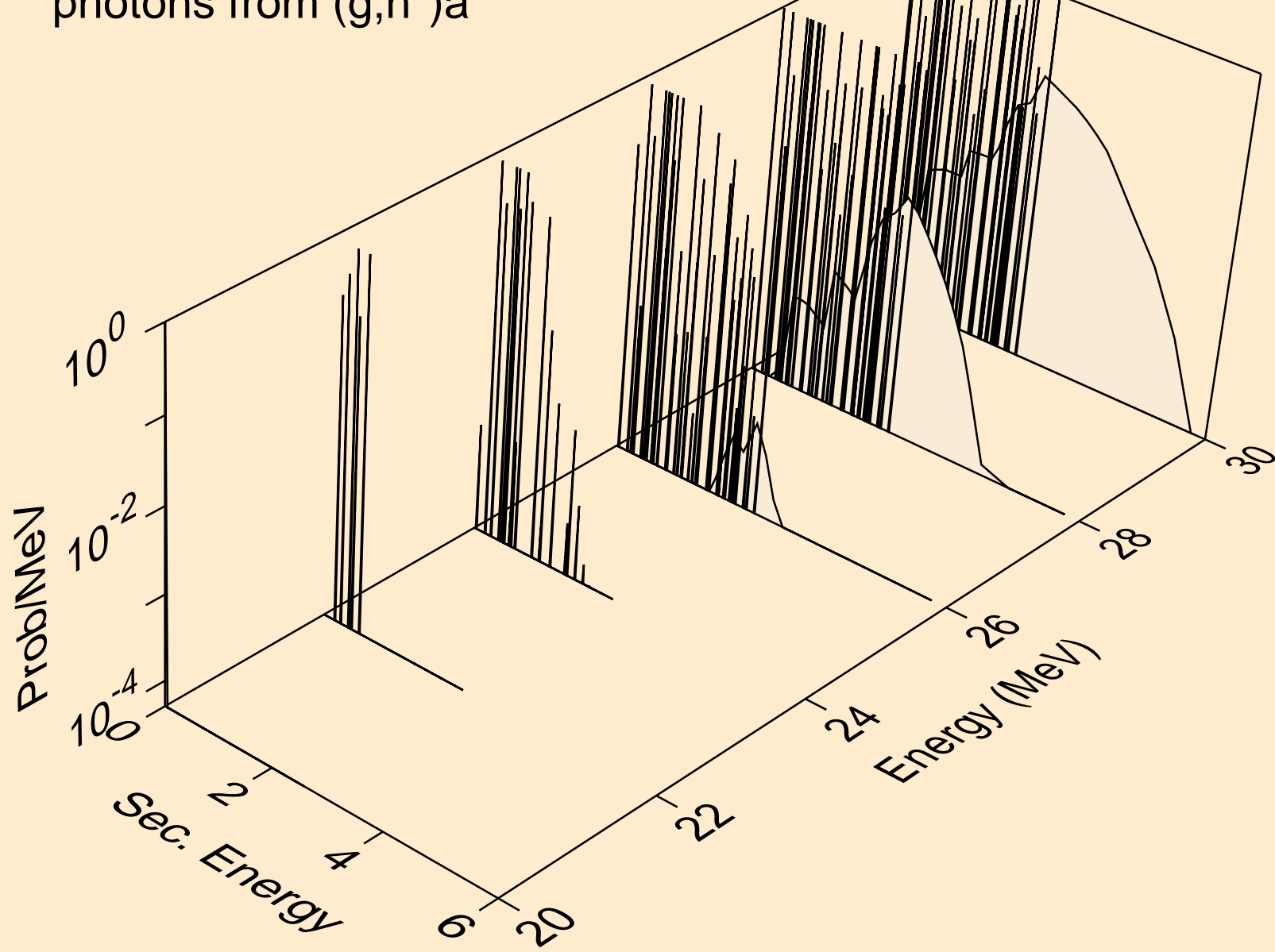

K039 PHOTON ACER TENDL-2021 LIBRARY; T=0.K  
photons from (g,n\*)p

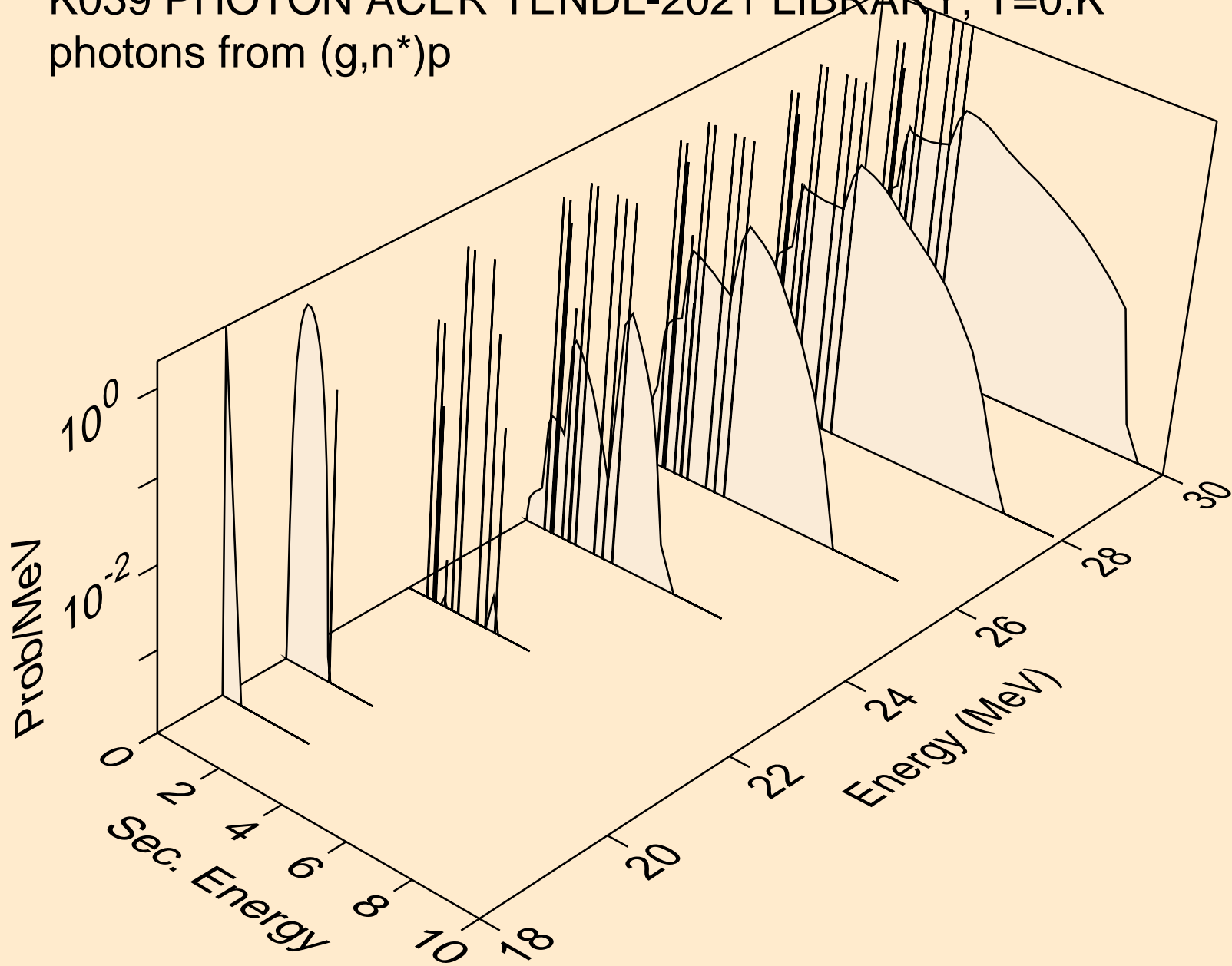

K039 PHOTON ACER TENDL-2021 LIBRARY; T=0.K  
photons from (g,n\*)d

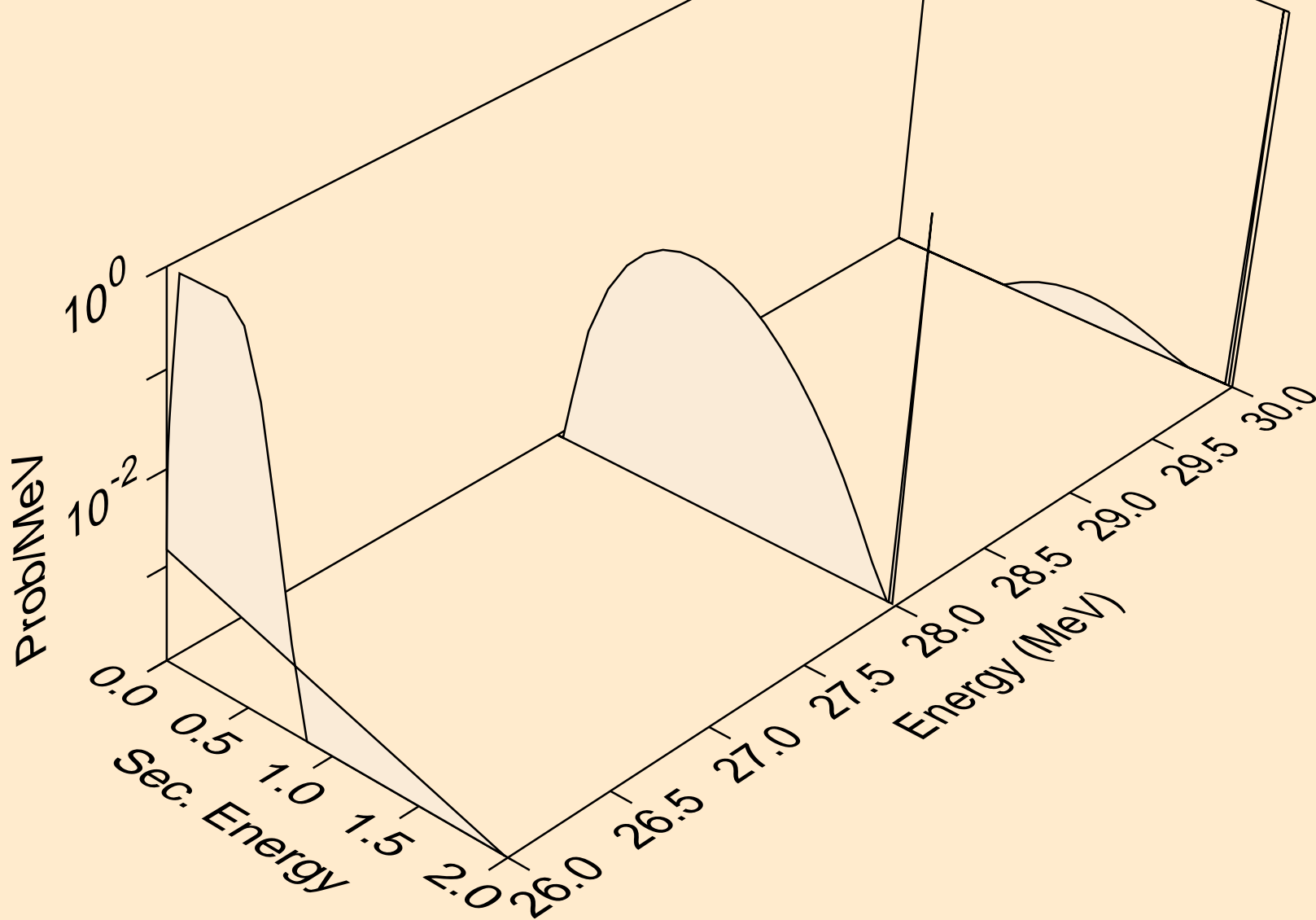

K039 PHOTON ACER TENDL-2021 LIBRARY; T=0.K  
photons from (g,2np)

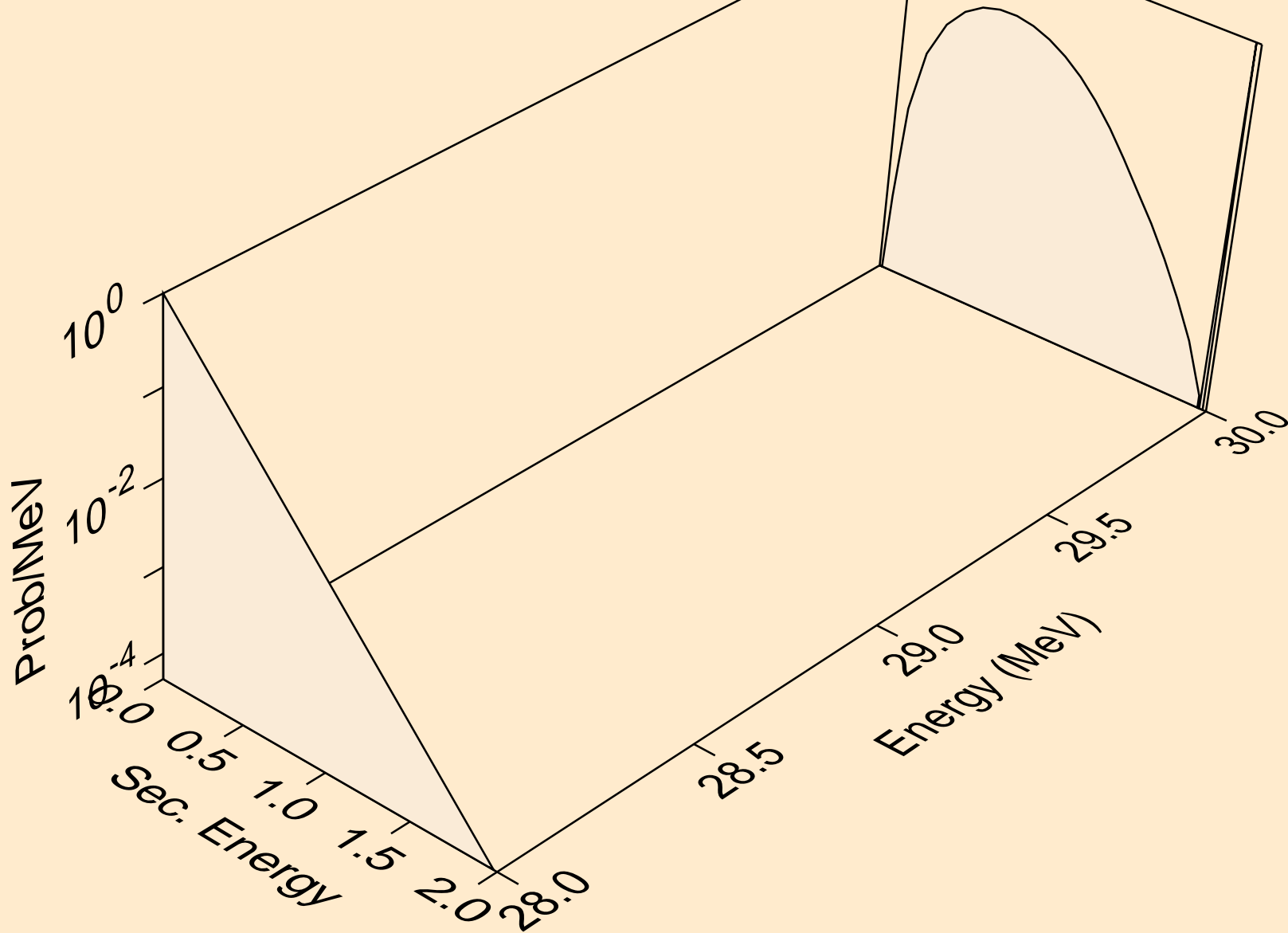

K039 PHOTON ACER TENDL-2021 LIBRARY; T=0.K  
photons from (g,2np)

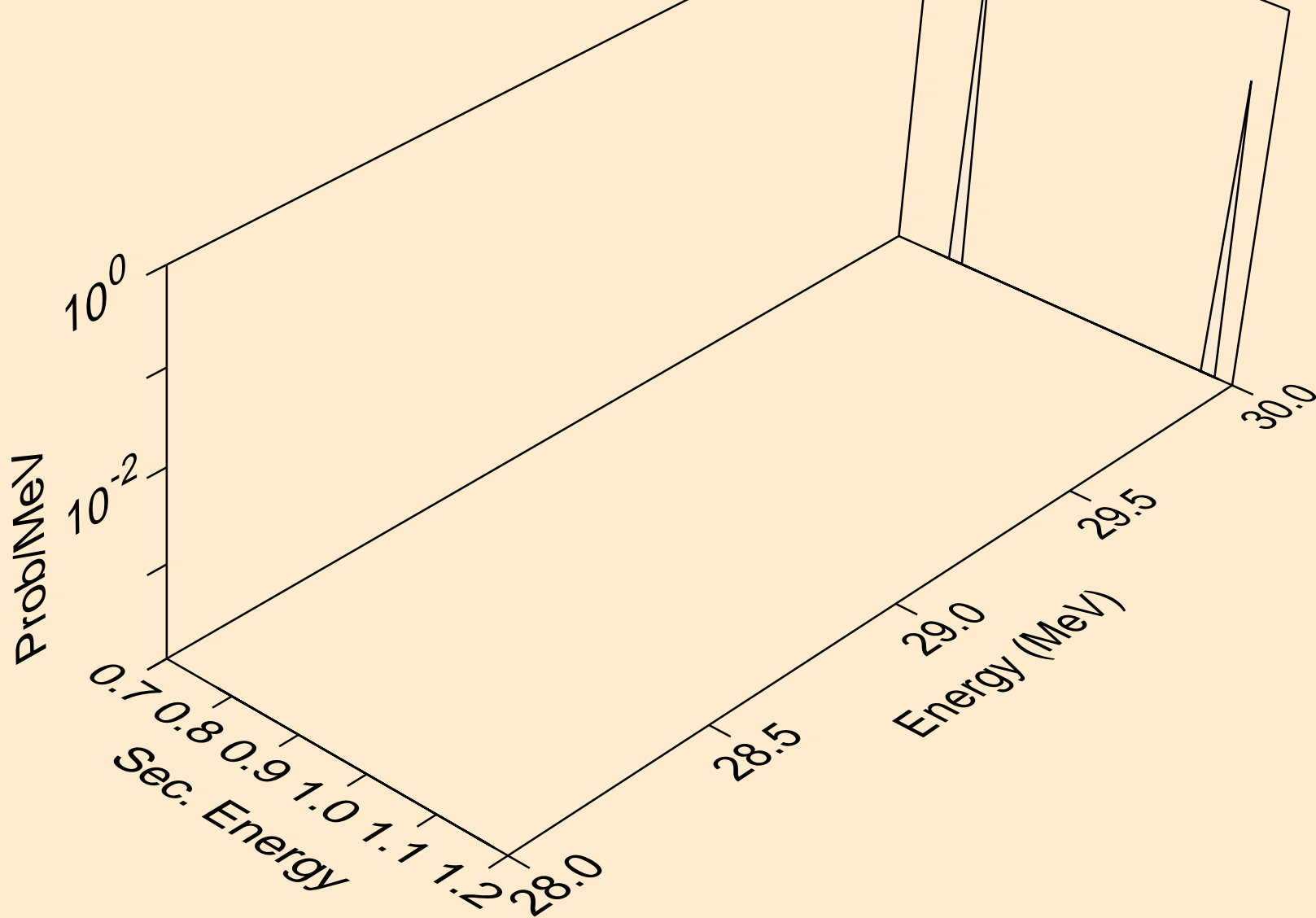

K039 PHOTON ACER TENDL-2021 LIBRARY; T=0.K  
photons from (g,npa)

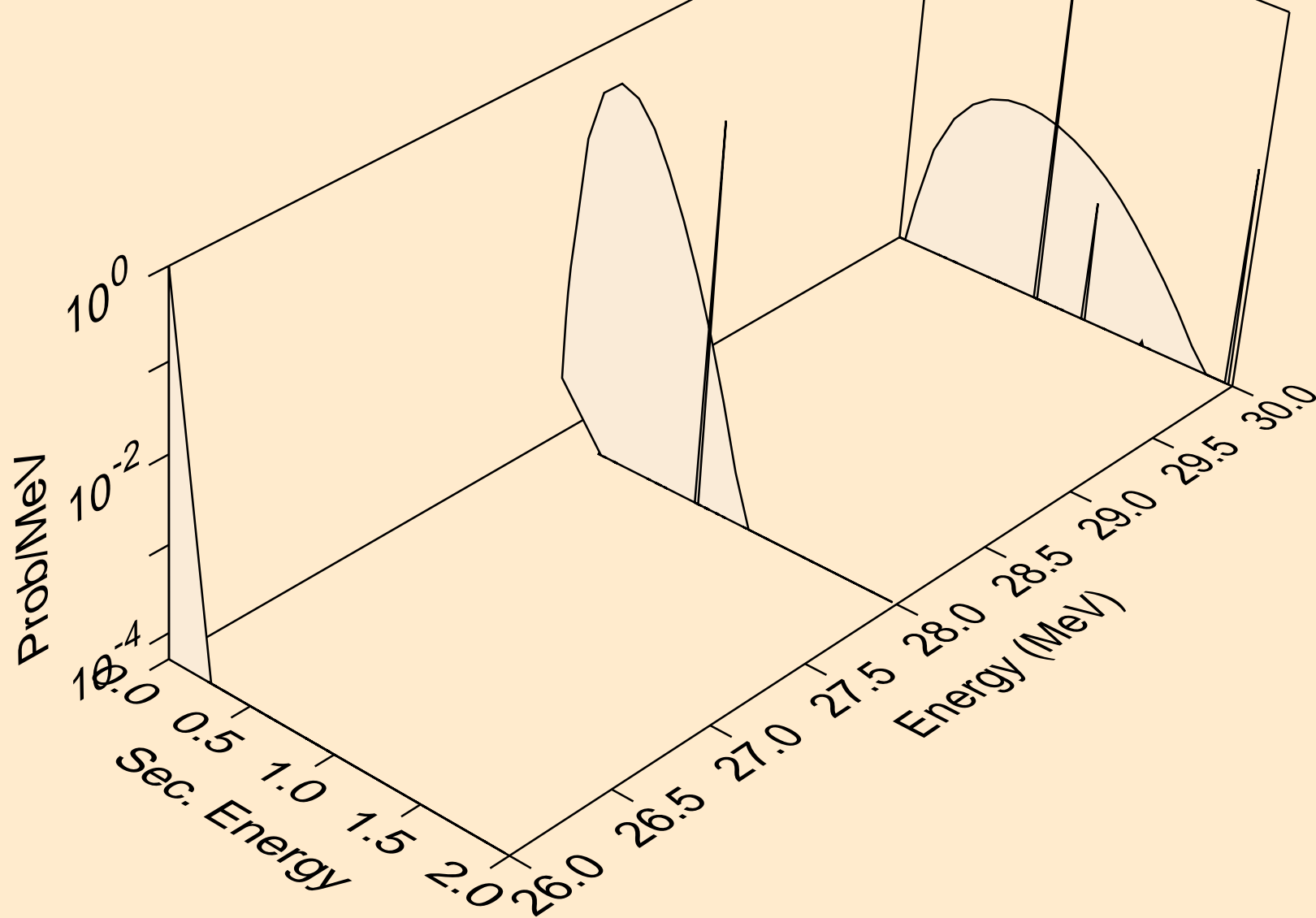

K039 PHOTON ACER TENDL-2021 LIBRARY; T=0.K  
photons from (g,n\*c)

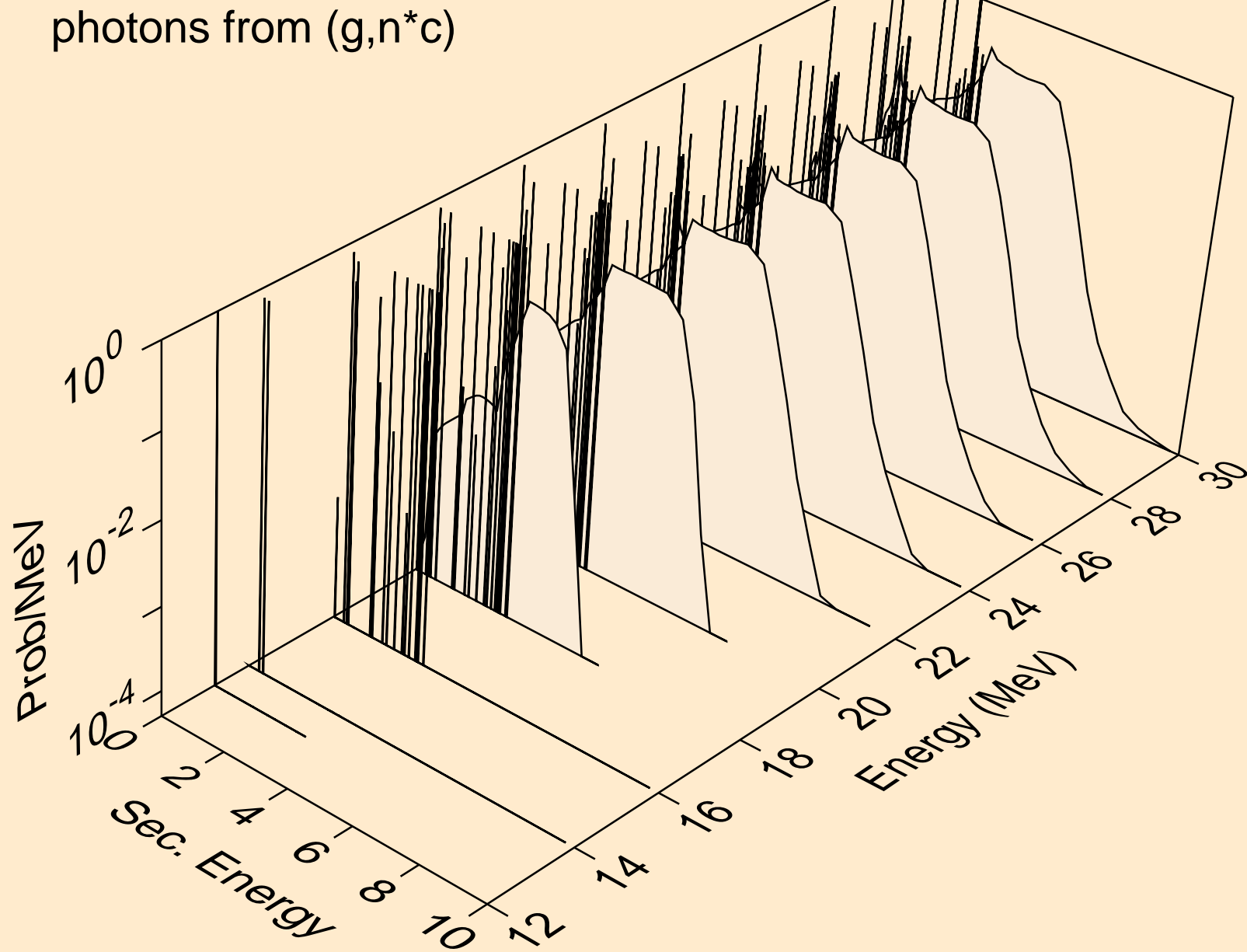

K039 PHOTON ACER TENDL-2021 LIBRARY; T=0.K  
photons from (g,gma)

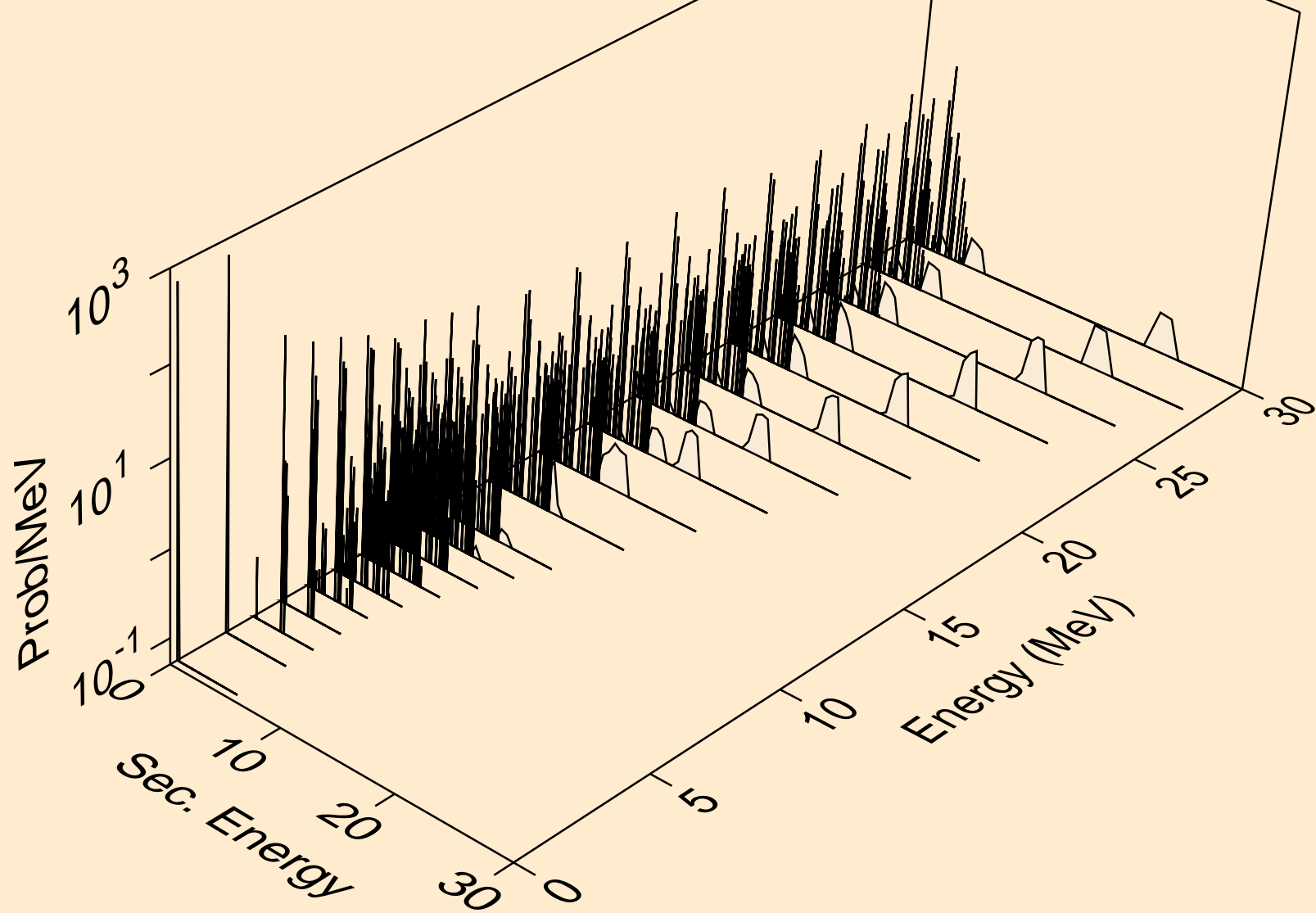

K039 PHOTON ACER TENDL-2021 LIBRARY; T=0.K  
photons from (g,p)

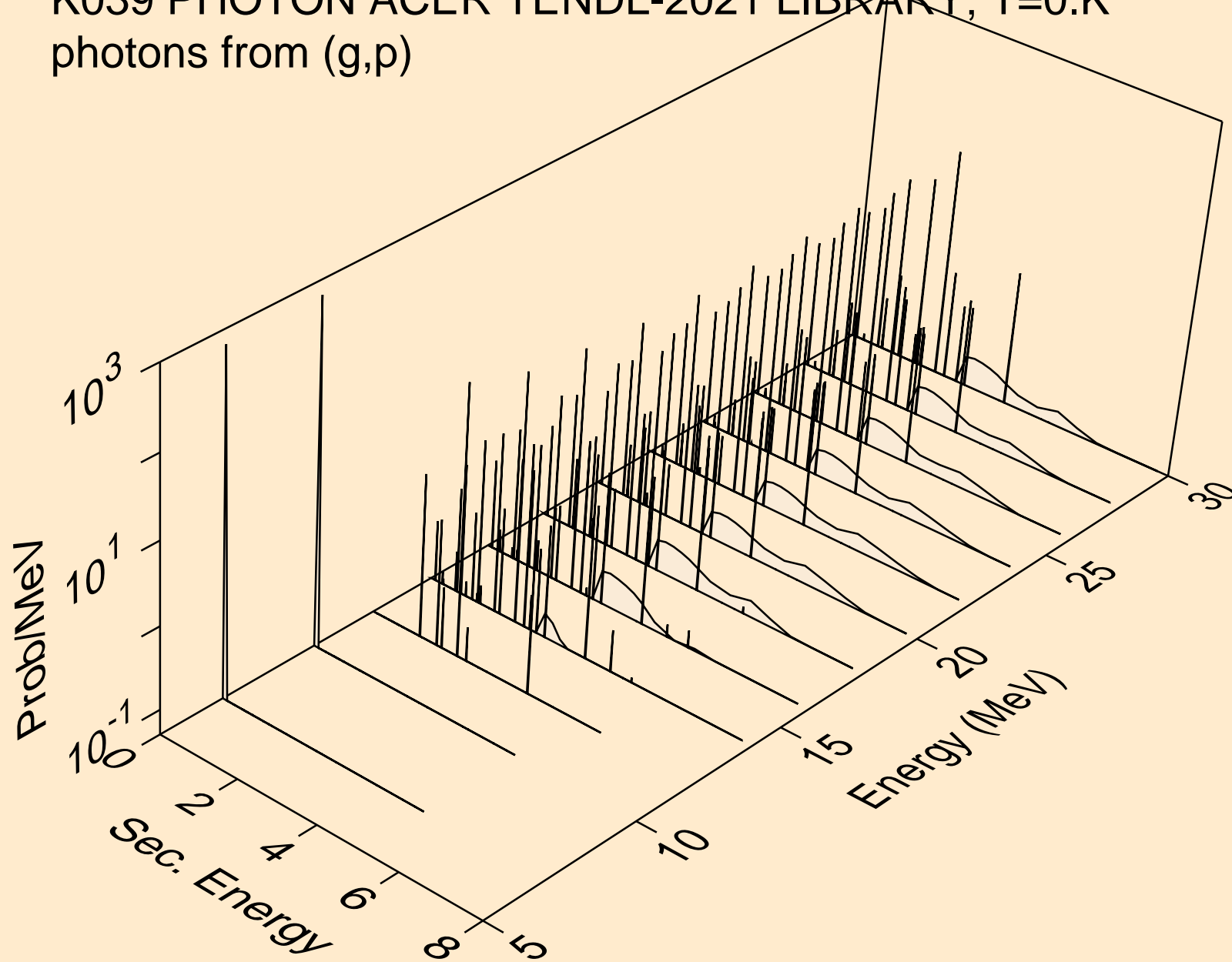

K039 PHOTON ACER TENDL-2021 LIBRARY; T=0.K  
photons from (g,d)

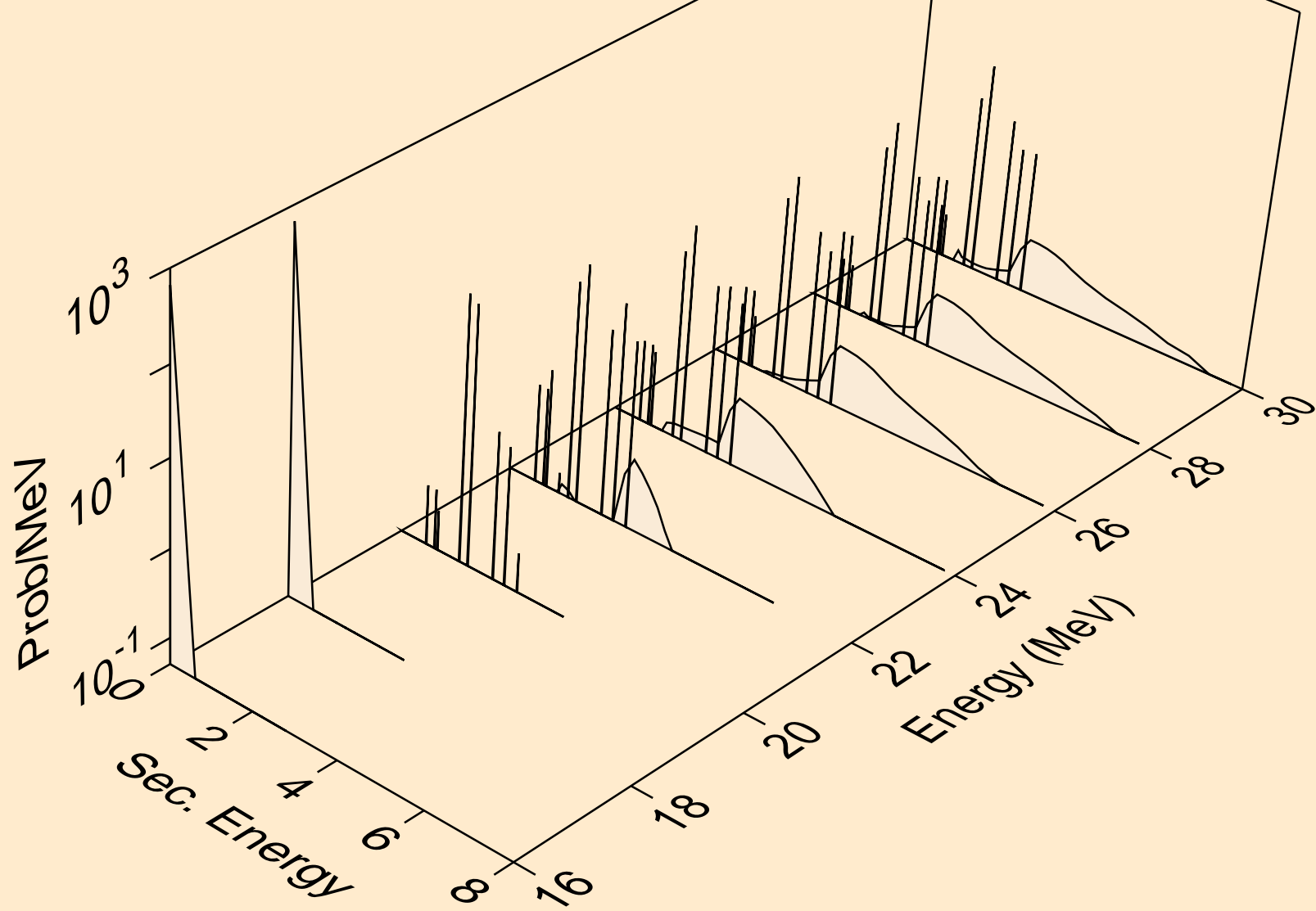

K039 PHOTON ACER TENDL-2021 LIBRARY; T=0.K  
photons from (g,t)

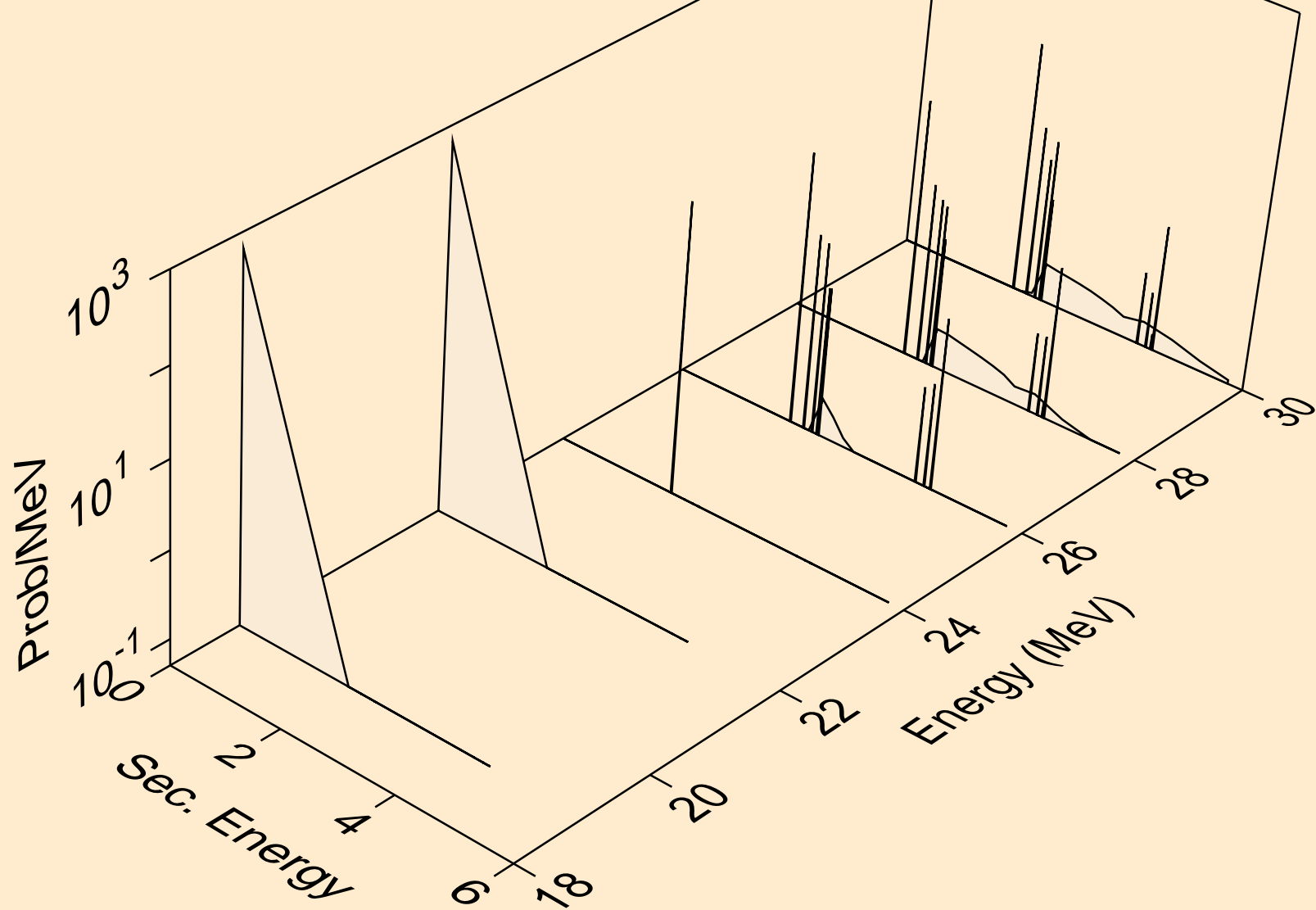

K039 PHOTON ACER TENDL-2021 LIBRARY; T=0.K  
photons from (g,he3)

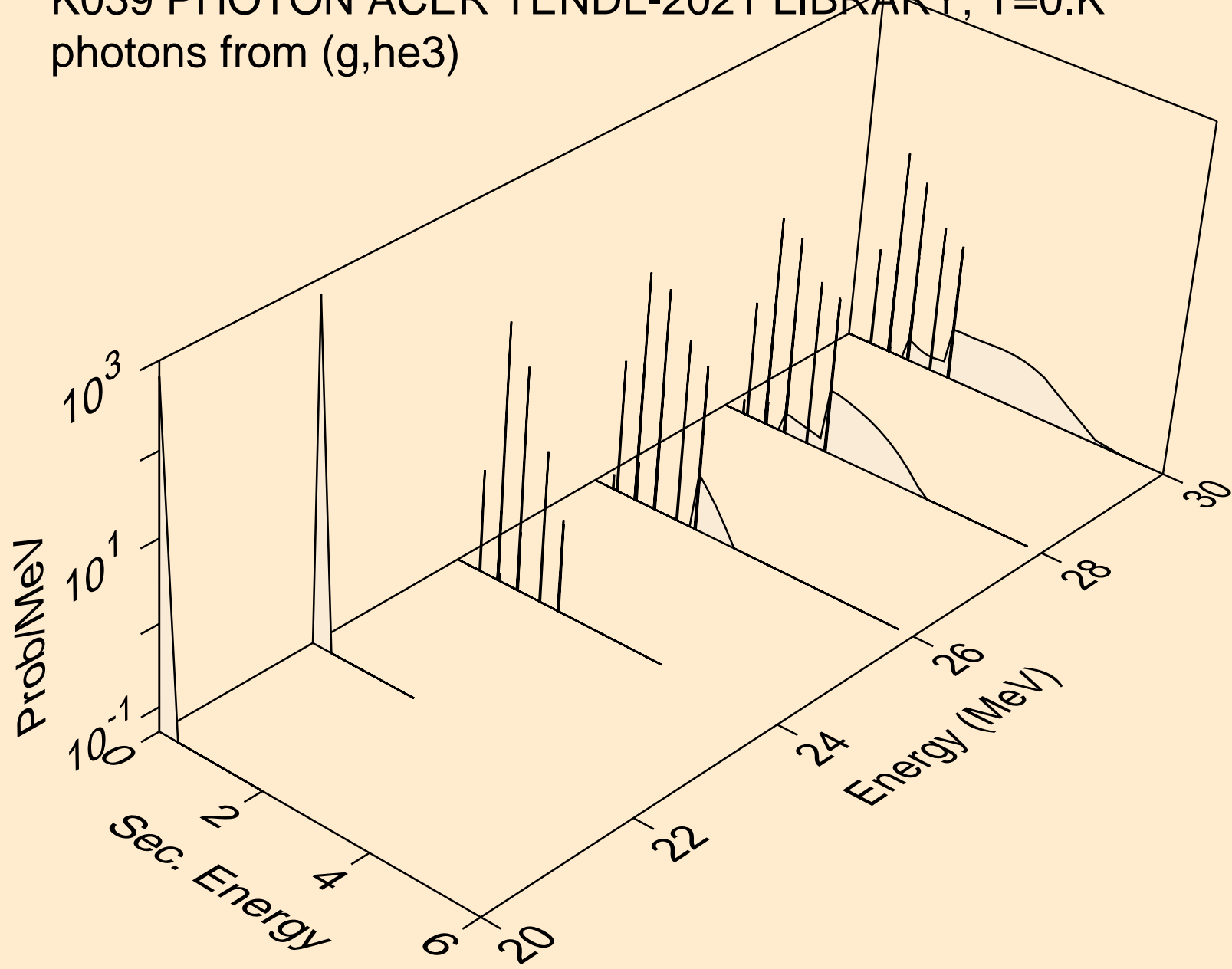

K039 PHOTON ACER TENDL-2021 LIBRARY; T=0.K  
photons from (g,a)

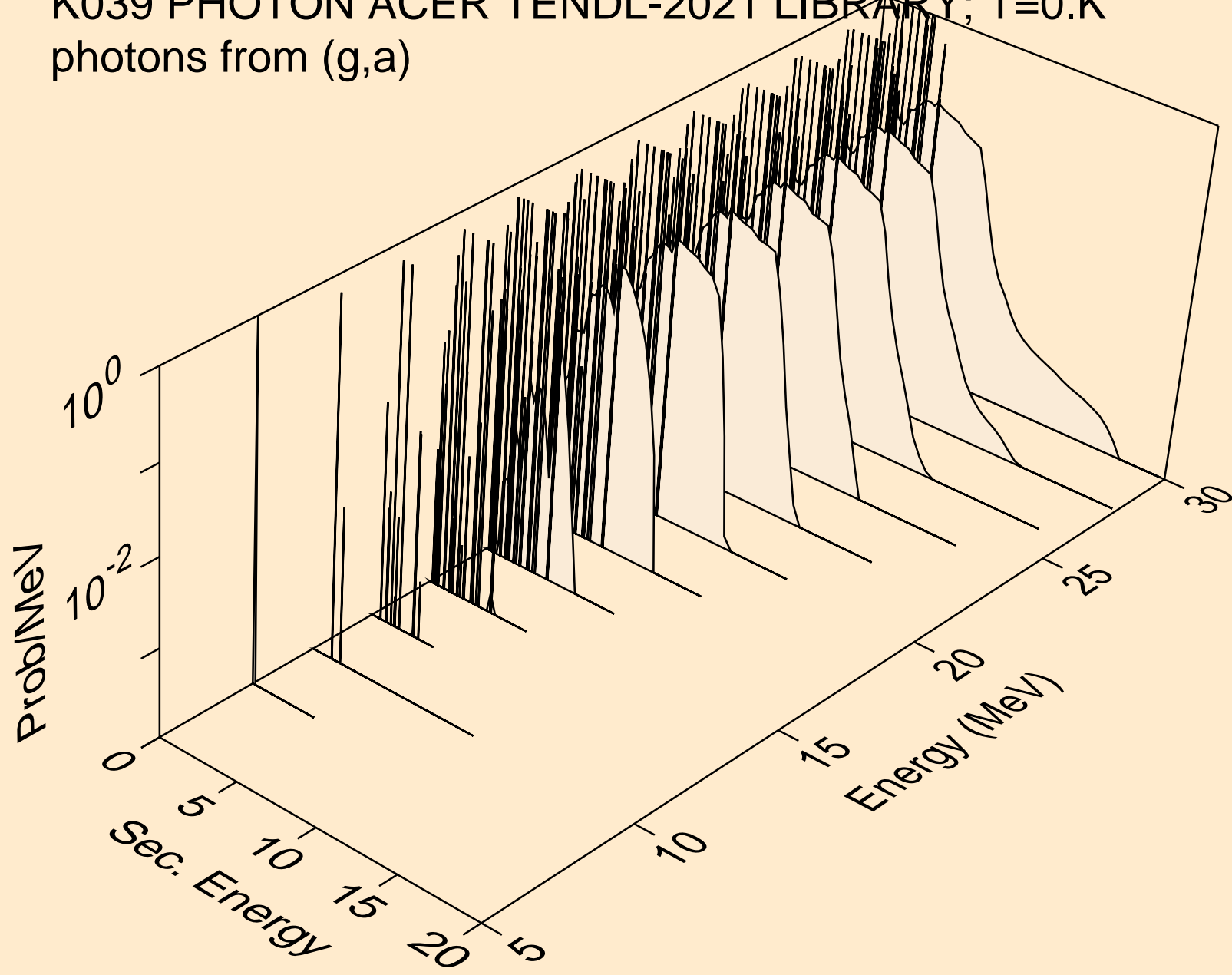

K039 PHOTON ACER TENDL-2021 LIBRARY; T=0.K  
photons from (g,2a)

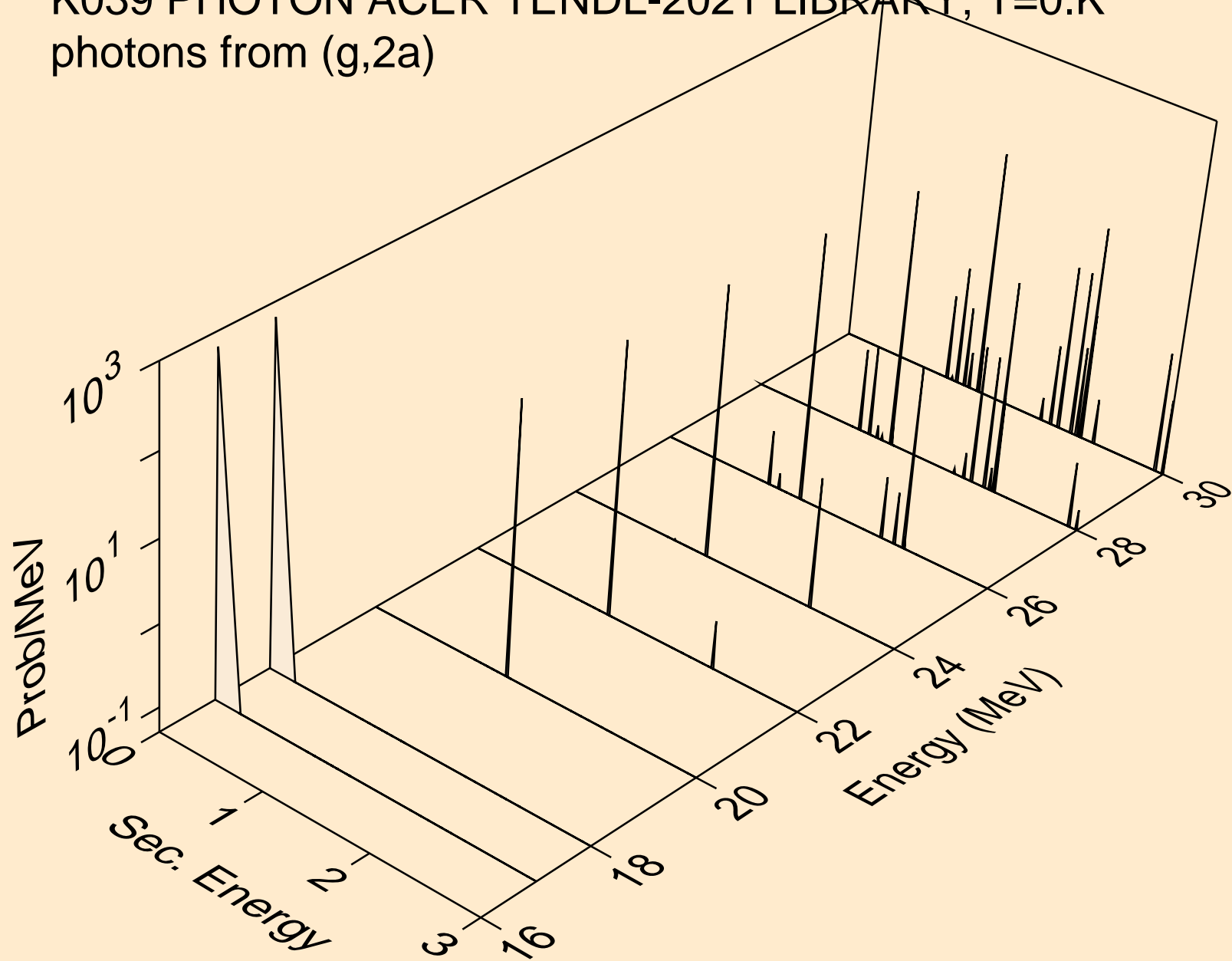

K039 PHOTON ACER TENDL-2021 LIBRARY; T=0.K  
photons from (g,2p)

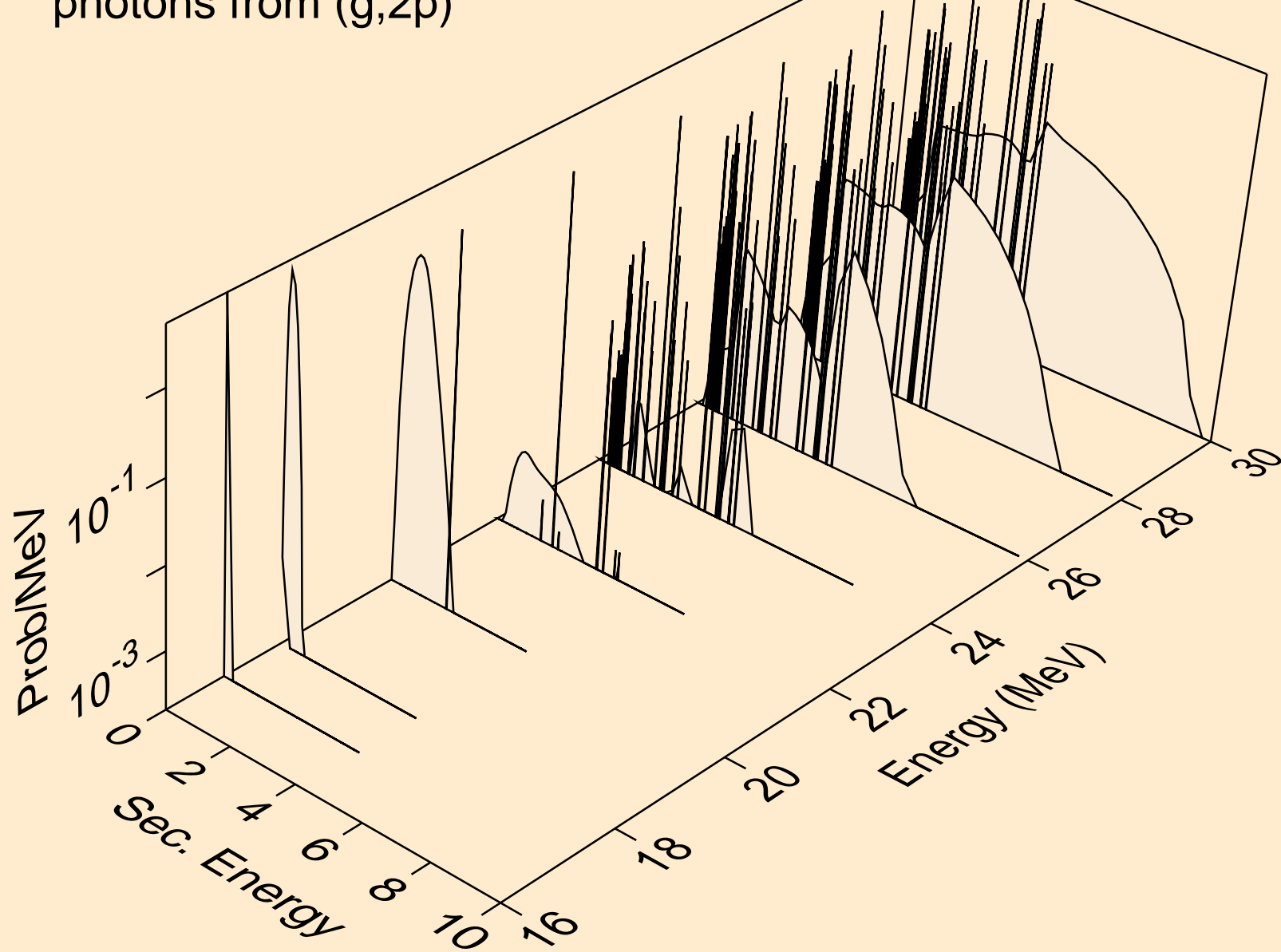

K039 PHOTON ACER TENDL-2021 LIBRARY; T=0.K  
photons from (g,pa)

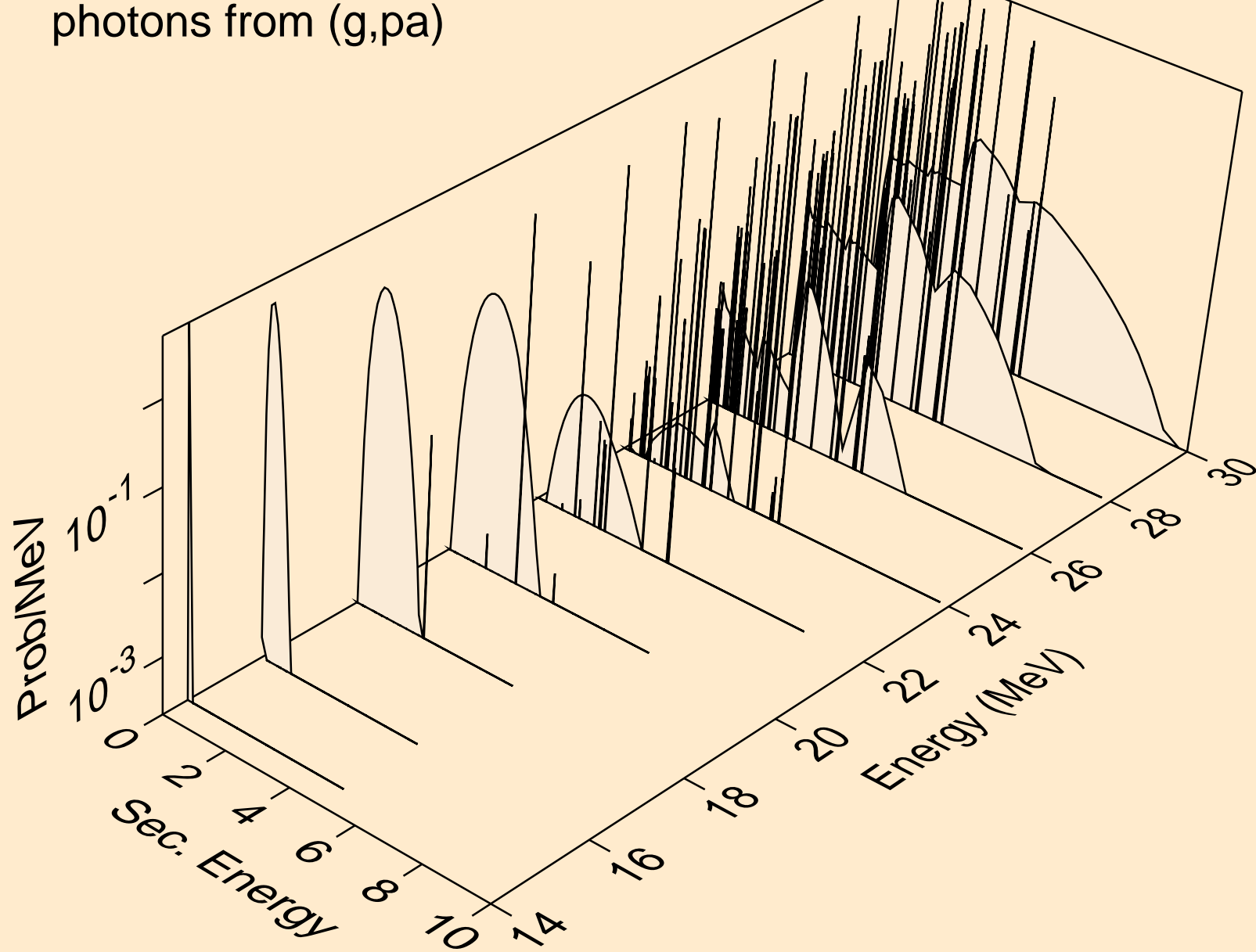

K039 PHOTON ACER TENDL-2021 LIBRARY; T=0.K  
photons from (g,pd)

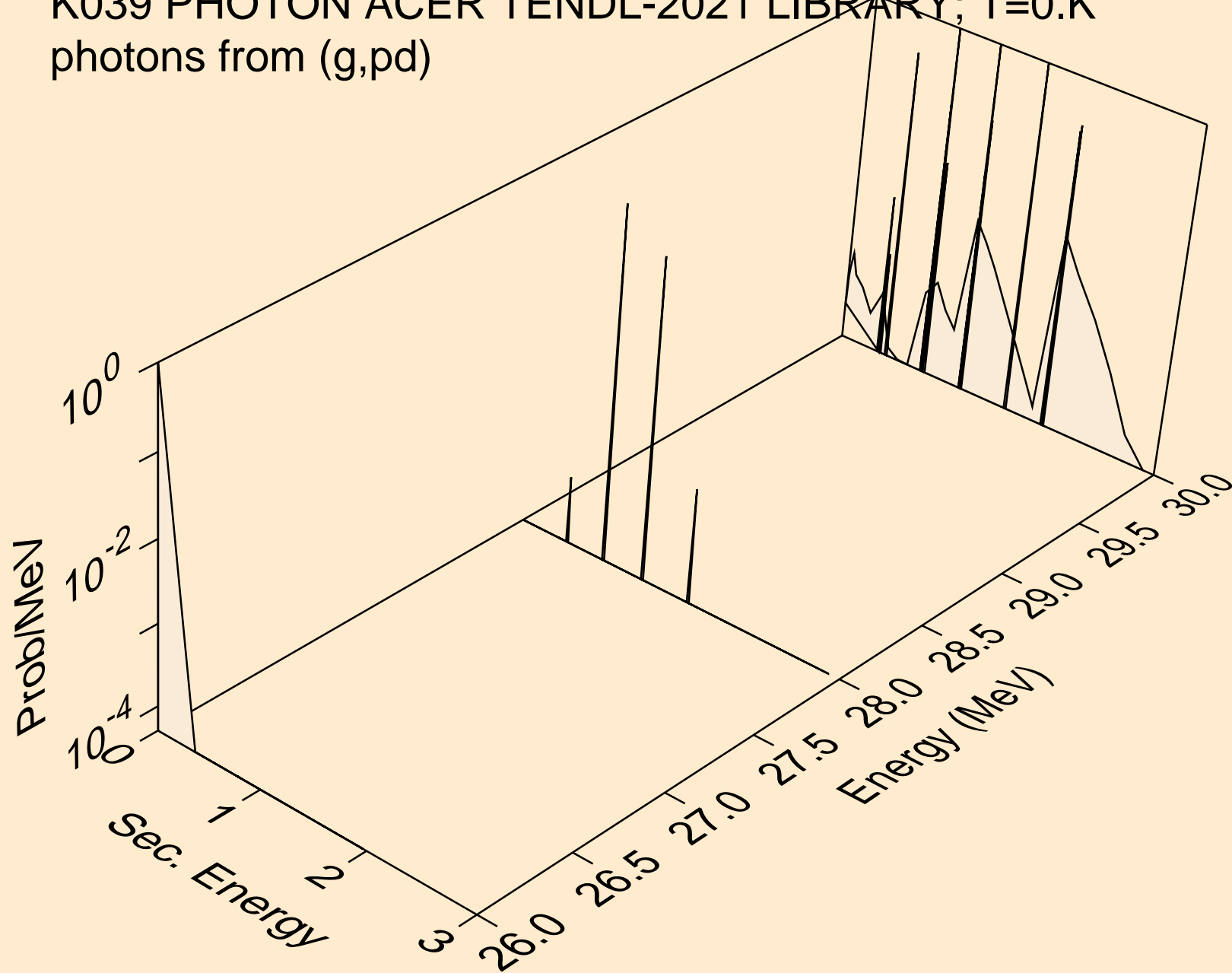

K039 PHOTON ACER TENDL-2021 LIBRARY; T=0.K  
photons from (g,pt)

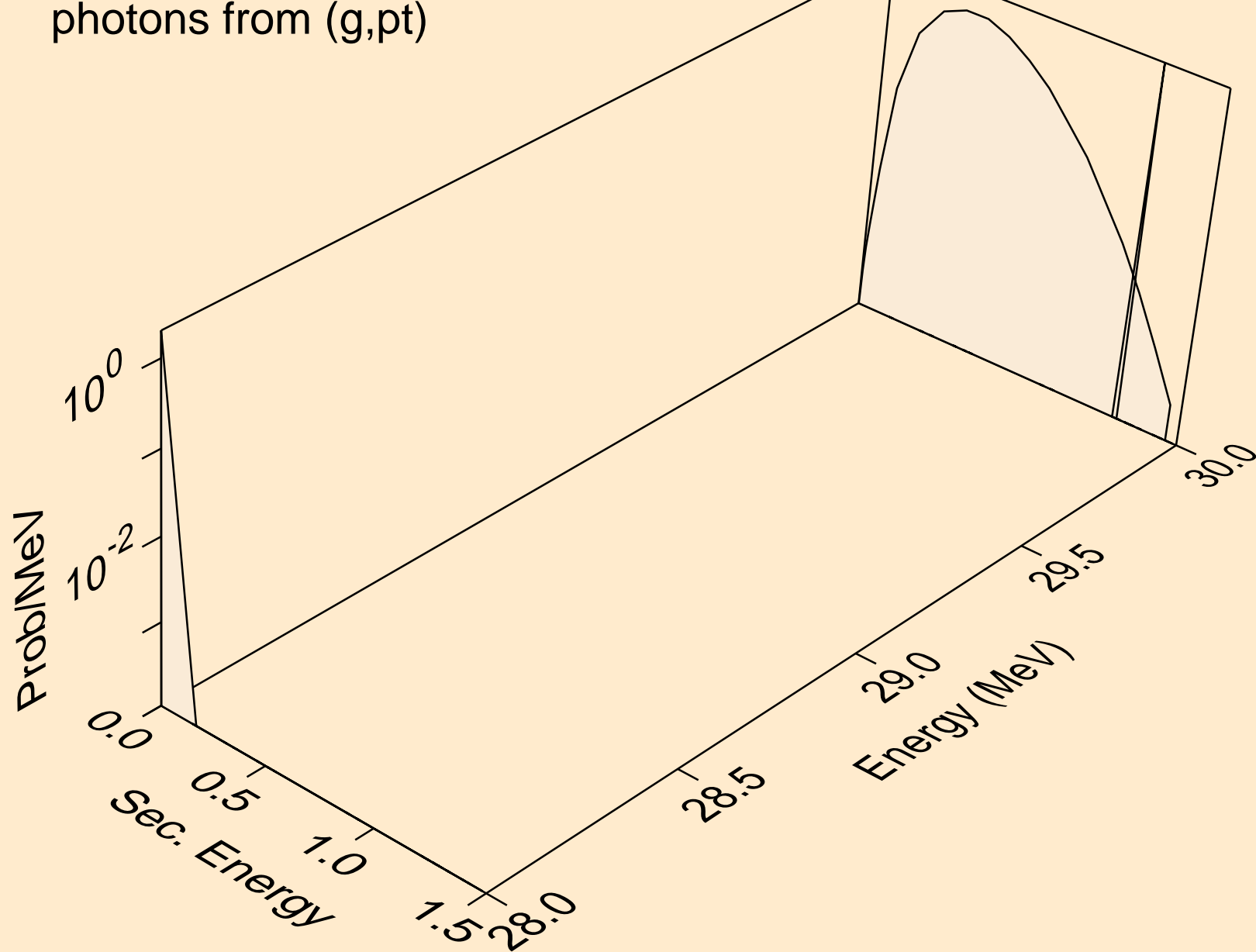

K039 PHOTON ACER TENDL-2021 LIBRARY; T=0.K  
photons from (g,da)

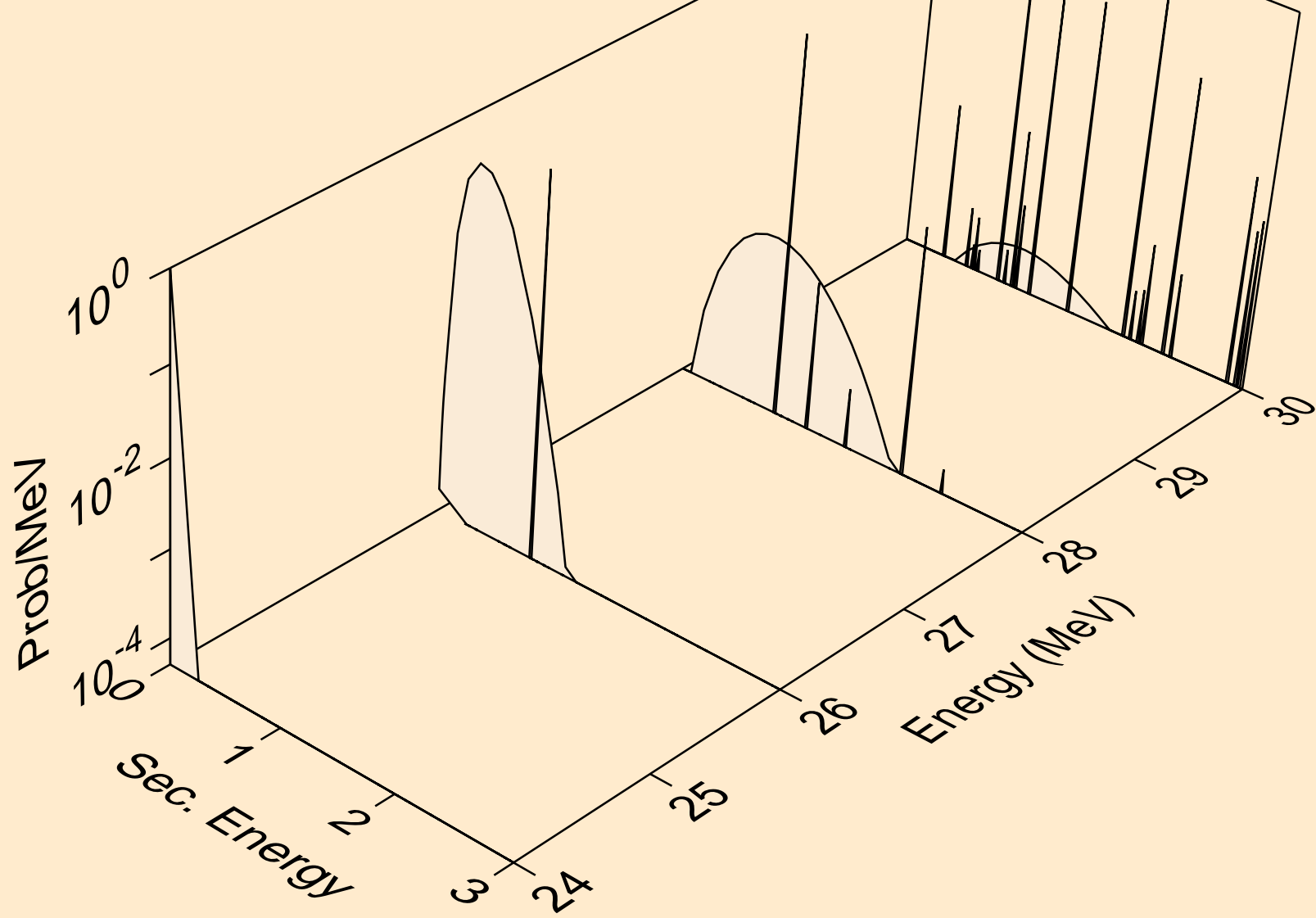

K039 PHOTON ACER TENDL-2021 LIBRARY; T=0.K  
protons from (g,x)

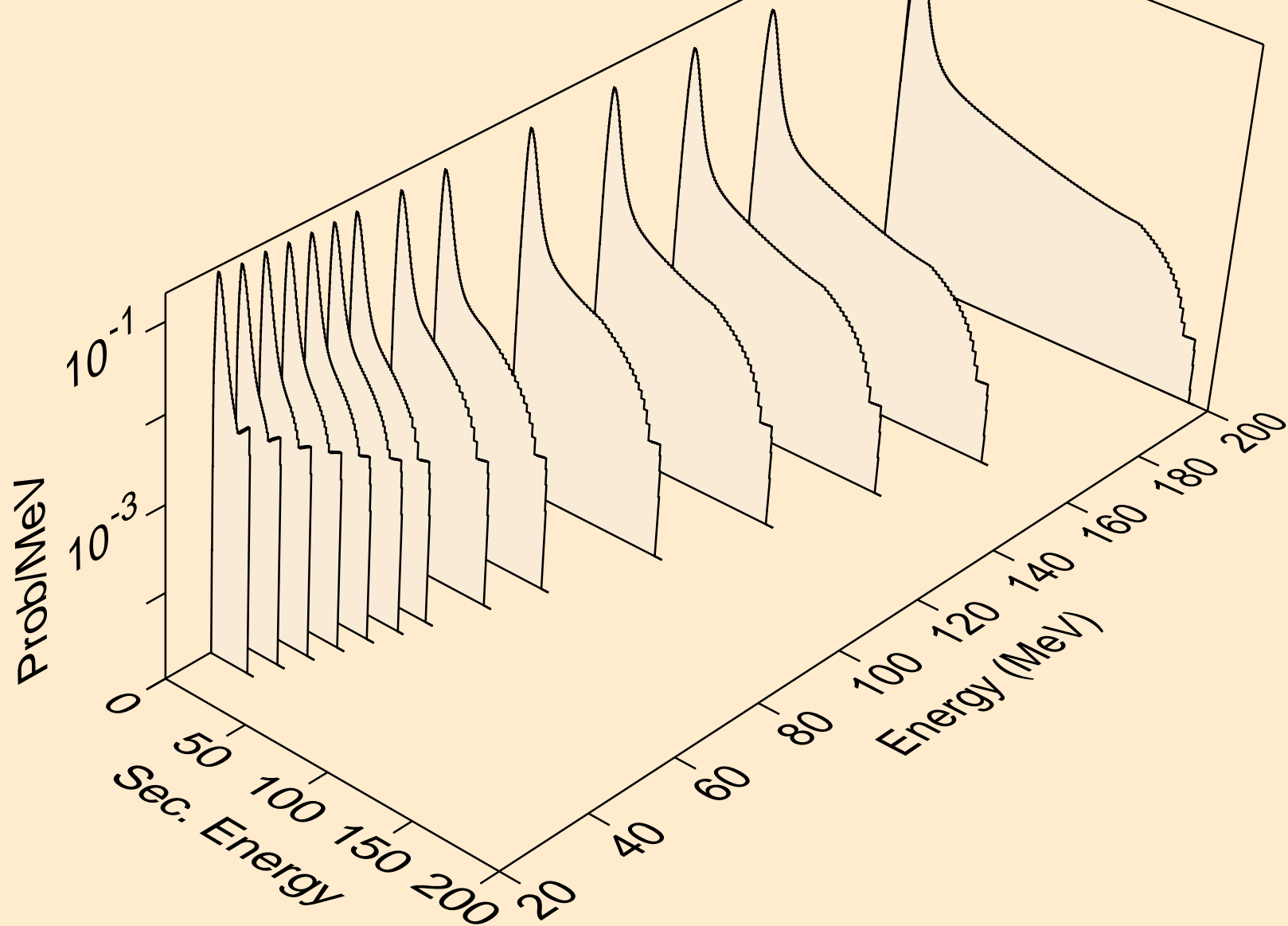

K039 PHOTON ACER TENDL-2021 LIBRARY; T=0.K  
protons from (g,n\*)p

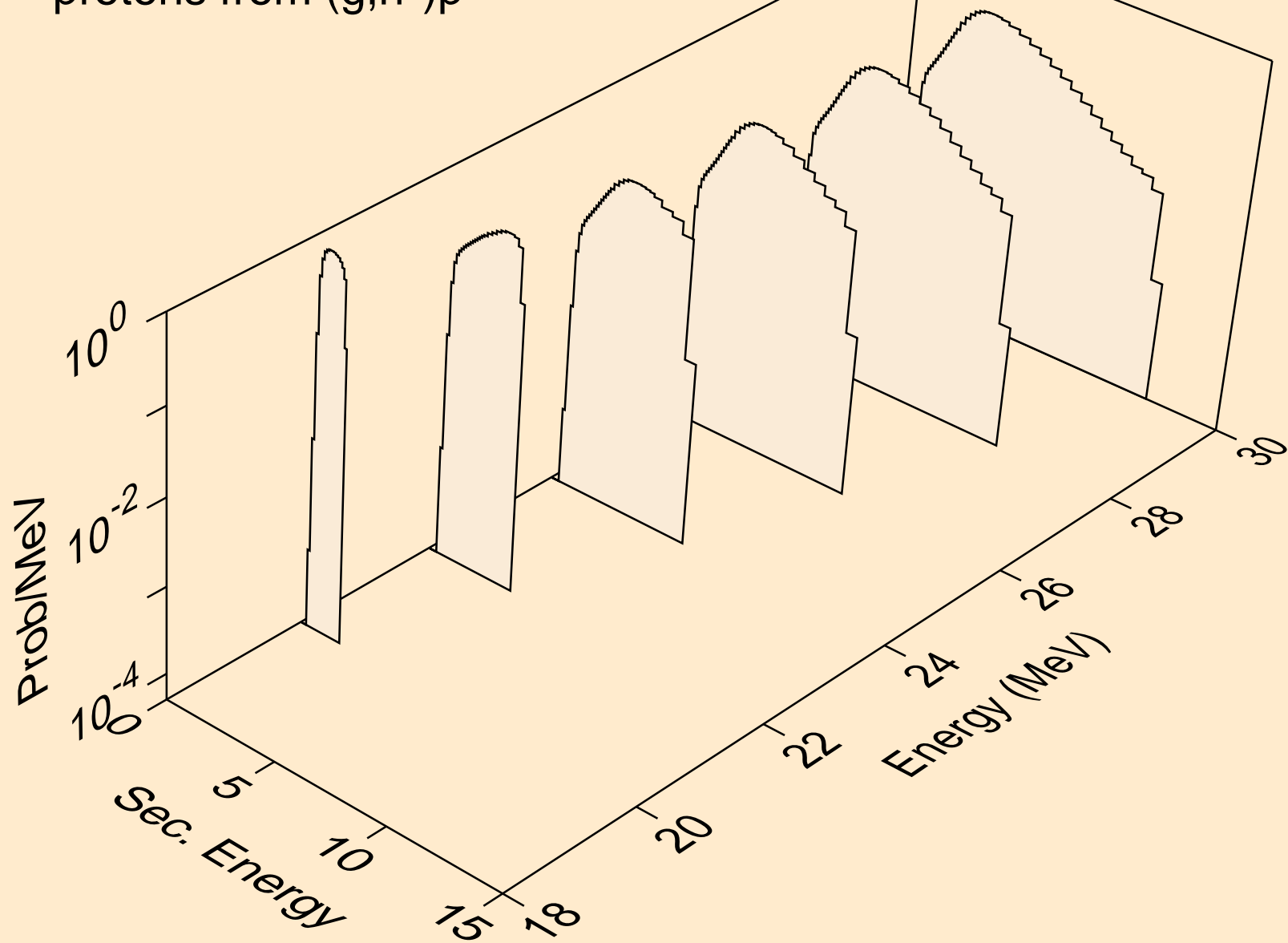

K039 PHOTON ACER TENDL-2021 LIBRARY; T=0.K  
protons from (g,2np)

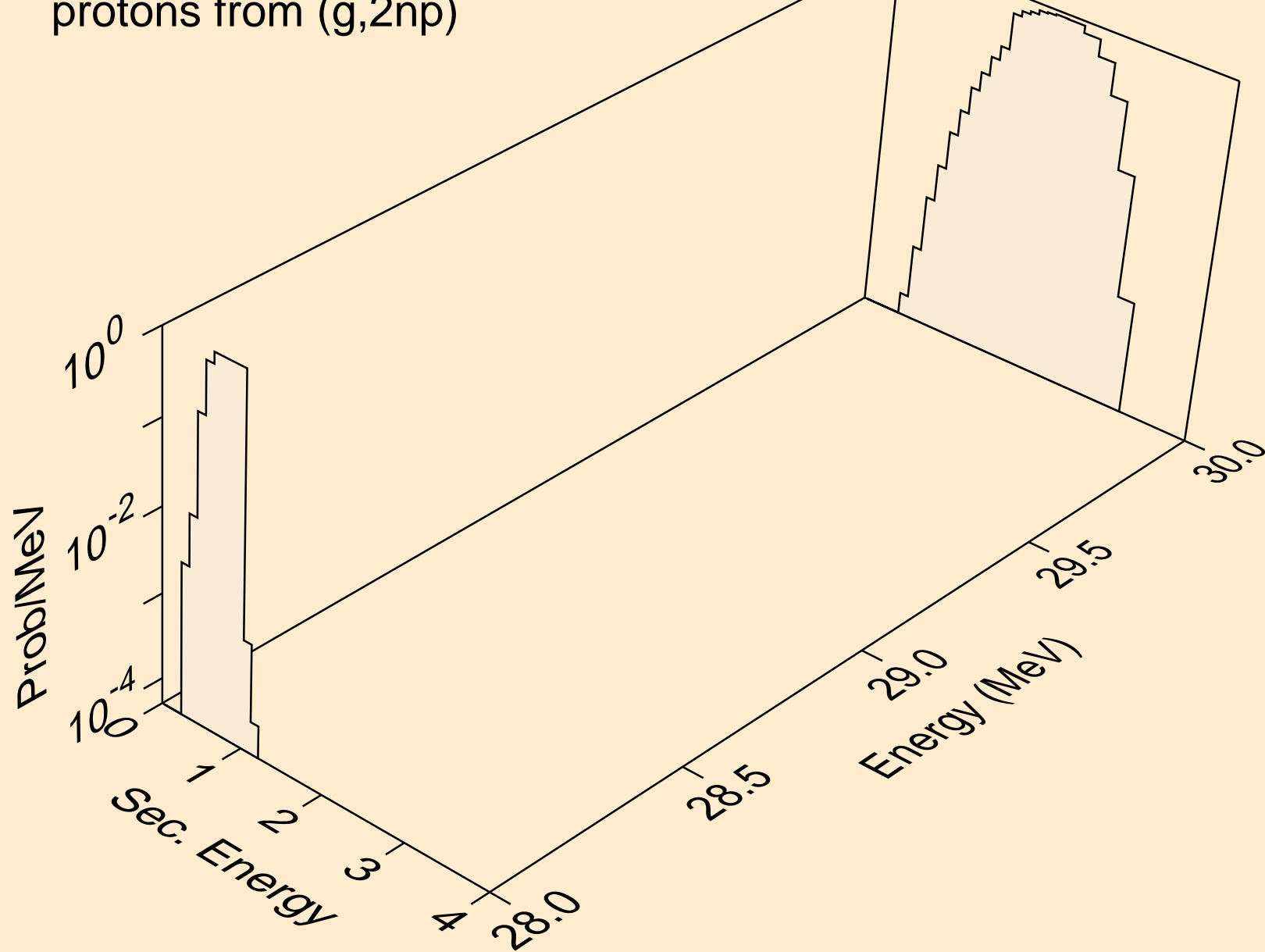

K039 PHOTON ACER TENDL-2021 LIBRARY; T=0.K  
protons from (g,2np)

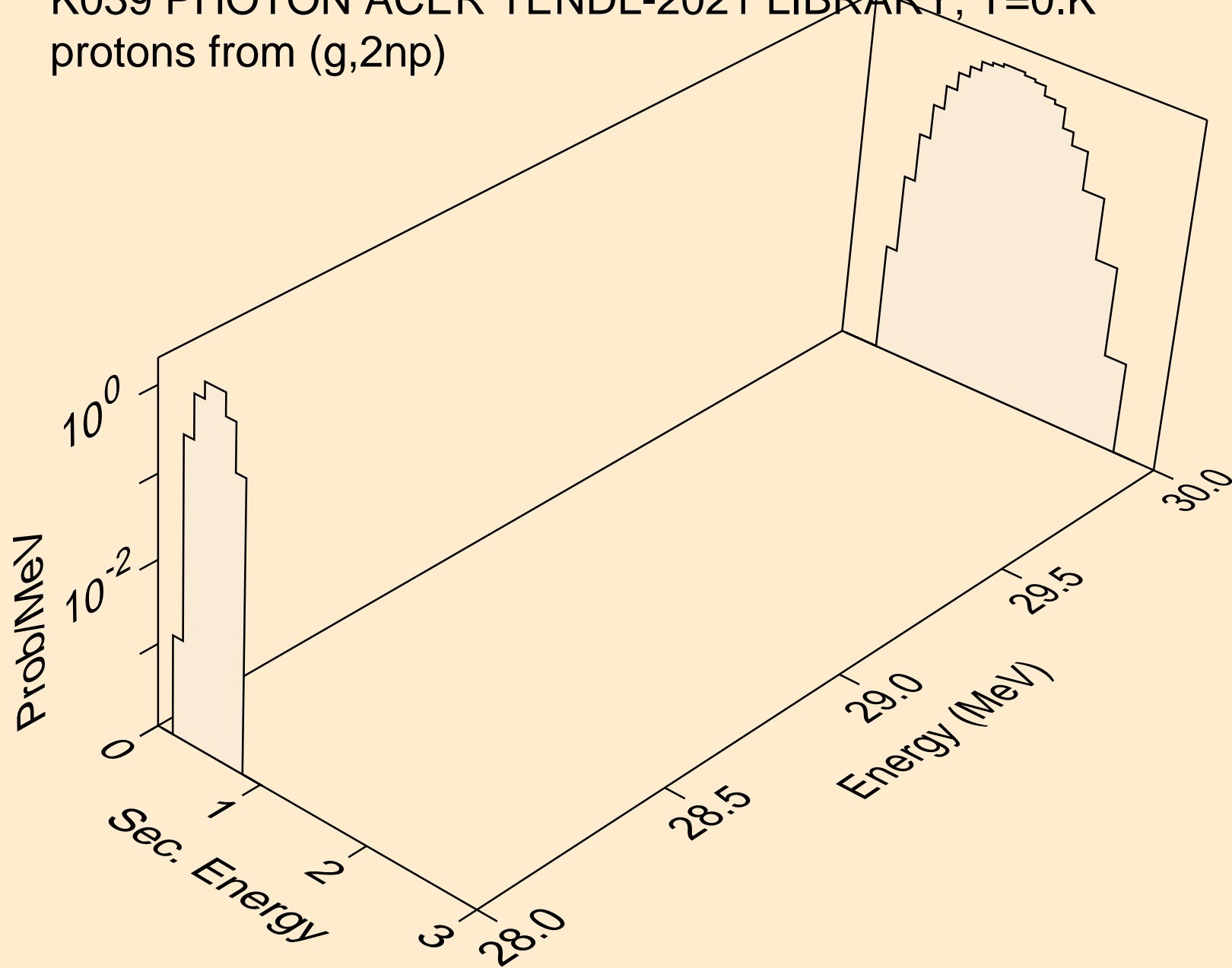

K039 PHOTON ACER TENDL-2021 LIBRARY; T=0.K  
protons from (g,npa)

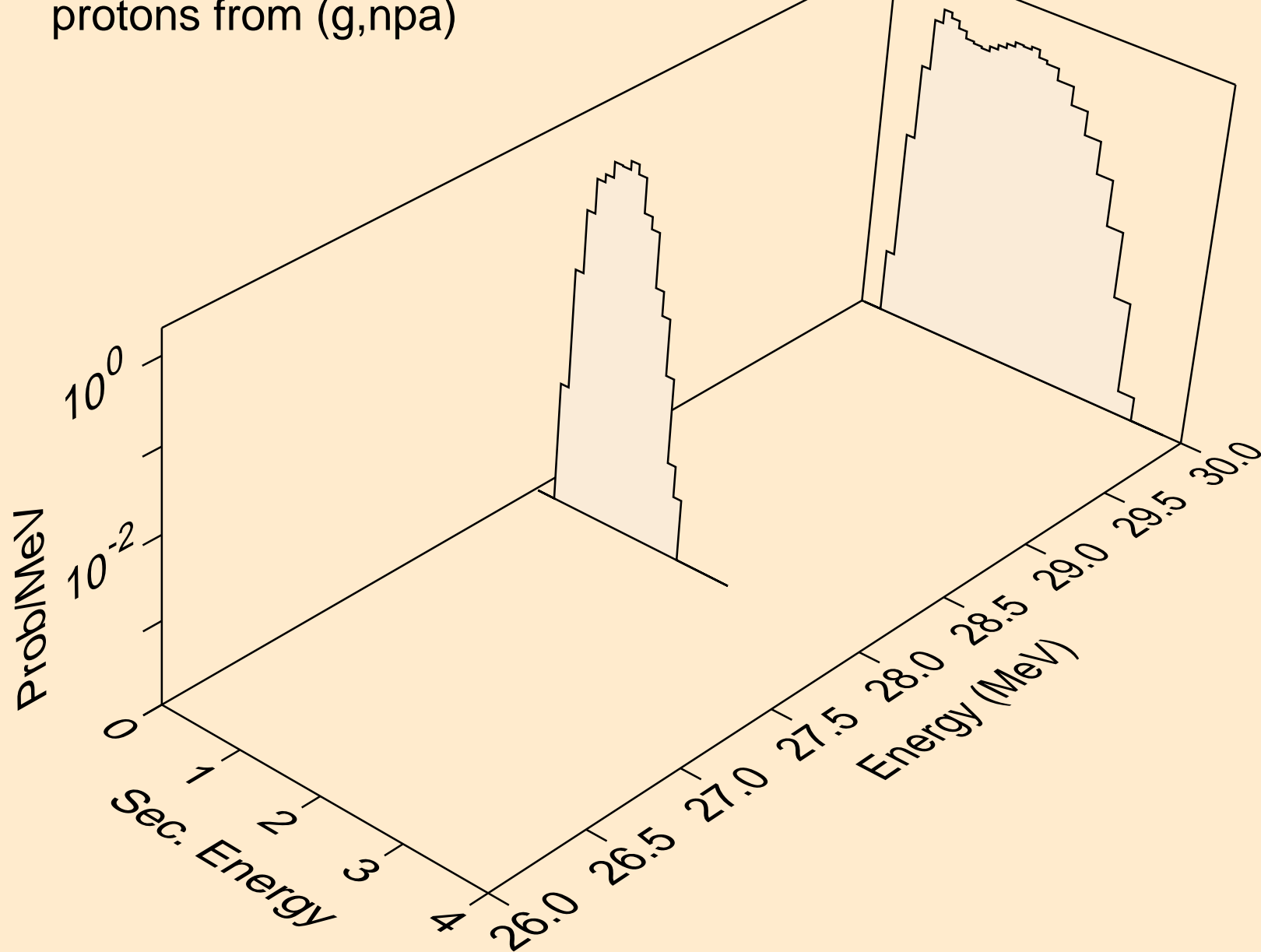

K039 PHOTON ACER TENDL-2021 LIBRARY; T=0.K  
protons from (g,p)

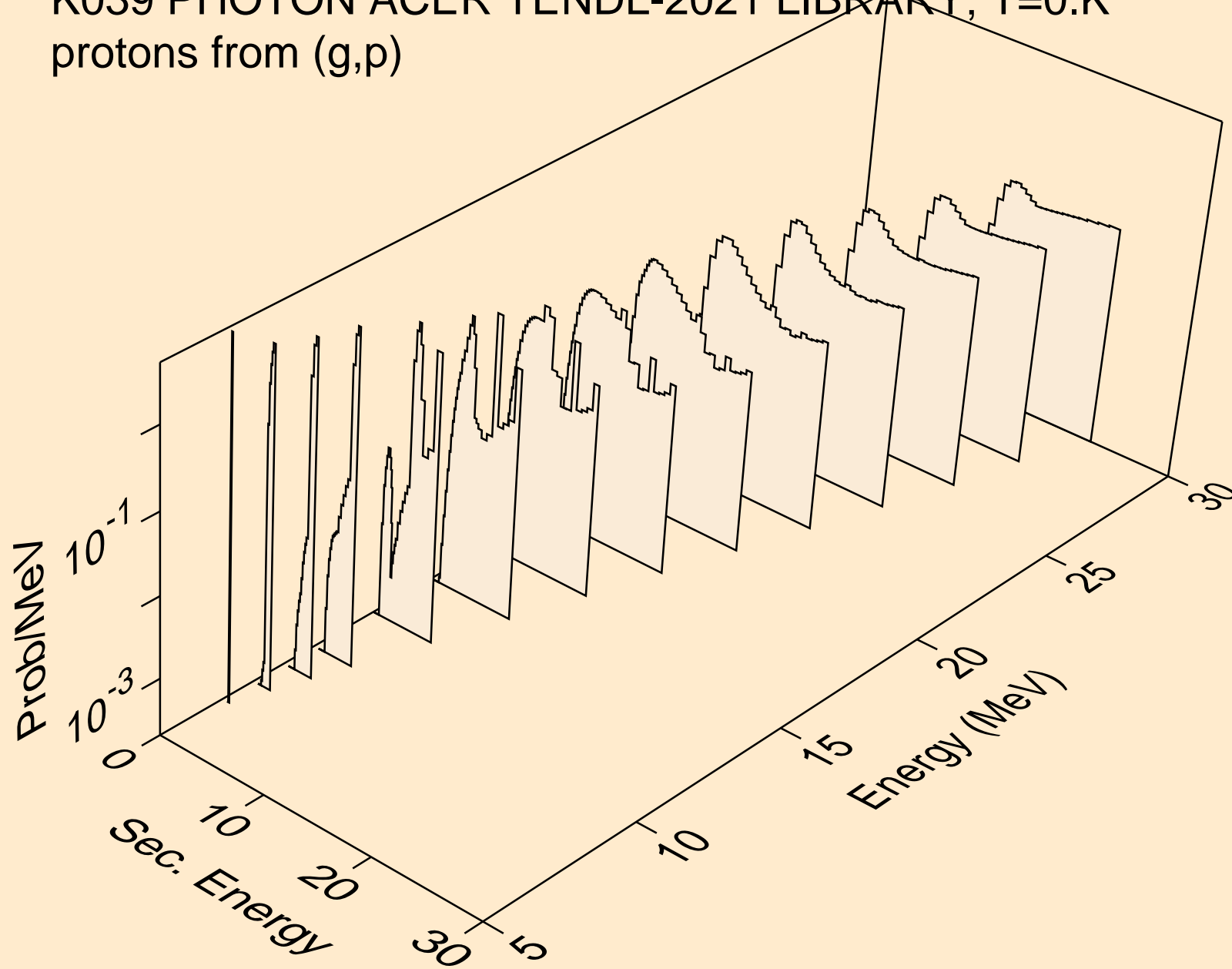

K039 PHOTON ACER TENDL-2021 LIBRARY; T=0.K  
protons from (g,2p)

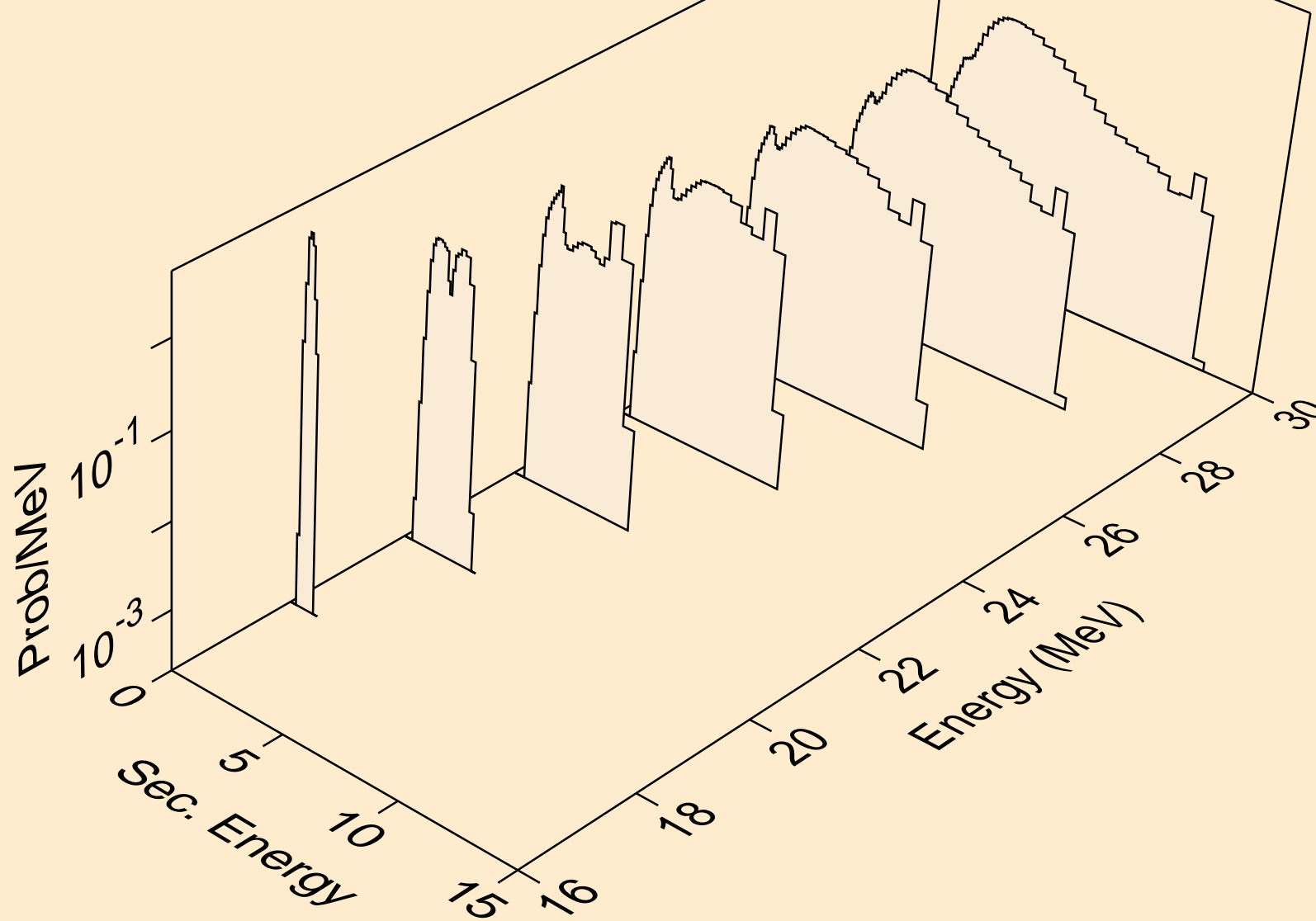

K039 PHOTON ACER TENDL-2021 LIBRARY; T=0.K  
protons from (g,pa)

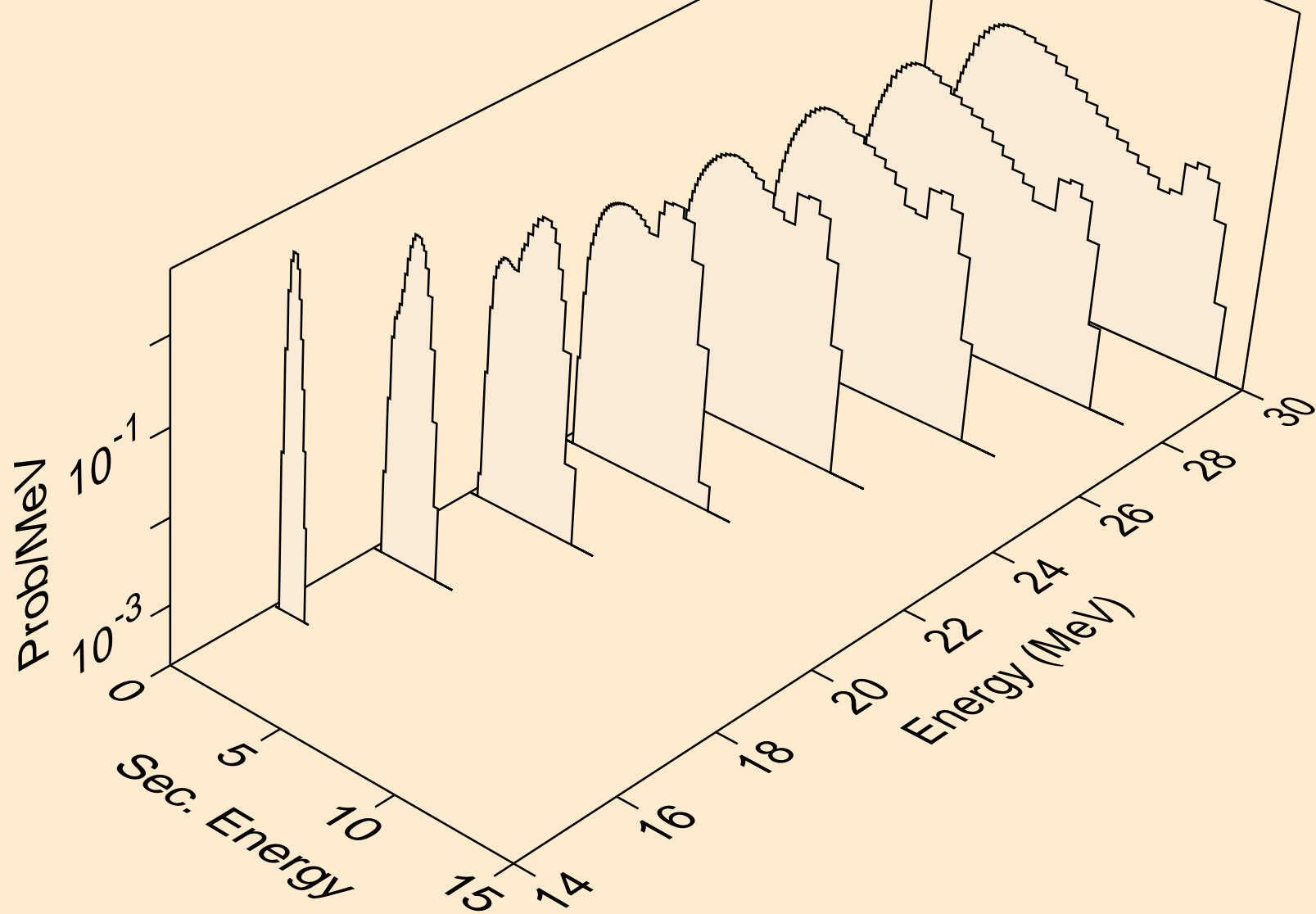

K039 PHOTON ACER TENDL-2021 LIBRARY; T=0.K  
protons from (g,pd)

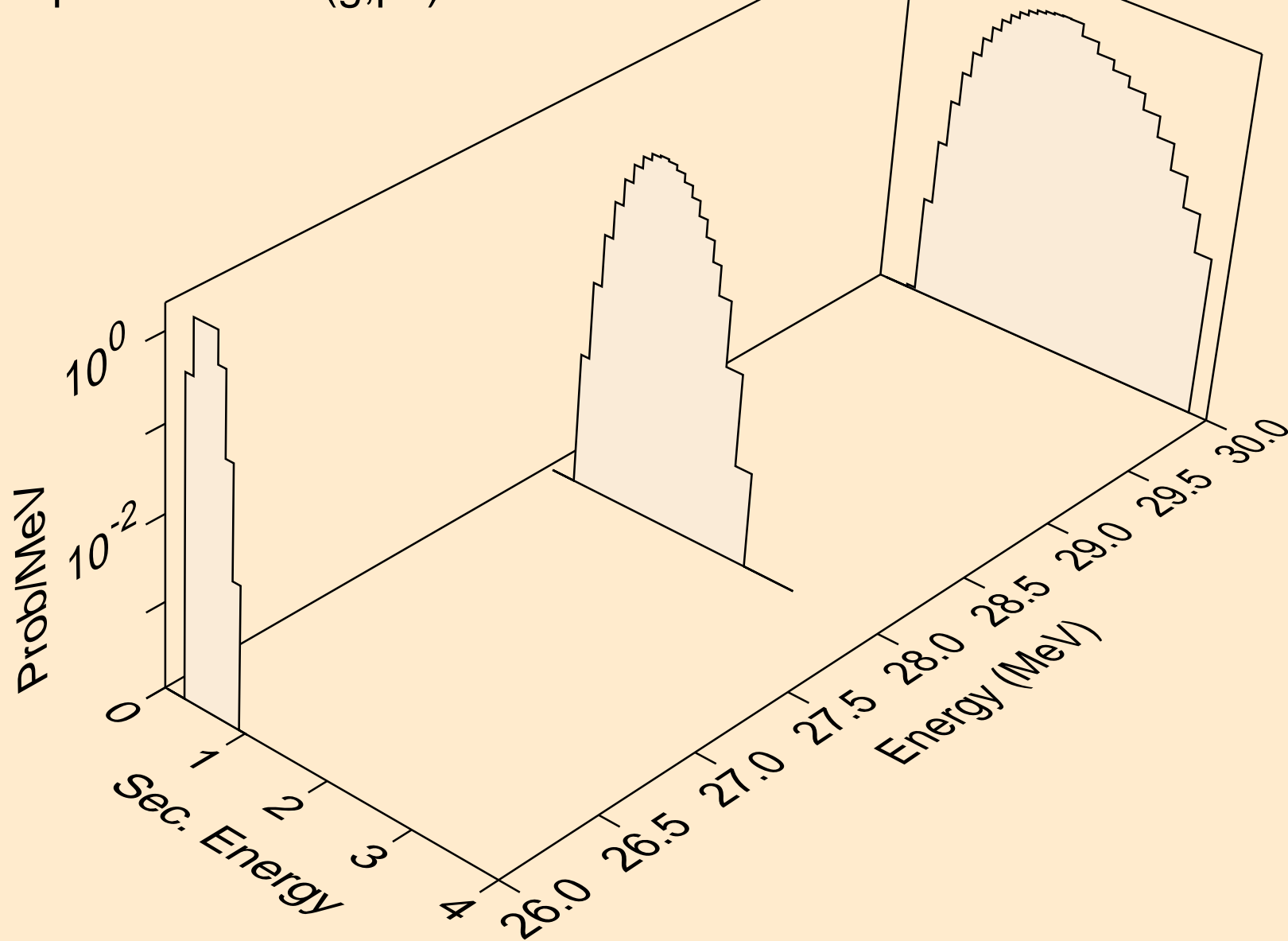

K039 PHOTON ACER TENDL-2021 LIBRARY; T=0.K  
protons from (g,pt)

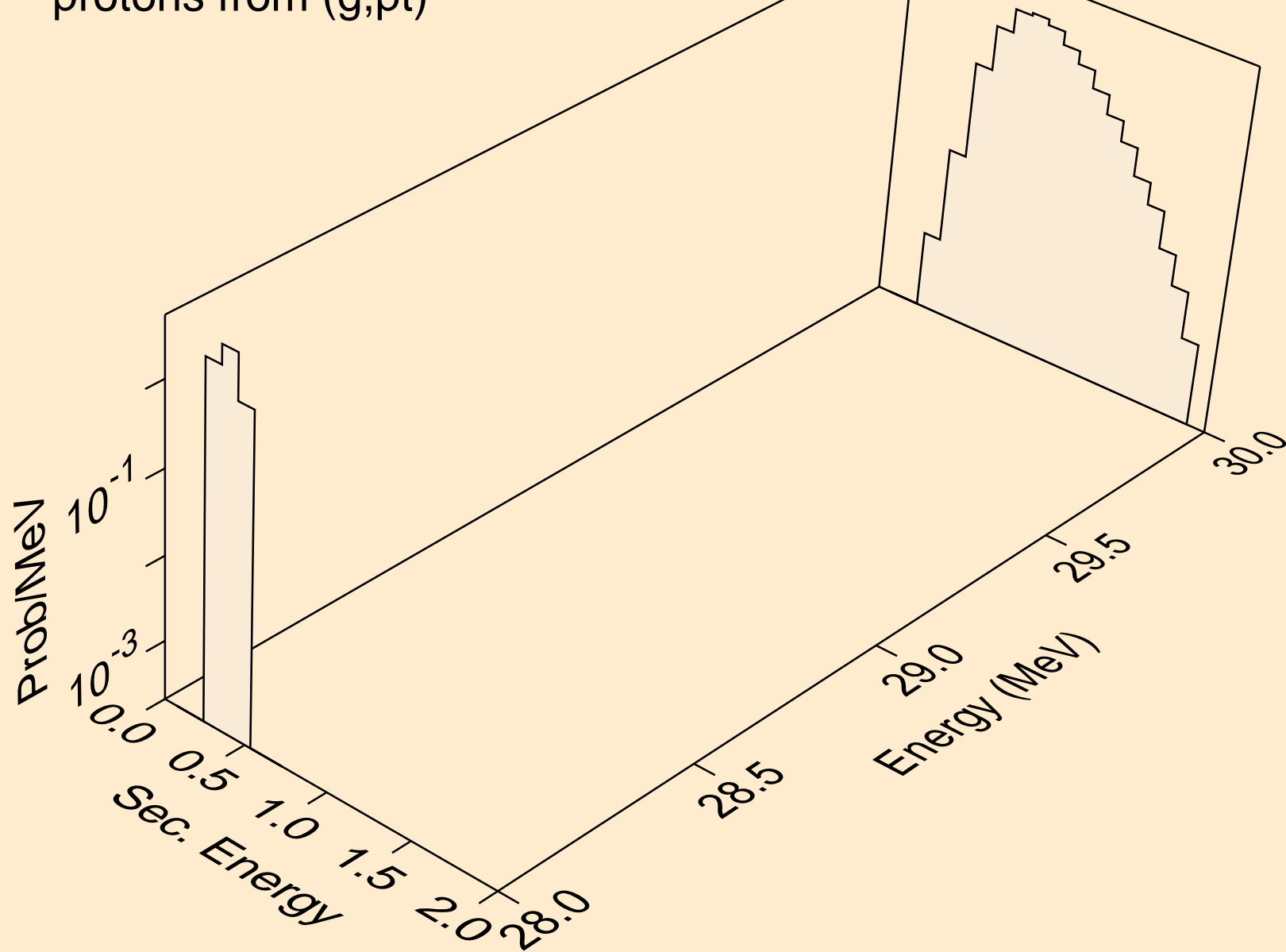

K039 PHOTON ACER TENDL-2021 LIBRARY; T=0.K  
deuterons from (g,x)

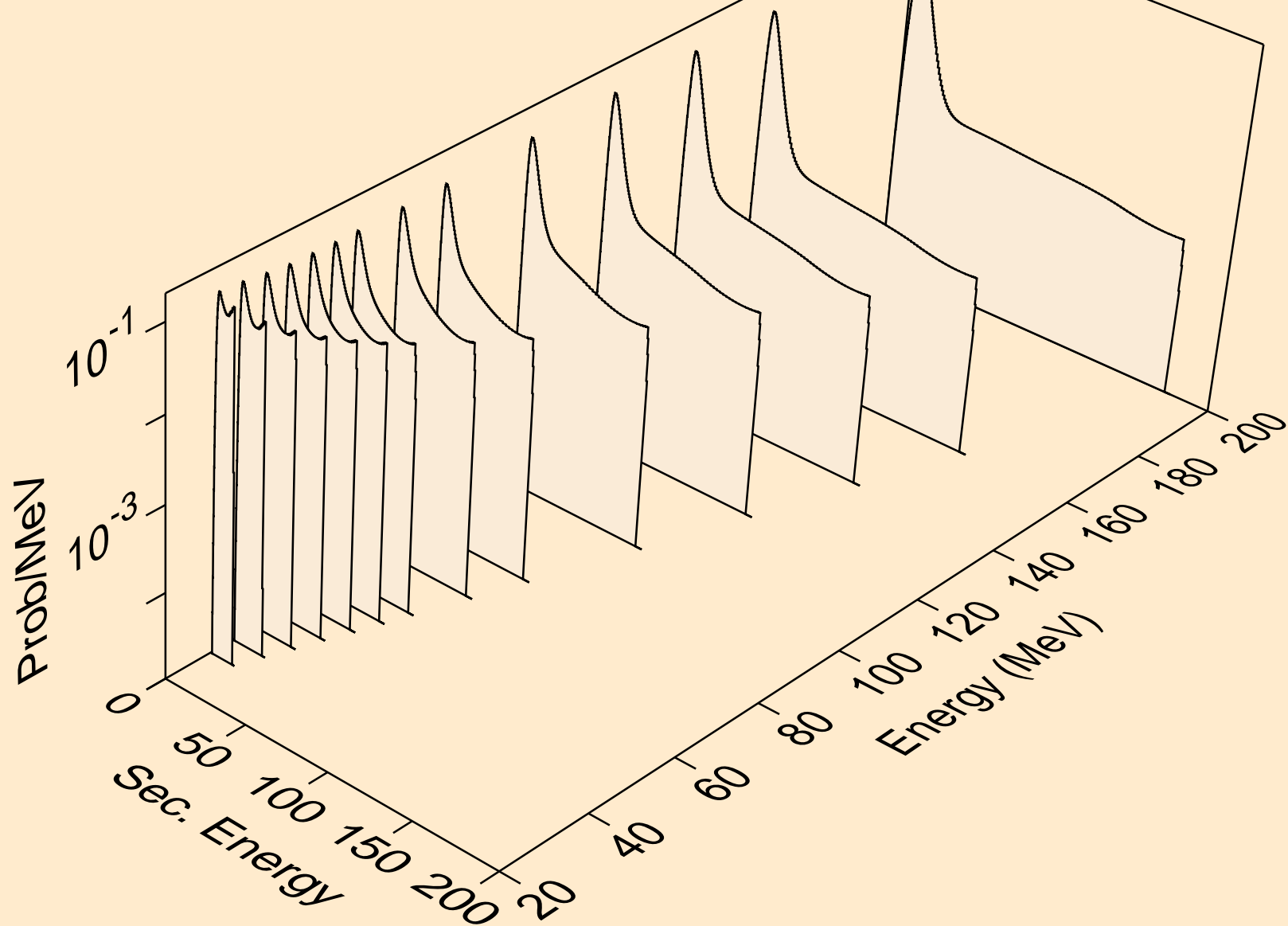

K039 PHOTON ACER TENDL-2021 LIBRARY; T=0.K  
deuterons from (g,n\*)d

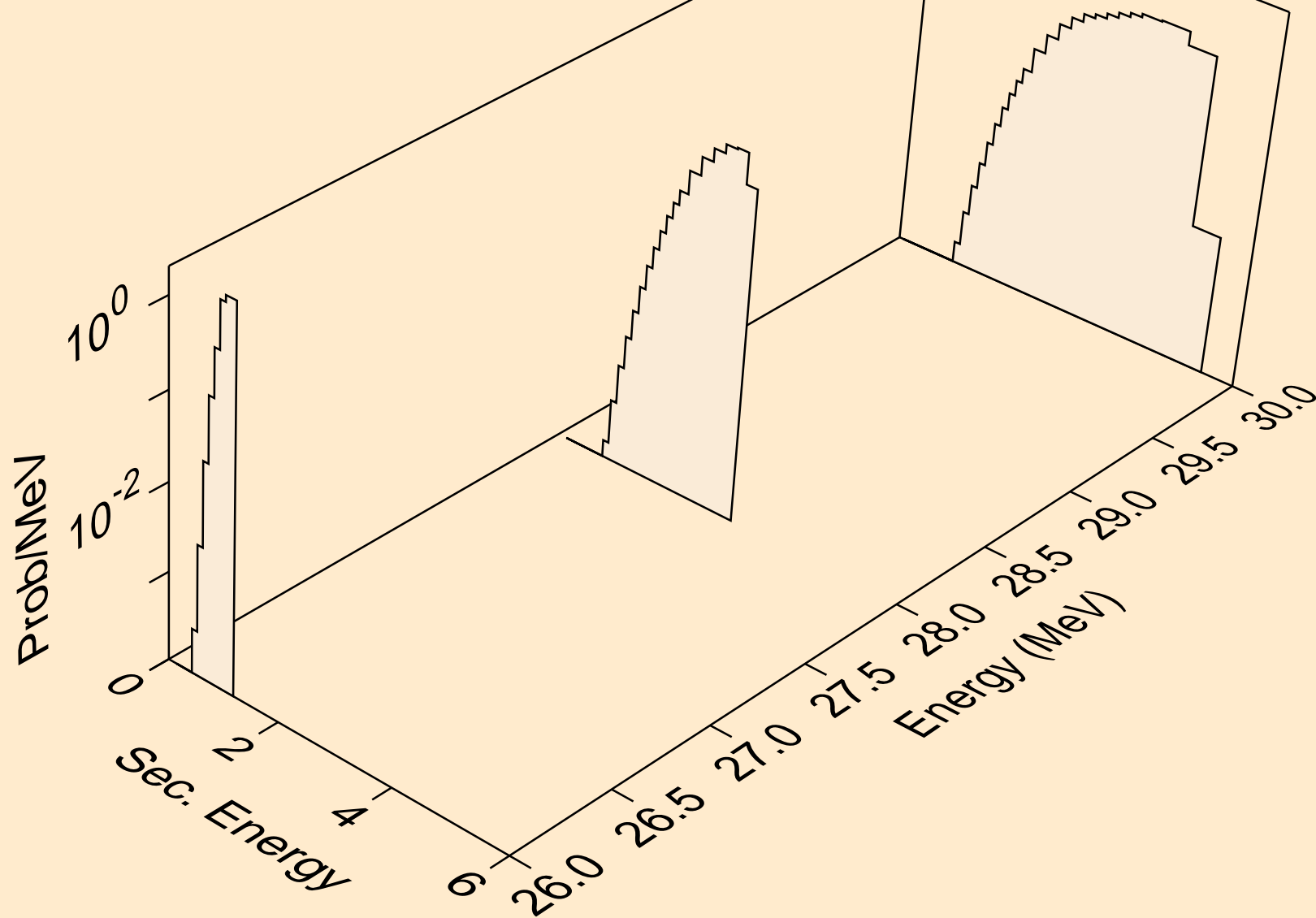

K039 PHOTON ACER TENDL-2021 LIBRARY; T=0.K  
deuterons from (g,d)

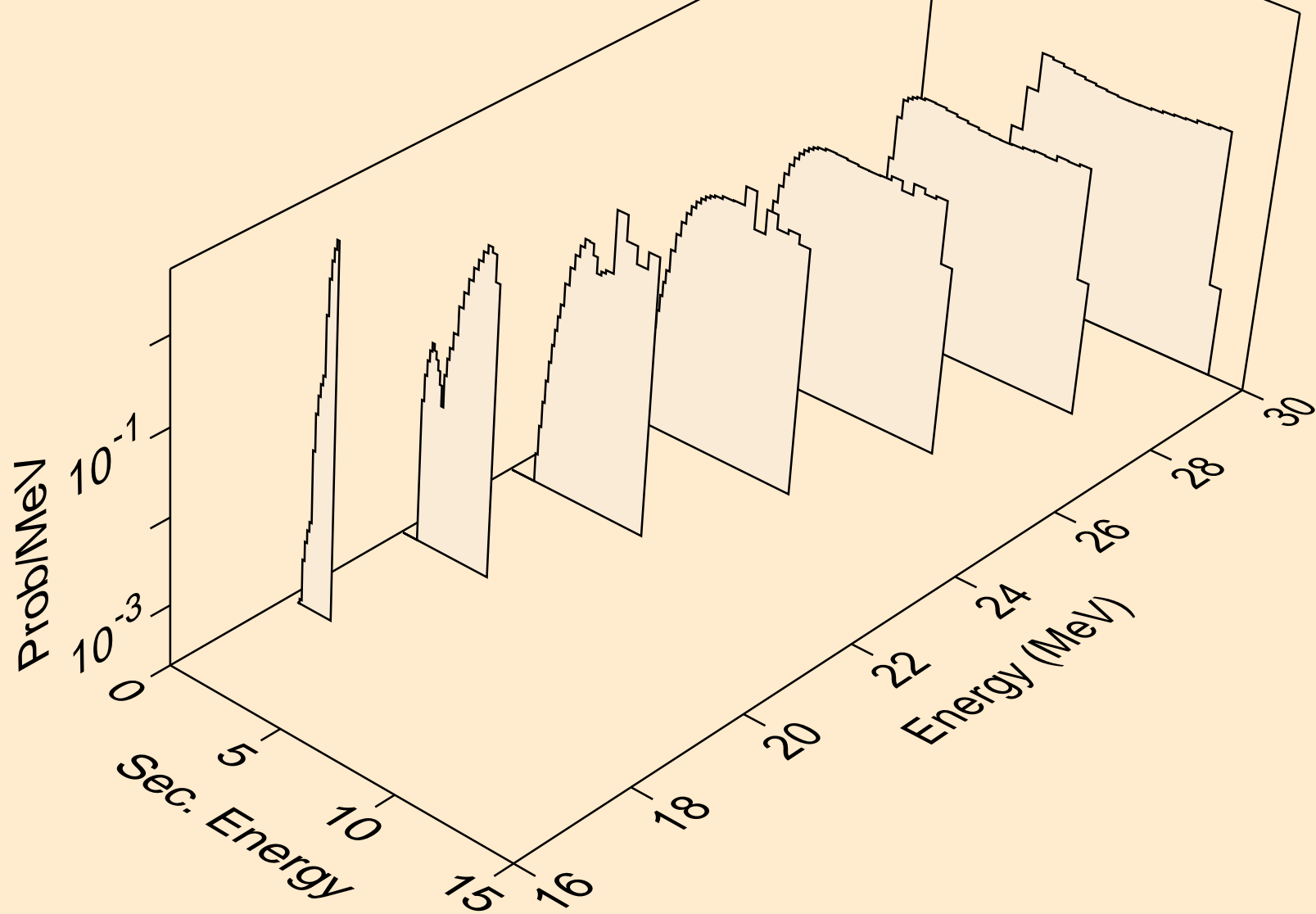

K039 PHOTON ACER TENDL-2021 LIBRARY; T=0.K  
deuterons from (g,pd)

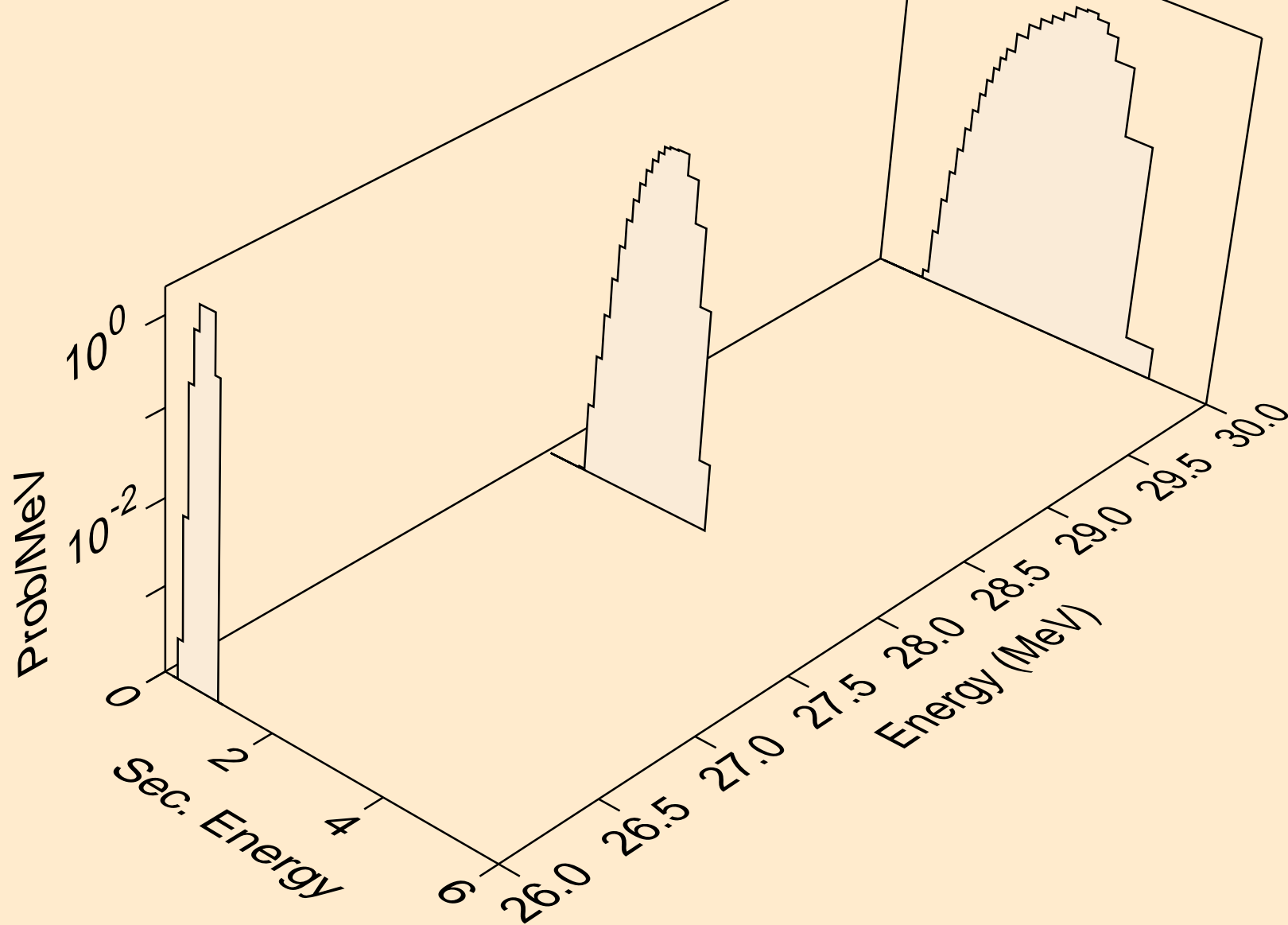

K039 PHOTON ACER TENDL-2021 LIBRARY; T=0.K  
deuterons from (g,da)

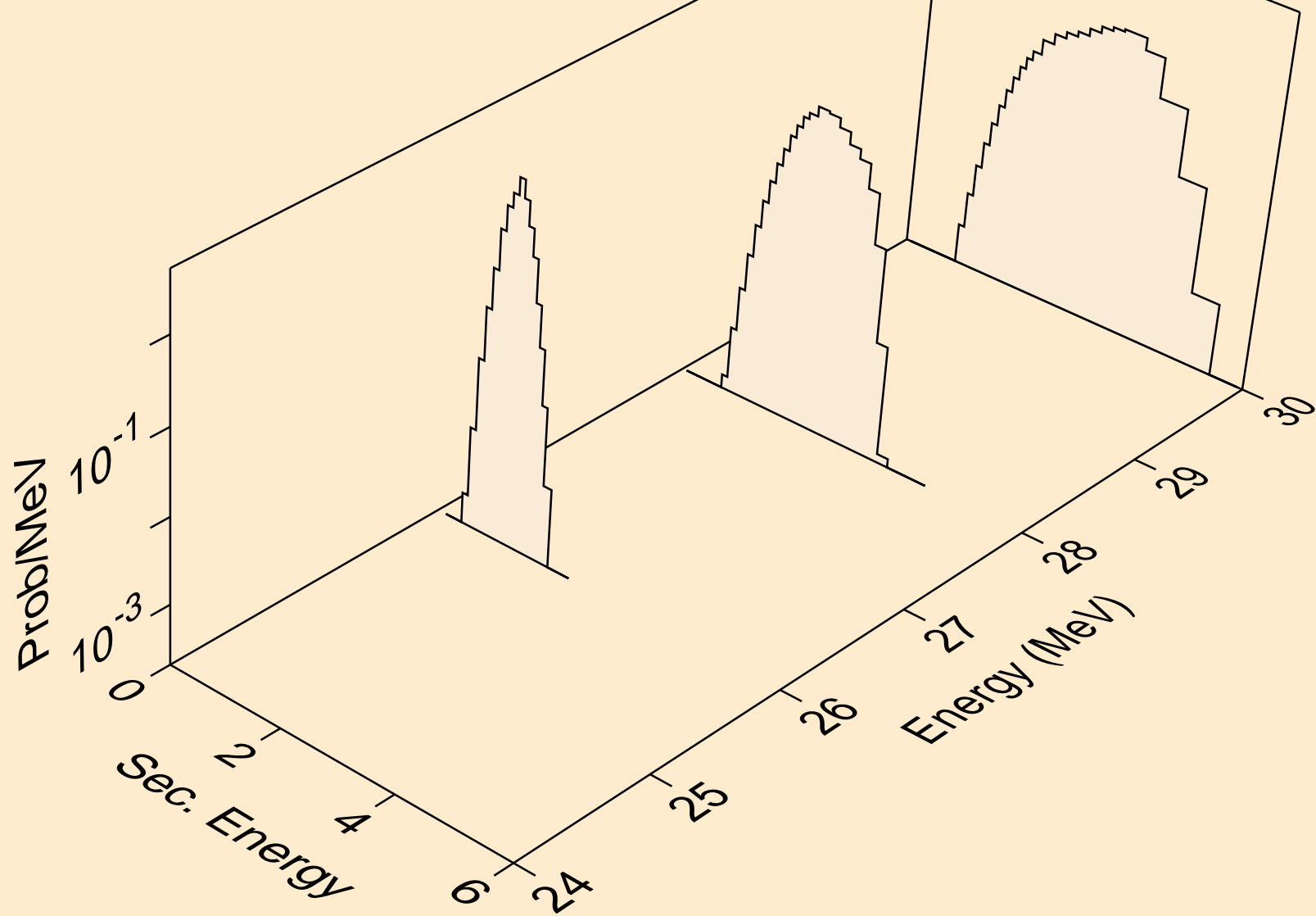

K039 PHOTON ACER TENDL-2021 LIBRARY; T=0.K  
tritons from (g,x)

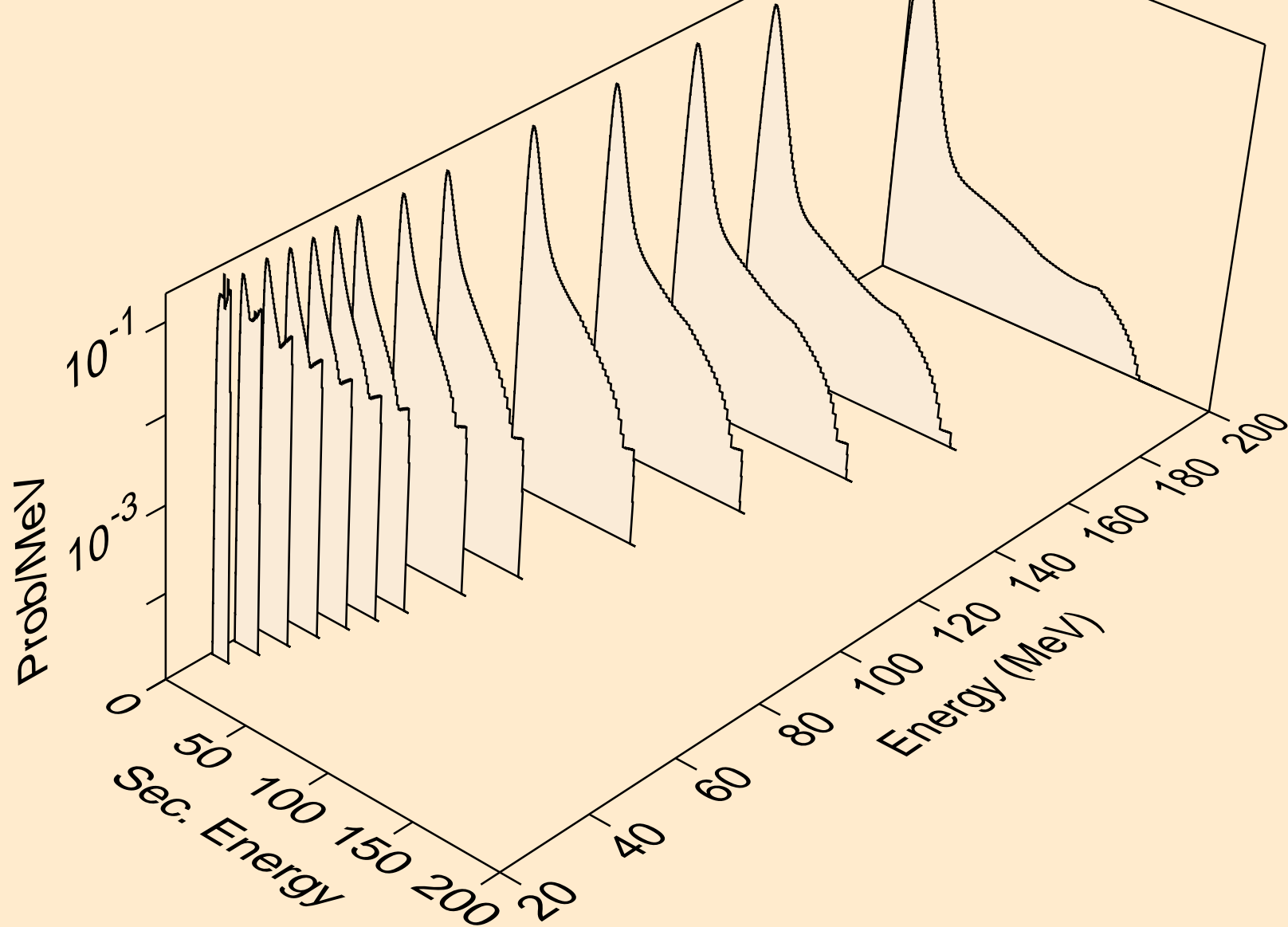

K039 PHOTON ACER TENDL-2021 LIBRARY; T=0.K  
tritons from (g,t)

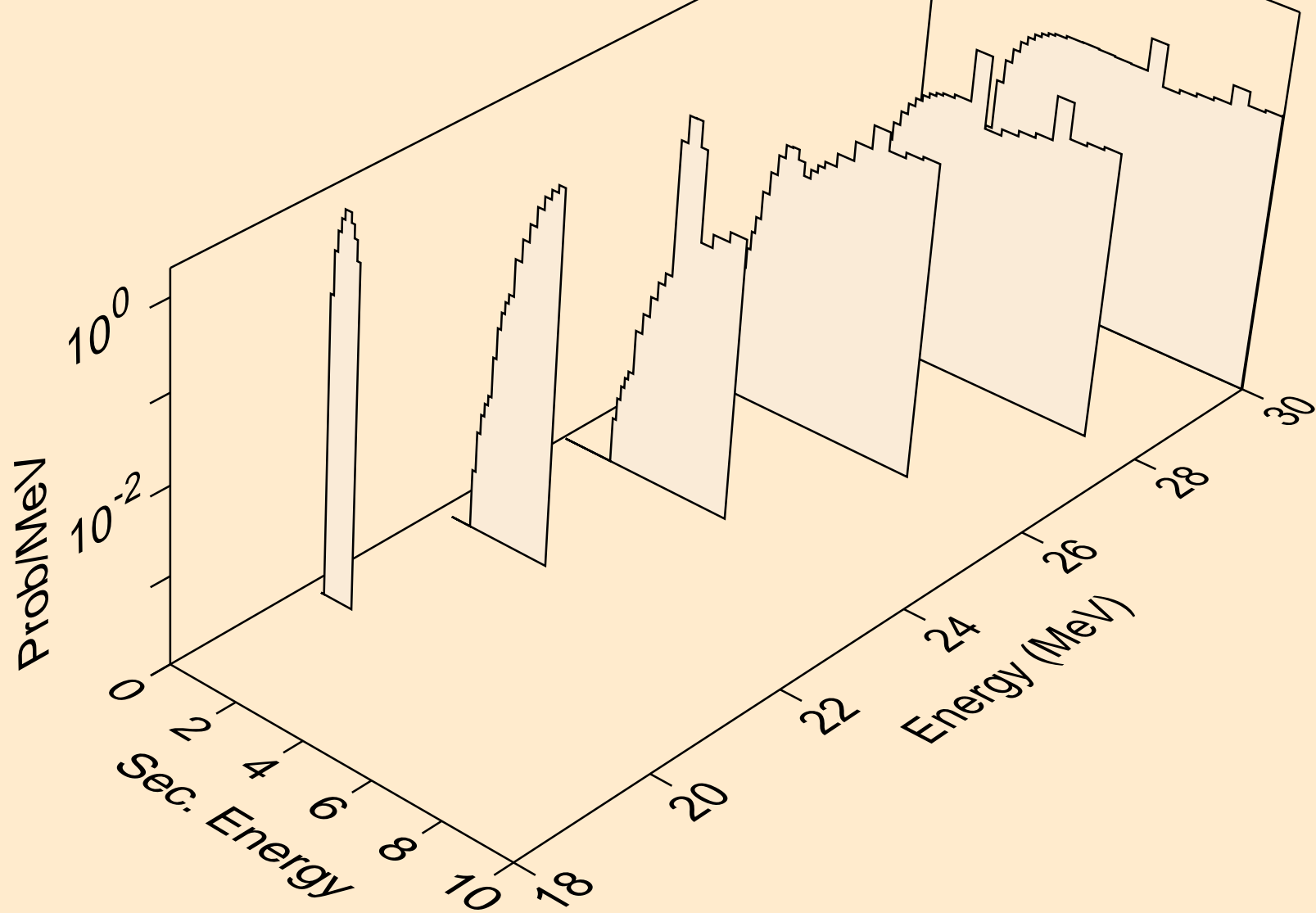

K039 PHOTON ACER TENDL-2021 LIBRARY; T=0.K  
tritons from (g,pt)

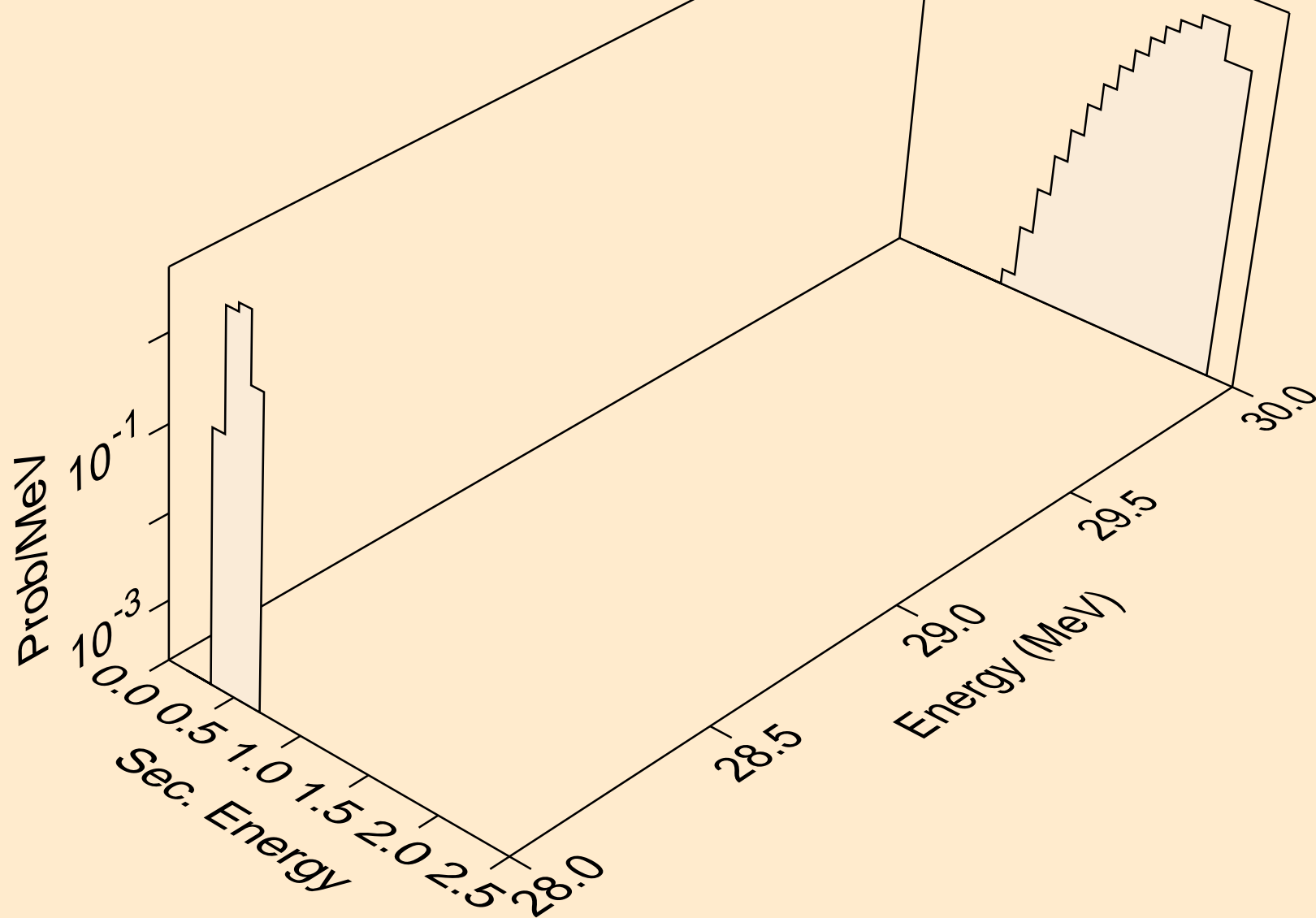

K039 PHOTON ACER TENDL-2021 LIBRARY; T=0.K  
he3s from (g,x)

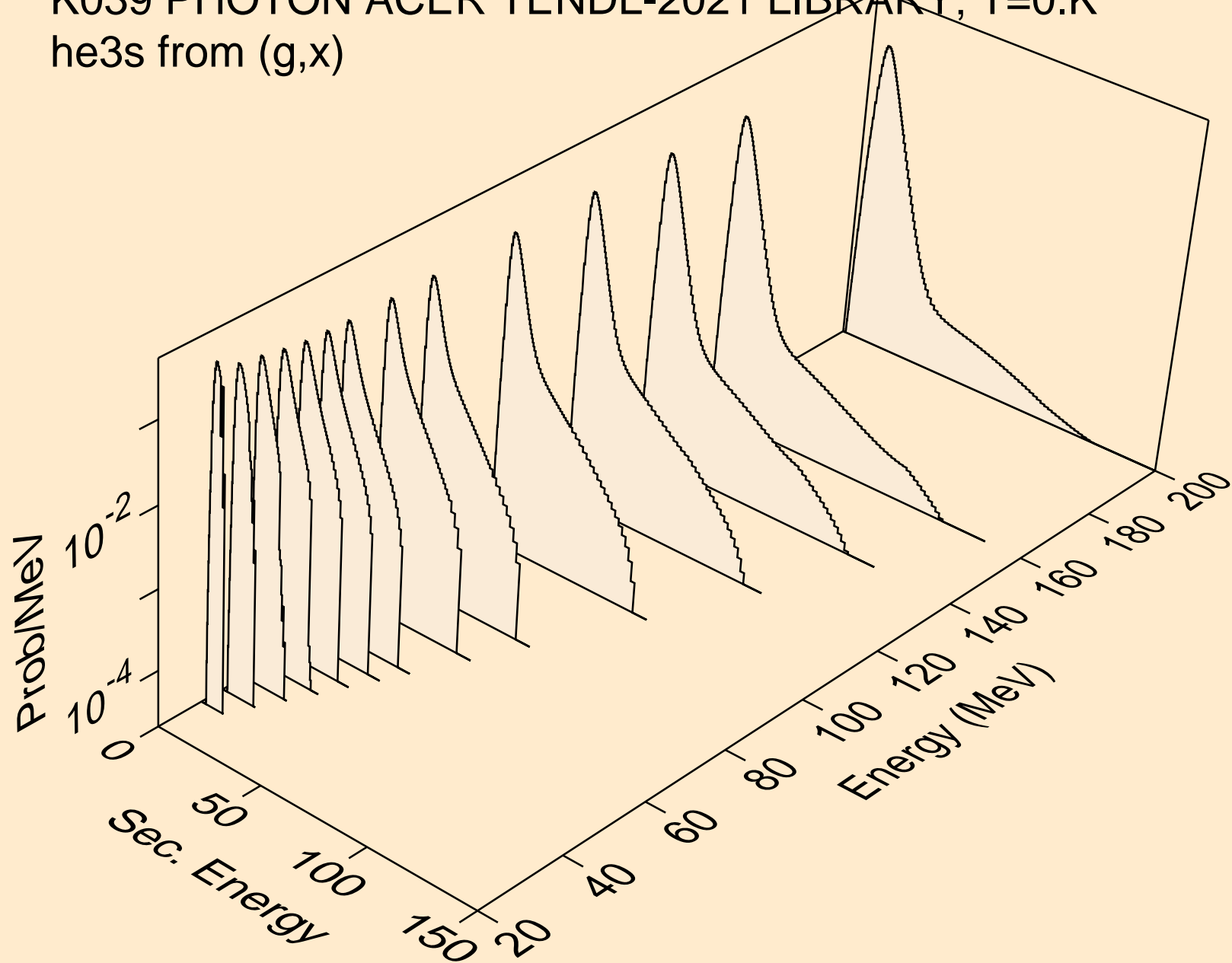

K039 PHOTON ACER TENDL-2021 LIBRARY; T=0.K  
he3s from (g,he3)

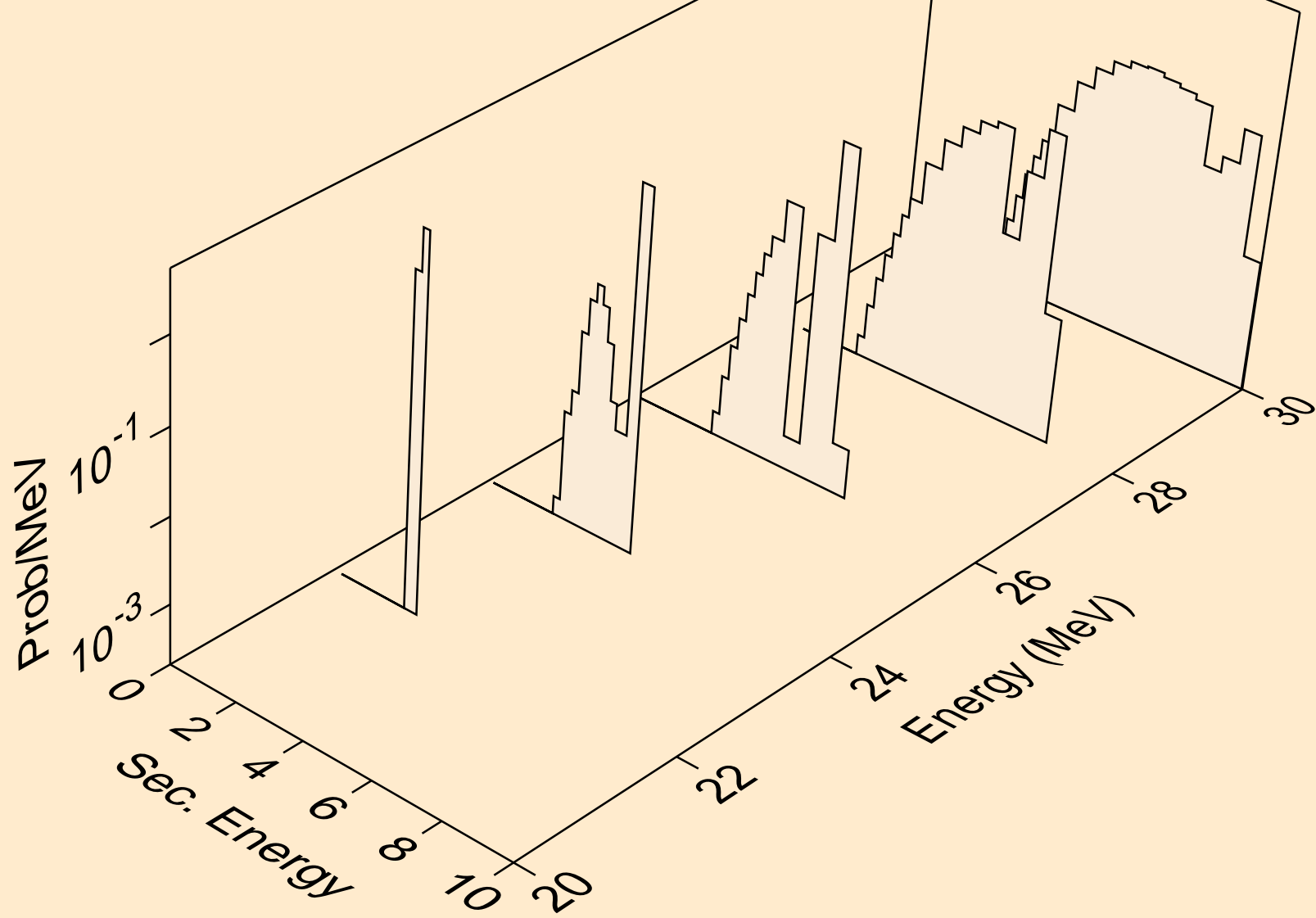

K039 PHOTON ACER TENDL-2021 LIBRARY; T=0.K  
alphas from (g,x)

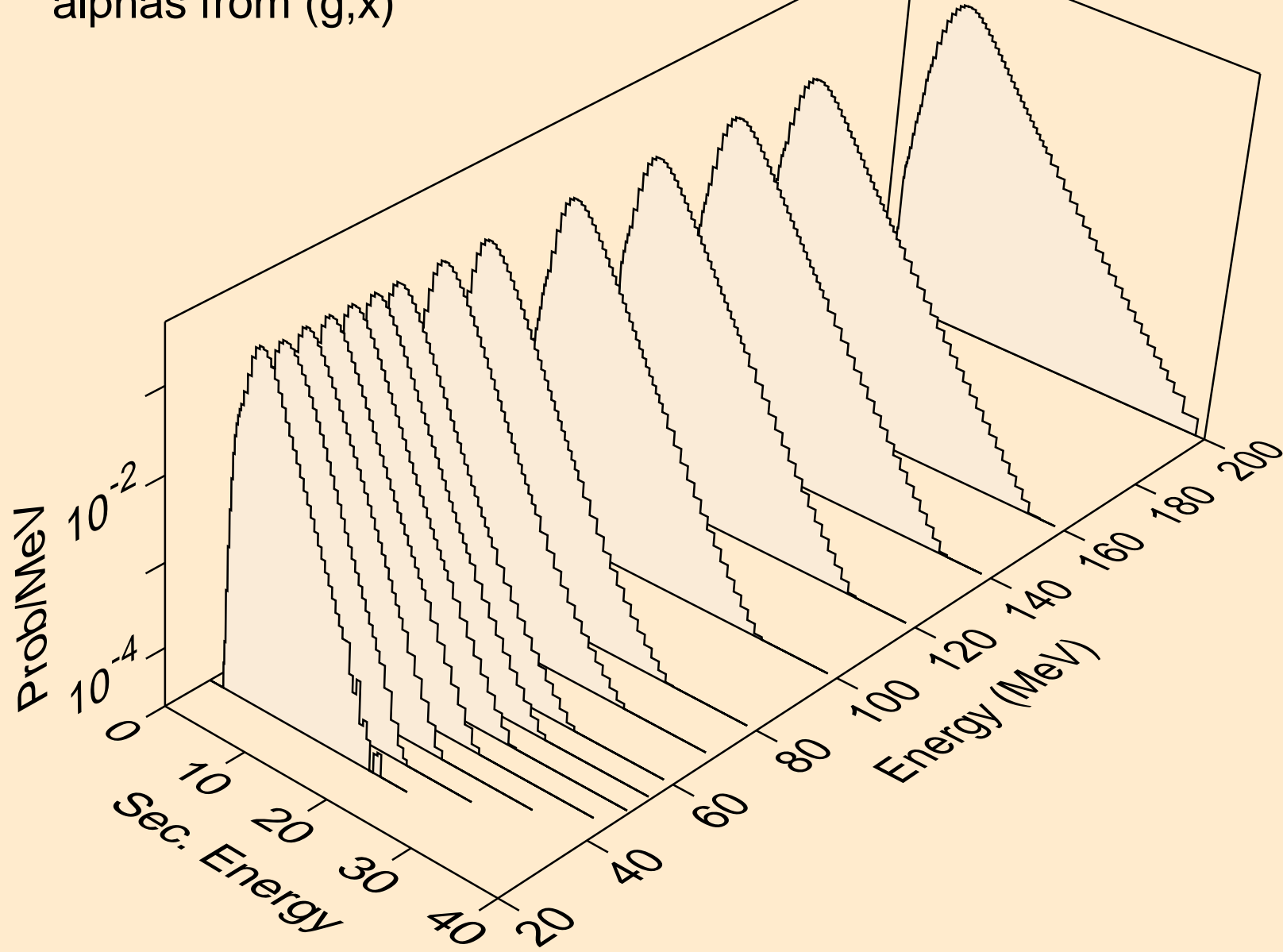

K039 PHOTON ACER TENDL-2021 LIBRARY; T=0.K  
alphas from (g,n\*)a

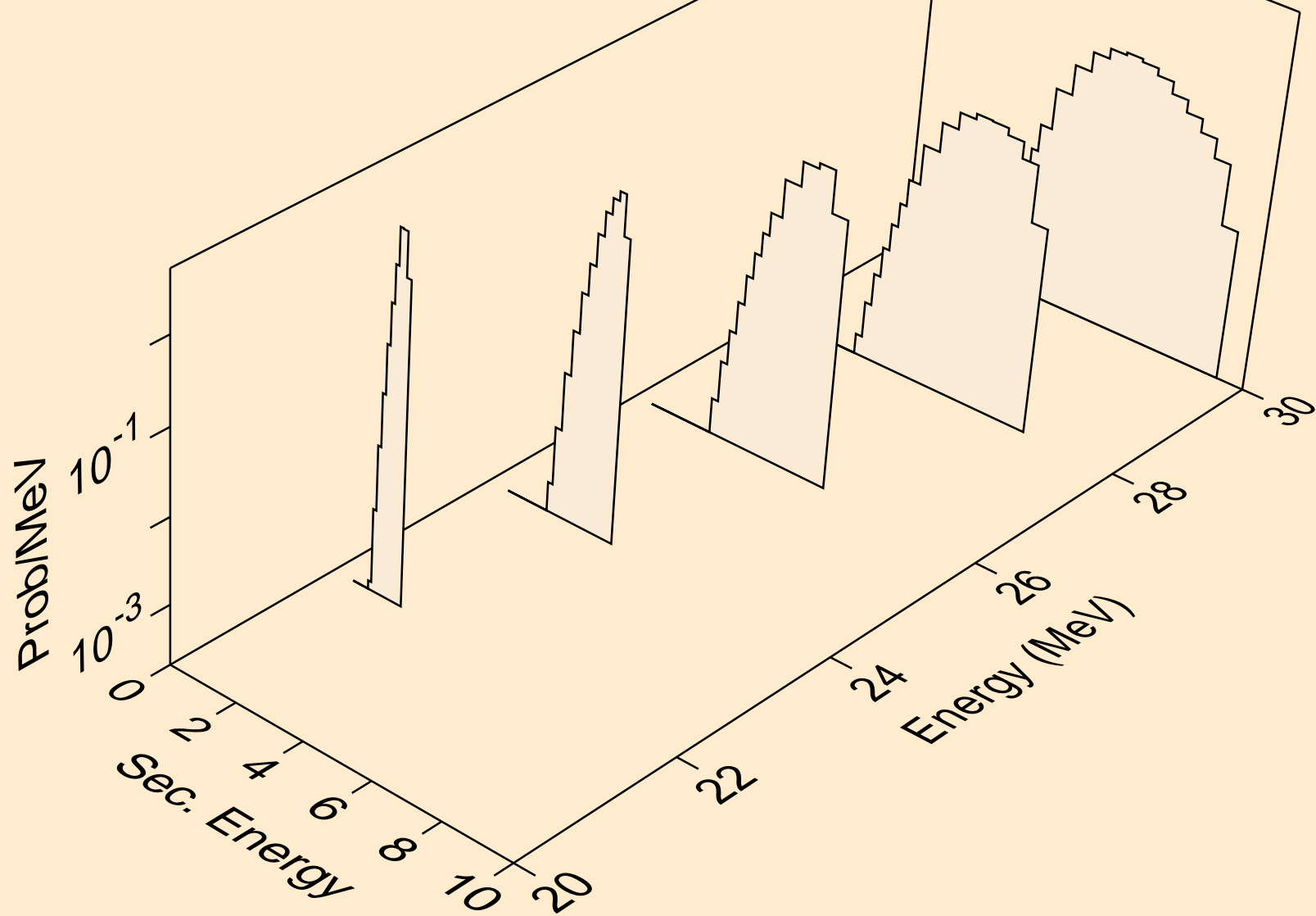

K039 PHOTON ACER TENDL-2021 LIBRARY; T=0.K  
alphas from (g,npa)

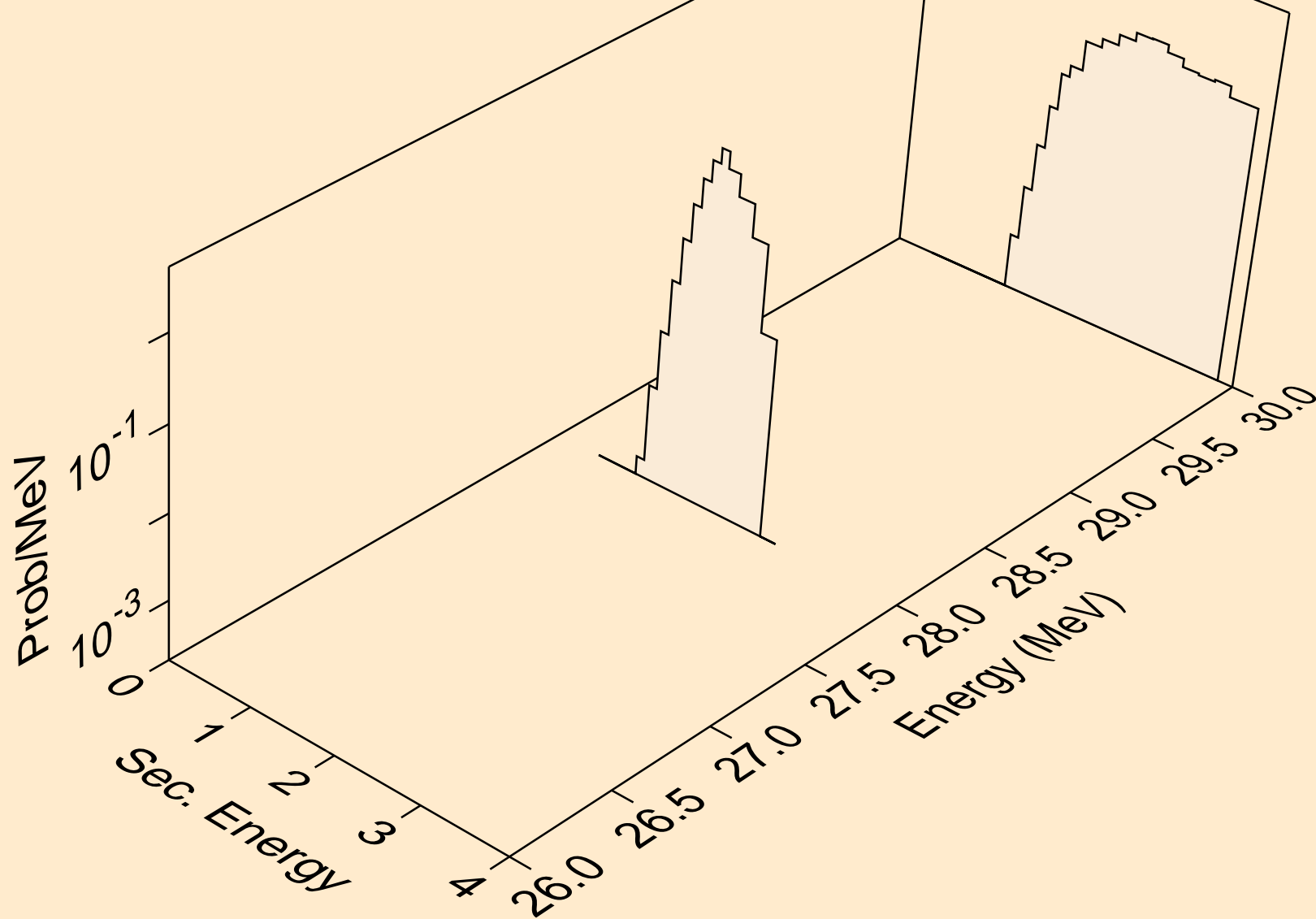

K039 PHOTON ACER TENDL-2021 LIBRARY; T=0.K  
alphas from (g,a)

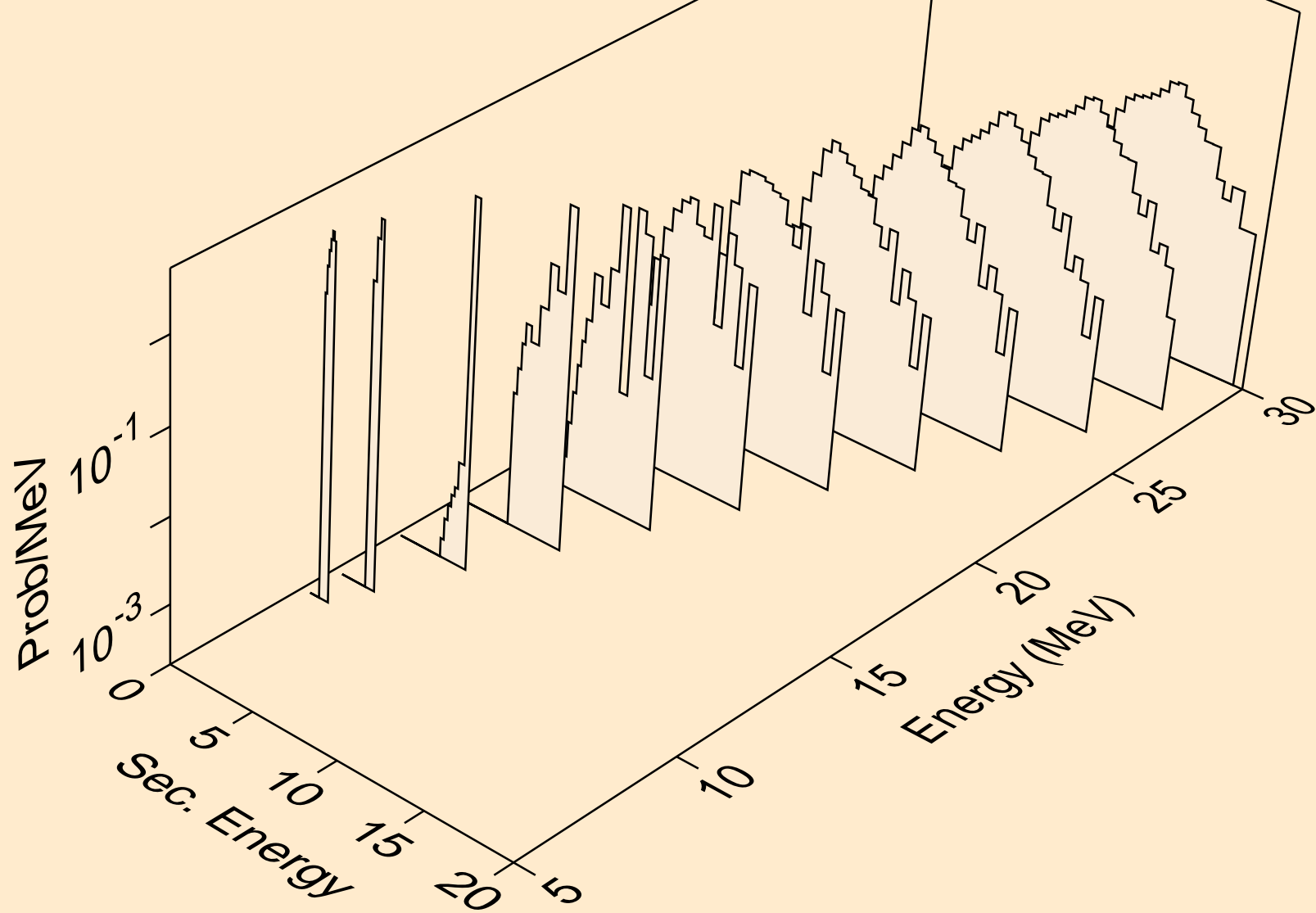

K039 PHOTON ACER TENDL-2021 LIBRARY; T=0.K  
alphas from (g,2a)

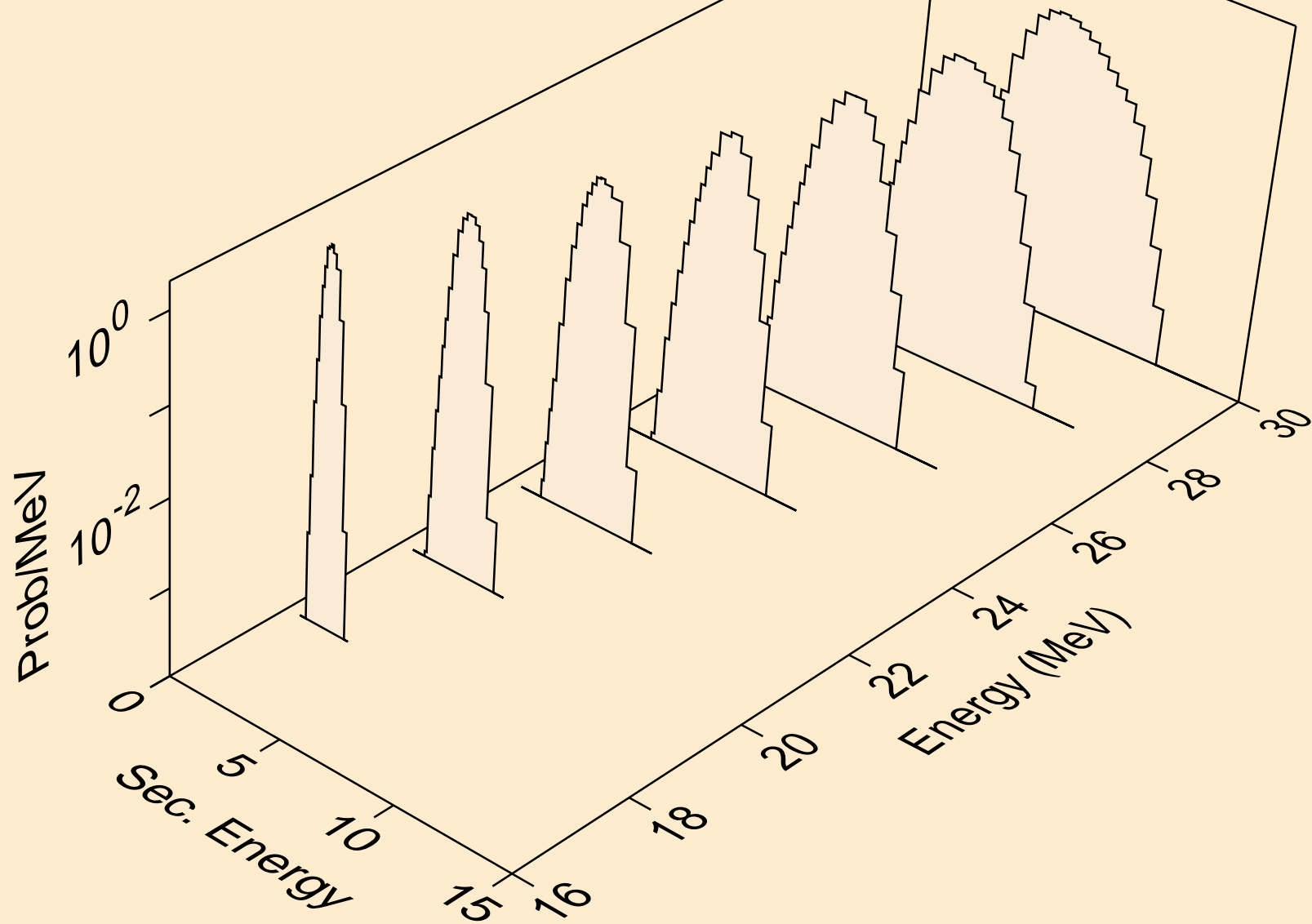

K039 PHOTON ACER TENDL-2021 LIBRARY; T=0.K  
alphas from (g,pa)

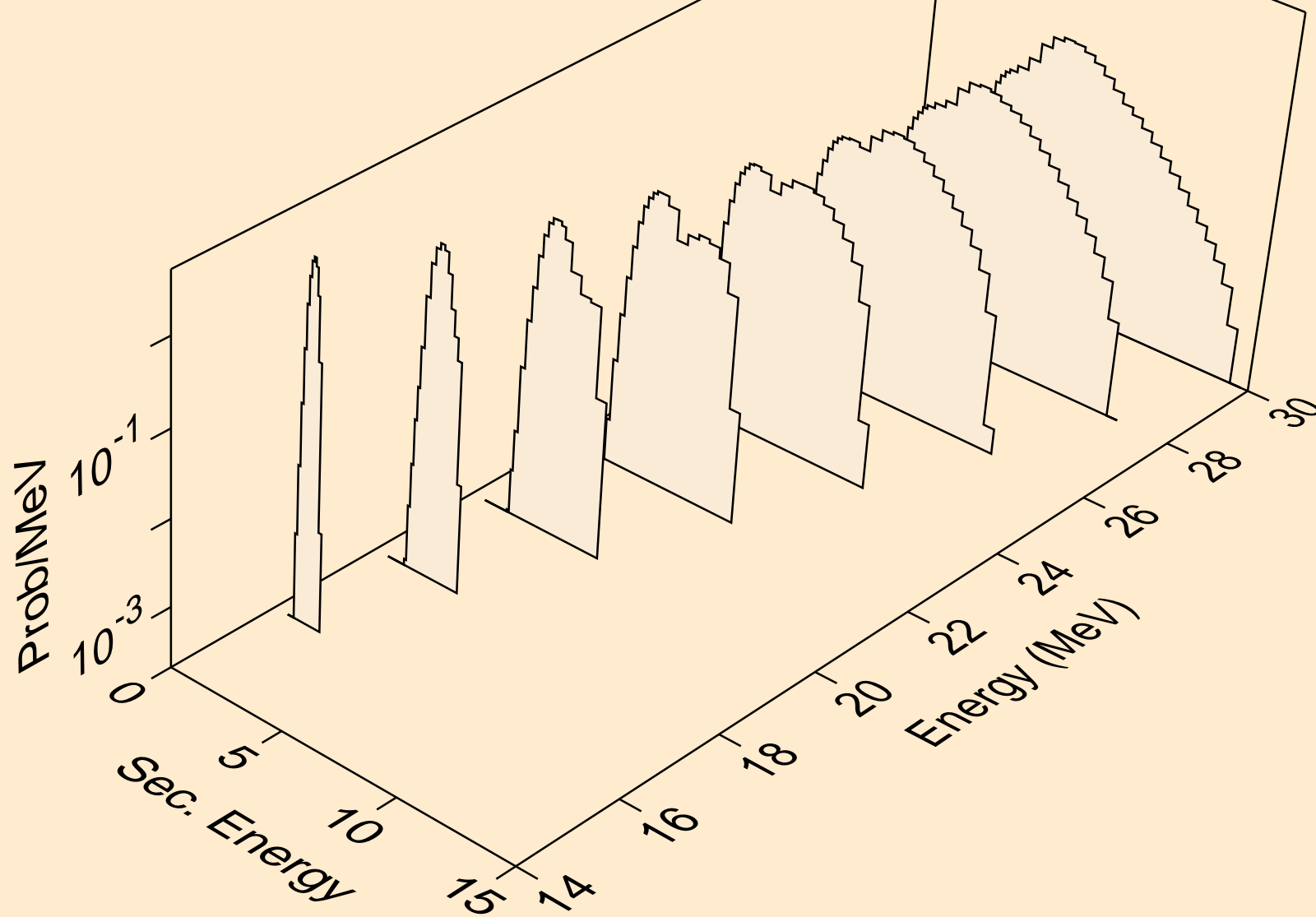

K039 PHOTON ACER TENDL-2021 LIBRARY; T=0.K  
alphas from (g,da)

