

PU232 PHOTON ACER TENDL-2021 LIBRARY; T=0.K  
Principal cross sections

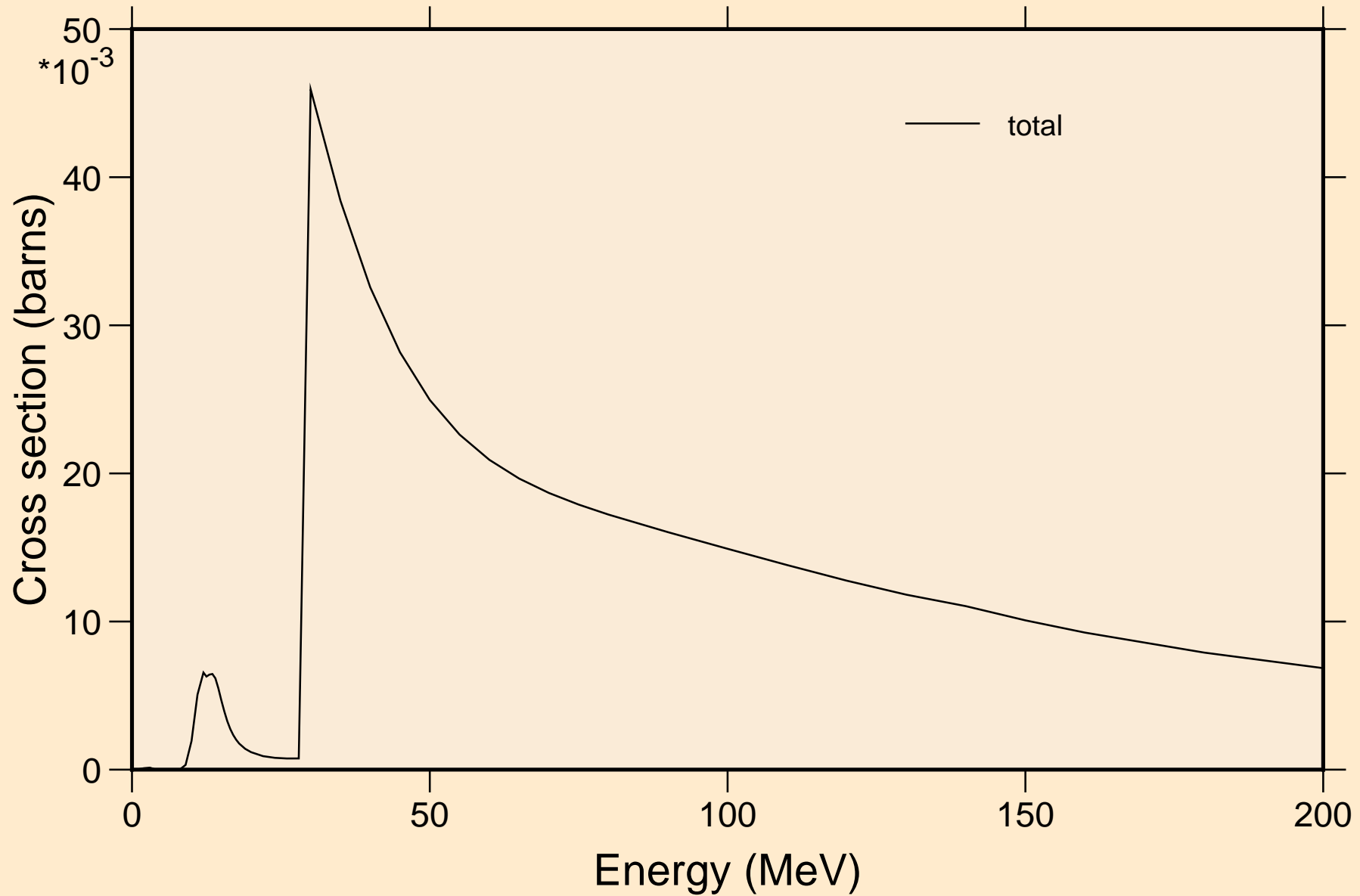



PU232 PHOTON ACER TENDL-2021 LIBRARY; T=0.K

Heating

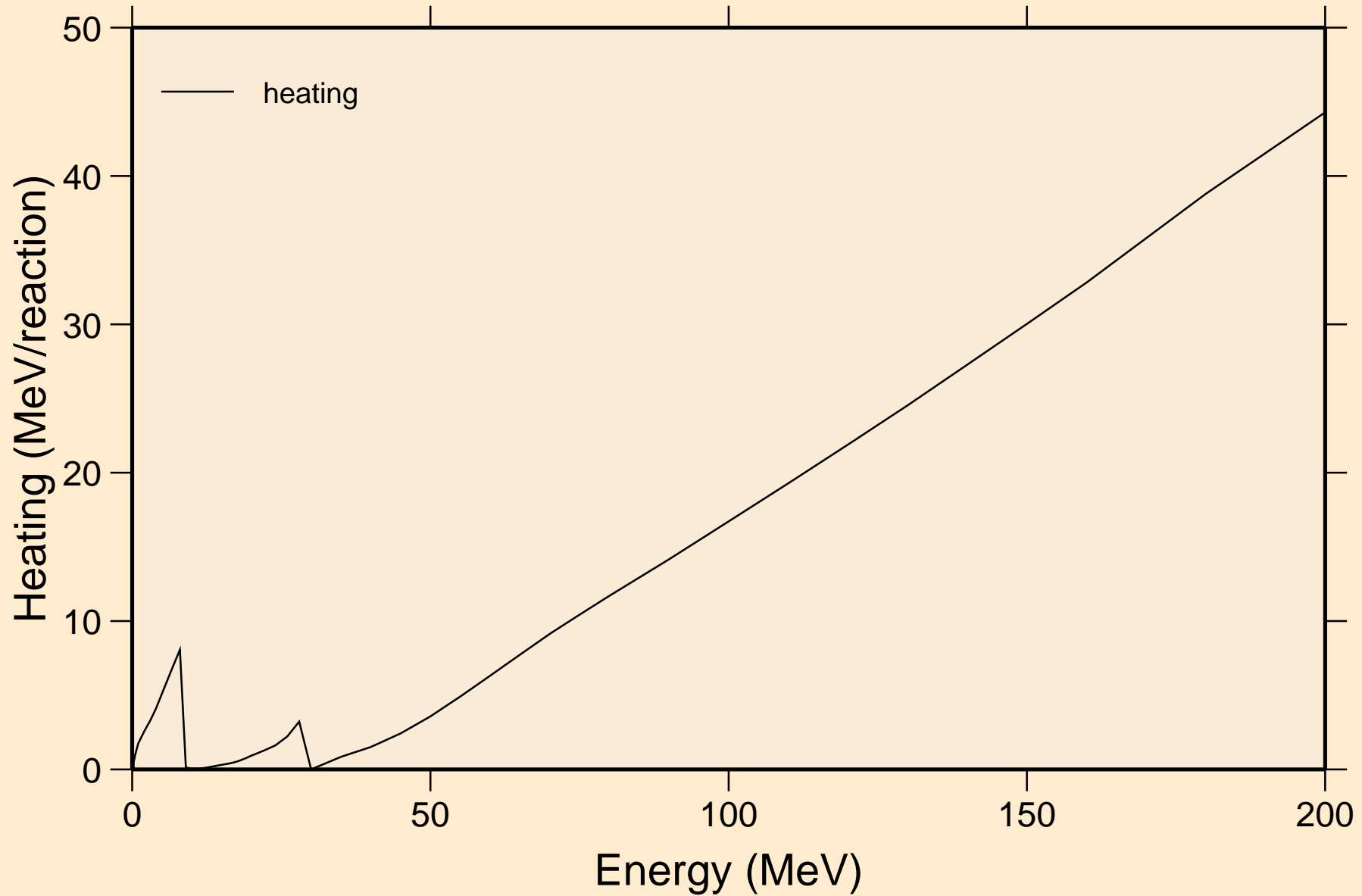

PU232 PHOTON ACER TENDL-2021 LIBRARY; T=0.K  
Particle heating contributions

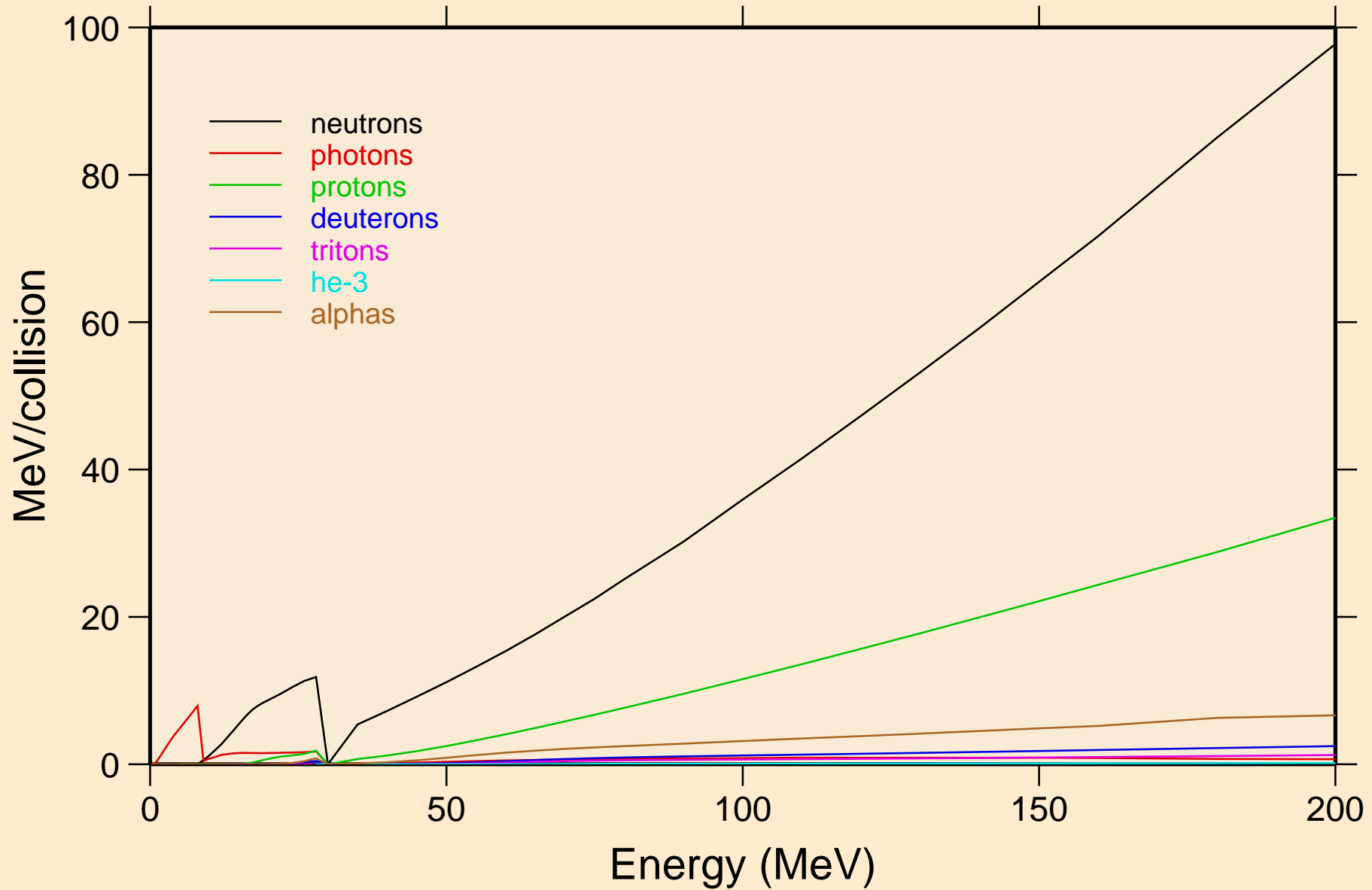

PU232 PHOTON ACER TENDL-2021 LIBRARY; T=0.K  
Particle production cross sections

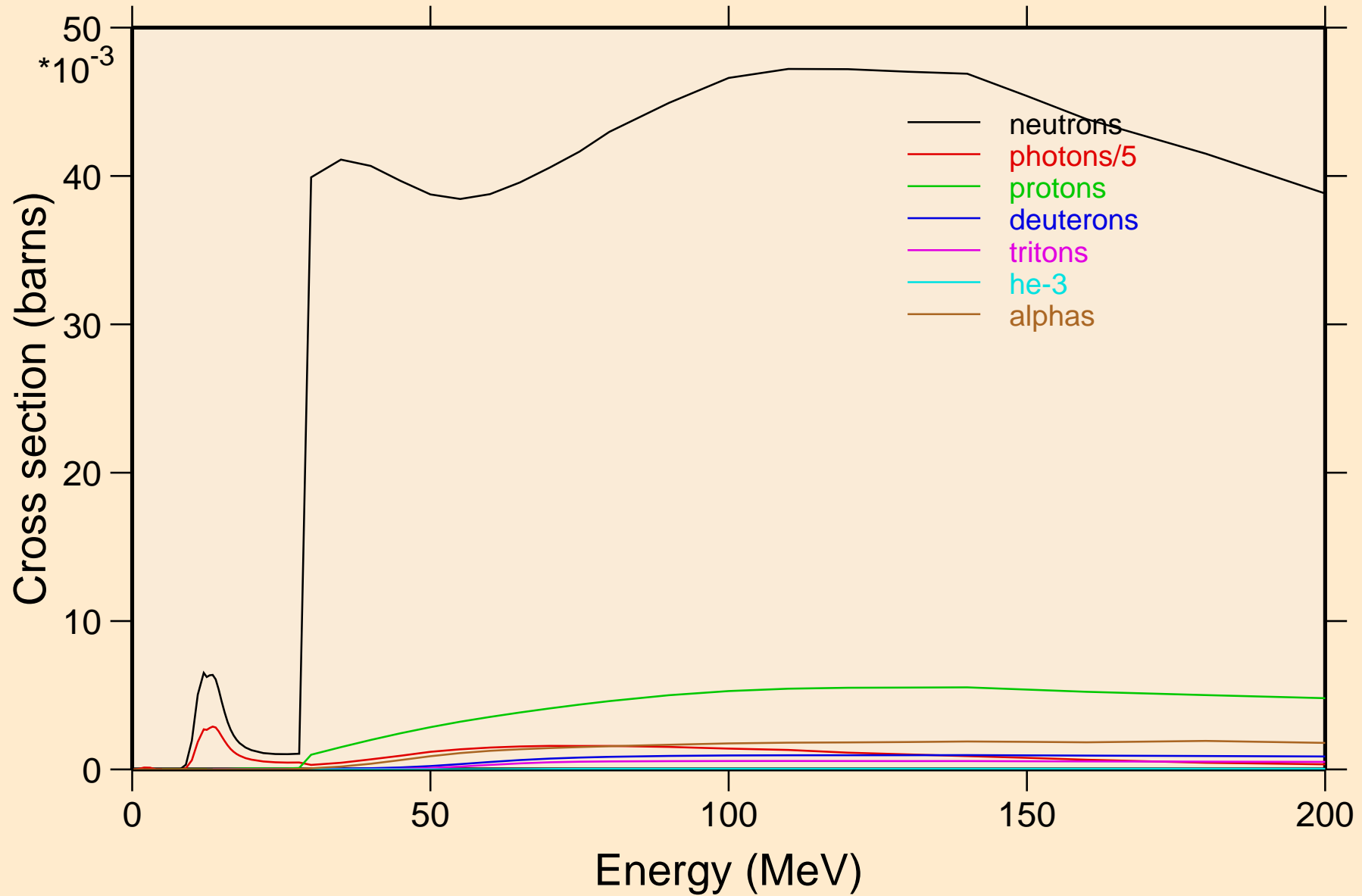

PU232 PHOTON ACER TENDL-2021 LIBRARY; T=0.K  
neutrons from (g,x)

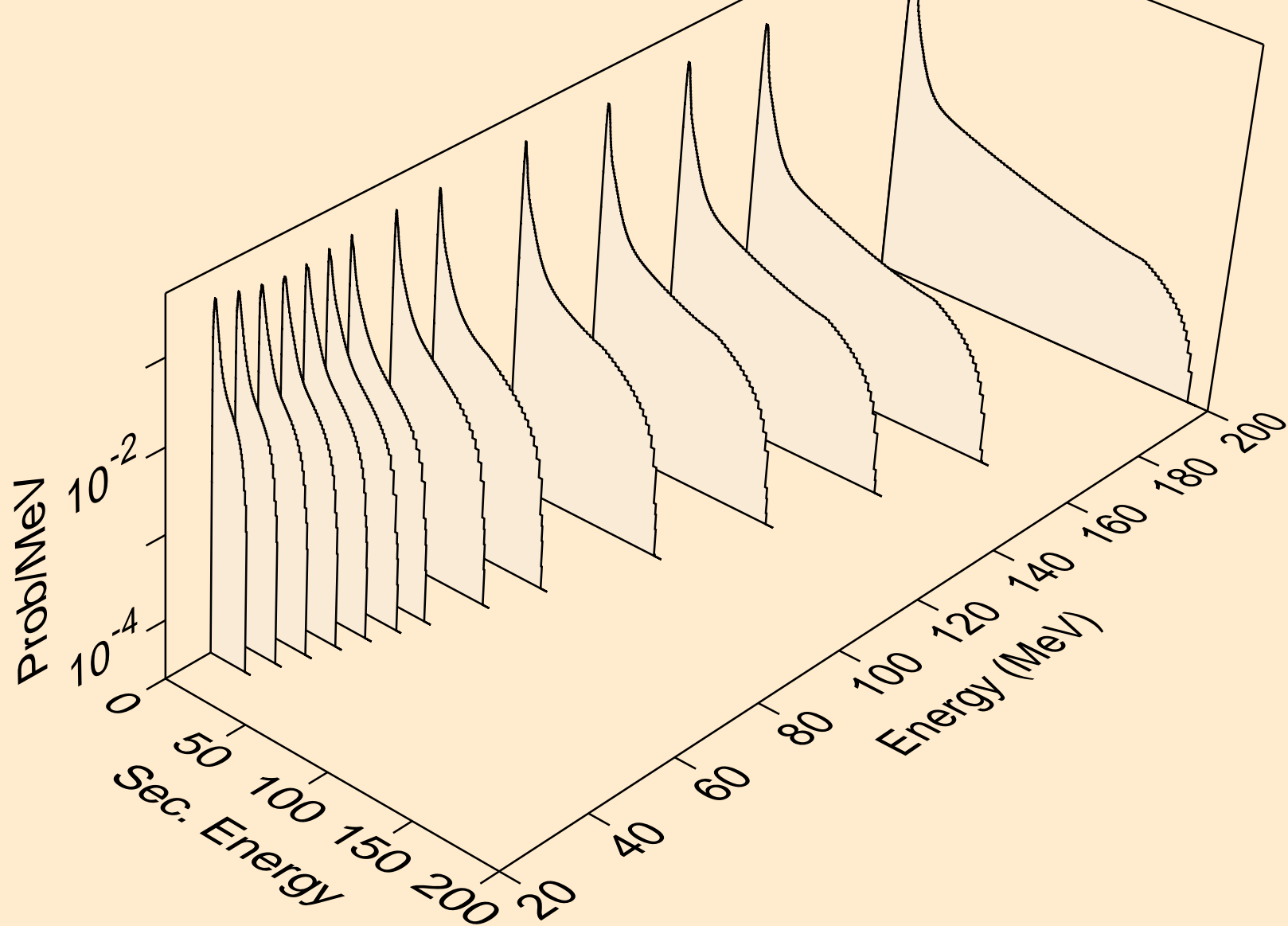

PU232 PHOTON ACER TENDL-2021 LIBRARY; T=0.K  
neutrons from (g,2n)

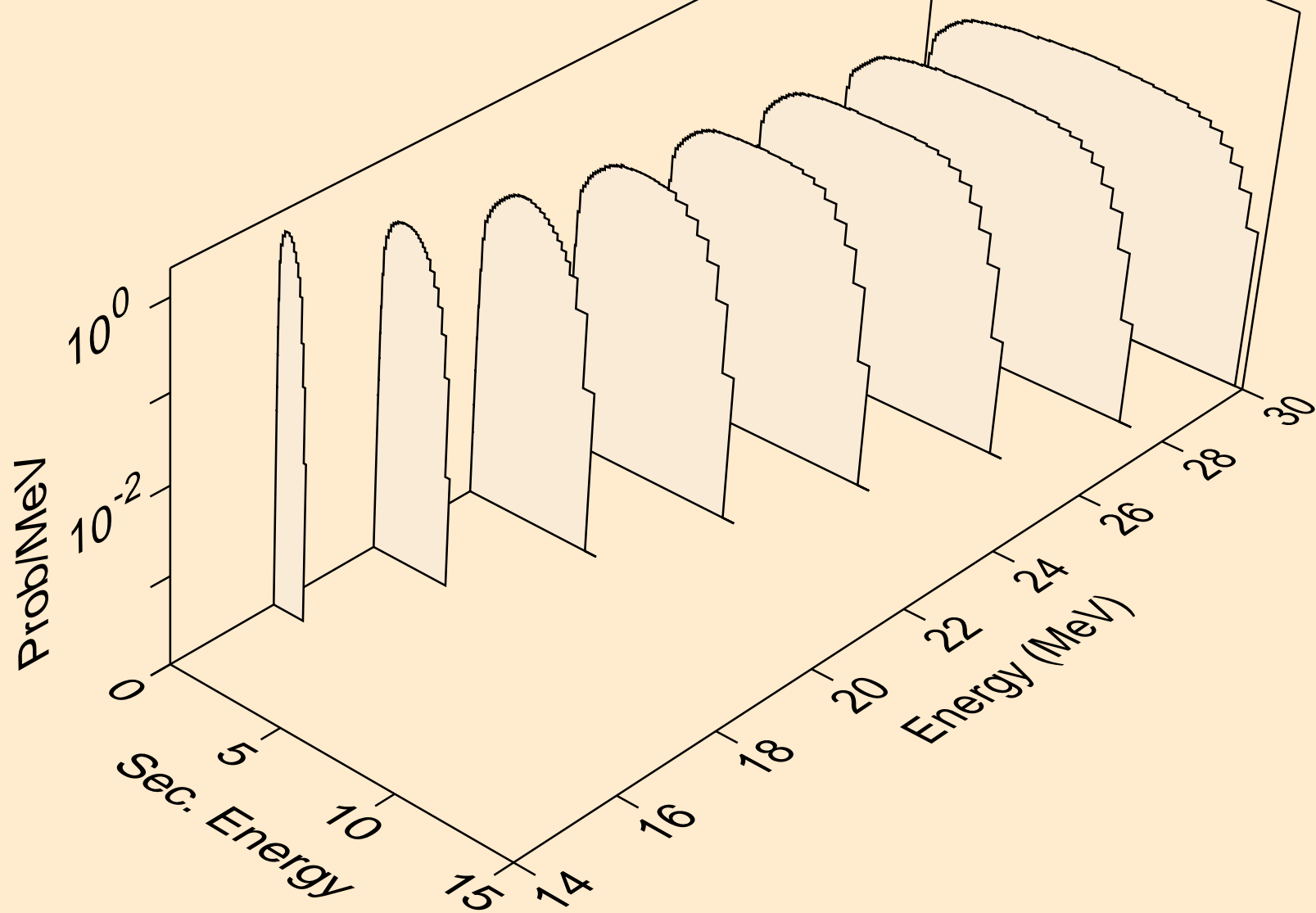

PU232 PHOTON ACER TENDL-2021 LIBRARY; T=0.K  
neutrons from (g,3n)

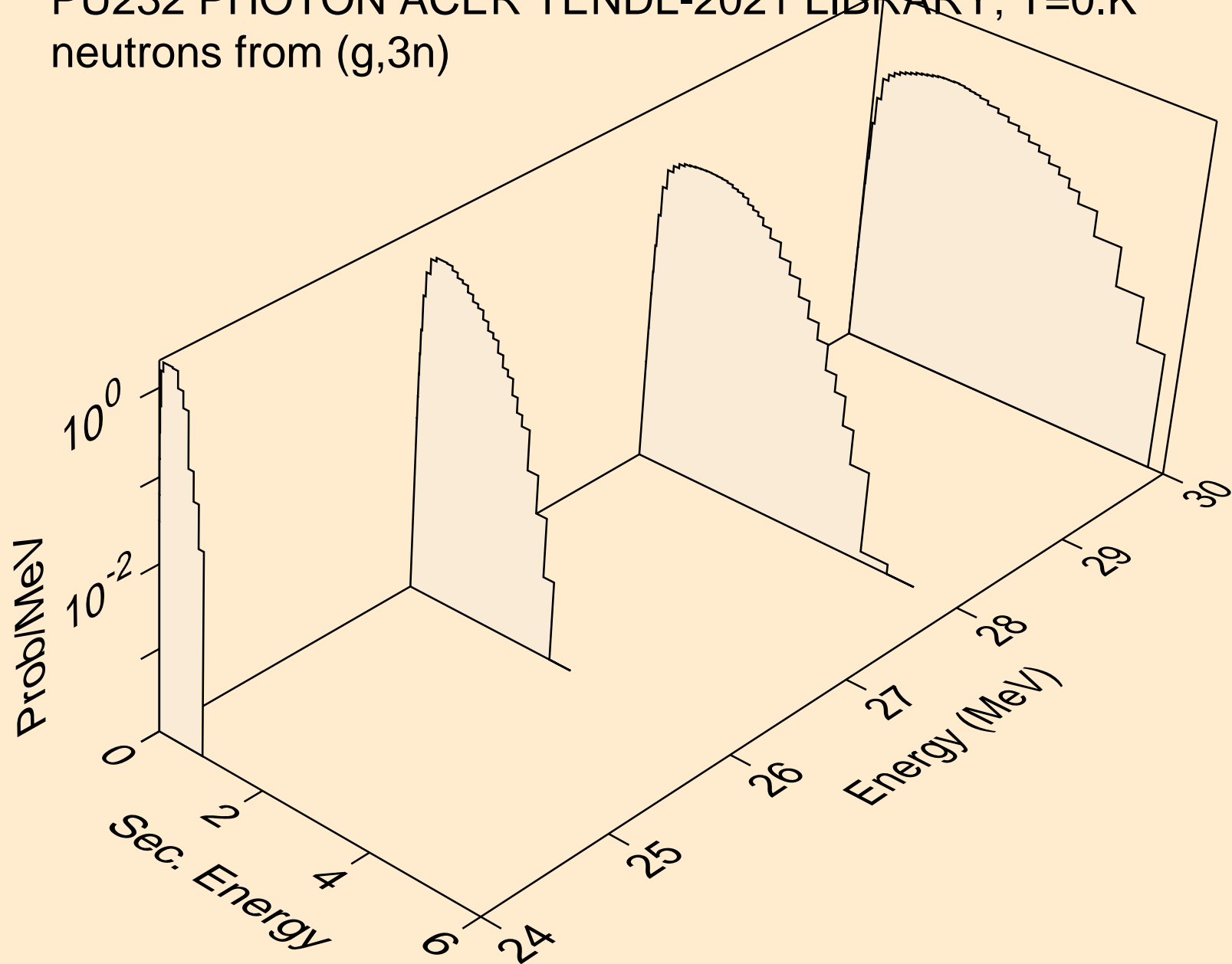

PU232 PHOTON ACER TENDL-2021 LIBRARY; T=0.K  
neutrons from (g,n\*)a

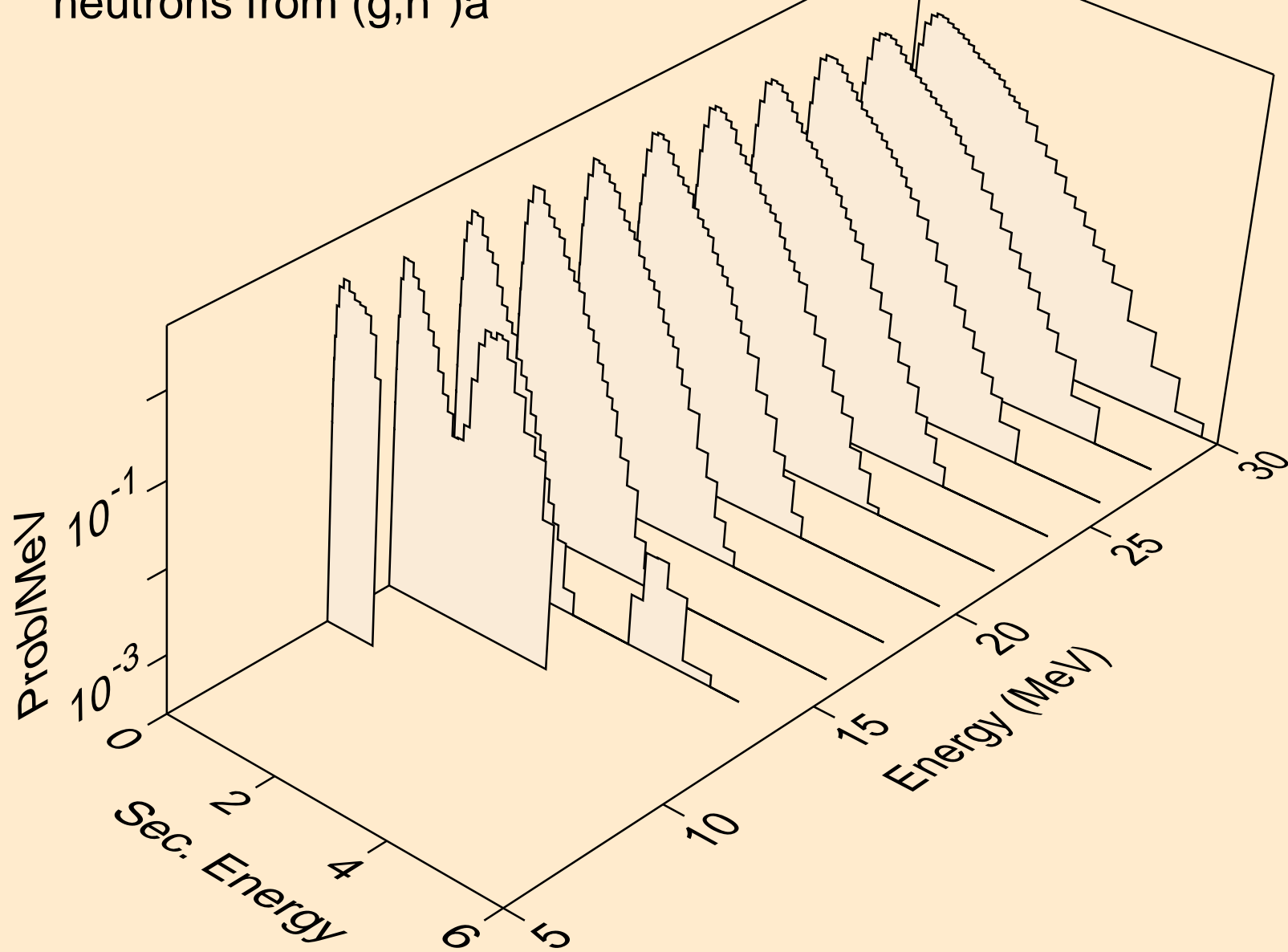

PU232 PHOTON ACER TENDL-2021 LIBRARY; T=0.K  
neutrons from (g,2n)a

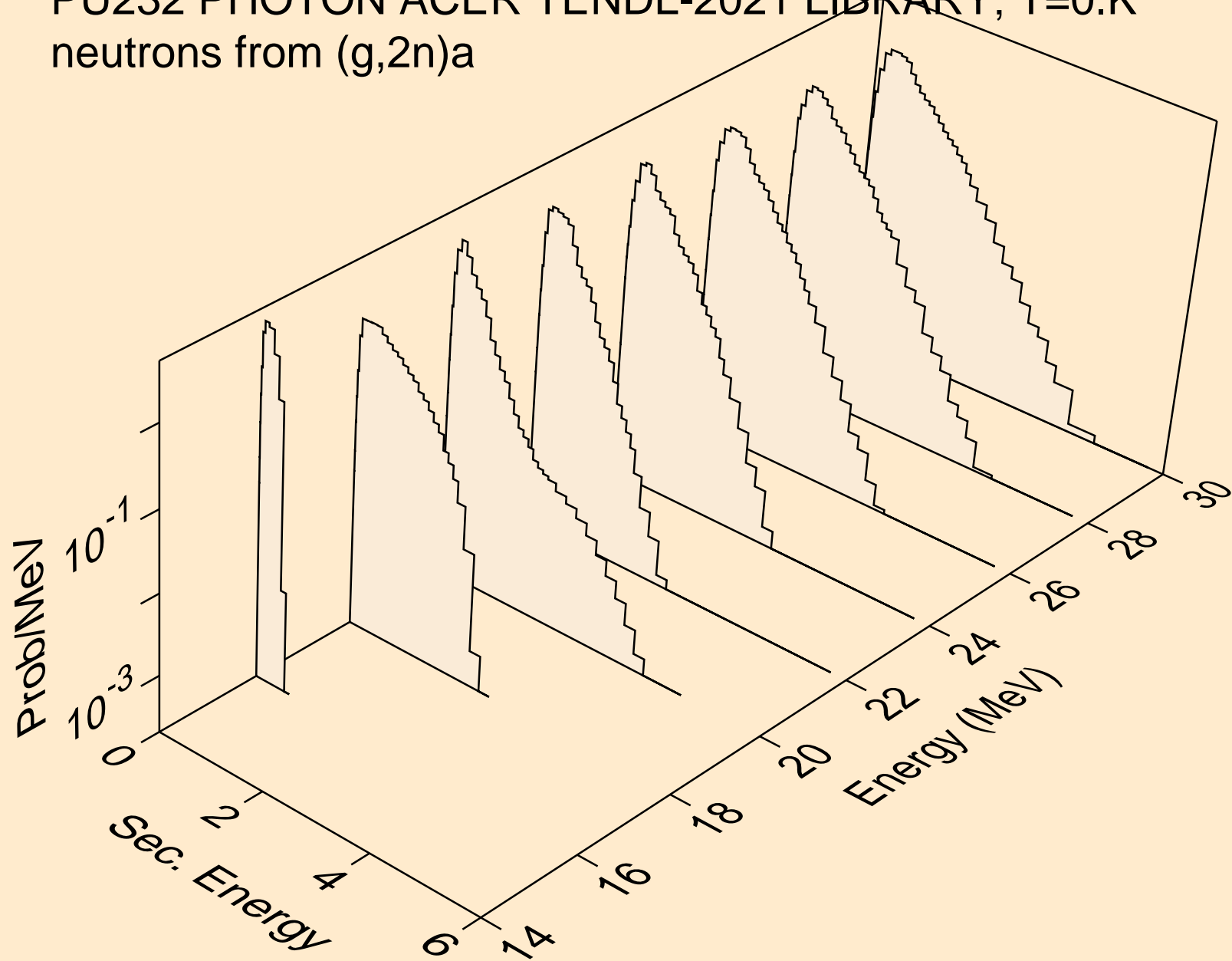

PU232 PHOTON ACER TENDL-2021 LIBRARY; T=0.K  
neutrons from (g,n\*)p

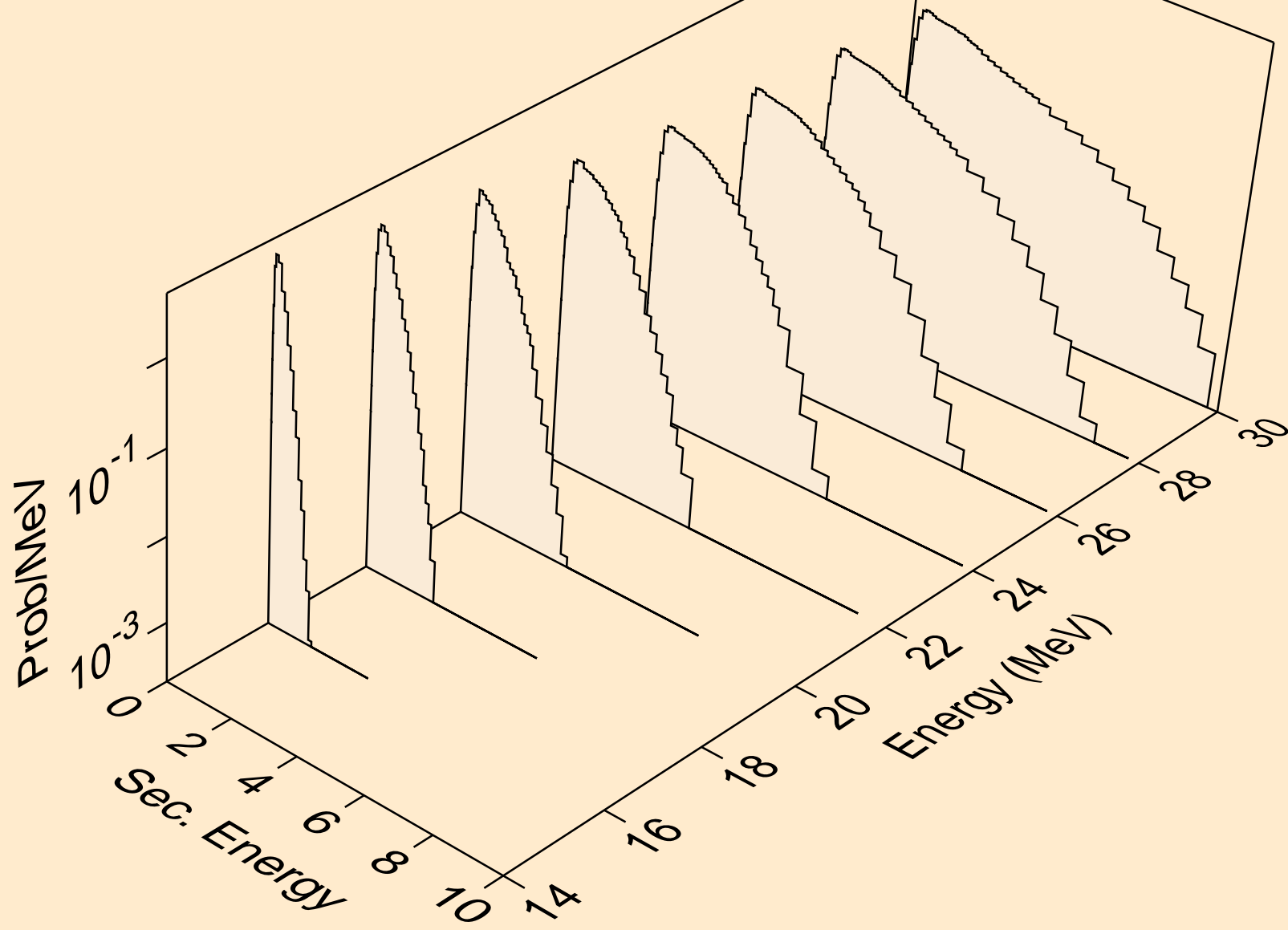

PU232 PHOTON ACER TENDL-2021 LIBRARY; T=0.K  
neutrons from (g,n\*)d

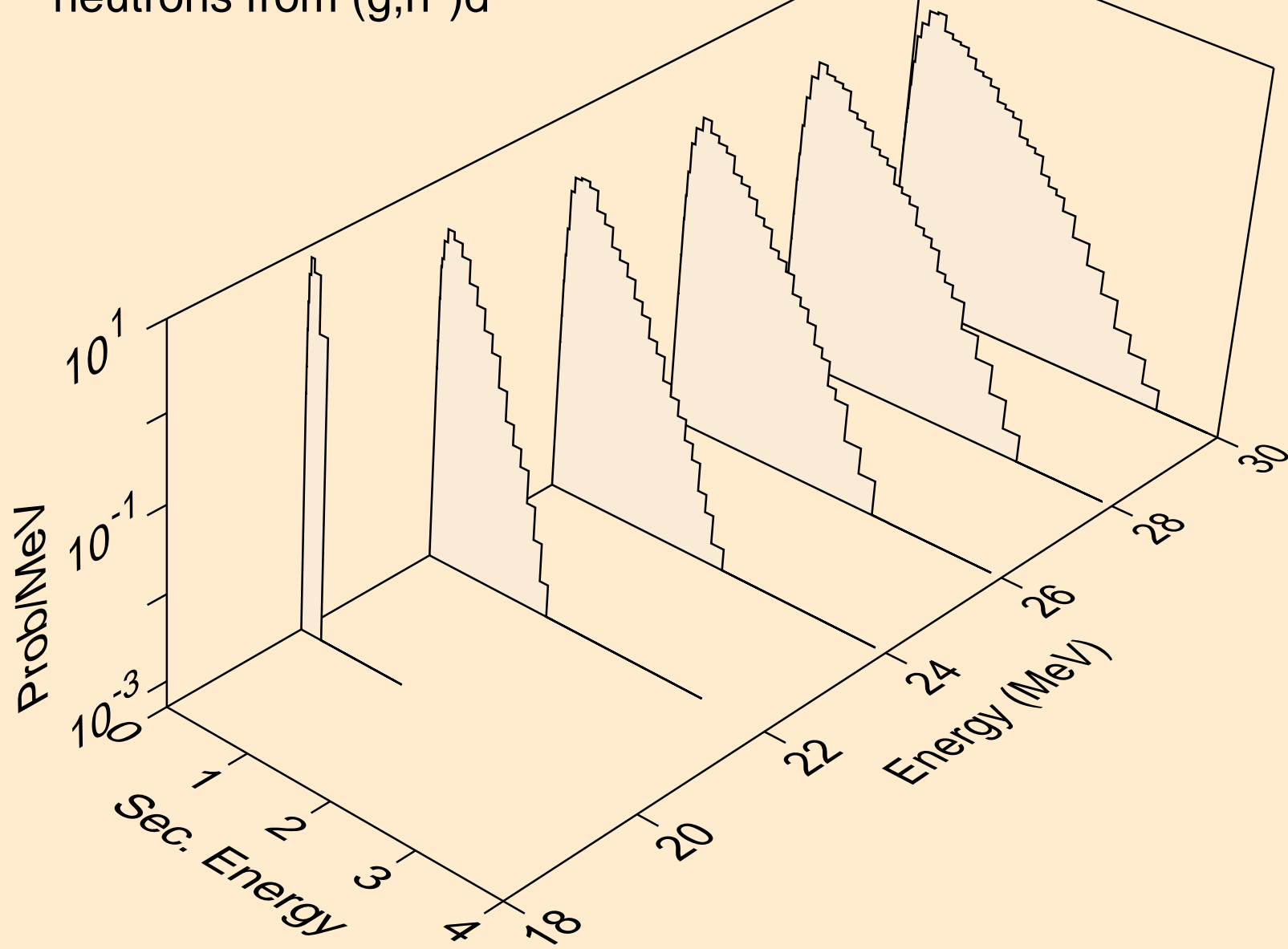

PU232 PHOTON ACER TENDL-2021 LIBRARY; T=0.K  
neutrons from (g,n\*)t

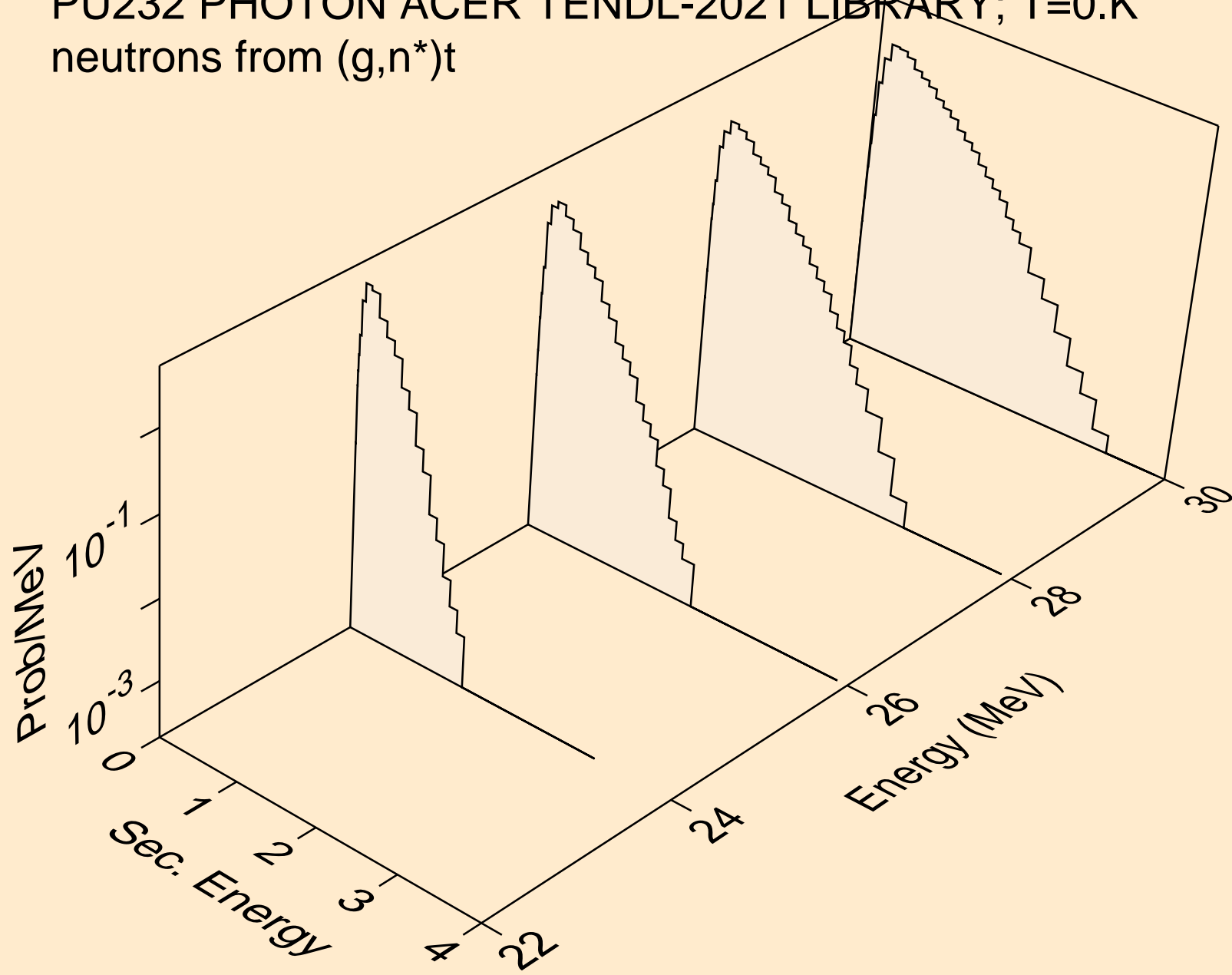

PU232 PHOTON ACER TENDL-2021 LIBRARY; T=0.K  
neutrons from (g,2np)

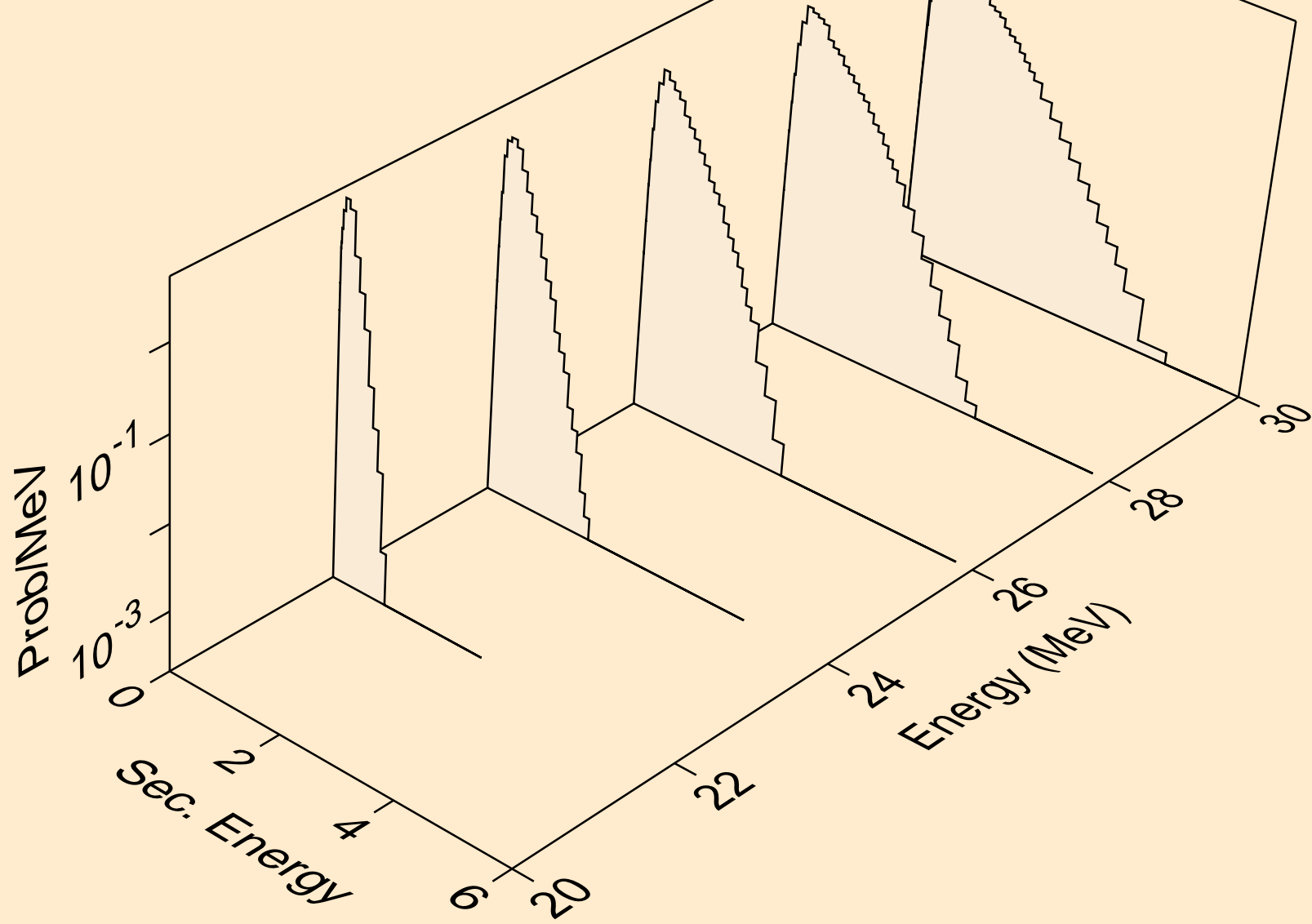

PU232 PHOTON ACER TENDL-2021 LIBRARY; T=0.K  
angular distribution for (g,n\*0) neutron

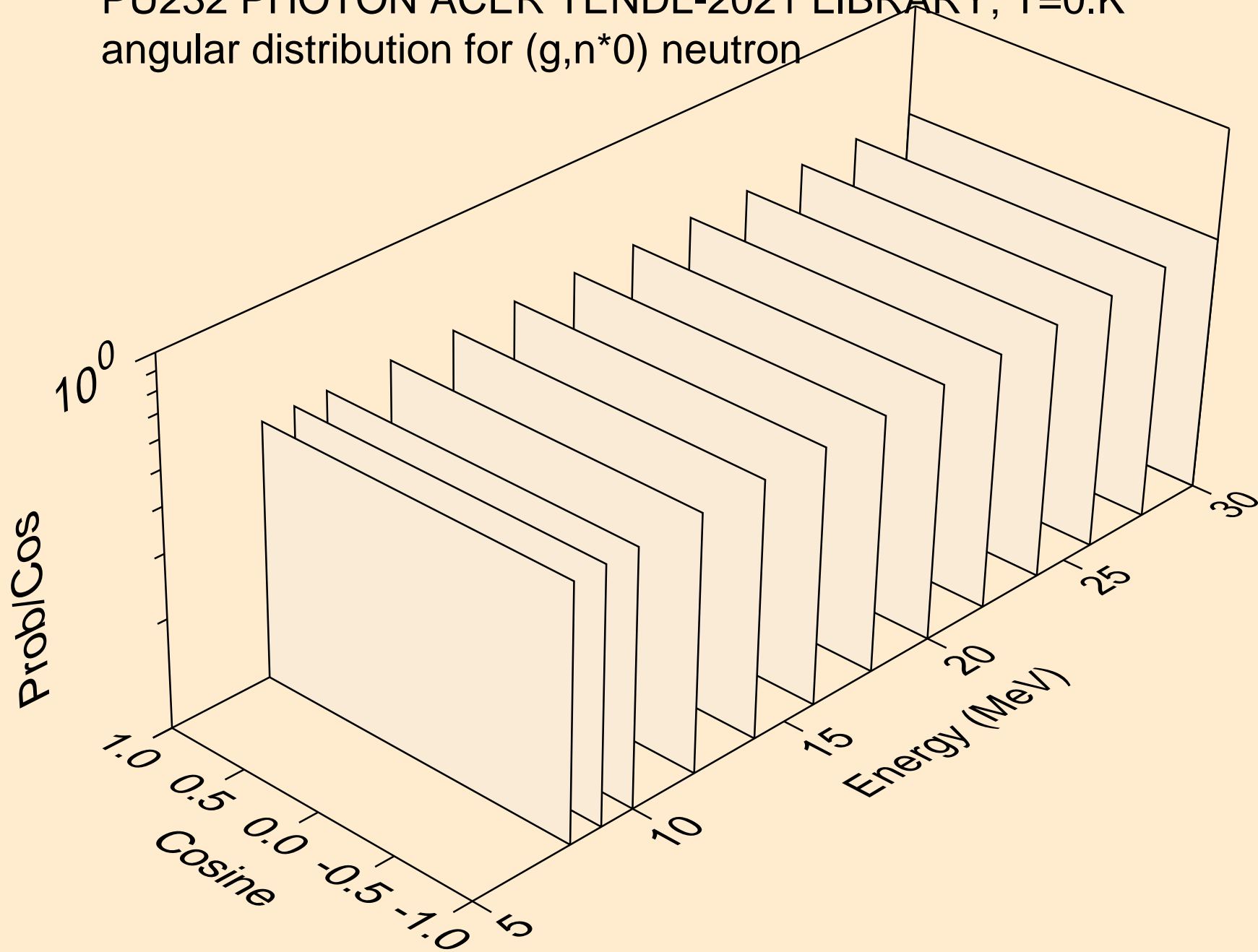

PU232 PHOTON ACER TENDL-2021 LIBRARY; T=0.K  
angular distribution for (g,n\*1) neutron

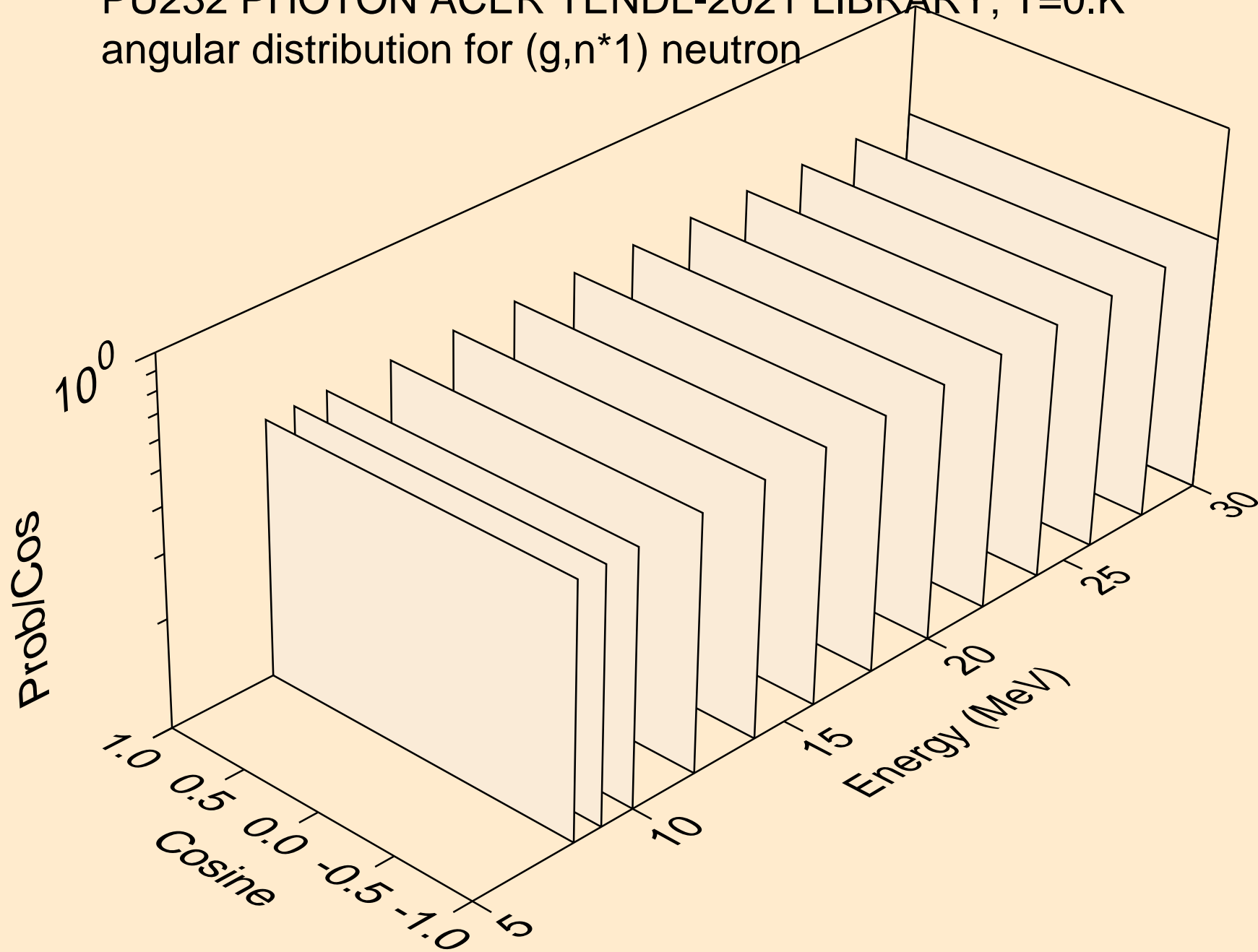

PU232 PHOTON ACER TENDL-2021 LIBRARY; T=0.K  
neutrons from (g,n\*c)

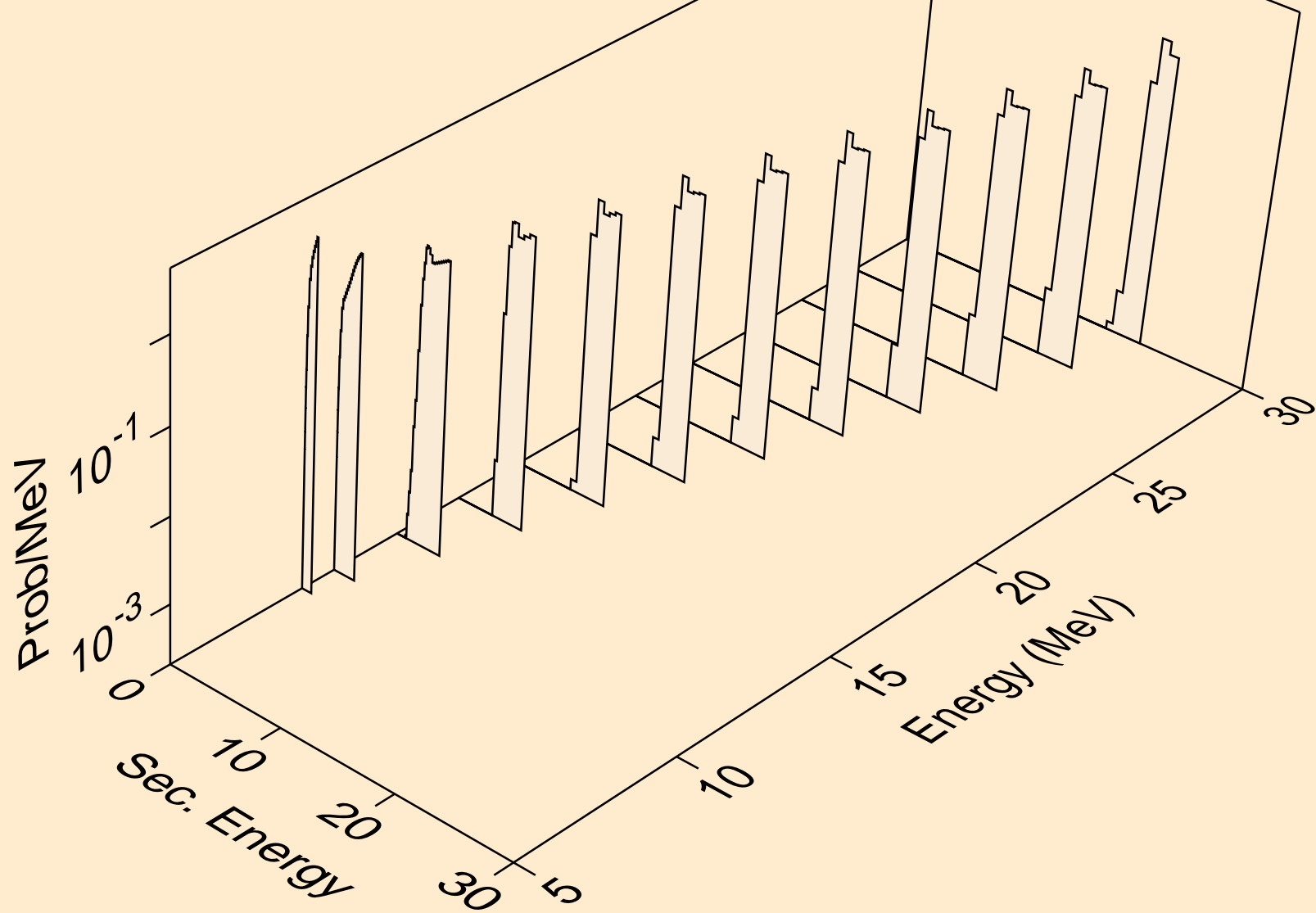

PU232 PHOTON ACER TENDL-2021 LIBRARY; T=0.K  
photons from (g,x)

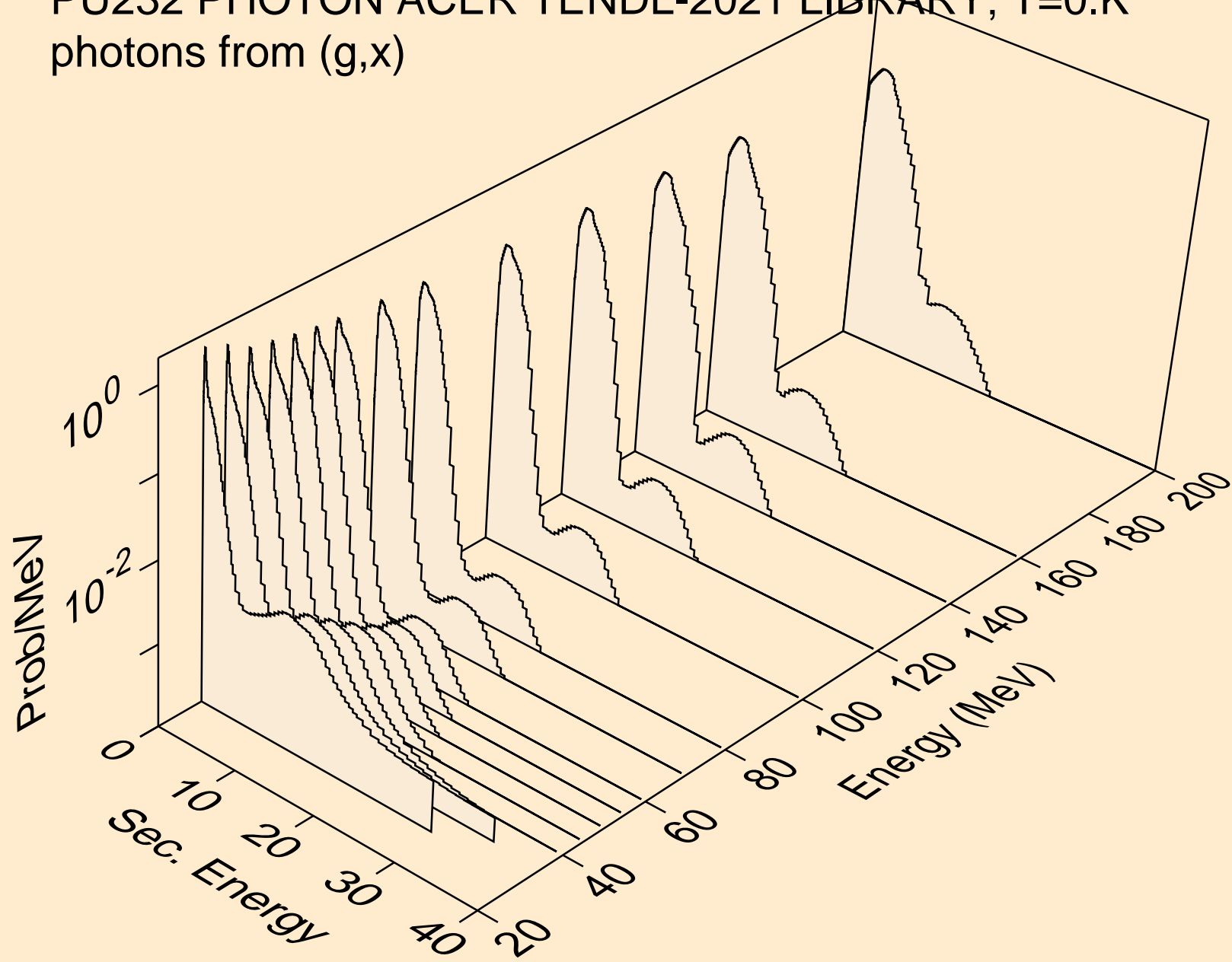

PU232 PHOTON ACER TENDL-2021 LIBRARY; T=0.K  
photons from (g,2n)

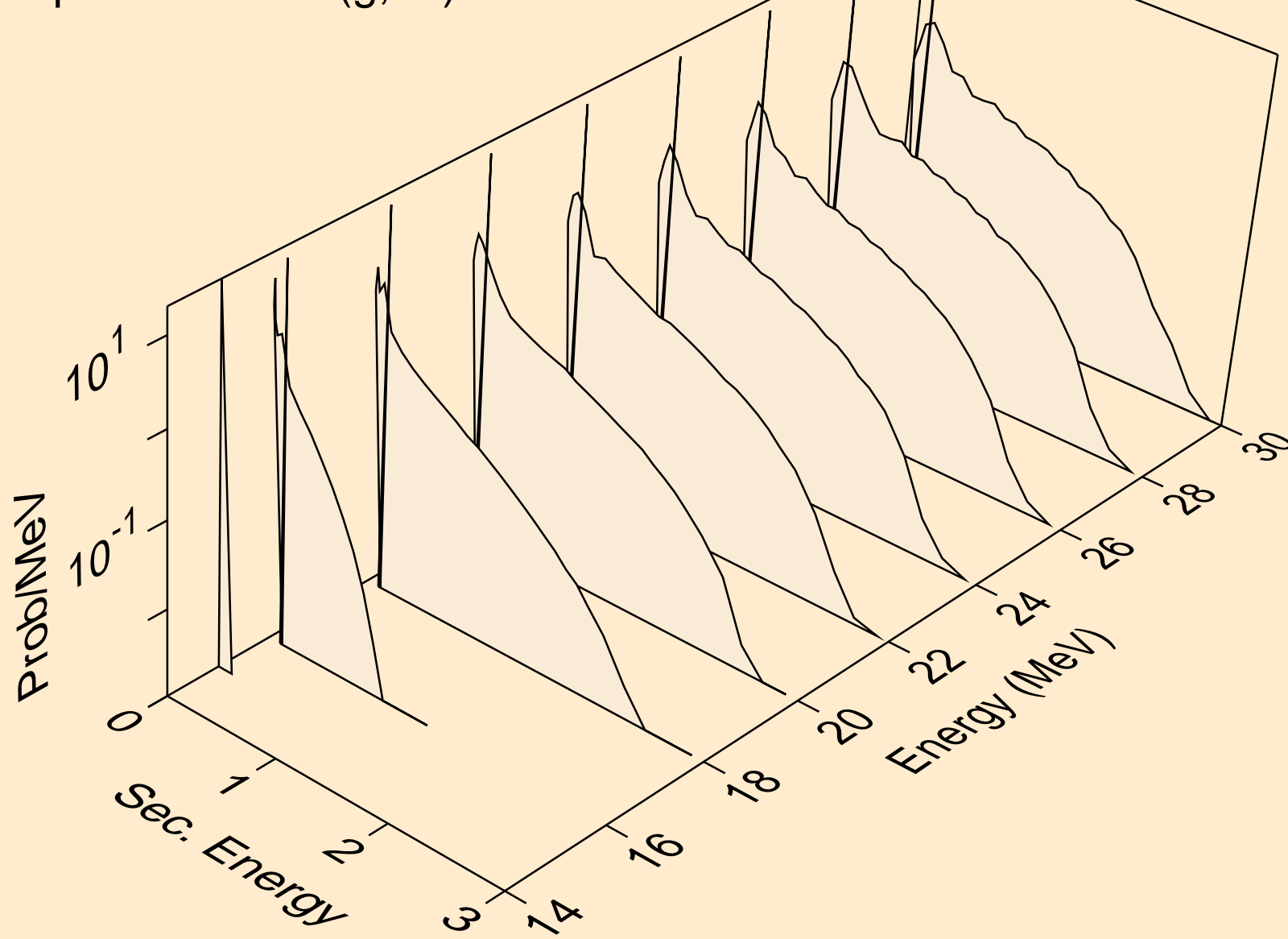

PU232 PHOTON ACER TENDL-2021 LIBRARY; T=0.K  
photons from (g,3n)

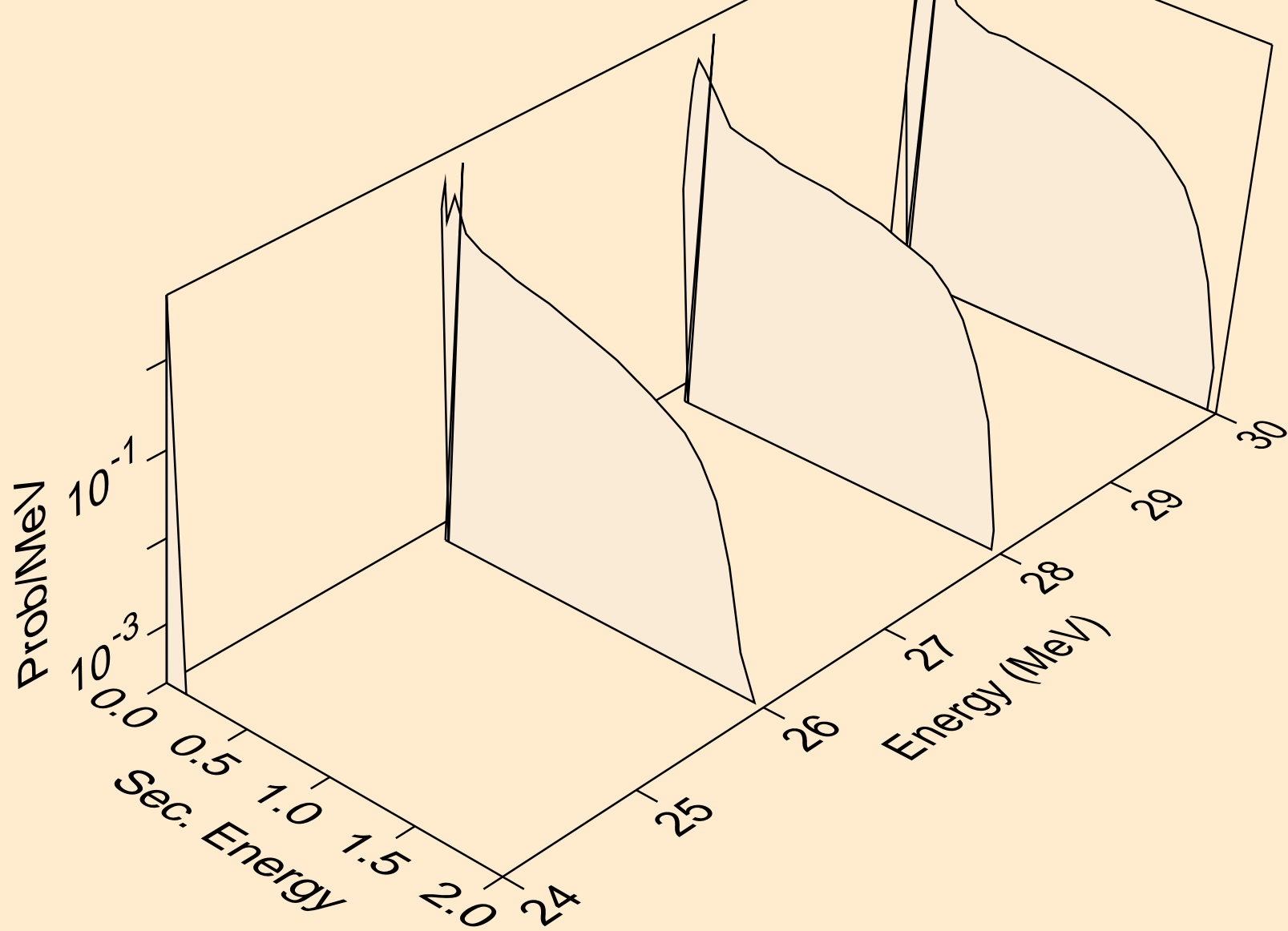

PU232 PHOTON ACER TENDL-2021 LIBRARY; T=0.K  
photons from (g,n\*)a

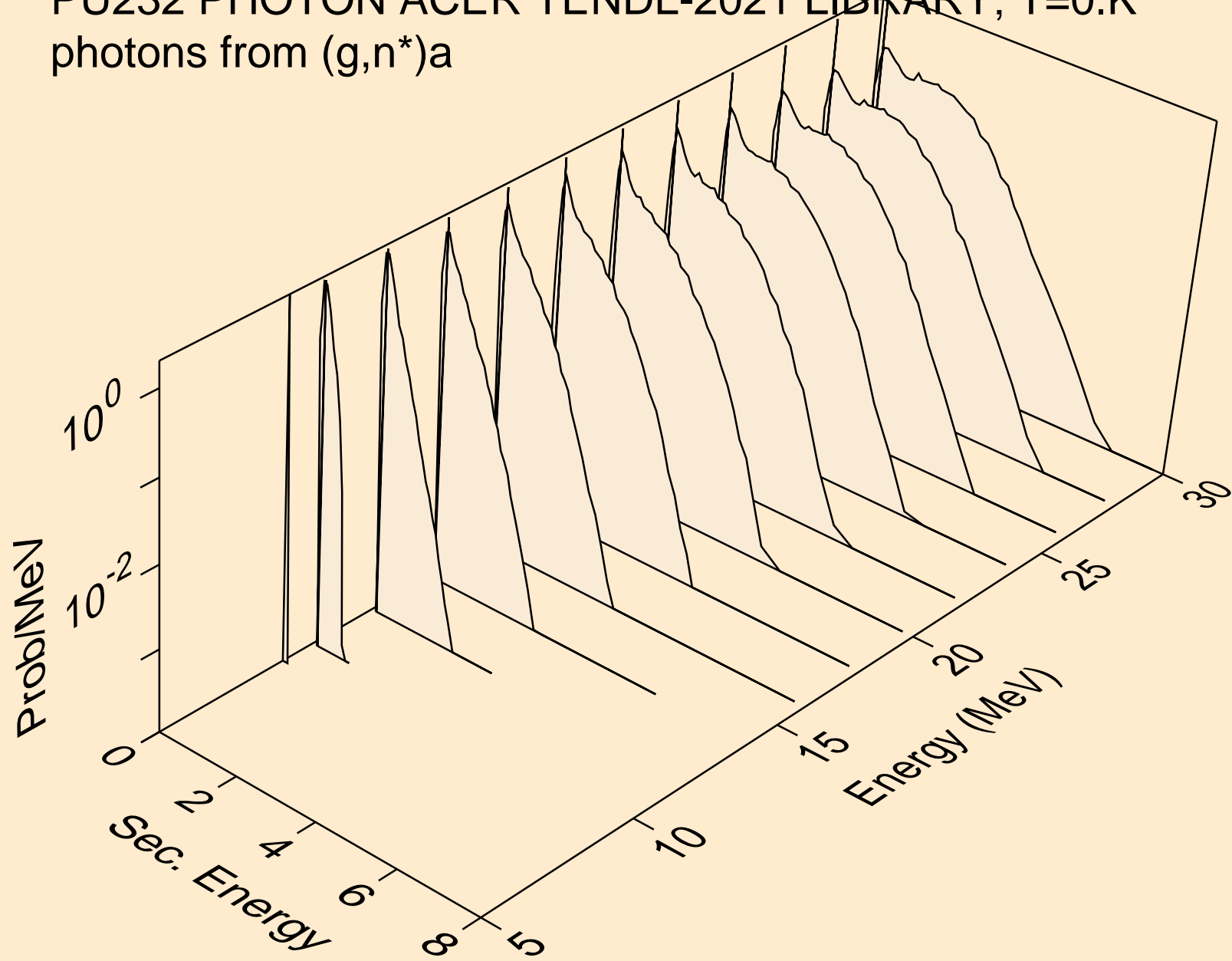

PU232 PHOTON ACER TENDL-2021 LIBRARY; T=0.K  
photons from (g,2n)a

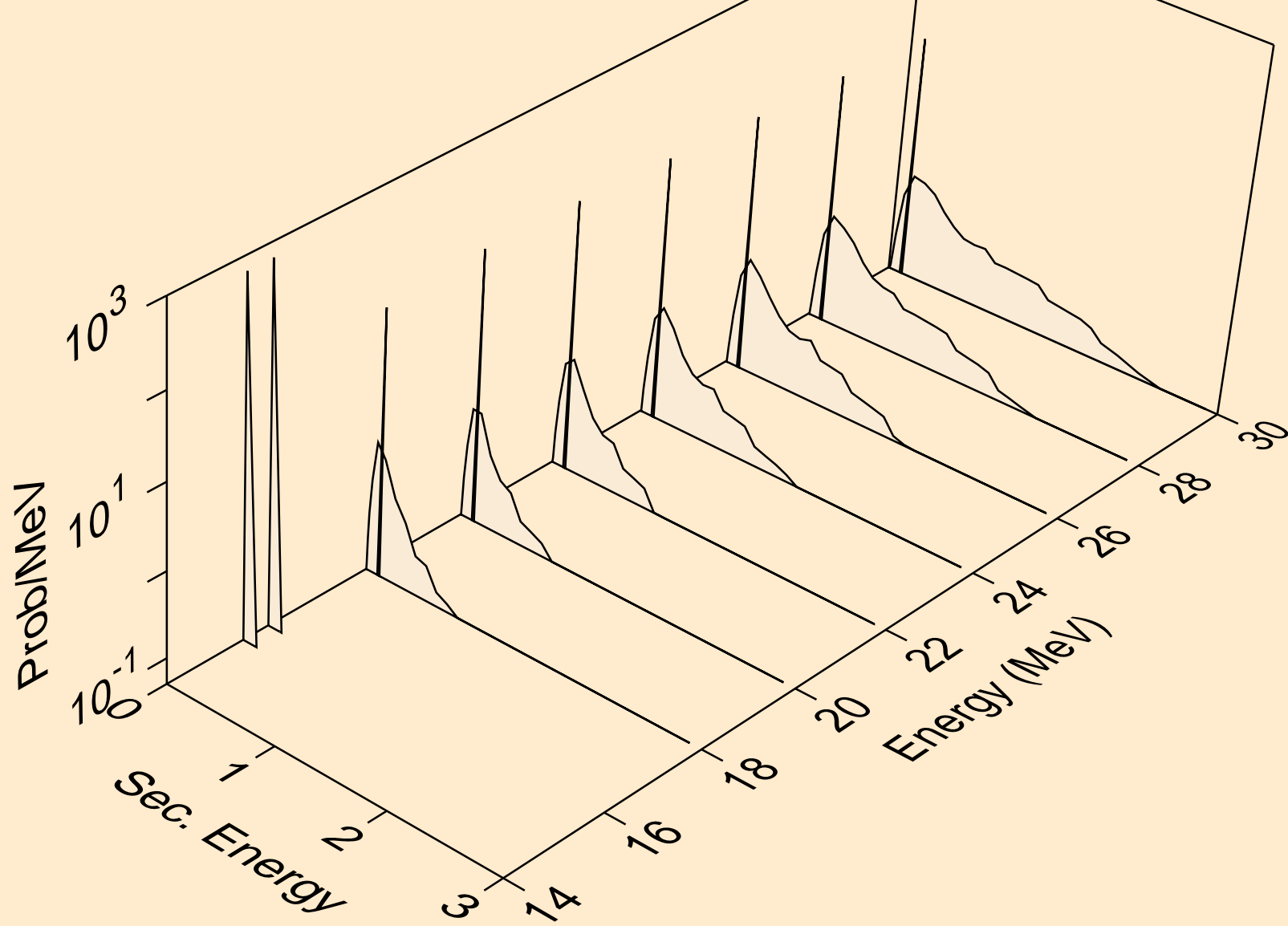

PU232 PHOTON ACER TENDL-2021 LIBRARY; T=0.K  
photons from (g,n\*)p

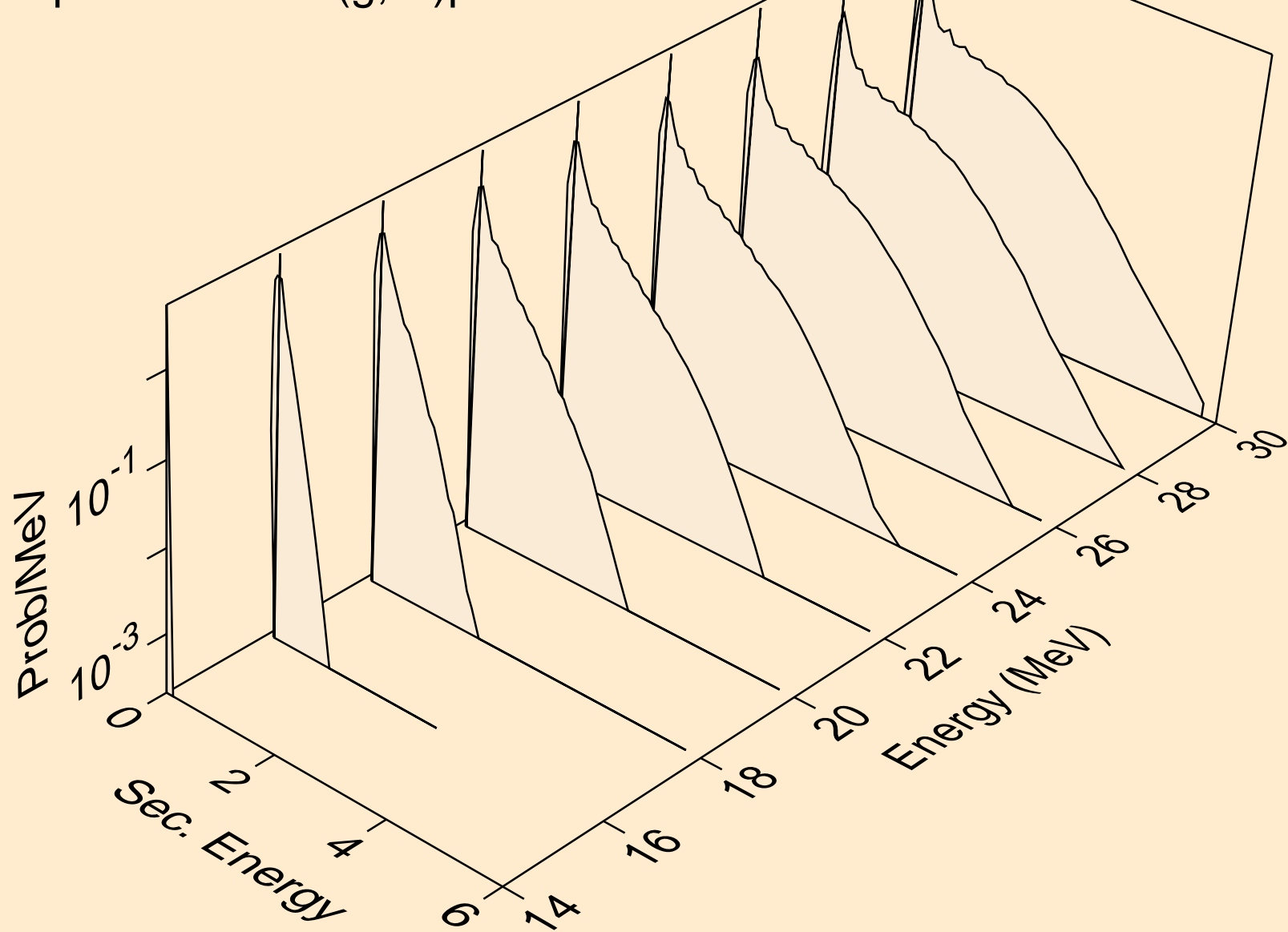

PU232 PHOTON ACER TENDL-2021 LIBRARY; T=0.K  
photons from (g,n\*)d

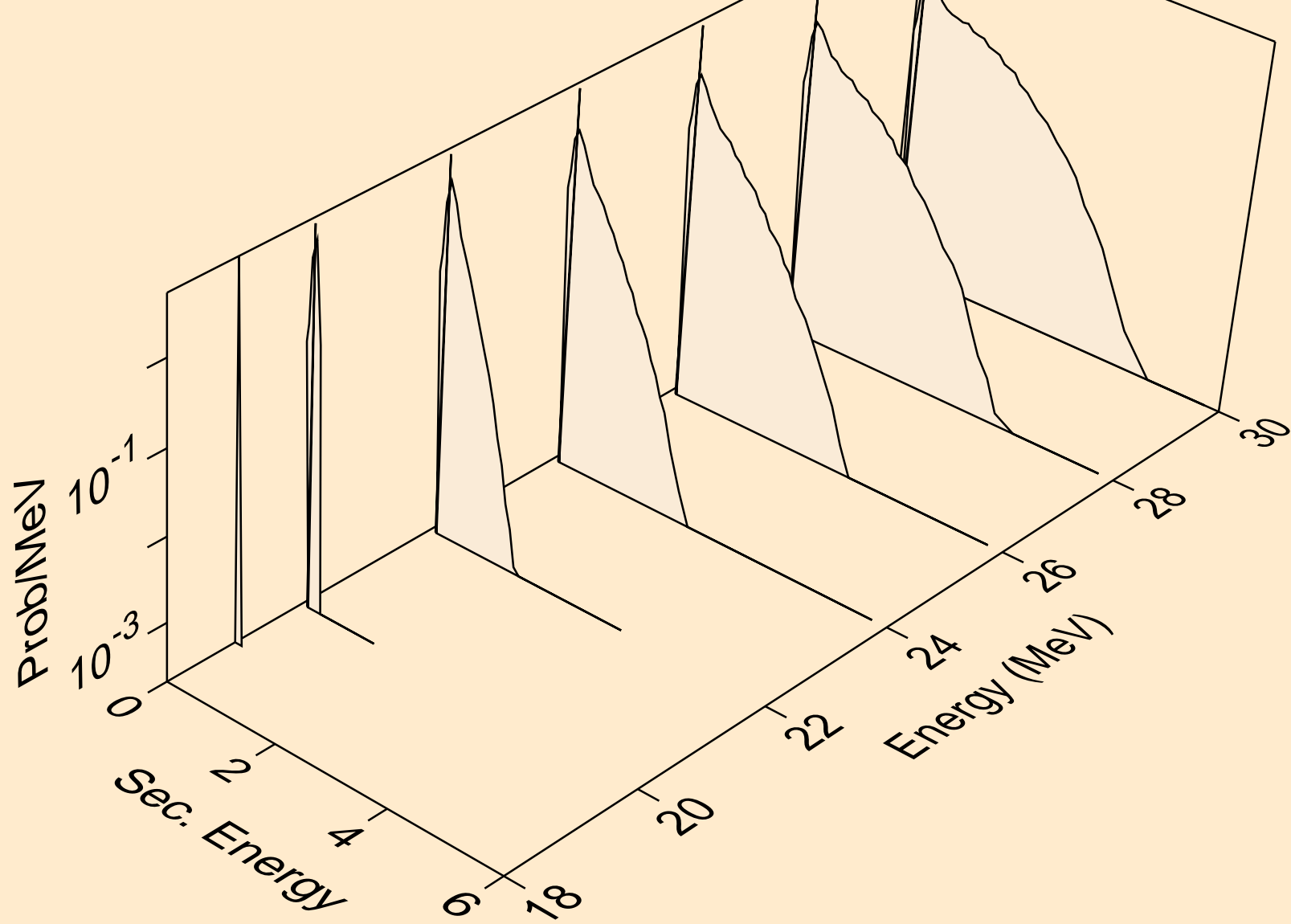

PU232 PHOTON ACER TENDL-2021 LIBRARY; T=0.K  
photons from (g,n\*)t

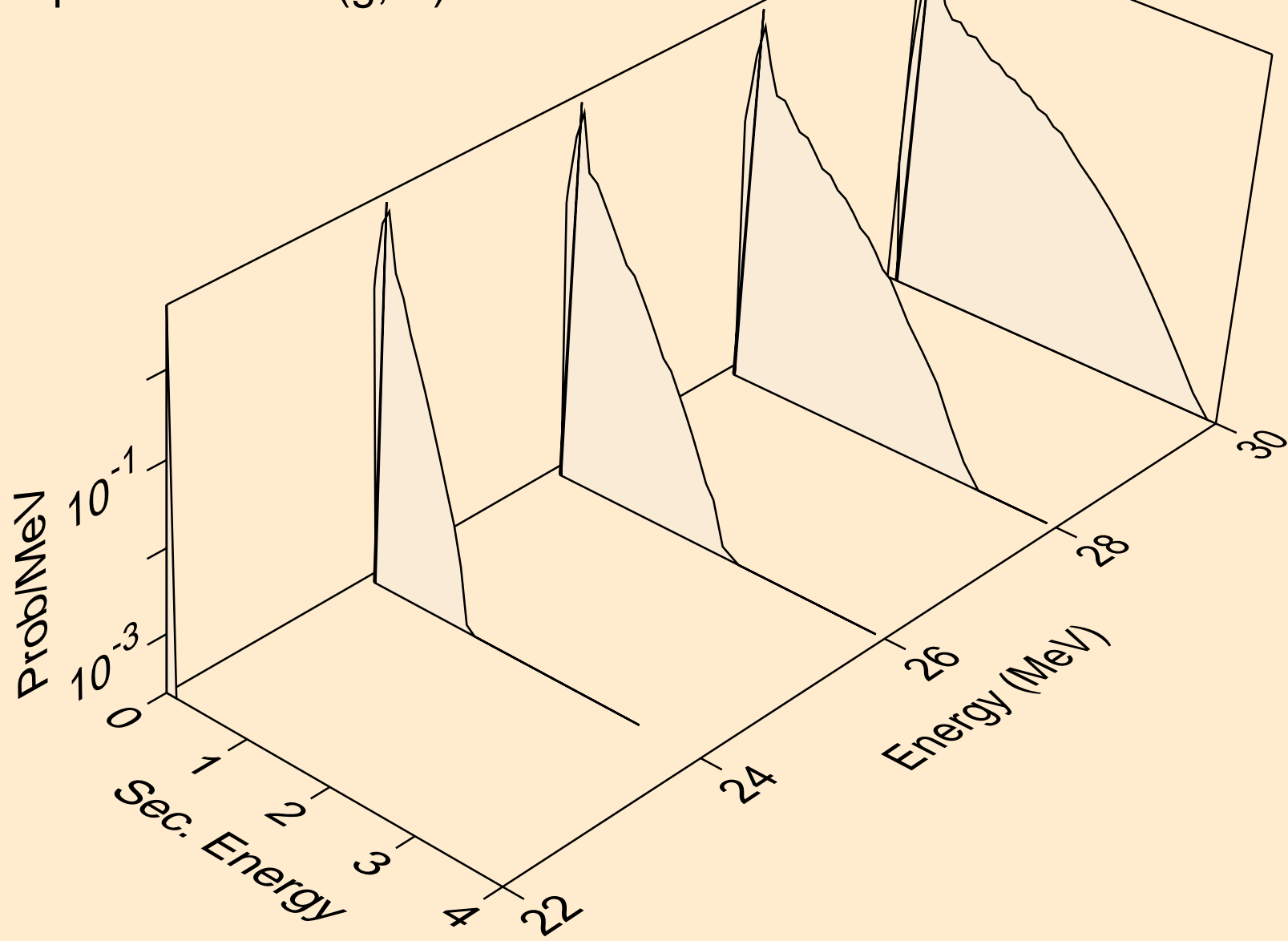

PU232 PHOTON ACER TENDL-2021 LIBRARY; T=0.K  
photons from (g,2np)

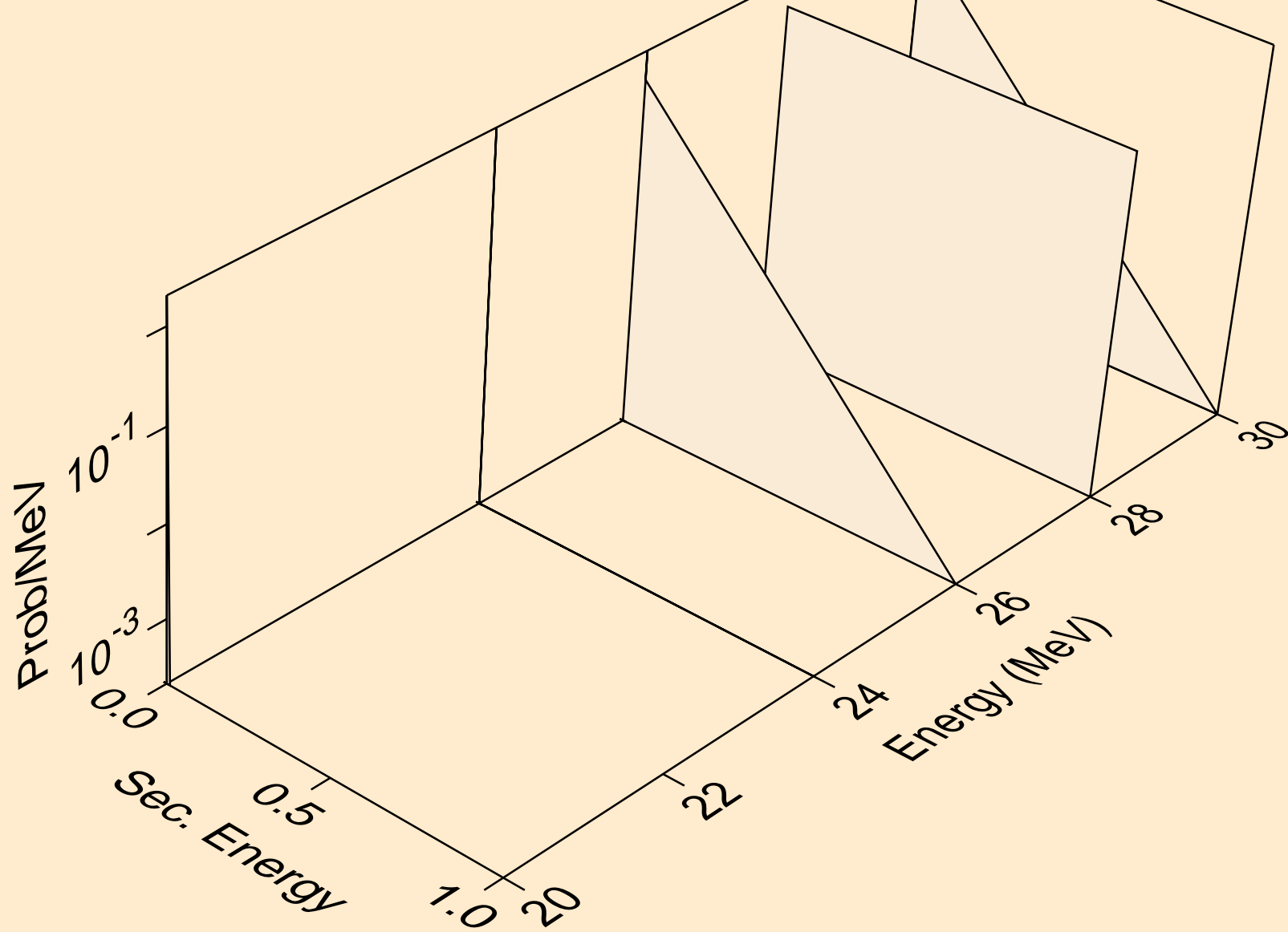

PU232 PHOTON ACER TENDL-2021 LIBRARY; T=0.K  
photons from (g,n\*c)

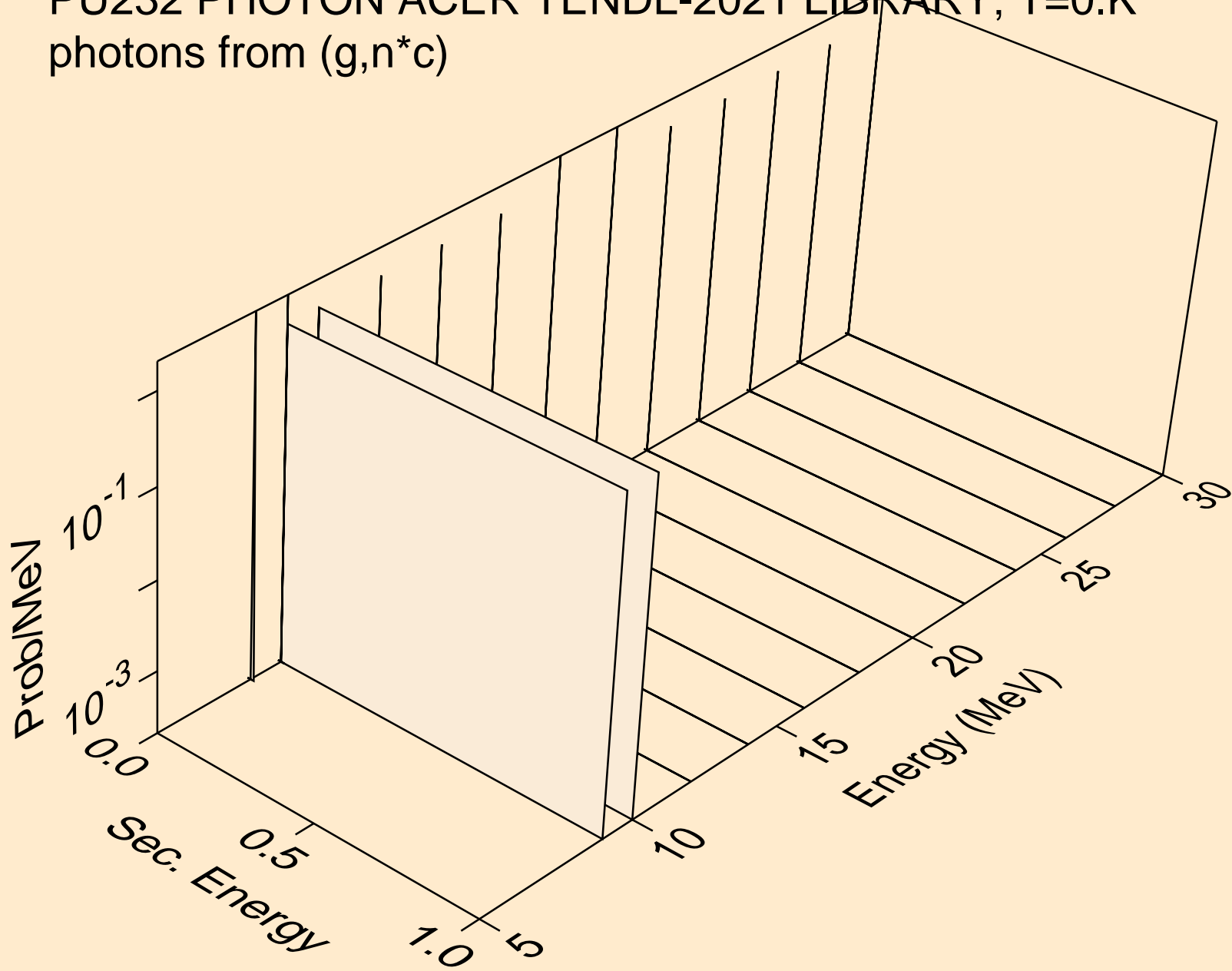

PU232 PHOTON ACER TENDL-2021 LIBRARY; T=0.K  
photons from (g,gma)

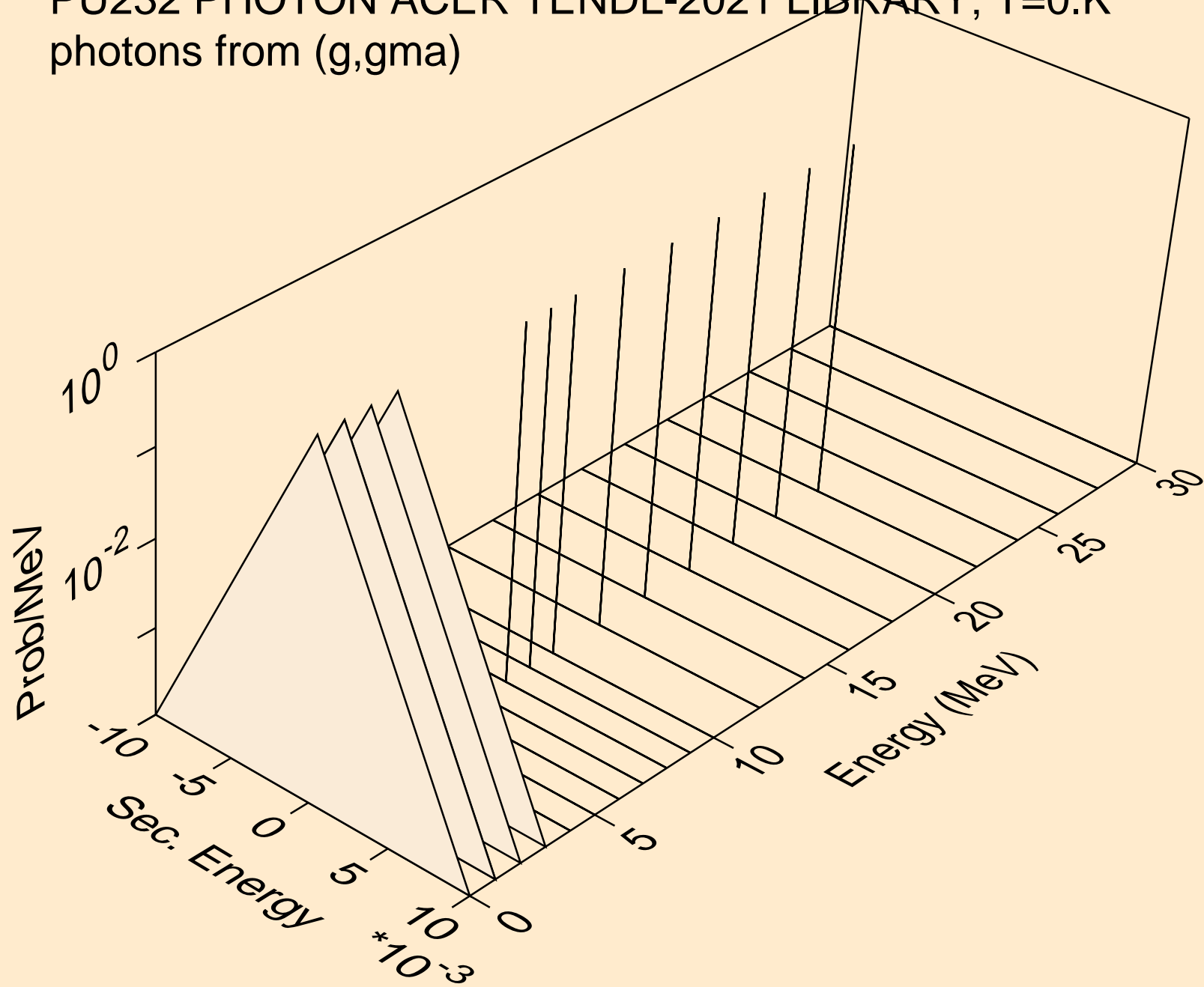

PU232 PHOTON ACER TENDL-2021 LIBRARY; T=0.K  
photons from (g,p)

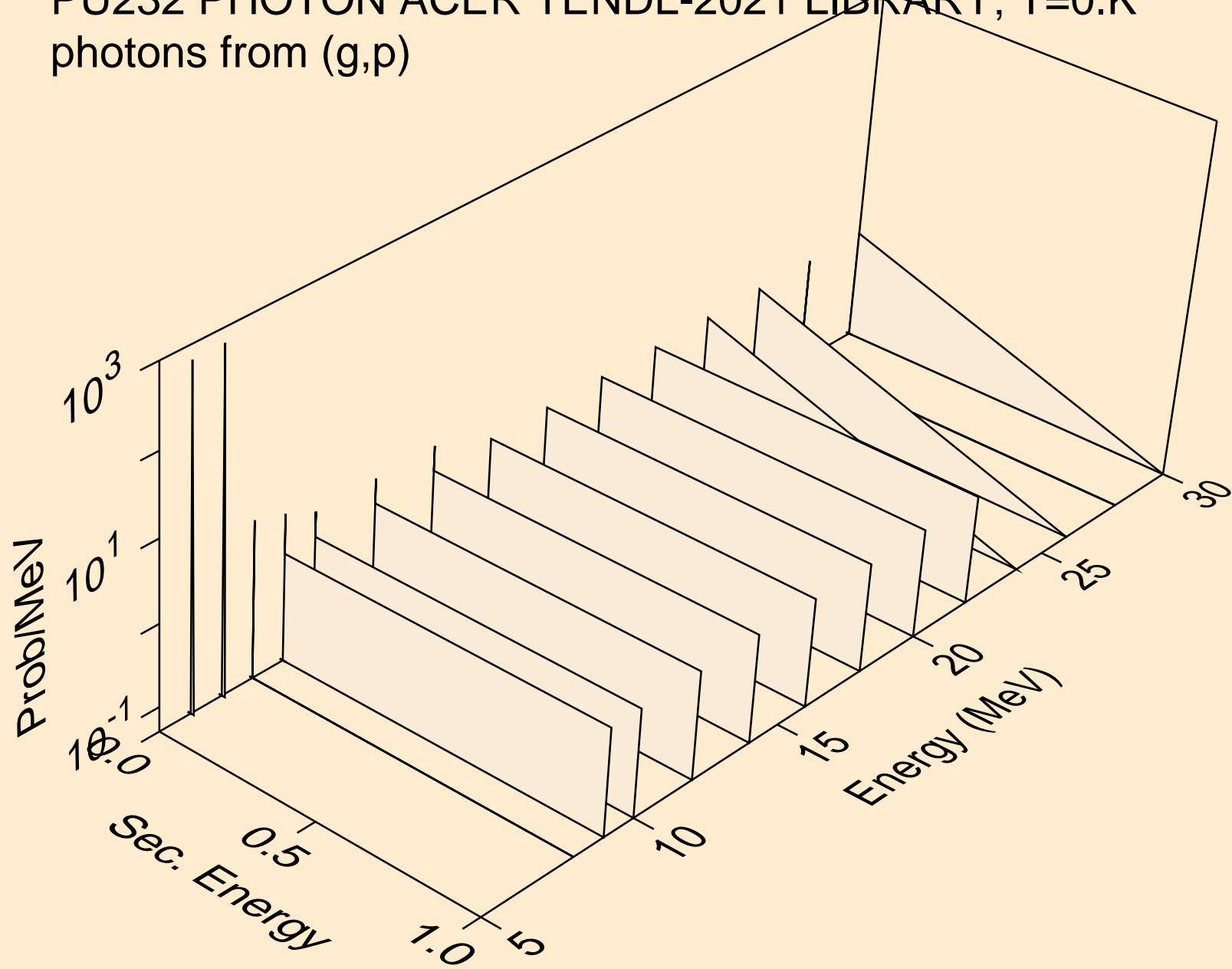

PU232 PHOTON ACER TENDL-2021 LIBRARY; T=0.K  
photons from (g,d)

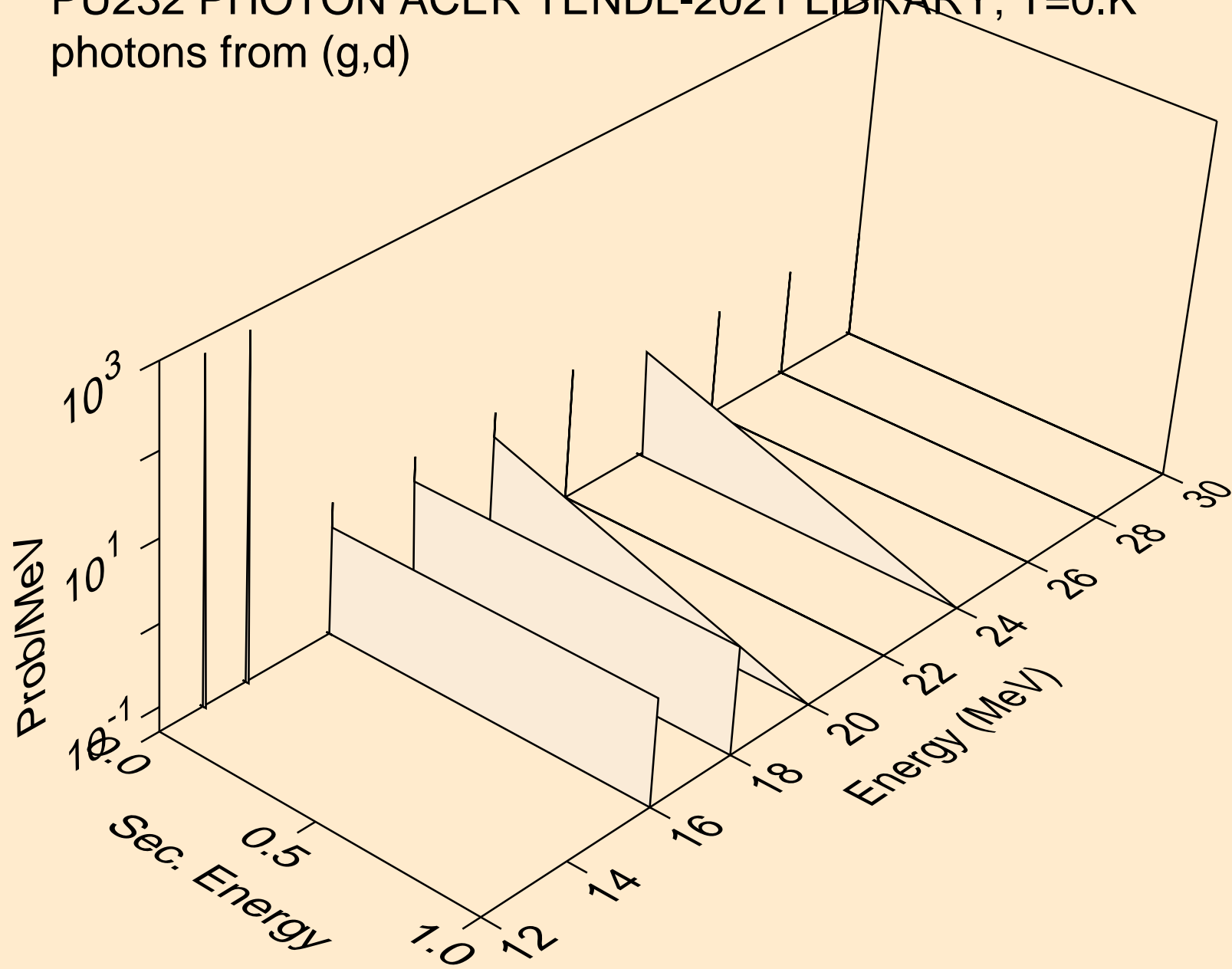

PU232 PHOTON ACER TENDL-2021 LIBRARY; T=0.K  
photons from (g,t)

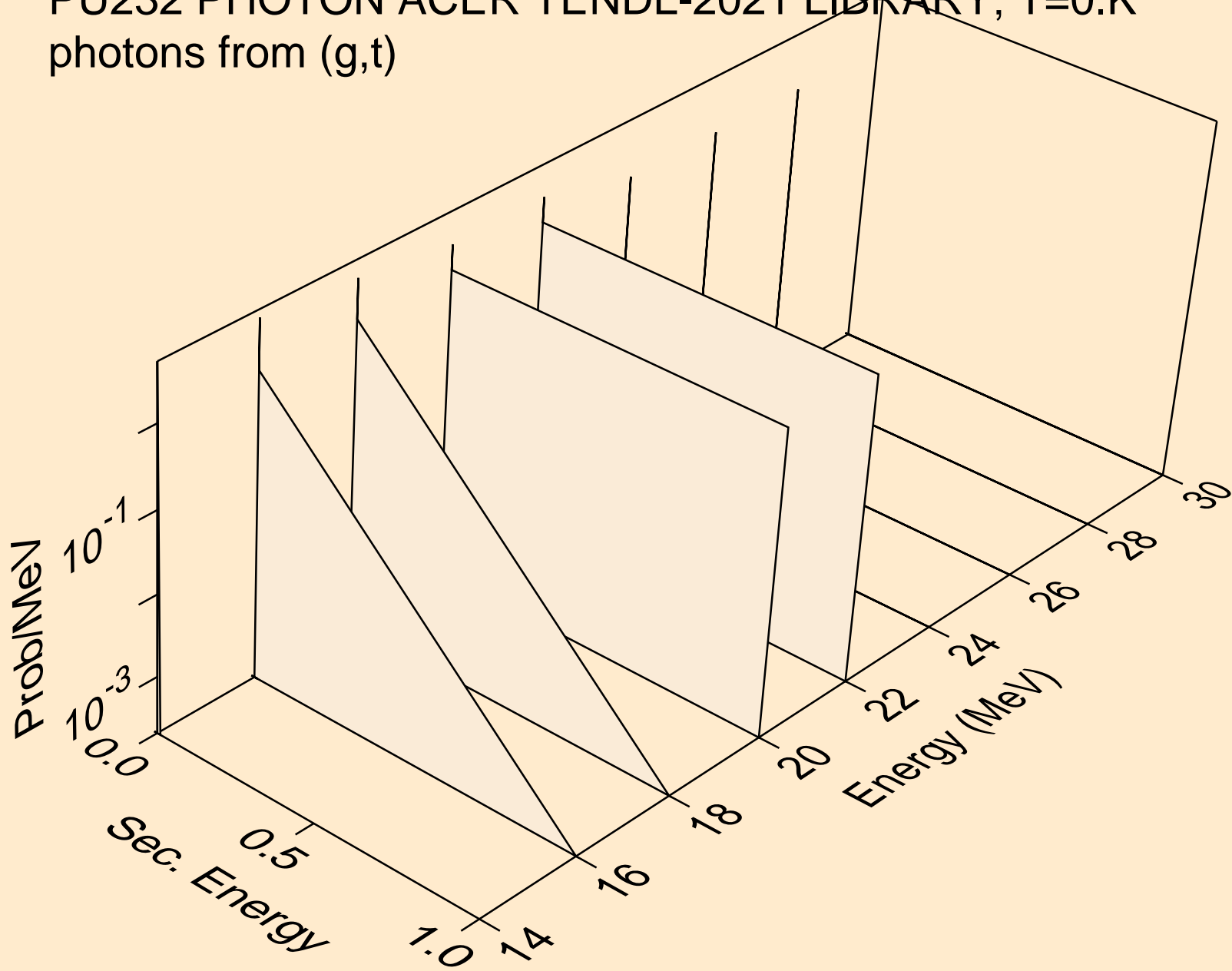

PU232 PHOTON ACER TENDL-2021 LIBRARY; T=0.K  
photons from (g,a)

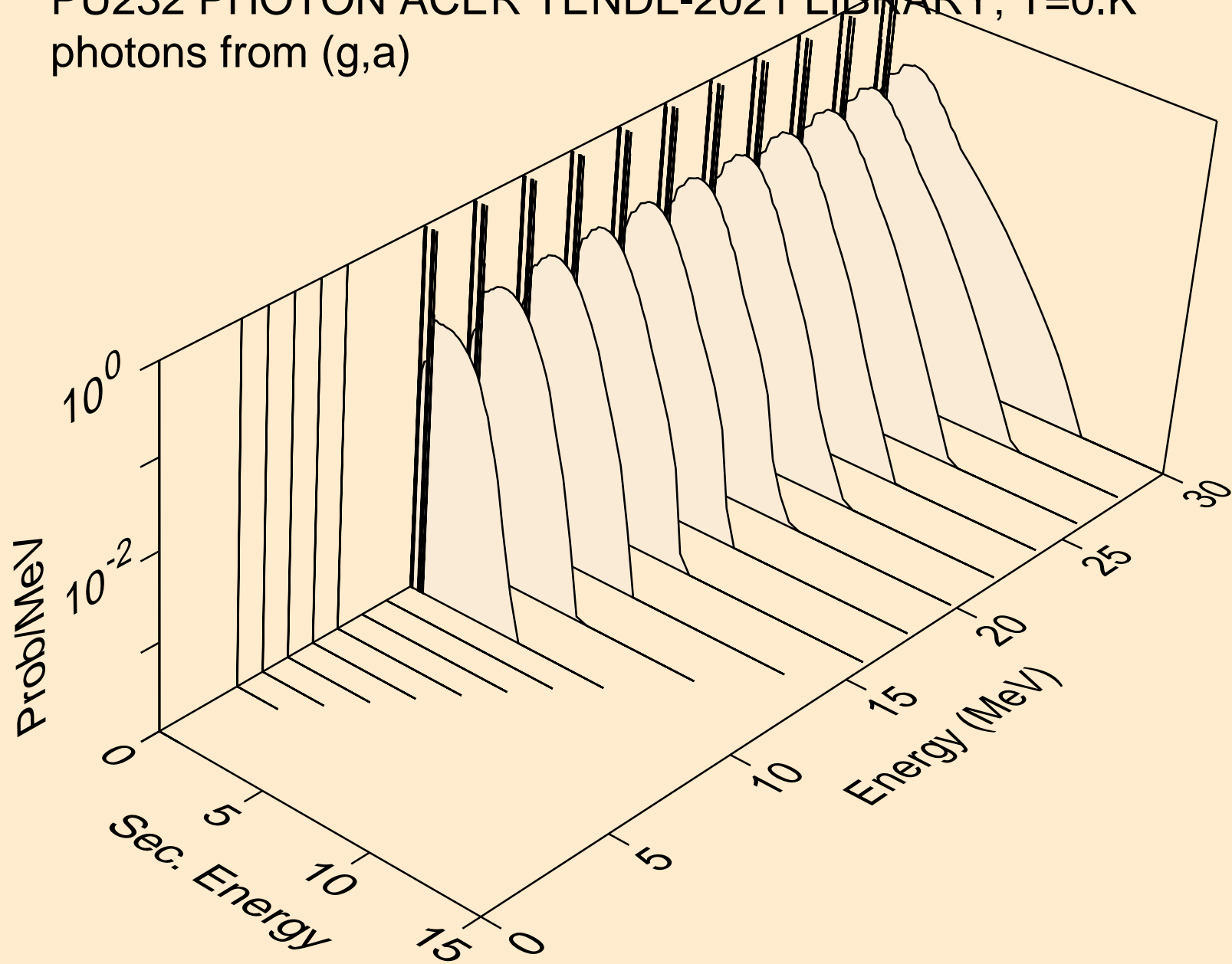

PU232 PHOTON ACER TENDL-2021 LIBRARY; T=0.K  
protons from (g,x)

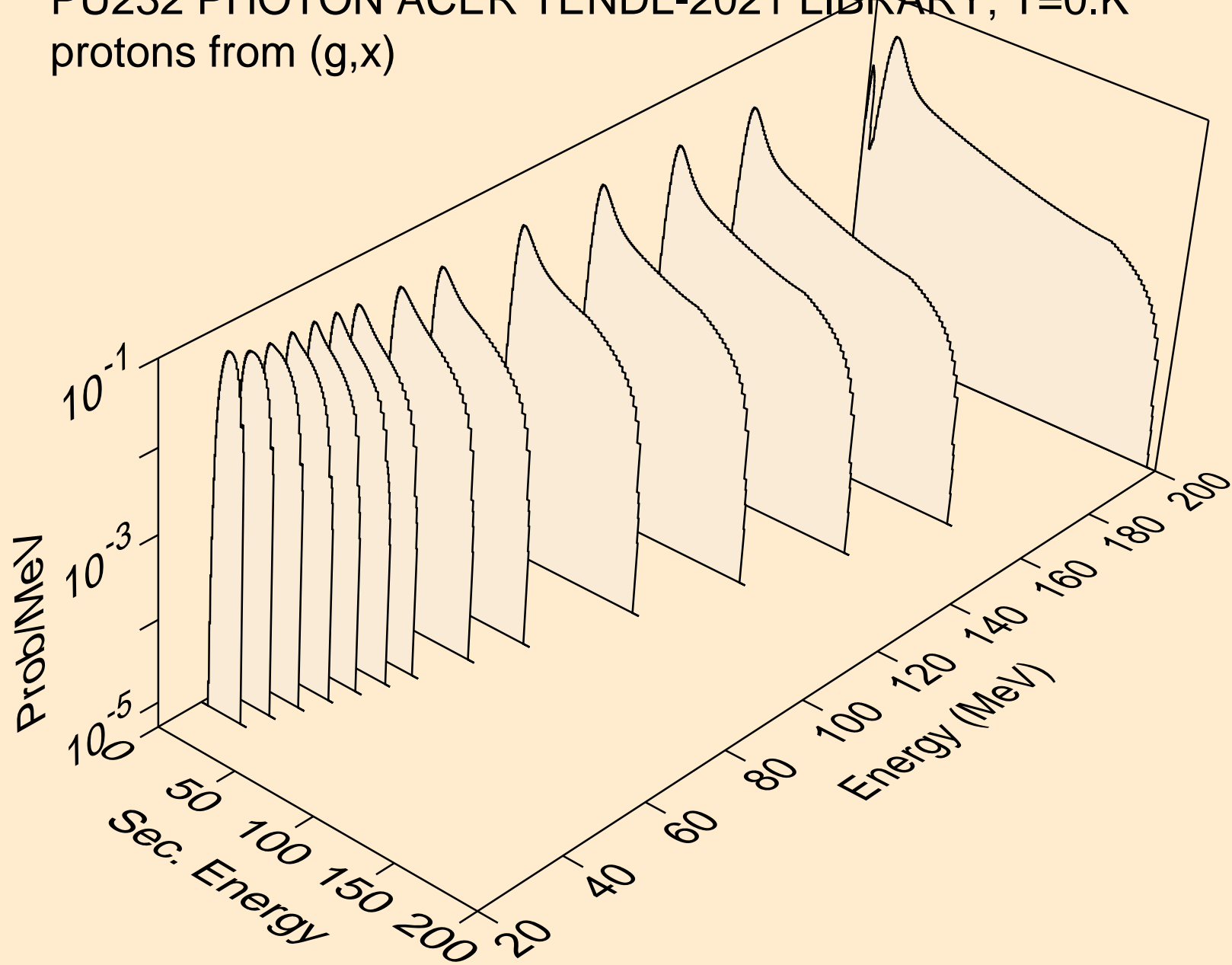

PU232 PHOTON ACER TENDL-2021 LIBRARY; T=0.K  
protons from (g,n\*)p

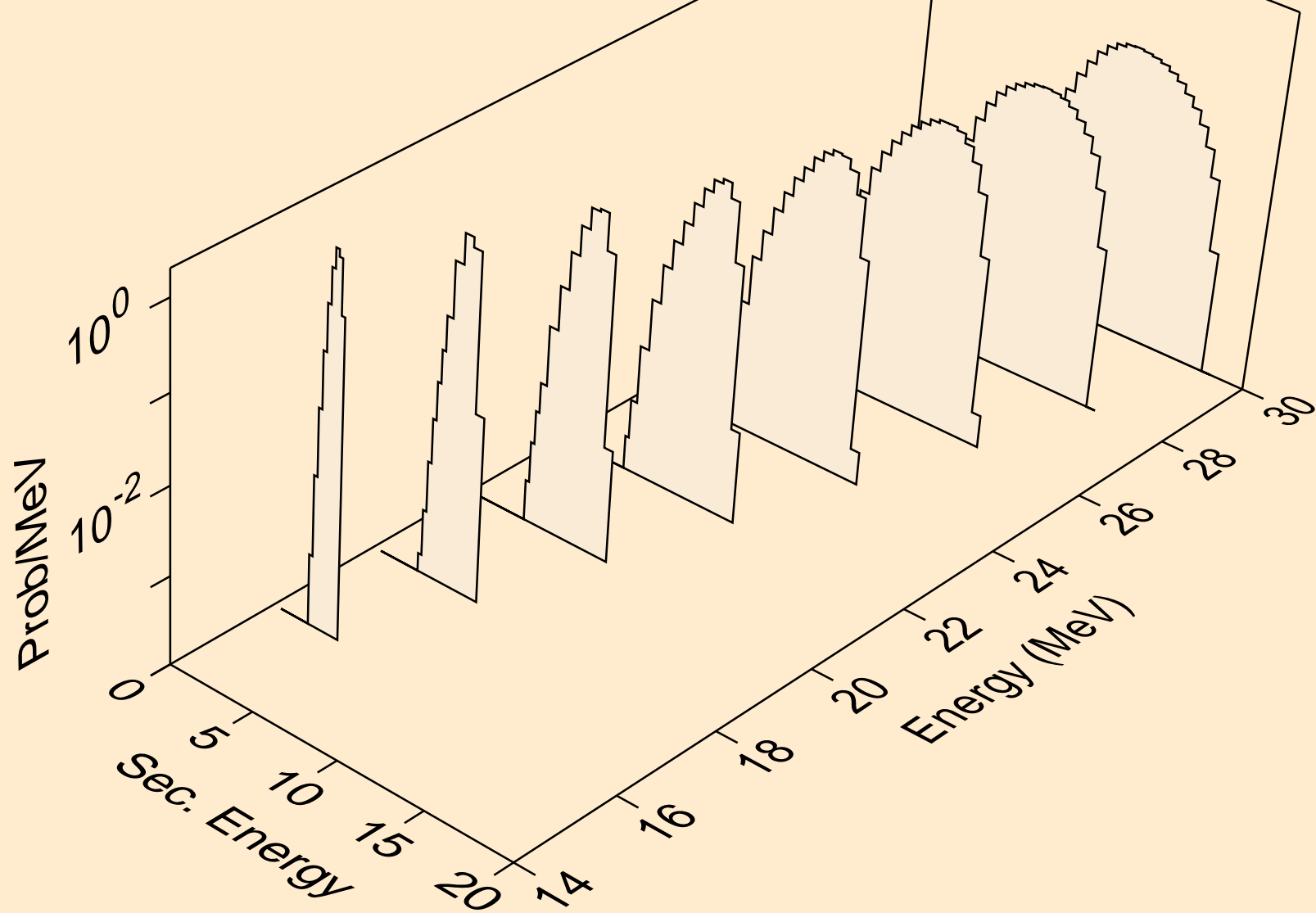

PU232 PHOTON ACER TENDL-2021 LIBRARY; T=0.K  
protons from (g,2np)

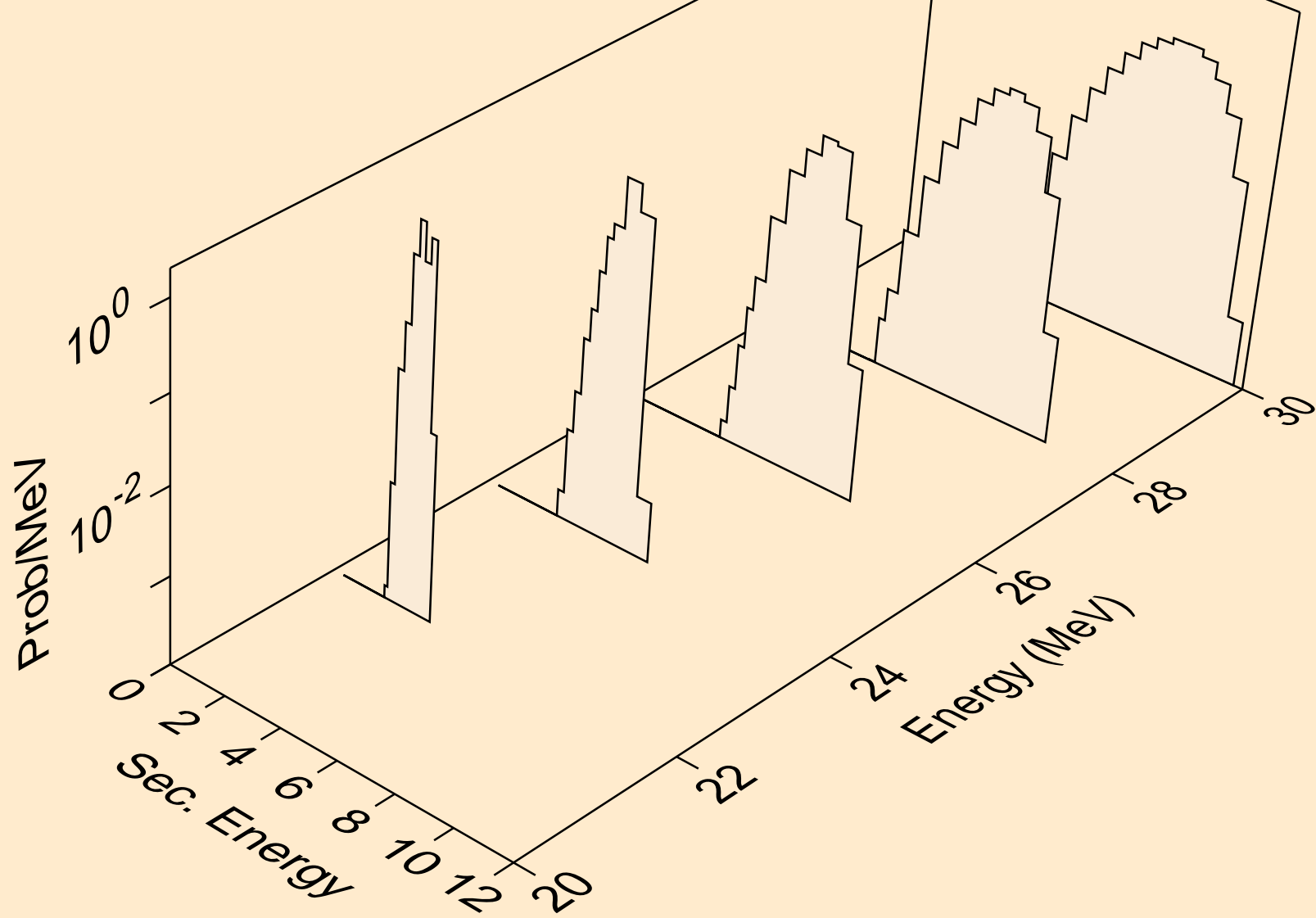

PU232 PHOTON ACER TENDL-2021 LIBRARY; T=0.K  
protons from (g,p)

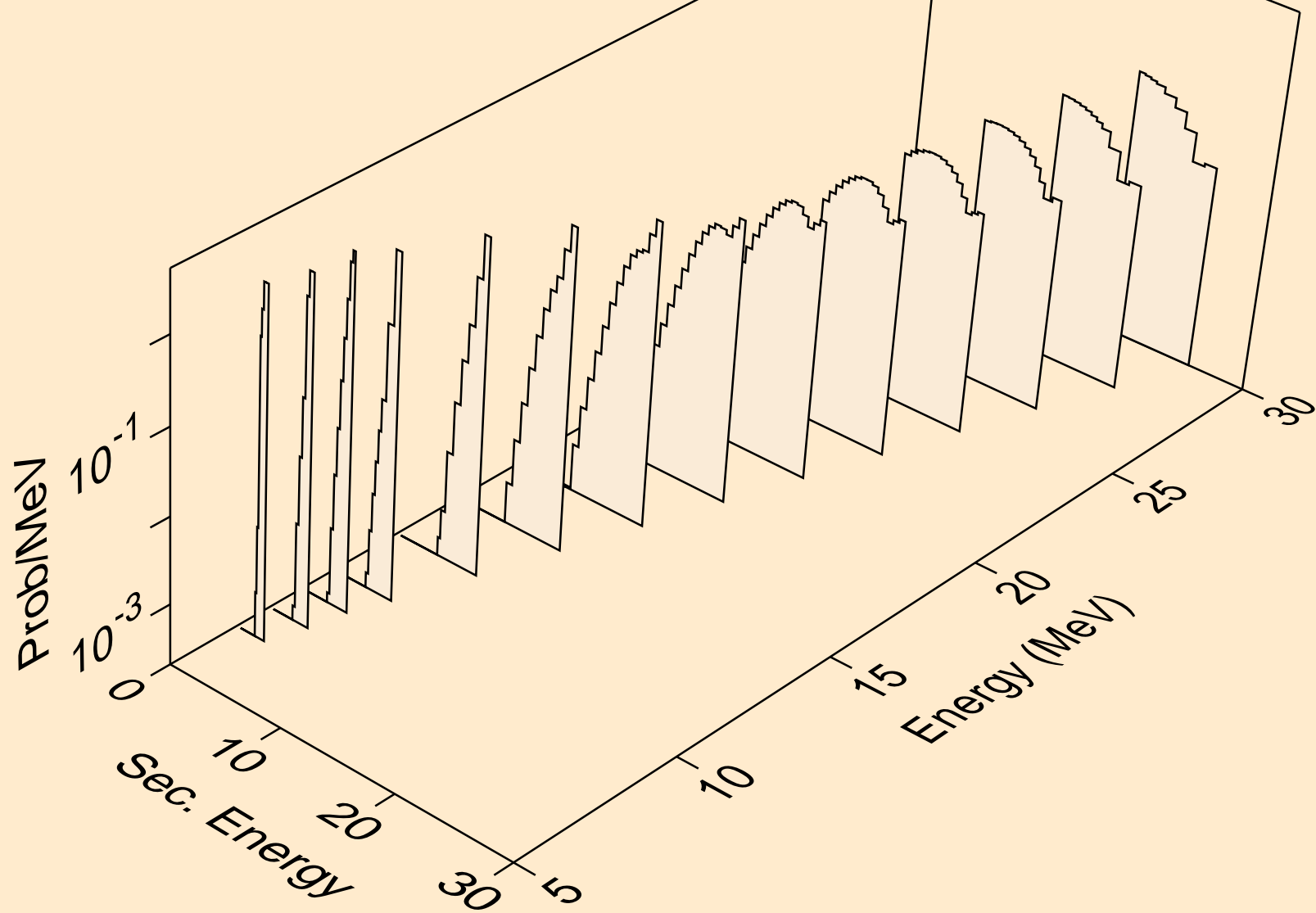

PU232 PHOTON ACER TENDL-2021 LIBRARY; T=0.K  
protons from (g,2p)

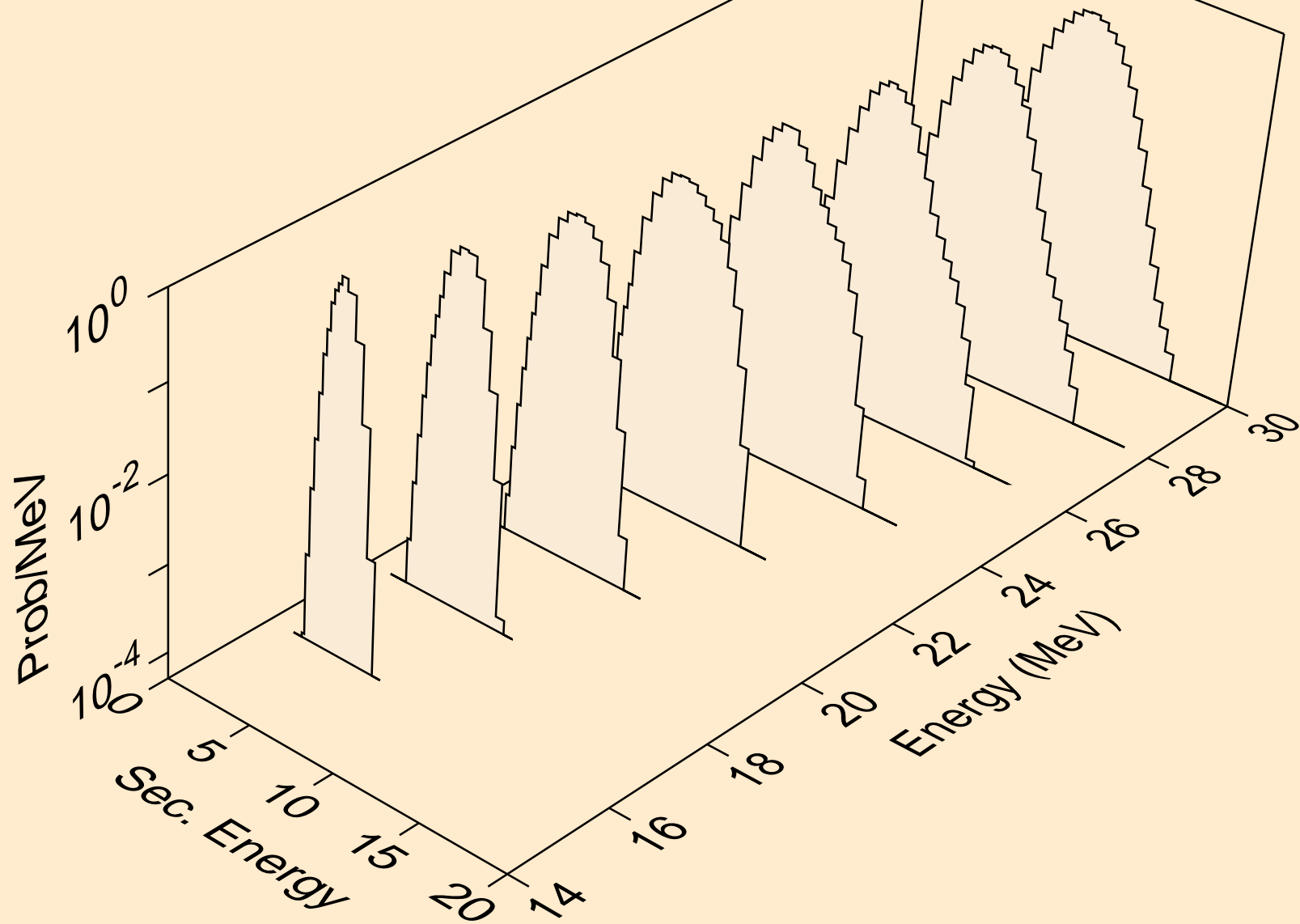

PU232 PHOTON ACER TENDL-2021 LIBRARY; T=0.K  
deuterons from (g,x)

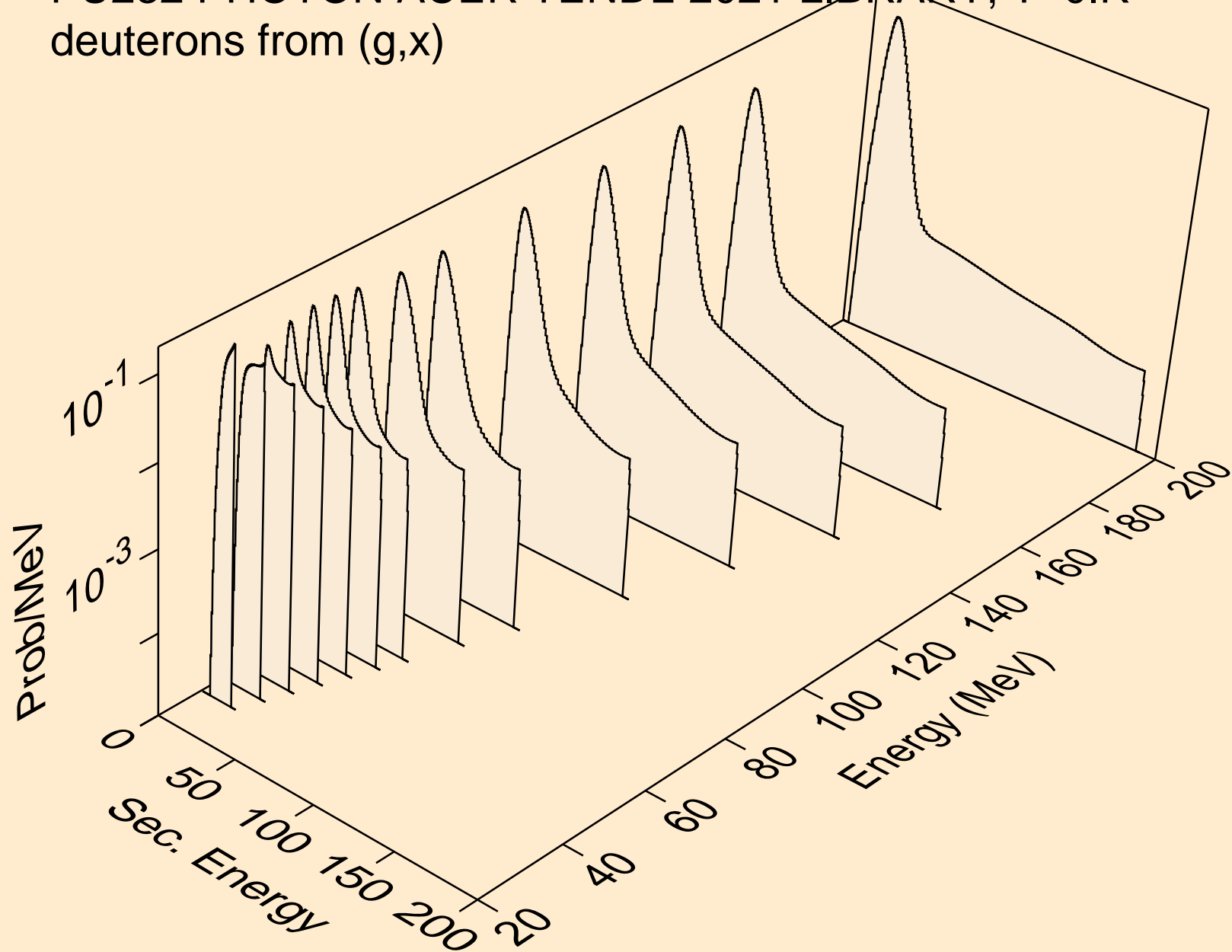

PU232 PHOTON ACER TENDL-2021 LIBRARY; T=0.K  
deuterons from (g,n\*)d

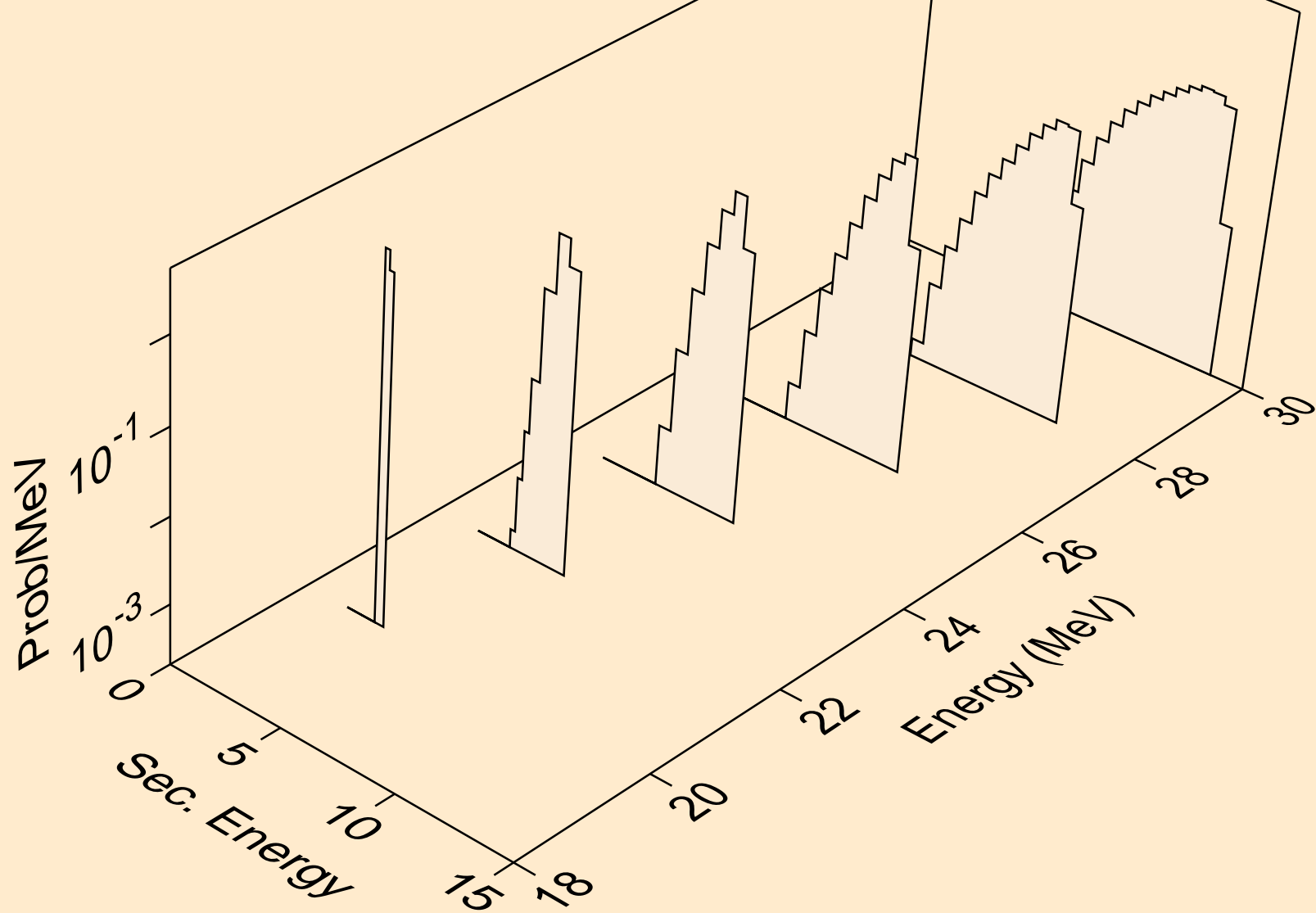

PU232 PHOTON ACER TENDL-2021 LIBRARY; T=0.K  
deuterons from (g,d)

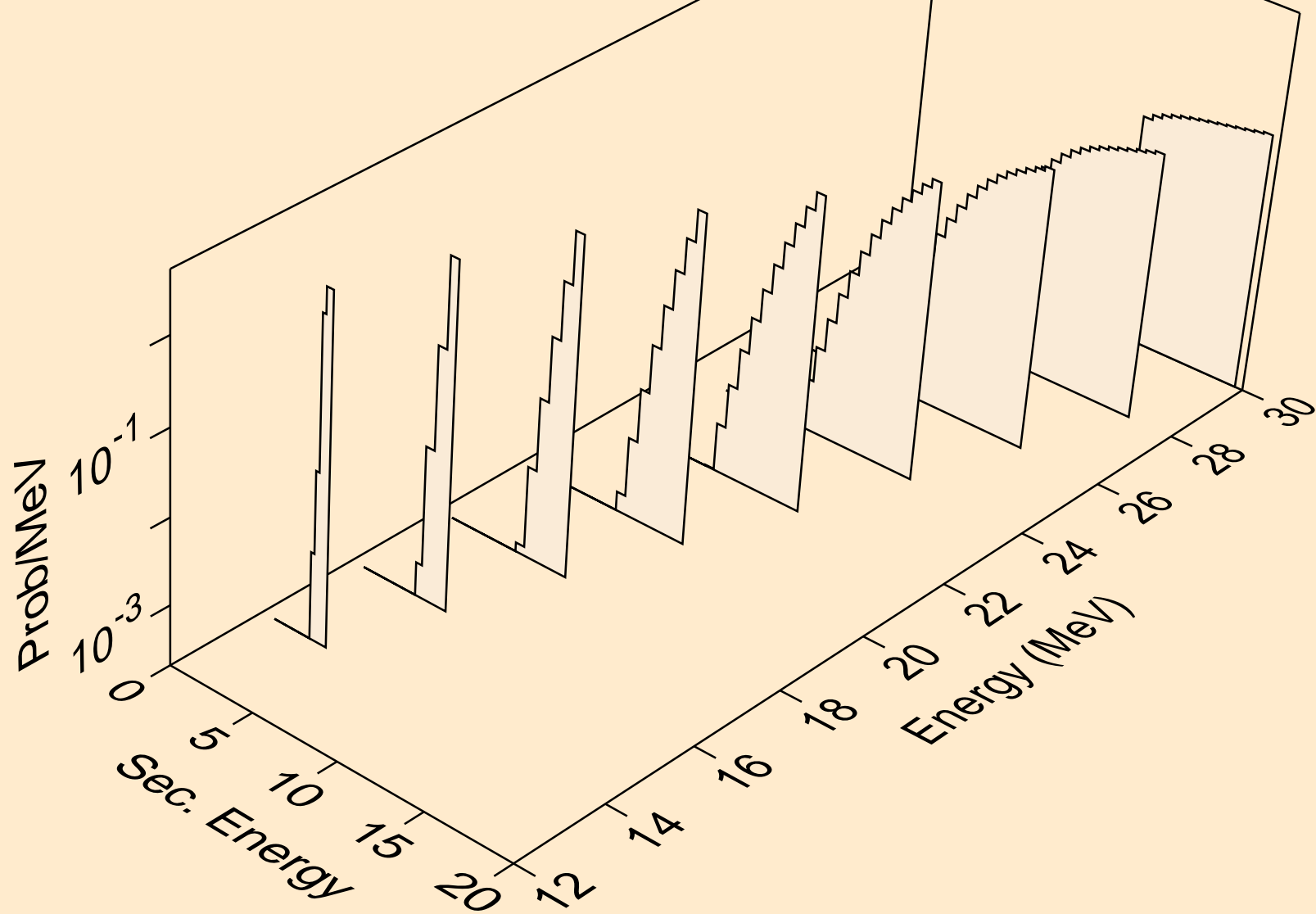

PU232 PHOTON ACER TENDL-2021 LIBRARY; T=0.K  
tritons from (g,x)

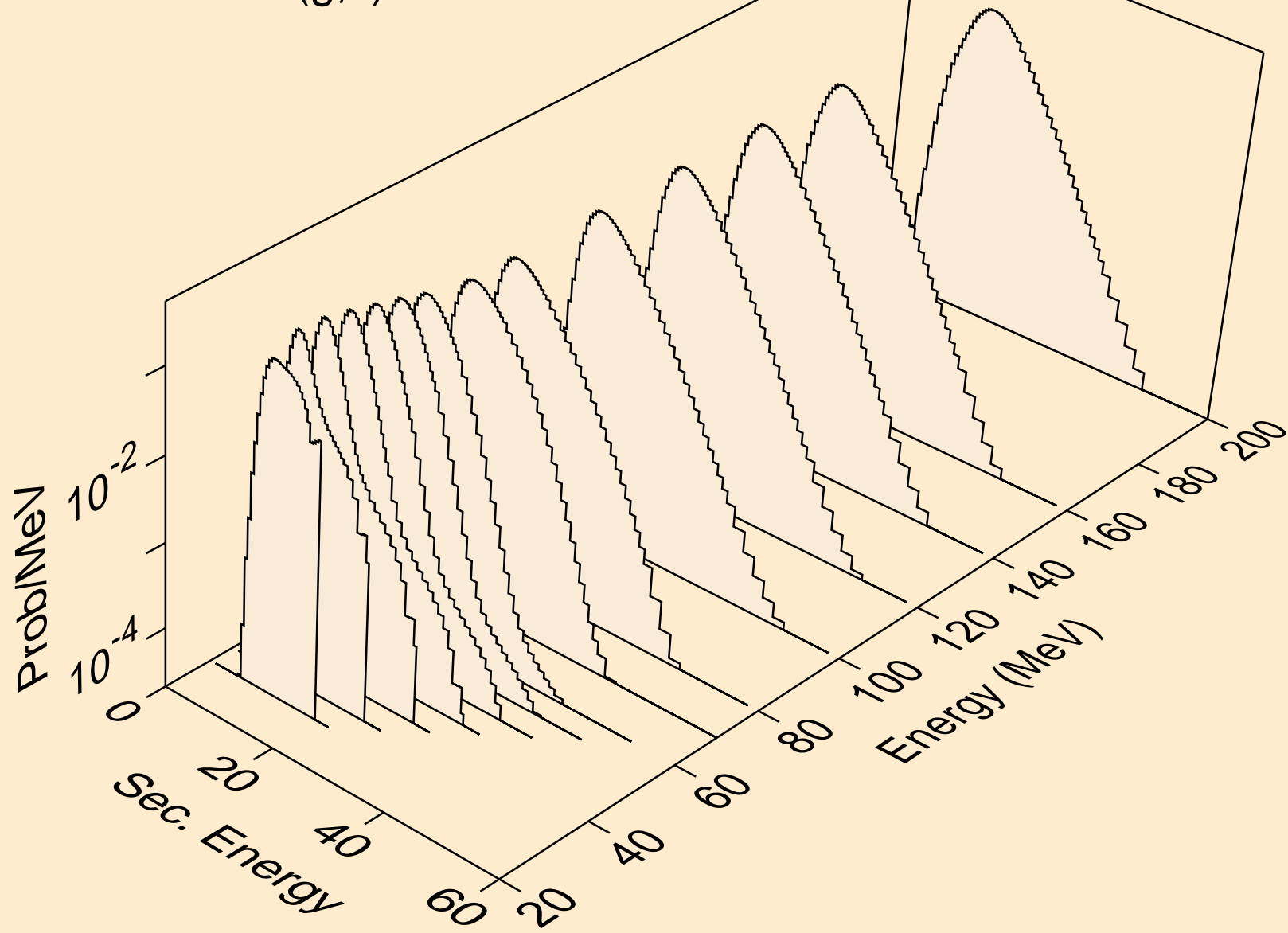

PU232 PHOTON ACER TENDL-2021 LIBRARY; T=0.K  
tritons from (g,n\*)t

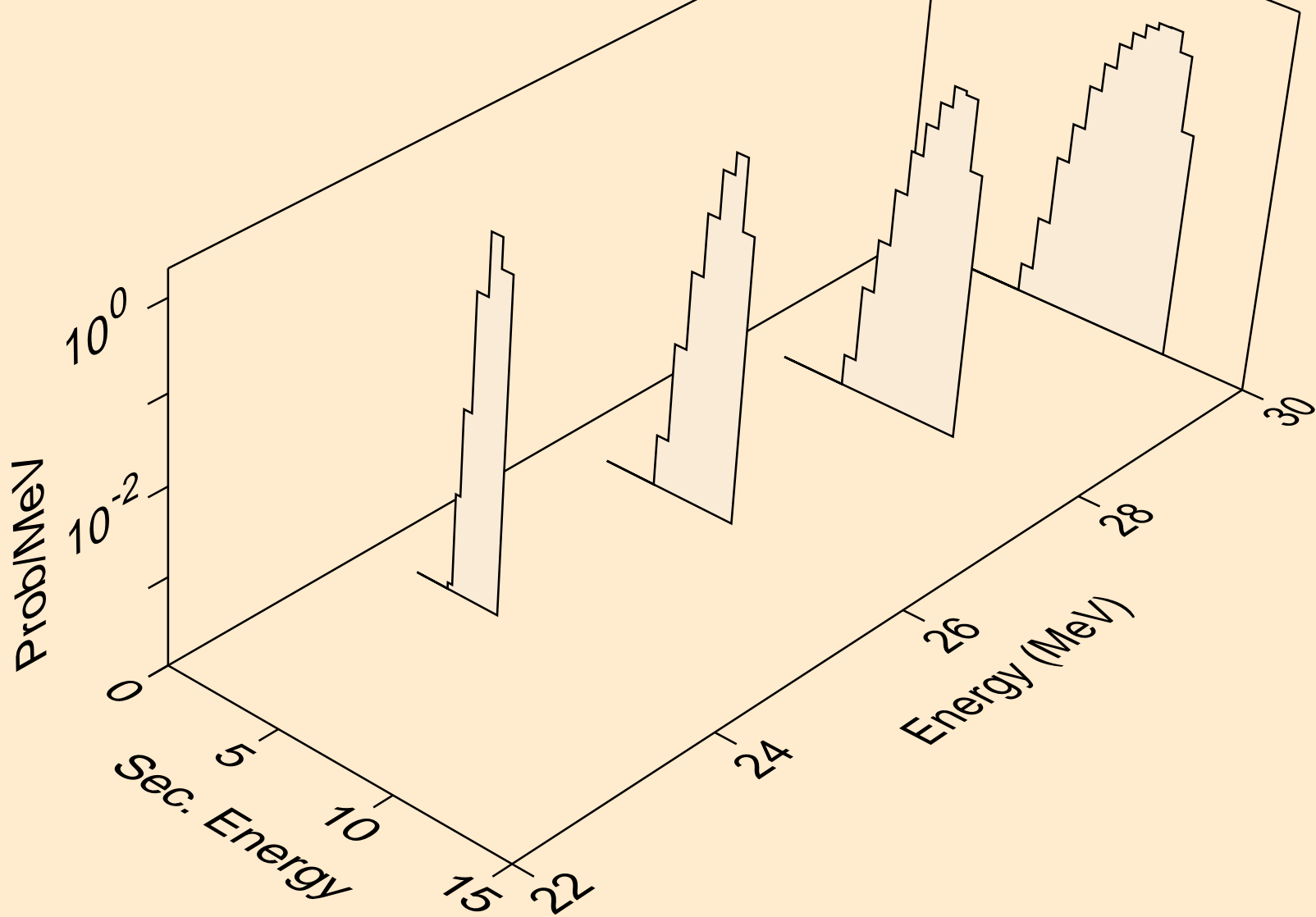

PU232 PHOTON ACER TENDL-2021 LIBRARY; T=0.K  
tritons from (g,t)

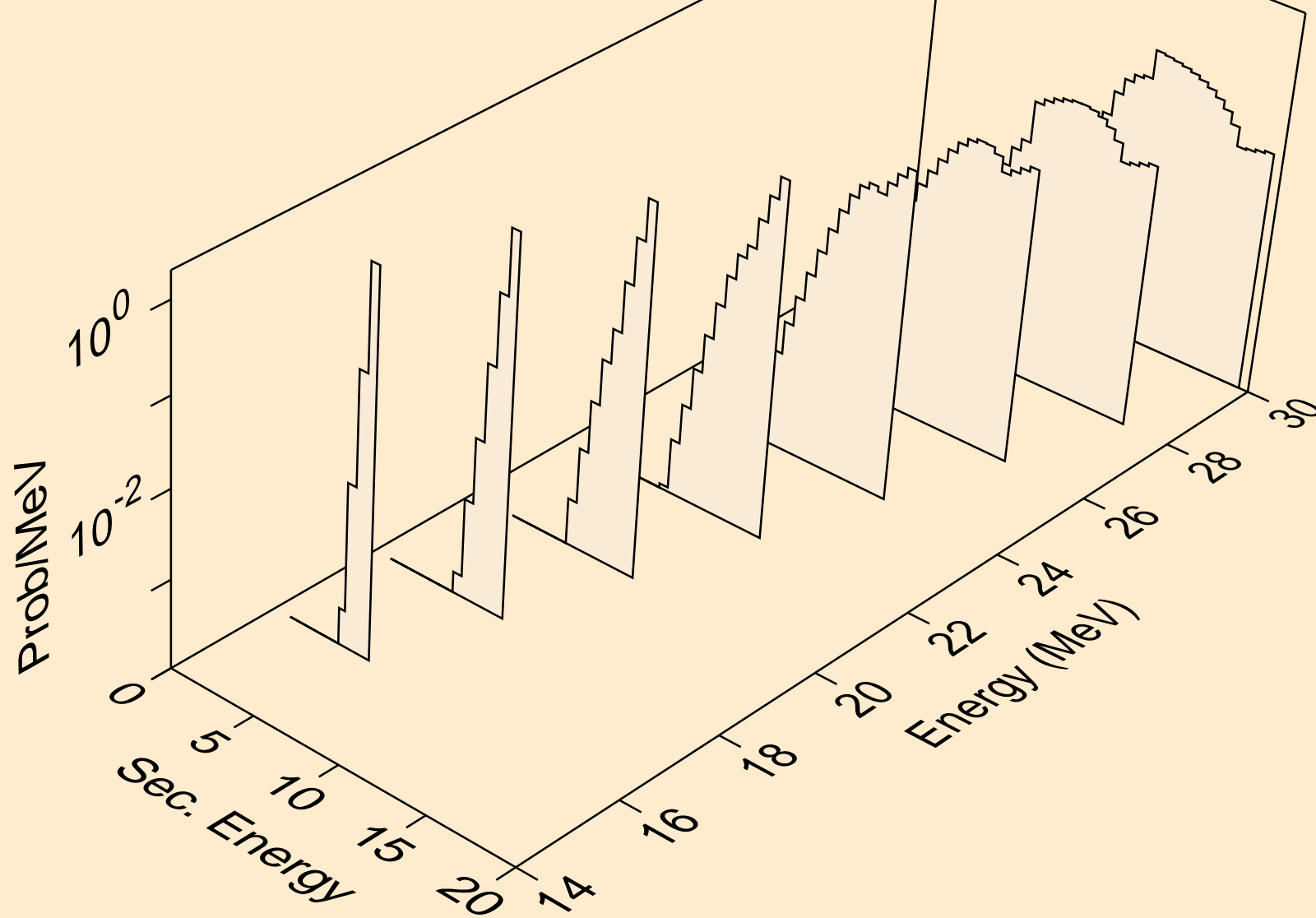

PU232 PHOTON ACER TENDL-2021 LIBRARY; T=0.K  
he3s from (g,x)

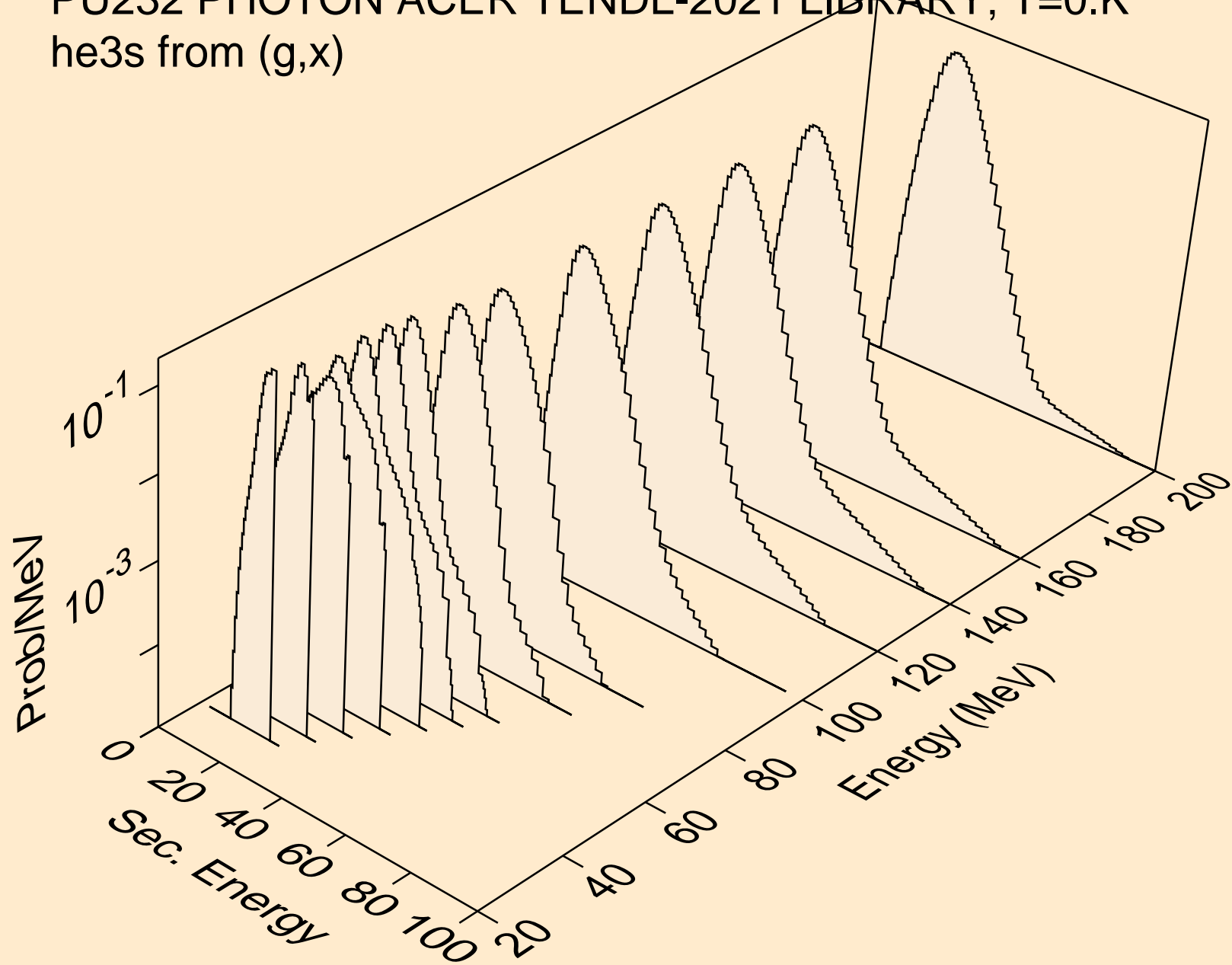

PU232 PHOTON ACER TENDL-2021 LIBRARY; T=0.K  
alphas from (g,x)

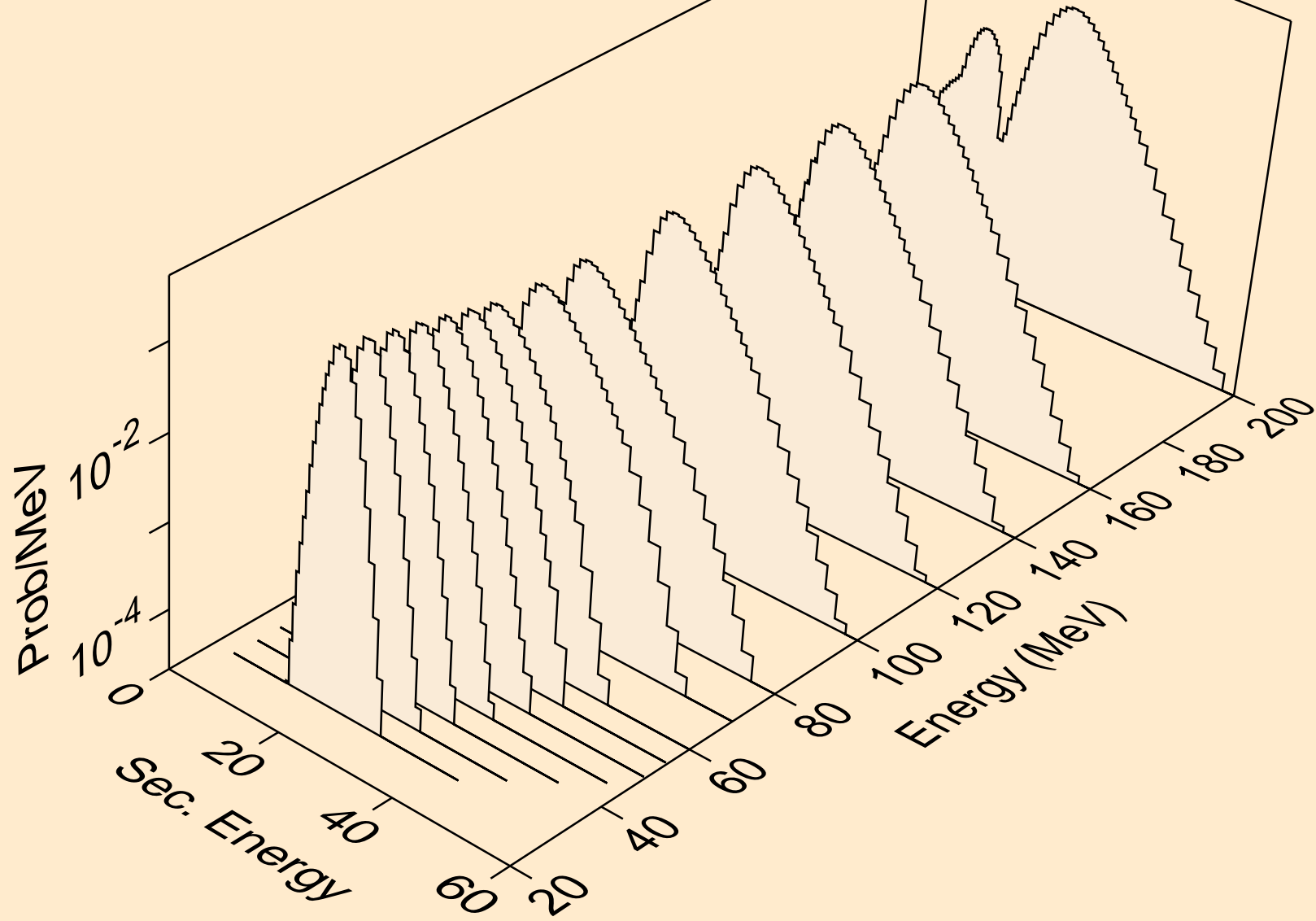

PU232 PHOTON ACER TENDL-2021 LIBRARY; T=0.K  
alphas from (g,n\*)a

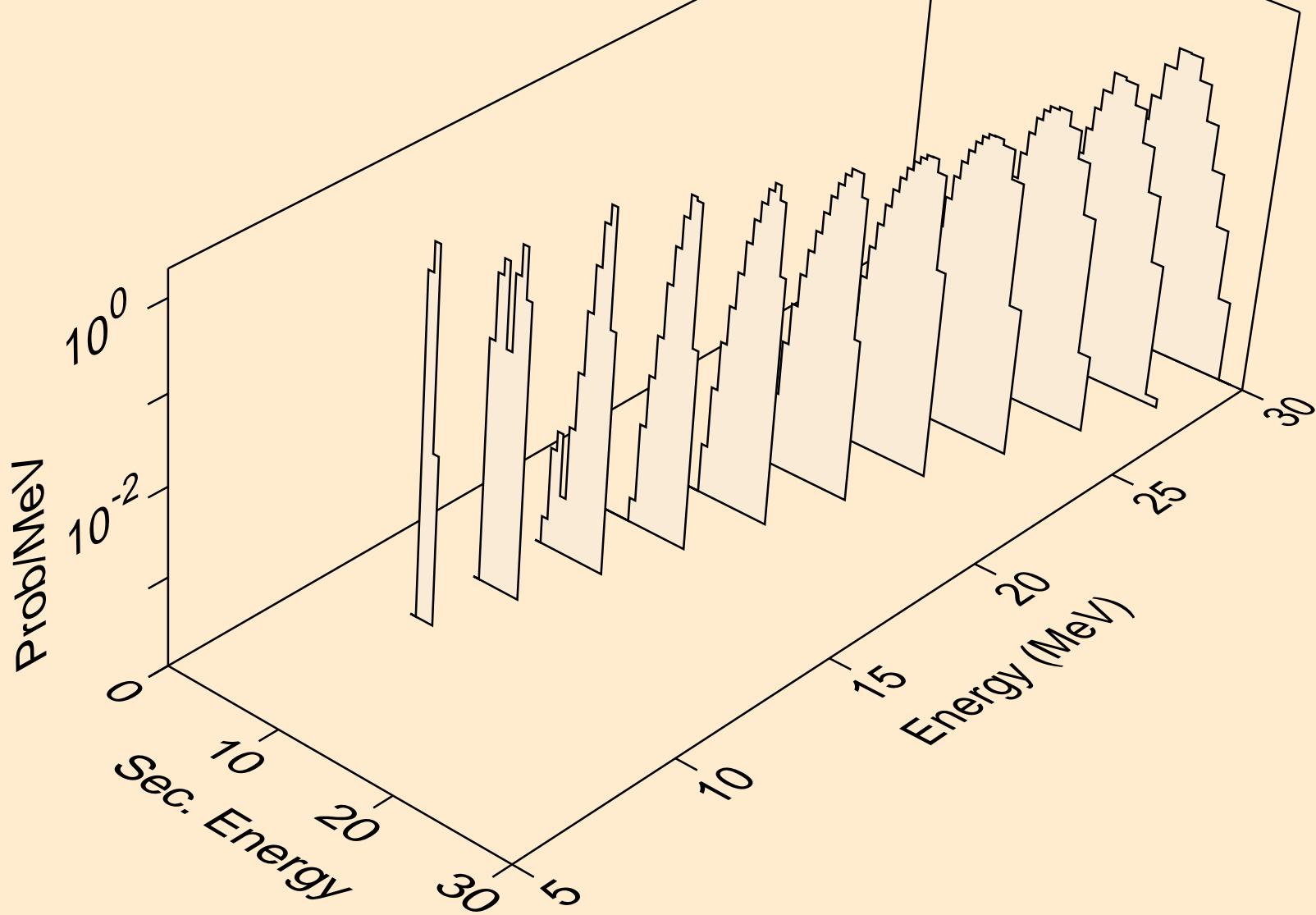

PU232 PHOTON ACER TENDL-2021 LIBRARY; T=0.K  
alphas from (g,2n)a

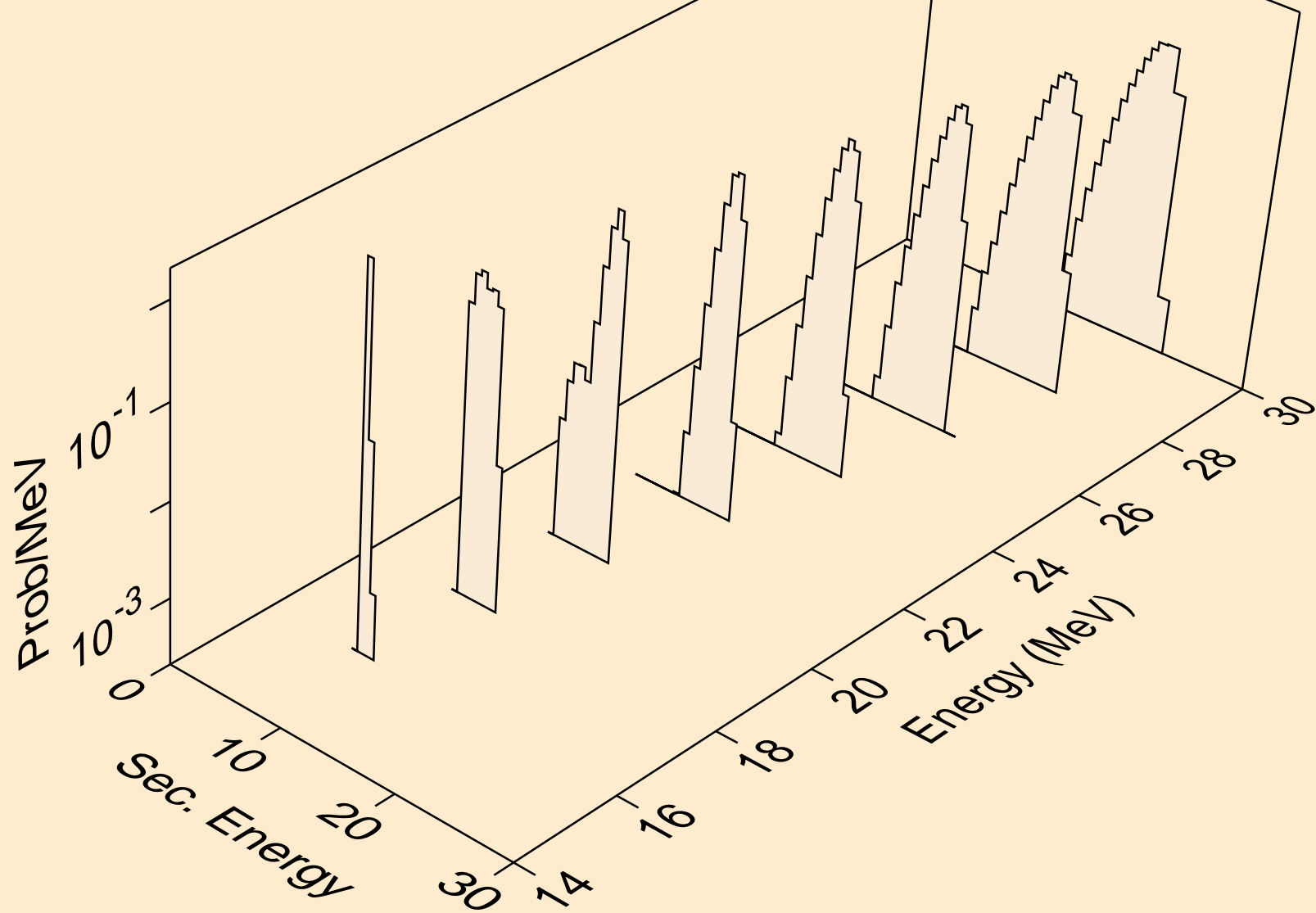

PU232 PHOTON ACER TENDL-2021 LIBRARY; T=0.K  
alphas from (g,a)

