

# HG214 TRITON ACER TENDL-2021 LIBRARY; T=0.K

## Principal cross sections

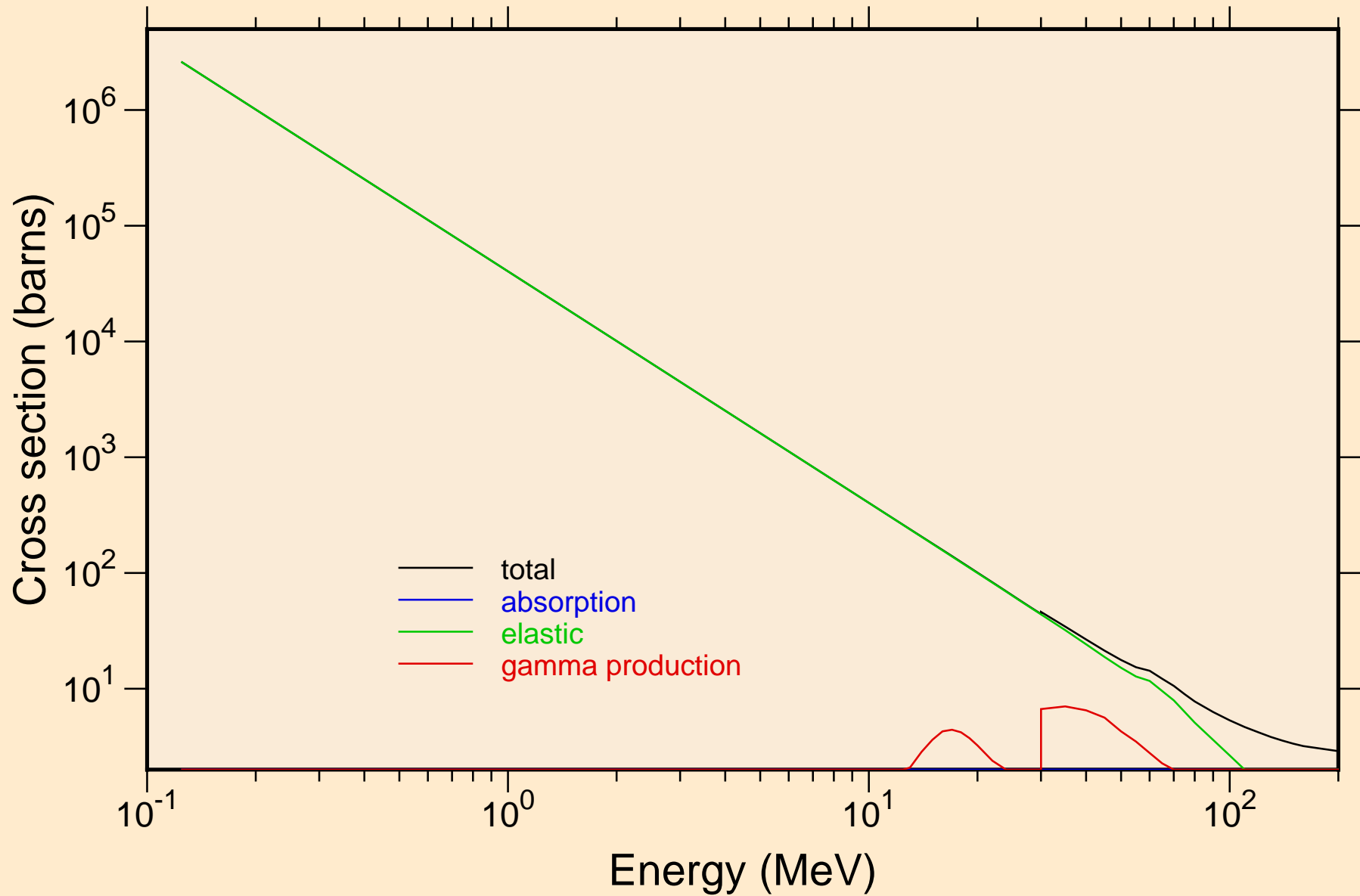

# HG214 TRITON ACER TENDL-2021 LIBRARY; T=0.K

## Heating

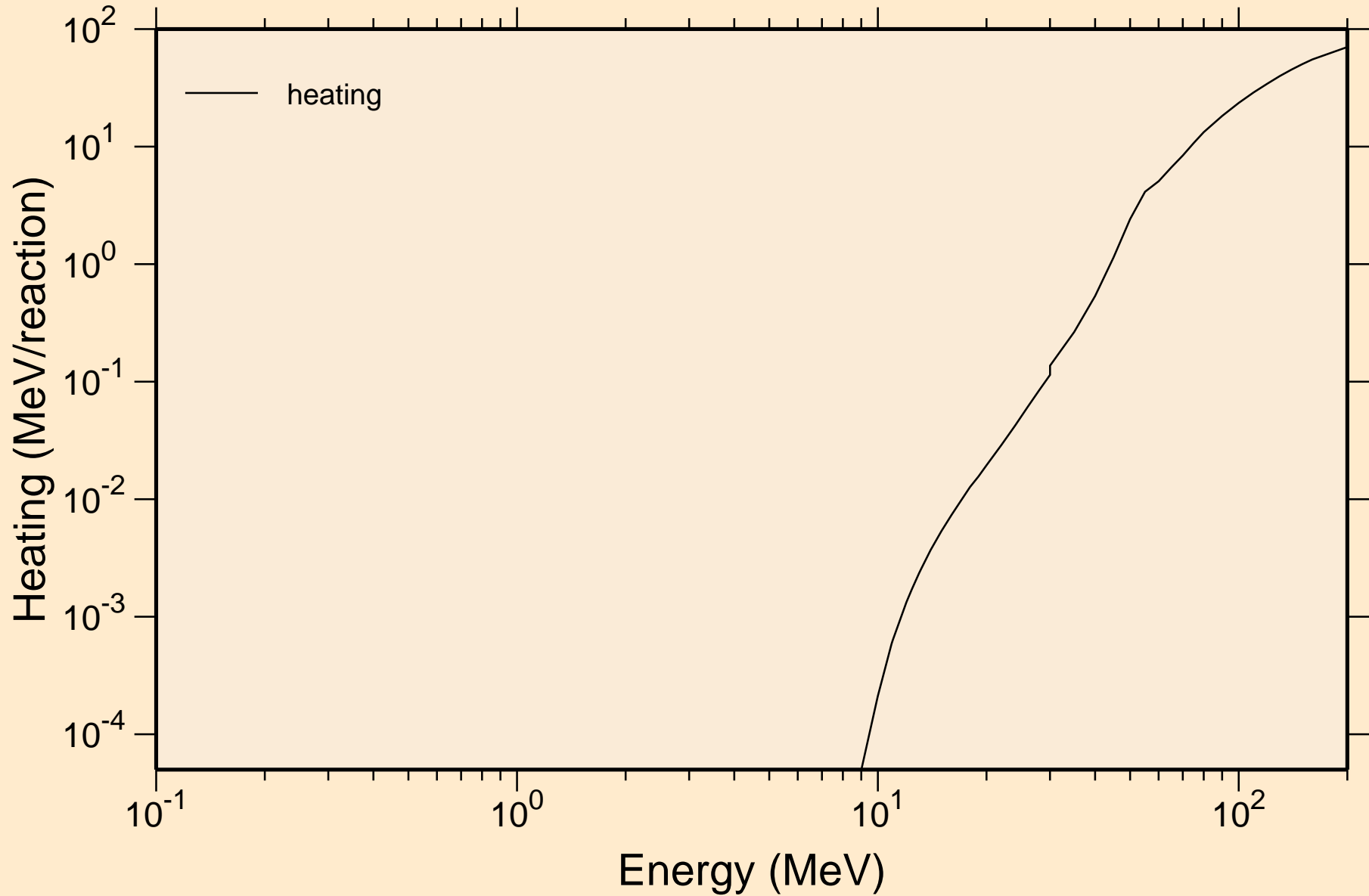

# HG214 TRITON ACER TENDL-2021 LIBRARY; T=0.K

## Principal cross sections

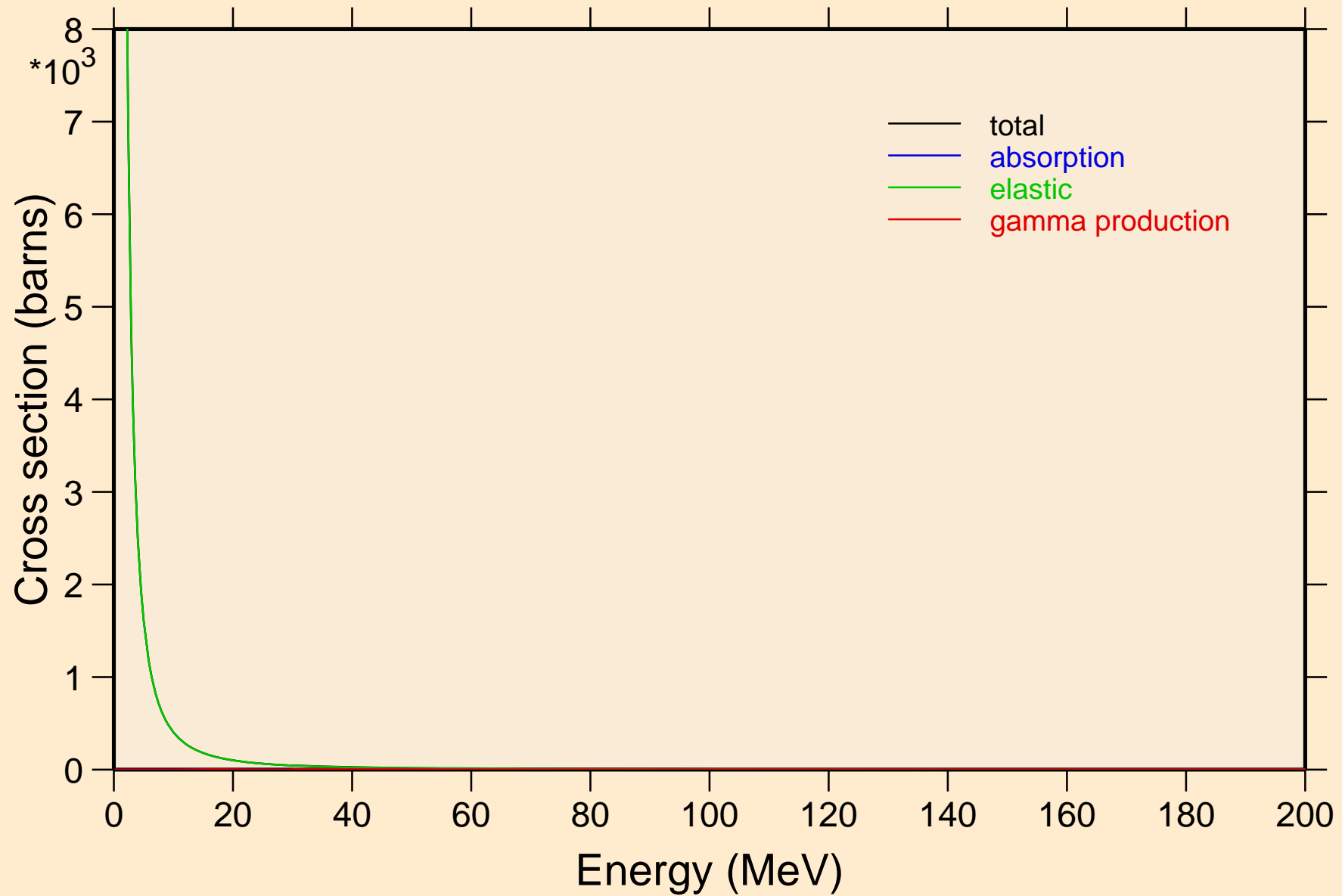

# HG214 TRITON ACER TENDL-2021 LIBRARY; T=0.K

## Heating

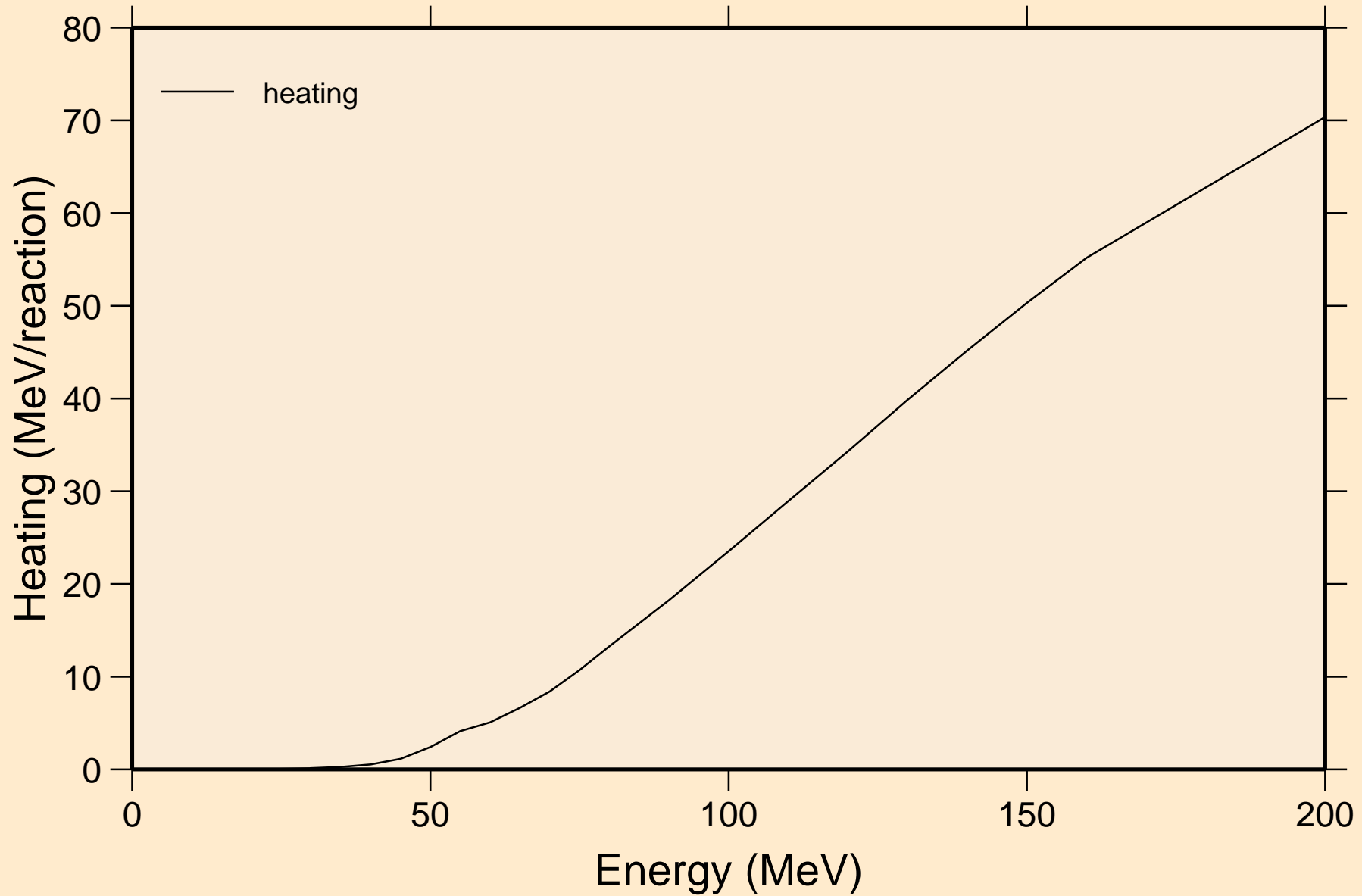

HG214 TRITON ACER TENDL-2021 LIBRARY; T=0.K  
Threshold reactions

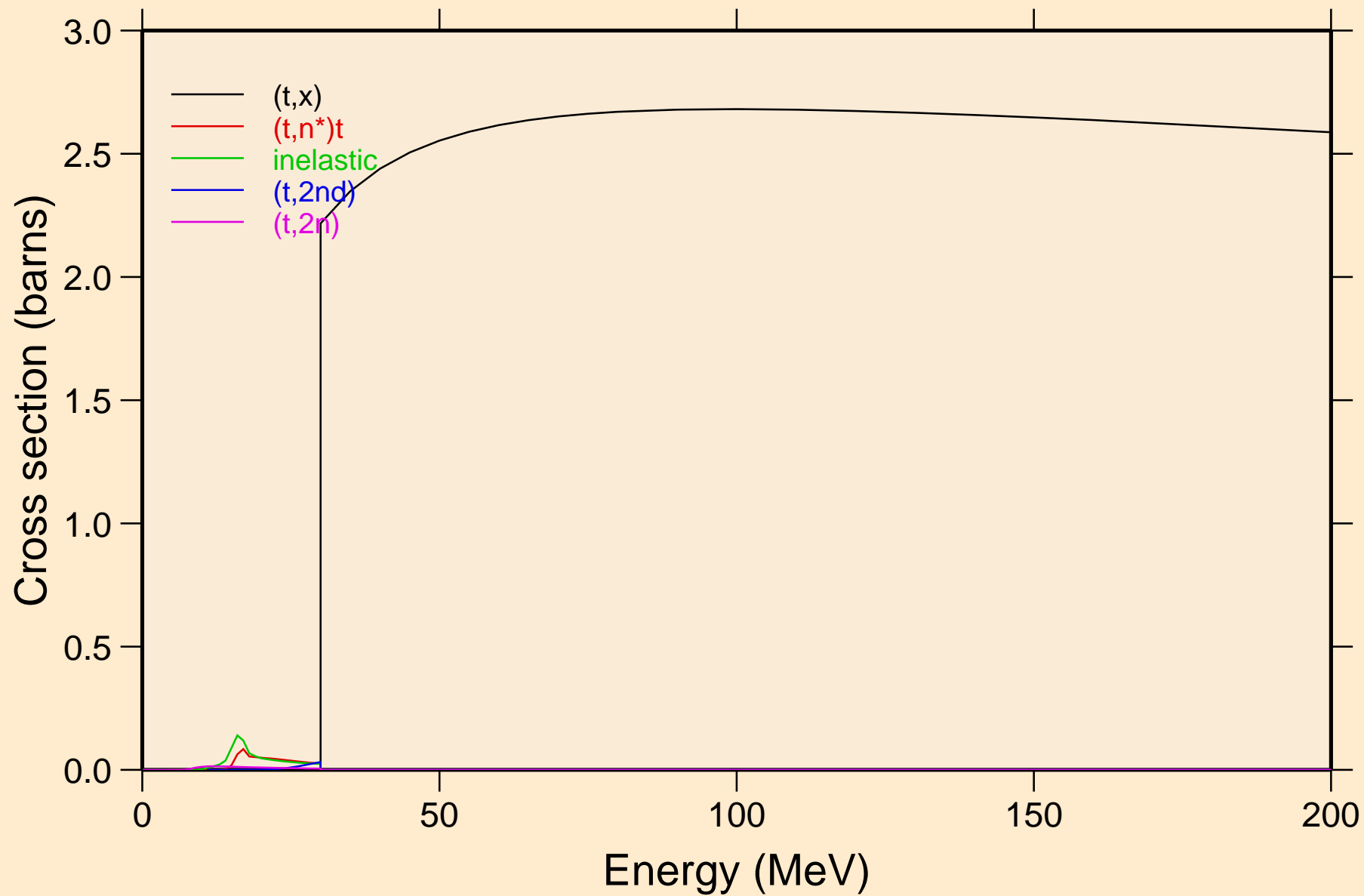

# HG214 TRITON ACER TENDL-2021 LIBRARY; T=0.K

## Threshold reactions

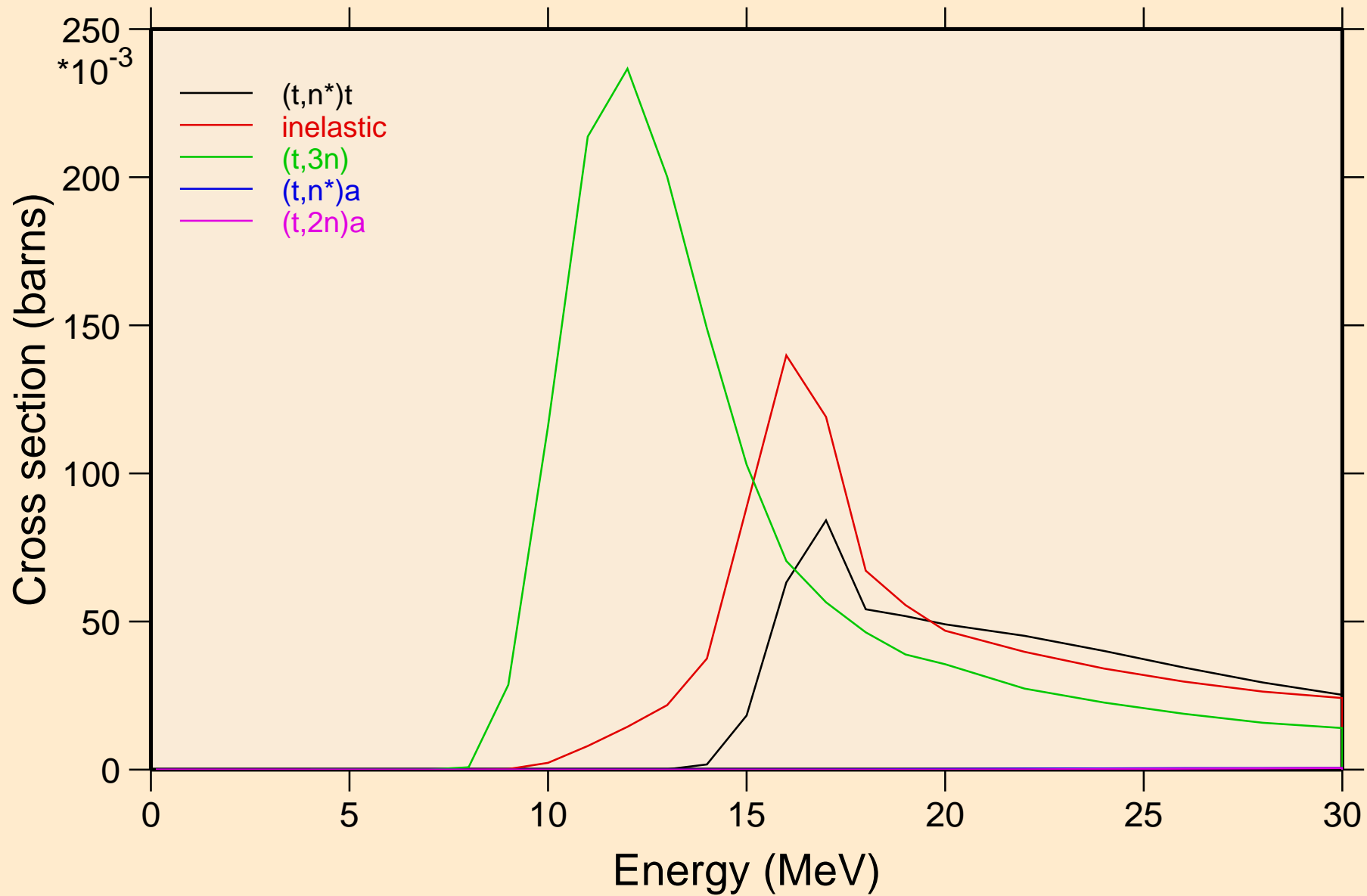

# HG214 TRITON ACER TENDL-2021 LIBRARY; T=0.K

## Threshold reactions

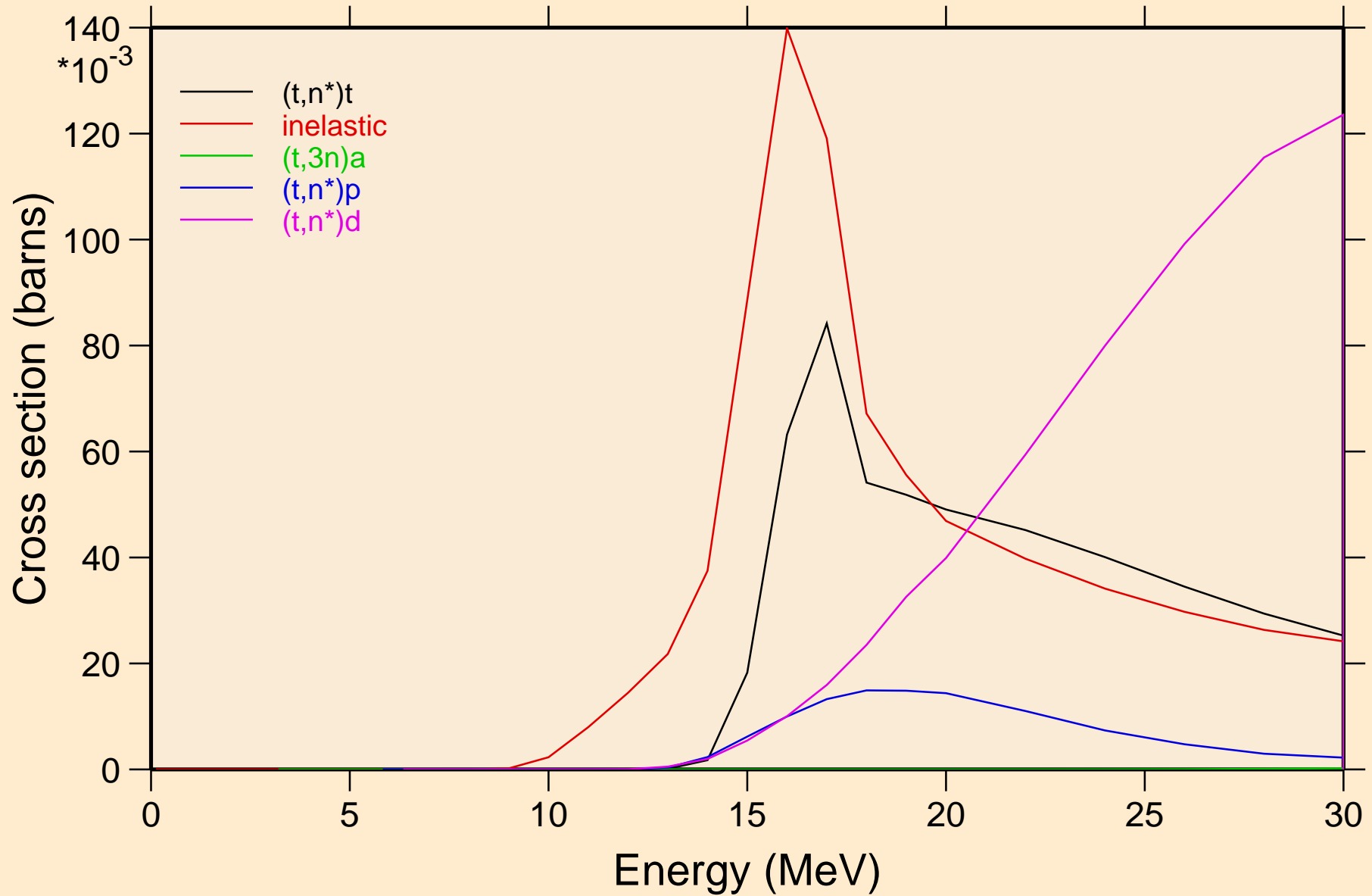

HG214 TRITON ACER TENDL-2021 LIBRARY; T=0.K  
Threshold reactions

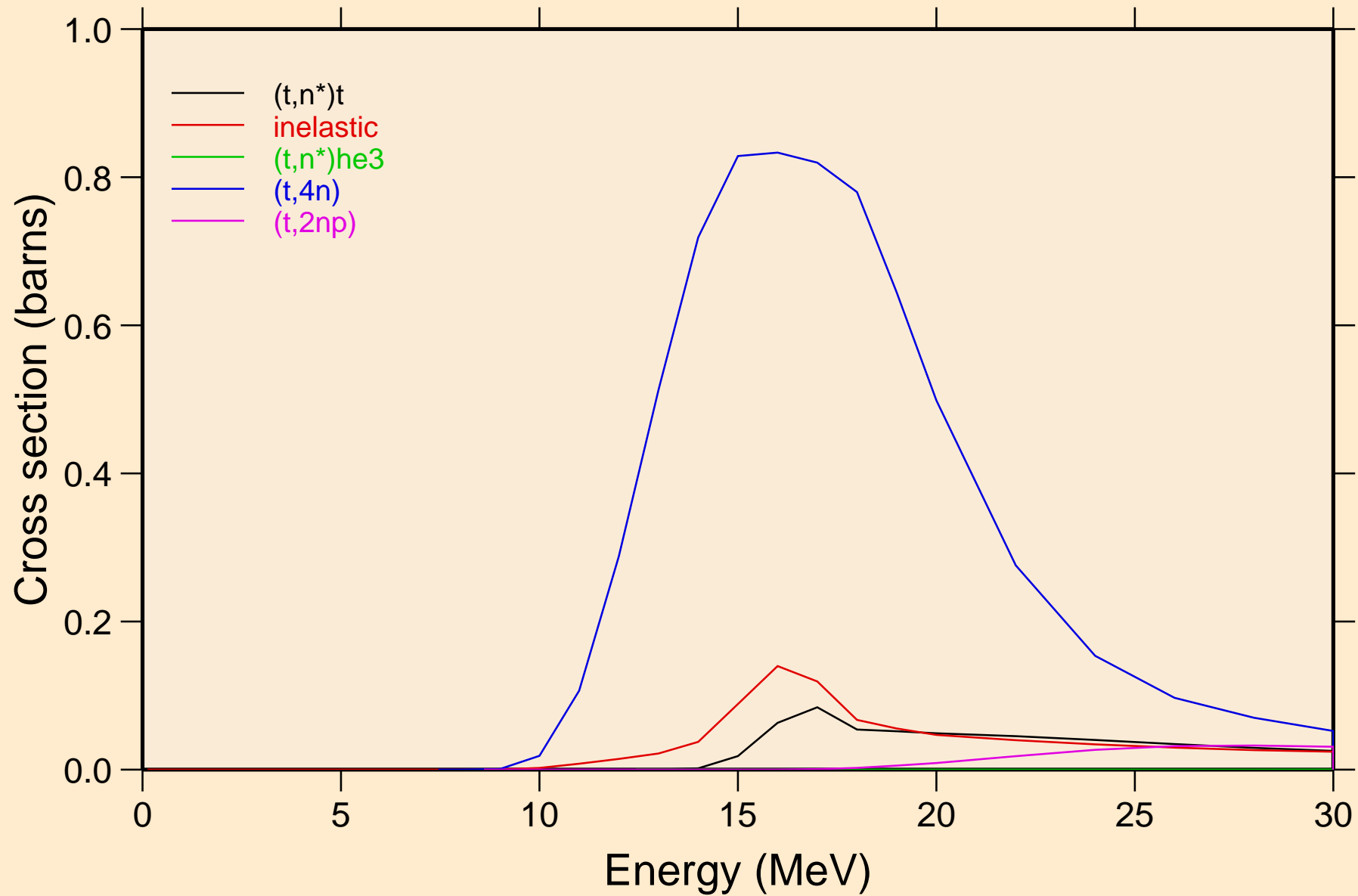

# HG214 TRITON ACER TENDL-2021 LIBRARY; T=0.K

## Threshold reactions

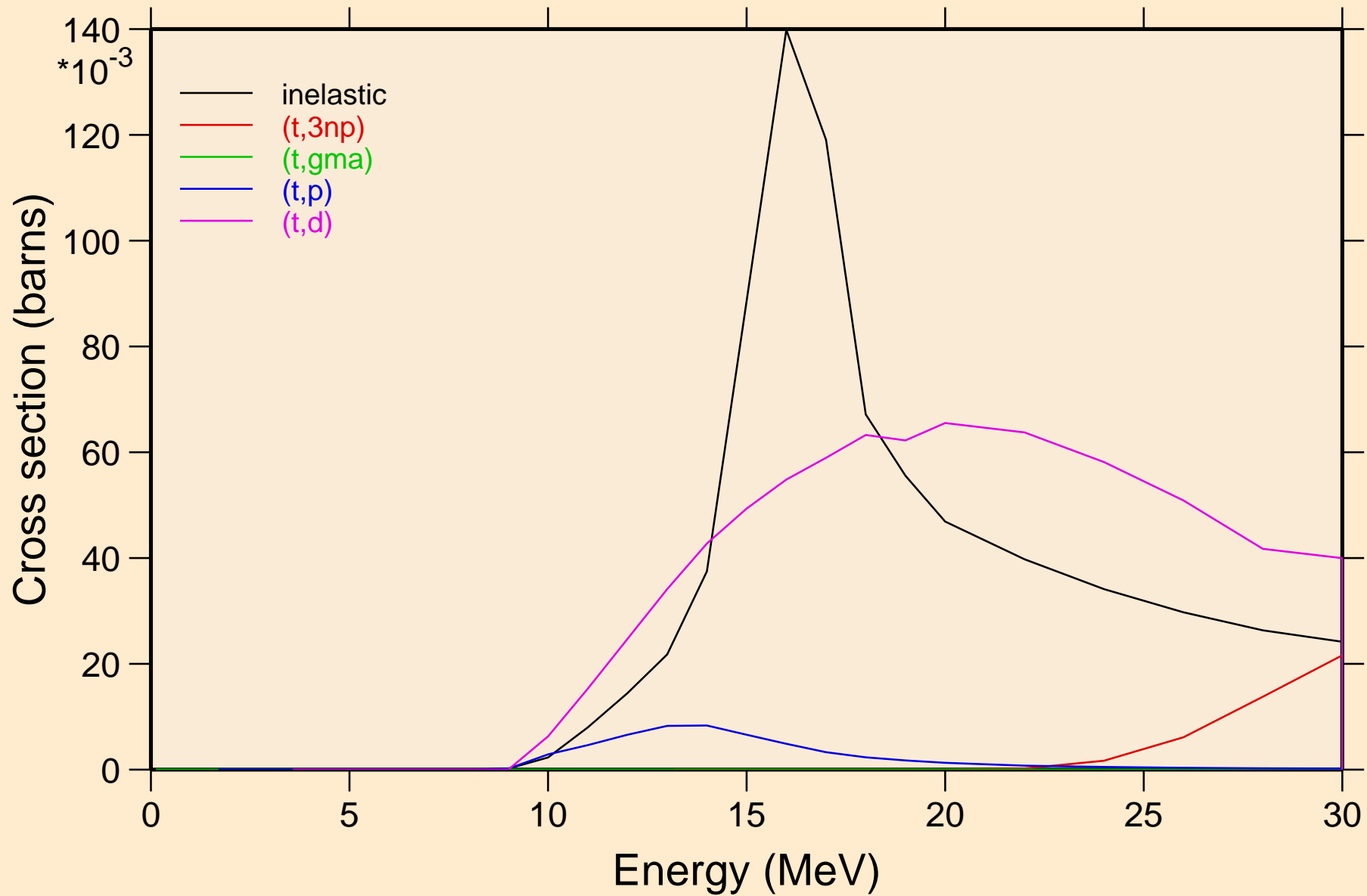

HG214 TRITON ACER TENDL-2021 LIBRARY; T=0.K  
Threshold reactions

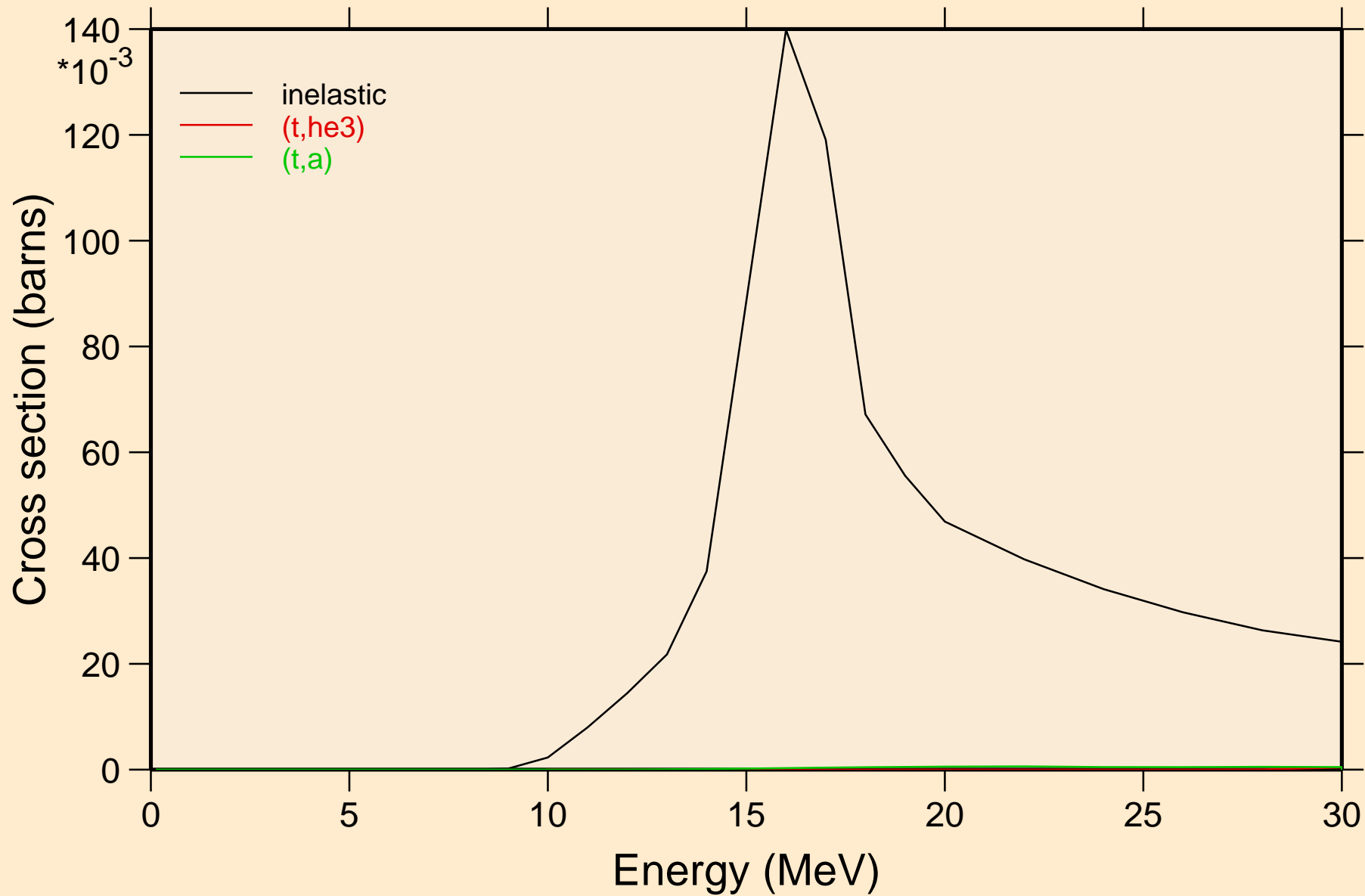

HG214 TRITON ACER TENDL-2021 LIBRARY; T=0.K  
angular distribution for elastic

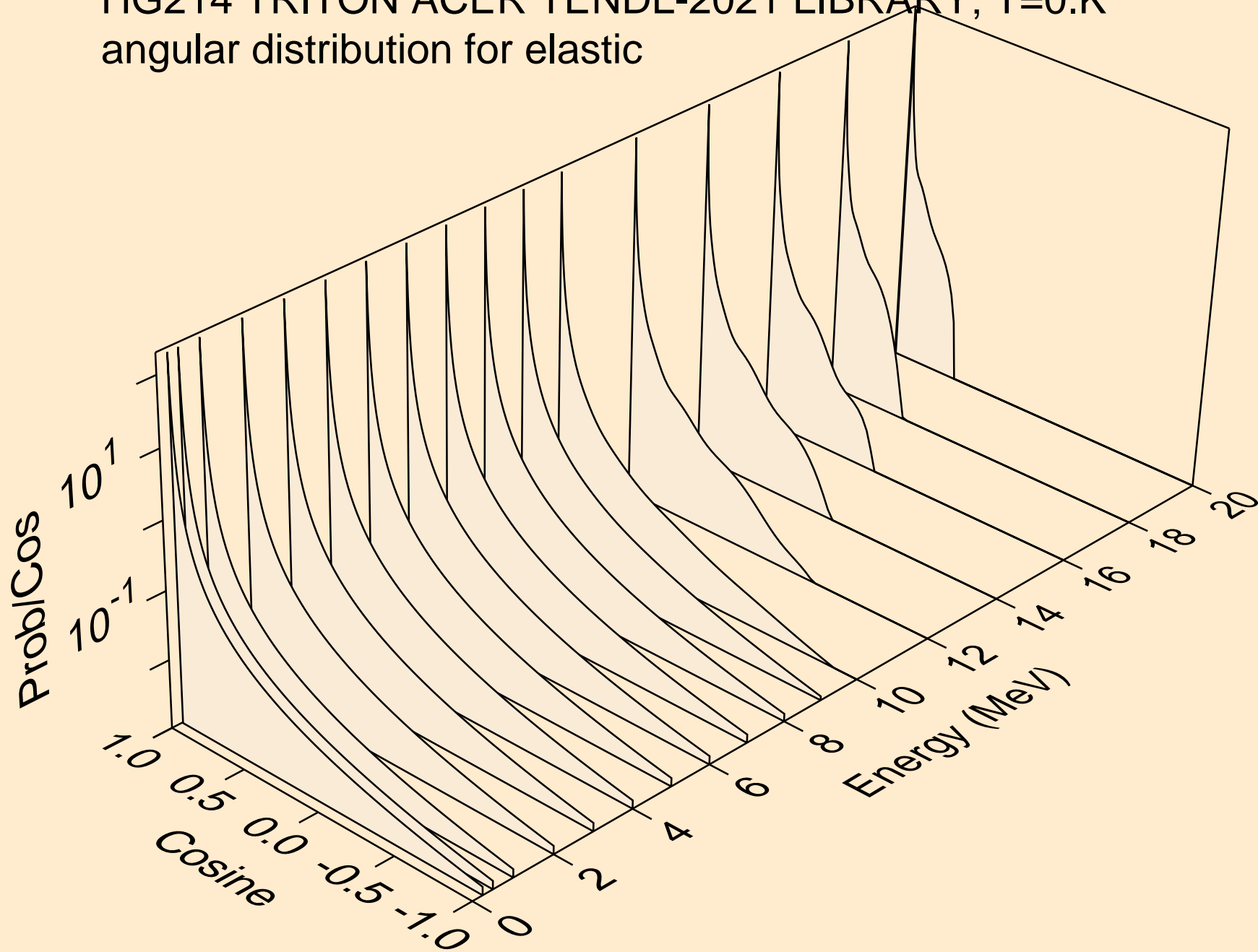

HG214 TRITON ACER TENDL-2021 LIBRARY; T=0.K  
angular distribution for elastic

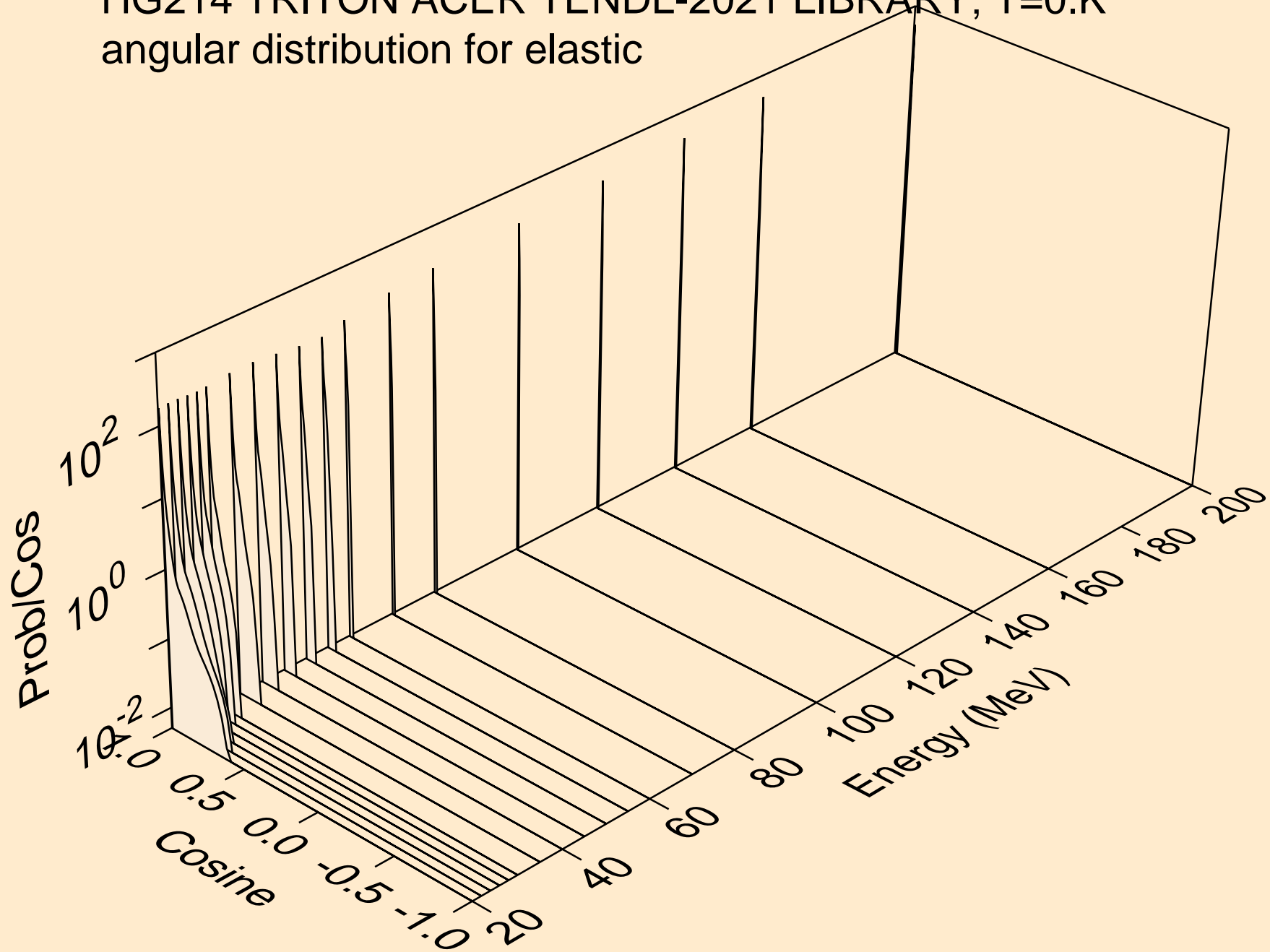

HG214 TRITON ACER TENDL-2021 LIBRARY; T=0.K  
Triton emission for (t,x)

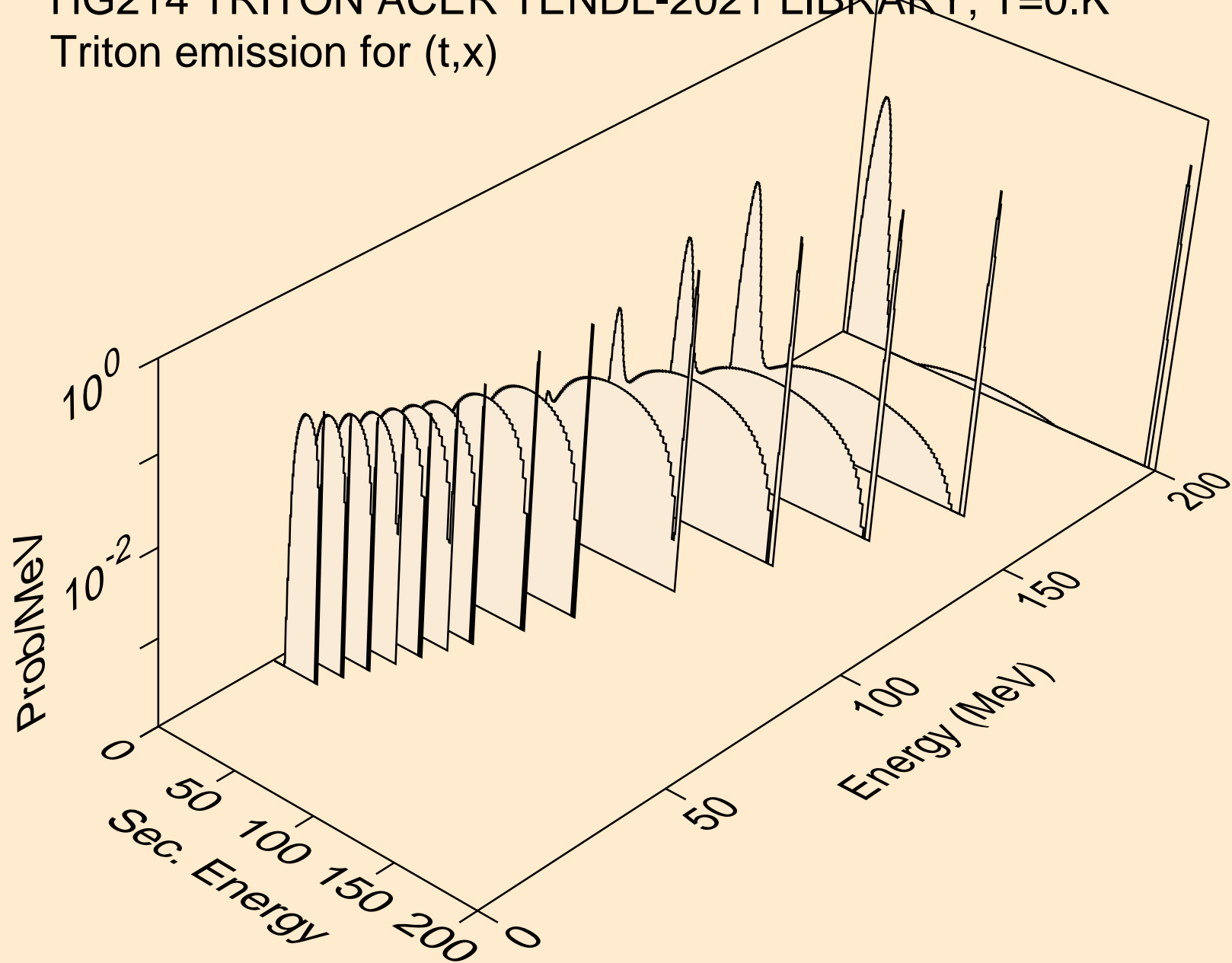

HG214 TRITON ACER TENDL-2021 LIBRARY; T=0.K  
Triton emission for (t,n\*)t

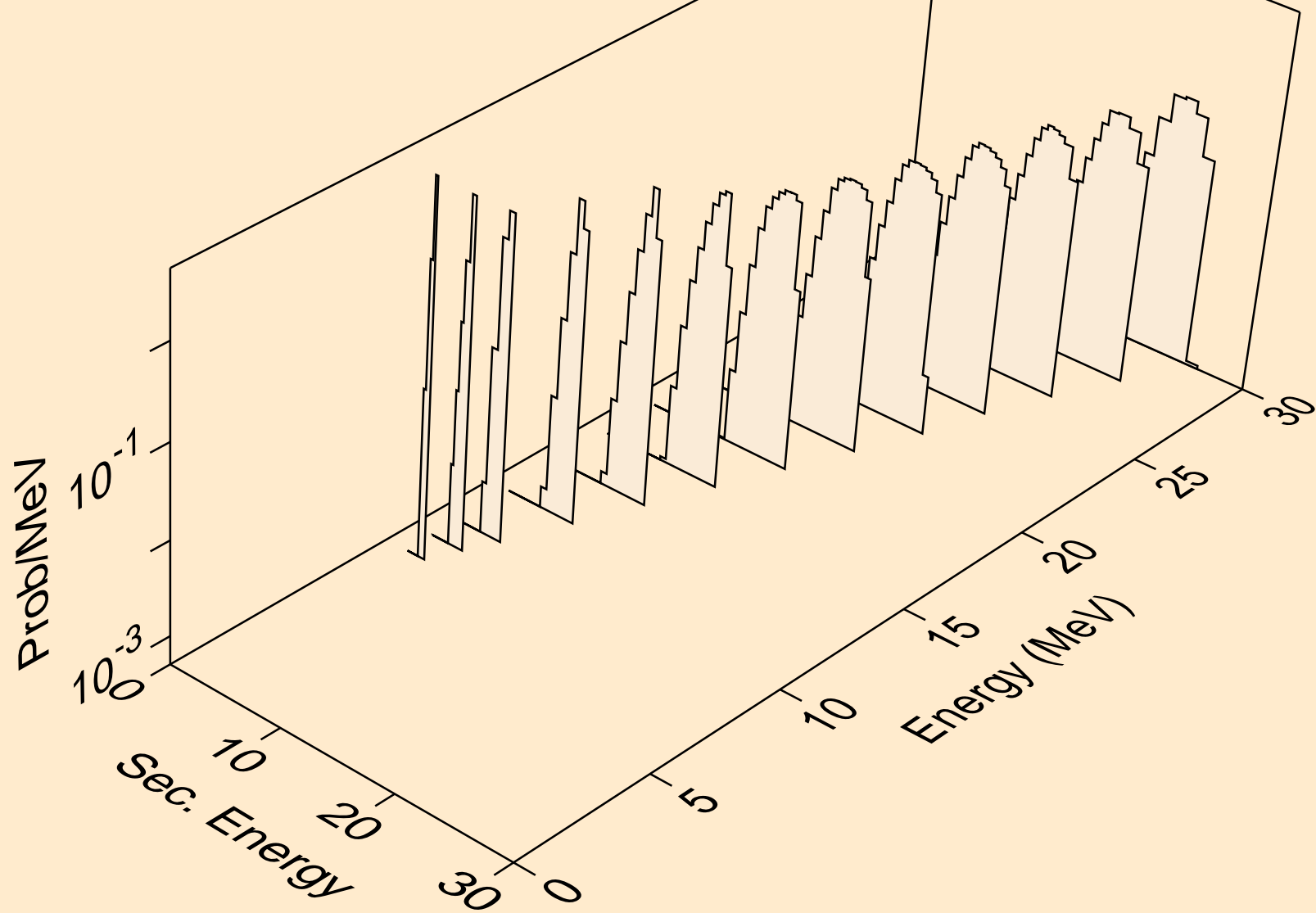

HG214 TRITON ACER TENDL-2021 LIBRARY; T=0.K  
Triton emission for inelastic

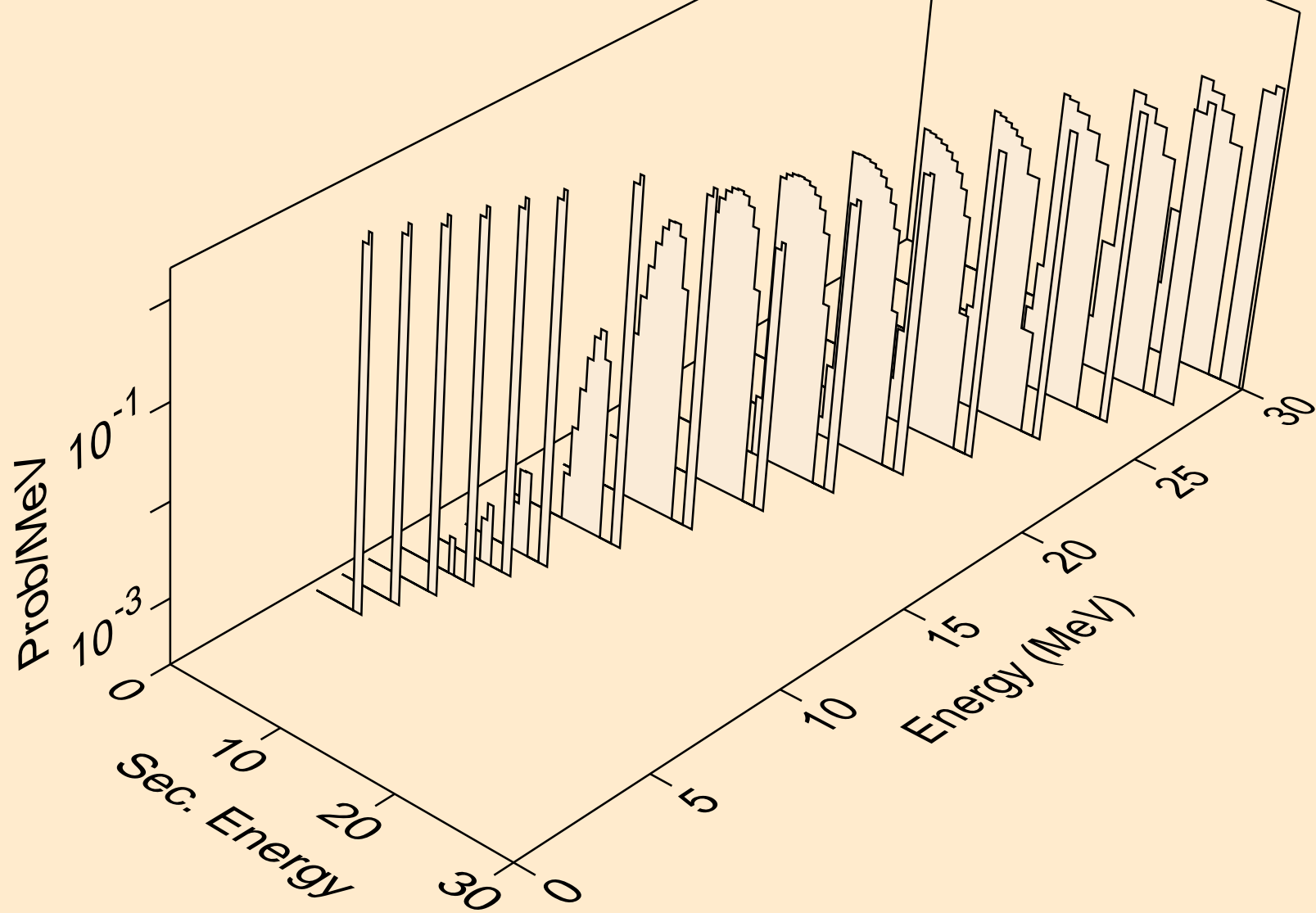

HG214 TRITON ACER TENDL-2021 LIBRARY; T=0.K  
Photon emission for (z,n)

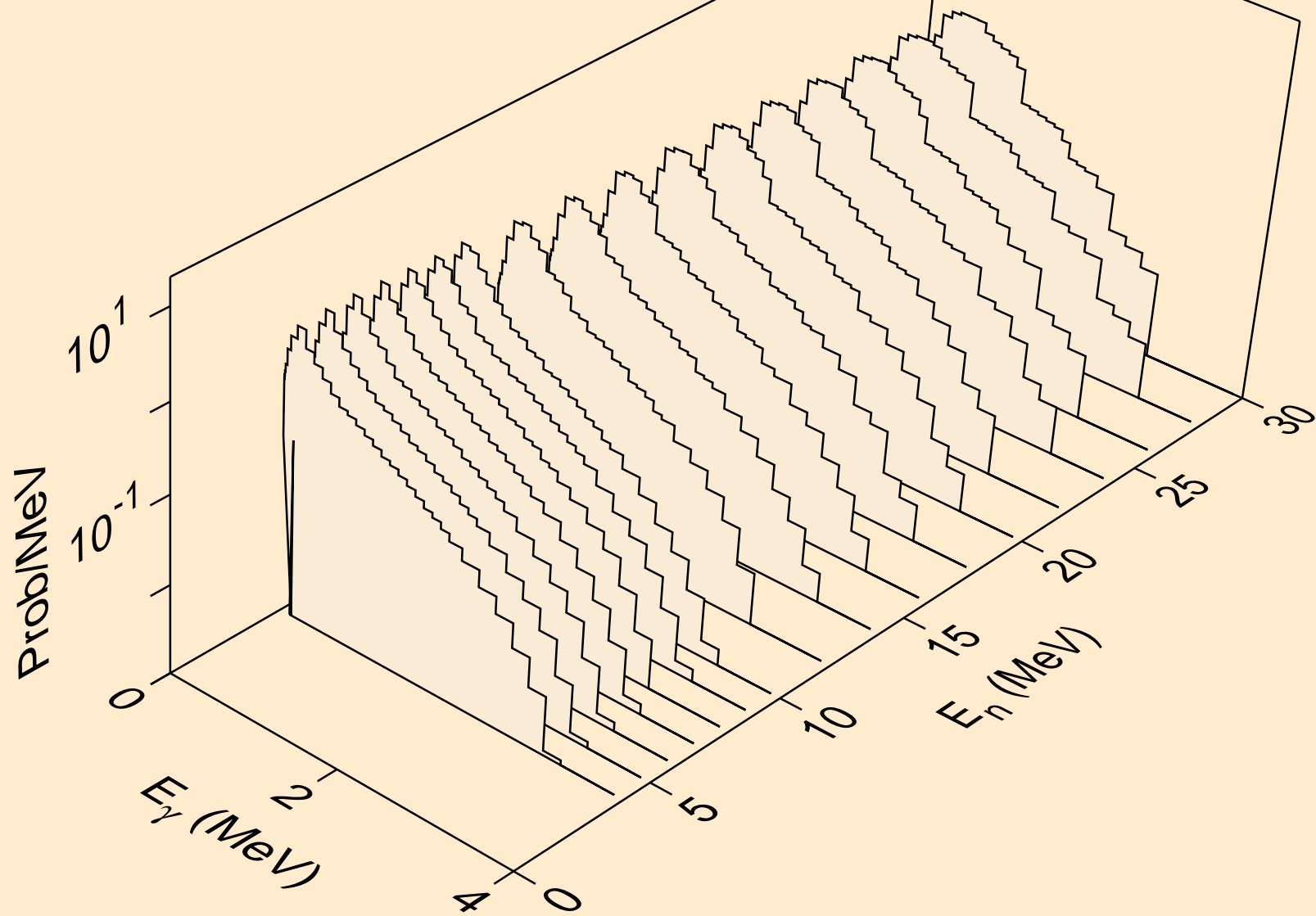

HG214 TRITON ACER TENDL-2021 LIBRARY; T=0.K  
Photon emission for (n,x)

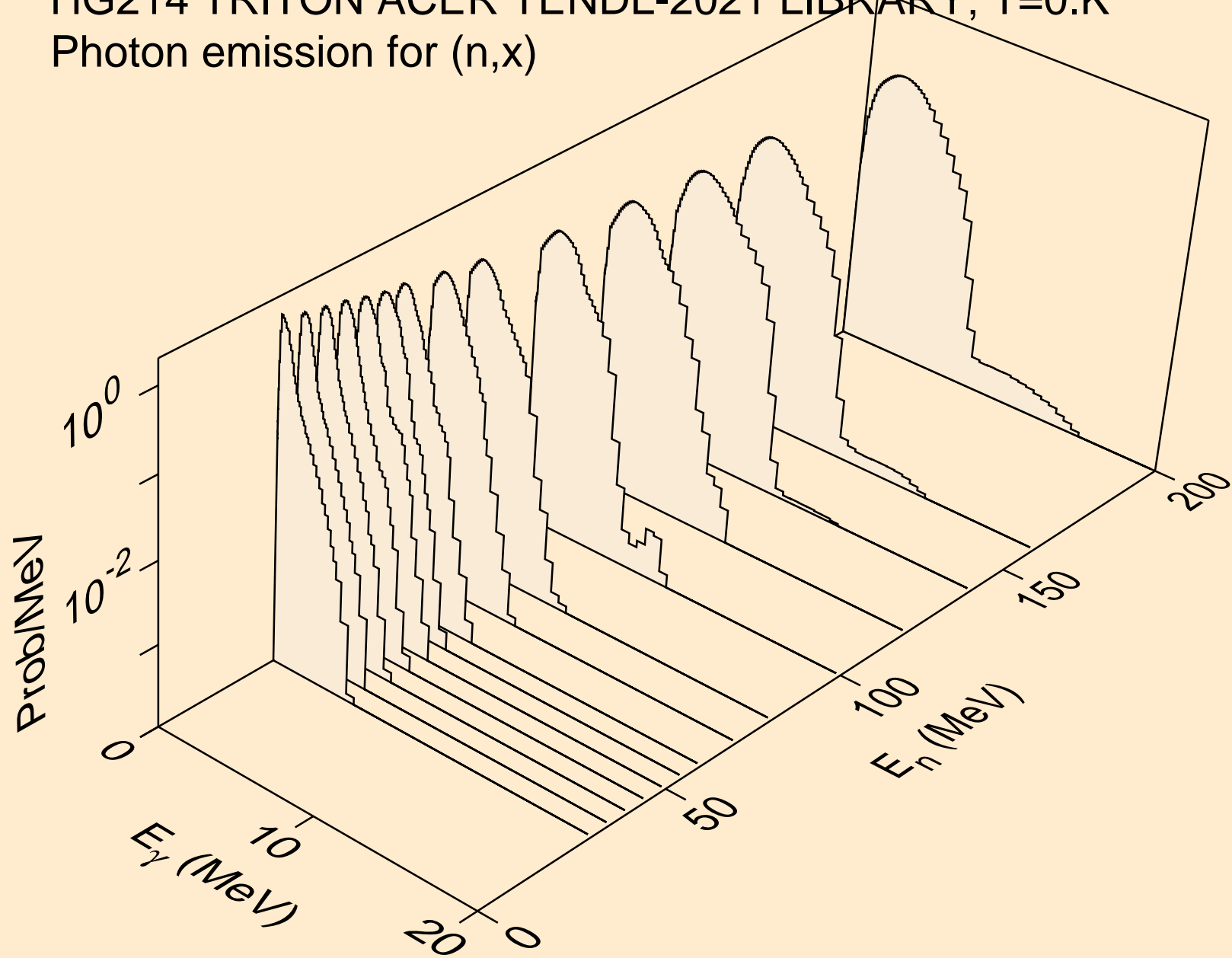

HG214 TRITON ACER TENDL-2021 LIBRARY; T=0.K  
Photon emission for (n,2nd)

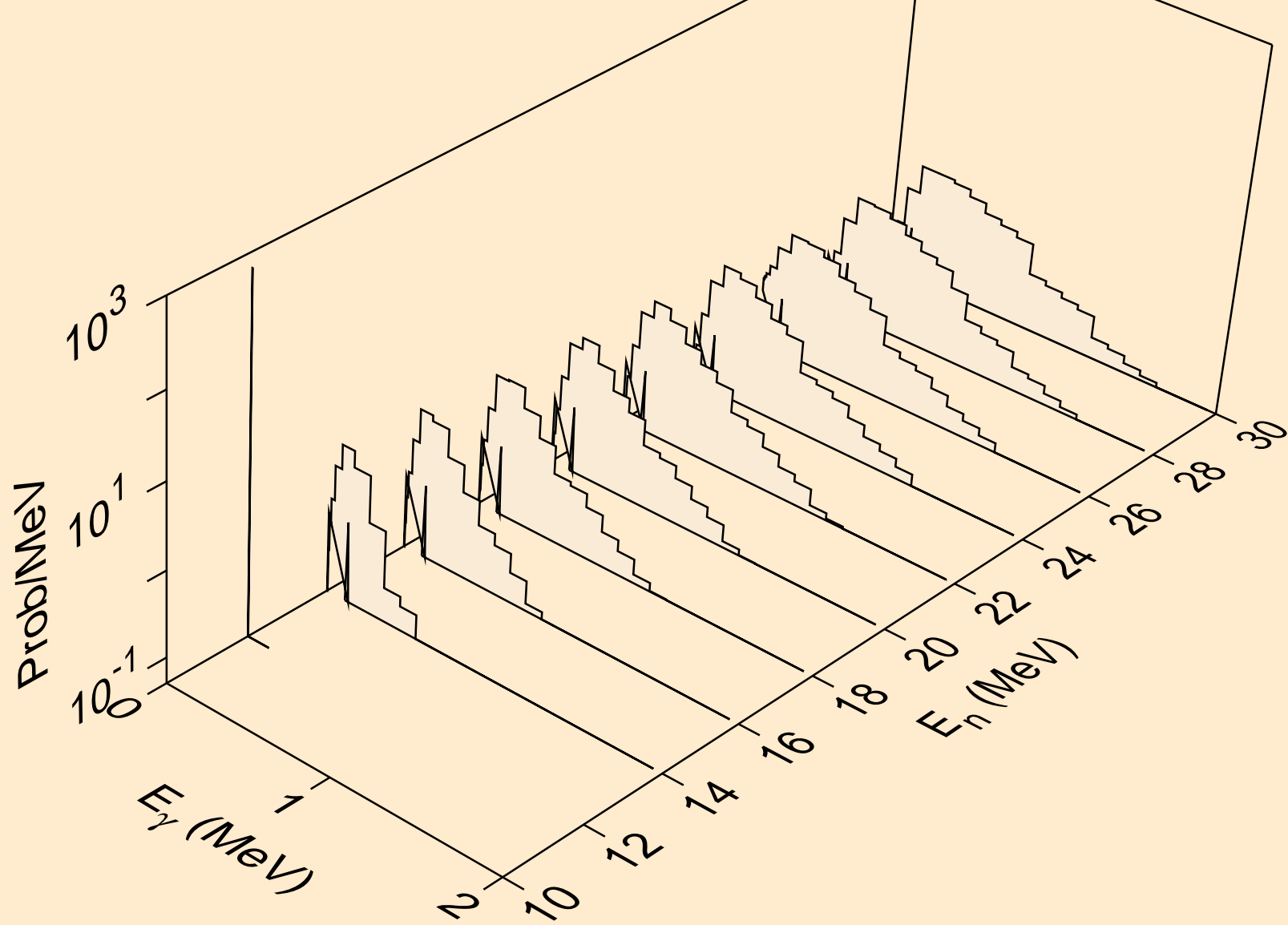

HG214 TRITON ACER TENDL-2021 LIBRARY; T=0.K  
Photon emission for (n,2n)

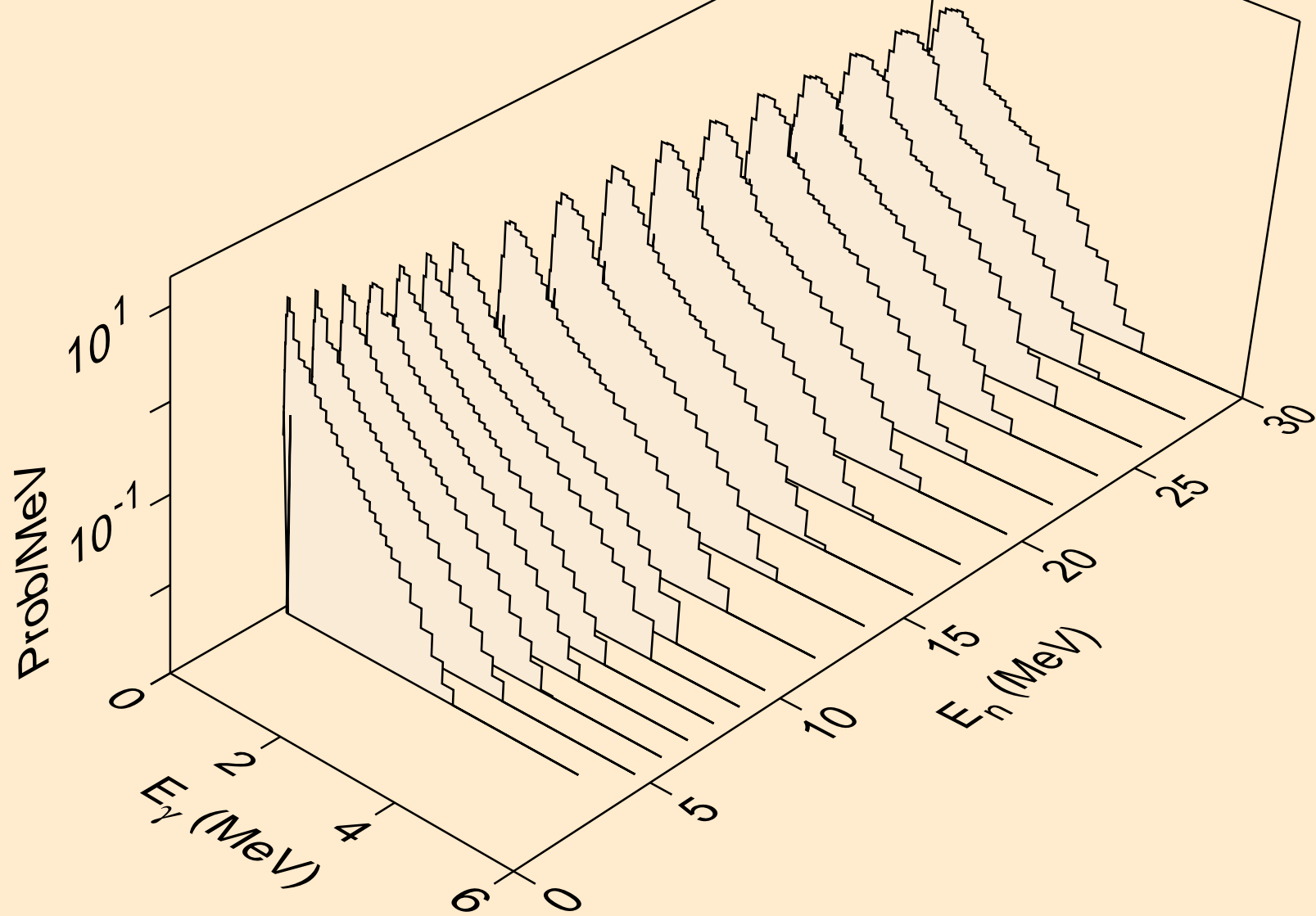

HG214 TRITON ACER TENDL-2021 LIBRARY; T=0.K  
Photon emission for (n,3n)

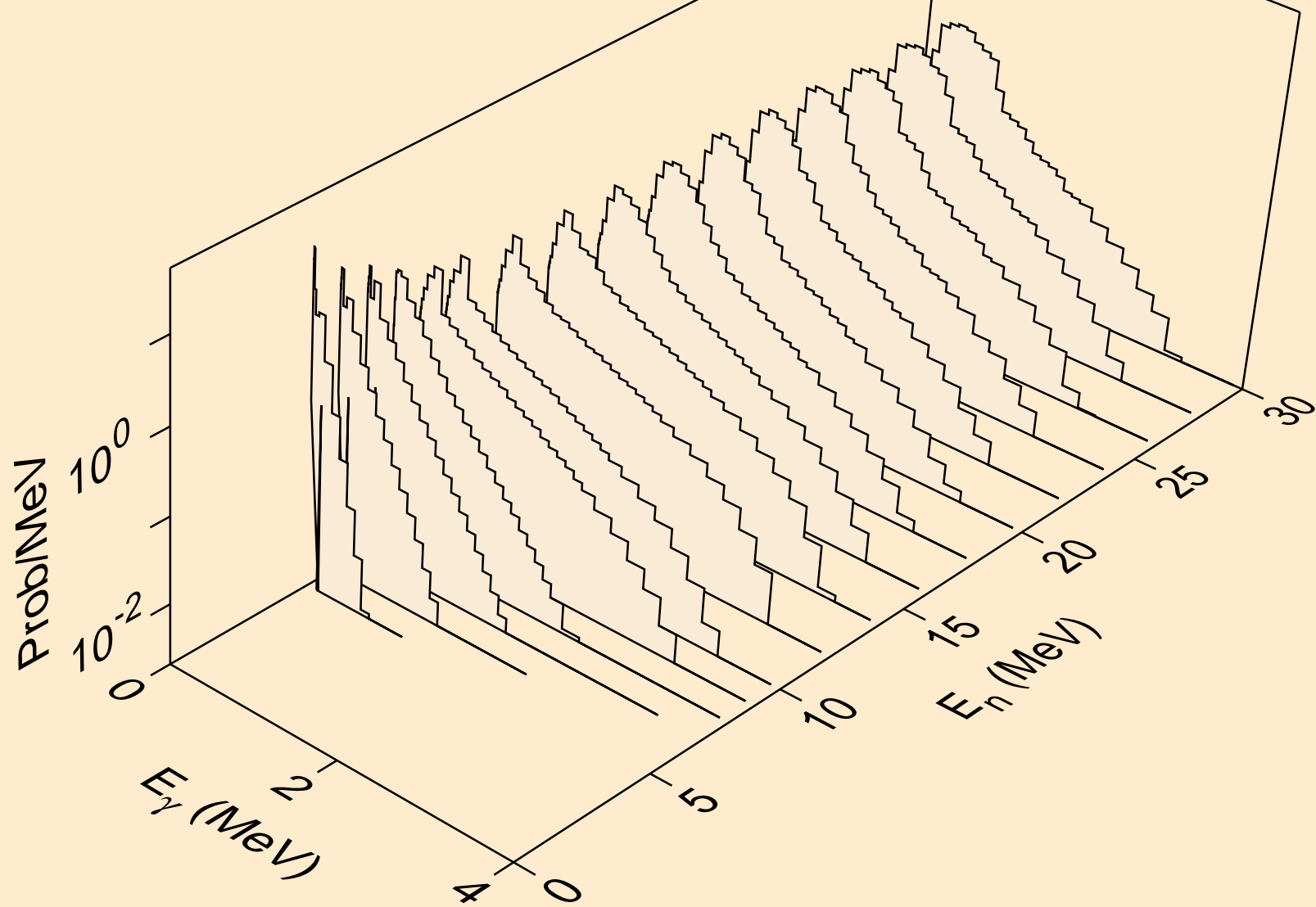

HG214 TRITON ACER TENDL-2021 LIBRARY; T=0.K  
Photon emission for (n,n\*)a

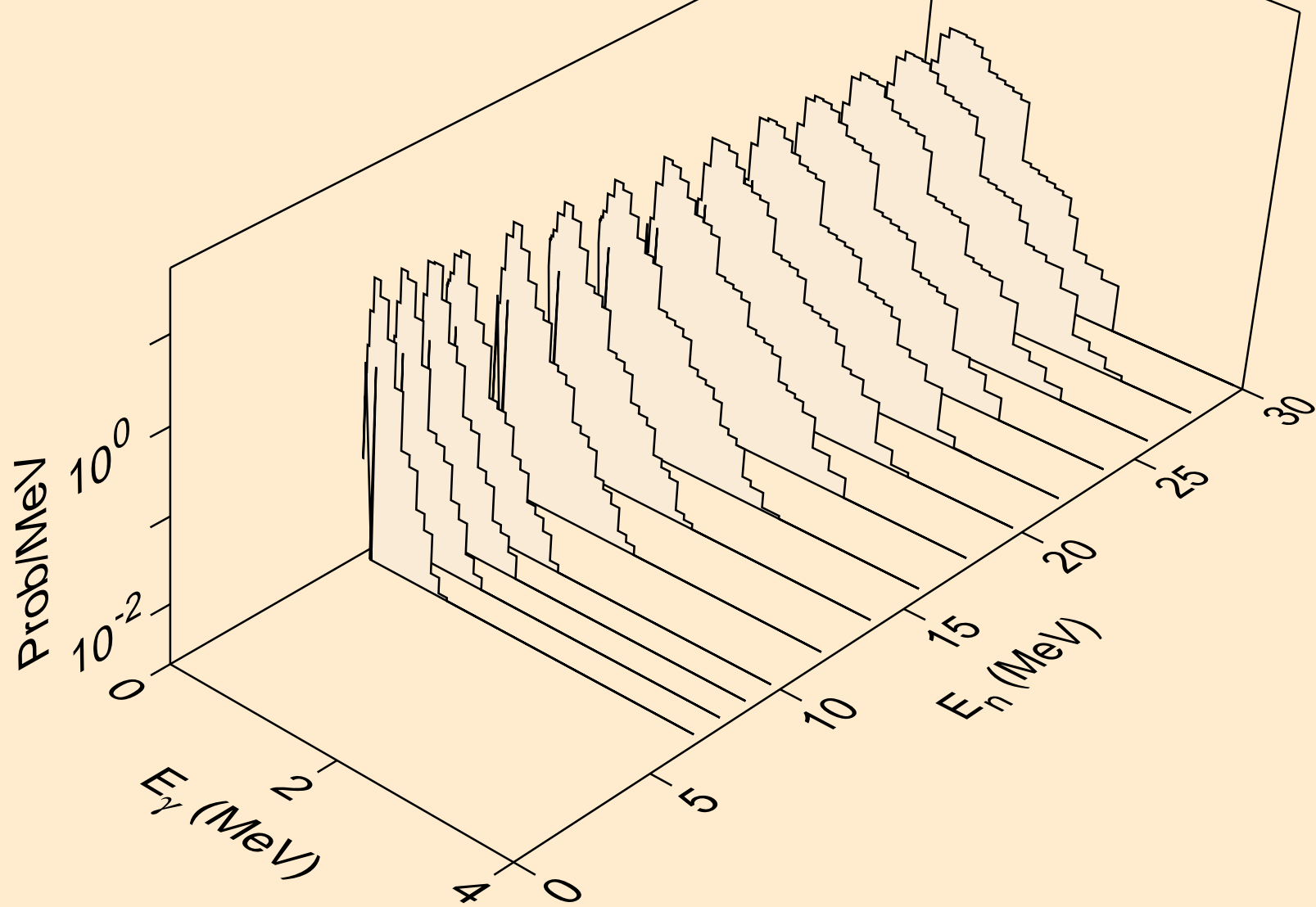

HG214 TRITON ACER TENDL-2021 LIBRARY; T=0.K  
Photon emission for (n,2n)a

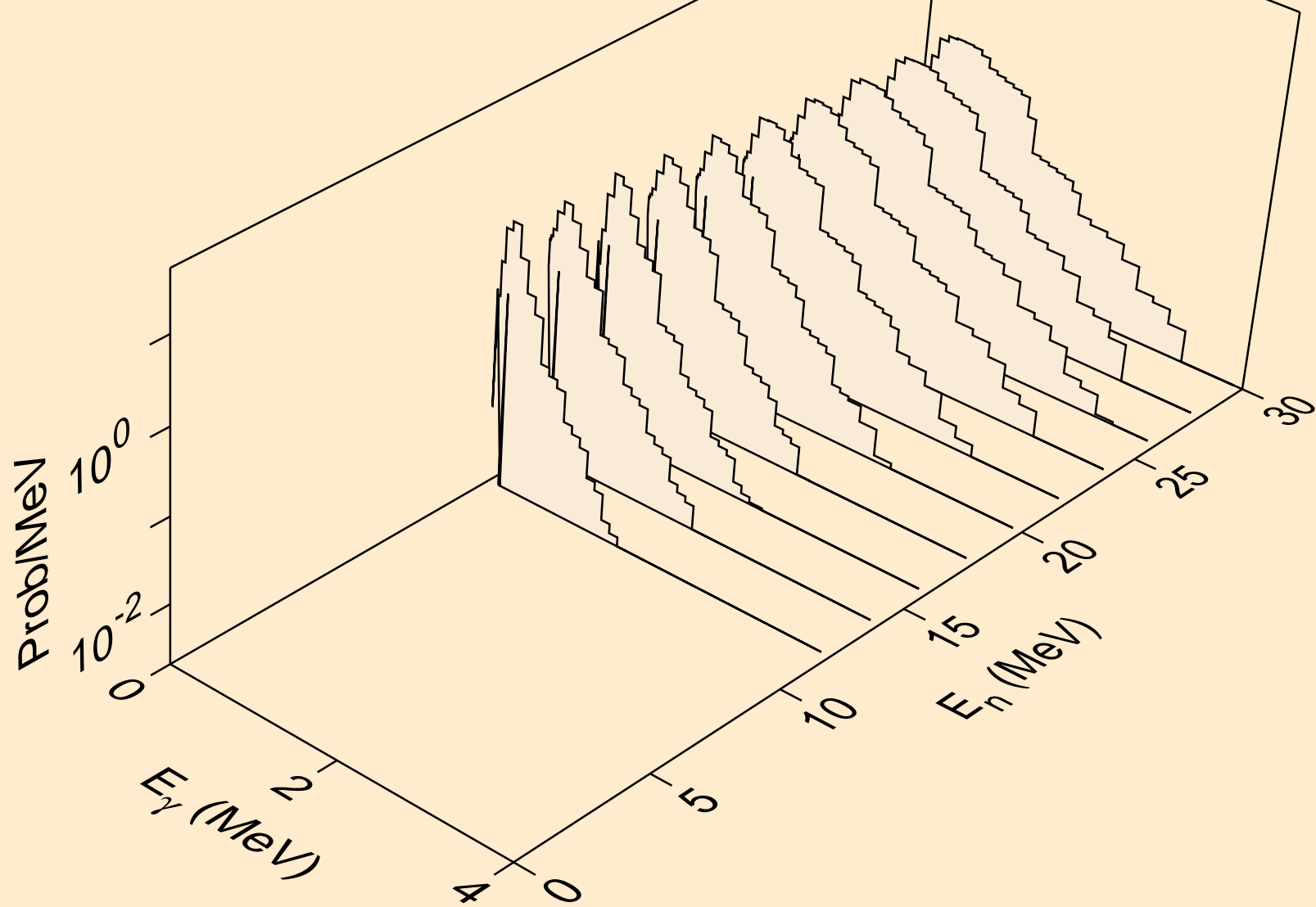

HG214 TRITON ACER TENDL-2021 LIBRARY; T=0.K  
Photon emission for (n,3n)a

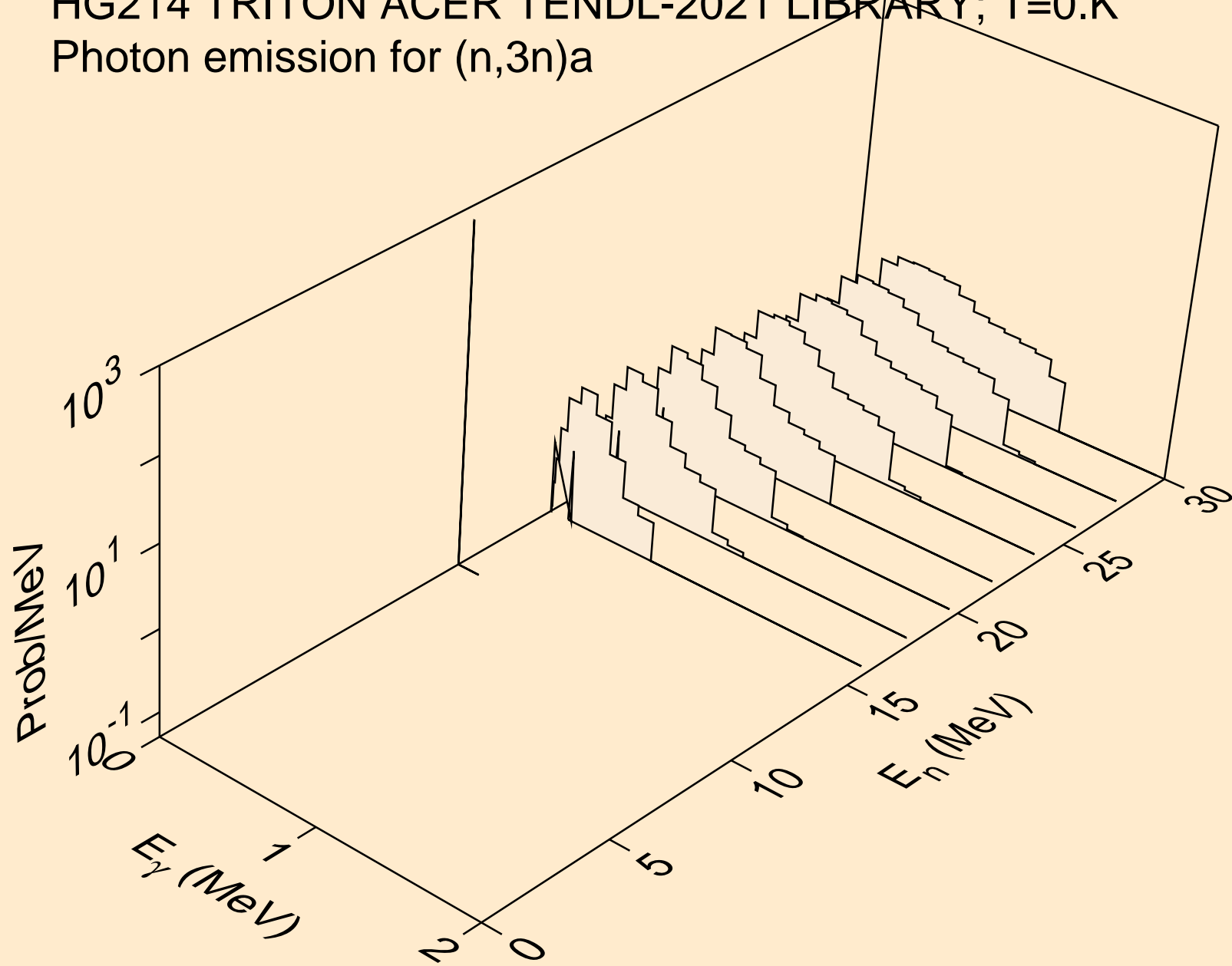

HG214 TRITON ACER TENDL-2021 LIBRARY; T=0.K  
Photon emission for (n,n\*)p

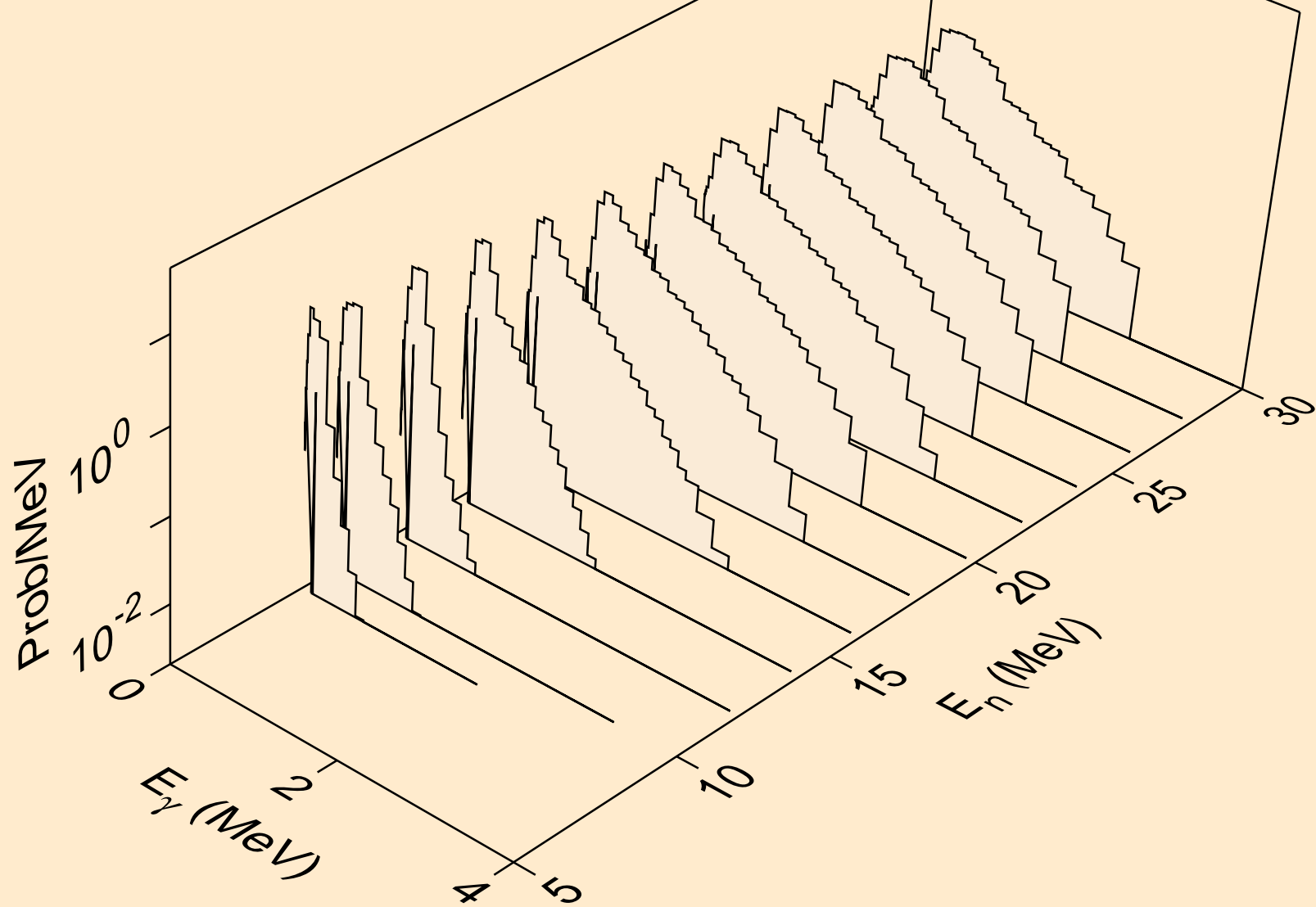

HG214 TRITON ACER TENDL-2021 LIBRARY; T=0.K  
Photon emission for (n,n\*)d

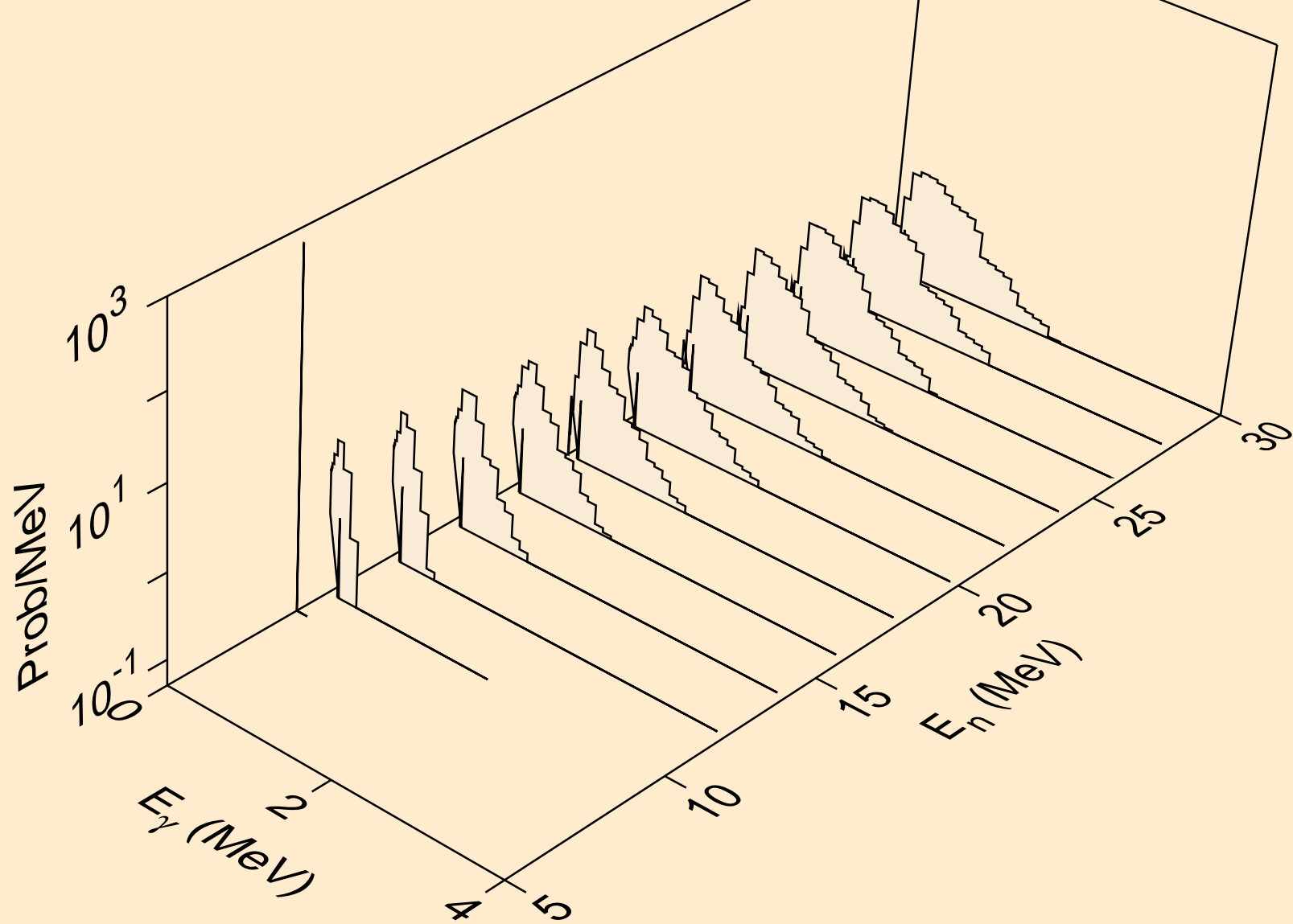

HG214 TRITON ACER TENDL-2021 LIBRARY; T=0.K  
Photon emission for (n,n\*)t

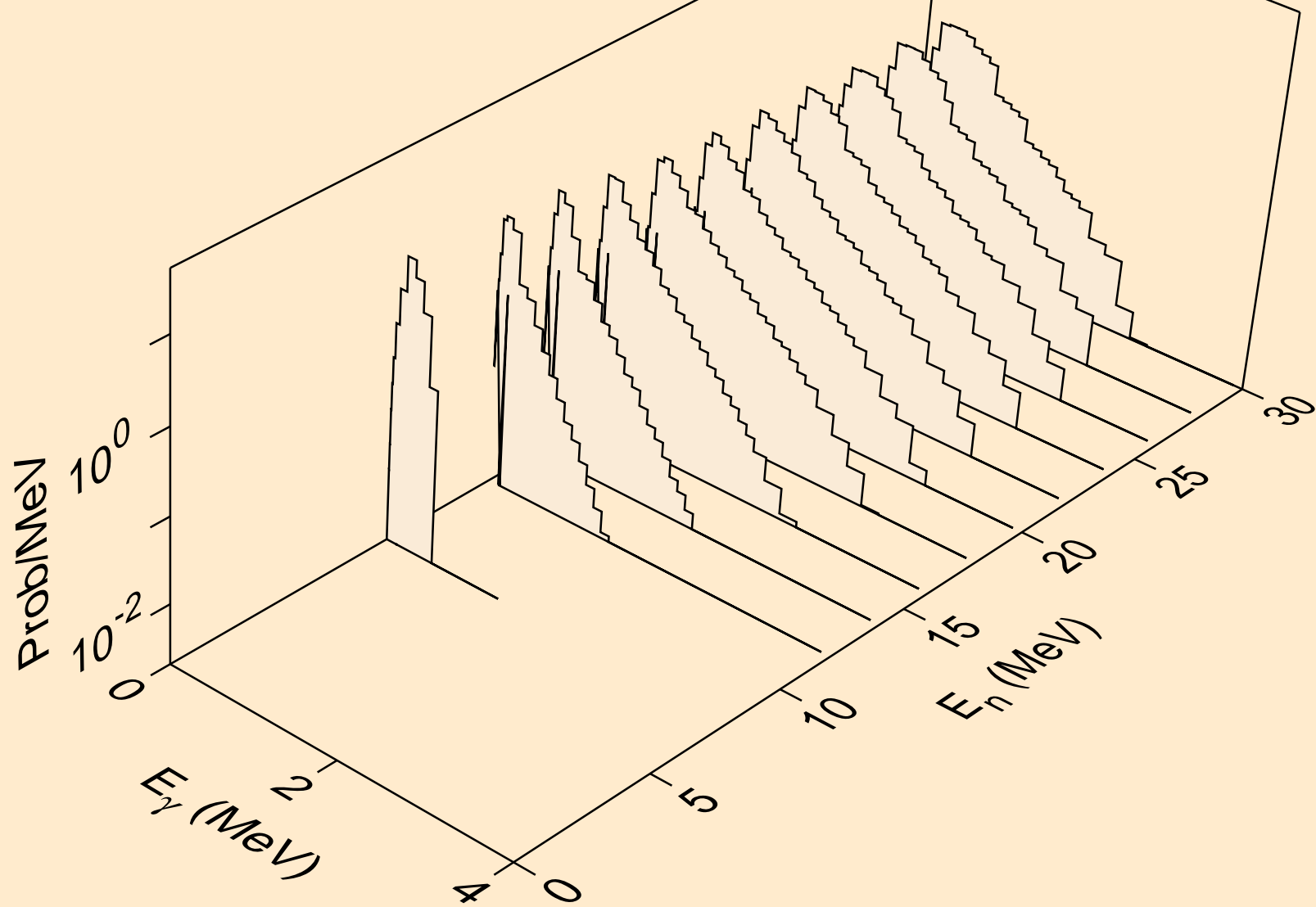

HG214 TRITON ACER TENDL-2021 LIBRARY; T=0.K  
Photon emission for (n,n\*)he3

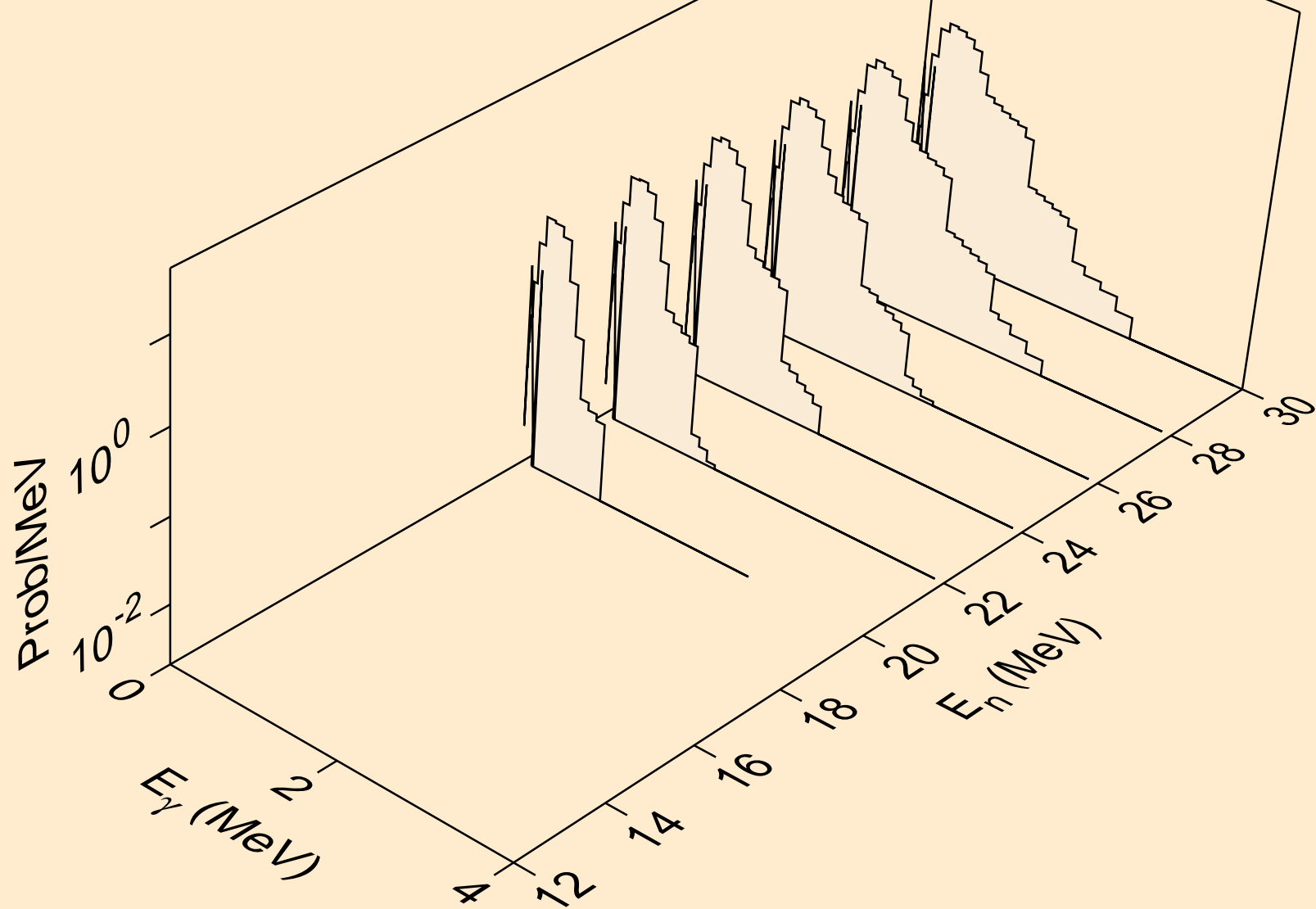

HG214 TRITON ACER TENDL-2021 LIBRARY; T=0.K  
Photon emission for (n,4n)

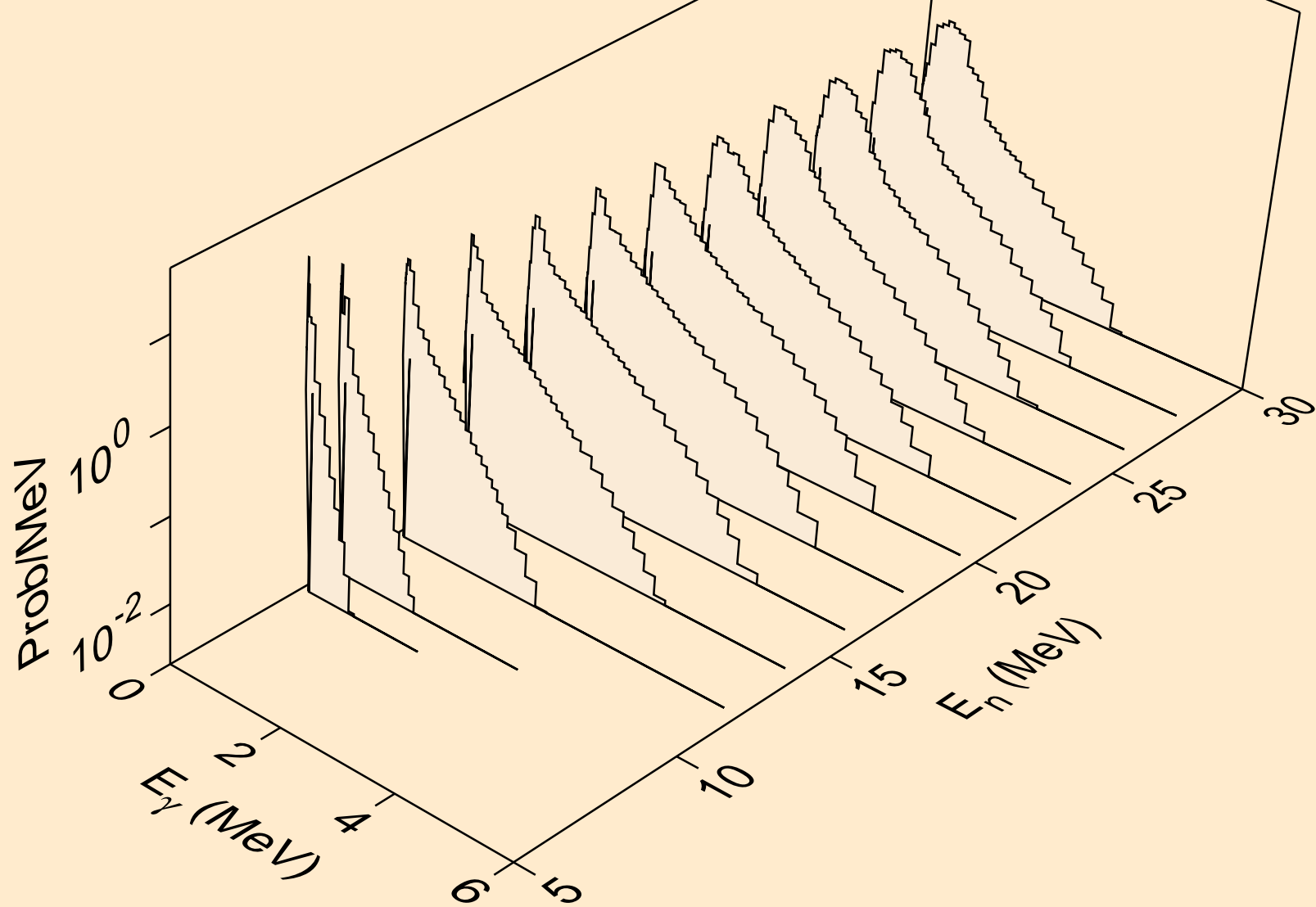

HG214 TRITON ACER TENDL-2021 LIBRARY; T=0.K  
Photon emission for (n,2np)

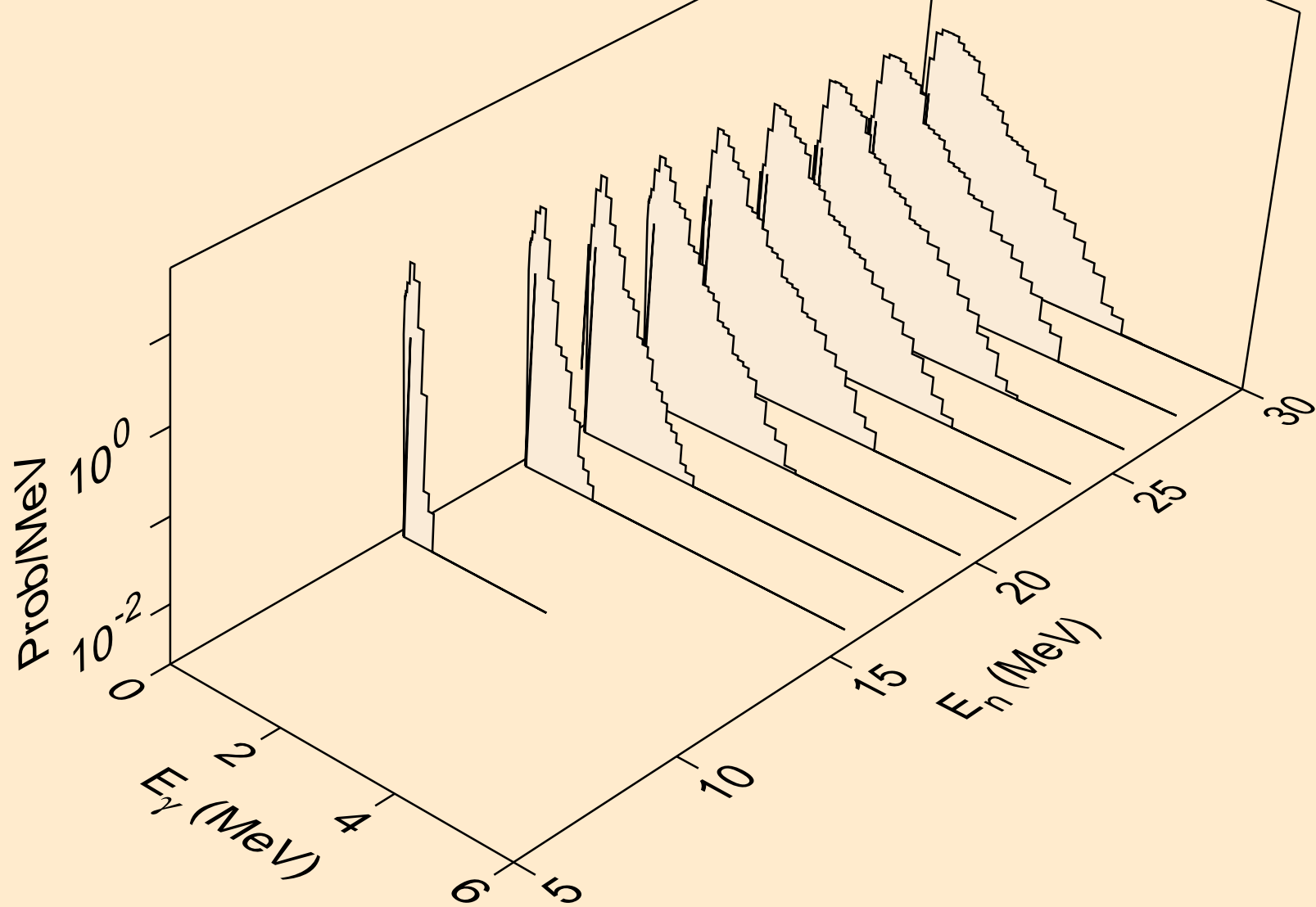

HG214 TRITON ACER TENDL-2021 LIBRARY; T=0.K  
Photon emission for (n,3np)

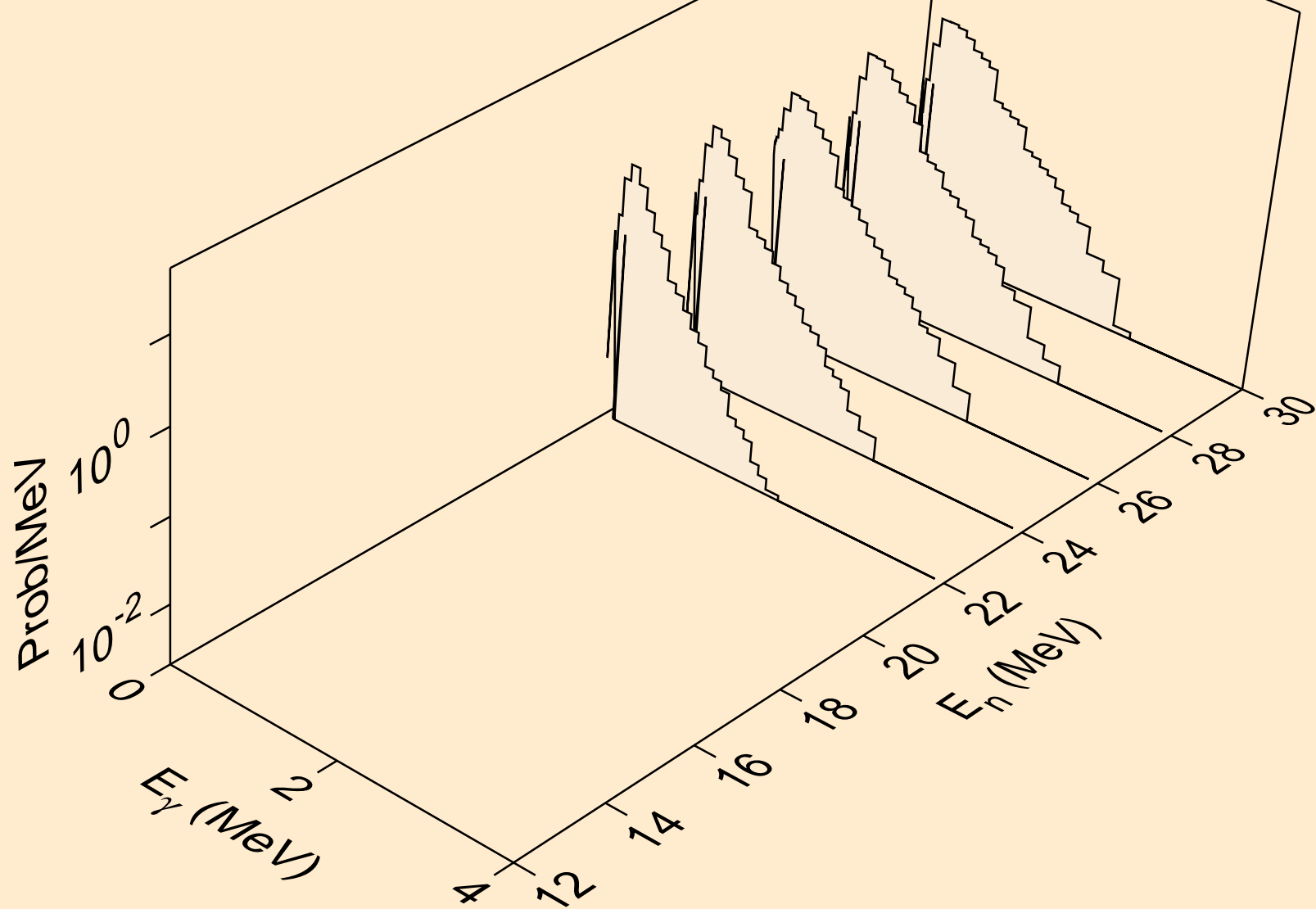

HG214 TRITON ACER TENDL-2021 LIBRARY; T=0.K  
Photon emission for (n,gma)

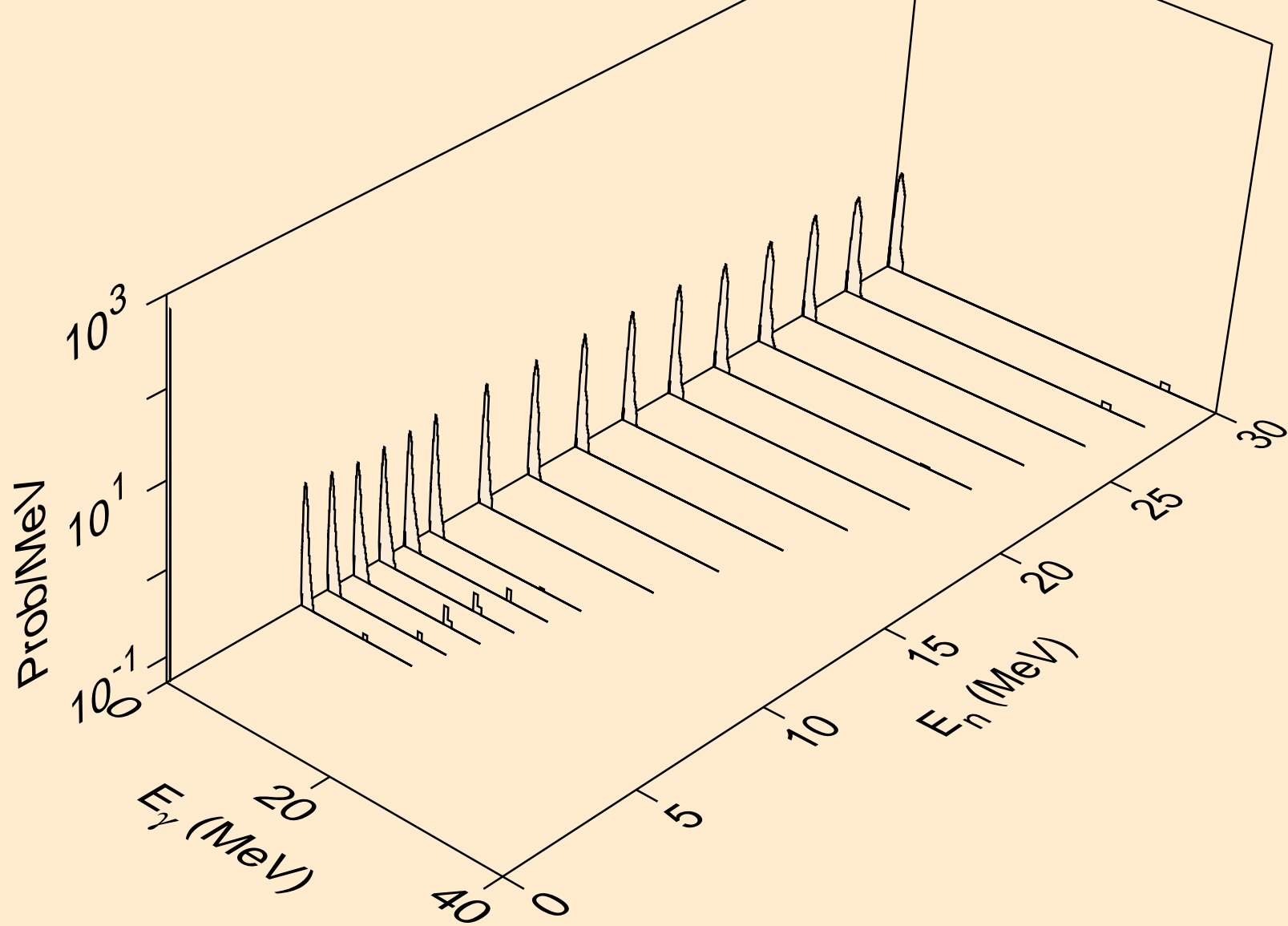

HG214 TRITON ACER TENDL-2021 LIBRARY; T=0.K  
Photon emission for (n,p)

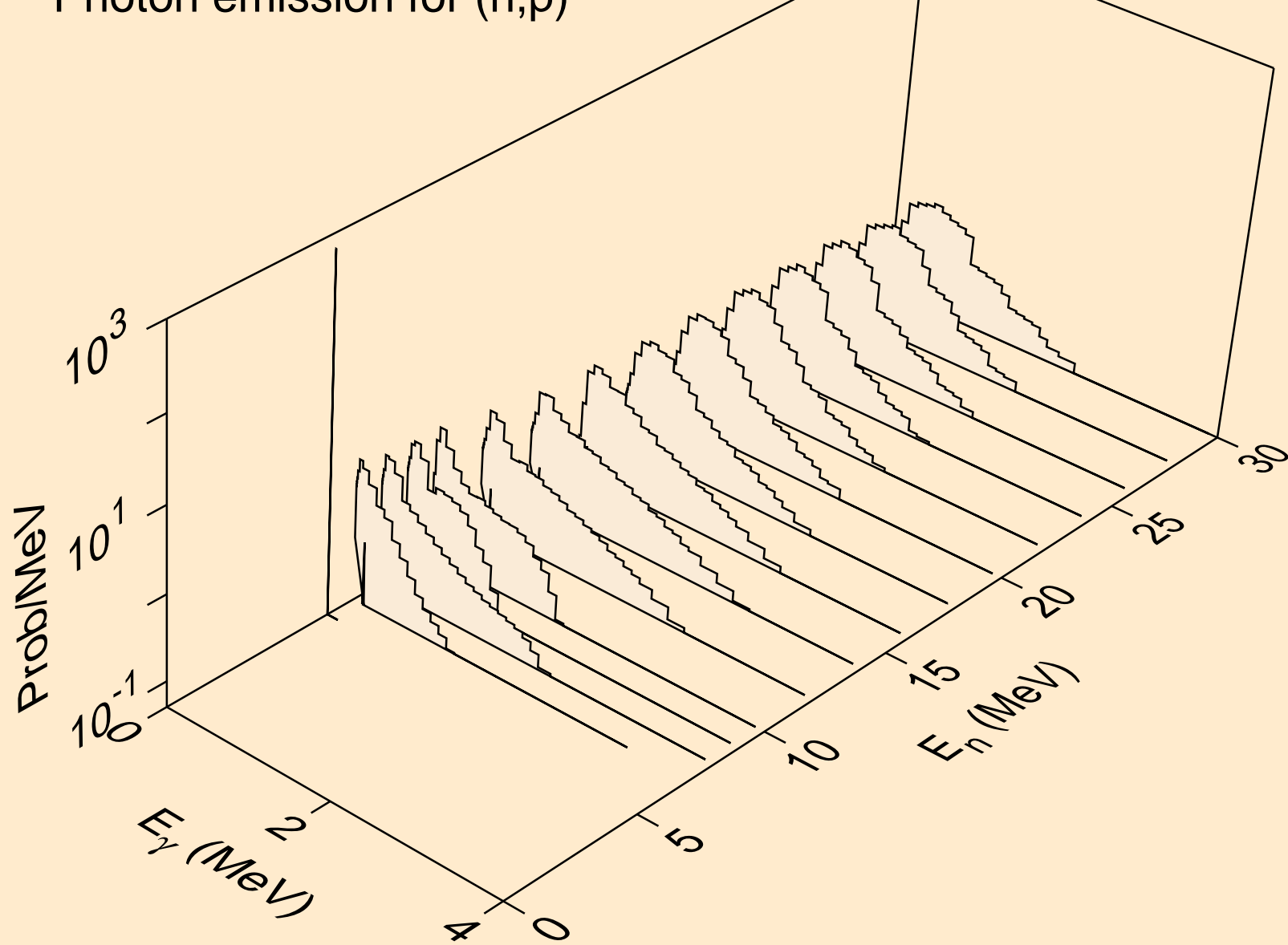

HG214 TRITON ACER TENDL-2021 LIBRARY; T=0.K  
Photon emission for (n,d)

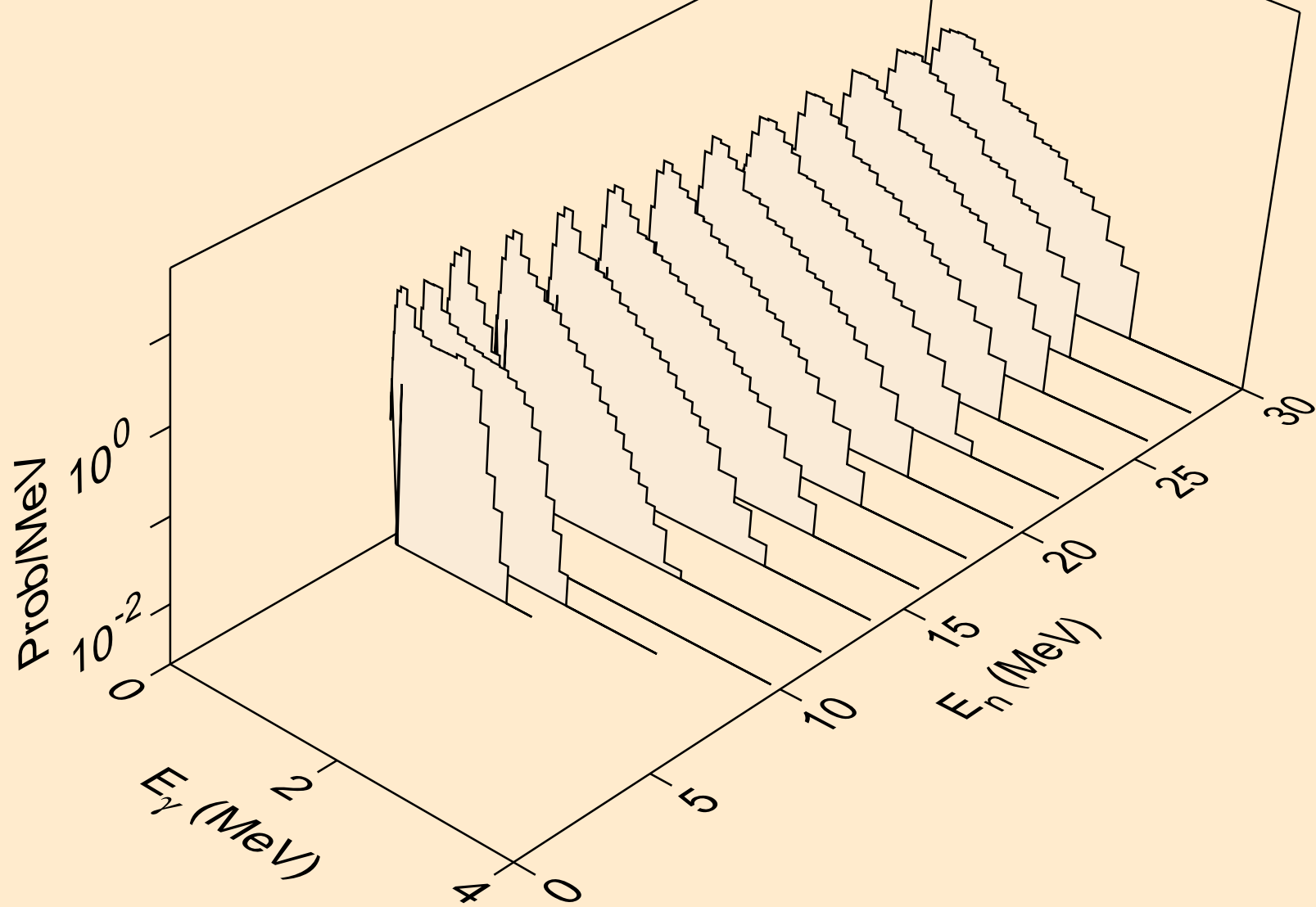

HG214 TRITON ACER TENDL-2021 LIBRARY; T=0.K  
Photon emission for inelastic

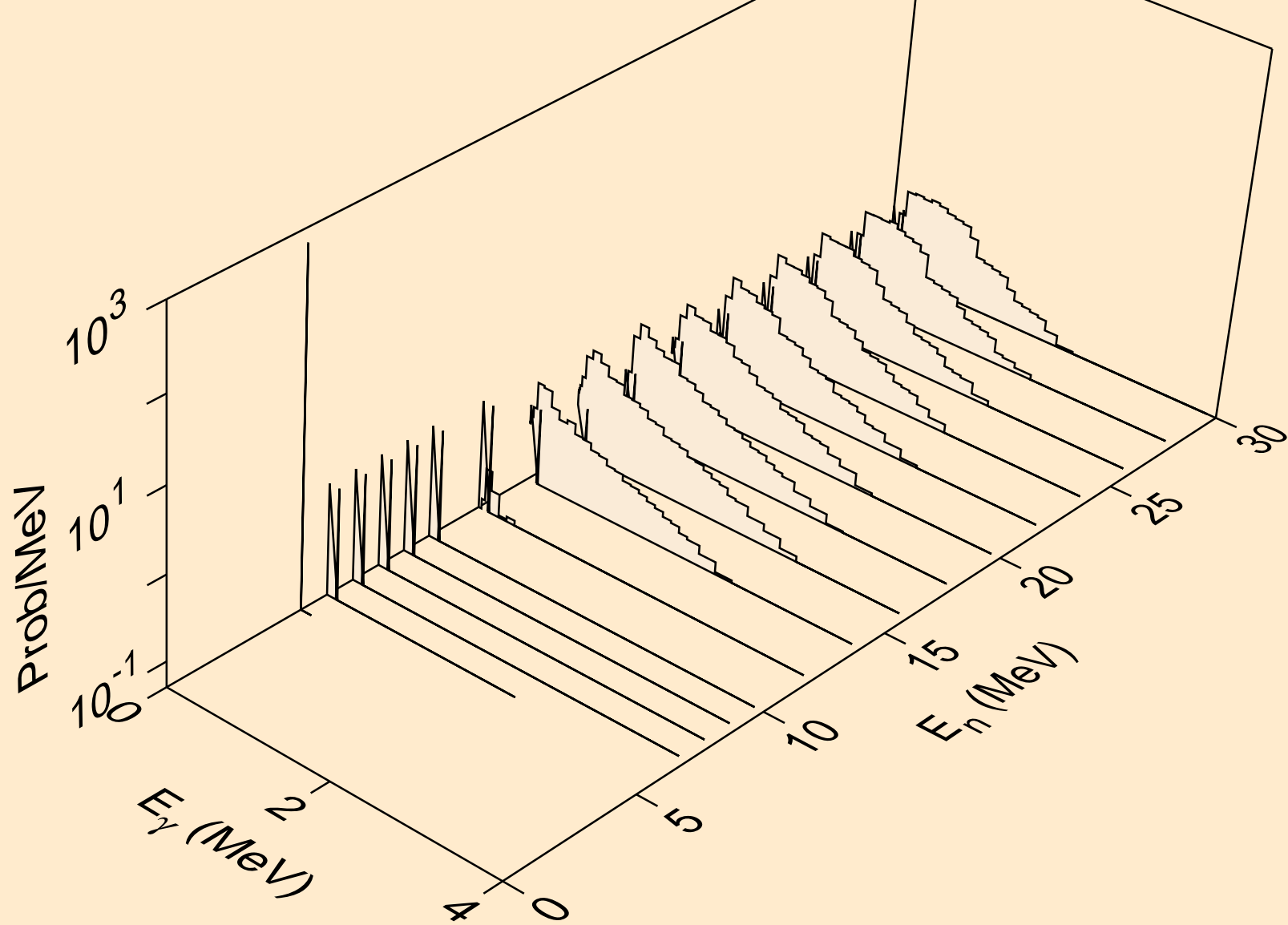

HG214 TRITON ACER TENDL-2021 LIBRARY; T=0.K  
Photon emission for (n,he3)

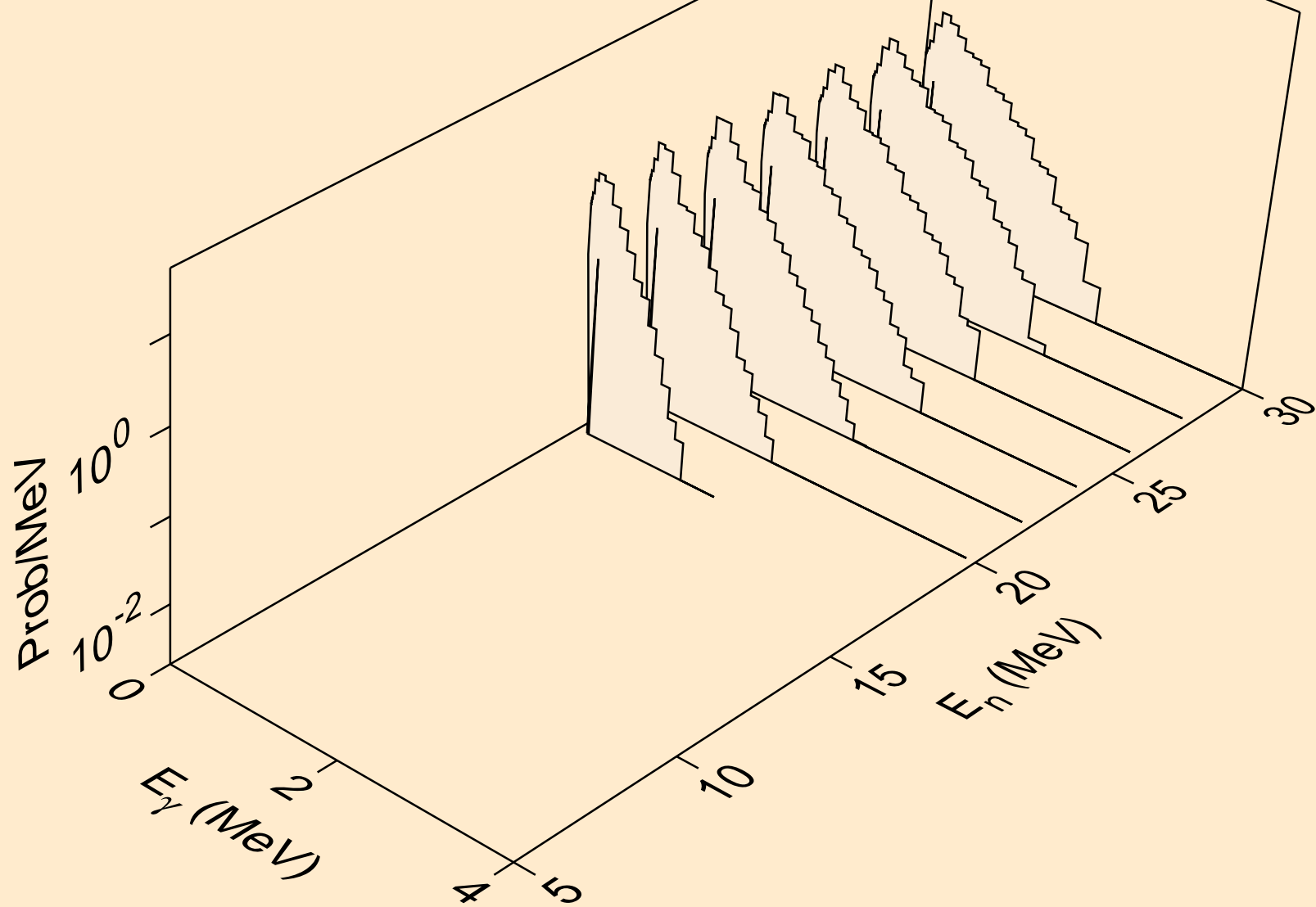

HG214 TRITON ACER TENDL-2021 LIBRARY; T=0.K  
Photon emission for (n,a)

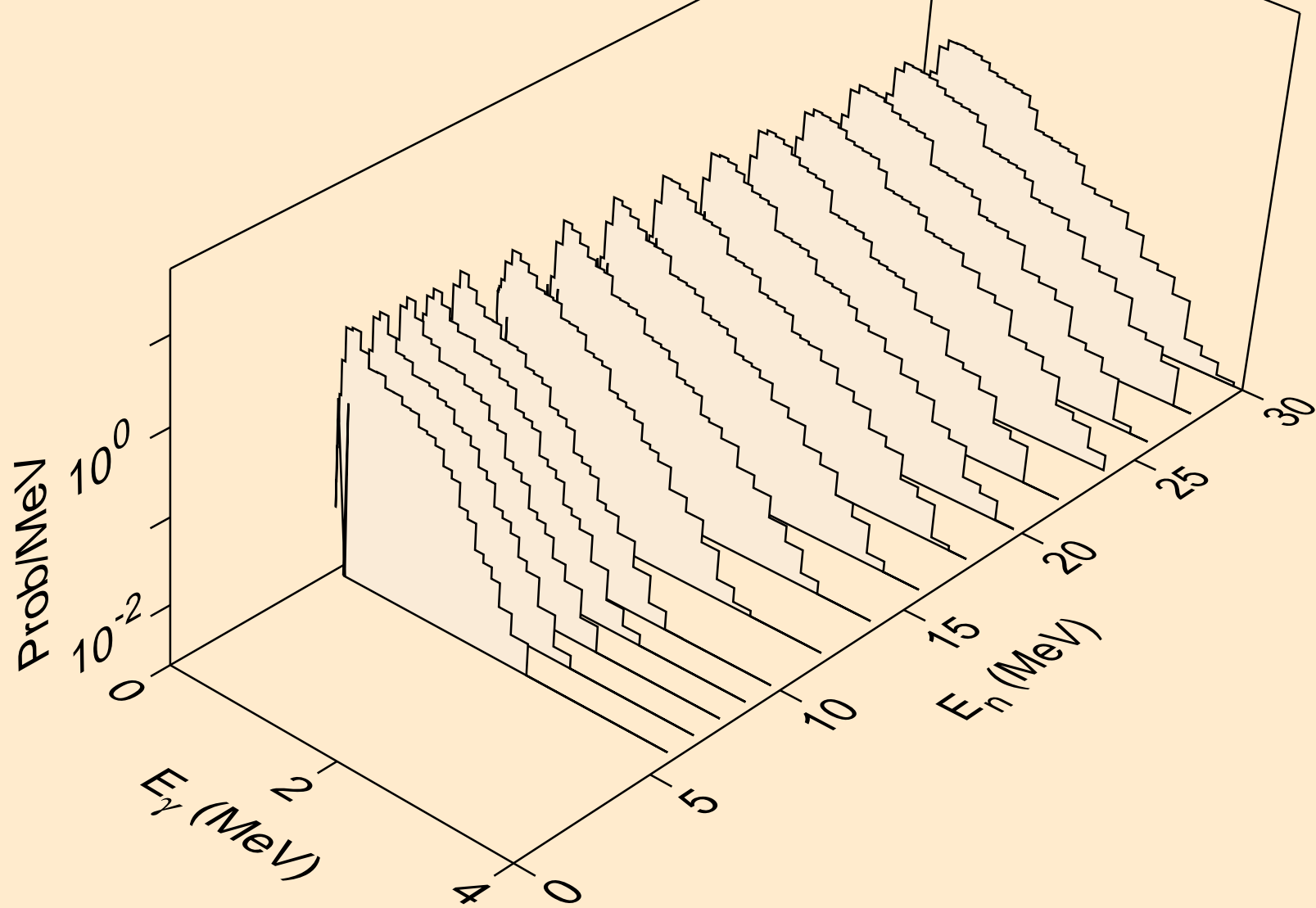

# HG214 TRITON ACER TENDL-2021 LIBRARY; T=0.K

## Particle heating contributions

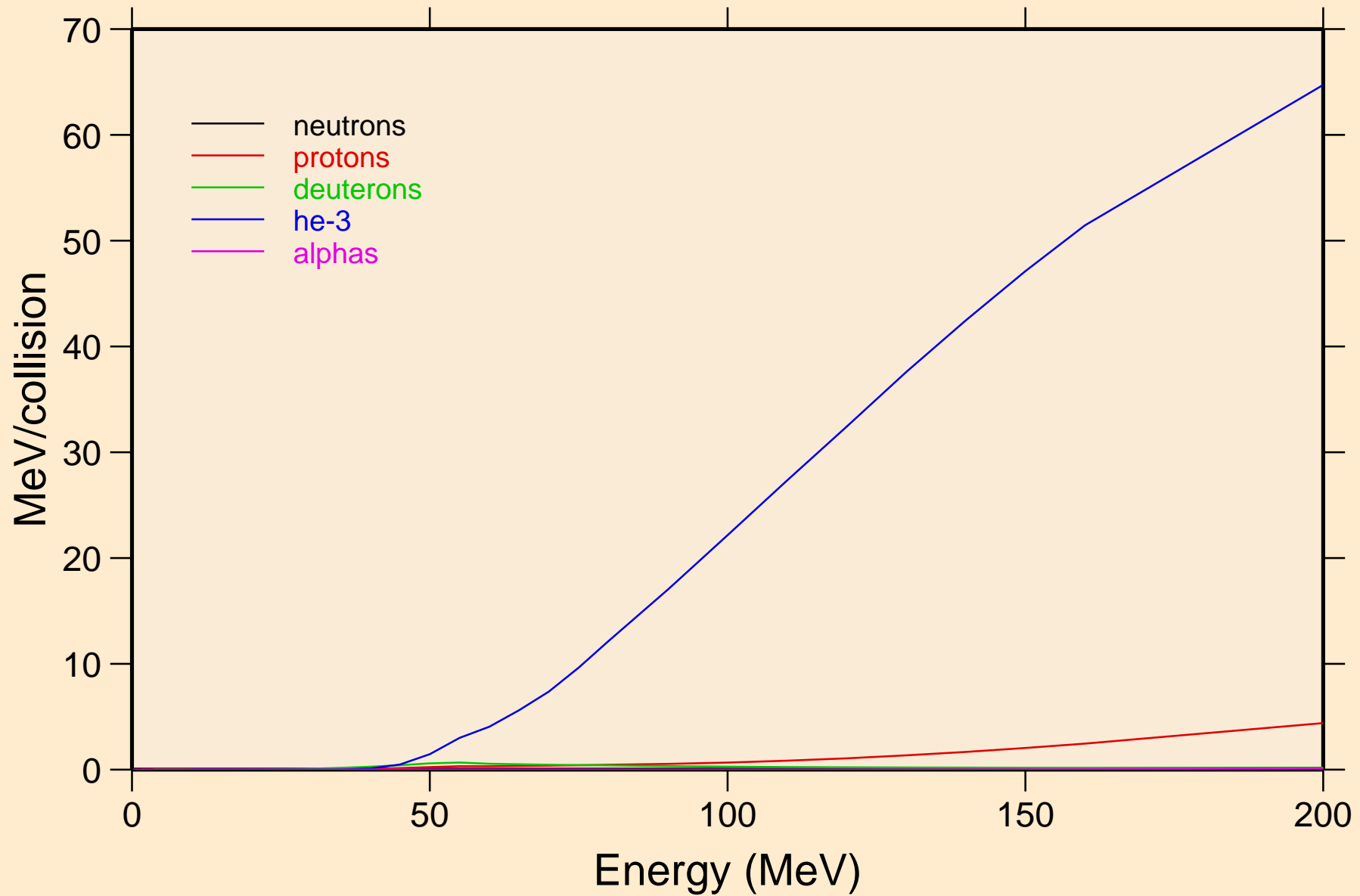

HG214 TRITON ACER TENDL-2021 LIBRARY; T=0.K  
Recoil Heating

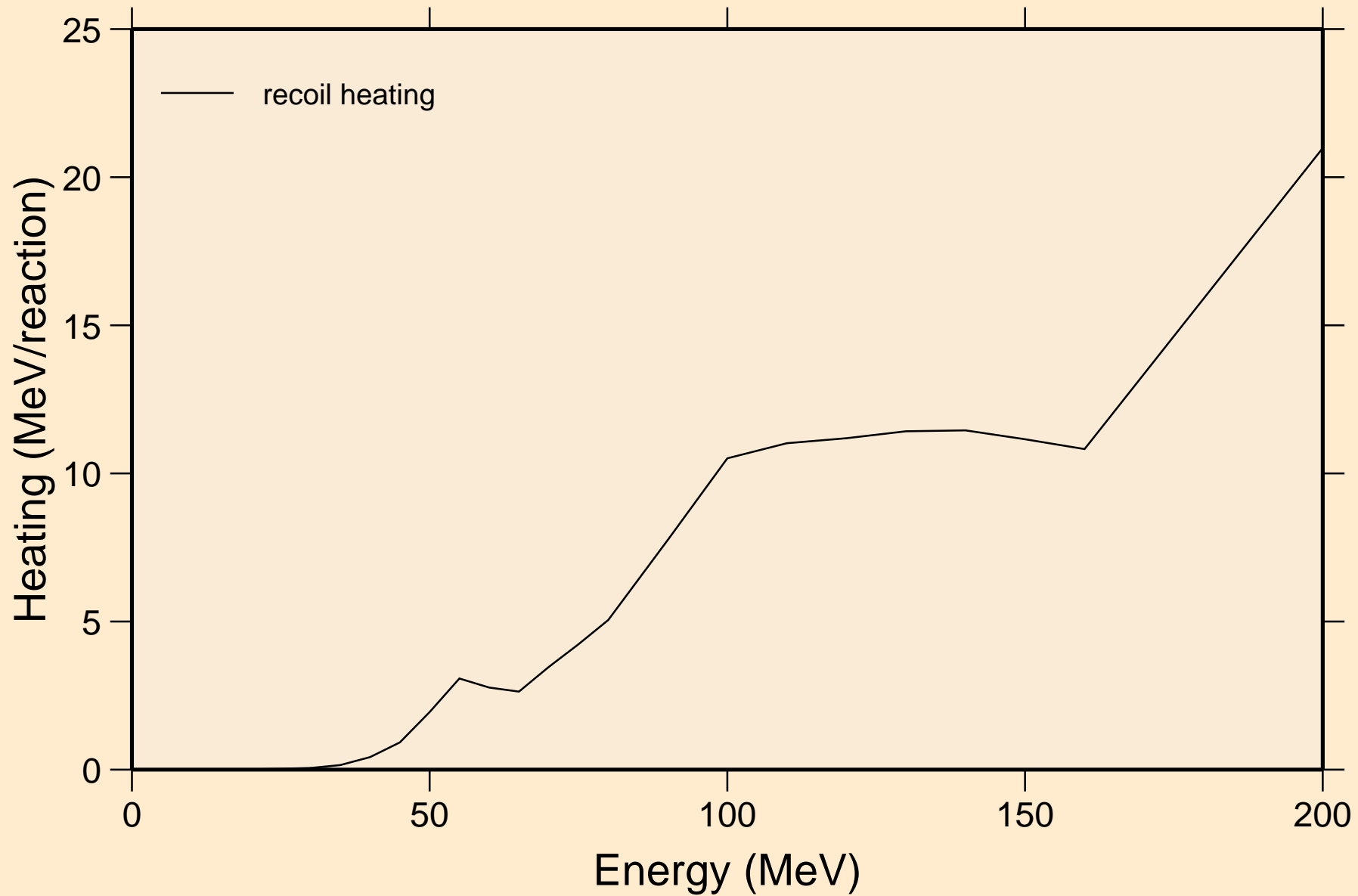

HG214 TRITON ACER TENDL-2021 LIBRARY; T=0.K  
Particle production cross sections

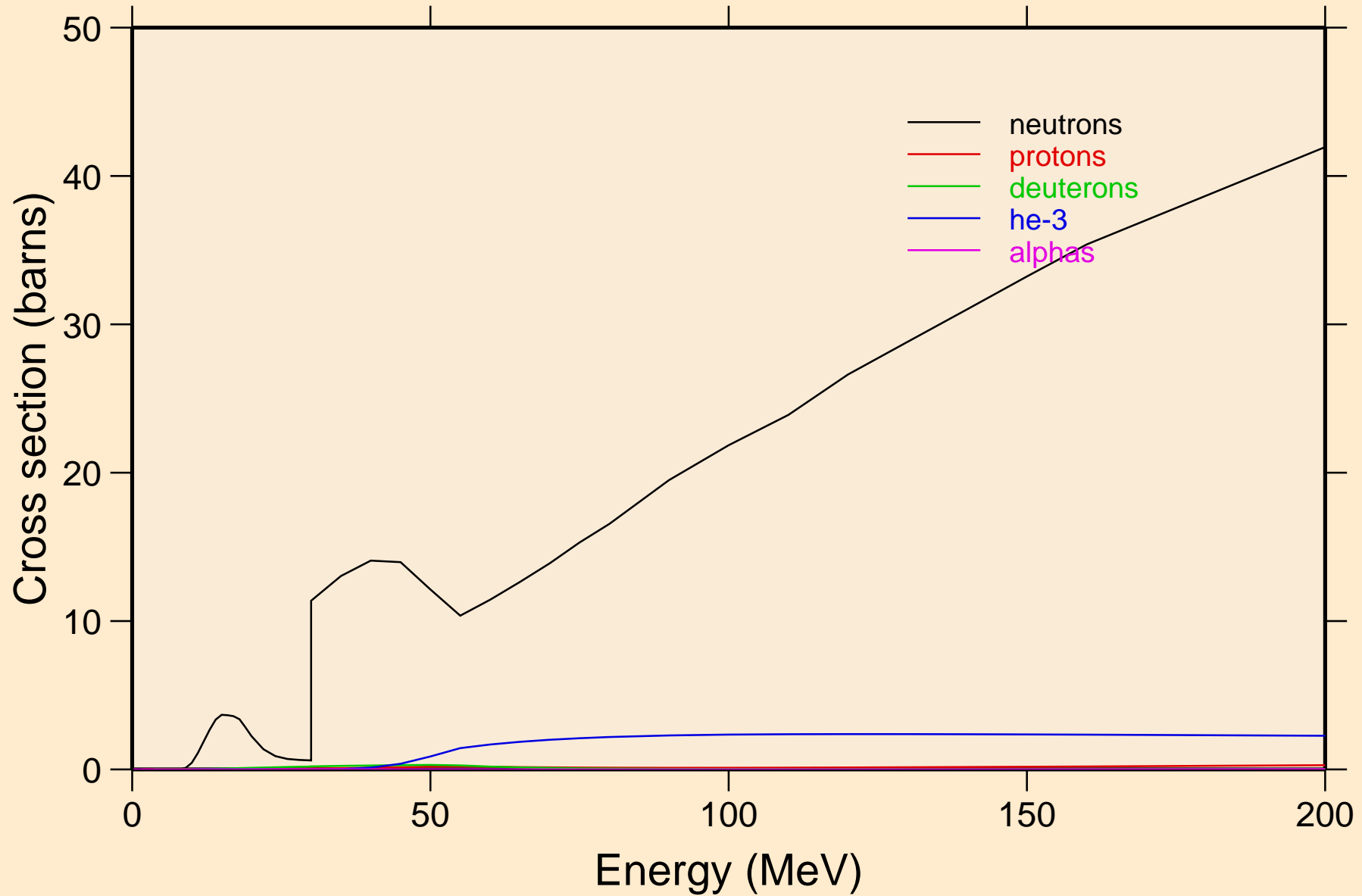

HG214 TRITON ACER TENDL-2021 LIBRARY; T=0.K  
neutrons from (t,n)

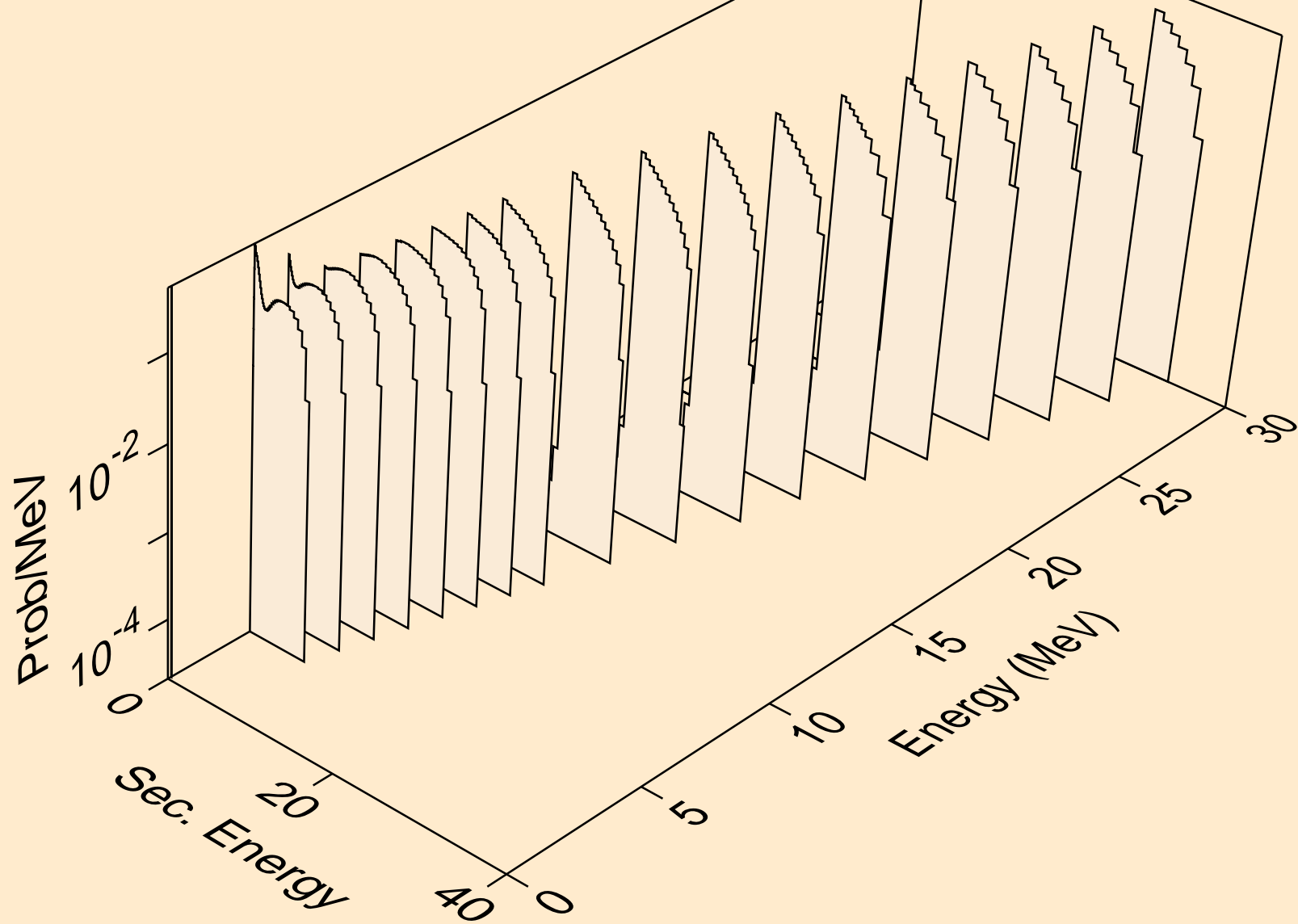

HG214 TRITON ACER TENDL-2021 LIBRARY; T=0.K  
neutrons from (t,x)

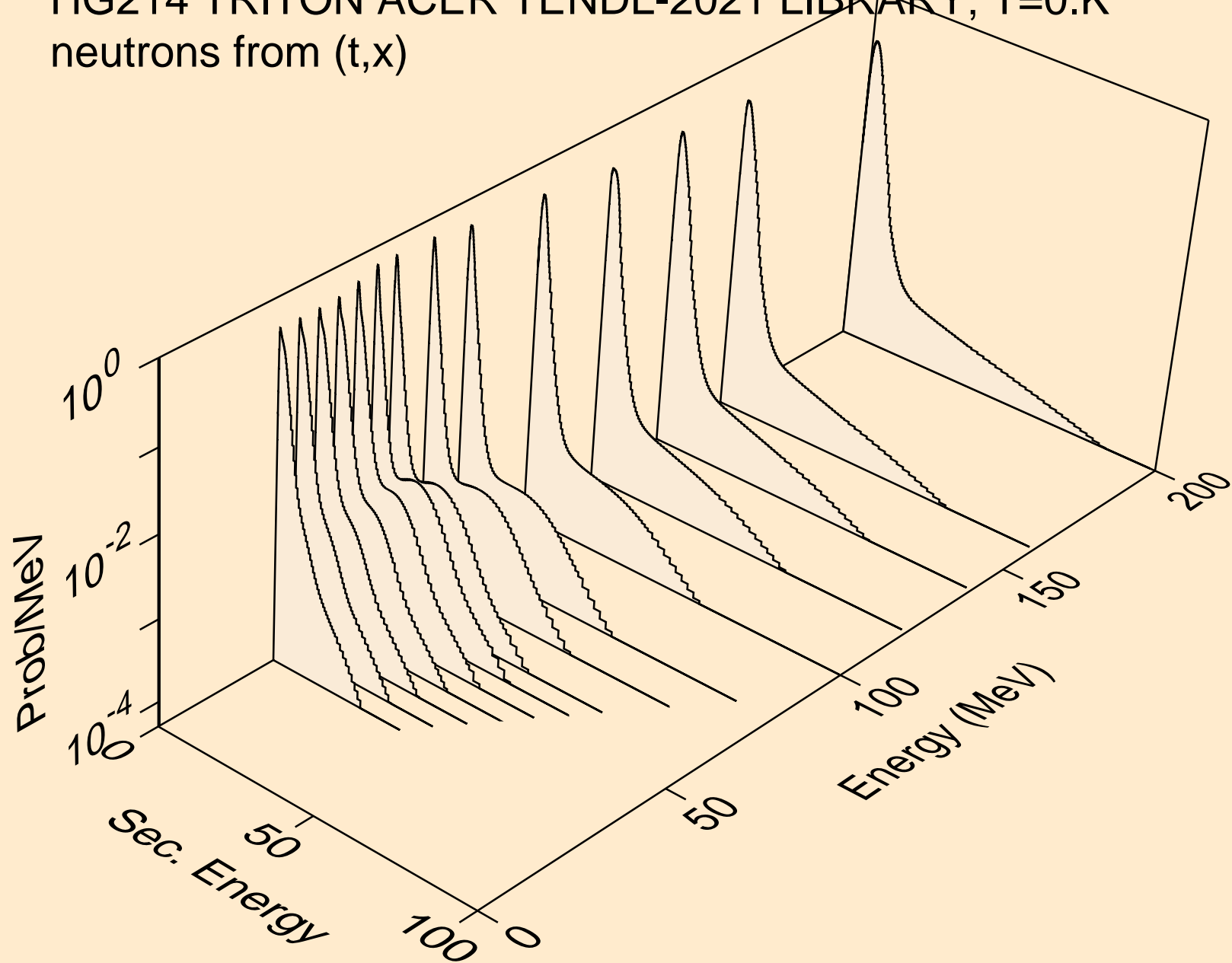

HG214 TRITON ACER TENDL-2021 LIBRARY; T=0.K  
neutrons from (t,2nd)

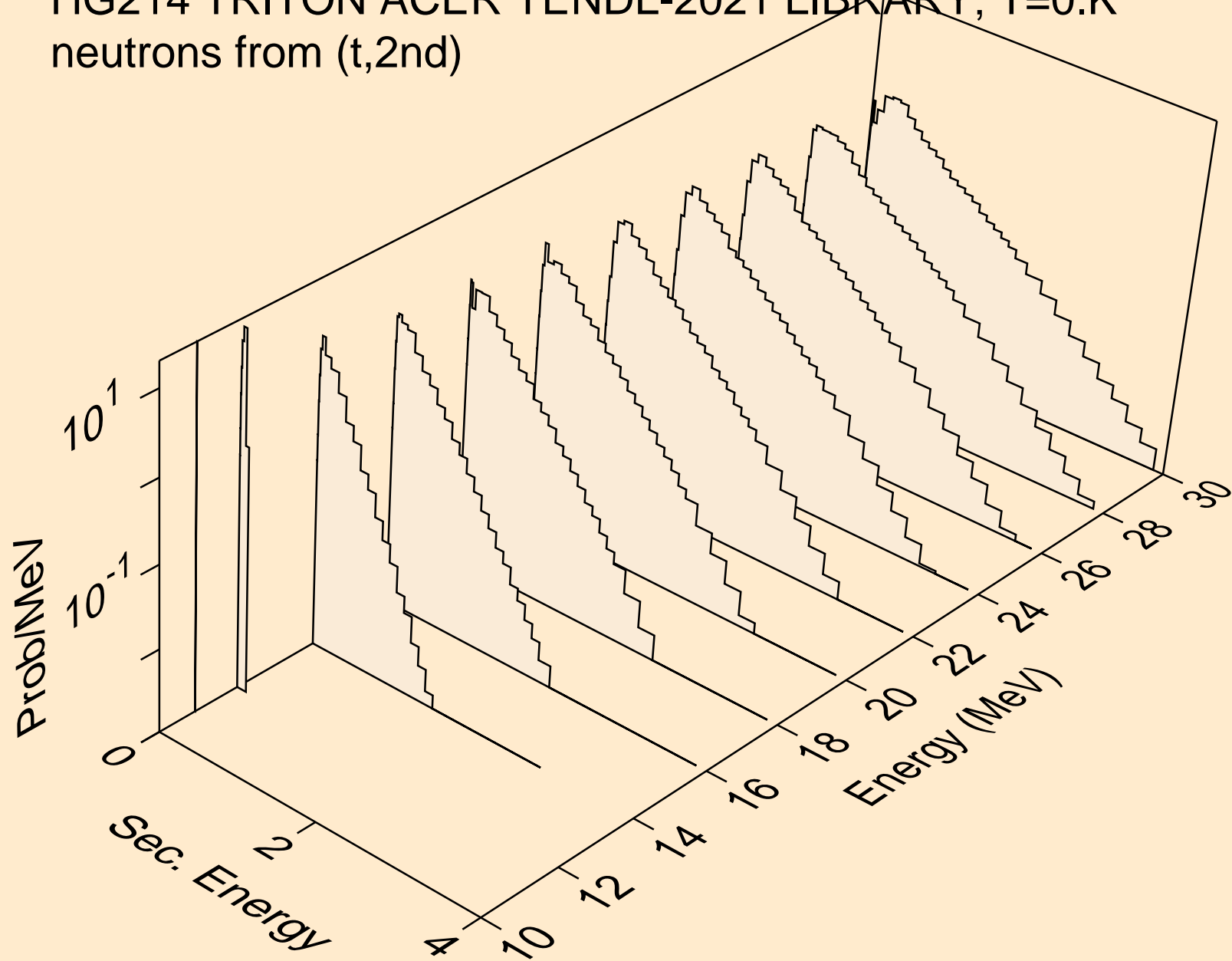

HG214 TRITON ACER TENDL-2021 LIBRARY; T=0.K  
neutrons from (t,2n)

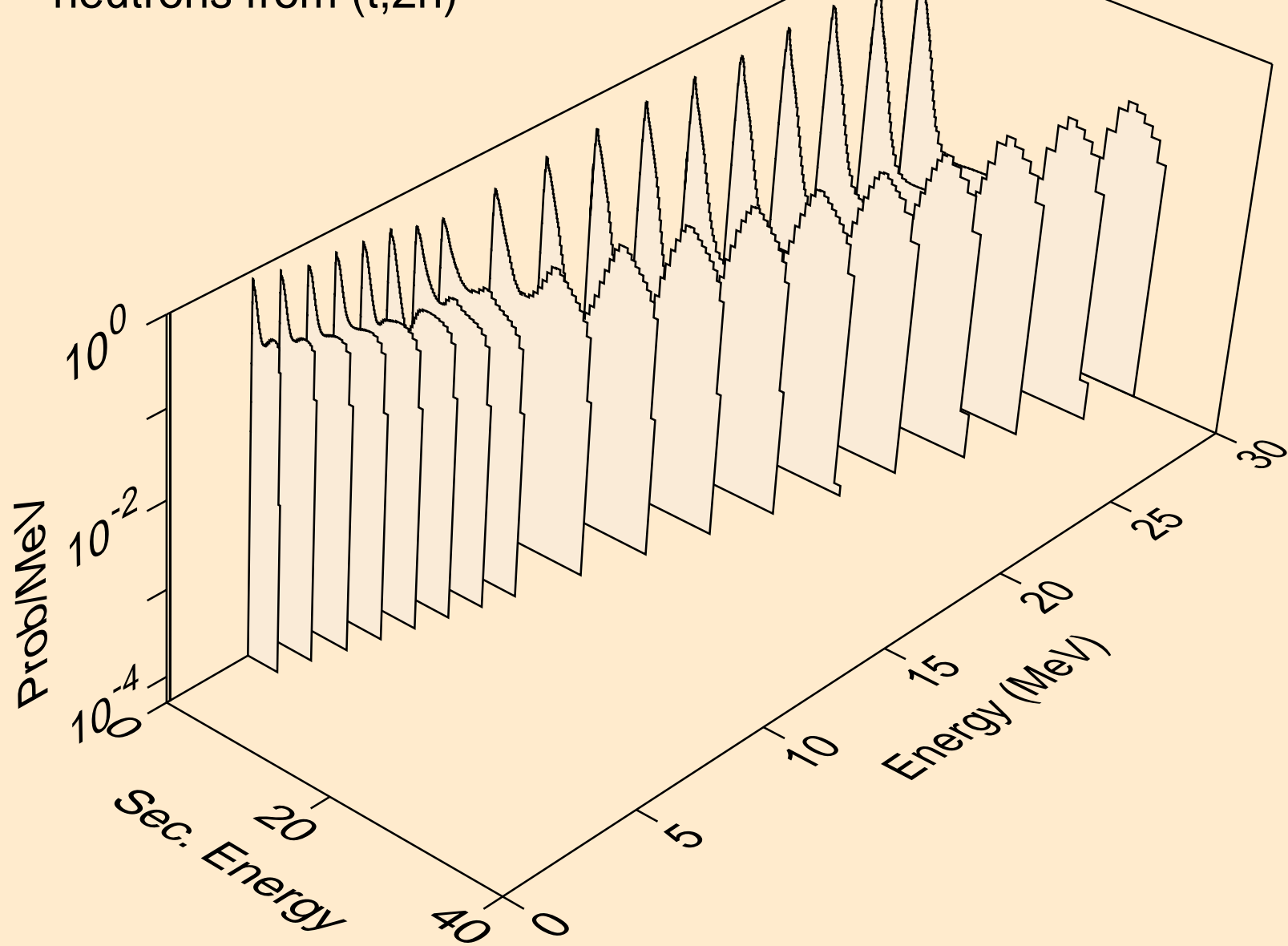

HG214 TRITON ACER TENDL-2021 LIBRARY; T=0.K  
neutrons from (t,3n)

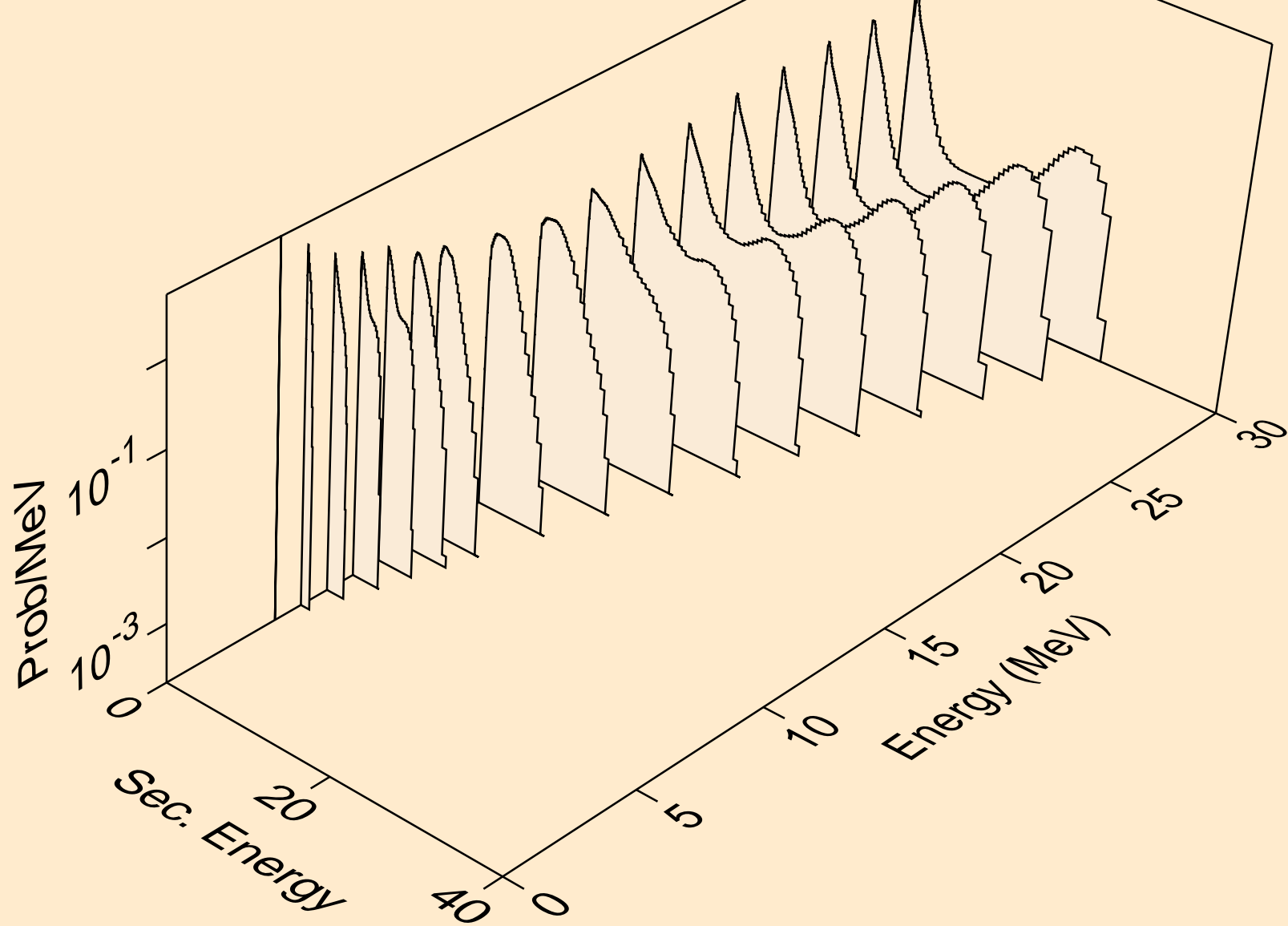

HG214 TRITON ACER TENDL-2021 LIBRARY; T=0.K  
neutrons from (t,n\*)a

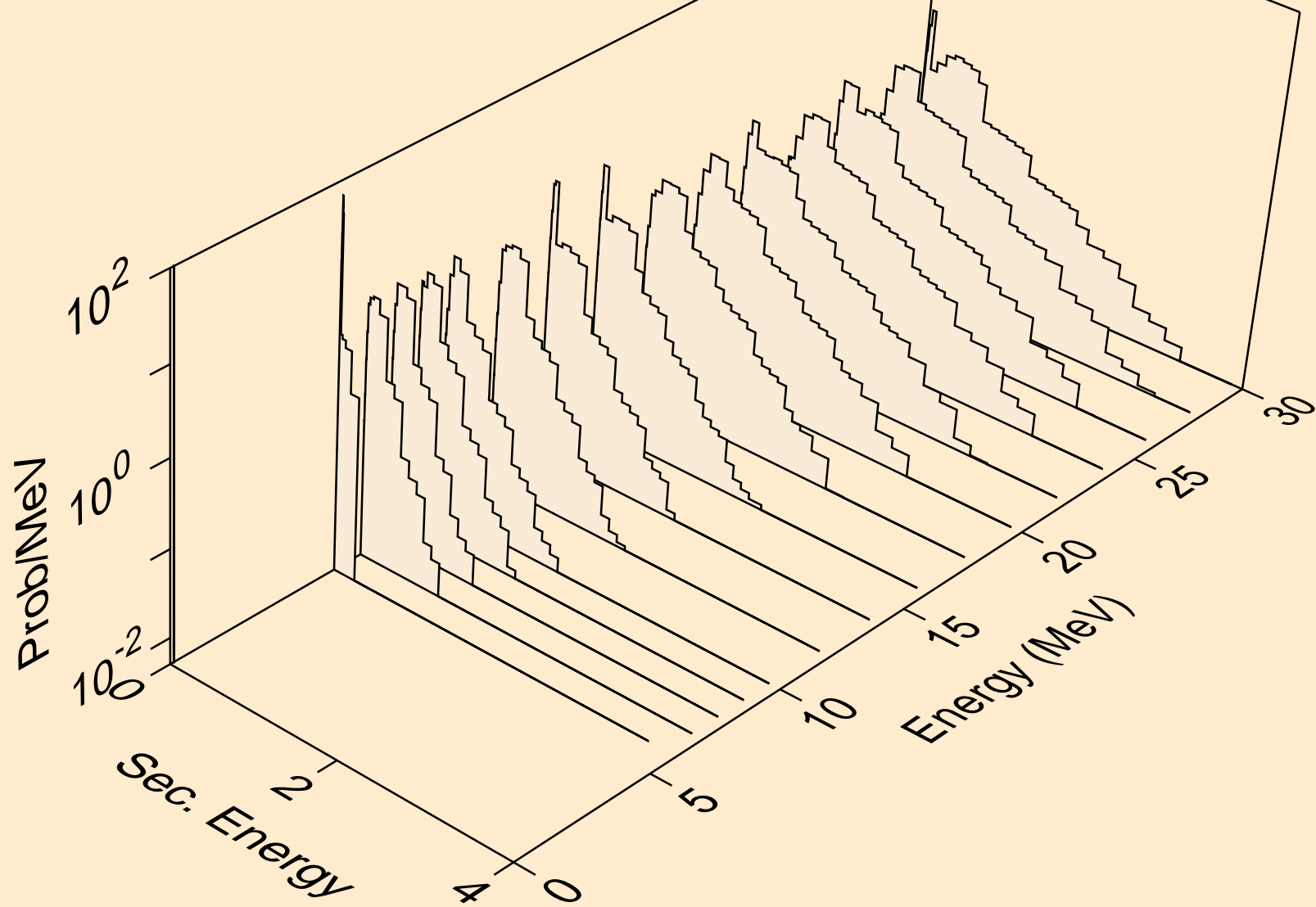

HG214 TRITON ACER TENDL-2021 LIBRARY; T=0.K  
neutrons from (t,2n)a

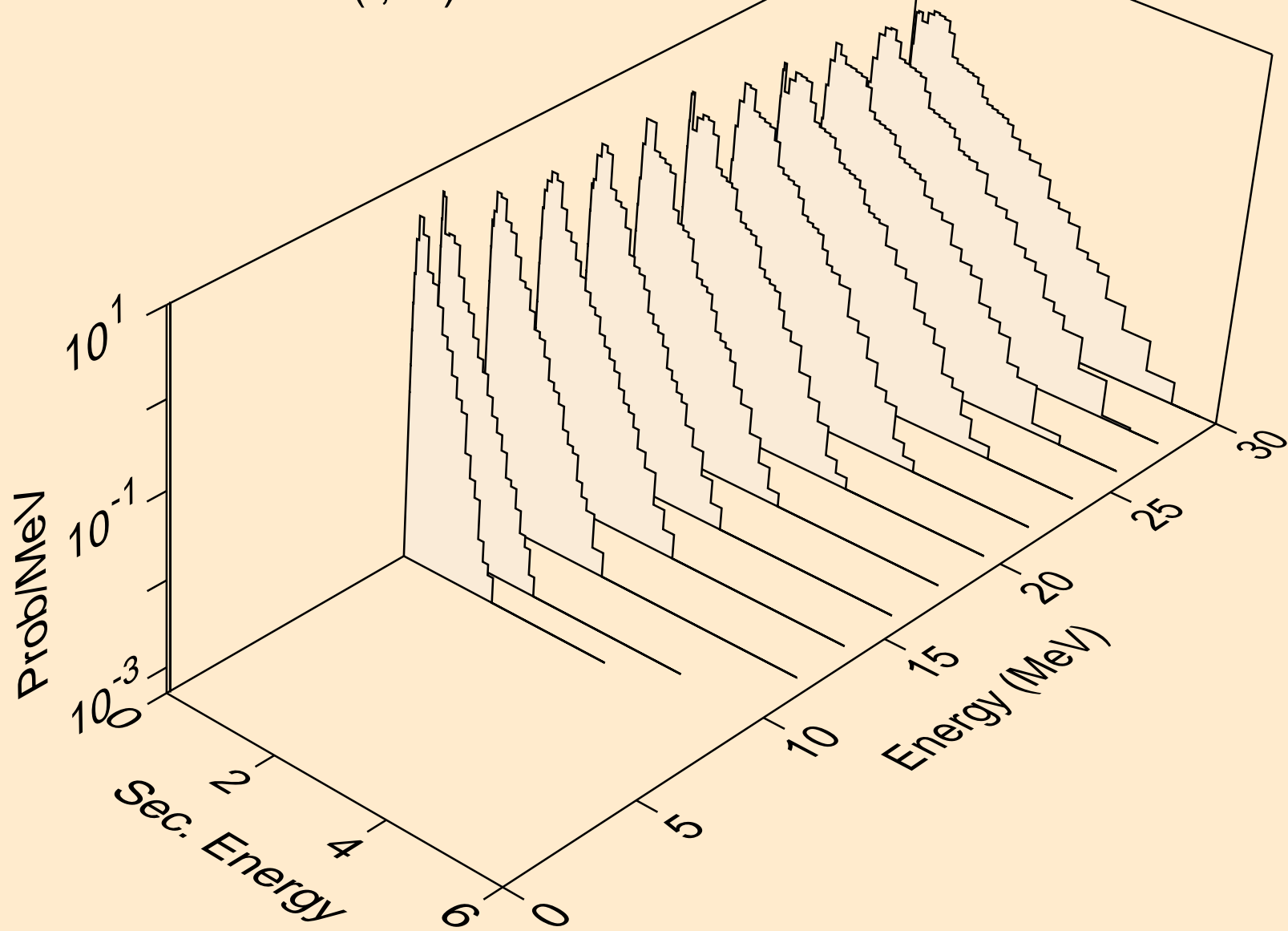

HG214 TRITON ACER TENDL-2021 LIBRARY; T=0.K  
neutrons from (t,3n)a

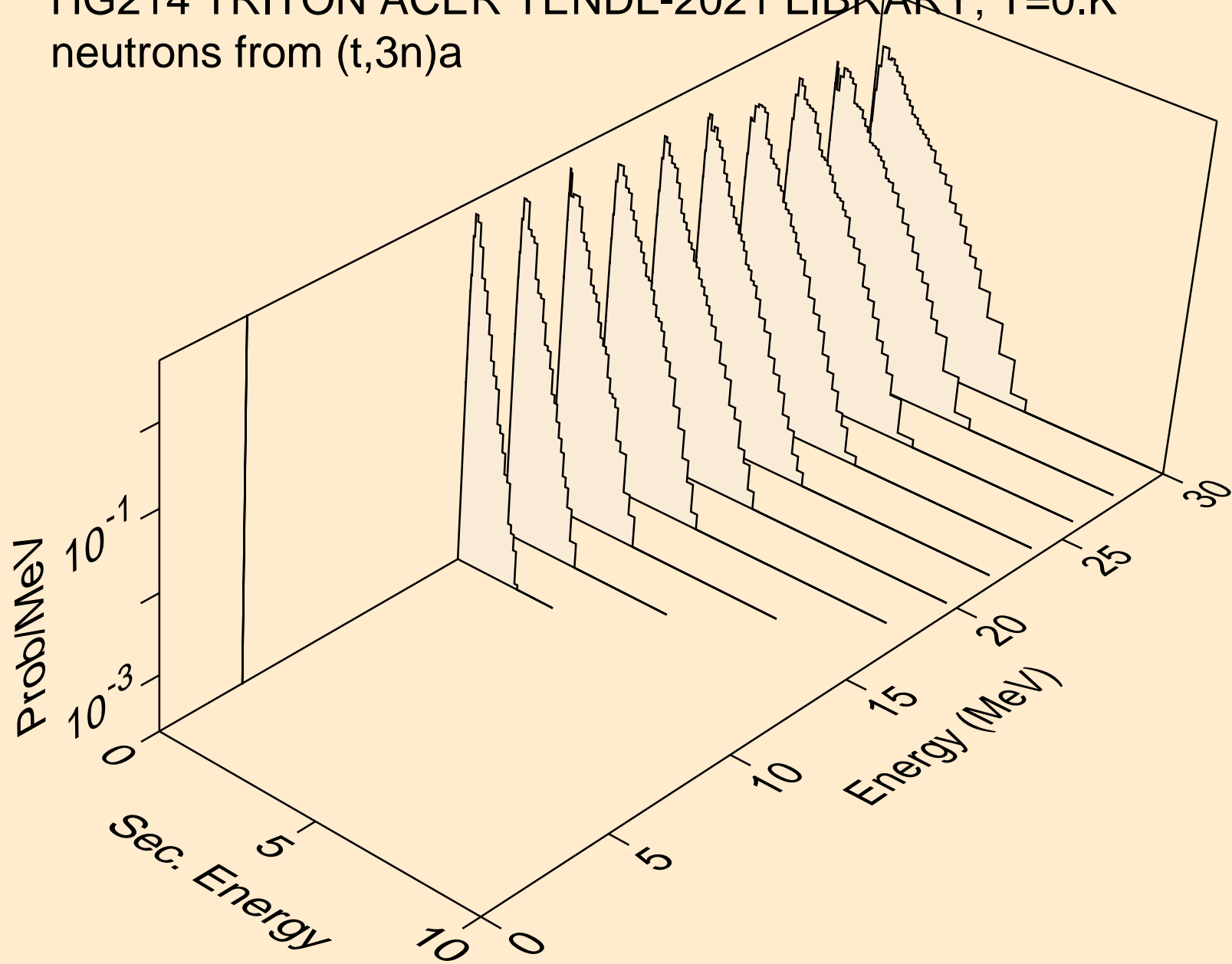

HG214 TRITON ACER TENDL-2021 LIBRARY; T=0.K  
neutrons from (t,n\*)p

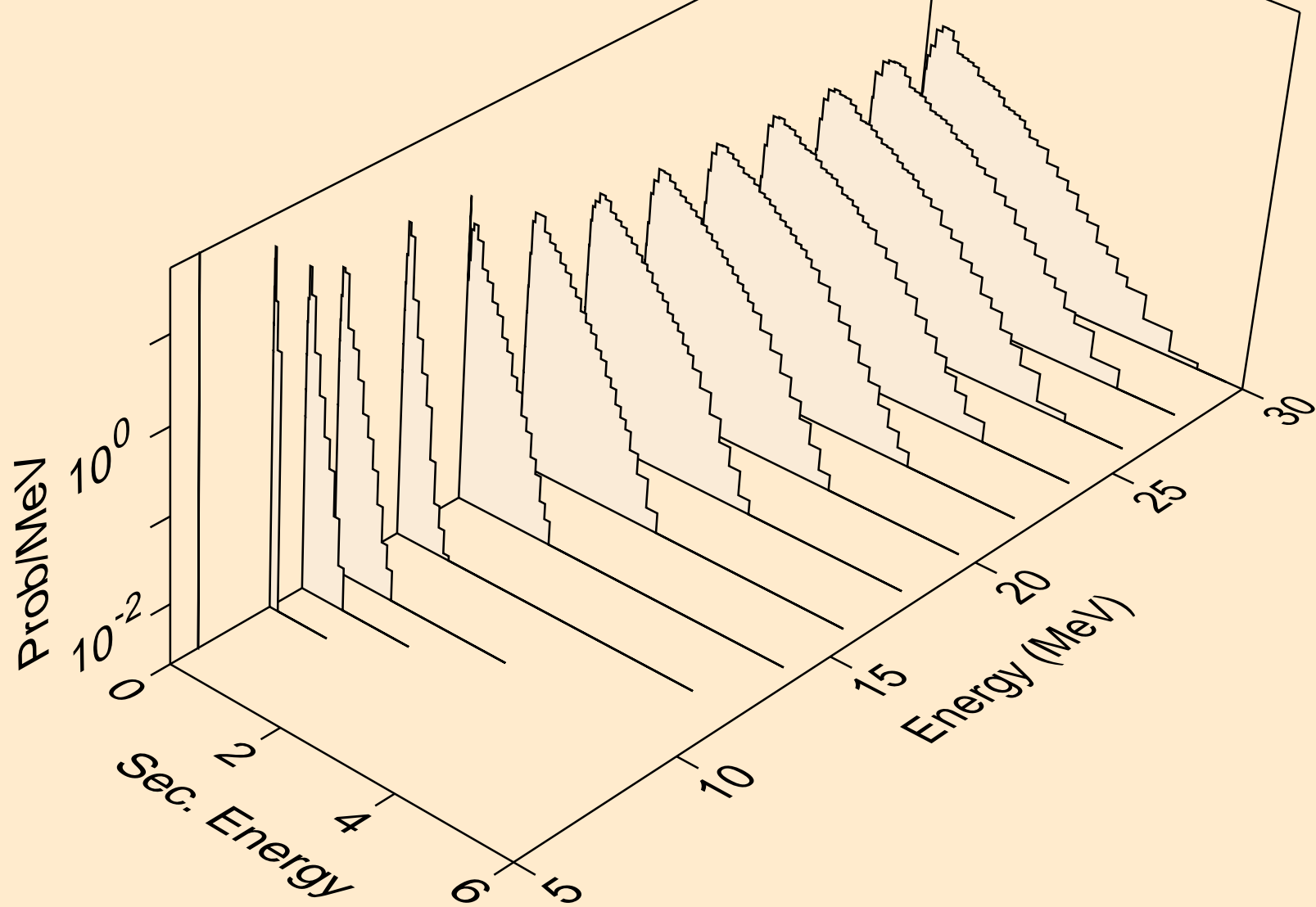

HG214 TRITON ACER TENDL-2021 LIBRARY; T=0.K  
neutrons from (t,n\*)d

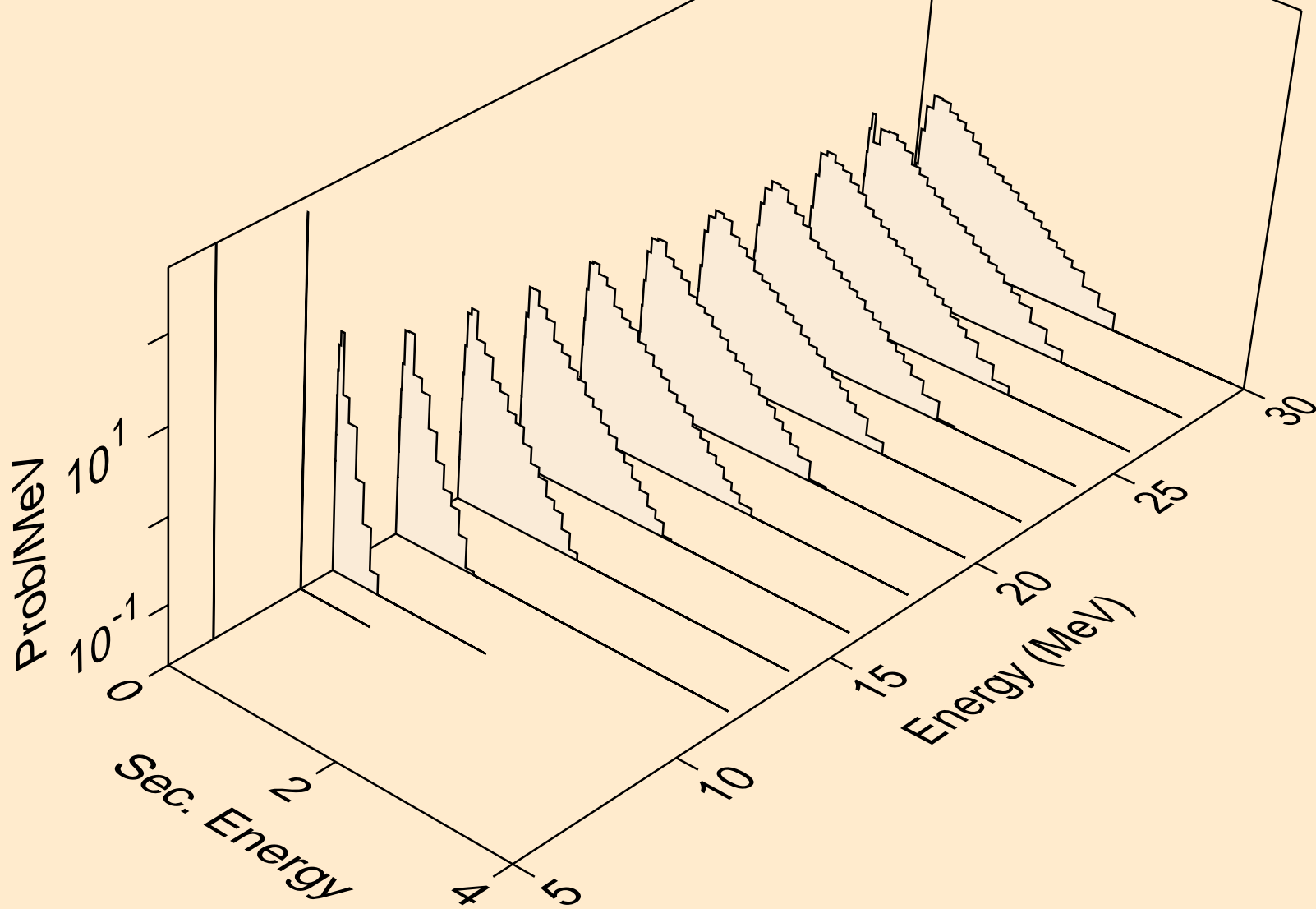

HG214 TRITON ACER TENDL-2021 LIBRARY; T=0.K  
neutrons from (t,n\*)t

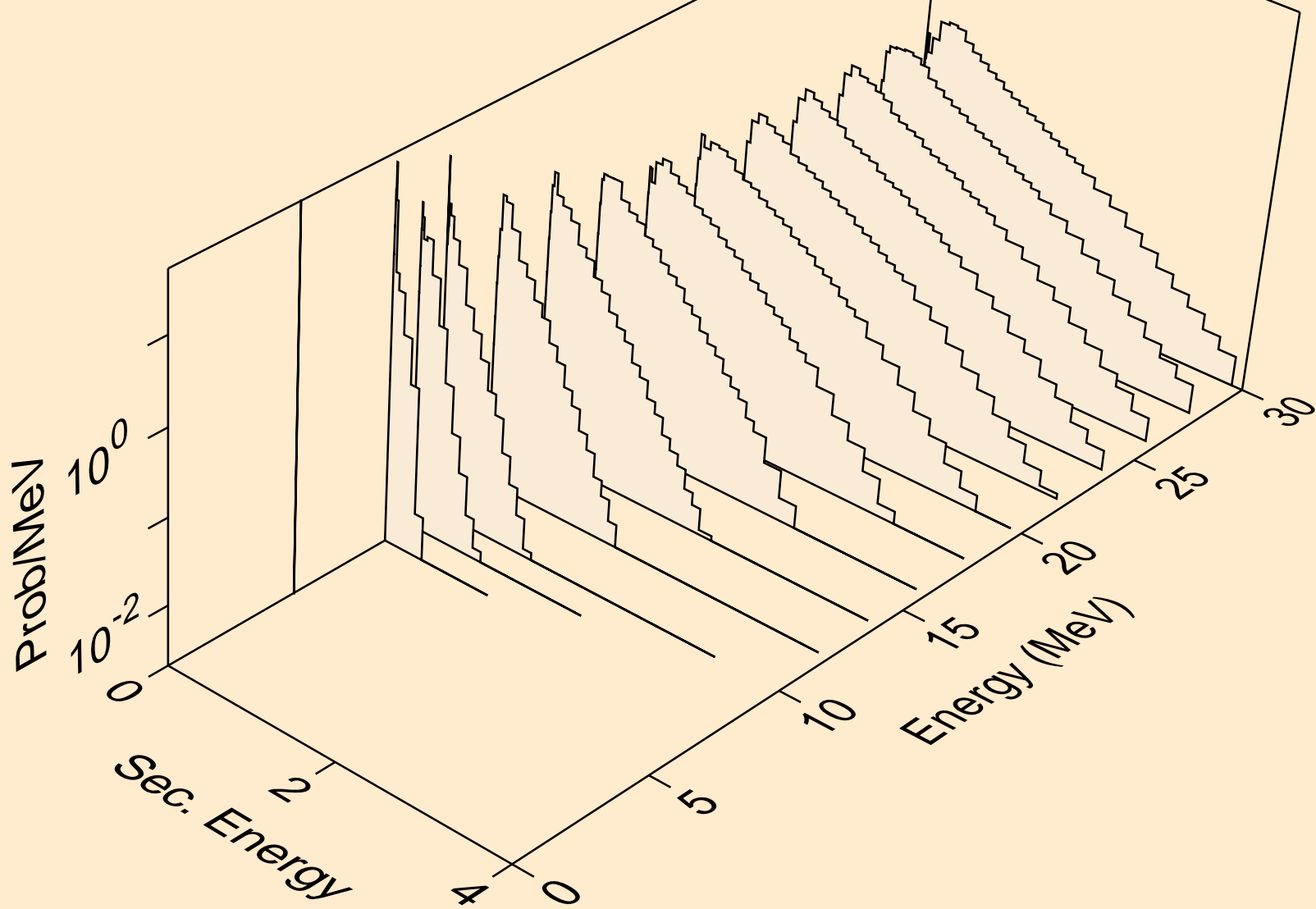

HG214 TRITON ACER TENDL-2021 LIBRARY; T=0.K  
neutrons from (t,n\*)he3

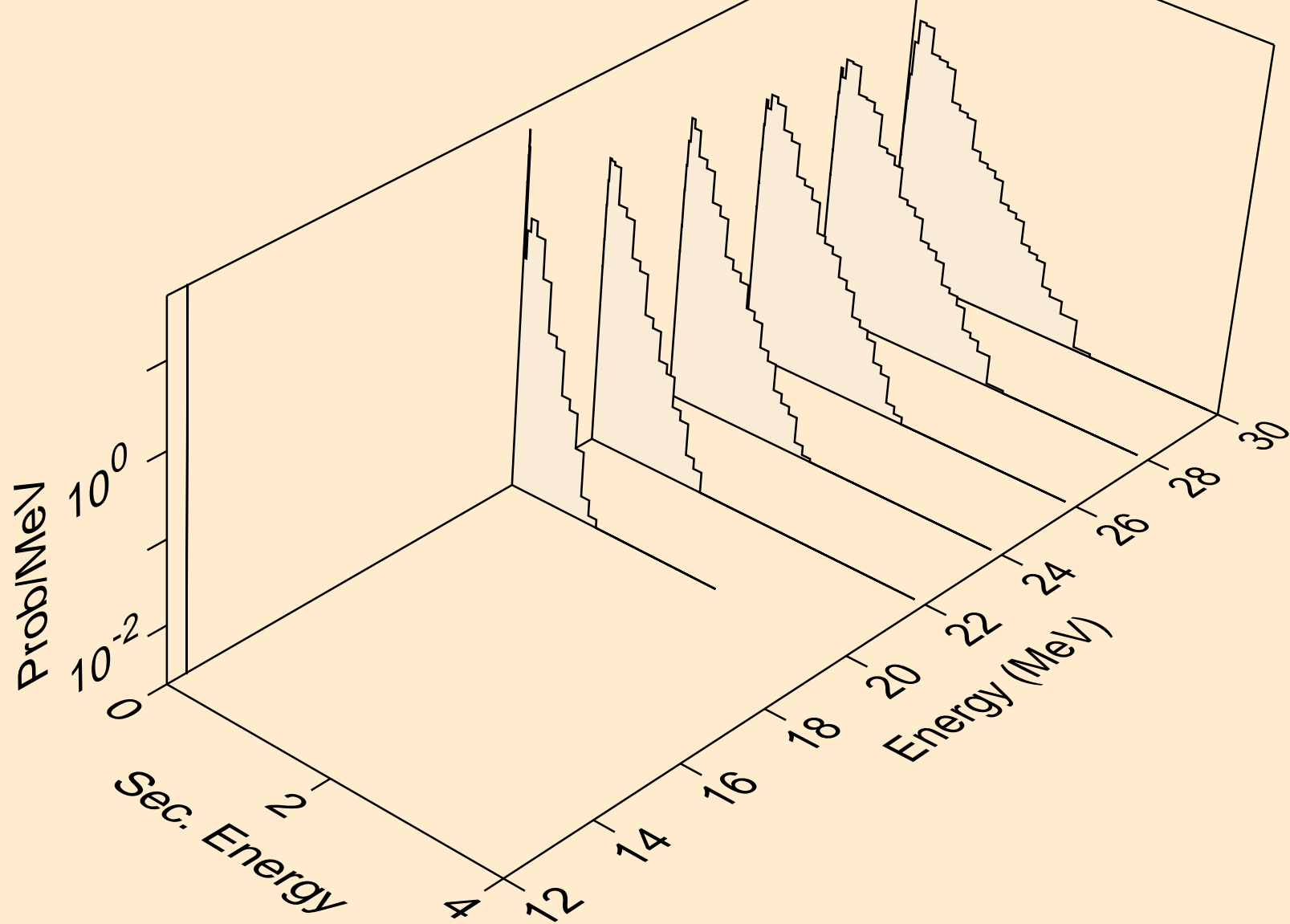

HG214 TRITON ACER TENDL-2021 LIBRARY; T=0.K  
neutrons from (t,4n)

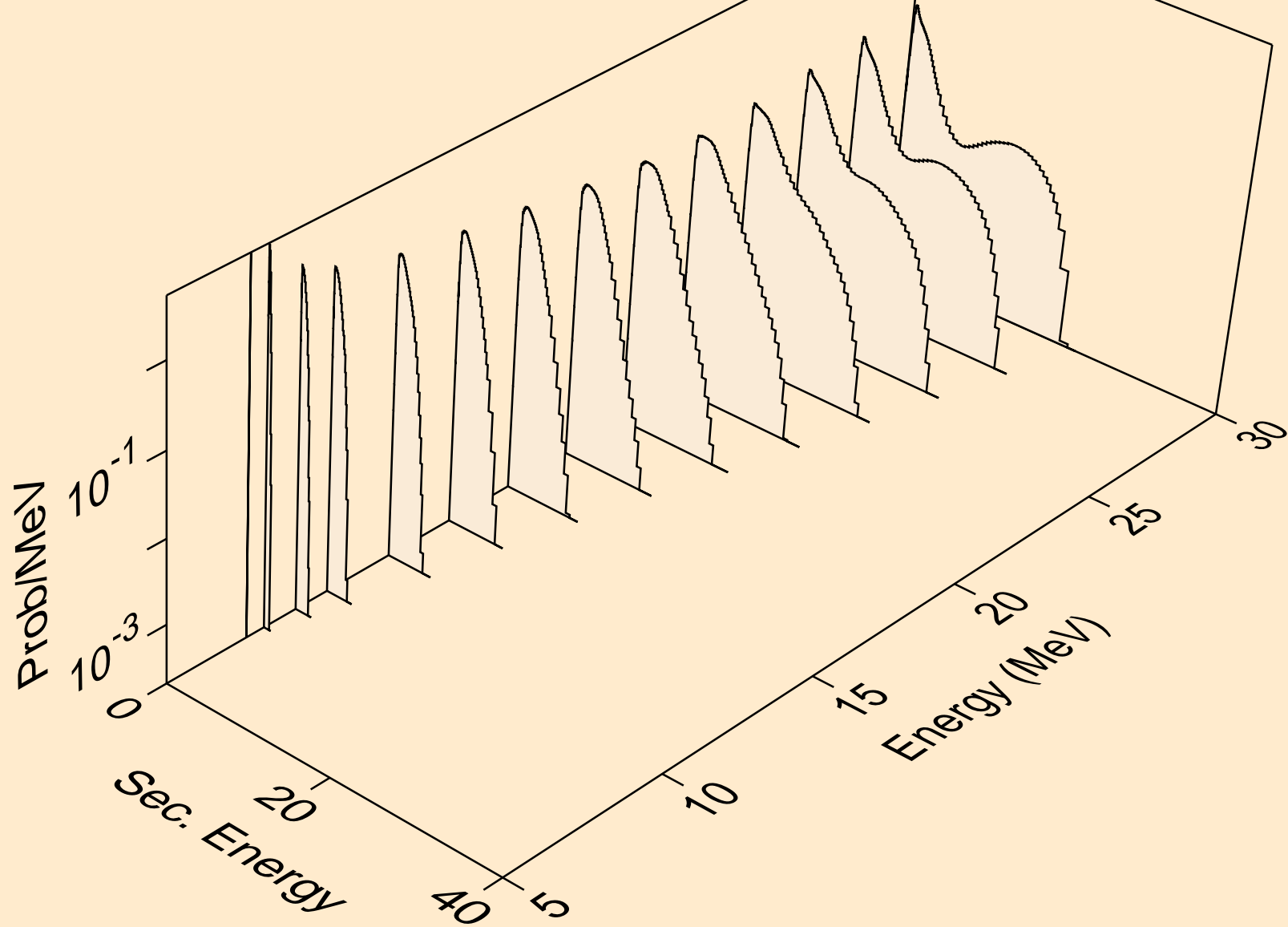

HG214 TRITON ACER TENDL-2021 LIBRARY; T=0.K  
neutrons from (t,2np)

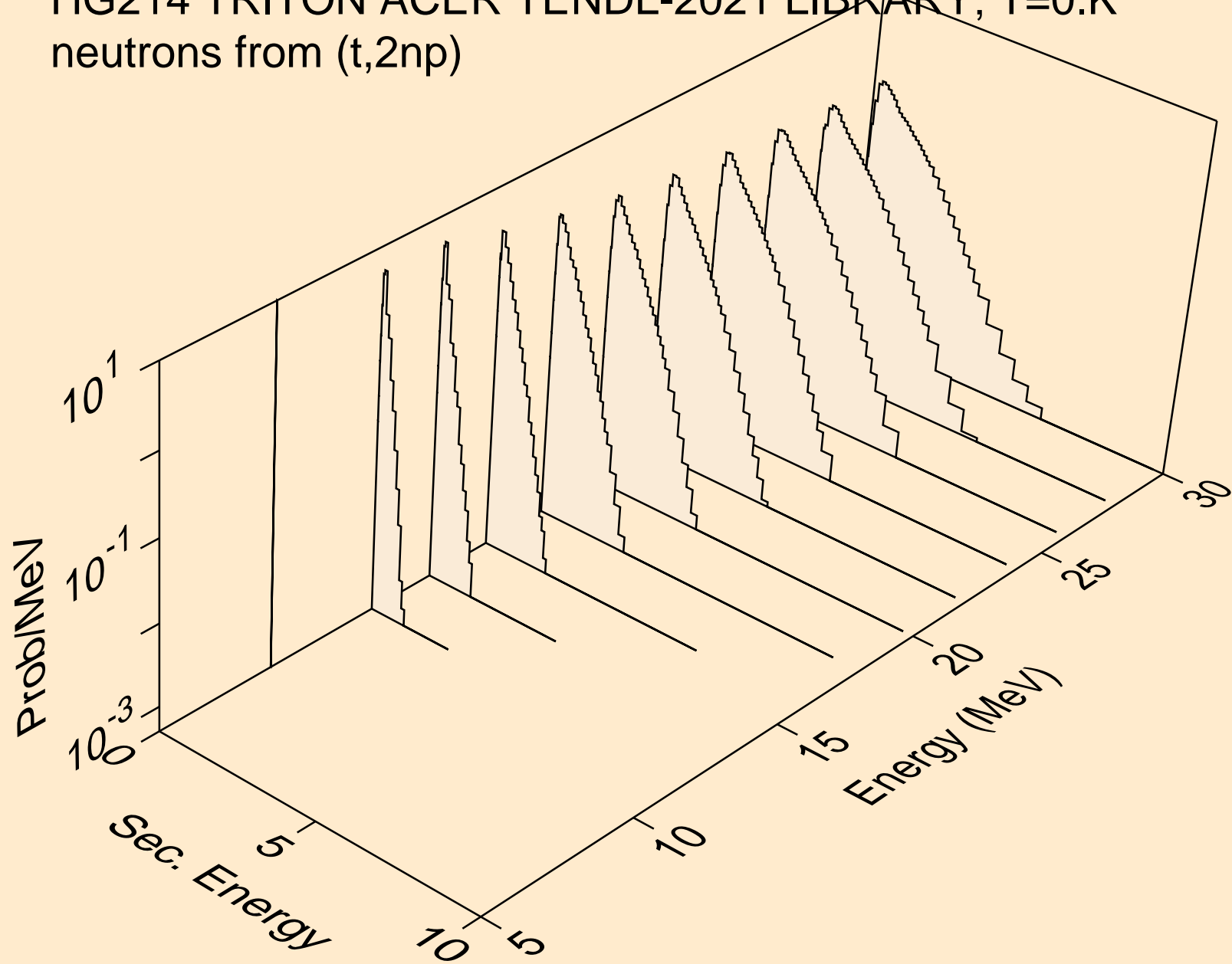

HG214 TRITON ACER TENDL-2021 LIBRARY; T=0.K  
neutrons from (t,3np)

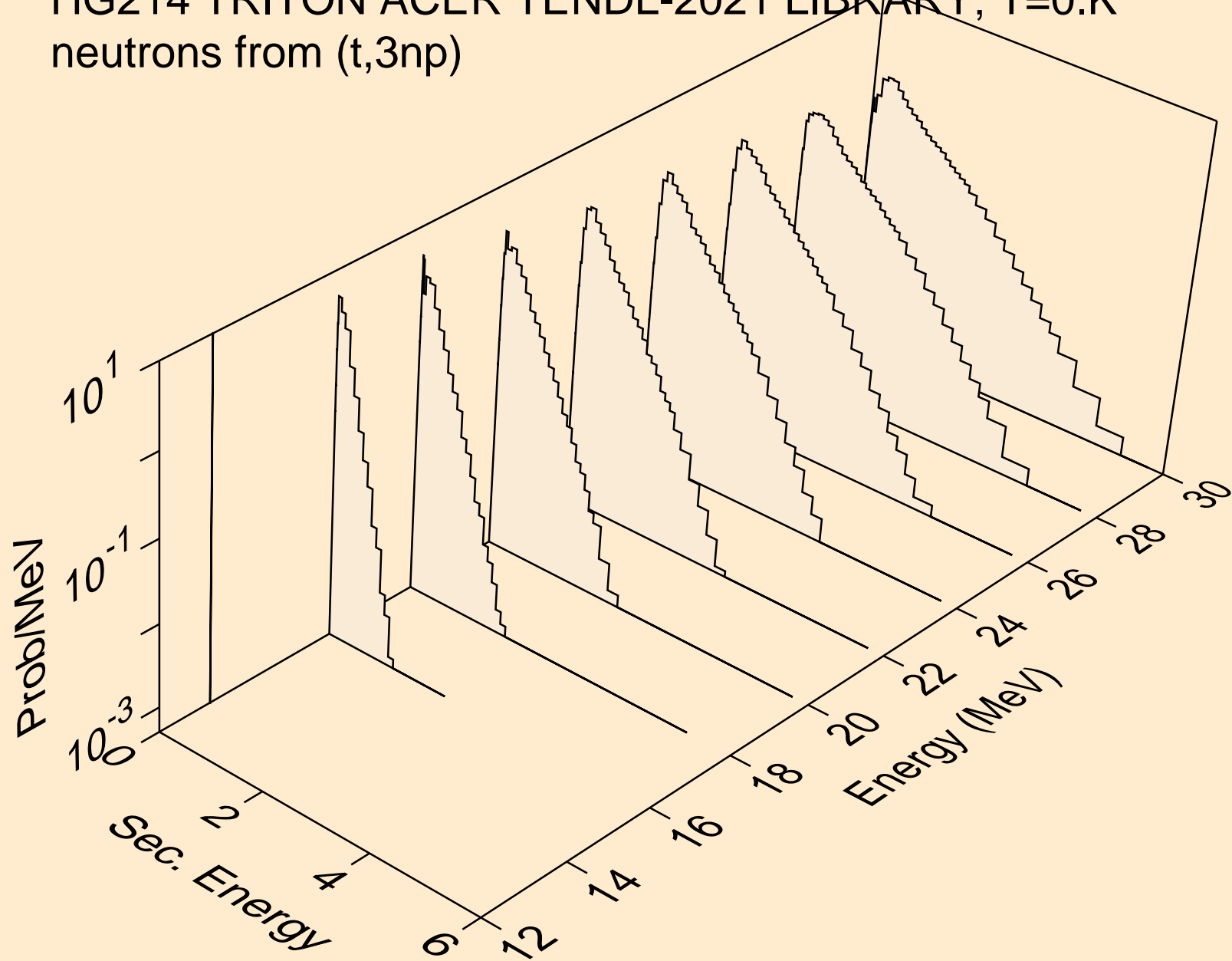

HG214 TRITON ACER TENDL-2021 LIBRARY; T=0.K  
protons from (t,x)

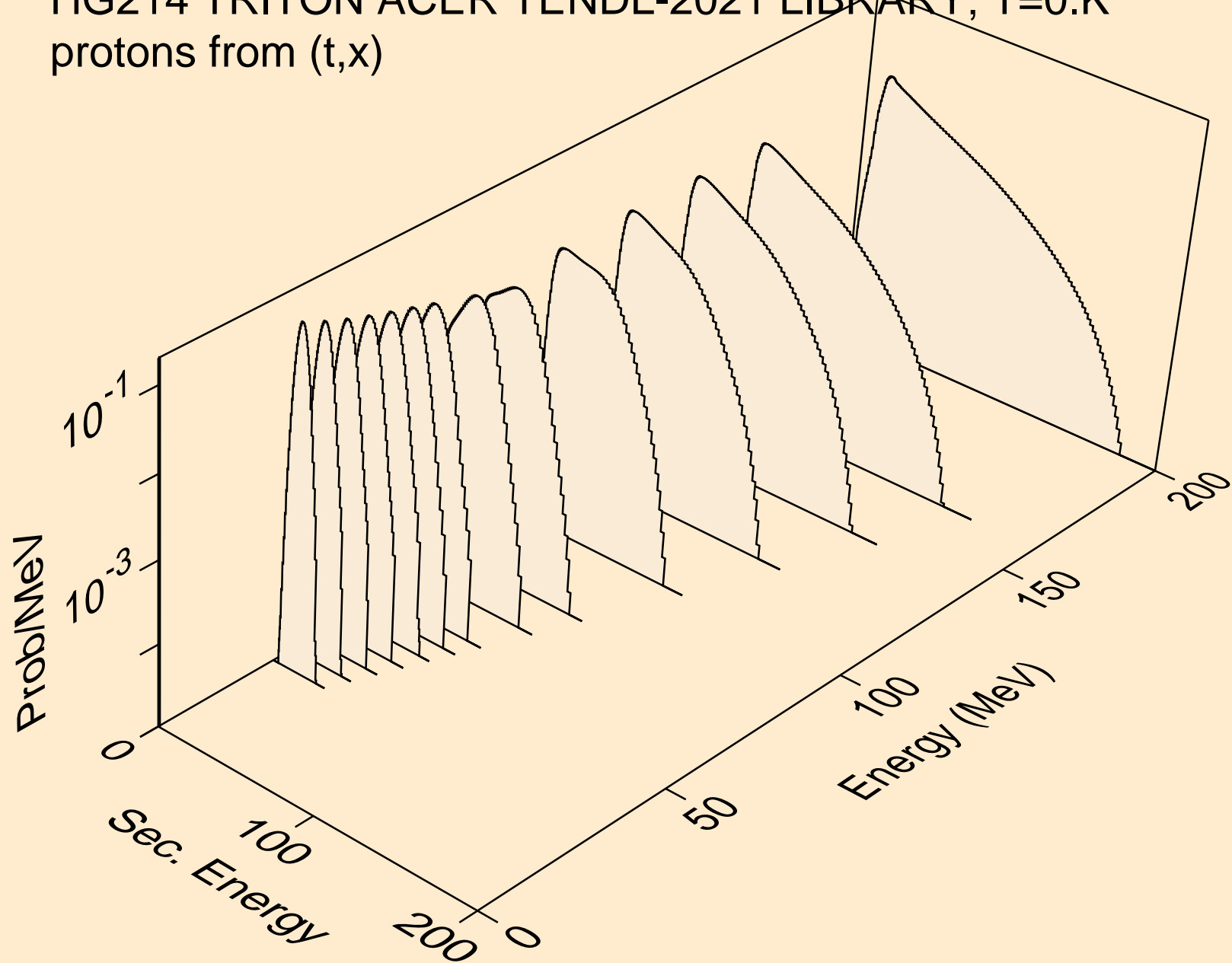

HG214 TRITON ACER TENDL-2021 LIBRARY; T=0.K  
protons from (t,n\*)p

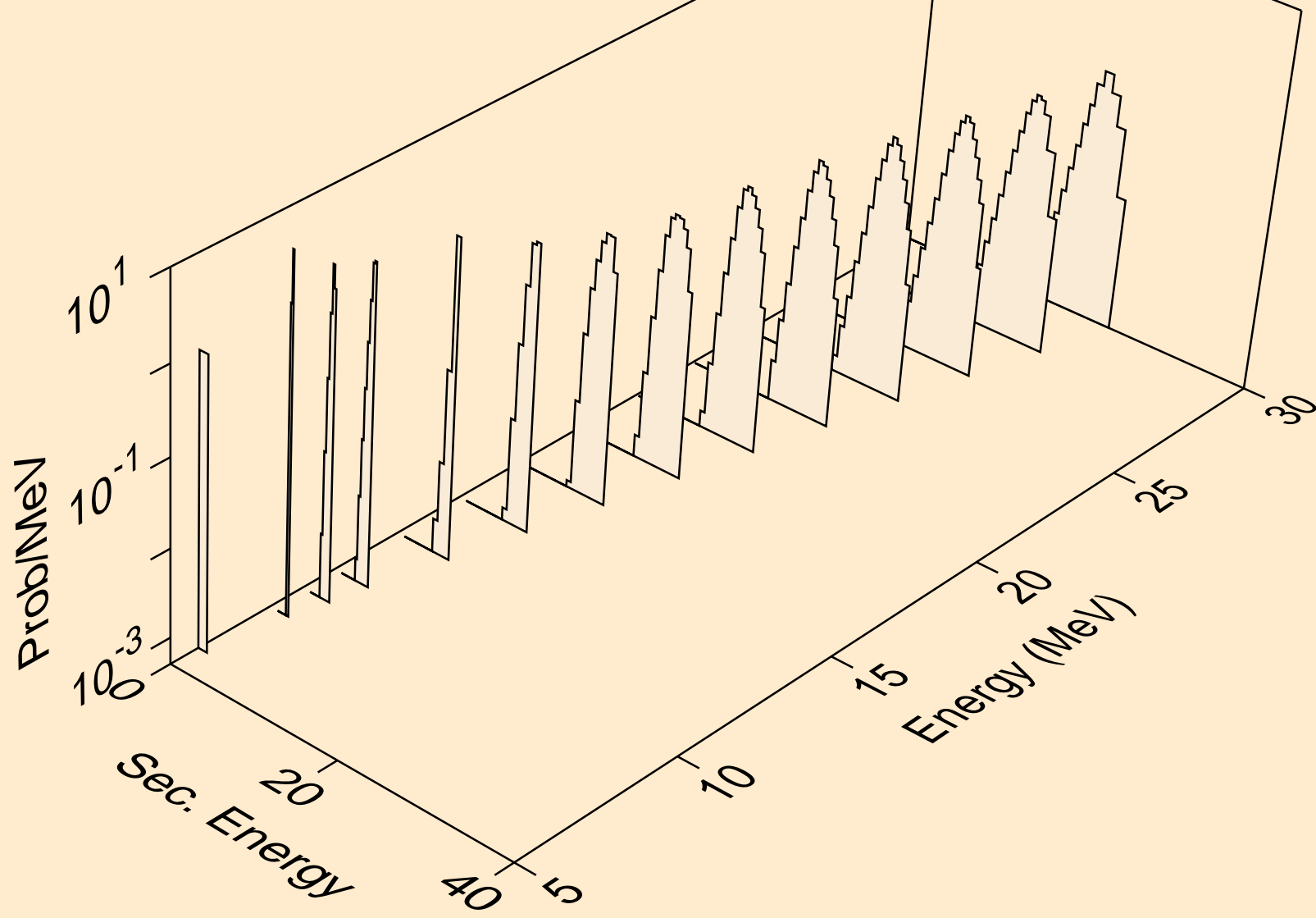

HG214 TRITON ACER TENDL-2021 LIBRARY; T=0.K  
protons from (t,2np)

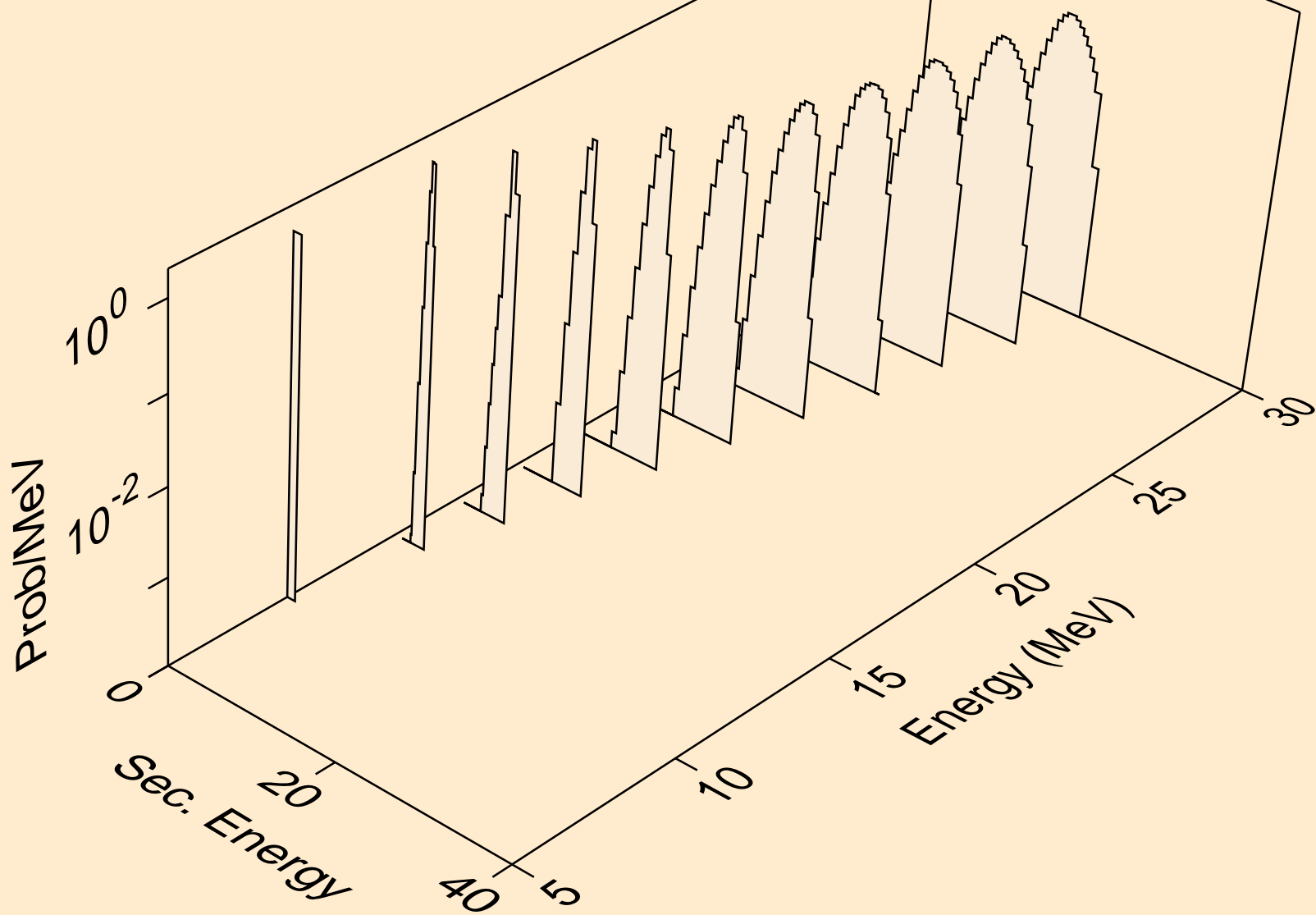

HG214 TRITON ACER TENDL-2021 LIBRARY; T=0.K  
protons from (t,3np)

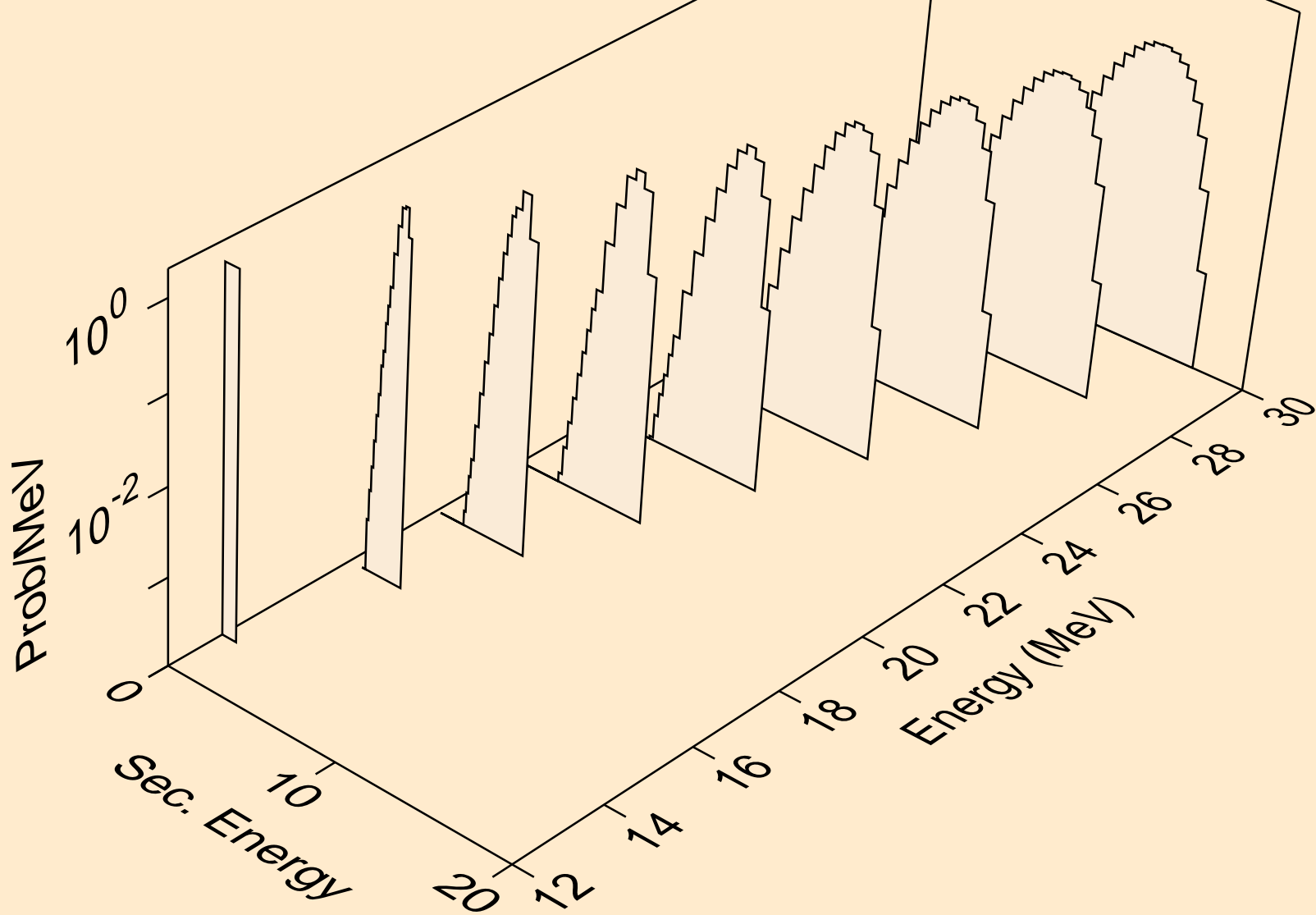

HG214 TRITON ACER TENDL-2021 LIBRARY; T=0.K  
protons from (t,p)

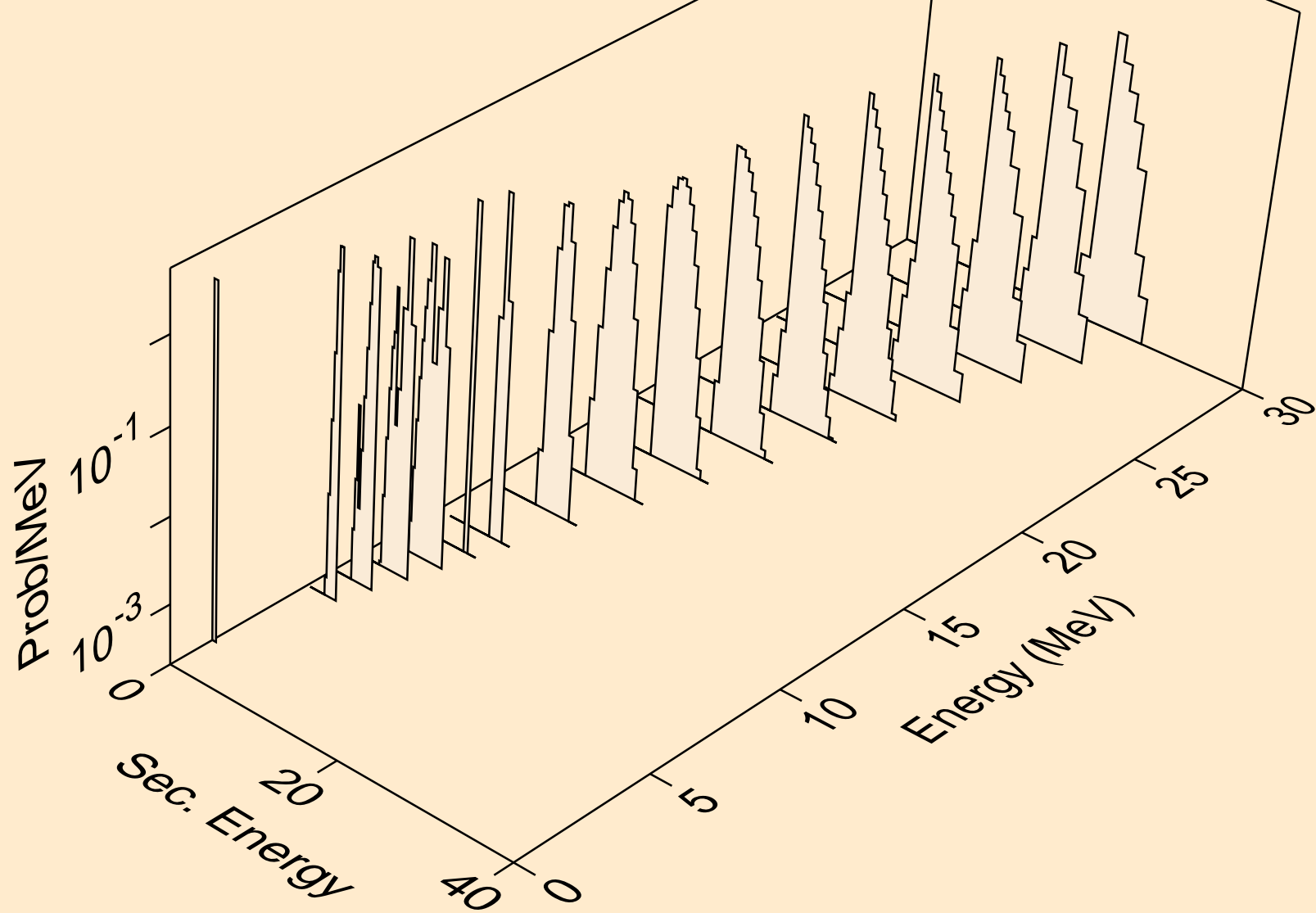

HG214 TRITON ACER TENDL-2021 LIBRARY; T=0.K  
deuterons from (t,x)

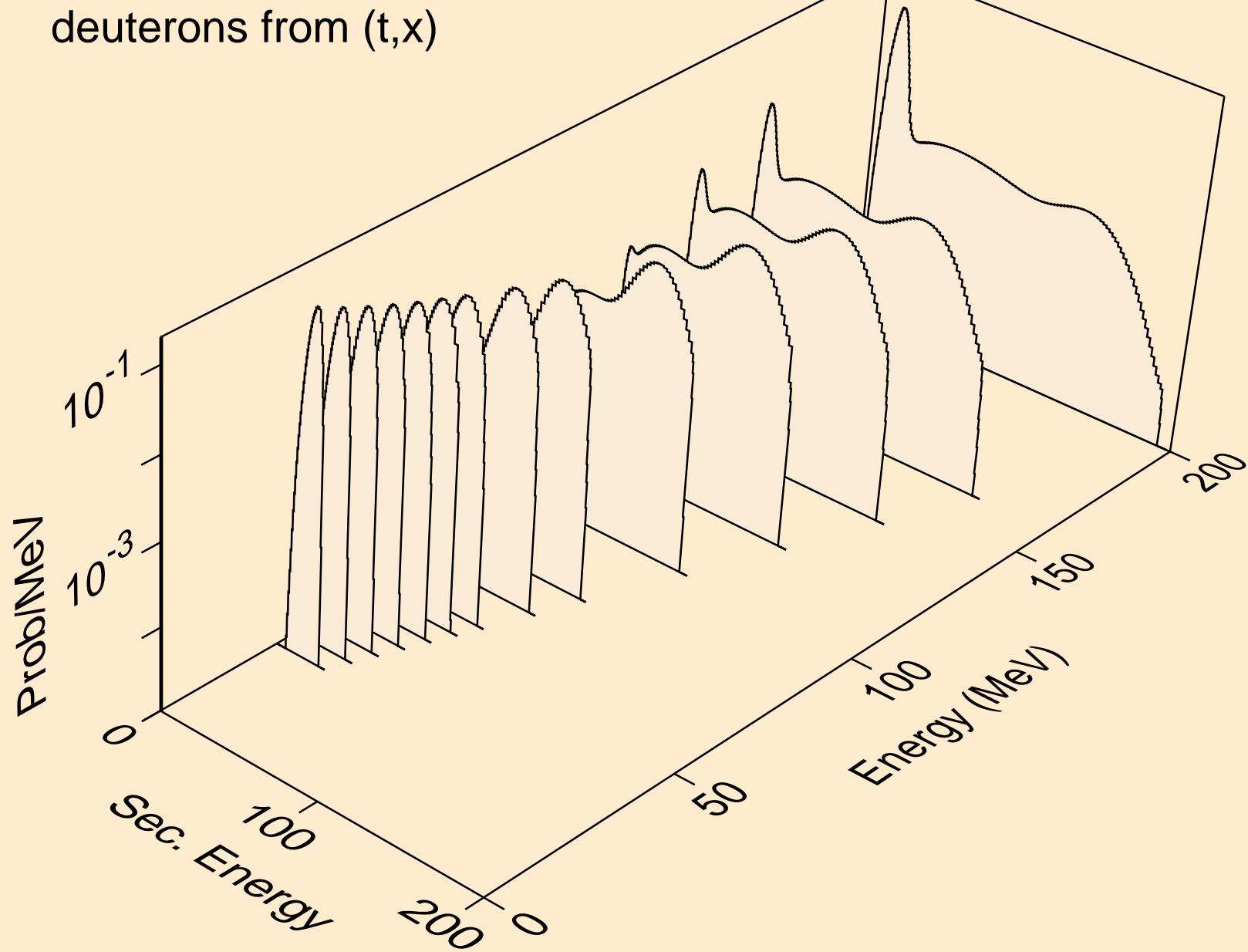

HG214 TRITON ACER TENDL-2021 LIBRARY; T=0.K  
deuterons from (t,2nd)

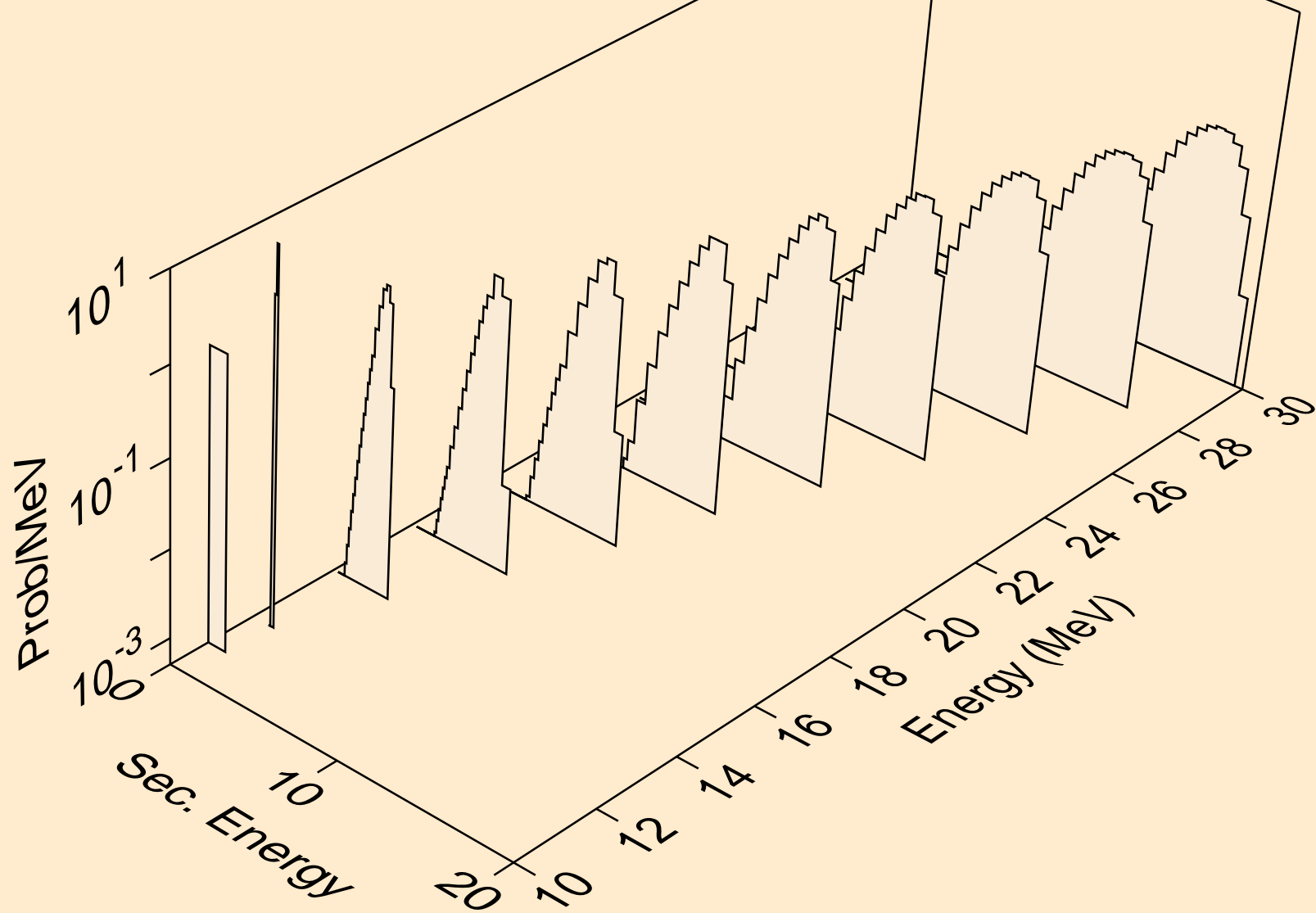

HG214 TRITON ACER TENDL-2021 LIBRARY; T=0.K  
deuterons from (t,n\*)d

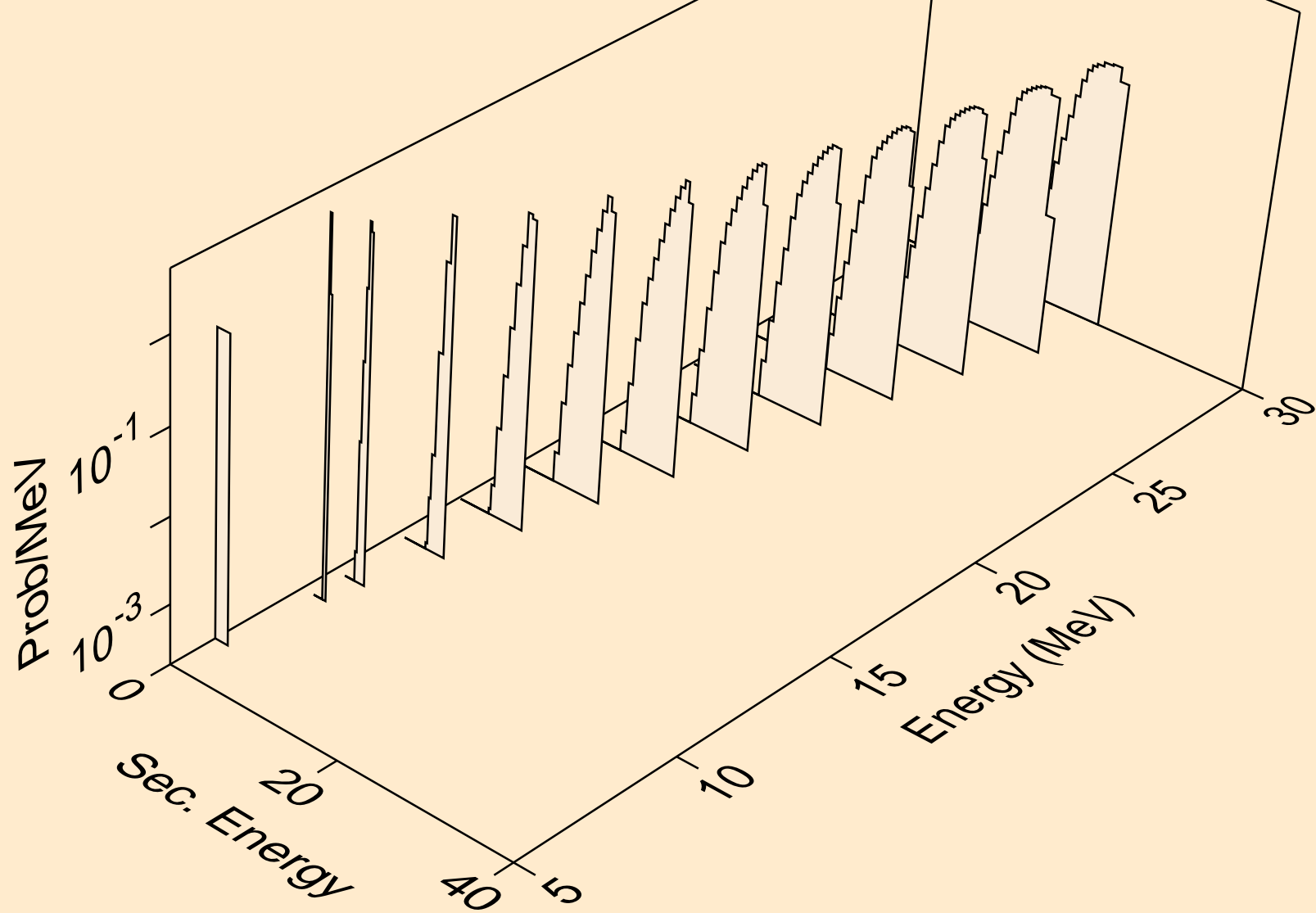

HG214 TRITON ACER TENDL-2021 LIBRARY; T=0.K  
deuterons from (t,d)

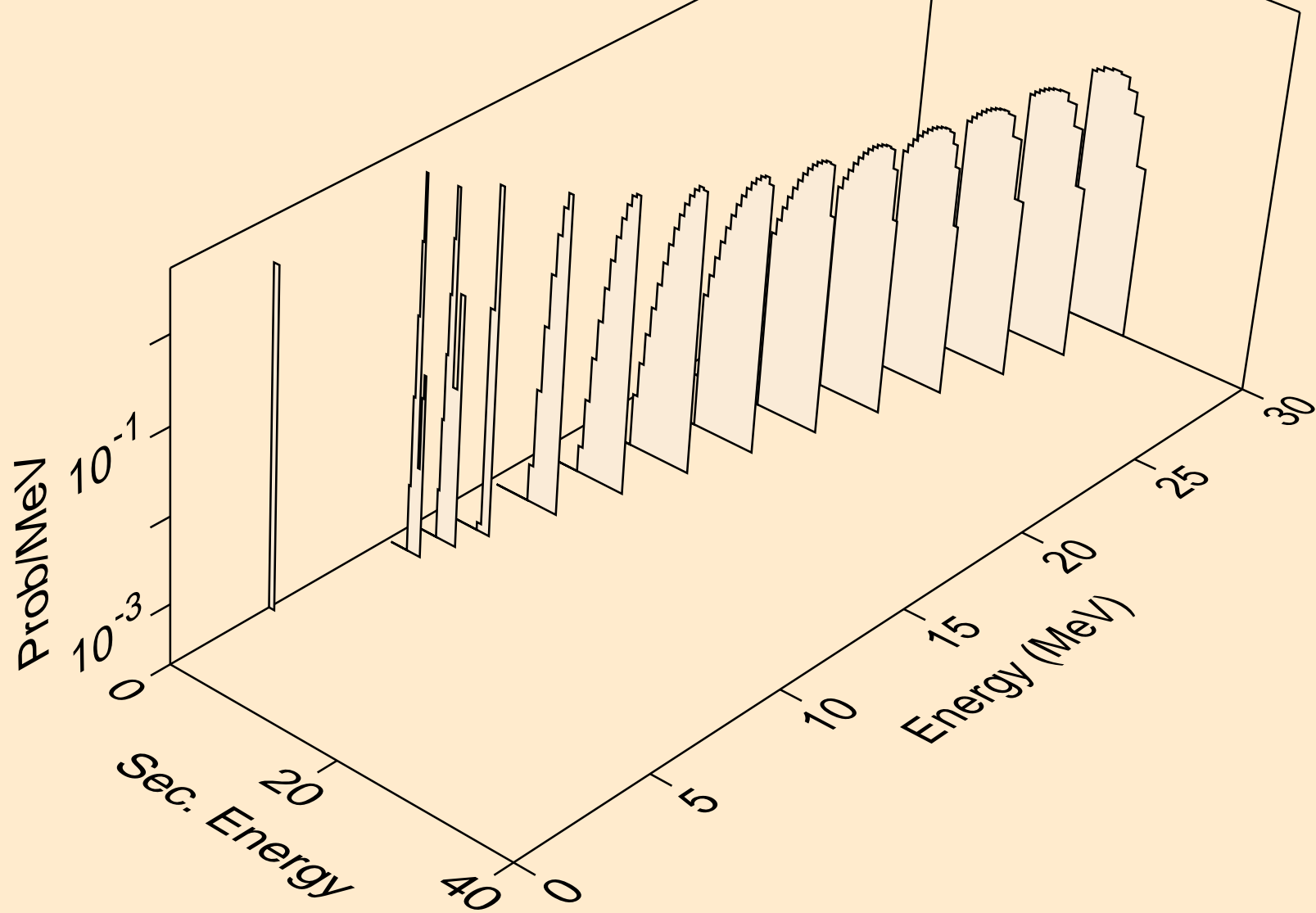

HG214 TRITON ACER TENDL-2021 LIBRARY; T=0.K  
he3s from (t,x)

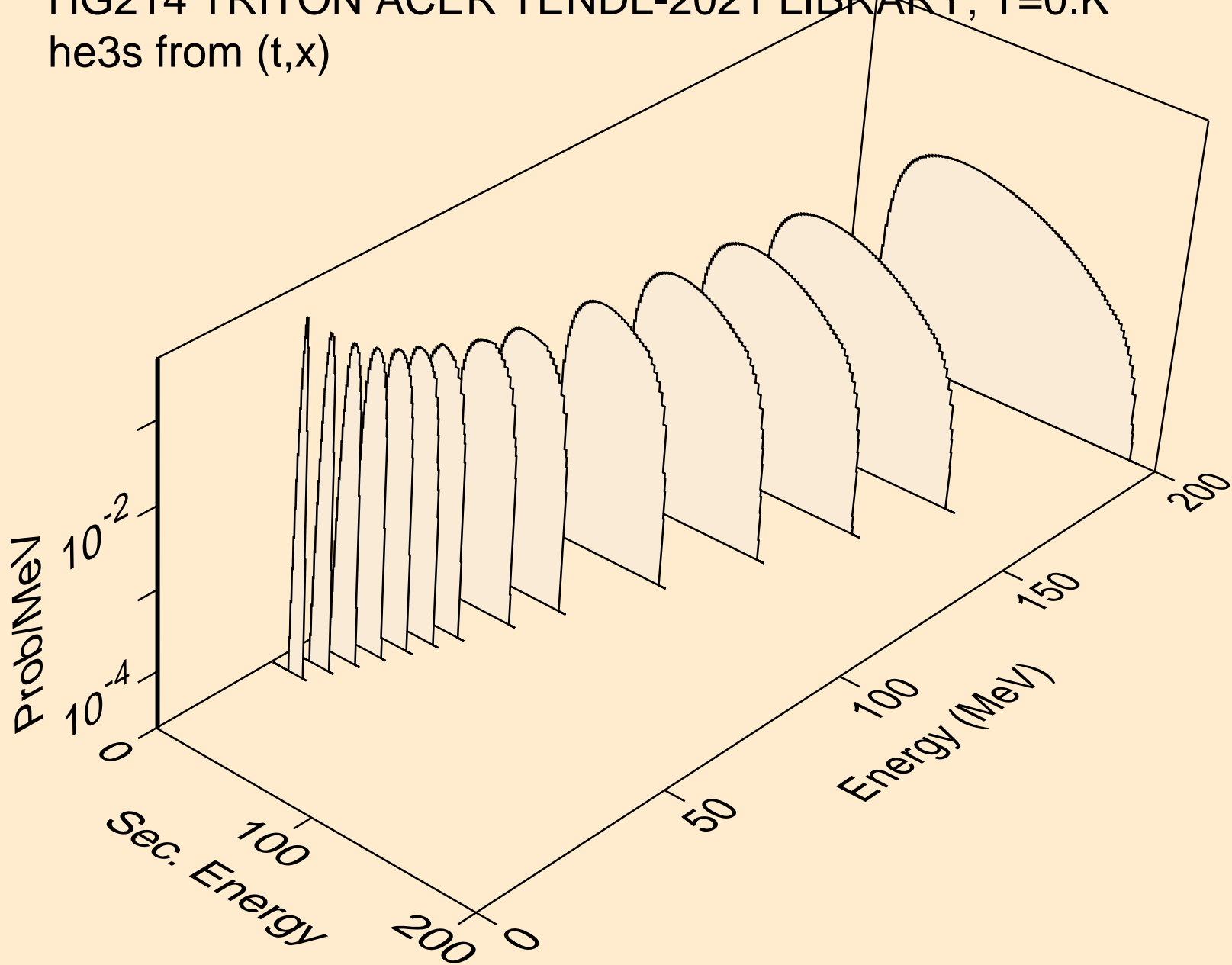

HG214 TRITON ACER TENDL-2021 LIBRARY; T=0.K  
he3s from (t,n\*)he3

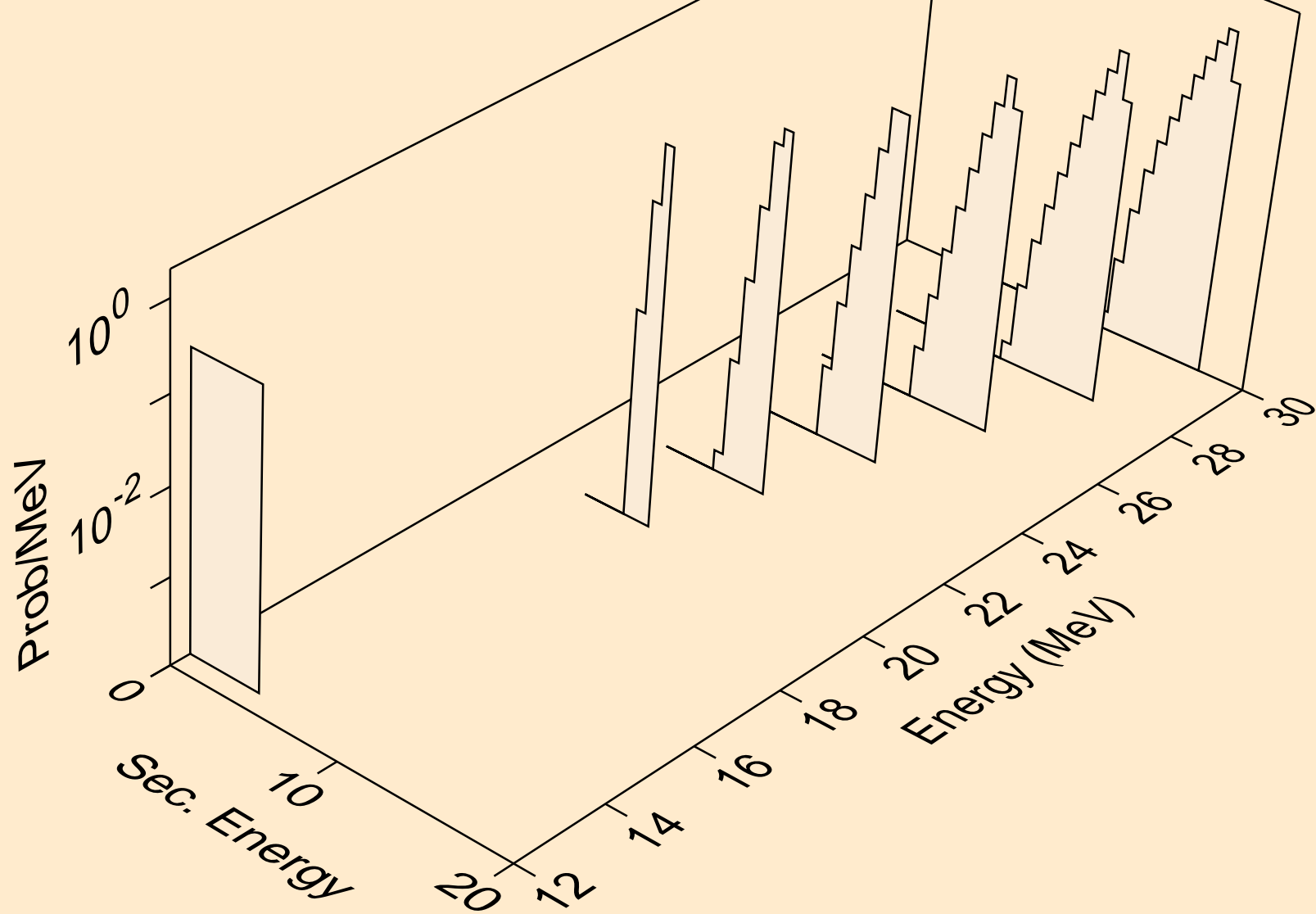

HG214 TRITON ACER TENDL-2021 LIBRARY; T=0.K  
he3s from (t,he3)

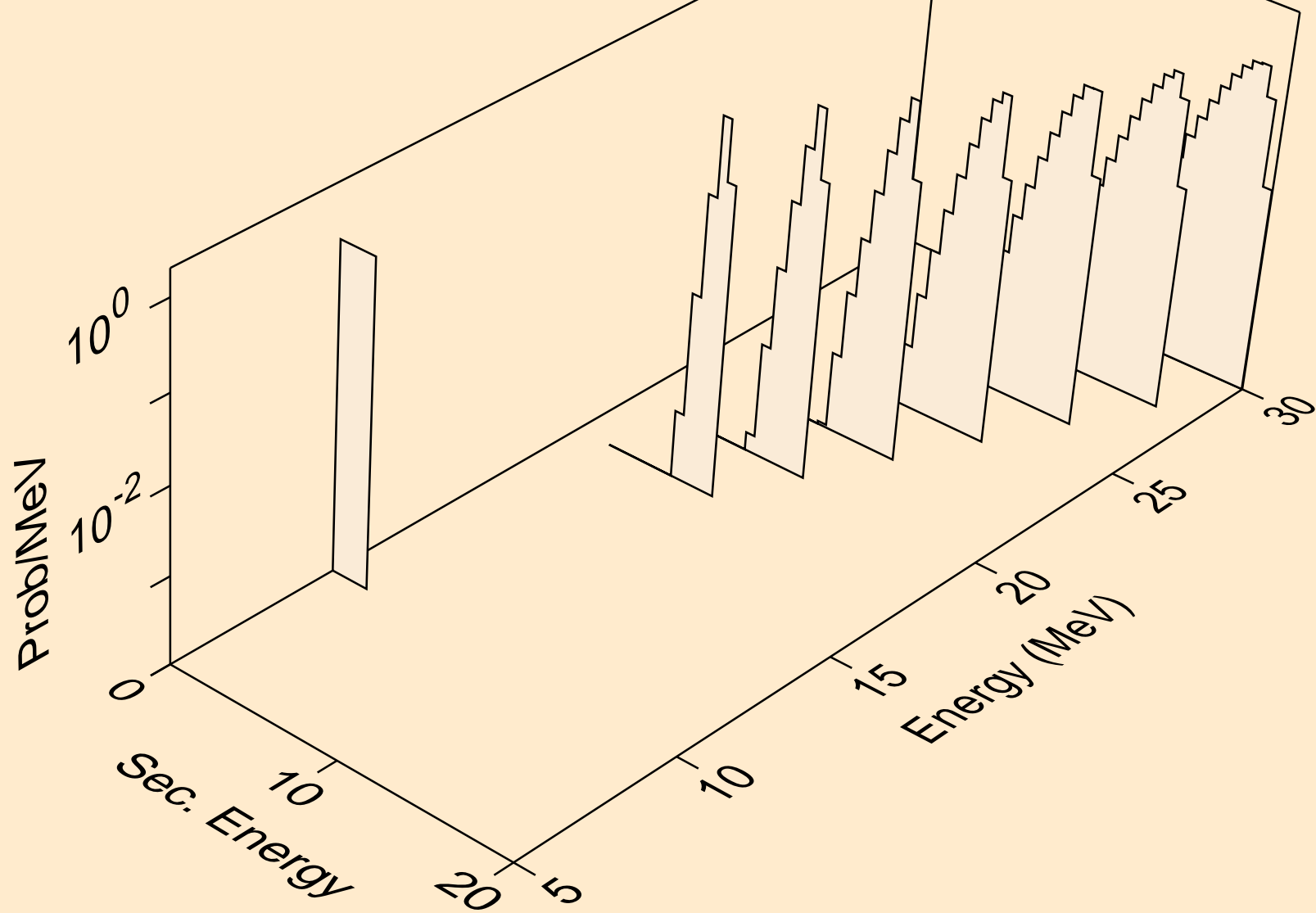

HG214 TRITON ACER TENDL-2021 LIBRARY; T=0.K  
alphas from (t,x)

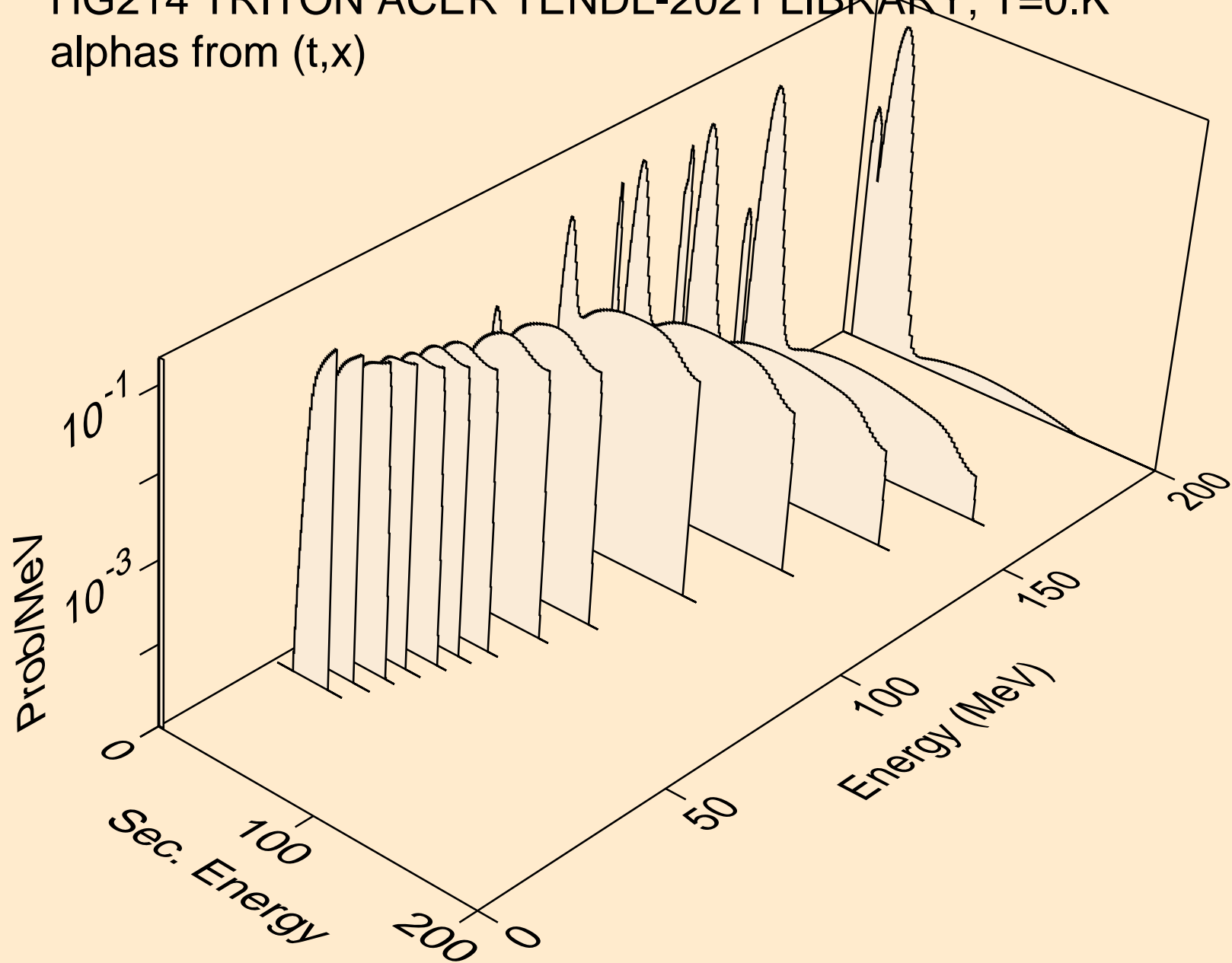

HG214 TRITON ACER TENDL-2021 LIBRARY; T=0.K  
alphas from (t,n\*)a

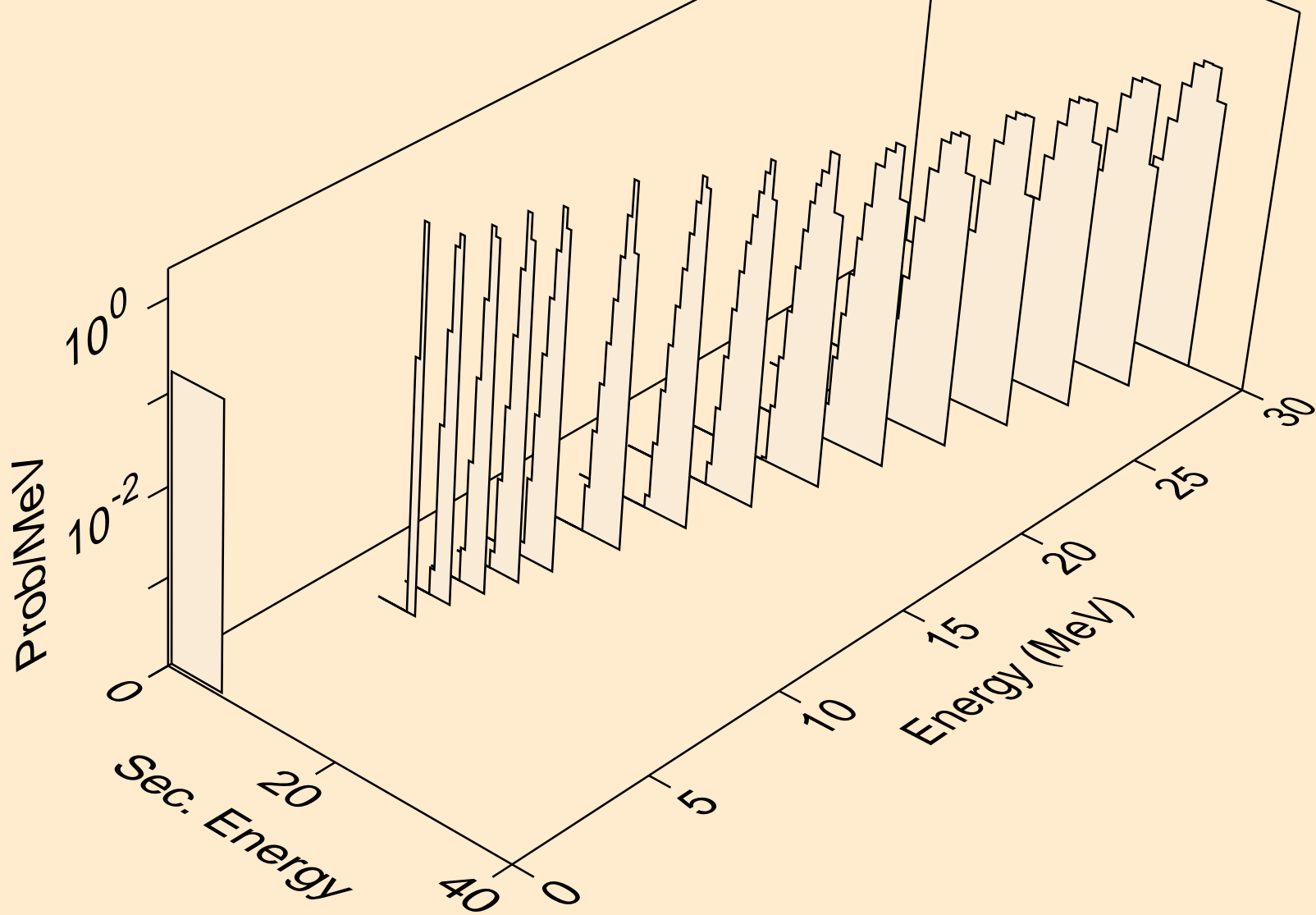

HG214 TRITON ACER TENDL-2021 LIBRARY; T=0.K  
alphas from (t,2n)a

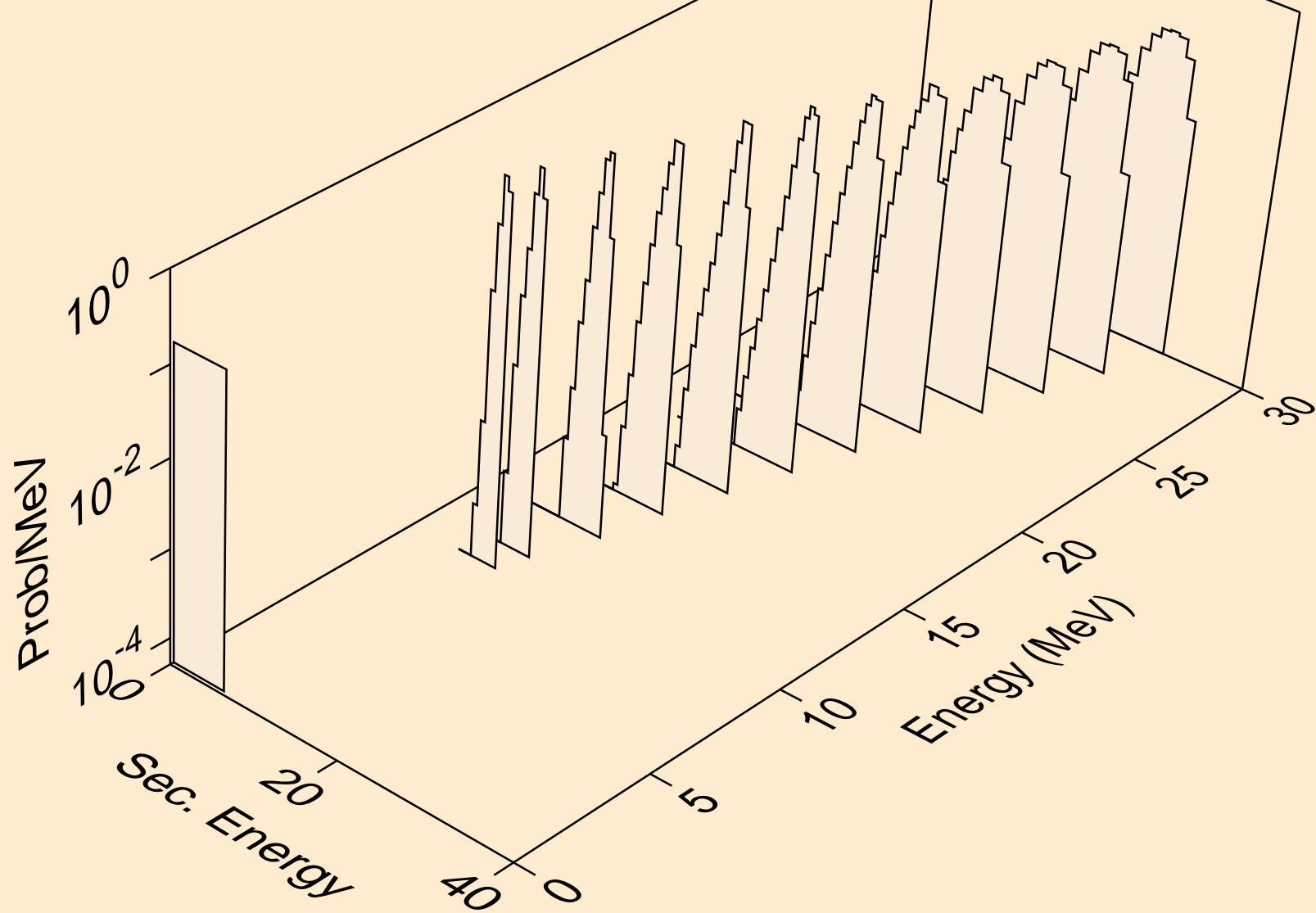

HG214 TRITON ACER TENDL-2021 LIBRARY; T=0.K  
alphas from (t,3n)a

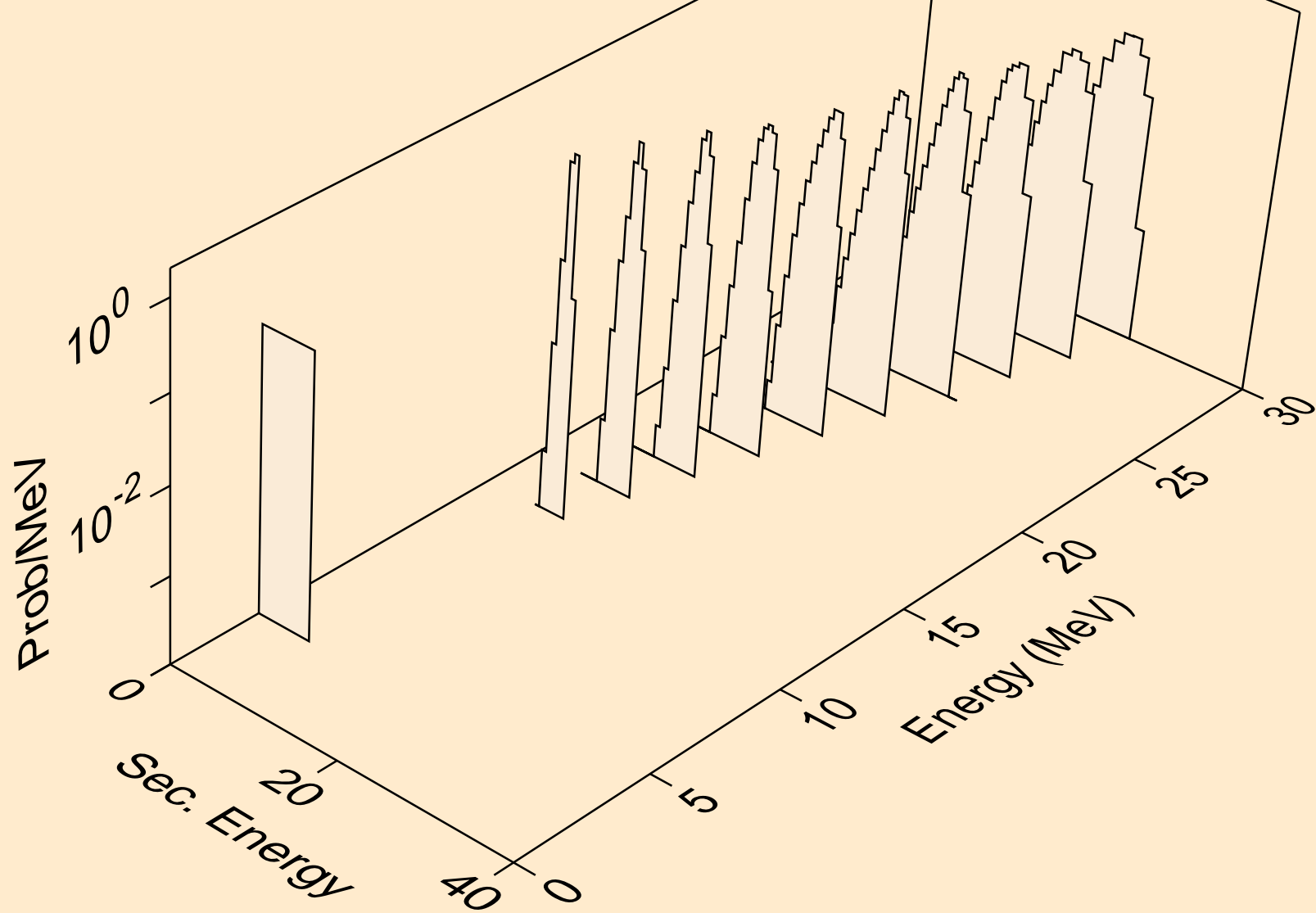

HG214 TRITON ACER TENDL-2021 LIBRARY; T=0.K  
alphas from (t,a)

