

C012 ALPHA ACER TENDL-2023 LIBRARY; T=0.K

Principal cross sections

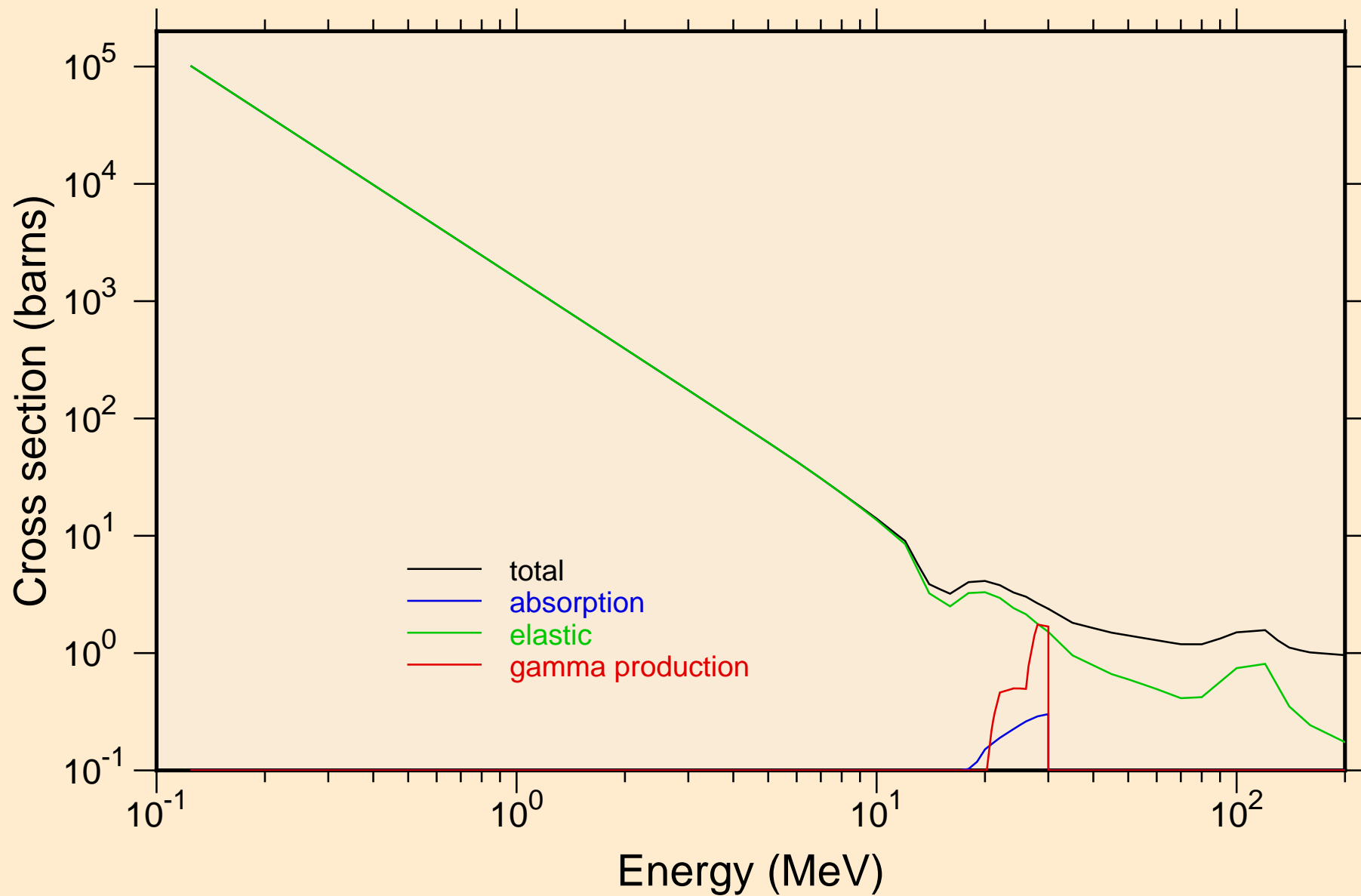

C012 ALPHA ACER TENDL-2023 LIBRARY; T=0.K
Heating

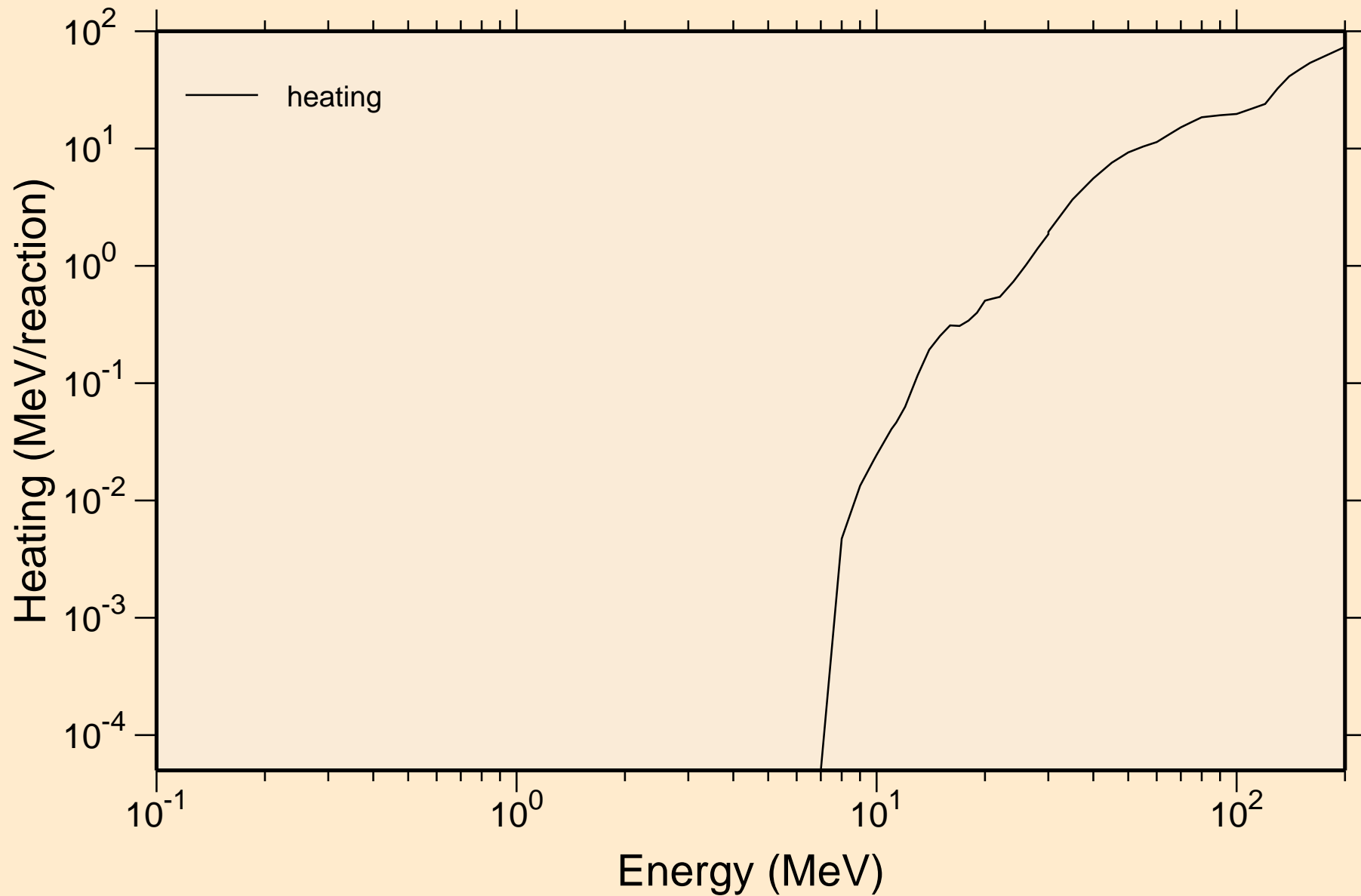

C012 ALPHA ACER TENDL-2023 LIBRARY; T=0.K

Principal cross sections



C012 ALPHA ACER TENDL-2023 LIBRARY; T=0.K

Heating

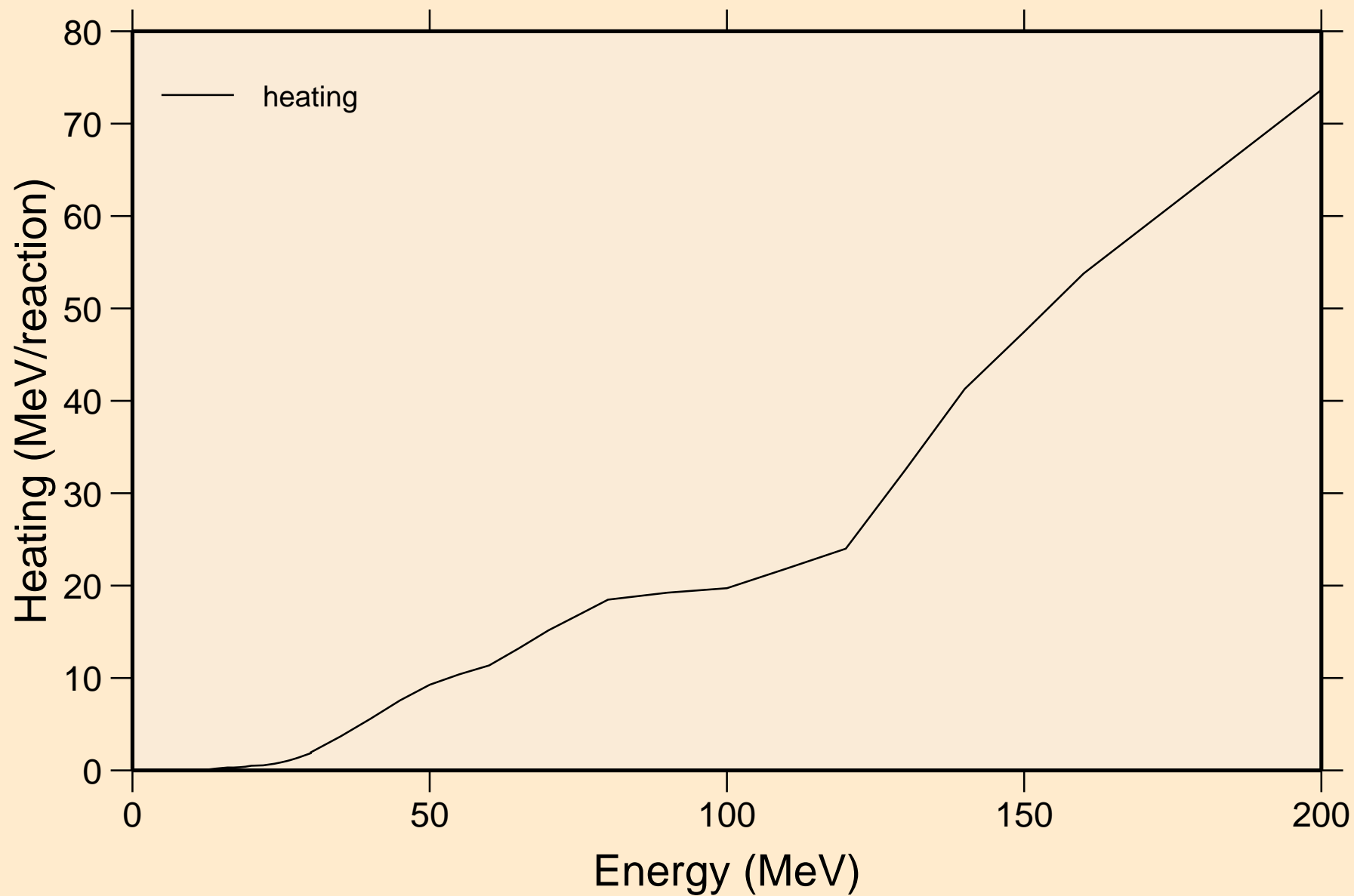

C012 ALPHA ACER TENDL-2023 LIBRARY; T=0.K

Threshold reactions

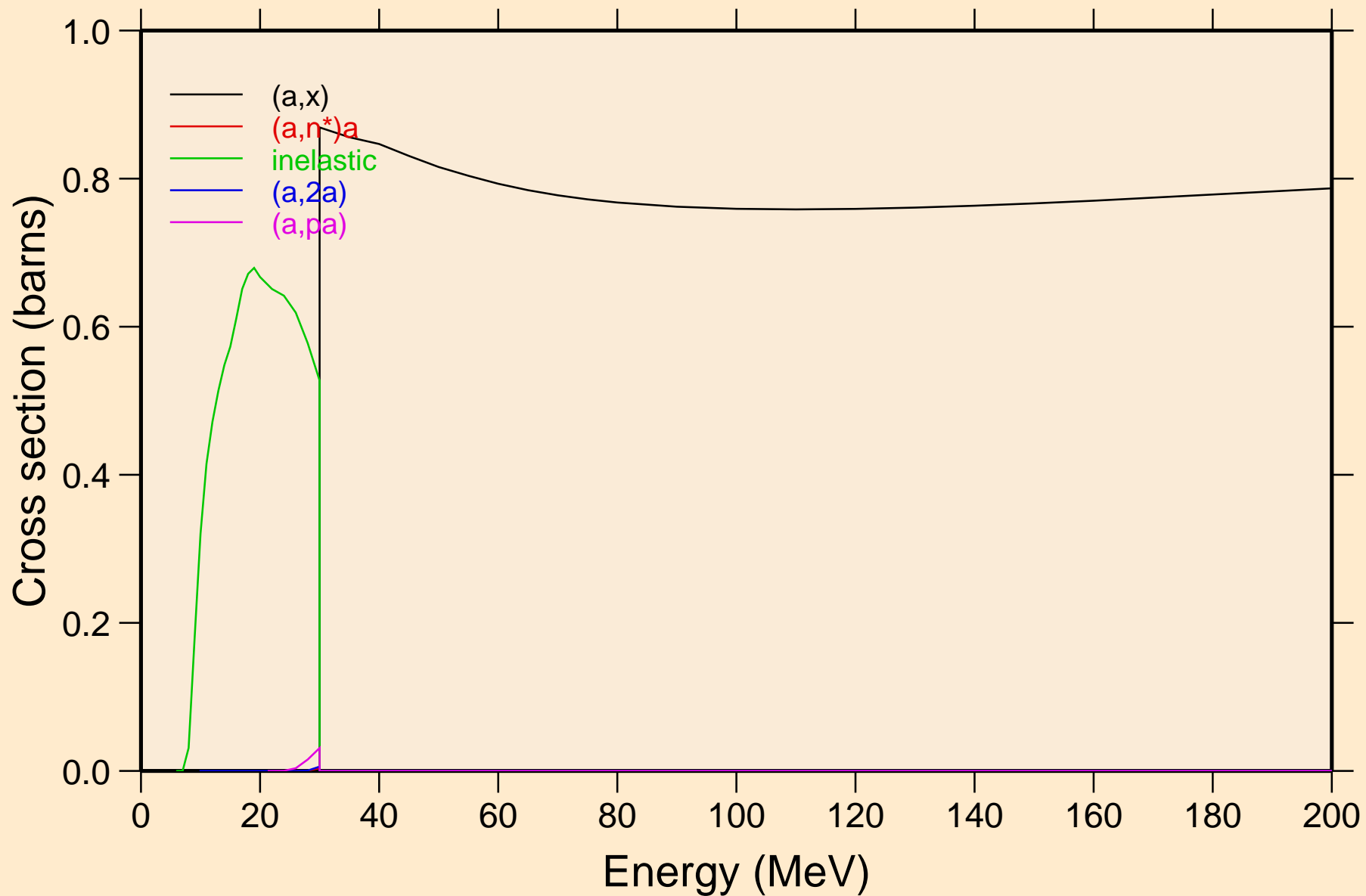

C012 ALPHA ACER TENDL-2023 LIBRARY; T=0.K
Threshold reactions

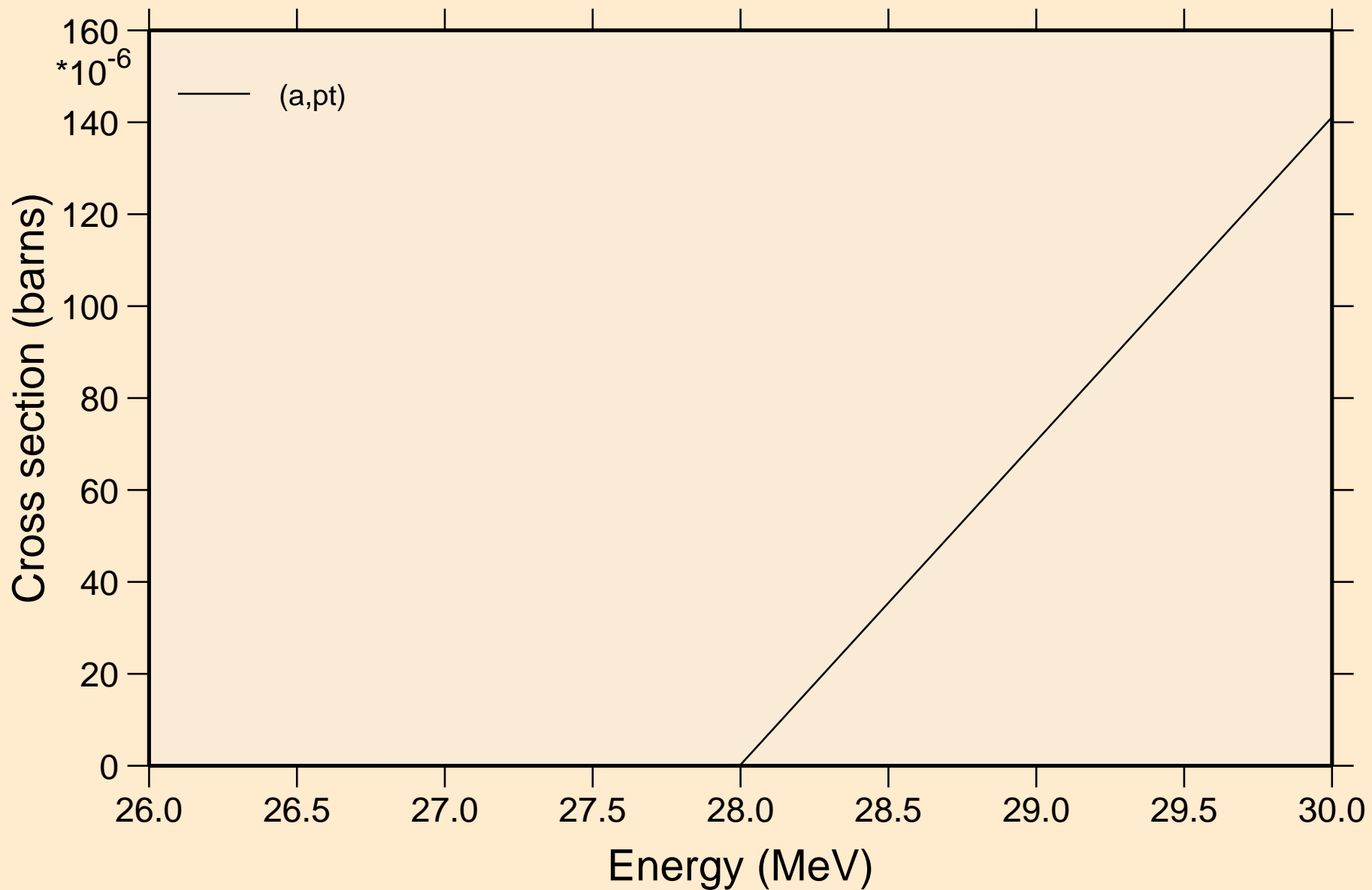

C012 ALPHA ACER TENDL-2023 LIBRARY; T=0.K
angular distribution for elastic

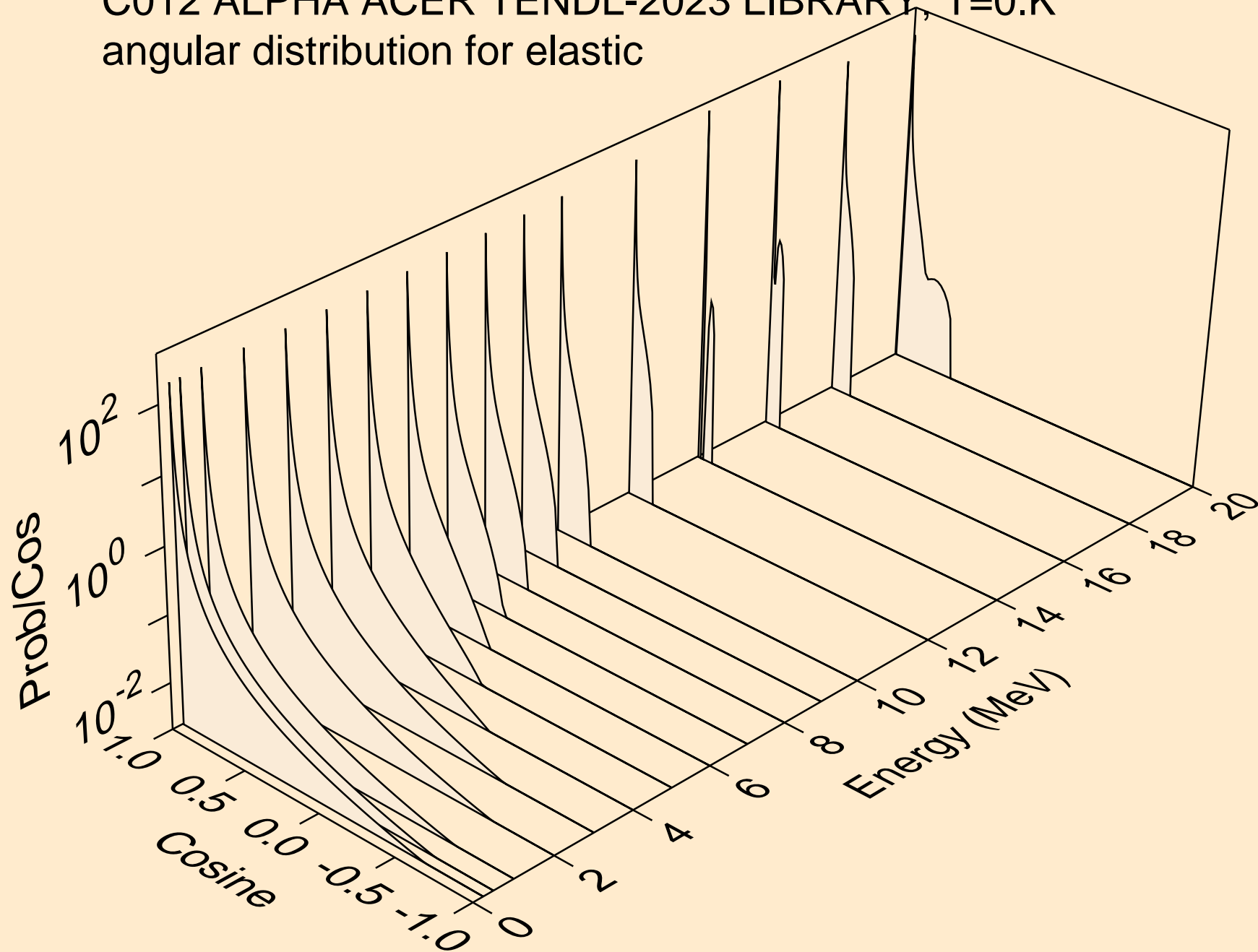

C012 ALPHA ACER TENDL-2023 LIBRARY; T=0.K
angular distribution for elastic

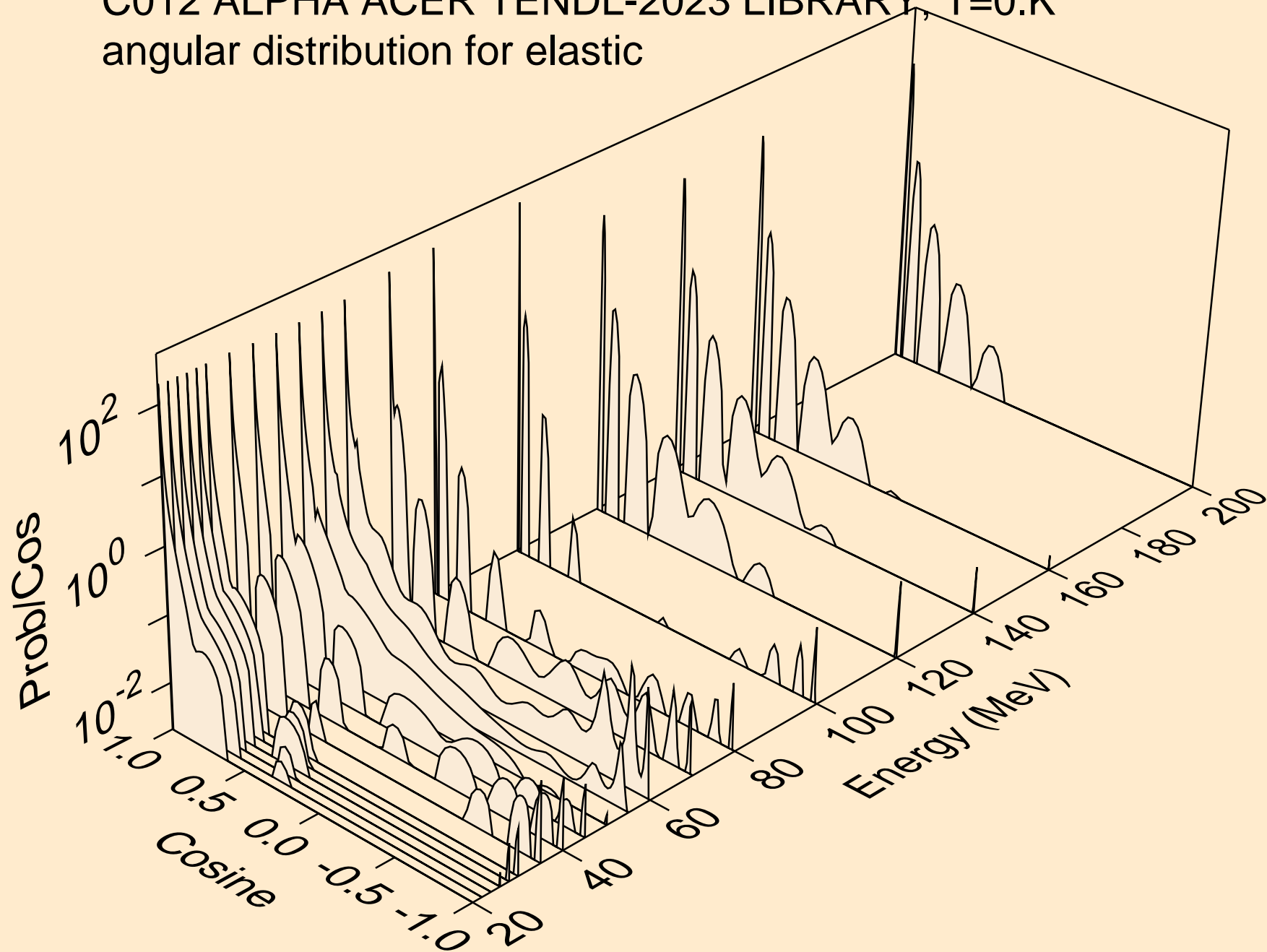

C012 ALPHA ACER TENDL-2023 LIBRARY; T=0.K
Alpha emission for (a,x)

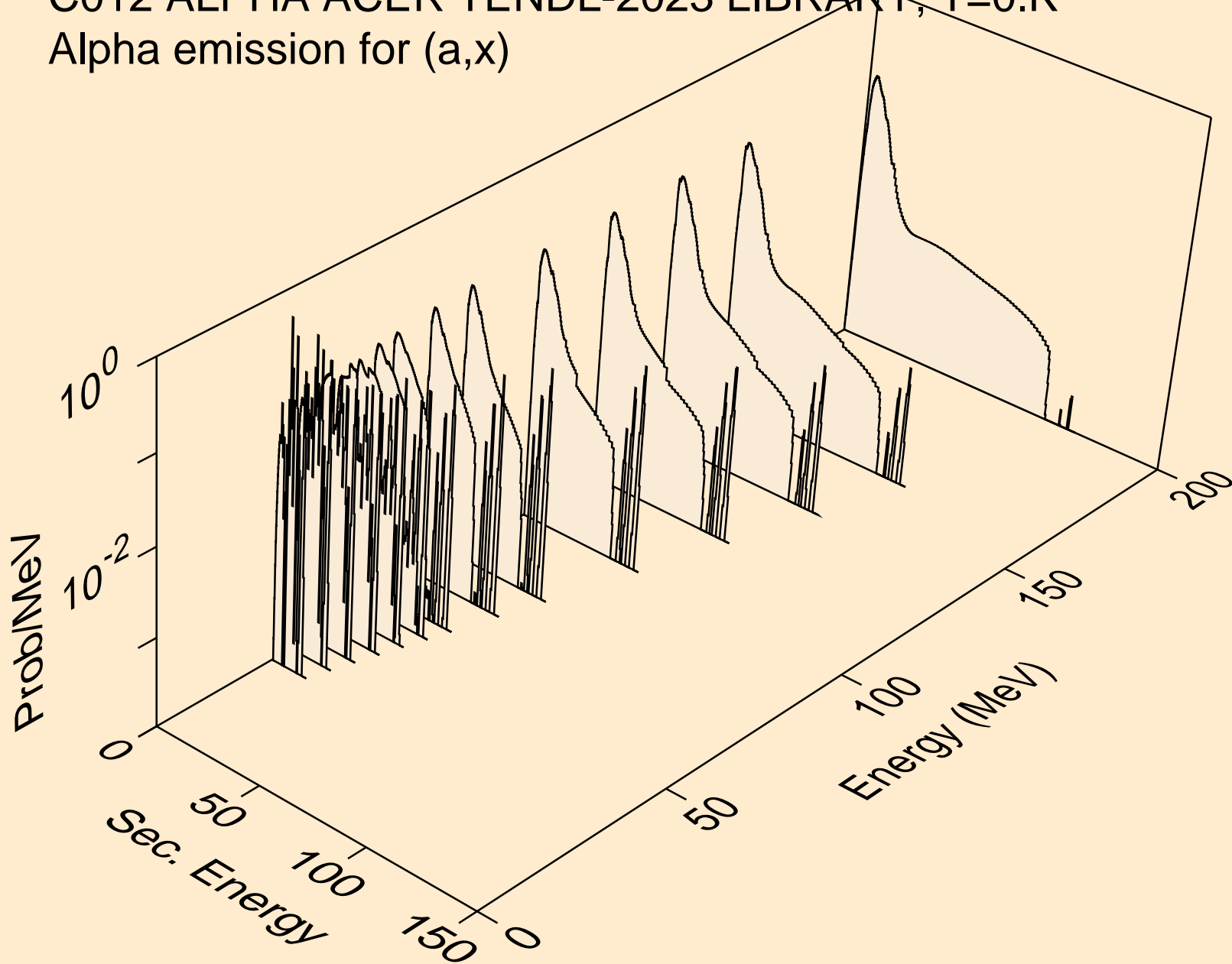

C012 ALPHA ACER TENDL-2023 LIBRARY; T=0.K
Alpha emission for (a,n*)a

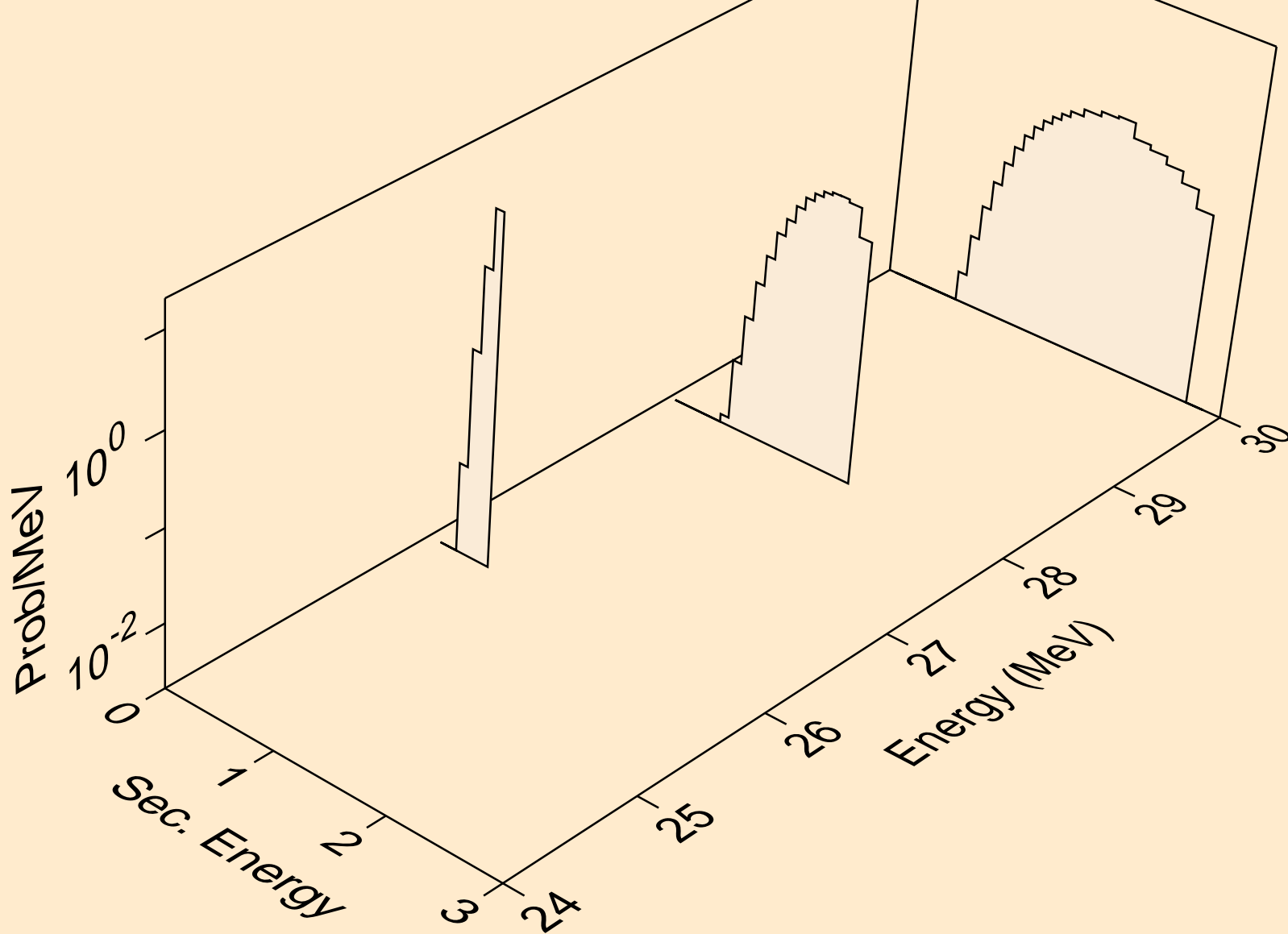

C012 ALPHA ACER TENDL-2023 LIBRARY; T=0.K
Alpha emission for inelastic

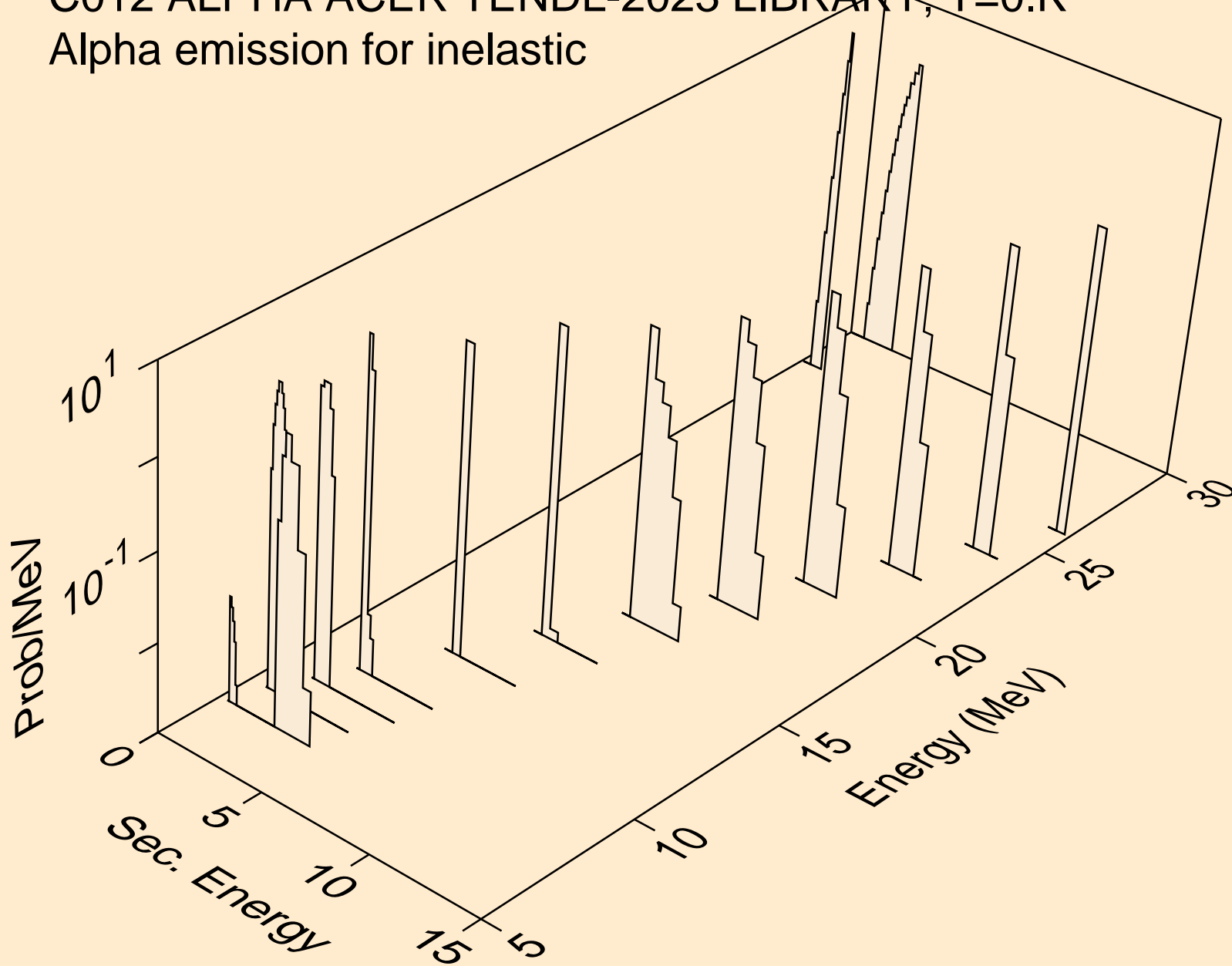

C012 ALPHA ACER TENDL-2023 LIBRARY; T=0.K
Alpha emission for (a,2a)

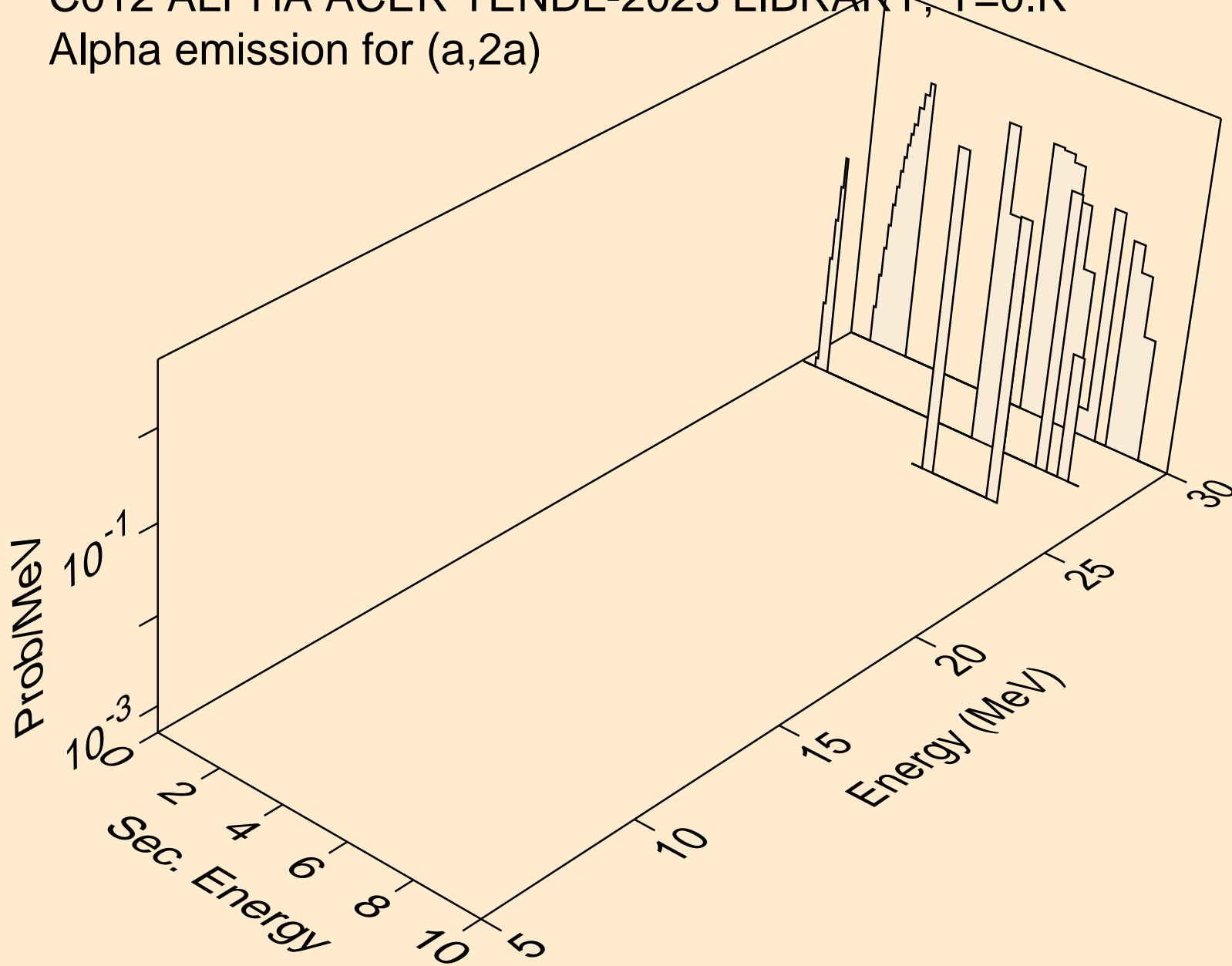

C012 ALPHA ACER TENDL-2023 LIBRARY; T=0.K
Alpha emission for (a,pa)

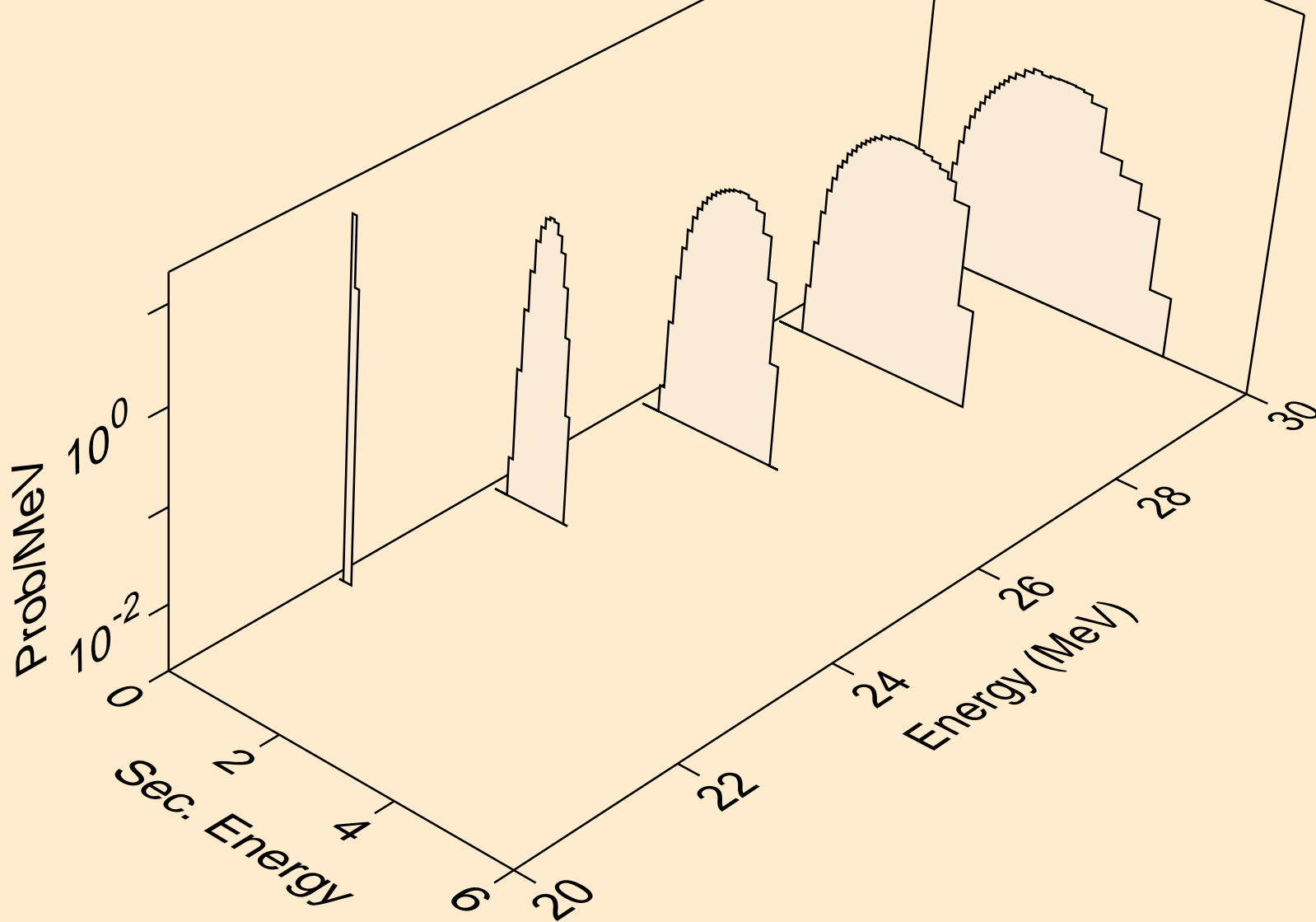

C012 ALPHA ACER TENDL-2023 LIBRARY; T=0.K
Photon emission for (z,n)

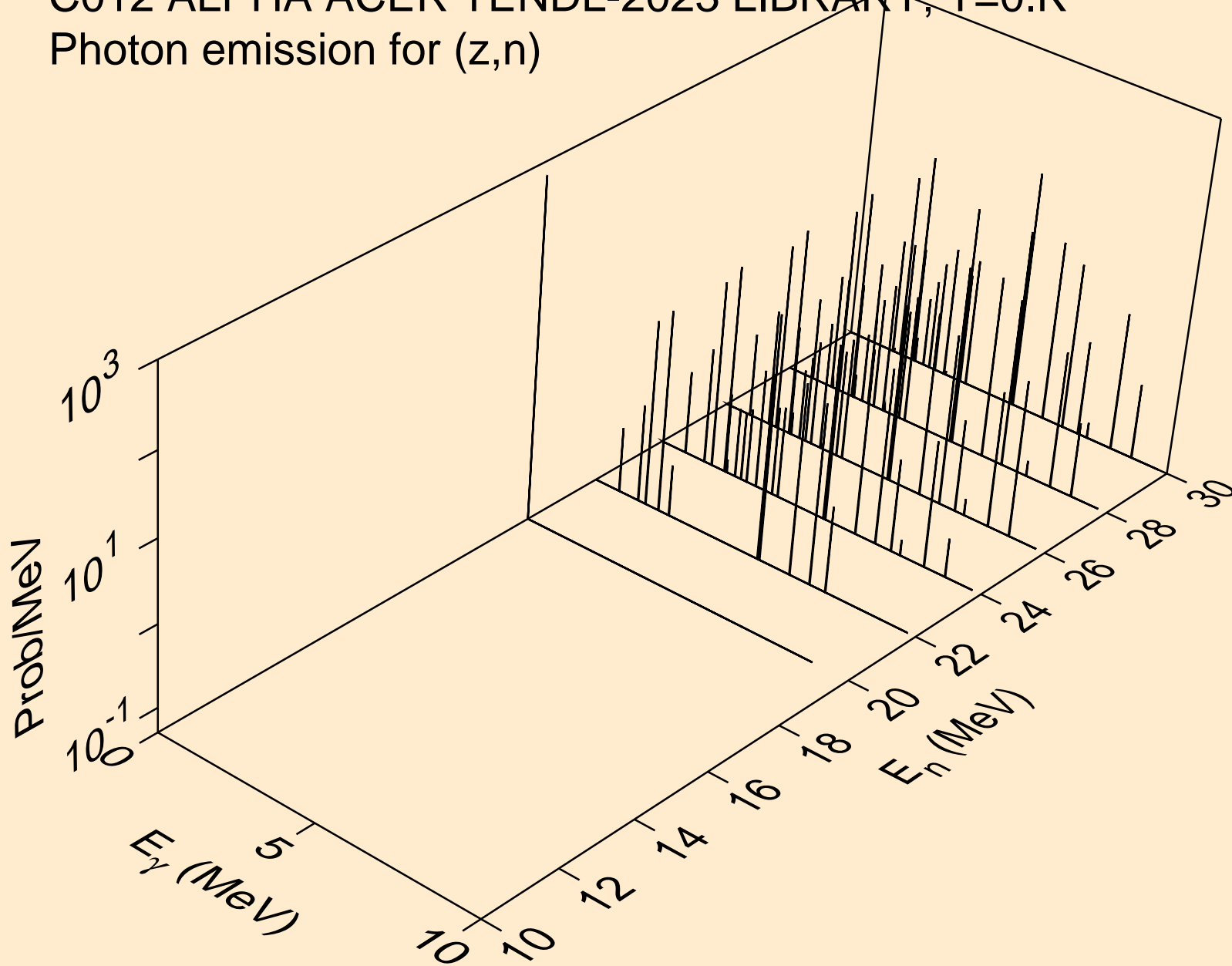

C012 ALPHA ACER TENDL-2023 LIBRARY; T=0.K
Photon emission for (z,x)

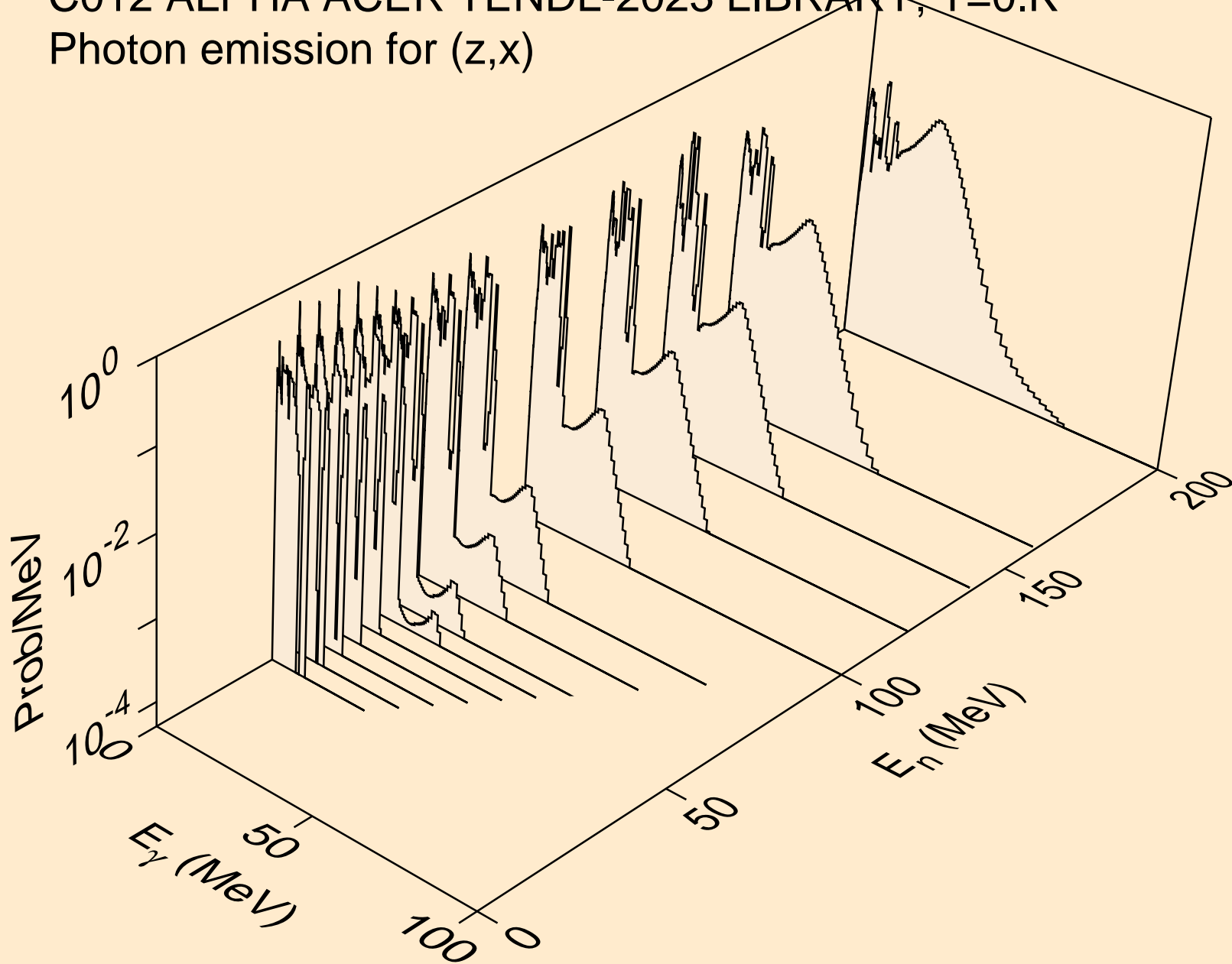

C012 ALPHA ACER TENDL-2023 LIBRARY; T=0.K
Photon emission for (n,n*)a

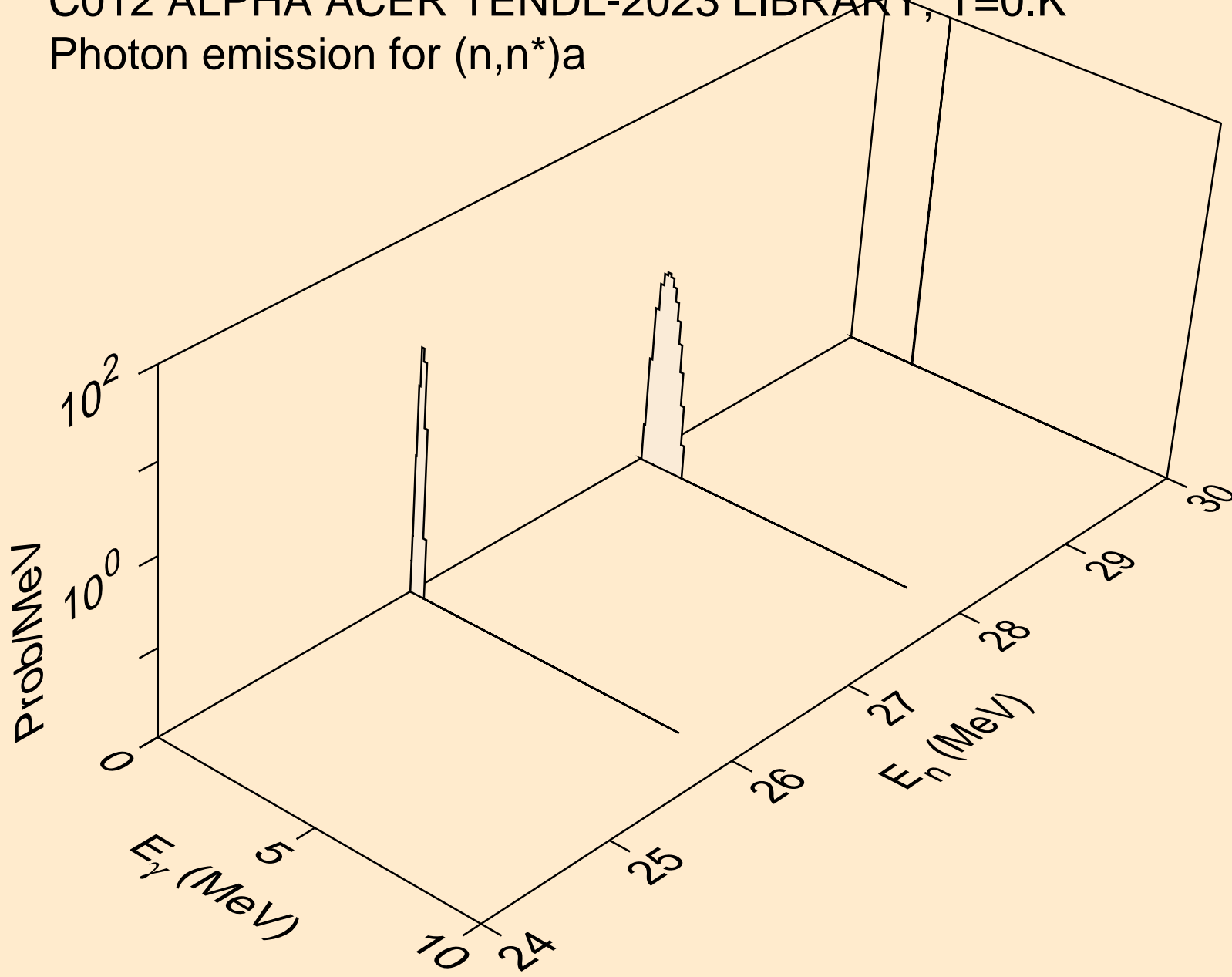

C012 ALPHA ACER TENDL-2023 LIBRARY; T=0.K
Photon emission for (n,n*)p

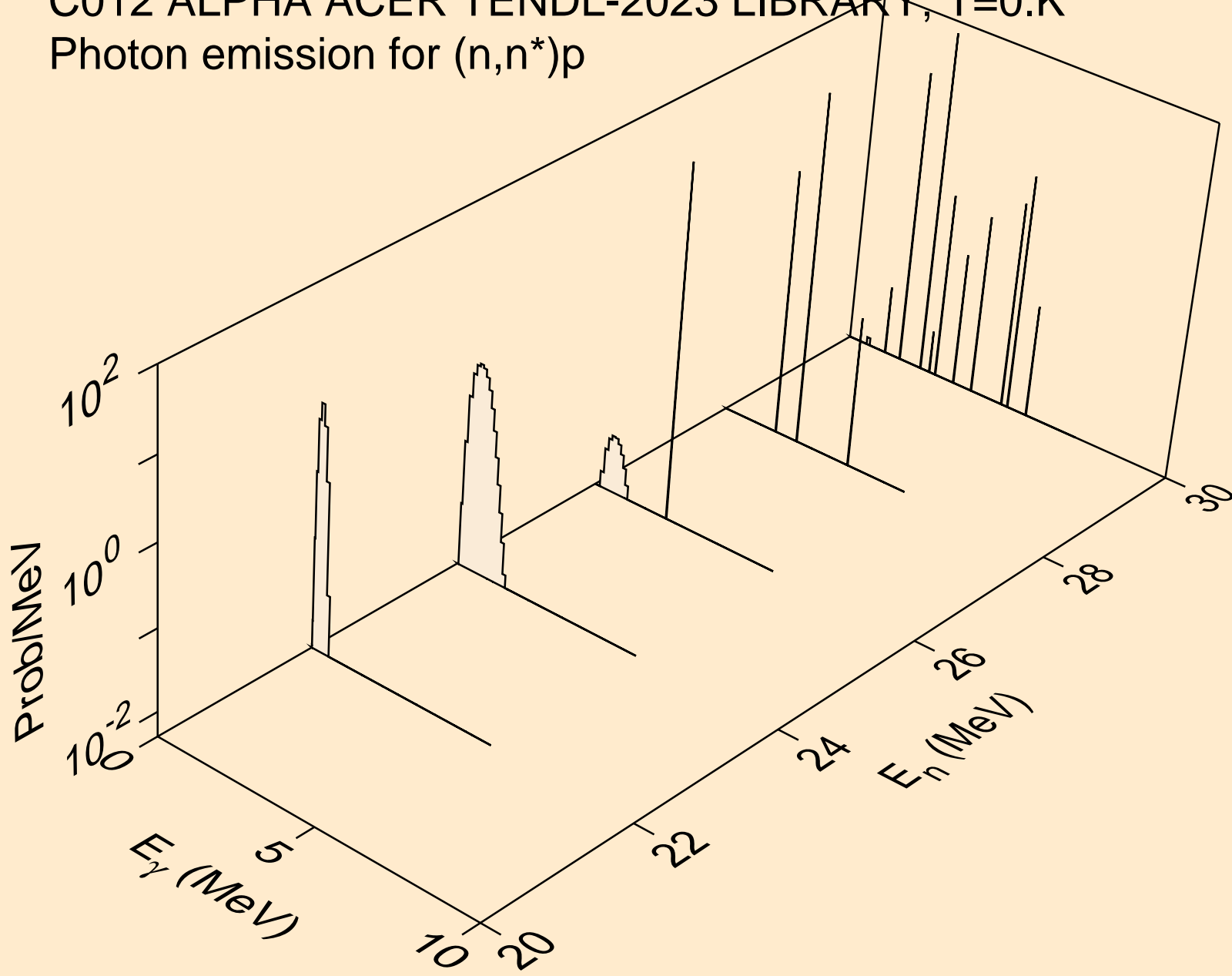

C012 ALPHA ACER TENDL-2023 LIBRARY; T=0.K
Photon emission for (n,n*)he3

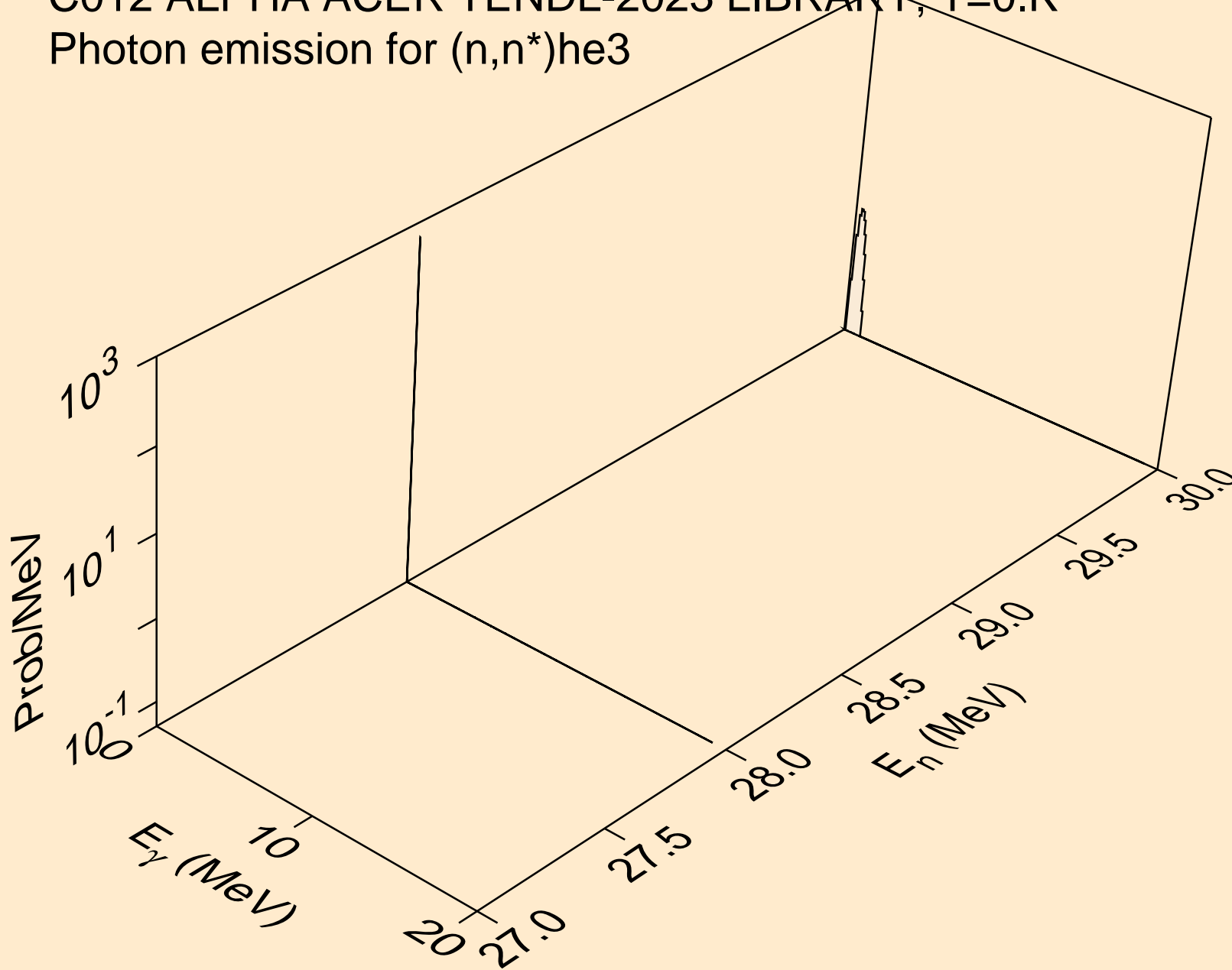

C012 ALPHA ACER TENDL-2023 LIBRARY; T=0.K
Photon emission for (n,gma)

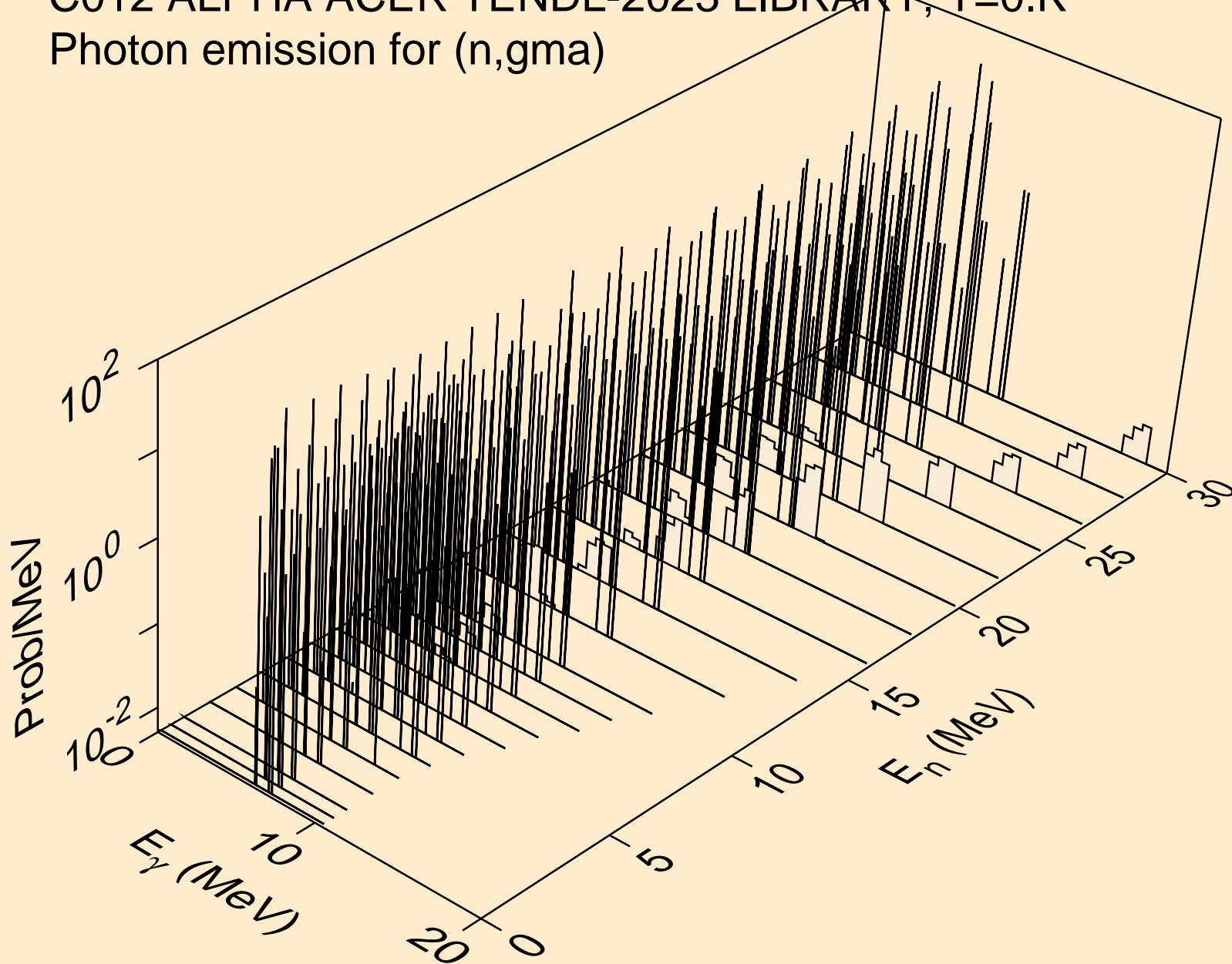

C012 ALPHA ACER TENDL-2023 LIBRARY; T=0.K
Photon emission for (n,p)

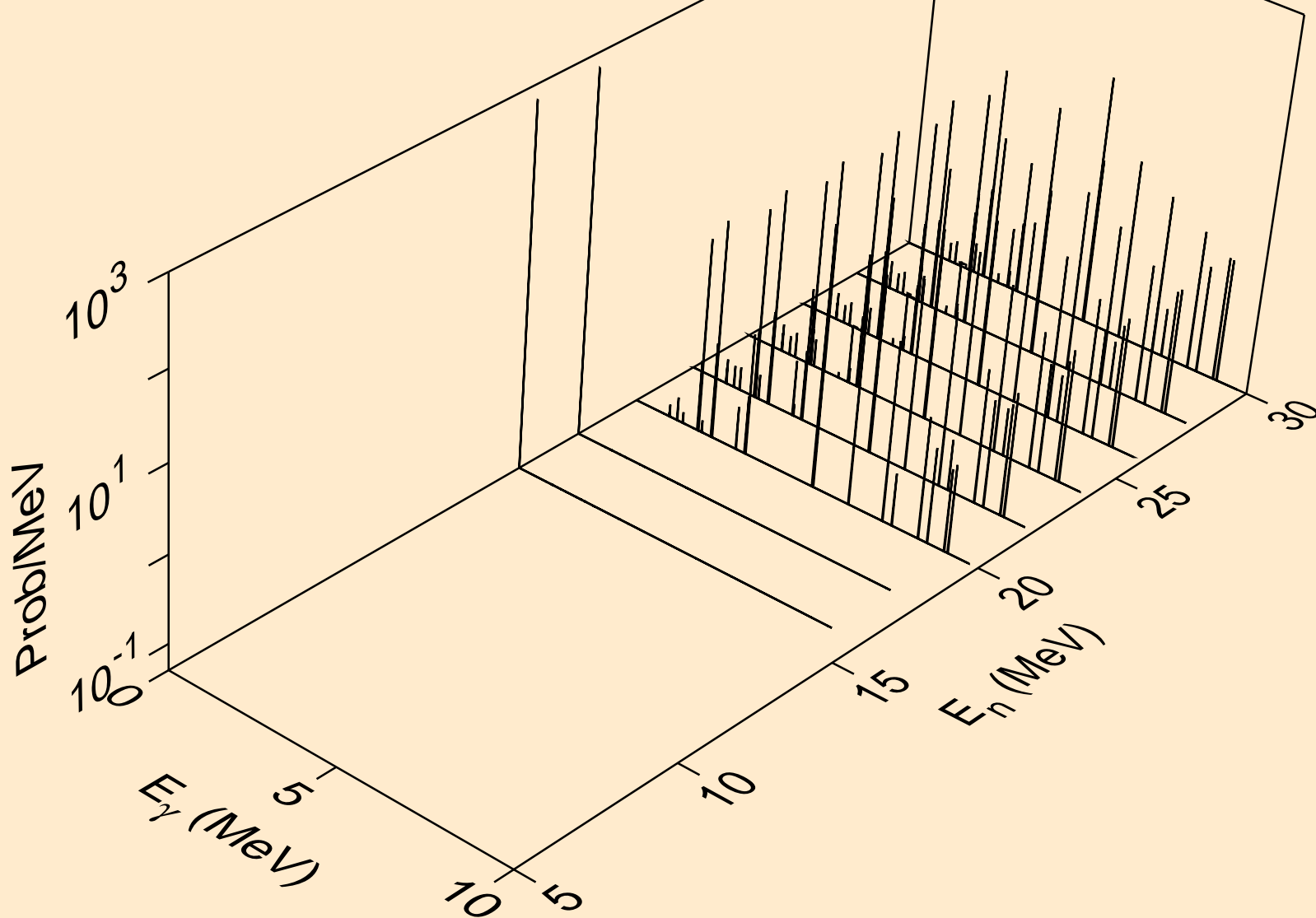

C012 ALPHA ACER TENDL-2023 LIBRARY; T=0.K
Photon emission for (n,d)

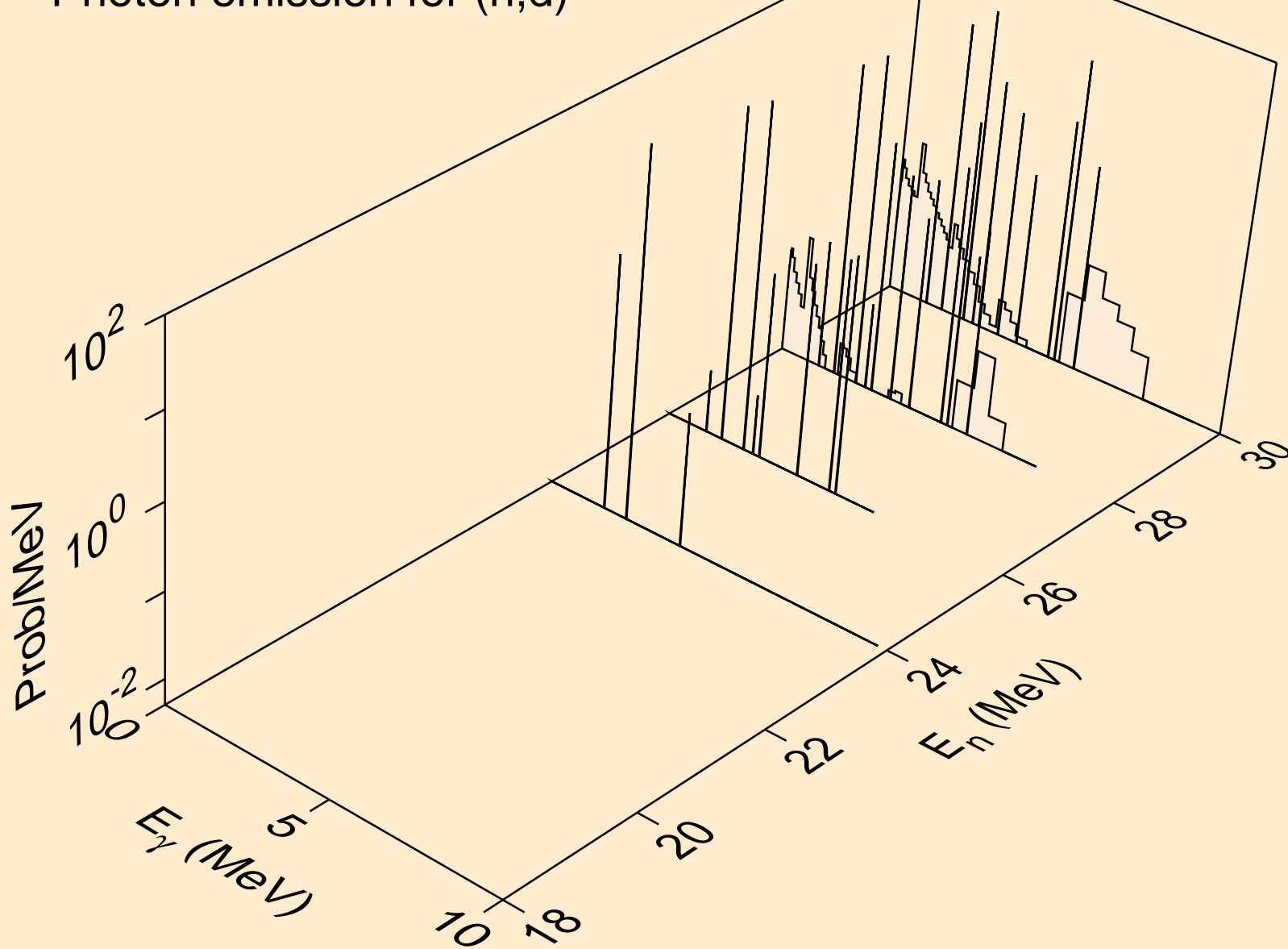

C012 ALPHA ACER TENDL-2023 LIBRARY; T=0.K
Photon emission for (n,t)

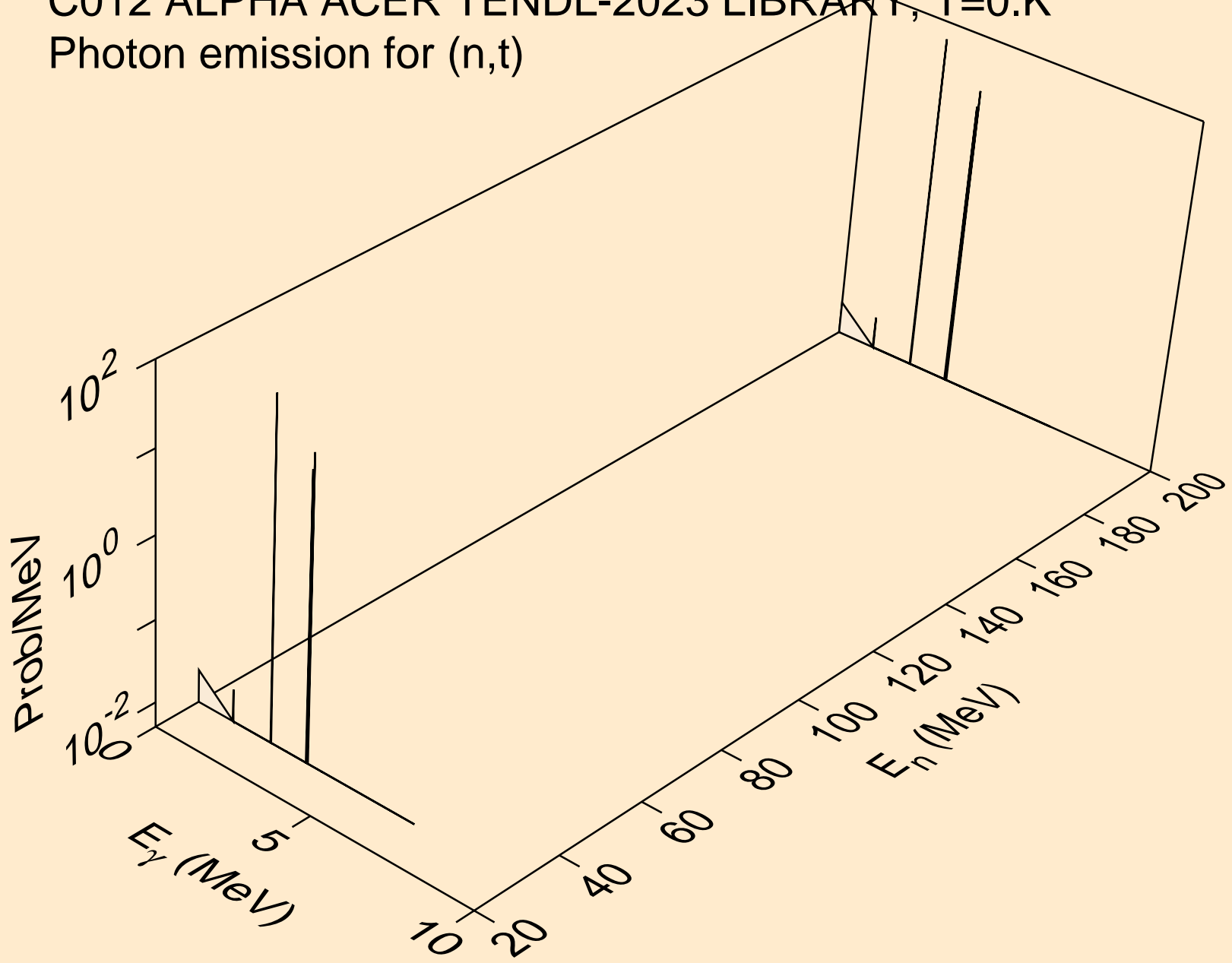

C012 ALPHA ACER TENDL-2023 LIBRARY; T=0.K
Photon emission for (n,he3)

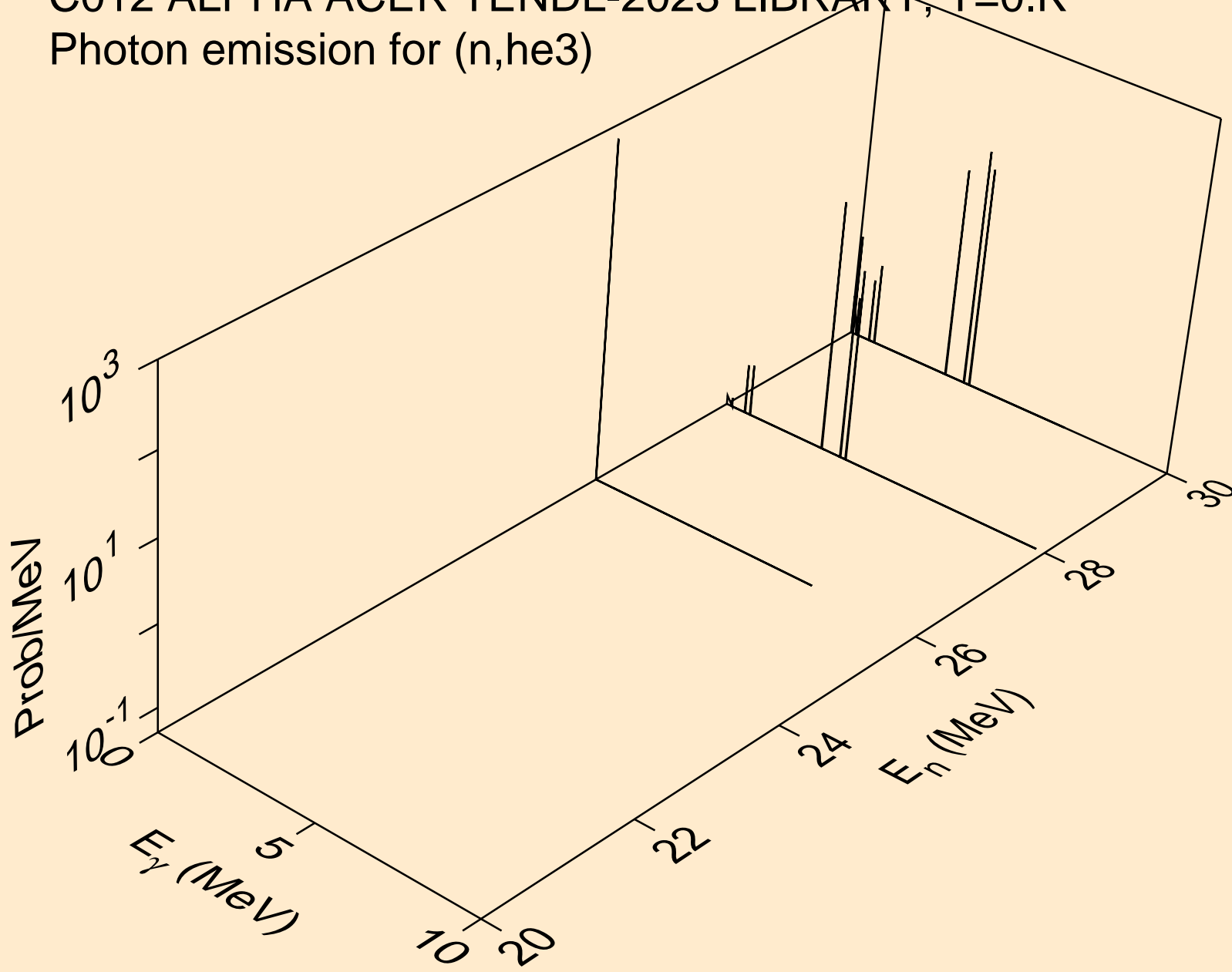

C012 ALPHA ACER TENDL-2023 LIBRARY; T=0.K
Photon emission for inelastic

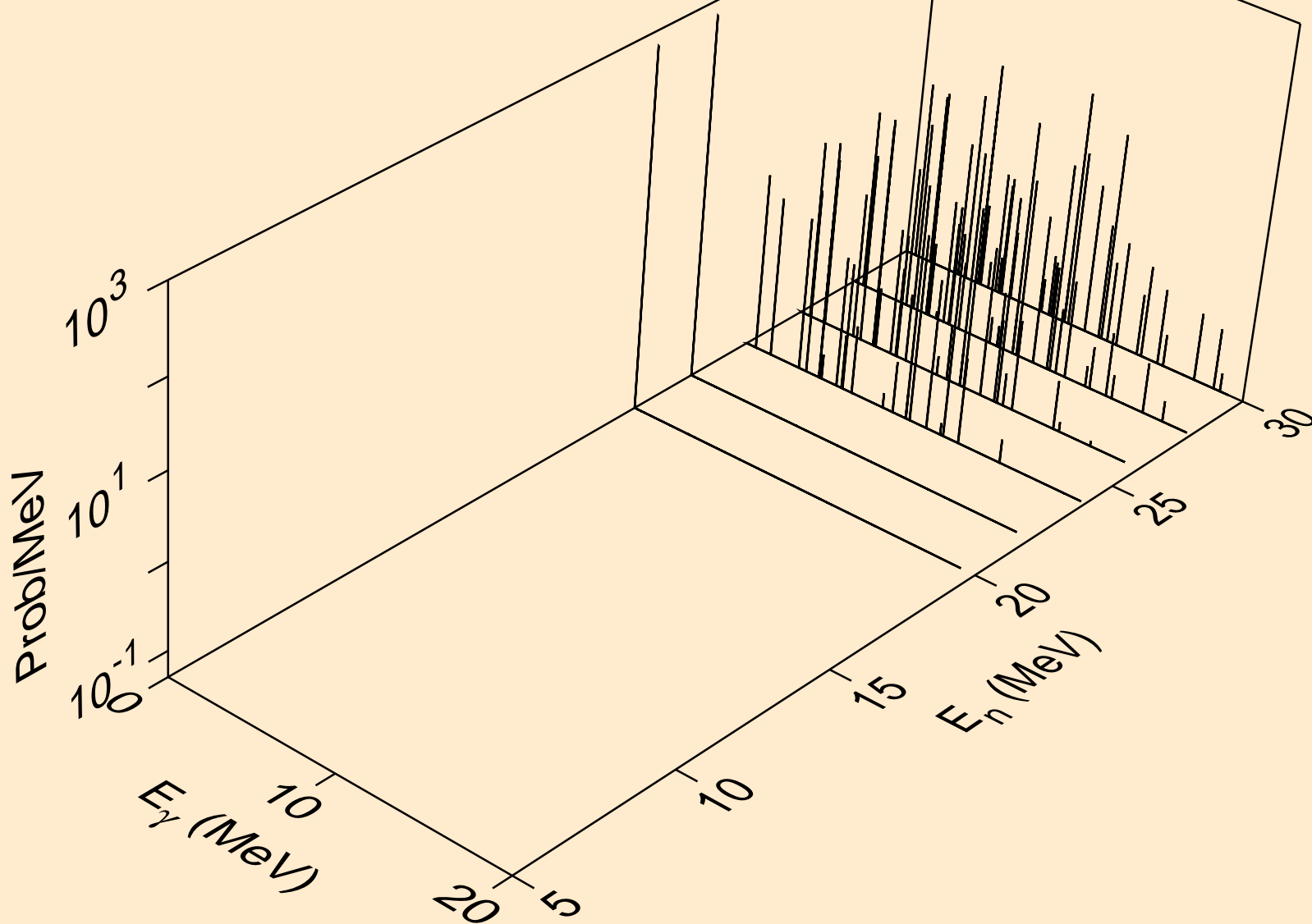

C012 ALPHA ACER TENDL-2023 LIBRARY; T=0.K
Photon emission for (n,2a)

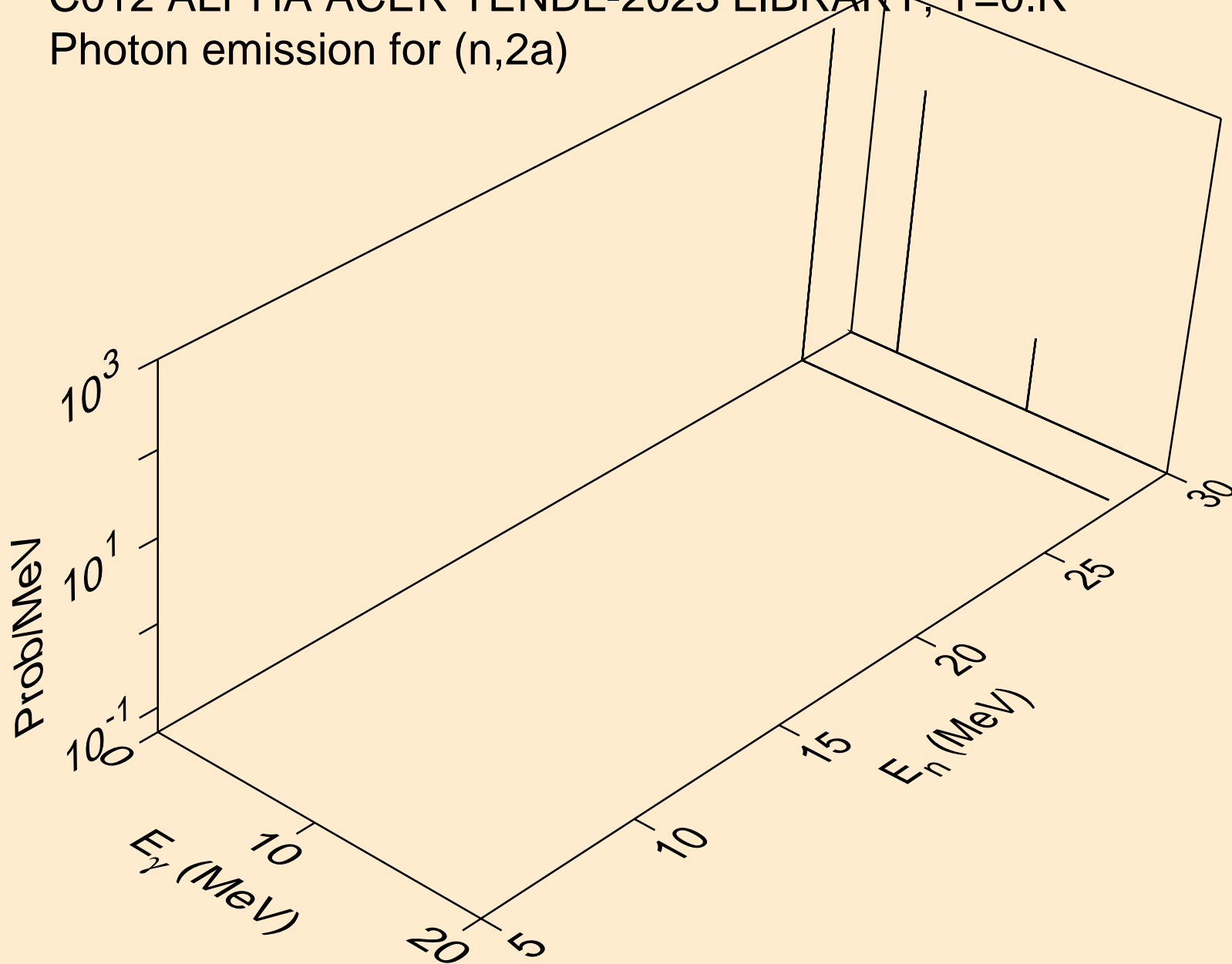

C012 ALPHA ACER TENDL-2023 LIBRARY; T=0.K
Photon emission for (n,2p)

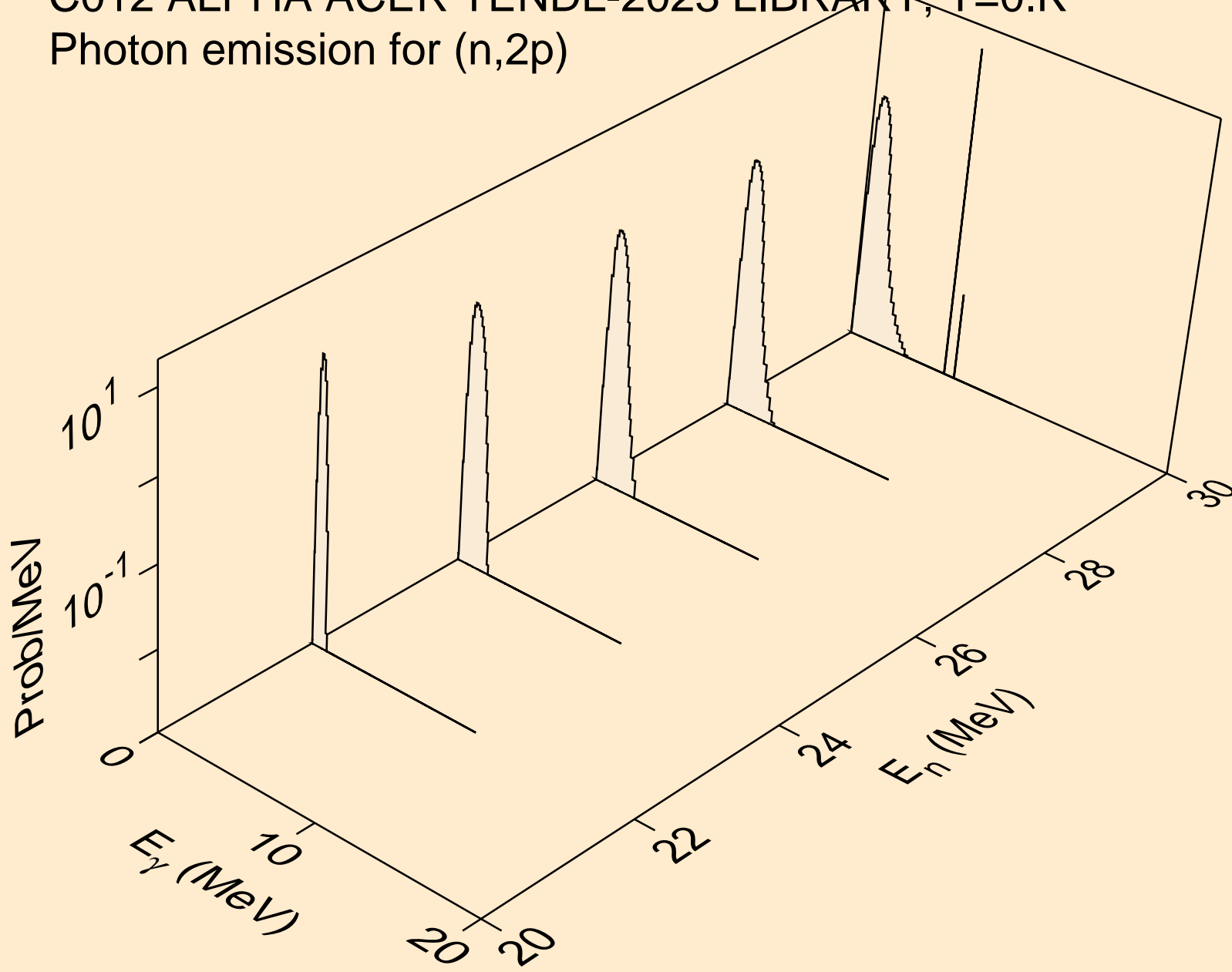

C012 ALPHA ACER TENDL-2023 LIBRARY; T=0.K
Photon emission for (n,pa)

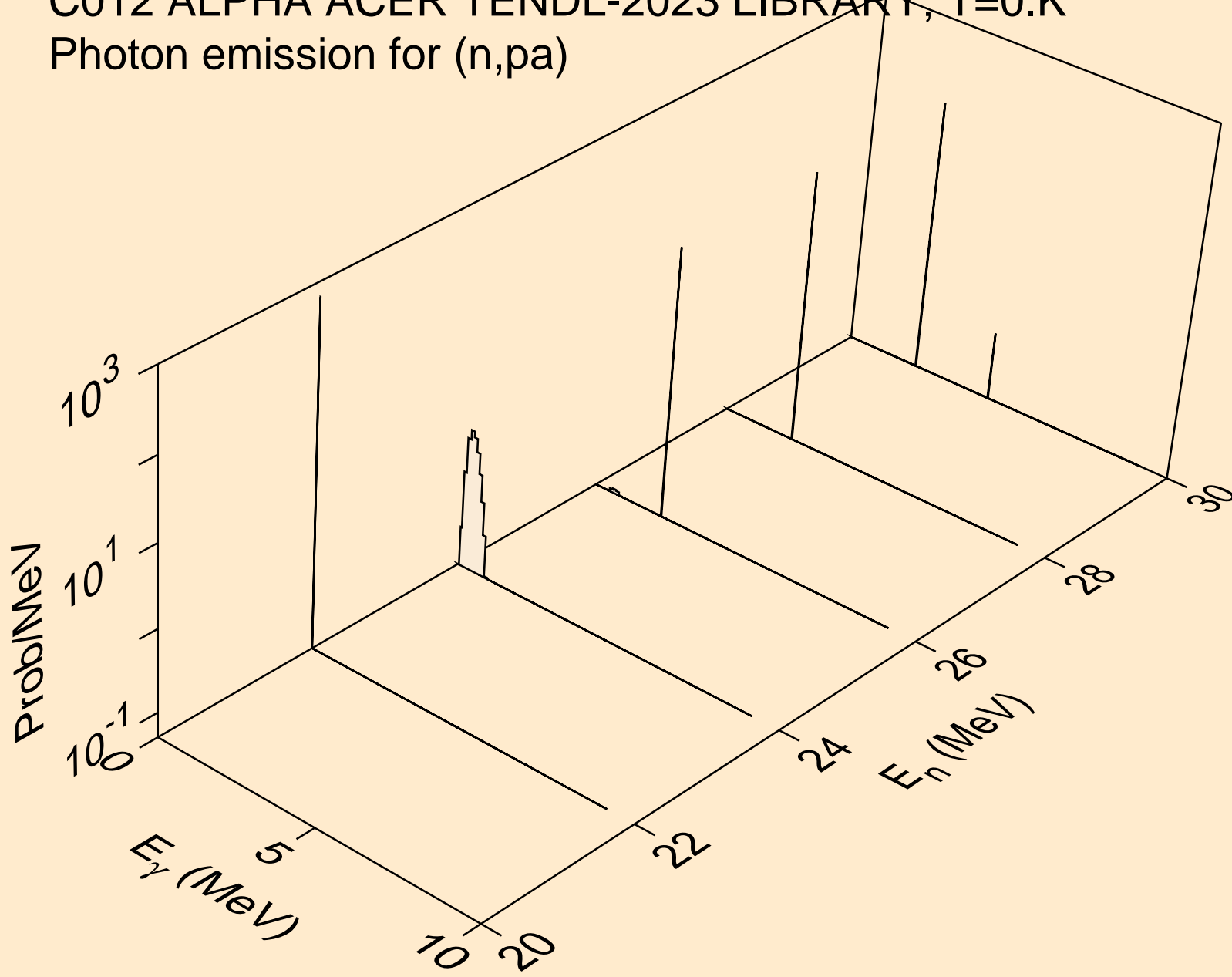

C012 ALPHA ACER TENDL-2023 LIBRARY; T=0.K
Photon emission for (n,pt)

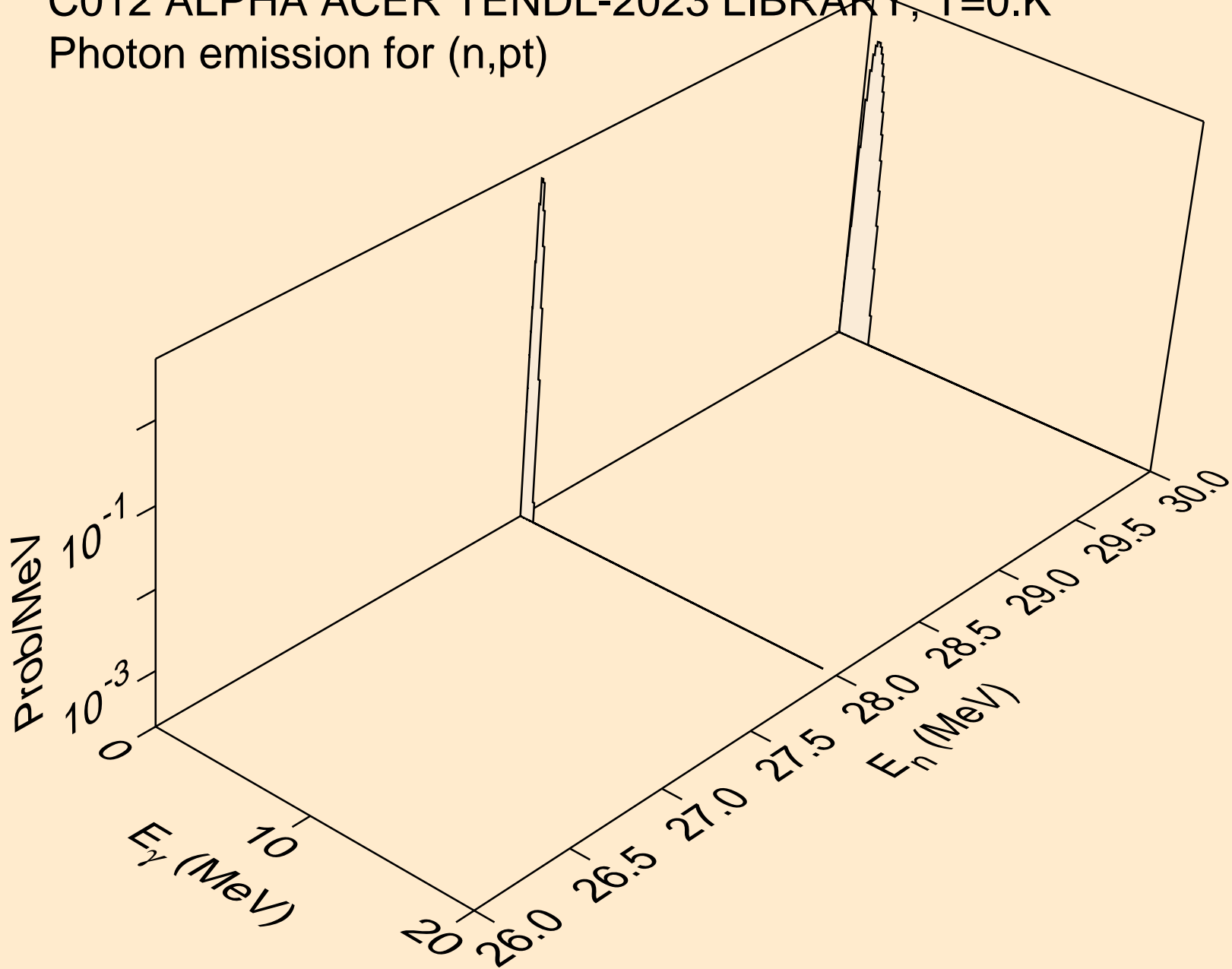

C012 ALPHA ACER TENDL-2023 LIBRARY; T=0.K

Particle heating contributions

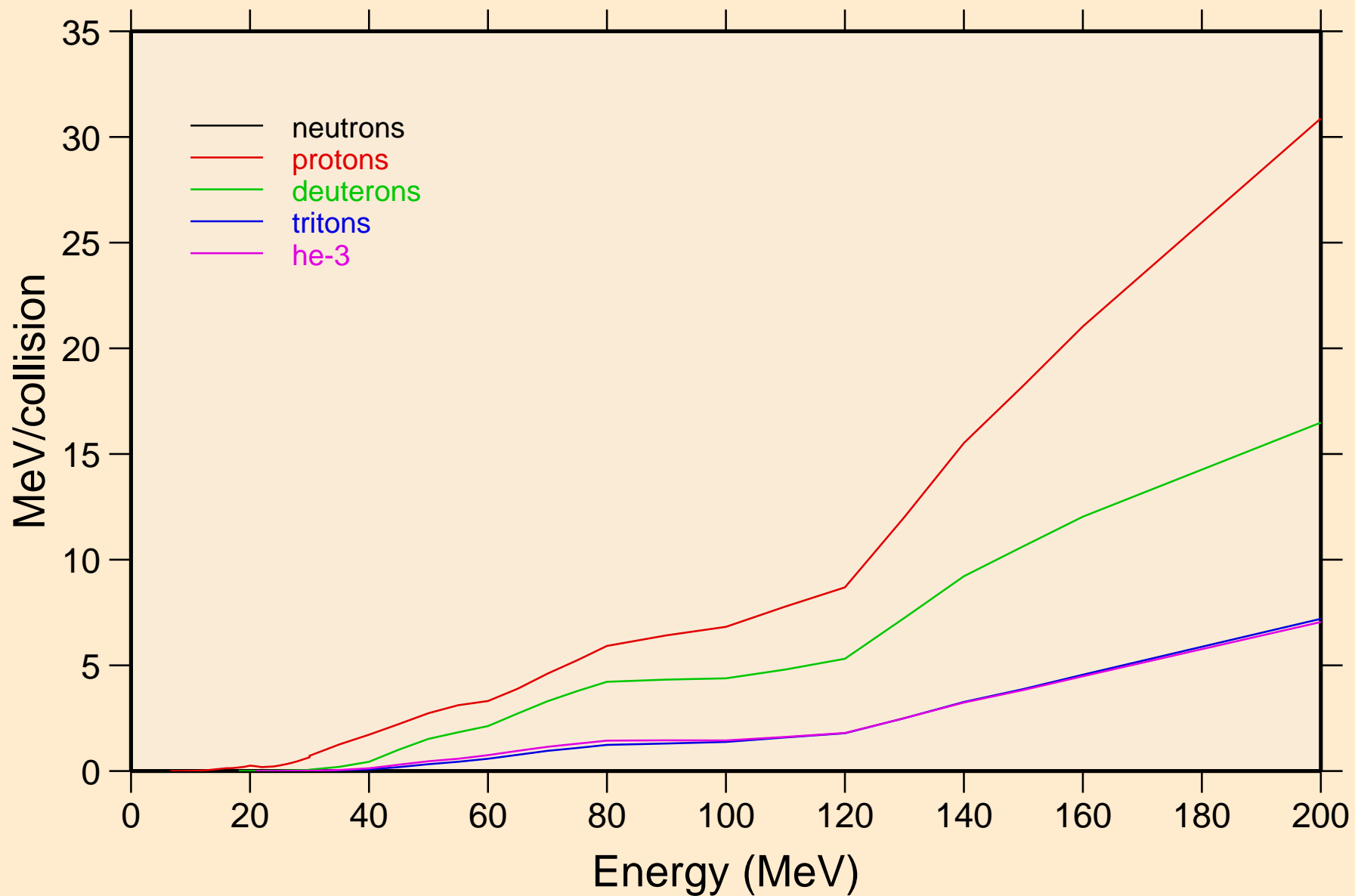

C012 ALPHA ACER TENDL-2023 LIBRARY; T=0.K
Recoil Heating

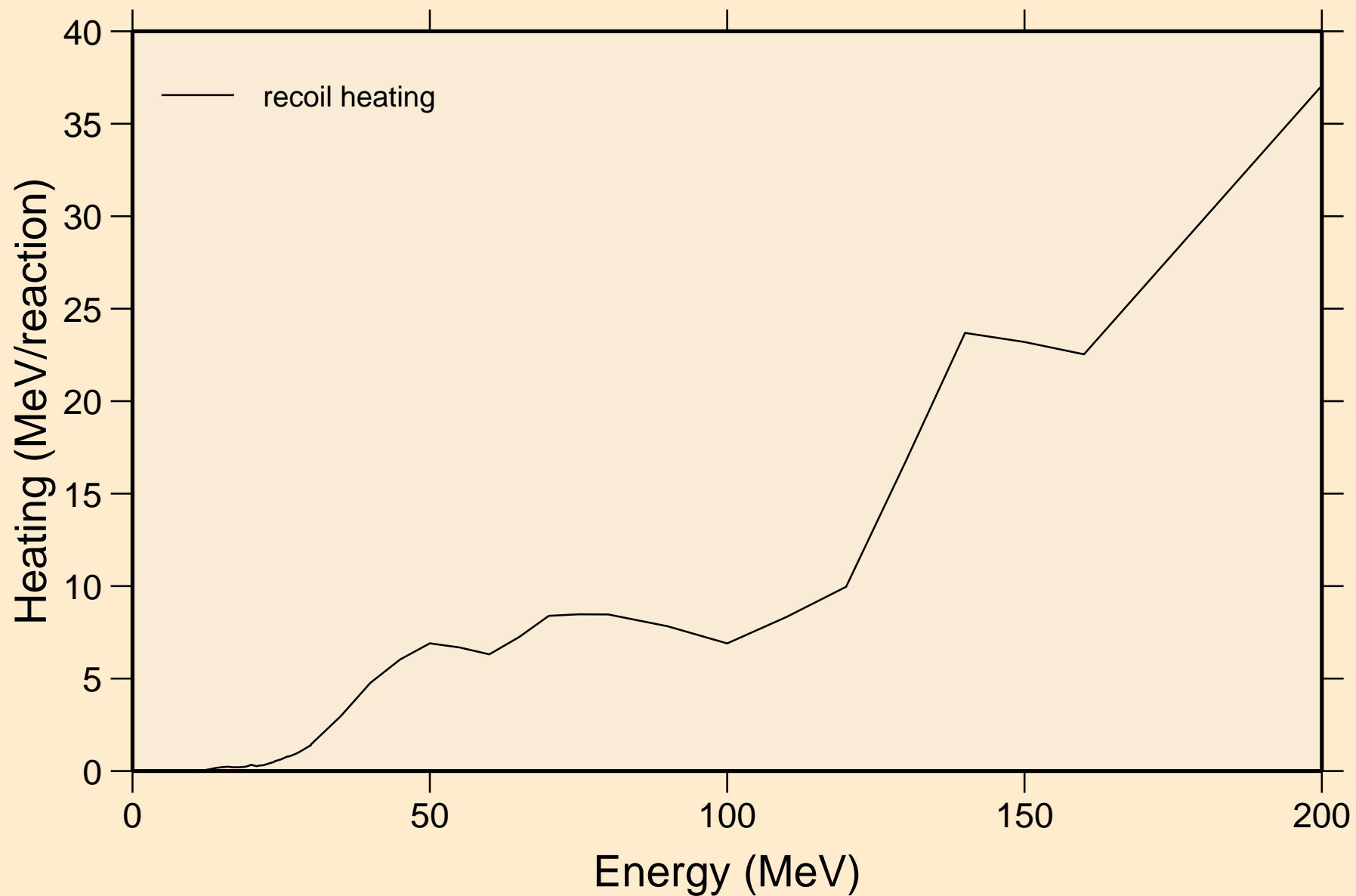

C012 ALPHA ACER TENDL-2023 LIBRARY; T=0.K

Particle production cross sections

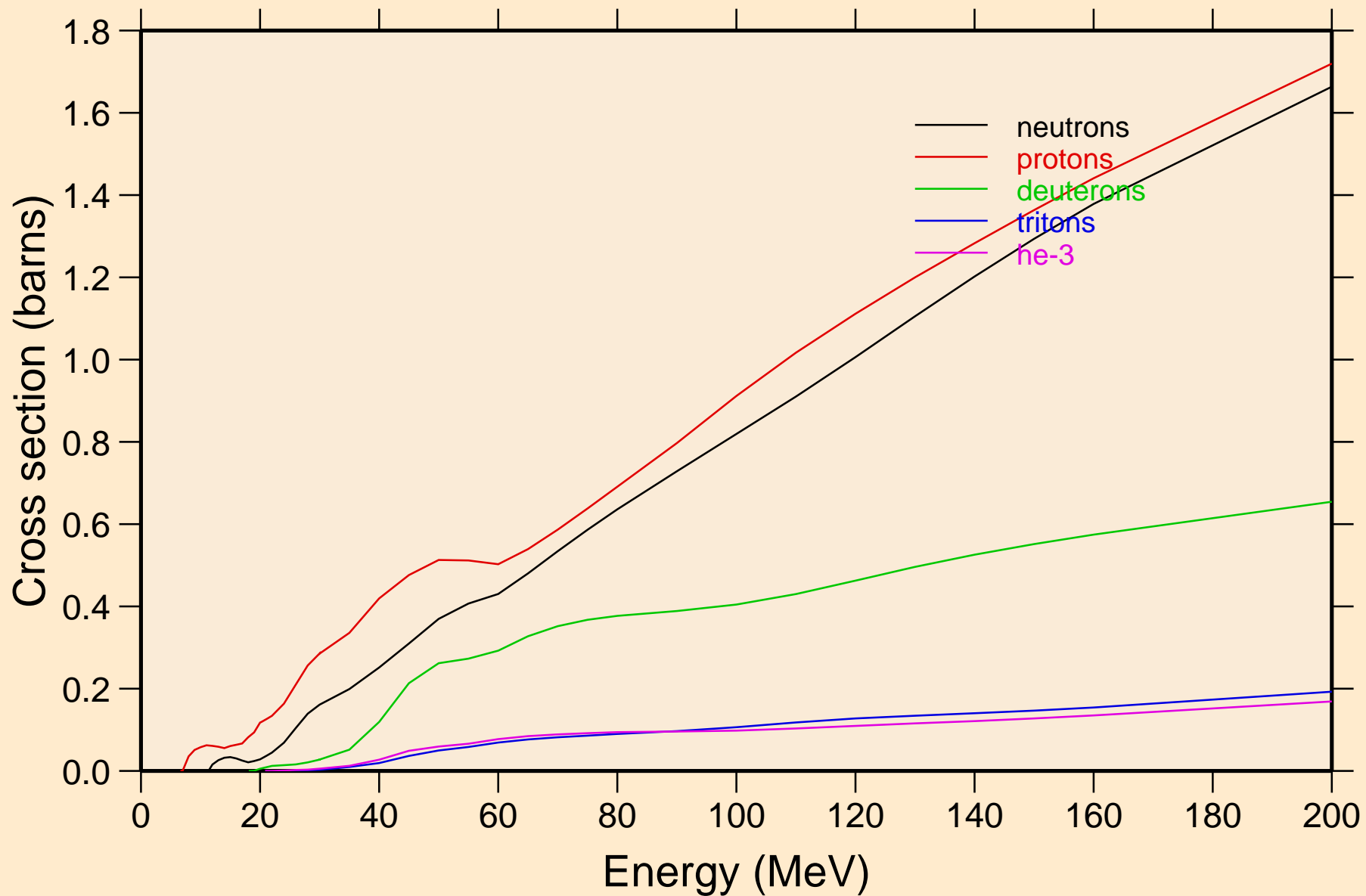

C012 ALPHA ACER TENDL-2023 LIBRARY; T=0.K
neutrons from (a,n)

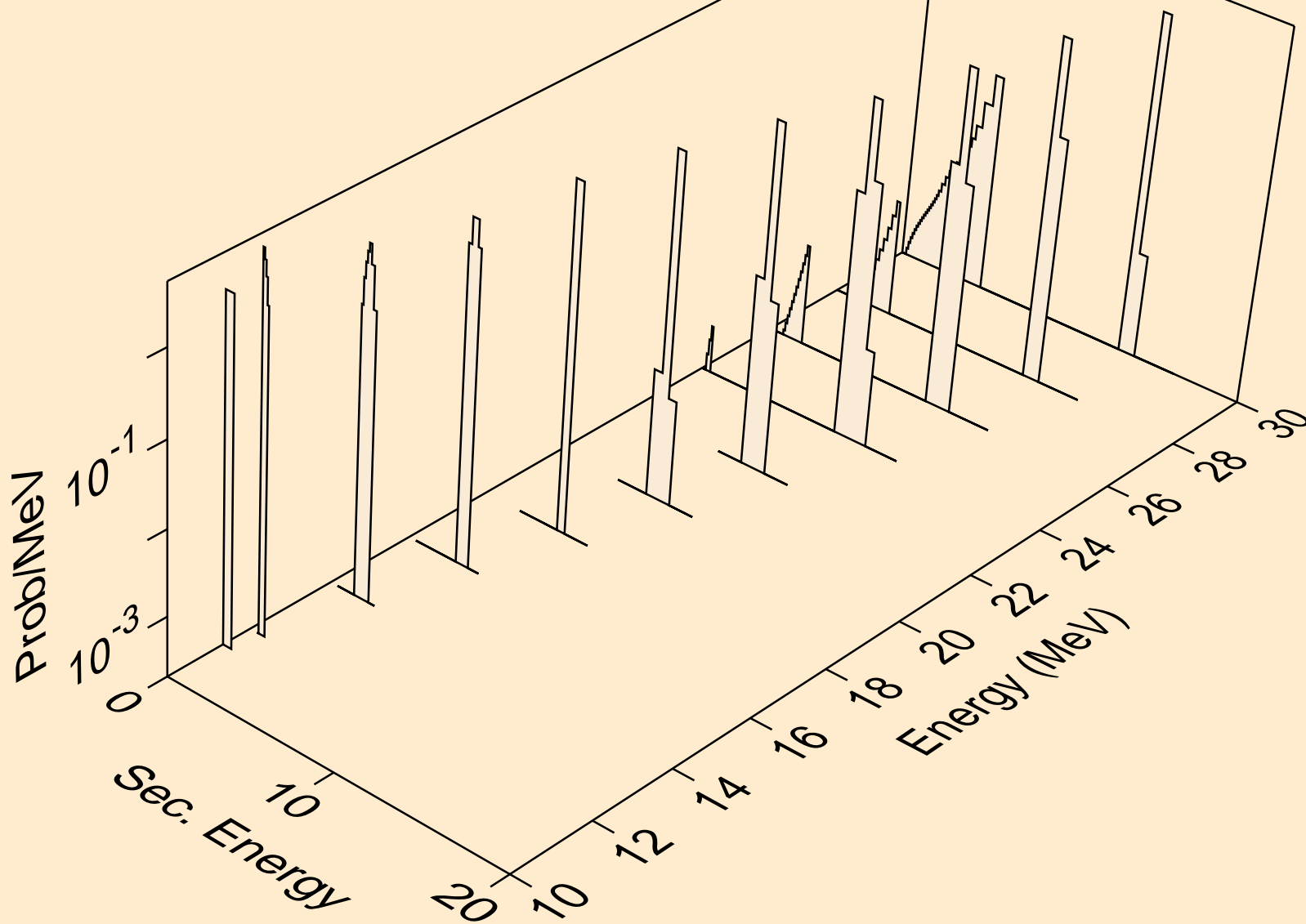

C012 ALPHA ACER TENDL-2023 LIBRARY; T=0.K
neutrons from (a,x)

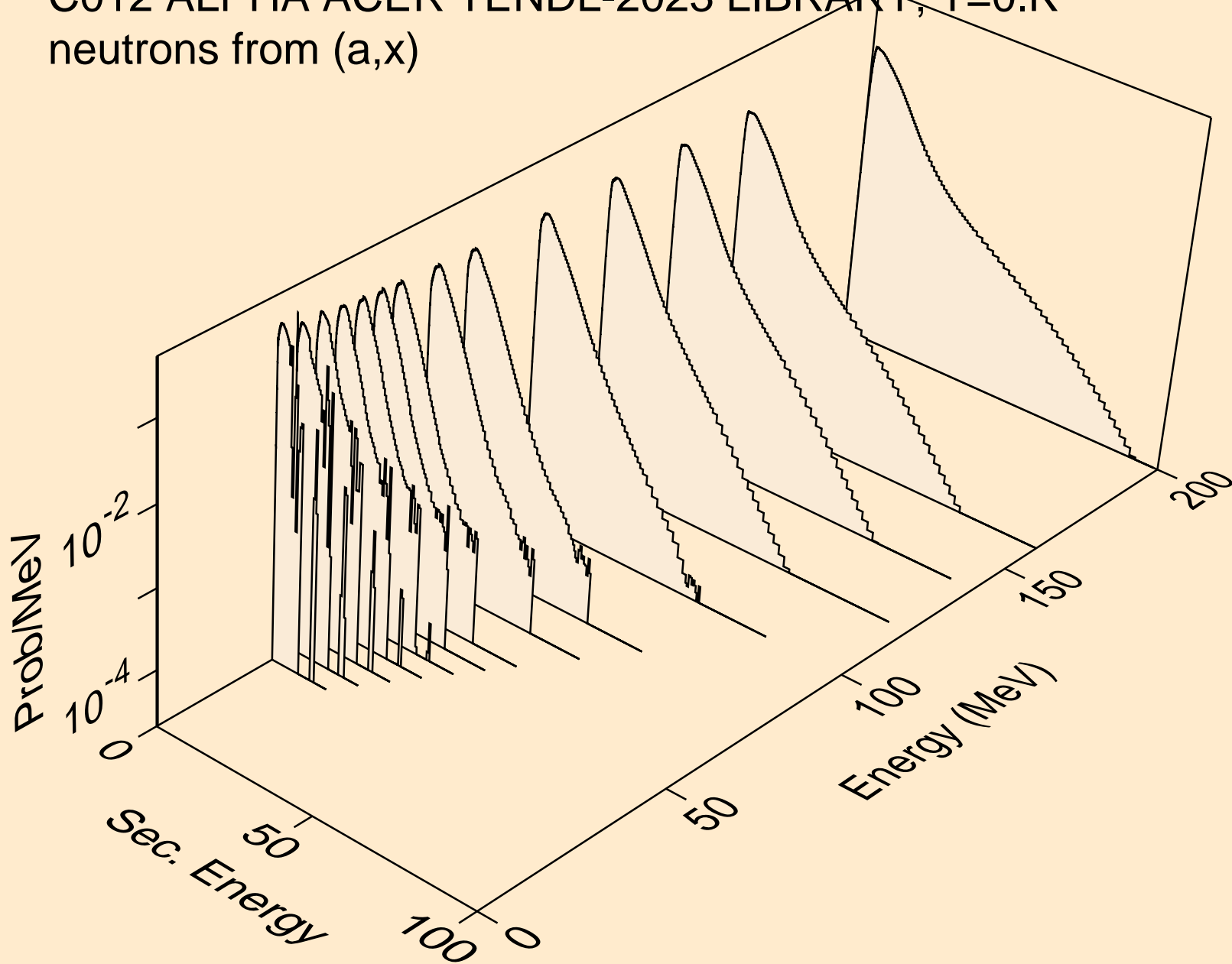

C012 ALPHA ACER TENDL-2023 LIBRARY; T=0.K
neutrons from (a,n*)a

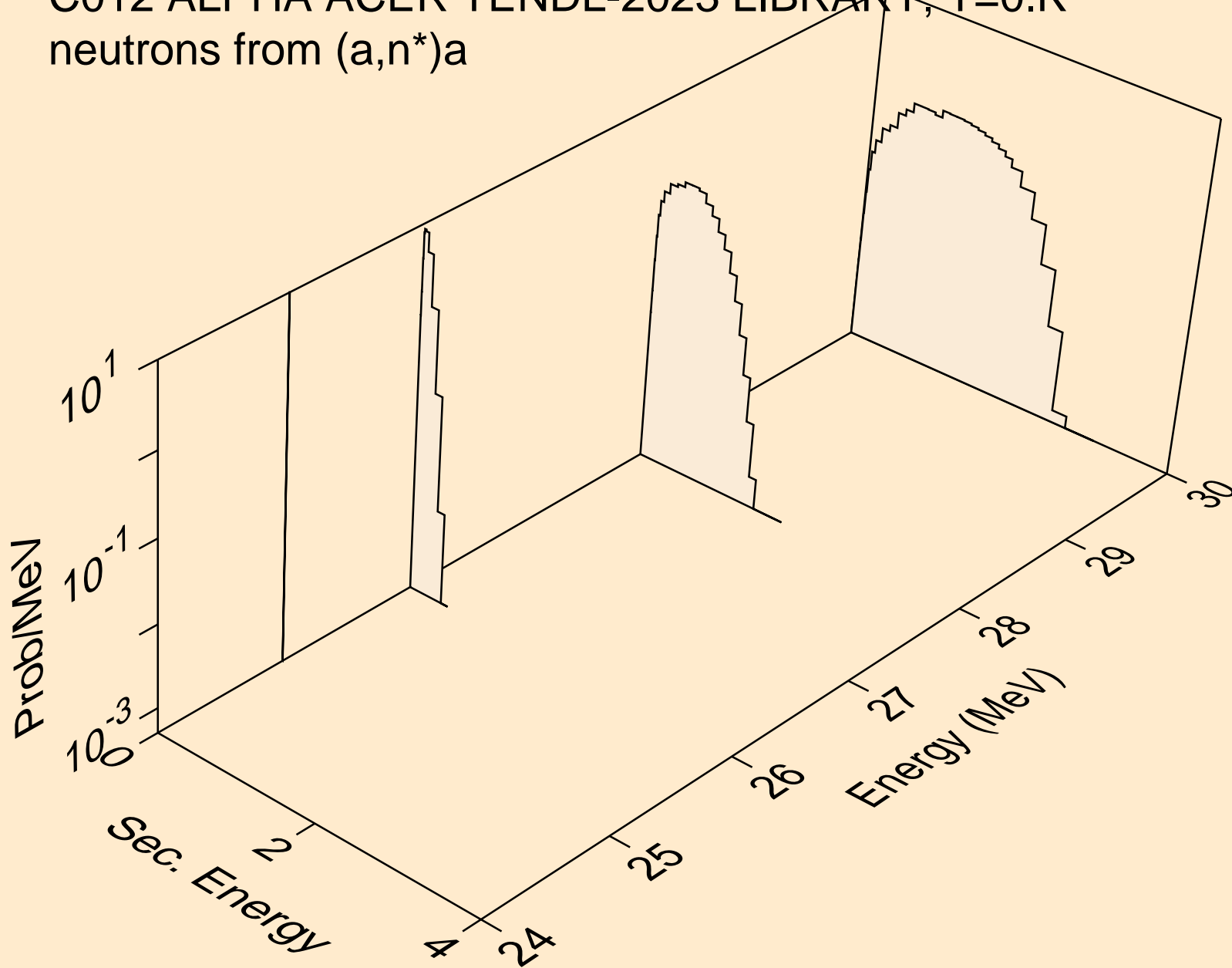

C012 ALPHA ACER TENDL-2023 LIBRARY; T=0.K
neutrons from (a,n*)p

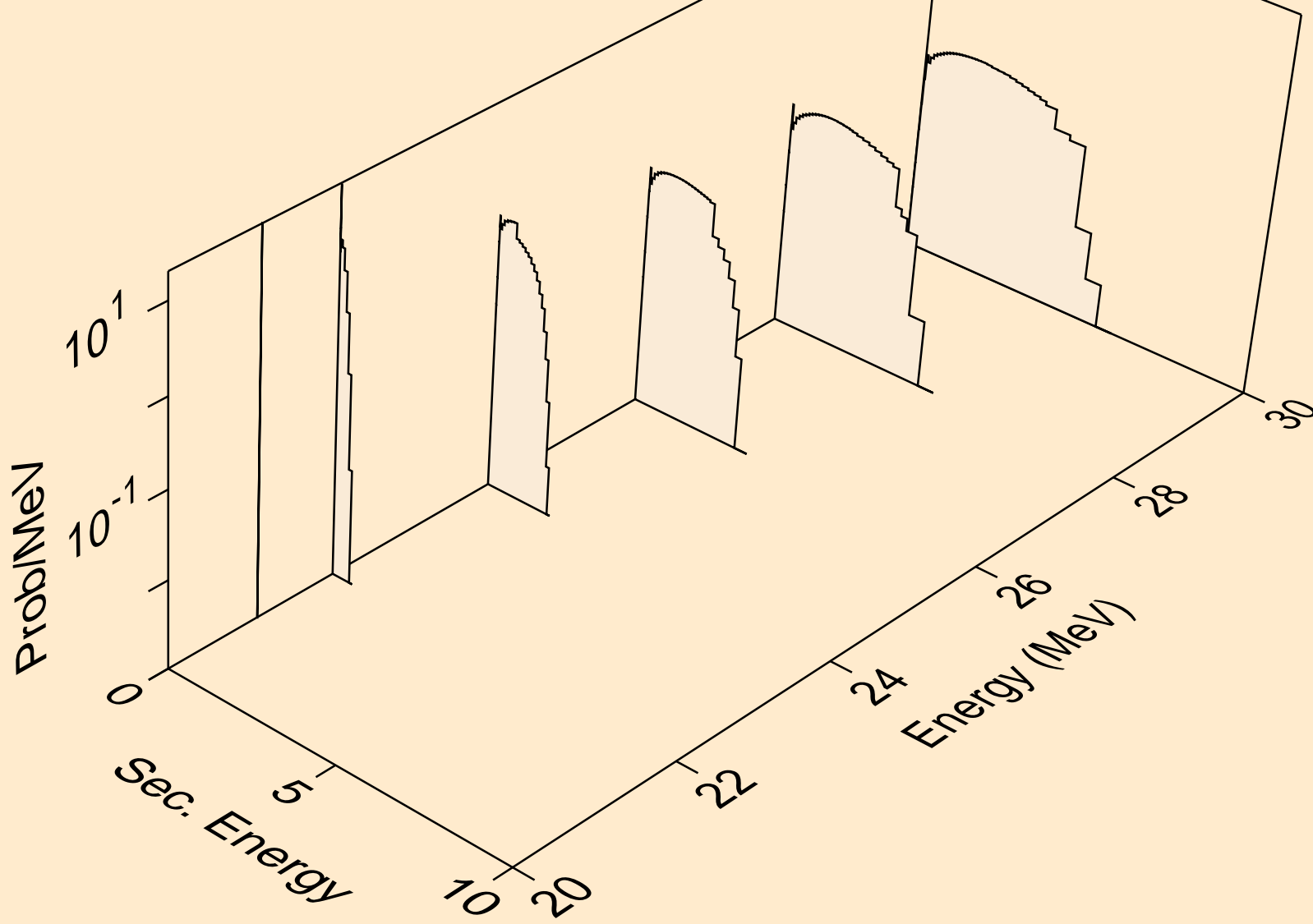

C012 ALPHA ACER TENDL-2023 LIBRARY; T=0.K
neutrons from (a,n*)he3

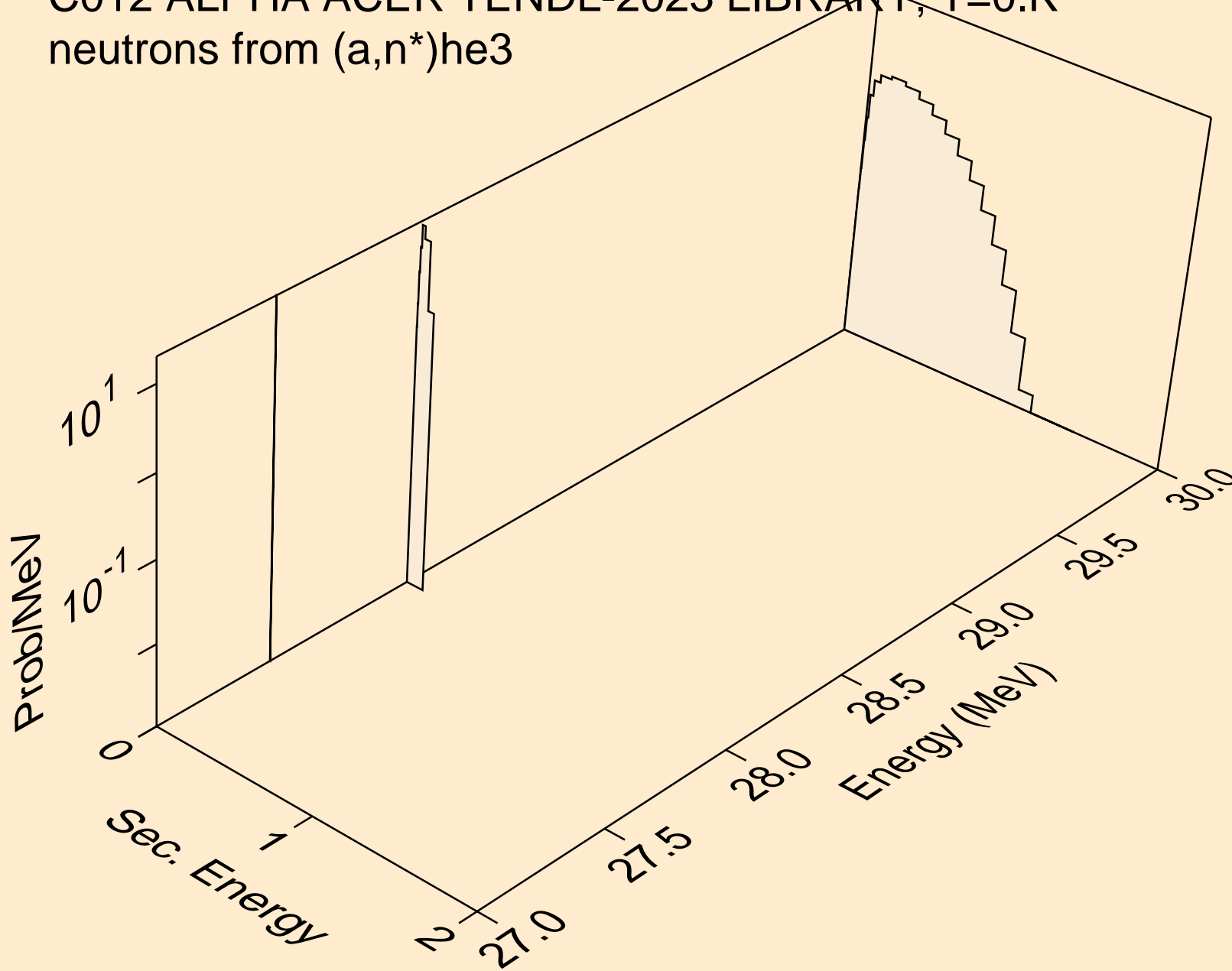

C012 ALPHA ACER TENDL-2023 LIBRARY; T=0.K
protons from (a,x)

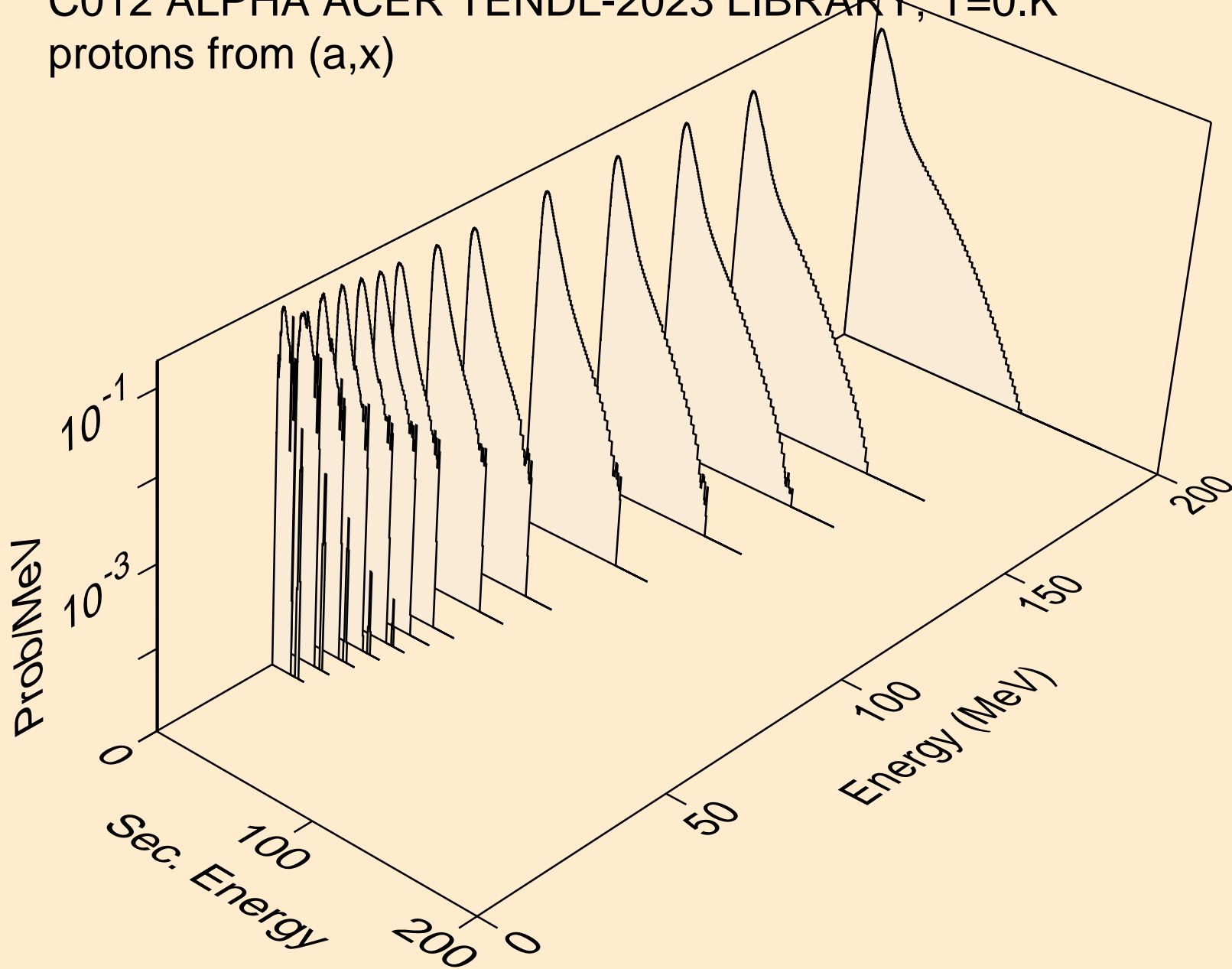

C012 ALPHA ACER TENDL-2023 LIBRARY; T=0.K
protons from (a,n*)p

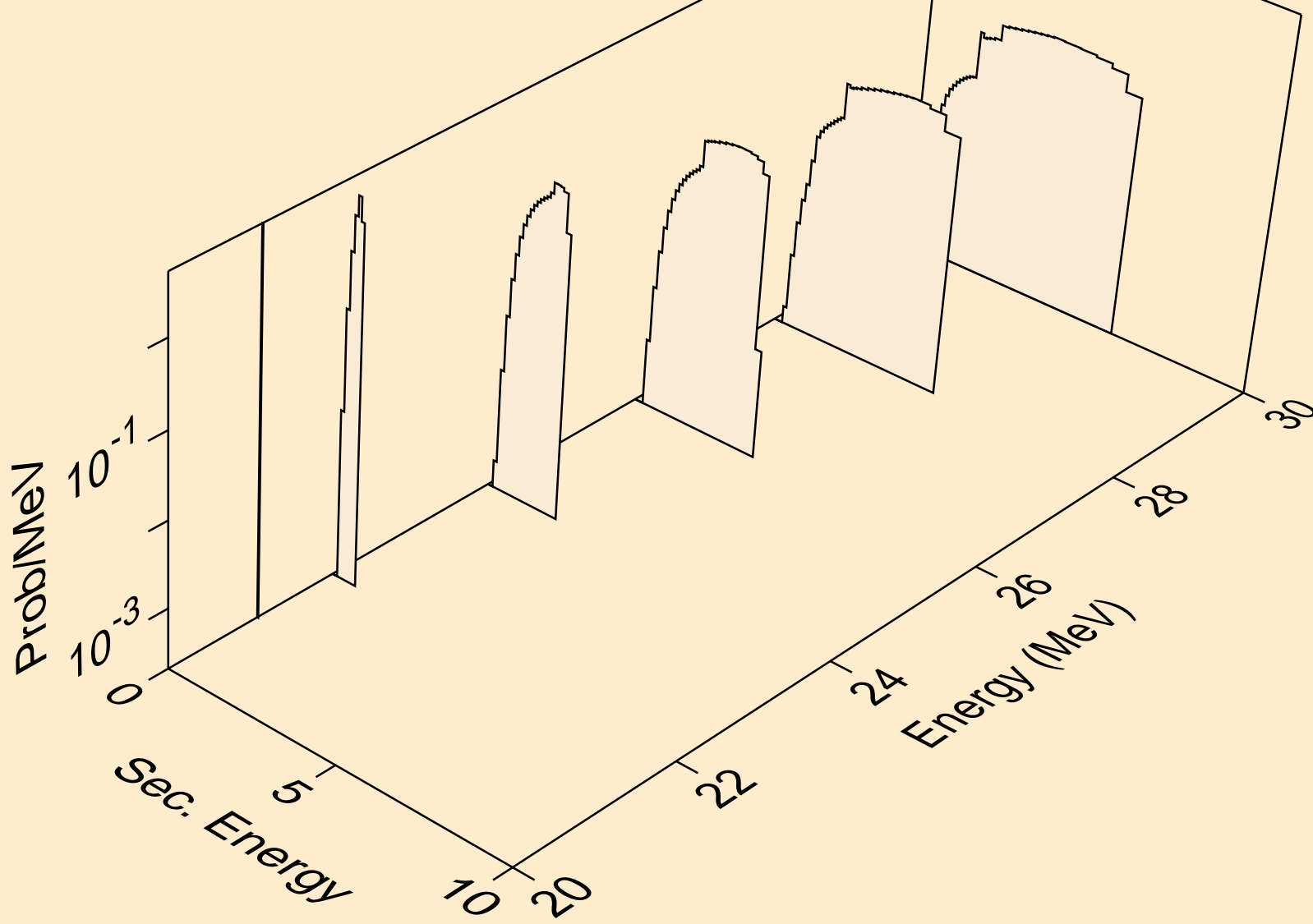

C012 ALPHA ACER TENDL-2023 LIBRARY; T=0.K
protons from (a,p)

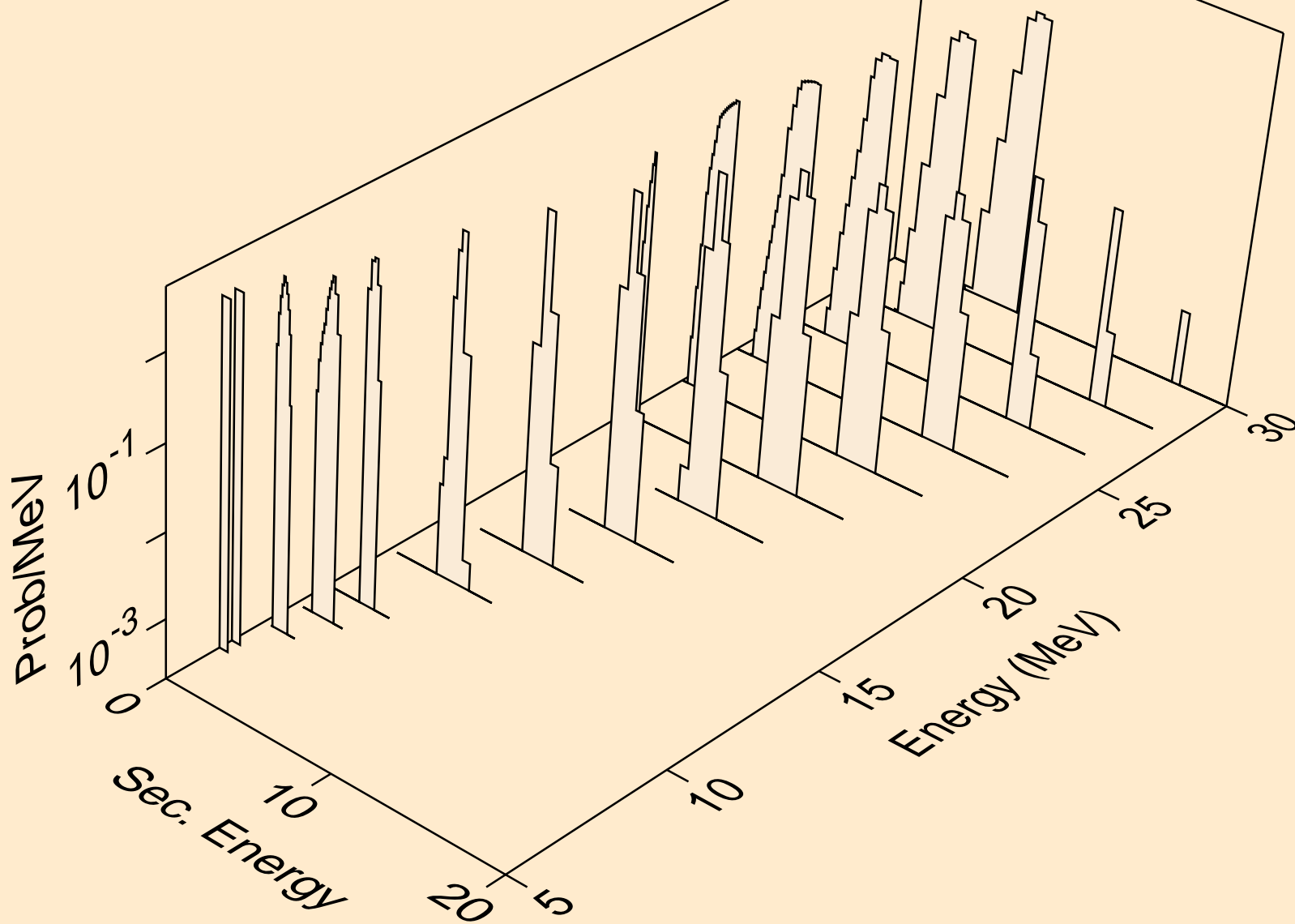

C012 ALPHA ACER TENDL-2023 LIBRARY; T=0.K
protons from (a,2p)

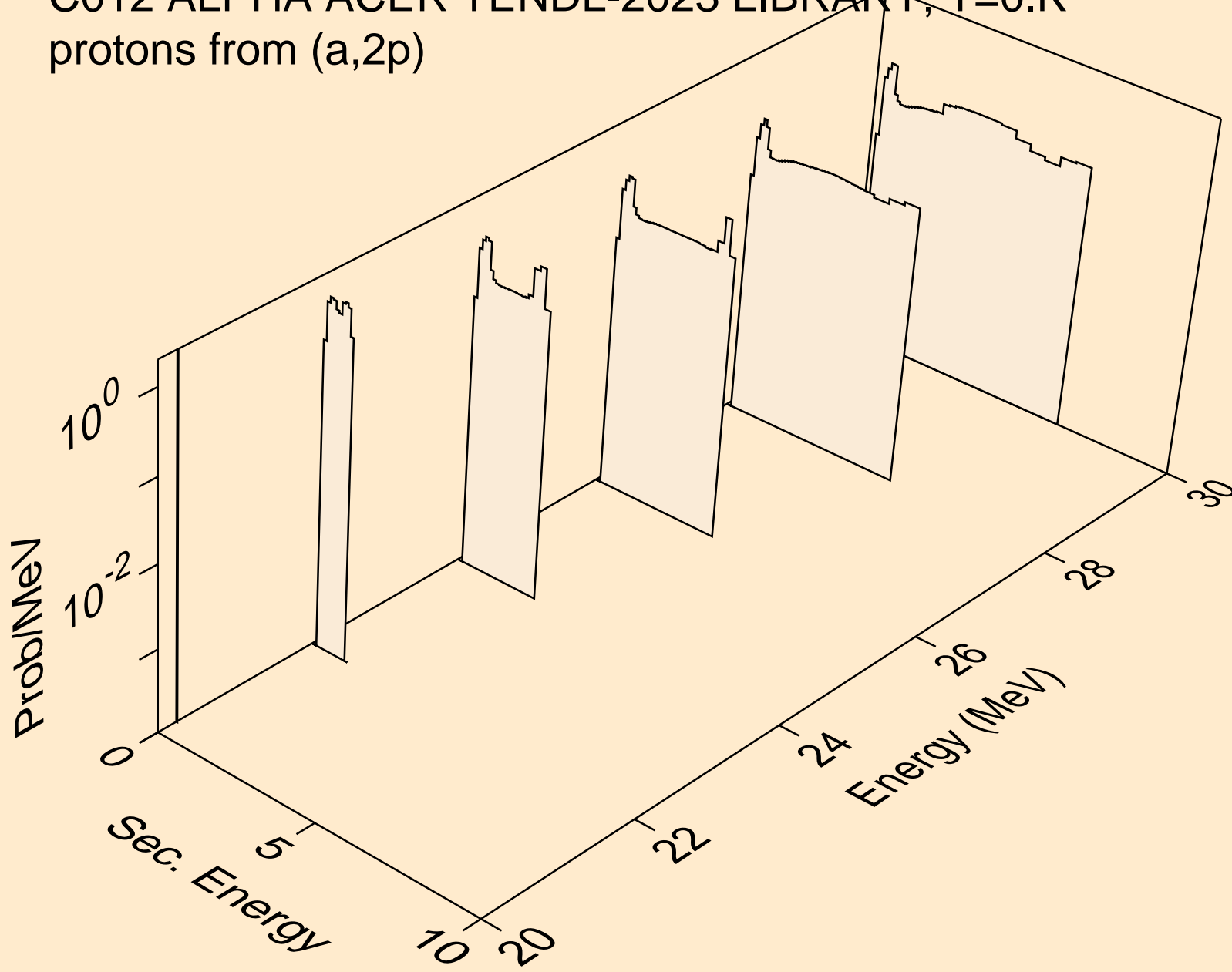

C012 ALPHA ACER TENDL-2023 LIBRARY; T=0.K
protons from (a,pa)

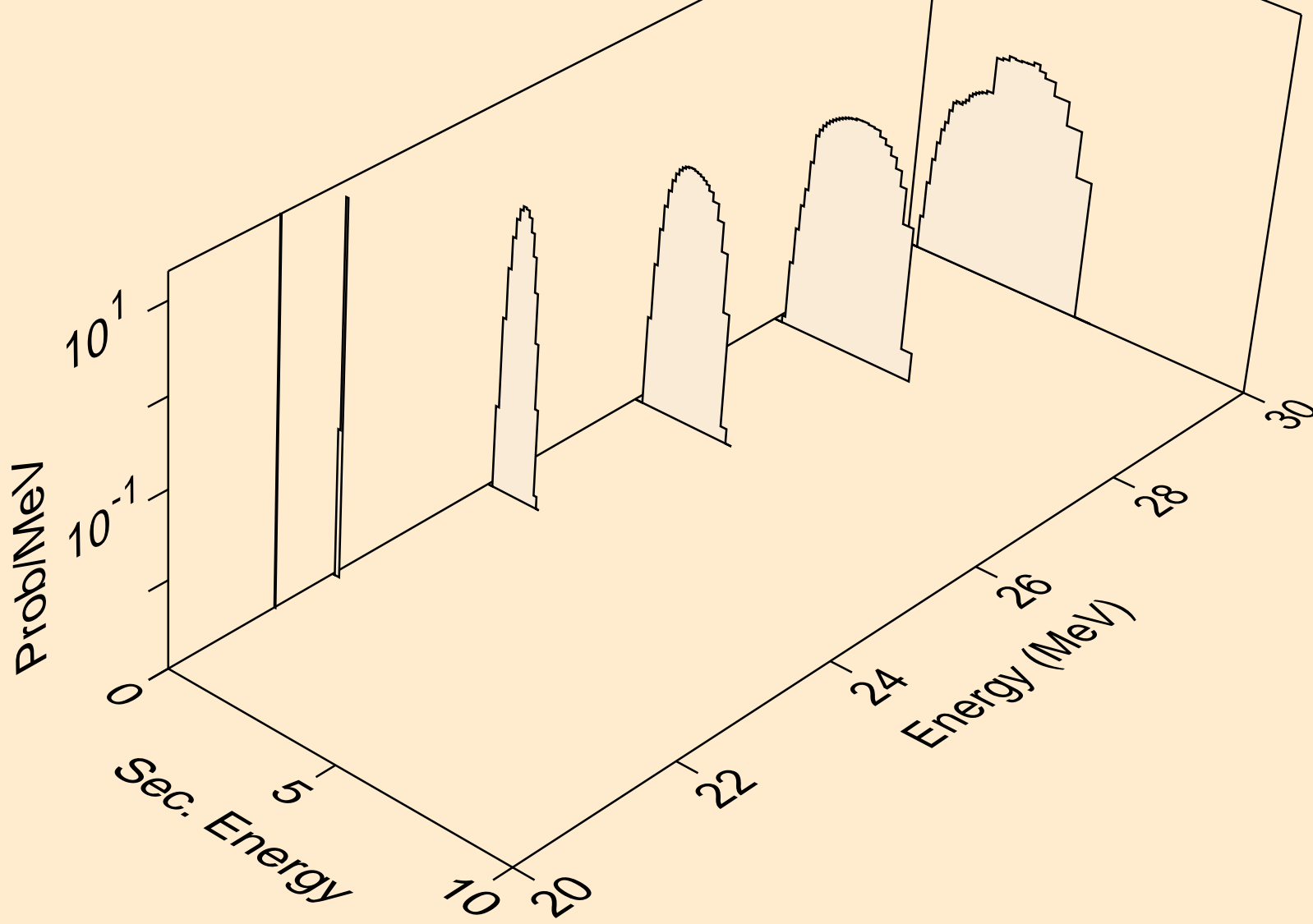

C012 ALPHA ACER TENDL-2023 LIBRARY; T=0.K
protons from (a,pt)

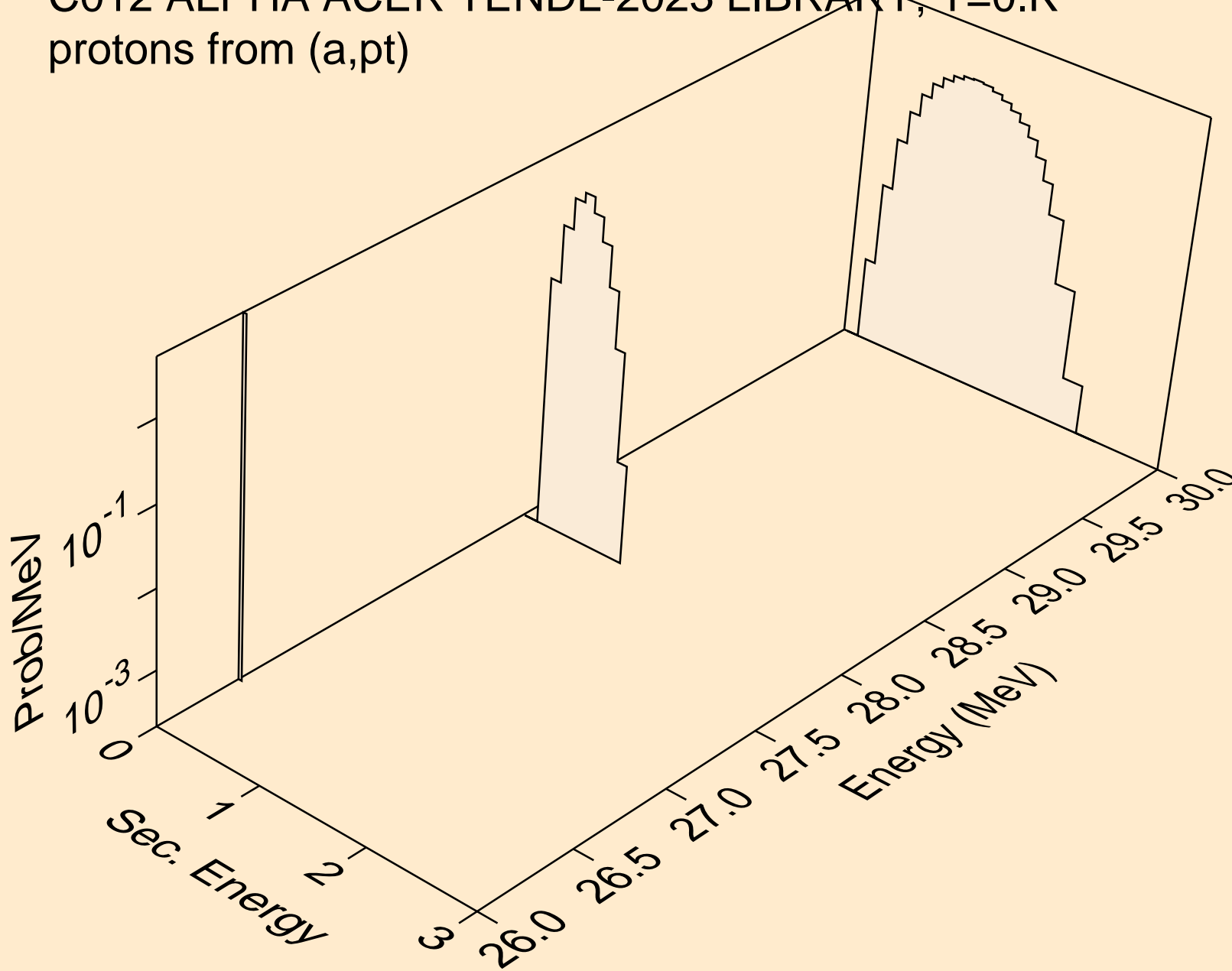

C012 ALPHA ACER TENDL-2023 LIBRARY; T=0.K
deuterons from (a,x)

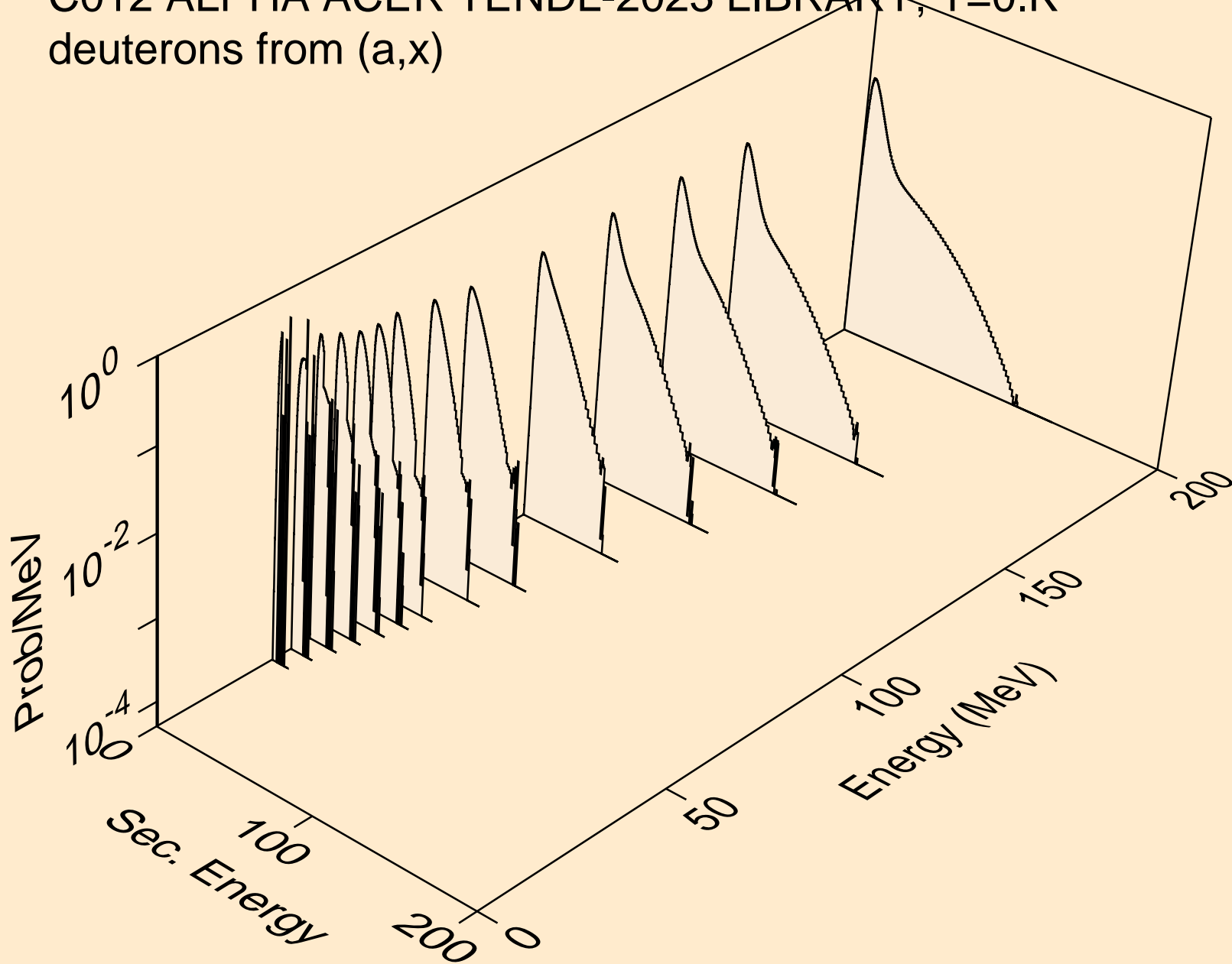

C012 ALPHA ACER TENDL-2023 LIBRARY; T=0.K
deuterons from (a,d)

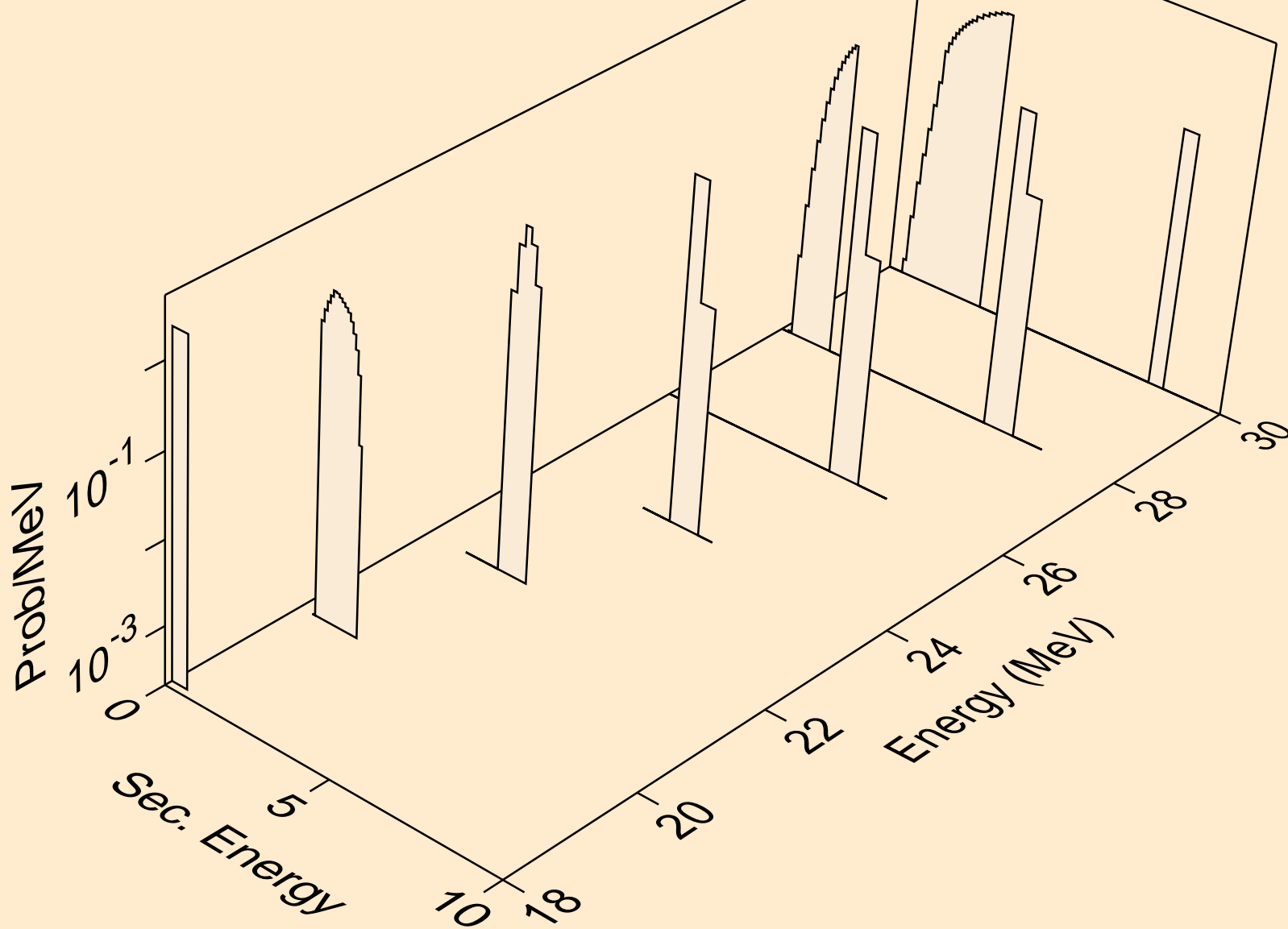

C012 ALPHA ACER TENDL-2023 LIBRARY; T=0.K
tritons from (a,x)

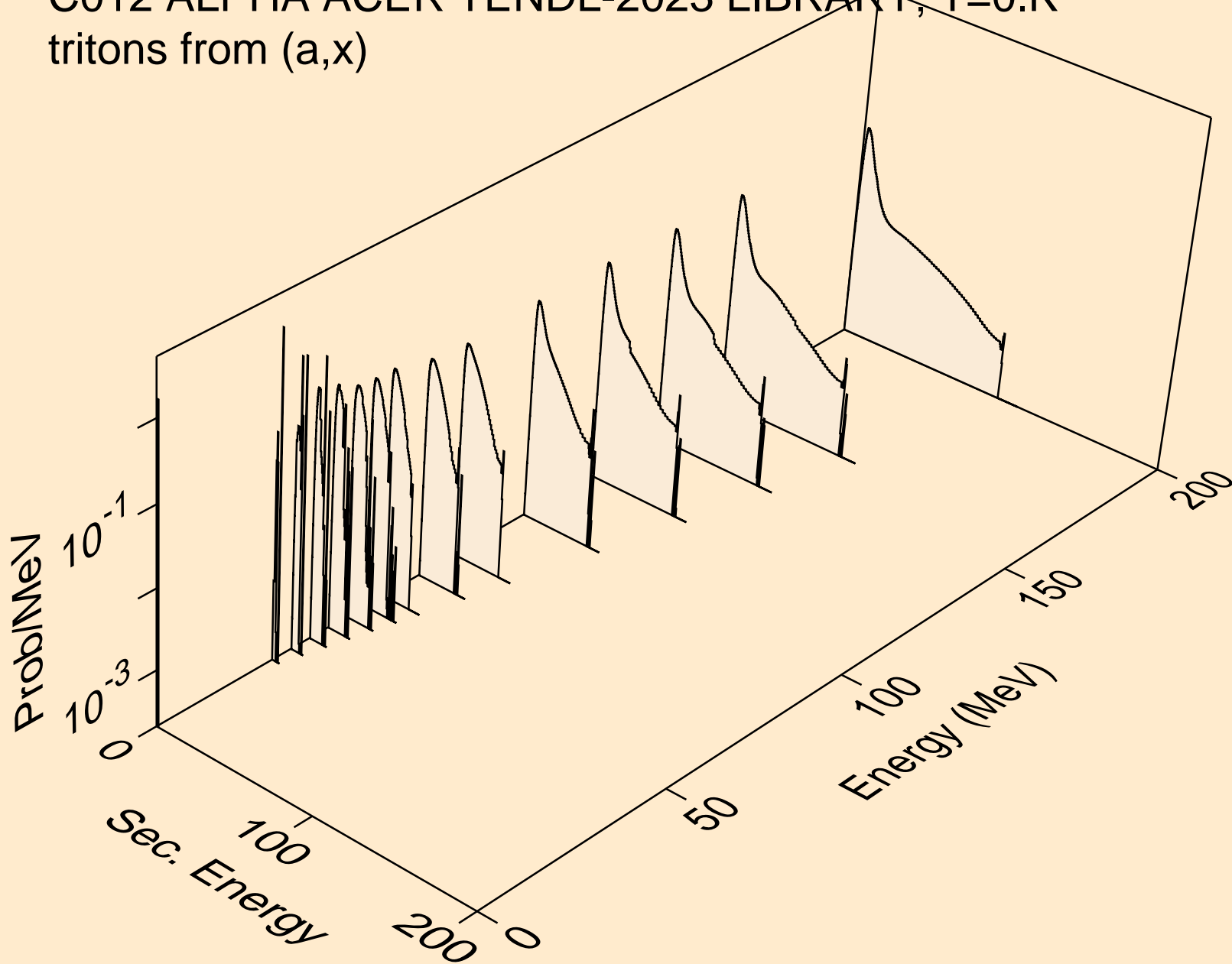

C012 ALPHA ACER TENDL-2023 LIBRARY; T=0.K
tritons from (a,t)

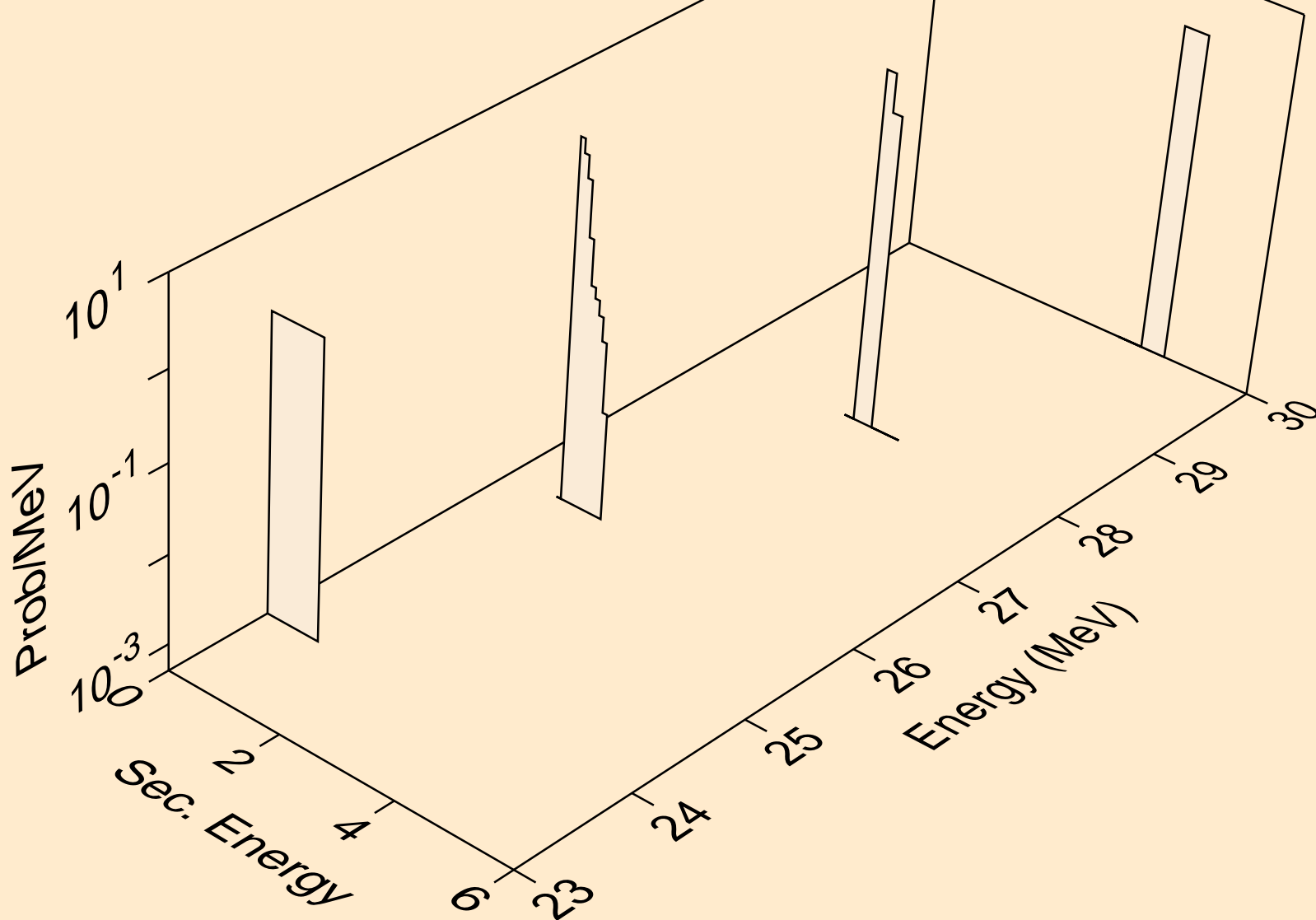

C012 ALPHA ACER TENDL-2023 LIBRARY; T=0.K
tritons from (a,pt)

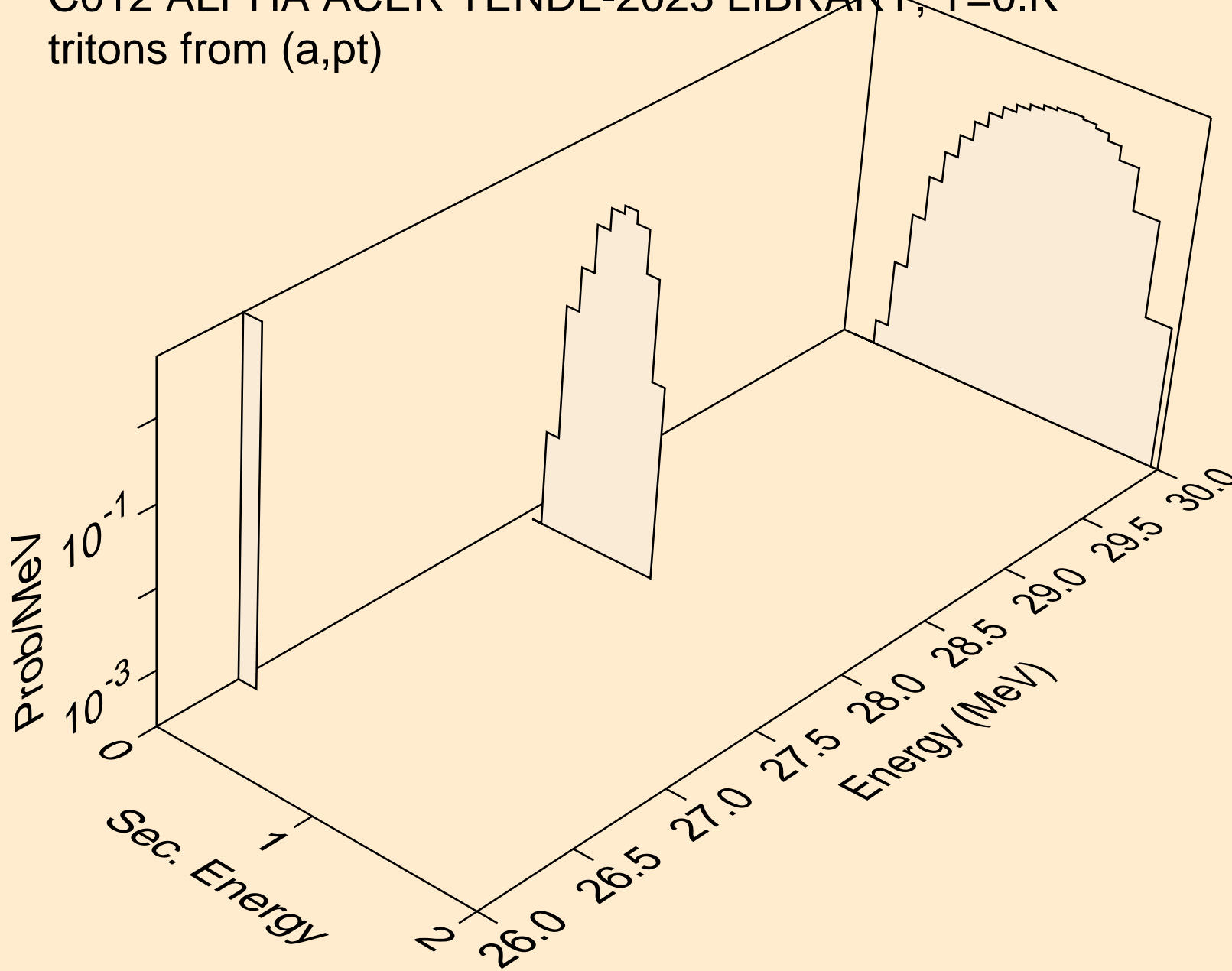

C012 ALPHA ACER TENDL-2023 LIBRARY; T=0.K
he3s from (a,x)

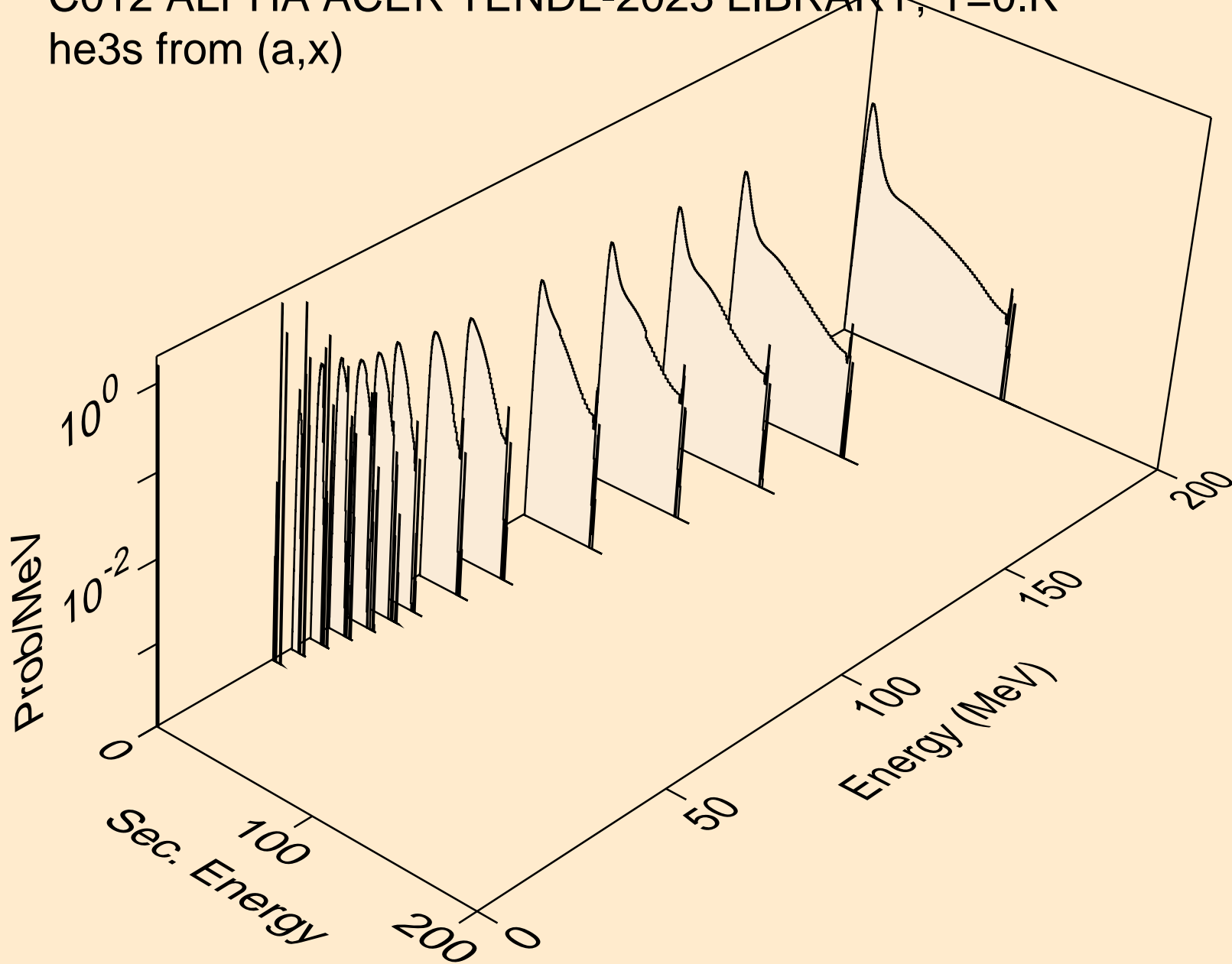

C012 ALPHA ACER TENDL-2023 LIBRARY; T=0.K
he3s from (a,n*)he3

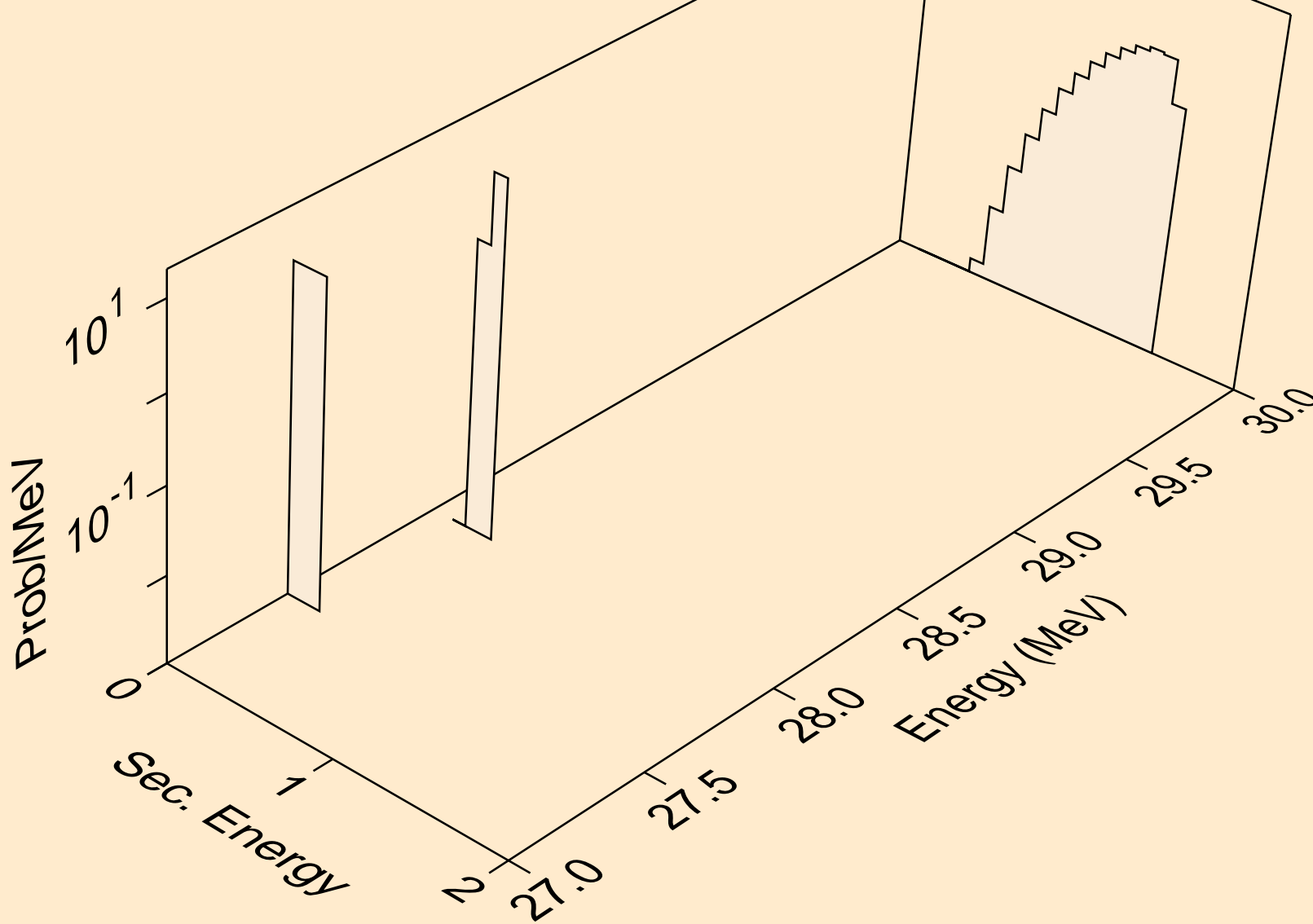

C012 ALPHA ACER TENDL-2023 LIBRARY; T=0.K
he3s from (a,he3)

