

# CL036 ALPHA ACER TENDL-2023 LIBRARY; T=0.K

## Principal cross sections

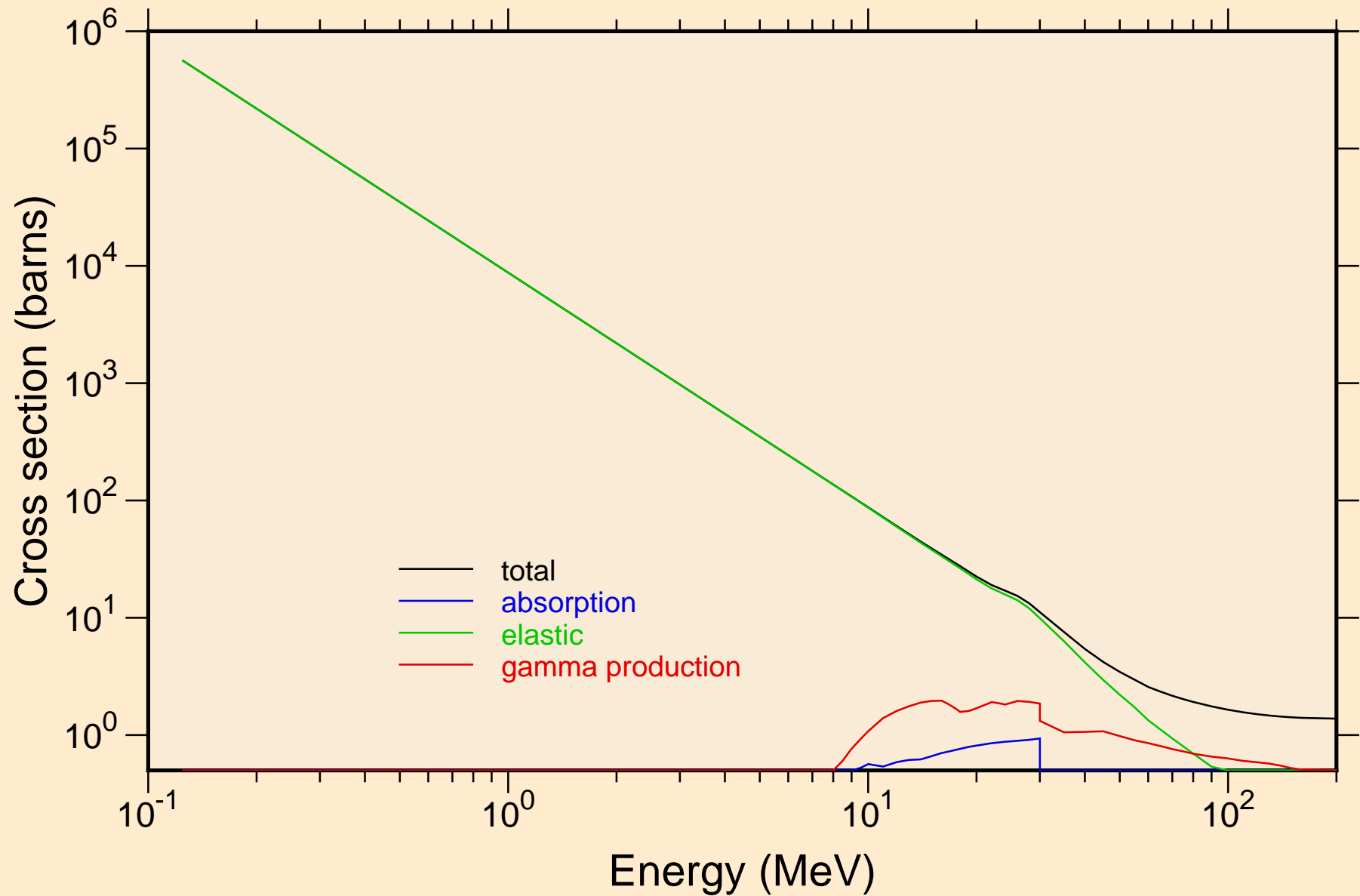

CL036 ALPHA ACER TENDL-2023 LIBRARY; T=0.K

Heating

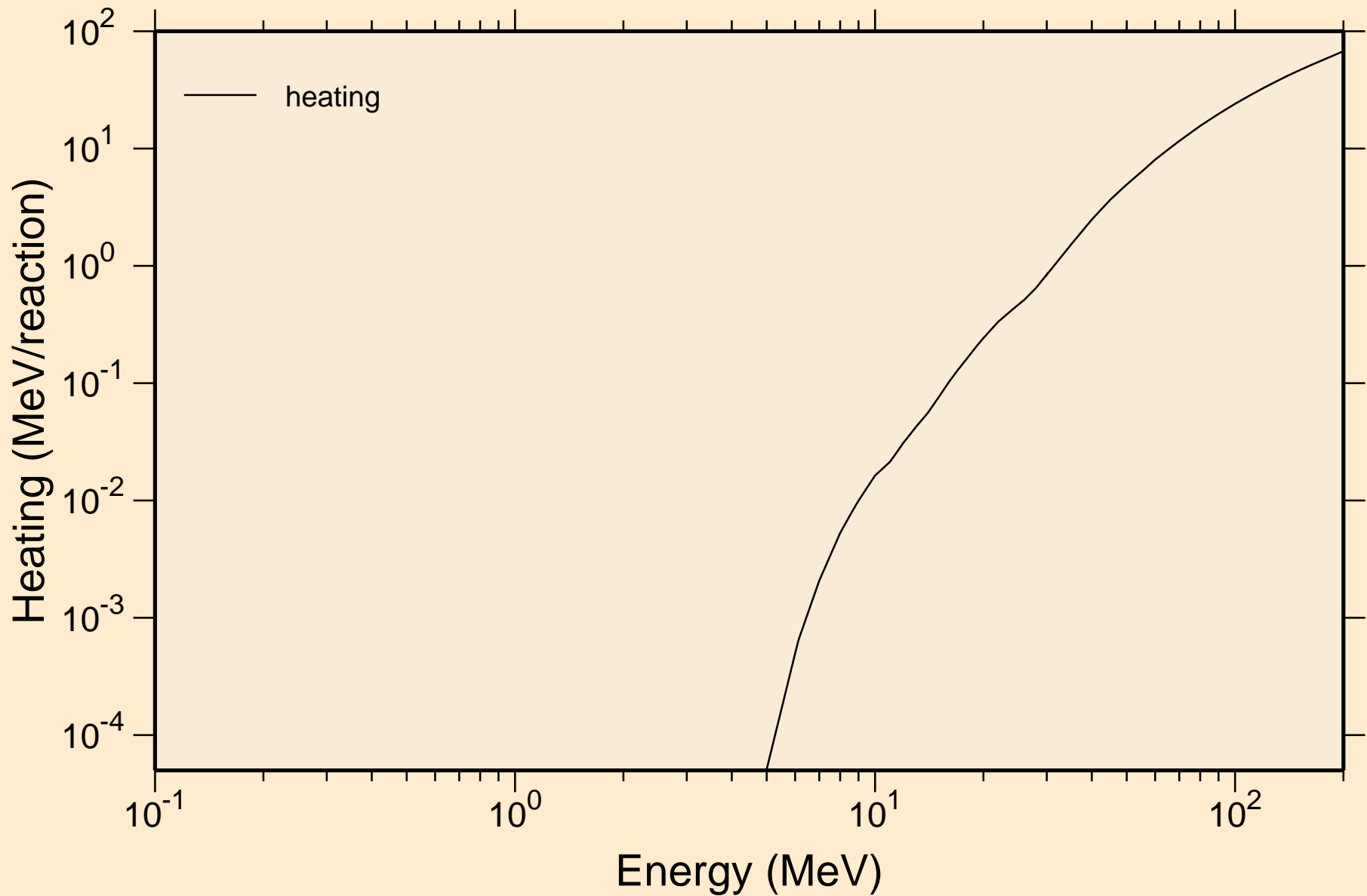

# CL036 ALPHA ACER TENDL-2023 LIBRARY; T=0.K

## Principal cross sections

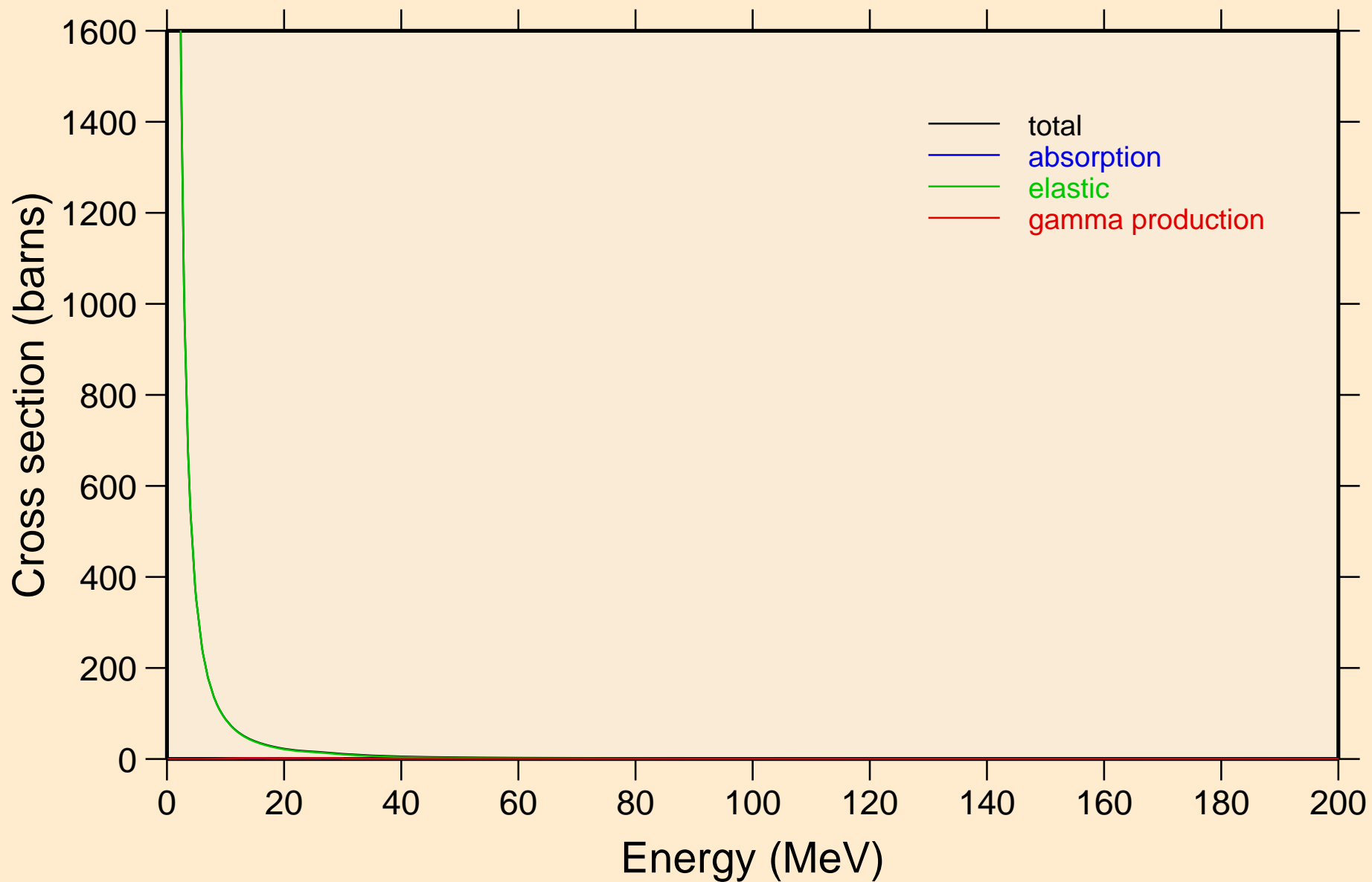

CL036 ALPHA ACER TENDL-2023 LIBRARY; T=0.K  
Heating

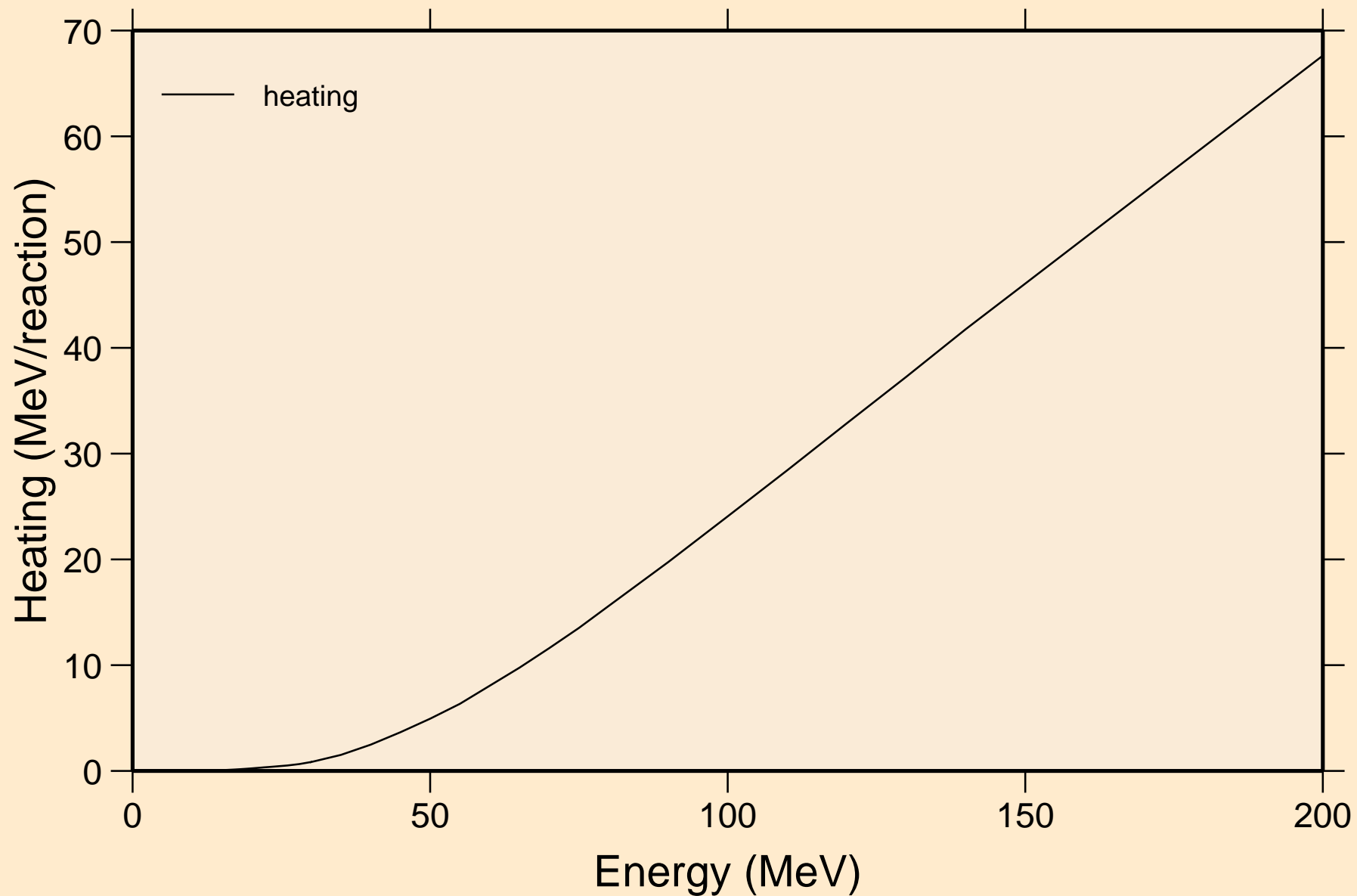

# CL036 ALPHA ACER TENDL-2023 LIBRARY; T=0.K

## Threshold reactions

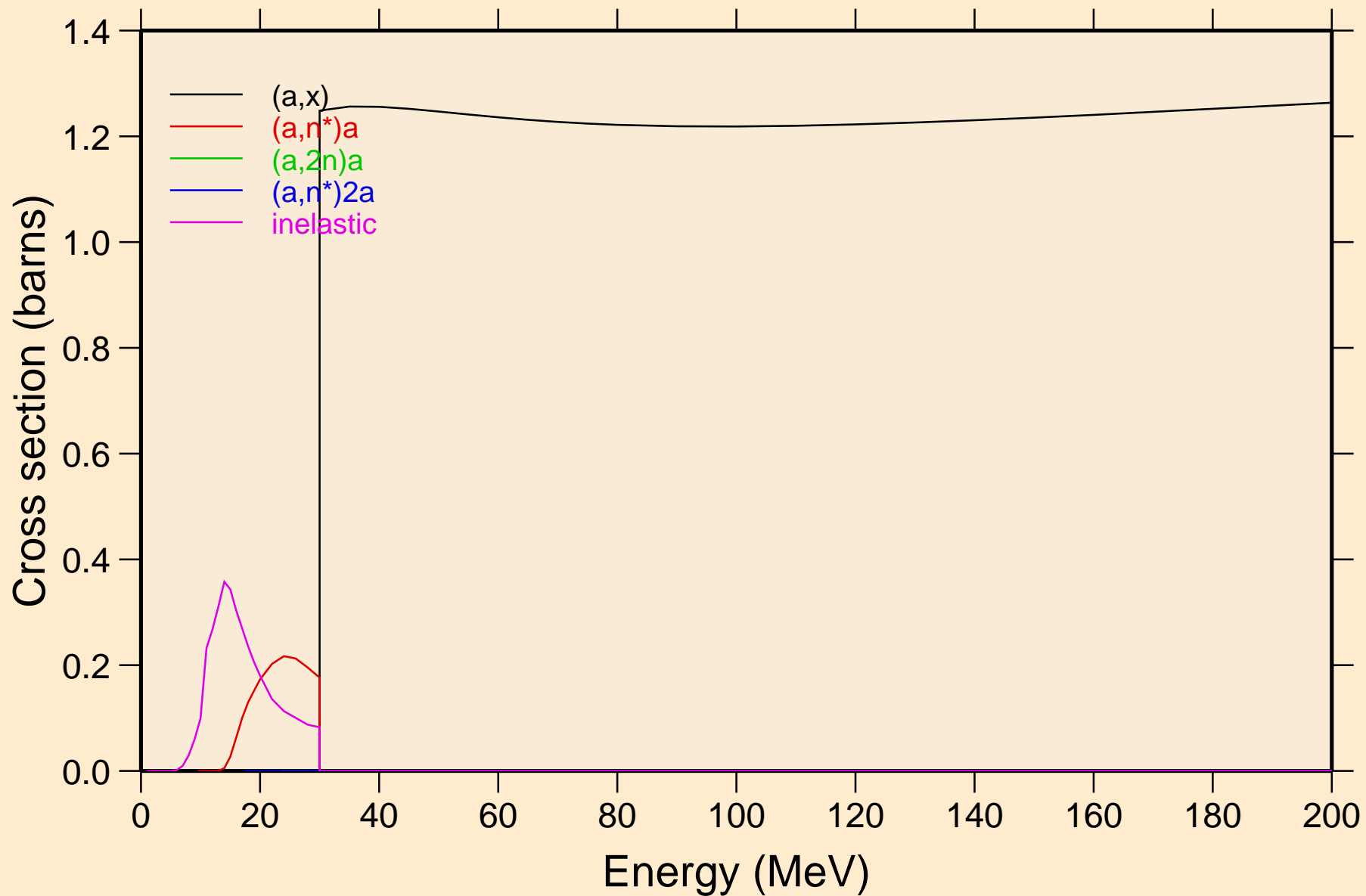

# CL036 ALPHA ACER TENDL-2023 LIBRARY; T=0.K

## Threshold reactions

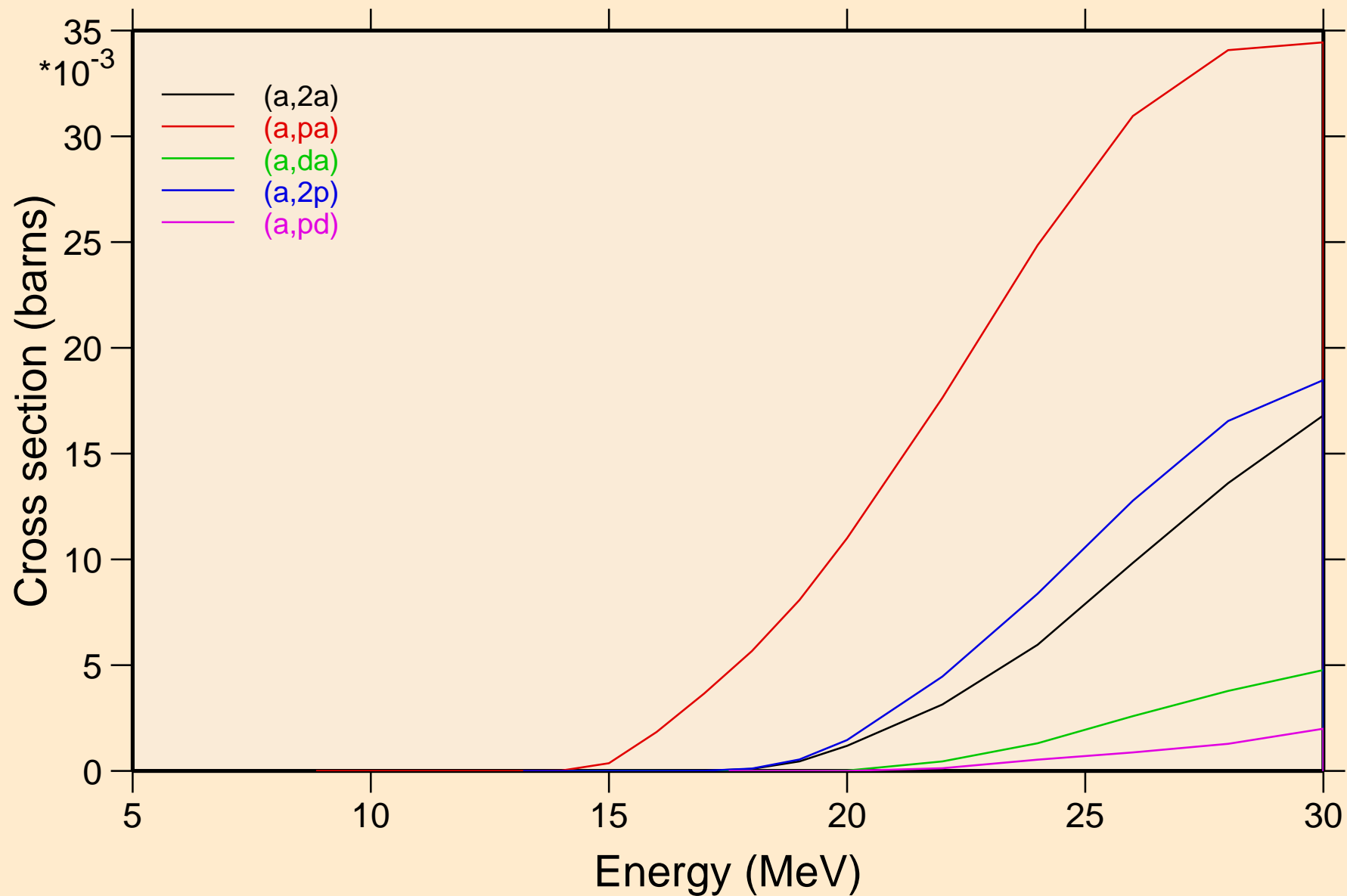

CL036 ALPHA ACER TENDL-2023 LIBRARY; T=0.K  
Threshold reactions

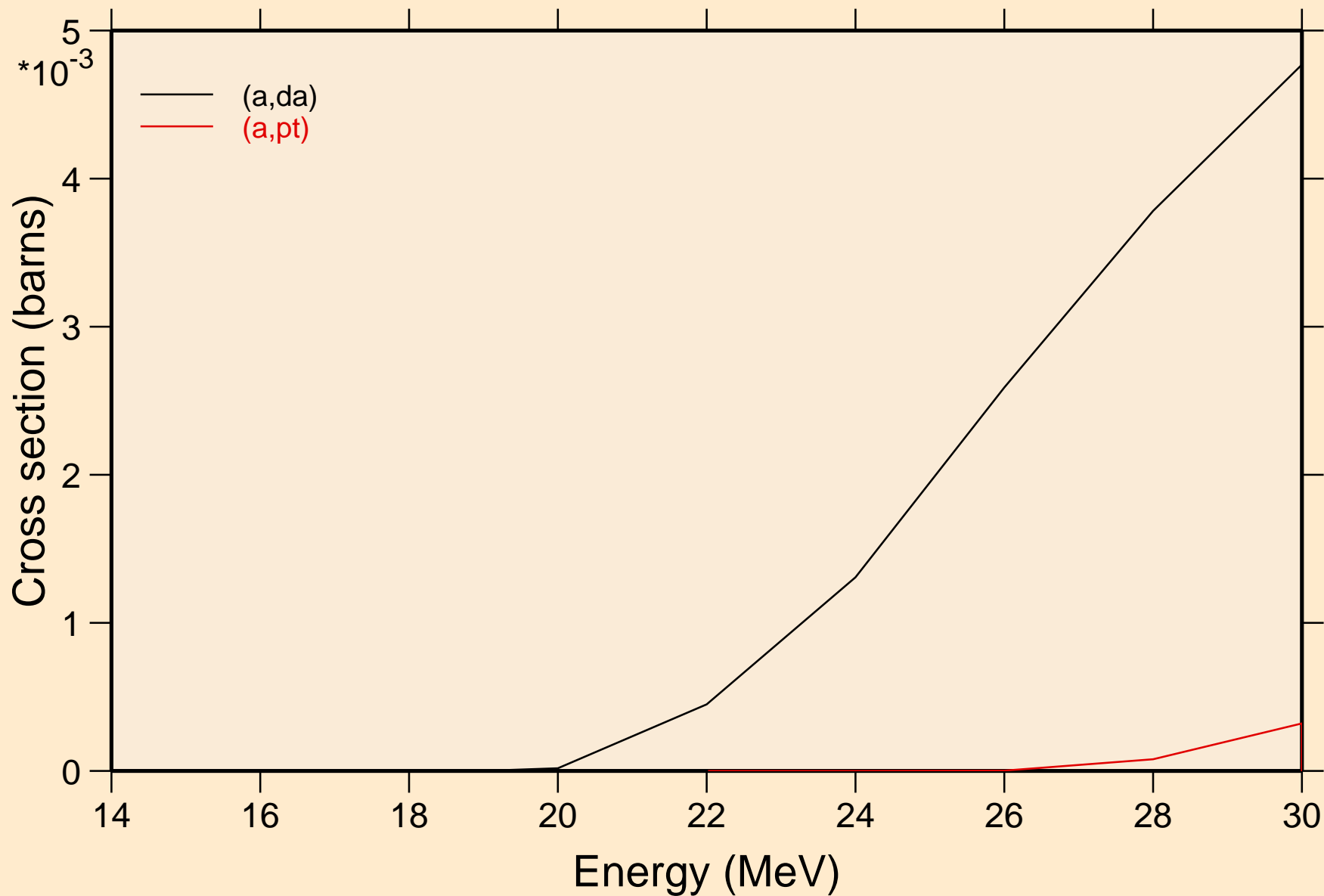

CL036 ALPHA ACER TENDL-2023 LIBRARY; T=0.K

Threshold reactions

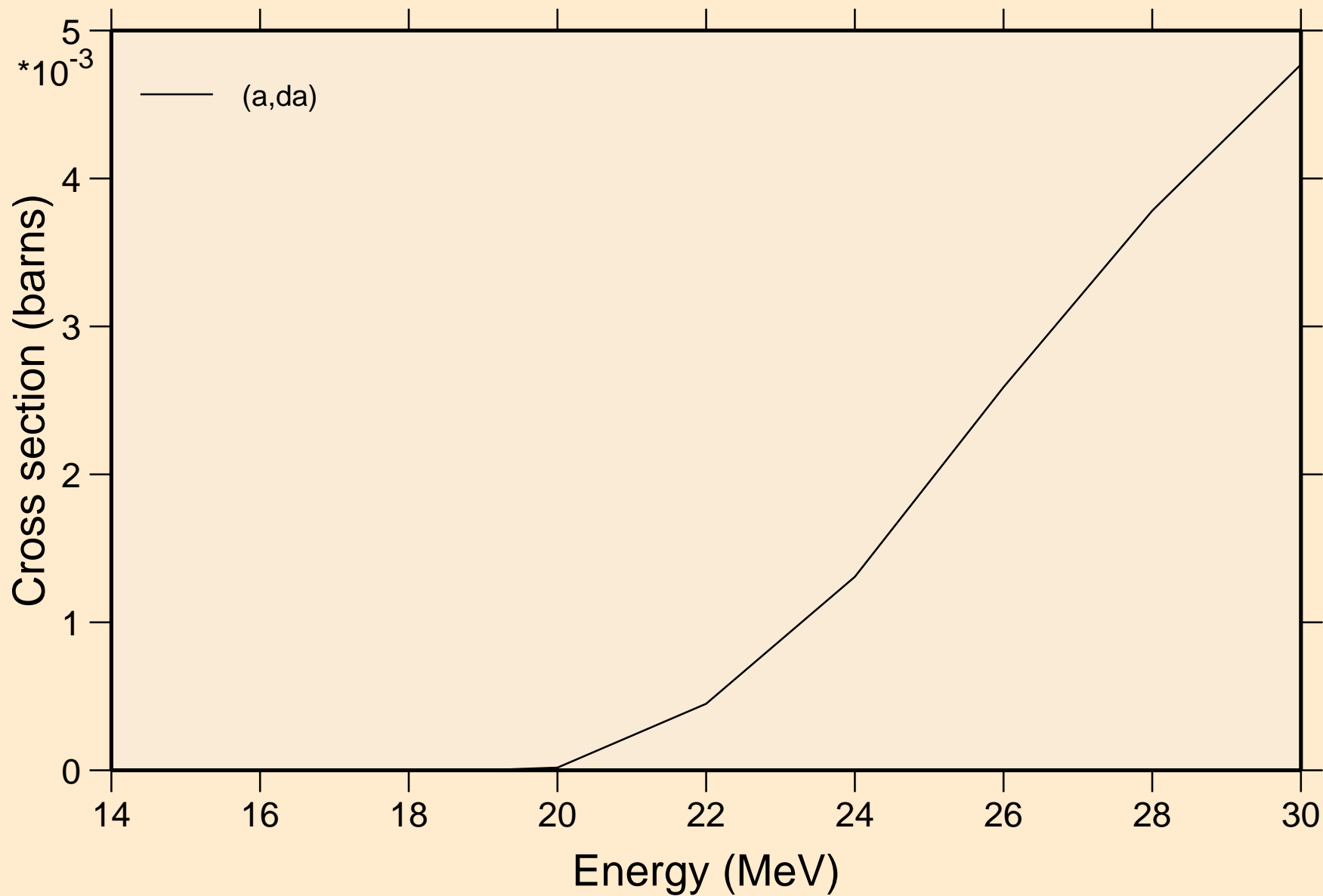

CL036 ALPHA ACER TENDL-2023 LIBRARY; T=0.K  
angular distribution for elastic

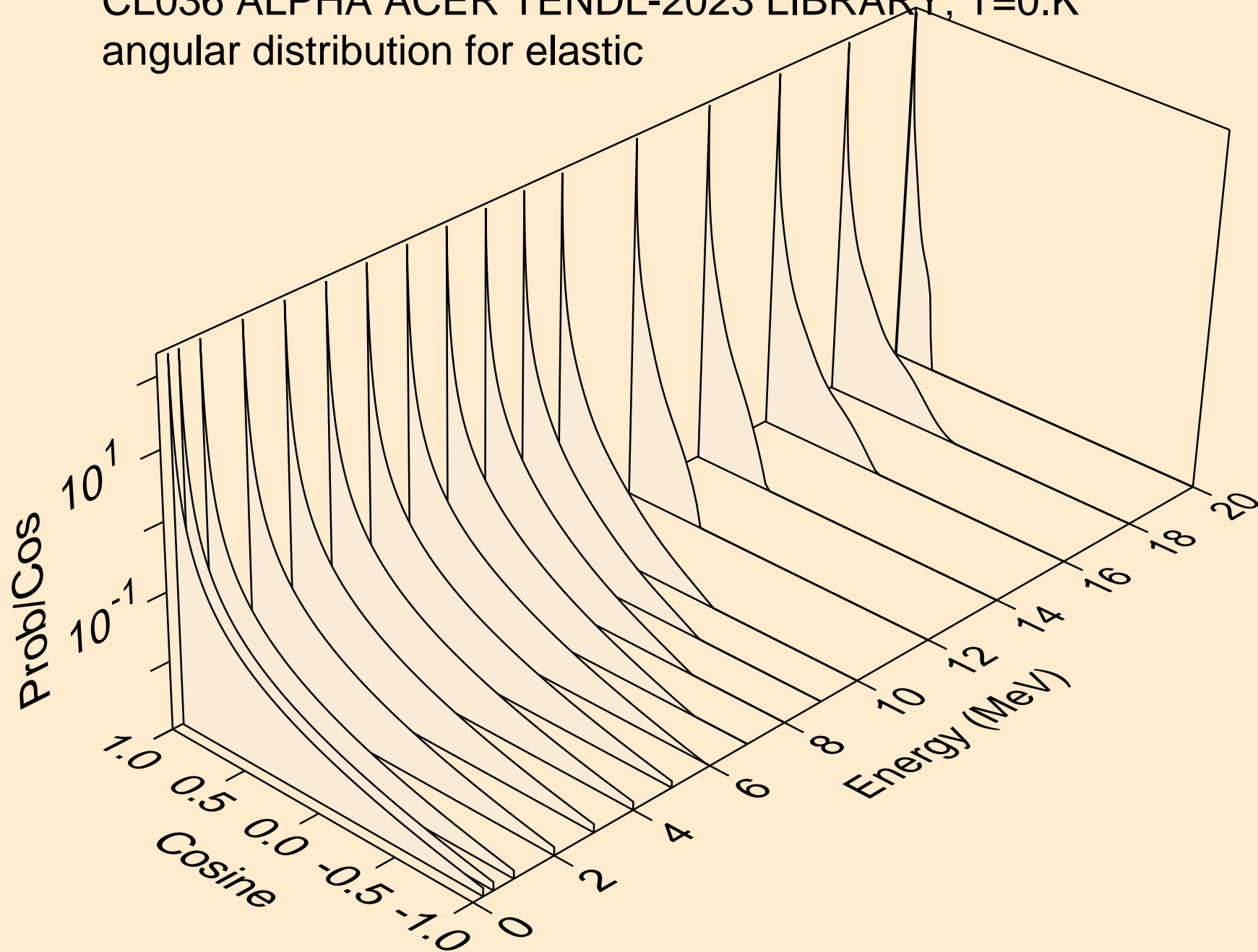

CL036 ALPHA ACER TENDL-2023 LIBRARY; T=0.K  
angular distribution for elastic

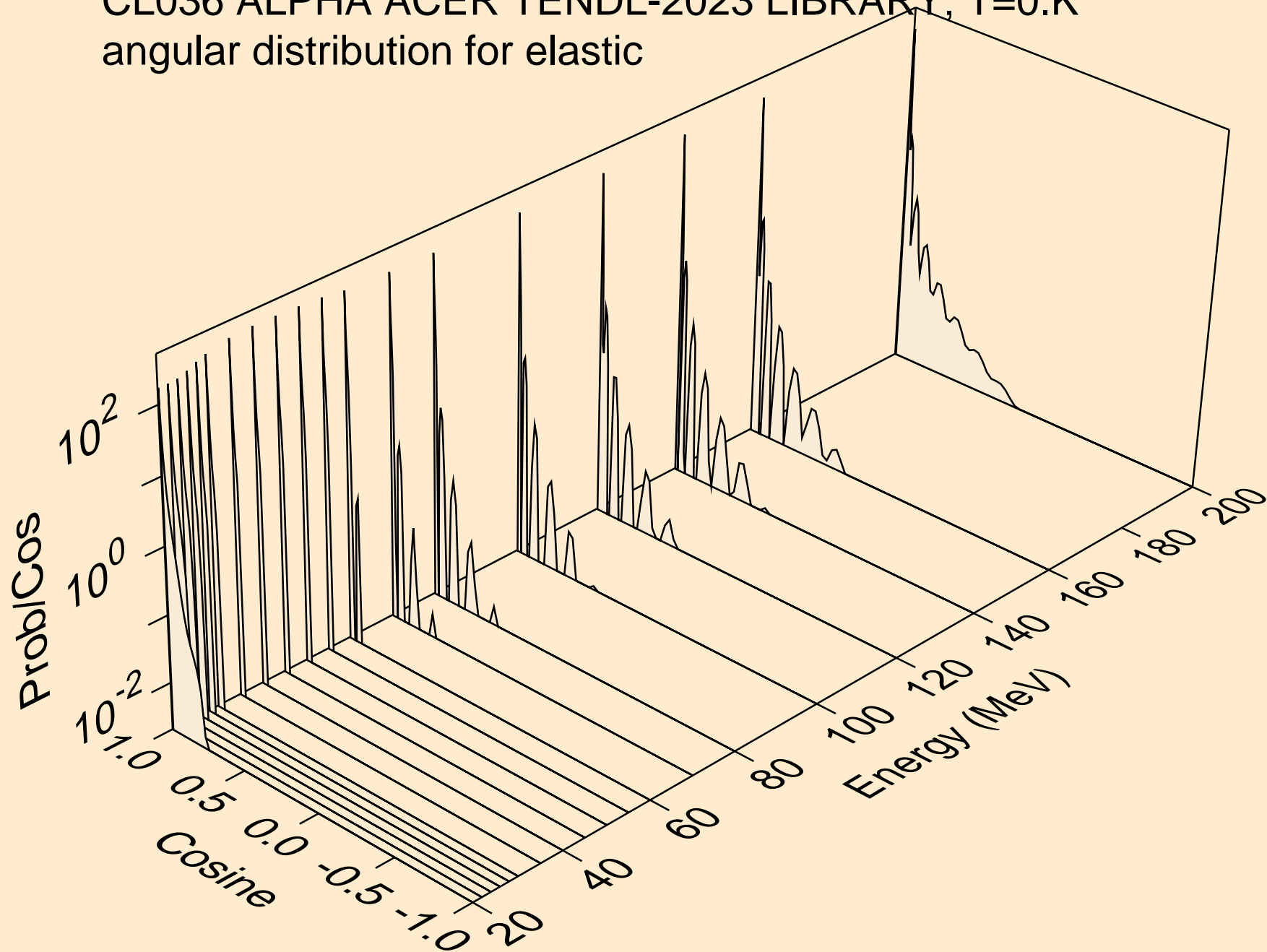

CL036 ALPHA ACER TENDL-2023 LIBRARY; T=0.K  
Alpha emission for (a,x)

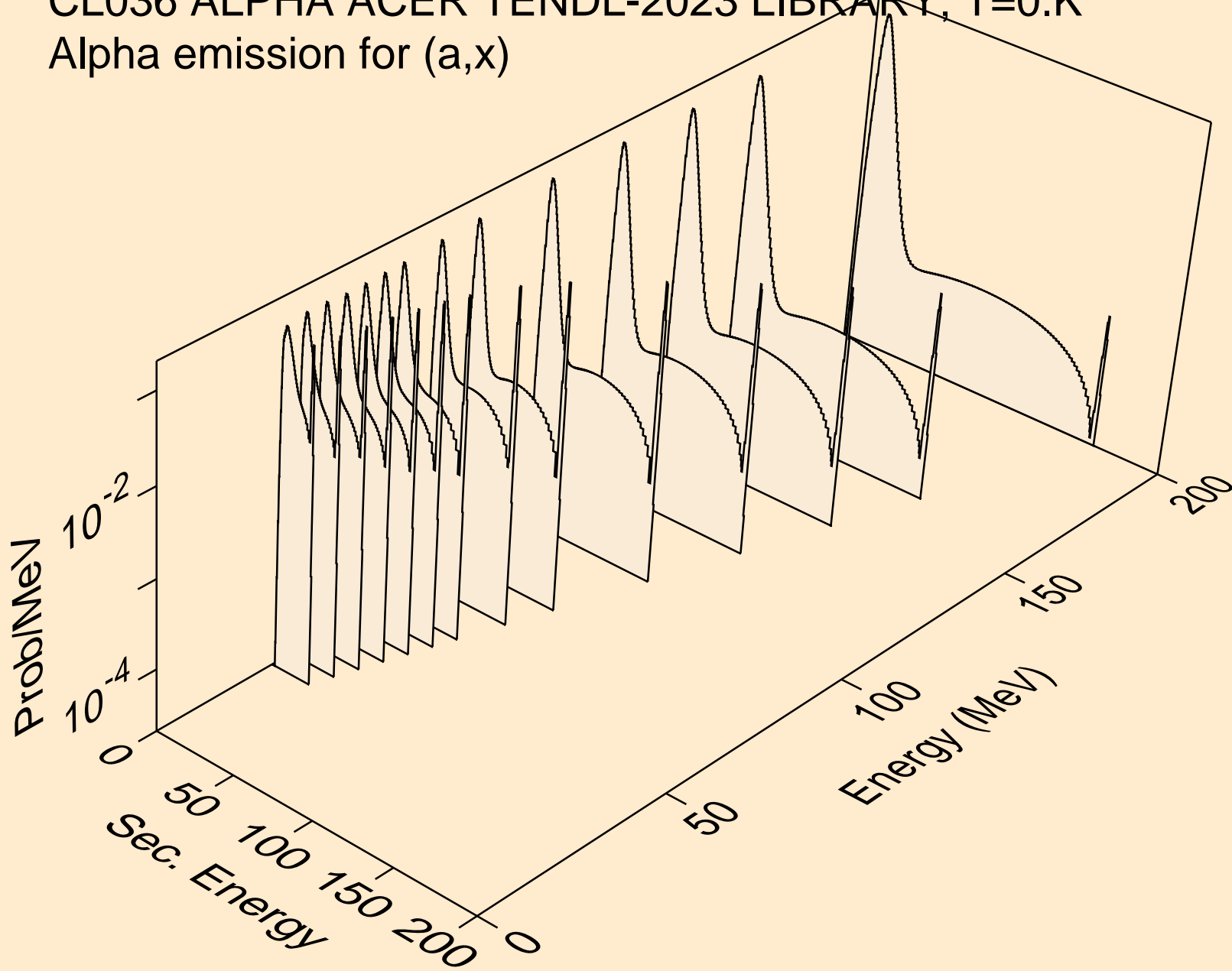

CL036 ALPHA ACER TENDL-2023 LIBRARY; T=0.K  
Alpha emission for (a,n\*)a

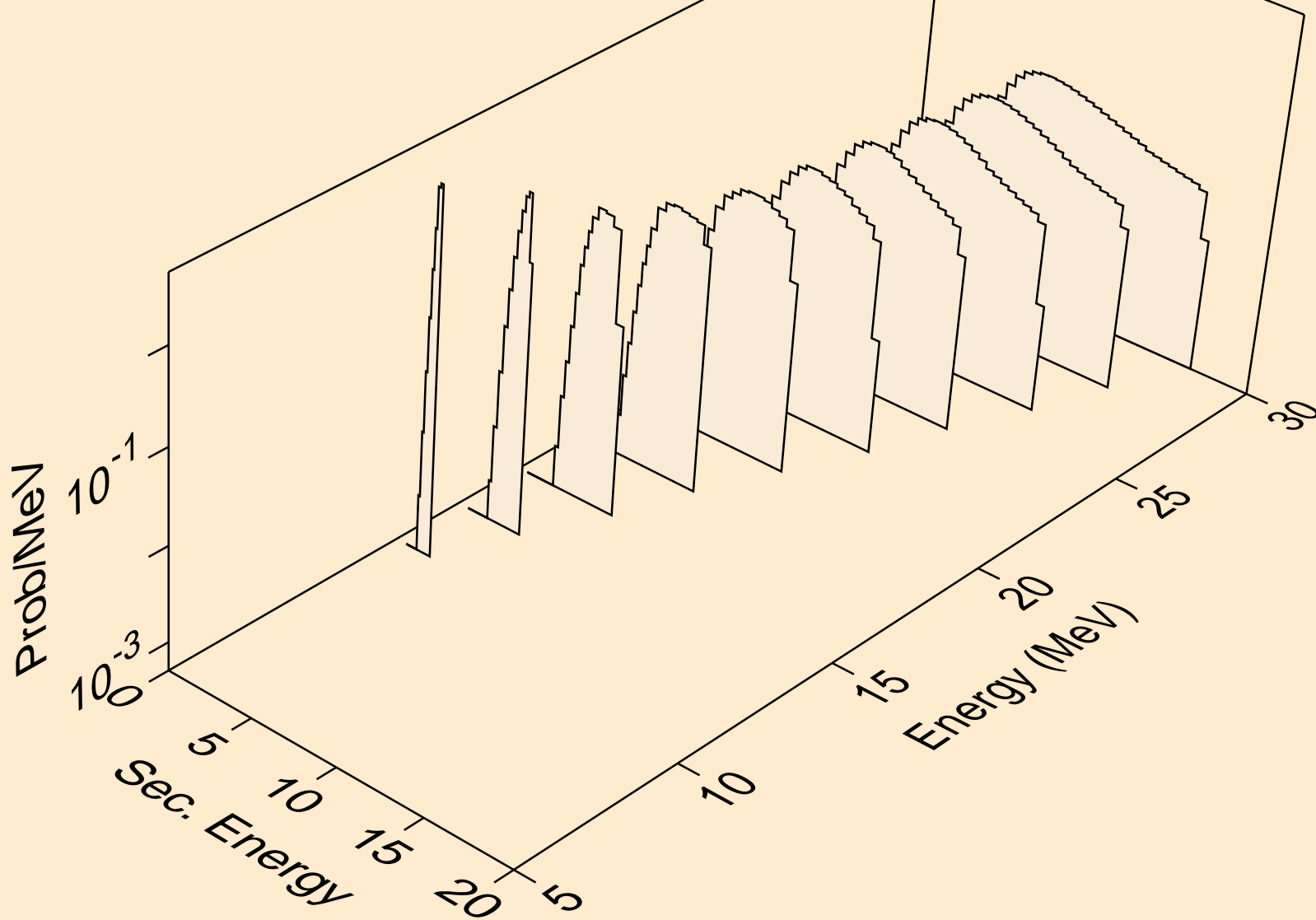

CL036 ALPHA ACER TENDL-2023 LIBRARY; T=0.K  
Alpha emission for (a,2n)a

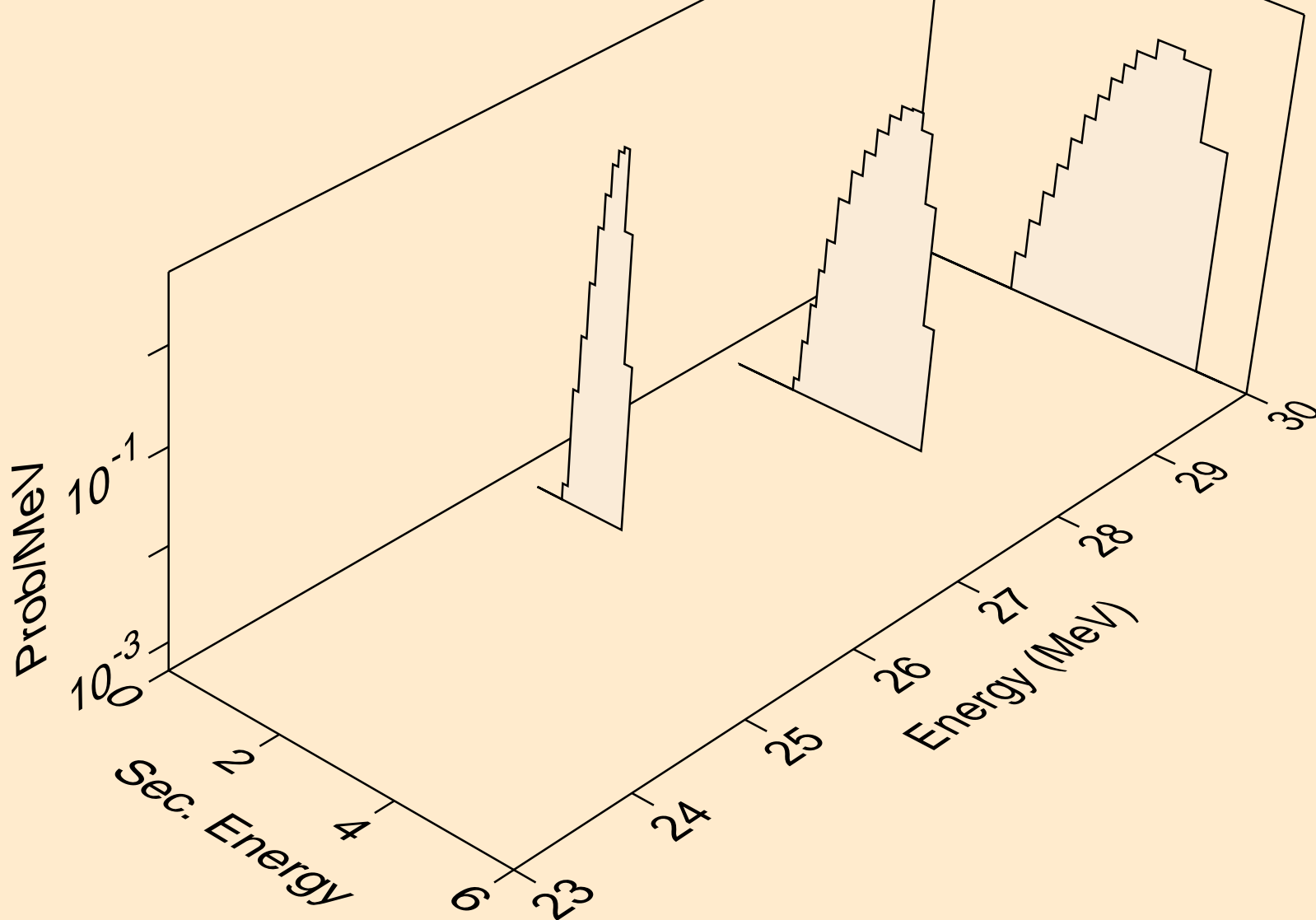

CL036 ALPHA ACER TENDL-2023 LIBRARY; T=0.K  
Alpha emission for (a,n\*)2a

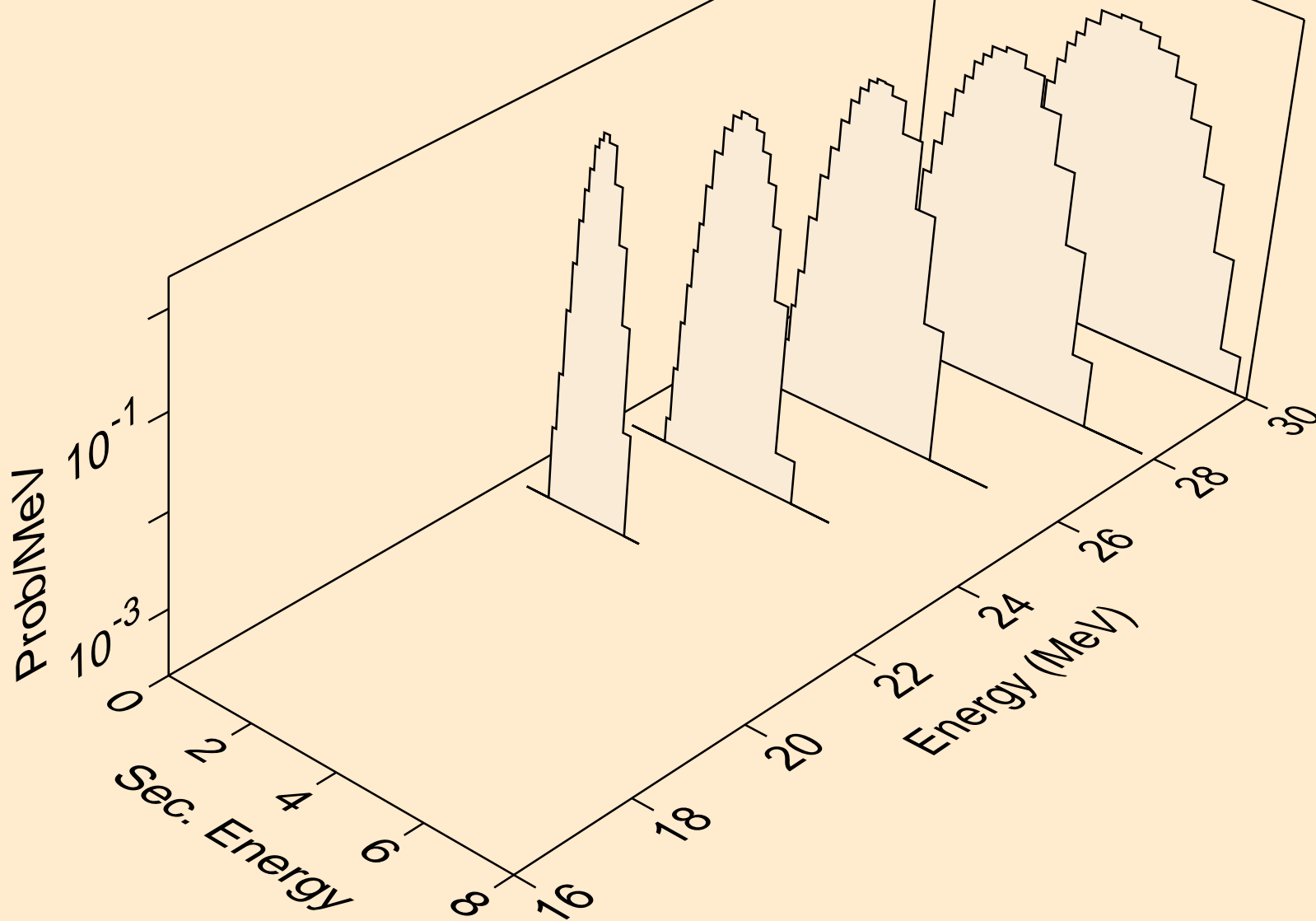

CL036 ALPHA ACER TENDL-2023 LIBRARY; T=0.K  
Alpha emission for inelastic

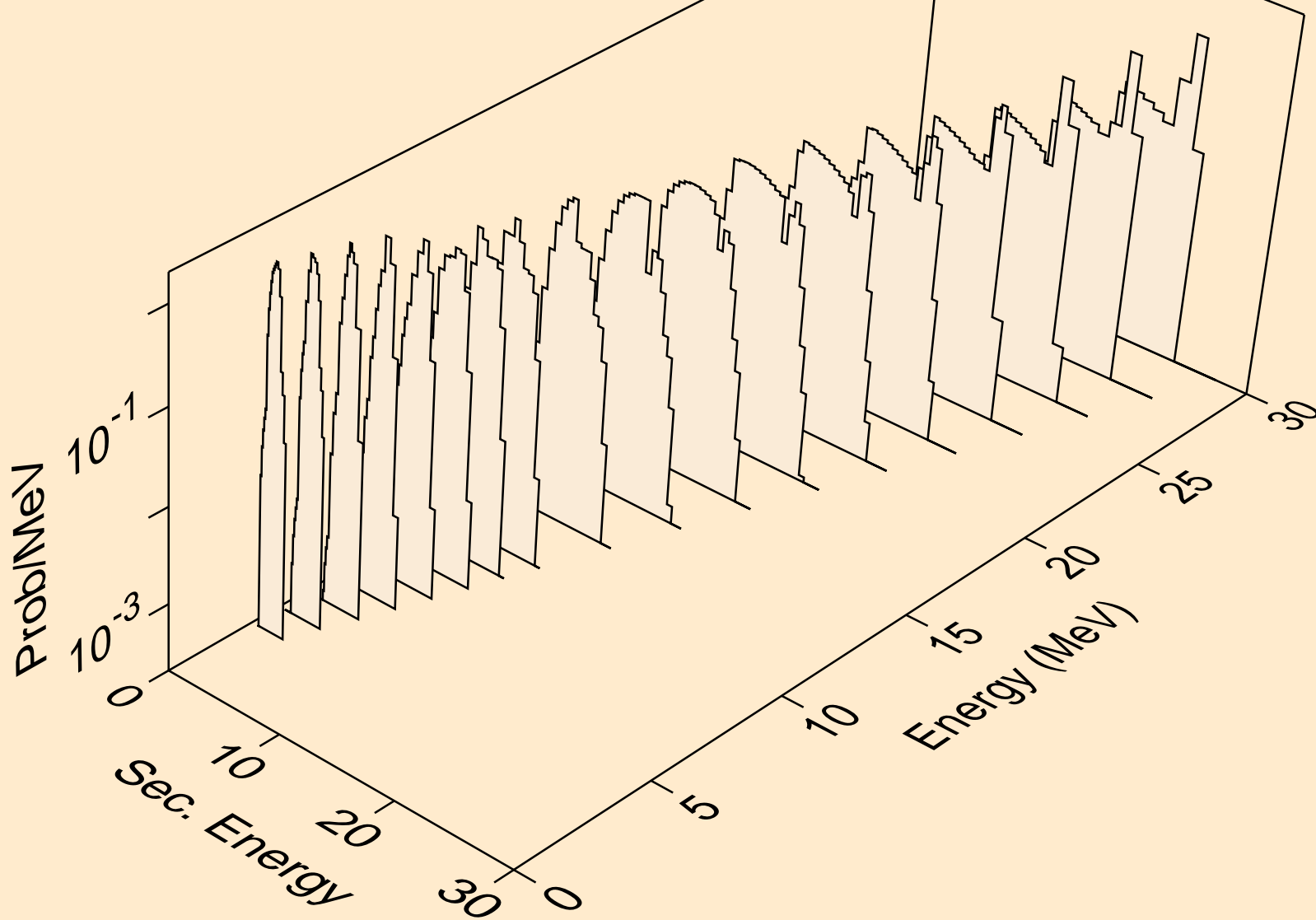

CL036 ALPHA ACER TENDL-2023 LIBRARY; T=0.K  
Alpha emission for (a,2a)

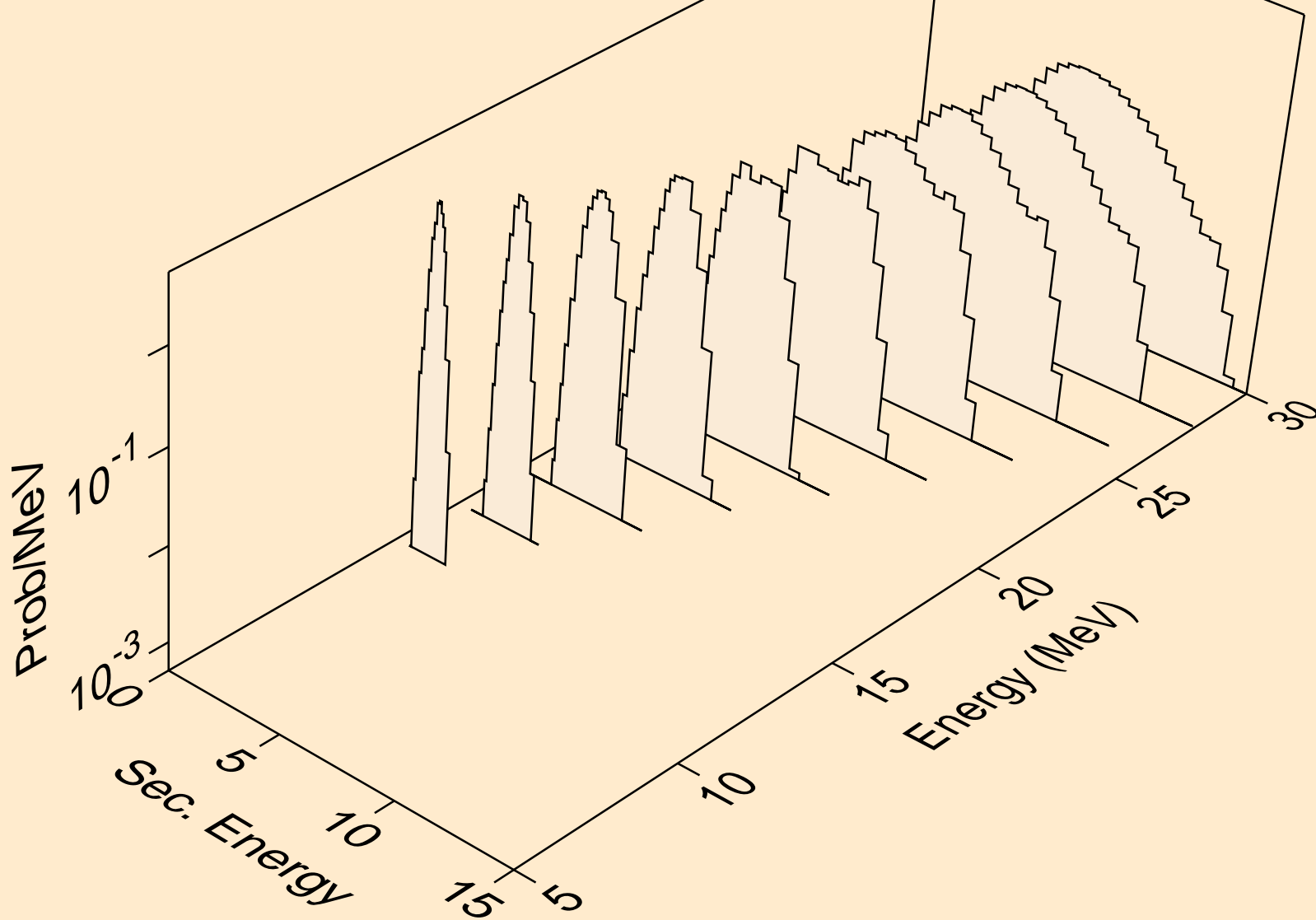

CL036 ALPHA ACER TENDL-2023 LIBRARY; T=0.K  
Alpha emission for (a,pa)

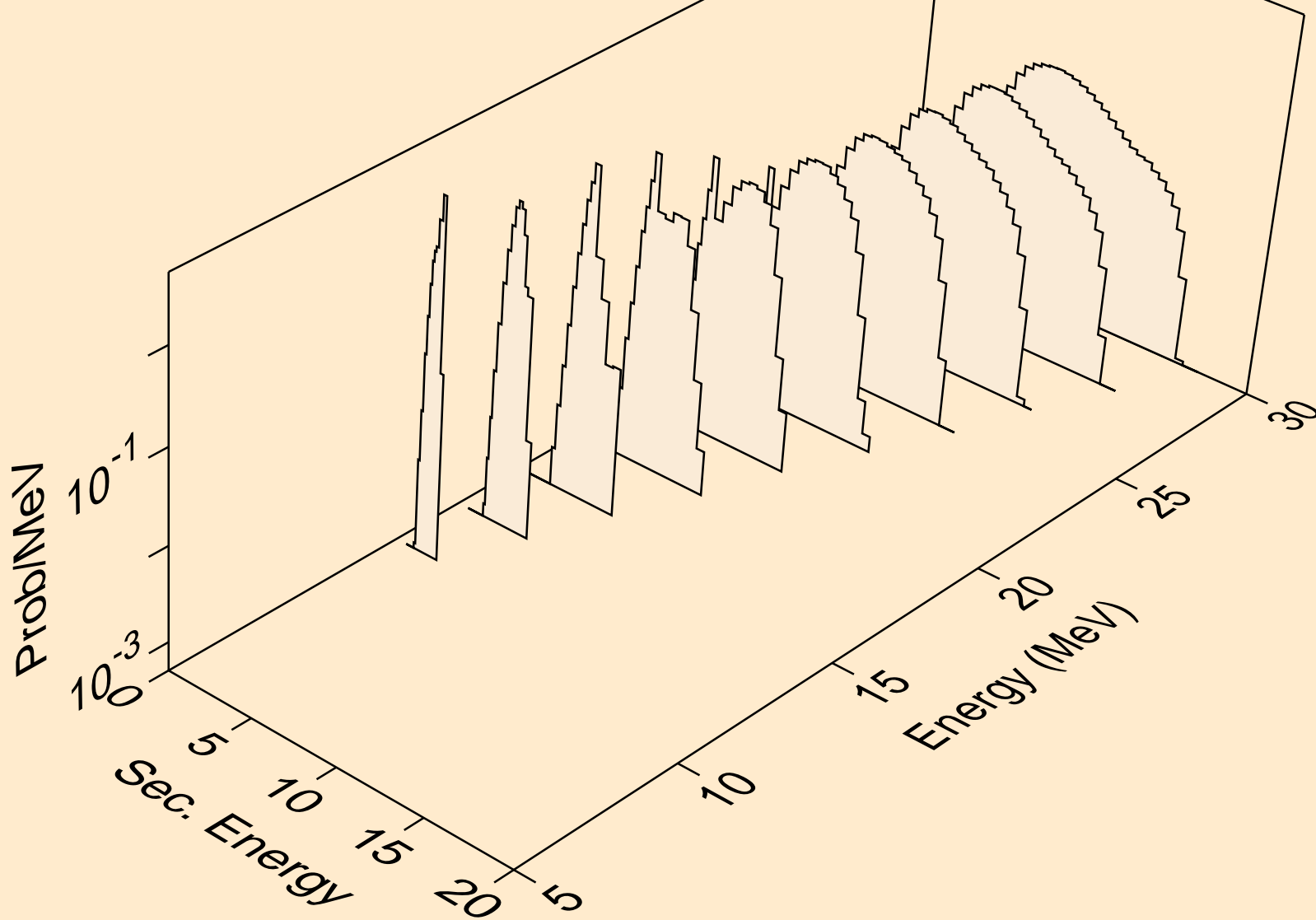

CL036 ALPHA ACER TENDL-2023 LIBRARY; T=0.K  
Alpha emission for (a,da)

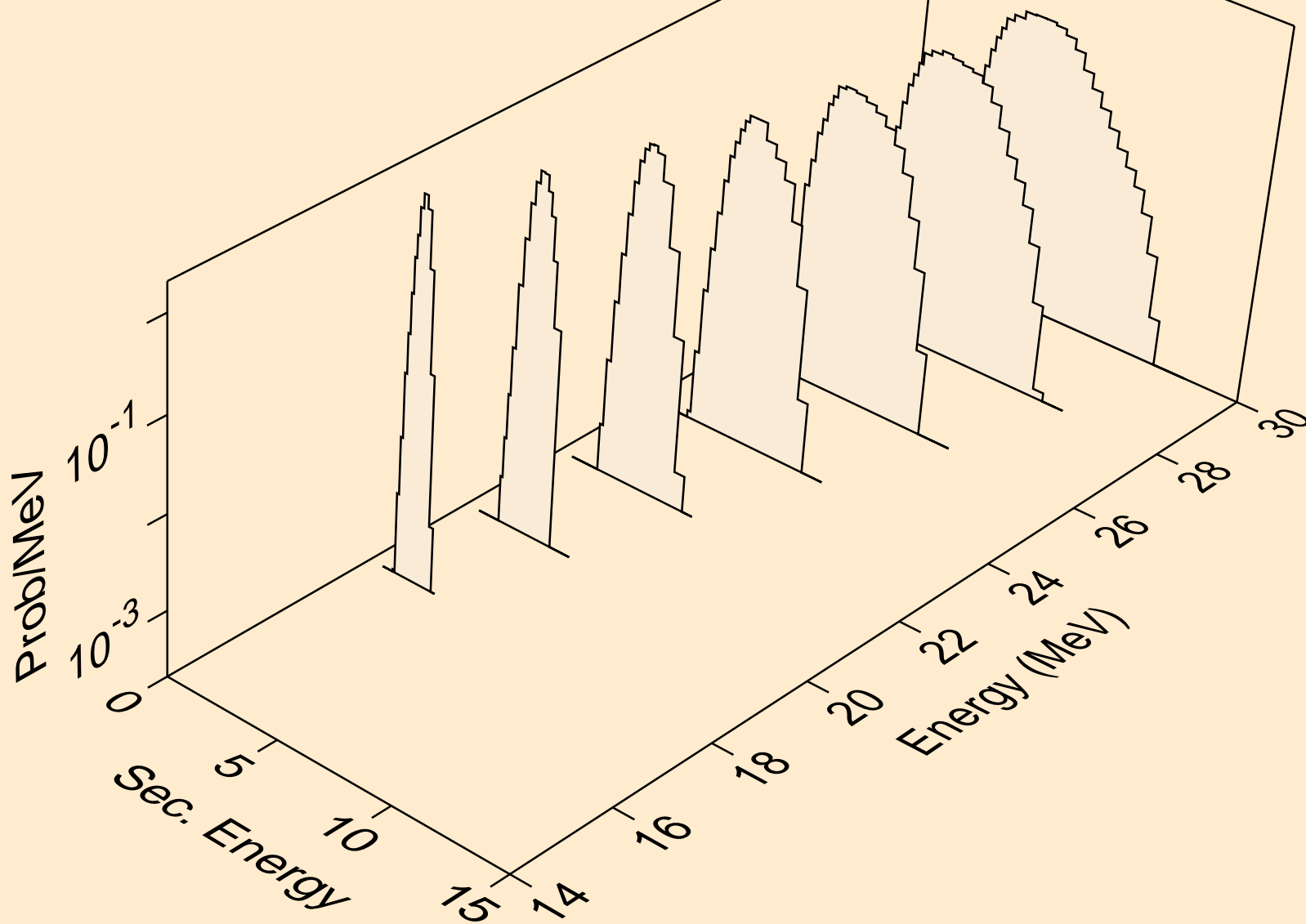

CL036 ALPHA ACER TENDL-2023 LIBRARY; T=0.K  
Photon emission for (z,n)

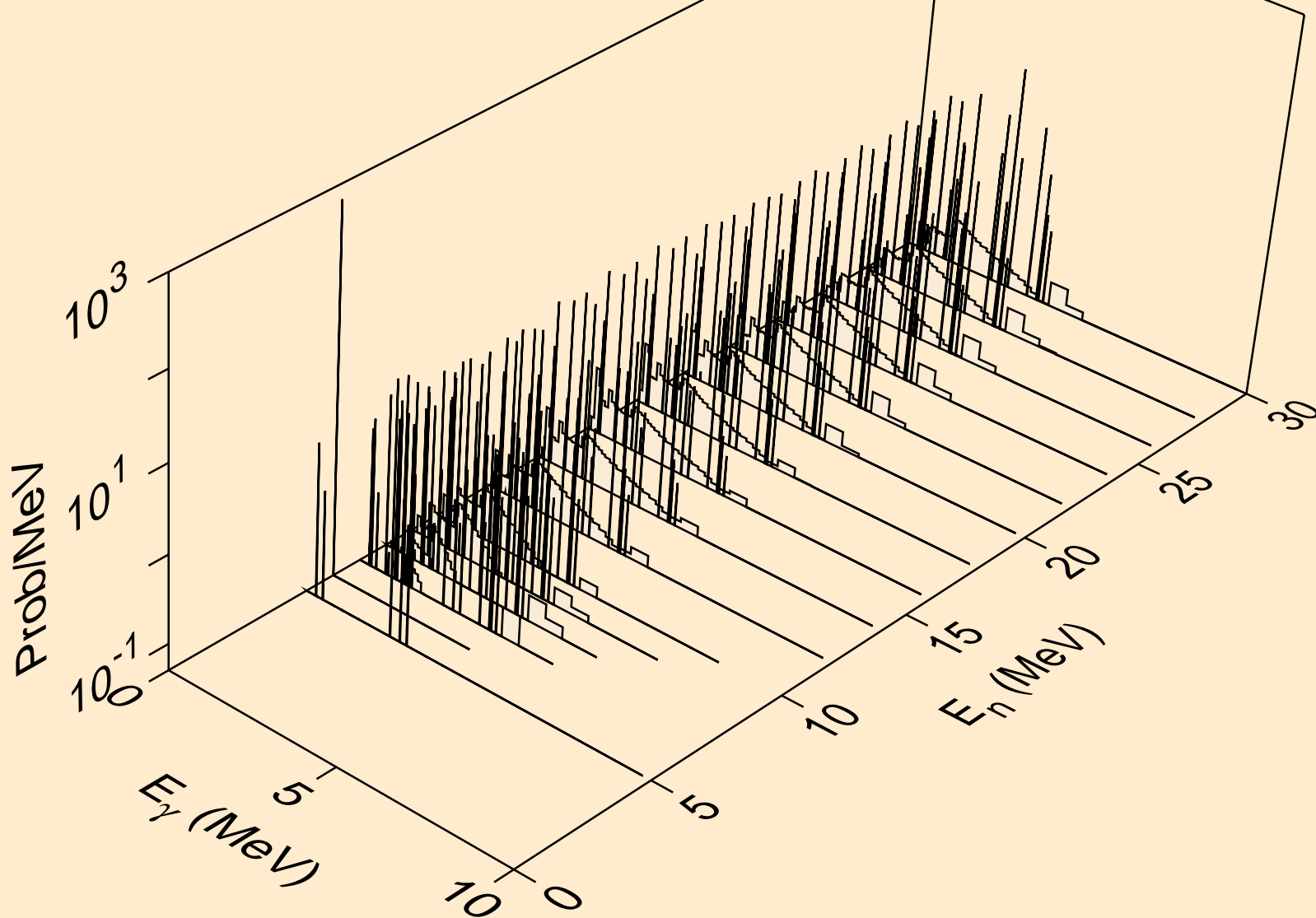

CL036 ALPHA ACER TENDL-2023 LIBRARY; T=0.K  
Photon emission for (z,x)

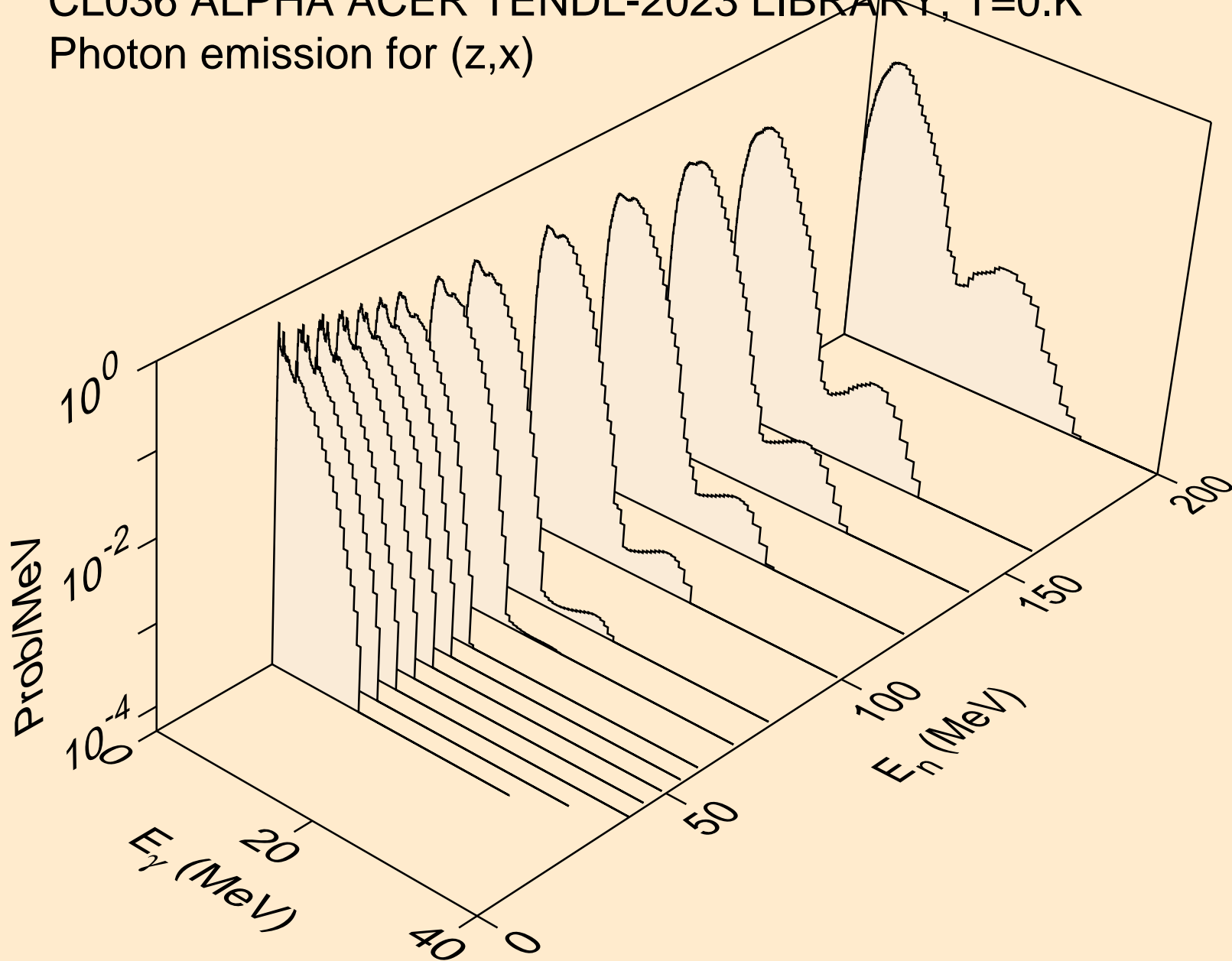

CL036 ALPHA ACER TENDL-2023 LIBRARY; T=0.K  
Photon emission for (n,2n)

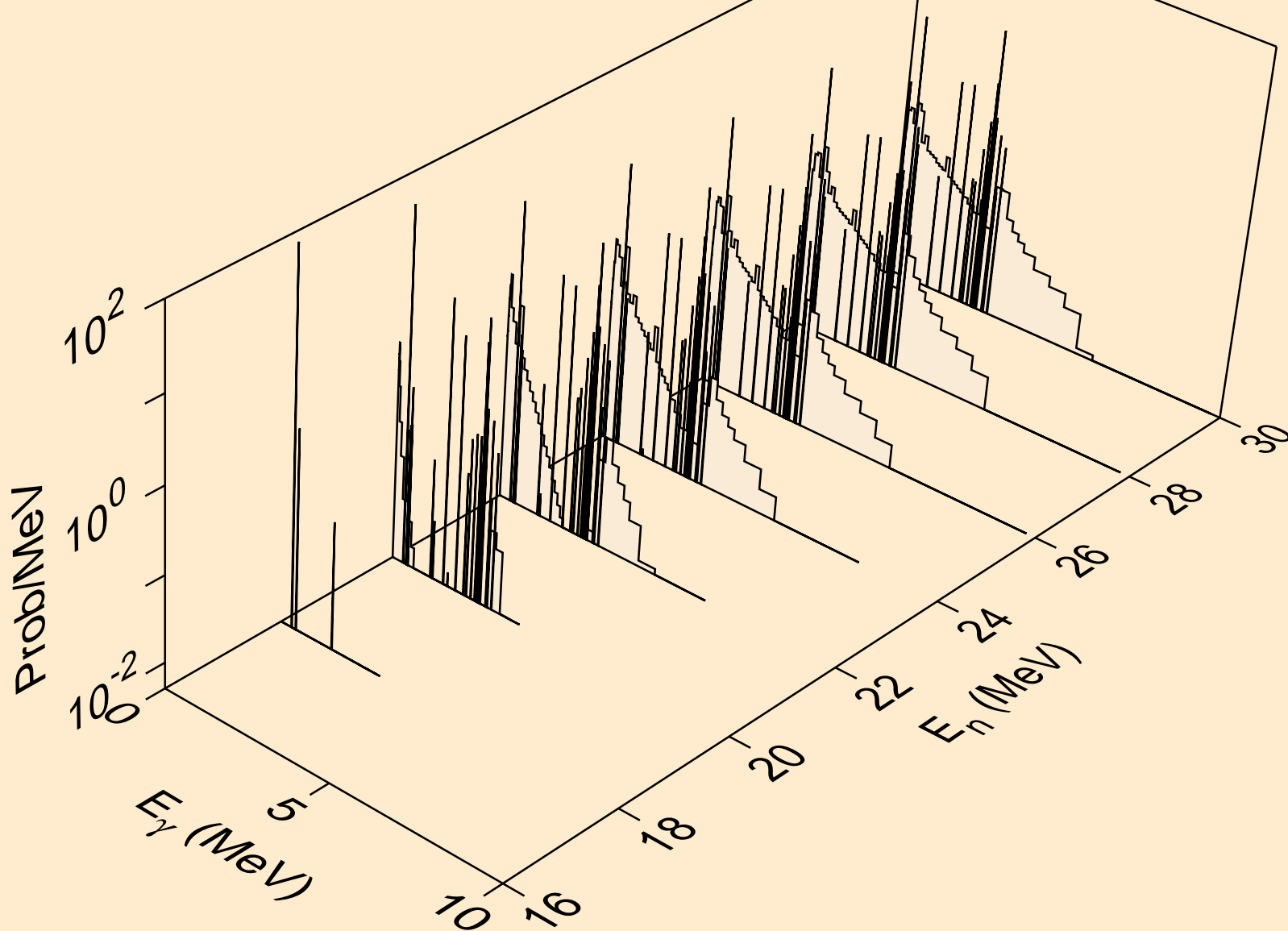

CL036 ALPHA ACER TENDL-2023 LIBRARY; T=0.K  
Photon emission for (n,n\*)a

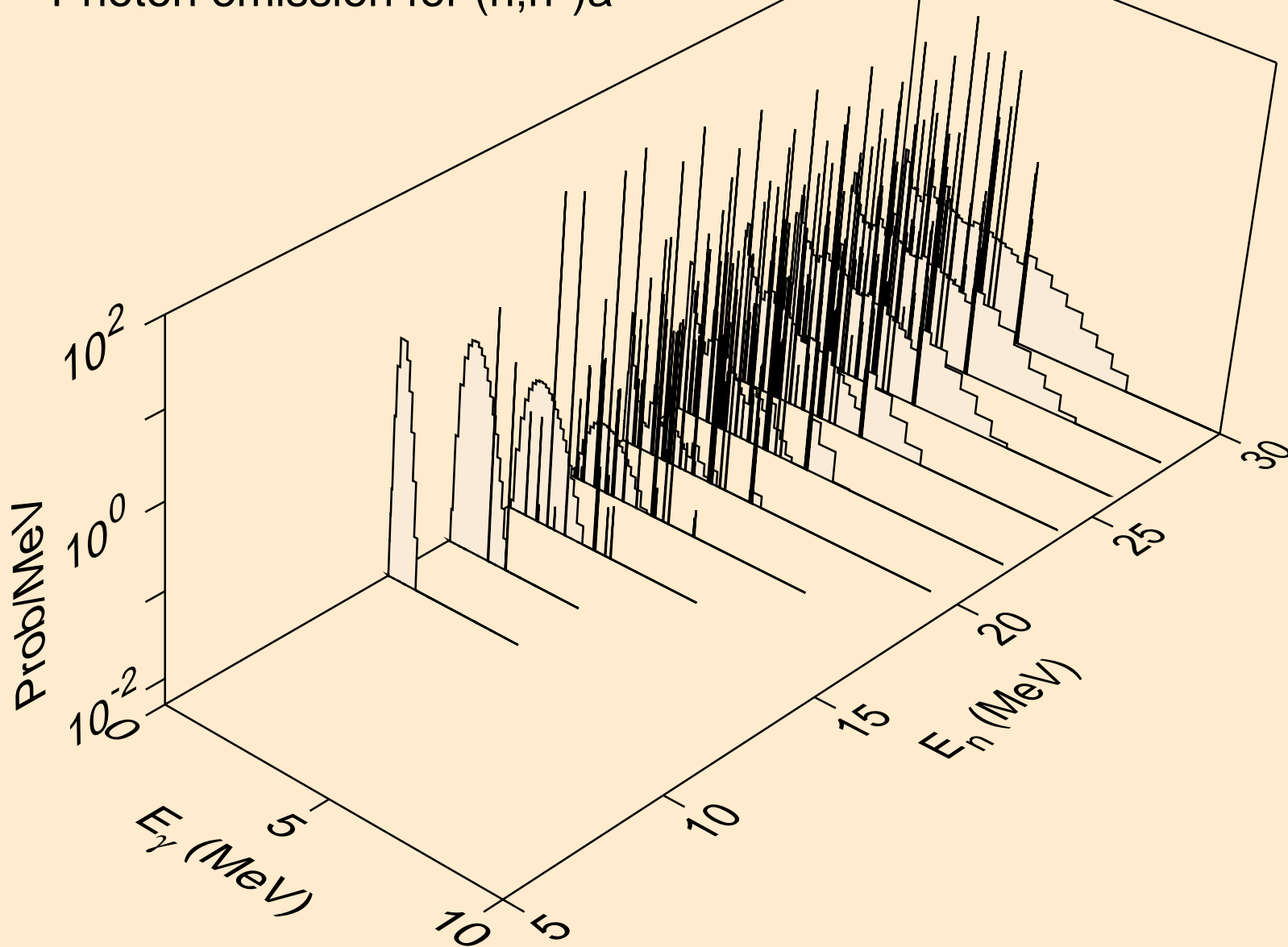

CL036 ALPHA ACER TENDL-2023 LIBRARY; T=0.K  
Photon emission for (n,2n)a

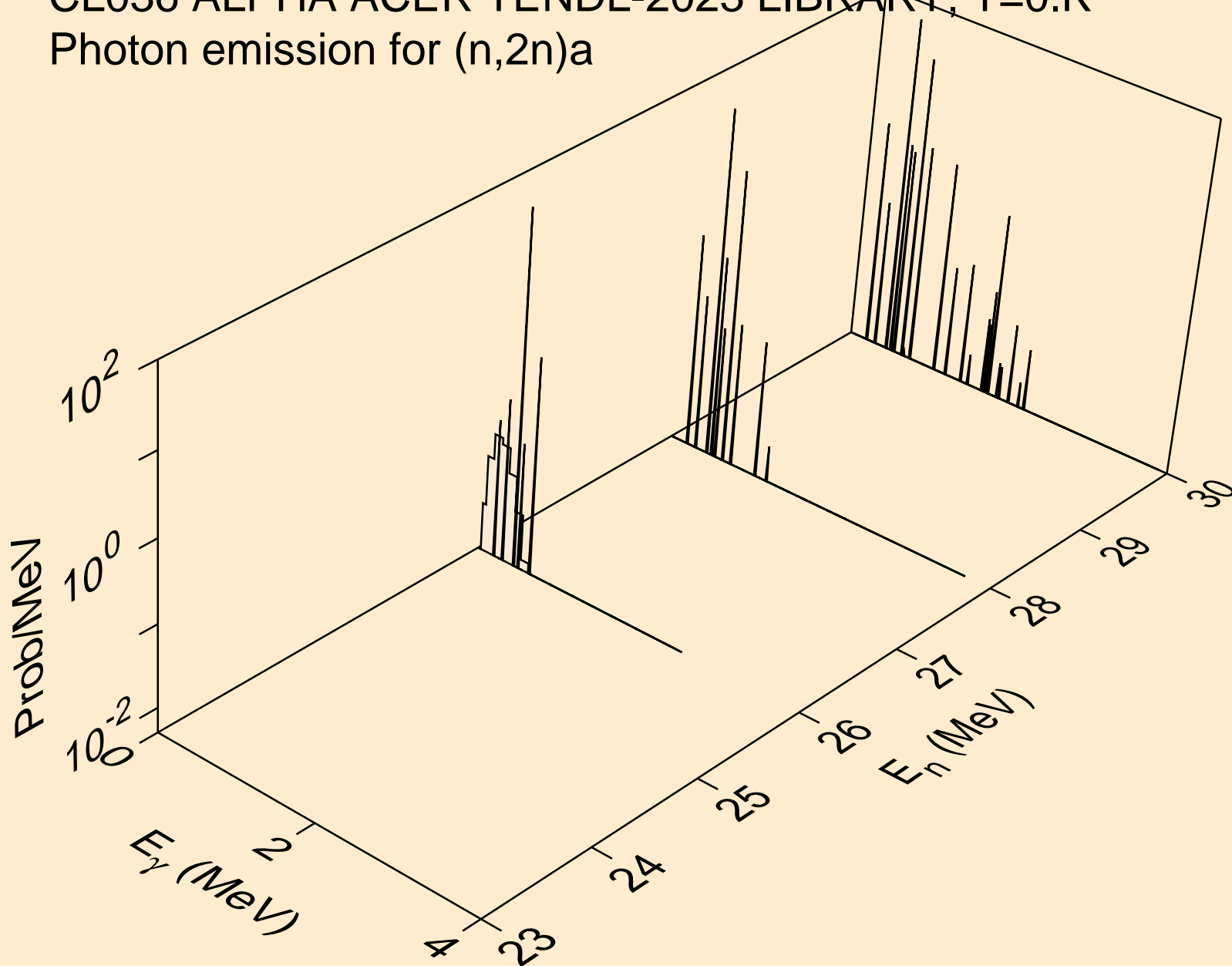

CL036 ALPHA ACER TENDL-2023 LIBRARY; T=0.K  
Photon emission for (n,n\*)p

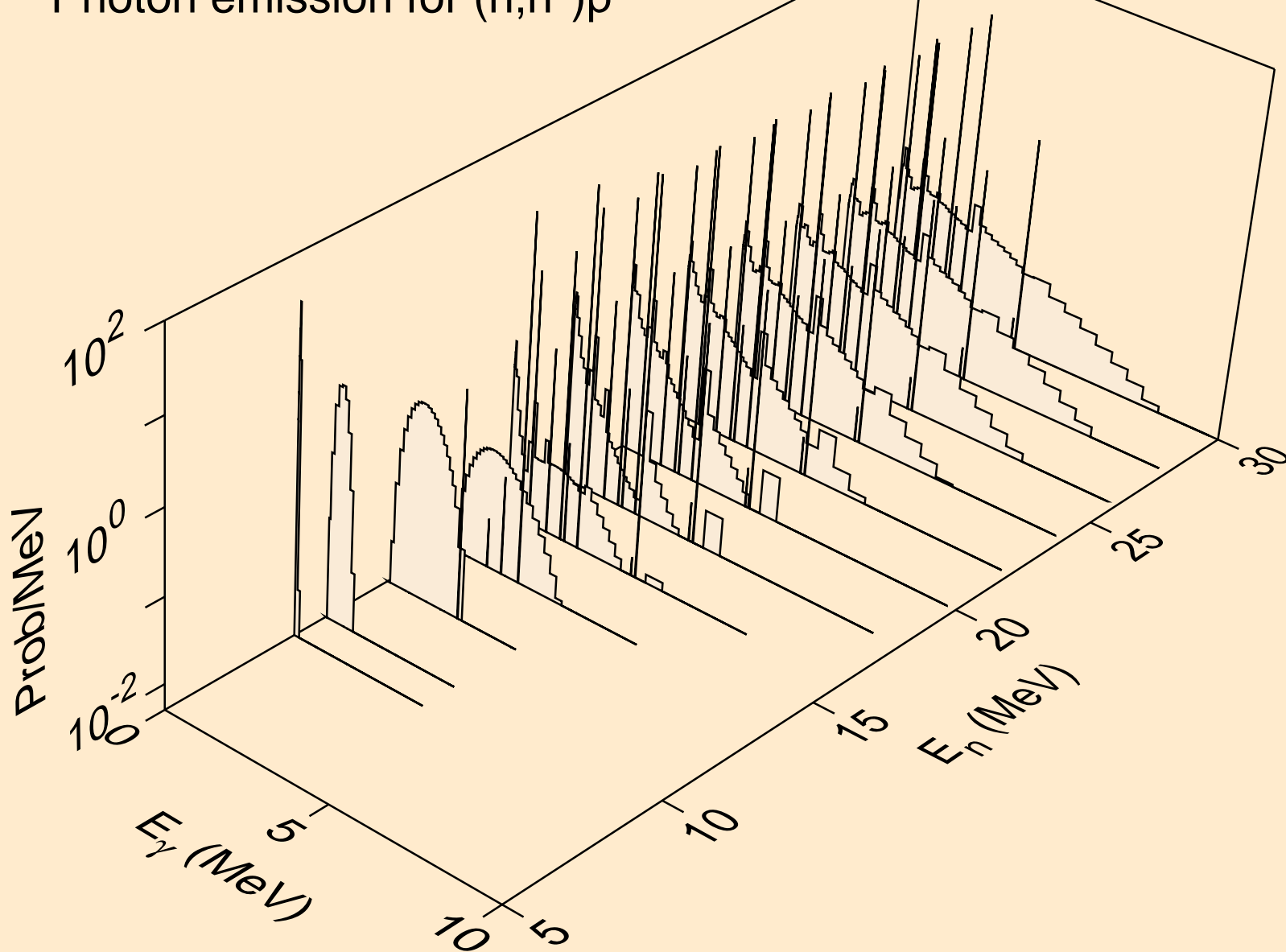

CL036 ALPHA ACER TENDL-2023 LIBRARY: T=0.K  
Photon emission for (n,n\*)2a

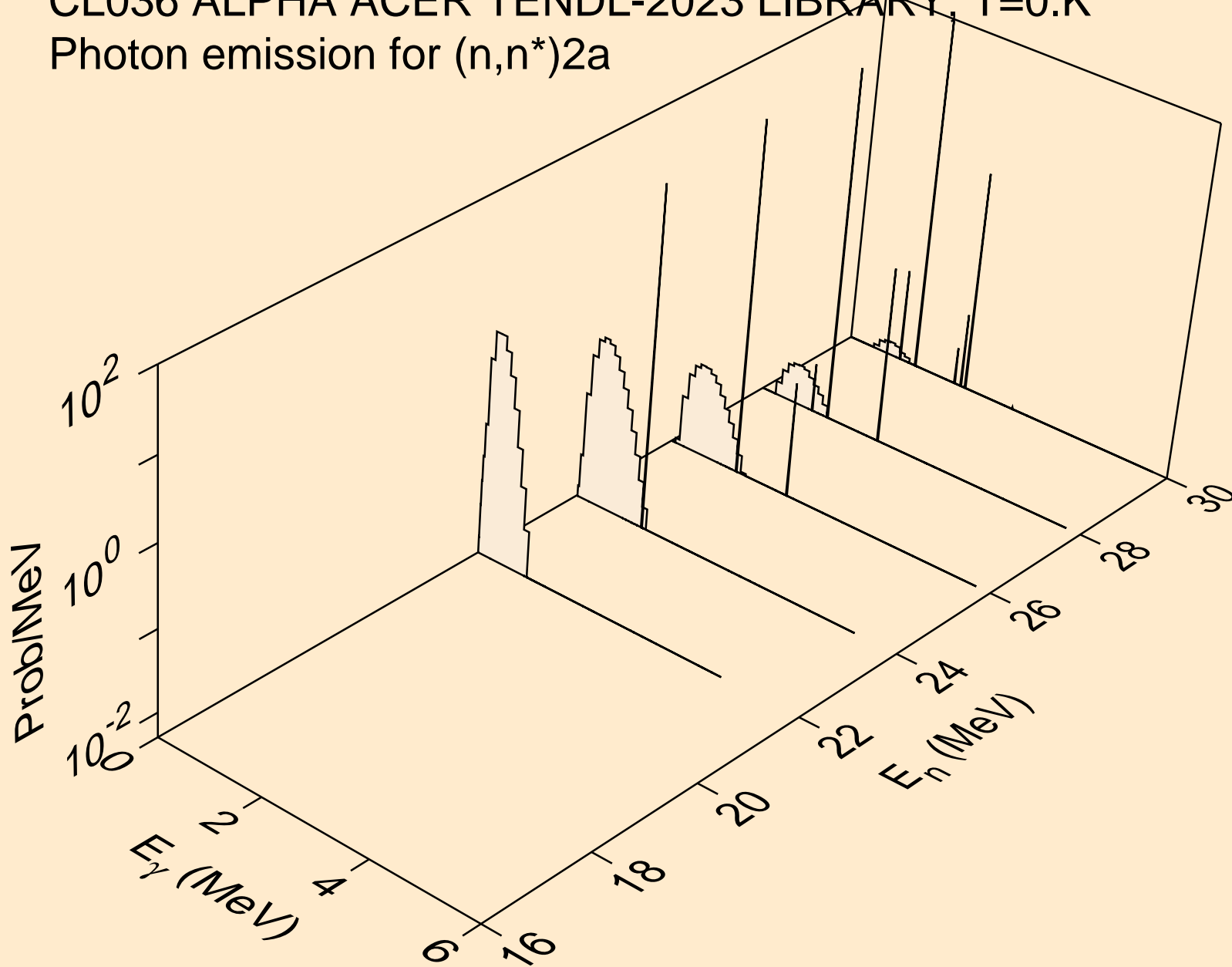

CL036 ALPHA ACER TENDL-2023 LIBRARY; T=0.K  
Photon emission for (n,n\*)d

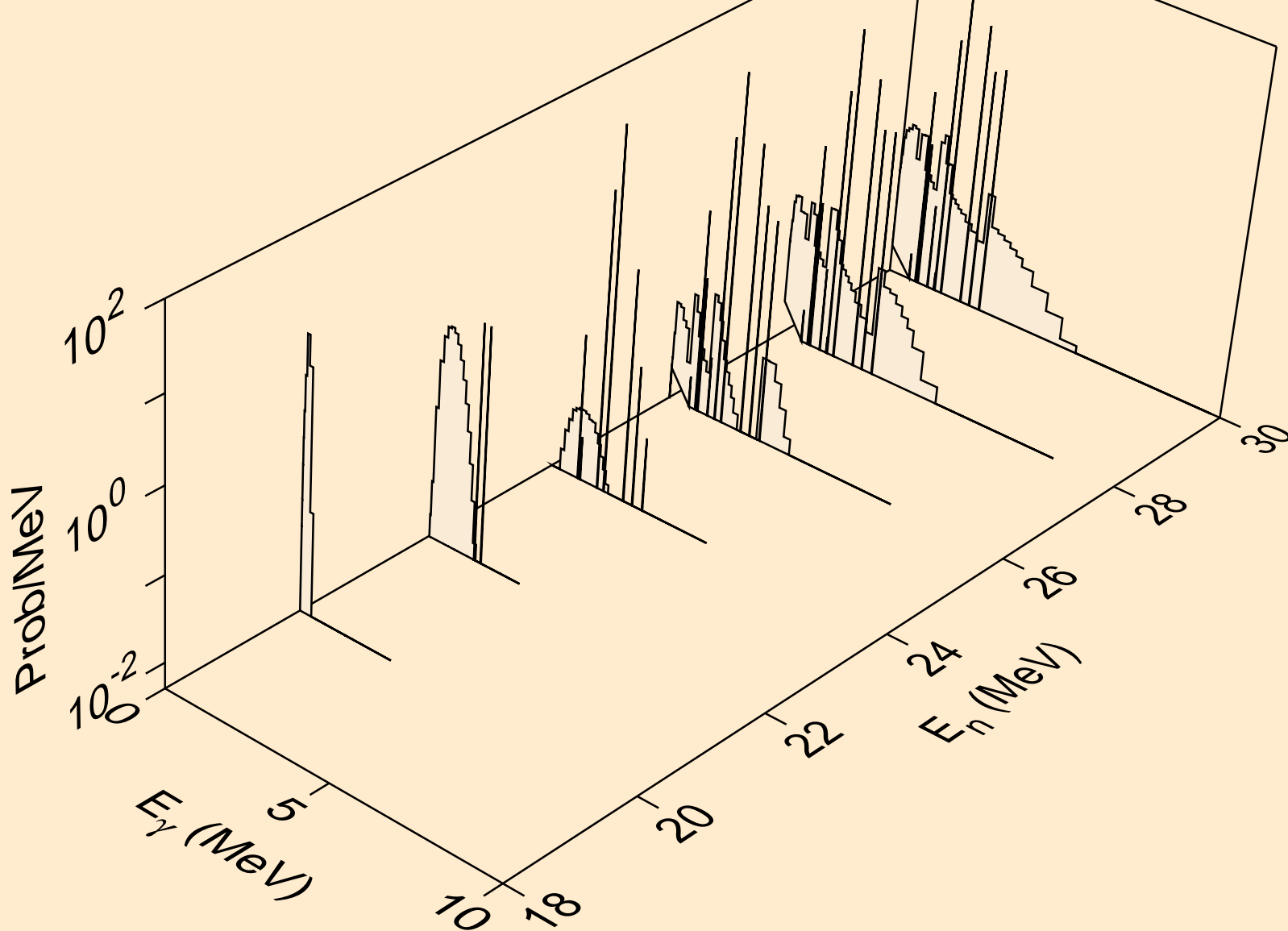

CL036 ALPHA ACER TENDL-2023 LIBRARY; T=0.K  
Photon emission for (n,n\*)t

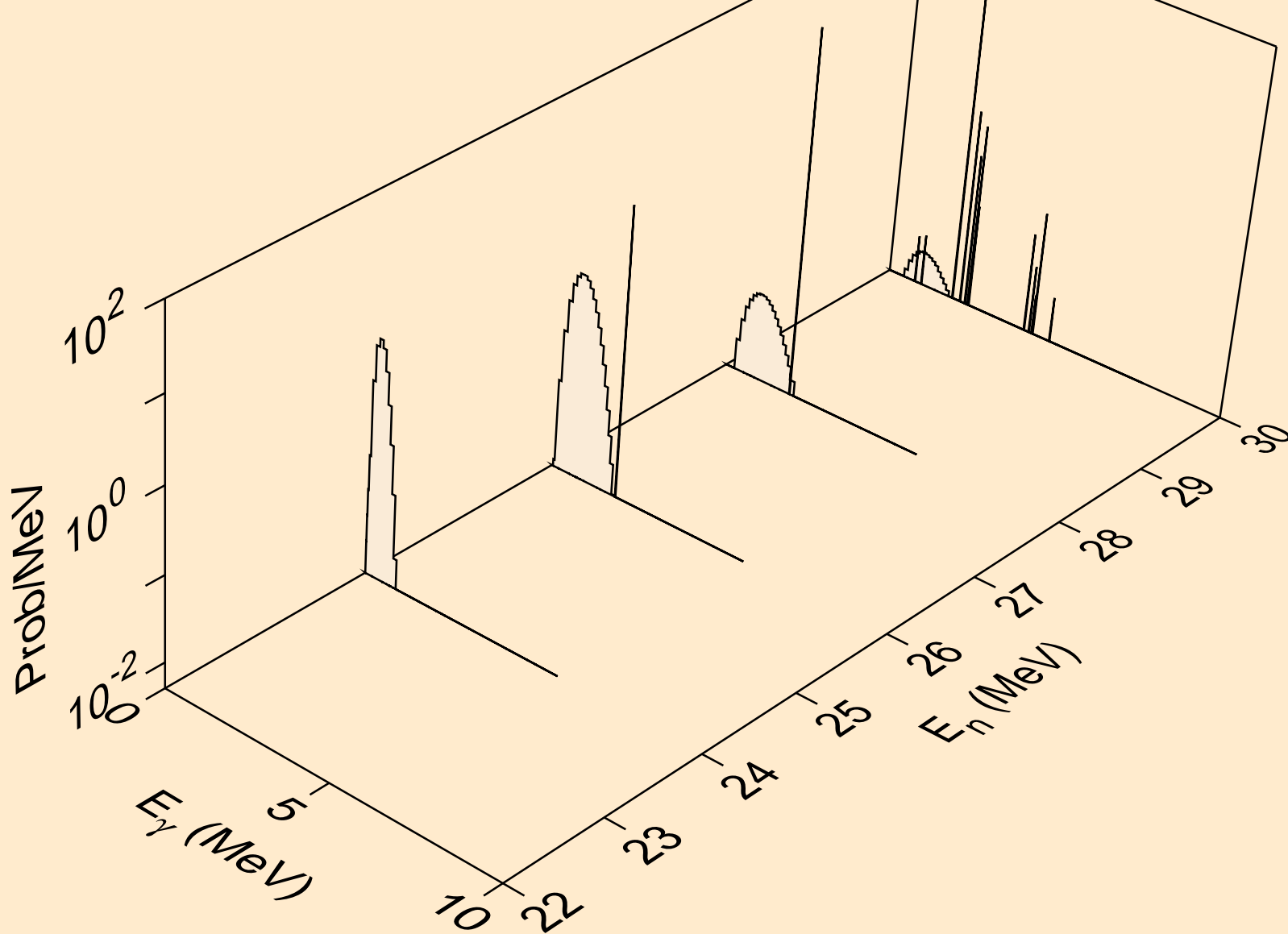

CL036 ALPHA ACER TENDL-2023 LIBRARY; T=0.K  
Photon emission for (n,n\*)he3

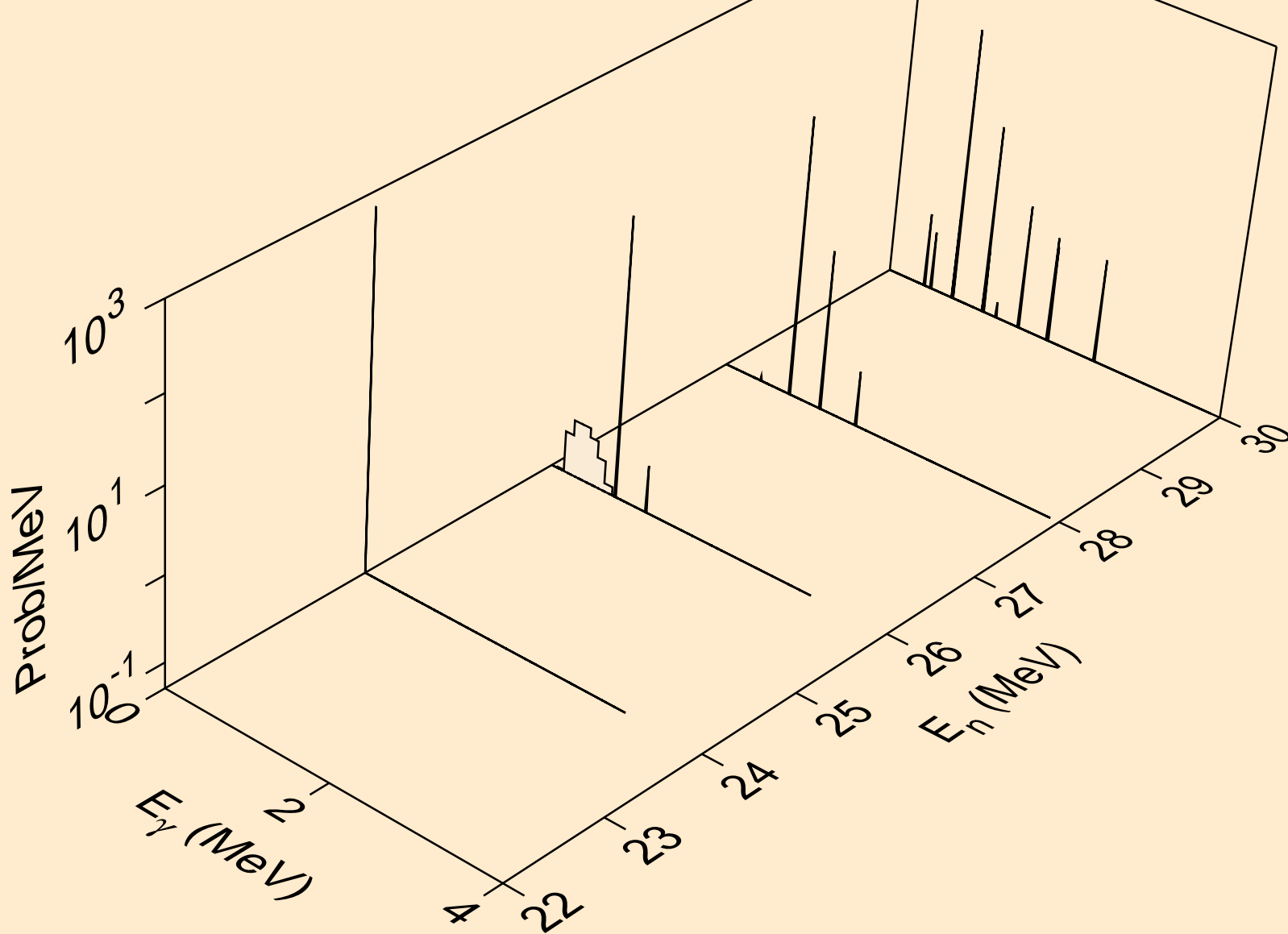

CL036 ALPHA ACER TENDL-2023 LIBRARY; T=0.K  
Photon emission for (n,2np)

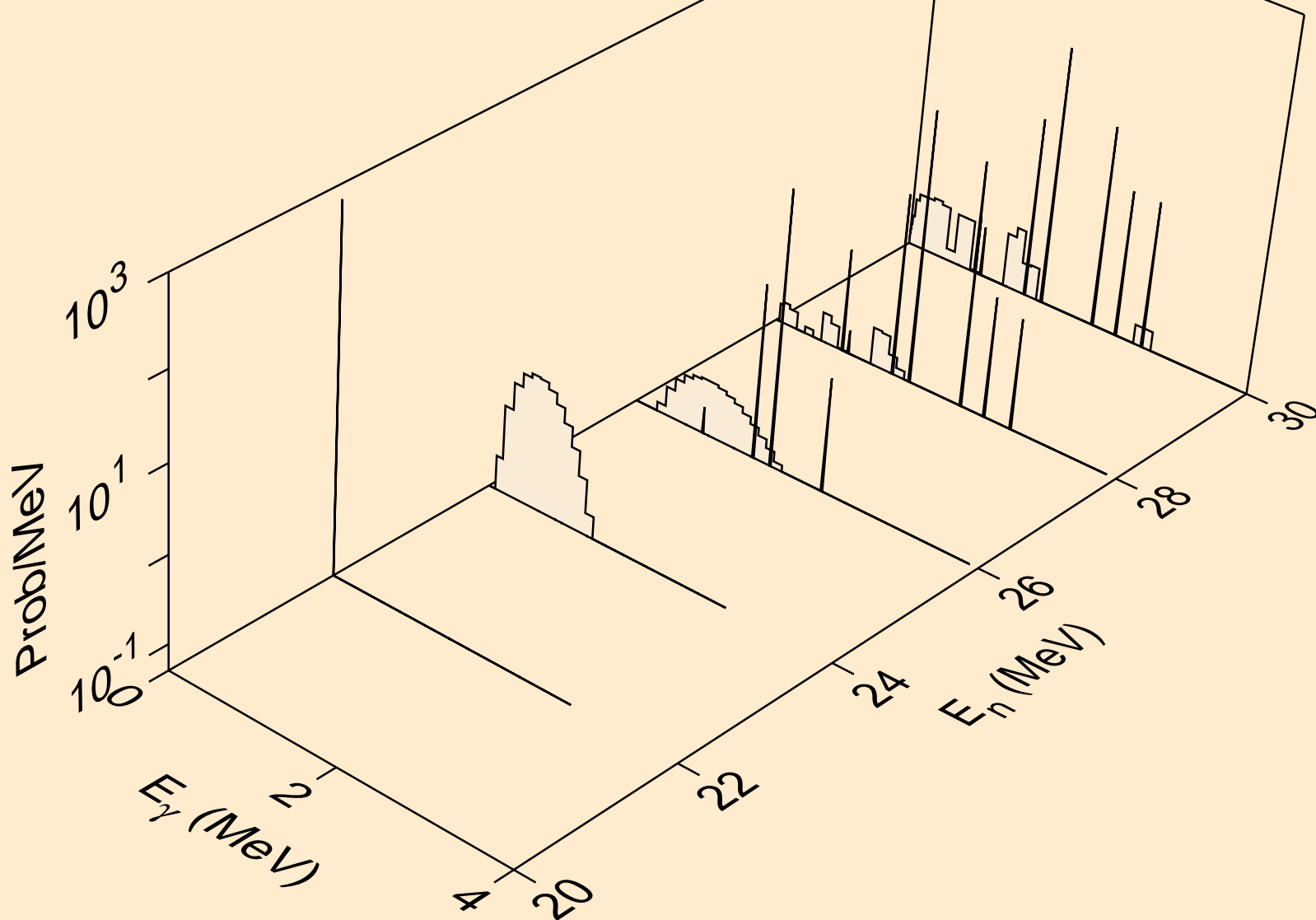

CL036 ALPHA ACER TENDL-2023 LIBRARY; T=0.K  
Photon emission for (n,n2p)

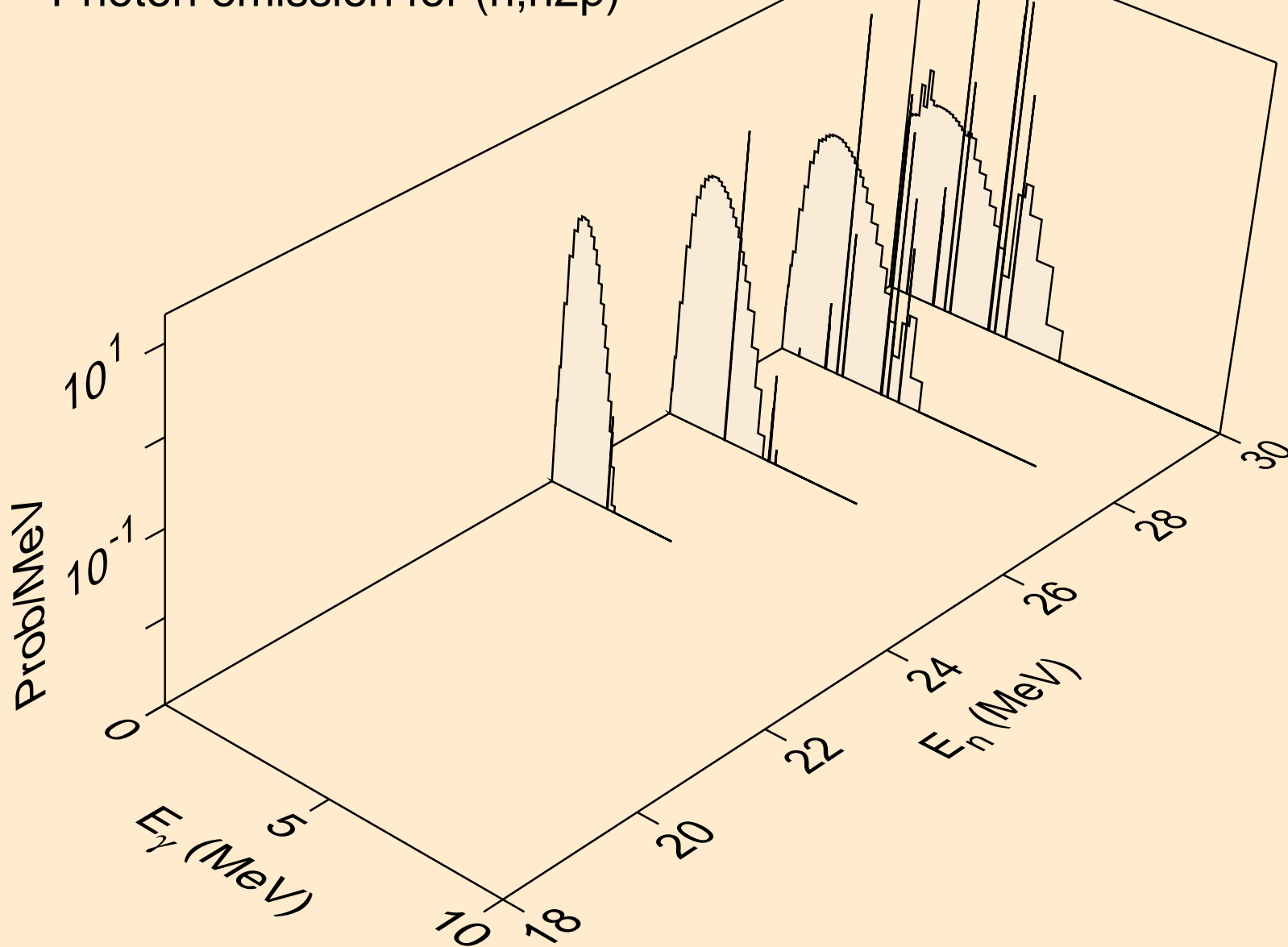

CL036 ALPHA ACER TENDL-2023 LIBRARY; T=0.K  
Photon emission for (n,npa)

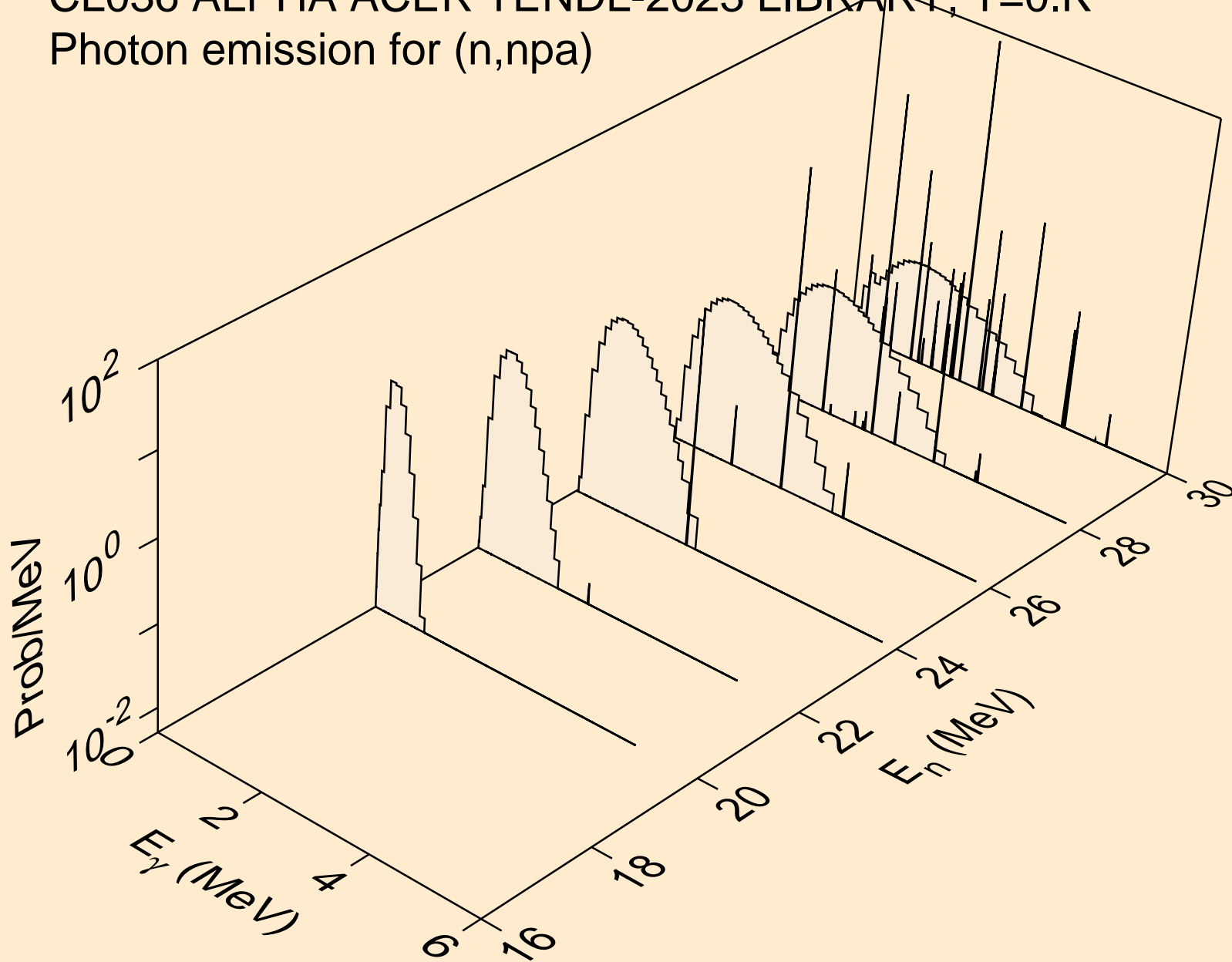

CL036 ALPHA ACER TENDL-2023 LIBRARY; T=0.K  
Photon emission for (n,gma)

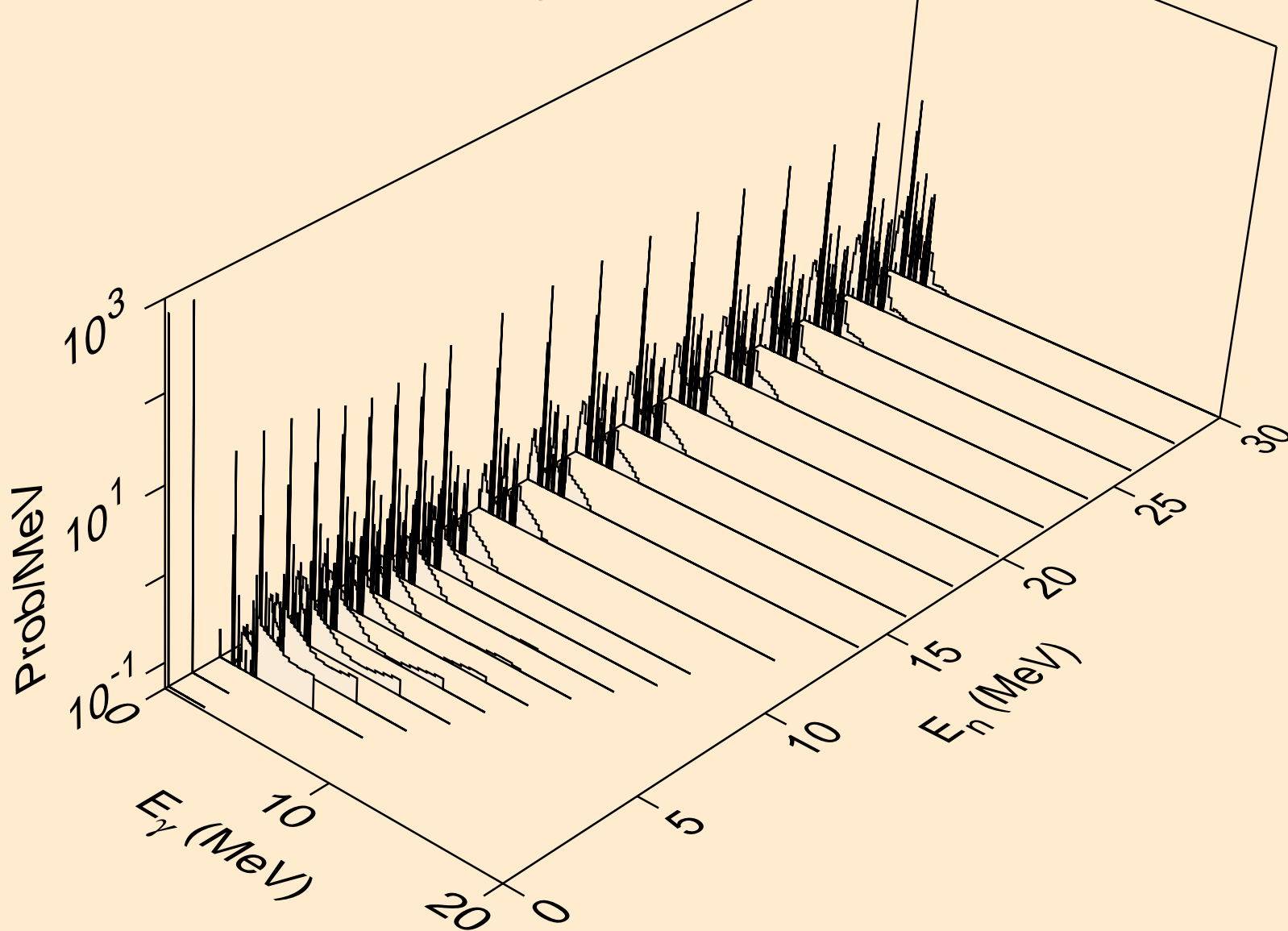

CL036 ALPHA ACER TENDL-2023 LIBRARY; T=0.K  
Photon emission for (n,p)

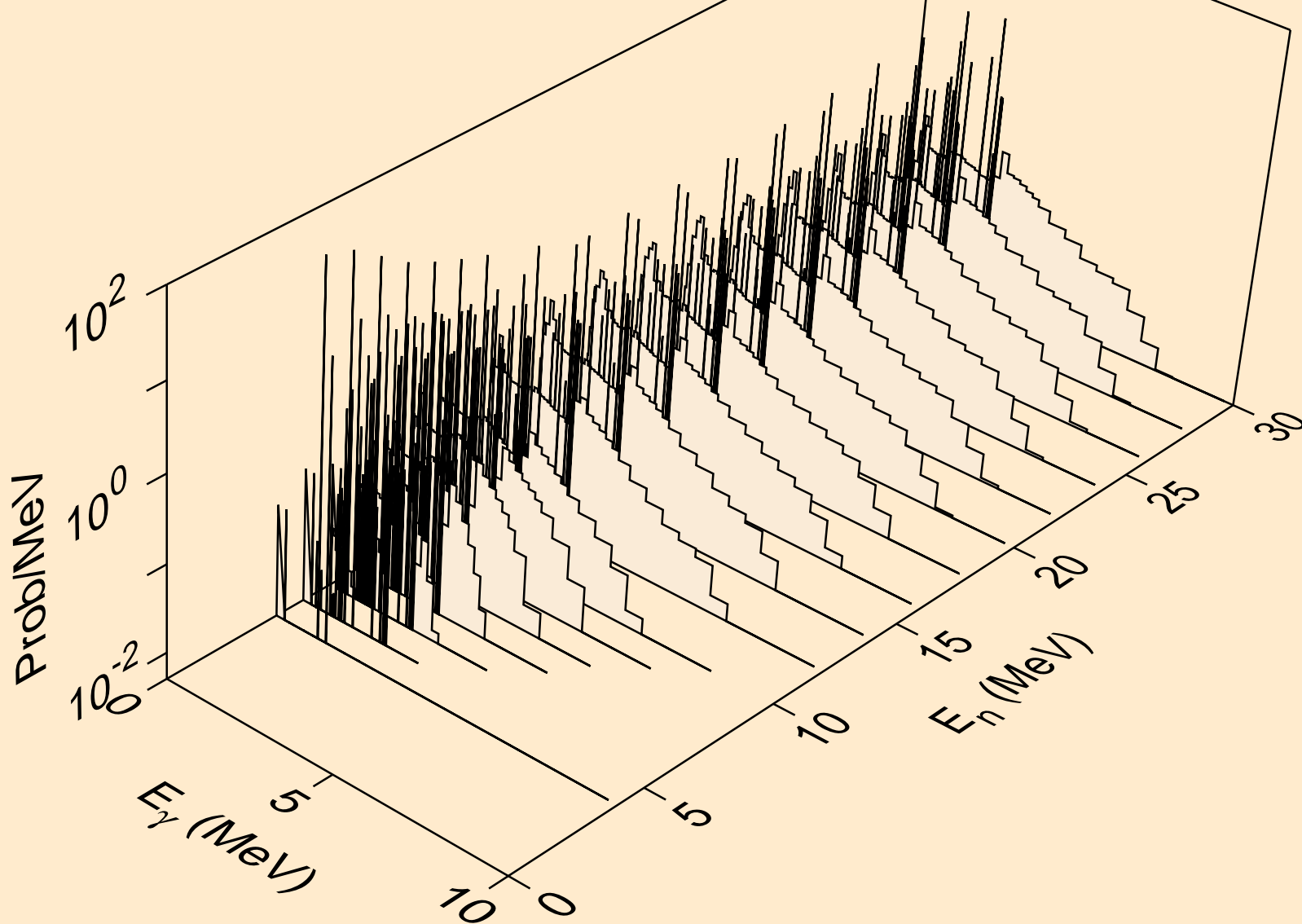

CL036 ALPHA ACER TENDL-2023 LIBRARY; T=0.K  
Photon emission for (n,d)

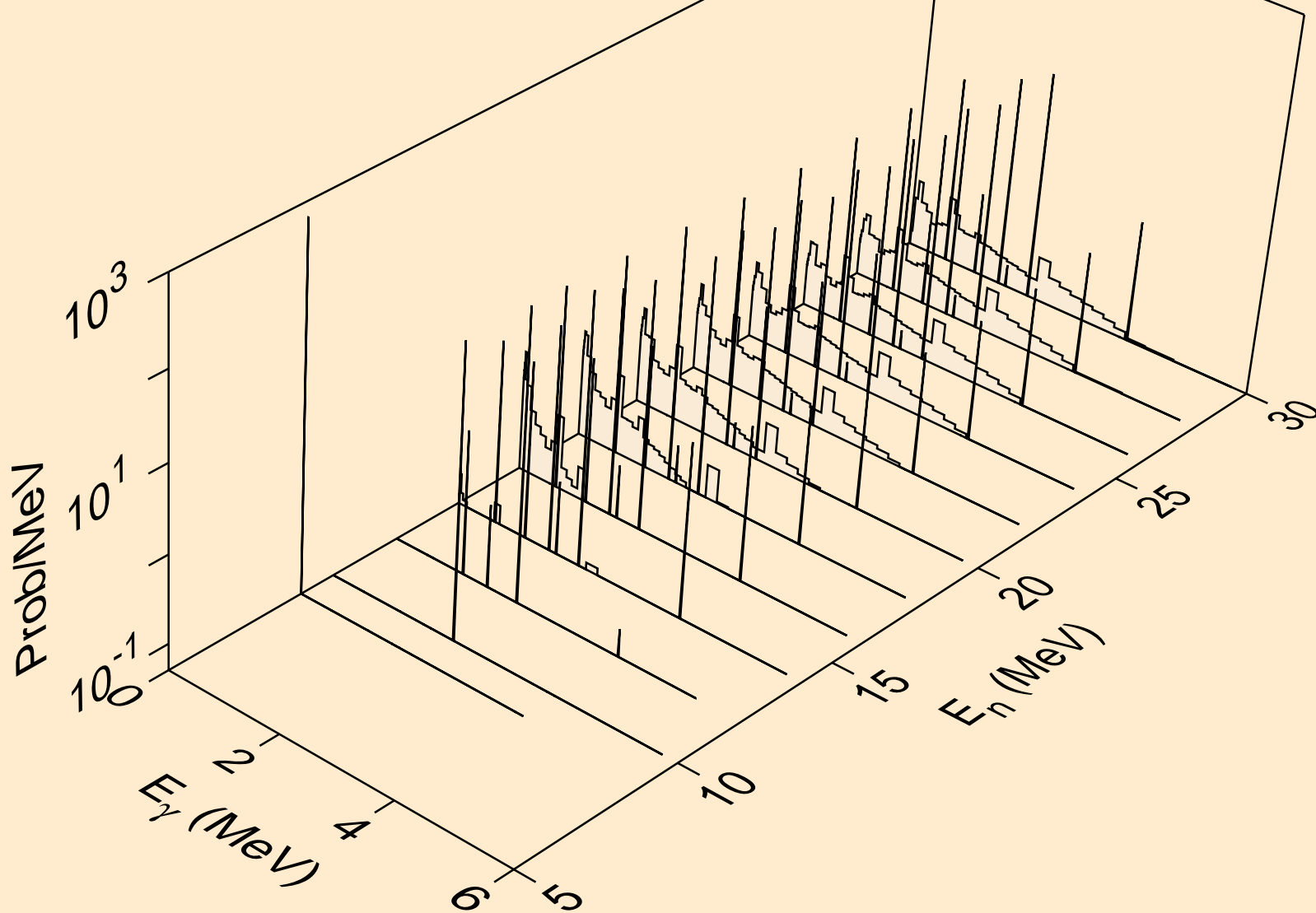

CL036 ALPHA ACER TENDL-2023 LIBRARY; T=0.K  
Photon emission for (n,t)

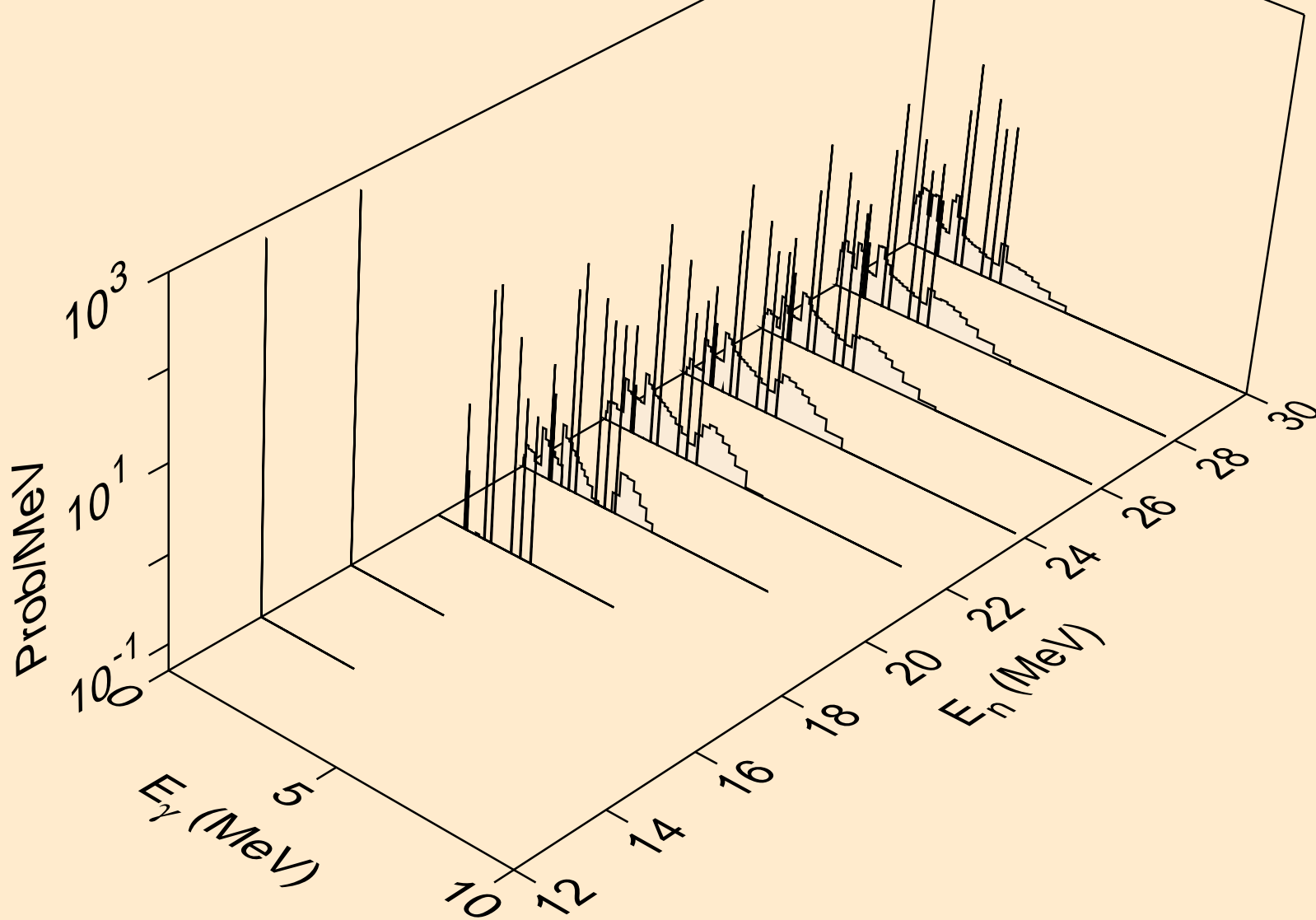

CL036 ALPHA ACER TENDL-2023 LIBRARY; T=0.K  
Photon emission for (n,he3)

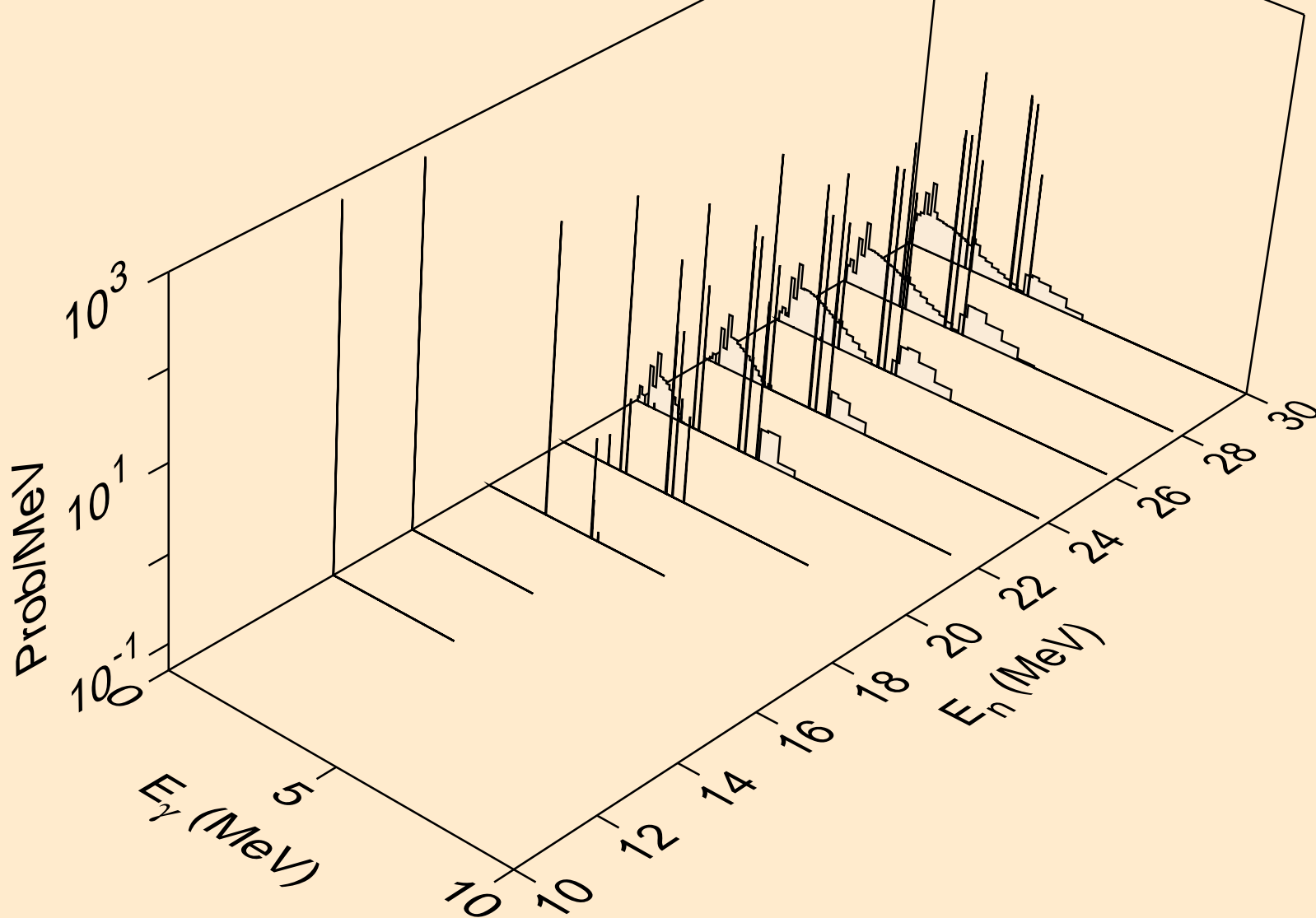

CL036 ALPHA ACER TENDL-2023 LIBRARY; T=0.K  
Photon emission for inelastic

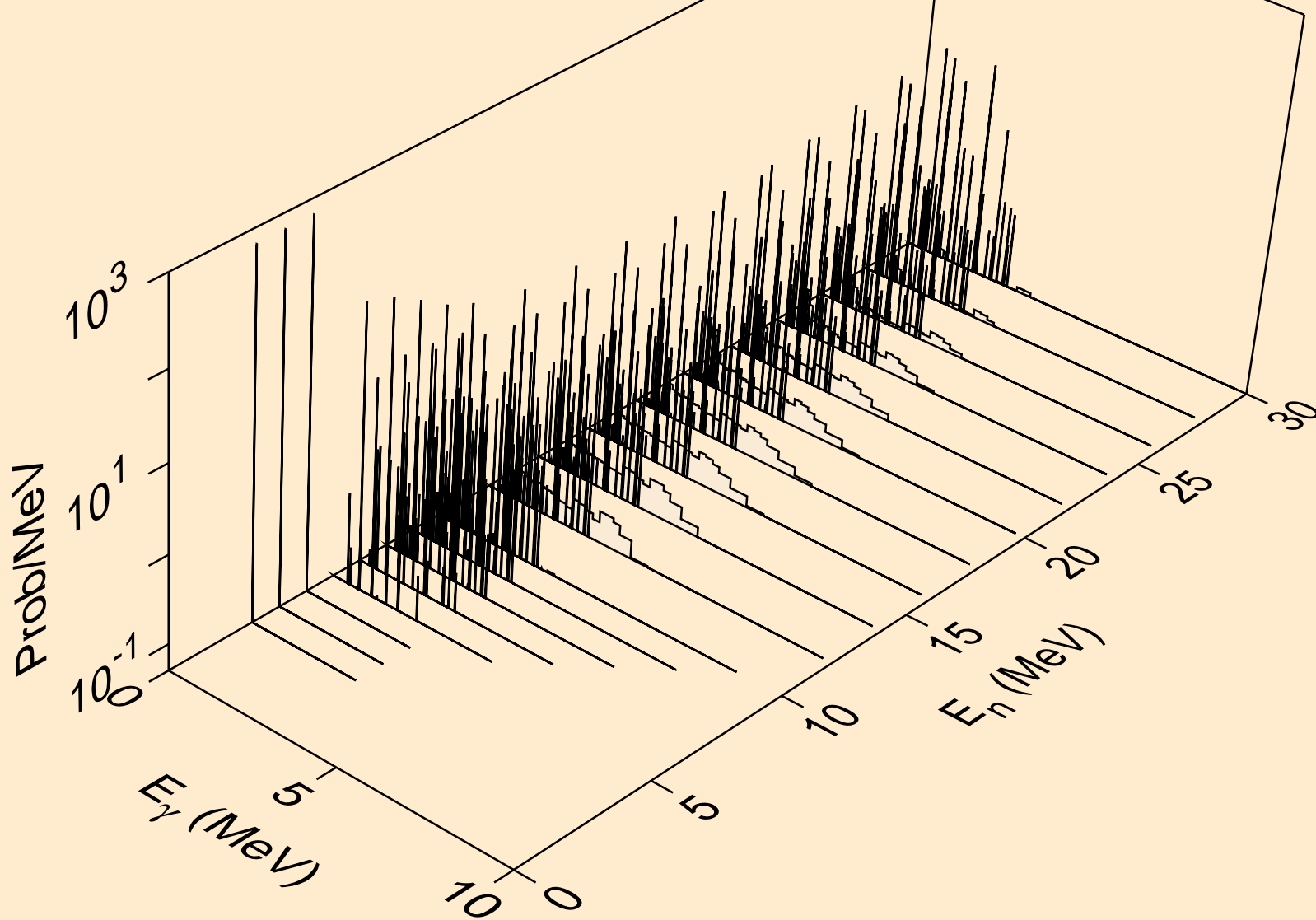

CL036 ALPHA ACER TENDL-2023 LIBRARY; T=0.K  
Photon emission for (n,2a)

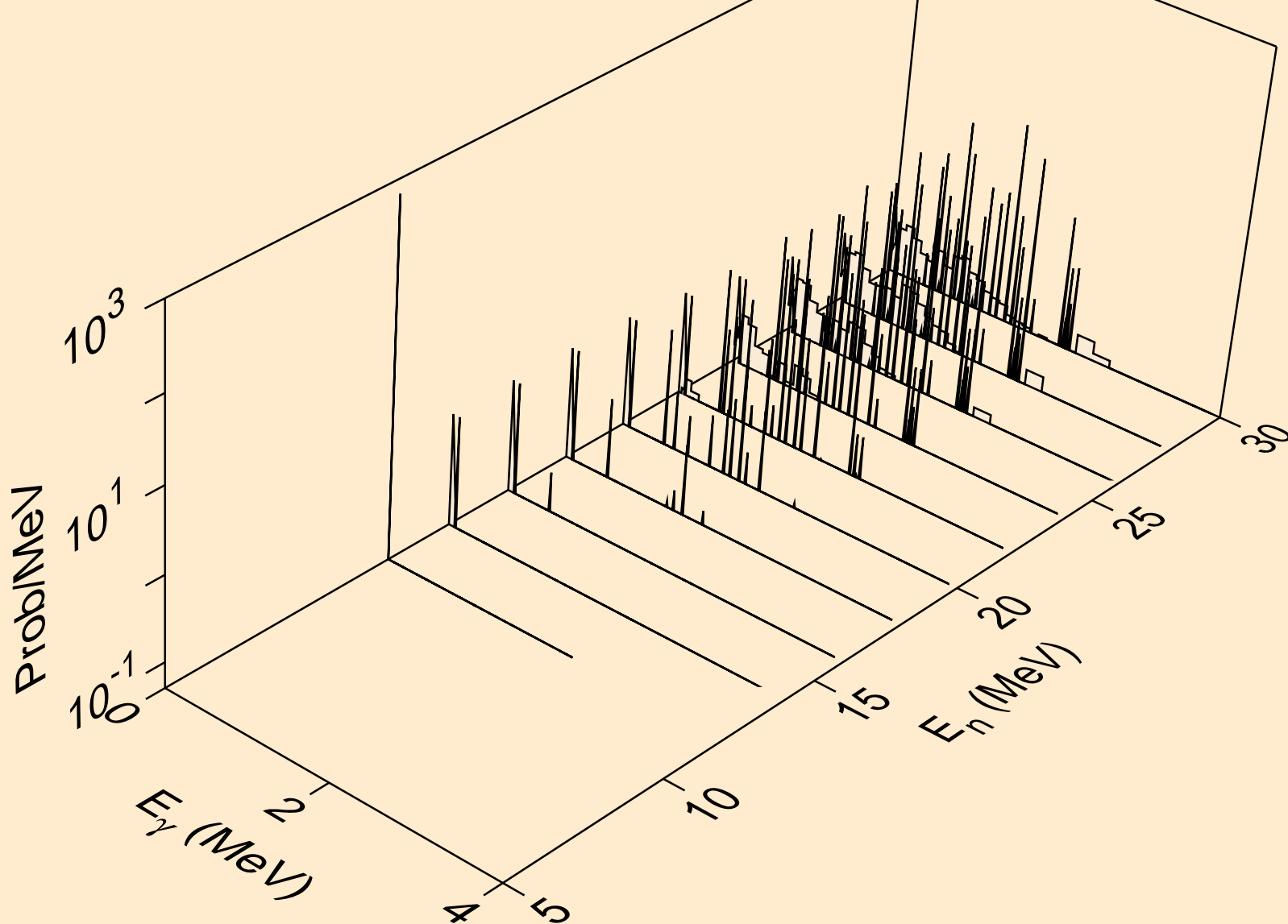

CL036 ALPHA ACER TENDL-2023 LIBRARY; T=0.K  
Photon emission for (n,2p)

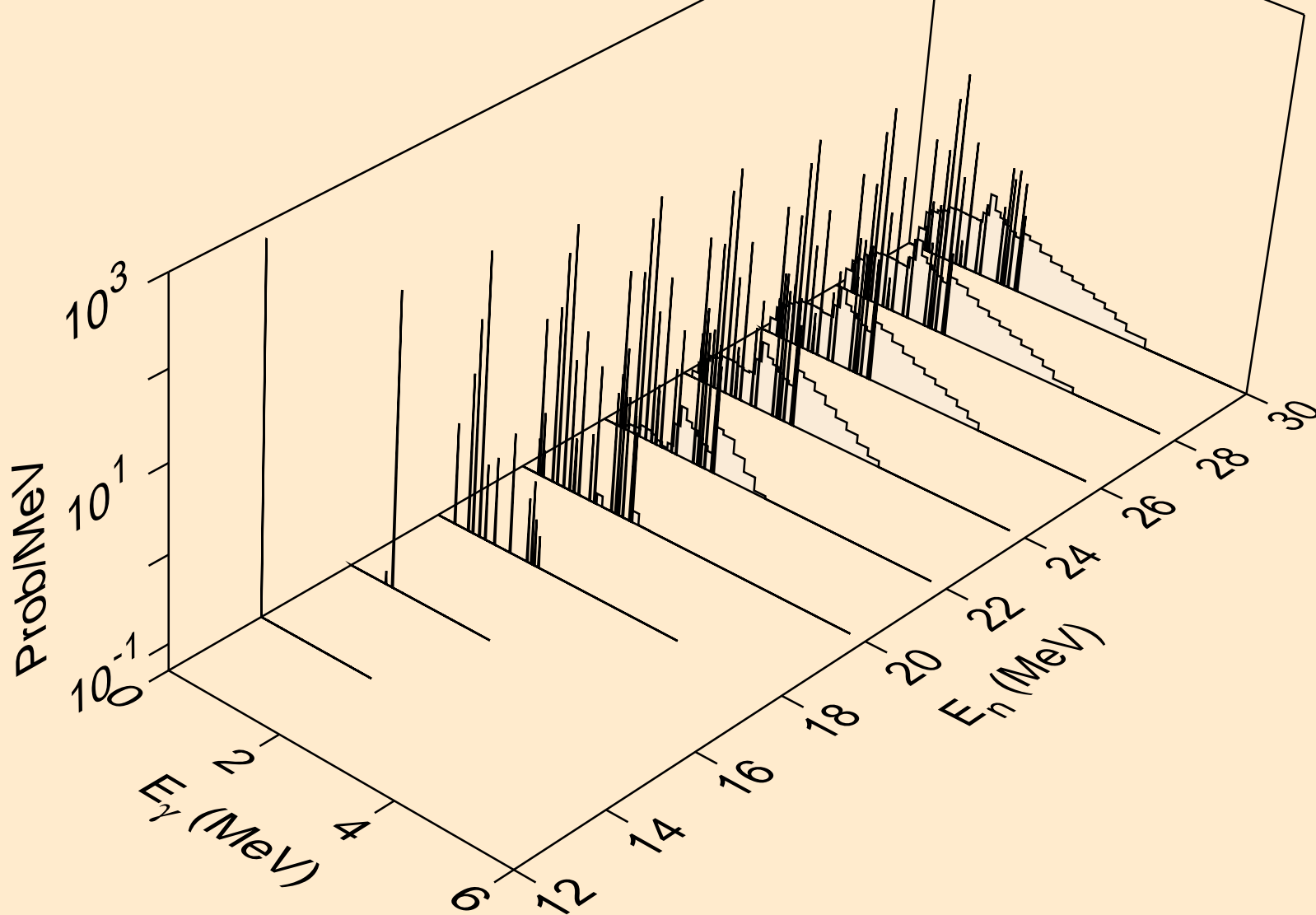

CL036 ALPHA ACER TENDL-2023 LIBRARY; T=0.K  
Photon emission for (n,pa)

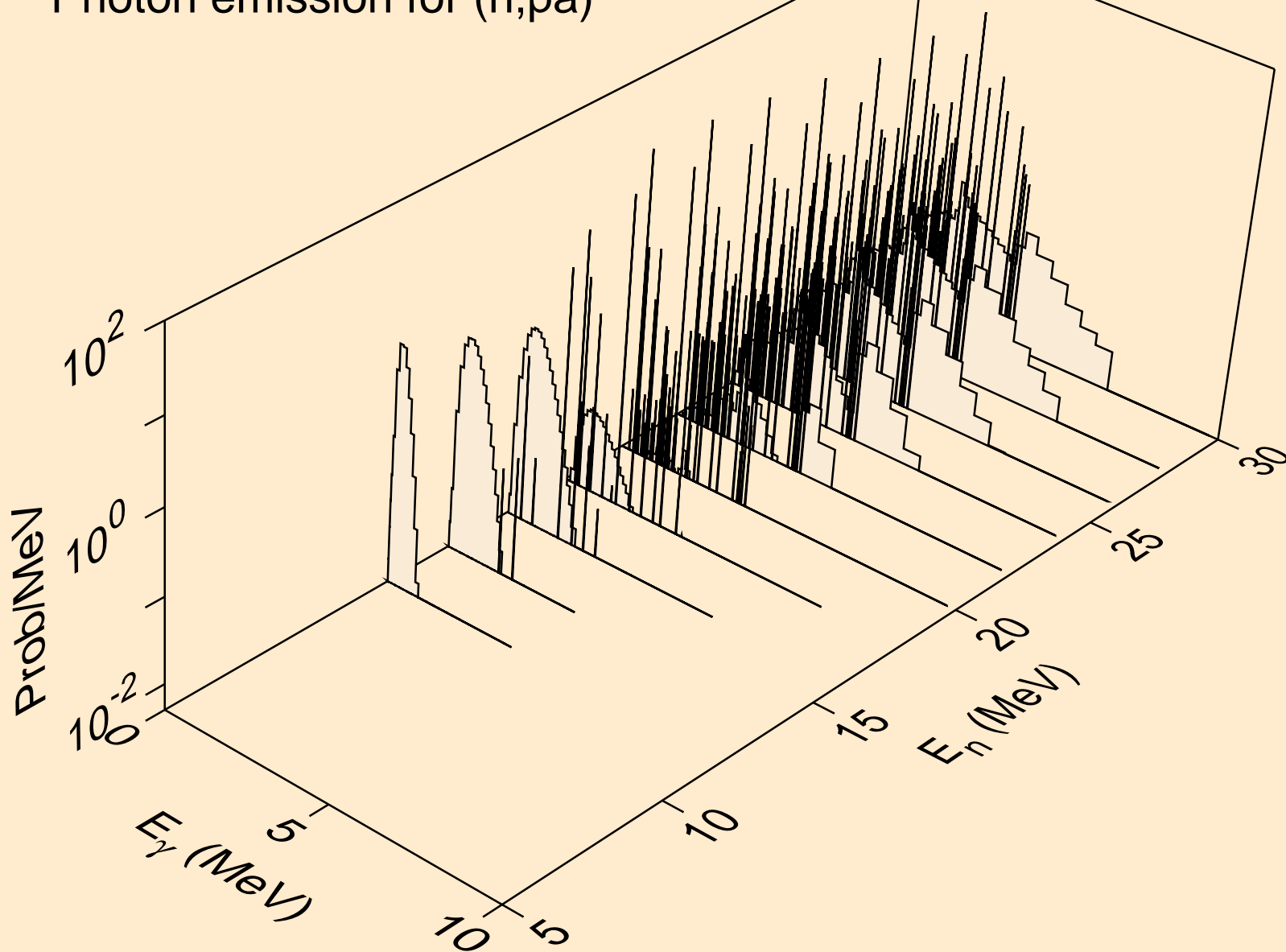

CL036 ALPHA ACER TENDL-2023 LIBRARY; T=0.K  
Photon emission for (n,pd)

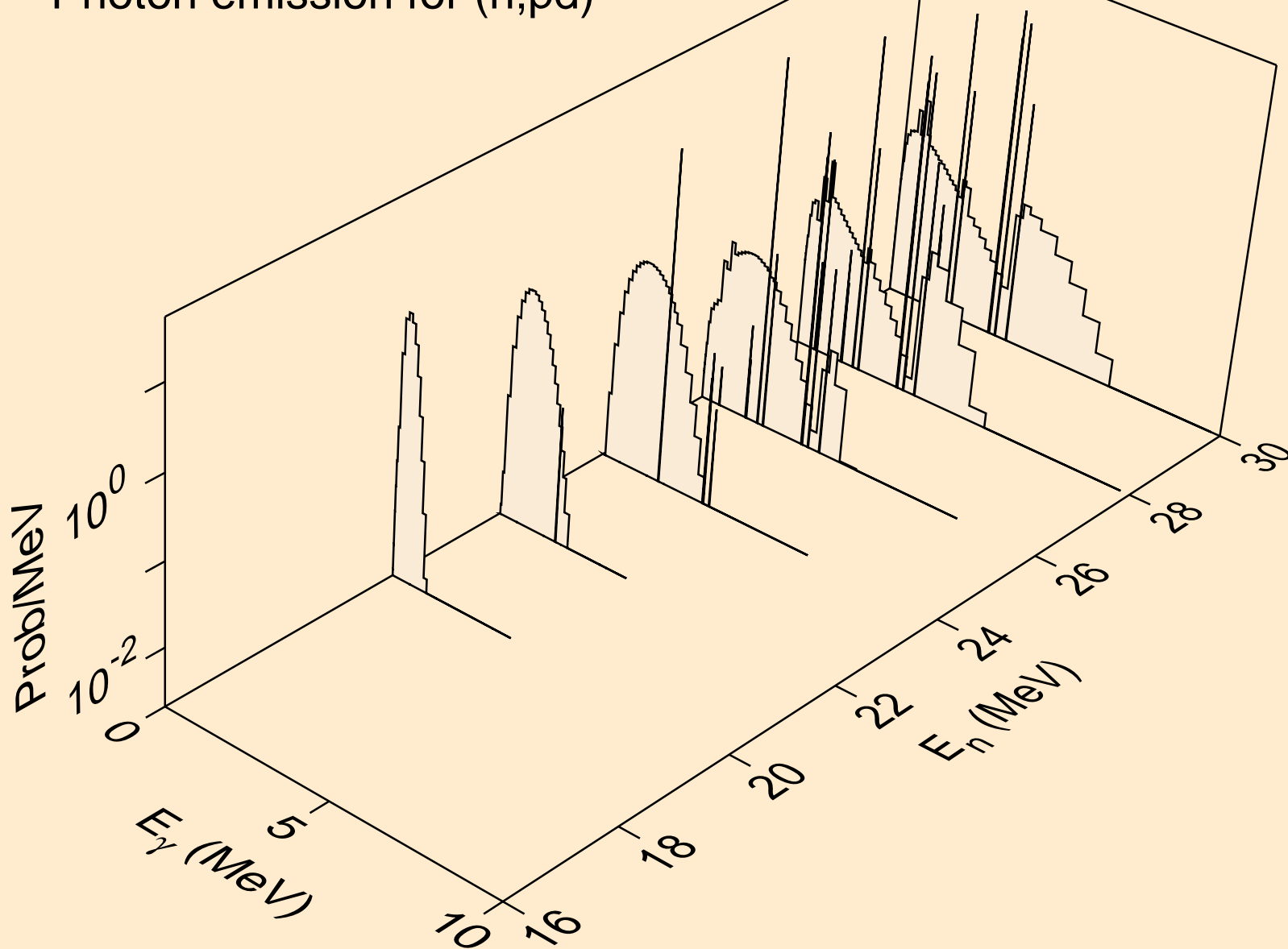

CL036 ALPHA ACER TENDL-2023 LIBRARY; T=0.K  
Photon emission for (n,pt)

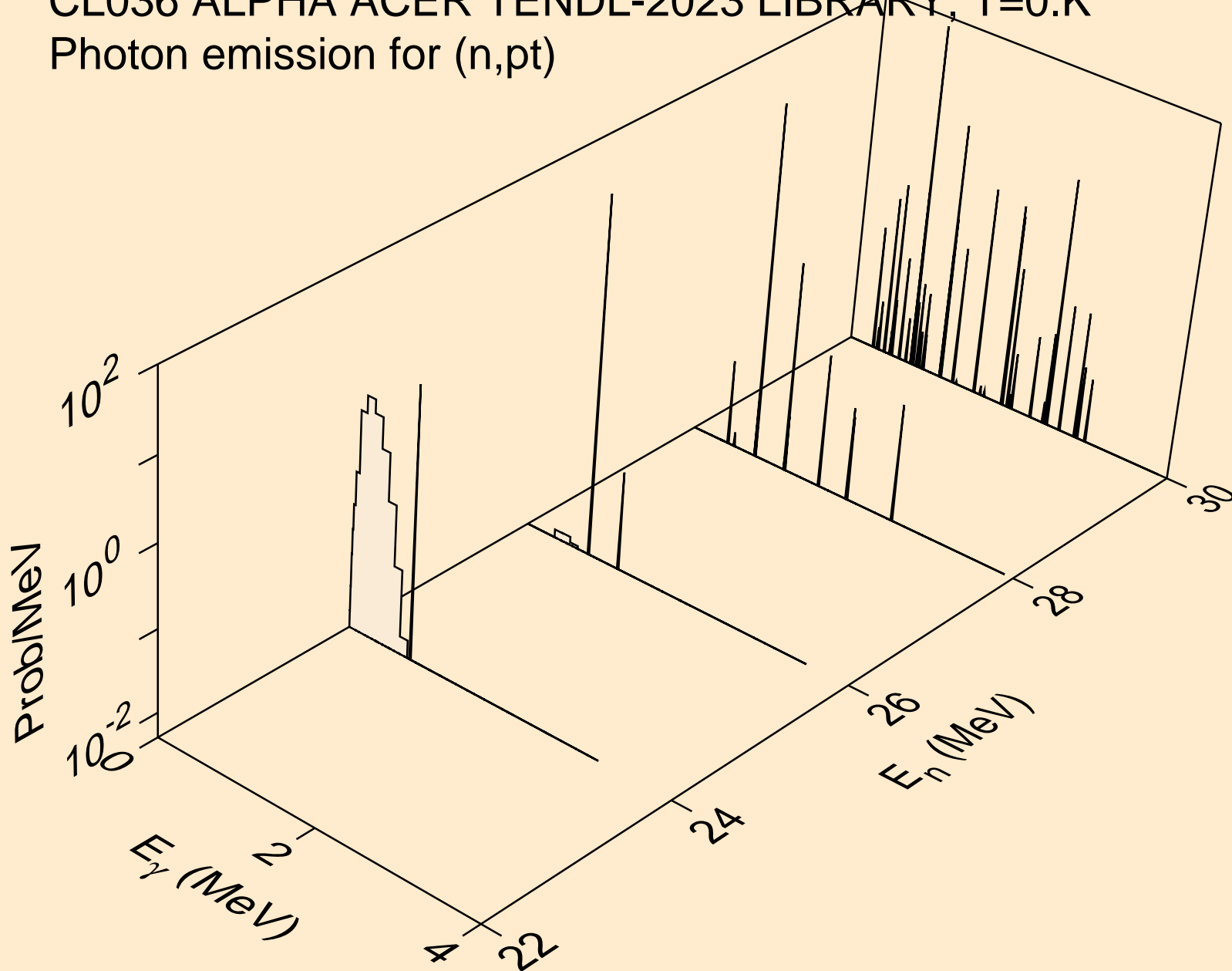

CL036 ALPHA ACER TENDL-2023 LIBRARY; T=0.K  
Photon emission for (n,da)

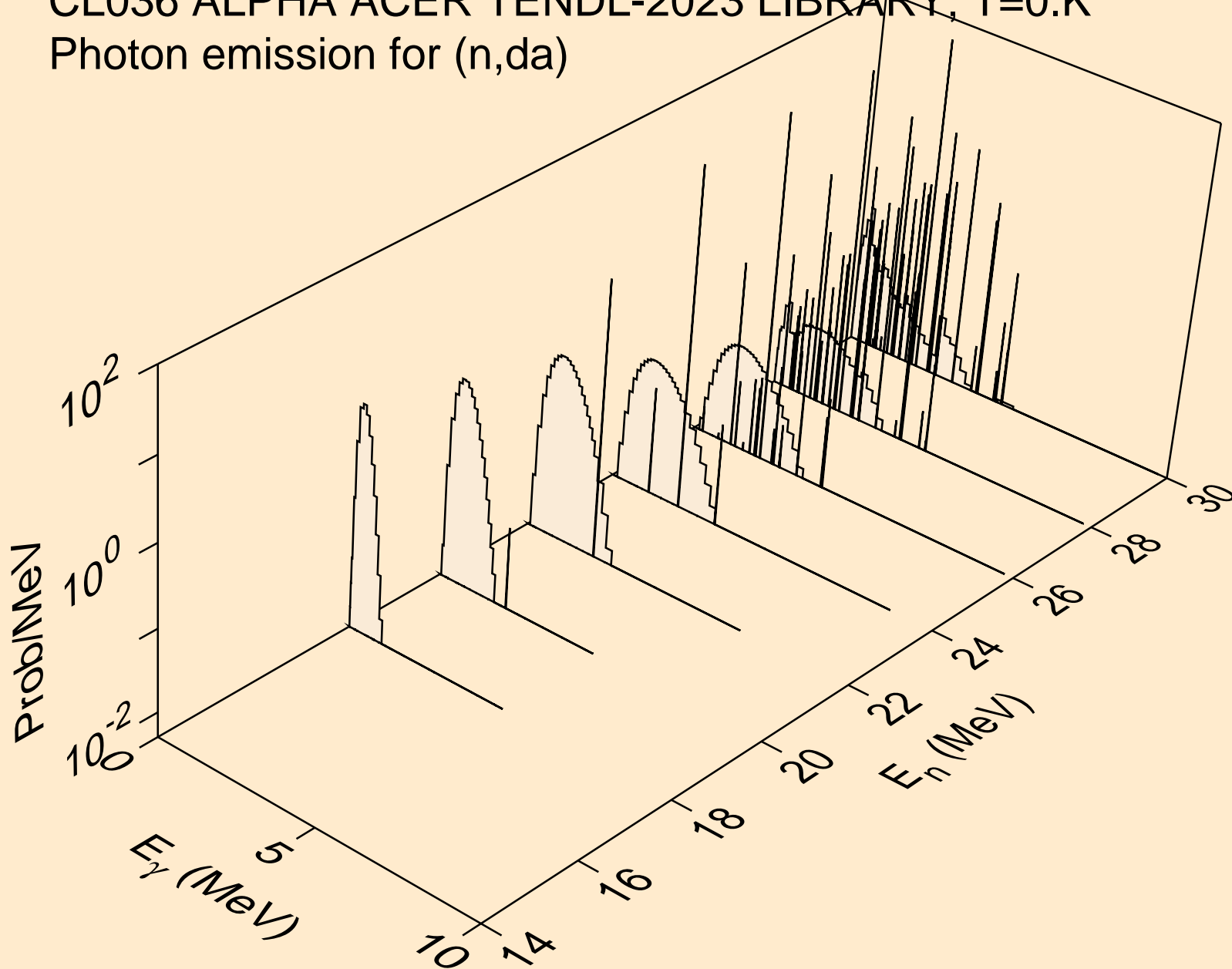

# CL036 ALPHA ACER TENDL-2023 LIBRARY; T=0.K

## Particle heating contributions

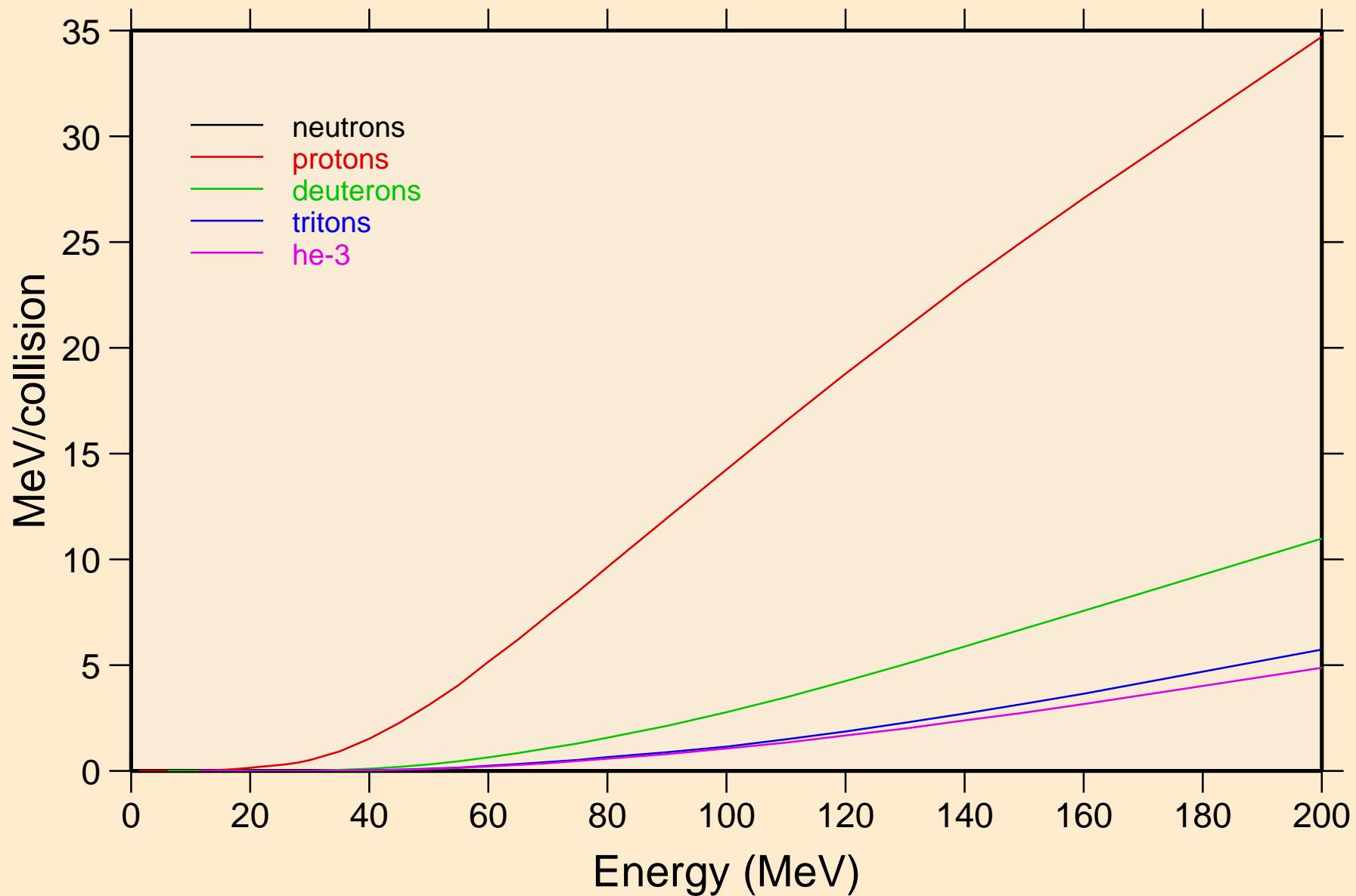

CL036 ALPHA ACER TENDL-2023 LIBRARY; T=0.K  
Recoil Heating

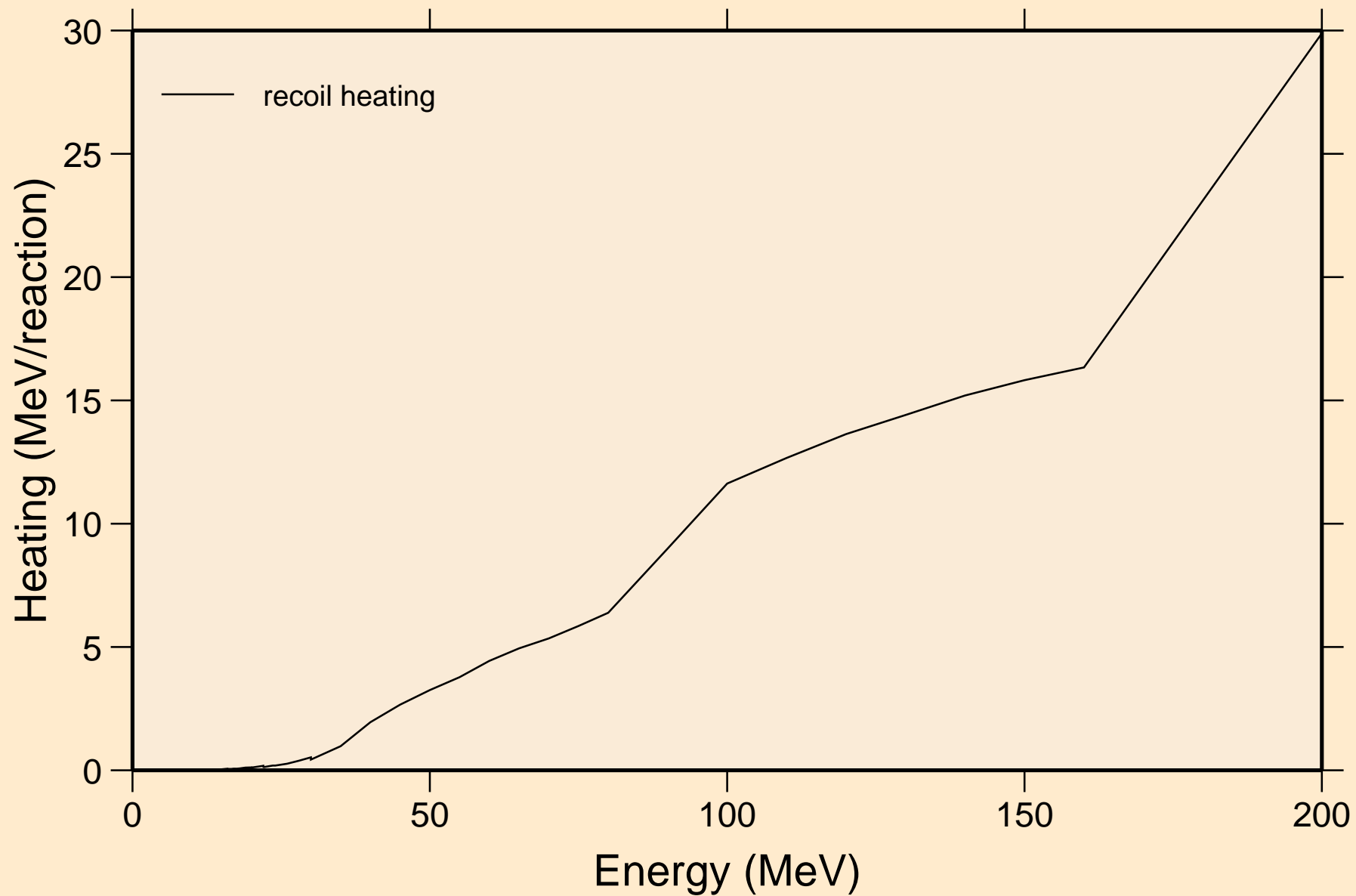

# CL036 ALPHA ACER TENDL-2023 LIBRARY; T=0.K

## Particle production cross sections

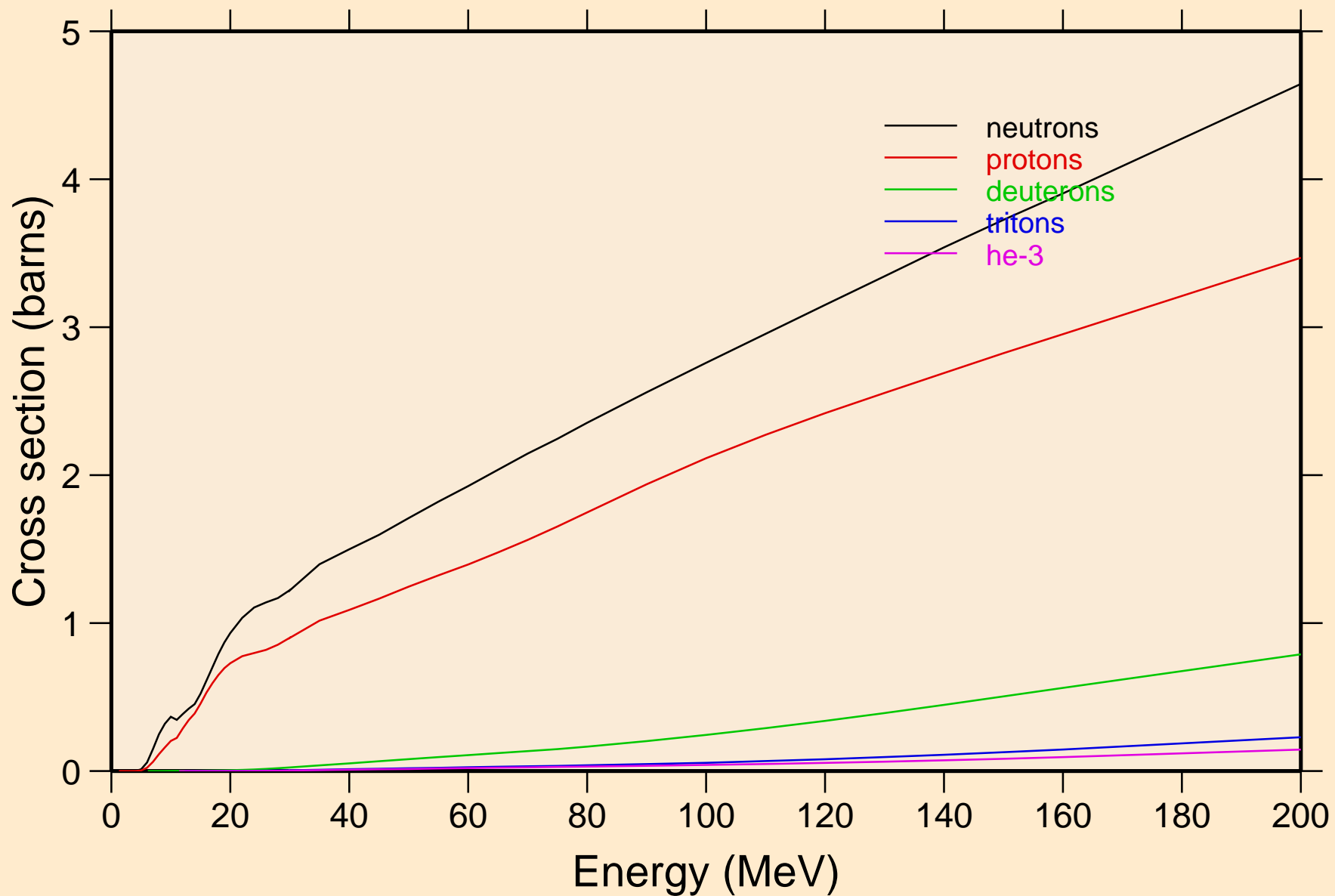

CL036 ALPHA ACER TENDL-2023 LIBRARY; T=0.K  
neutrons from (a,n)

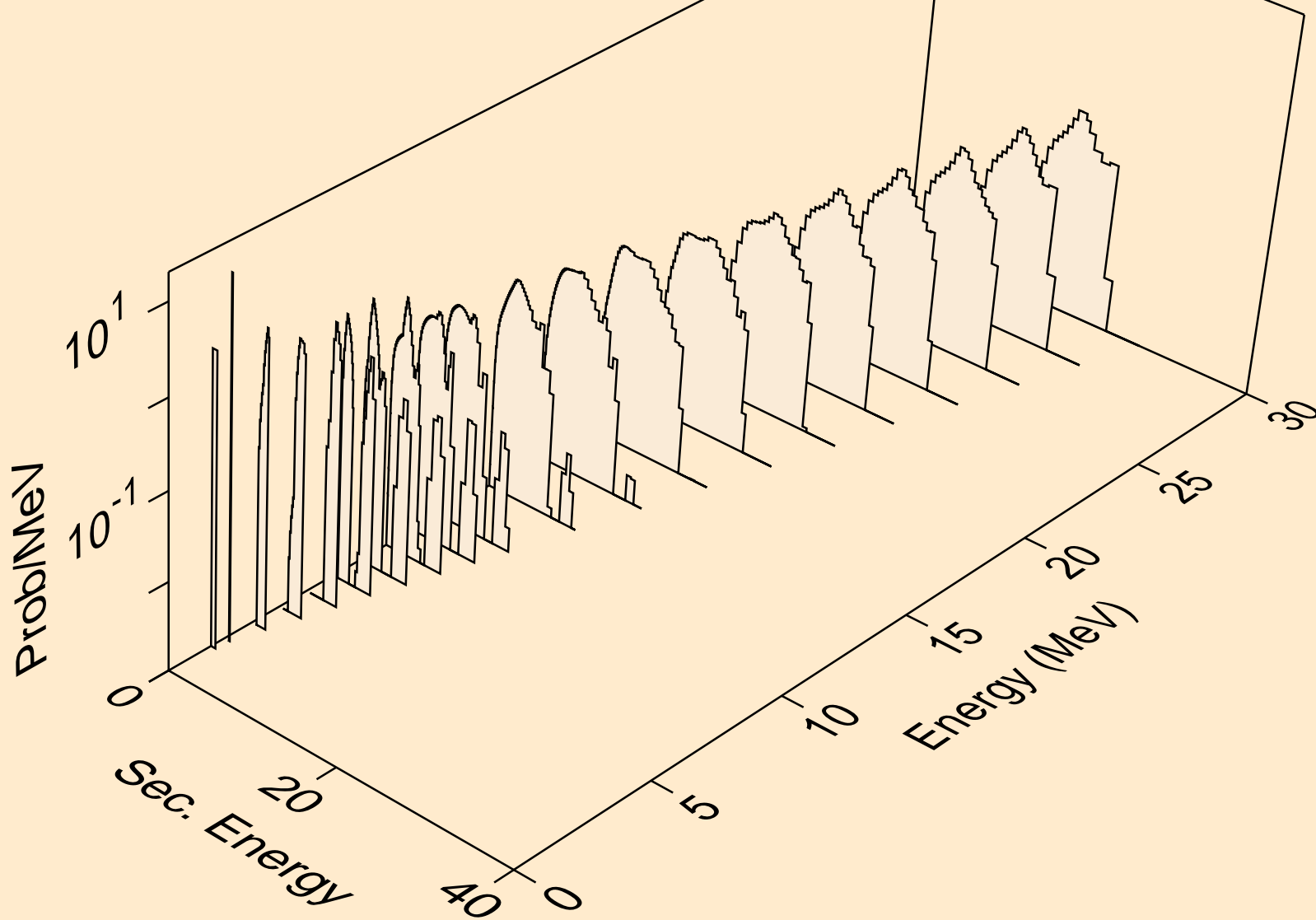

CL036 ALPHA ACER TENDL-2023 LIBRARY; T=0.K  
neutrons from (a,x)

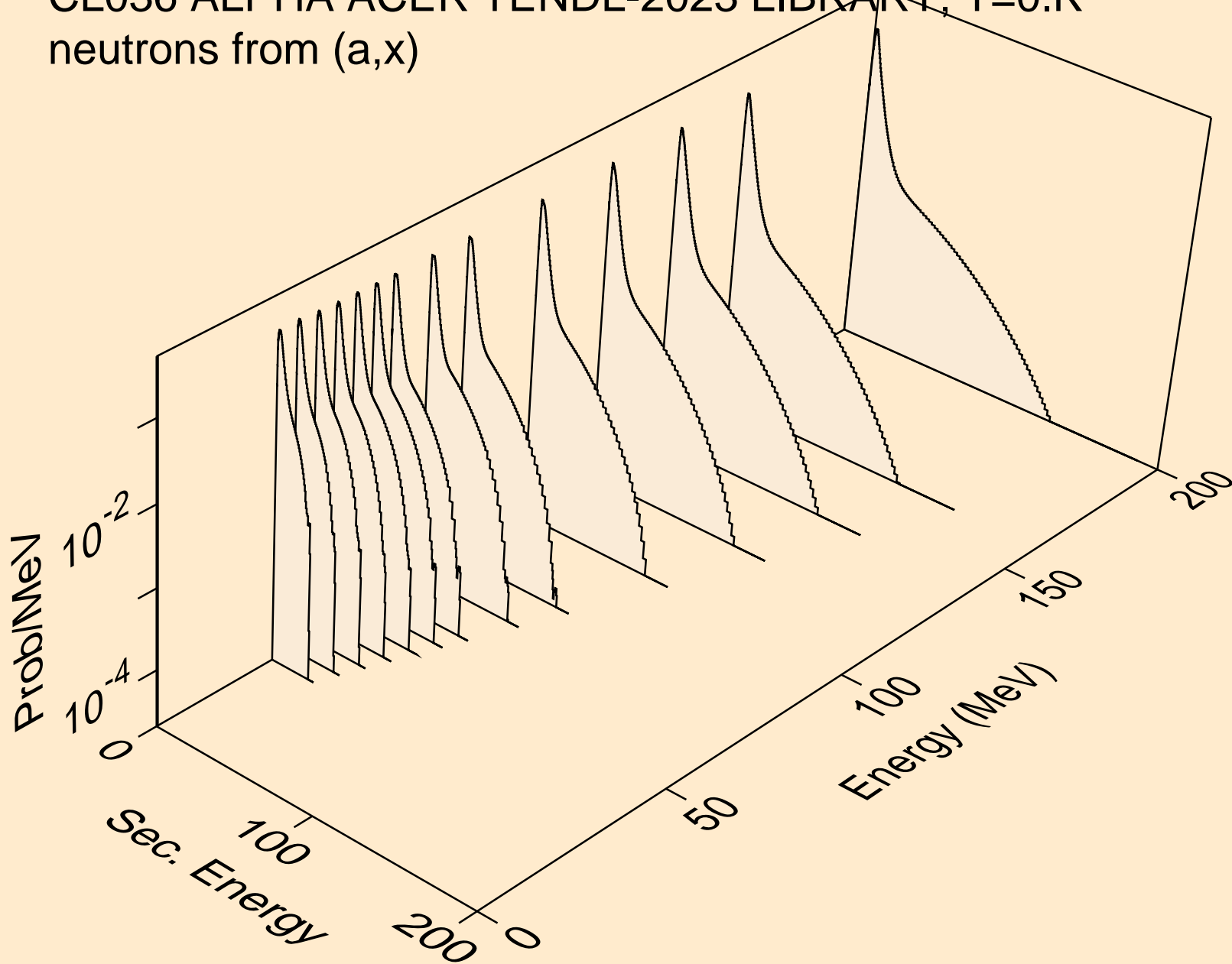

CL036 ALPHA ACER TENDL-2023 LIBRARY; T=0.K  
neutrons from (a,2n)

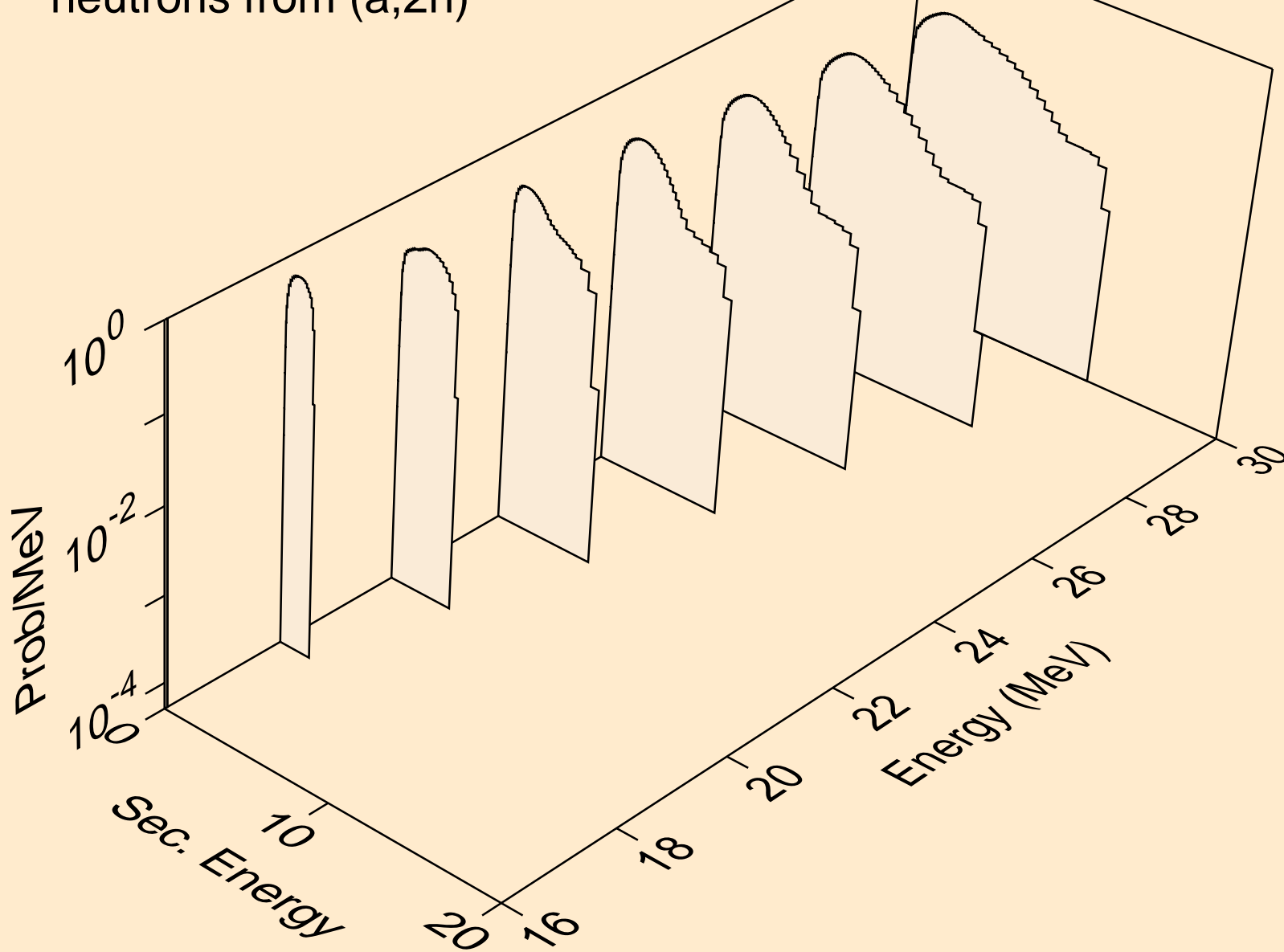

CL036 ALPHA ACER TENDL-2023 LIBRARY; T=0.K  
neutrons from (a,n\*)a

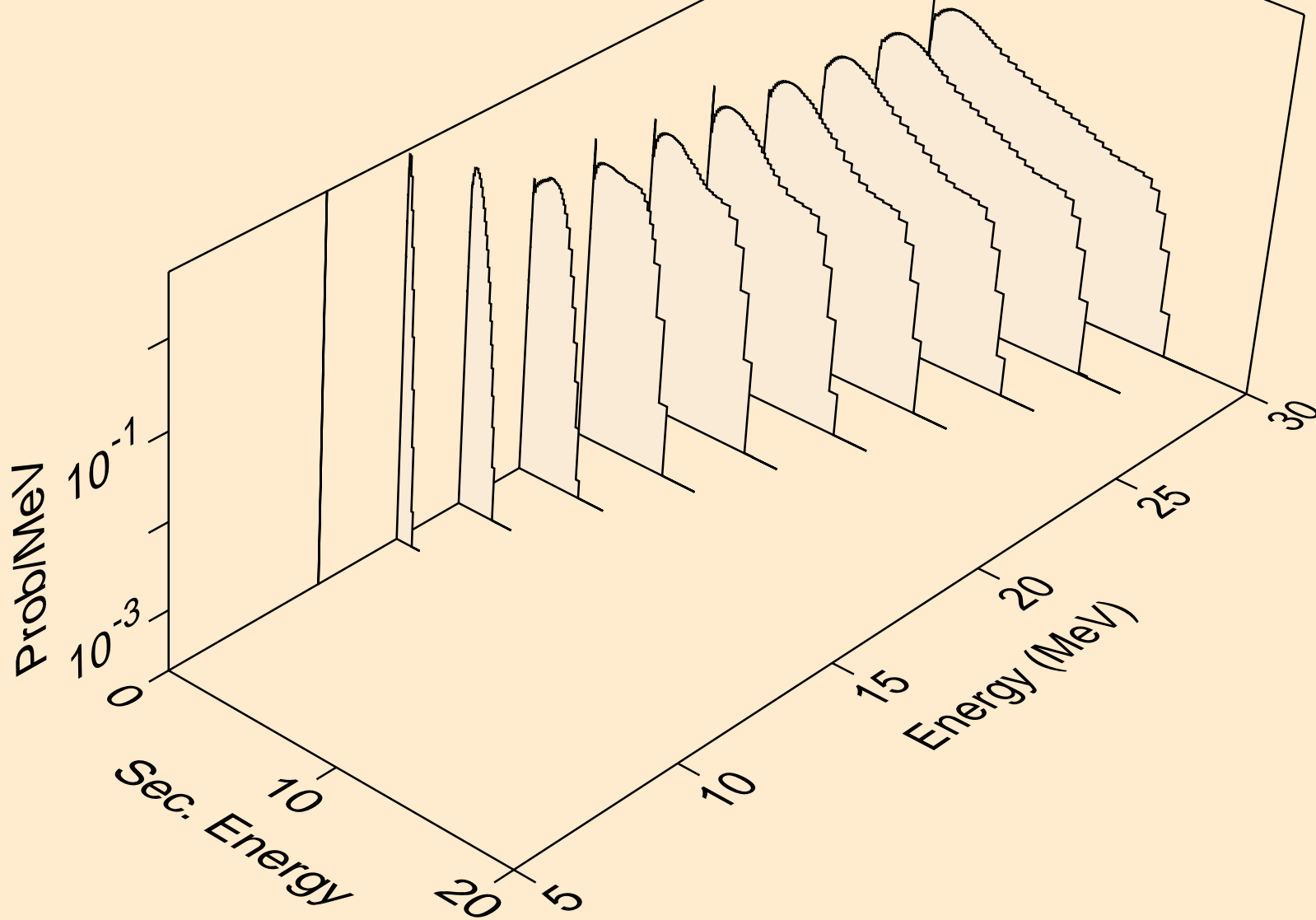

CL036 ALPHA ACER TENDL-2023 LIBRARY; T=0.K  
neutrons from (a,2n)a

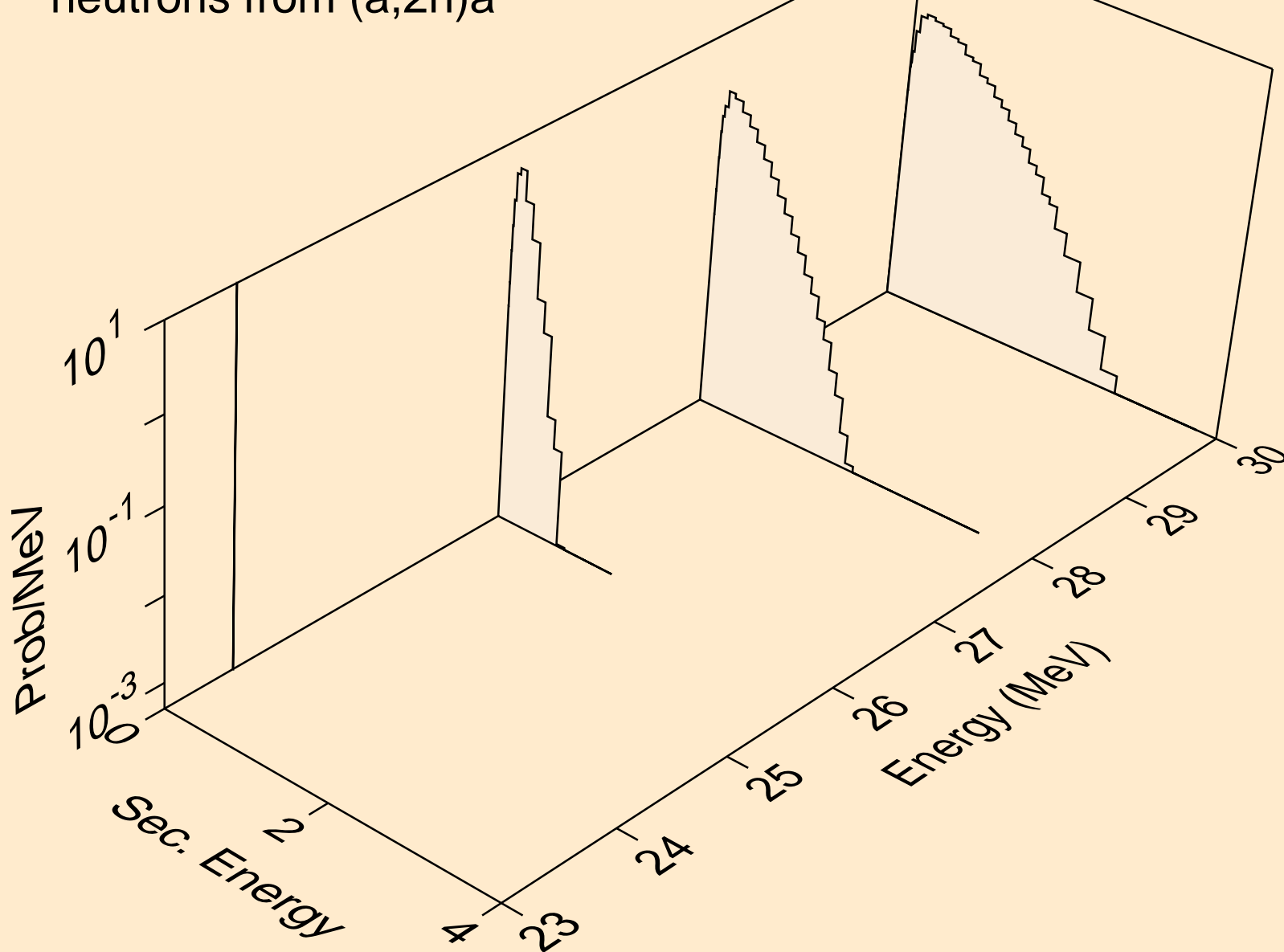

CL036 ALPHA ACER TENDL-2023 LIBRARY; T=0.K  
neutrons from (a,n\*)p

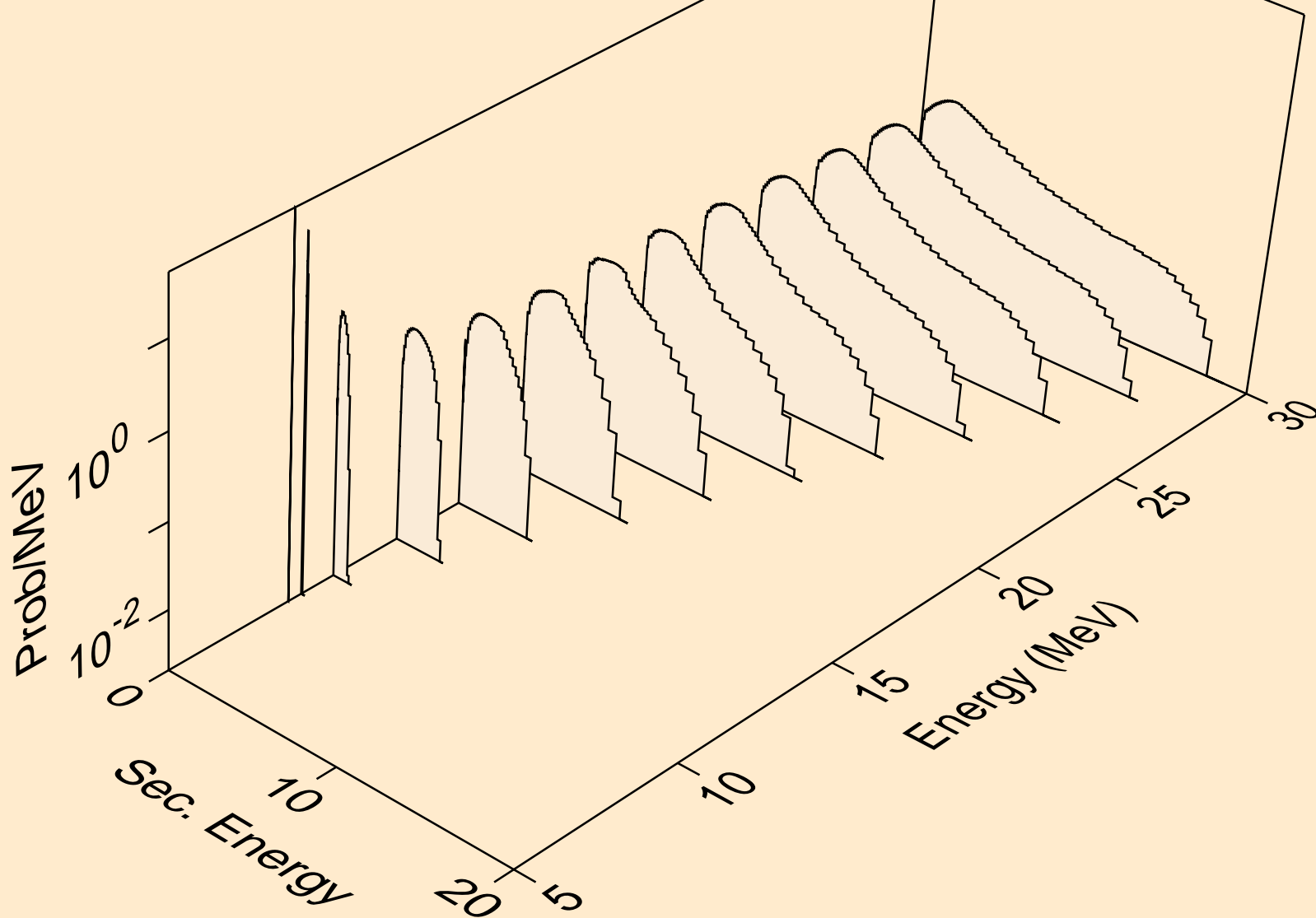

CL036 ALPHA ACER TENDL-2023 LIBRARY; T=0.K  
neutrons from (a,n\*)2a

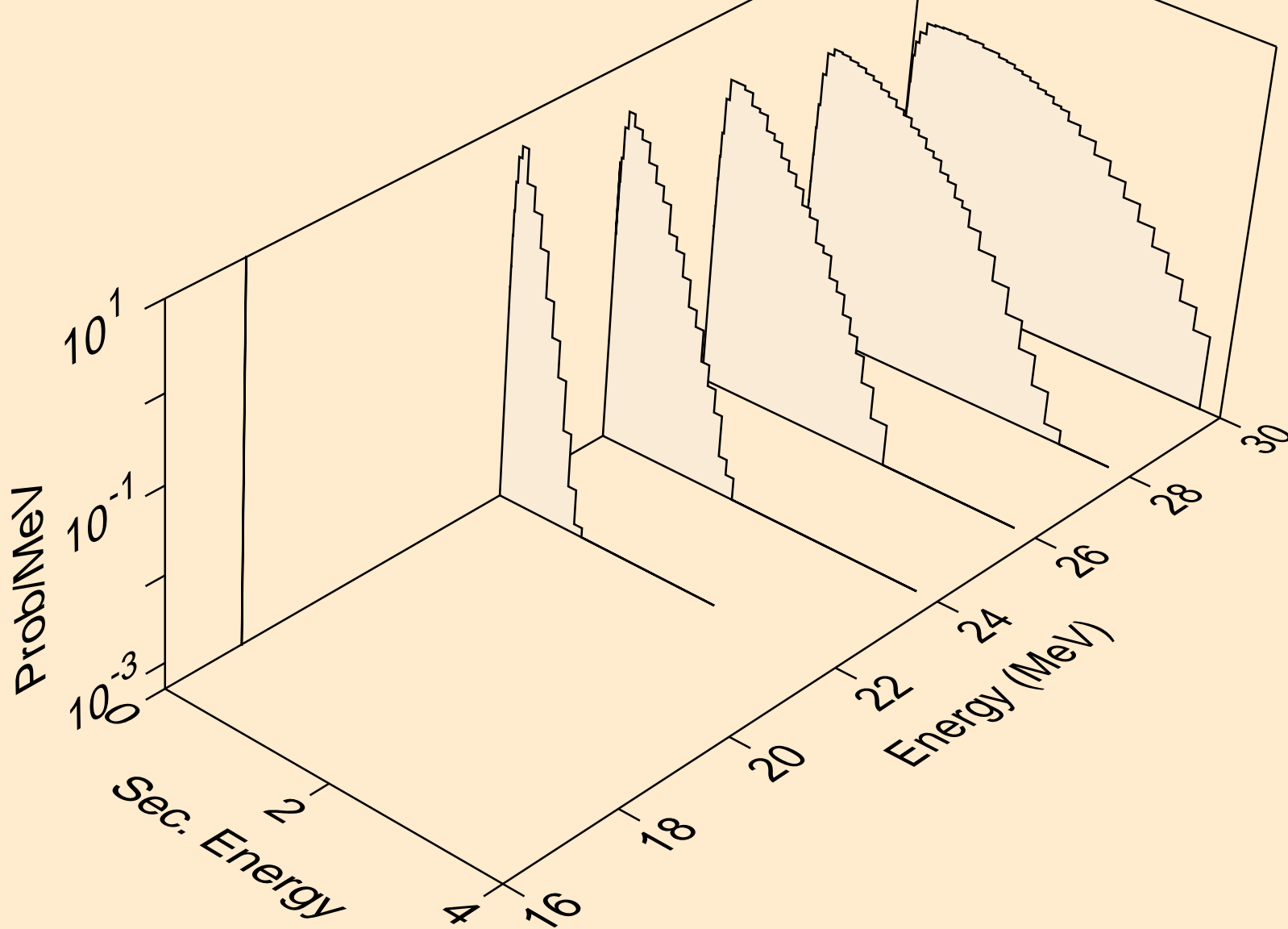

CL036 ALPHA ACER TENDL-2023 LIBRARY; T=0.K  
neutrons from (a,n\*)d

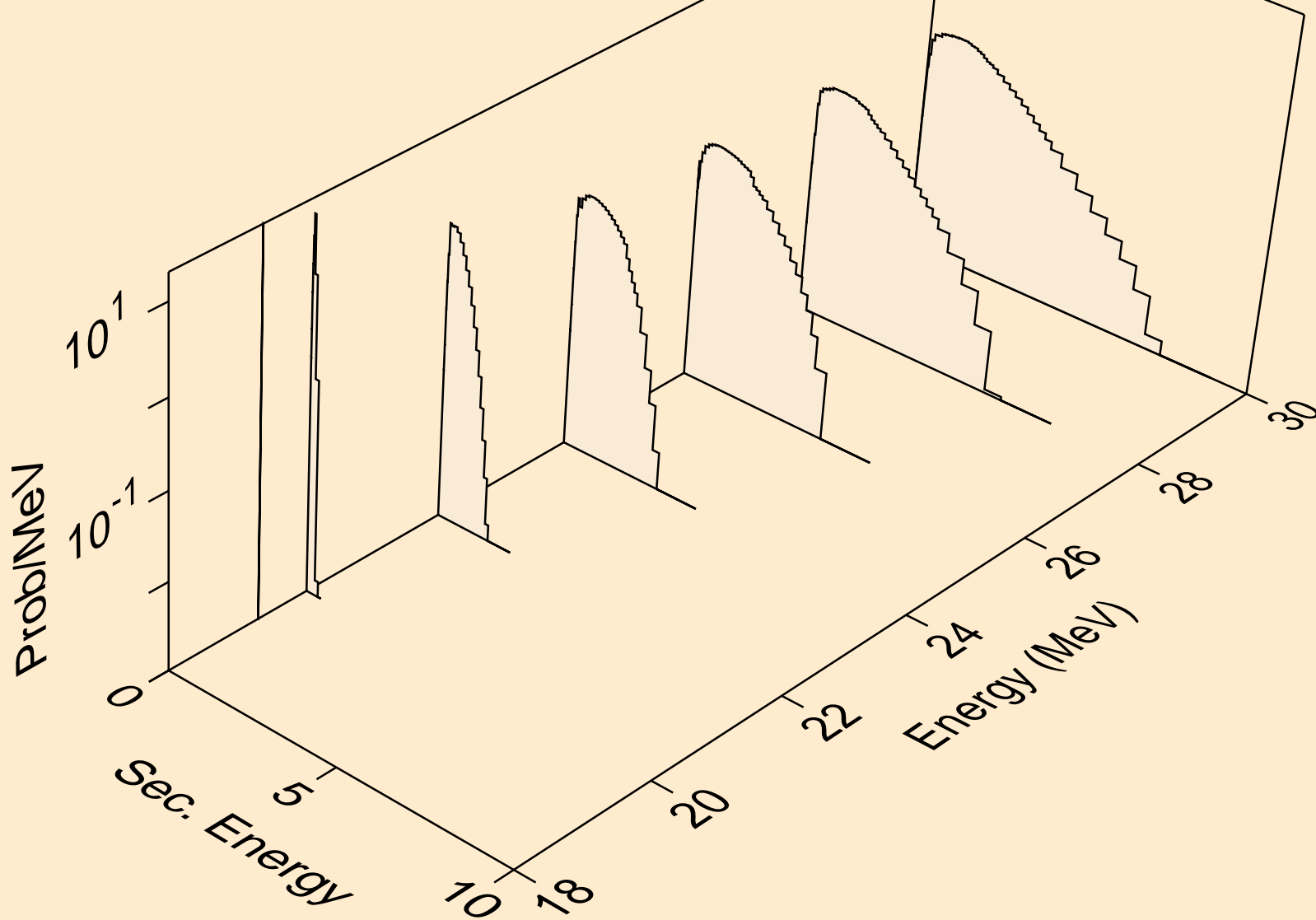

CL036 ALPHA ACER TENDL-2023 LIBRARY; T=0.K  
neutrons from (a,n\*)t

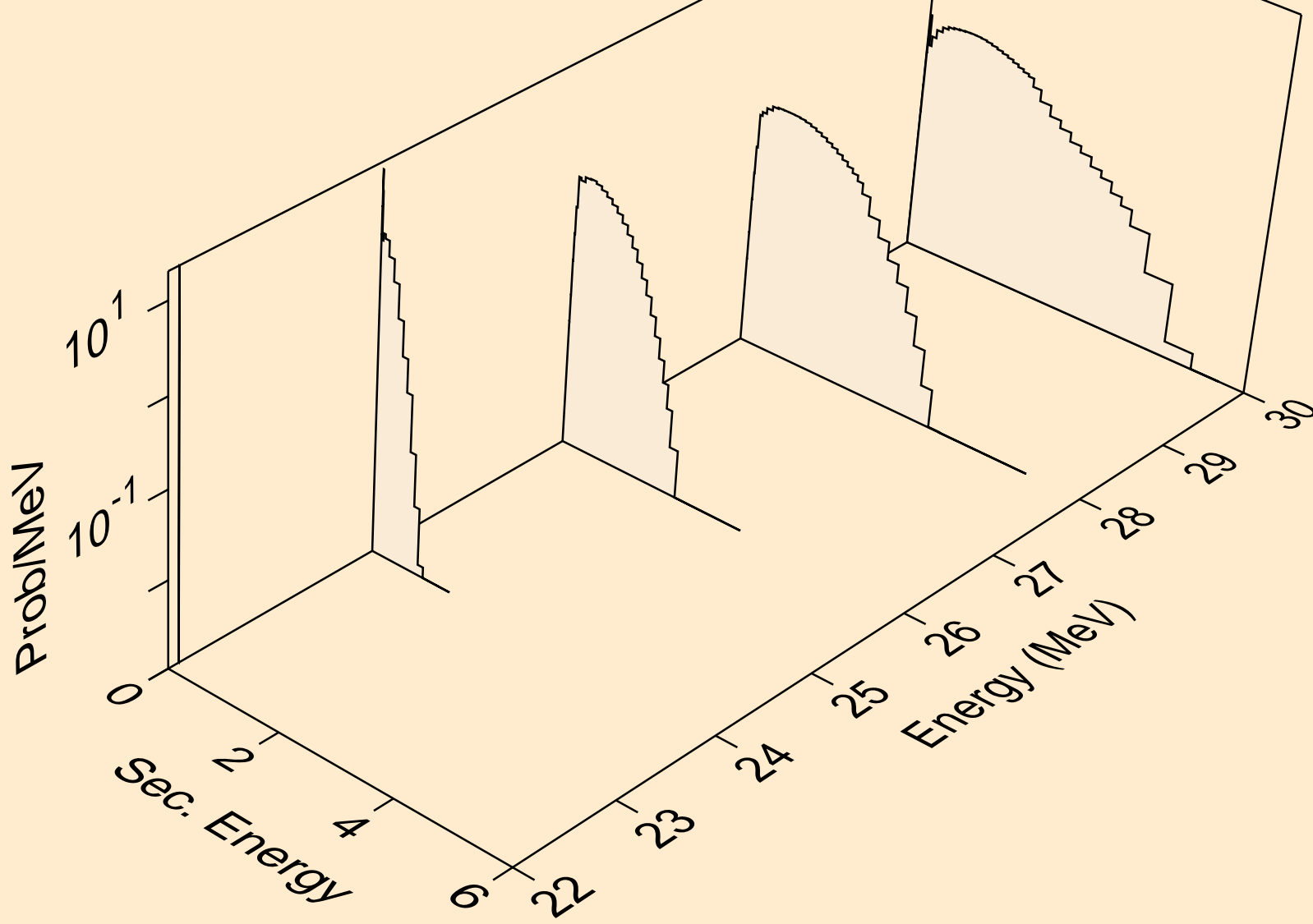

CL036 ALPHA ACER TENDL-2023 LIBRARY; T=0.K  
neutrons from (a,n\*)he3

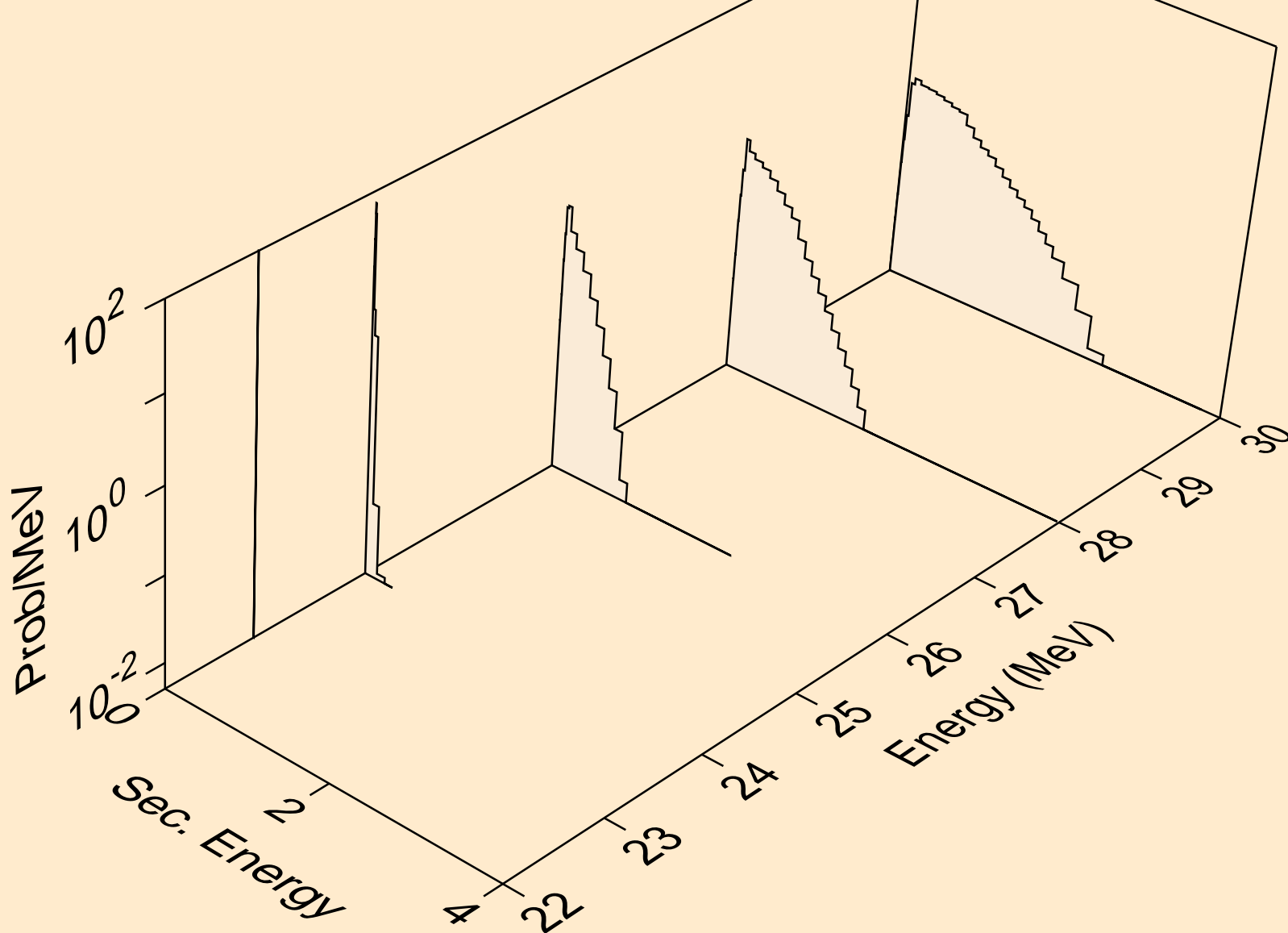

CL036 ALPHA ACER TENDL-2023 LIBRARY; T=0.K  
neutrons from (a,2np)

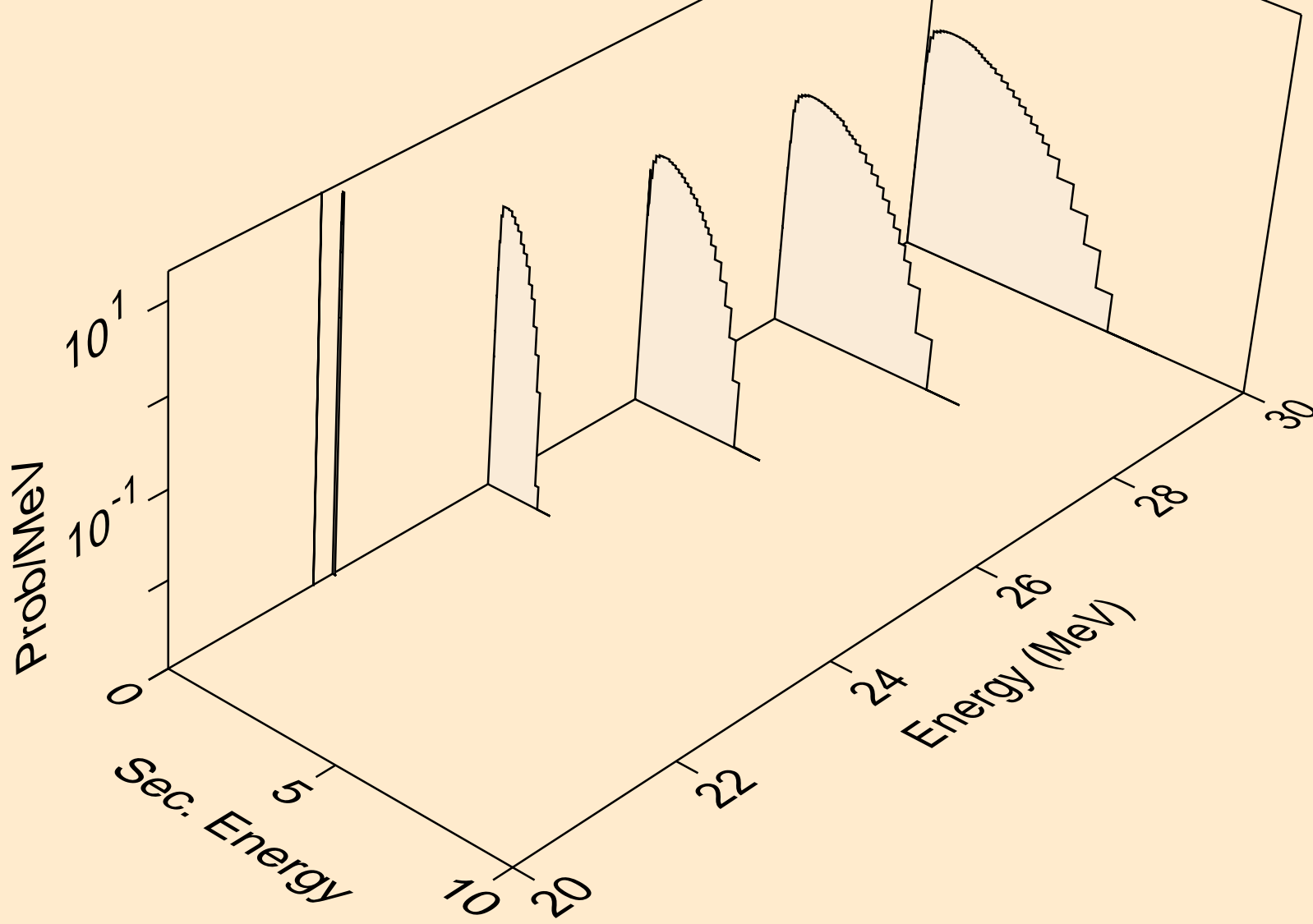

CL036 ALPHA ACER TENDL-2023 LIBRARY; T=0.K  
neutrons from (a,n2p)

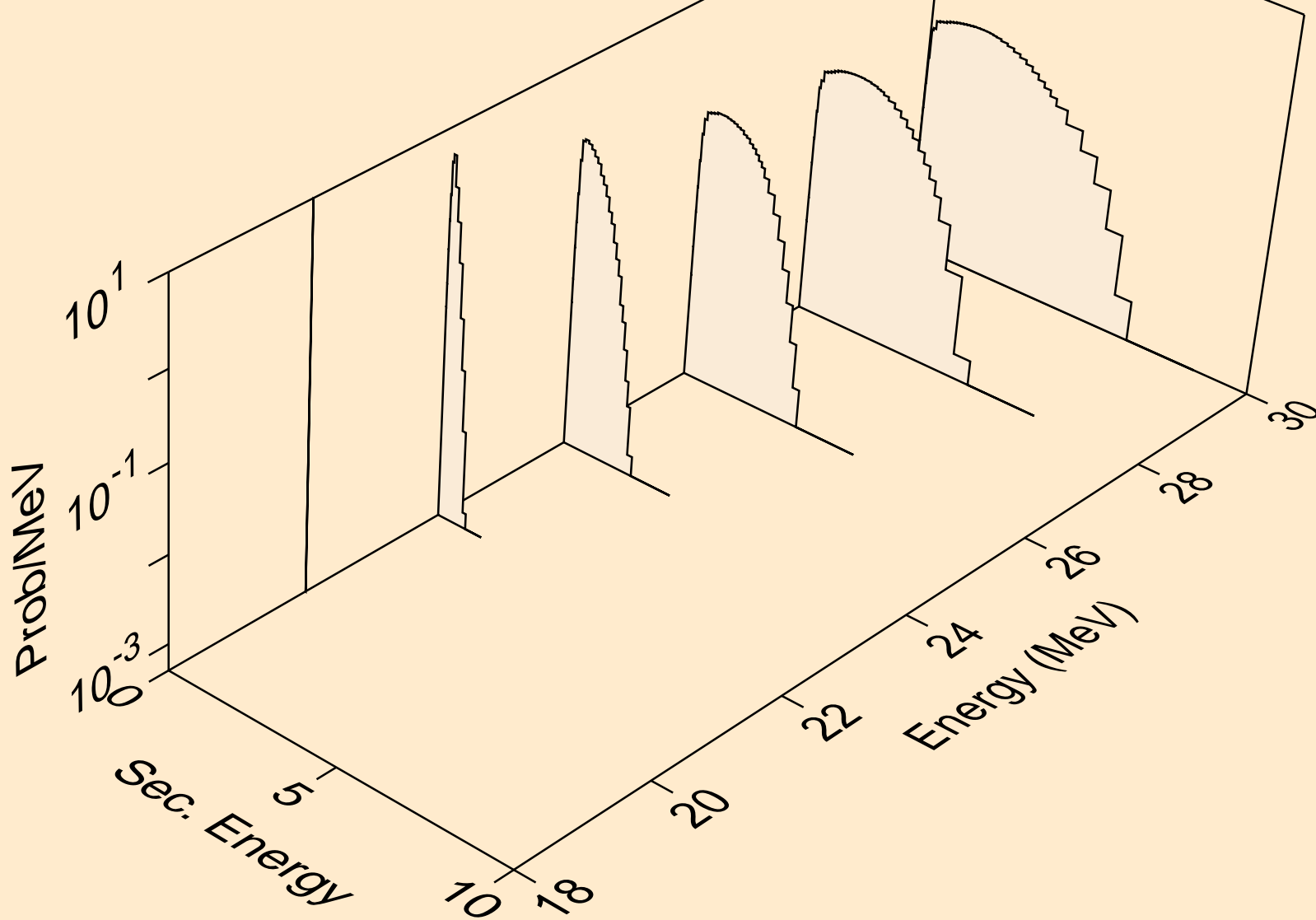

CL036 ALPHA ACER TENDL-2023 LIBRARY; T=0.K  
neutrons from (a,npa)

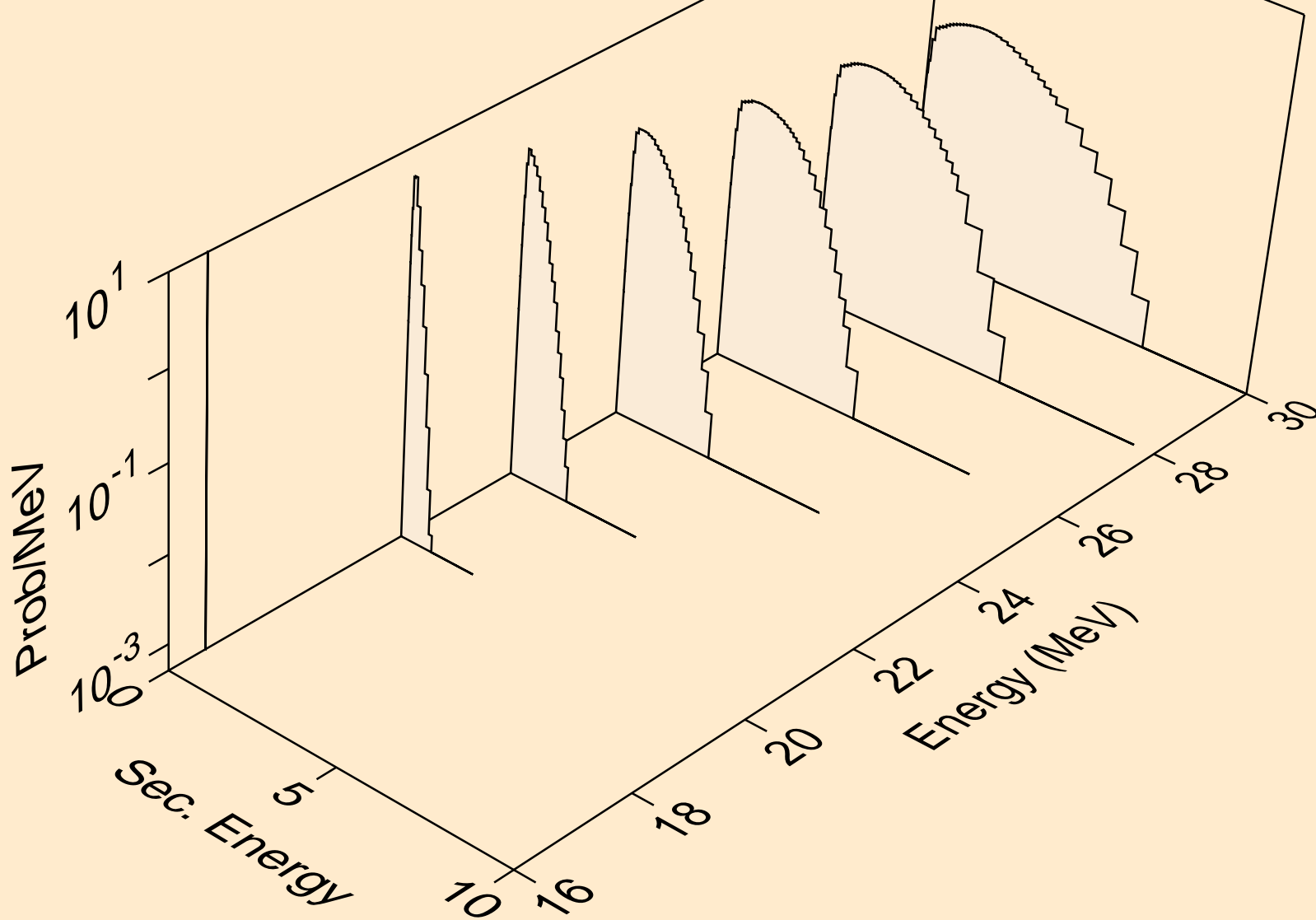

CL036 ALPHA ACER TENDL-2023 LIBRARY; T=0.K  
protons from (a,x)

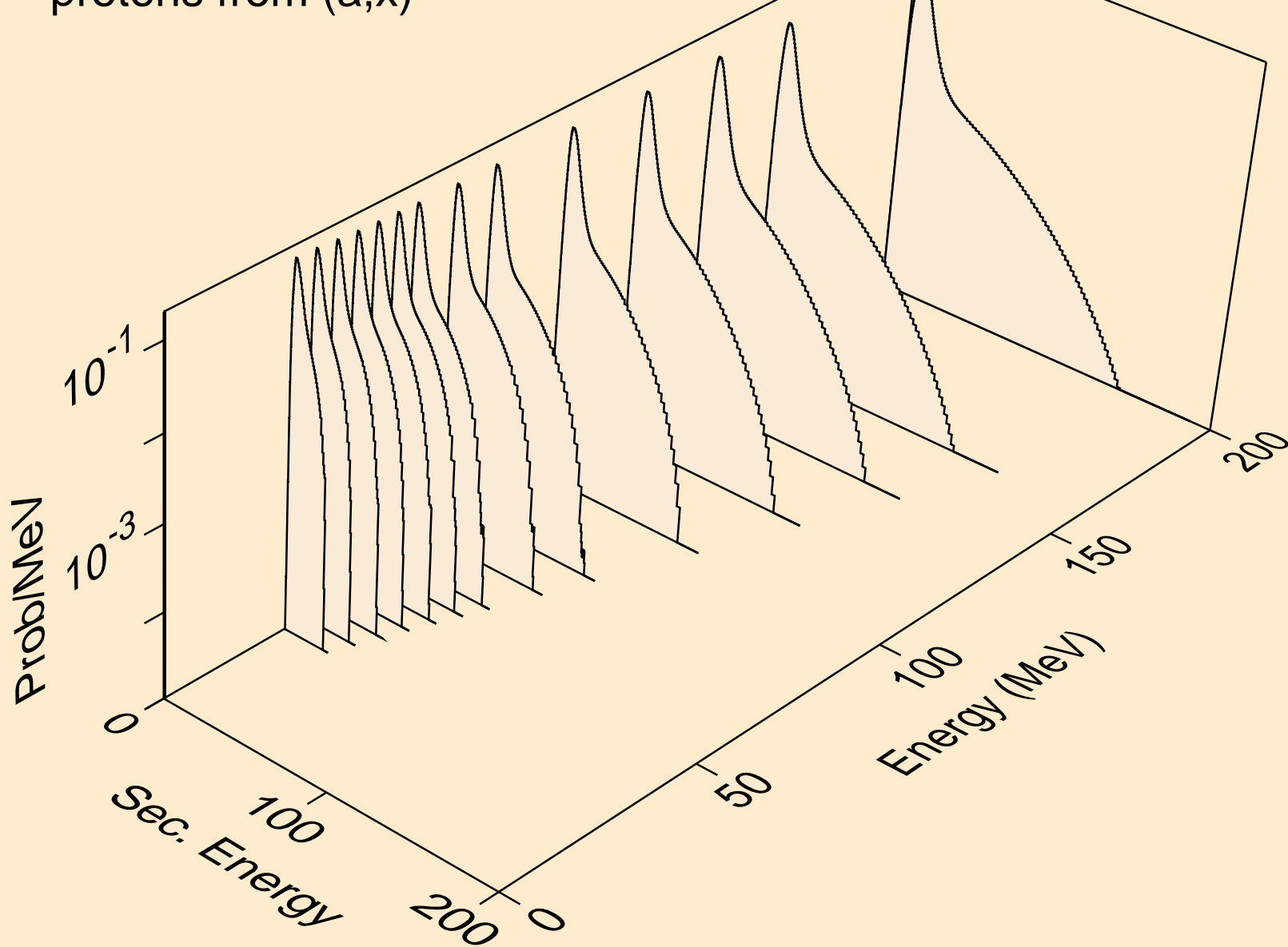

CL036 ALPHA ACER TENDL-2023 LIBRARY; T=0.K  
protons from (a,n\*)p

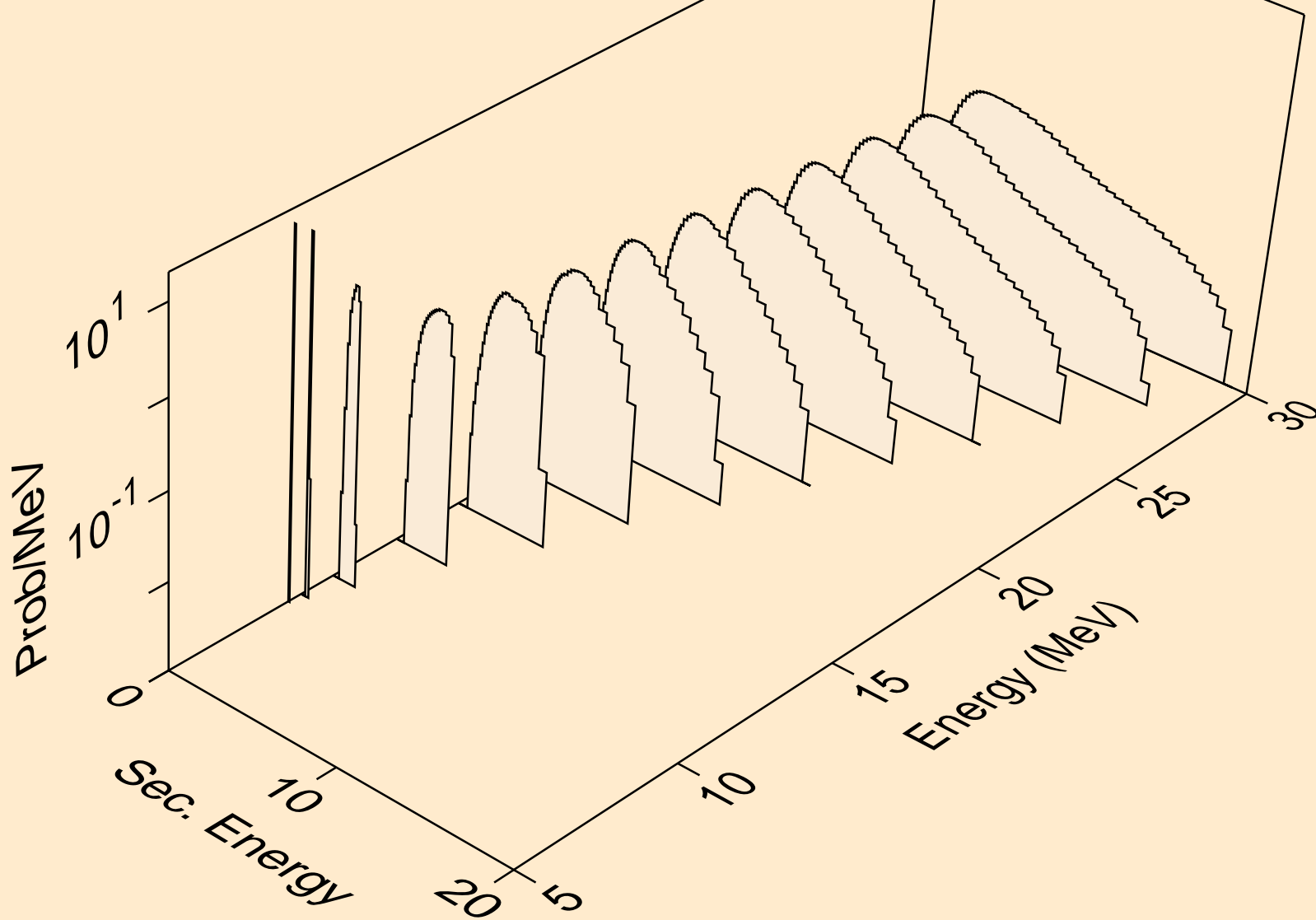

CL036 ALPHA ACER TENDL-2023 LIBRARY; T=0.K  
protons from (a,2np)

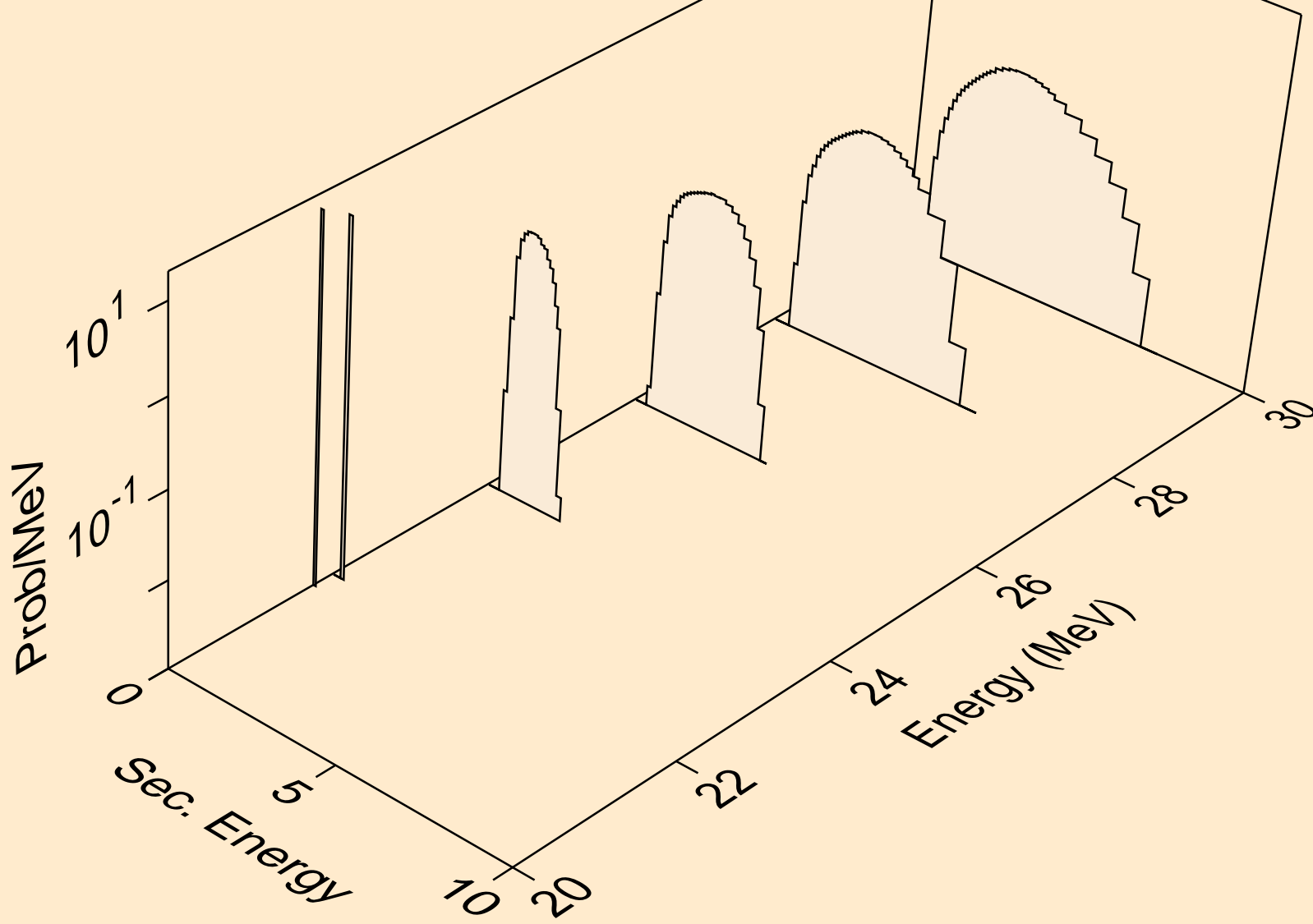

CL036 ALPHA ACER TENDL-2023 LIBRARY; T=0.K  
protons from (a,n2p)

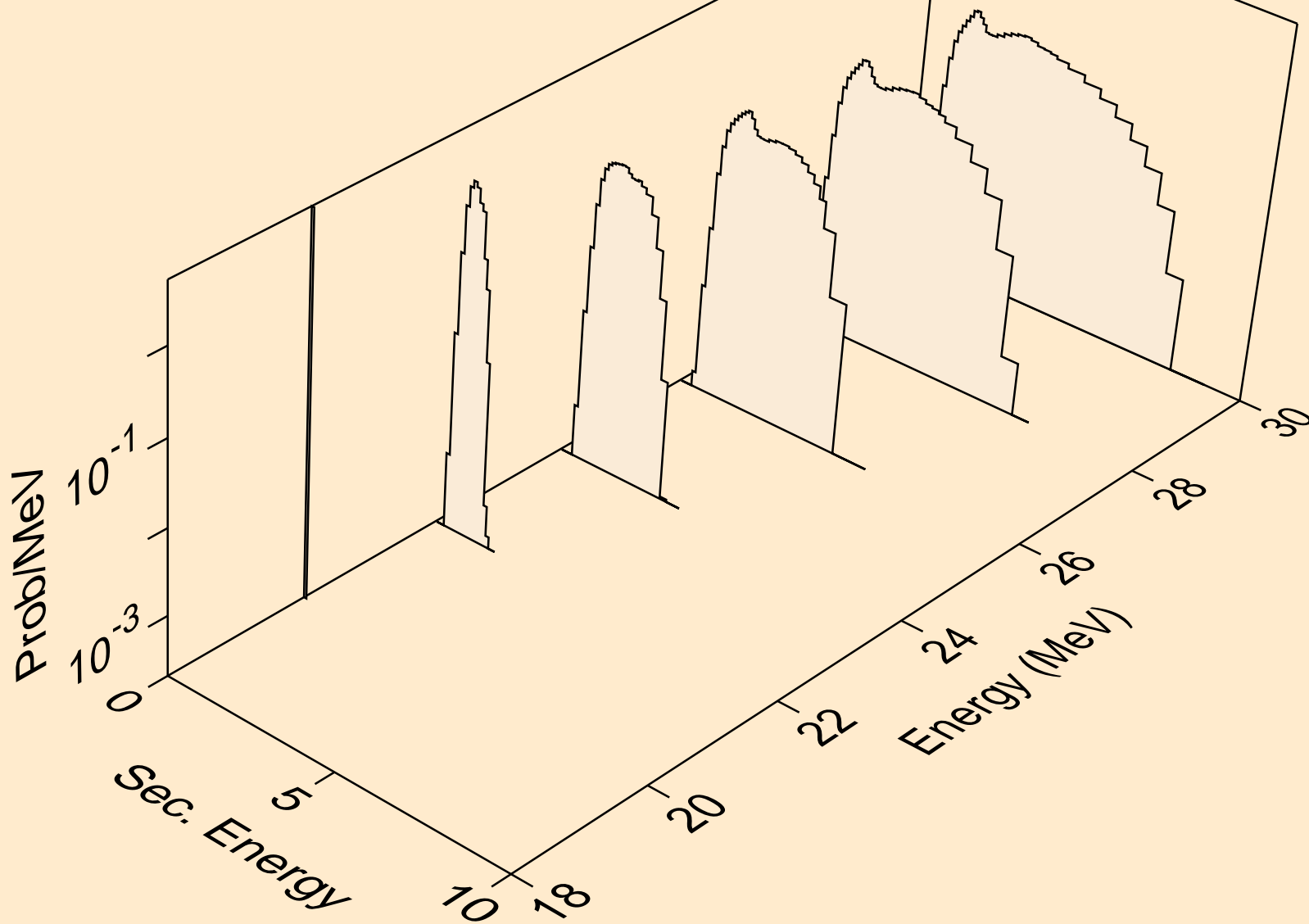

CL036 ALPHA ACER TENDL-2023 LIBRARY; T=0.K  
protons from (a,npa)

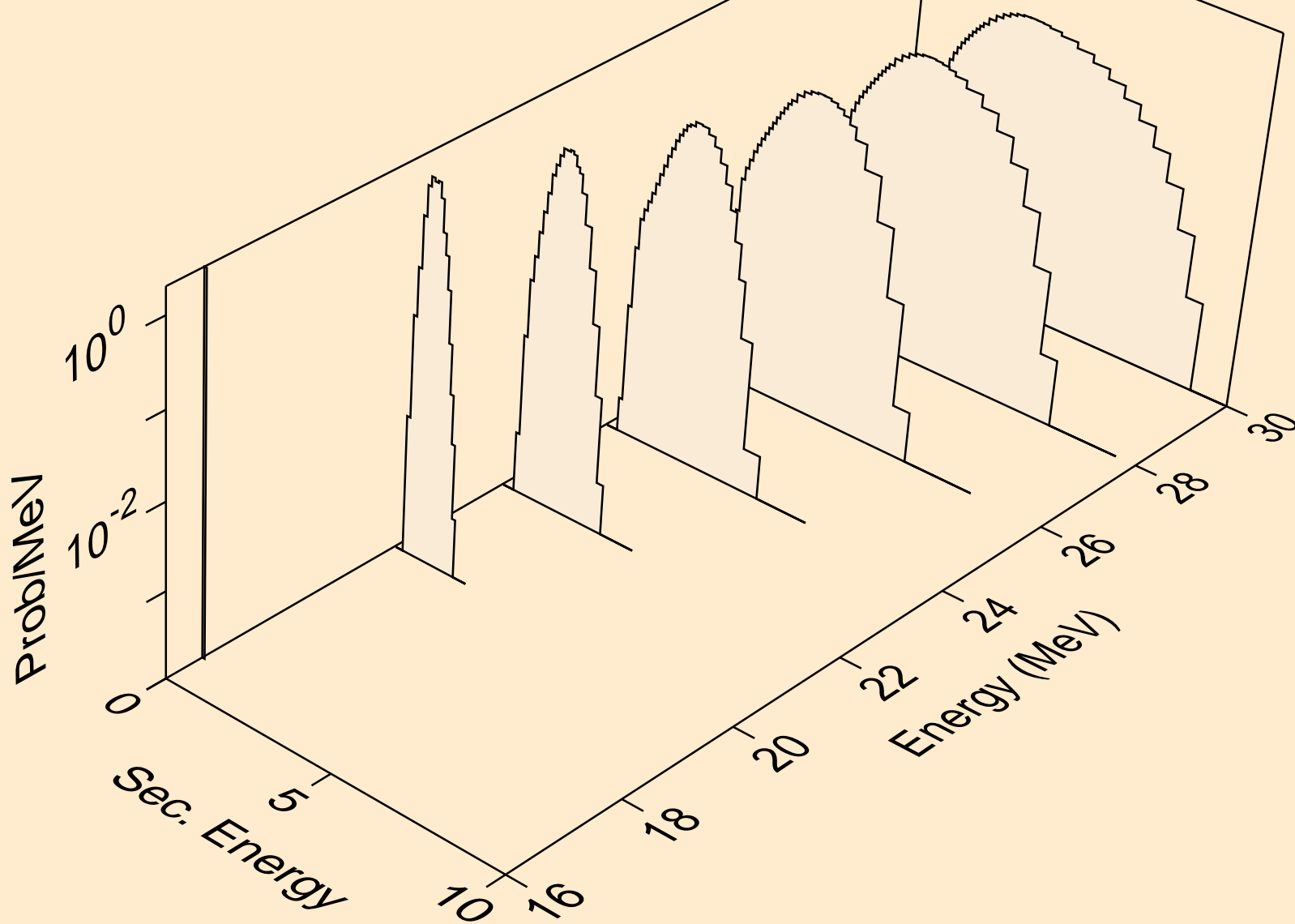

CL036 ALPHA ACER TENDL-2023 LIBRARY; T=0.K  
protons from (a,p)

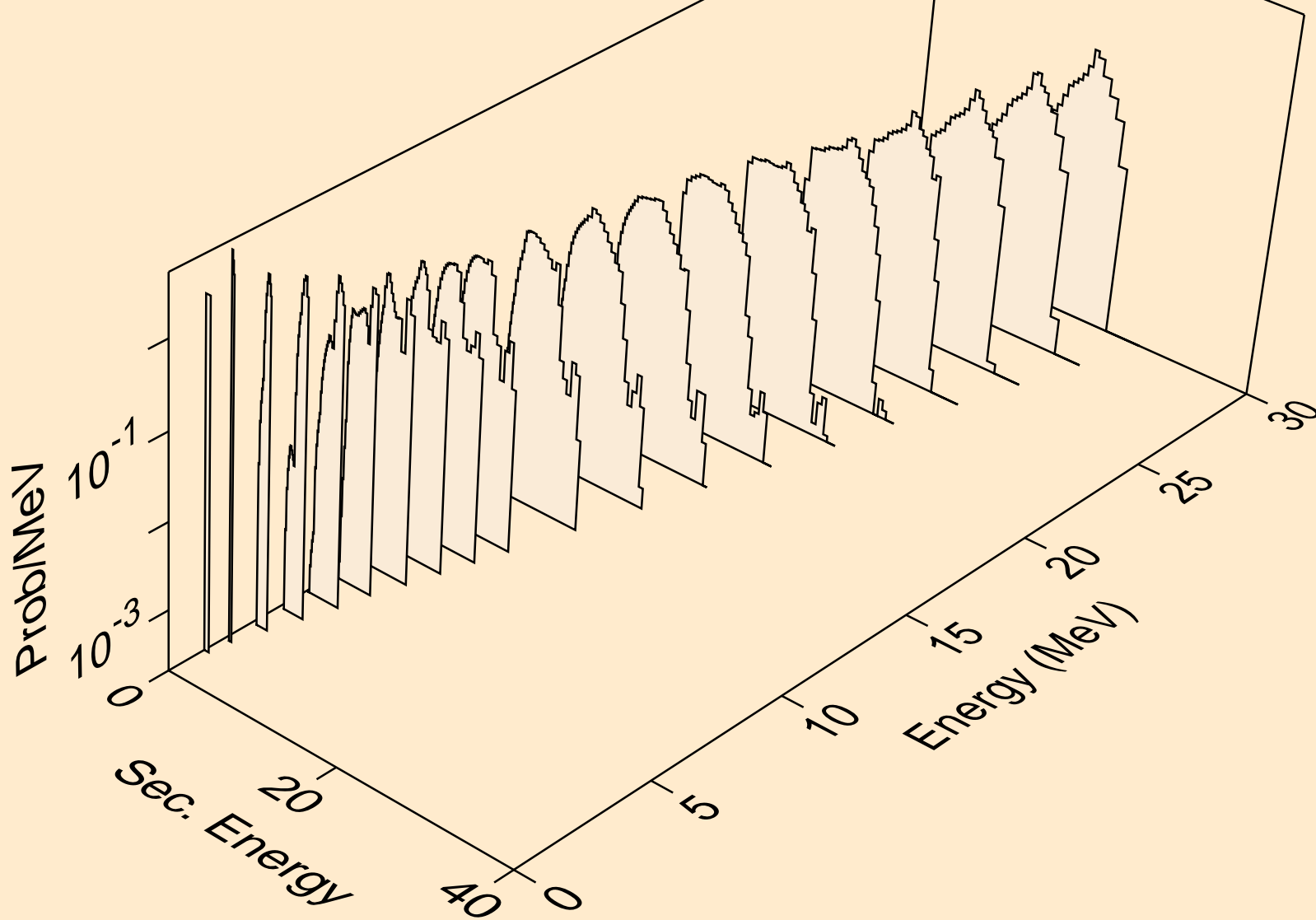

CL036 ALPHA ACER TENDL-2023 LIBRARY; T=0.K  
protons from (a,2p)

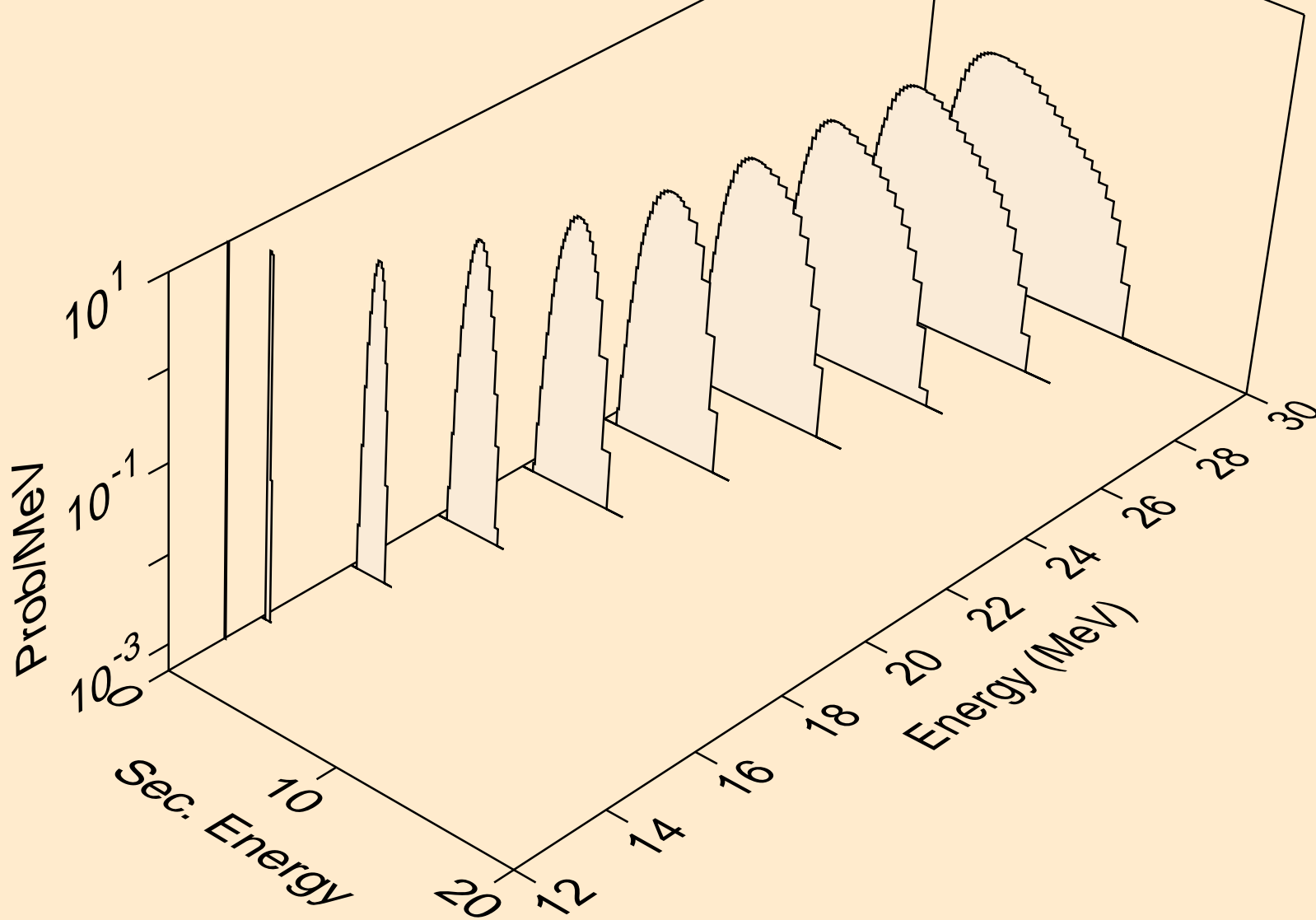

CL036 ALPHA ACER TENDL-2023 LIBRARY; T=0.K  
protons from (a,pa)

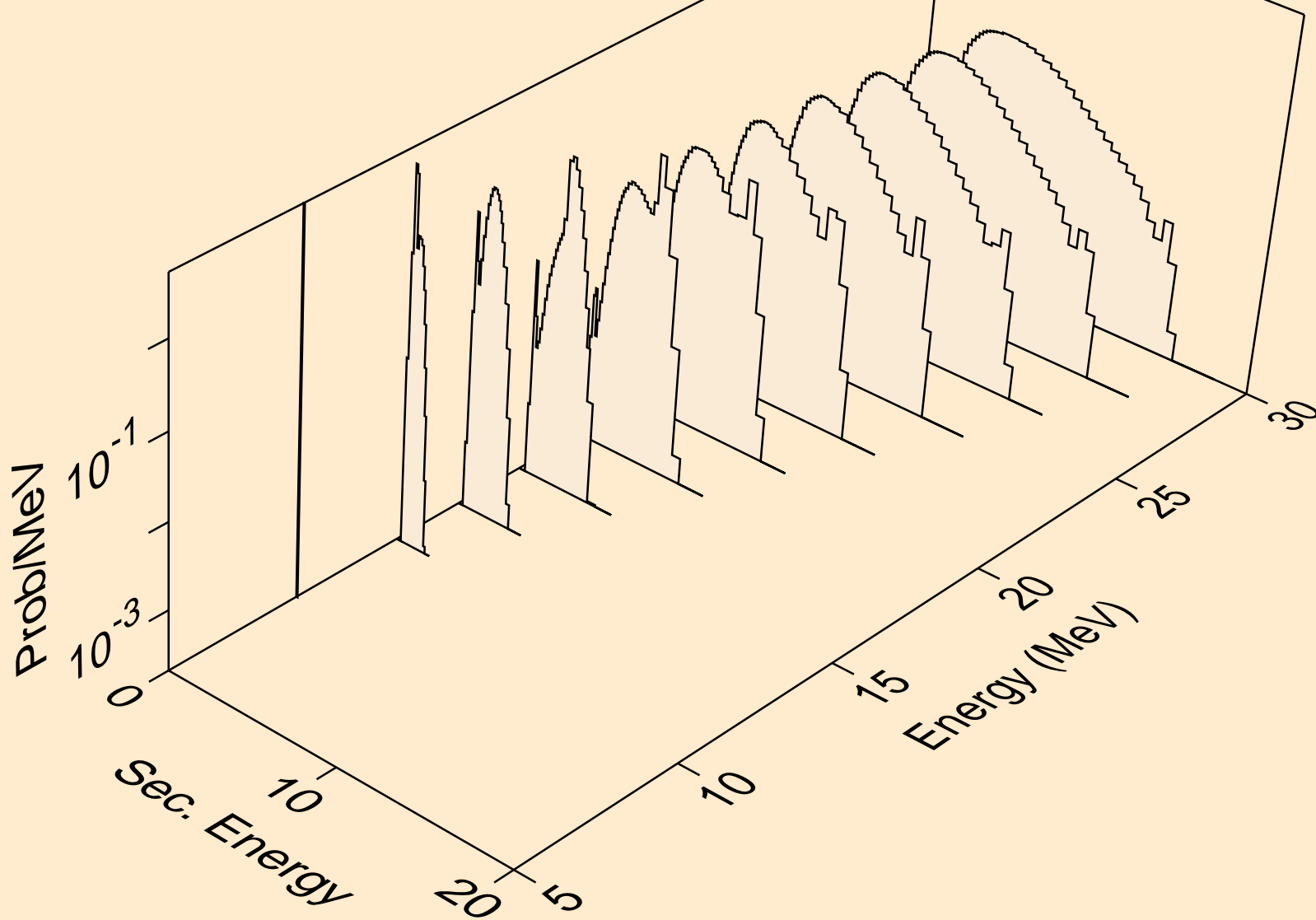

CL036 ALPHA ACER TENDL-2023 LIBRARY; T=0.K  
protons from (a,pd)

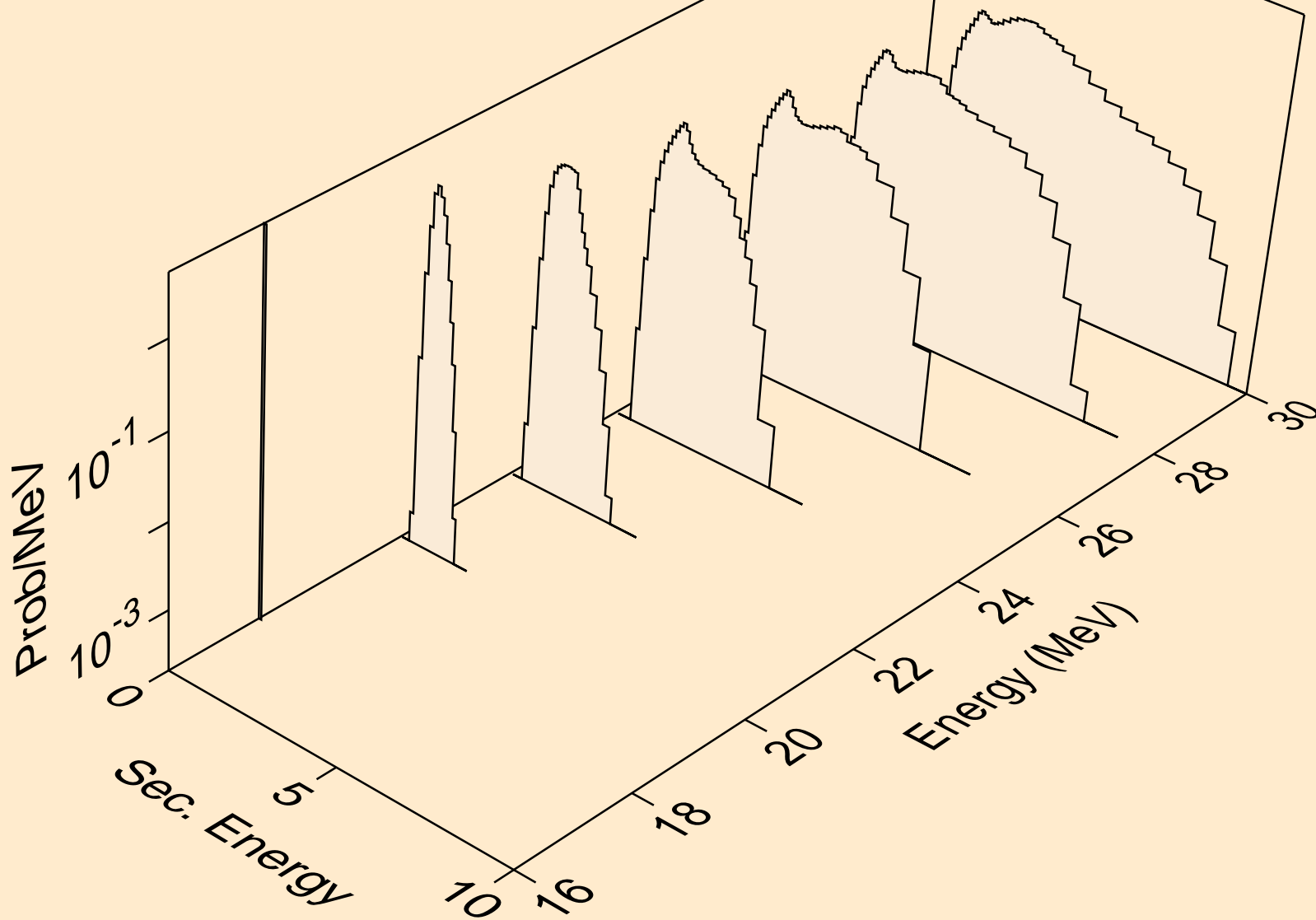

CL036 ALPHA ACER TENDL-2023 LIBRARY; T=0.K  
protons from (a,pt)

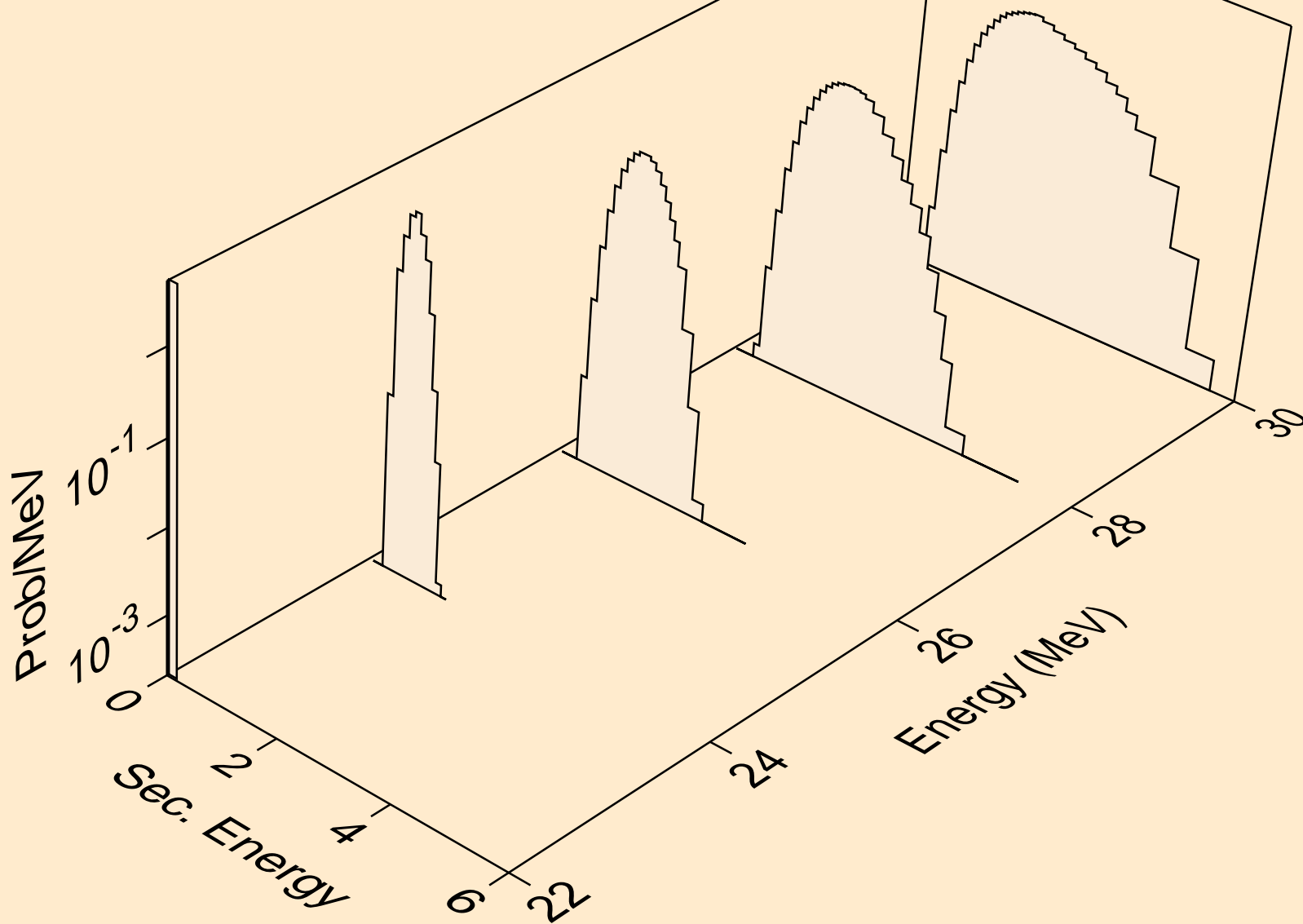

CL036 ALPHA ACER TENDL-2023 LIBRARY; T=0.K  
deuterons from (a,x)

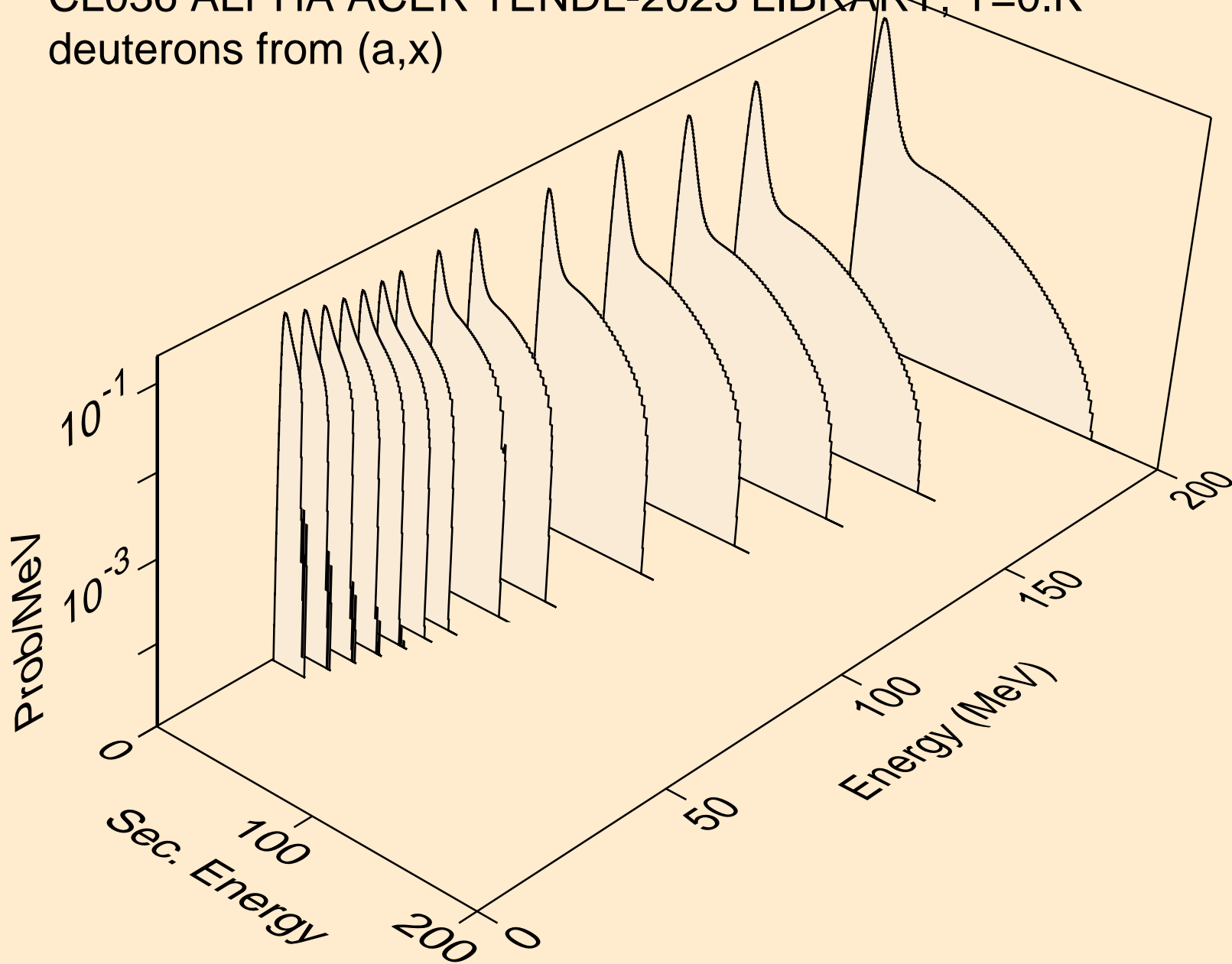

CL036 ALPHA ACER TENDL-2023 LIBRARY; T=0.K  
deuterons from (a,n\*)d

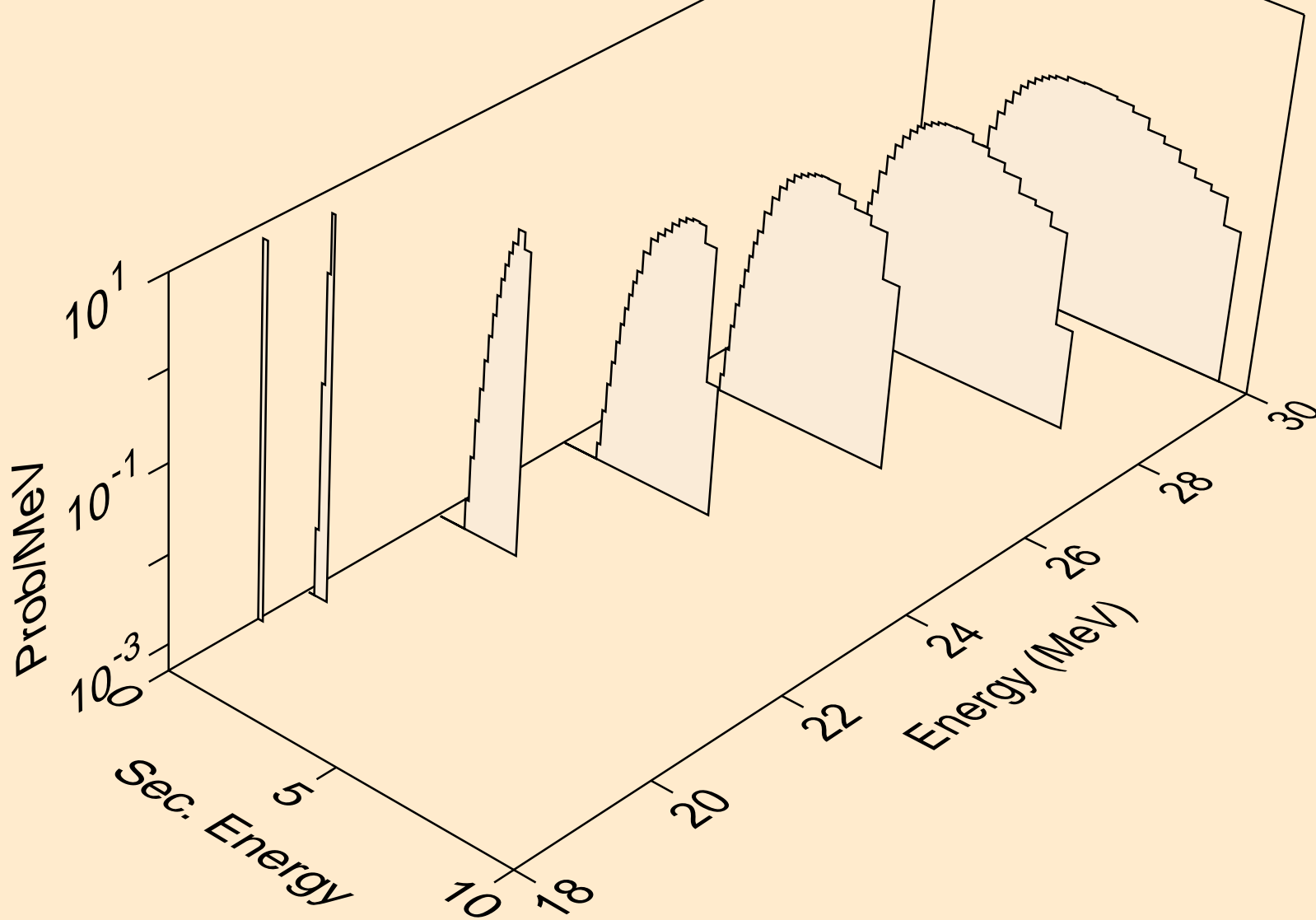

CL036 ALPHA ACER TENDL-2023 LIBRARY; T=0.K  
deuterons from (a,d)

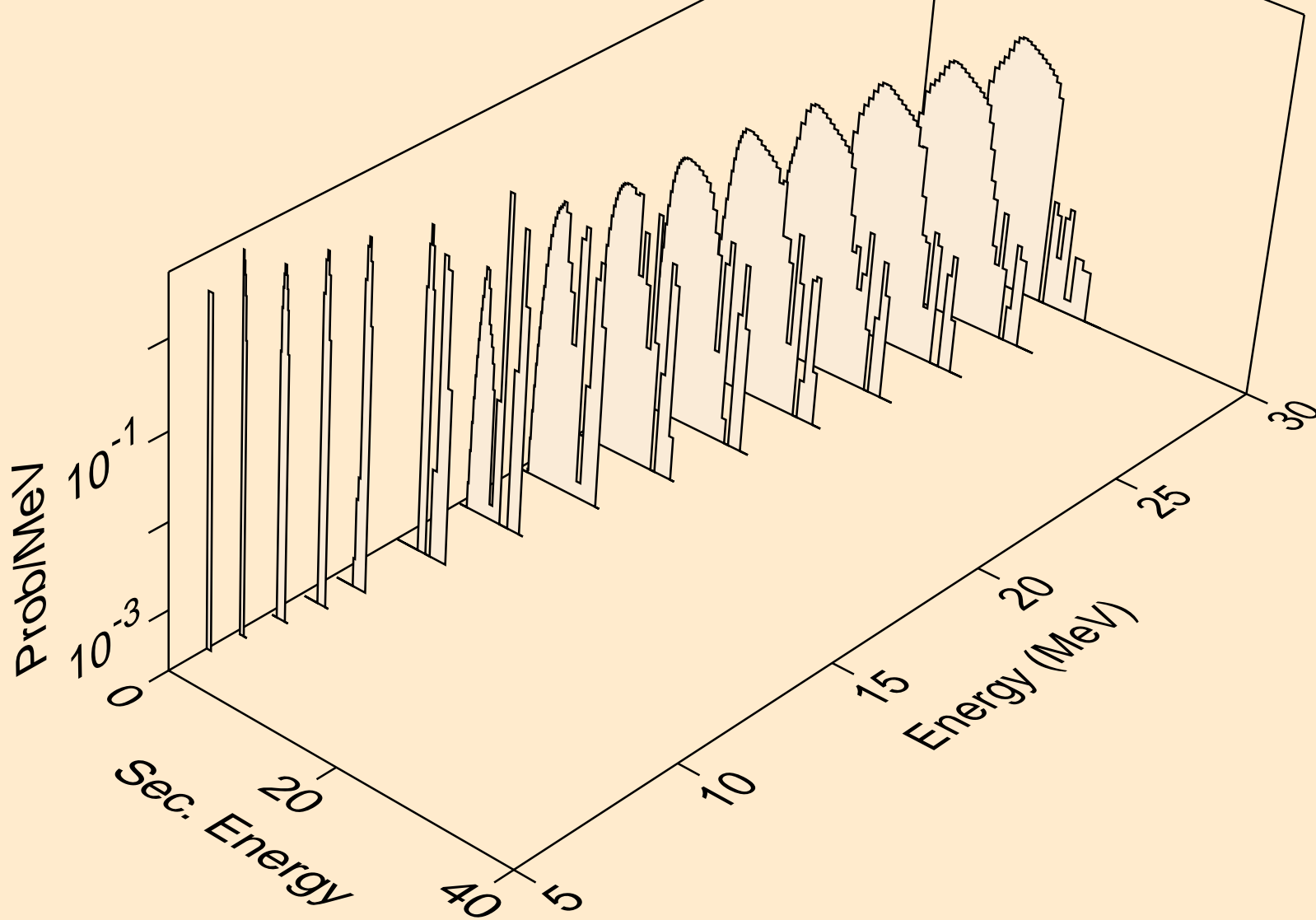

CL036 ALPHA ACER TENDL-2023 LIBRARY; T=0.K  
deuterons from (a,pd)

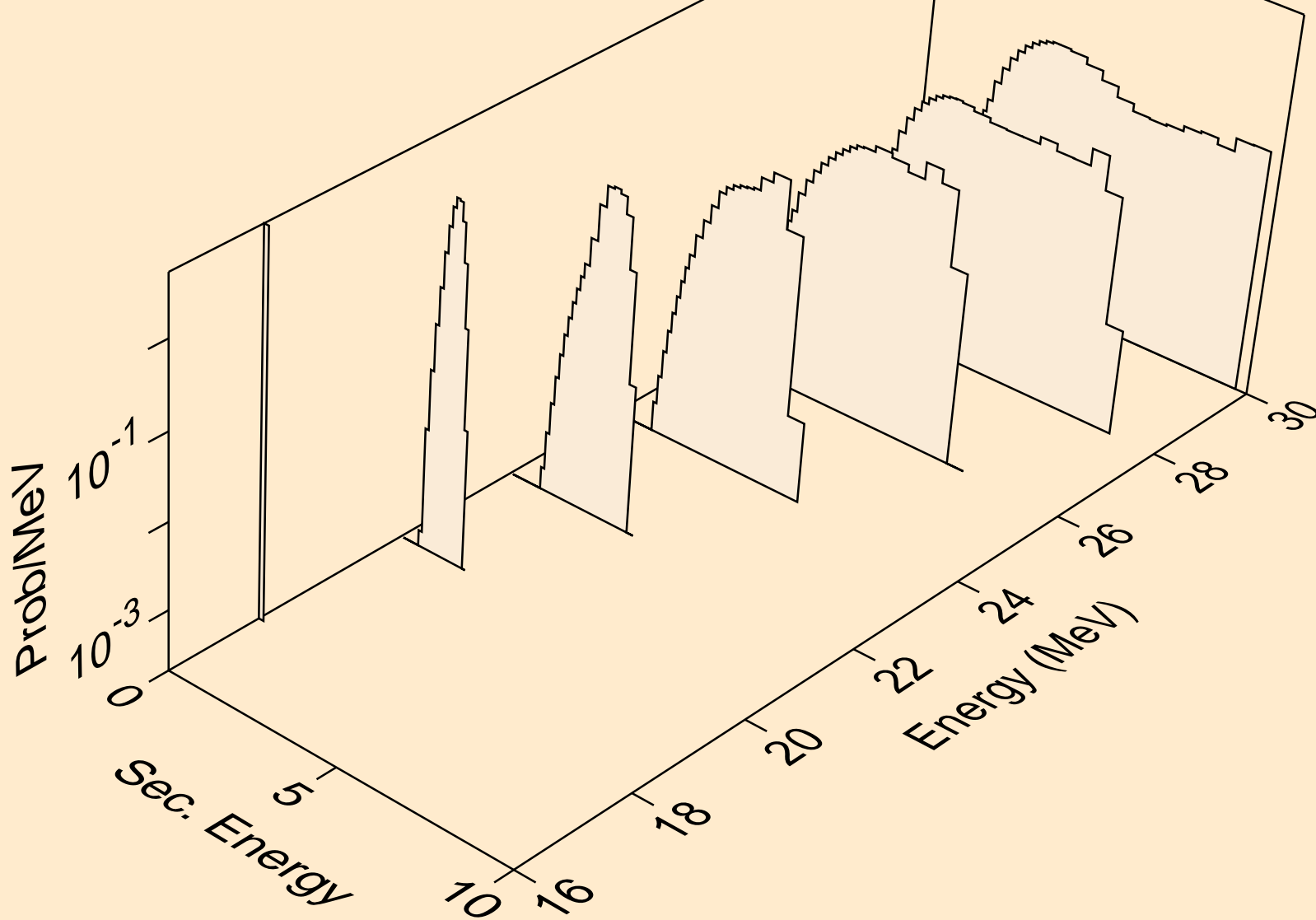

CL036 ALPHA ACER TENDL-2023 LIBRARY; T=0.K  
deuterons from (a,da)

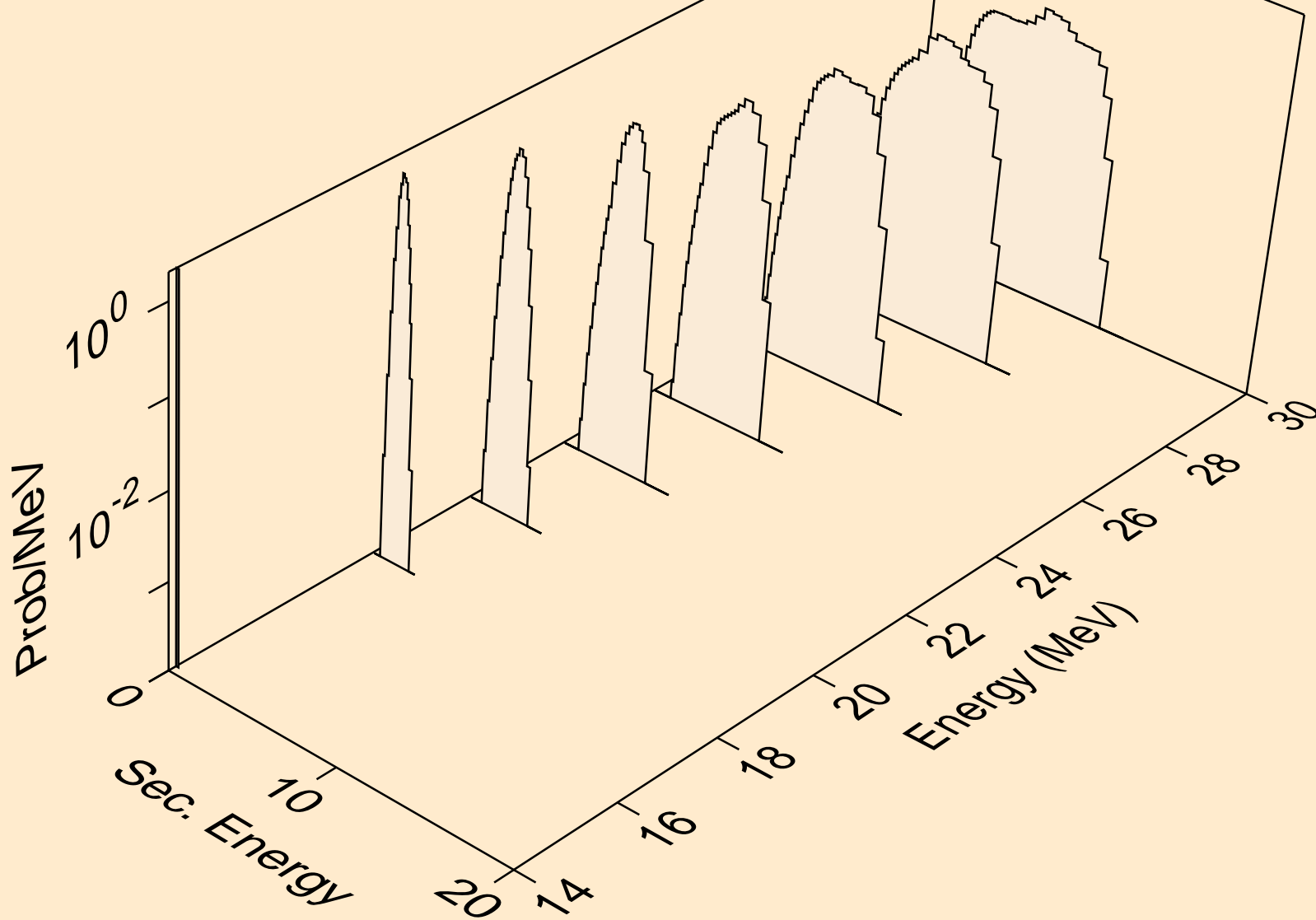

CL036 ALPHA ACER TENDL-2023 LIBRARY; T=0.K  
tritons from (a,x)

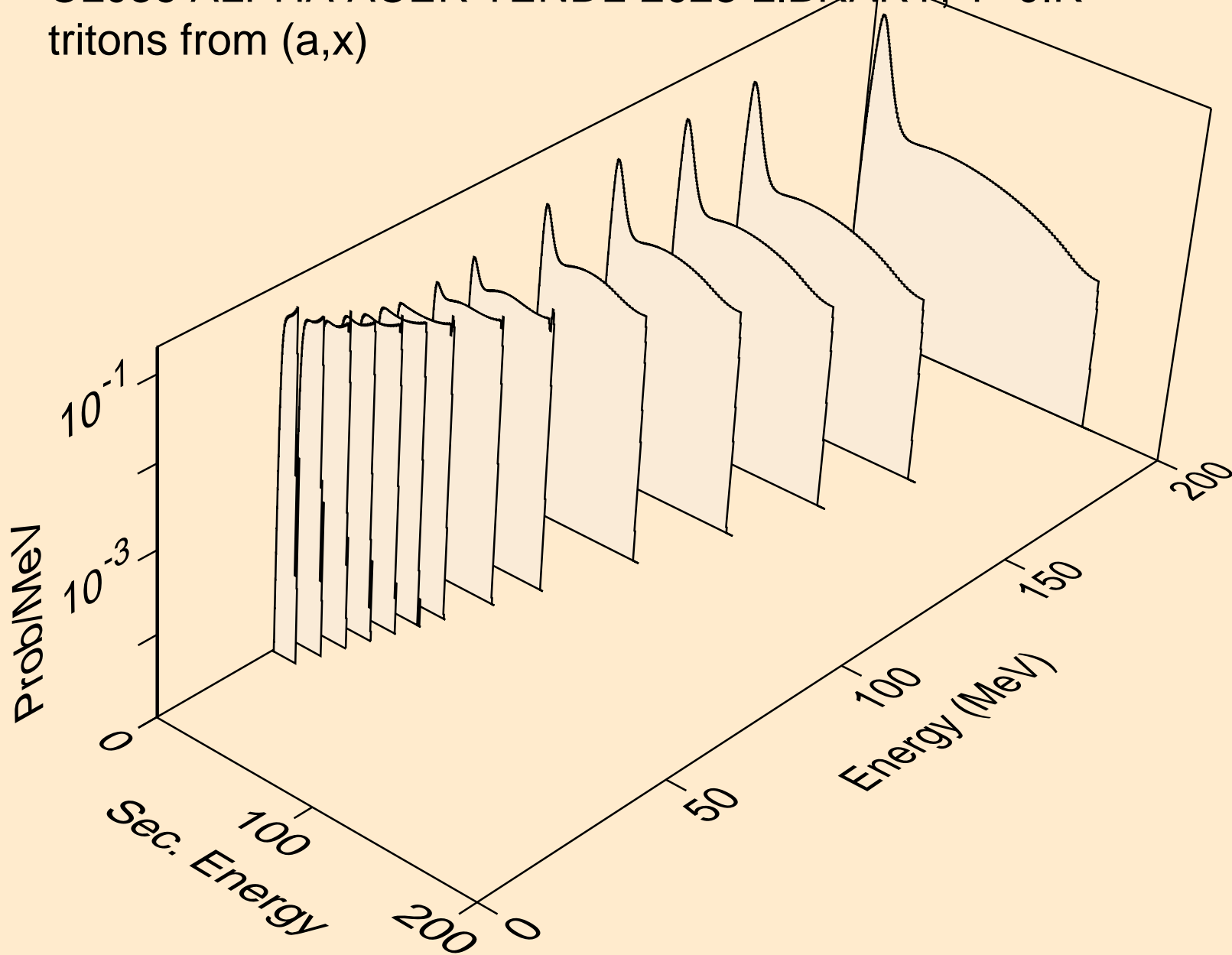

CL036 ALPHA ACER TENDL-2023 LIBRARY; T=0.K  
tritons from (a,n\*)t

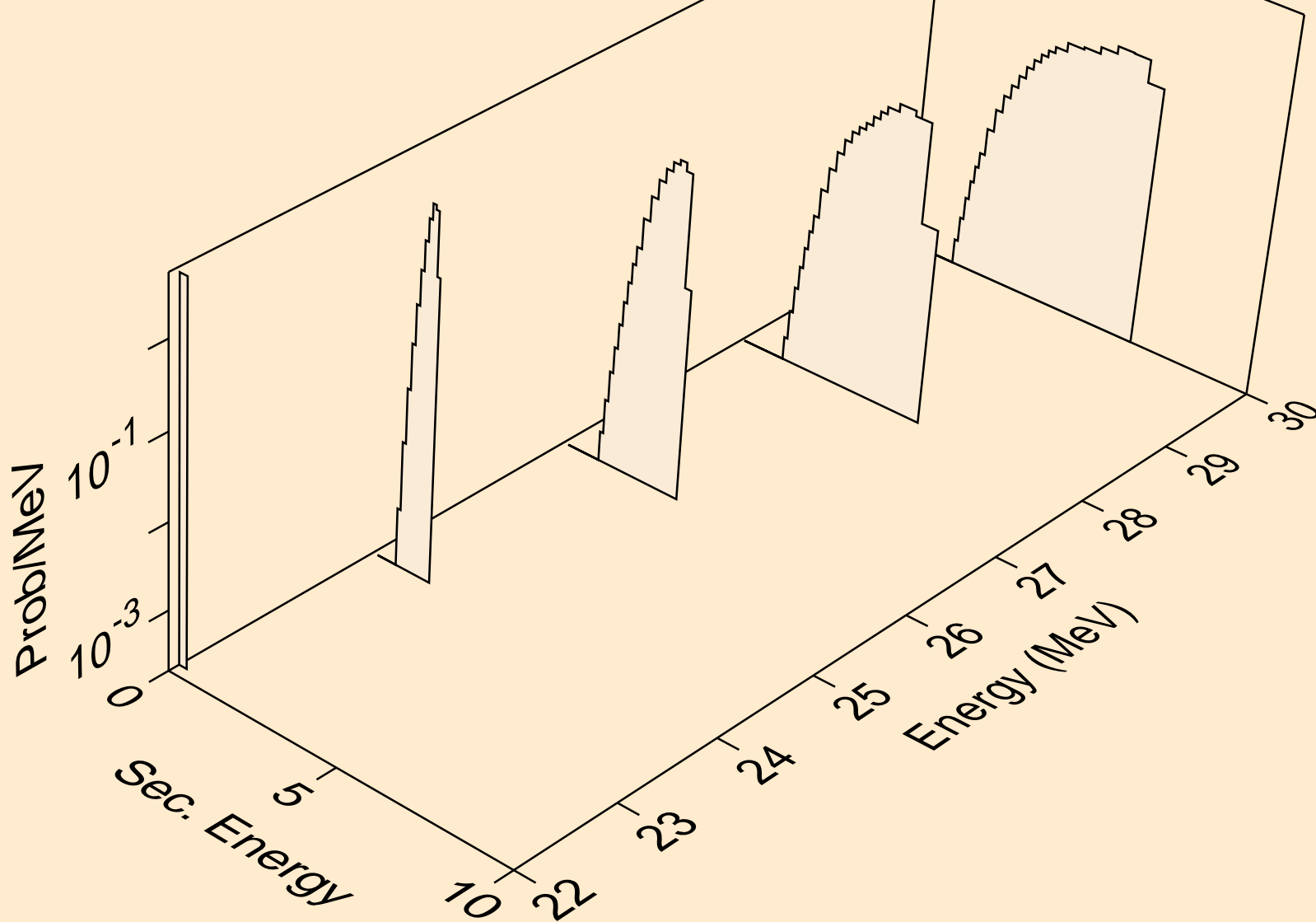

CL036 ALPHA ACER TENDL-2023 LIBRARY; T=0.K  
tritons from (a,t)

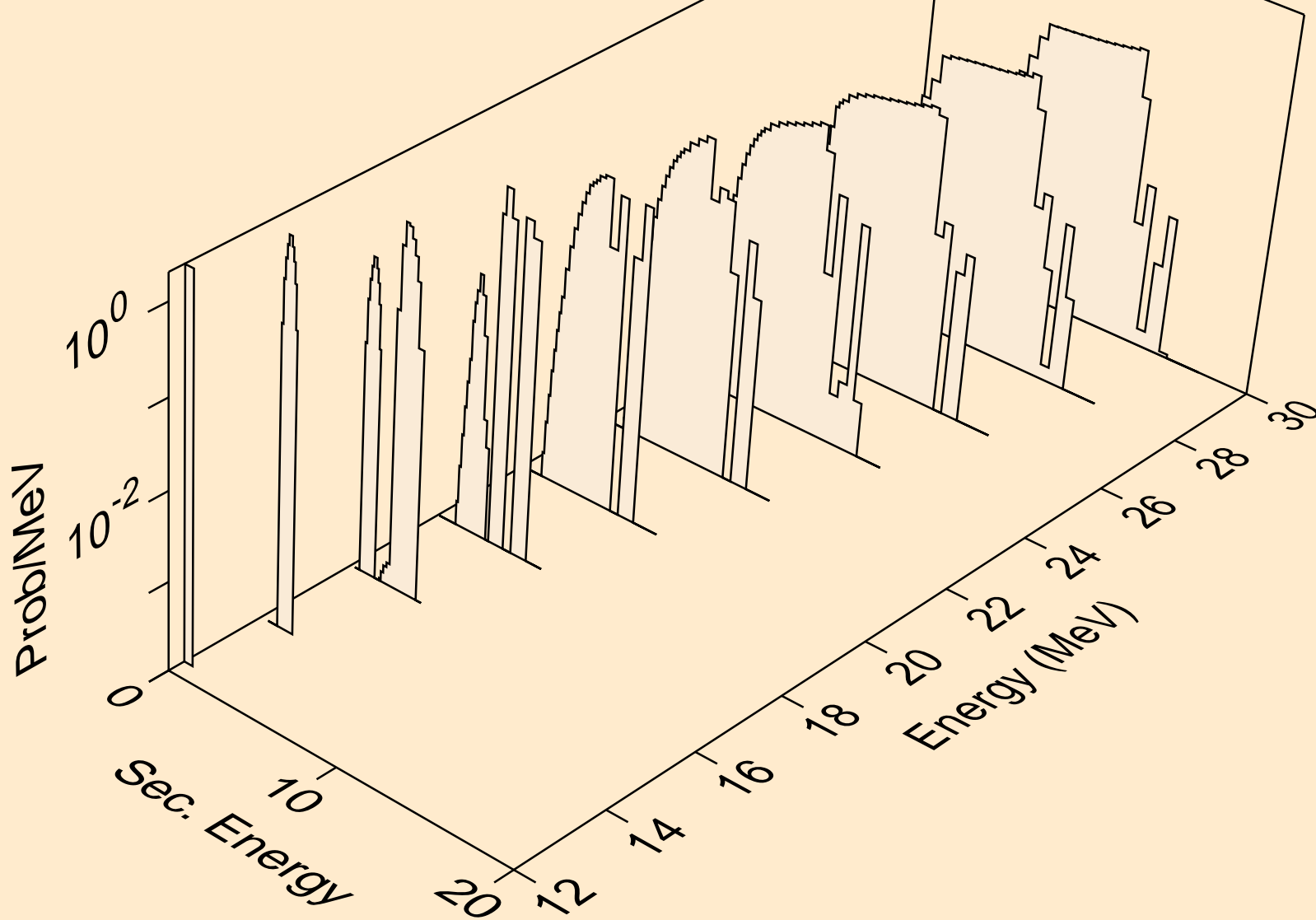

CL036 ALPHA ACER TENDL-2023 LIBRARY; T=0.K  
tritons from (a,pt)

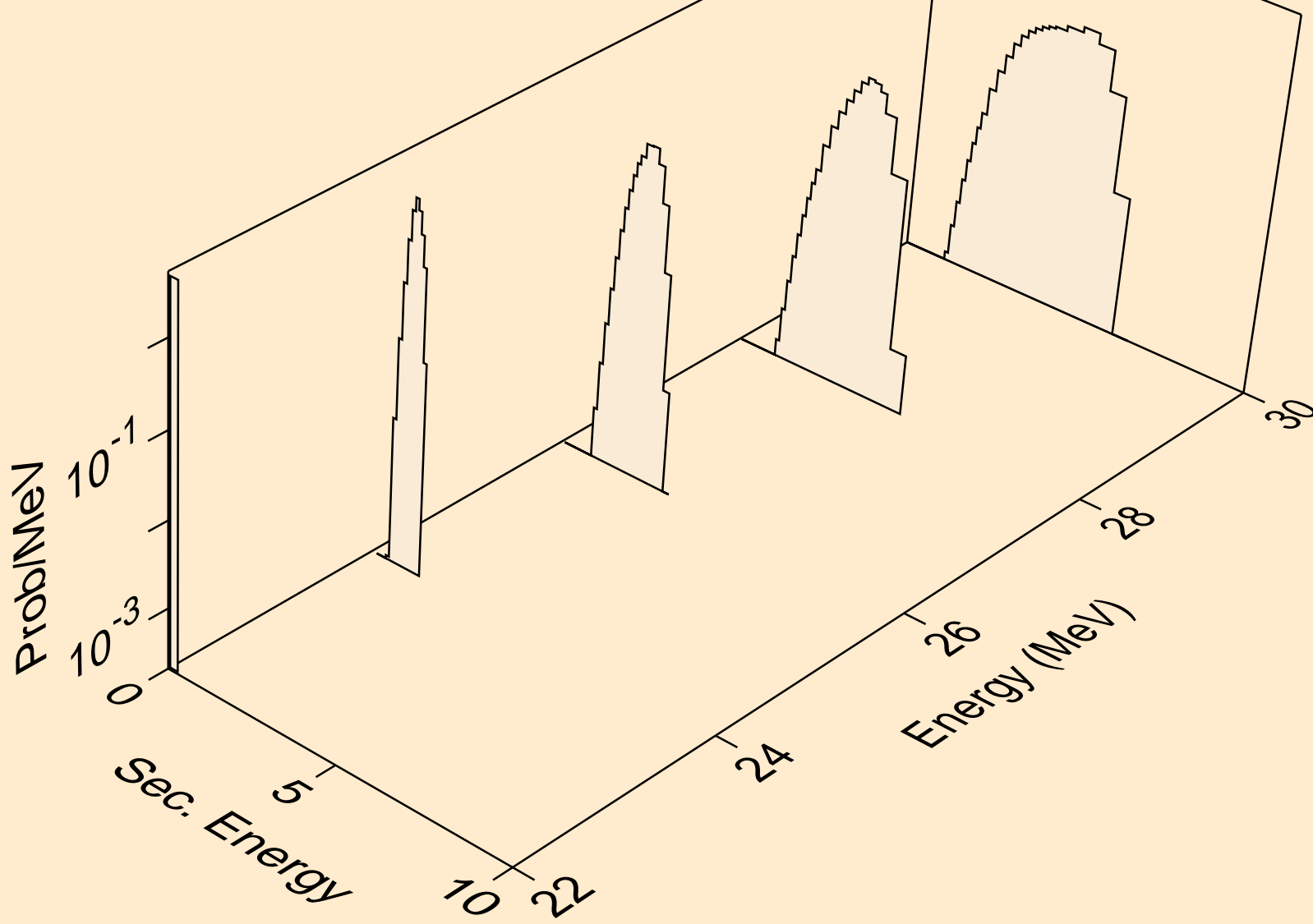

CL036 ALPHA ACER TENDL-2023 LIBRARY; T=0.K  
he3s from (a,x)

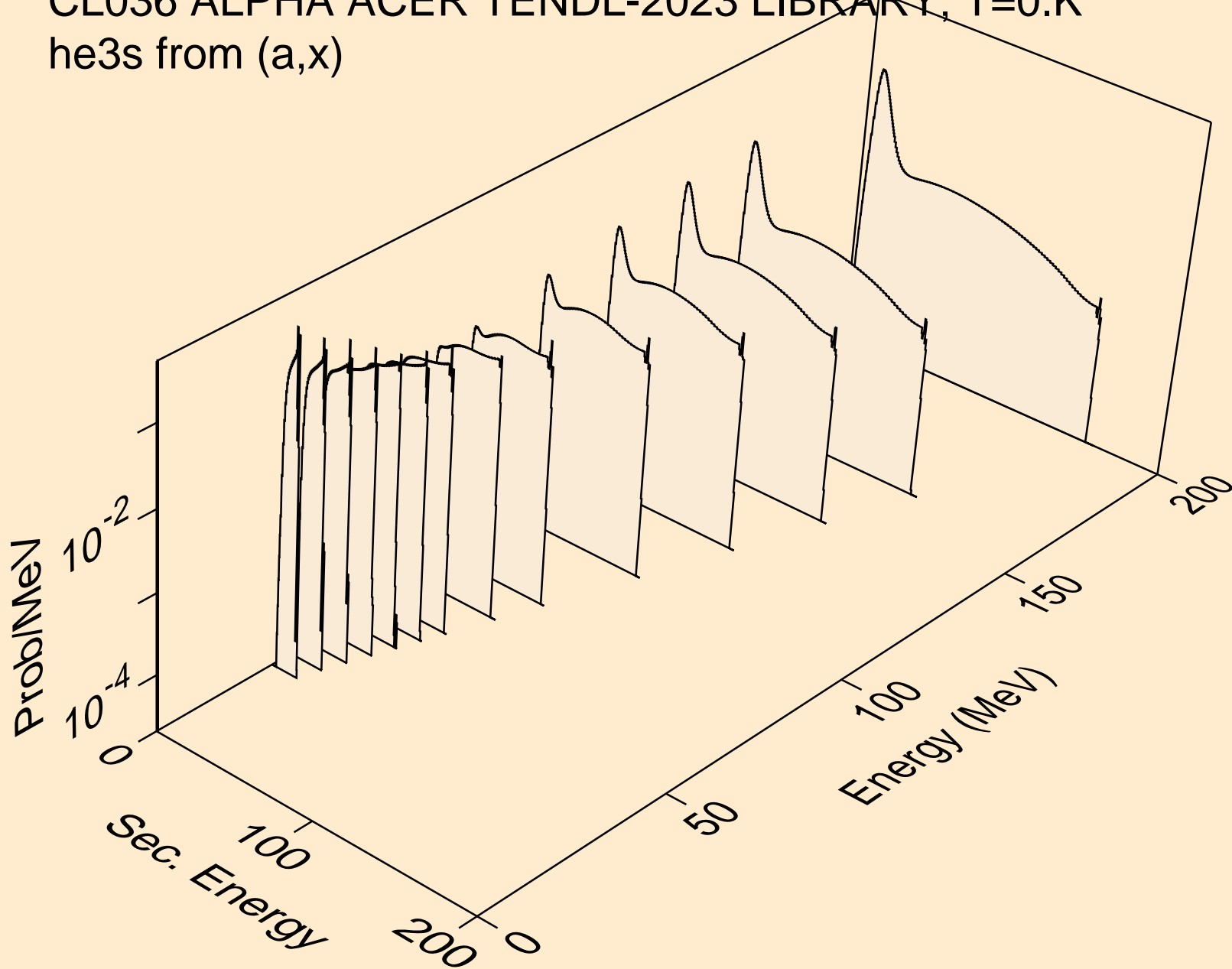

CL036 ALPHA ACER TENDL-2023 LIBRARY; T=0.K  
he3s from (a,n\*)he3

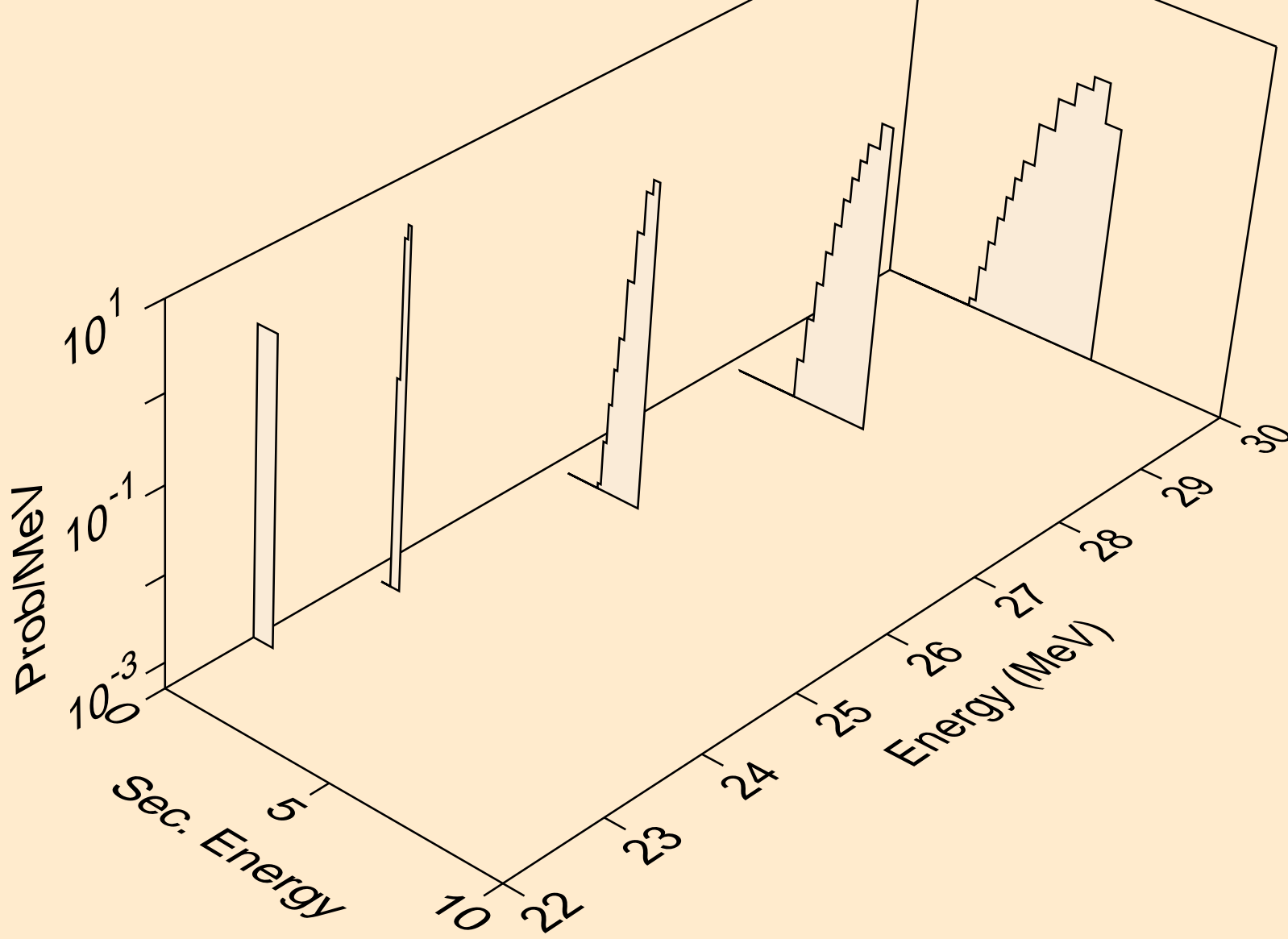

CL036 ALPHA ACER TENDL-2023 LIBRARY; T=0.K  
he3s from (a,he3)

