

# N013 ALPHA ACER TENDL-2023 LIBRARY; T=0.K

## Principal cross sections

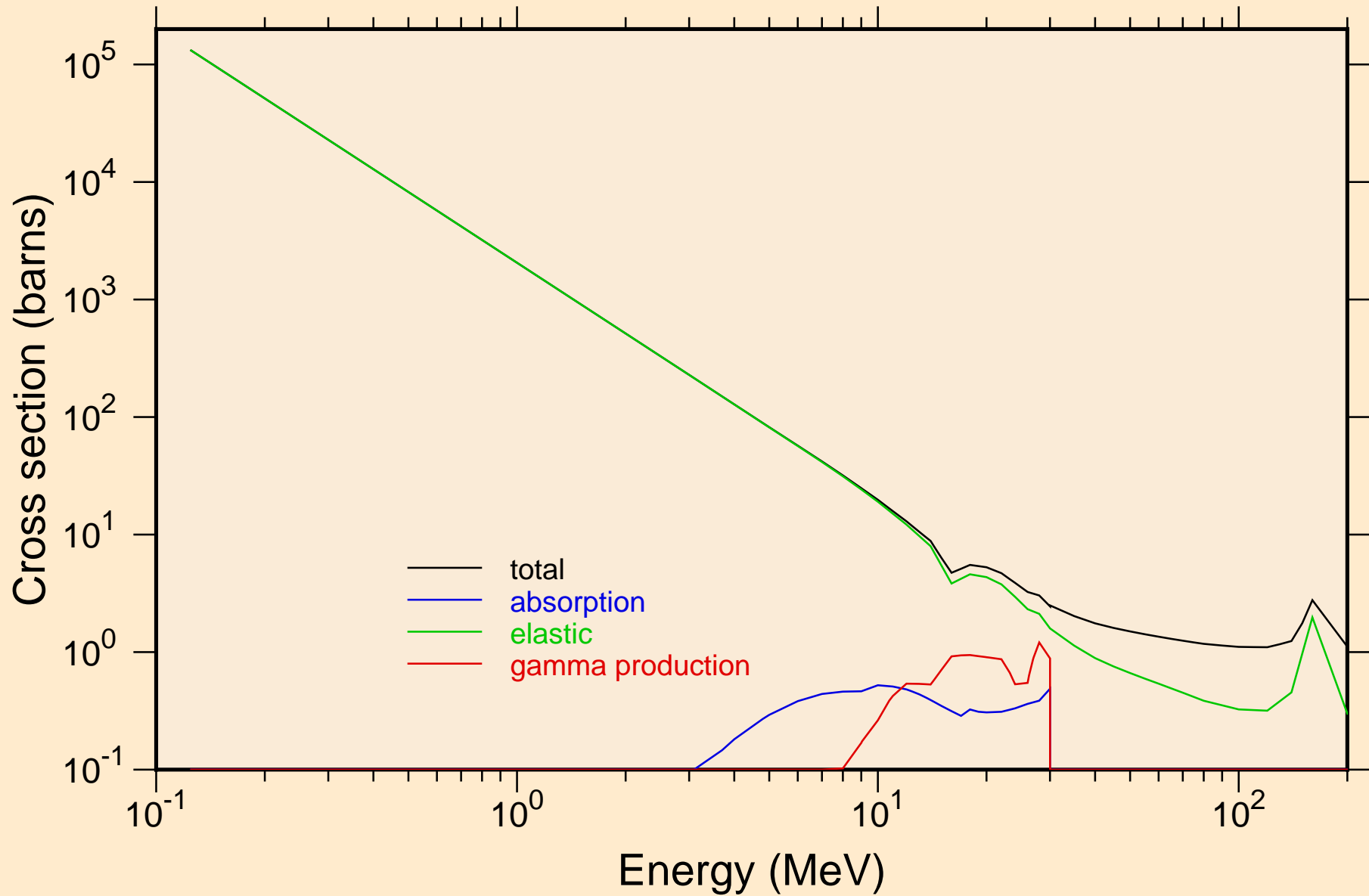

# N013 ALPHA ACER TENDL-2023 LIBRARY; T=0.K

## Heating

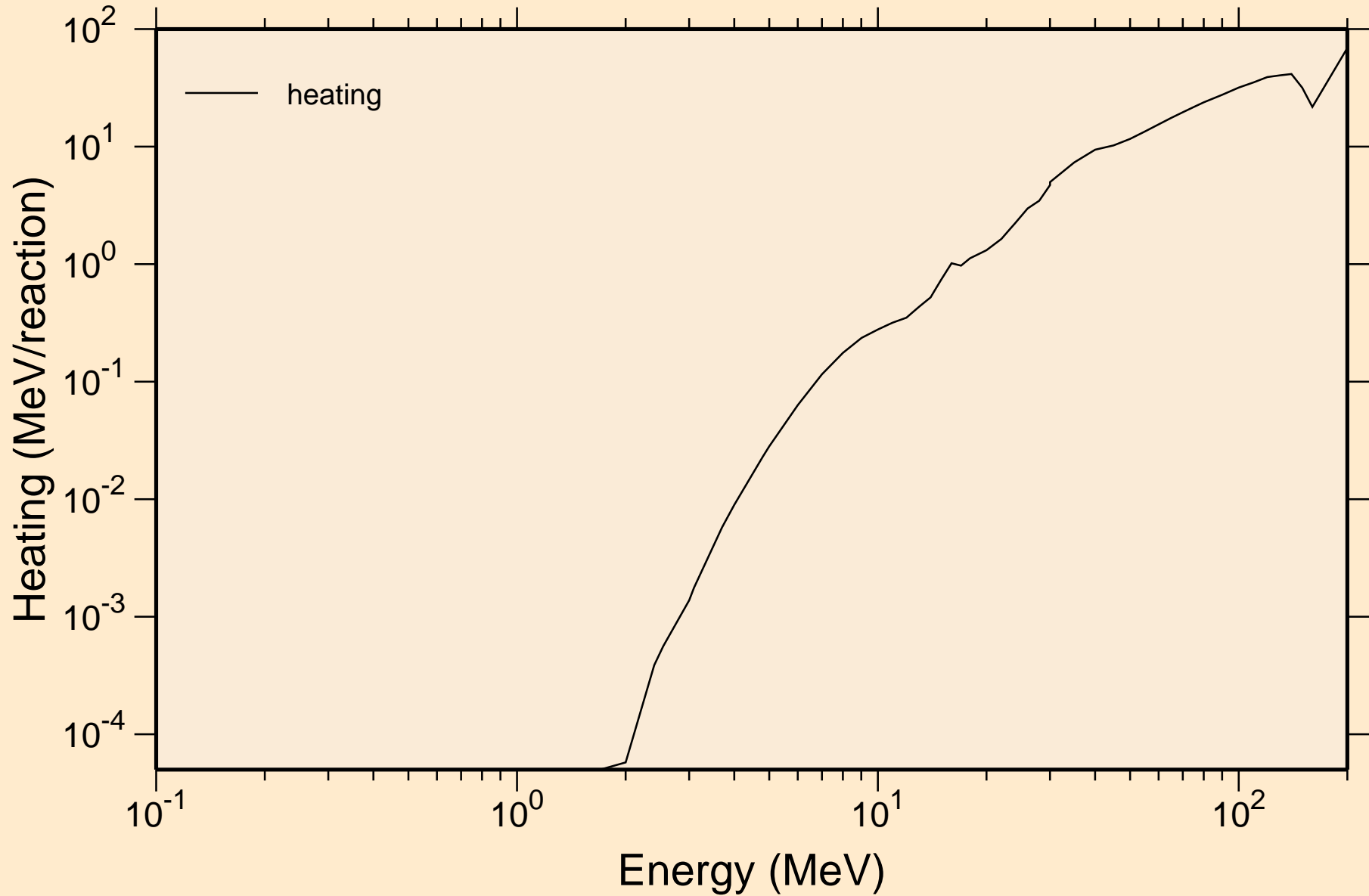

# N013 ALPHA ACER TENDL-2023 LIBRARY; T=0.K

## Principal cross sections

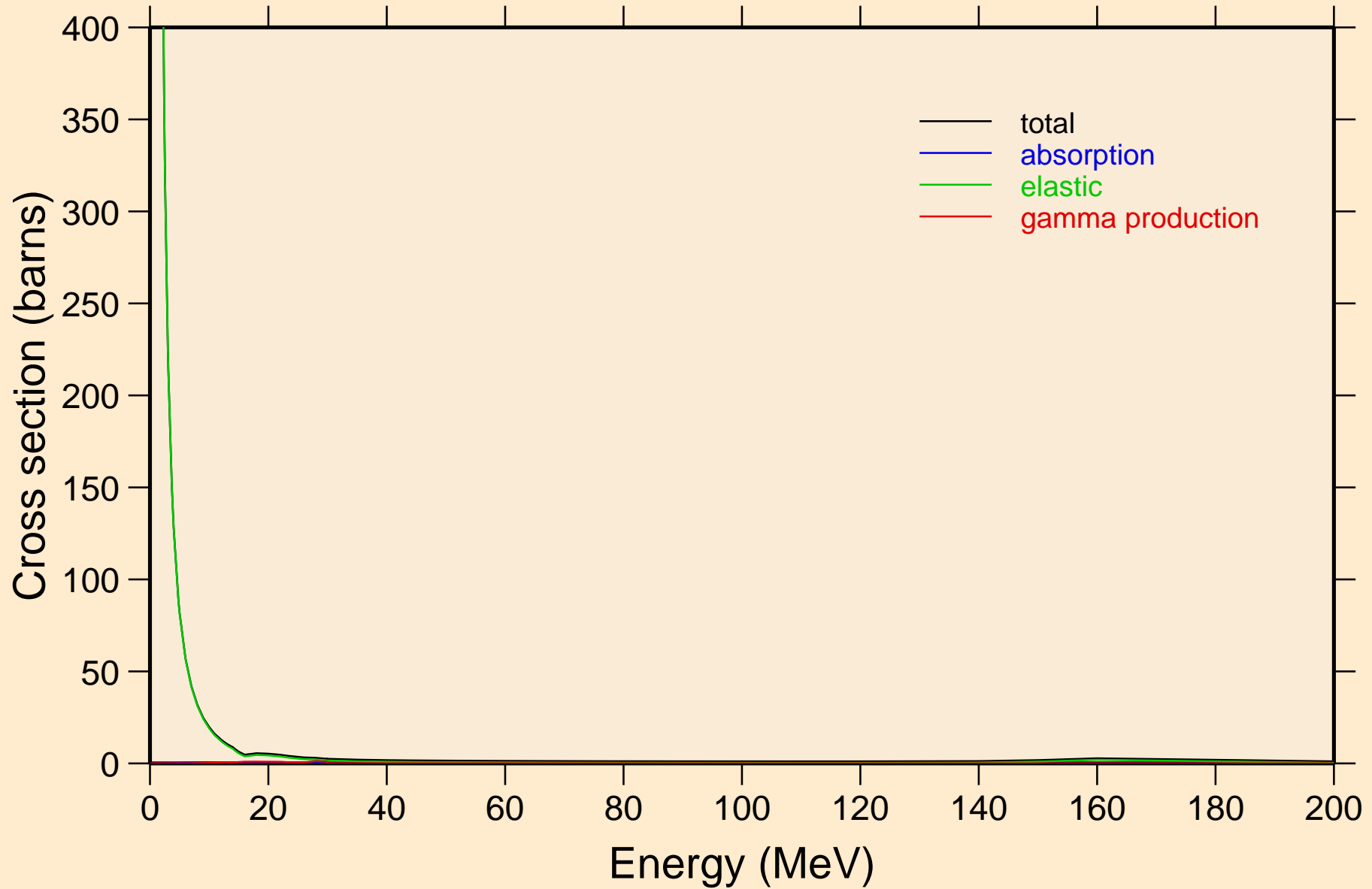

N013 ALPHA ACER TENDL-2023 LIBRARY; T=0.K

Heating

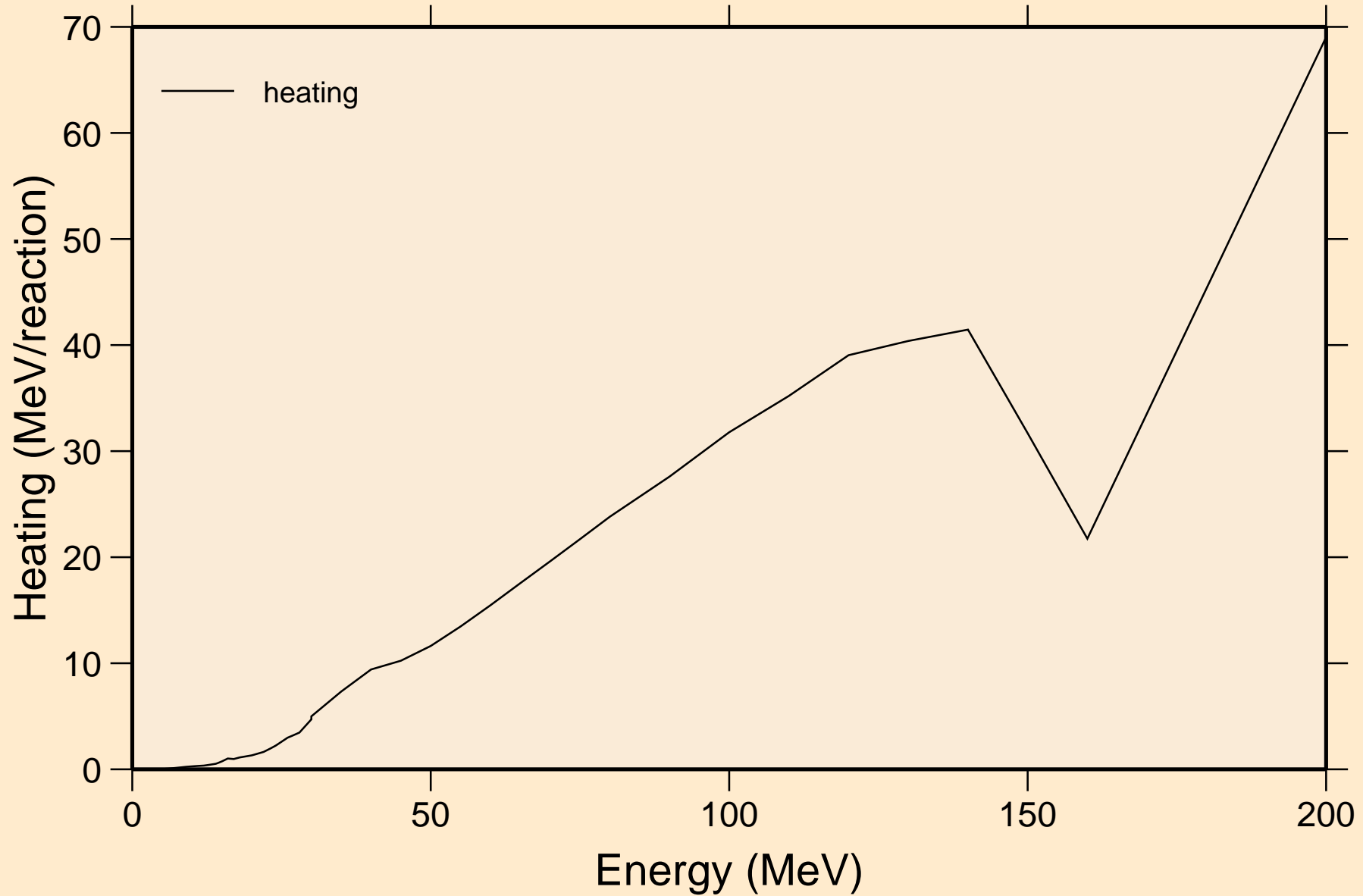

N013 ALPHA ACER TENDL-2023 LIBRARY; T=0.K  
Threshold reactions

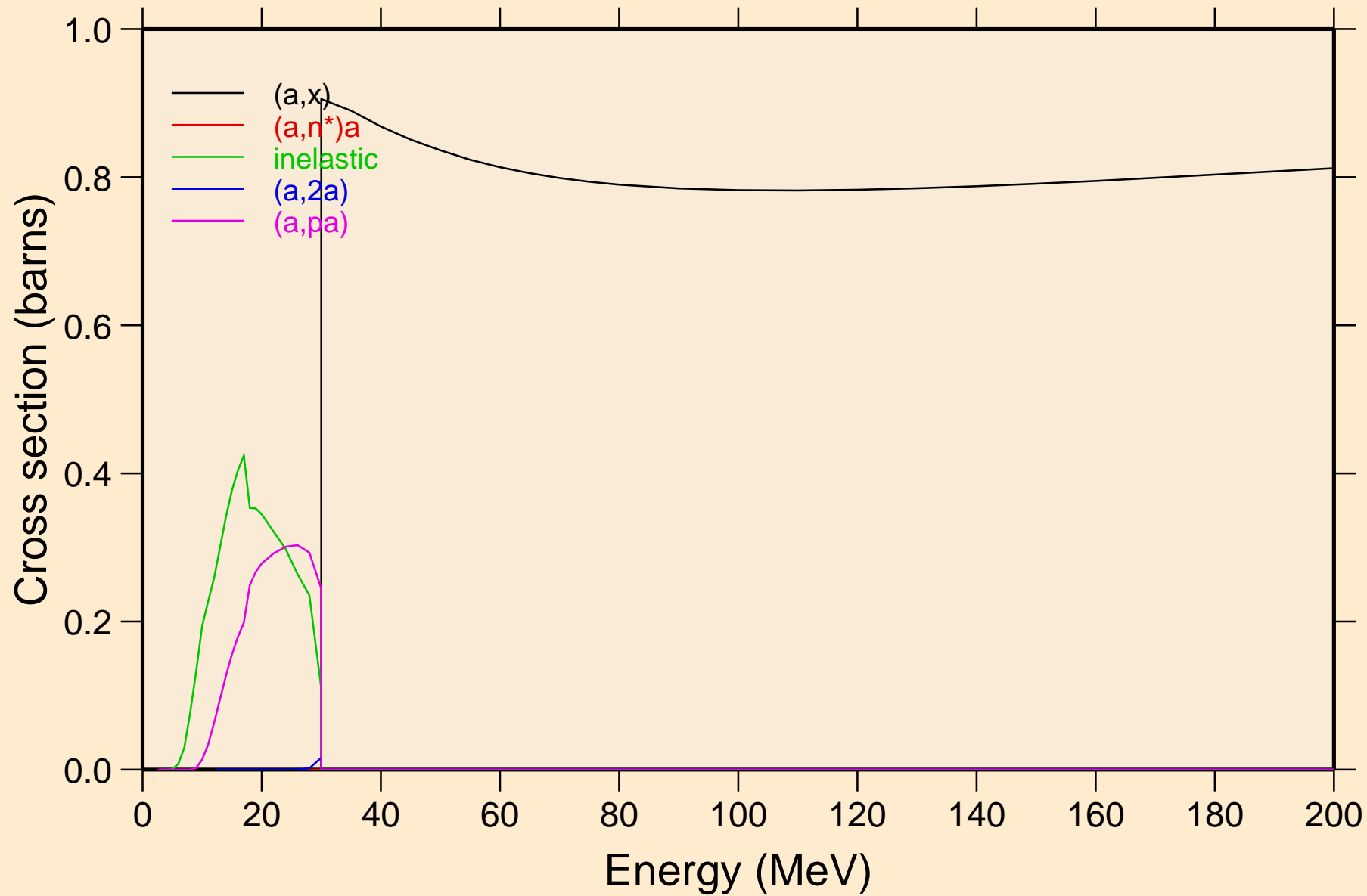

N013 ALPHA ACER TENDL-2023 LIBRARY; T=0.K  
Threshold reactions

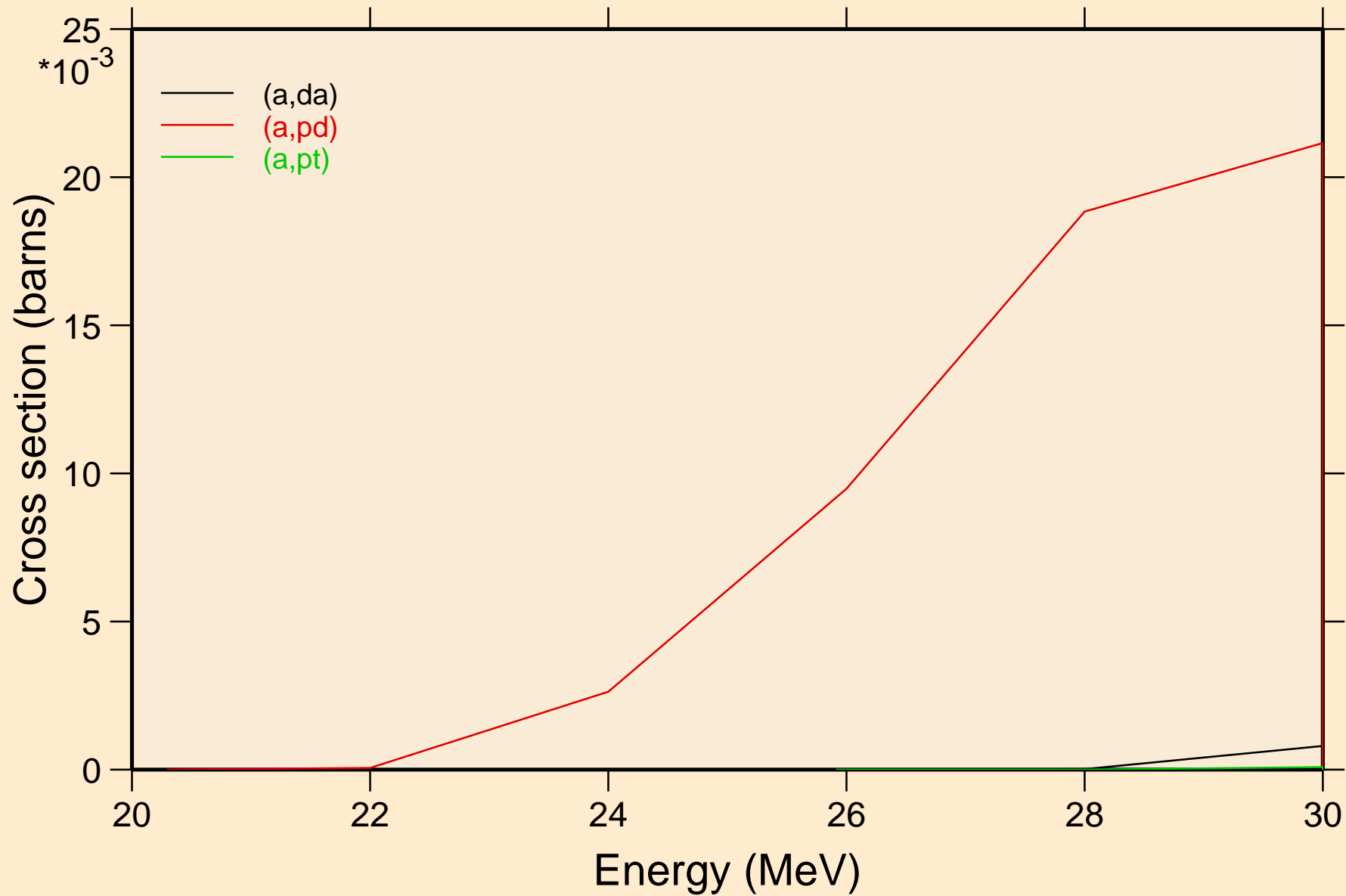

N013 ALPHA ACER TENDL-2023 LIBRARY; T=0.K  
Threshold reactions

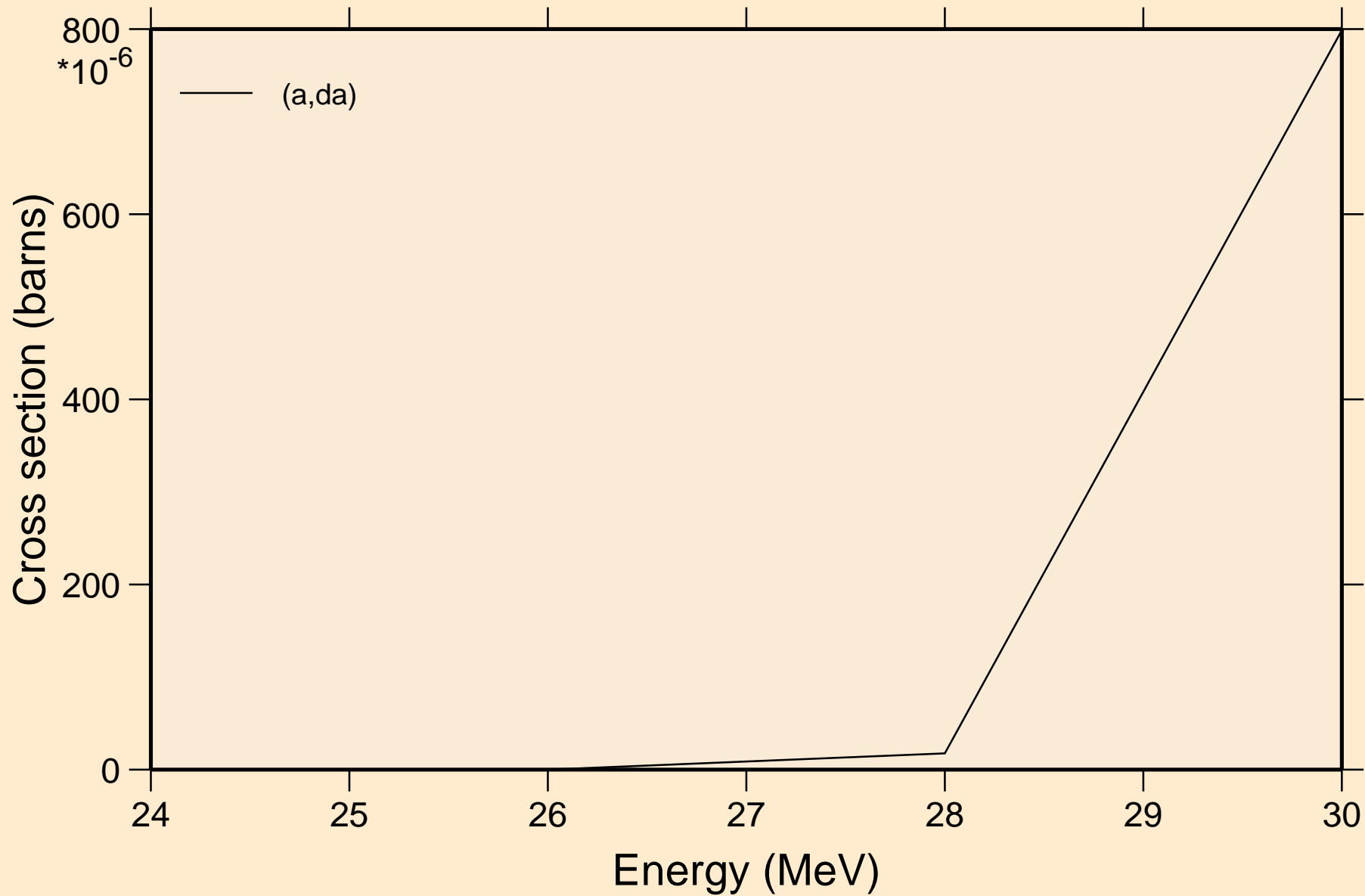

N013 ALPHA ACER TENDL-2023 LIBRARY; T=0.K  
angular distribution for elastic

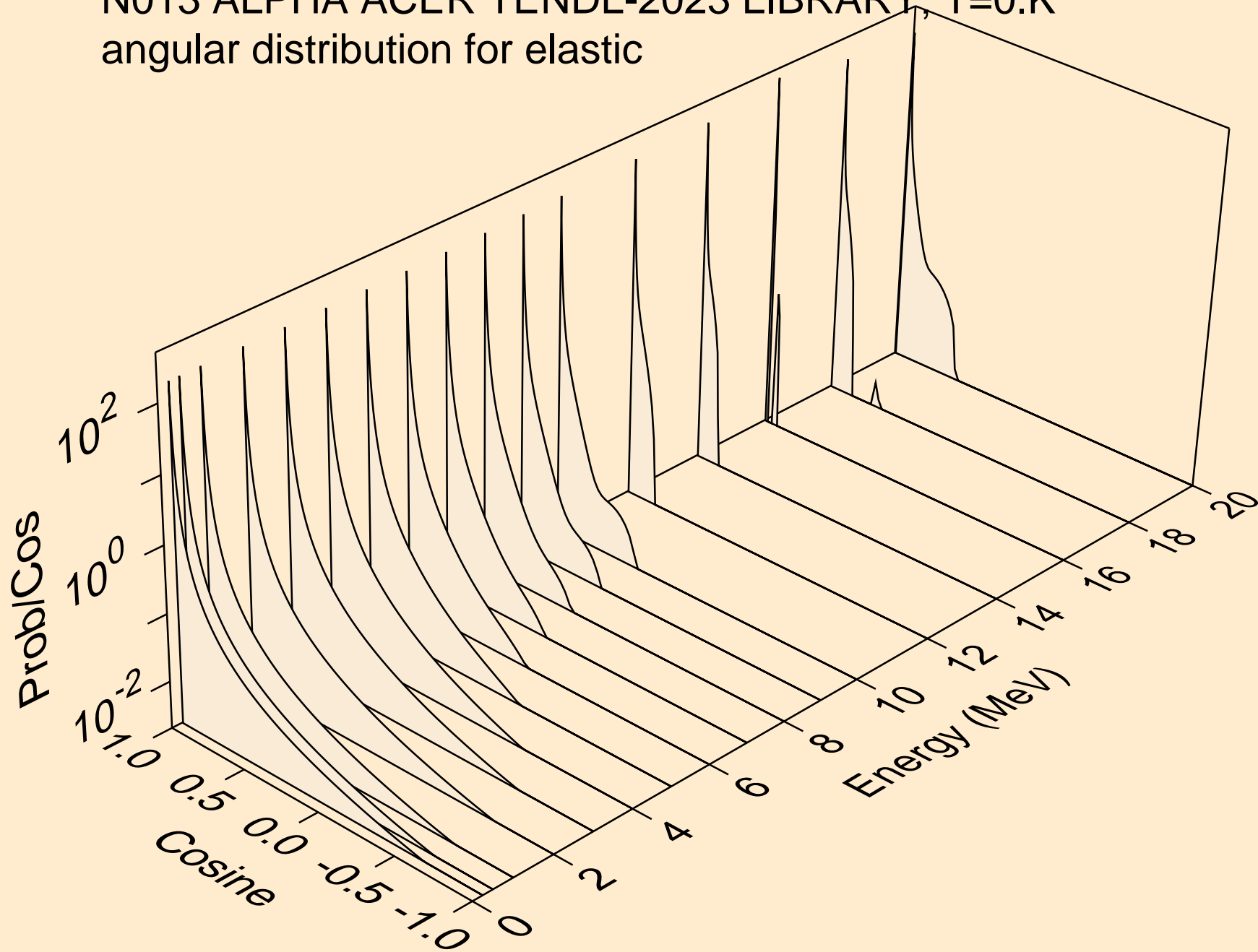

N013 ALPHA ACER TENDL-2023 LIBRARY: T=0.K  
angular distribution for elastic

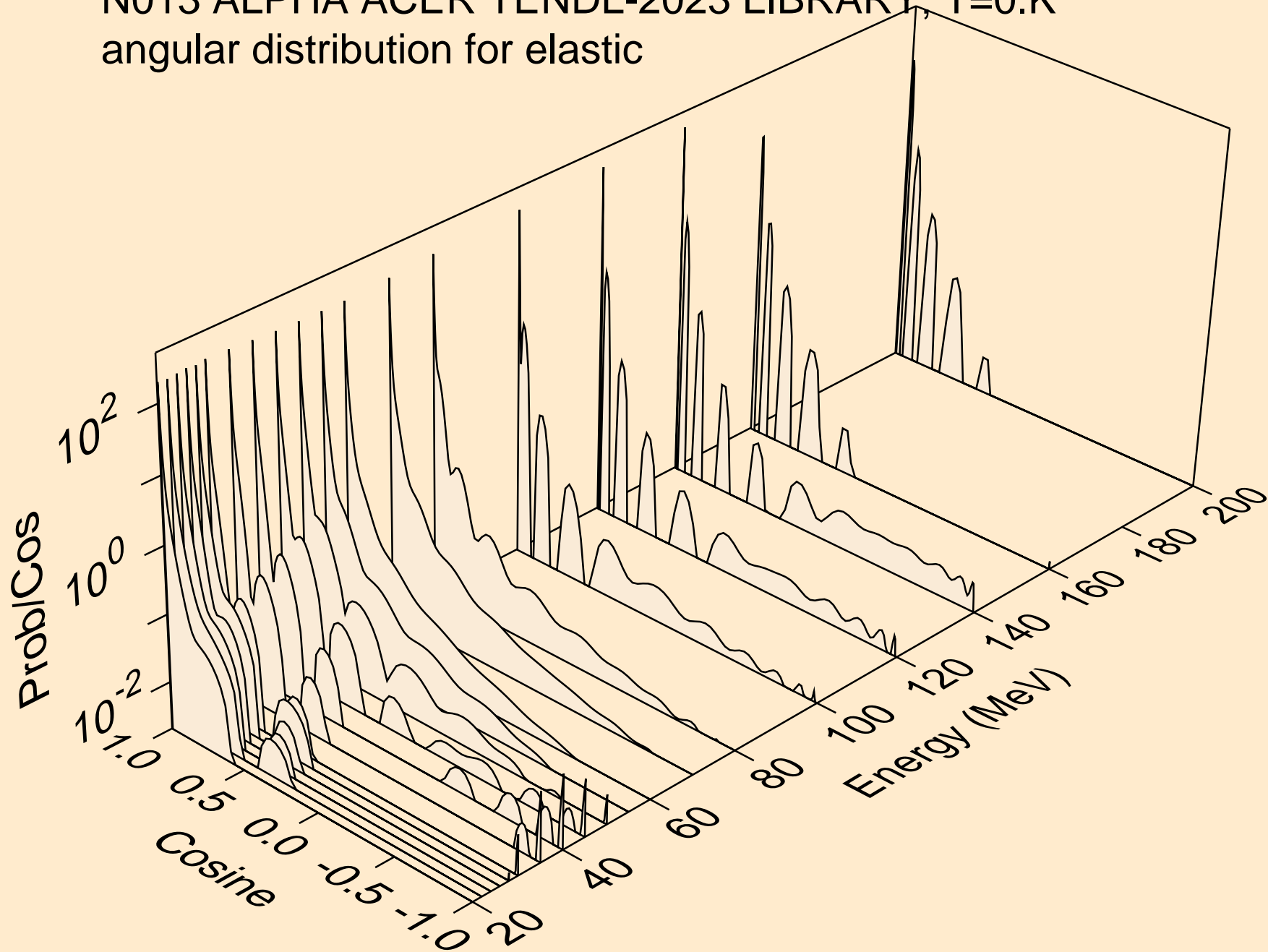

N013 ALPHA ACER TENDL-2023 LIBRARY; T=0.K  
Alpha emission for (a,x)

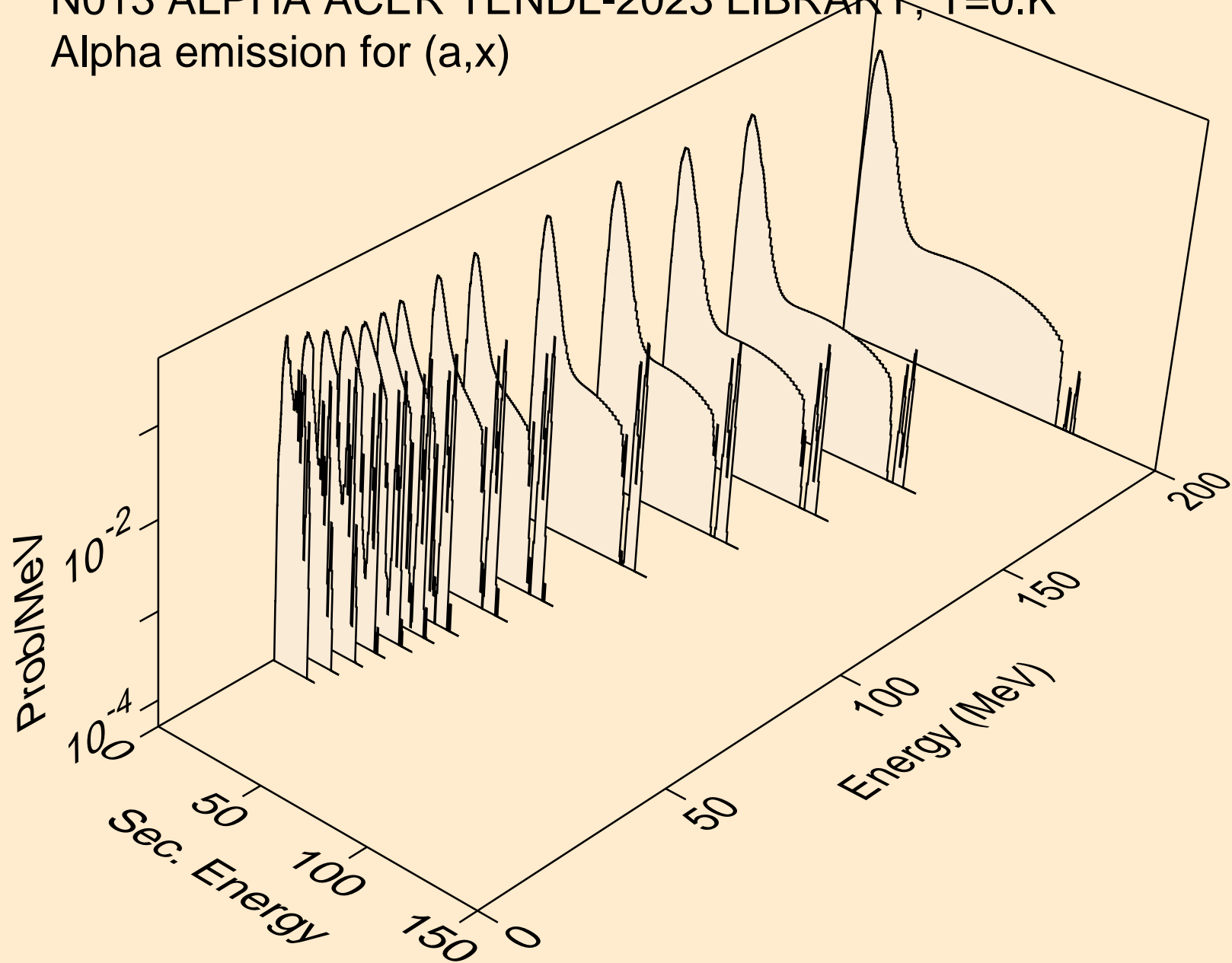

N013 ALPHA ACER TENDL-2023 LIBRARY; T=0.K  
Alpha emission for (a,n\*)a

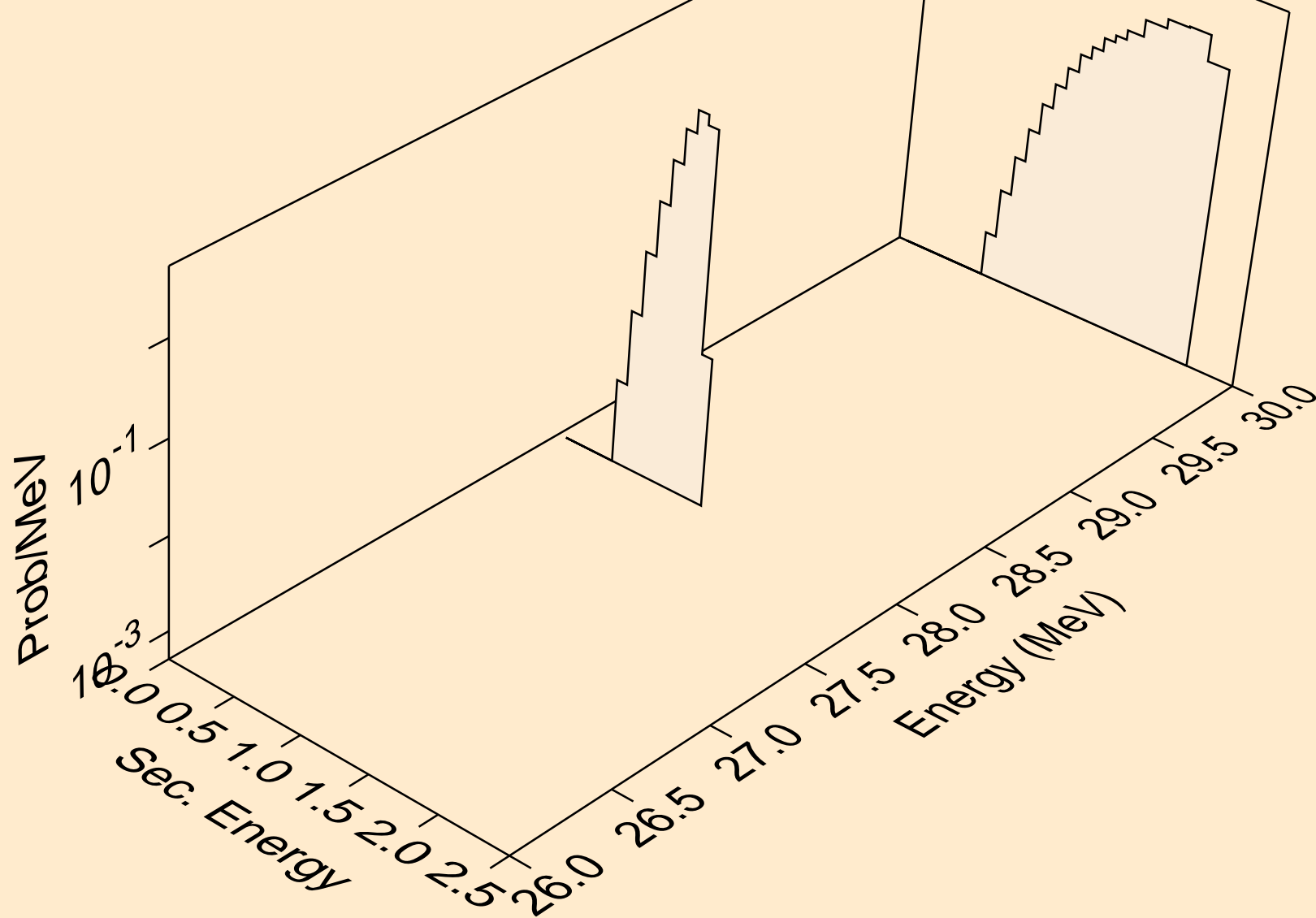

N013 ALPHA ACER TENDL-2023 LIBRARY; T=0.K  
Alpha emission for inelastic

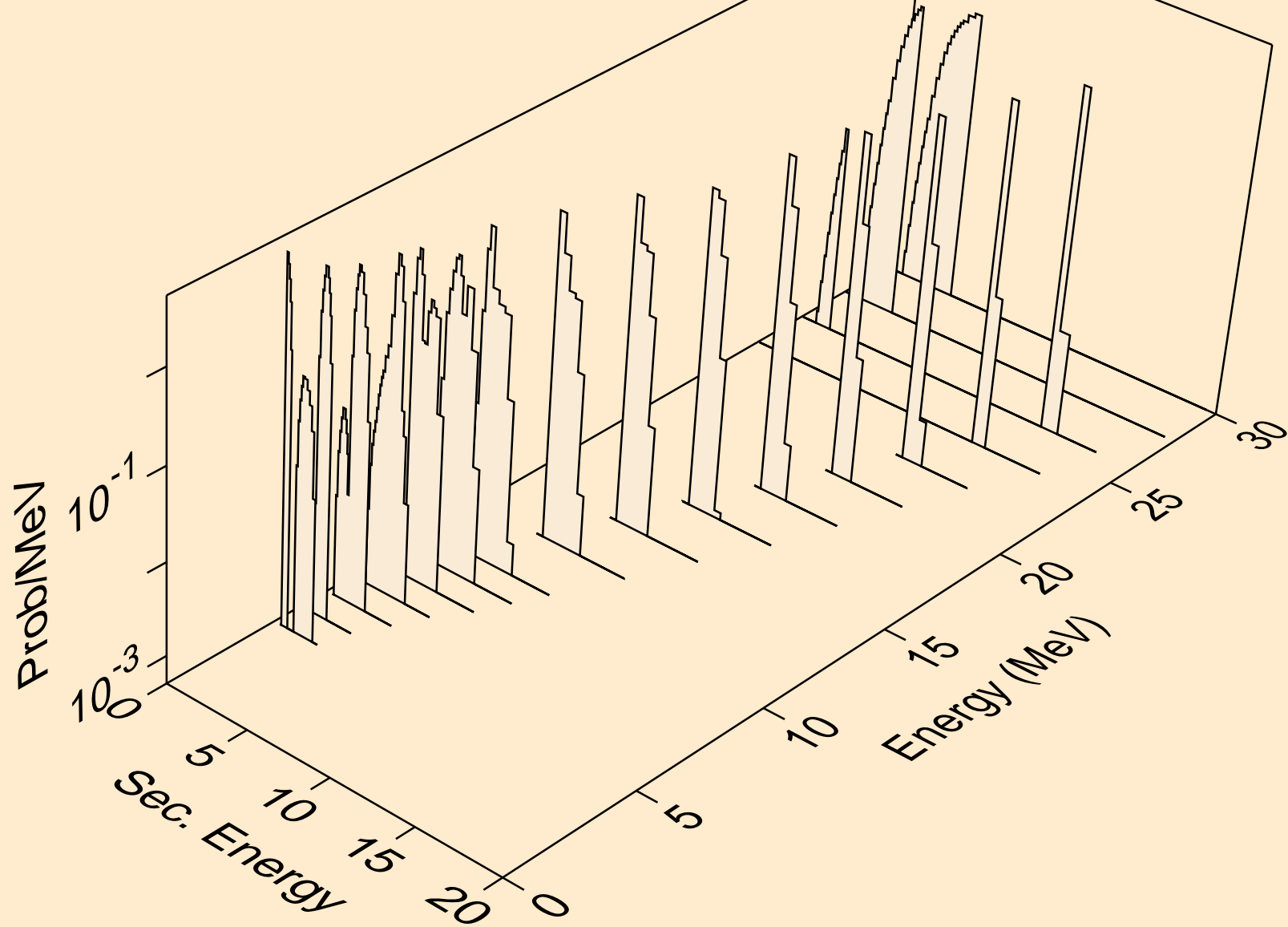

N013 ALPHA ACER TENDL-2023 LIBRARY; T=0.K  
Alpha emission for (a,2a)

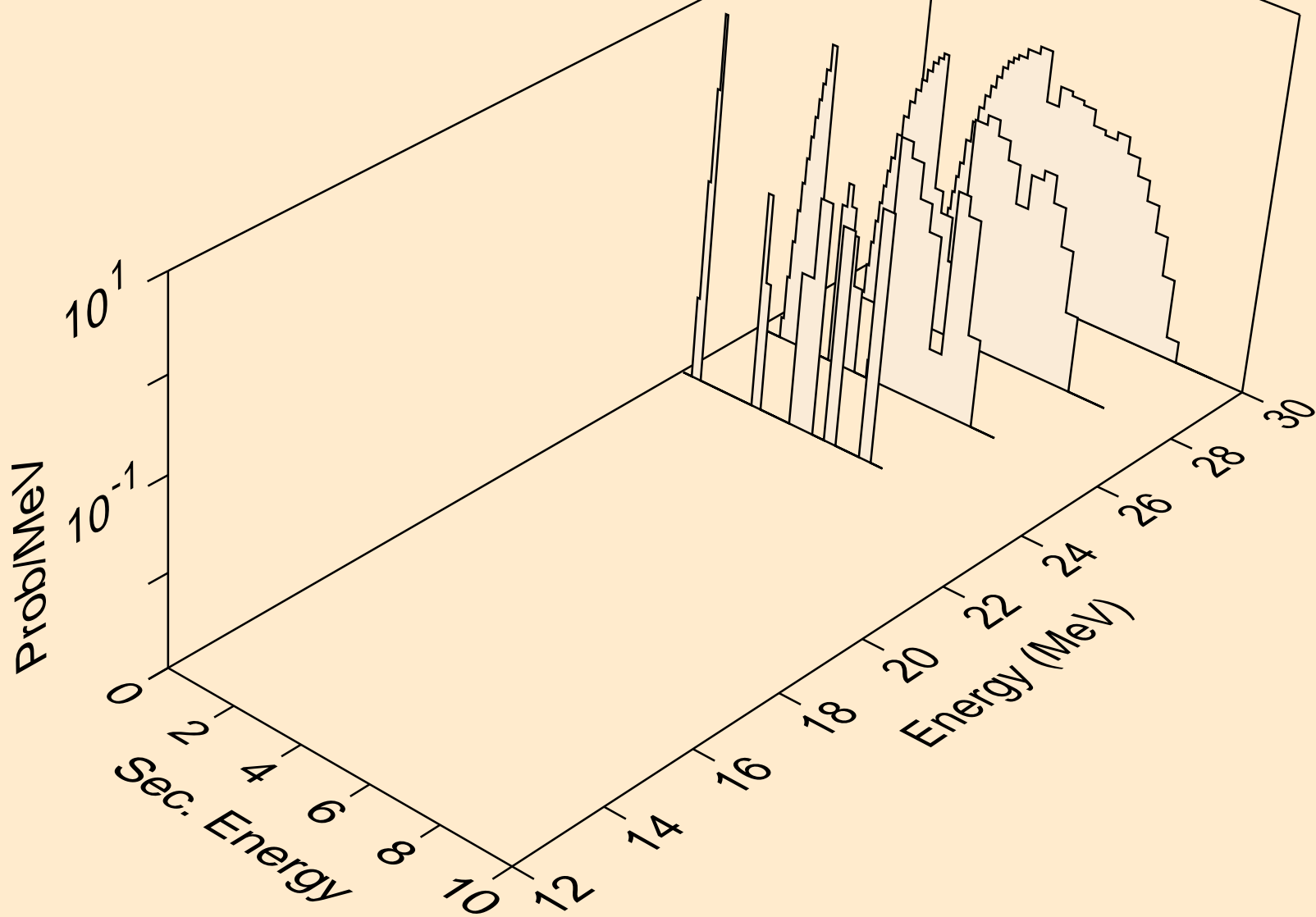

N013 ALPHA ACER TENDL-2023 LIBRARY; T=0.K  
Alpha emission for (a,pa)

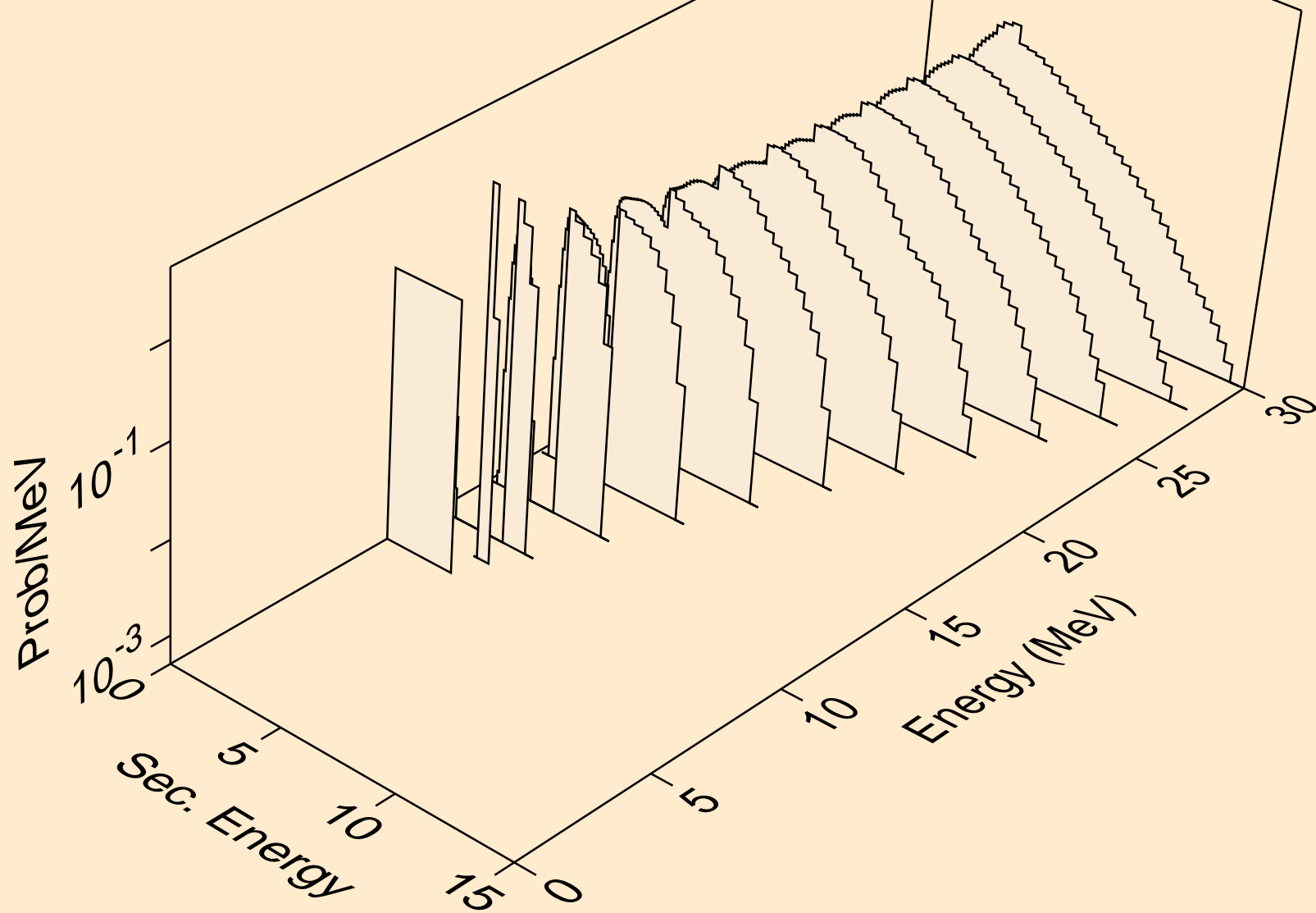

N013 ALPHA ACER TENDL-2023 LIBRARY; T=0.K  
Alpha emission for (a,da)

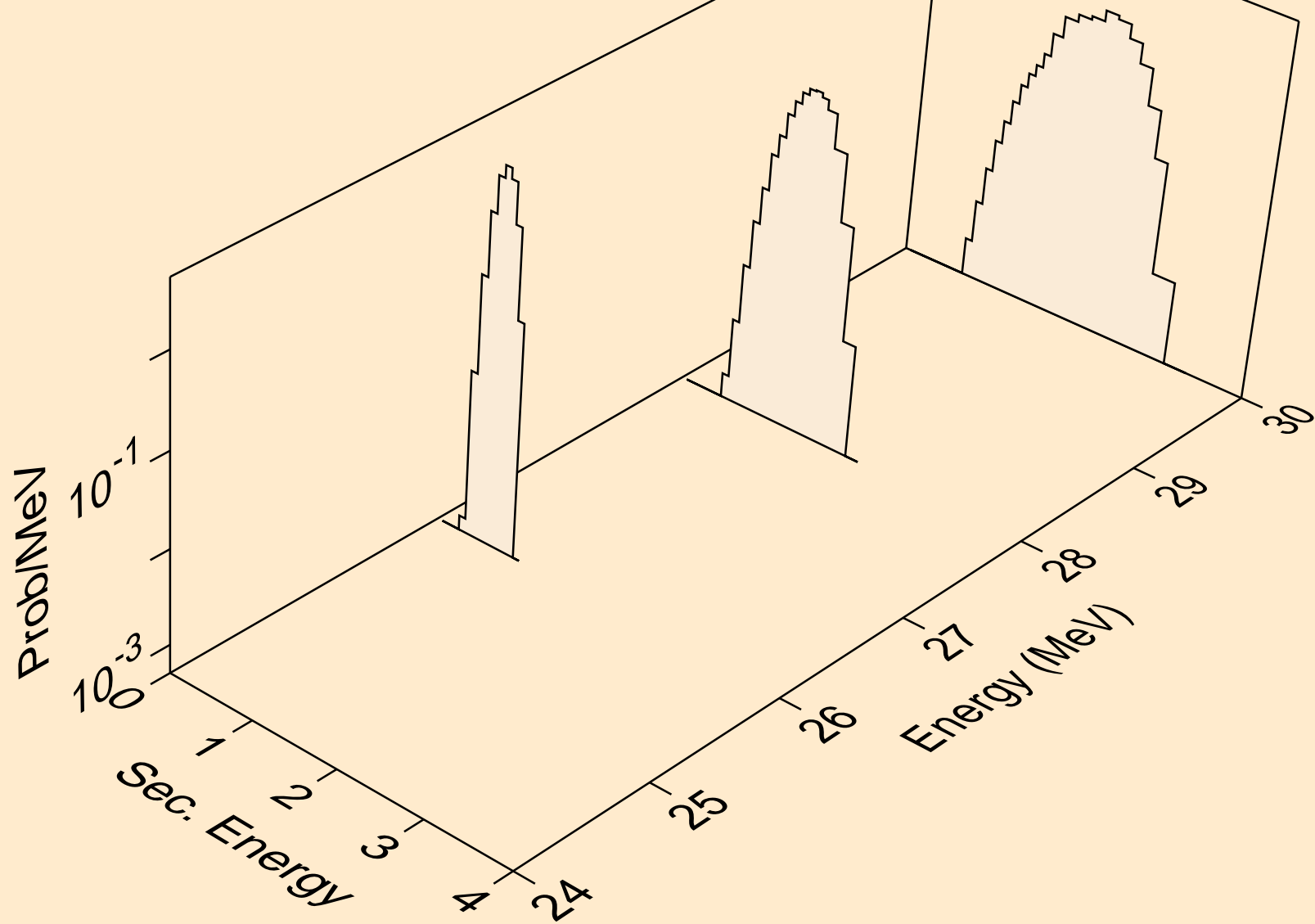

N013 ALPHA ACER TENDL-2023 LIBRARY; T=0.K  
Photon emission for (z,n)

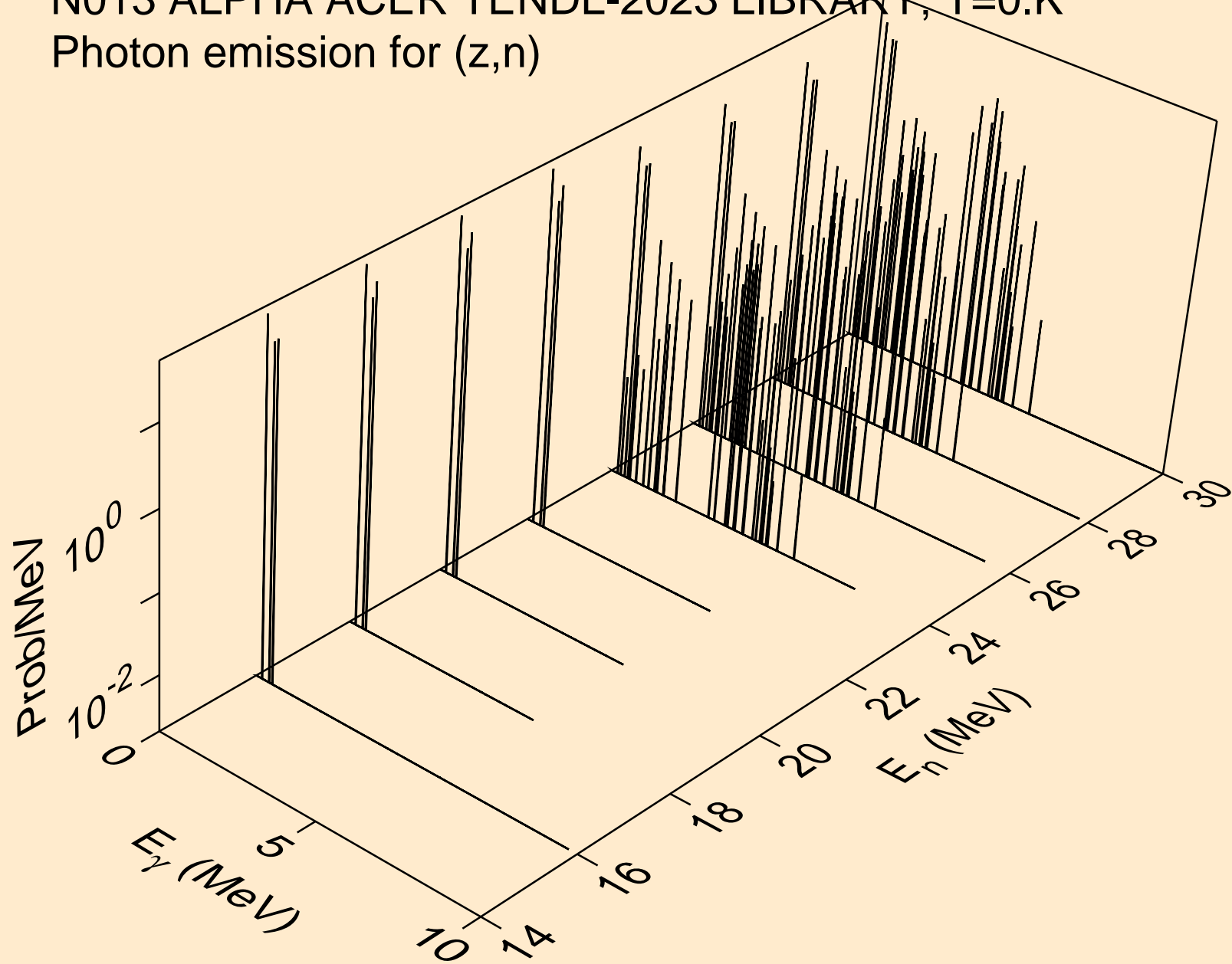

N013 ALPHA ACER TENDL-2023 LIBRARY; T=0.K  
Photon emission for (z,x)

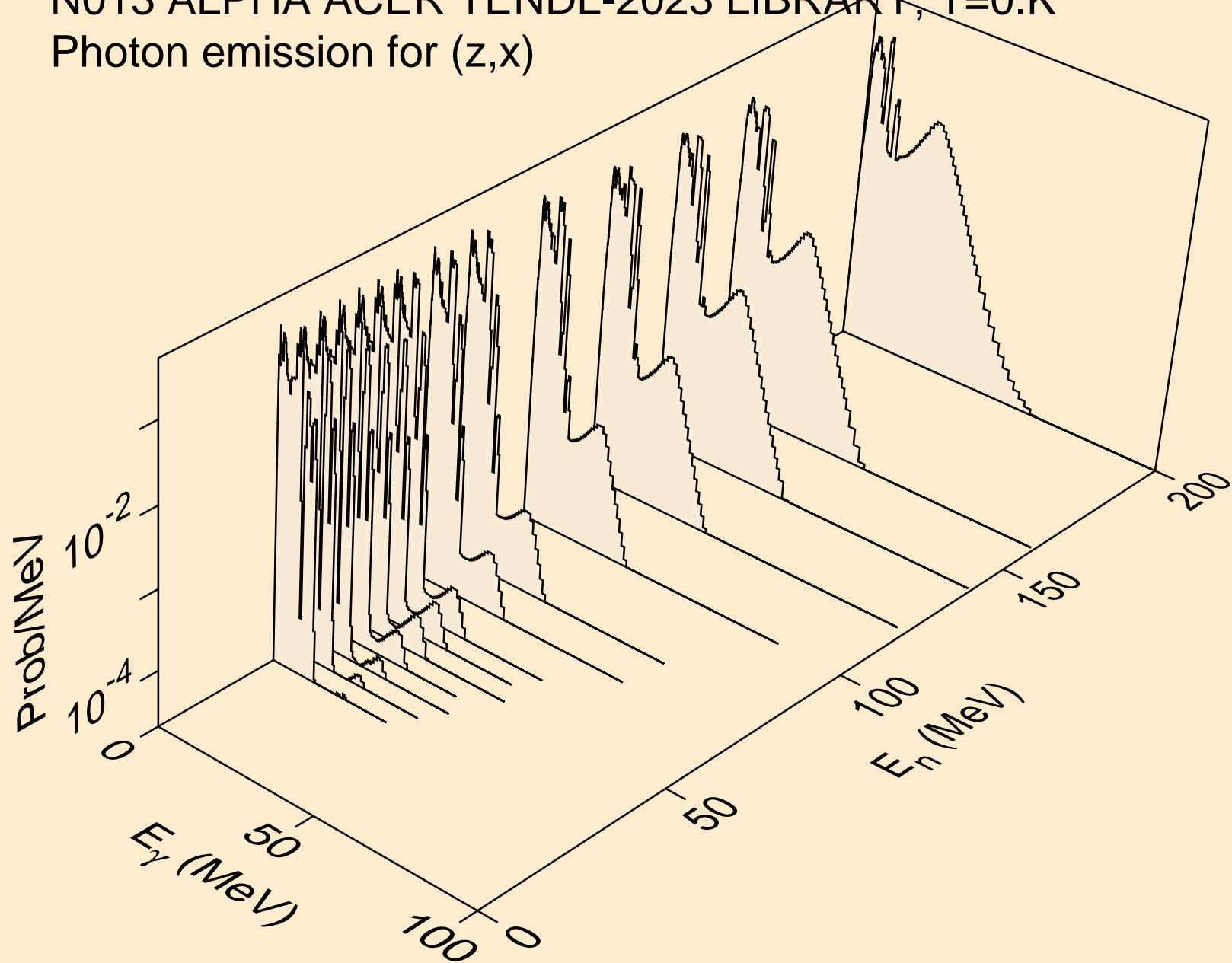

N013 ALPHA ACER TENDL-2023 LIBRARY; T=0.K  
Photon emission for (n,n\*)a

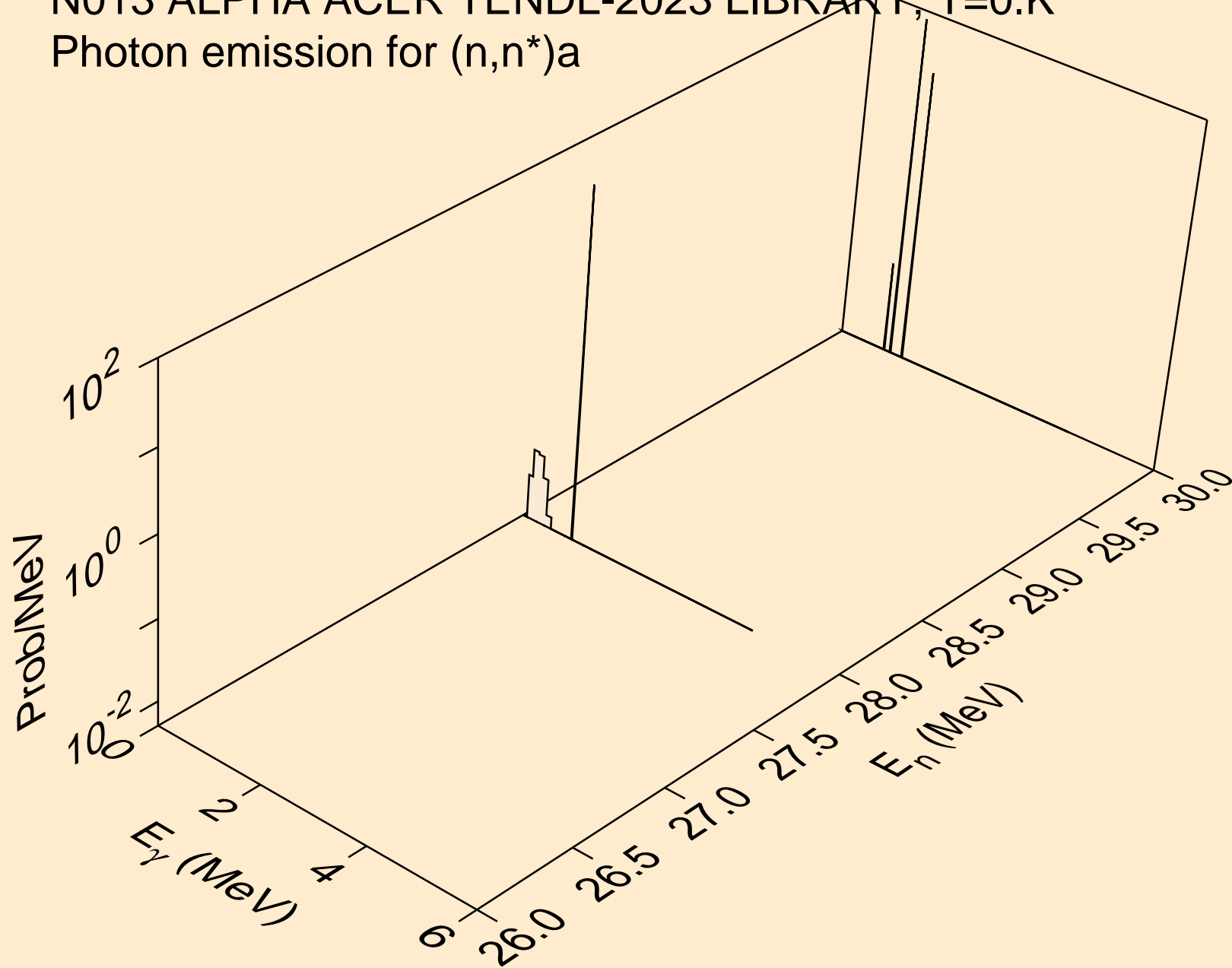

N013 ALPHA ACER TENDL-2023 LIBRARY; T=0.K  
Photon emission for (n,n\*)p

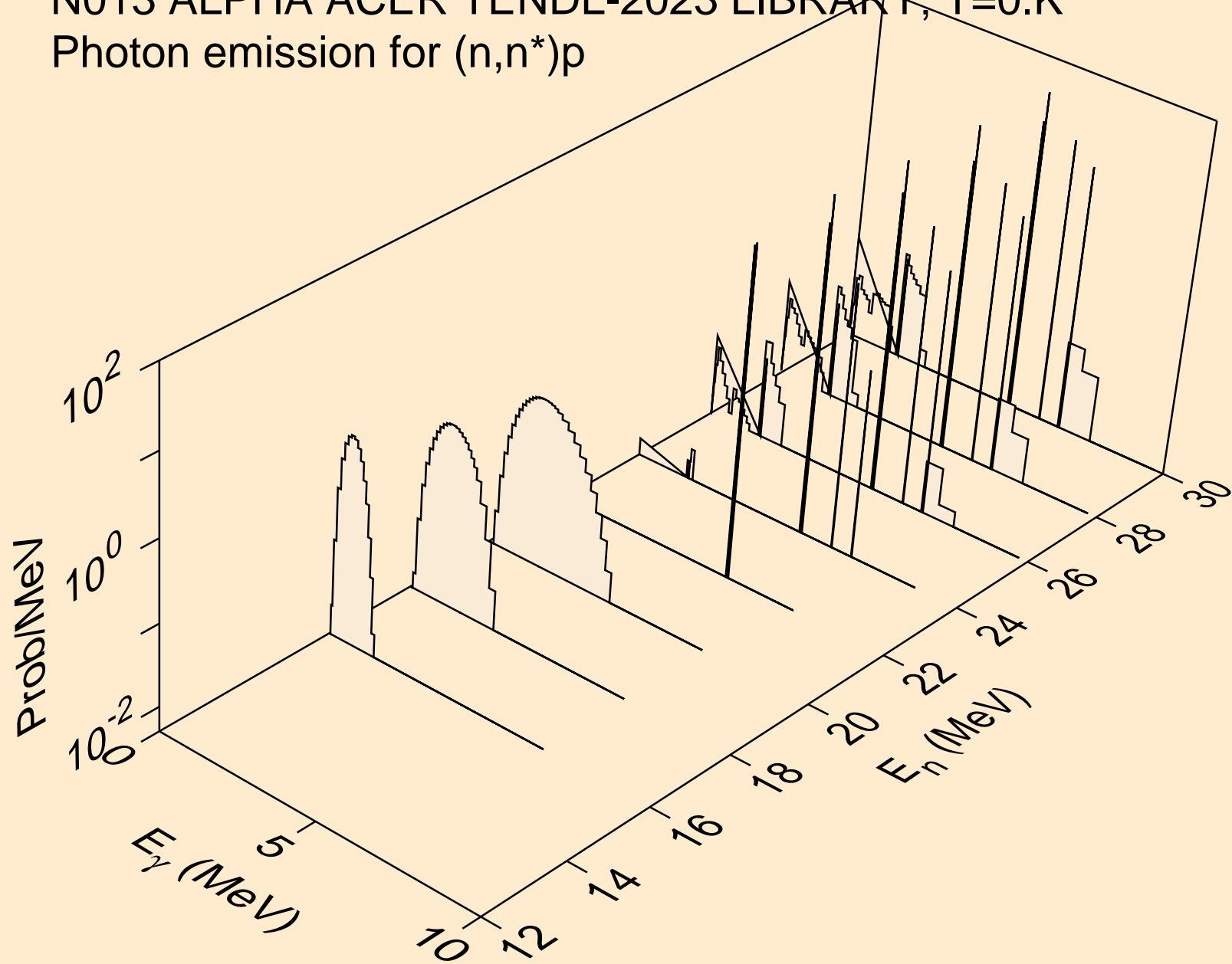

N013 ALPHA ACER TENDL-2023 LIBRARY; T=0.K  
Photon emission for (n,n\*)he3

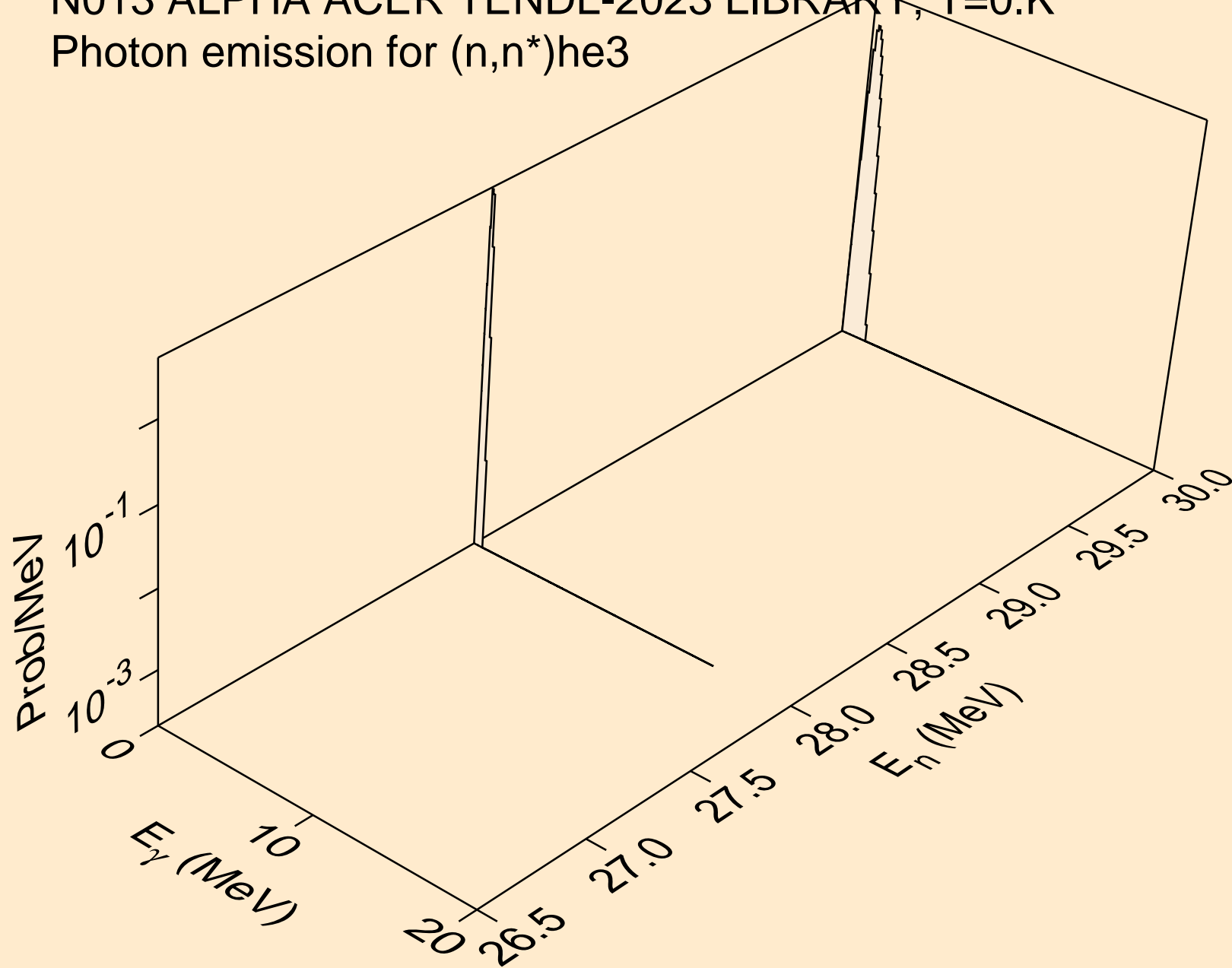

N013 ALPHA ACER TENDL-2023 LIBRARY; T=0.K  
Photon emission for (n,n2p)

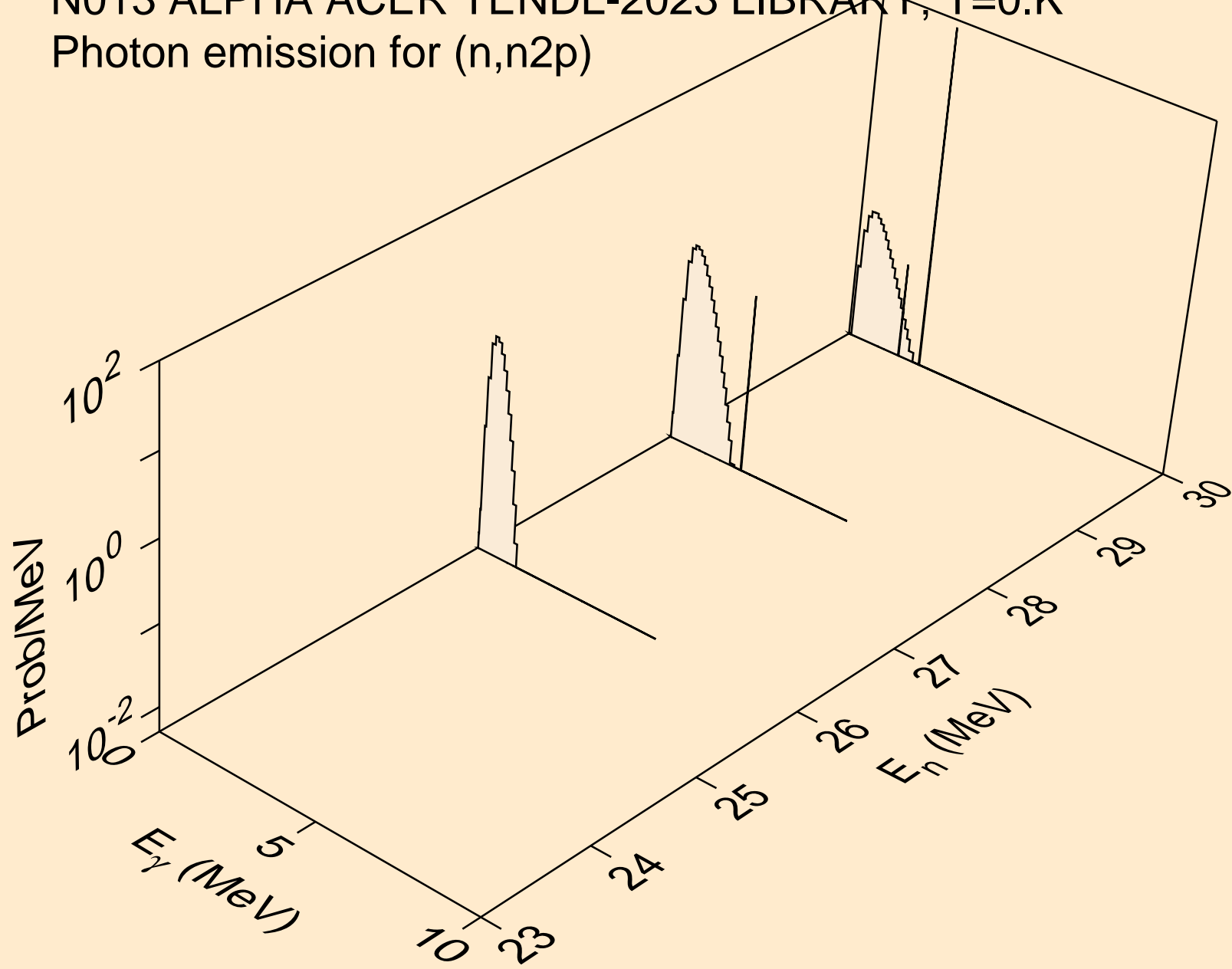

N013 ALPHA ACER TENDL-2023 LIBRARY; T=0.K  
Photon emission for (n,npa)

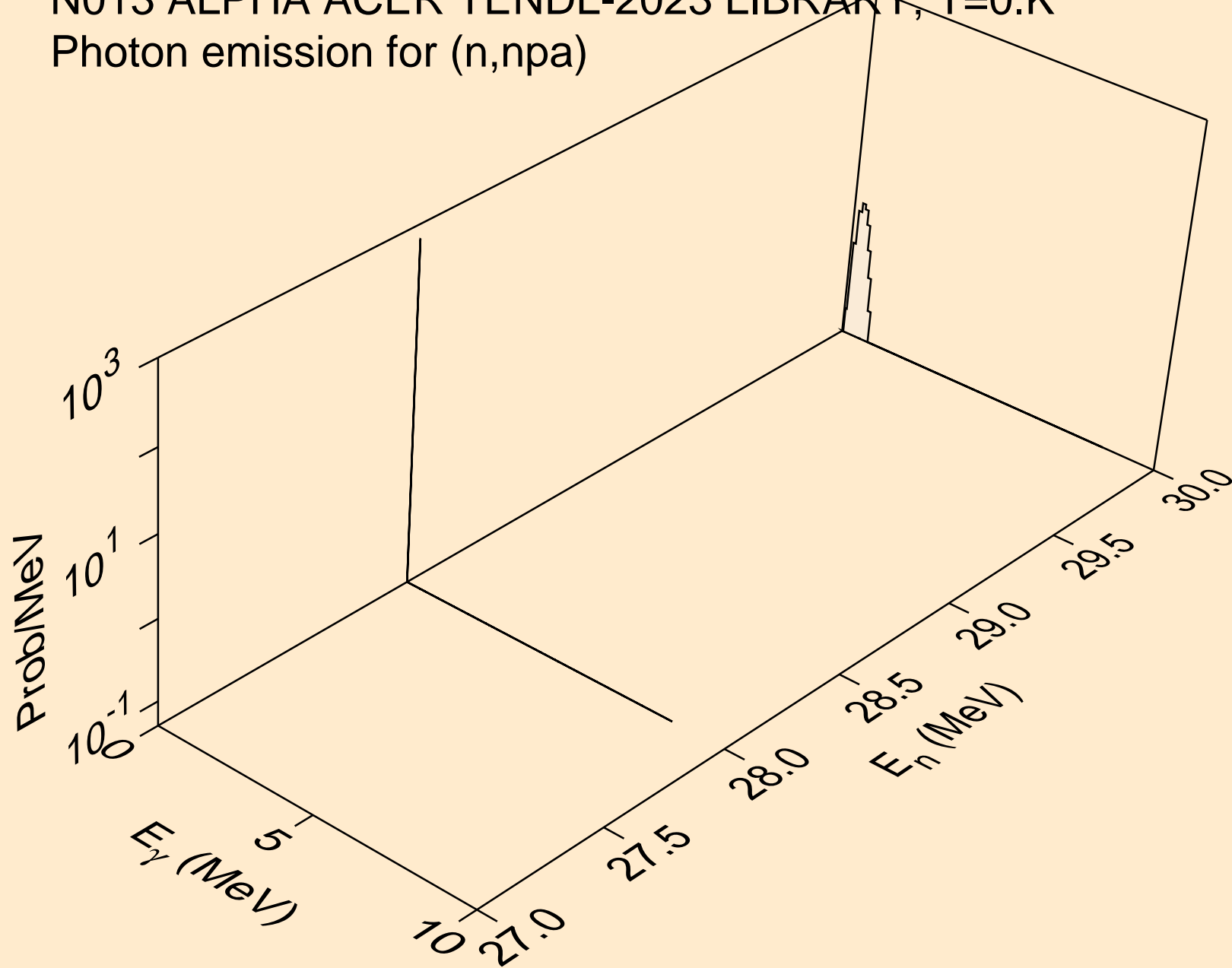

N013 ALPHA ACER TENDL-2023 LIBRARY; T=0.K  
Photon emission for (n,gma)

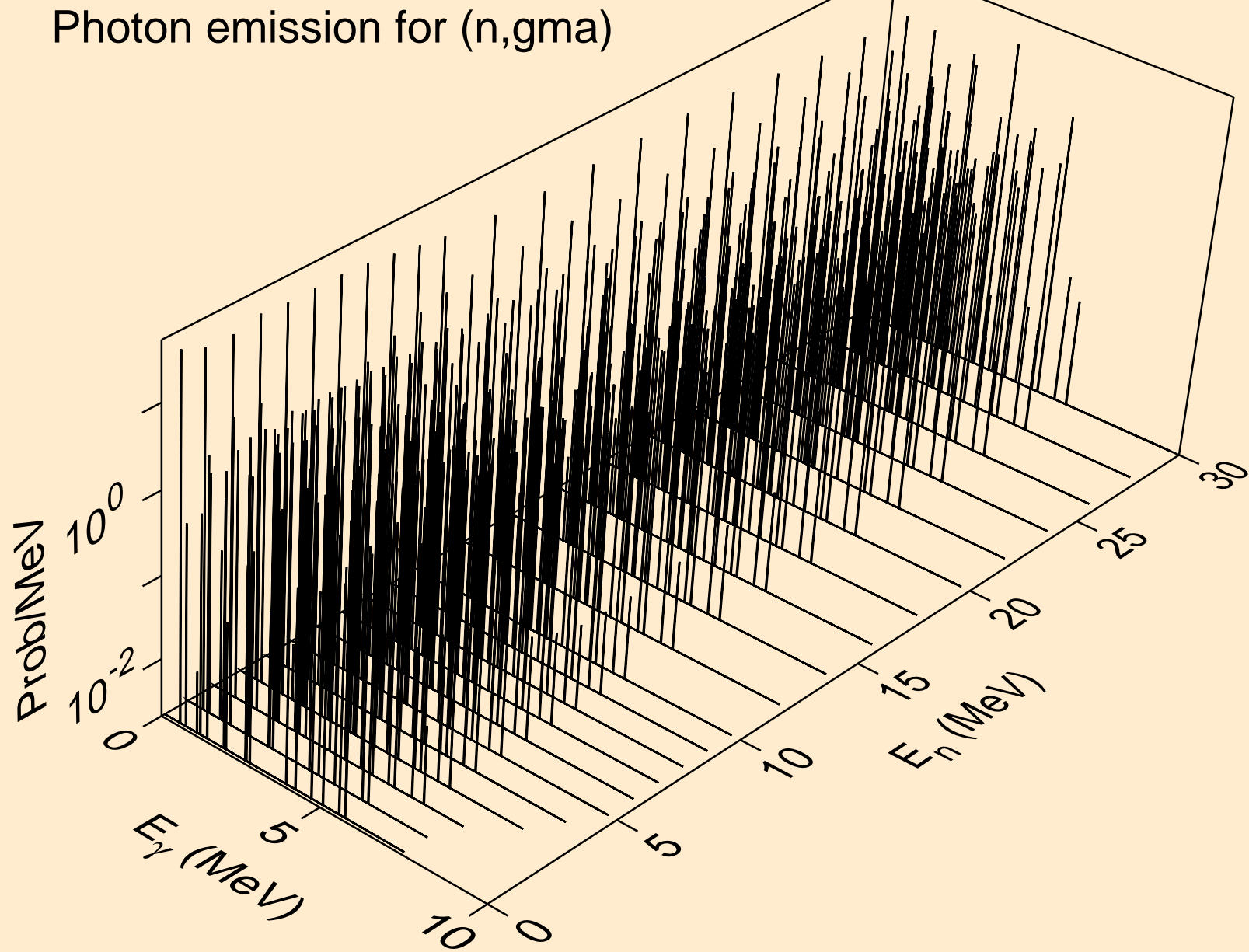

N013 ALPHA ACER TENDL-2023 LIBRARY; T=0.K  
Photon emission for (n,p)

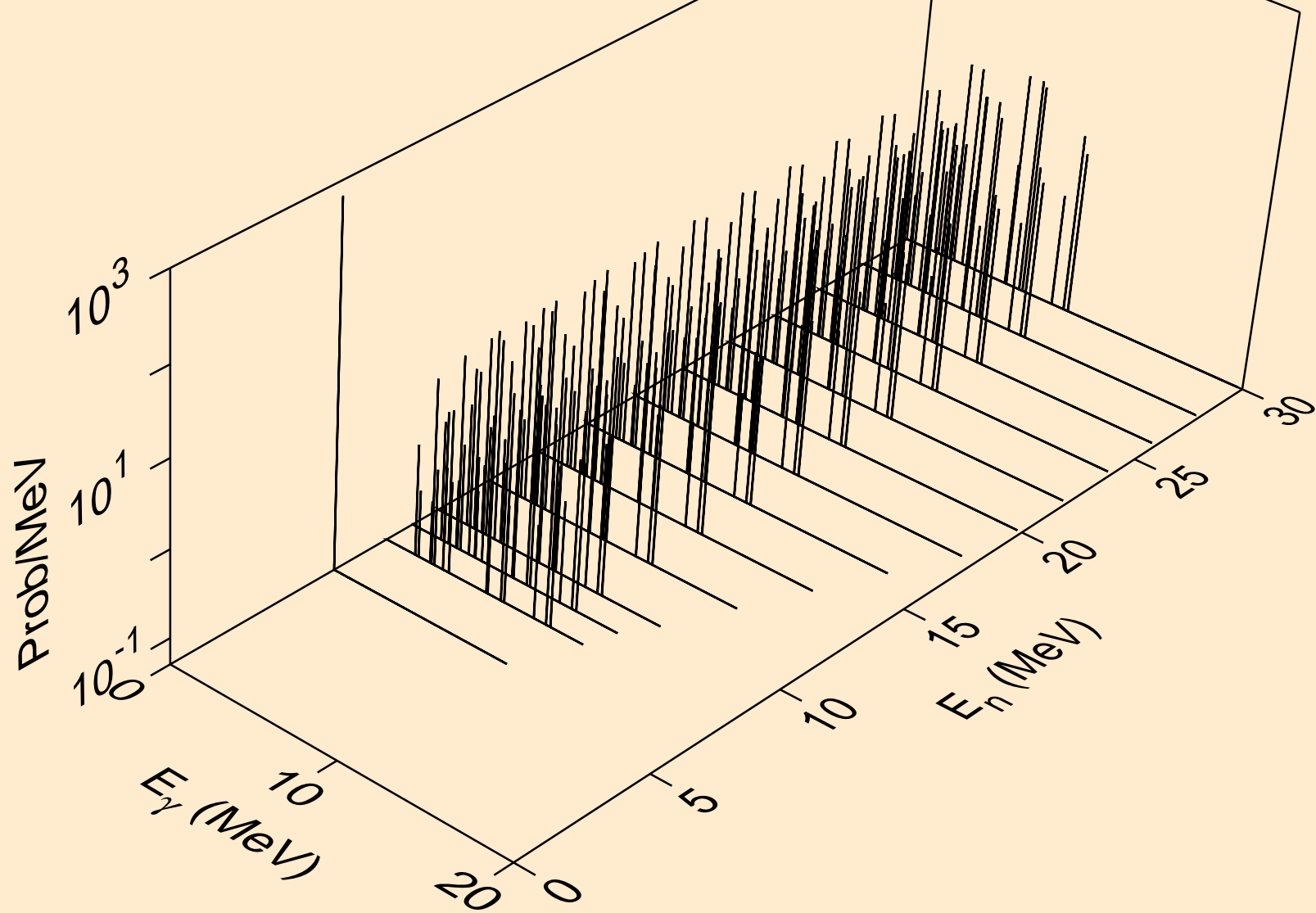

N013 ALPHA ACER TENDL-2023 LIBRARY; T=0.K  
Photon emission for (n,d)

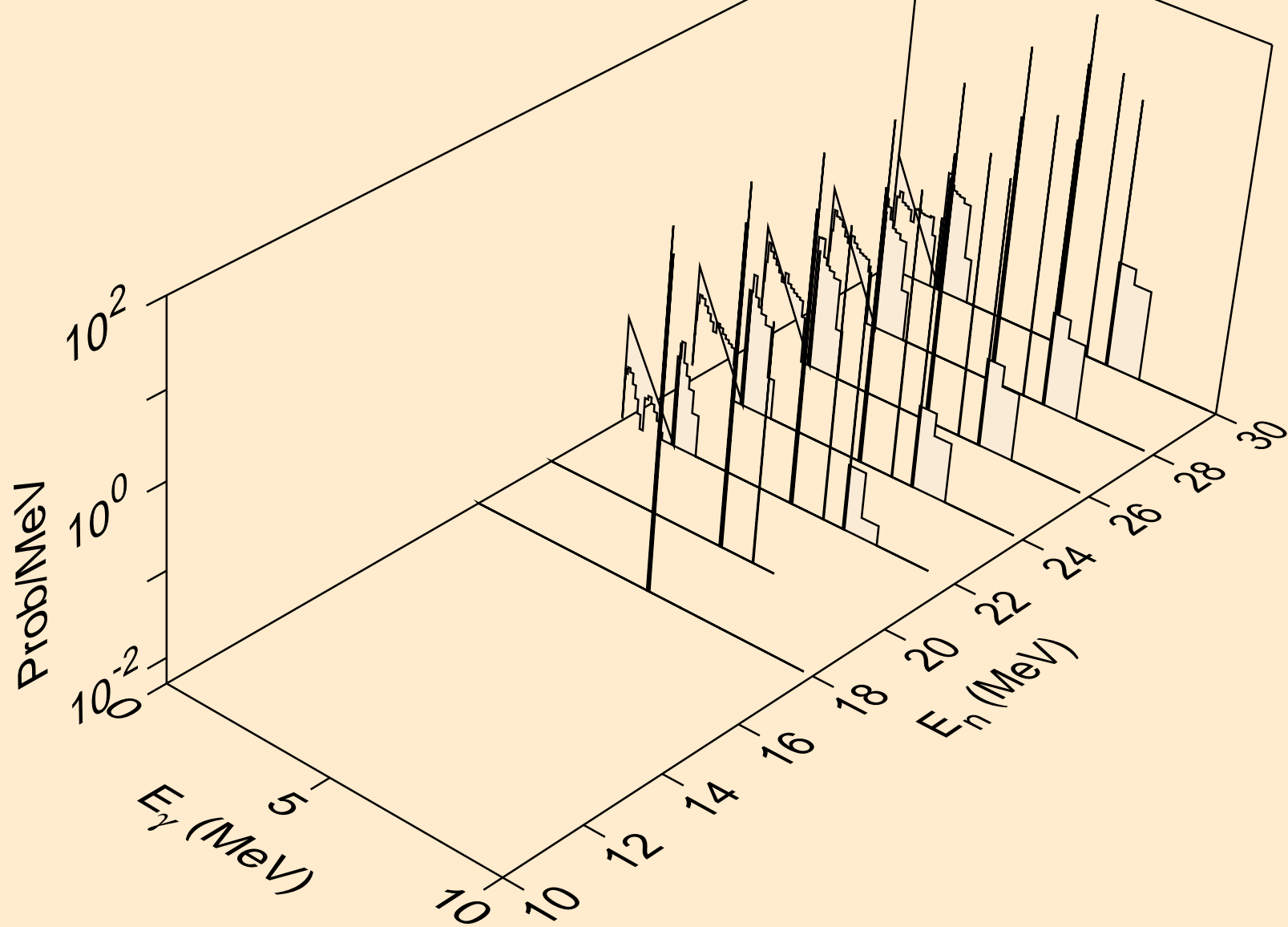

N013 ALPHA ACER TENDL-2023 LIBRARY; T=0.K  
Photon emission for (n,t)

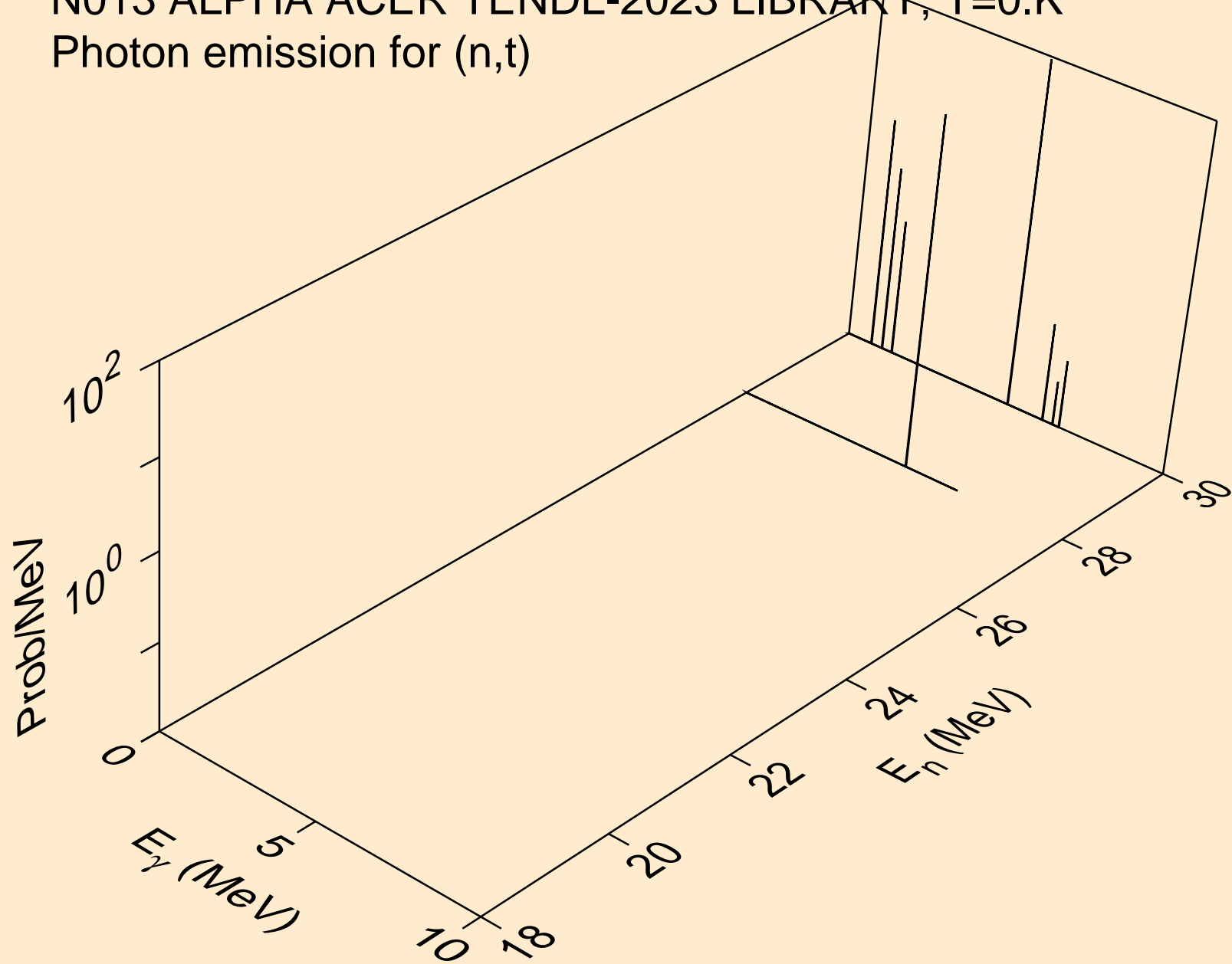

N013 ALPHA ACER TENDL-2023 LIBRARY; T=0.K  
Photon emission for (n,he3)

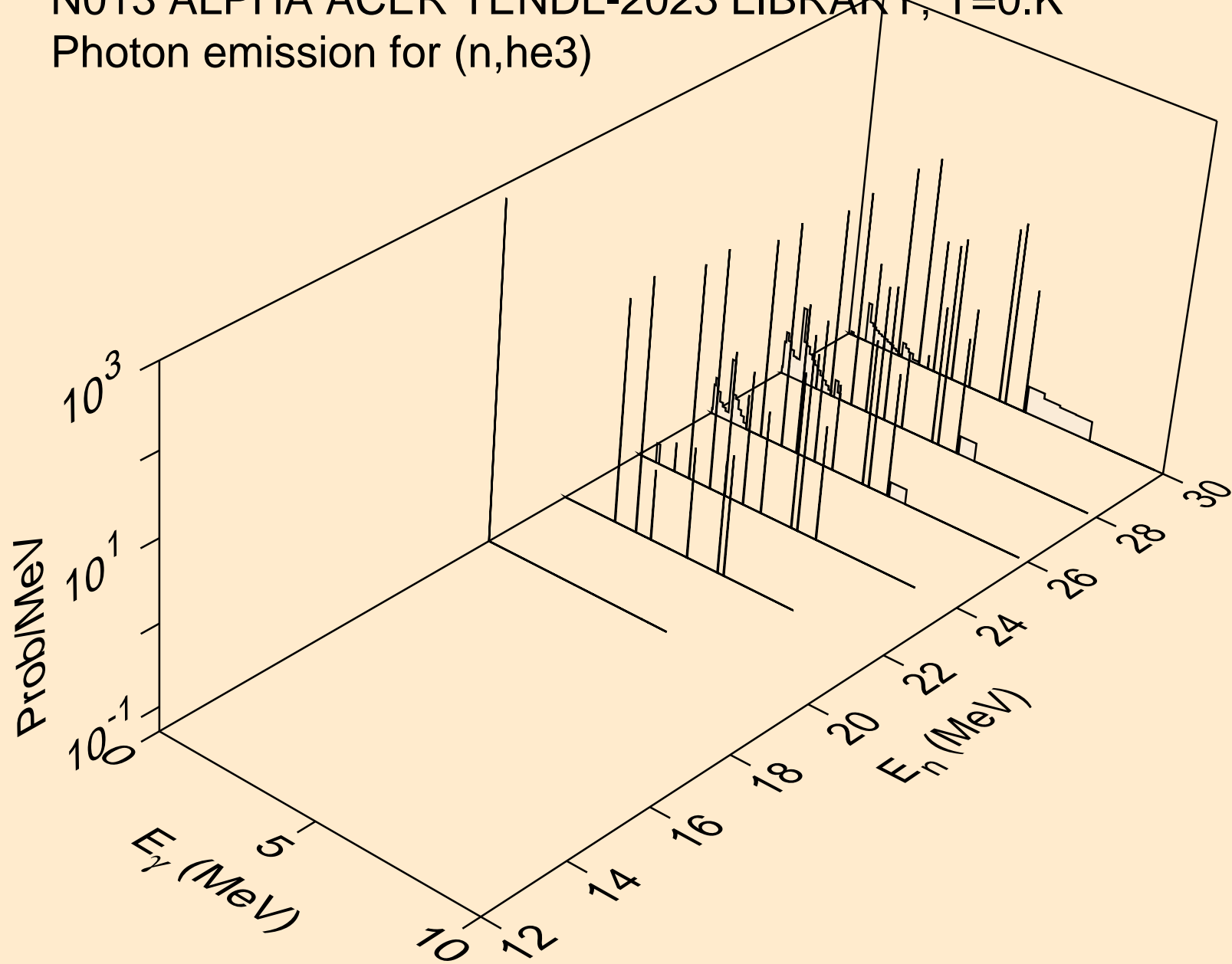

N013 ALPHA ACER TENDL-2023 LIBRARY; T=0.K  
Photon emission for inelastic

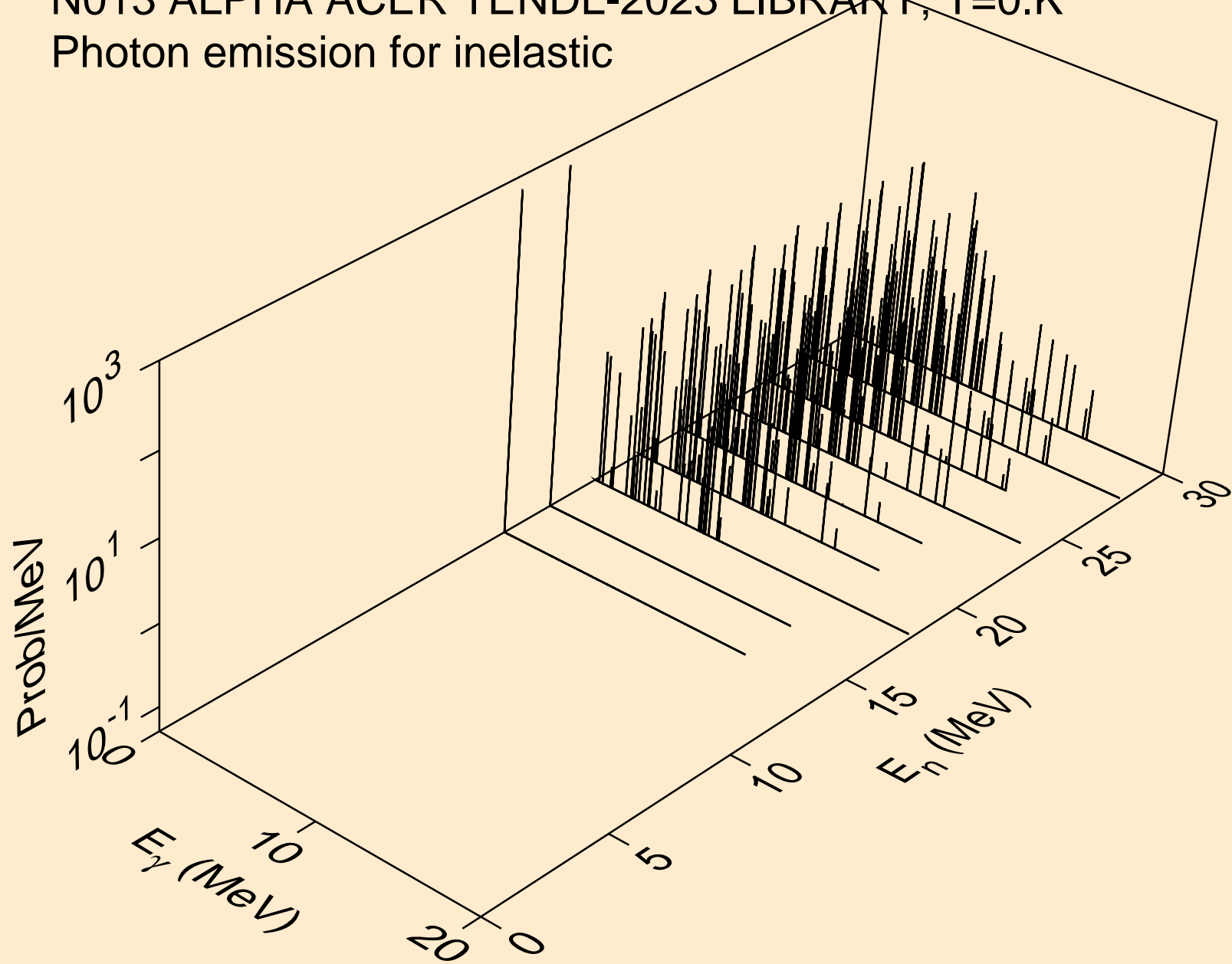

N013 ALPHA ACER TENDL-2023 LIBRARY; T=0.K  
Photon emission for (n,2a)

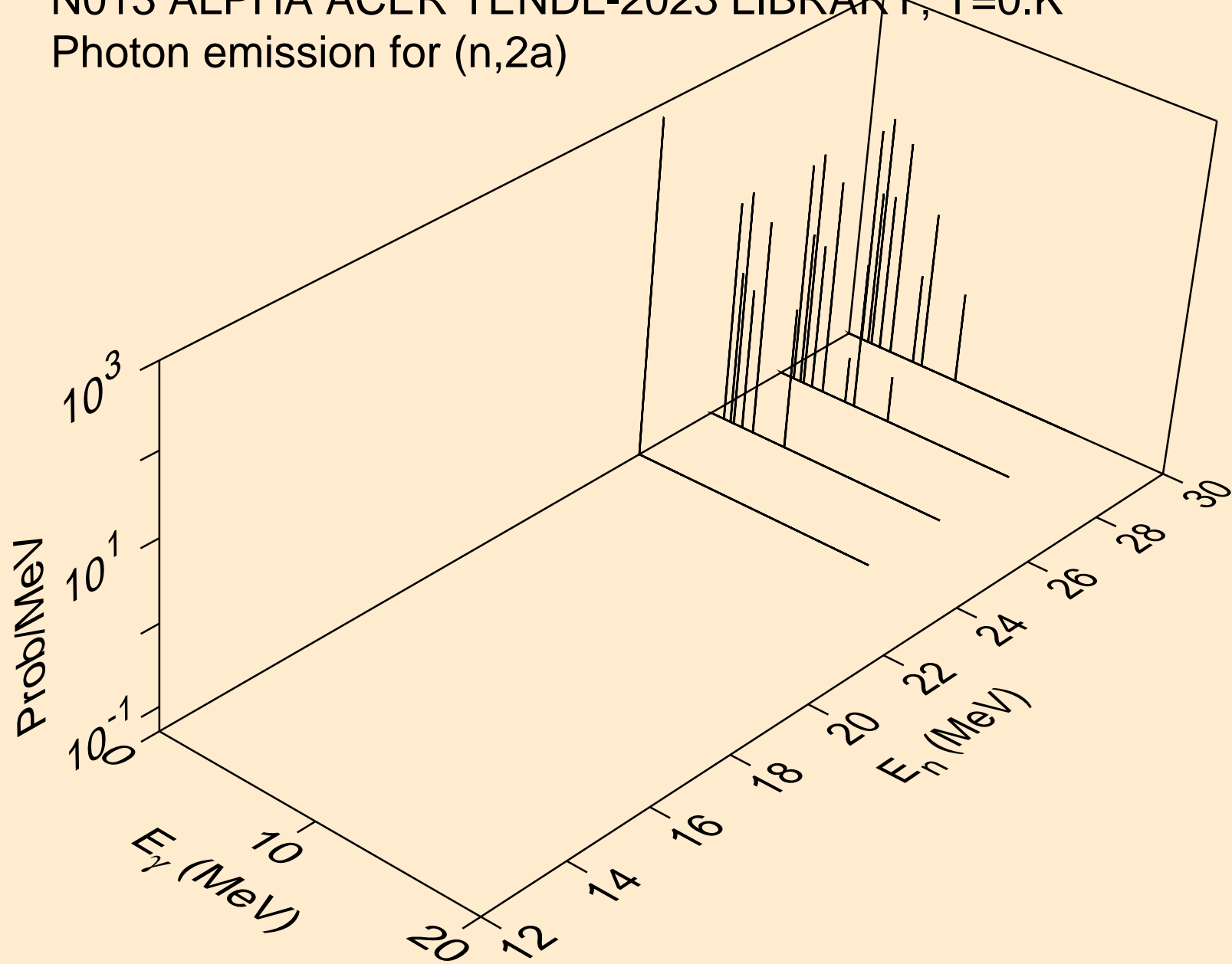

N013 ALPHA ACER TENDL-2023 LIBRARY; T=0.K  
Photon emission for (n,2p)

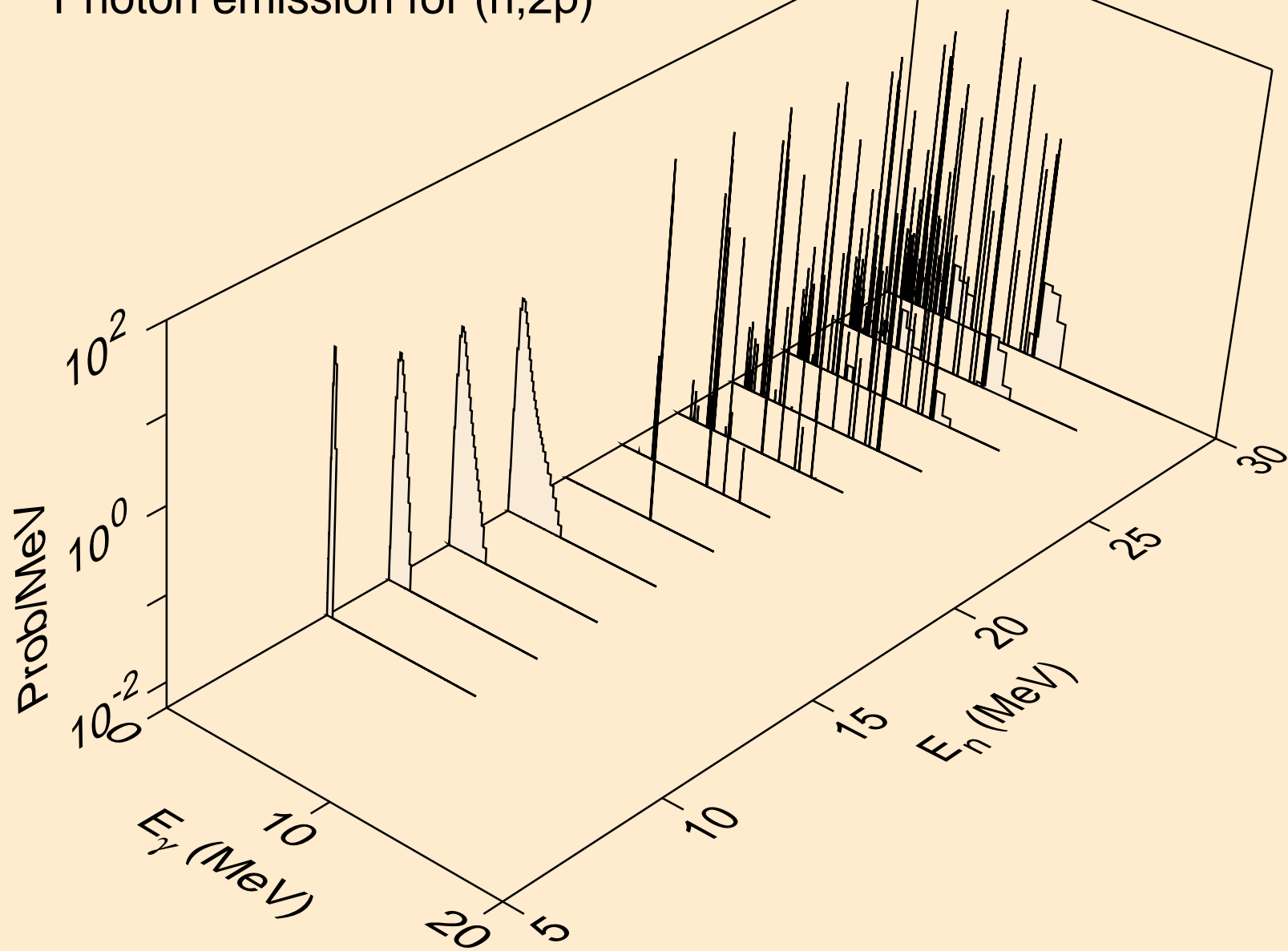

N013 ALPHA ACER TENDL-2023 LIBRARY; T=0.K  
Photon emission for (n,pa)

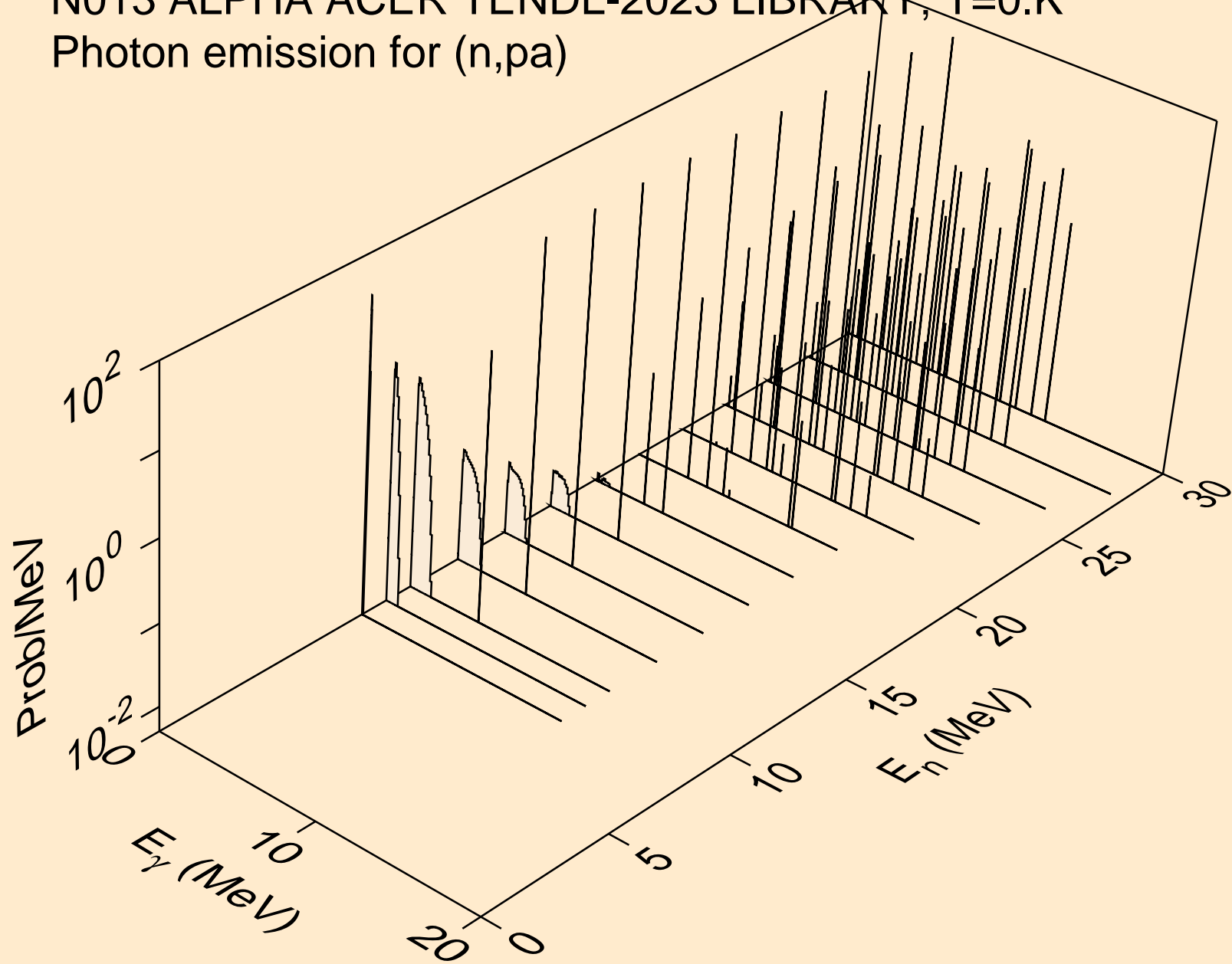

N013 ALPHA ACER TENDL-2023 LIBRARY; T=0.K  
Photon emission for (n,pd)

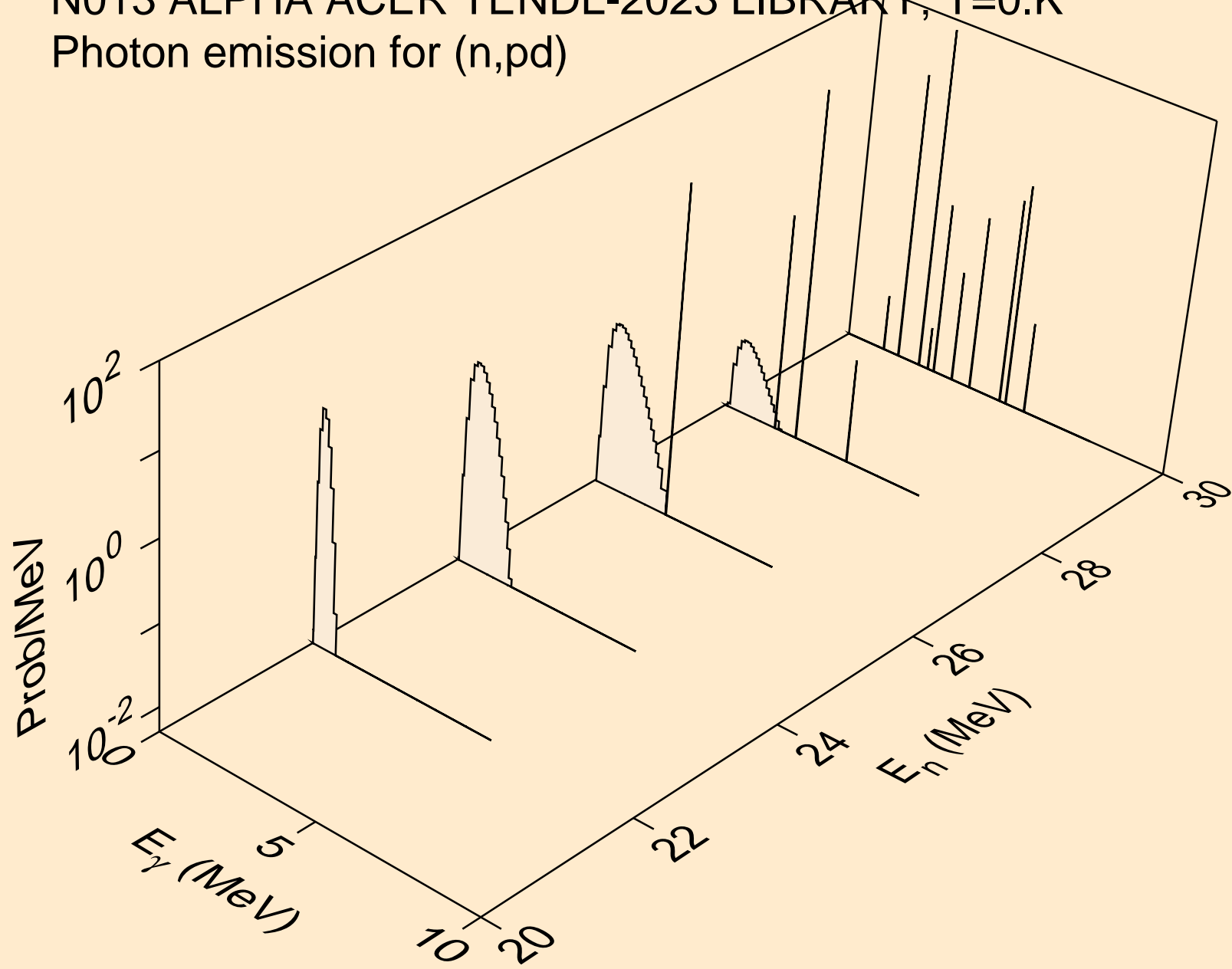

N013 ALPHA ACER TENDL-2023 LIBRARY: T=0.K  
Photon emission for (n,pt)

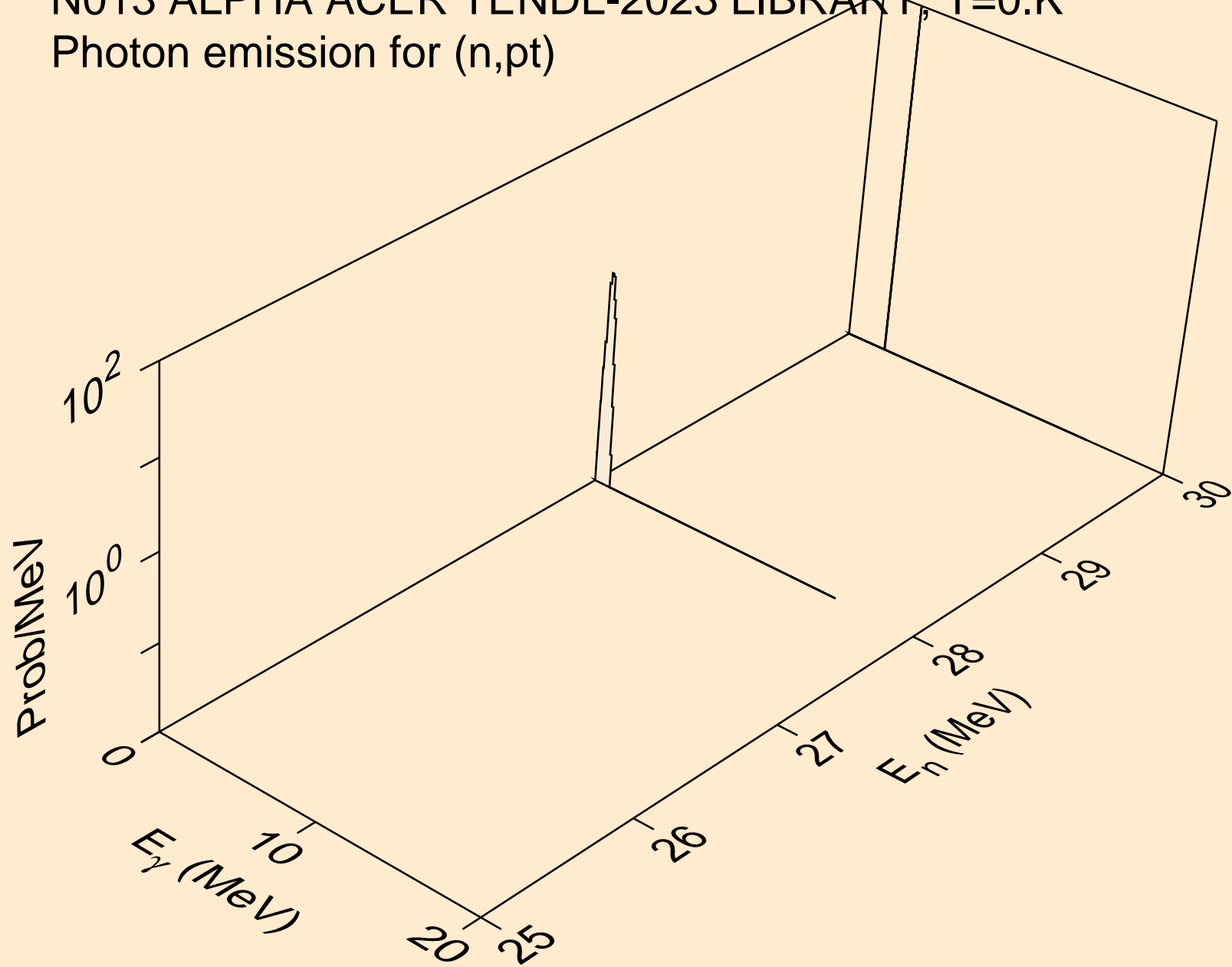

N013 ALPHA ACER TENDL-2023 LIBRARY; T=0.K  
Photon emission for (n,da)

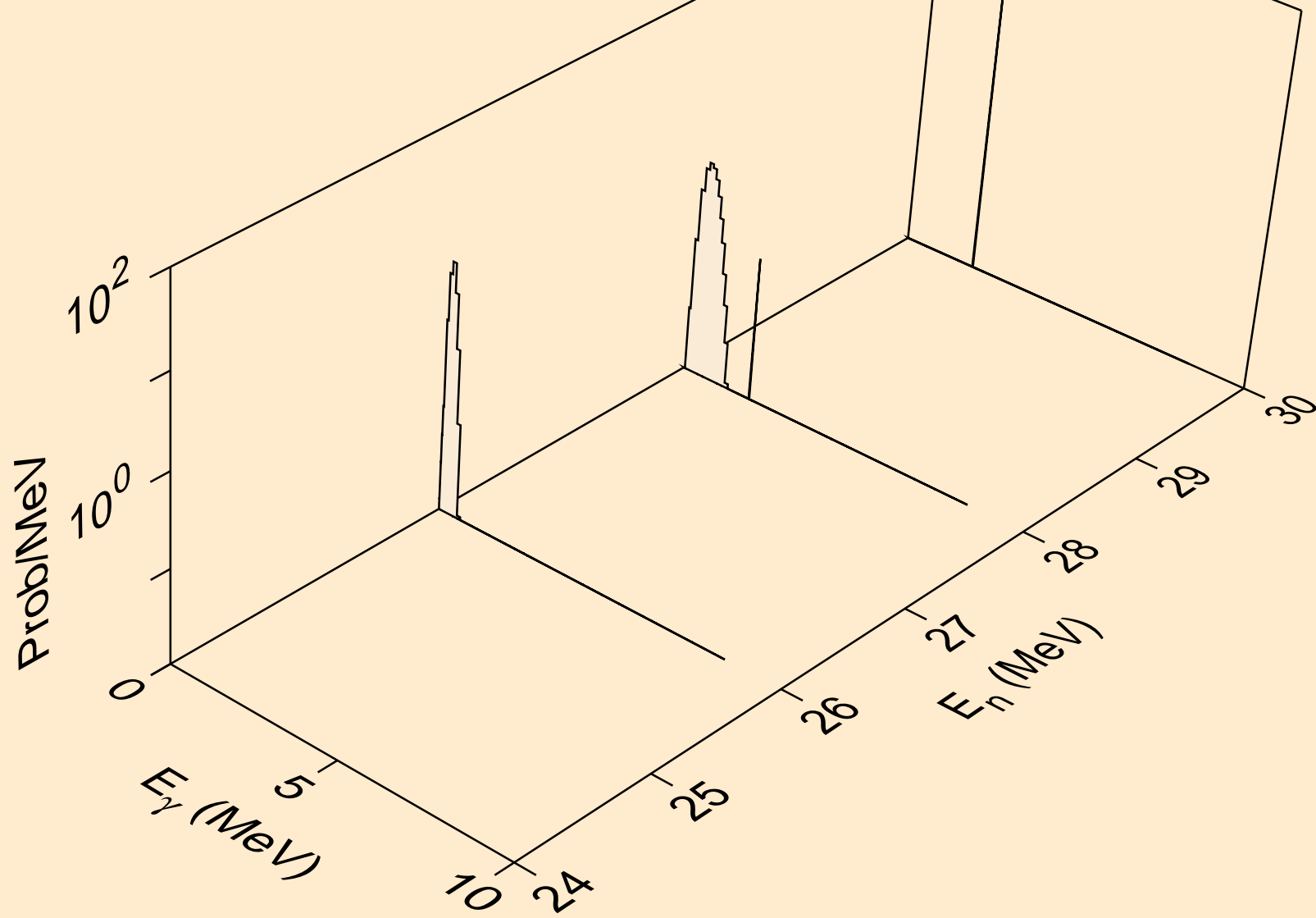

# N013 ALPHA ACER TENDL-2023 LIBRARY; T=0.K

## Particle heating contributions

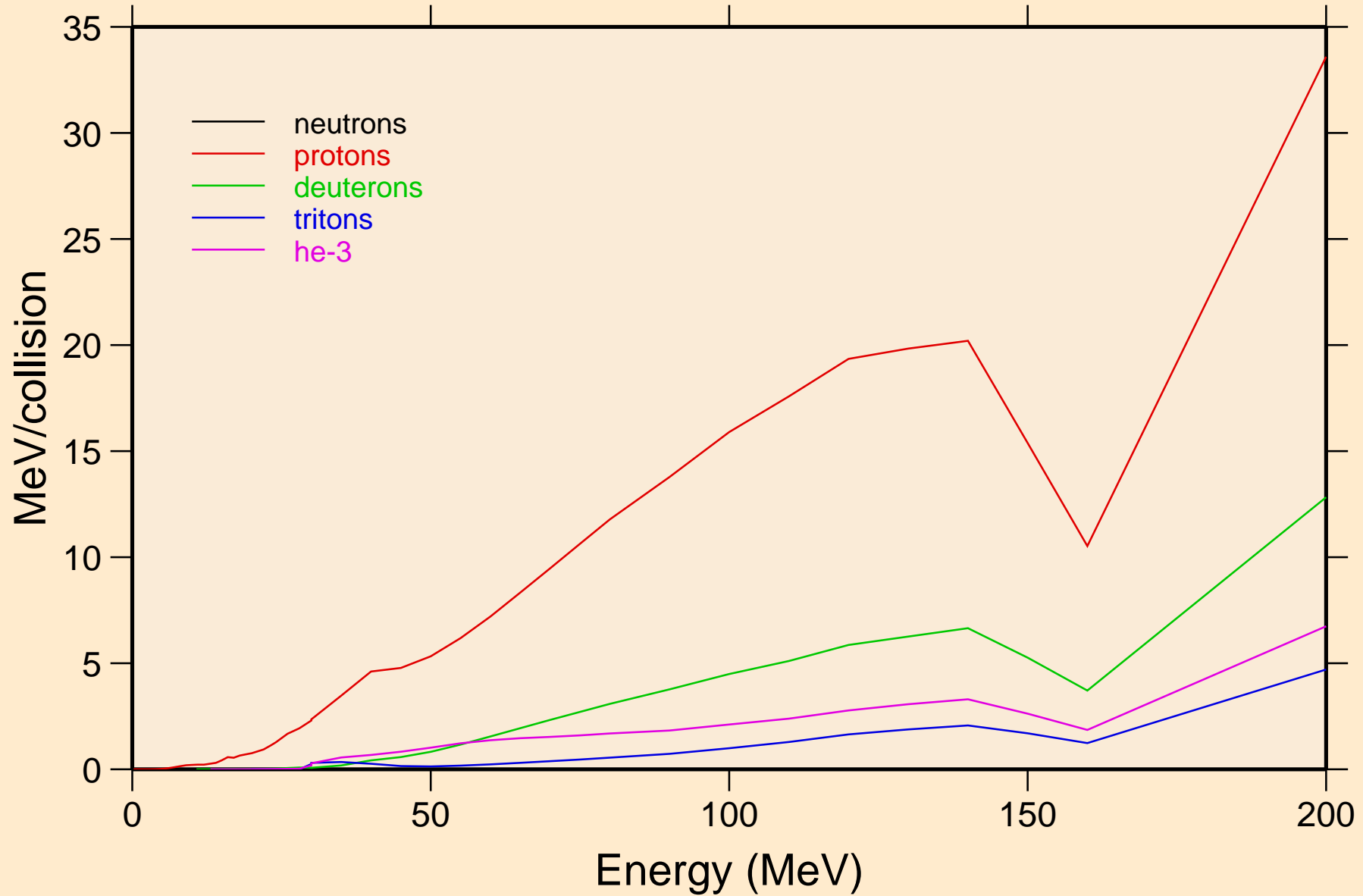

N013 ALPHA ACER TENDL-2023 LIBRARY; T=0.K  
Recoil Heating

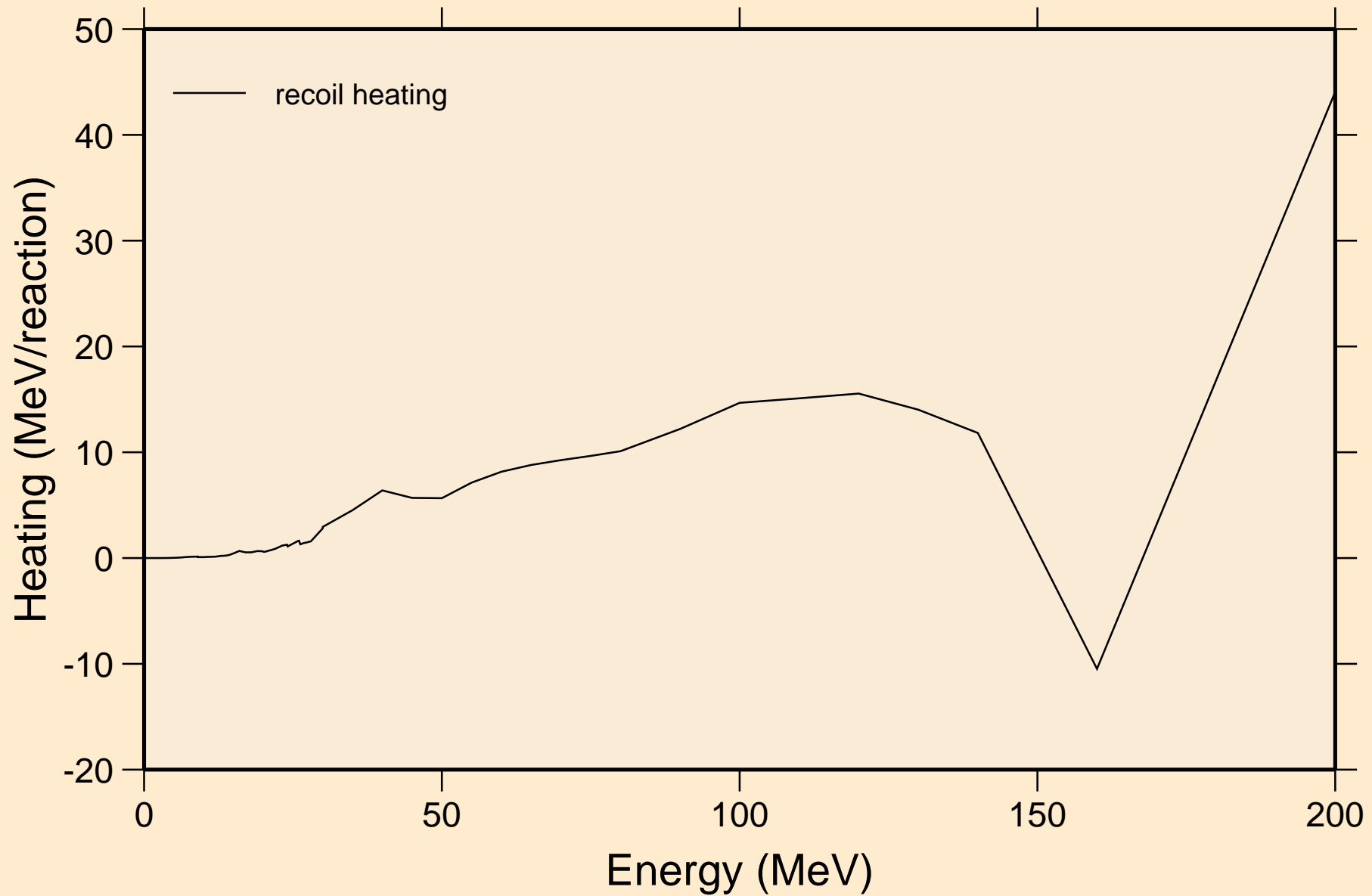

N013 ALPHA ACER TENDL-2023 LIBRARY; T=0.K  
Particle production cross sections

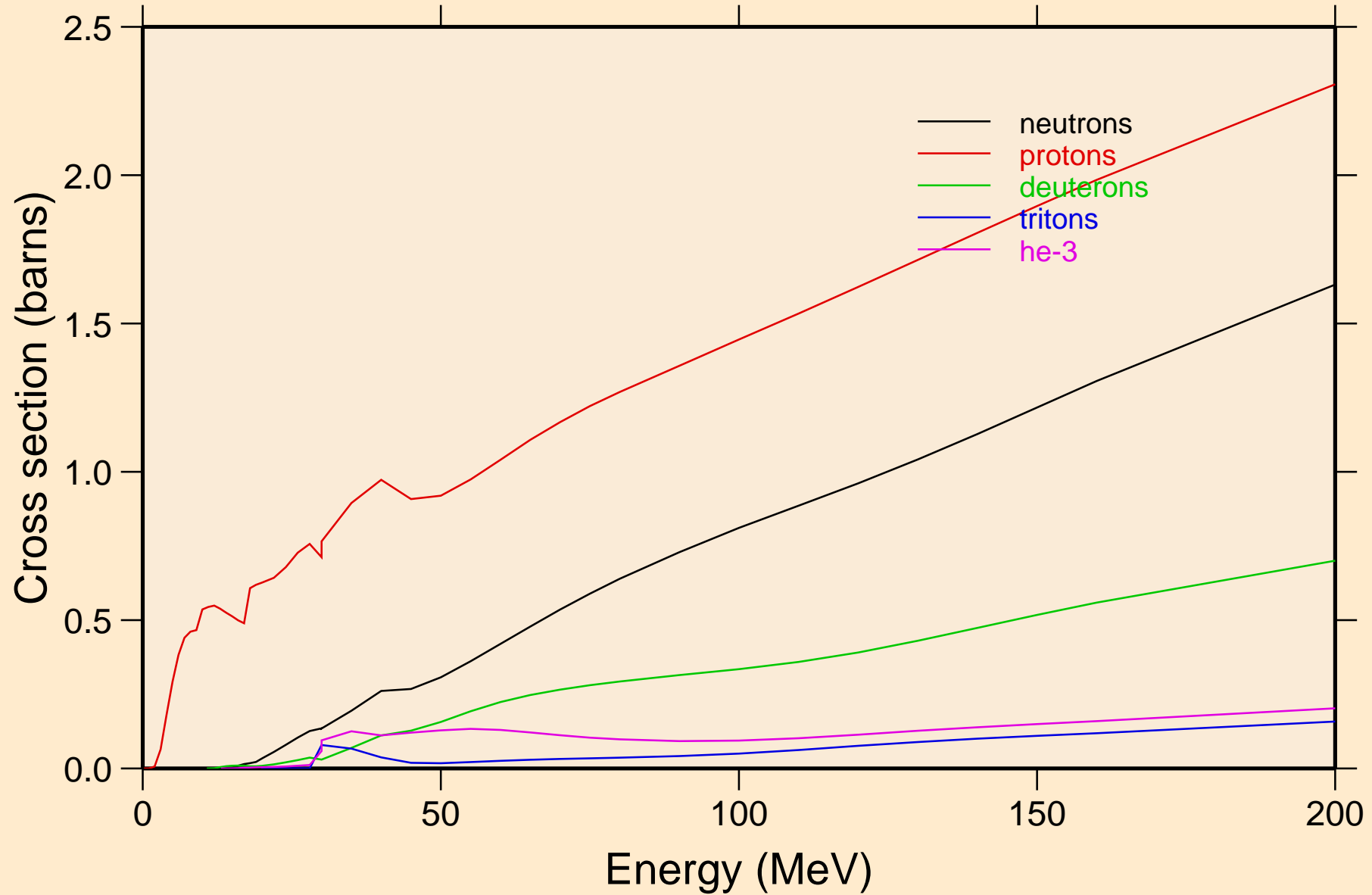

N013 ALPHA ACER TENDL-2023 LIBRARY; T=0.K  
neutrons from (a,n)

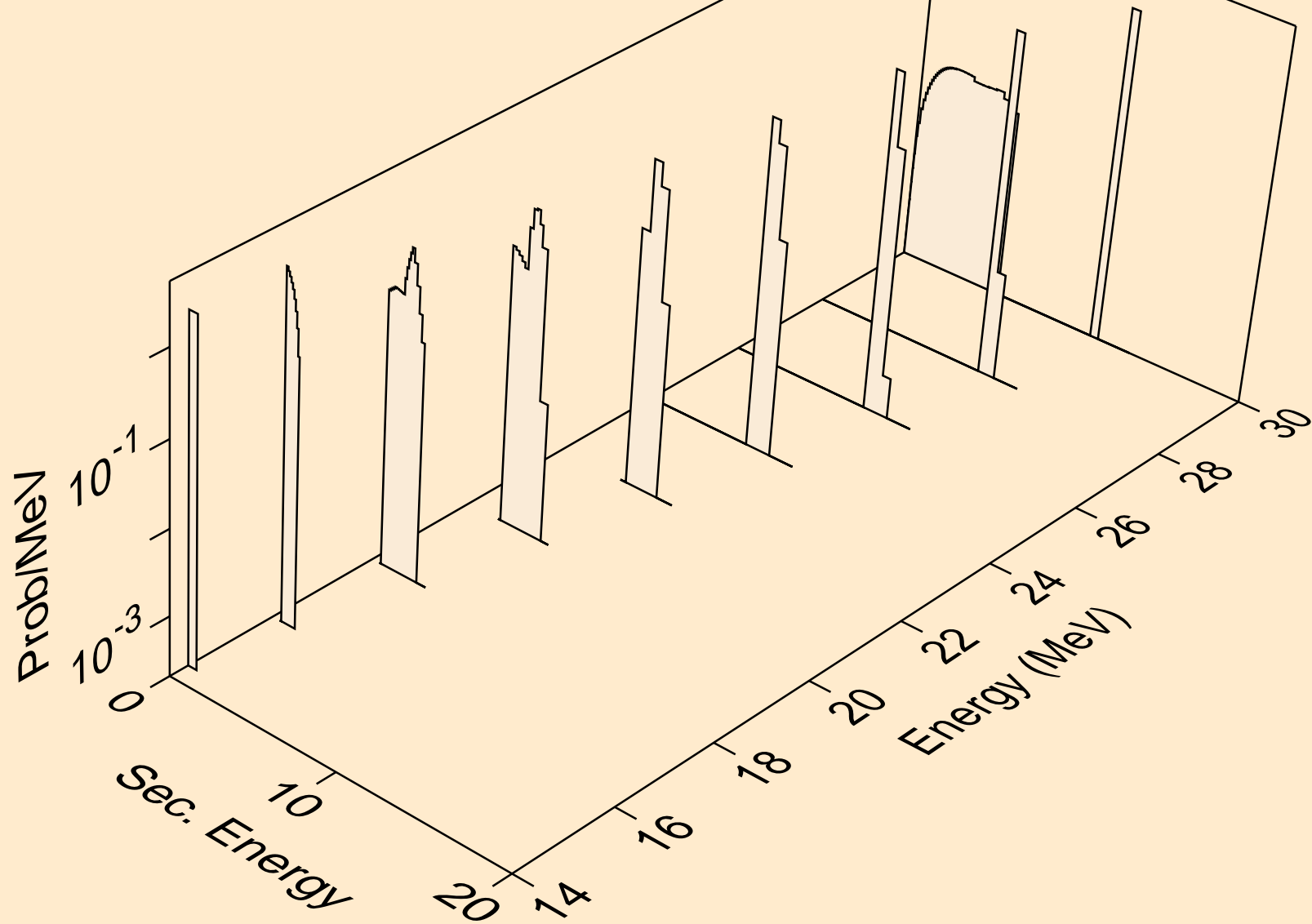

N013 ALPHA ACER TENDL-2023 LIBRARY; T=0.K  
neutrons from (a,x)

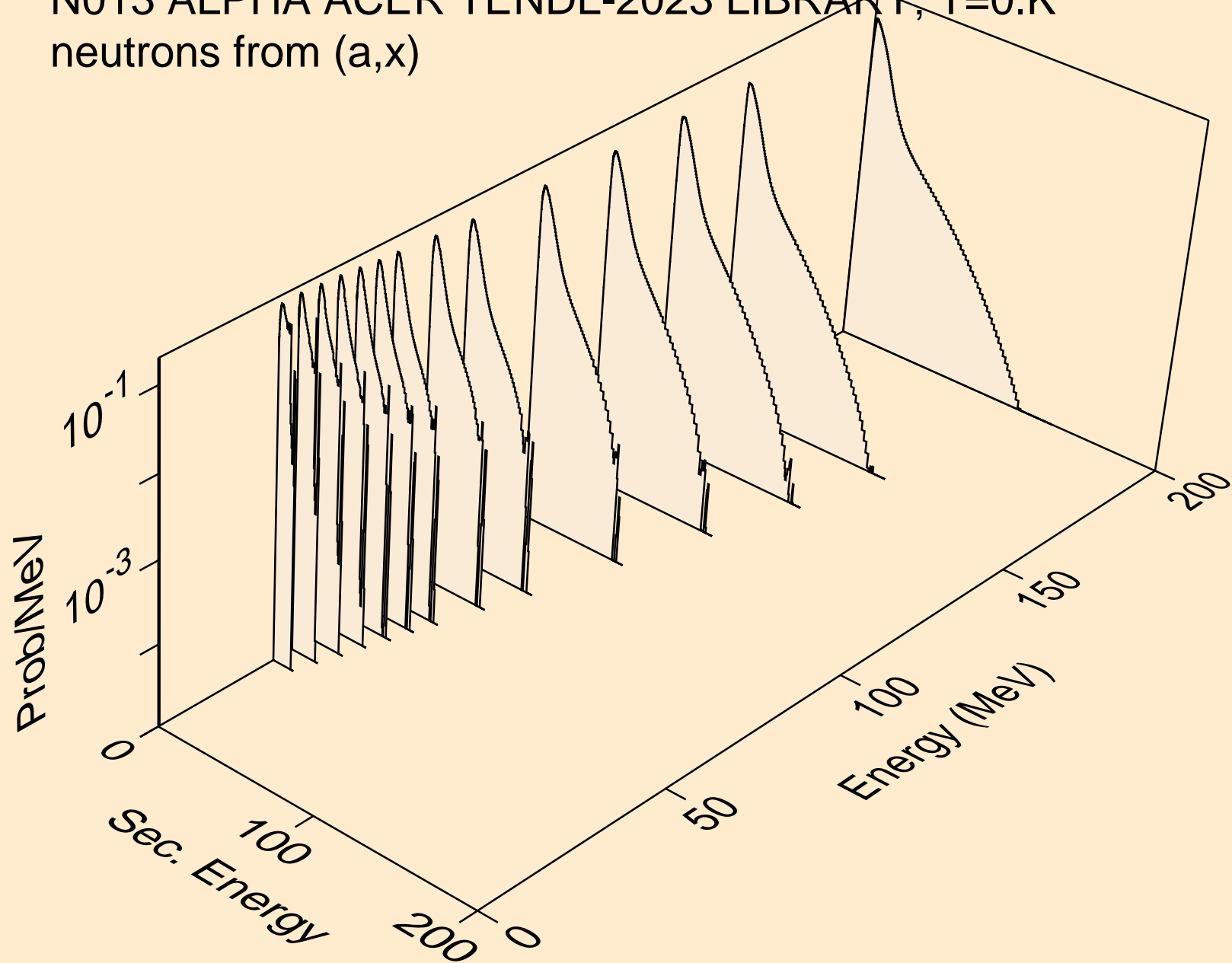

N013 ALPHA ACER TENDL-2023 LIBRARY; T=0.K  
neutrons from (a,n\*)a

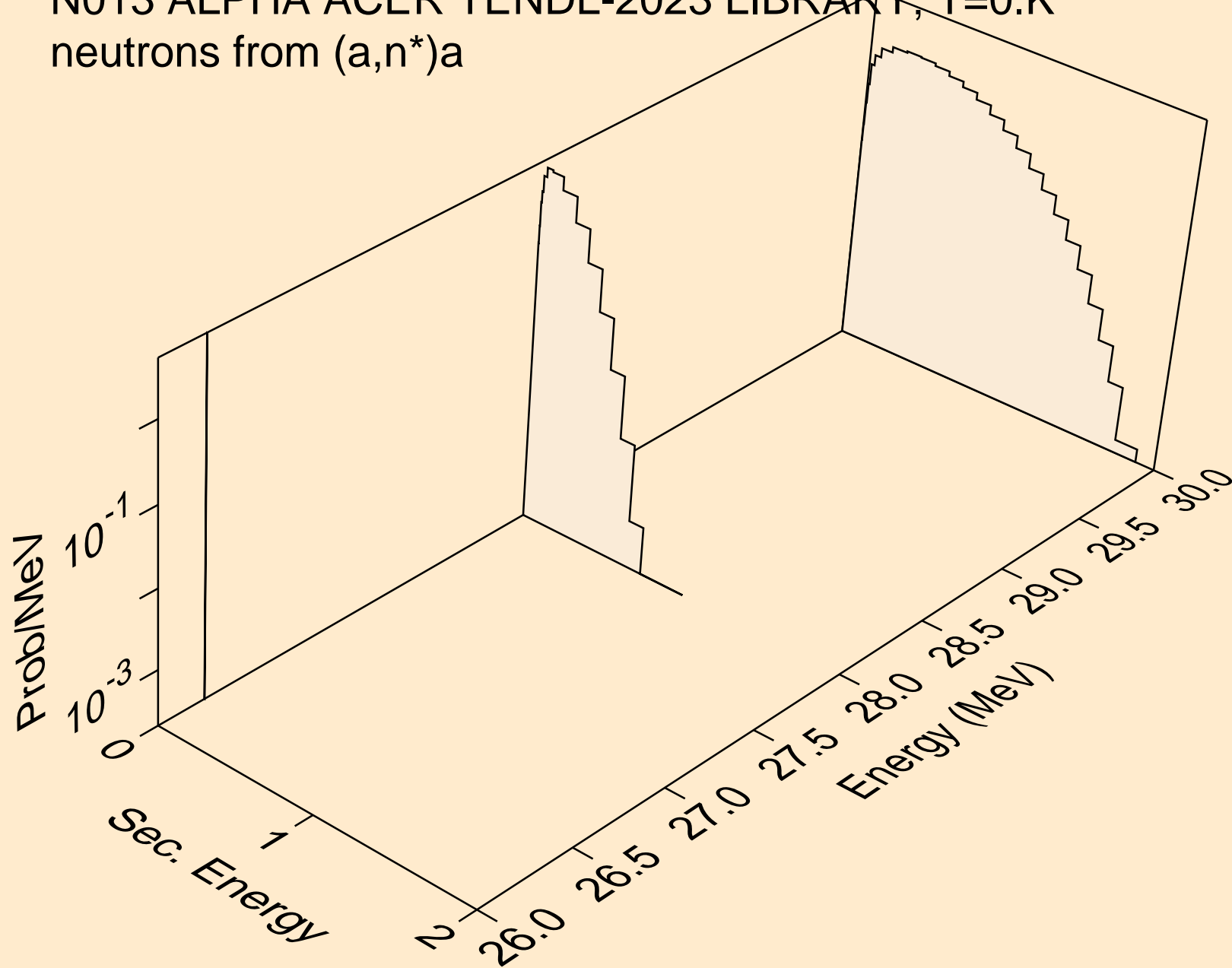

N013 ALPHA ACER TENDL-2023 LIBRARY; T=0.K  
neutrons from (a,n\*)p

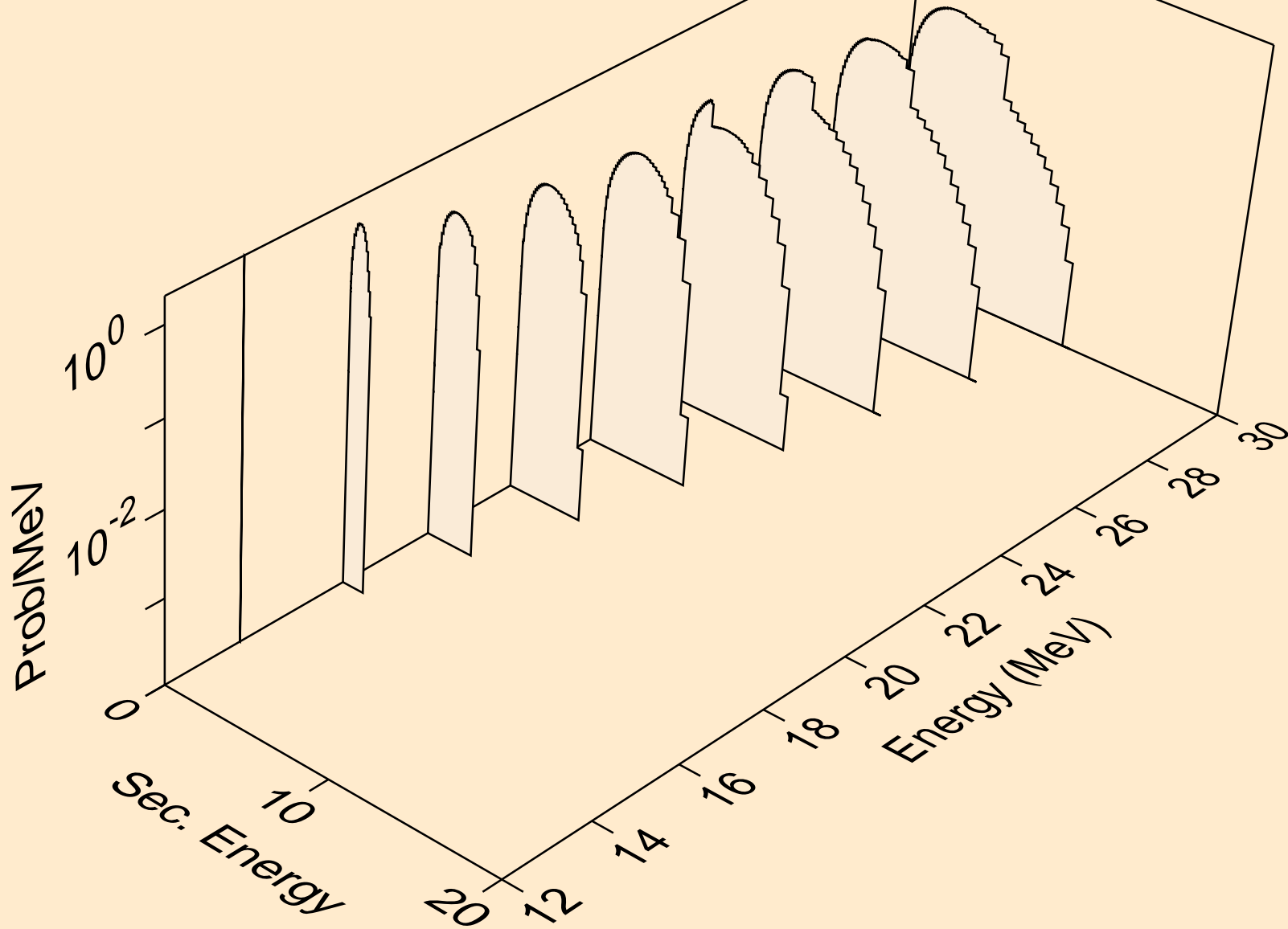

N013 ALPHA ACER TENDL-2023 LIBRARY; T=0.K  
neutrons from (a,n\*)he3

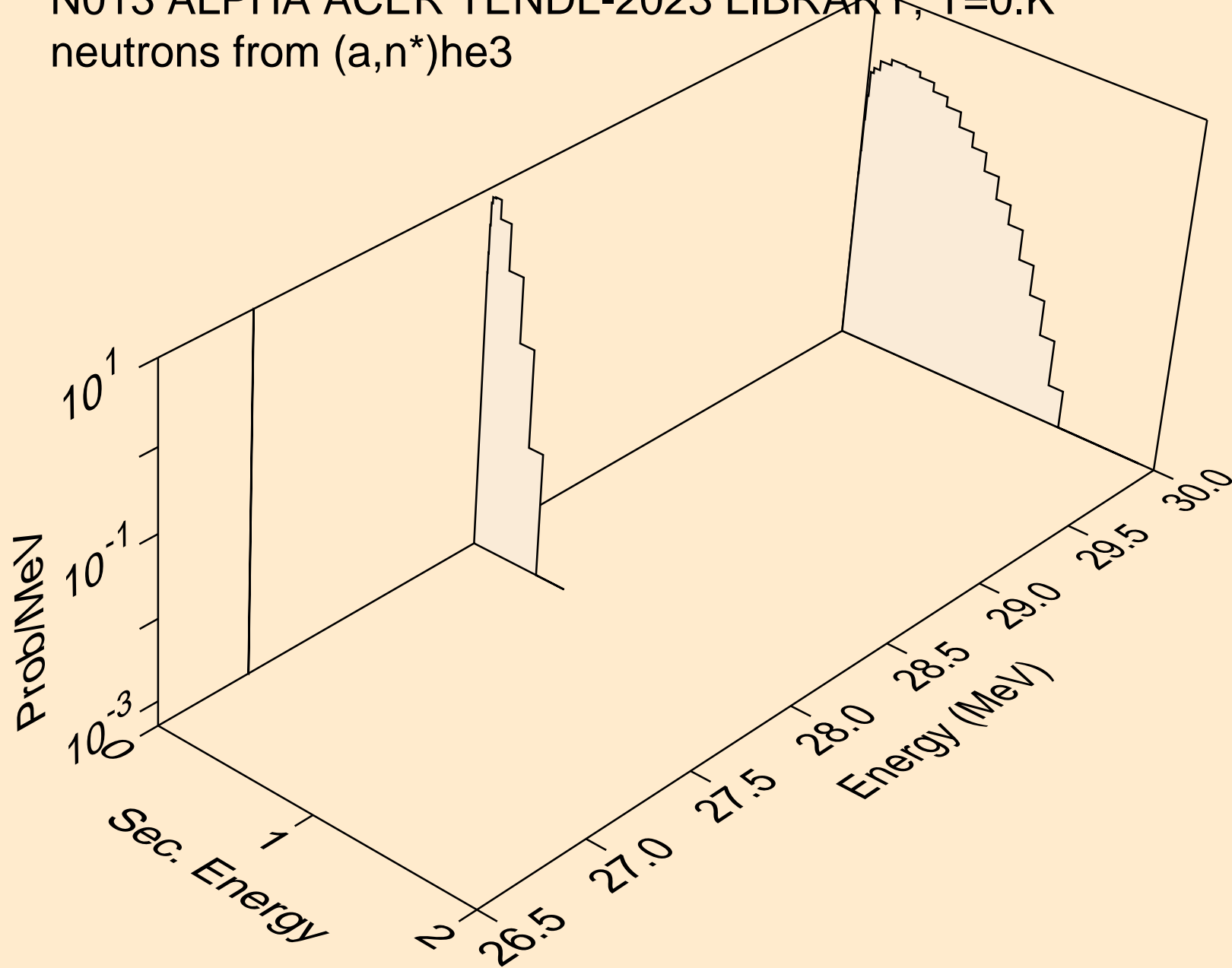

N013 ALPHA ACER TENDL-2023 LIBRARY; T=0.K  
neutrons from (a,n2p)

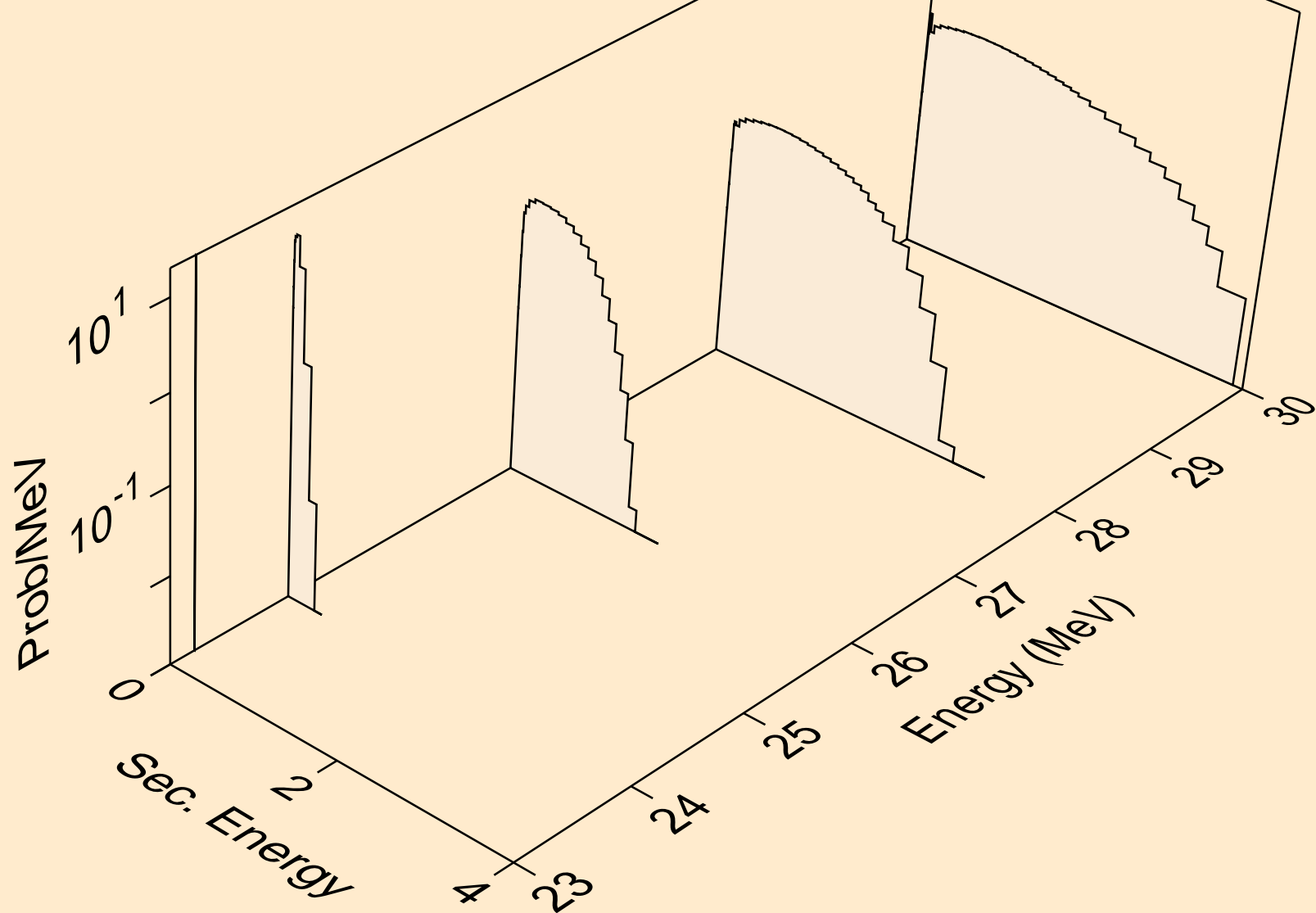

N013 ALPHA ACER TENDL-2023 LIBRARY; T=0.K  
neutrons from (a,npa)

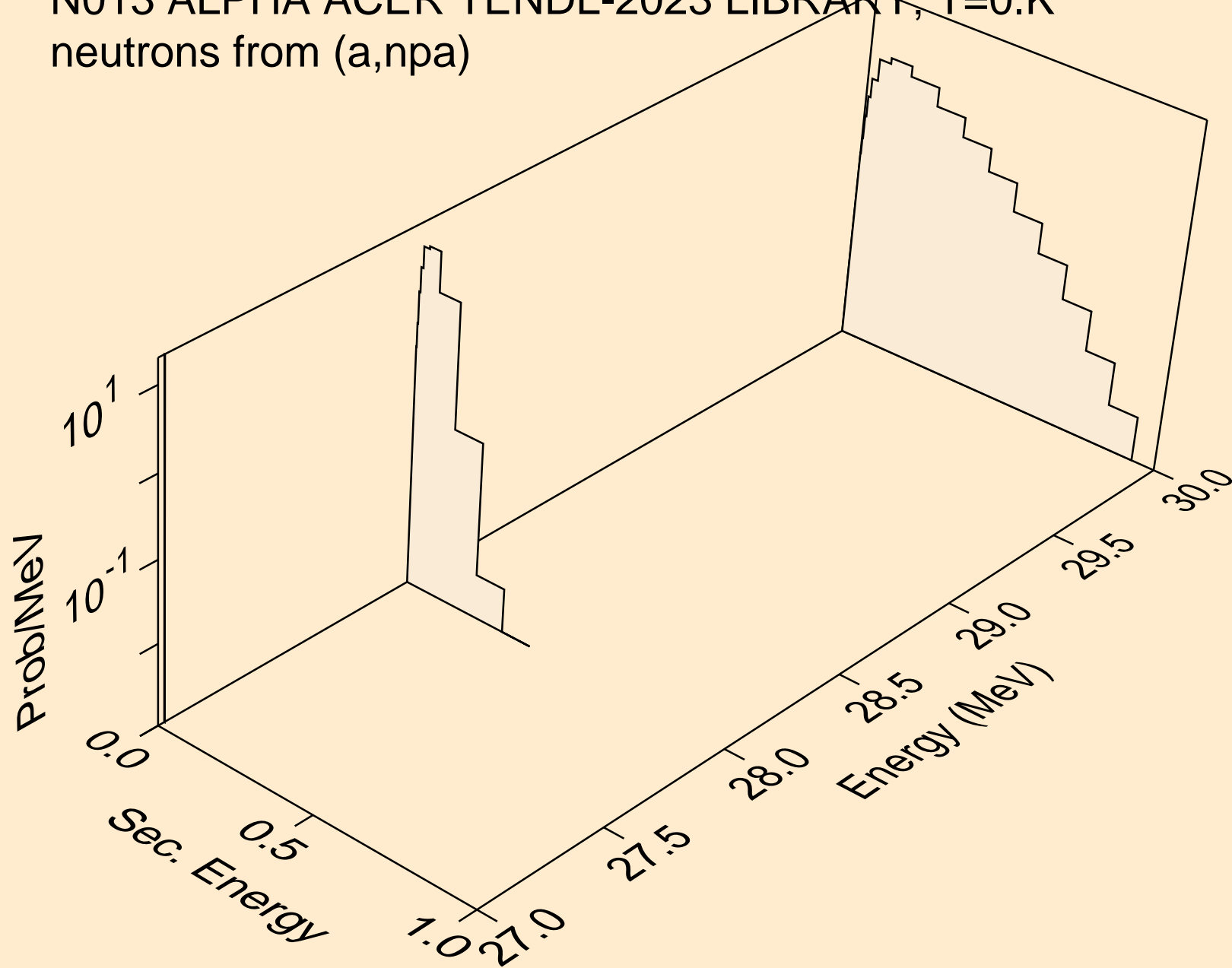

N013 ALPHA ACER TENDL-2023 LIBRARY; T=0.K  
protons from (a,x)

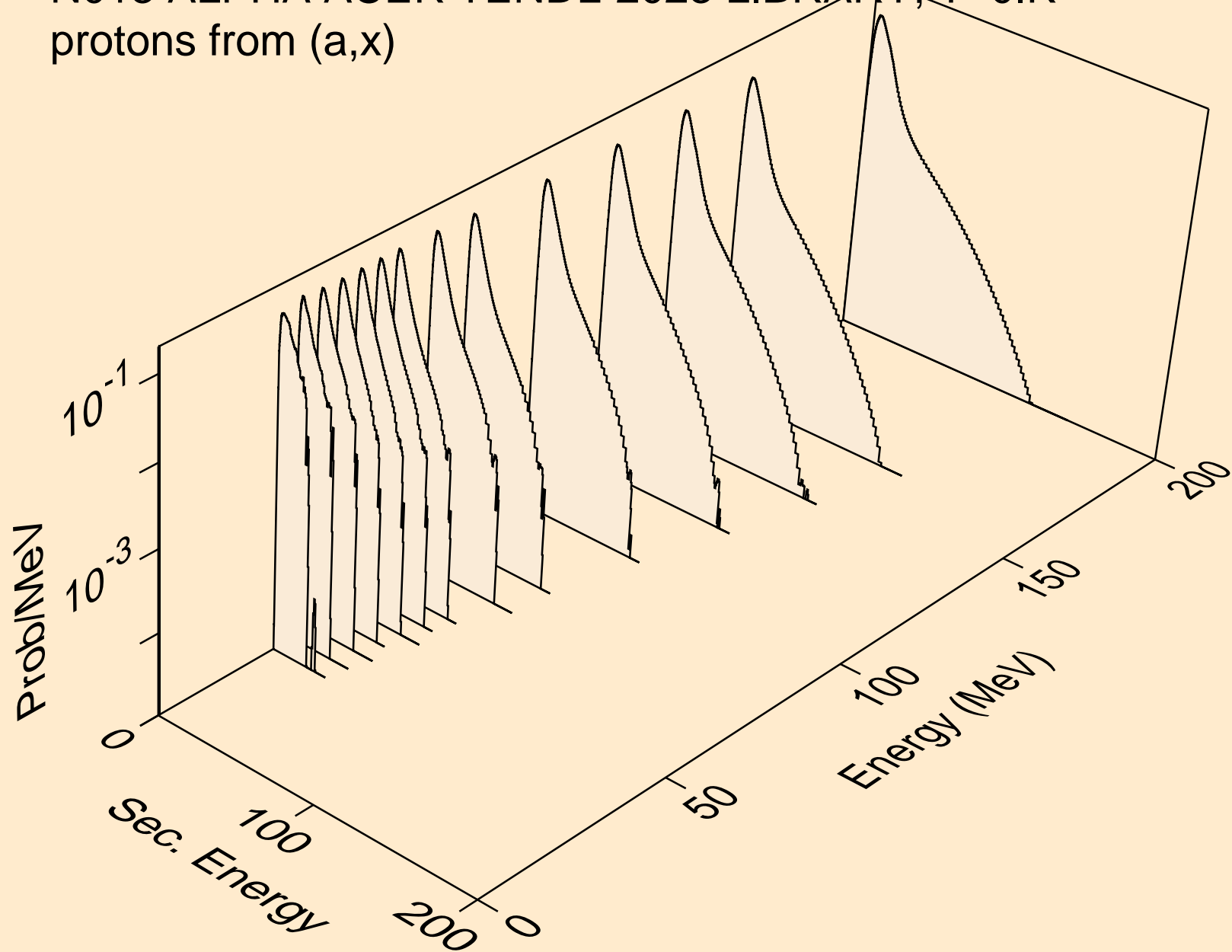

N013 ALPHA ACER TENDL-2023 LIBRARY; T=0.K  
protons from (a,n\*)p

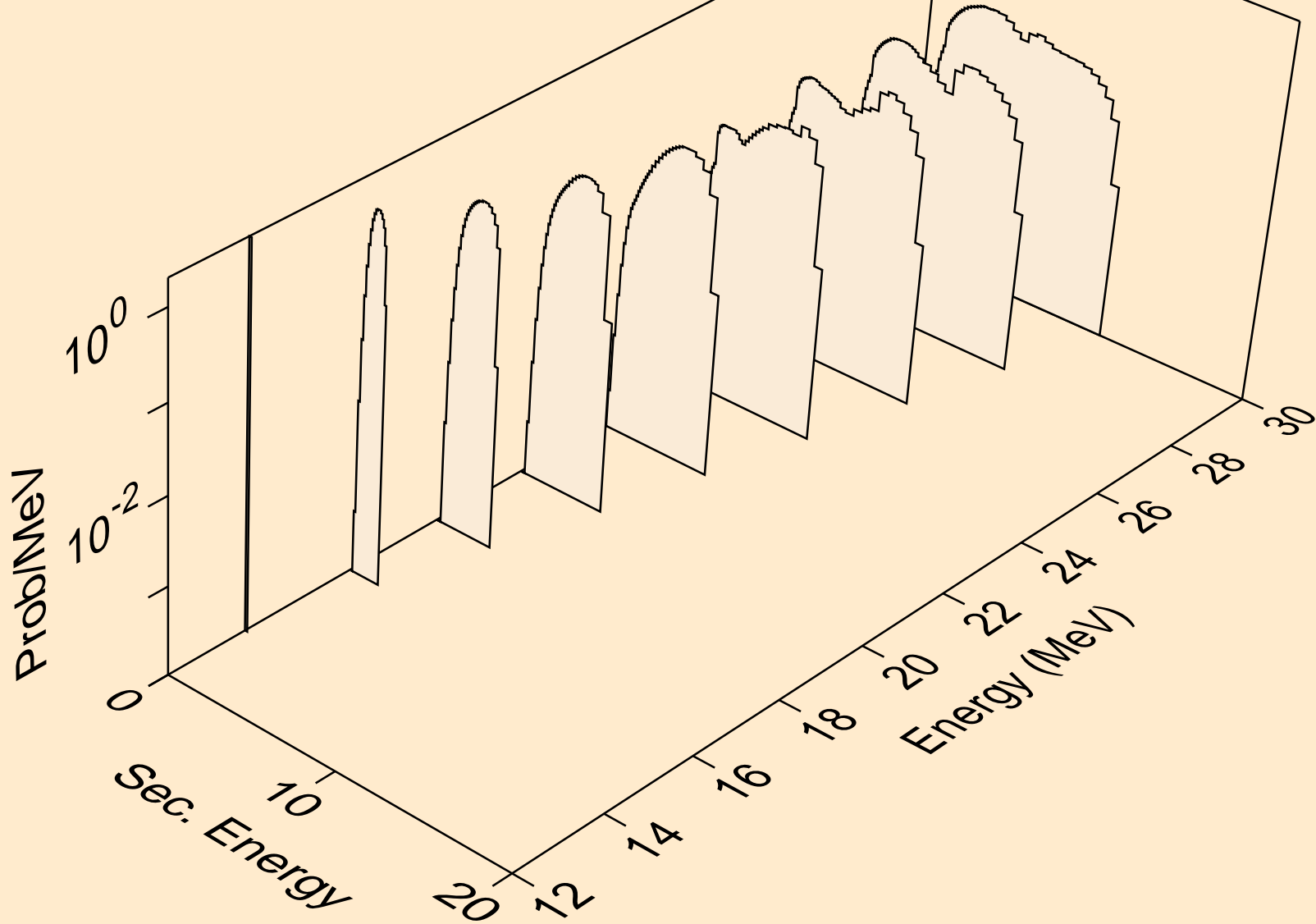

N013 ALPHA ACER TENDL-2023 LIBRARY; T=0.K  
protons from (a,n2p)

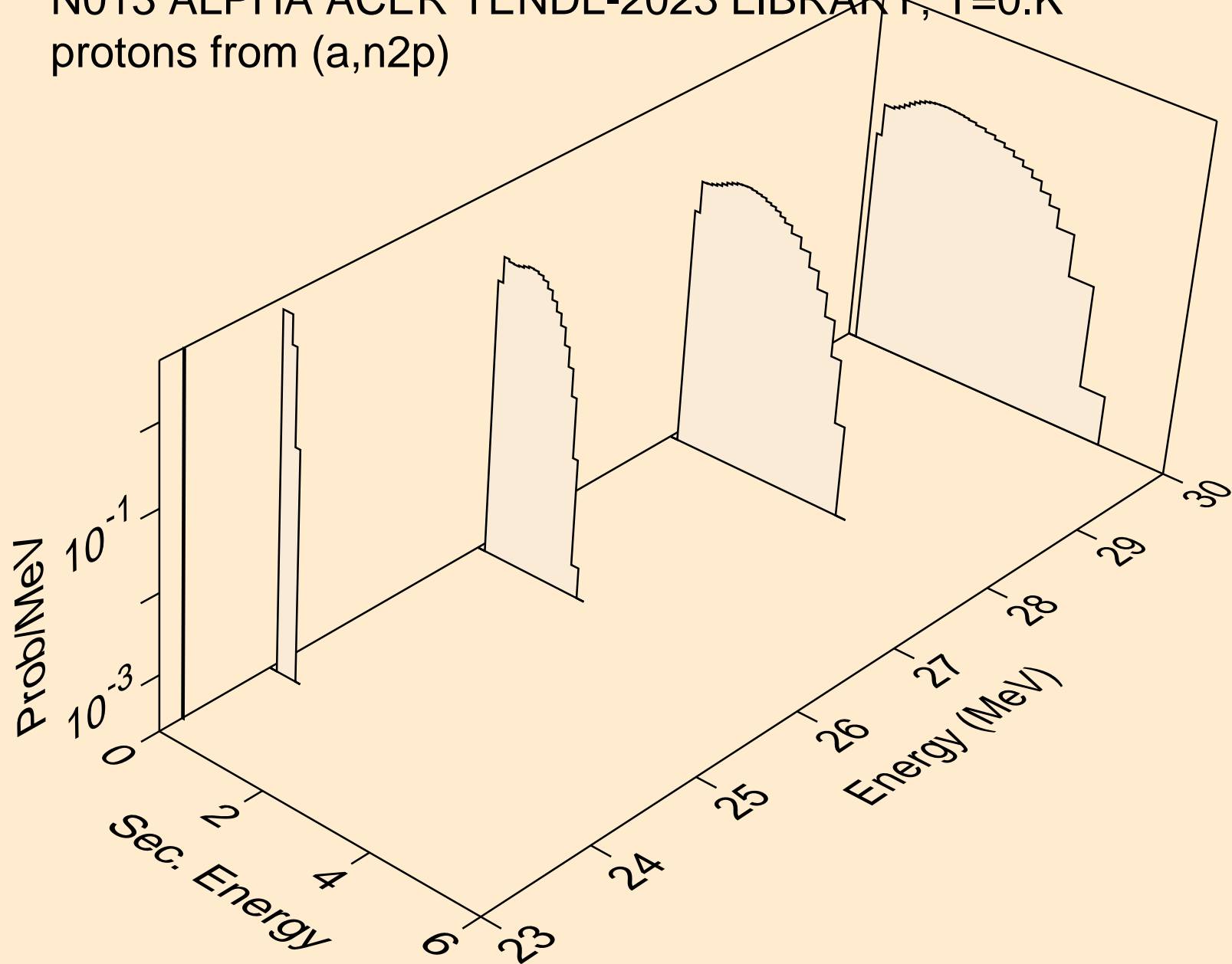

N013 ALPHA ACER TENDL-2023 LIBRARY; T=0.K  
protons from (a,npa)

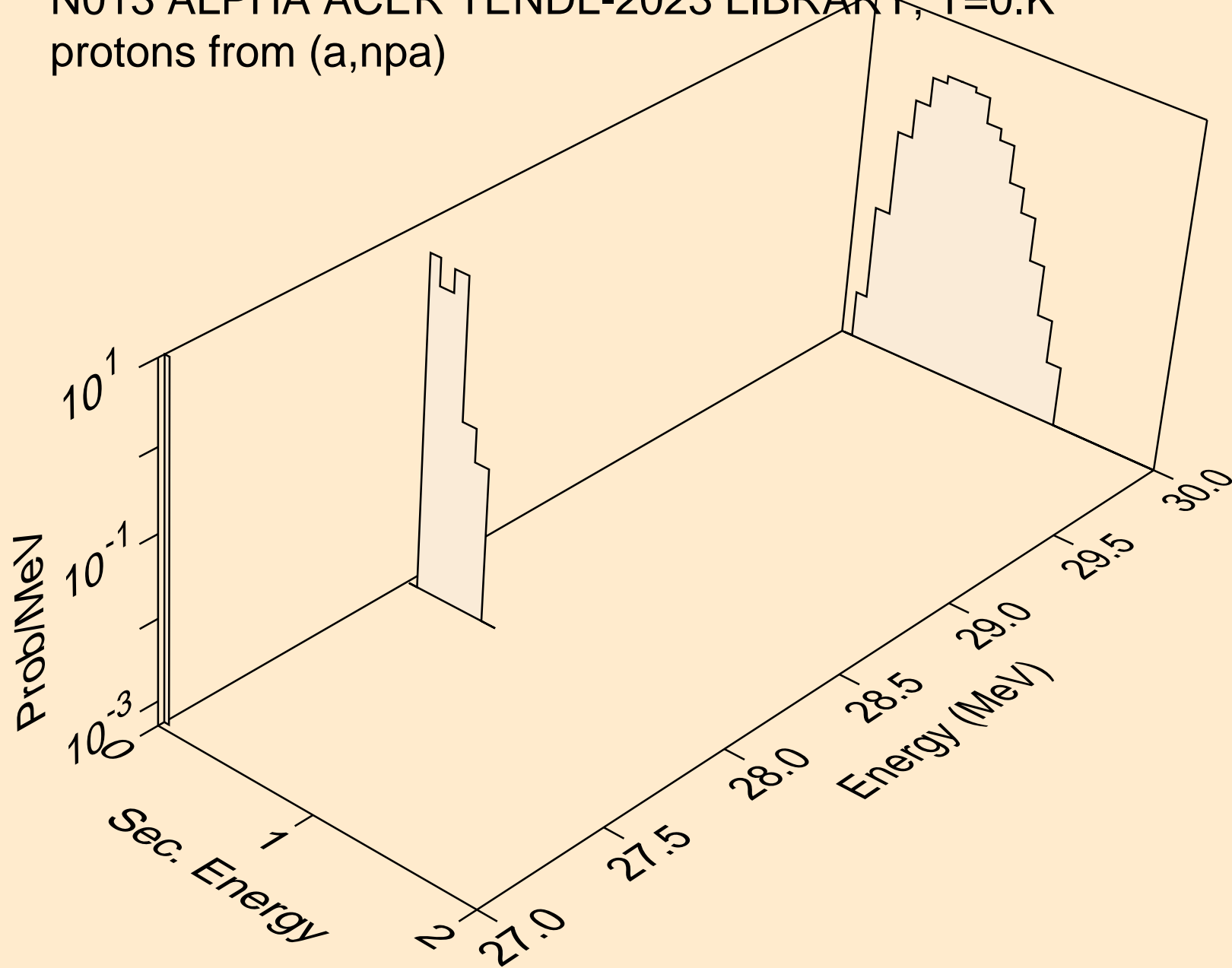

N013 ALPHA ACER TENDL-2023 LIBRARY; T=0.K  
protons from (a,p)

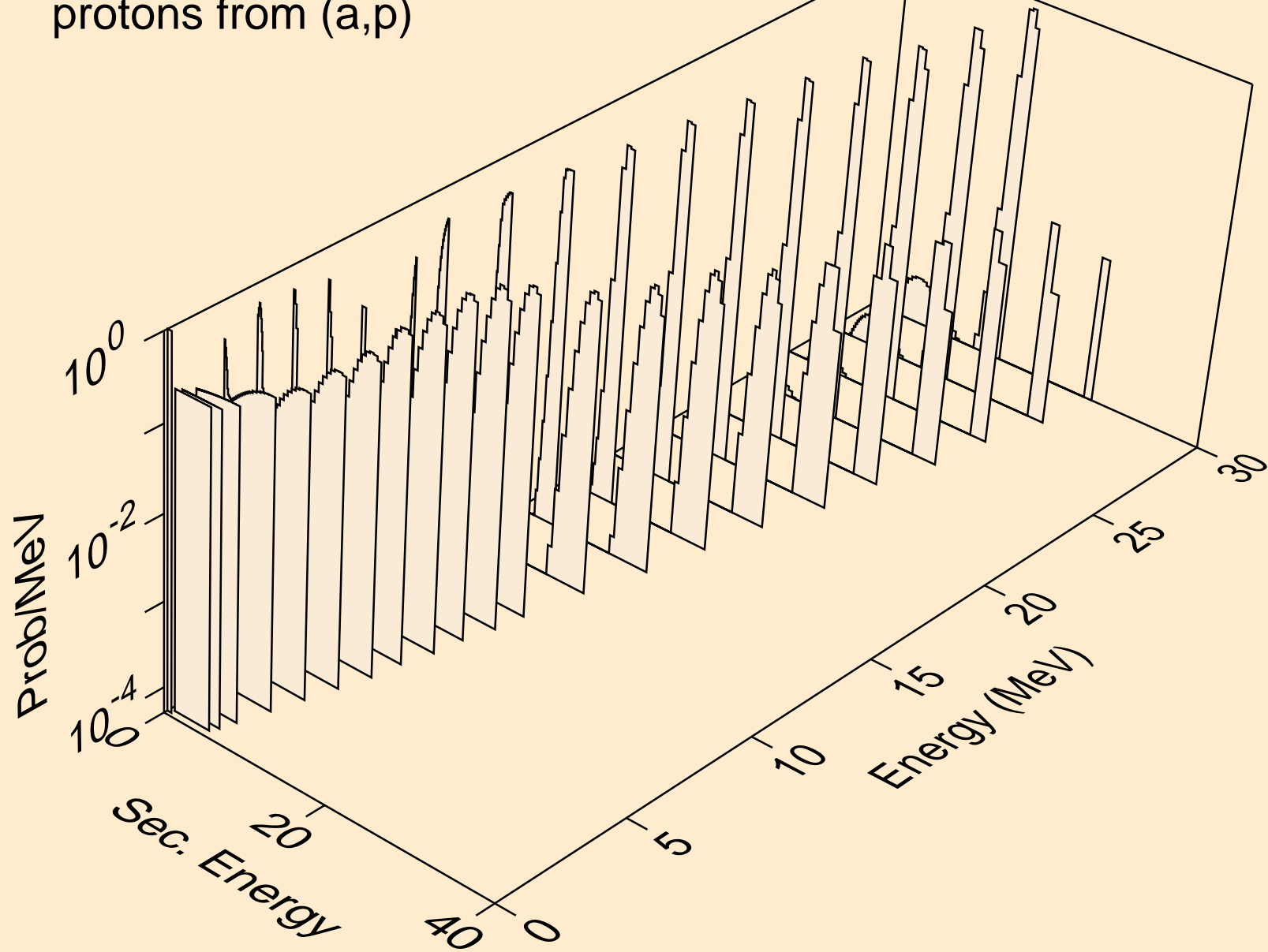

N013 ALPHA ACER TENDL-2023 LIBRARY; T=0.K  
protons from (a,2p)

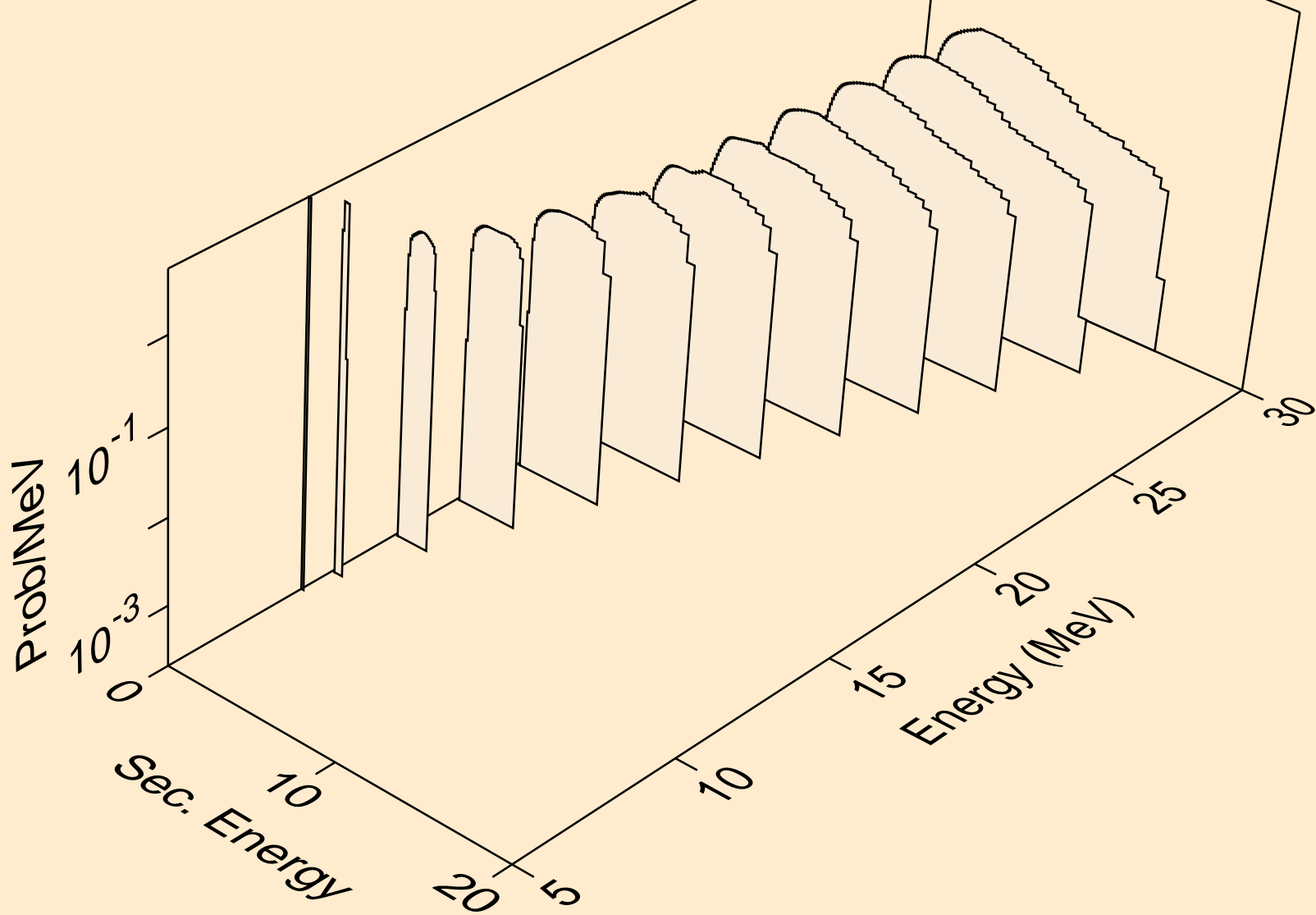

N013 ALPHA ACER TENDL-2023 LIBRARY; T=0.K  
protons from (a,pa)

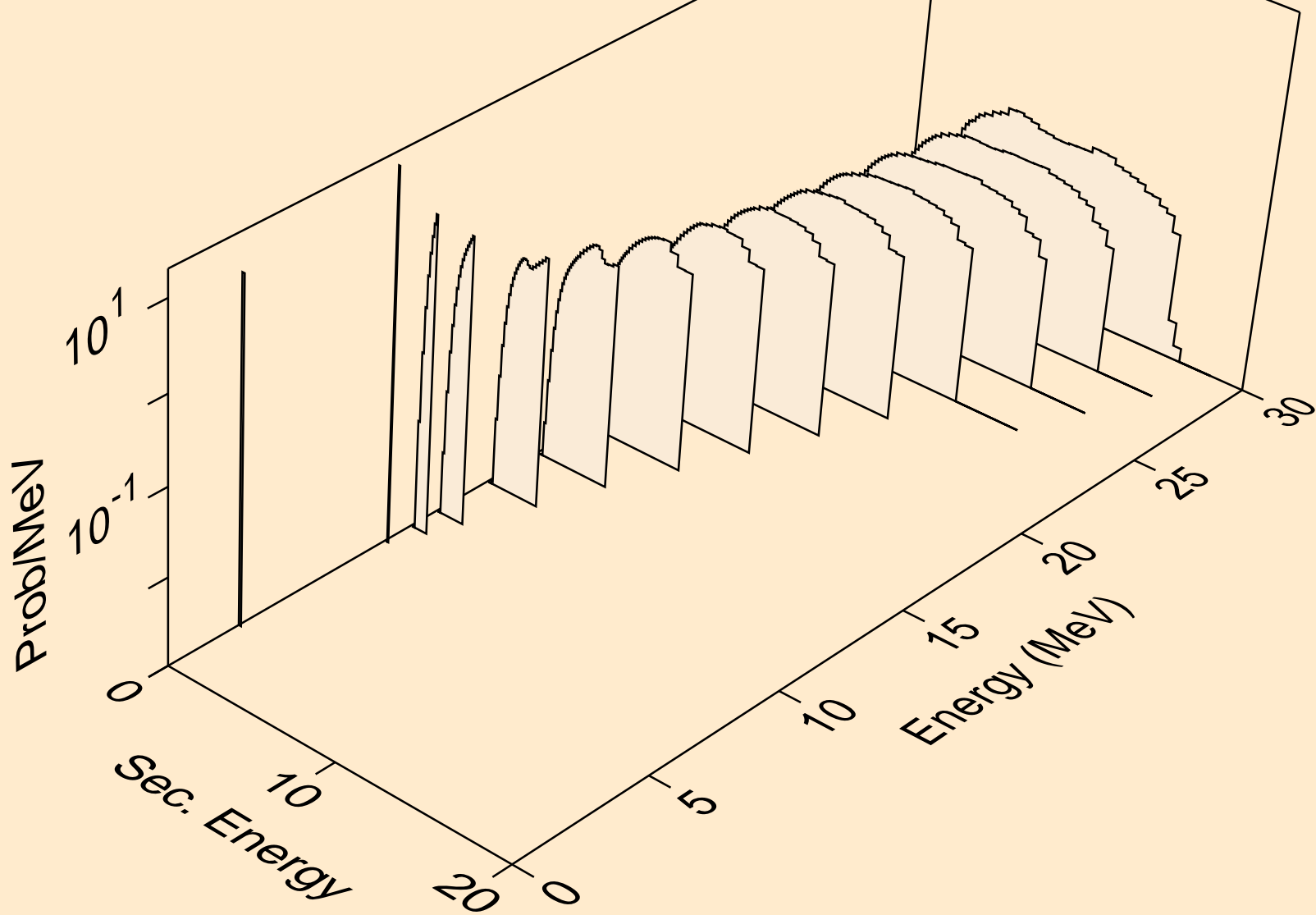

N013 ALPHA ACER TENDL-2023 LIBRARY; T=0.K  
protons from (a,pd)

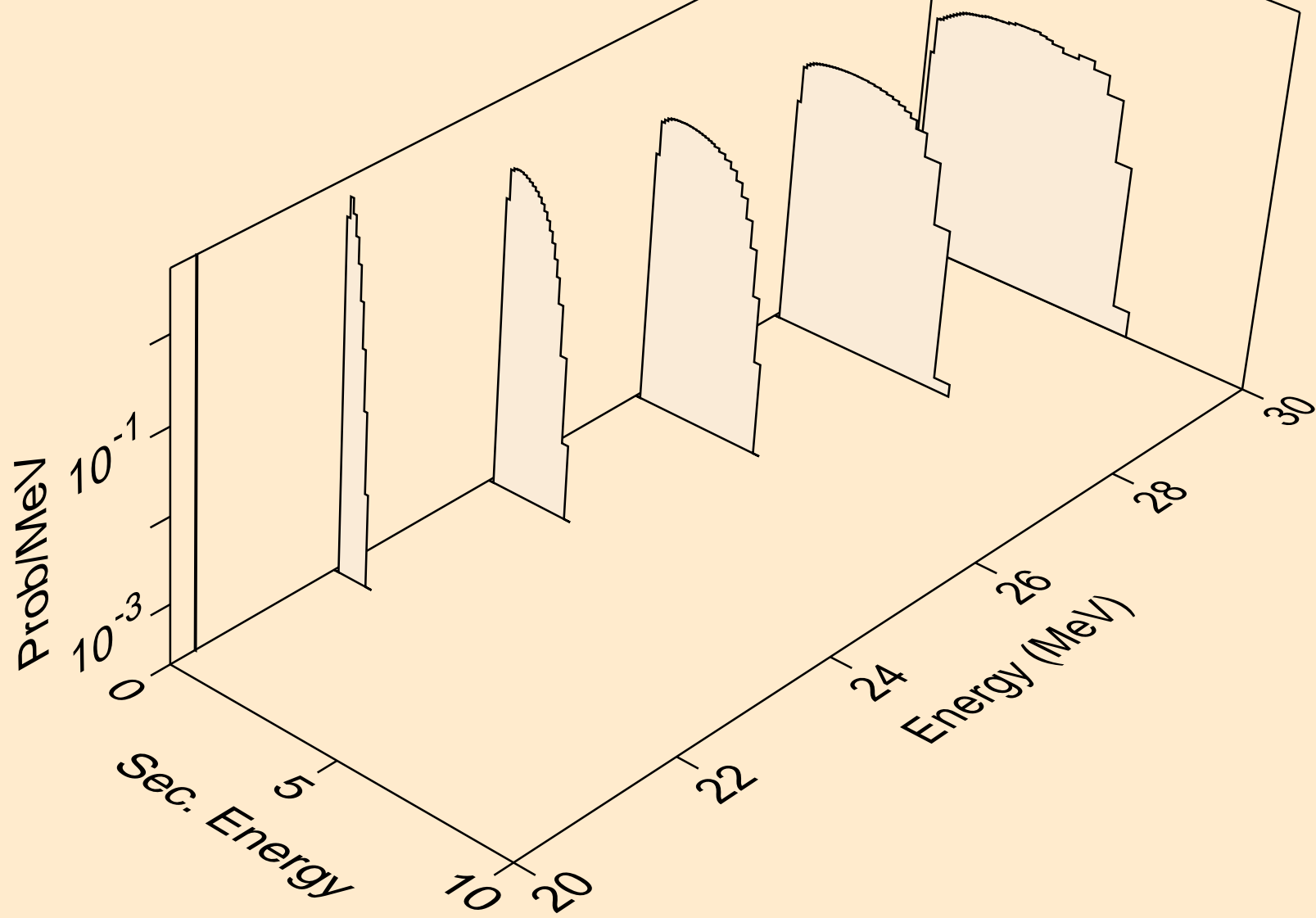

N013 ALPHA ACER TENDL-2023 LIBRARY; T=0.K  
protons from (a,pt)

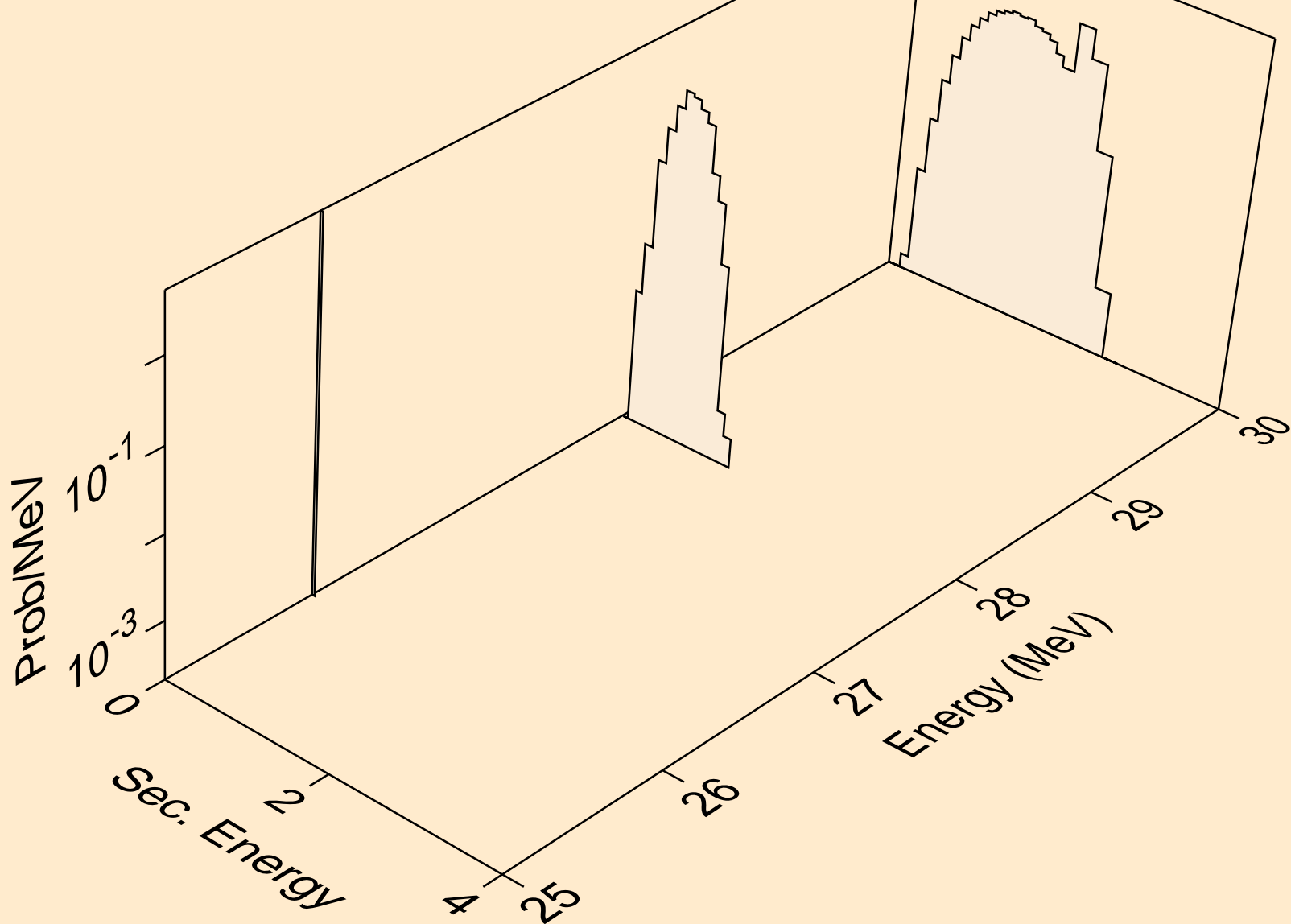

N013 ALPHA ACER TENDL-2023 LIBRARY; T=0.K  
deuterons from (a,x)

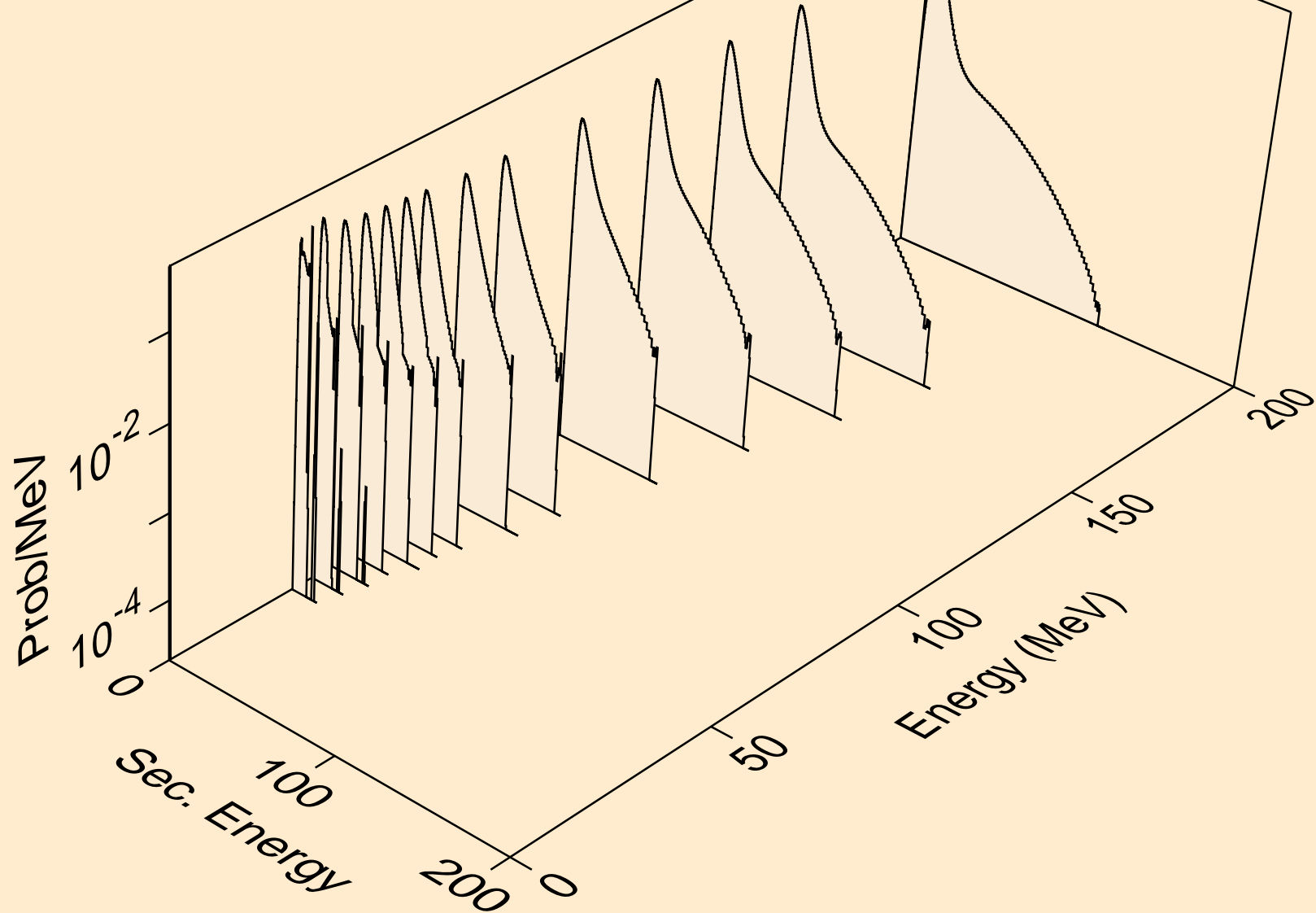

N013 ALPHA ACER TENDL-2023 LIBRARY; T=0.K  
deuterons from (a,d)

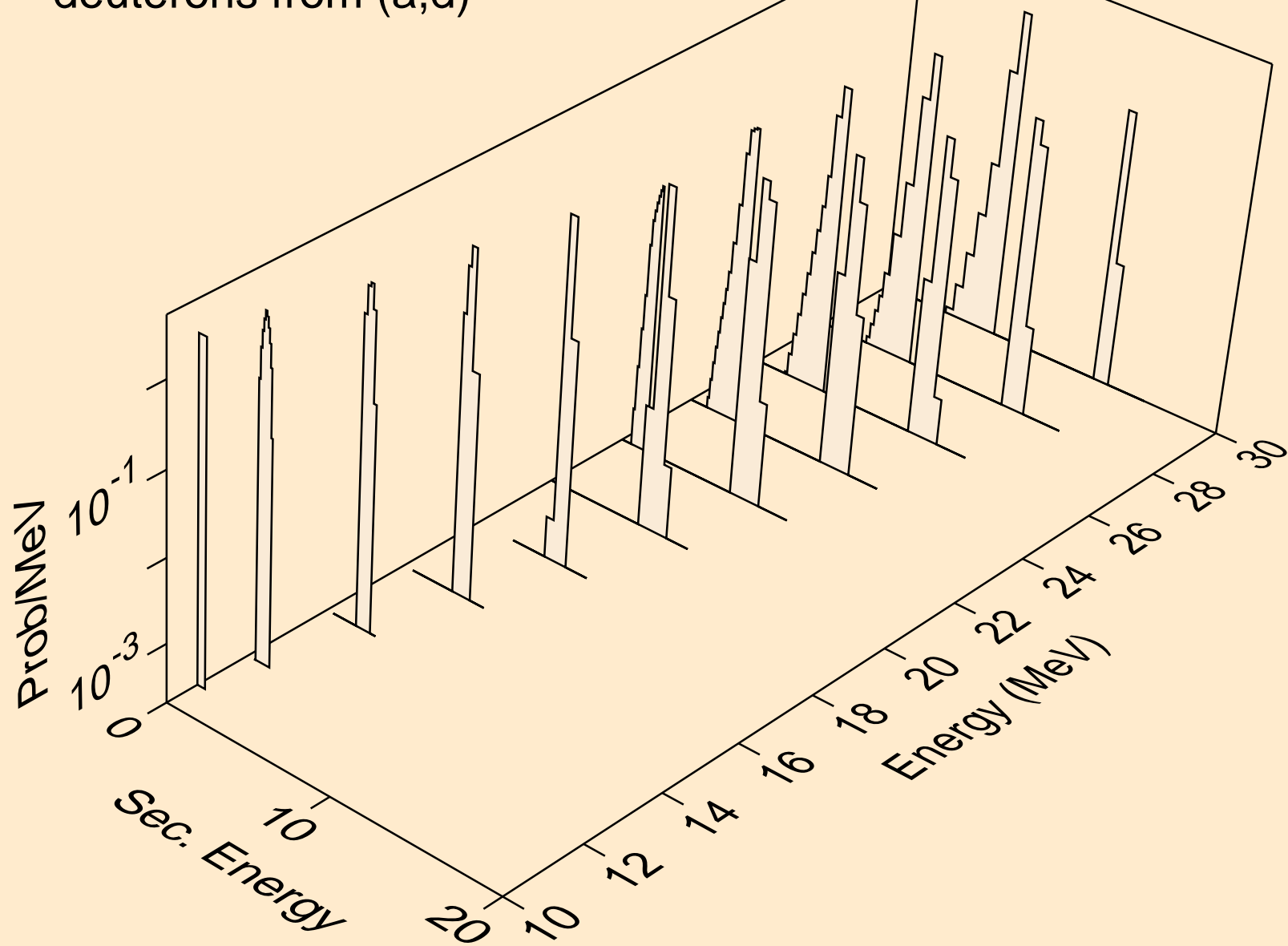

N013 ALPHA ACER TENDL-2023 LIBRARY; T=0.K  
deuterons from (a,pd)

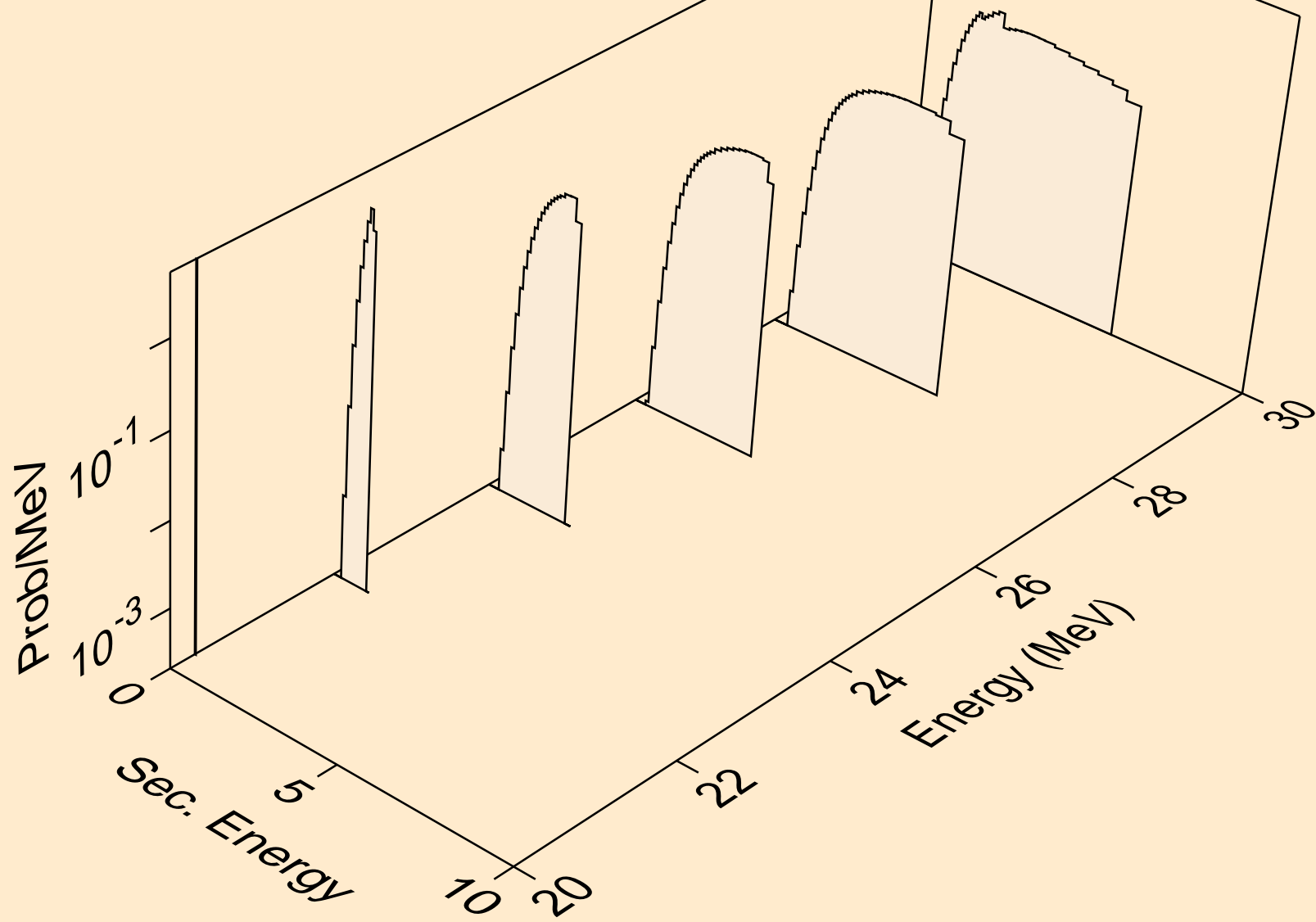

N013 ALPHA ACER TENDL-2023 LIBRARY; T=0.K  
deuterons from (a,da)

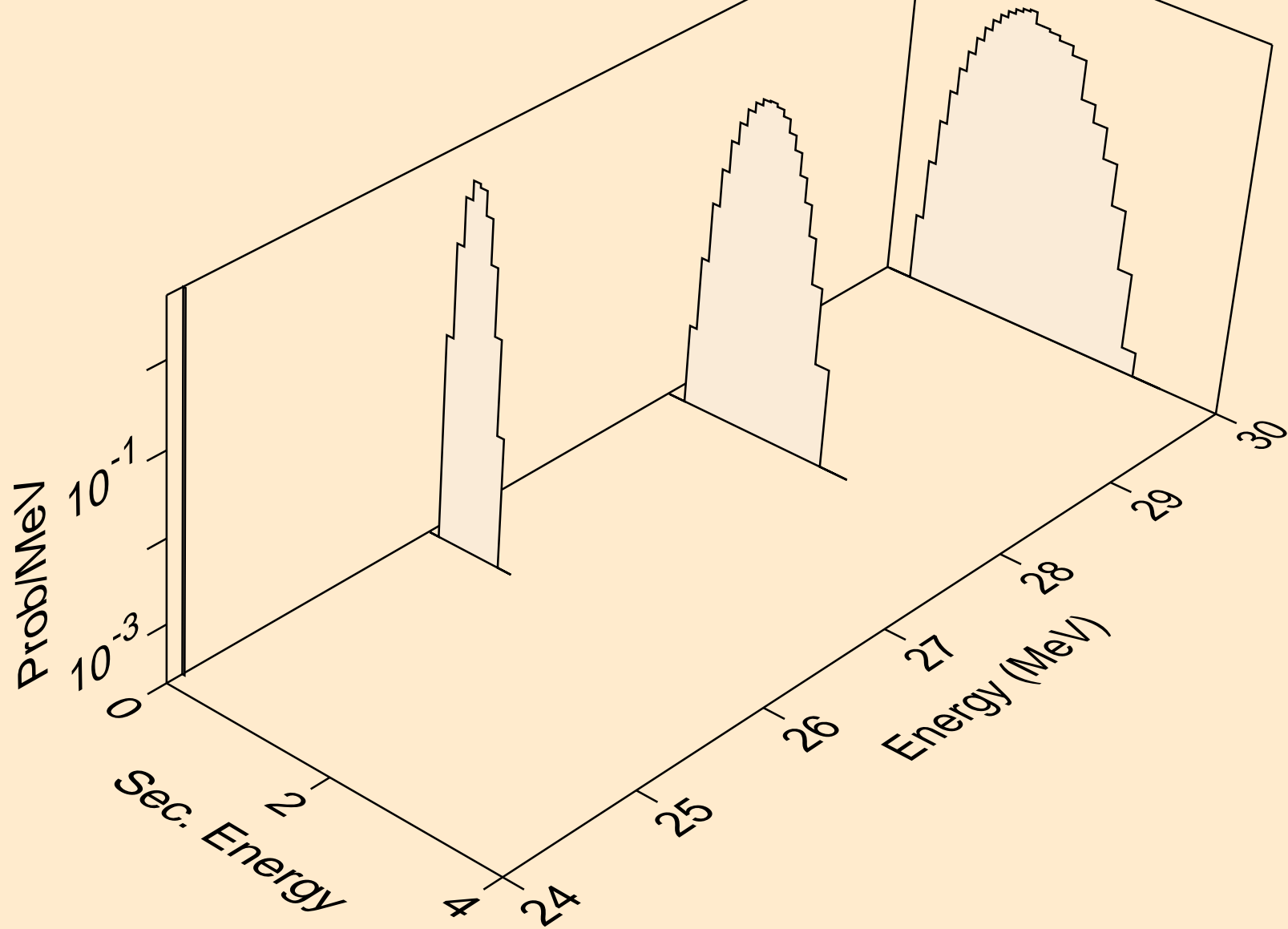

N013 ALPHA ACER TENDL-2023 LIBRARY; T=0.K  
tritons from (a,x)

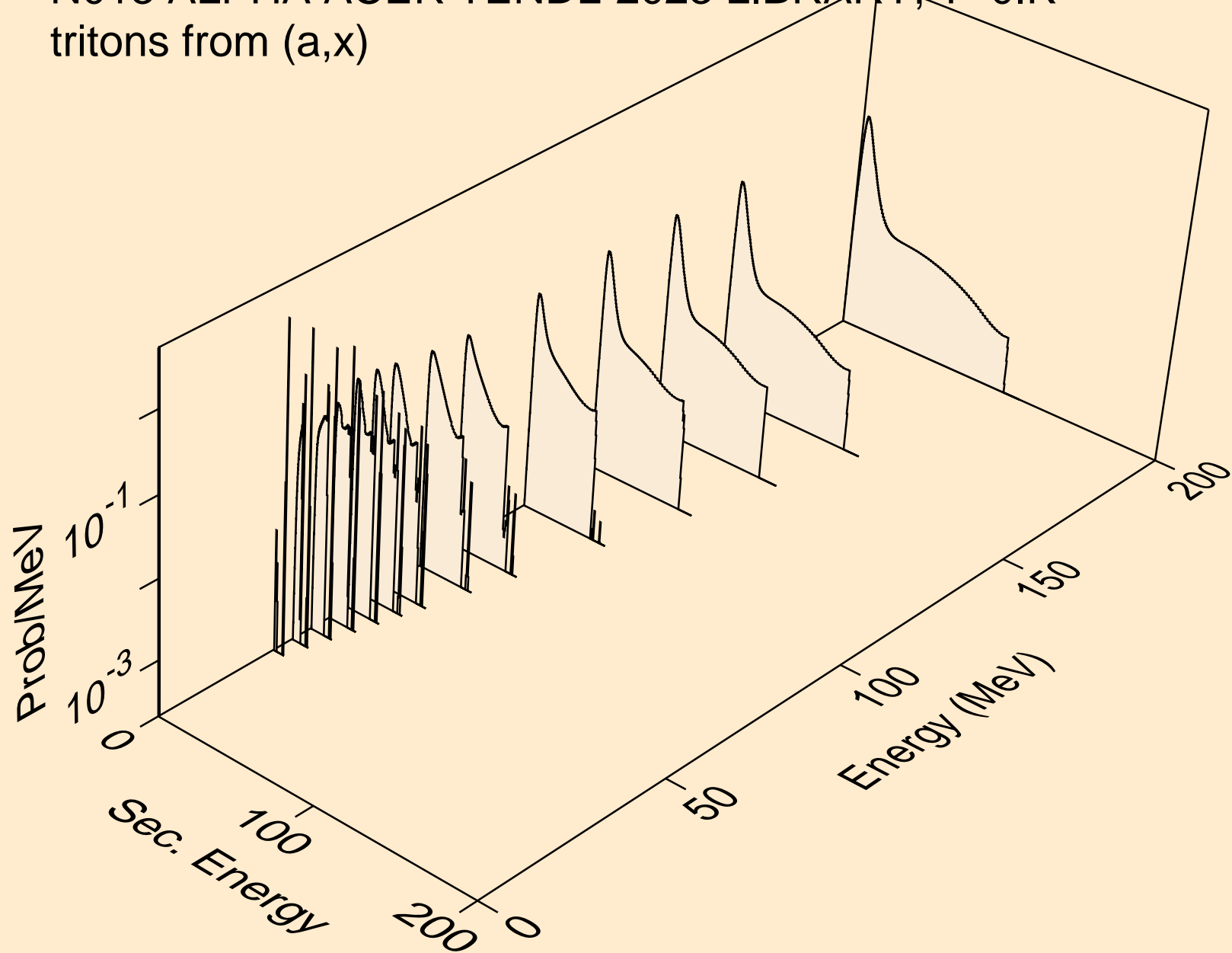

N013 ALPHA ACER TENDL-2023 LIBRARY; T=0.K  
tritons from (a,t)

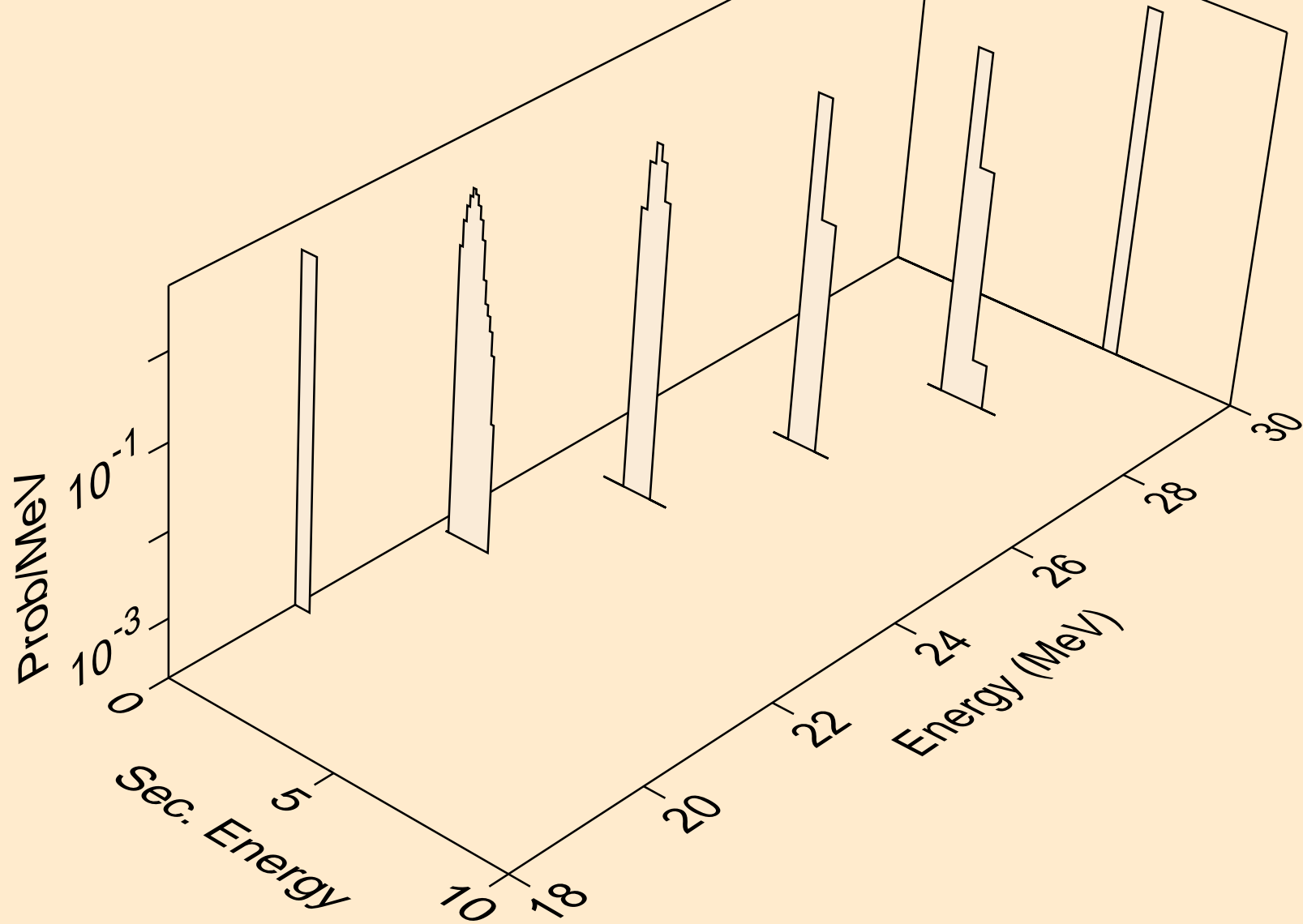

N013 ALPHA ACER TENDL-2023 LIBRARY; T=0.K  
tritons from (a,pt)

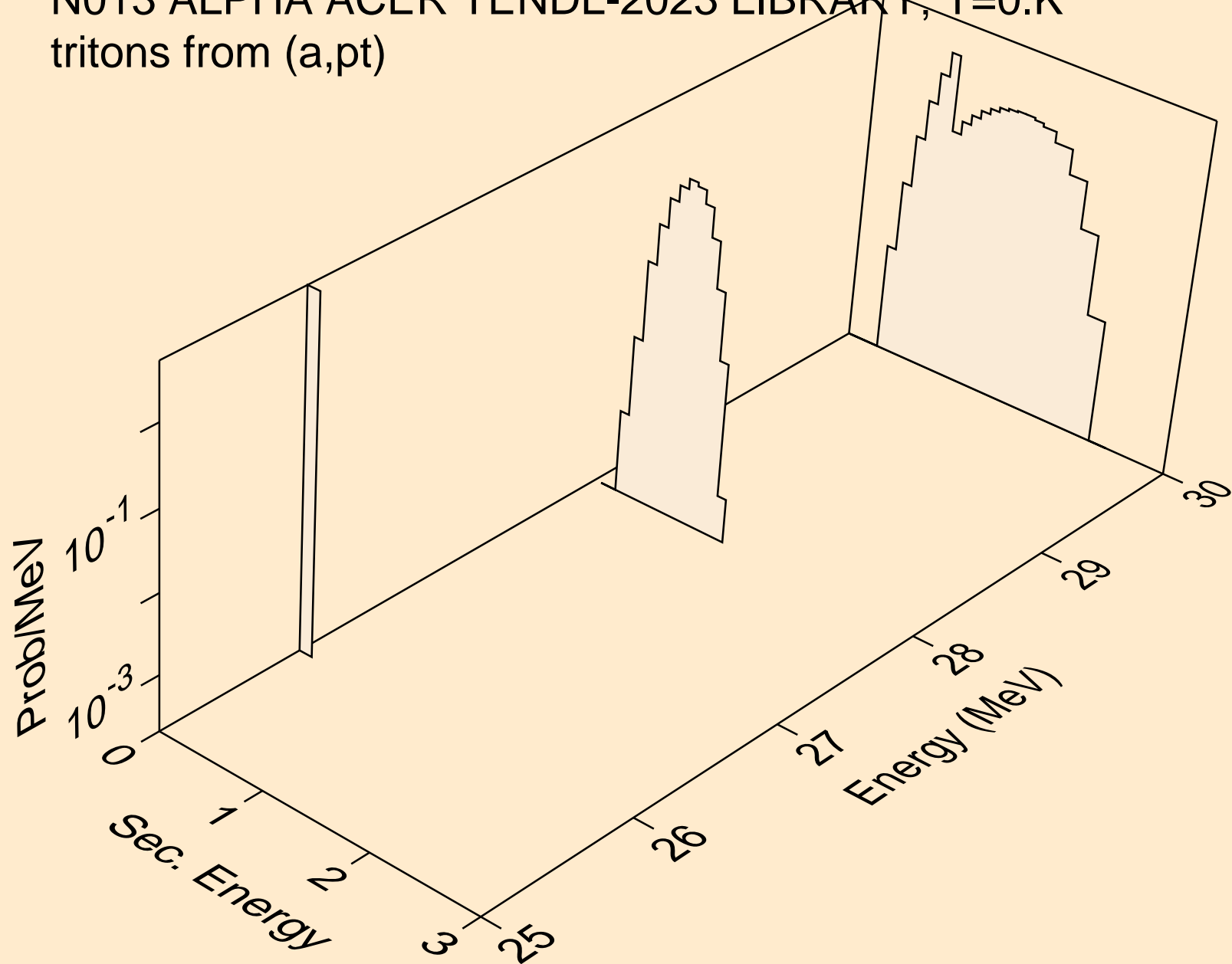

N013 ALPHA ACER TENDL-2023 LIBRARY; T=0.K  
he3s from (a,x)

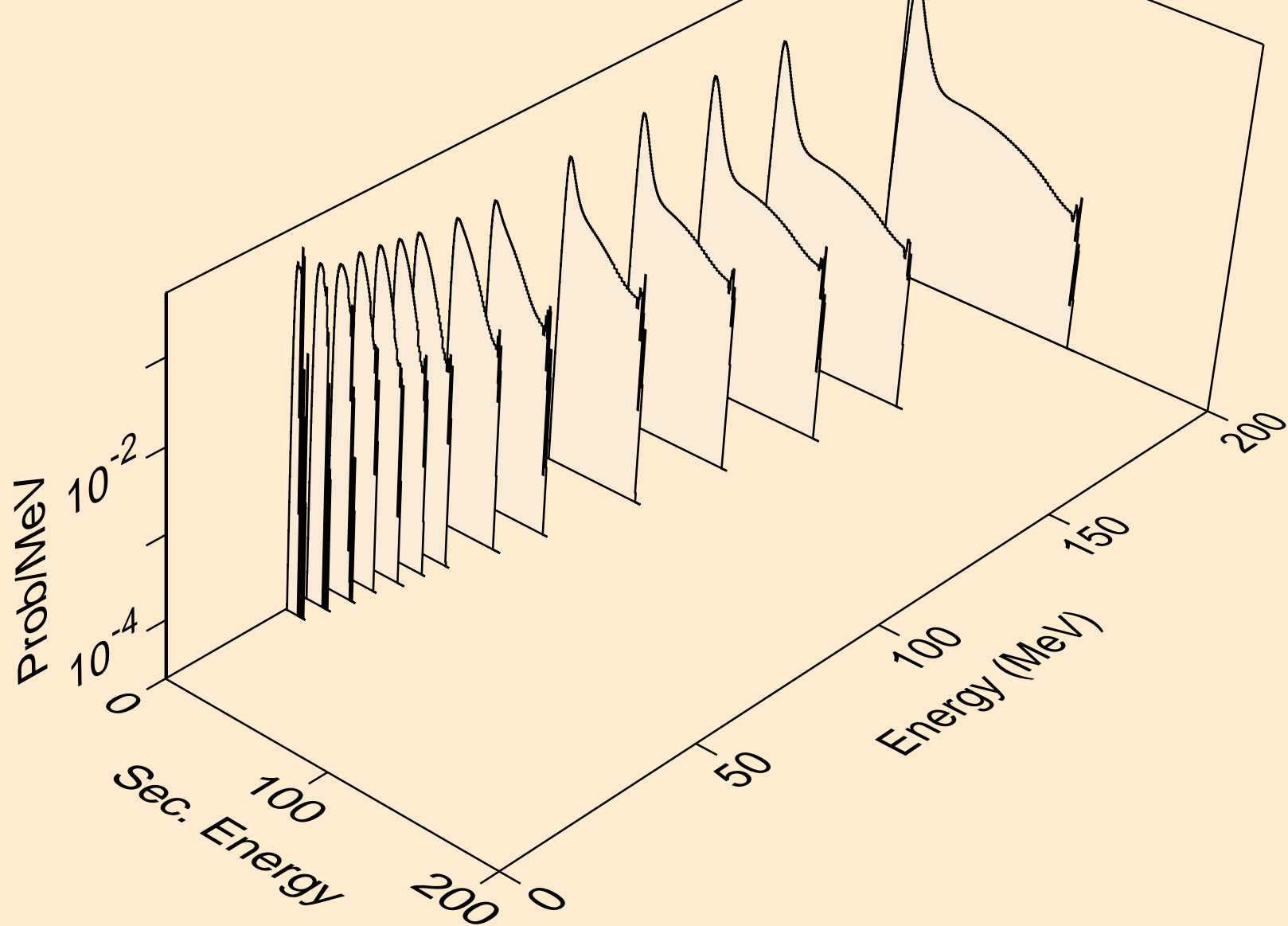

N013 ALPHA ACER TENDL-2023 LIBRARY; T=0.K  
he3s from (a,n\*)he3

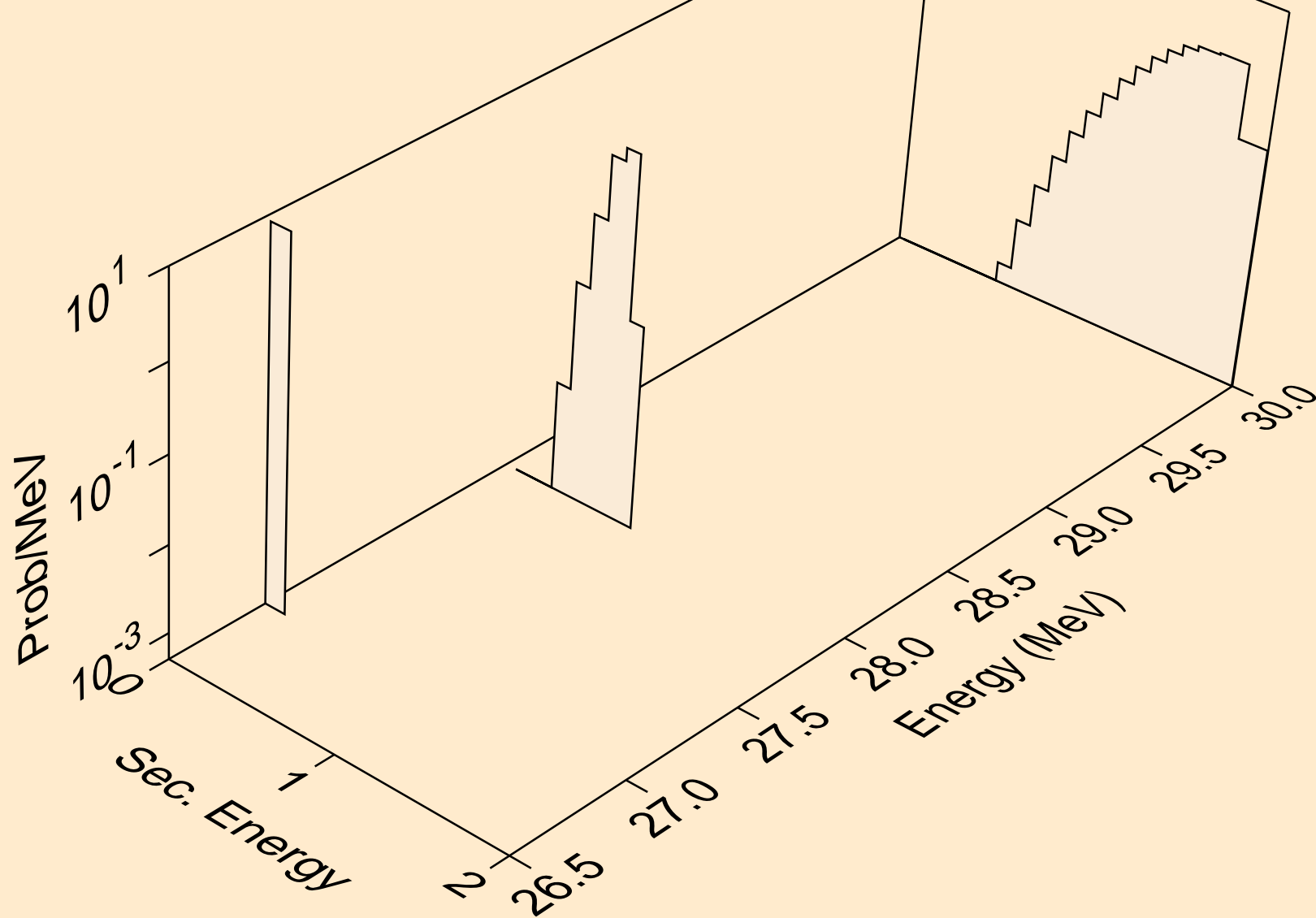

N013 ALPHA ACER TENDL-2023 LIBRARY; T=0.K  
he3s from (a,he3)

