

NB093 ALPHA ACER TENDL-2023 LIBRARY; T=0.K

Principal cross sections

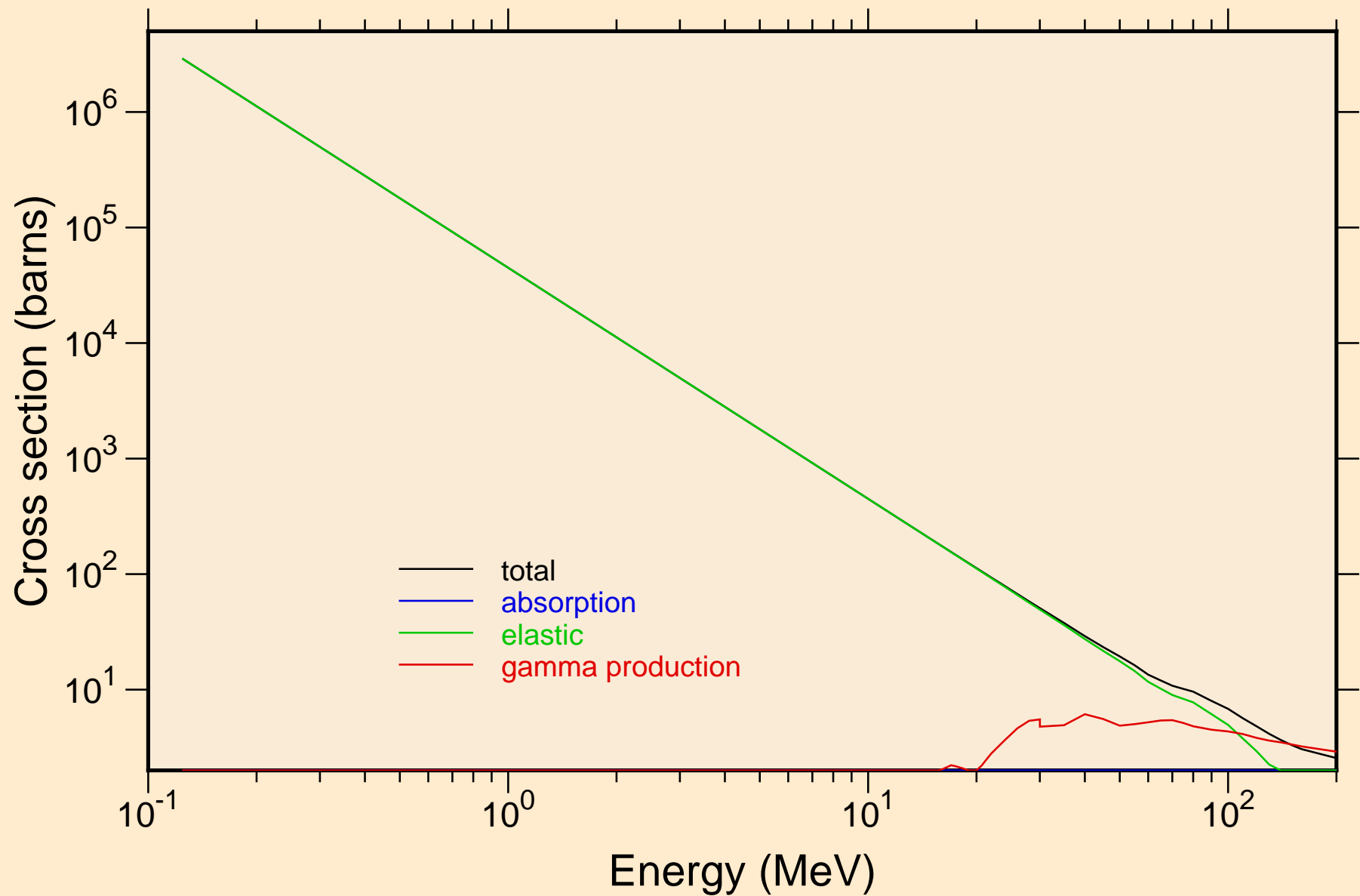

NB093 ALPHA ACER TENDL-2023 LIBRARY; T=0.K

Heating

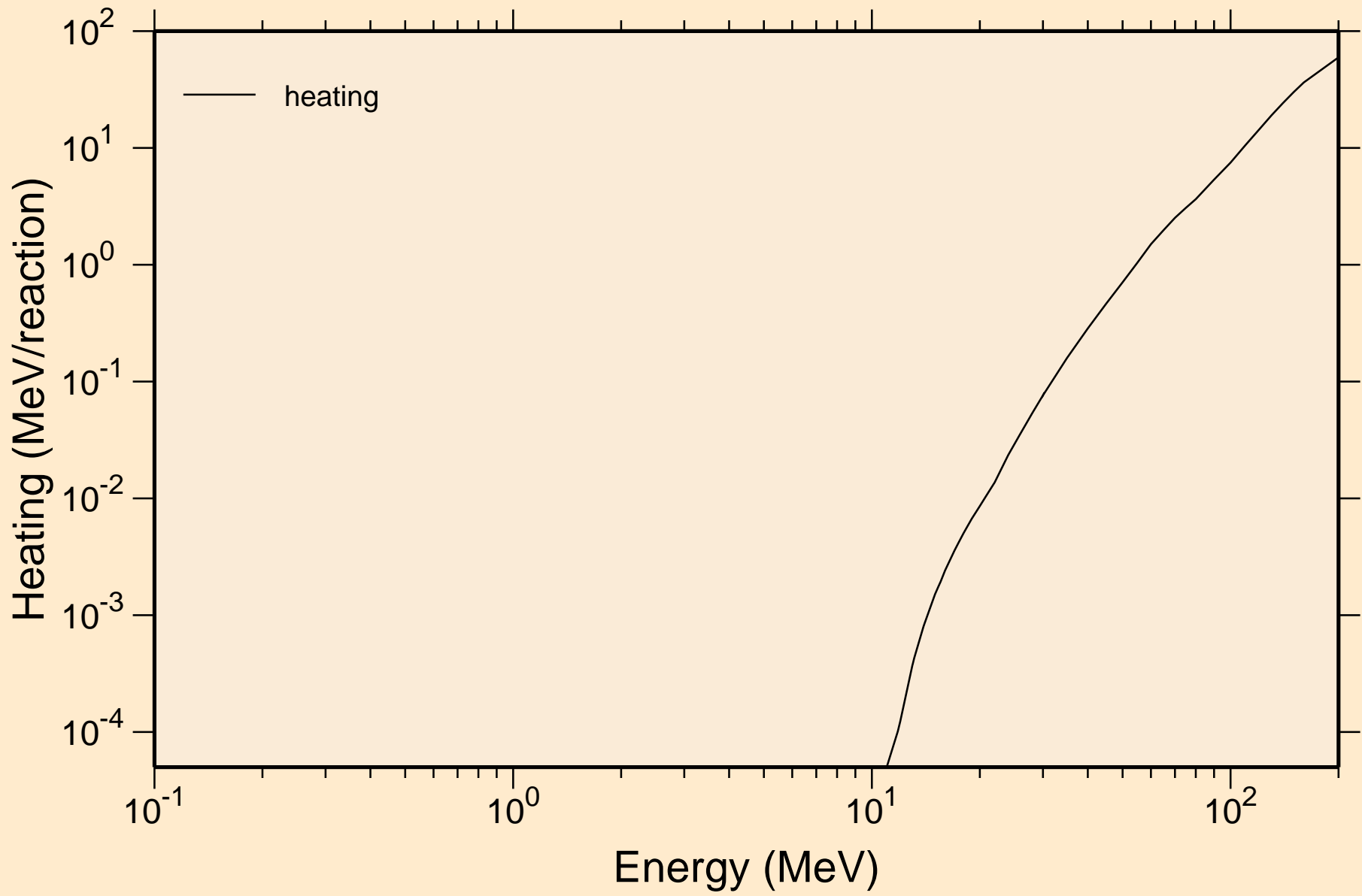

NB093 ALPHA ACER TENDL-2023 LIBRARY; T=0.K

Principal cross sections

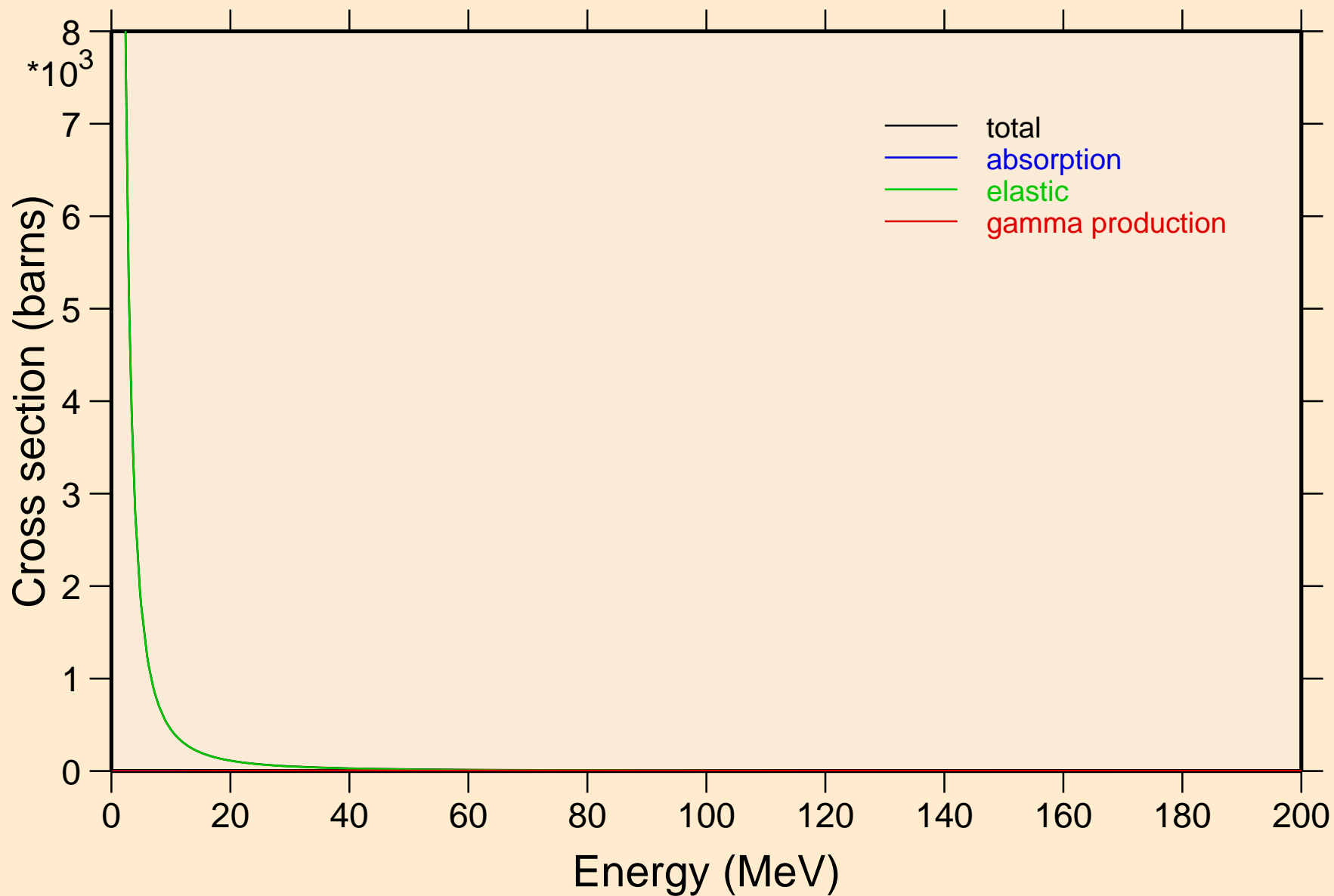

NB093 ALPHA ACER TENDL-2023 LIBRARY; T=0.K

Heating

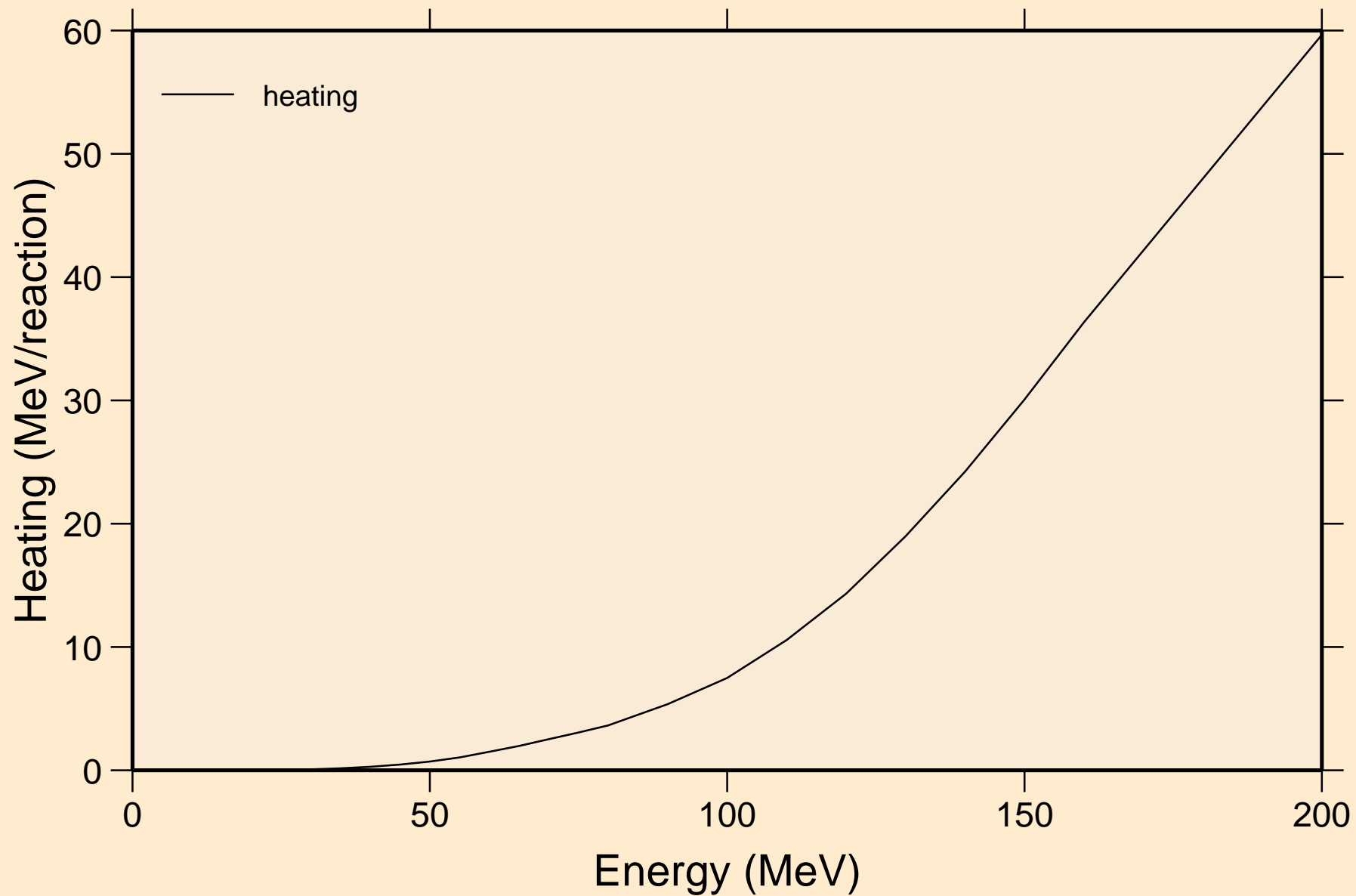

NB093 ALPHA ACER TENDL-2023 LIBRARY; T=0.K

Threshold reactions

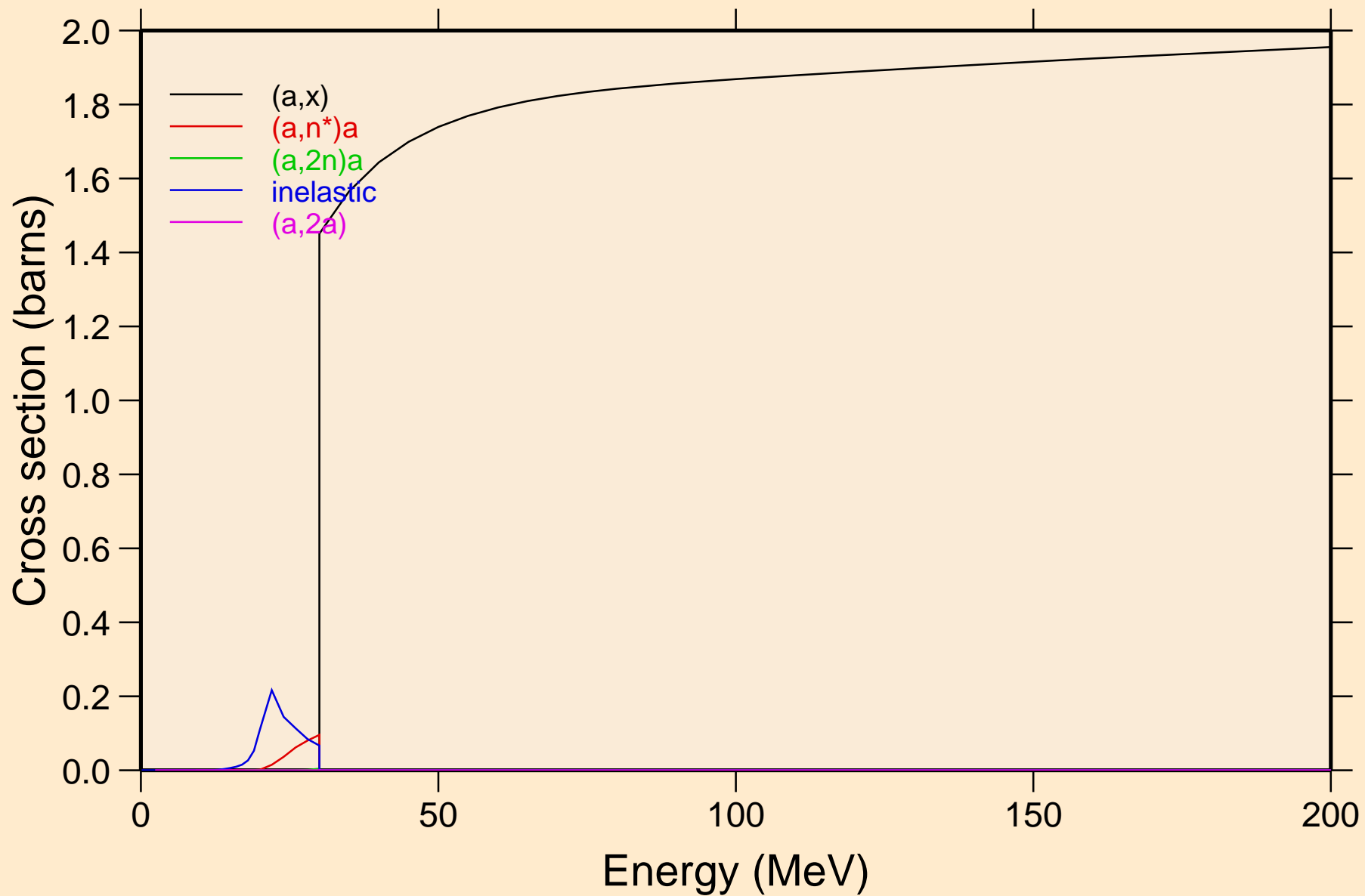

NB093 ALPHA ACER TENDL-2023 LIBRARY; T=0.K
Threshold reactions

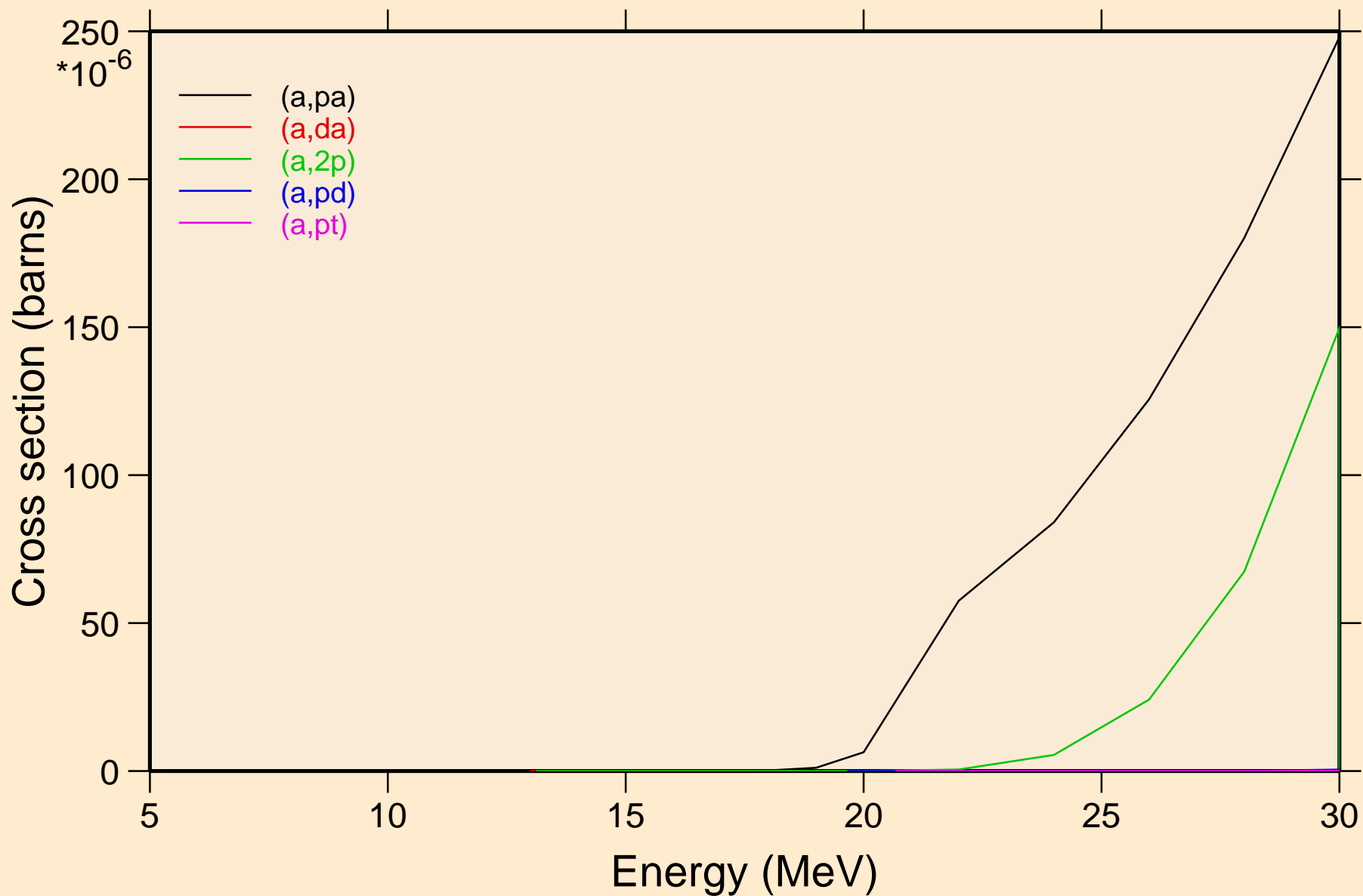

NB093 ALPHA ACER TENDL-2023 LIBRARY; T=0.K
Threshold reactions

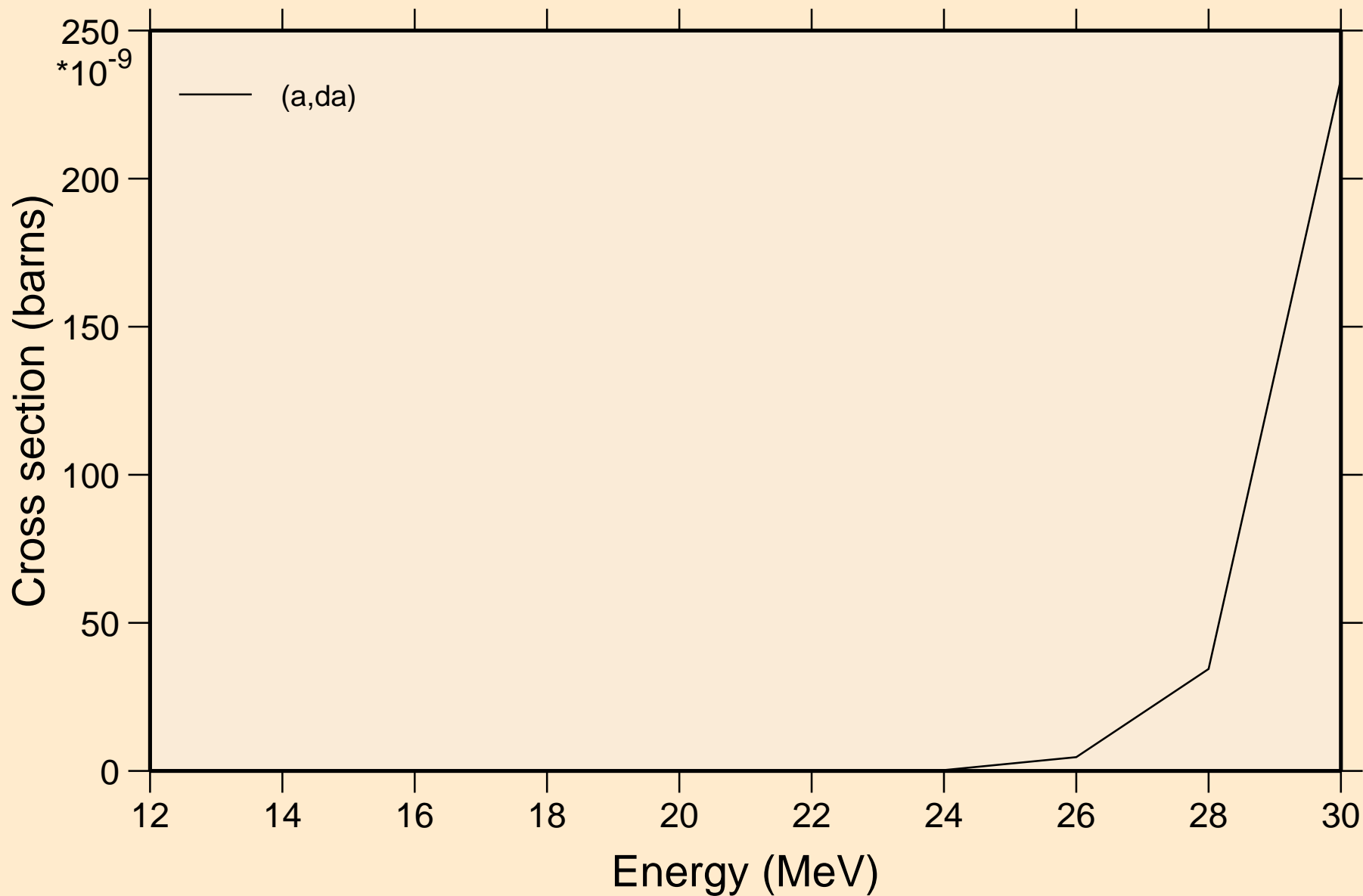

NB093 ALPHA ACER TENDL-2023 LIBRARY; T=0.K
angular distribution for elastic

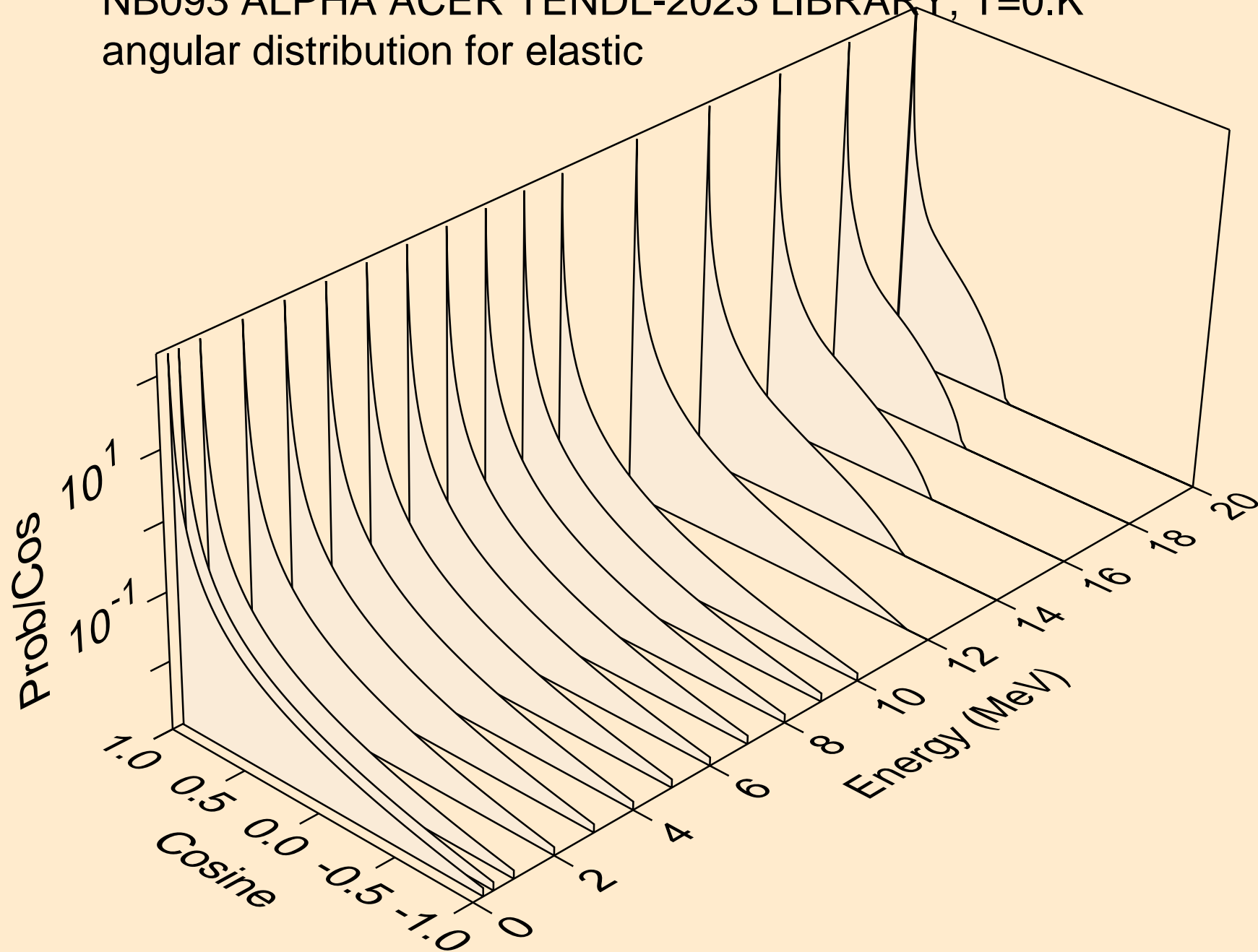

NB093 ALPHA ACER TENDL-2023 LIBRARY; T=0.K
angular distribution for elastic

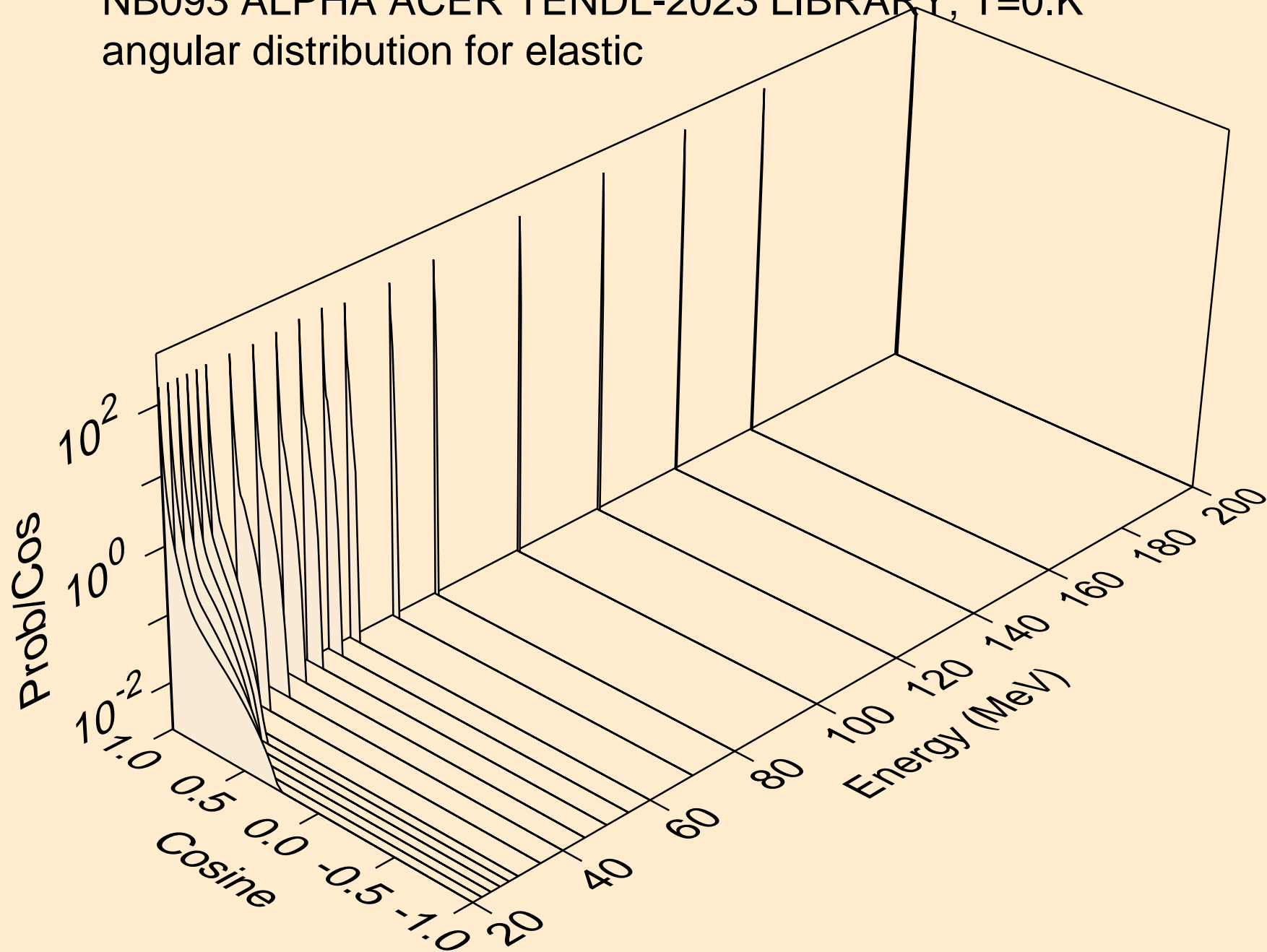

NB093 ALPHA ACER TENDL-2023 LIBRARY; T=0.K
Alpha emission for (a,x)

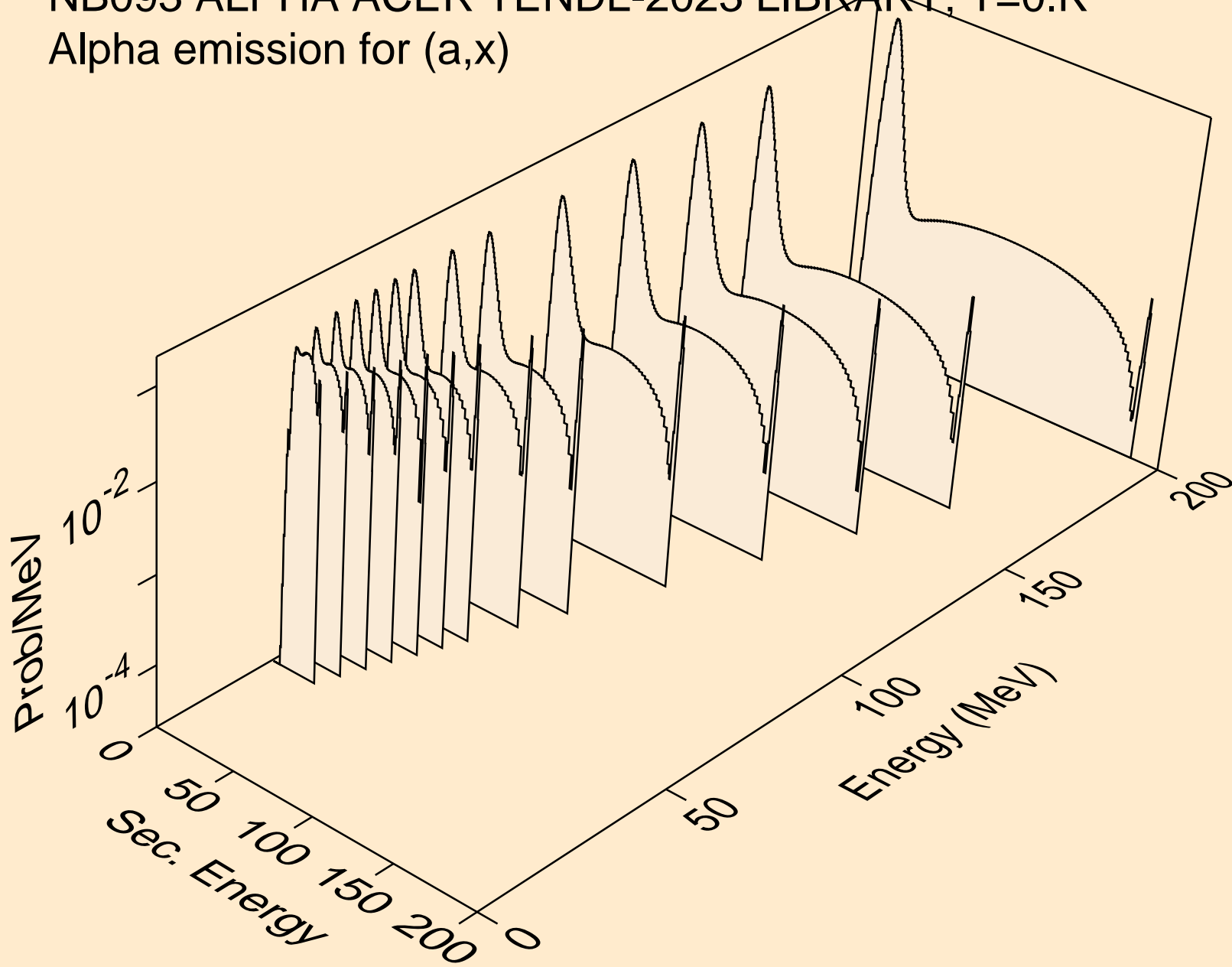

NB093 ALPHA ACER TENDL-2023 LIBRARY; T=0.K
Alpha emission for (a,n*)a

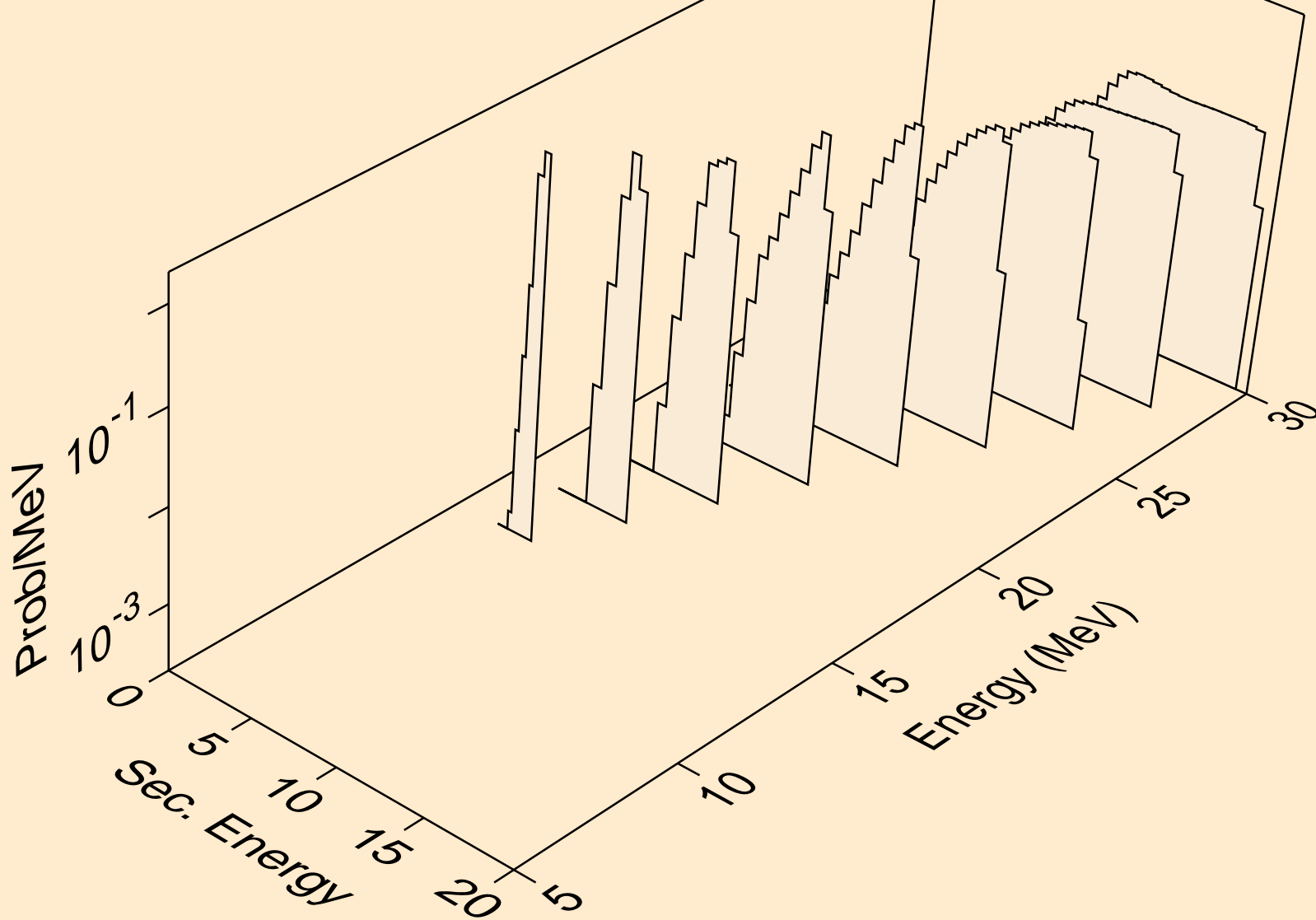

NB093 ALPHA ACER TENDL-2023 LIBRARY; T=0.K
Alpha emission for (a,2n)a

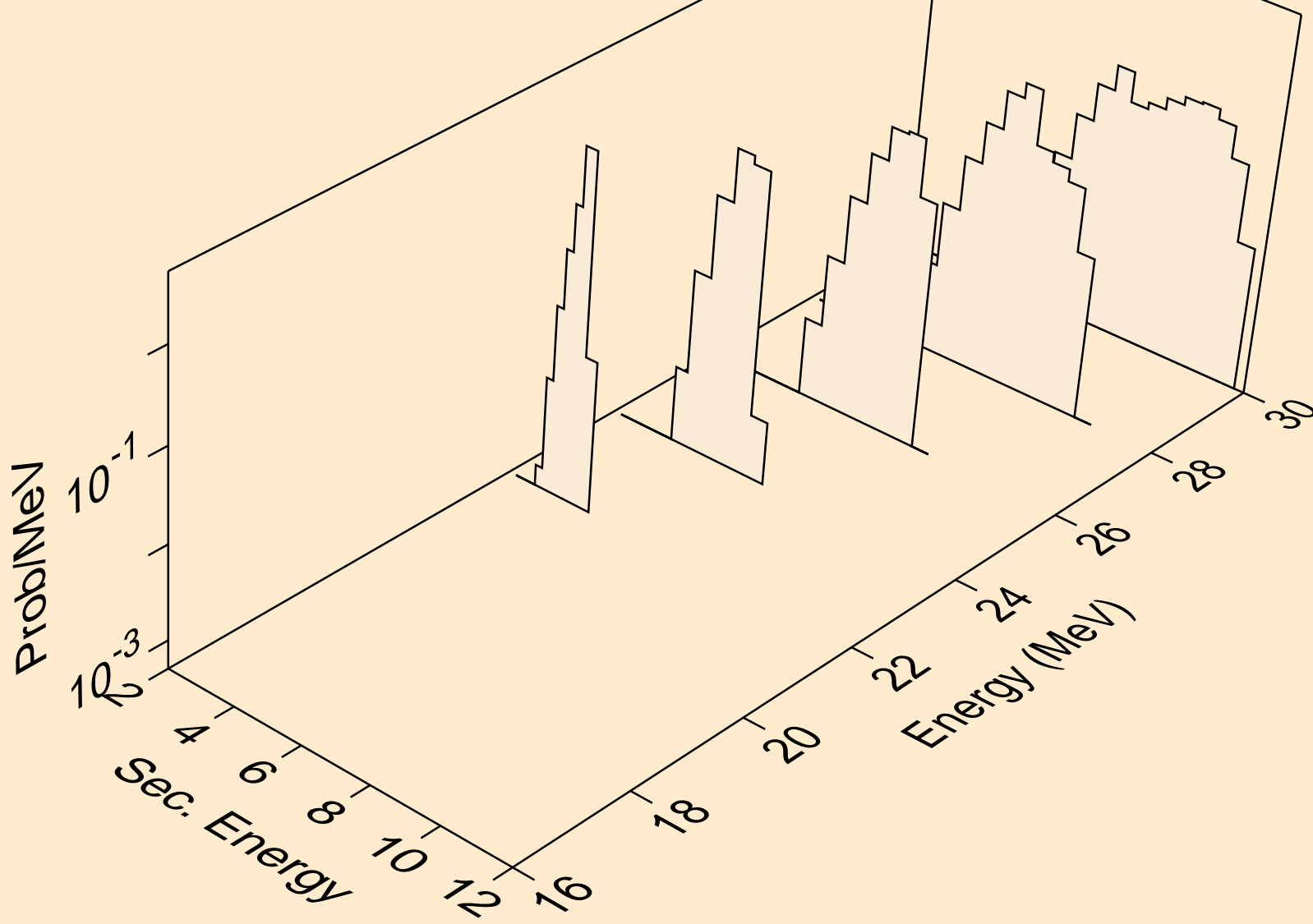

NB093 ALPHA ACER TENDL-2023 LIBRARY; T=0.K
Alpha emission for inelastic

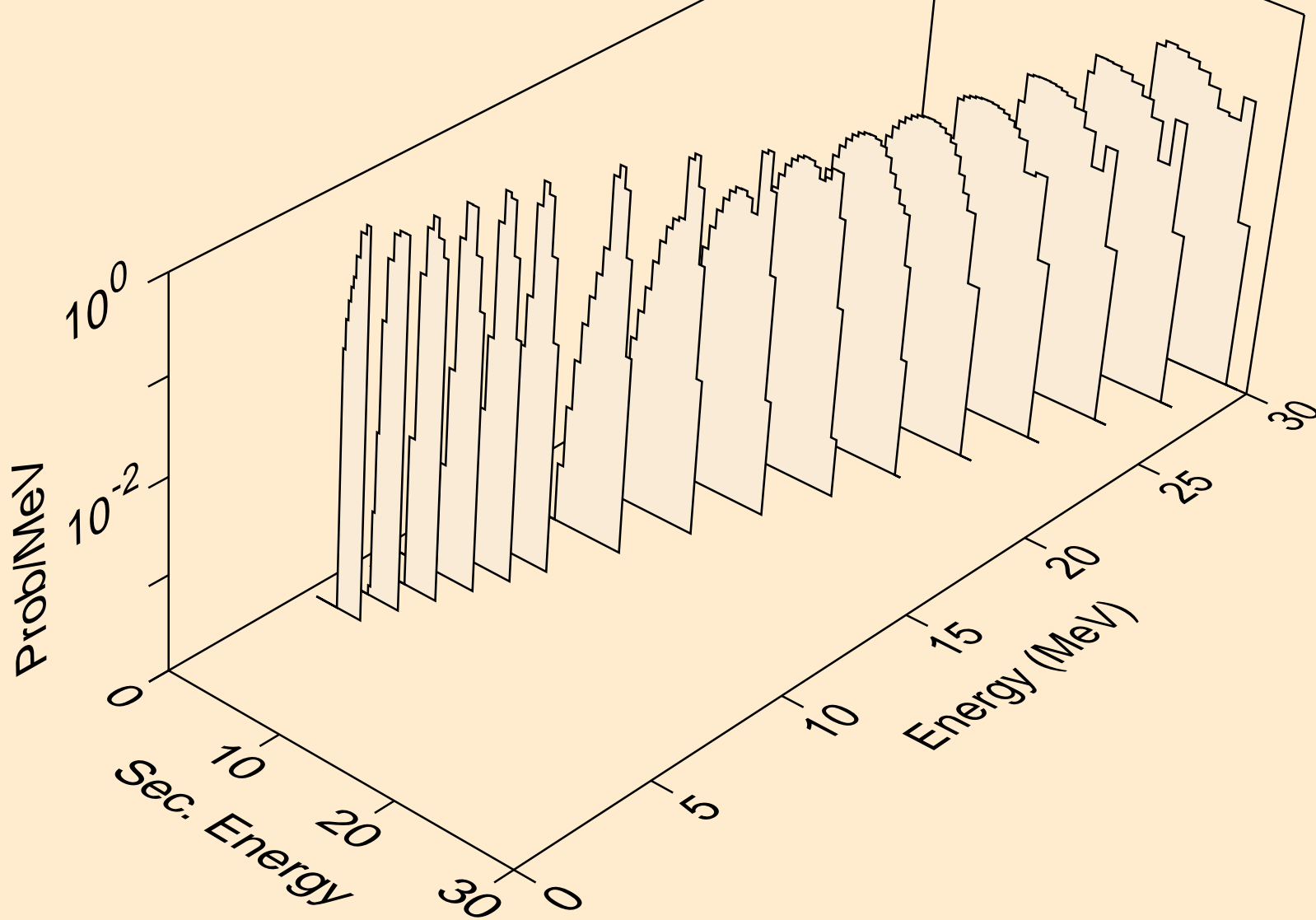

NB093 ALPHA ACER TENDL-2023 LIBRARY; T=0.K
Alpha emission for (a,2a)

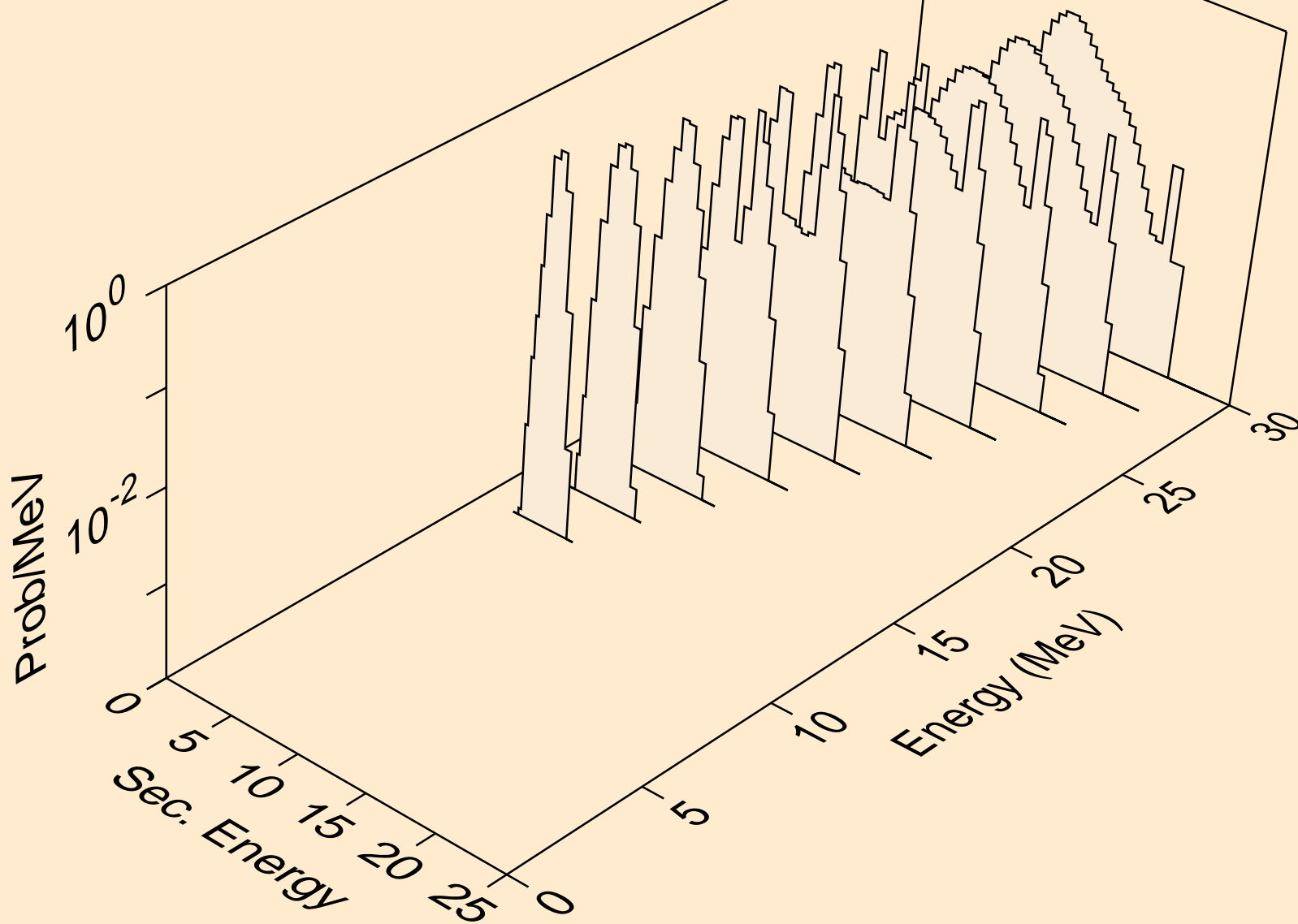

NB093 ALPHA ACER TENDL-2023 LIBRARY; T=0.K
Alpha emission for (a,pa)

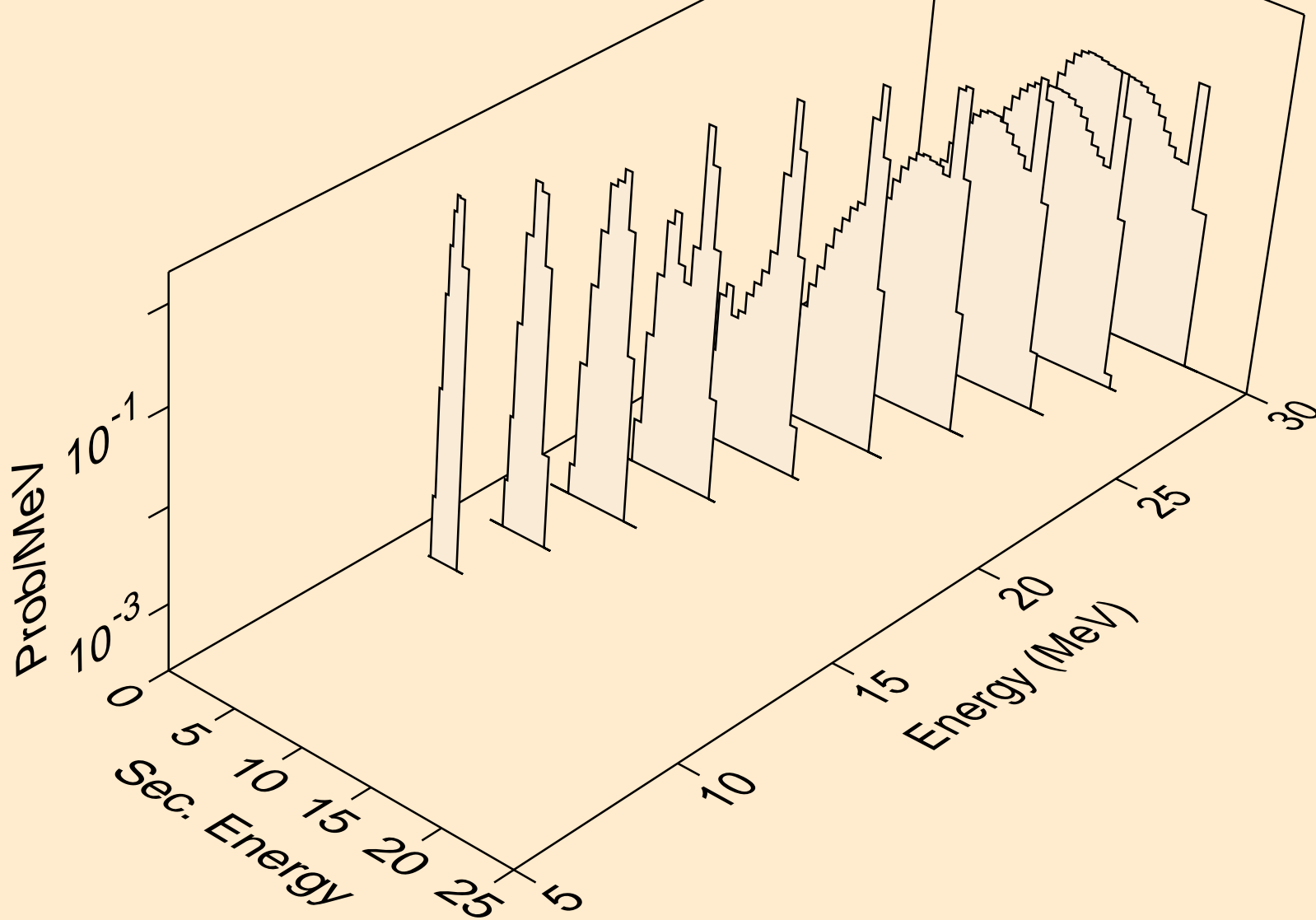

NB093 ALPHA ACER TENDL-2023 LIBRARY; T=0.K

Alpha emission for (a,da)

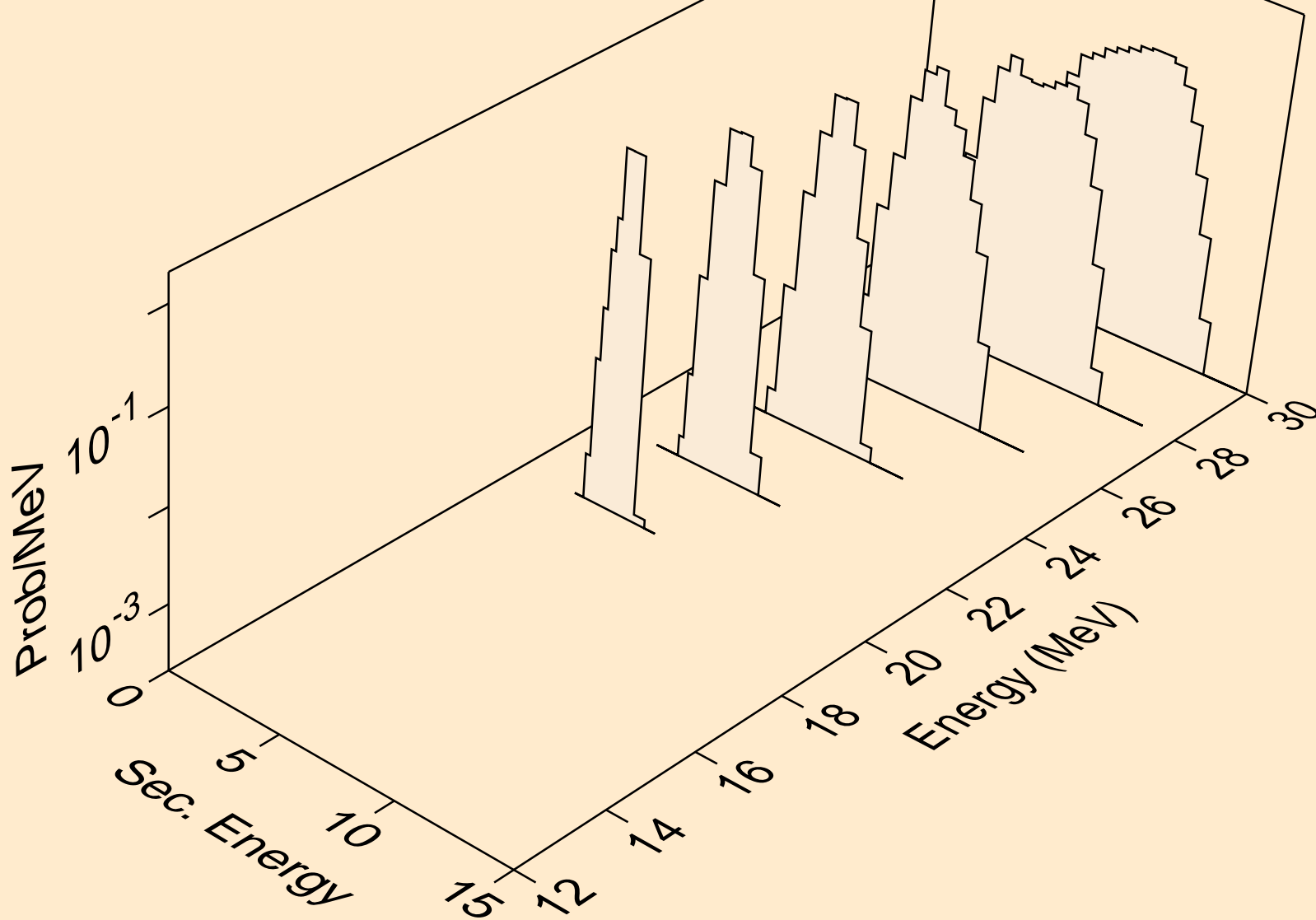

NB093 ALPHA ACER TENDL-2023 LIBRARY; T=0.K
Photon emission for (z,n)

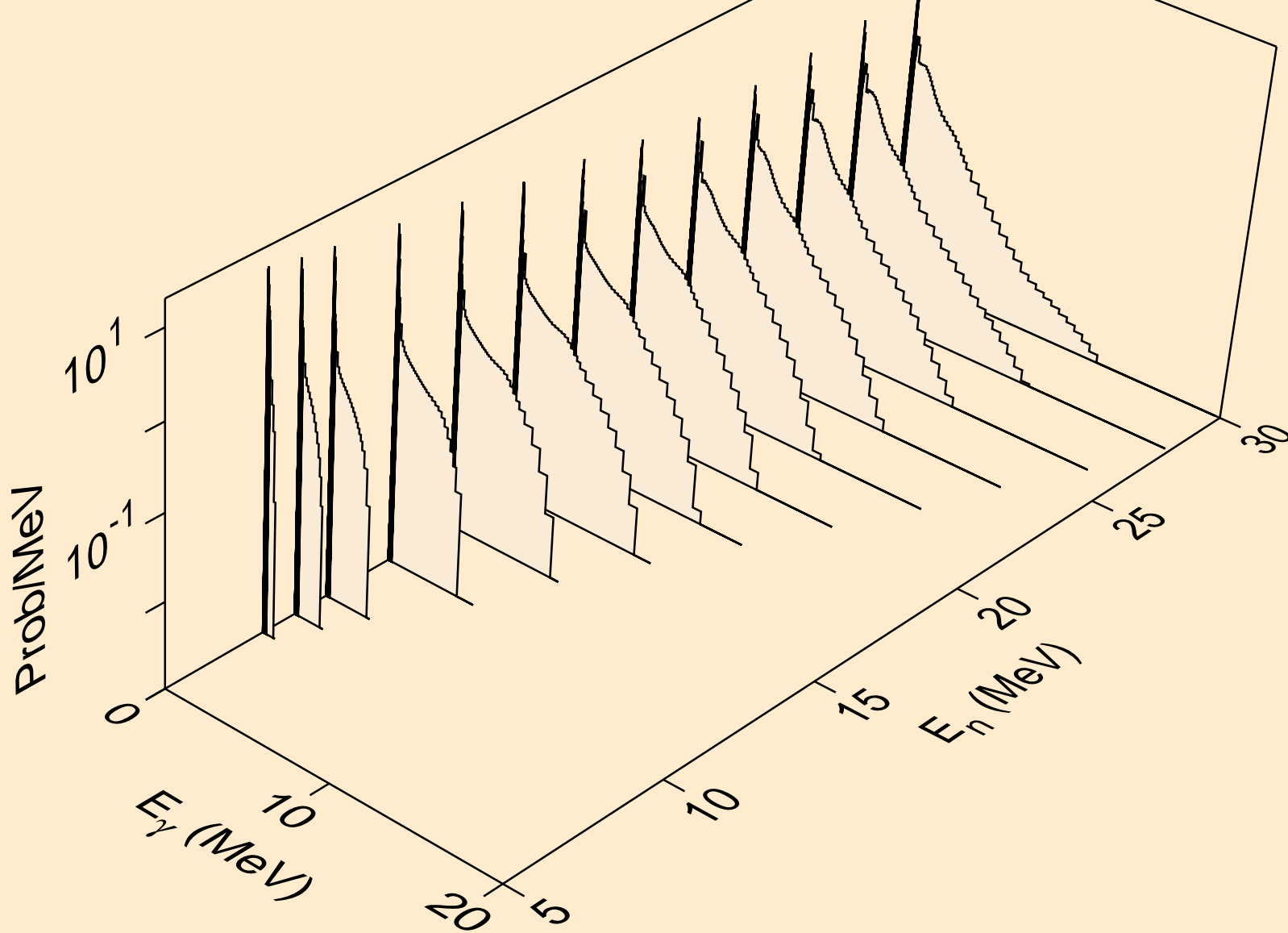

NB093 ALPHA ACER TENDL-2023 LIBRARY; T=0.K

Photon emission for (z,x)

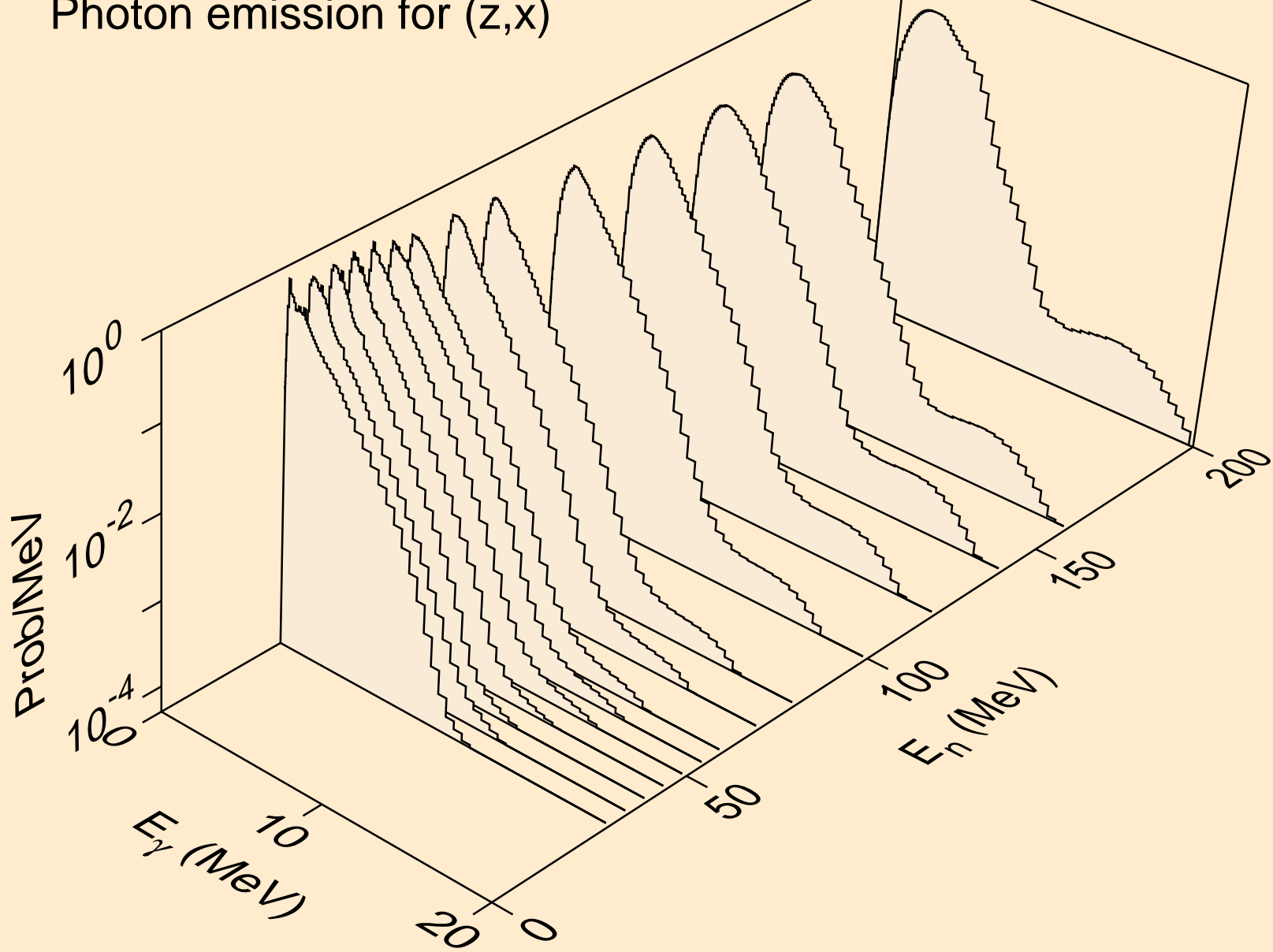

NB093 ALPHA ACER TENDL-2023 LIBRARY; T=0.K
Photon emission for (n,2n)

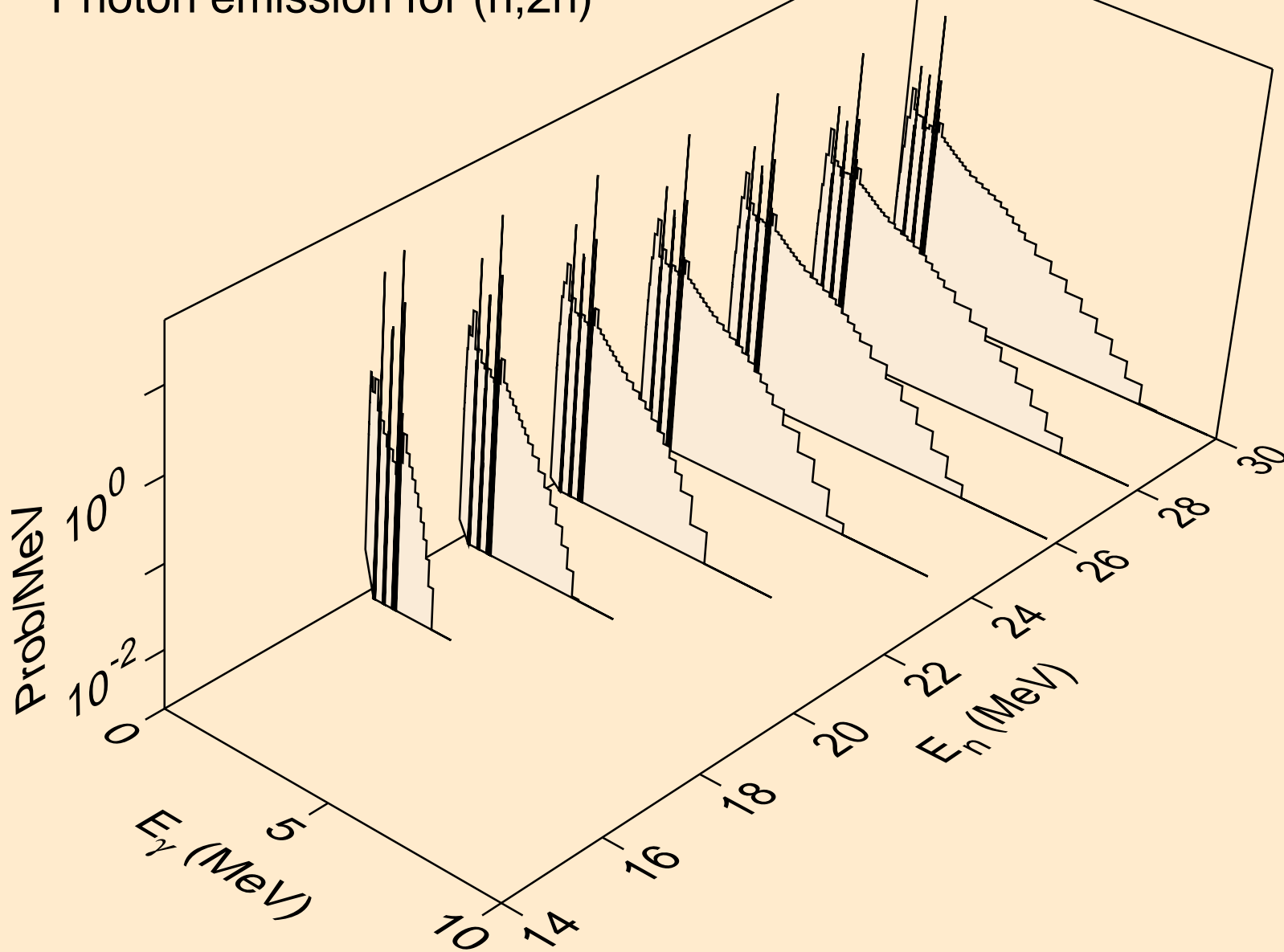

NB093 ALPHA ACER TENDL-2023 LIBRARY; T=0.K
Photon emission for (n,3n)

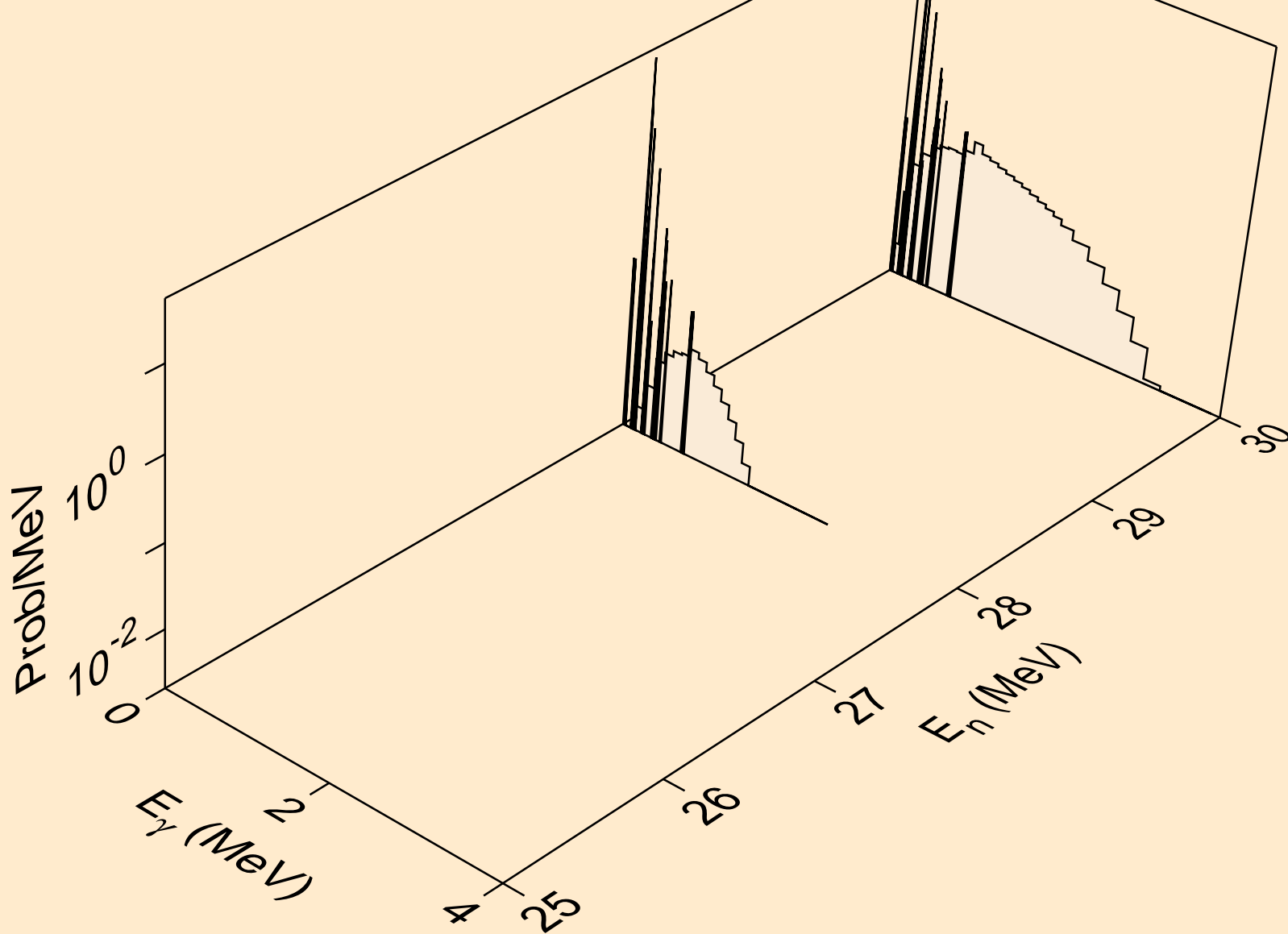

NB093 ALPHA ACER TENDL-2023 LIBRARY; T=0.K
Photon emission for (n,n*)a

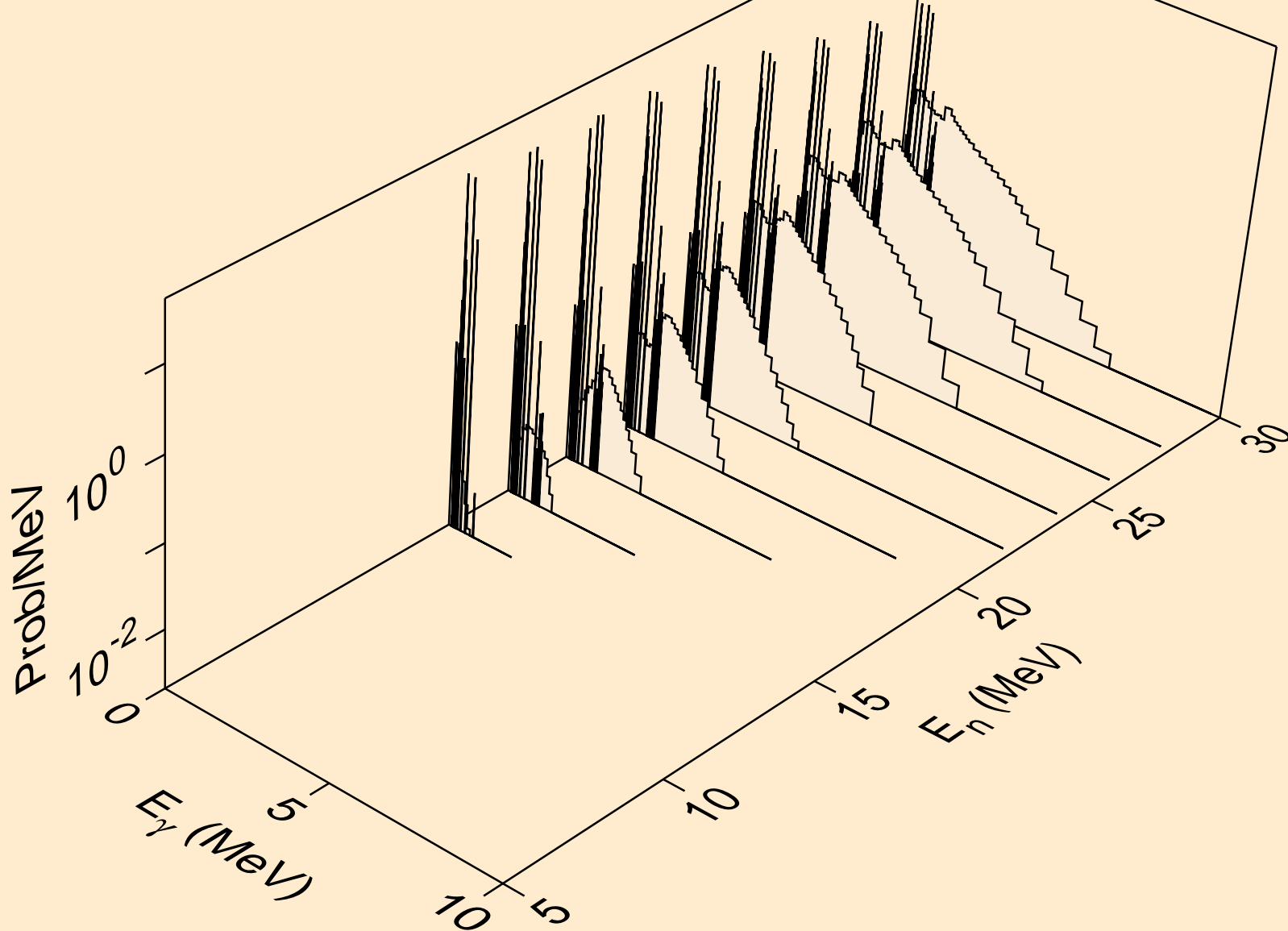

NB093 ALPHA ACER TENDL-2023 LIBRARY; T=0.K
Photon emission for (n,2n) α

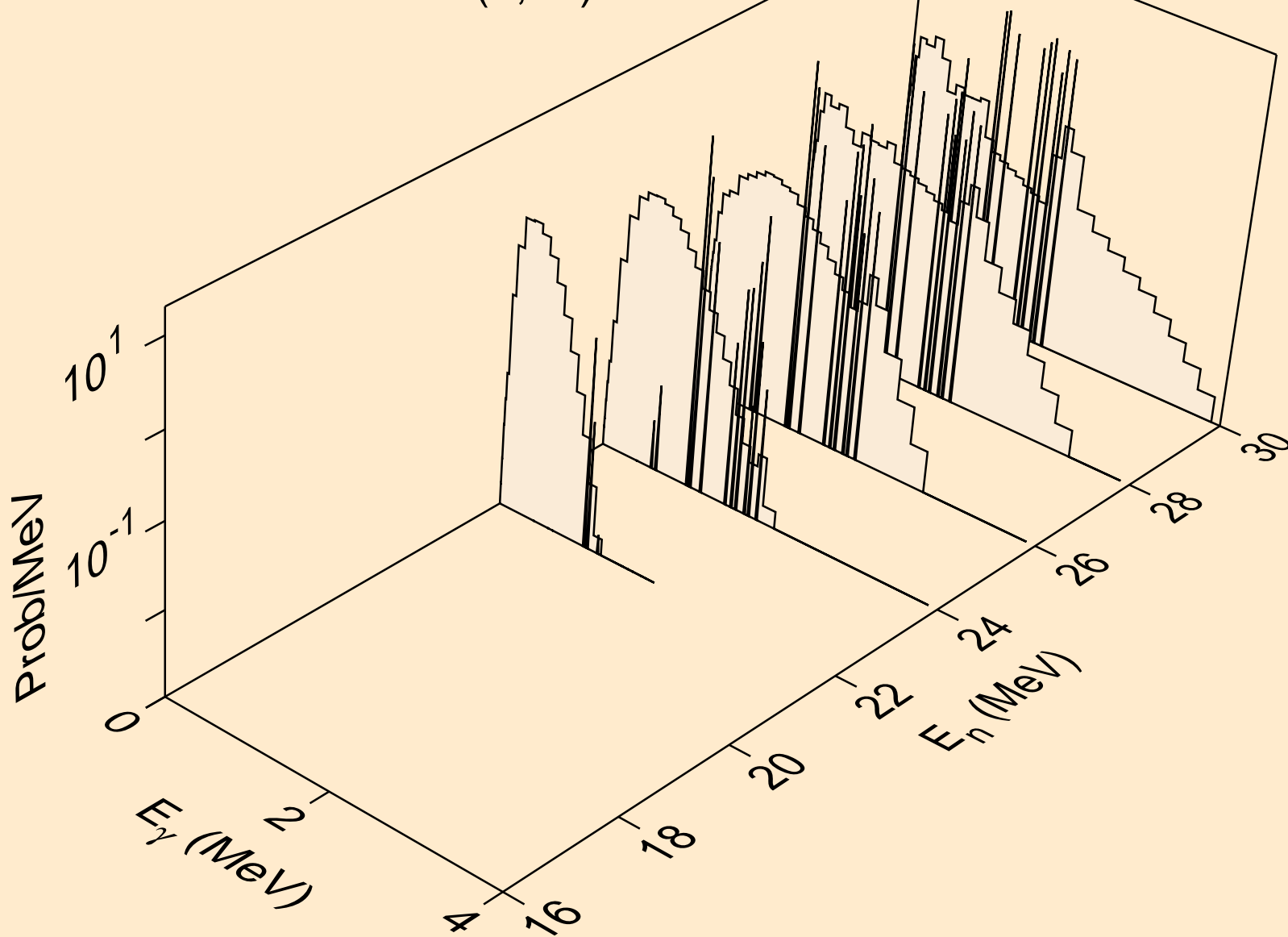

NB093 ALPHA ACER TENDL-2023 LIBRARY; T=0.K
Photon emission for (n,n*)p

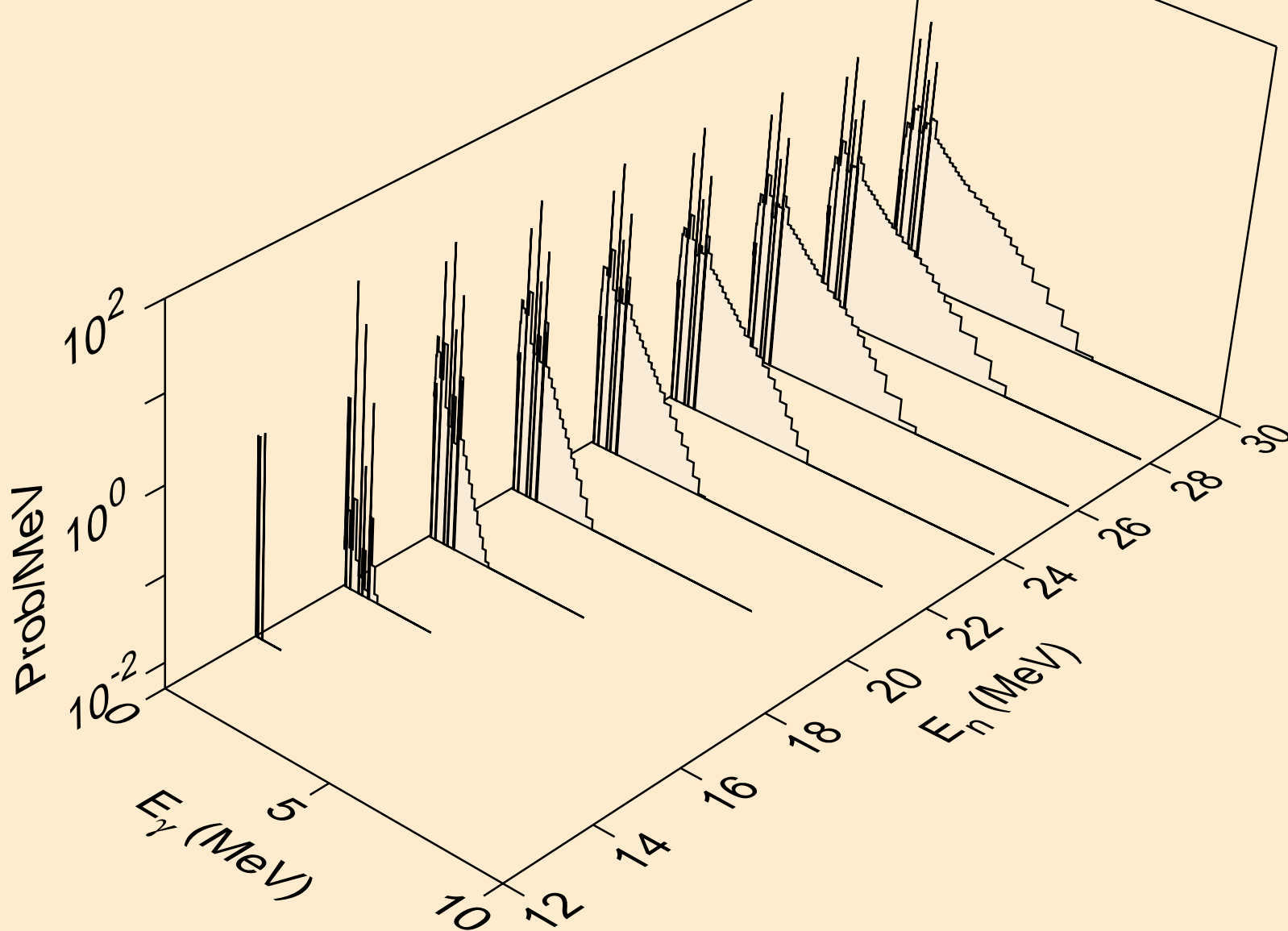

NB093 ALPHA ACER TENDL-2023 LIBRARY; T=0.K
Photon emission for (n,n*)d

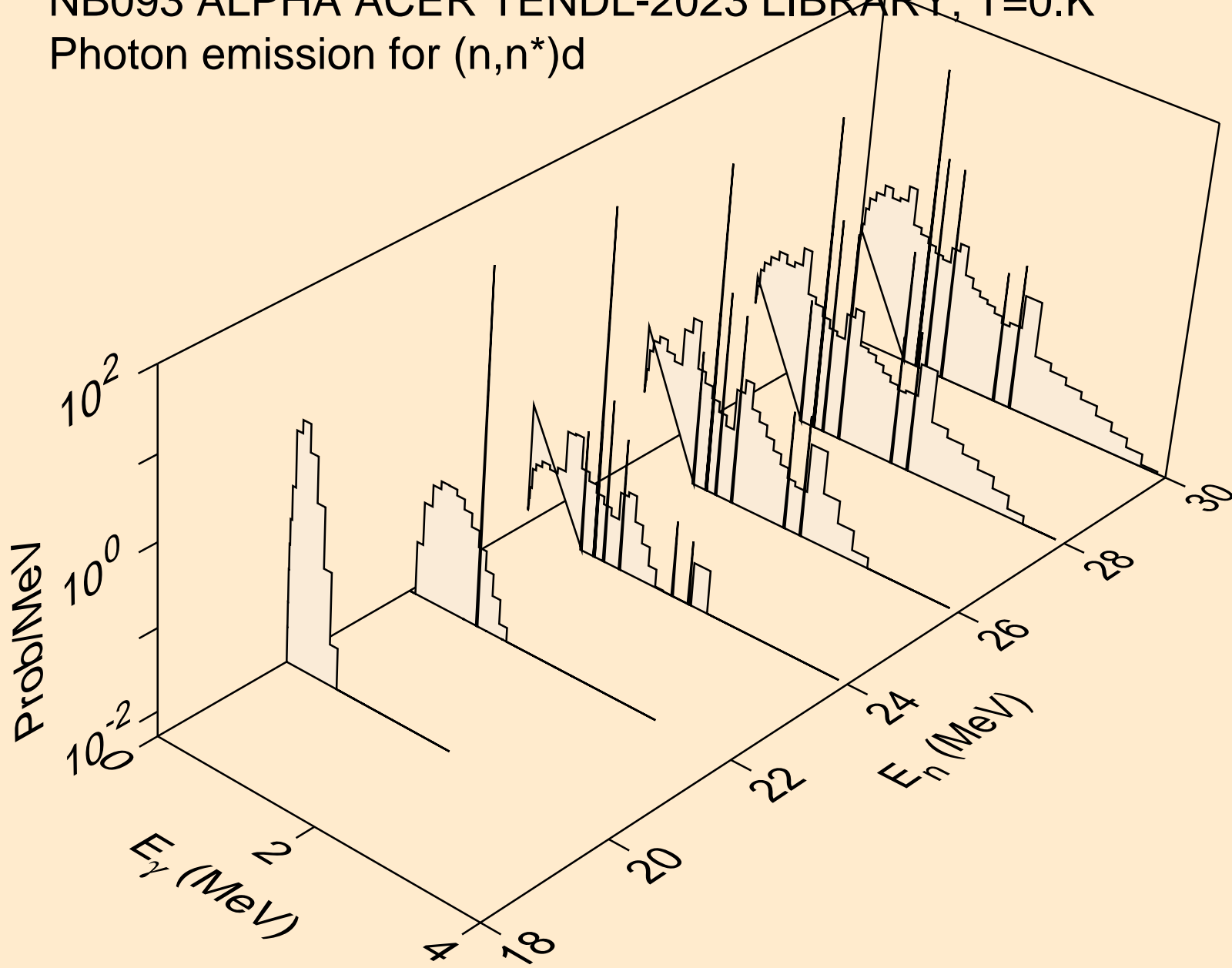

NB093 ALPHA ACER TENDL-2023 LIBRARY; T=0.K
Photon emission for (n,n*)t

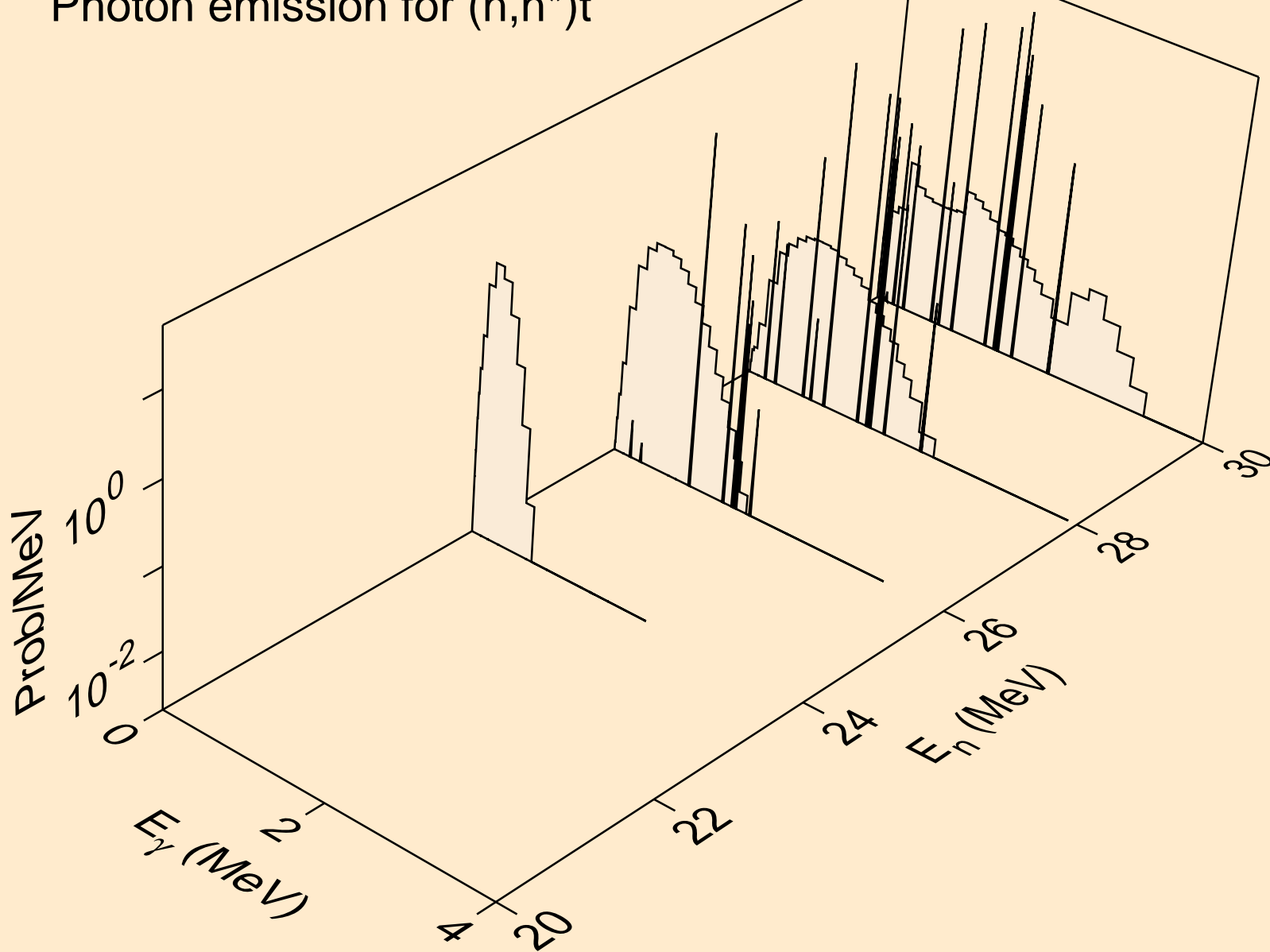

NB093 ALPHA ACER TENDL-2023 LIBRARY; T=0.K
Photon emission for (n,n*)he3

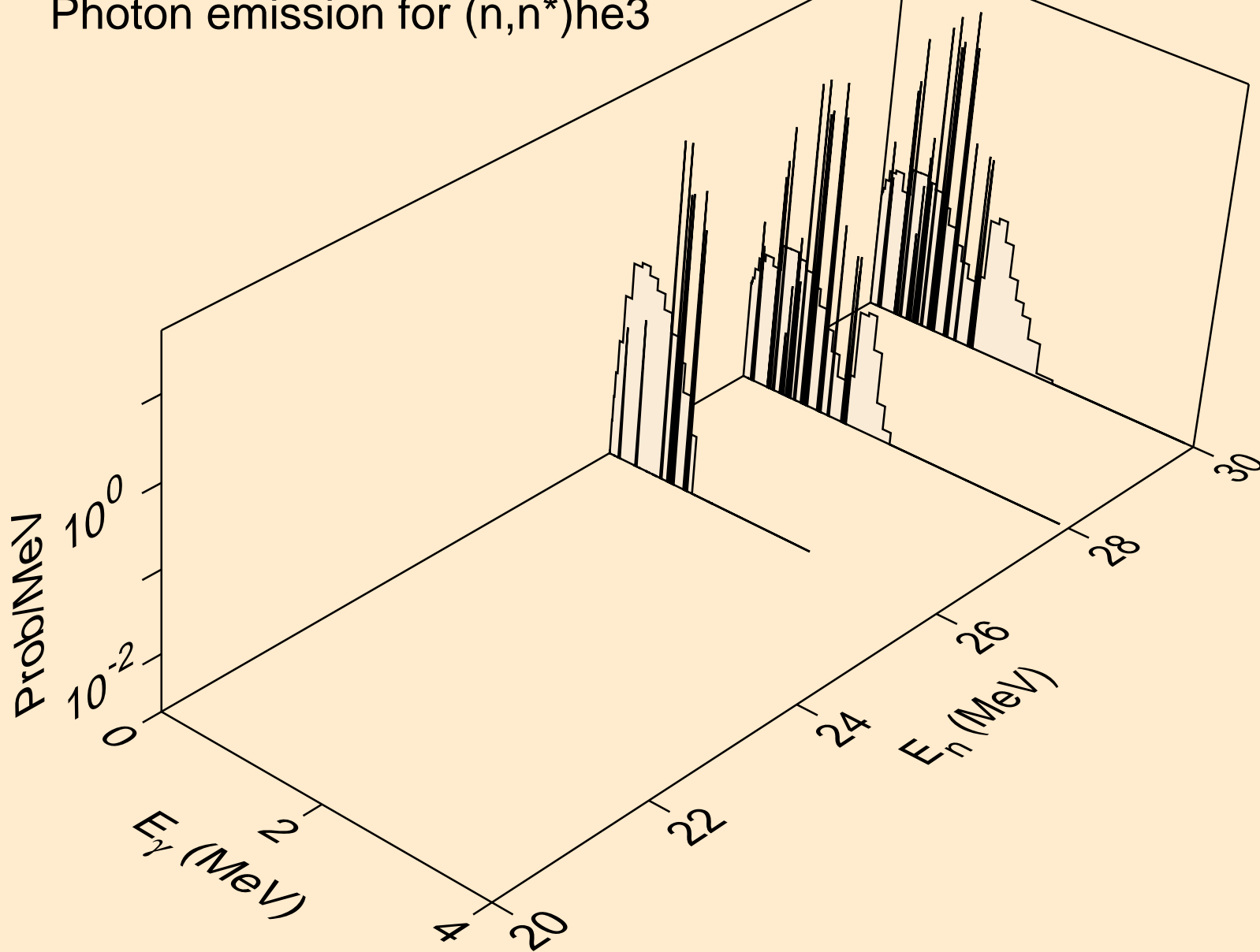

NB093 ALPHA ACER TENDL-2023 LIBRARY; T=0.K
Photon emission for (n,2np)

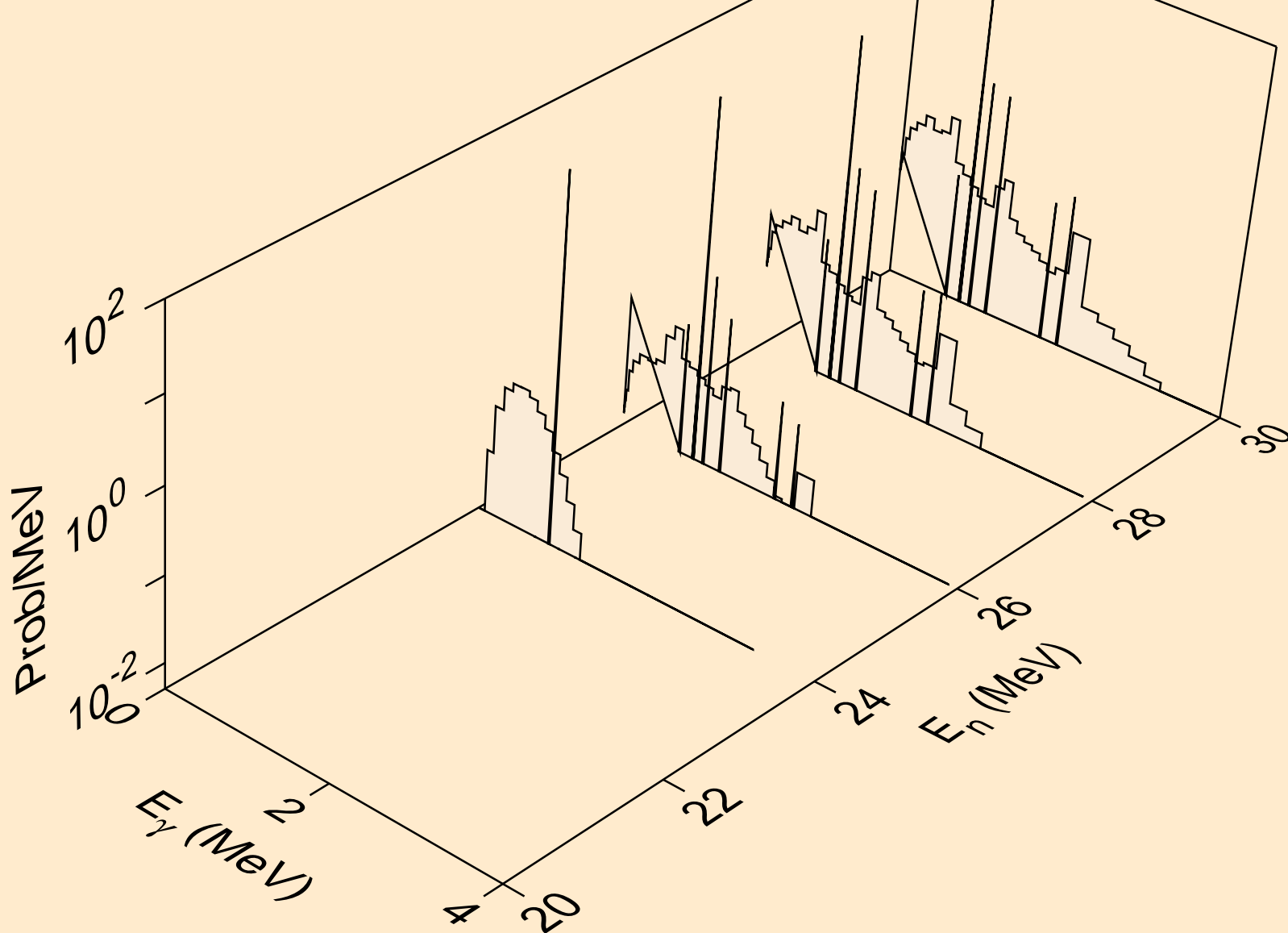

NB093 ALPHA ACER TENDL-2023 LIBRARY; T=0.K
Photon emission for (n,n2p)

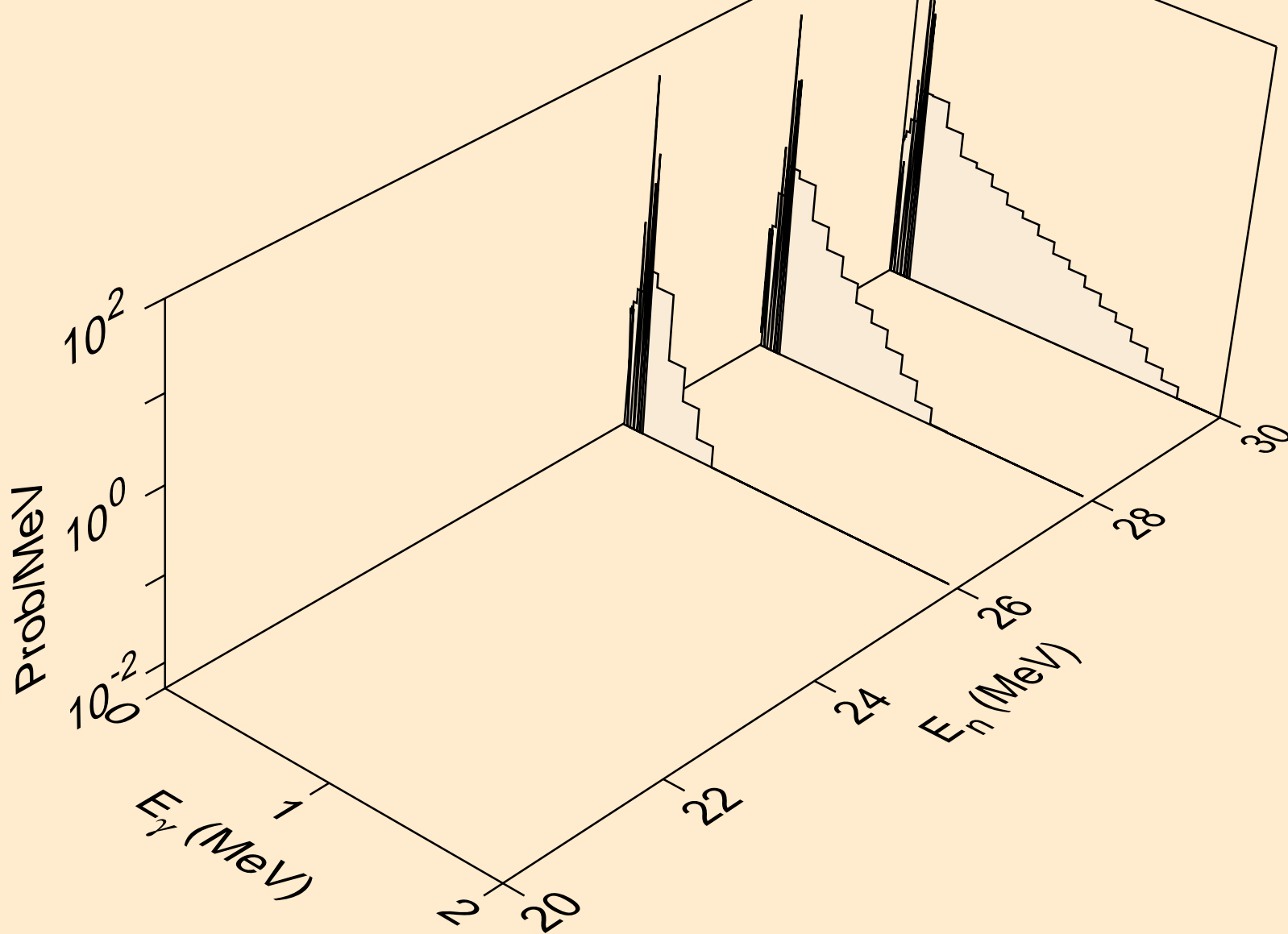

NB093 ALPHA ACER TENDL-2023 LIBRARY; T=0.K
Photon emission for (n,npa)

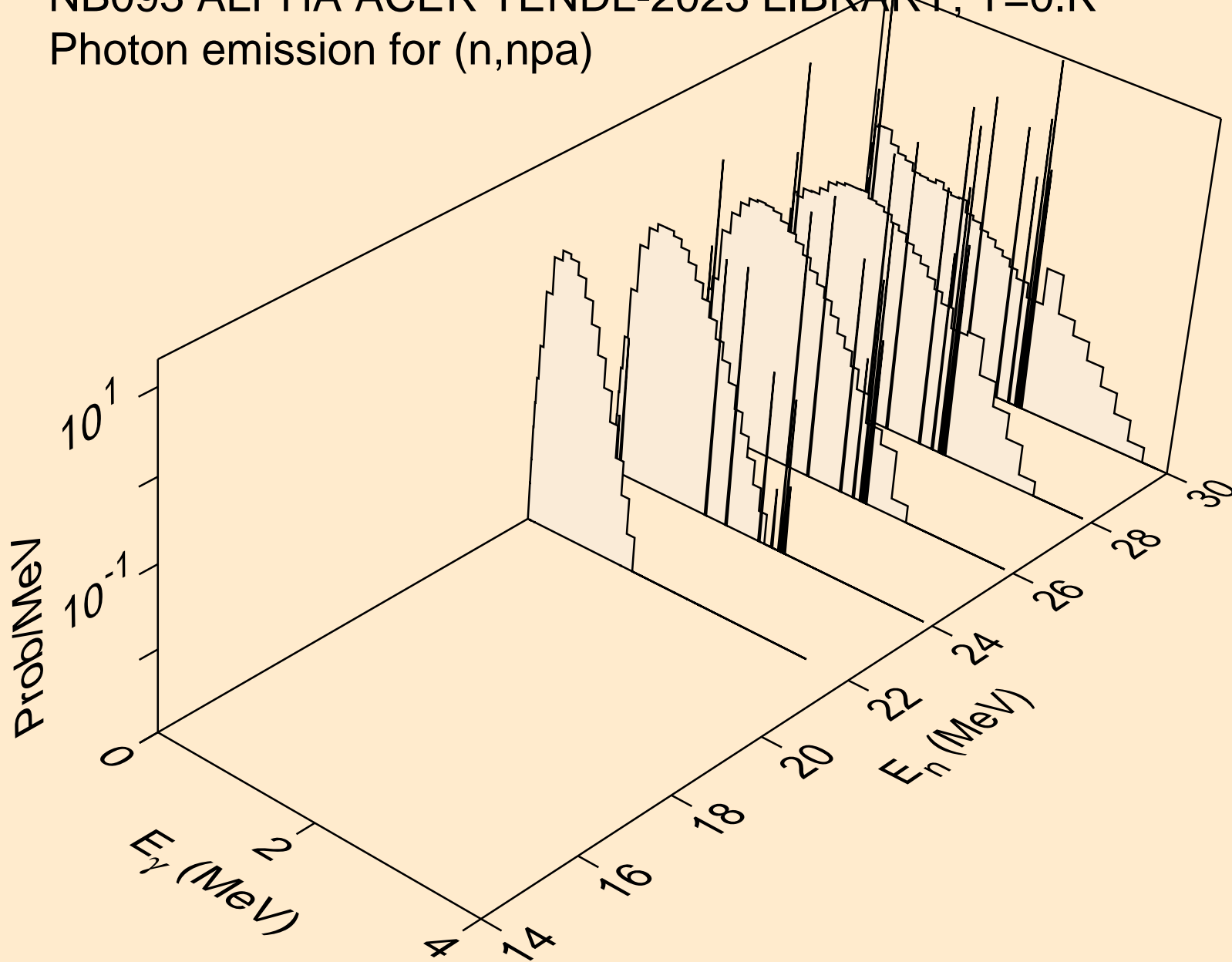

NB093 ALPHA ACER TENDL-2023 LIBRARY; T=0.K
Photon emission for (n,gma)

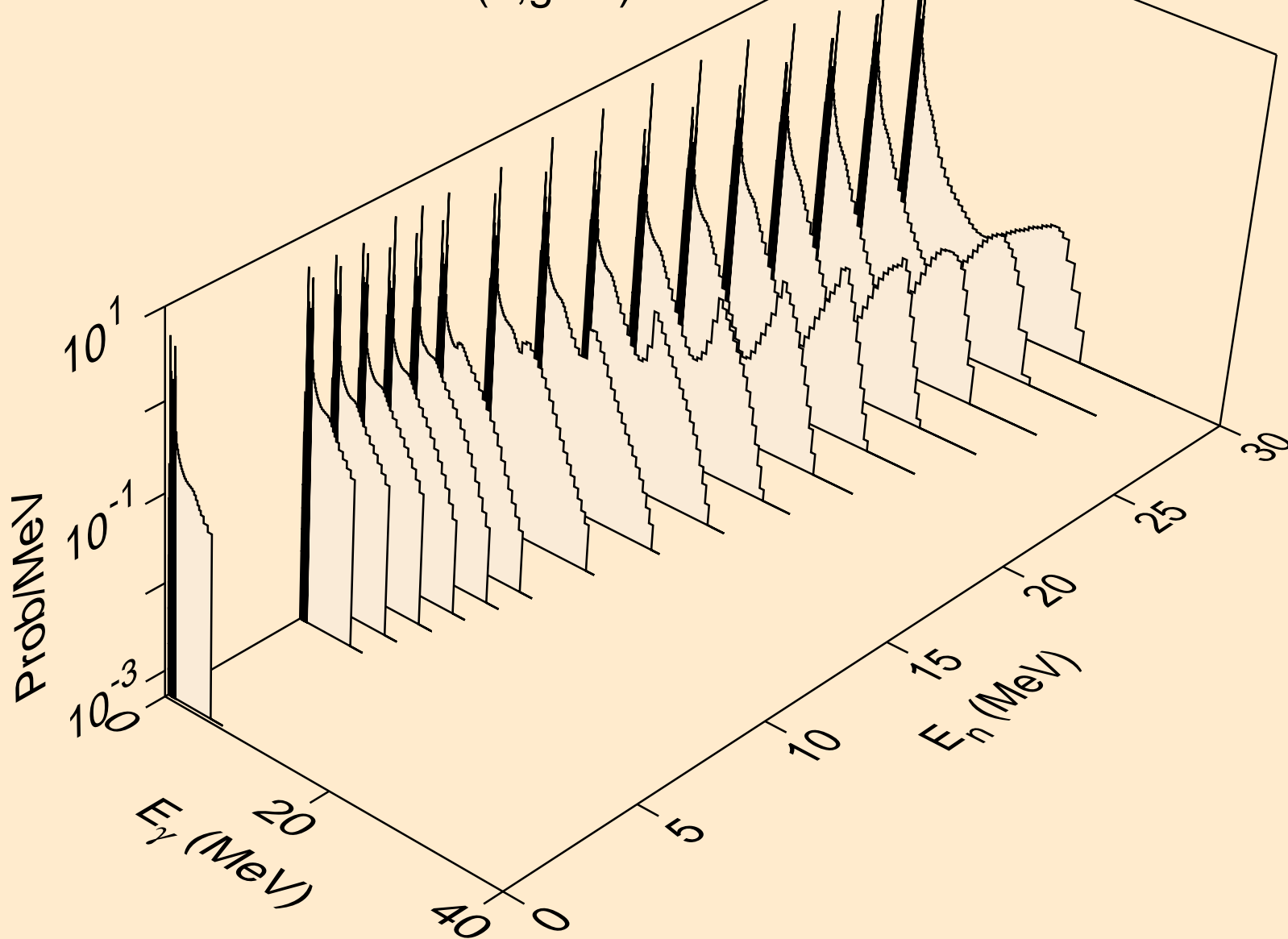

NB093 ALPHA ACER TENDL-2023 LIBRARY; T=0.K
Photon emission for (n,p)

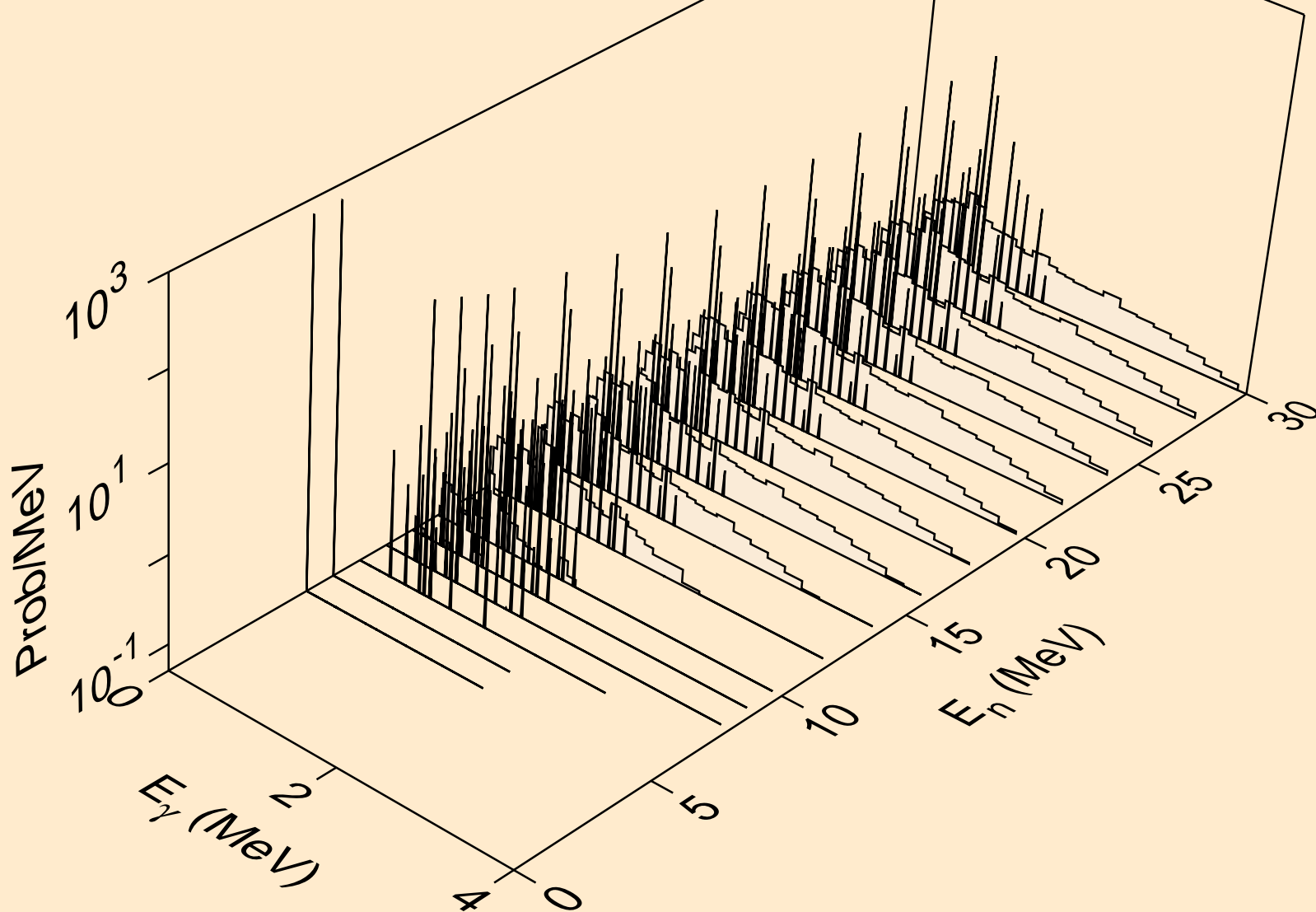

NB093 ALPHA ACER TENDL-2023 LIBRARY; T=0.K
Photon emission for (n,d)

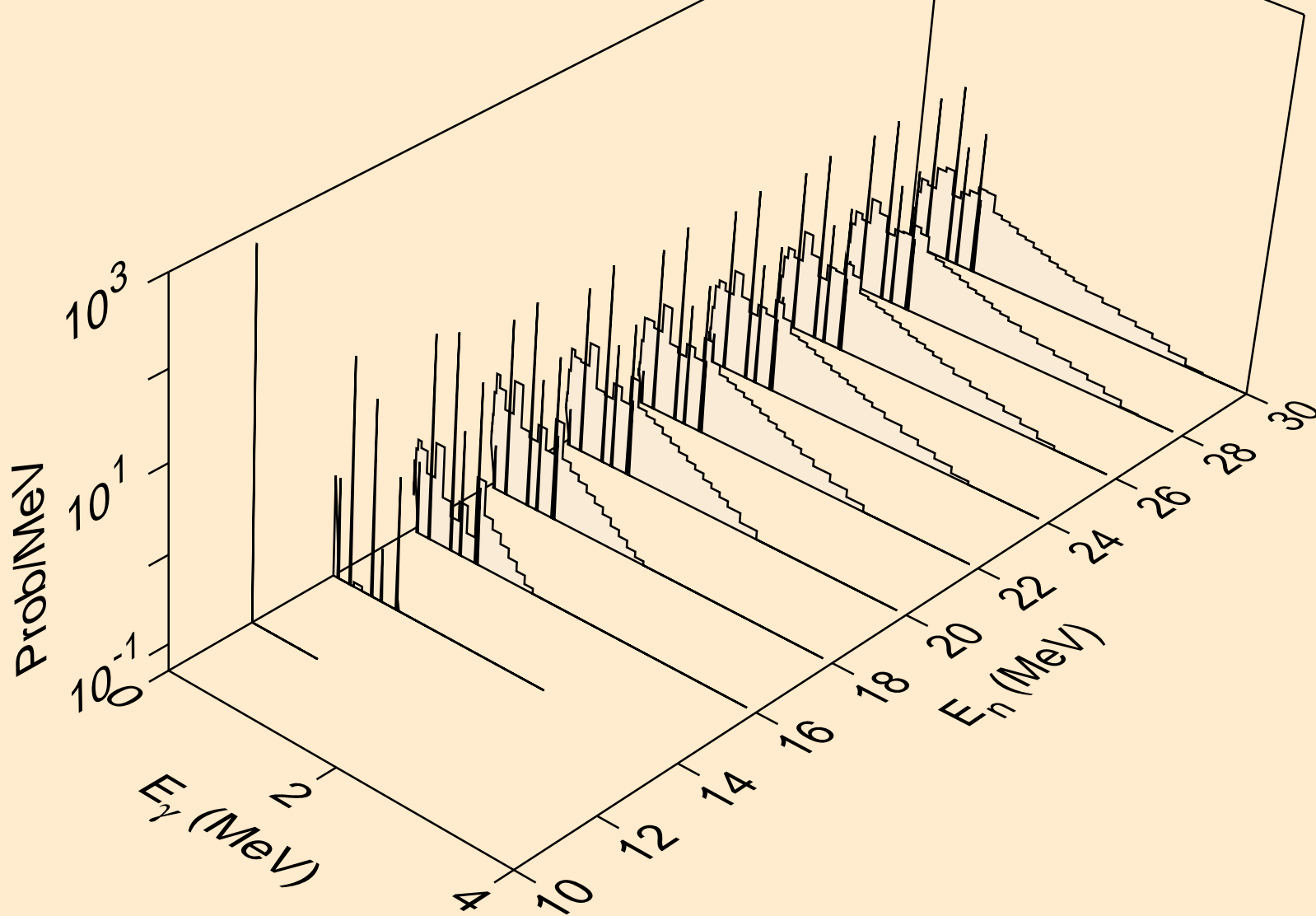

NB093 ALPHA ACER TENDL-2023 LIBRARY; T=0.K
Photon emission for (n,t)

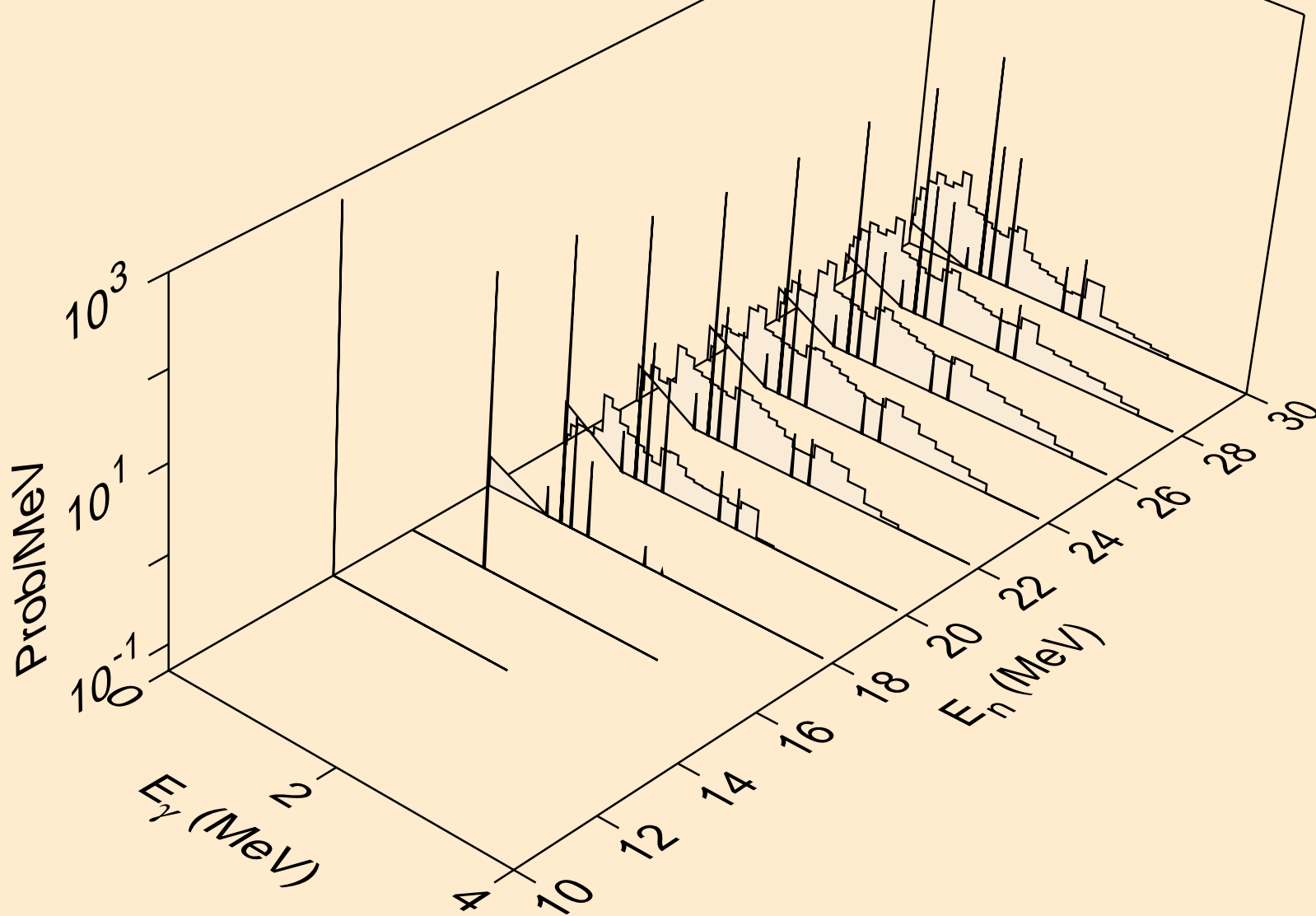

NB093 ALPHA ACER TENDL-2023 LIBRARY; T=0.K
Photon emission for (n,he3)

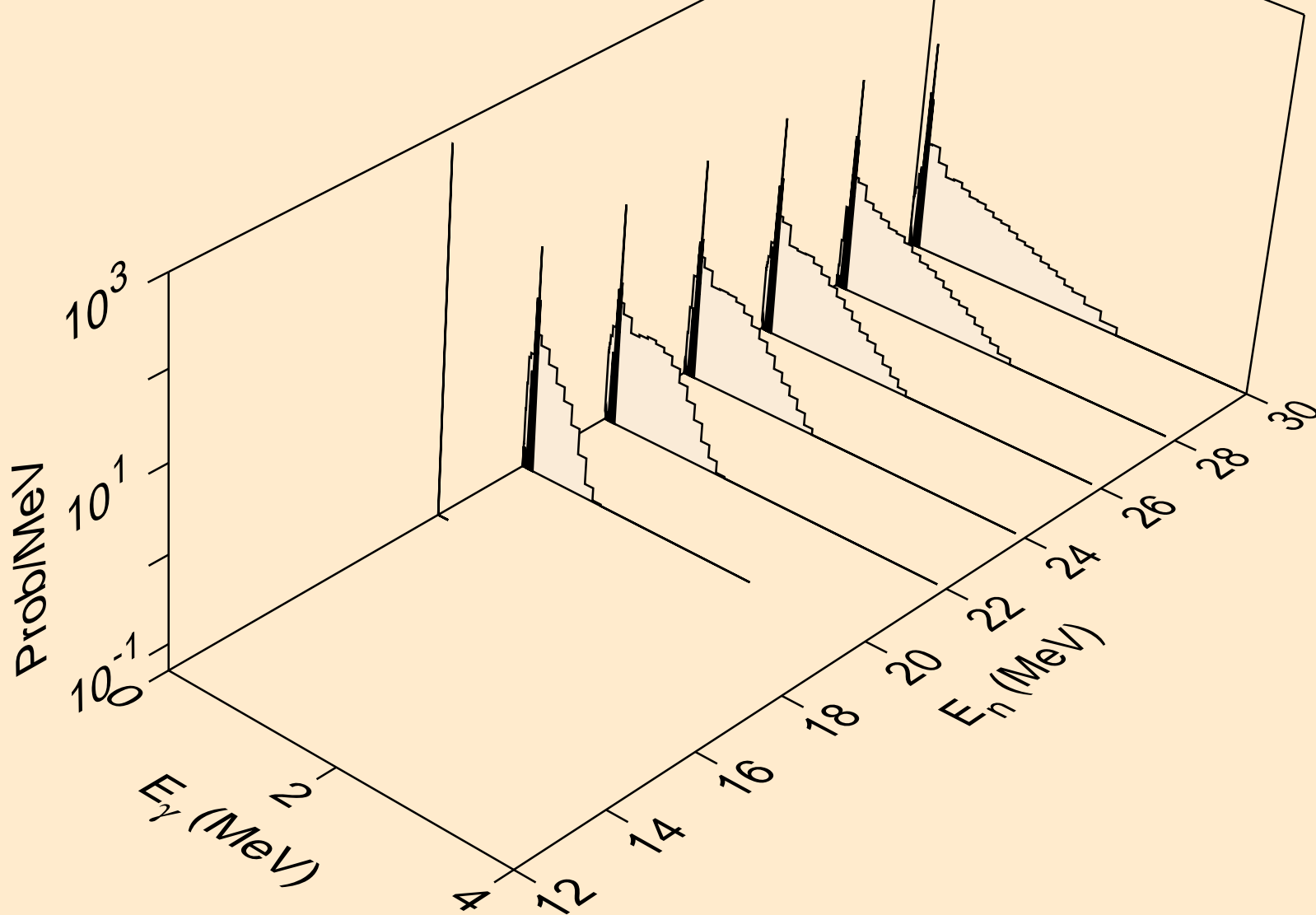

NB093 ALPHA ACER TENDL-2023 LIBRARY; T=0.K
Photon emission for inelastic

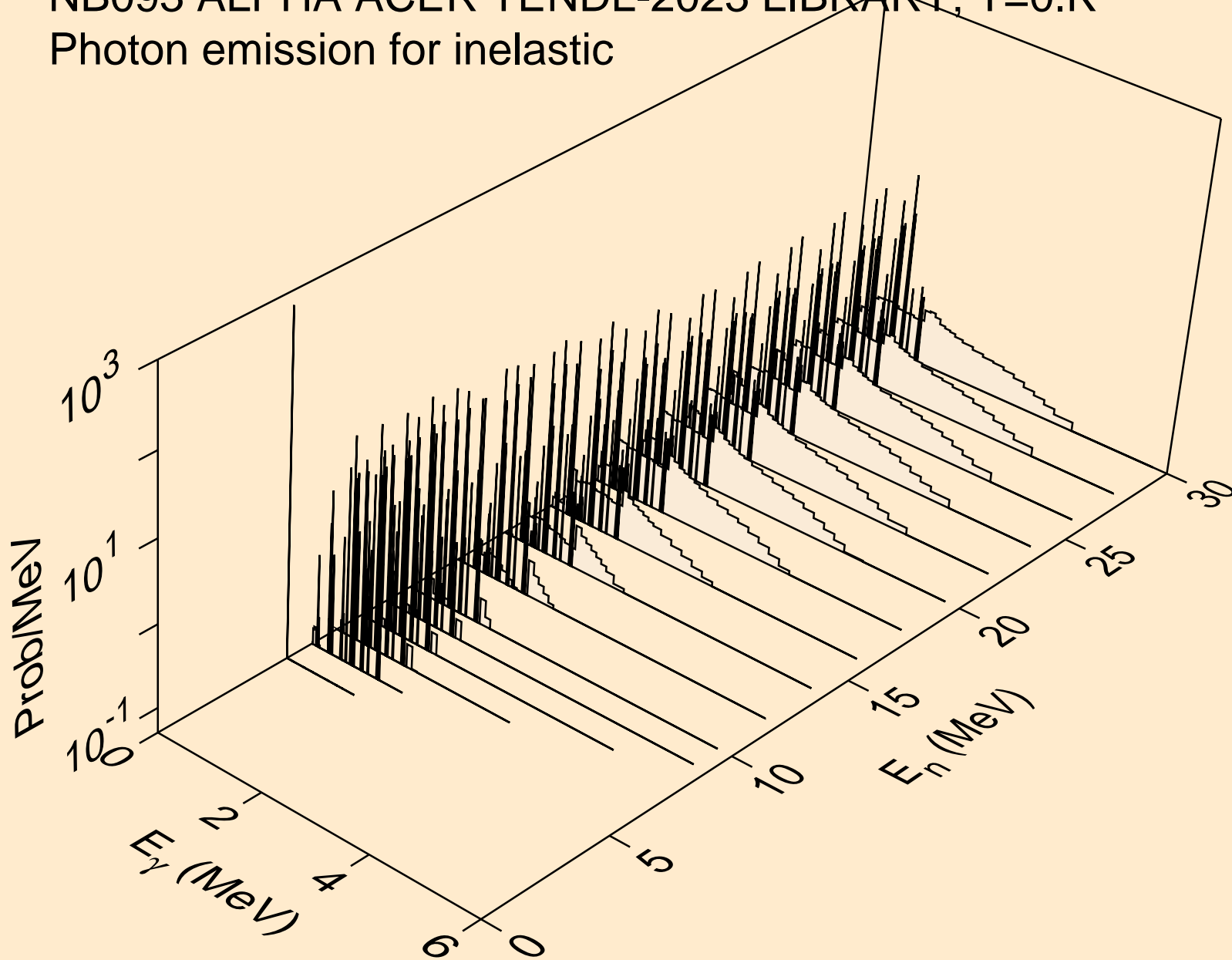

NB093 ALPHA ACER TENDL-2023 LIBRARY; T=0.K
Photon emission for (n,2a)

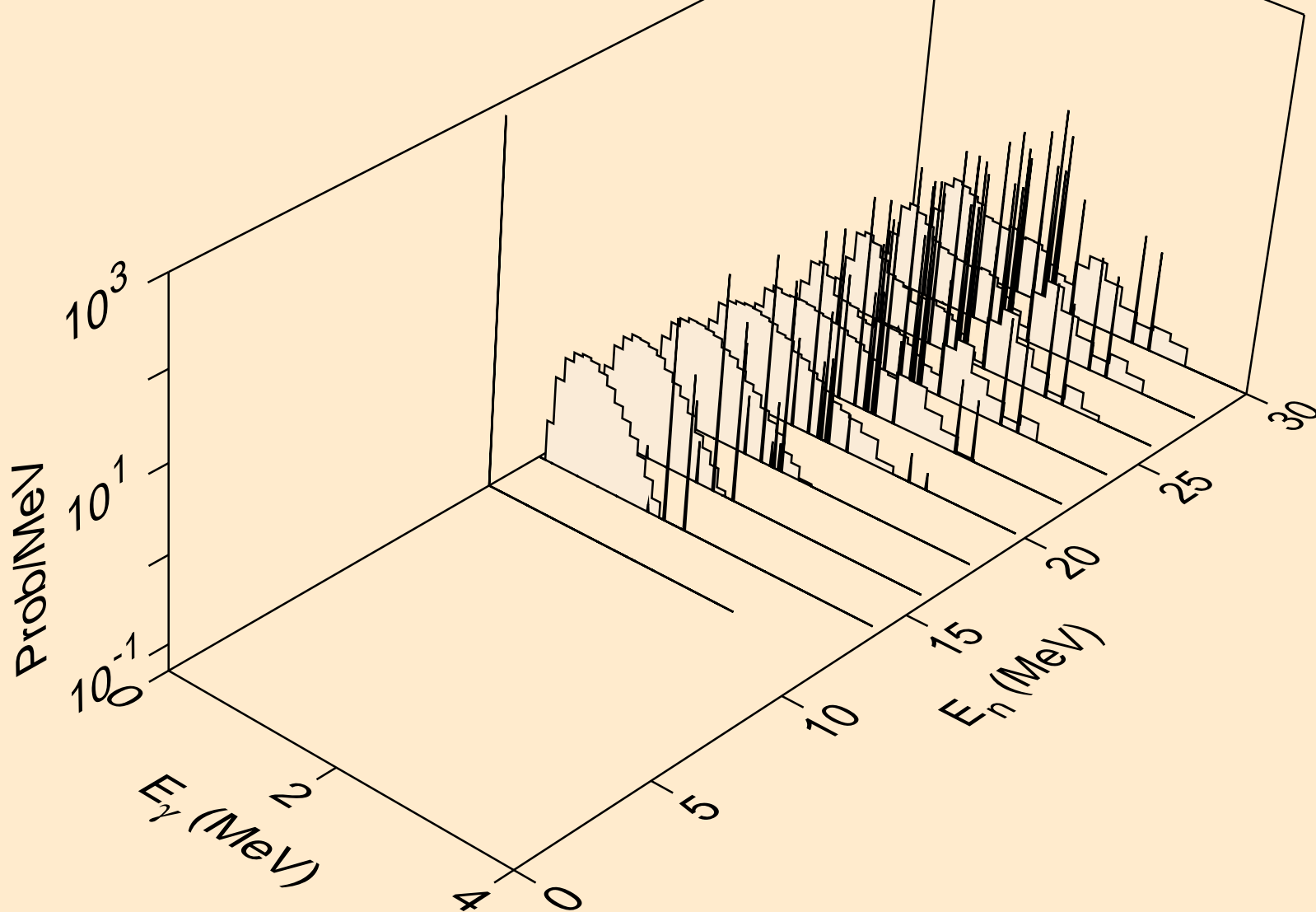

NB093 ALPHA ACER TENDL-2023 LIBRARY; T=0.K
Photon emission for (n,2p)

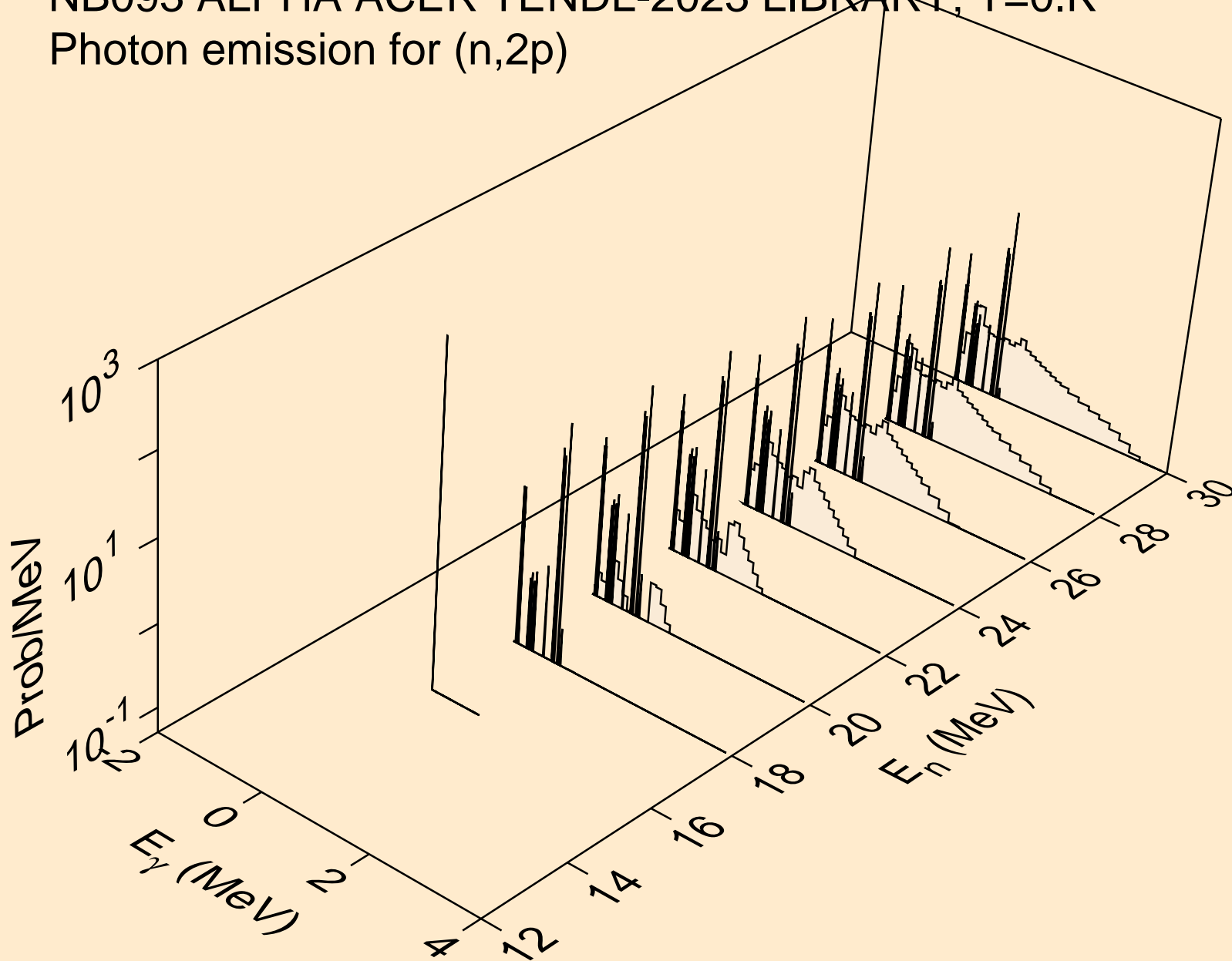

NB093 ALPHA ACER TENDL-2023 LIBRARY; T=0.K
Photon emission for (n,pa)

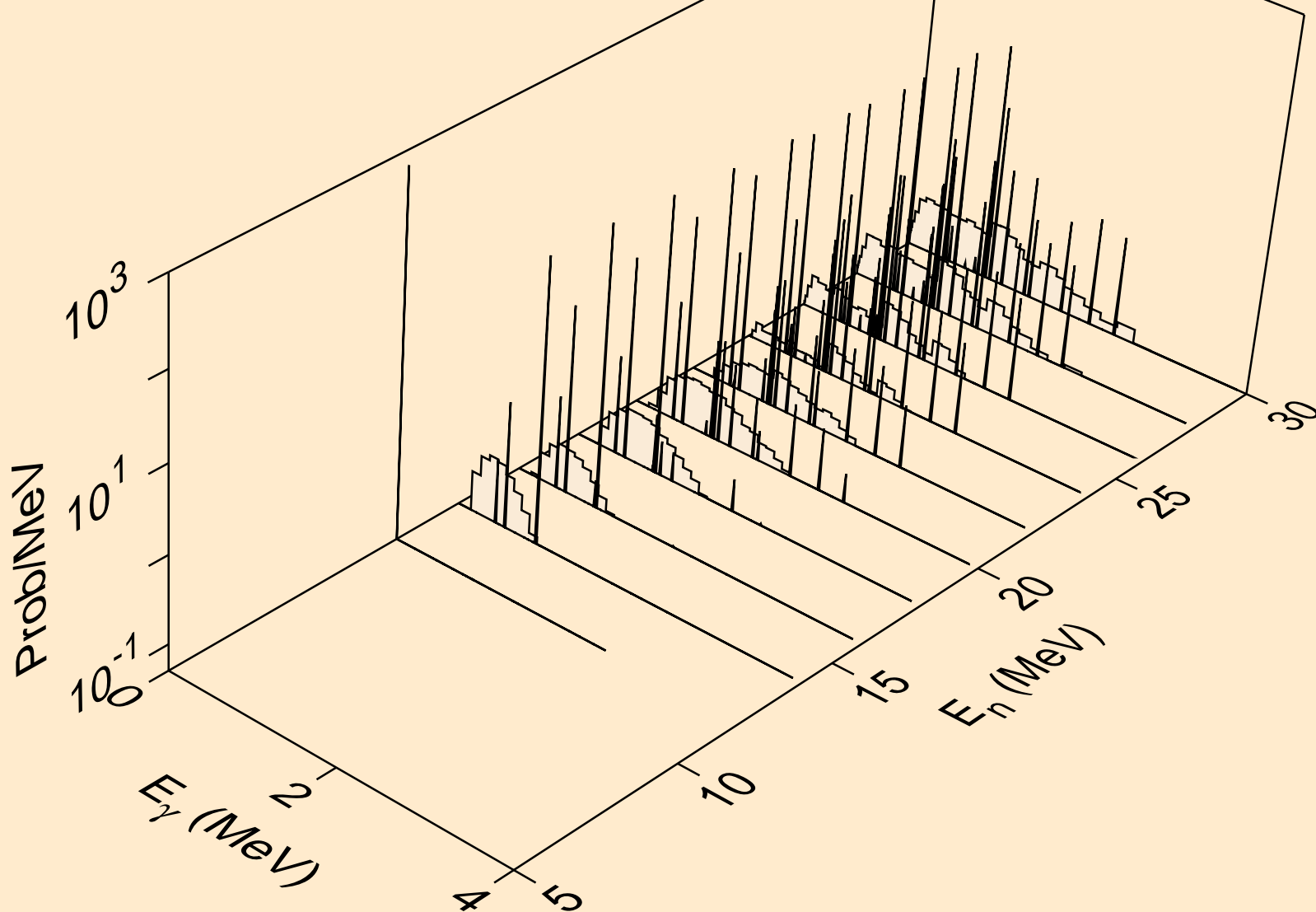

NB093 ALPHA ACER TENDL-2023 LIBRARY; T=0.K
Photon emission for (n,pd)

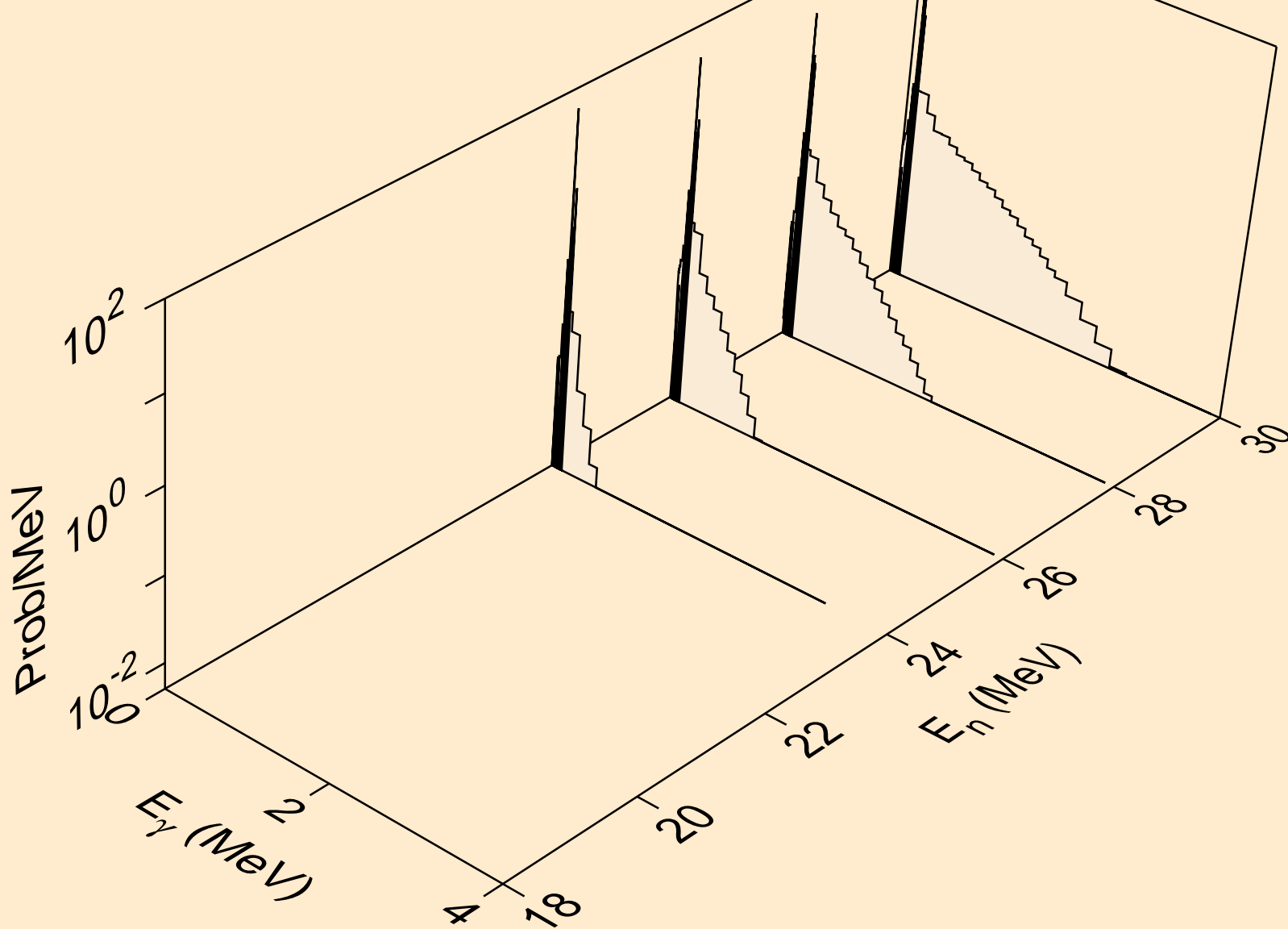

NB093 ALPHA ACER TENDL-2023 LIBRARY; T=0.K
Photon emission for (n,pt)

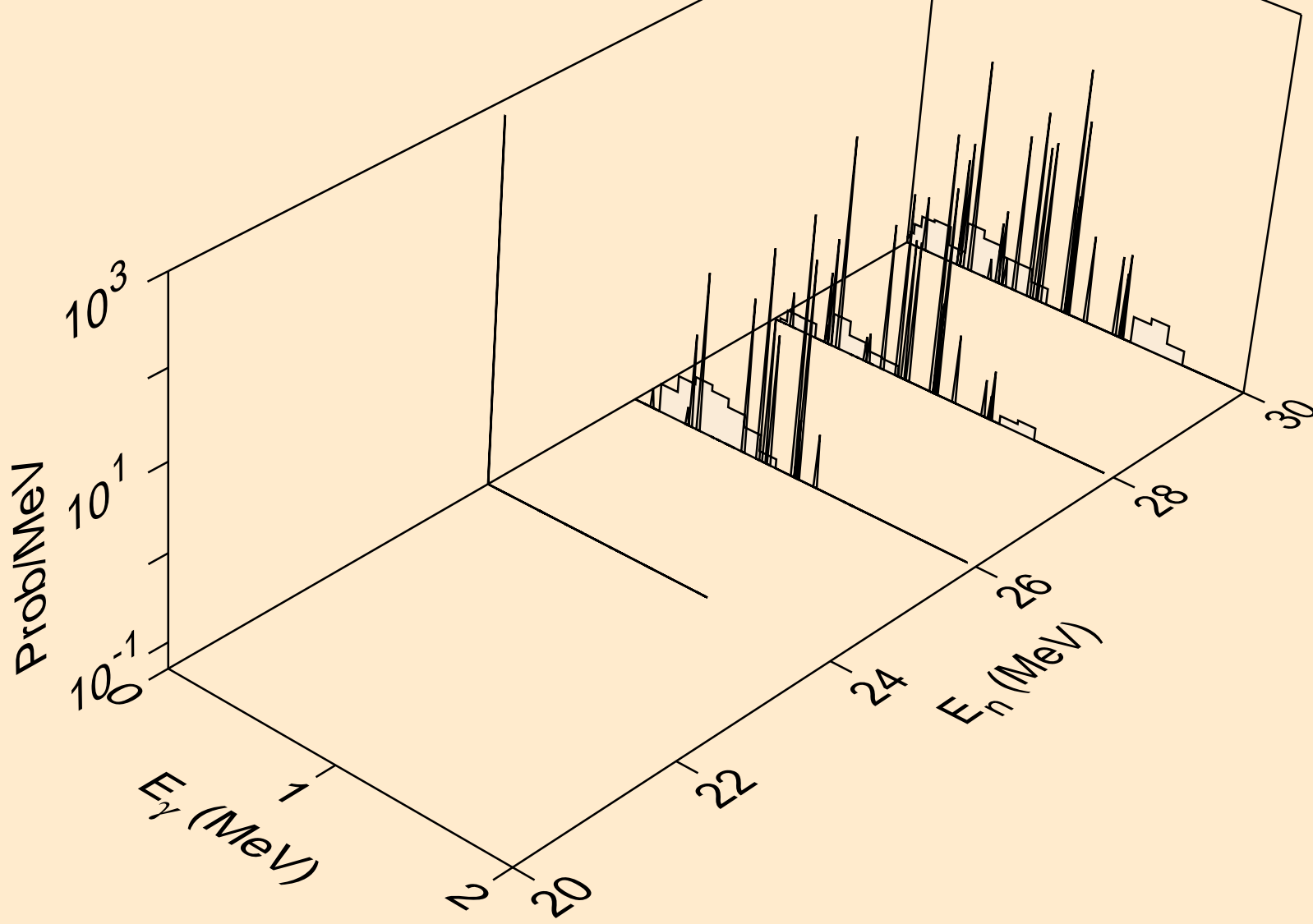

NB093 ALPHA ACER TENDL-2023 LIBRARY; T=0.K
Photon emission for (n,da)

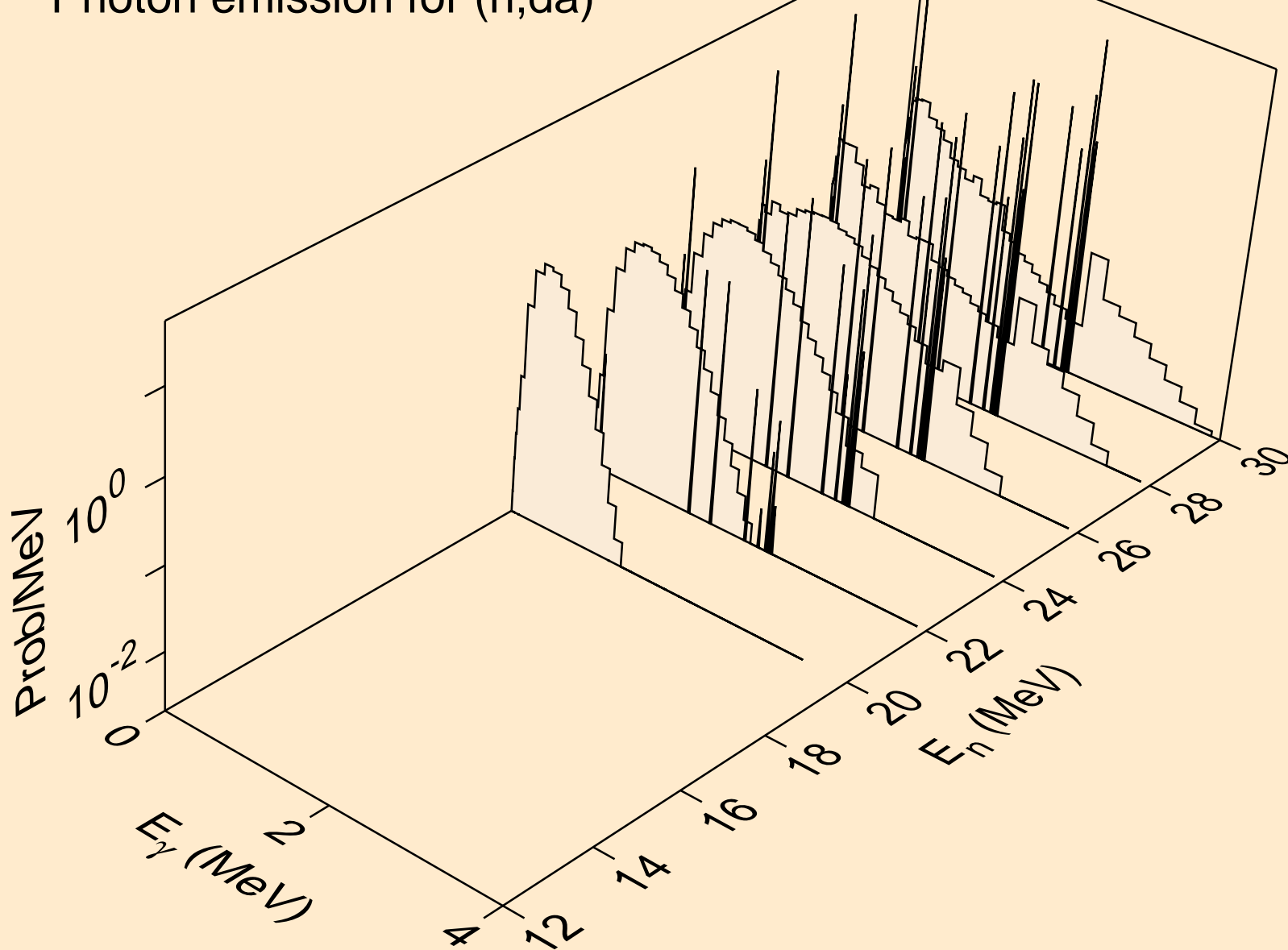

NB093 ALPHA ACER TENDL-2023 LIBRARY; T=0.K

Particle heating contributions

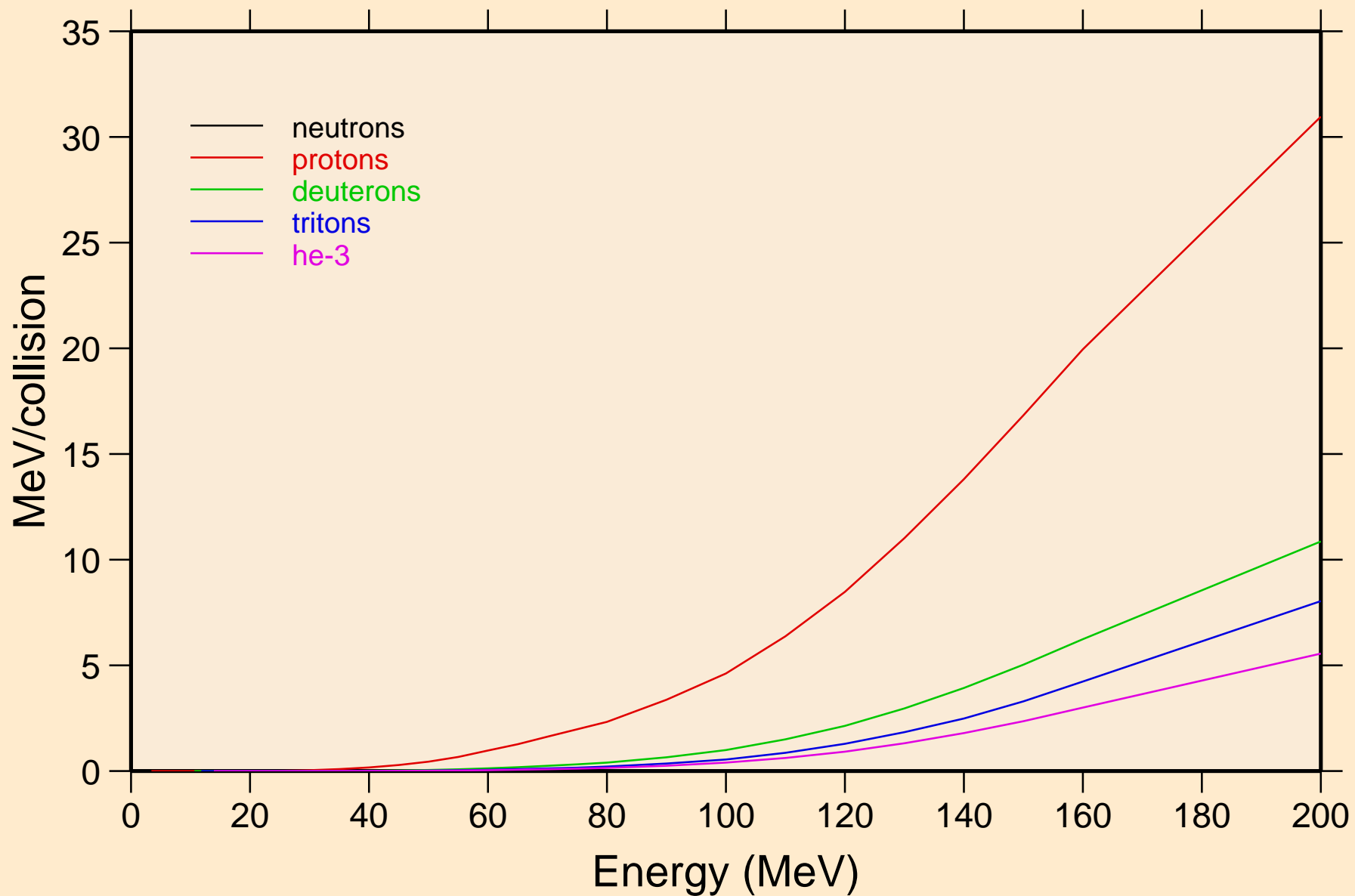

NB093 ALPHA ACER TENDL-2023 LIBRARY; T=0.K
Recoil Heating

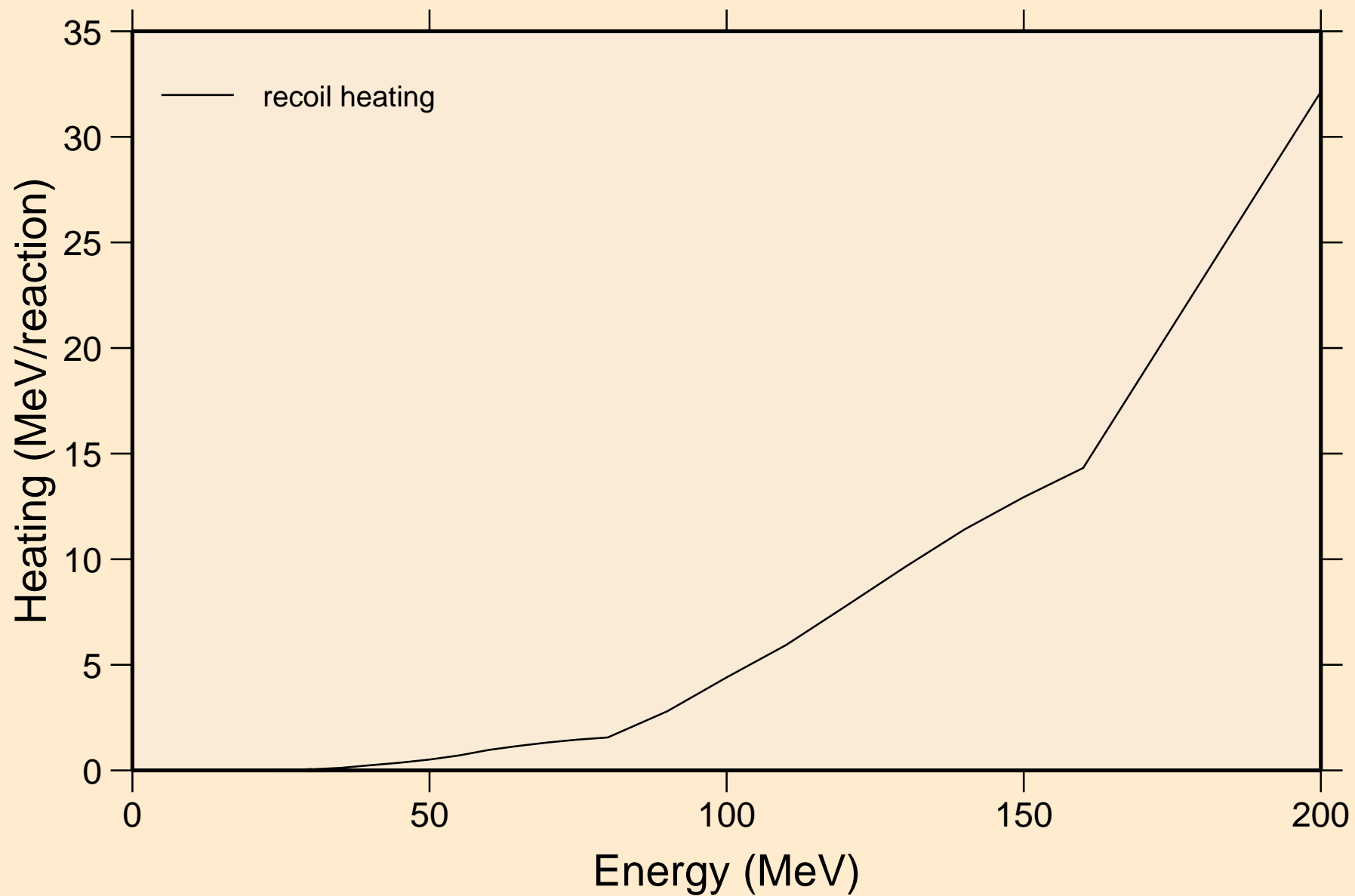

NB093 ALPHA ACER TENDL-2023 LIBRARY; T=0.K

Particle production cross sections

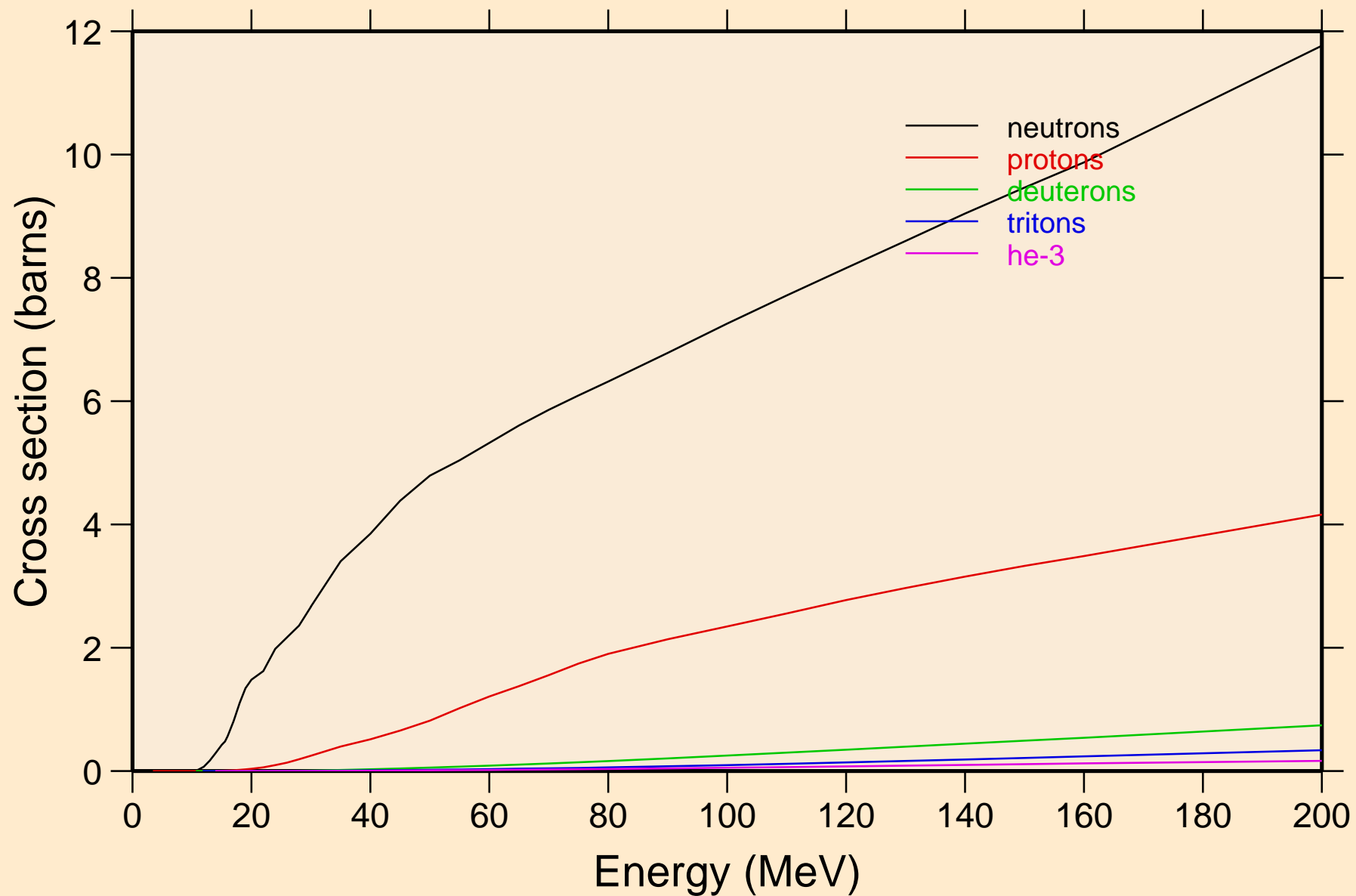

NB093 ALPHA ACER TENDL-2023 LIBRARY; T=0.K
neutrons from (a,n)

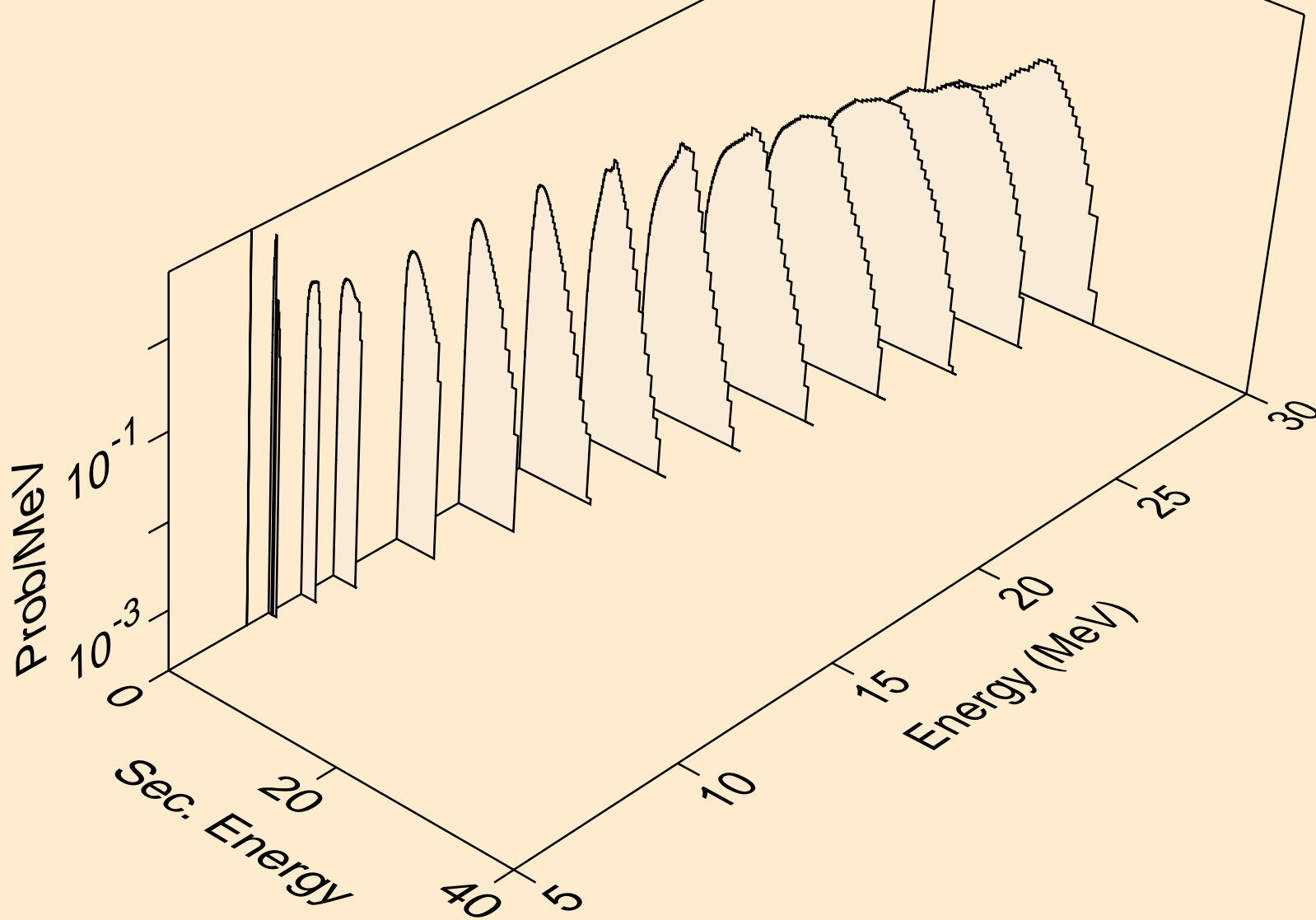

NB093 ALPHA ACER TENDL-2023 LIBRARY; T=0.K
neutrons from (a,x)

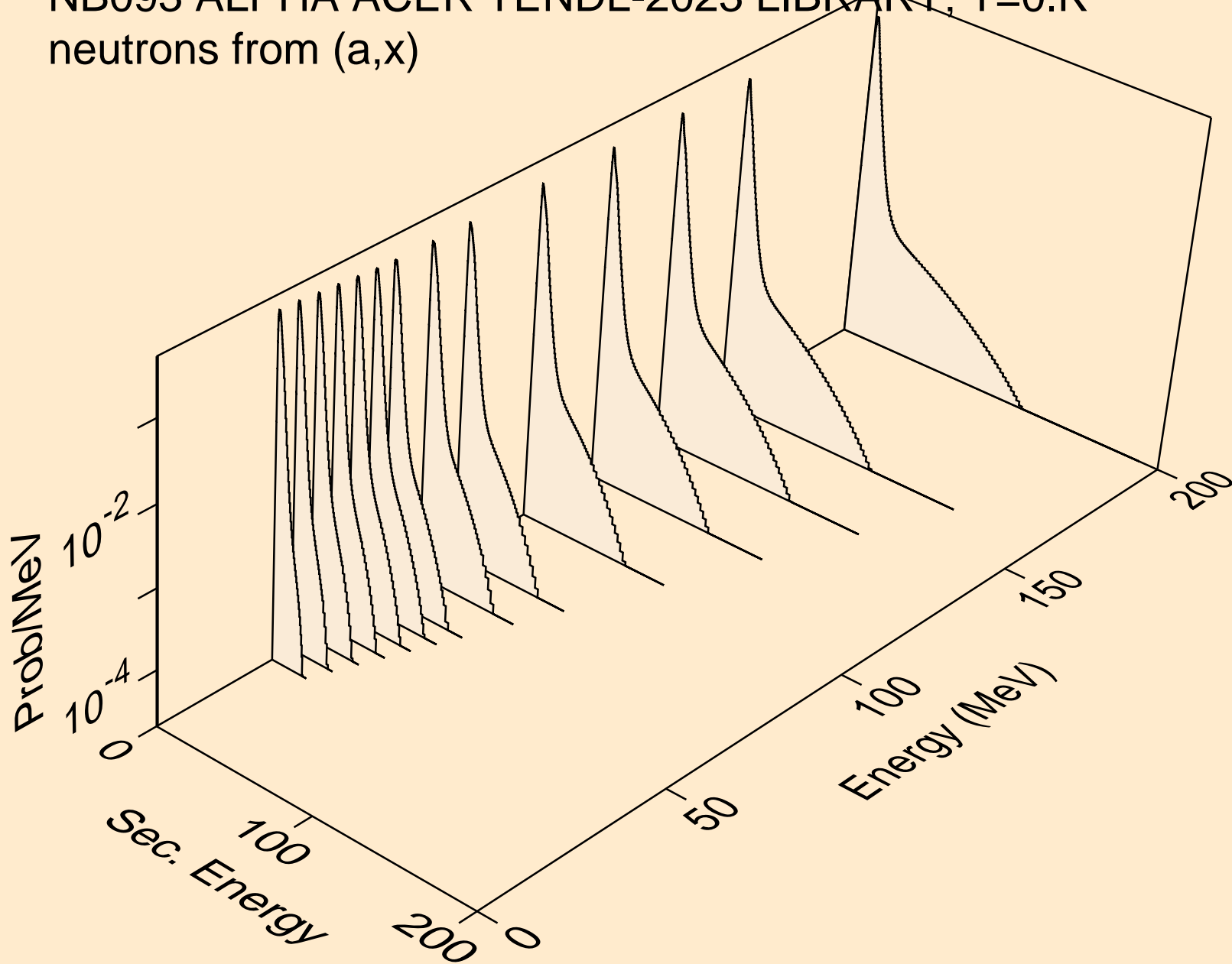

NB093 ALPHA ACER TENDL-2023 LIBRARY; T=0.K
neutrons from (a,2n)

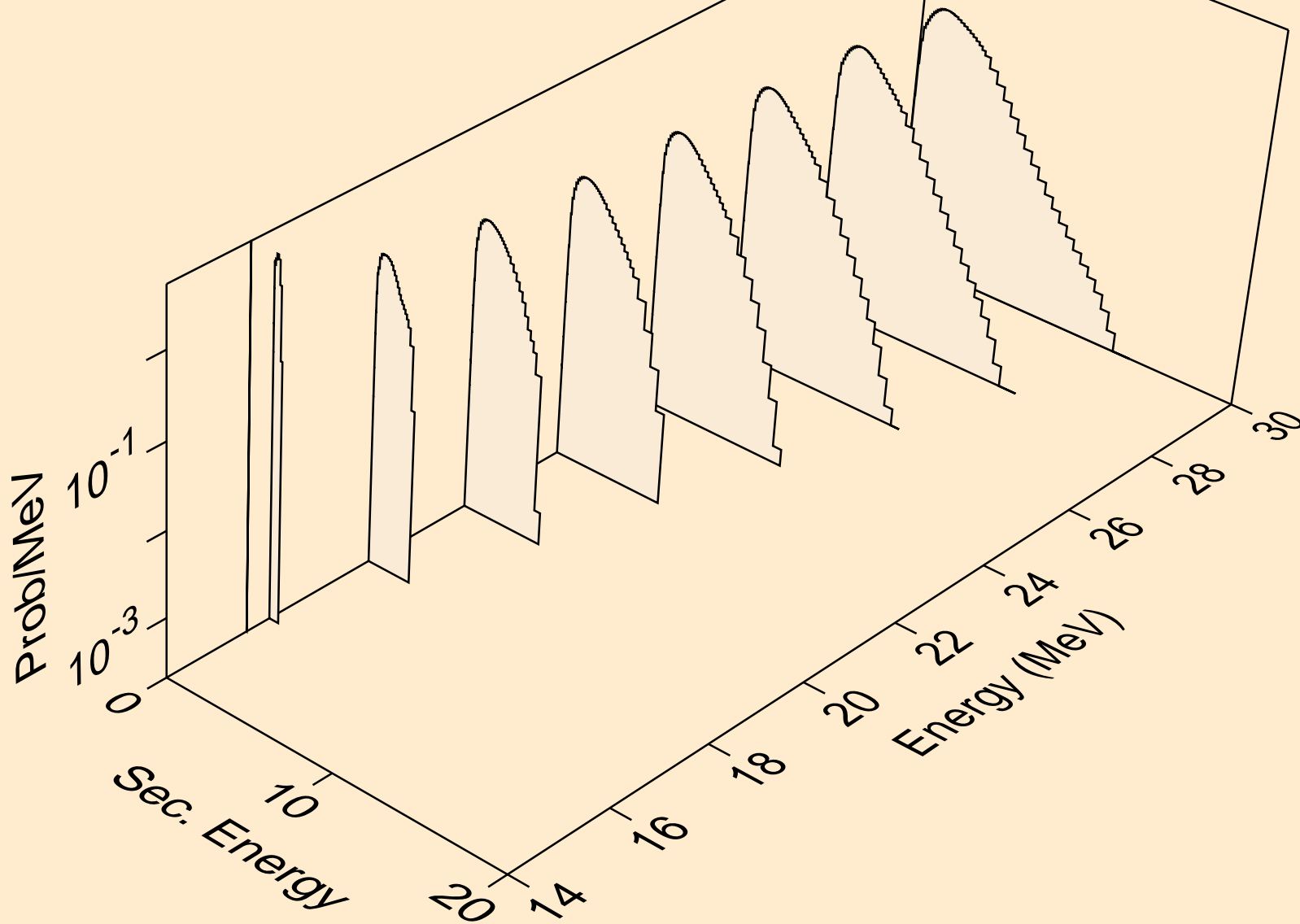

NB093 ALPHA ACER TENDL-2023 LIBRARY; T=0.K
neutrons from (a,3n)

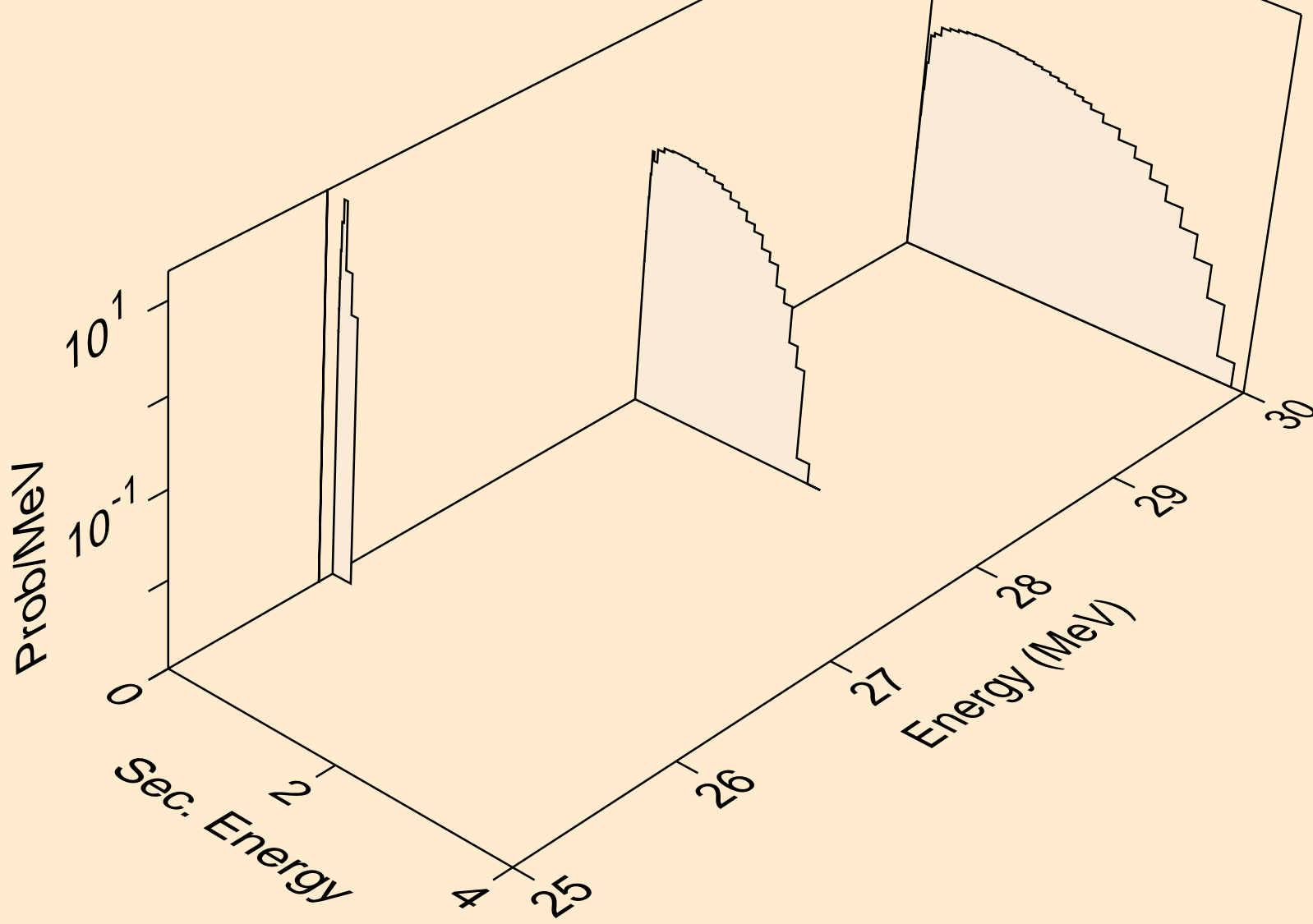

NB093 ALPHA ACER TENDL-2023 LIBRARY; T=0.K
neutrons from (a,n*)a

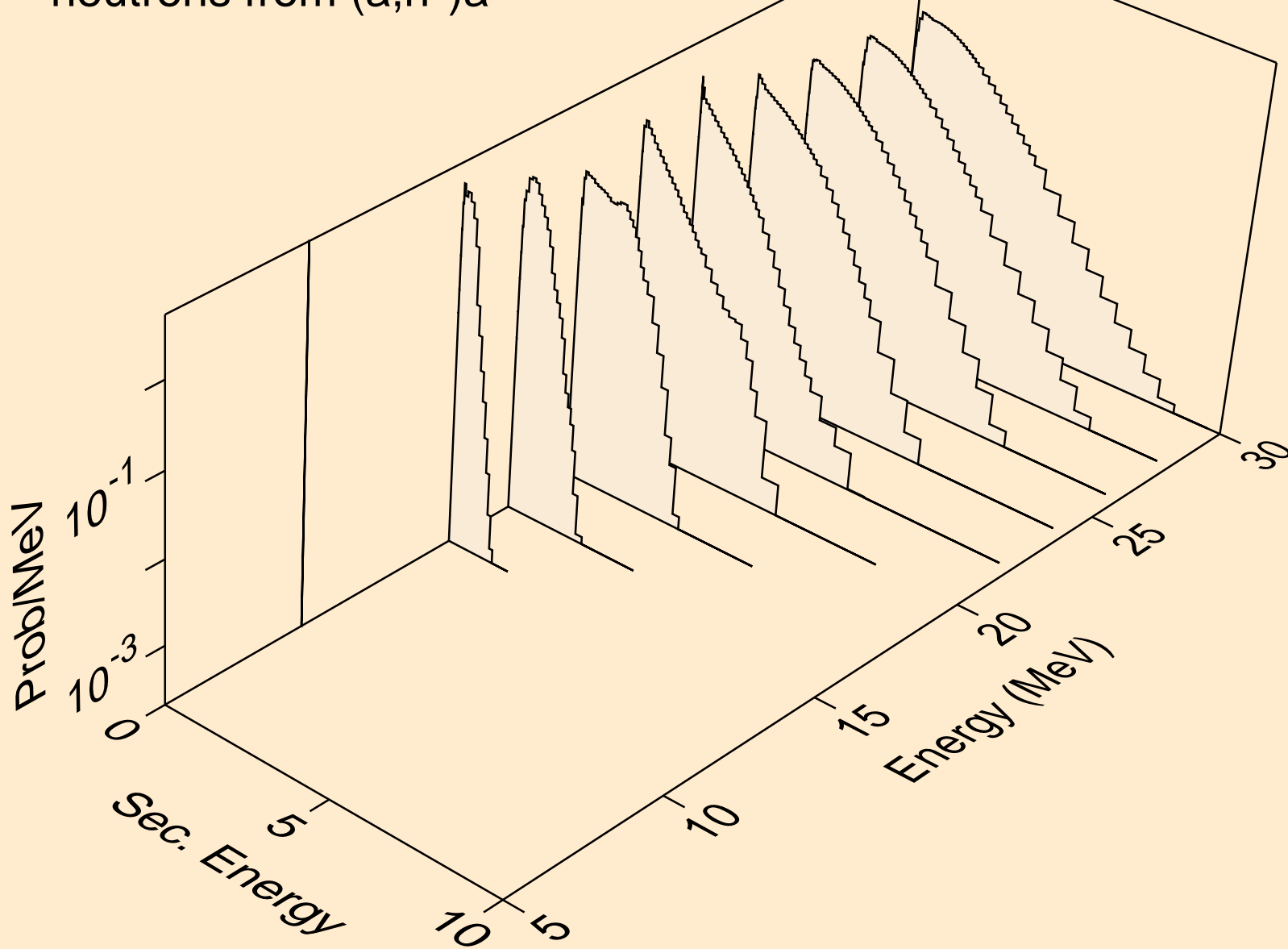

NB093 ALPHA ACER TENDL-2023 LIBRARY; T=0.K
neutrons from (a,2n)a

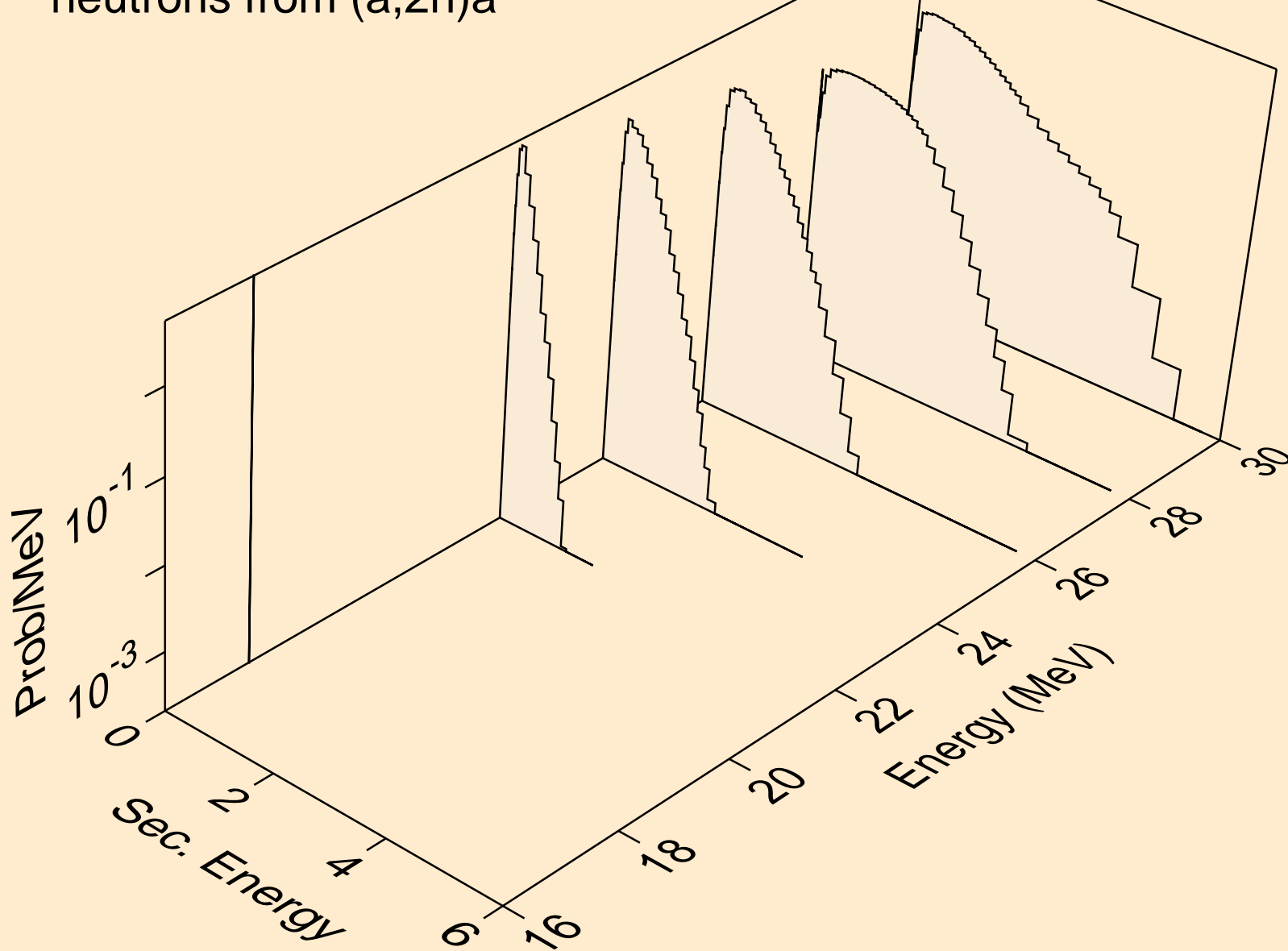

NB093 ALPHA ACER TENDL-2023 LIBRARY; T=0.K
neutrons from (a,n*)p

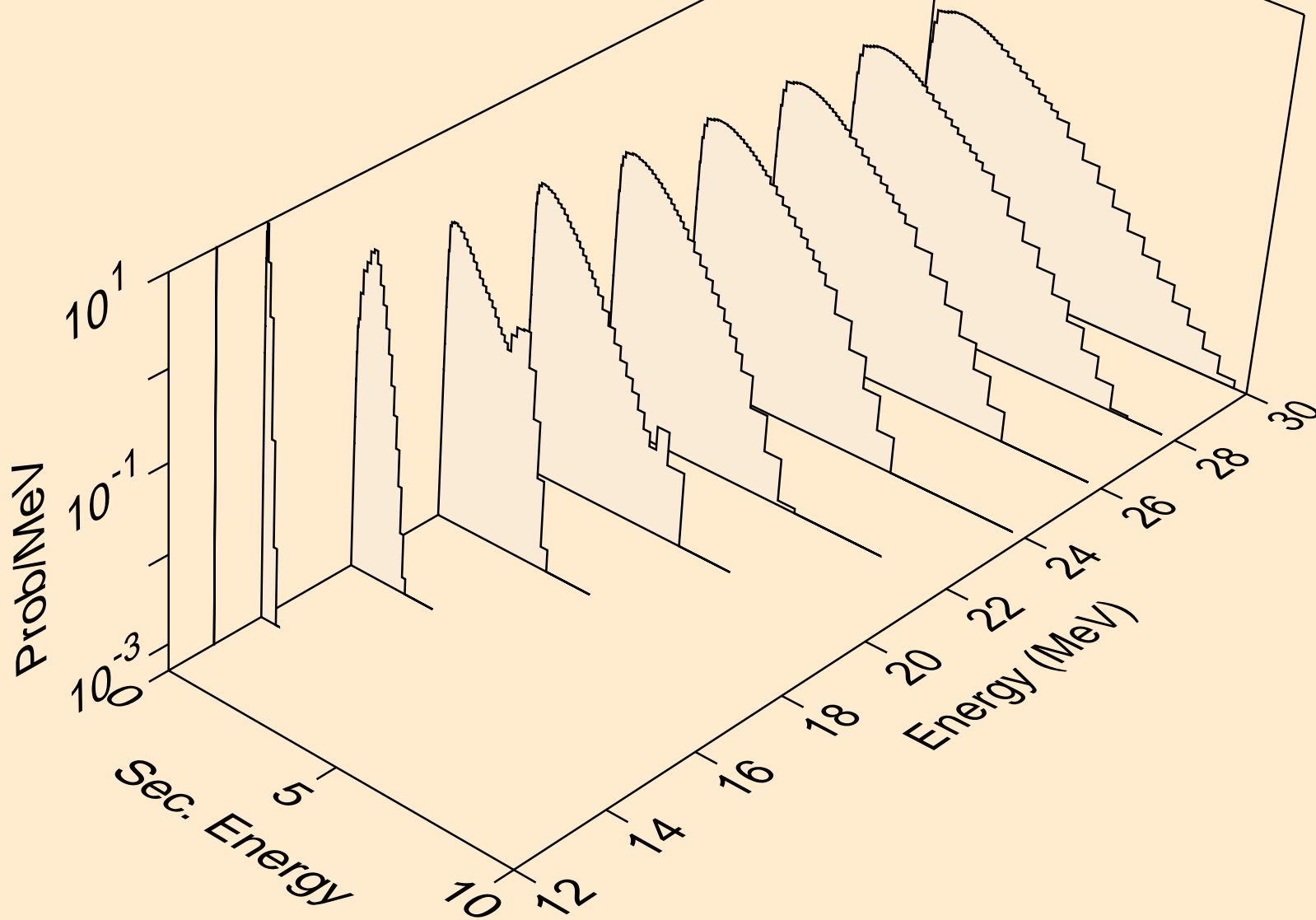

NB093 ALPHA ACER TENDL-2023 LIBRARY; T=0.K
neutrons from (a,n*)d

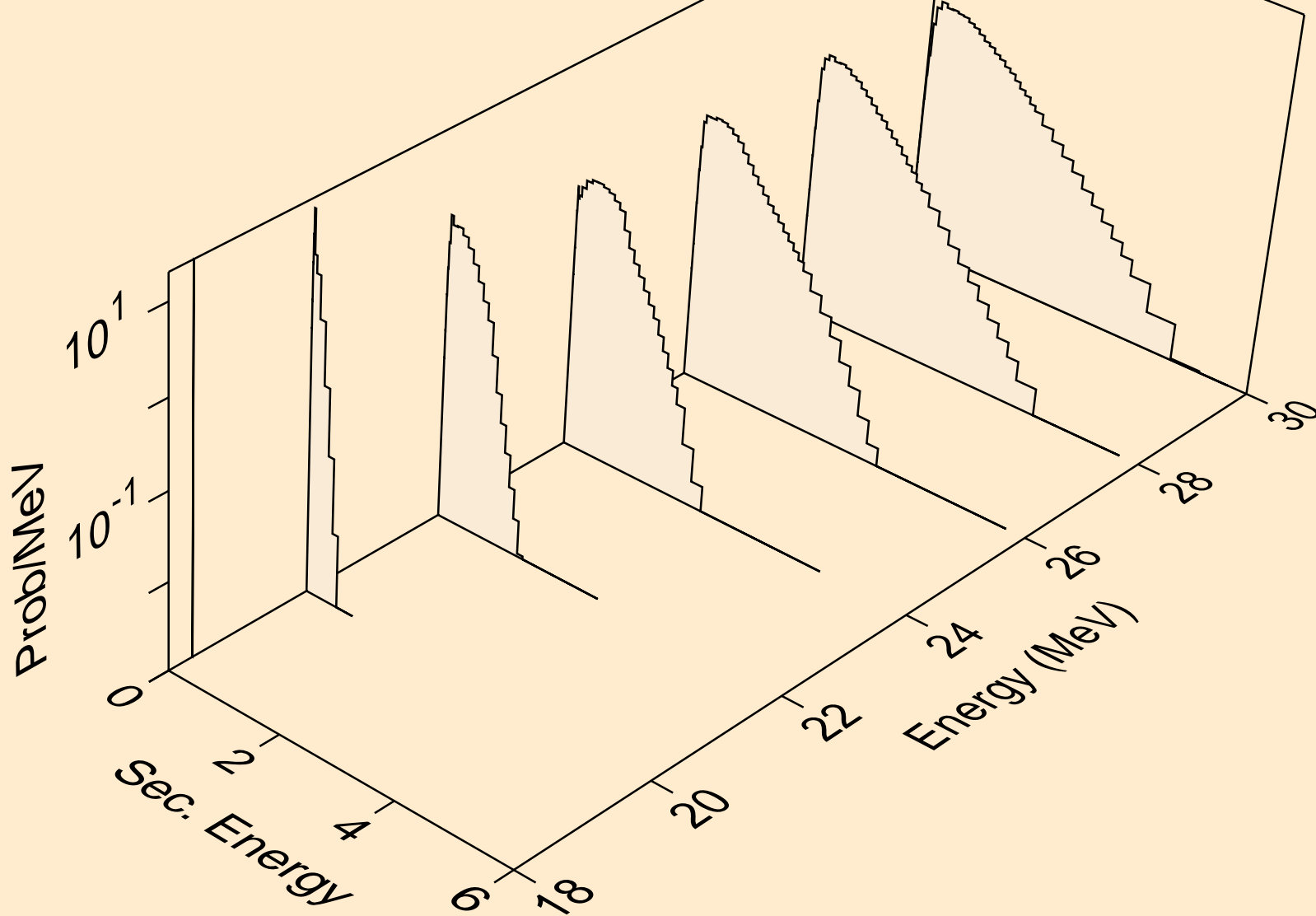

NB093 ALPHA ACER TENDL-2023 LIBRARY; T=0.K
neutrons from (a,n*)t

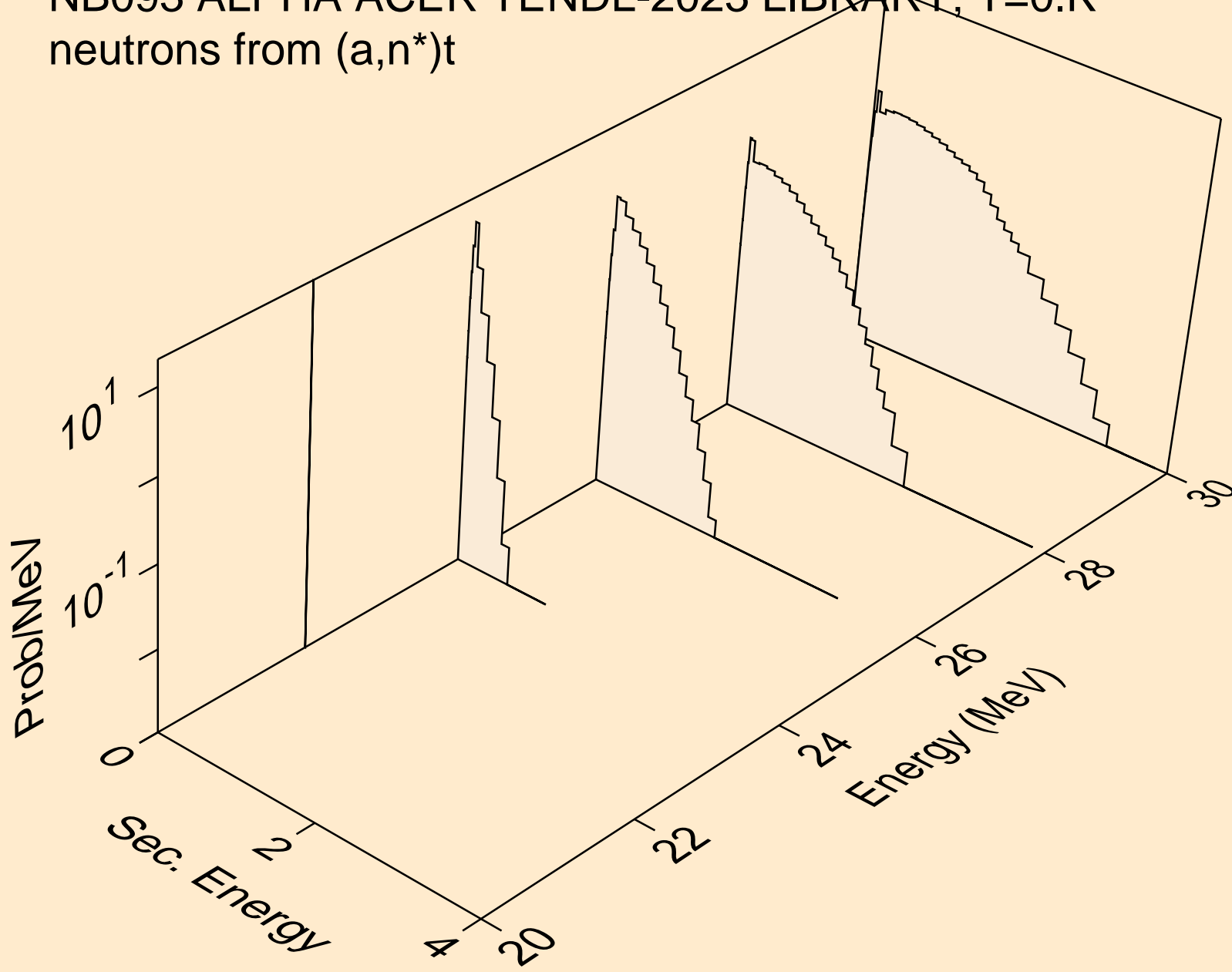

NB093 ALPHA ACER TENDL-2023 LIBRARY; T=0.K
neutrons from (a,n*)he3

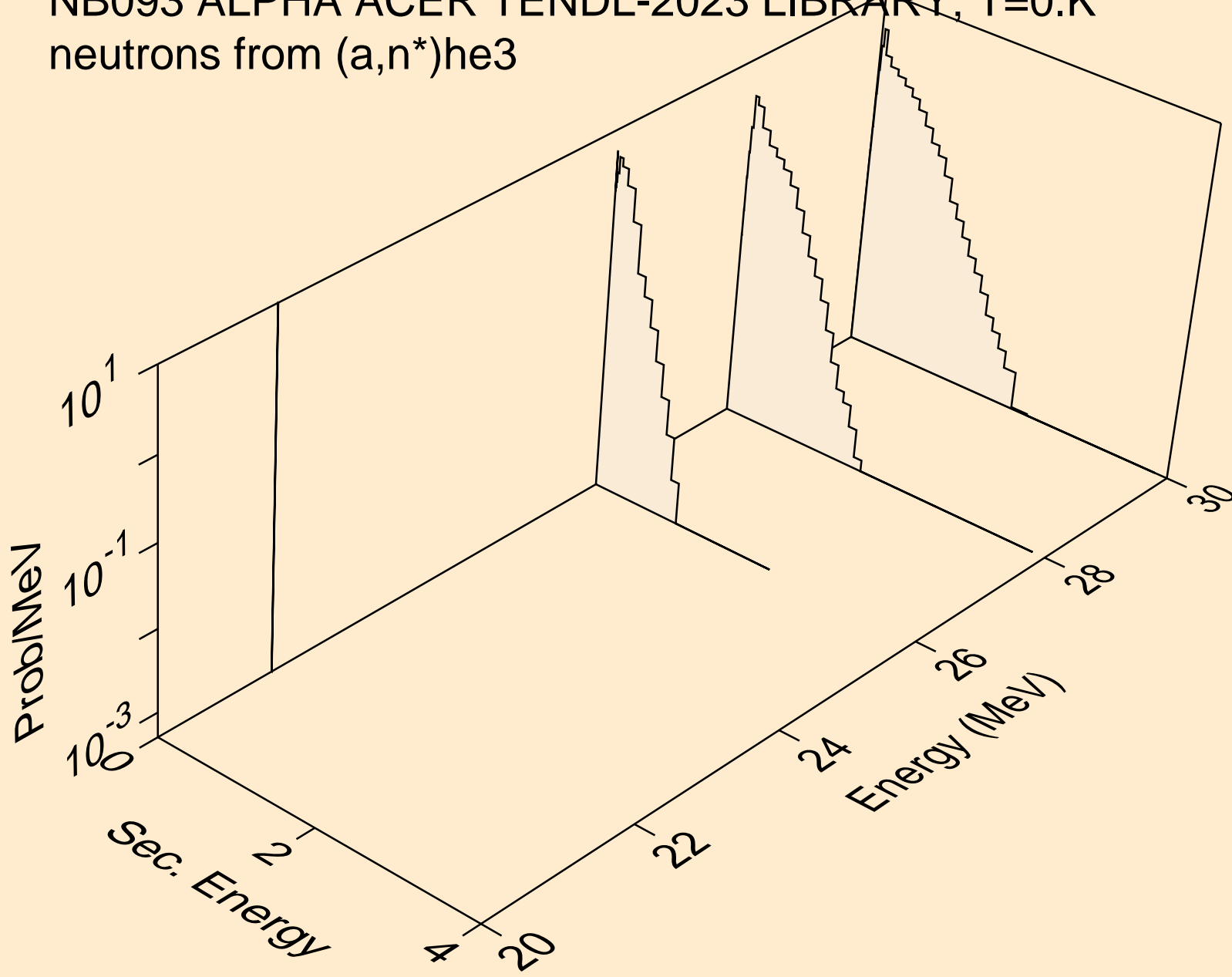

NB093 ALPHA ACER TENDL-2023 LIBRARY; T=0.K
neutrons from (a,2np)

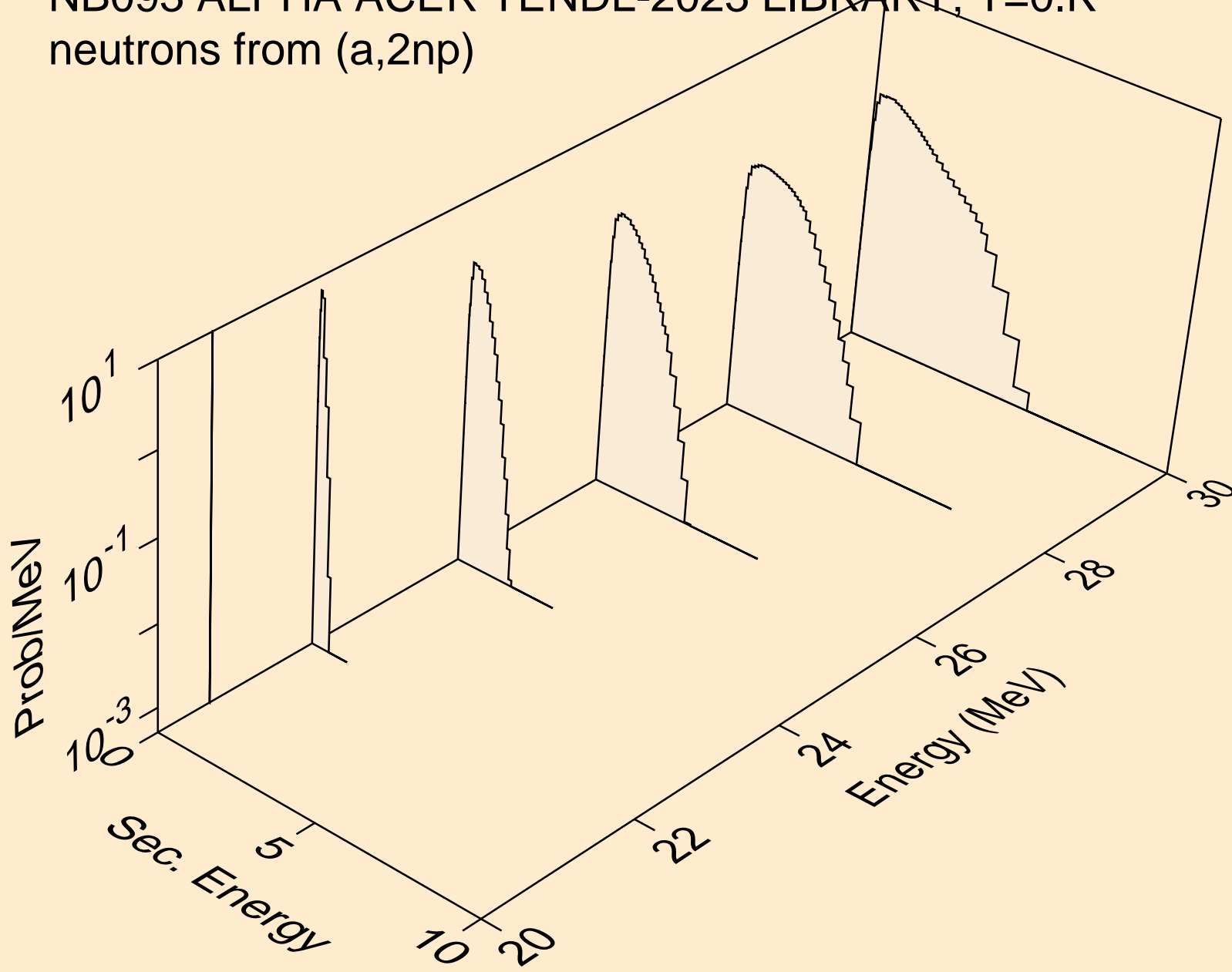

NB093 ALPHA ACER TENDL-2023 LIBRARY; T=0.K
neutrons from (a,n2p)

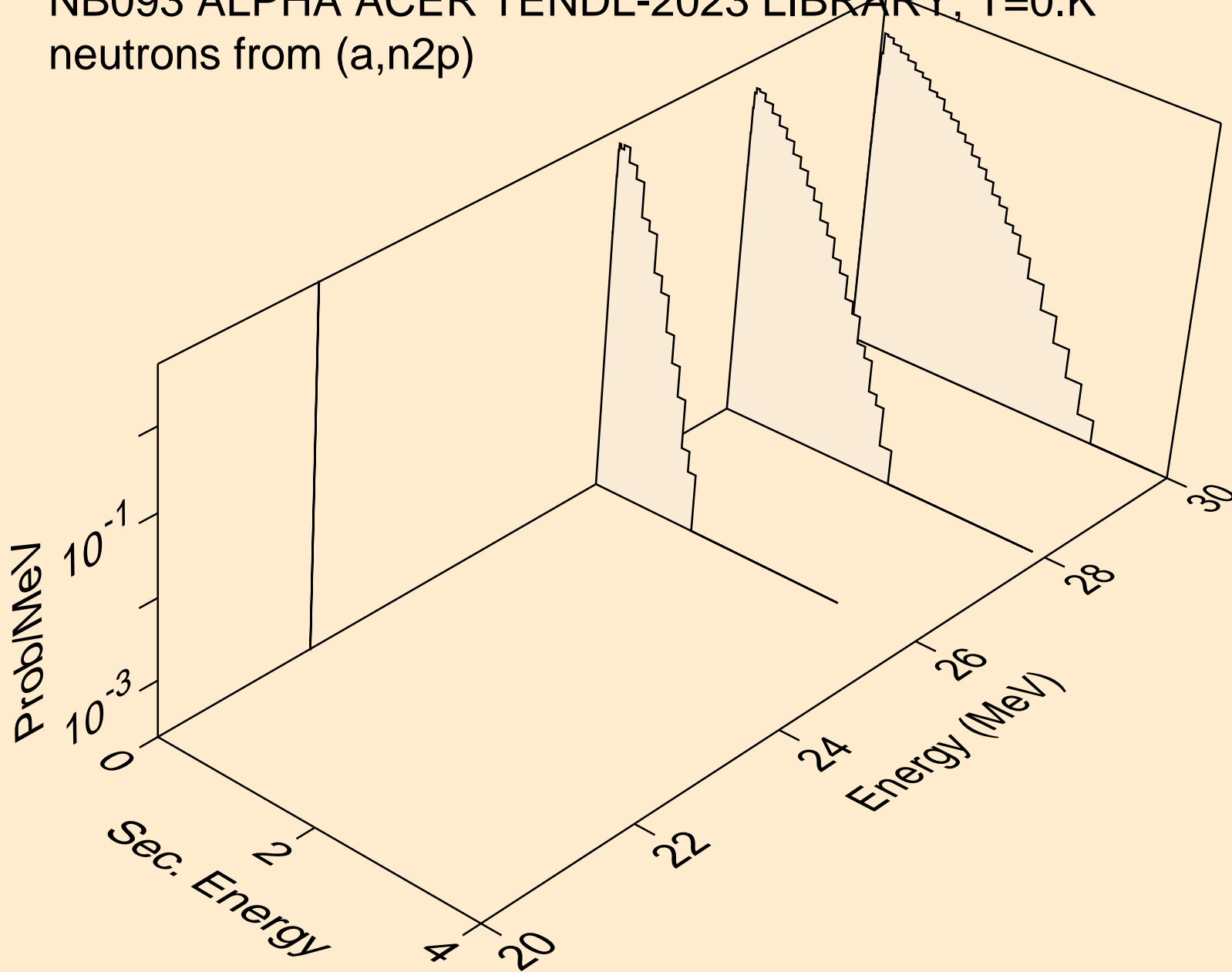

NB093 ALPHA ACER TENDL-2023 LIBRARY; T=0.K
neutrons from (a,npa)

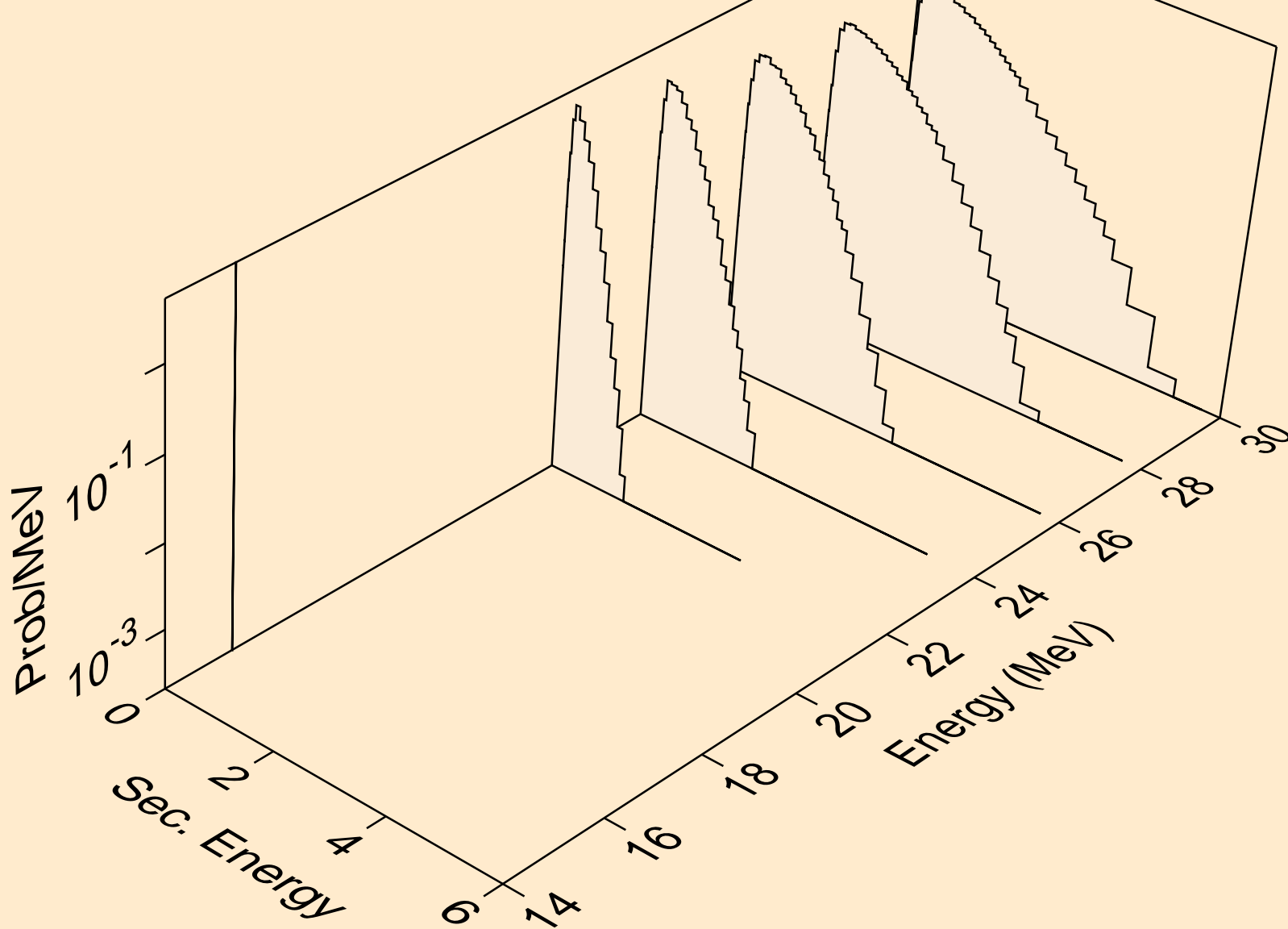

NB093 ALPHA ACER TENDL-2023 LIBRARY; T=0.K
protons from (a,x)

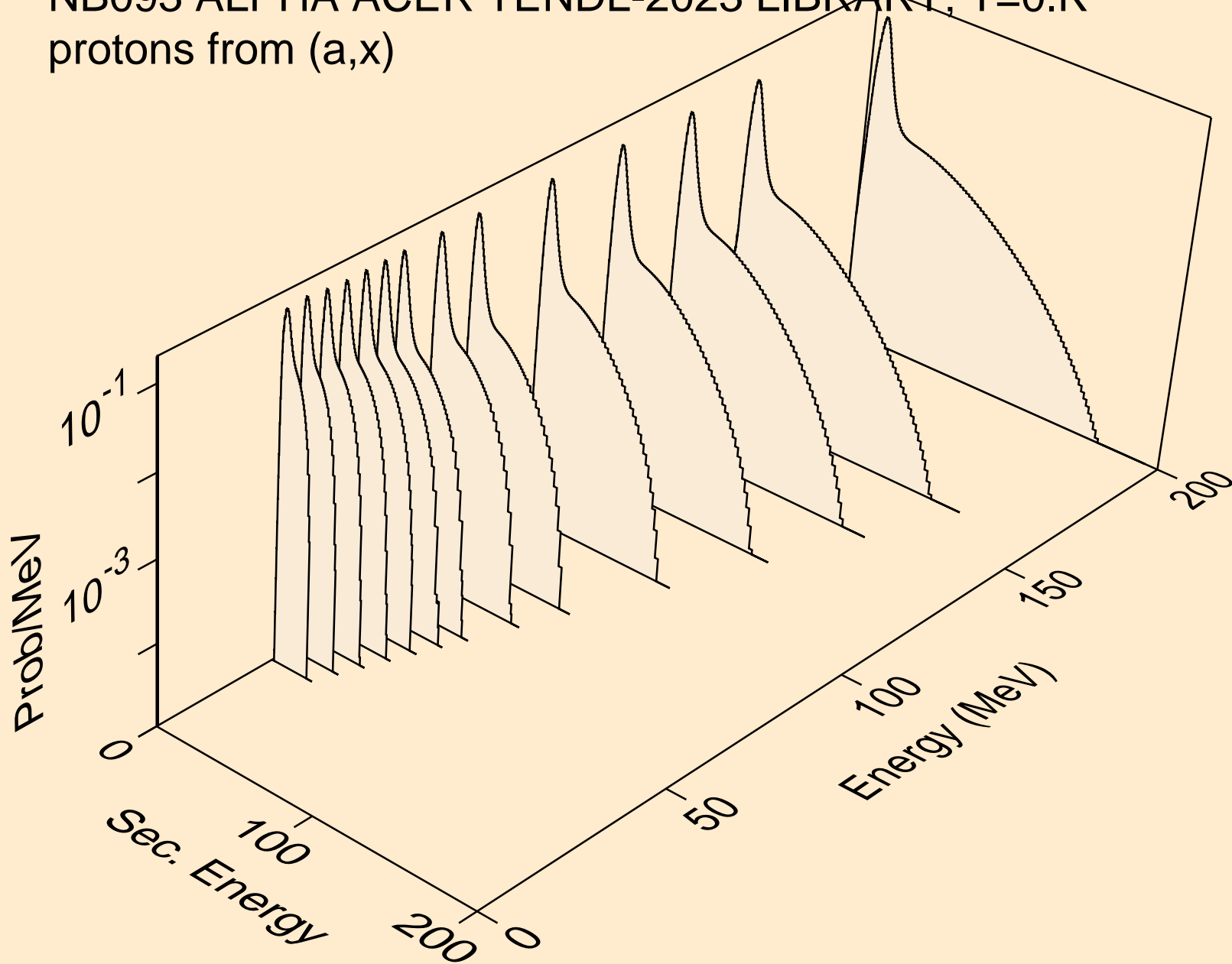

NB093 ALPHA ACER TENDL-2023 LIBRARY; T=0.K
protons from (a,n*)p

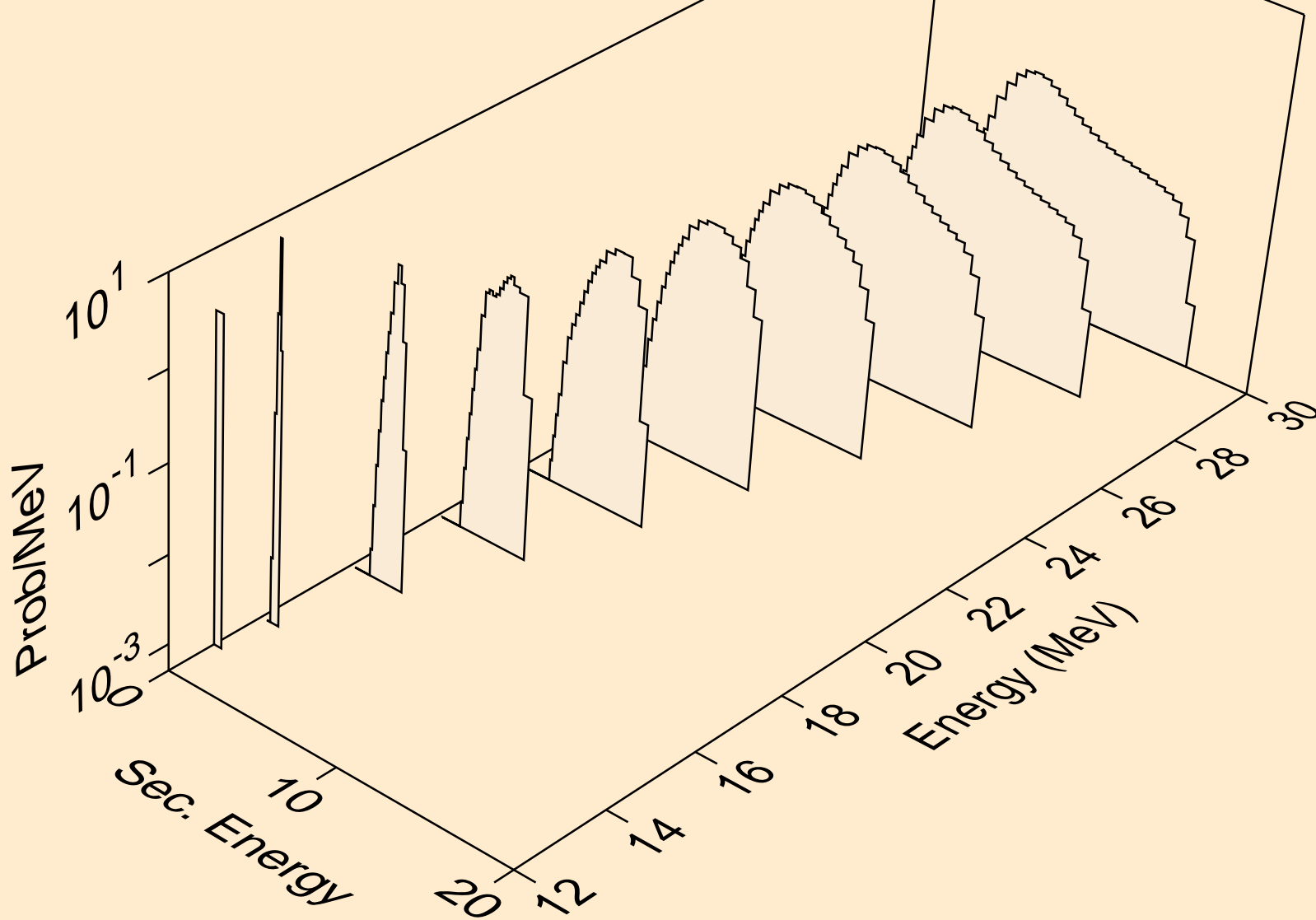

NB093 ALPHA ACER TENDL-2023 LIBRARY; T=0.K
protons from (a,2np)

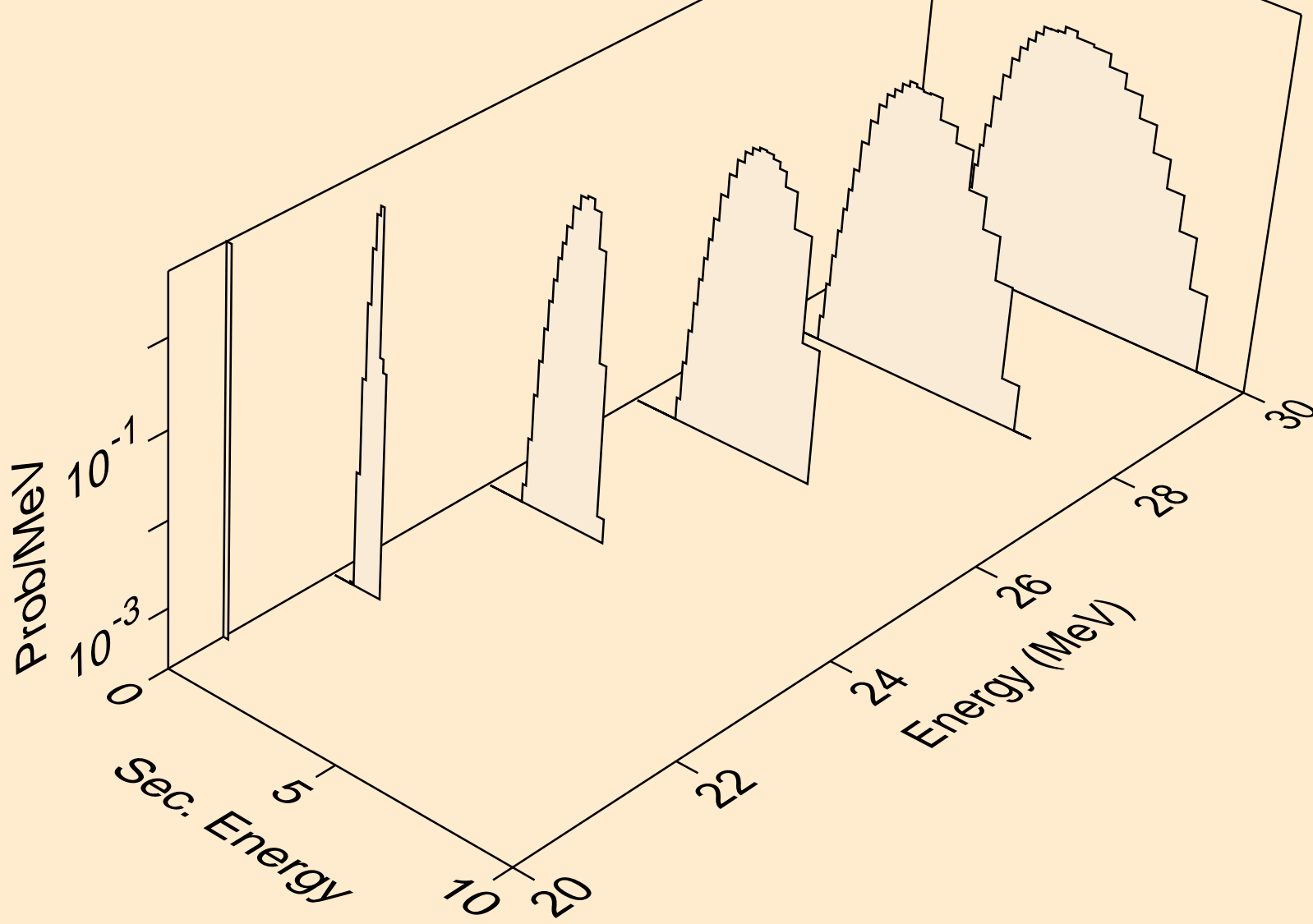

NB093 ALPHA ACER TENDL-2023 LIBRARY; T=0.K
protons from (a,n2p)

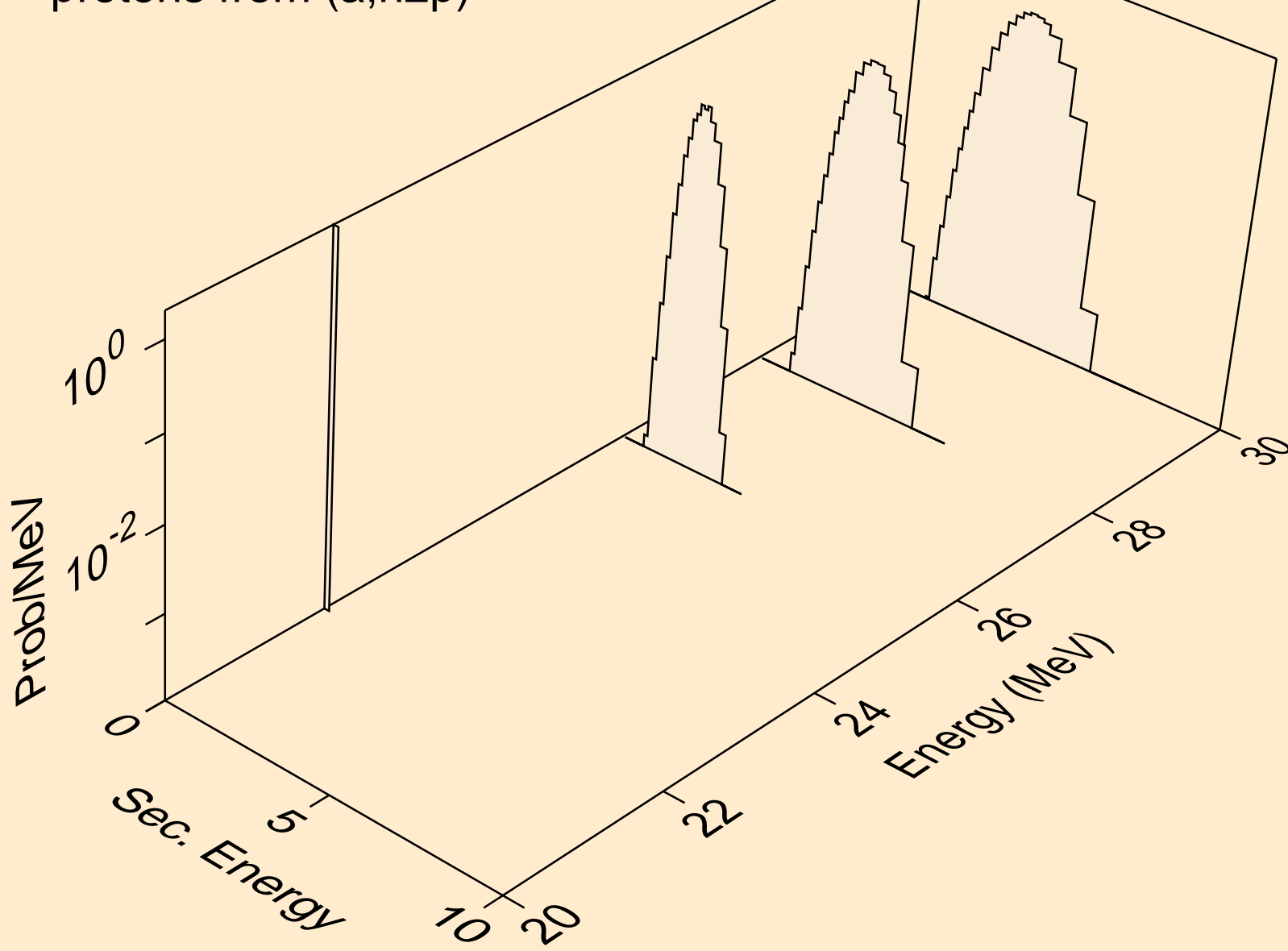

NB093 ALPHA ACER TENDL-2023 LIBRARY; T=0.K
protons from (a,npa)

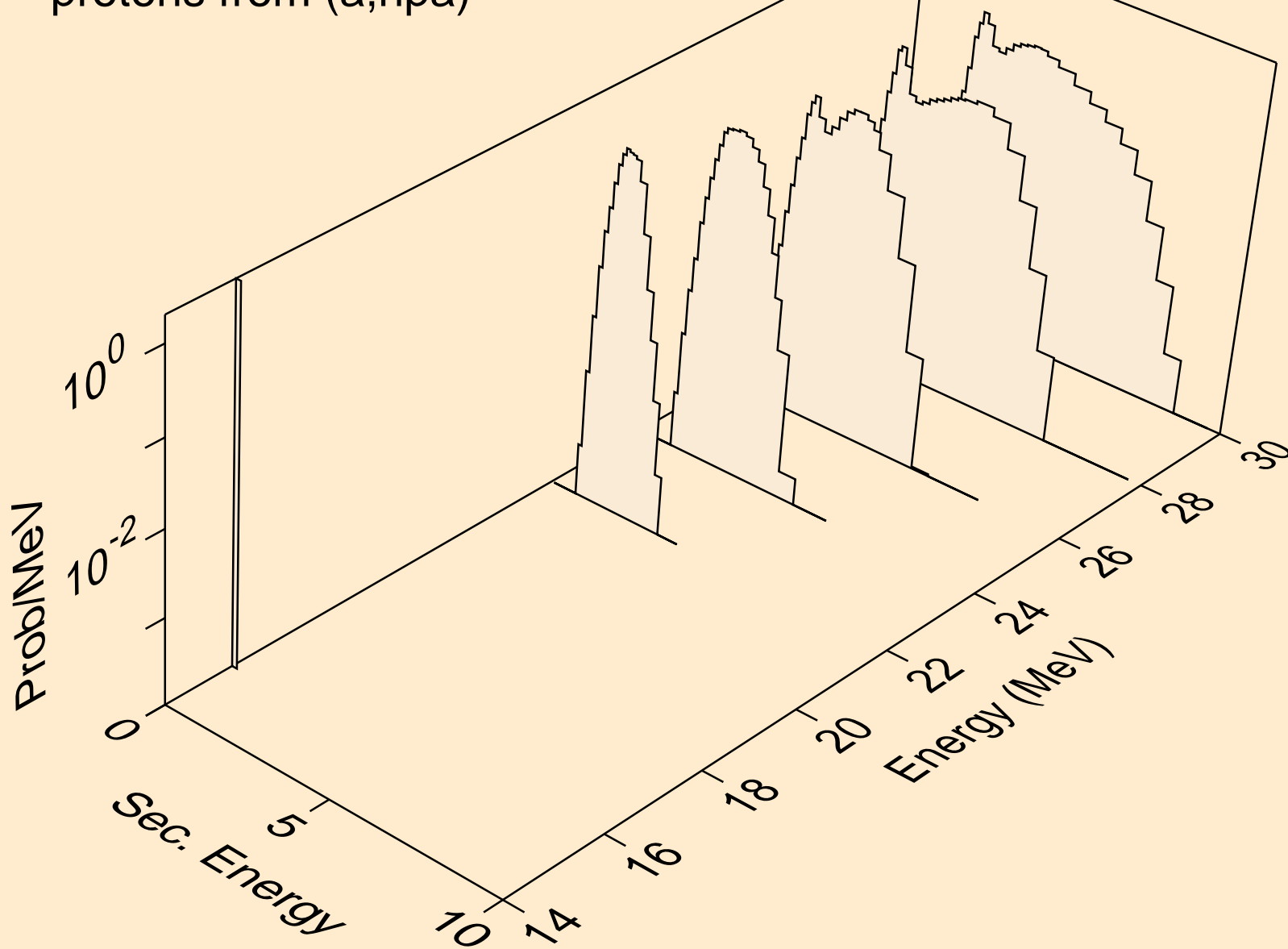

NB093 ALPHA ACER TENDL-2023 LIBRARY; T=0.K
protons from (a,p)

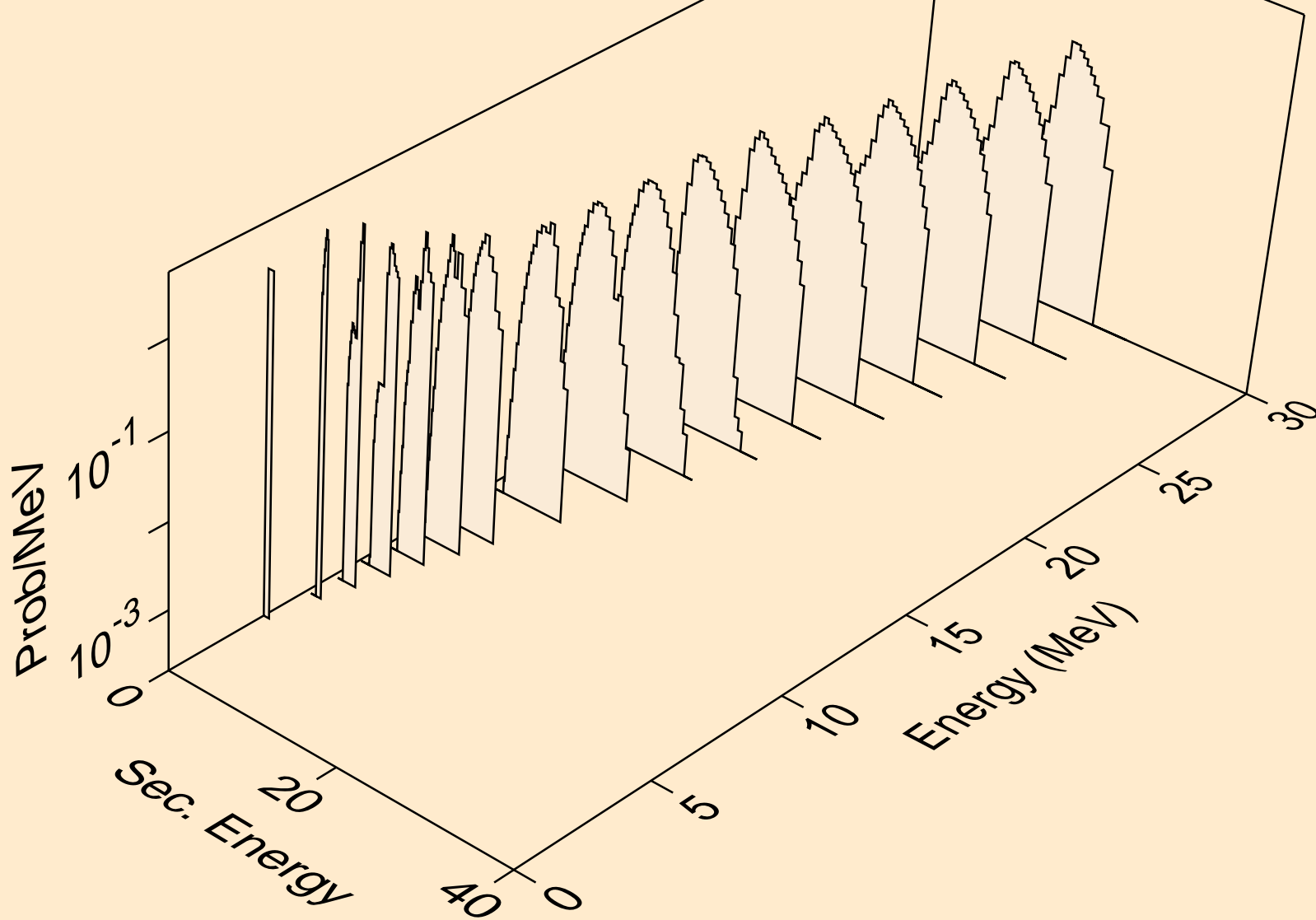

NB093 ALPHA ACER TENDL-2023 LIBRARY; T=0.K
protons from (a,2p)

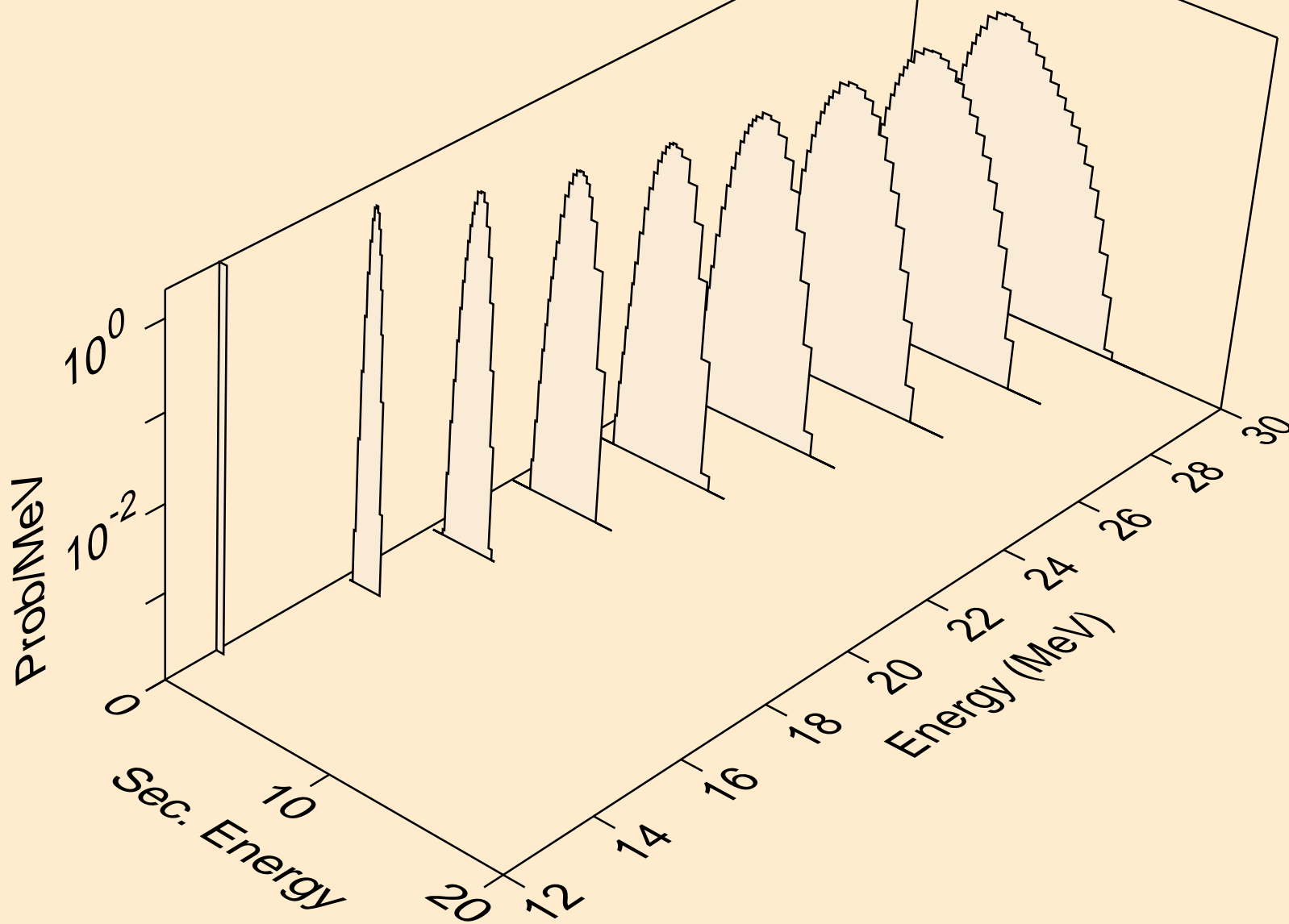

NB093 ALPHA ACER TENDL-2023 LIBRARY; T=0.K
protons from (a,pa)

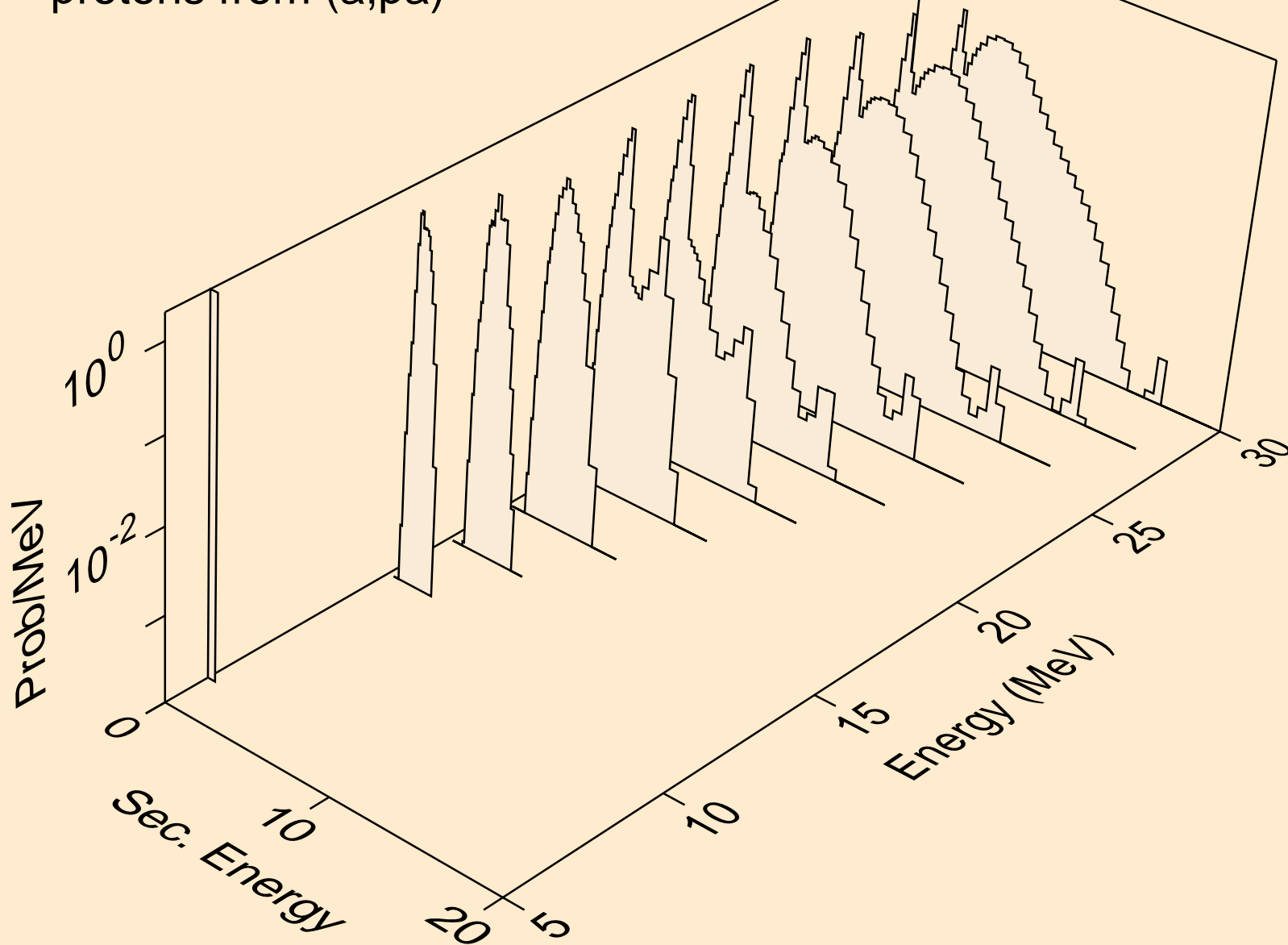

NB093 ALPHA ACER TENDL-2023 LIBRARY; T=0.K
protons from (a,pd)

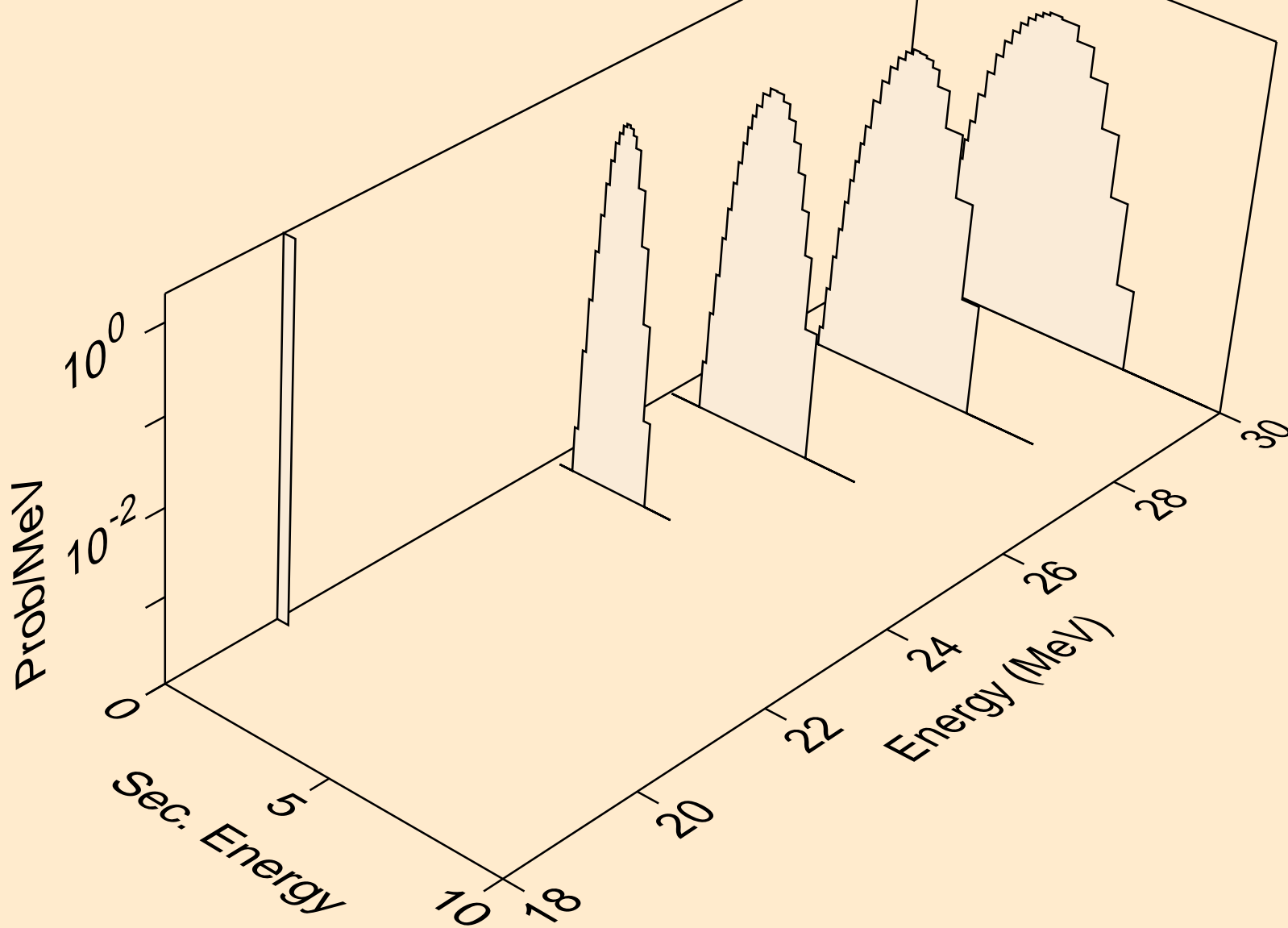

NB093 ALPHA ACER TENDL-2023 LIBRARY; T=0.K
protons from (a,pt)

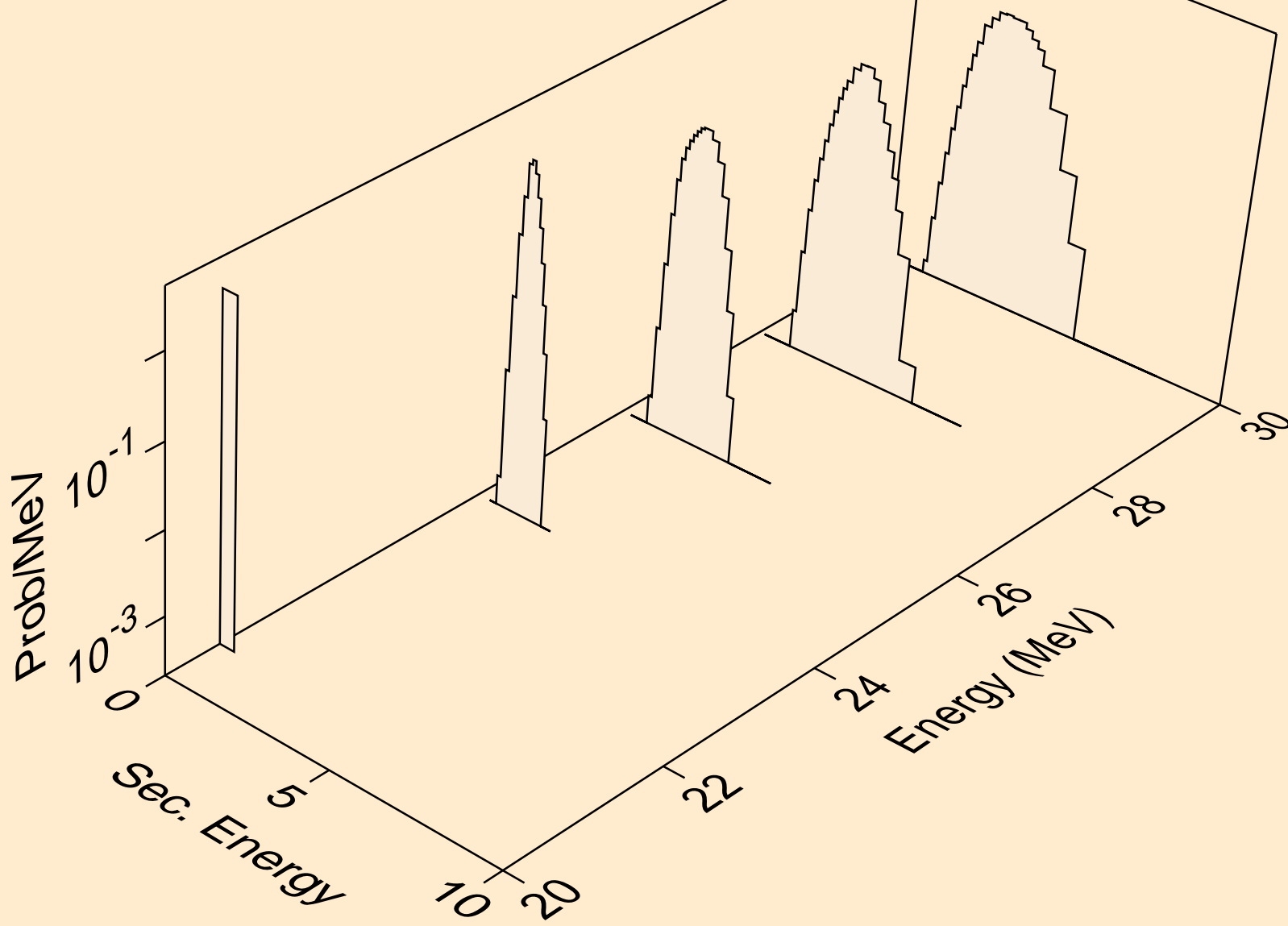

NB093 ALPHA ACER TENDL-2023 LIBRARY; T=0.K
deuterons from (a,x)

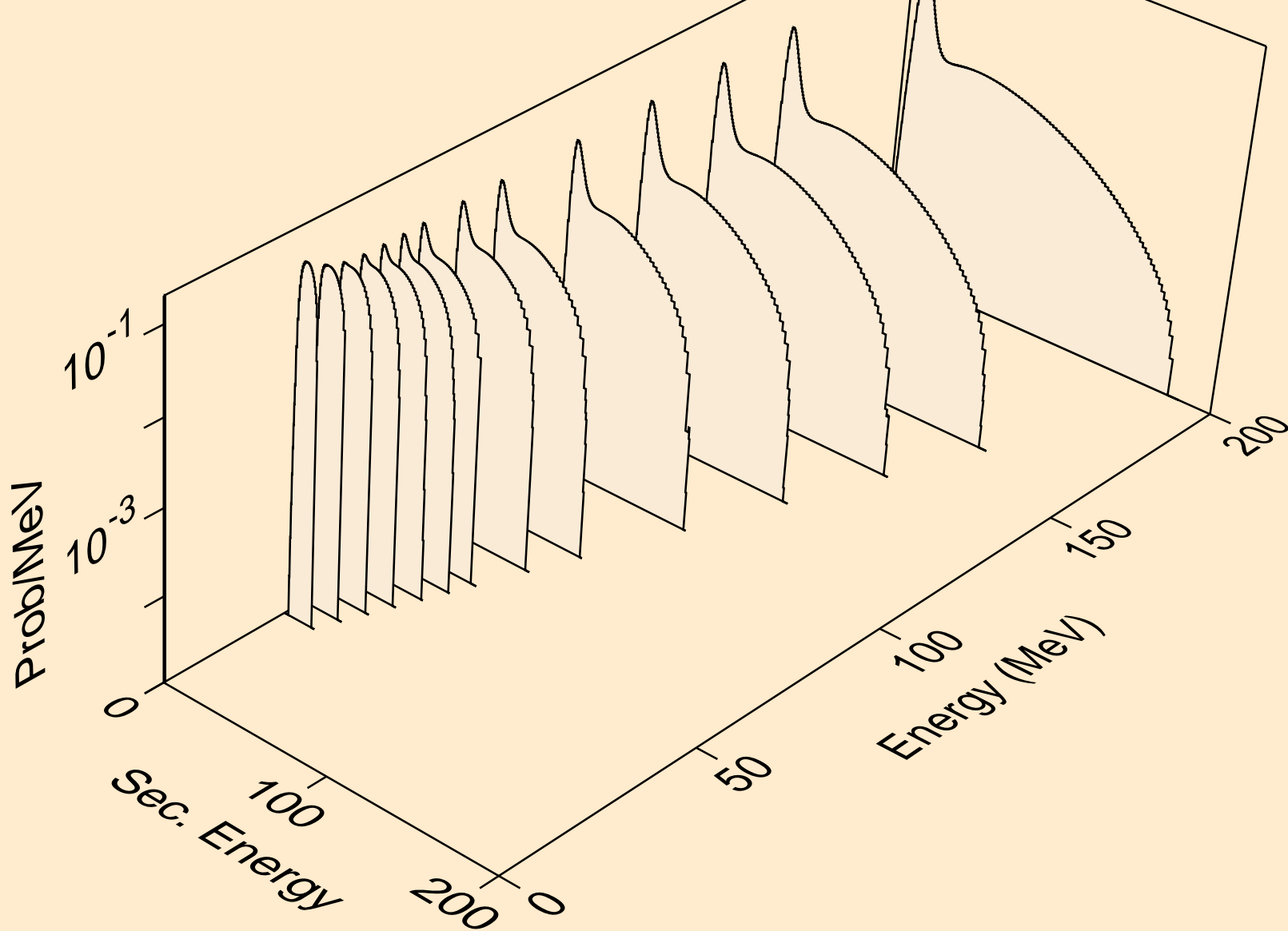

NB093 ALPHA ACER TENDL-2023 LIBRARY; T=0.K
deuterons from (a,n*)d

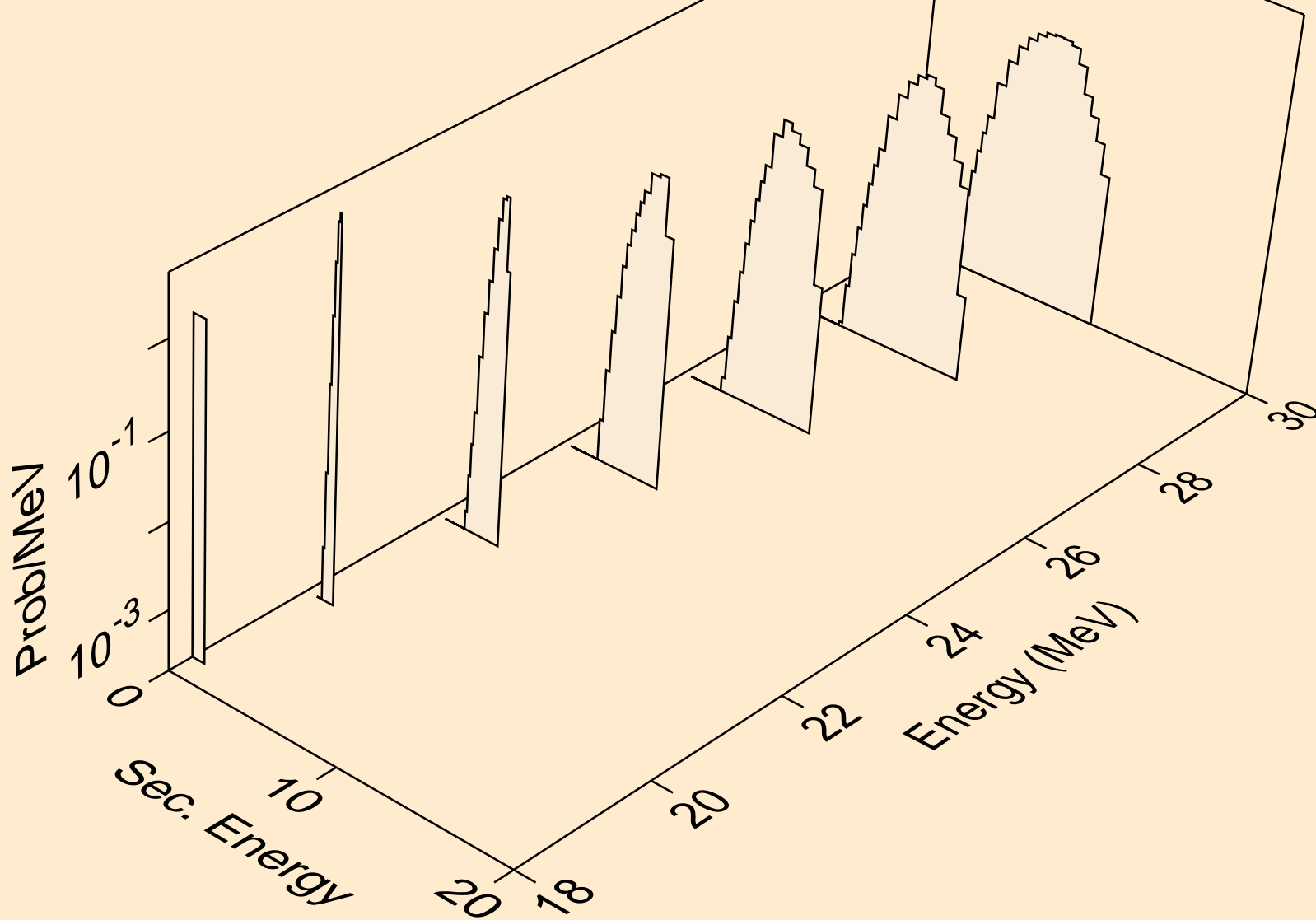

NB093 ALPHA ACER TENDL-2023 LIBRARY; T=0.K
deuterons from (a,d)

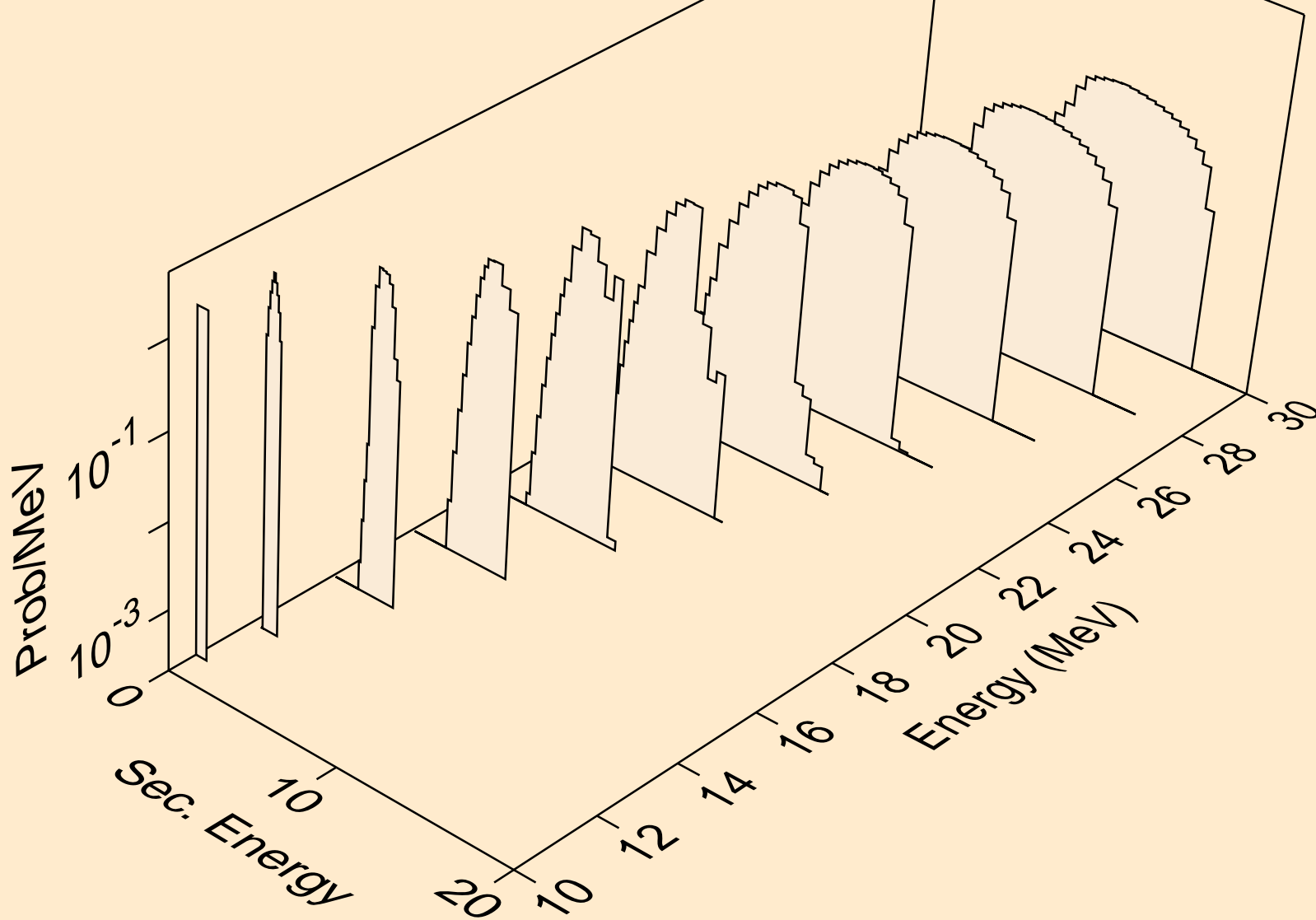

NB093 ALPHA ACER TENDL-2023 LIBRARY; T=0.K
deuterons from (a,pd)

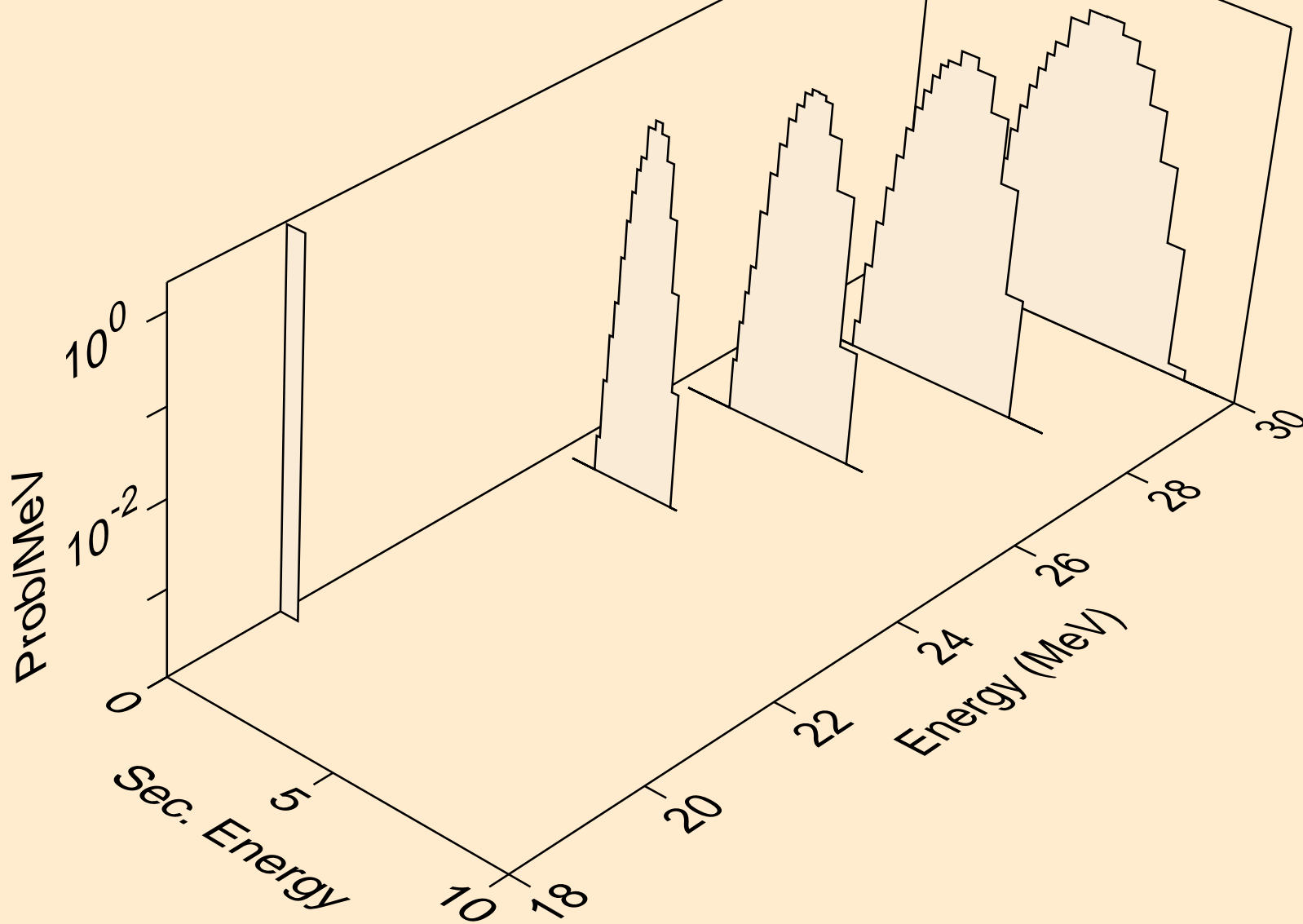

NB093 ALPHA ACER TENDL-2023 LIBRARY; T=0.K
deuterons from (a,da)

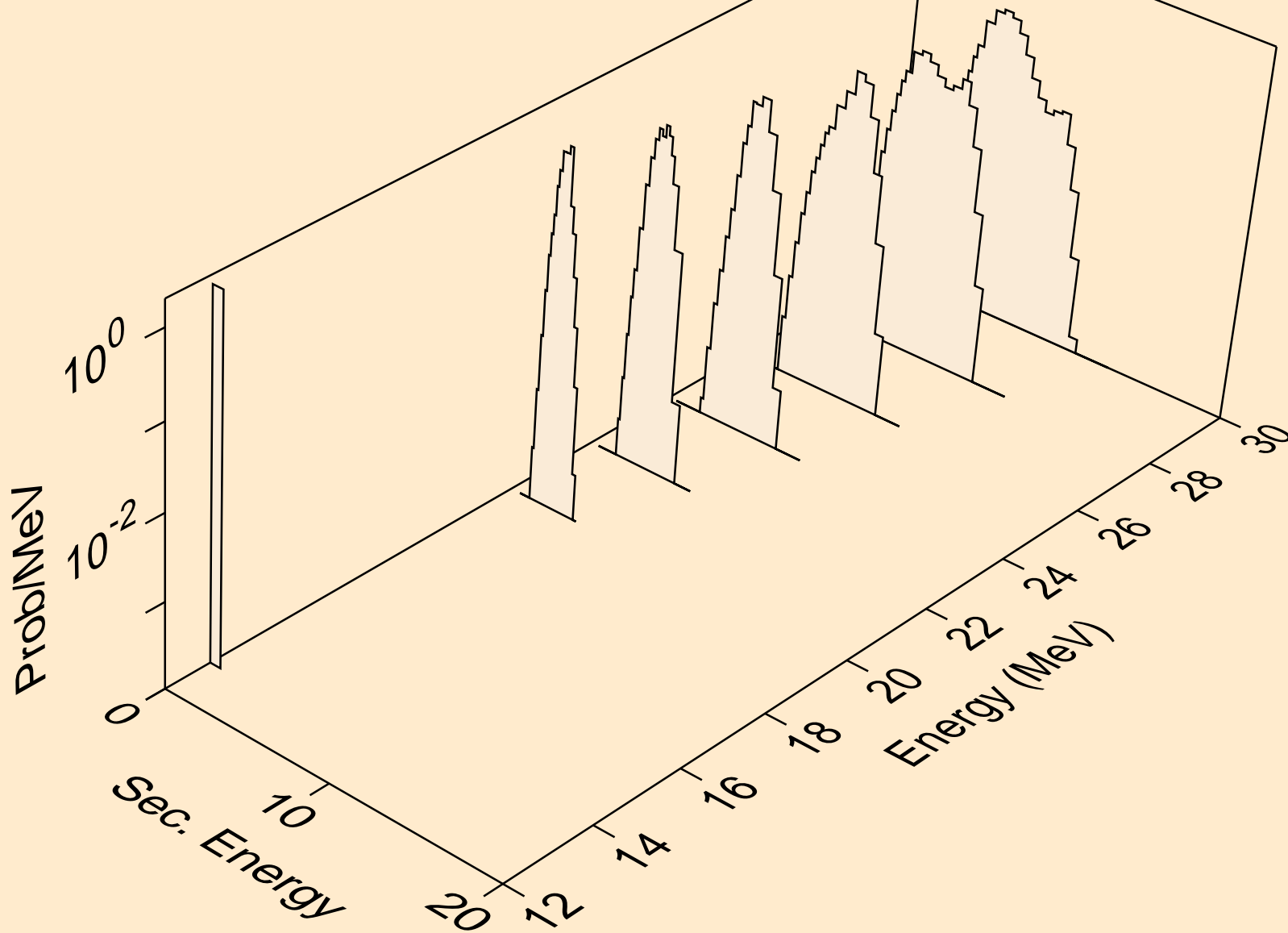

NB093 ALPHA ACER TENDL-2023 LIBRARY; T=0.K
tritons from (a,x)

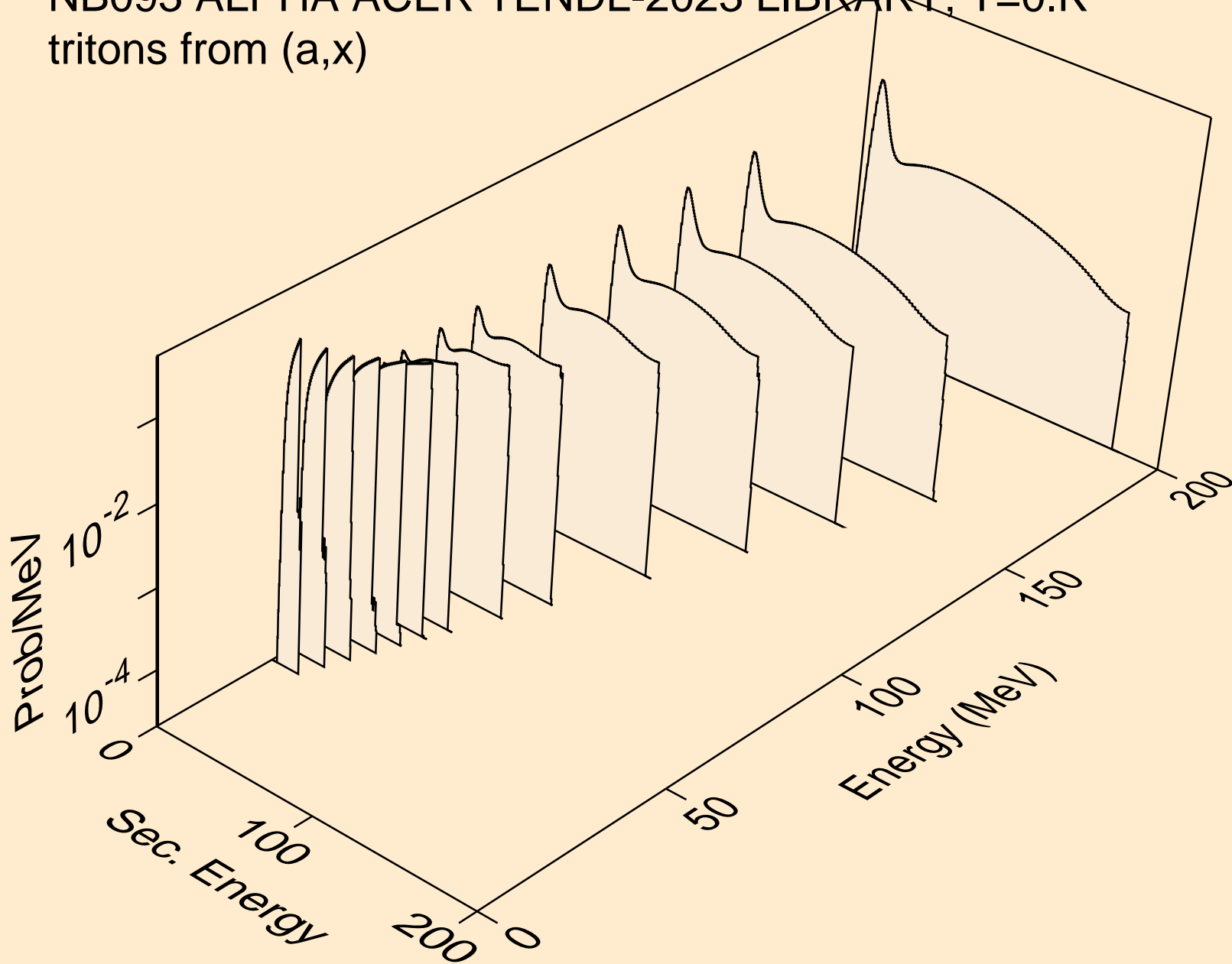

NB093 ALPHA ACER TENDL-2023 LIBRARY; T=0.K
tritons from (a,n*)t

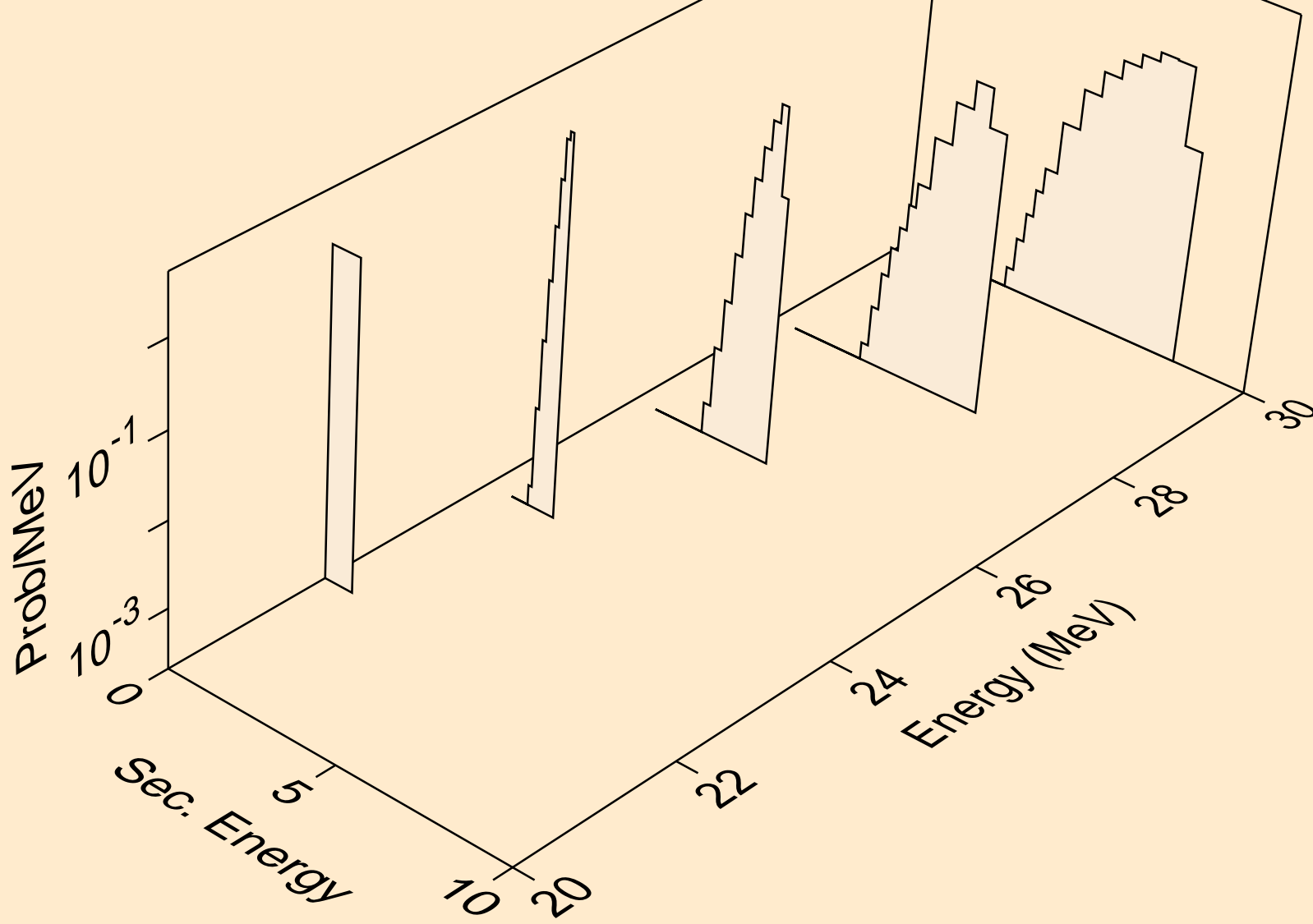

NB093 ALPHA ACER TENDL-2023 LIBRARY; T=0.K
tritons from (a,t)

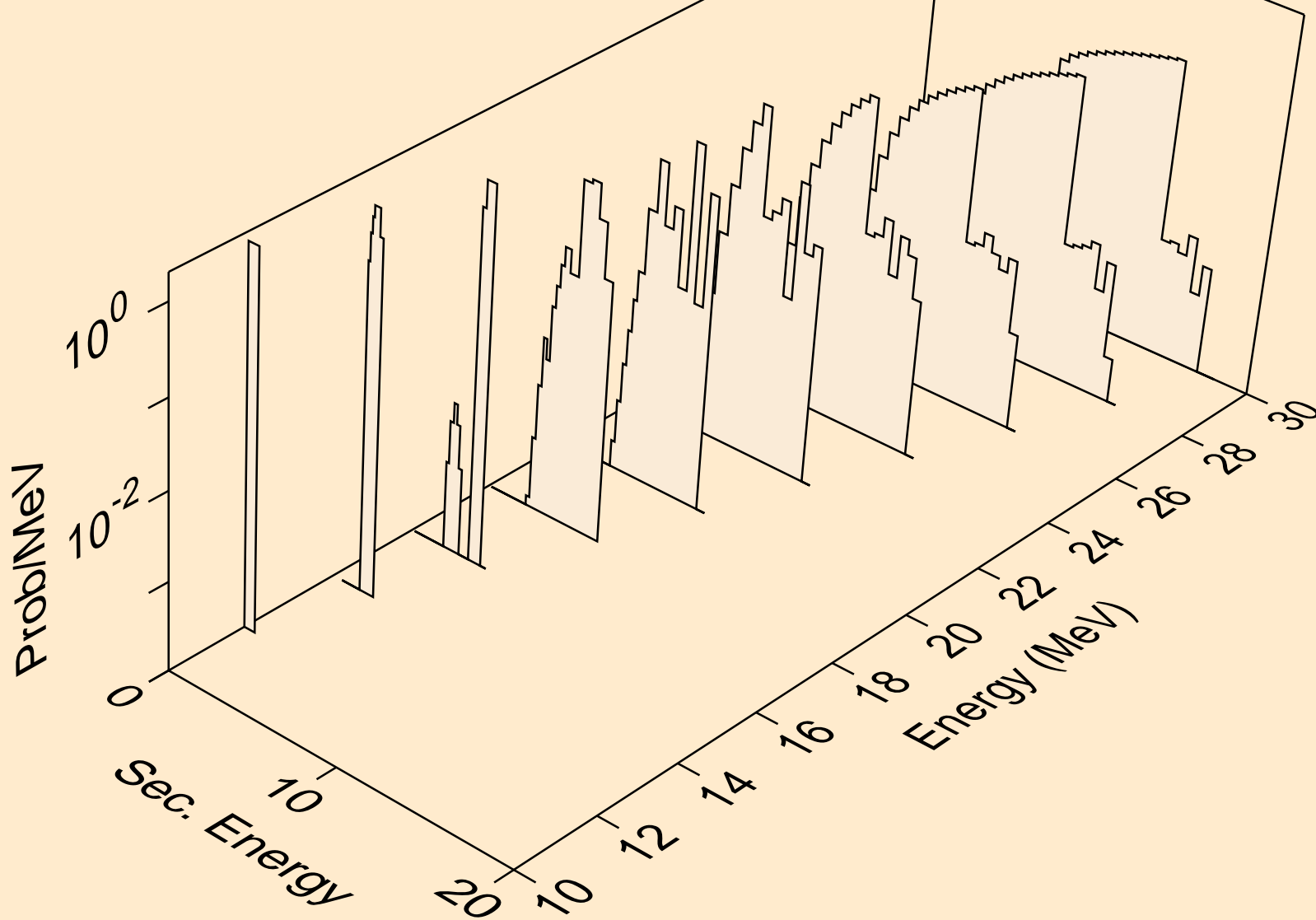

NB093 ALPHA ACER TENDL-2023 LIBRARY; T=0.K
tritons from (a,pt)

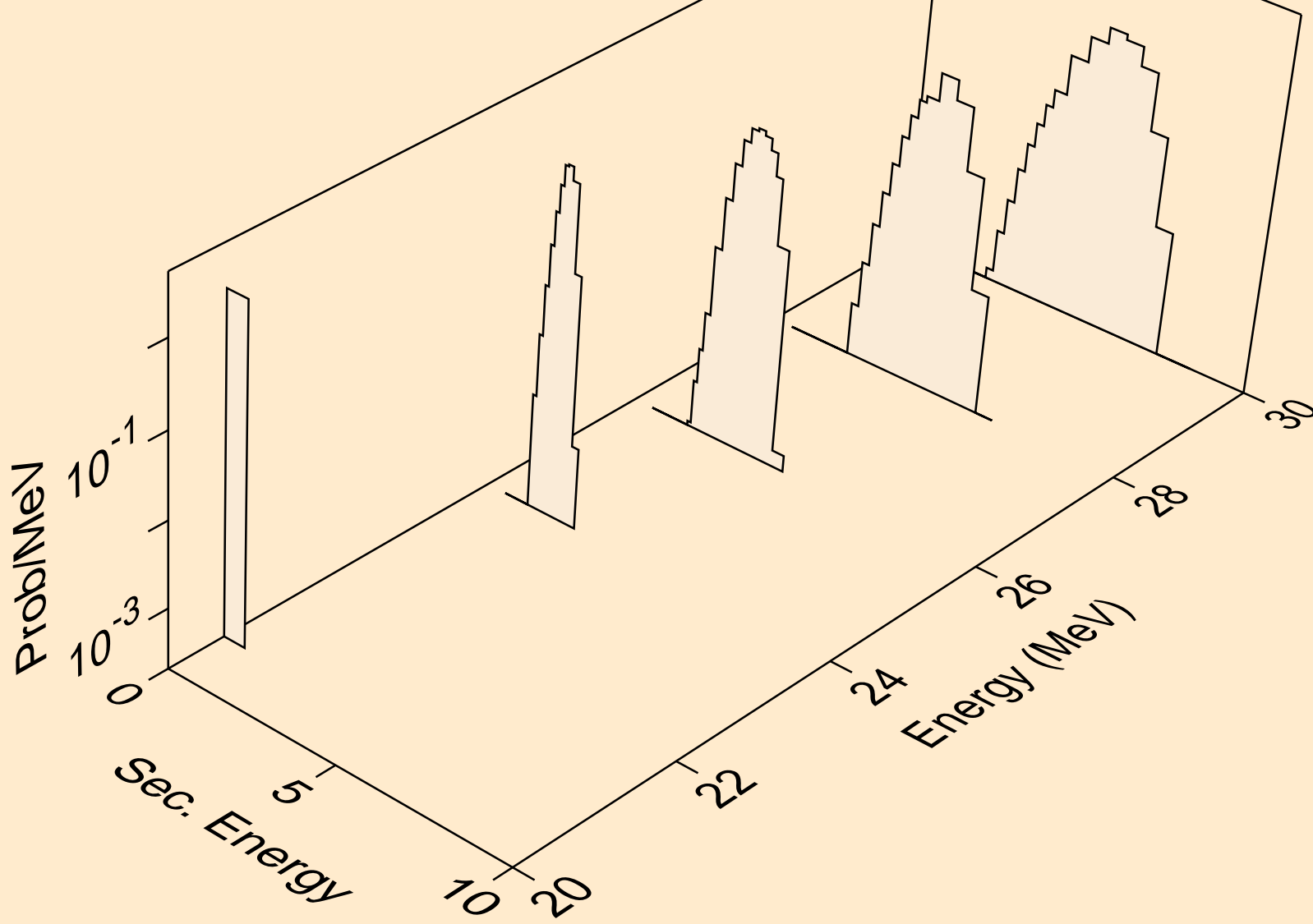

NB093 ALPHA ACER TENDL-2023 LIBRARY; T=0.K
he3s from (a,x)

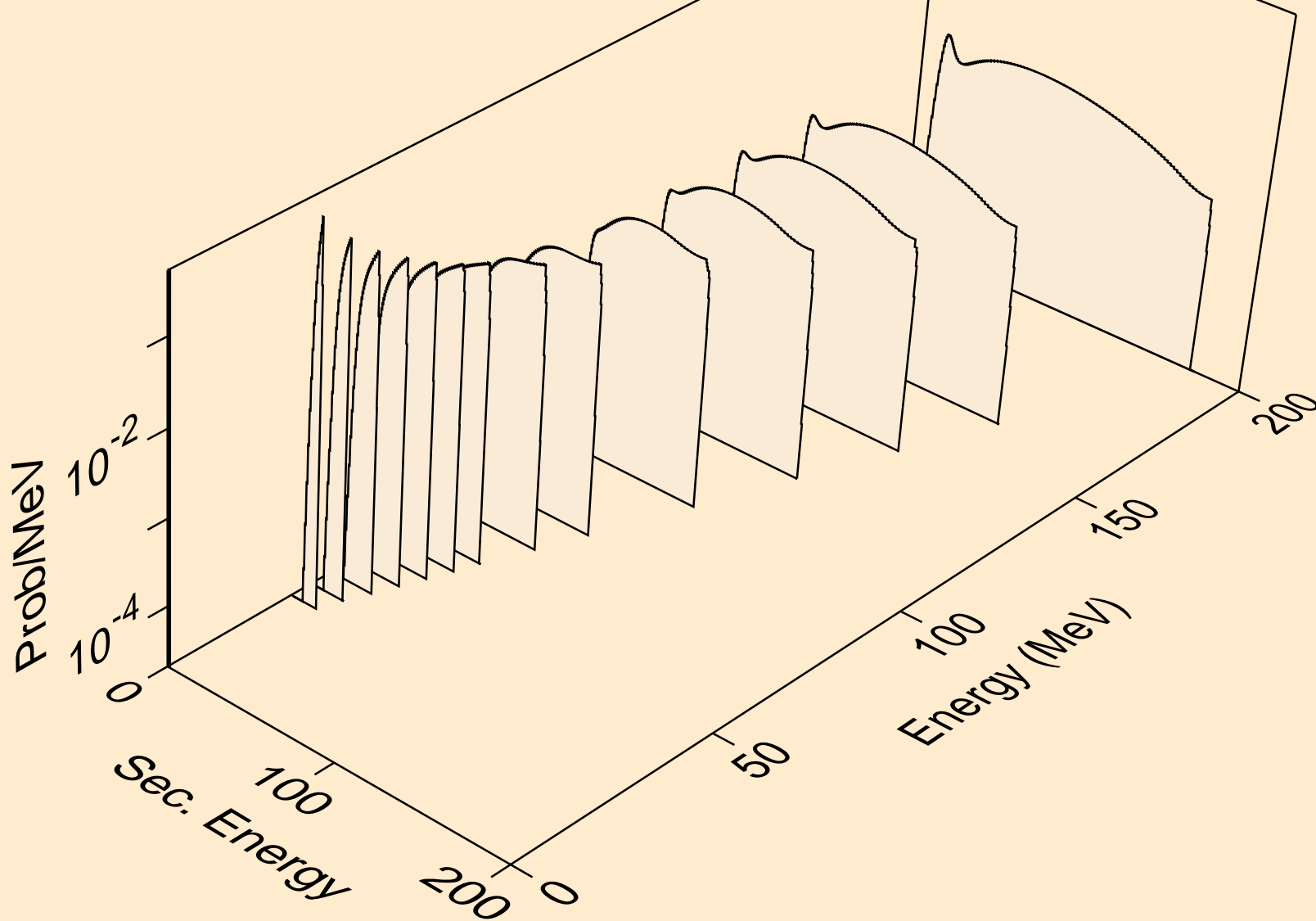

NB093 ALPHA ACER TENDL-2023 LIBRARY; T=0.K
he3s from (a,n*)he3

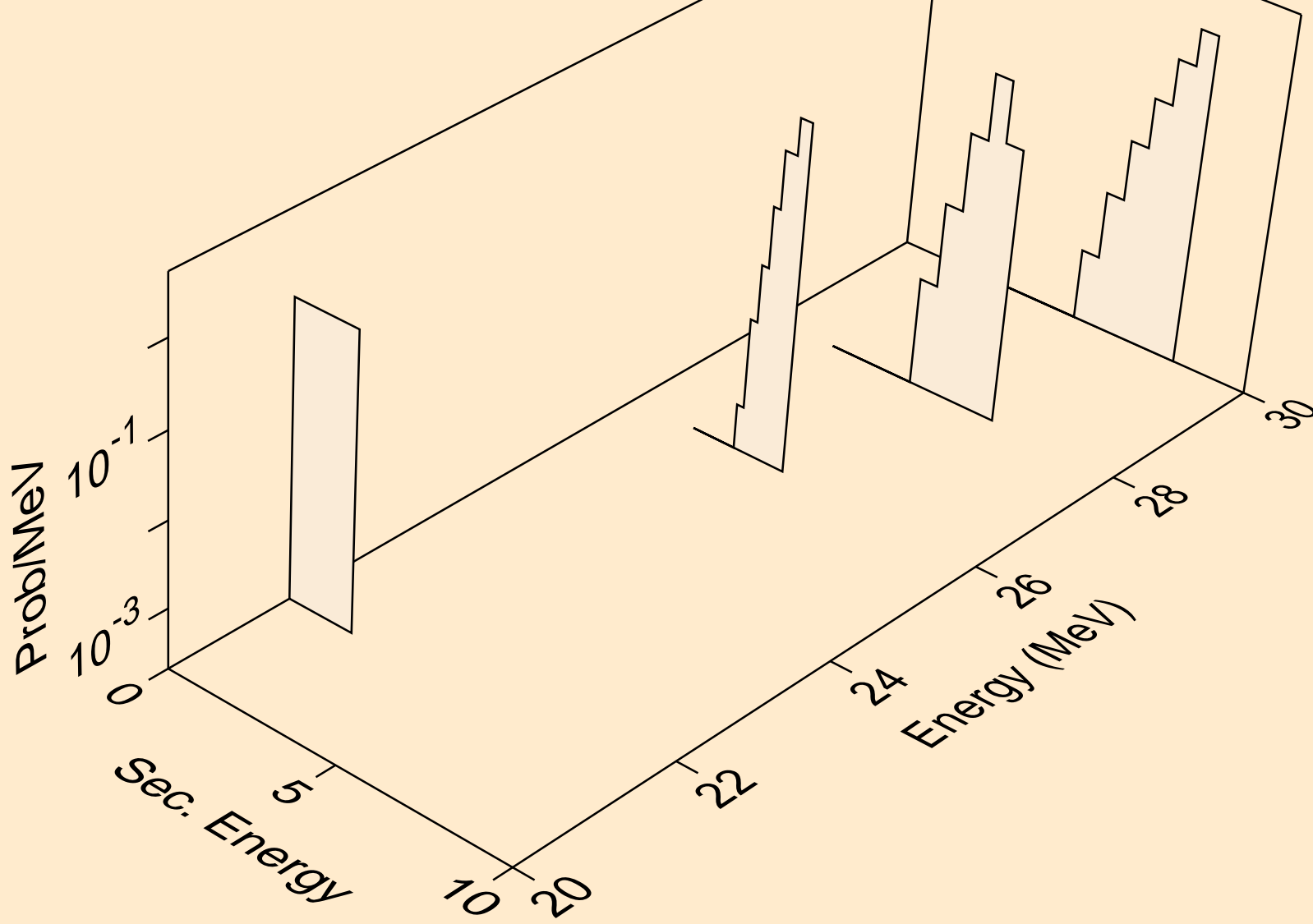

NB093 ALPHA ACER TENDL-2023 LIBRARY; T=0.K
he3s from (a,he3)

