

SN131M ALPHA ACER TENDL-2023 LIBRARY; T=0.K

Principal cross sections

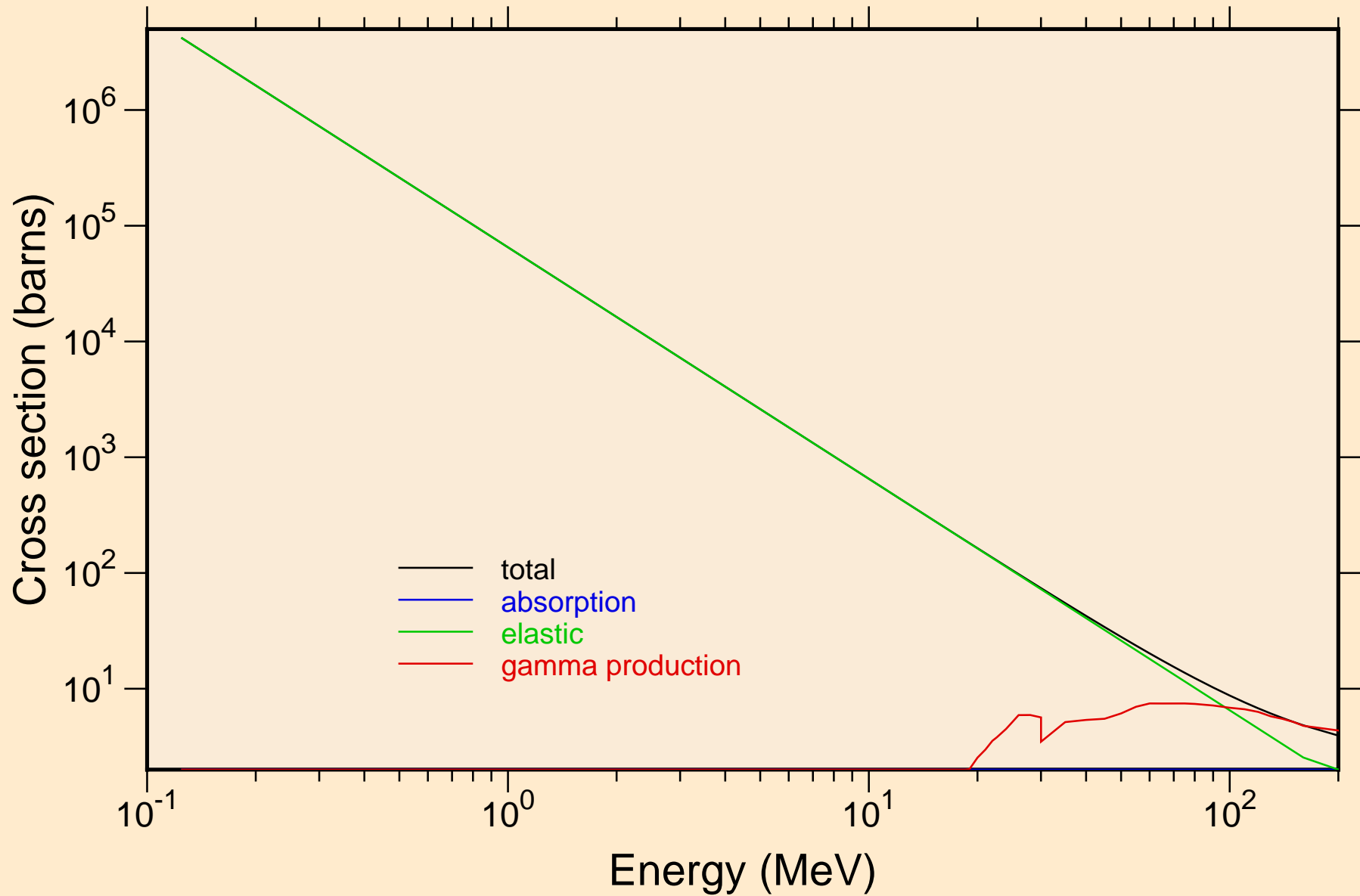

SN131M ALPHA ACER TENDL-2023 LIBRARY; T=0.K

Heating

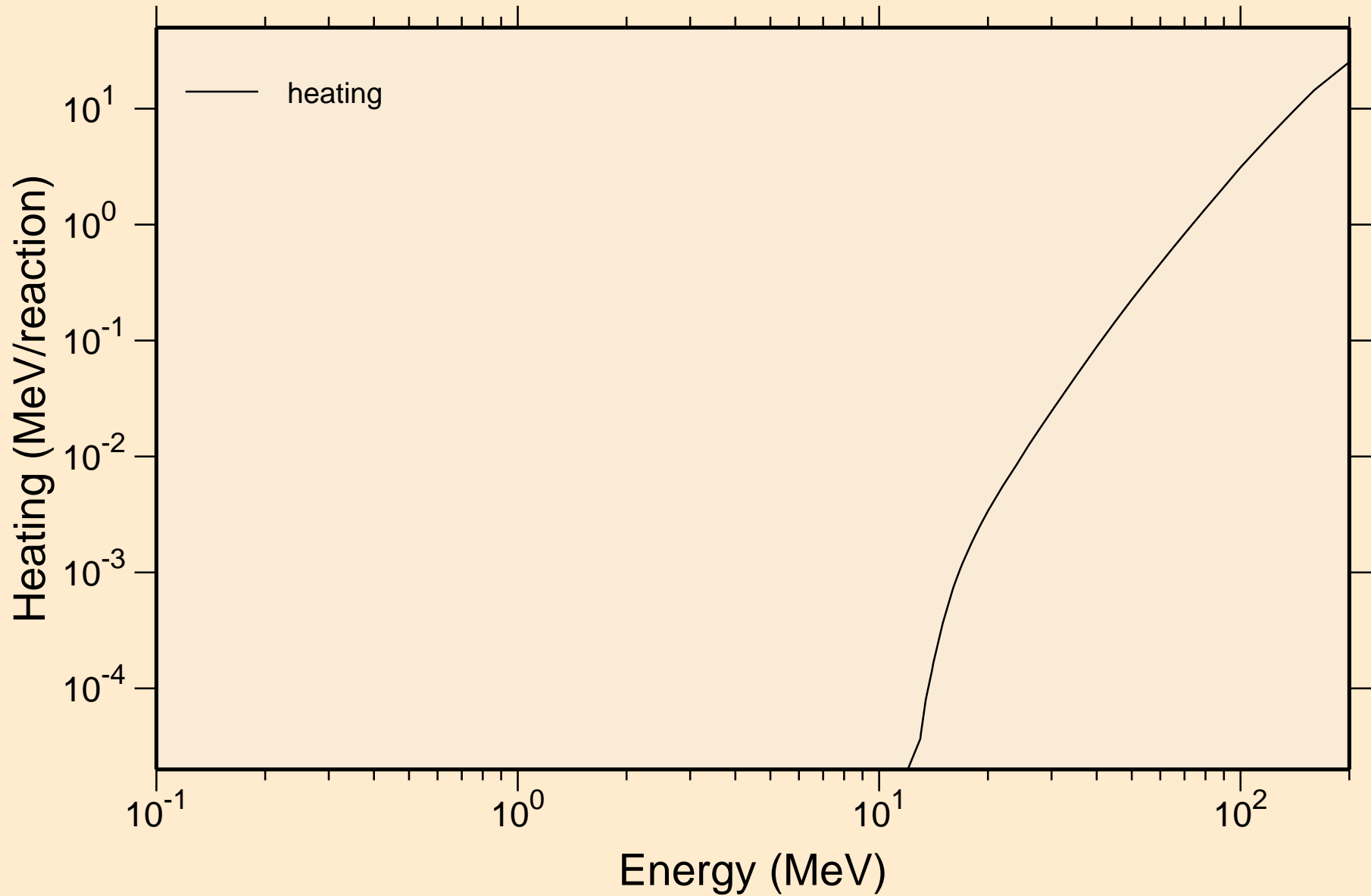

SN131M ALPHA ACER TENDL-2023 LIBRARY; T=0.K

Principal cross sections

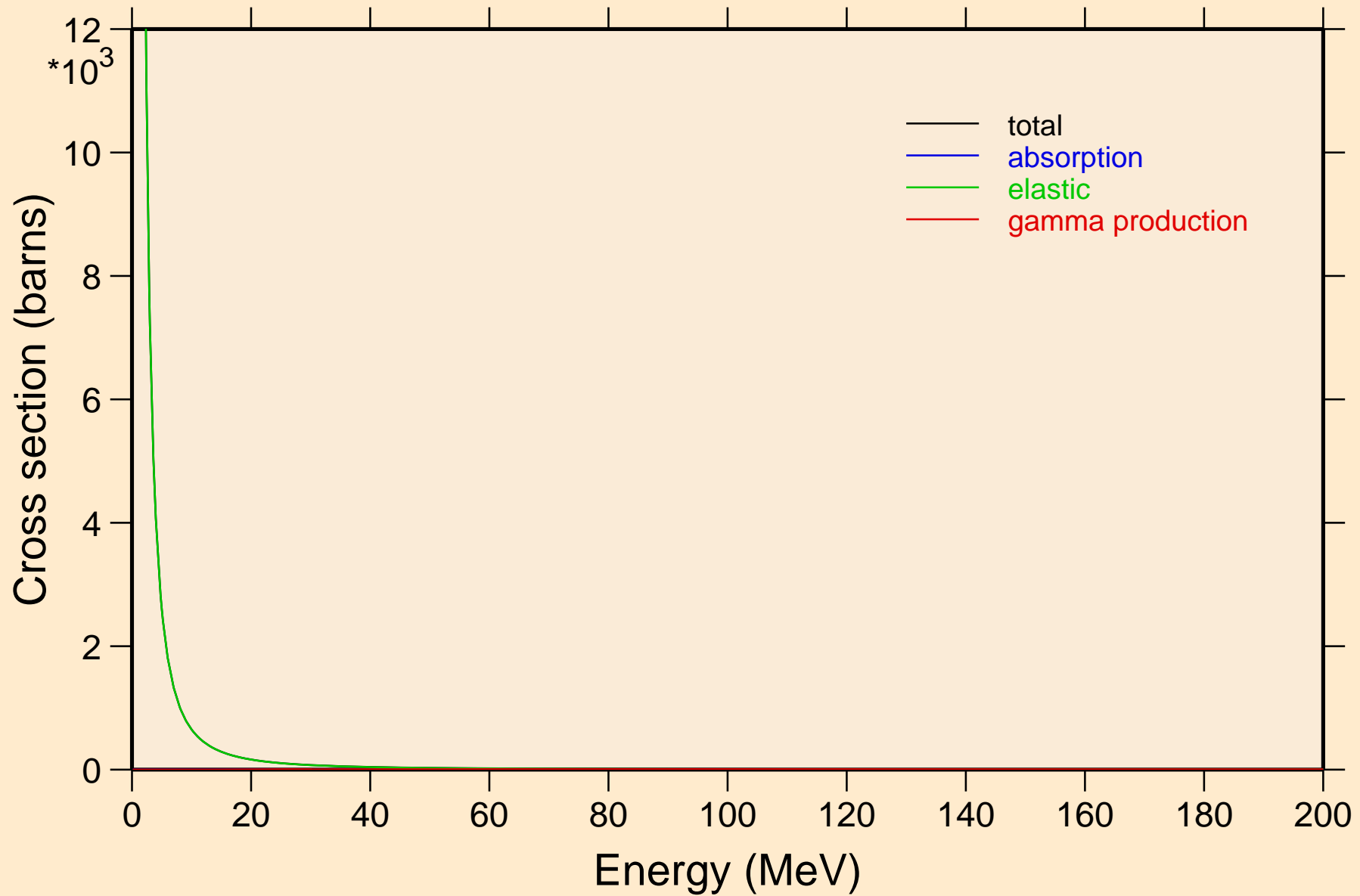

SN131M ALPHA ACER TENDL-2023 LIBRARY; T=0.K

Heating

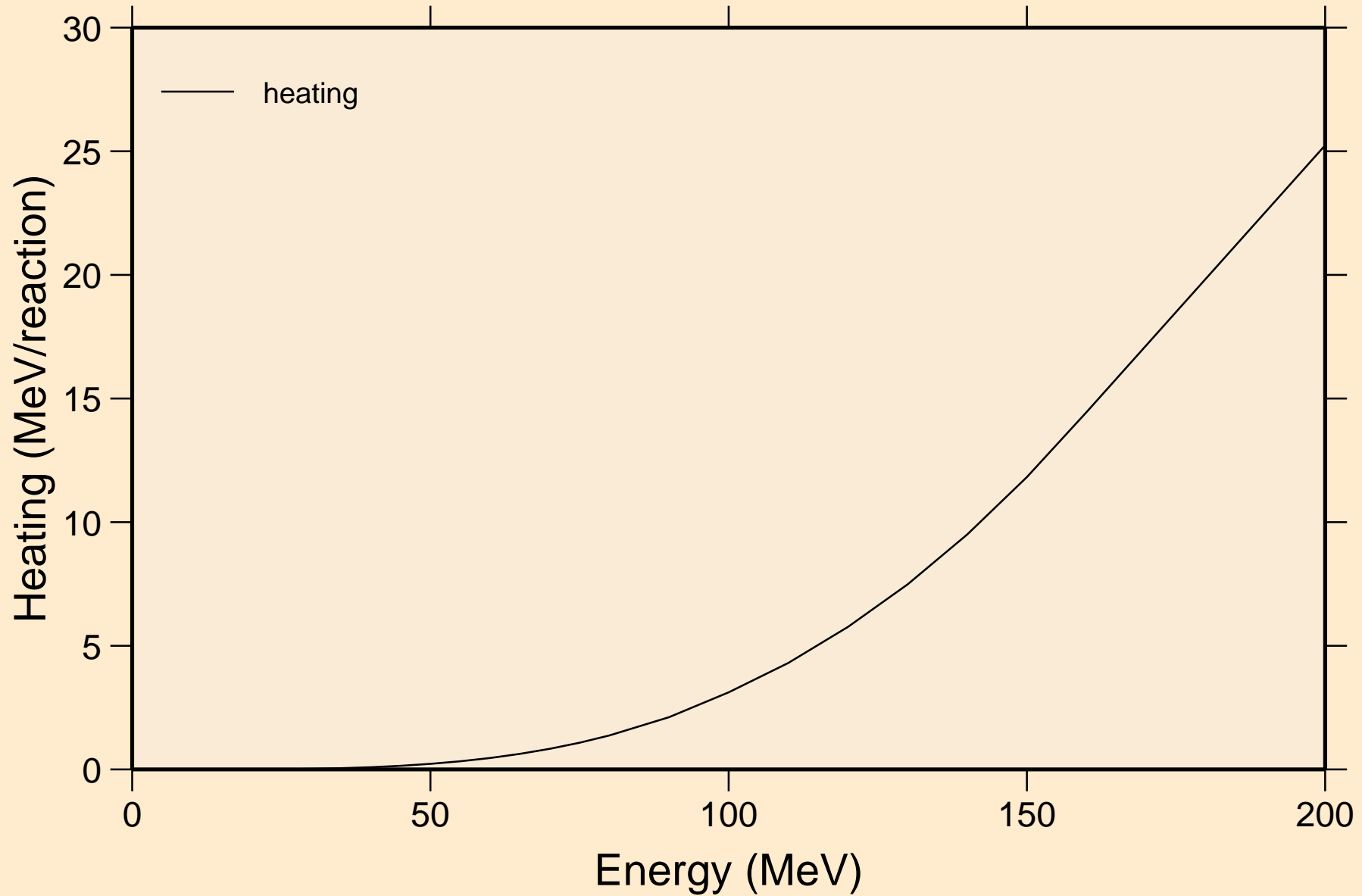

SN131M ALPHA ACER TENDL-2023 LIBRARY; T=0.K

Threshold reactions

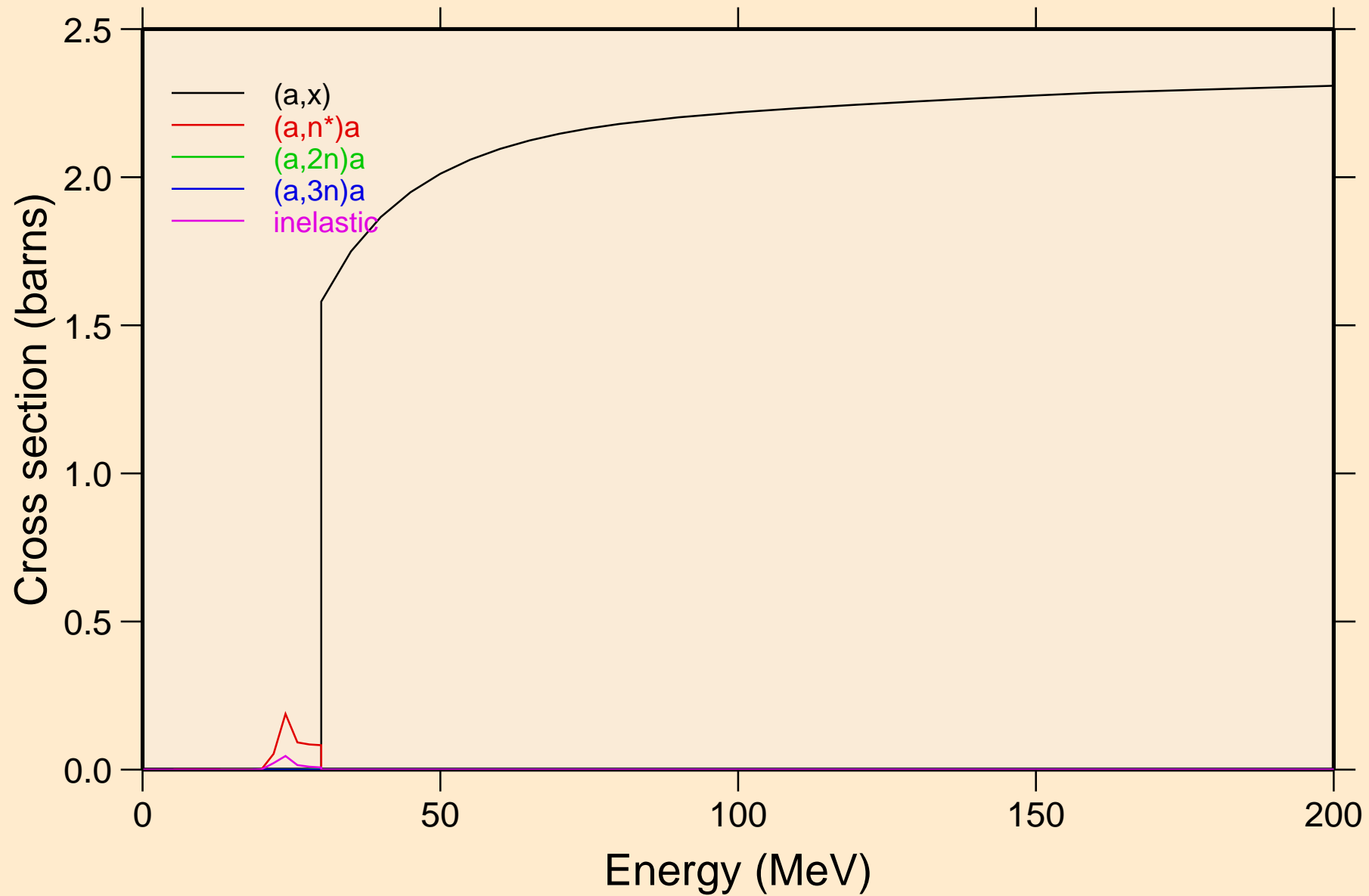

SN131M ALPHA ACER TENDL-2023 LIBRARY; T=0.K
angular distribution for elastic

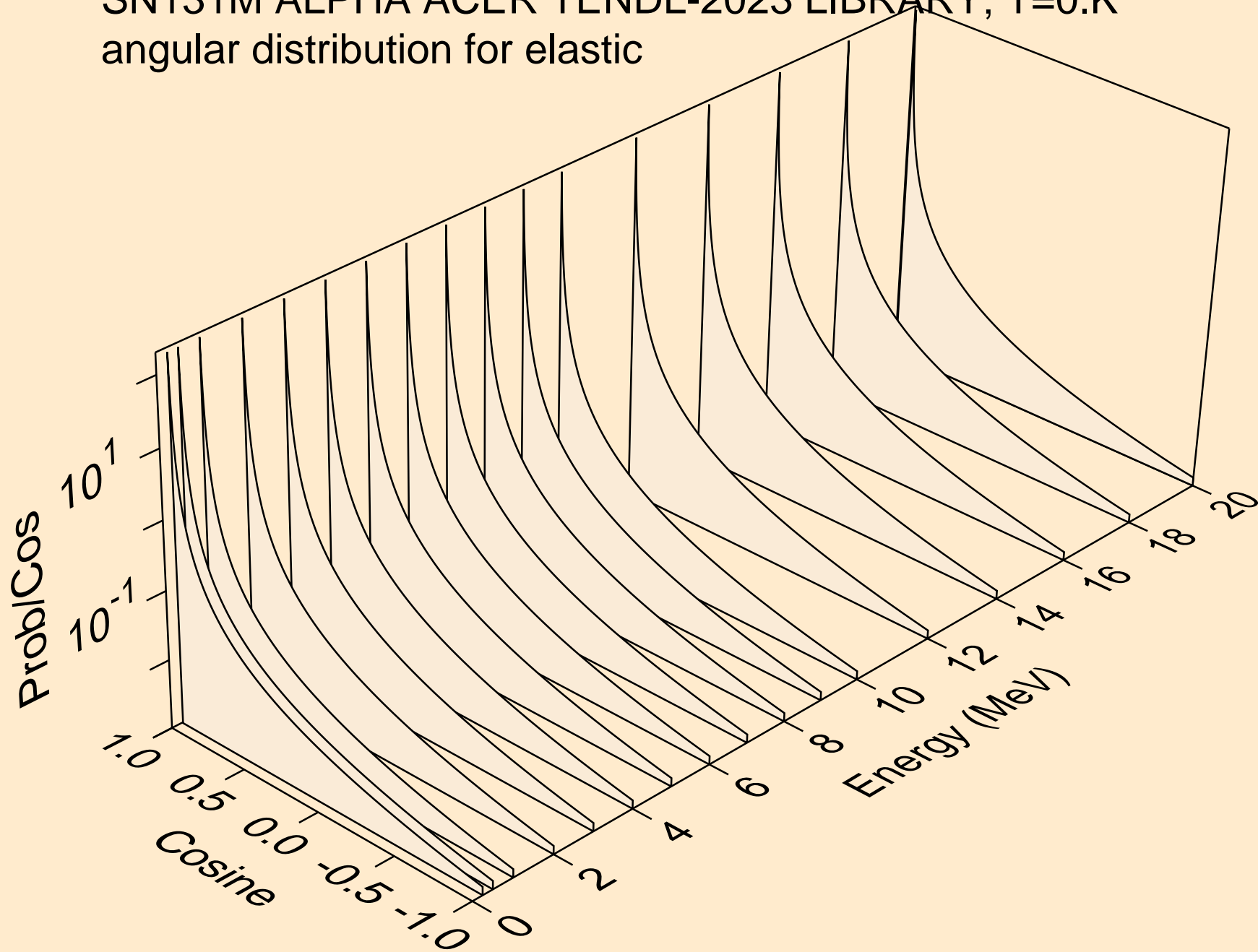

SN131M ALPHA ACER TENDL-2023 LIBRARY; T=0.K
angular distribution for elastic

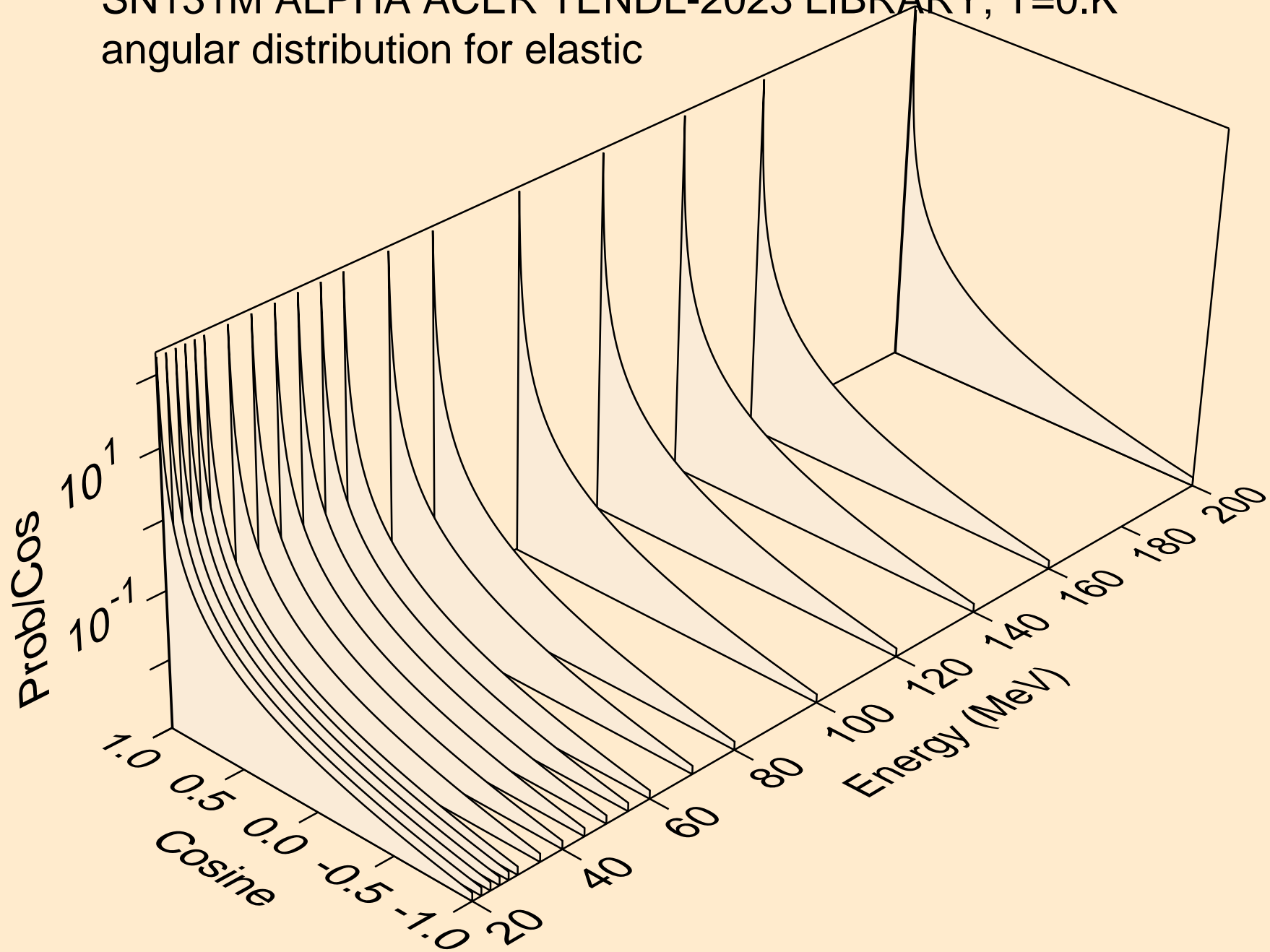

SN131M ALPHA ACER TENDL-2023 LIBRARY; T=0.K
Alpha emission for (a,x)

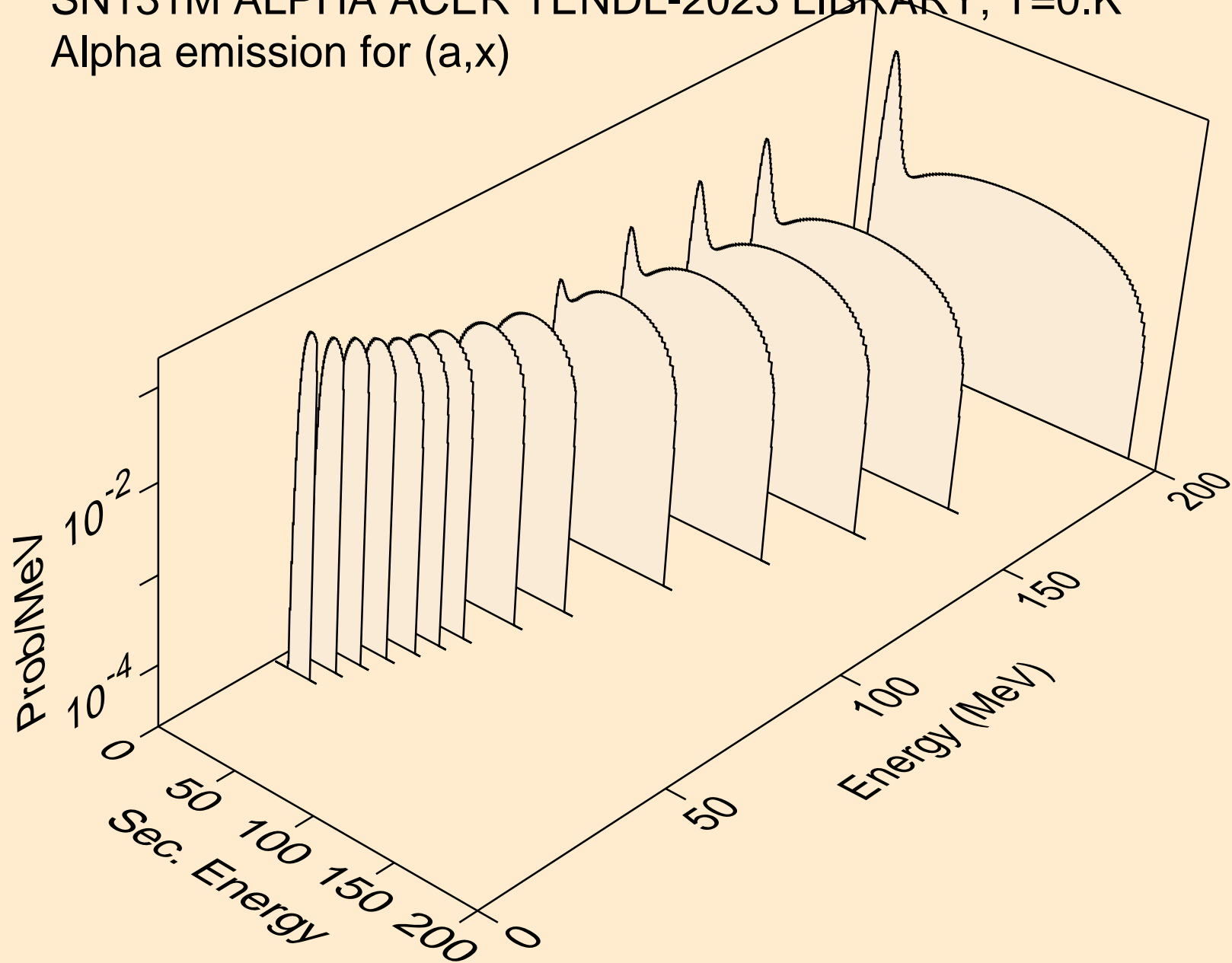

SN131M ALPHA ACER TENDL-2023 LIBRARY; T=0.K
Alpha emission for (a,n*)a

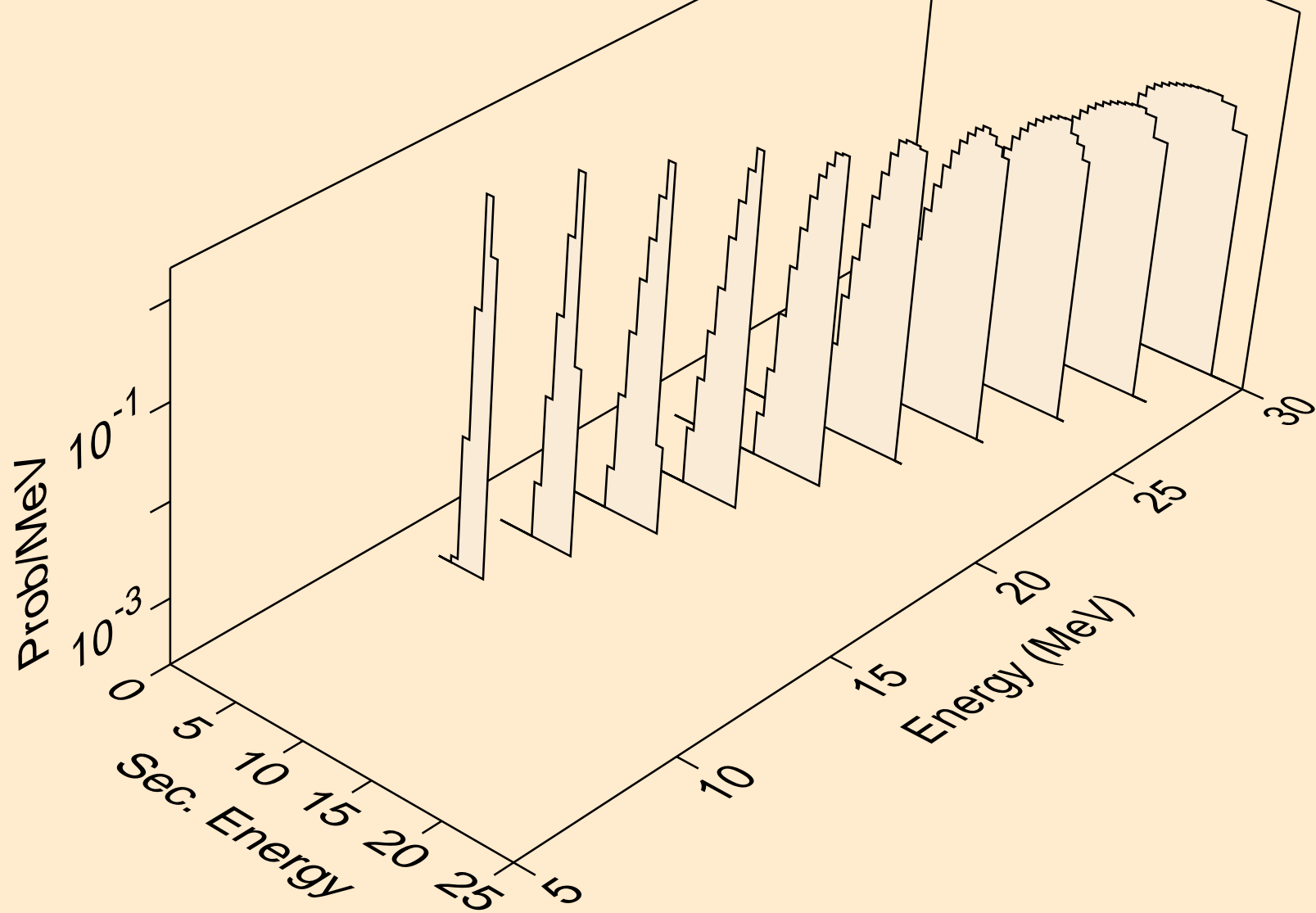

SN131M ALPHA ACER TENDL-2023 LIBRARY; T=0.K
Alpha emission for (a,2n)a

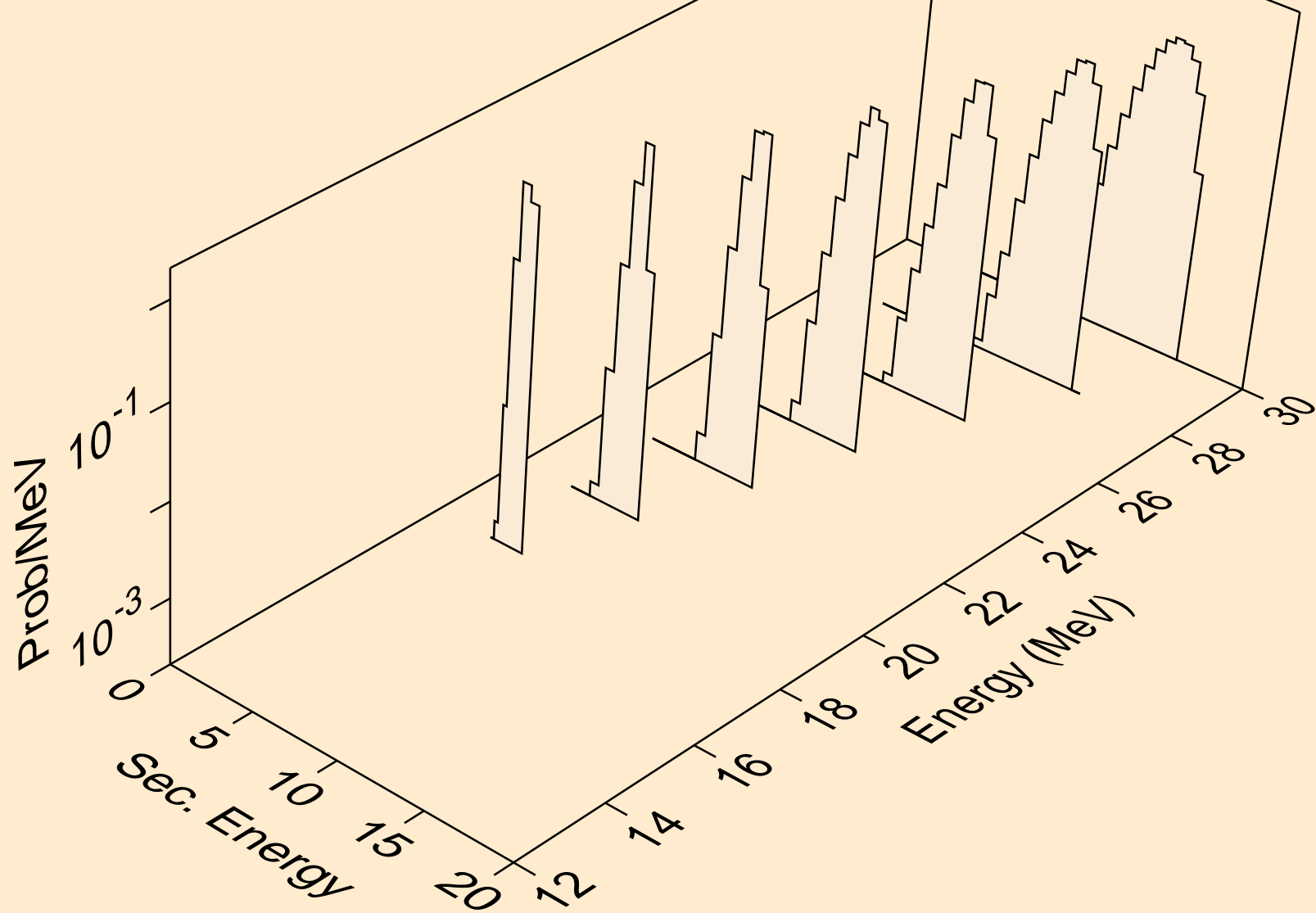

SN131M ALPHA ACER TENDL-2023 LIBRARY; T=0.K
Alpha emission for (a,3n)a

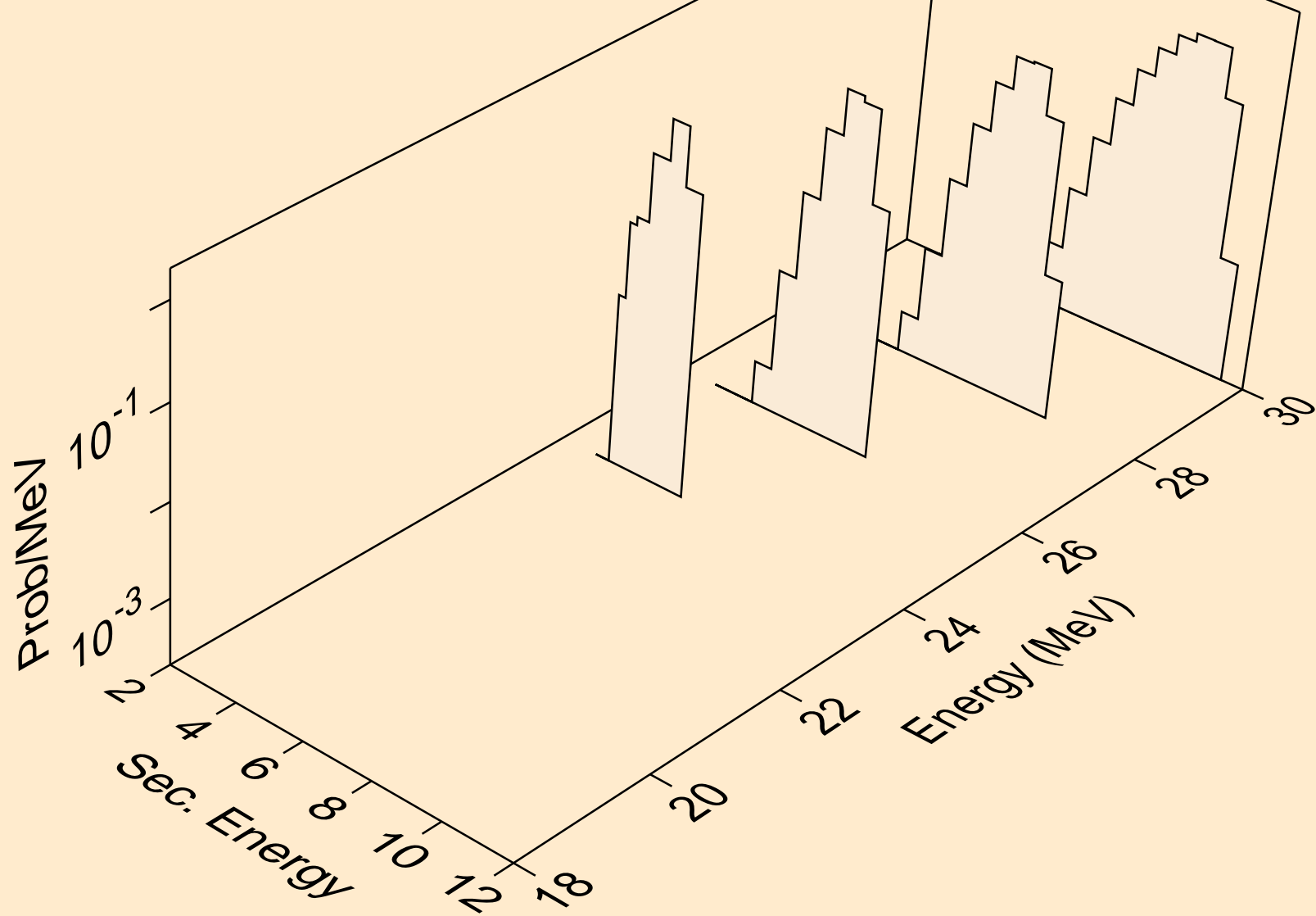

SN131M ALPHA ACER TENDL-2023 LIBRARY; T=0.K
Alpha emission for inelastic

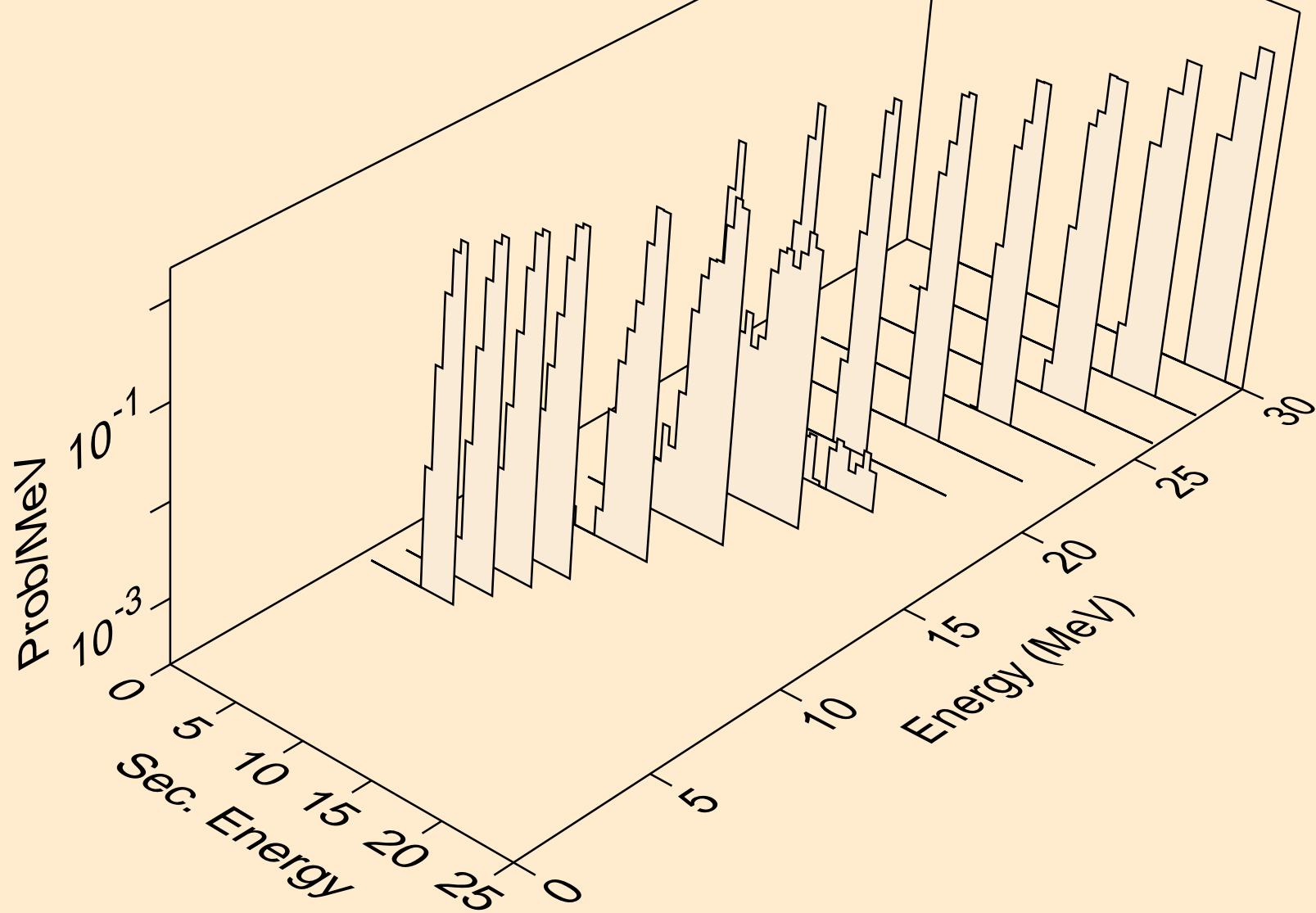

SN131M ALPHA ACER TENDL-2023 LIBRARY; T=0.K
Photon emission for (z,n)

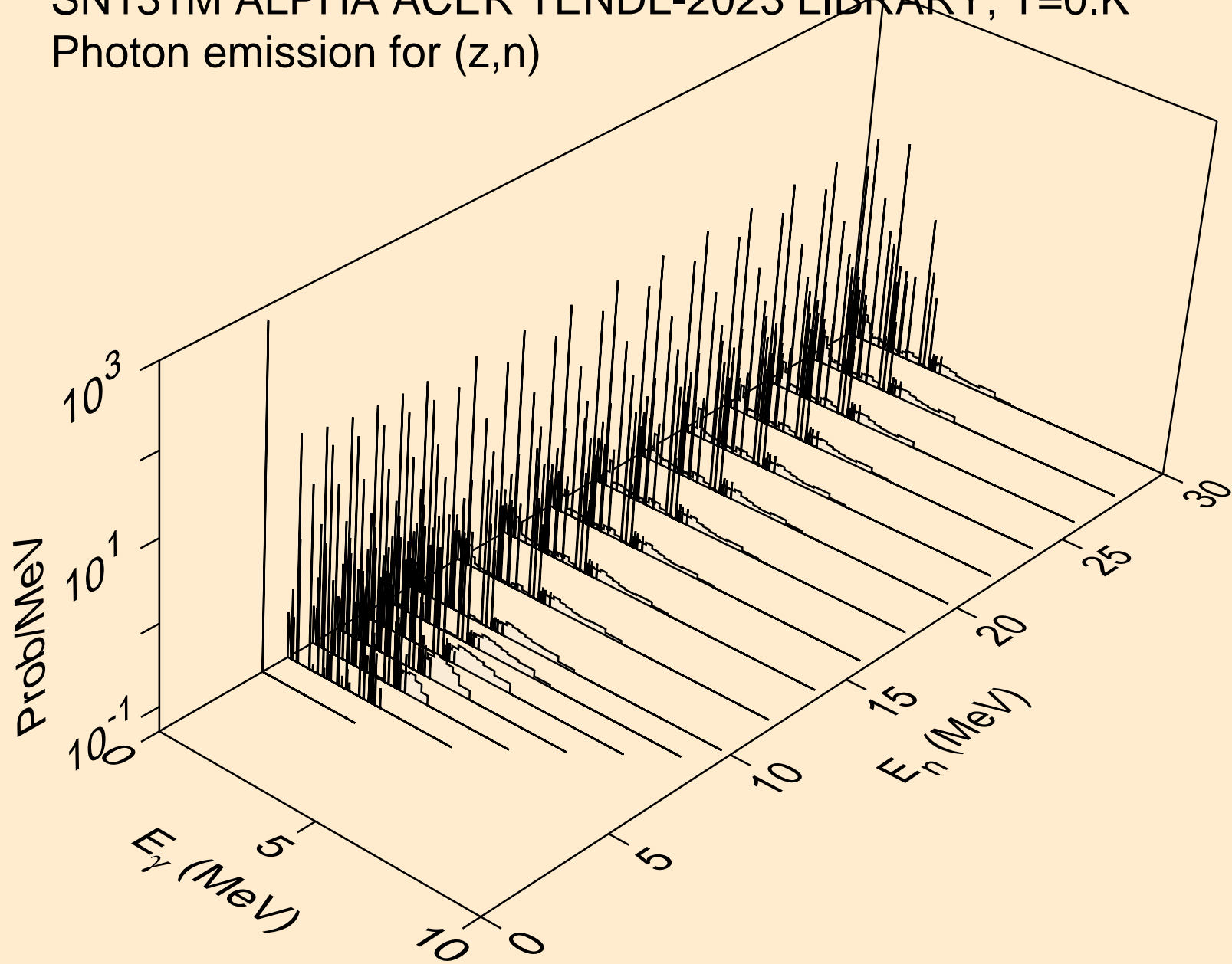

SN131M ALPHA ACER TENDL-2023 LIBRARY; T=0.K
Photon emission for (z,x)

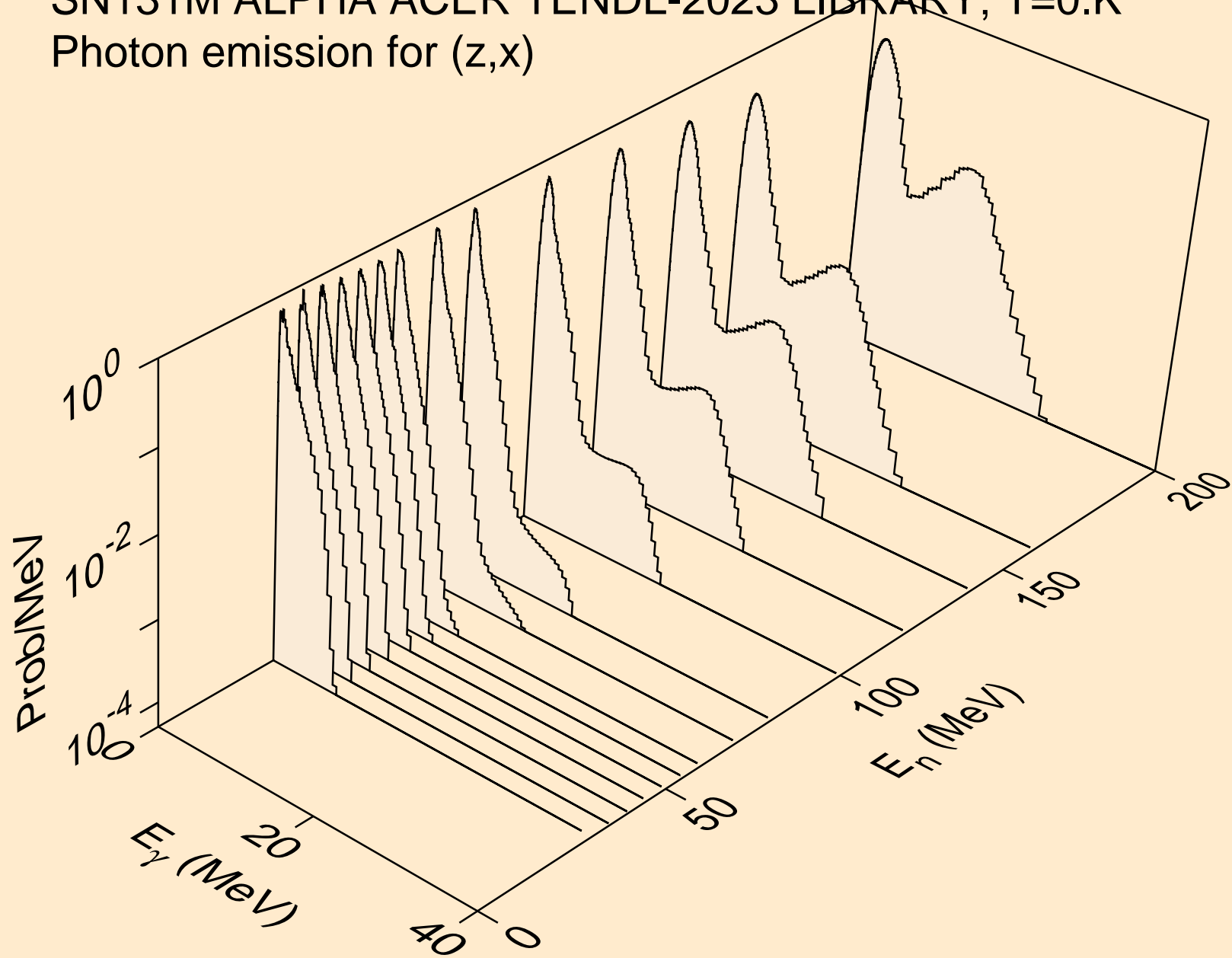

SN131M ALPHA ACER TENDL-2023 LIBRARY; T=0.K
Photon emission for (n,2nd)

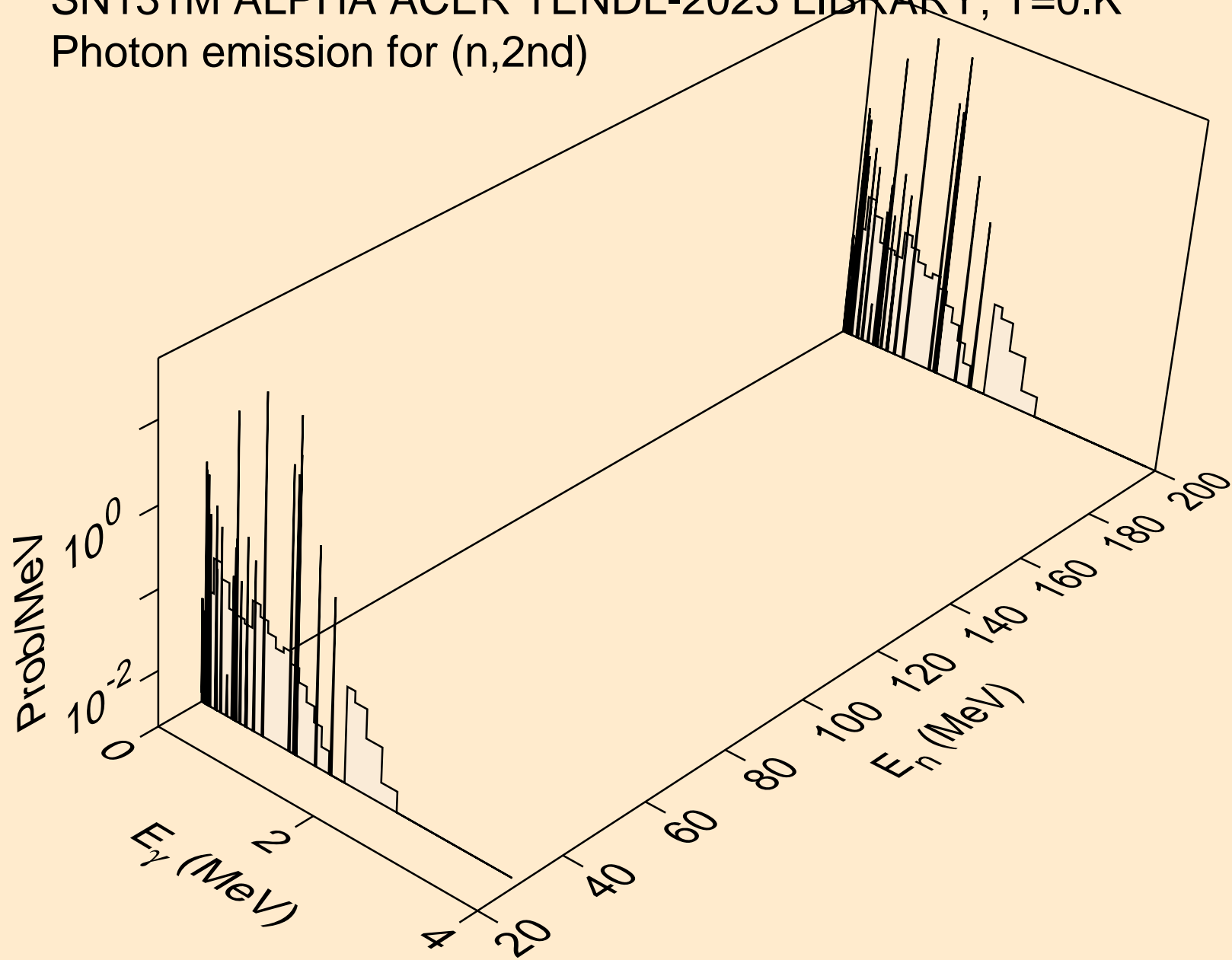

SN131M ALPHA ACER TENDL-2023 LIBRARY; T=0.K
Photon emission for (n,2n)

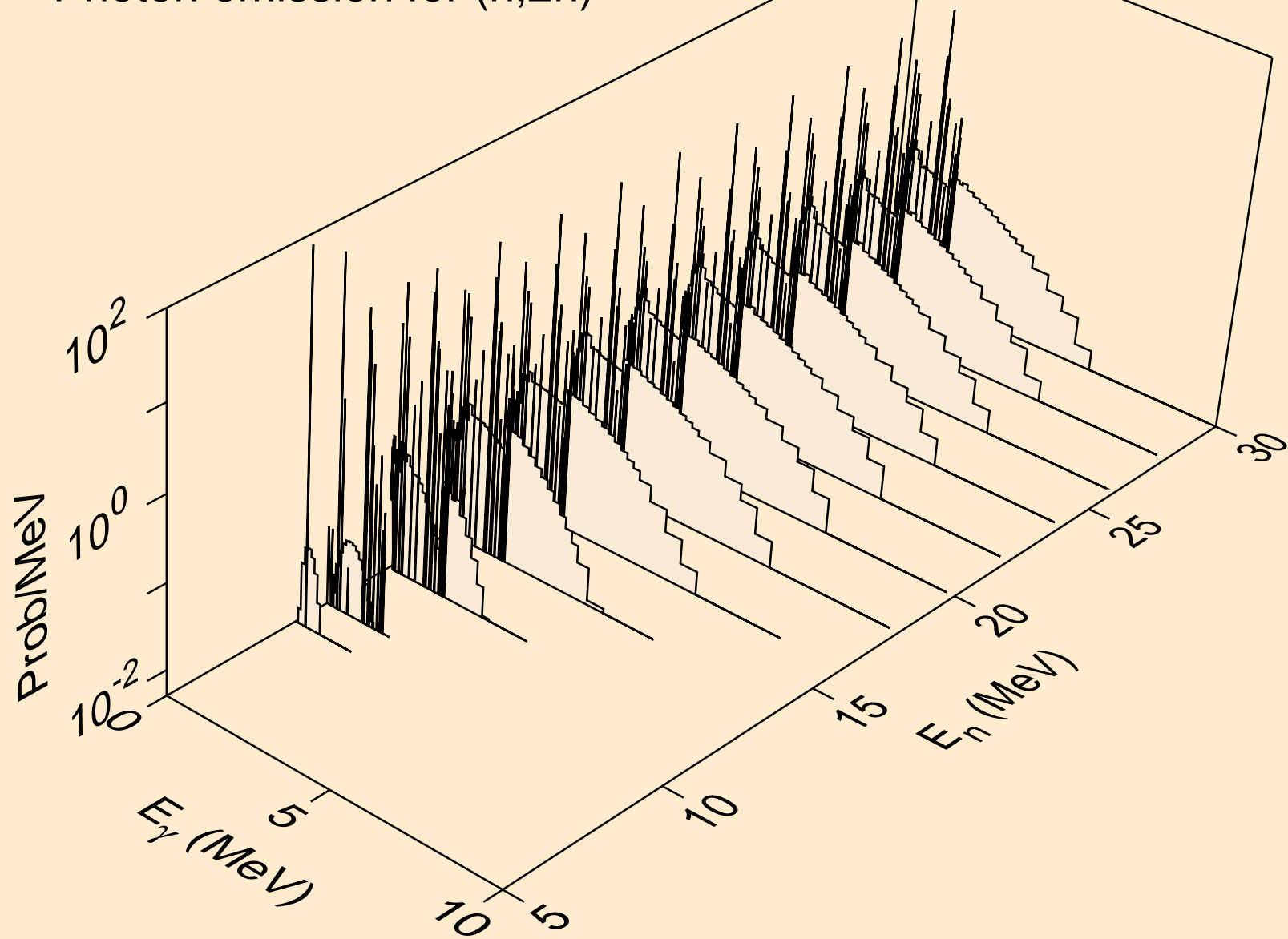

SN131M ALPHA ACER TENDL-2023 LIBRARY; T=0.K
Photon emission for (n,3n)

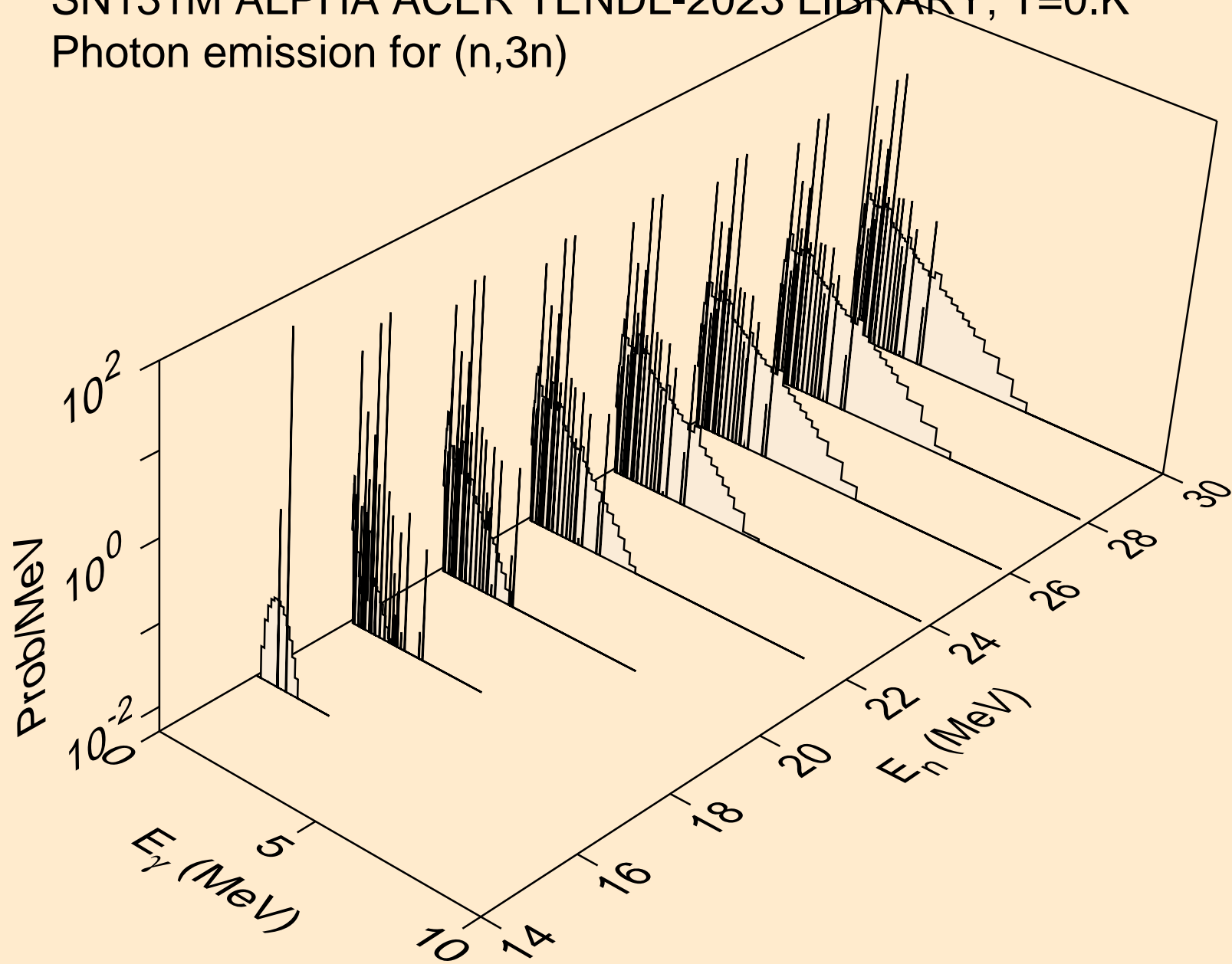

SN131M ALPHA ACER TENDL-2023 LIBRARY; T=0.K
Photon emission for (n,n*)a

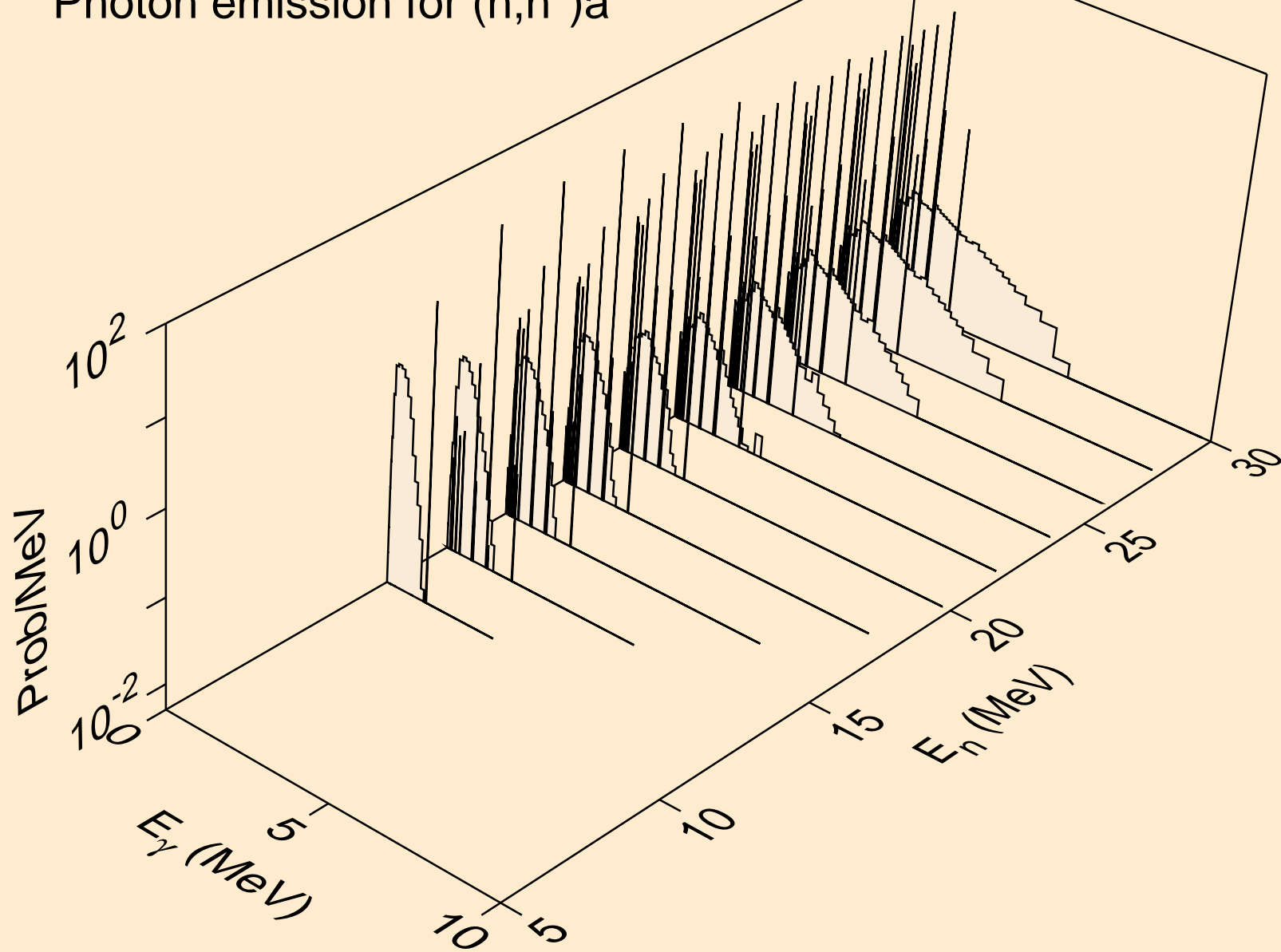

SN131M ALPHA ACER TENDL-2023 LIBRARY; T=0.K
Photon emission for (n,2n)a

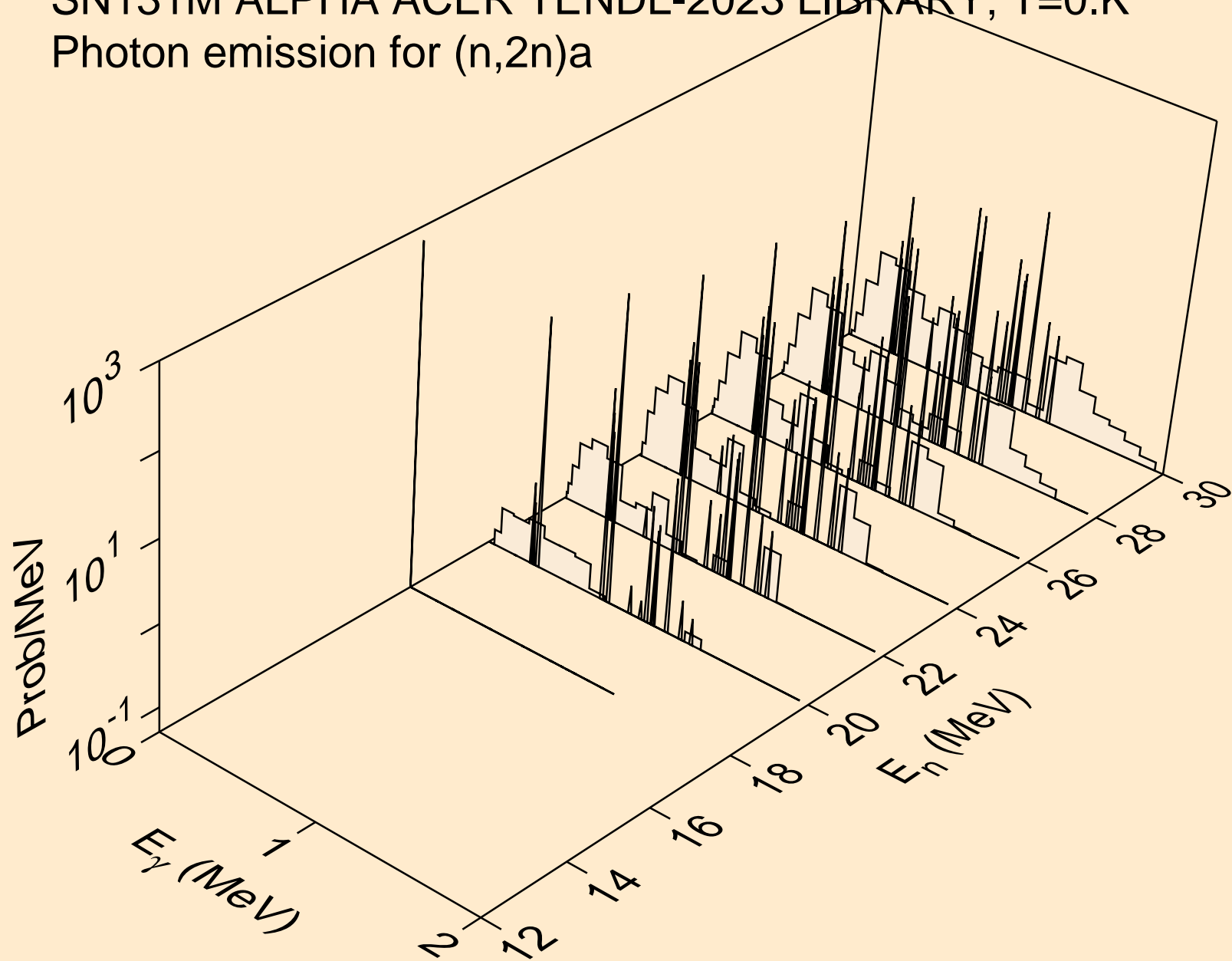

SN131M ALPHA ACER TENDL-2023 LIBRARY; T=0.K
Photon emission for (n,3n)a

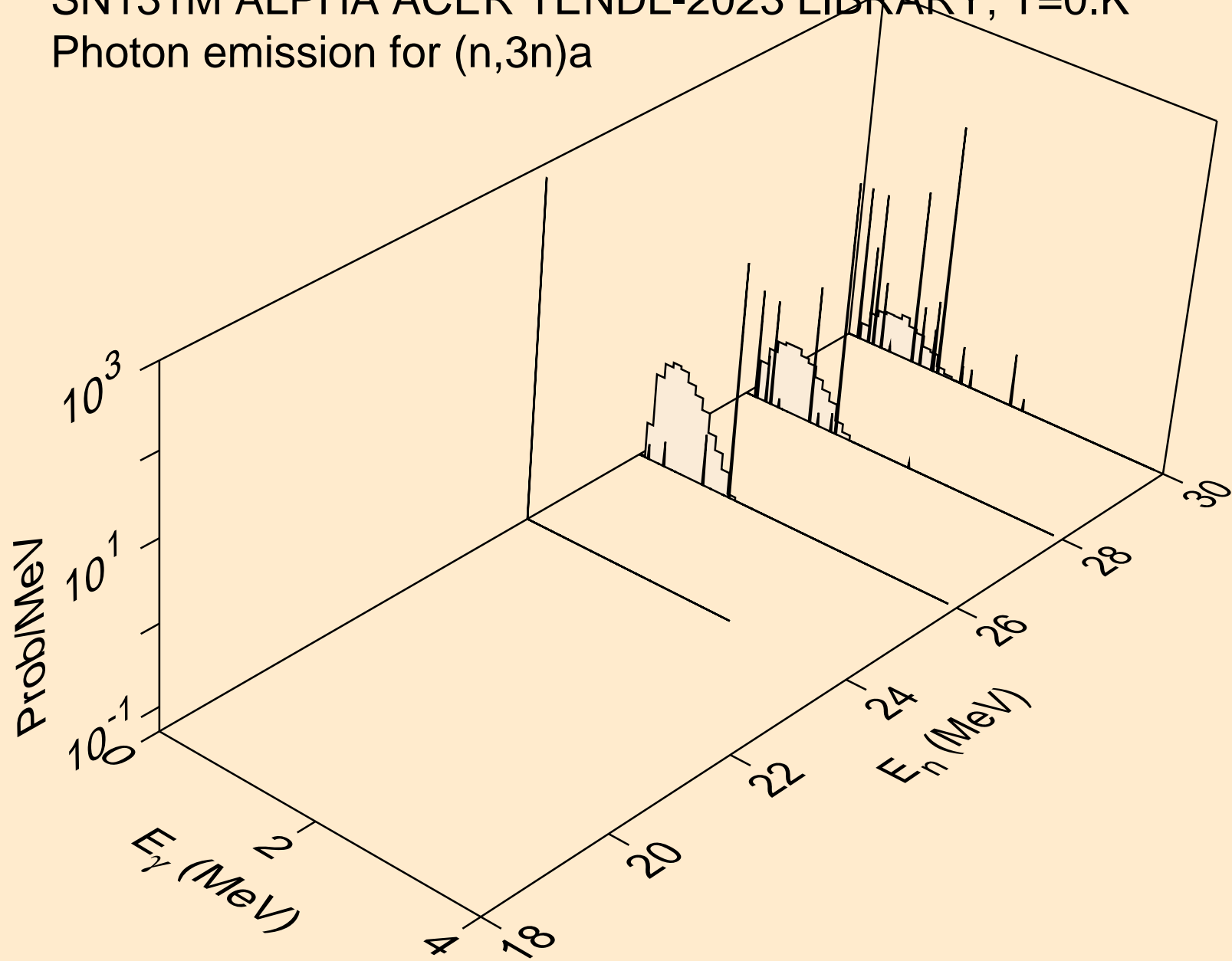

SN131M ALPHA ACER TENDL-2023 LIBRARY; T=0.K
Photon emission for (n,n*)p

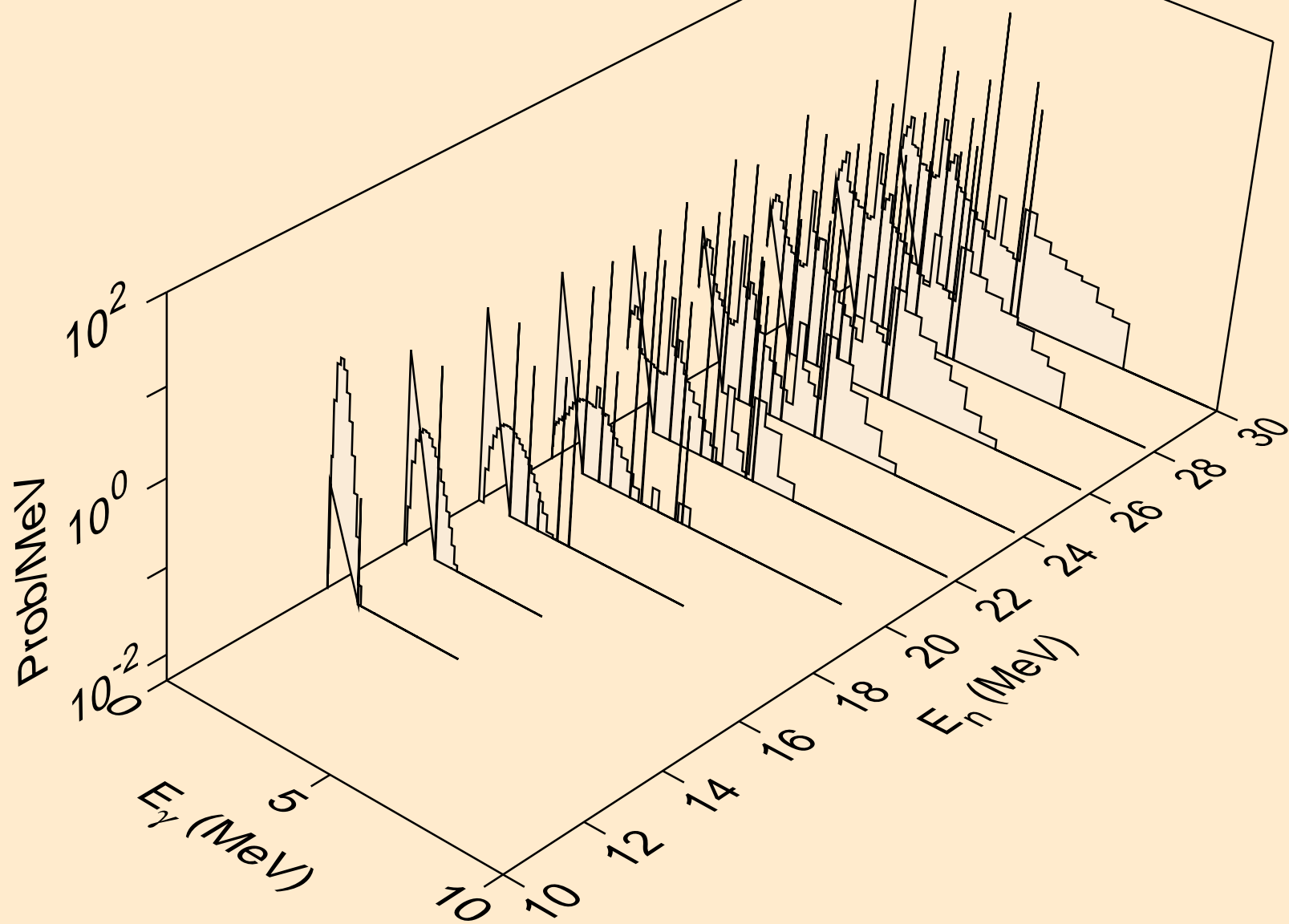

SN131M ALPHA ACER TENDL-2023 LIBRARY; T=0.K
Photon emission for (n,n*)d

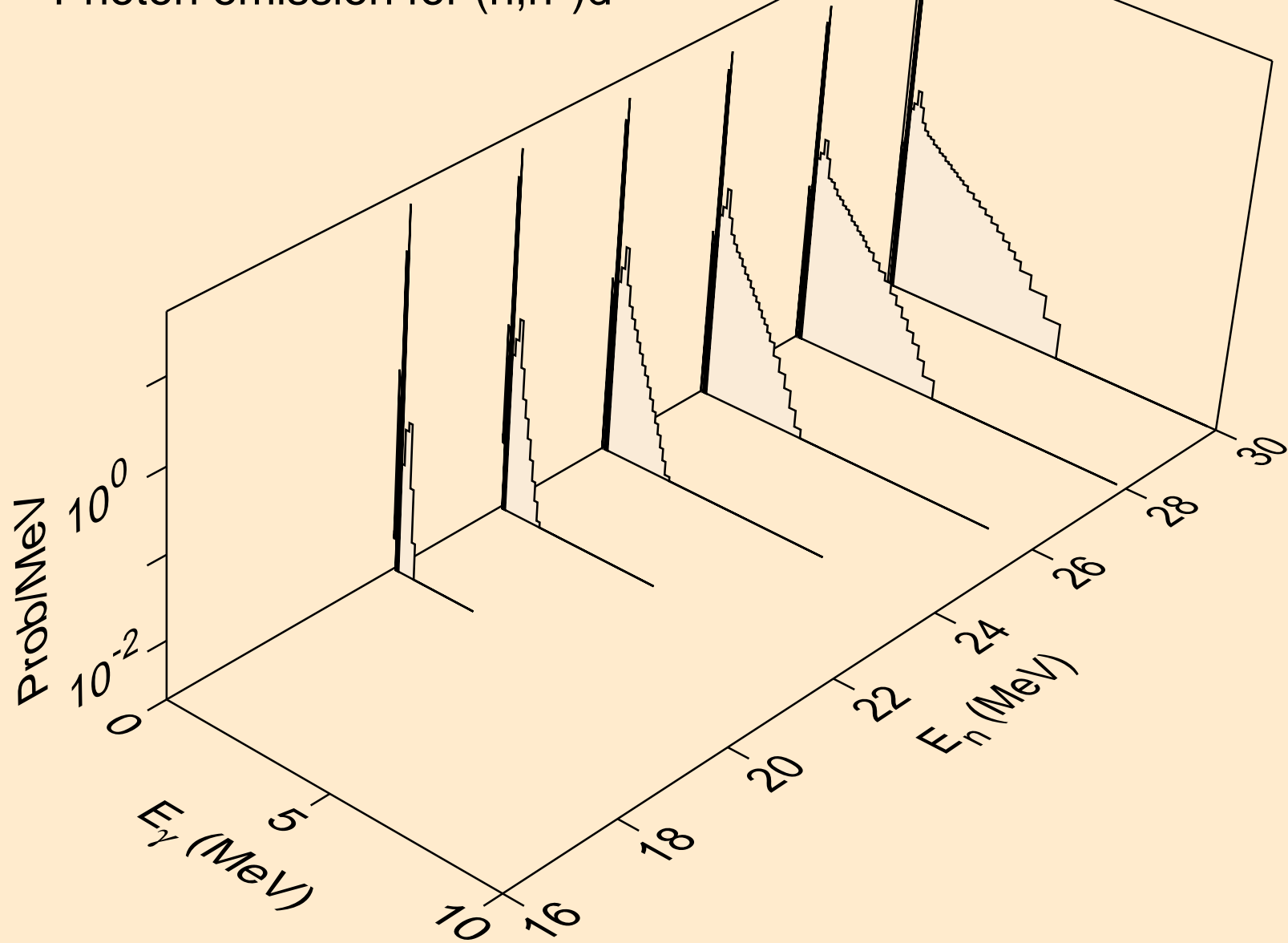

SN131M ALPHA ACER TENDL-2023 LIBRARY; T=0.K
Photon emission for (n,n*)t

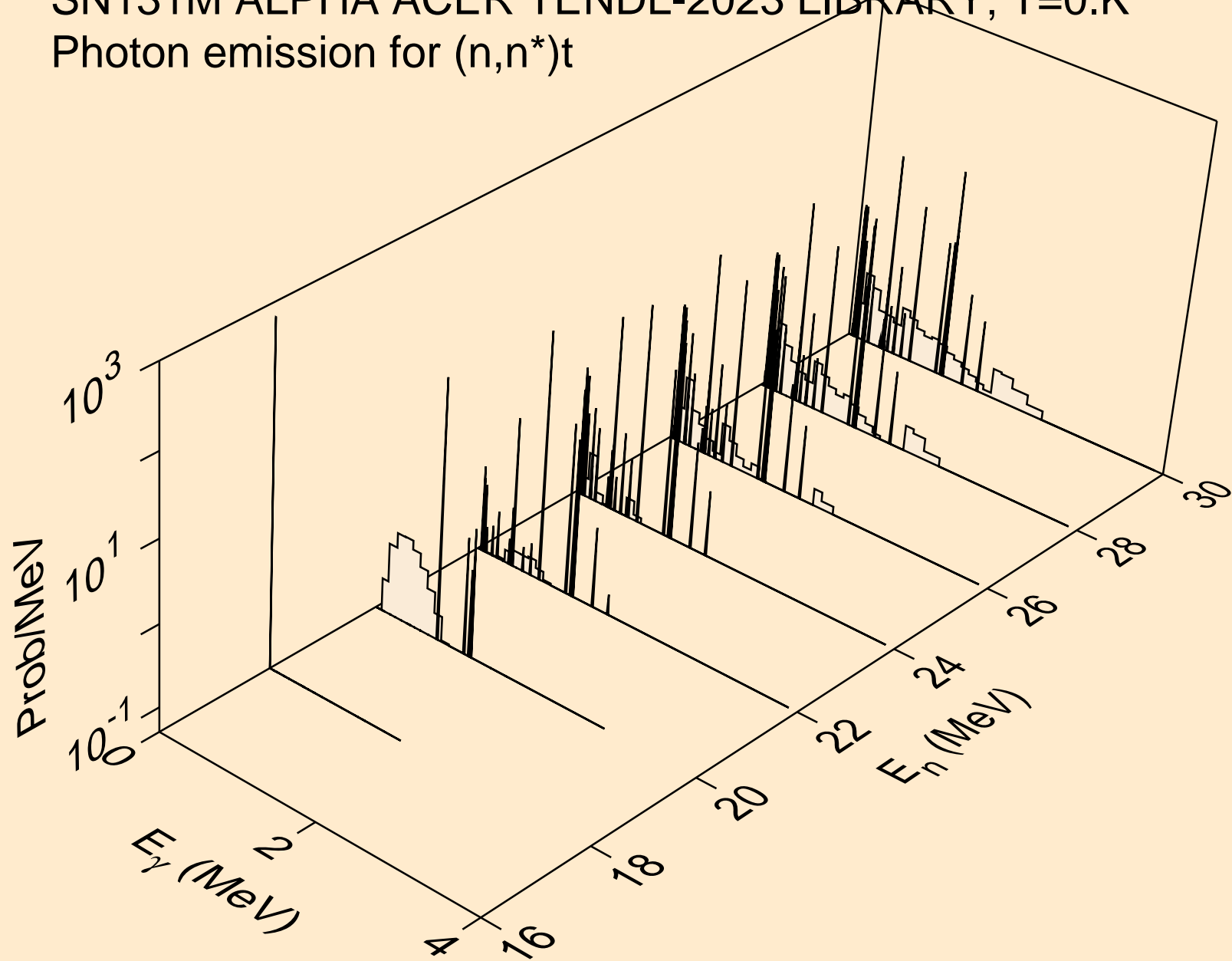

SN131M ALPHA ACER TENDL-2023 LIBRARY; T=0.K
Photon emission for (n,n*)he3

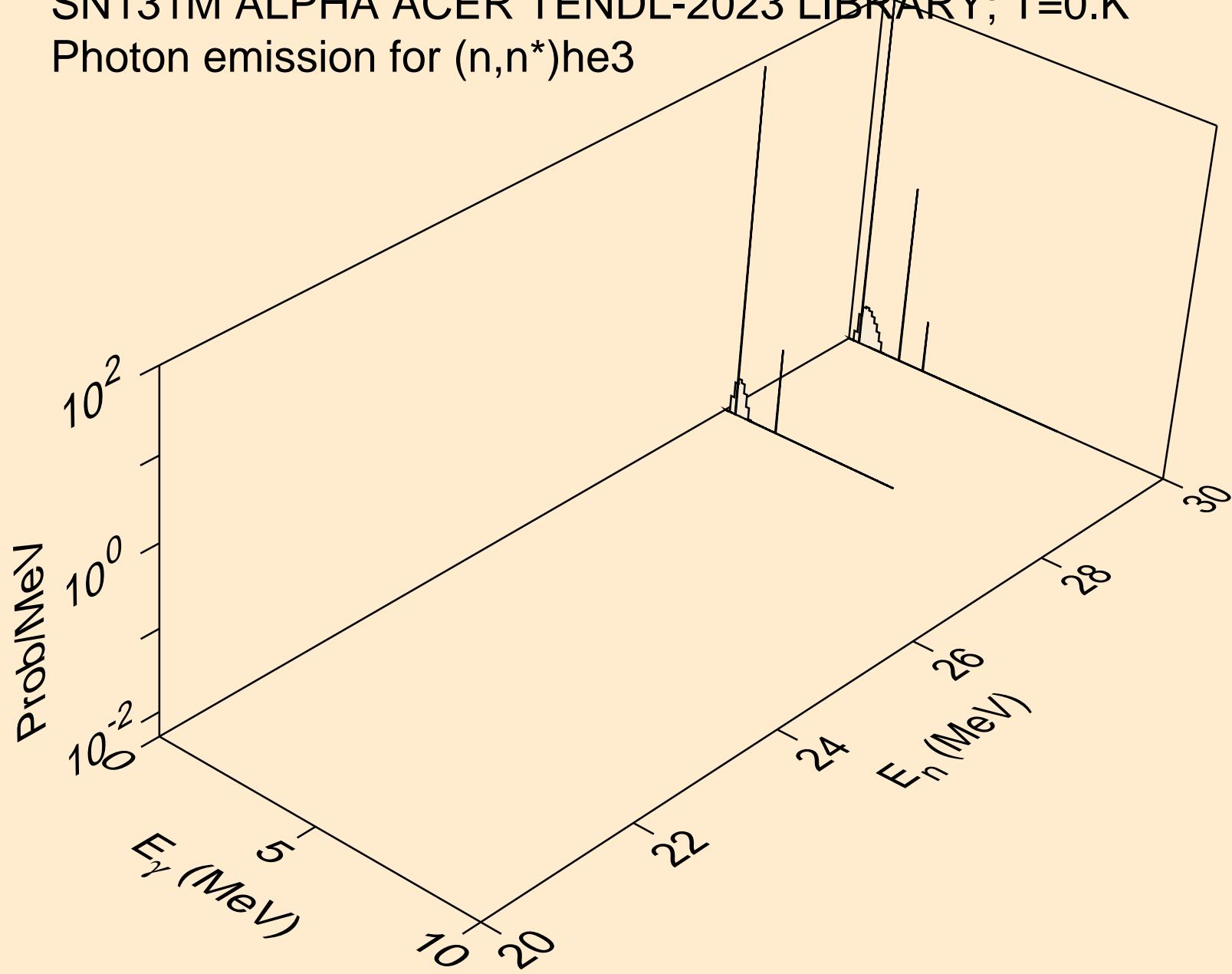

SN131M ALPHA ACER TENDL-2023 LIBRARY; T=0.K
Photon emission for (n,4n)

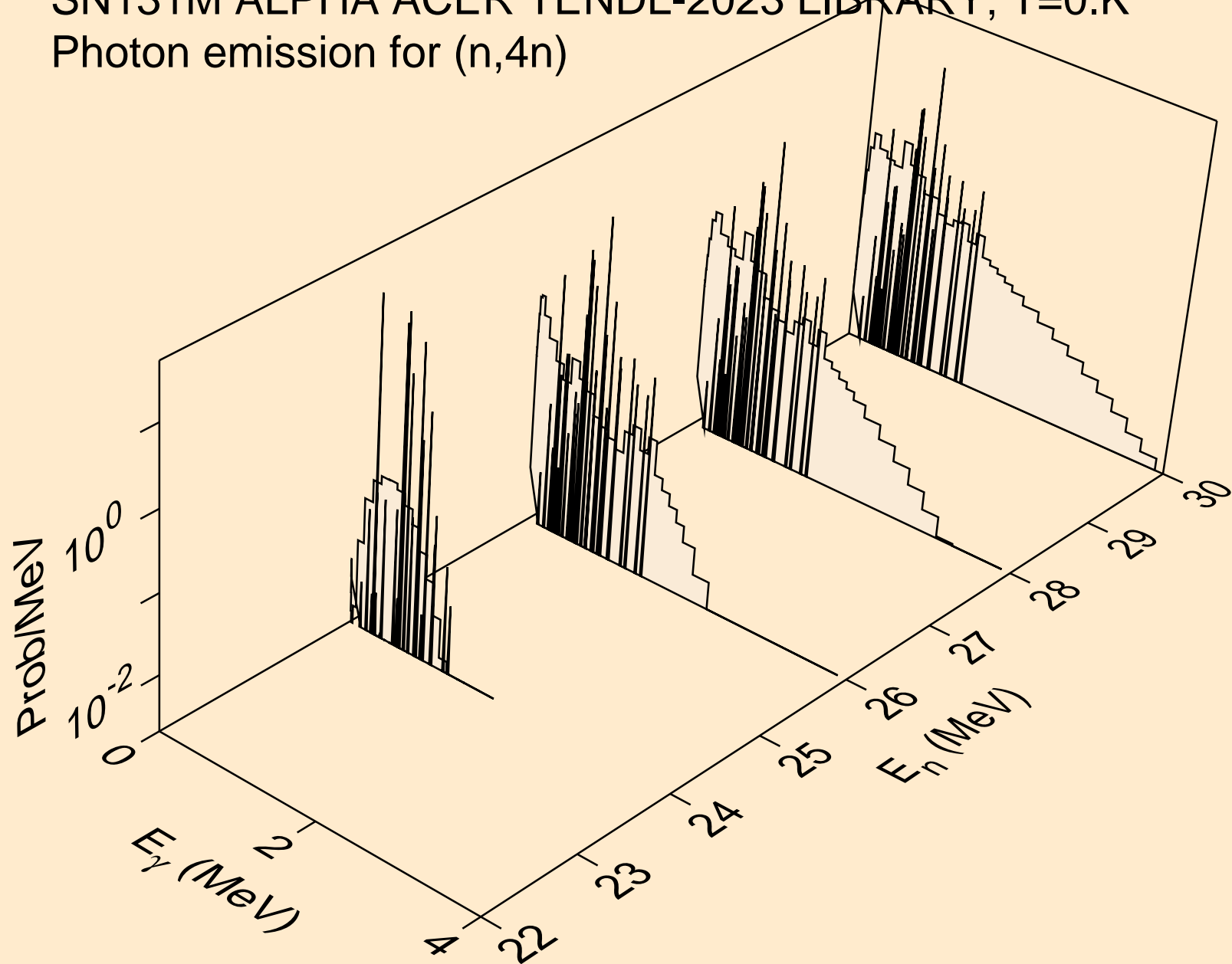

SN131M ALPHA ACER TENDL-2023 LIBRARY; T=0.K
Photon emission for (n,2np)

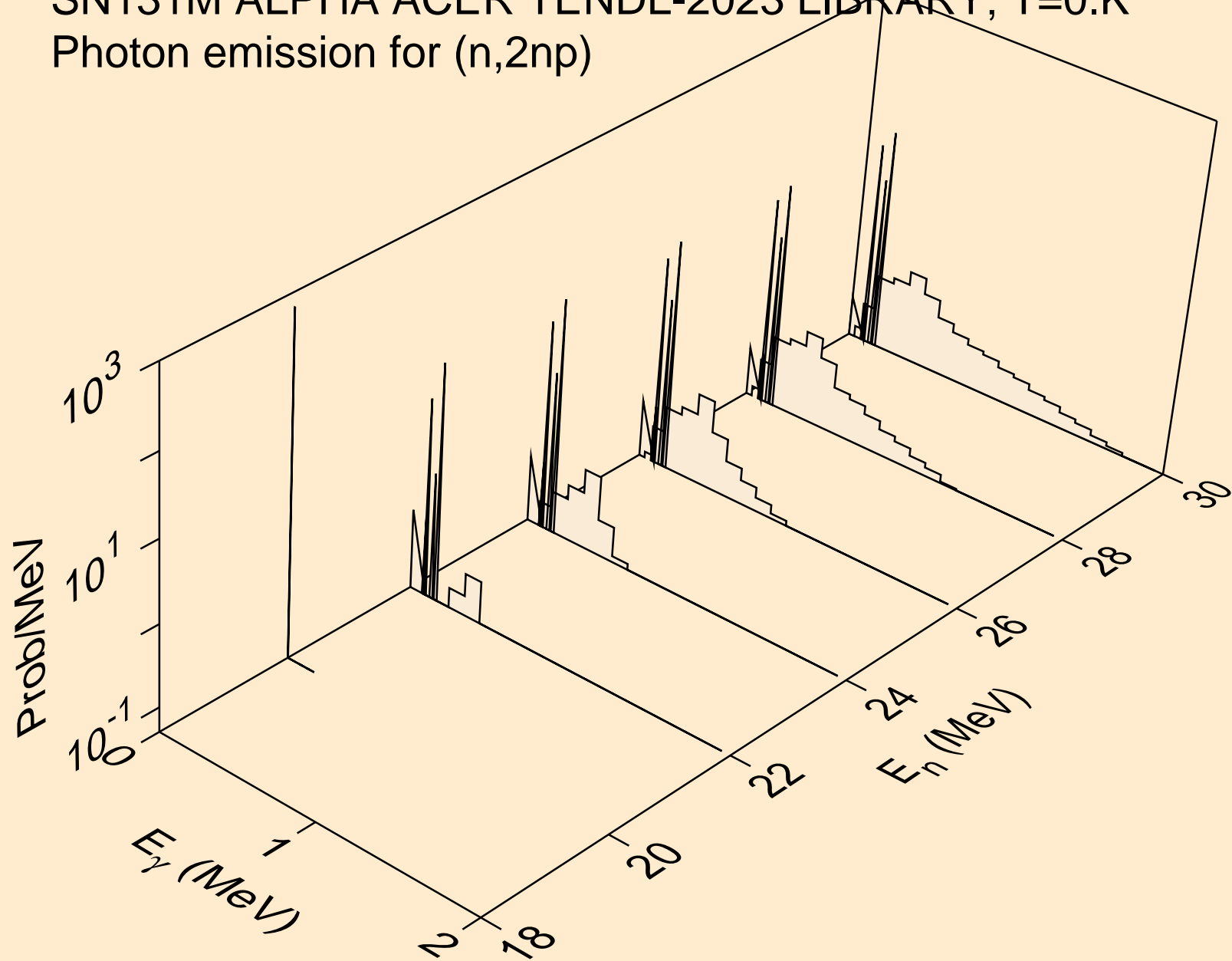

SN131M ALPHA ACER TENDL-2023 LIBRARY; T=0.K
Photon emission for (n,3np)

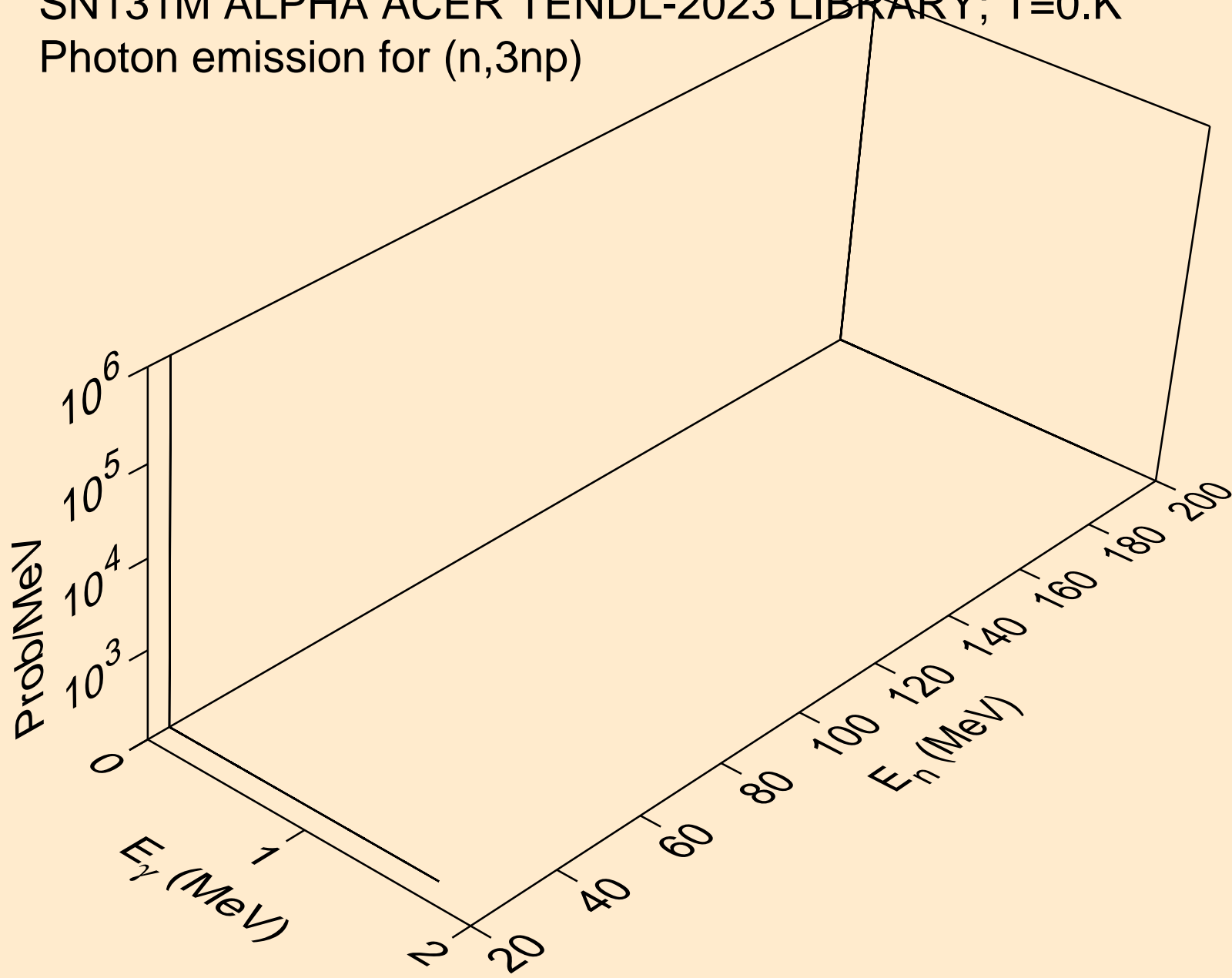

SN131M ALPHA ACER TENDL-2023 LIBRARY; T=0.K
Photon emission for (n,gma)

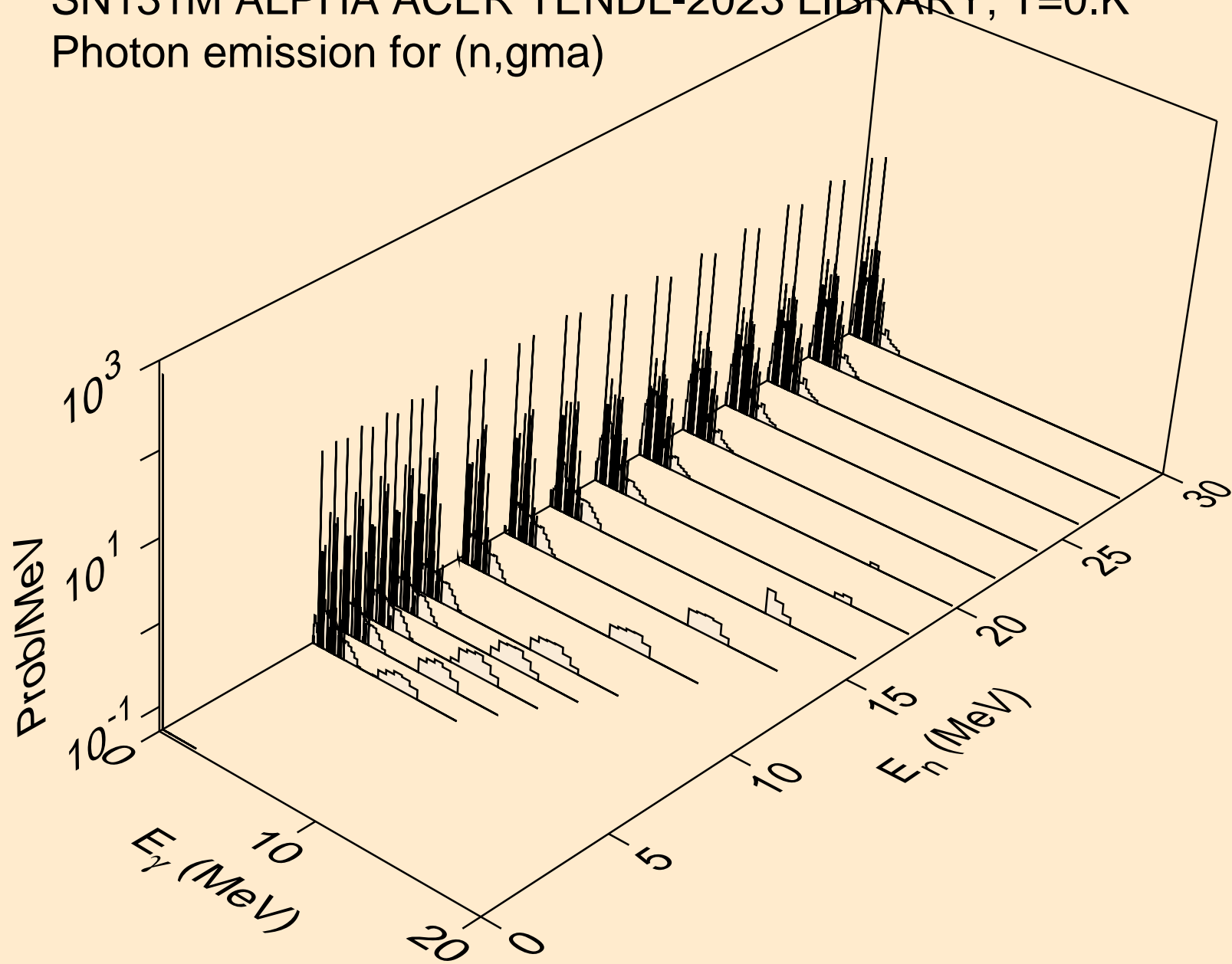

SN131M ALPHA ACER TENDL-2023 LIBRARY; T=0.K
Photon emission for (n,p)

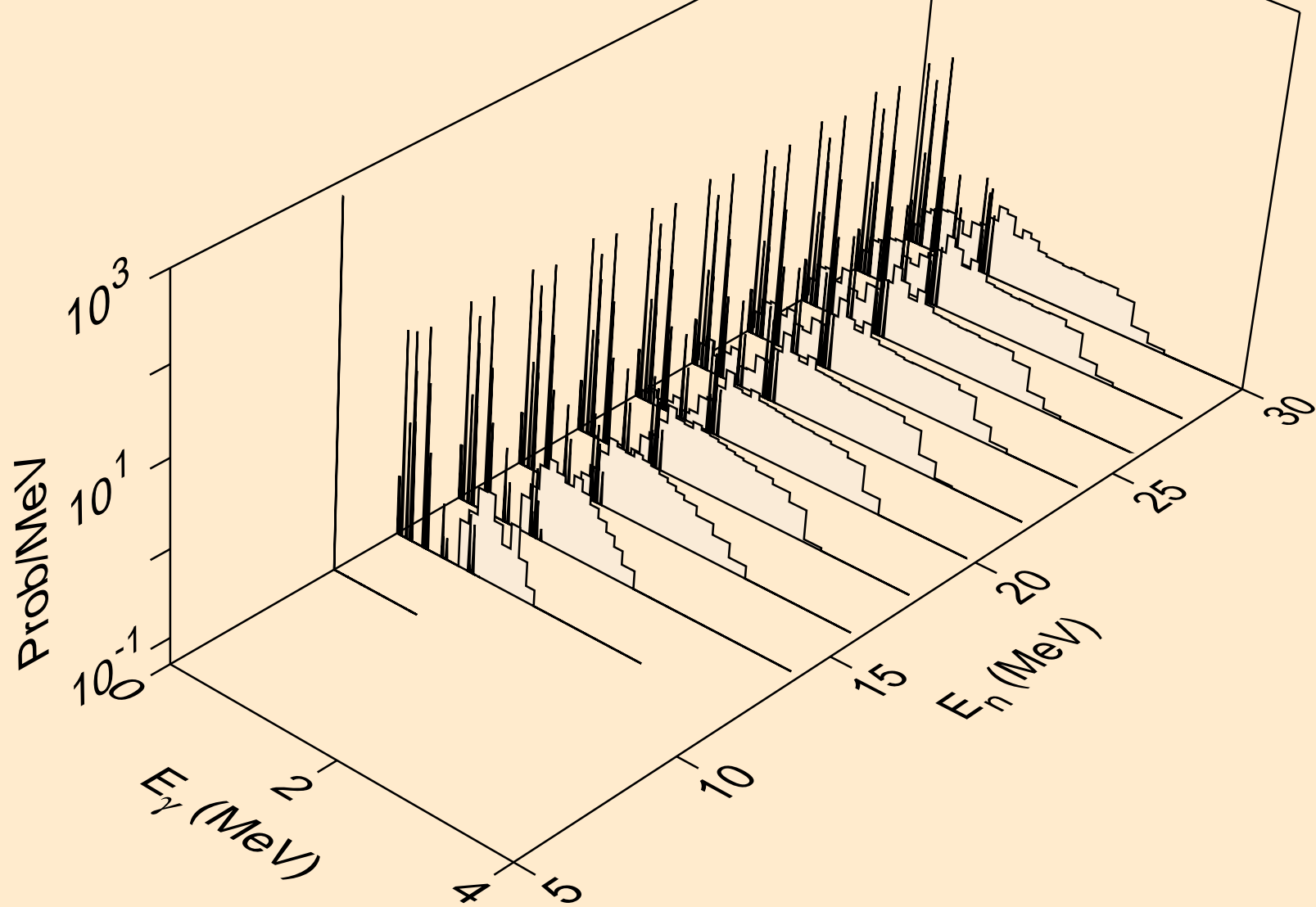

SN131M ALPHA ACER TENDL-2023 LIBRARY; T=0.K
Photon emission for (n,d)

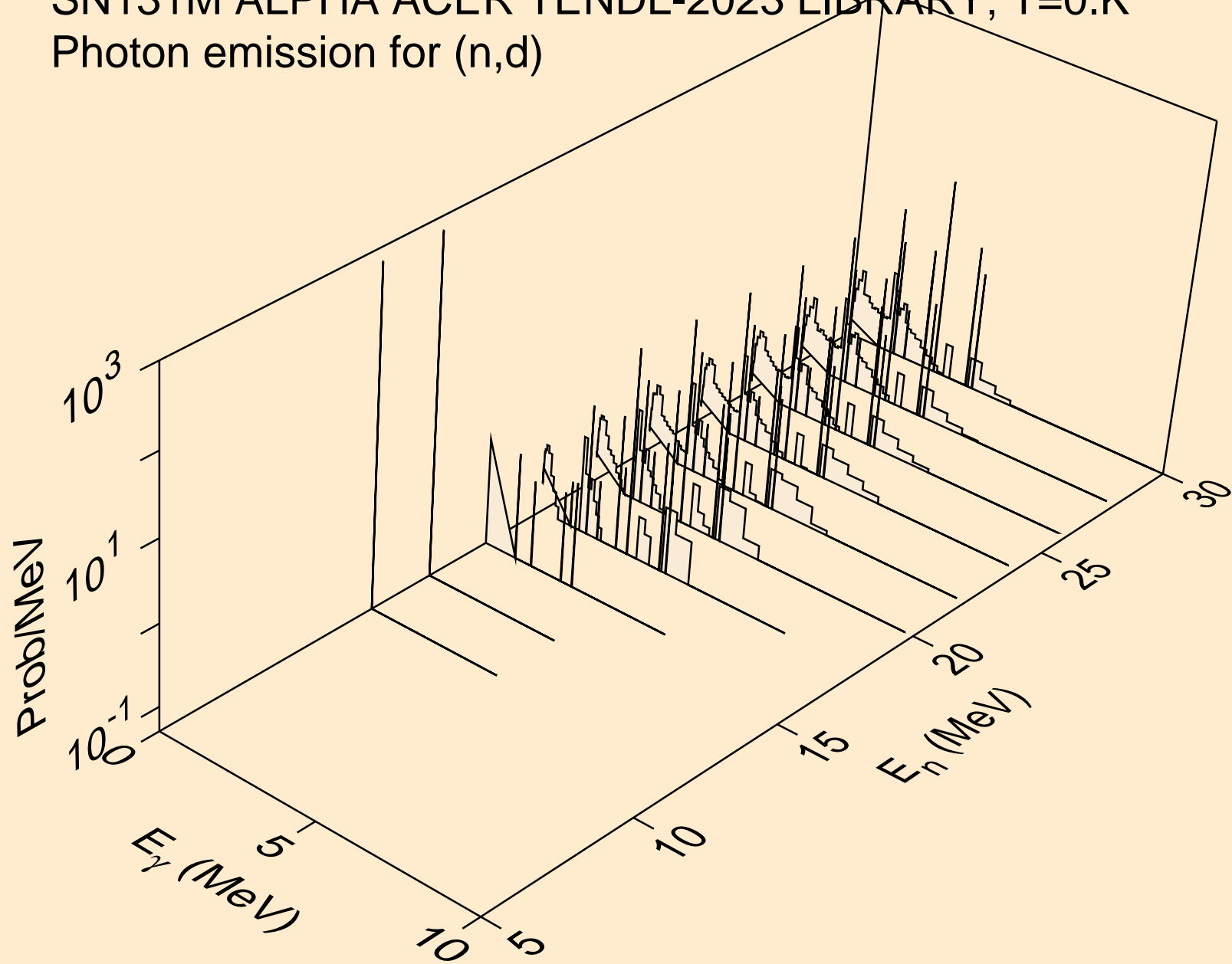

SN131M ALPHA ACER TENDL-2023 LIBRARY; T=0.K
Photon emission for (n,t)

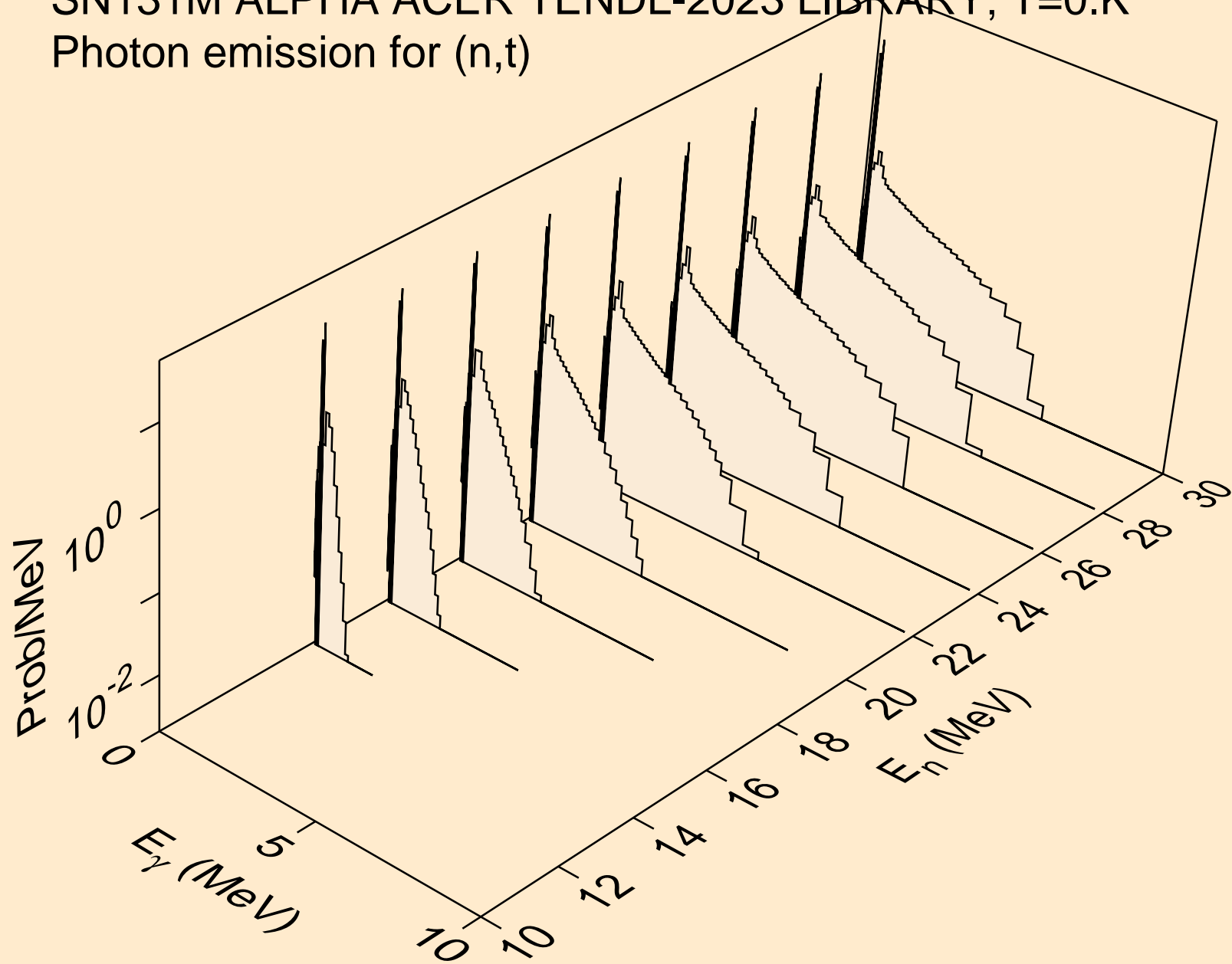

SN131M ALPHA ACER TENDL-2023 LIBRARY; T=0.K
Photon emission for (n,he3)

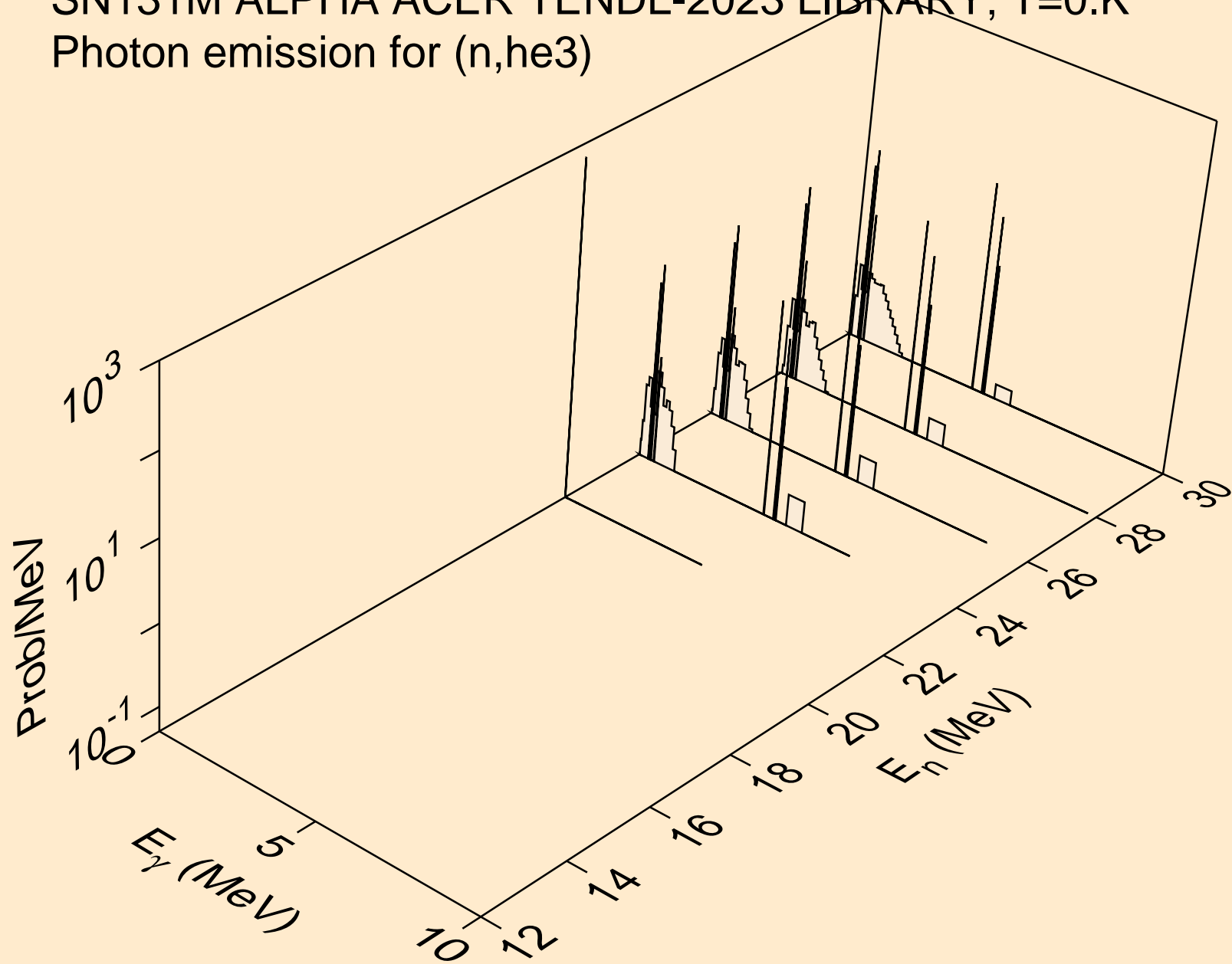

SN131M ALPHA ACER TENDL-2023 LIBRARY; T=0.K
Photon emission for inelastic

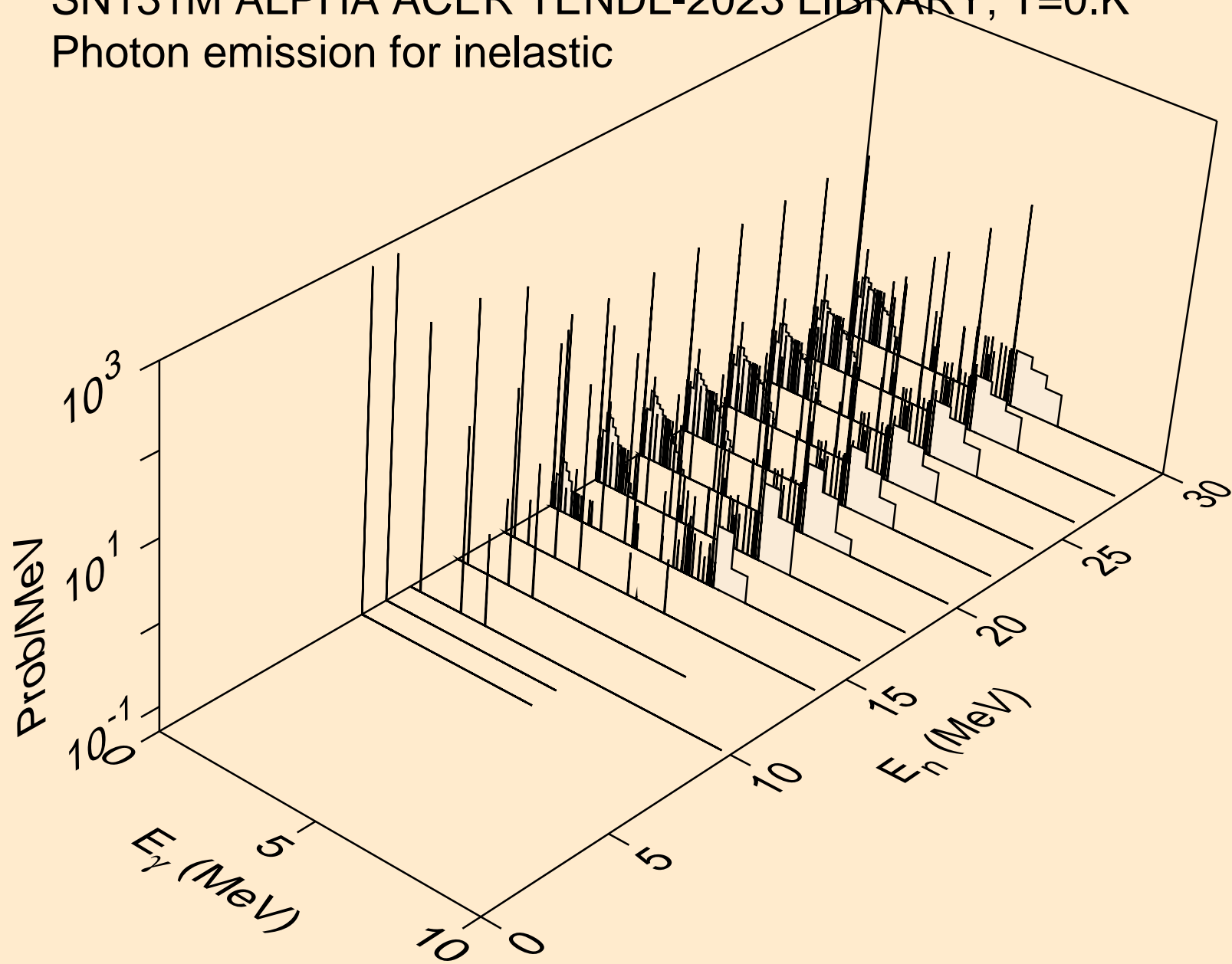

SN131M ALPHA ACER TENDL-2023 LIBRARY; T=0.K
Particle heating contributions

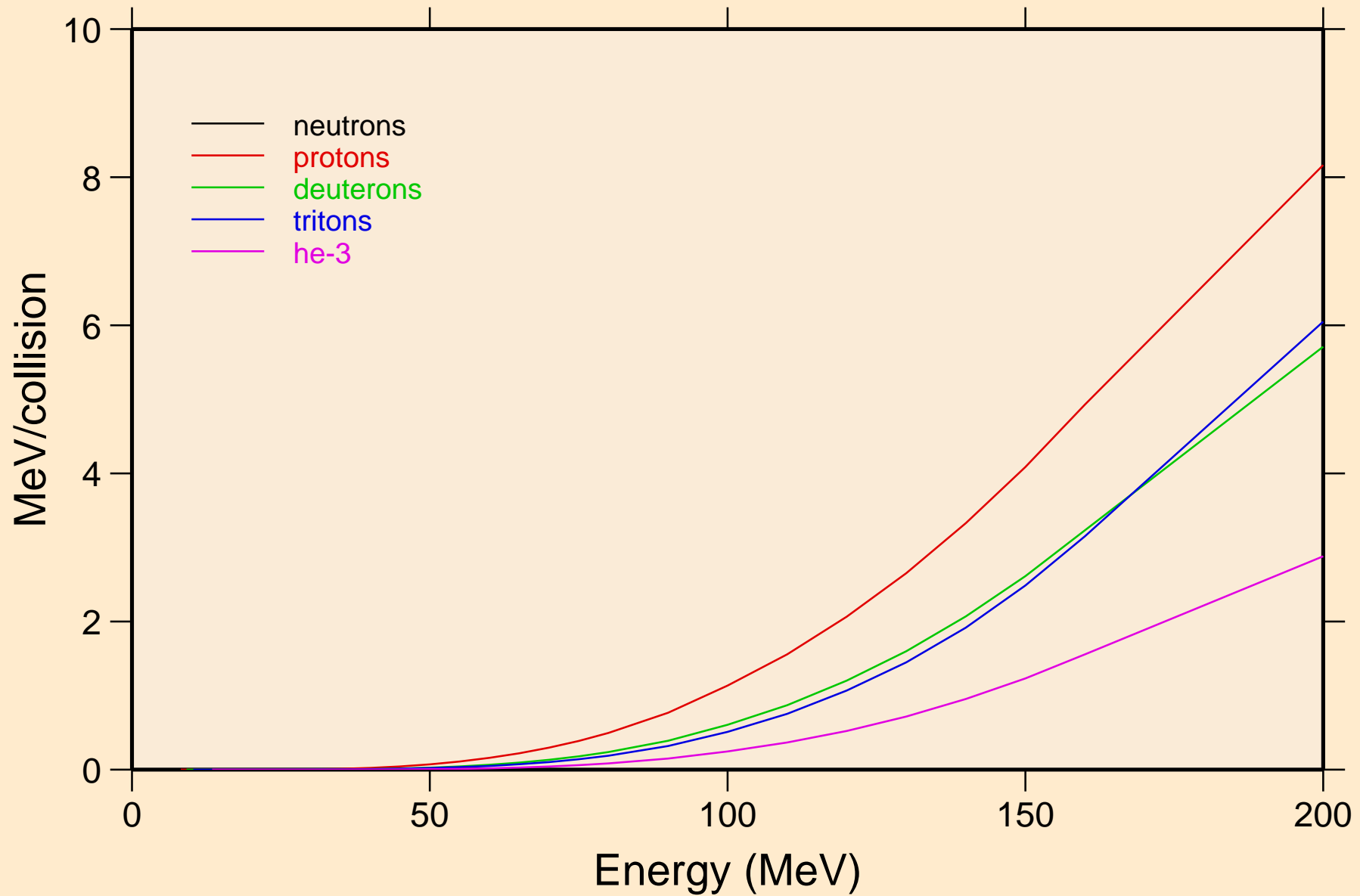

SN131M ALPHA ACER TENDL-2023 LIBRARY; T=0.K
Recoil Heating

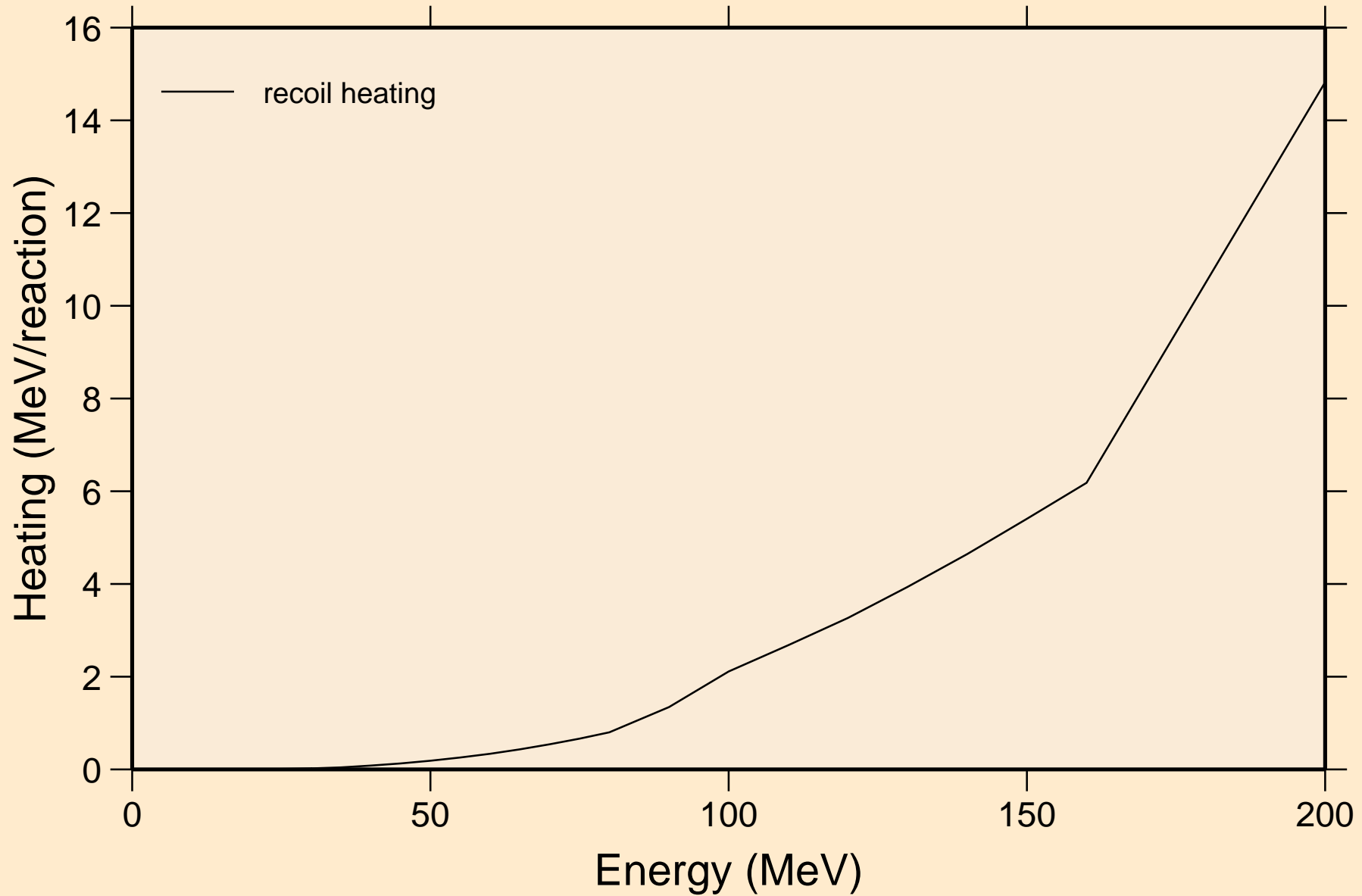

SN131M ALPHA ACER TENDL-2023 LIBRARY; T=0.K

Particle production cross sections

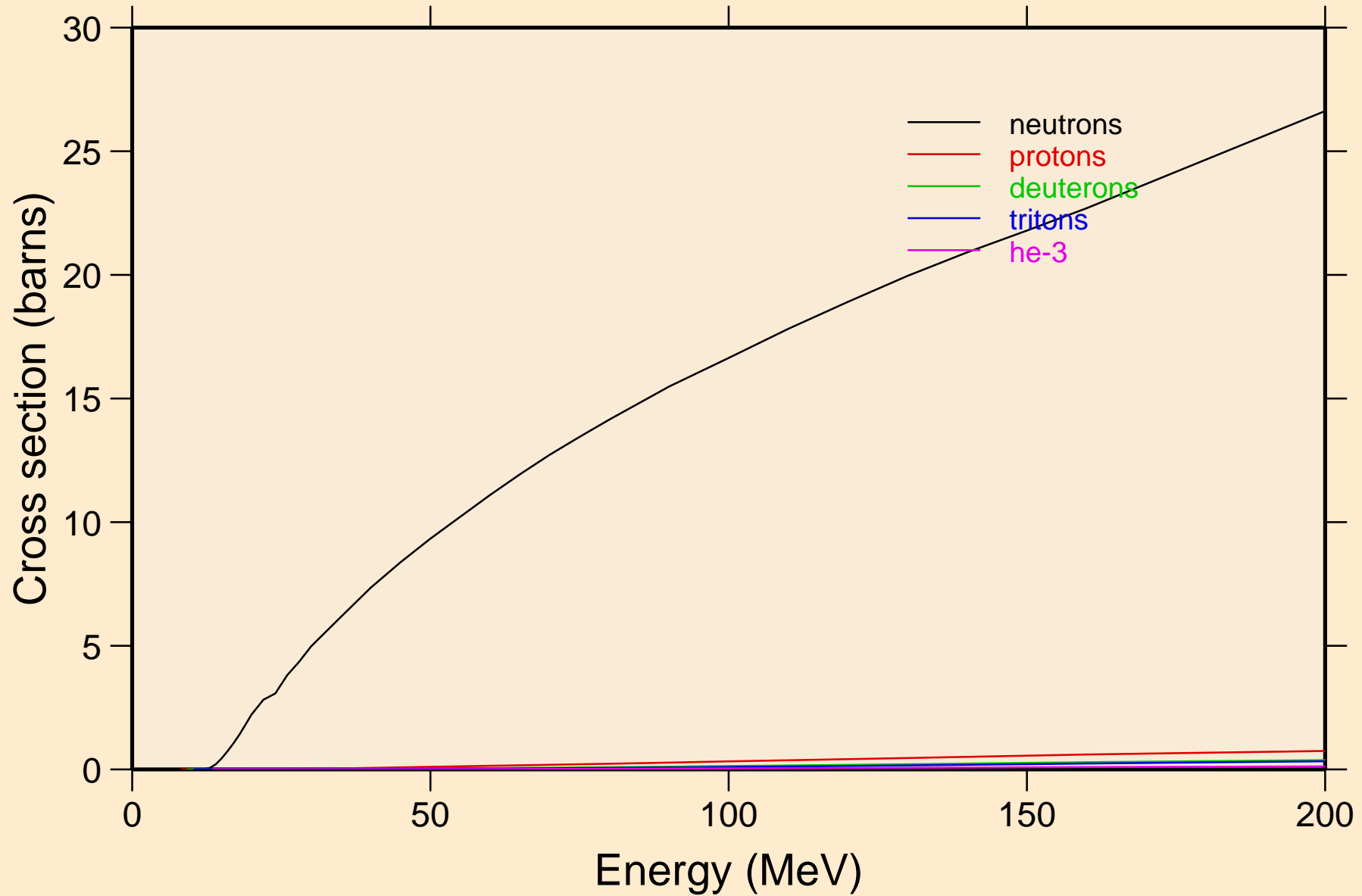

SN131M ALPHA ACER TENDL-2023 LIBRARY; T=0.K
neutrons from (a,n)

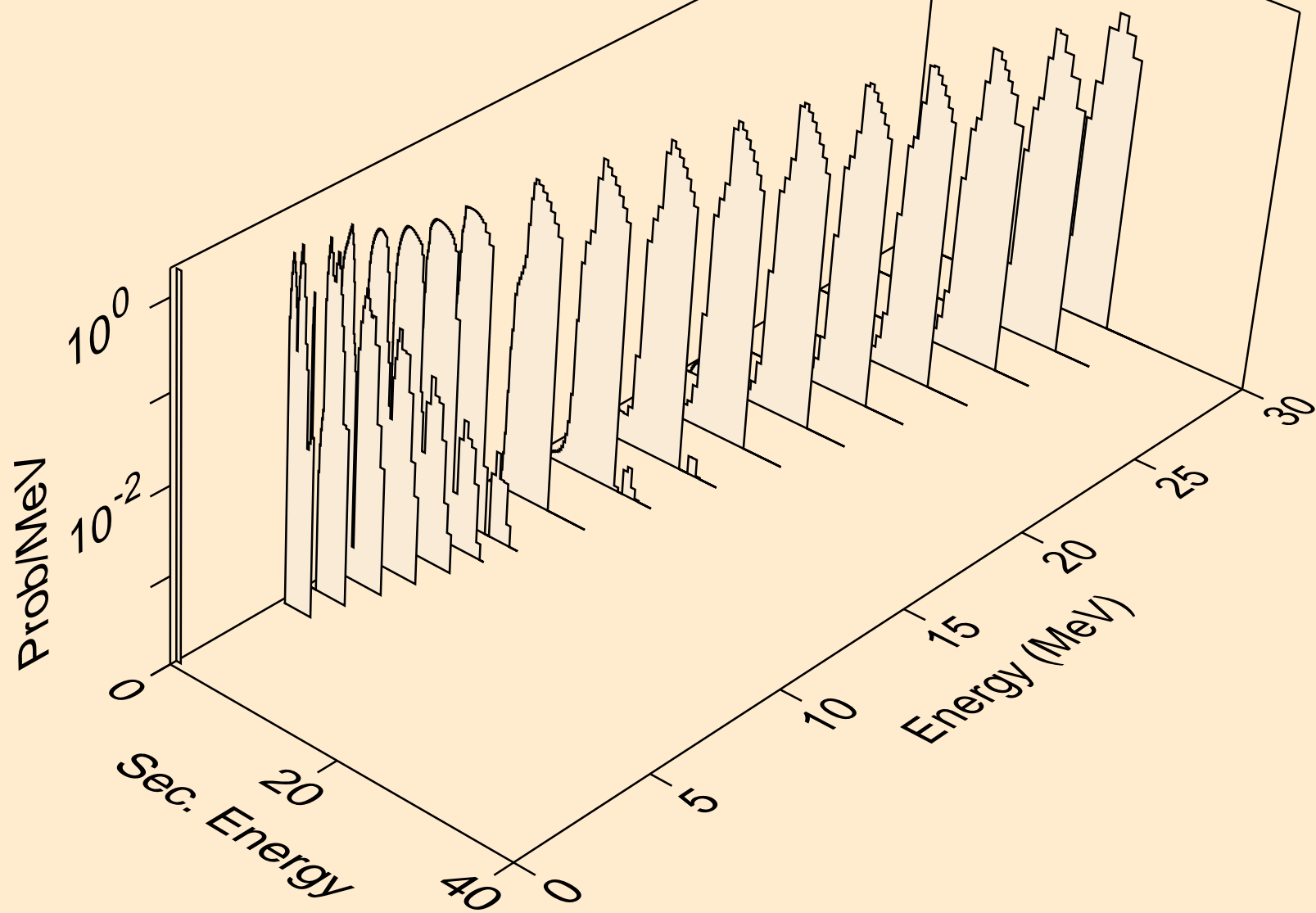

SN131M ALPHA ACER TENDL-2023 LIBRARY; T=0.K
neutrons from (a,x)

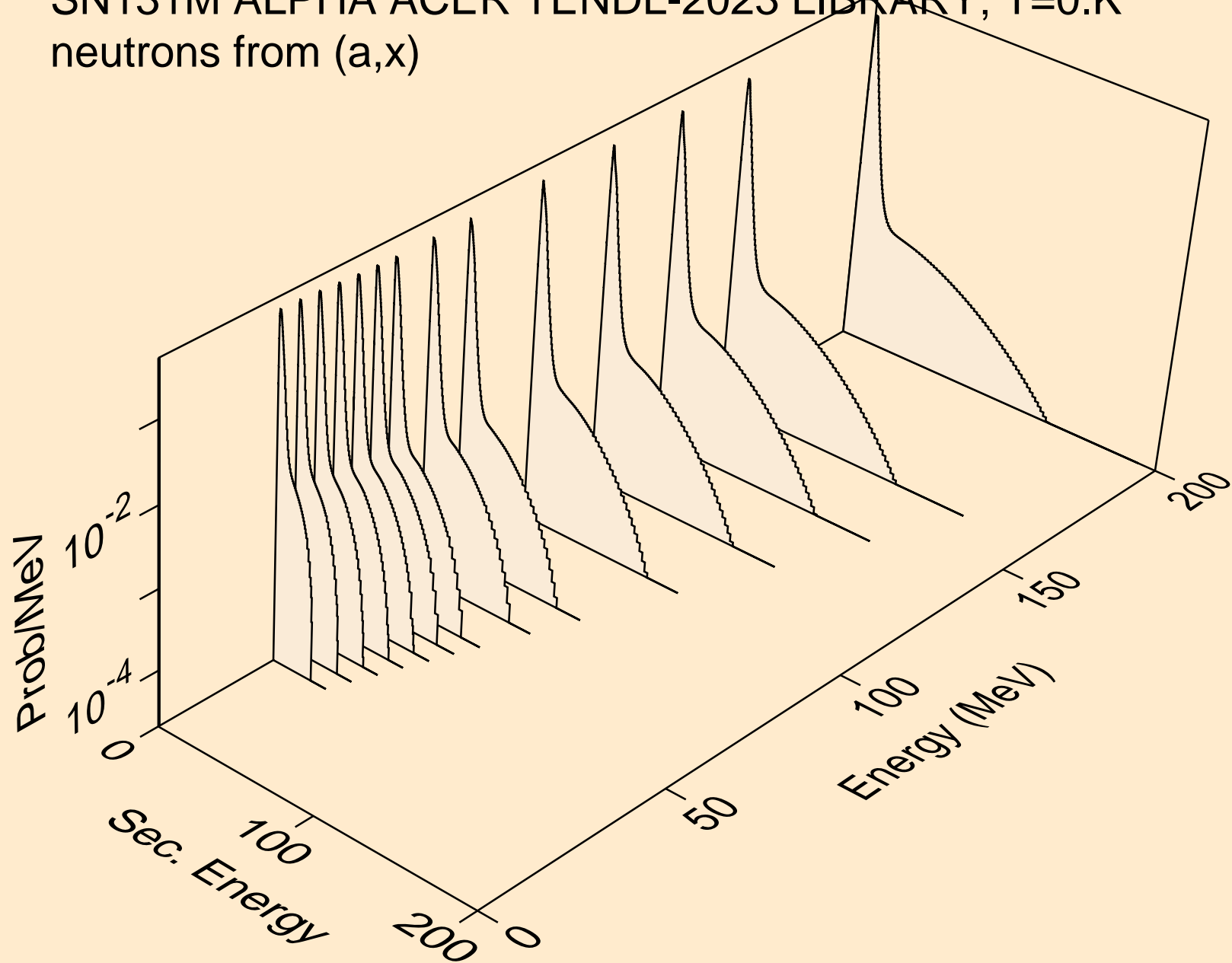

SN131M ALPHA ACER TENDL-2023 LIBRARY; T=0.K
neutrons from (a,2nd)

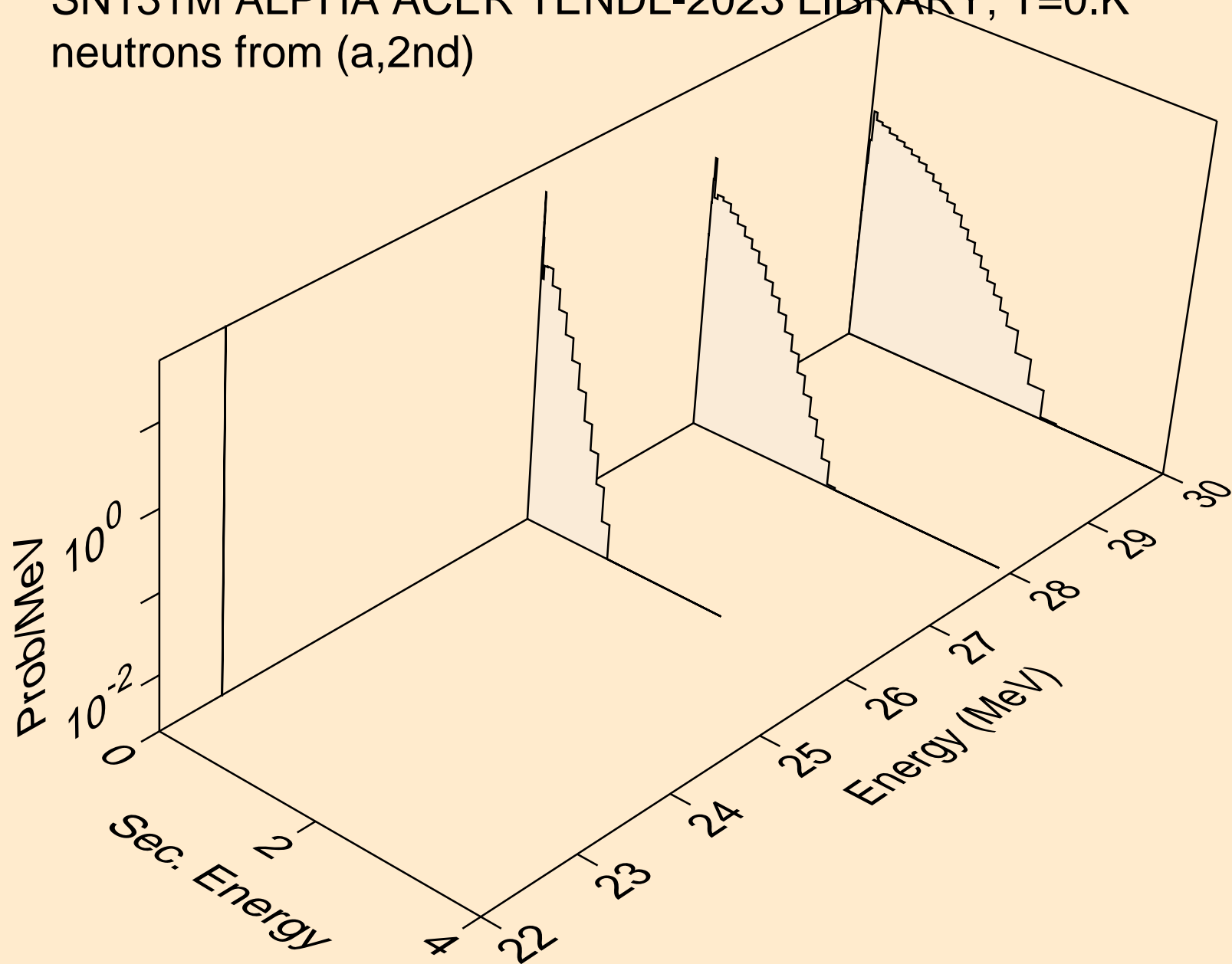

SN131M ALPHA ACER TENDL-2023 LIBRARY; T=0.K
neutrons from (a,2n)

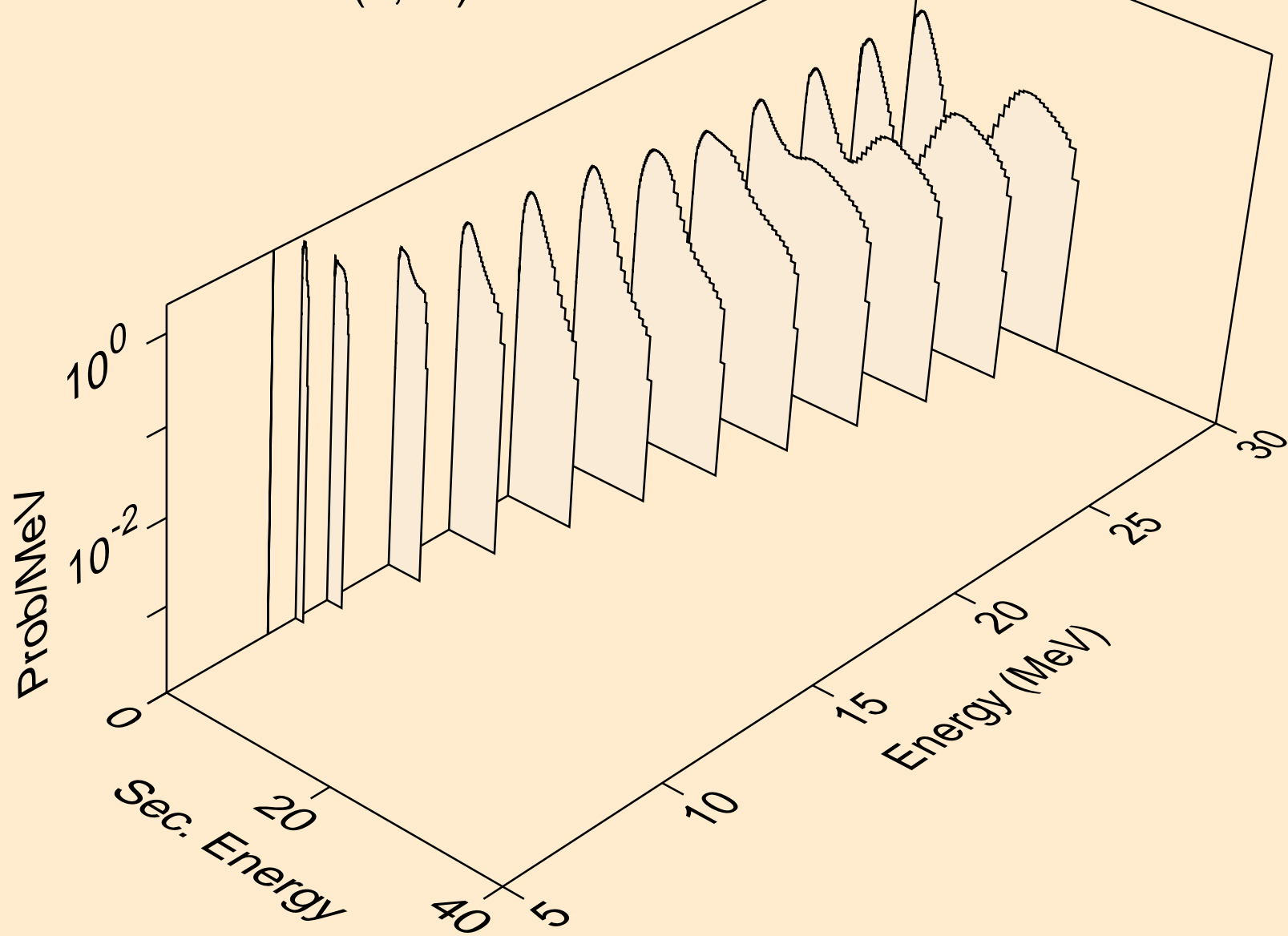

SN131M ALPHA ACER TENDL-2023 LIBRARY; T=0.K
neutrons from (a,3n)

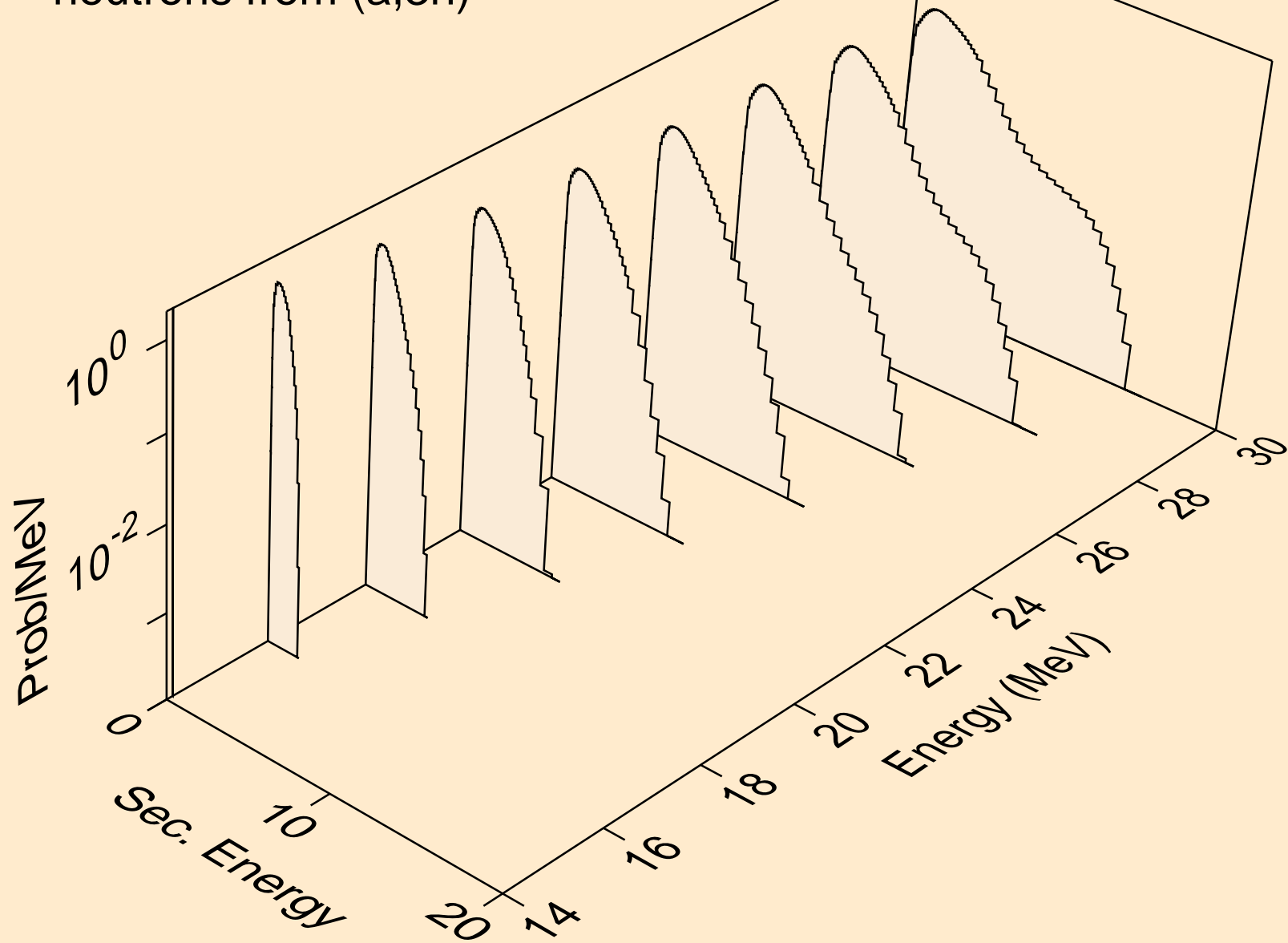

SN131M ALPHA ACER TENDL-2023 LIBRARY; T=0.K
neutrons from (a,n*)a

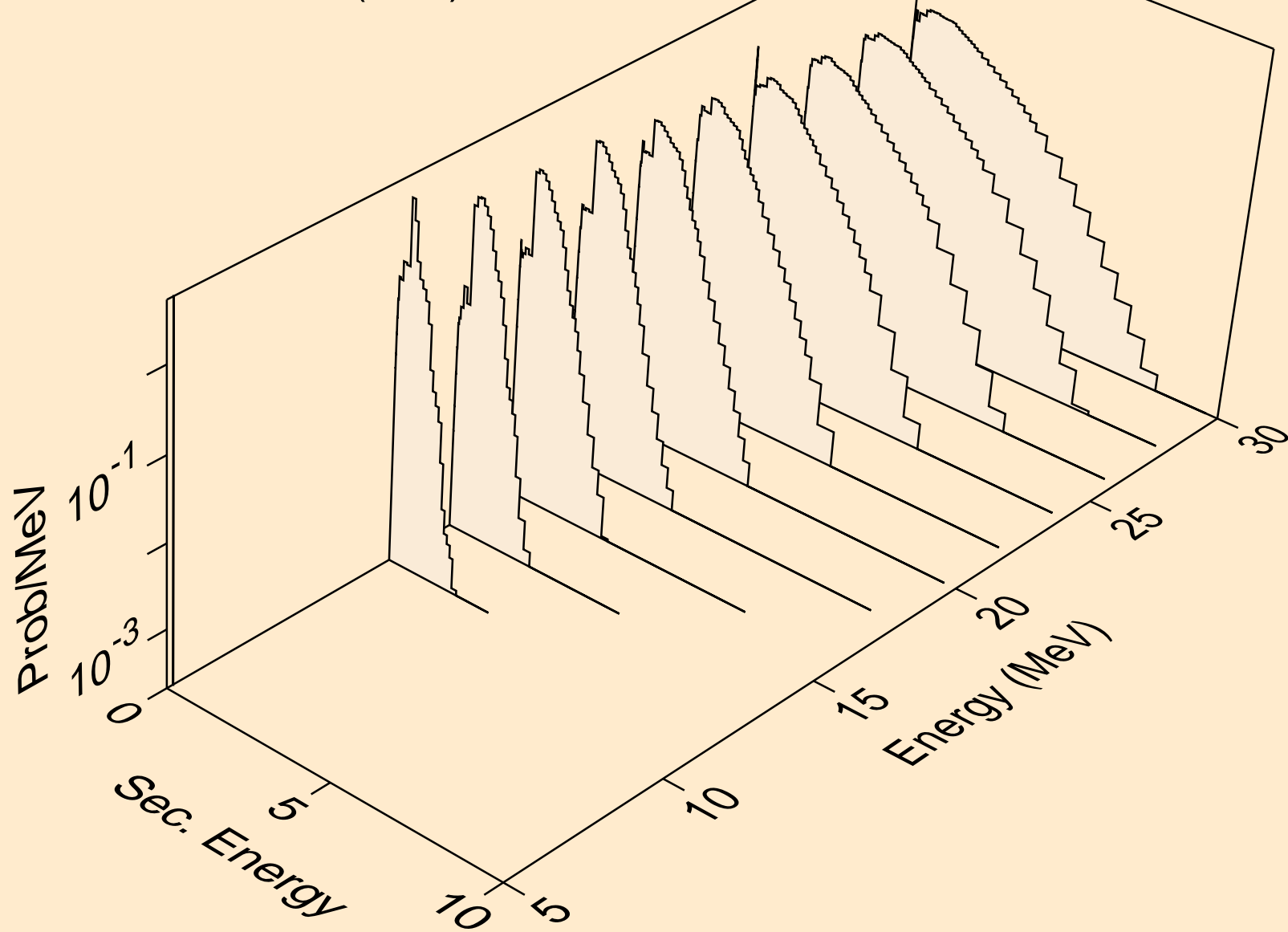

SN131M ALPHA ACER TENDL-2023 LIBRARY; T=0.K
neutrons from (a,2n)a

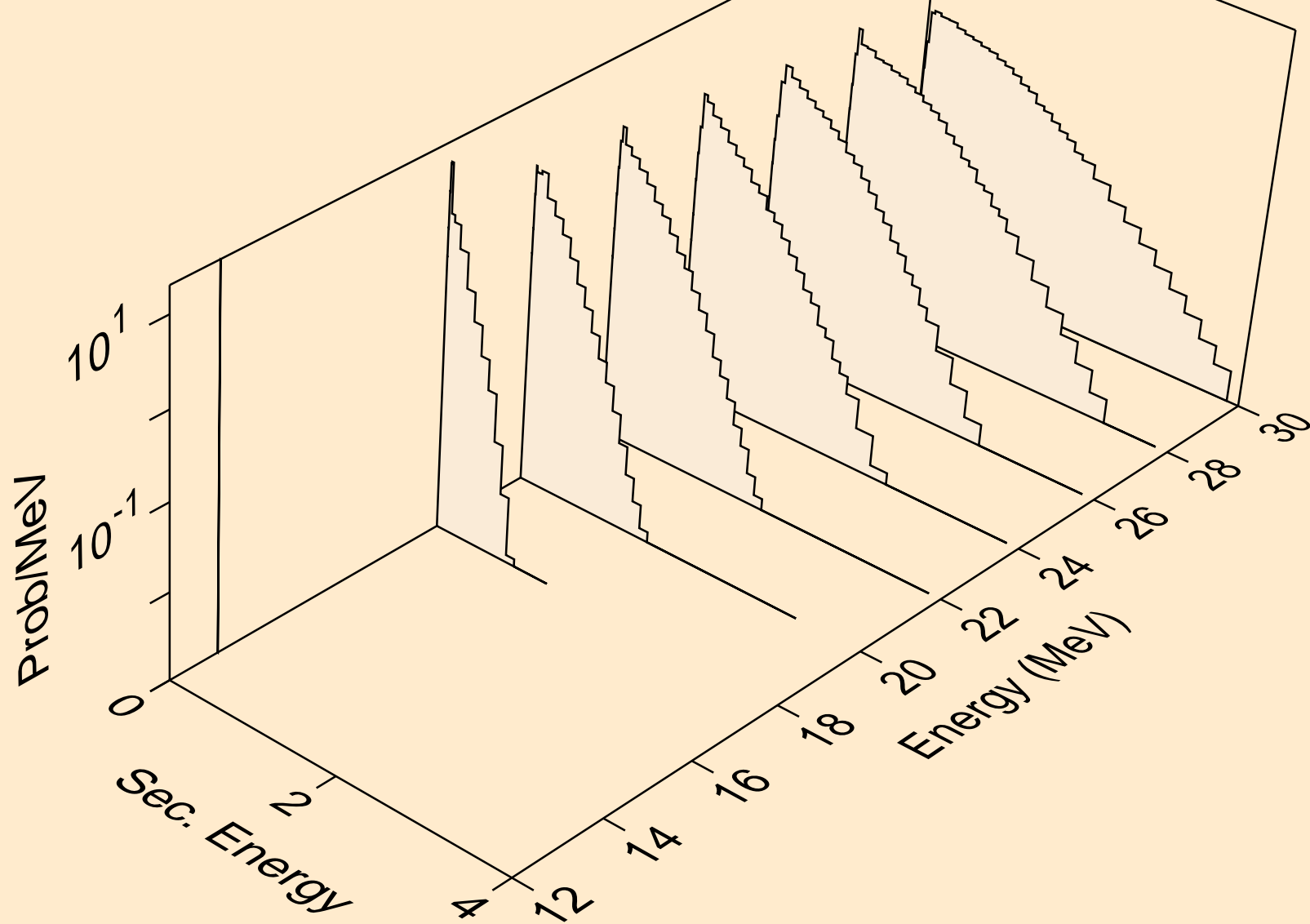

SN131M ALPHA ACER TENDL-2023 LIBRARY; T=0.K
neutrons from (a,3n)a

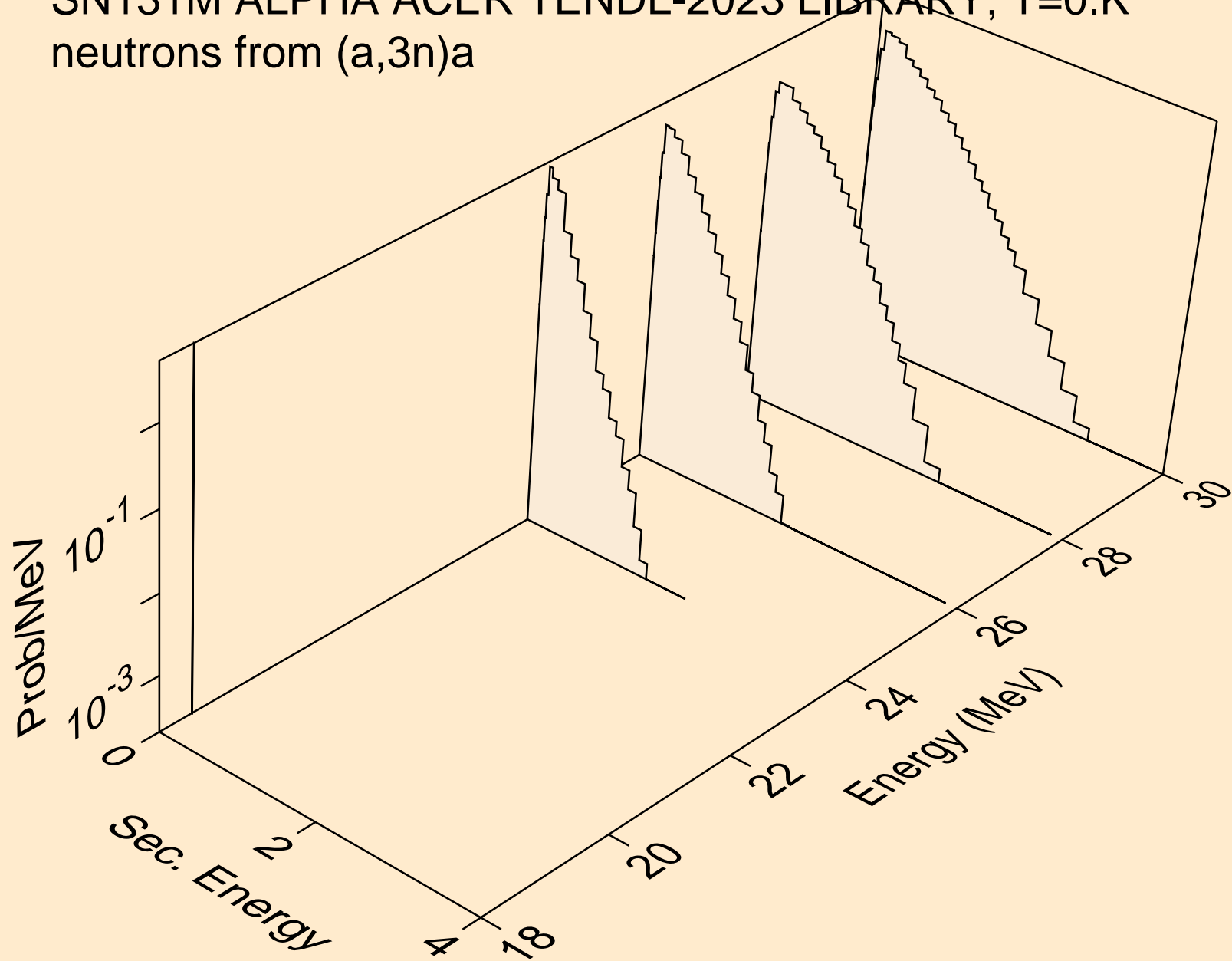

SN131M ALPHA ACER TENDL-2023 LIBRARY; T=0.K
neutrons from (a,n*)p

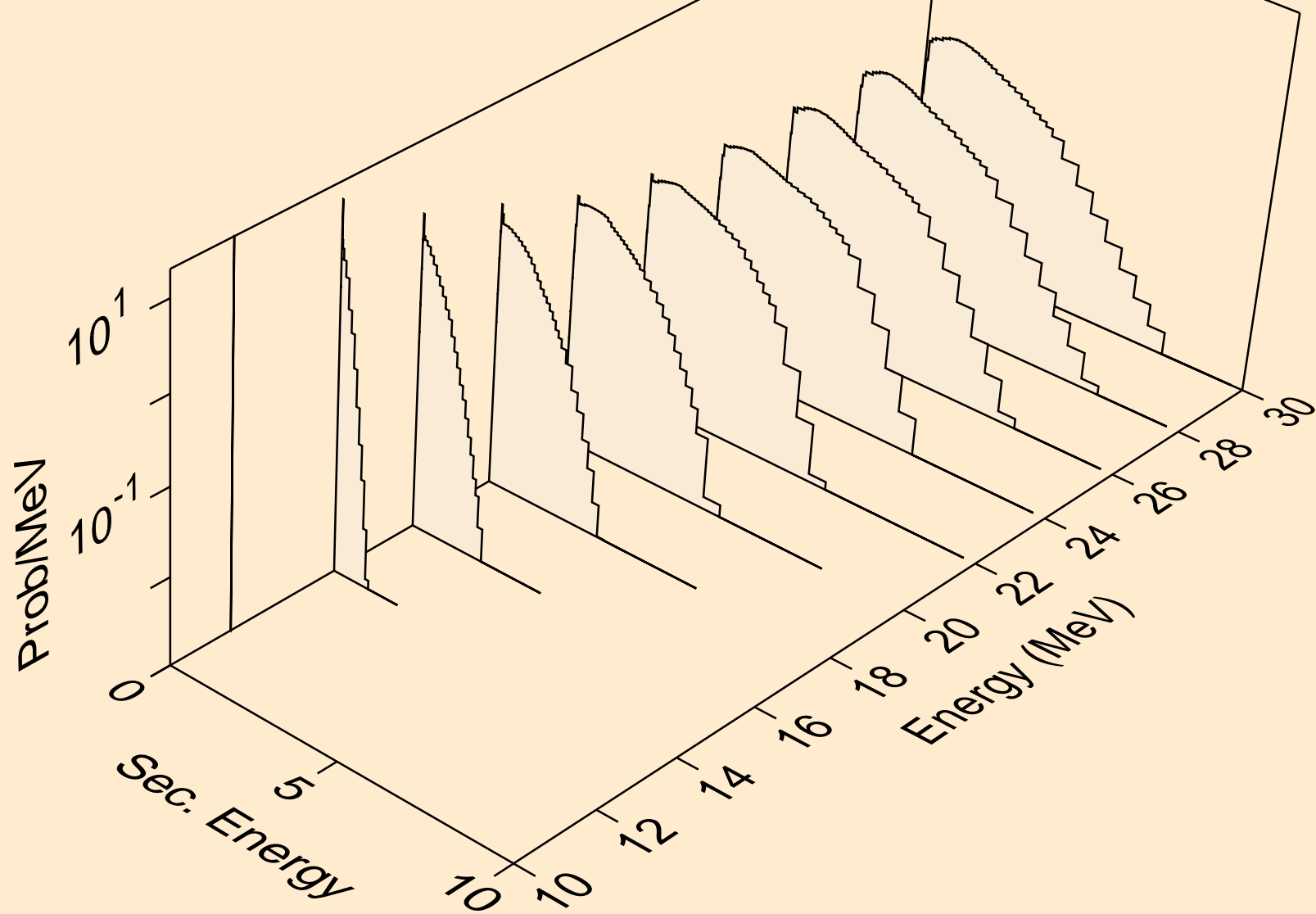

SN131M ALPHA ACER TENDL-2023 LIBRARY; T=0.K
neutrons from (a,n*)d

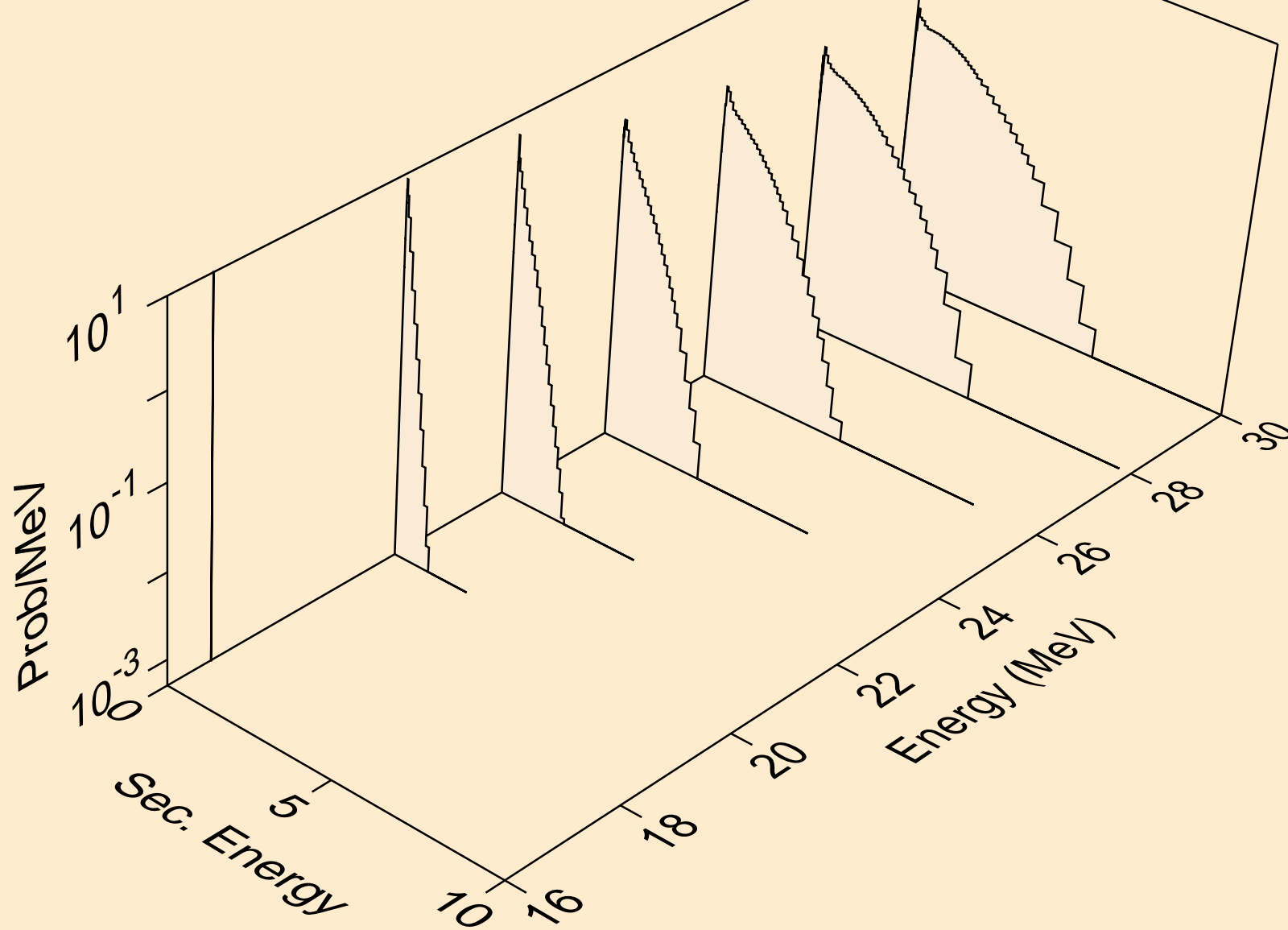

SN131M ALPHA ACER TENDL-2023 LIBRARY; T=0.K
neutrons from (a,n*)t

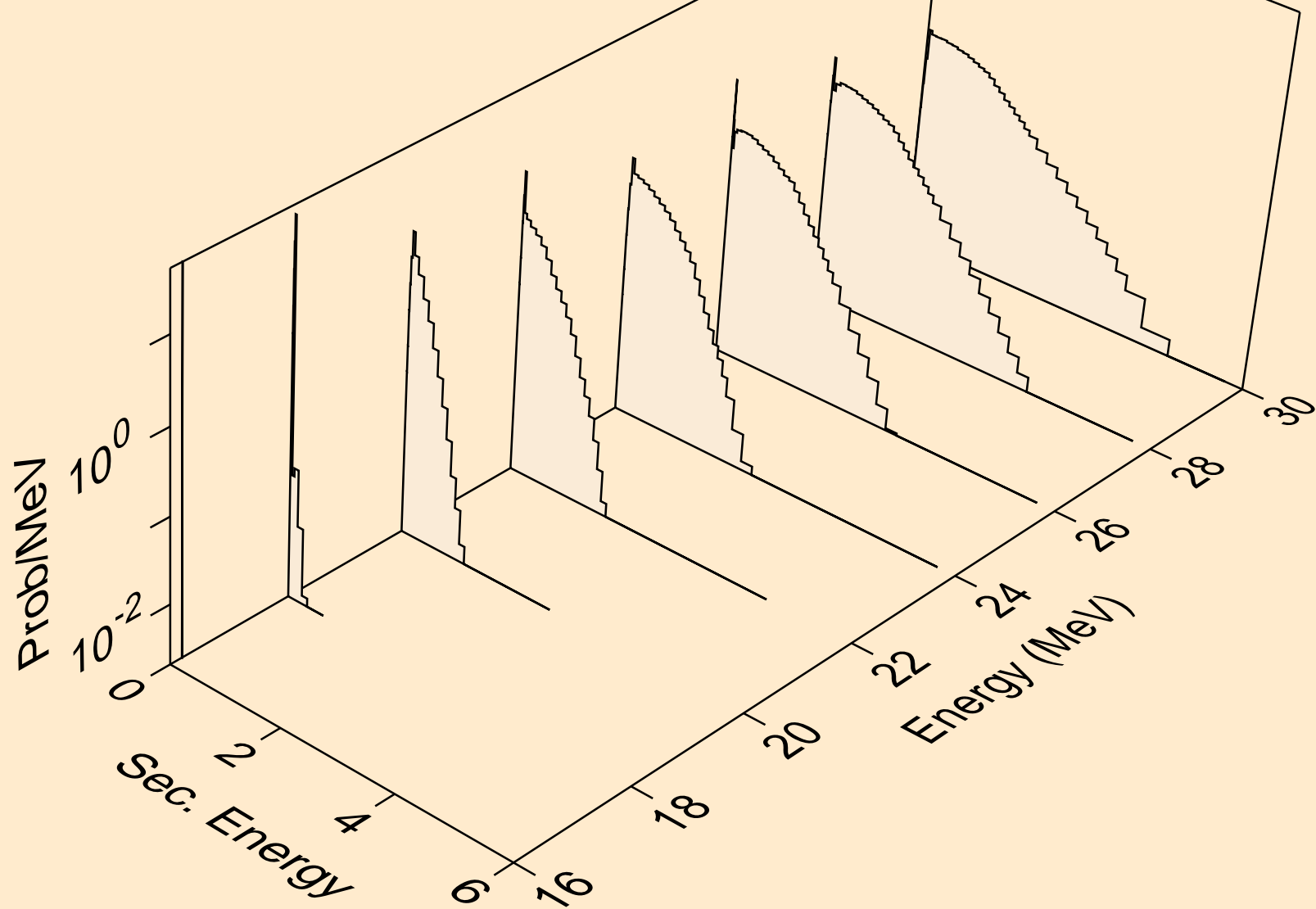

SN131M ALPHA ACER TENDL-2023 LIBRARY; T=0.K
neutrons from (a,n*)he3

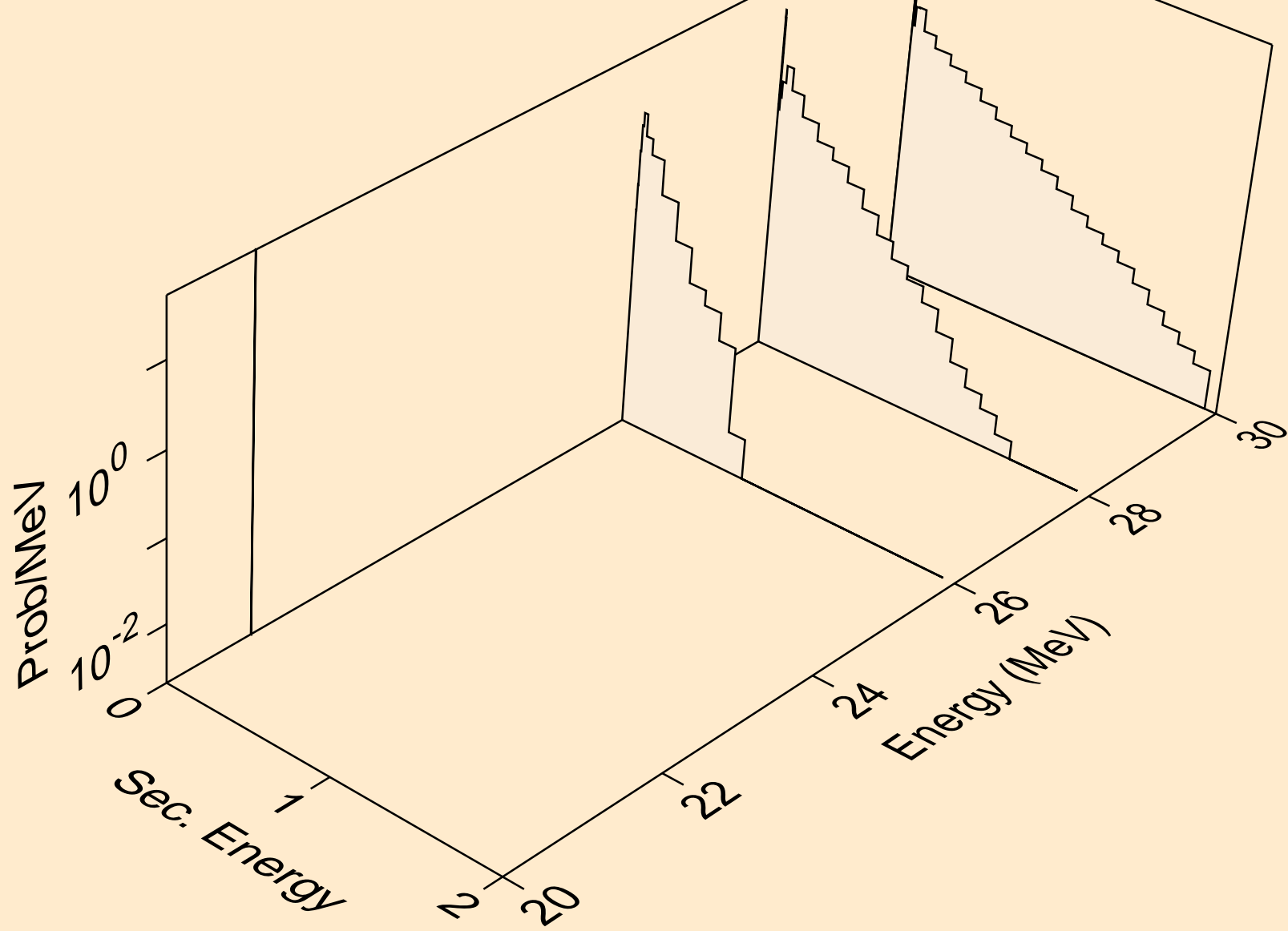

SN131M ALPHA ACER TENDL-2023 LIBRARY; T=0.K
neutrons from (a,4n)

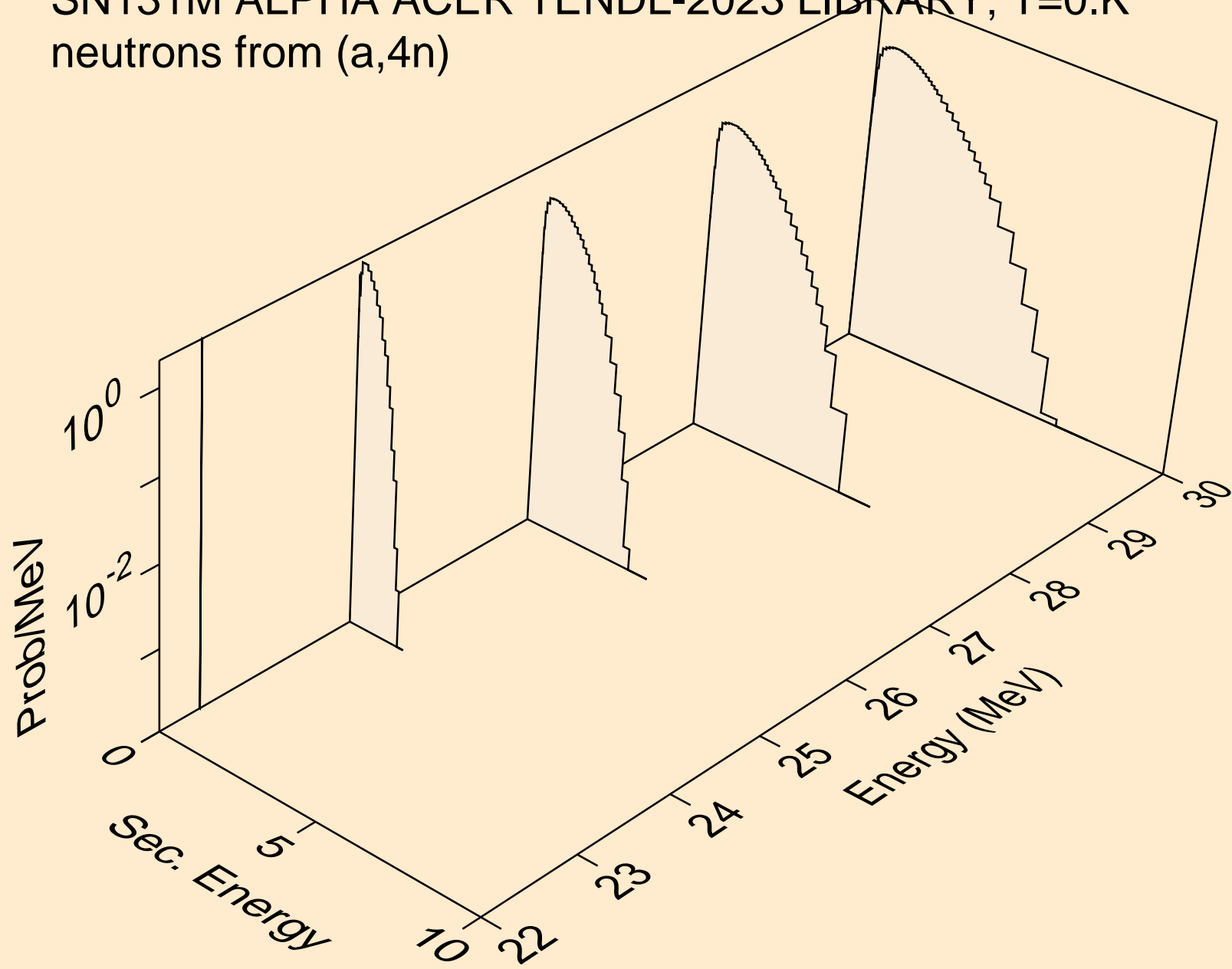

SN131M ALPHA ACER TENDL-2023 LIBRARY; T=0.K
neutrons from (a,2np)

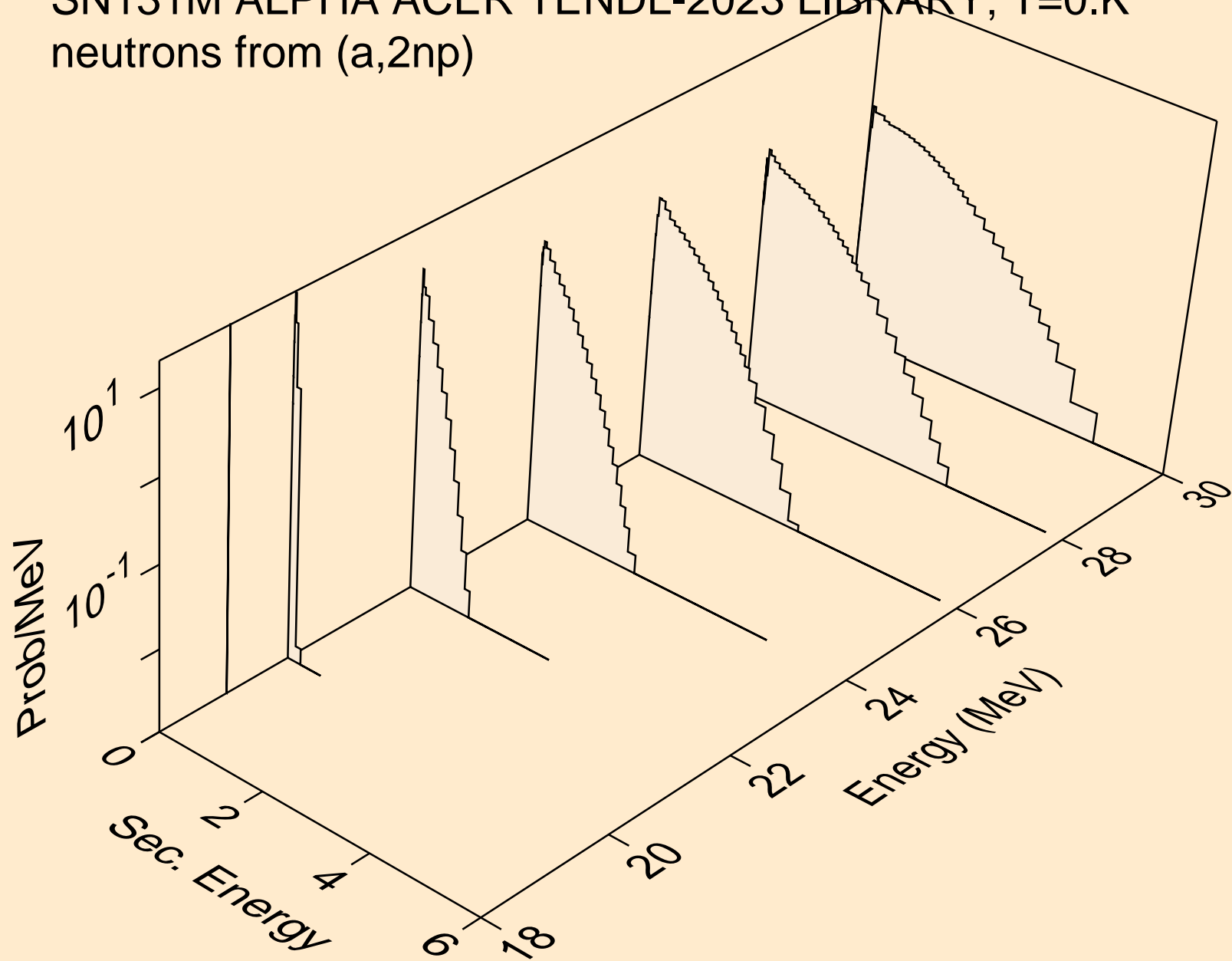

SN131M ALPHA ACER TENDL-2023 LIBRARY; T=0.K
neutrons from (a,3np)

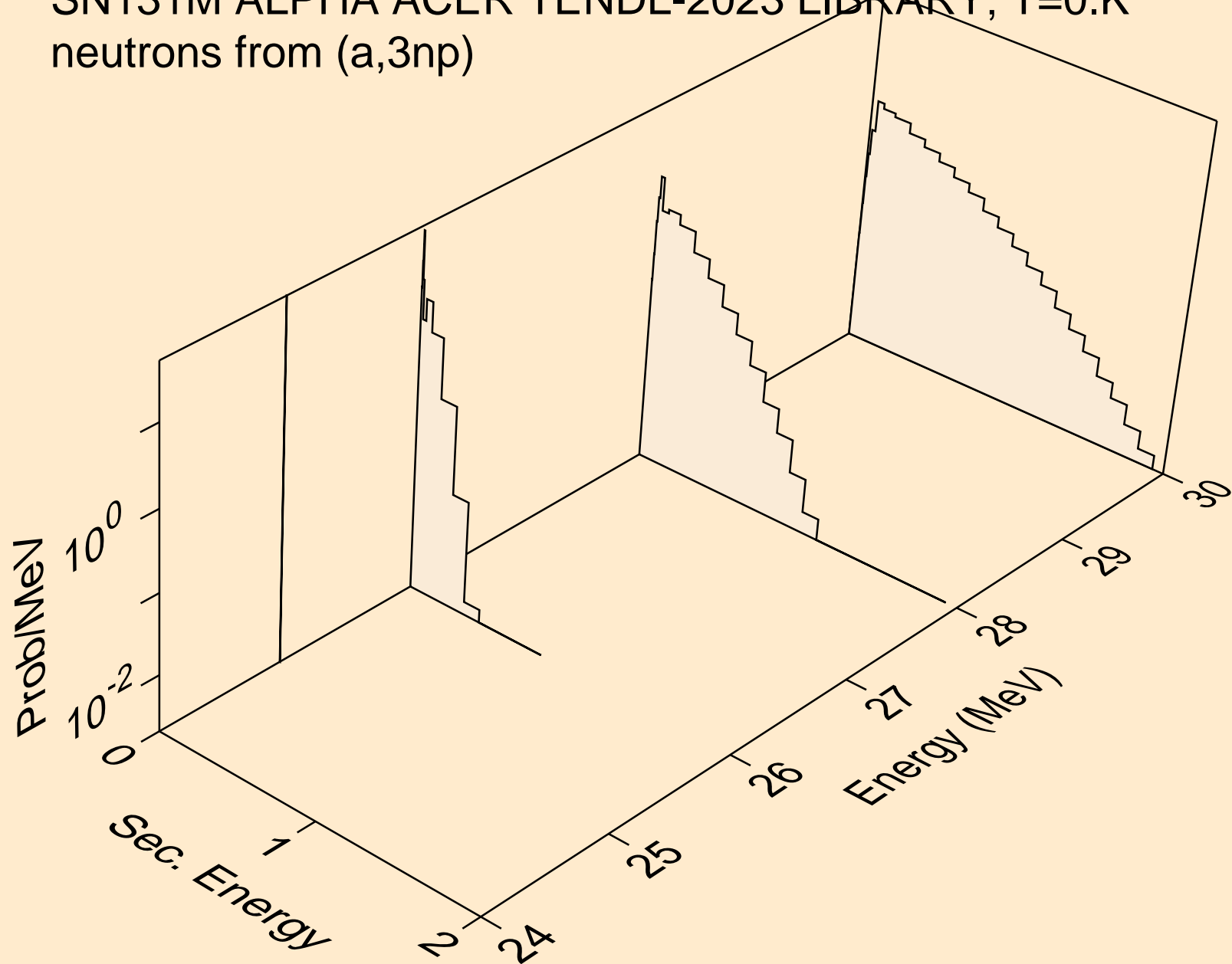

SN131M ALPHA ACER TENDL-2023 LIBRARY; T=0.K
protons from (a,x)

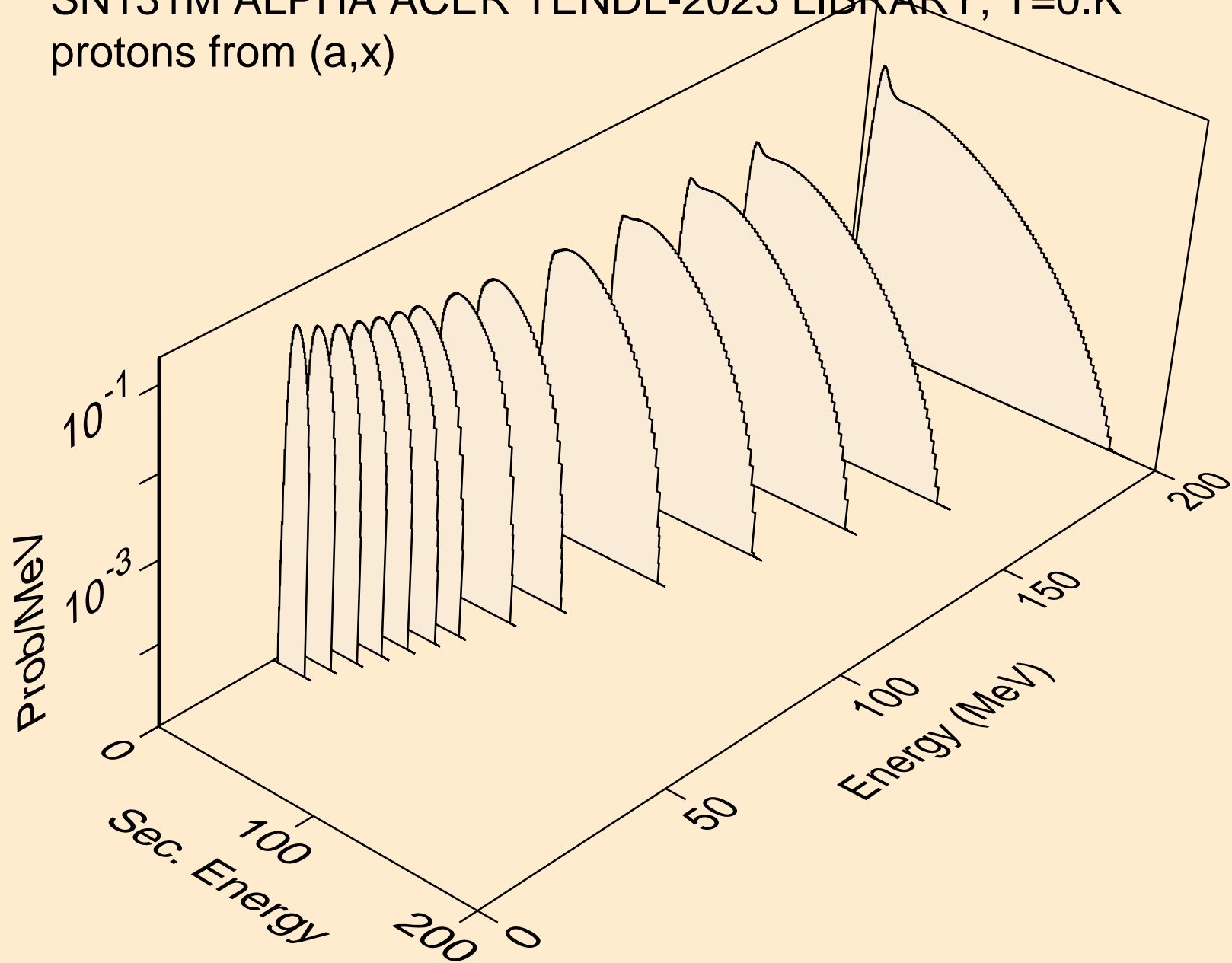

SN131M ALPHA ACER TENDL-2023 LIBRARY; T=0.K
protons from (a,n*)p

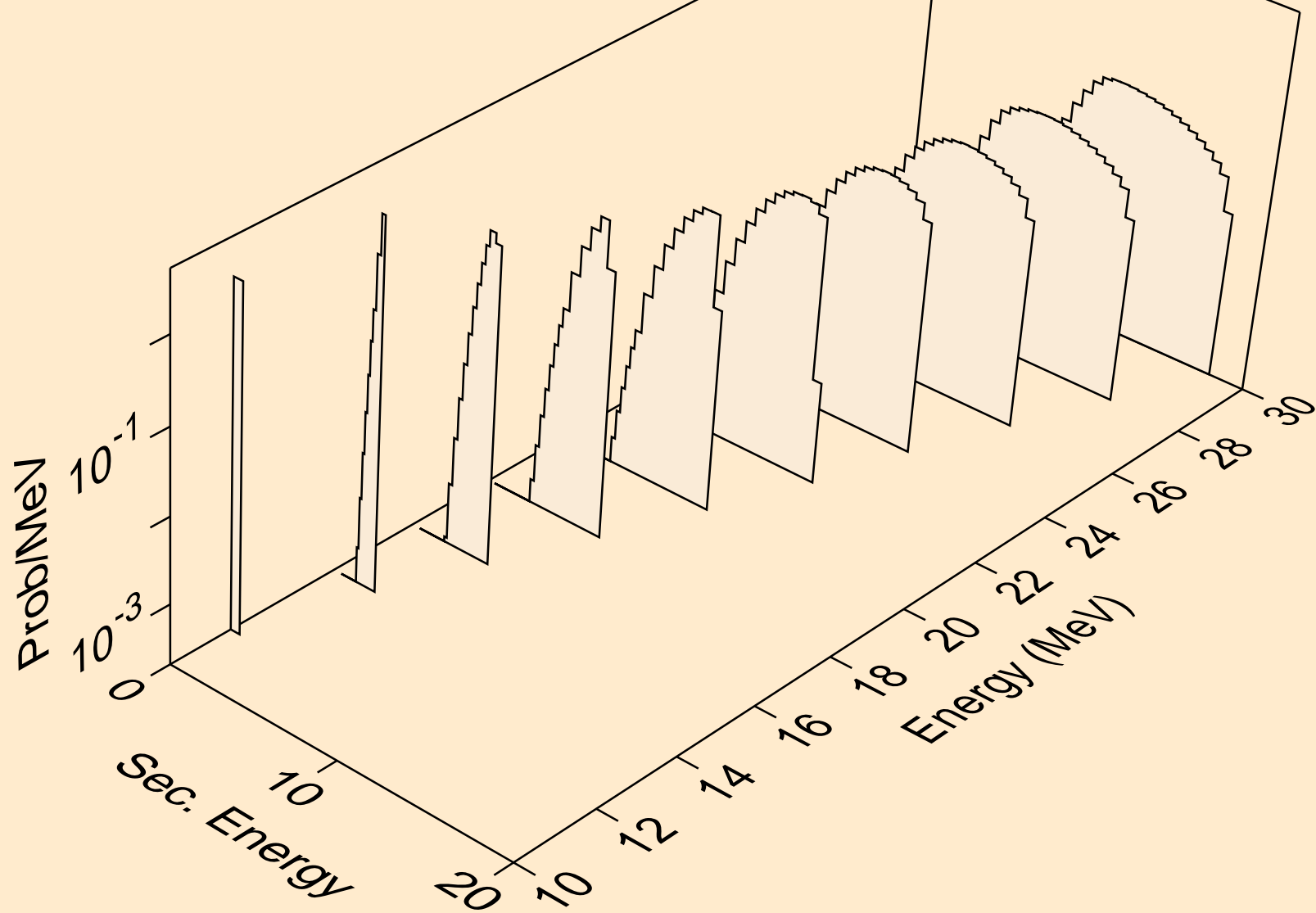

SN131M ALPHA ACER TENDL-2023 LIBRARY; T=0.K
protons from (a,2np)

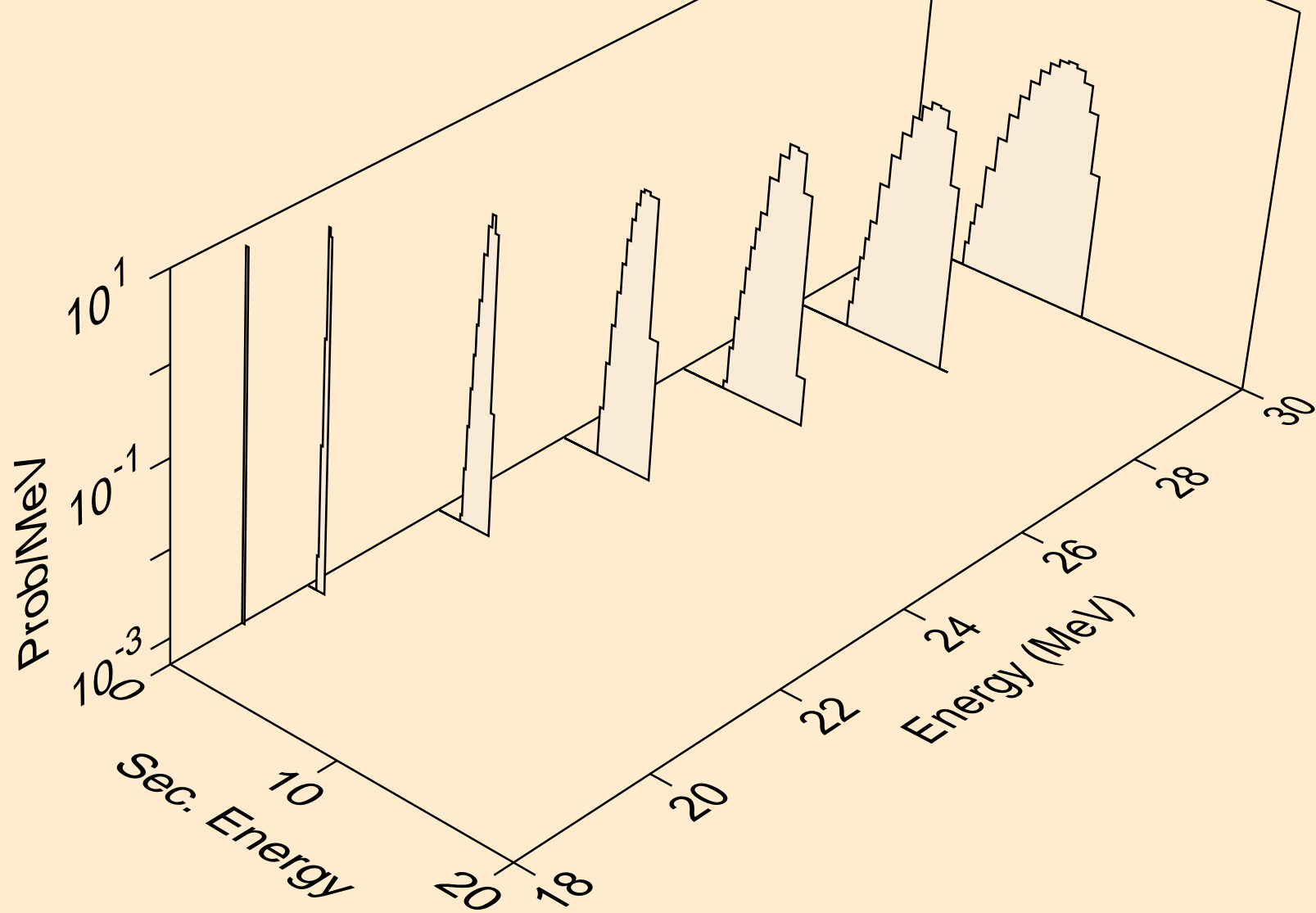

SN131M ALPHA ACER TENDL-2023 LIBRARY; T=0.K
protons from (a,3np)

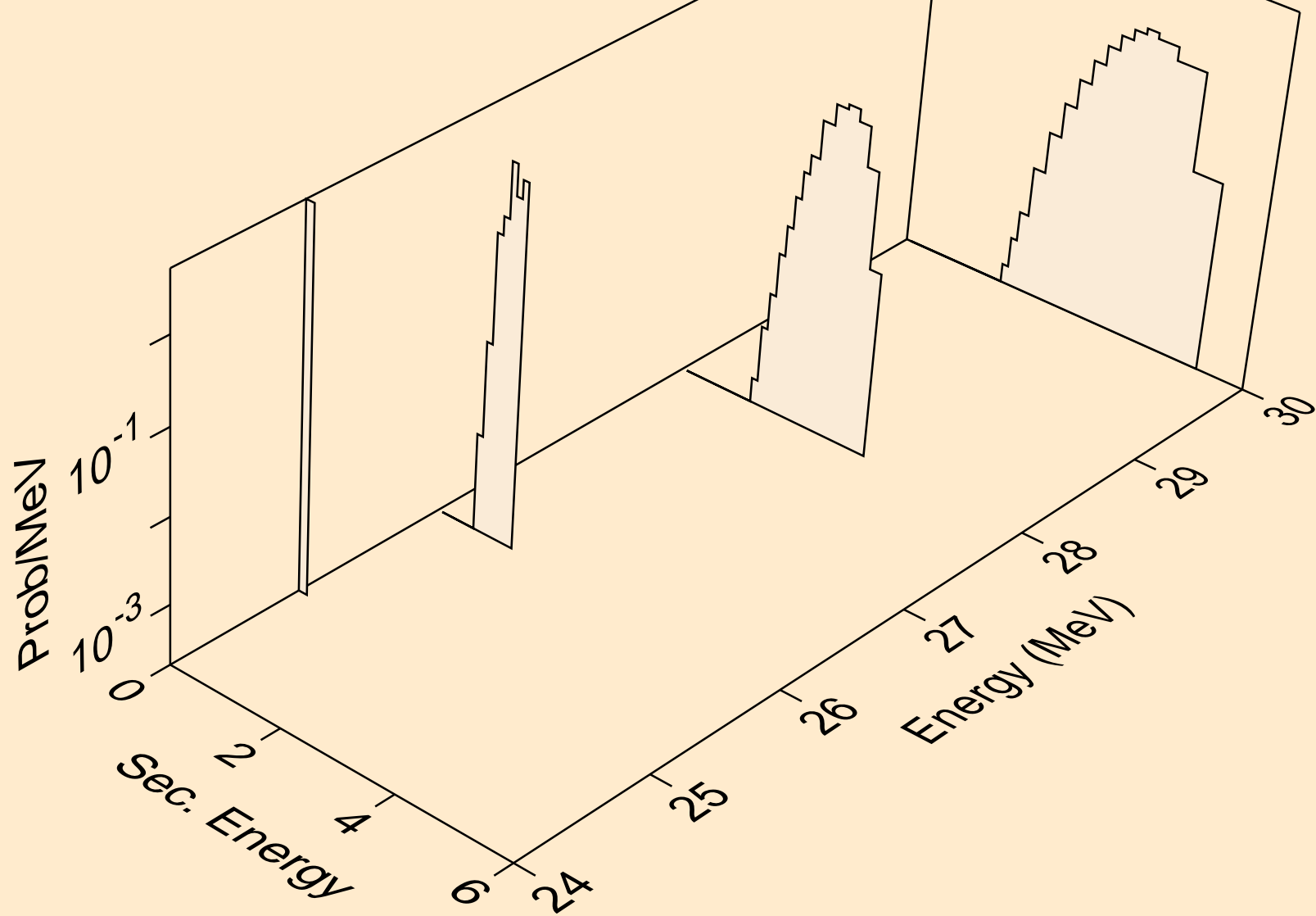

SN131M ALPHA ACER TENDL-2023 LIBRARY; T=0.K
protons from (a,p)

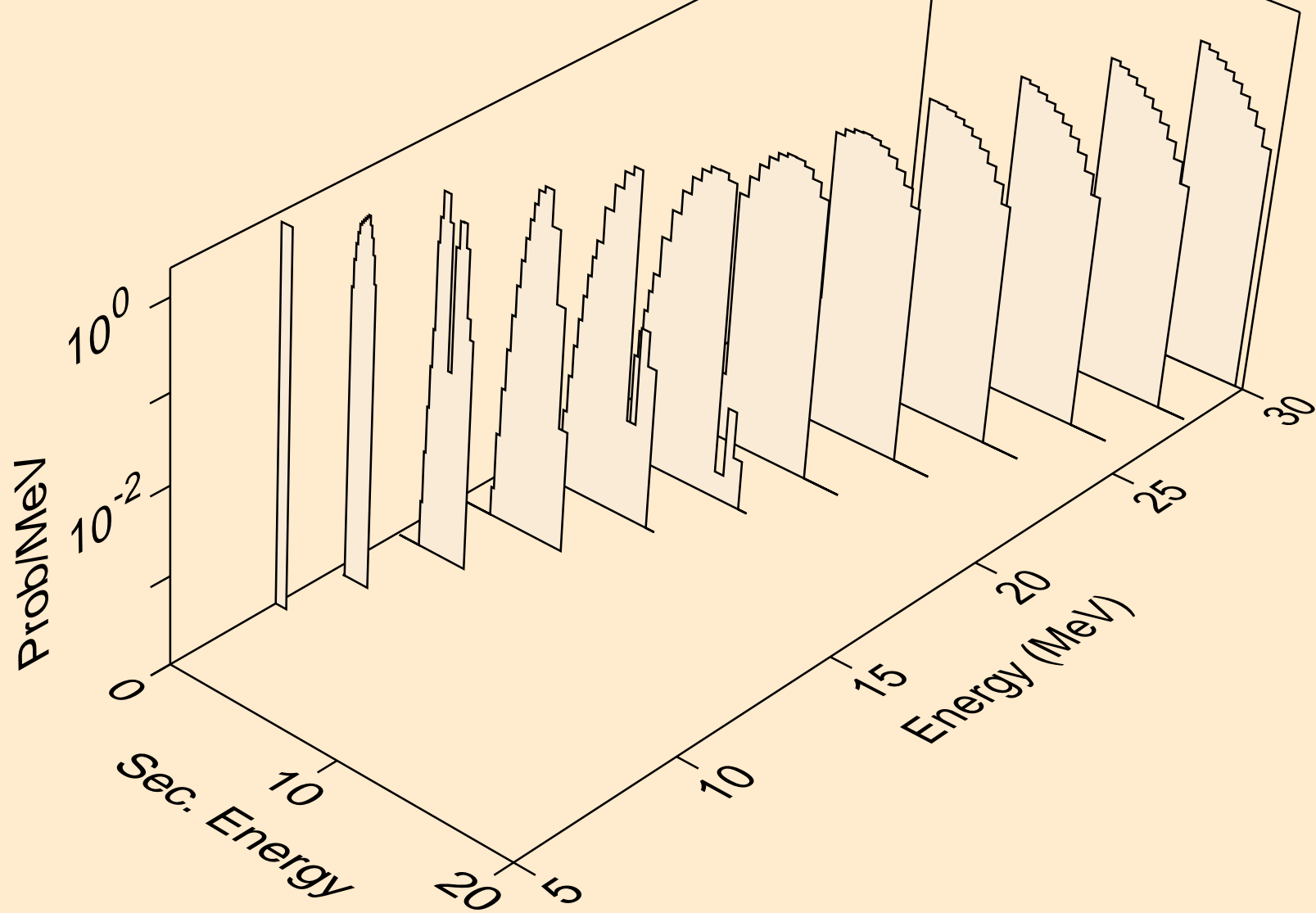

SN131M ALPHA ACER TENDL-2023 LIBRARY; T=0.K
deuterons from (a,x)

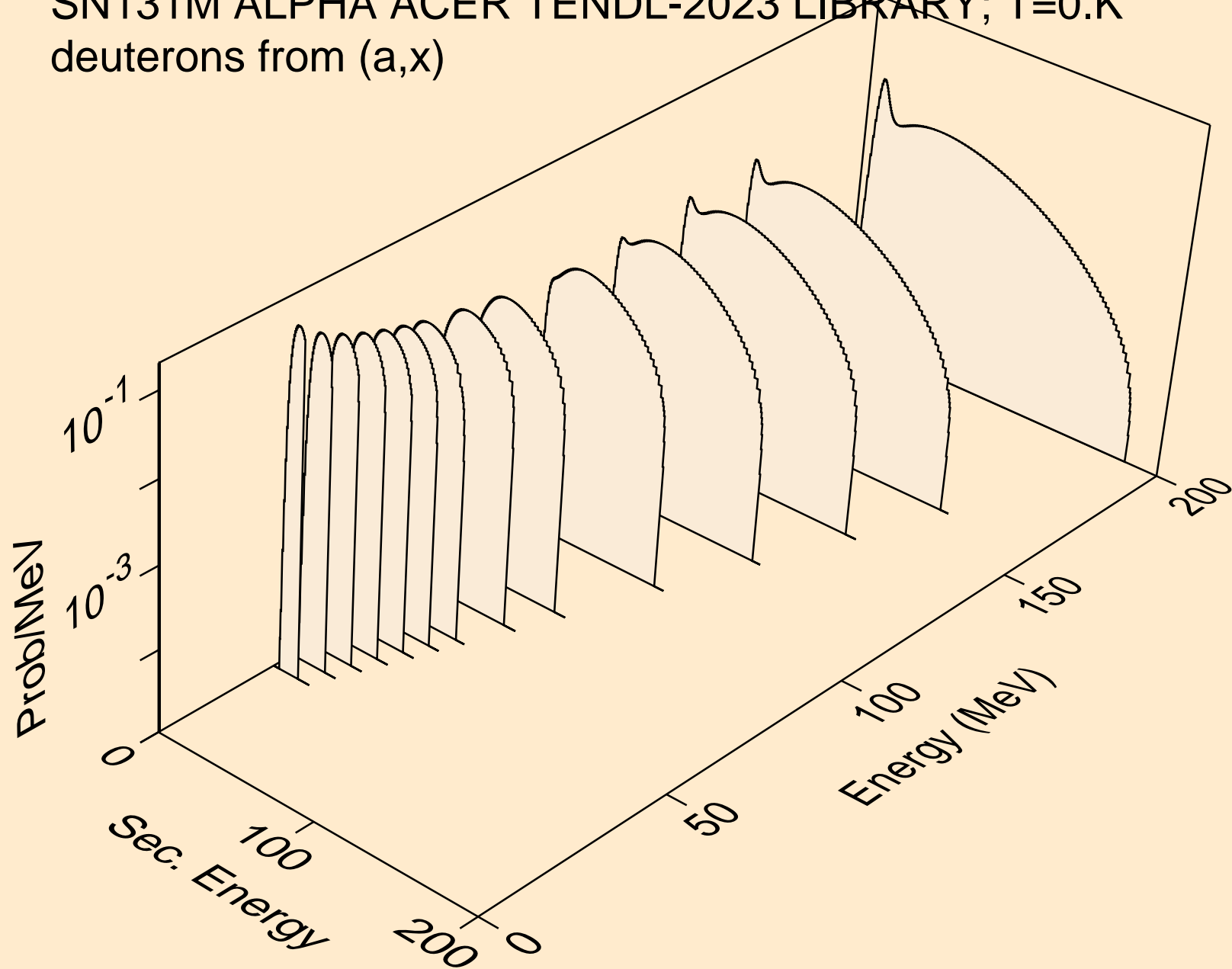

SN131M ALPHA ACER TENDL-2023 LIBRARY; T=0.K
deuterons from (a,2nd)

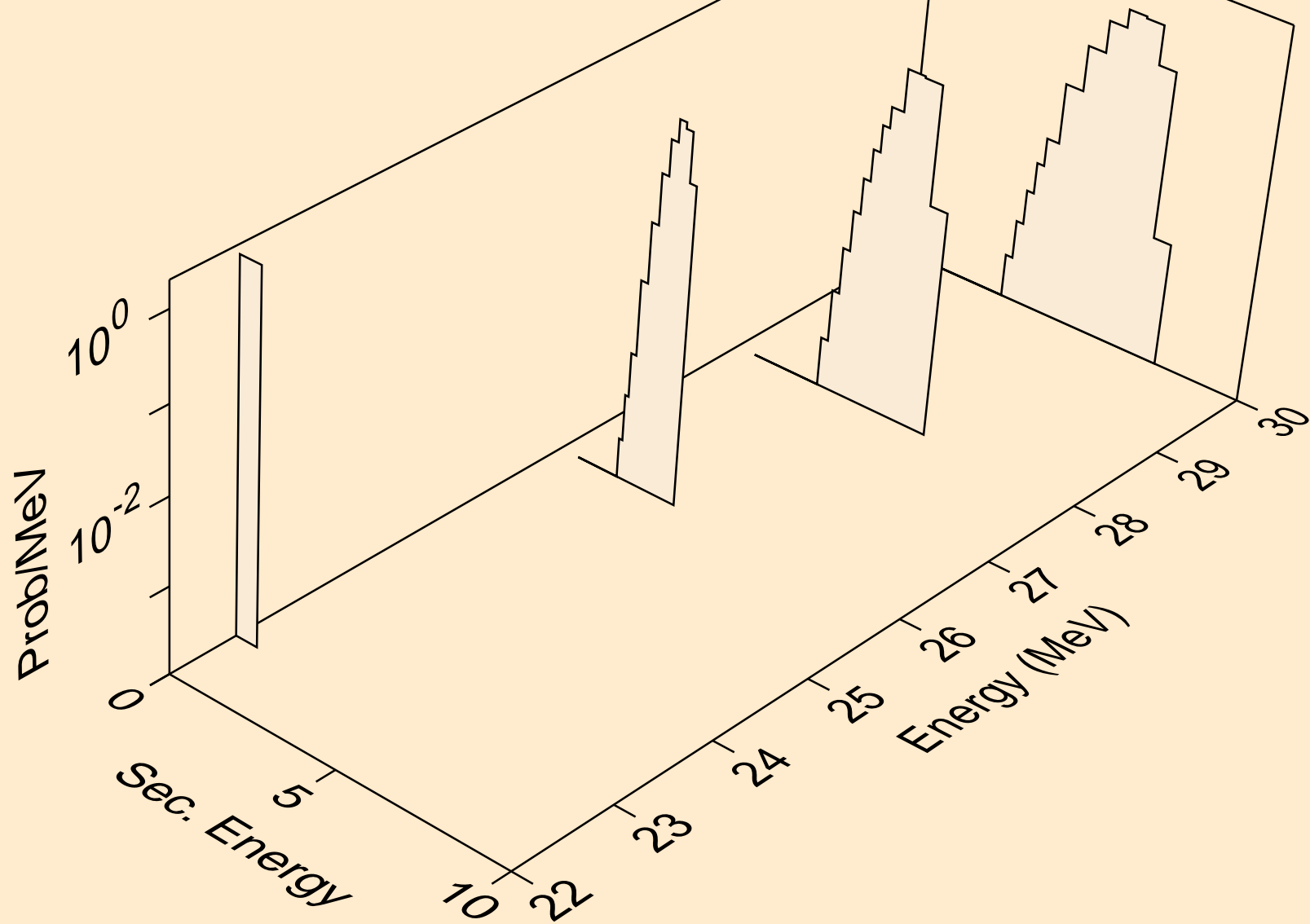

SN131M ALPHA ACER TENDL-2023 LIBRARY; T=0.K
deuterons from (a,n*)d

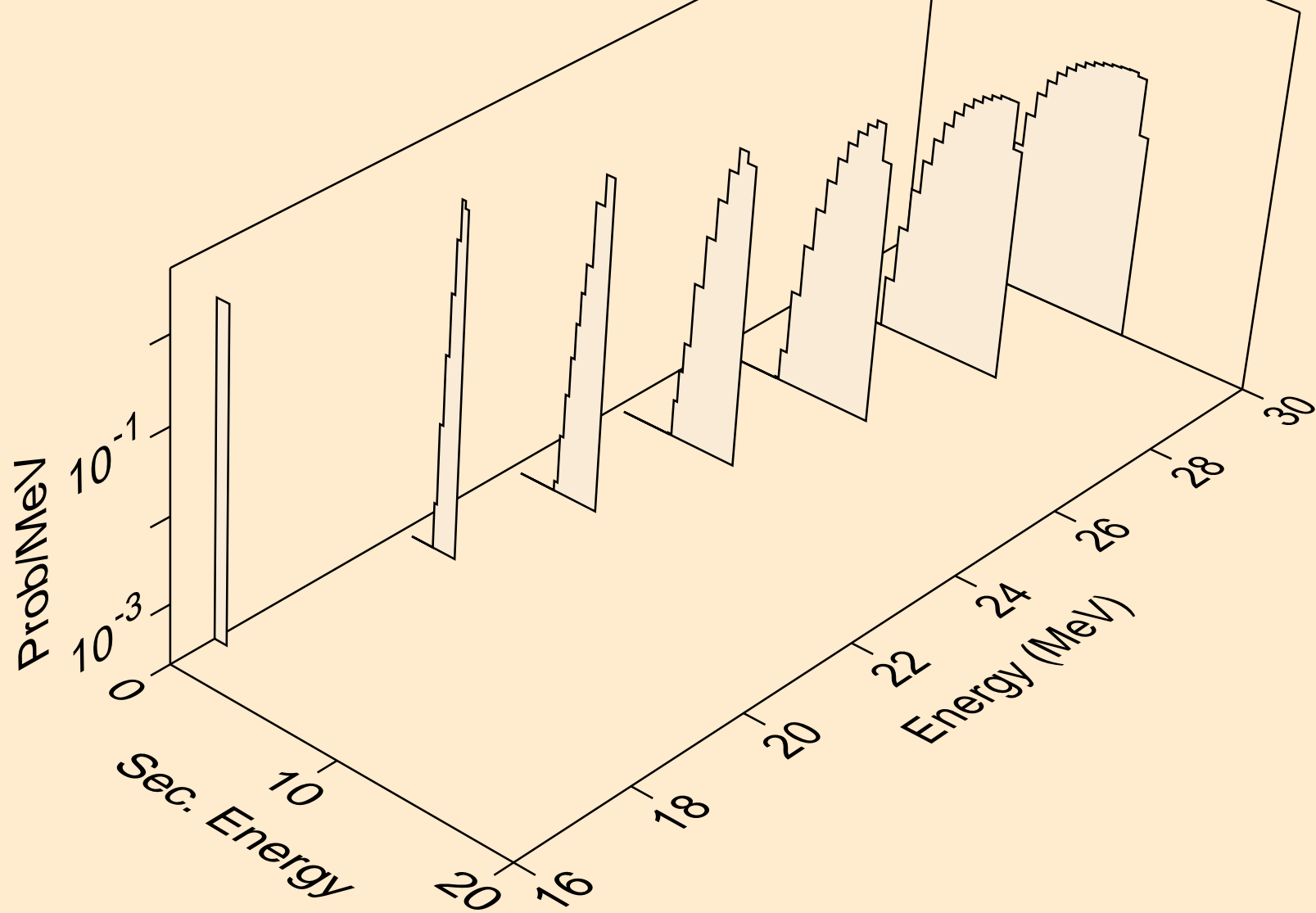

SN131M ALPHA ACER TENDL-2023 LIBRARY; T=0.K
deuterons from (a,d)



SN131M ALPHA ACER TENDL-2023 LIBRARY; T=0.K
tritons from (a,x)

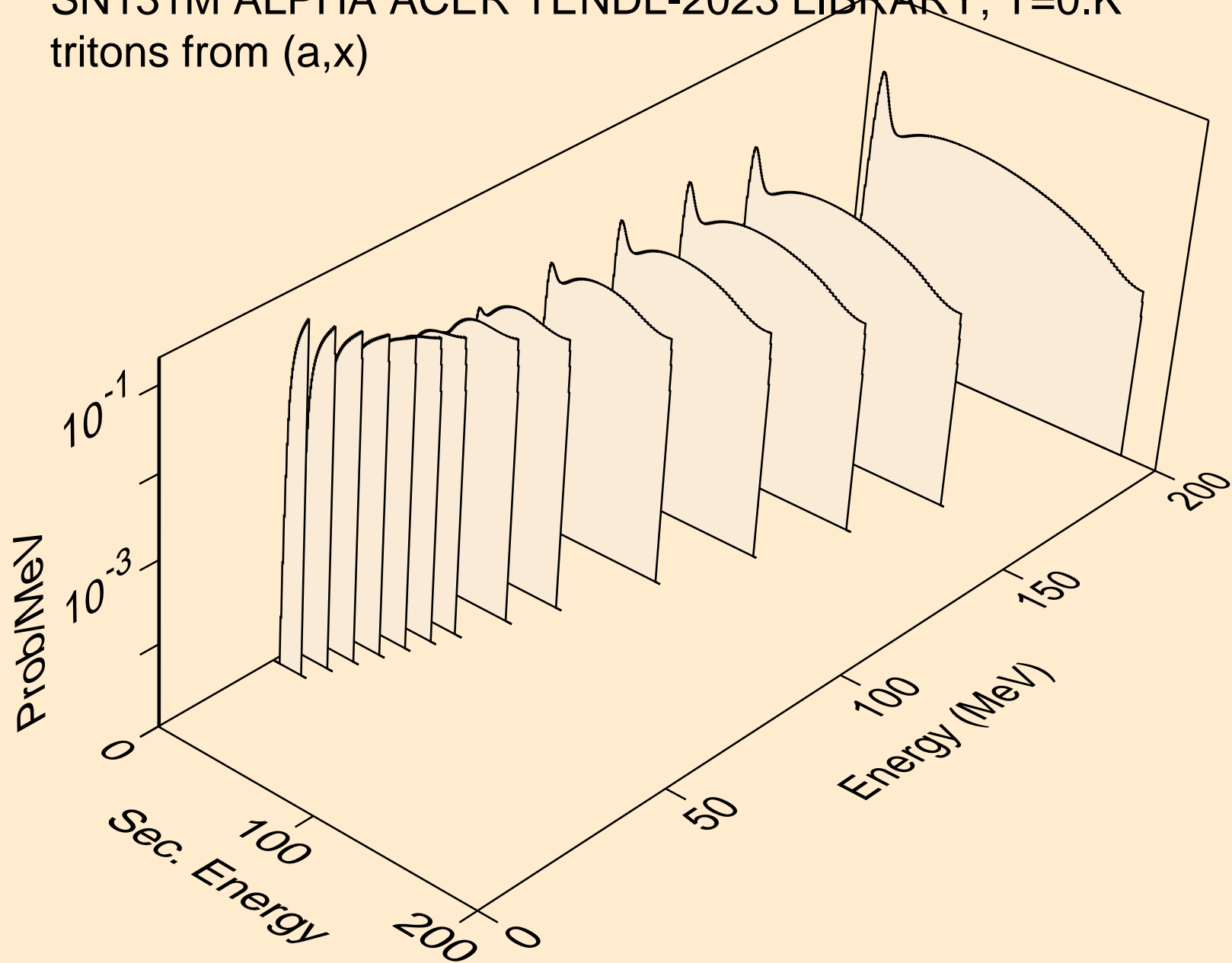

SN131M ALPHA ACER TENDL-2023 LIBRARY; T=0.K
tritons from (a,n*)t

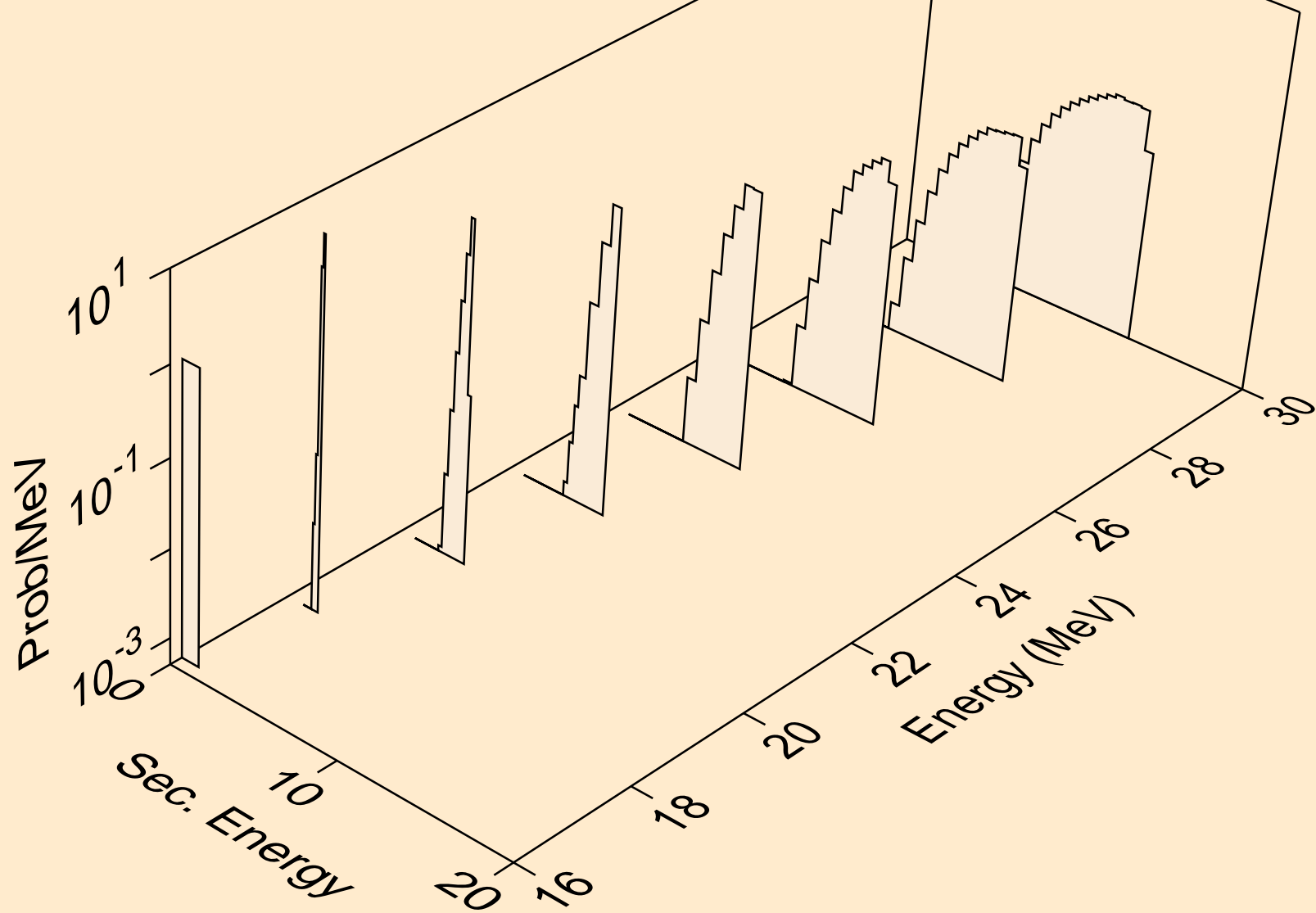

SN131M ALPHA ACER TENDL-2023 LIBRARY; T=0.K
tritons from (a,t)

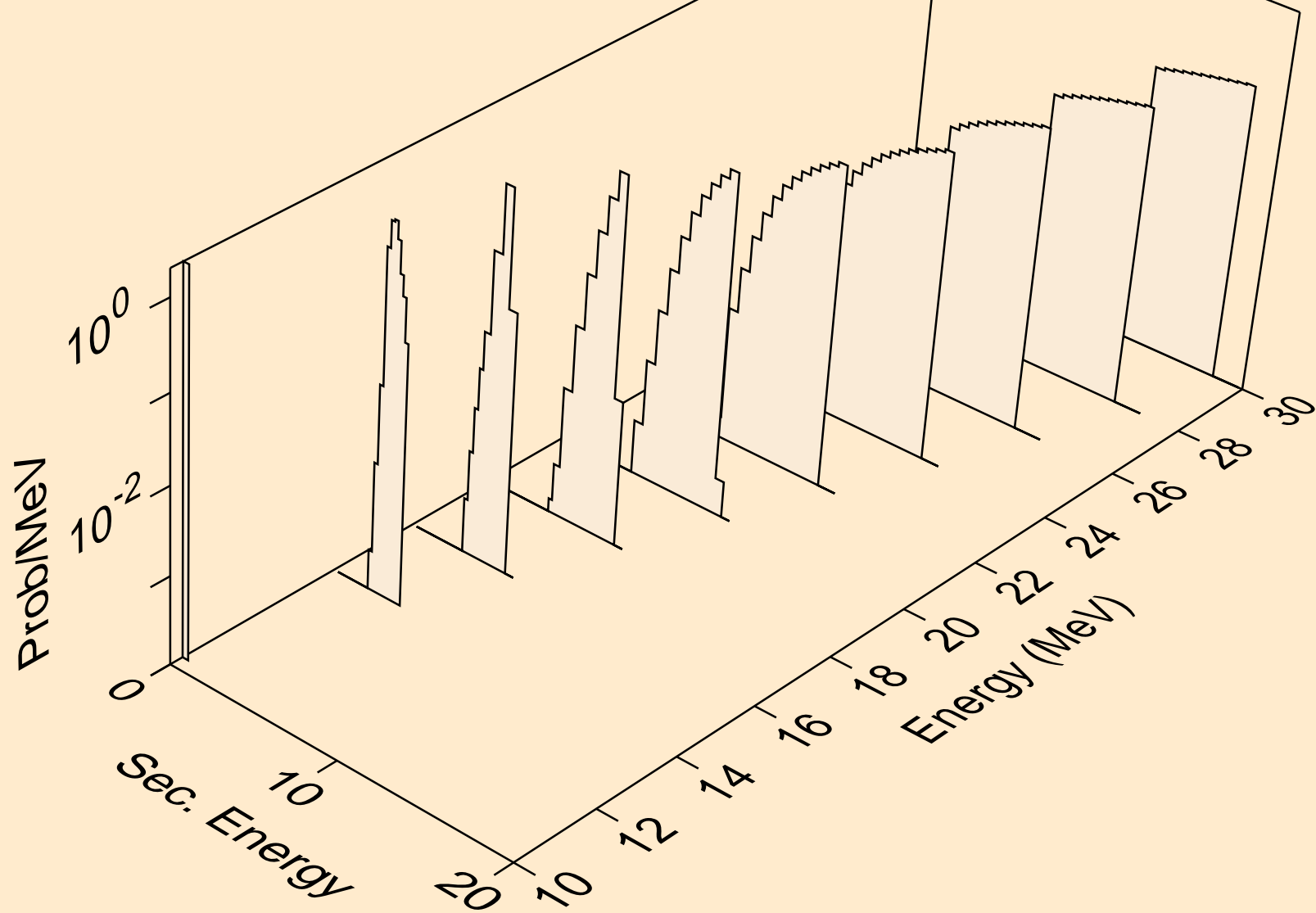

SN131M ALPHA ACER TENDL-2023 LIBRARY; T=0.K
he3s from (a,x)

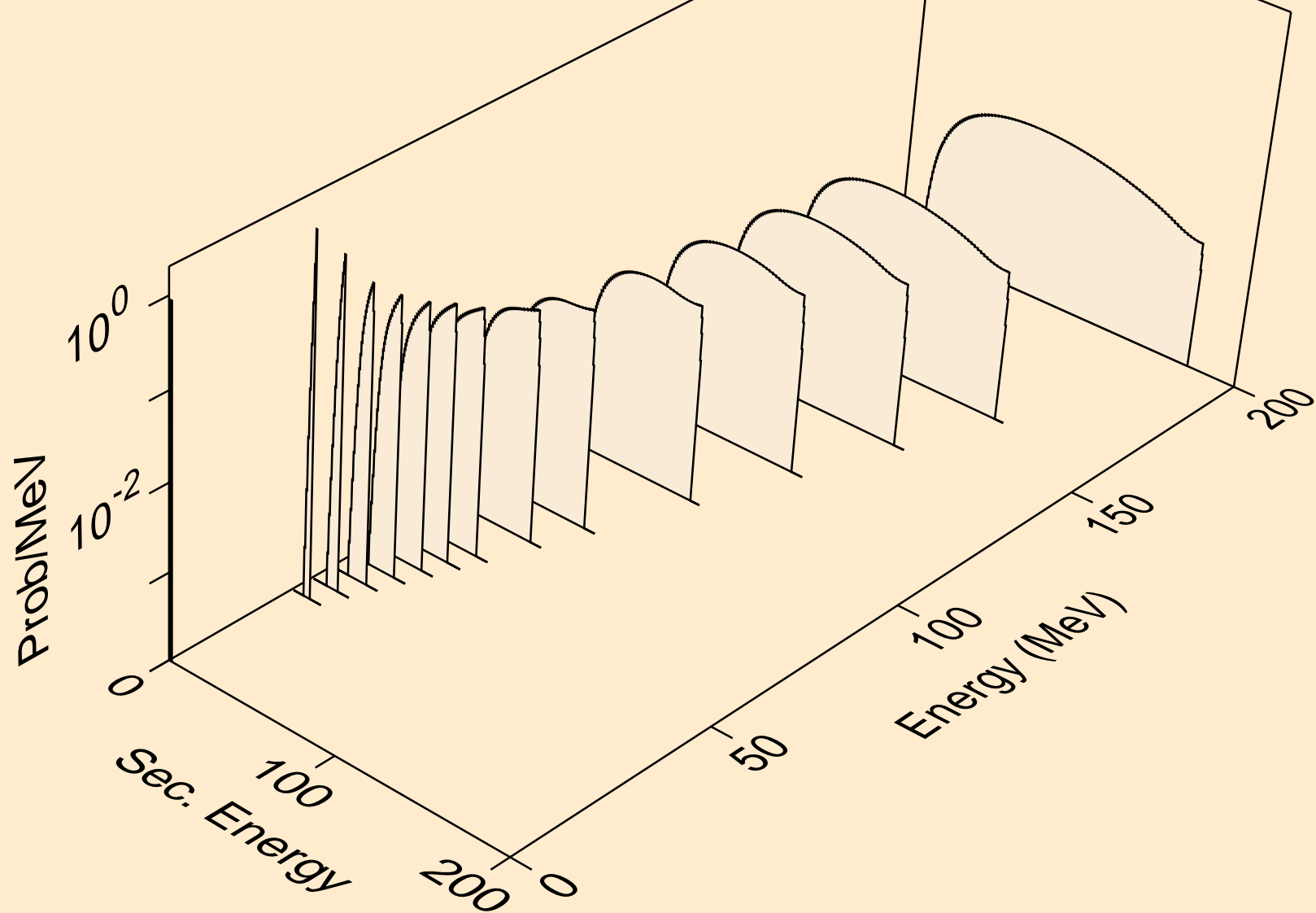

SN131M ALPHA ACER TENDL-2023 LIBRARY; T=0.K
he3s from (a,n*)he3

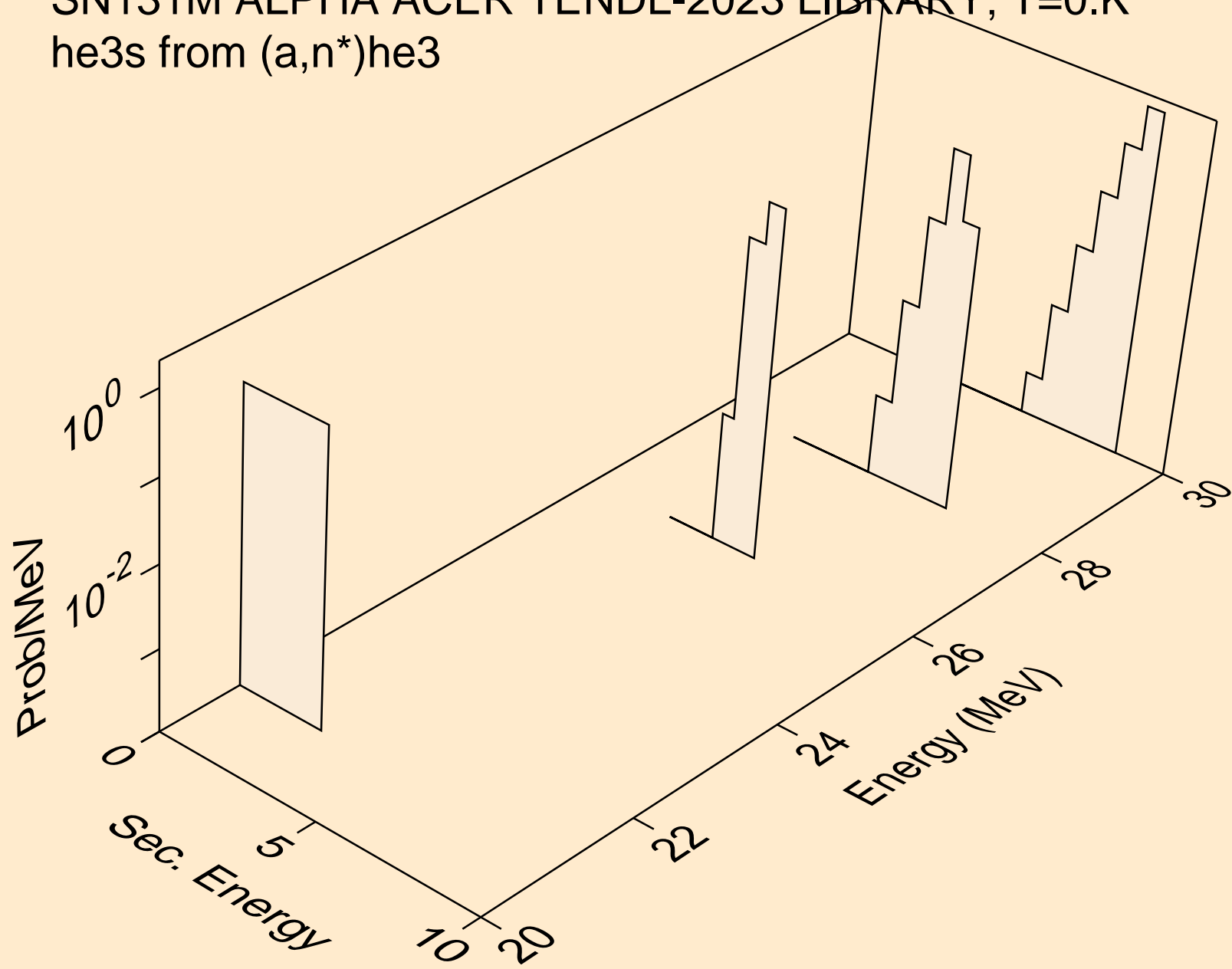

SN131M ALPHA ACER TENDL-2023 LIBRARY; T=0.K
he3s from (a,he3)

