

TM155 ALPHA ACER TENDL-2023 LIBRARY; T=0.K  
Principal cross sections

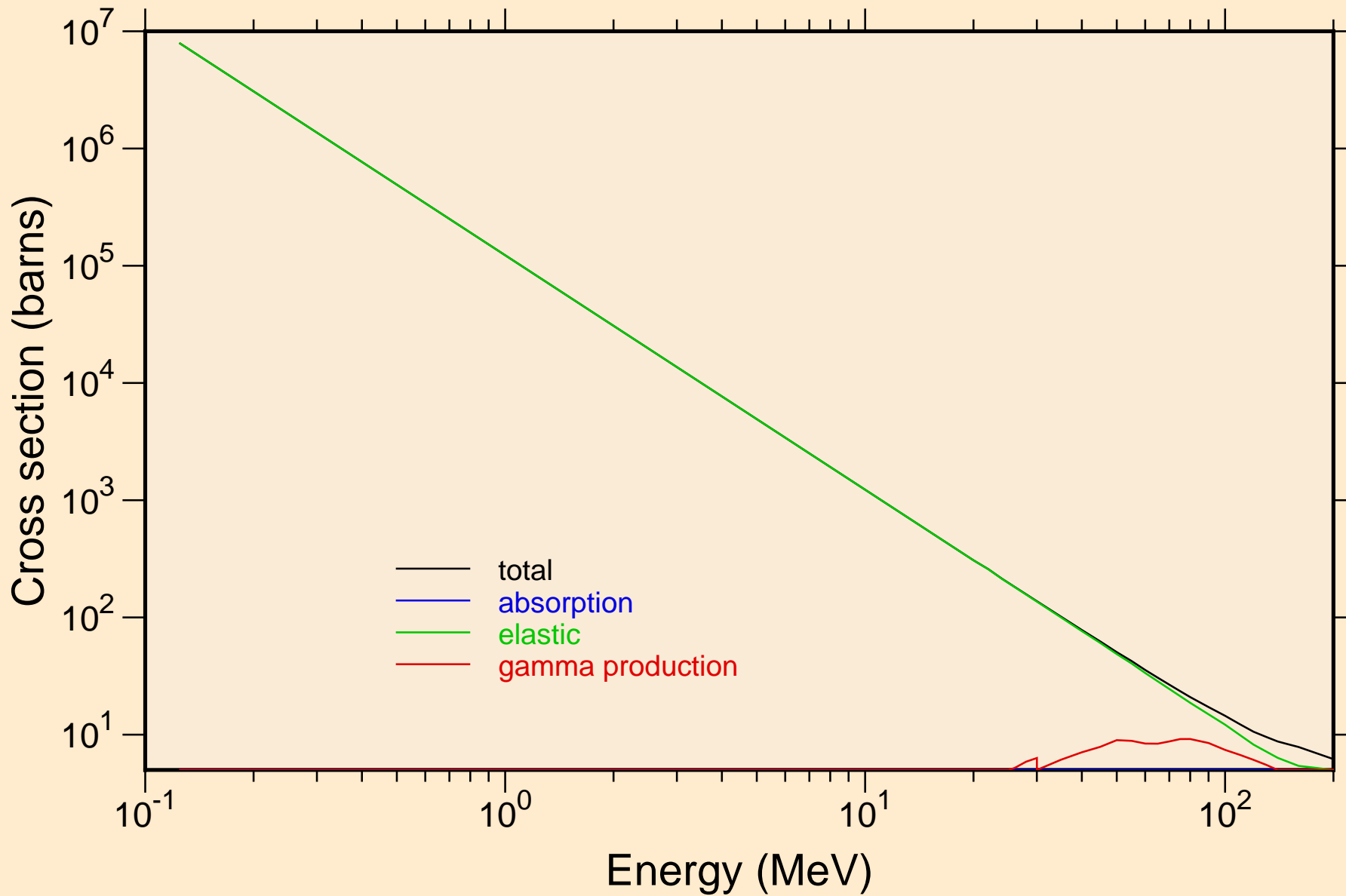

TM155 ALPHA ACER TENDL-2023 LIBRARY; T=0.K

Heating

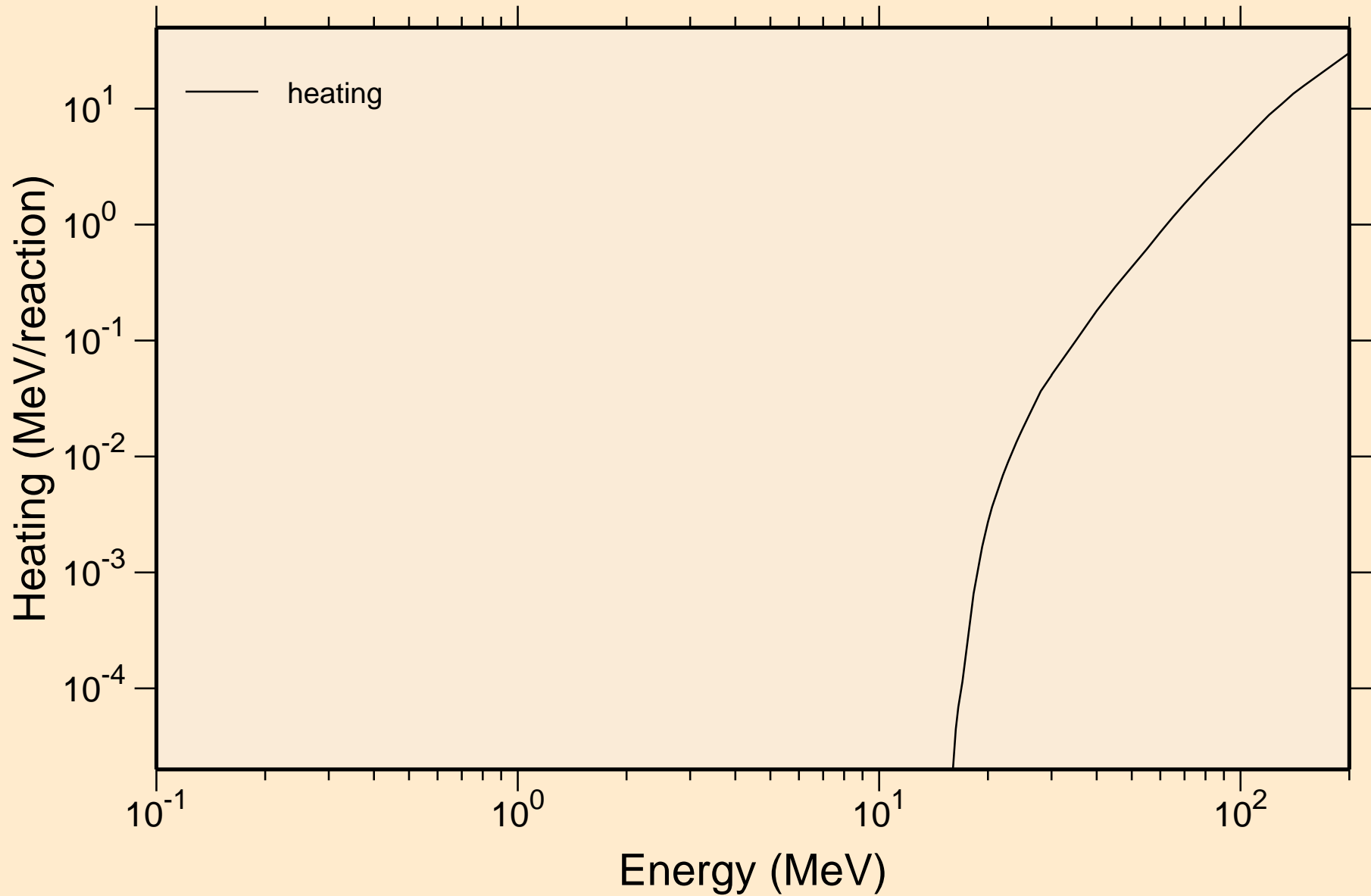

# TM155 ALPHA ACER TENDL-2023 LIBRARY; T=0.K

## Principal cross sections

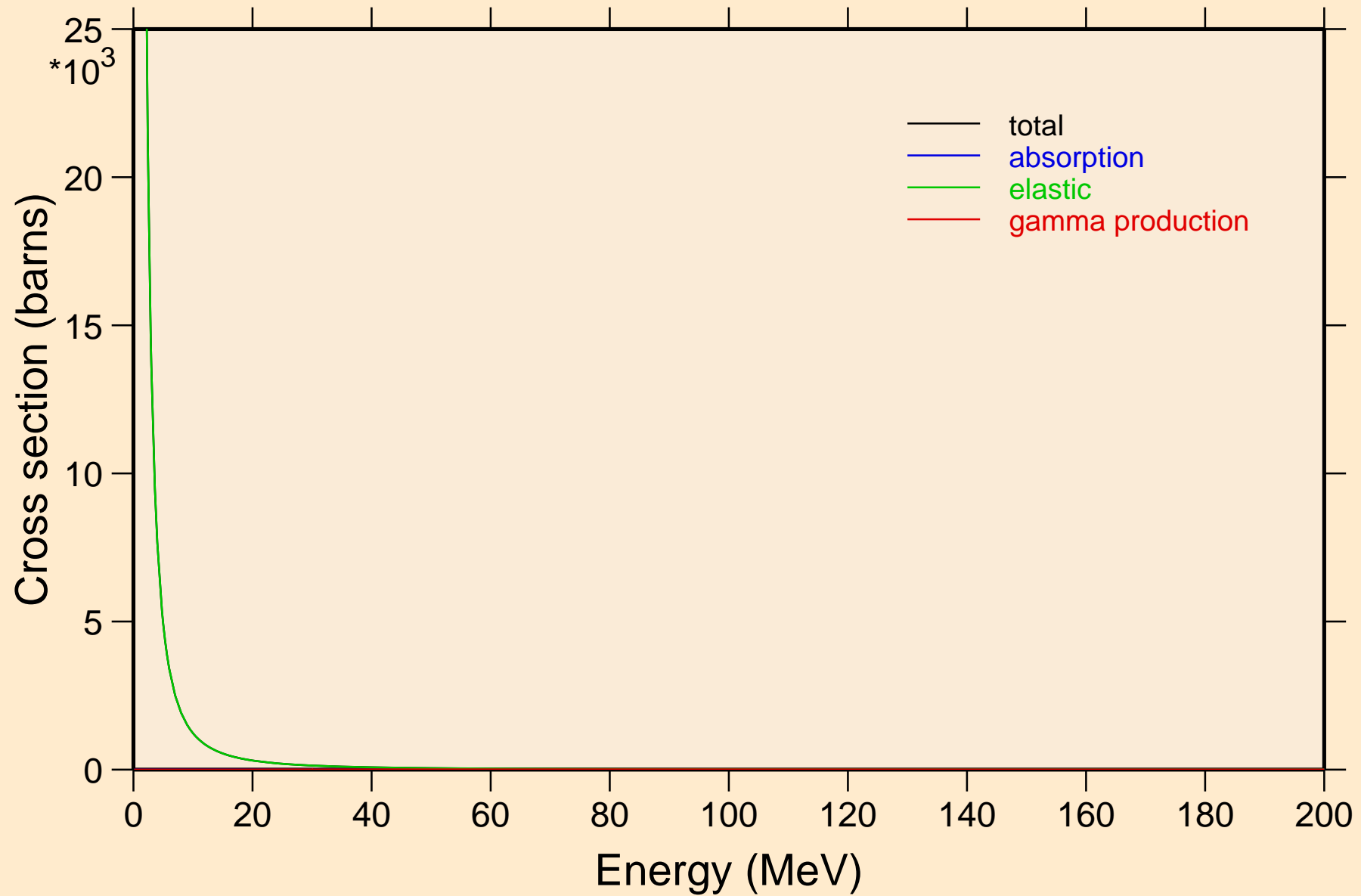

TM155 ALPHA ACER TENDL-2023 LIBRARY; T=0.K

Heating

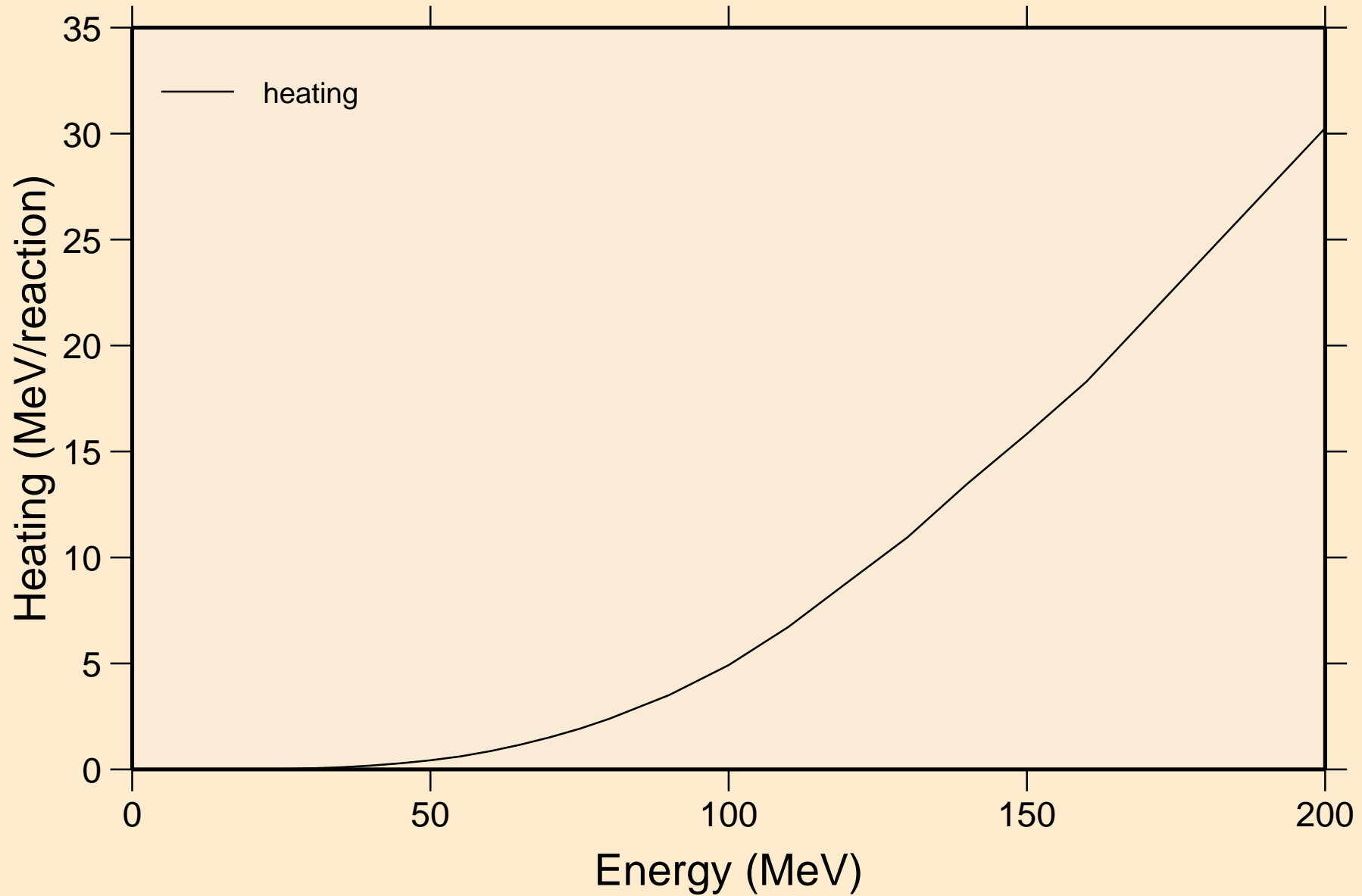

TM155 ALPHA ACER TENDL-2023 LIBRARY; T=0.K  
Threshold reactions

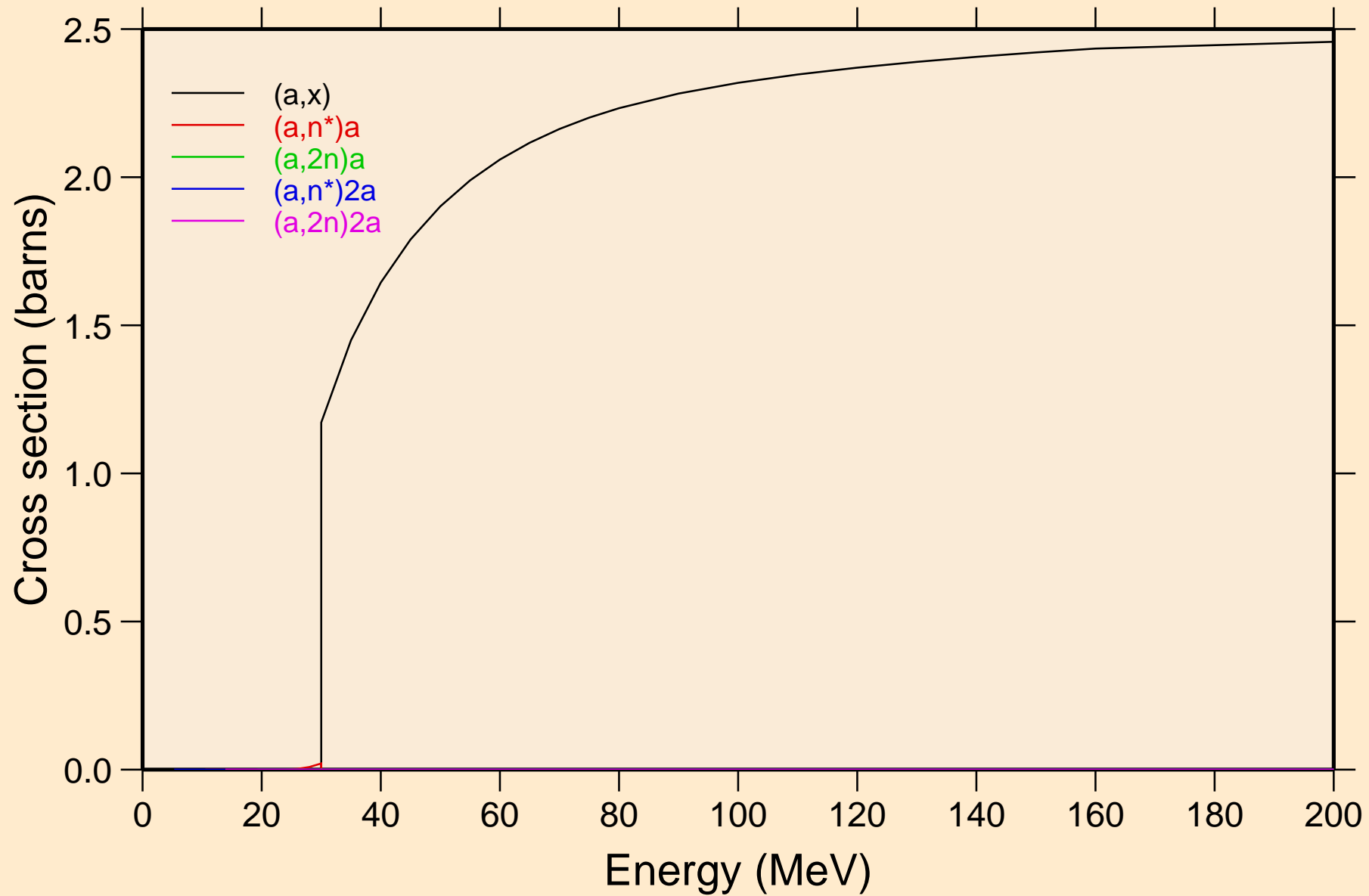

TM155 ALPHA ACER TENDL-2023 LIBRARY; T=0.K  
Threshold reactions

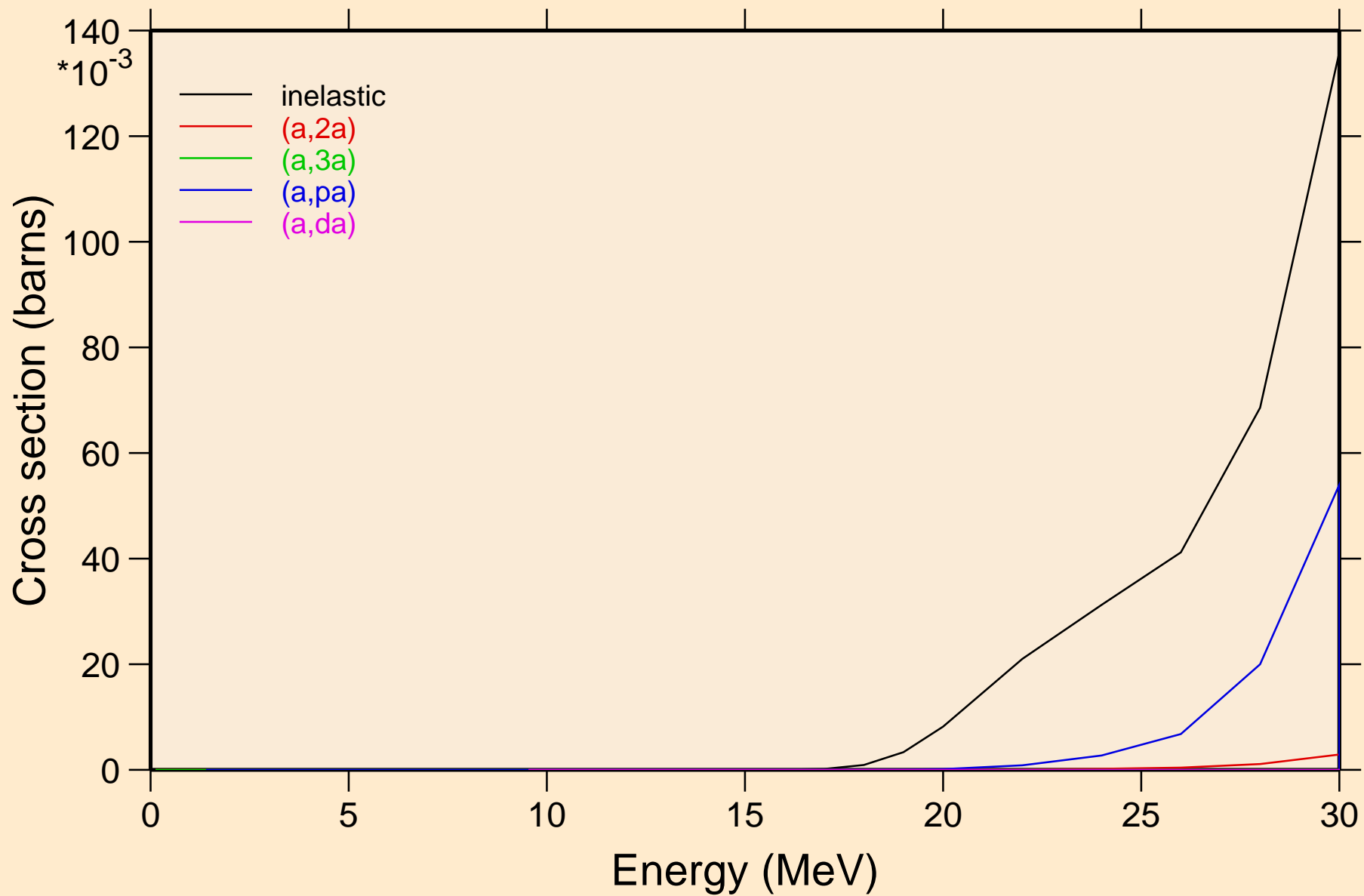

TM155 ALPHA ACER TENDL-2023 LIBRARY; T=0.K  
angular distribution for elastic

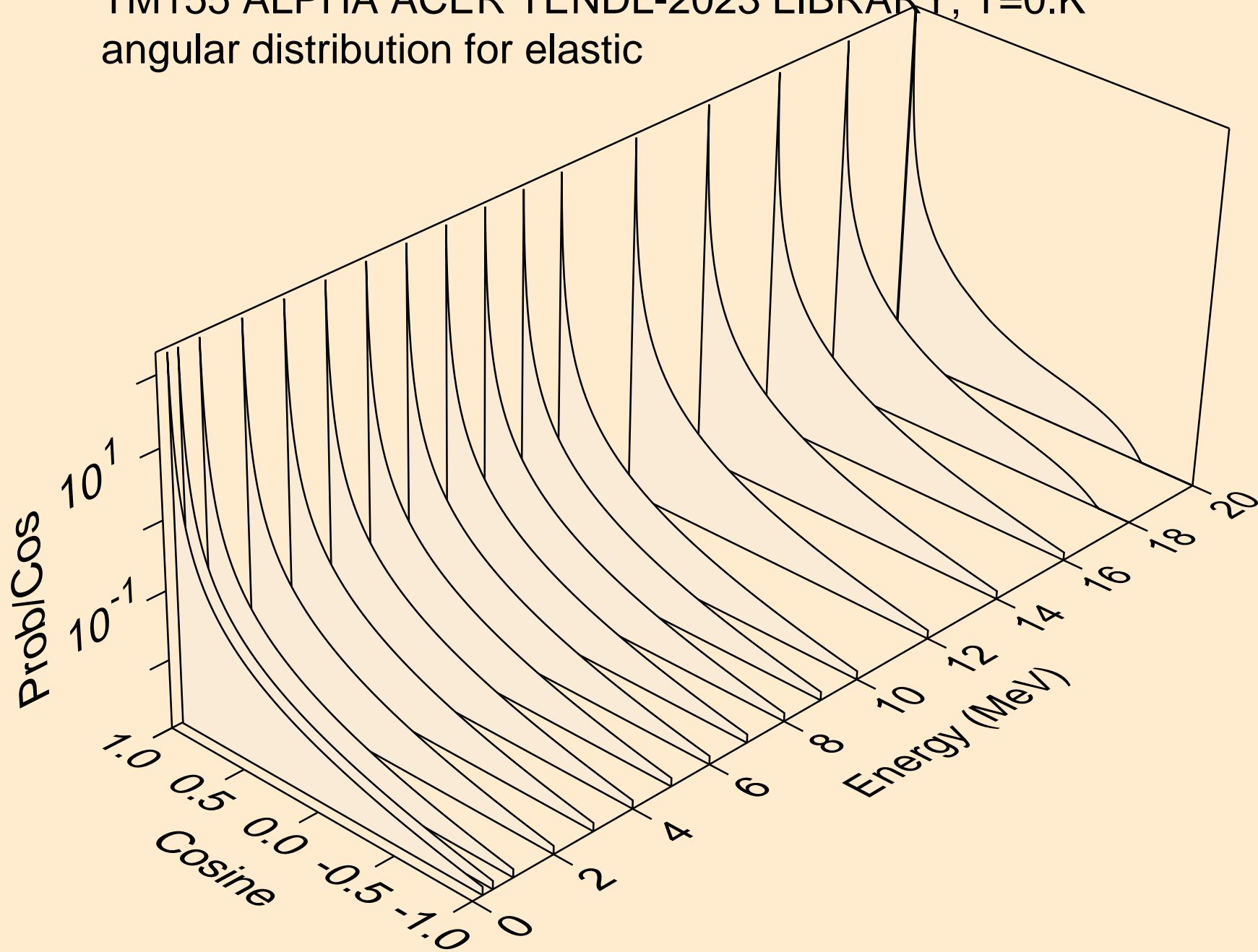

TM155 ALPHA ACER TENDL-2023 LIBRARY; T=0.K  
angular distribution for elastic

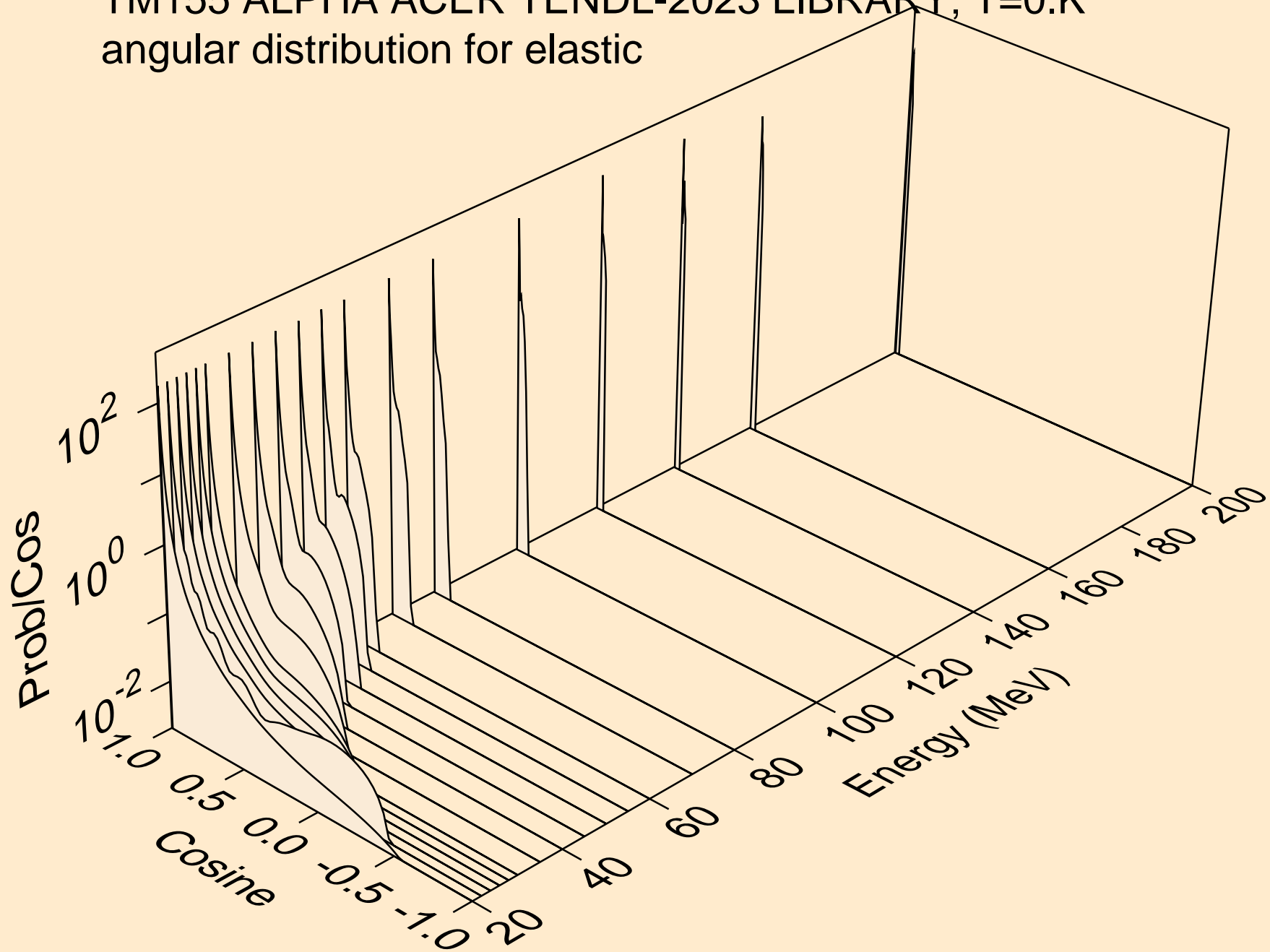

TM155 ALPHA ACER TENDL-2023 LIBRARY; T=0.K  
Alpha emission for (a,x)

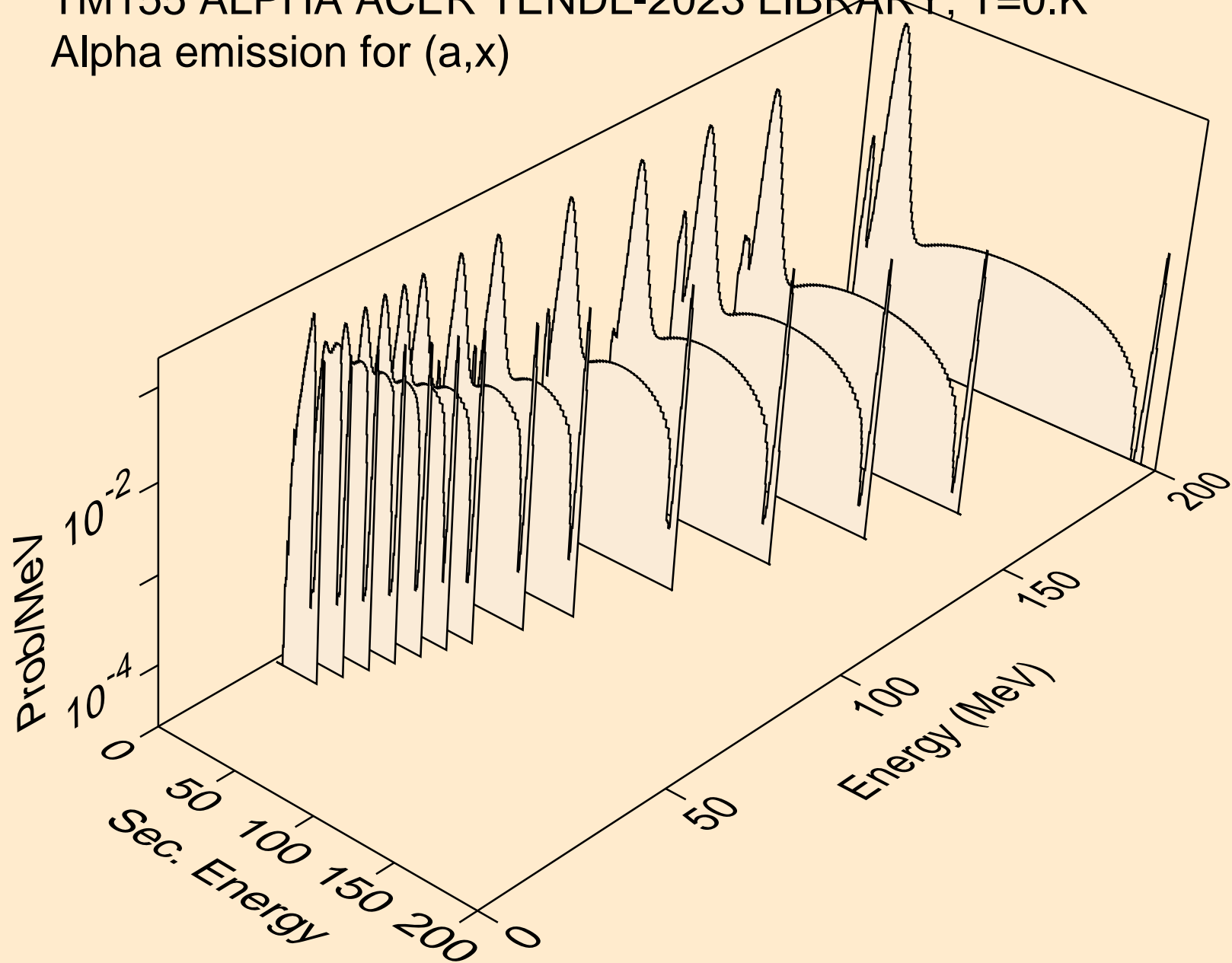

TM155 ALPHA ACER TENDL-2023 LIBRARY; T=0.K  
Alpha emission for (a,n\*)a

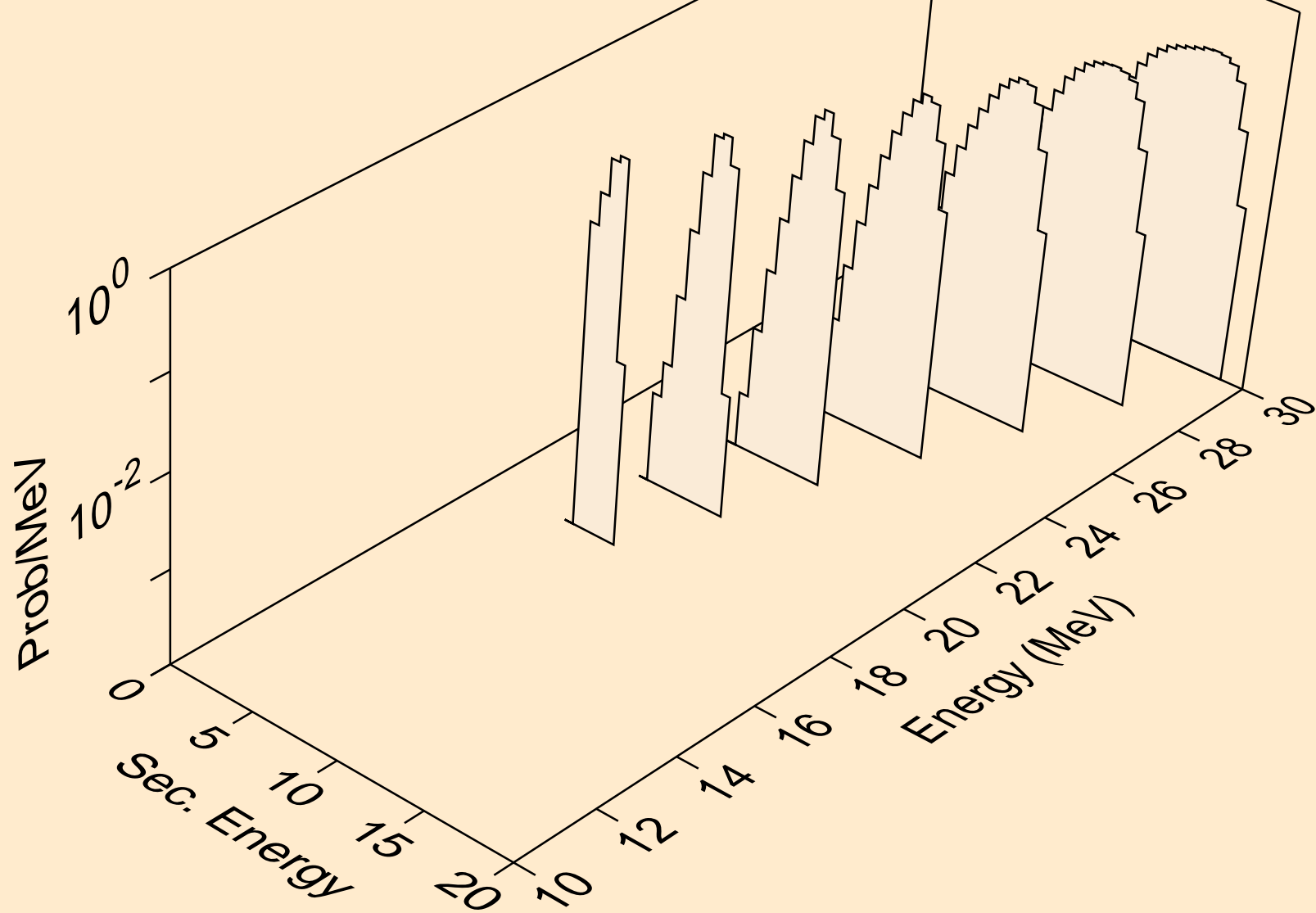

TM155 ALPHA ACER TENDL-2023 LIBRARY; T=0.K  
Alpha emission for (a,2n)a

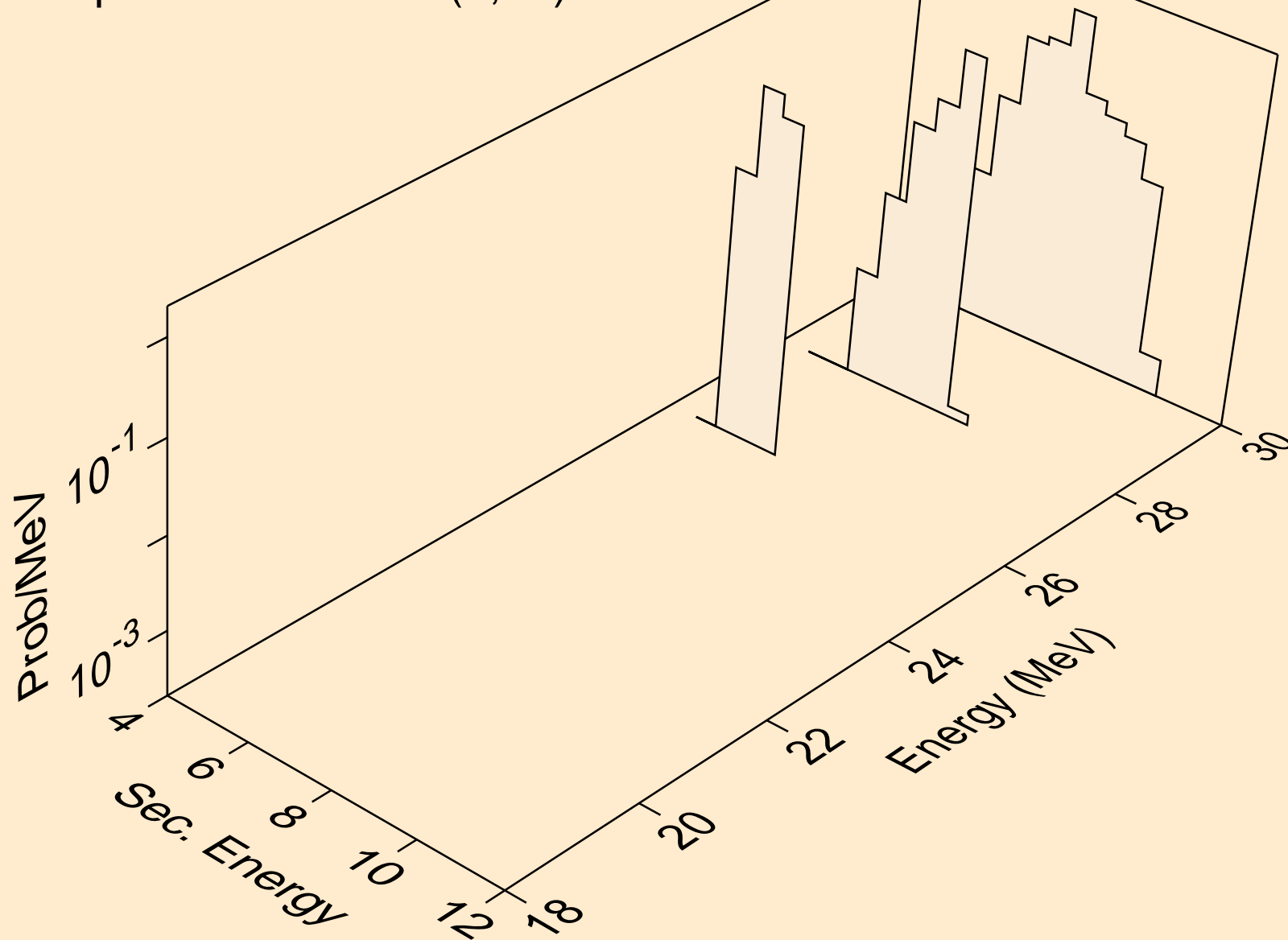

TM155 ALPHA ACER TENDL-2023 LIBRARY; T=0.K  
Alpha emission for (a,n\*)2a

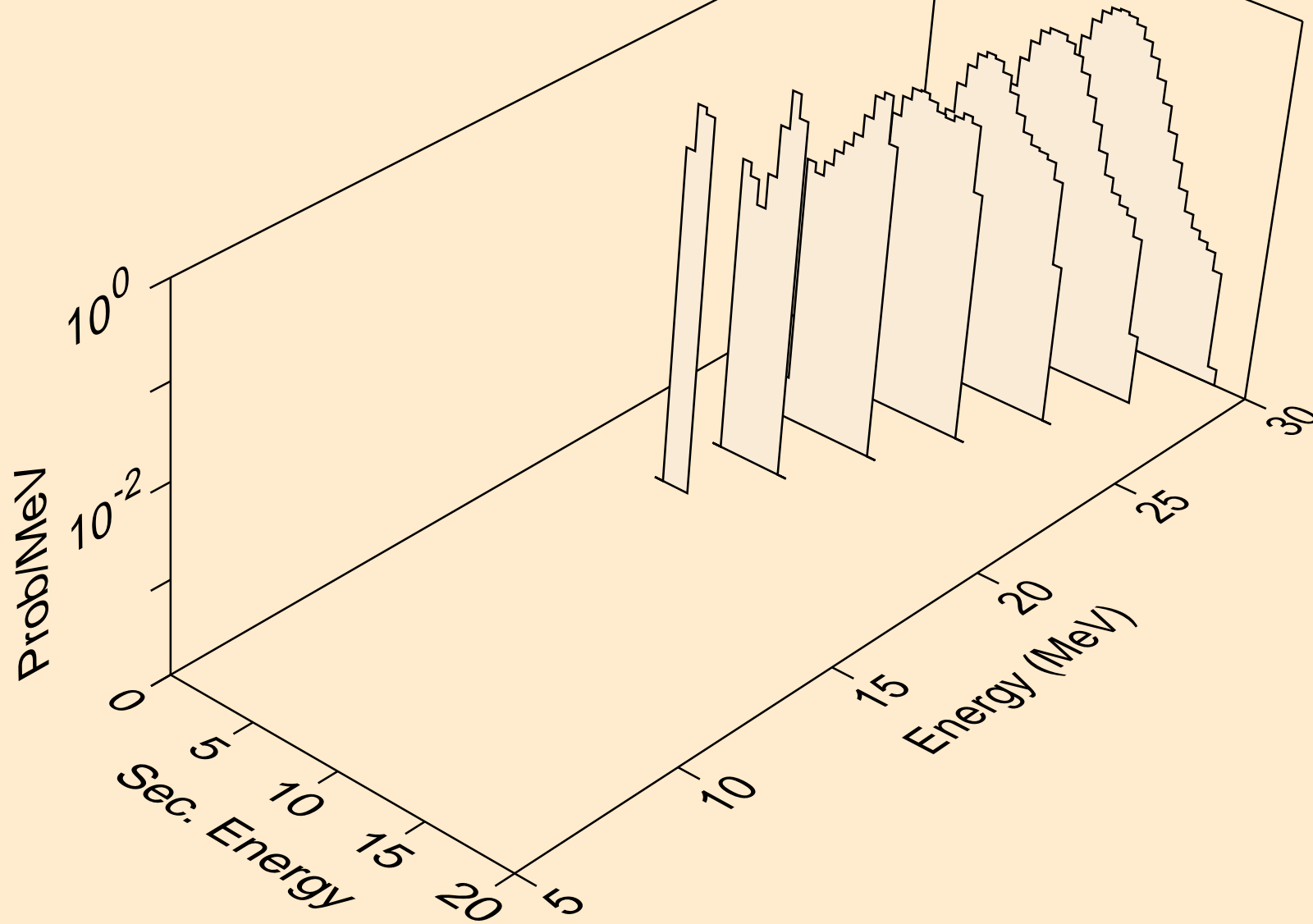

TM155 ALPHA ACER TENDL-2023 LIBRARY; T=0.K  
Alpha emission for (a,2n)2a

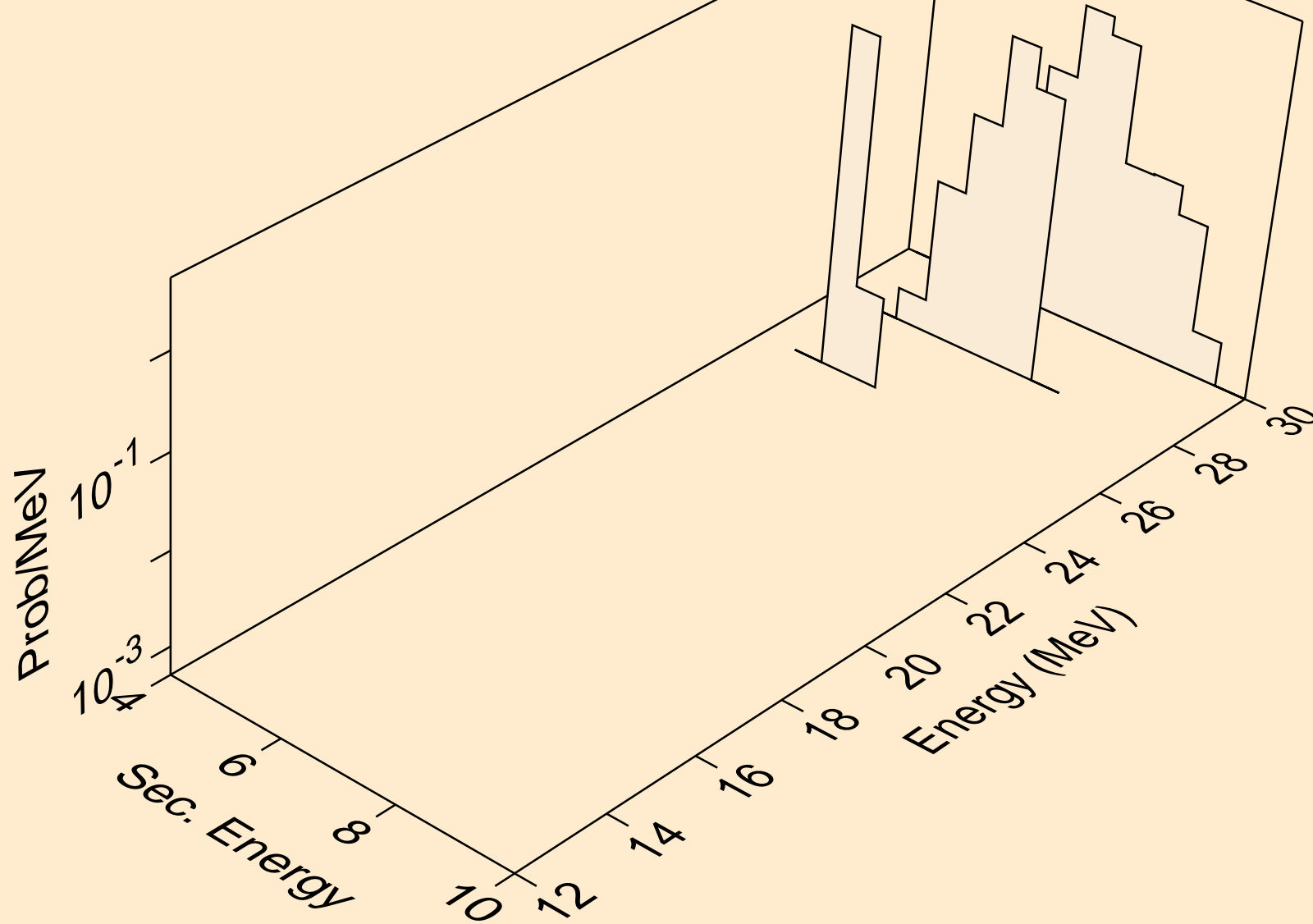

TM155 ALPHA ACER TENDL-2023 LIBRARY; T=0.K  
Alpha emission for inelastic

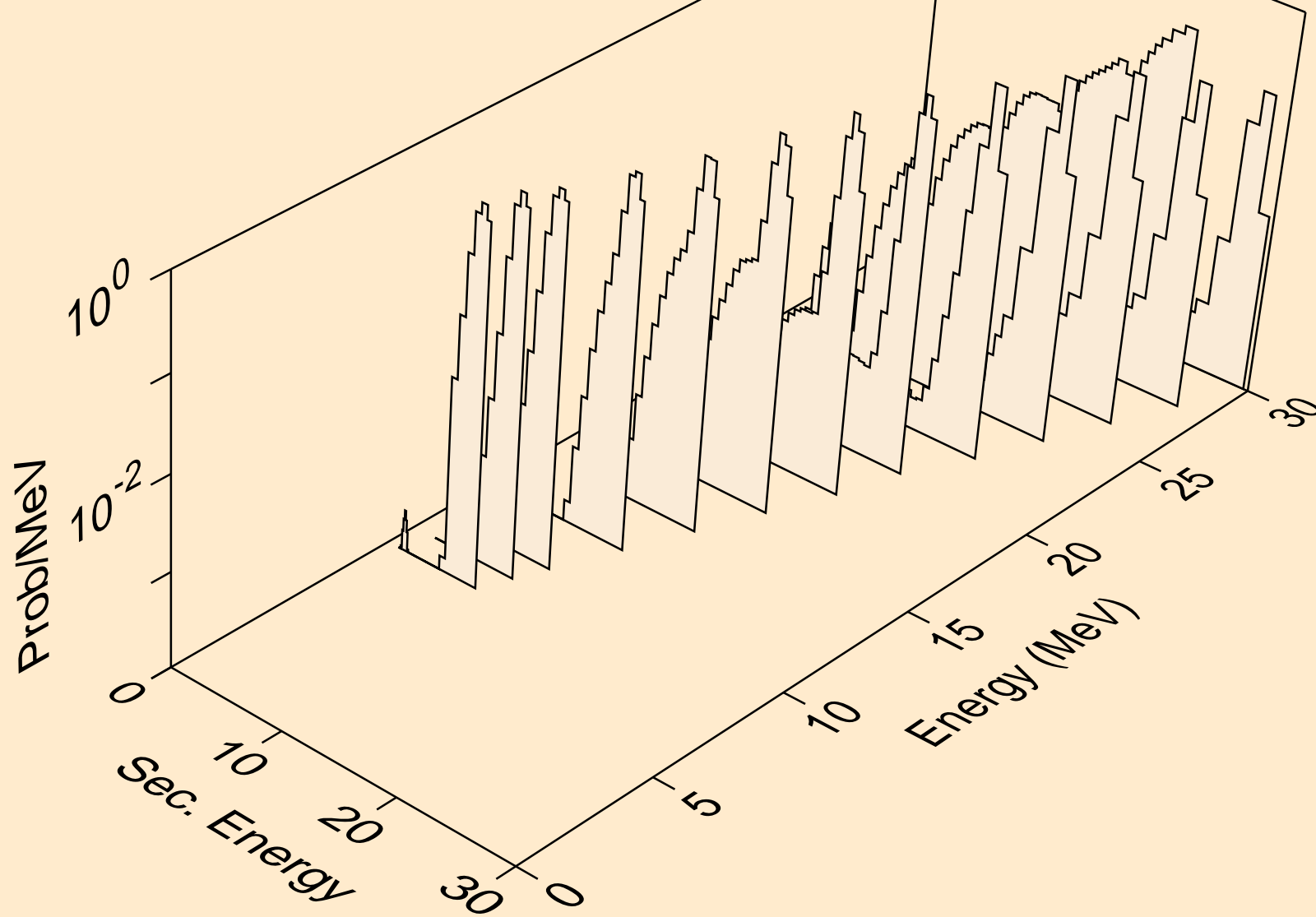

TM155 ALPHA ACER TENDL-2023 LIBRARY; T=0.K  
Alpha emission for (a,2a)

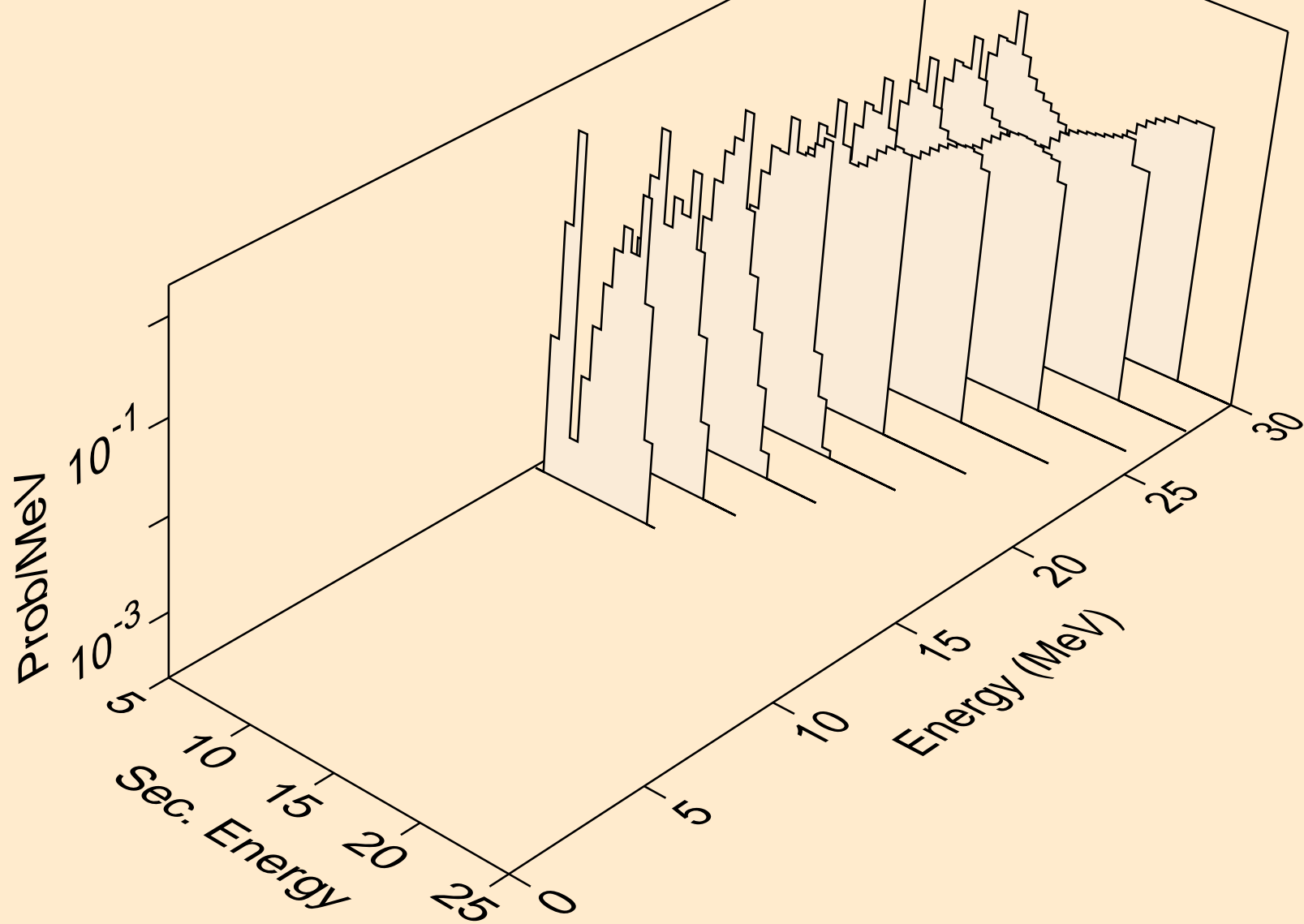

TM155 ALPHA ACER TENDL-2023 LIBRARY; T=0.K  
Alpha emission for (a,3a)

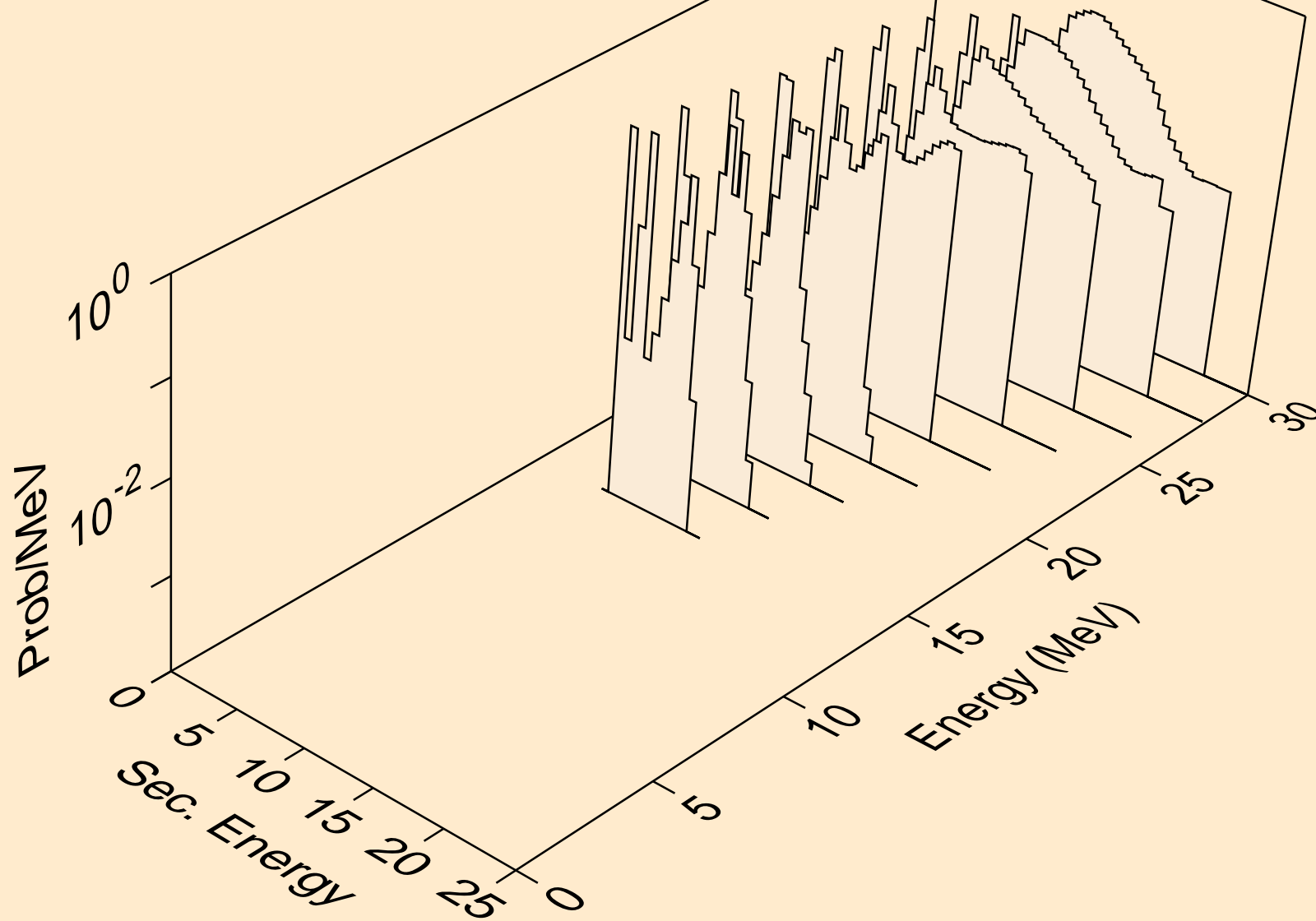

TM155 ALPHA ACER TENDL-2023 LIBRARY; T=0.K  
Alpha emission for (a,pa)

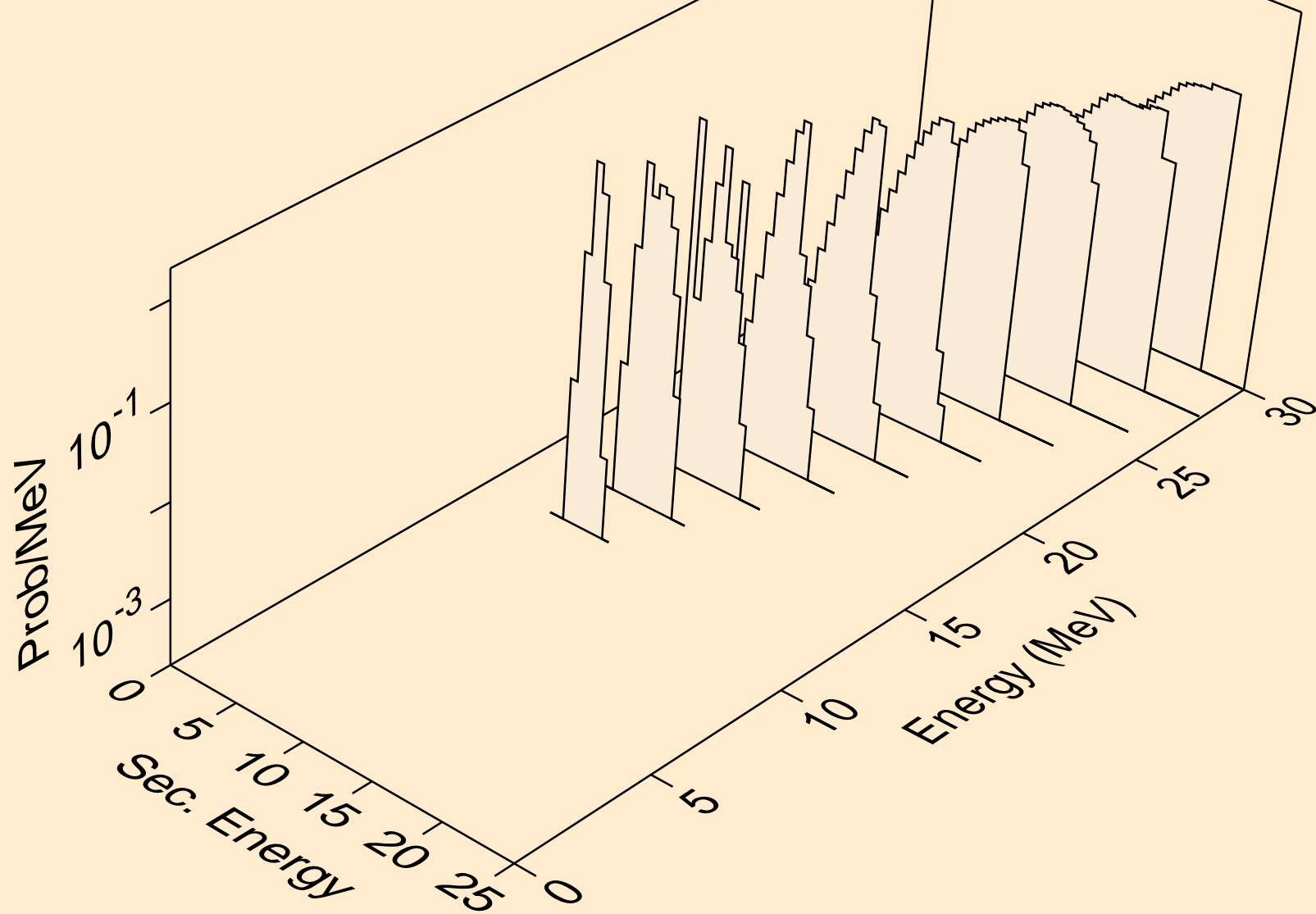

TM155 ALPHA ACER TENDL-2023 LIBRARY; T=0.K  
Alpha emission for (a,da)

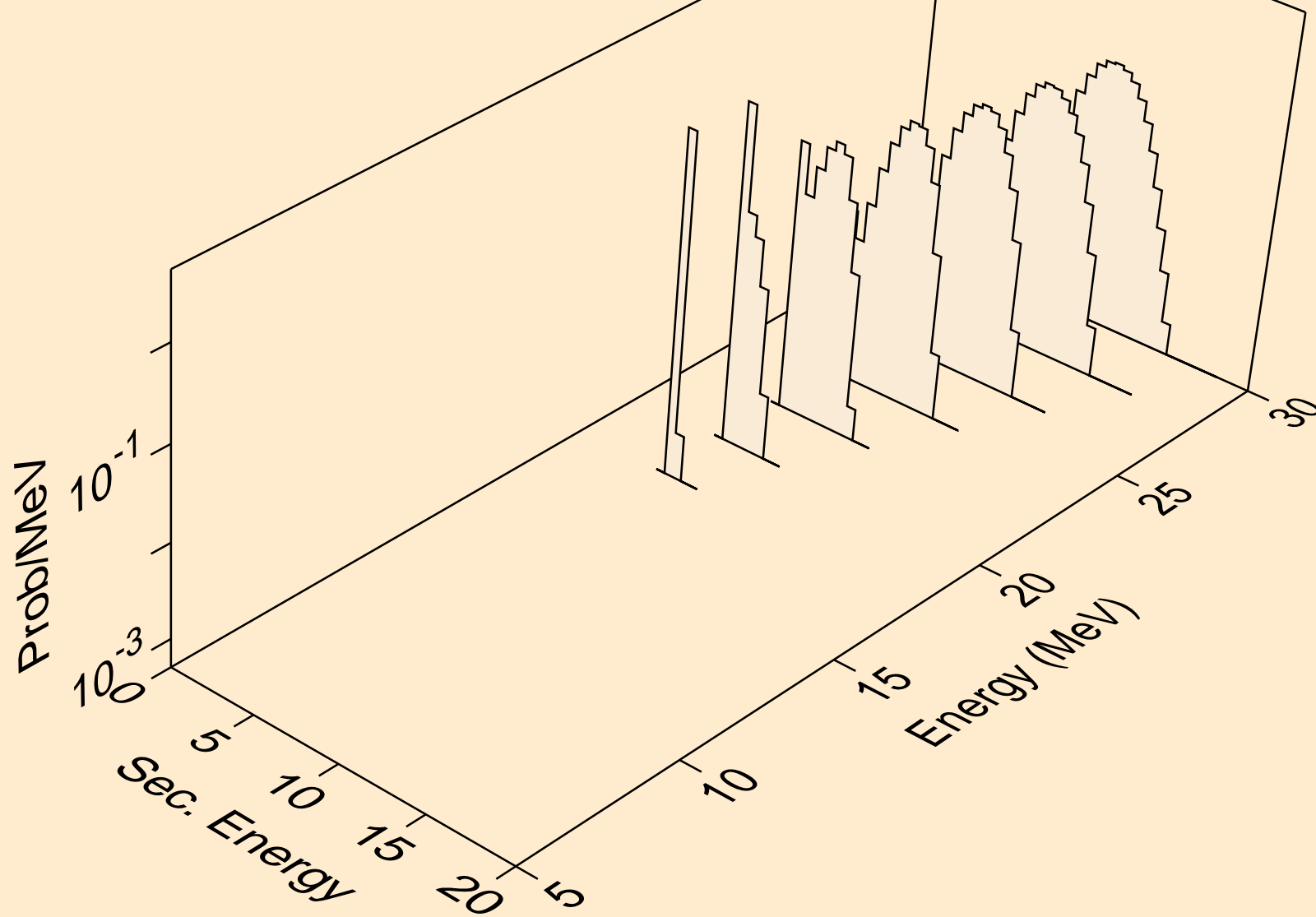

TM155 ALPHA ACER TENDL-2023 LIBRARY; T=0.K  
Photon emission for (z,n)

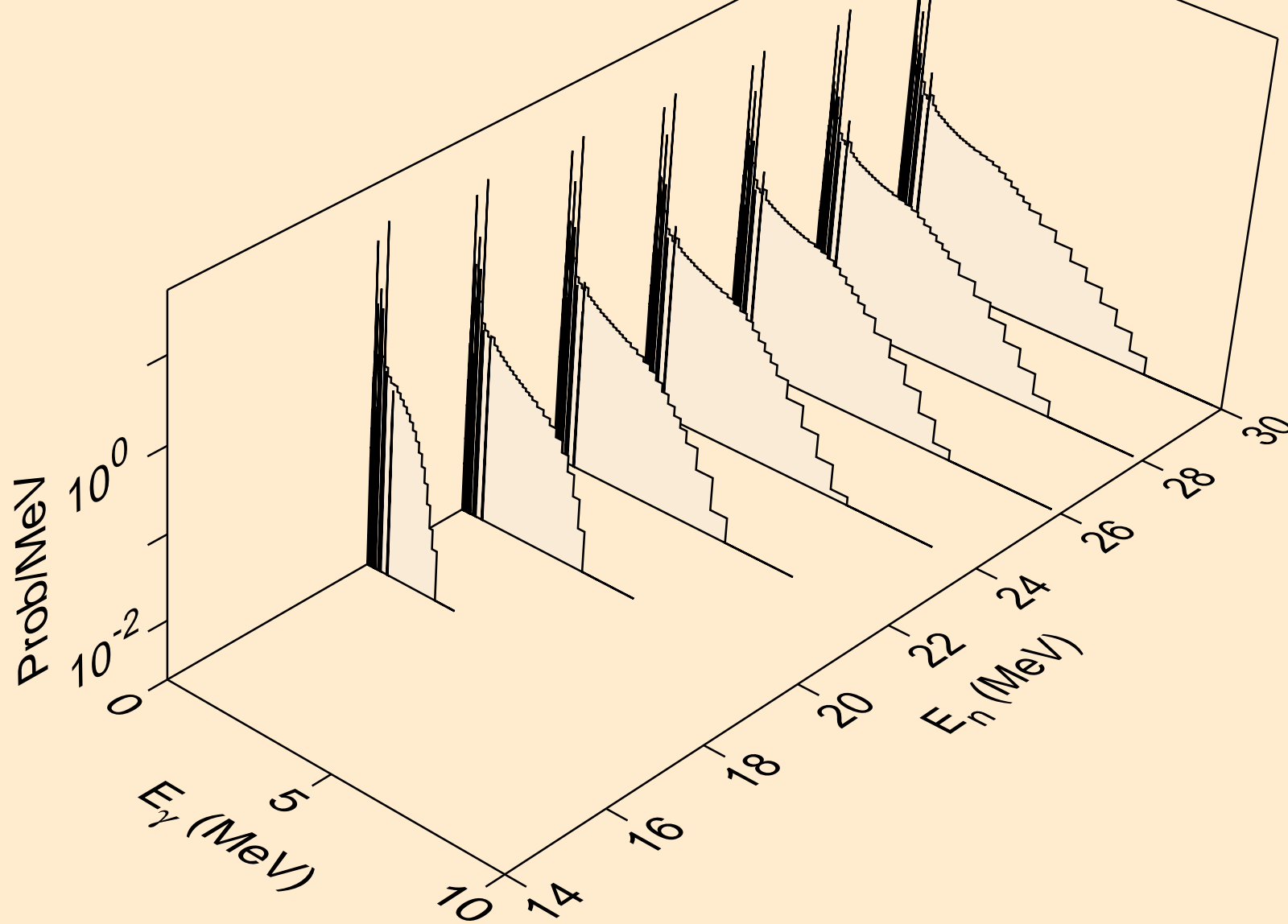

TM155 ALPHA ACER TENDL-2023 LIBRARY; T=0.K  
Photon emission for (z,x)

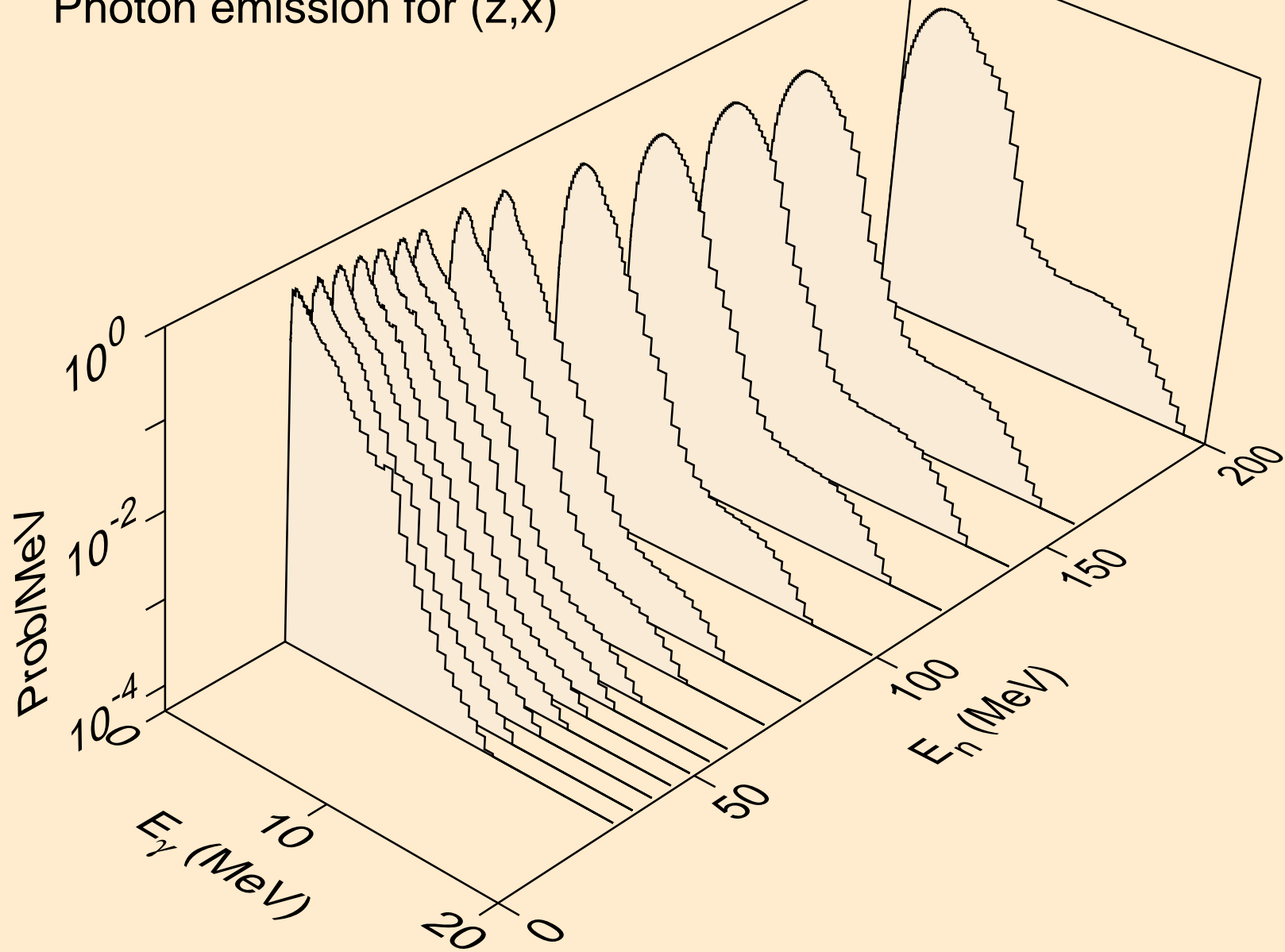

TM155 ALPHA ACER TENDL-2023 LIBRARY; T=0.K  
Photon emission for (n,2n)

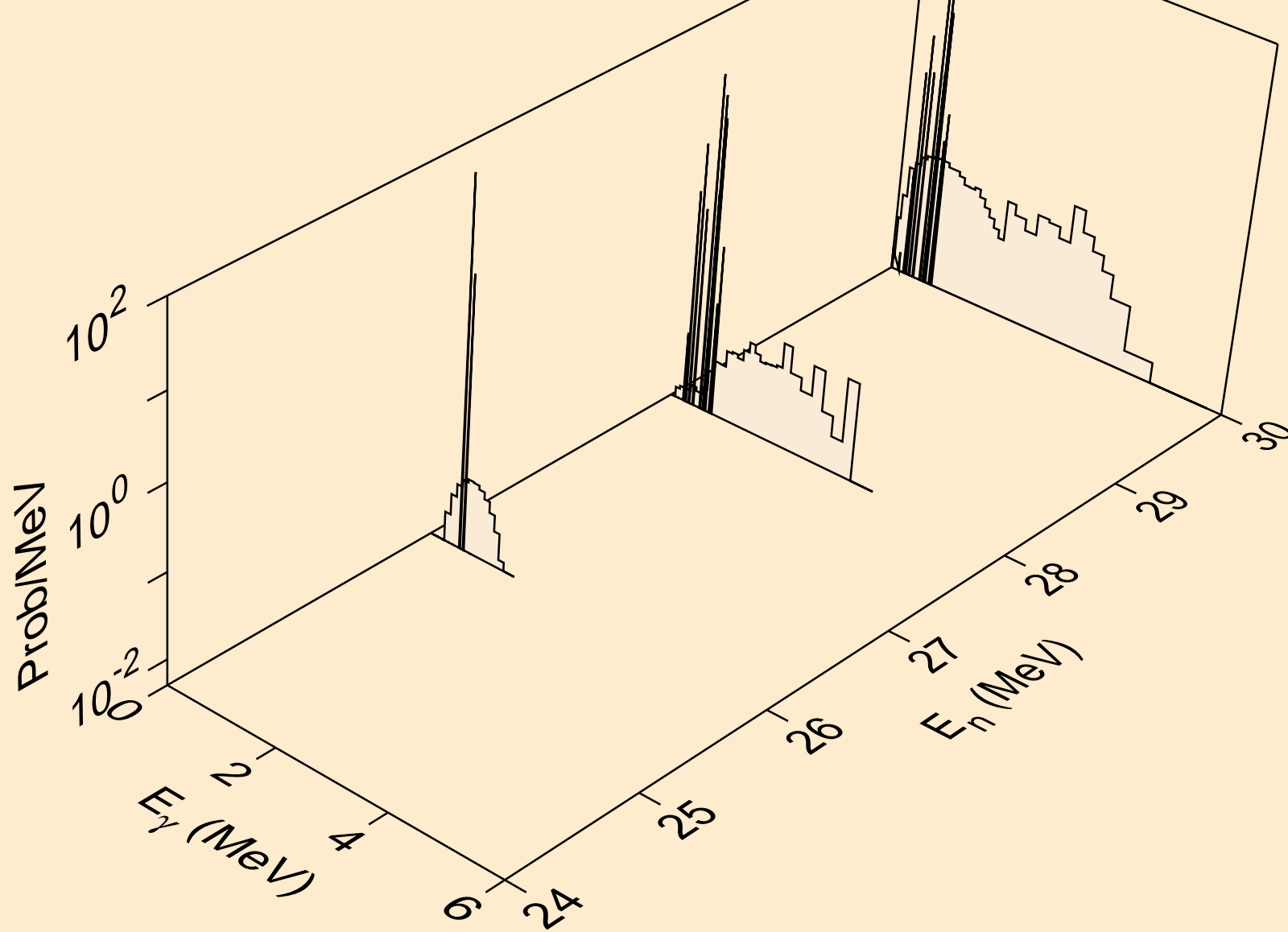

TM155 ALPHA ACER TENDL-2023 LIBRARY; T=0.K  
Photon emission for (n,n\*)a

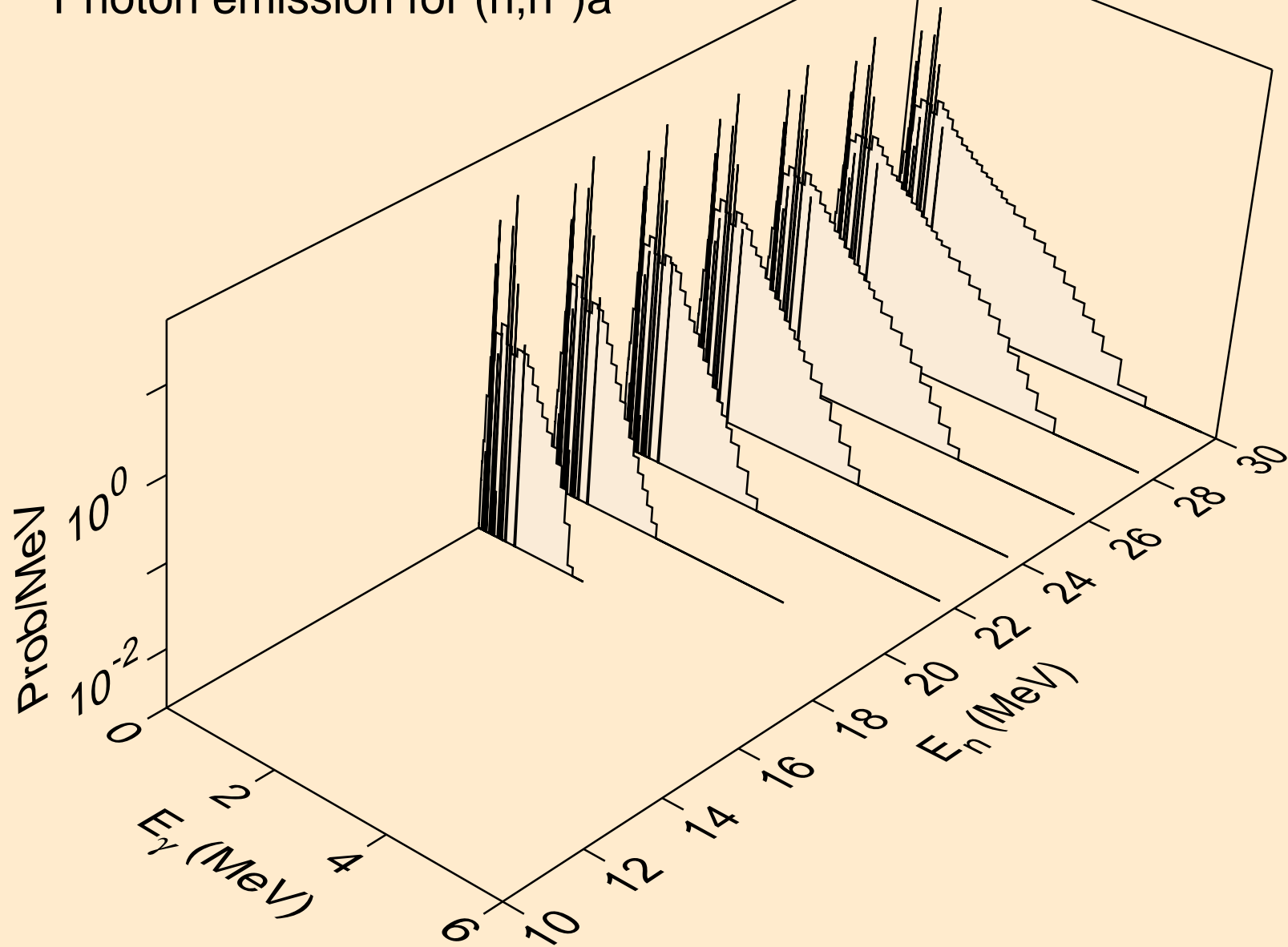

TM155 ALPHA ACER TENDL-2023 LIBRARY; T=0.K  
Photon emission for (n,2n)a

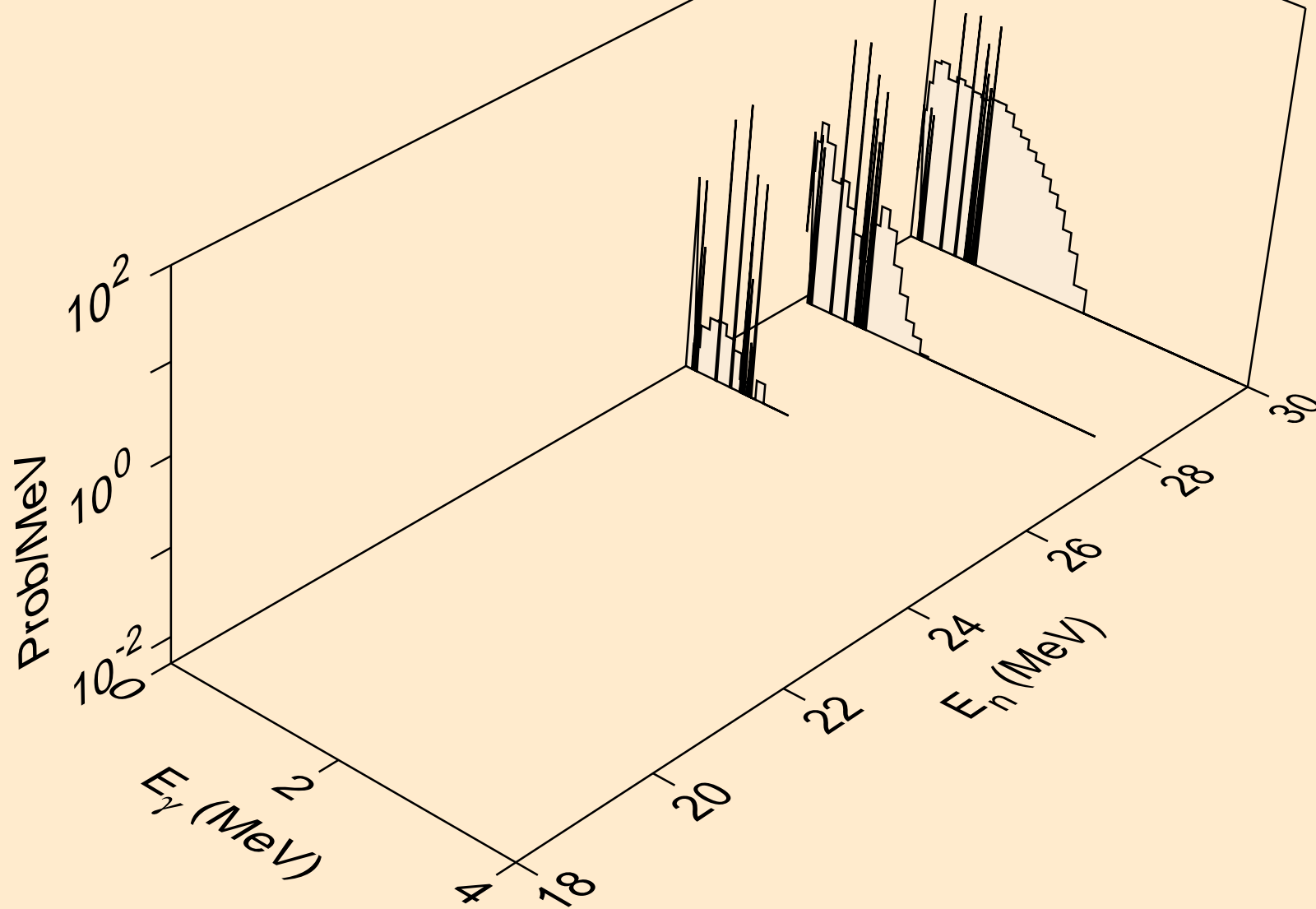

TM155 ALPHA ACER TENDL-2023 LIBRARY; T=0.K  
Photon emission for (n,n\*)p

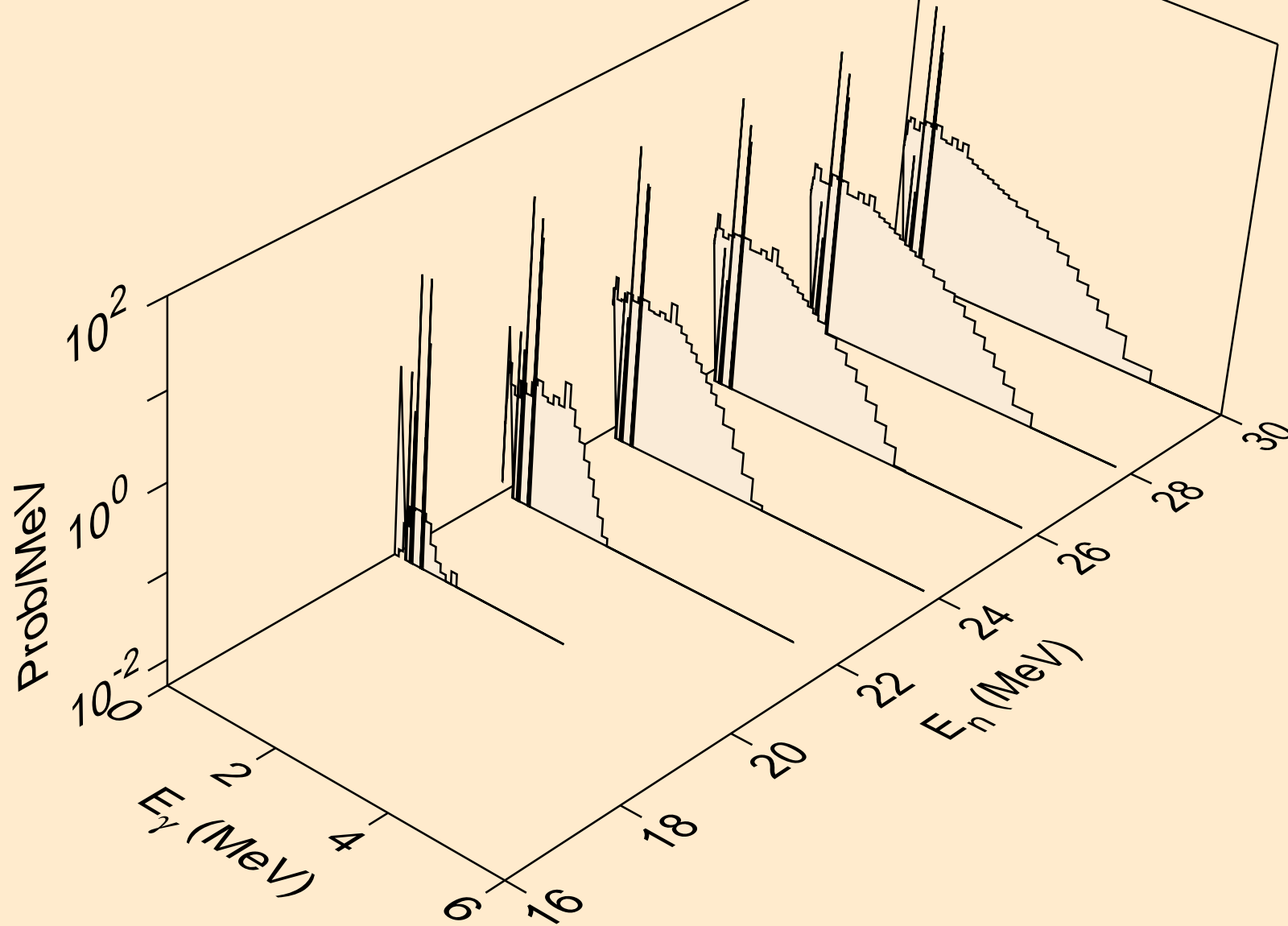

TM155 ALPHA ACER TENDL-2023 LIBRARY; T=0.K  
Photon emission for (n,n\*)2a

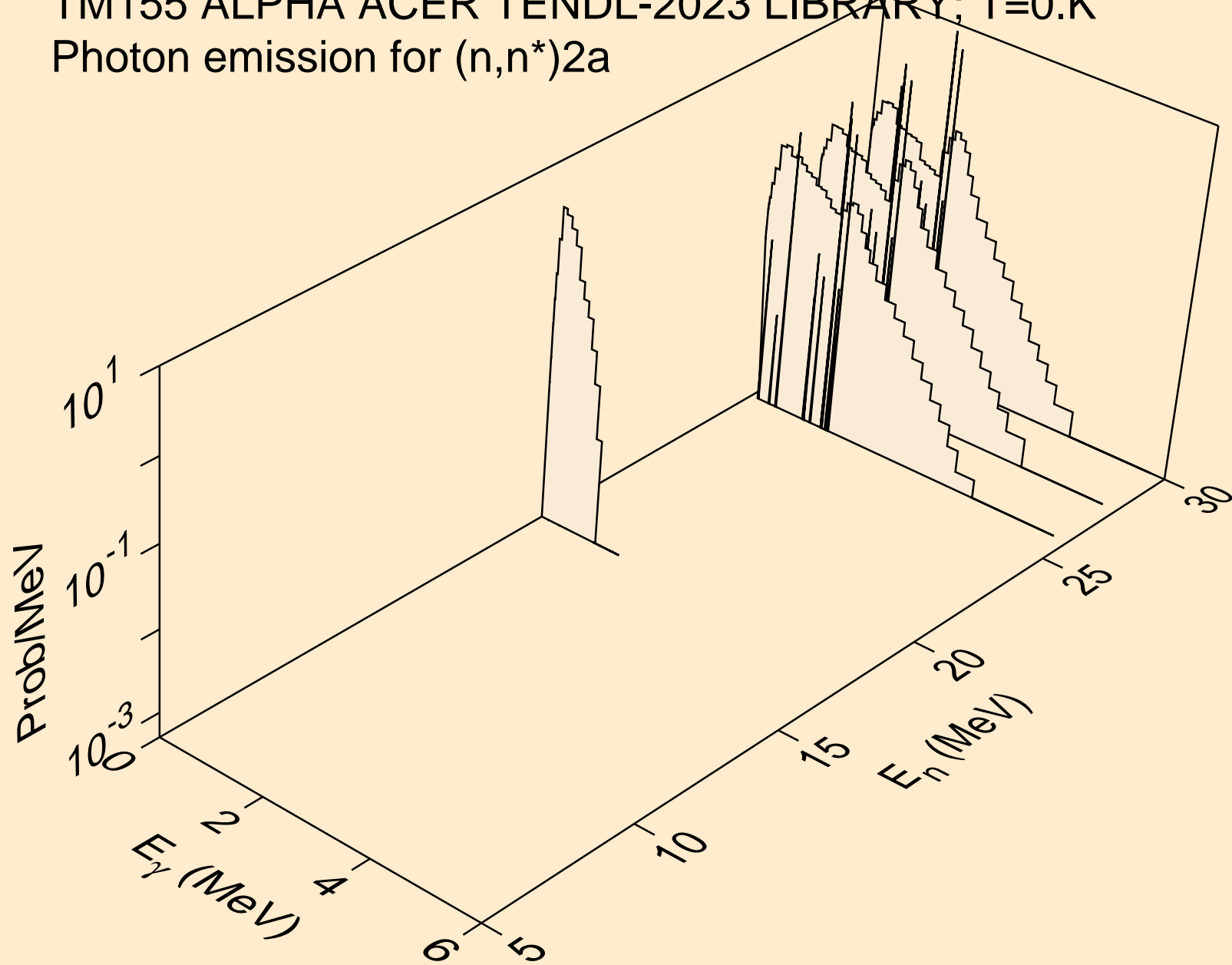

TM155 ALPHA ACER TENDL-2023 LIBRARY; T=0.K  
Photon emission for (n,2n)2a

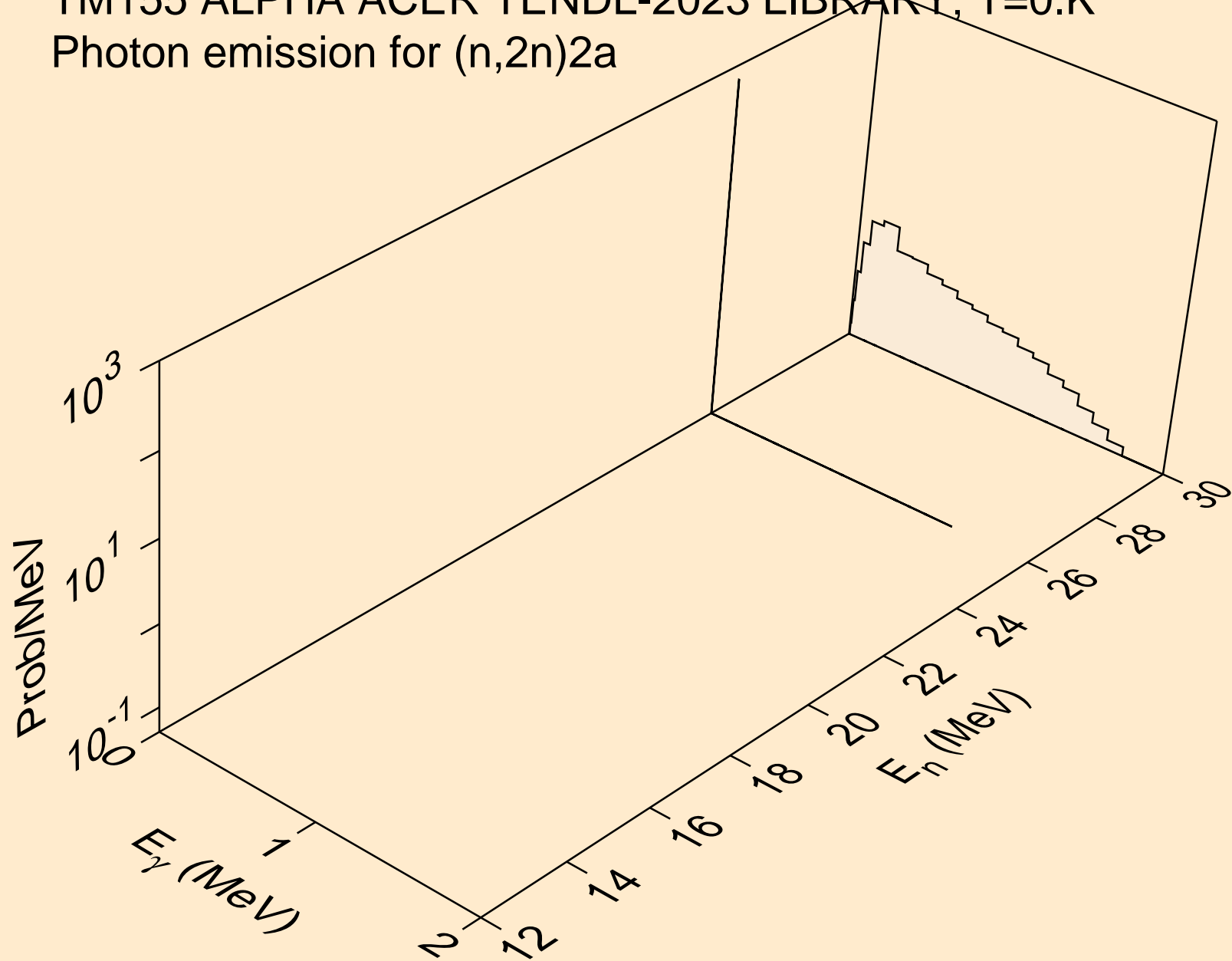

TM155 ALPHA ACER TENDL-2023 LIBRARY; T=0.K  
Photon emission for (n,n\*)d

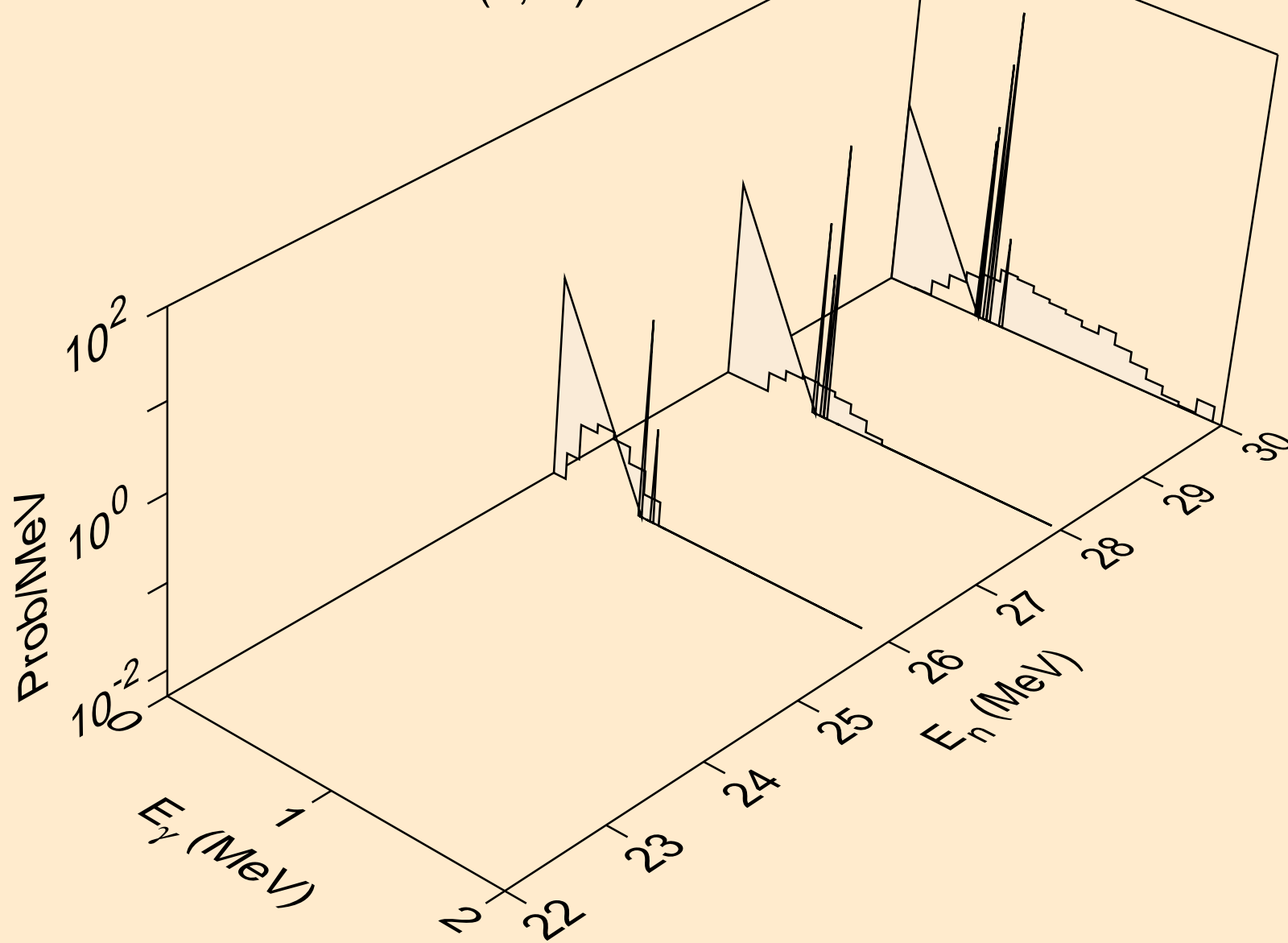

TM155 ALPHA ACER TENDL-2023 LIBRARY; T=0.K  
Photon emission for (n,2np)

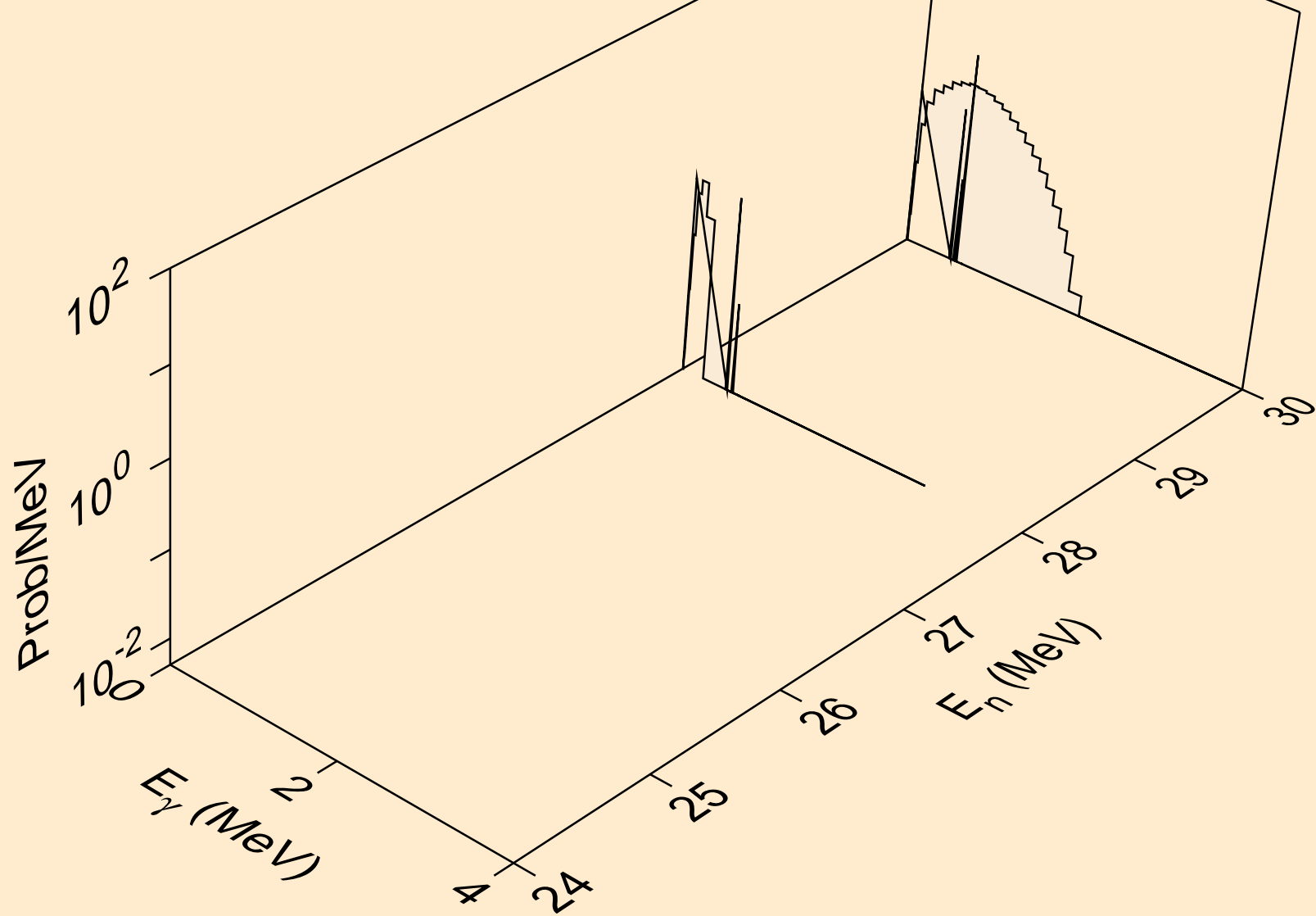

TM155 ALPHA ACER TENDL-2023 LIBRARY; T=0.K  
Photon emission for (n,n2p)

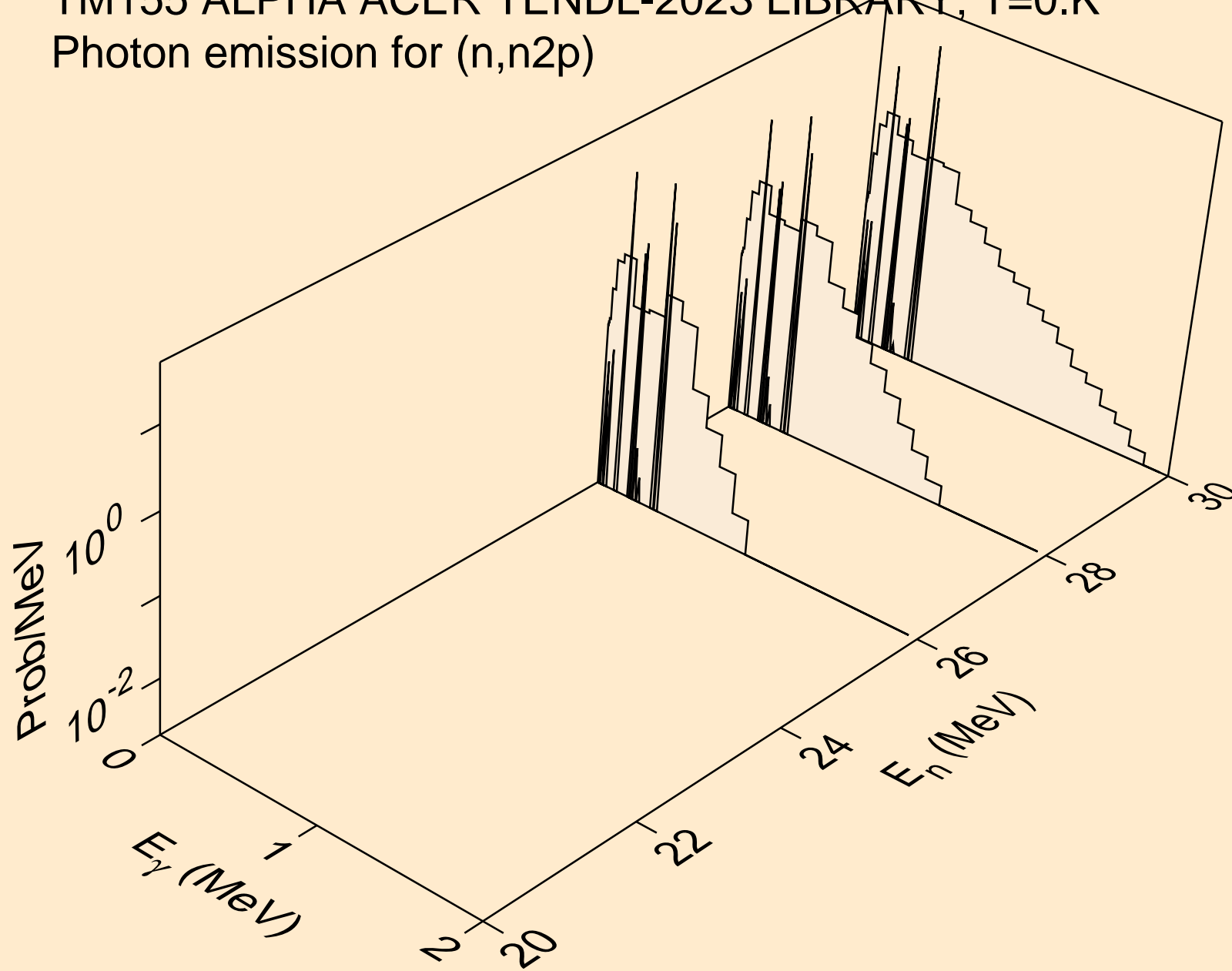

TM155 ALPHA ACER TENDL-2023 LIBRARY; T=0.K  
Photon emission for (n,npa)

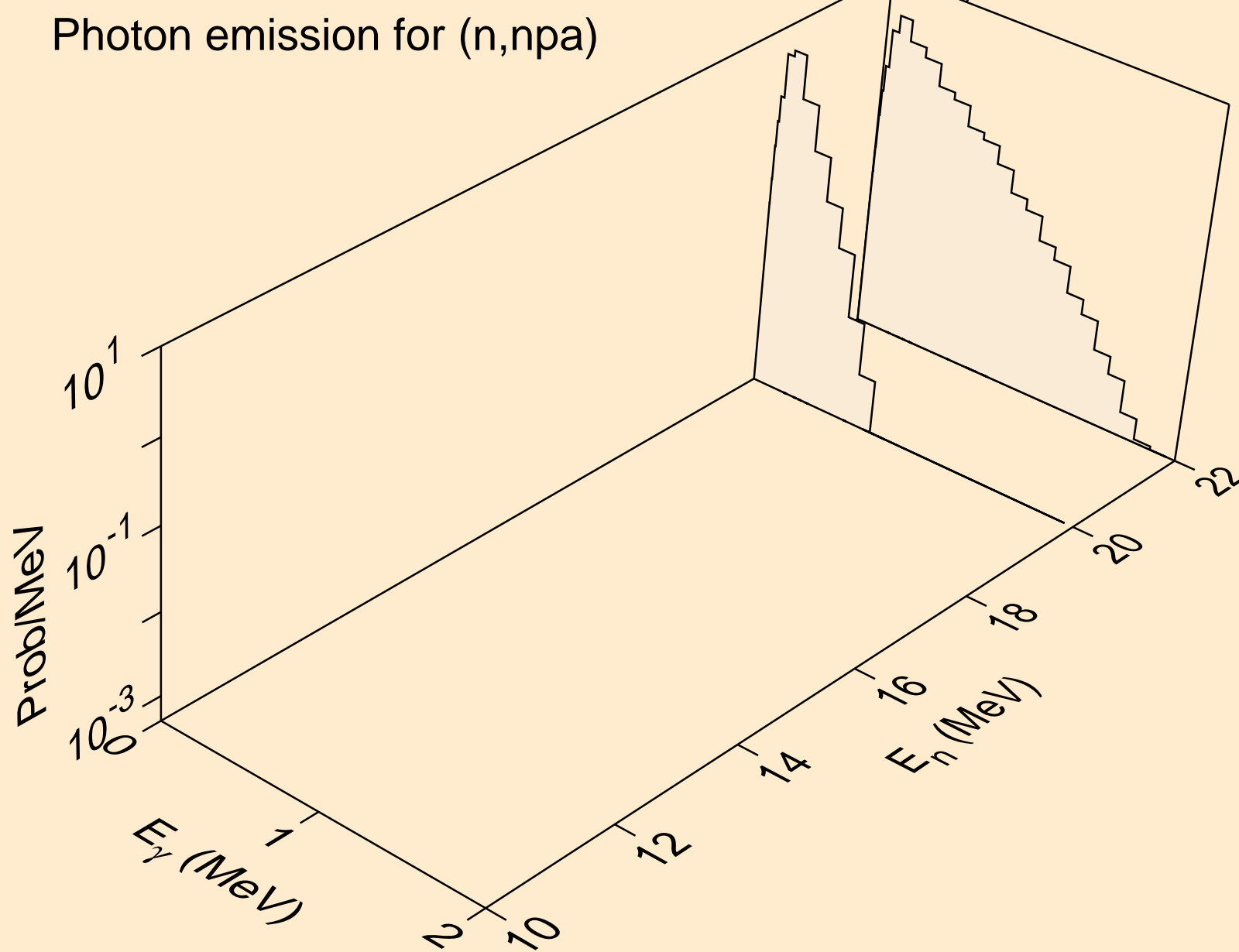

TM155 ALPHA ACER TENDL-2023 LIBRARY; T=0.K  
Photon emission for (n,gma)

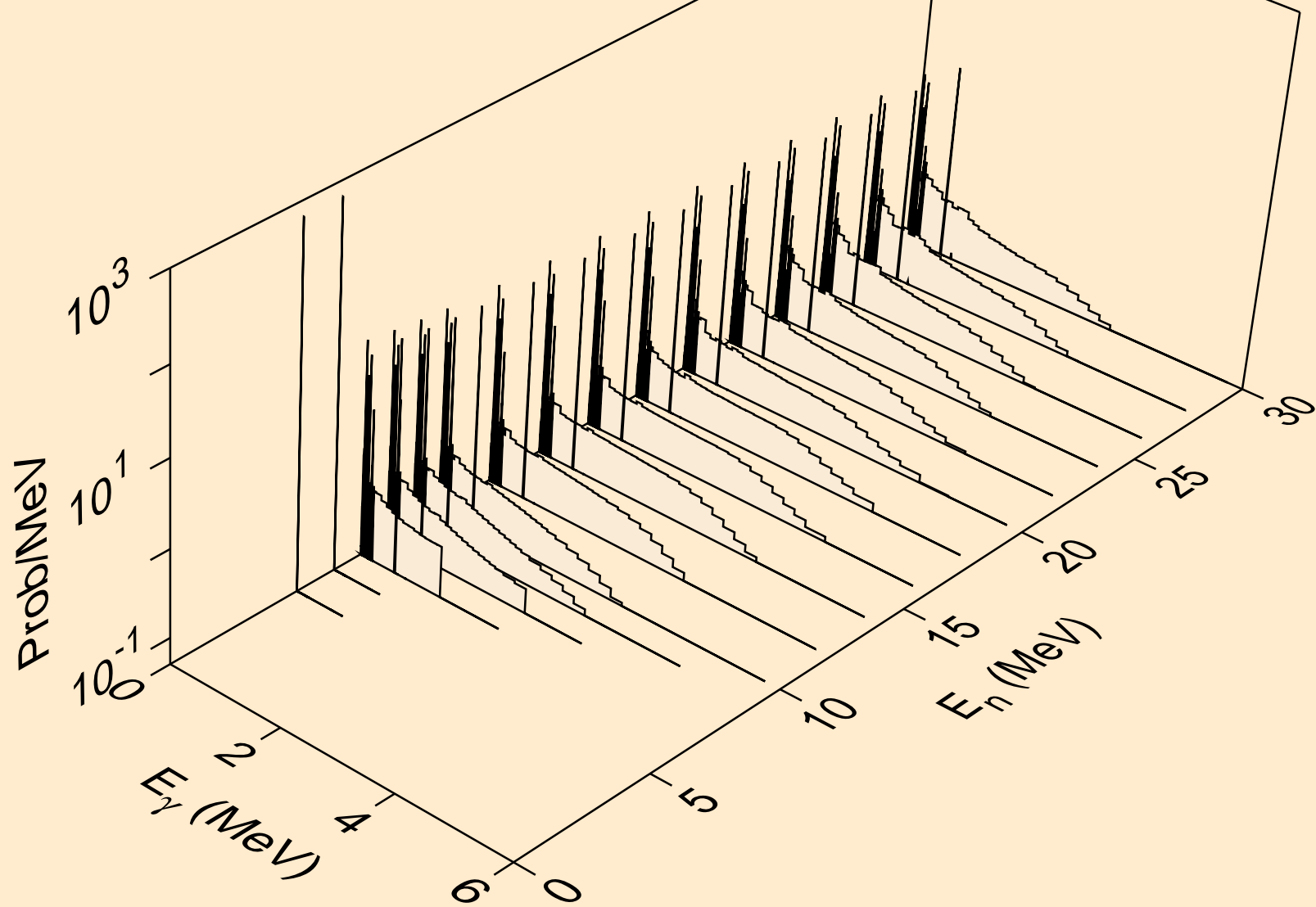

TM155 ALPHA ACER TENDL-2023 LIBRARY; T=0.K  
Photon emission for (n,p)

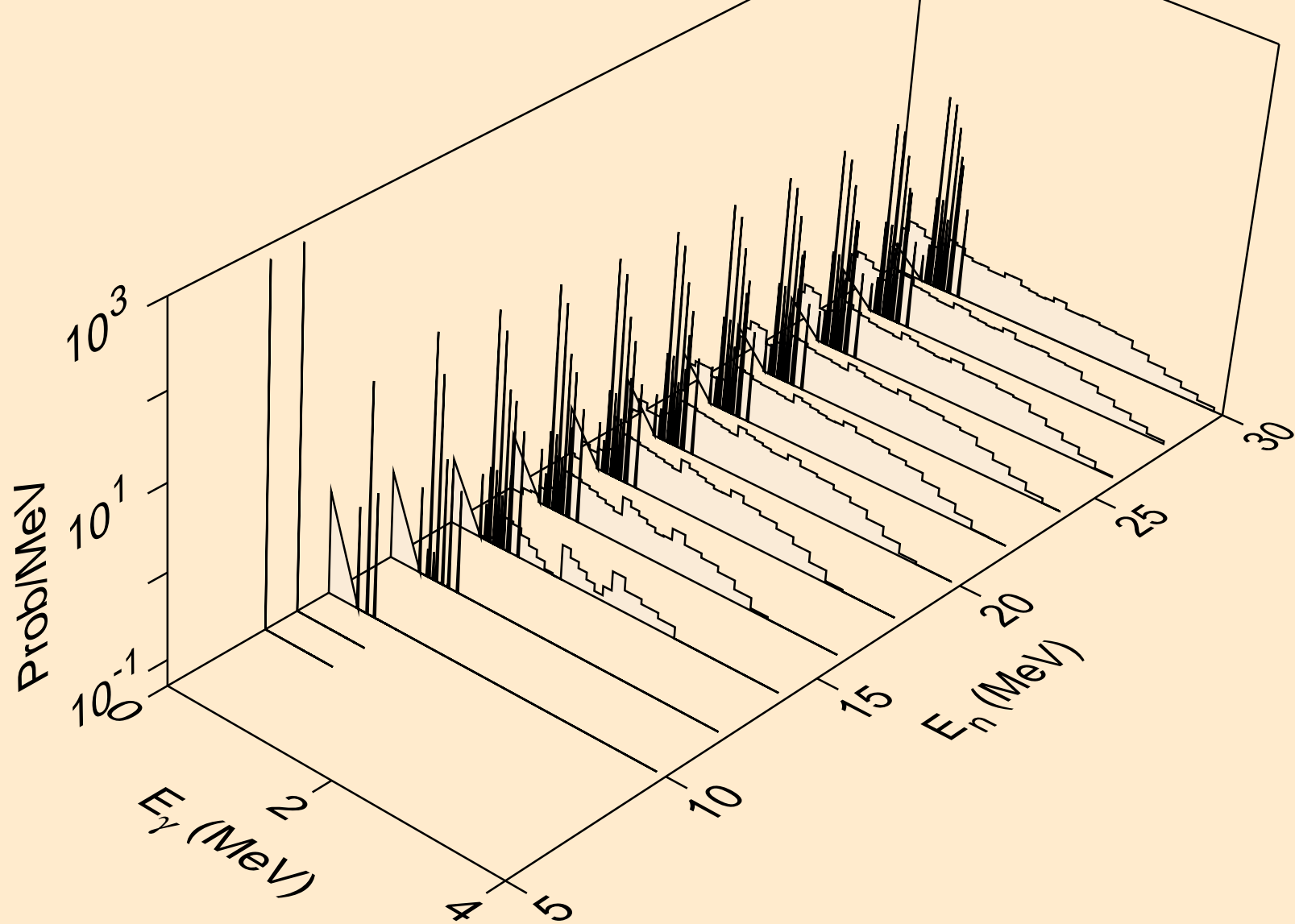

TM155 ALPHA ACER TENDL-2023 LIBRARY; T=0.K  
Photon emission for (n,d)

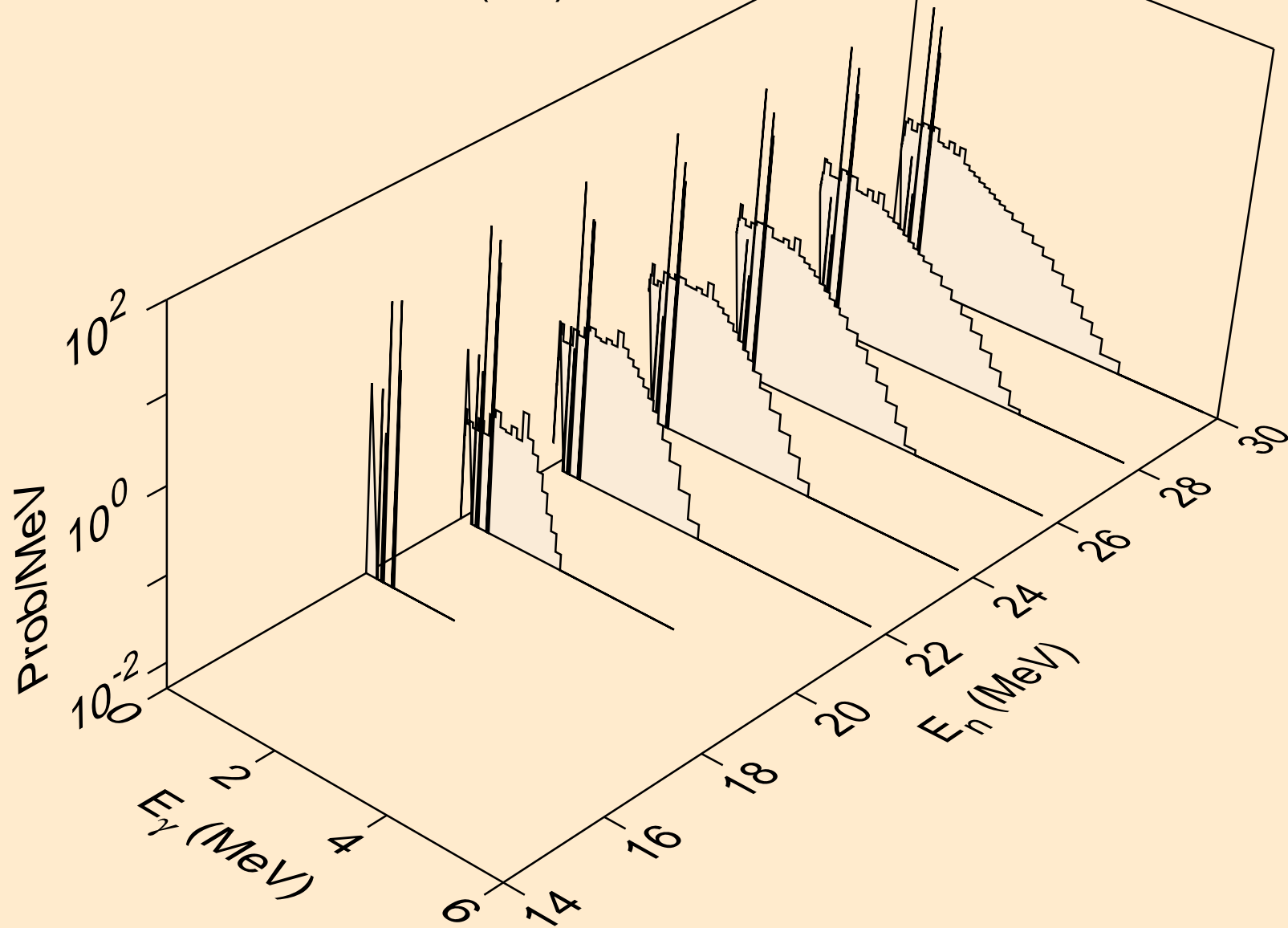

TM155 ALPHA ACER TENDL-2023 LIBRARY; T=0.K  
Photon emission for (n,t)

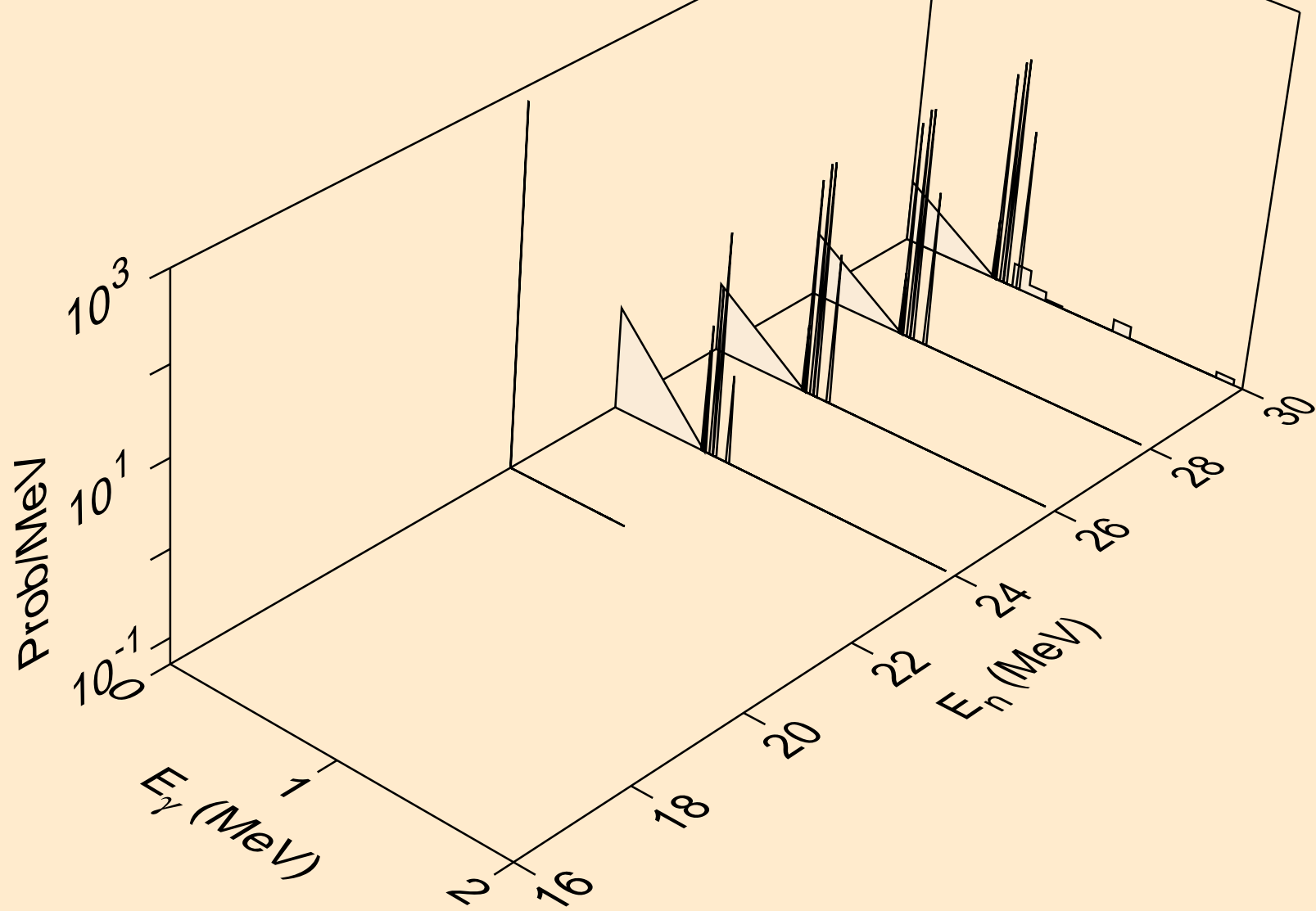

TM155 ALPHA ACER TENDL-2023 LIBRARY; T=0.K  
Photon emission for (n,he3)

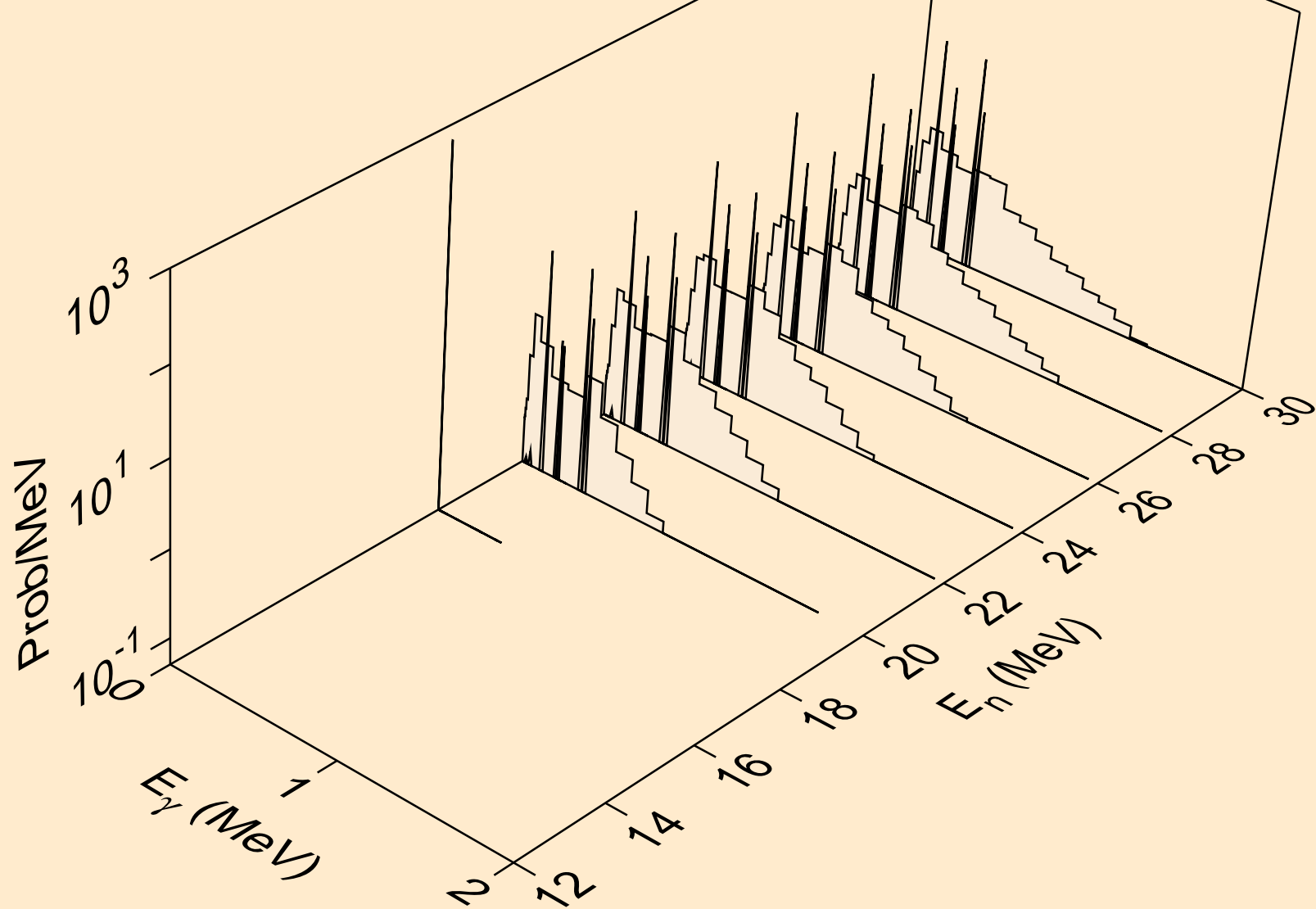

TM155 ALPHA ACER TENDL-2023 LIBRARY; T=0.K  
Photon emission for inelastic

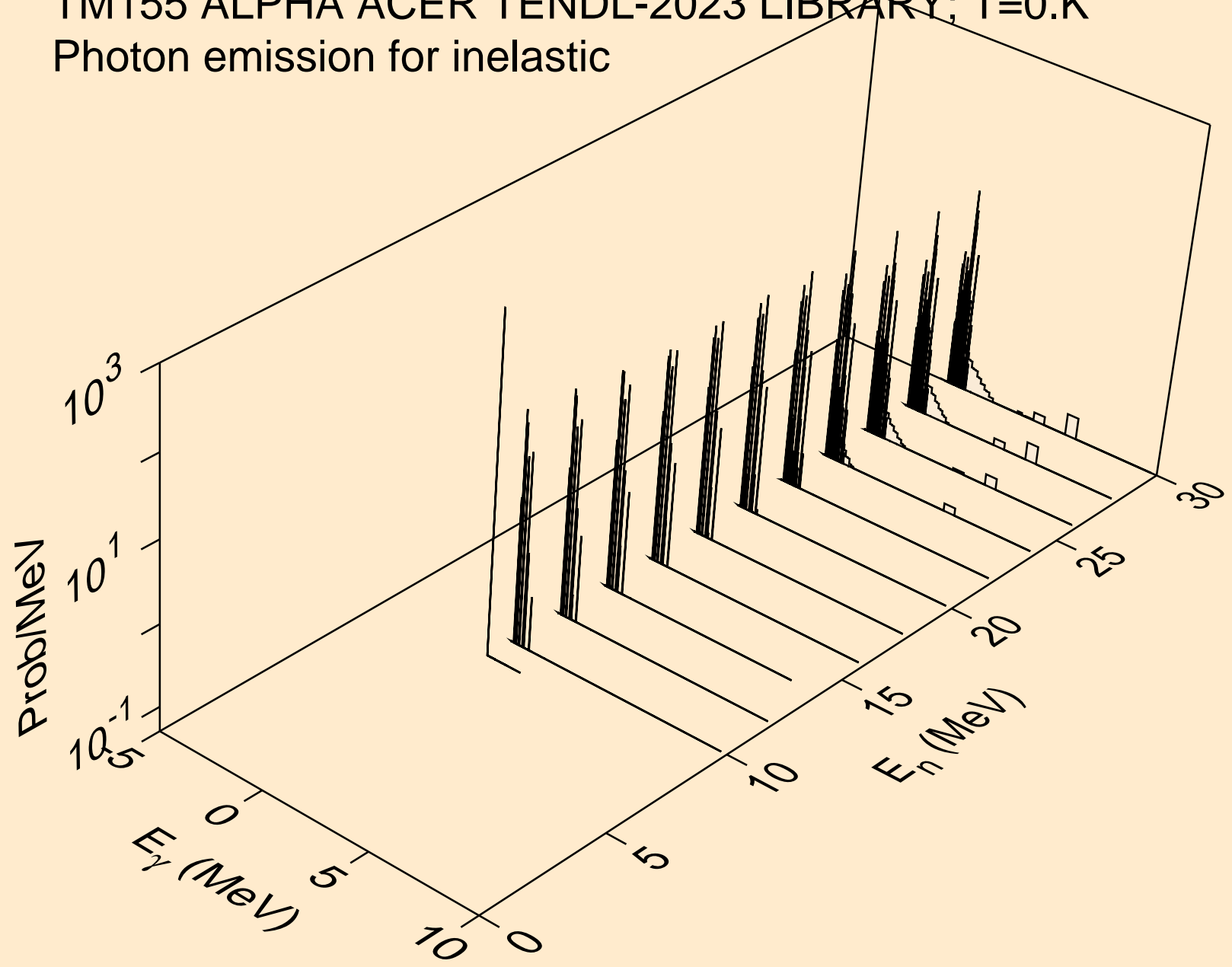

TM155 ALPHA ACER TENDL-2023 LIBRARY; T=0.K  
Photon emission for (n,2a)

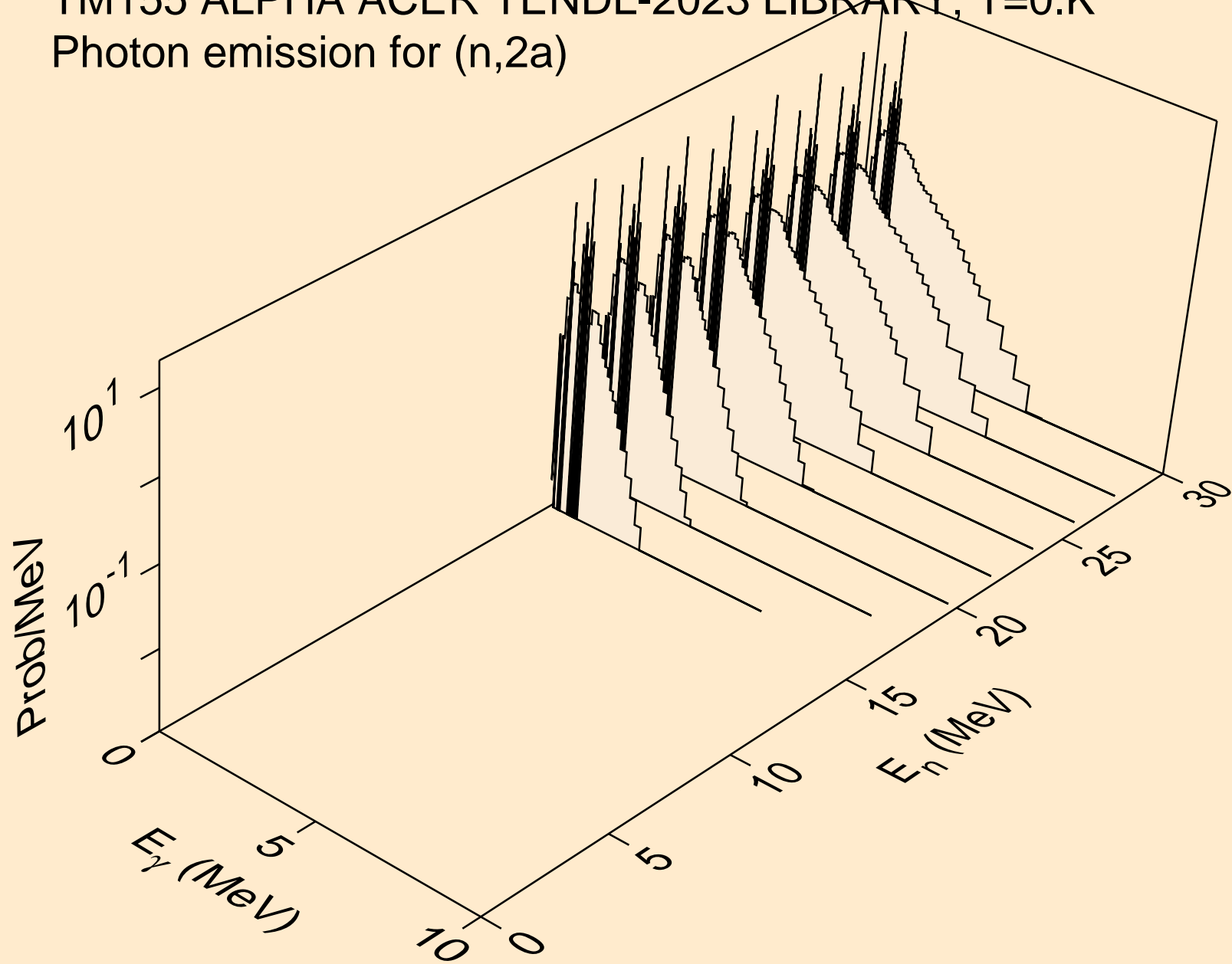

TM155 ALPHA ACER TENDL-2023 LIBRARY; T=0.K  
Photon emission for (n,3a)

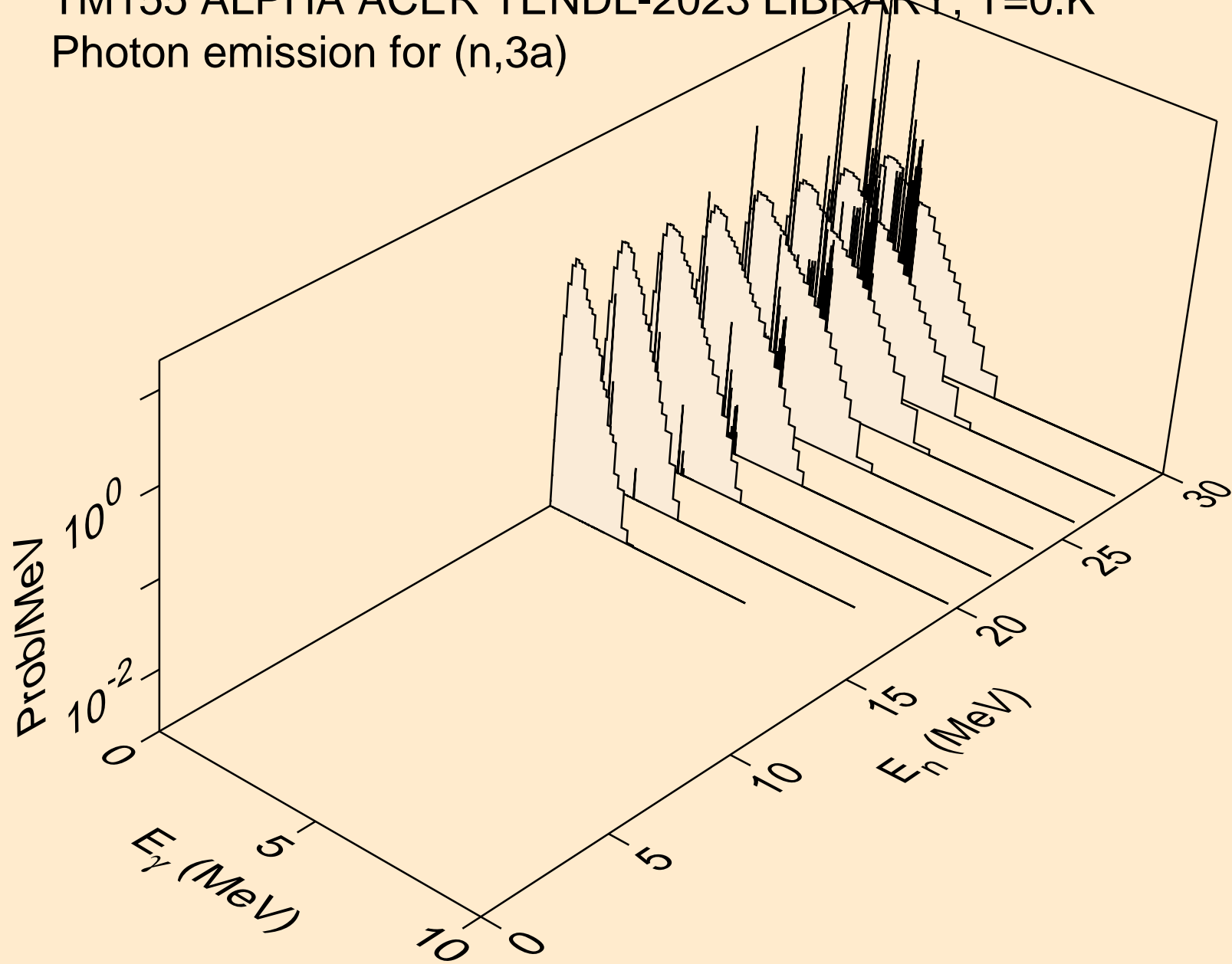

TM155 ALPHA ACER TENDL-2023 LIBRARY; T=0.K  
Photon emission for (n,2p)

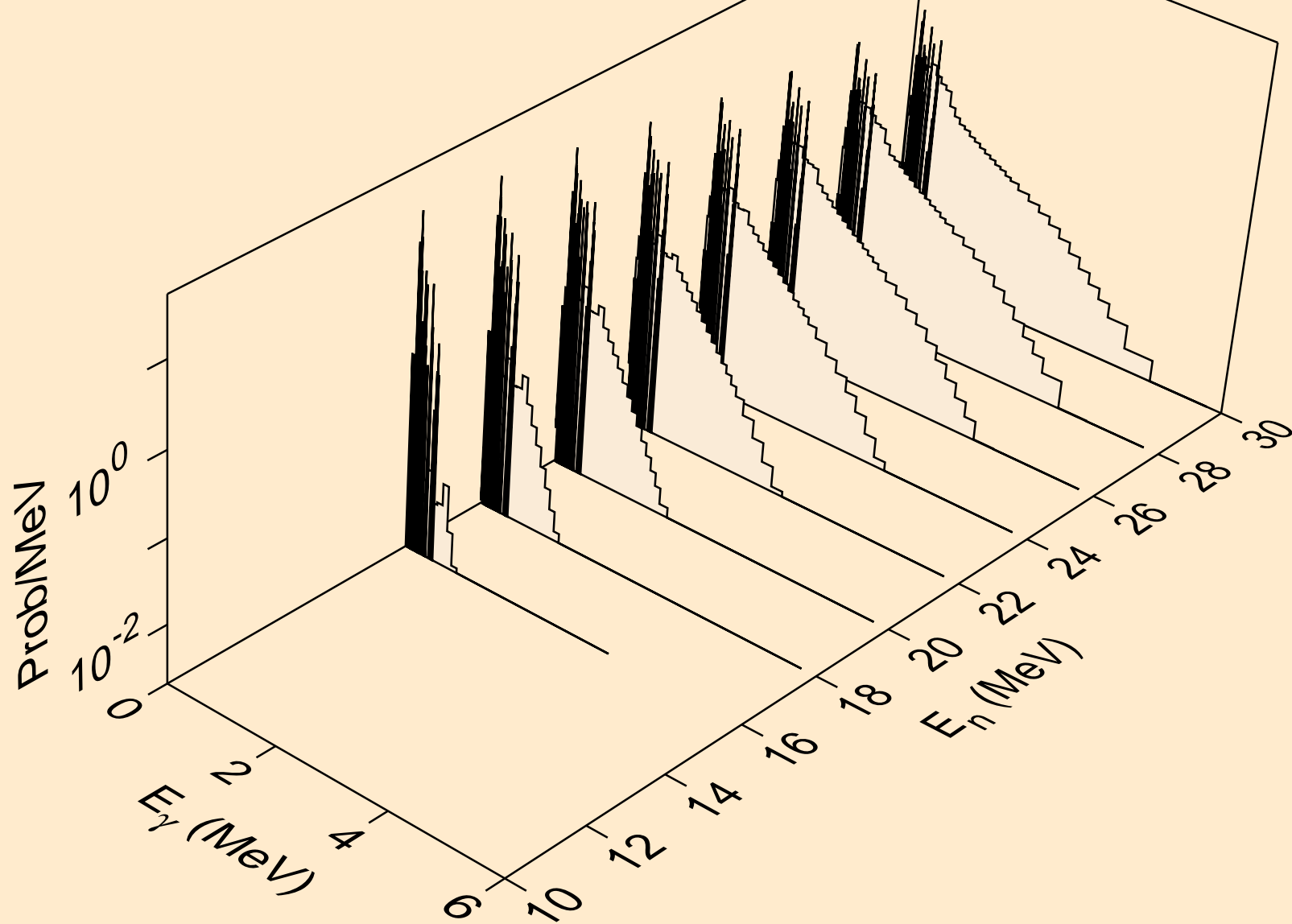

TM155 ALPHA ACER TENDL-2023 LIBRARY; T=0.K  
Photon emission for (n,pa)

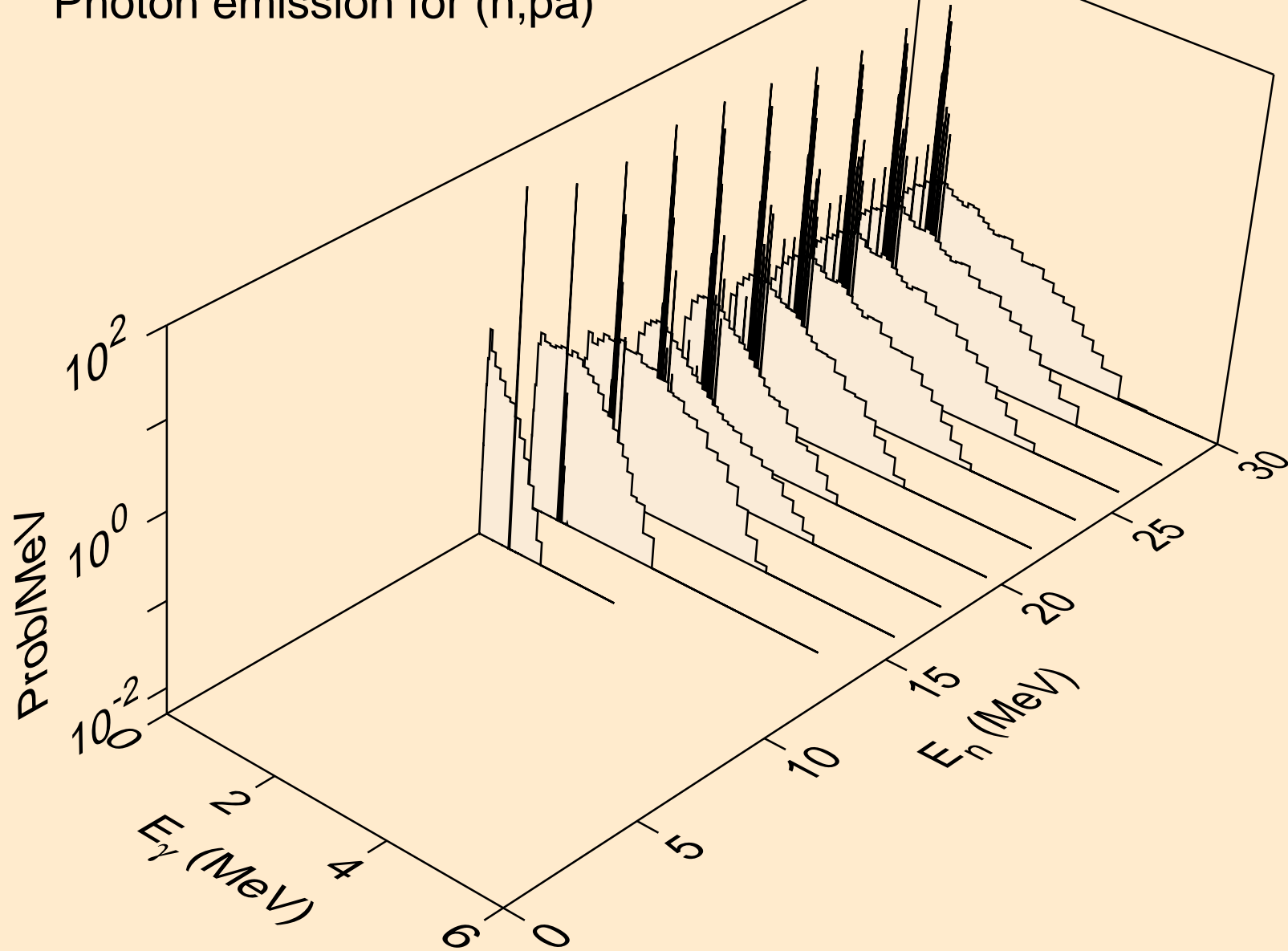

TM155 ALPHA ACER TENDL-2023 LIBRARY; T=0.K  
Photon emission for (n,pd)

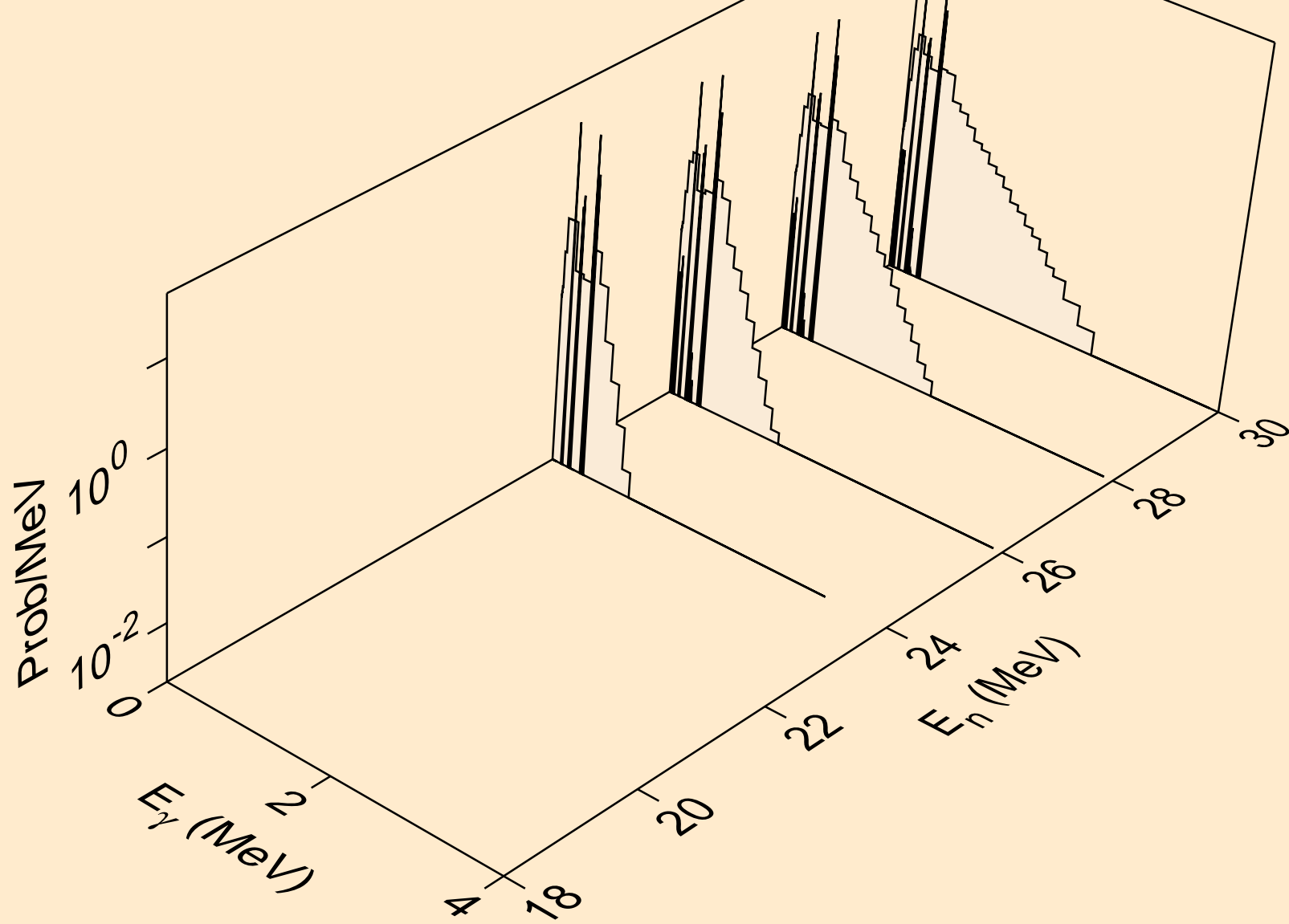

TM155 ALPHA ACER TENDL-2023 LIBRARY; T=0.K  
Photon emission for (n,da)

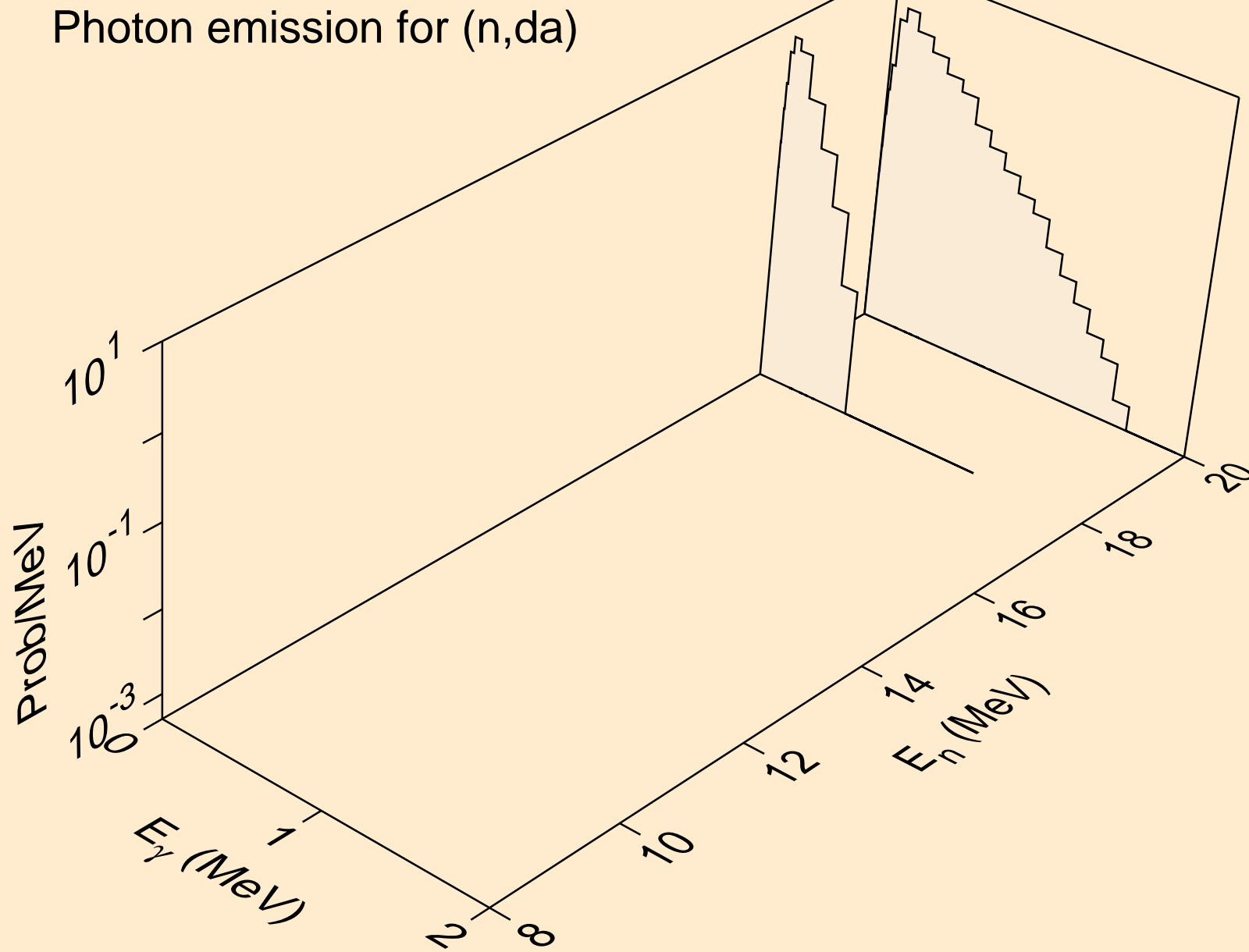

TM155 ALPHA ACER TENDL-2023 LIBRARY; T=0.K  
Particle heating contributions

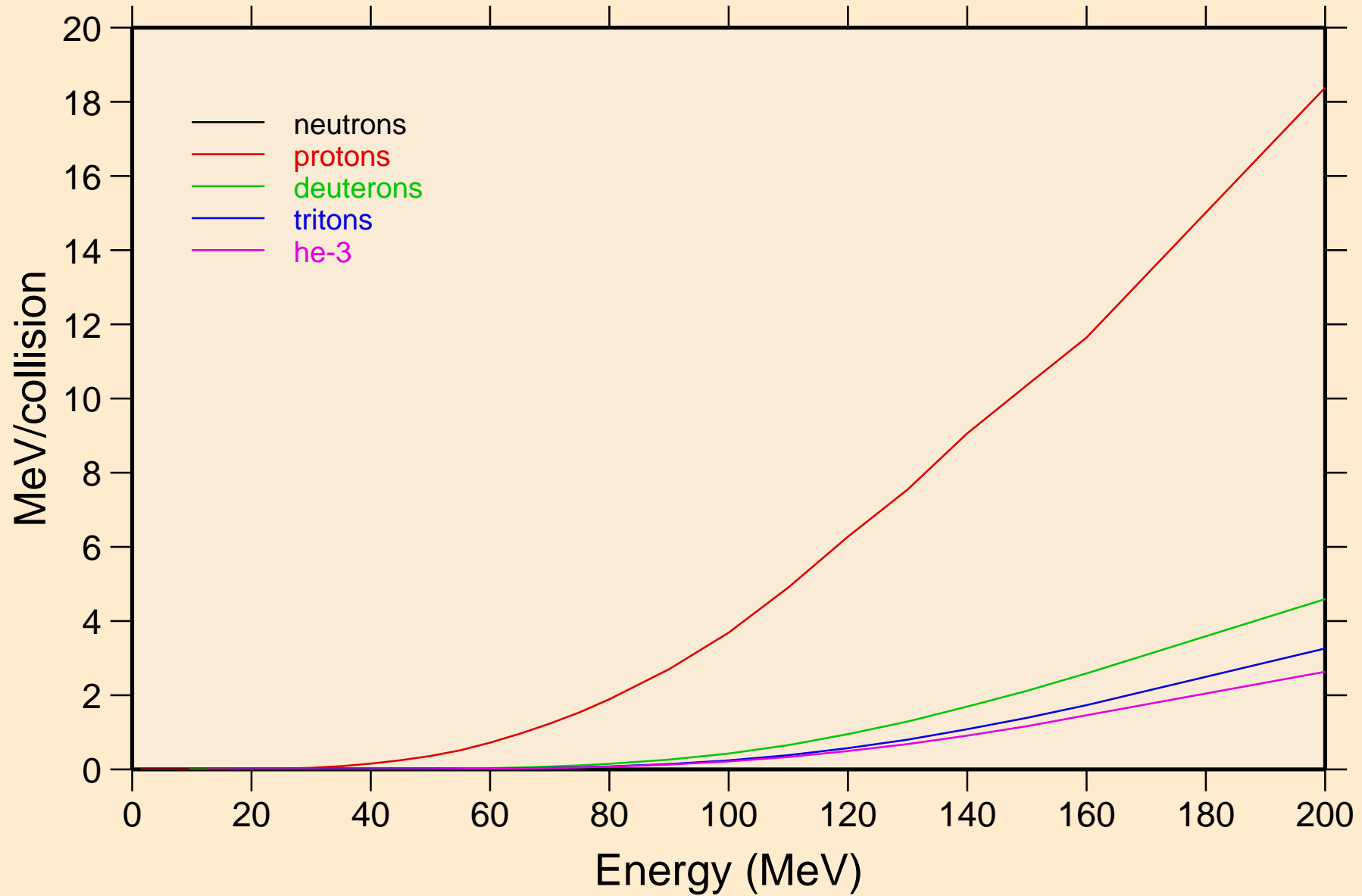

TM155 ALPHA ACER TENDL-2023 LIBRARY; T=0.K  
Recoil Heating

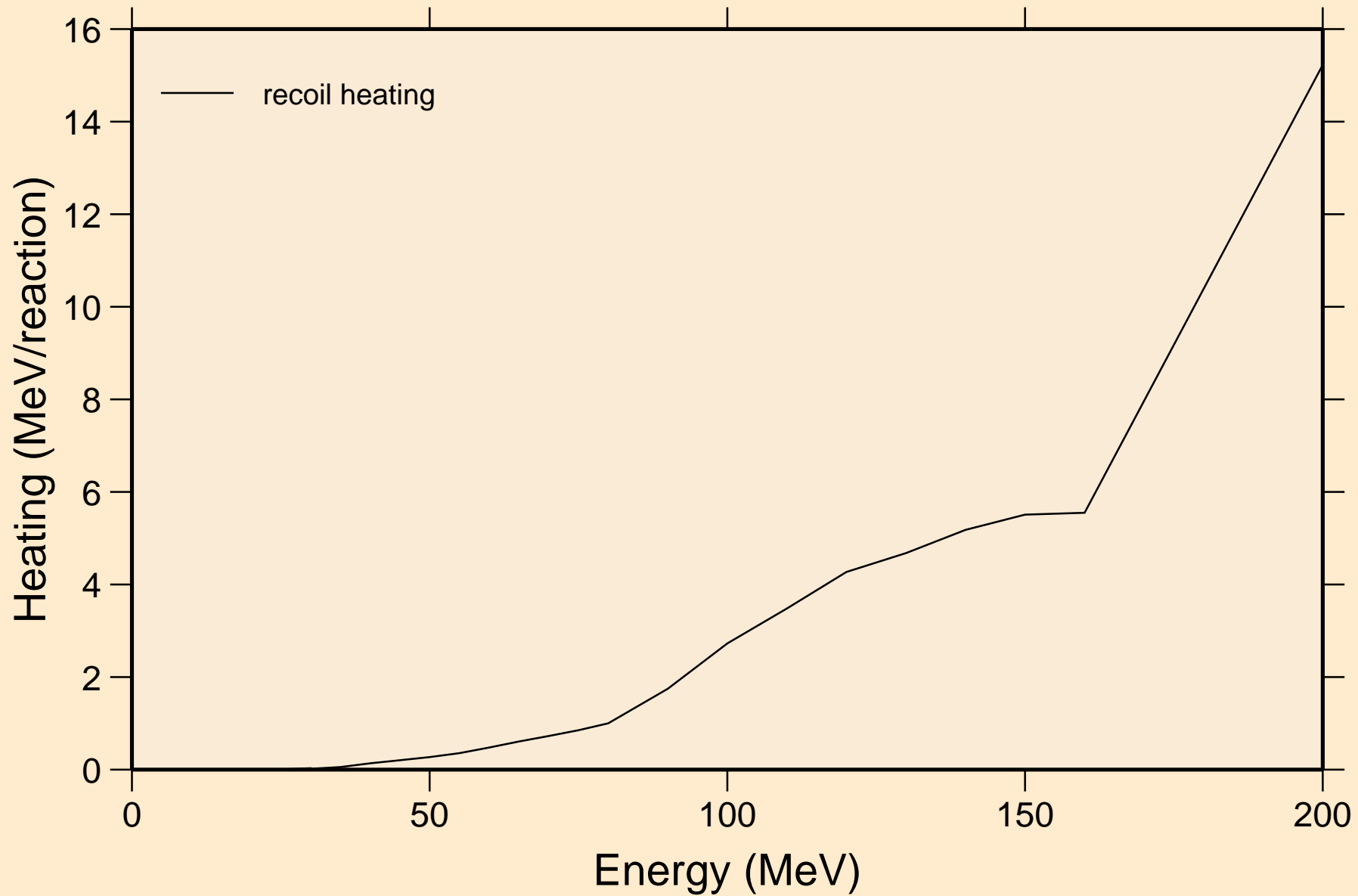

TM155 ALPHA ACER TENDL-2023 LIBRARY; T=0.K  
Particle production cross sections

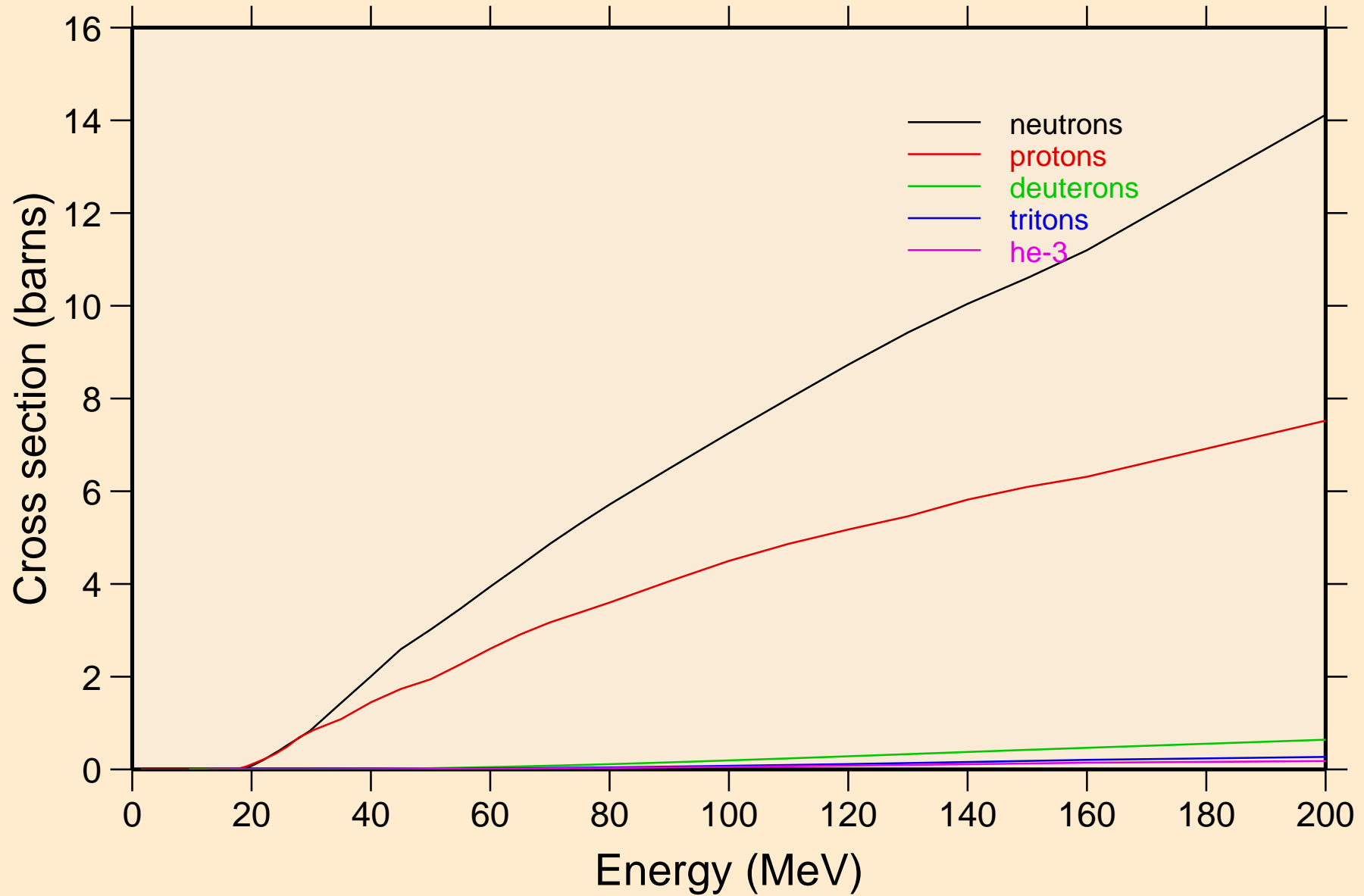

TM155 ALPHA ACER TENDL-2023 LIBRARY; T=0.K  
neutrons from (a,n)

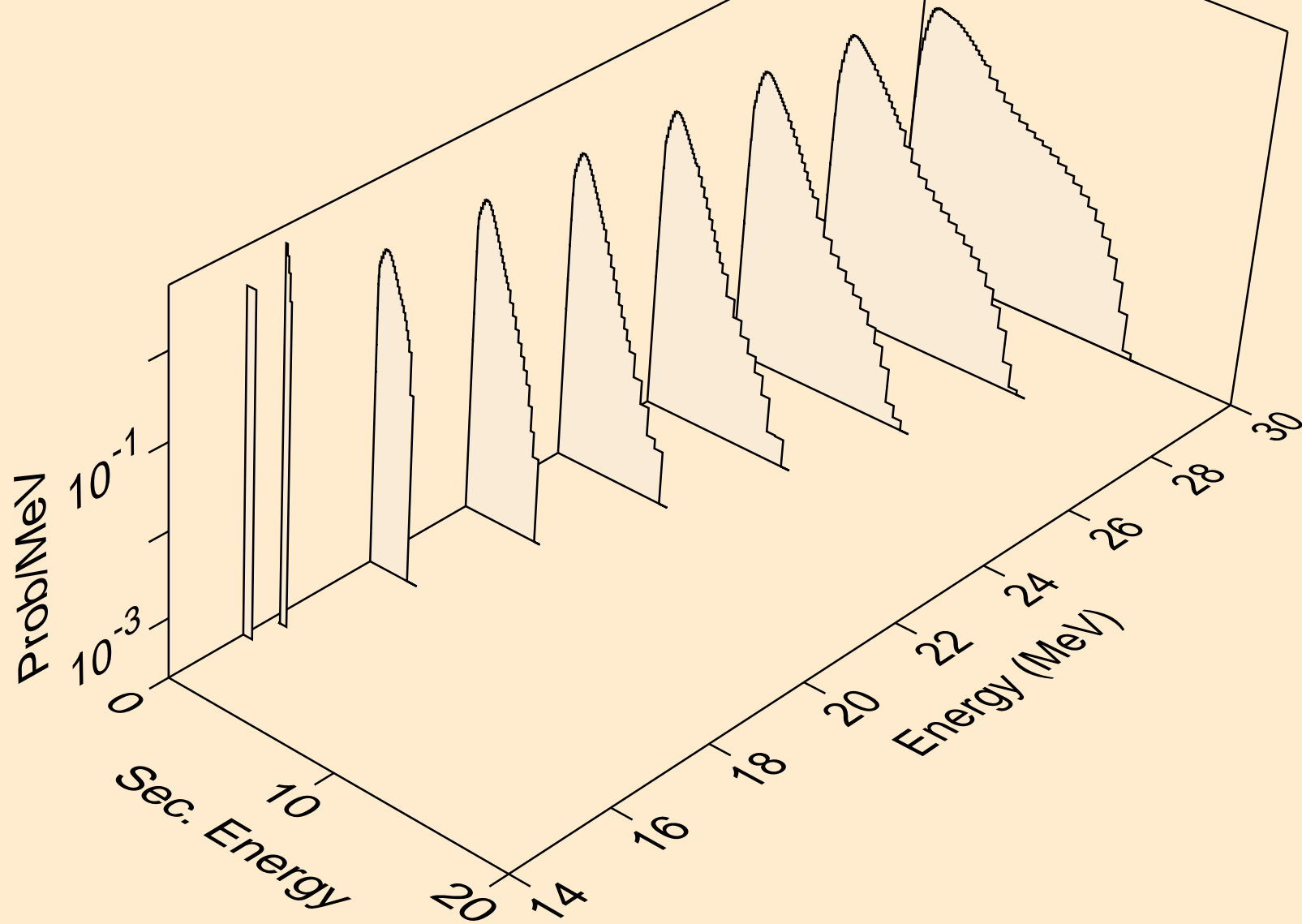

TM155 ALPHA ACER TENDL-2023 LIBRARY; T=0.K  
neutrons from (a,x)

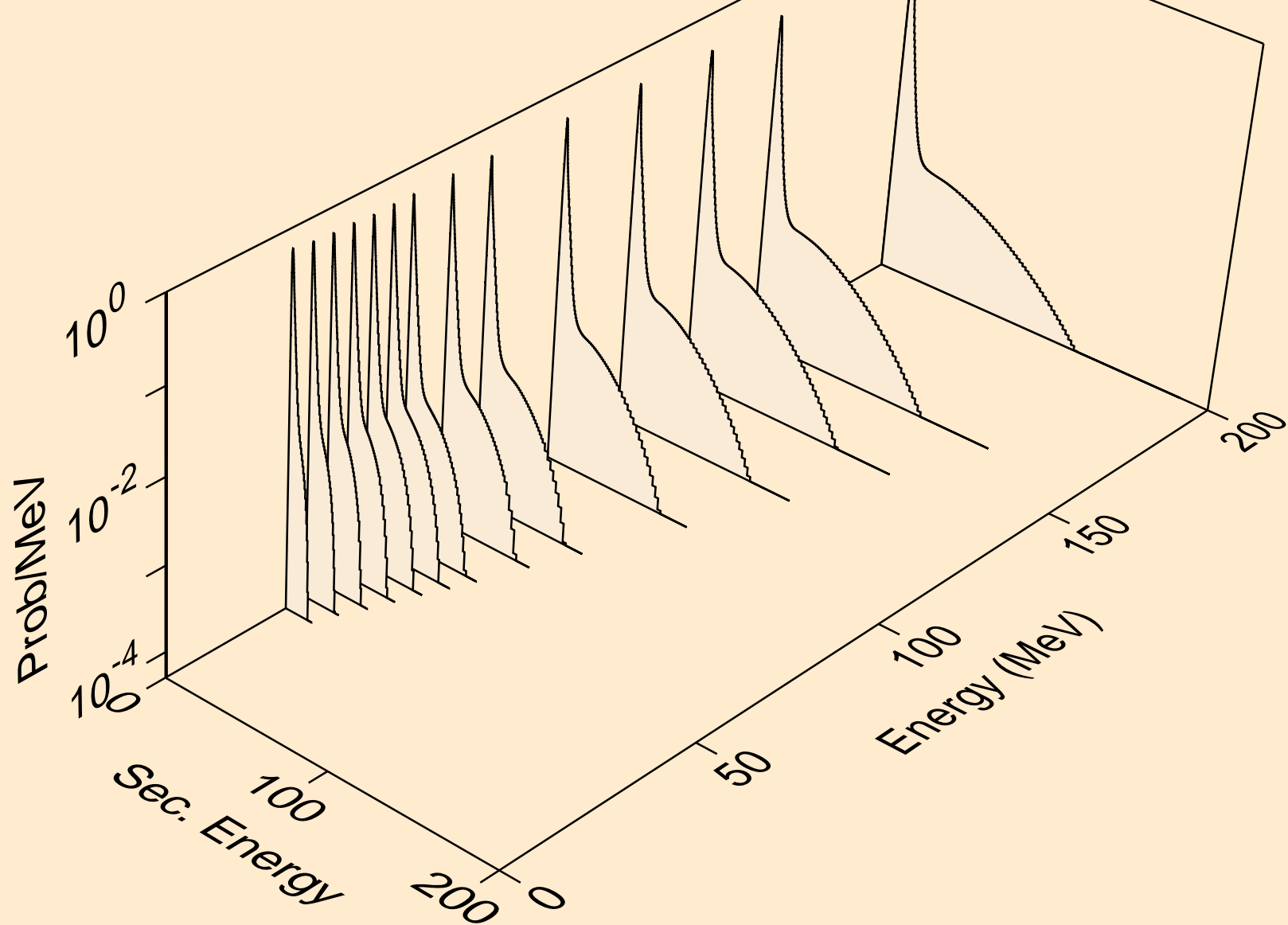

TM155 ALPHA ACER TENDL-2023 LIBRARY; T=0.K  
neutrons from (a,2n)

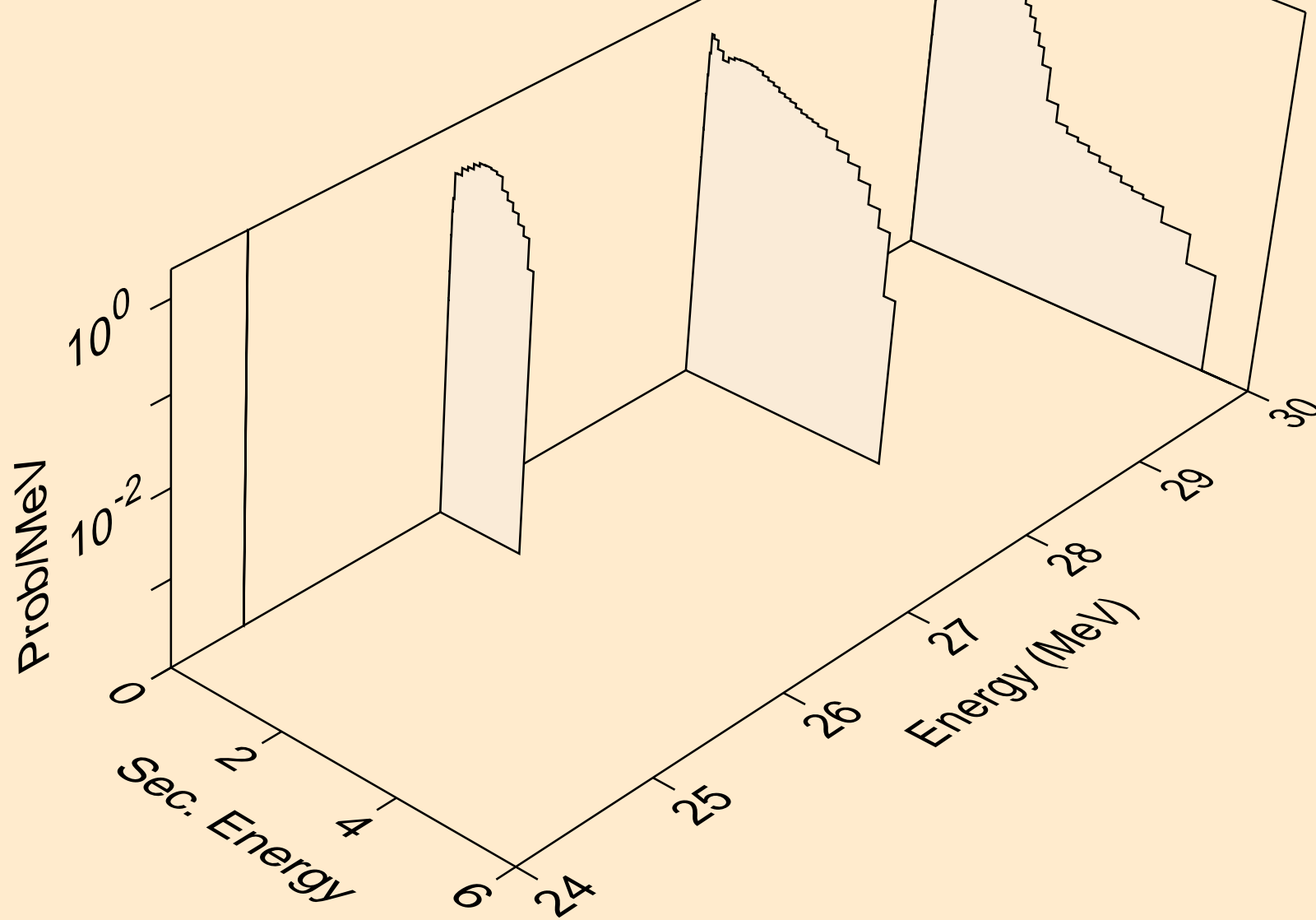

TM155 ALPHA ACER TENDL-2023 LIBRARY; T=0.K  
neutrons from (a,n\*)a

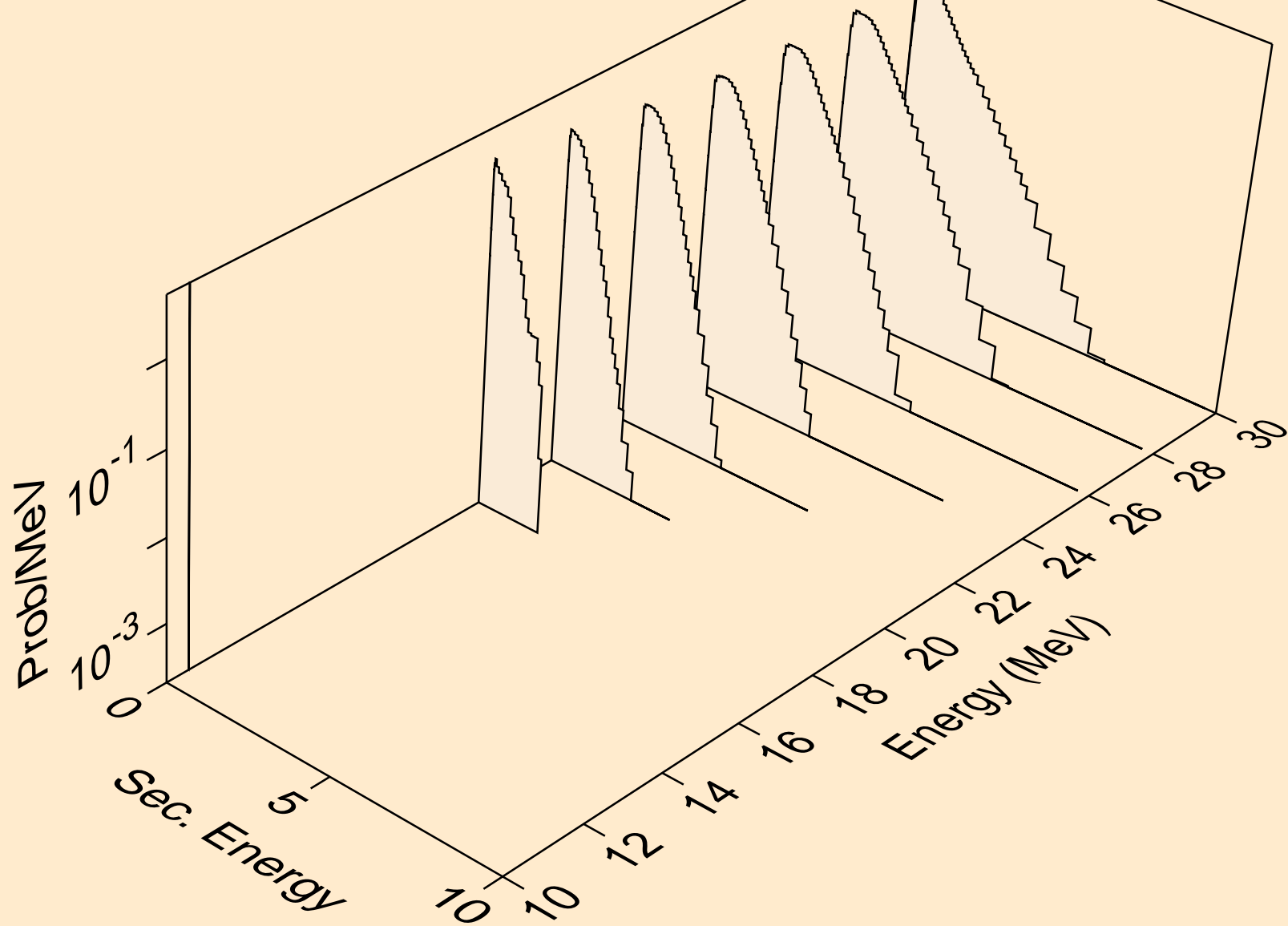

TM155 ALPHA ACER TENDL-2023 LIBRARY; T=0.K  
neutrons from (a,2n)a

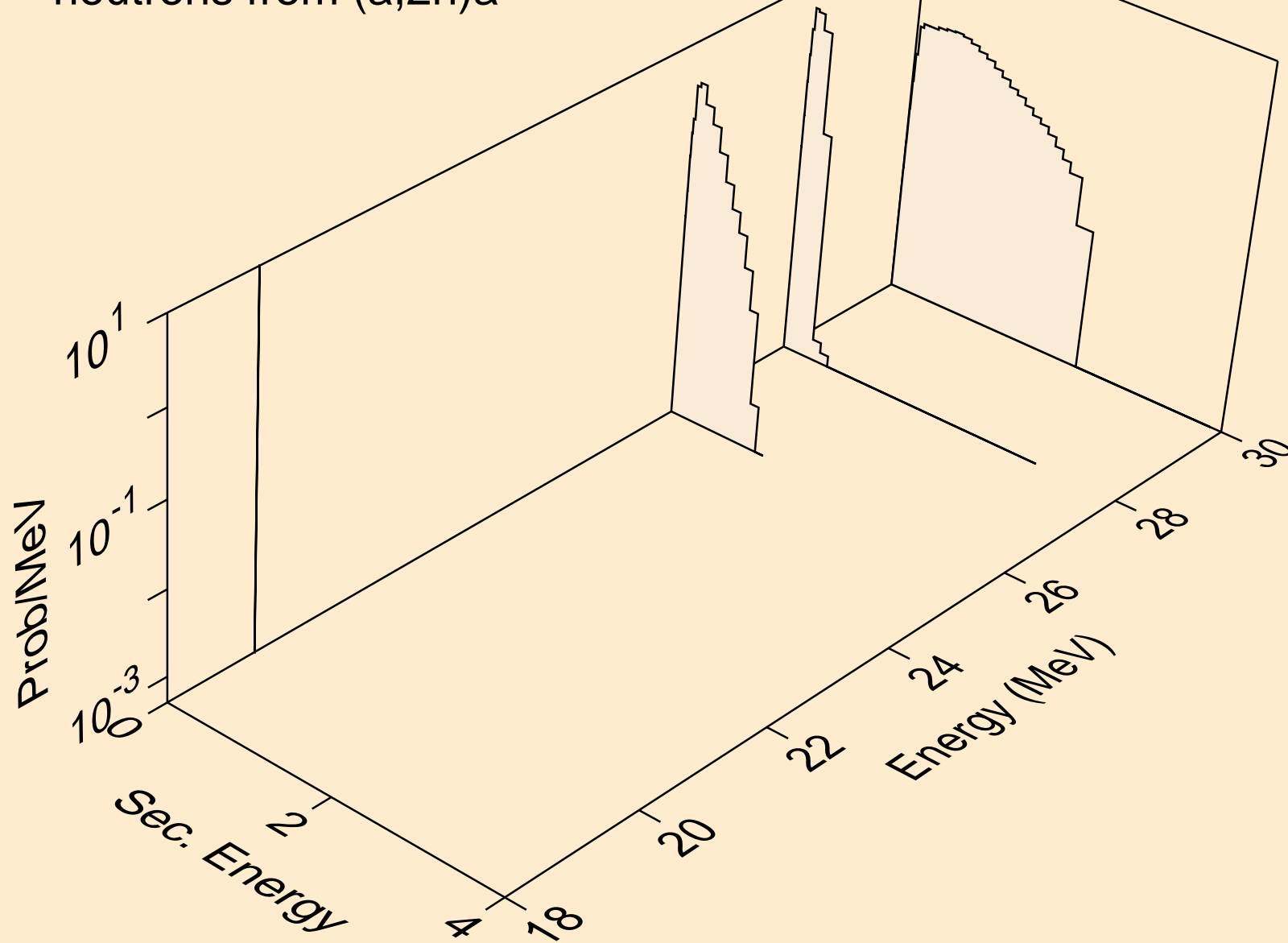

TM155 ALPHA ACER TENDL-2023 LIBRARY; T=0.K  
neutrons from (a,n\*)p

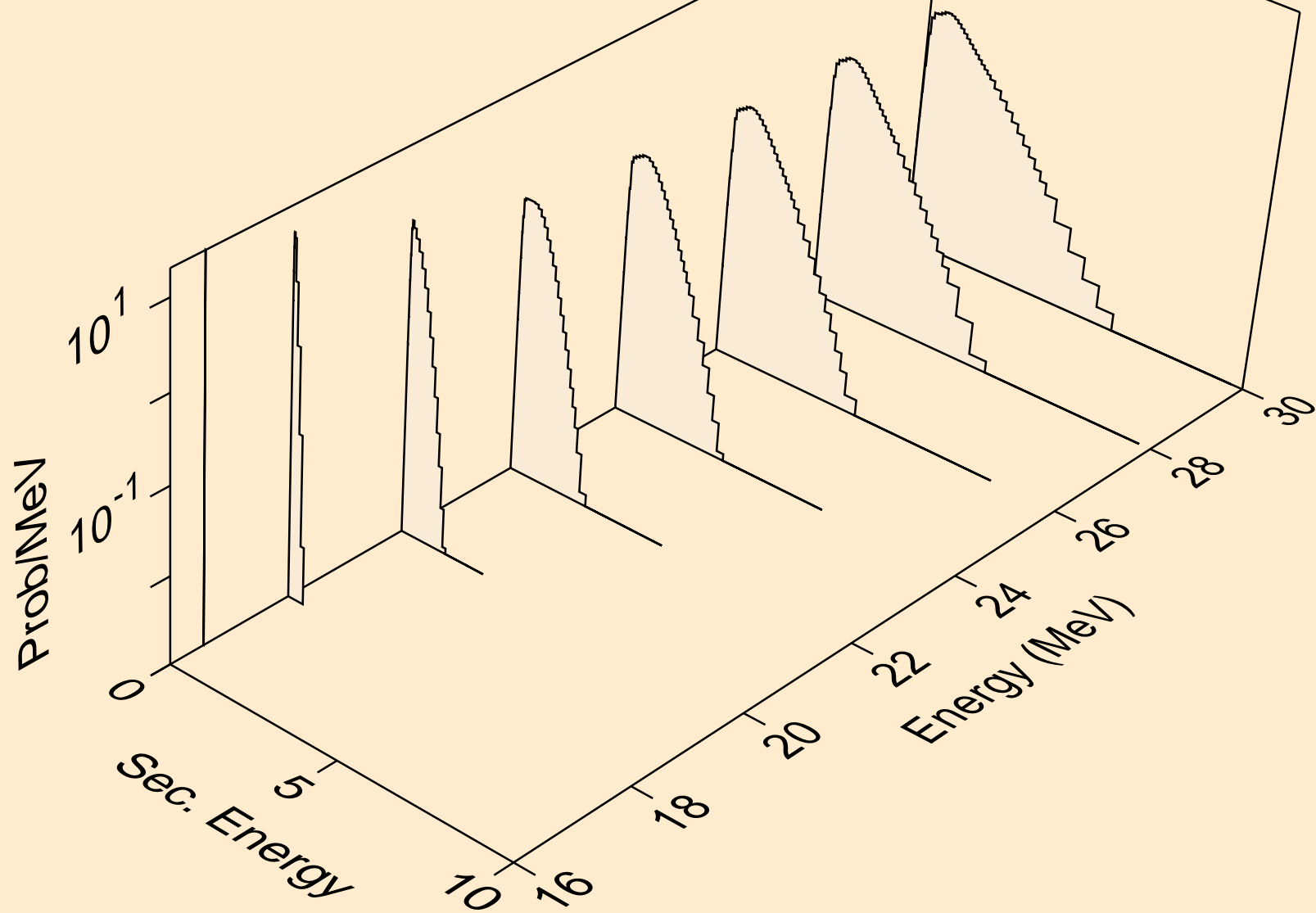

TM155 ALPHA ACER TENDL-2023 LIBRARY; T=0.K  
neutrons from (a,n\*)2a

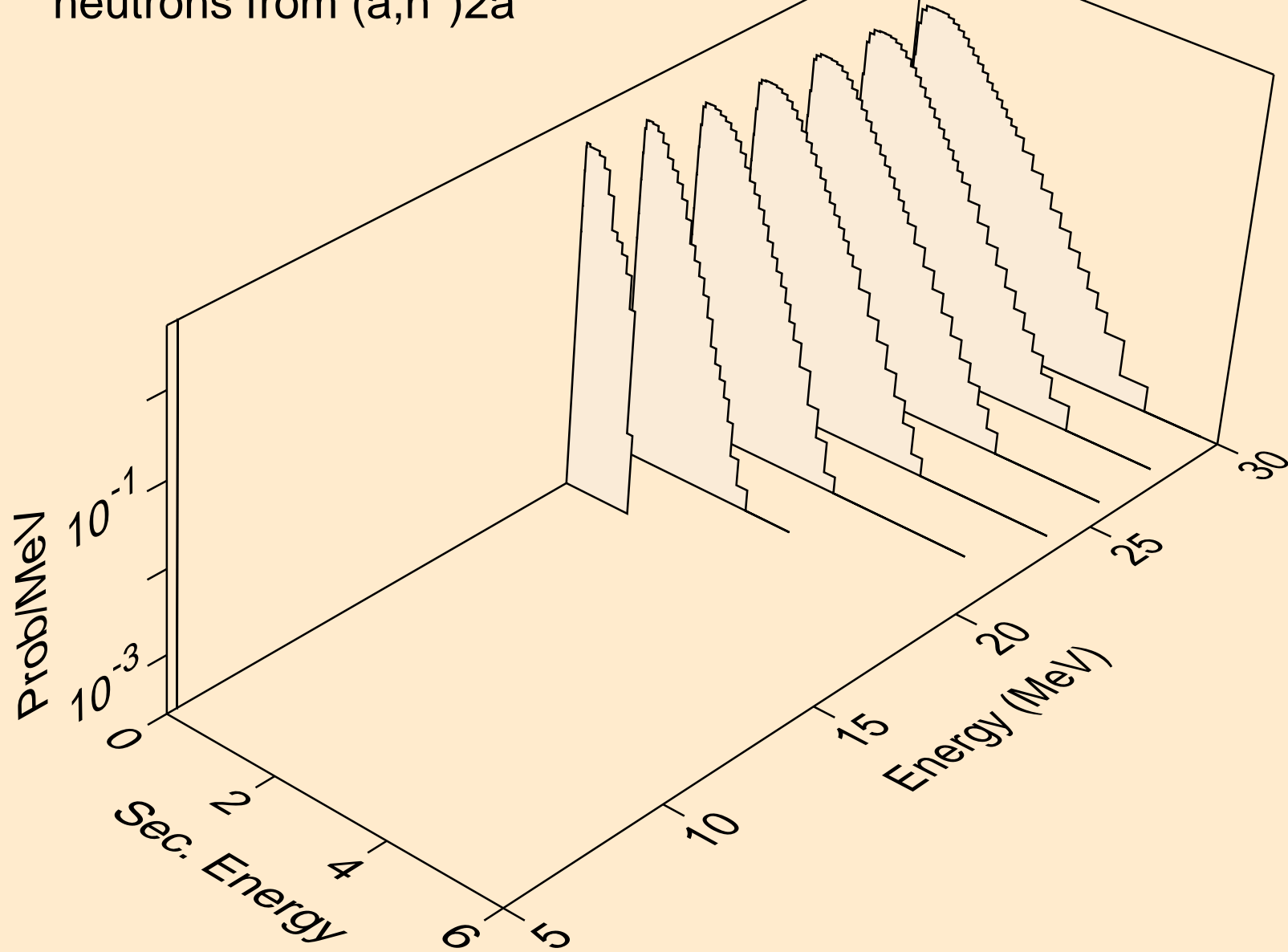

TM155 ALPHA ACER TENDL-2023 LIBRARY; T=0.K  
neutrons from (a,2n)2a

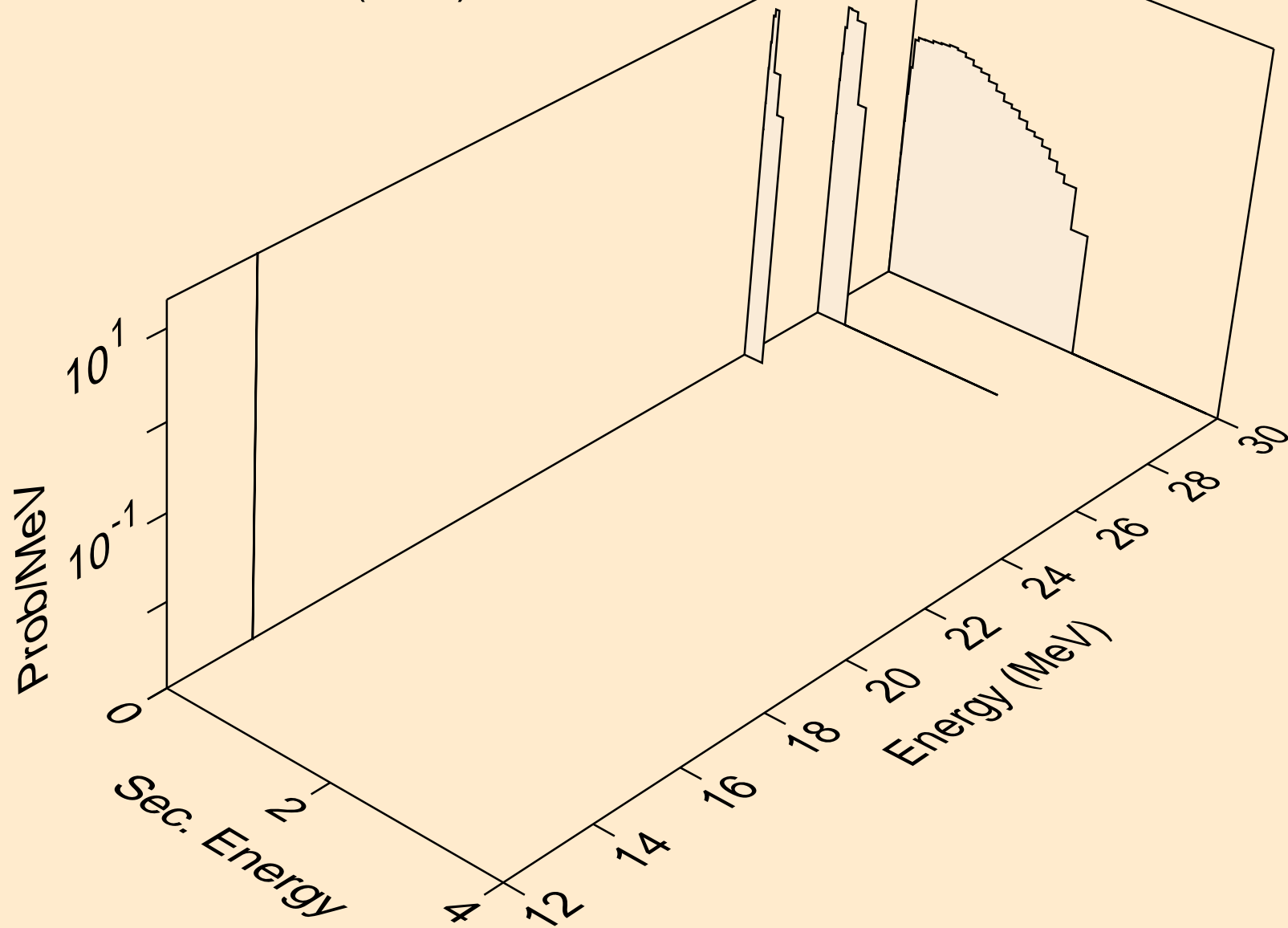

TM155 ALPHA ACER TENDL-2023 LIBRARY; T=0.K  
neutrons from (a,n\*)d

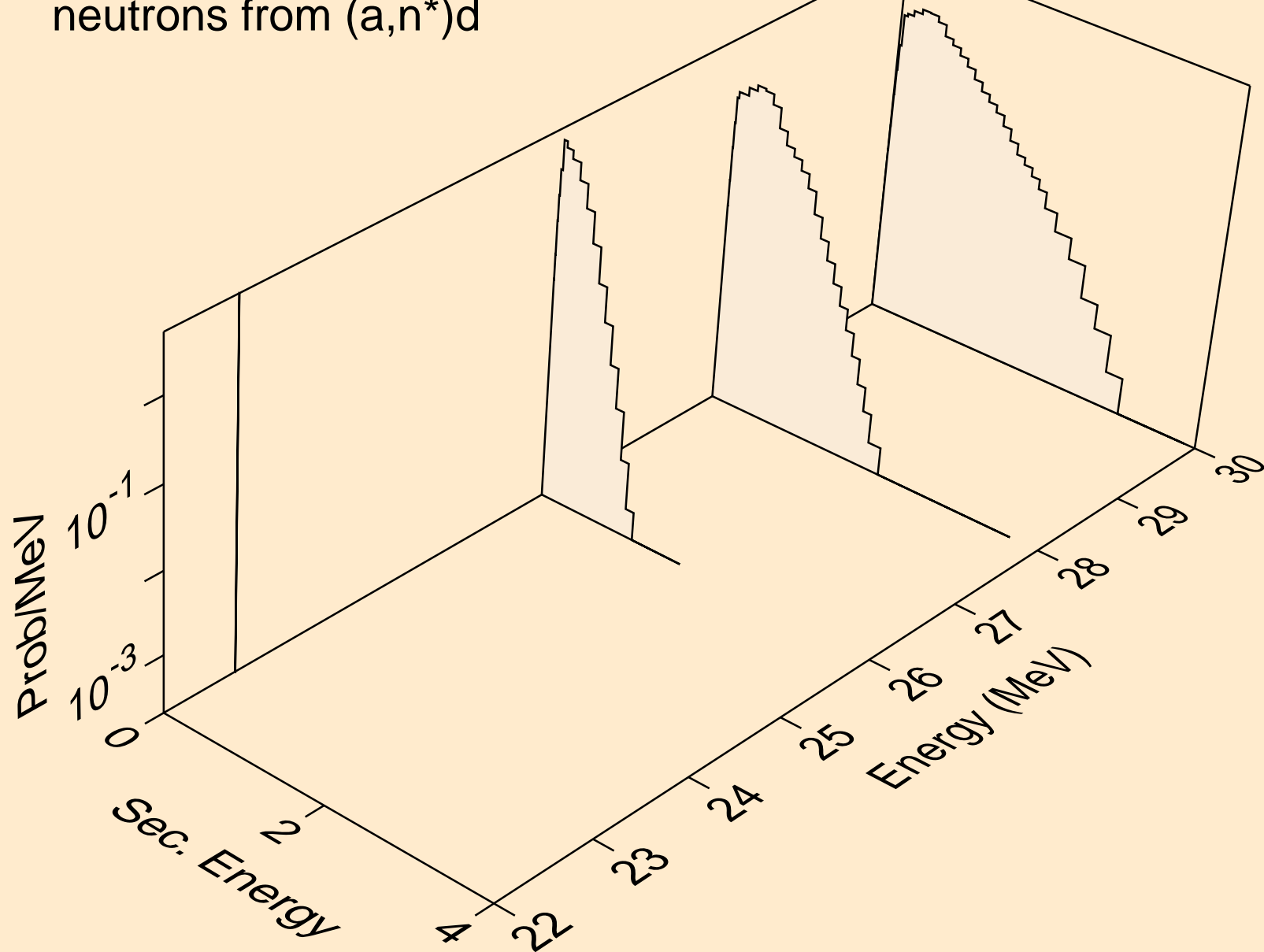

TM155 ALPHA ACER TENDL-2023 LIBRARY; T=0.K  
neutrons from (a,2np)

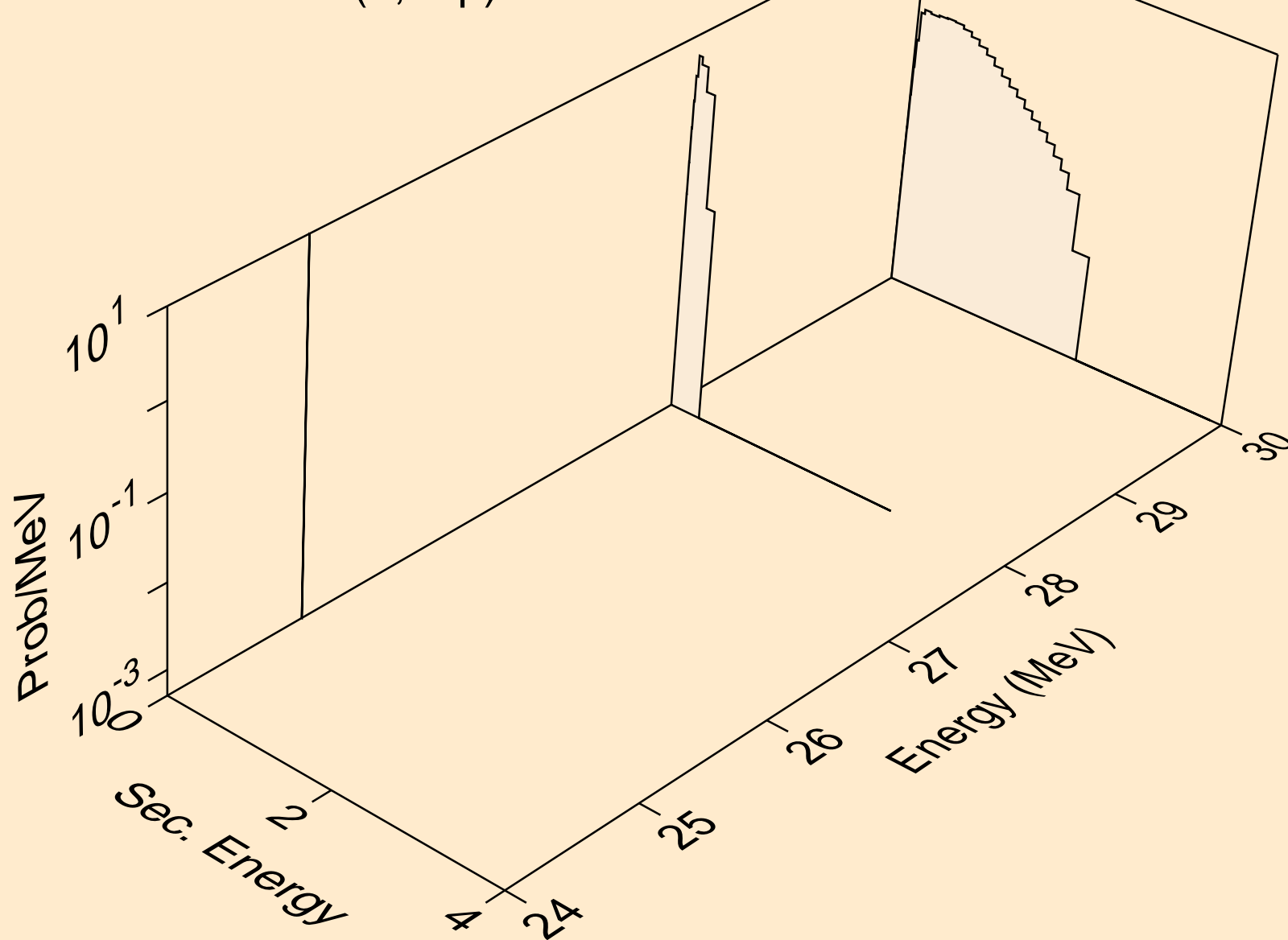

TM155 ALPHA ACER TENDL-2023 LIBRARY; T=0.K  
neutrons from (a,n2p)

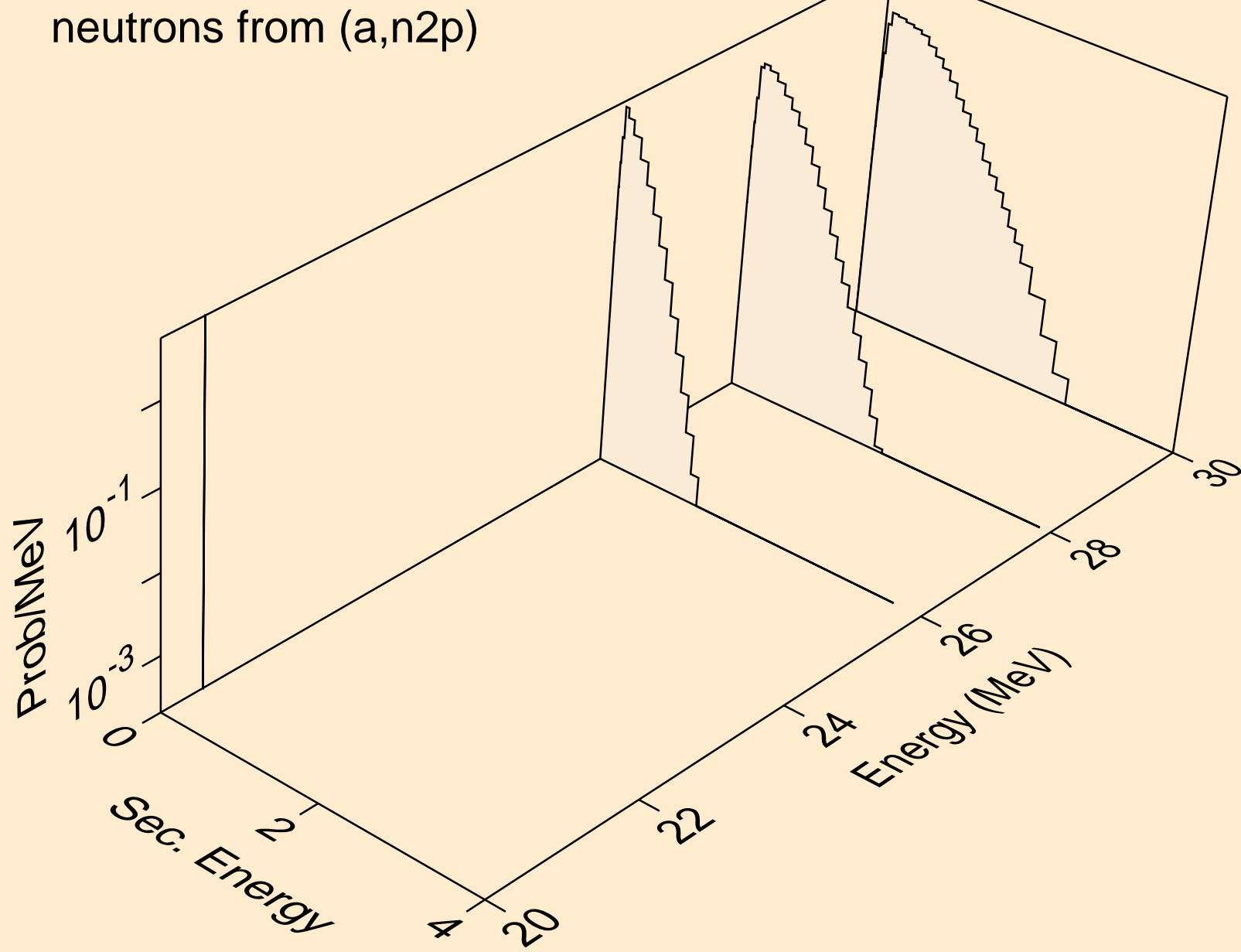

TM155 ALPHA ACER TENDL-2023 LIBRARY; T=0.K  
neutrons from (a,npa)

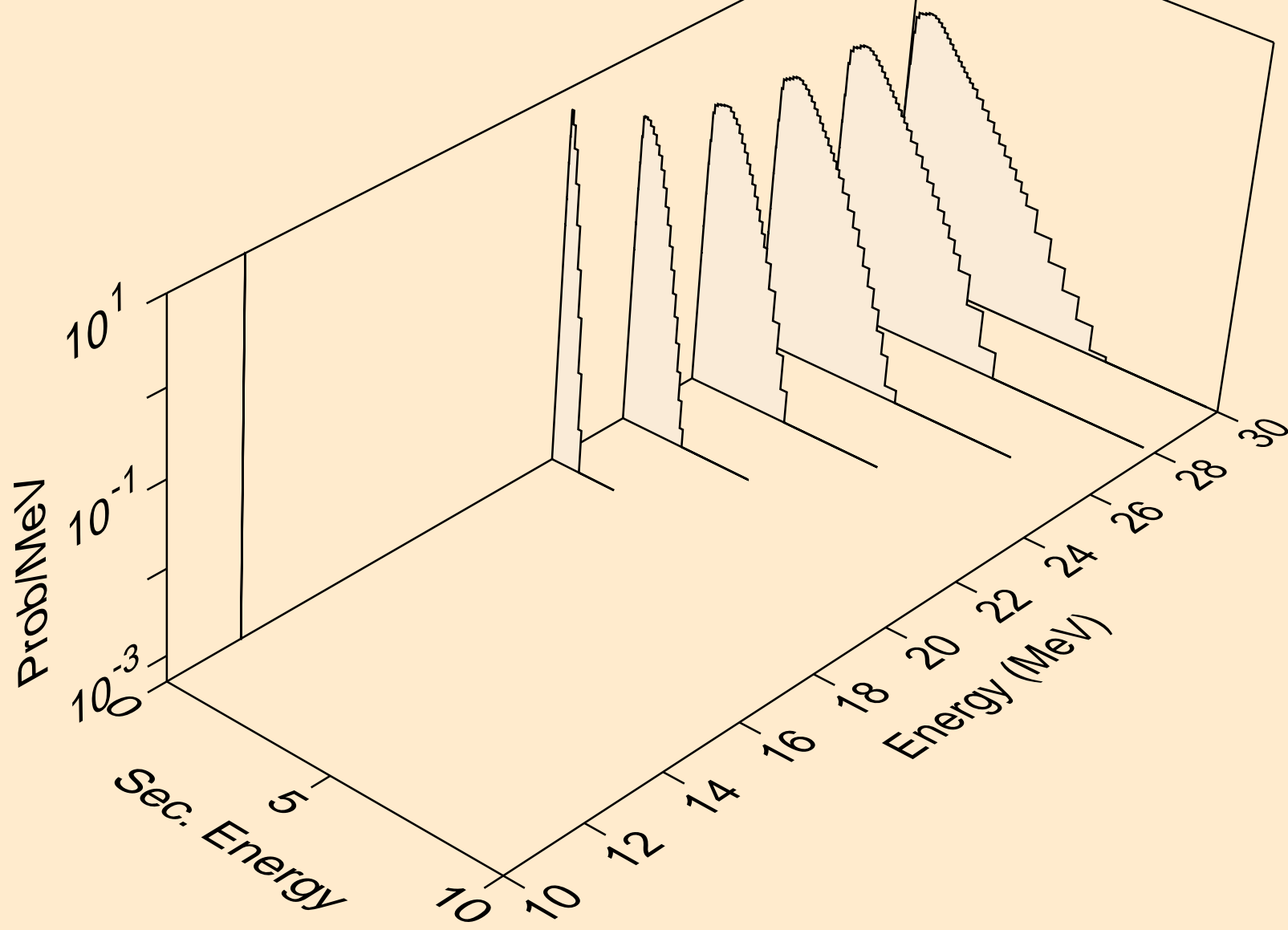

TM155 ALPHA ACER TENDL-2023 LIBRARY; T=0.K  
protons from (a,x)

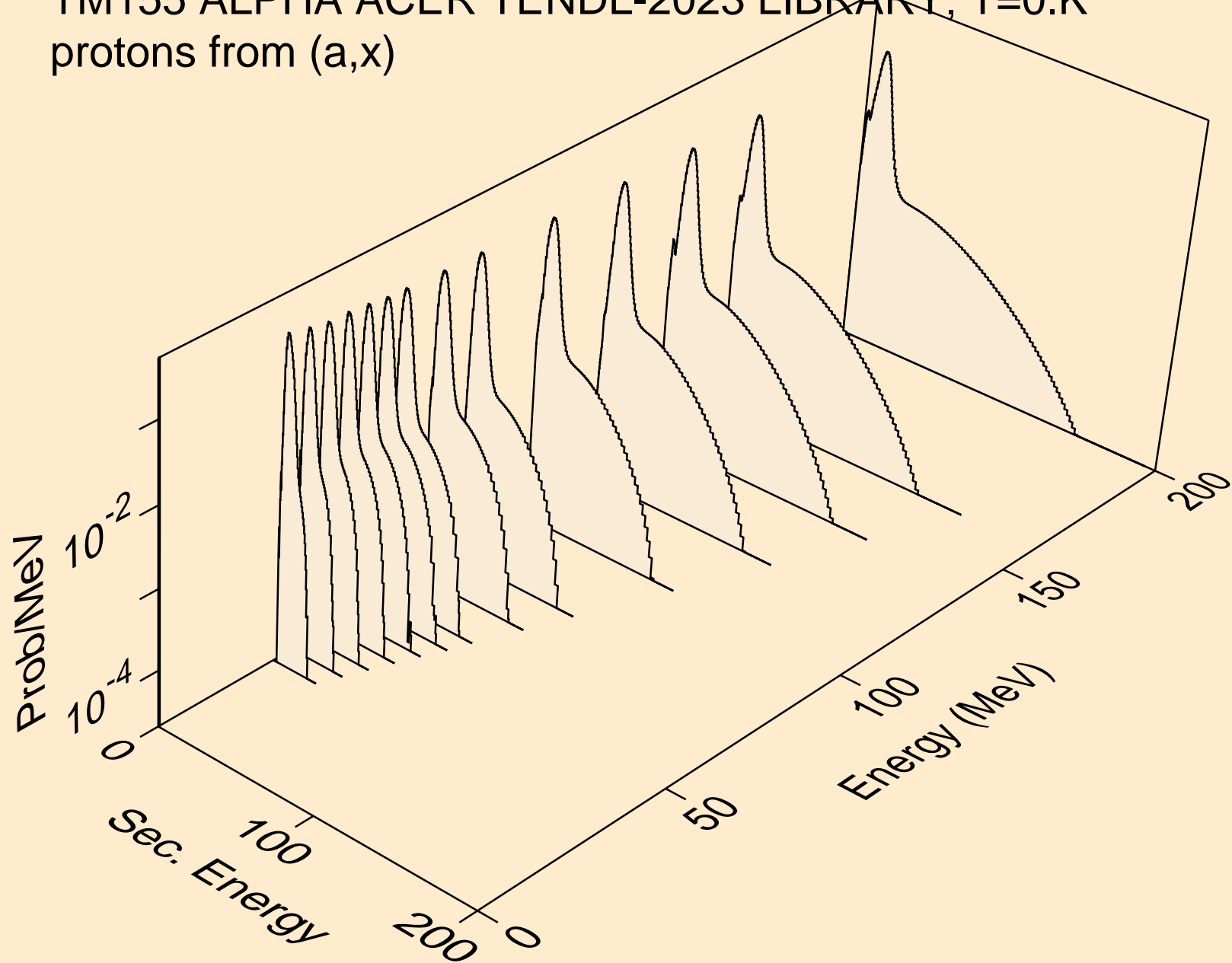

TM155 ALPHA ACER TENDL-2023 LIBRARY; T=0.K  
protons from (a,n\*)p

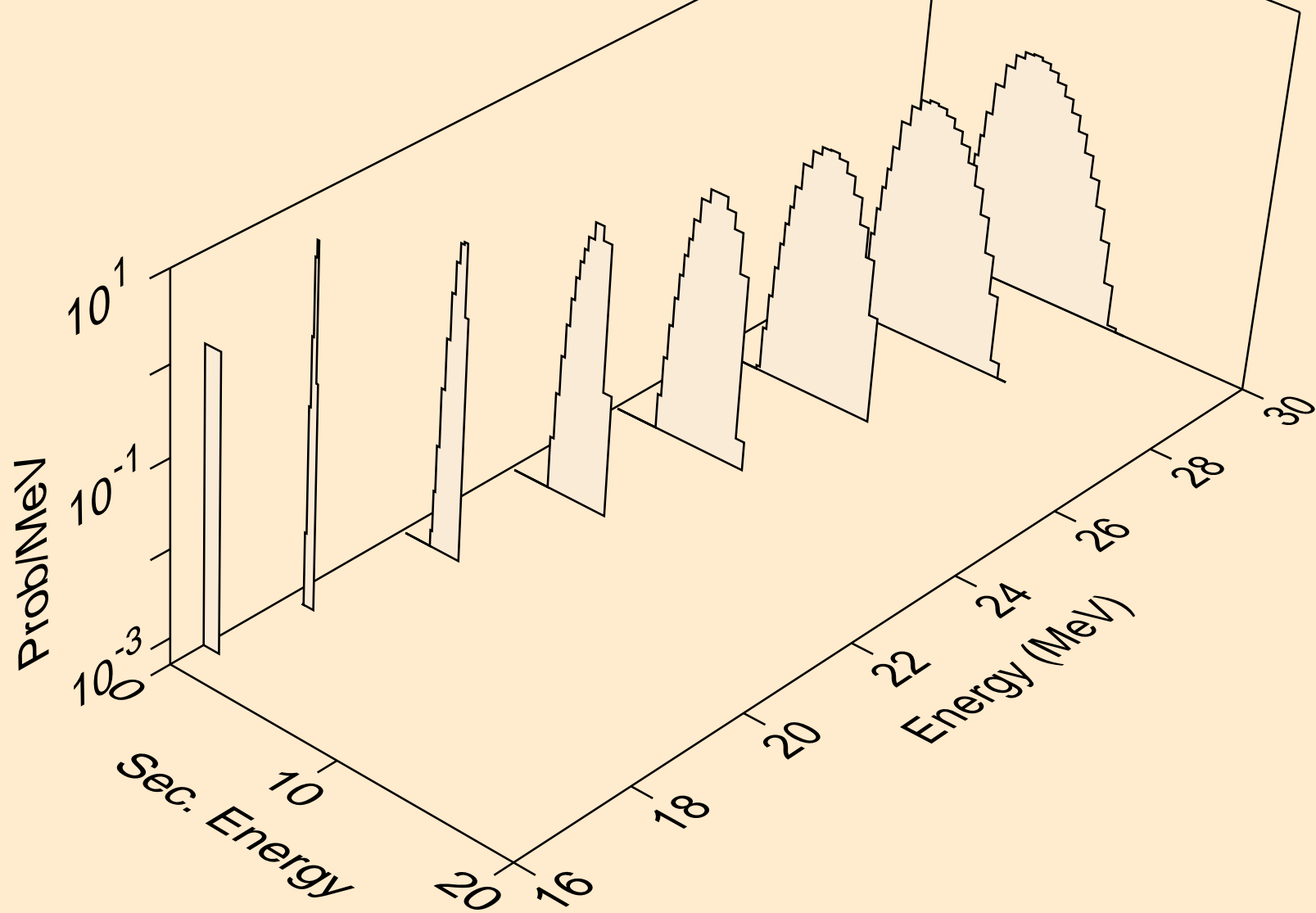

TM155 ALPHA ACER TENDL-2023 LIBRARY; T=0.K  
protons from (a,2np)

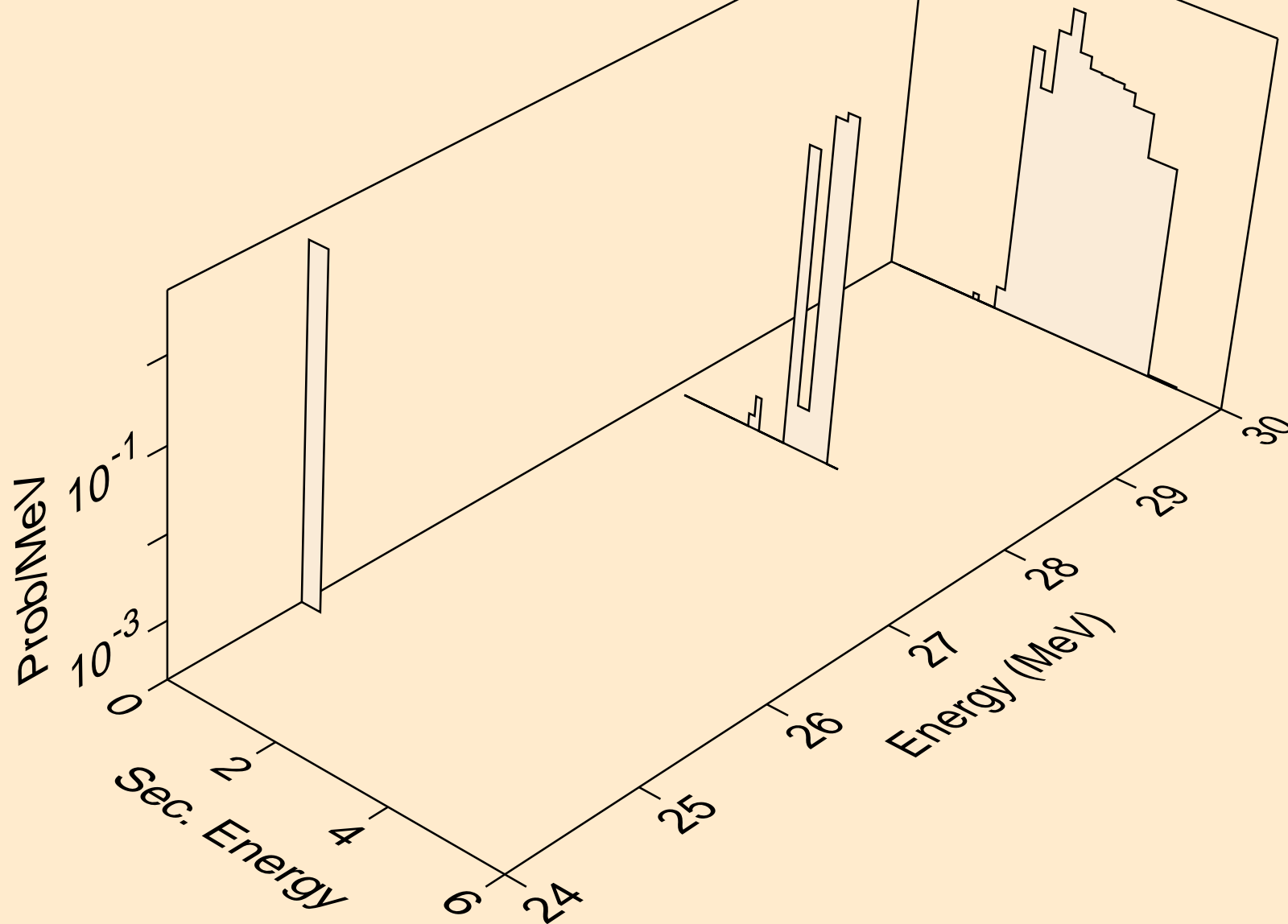

TM155 ALPHA ACER TENDL-2023 LIBRARY; T=0.K  
protons from (a,n2p)

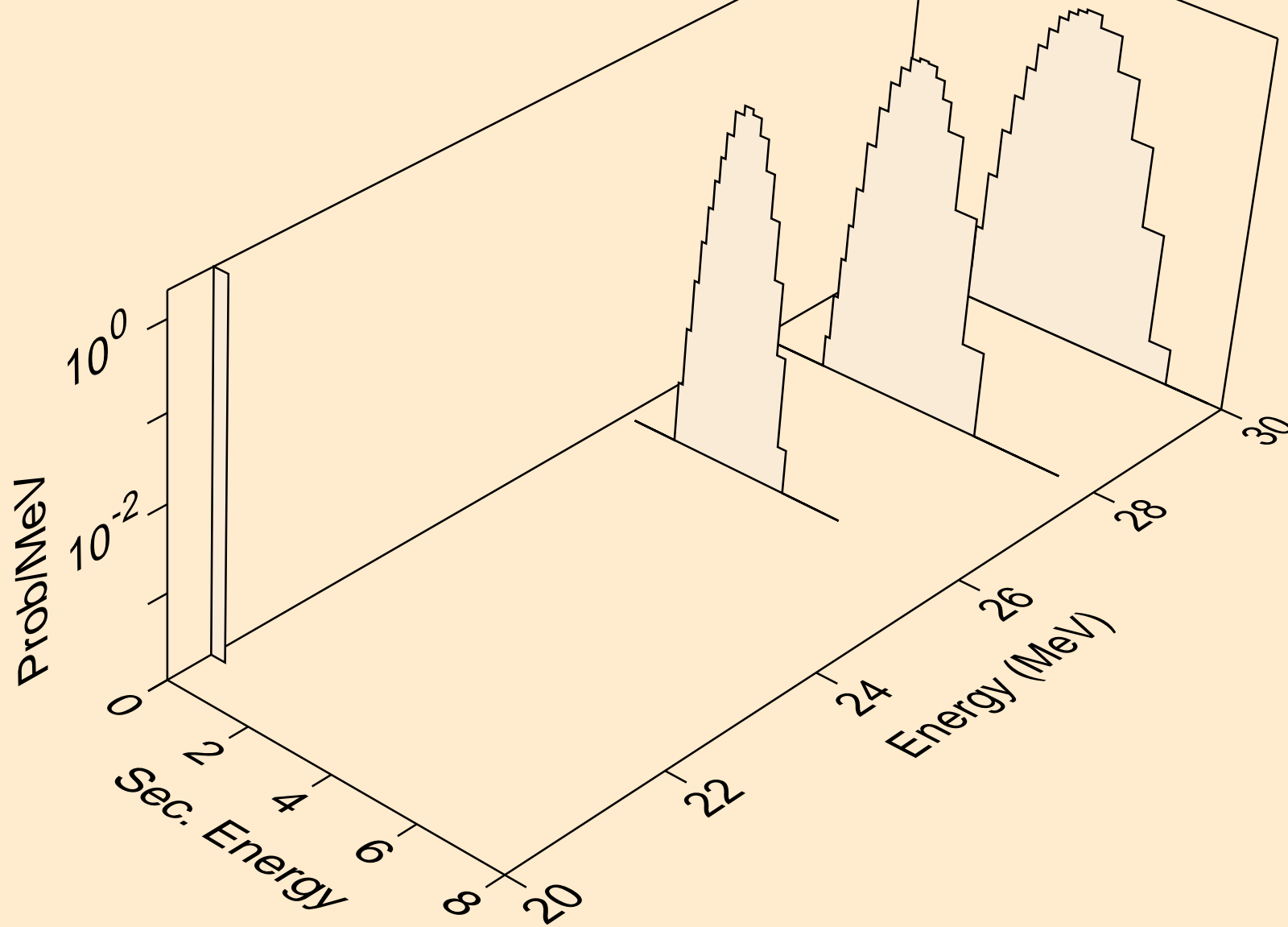

TM155 ALPHA ACER TENDL-2023 LIBRARY; T=0.K  
protons from (a,npa)

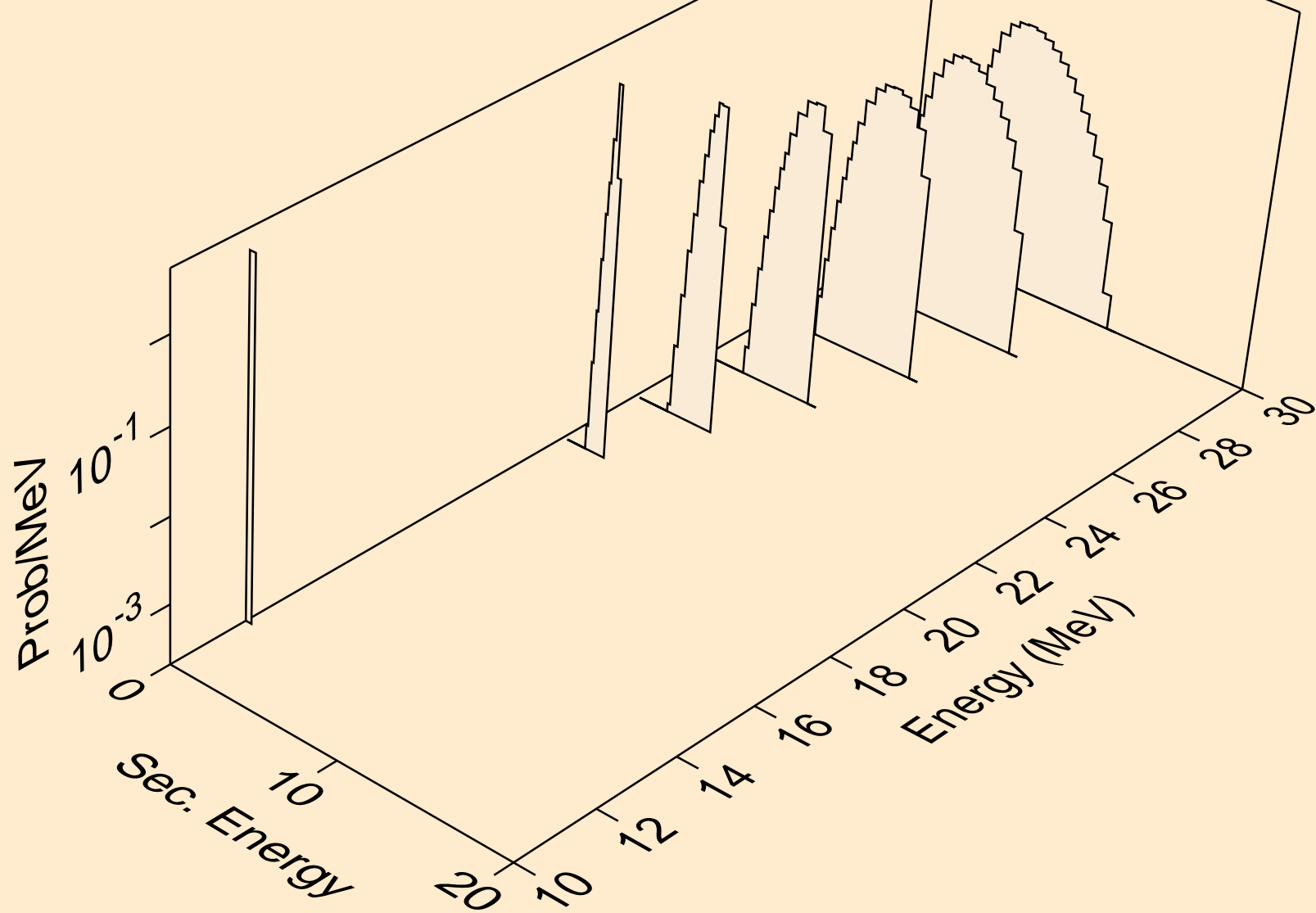

TM155 ALPHA ACER TENDL-2023 LIBRARY; T=0.K  
protons from (a,p)

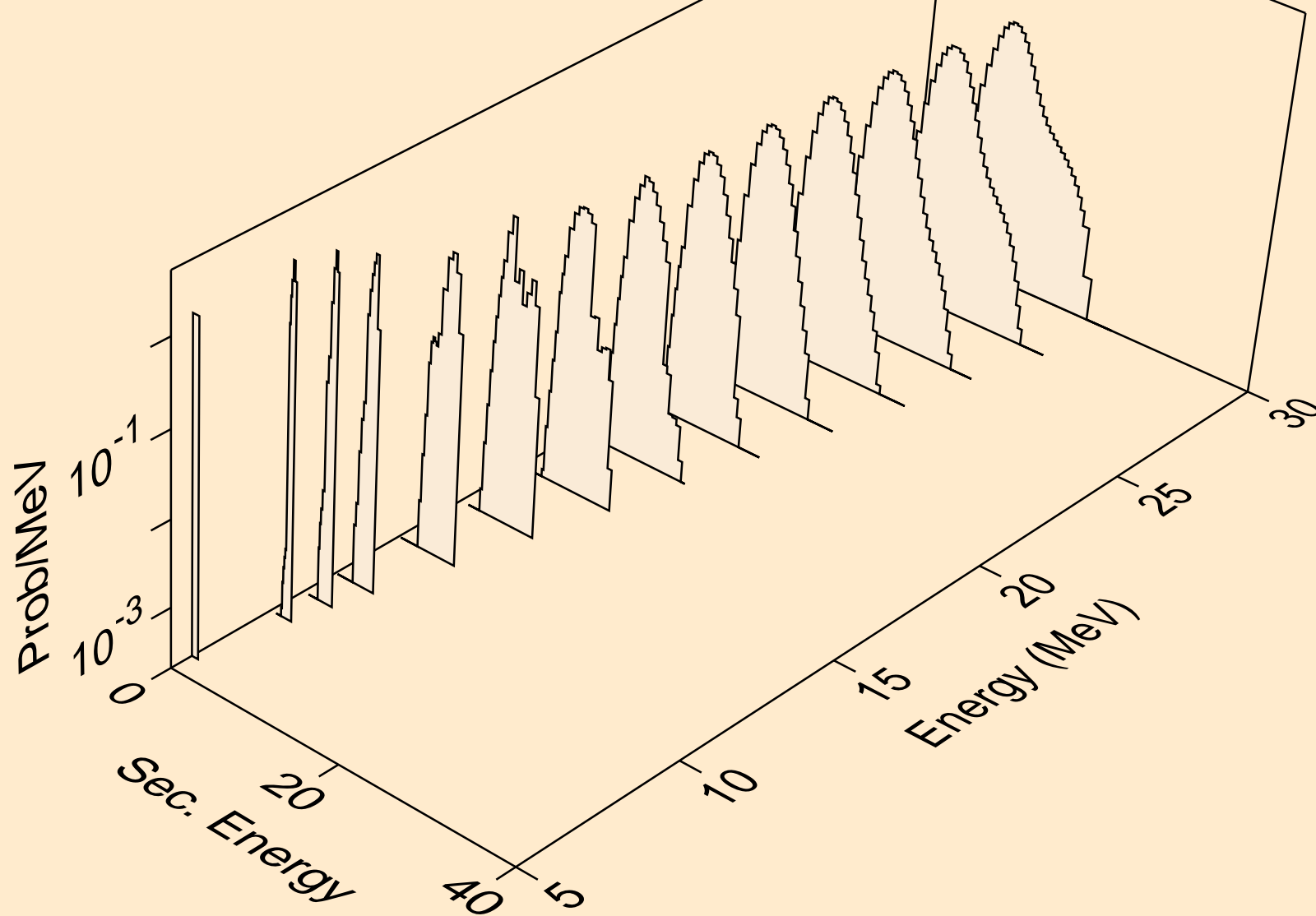

TM155 ALPHA ACER TENDL-2023 LIBRARY; T=0.K  
protons from (a,2p)

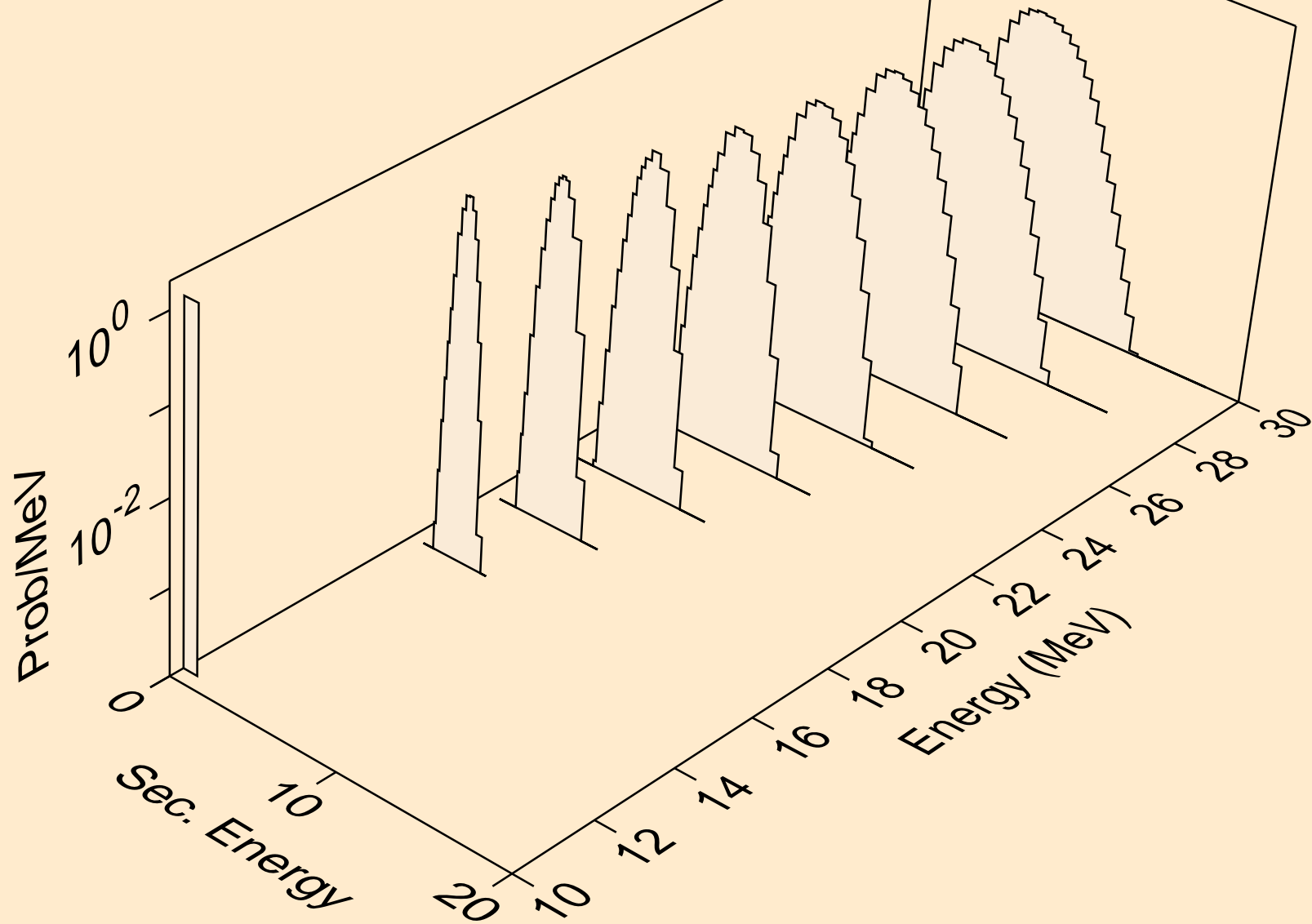

TM155 ALPHA ACER TENDL-2023 LIBRARY; T=0.K  
protons from (a,pa)

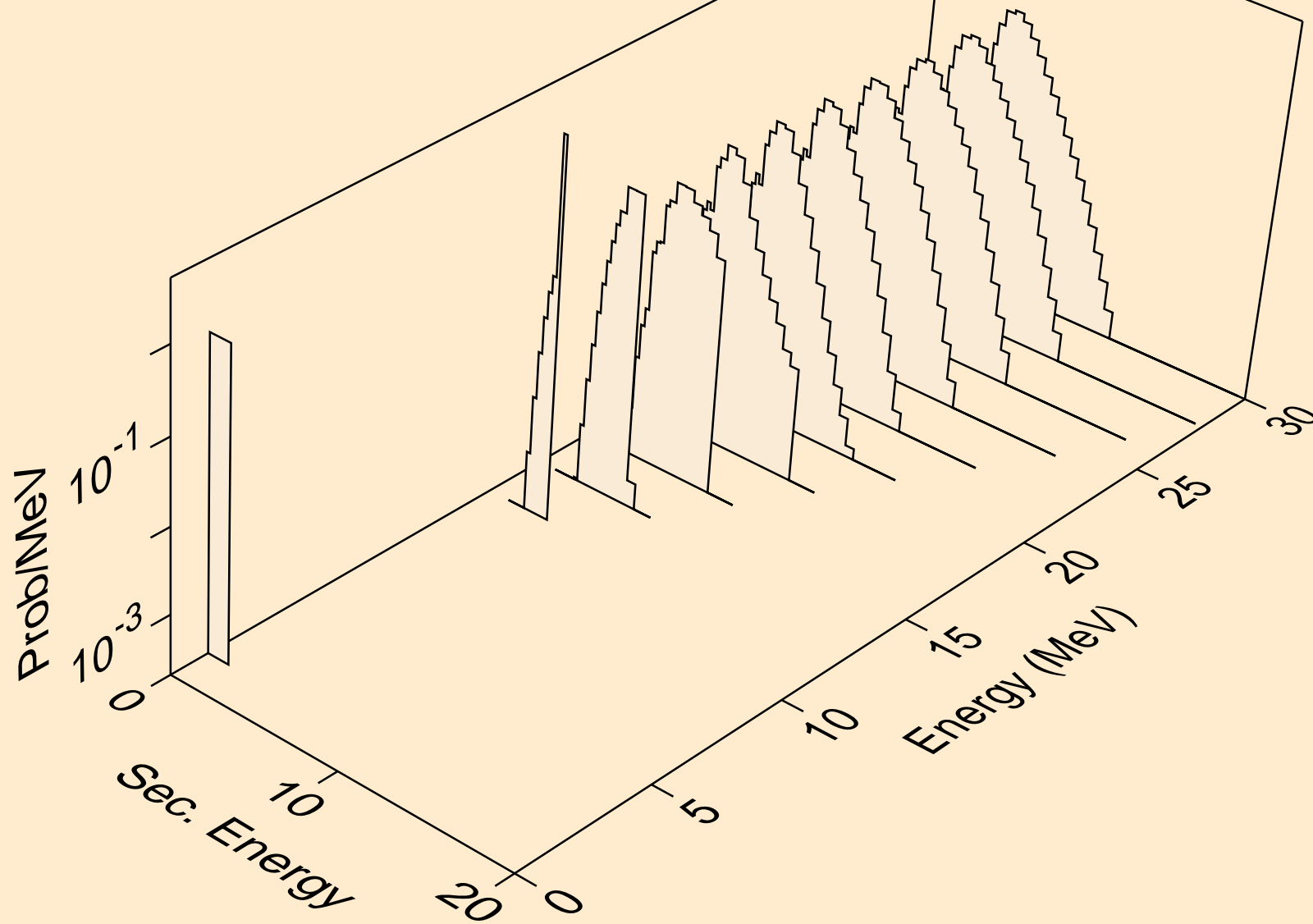

TM155 ALPHA ACER TENDL-2023 LIBRARY; T=0.K  
protons from (a,pd)

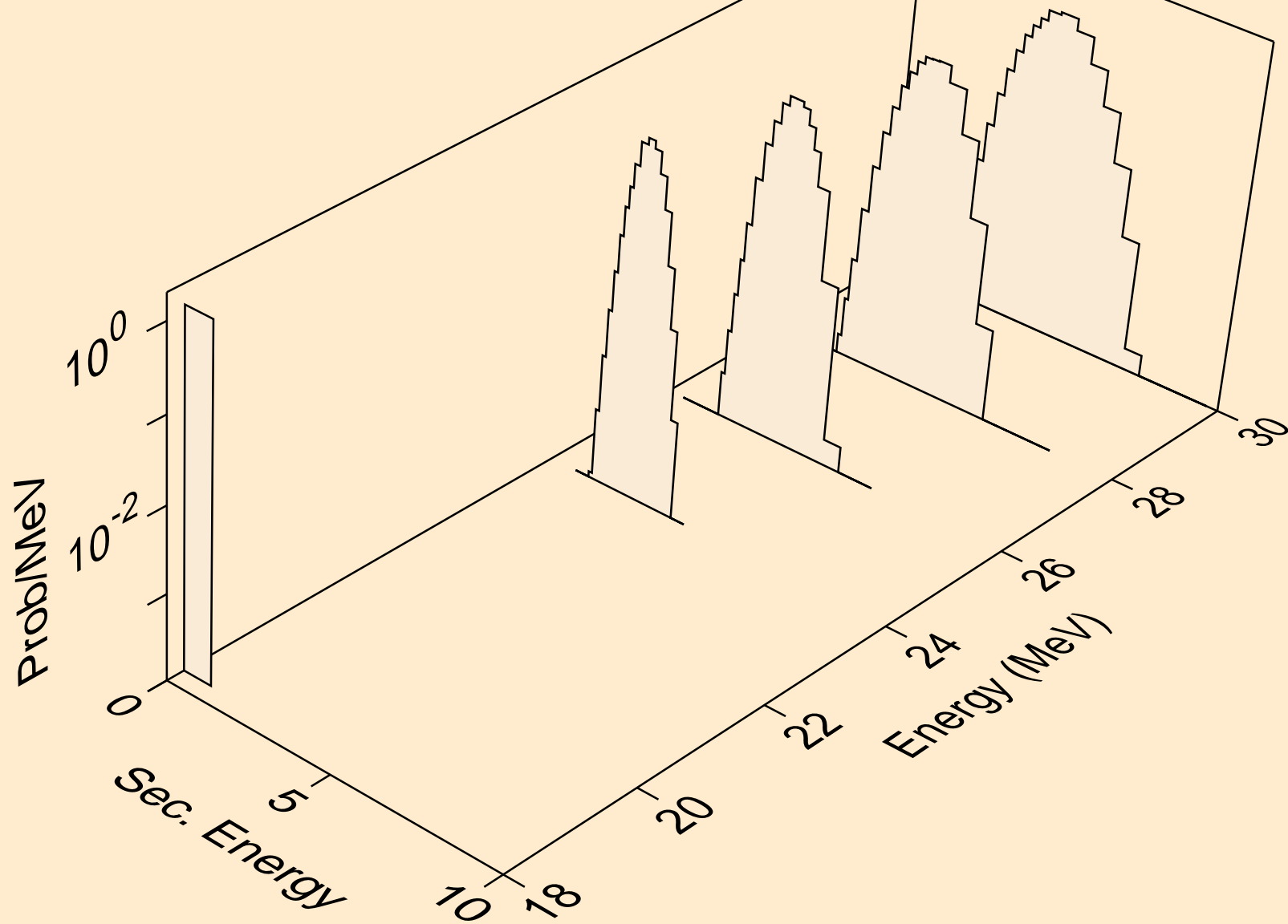

TM155 ALPHA ACER TENDL-2023 LIBRARY; T=0.K  
deuterons from (a,x)

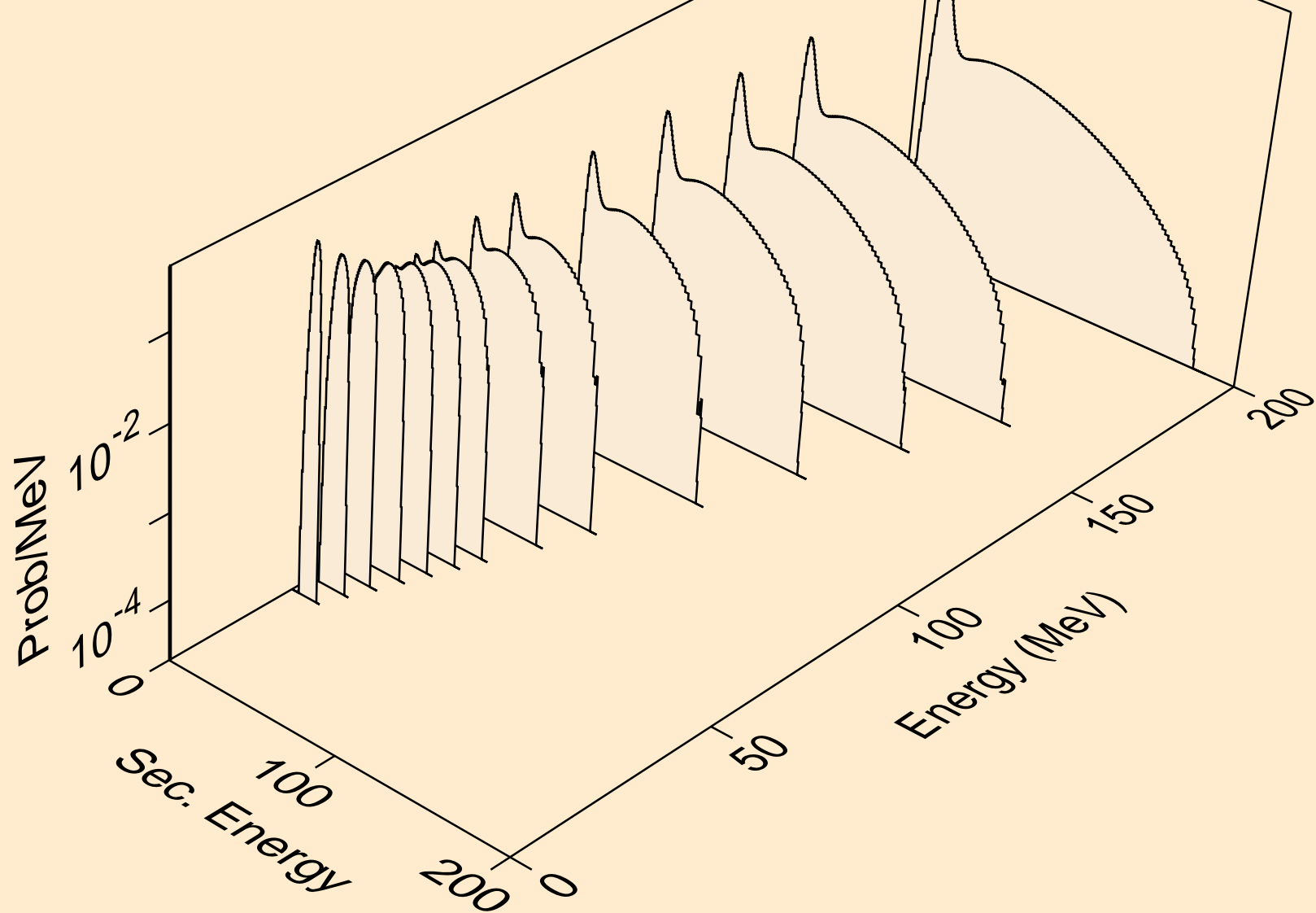

TM155 ALPHA ACER TENDL-2023 LIBRARY; T=0.K  
deuterons from (a,n\*)d

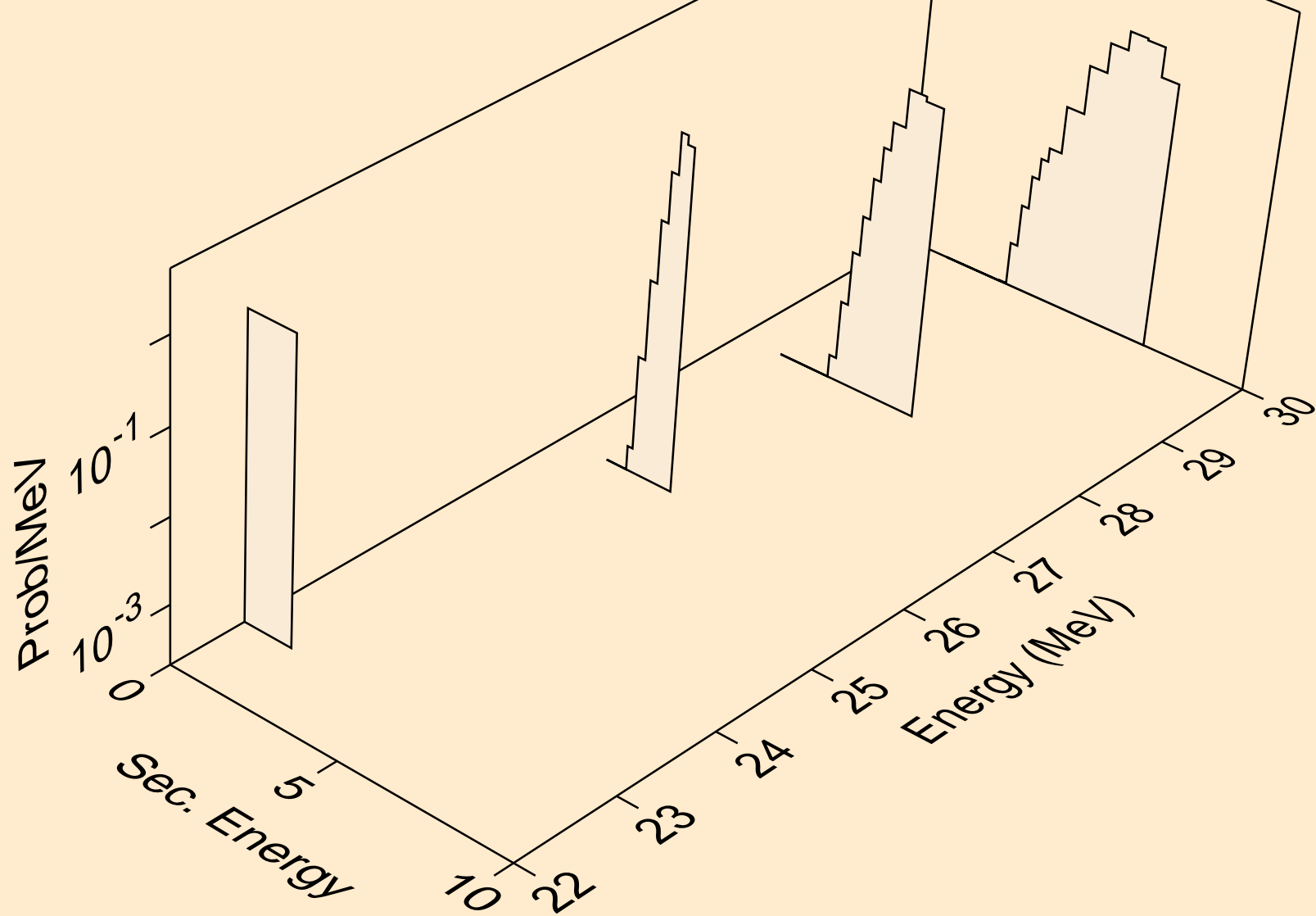

TM155 ALPHA ACER TENDL-2023 LIBRARY; T=0.K  
deuterons from (a,d)

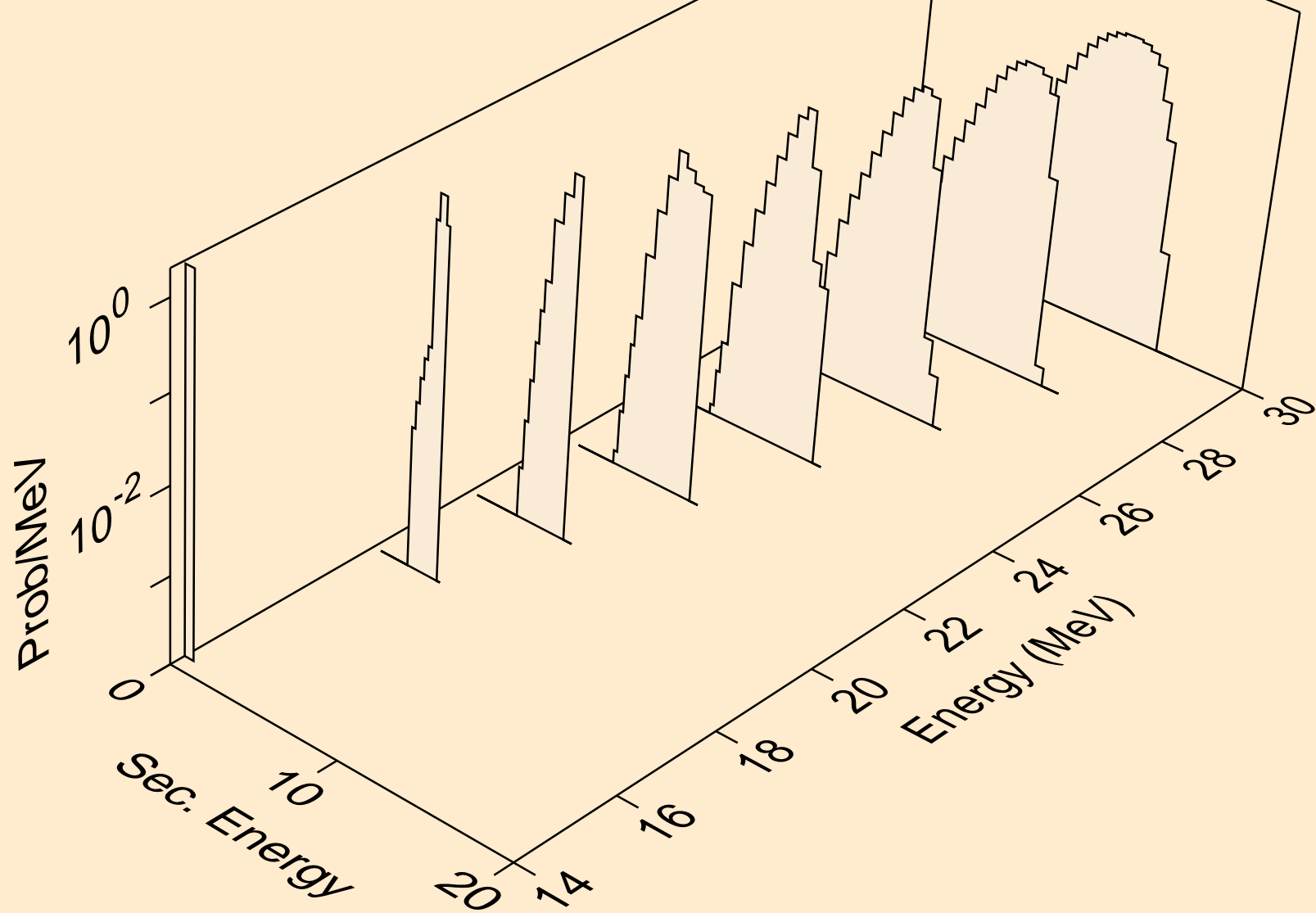

TM155 ALPHA ACER TENDL-2023 LIBRARY; T=0.K  
deuterons from (a,pd)

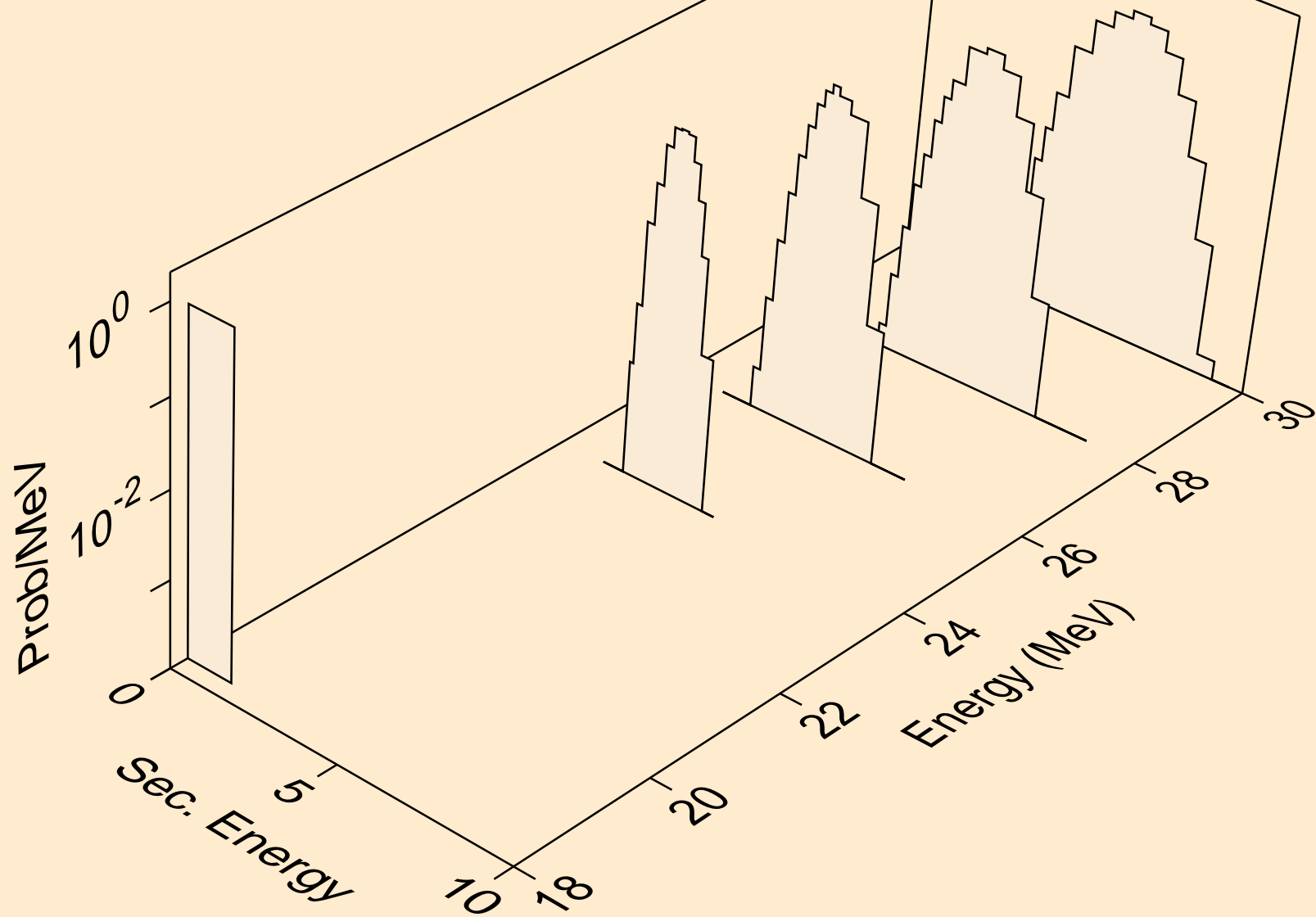

TM155 ALPHA ACER TENDL-2023 LIBRARY; T=0.K  
deuterons from (a,da)

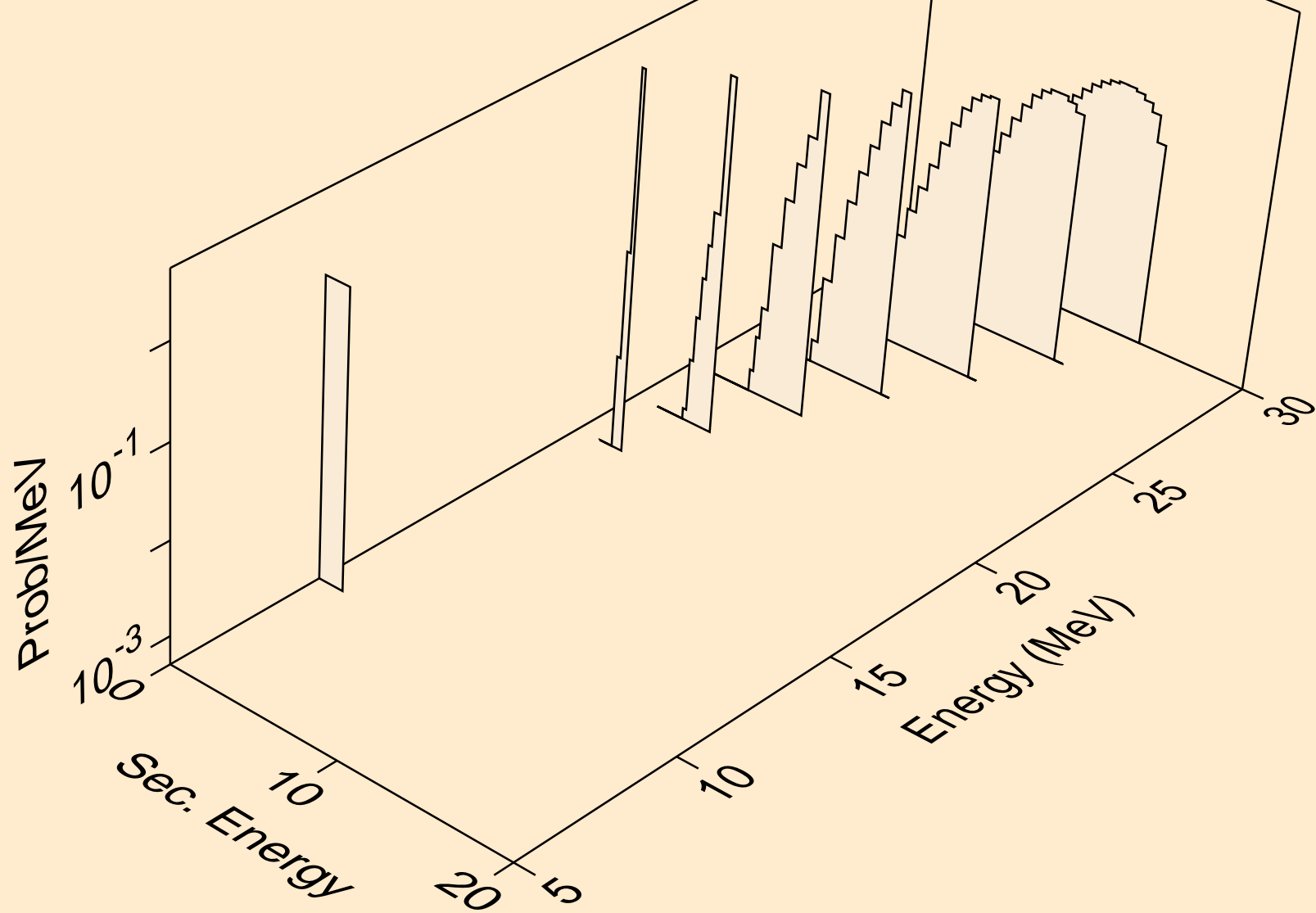

TM155 ALPHA ACER TENDL-2023 LIBRARY; T=0.K  
tritons from (a,x)

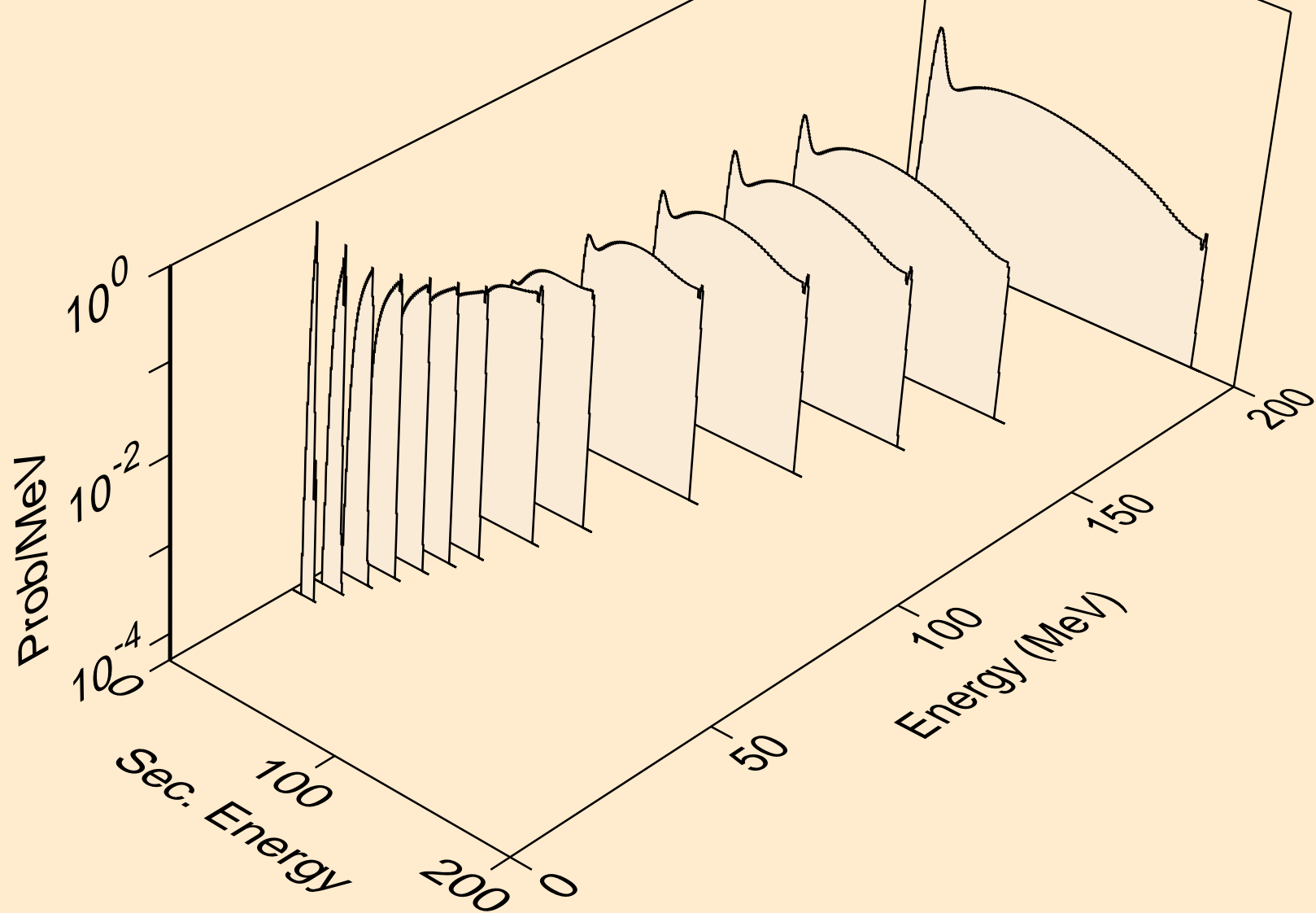

TM155 ALPHA ACER TENDL-2023 LIBRARY; T=0.K  
tritons from (a,t)

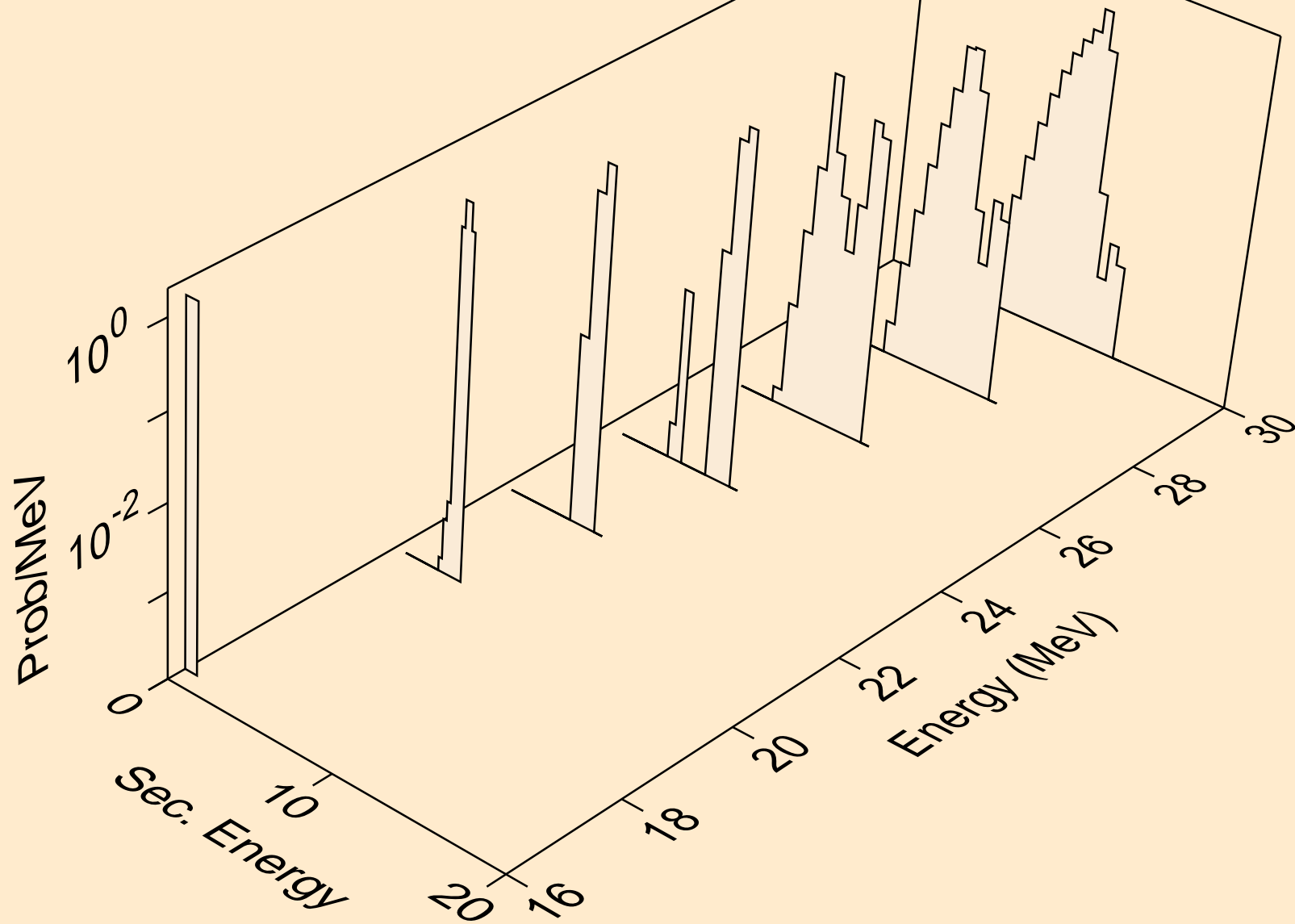

TM155 ALPHA ACER TENDL-2023 LIBRARY; T=0.K  
he3s from (a,x)

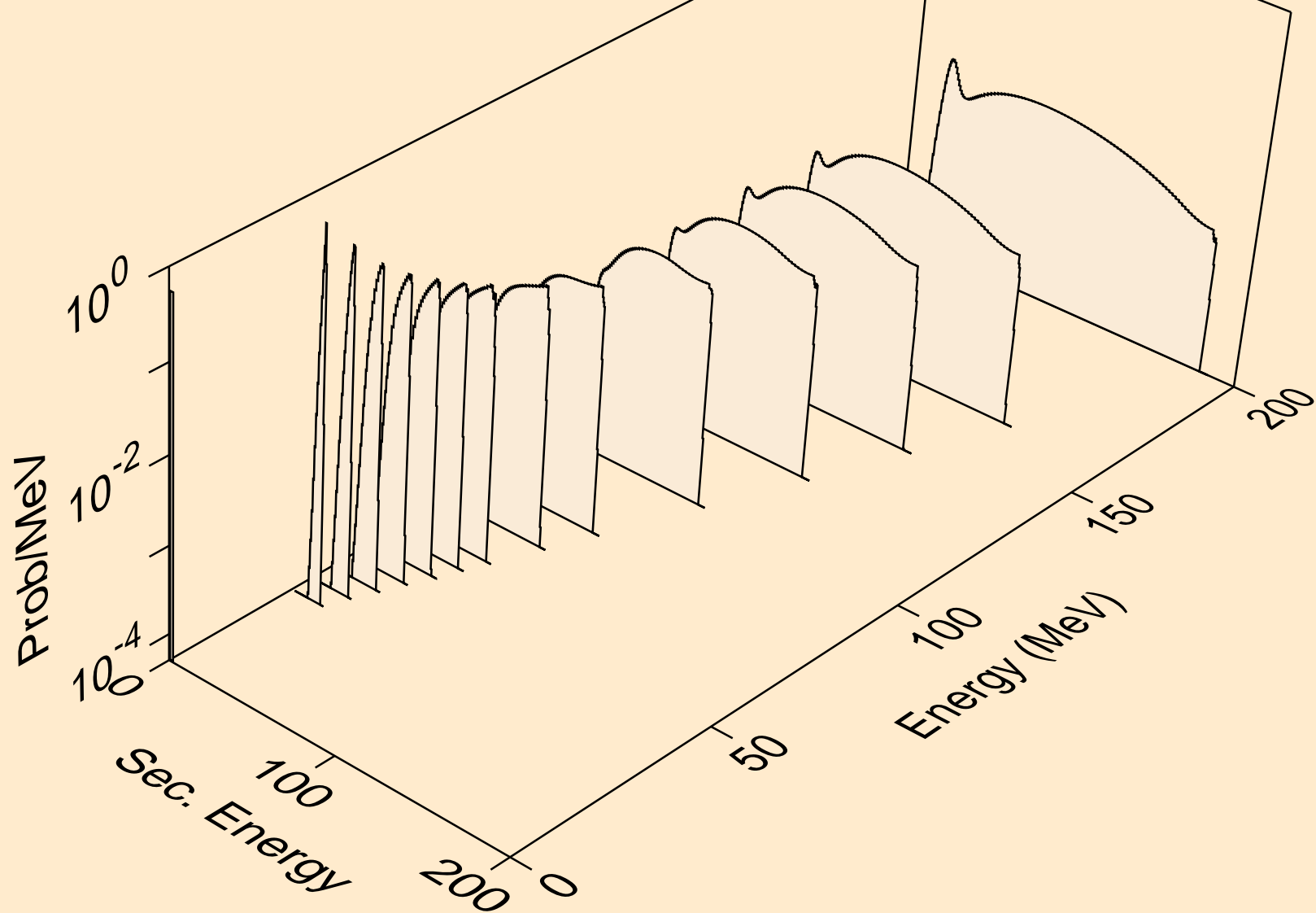

TM155 ALPHA ACER TENDL-2023 LIBRARY; T=0.K  
he3s from (a,he3)

