

# FL289 PHOTON ACER TENDL-2023 LIBRARY; T=0.K

## Principal cross sections

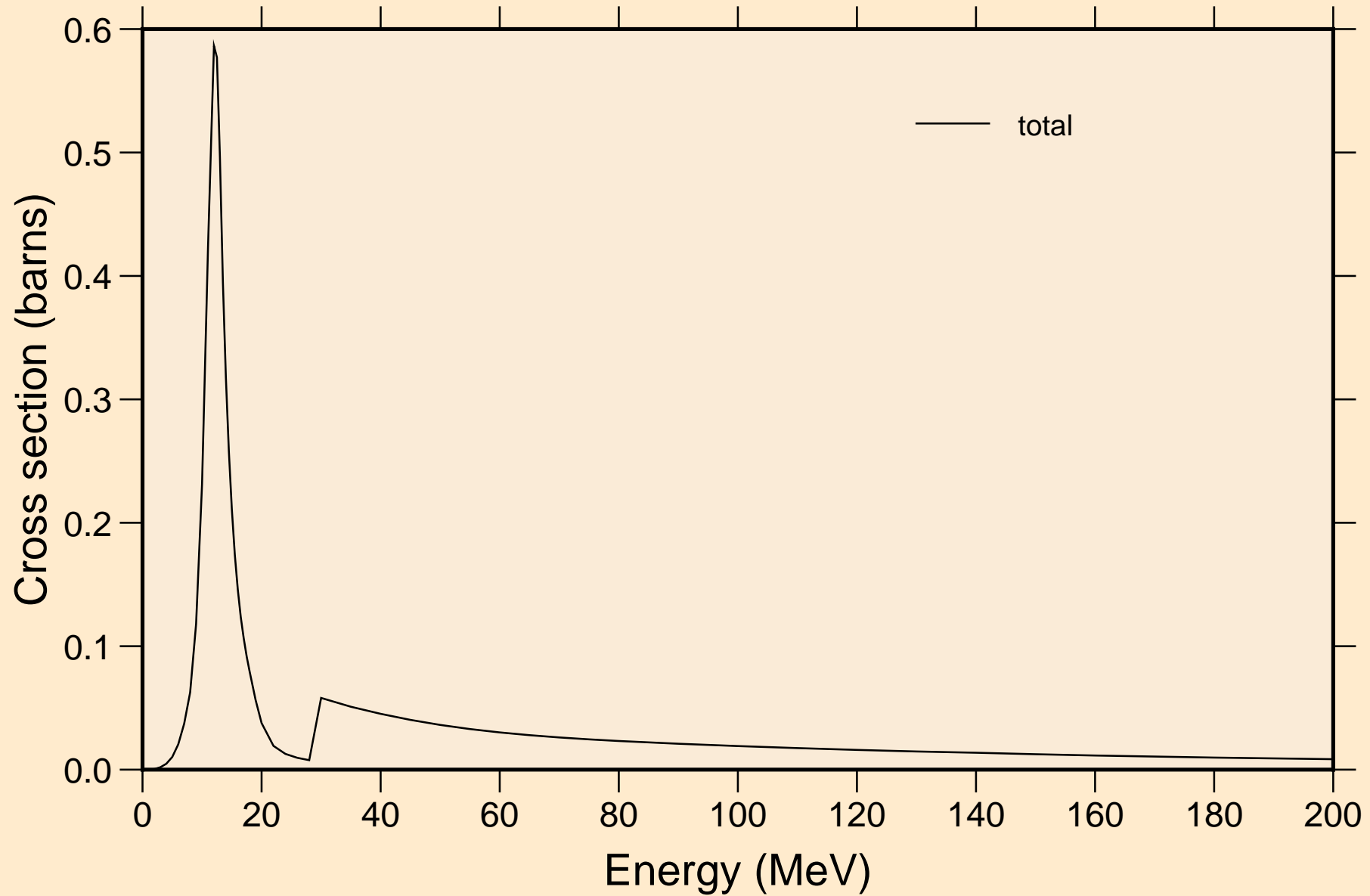

FL289 PHOTON ACER TENDL-2023 LIBRARY; T=0.K  
Partial cross sections

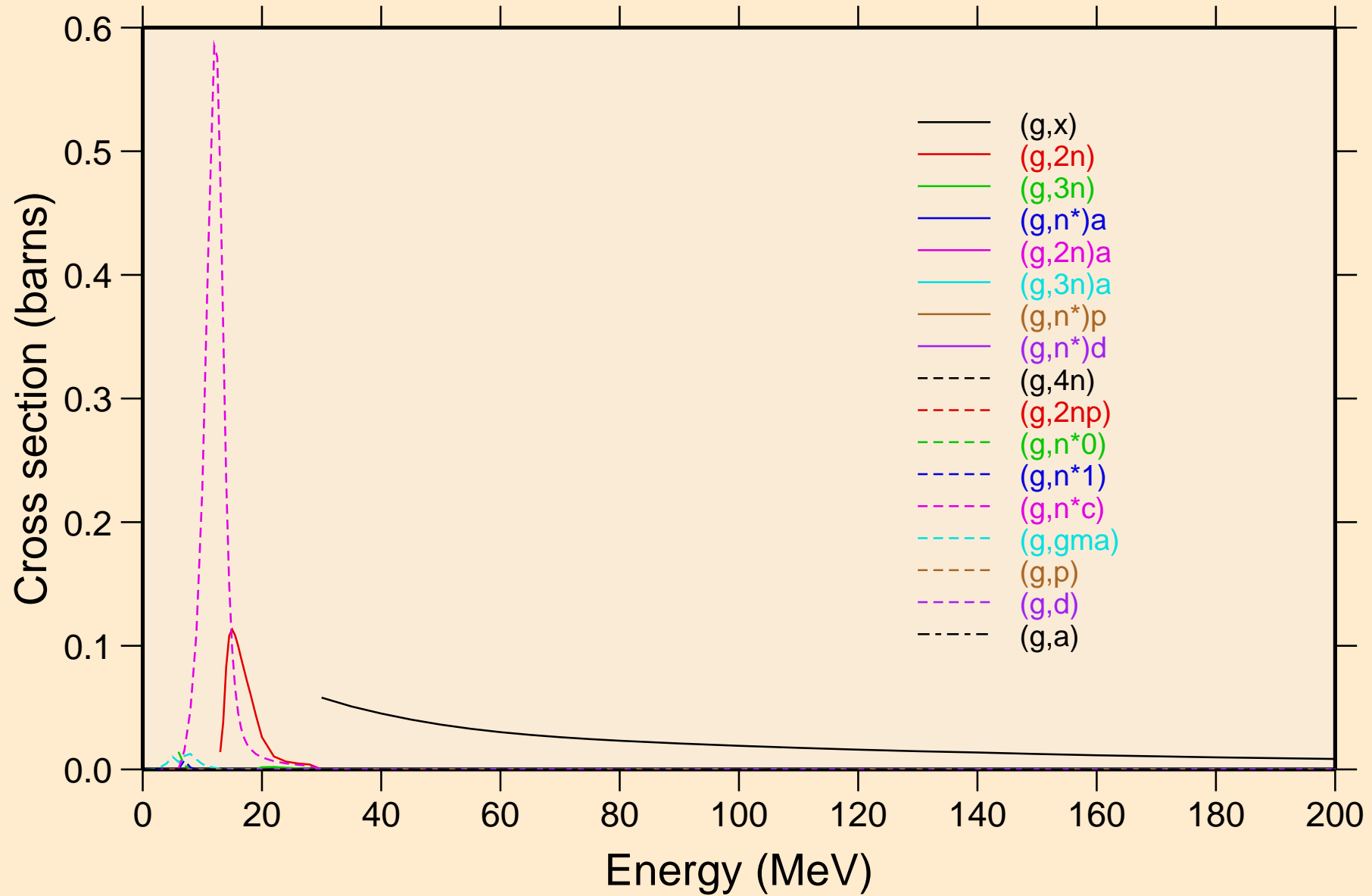

# FL289 PHOTON ACER TENDL-2023 LIBRARY; T=0.K

## Heating

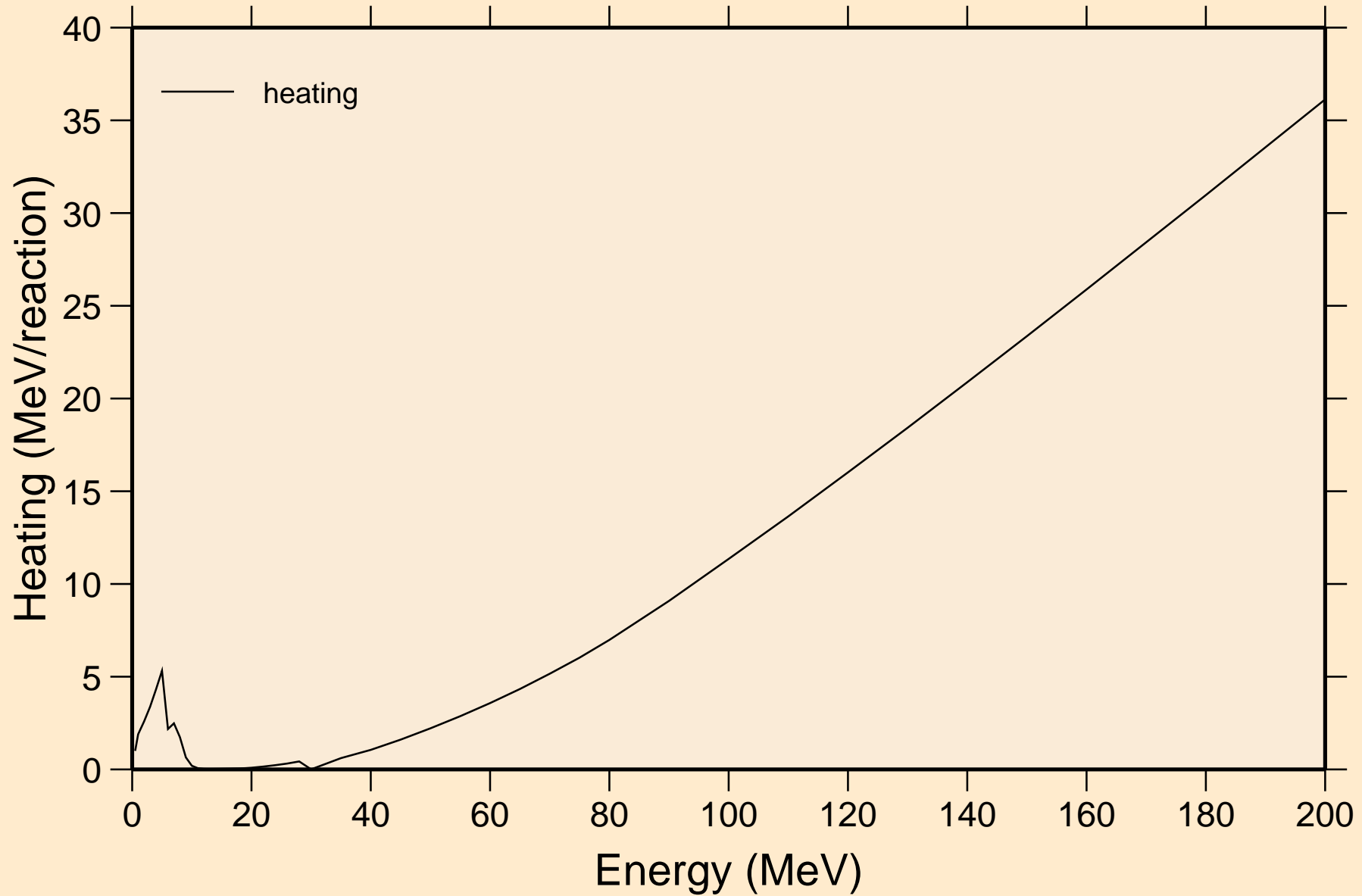

# FL289 PHOTON ACER TENDL-2023 LIBRARY; T=0.K

## Particle heating contributions

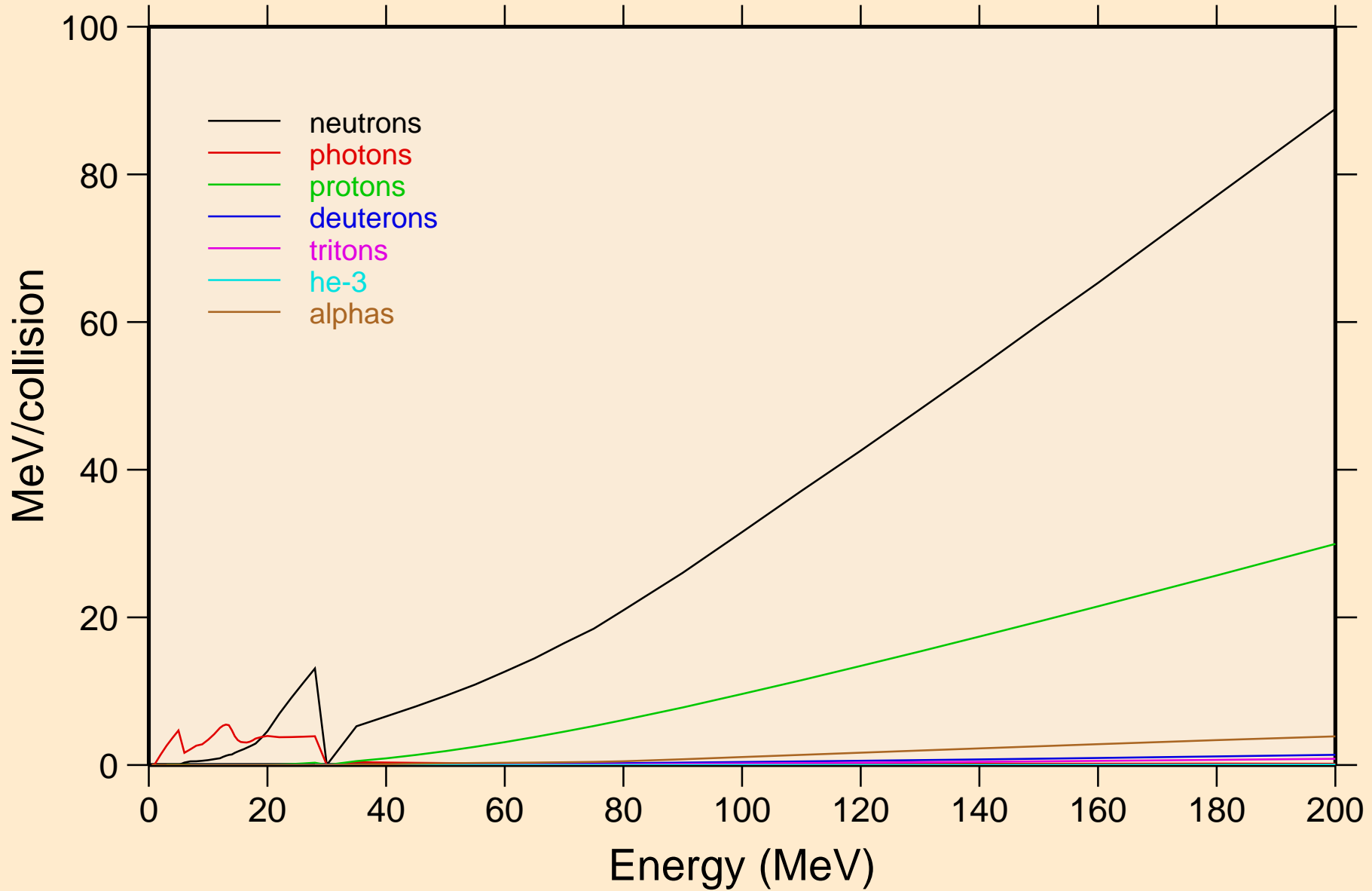

FL289 PHOTON ACER TENDL-2023 LIBRARY; T=0.K  
Particle production cross sections

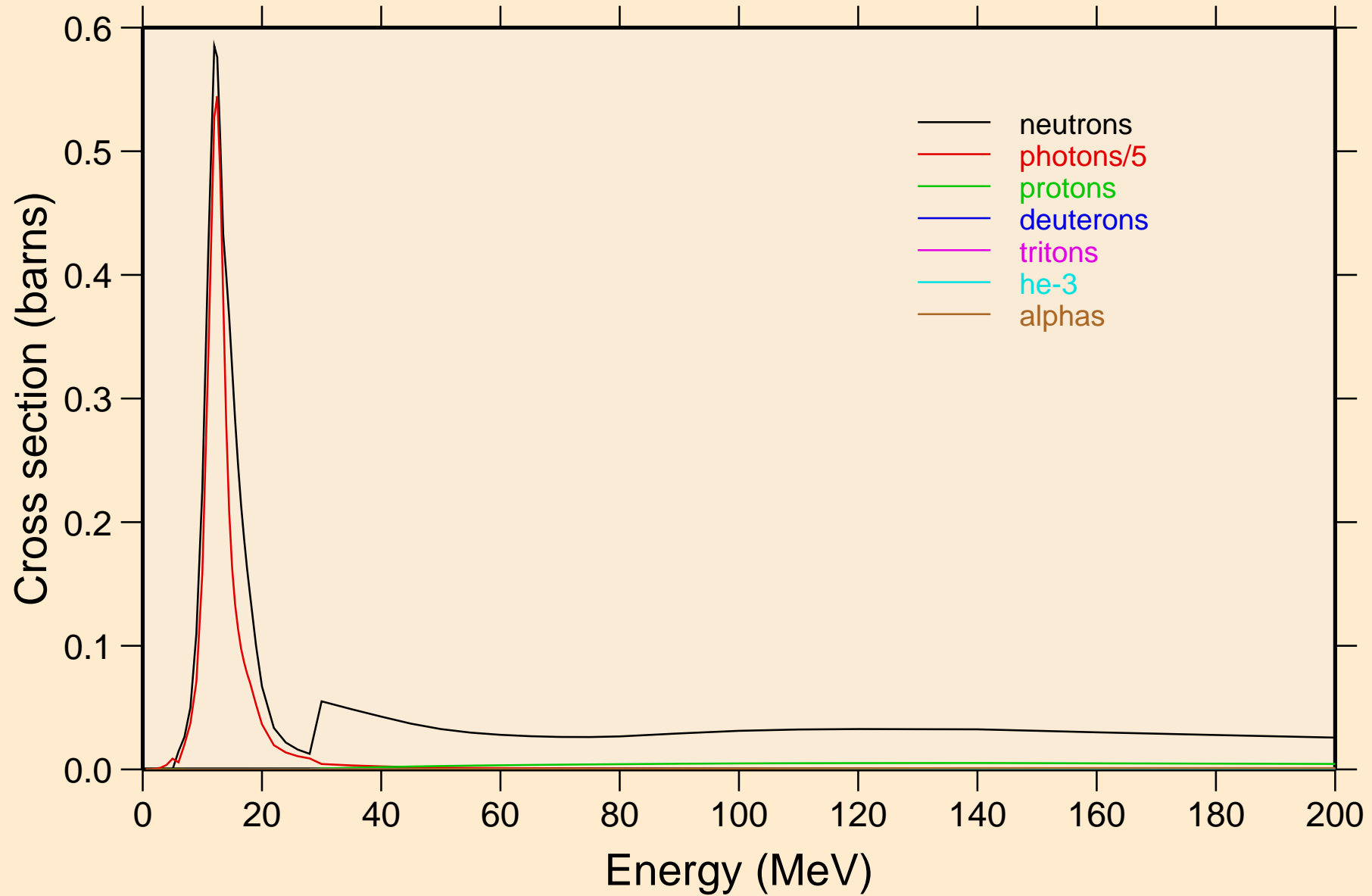

FL289 PHOTON ACER TENDL-2023 LIBRARY; T=0.K  
neutrons from (g,x)

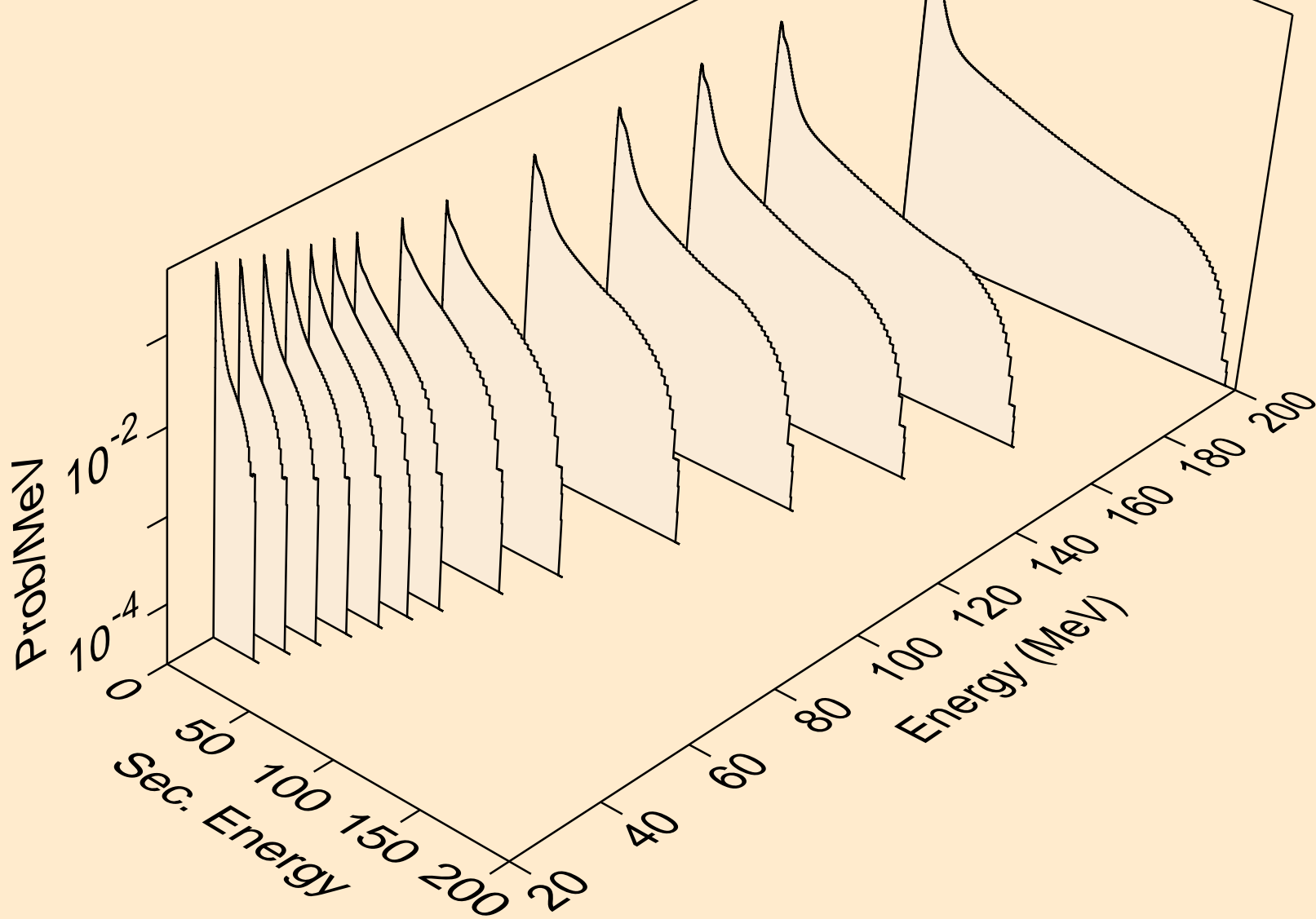

FL289 PHOTON ACER TENDL-2023 LIBRARY; T=0.K  
neutrons from (g,2n)

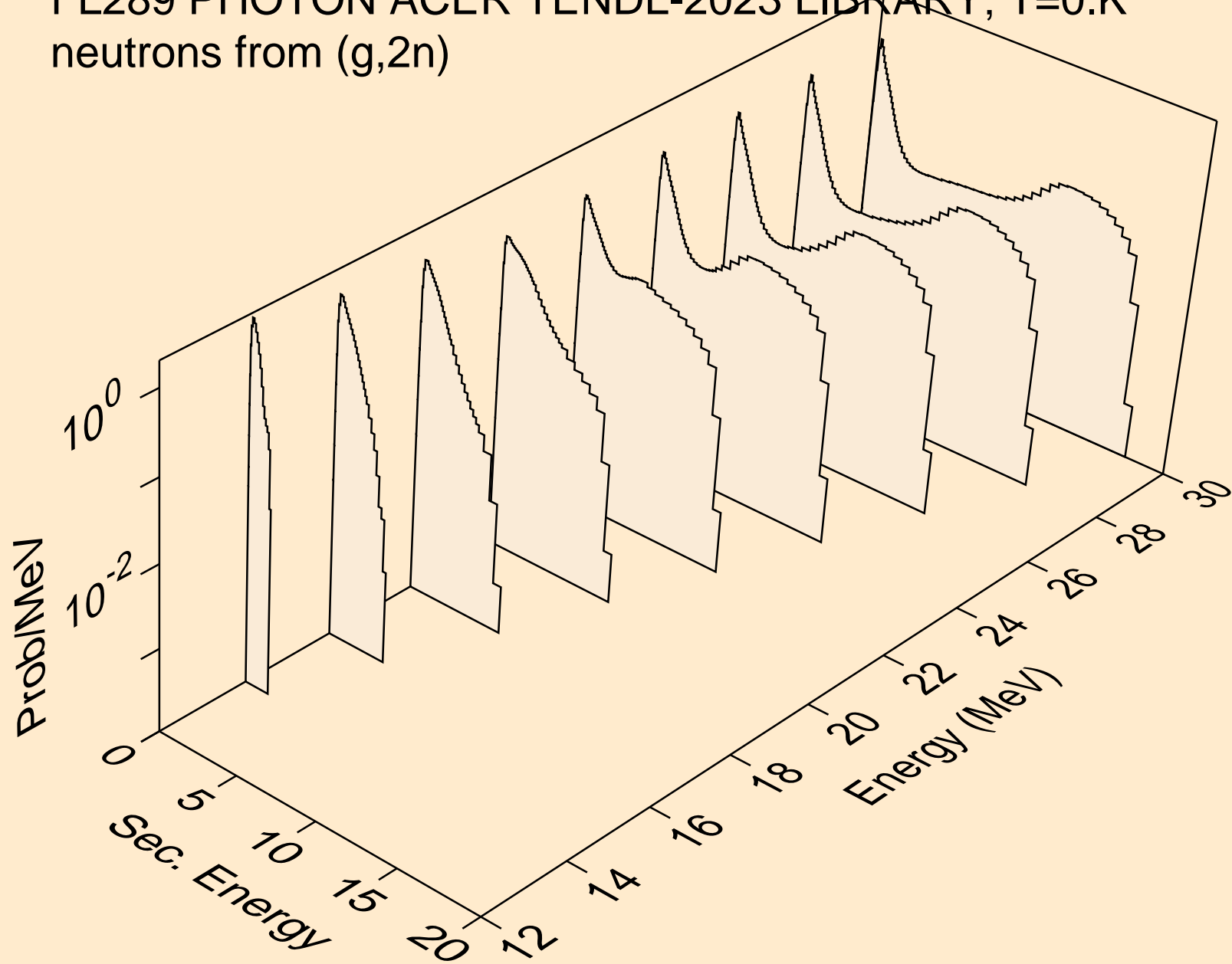

FL289 PHOTON ACER TENDL-2023 LIBRARY; T=0.K  
neutrons from (g,3n)

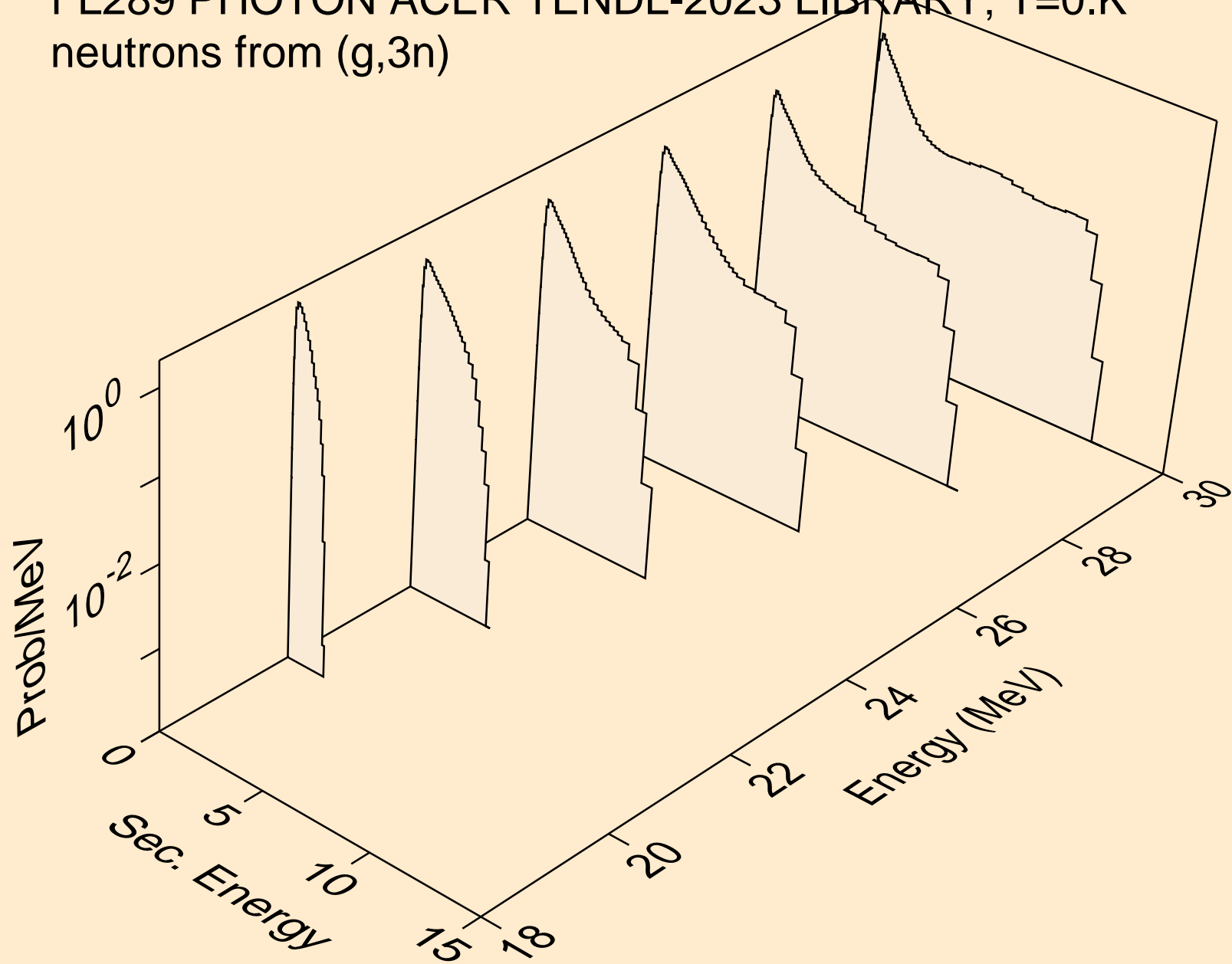

FL289 PHOTON ACER TENDL-2023 LIBRARY; T=0.K  
neutrons from (g,n\*)a

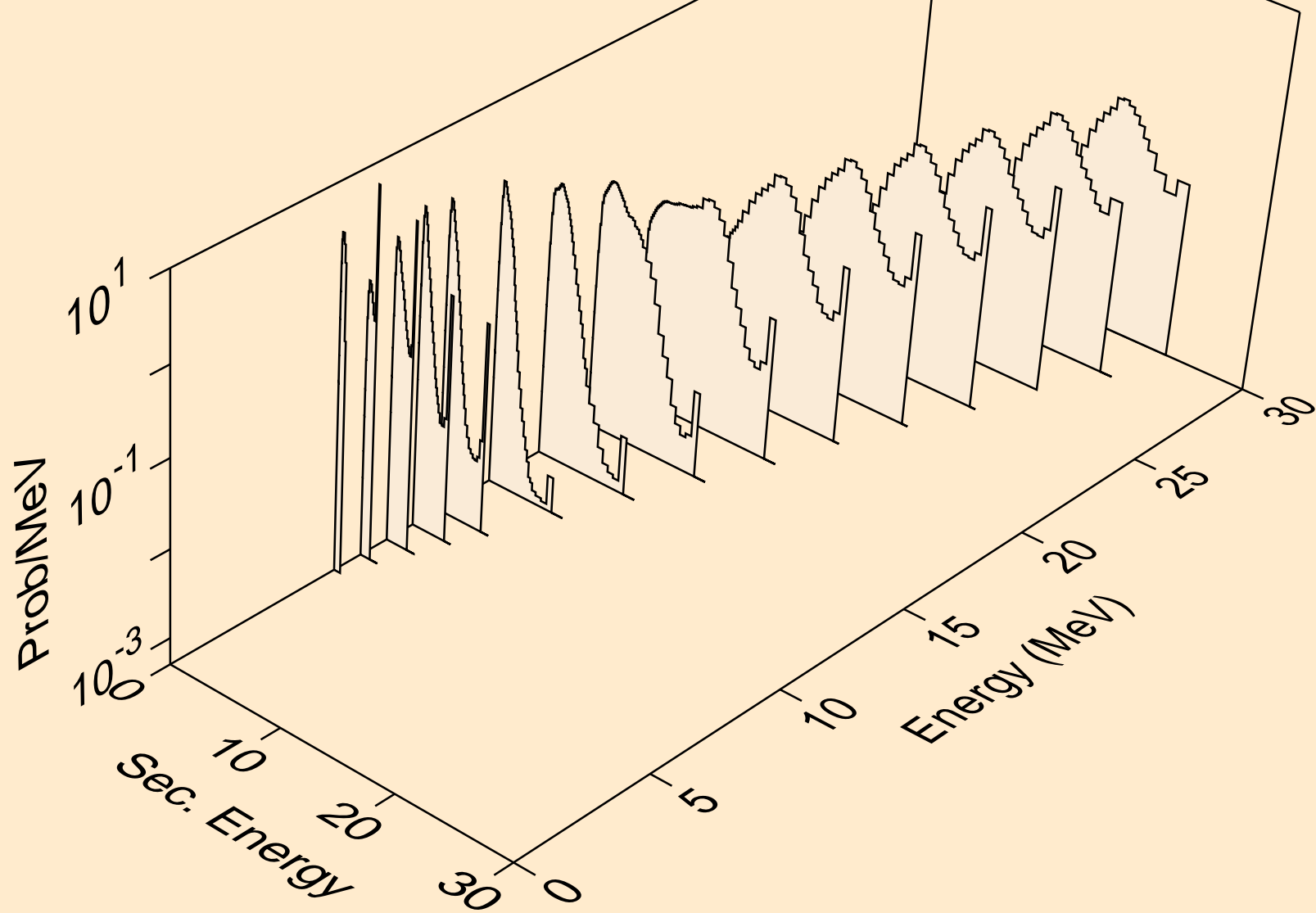

FL289 PHOTON ACER TENDL-2023 LIBRARY; T=0.K  
neutrons from (g,2n)a

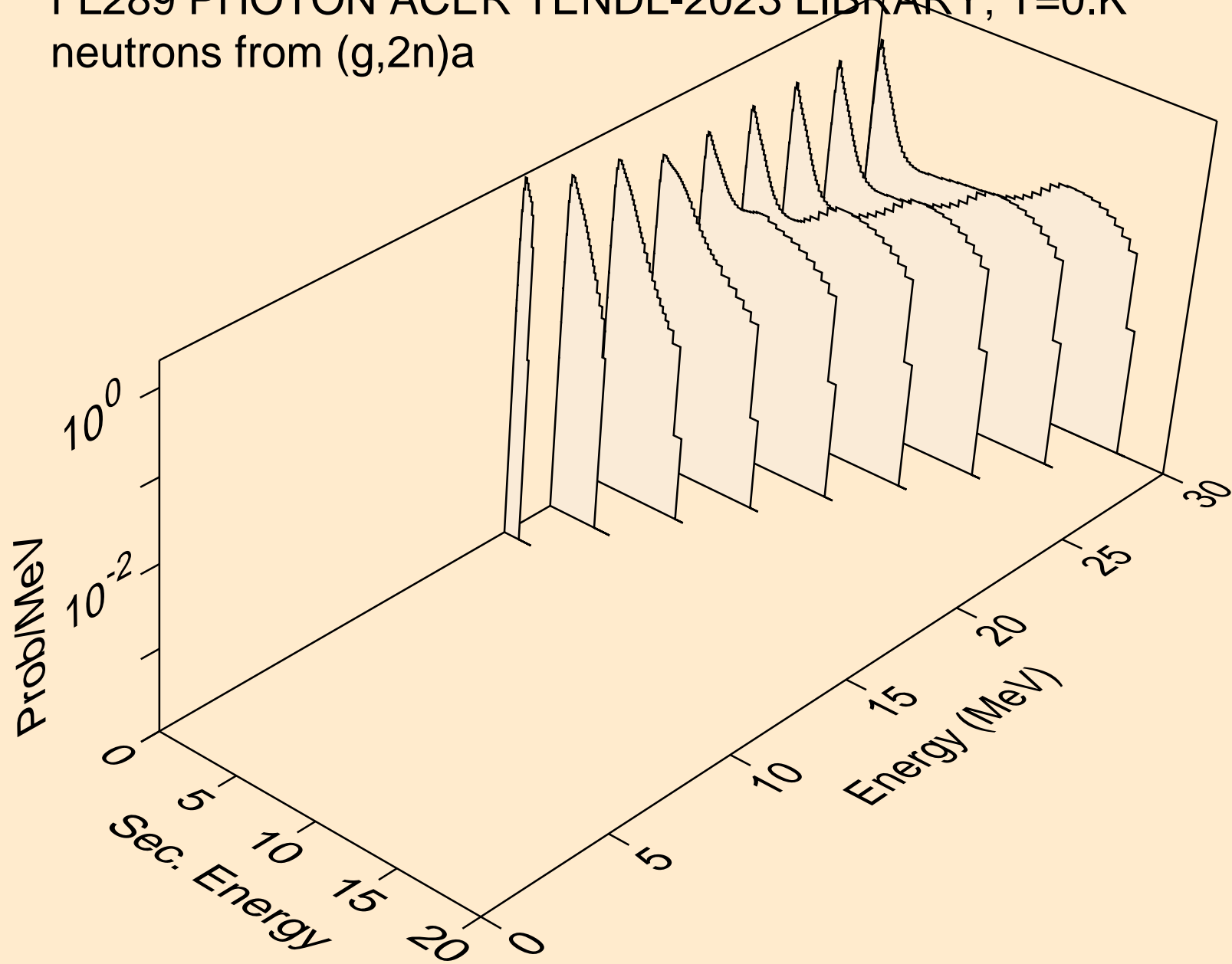

FL289 PHOTON ACER TENDL-2023 LIBRARY; T=0.K  
neutrons from (g,3n)a

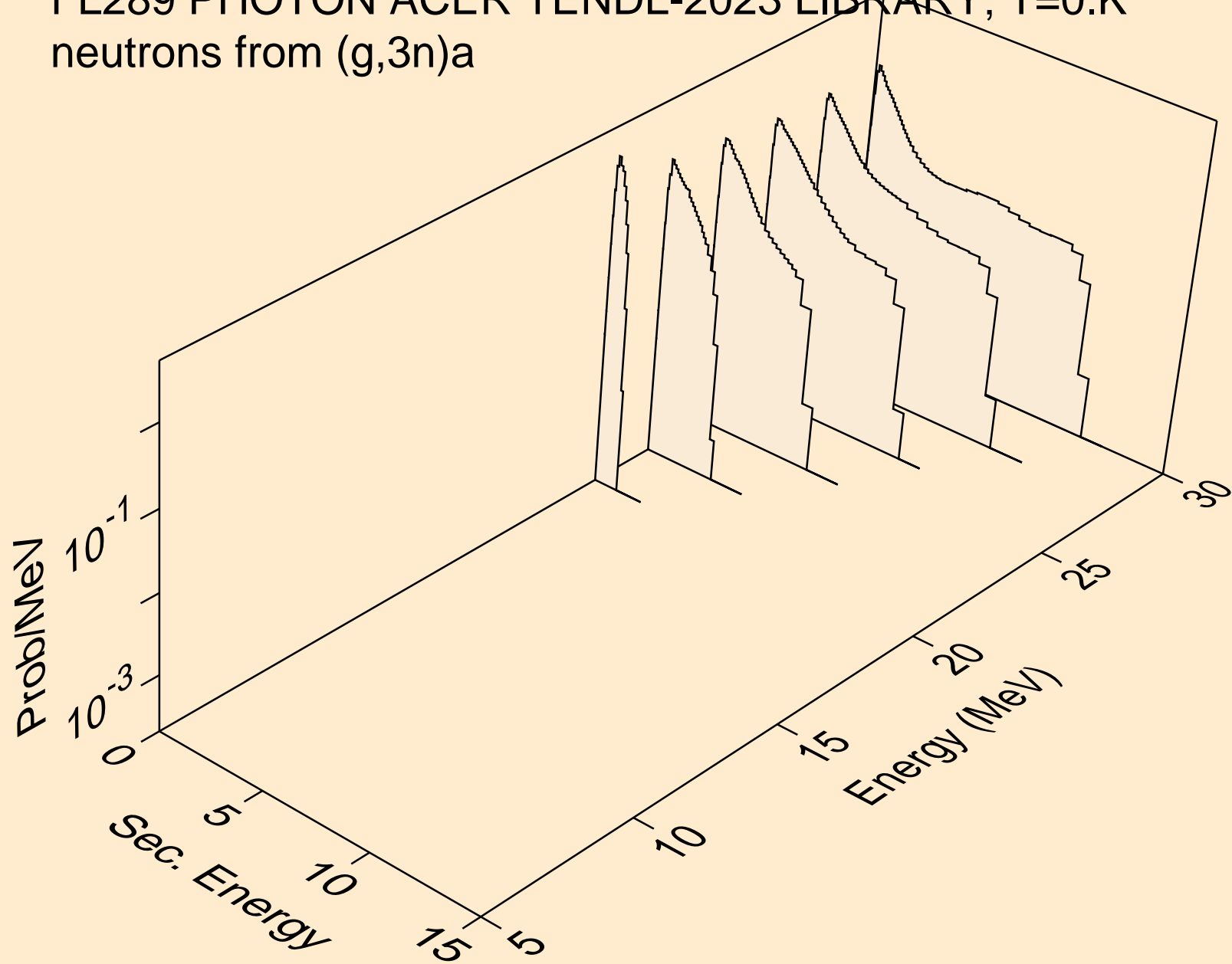

FL289 PHOTON ACER TENDL-2023 LIBRARY; T=0.K  
neutrons from (g,n\*)p

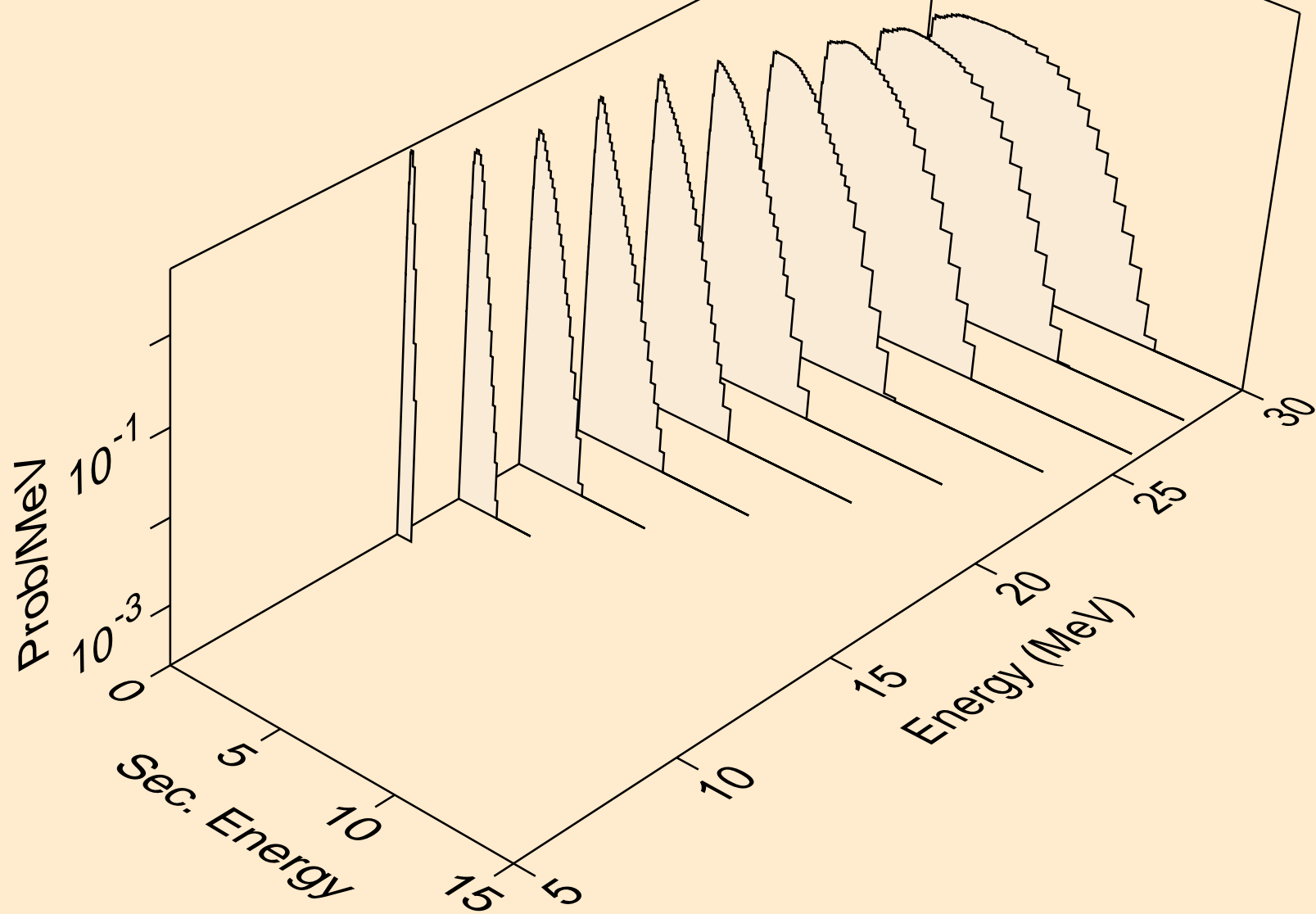

FL289 PHOTON ACER TENDL-2023 LIBRARY; T=0.K  
neutrons from (g,n\*)d

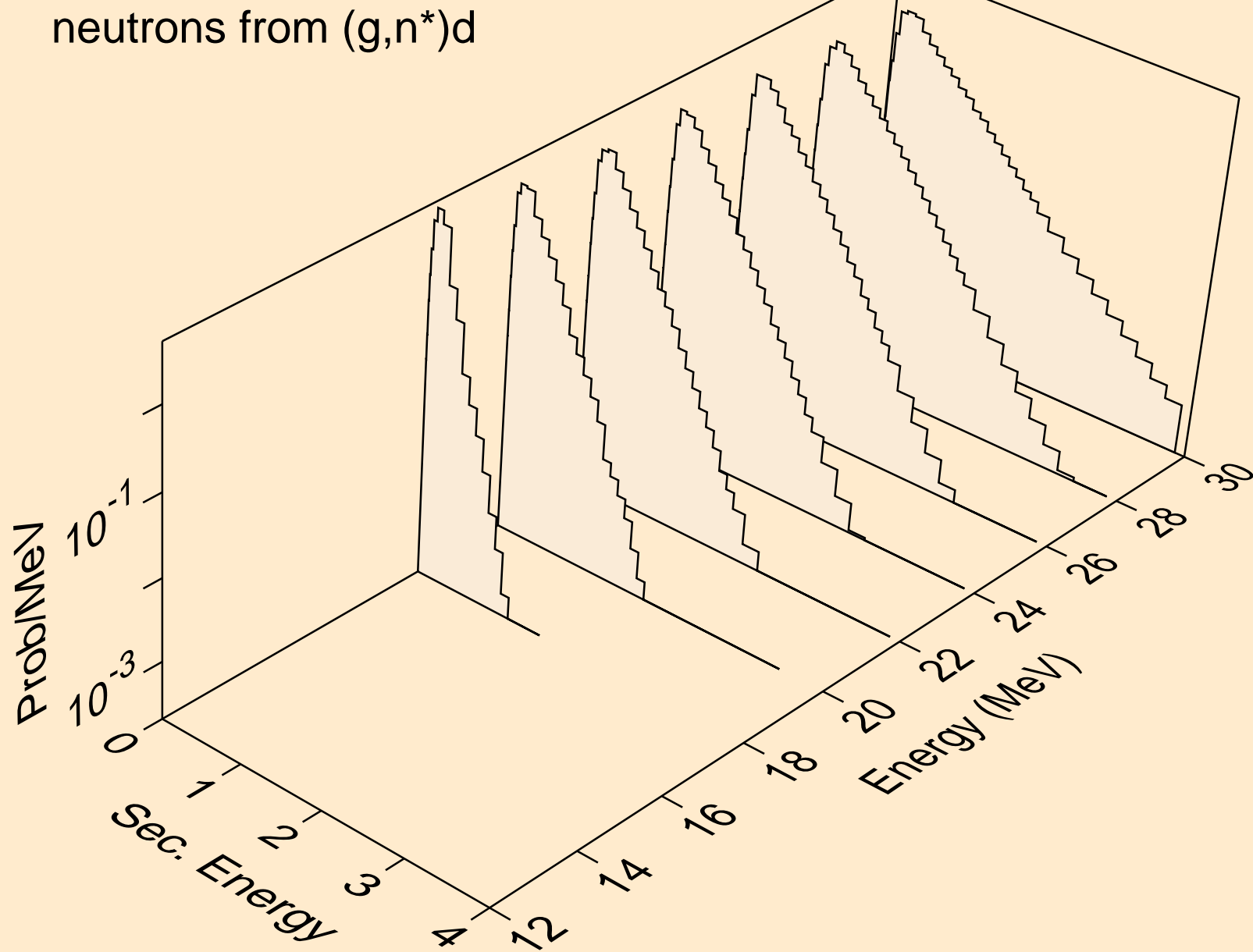

FL289 PHOTON ACER TENDL-2023 LIBRARY; T=0.K  
neutrons from (g,4n)

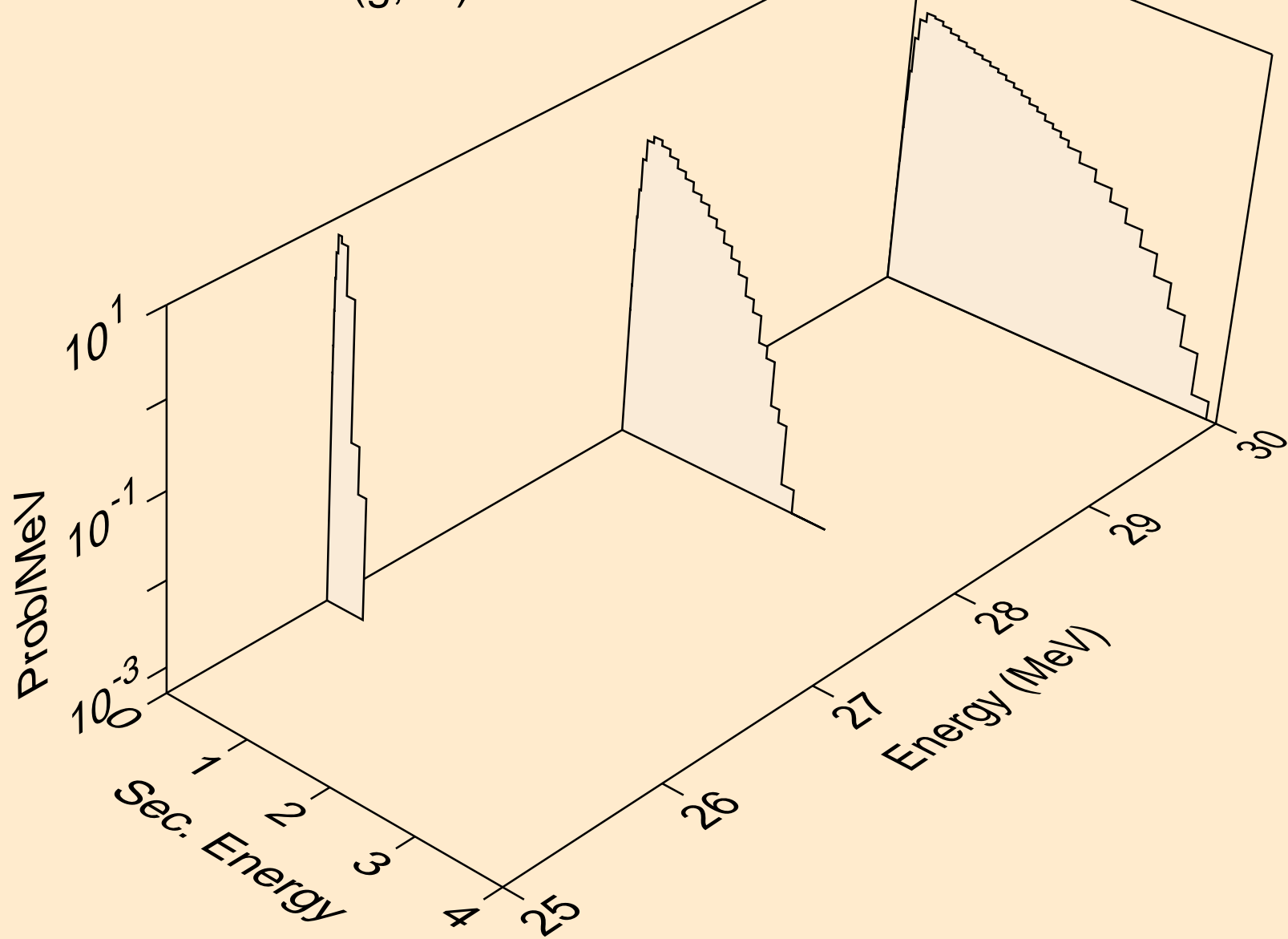

FL289 PHOTON ACER TENDL-2023 LIBRARY; T=0.K  
neutrons from (g,2np)

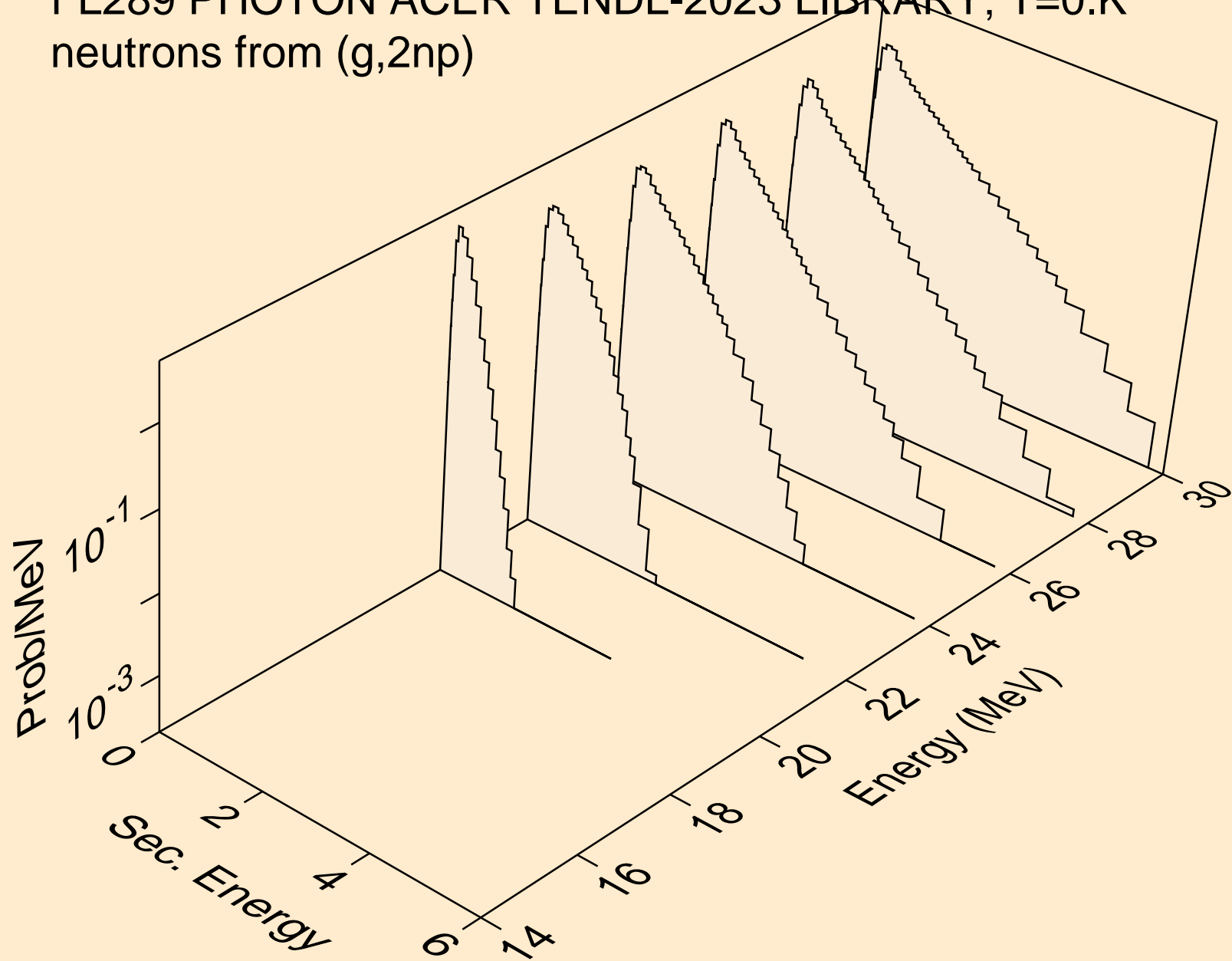

FL289 PHOTON ACER TENDL-2023 LIBRARY; T=0.K  
angular distribution for (g,n\*0) neutron

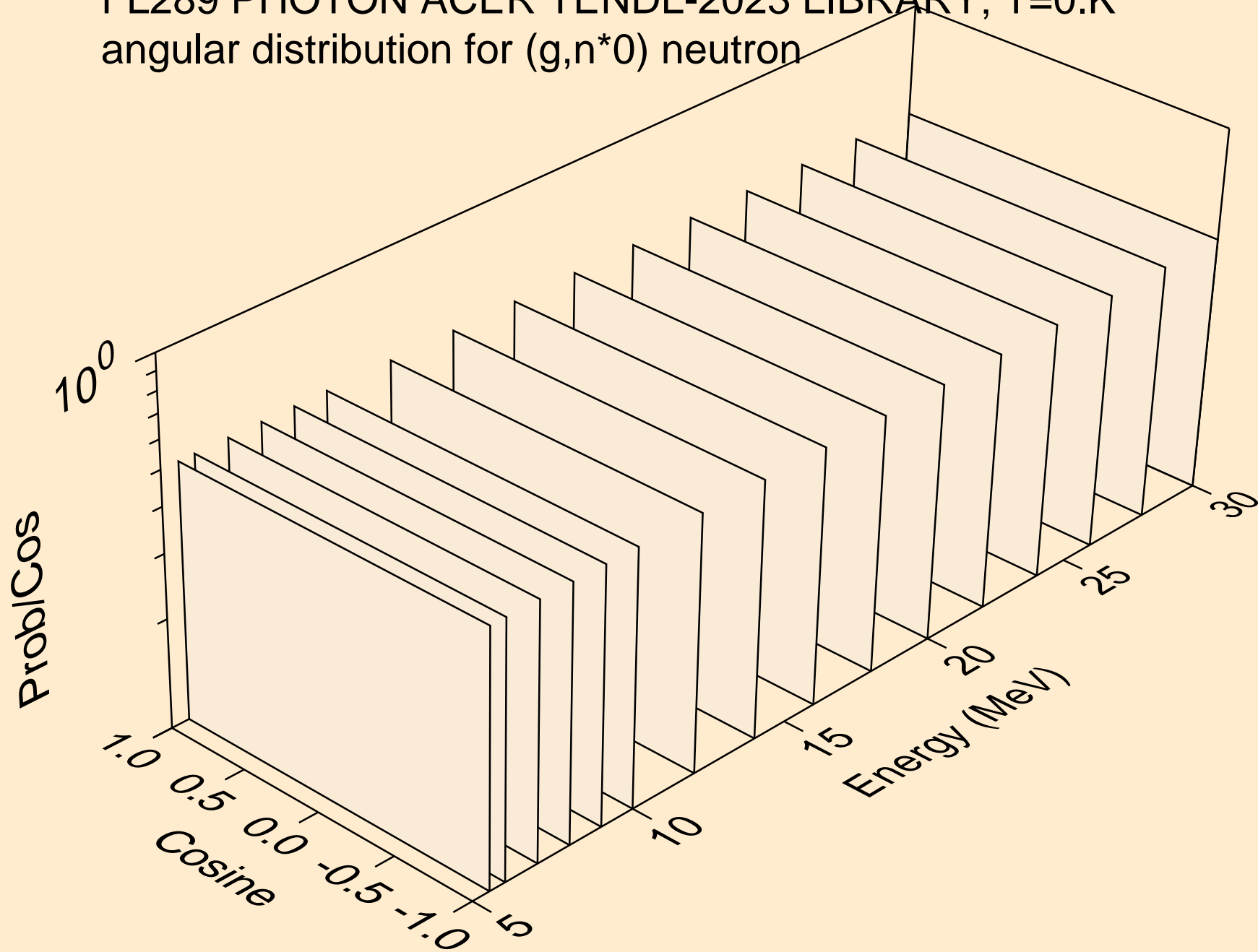

FL289 PHOTON ACER TENDL-2023 LIBRARY; T=0.K  
angular distribution for (g,n\*1) neutron

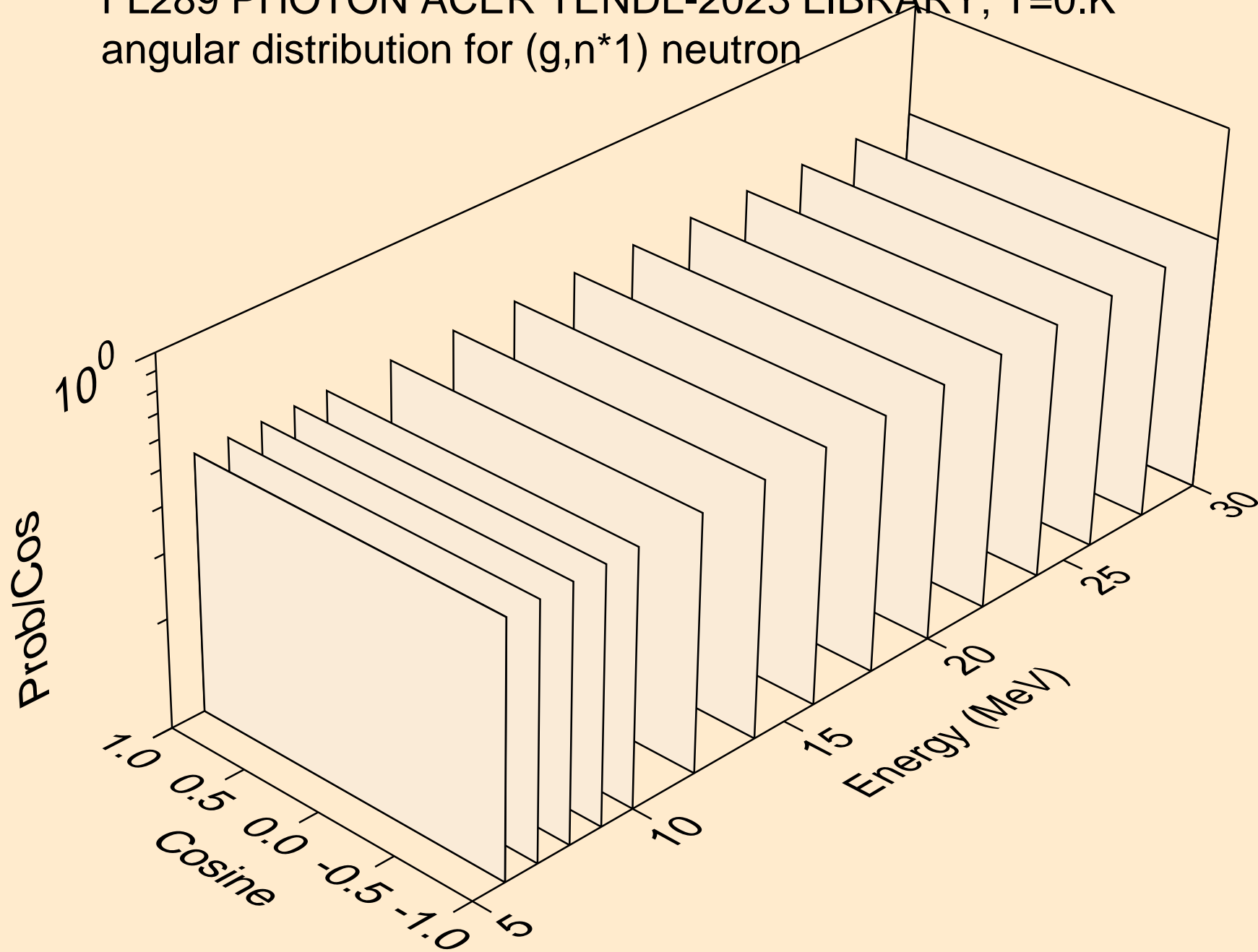

FL289 PHOTON ACER TENDL-2023 LIBRARY; T=0.K  
neutrons from (g,n\*c)

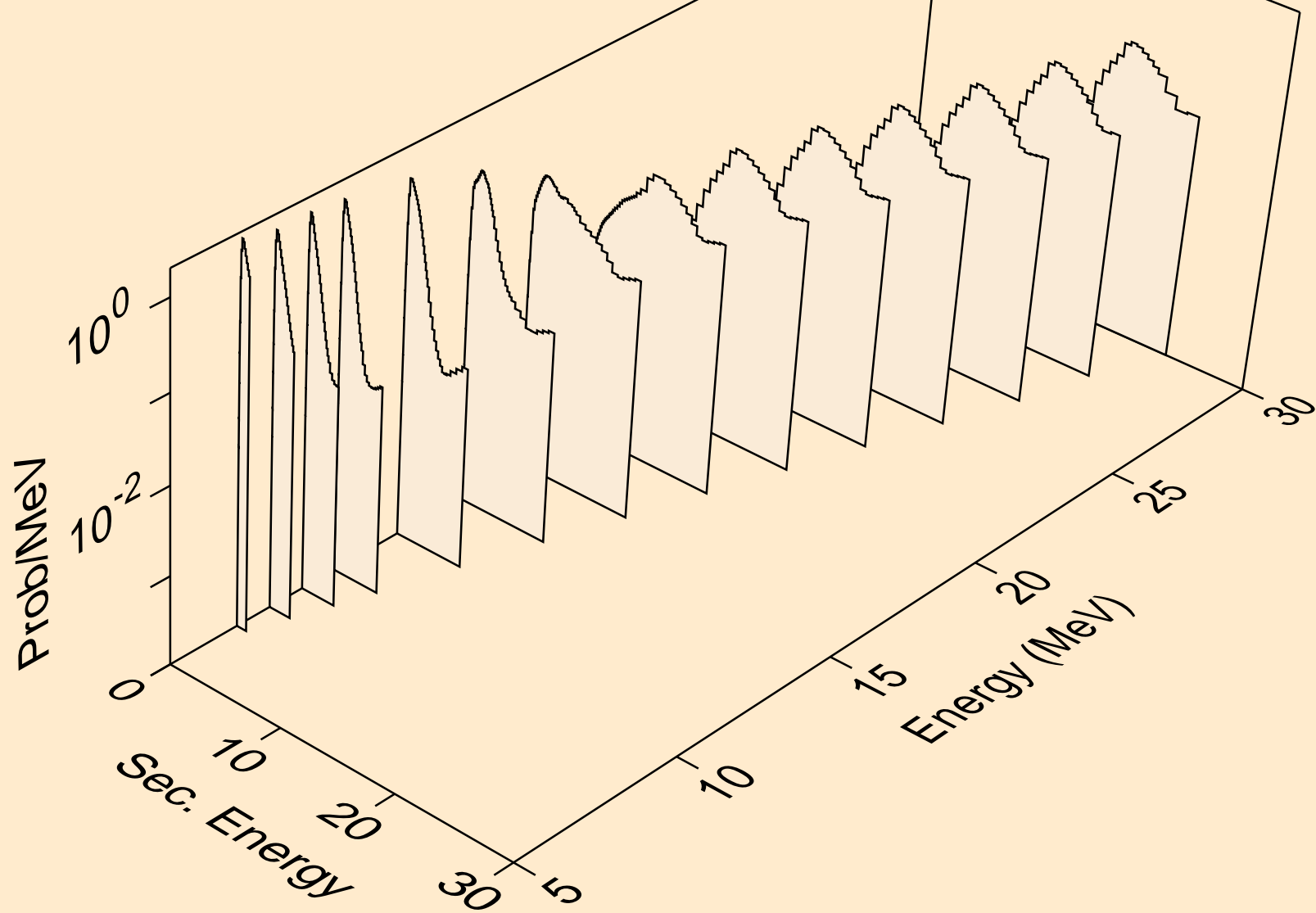

FL289 PHOTON ACER TENDL-2023 LIBRARY; T=0.K  
photons from (g,x)

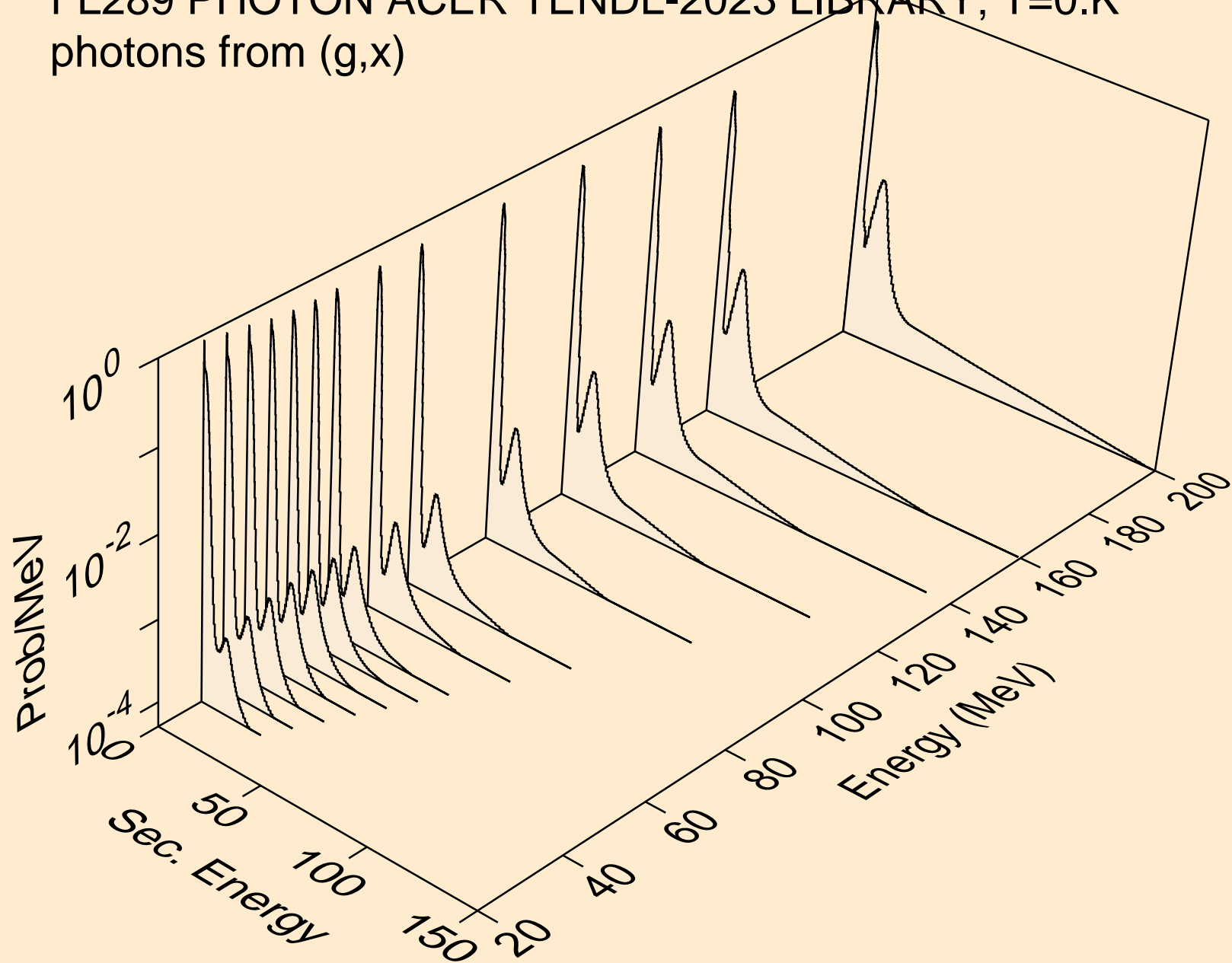

FL289 PHOTON ACER TENDL-2023 LIBRARY; T=0.K  
photons from (g,2n)

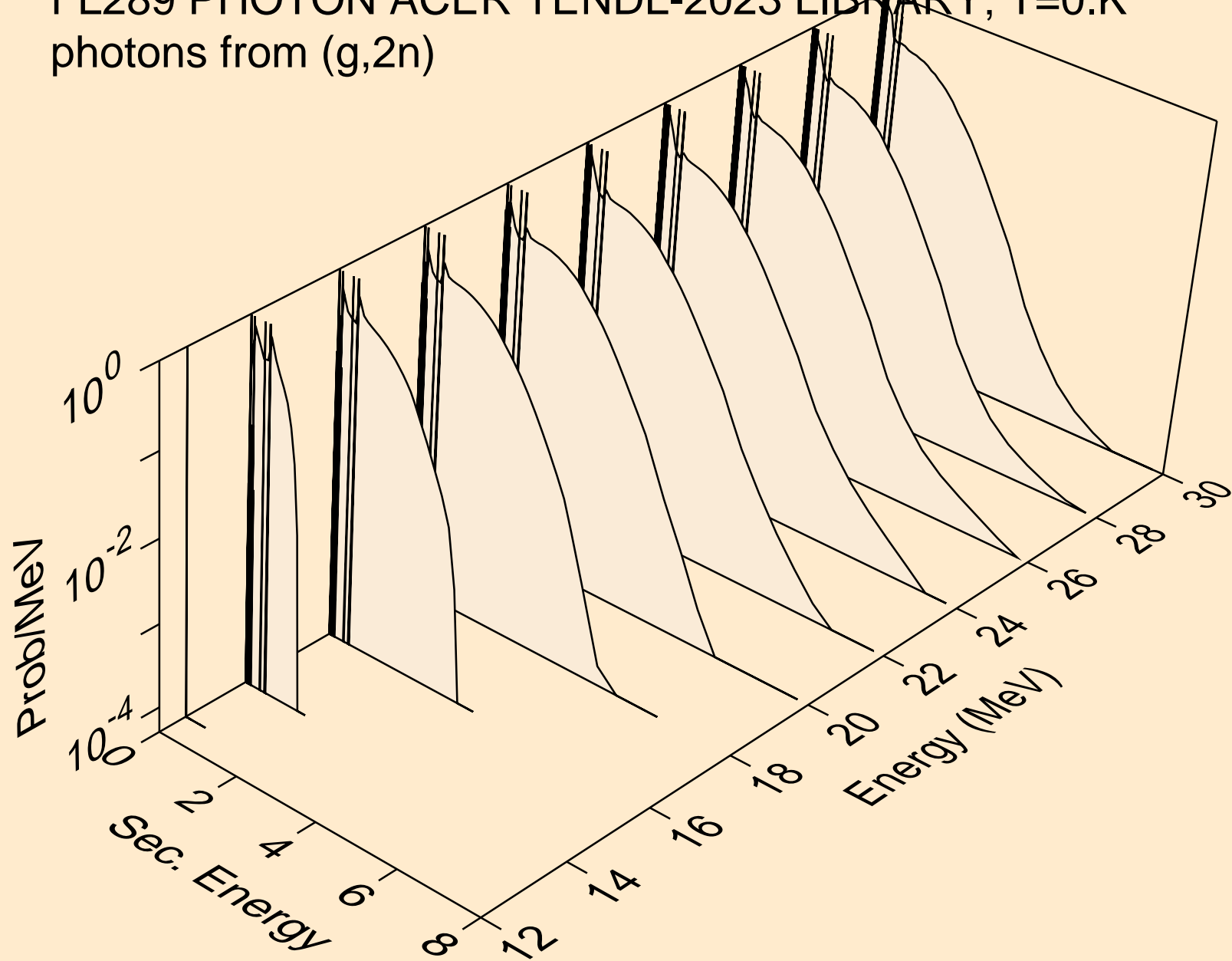

FL289 PHOTON ACER TENDL-2023 LIBRARY; T=0.K  
photons from (g,3n)

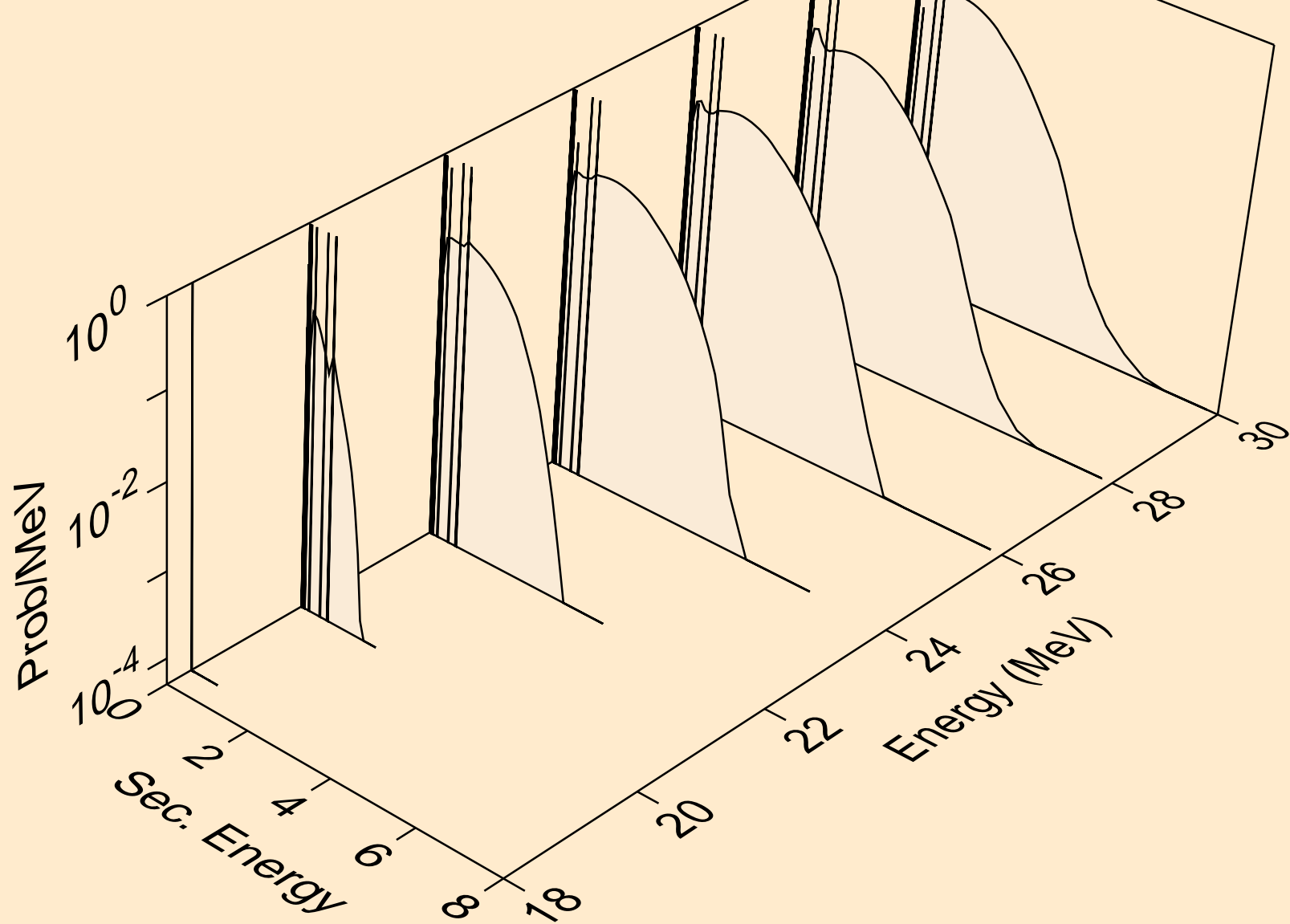

FL289 PHOTON ACER TENDL-2023 LIBRARY; T=0.K  
photons from (g,n\*)a

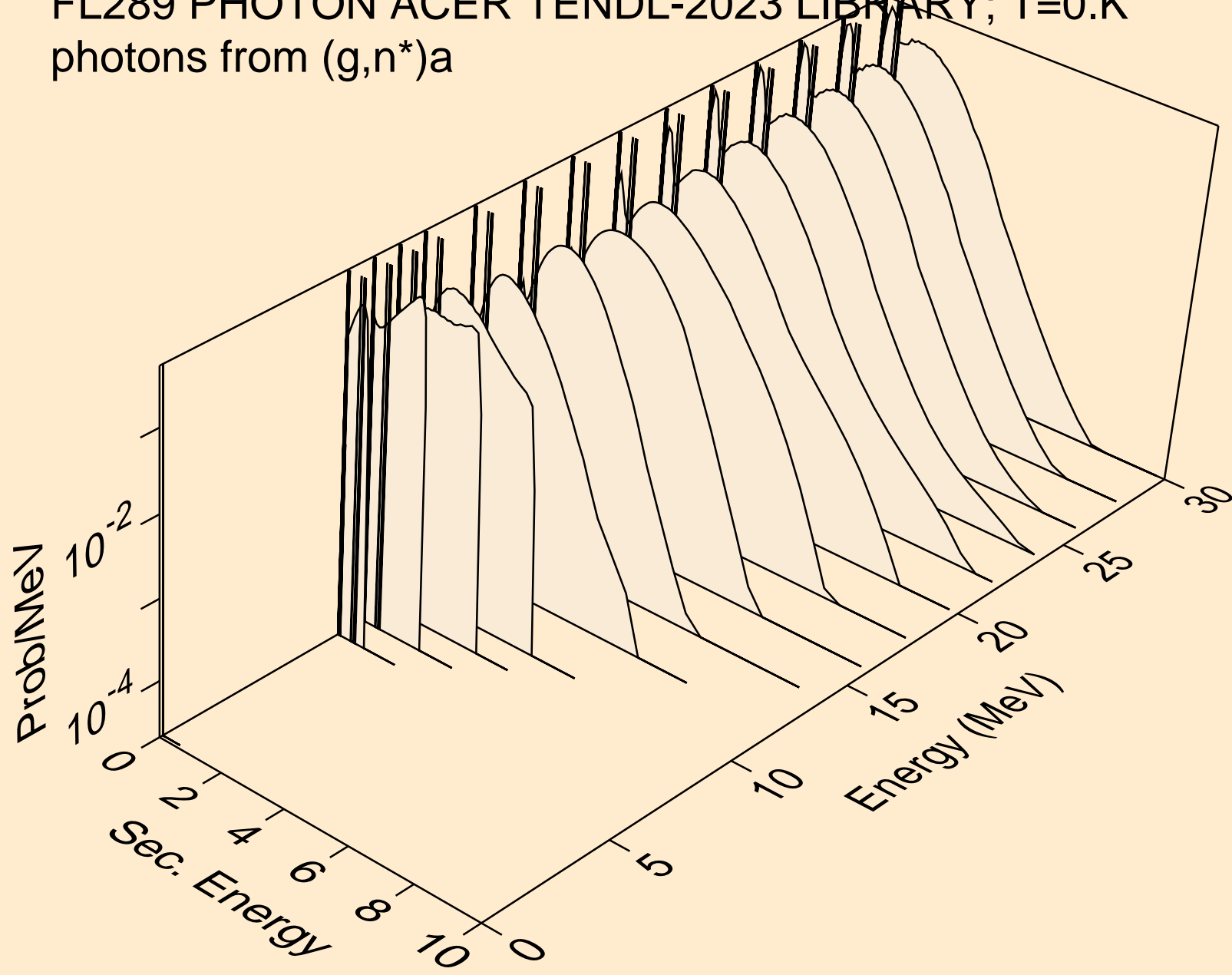

FL289 PHOTON ACER TENDL-2023 LIBRARY; T=0.K  
photons from (g,2n)a

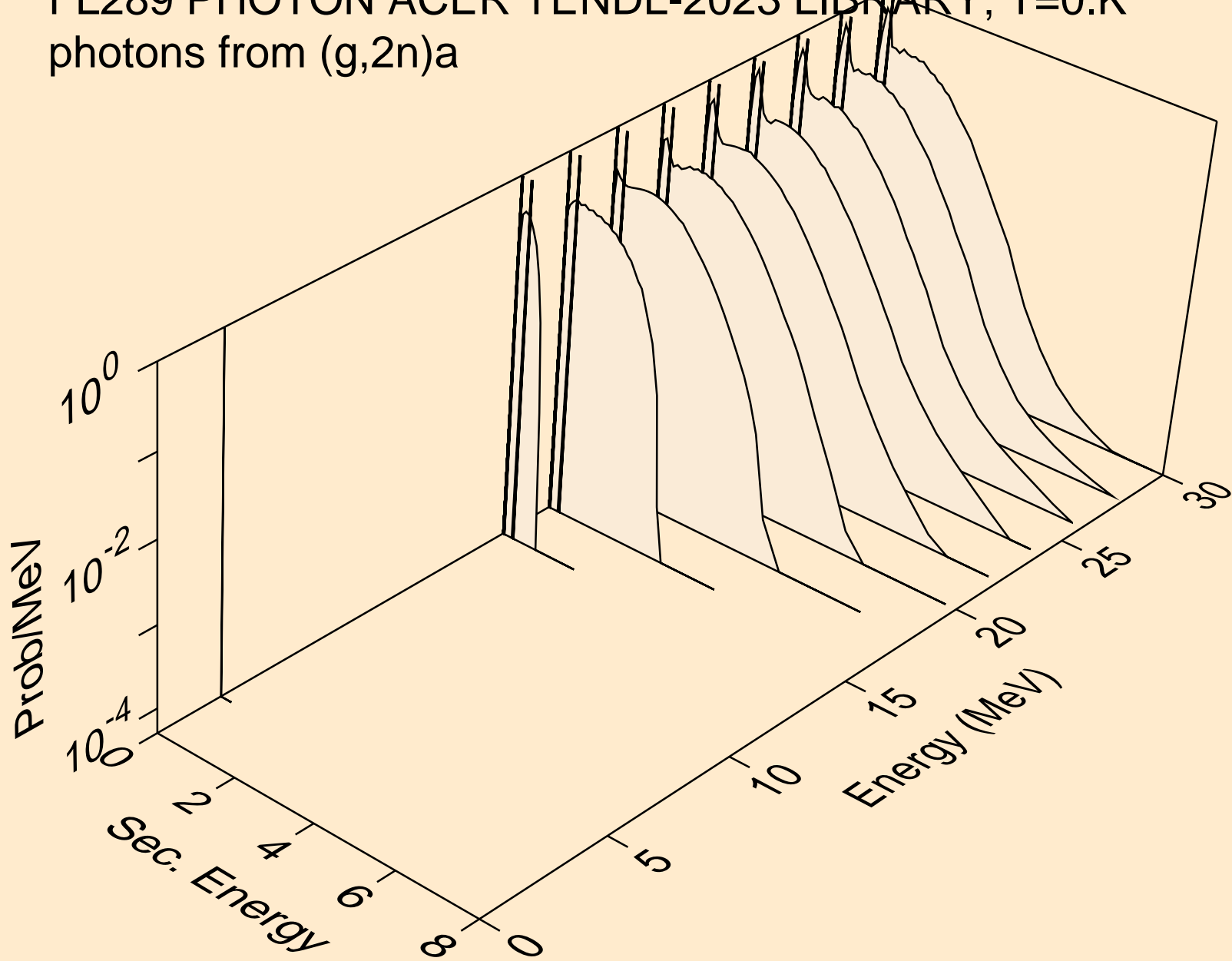

FL289 PHOTON ACER TENDL-2023 LIBRARY; T=0.K  
photons from (g,3n)a

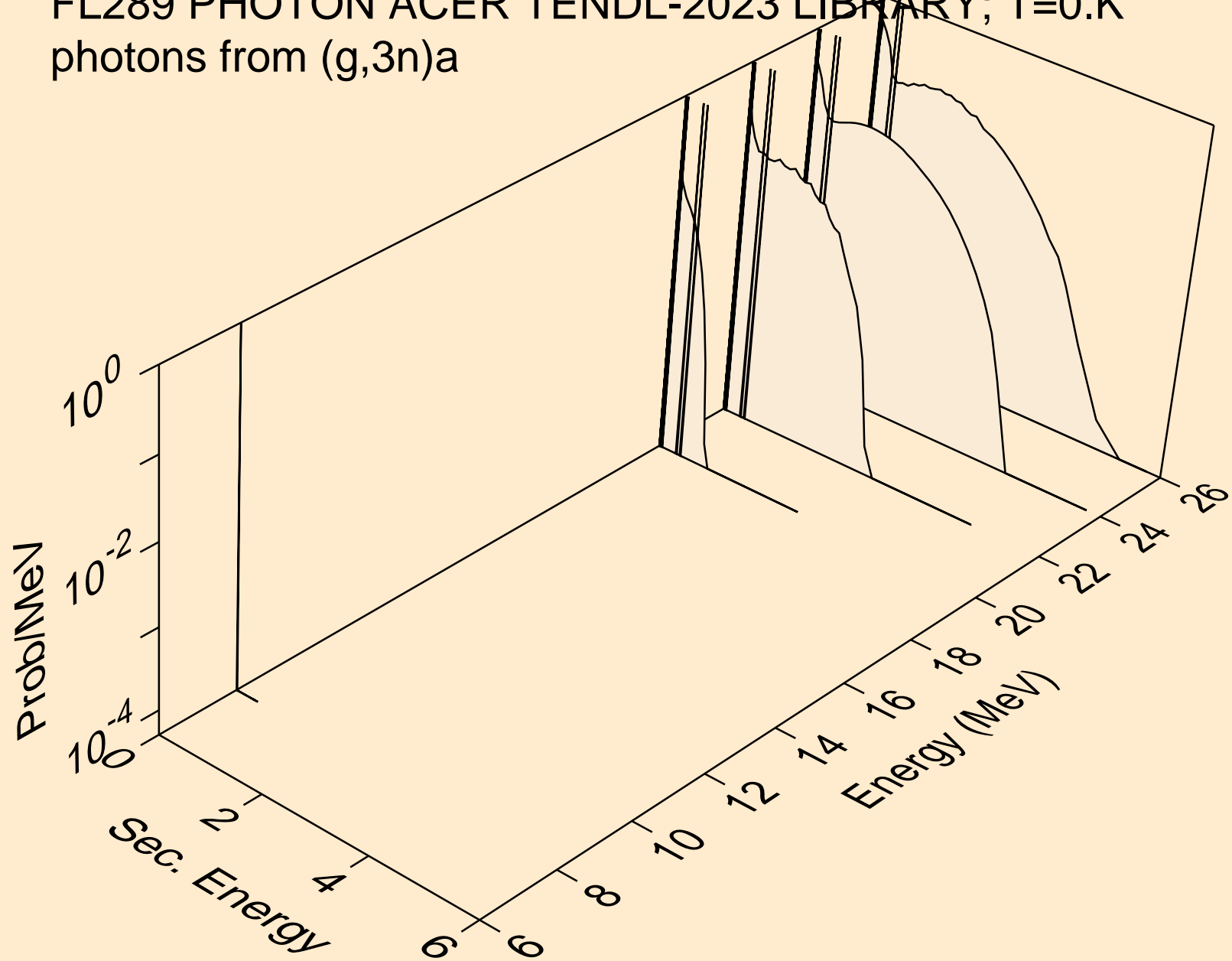

FL289 PHOTON ACER TENDL-2023 LIBRARY; T=0.K  
photons from (g,n\*)p

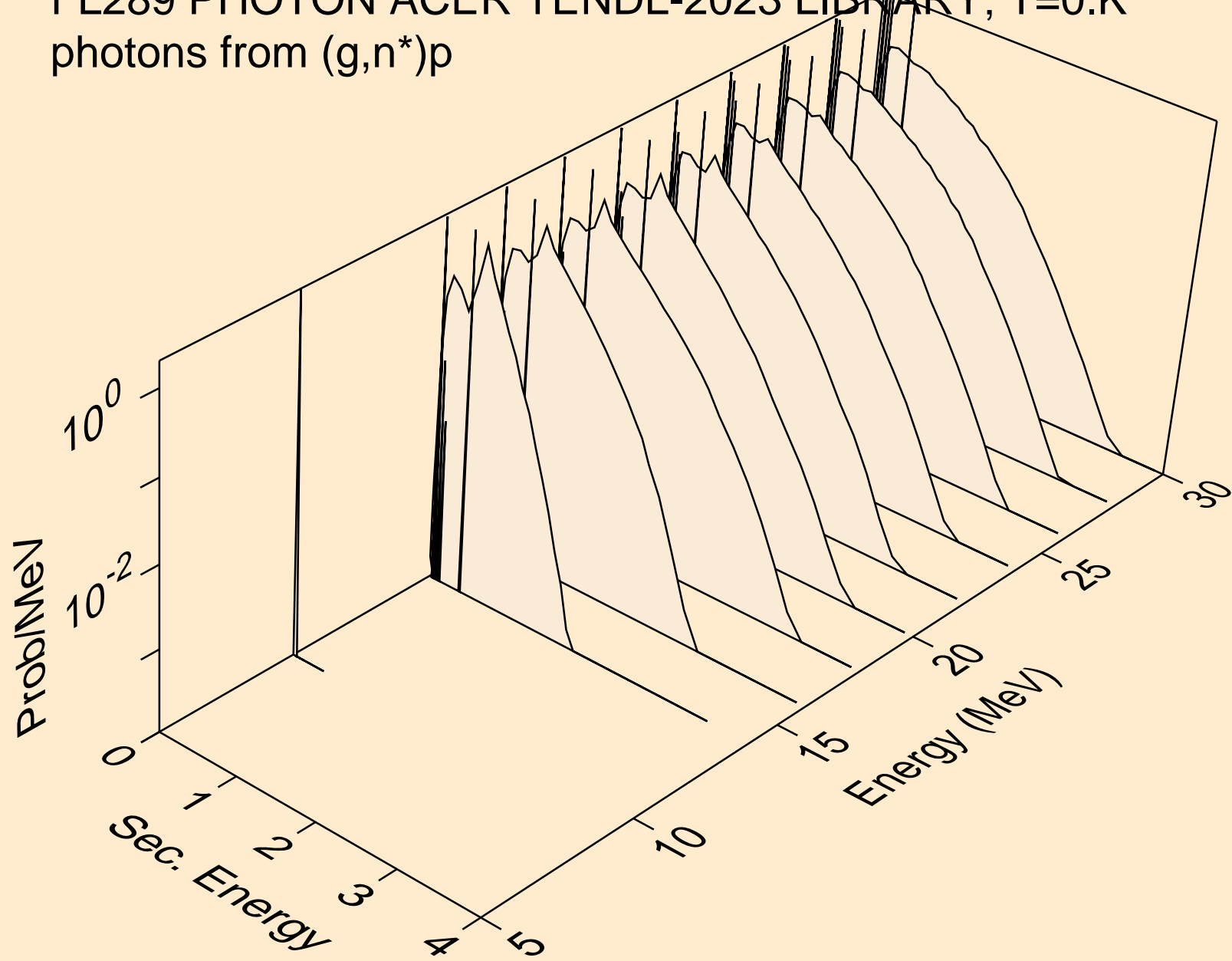

FL289 PHOTON ACER TENDL-2023 LIBRARY; T=0.K  
photons from (g,n\*)d

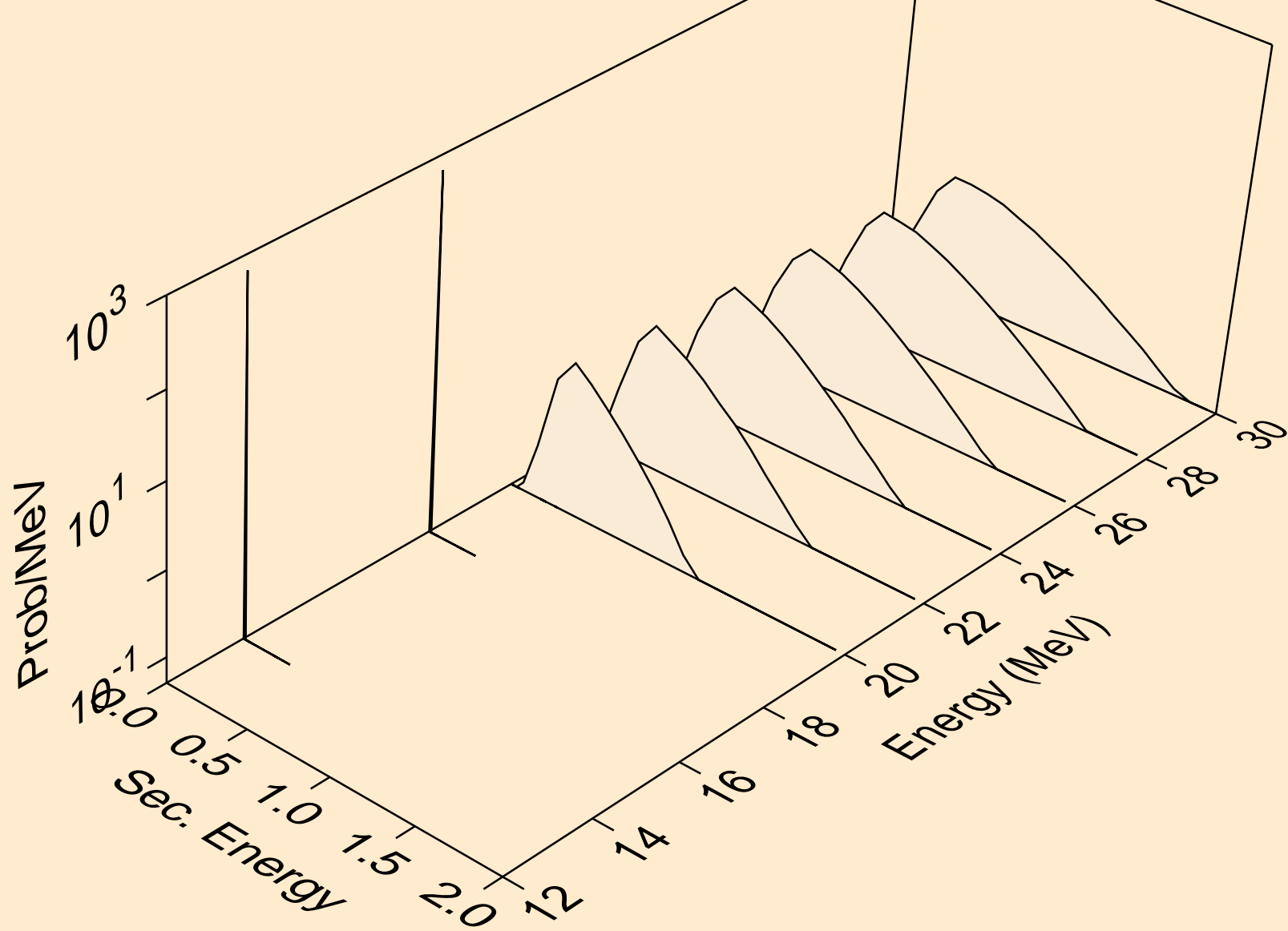

FL289 PHOTON ACER TENDL-2023 LIBRARY; T=0.K  
photons from (g,4n)

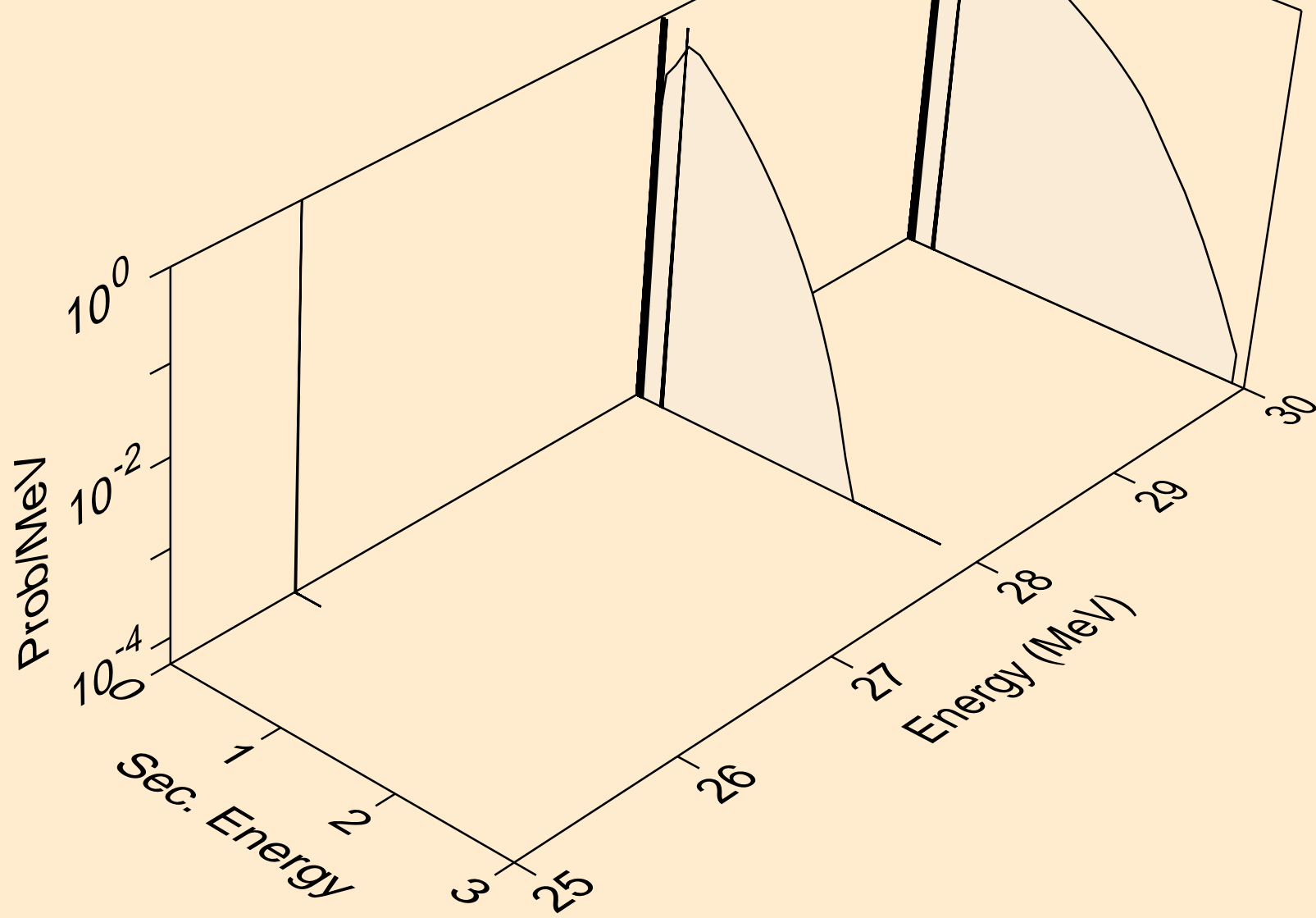

FL289 PHOTON ACER TENDL-2023 LIBRARY; T=0.K  
photons from (g,2np)

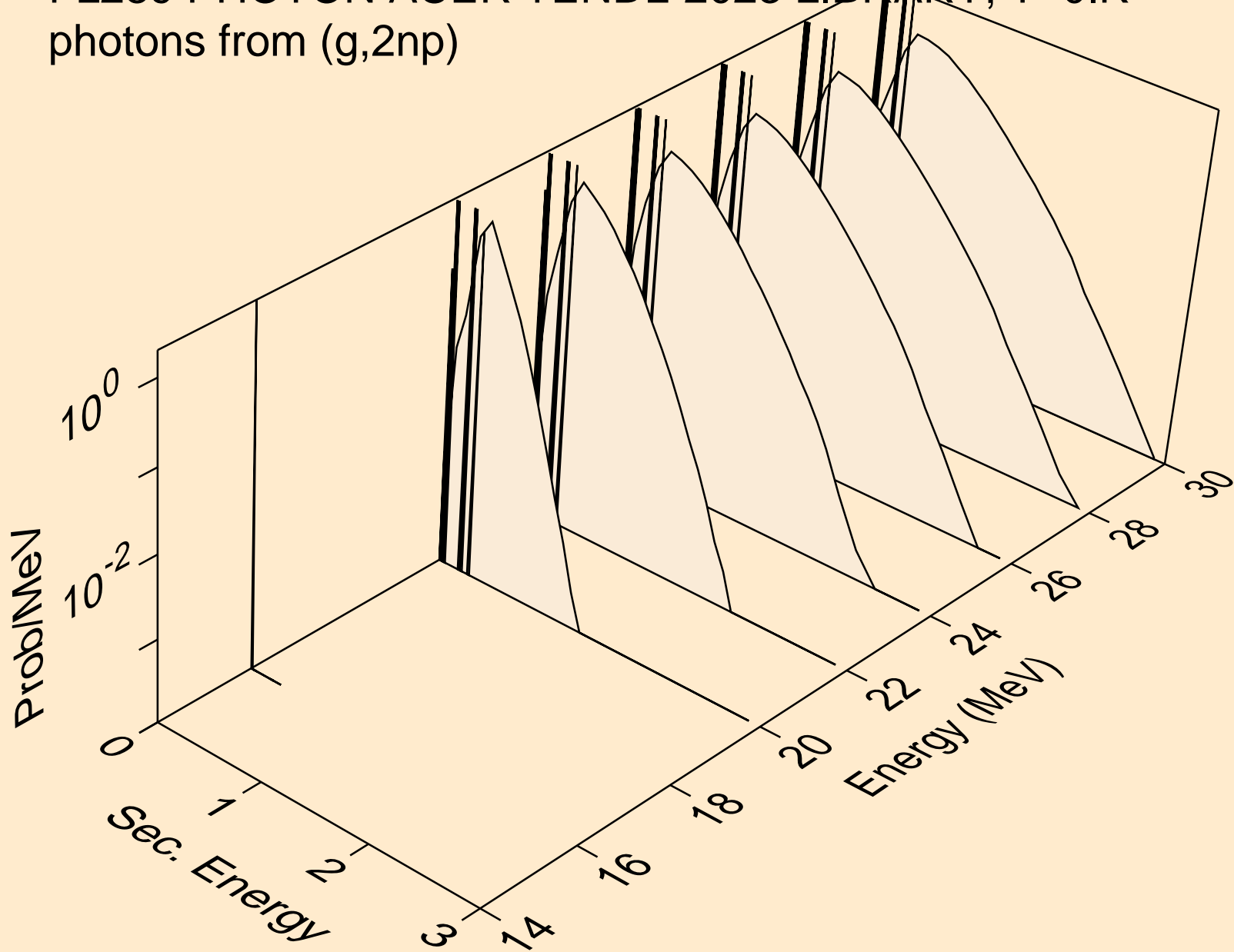

FL289 PHOTON ACER TENDL-2023 LIBRARY; T=0.K  
photons from (g,n\*c)

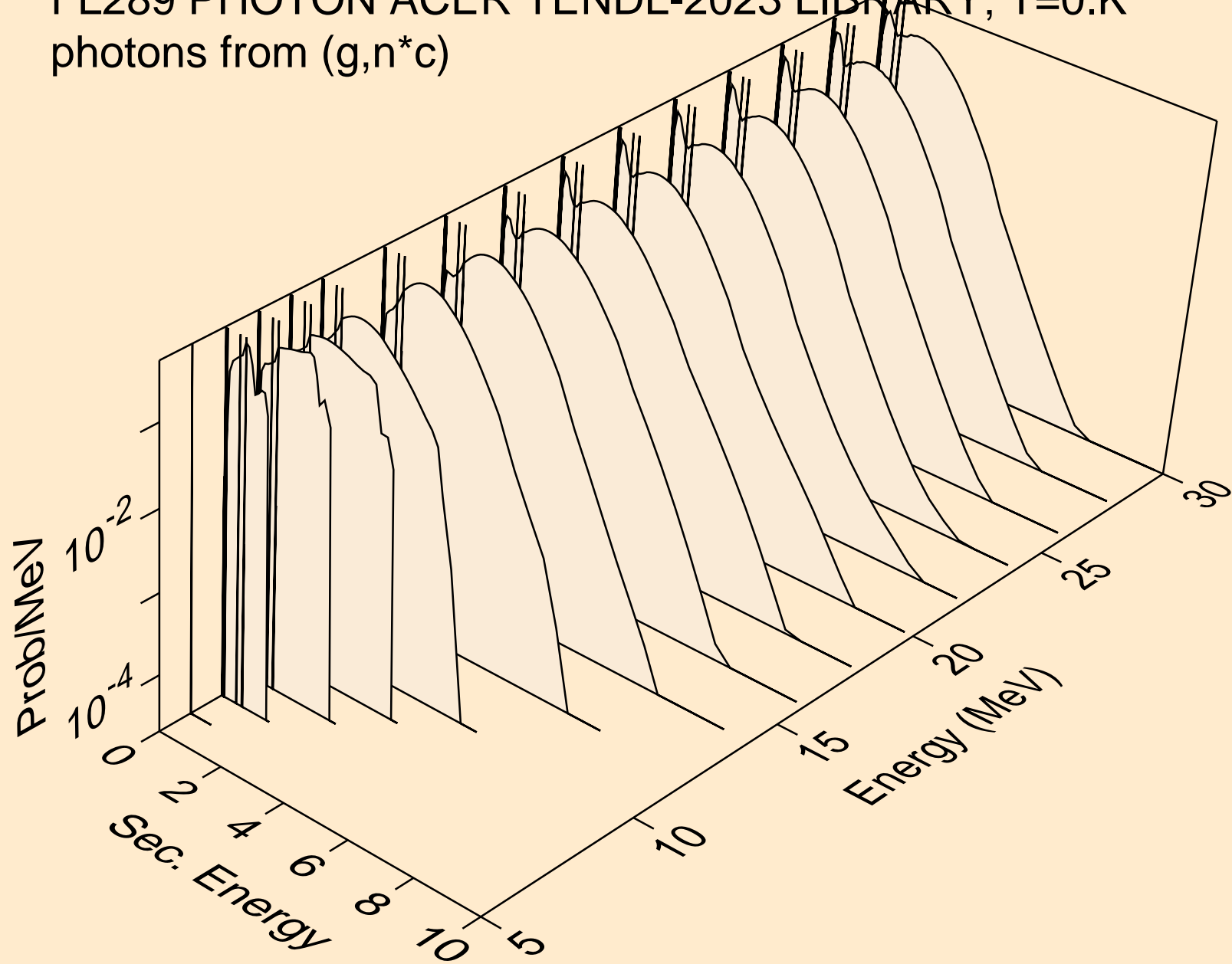

FL289 PHOTON ACER TENDL-2023 LIBRARY; T=0.K  
photons from (g,gma)

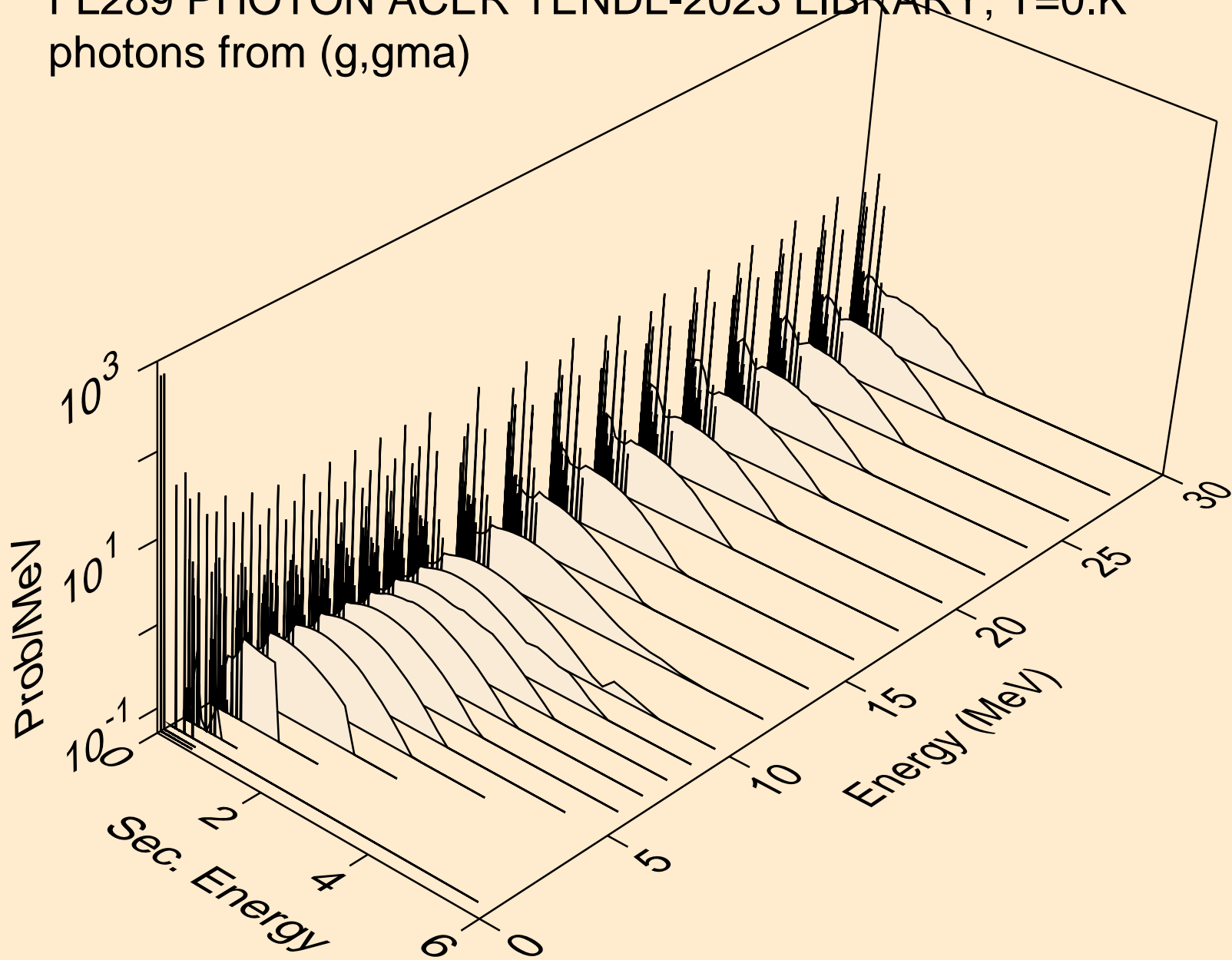

FL289 PHOTON ACER TENDL-2023 LIBRARY; T=0.K  
photons from (g,p)

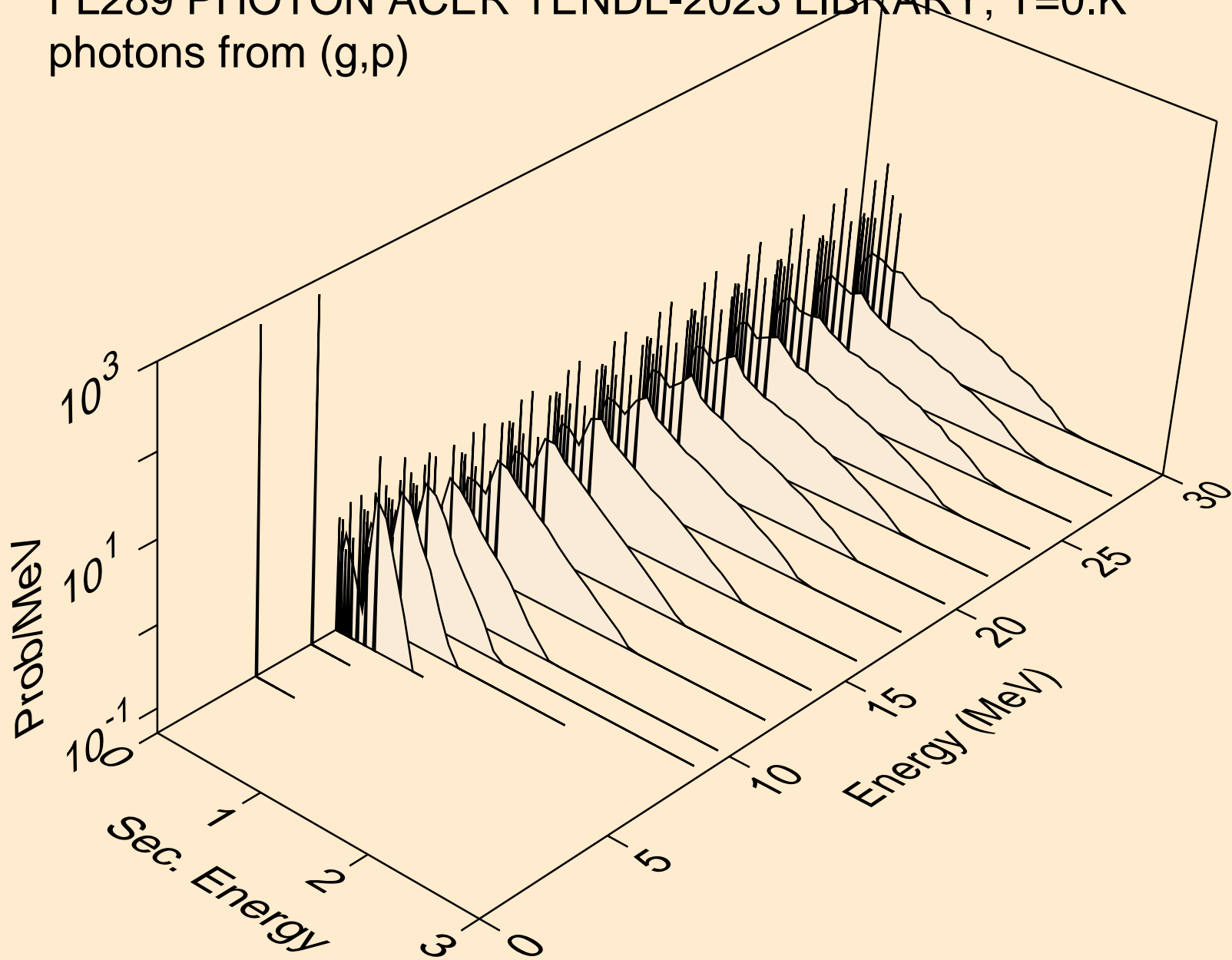

FL289 PHOTON ACER TENDL-2023 LIBRARY; T=0.K  
photons from (g,d)

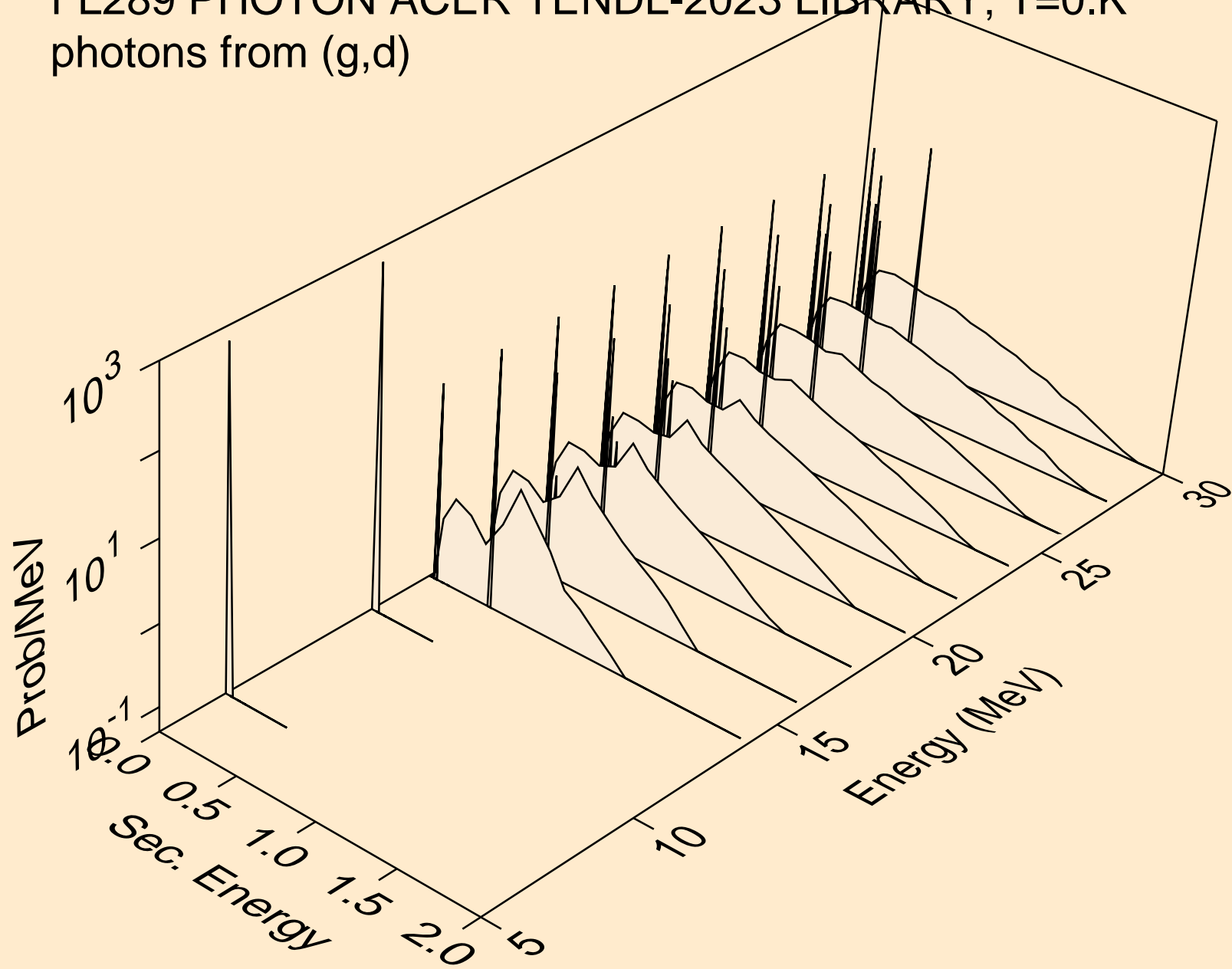

FL289 PHOTON ACER TENDL-2023 LIBRARY; T=0.K  
photons from (g,a)

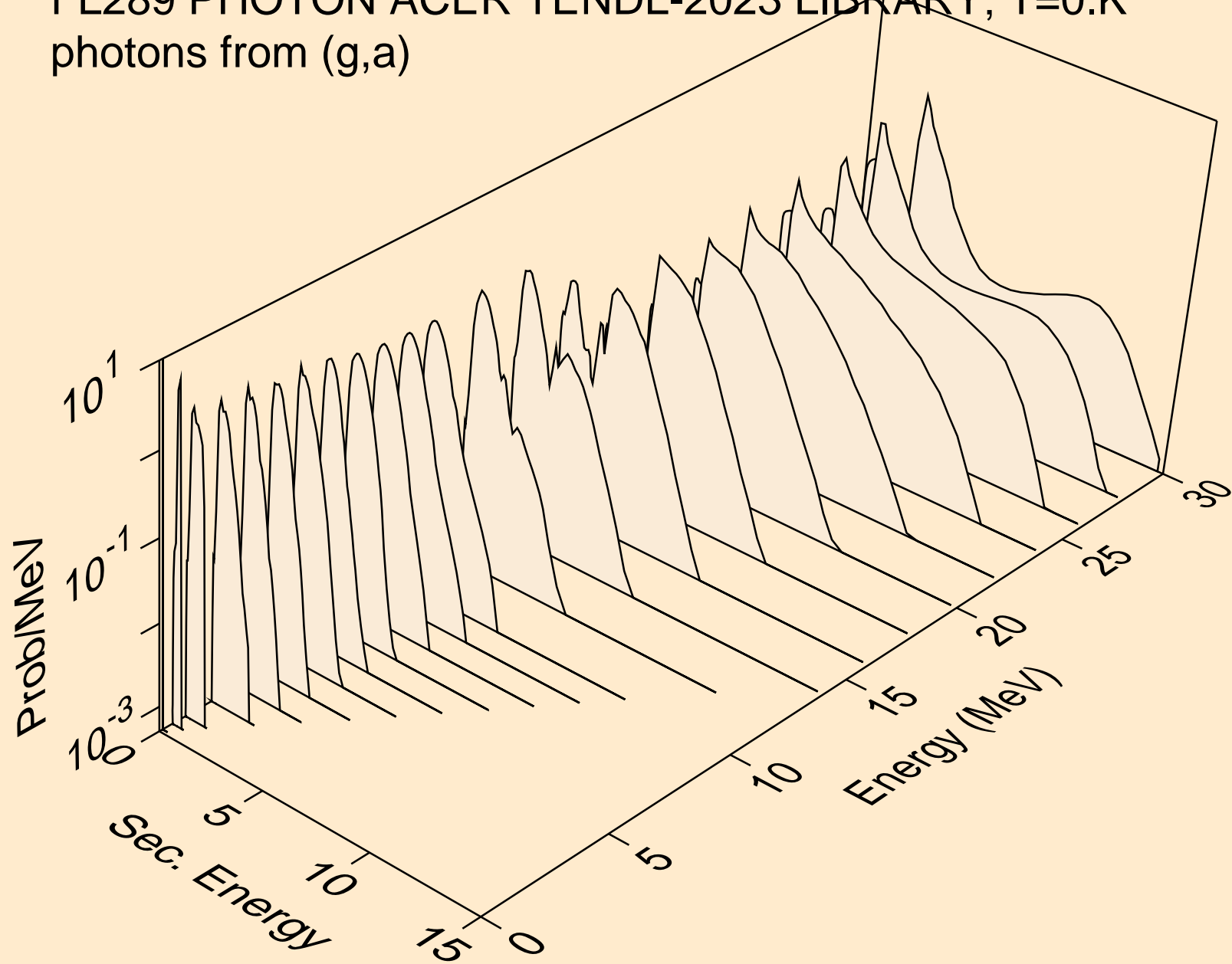

FL289 PHOTON ACER TENDL-2023 LIBRARY; T=0.K  
protons from (g,x)

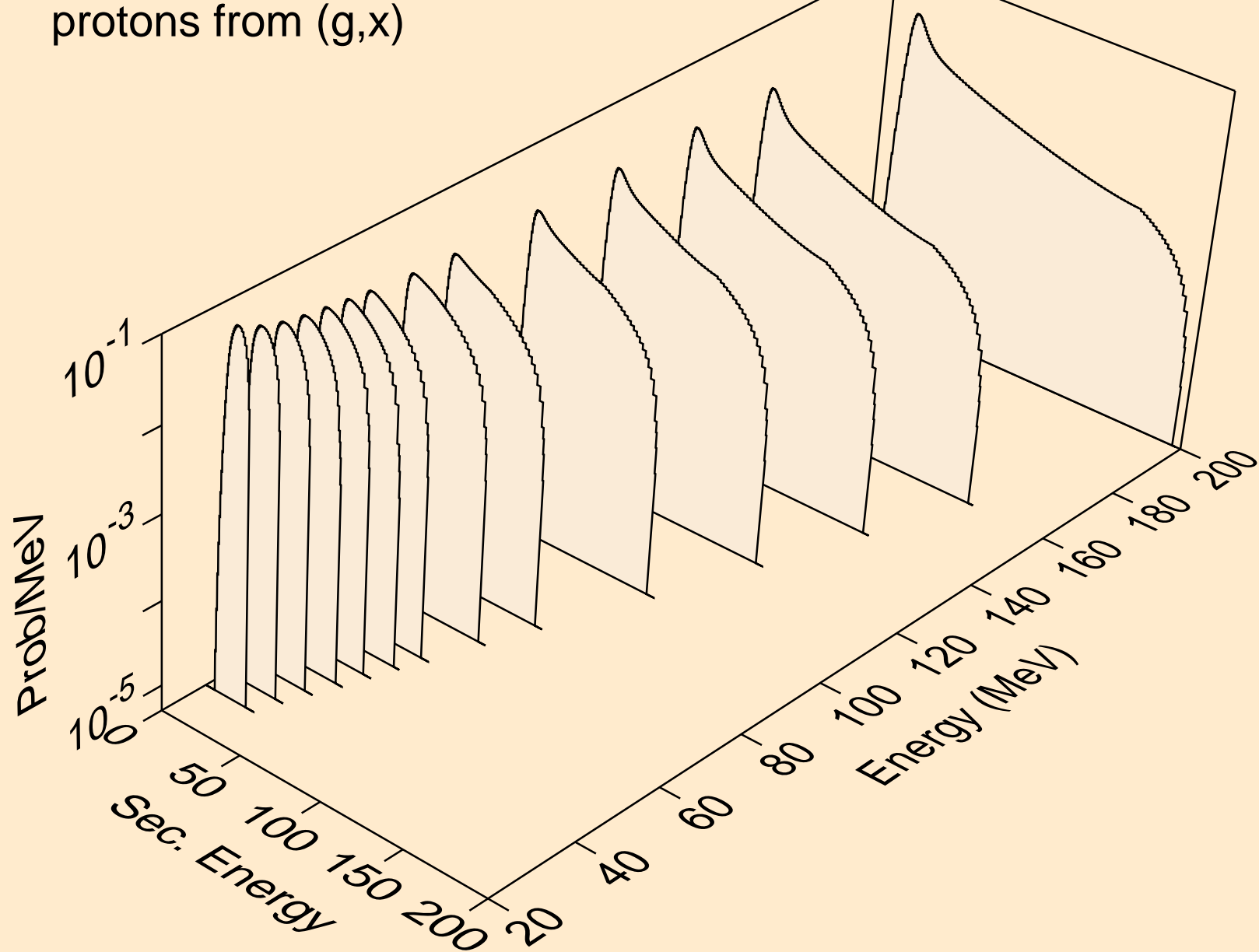

FL289 PHOTON ACER TENDL-2023 LIBRARY; T=0.K  
protons from (g,n\*)p

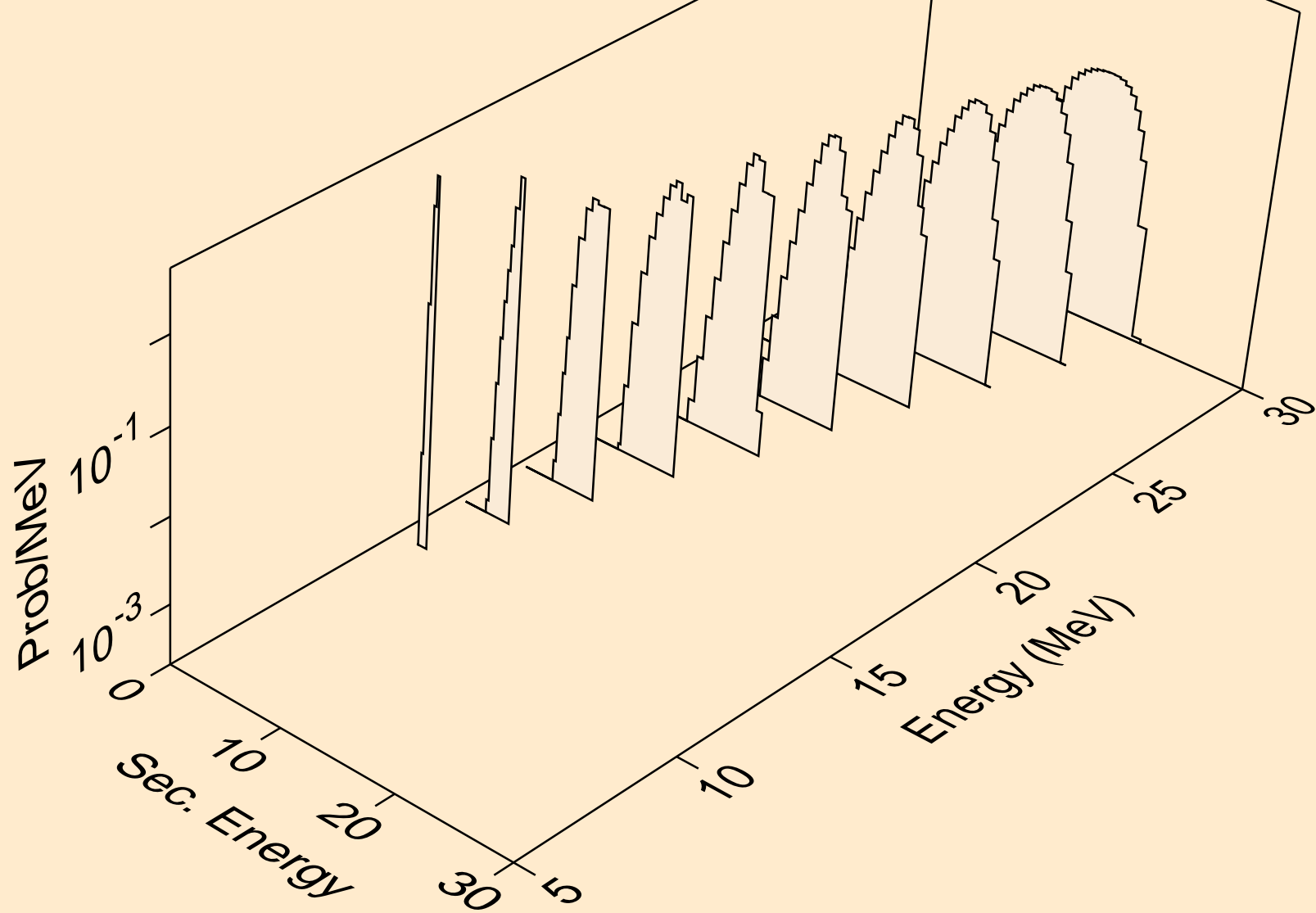

FL289 PHOTON ACER TENDL-2023 LIBRARY; T=0.K  
protons from (g,2np)

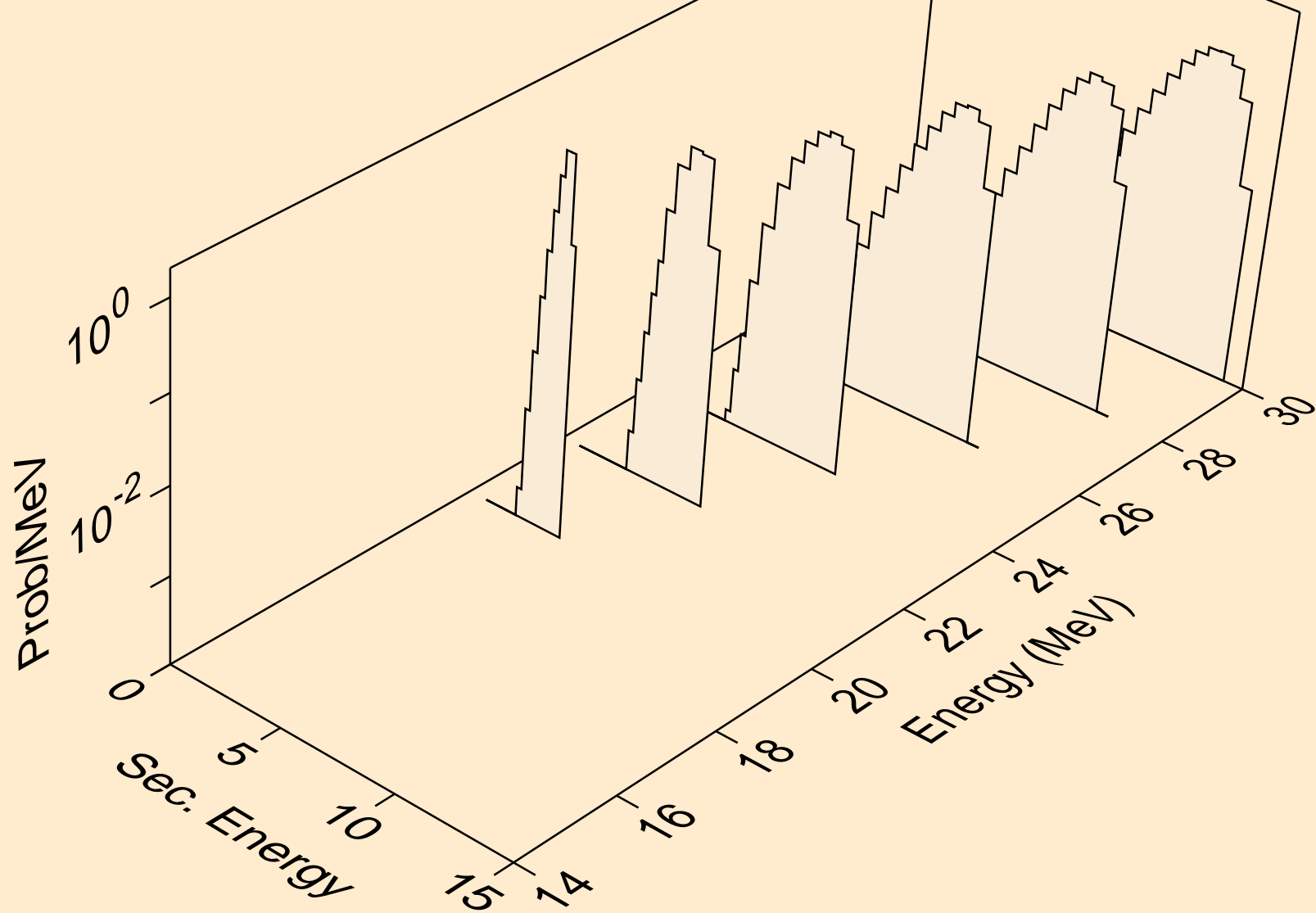

FL289 PHOTON ACER TENDL-2023 LIBRARY; T=0.K  
protons from (g,p)

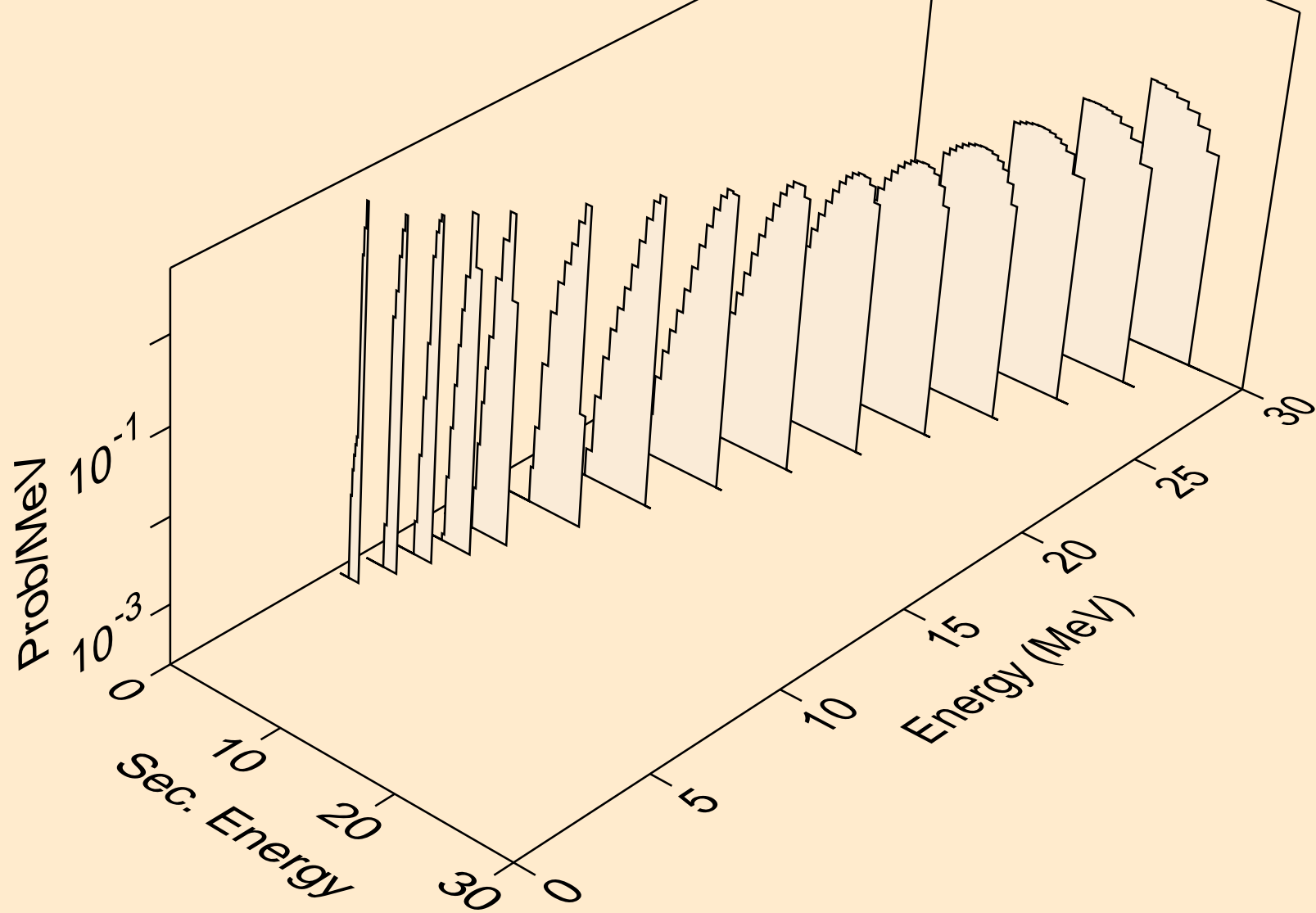

FL289 PHOTON ACER TENDL-2023 LIBRARY; T=0.K  
deuterons from (g,x)

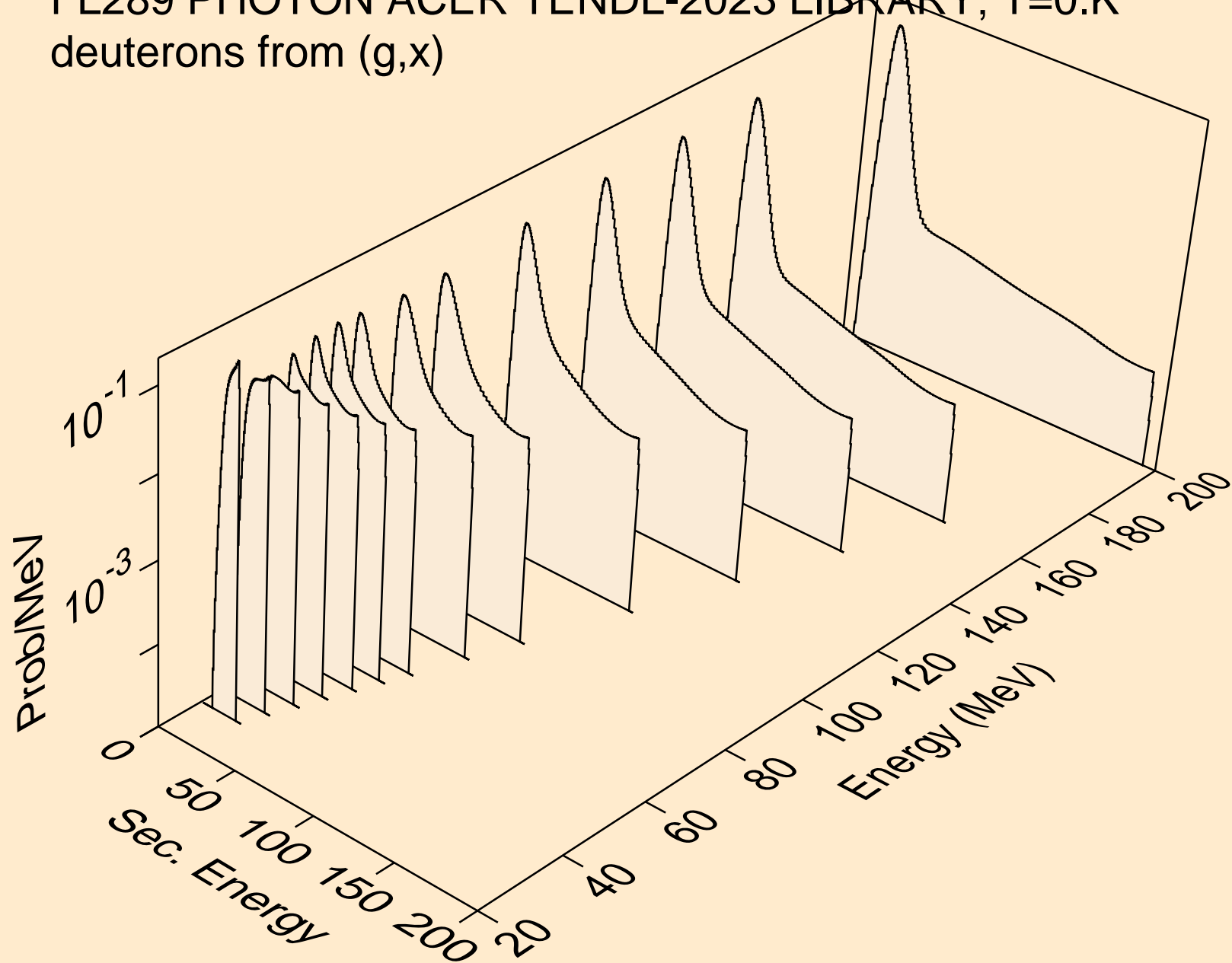

FL289 PHOTON ACER TENDL-2023 LIBRARY; T=0.K  
deuterons from (g,n\*)d

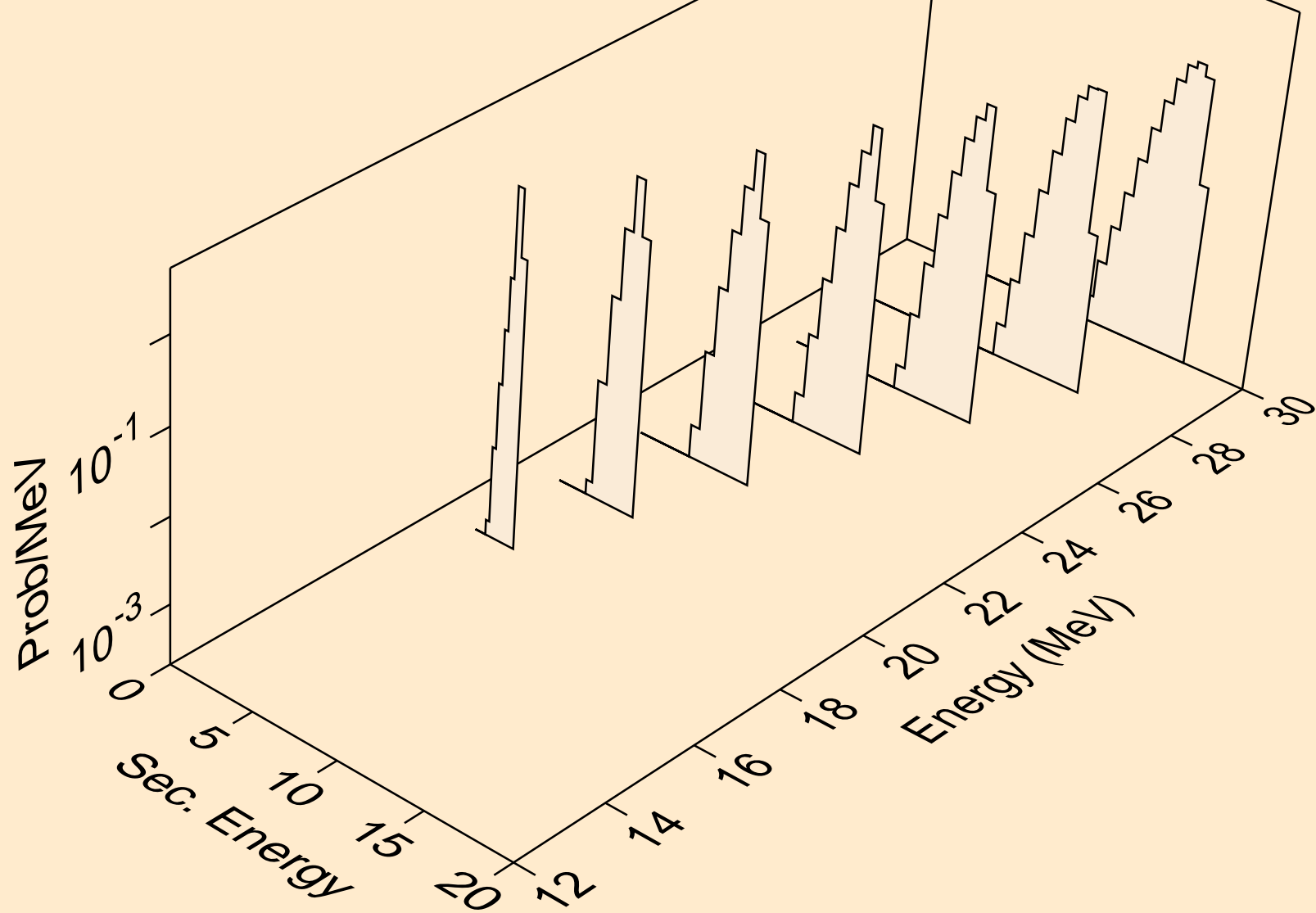

FL289 PHOTON ACER TENDL-2023 LIBRARY; T=0.K  
deuterons from (g,d)

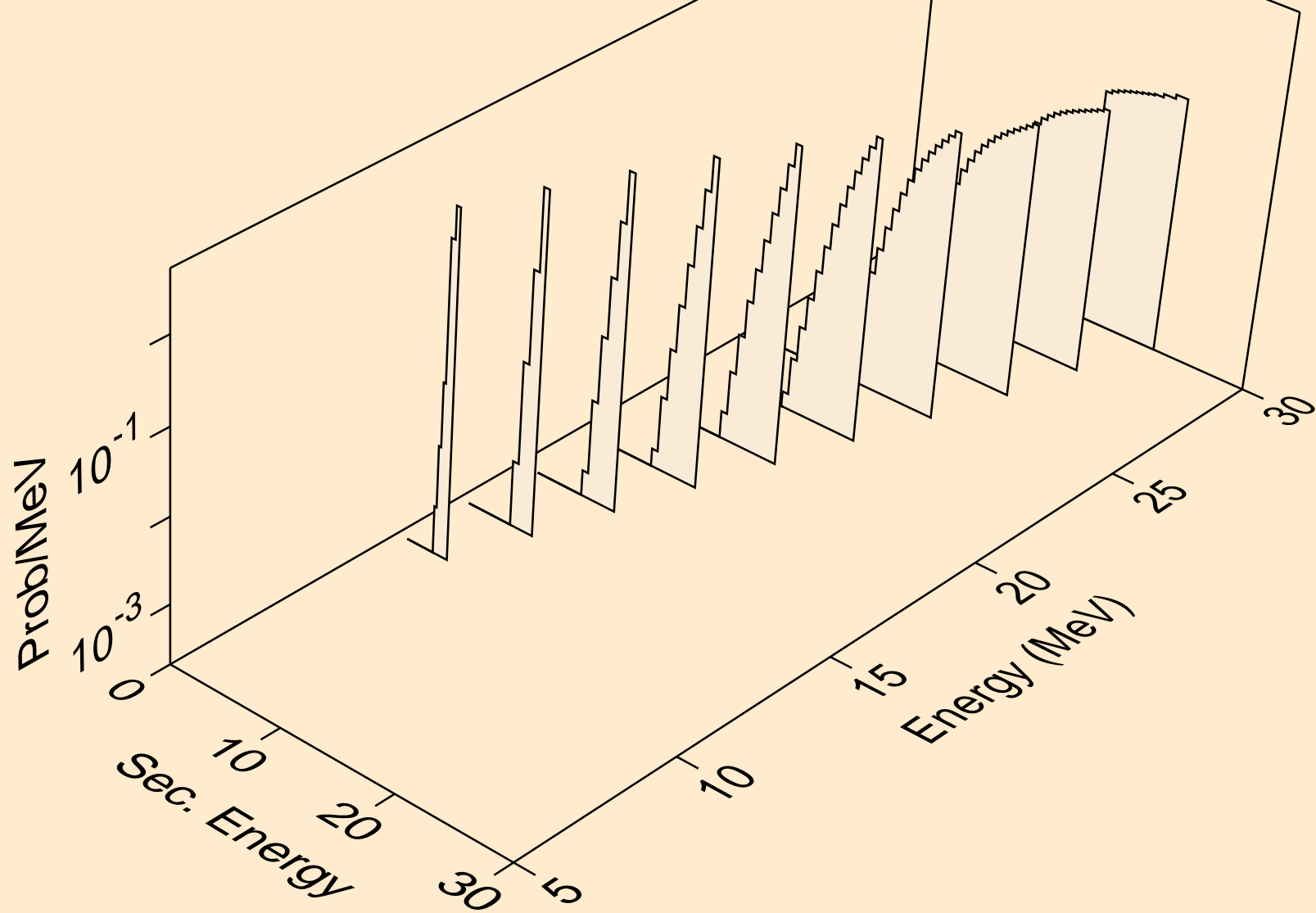

FL289 PHOTON ACER TENDL-2023 LIBRARY; T=0.K  
tritons from (g,x)

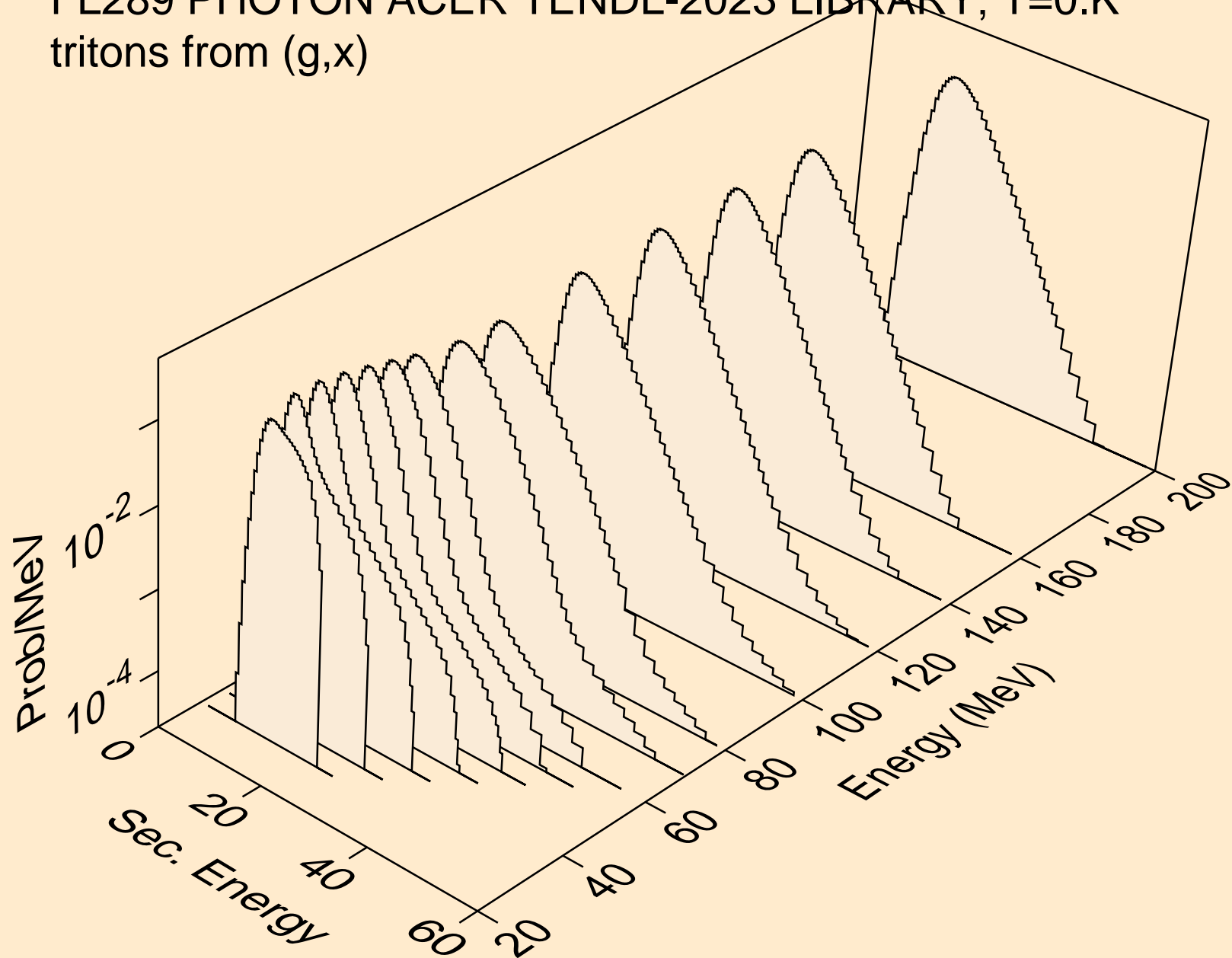

FL289 PHOTON ACER TENDL-2023 LIBRARY; T=0.K  
he3s from (g,x)

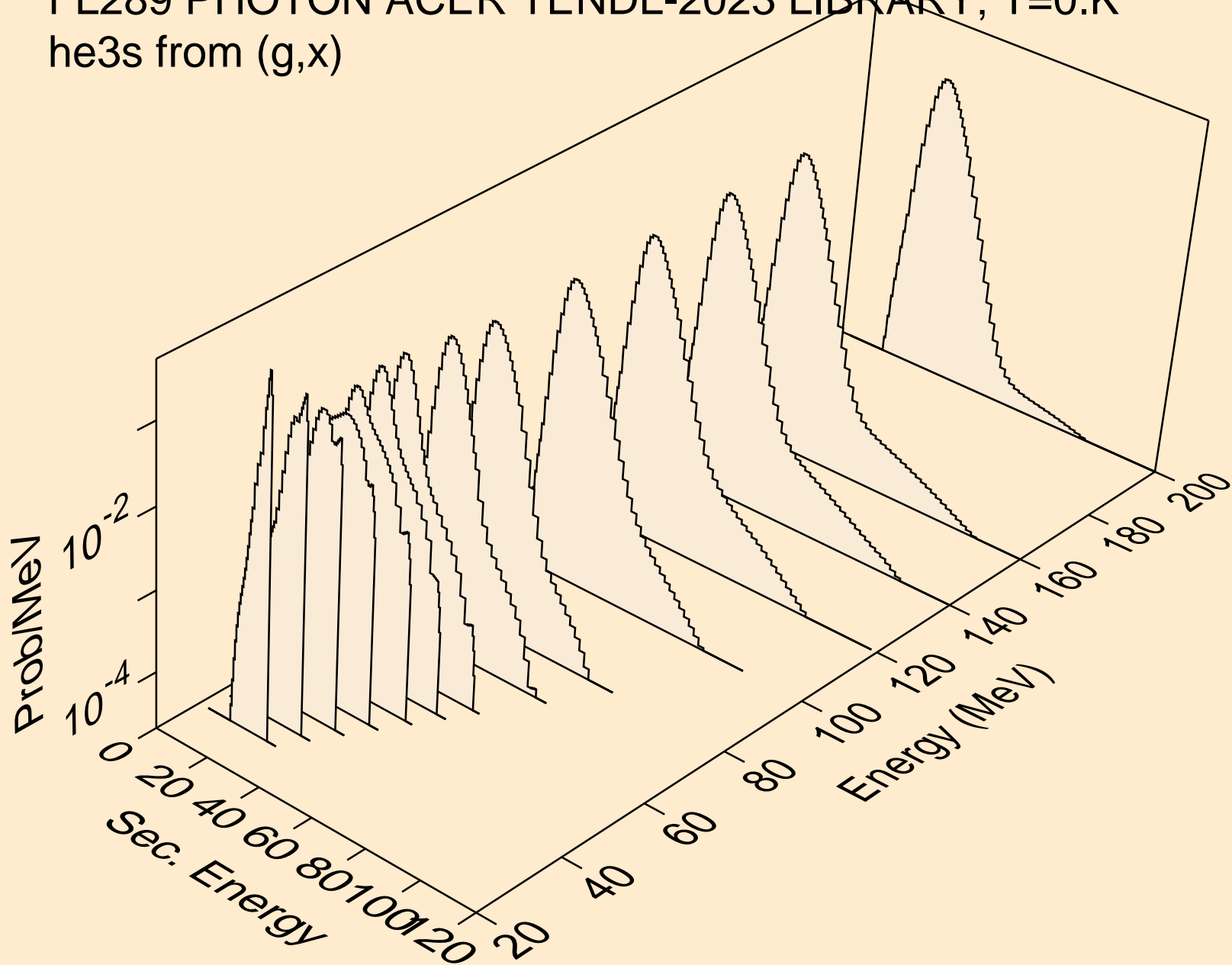

FL289 PHOTON ACER TENDL-2023 LIBRARY; T=0.K  
alphas from (g,x)

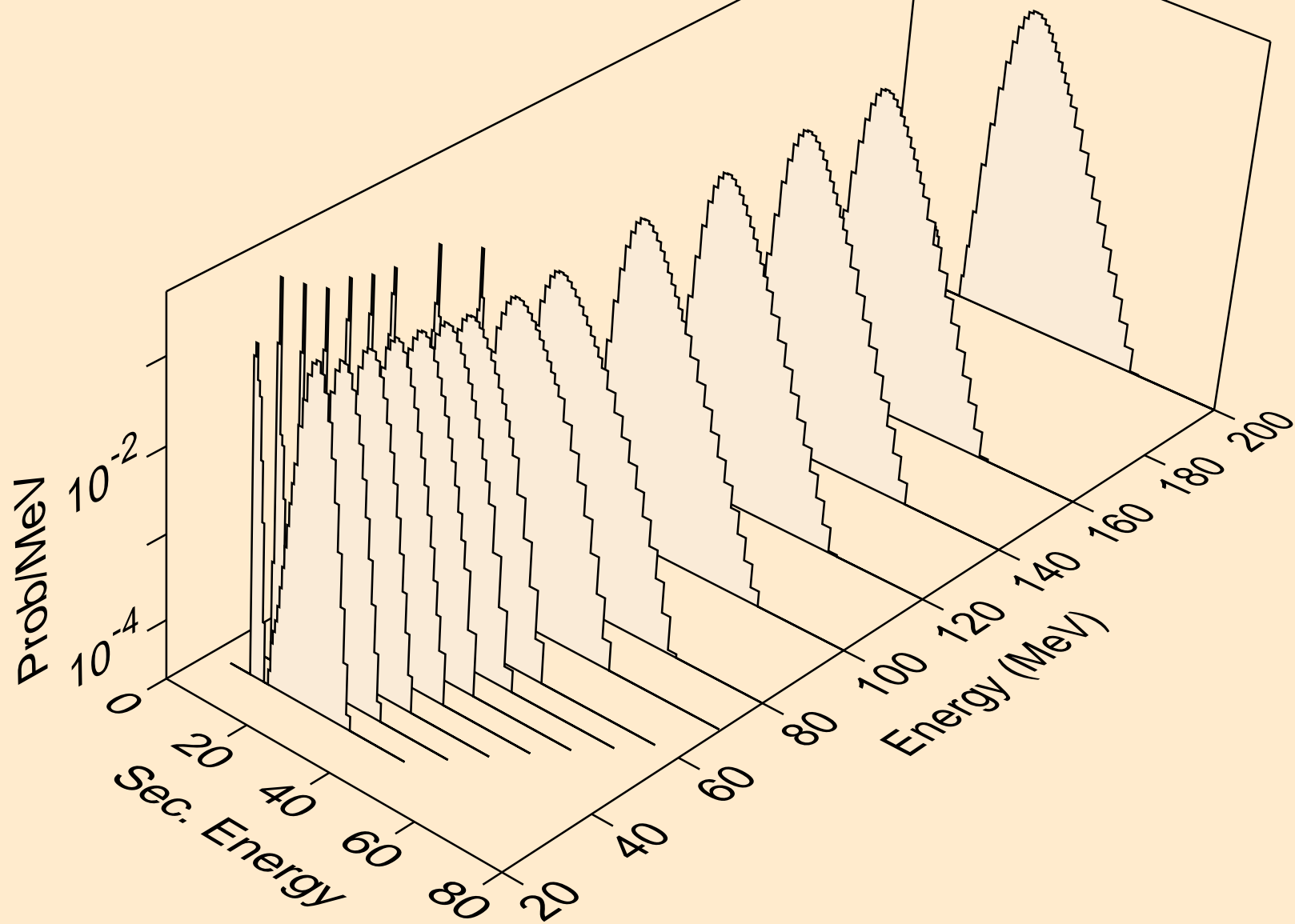

FL289 PHOTON ACER TENDL-2023 LIBRARY; T=0.K  
alphas from (g,n\*)a

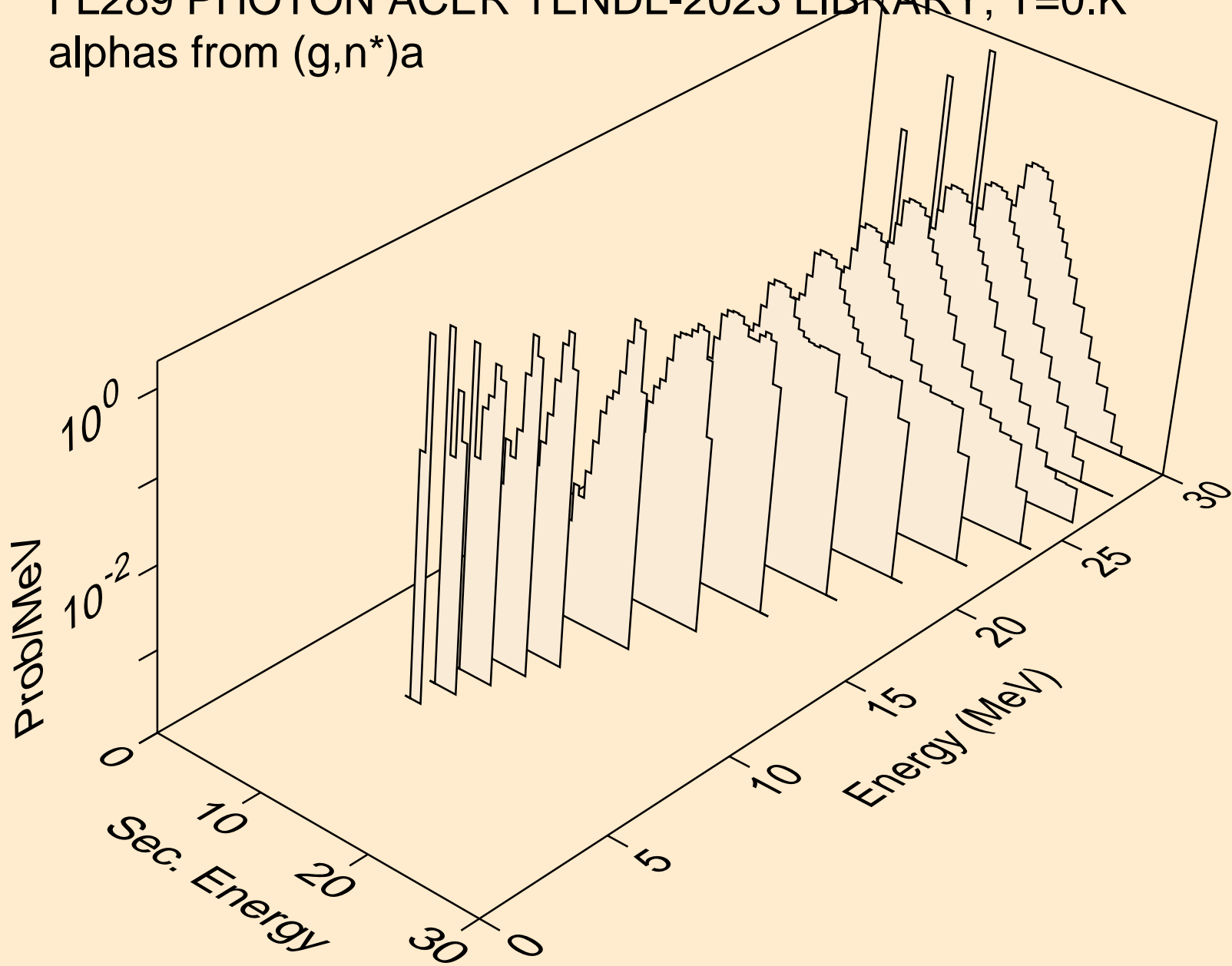

FL289 PHOTON ACER TENDL-2023 LIBRARY; T=0.K  
alphas from (g,2n)a

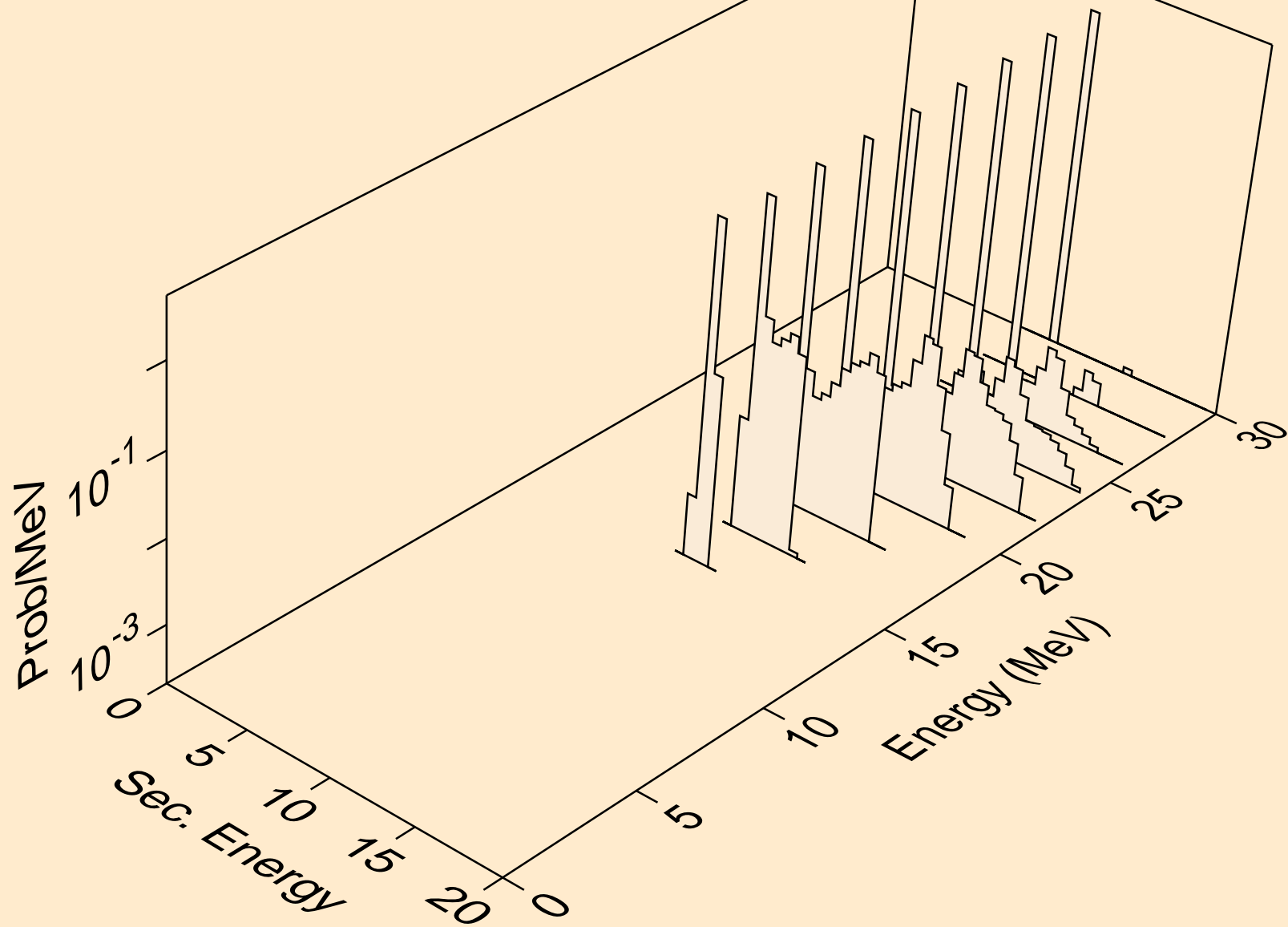

FL289 PHOTON ACER TENDL-2023 LIBRARY; T=0.K  
alphas from (g,3n)a

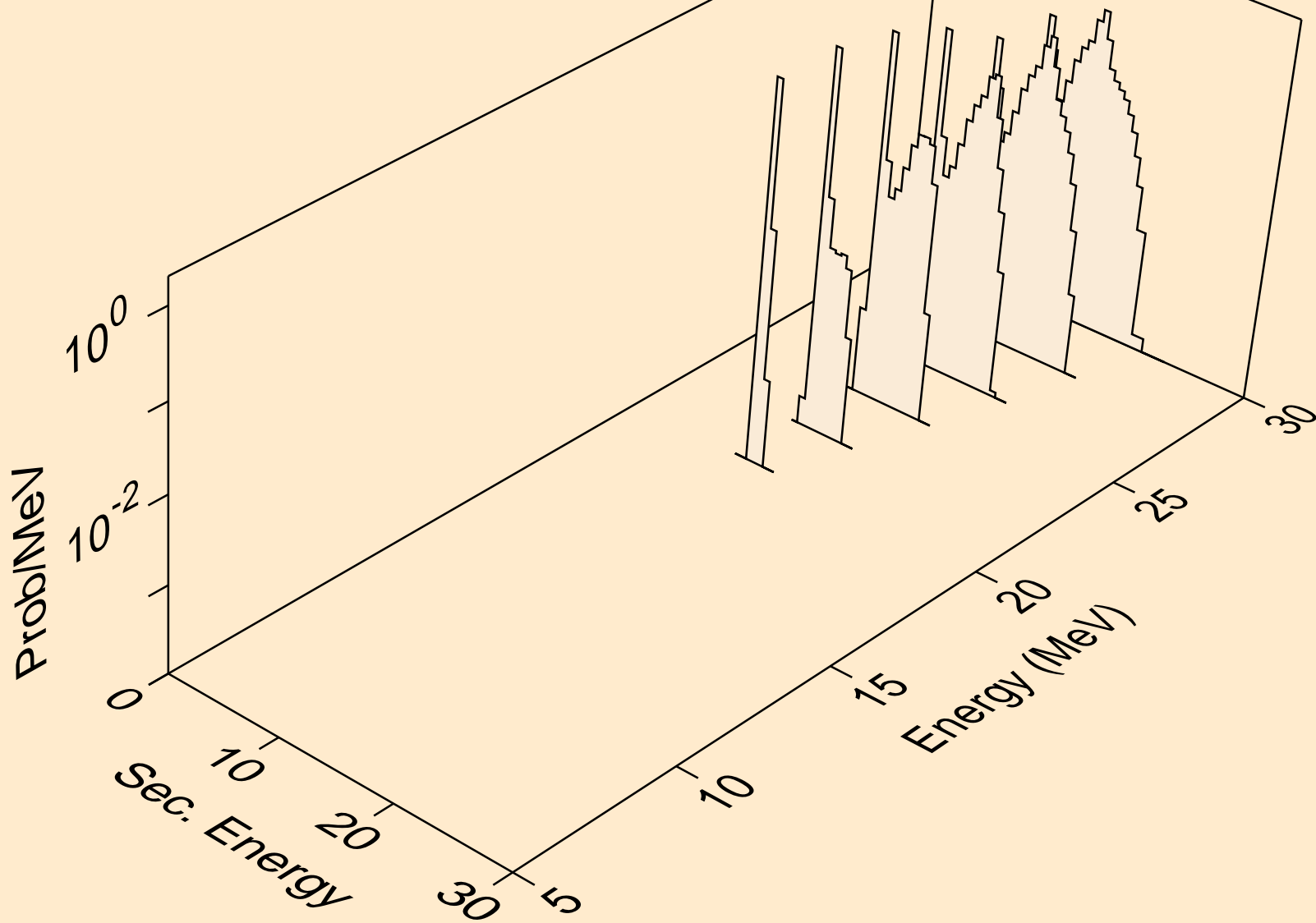

FL289 PHOTON ACER TENDL-2023 LIBRARY; T=0.K  
alphas from (g,a)

