

RE169M PHOTON ACER TENDL-2023 LIBRARY; T=0.K
Principal cross sections

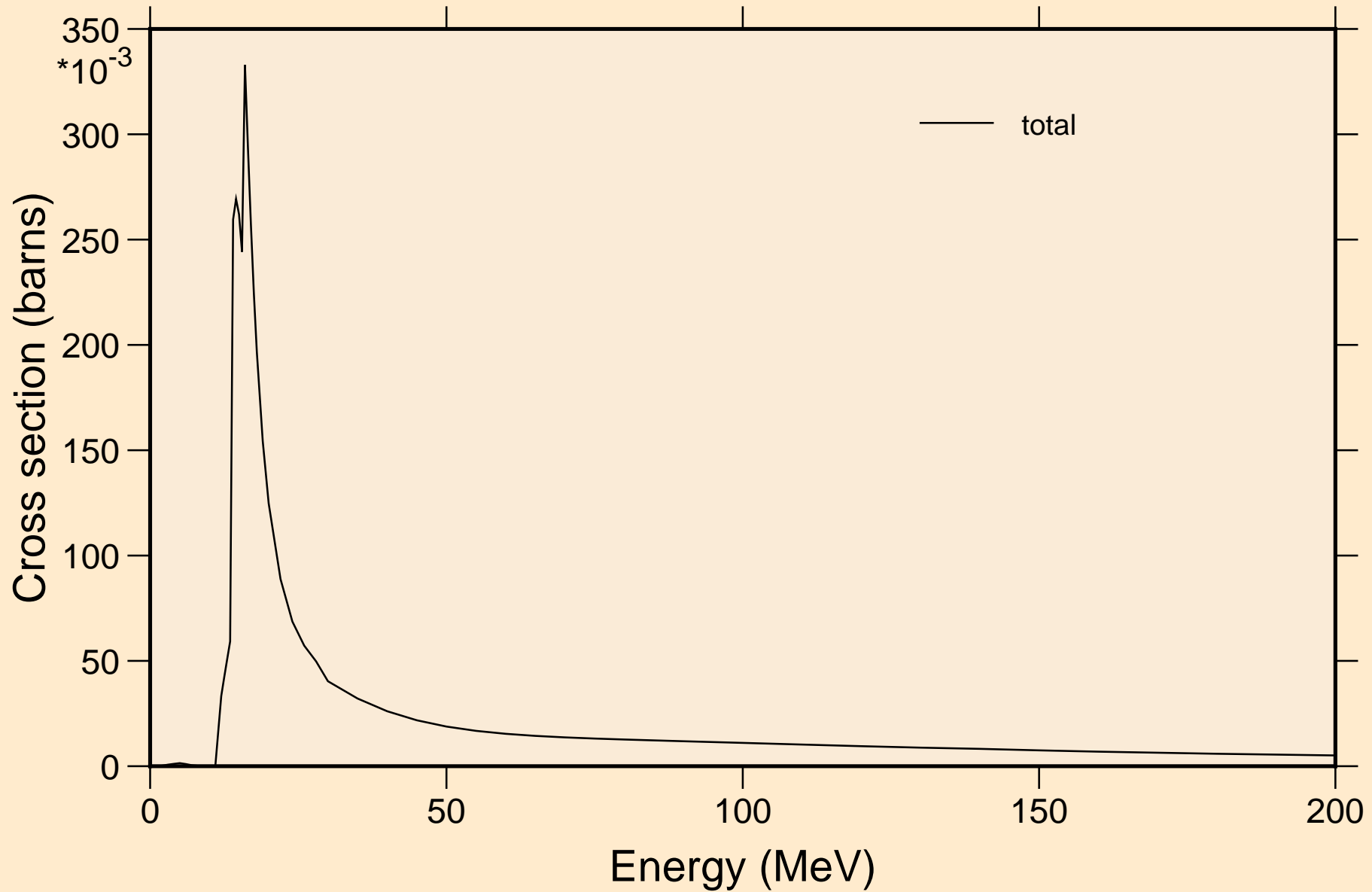

RE169M PHOTON ACER TENDL-2023 LIBRARY; T=0.K

Partial cross sections

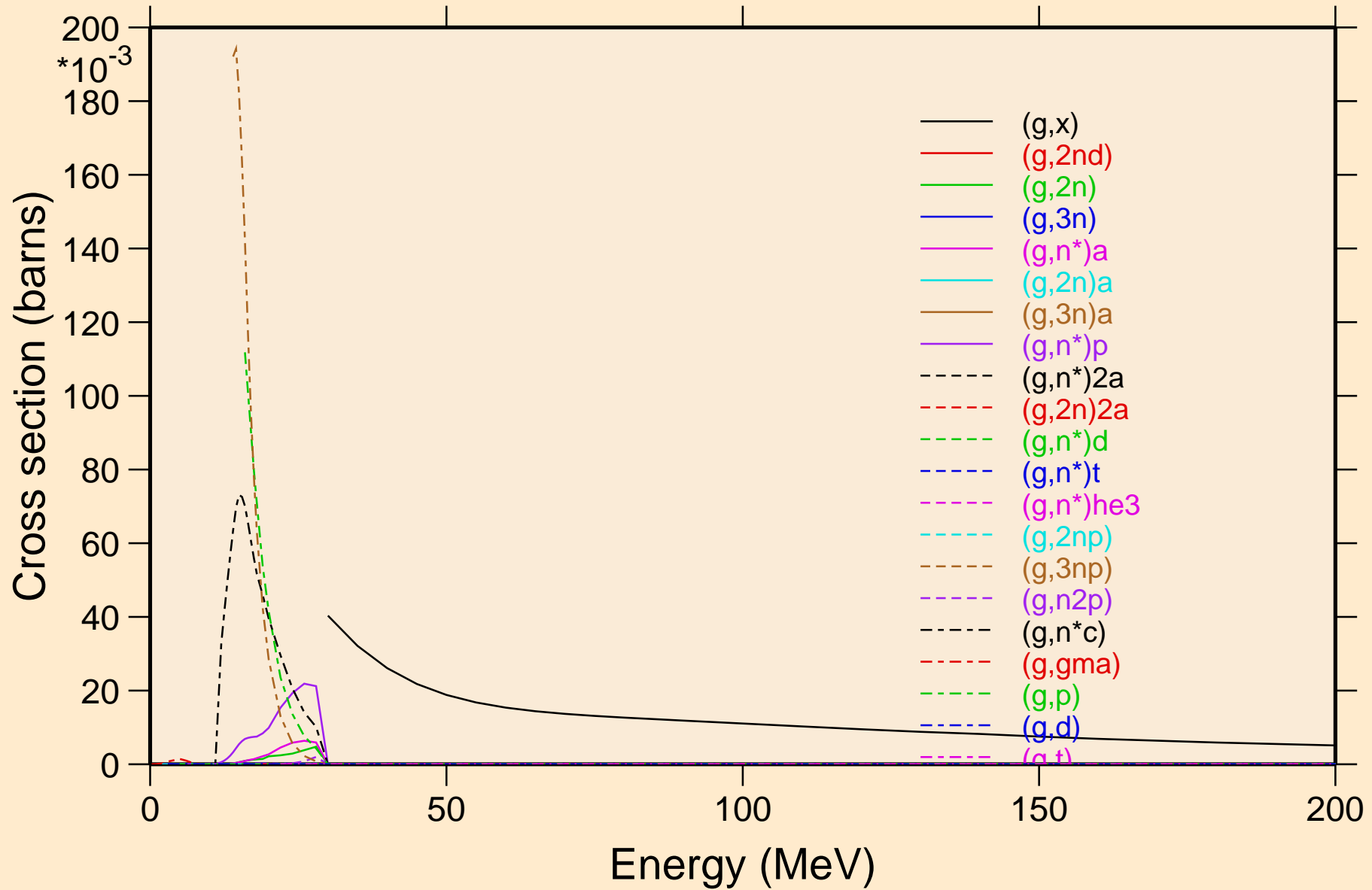

RE169M PHOTON ACER TENDL-2023 LIBRARY; T=0.K

Heating

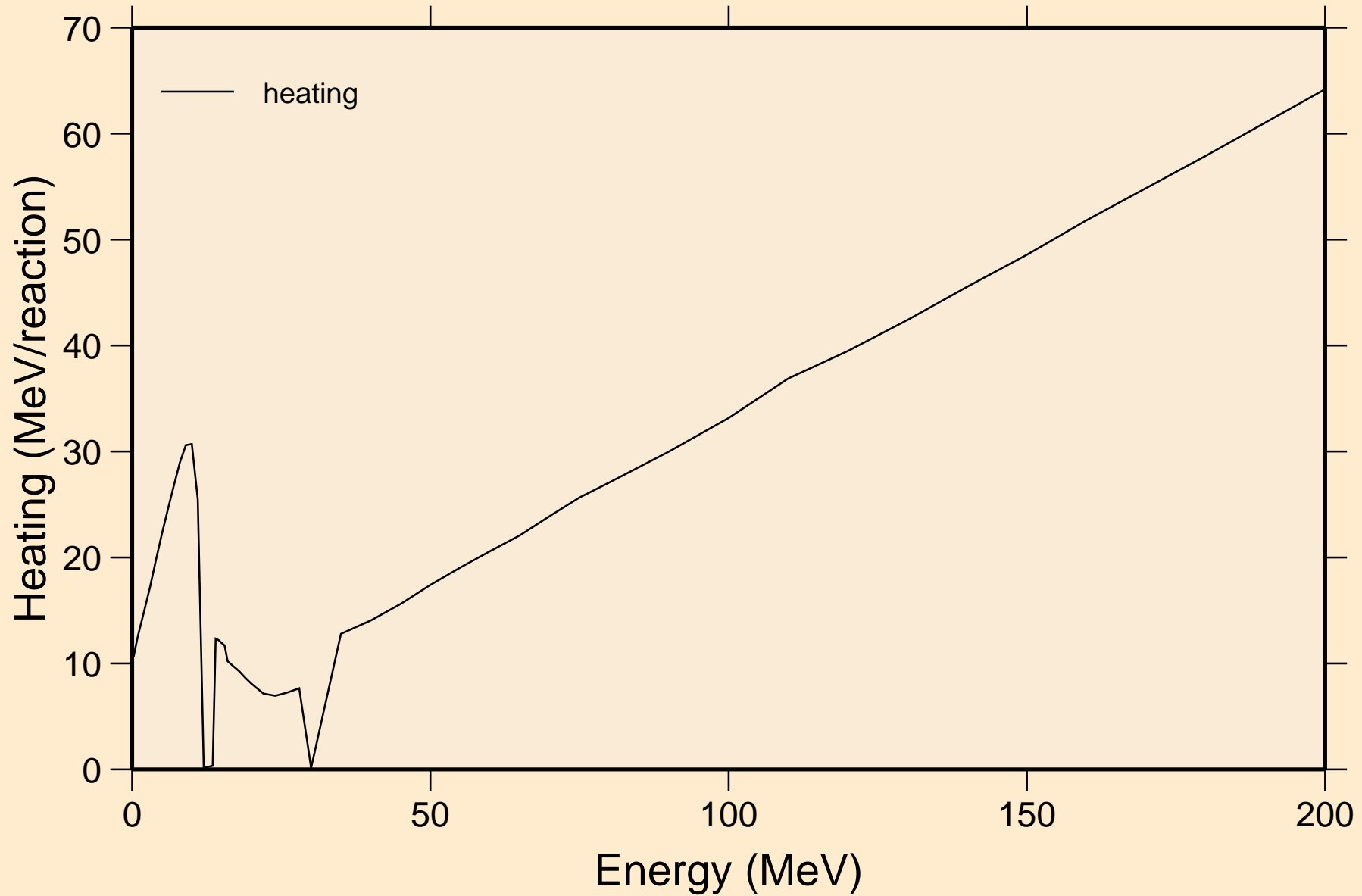

RE169M PHOTON ACER TENDL-2023 LIBRARY; T=0.K

Particle heating contributions

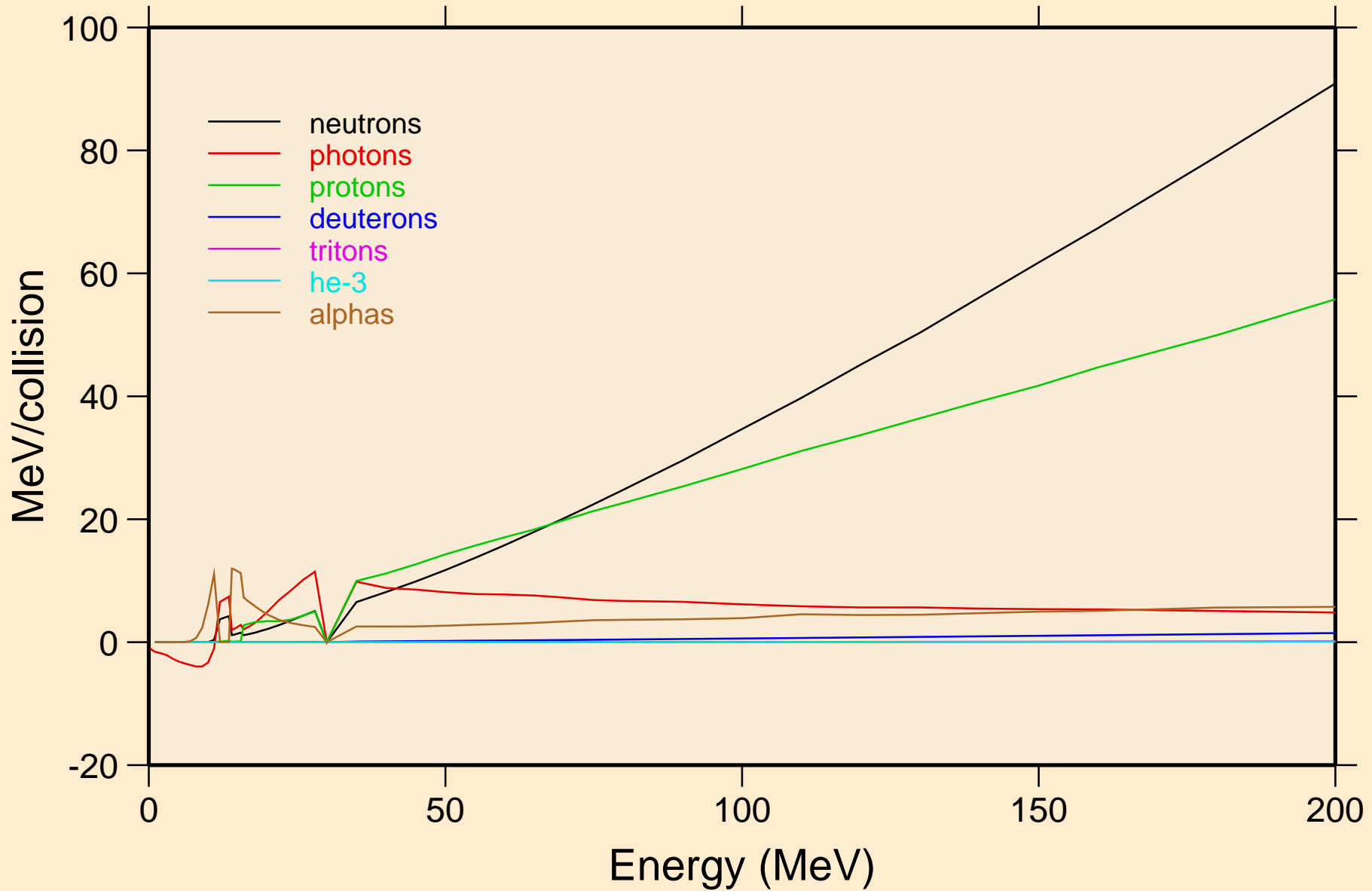

RE169M PHOTON ACER TENDL-2023 LIBRARY; T=0.K

Particle production cross sections

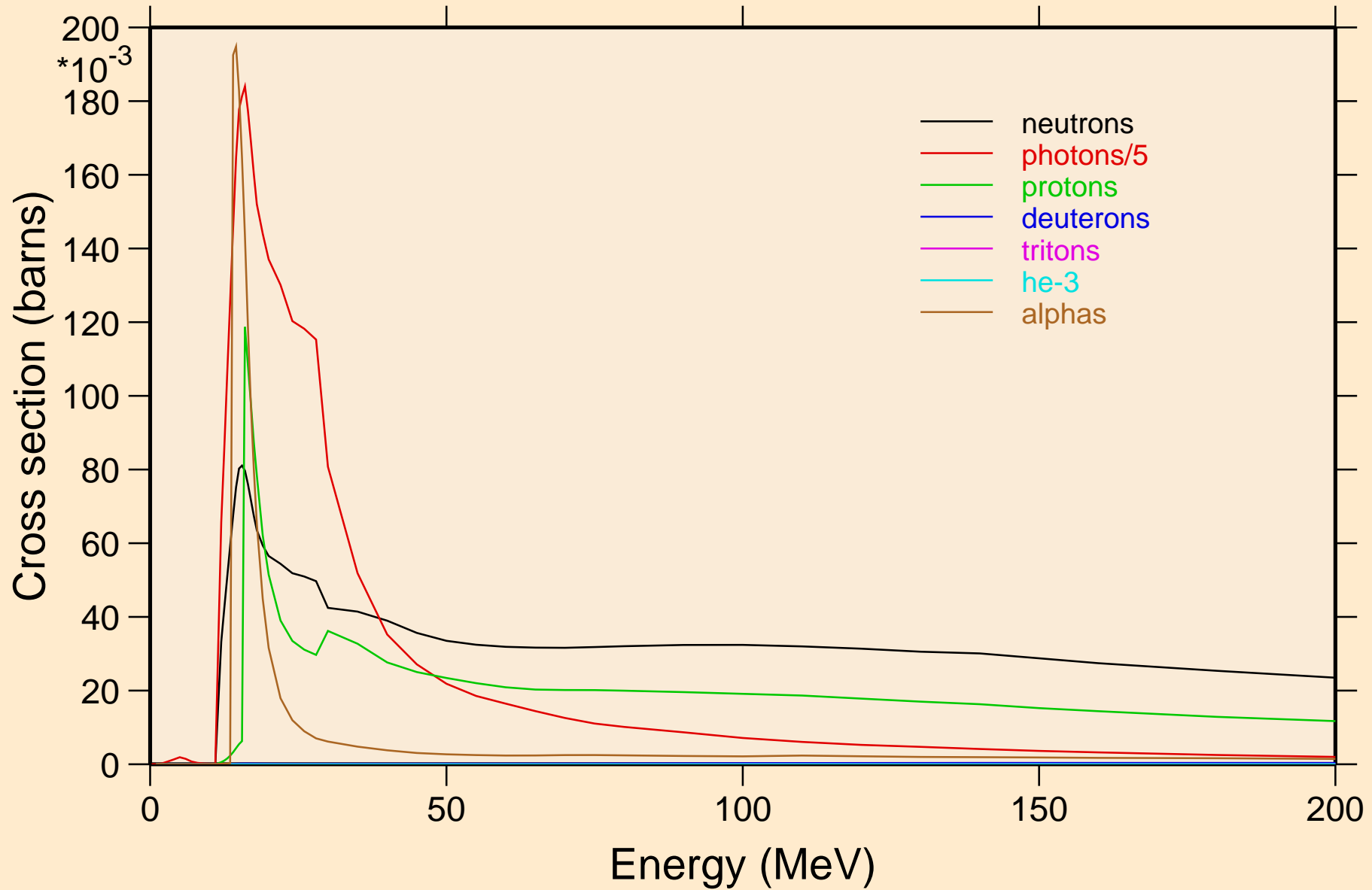

RE169M PHOTON ACER TENDL-2023 LIBRARY; T=0.K
neutrons from (g,x)

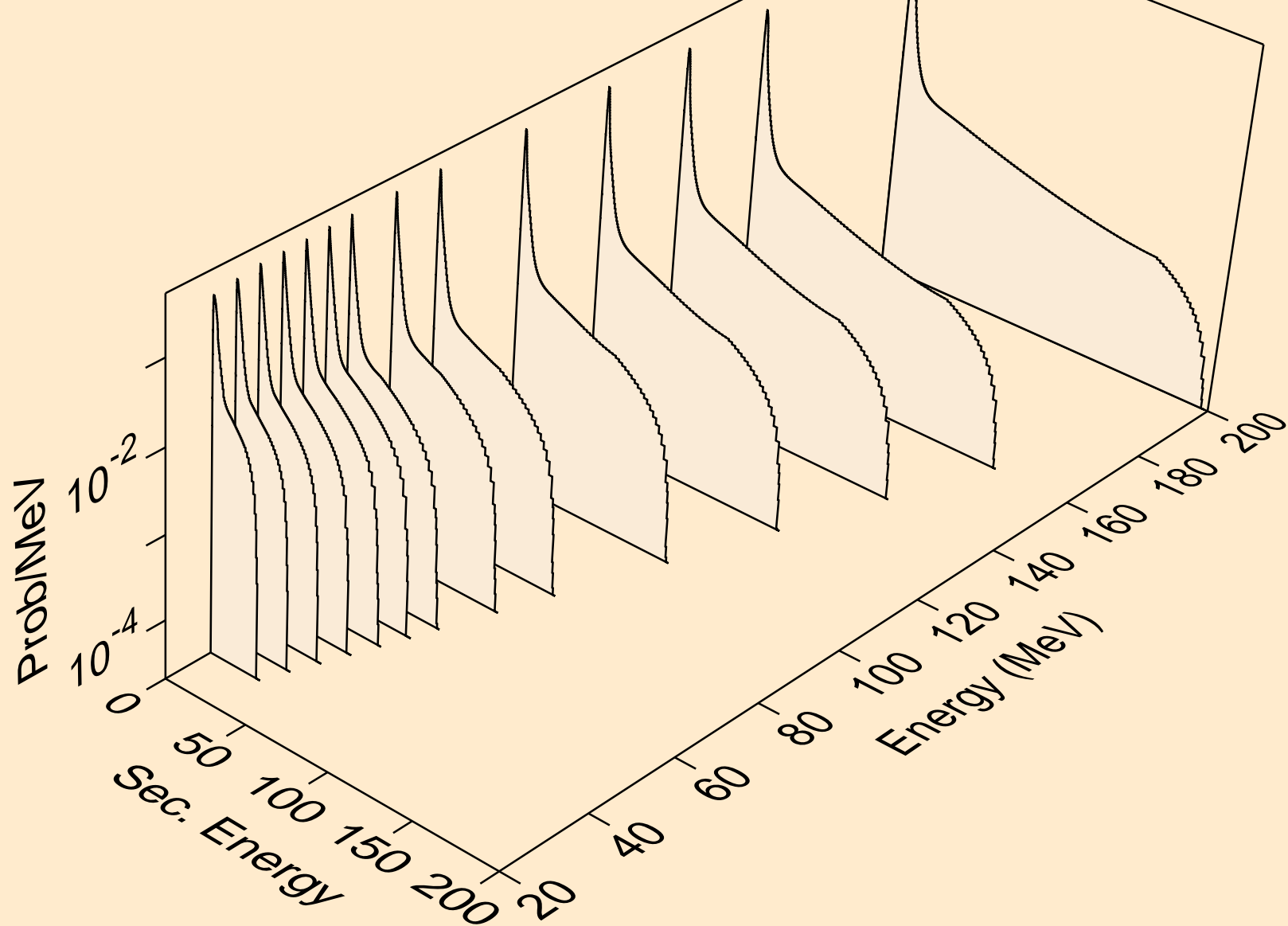

RE169M PHOTON ACER TENDL-2023 LIBRARY; T=0.K
neutrons from (g,2nd)

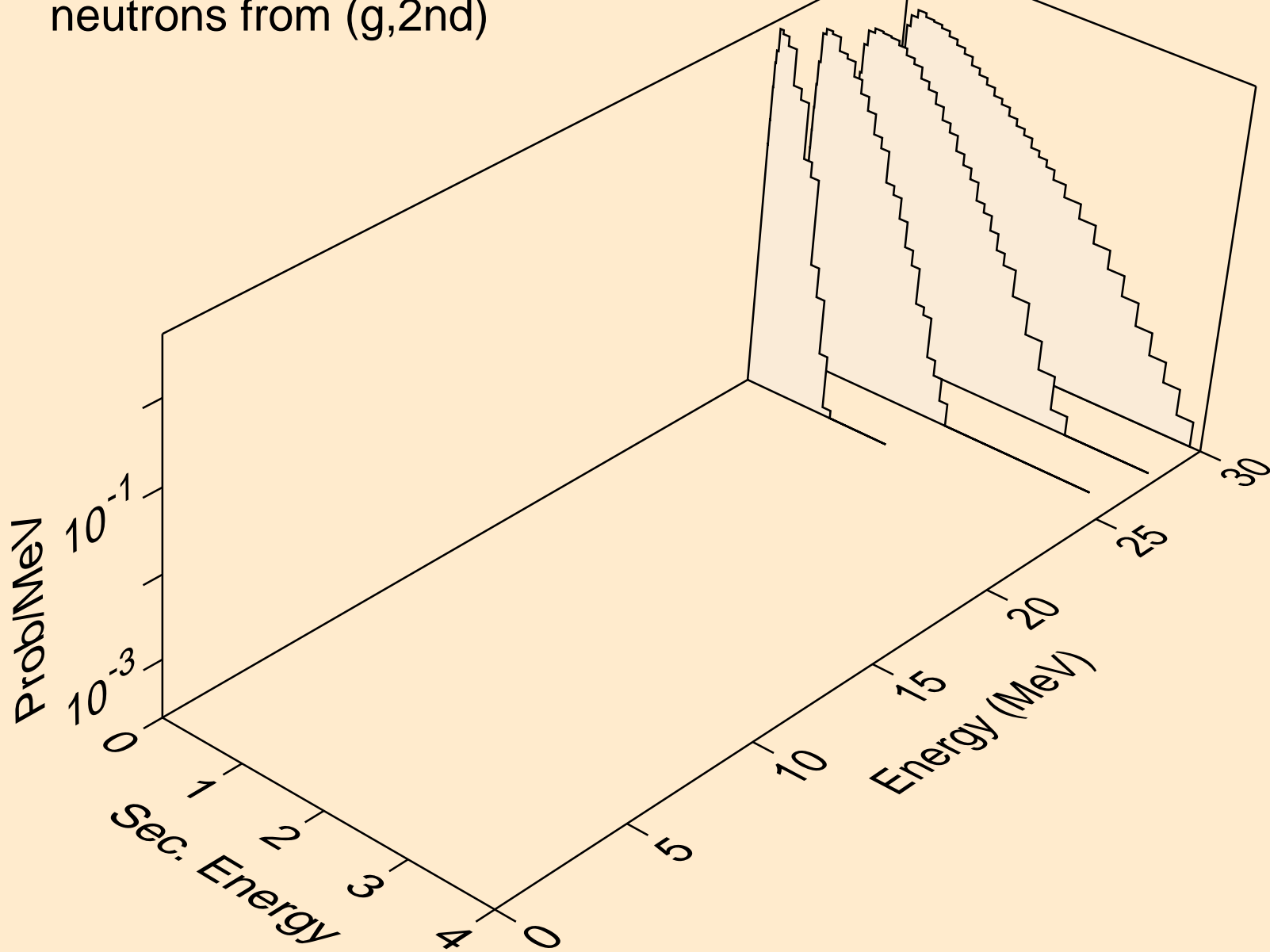

RE169M PHOTON ACER TENDL-2023 LIBRARY; T=0.K
neutrons from (g,2n)

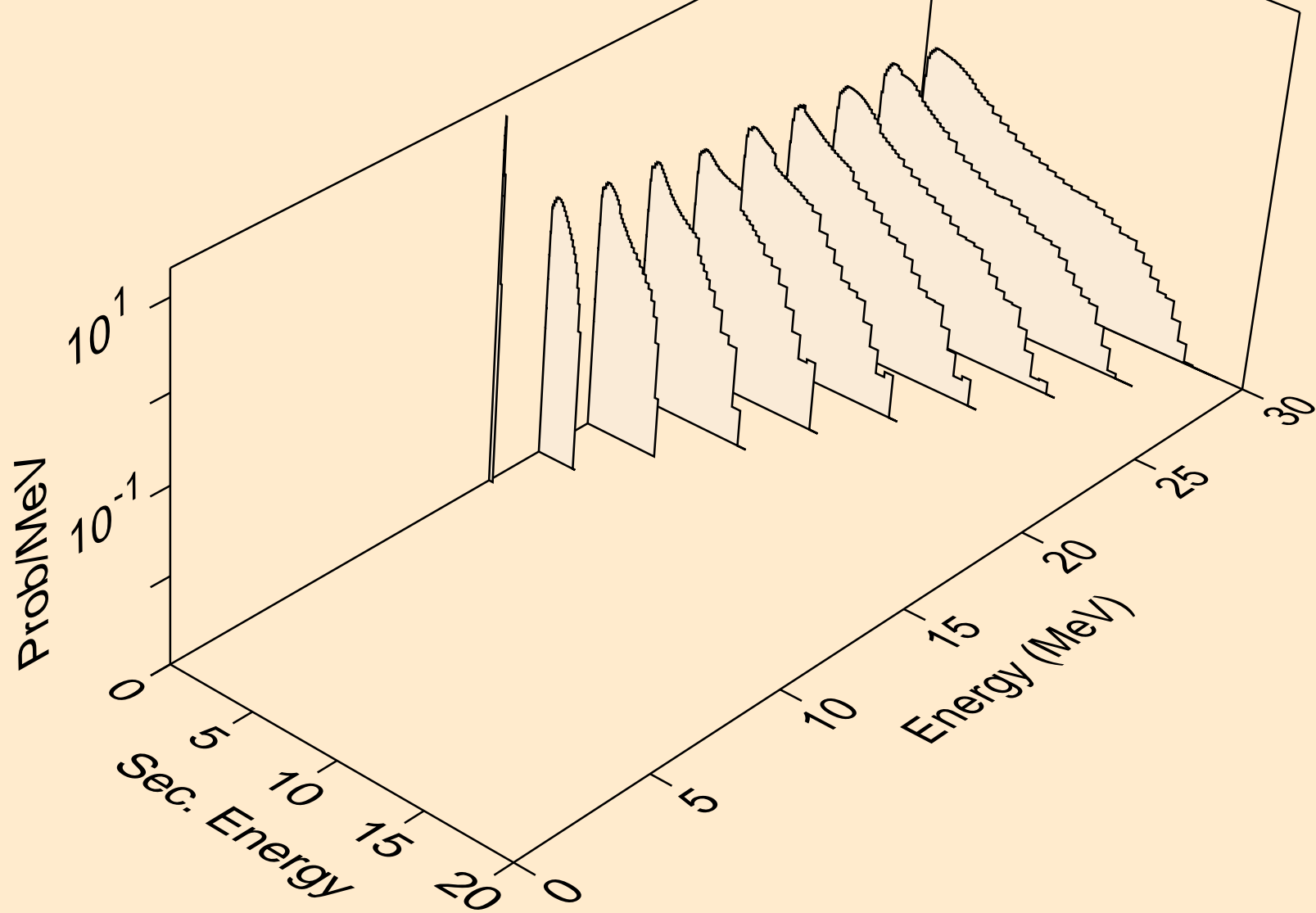

RE169M PHOTON ACER TENDL-2023 LIBRARY; T=0.K
neutrons from (g,3n)

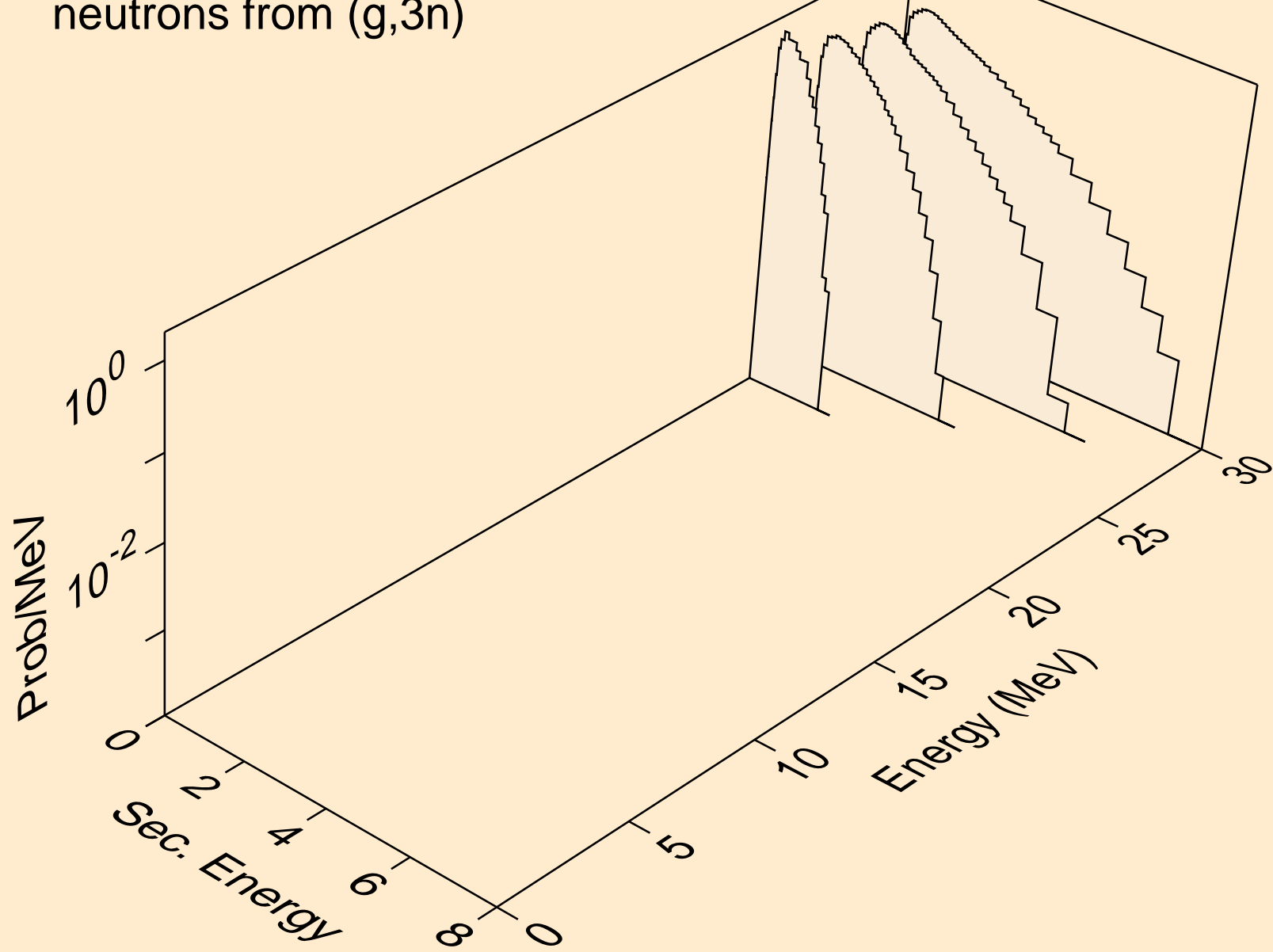

RE169M PHOTON ACER TENDL-2023 LIBRARY; T=0.K
neutrons from (g,n*)a

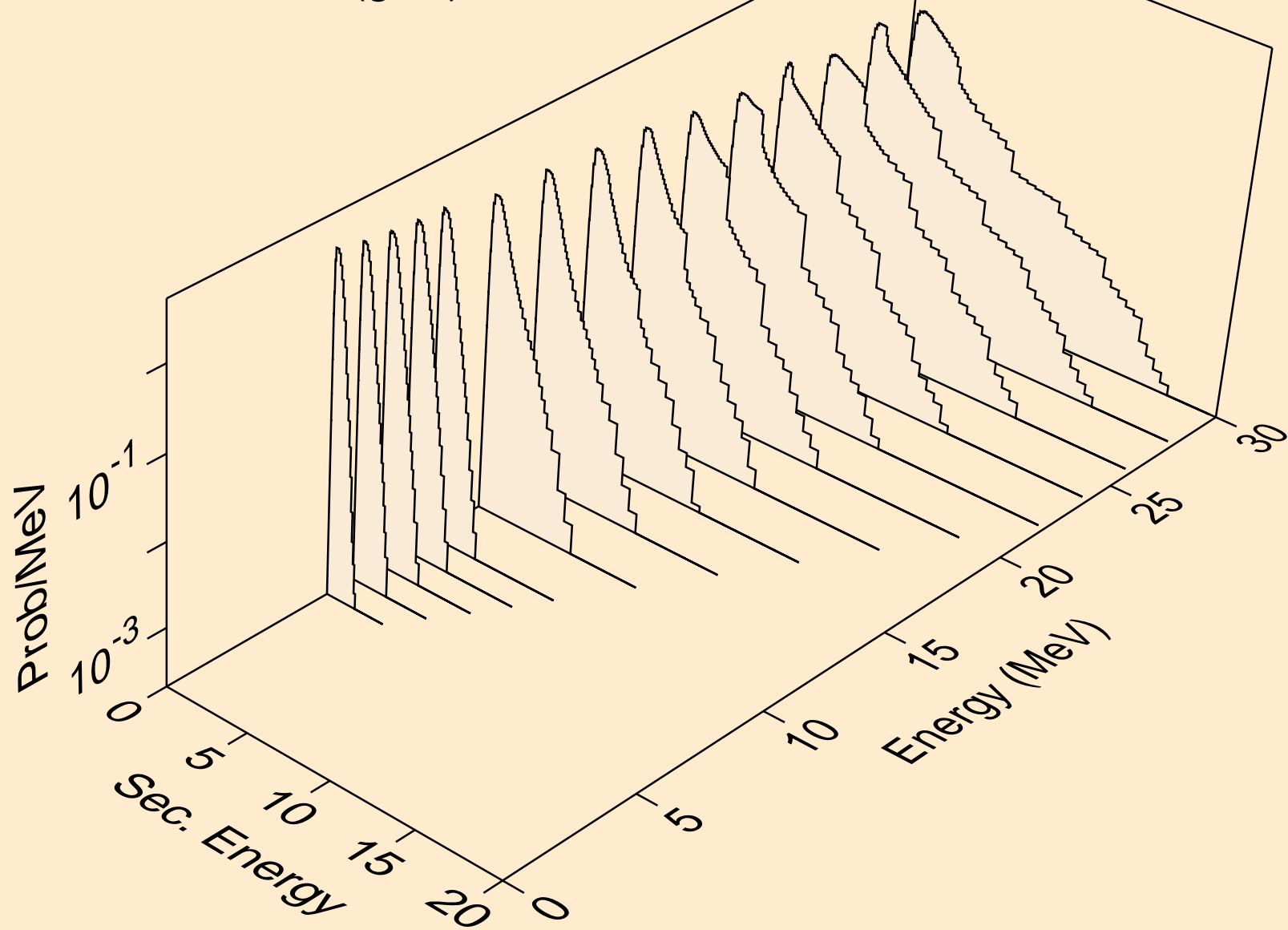

RE169M PHOTON ACER TENDL-2023 LIBRARY; T=0.K
neutrons from (g,2n)a

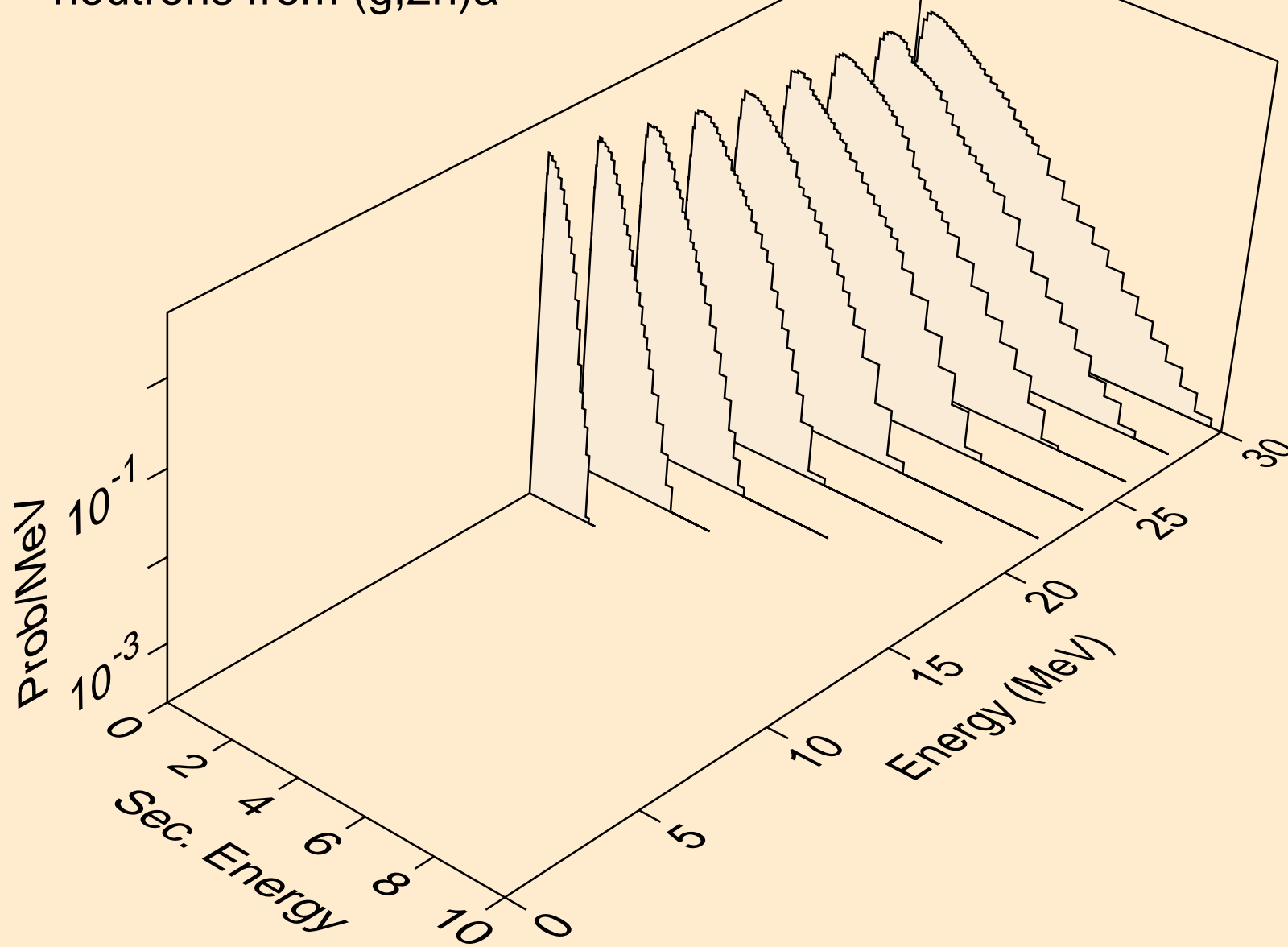

RE169M PHOTON ACER TENDL-2023 LIBRARY; T=0.K
neutrons from (g,3n)a

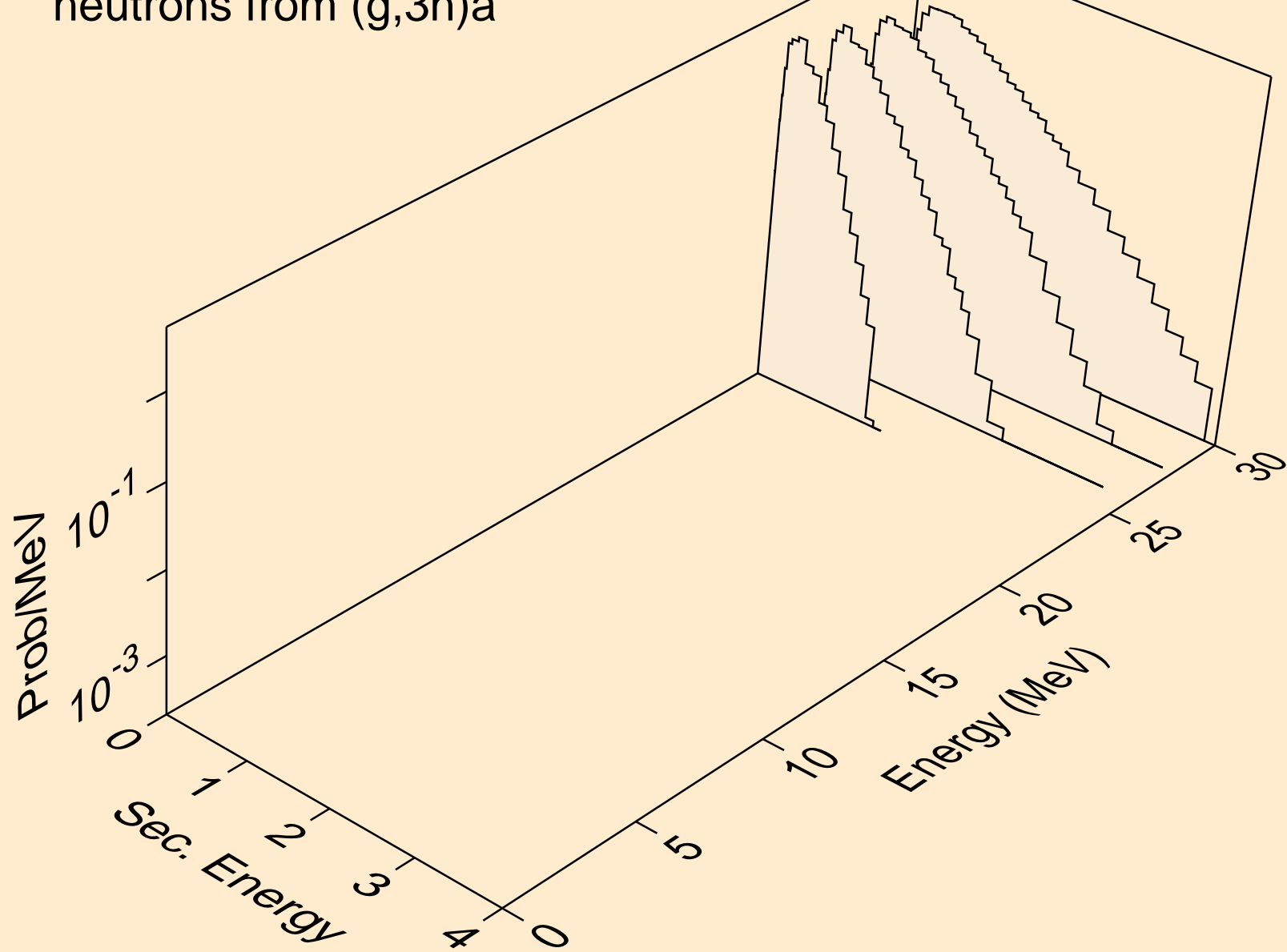

RE169M PHOTON ACER TENDL-2023 LIBRARY; T=0.K
neutrons from (g,n*)p

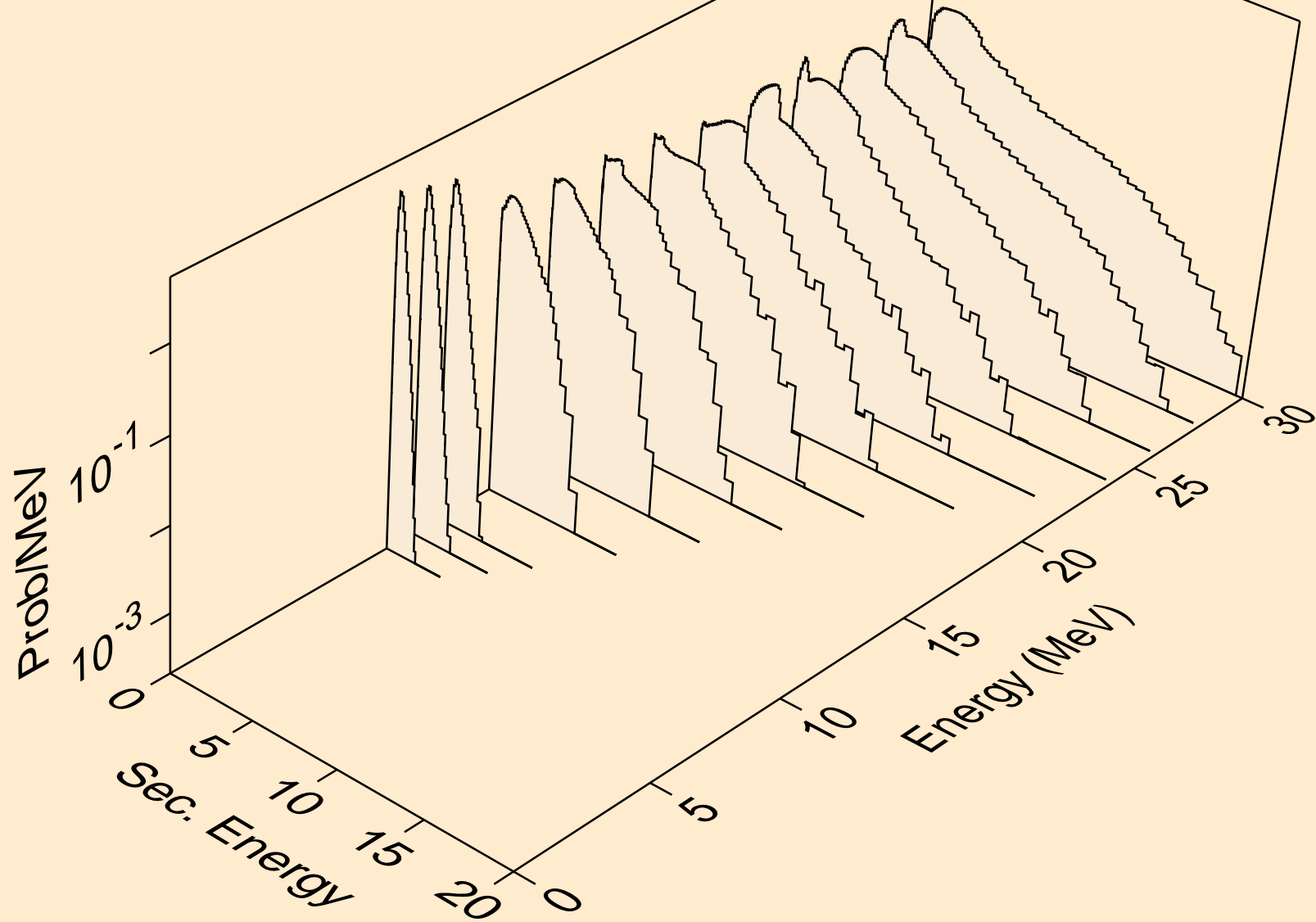

RE169M PHOTON ACER TENDL-2023 LIBRARY; T=0.K
neutrons from (g,n*)2a

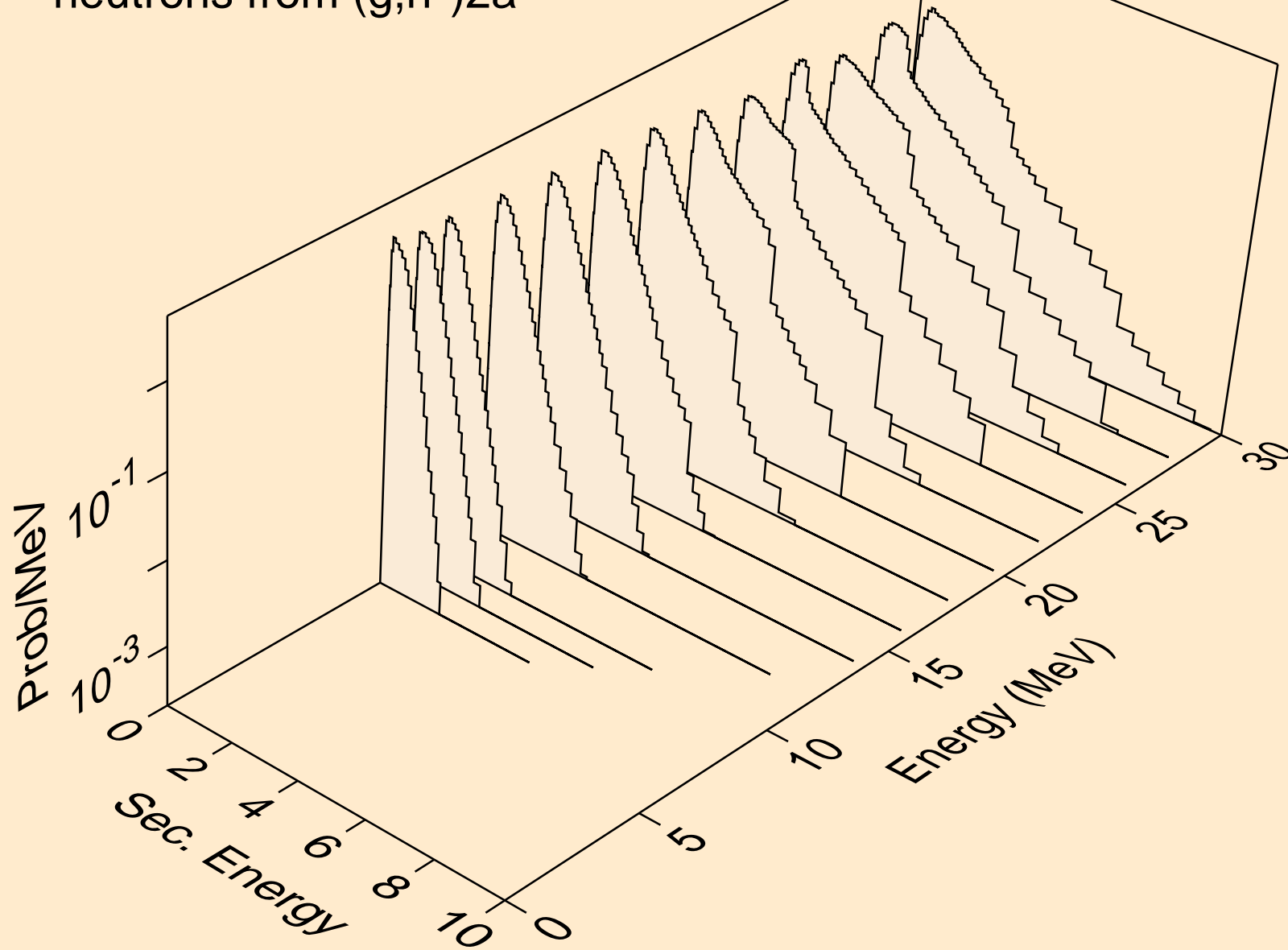

RE169M PHOTON ACER TENDL-2023 LIBRARY; T=0.K
neutrons from (g,2n)2a

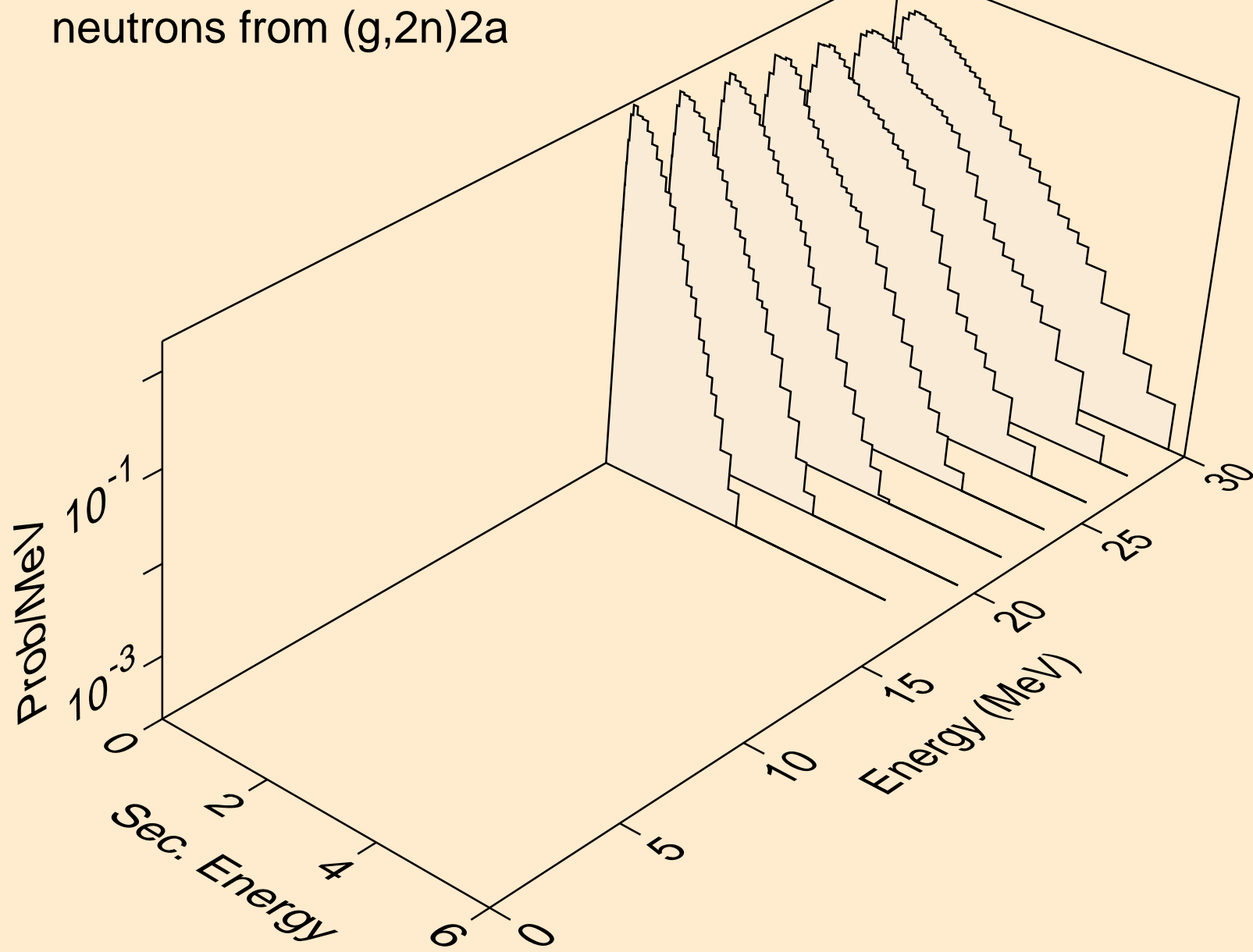

RE169M PHOTON ACER TENDL-2023 LIBRARY; T=0.K
neutrons from (g,n*)d

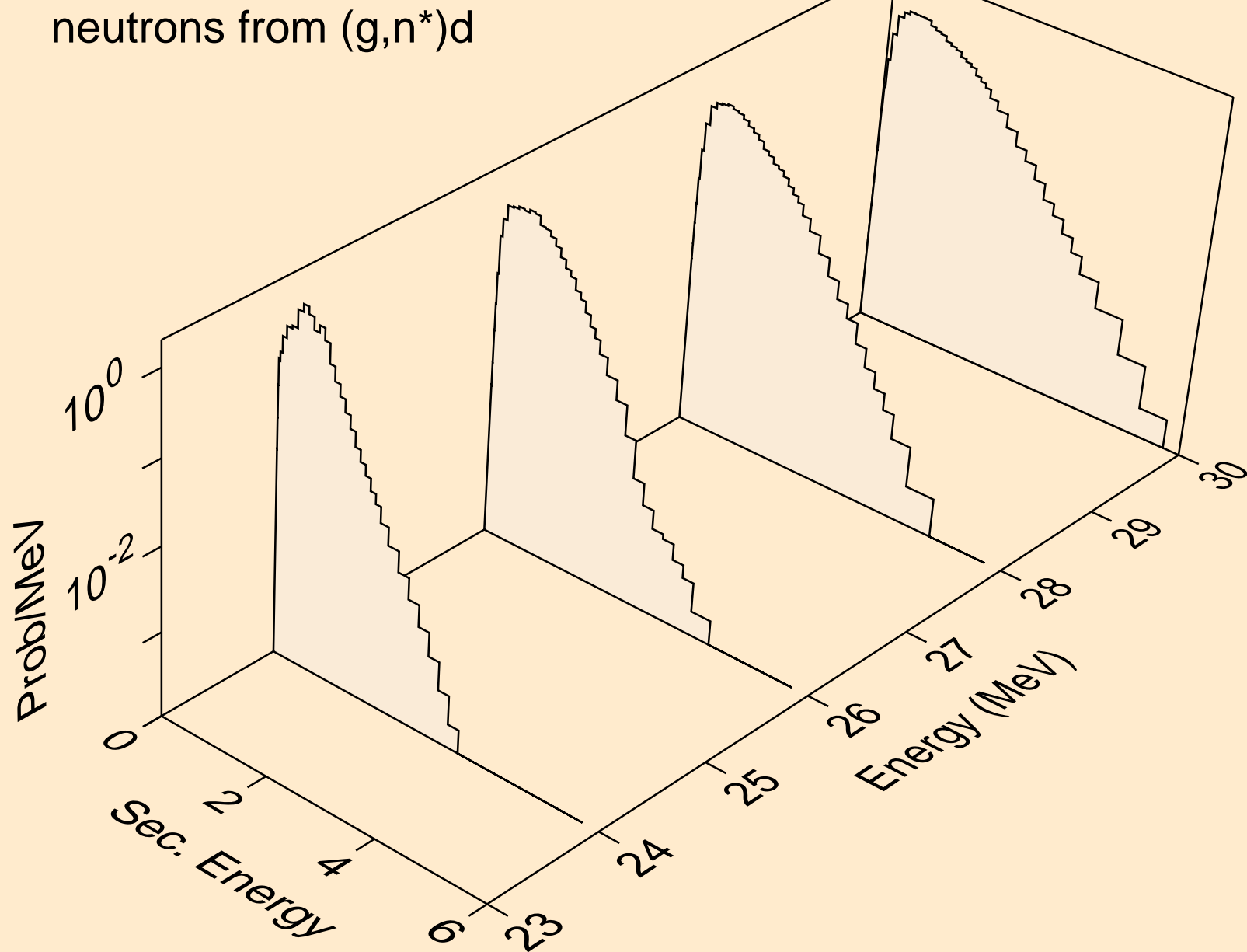

RE169M PHOTON ACER TENDL-2023 LIBRARY; T=0.K
neutrons from (g,n*)t

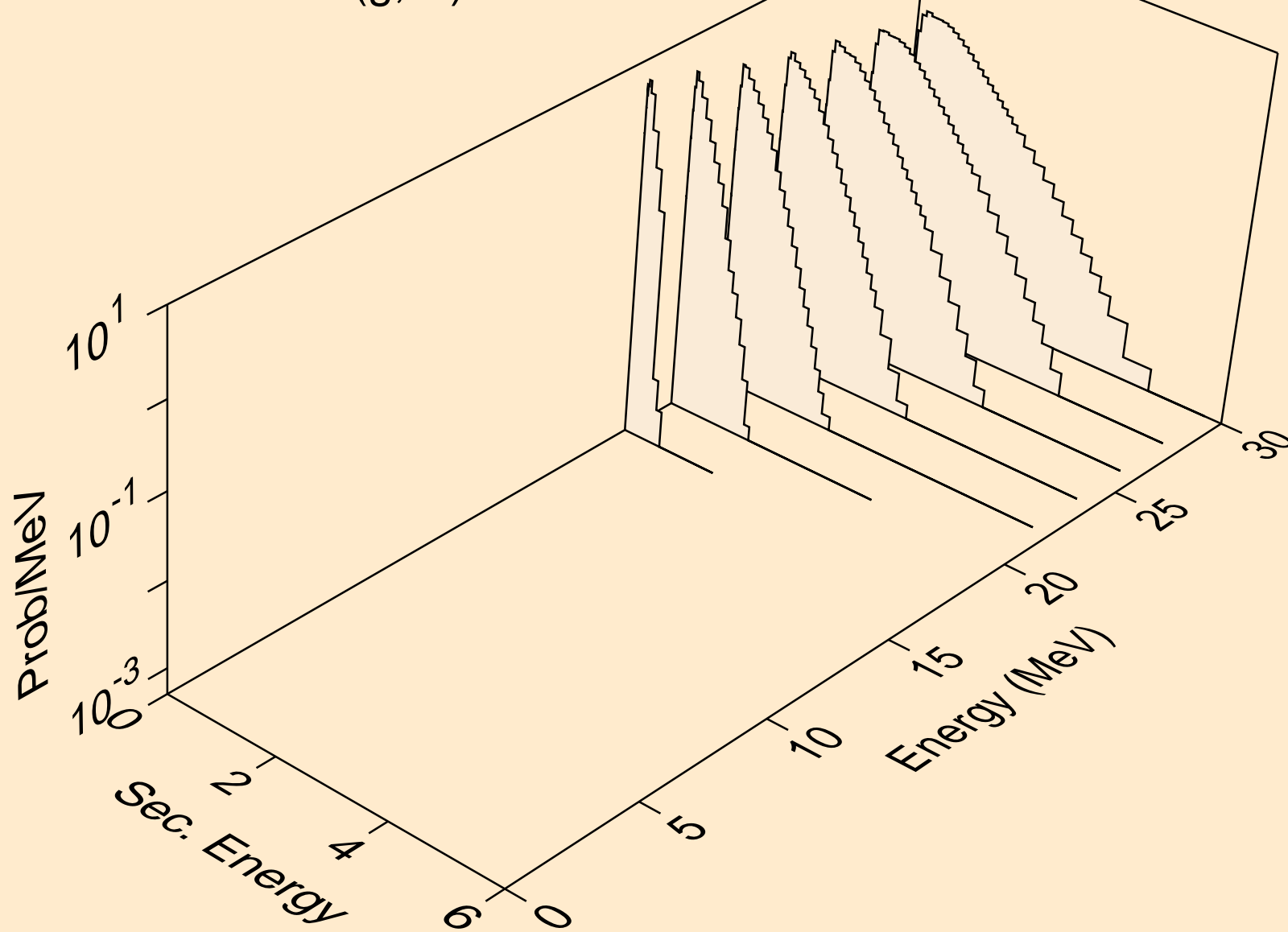

RE169M PHOTON ACER TENDL-2023 LIBRARY; T=0.K
neutrons from (g,n*)he3

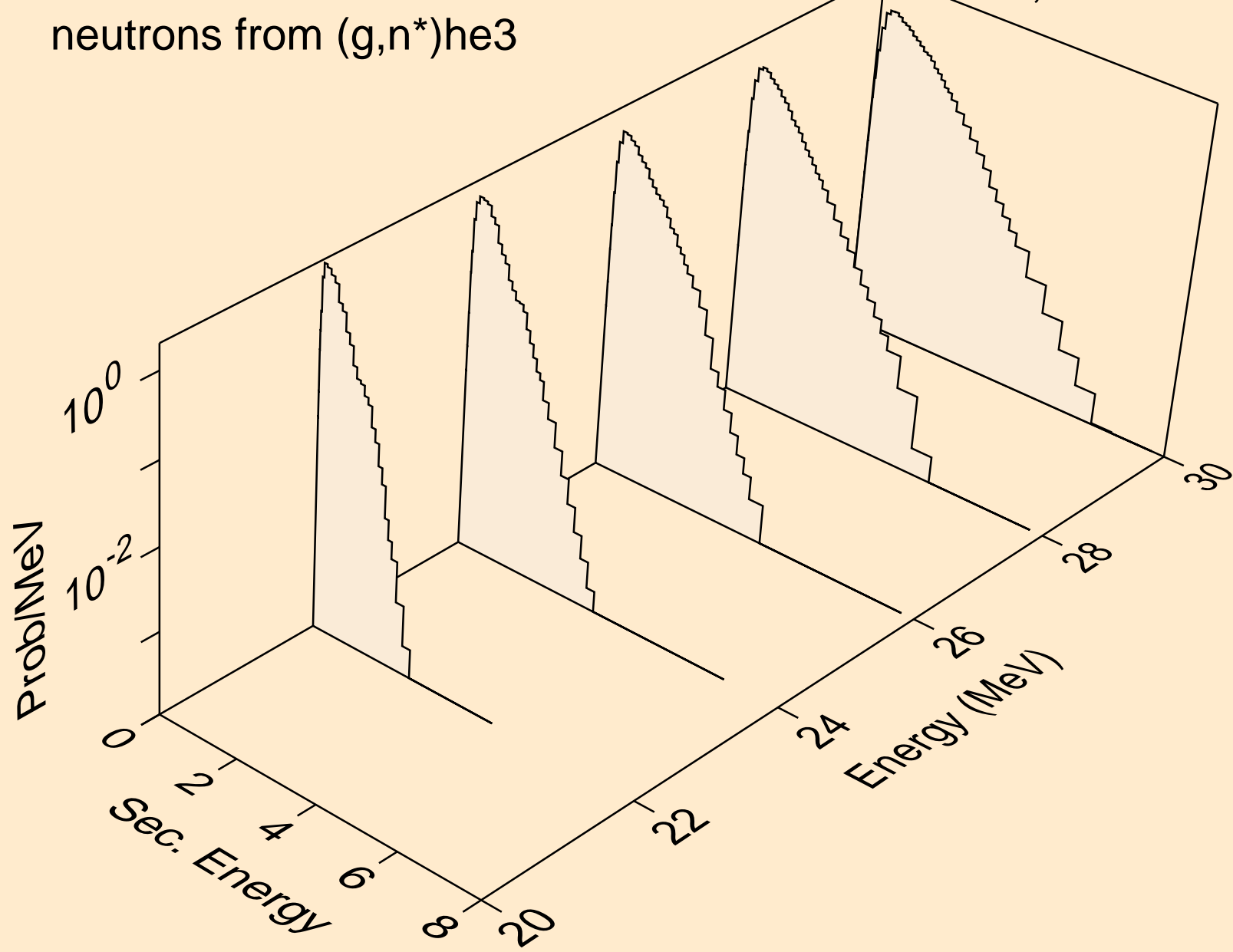

RE169M PHOTON ACER TENDL-2023 LIBRARY; T=0.K
neutrons from (g,2np)

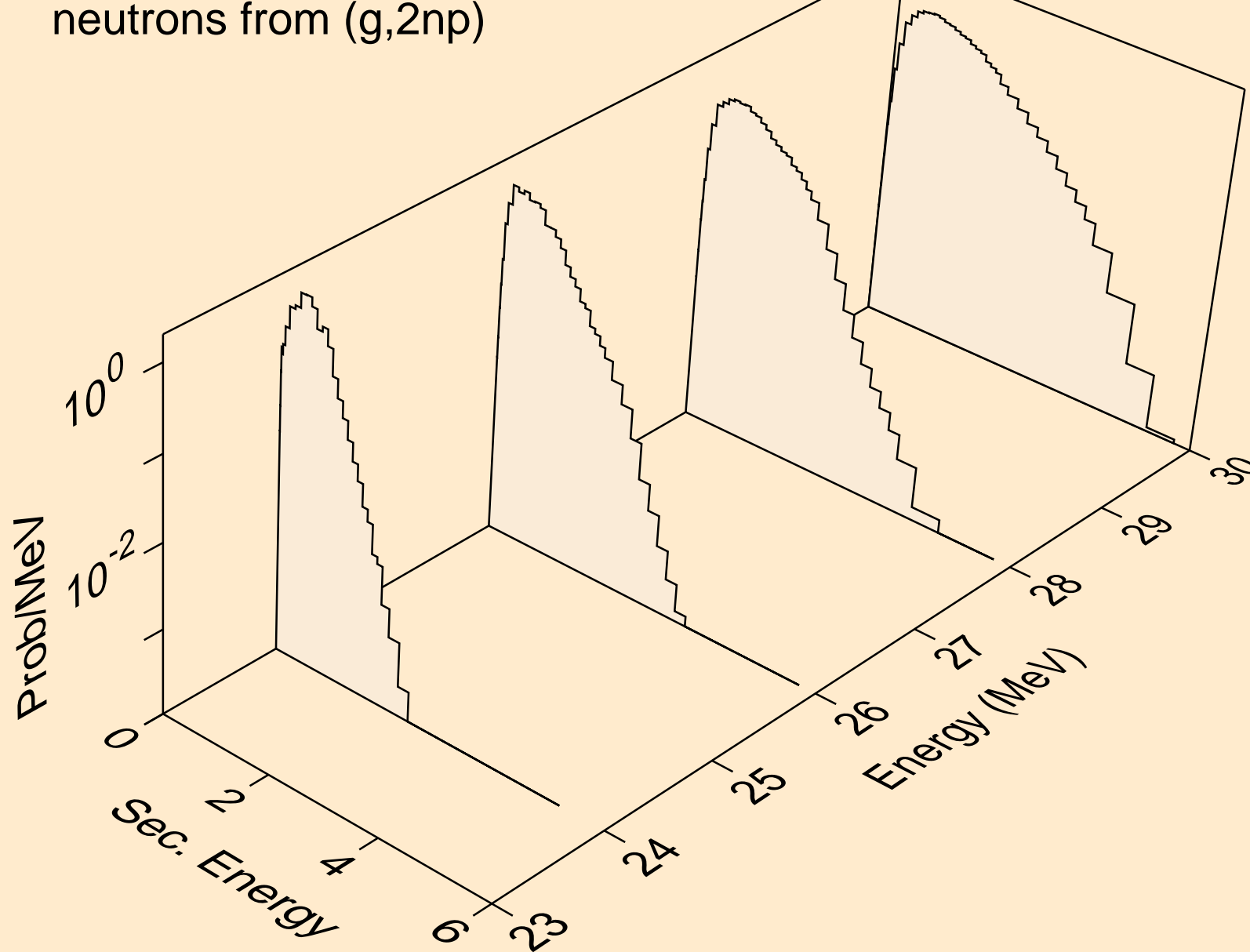

RE169M PHOTON ACER TENDL-2023 LIBRARY; T=0.K
neutrons from (g,3np)

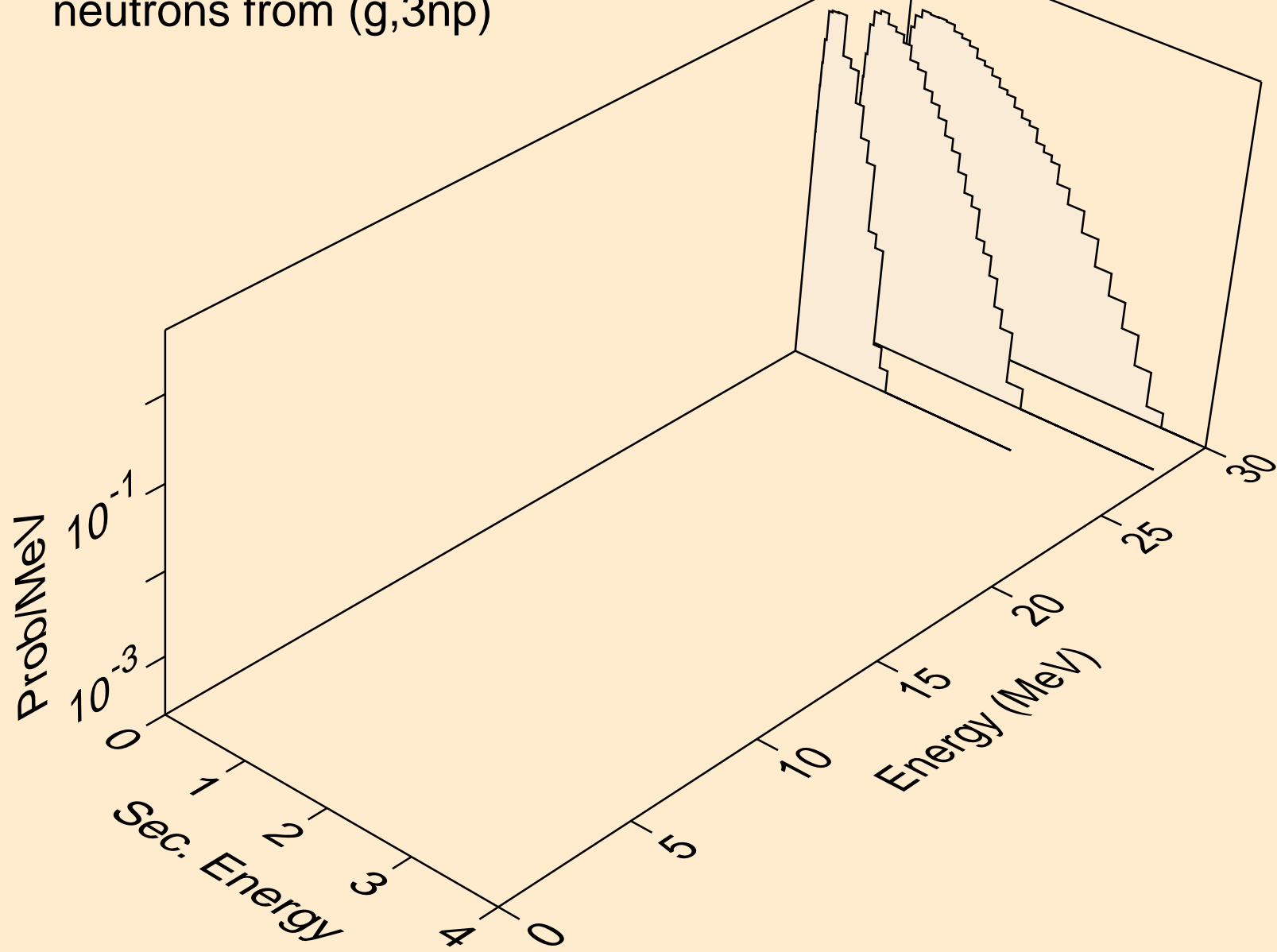

RE169M PHOTON ACER TENDL-2023 LIBRARY; T=0.K
neutrons from (g,n2p)

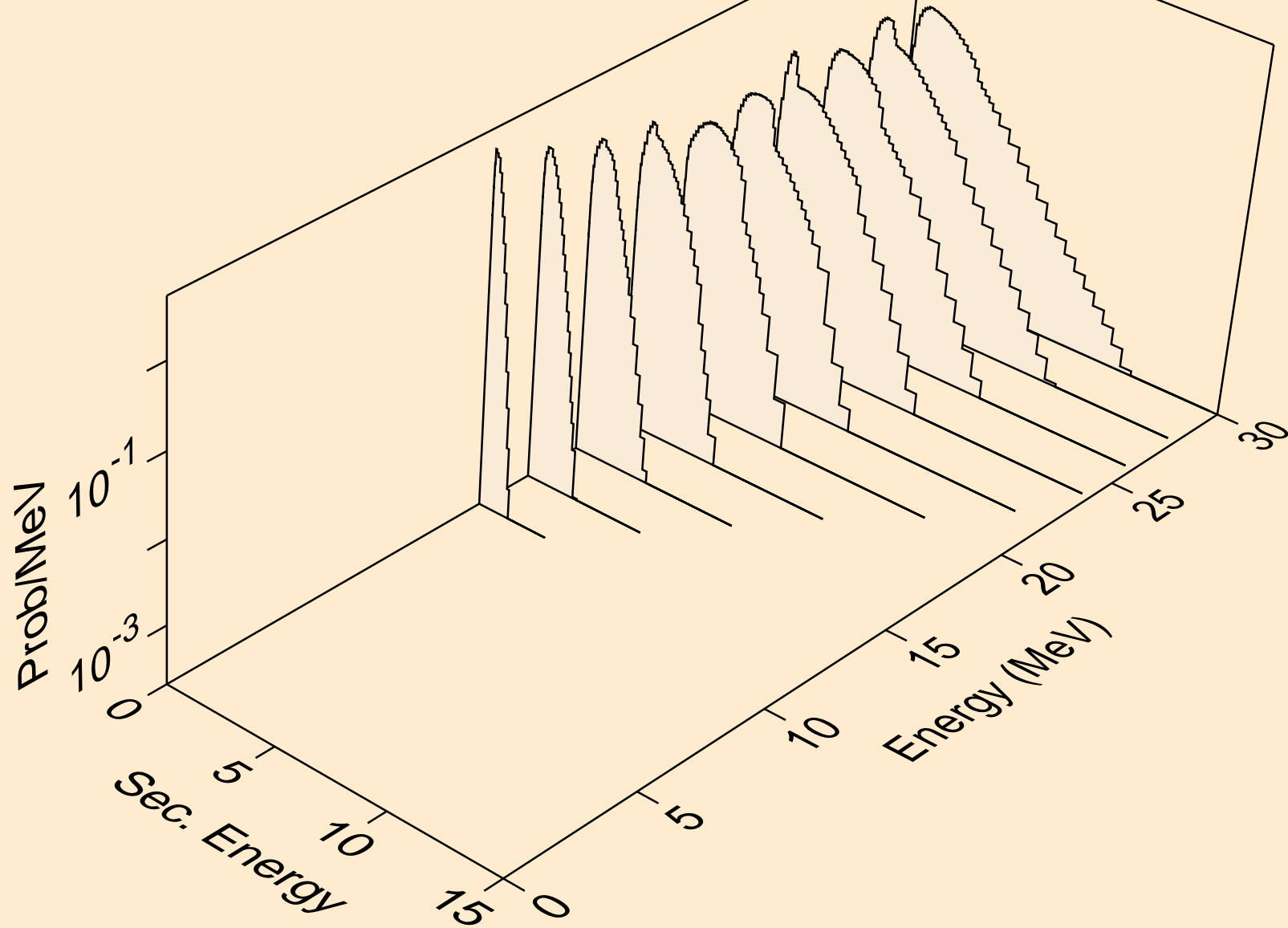

RE169M PHOTON ACER TENDL-2023 LIBRARY; T=0.K
neutrons from (g,n*c)

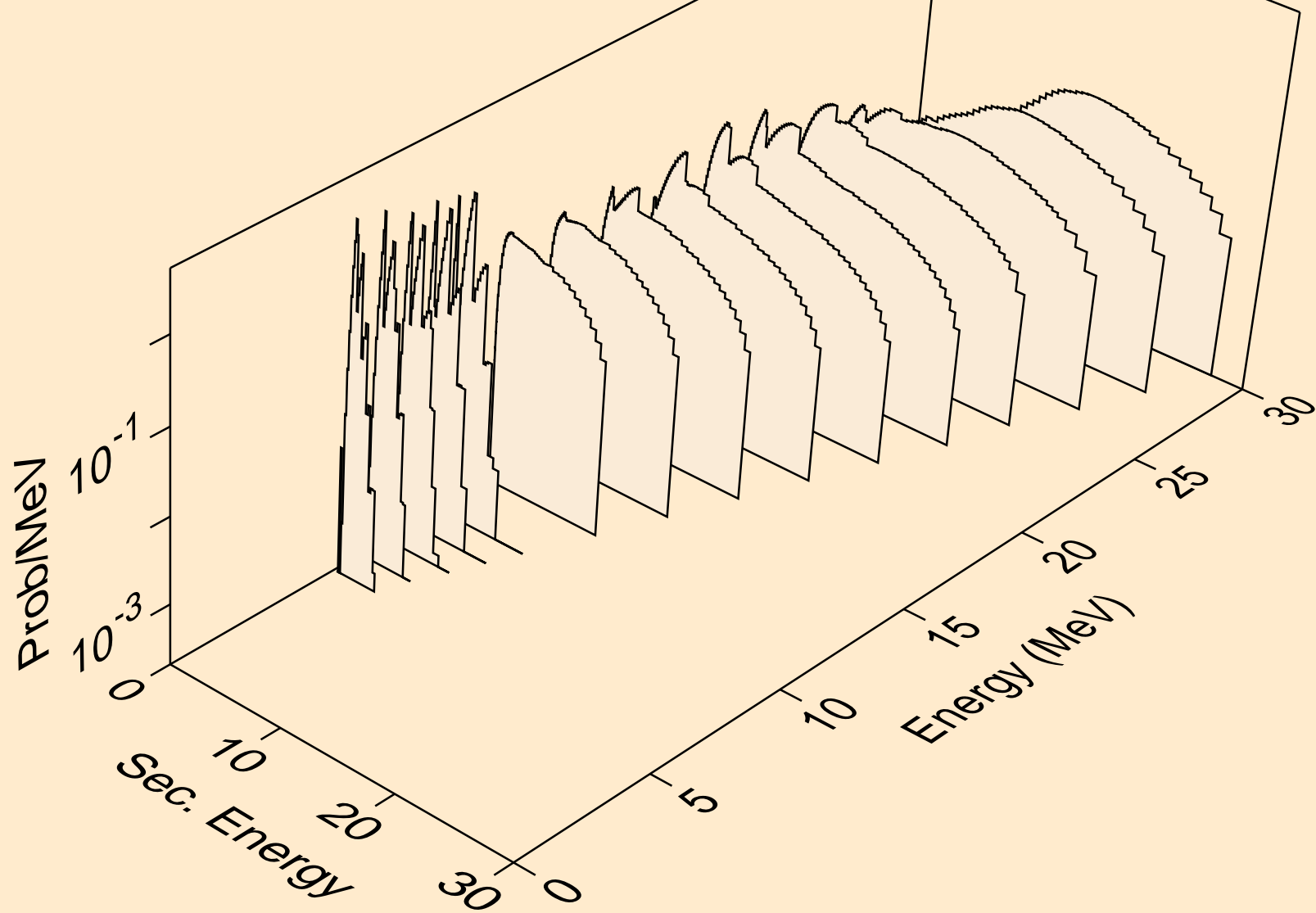

RE169M PHOTON ACER TENDL-2023 LIBRARY; T=0.K
photons from (g,x)

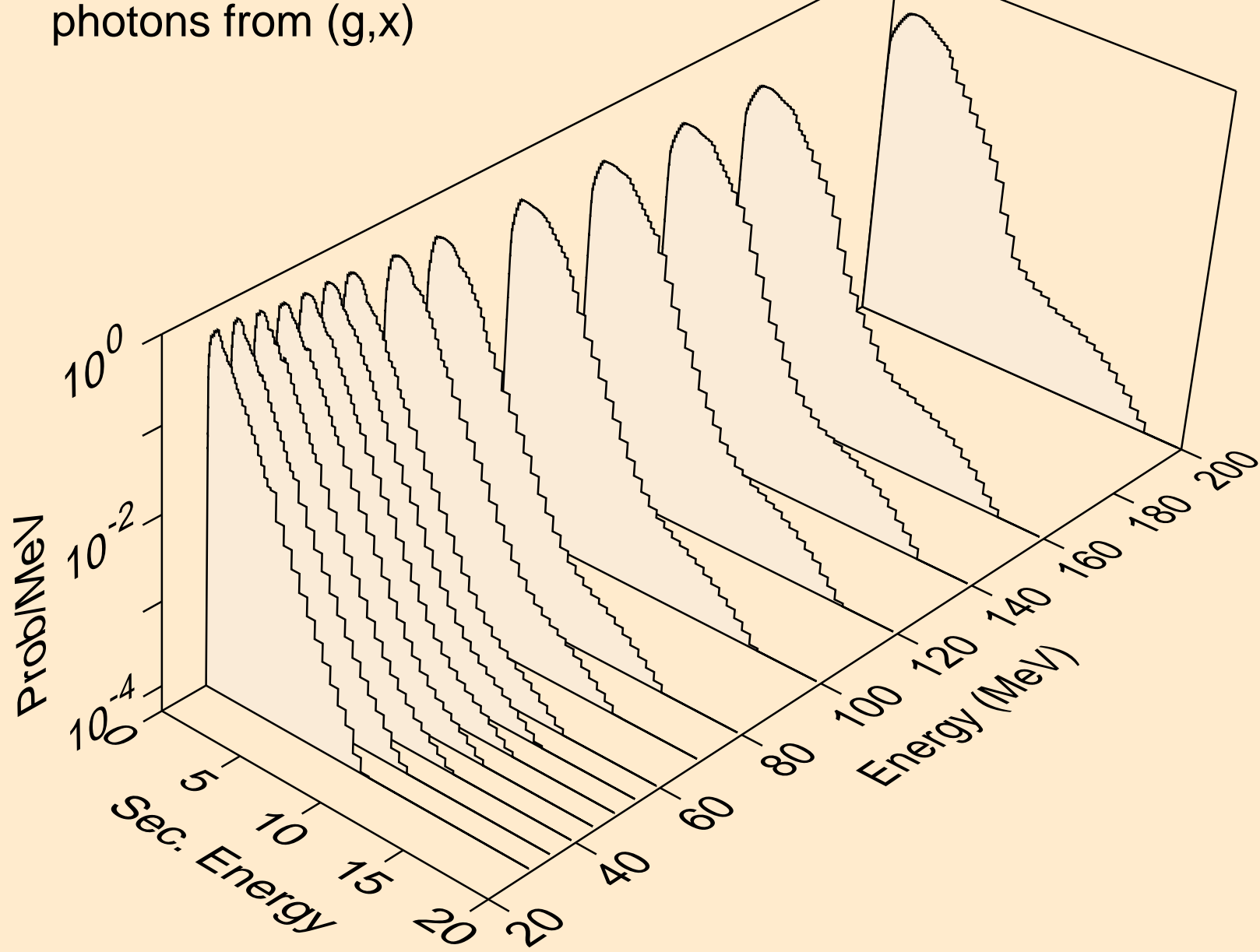

RE169M PHOTON ACER TENDL-2023 LIBRARY; T=0.K
photons from (g,2nd)

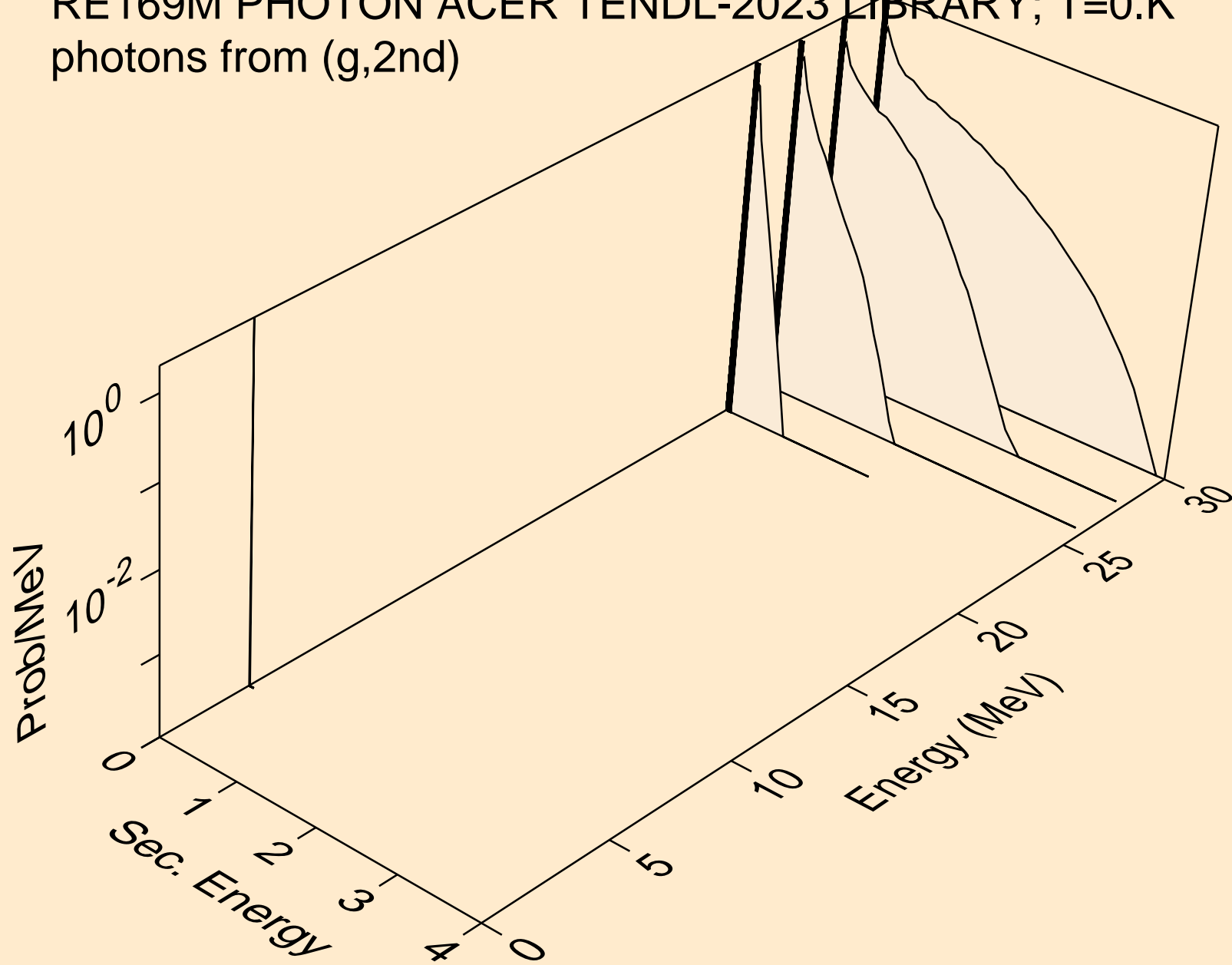

RE169M PHOTON ACER TENDL-2023 LIBRARY; T=0.K
photons from (g,2n)

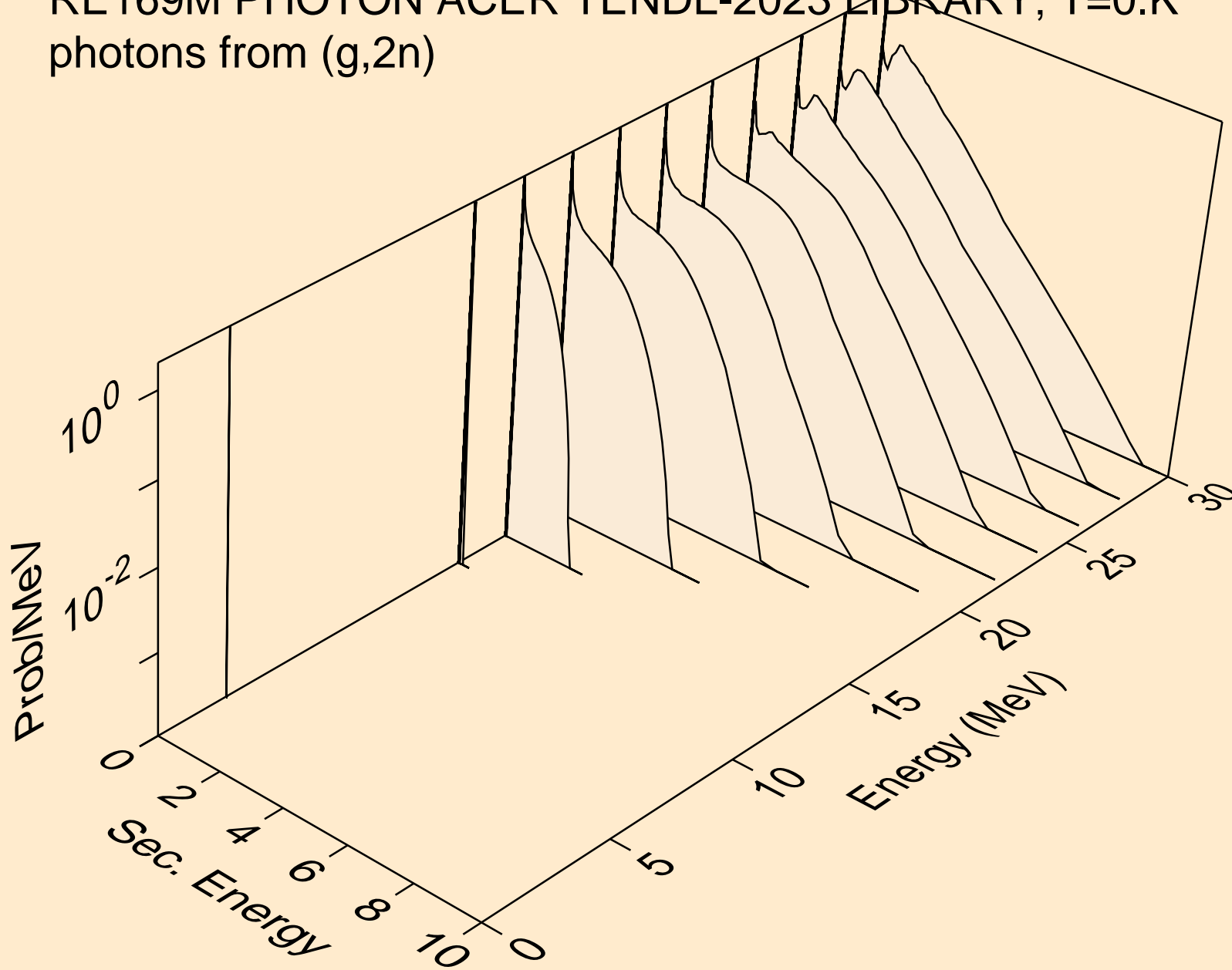

RE169M PHOTON ACER TENDL-2023 LIBRARY; T=0.K
photons from (g,3n)

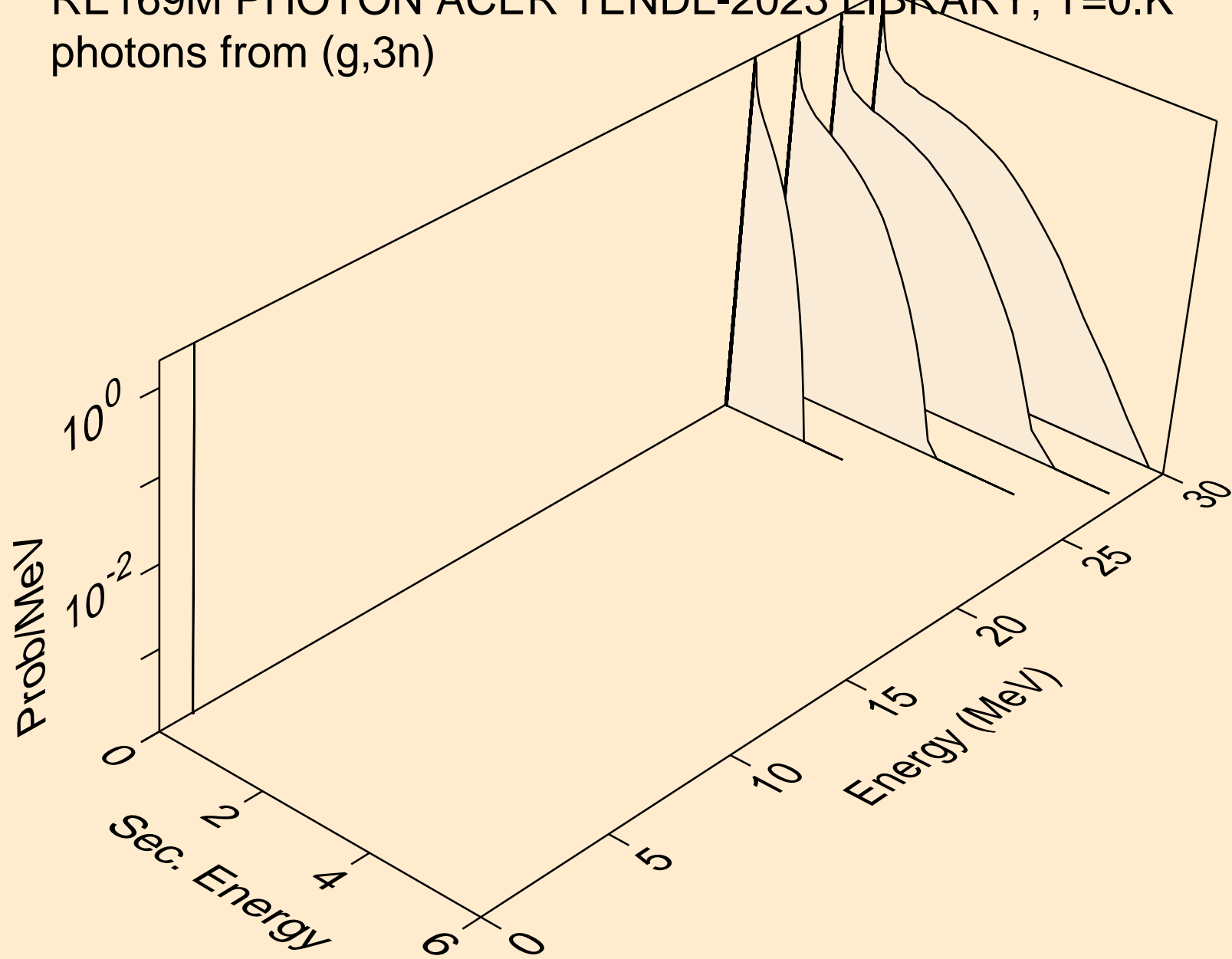

RE169M PHOTON ACER TENDL-2023 LIBRARY; T=0.K
photons from (g,n*)a

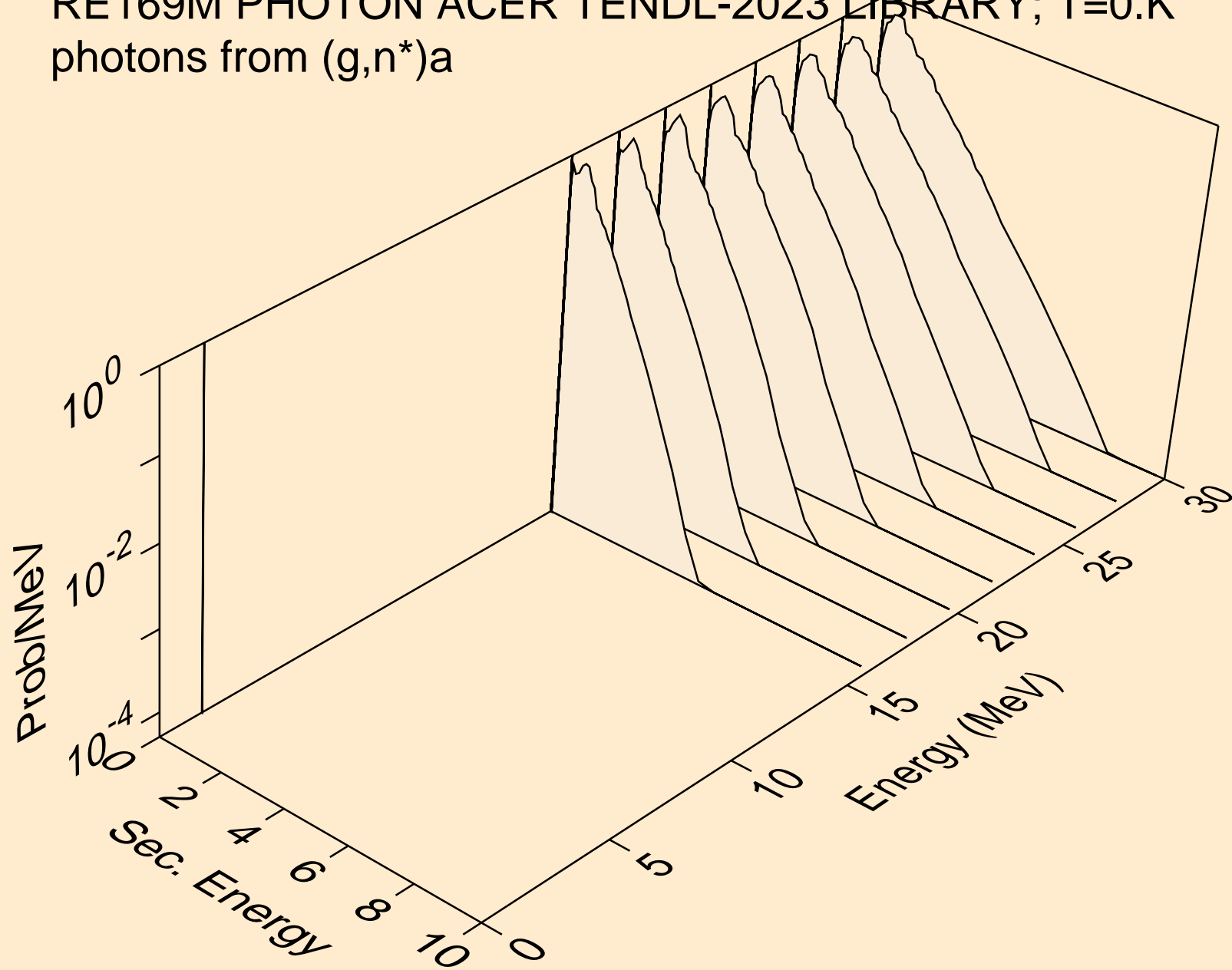

RE169M PHOTON ACER TENDL-2023 LIBRARY; T=0.K
photons from (g,2n)a

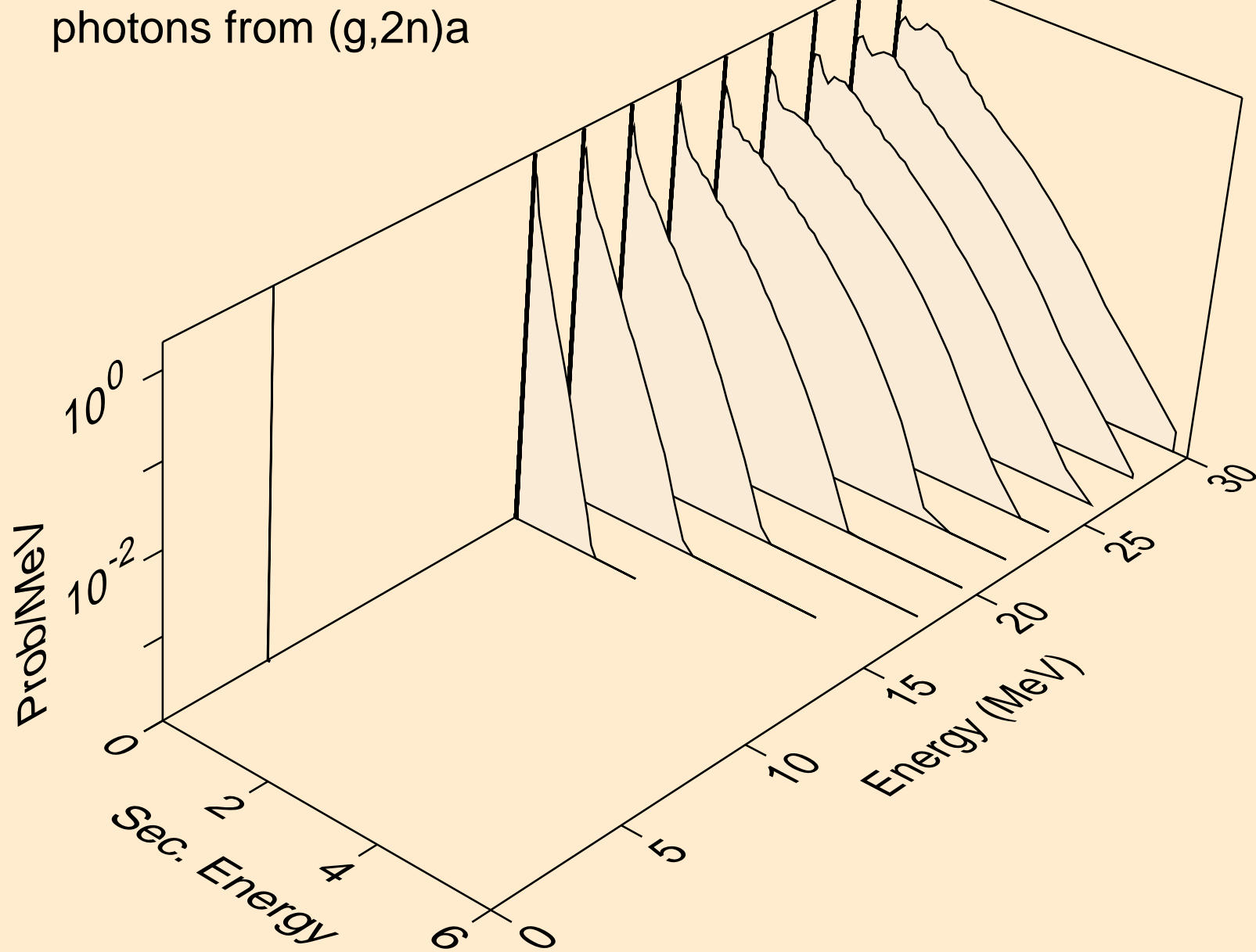

RE169M PHOTON ACER TENDL-2023 LIBRARY; T=0.K
photons from (g,3n)a

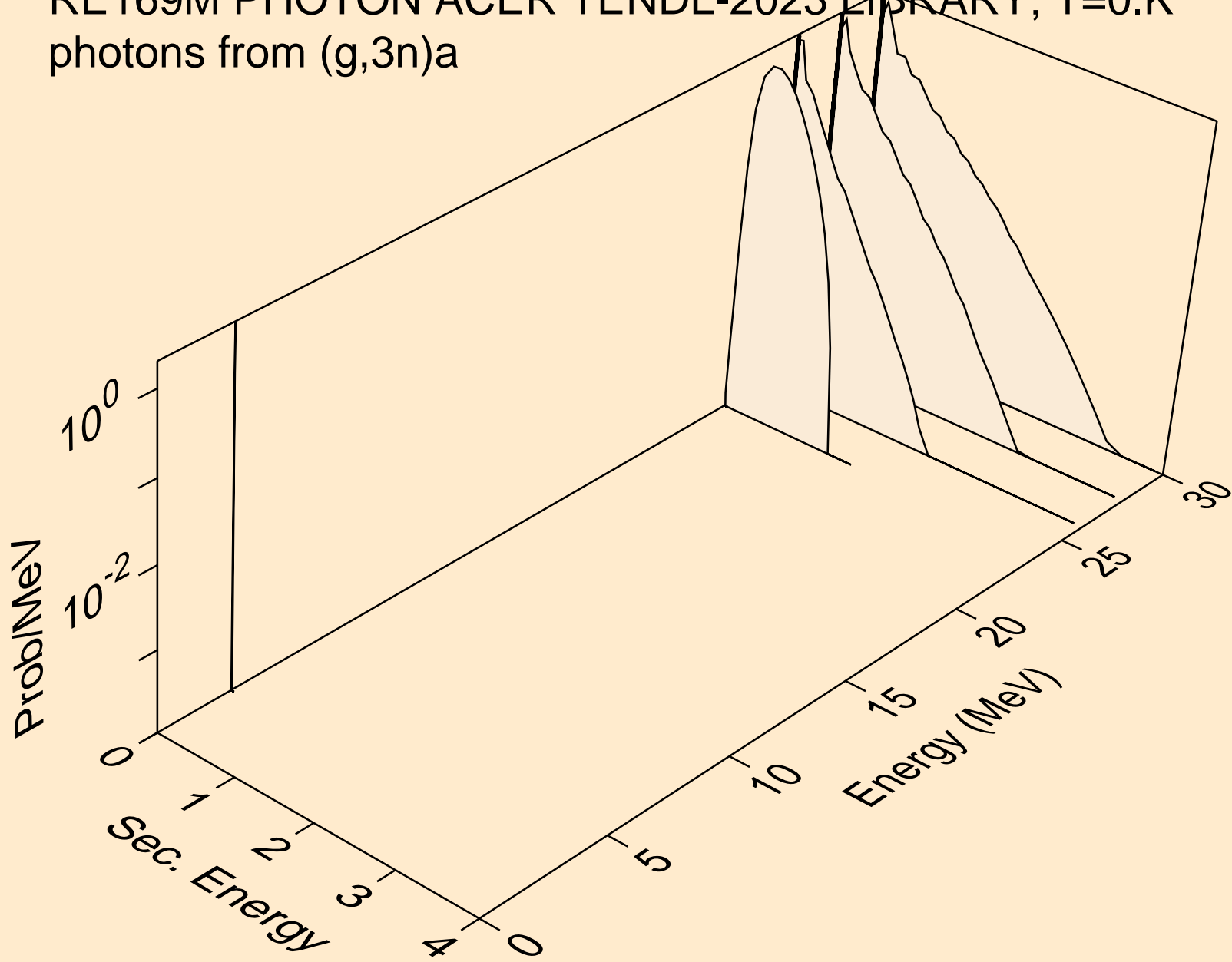

RE169M PHOTON ACER TENDL-2023 LIBRARY; T=0.K
photons from (g,n*)p

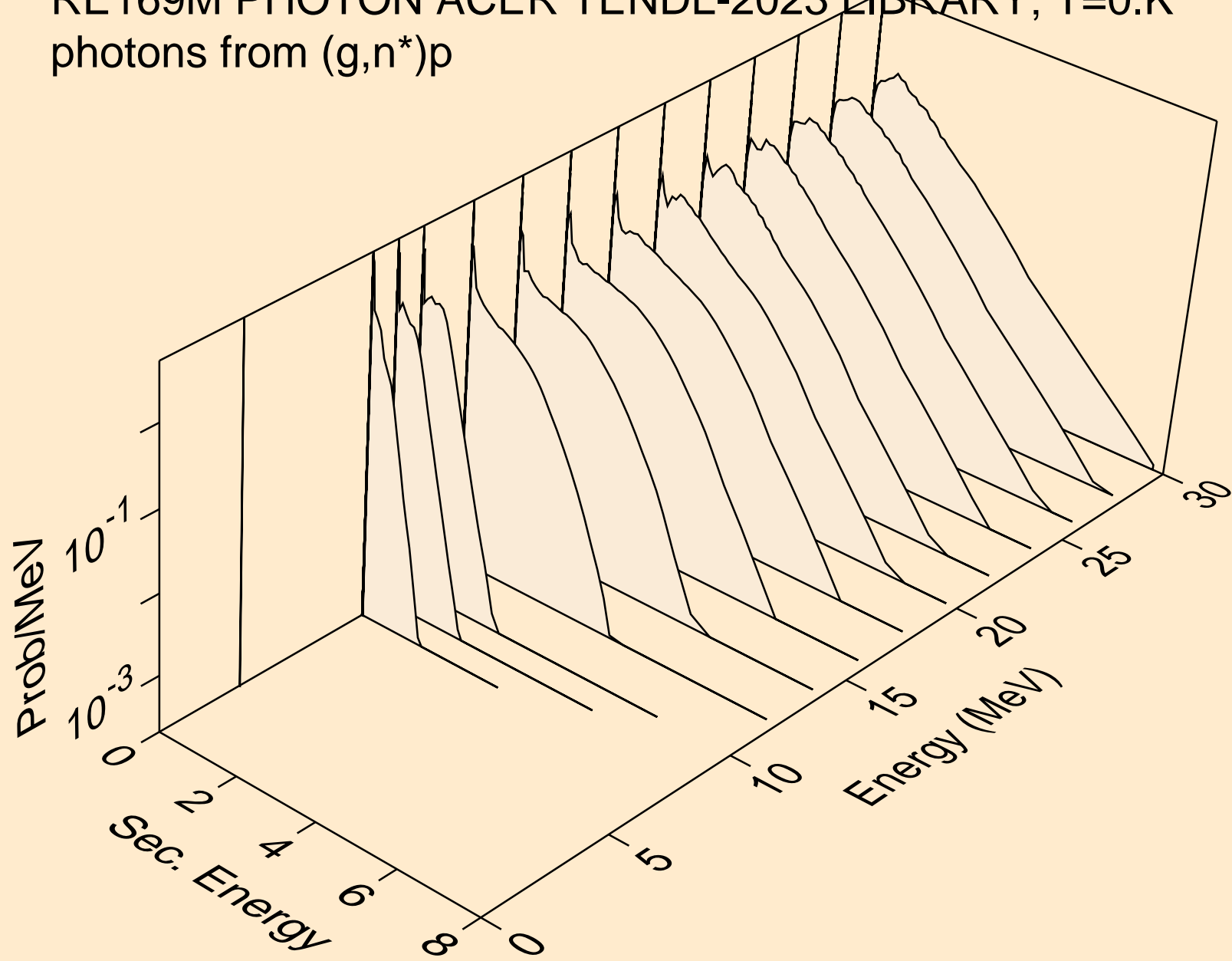

RE169M PHOTON ACER TENDL-2023 LIBRARY; T=0.K
photons from (g,2n)2a

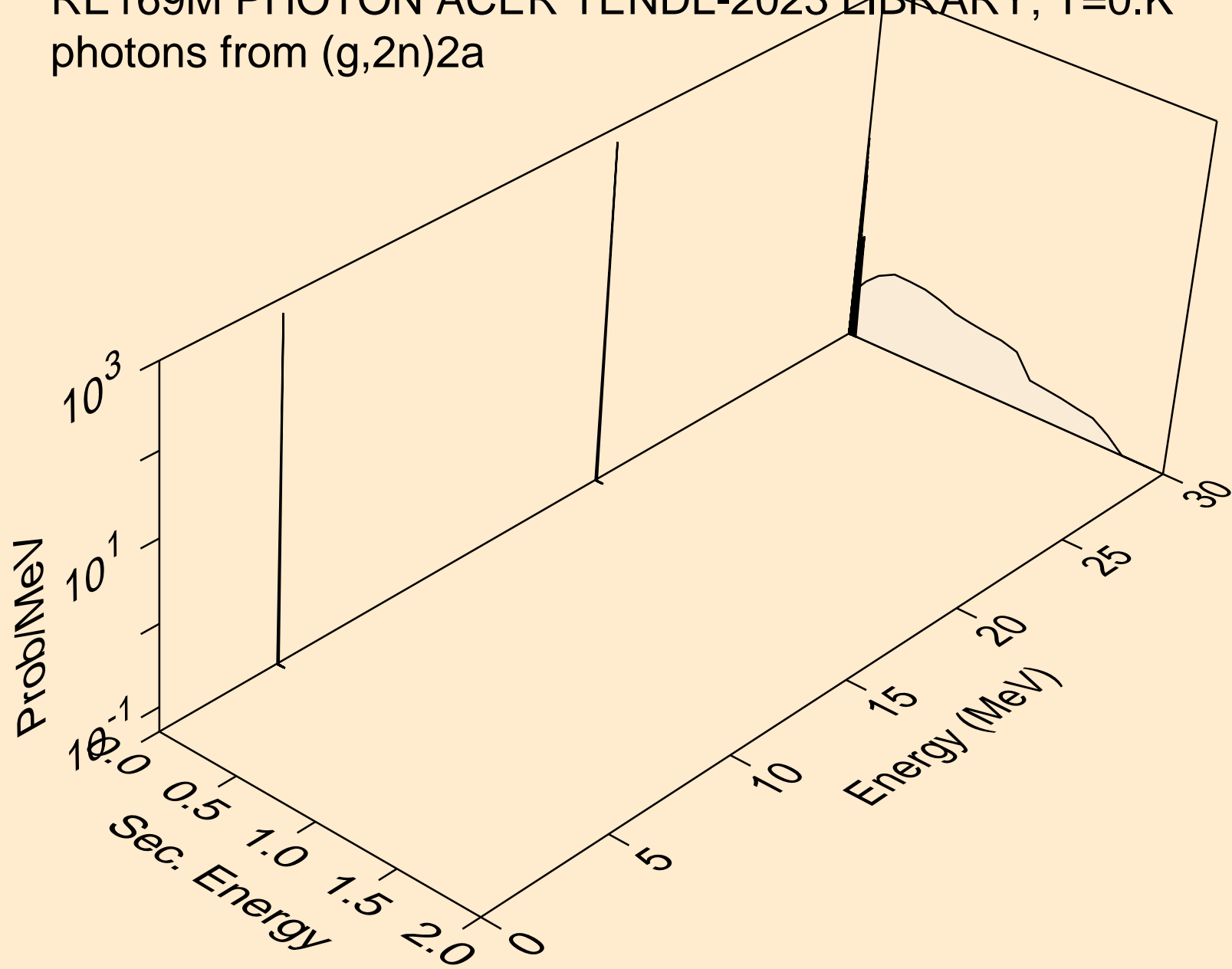

RE169M PHOTON ACER TENDL-2023 LIBRARY; T=0.K
photons from (g,n*)t

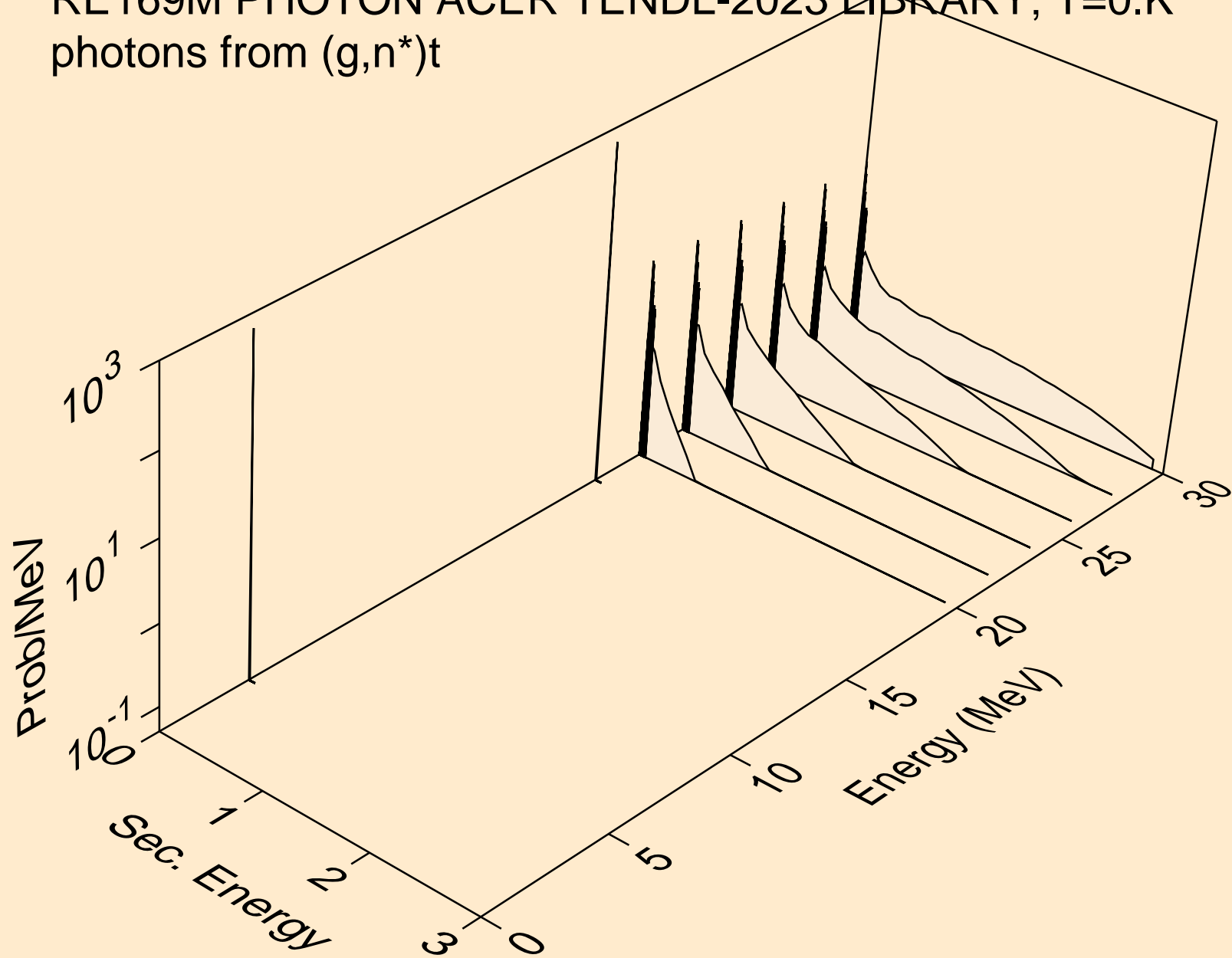

RE169M PHOTON ACER TENDL-2023 LIBRARY; T=0.K
photons from (g,3np)

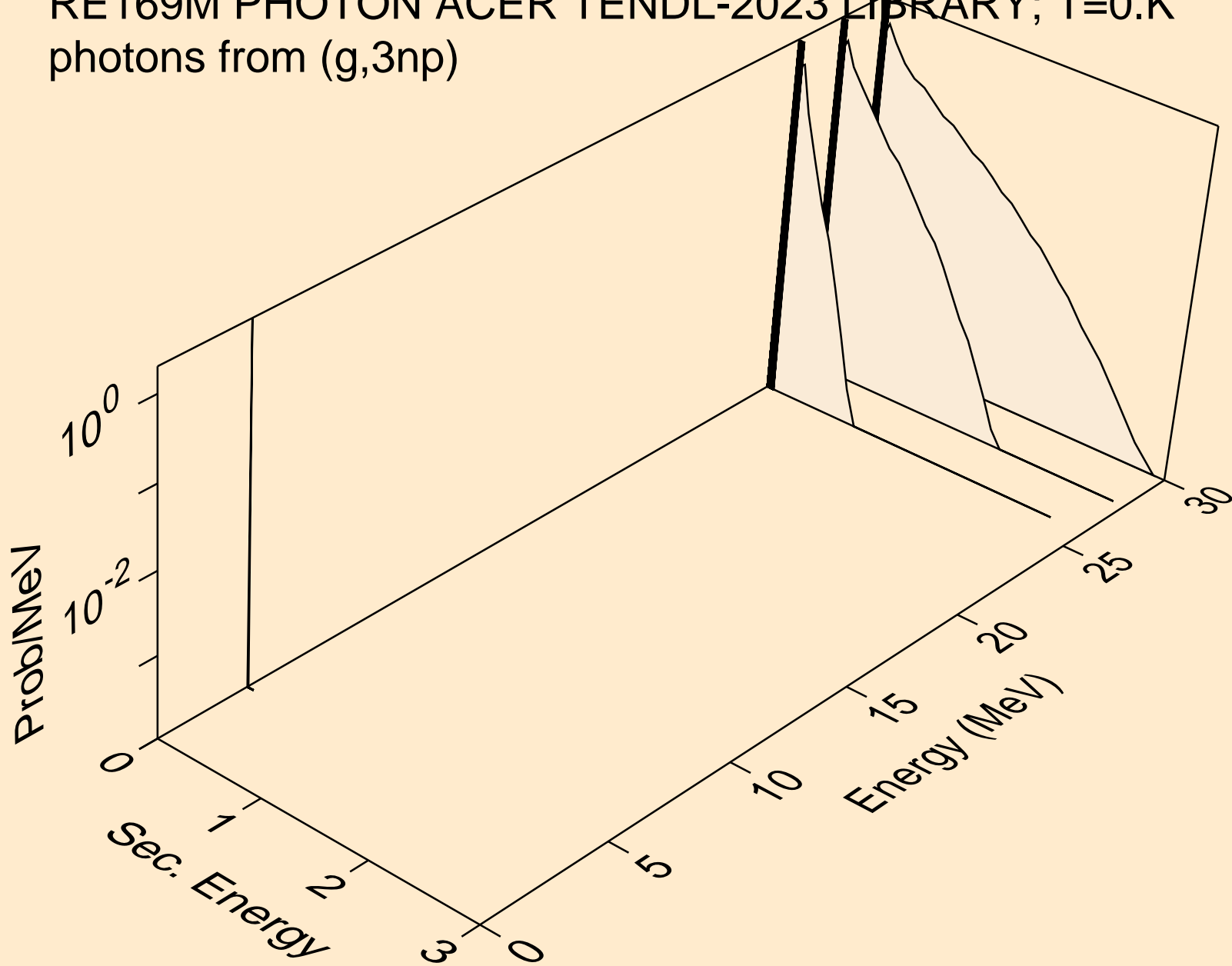

RE169M PHOTON ACER TENDL-2023 LIBRARY; T=0.K
photons from (g,n2p)

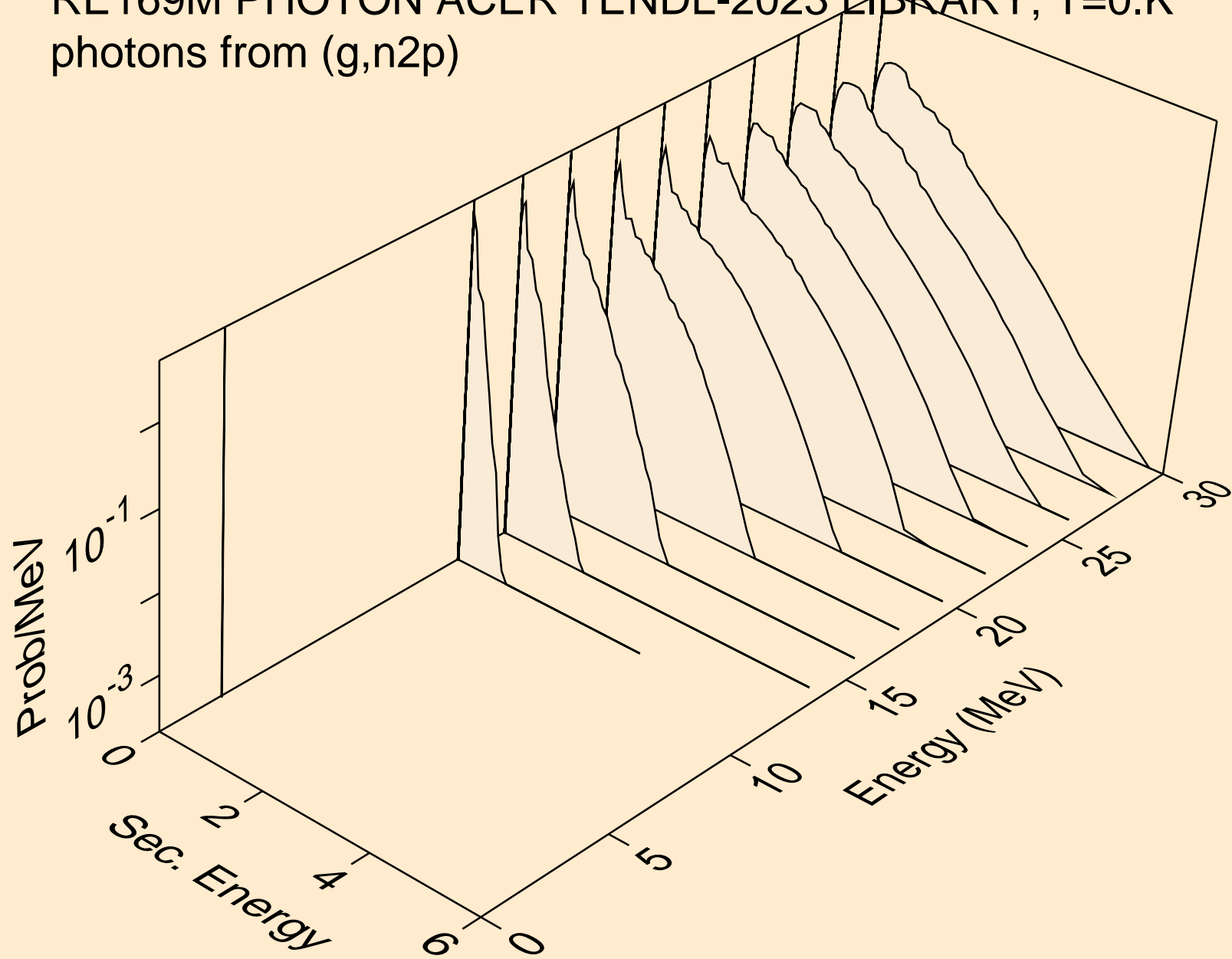

RE169M PHOTON ACER TENDL-2023 LIBRARY; T=0.K
photons from (g,n*c)

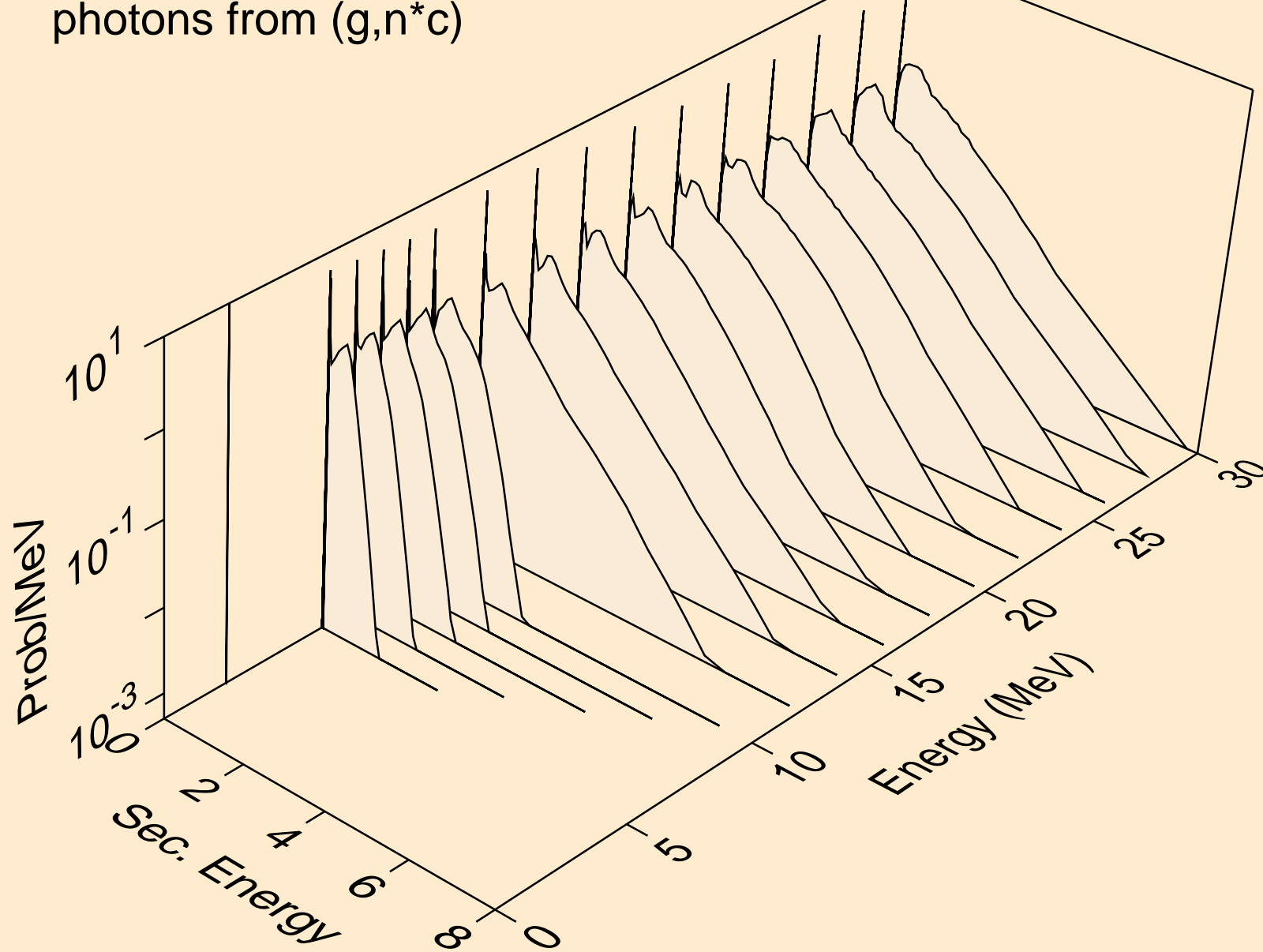

RE169M PHOTON ACER TENDL-2023 LIBRARY; T=0.K
photons from (g,gma)

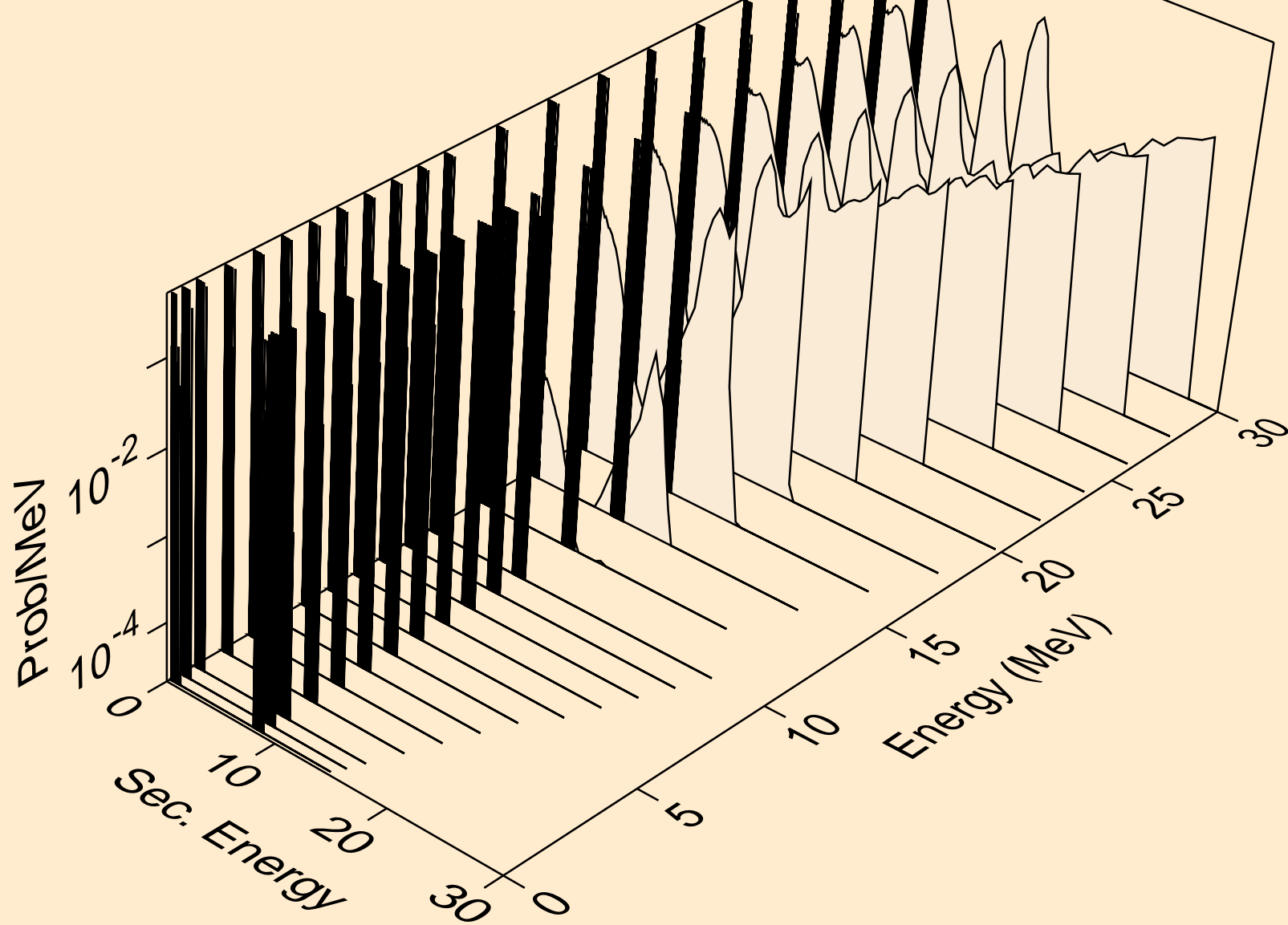

RE169M PHOTON ACER TENDL-2023 LIBRARY; T=0.K
photons from (g,p)

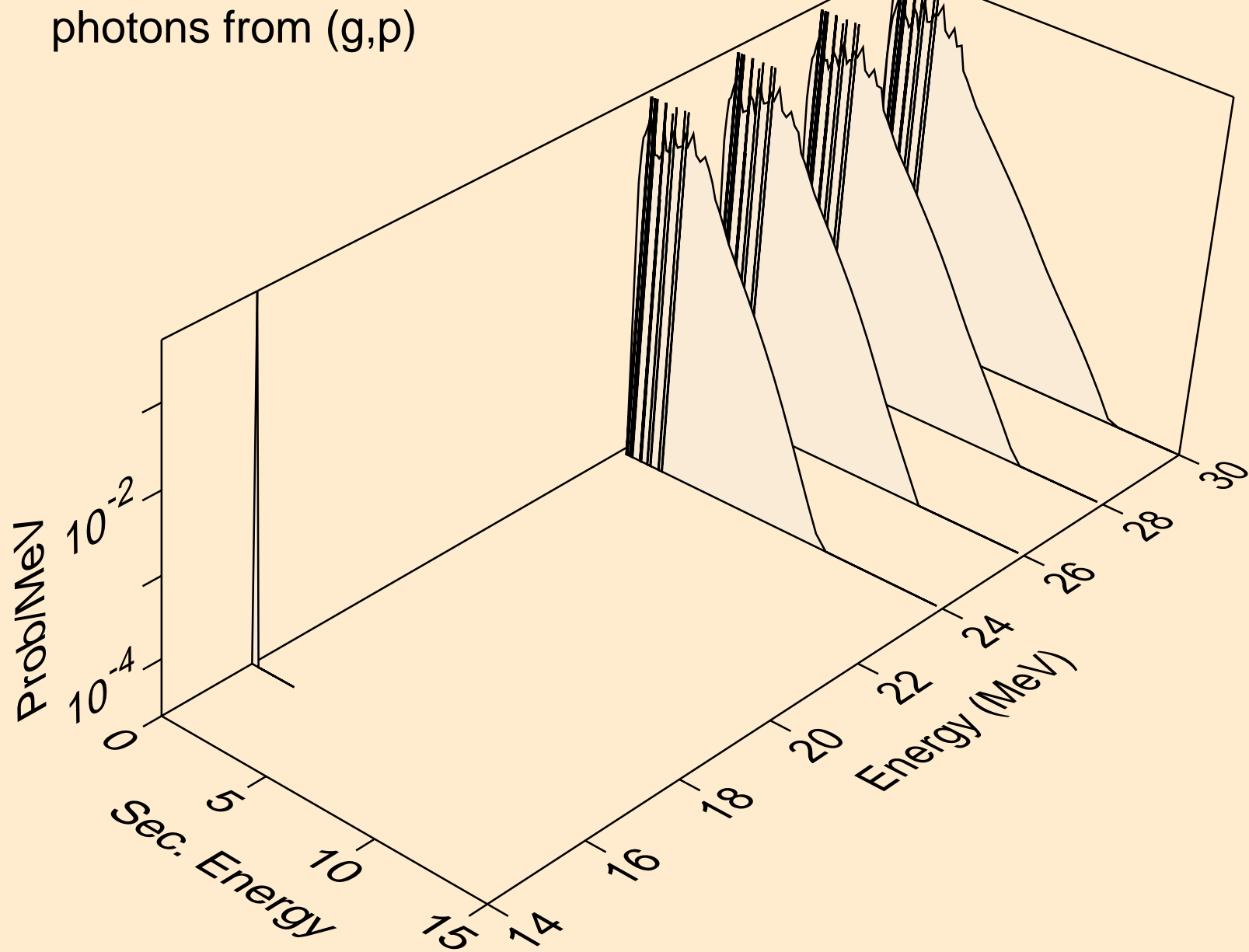

RE169M PHOTON ACER TENDL-2023 LIBRARY; T=0.K
photons from (g,d)

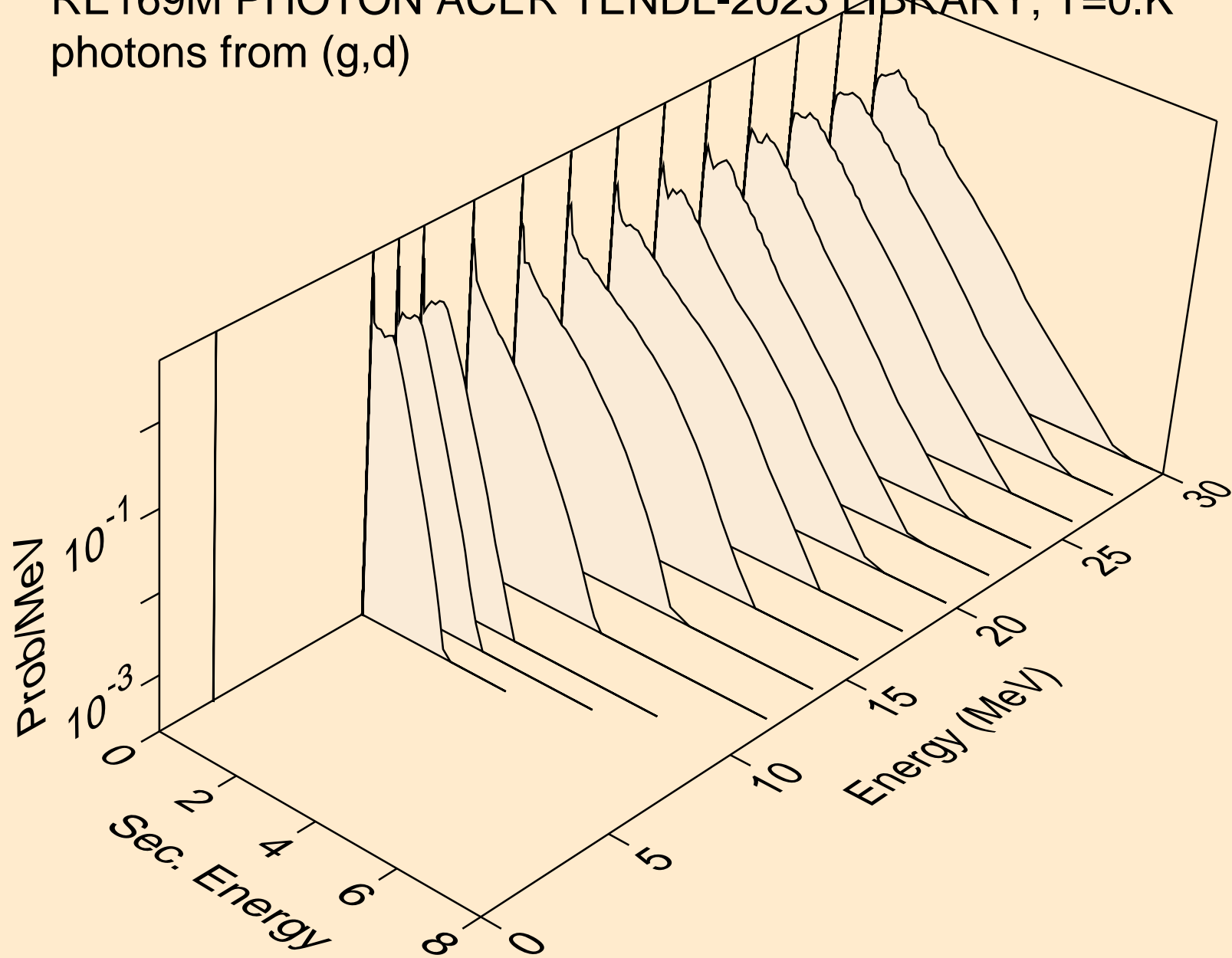

RE169M PHOTON ACER TENDL-2023 LIBRARY; T=0.K
photons from (g,t)

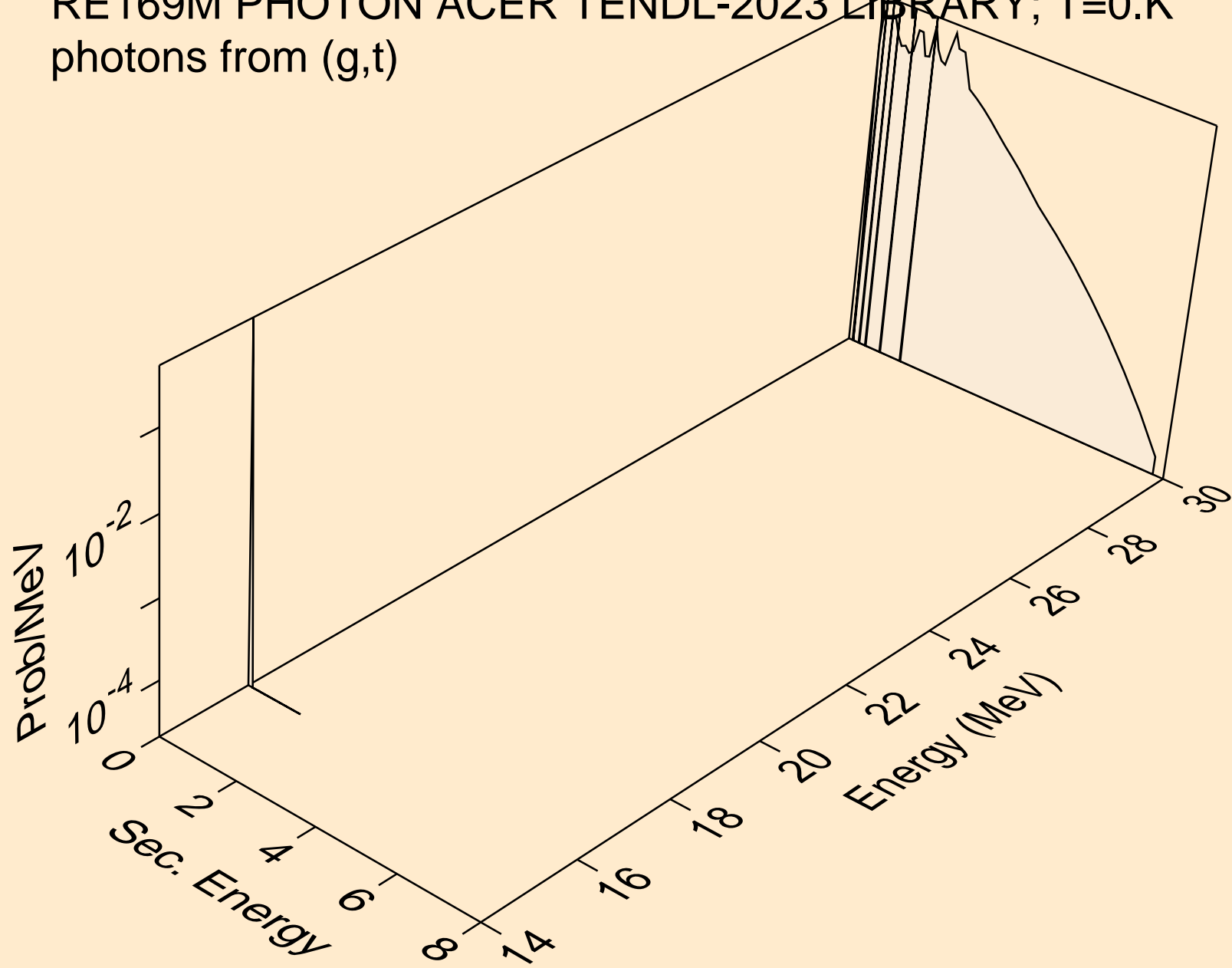

RE169M PHOTON ACER TENDL-2023 LIBRARY; T=0.K
photons from (g,he3)

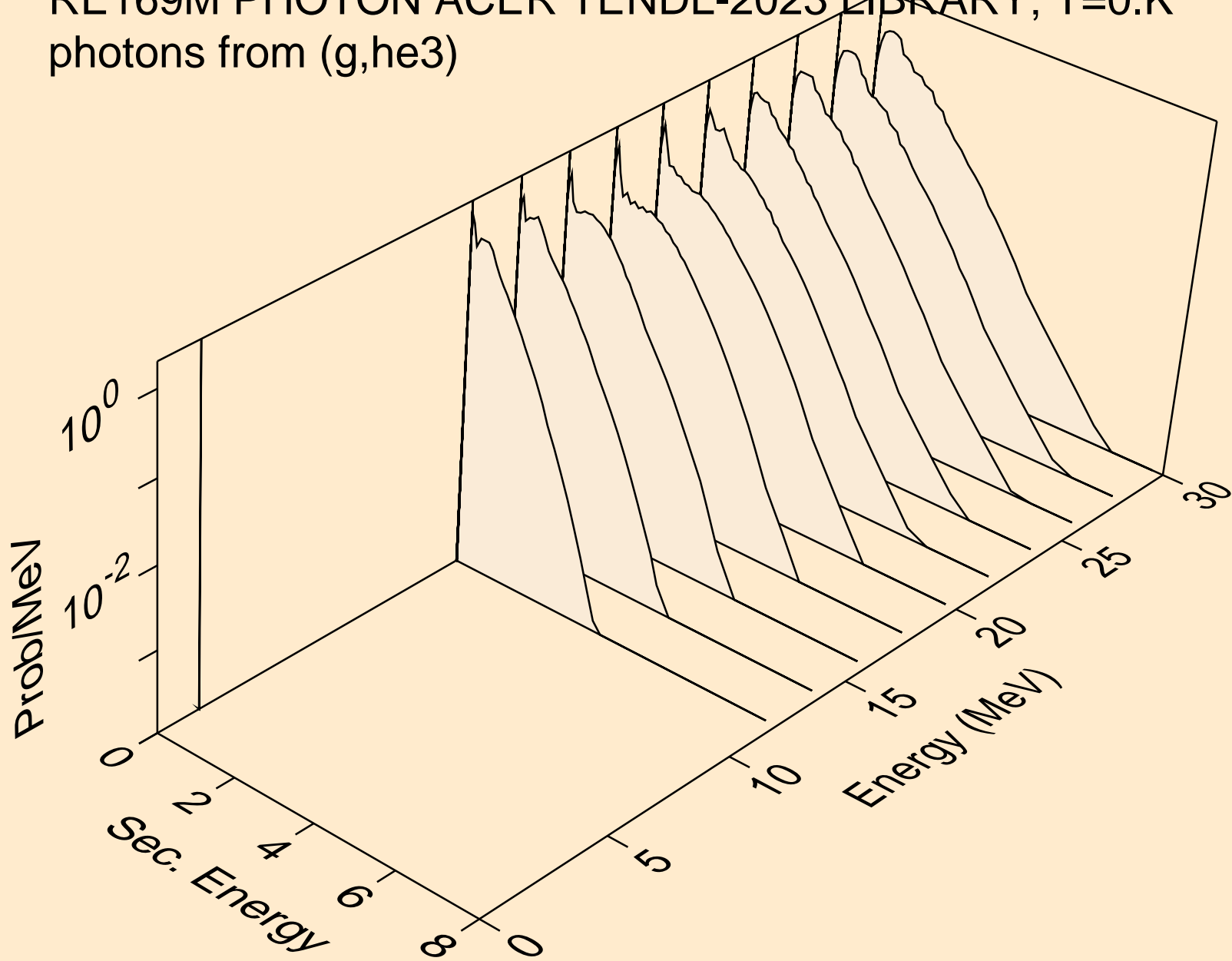

RE169M PHOTON ACER TENDL-2023 LIBRARY; T=0.K
photons from (g,a)

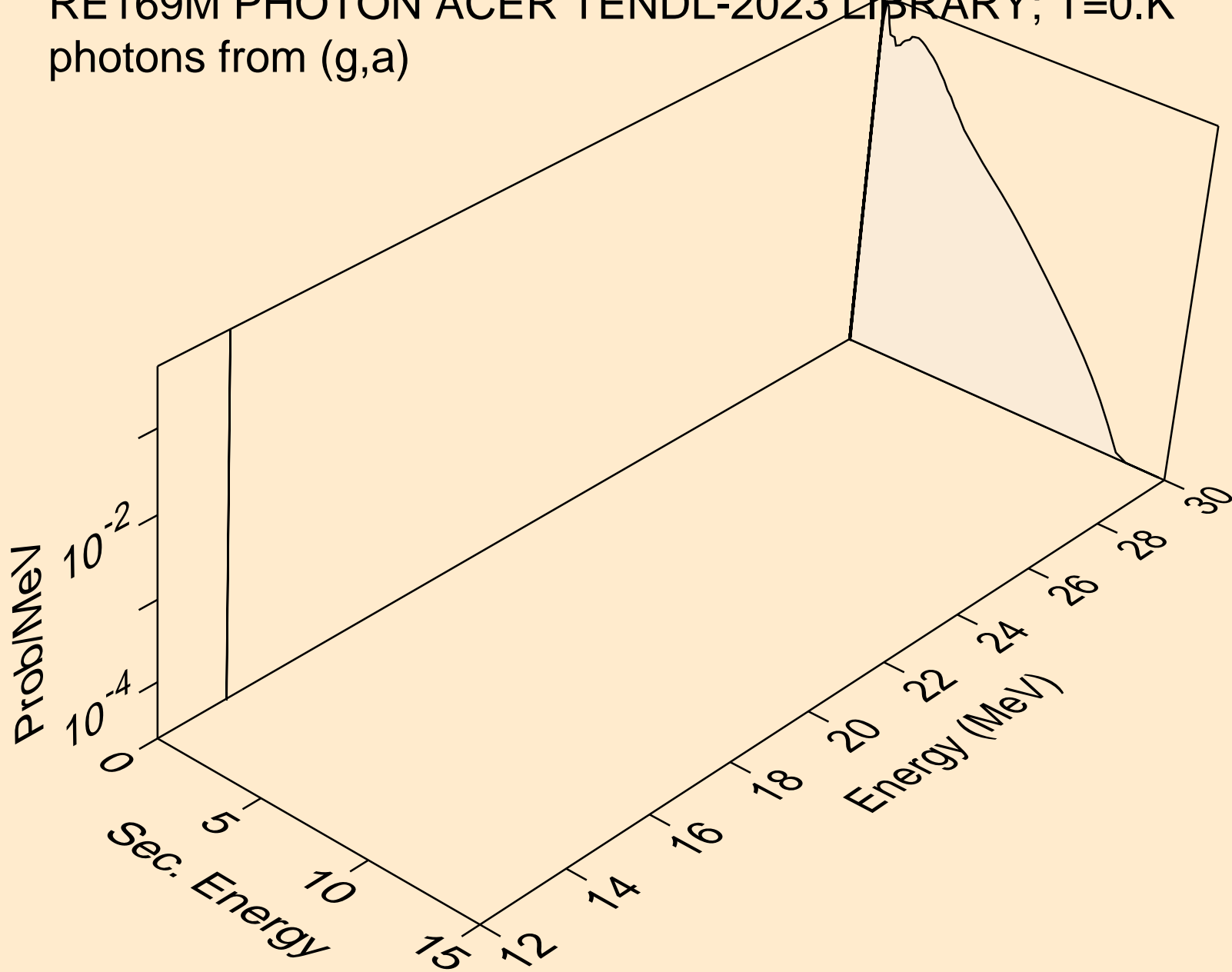

RE169M PHOTON ACER TENDL-2023 LIBRARY; T=0.K
photons from (g,pd)

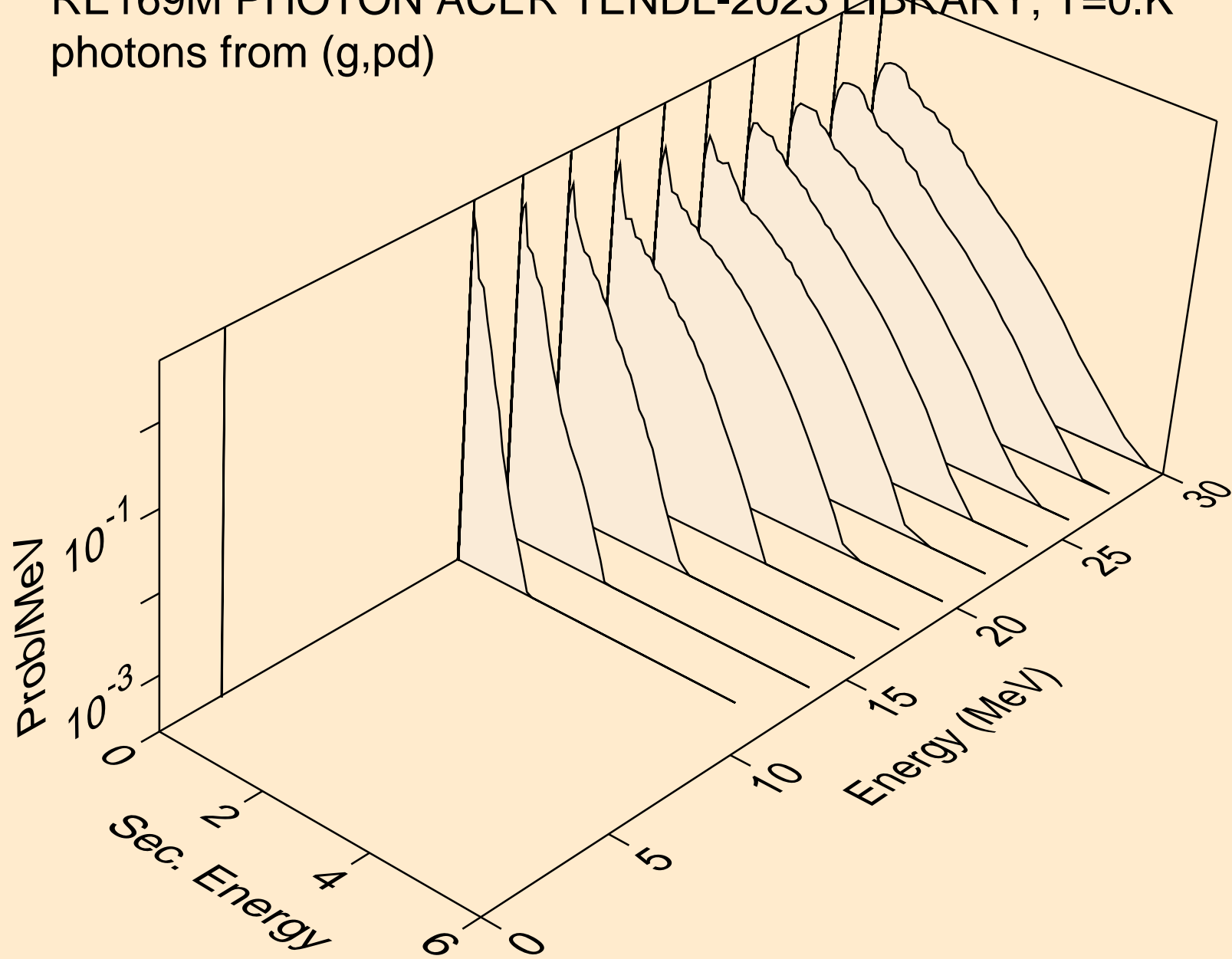

RE169M PHOTON ACER TENDL-2023 LIBRARY; T=0.K
protons from (g,x)

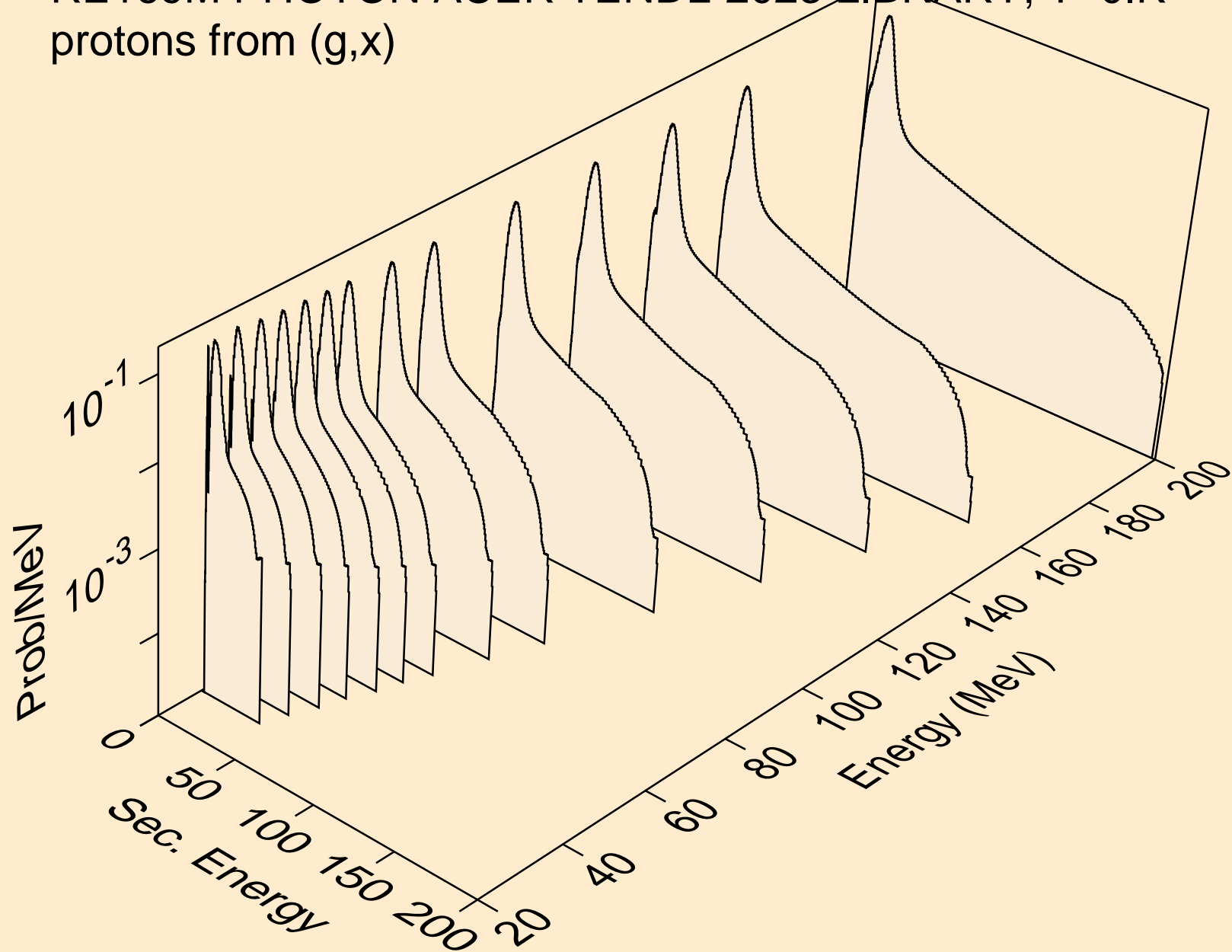

RE169M PHOTON ACER TENDL-2023 LIBRARY; T=0.K
protons from (g,n*)p

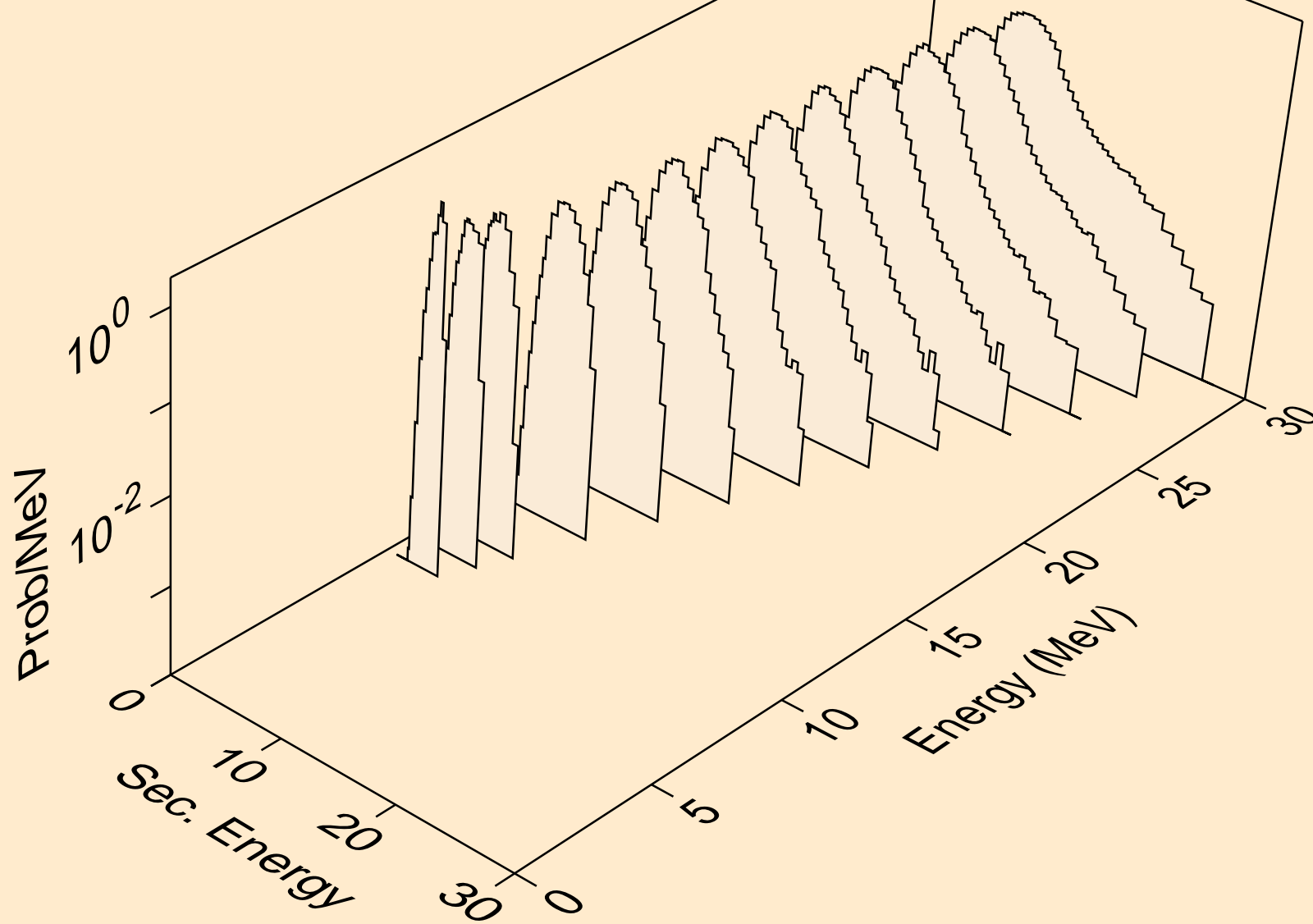

RE169M PHOTON ACER TENDL-2023 LIBRARY; T=0.K
protons from (g,2np)

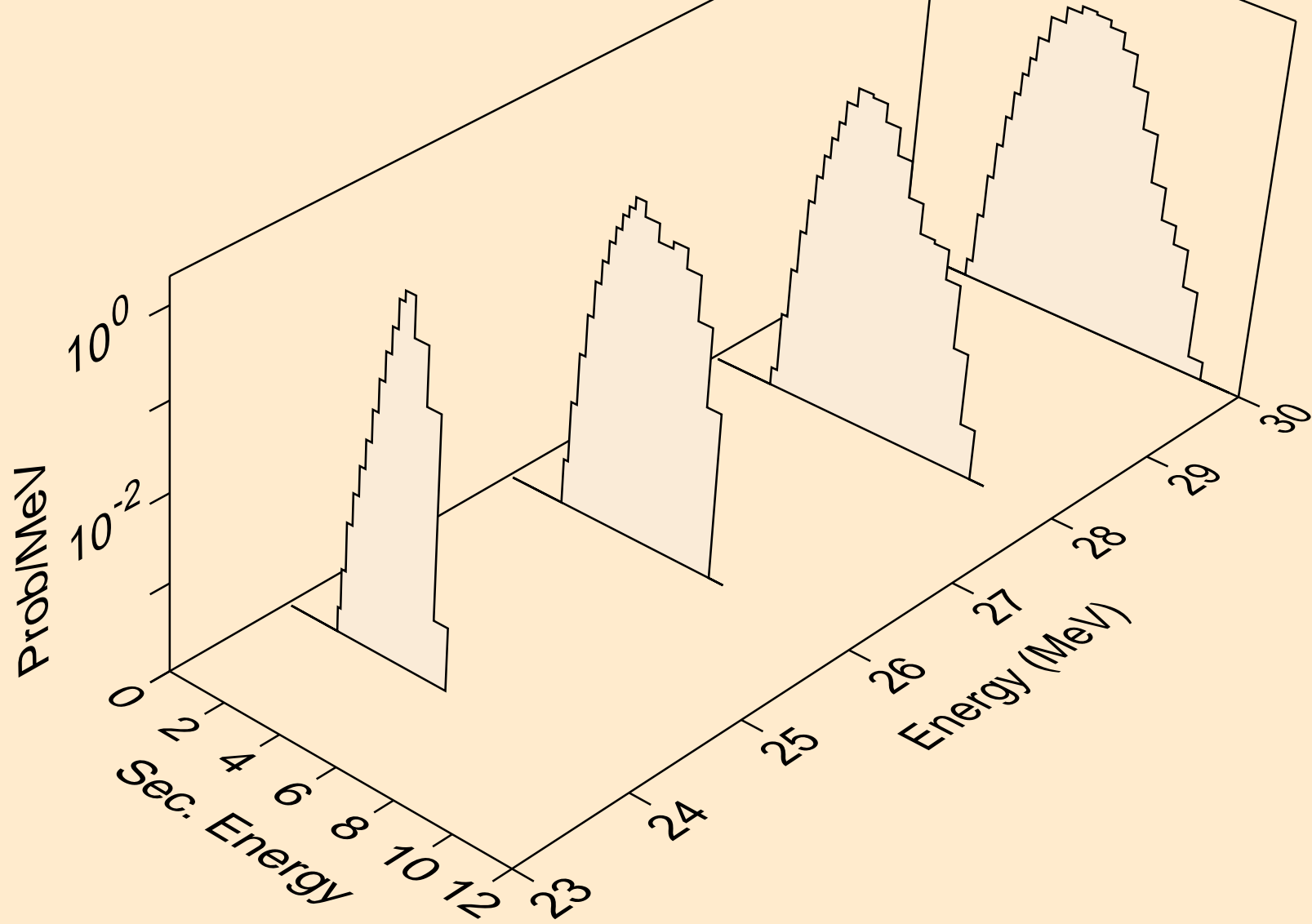

RE169M PHOTON ACER TENDL-2023 LIBRARY; T=0.K
protons from (g,3np)

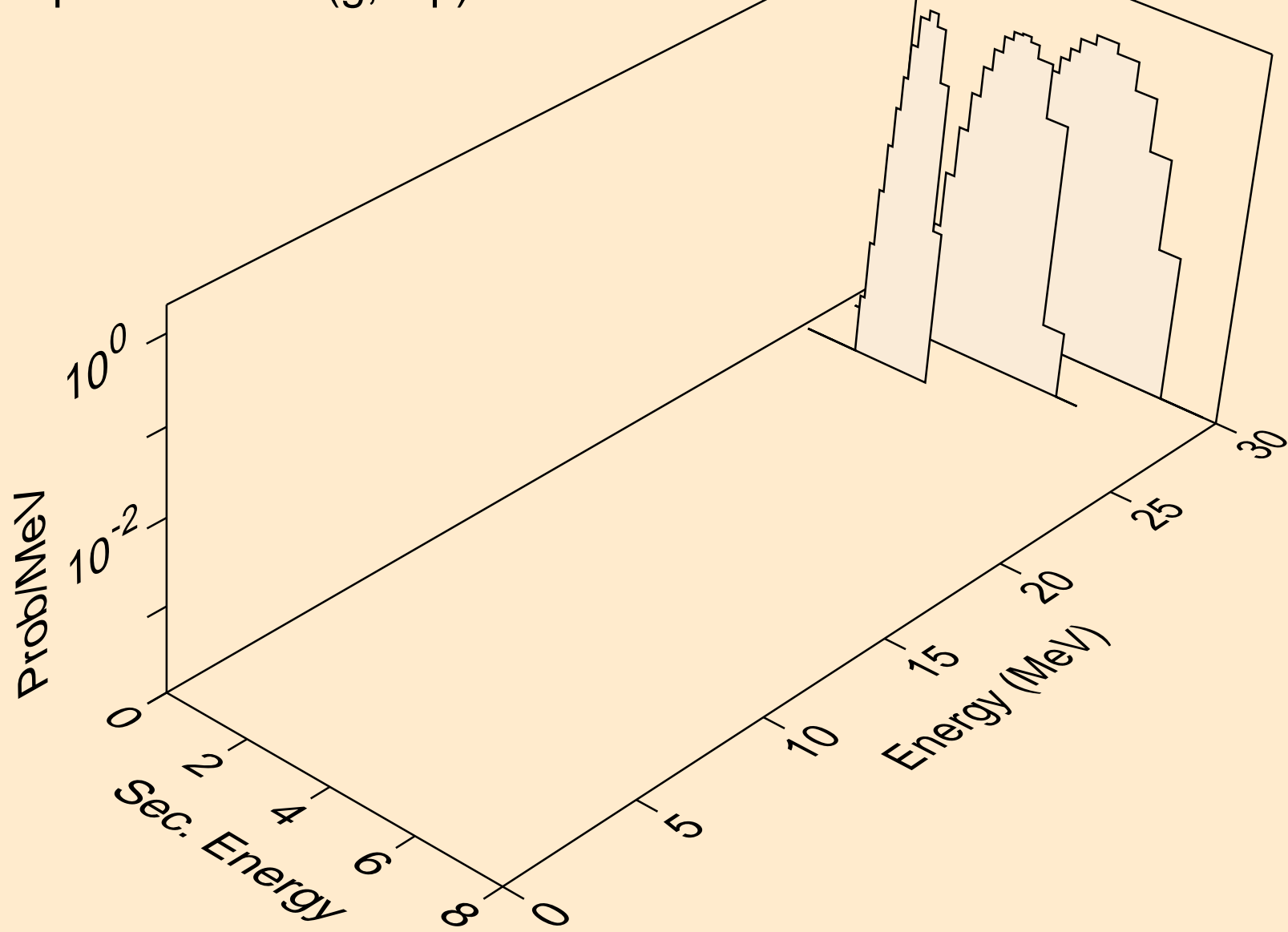

RE169M PHOTON ACER TENDL-2023 LIBRARY; T=0.K
protons from (g,n2p)

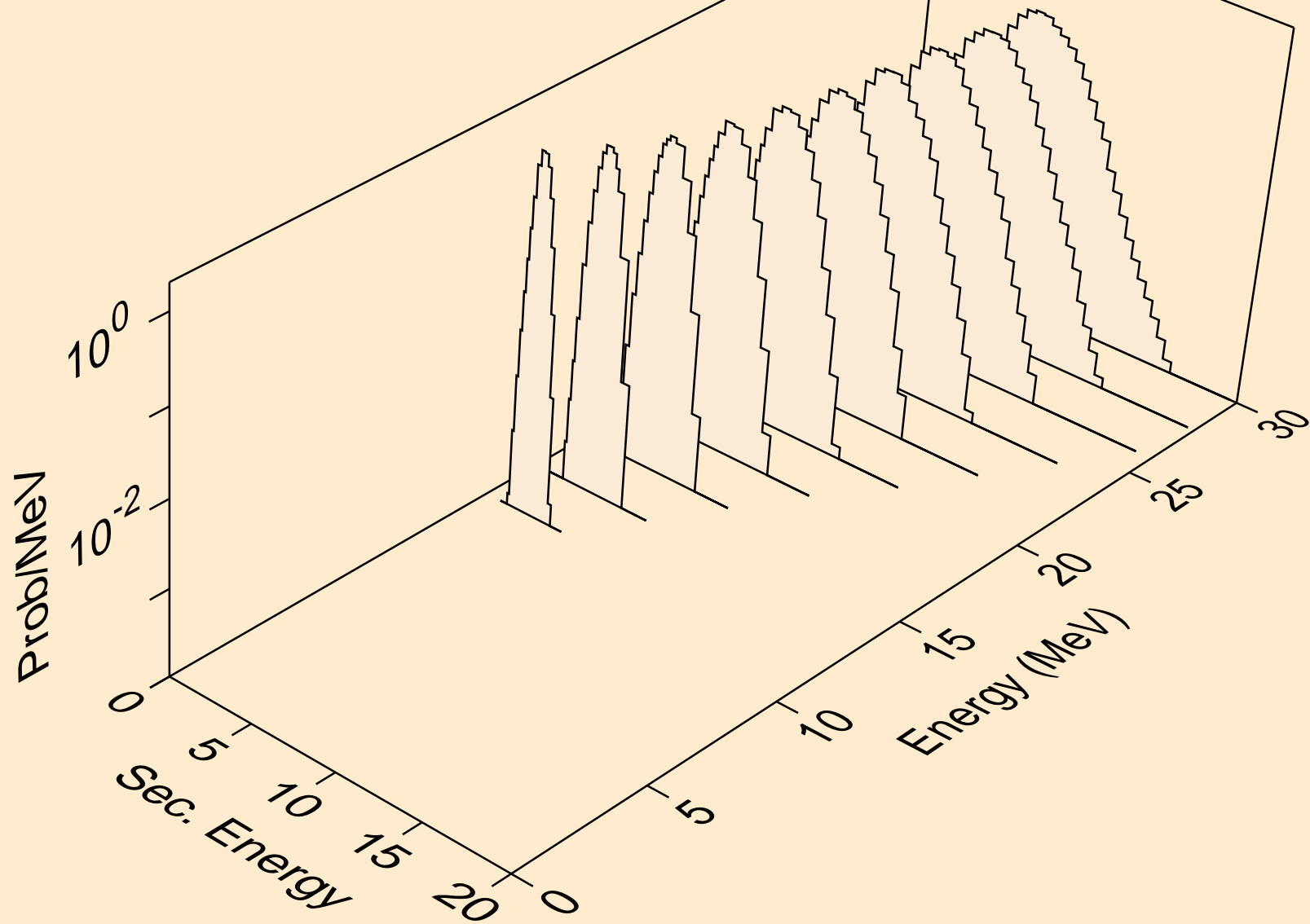

RE169M PHOTON ACER TENDL-2023 LIBRARY; T=0.K
protons from (g,p)

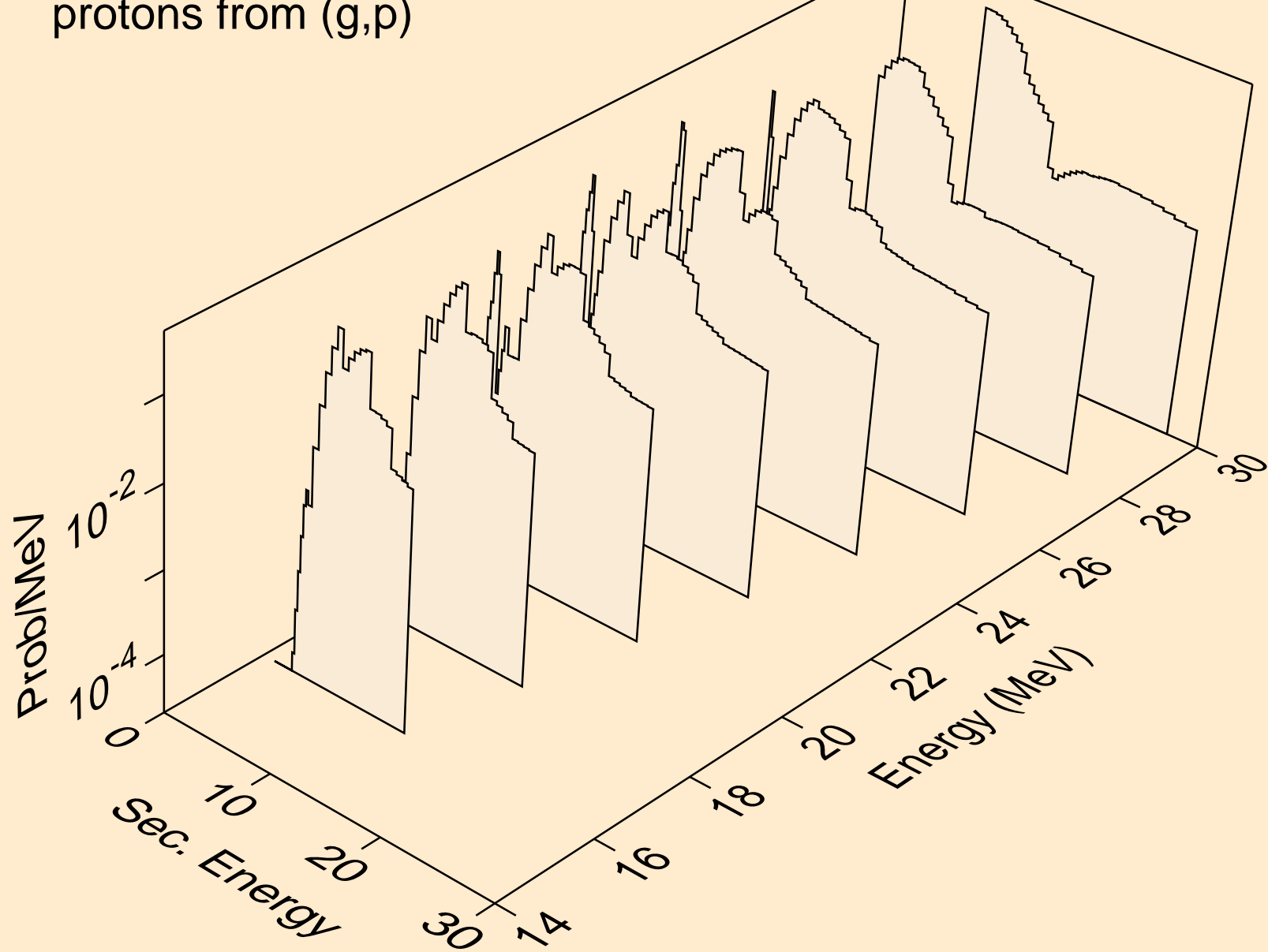

RE169M PHOTON ACER TENDL-2023 LIBRARY; T=0.K
protons from (g,2p)

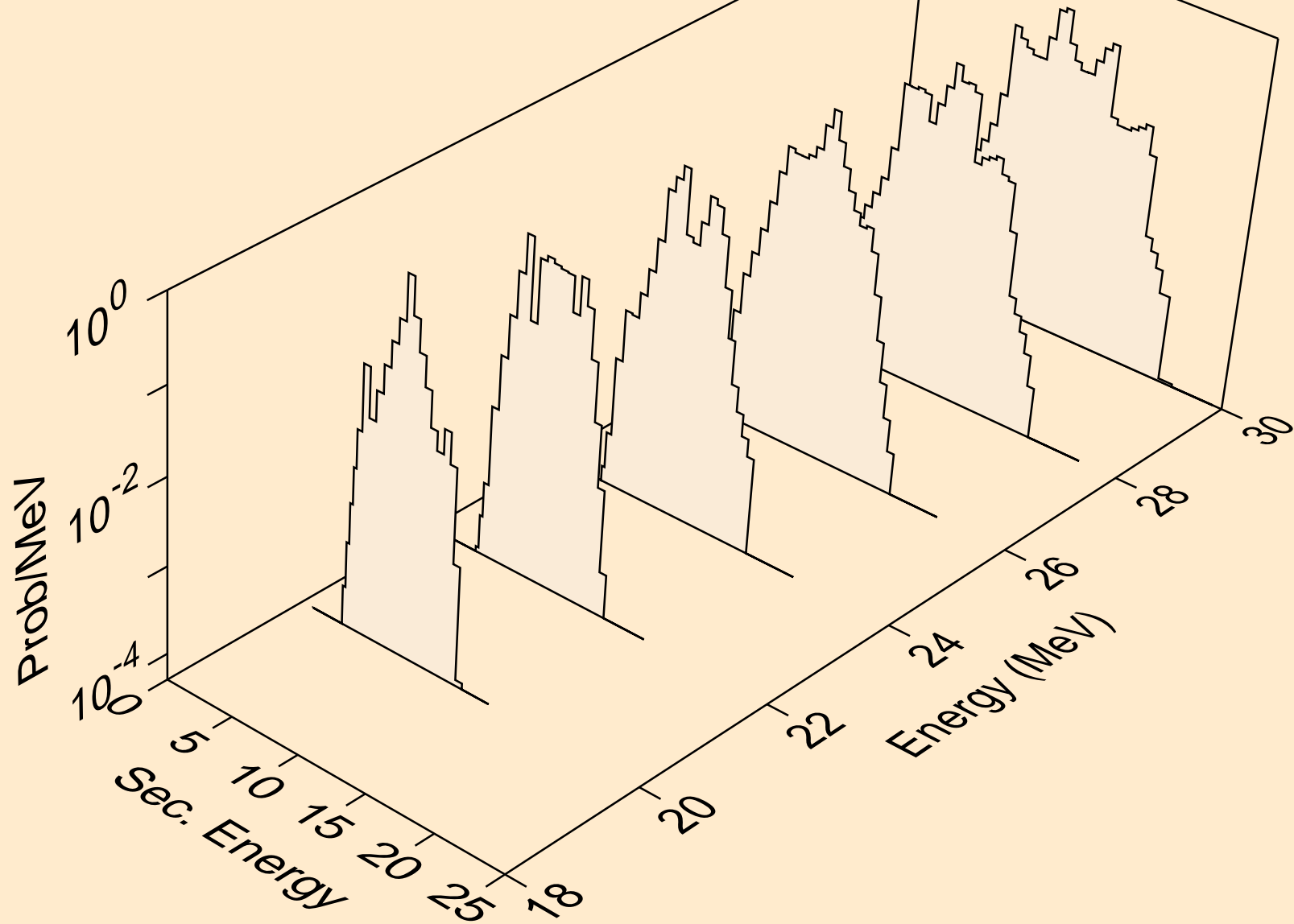

RE169M PHOTON ACER TENDL-2023 LIBRARY; T=0.K
protons from (g,pd)

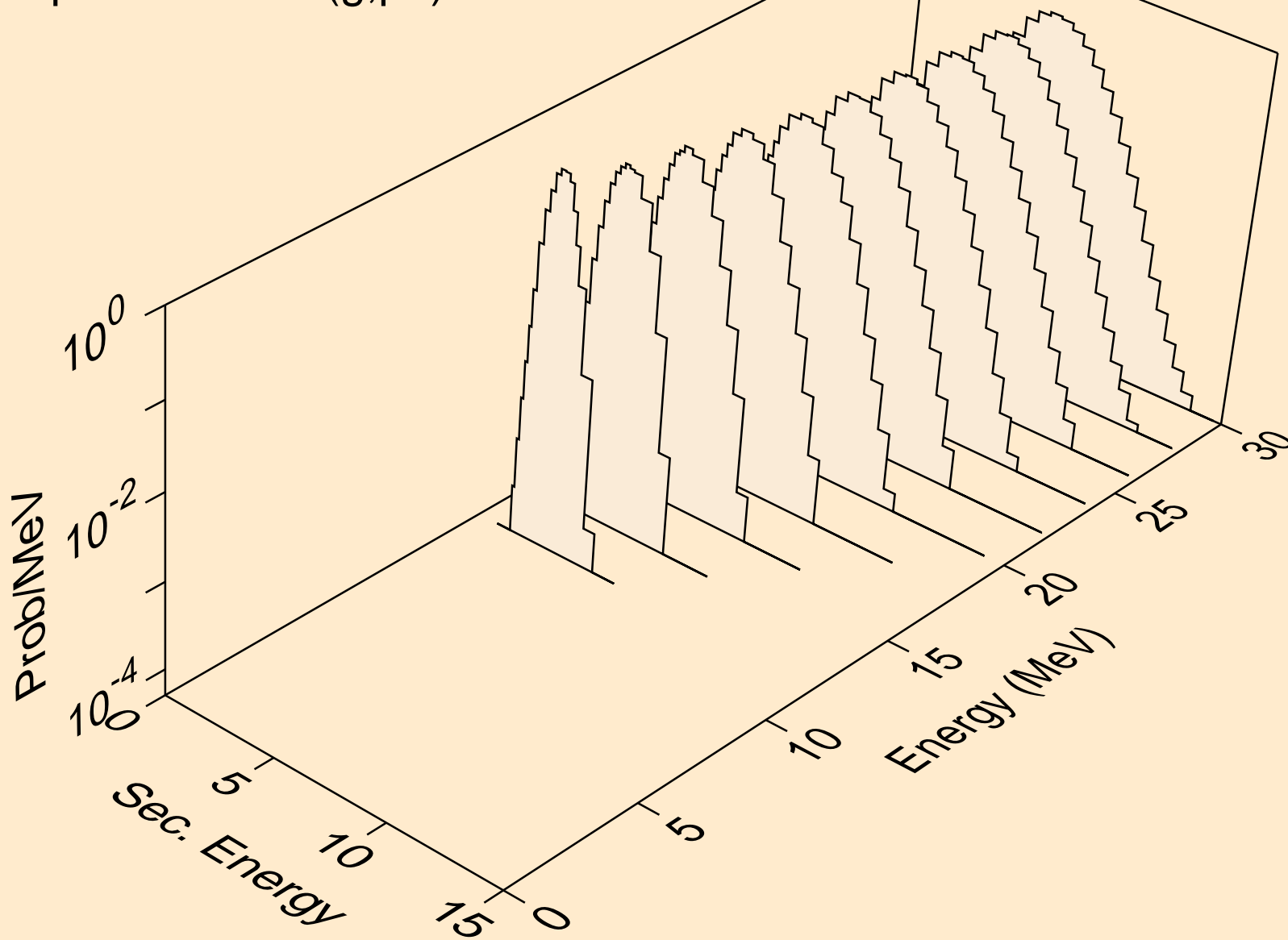

RE169M PHOTON ACER TENDL-2023 LIBRARY; T=0.K
protons from (g,pt)

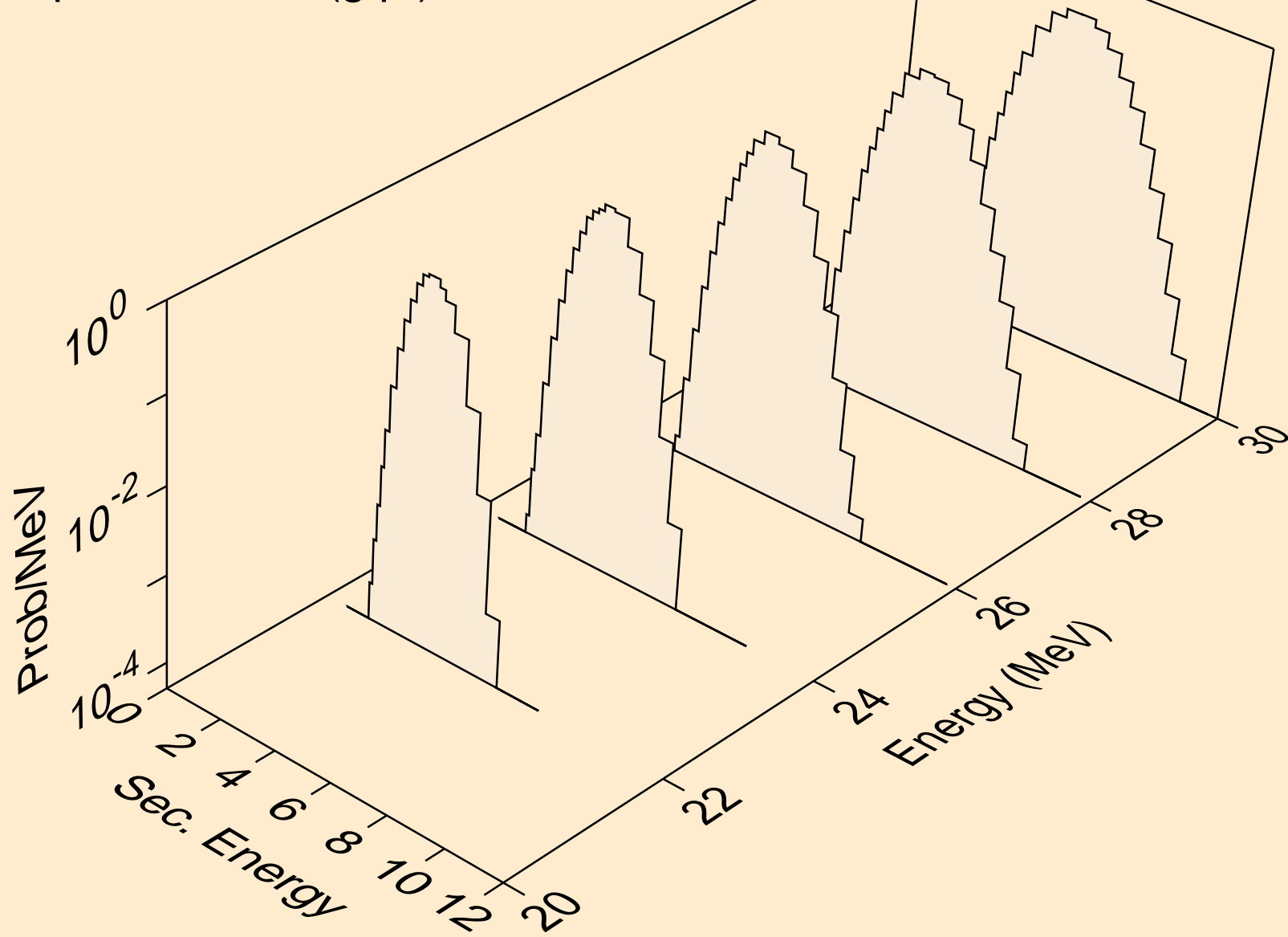

RE169M PHOTON ACER TENDL-2023 LIBRARY; T=0.K
deuterons from (g,x)

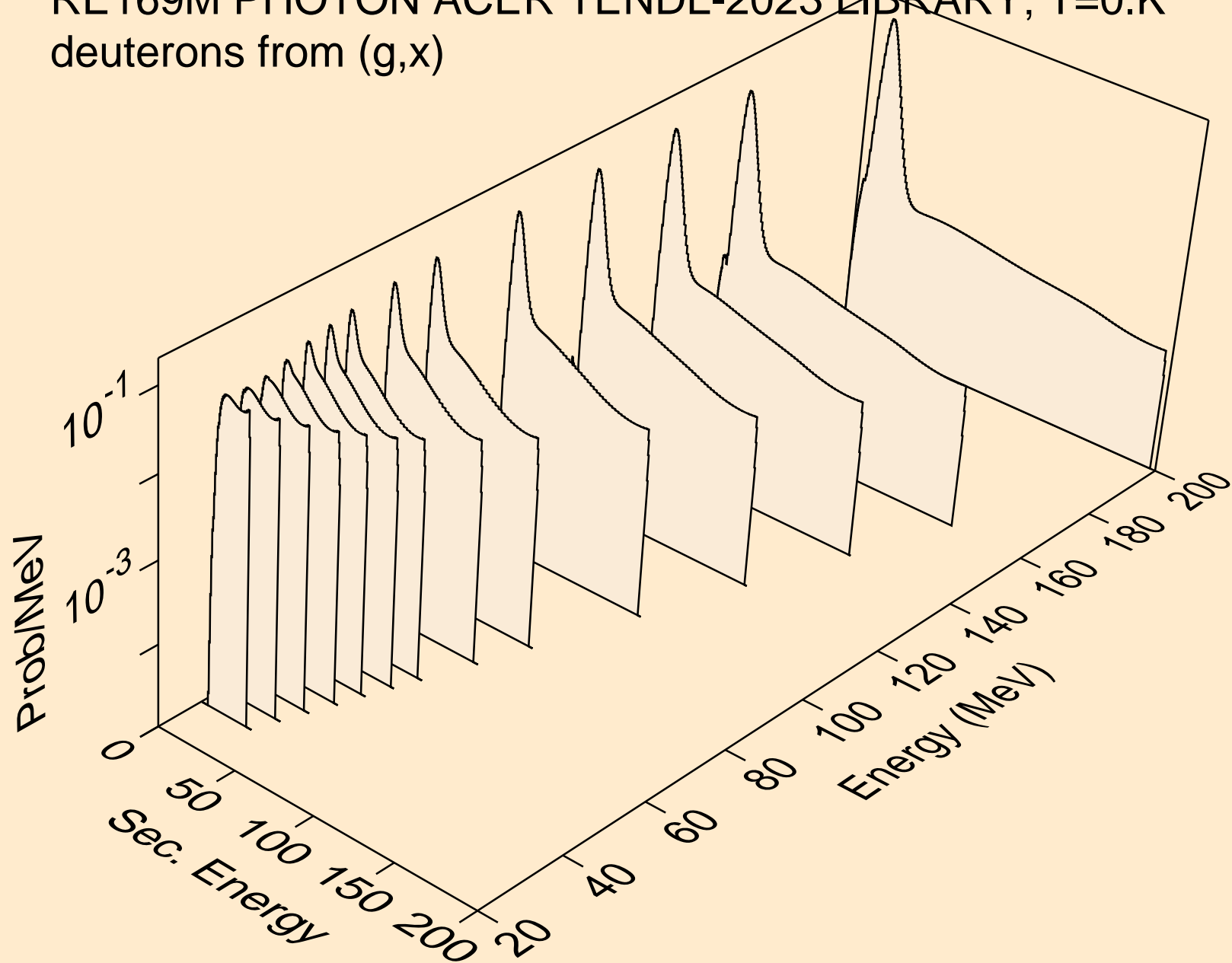

RE169M PHOTON ACER TENDL-2023 LIBRARY; T=0.K
deuterons from (g,2nd)

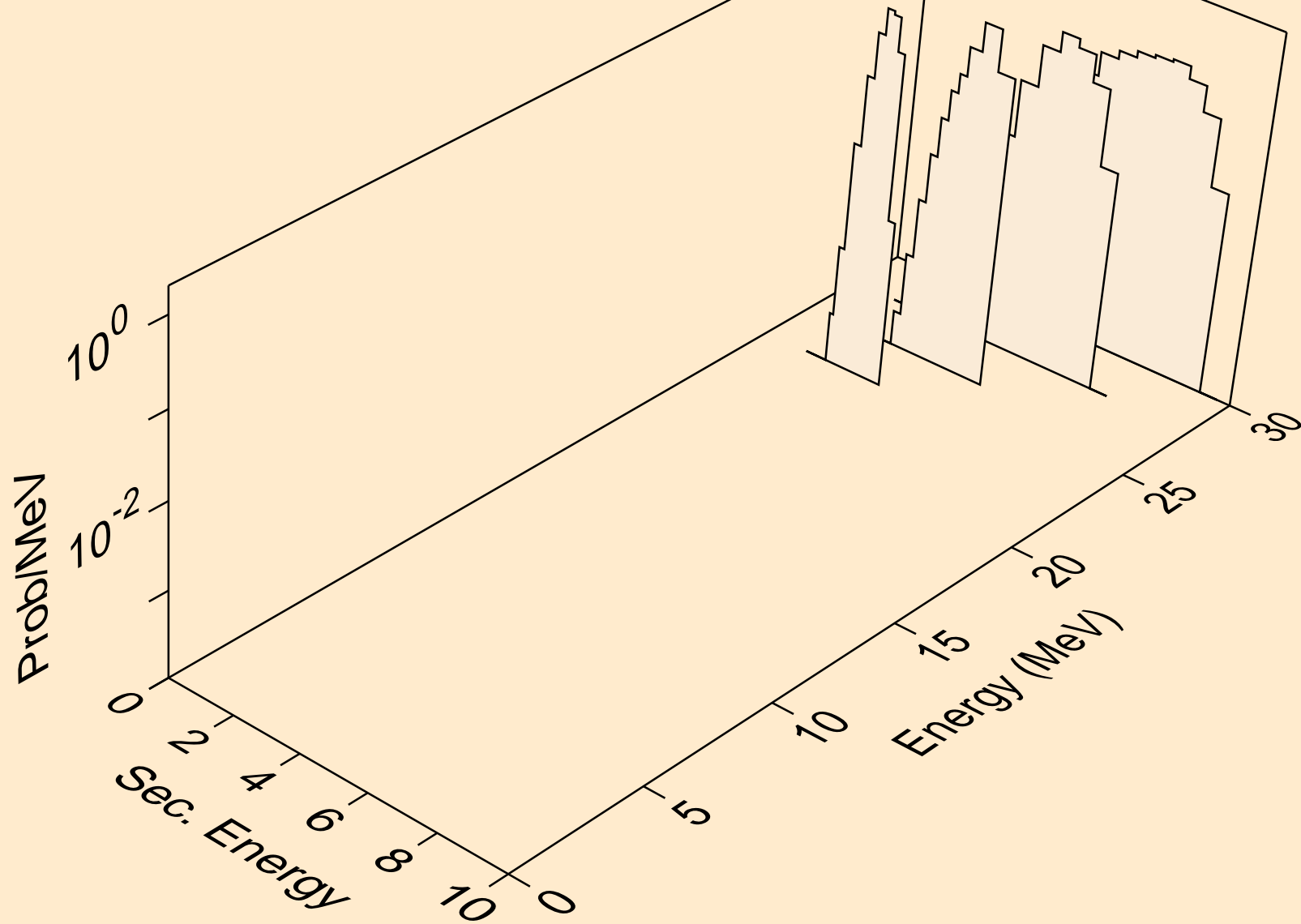

RE169M PHOTON ACER TENDL-2023 LIBRARY; T=0.K
deuterons from (g,n*)d

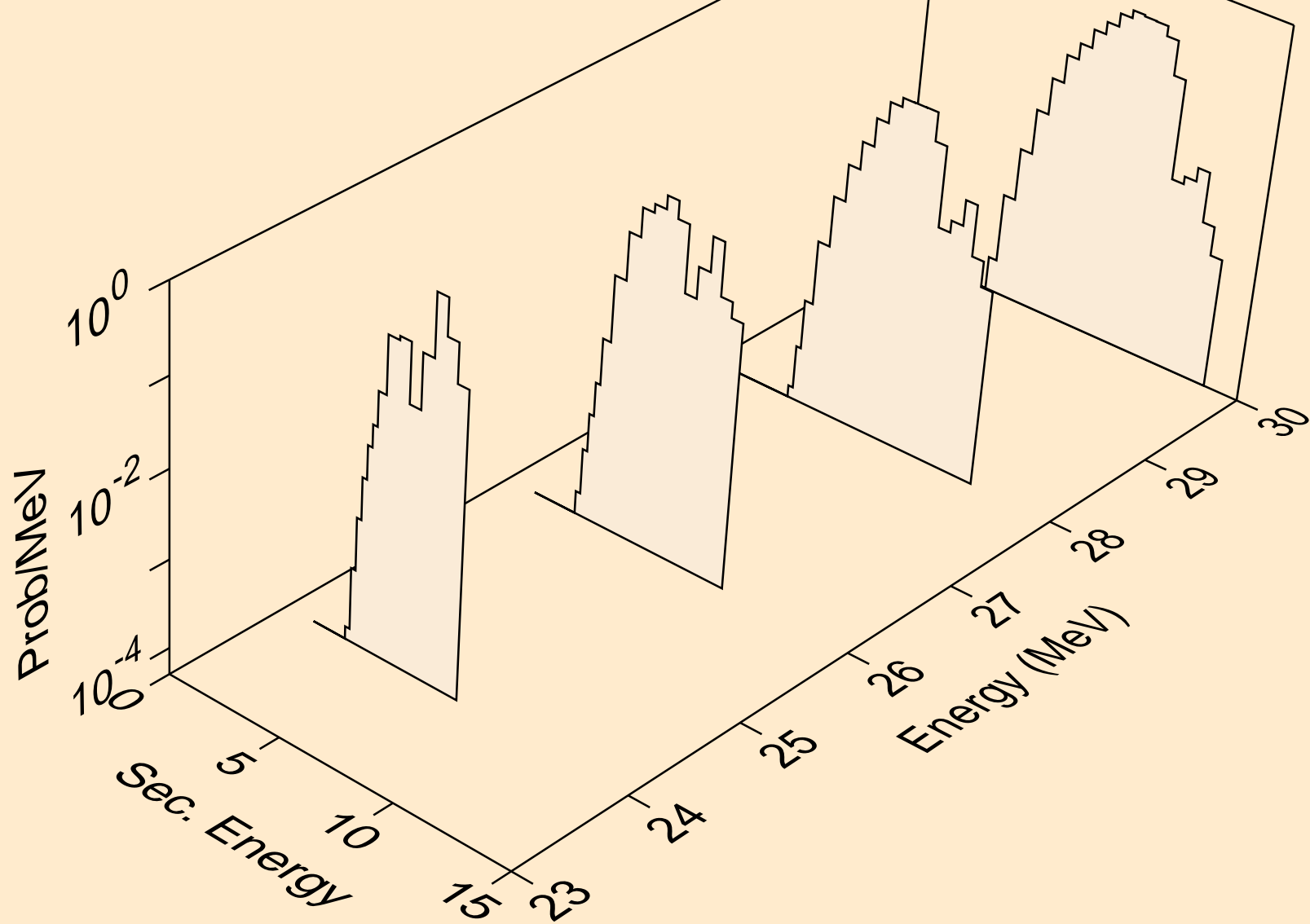

RE169M PHOTON ACER TENDL-2023 LIBRARY; T=0.K
deuterons from (g,d)

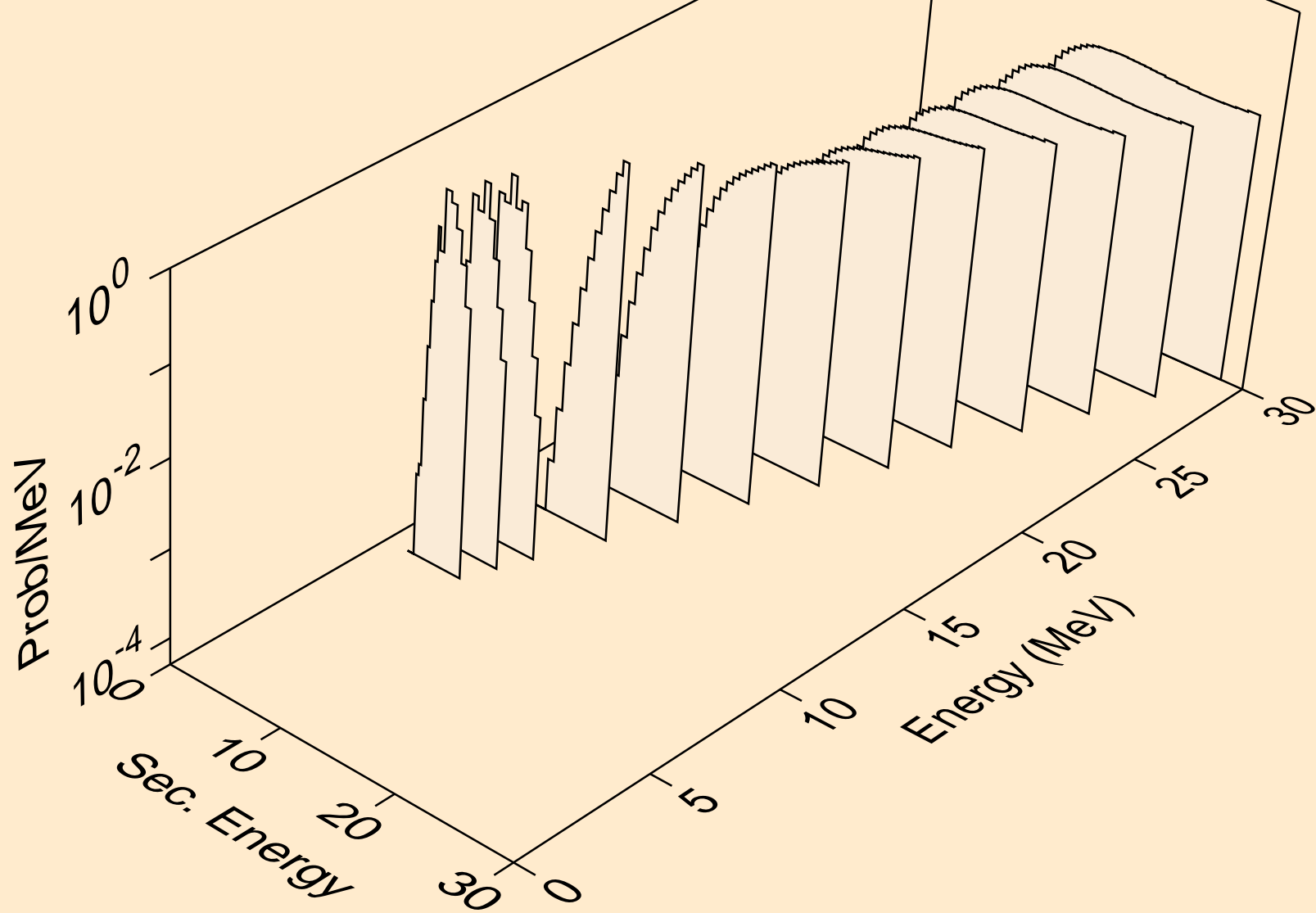

RE169M PHOTON ACER TENDL-2023 LIBRARY; T=0.K
deuterons from (g,d2a)

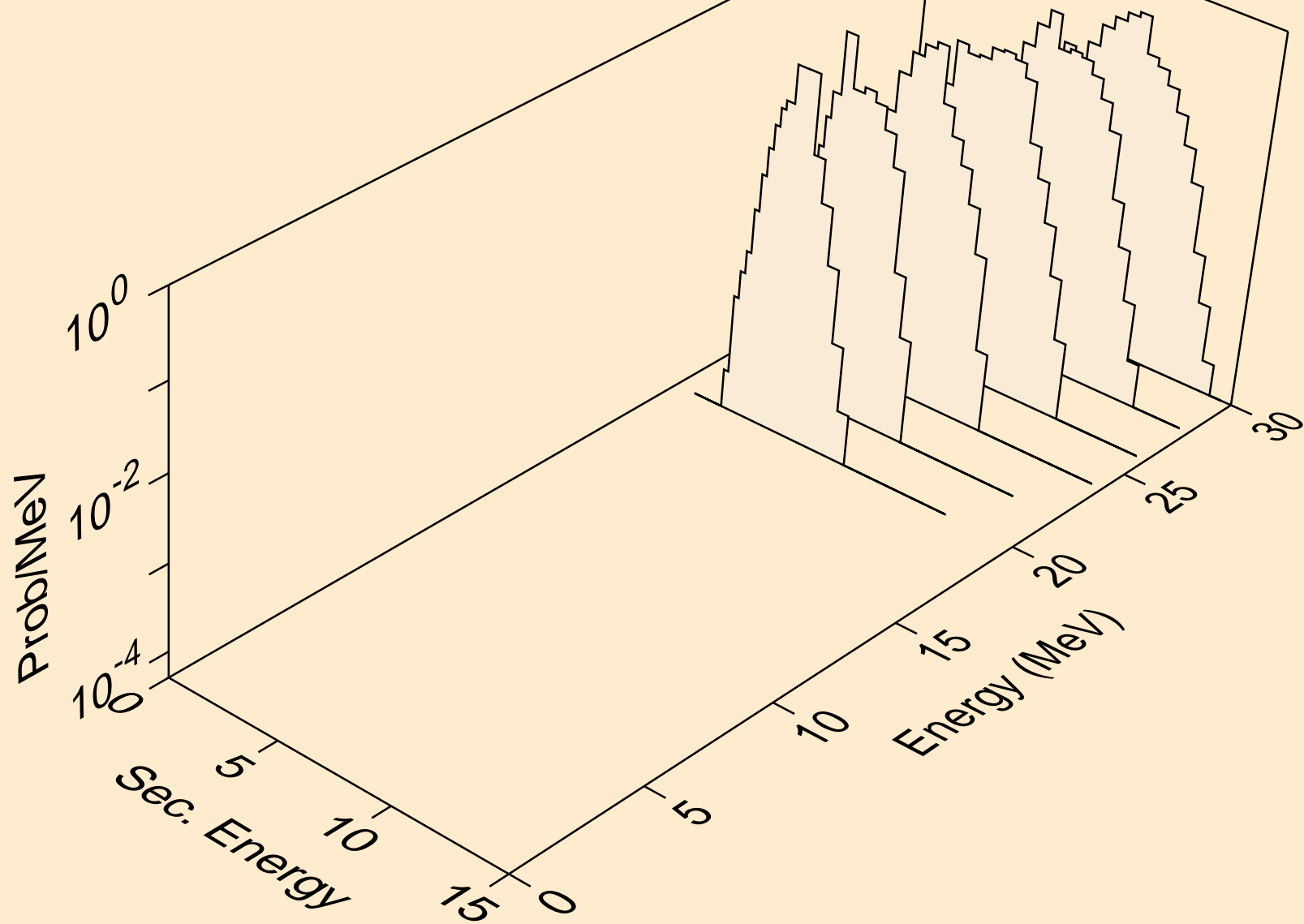

RE169M PHOTON ACER TENDL-2023 LIBRARY; T=0.K
deuterons from (g,pd)

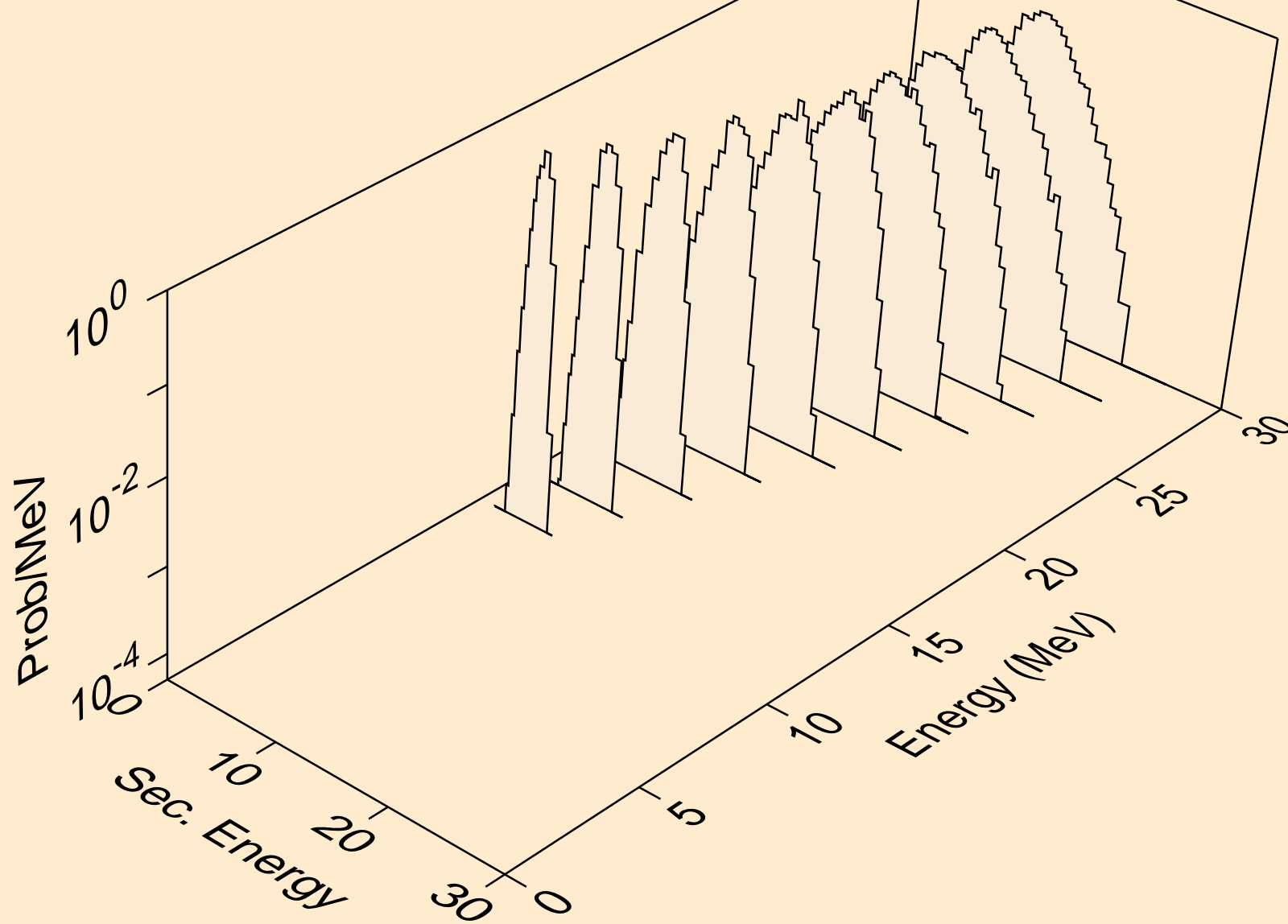

RE169M PHOTON ACER TENDL-2023 LIBRARY; T=0.K
tritons from (g,x)

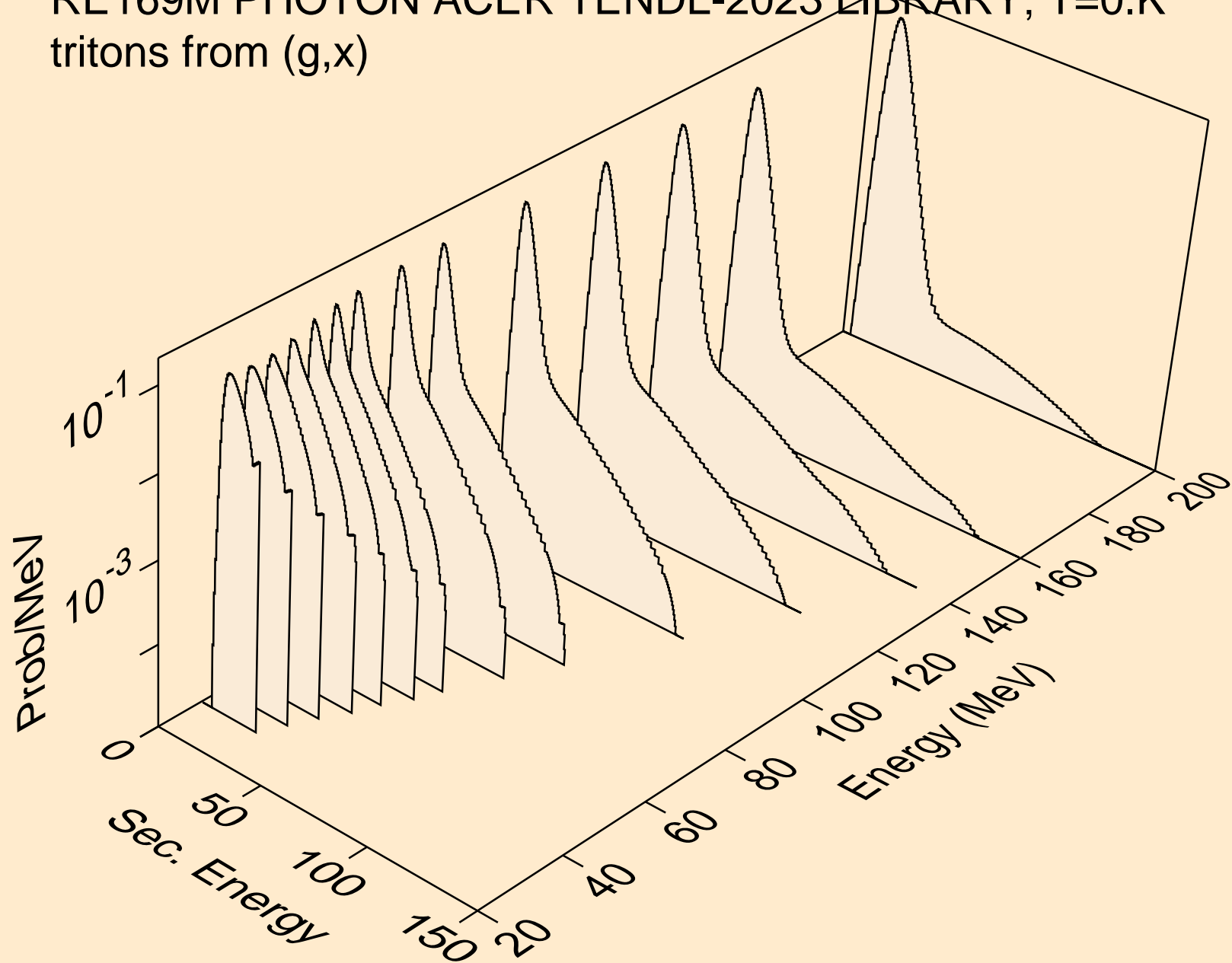

RE169M PHOTON ACER TENDL-2023 LIBRARY; T=0.K
tritons from (g,n*)t

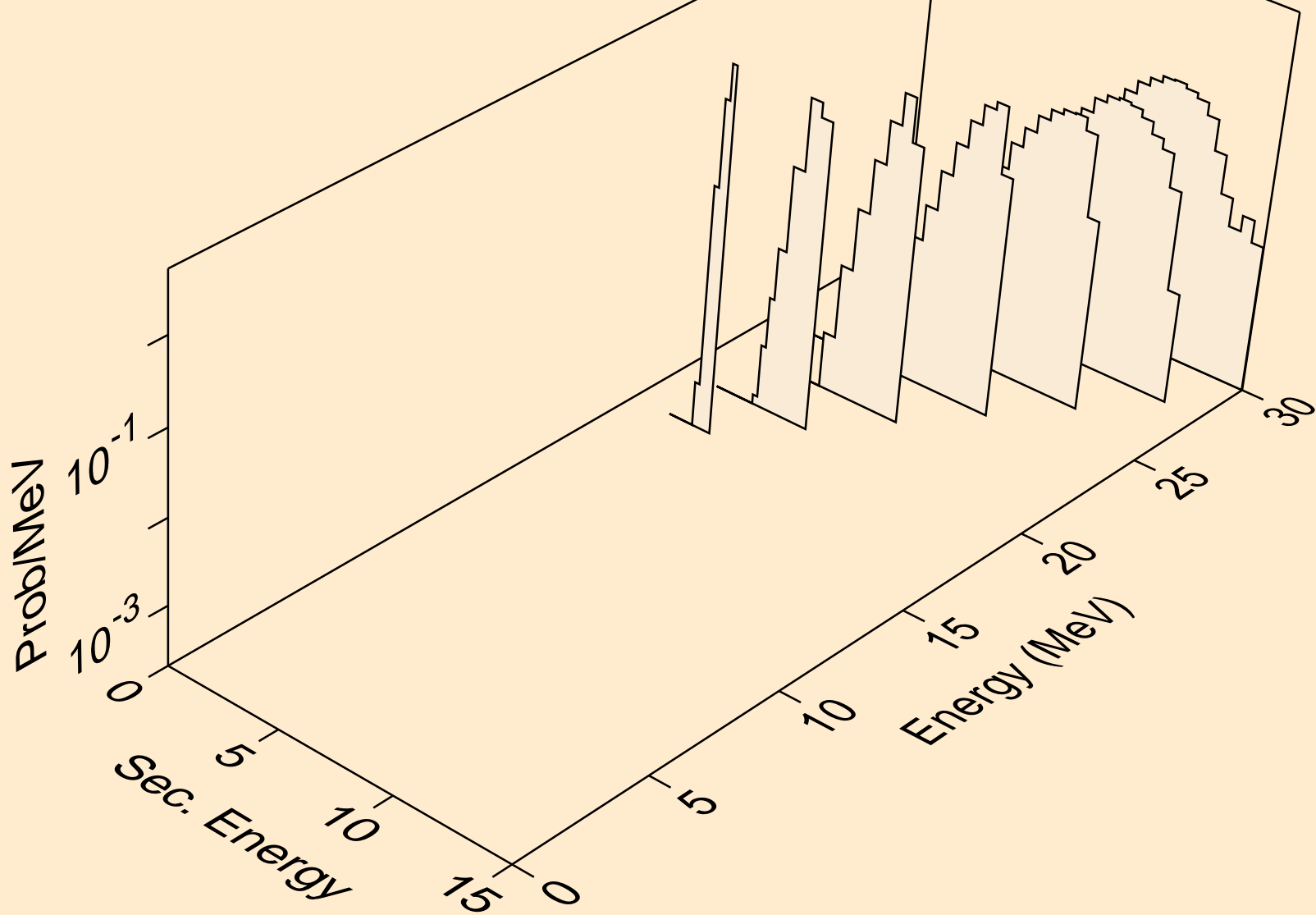

RE169M PHOTON ACER TENDL-2023 LIBRARY; T=0.K
tritons from (g,t)

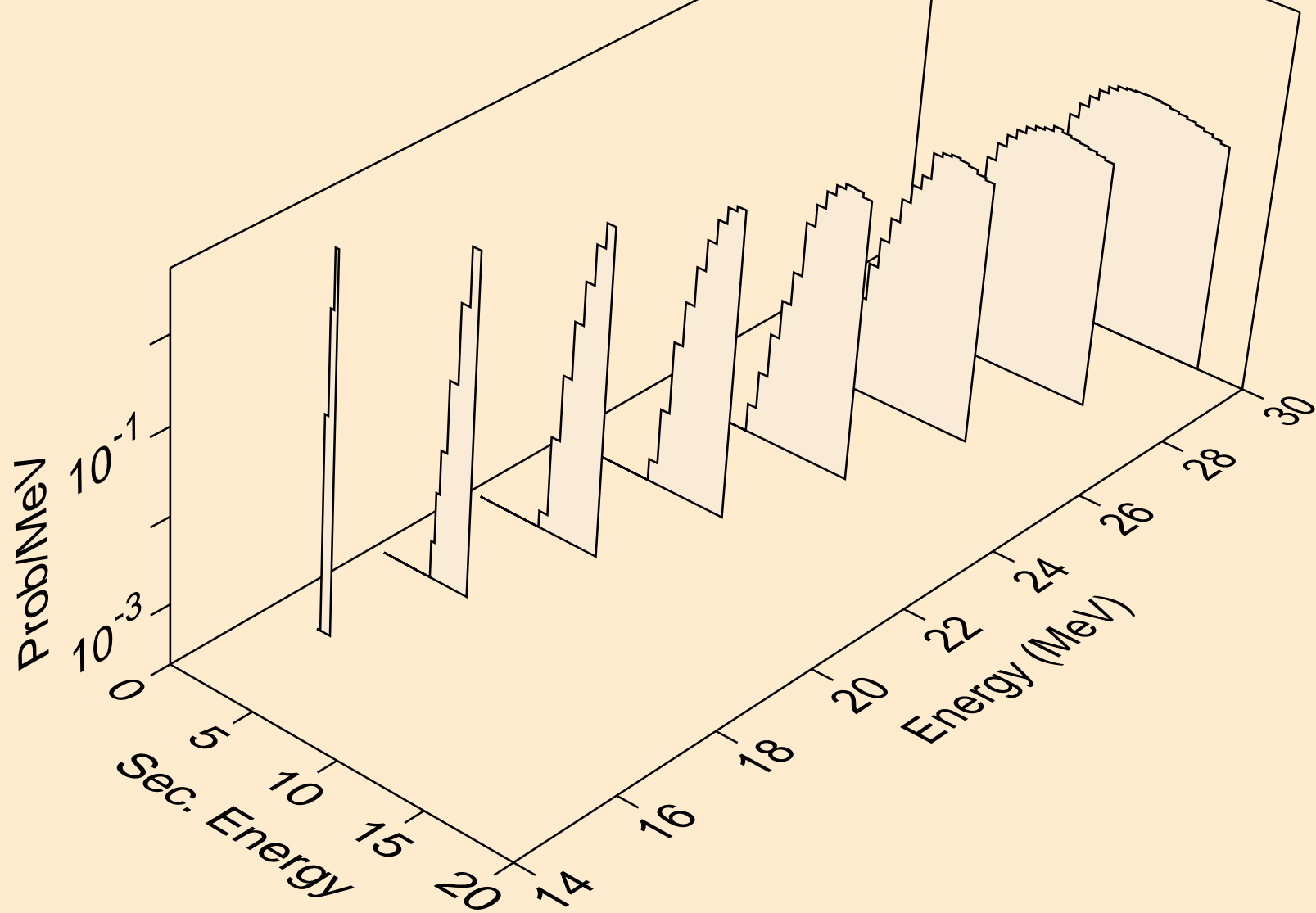

RE169M PHOTON ACER TENDL-2023 LIBRARY; T=0.K
tritons from (g,pt)

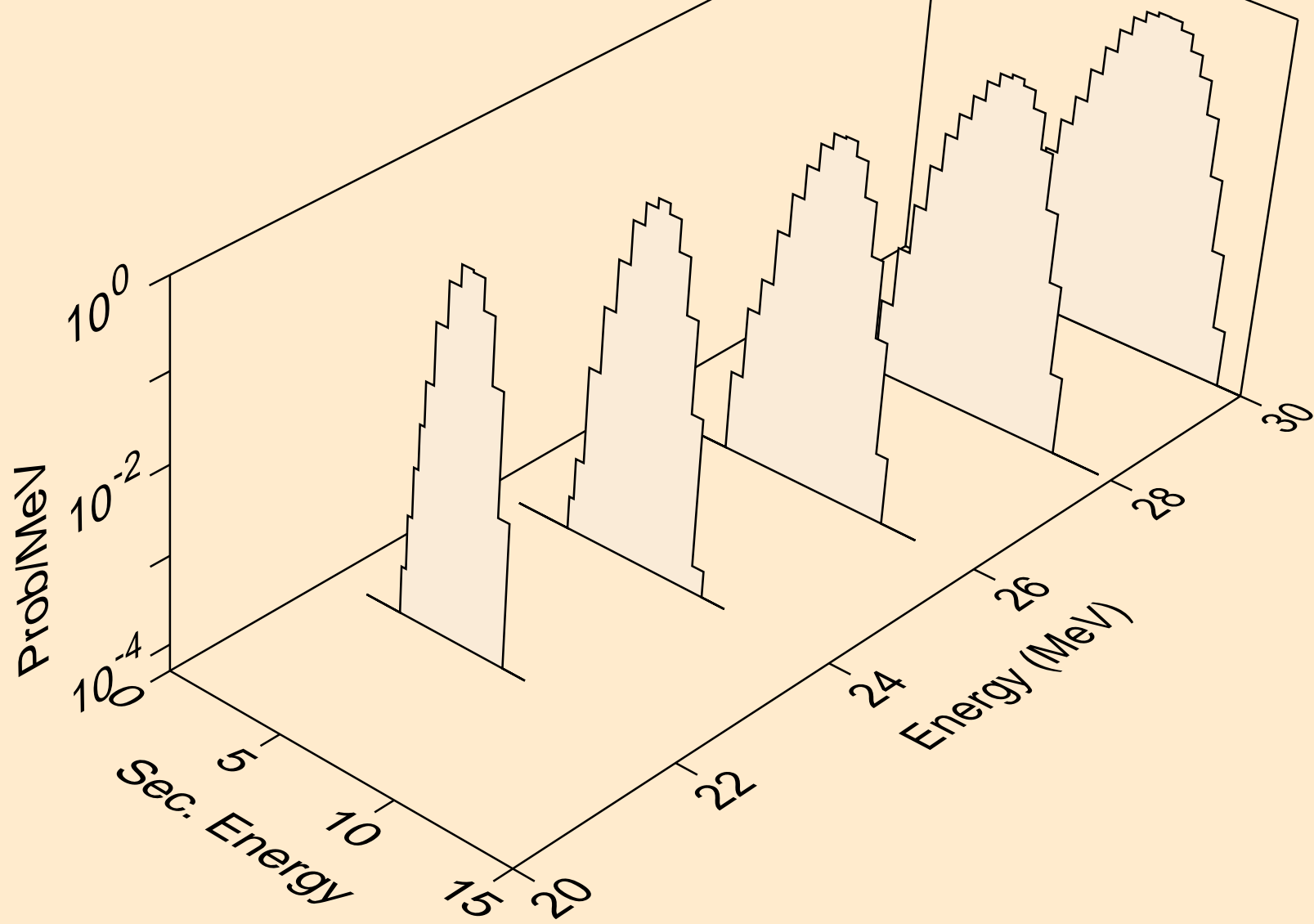

RE169M PHOTON ACER TENDL-2023 LIBRARY; T=0.K
he3s from (g,x)

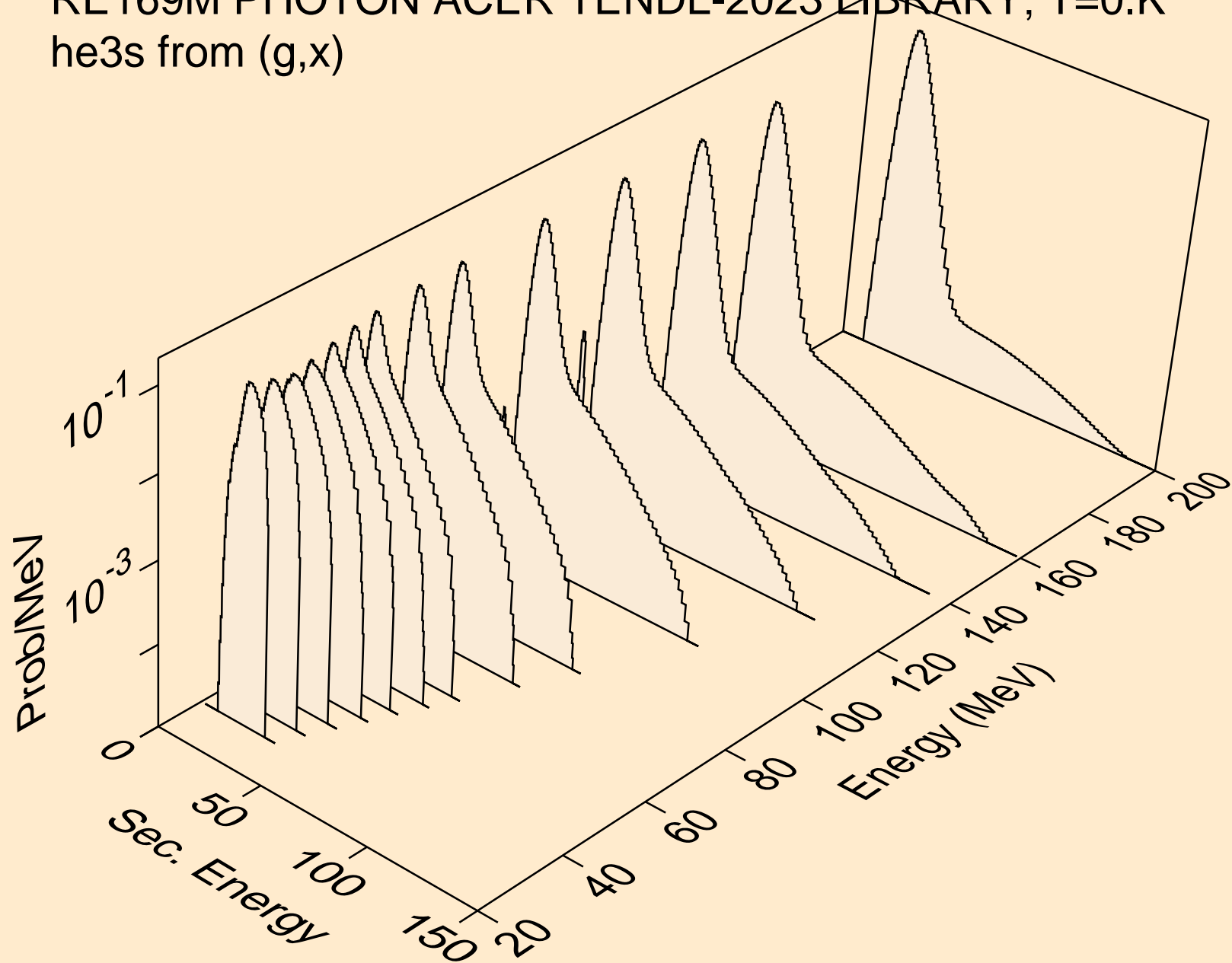

RE169M PHOTON ACER TENDL-2023 LIBRARY; T=0.K
he3s from (g,n*)he3

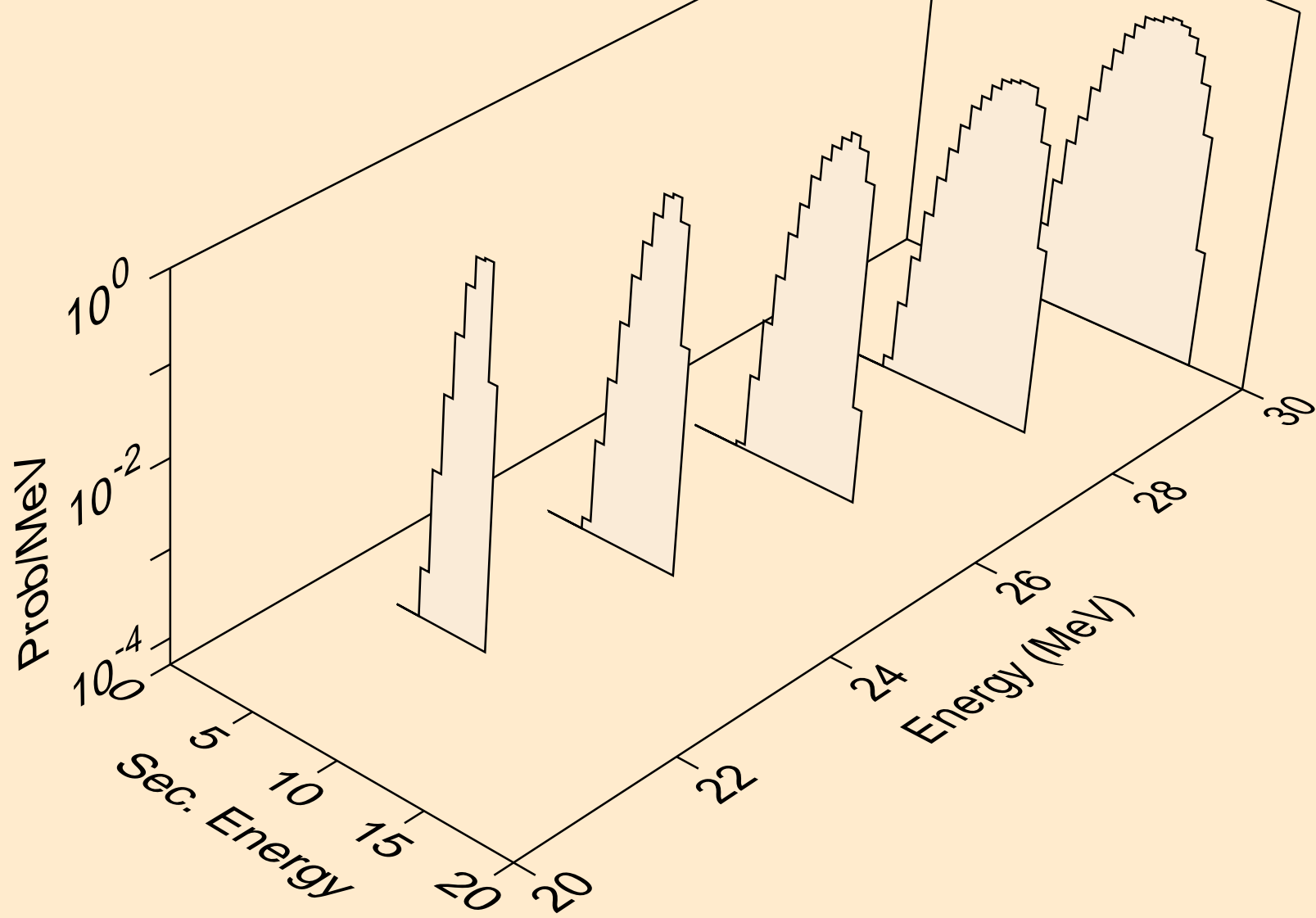

RE169M PHOTON ACER TENDL-2023 LIBRARY; T=0.K
he3s from (g,he3)

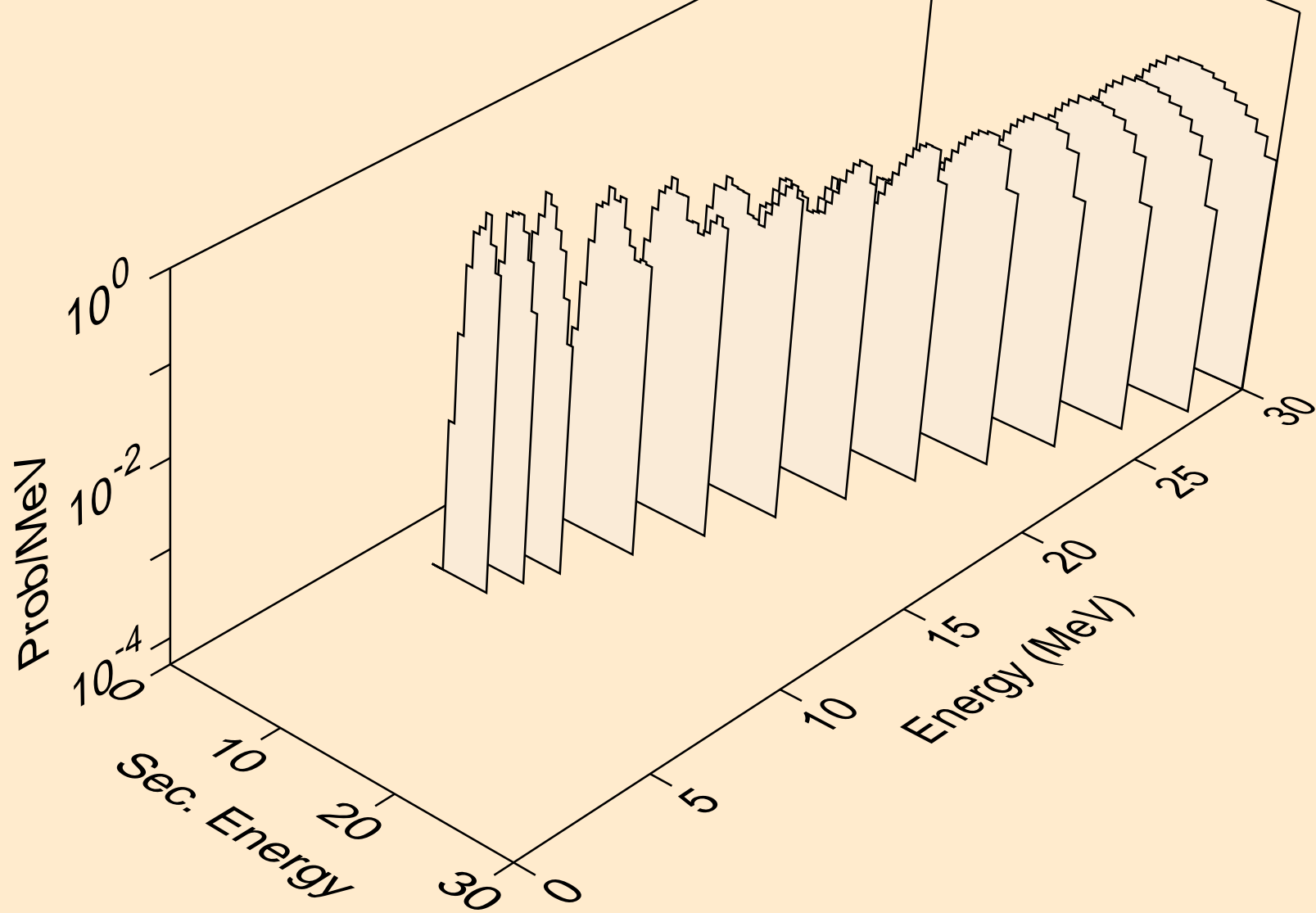

RE169M PHOTON ACER TENDL-2023 LIBRARY; T=0.K
alphas from (g,x)

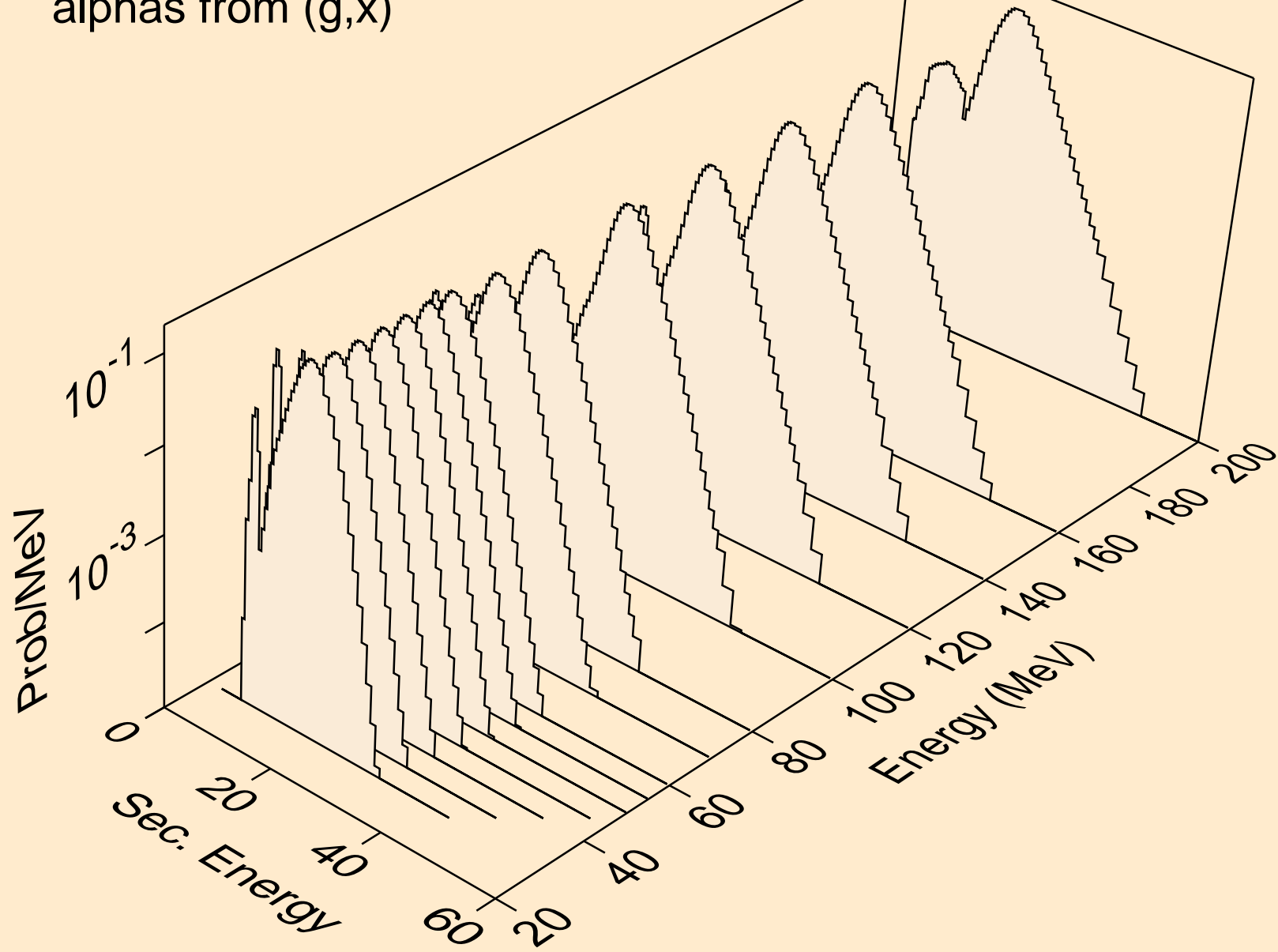

RE169M PHOTON ACER TENDL-2023 LIBRARY; T=0.K
alphas from (g,n*)a

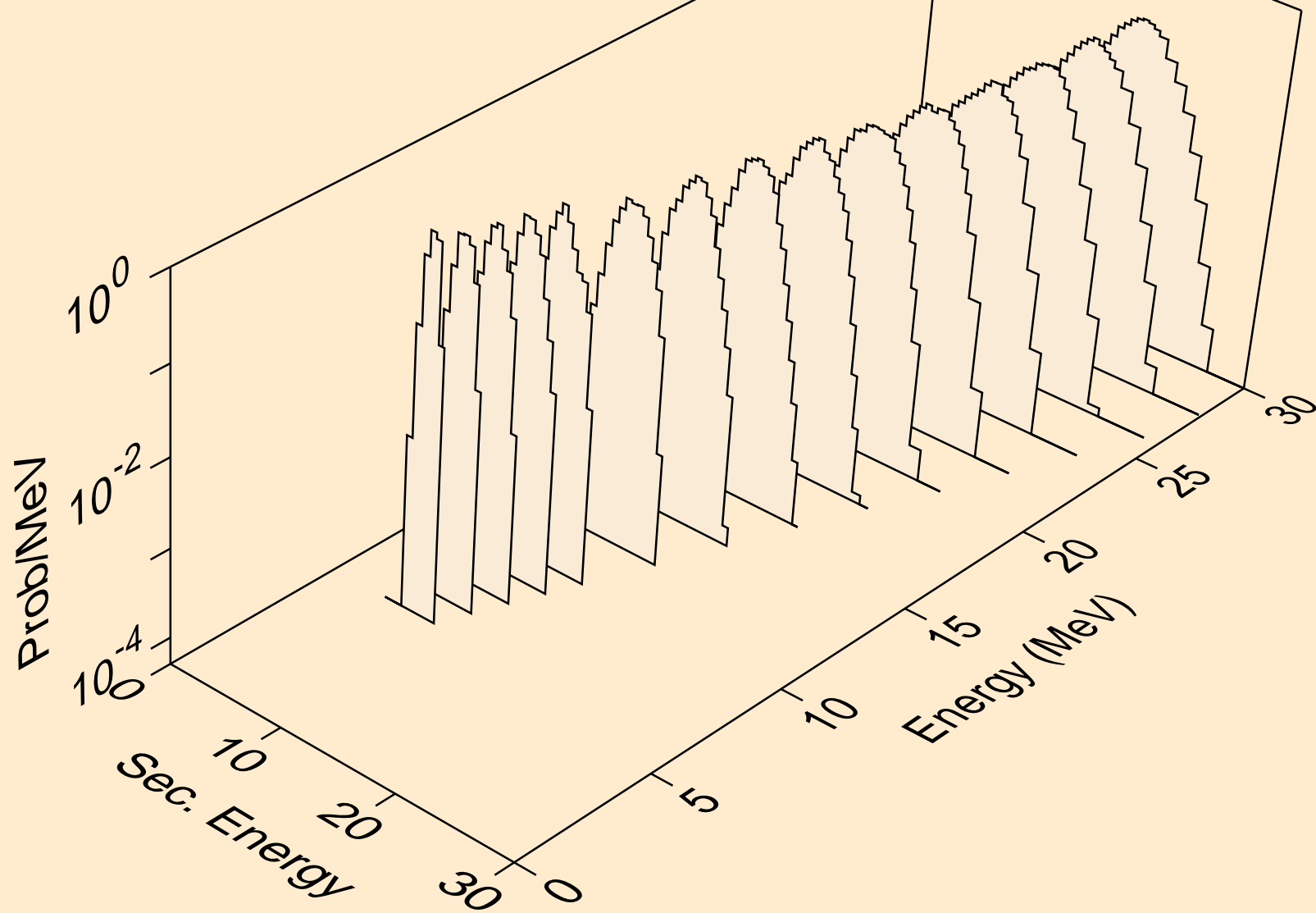

RE169M PHOTON ACER TENDL-2023 LIBRARY; T=0.K
alphas from (g,2n)a

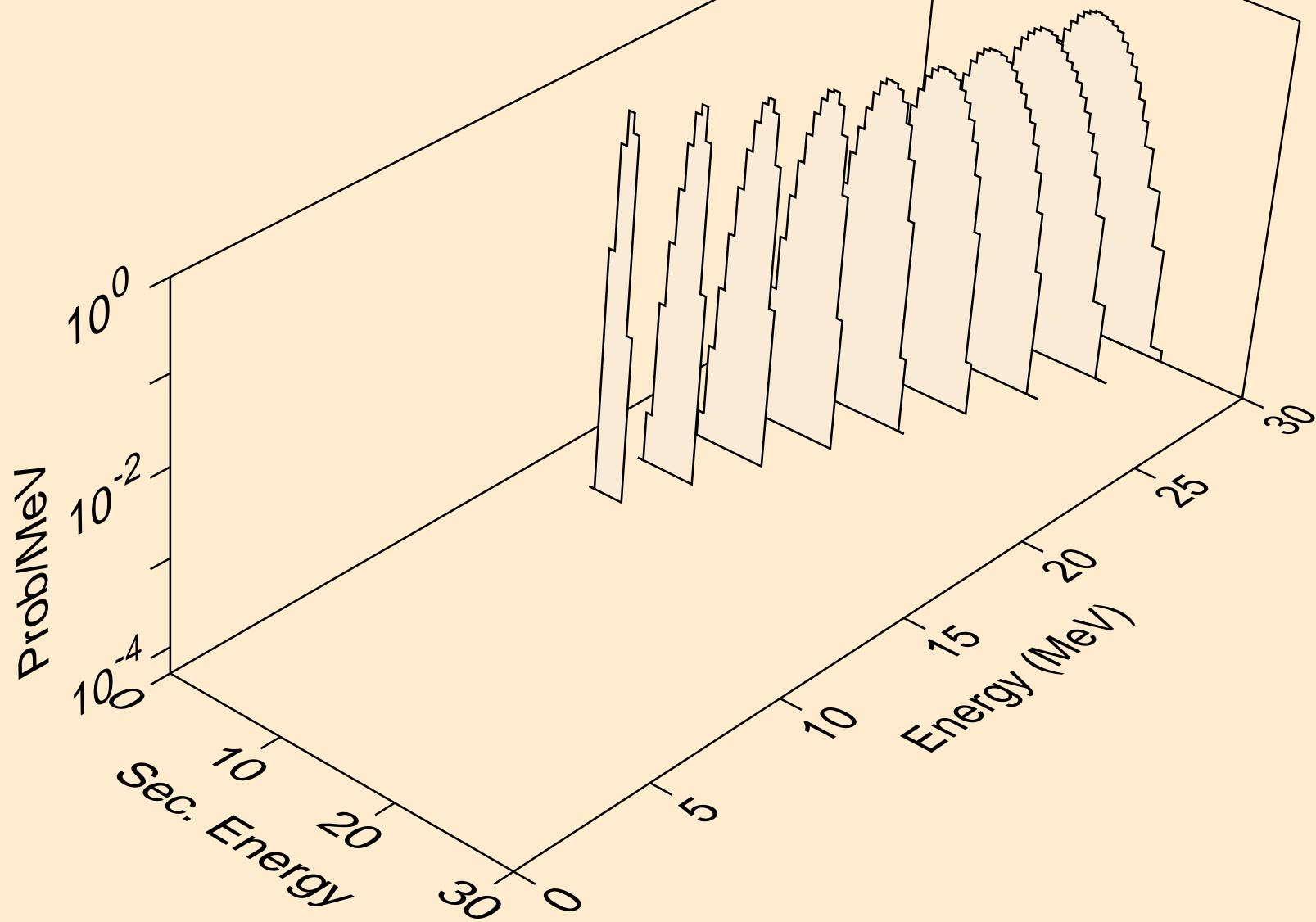

RE169M PHOTON ACER TENDL-2023 LIBRARY; T=0.K
alphas from (g,3n)a

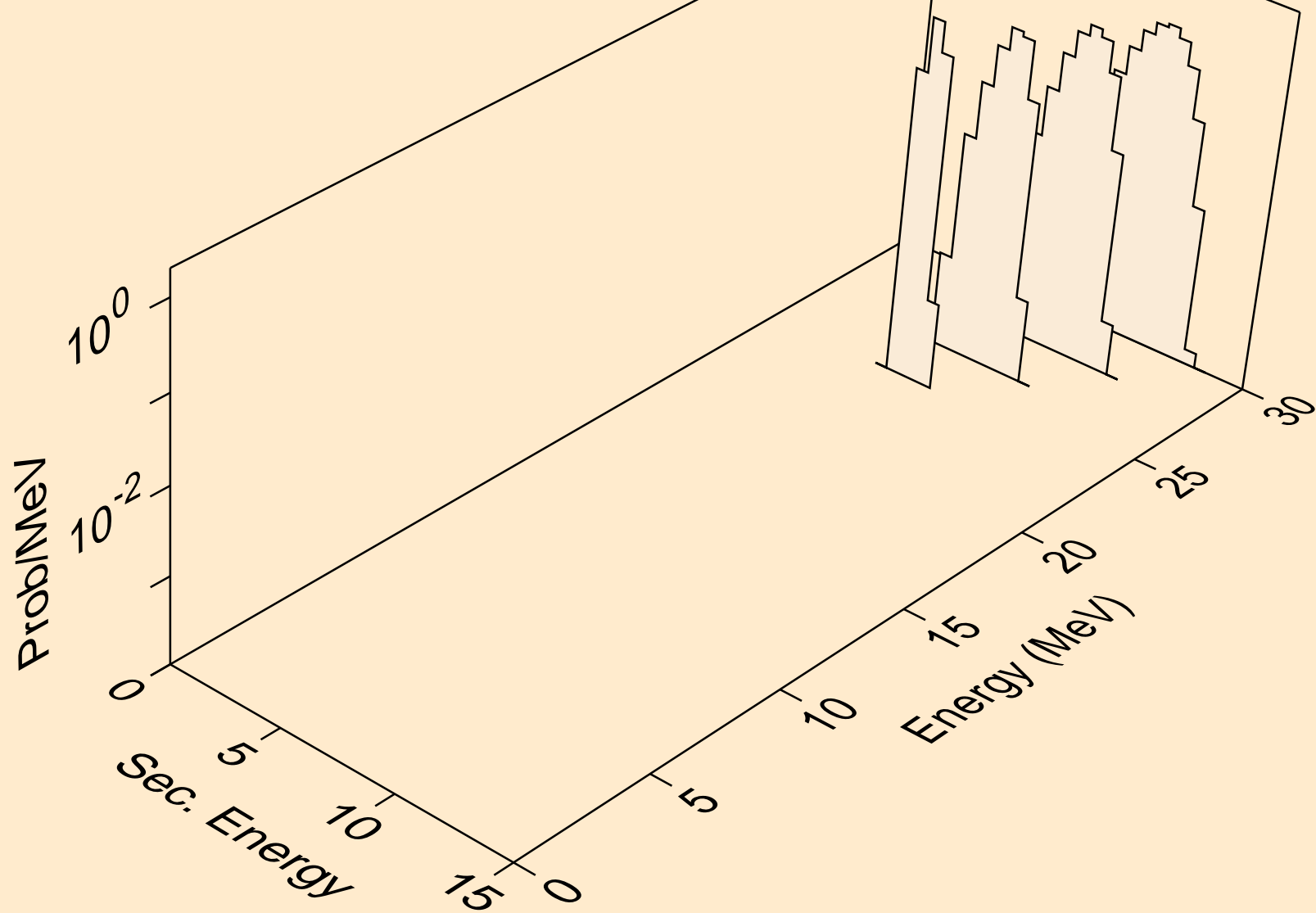

RE169M PHOTON ACER TENDL-2023 LIBRARY; T=0.K
alphas from (g,n*)2a

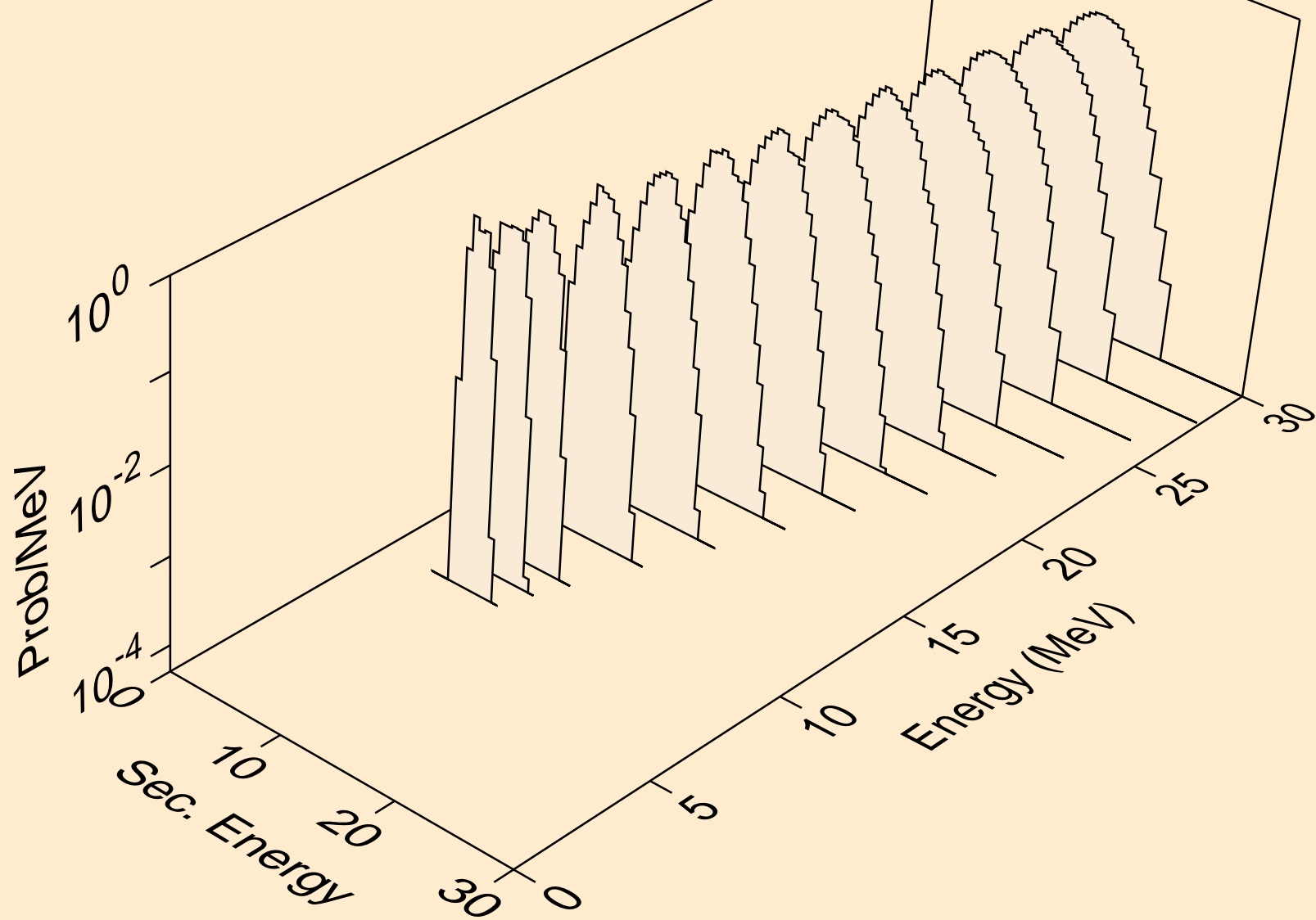

RE169M PHOTON ACER TENDL-2023 LIBRARY; T=0.K
alphas from (g,2n)2a

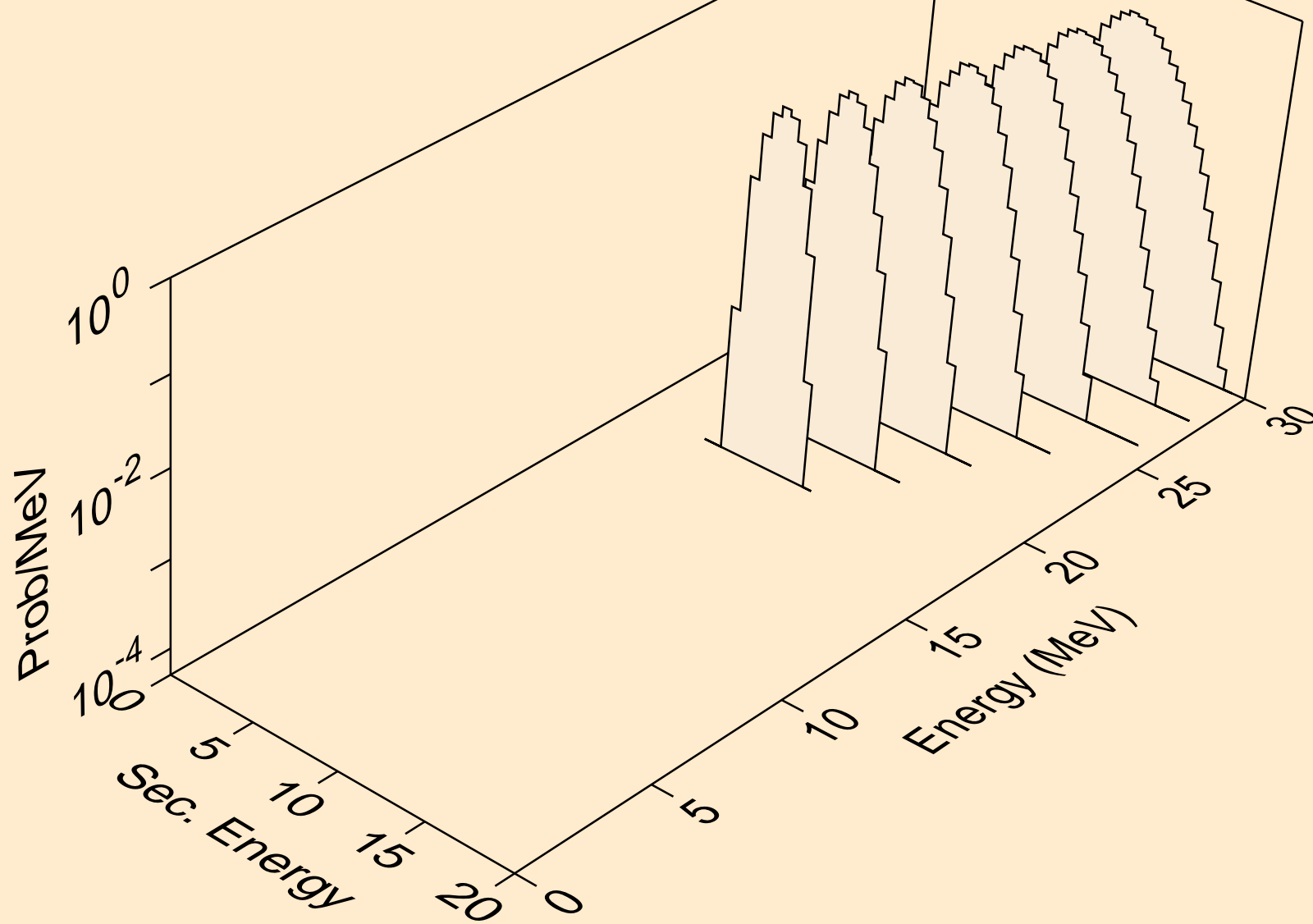

RE169M PHOTON ACER TENDL-2023 LIBRARY; T=0.K
alphas from (g,a)

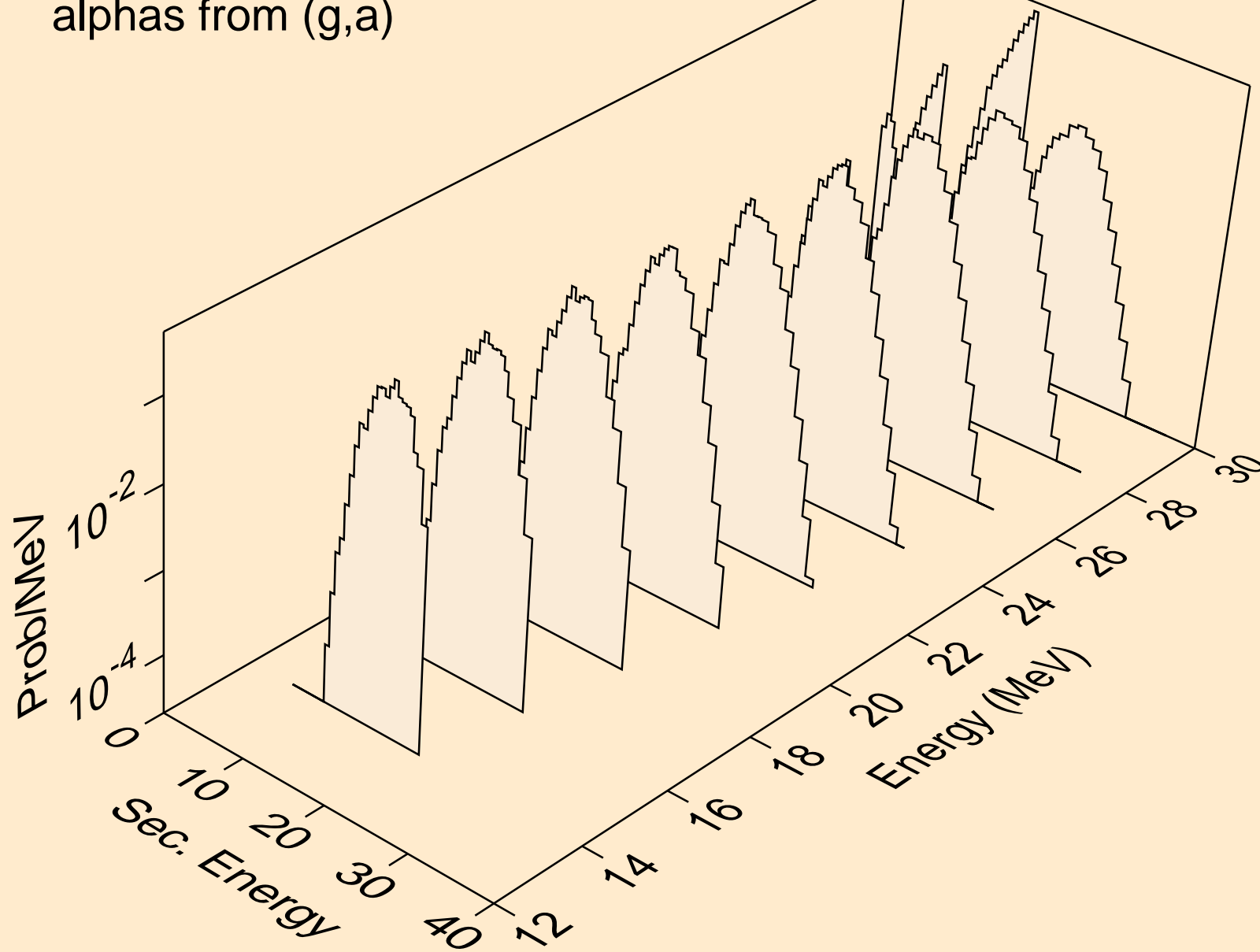

RE169M PHOTON ACER TENDL-2023 LIBRARY; T=0.K
alphas from (g,2a)

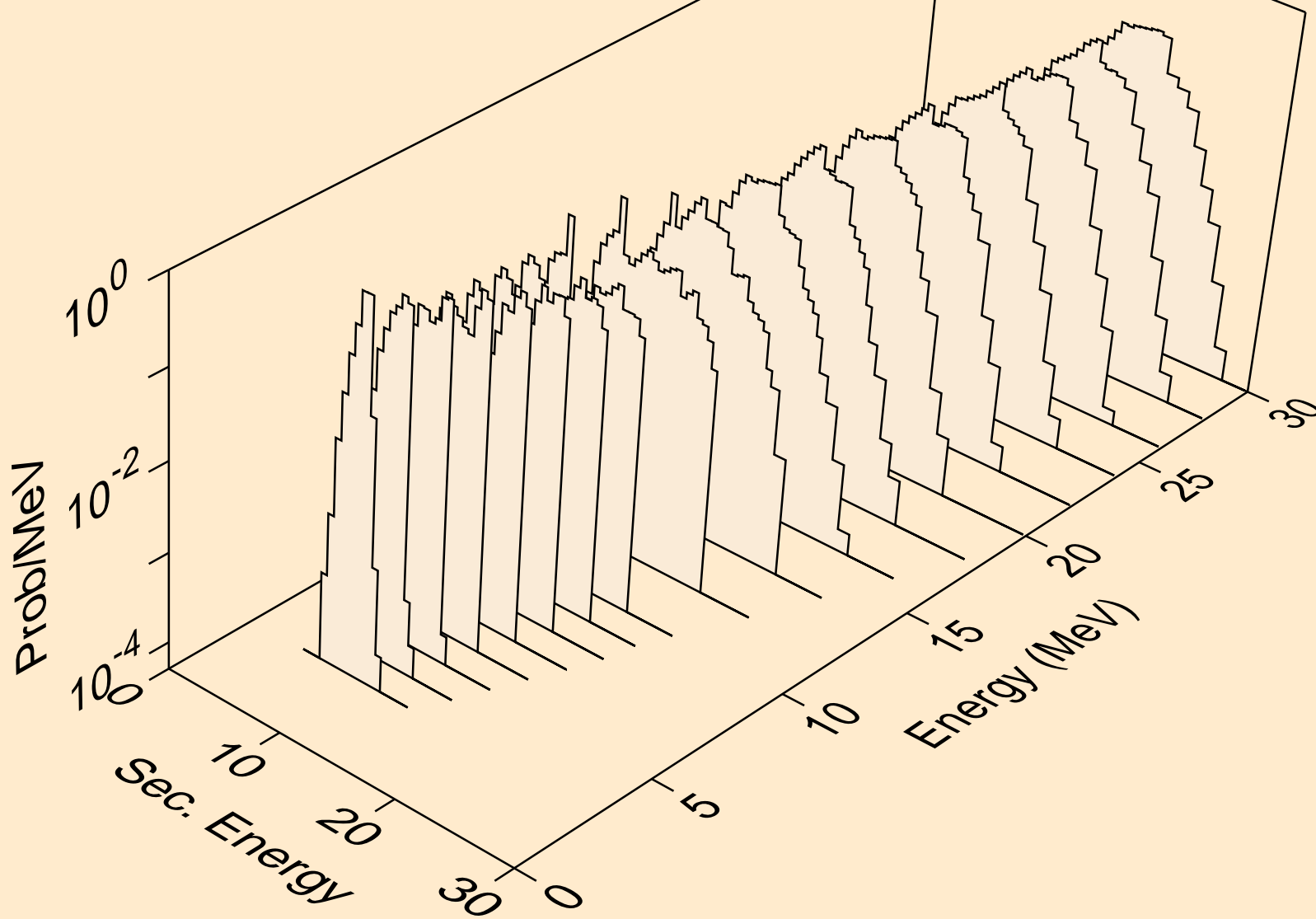

RE169M PHOTON ACER TENDL-2023 LIBRARY; T=0.K
alphas from (g,3a)

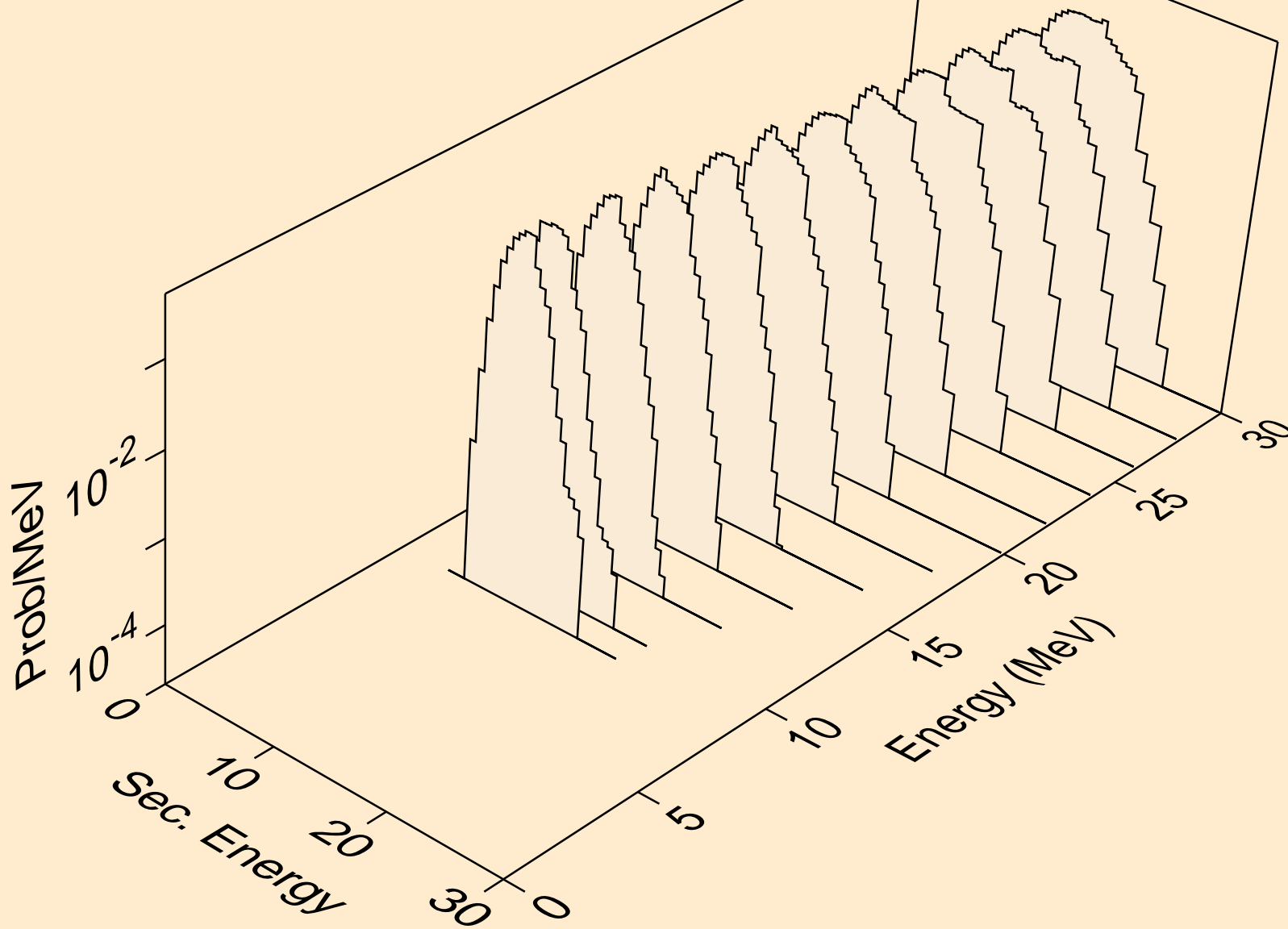

RE169M PHOTON ACER TENDL-2023 LIBRARY; T=0.K
alphas from (g,d2a)

