

BH265 HELION ACER TENDL-2023 LIBRARY; T=0.K  
Principal cross sections

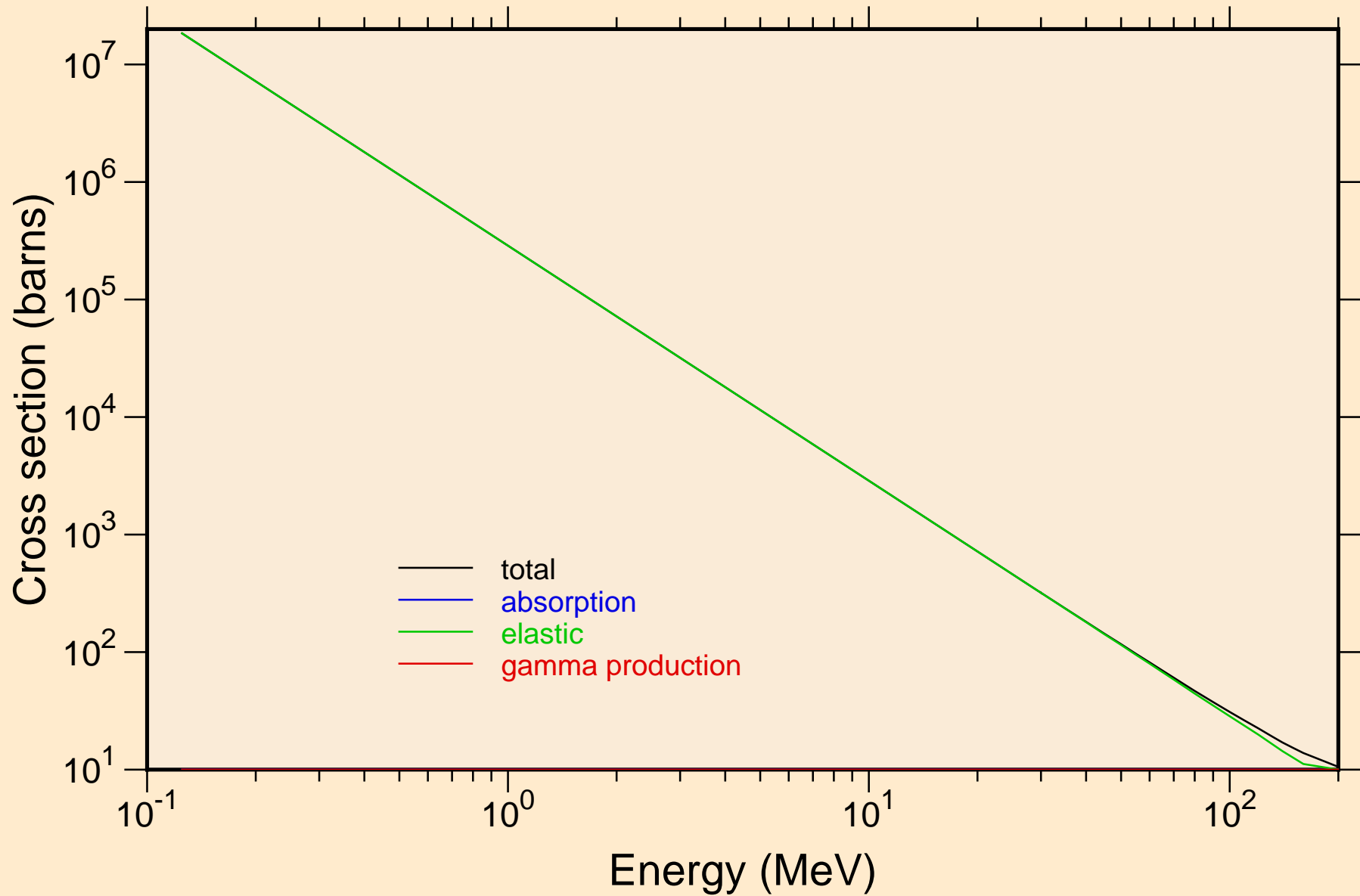

BH265 HELION ACER TENDL-2023 LIBRARY; T=0.K

Heating

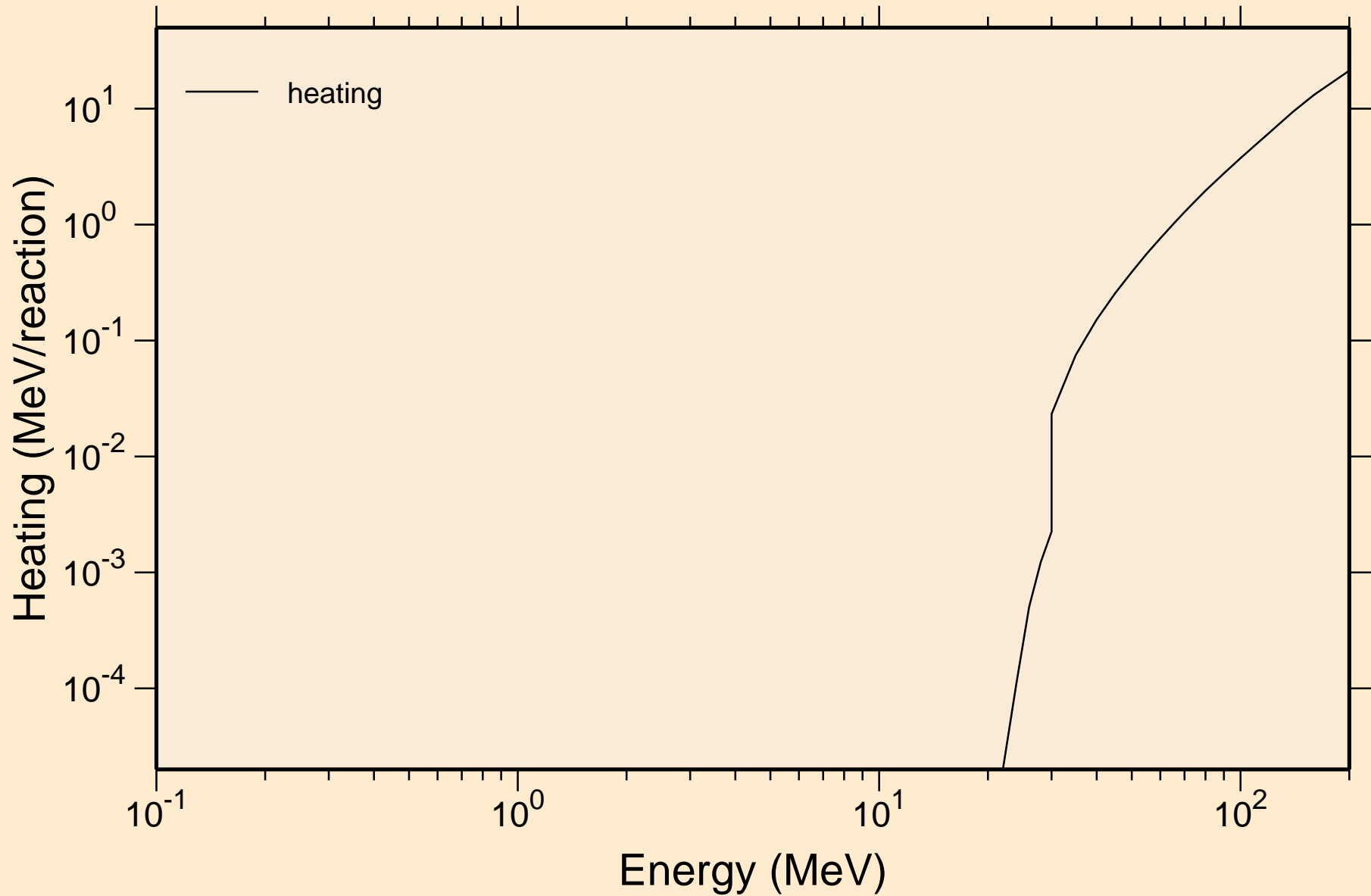

# BH265 HELION ACER TENDL-2023 LIBRARY; T=0.K

## Principal cross sections

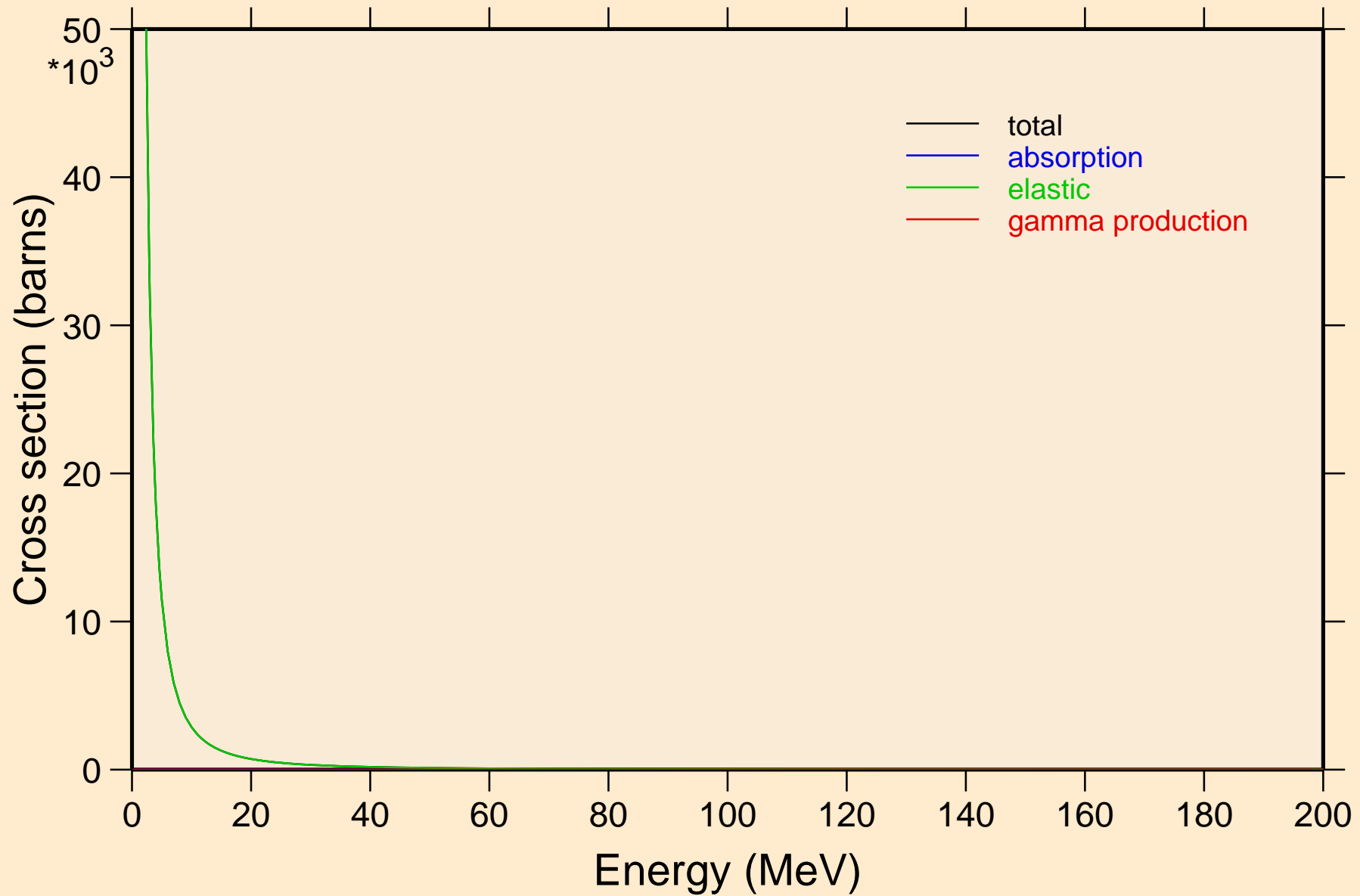

BH265 HELION ACER TENDL-2023 LIBRARY; T=0.K

Heating

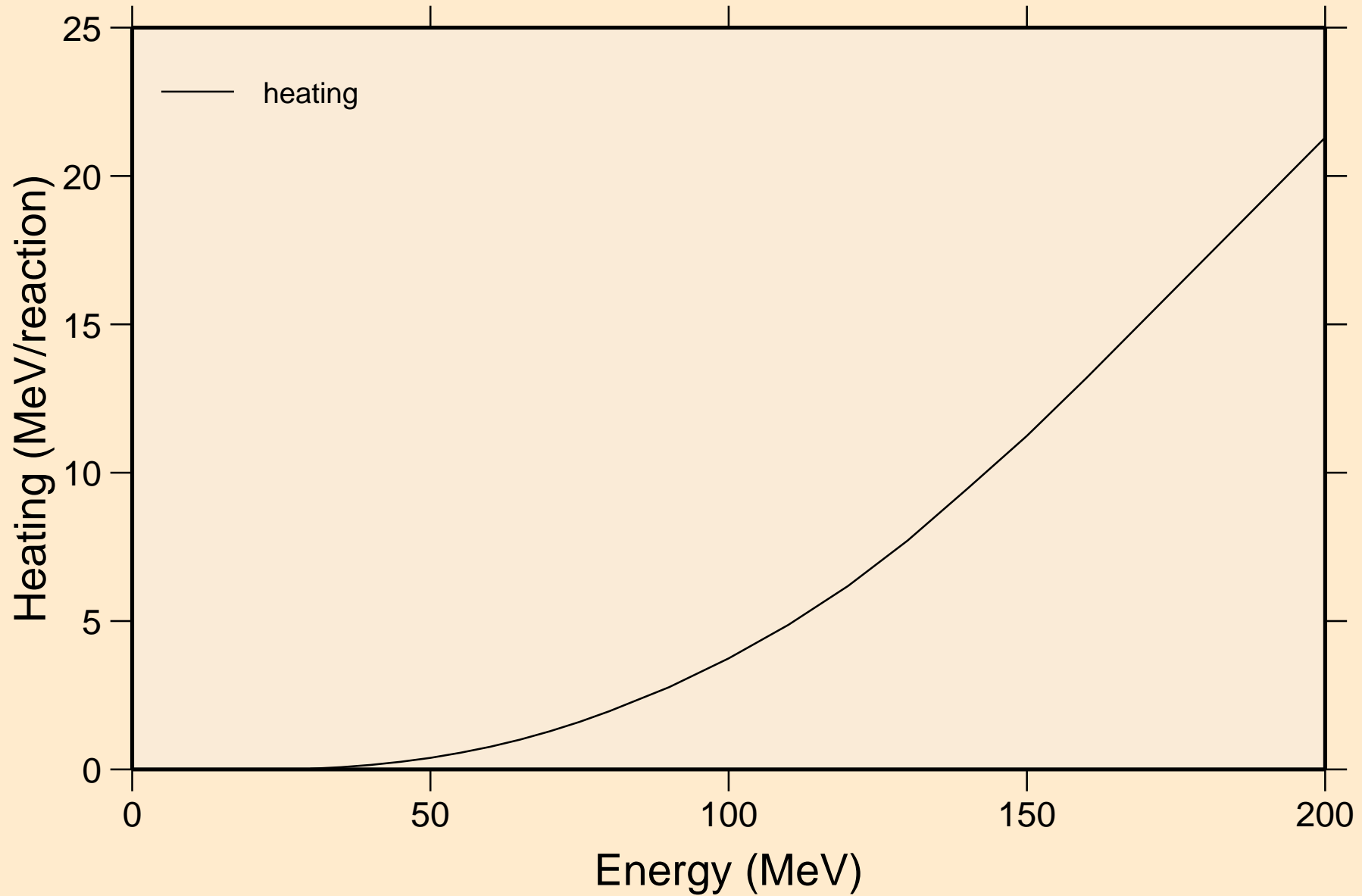

BH265 HELION ACER TENDL-2023 LIBRARY; T=0.K  
Threshold reactions

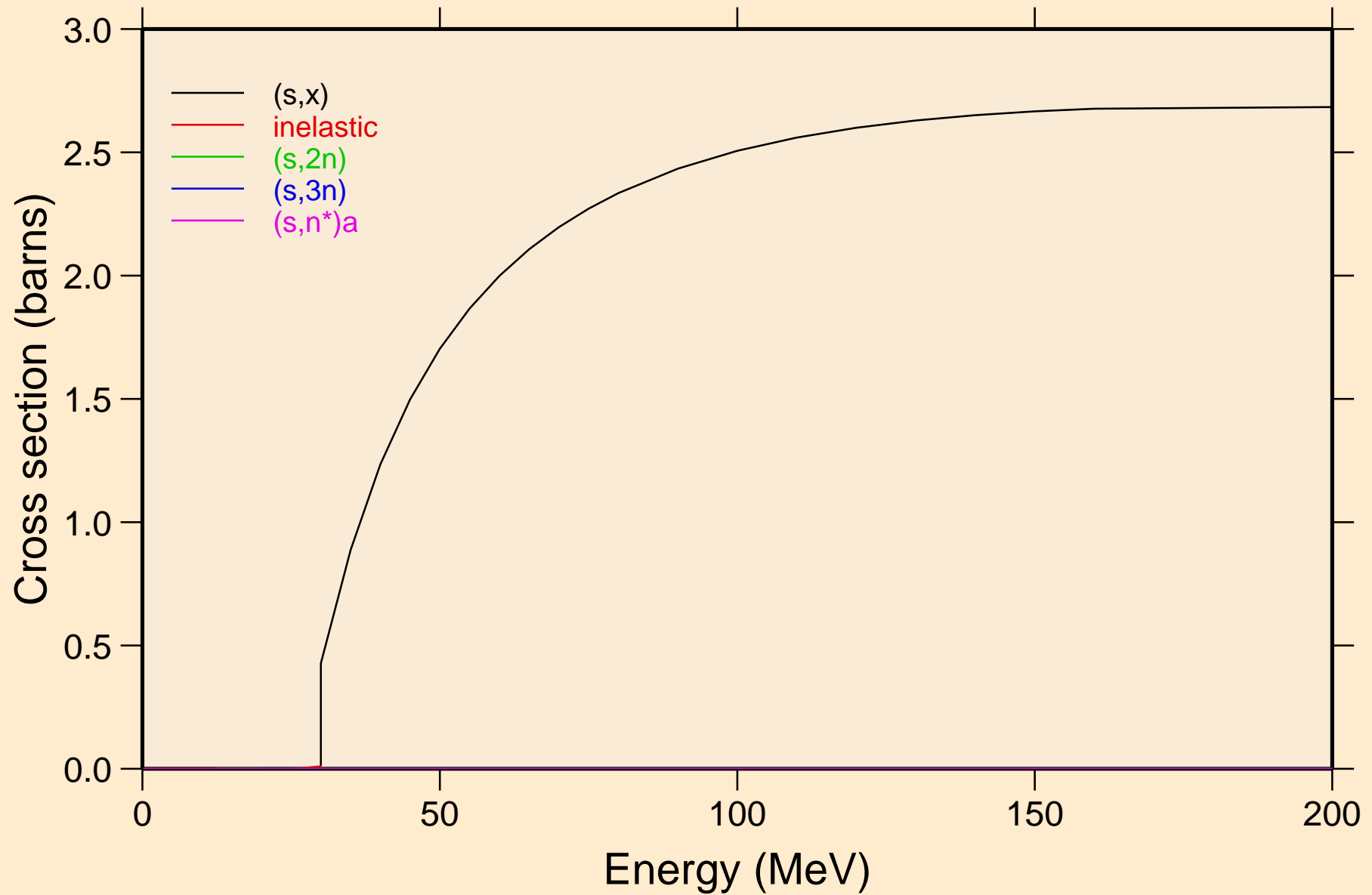

BH265 HELION ACER TENDL-2023 LIBRARY; T=0.K  
Threshold reactions

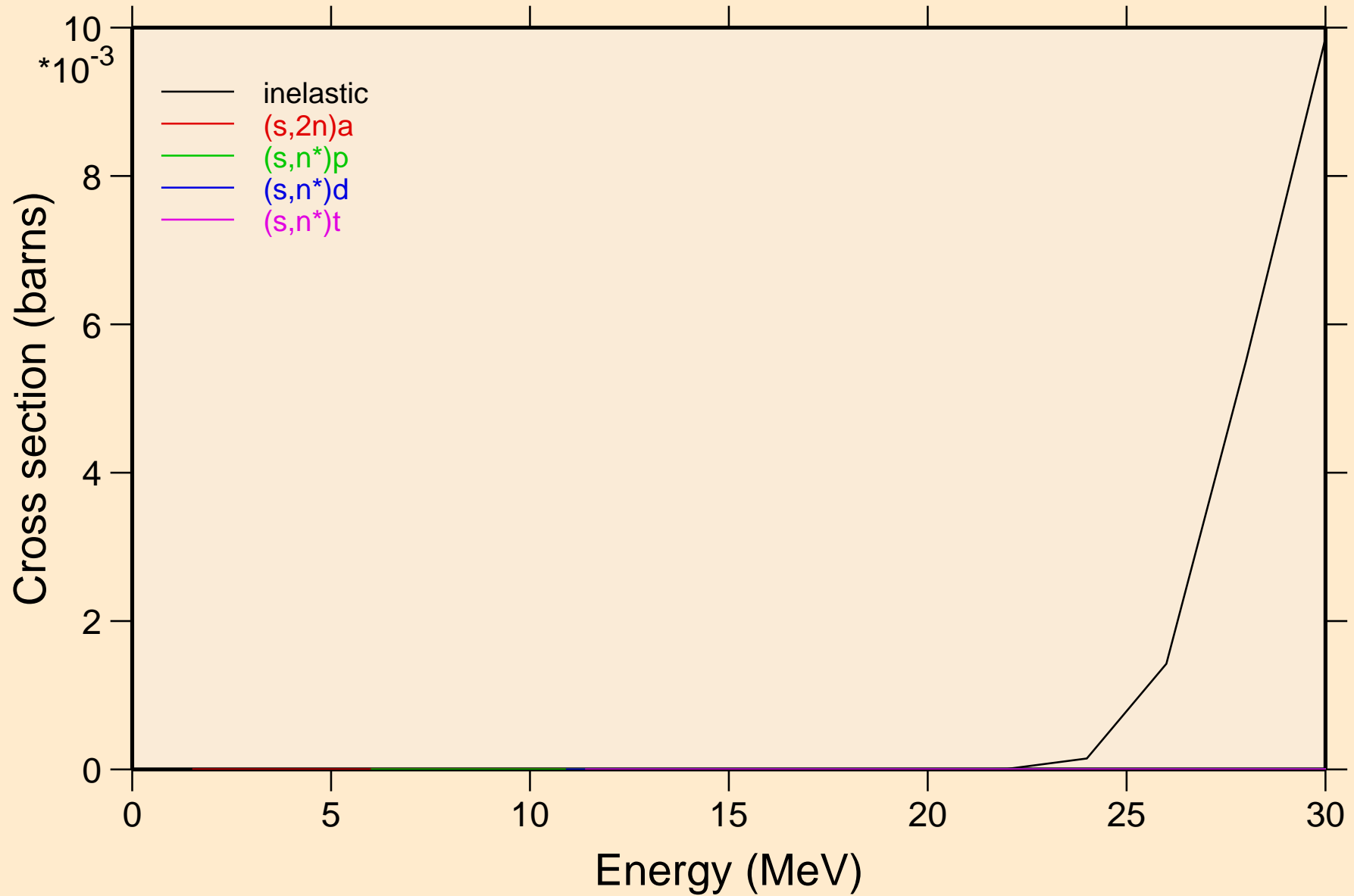

BH265 HELION ACER TENDL-2023 LIBRARY; T=0.K  
Threshold reactions

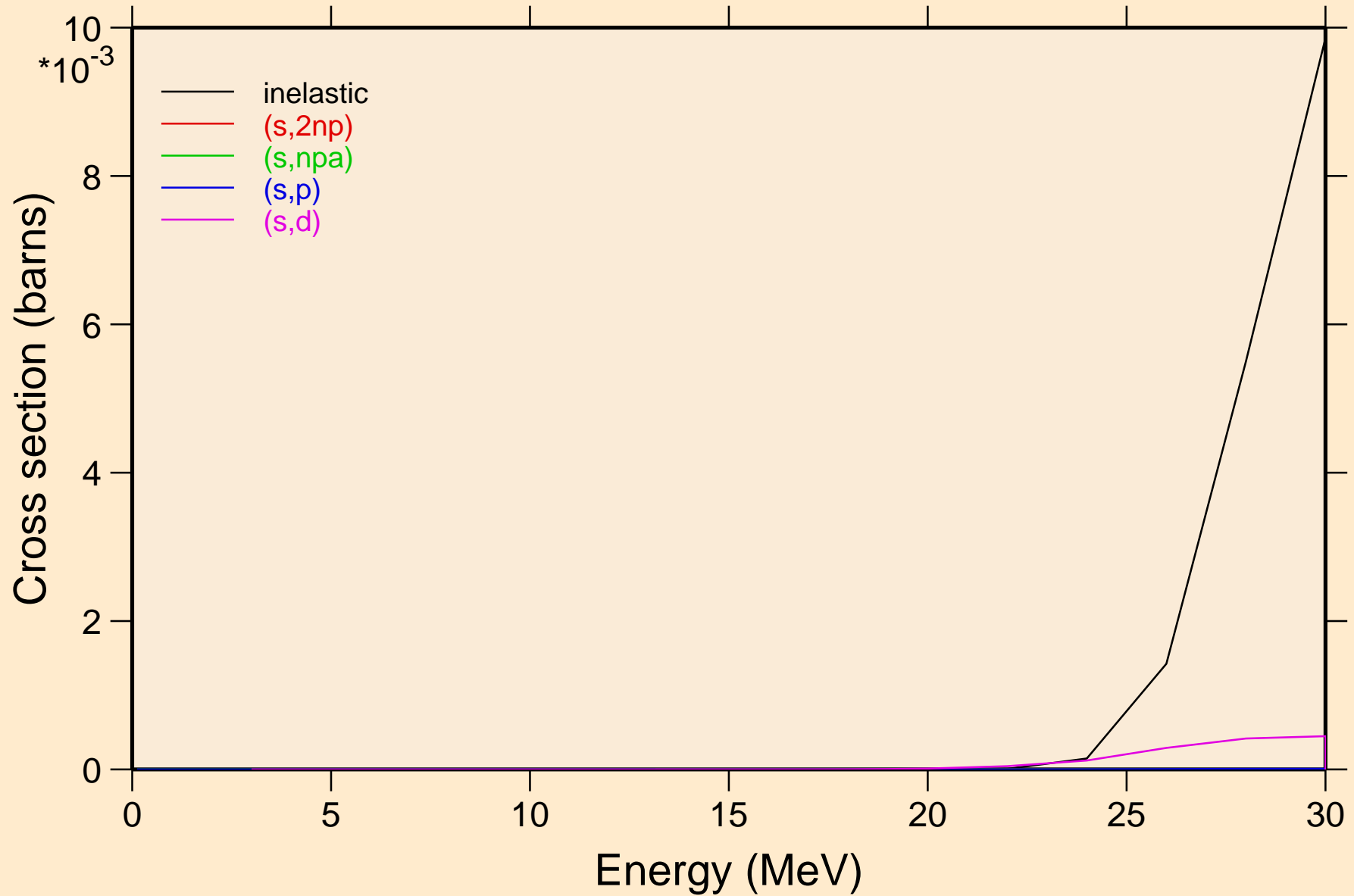

BH265 HELION ACER TENDL-2023 LIBRARY; T=0.K  
Threshold reactions

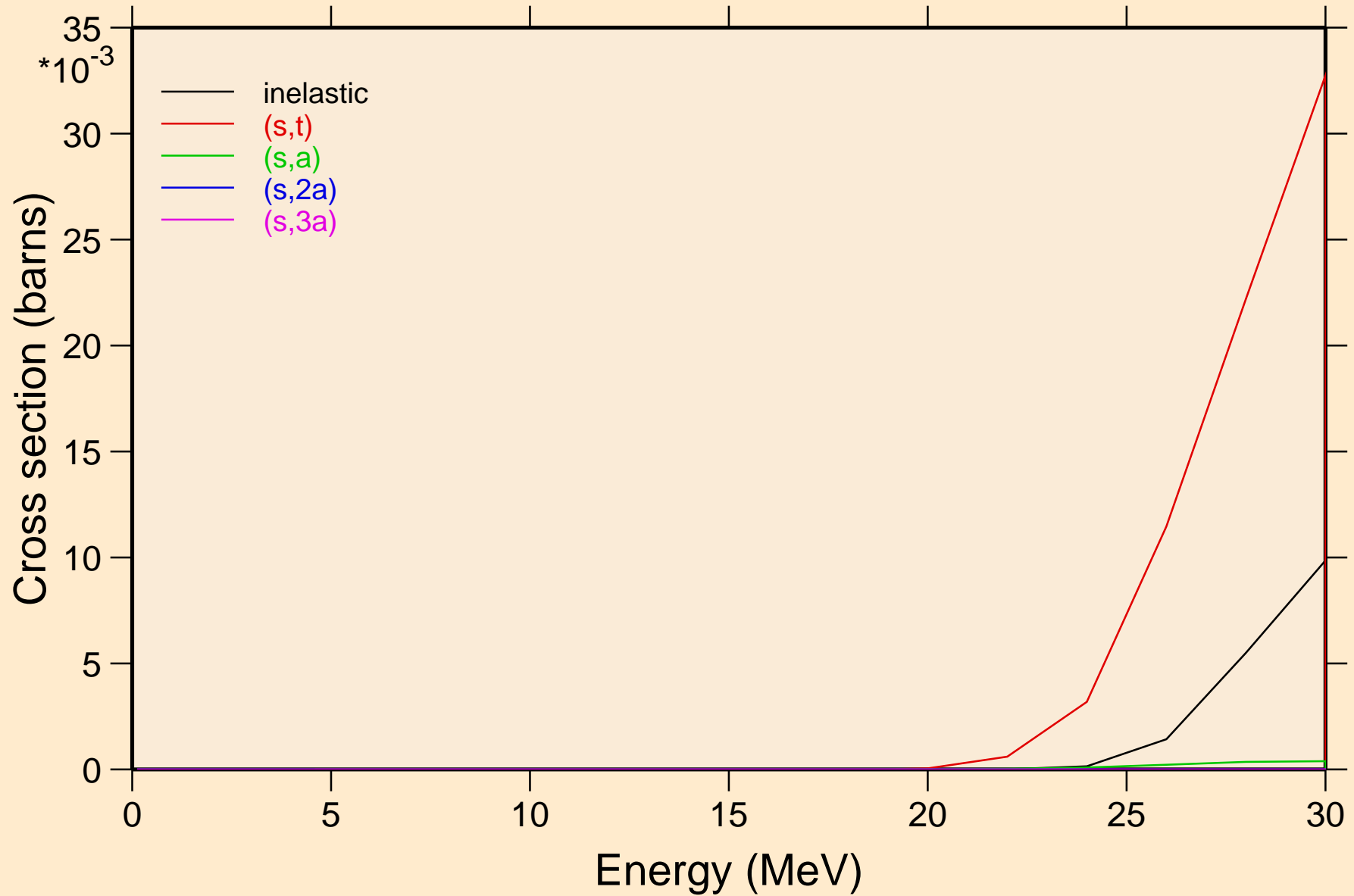

BH265 HELION ACER TENDL-2023 LIBRARY; T=0.K  
Threshold reactions

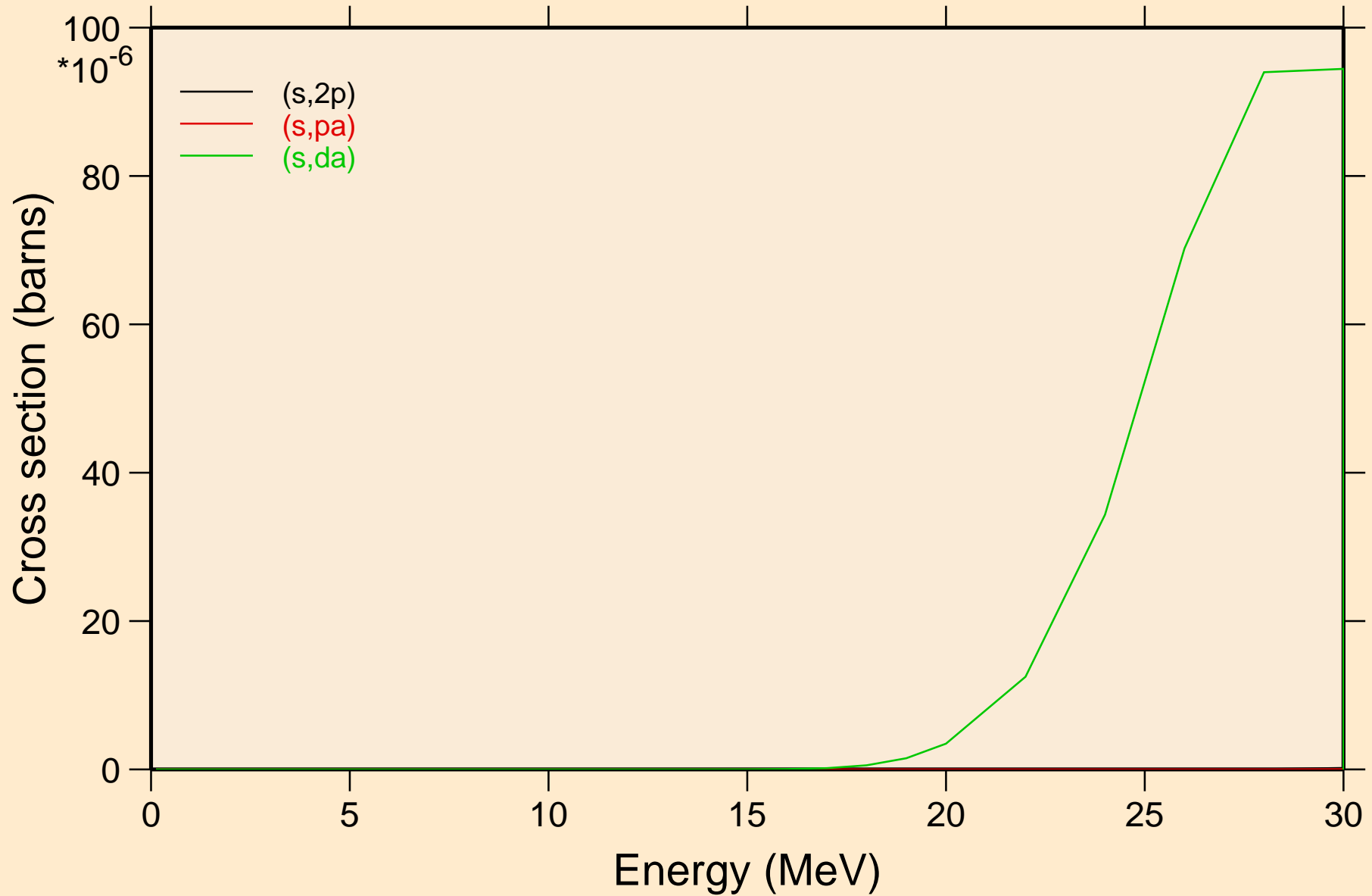

BH265 HELION ACER TENDL-2023 LIBRARY; T=0.K  
angular distribution for elastic

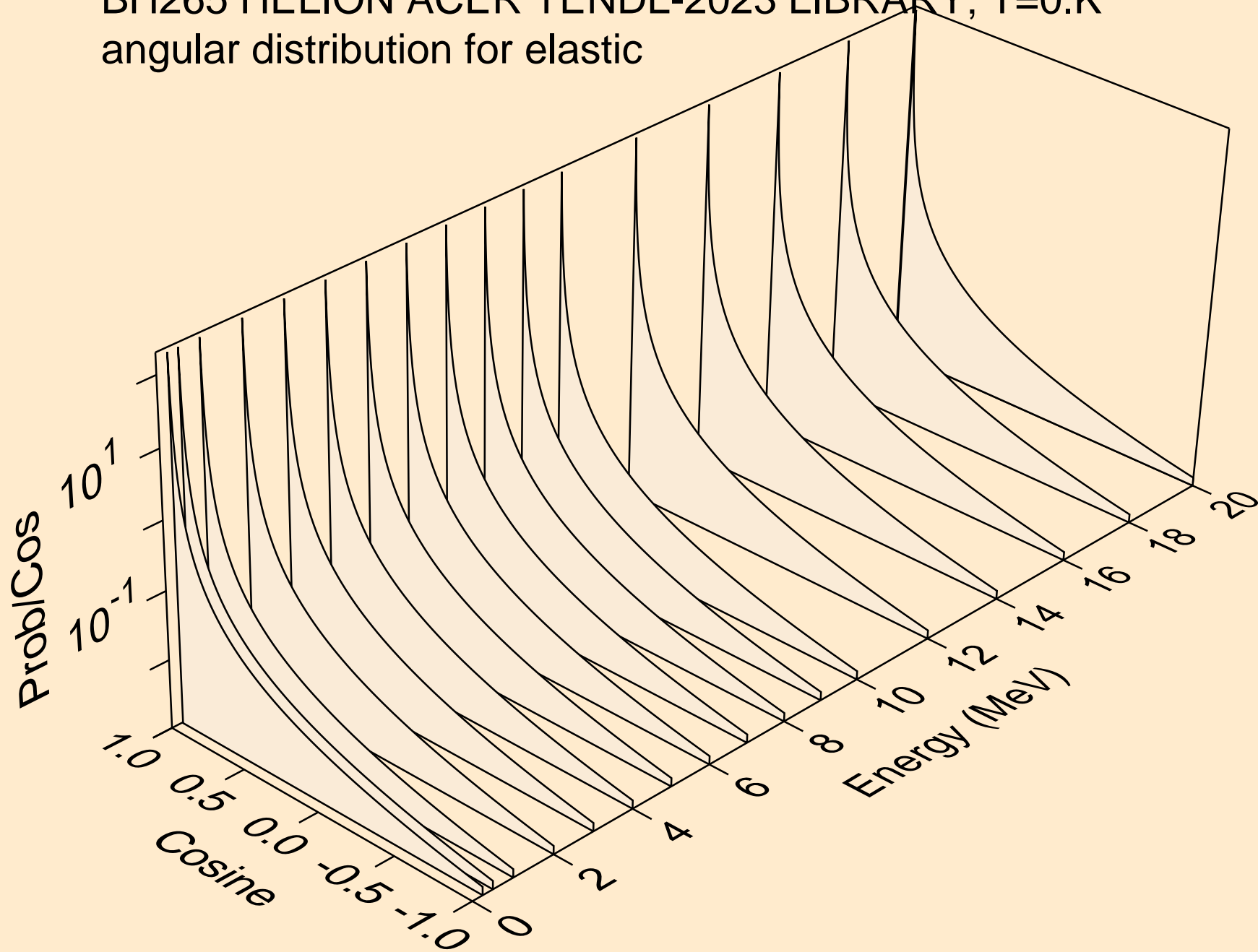

BH265 HELION ACER TENDL-2023 LIBRARY; T=0.K  
angular distribution for elastic

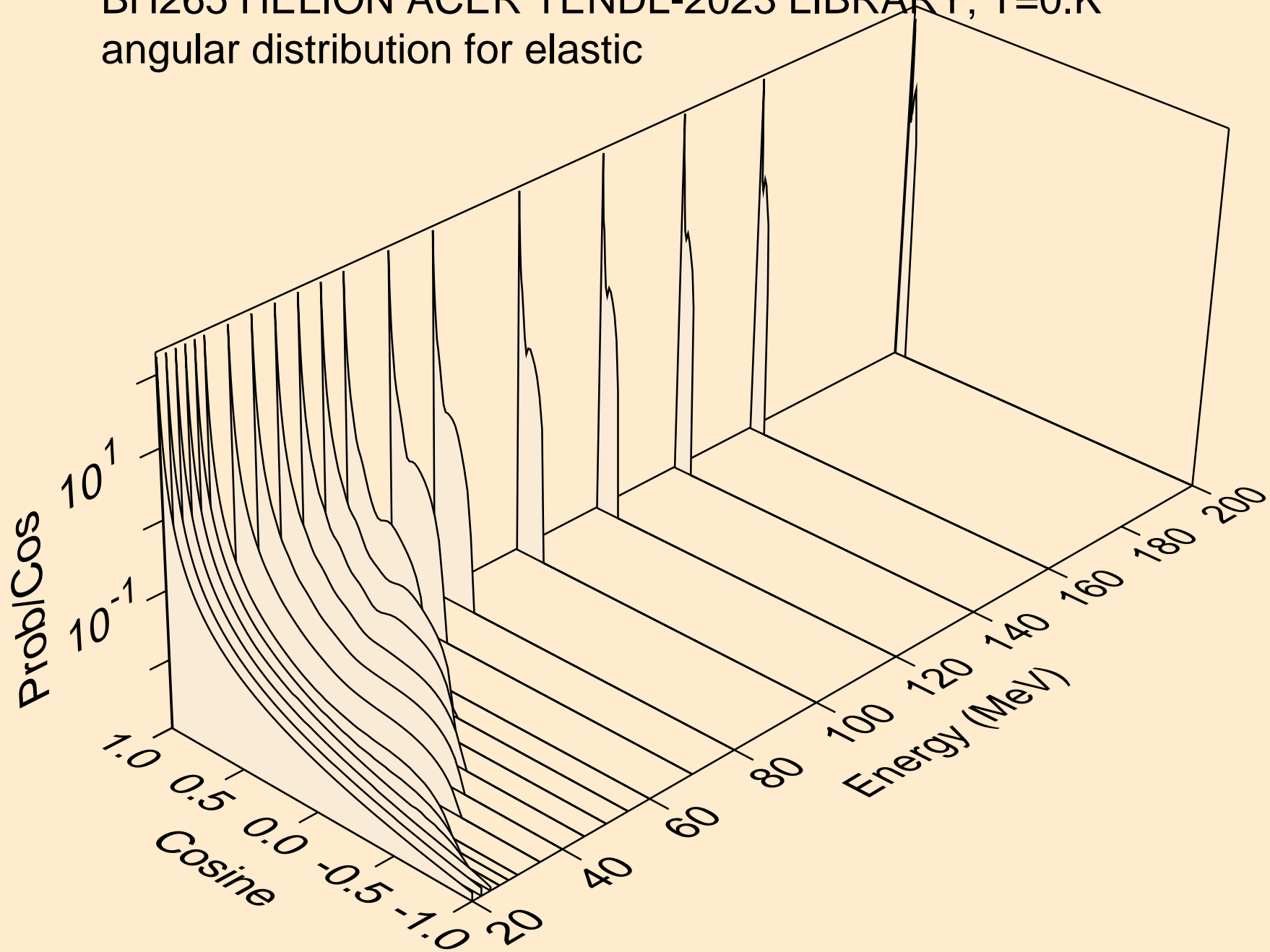

BH265 HELION ACER TENDL-2023 LIBRARY; T=0.K  
He-3 emission for (s,x)

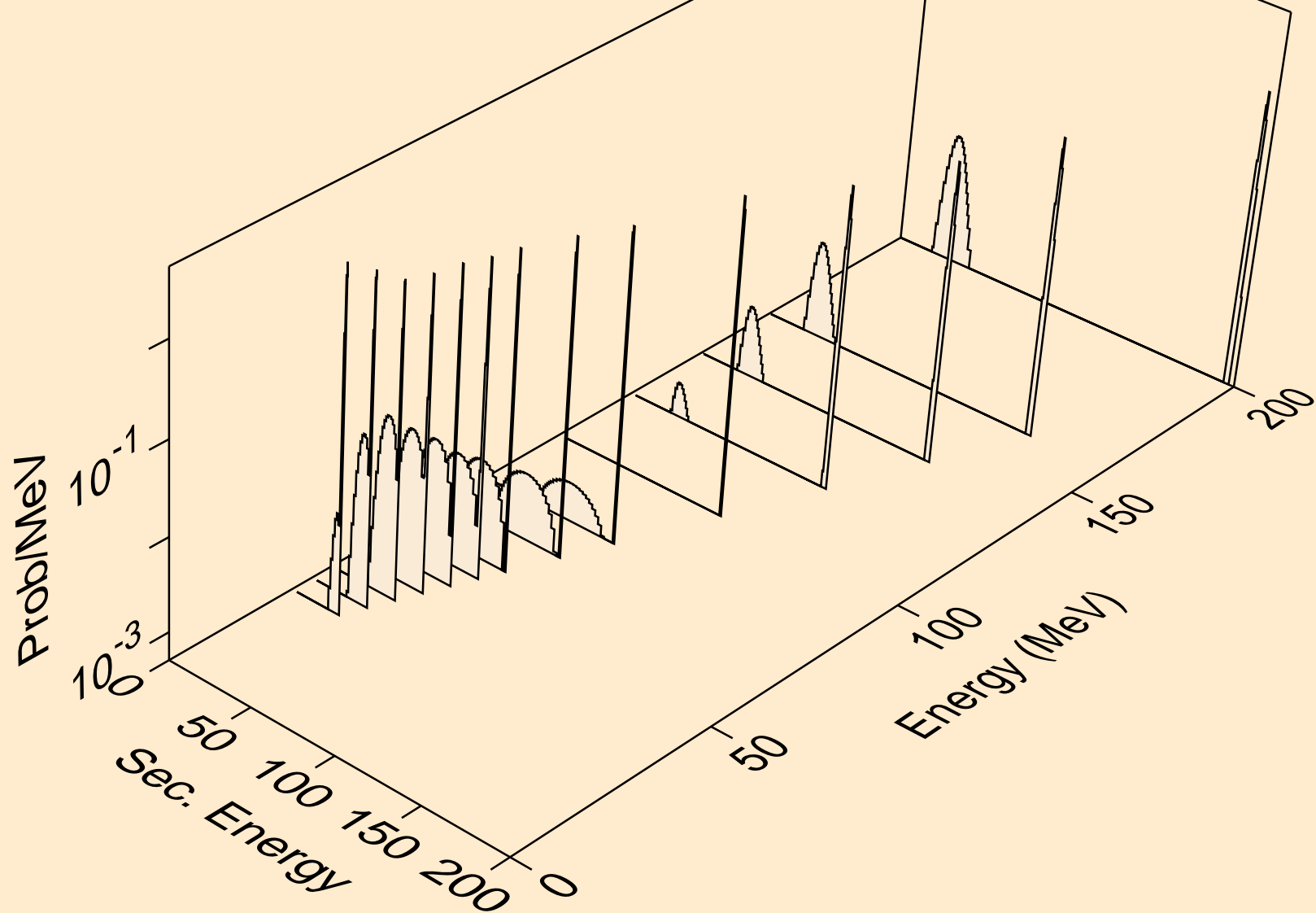

BH265 HELION ACER TENDL-2023 LIBRARY; T=0.K  
He-3 emission for inelastic

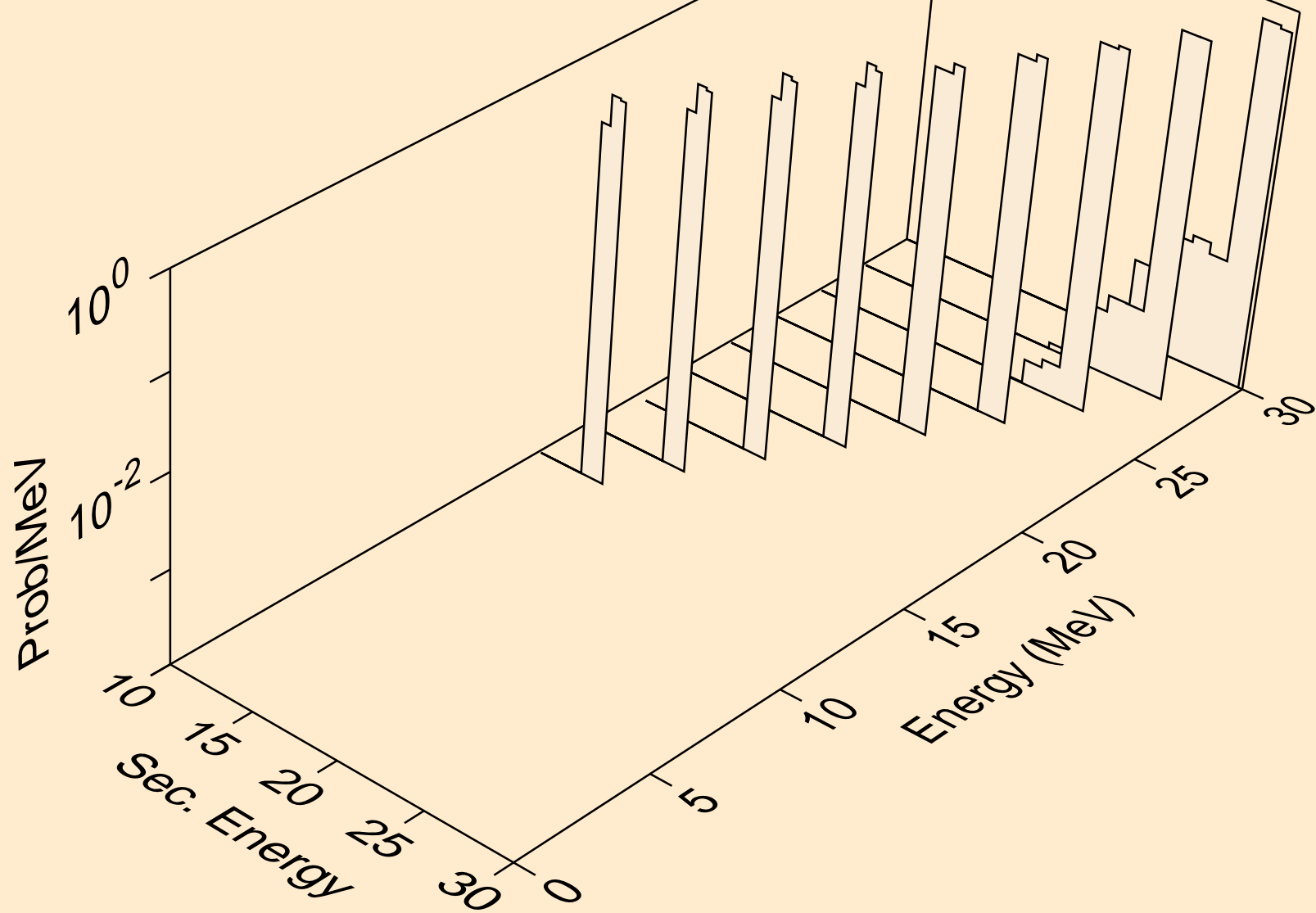

BH265 HELION ACER TENDL-2023 LIBRARY; T=0.K  
Photon emission for (z,n)

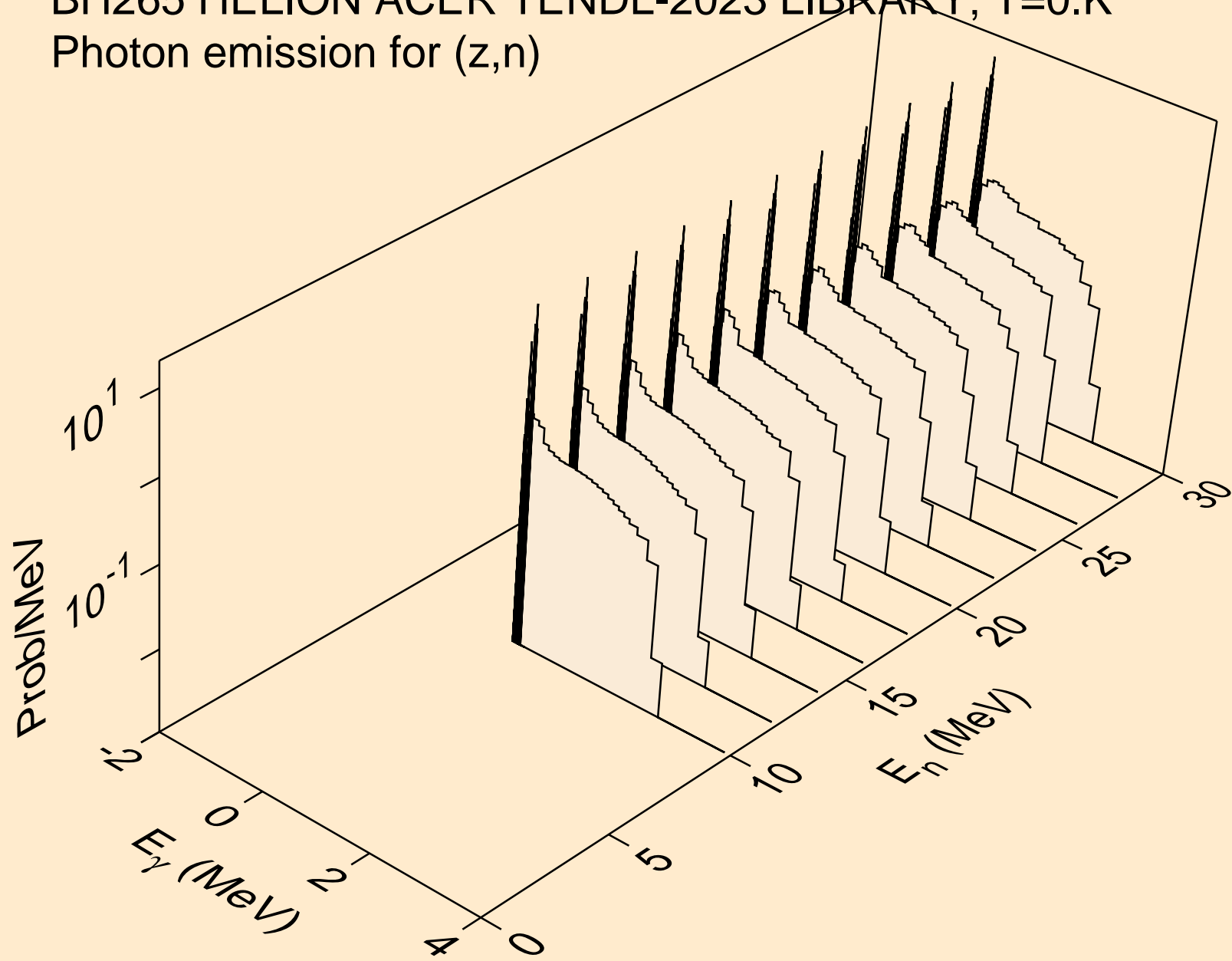

BH265 HELION ACER TENDL-2023 LIBRARY; T=0.K  
Photon emission for (z,x)

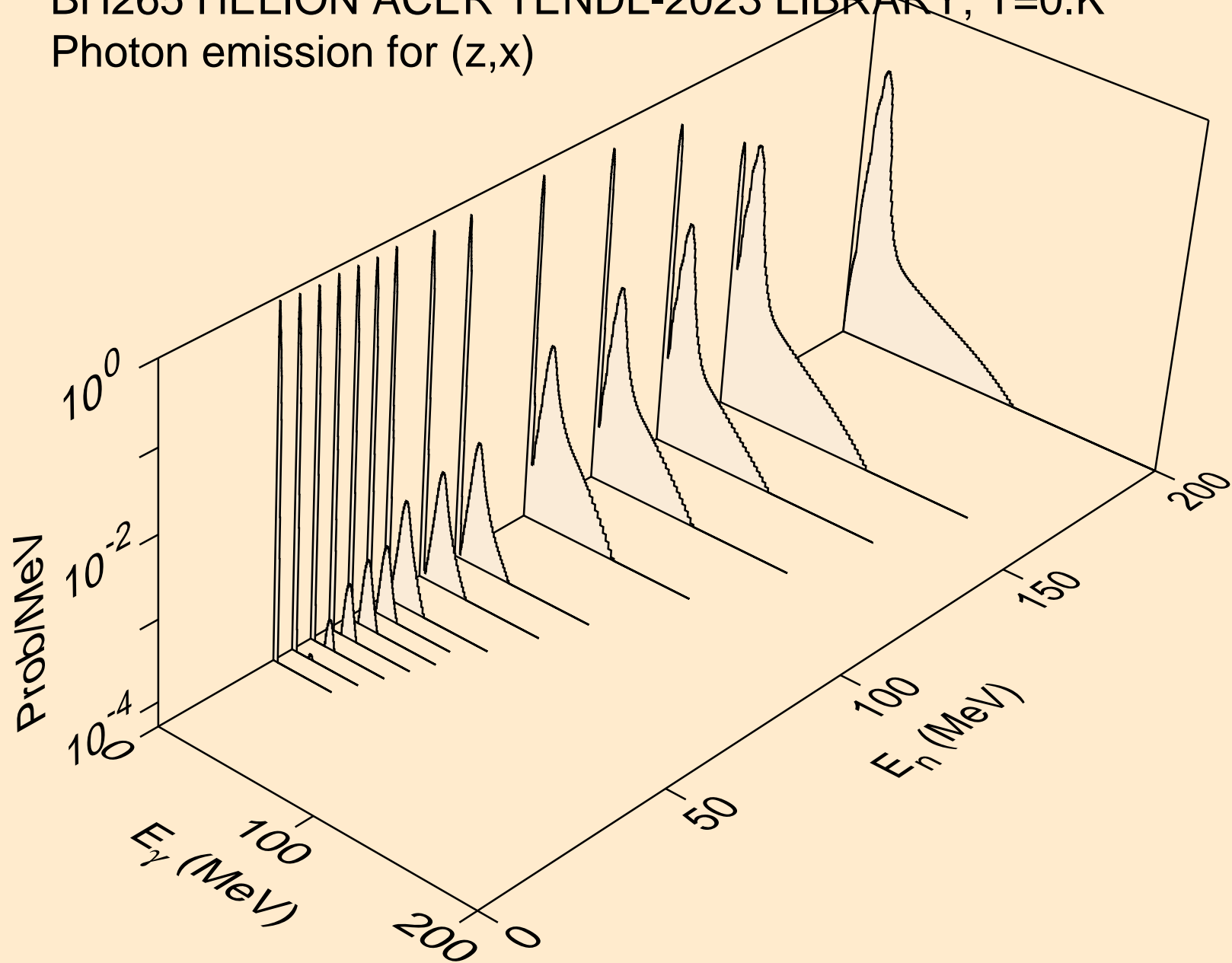

BH265 HELION ACER TENDL-2023 LIBRARY; T=0.K  
Photon emission for (n,2n)

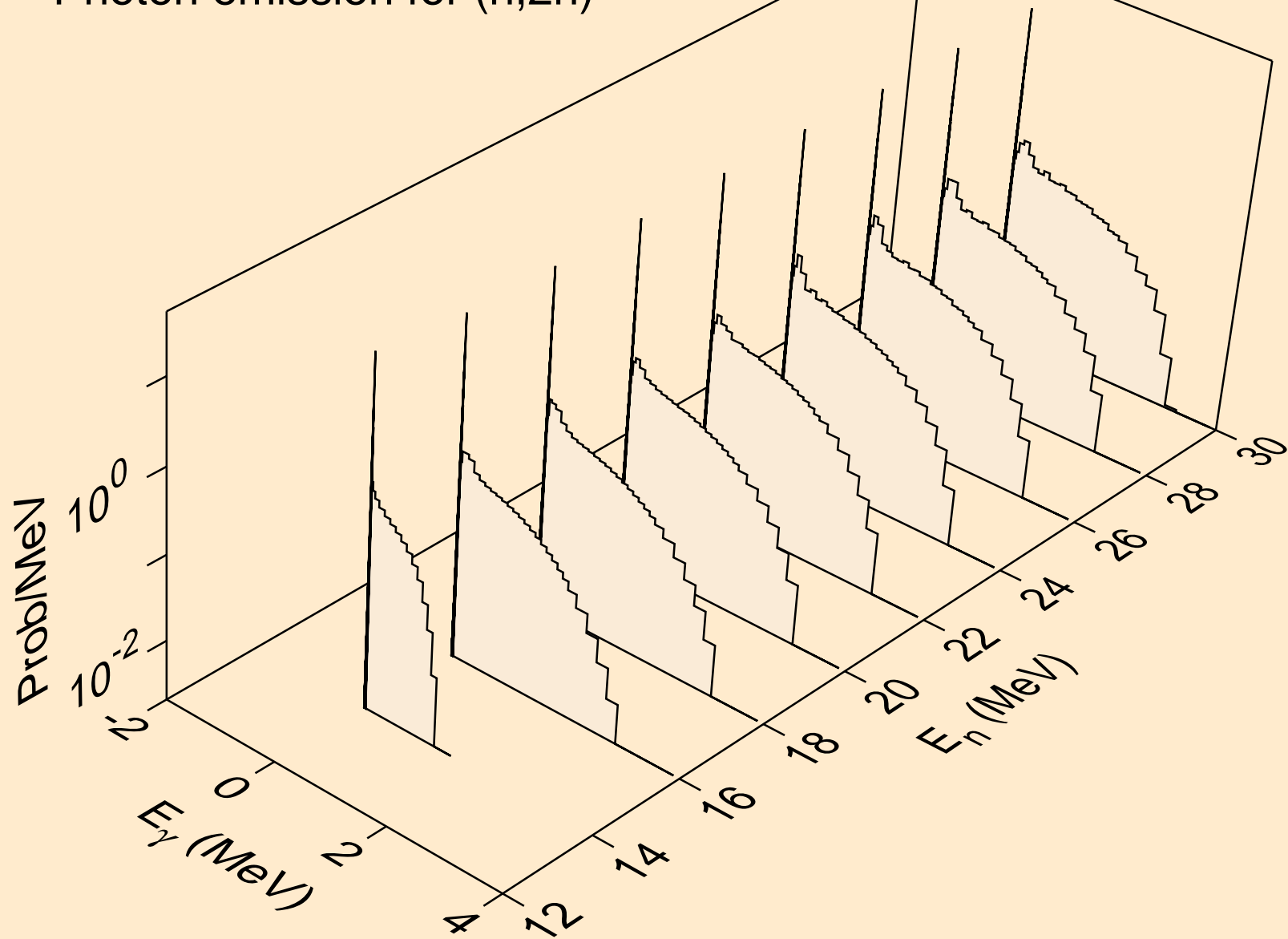

BH265 HELION ACER TENDL-2023 LIBRARY; T=0.K  
Photon emission for (n,3n)

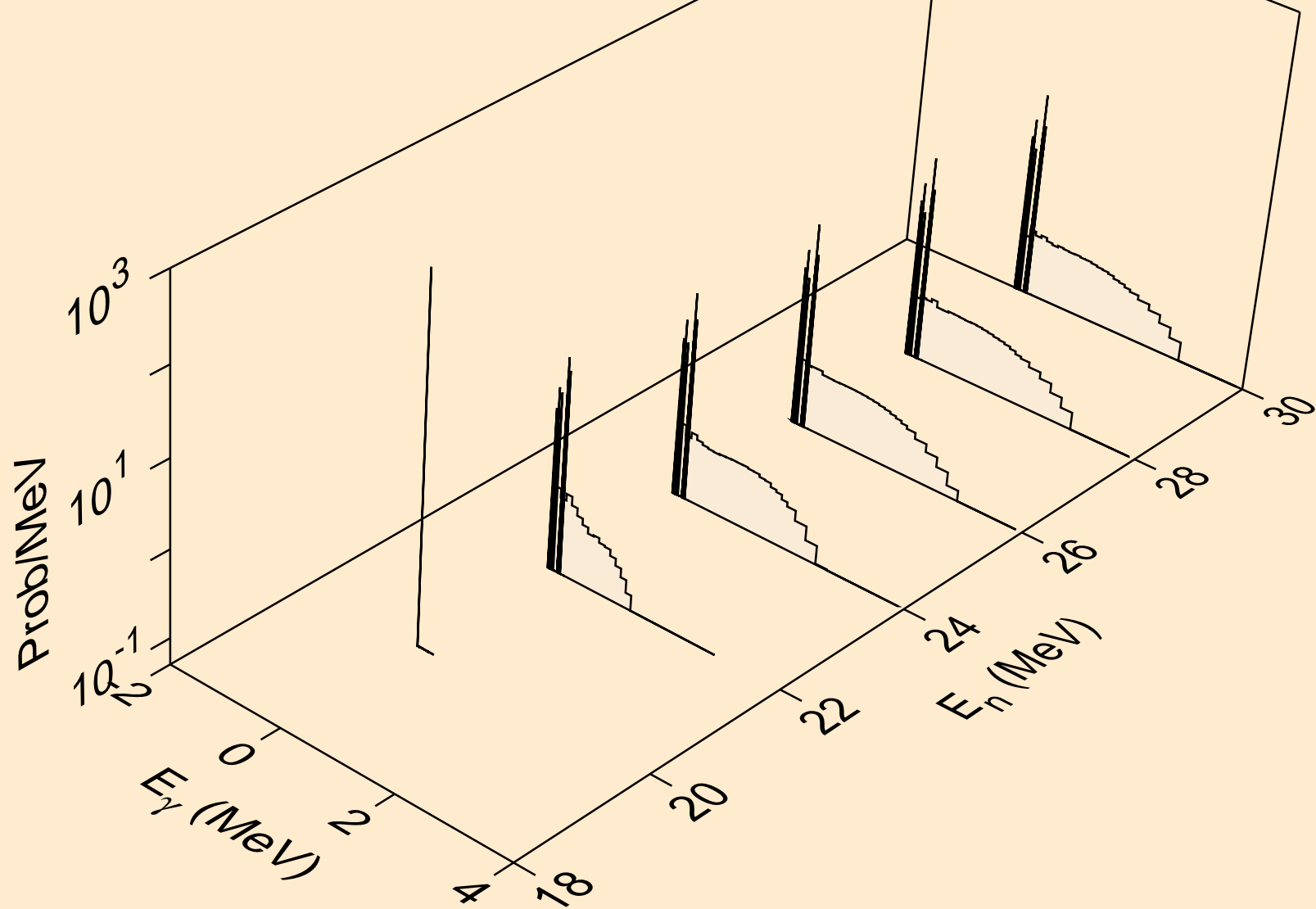

BH265 HELION ACER TENDL-2023 LIBRARY; T=0.K  
Photon emission for (n,n\*)a

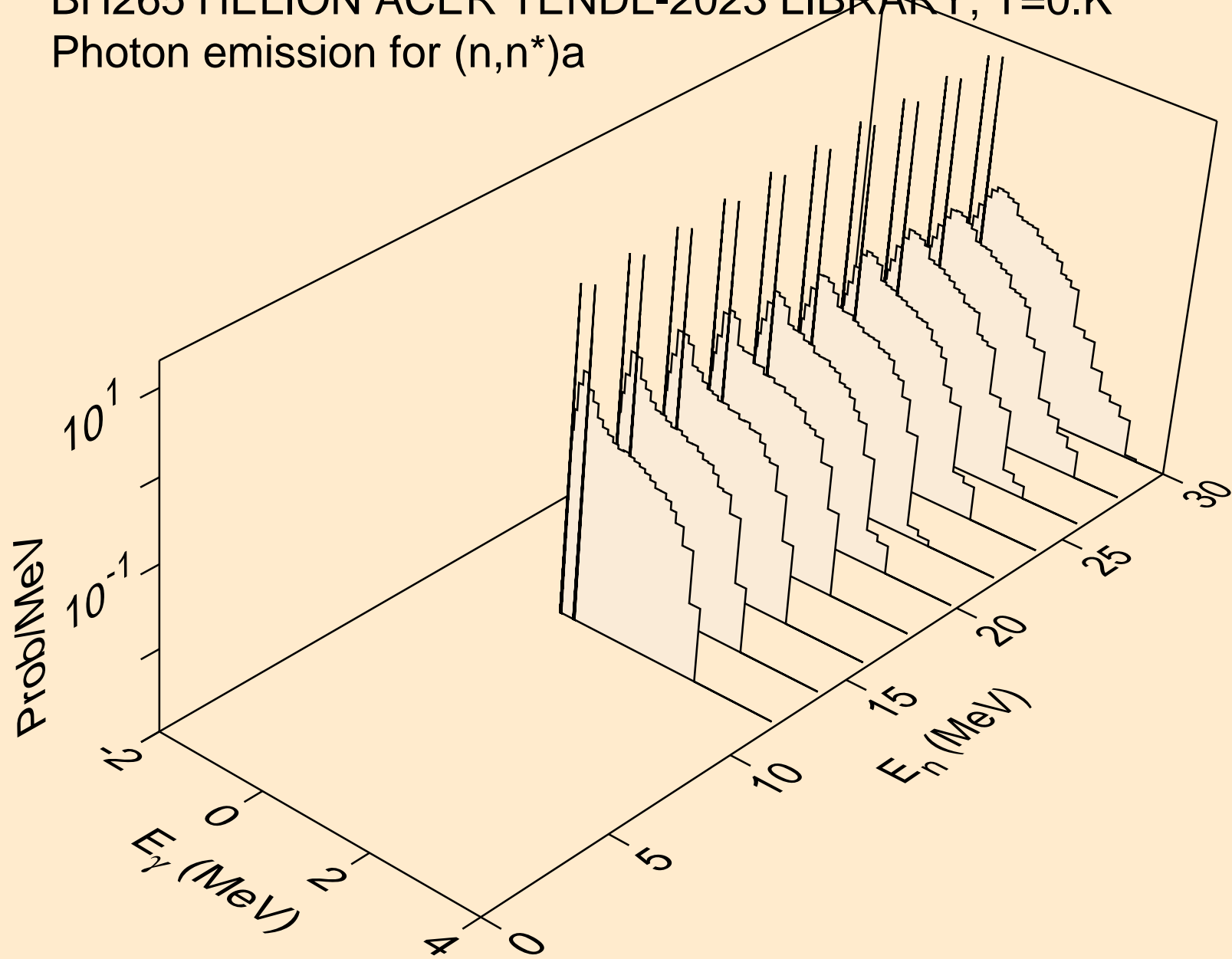

BH265 HELION ACER TENDL-2023 LIBRARY; T=0.K  
Photon emission for (n,2n)a

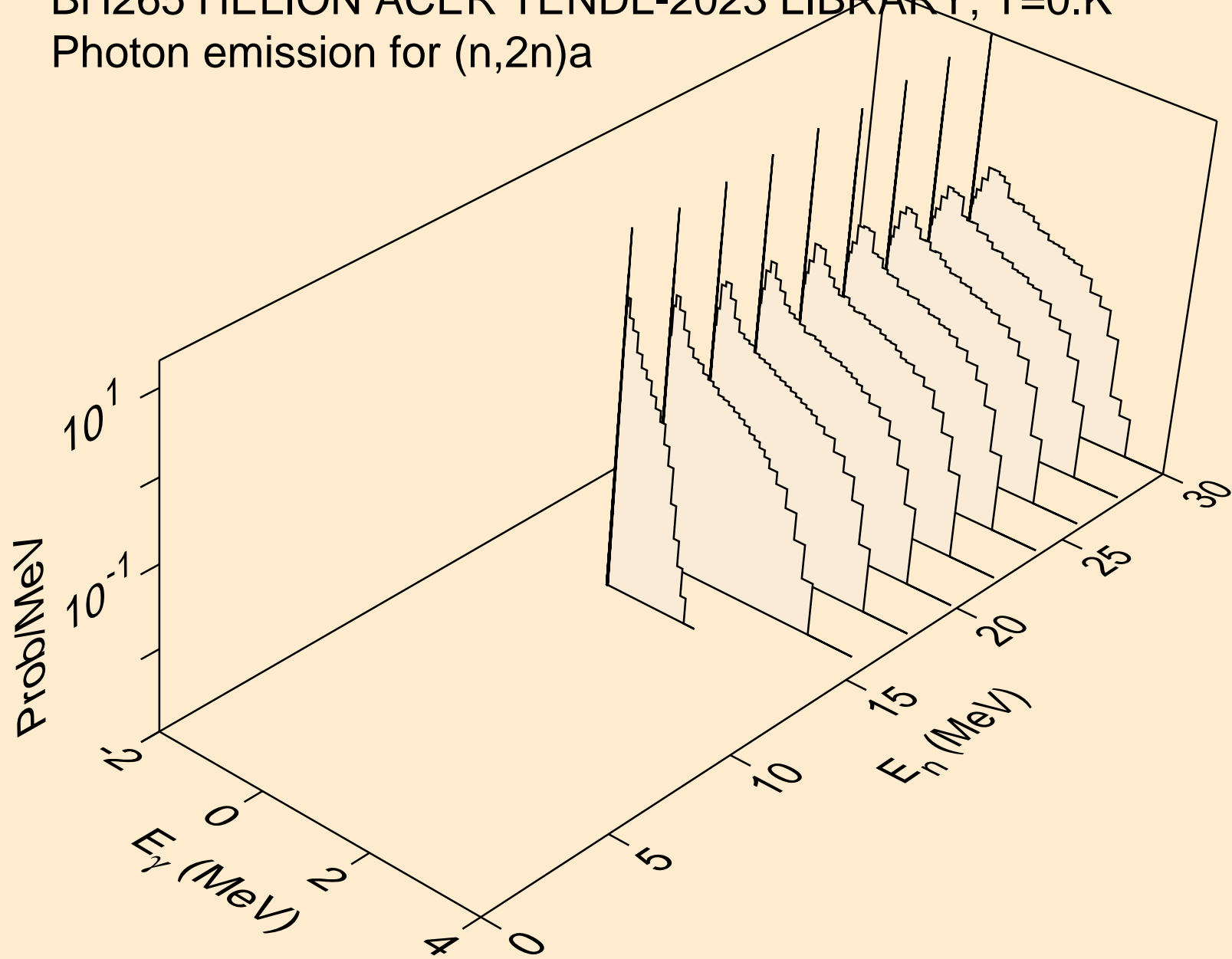

BH265 HELION ACER TENDL-2023 LIBRARY; T=0.K  
Photon emission for (n,n\*)p

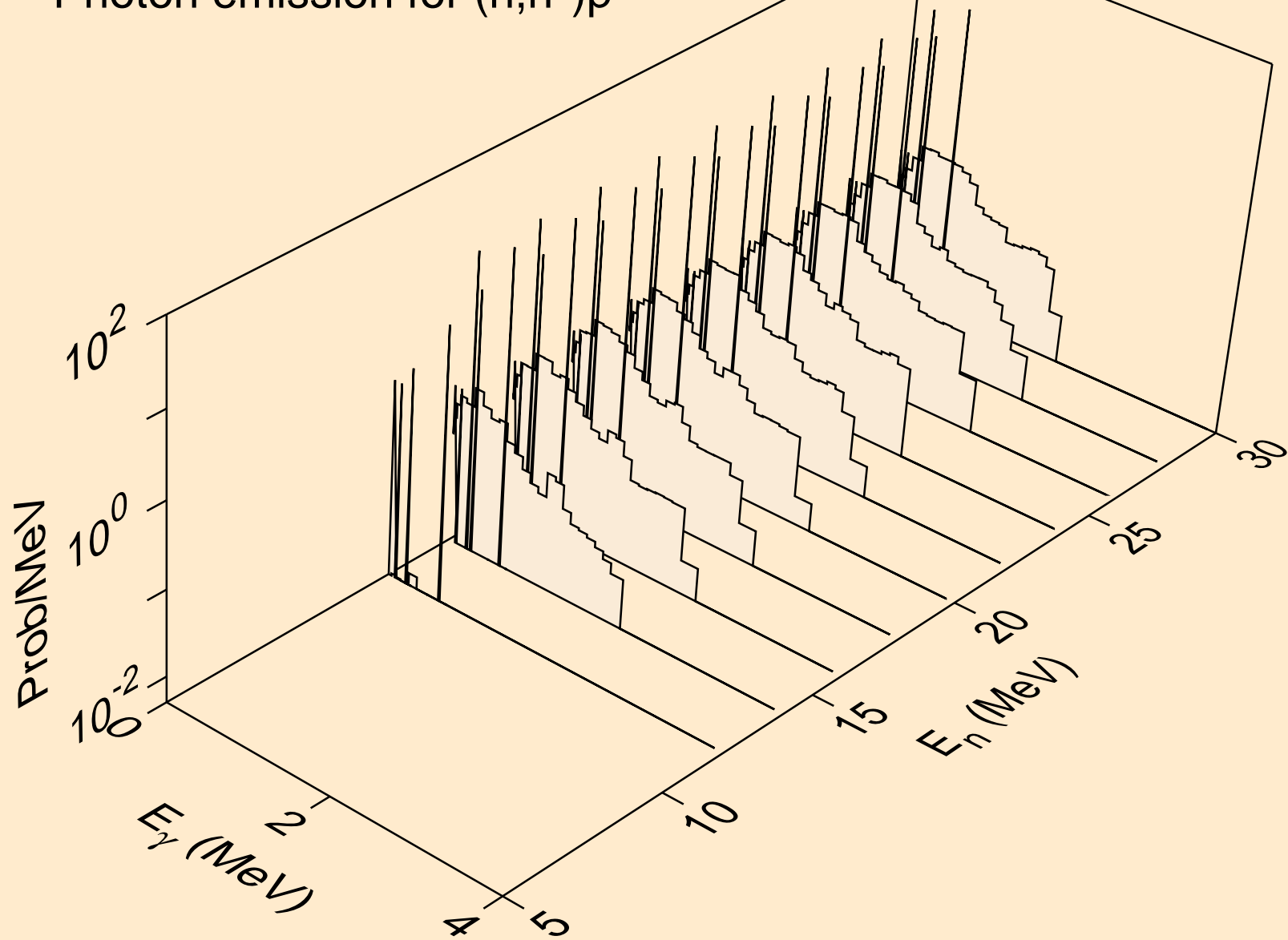

BH265 HELION ACER TENDL-2023 LIBRARY; T=0.K  
Photon emission for (n,n\*)d

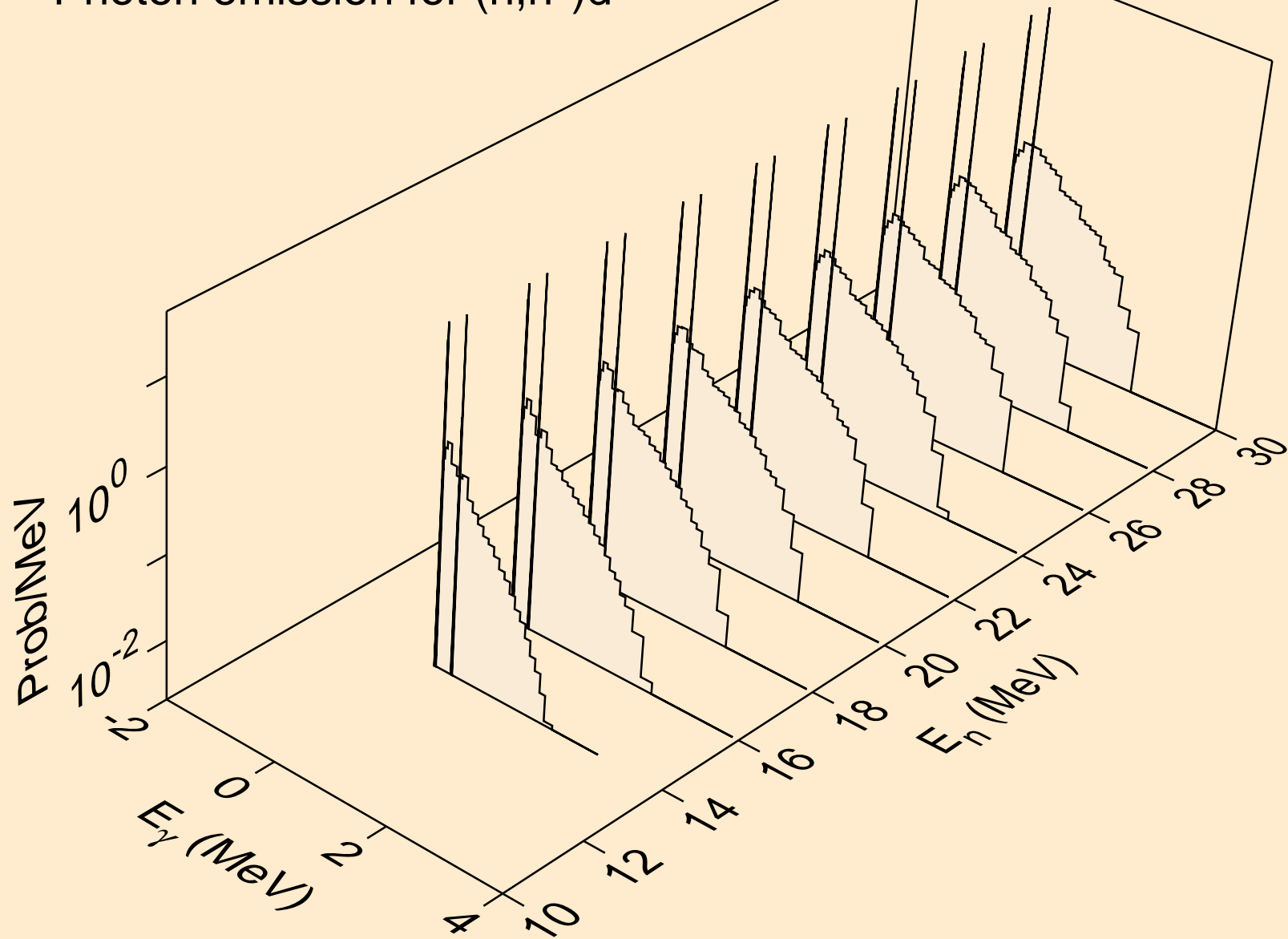

BH265 HELION ACER TENDL-2023 LIBRARY; T=0.K  
Photon emission for (n,n\*)t

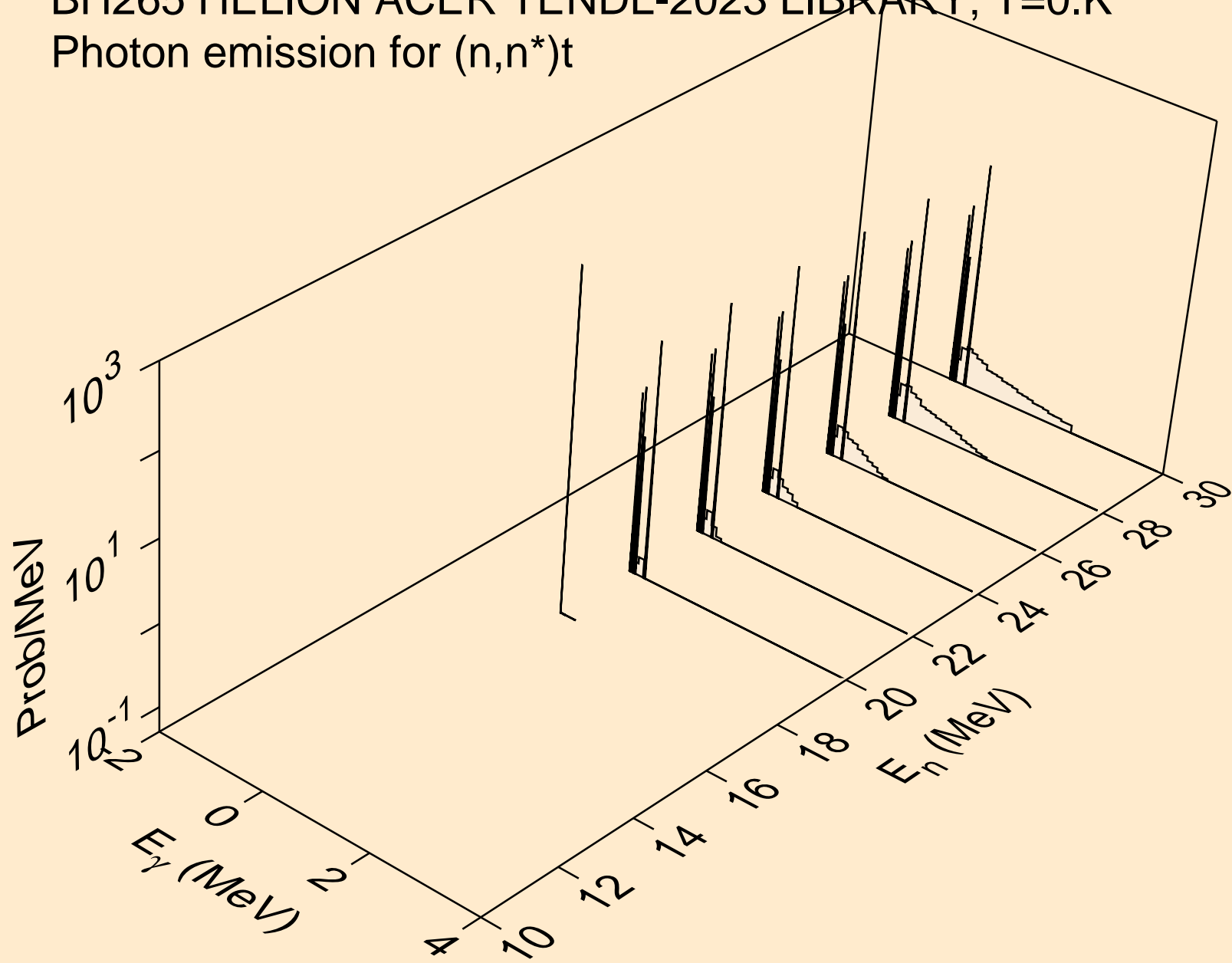

BH265 HELION ACER TENDL-2023 LIBRARY; T=0.K  
Photon emission for (n,2np)

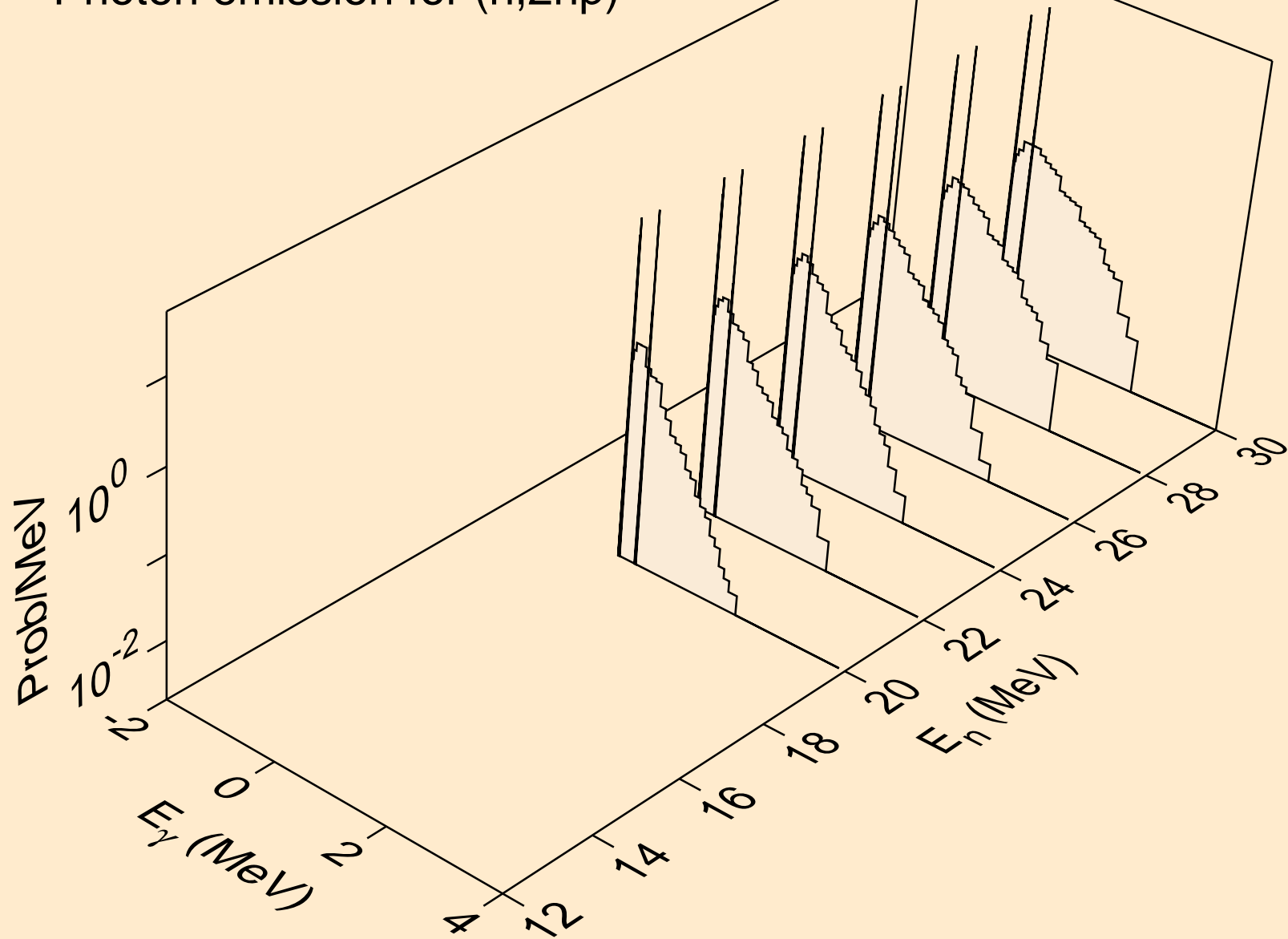

BH265 HELION ACER TENDL-2023 LIBRARY; T=0.K  
Photon emission for (n,npa)

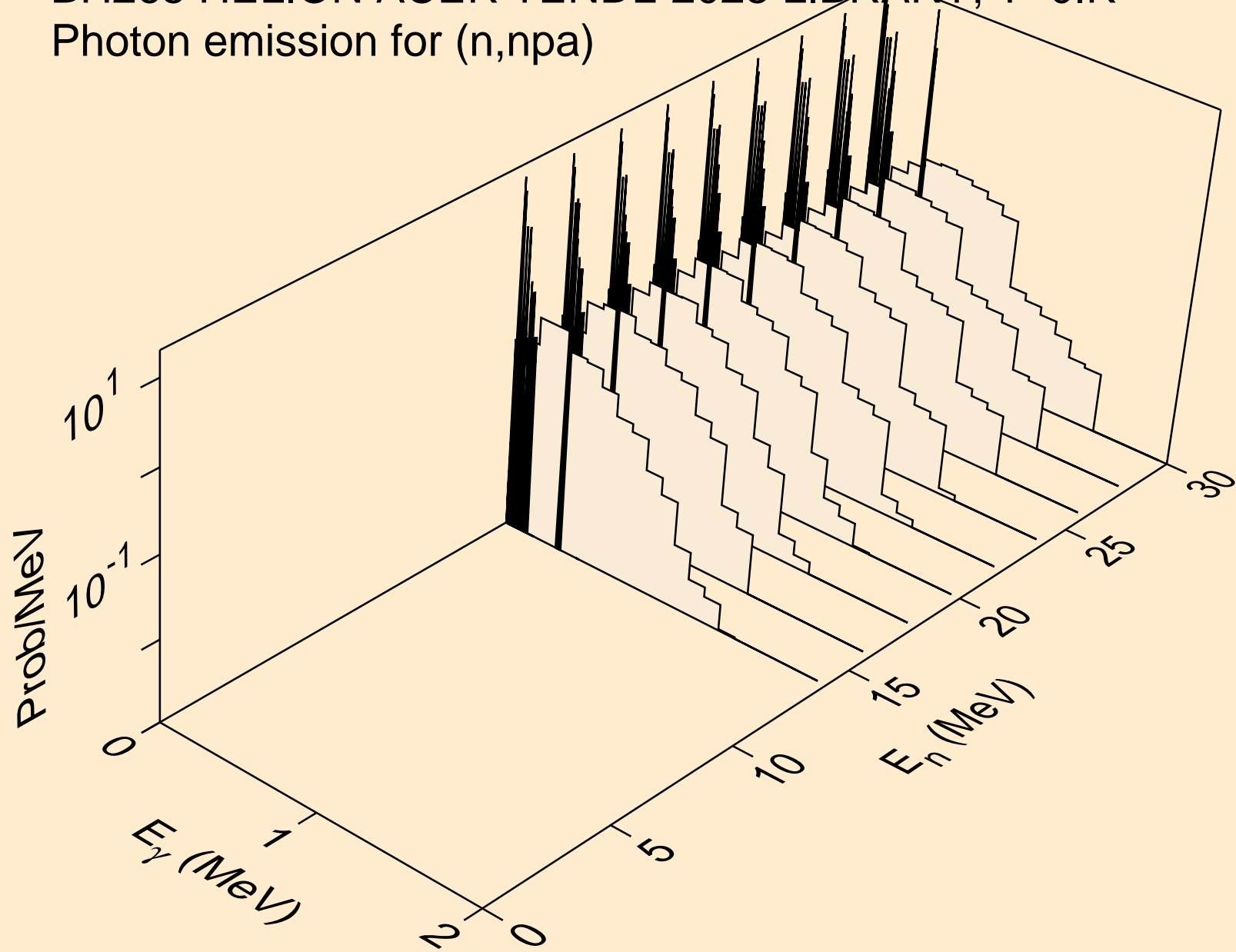

BH265 HELION ACER TENDL-2023 LIBRARY; T=0.K  
Photon emission for (n,p)

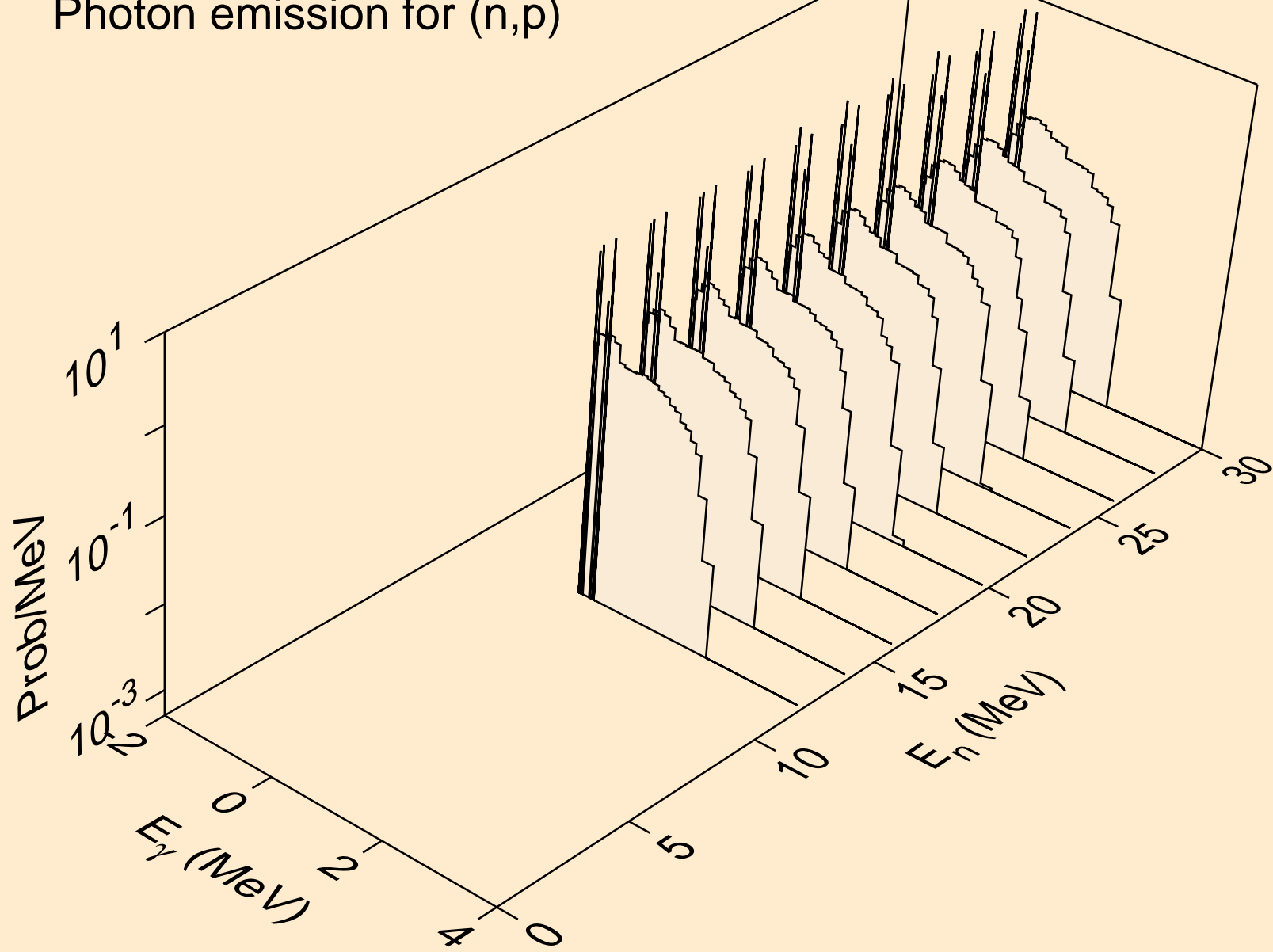

BH265 HELION ACER TENDL-2023 LIBRARY; T=0.K  
Photon emission for (n,d)

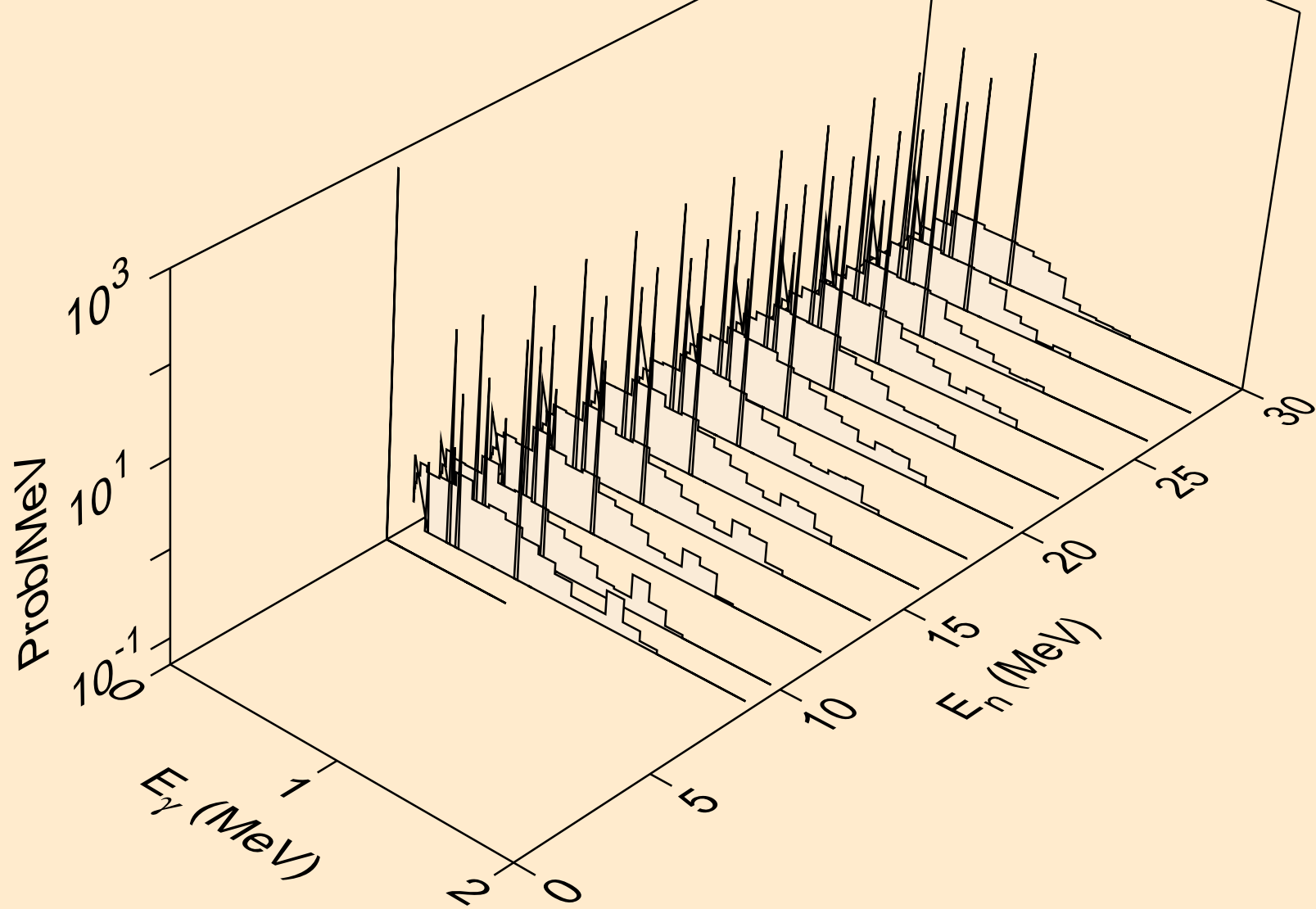

BH265 HELION ACER TENDL-2023 LIBRARY; T=0.K  
Photon emission for (n,t)

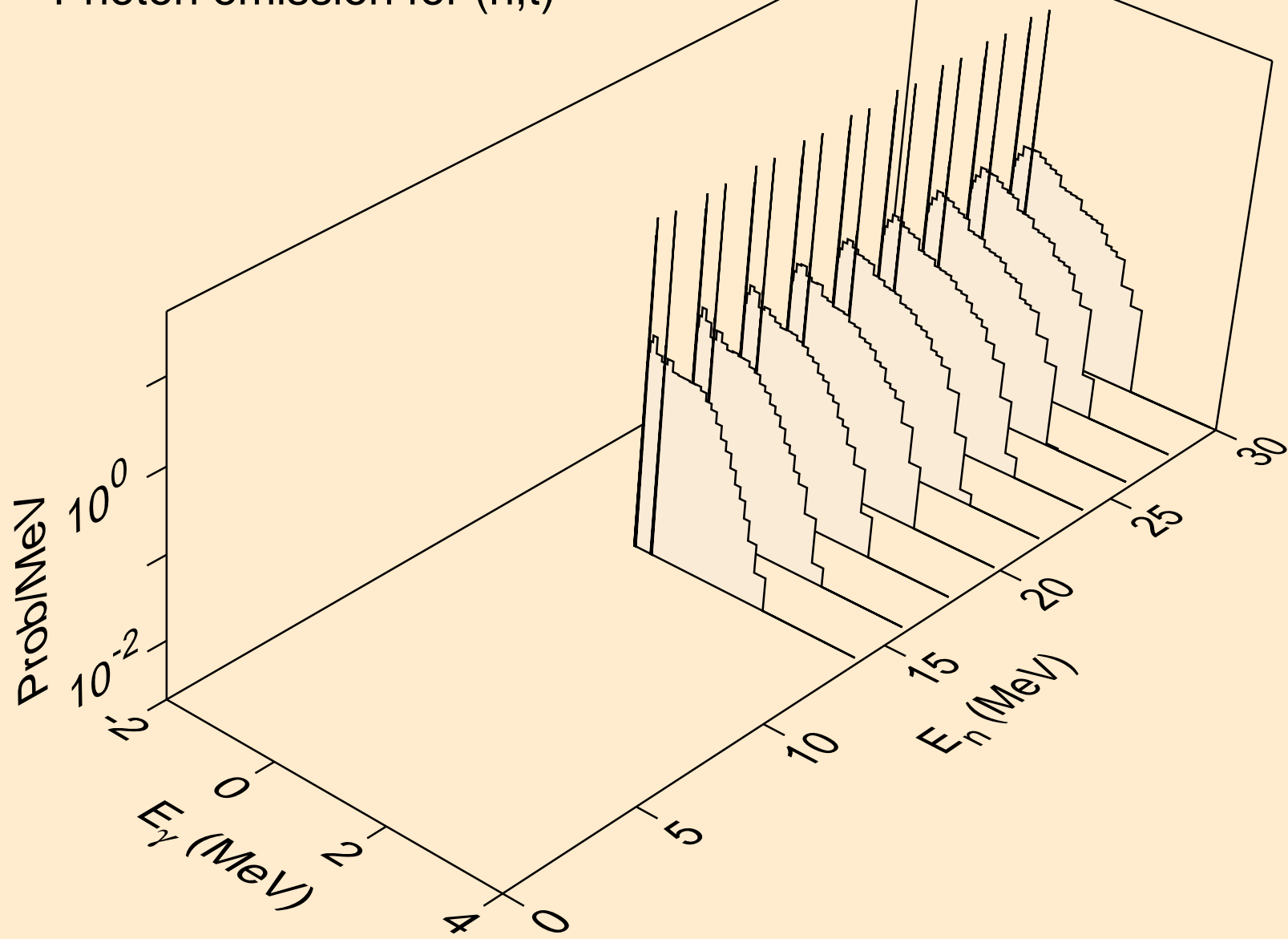

BH265 HELION ACER TENDL-2023 LIBRARY; T=0.K  
Photon emission for inelastic

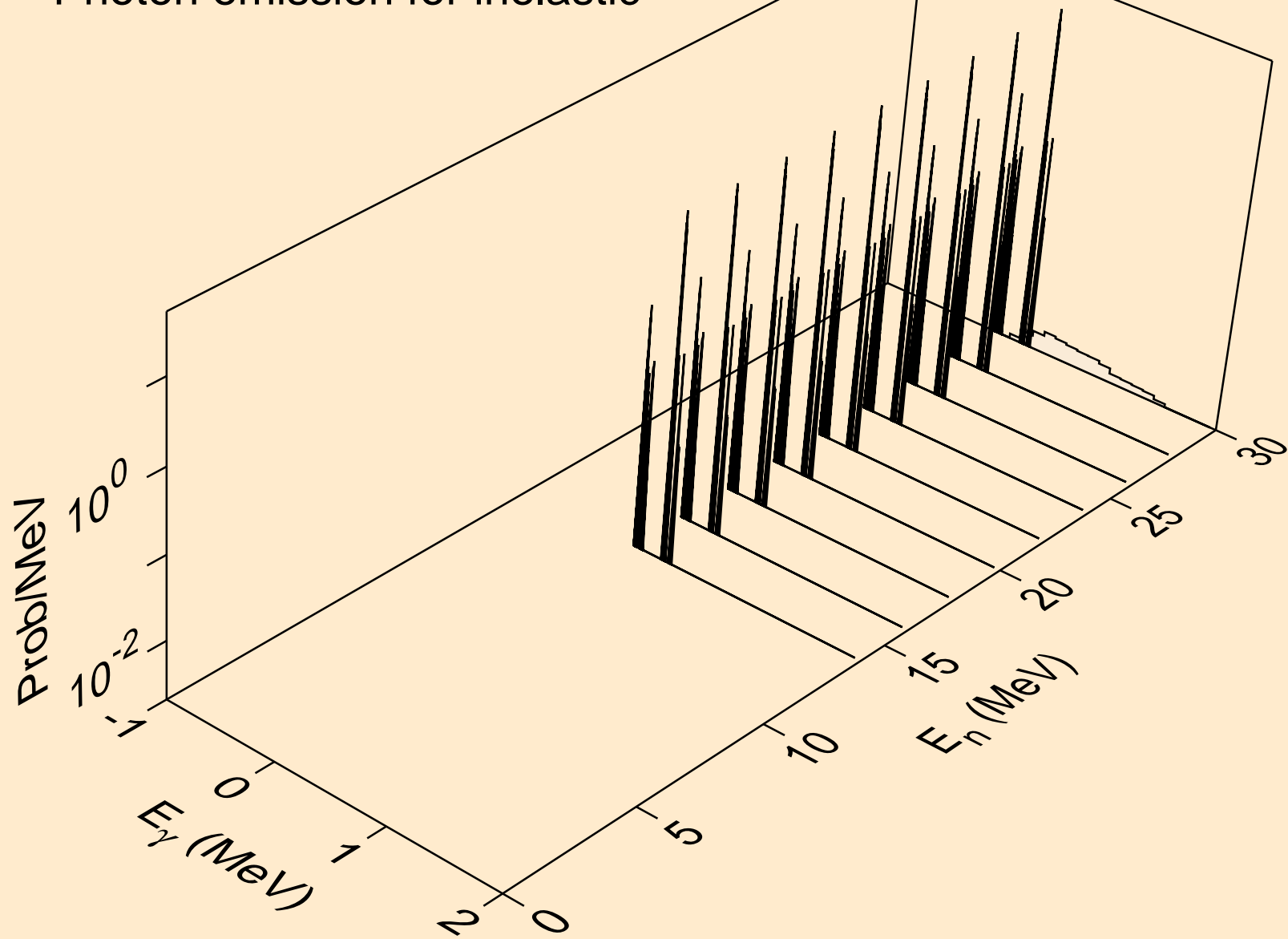

BH265 HELION ACER TENDL-2023 LIBRARY; T=0.K  
Photon emission for (n,a)

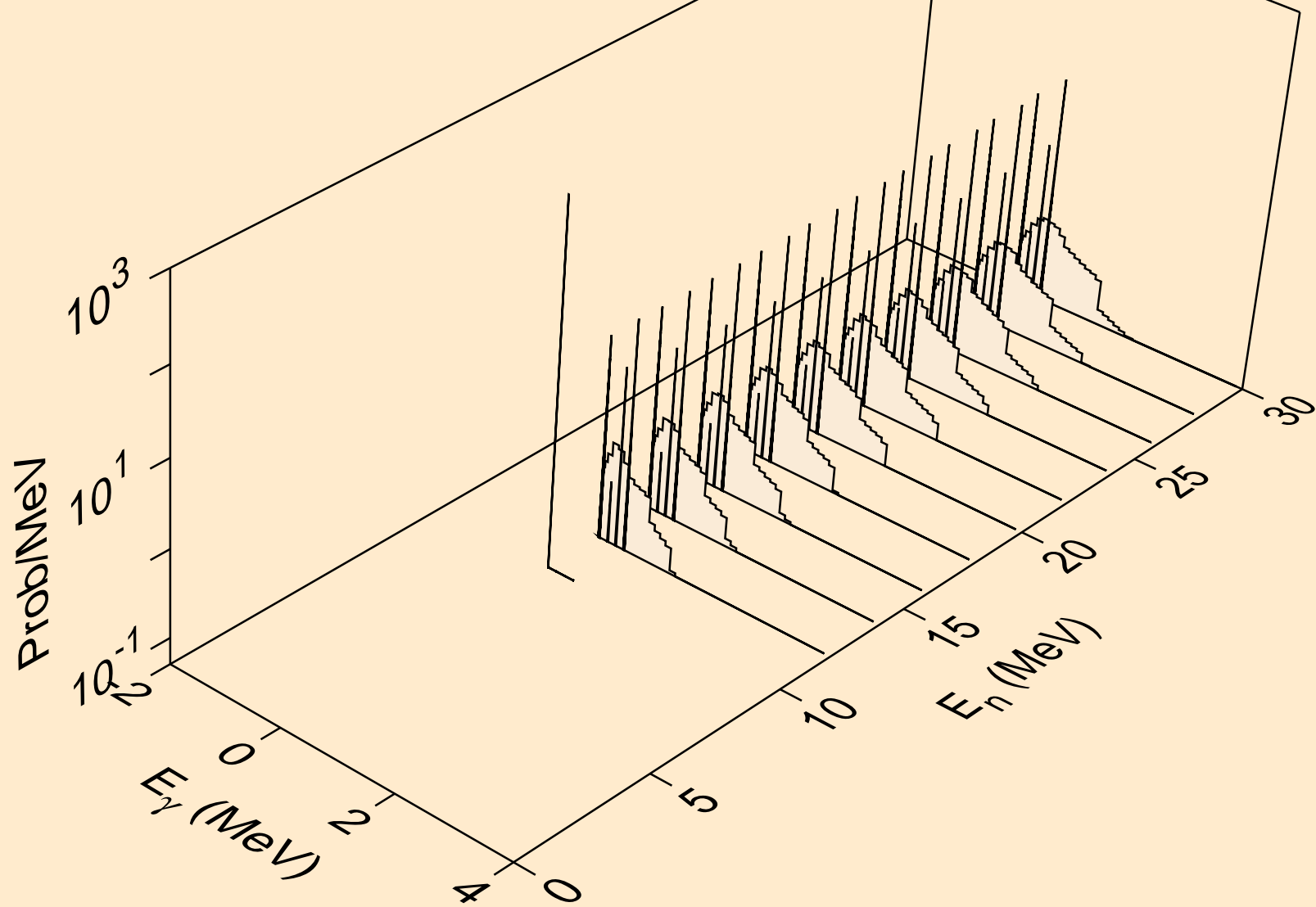

BH265 HELION ACER TENDL-2023 LIBRARY; T=0.K  
Photon emission for (n,2a)

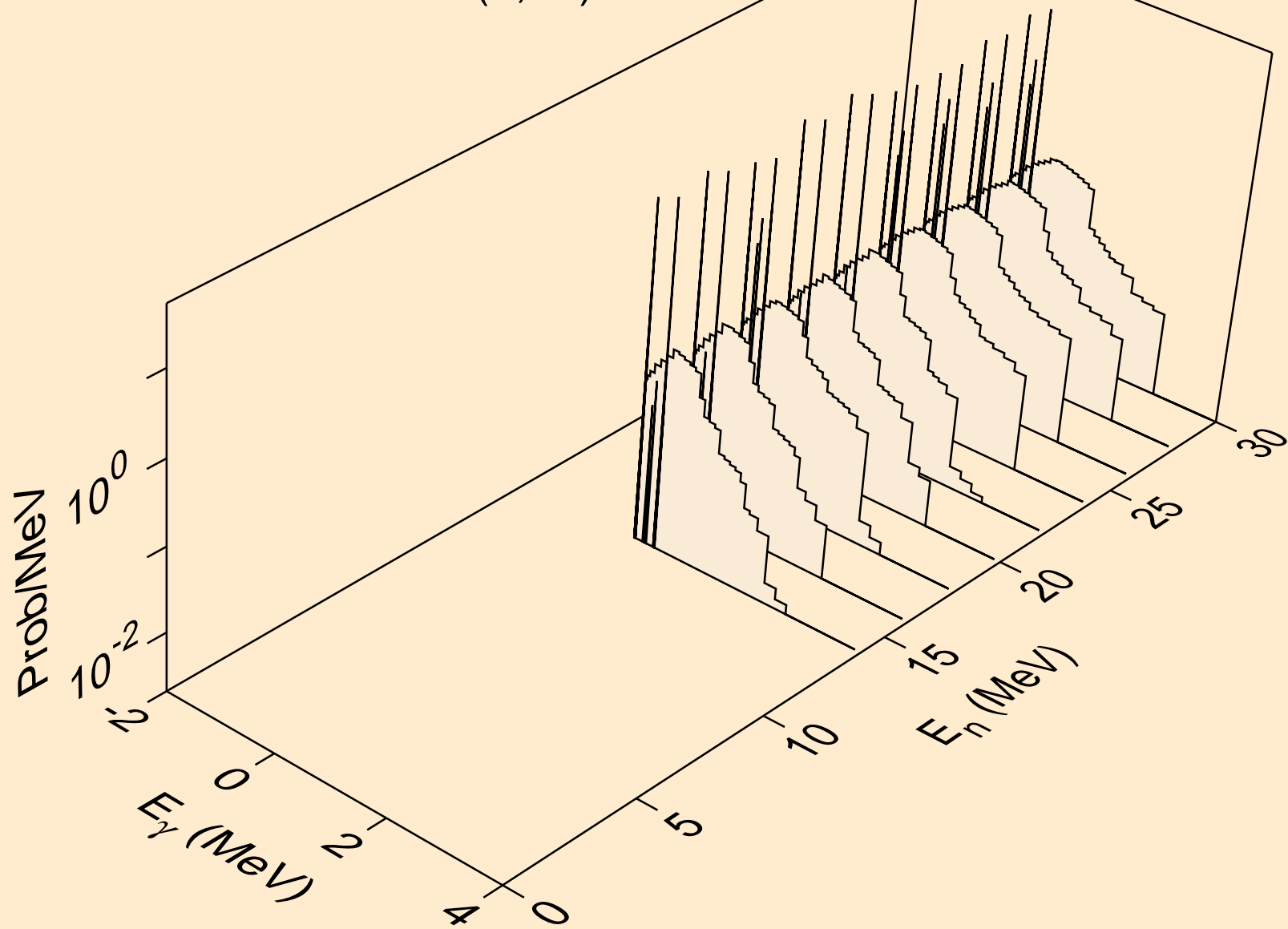

BH265 HELION ACER TENDL-2023 LIBRARY; T=0.K  
Photon emission for (n,3a)

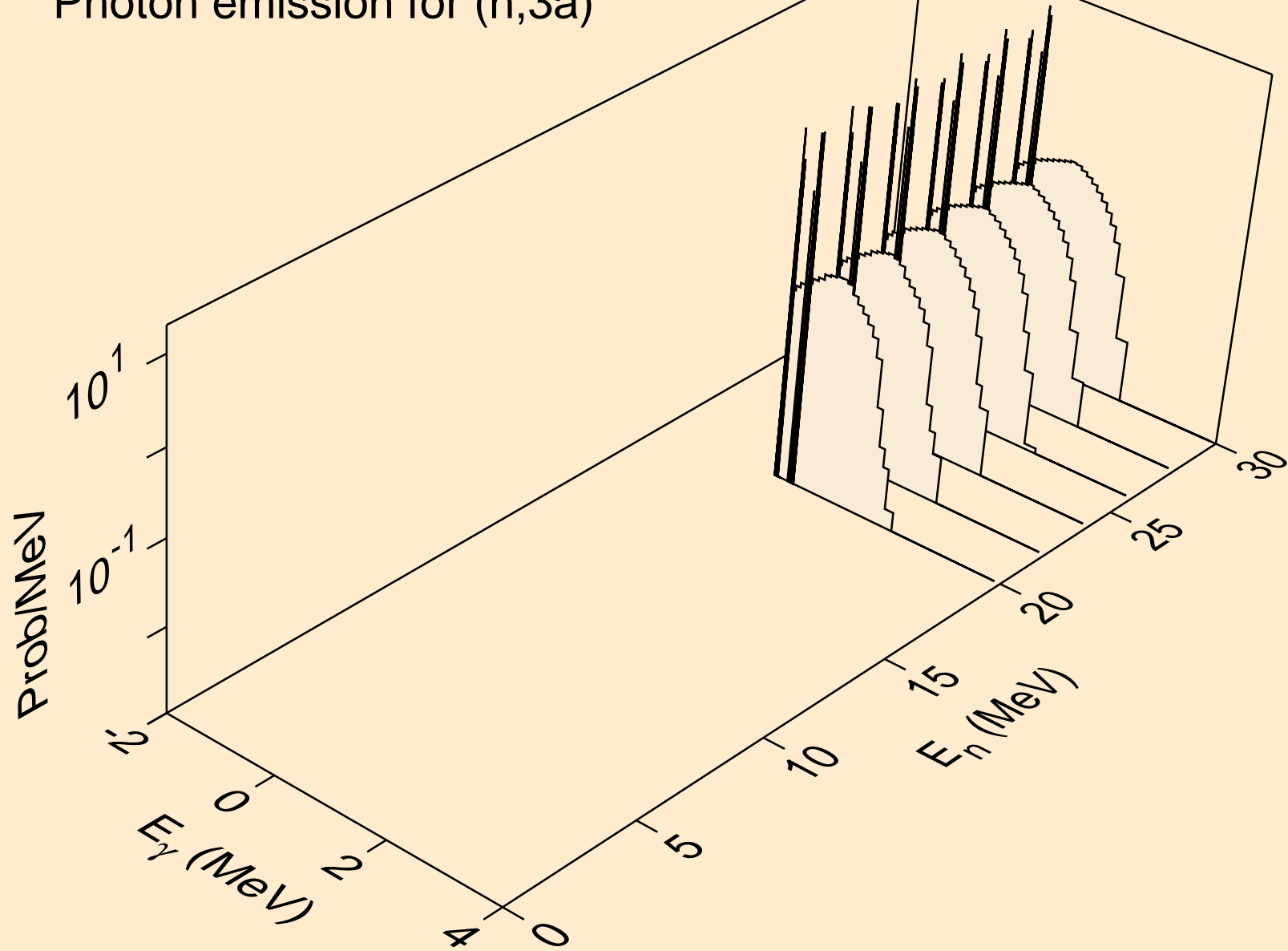

BH265 HELION ACER TENDL-2023 LIBRARY; T=0.K  
Photon emission for (n,2p)

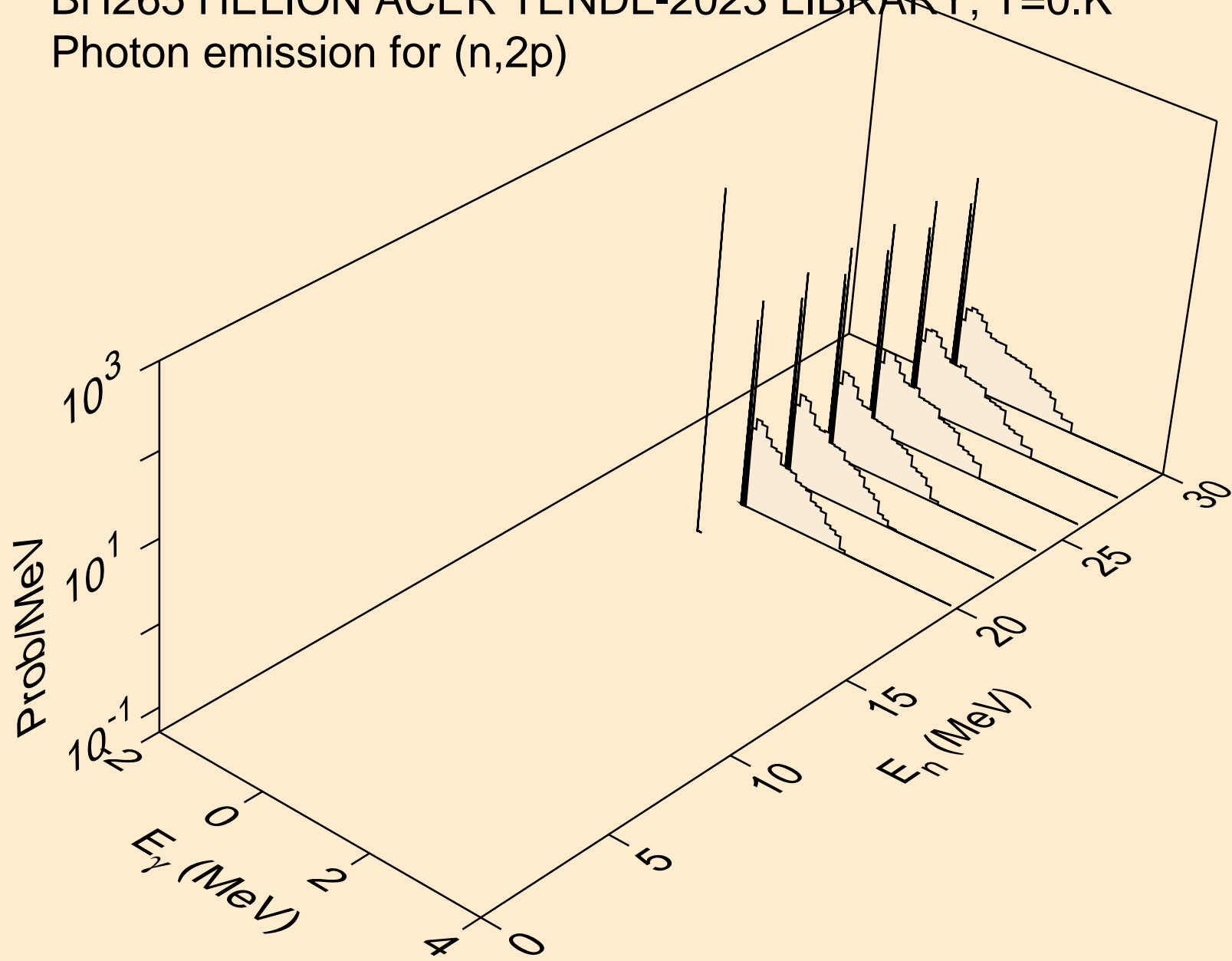

BH265 HELION ACER TENDL-2023 LIBRARY; T=0.K  
Photon emission for (n,pa)

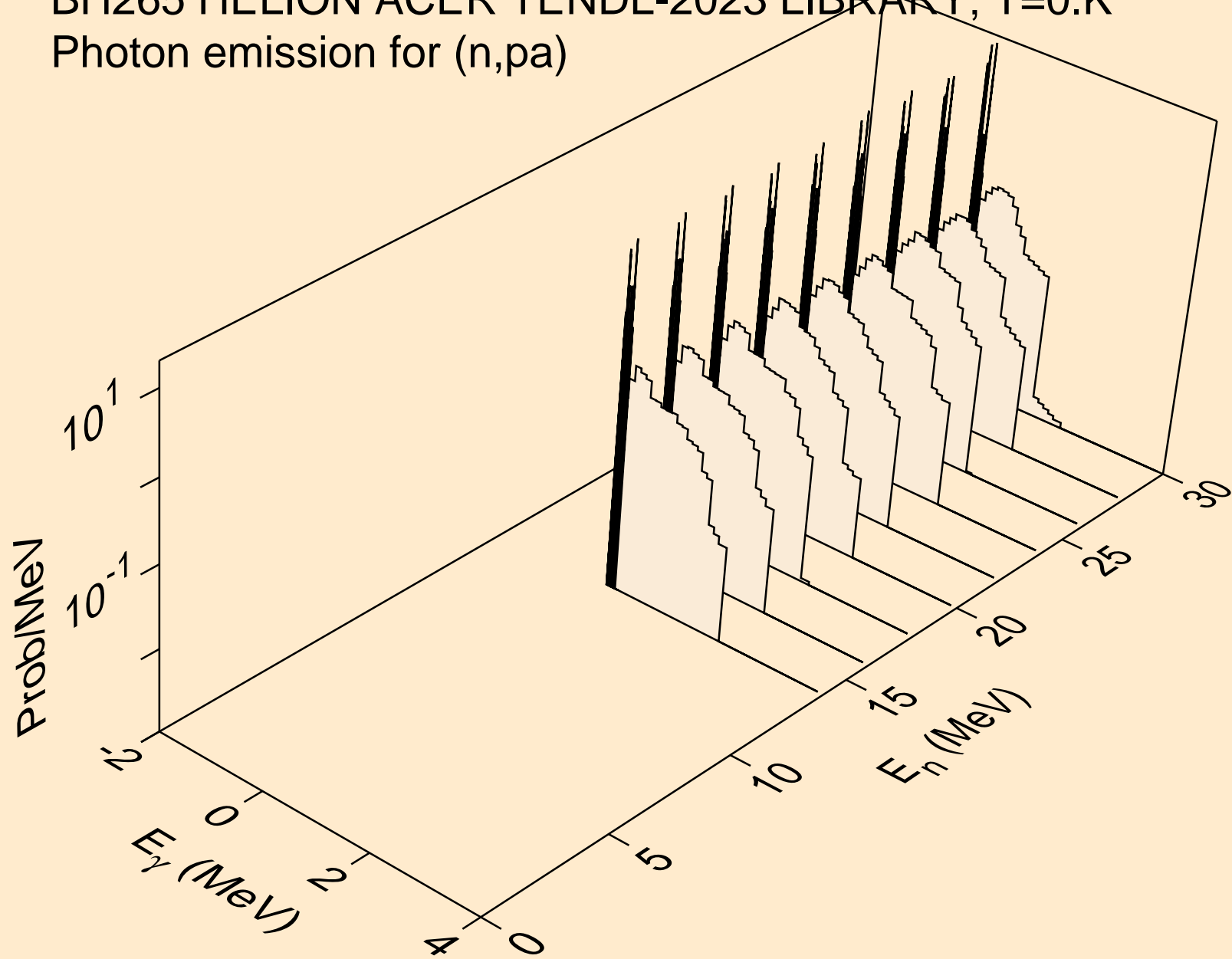

BH265 HELION ACER TENDL-2023 LIBRARY; T=0.K  
Photon emission for (n,da)

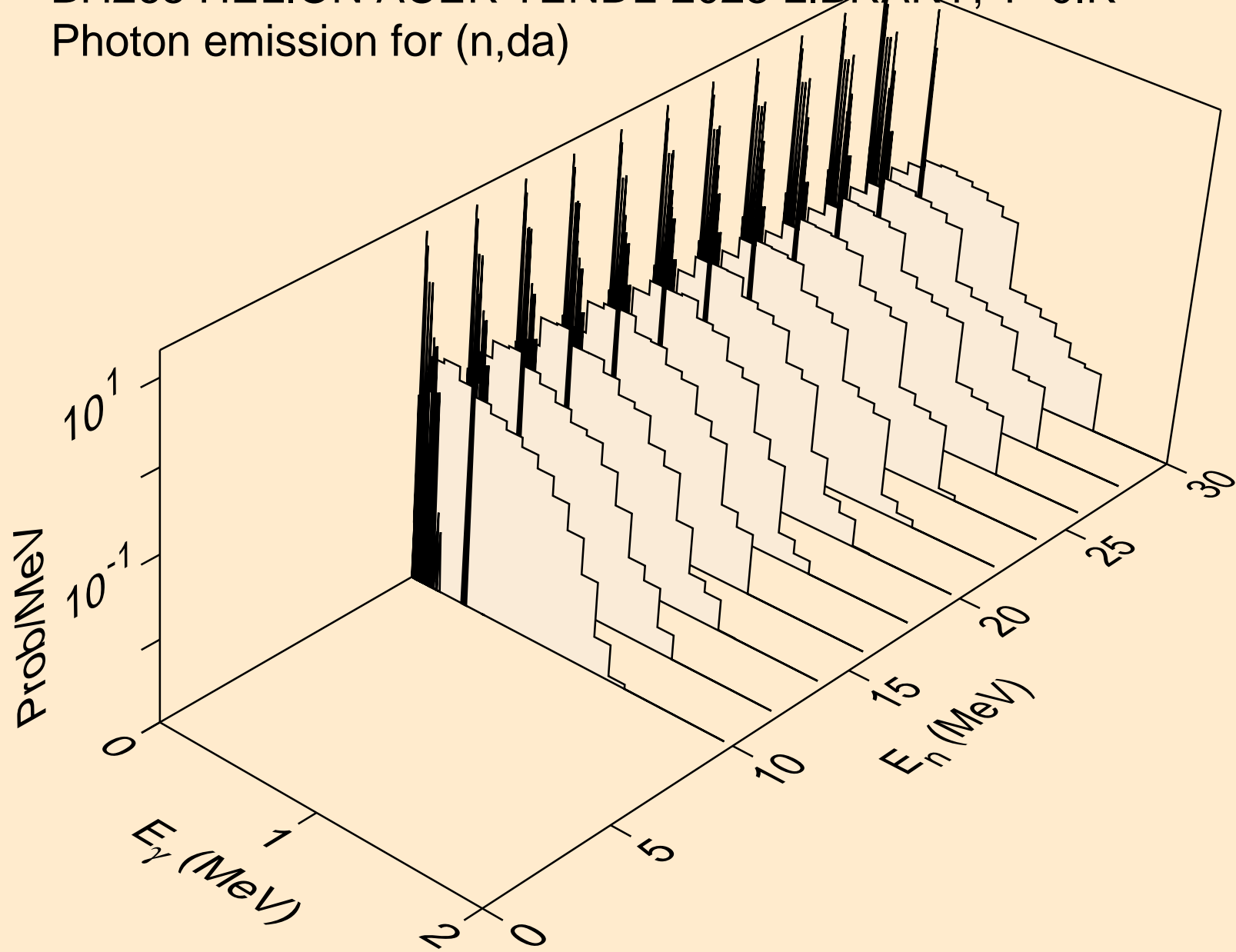

BH265 HELION ACER TENDL-2023 LIBRARY; T=0.K  
Particle heating contributions

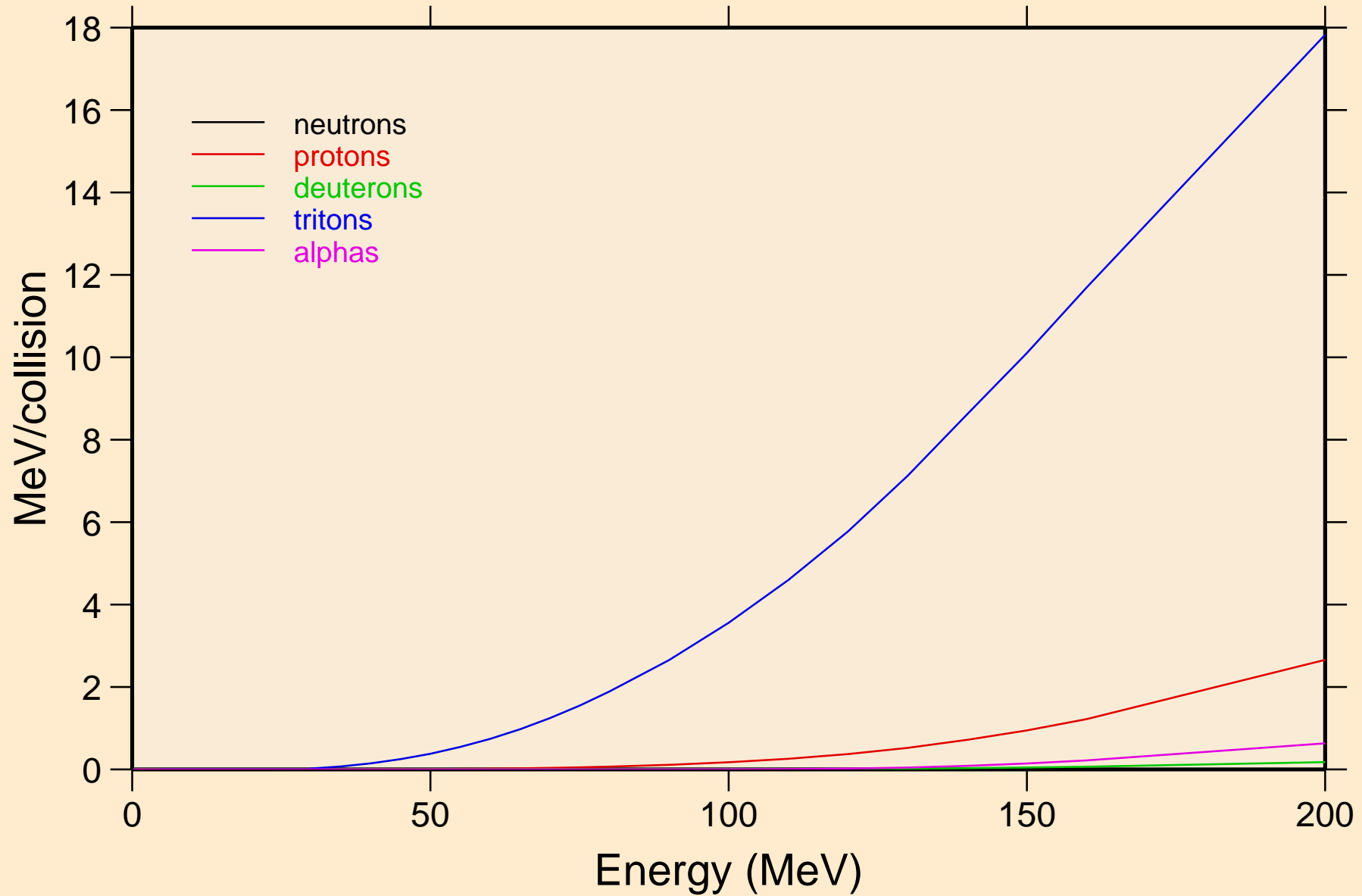

BH265 HELION ACER TENDL-2023 LIBRARY; T=0.K  
Recoil Heating

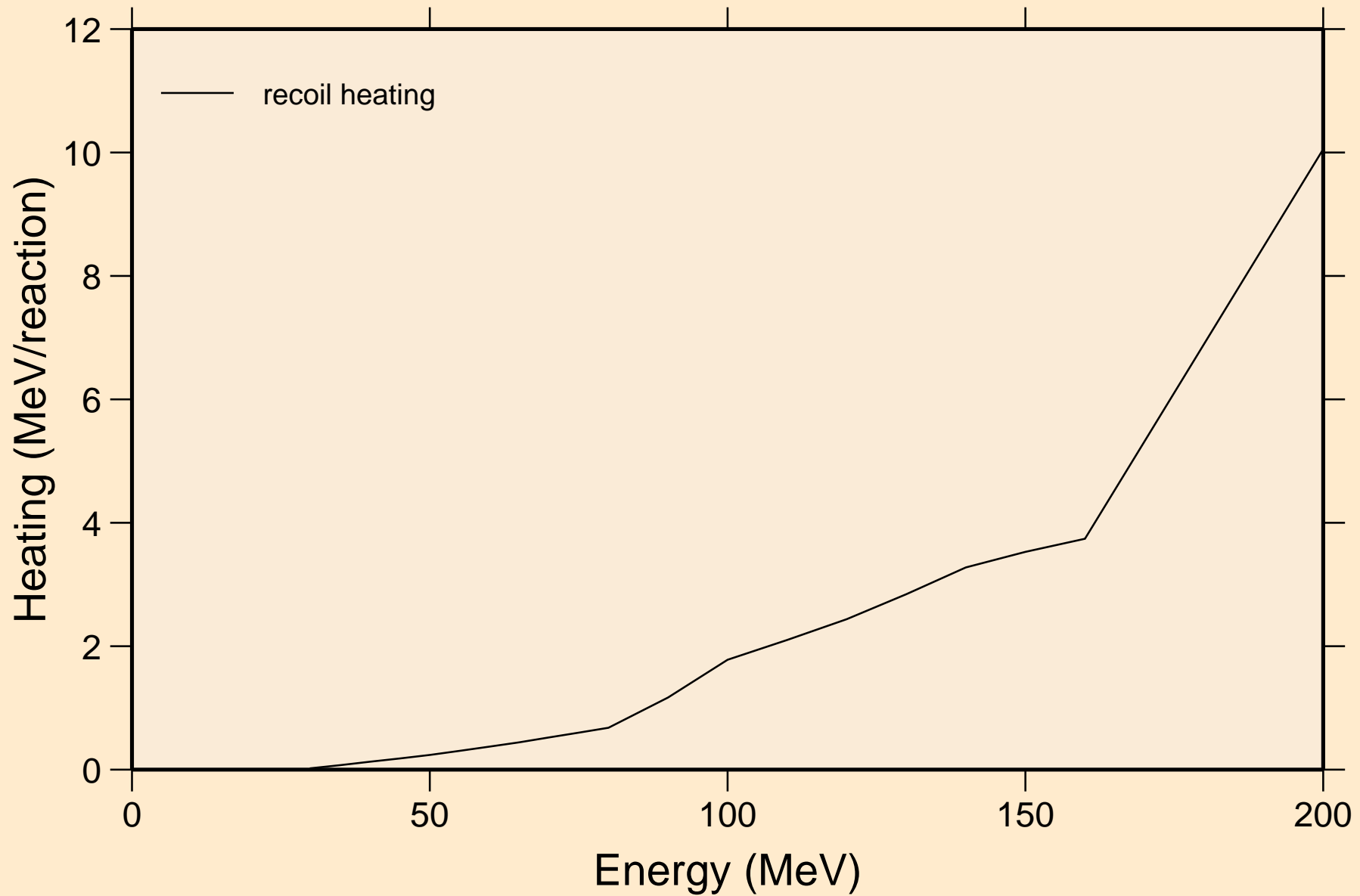

BH265 HELION ACER TENDL-2023 LIBRARY; T=0.K  
Particle production cross sections

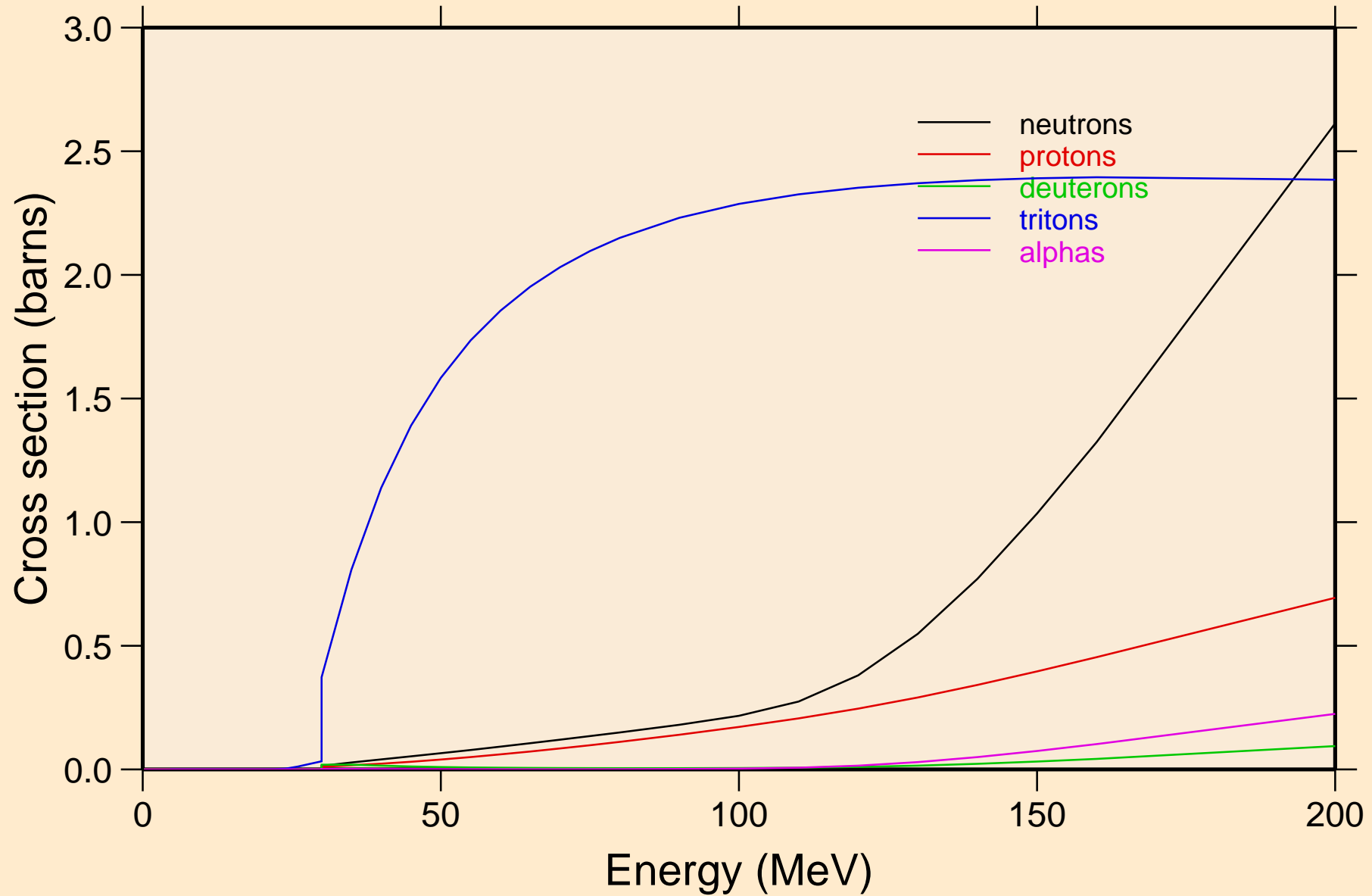

BH265 HELION ACER TENDL-2023 LIBRARY; T=0.K  
neutrons from (s,n)

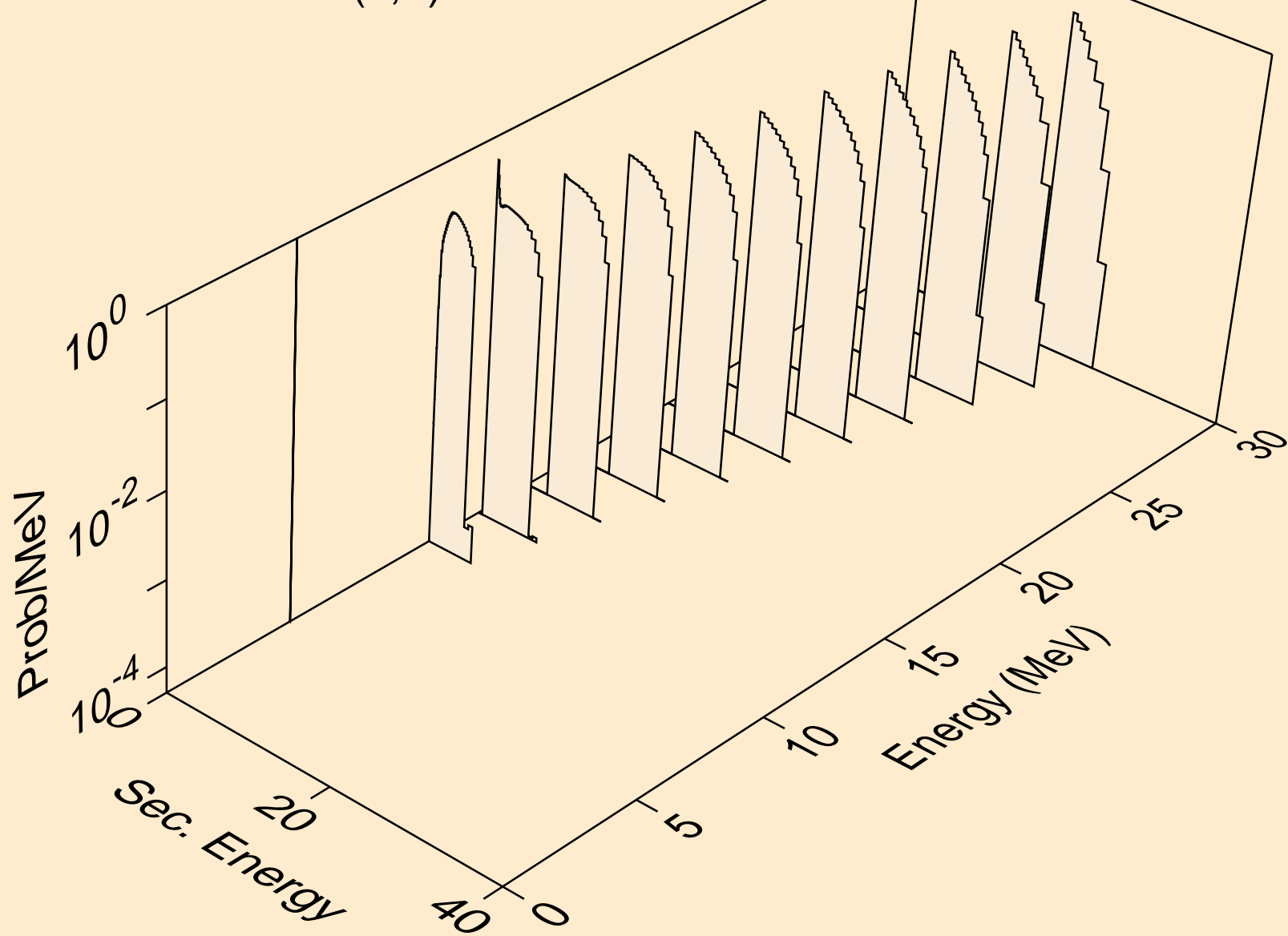

BH265 HELION ACER TENDL-2023 LIBRARY; T=0.K  
neutrons from (s,x)

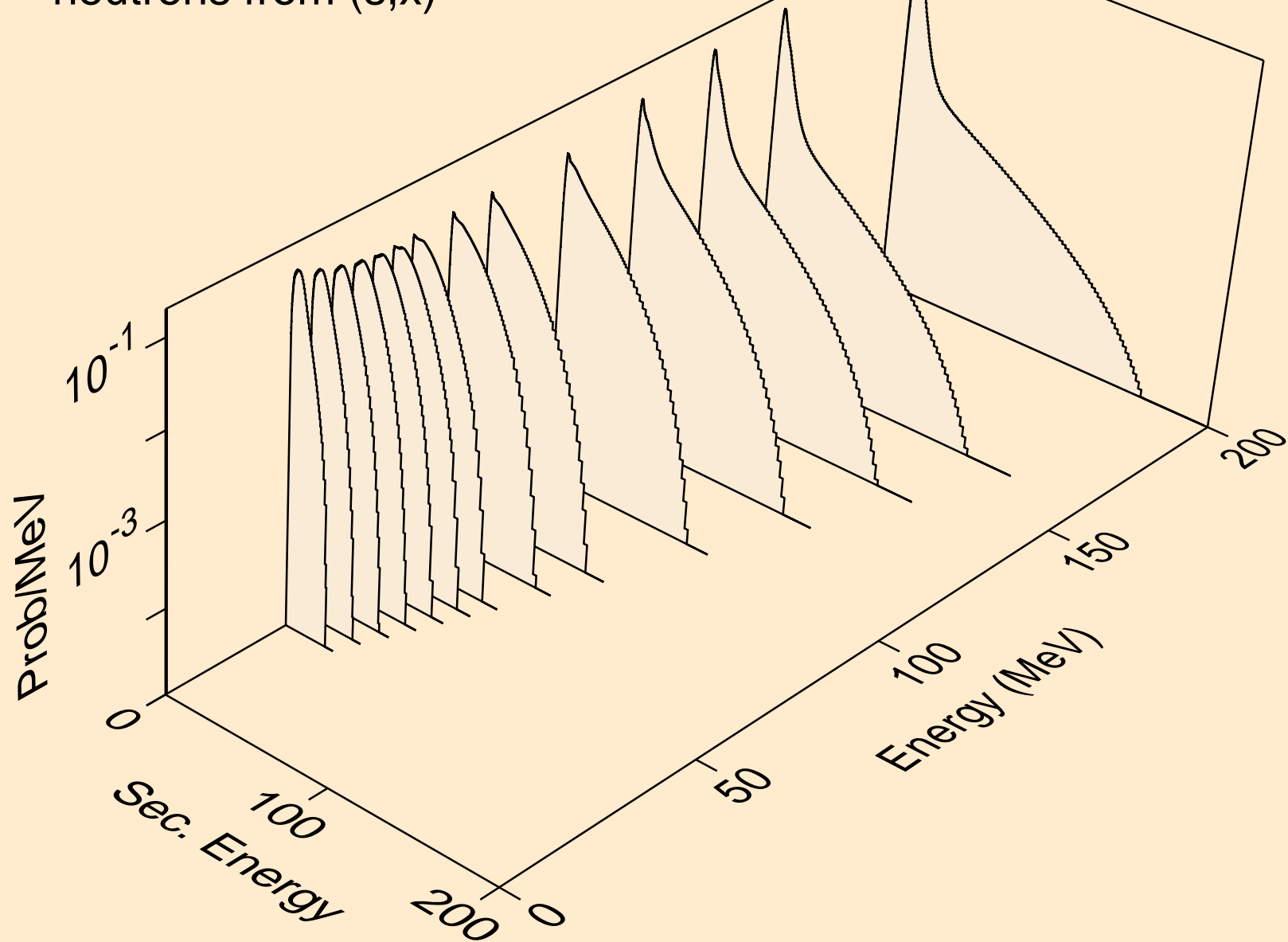

BH265 HELION ACER TENDL-2023 LIBRARY; T=0.K  
neutrons from (s,2n)

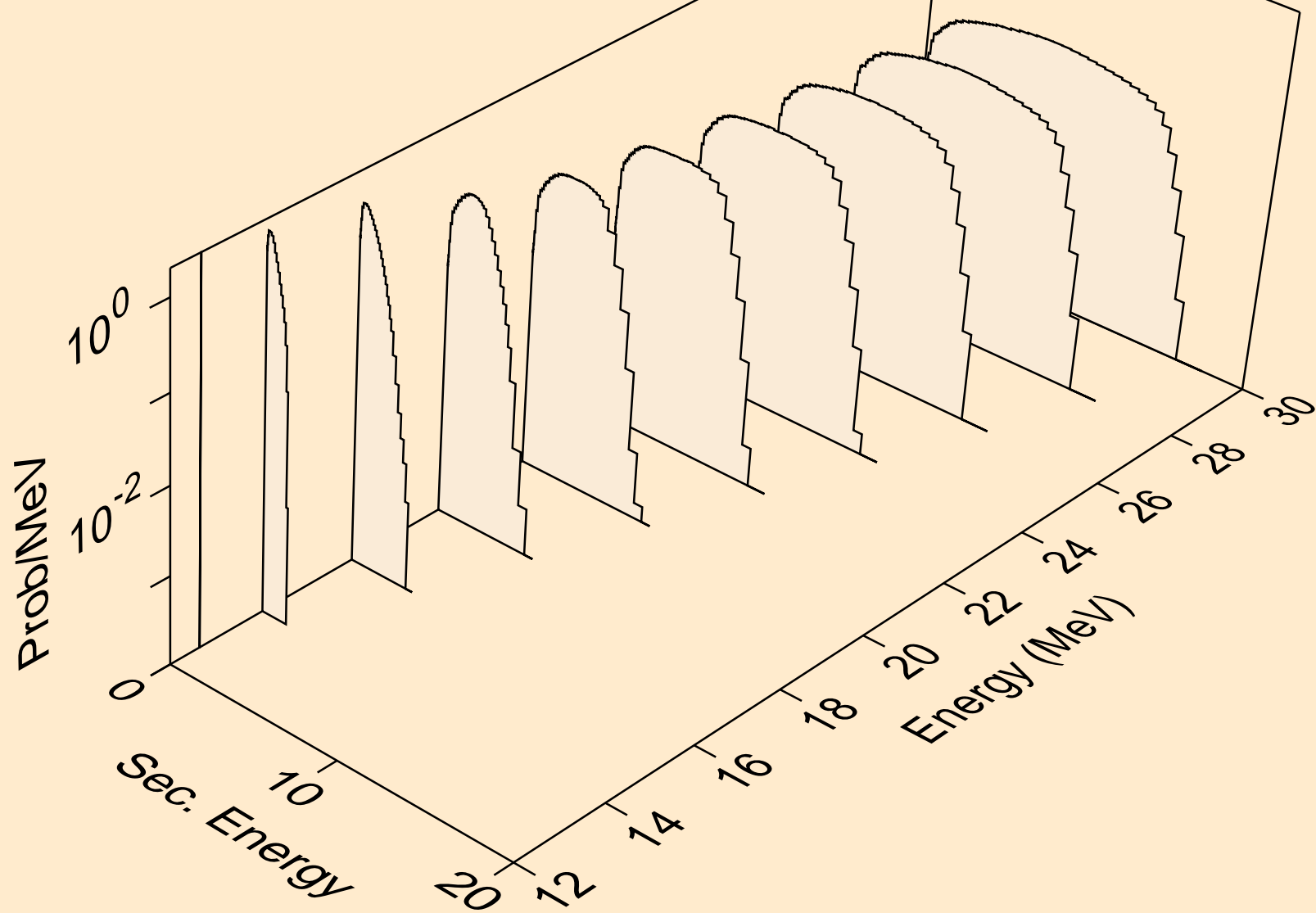

BH265 HELION ACER TENDL-2023 LIBRARY; T=0.K  
neutrons from (s,3n)

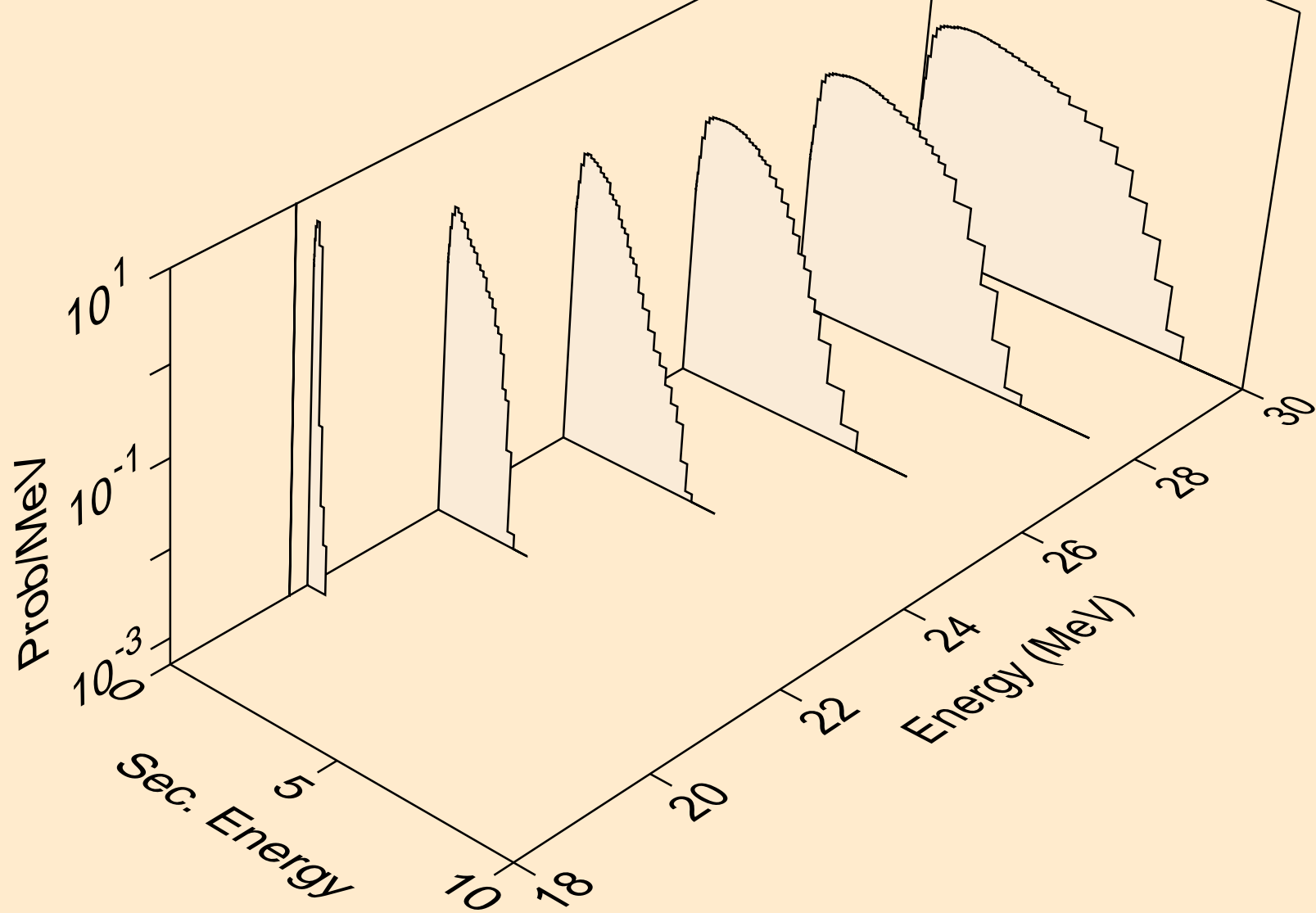

BH265 HELION ACER TENDL-2023 LIBRARY; T=0.K  
neutrons from (s,n\*)a

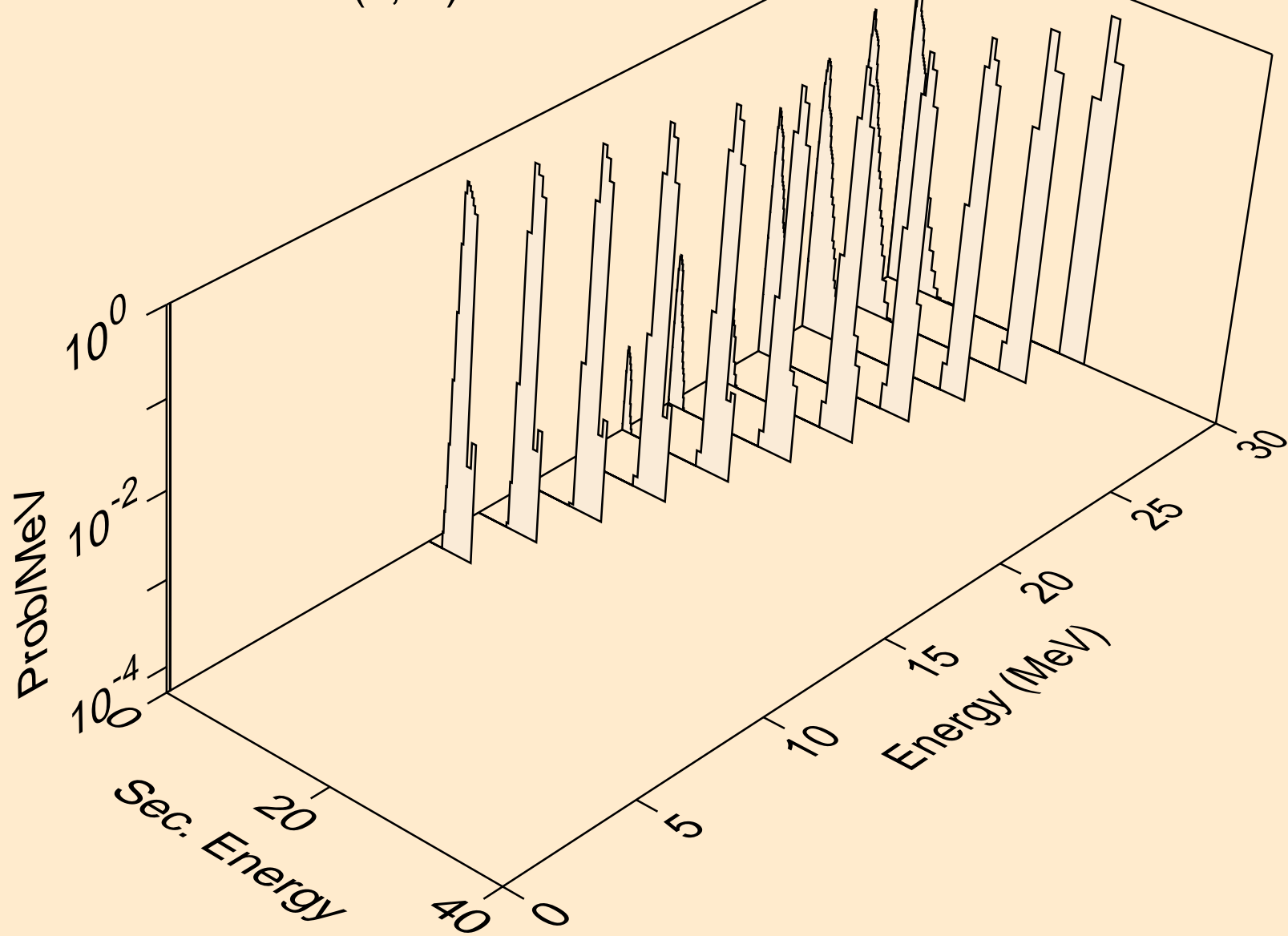

BH265 HELION ACER TENDL-2023 LIBRARY; T=0.K  
neutrons from (s,2n)a

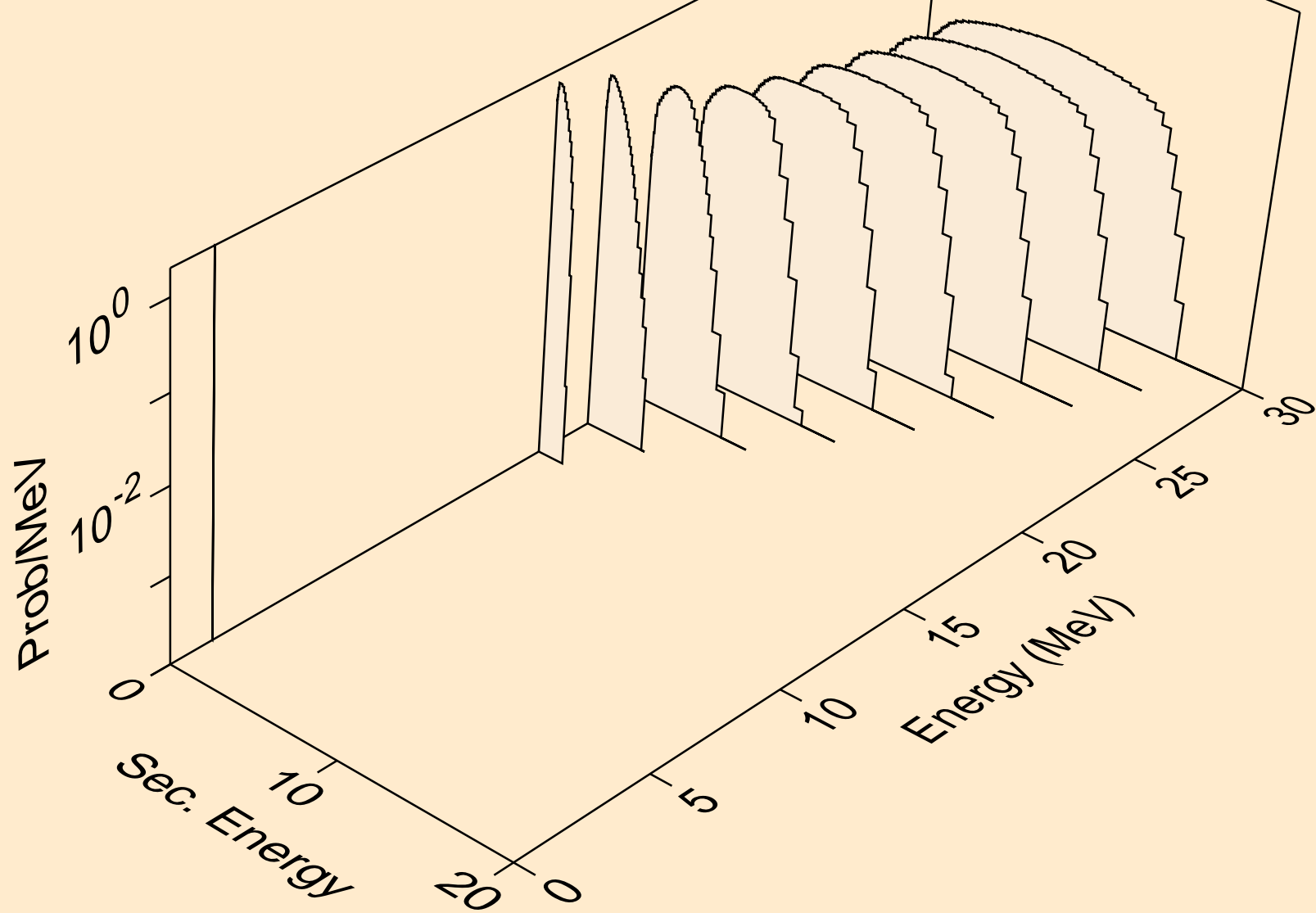

BH265 HELION ACER TENDL-2023 LIBRARY; T=0.K  
neutrons from (s,n\*)p

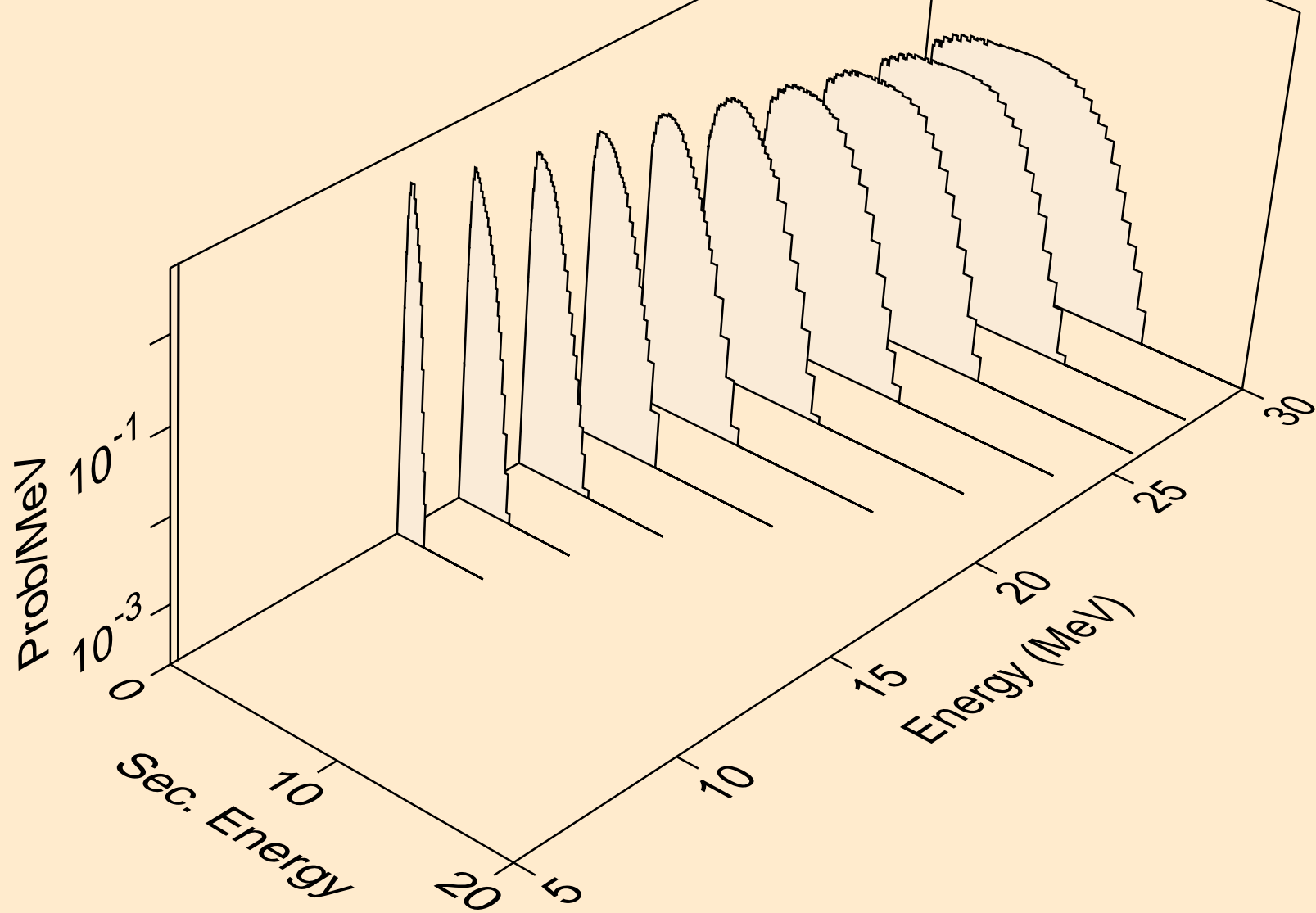

BH265 HELION ACER TENDL-2023 LIBRARY; T=0.K  
neutrons from (s,n\*)d

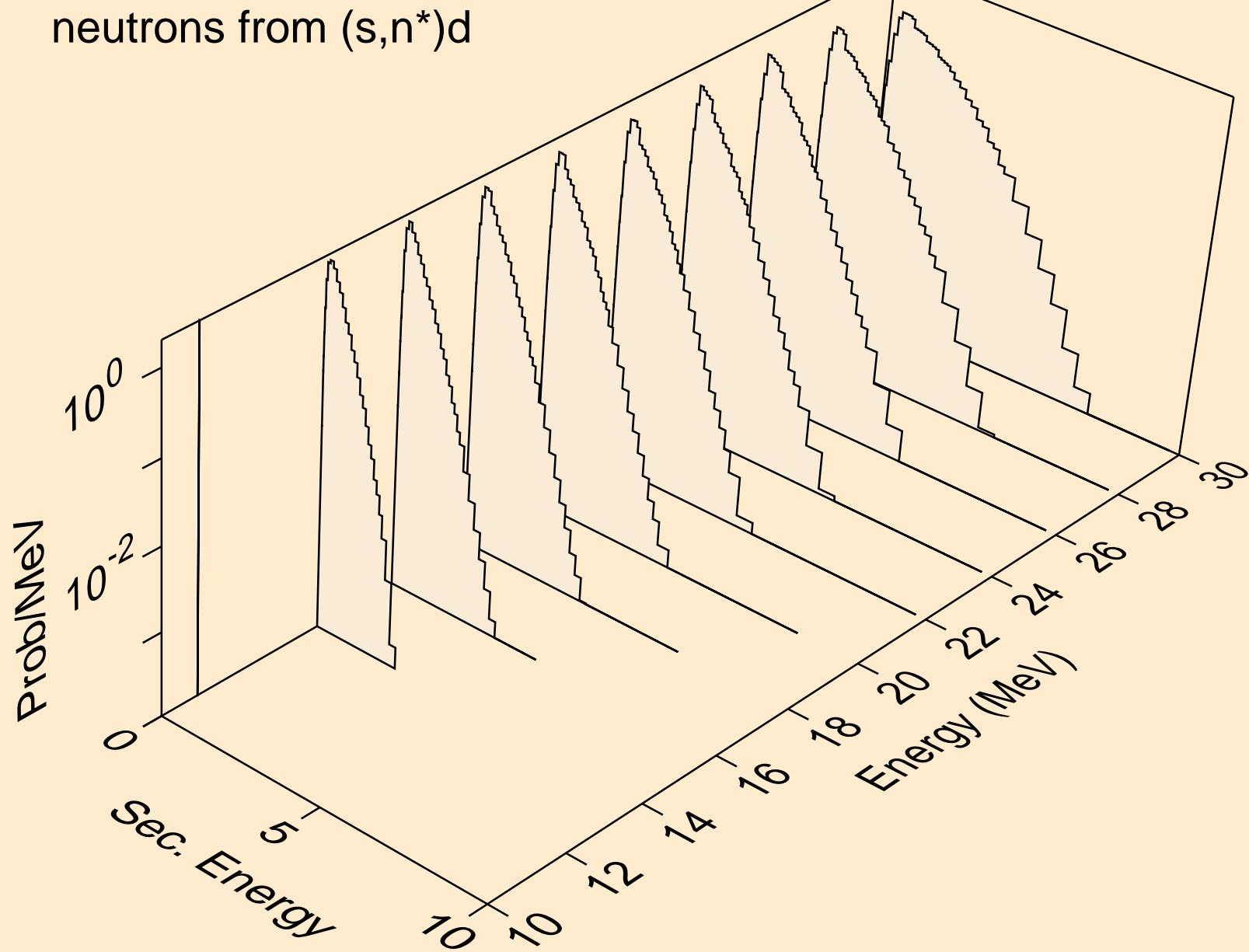

BH265 HELION ACER TENDL-2023 LIBRARY; T=0.K  
neutrons from (s,n\*)t

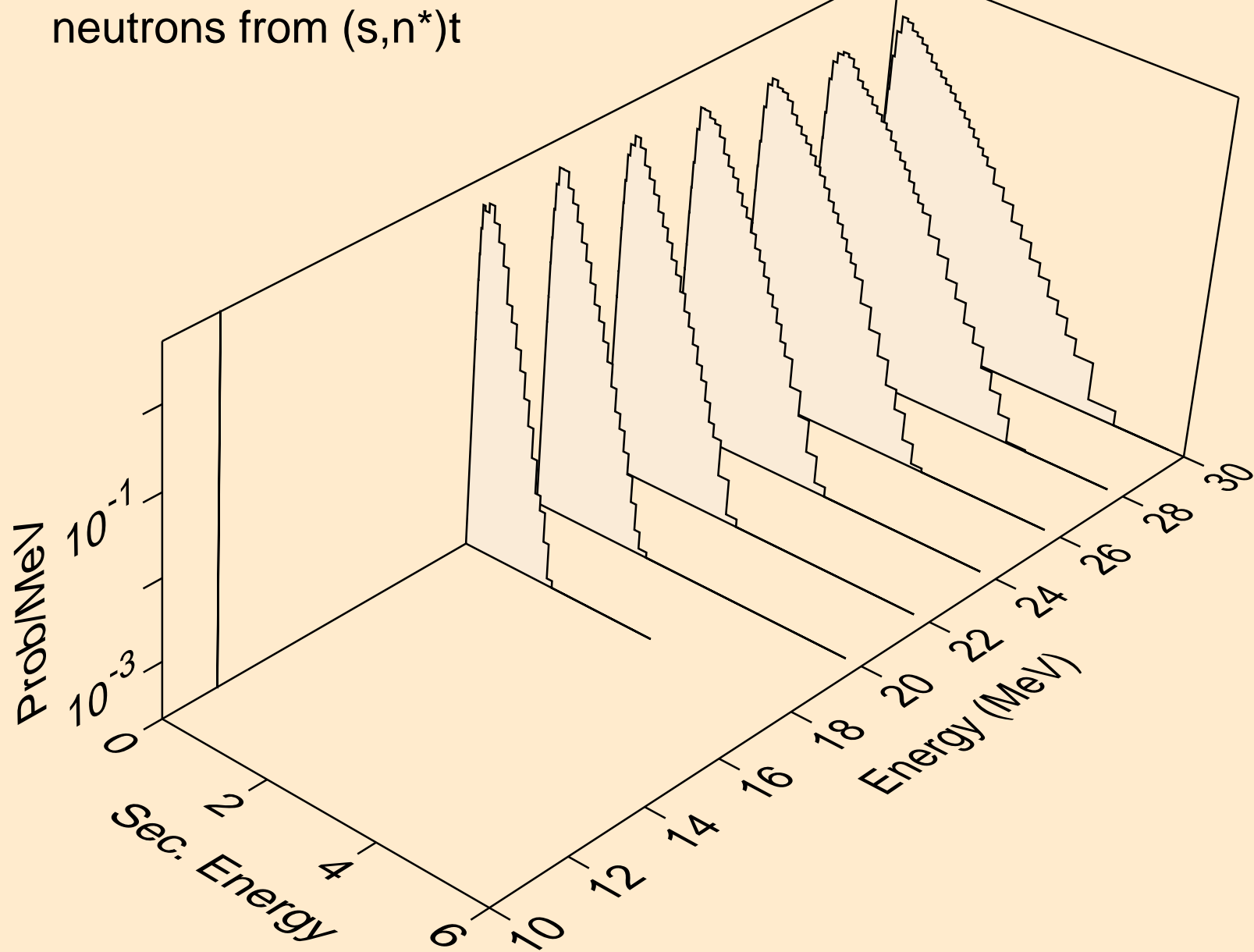

BH265 HELION ACER TENDL-2023 LIBRARY; T=0.K  
neutrons from (s,2np)

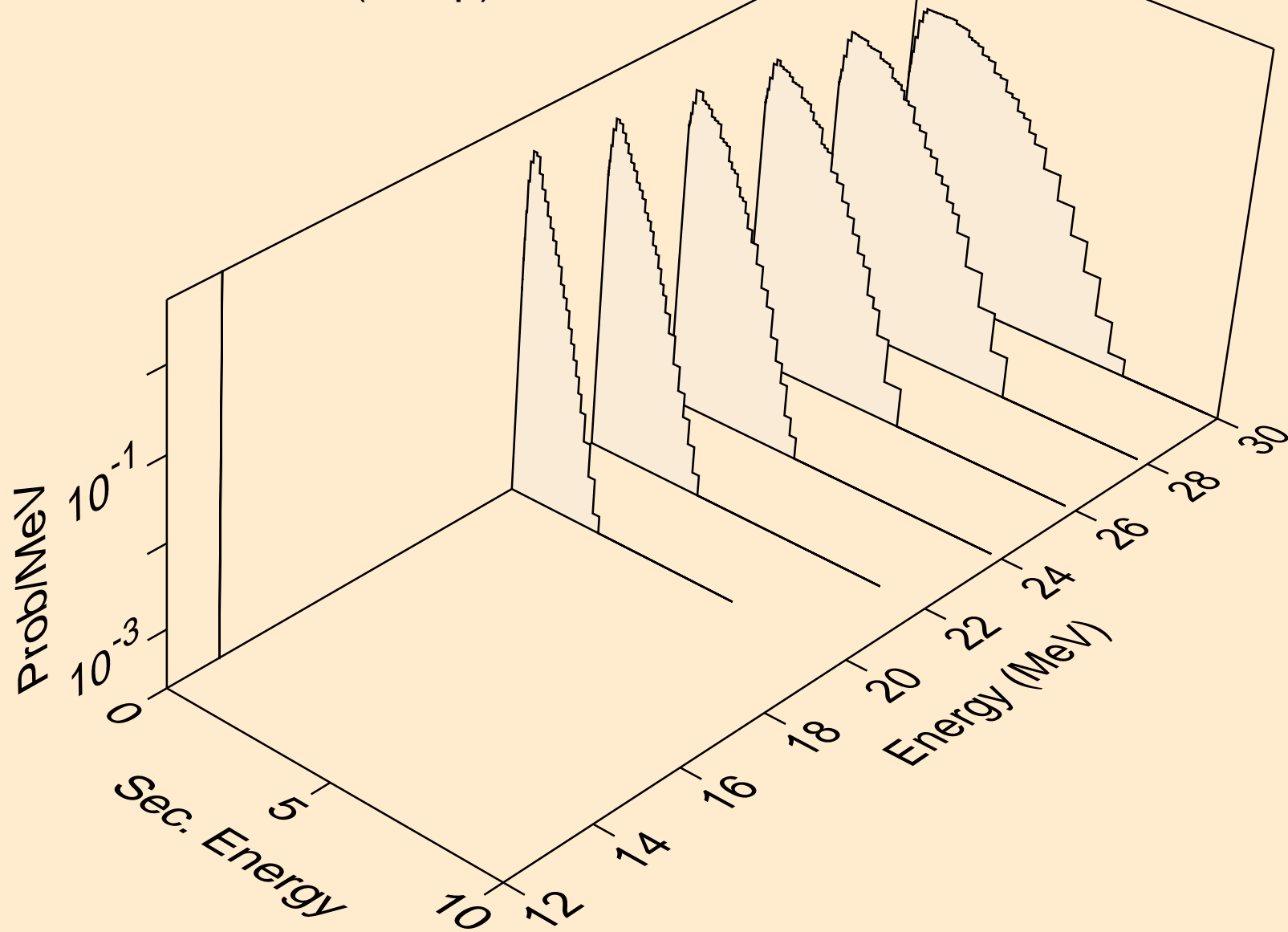

BH265 HELION ACER TENDL-2023 LIBRARY; T=0.K  
neutrons from (s,npa)

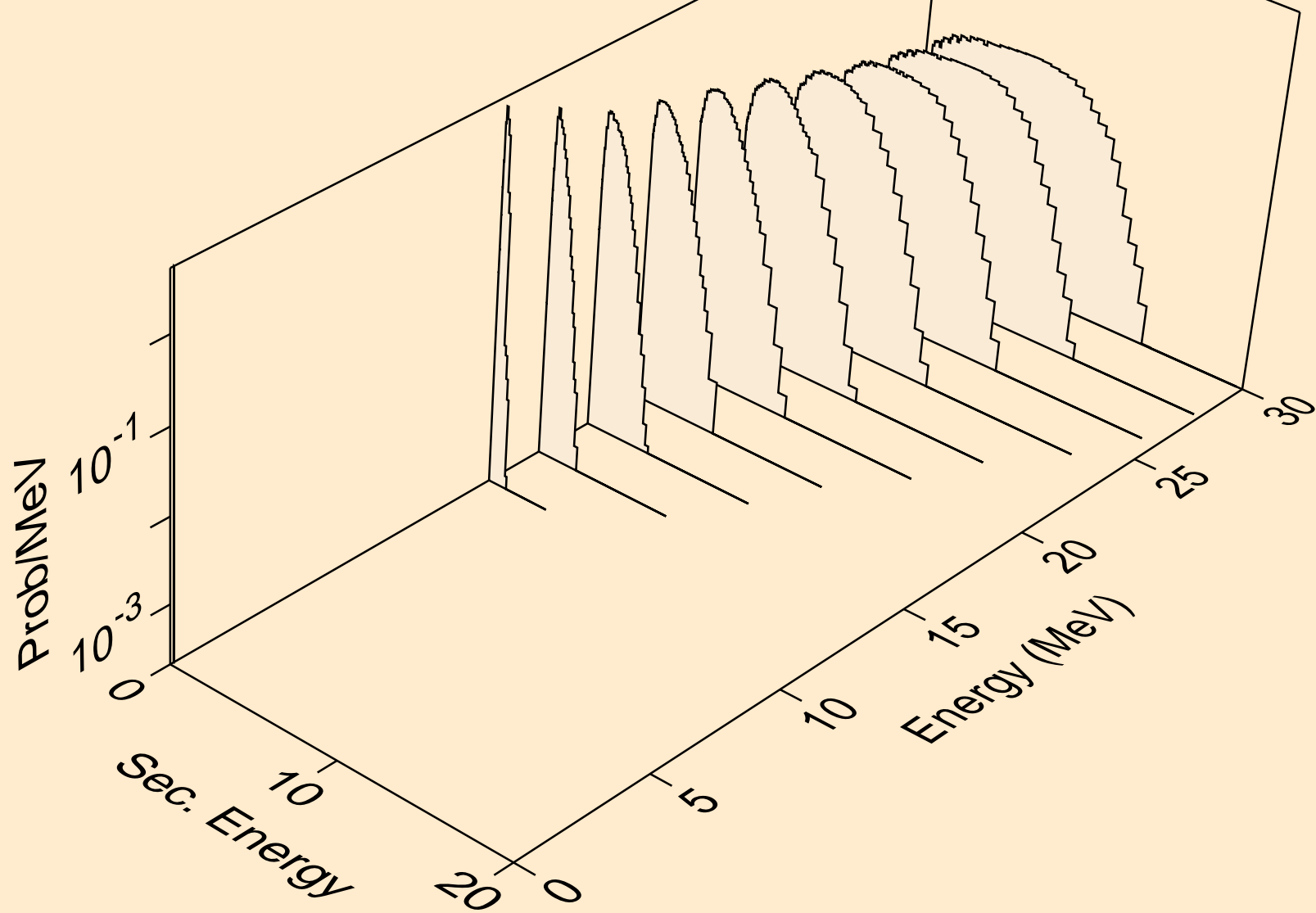

BH265 HELION ACER TENDL-2023 LIBRARY; T=0.K  
protons from (s,x)

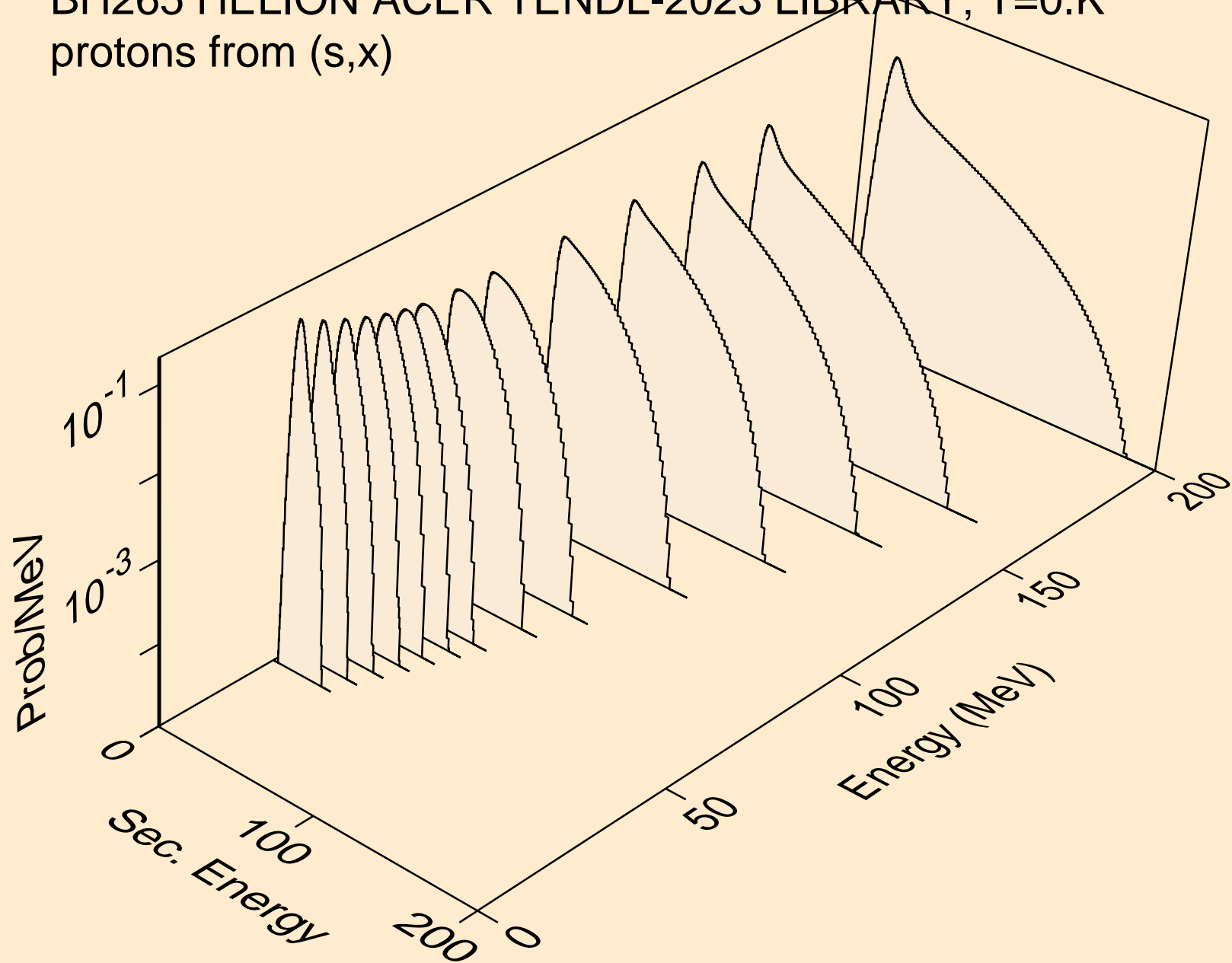

BH265 HELION ACER TENDL-2023 LIBRARY; T=0.K  
protons from (s,n\*)p

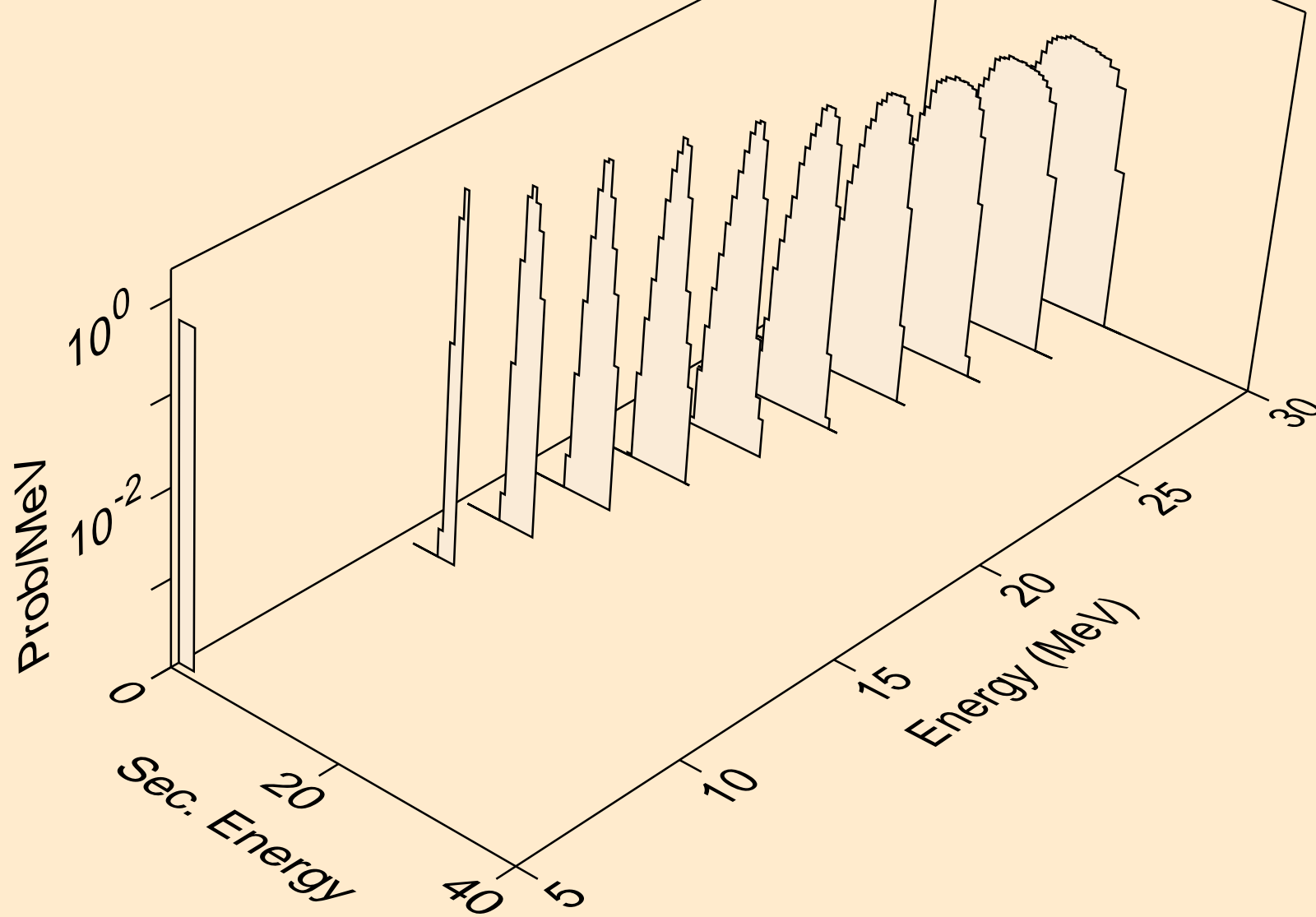

BH265 HELION ACER TENDL-2023 LIBRARY; T=0.K  
protons from (s,2np)

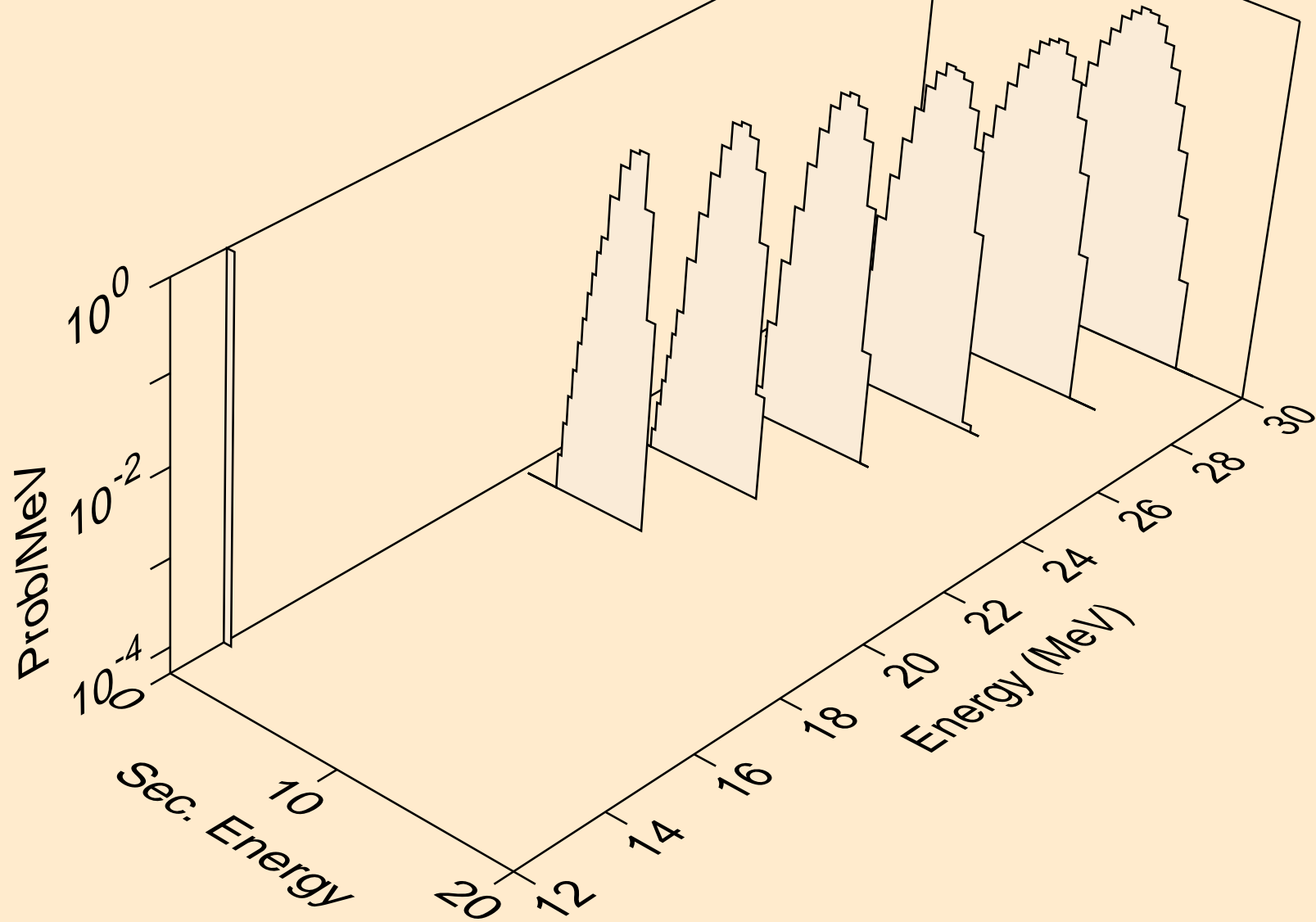

BH265 HELION ACER TENDL-2023 LIBRARY; T=0.K  
protons from (s,npa)

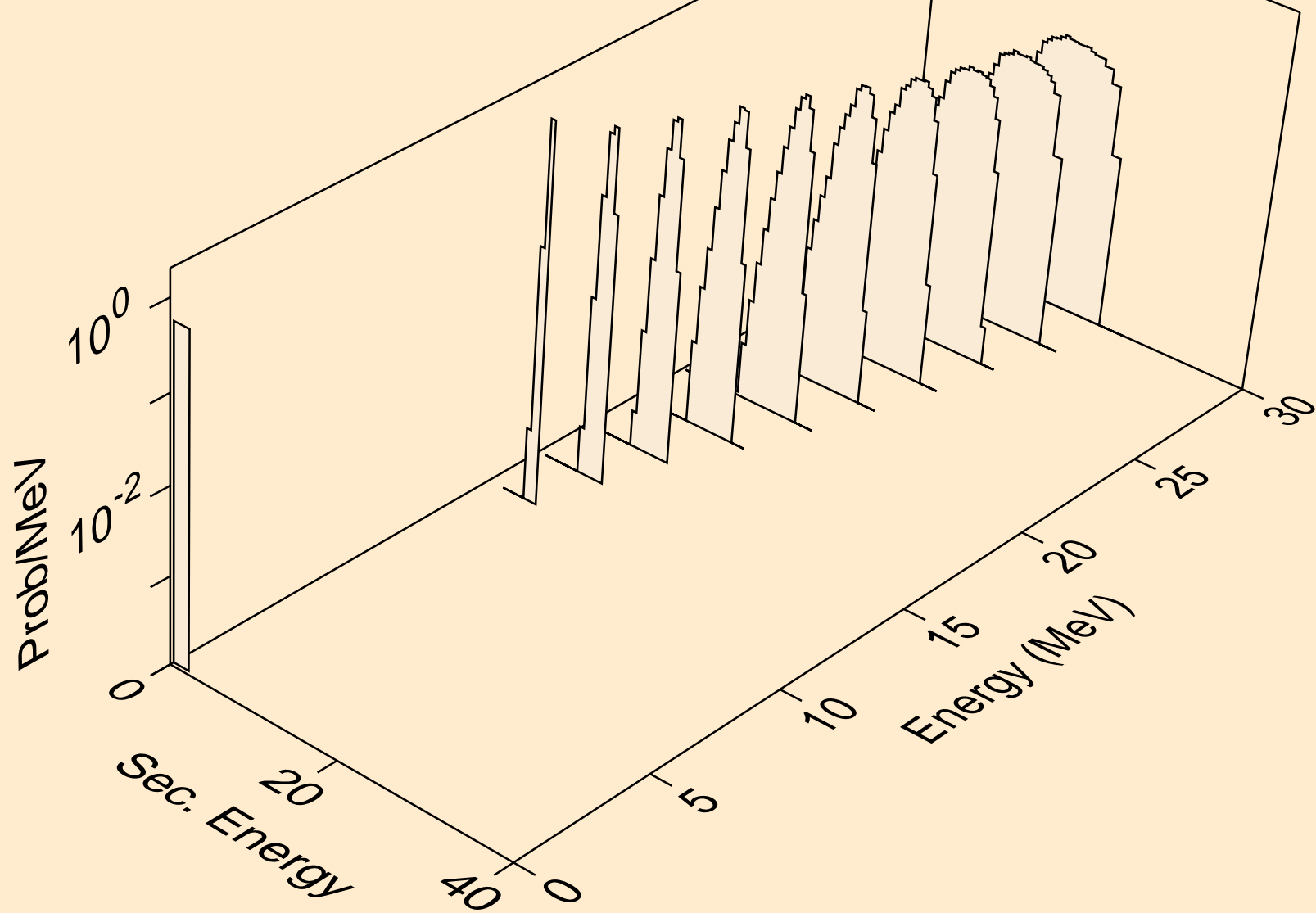

BH265 HELION ACER TENDL-2023 LIBRARY; T=0.K  
protons from (s,p)

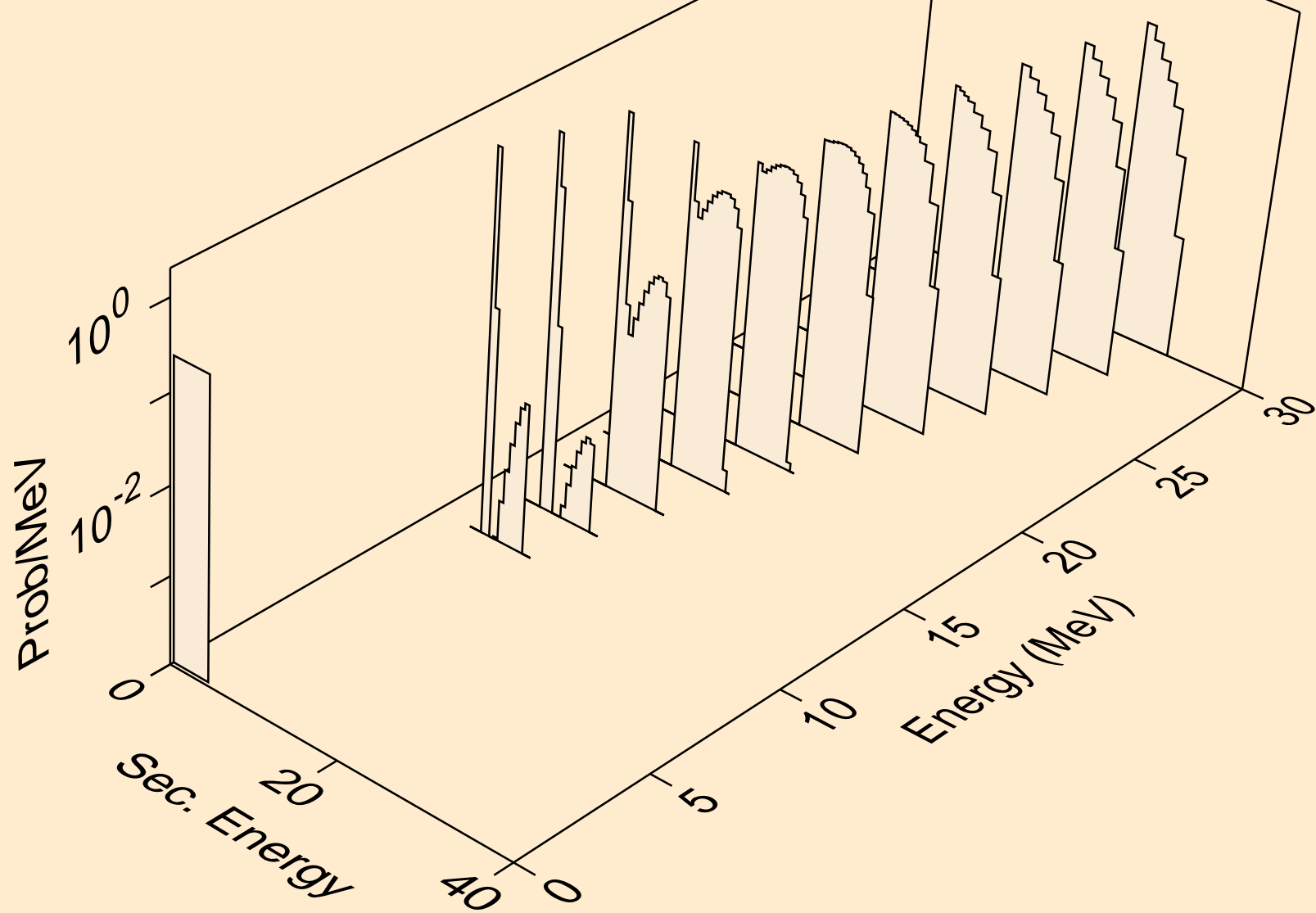

BH265 HELION ACER TENDL-2023 LIBRARY; T=0.K  
protons from (s,2p)

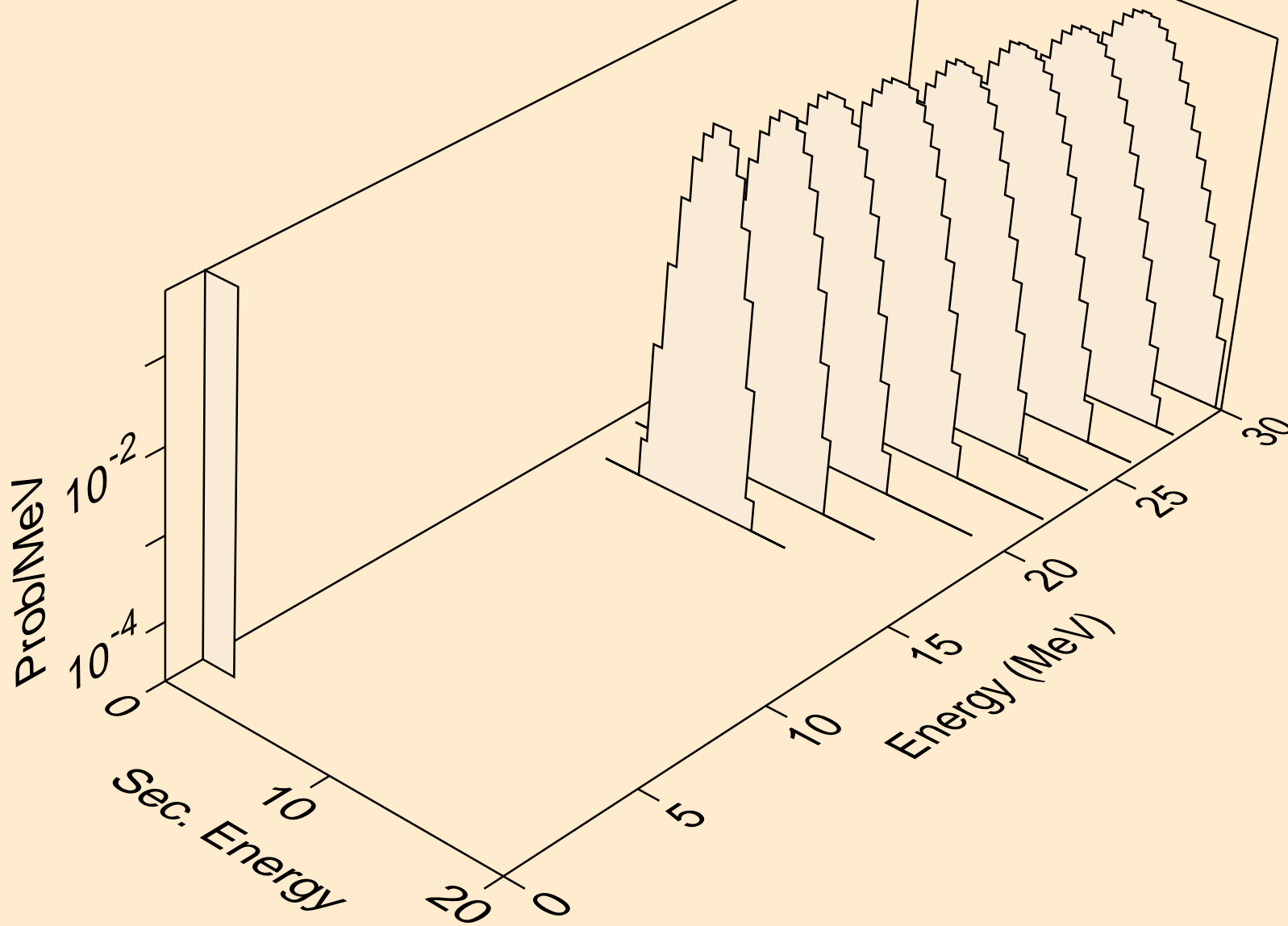

BH265 HELION ACER TENDL-2023 LIBRARY; T=0.K  
protons from (s,pa)

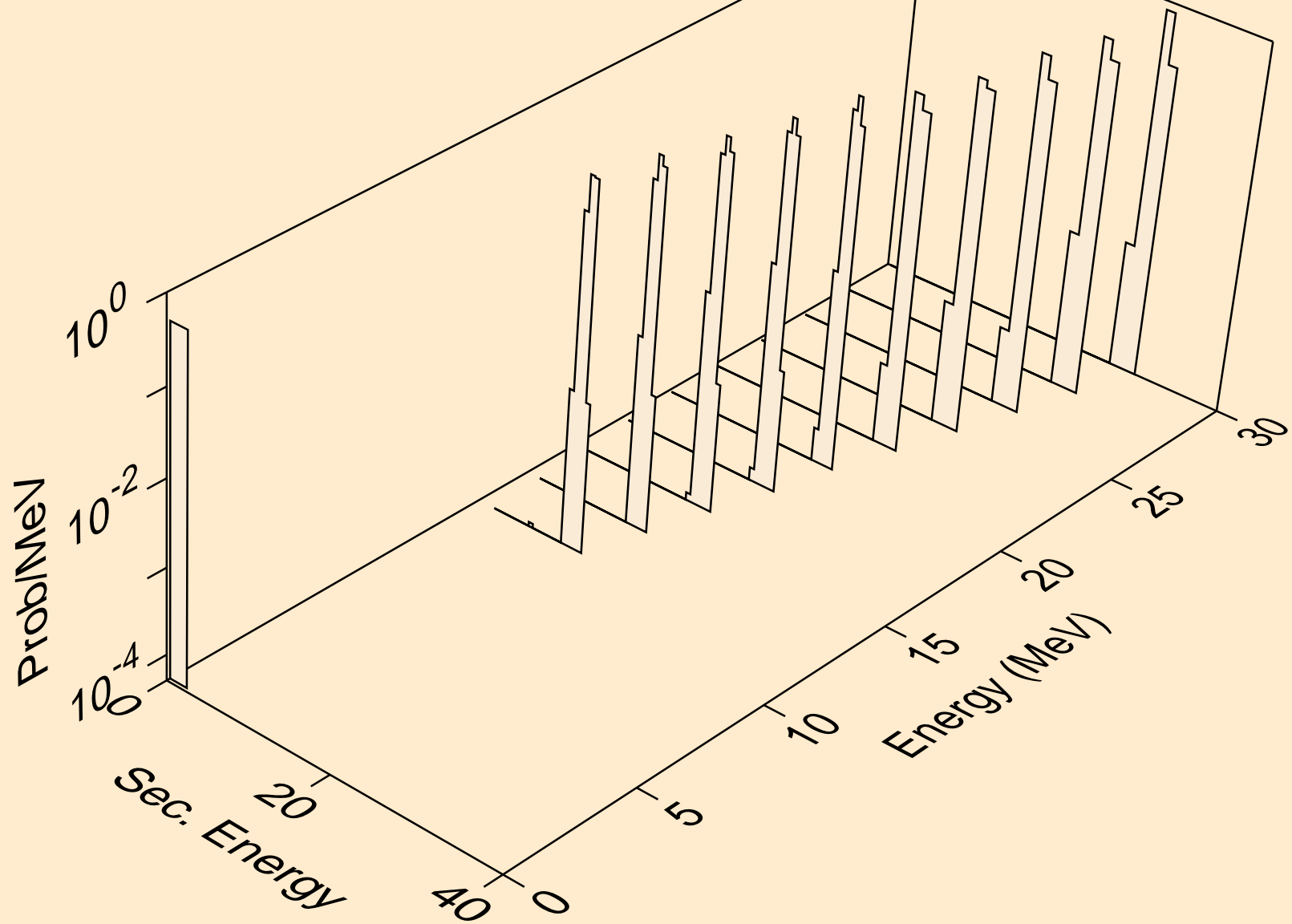

BH265 HELION ACER TENDL-2023 LIBRARY; T=0.K  
deuterons from (s,x)

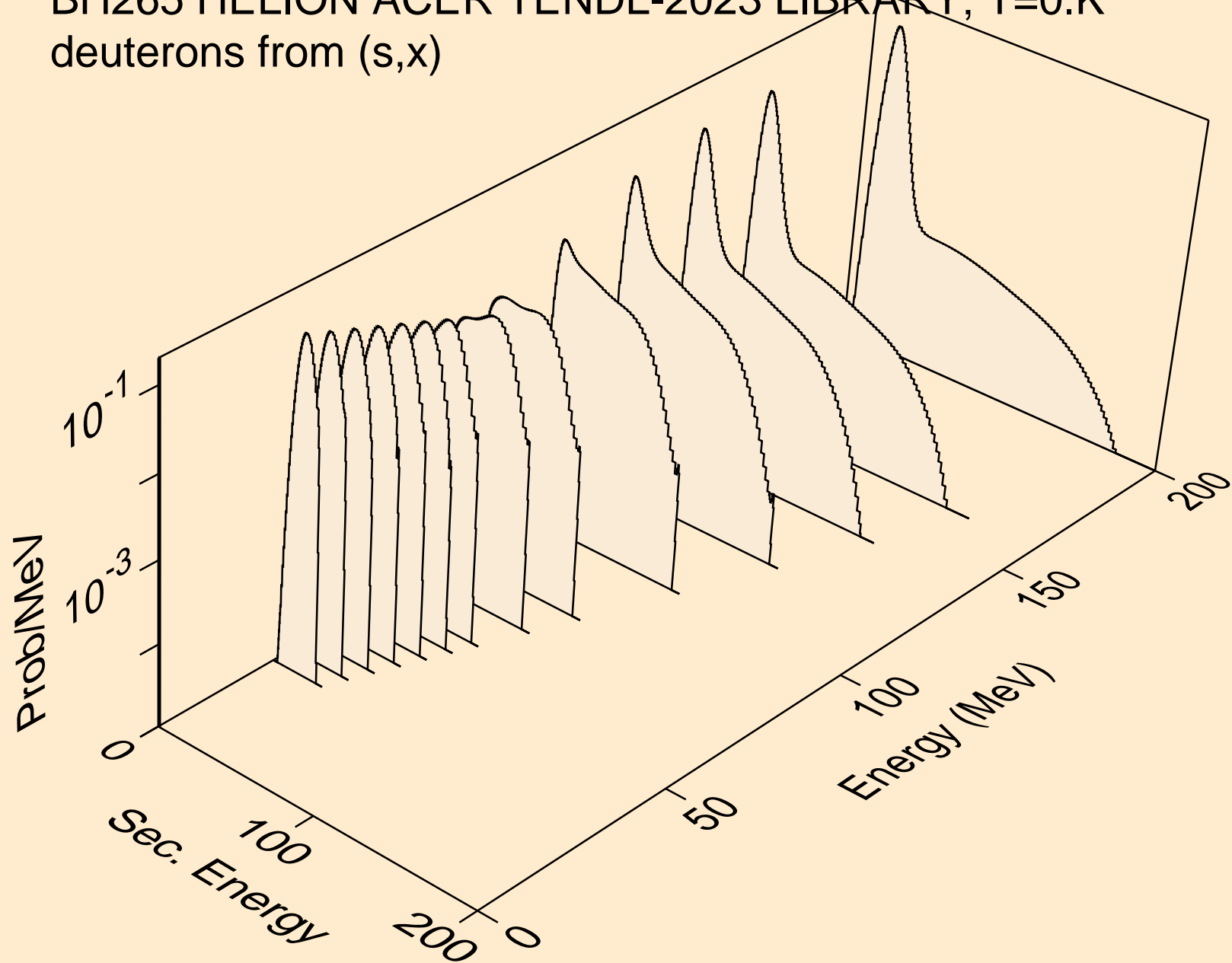

BH265 HELION ACER TENDL-2023 LIBRARY; T=0.K  
deuterons from (s,n\*)d

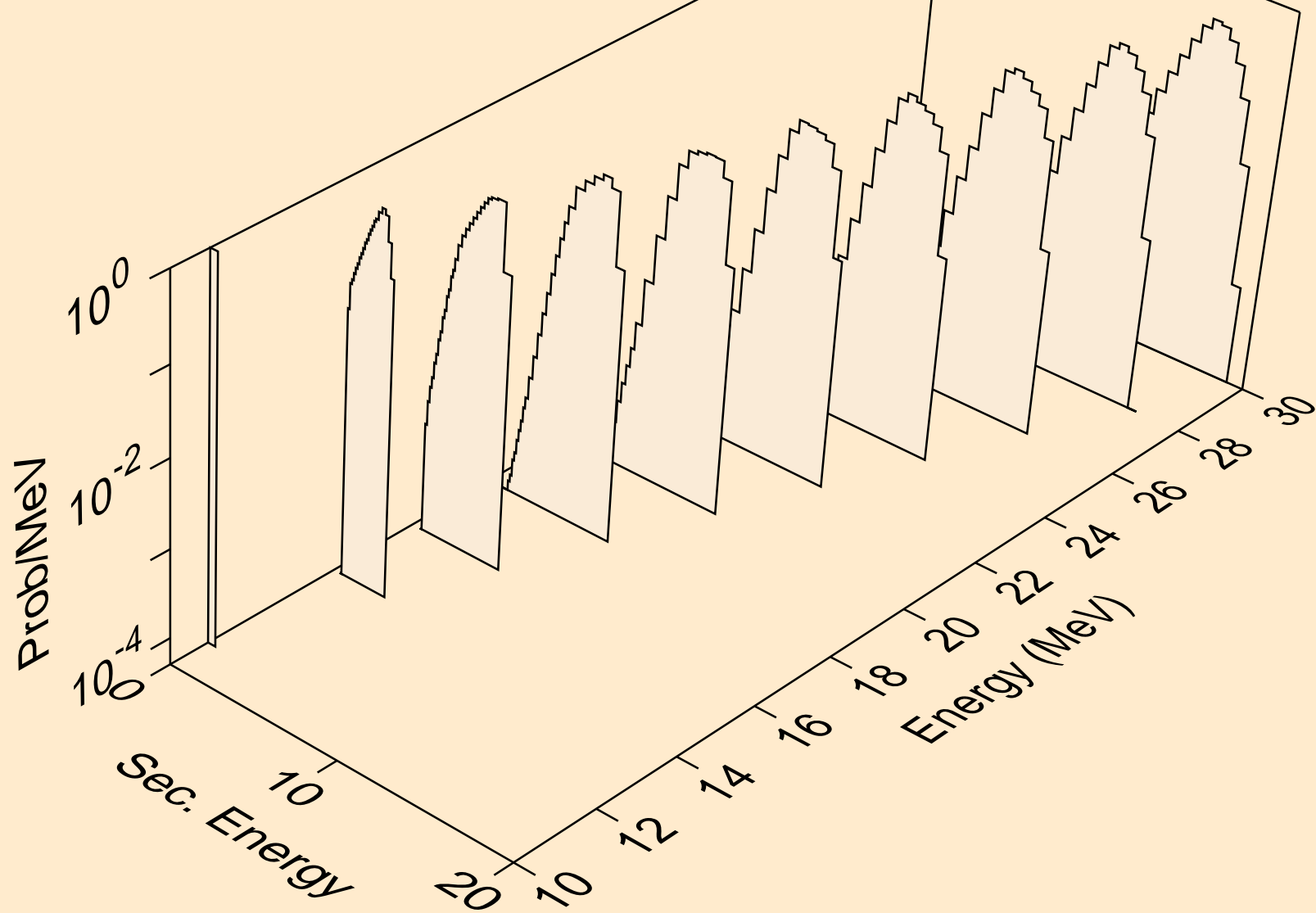

BH265 HELION ACER TENDL-2023 LIBRARY; T=0.K  
deuterons from (s,d)

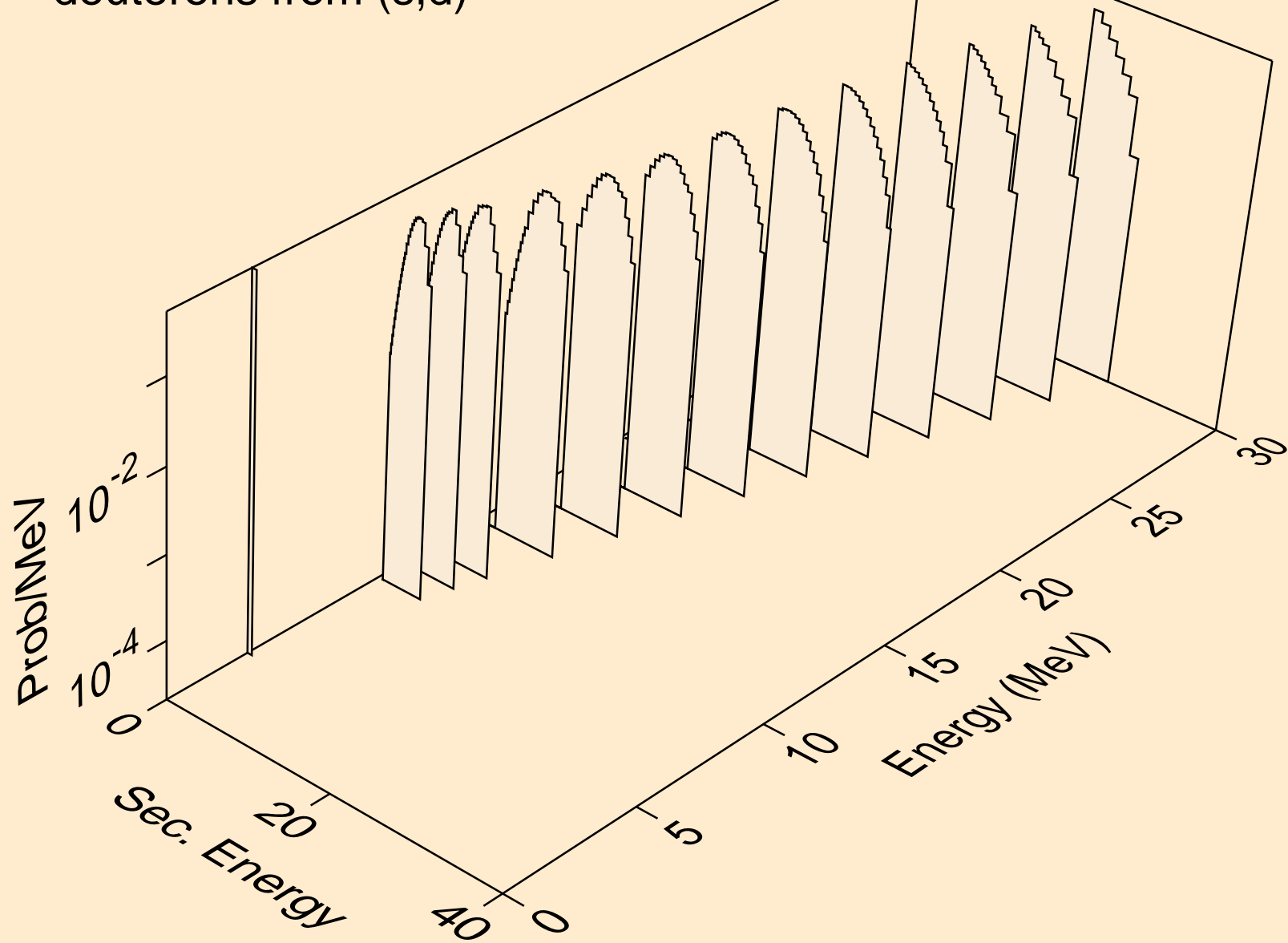

BH265 HELION ACER TENDL-2023 LIBRARY; T=0.K  
deuterons from (s,da)

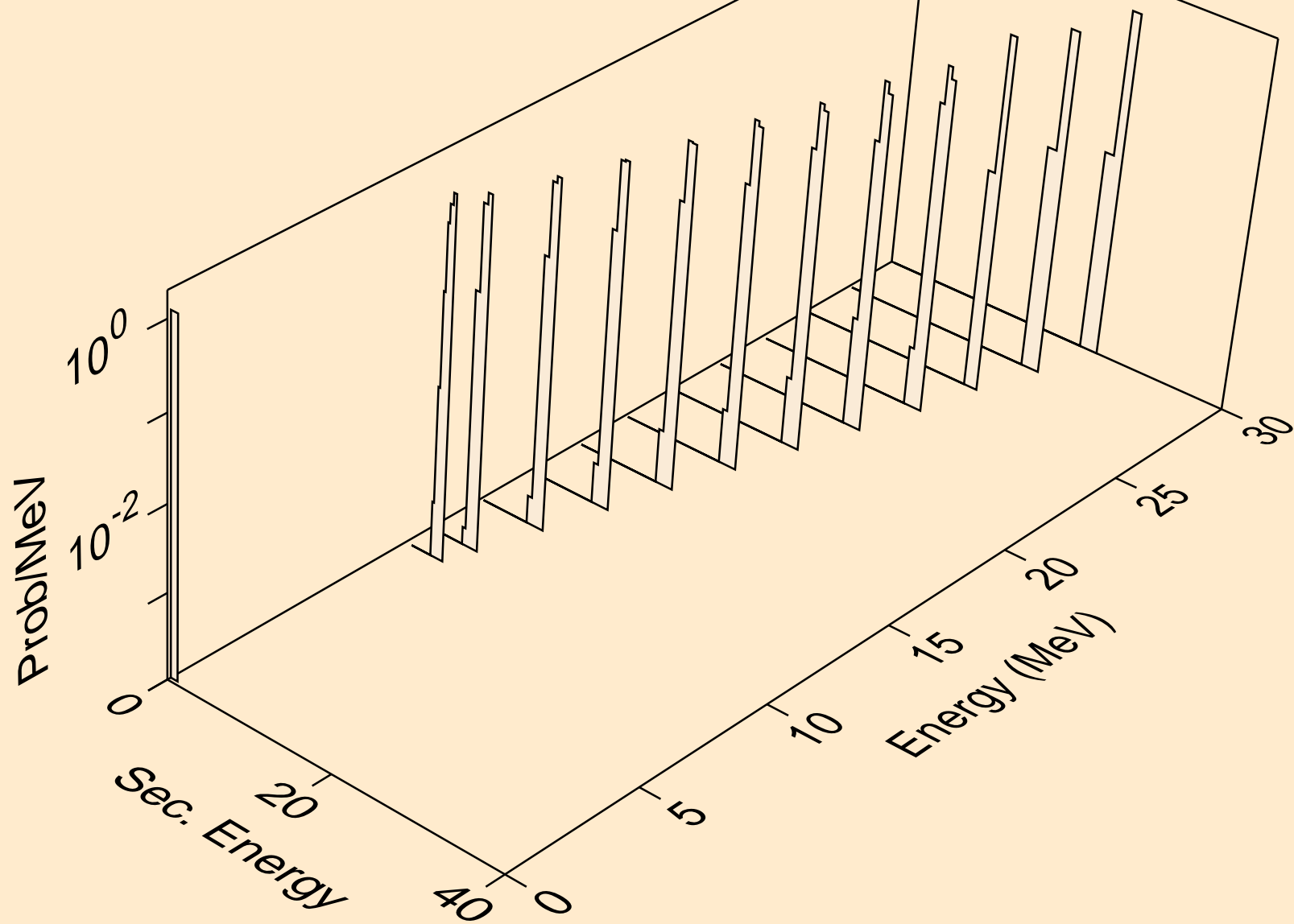

BH265 HELION ACER TENDL-2023 LIBRARY; T=0.K  
tritons from (s,x)

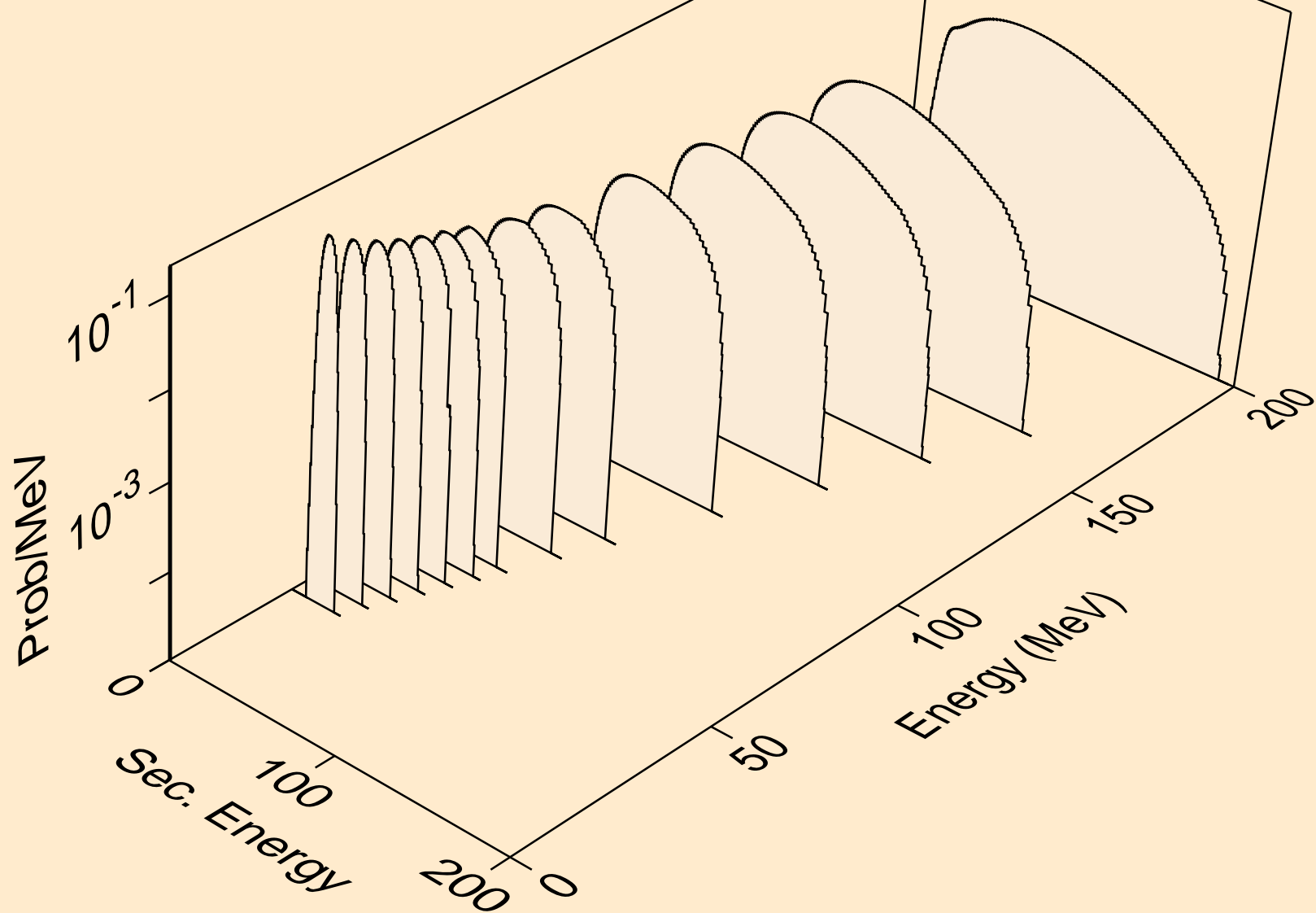

BH265 HELION ACER TENDL-2023 LIBRARY; T=0.K  
tritons from (s,n\*)t

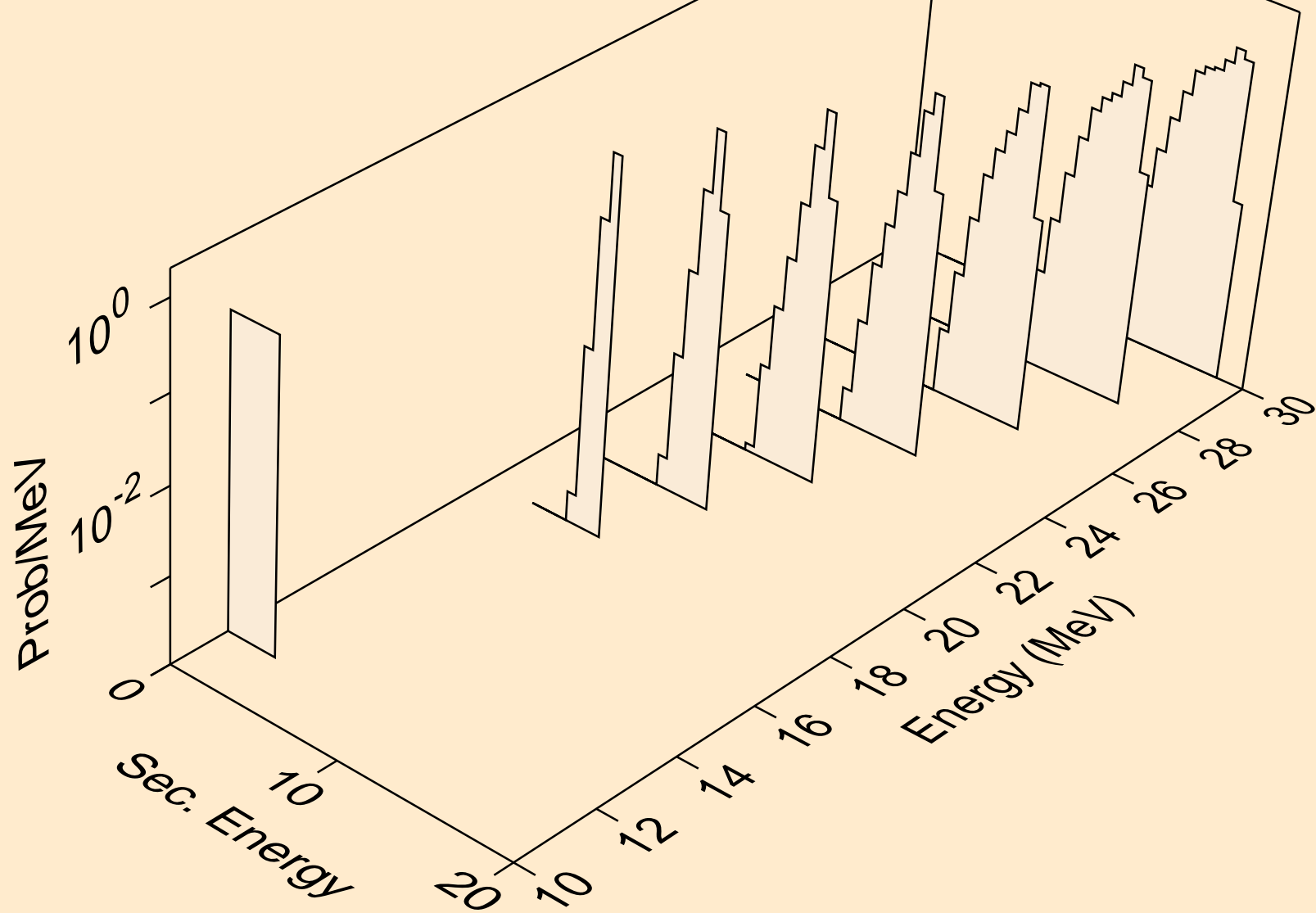

BH265 HELION ACER TENDL-2023 LIBRARY; T=0.K  
tritons from (s,t)

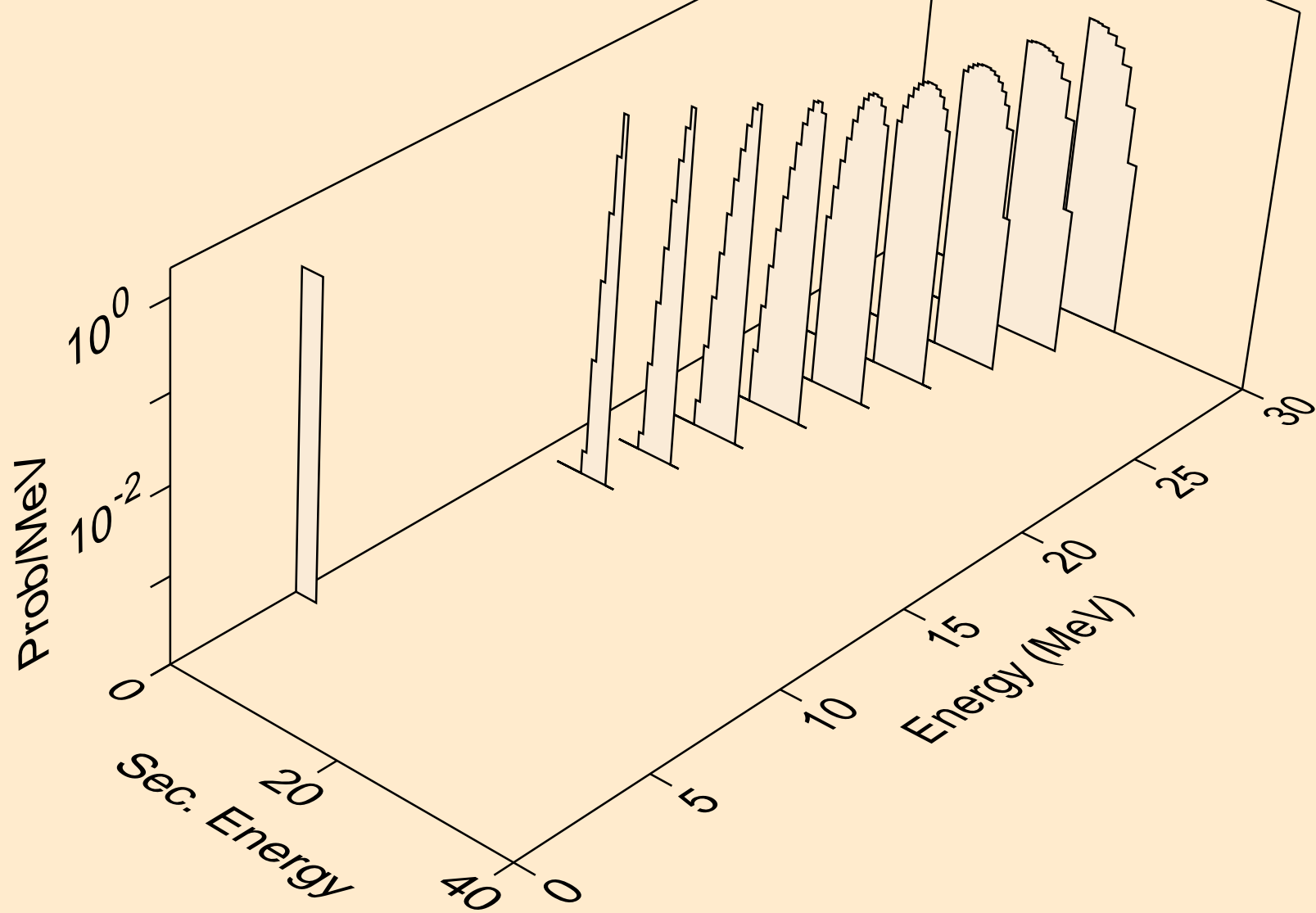

BH265 HELION ACER TENDL-2023 LIBRARY; T=0.K  
alphas from (s,x)

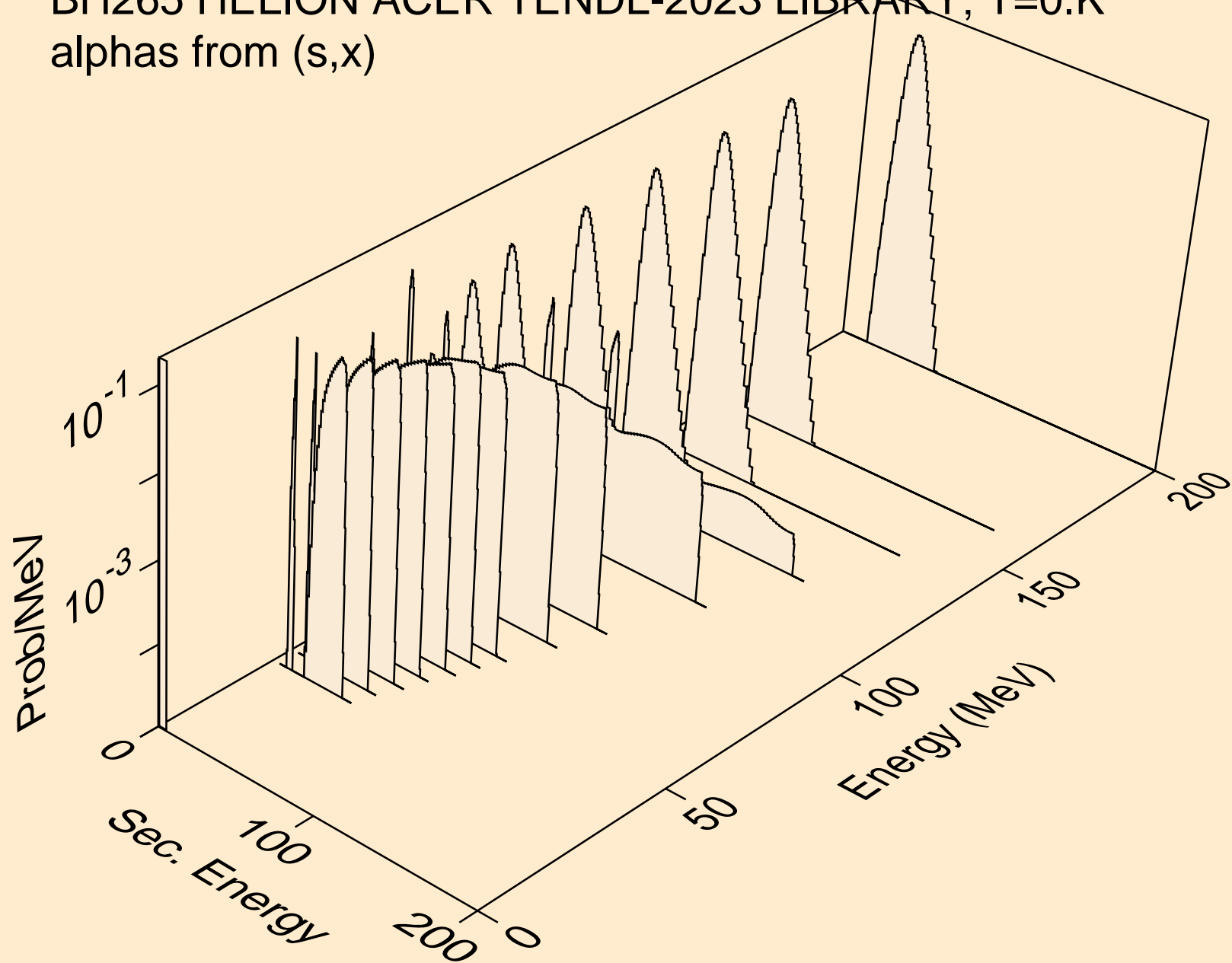

BH265 HELION ACER TENDL-2023 LIBRARY; T=0.K  
alphas from (s,n\*)a

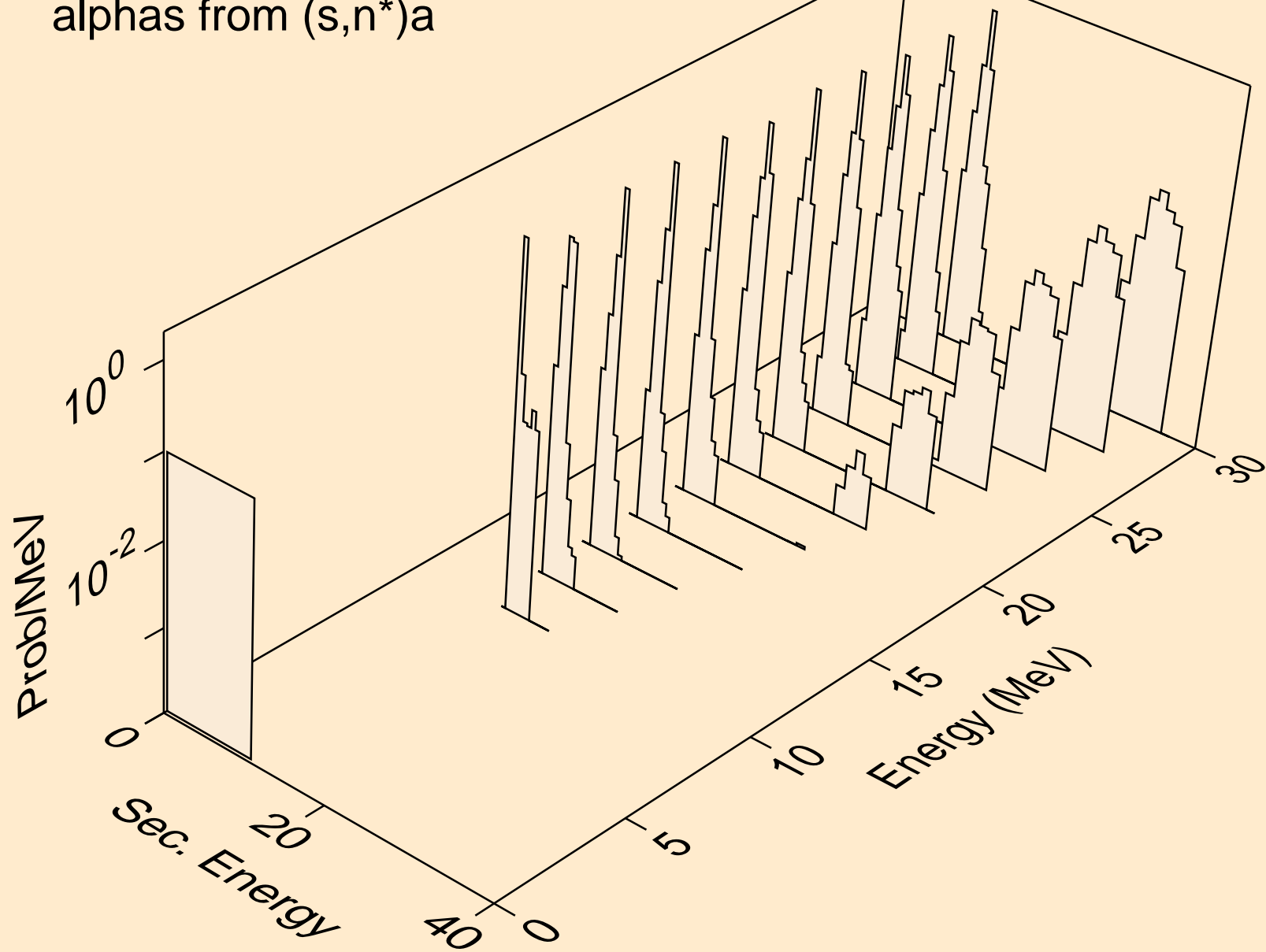

BH265 HELION ACER TENDL-2023 LIBRARY; T=0.K  
alphas from (s,2n)a

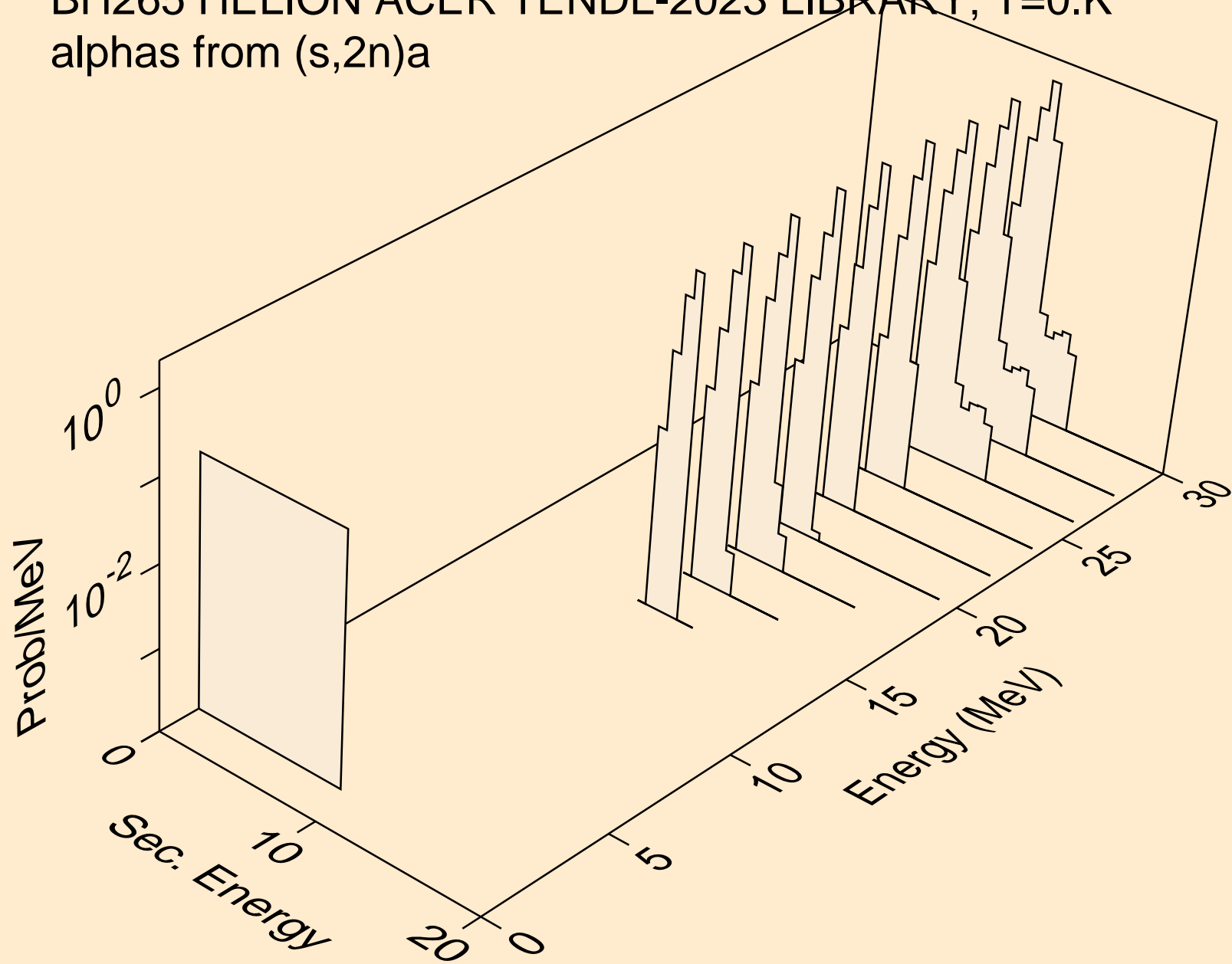

BH265 HELION ACER TENDL-2023 LIBRARY; T=0.K  
alphas from (s,npa)

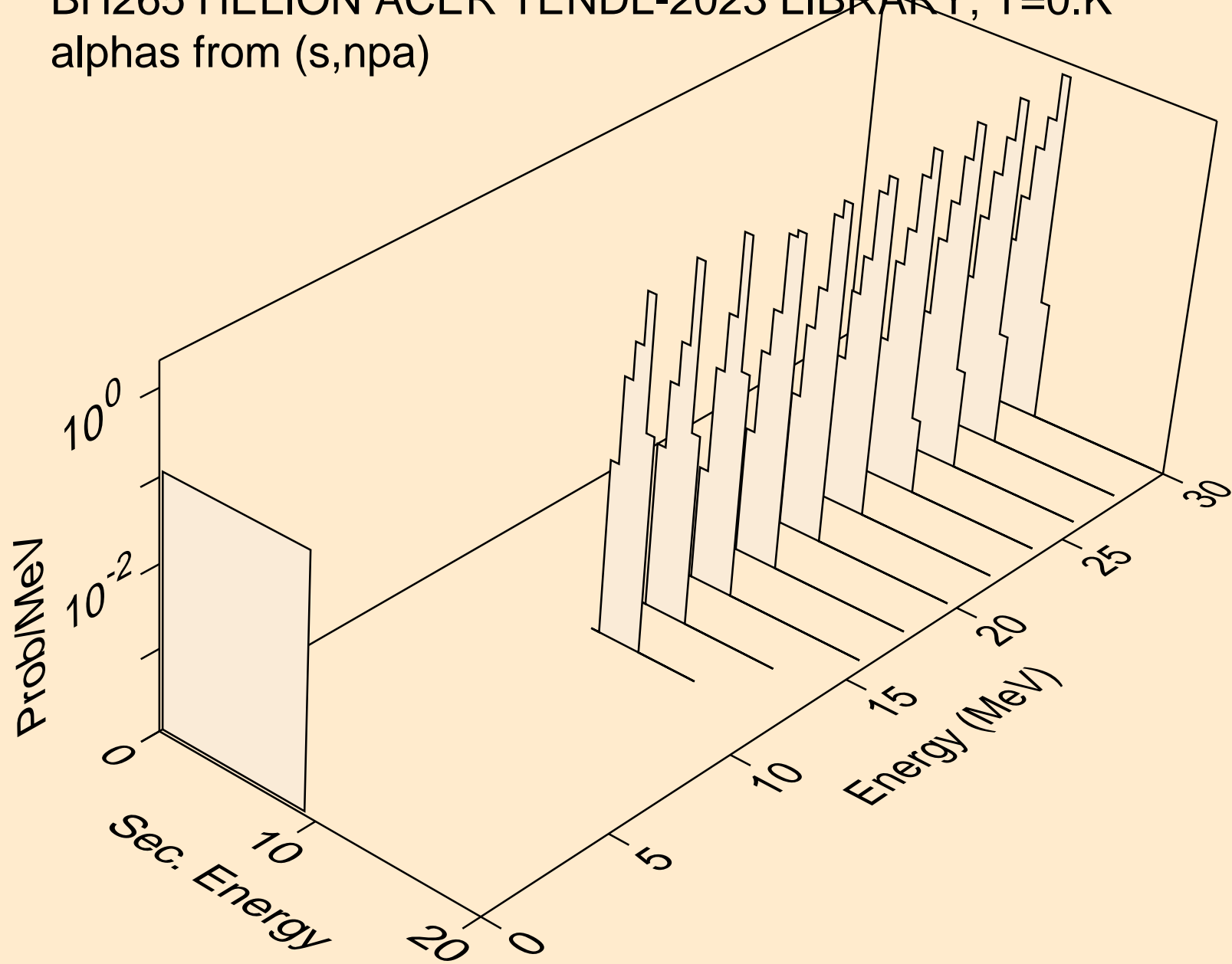

BH265 HELION ACER TENDL-2023 LIBRARY; T=0.K  
alphas from (s,a)

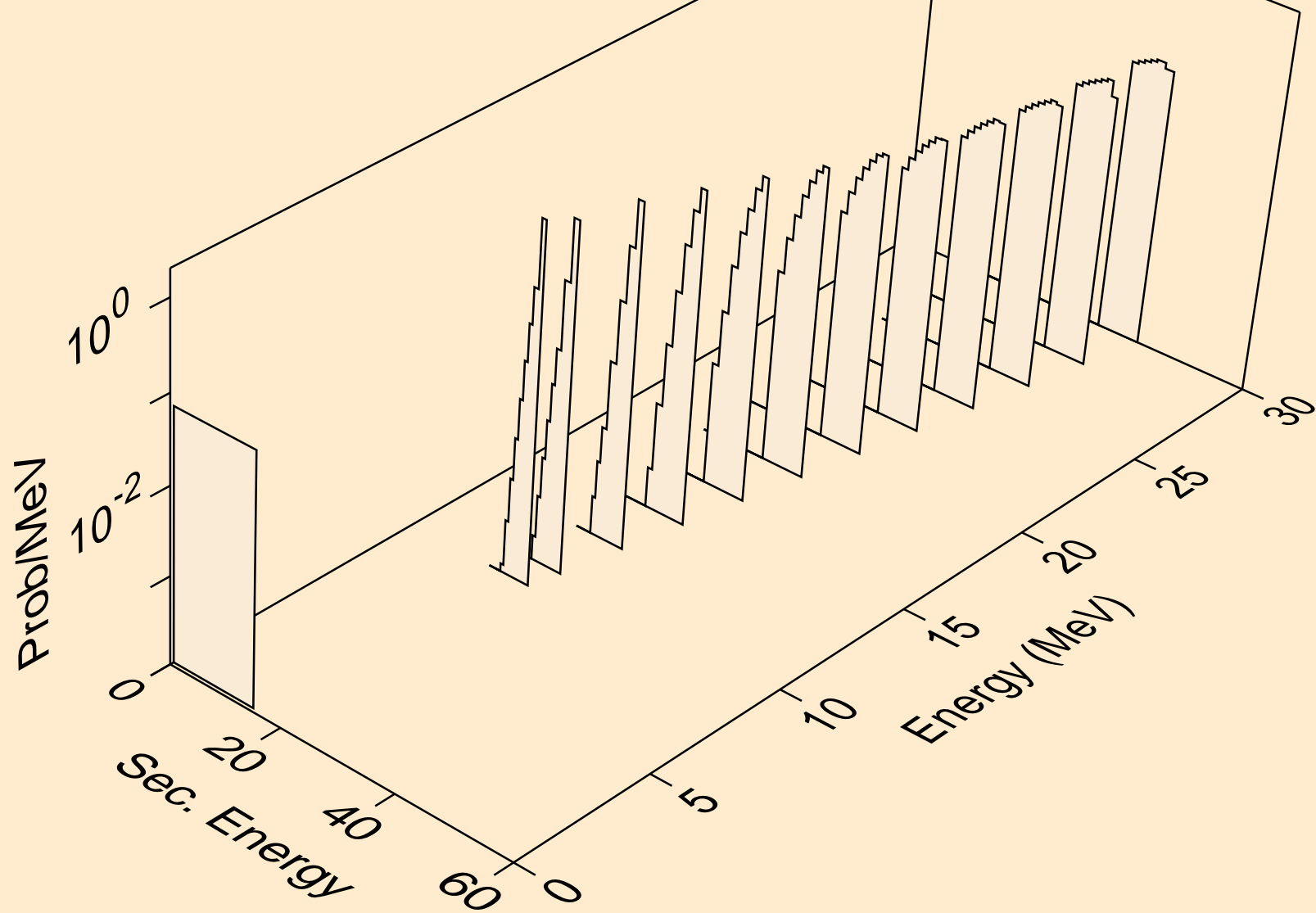

BH265 HELION ACER TENDL-2023 LIBRARY; T=0.K  
alphas from (s,2a)

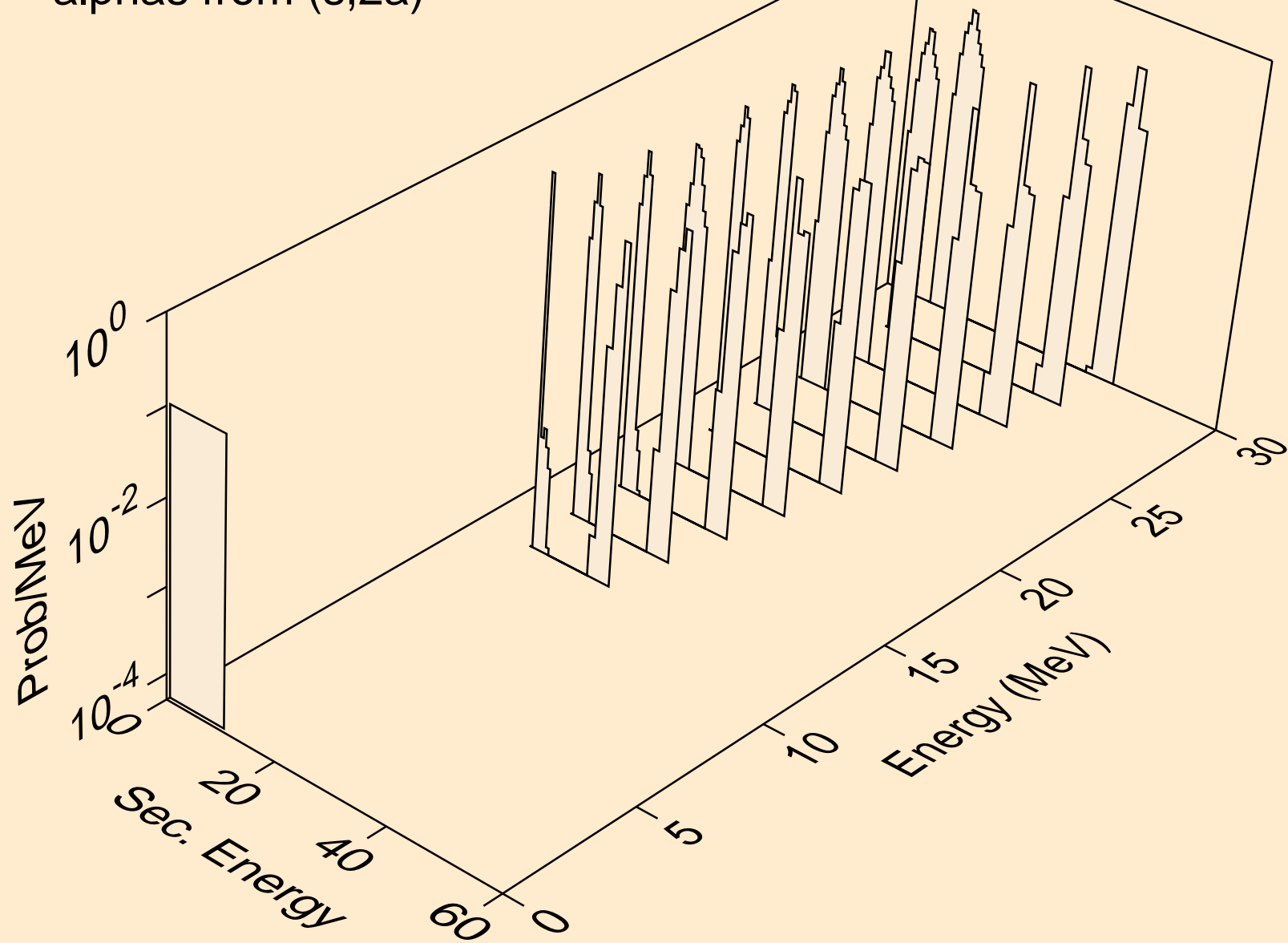

BH265 HELION ACER TENDL-2023 LIBRARY; T=0.K  
alphas from (s,3a)

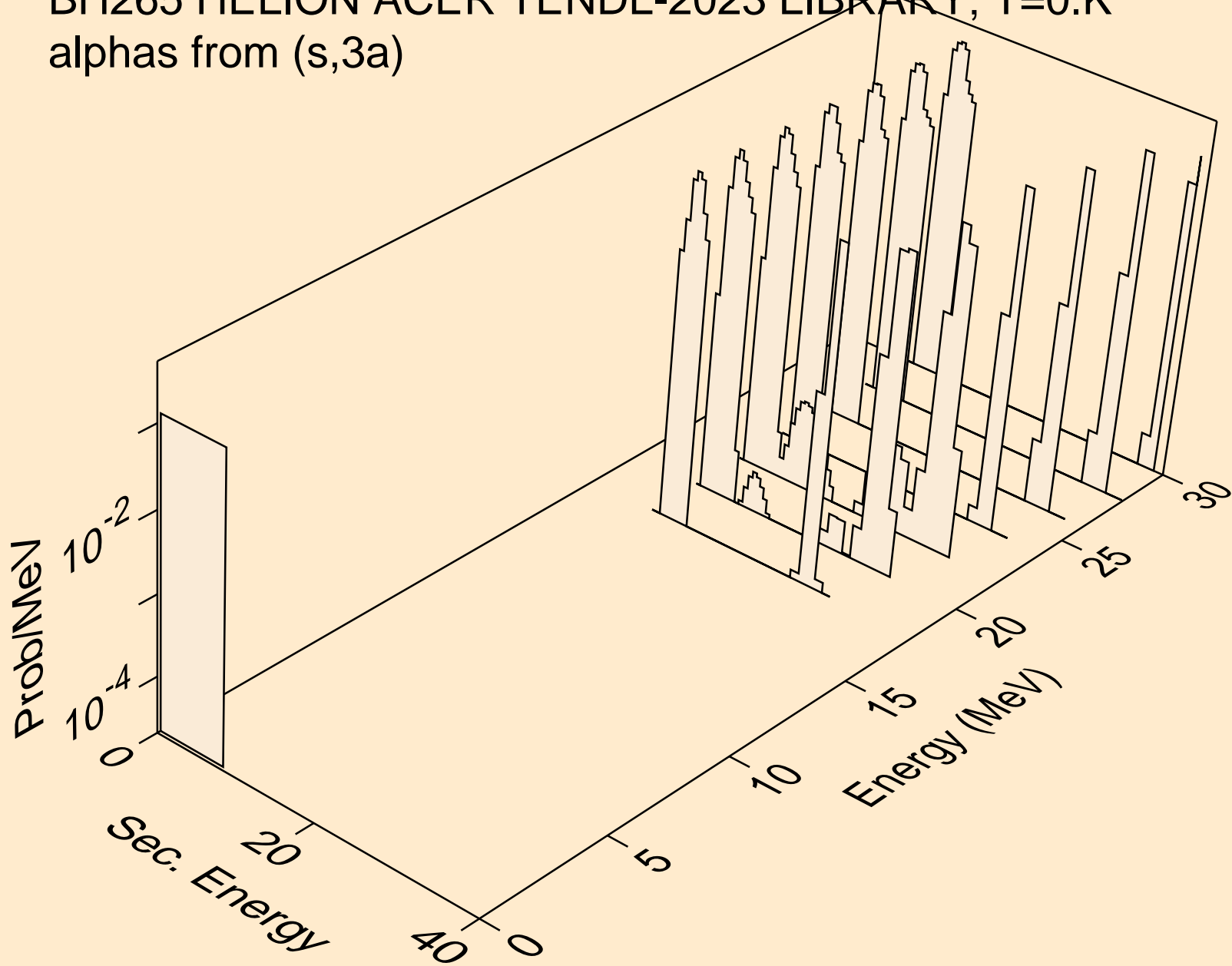

BH265 HELION ACER TENDL-2023 LIBRARY; T=0.K  
alphas from (s,pa)

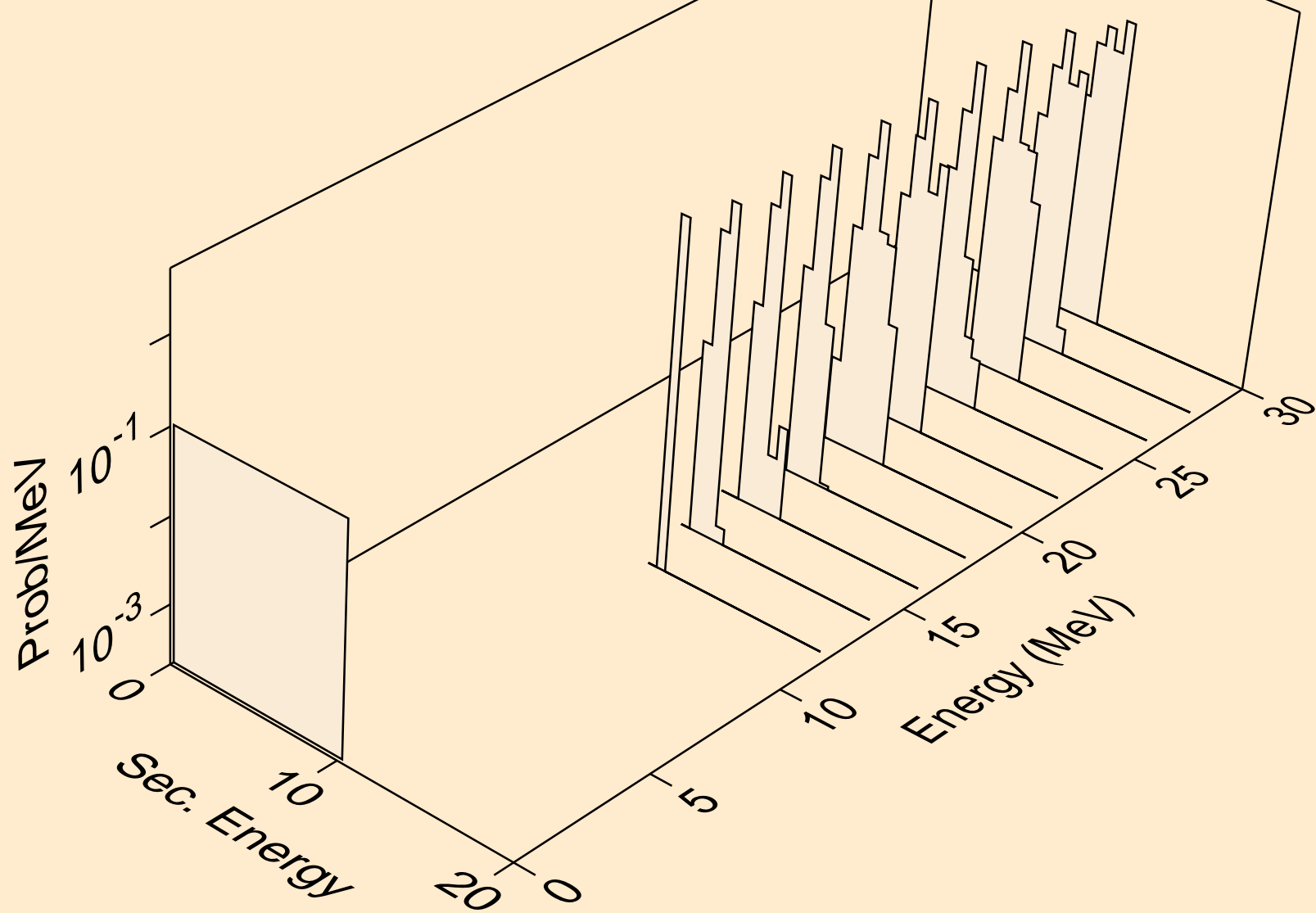

BH265 HELION ACER TENDL-2023 LIBRARY; T=0.K  
alphas from (s,da)

