

HG202 HELION ACER TENDL-2023 LIBRARY; T=0.K  
Principal cross sections

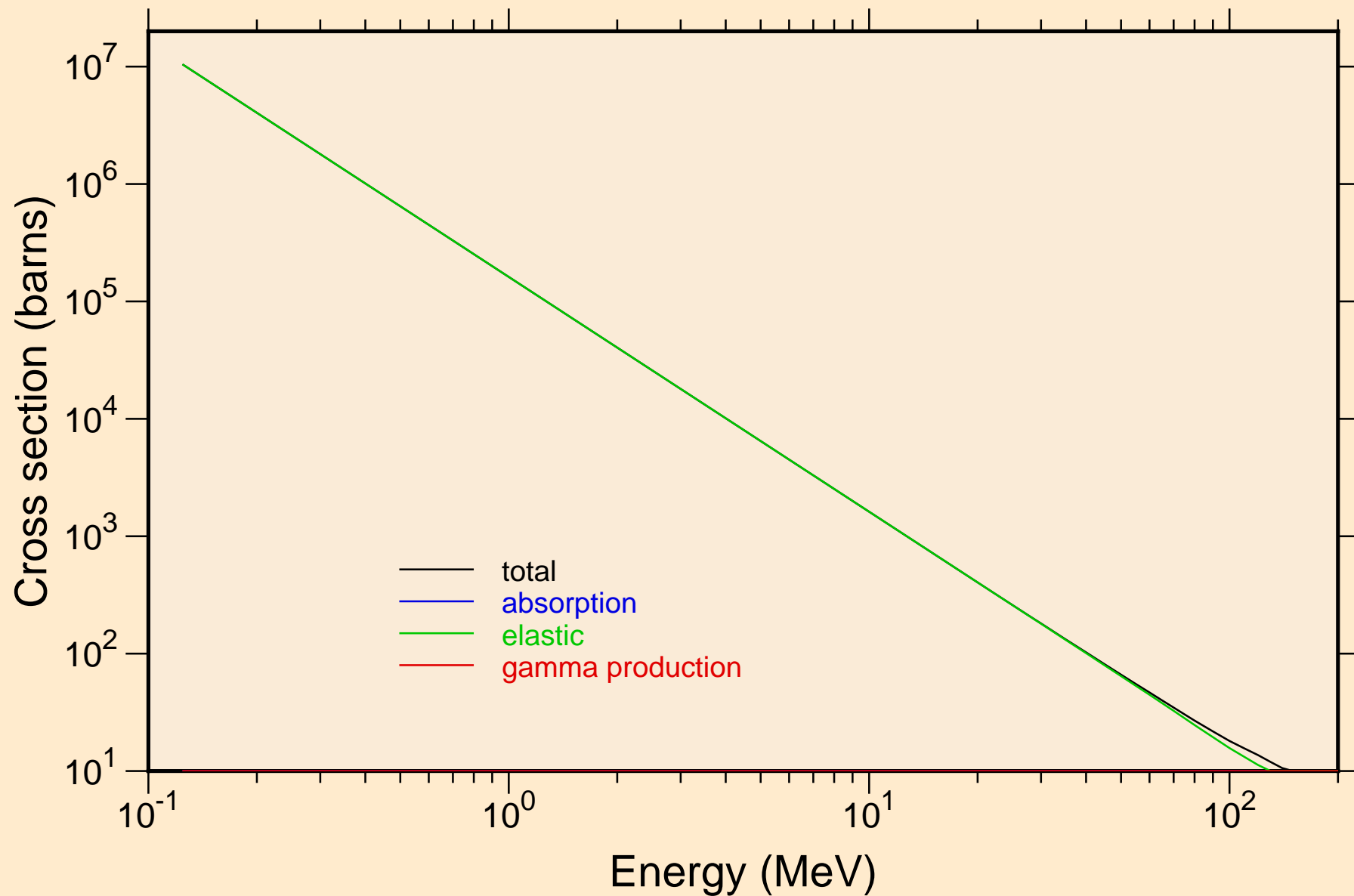

HG202 HELION ACER TENDL-2023 LIBRARY; T=0.K  
Heating

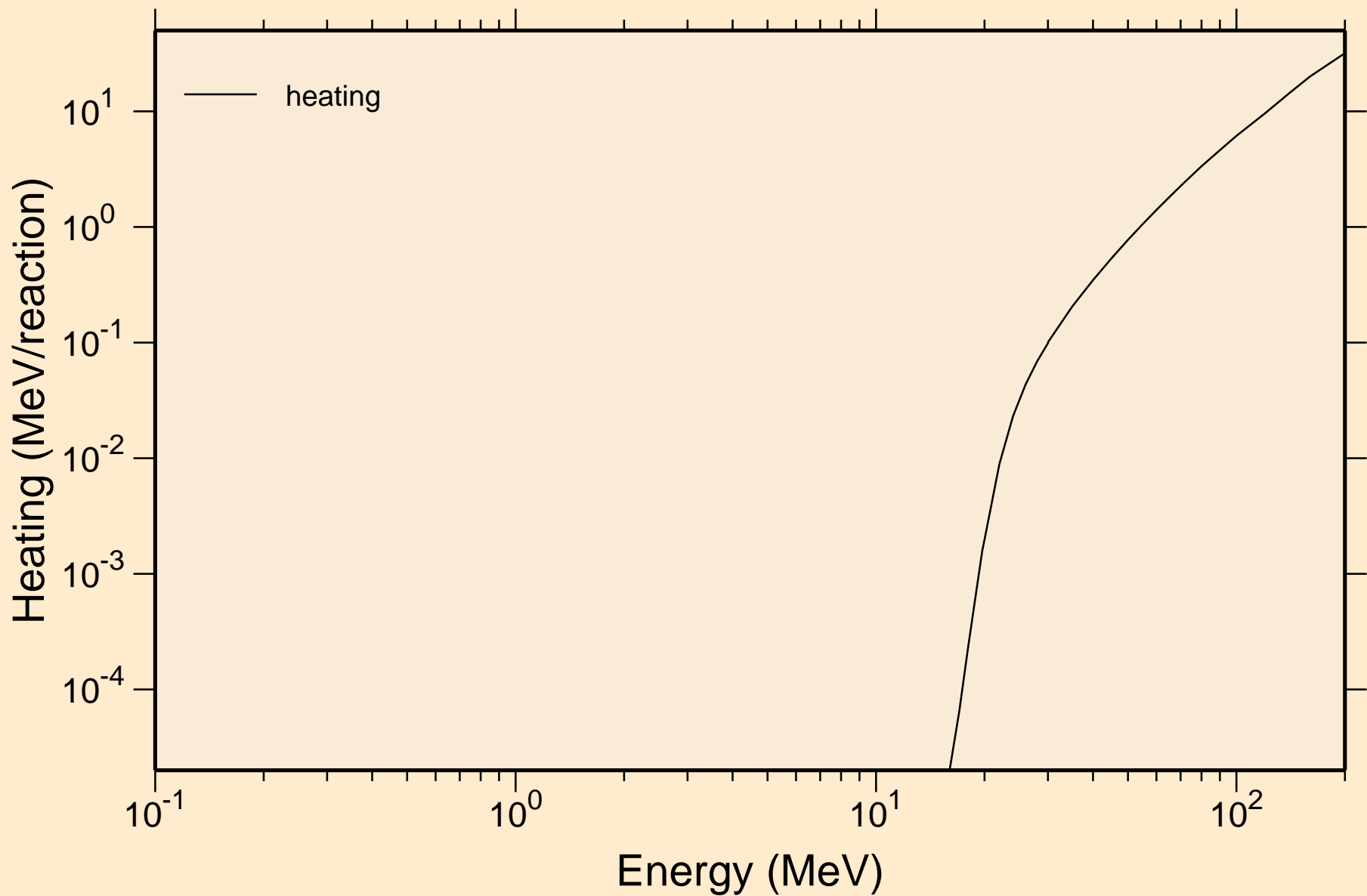

# HG202 HELION ACER TENDL-2023 LIBRARY; T=0.K

## Principal cross sections

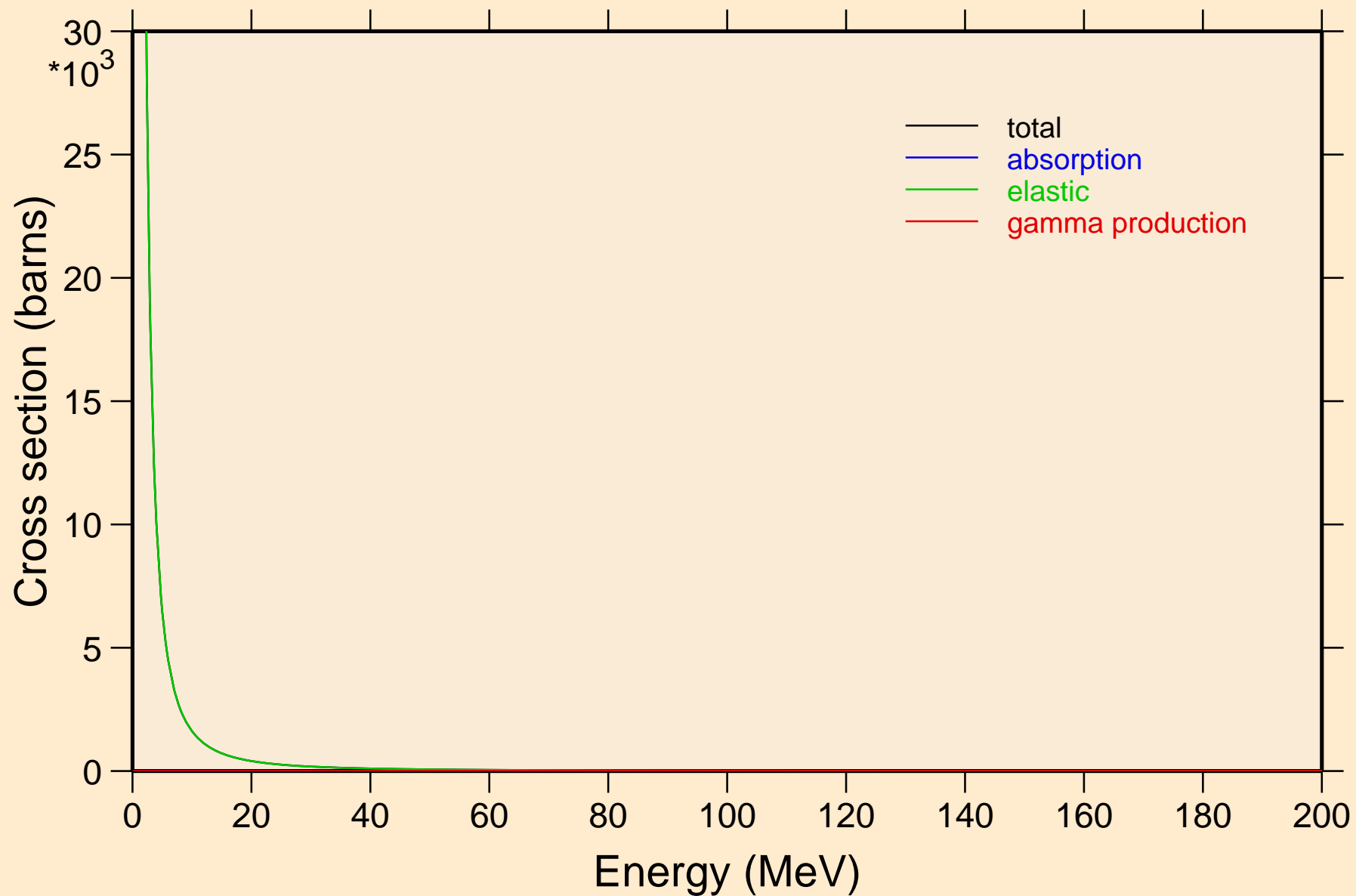

HG202 HELION ACER TENDL-2023 LIBRARY; T=0.K  
Heating

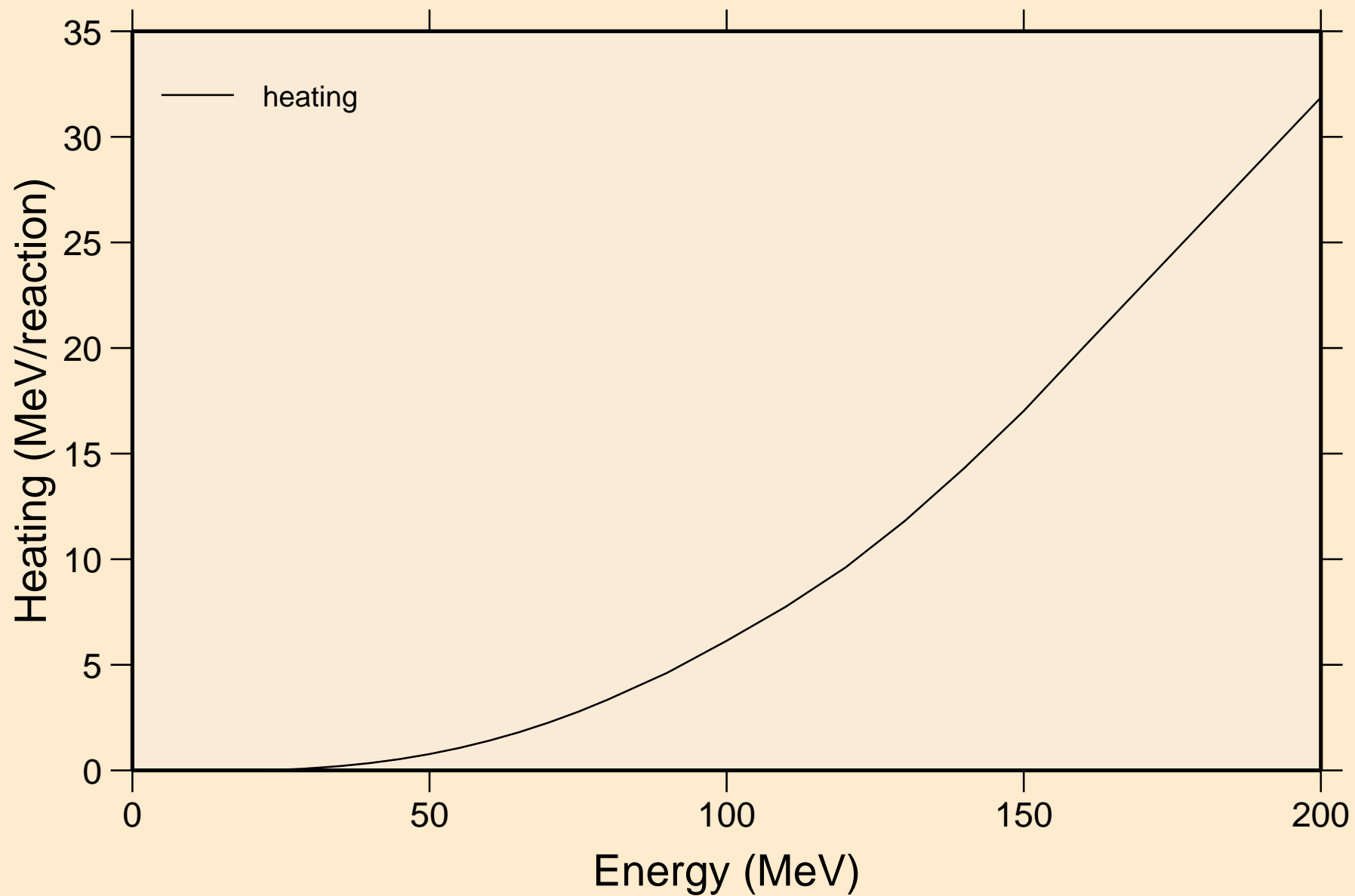

HG202 HELION ACER TENDL-2023 LIBRARY; T=0.K  
Threshold reactions

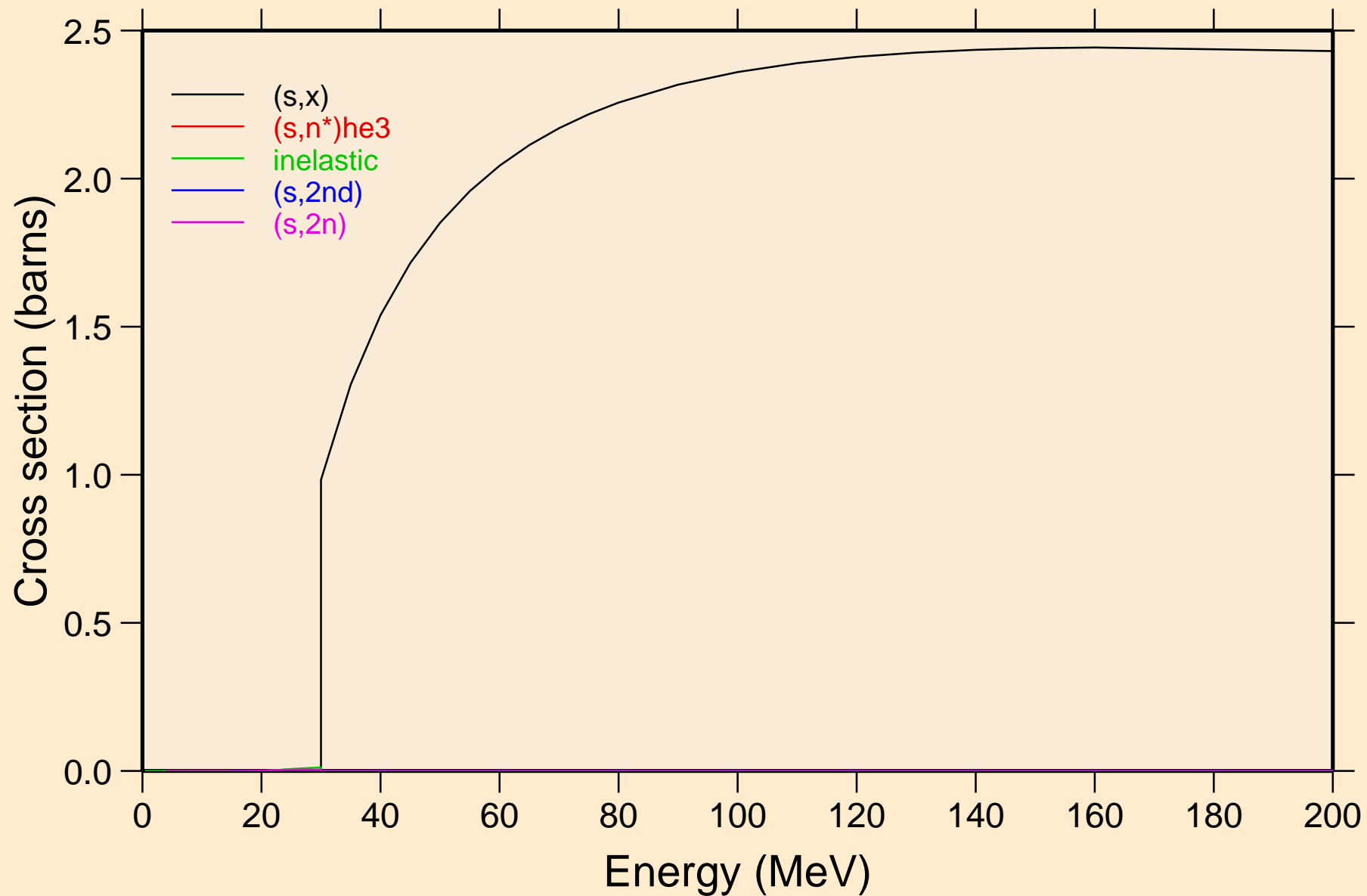

HG202 HELION ACER TENDL-2023 LIBRARY; T=0.K  
Threshold reactions

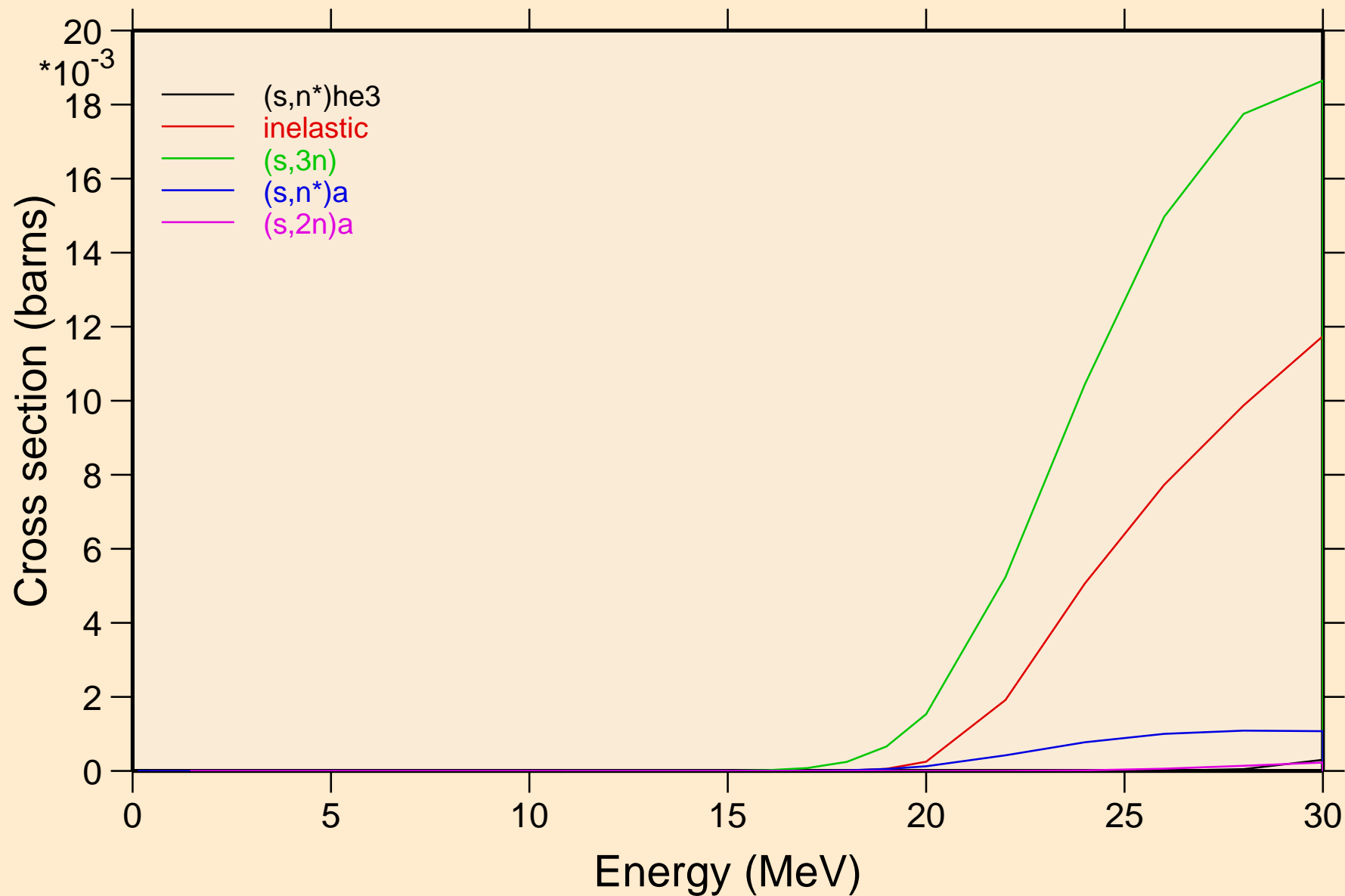

HG202 HELION ACER TENDL-2023 LIBRARY; T=0.K  
Threshold reactions

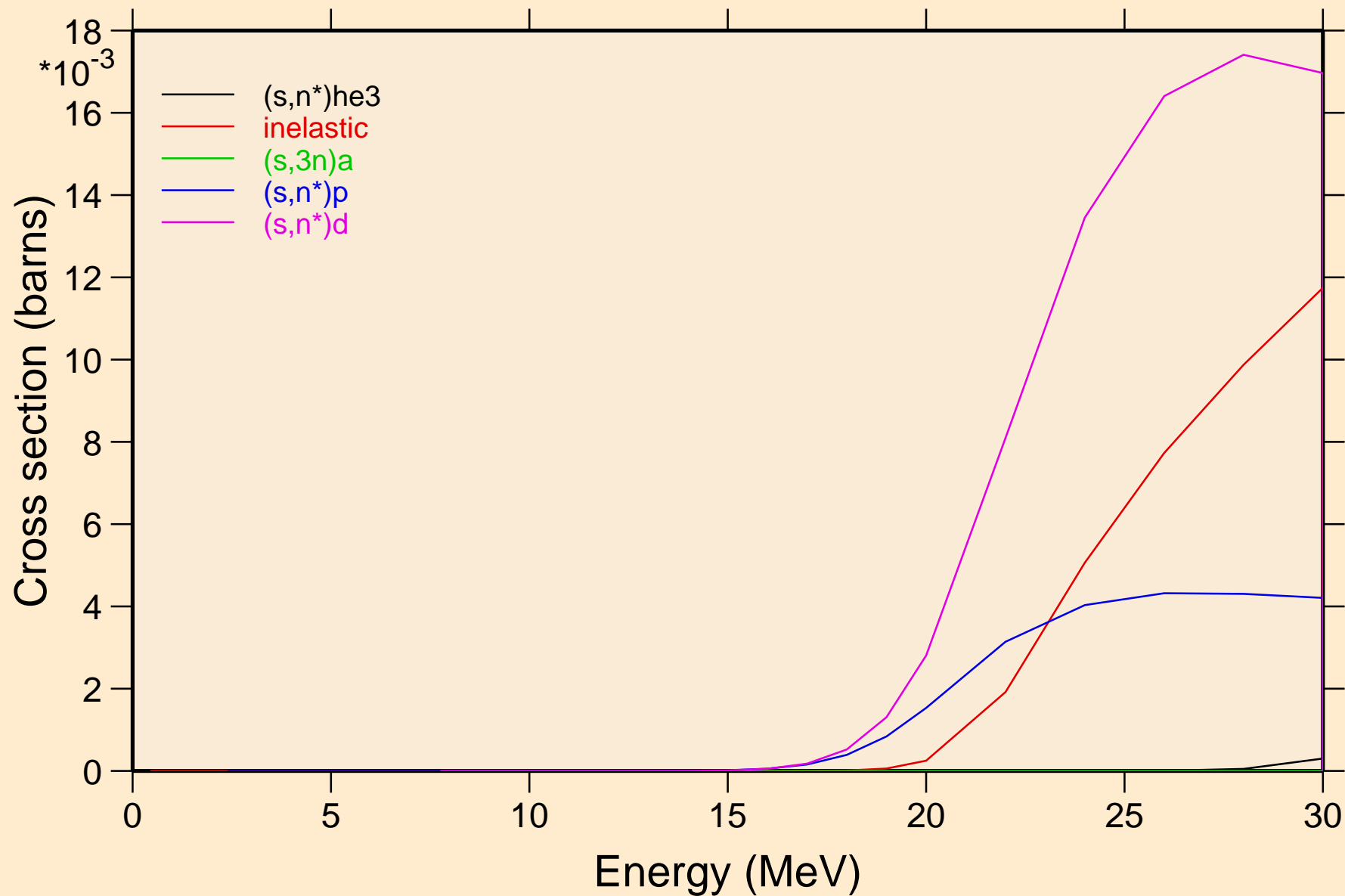

HG202 HELION ACER TENDL-2023 LIBRARY; T=0.K  
Threshold reactions

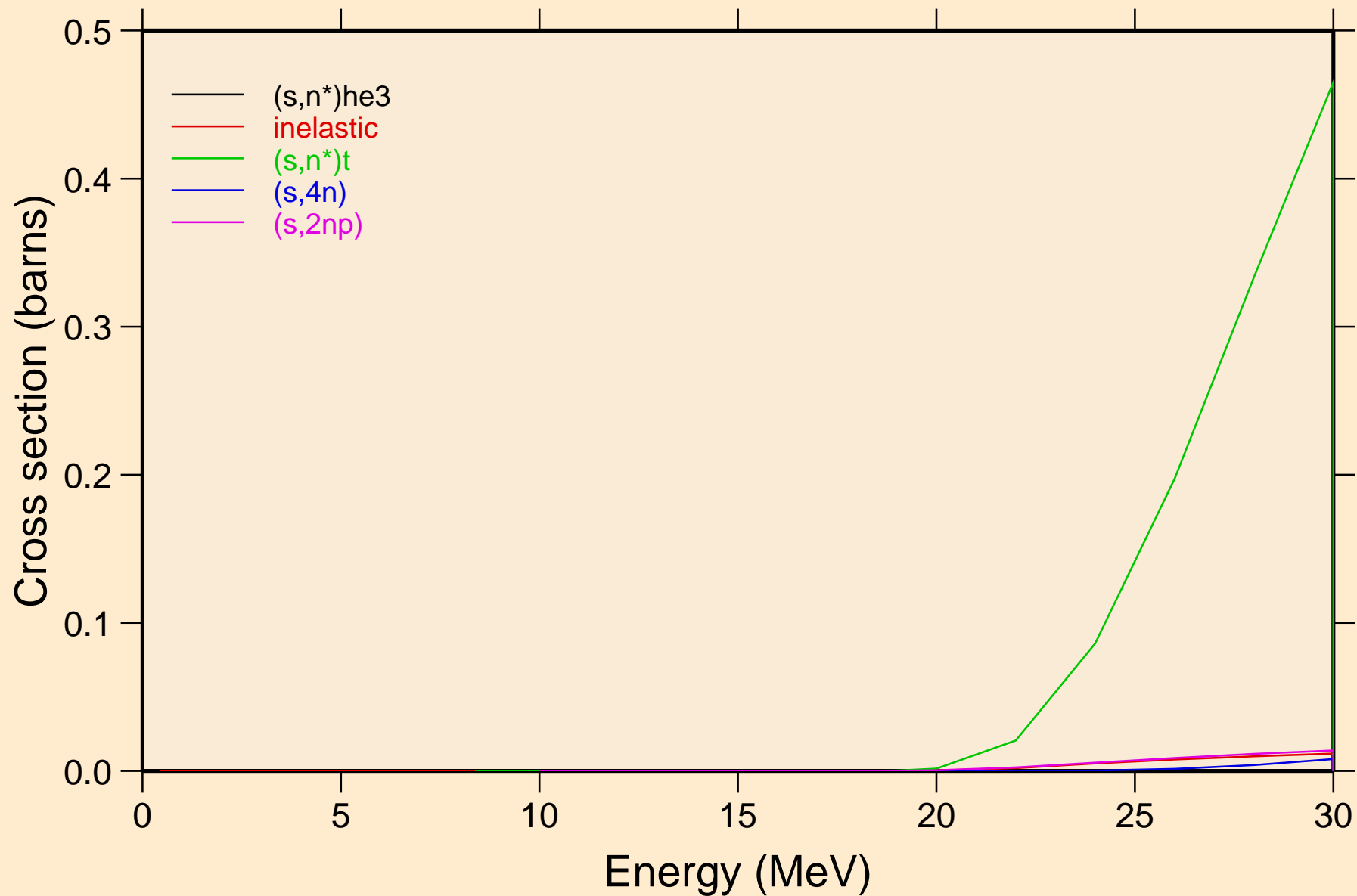

HG202 HELION ACER TENDL-2023 LIBRARY; T=0.K  
Threshold reactions

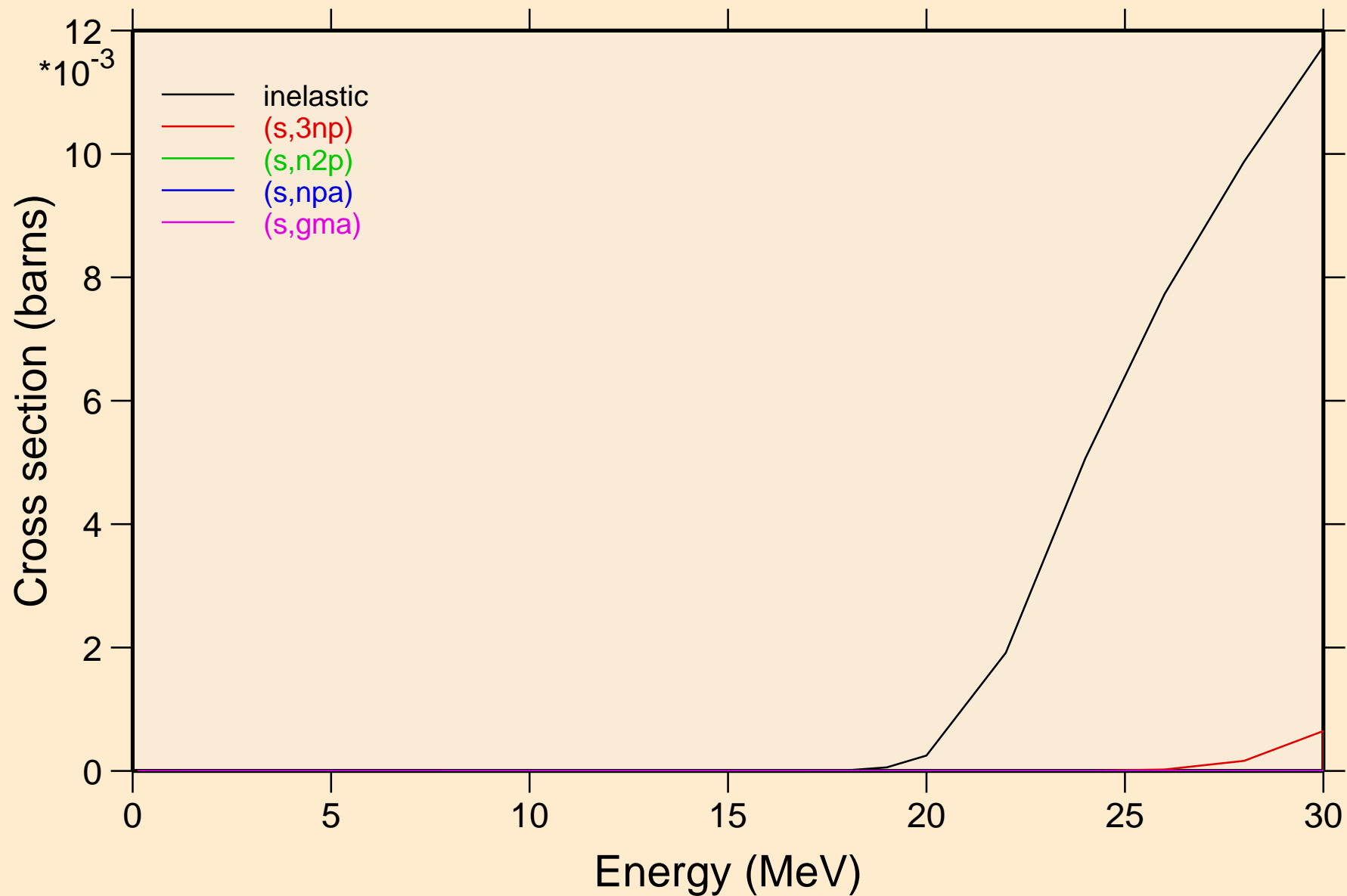

HG202 HELION ACER TENDL-2023 LIBRARY; T=0.K  
Threshold reactions

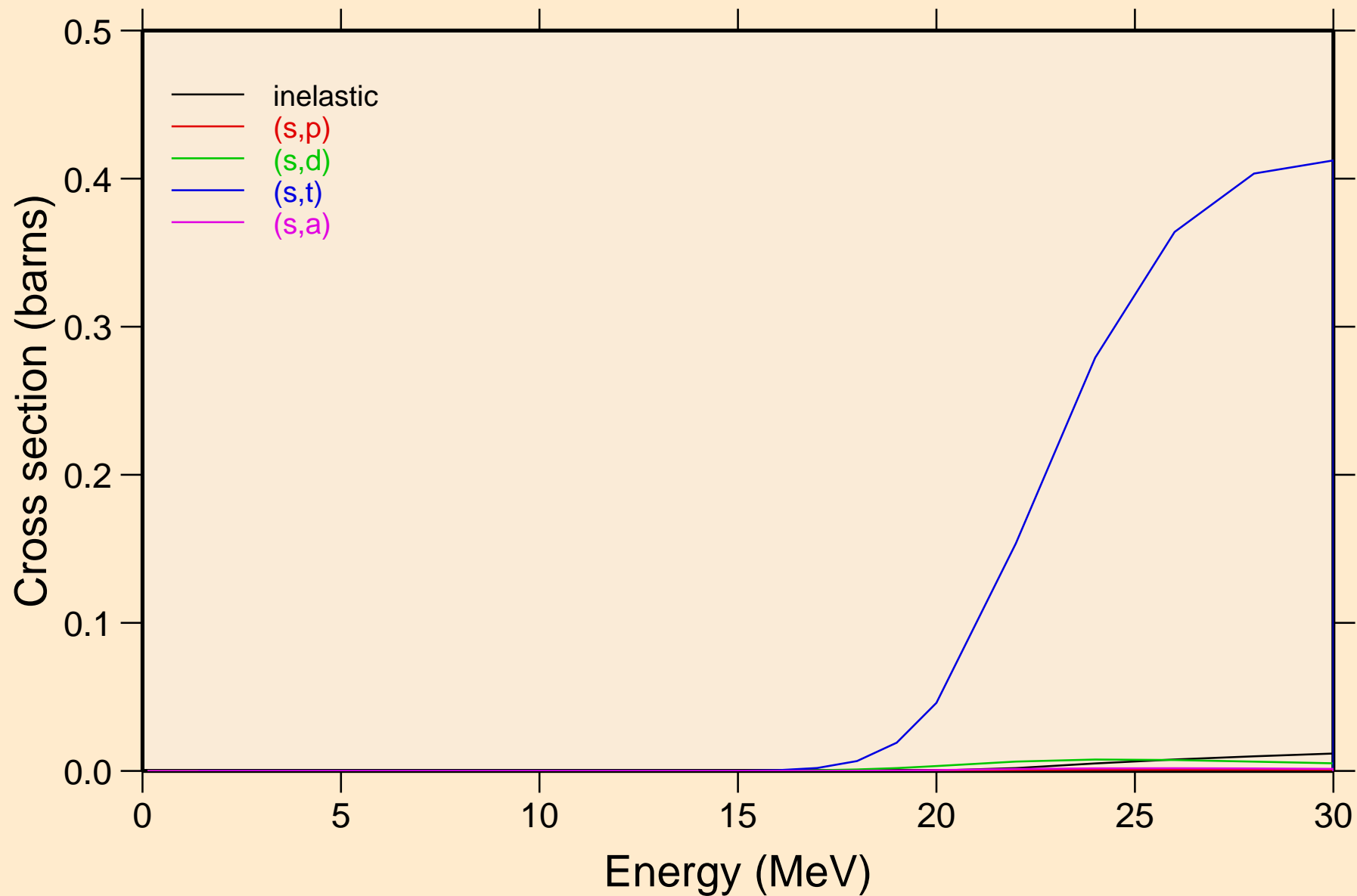

HG202 HELION ACER TENDL-2023 LIBRARY; T=0.K  
Threshold reactions

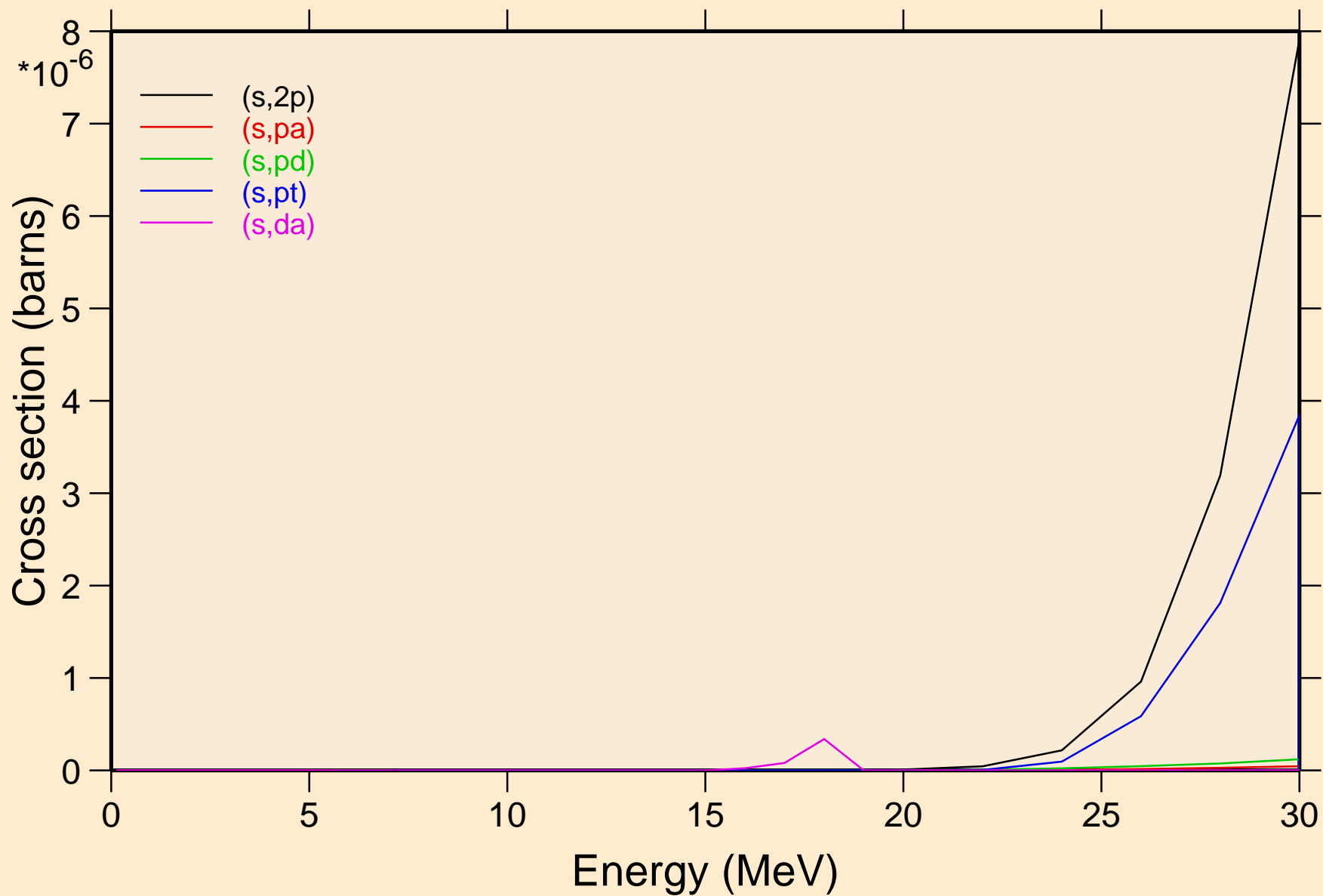

HG202 HELION ACER TENDL-2023 LIBRARY; T=0.K  
angular distribution for elastic

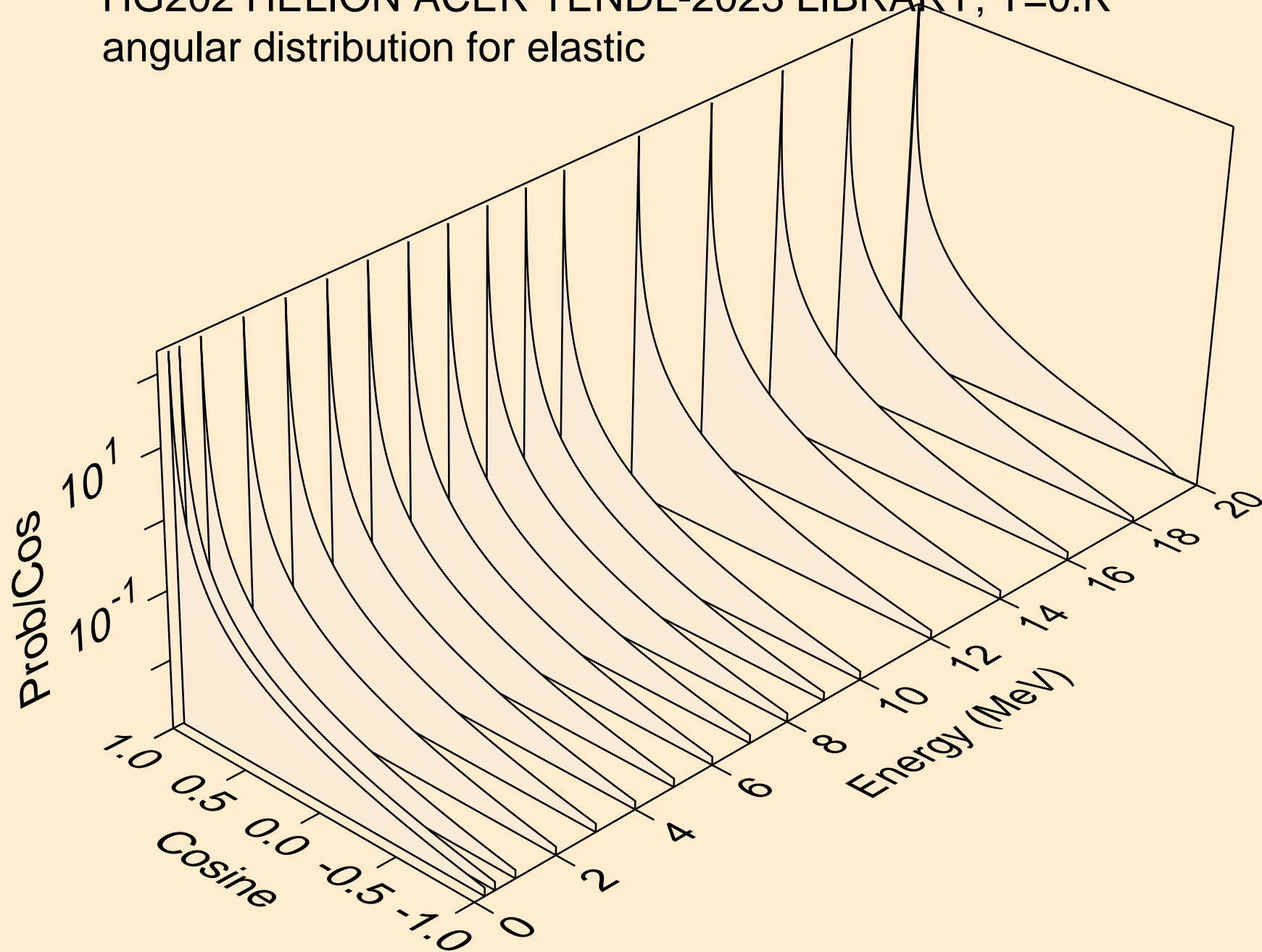

HG202 HELION ACER TENDL-2023 LIBRARY; T=0.K  
angular distribution for elastic

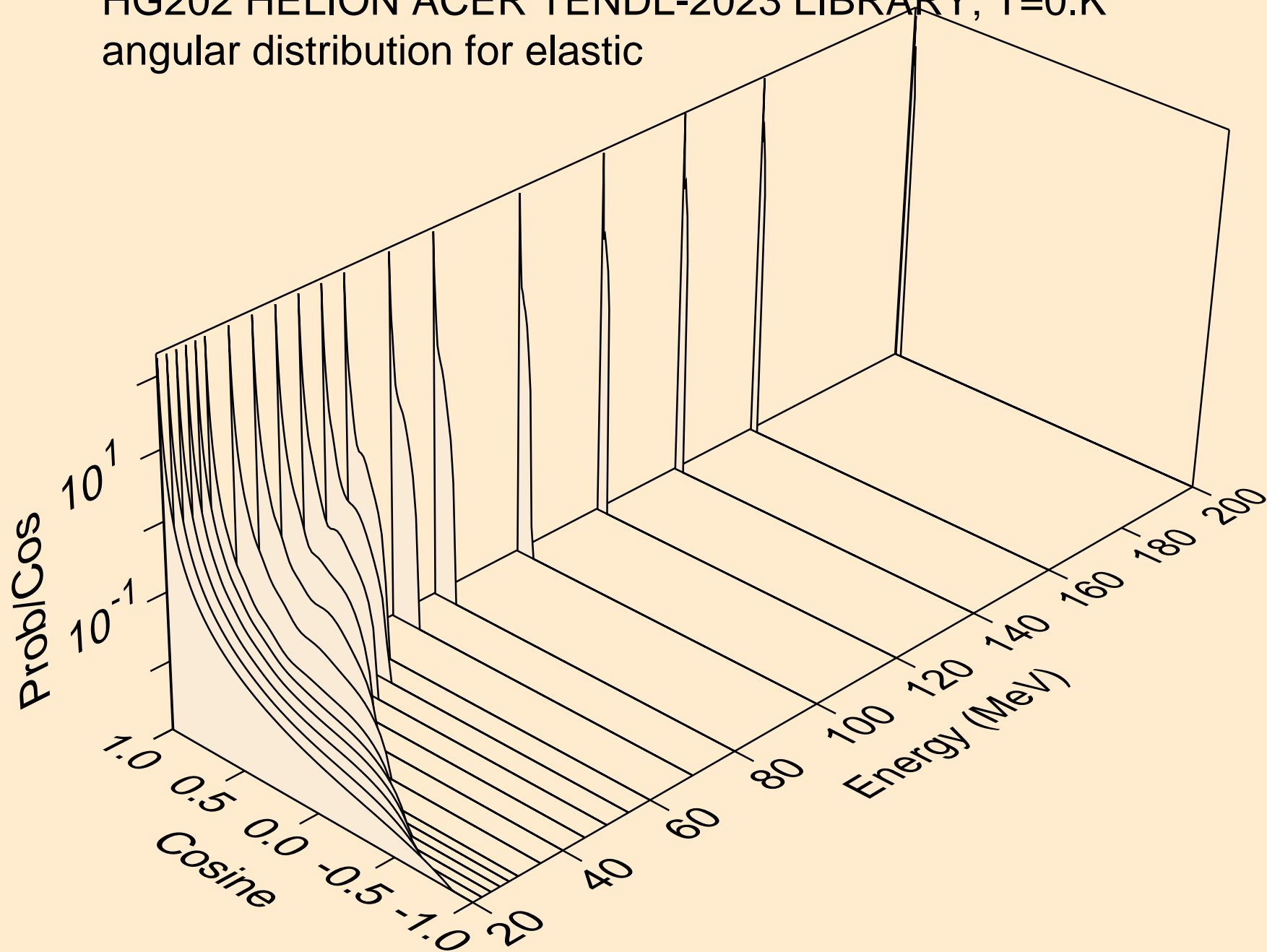

HG202 HELION ACER TENDL-2023 LIBRARY; T=0.K  
He-3 emission for (s,x)

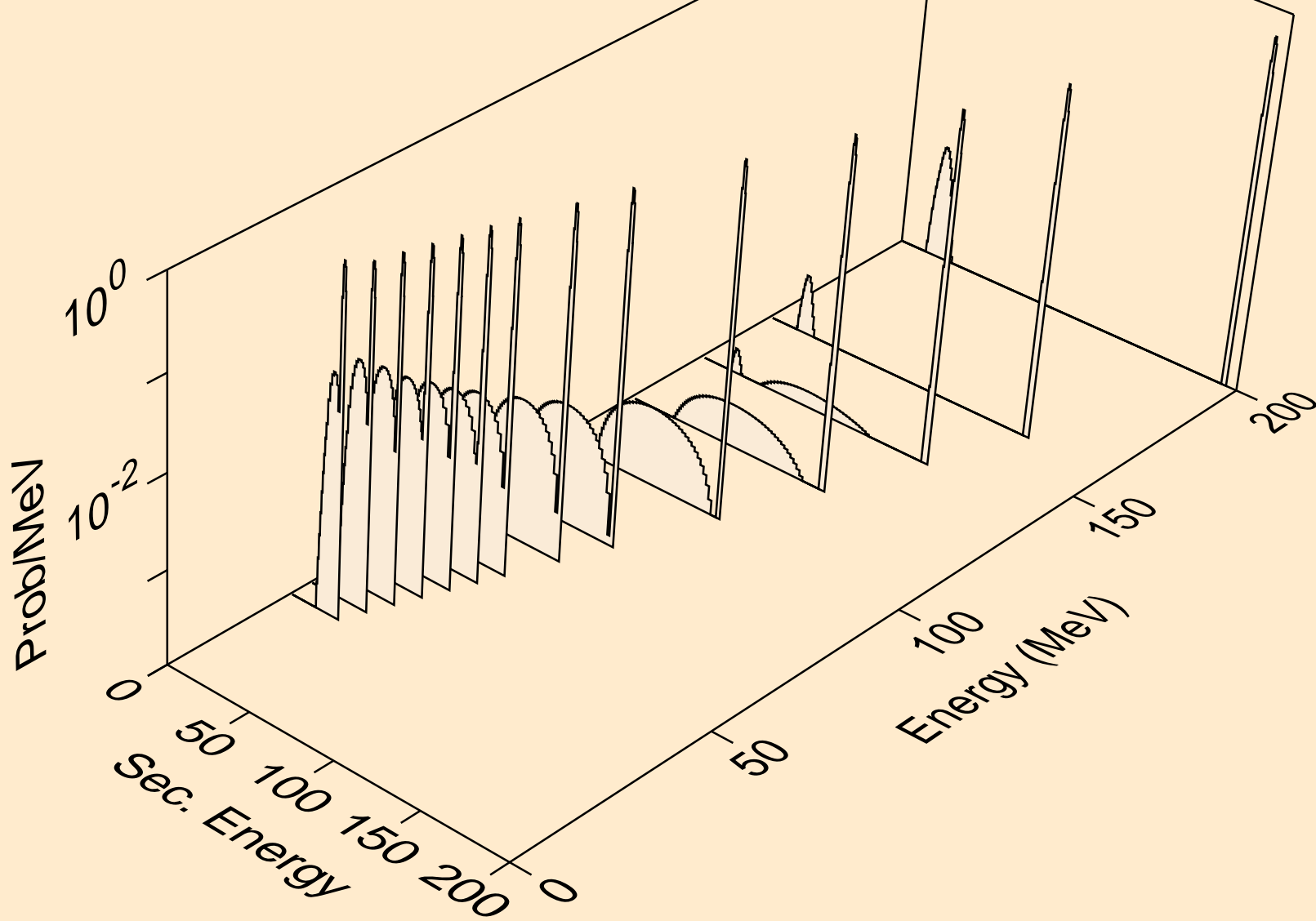

HG202 HELION ACER TENDL-2023 LIBRARY; T=0.K  
He-3 emission for (s,n\*)he3

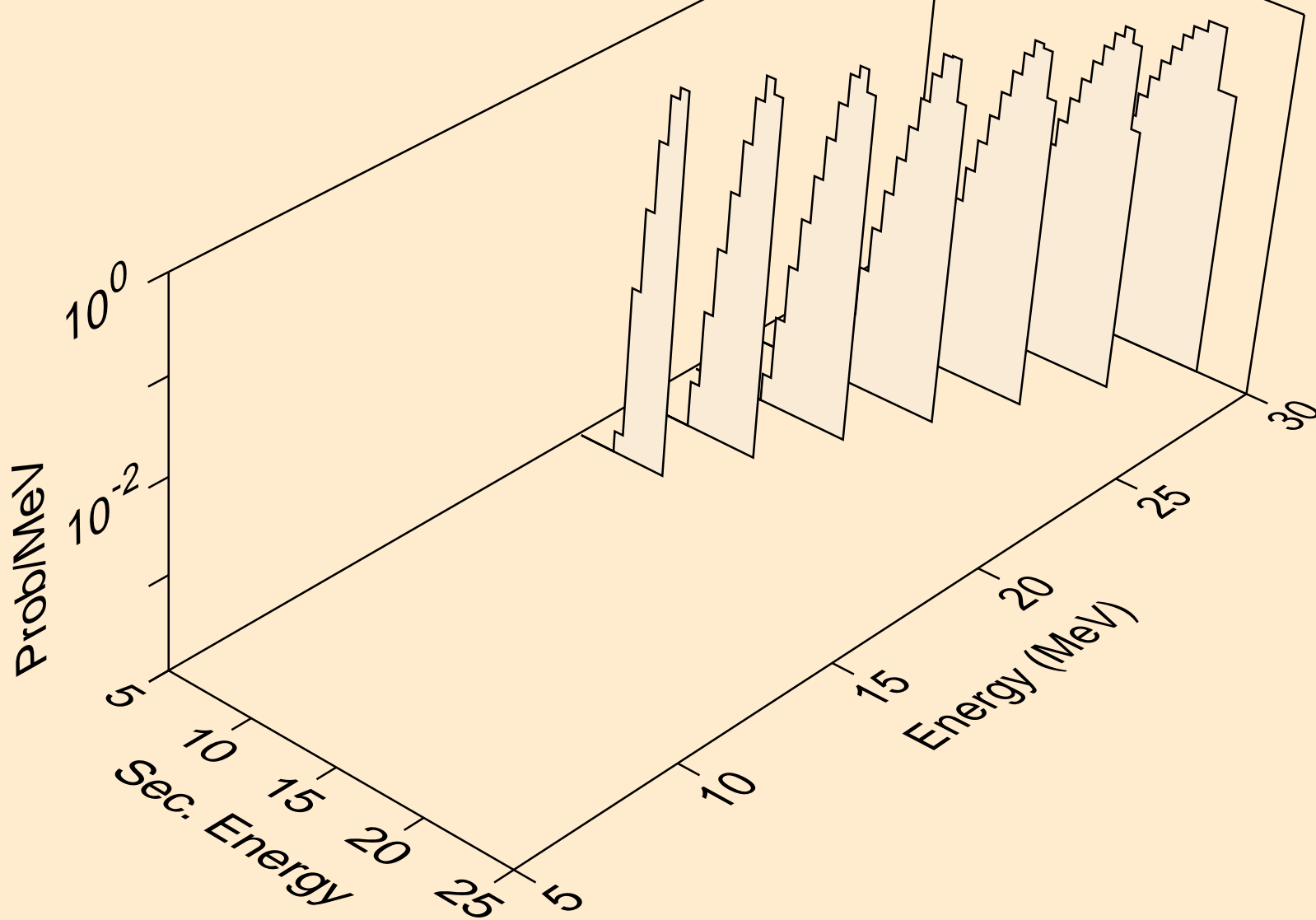

HG202 HELION ACER TENDL-2023 LIBRARY; T=0.K  
He-3 emission for inelastic

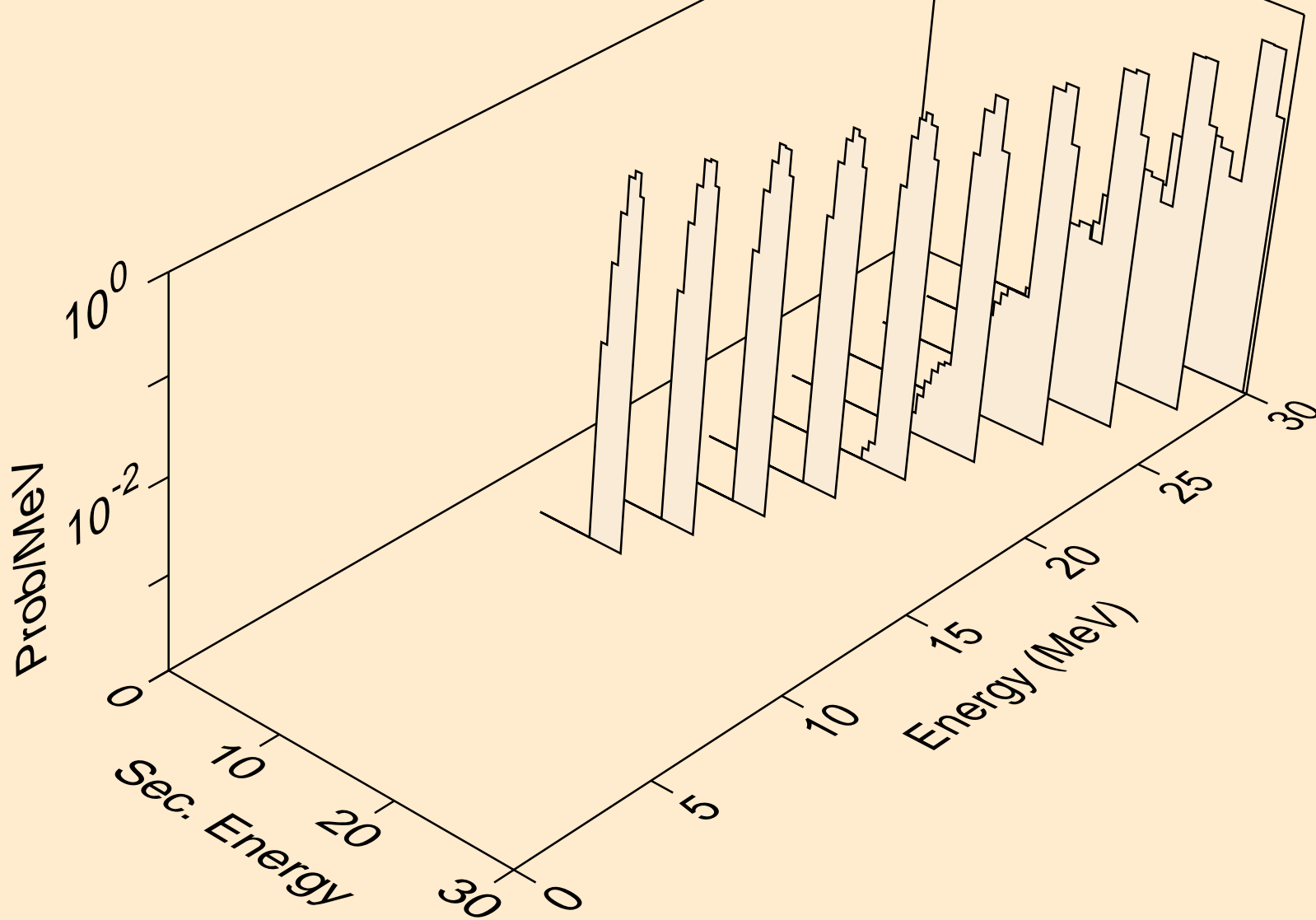

HG202 HELION ACER TENDL-2023 LIBRARY; T=0.K  
Photon emission for (z,n)

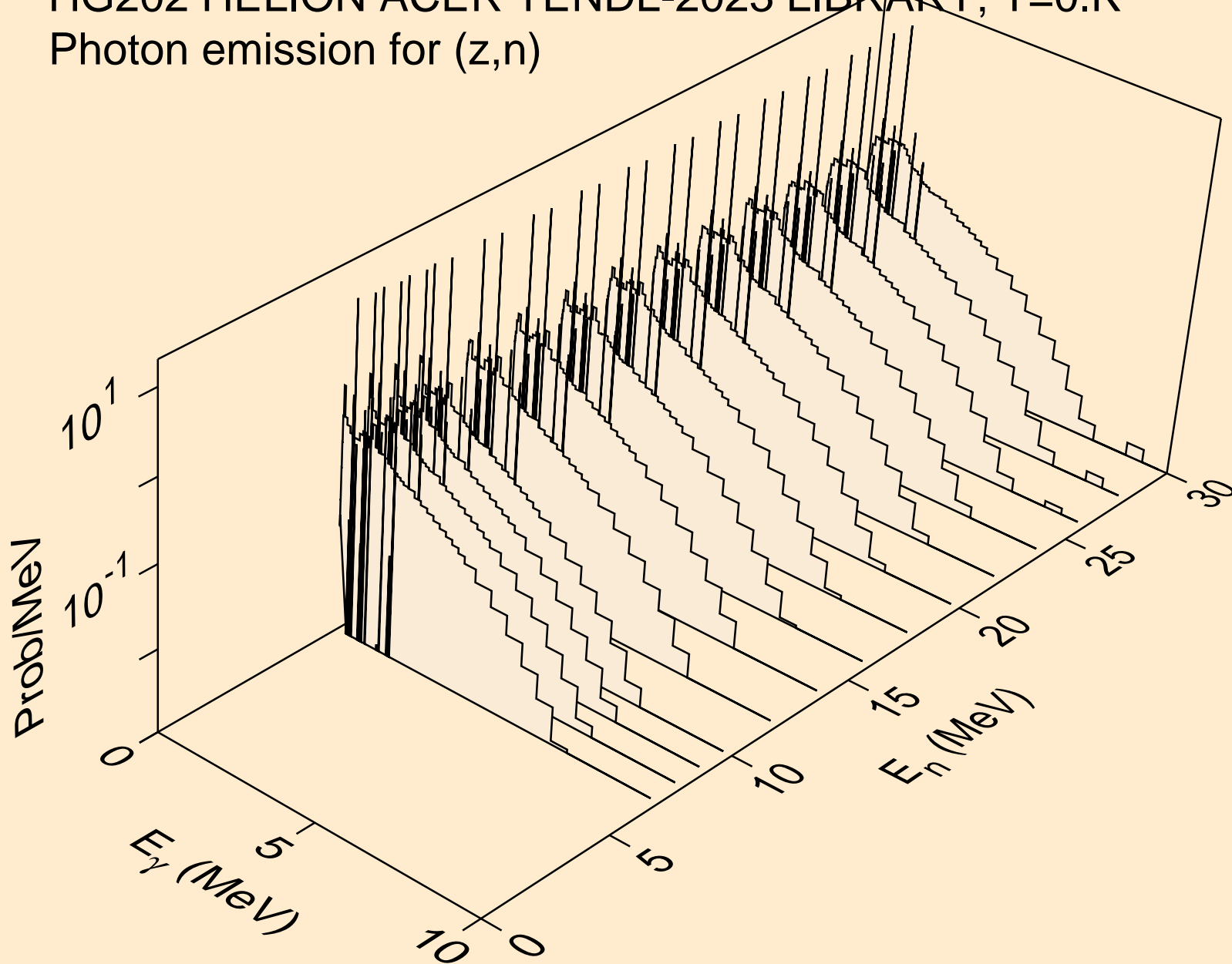

HG202 HELION ACER TENDL-2023 LIBRARY; T=0.K  
Photon emission for (z,x)

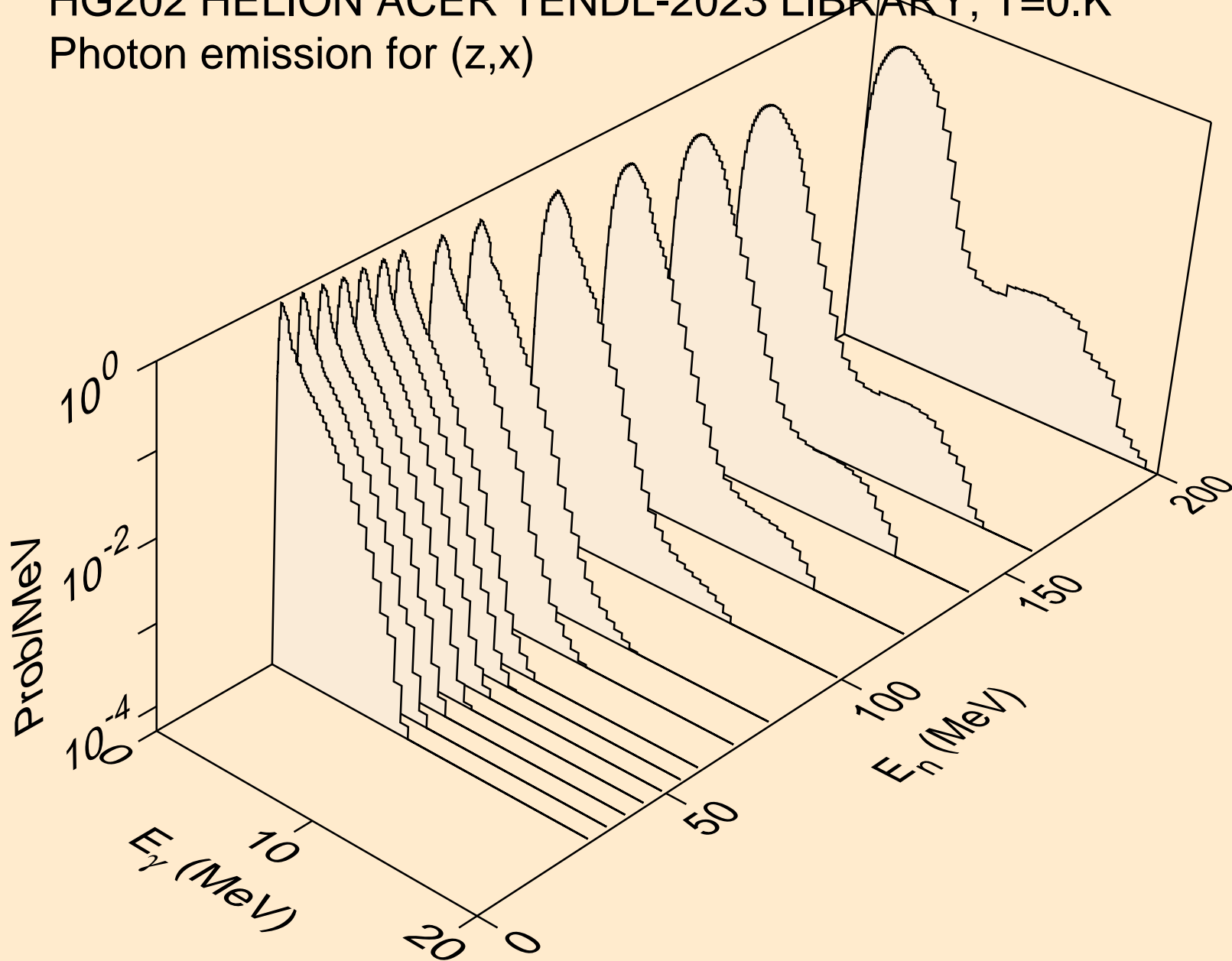

HG202 HELION ACER TENDL-2023 LIBRARY; T=0.K  
Photon emission for (n,2nd)

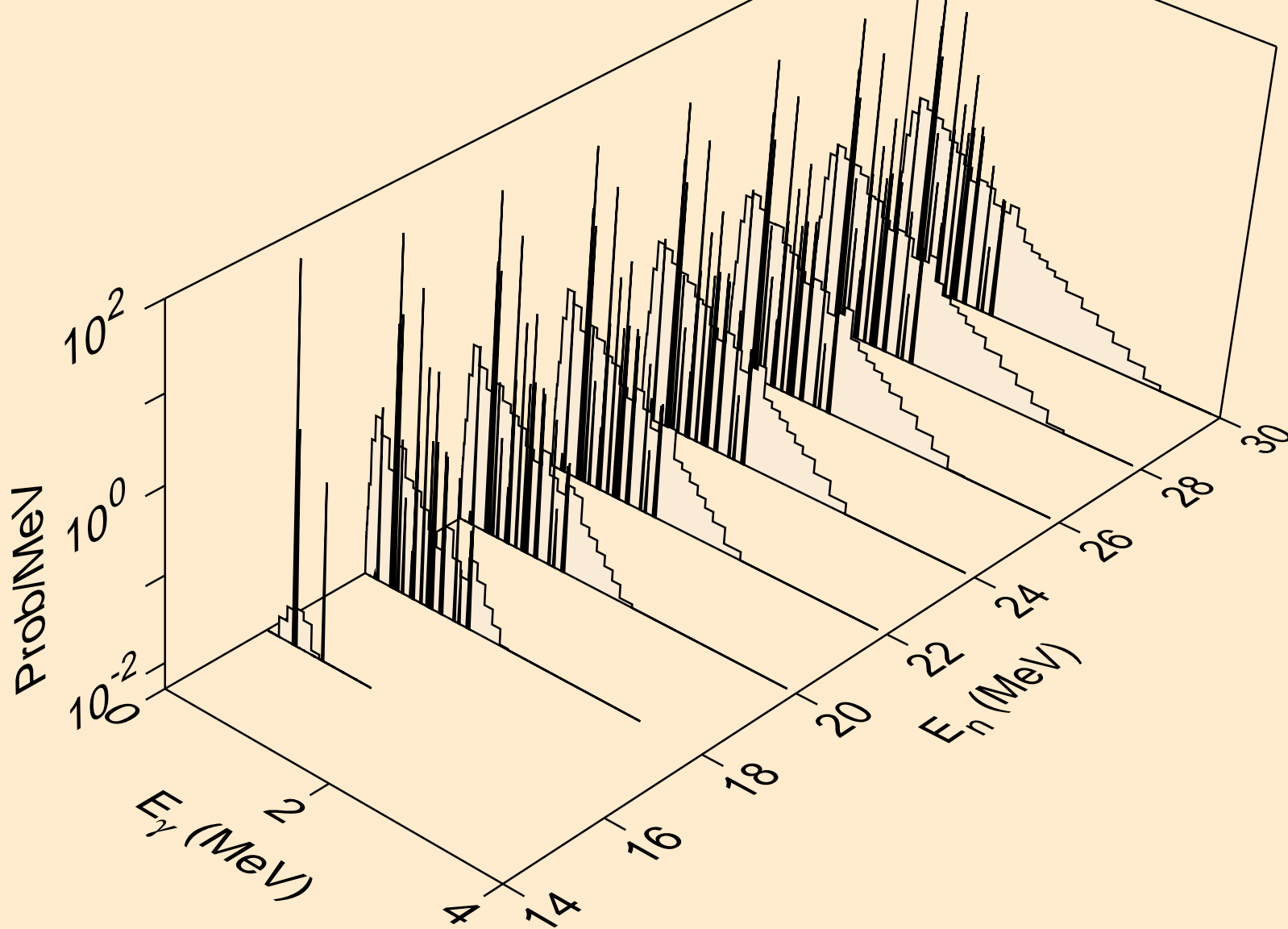

HG202 HELION ACER TENDL-2023 LIBRARY; T=0.K  
Photon emission for (n,2n)

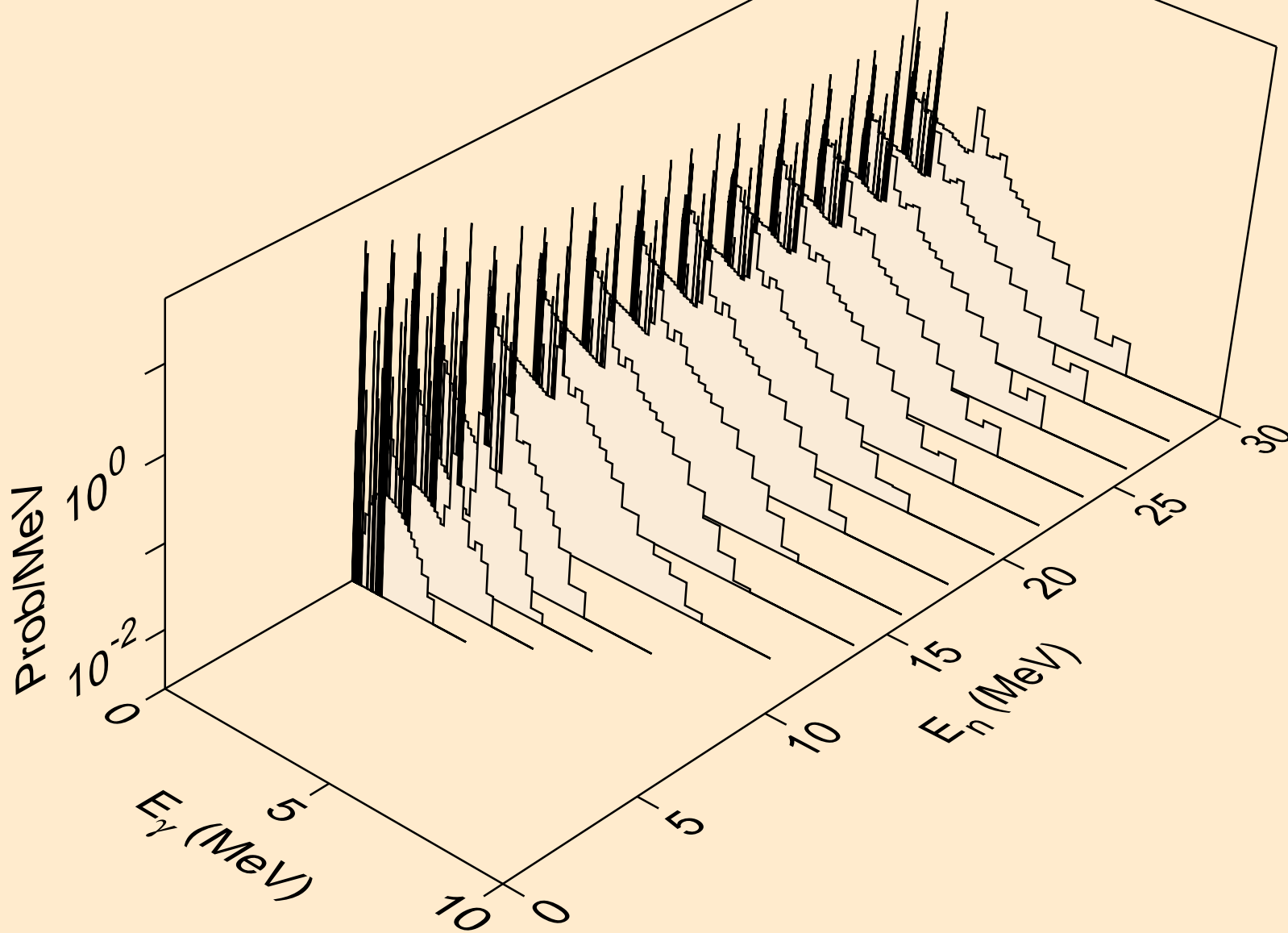

HG202 HELION ACER TENDL-2023 LIBRARY; T=0.K  
Photon emission for (n,3n)

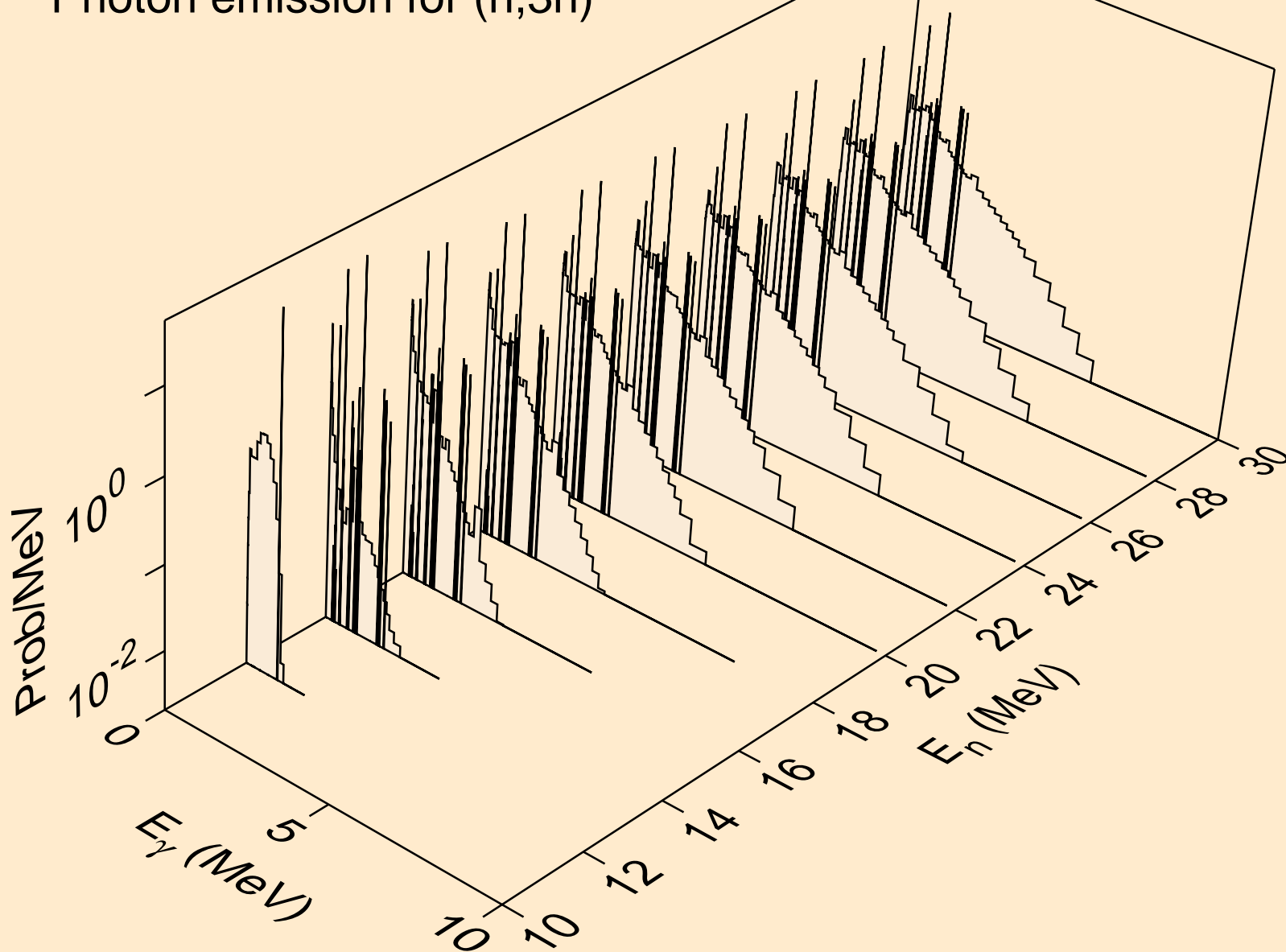

HG202 HELION ACER TENDL-2023 LIBRARY; T=0.K  
Photon emission for (n,n\*)a

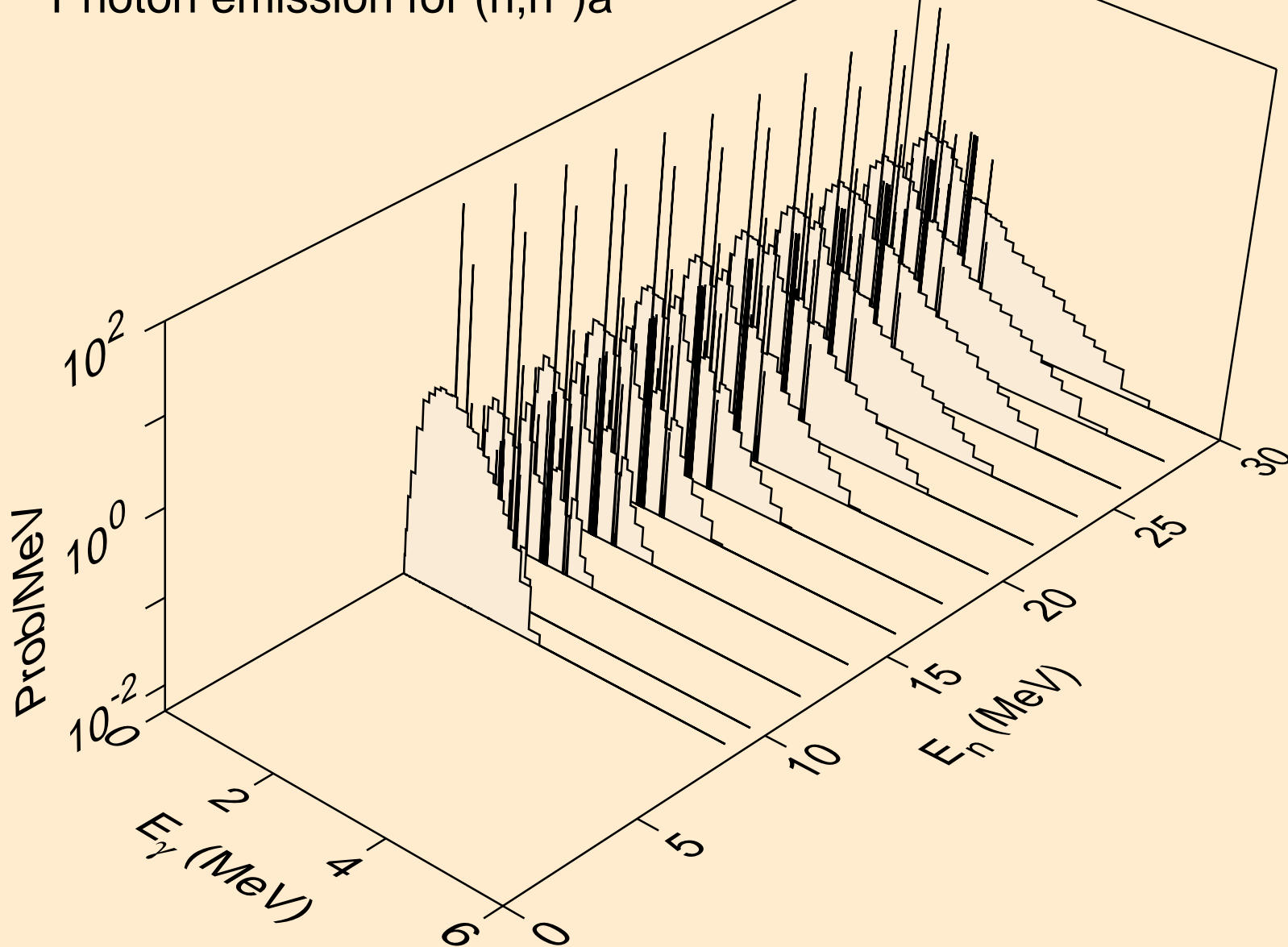

HG202 HELION ACER TENDL-2023 LIBRARY; T=0.K  
Photon emission for (n,2n) $\alpha$

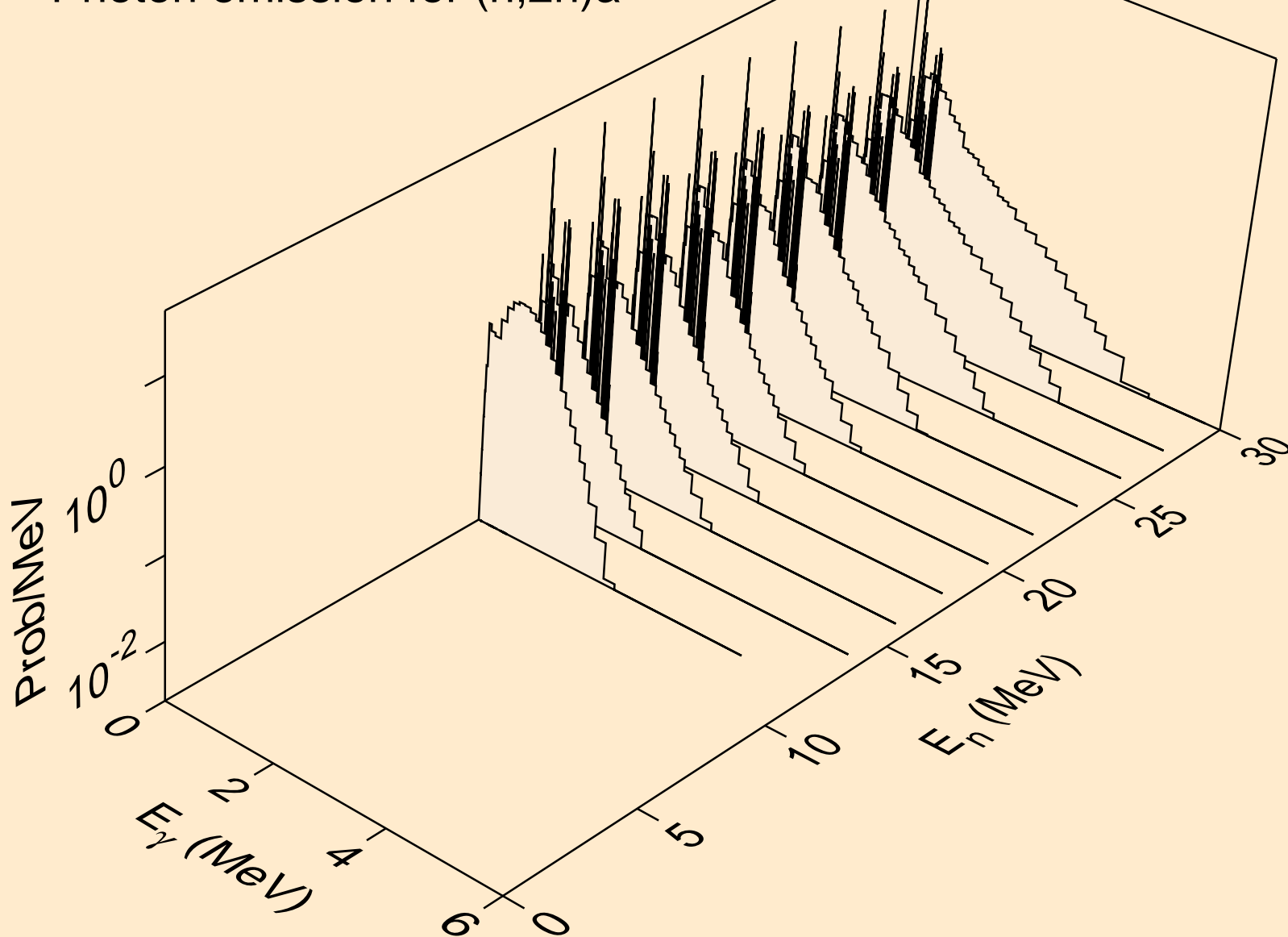

HG202 HELION ACER TENDL-2023 LIBRARY; T=0.K  
Photon emission for (n,3n)a

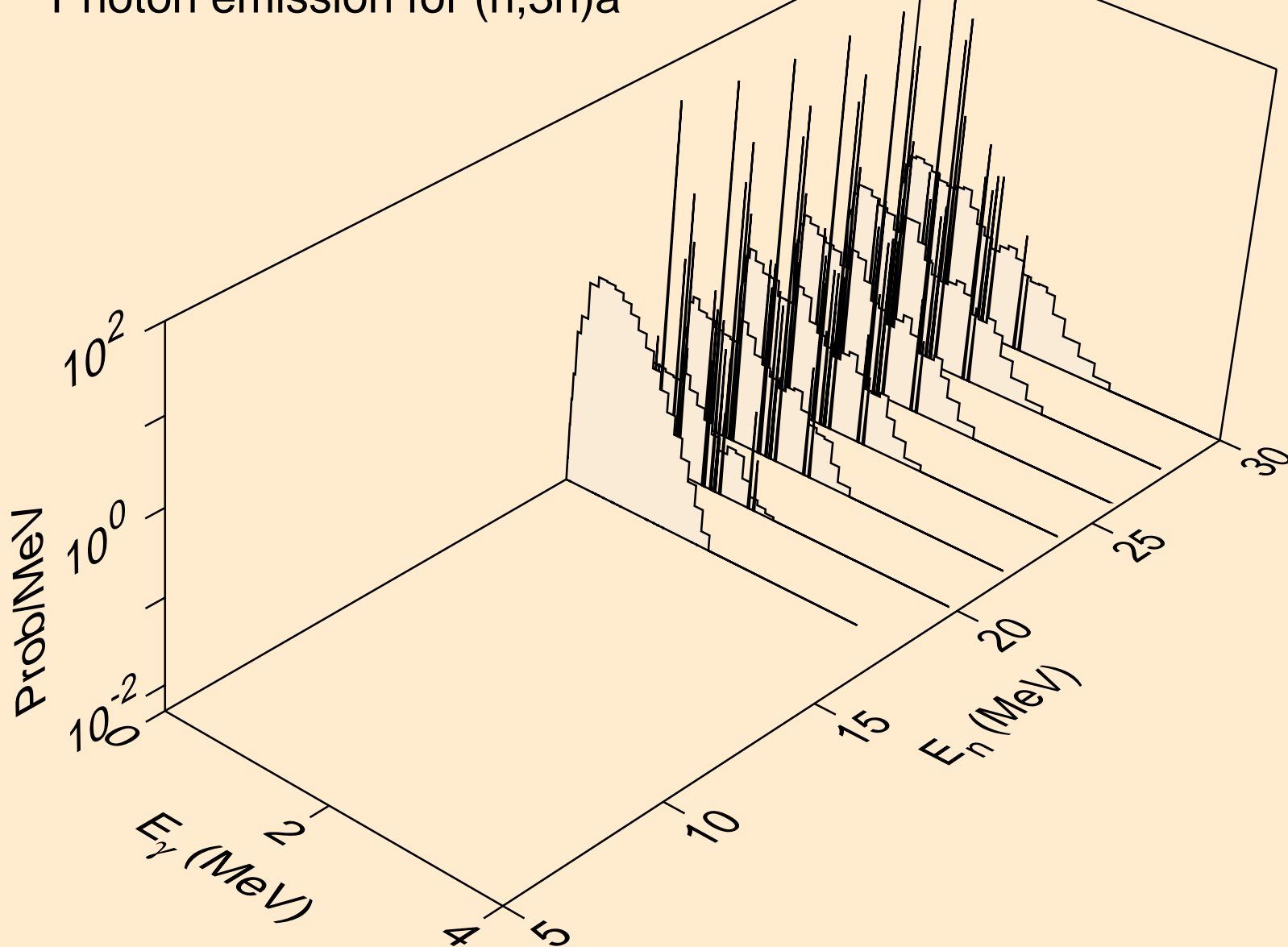

HG202 HELION ACER TENDL-2023 LIBRARY; T=0.K  
Photon emission for (n,n\*)p

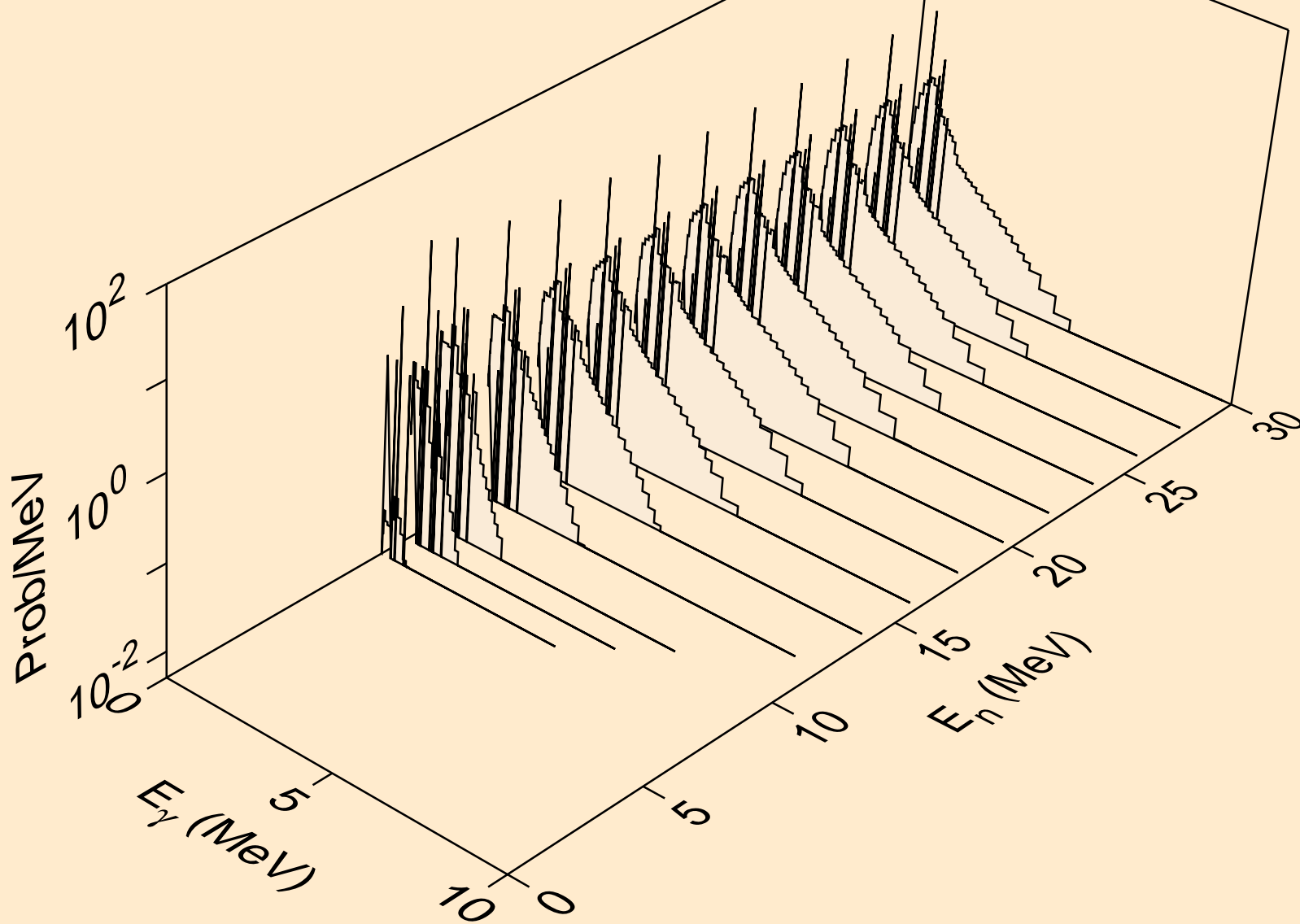

HG202 HELION ACER TENDL-2023 LIBRARY; T=0.K  
Photon emission for (n,n\*)d

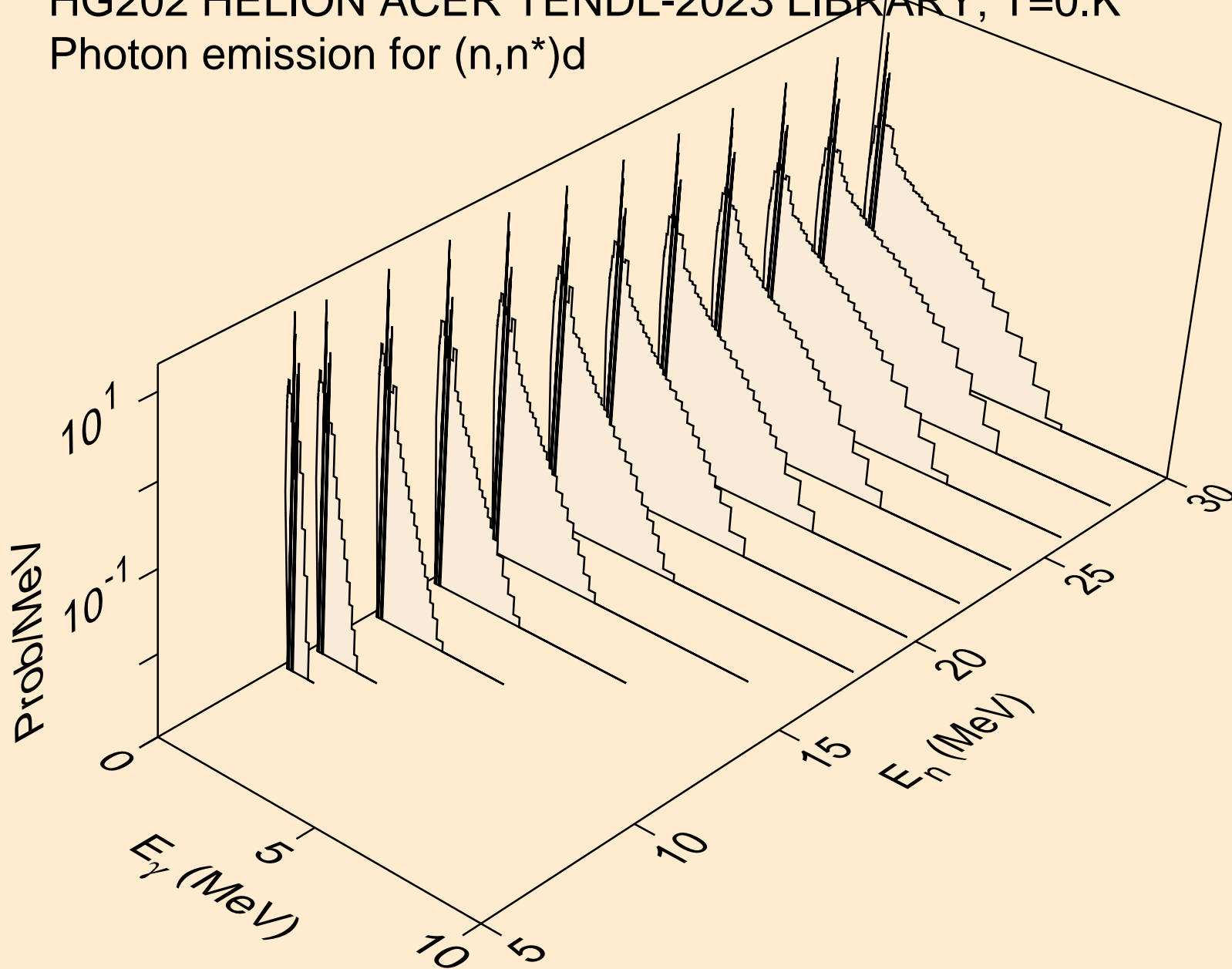

HG202 HELION ACER TENDL-2023 LIBRARY; T=0.K  
Photon emission for (n,n\*)t

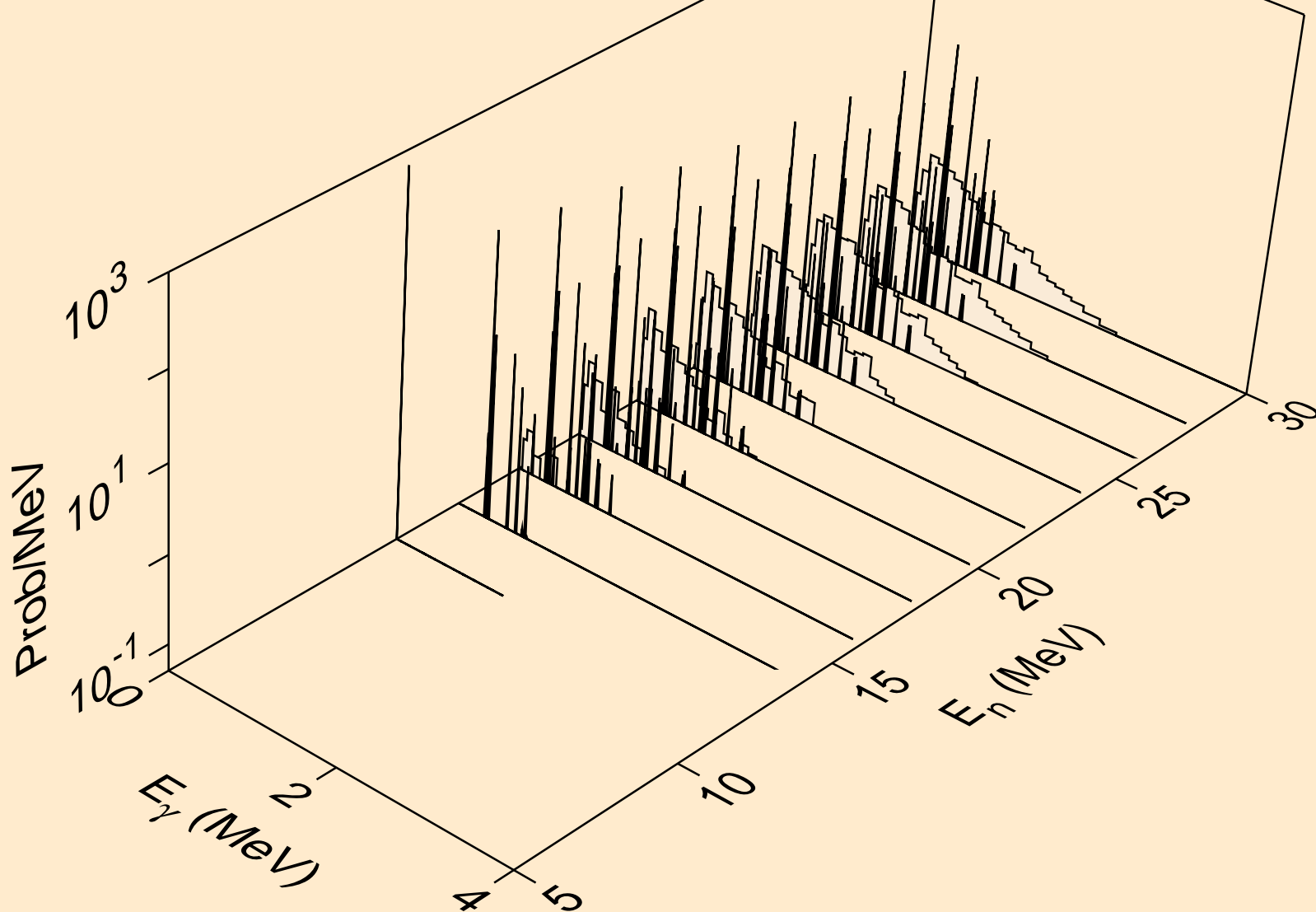

HG202 HELION ACER TENDL-2023 LIBRARY; T=0.K  
Photon emission for (n,n\*)he3

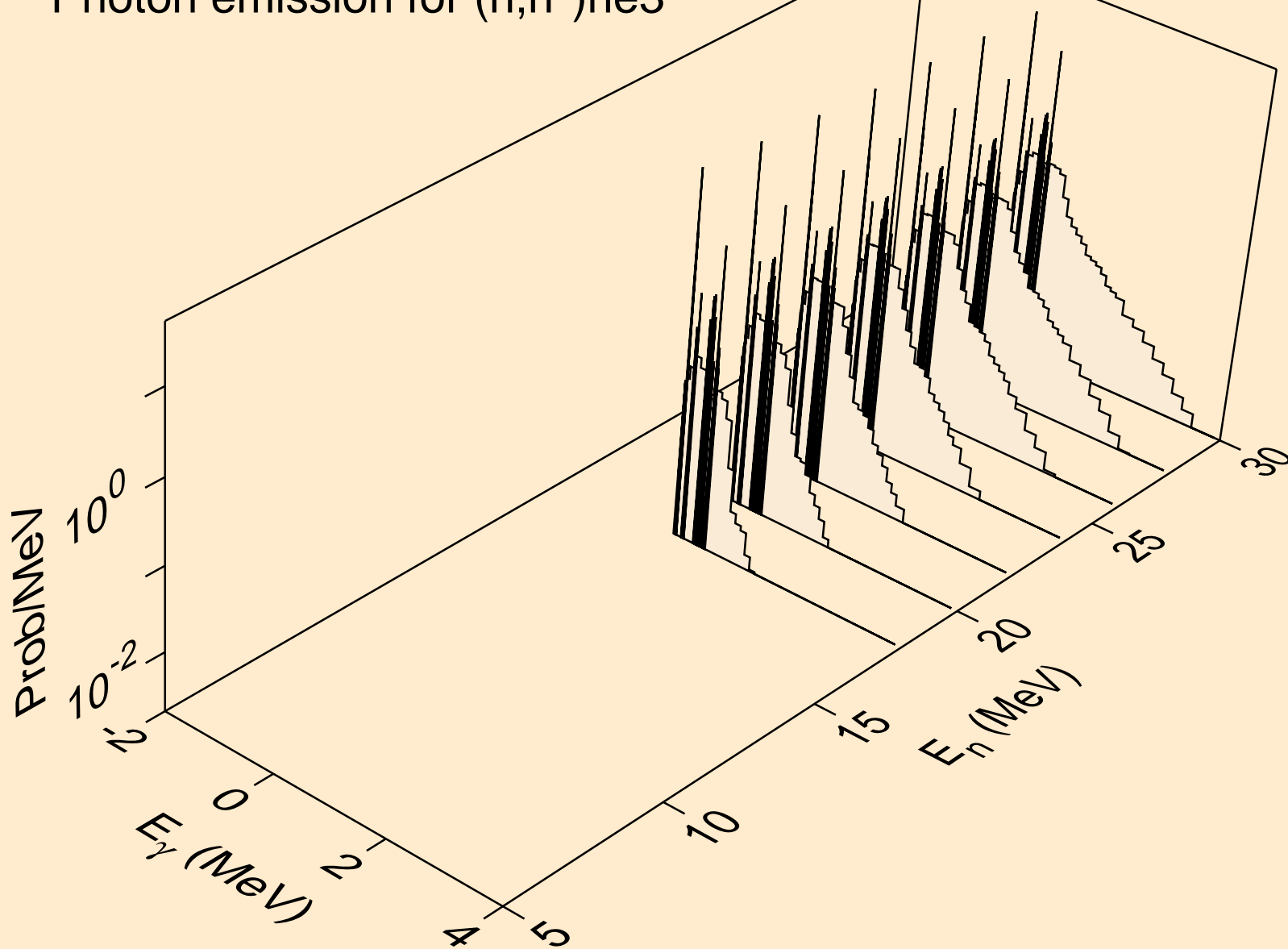

HG202 HELION ACER TENDL-2023 LIBRARY; T=0.K  
Photon emission for (n,4n)

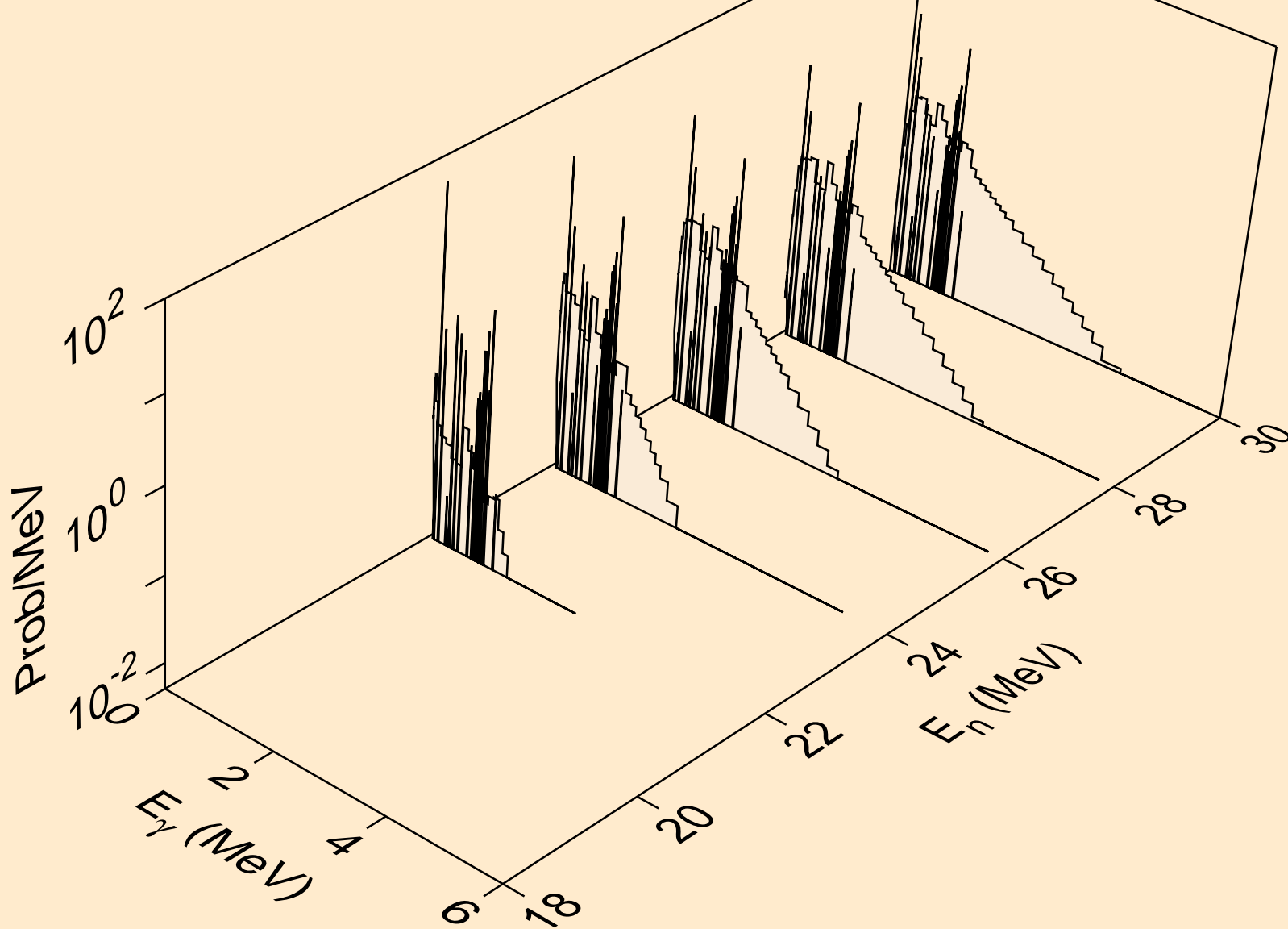

HG202 HELION ACER TENDL-2023 LIBRARY; T=0.K  
Photon emission for (n,2np)

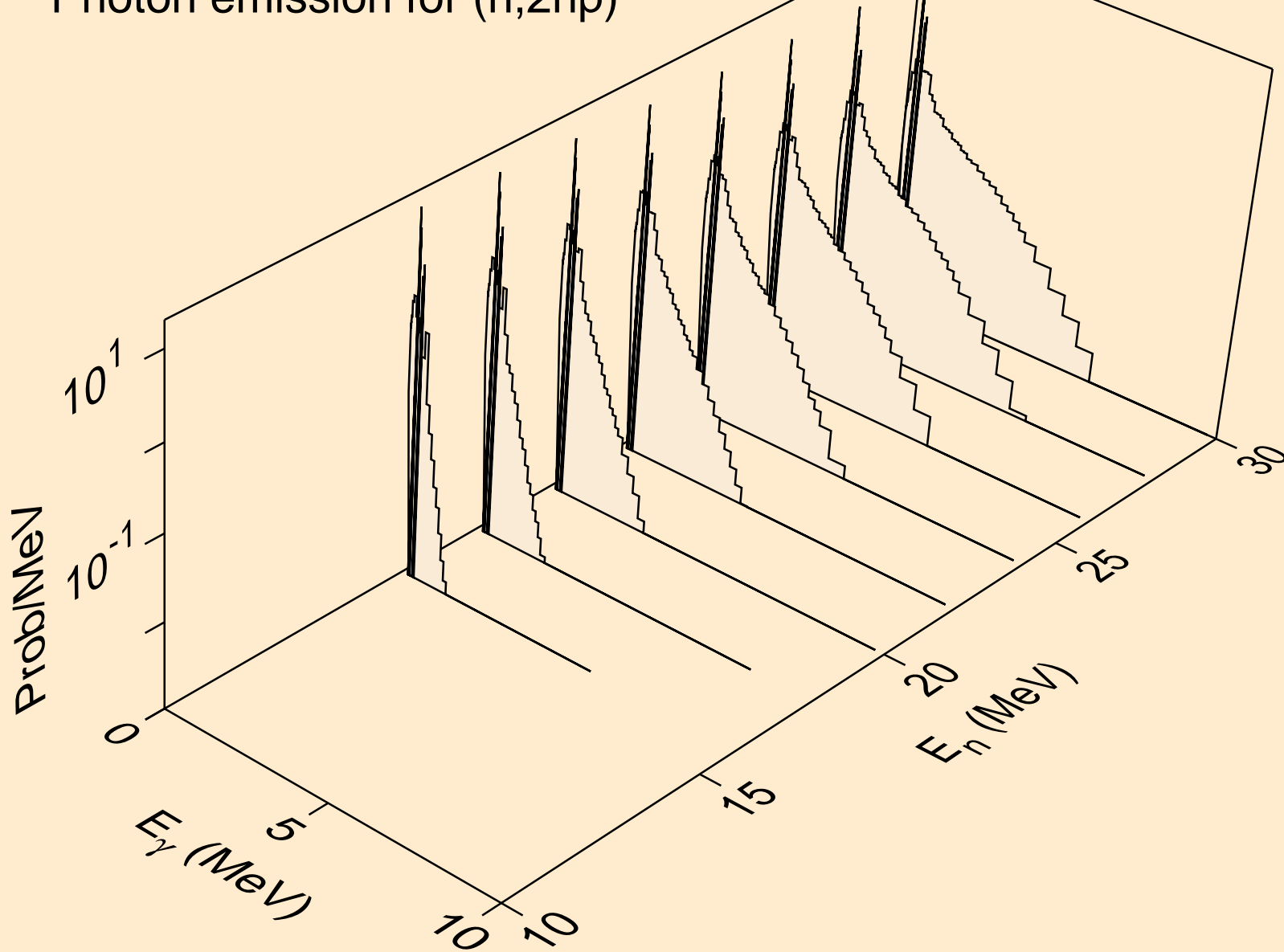

HG202 HELION ACER TENDL-2023 LIBRARY; T=0.K  
Photon emission for (n,3np)

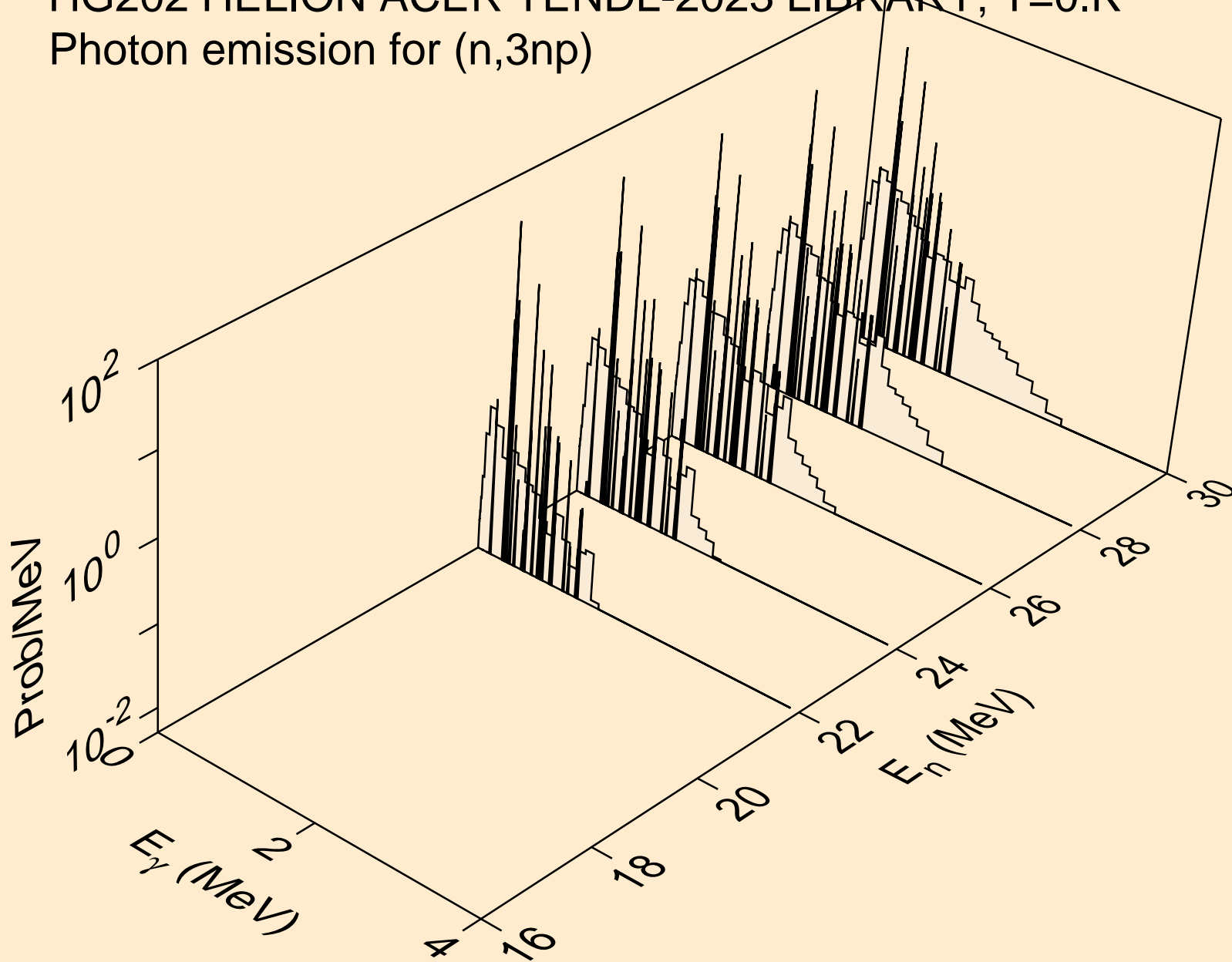

HG202 HELION ACER TENDL-2023 LIBRARY; T=0.K  
Photon emission for (n,n2p)

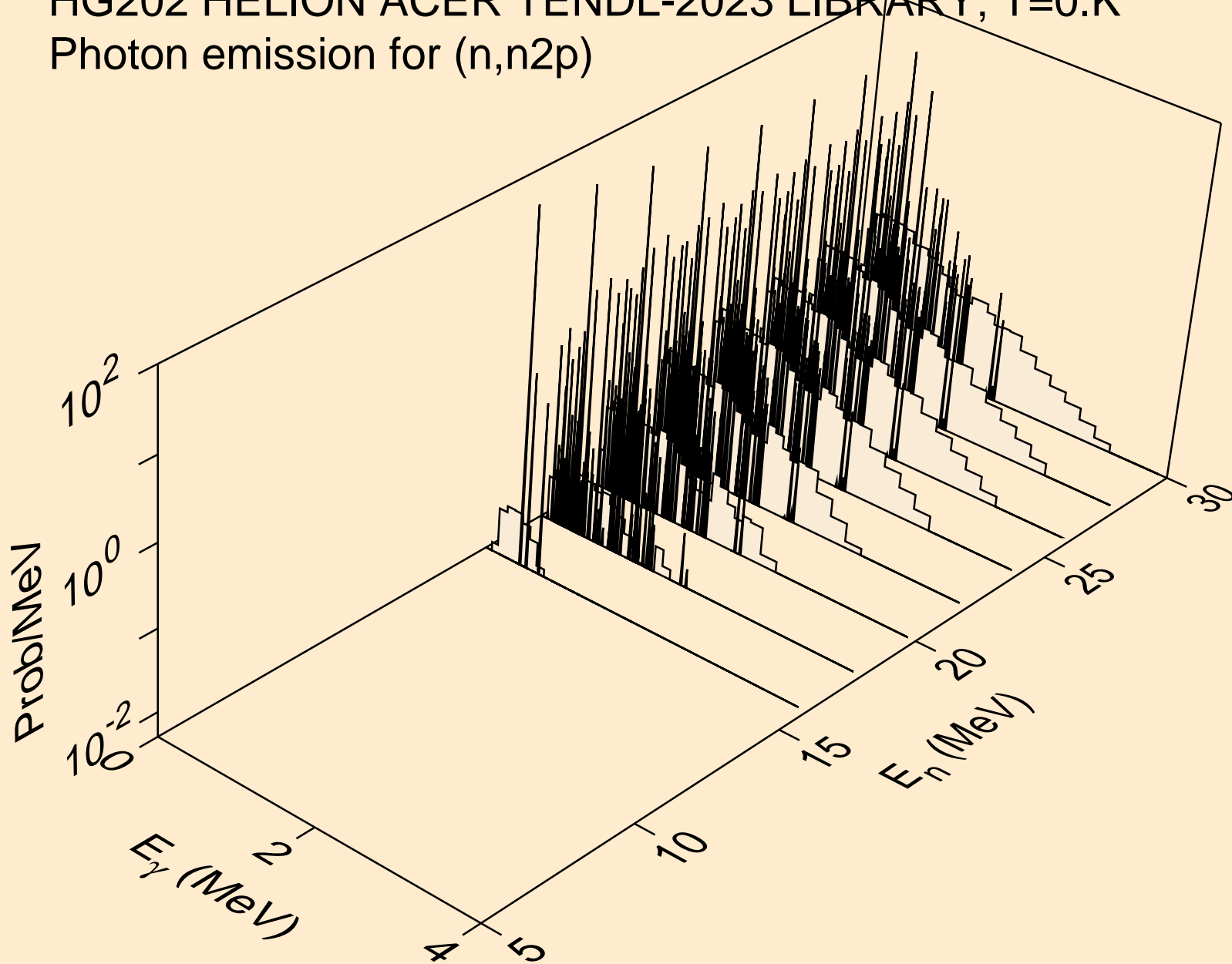

HG202 HELION ACER TENDL-2023 LIBRARY; T=0.K  
Photon emission for (n,npa)

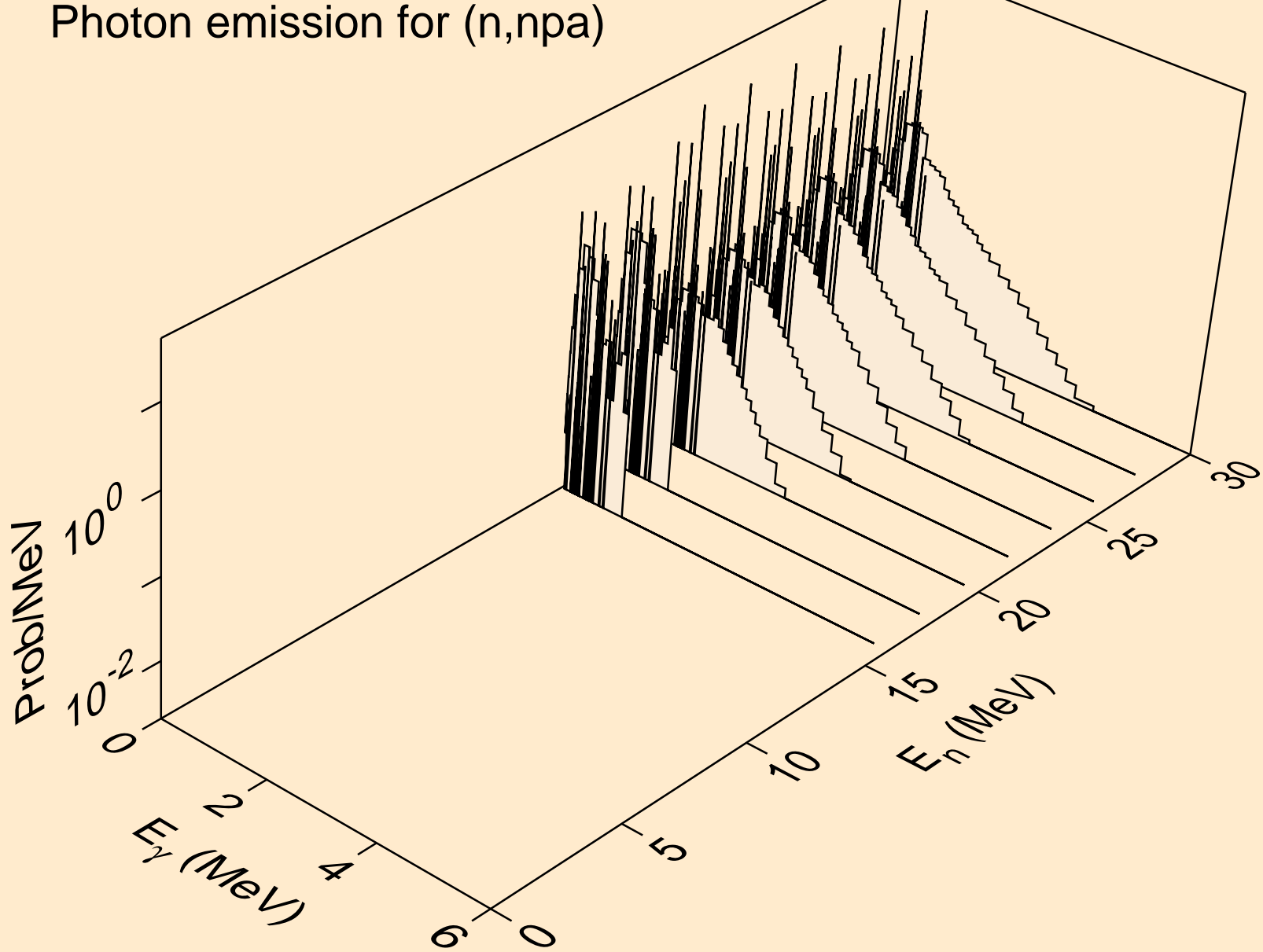

HG202 HELION ACER TENDL-2023 LIBRARY; T=0.K  
Photon emission for (n,gma)

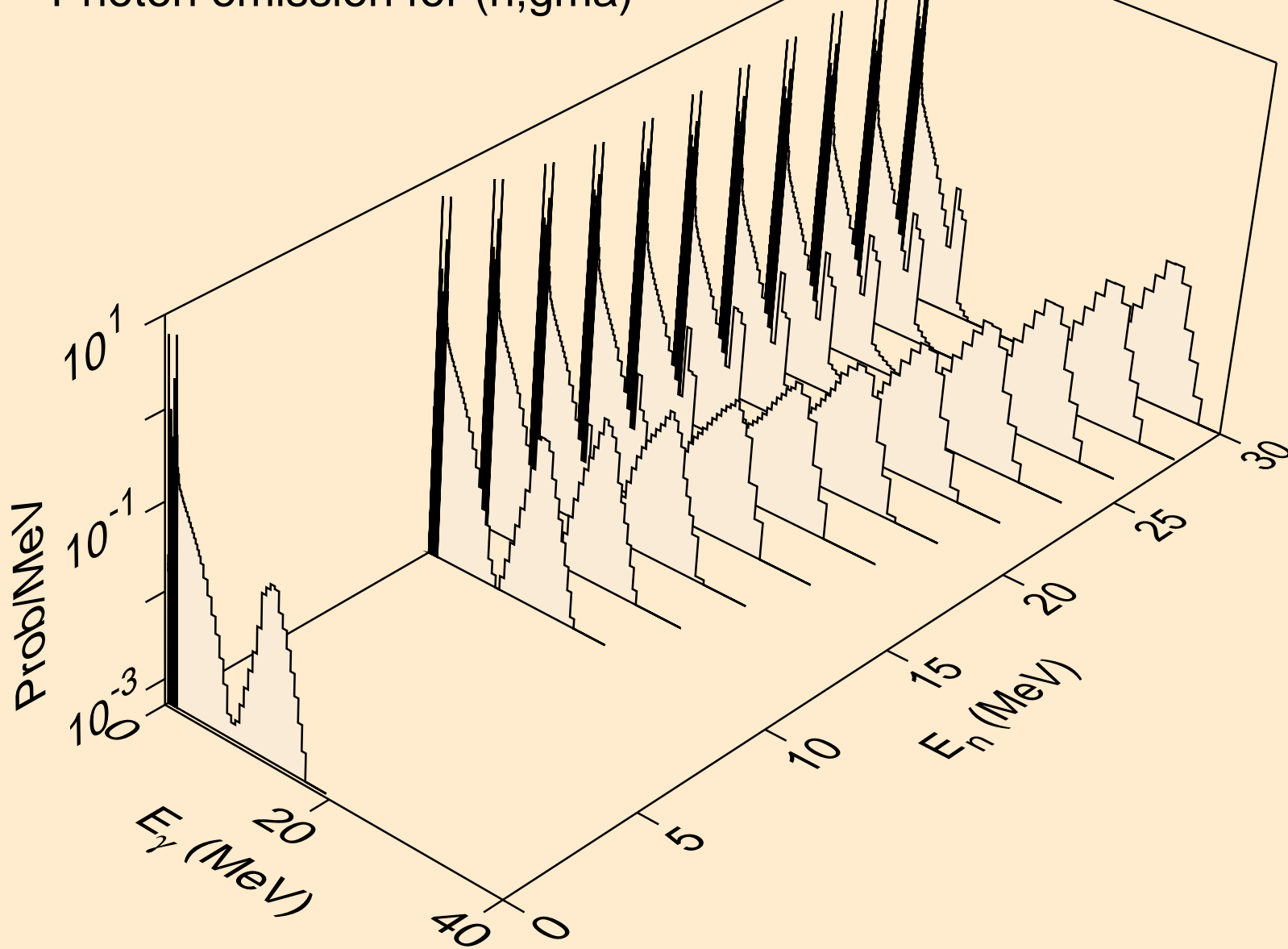

HG202 HELION ACER TENDL-2023 LIBRARY; T=0.K  
Photon emission for (n,p)

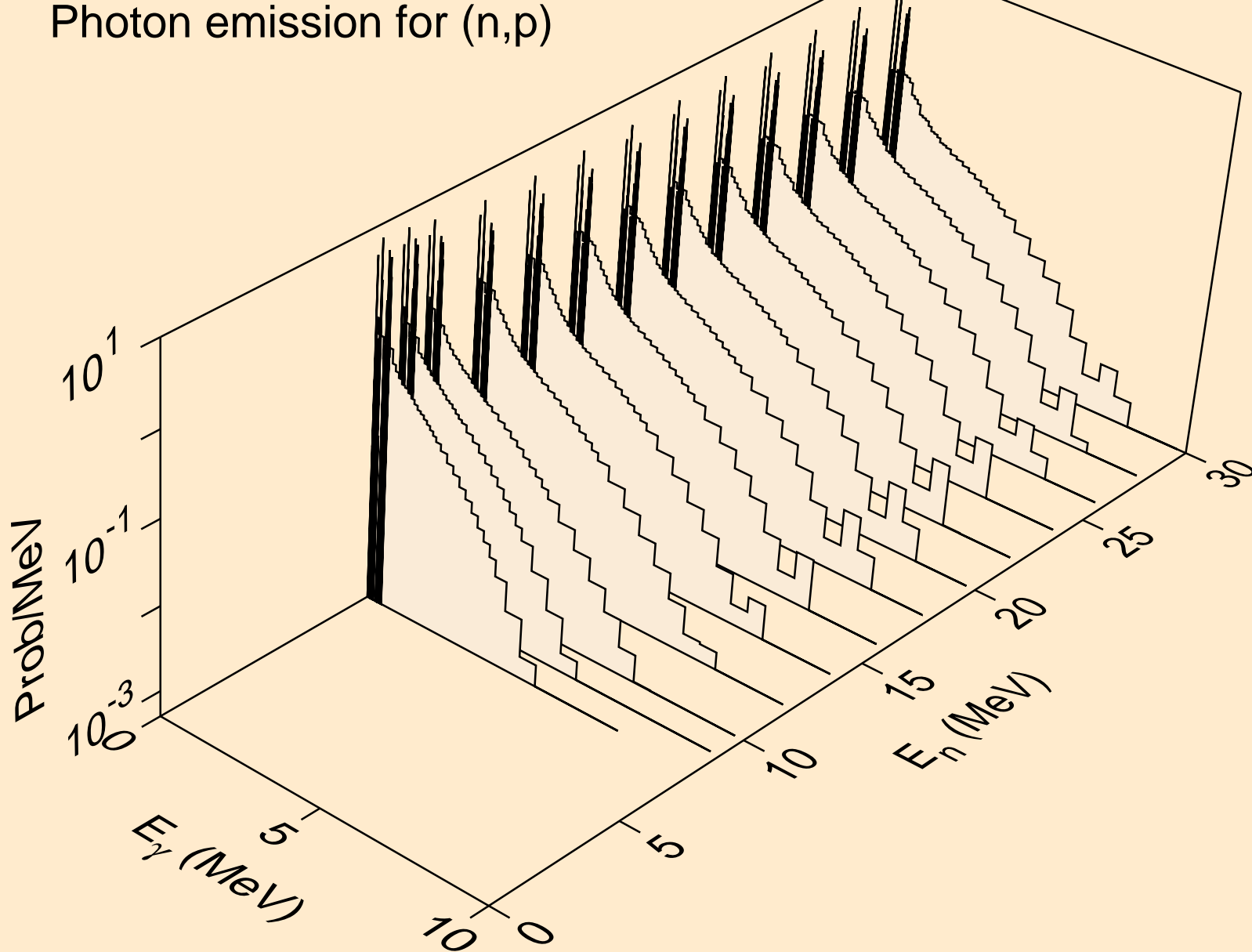

HG202 HELION ACER TENDL-2023 LIBRARY; T=0.K  
Photon emission for (n,d)

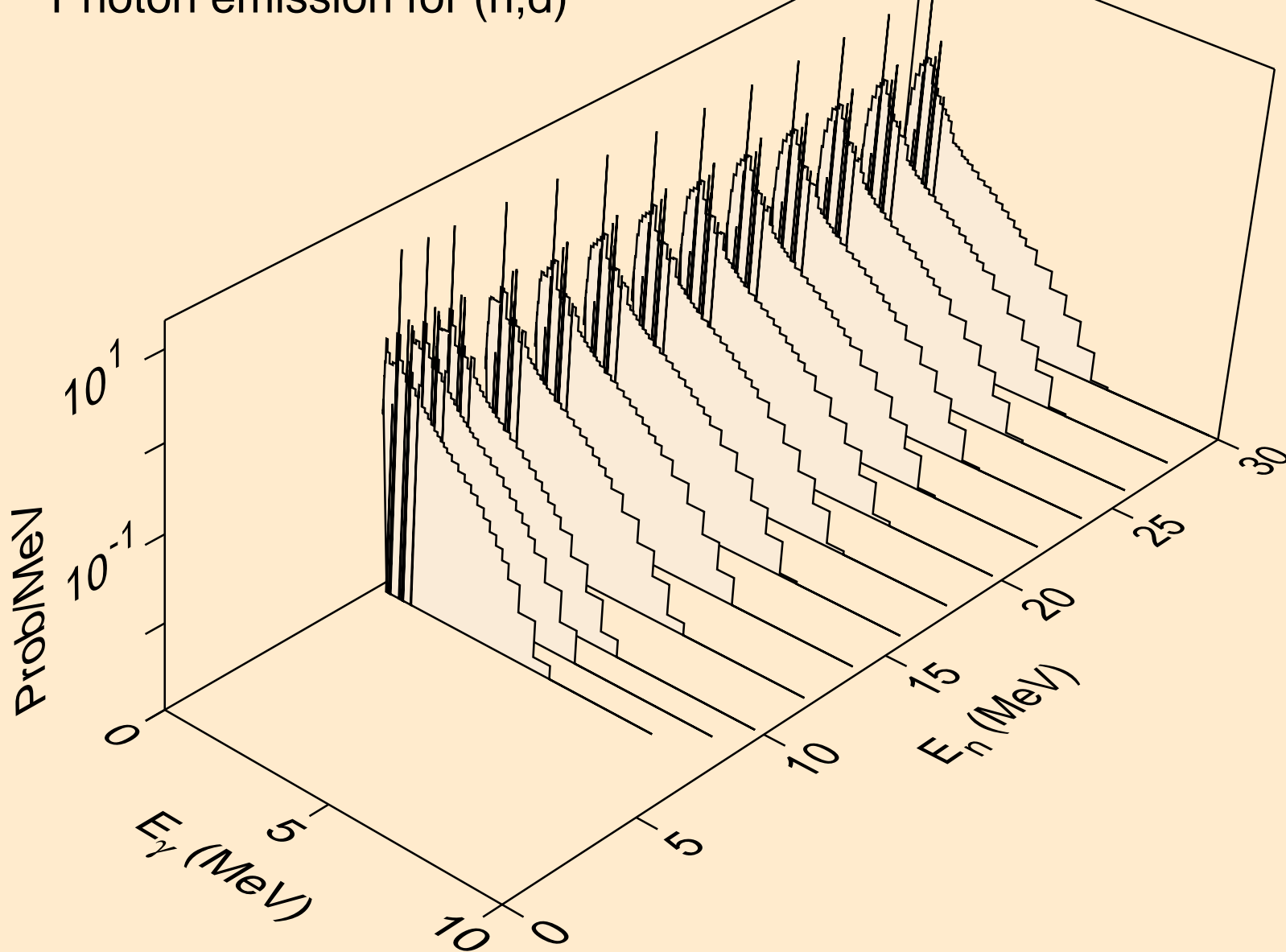

HG202 HELION ACER TENDL-2023 LIBRARY; T=0.K  
Photon emission for (n,t)

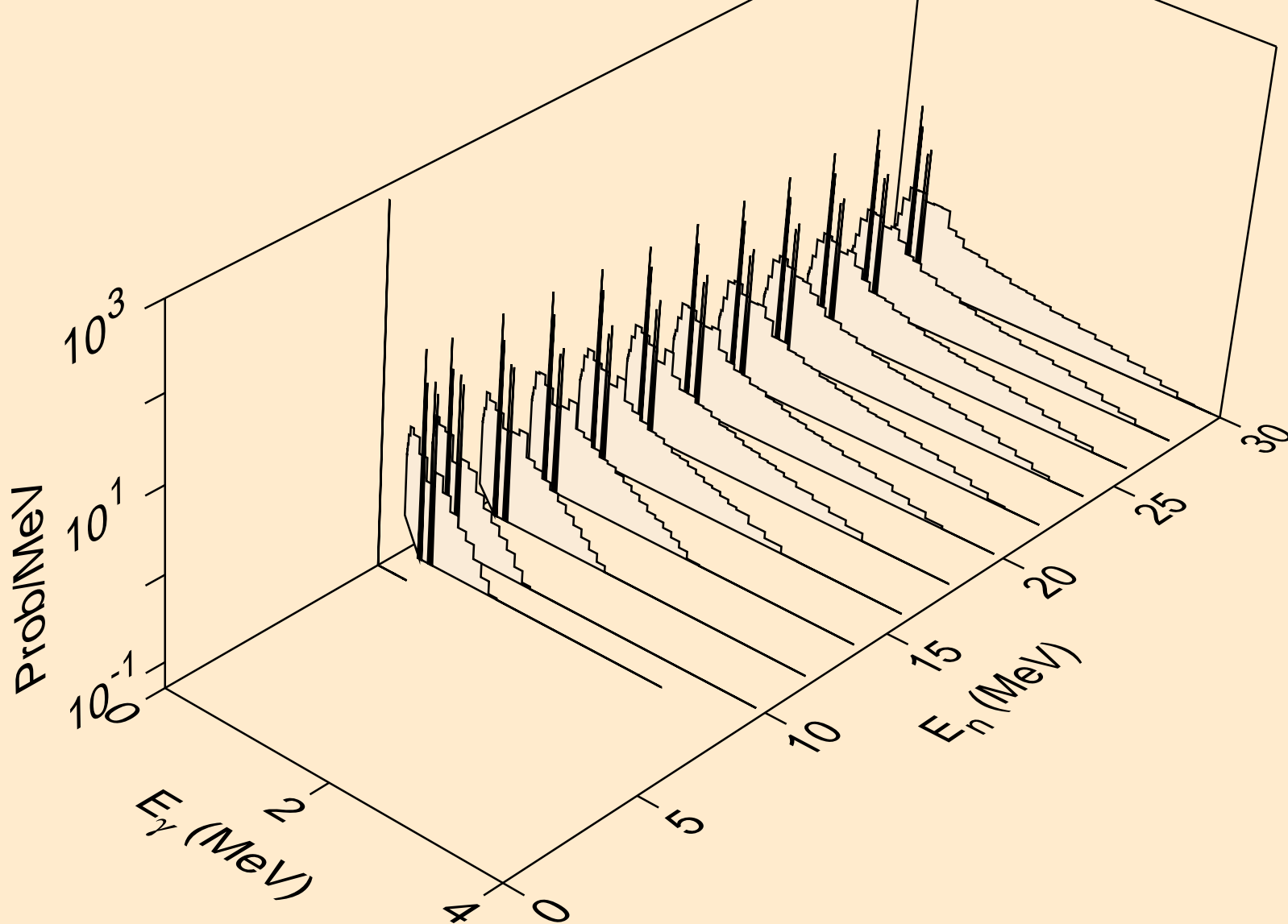

HG202 HELION ACER TENDL-2023 LIBRARY; T=0.K  
Photon emission for inelastic

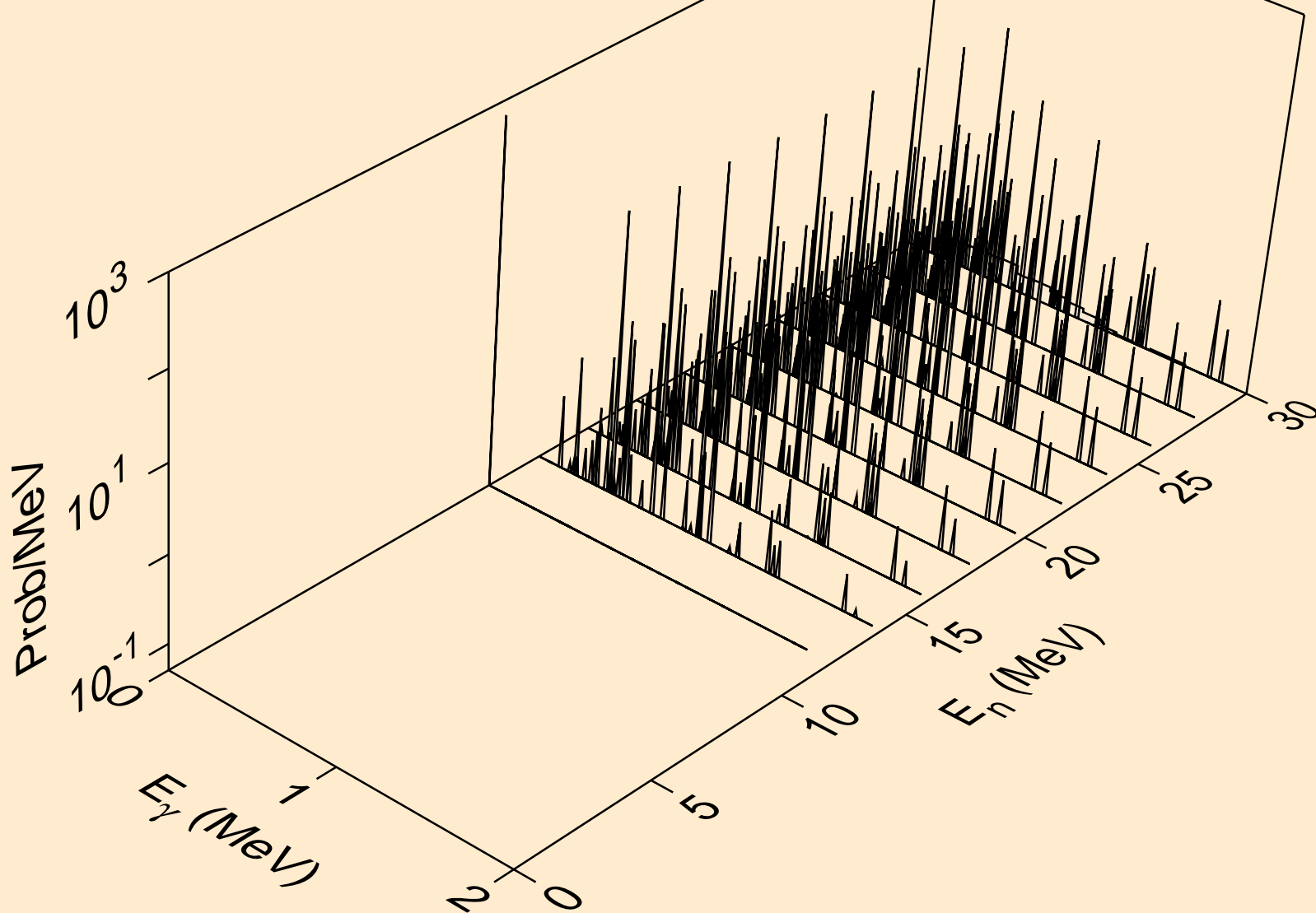

HG202 HELION ACER TENDL-2023 LIBRARY; T=0.K  
Photon emission for (n,a)

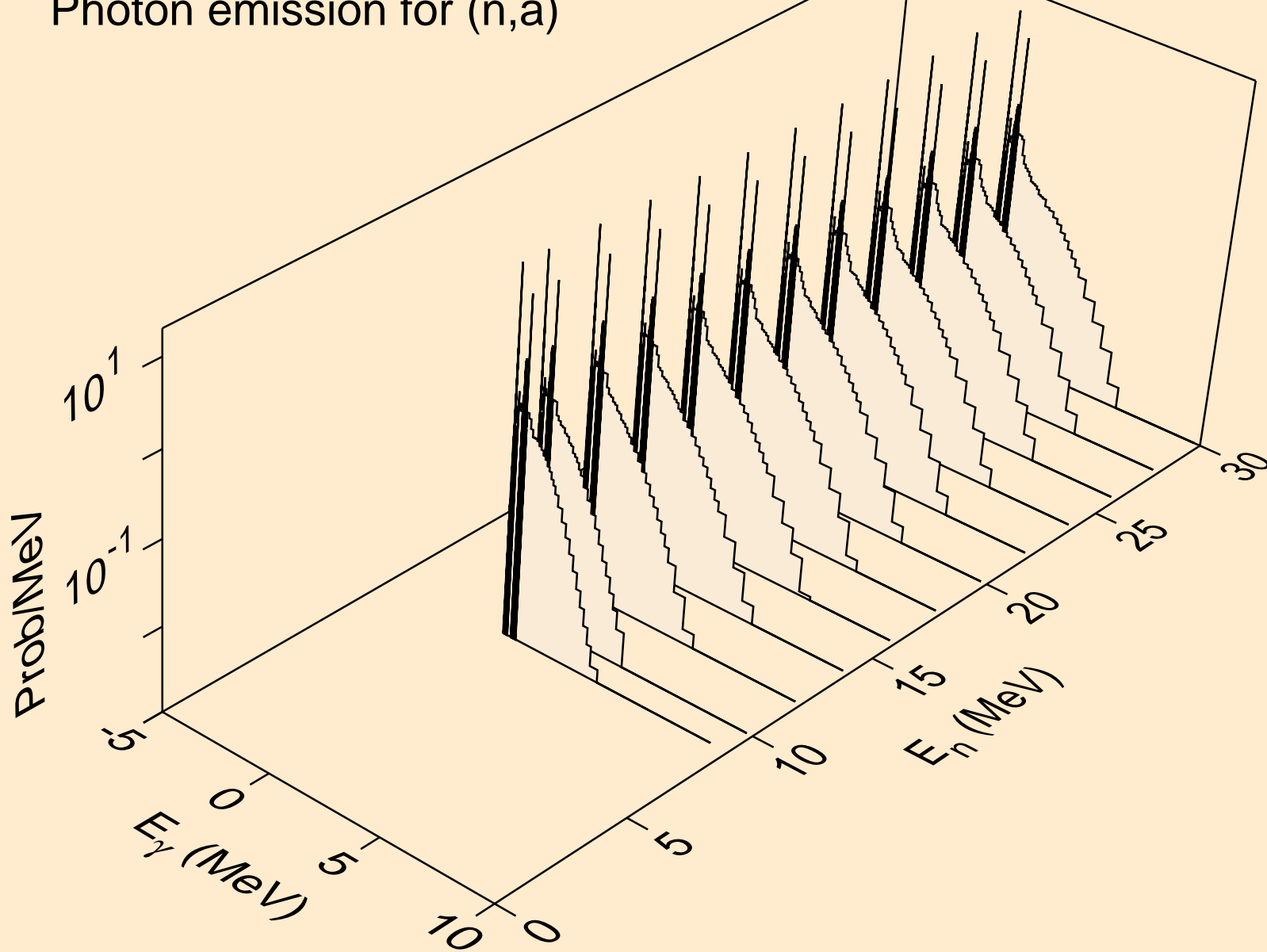

HG202 HELION ACER TENDL-2023 LIBRARY; T=0.K  
Photon emission for (n,2p)

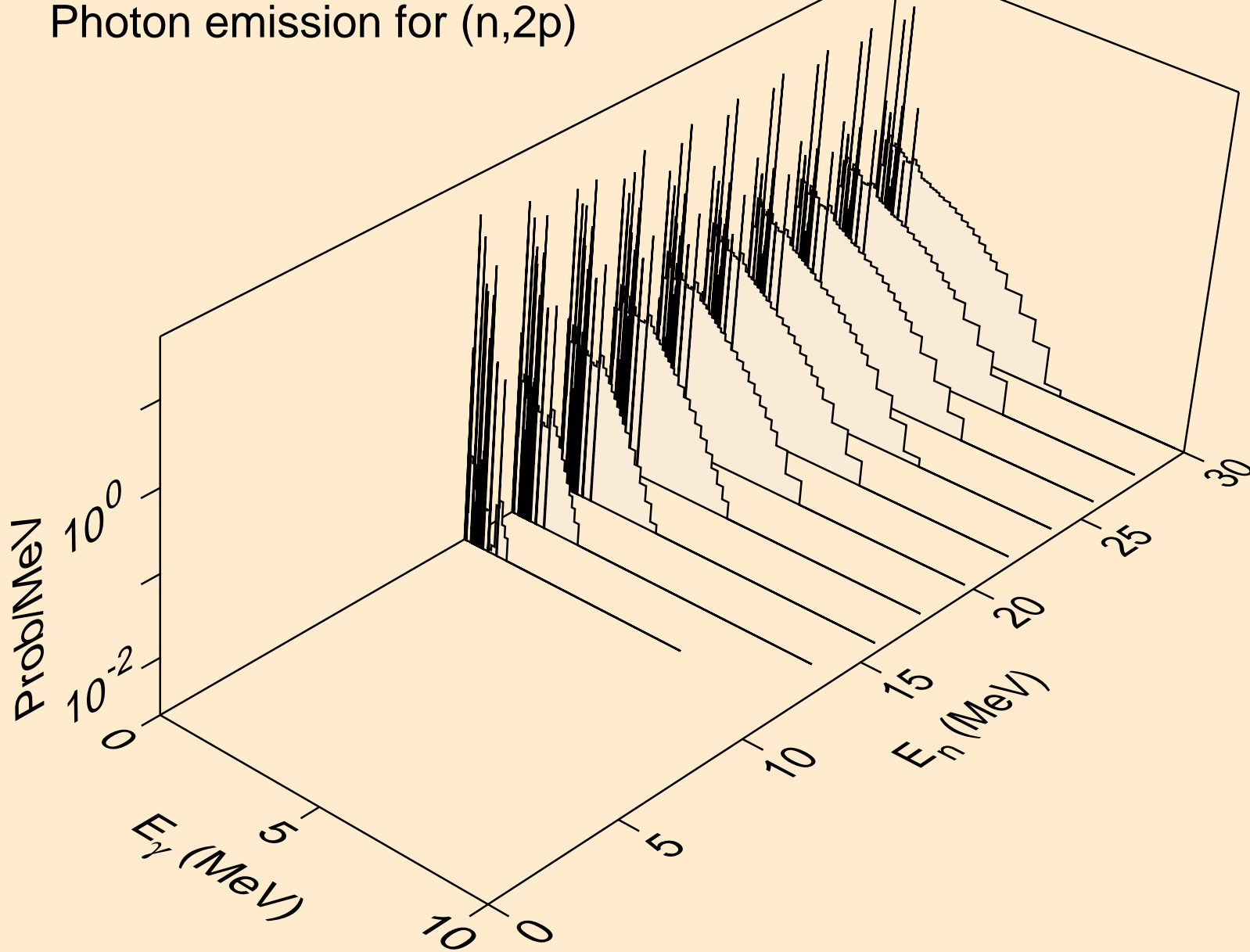

HG202 HELION ACER TENDL-2023 LIBRARY; T=0.K  
Photon emission for (n,pa)

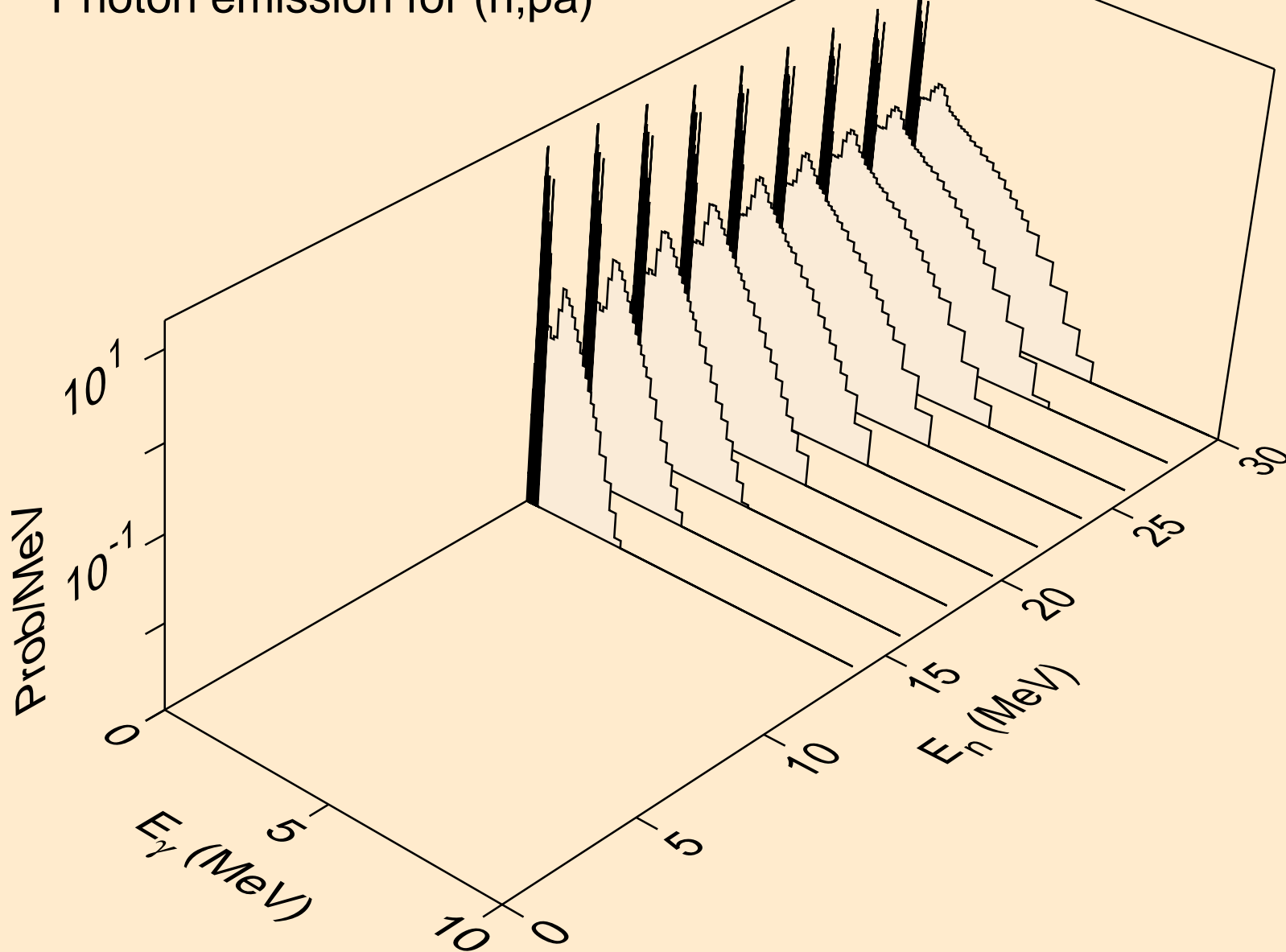

HG202 HELION ACER TENDL-2023 LIBRARY; T=0.K  
Photon emission for (n,pd)

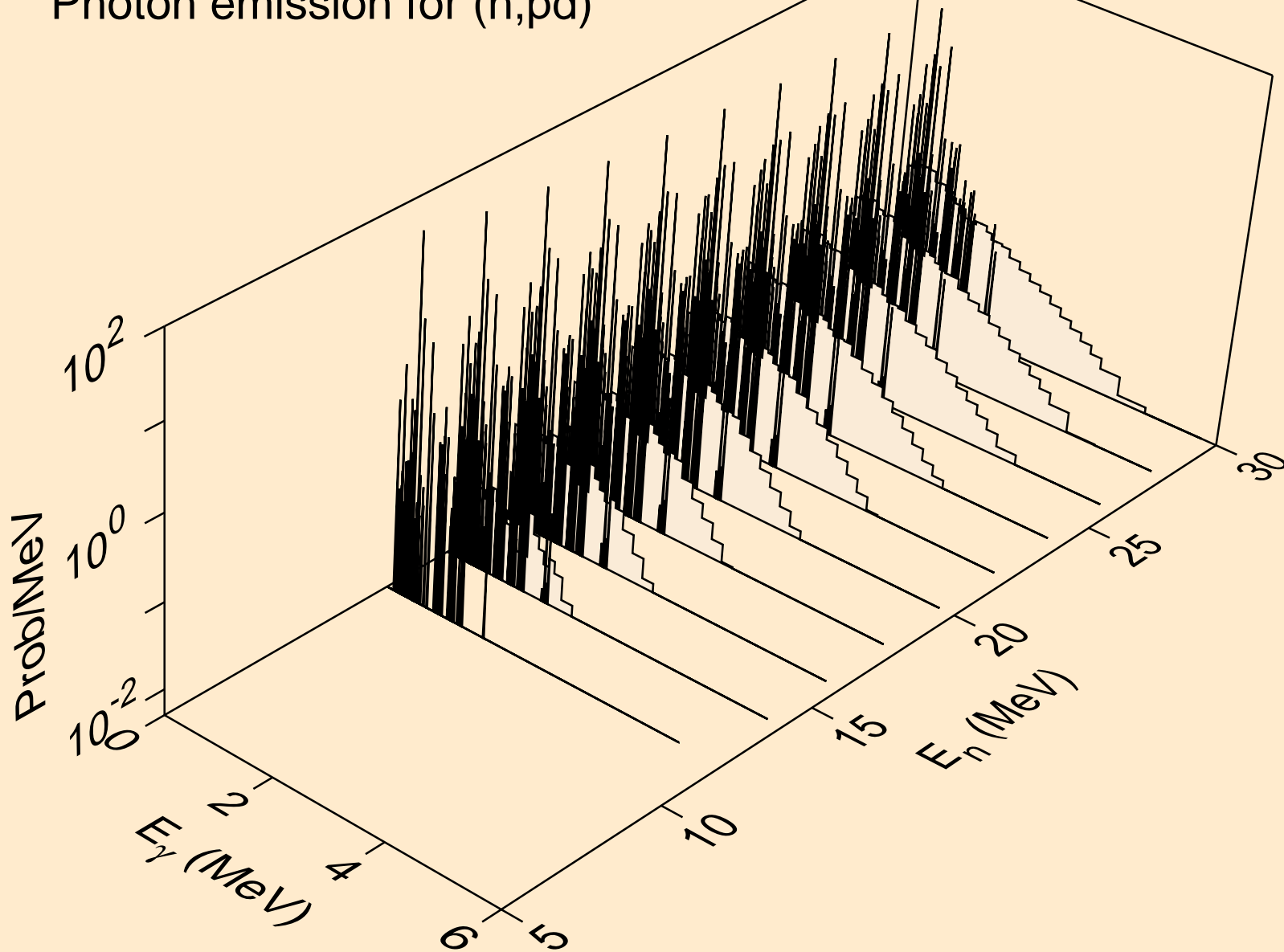

HG202 HELION ACER TENDL-2023 LIBRARY; T=0.K  
Photon emission for (n,pt)

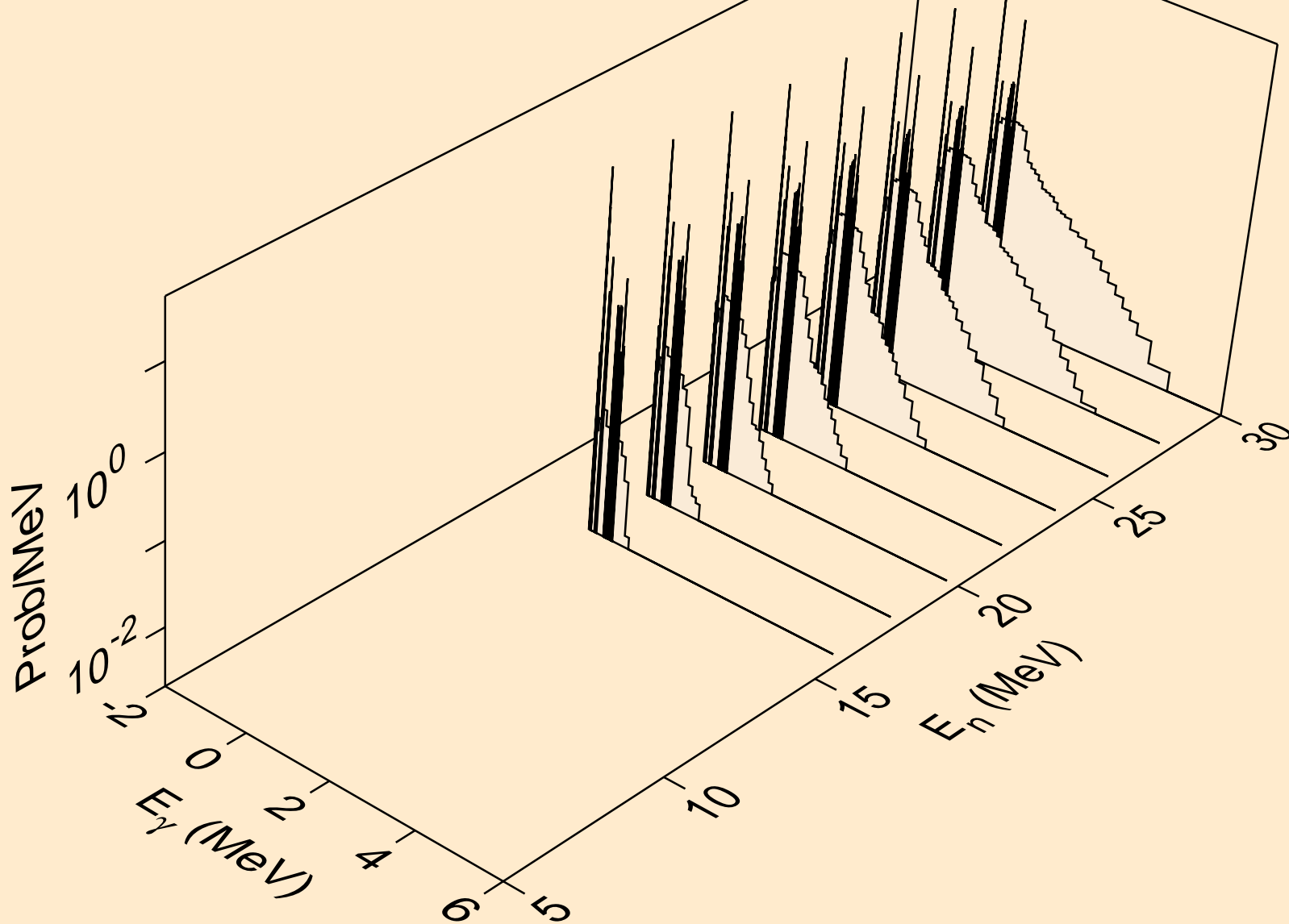

HG202 HELION ACER TENDL-2023 LIBRARY; T=0.K  
Photon emission for (n,da)

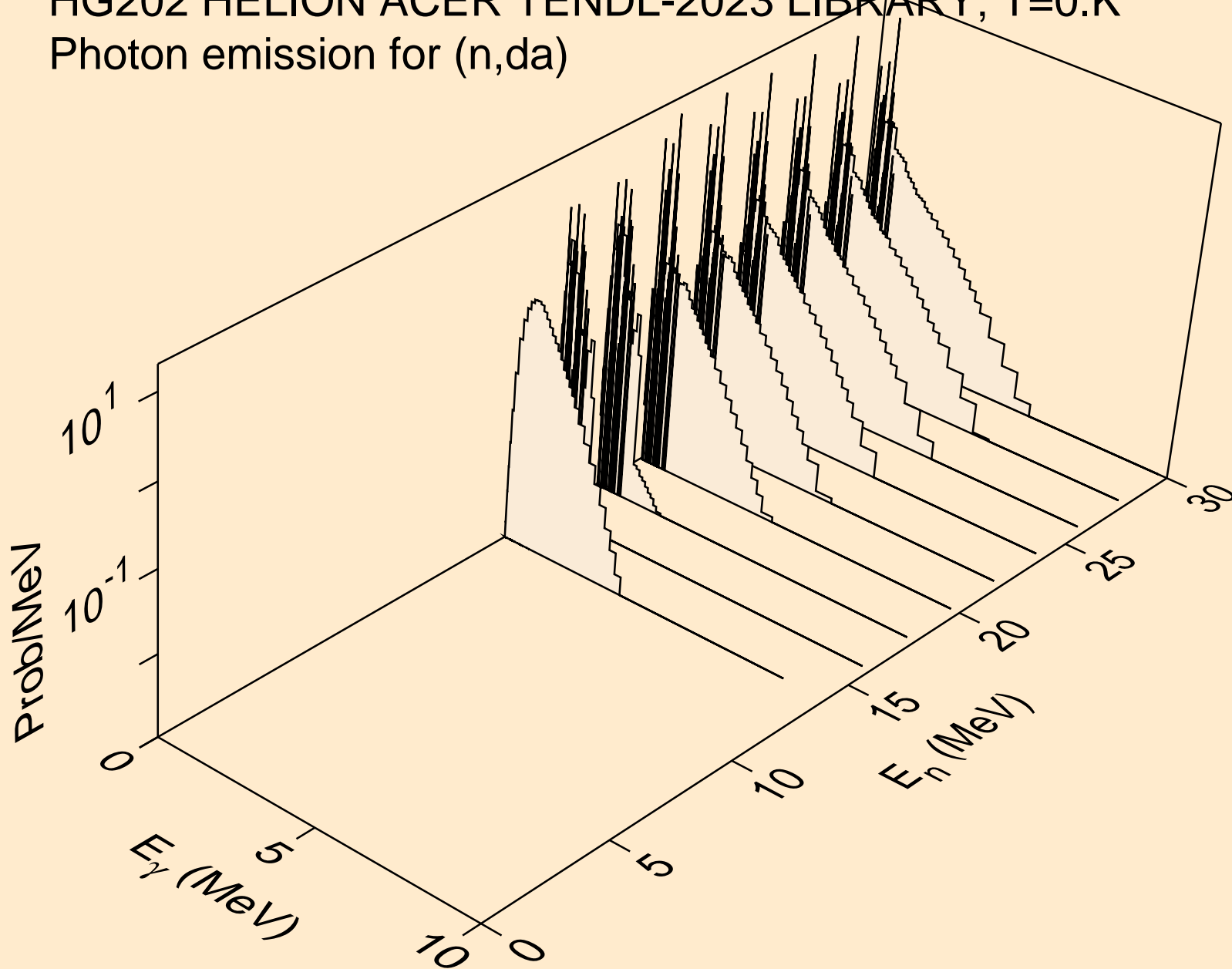

# HG202 HELION ACER TENDL-2023 LIBRARY; T=0.K

## Particle heating contributions

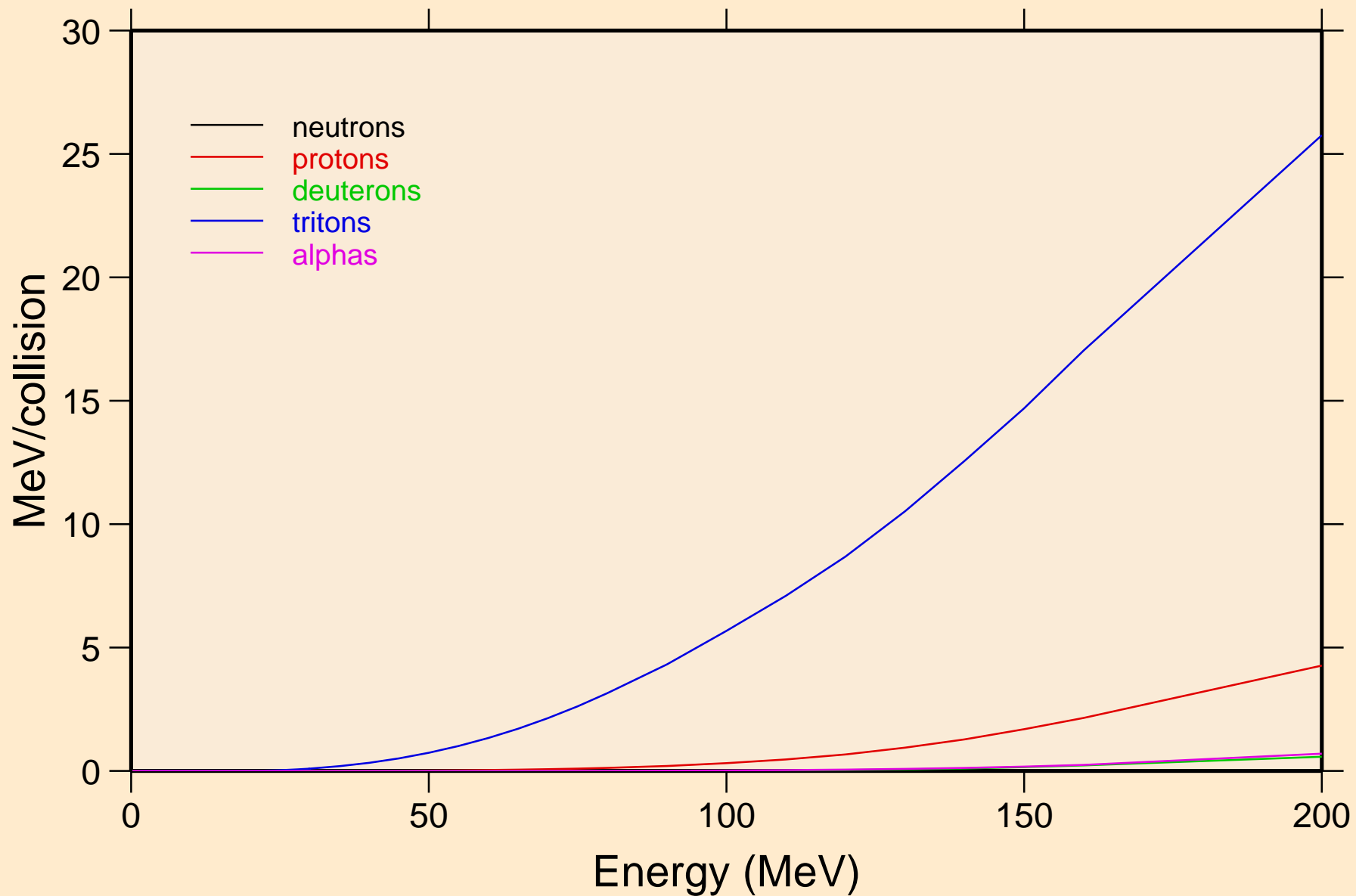

HG202 HELION ACER TENDL-2023 LIBRARY; T=0.K  
Recoil Heating

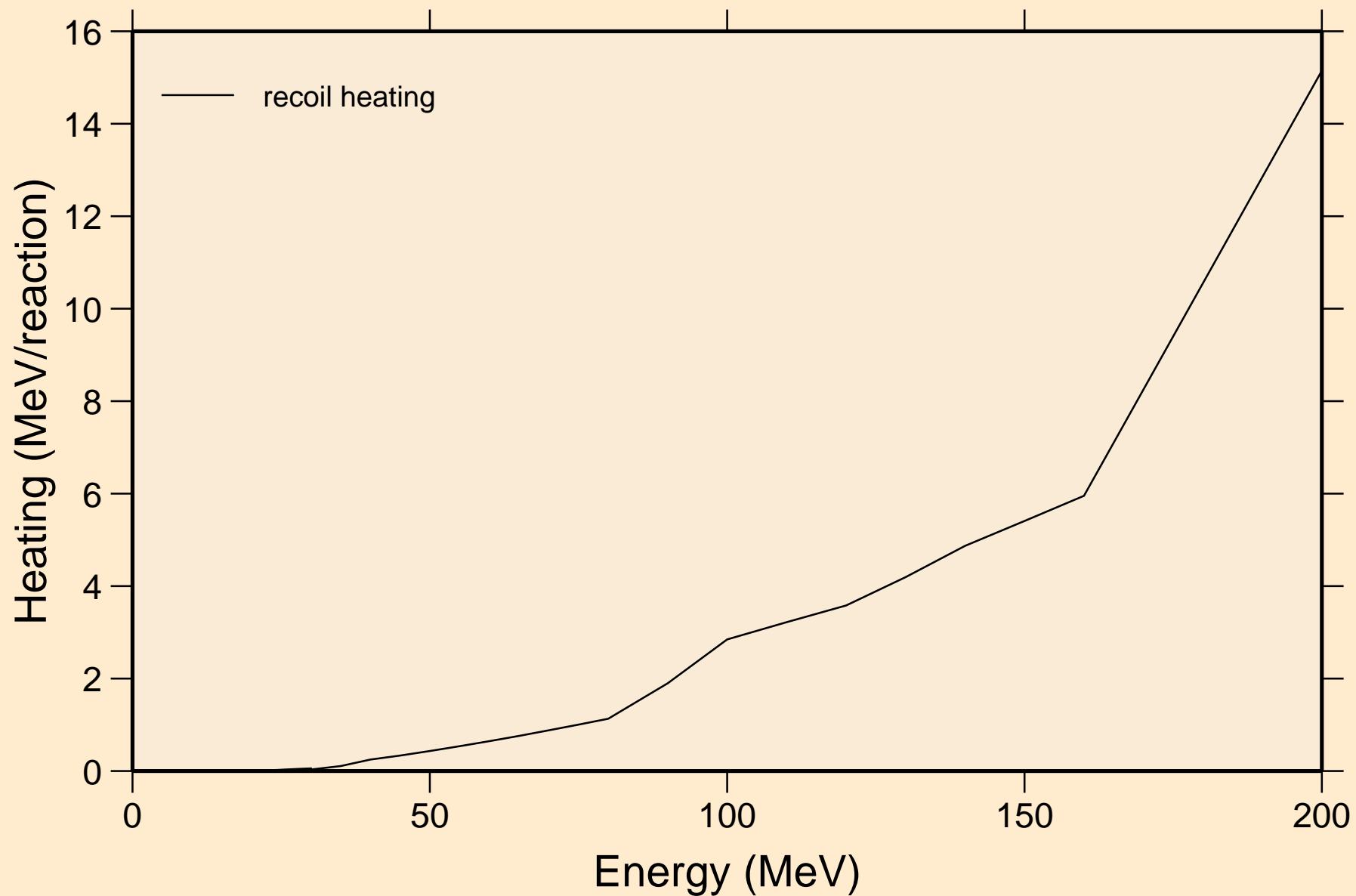

# HG202 HELION ACER TENDL-2023 LIBRARY; T=0.K

## Particle production cross sections

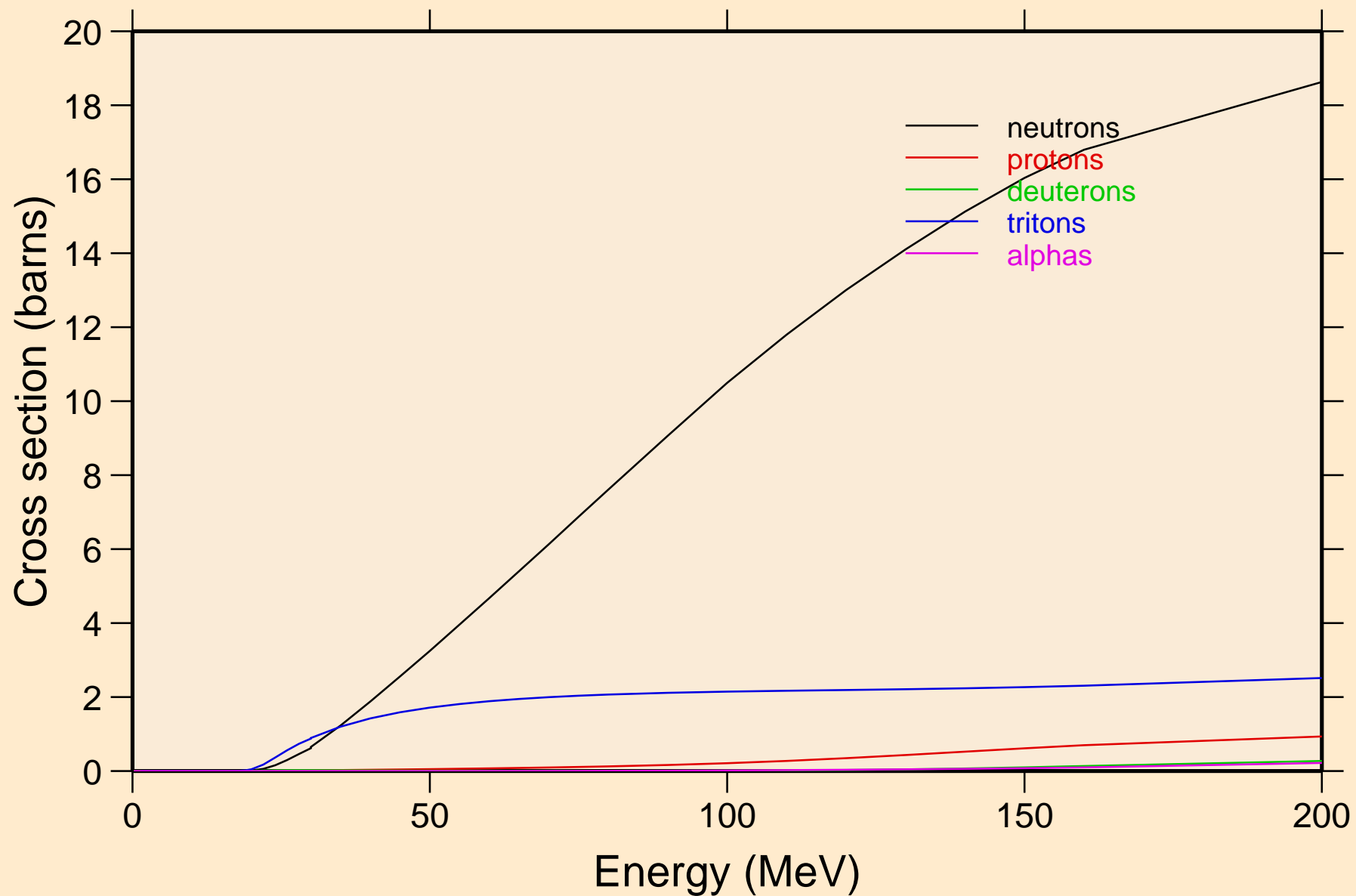

HG202 HELION ACER TENDL-2023 LIBRARY; T=0.K  
neutrons from (s,n)

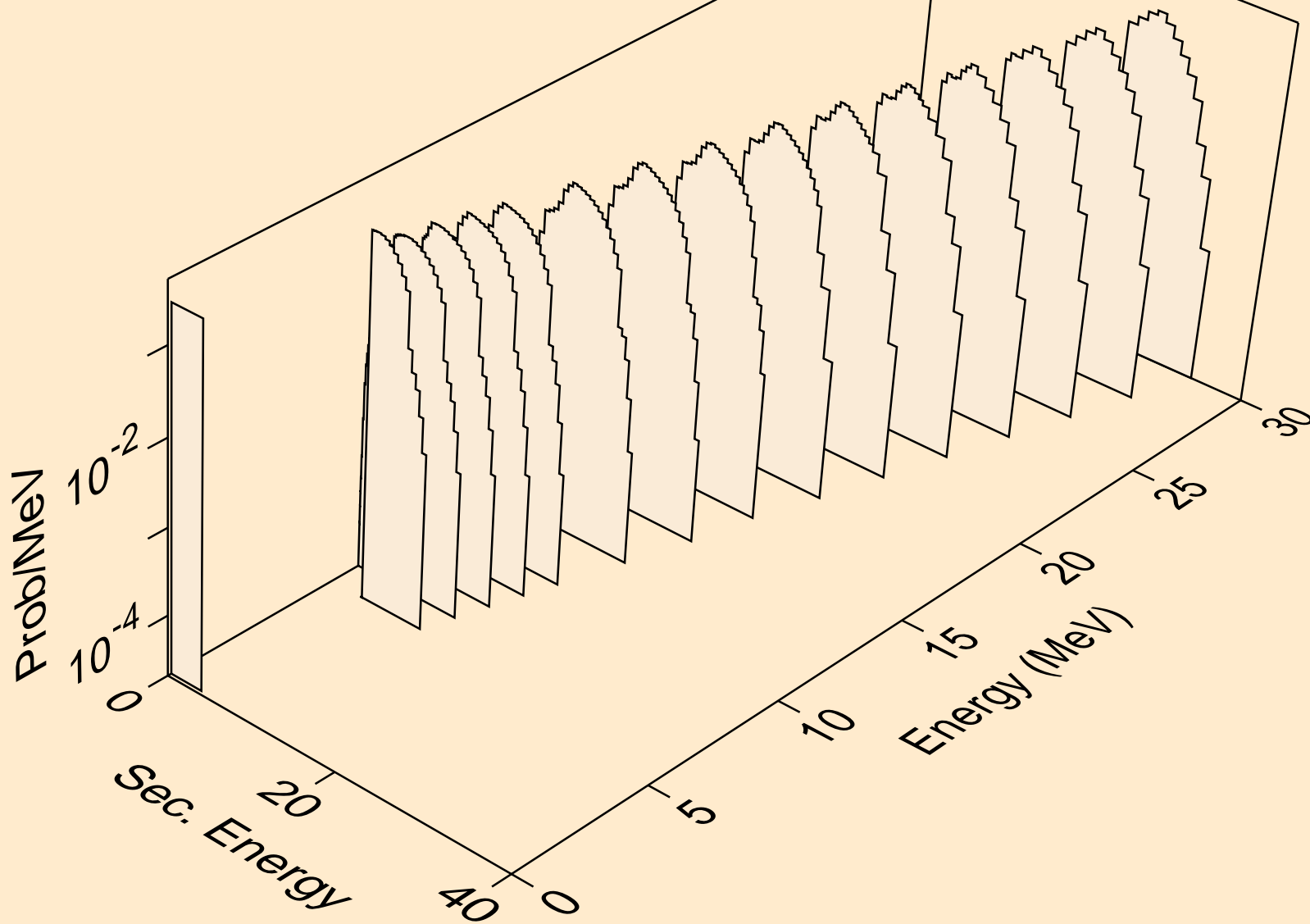

HG202 HELION ACER TENDL-2023 LIBRARY; T=0.K  
neutrons from (s,x)

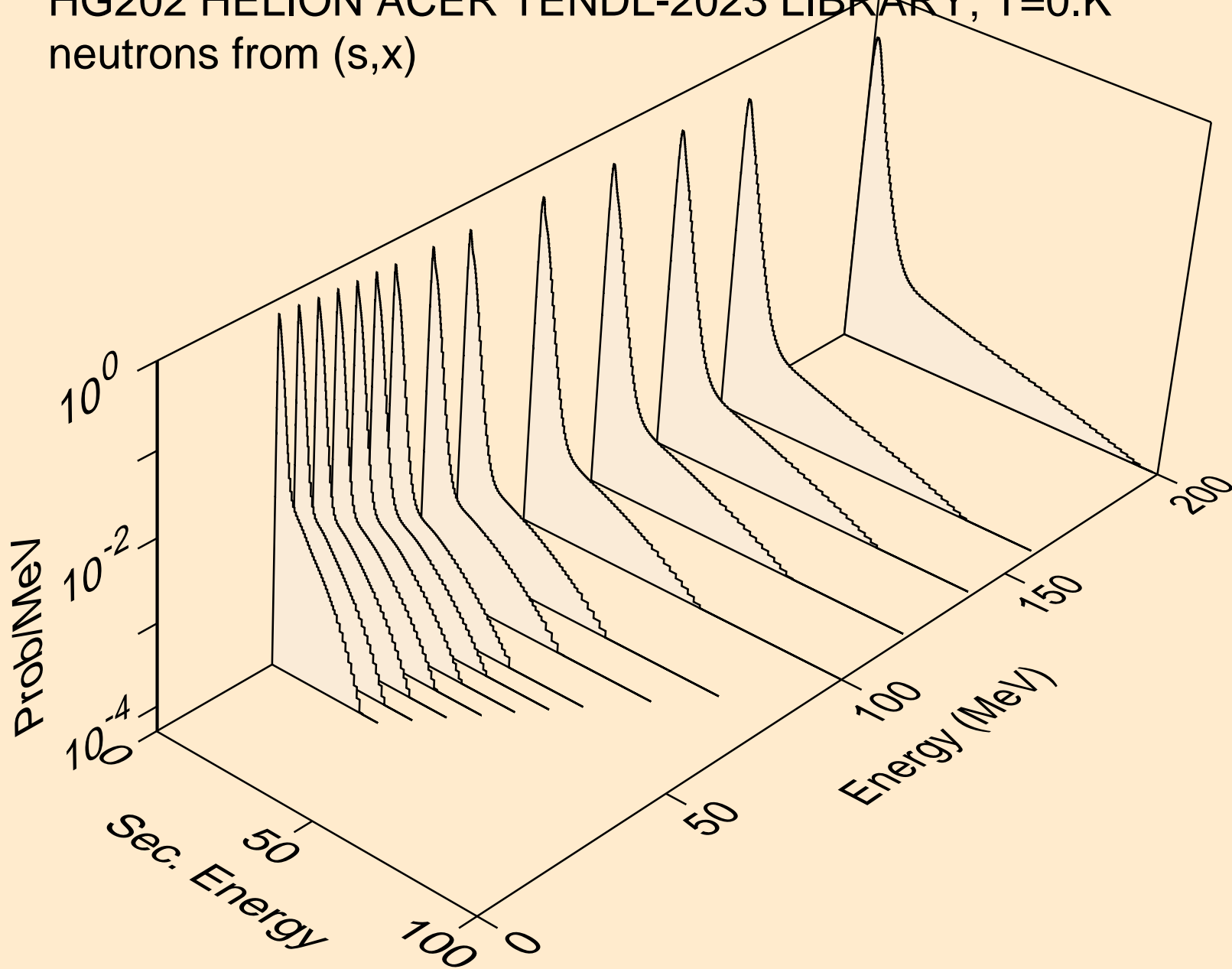

HG202 HELION ACER TENDL-2023 LIBRARY; T=0.K  
neutrons from (s,2nd)

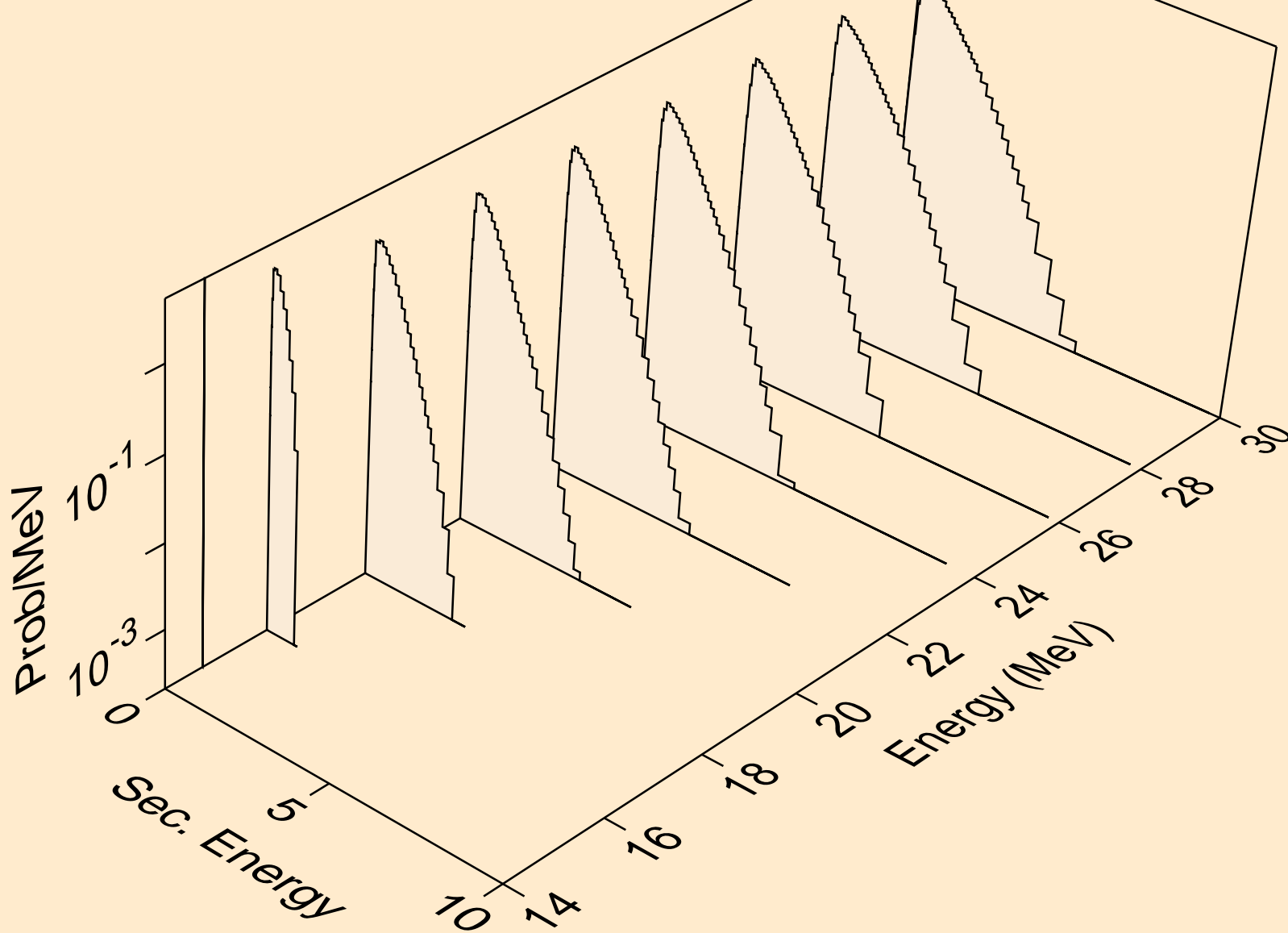

HG202 HELION ACER TENDL-2023 LIBRARY; T=0.K  
neutrons from (s,2n)

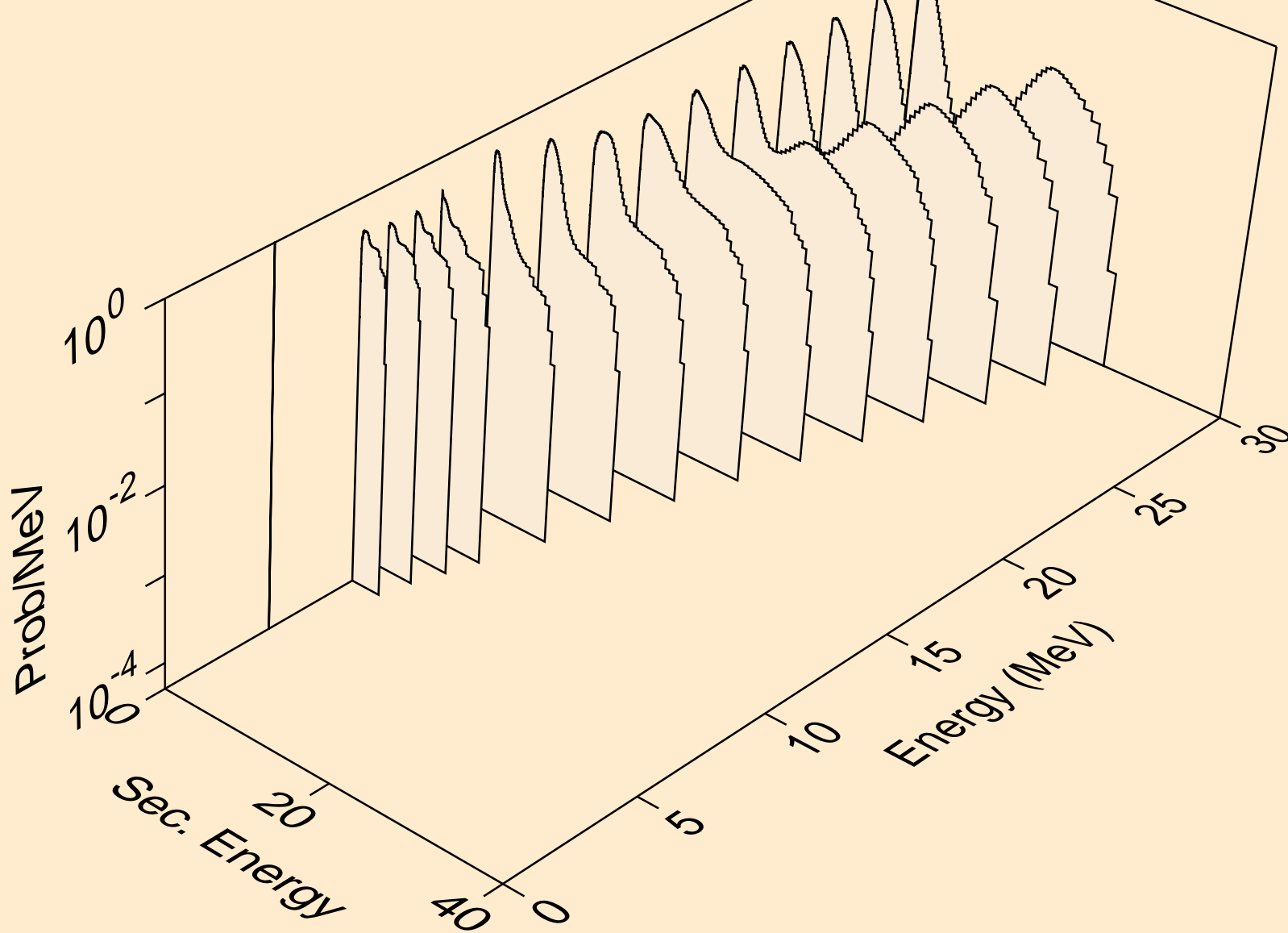

HG202 HELION ACER TENDL-2023 LIBRARY; T=0.K  
neutrons from (s,3n)

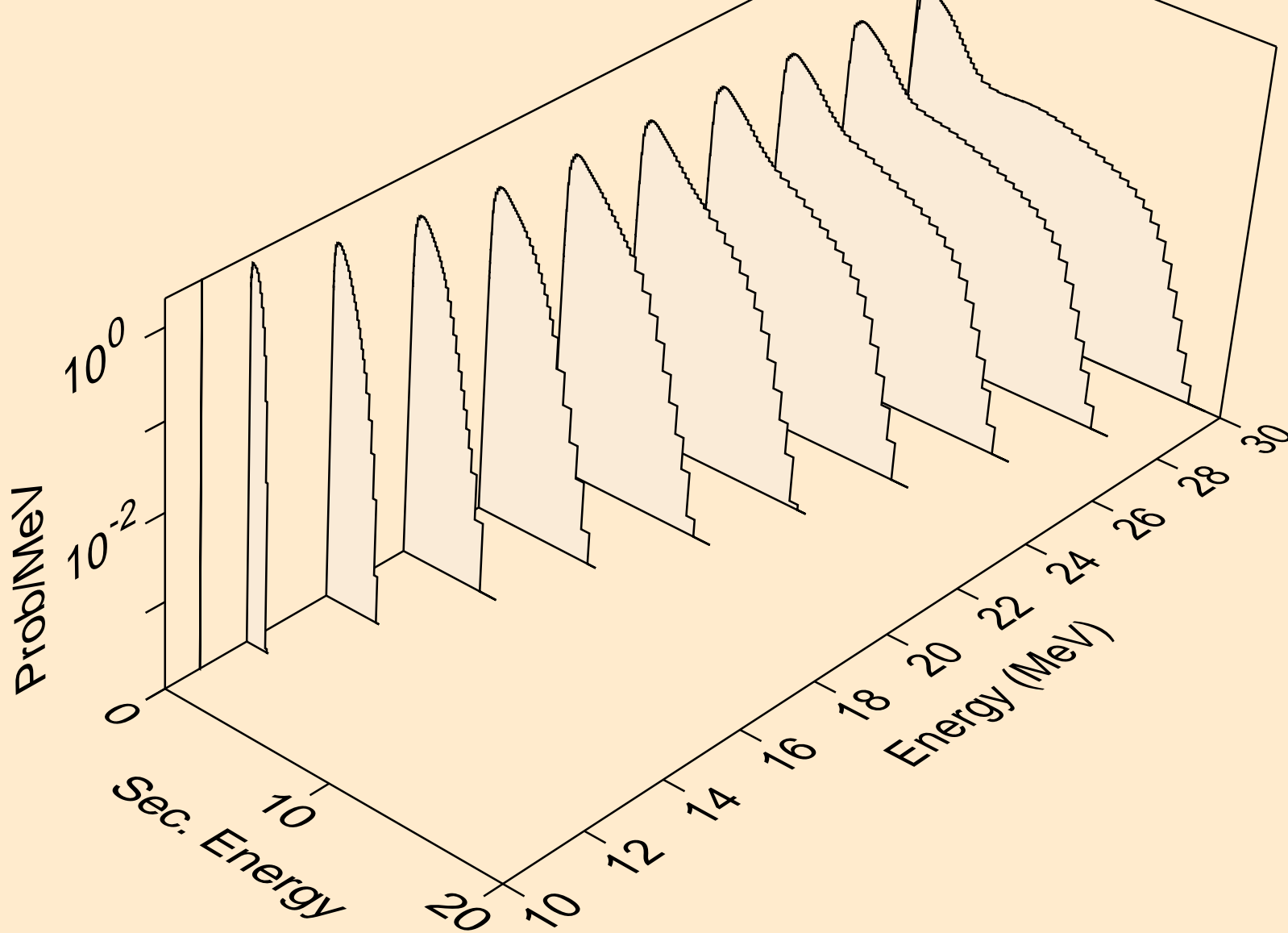

HG202 HELION ACER TENDL-2023 LIBRARY; T=0.K  
neutrons from (s,n\*)a

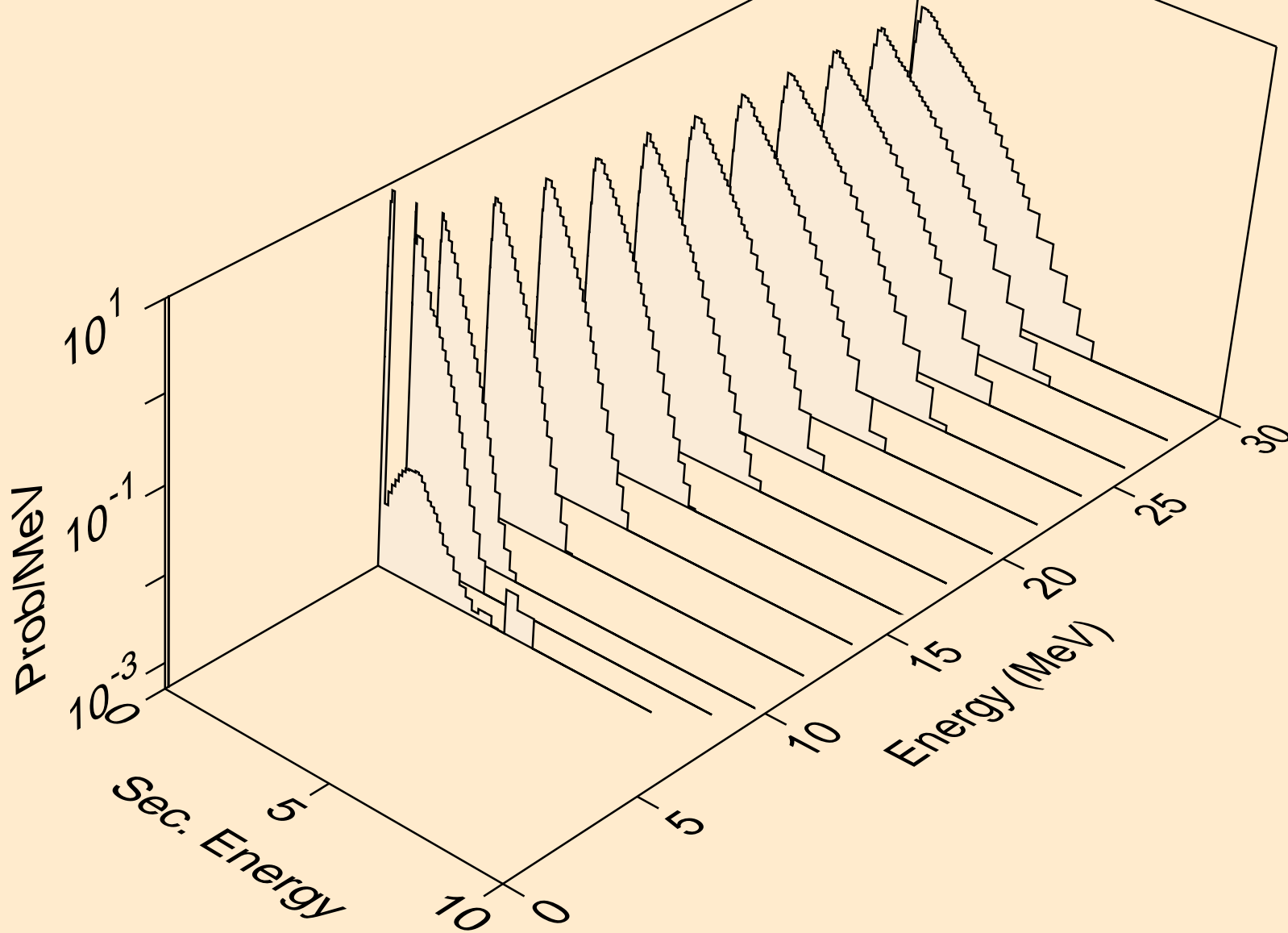

HG202 HELION ACER TENDL-2023 LIBRARY; T=0.K  
neutrons from (s,2n)a

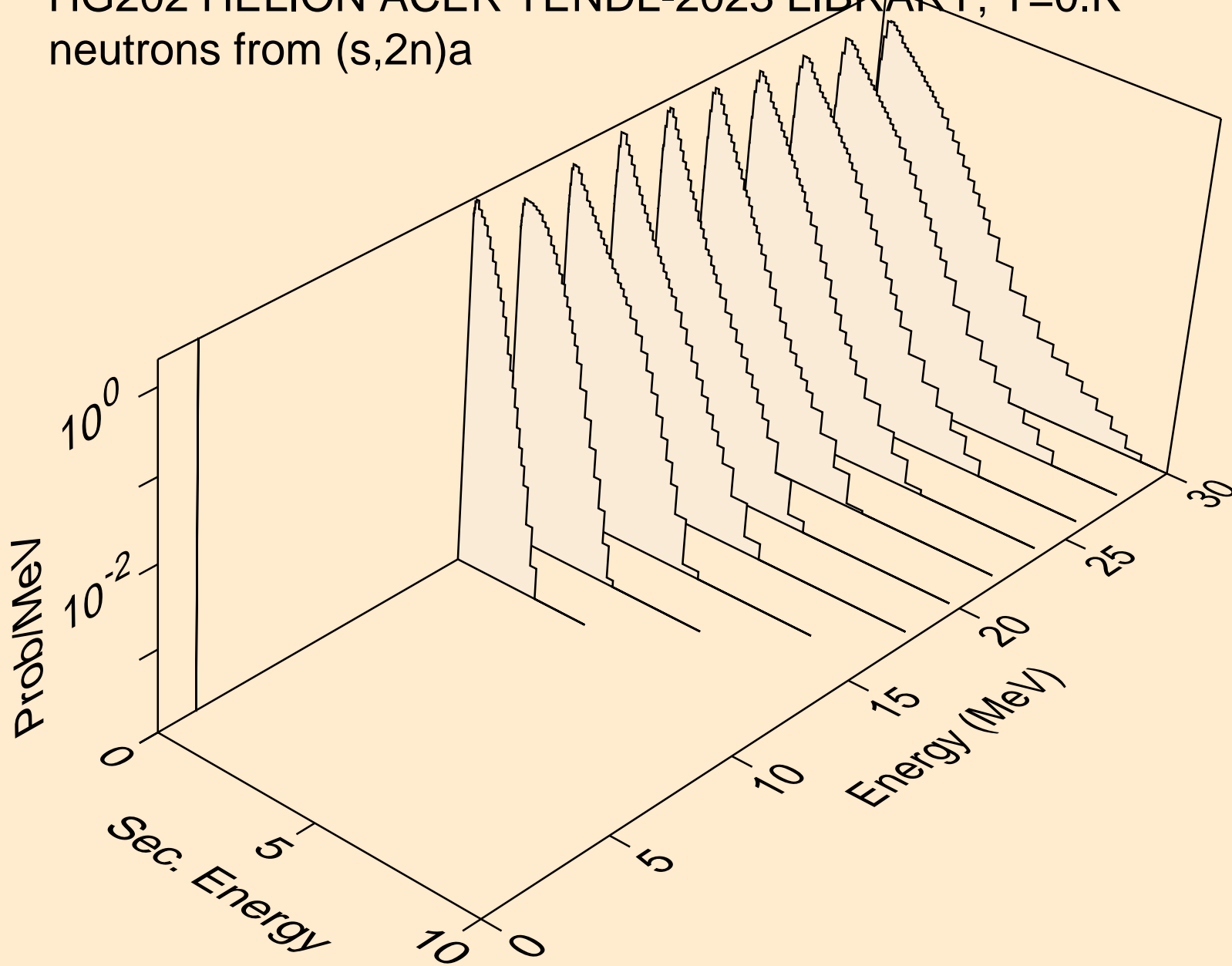

HG202 HELION ACER TENDL-2023 LIBRARY; T=0.K  
neutrons from (s,3n)a

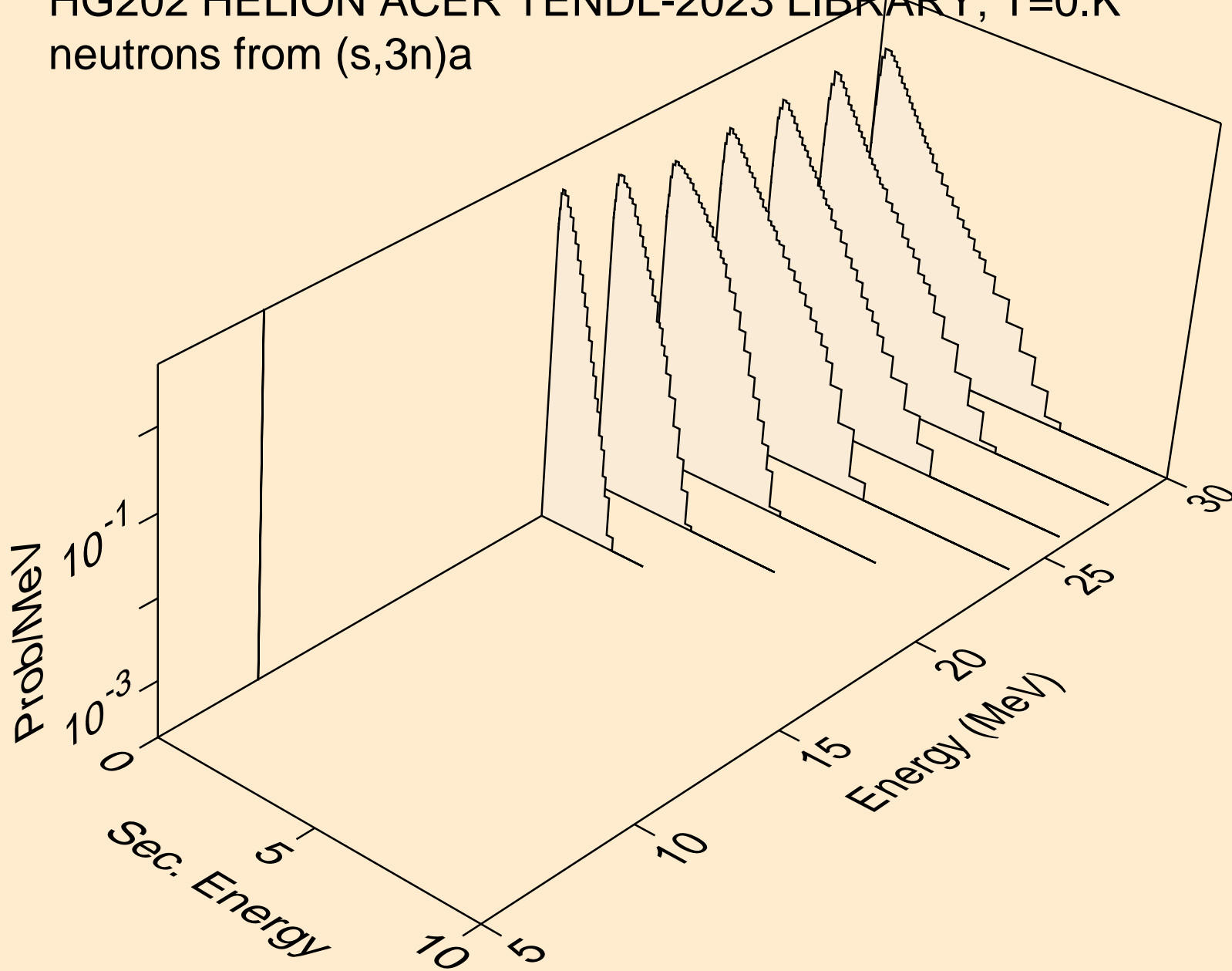

HG202 HELION ACER TENDL-2023 LIBRARY; T=0.K  
neutrons from (s,n\*)p

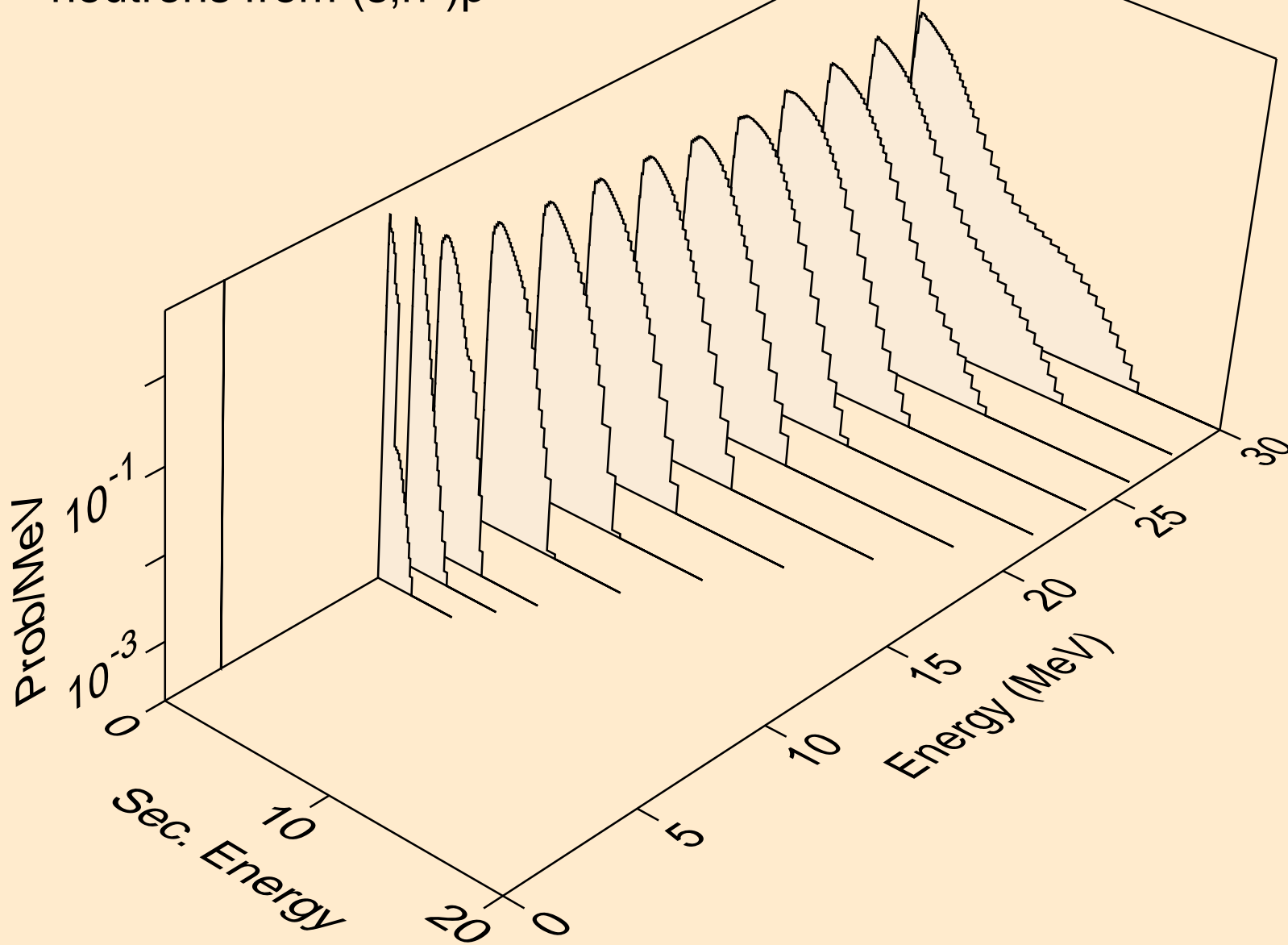

HG202 HELION ACER TENDL-2023 LIBRARY; T=0.K  
neutrons from (s,n\*)d

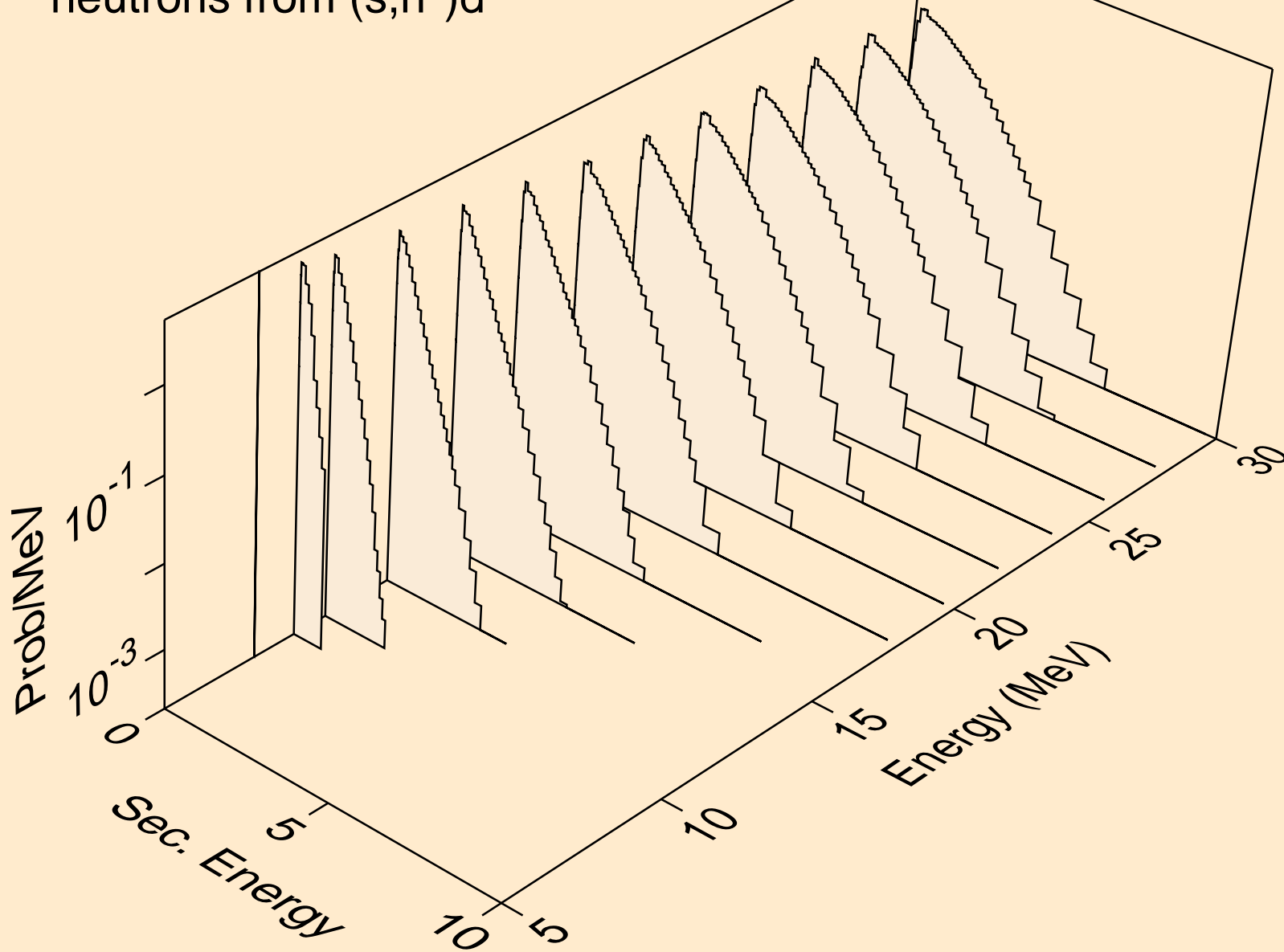

HG202 HELION ACER TENDL-2023 LIBRARY; T=0.K  
neutrons from (s,n\*)t

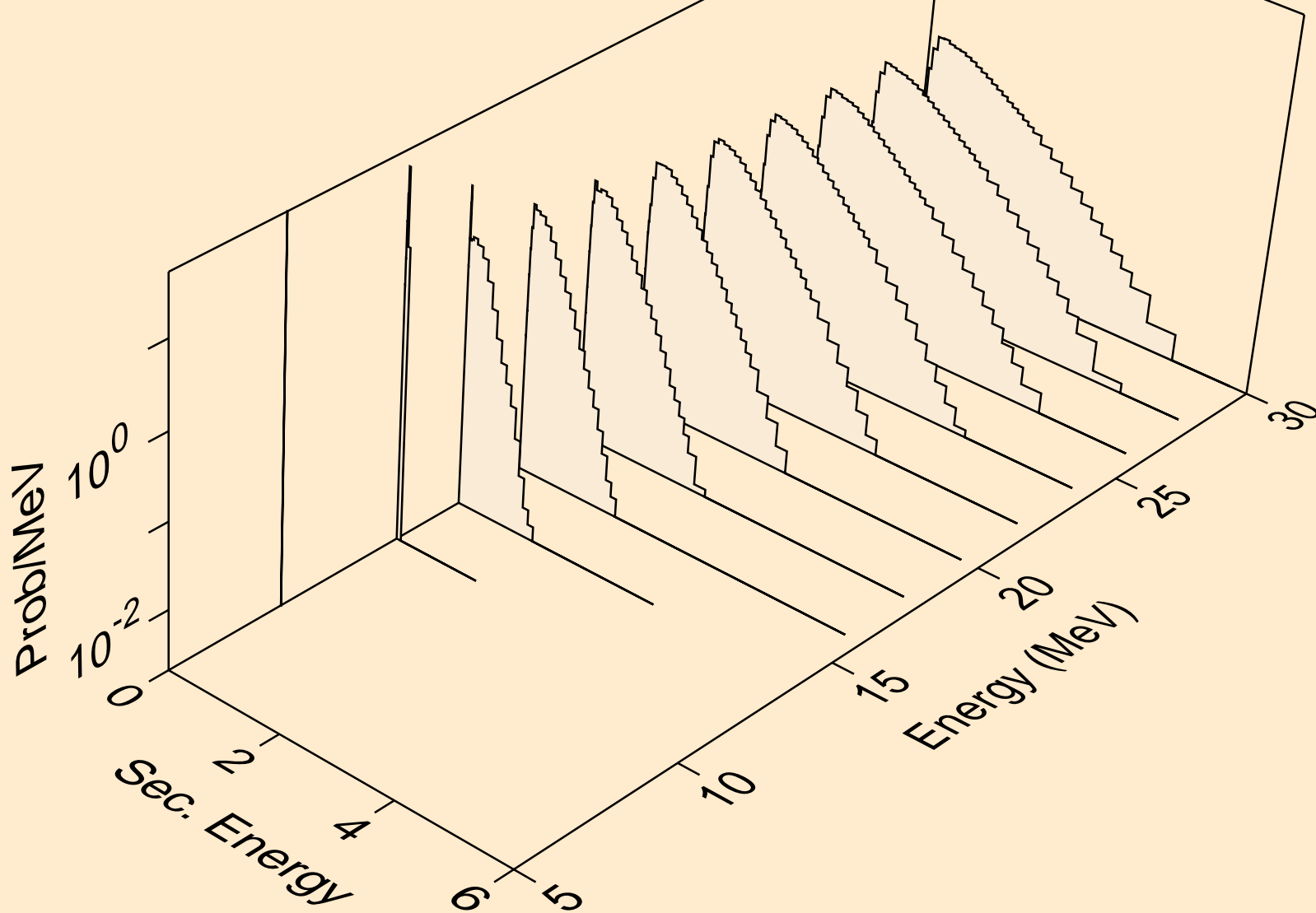

HG202 HELION ACER TENDL-2023 LIBRARY; T=0.K  
neutrons from (s,n\*)he3

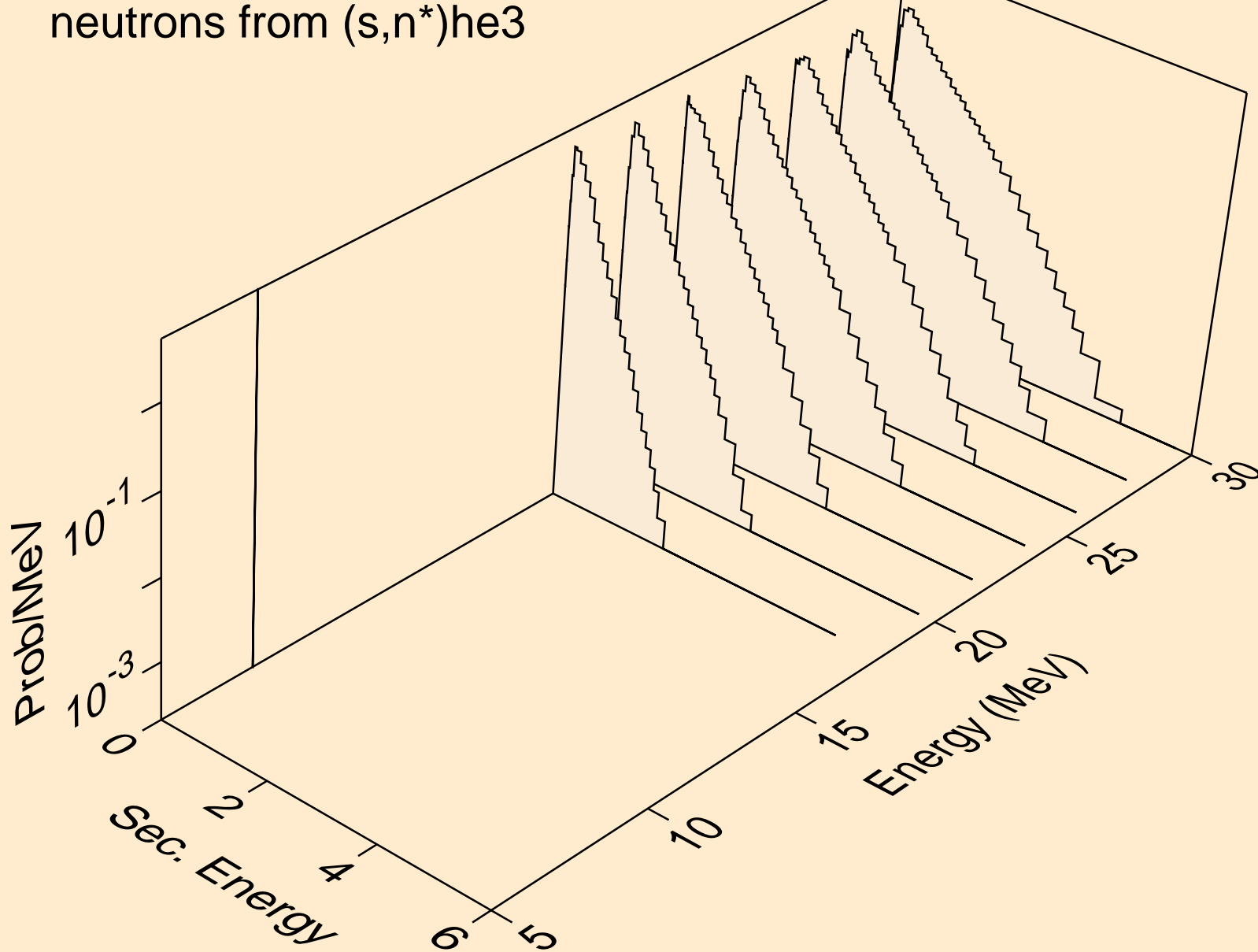

HG202 HELION ACER TENDL-2023 LIBRARY; T=0.K  
neutrons from (s,4n)

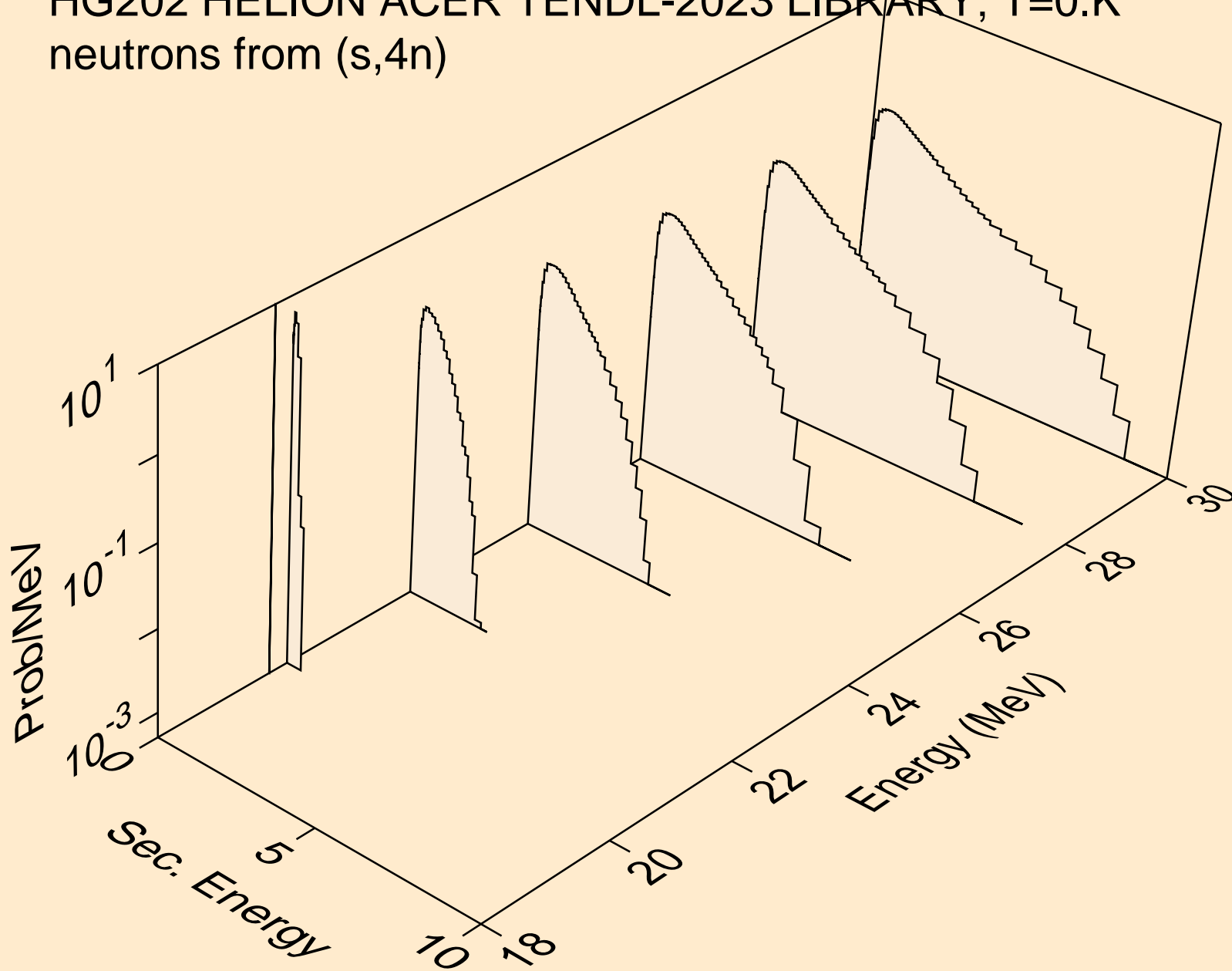

HG202 HELION ACER TENDL-2023 LIBRARY; T=0.K  
neutrons from (s,2np)

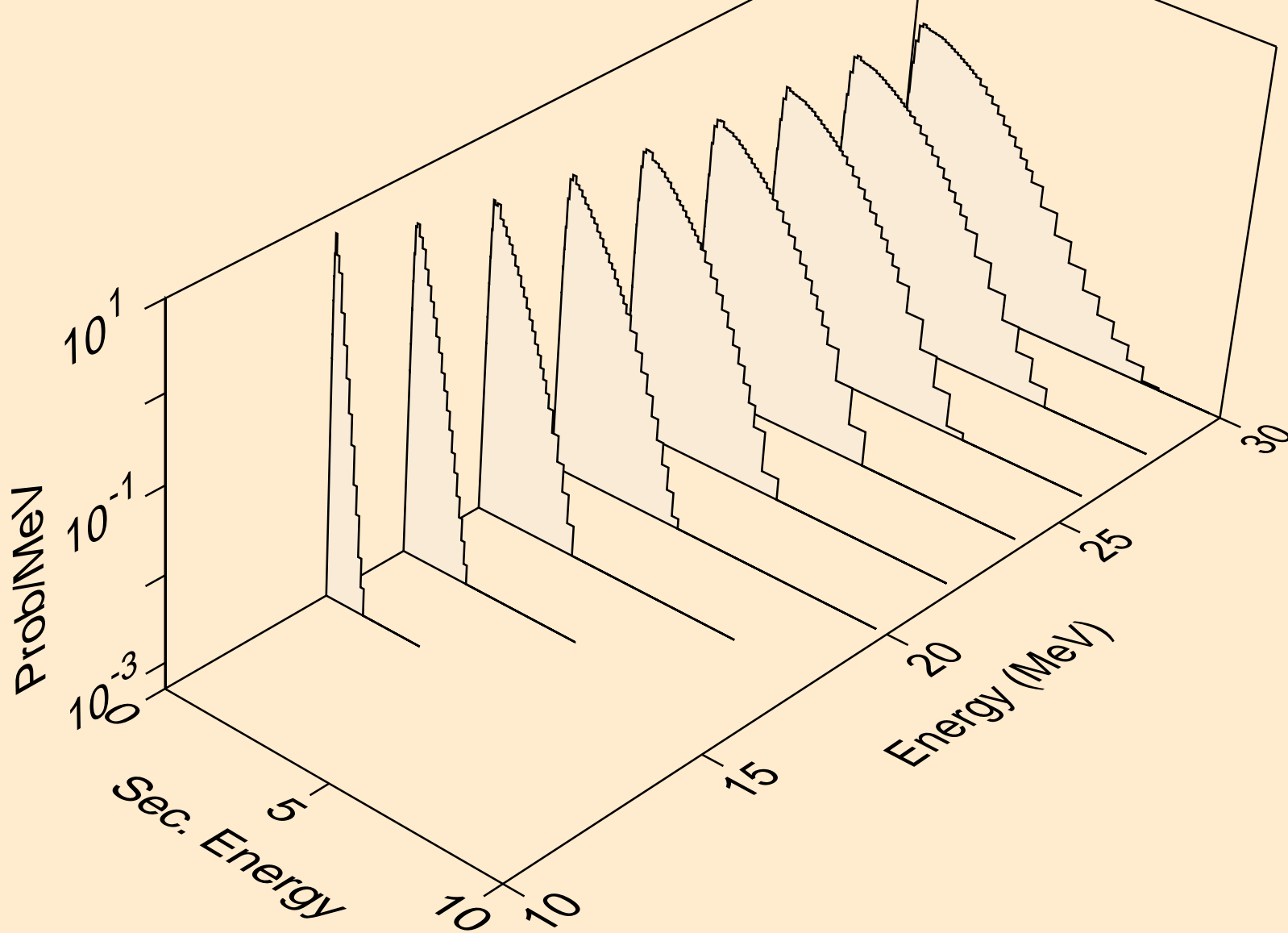

HG202 HELION ACER TENDL-2023 LIBRARY; T=0.K  
neutrons from (s,3np)

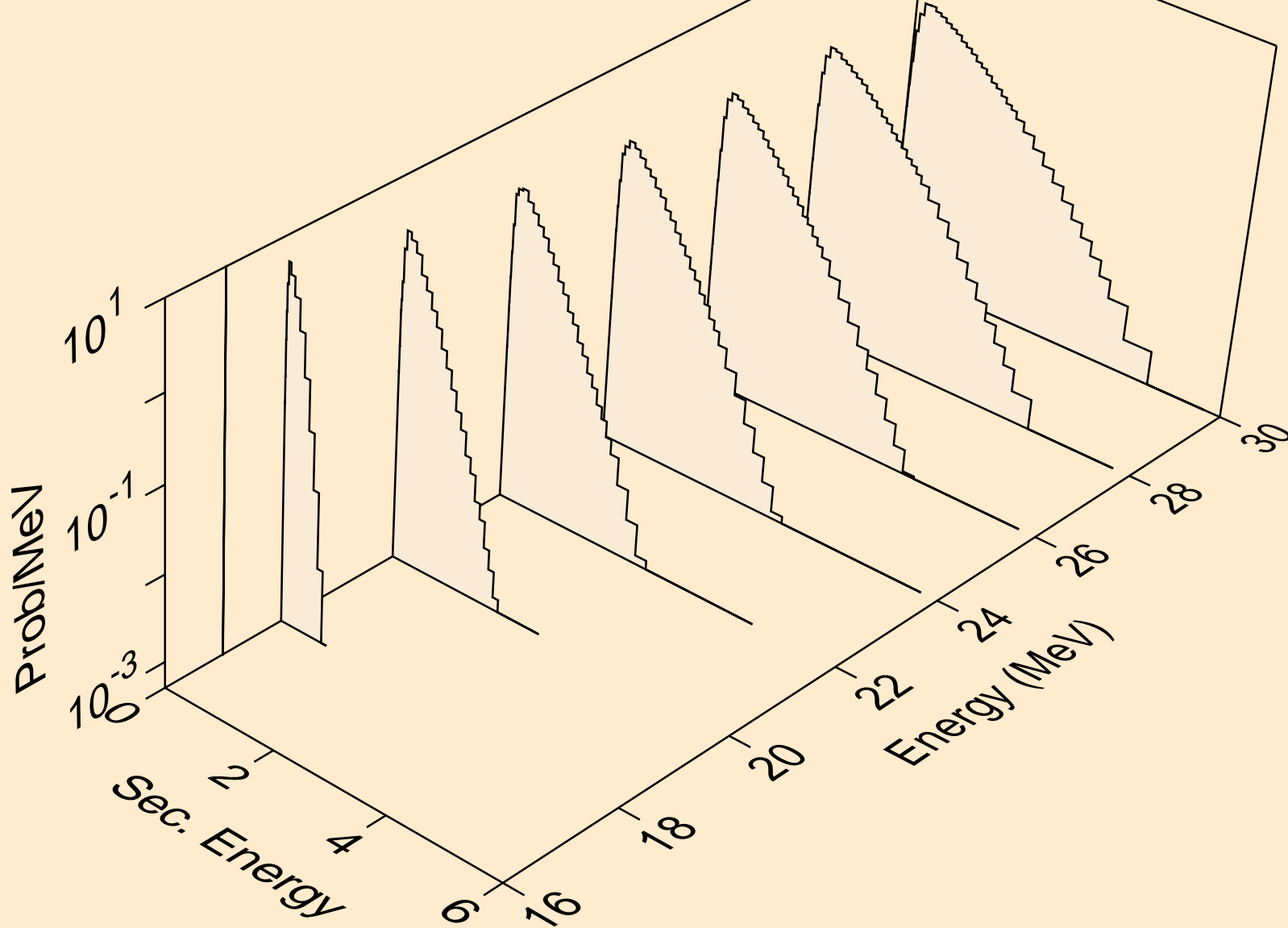

HG202 HELION ACER TENDL-2023 LIBRARY; T=0.K  
neutrons from (s,n2p)

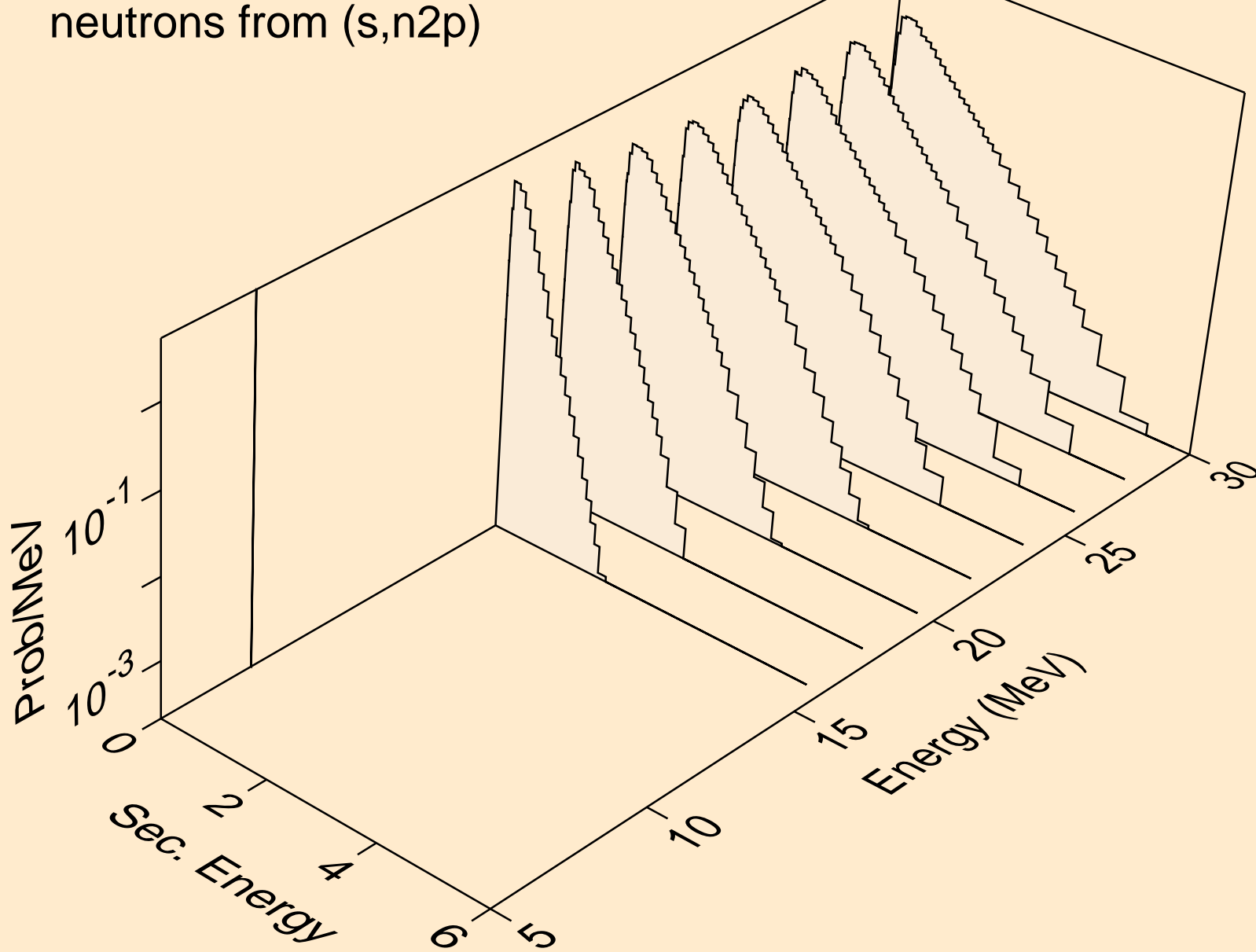

HG202 HELION ACER TENDL-2023 LIBRARY; T=0.K  
neutrons from (s,npa)

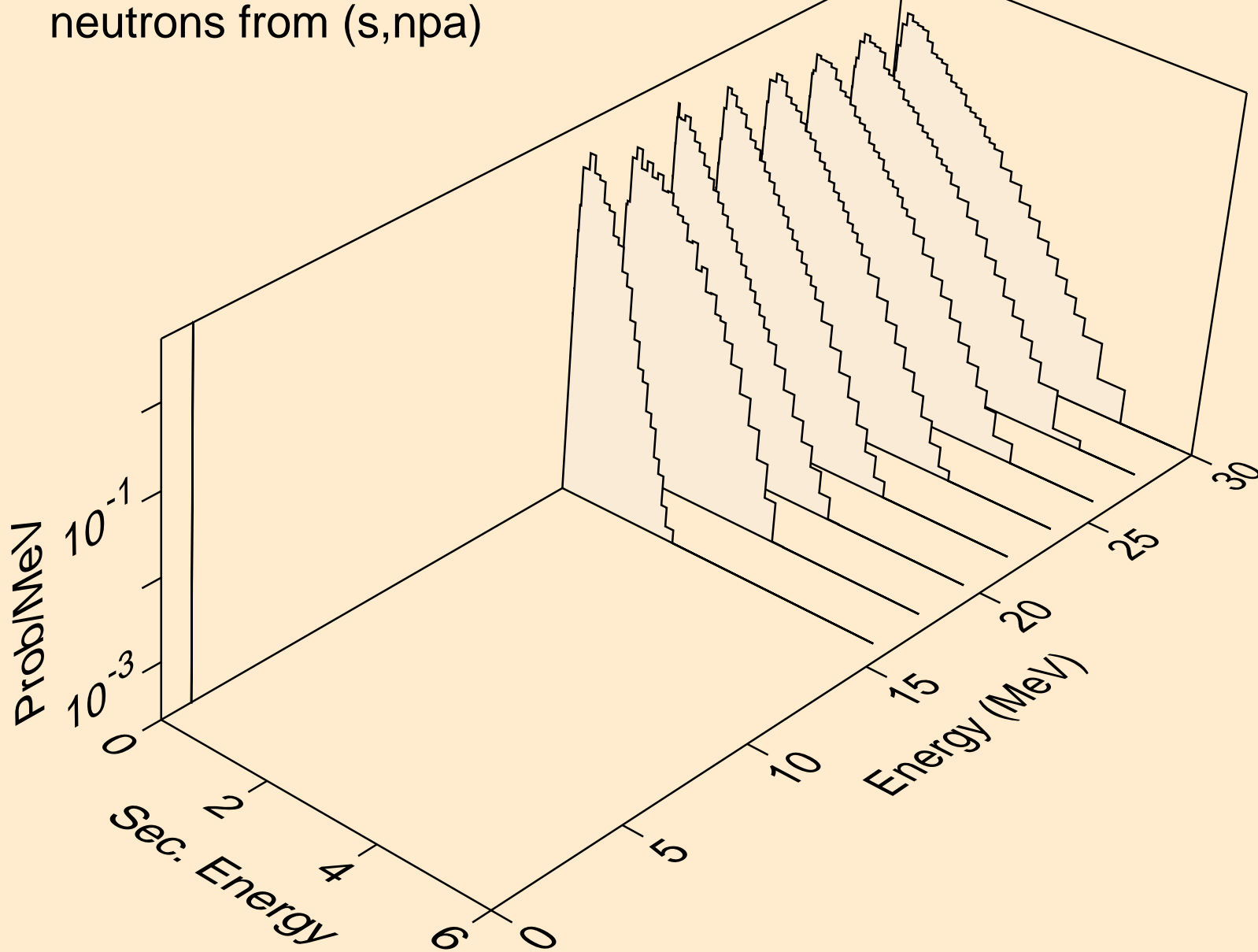

HG202 HELION ACER TENDL-2023 LIBRARY; T=0.K  
protons from (s,x)

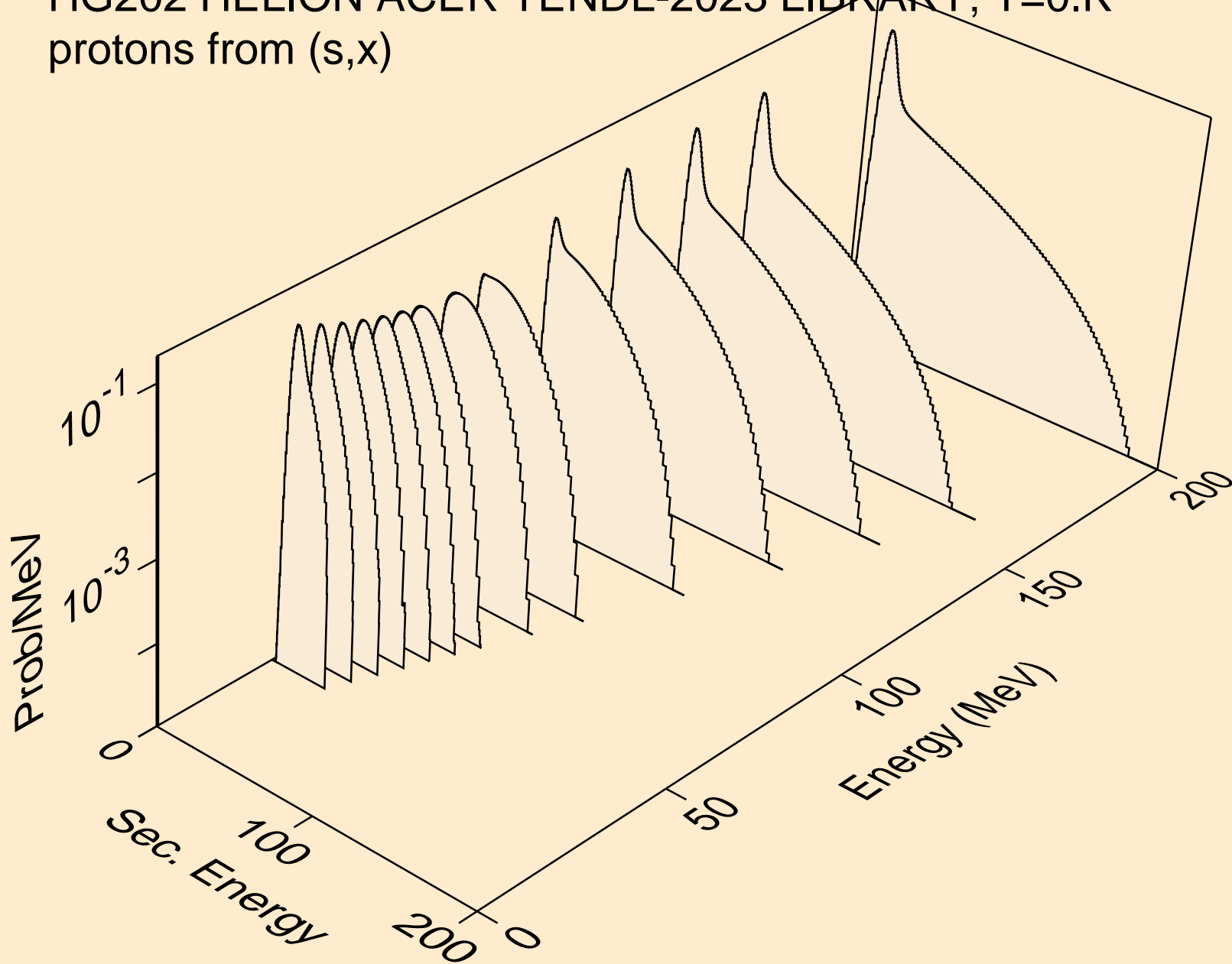

HG202 HELION ACER TENDL-2023 LIBRARY; T=0.K  
protons from (s,n\*)p

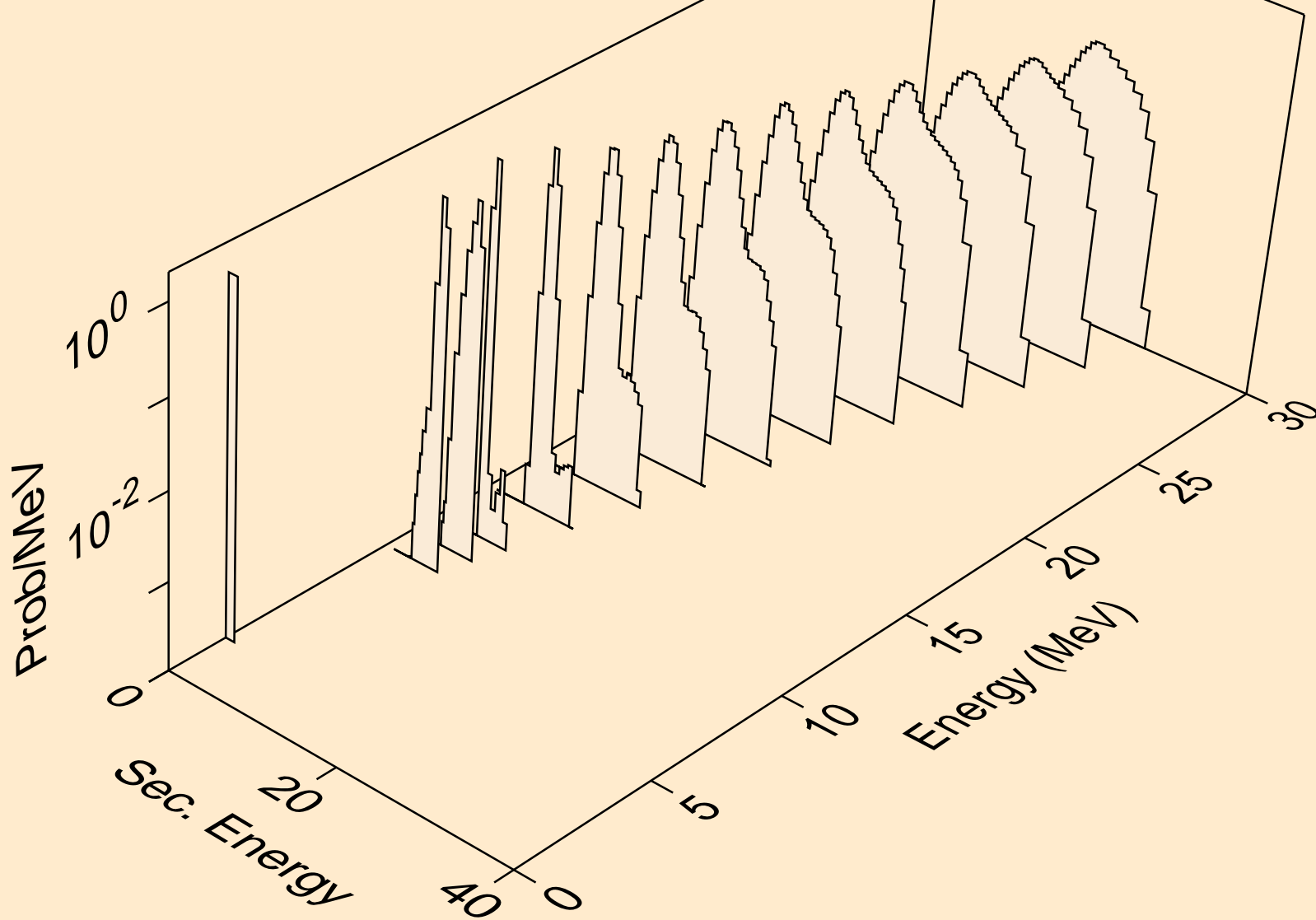

HG202 HELION ACER TENDL-2023 LIBRARY; T=0.K  
protons from (s,2np)

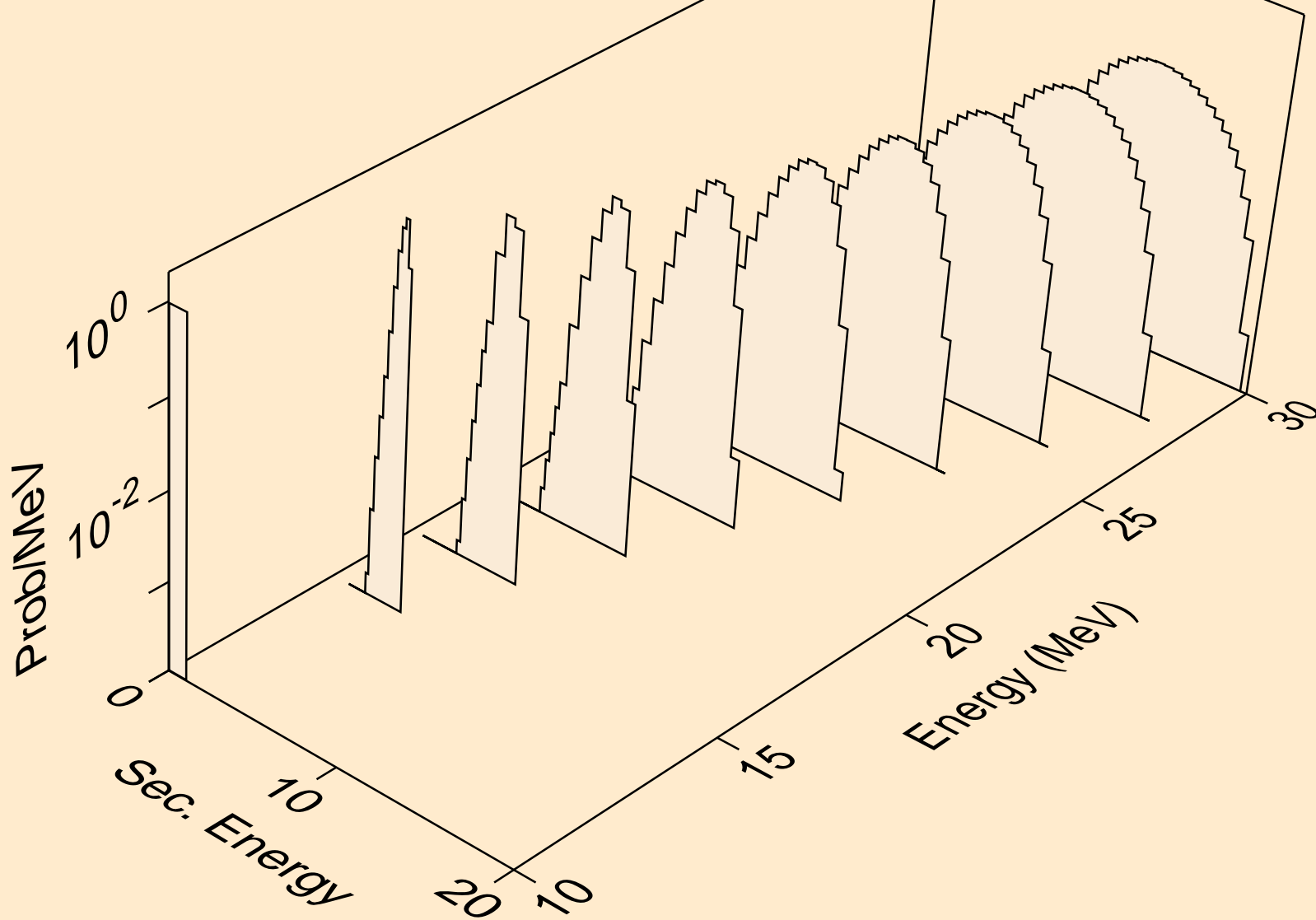

HG202 HELION ACER TENDL-2023 LIBRARY; T=0.K  
protons from (s,3np)

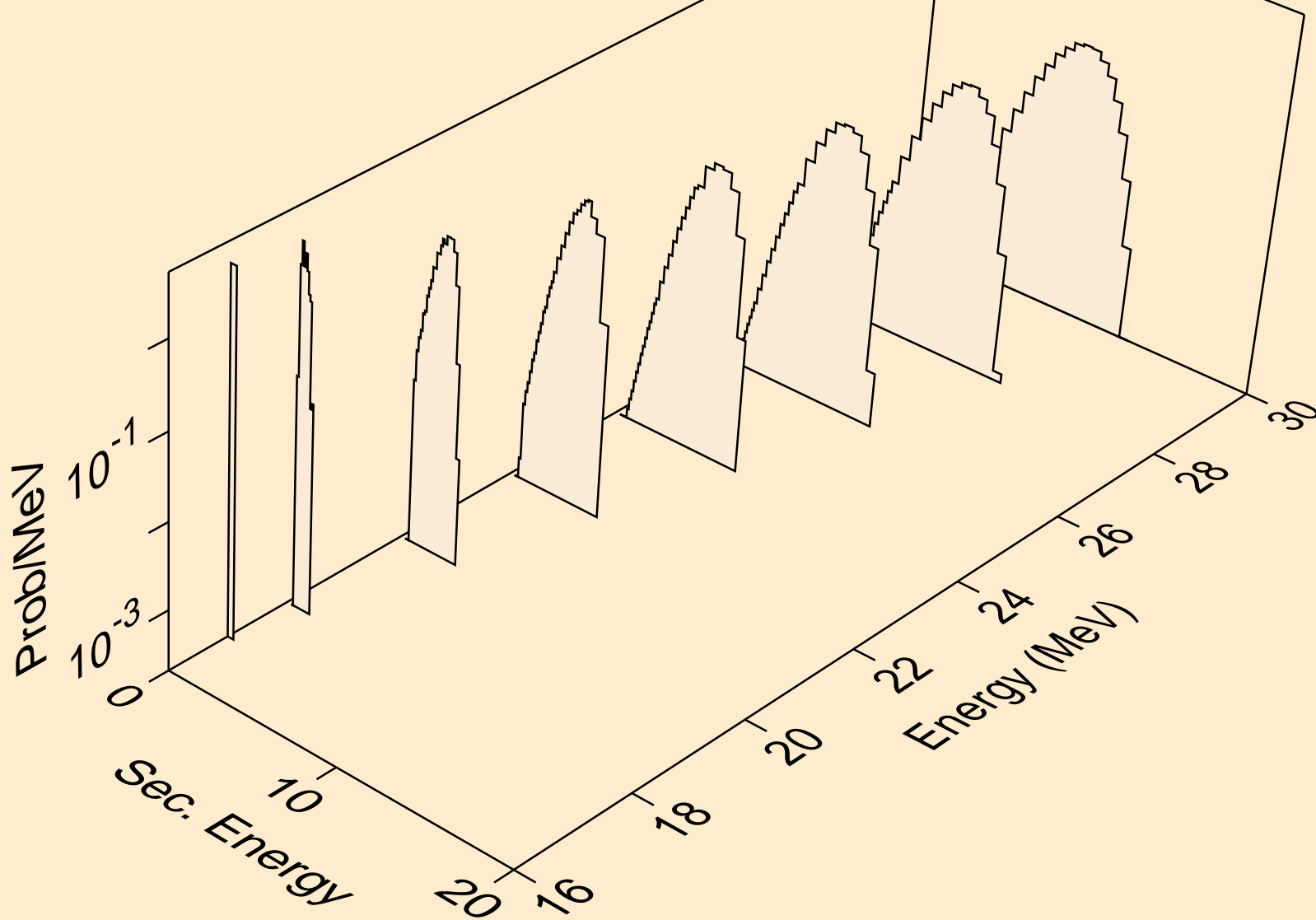

HG202 HELION ACER TENDL-2023 LIBRARY; T=0.K  
protons from (s,n2p)

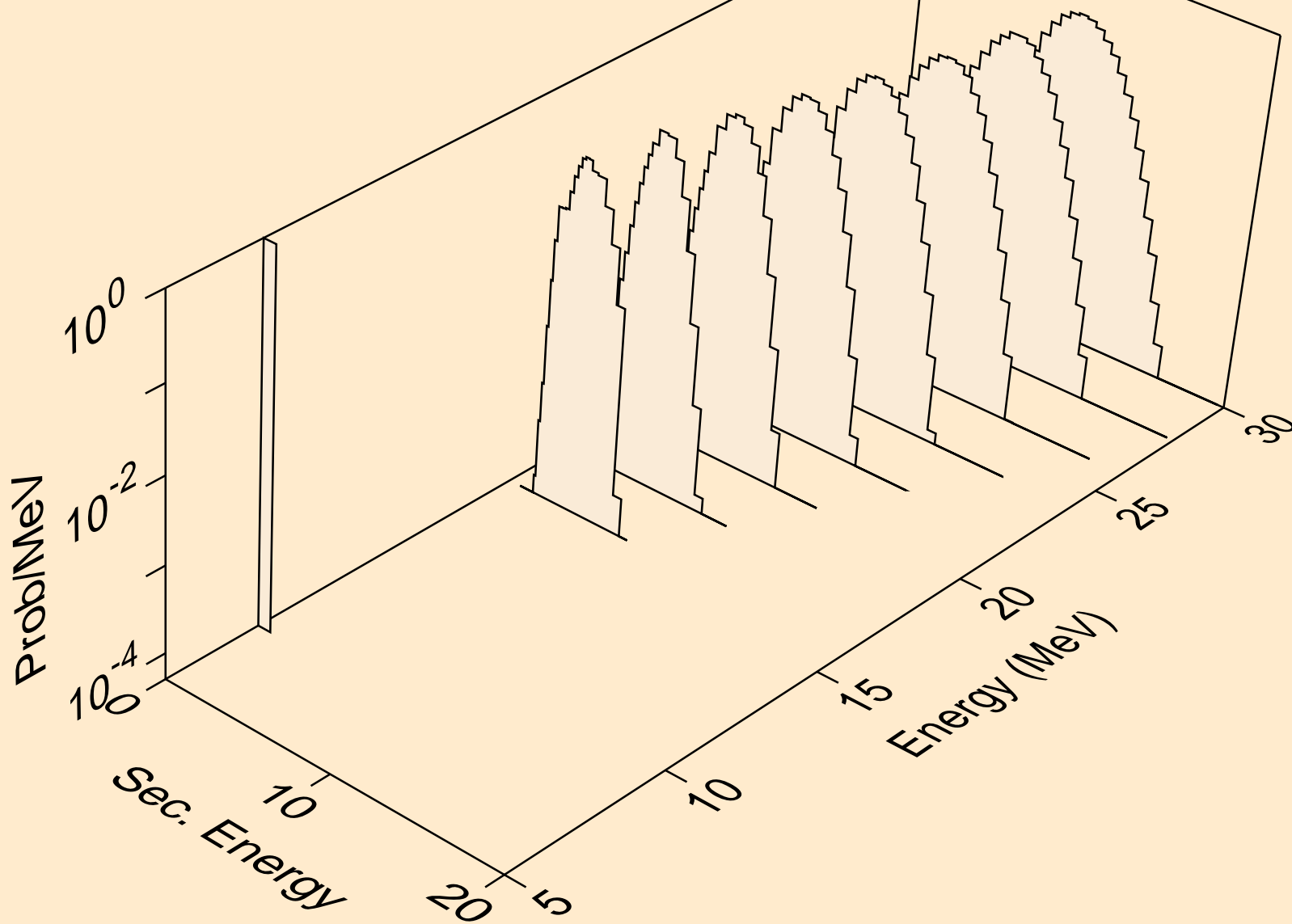

HG202 HELION ACER TENDL-2023 LIBRARY; T=0.K  
protons from (s,npa)

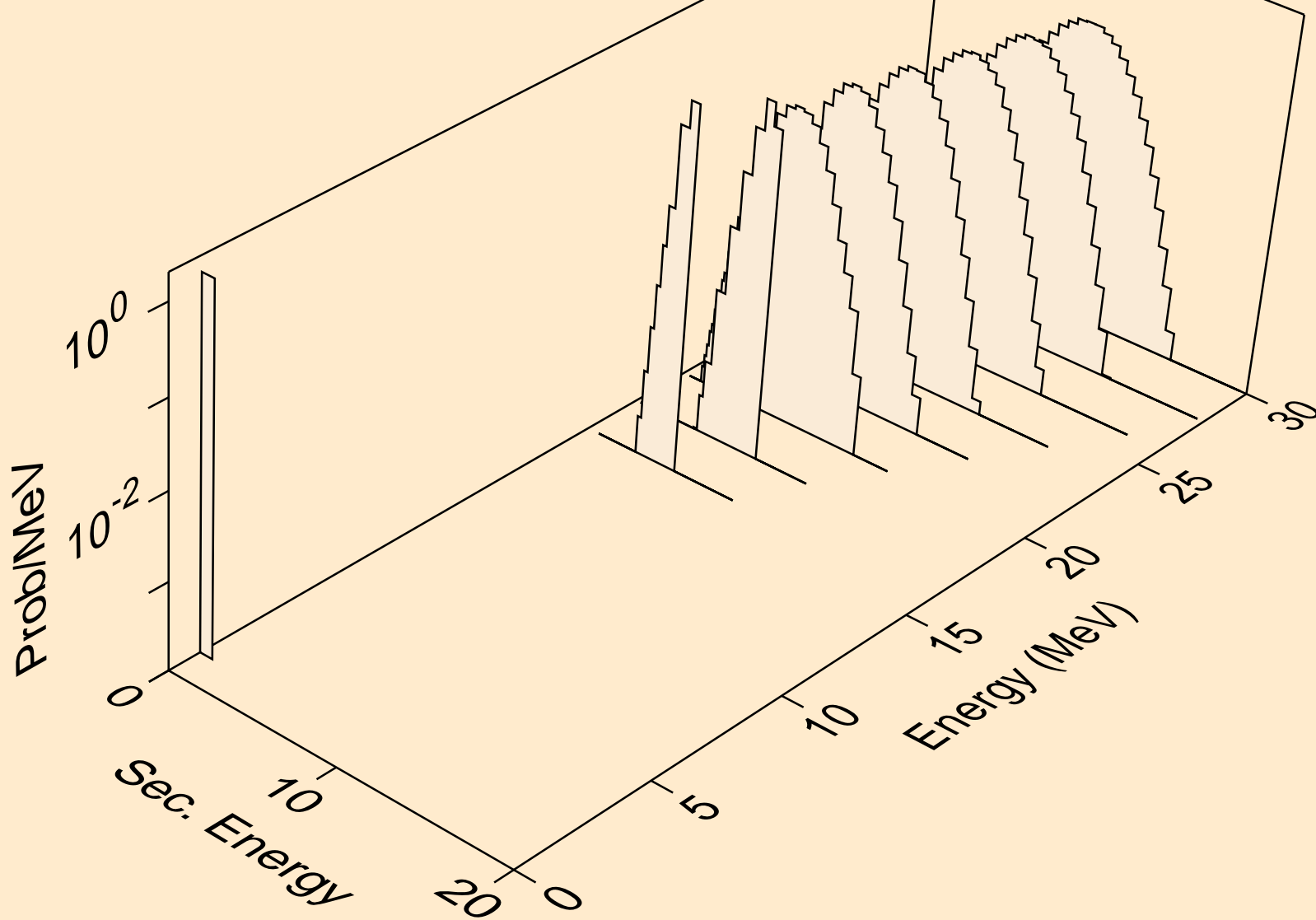

HG202 HELION ACER TENDL-2023 LIBRARY; T=0.K  
protons from (s,p)

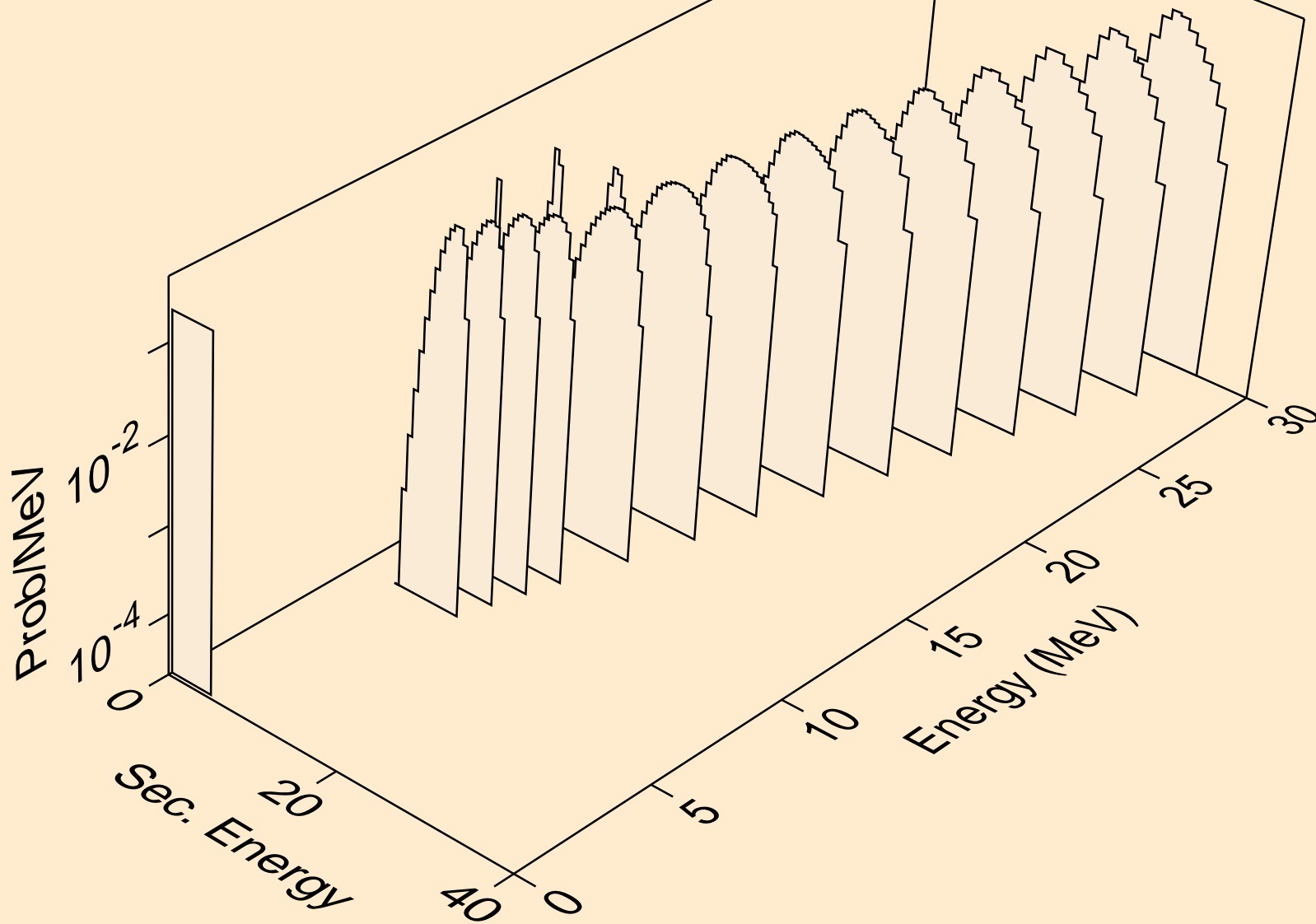

HG202 HELION ACER TENDL-2023 LIBRARY; T=0.K  
protons from (s,2p)

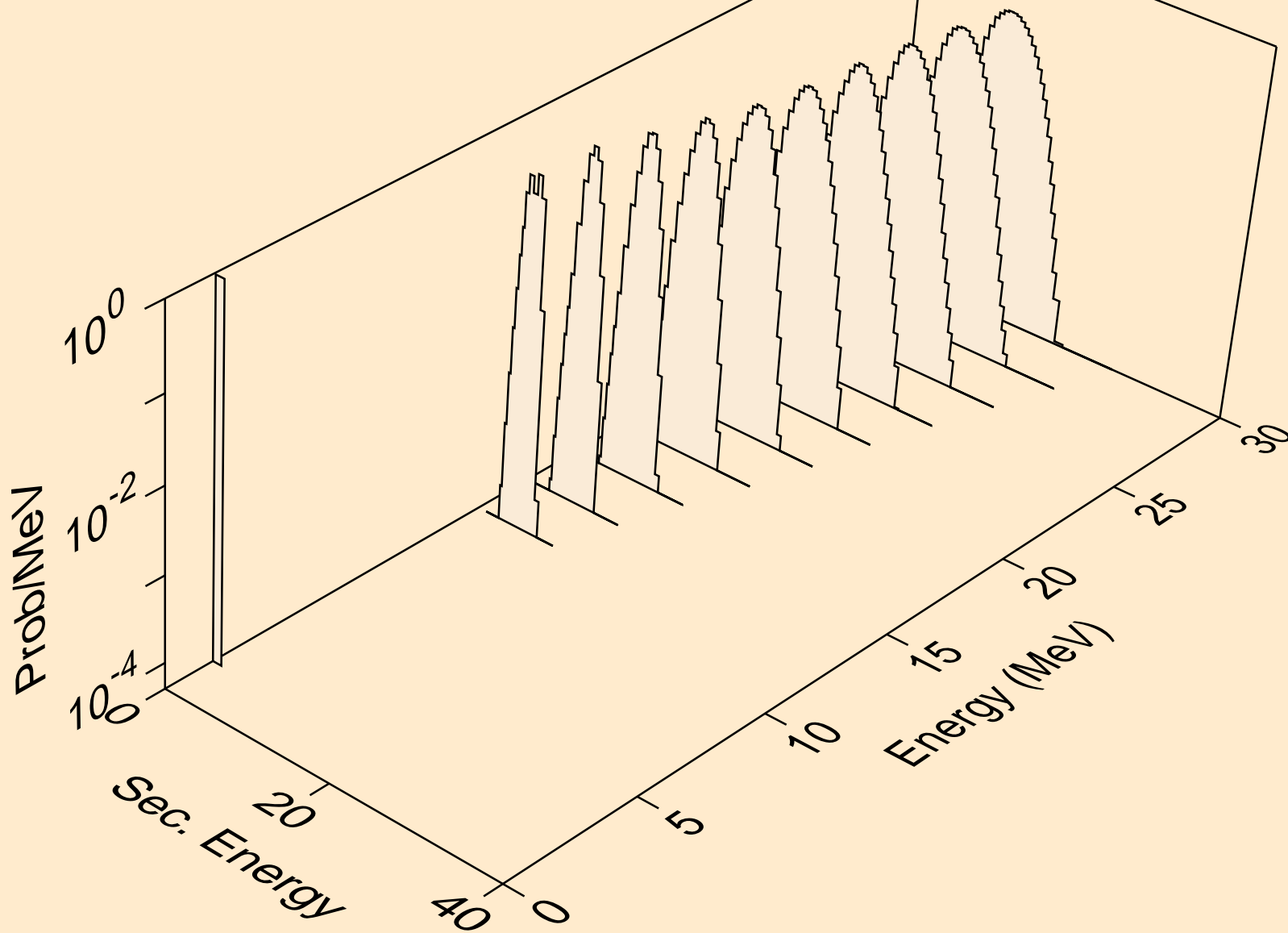

HG202 HELION ACER TENDL-2023 LIBRARY; T=0.K  
protons from (s,pa)

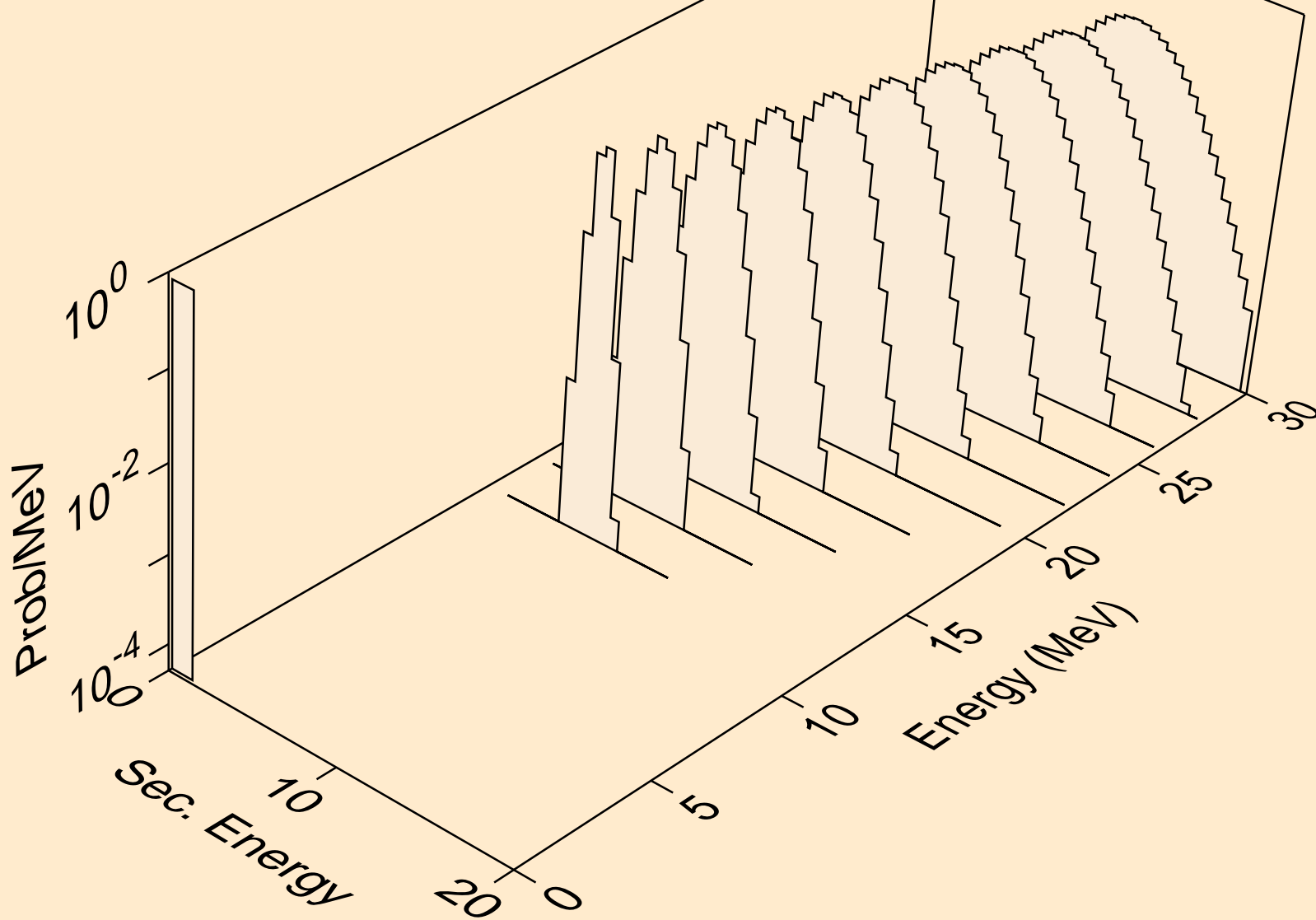

HG202 HELION ACER TENDL-2023 LIBRARY; T=0.K  
protons from (s,pd)

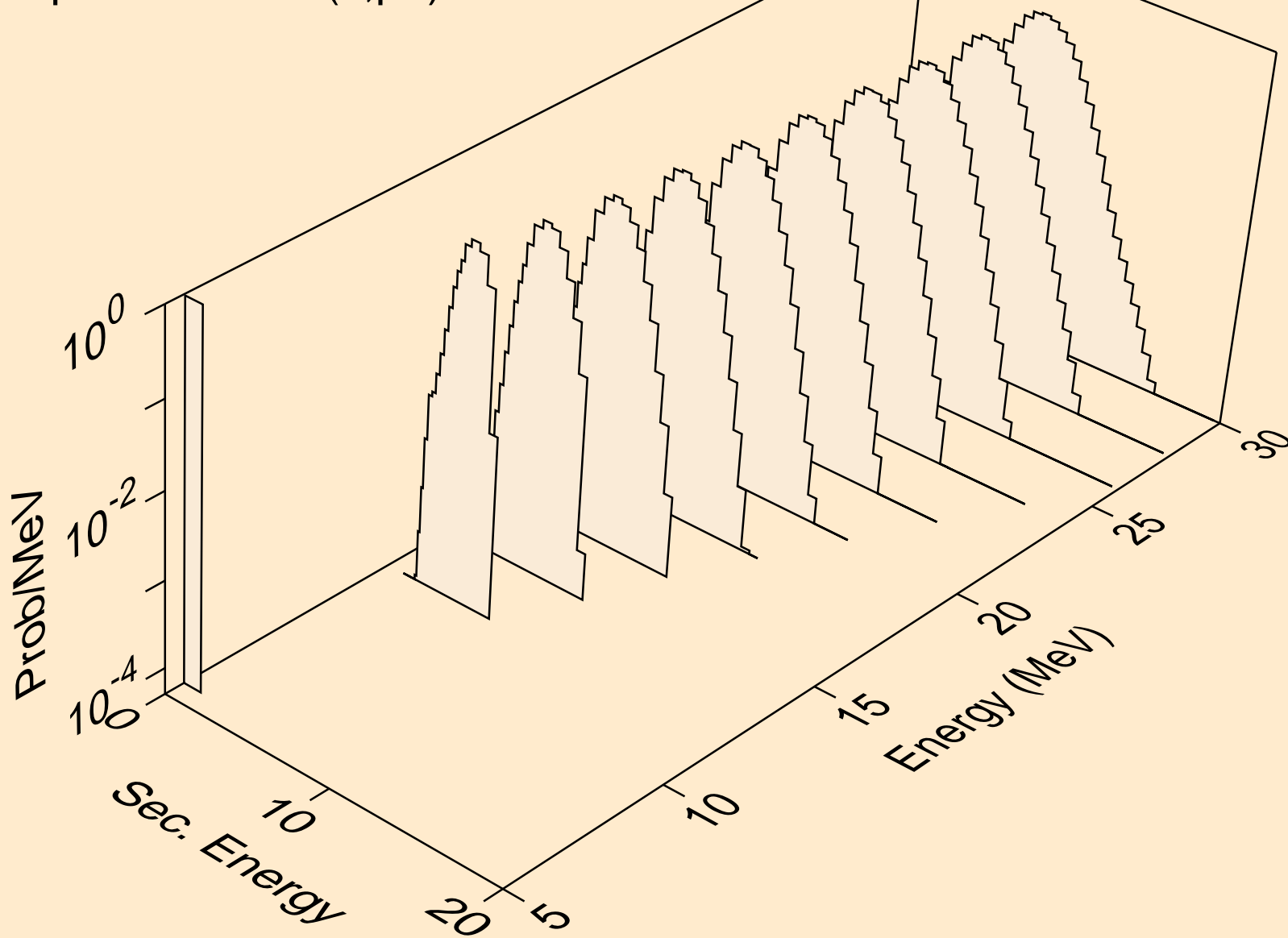

HG202 HELION ACER TENDL-2023 LIBRARY; T=0.K  
protons from (s,pt)

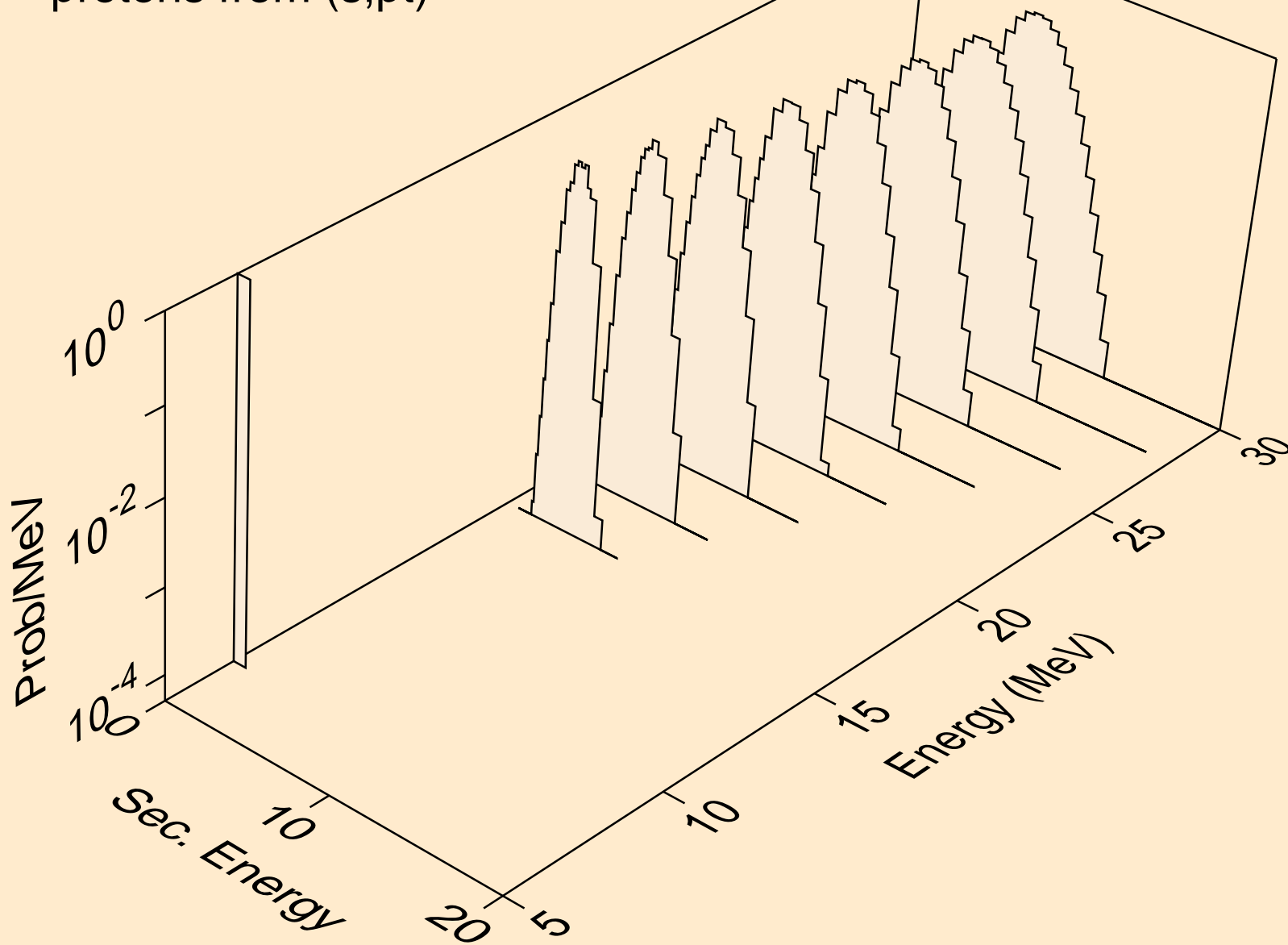

HG202 HELION ACER TENDL-2023 LIBRARY; T=0.K  
deuterons from (s,x)

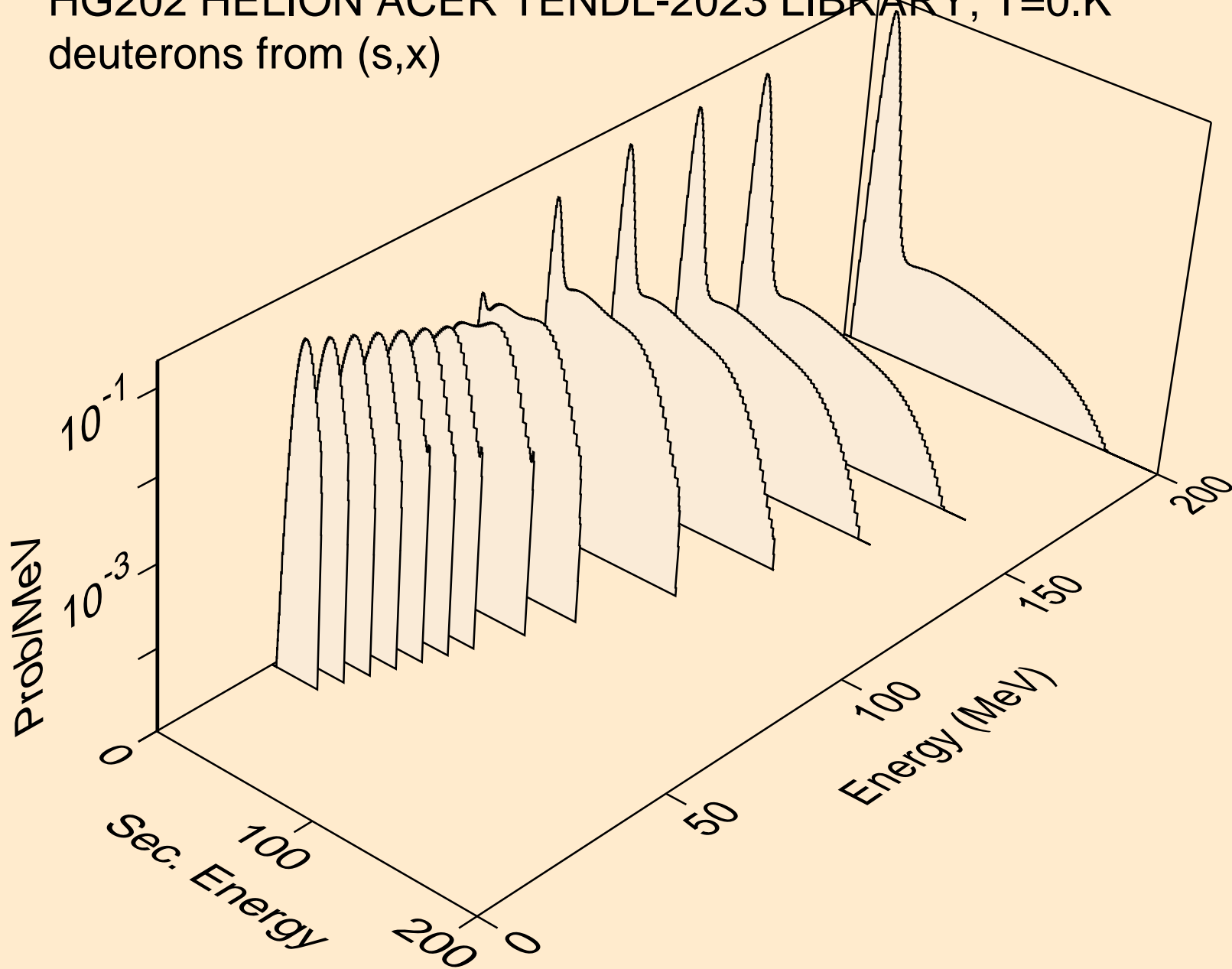

HG202 HELION ACER TENDL-2023 LIBRARY; T=0.K  
deuterons from (s,2nd)

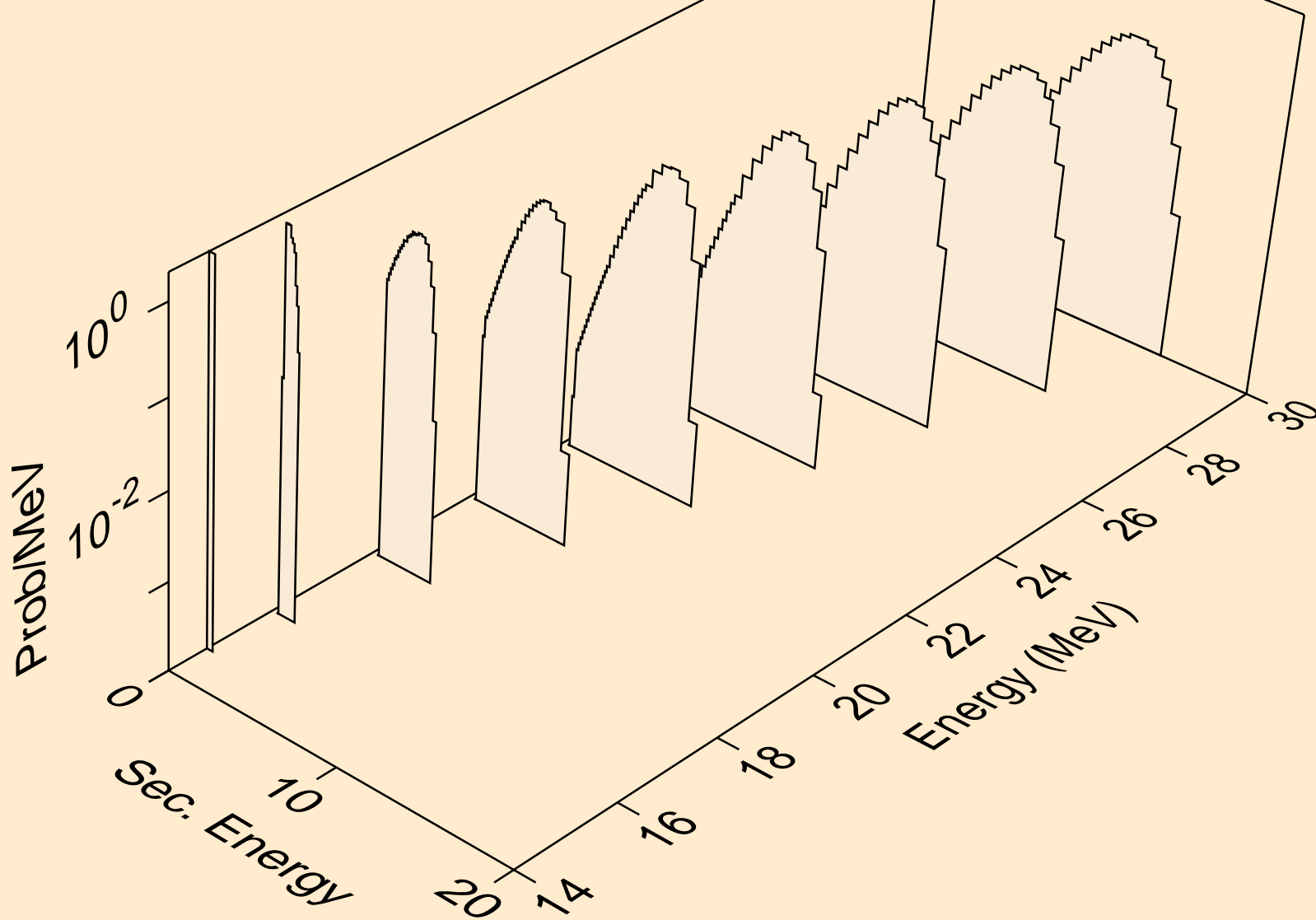

HG202 HELION ACER TENDL-2023 LIBRARY; T=0.K  
deuterons from (s,n\*)d

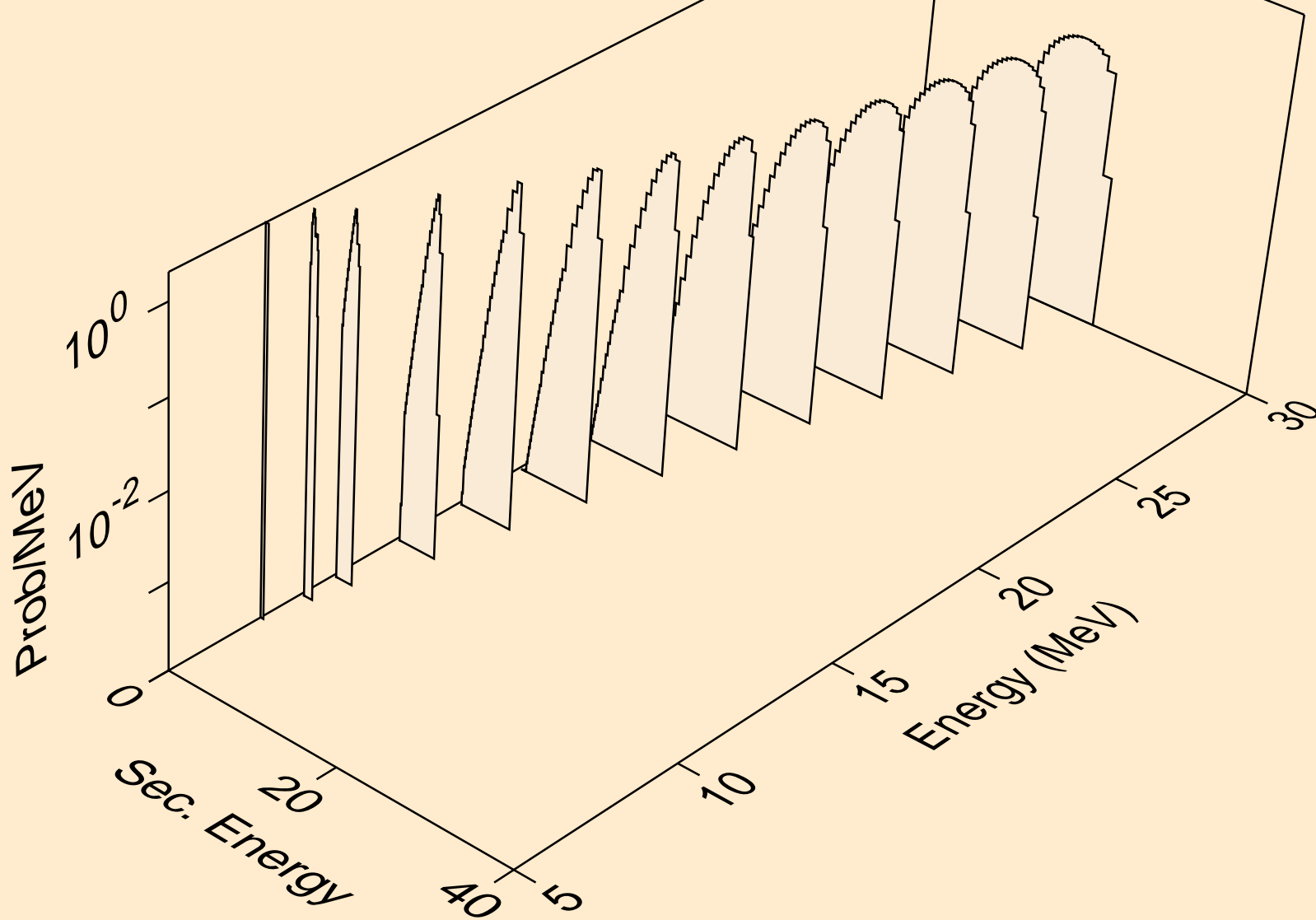

HG202 HELION ACER TENDL-2023 LIBRARY; T=0.K  
deuterons from (s,d)

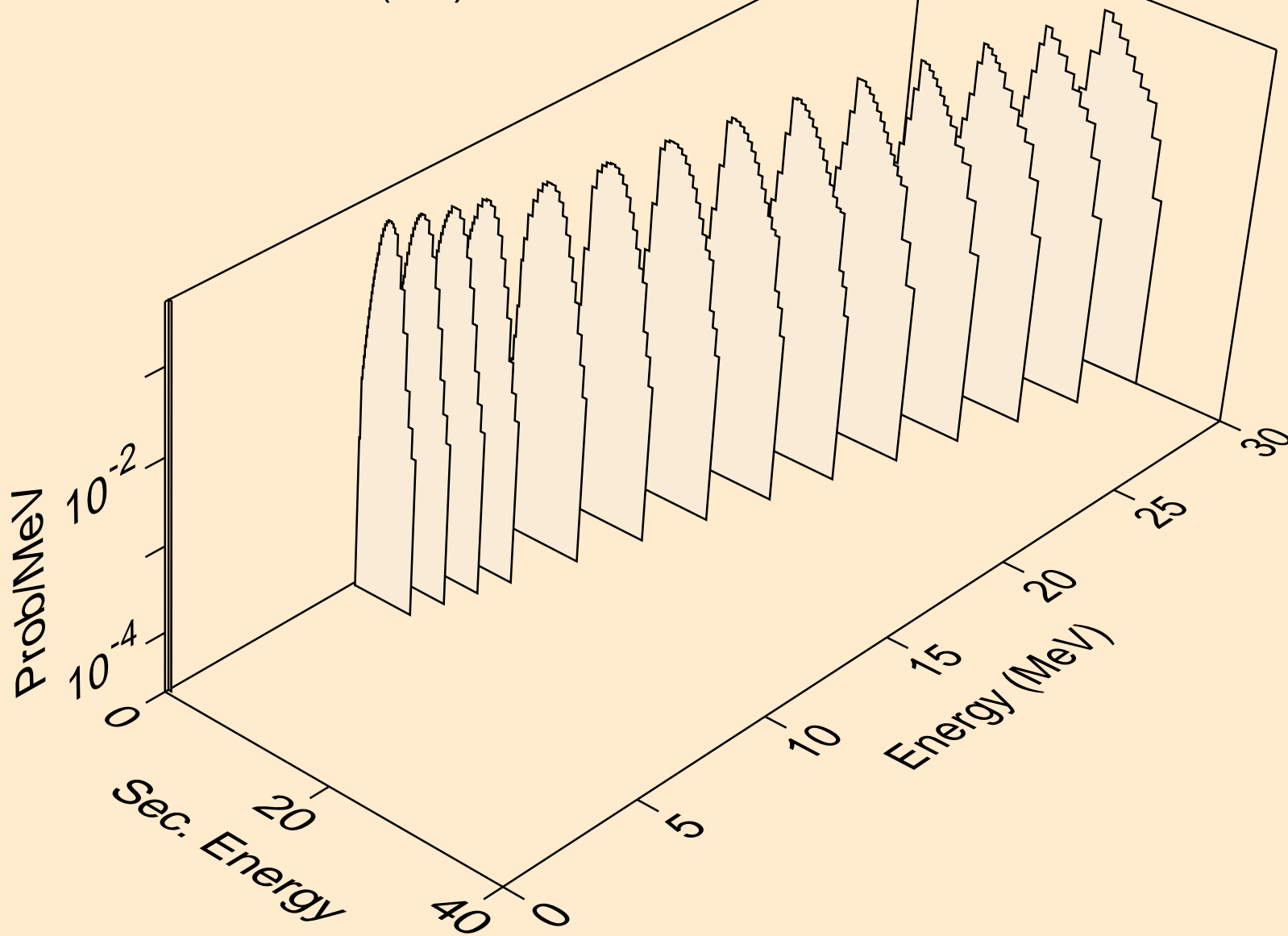

HG202 HELION ACER TENDL-2023 LIBRARY; T=0.K  
deuterons from (s,pd)

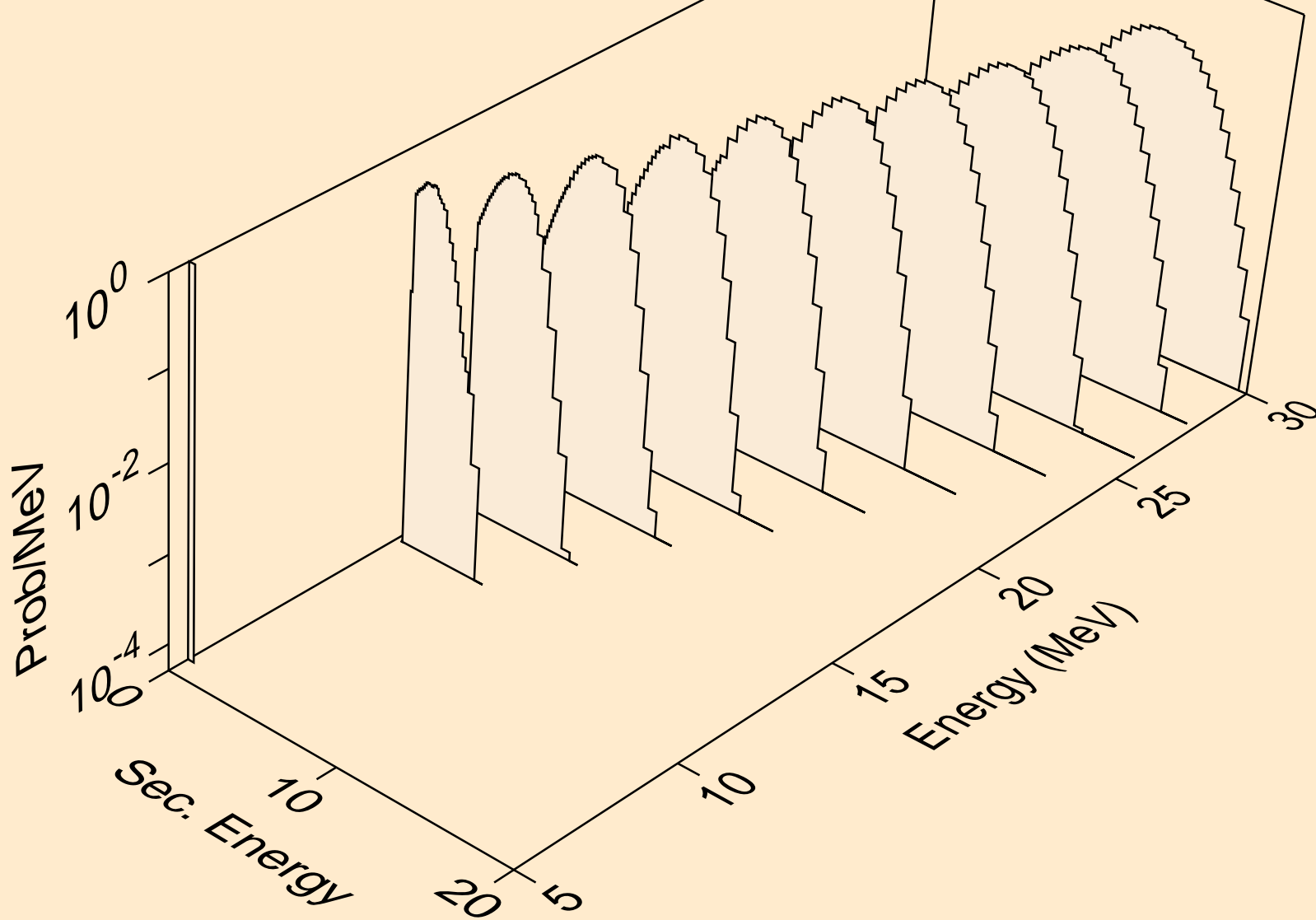

HG202 HELION ACER TENDL-2023 LIBRARY; T=0.K  
deuterons from (s,da)

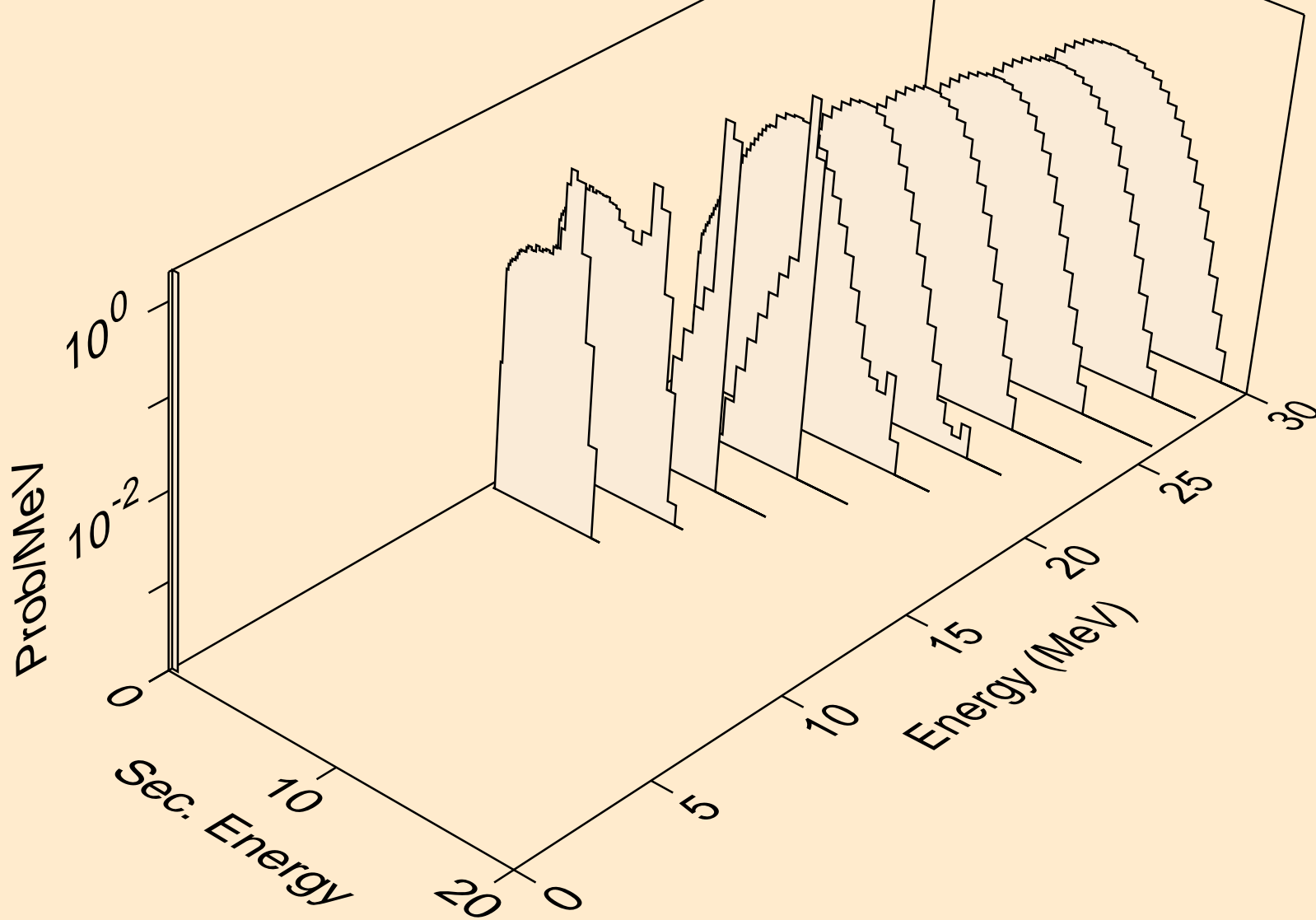

HG202 HELION ACER TENDL-2023 LIBRARY; T=0.K  
tritons from (s,x)

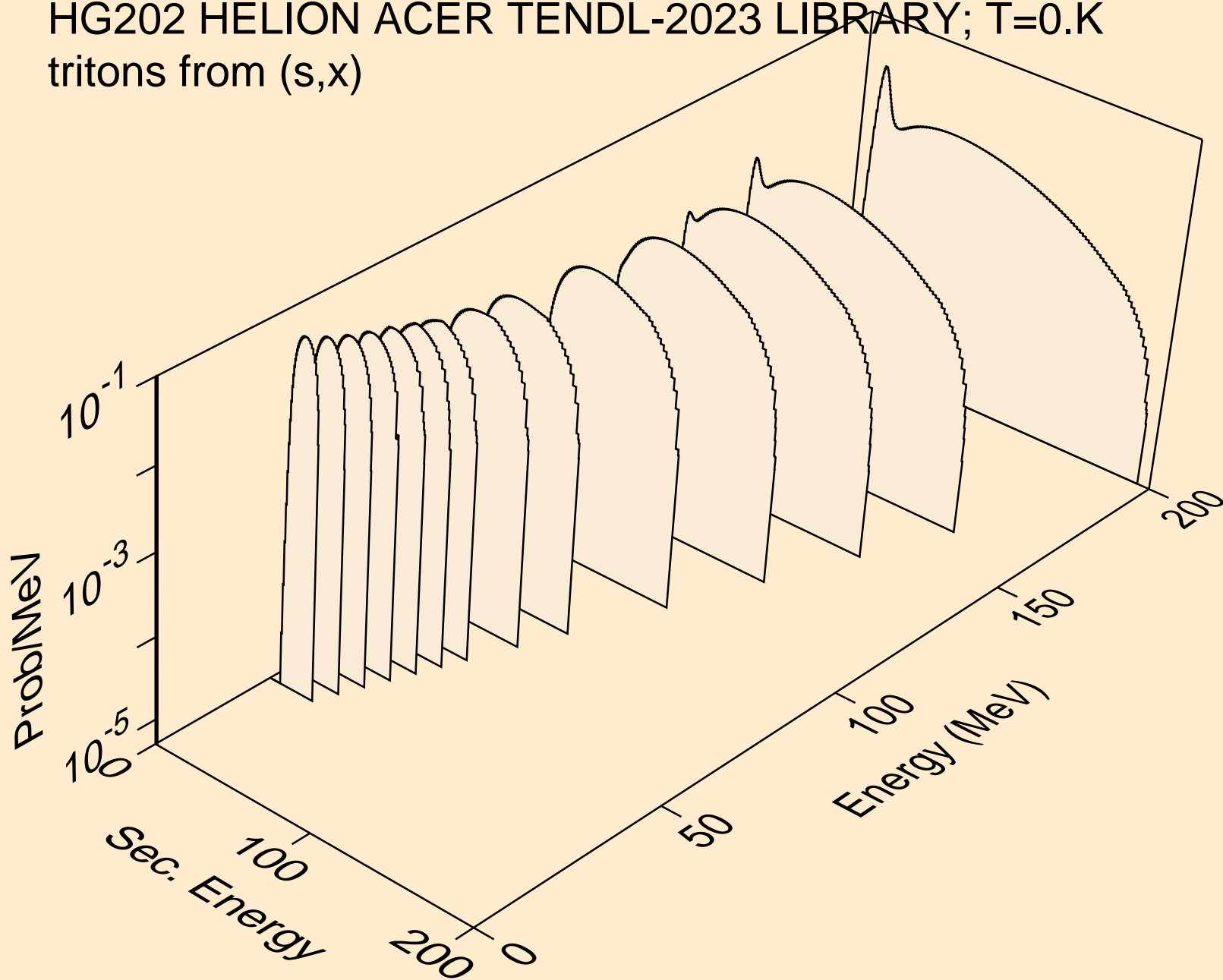

HG202 HELION ACER TENDL-2023 LIBRARY; T=0.K  
tritons from (s,n\*)t

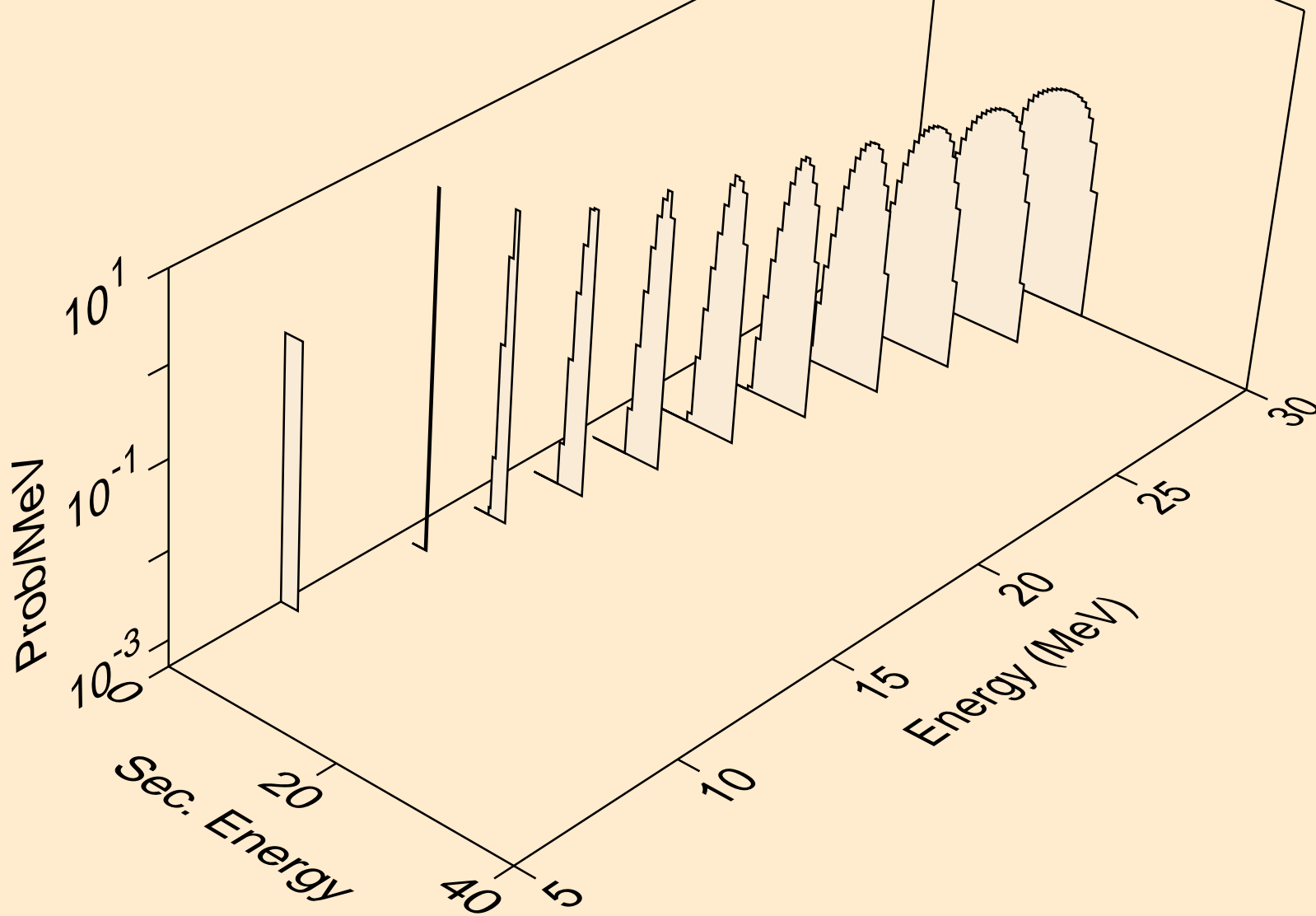

HG202 HELION ACER TENDL-2023 LIBRARY; T=0.K  
tritons from (s,t)

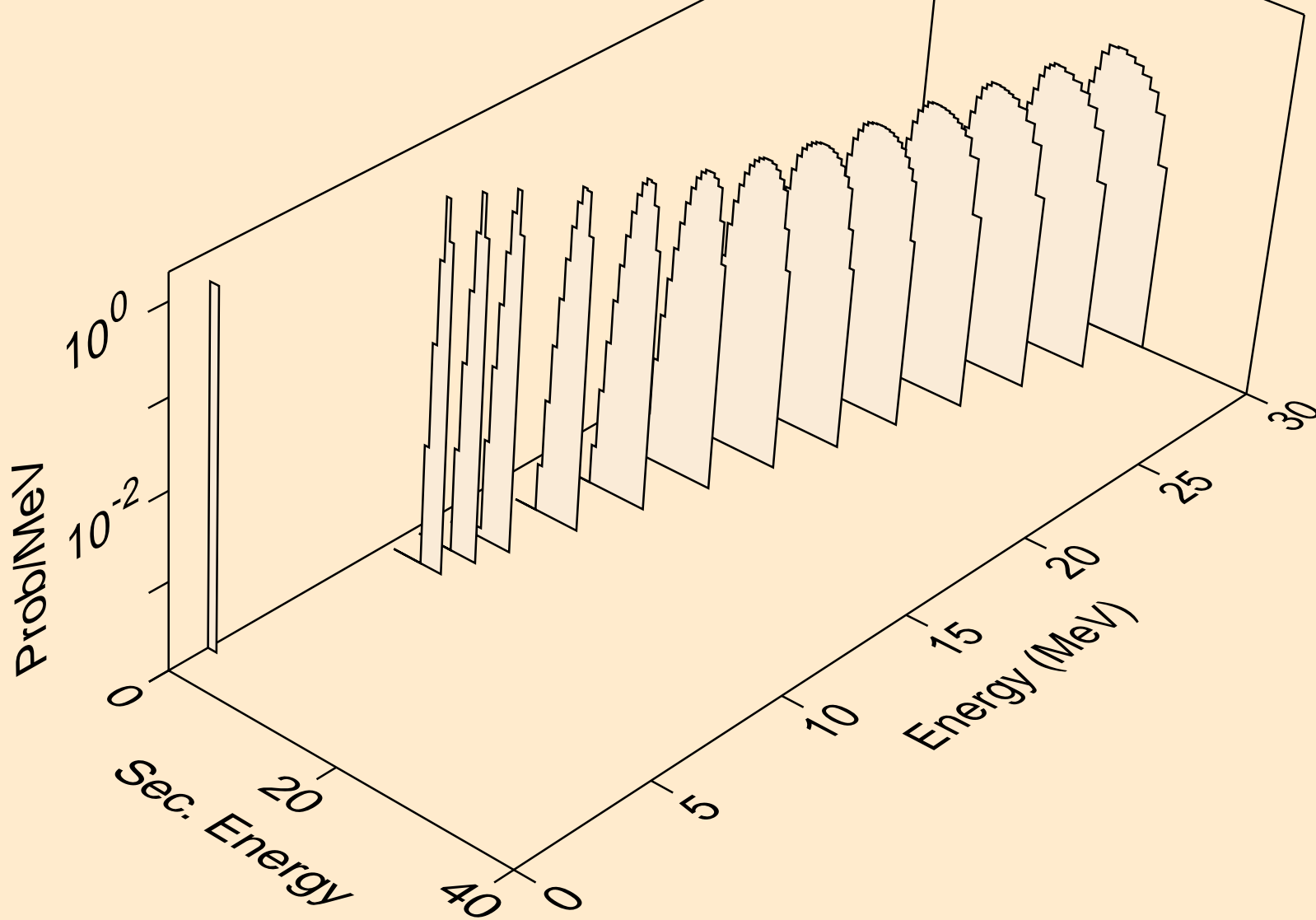

HG202 HELION ACER TENDL-2023 LIBRARY; T=0.K  
tritons from (s,pt)

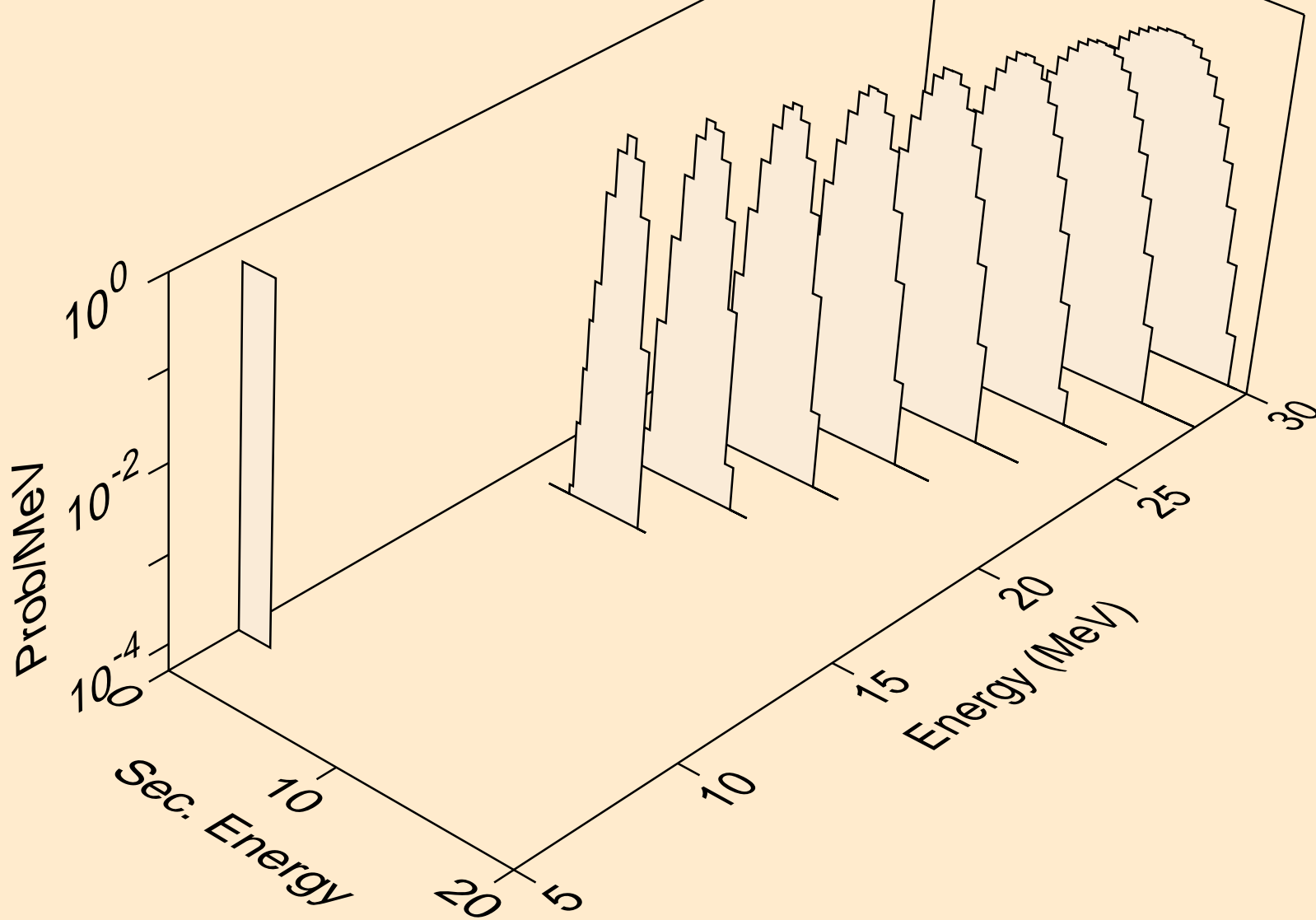

HG202 HELION ACER TENDL-2023 LIBRARY; T=0.K  
alphas from (s,x)

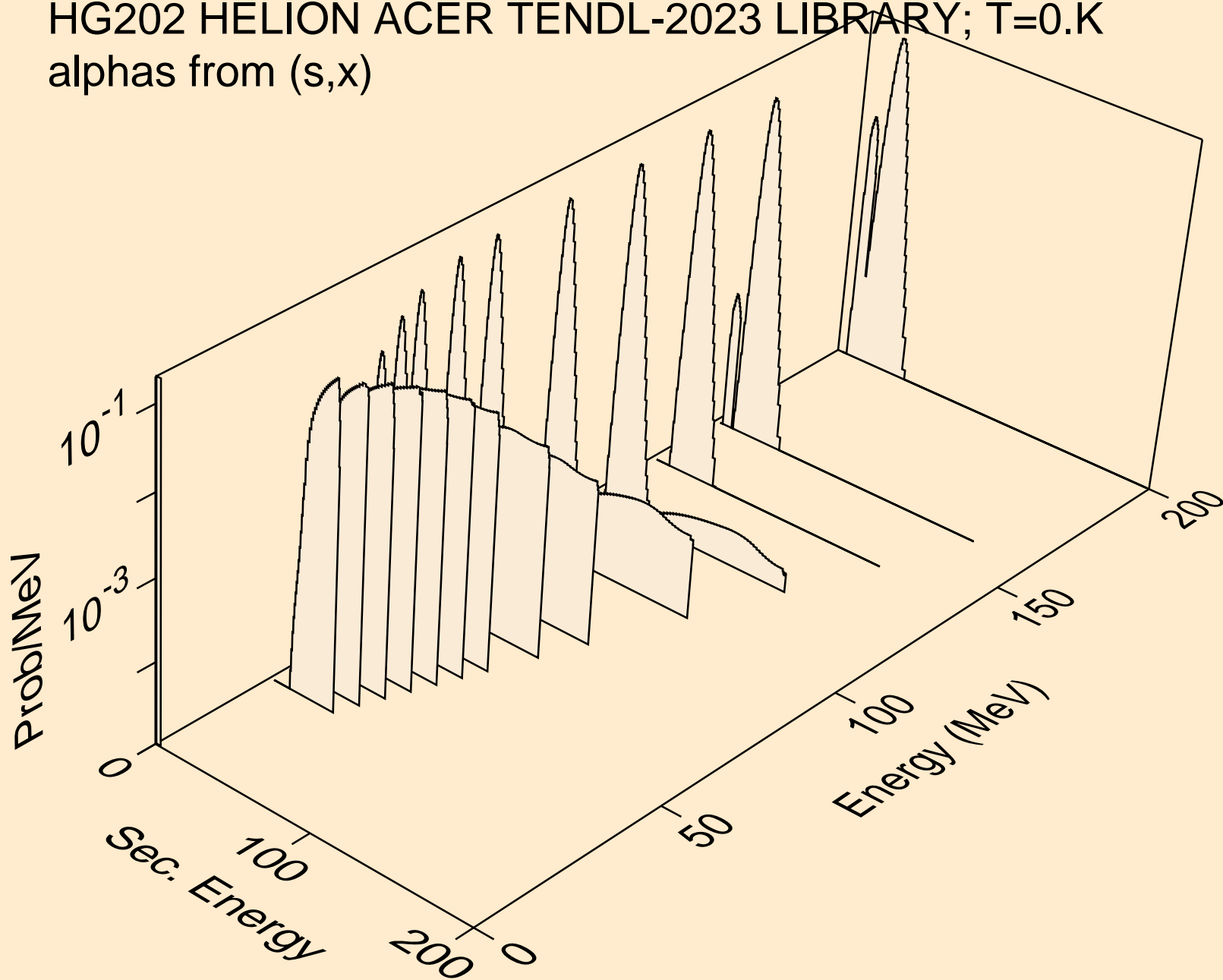

HG202 HELION ACER TENDL-2023 LIBRARY; T=0.K  
alphas from (s,n\*)a

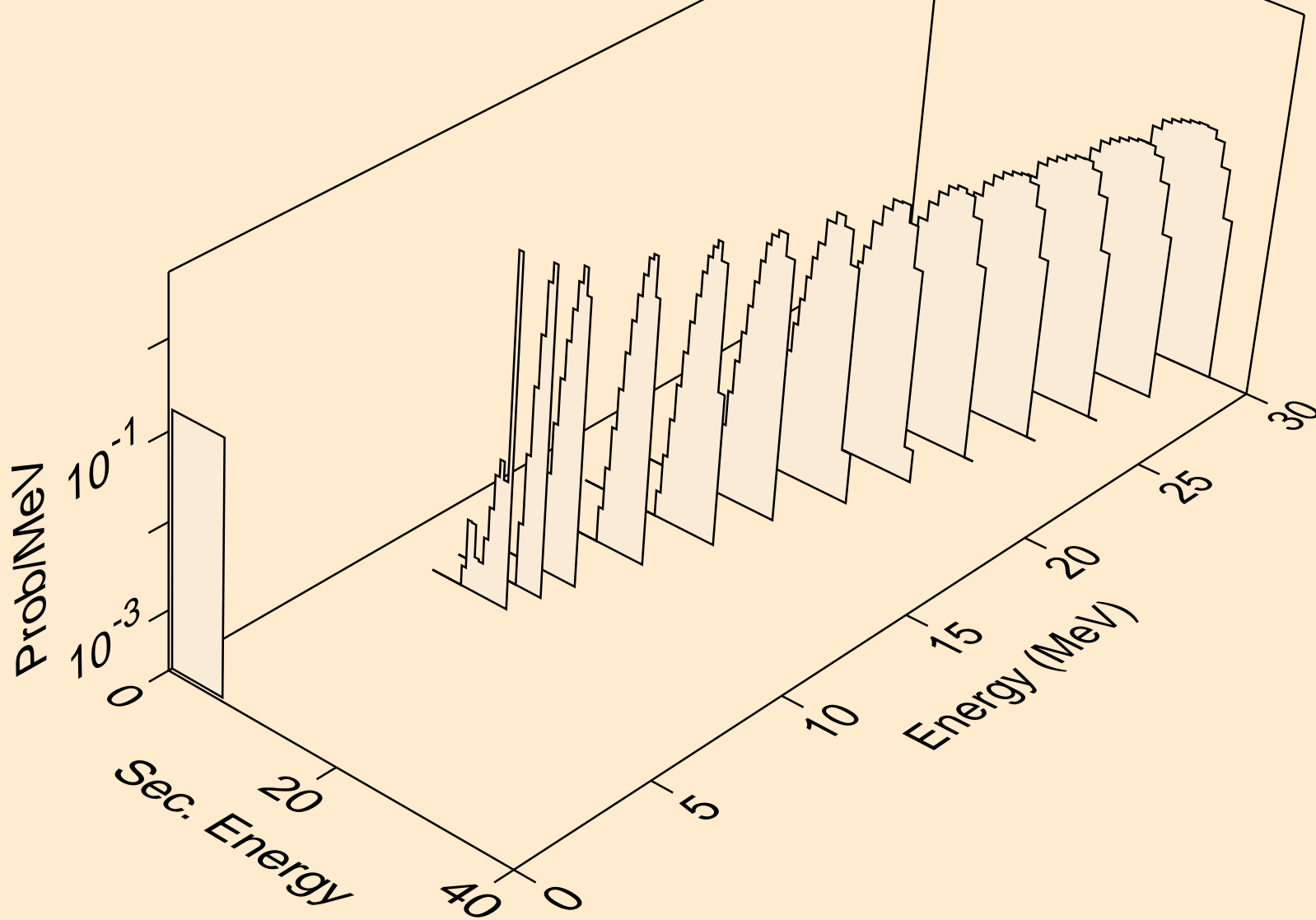

HG202 HELION ACER TENDL-2023 LIBRARY; T=0.K  
alphas from (s,2n)a

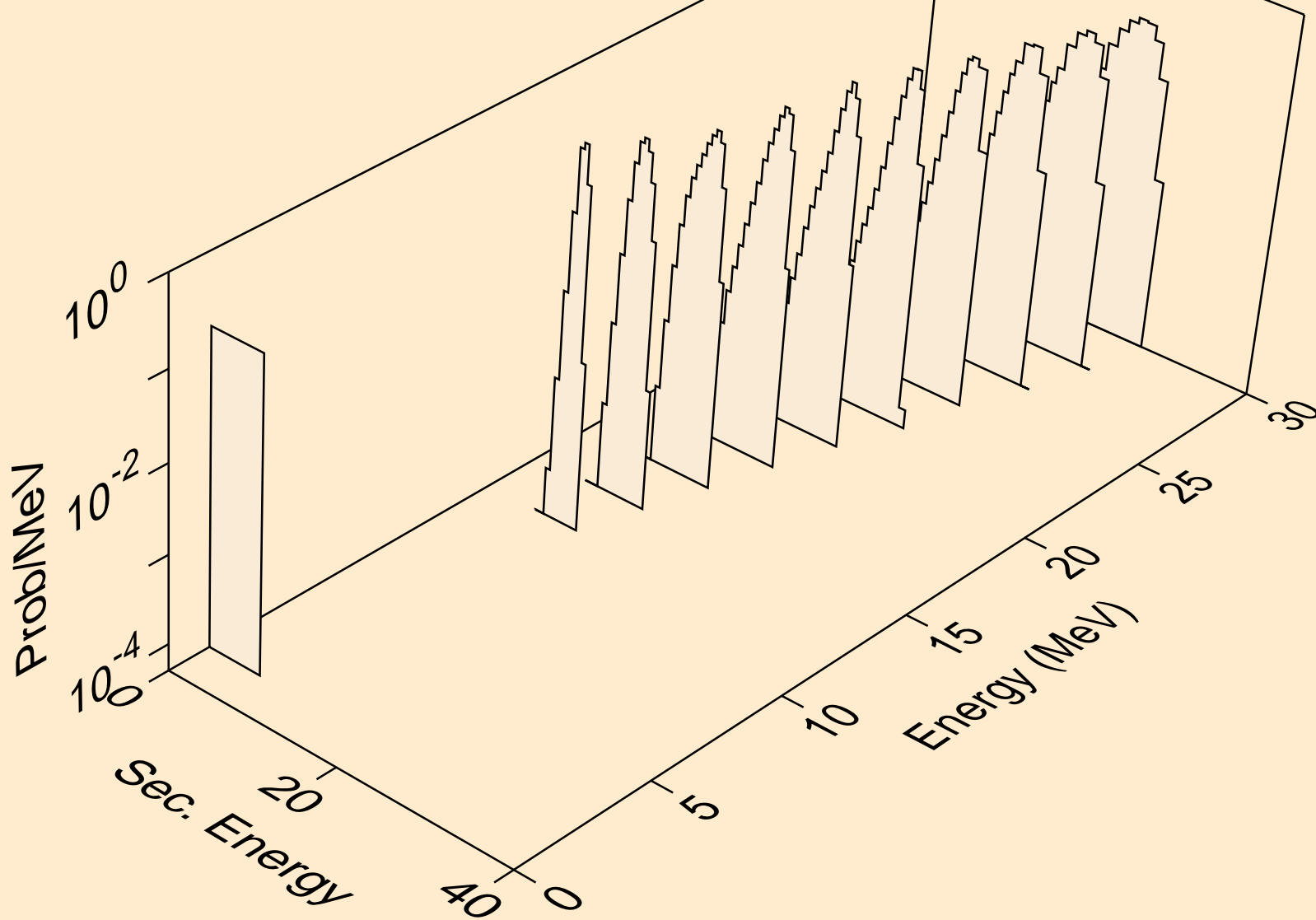

HG202 HELION ACER TENDL-2023 LIBRARY; T=0.K  
alphas from (s,3n)a

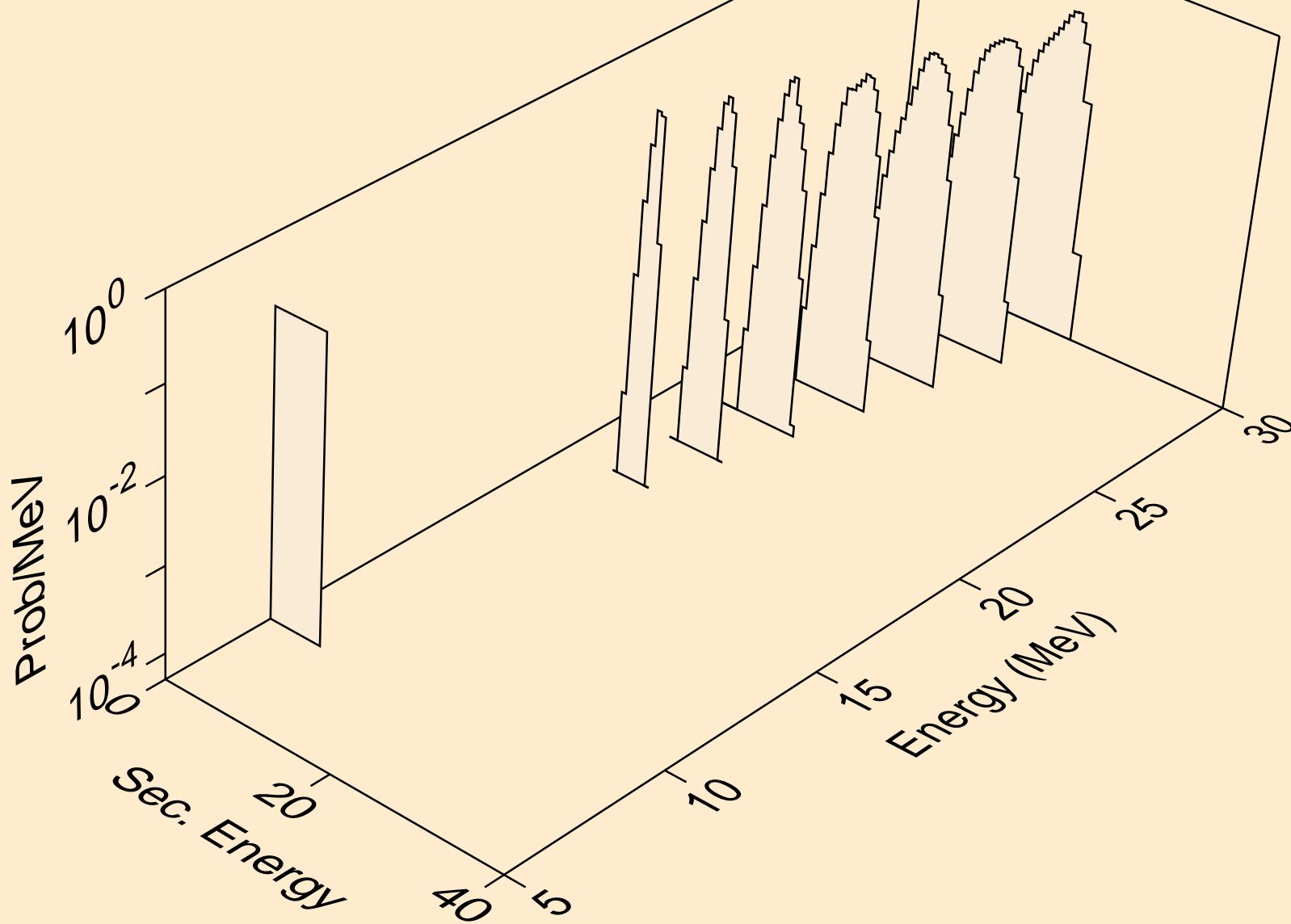

HG202 HELION ACER TENDL-2023 LIBRARY; T=0.K  
alphas from (s,npa)

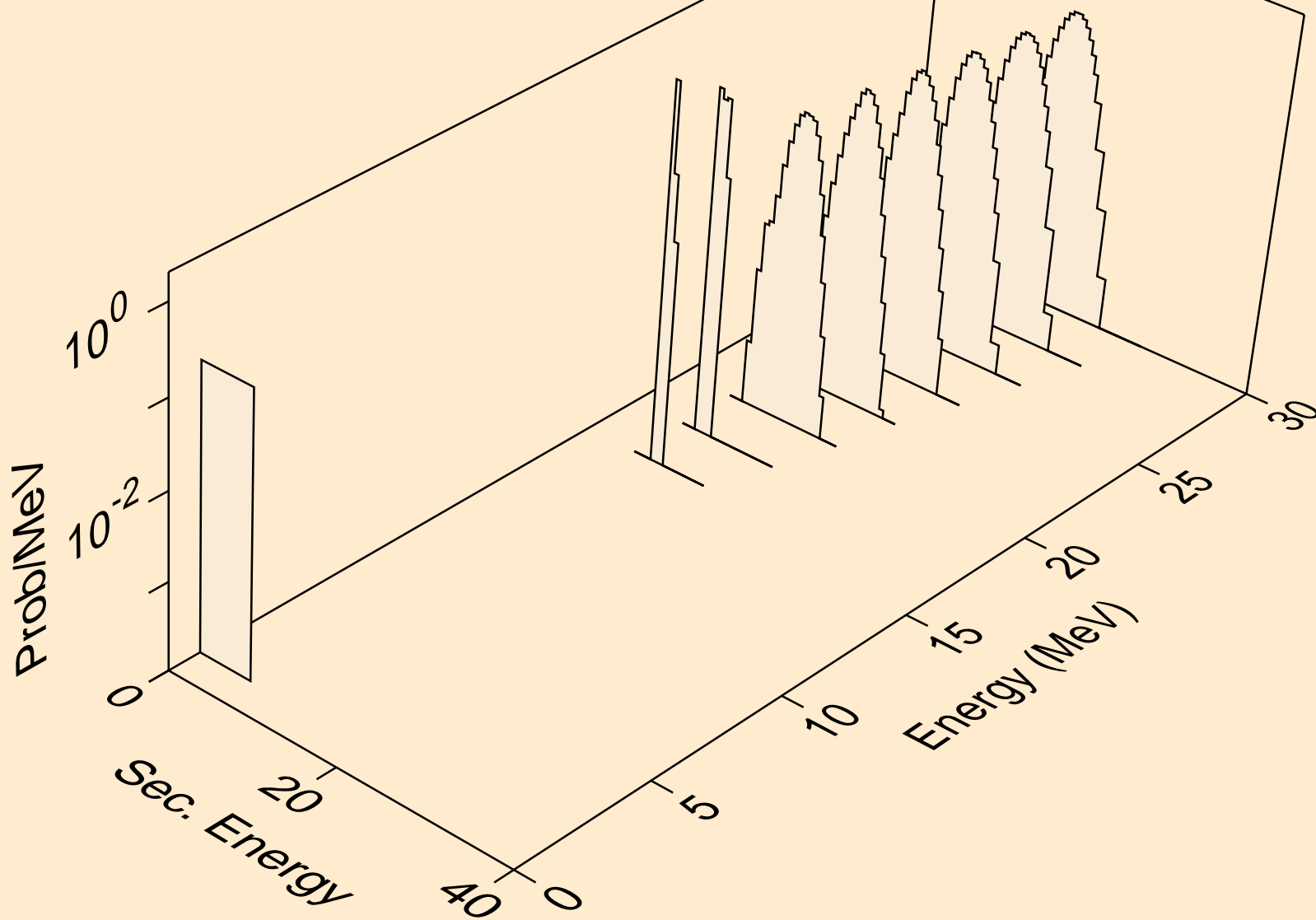

HG202 HELION ACER TENDL-2023 LIBRARY; T=0.K  
alphas from (s,a)

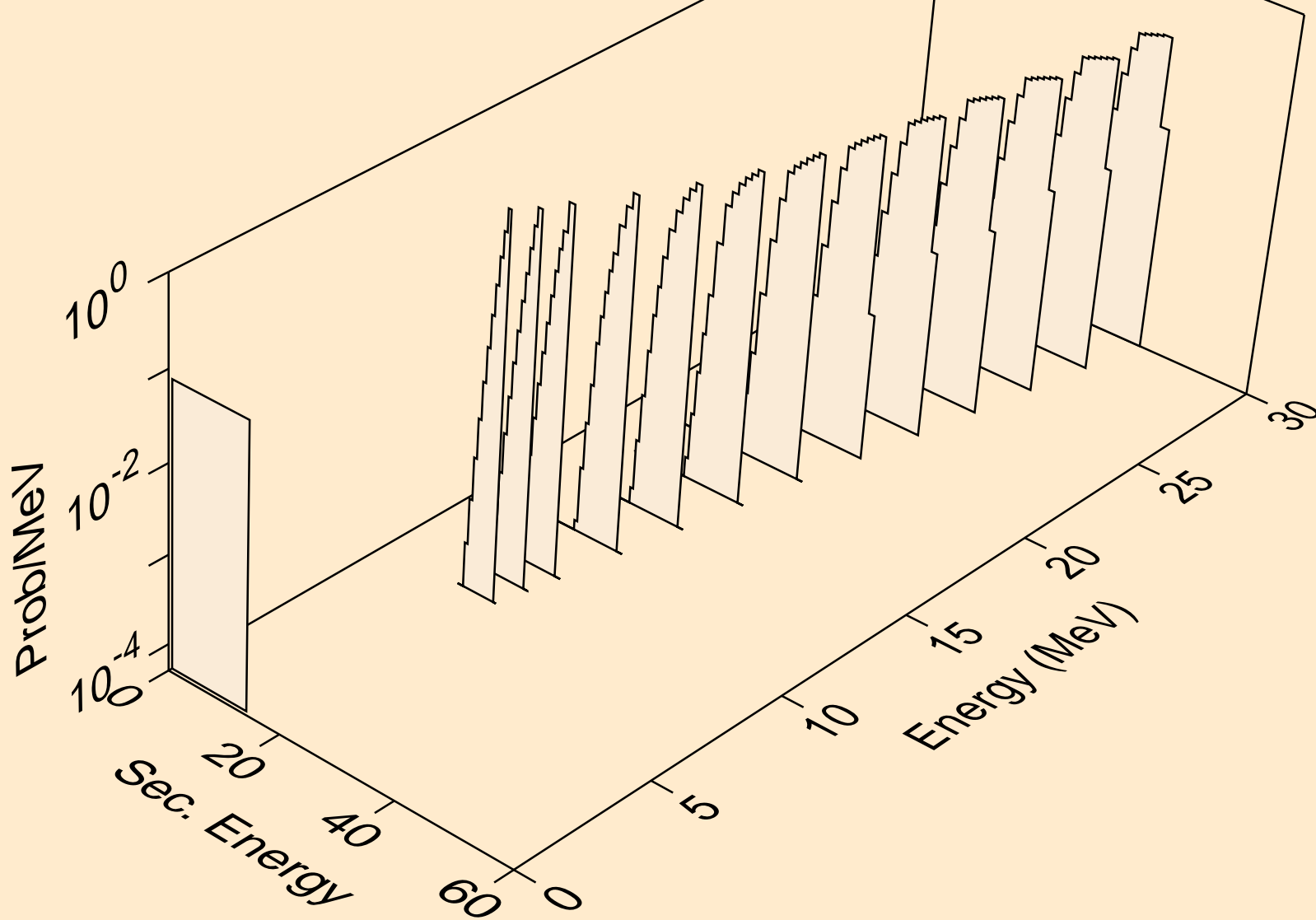

HG202 HELION ACER TENDL-2023 LIBRARY; T=0.K  
alphas from (s,pa)

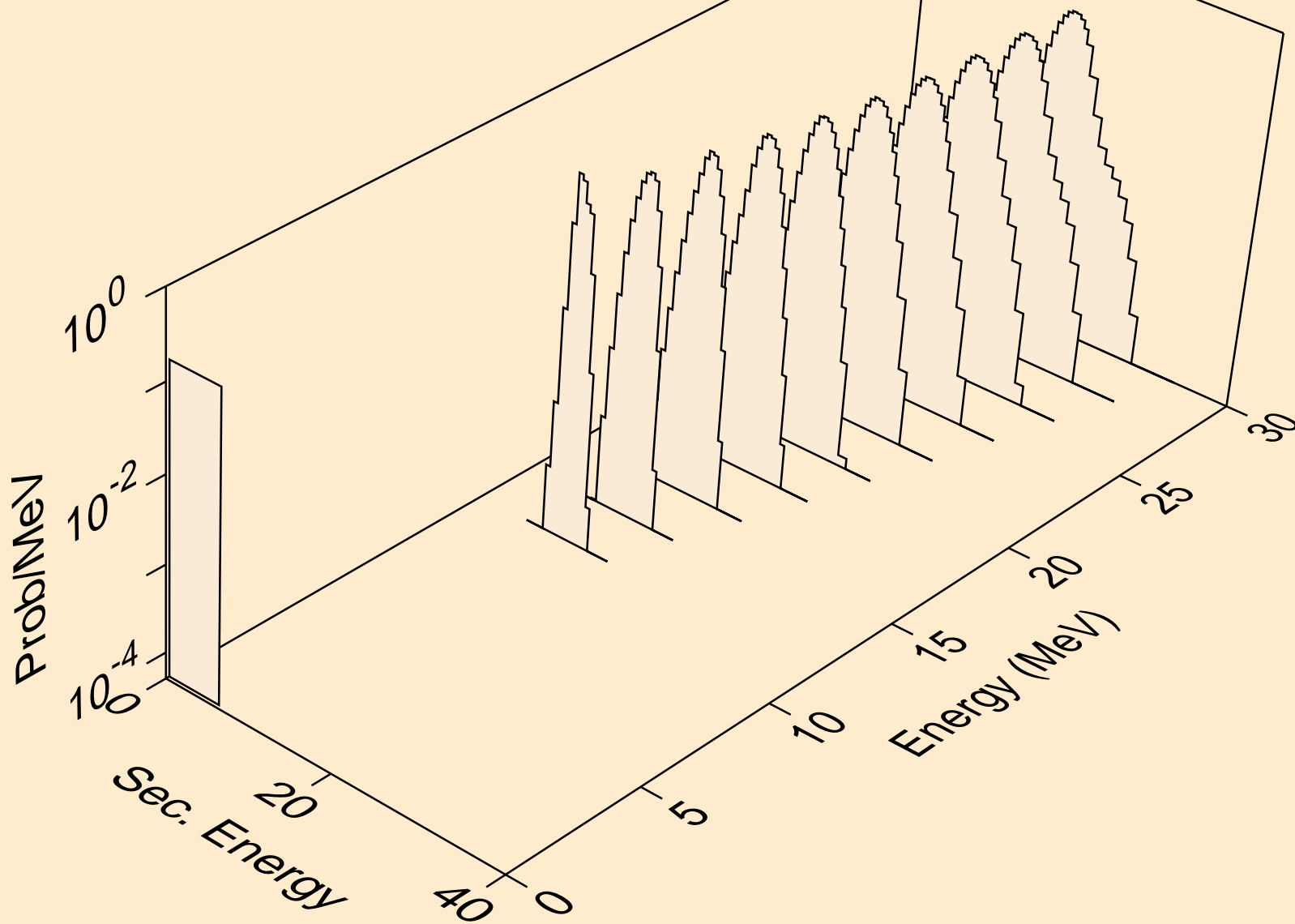

HG202 HELION ACER TENDL-2023 LIBRARY; T=0.K  
alphas from (s,da)

