

AC236 NEUTRON ACER TENDL-2023 LIBRARY; T=0.K

Principal cross sections

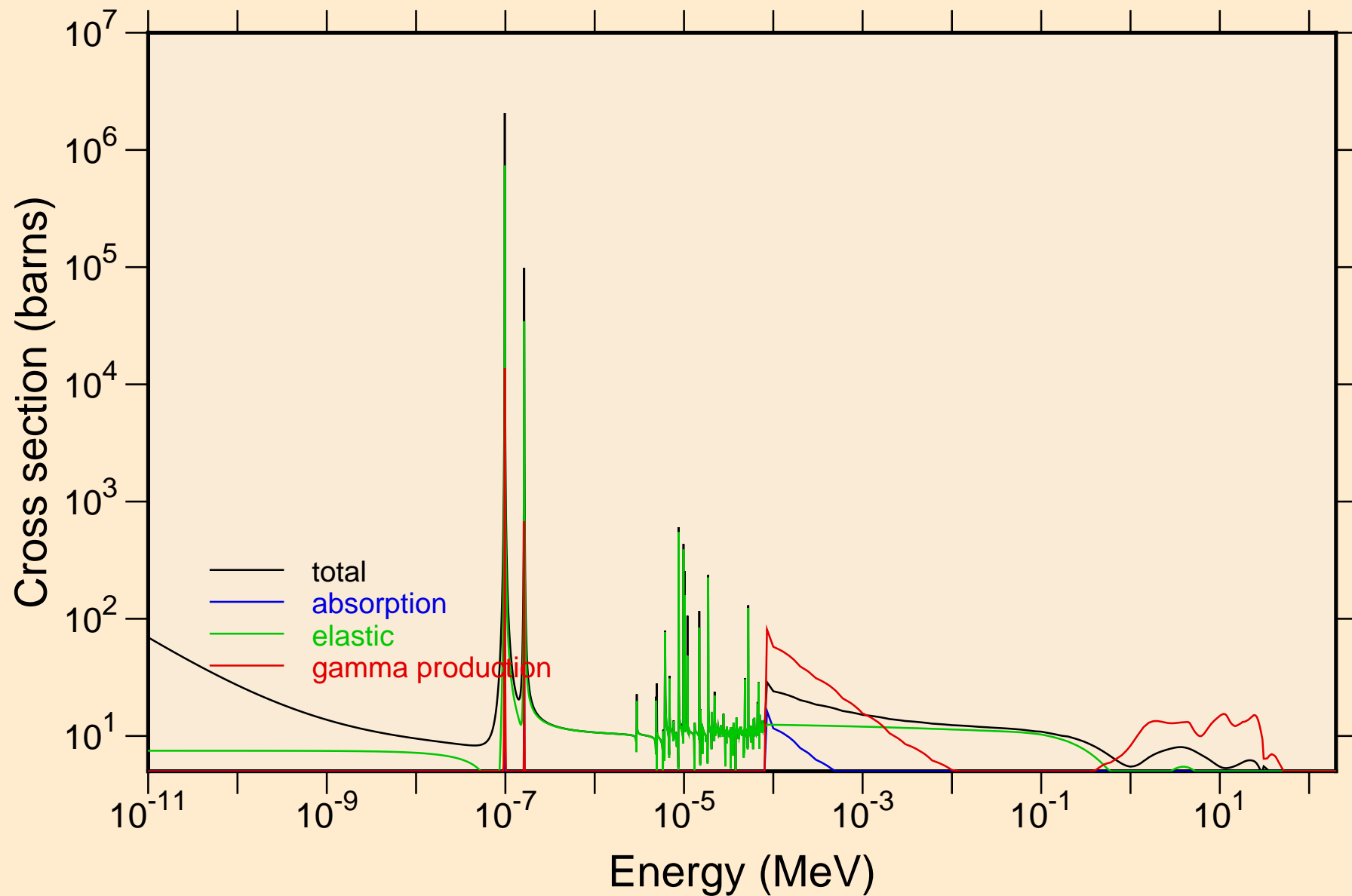

AC236 NEUTRON ACER TENDL-2023 LIBRARY; T=0.K
resonance total cross section

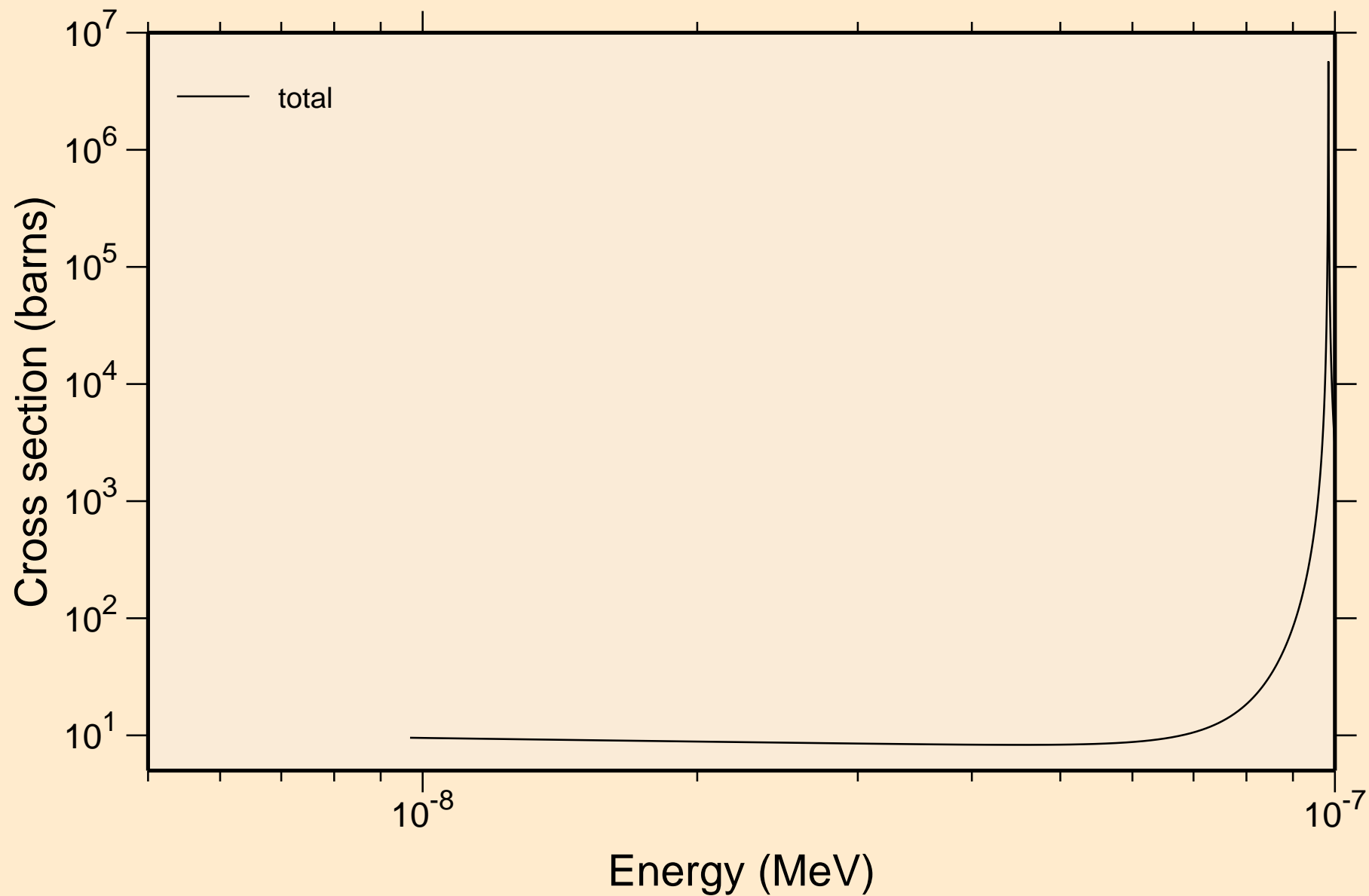

AC236 NEUTRON ACER TENDL-2023 LIBRARY; T=0.K
resonance total cross section

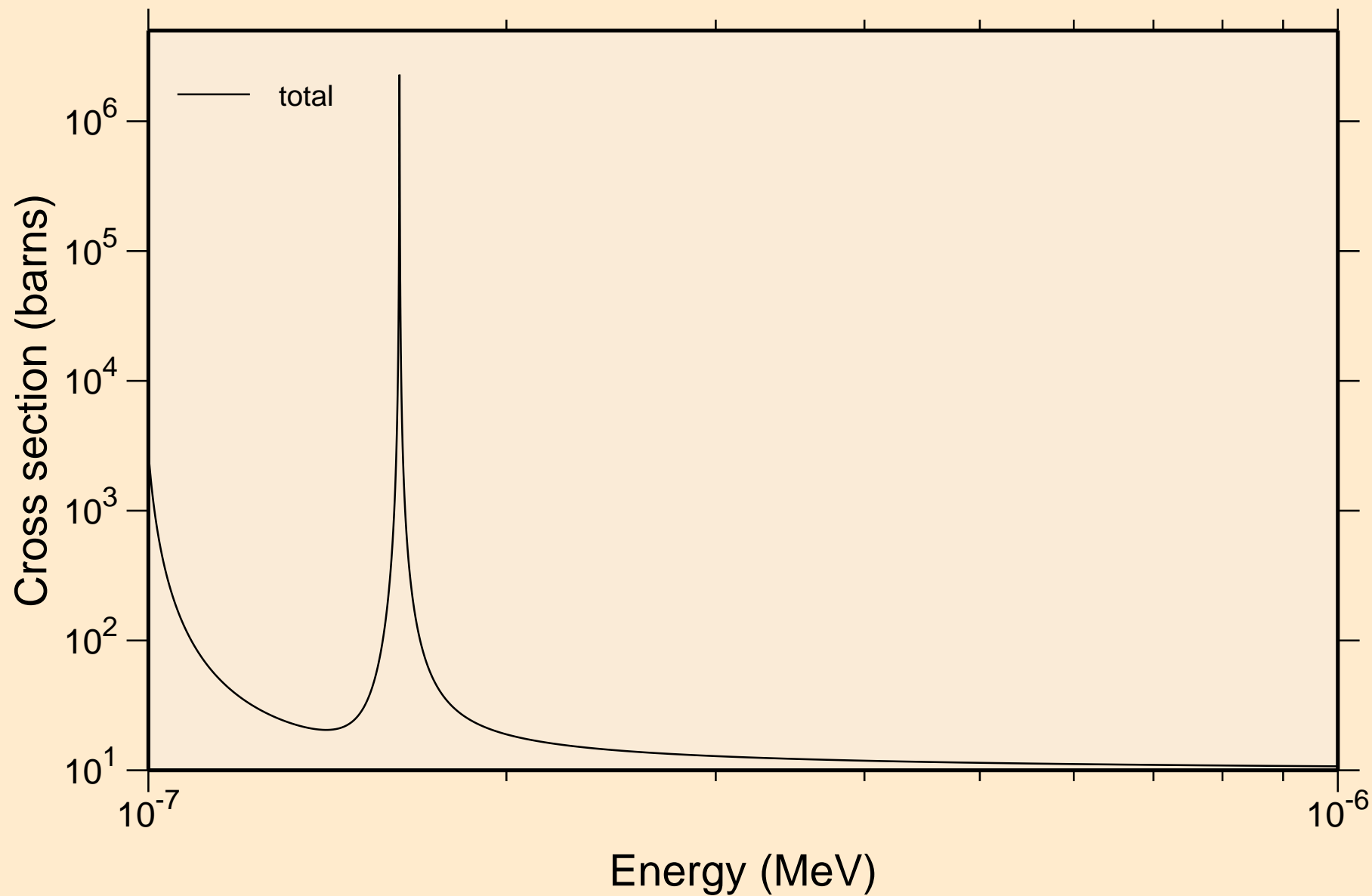

AC236 NEUTRON ACER TENDL-2023 LIBRARY; T=0.K
resonance total cross section

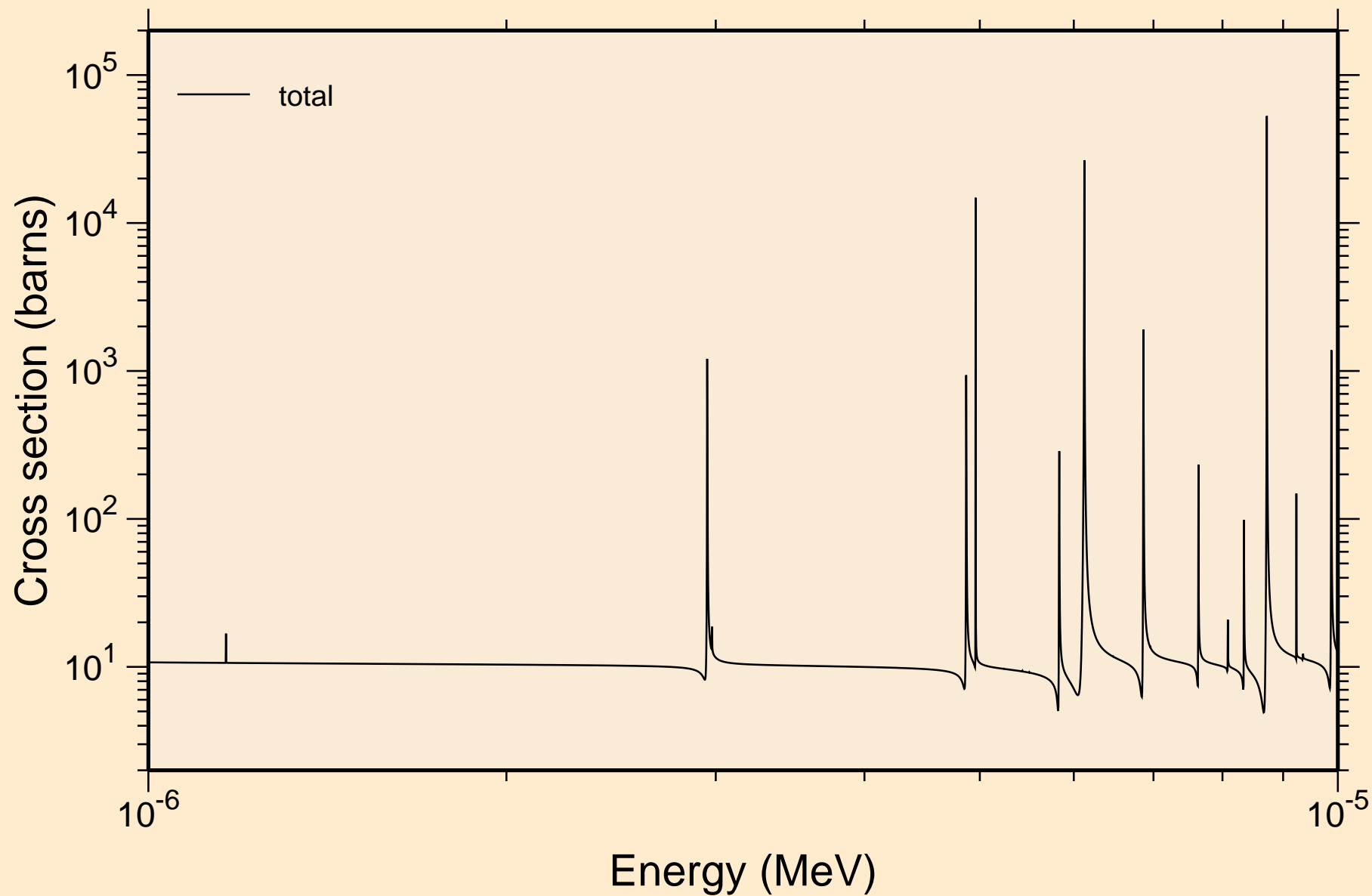

AC236 NEUTRON ACER TENDL-2023 LIBRARY; T=0.K
resonance total cross section

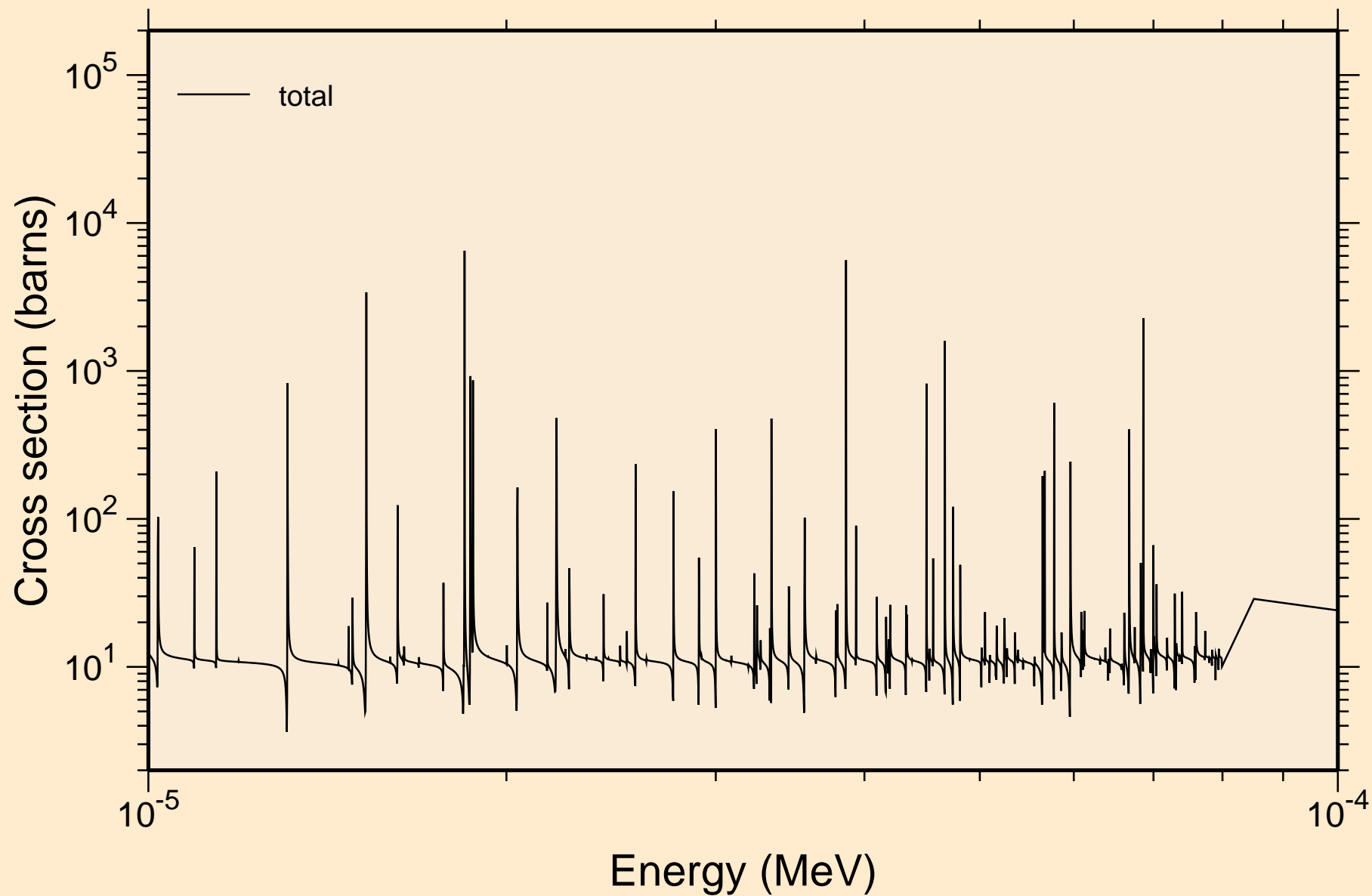

AC236 NEUTRON ACER TENDL-2023 LIBRARY; T=0.K
resonance total cross section

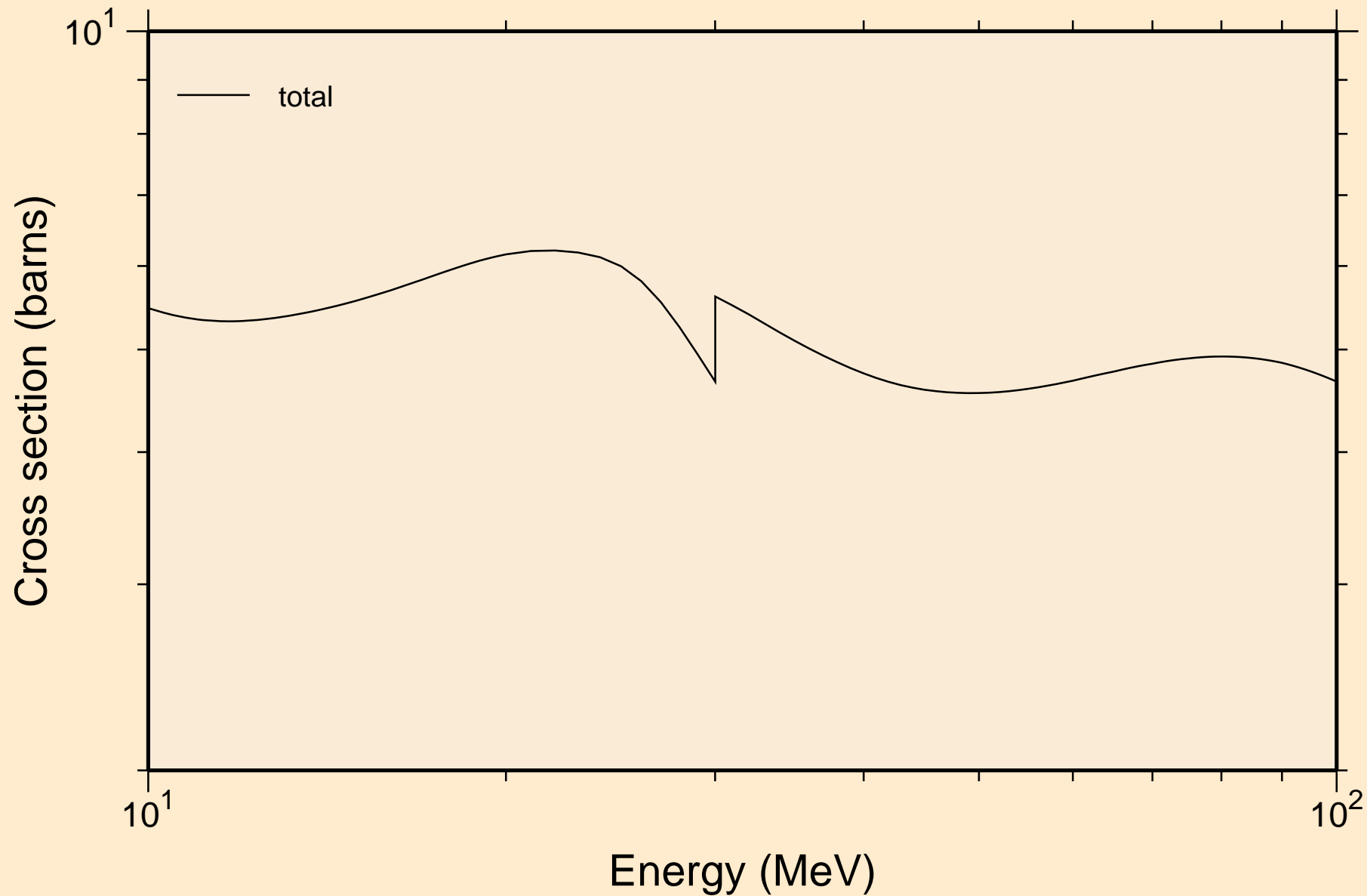

AC236 NEUTRON ACER TENDL-2023 LIBRARY; T=0.K
resonance absorption cross sections

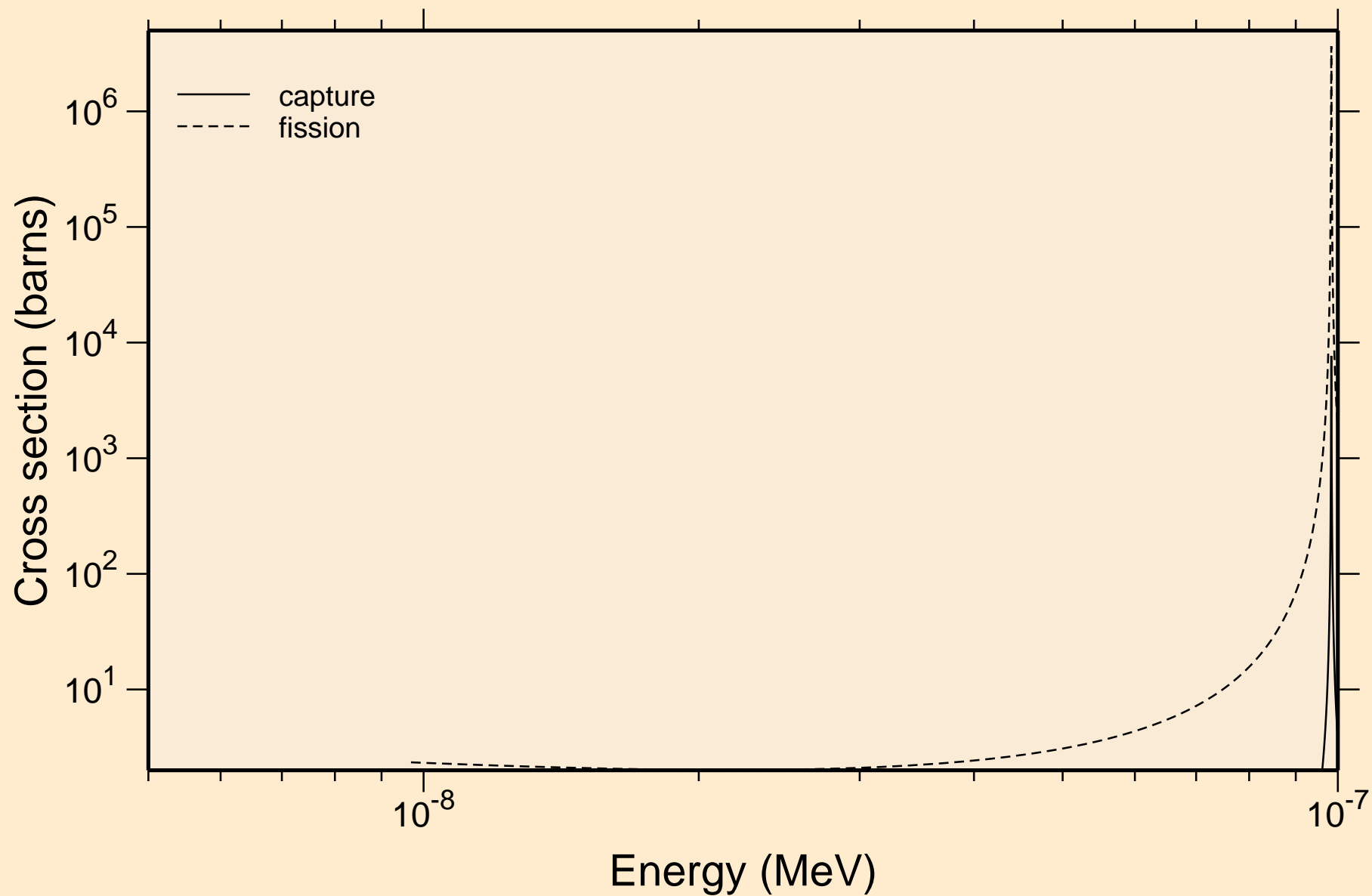

AC236 NEUTRON ACER TENDL-2023 LIBRARY; T=0.K
resonance absorption cross sections

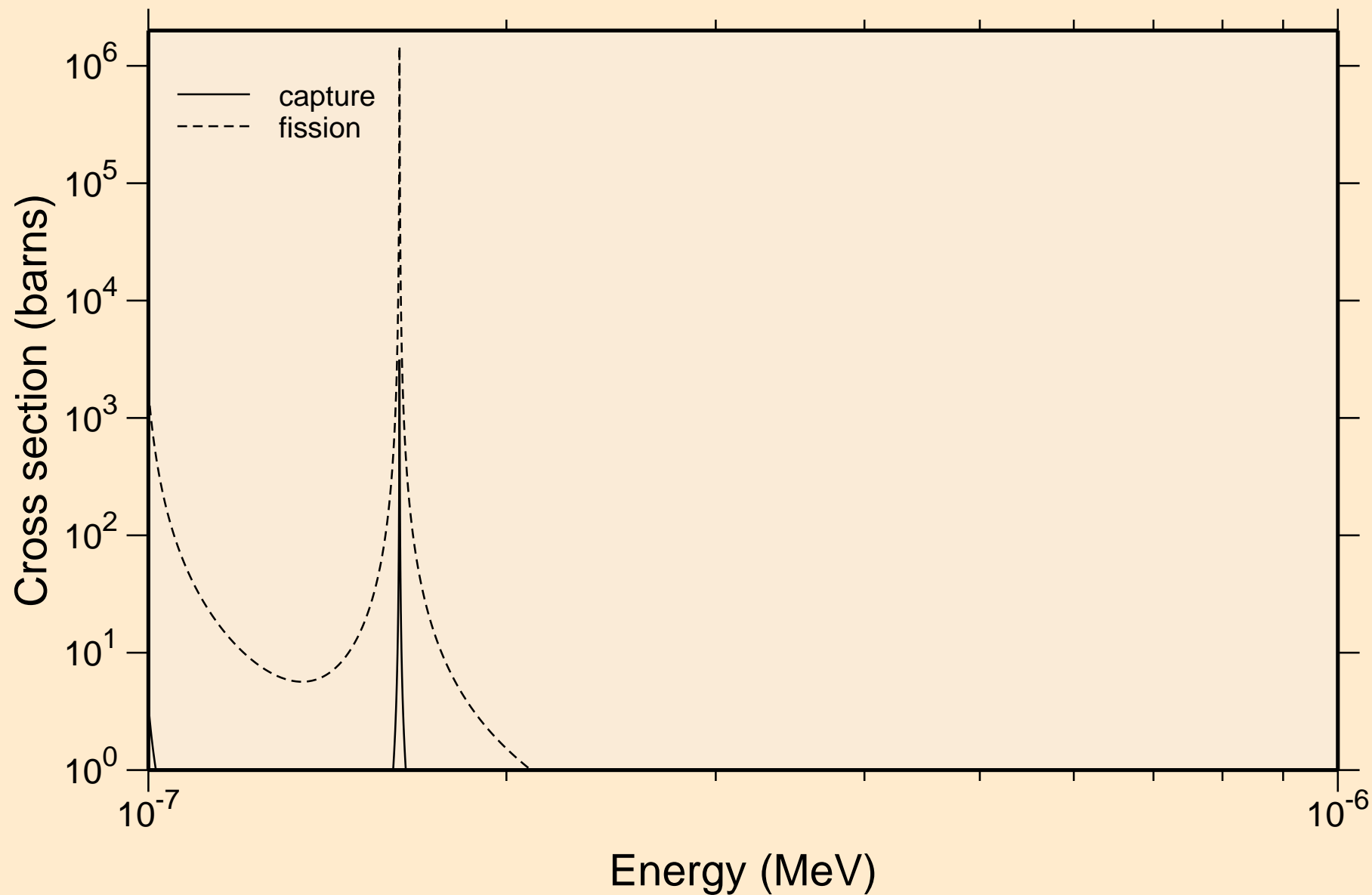

AC236 NEUTRON ACER TENDL-2023 LIBRARY; T=0.K
resonance absorption cross sections

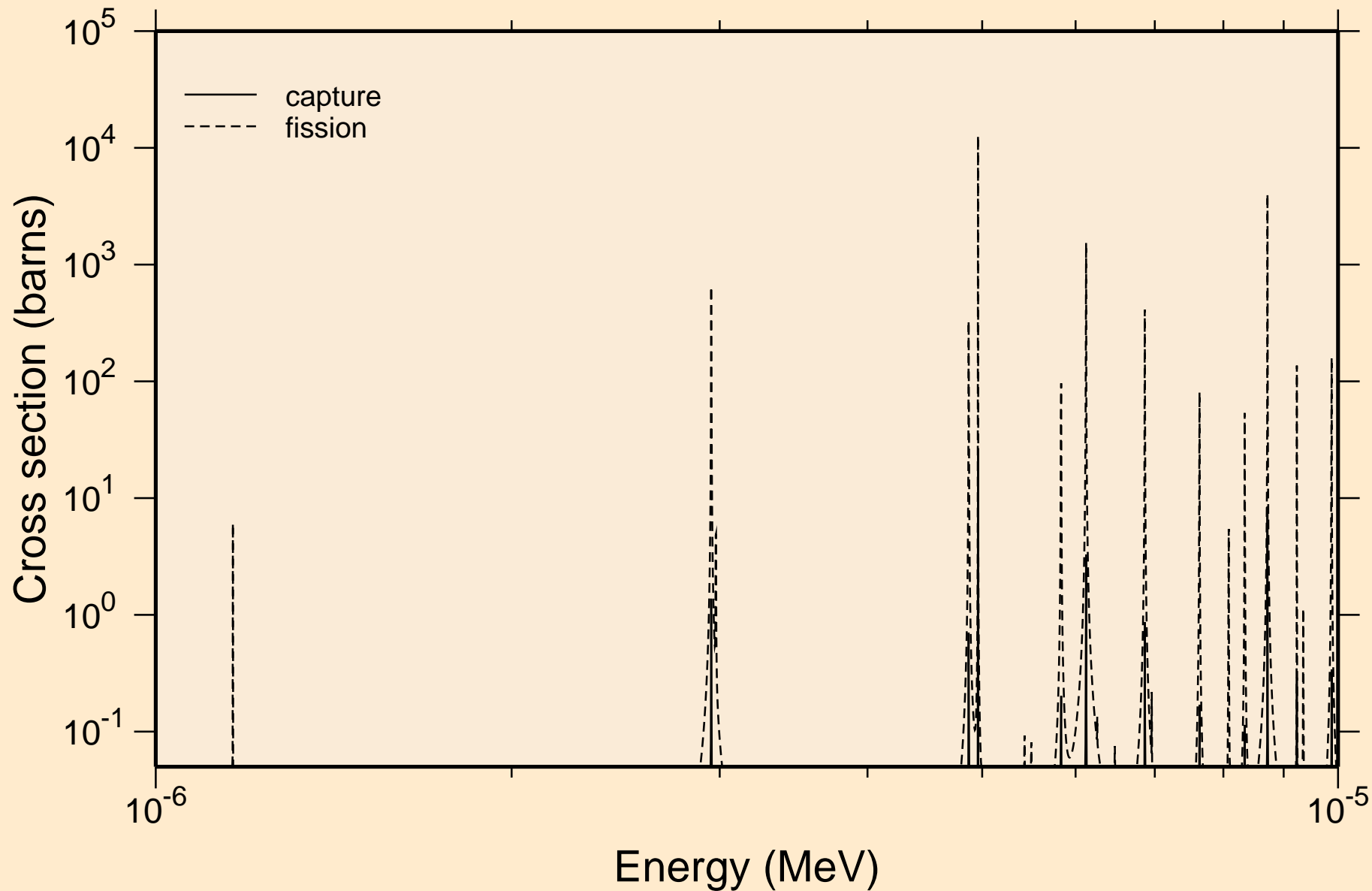

AC236 NEUTRON ACER TENDL-2023 LIBRARY; T=0.K
resonance absorption cross sections

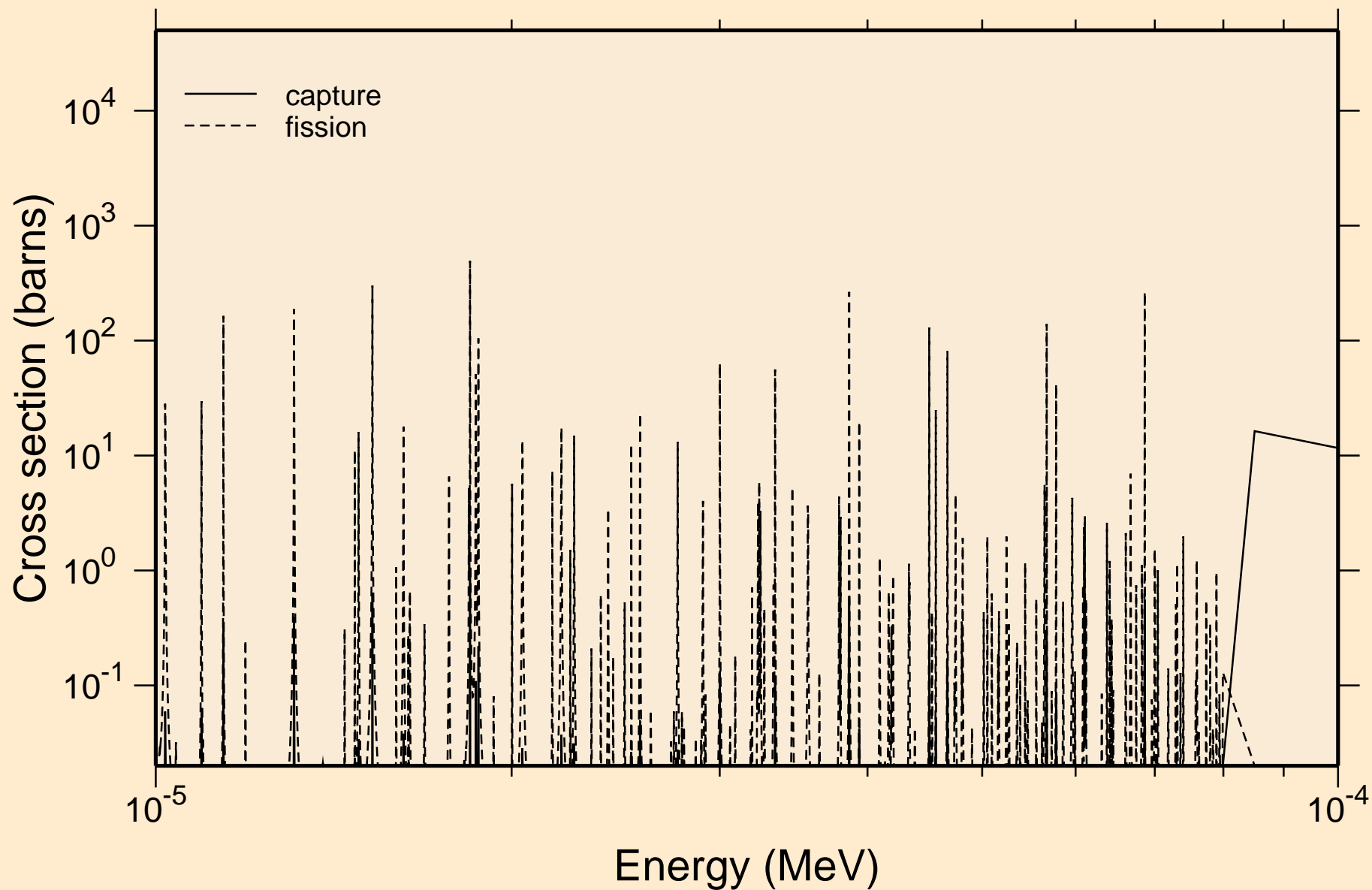

AC236 NEUTRON ACER TENDL-2023 LIBRARY; T=0.K
resonance absorption cross sections

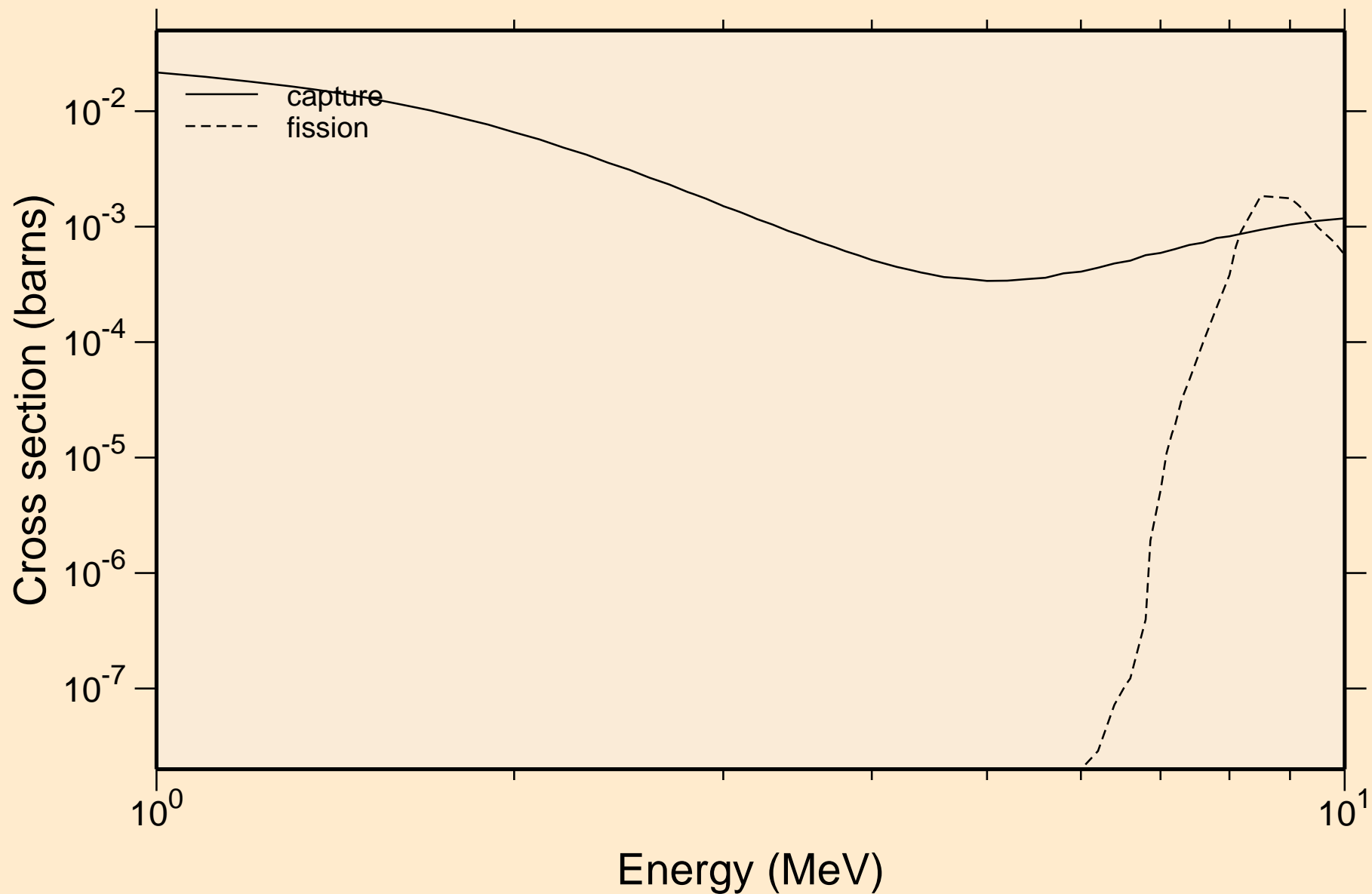

AC236 NEUTRON ACER TENDL-2023 LIBRARY; T=0.K
Heating

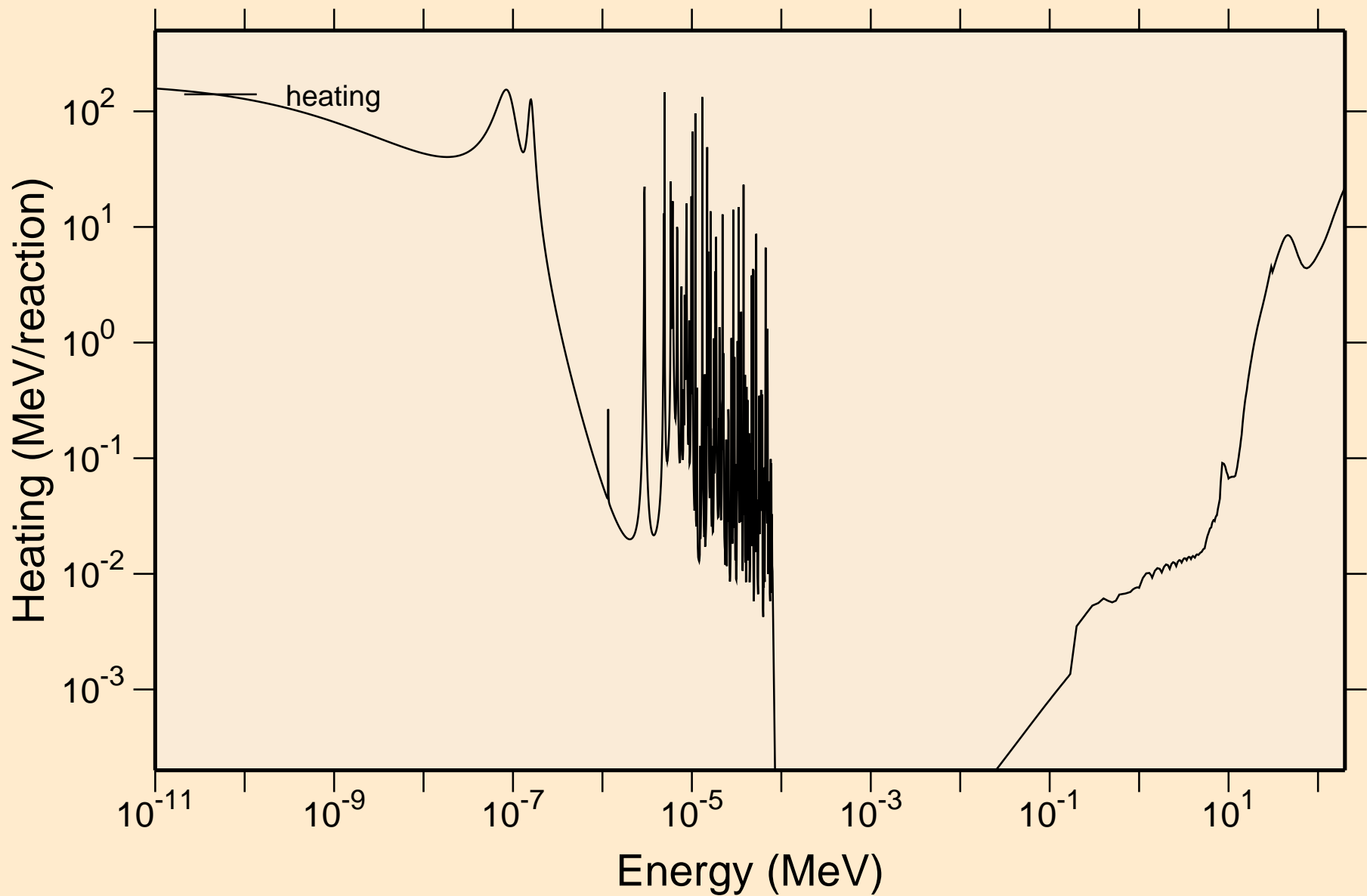

AC236 NEUTRON ACER TENDL-2023 LIBRARY; T=0.K

Damage

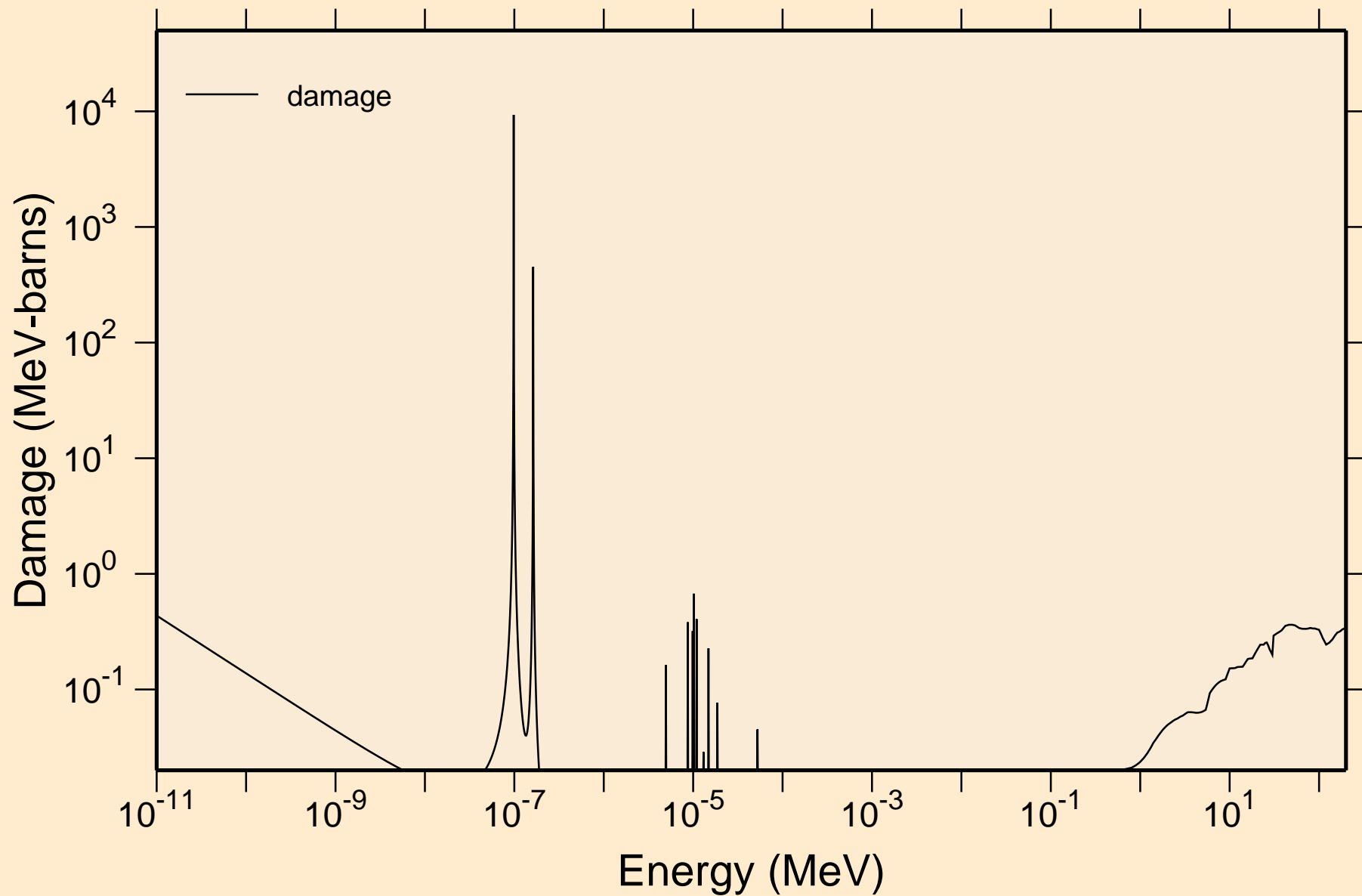

AC236 NEUTRON ACER TENDL-2023 LIBRARY; T=0.K

Non-threshold reactions

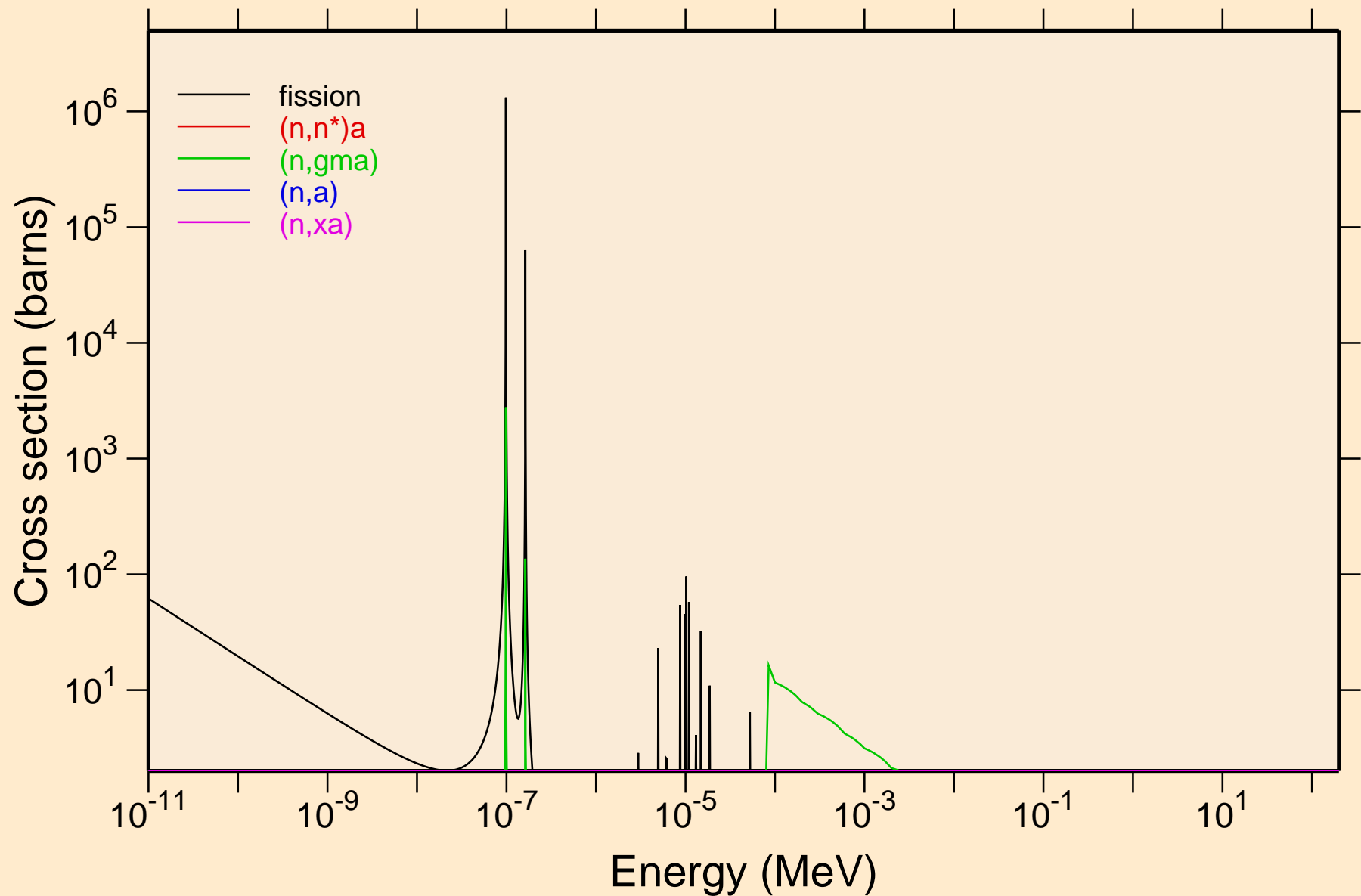

AC236 NEUTRON ACER TENDL-2023 LIBRARY; T=0.K
Principal cross sections

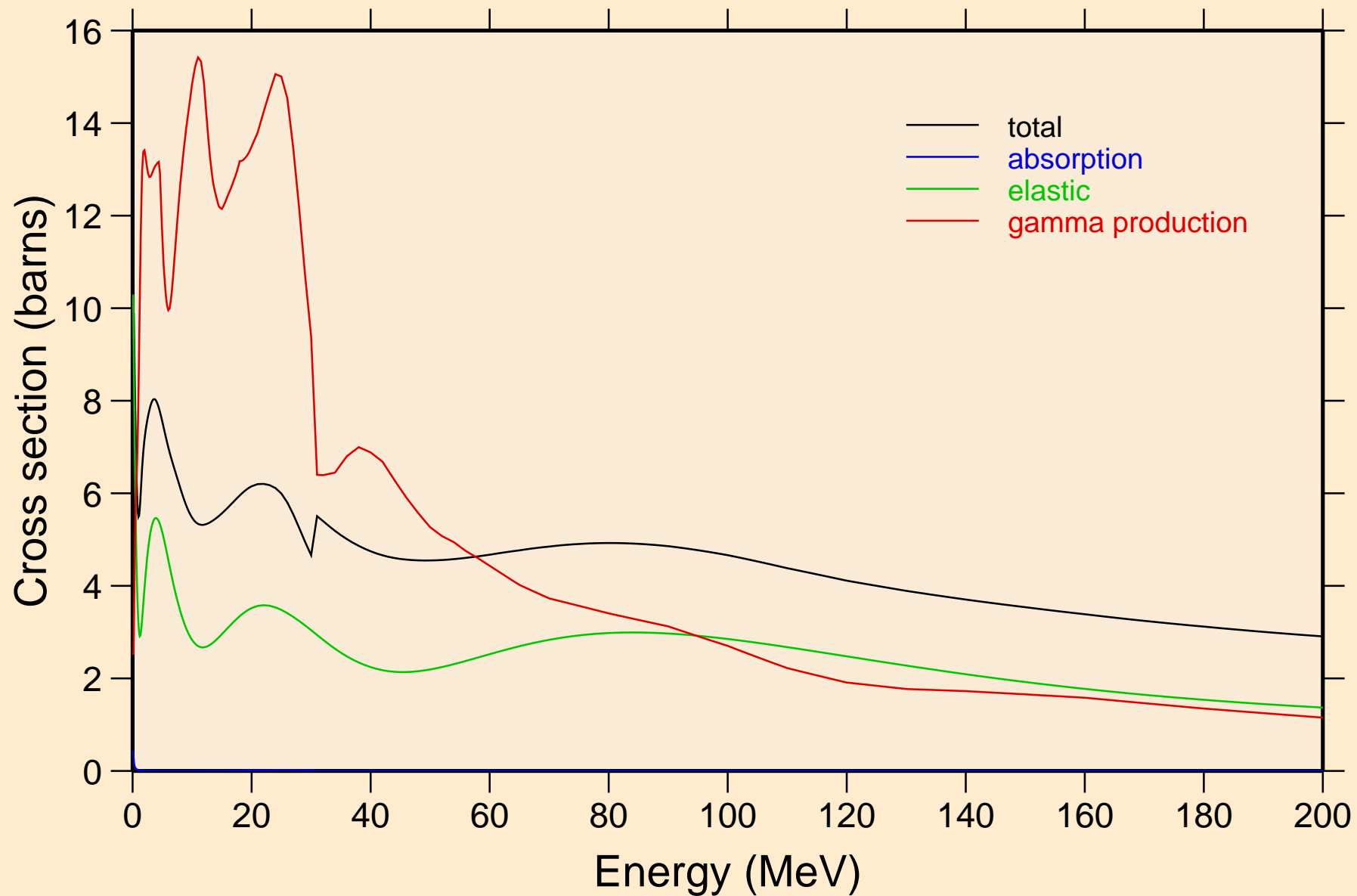

AC236 NEUTRON ACER TENDL-2023 LIBRARY; T=0.K
Heating

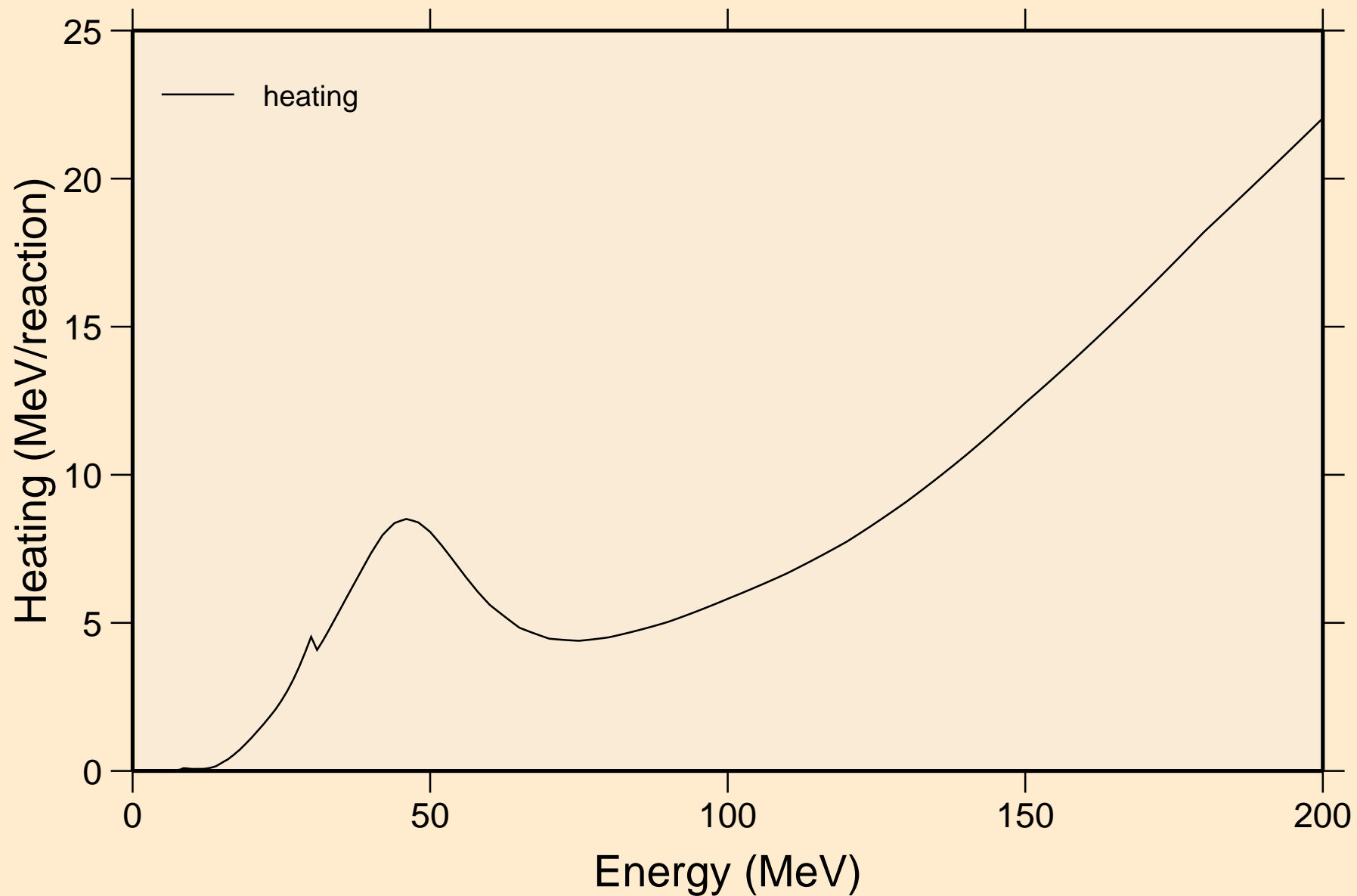

AC236 NEUTRON ACER TENDL-2023 LIBRARY; T=0.K
Damage

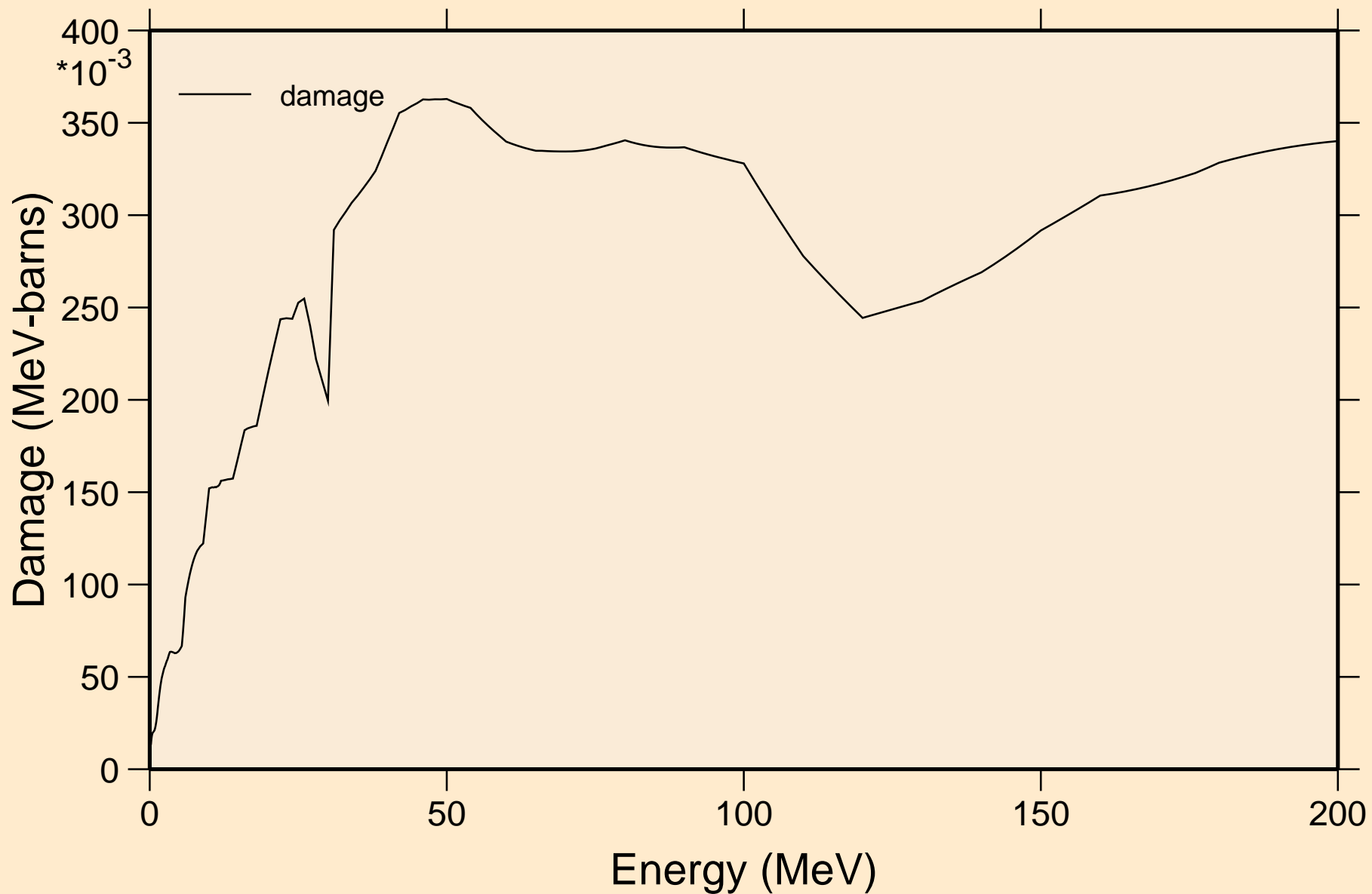

AC236 NEUTRON ACER TENDL-2023 LIBRARY; T=0.K
Non-threshold reactions

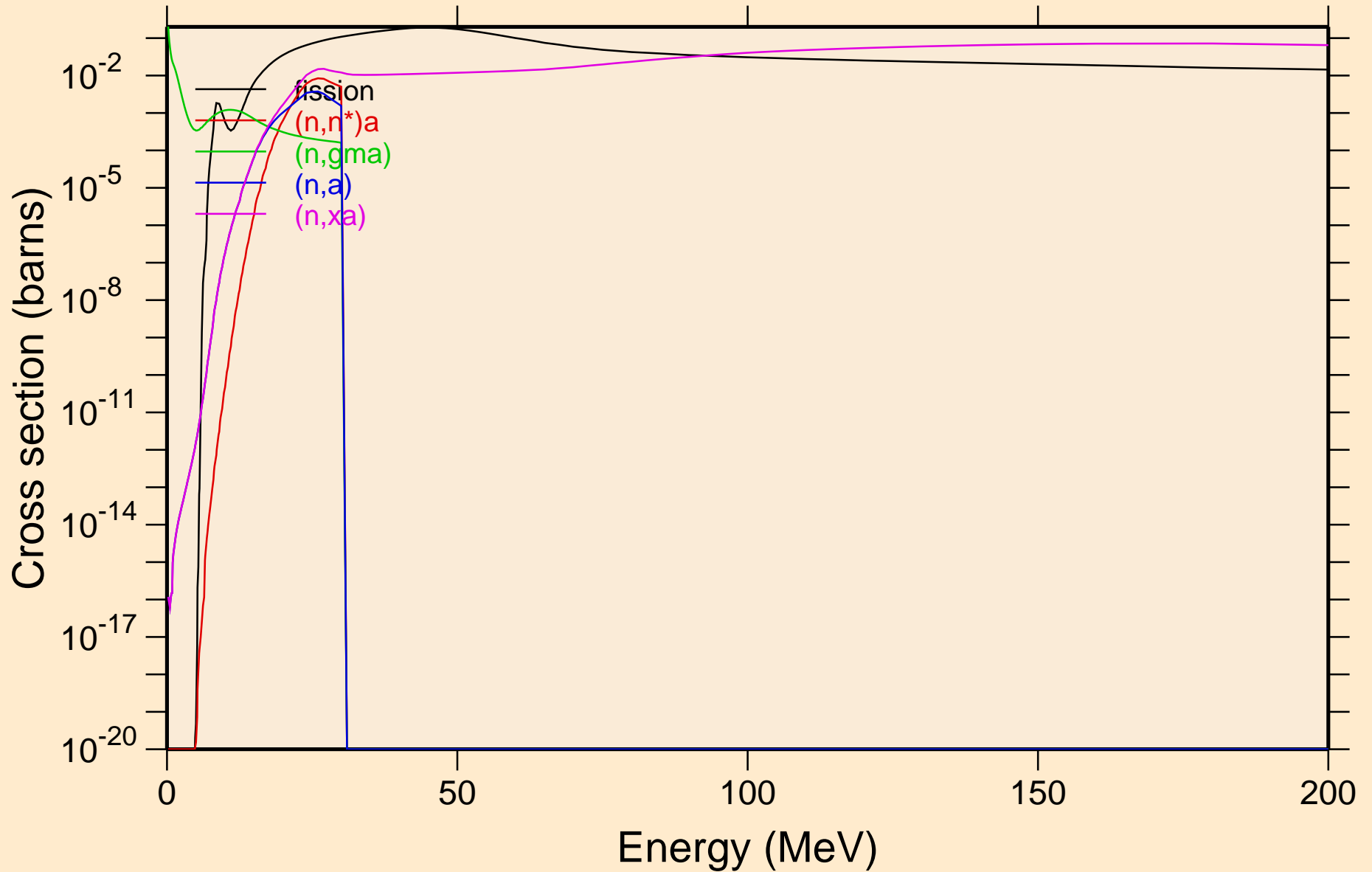

AC236 NEUTRON ACER TENDL-2023 LIBRARY; T=0.K
Inelastic levels

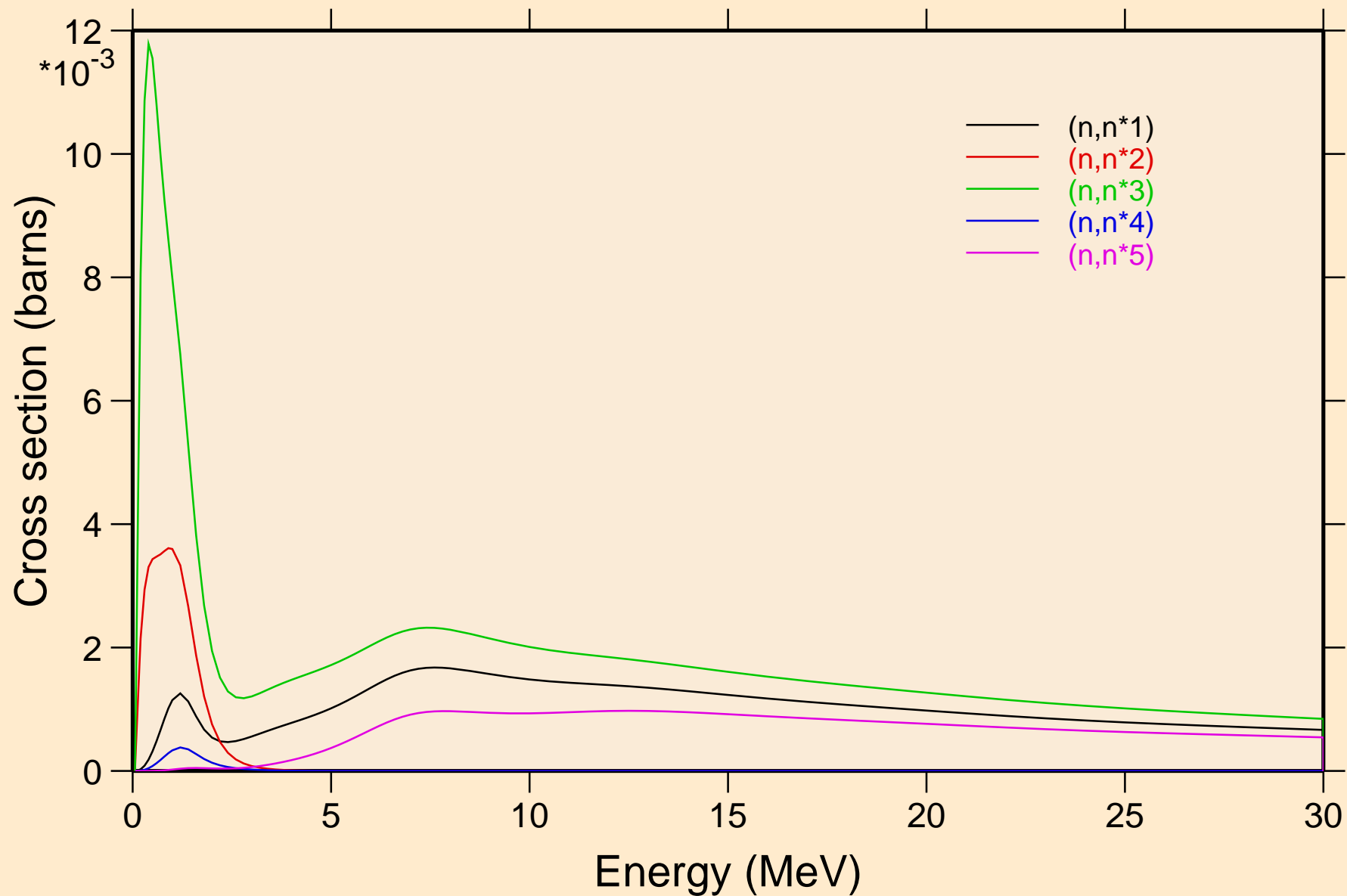

AC236 NEUTRON ACER TENDL-2023 LIBRARY; T=0.K
Inelastic levels

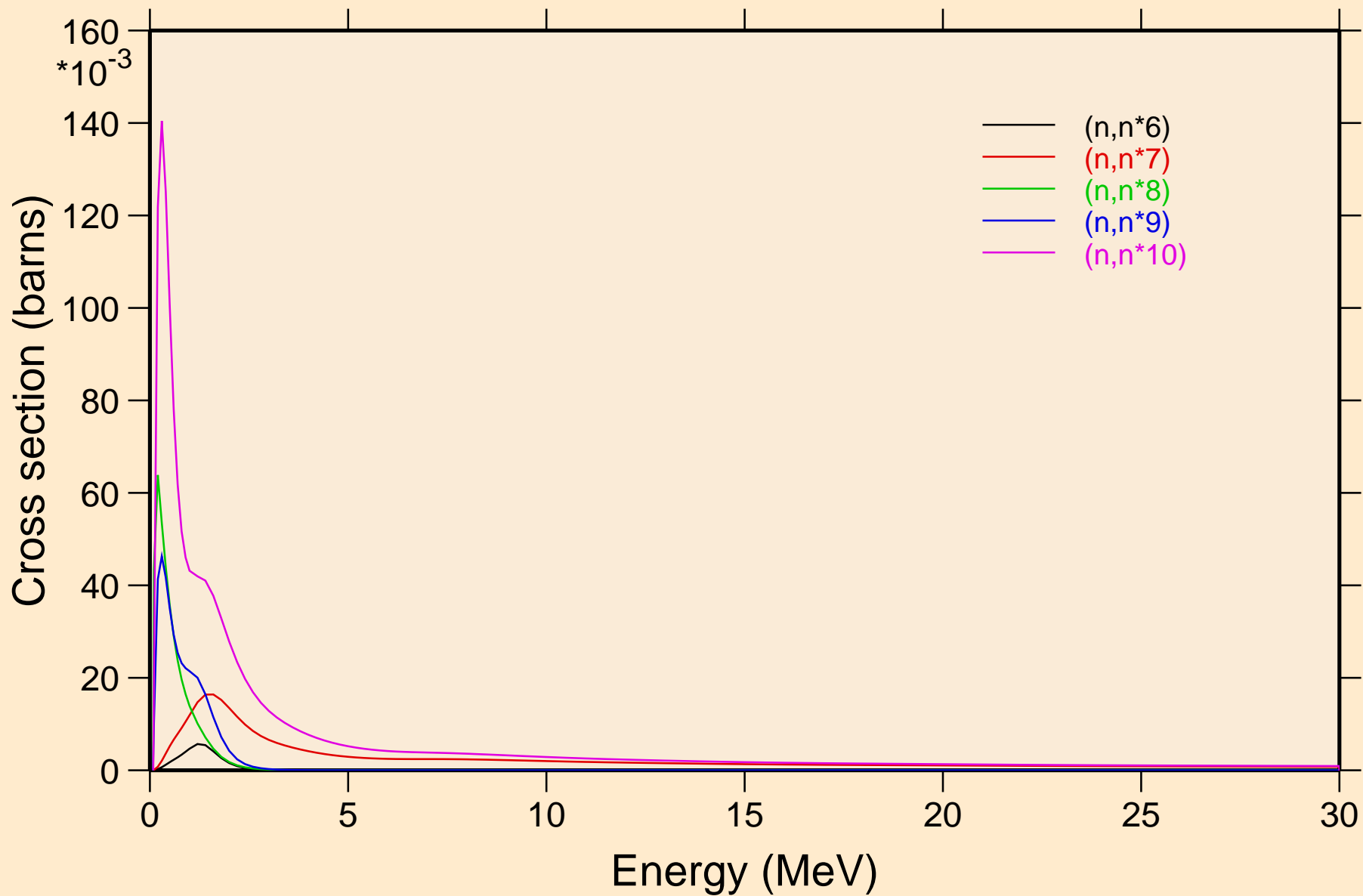

AC236 NEUTRON ACER TENDL-2023 LIBRARY; T=0.K
Inelastic levels

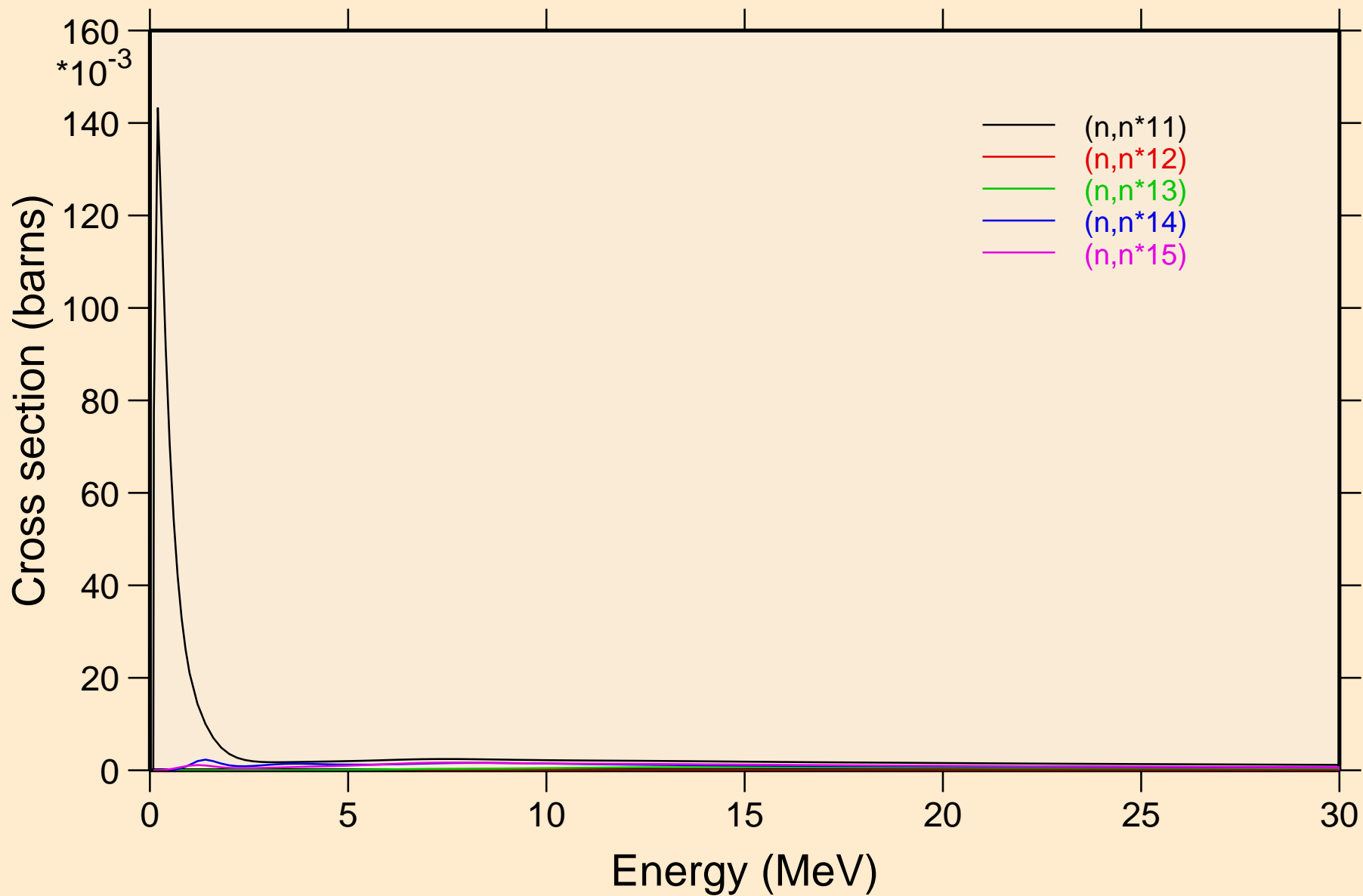

AC236 NEUTRON ACER TENDL-2023 LIBRARY; T=0.K
Inelastic levels

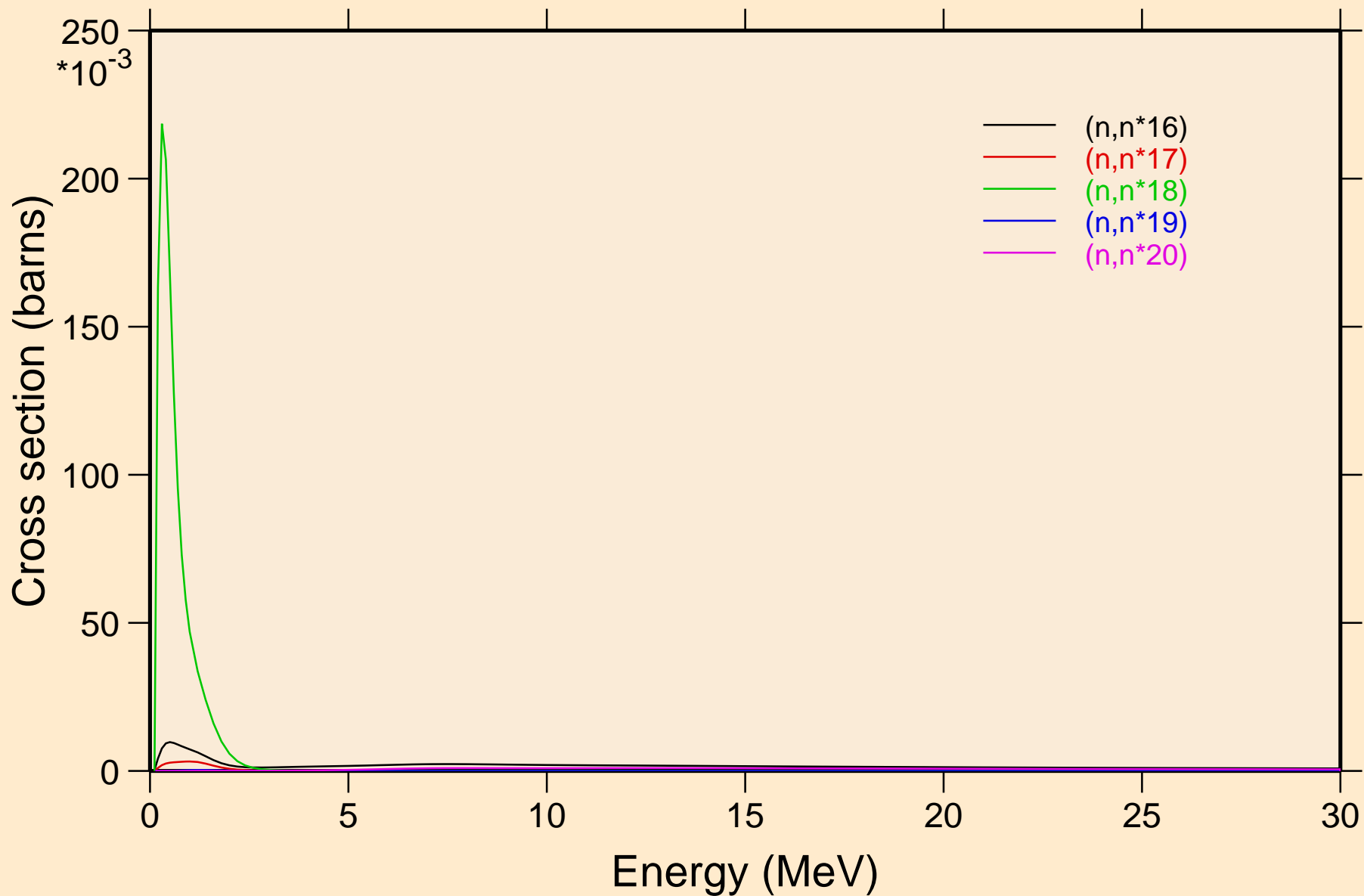

AC236 NEUTRON ACER TENDL-2023 LIBRARY; T=0.K
Inelastic levels

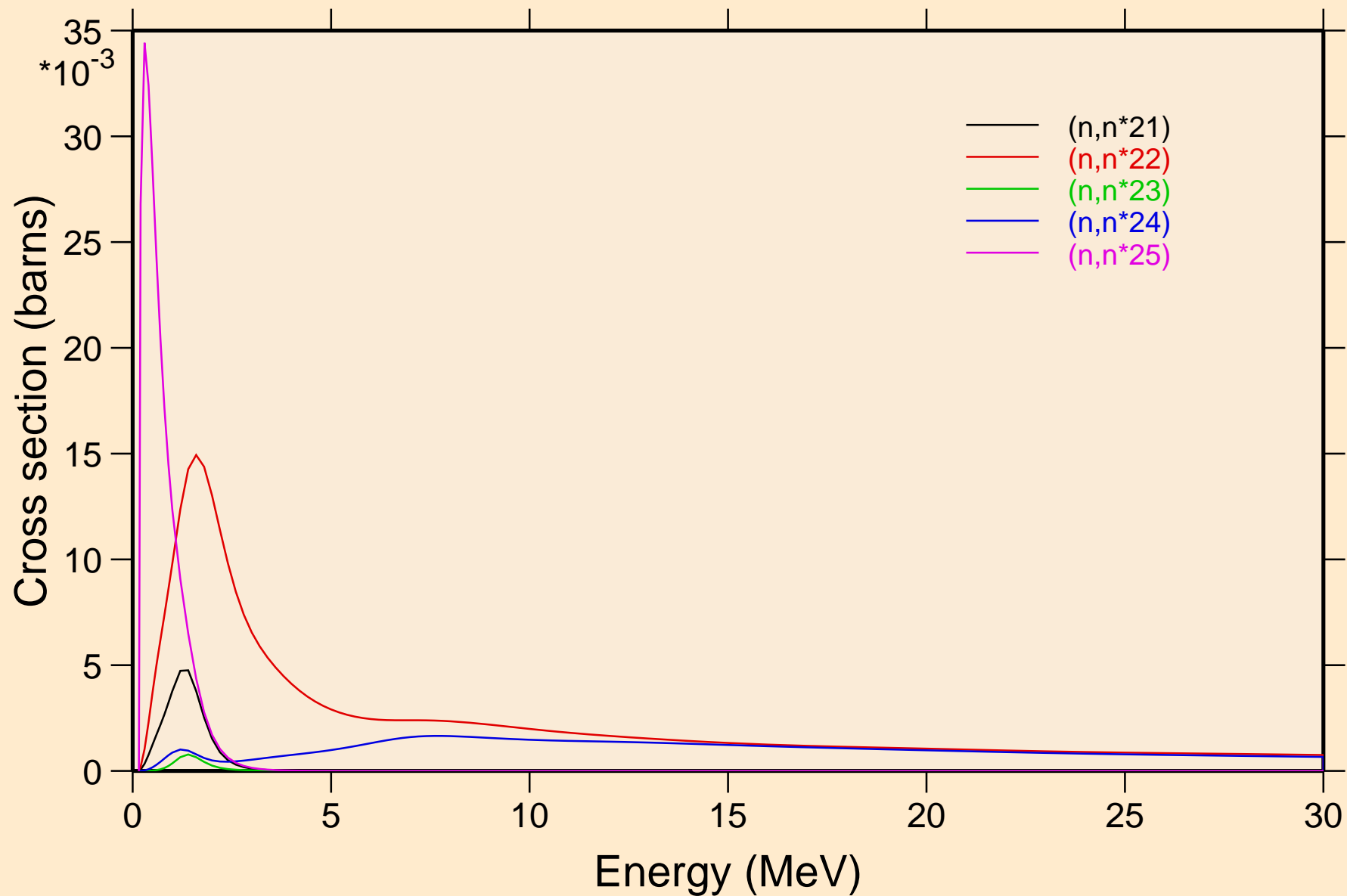

AC236 NEUTRON ACER TENDL-2023 LIBRARY; T=0.K
Inelastic levels

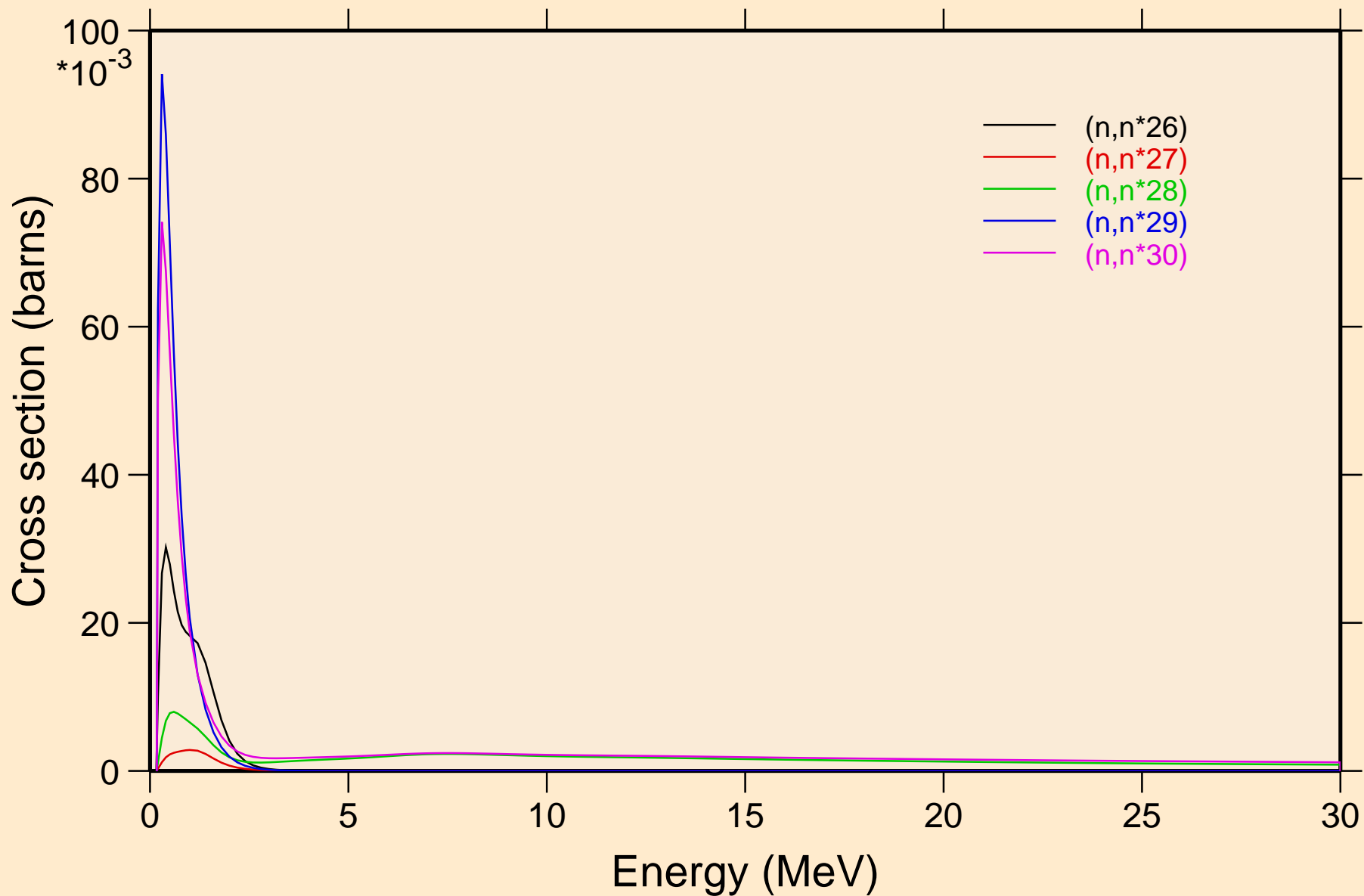

AC236 NEUTRON ACER TENDL-2023 LIBRARY; T=0.K
Threshold reactions

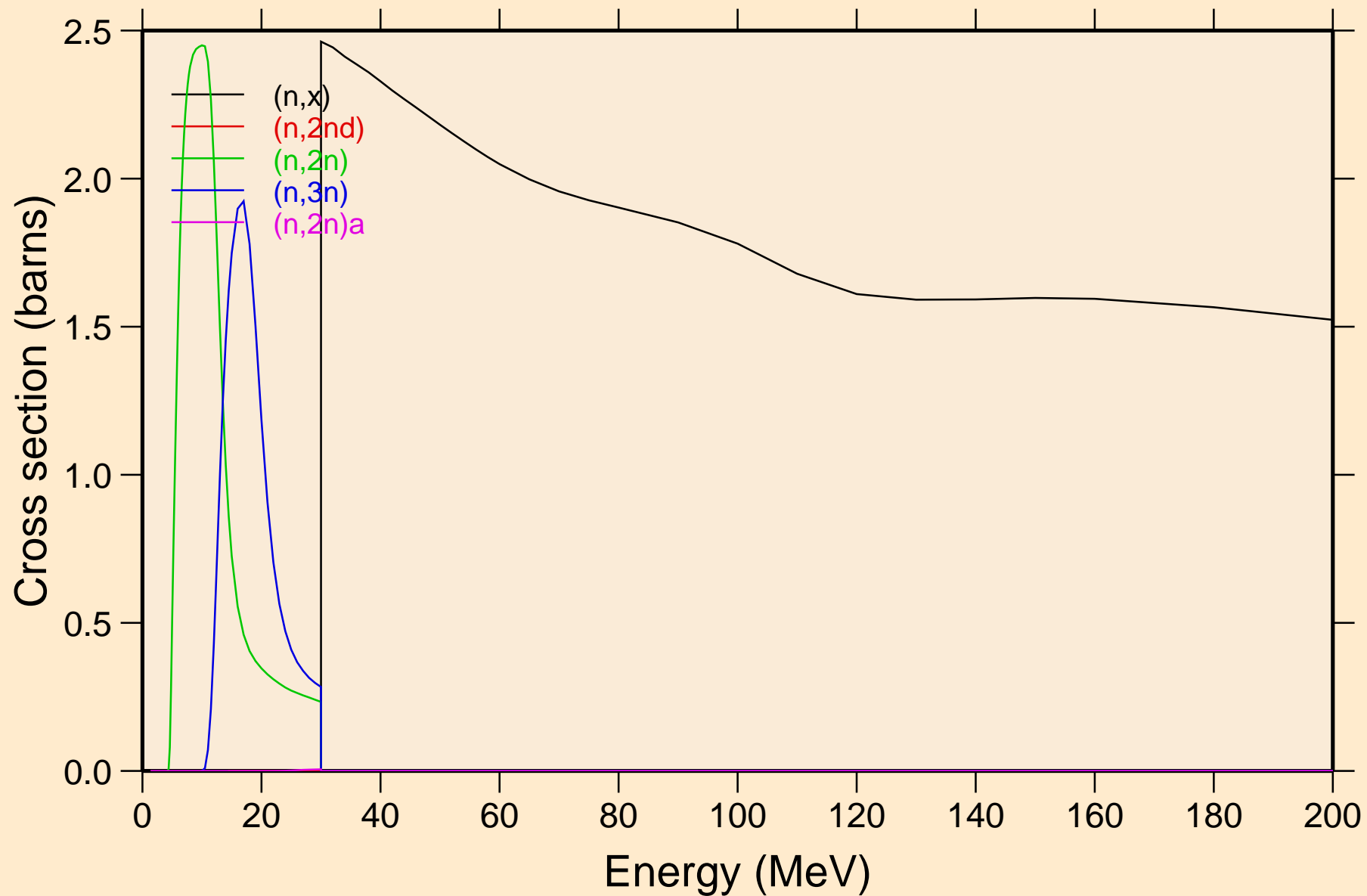

AC236 NEUTRON ACER TENDL-2023 LIBRARY; T=0.K
Threshold reactions

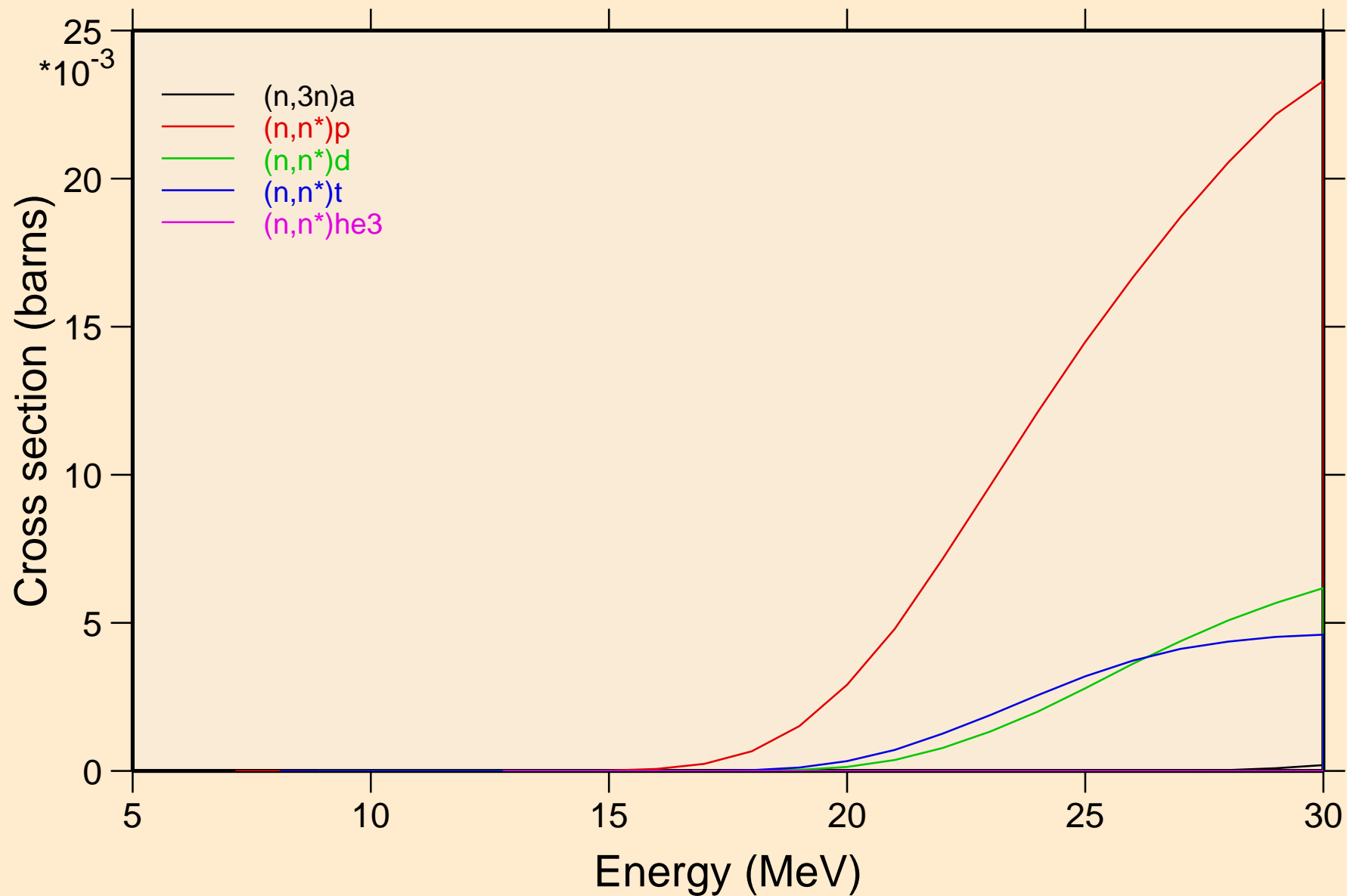

AC236 NEUTRON ACER TENDL-2023 LIBRARY; T=0.K
Threshold reactions

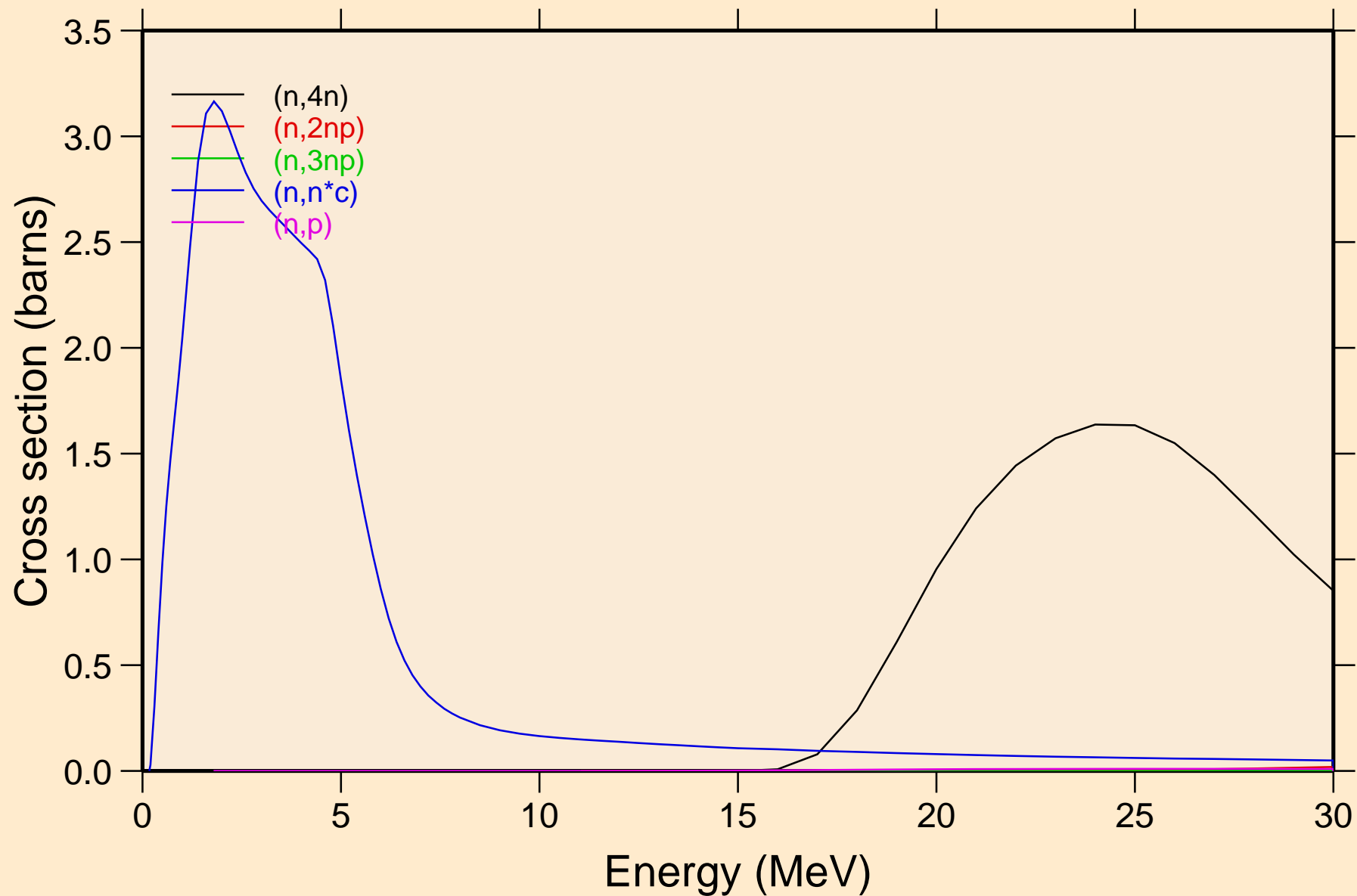

AC236 NEUTRON ACER TENDL-2023 LIBRARY; T=0.K
Threshold reactions

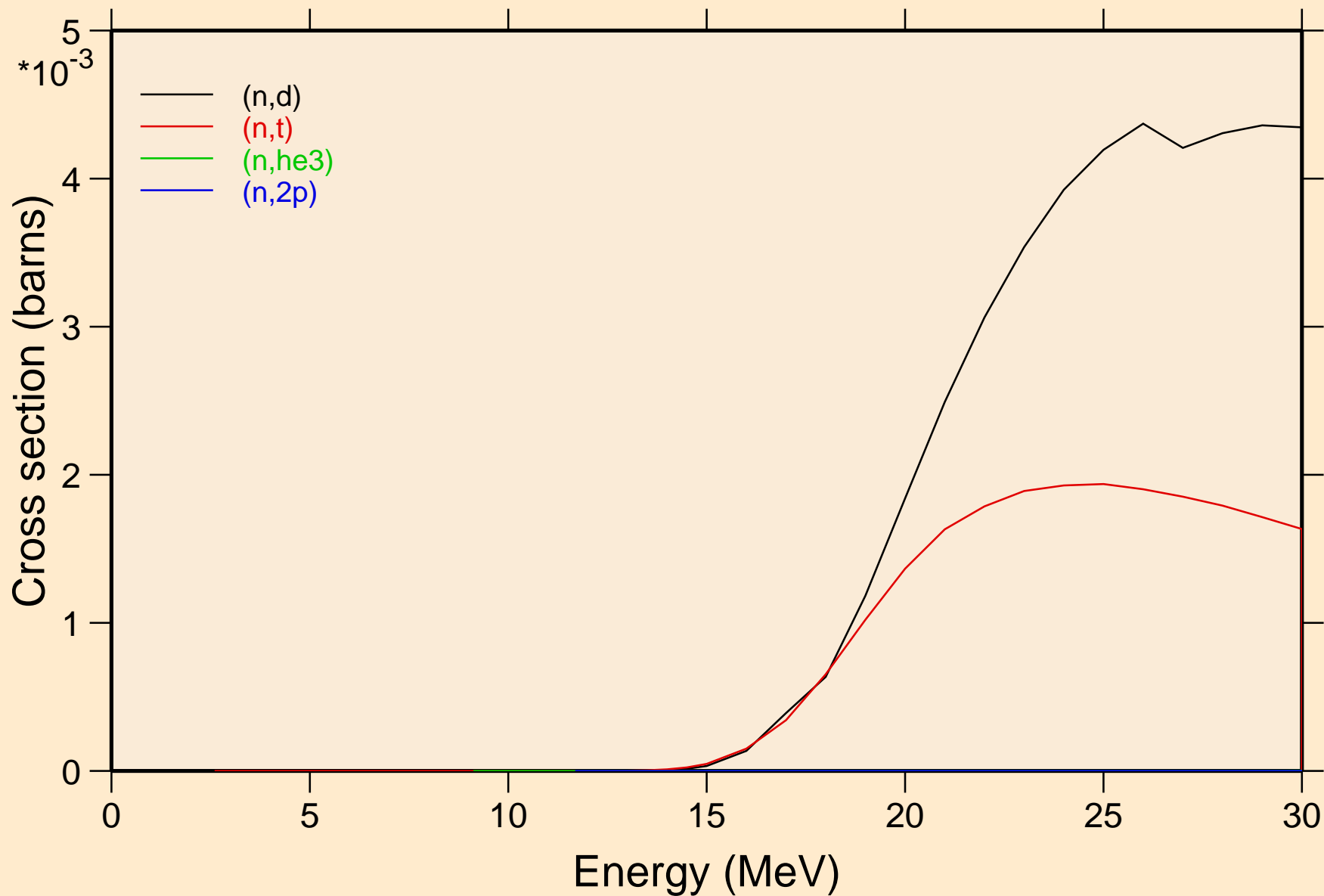

AC236 NEUTRON ACER TENDL-2023 LIBRARY; T=0.K
Threshold reactions

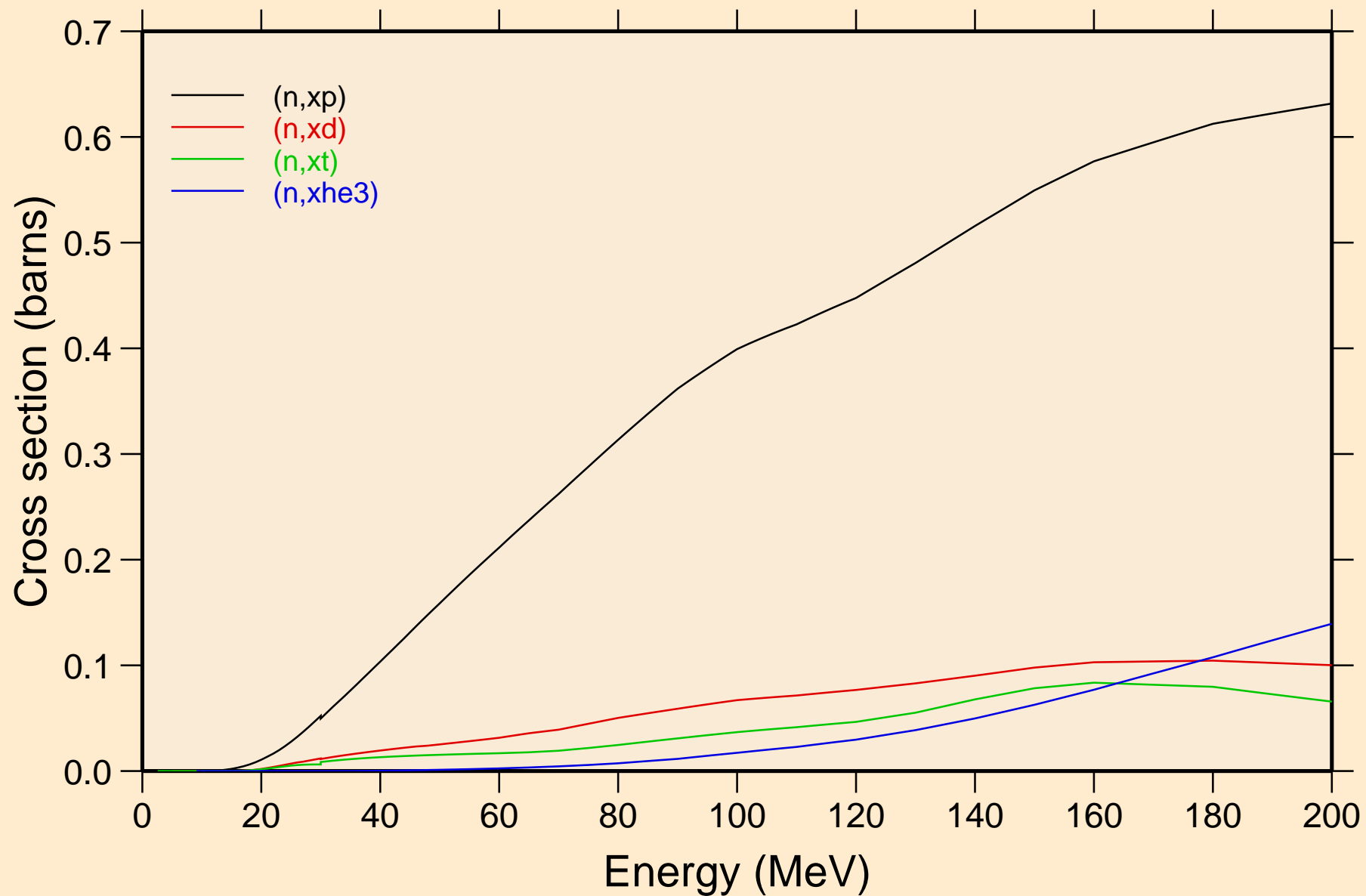

AC236 NEUTRON ACER TENDL-2023 LIBRARY; T=0.K
angular distribution for elastic

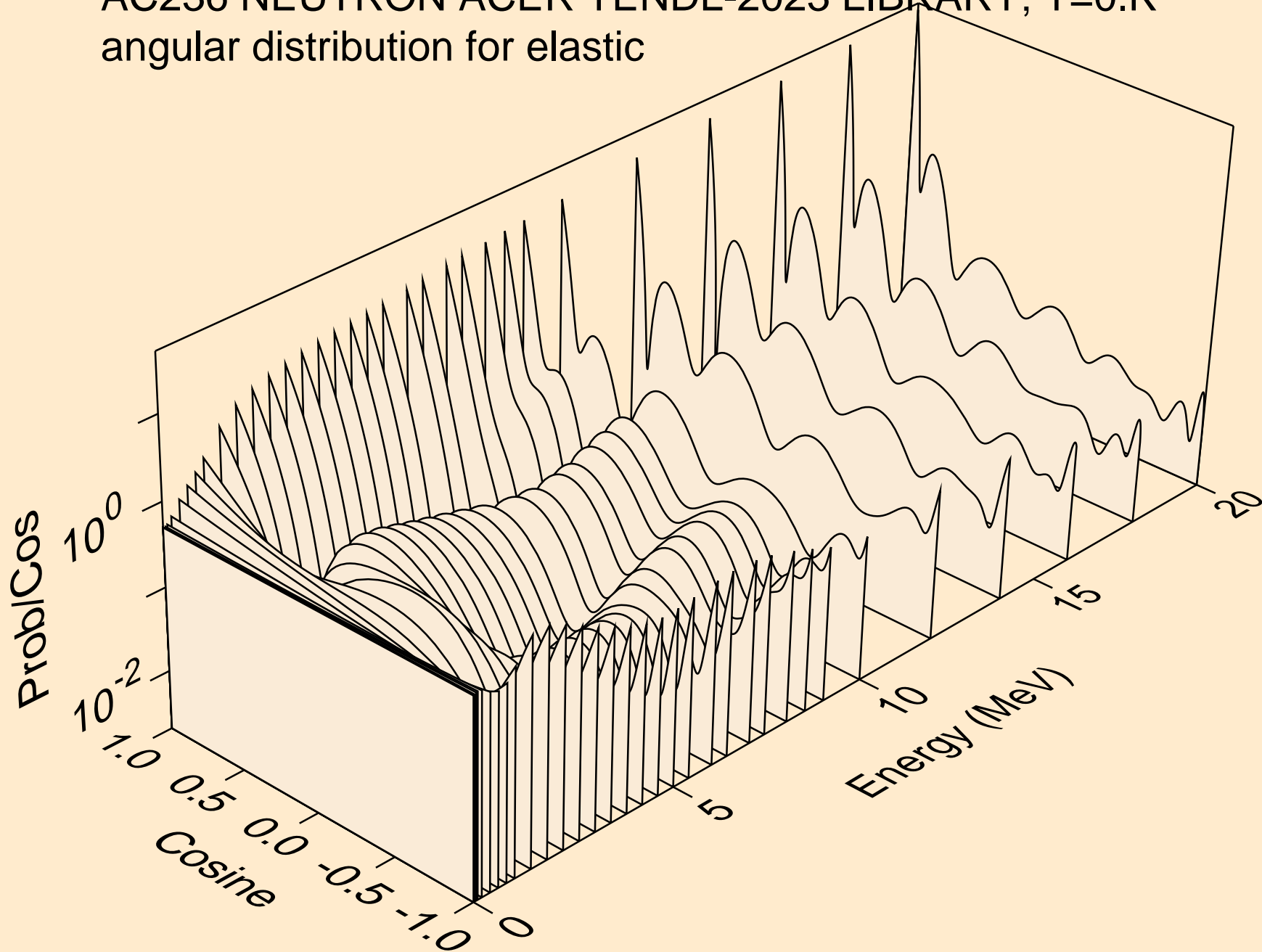

AC236 NEUTRON ACER TENDL-2023 LIBRARY; T=0.K
angular distribution for elastic

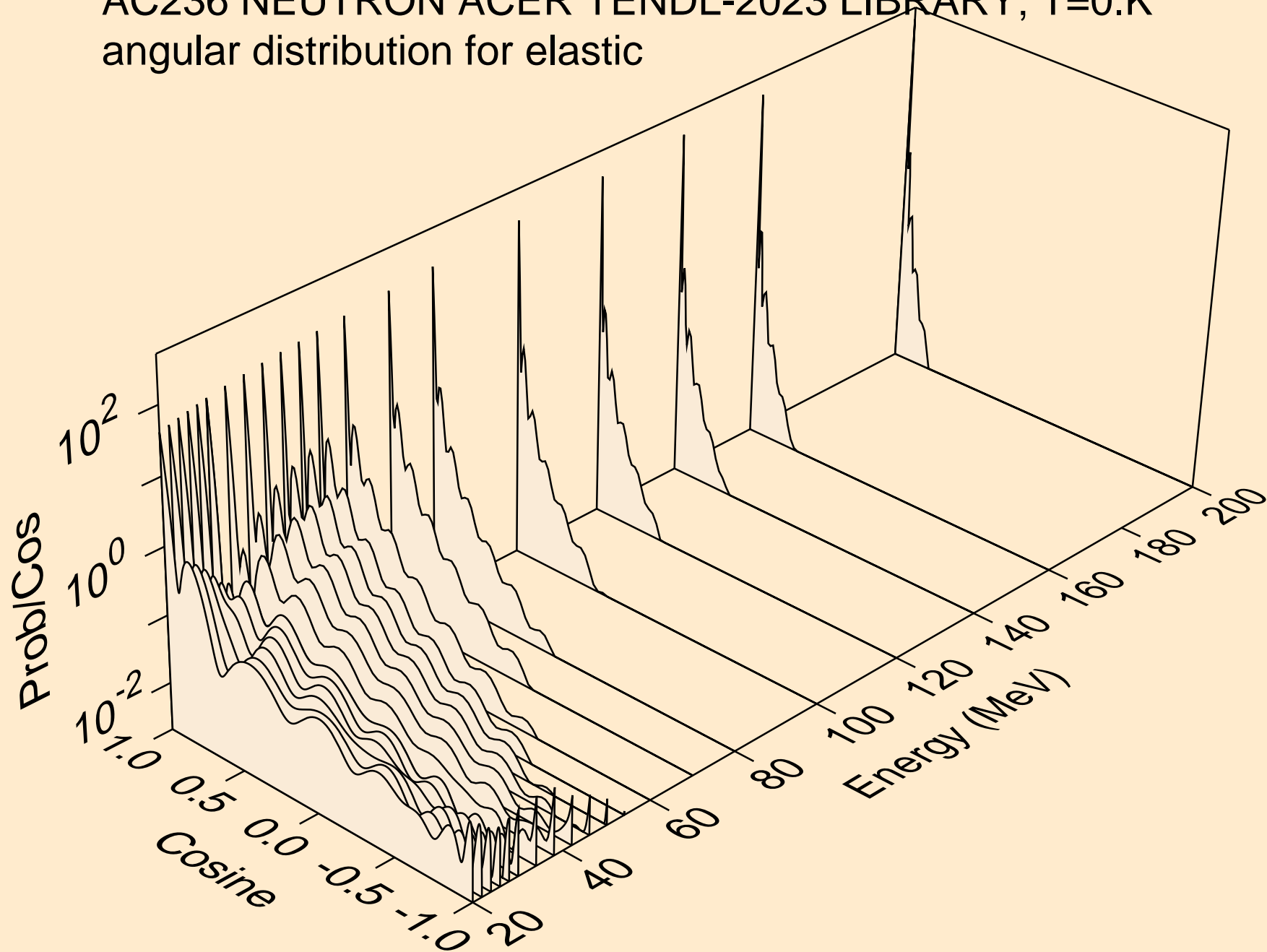

AC236 NEUTRON ACER TENDL-2023 LIBRARY; T=0.K
angular distribution for (n,n*1)

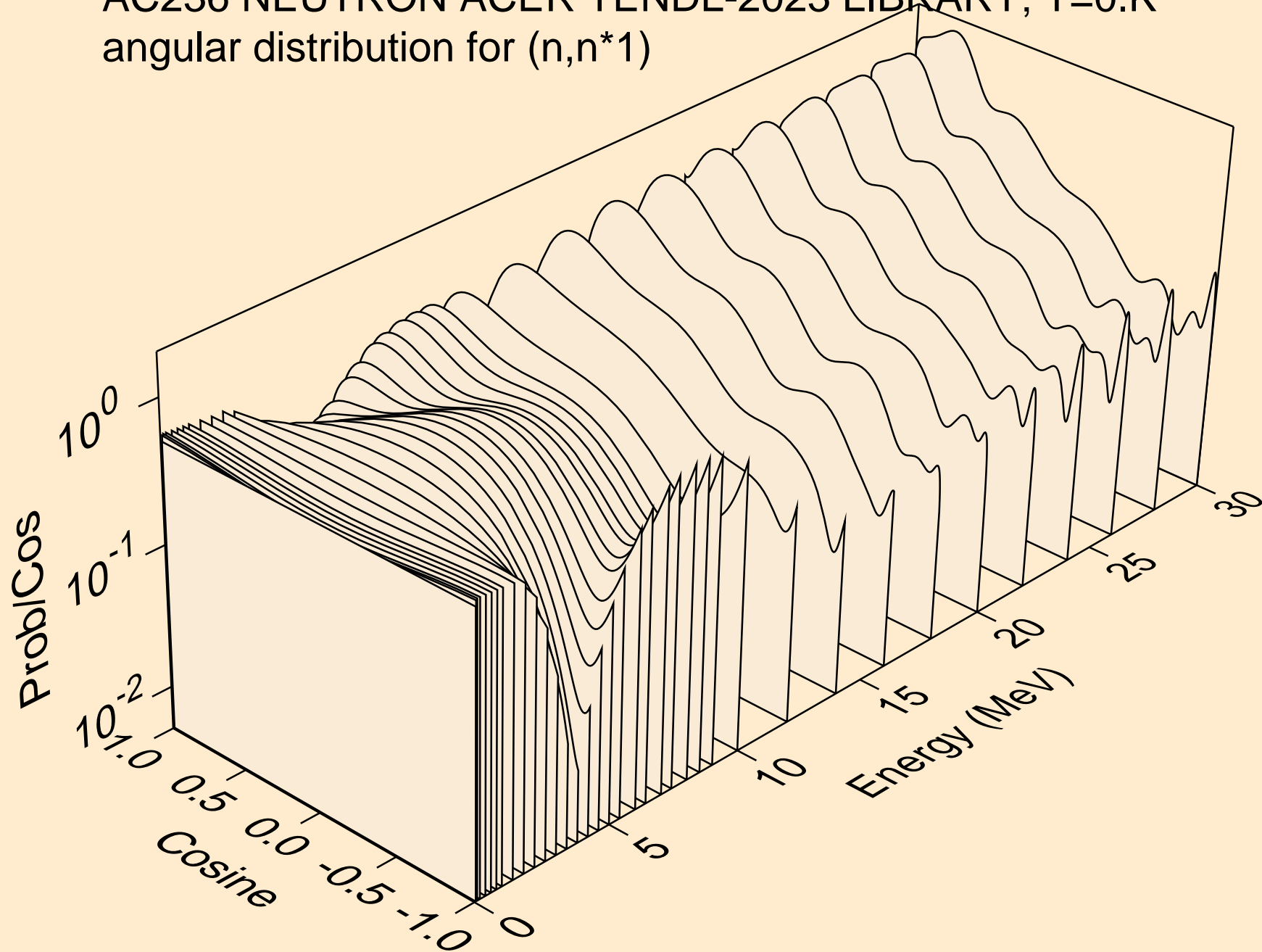

AC236 NEUTRON ACER TENDL-2023 LIBRARY; T=0.K
angular distribution for (n,n*2)

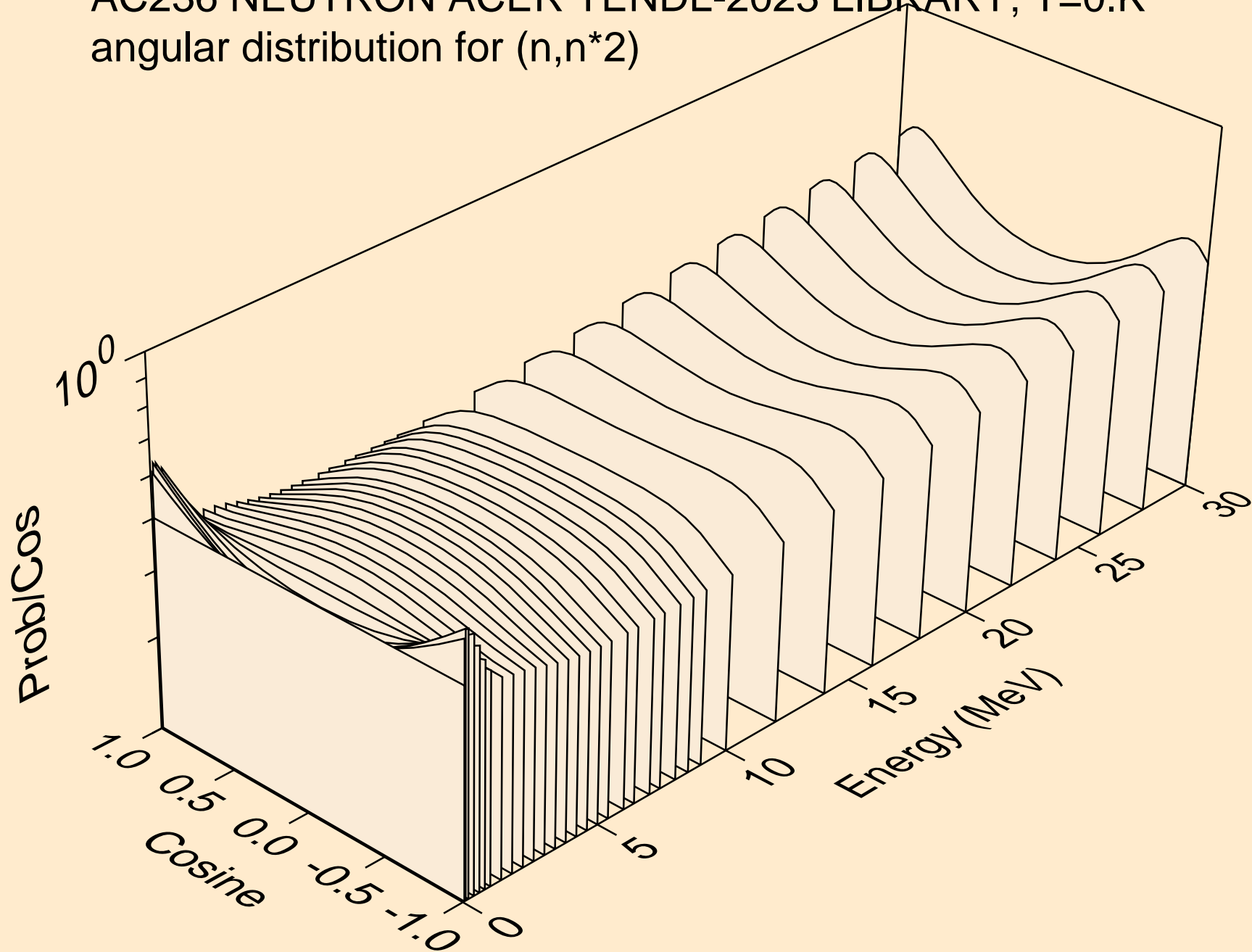

AC236 NEUTRON ACER TENDL-2023 LIBRARY; T=0.K
angular distribution for (n,n*3)

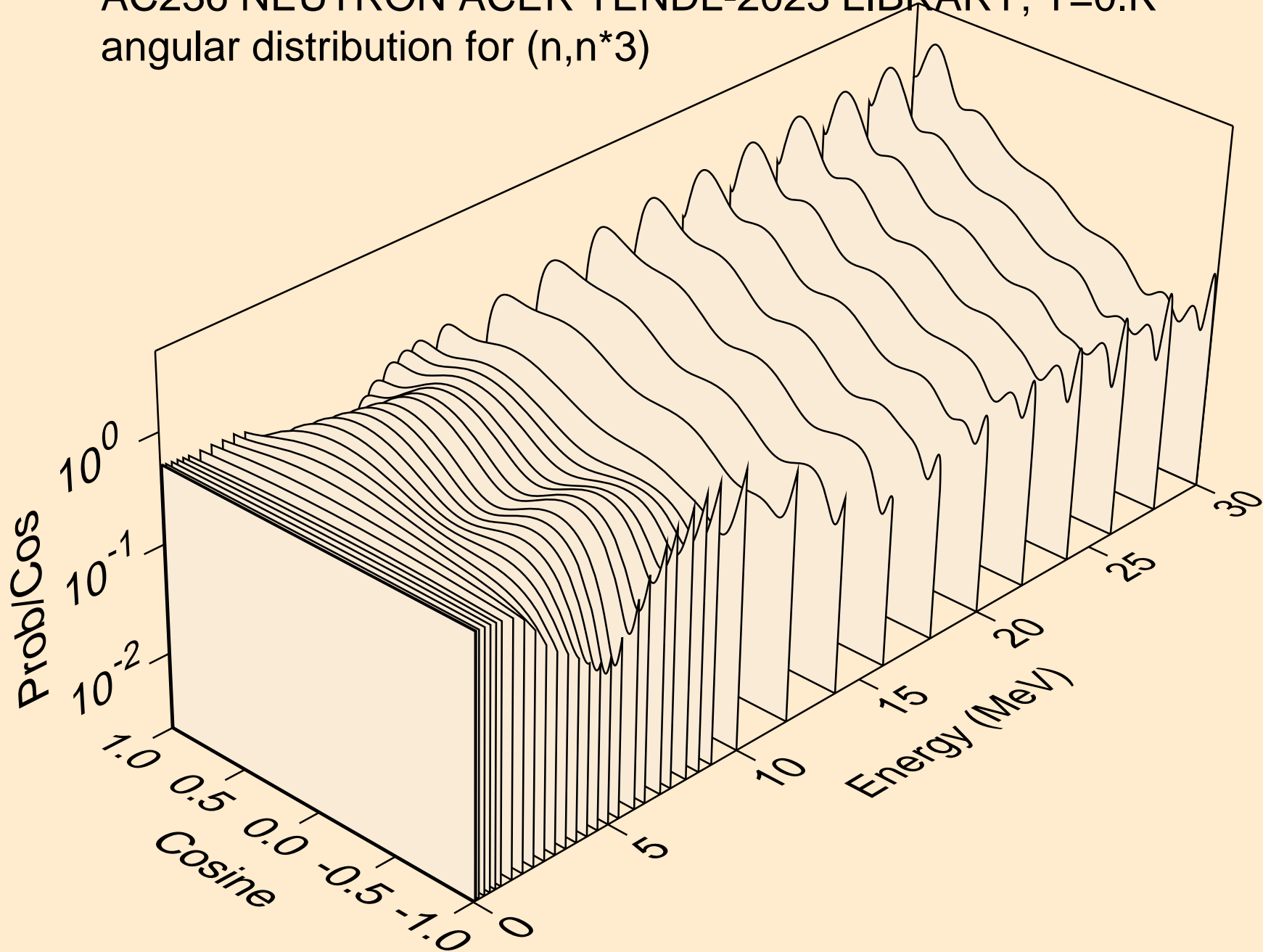

AC236 NEUTRON ACER TENDL-2023 LIBRARY; T=0.K
angular distribution for (n,n*4)

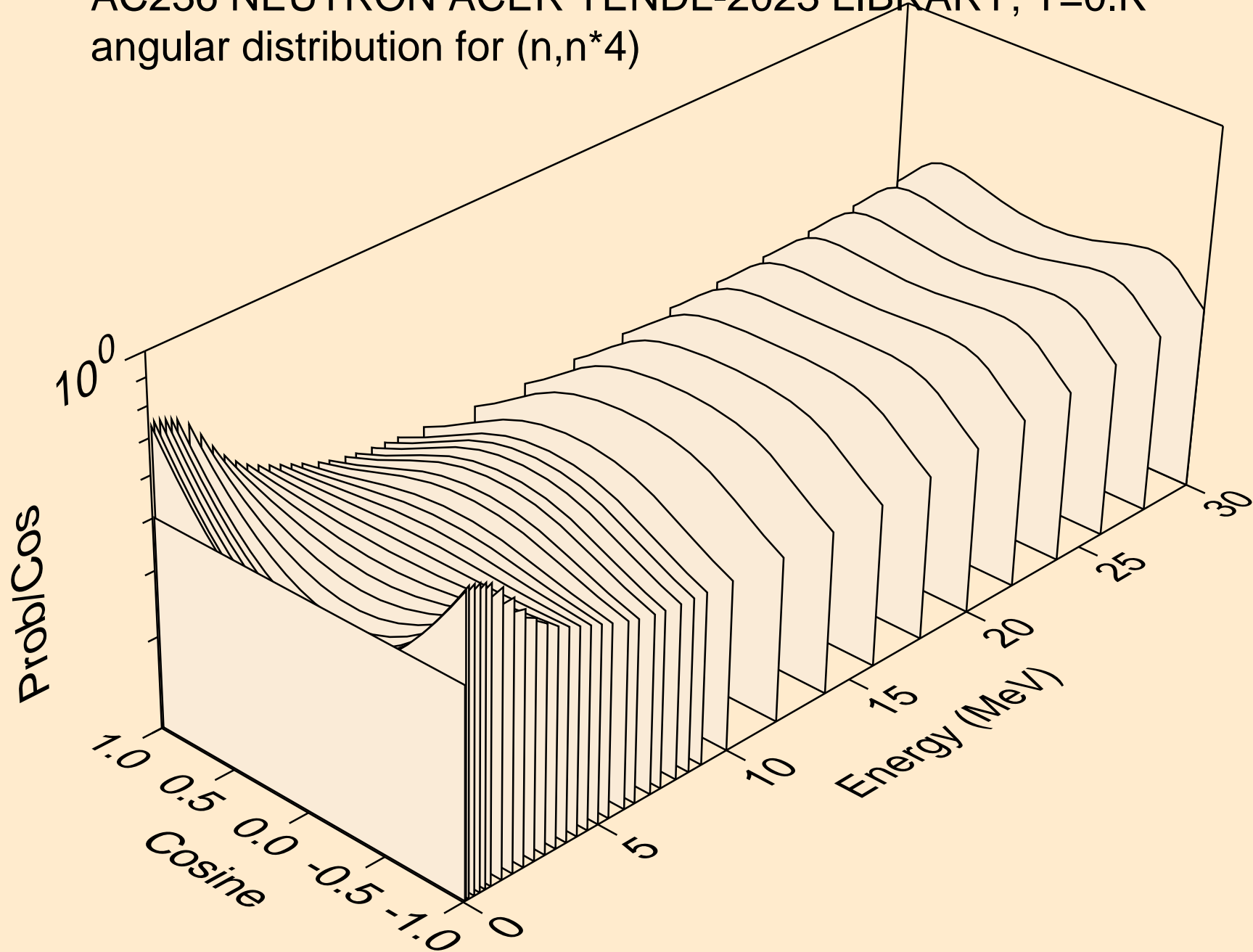

AC236 NEUTRON ACER TENDL-2023 LIBRARY; T=0.K
angular distribution for (n,n*5)

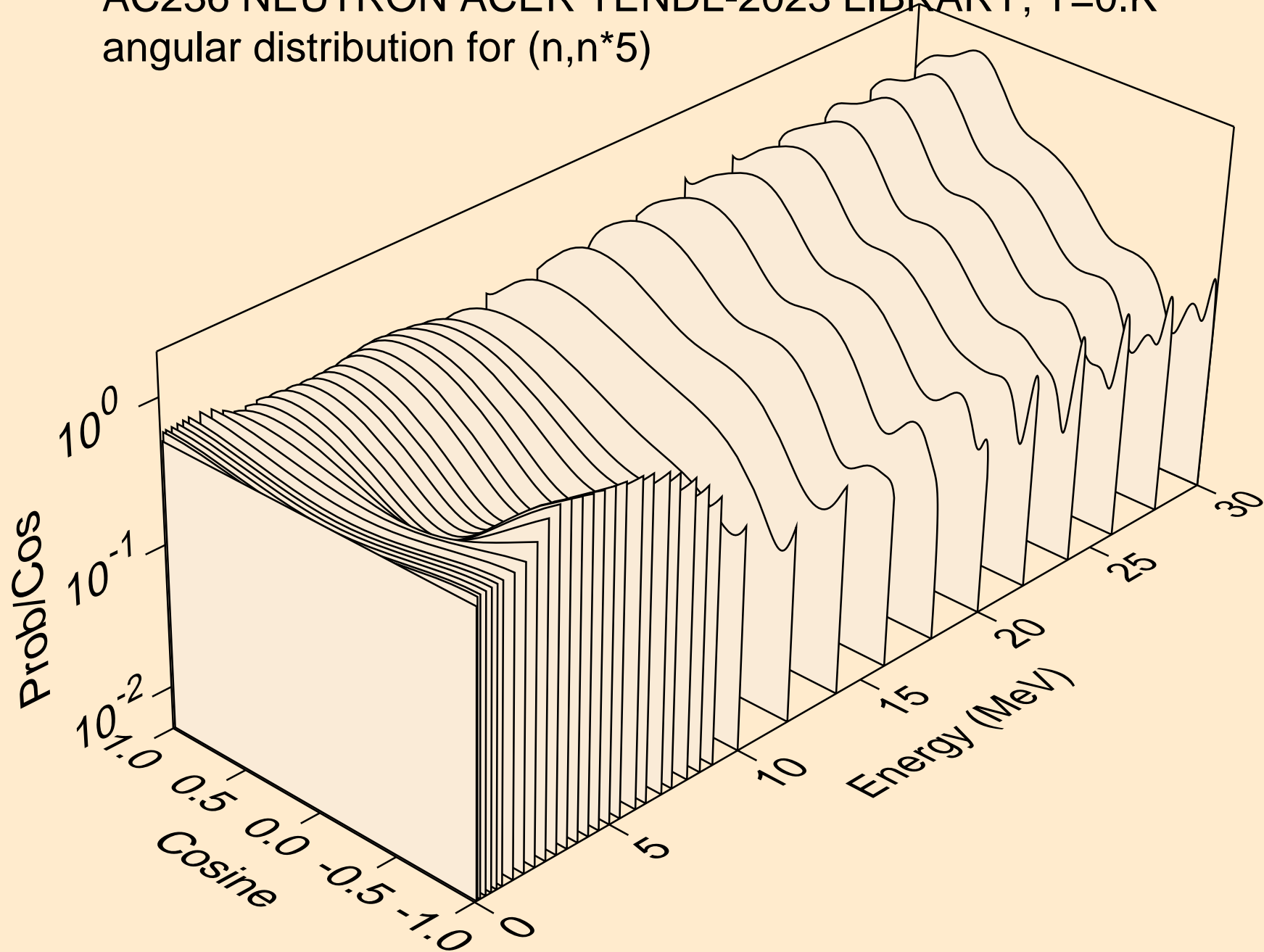

AC236 NEUTRON ACER TENDL-2023 LIBRARY; T=0.K
angular distribution for (n,n*6)

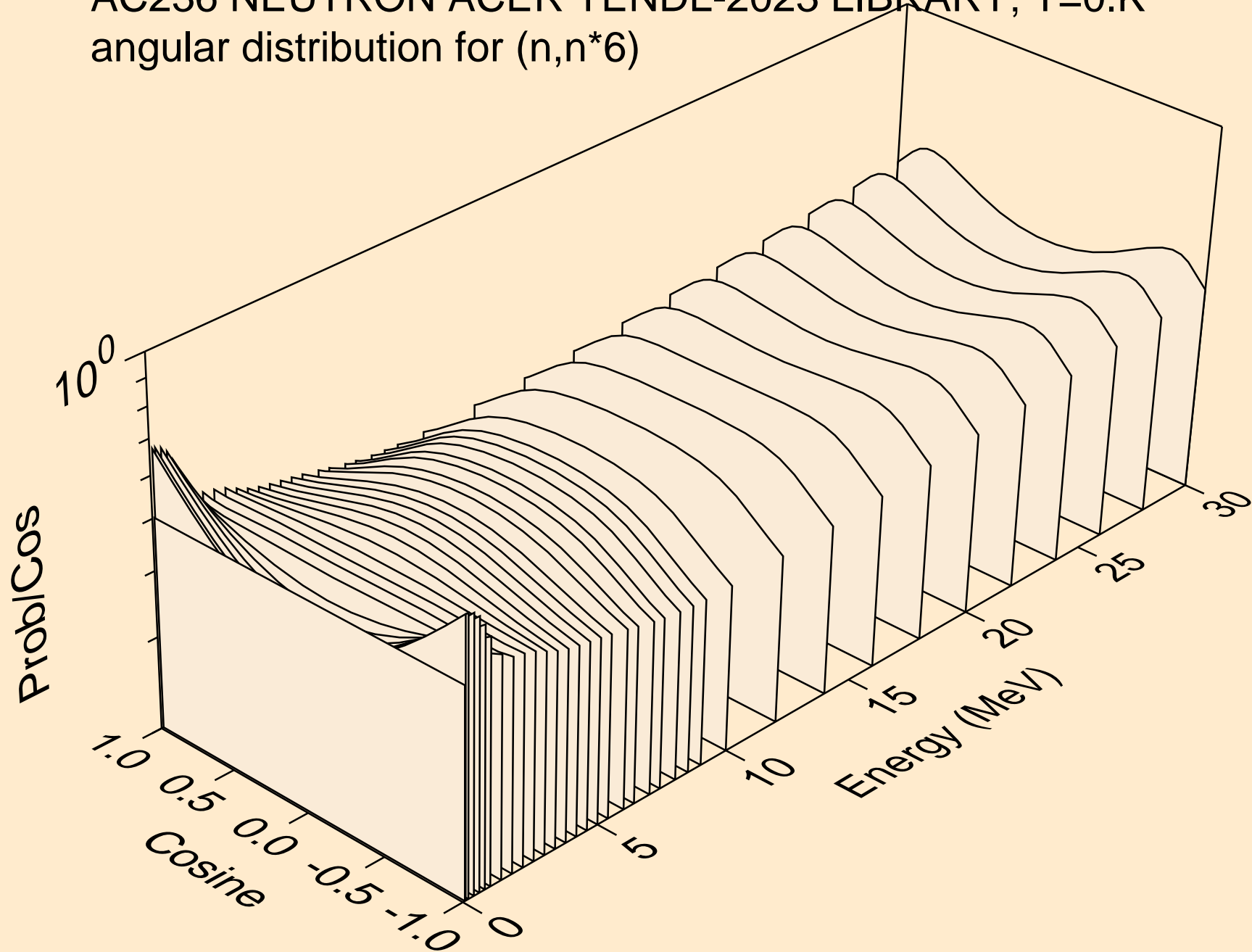

AC236 NEUTRON ACER TENDL-2023 LIBRARY; T=0.K
angular distribution for (n,n*7)

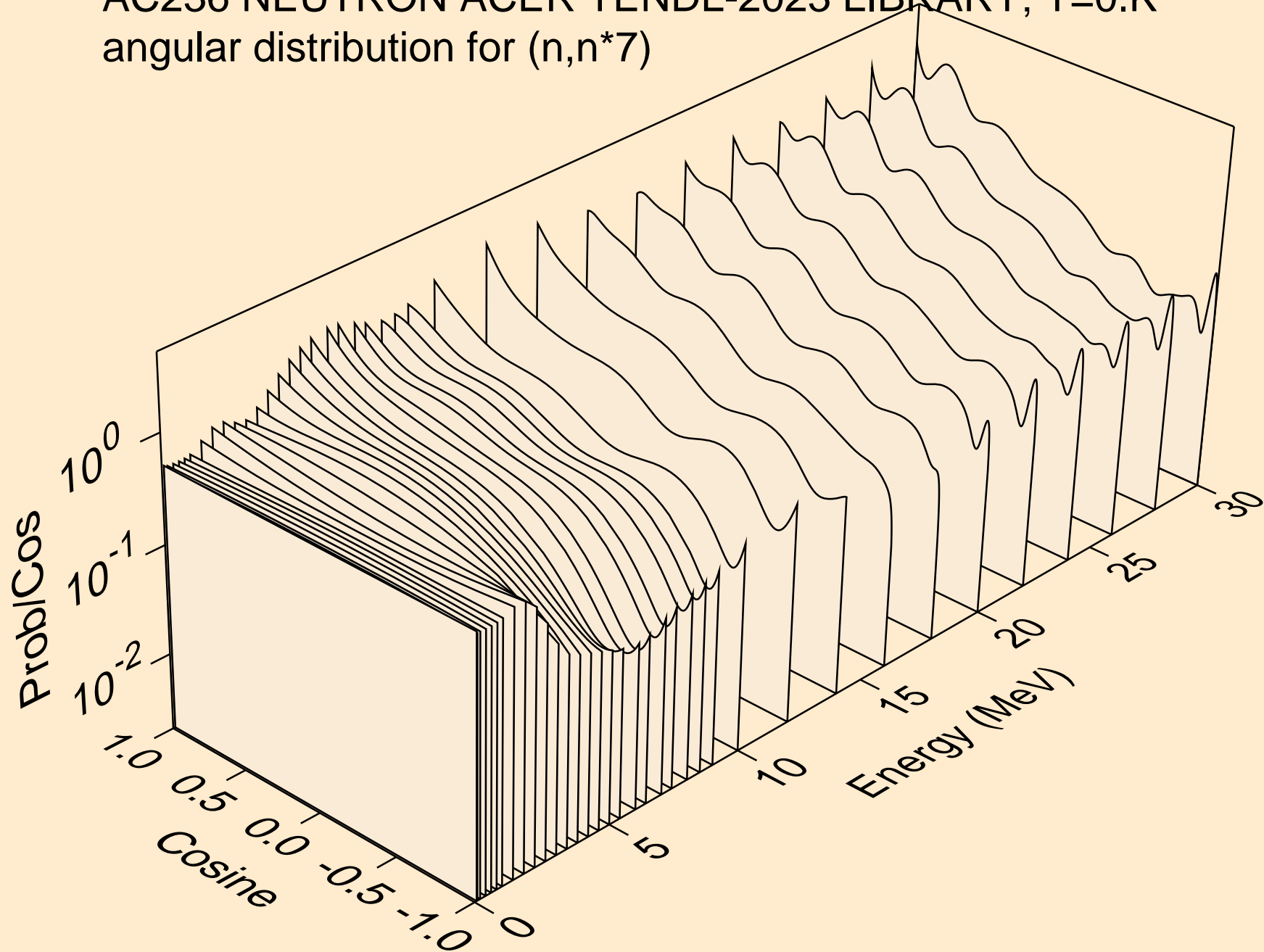

AC236 NEUTRON ACER TENDL-2023 LIBRARY; T=0.K
angular distribution for (n,n*8)

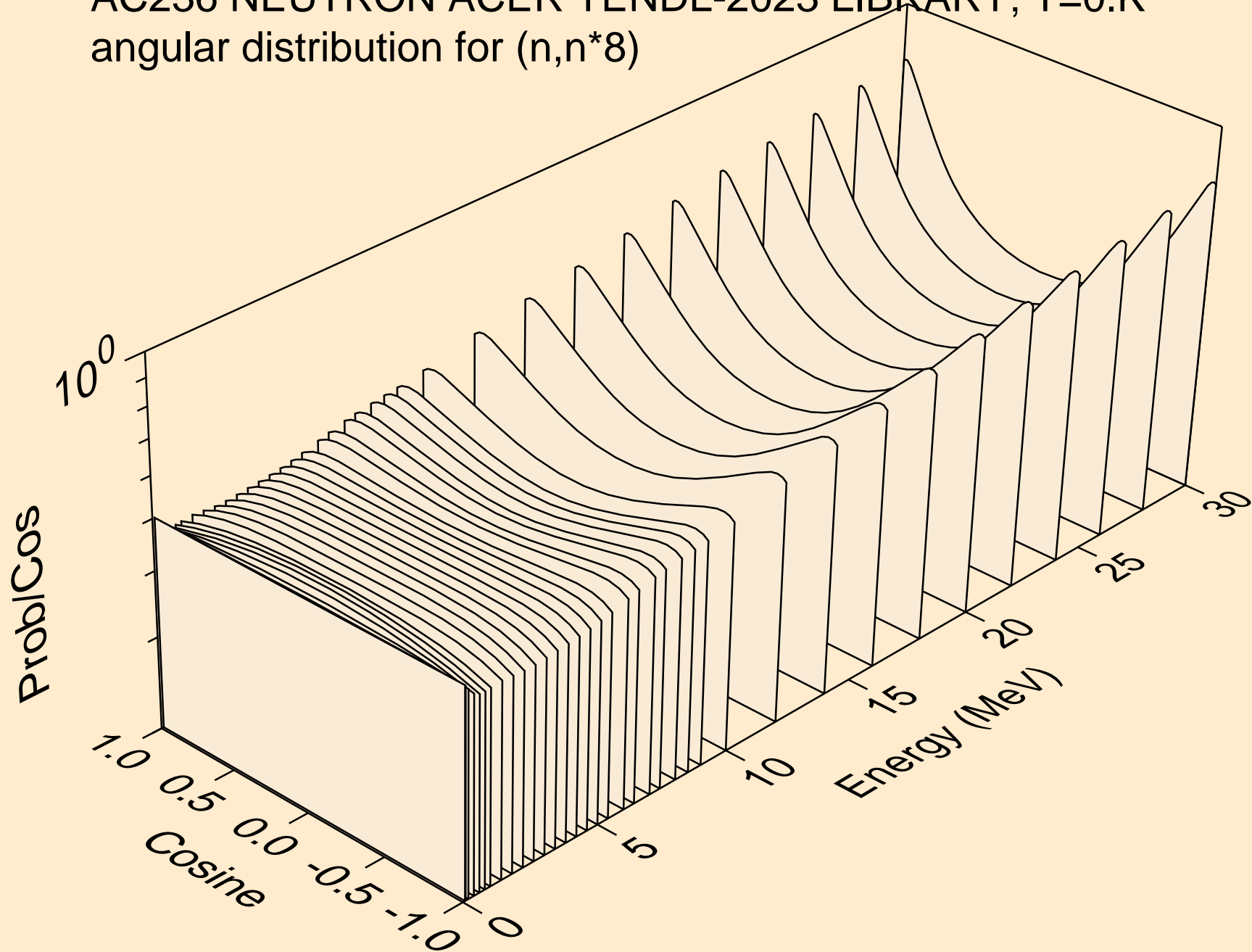

AC236 NEUTRON ACER TENDL-2023 LIBRARY; T=0.K
angular distribution for (n,n*9)

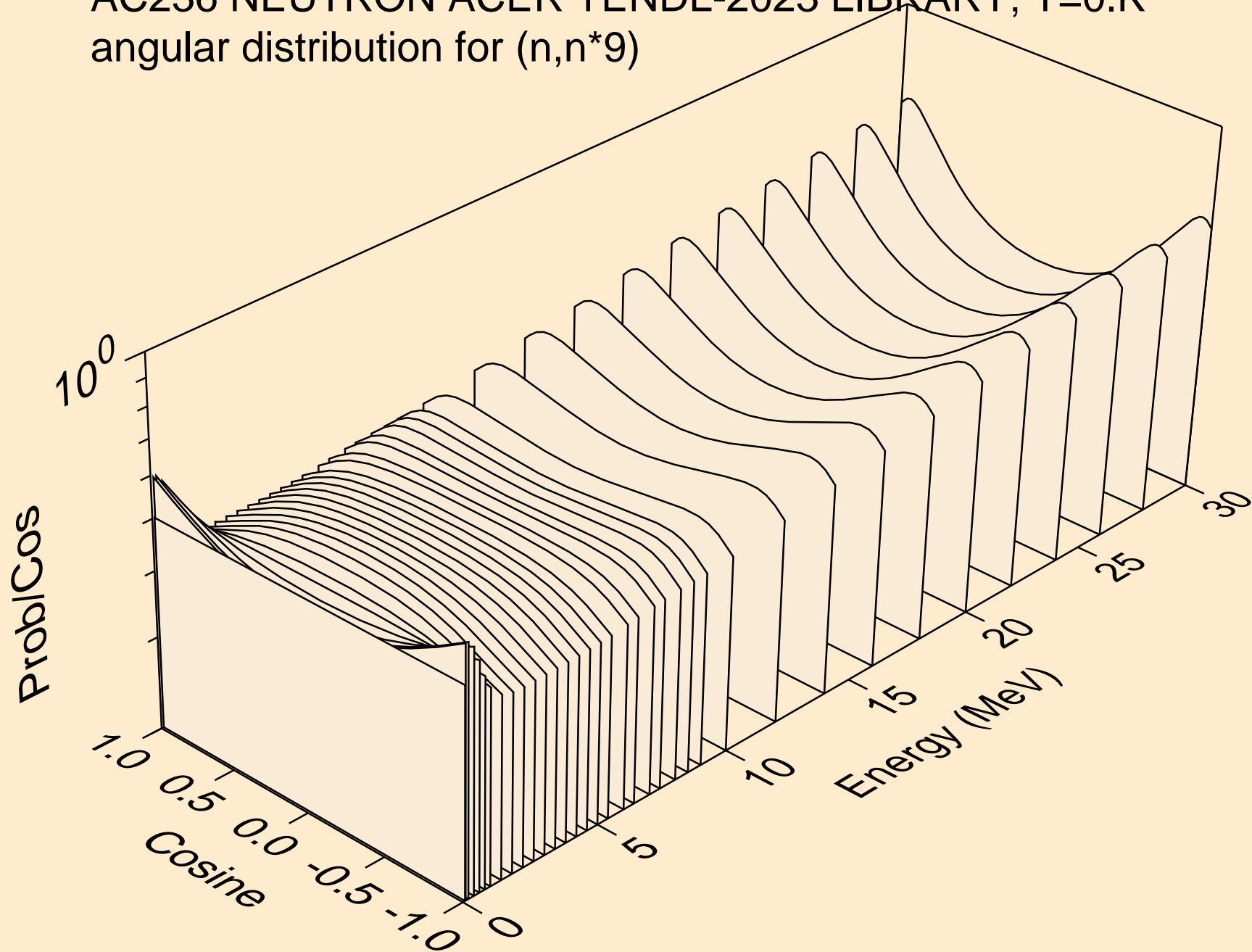

AC236 NEUTRON ACER TENDL-2023 LIBRARY; T=0.K
angular distribution for (n,n*10)

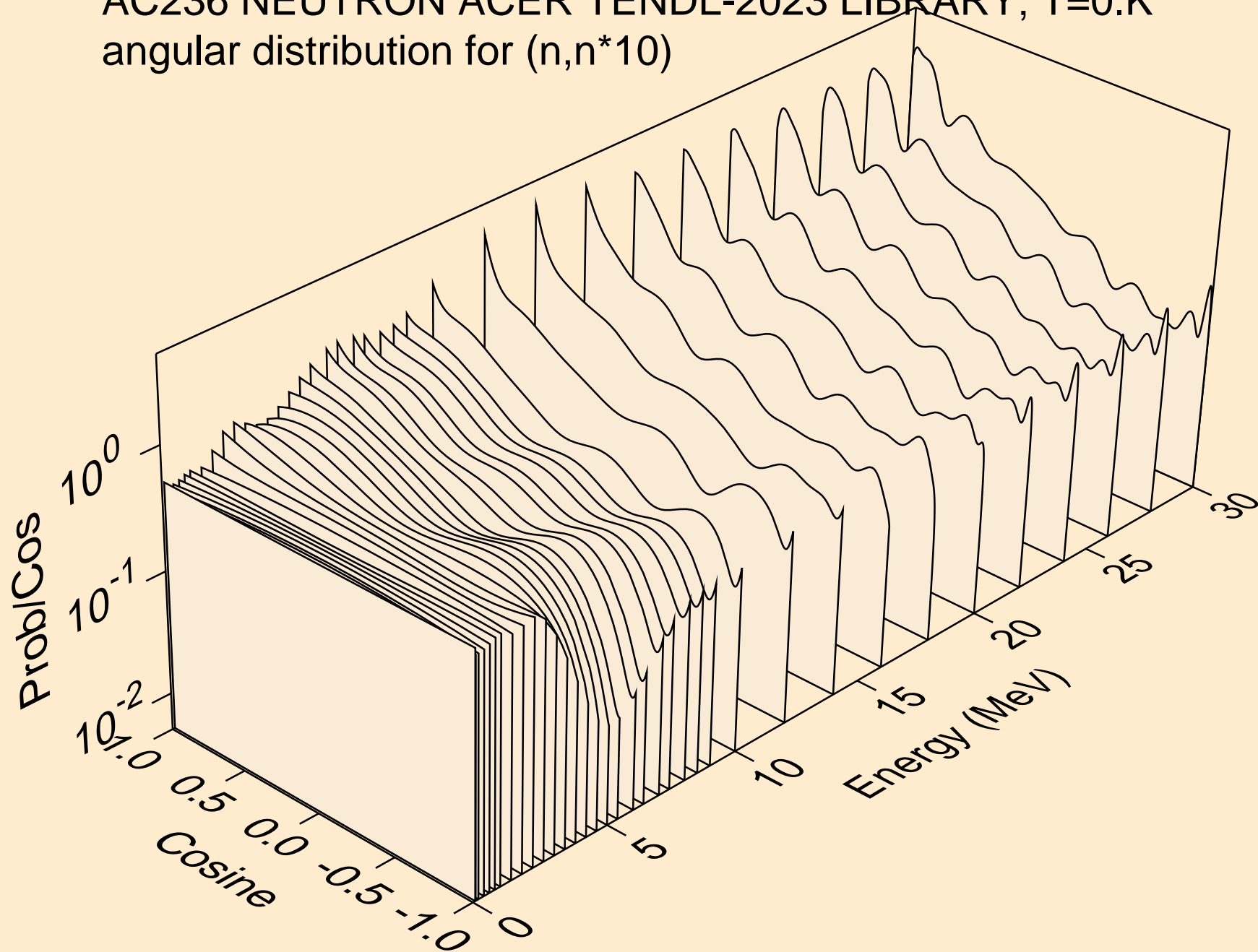

AC236 NEUTRON ACER TENDL-2023 LIBRARY; T=0.K
angular distribution for (n,n*11)

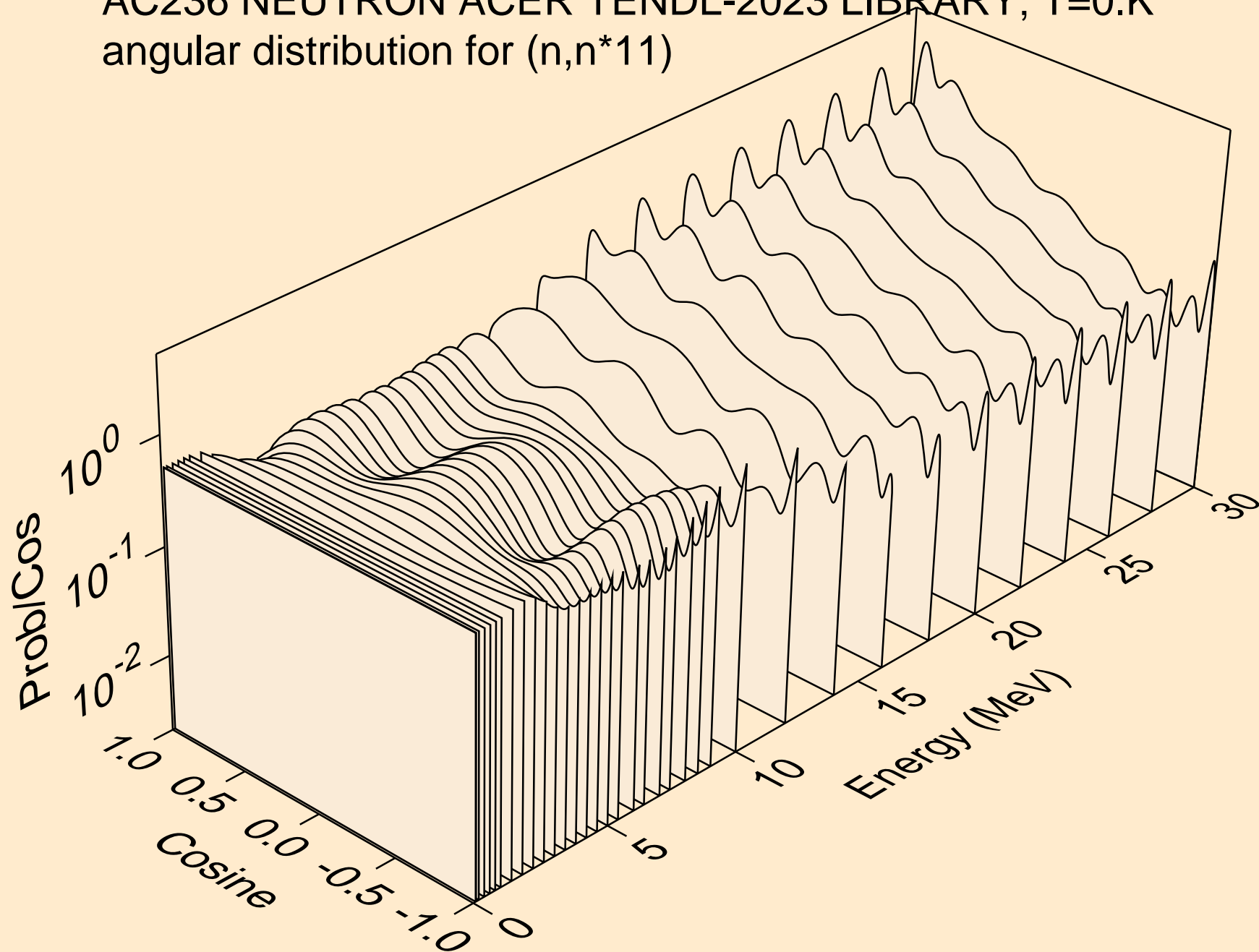

AC236 NEUTRON ACER TENDL-2023 LIBRARY; T=0.K
angular distribution for (n,n*12)

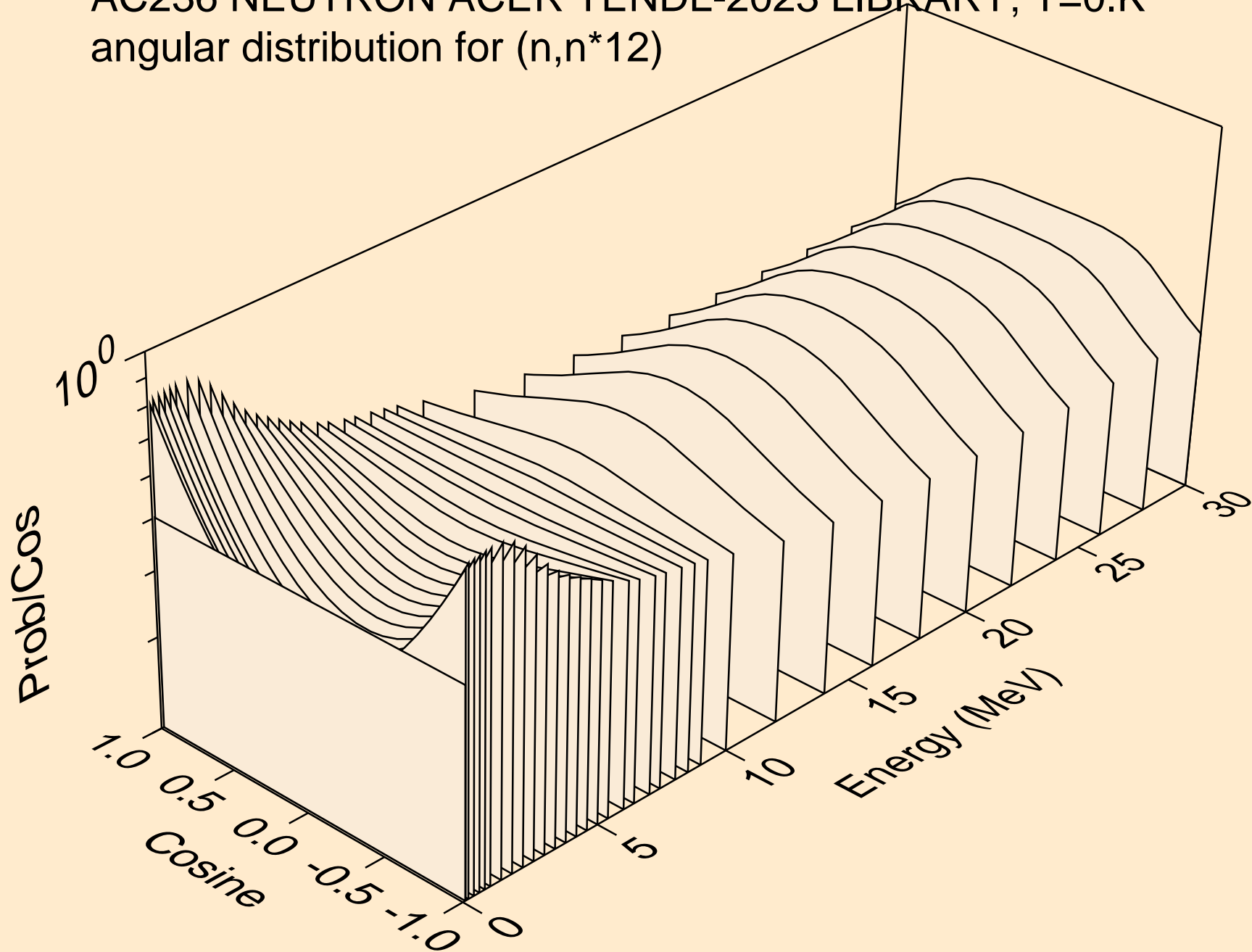

AC236 NEUTRON ACER TENDL-2023 LIBRARY; T=0.K
angular distribution for (n,n*13)

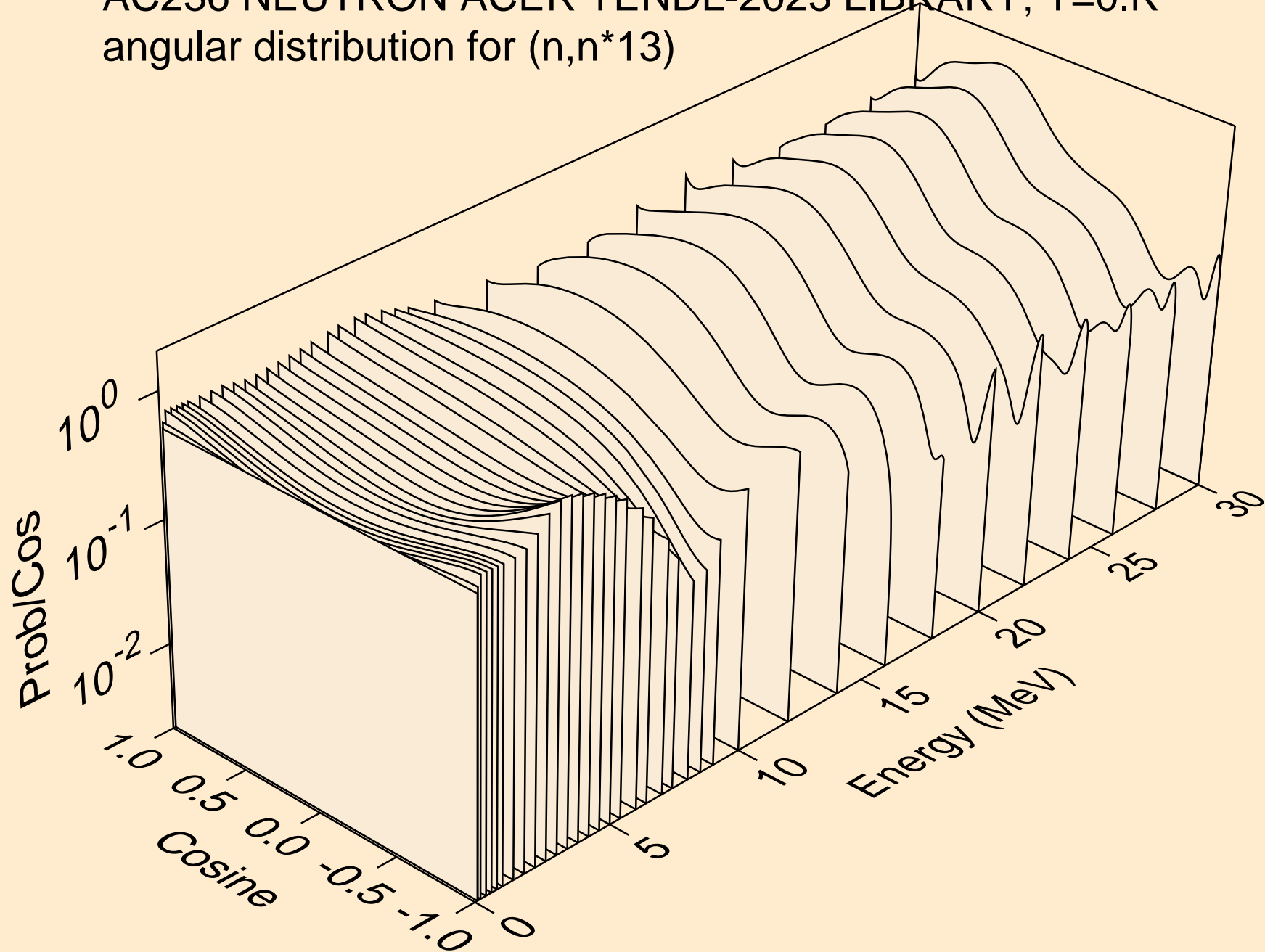

AC236 NEUTRON ACER TENDL-2023 LIBRARY; T=0.K
angular distribution for (n,n*14)

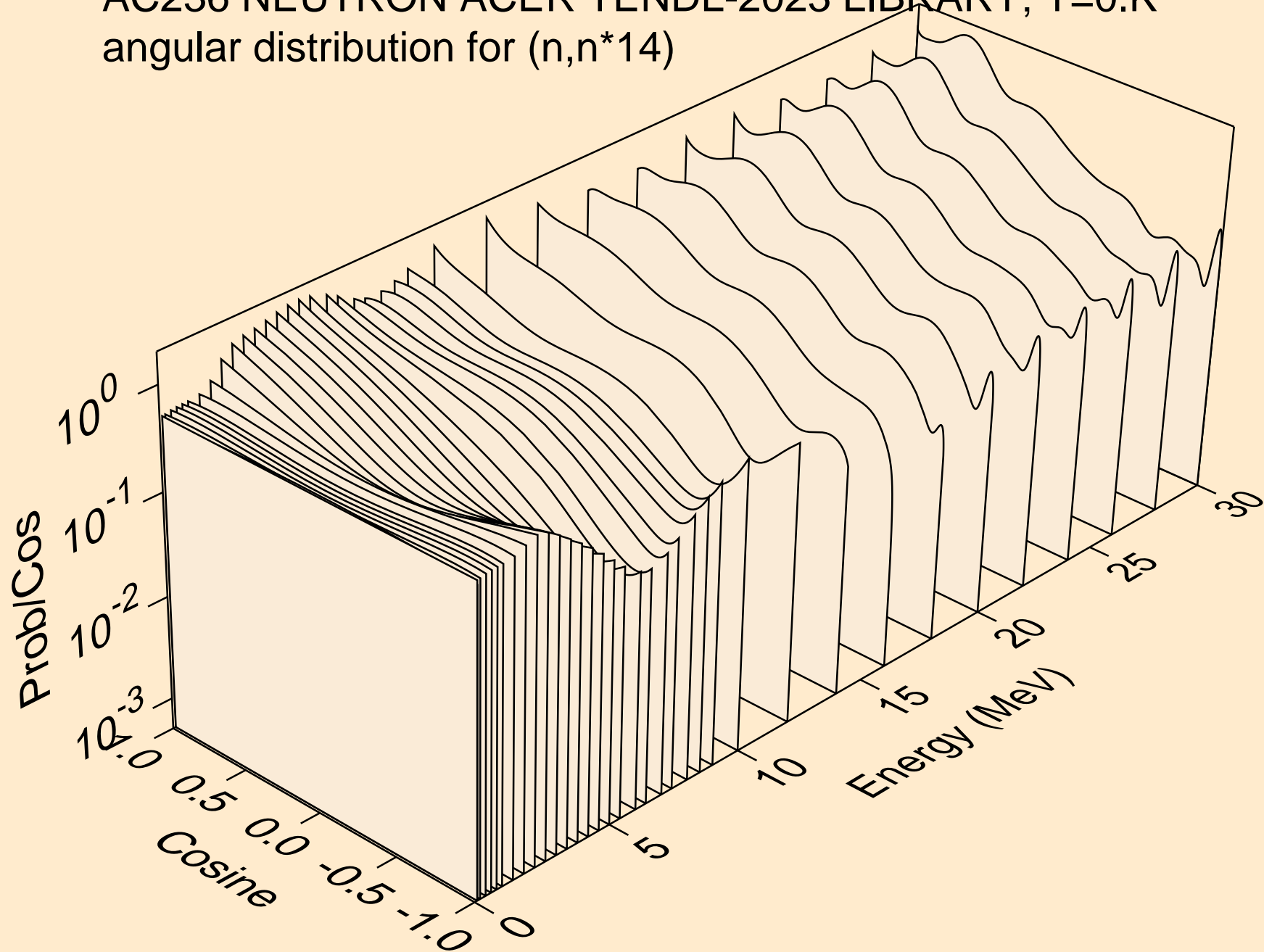

AC236 NEUTRON ACER TENDL-2023 LIBRARY; T=0.K
angular distribution for (n,n*15)

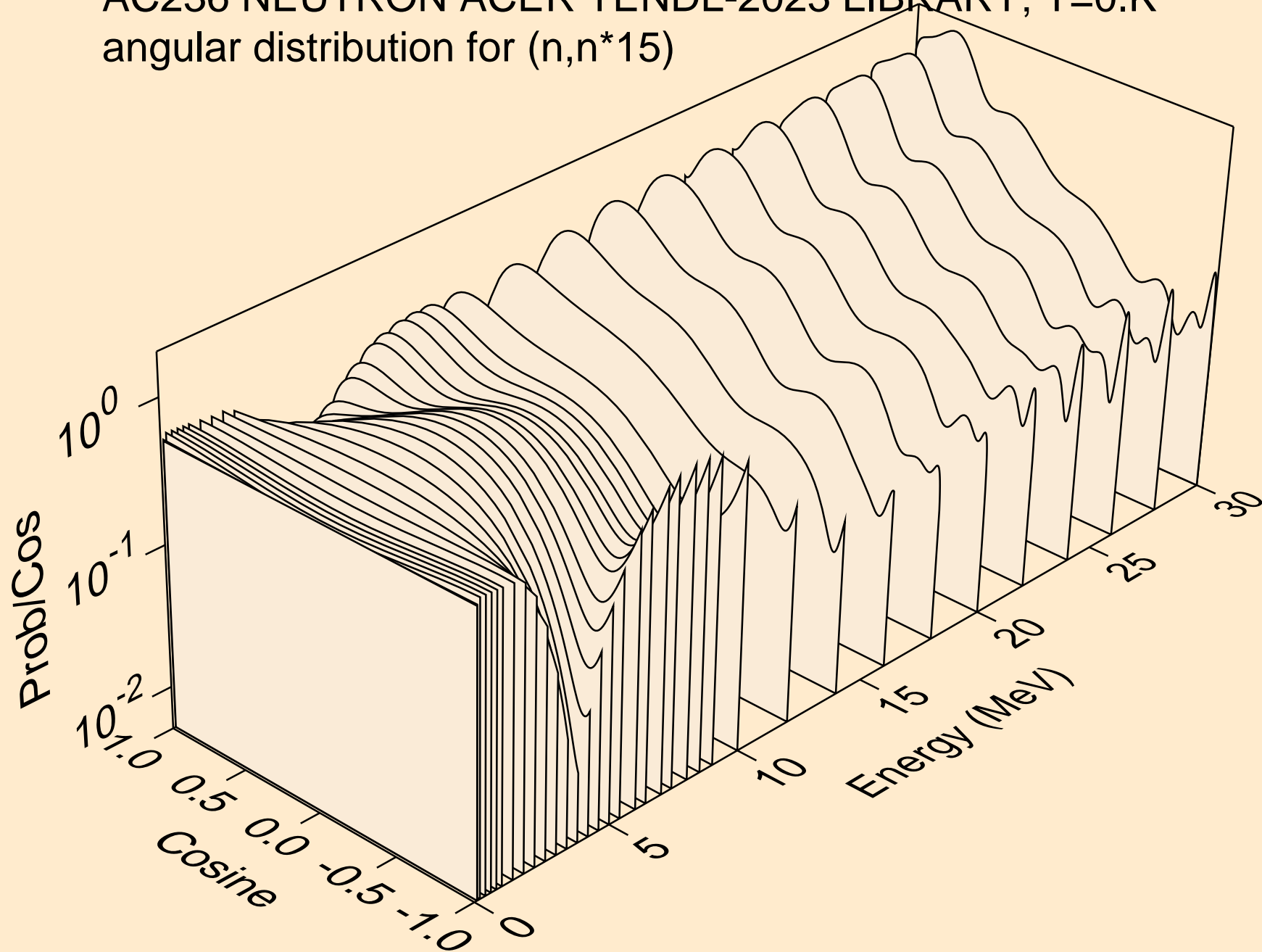

AC236 NEUTRON ACER TENDL-2023 LIBRARY; T=0.K
angular distribution for (n,n*16)

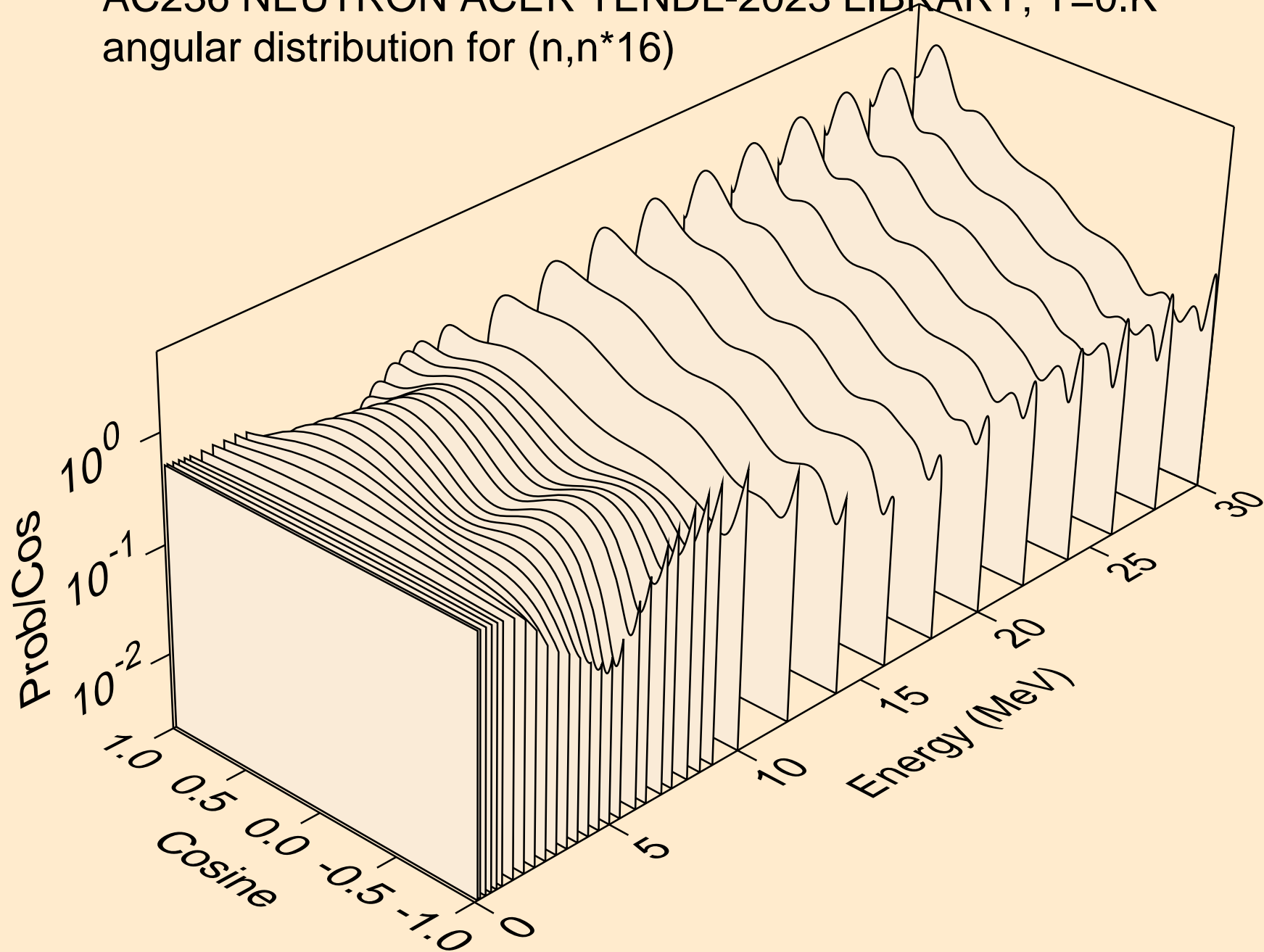

AC236 NEUTRON ACER TENDL-2023 LIBRARY; T=0.K
angular distribution for (n,n*17)

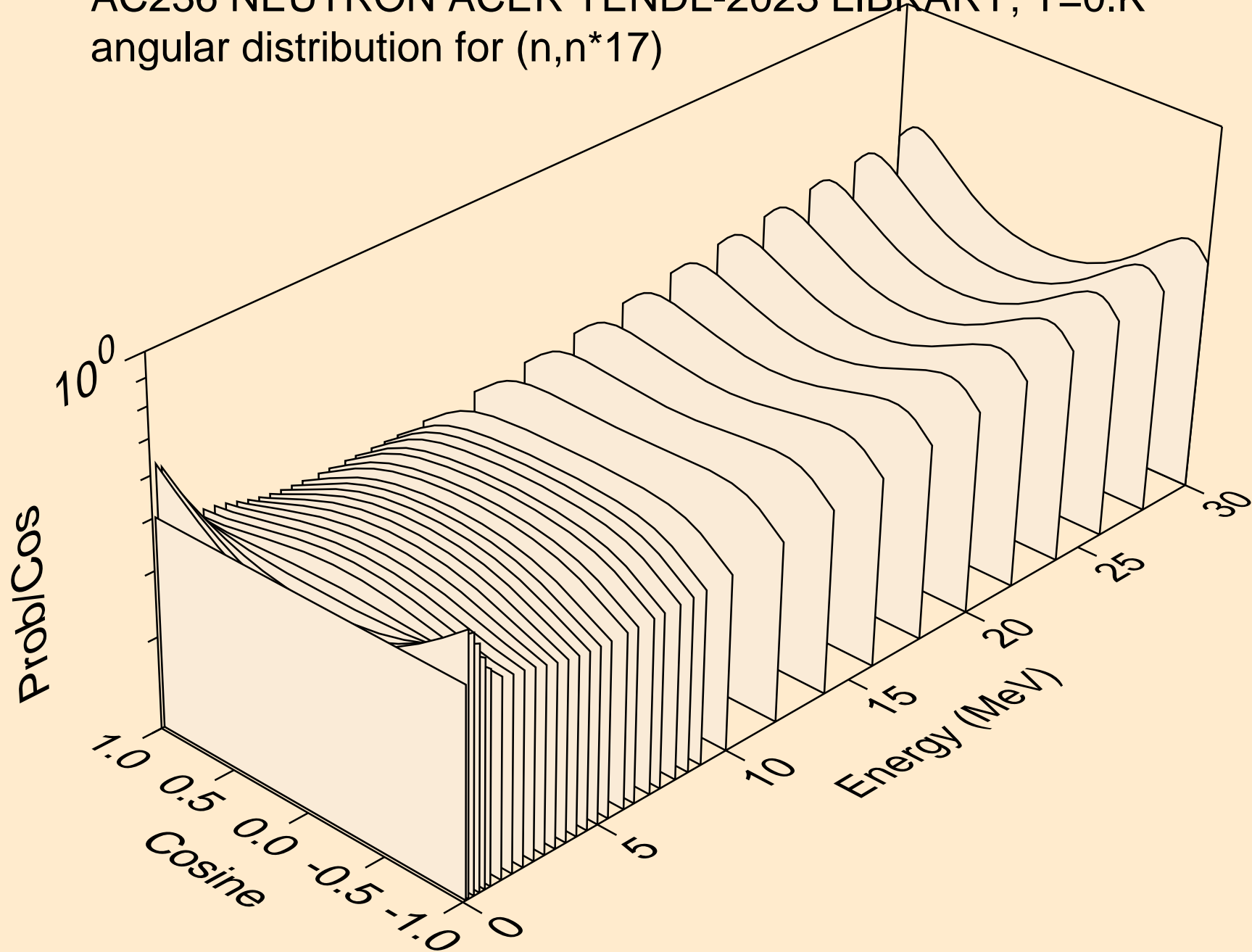

AC236 NEUTRON ACER TENDL-2023 LIBRARY; T=0.K
angular distribution for (n,n*18)

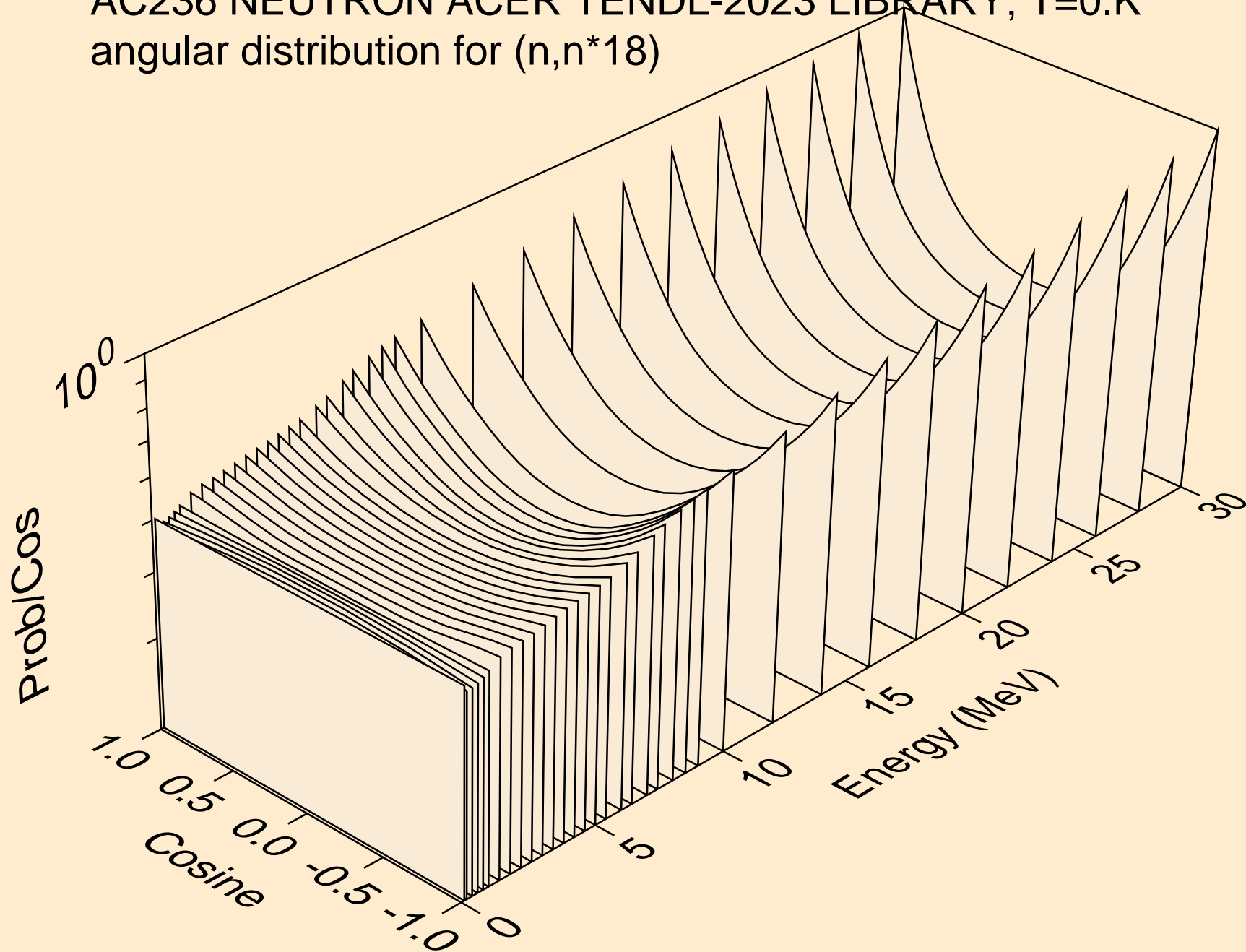

AC236 NEUTRON ACER TENDL-2023 LIBRARY; T=0.K
angular distribution for (n,n*19)

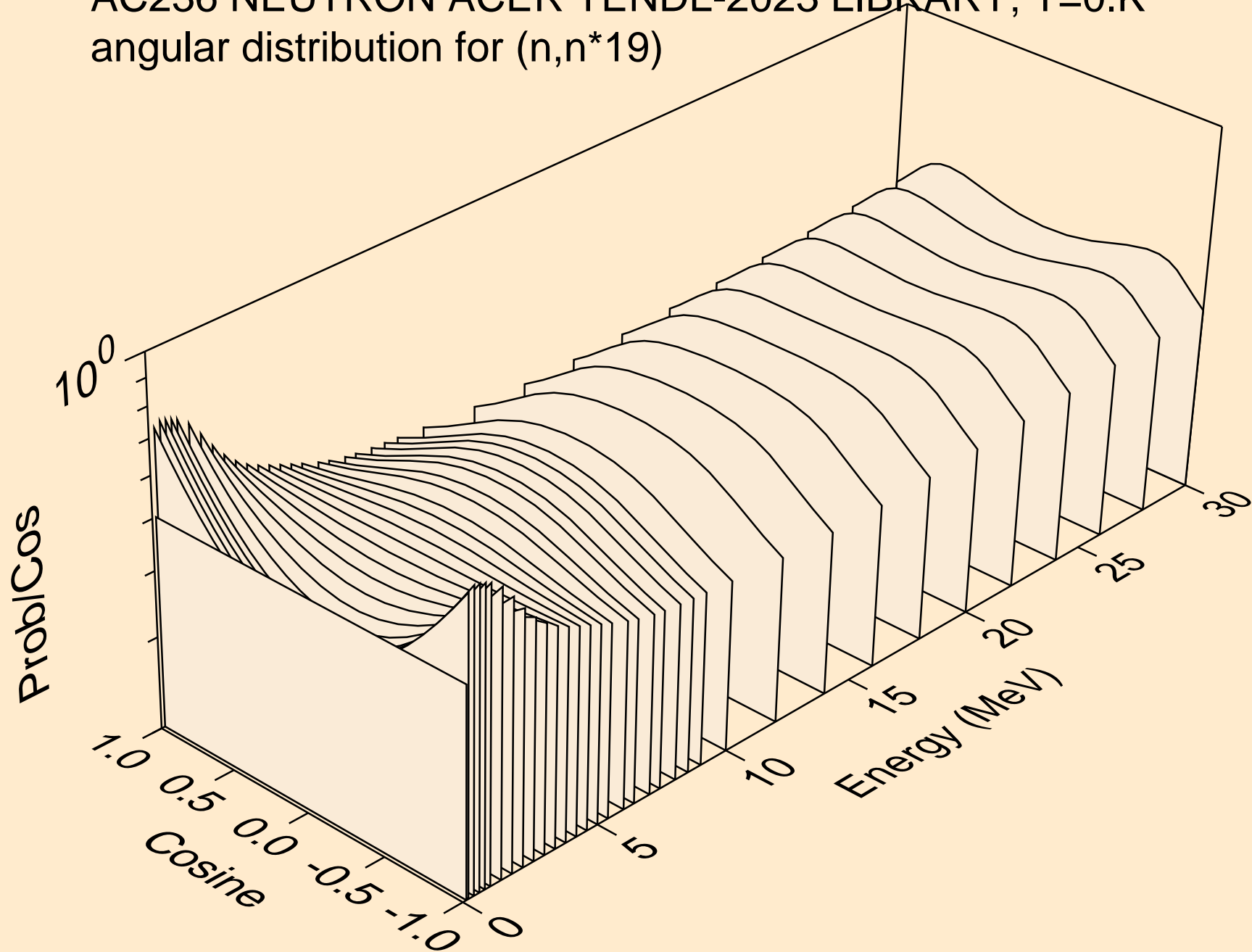

AC236 NEUTRON ACER TENDL-2023 LIBRARY; T=0.K
angular distribution for (n,n*20)

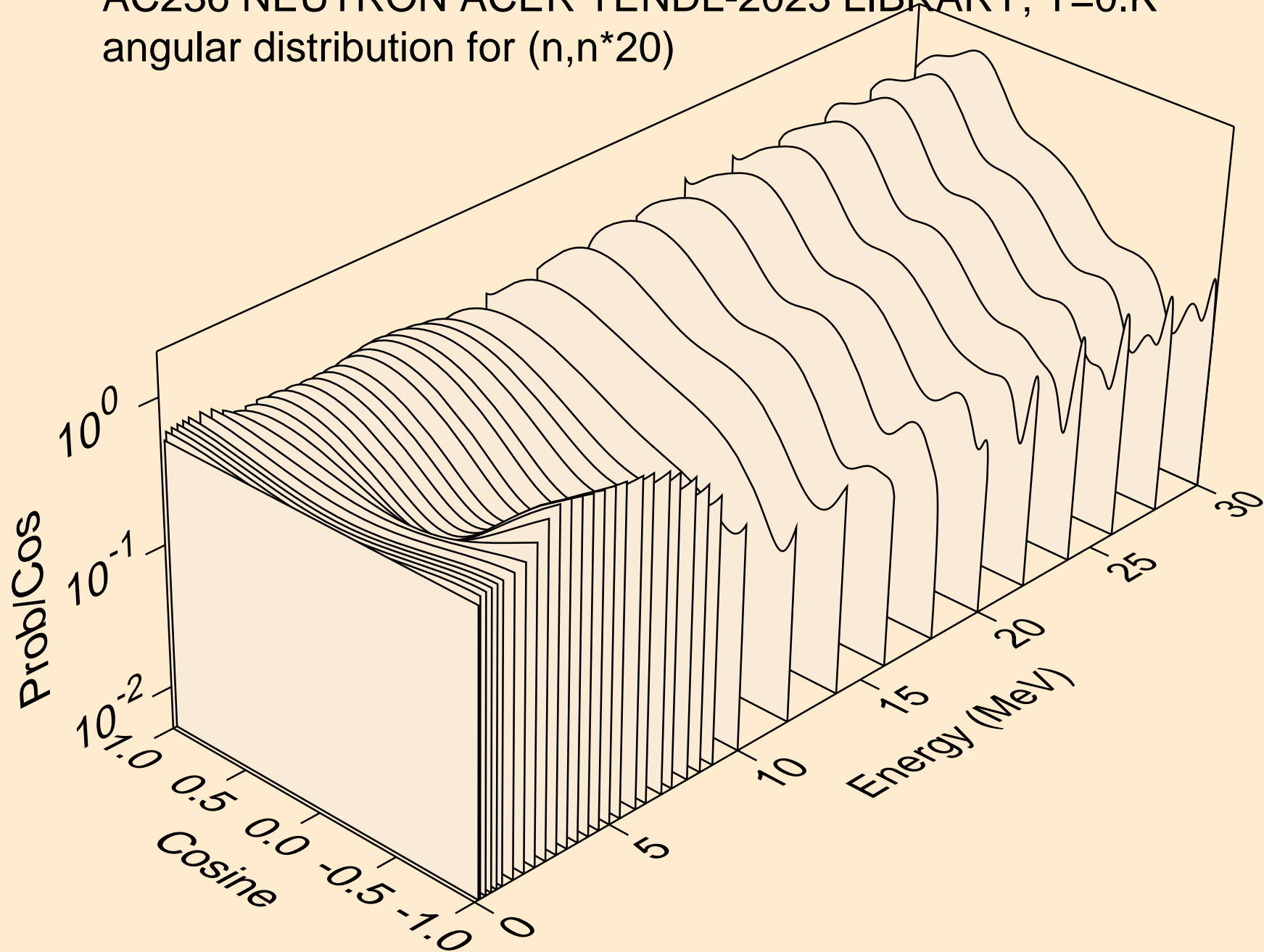

AC236 NEUTRON ACER TENDL-2023 LIBRARY; T=0.K
angular distribution for (n,n*21)

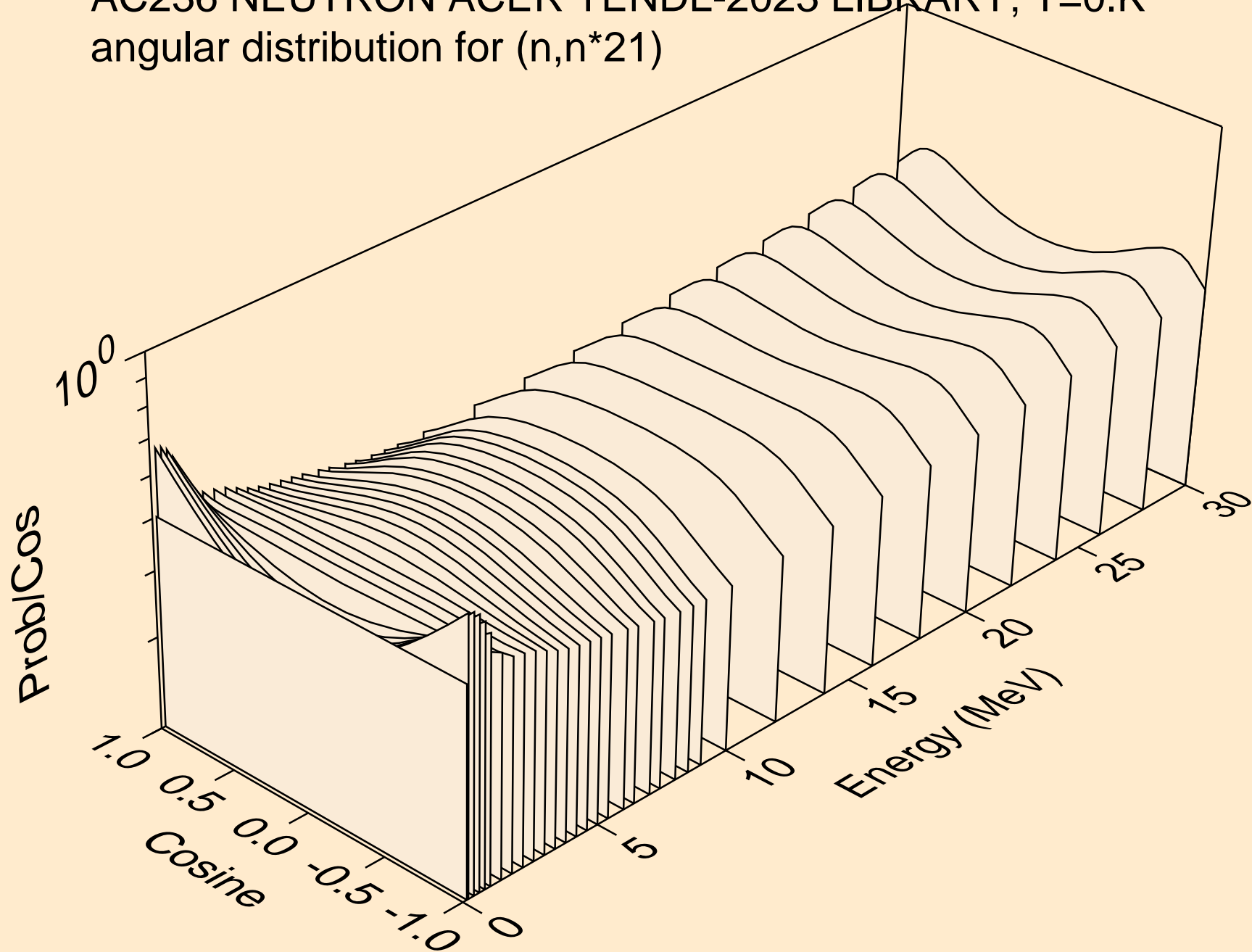

AC236 NEUTRON ACER TENDL-2023 LIBRARY; T=0.K
angular distribution for (n,n*22)

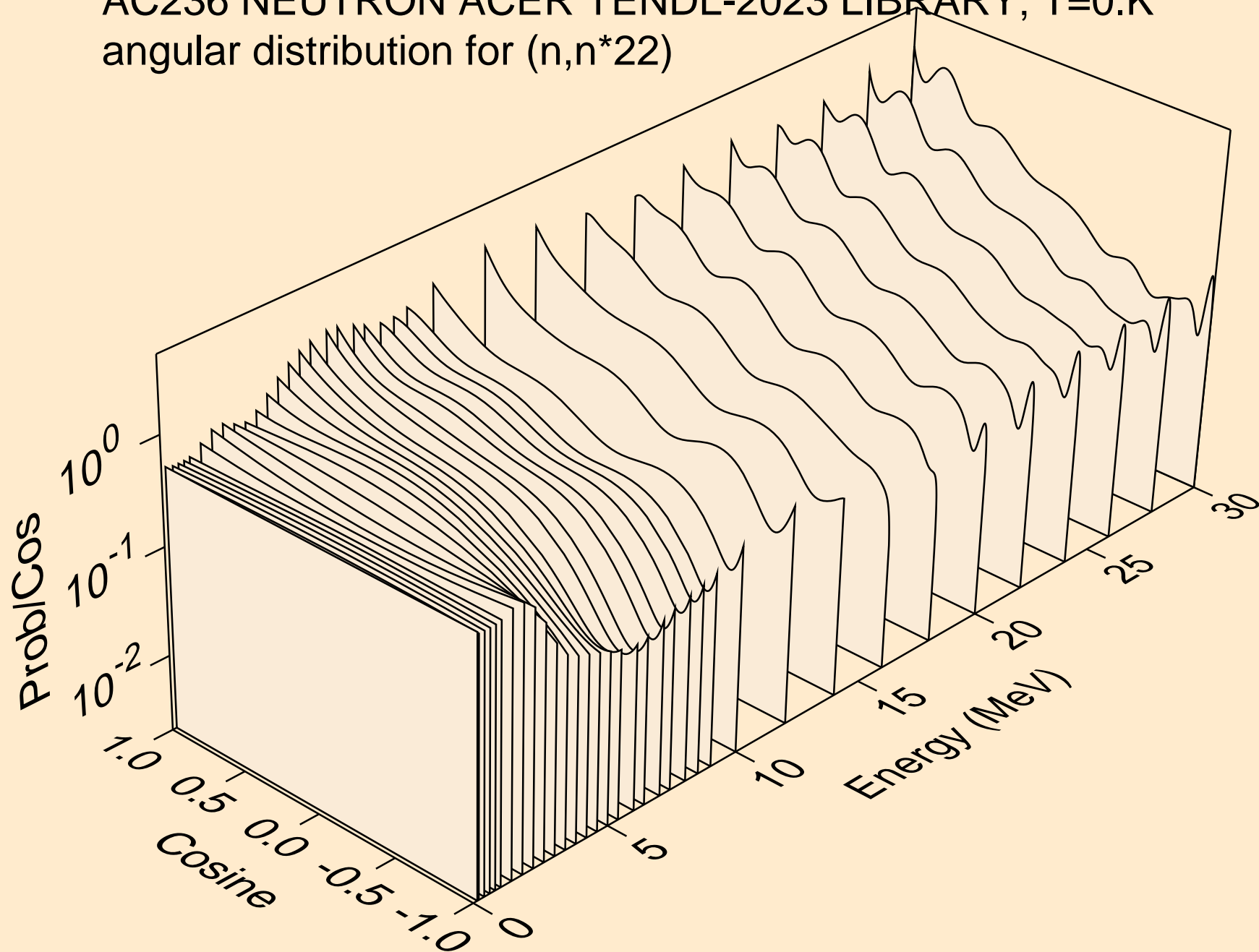

AC236 NEUTRON ACER TENDL-2023 LIBRARY; T=0.K
angular distribution for (n,n*23)

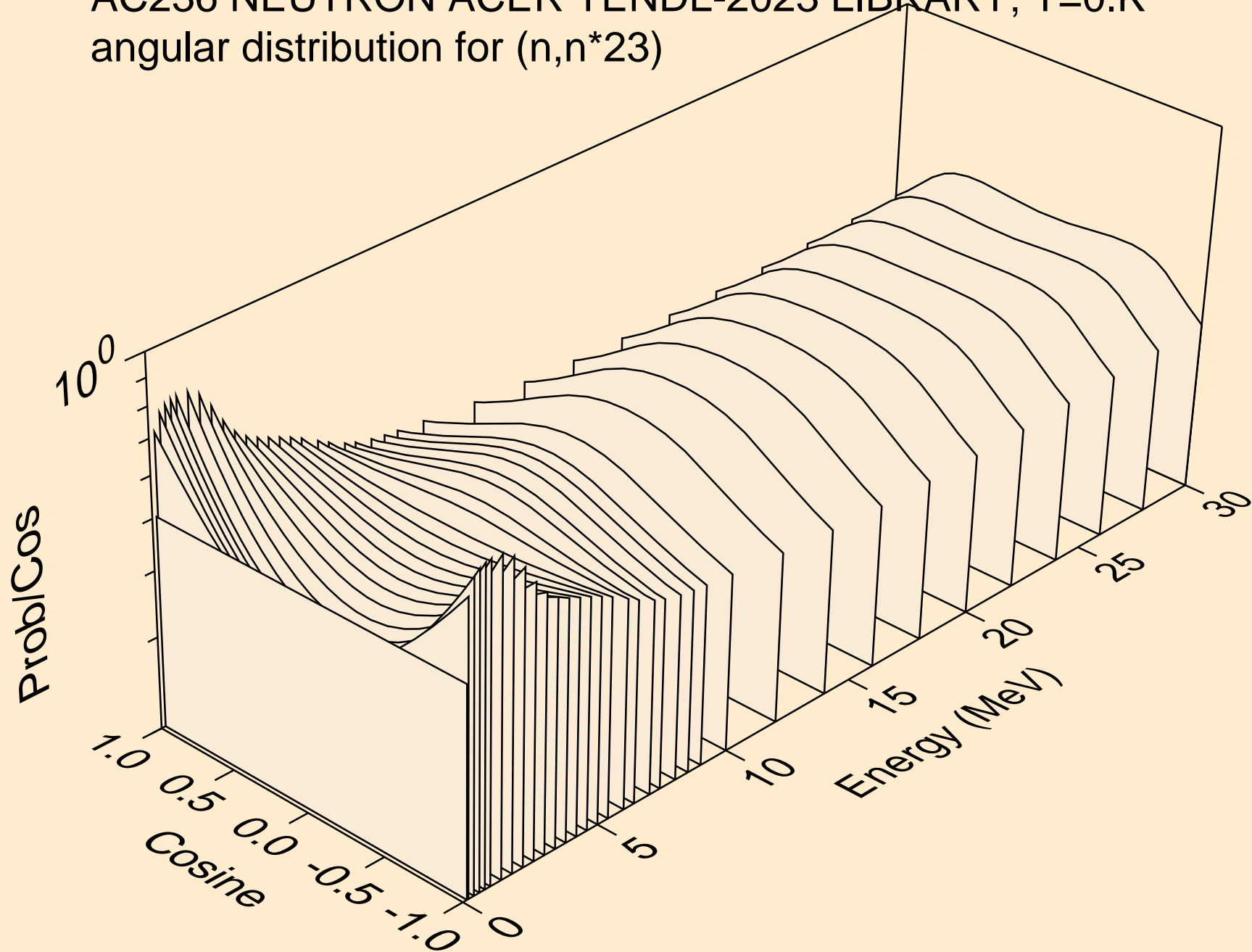

AC236 NEUTRON ACER TENDL-2023 LIBRARY; T=0.K
angular distribution for (n,n*24)

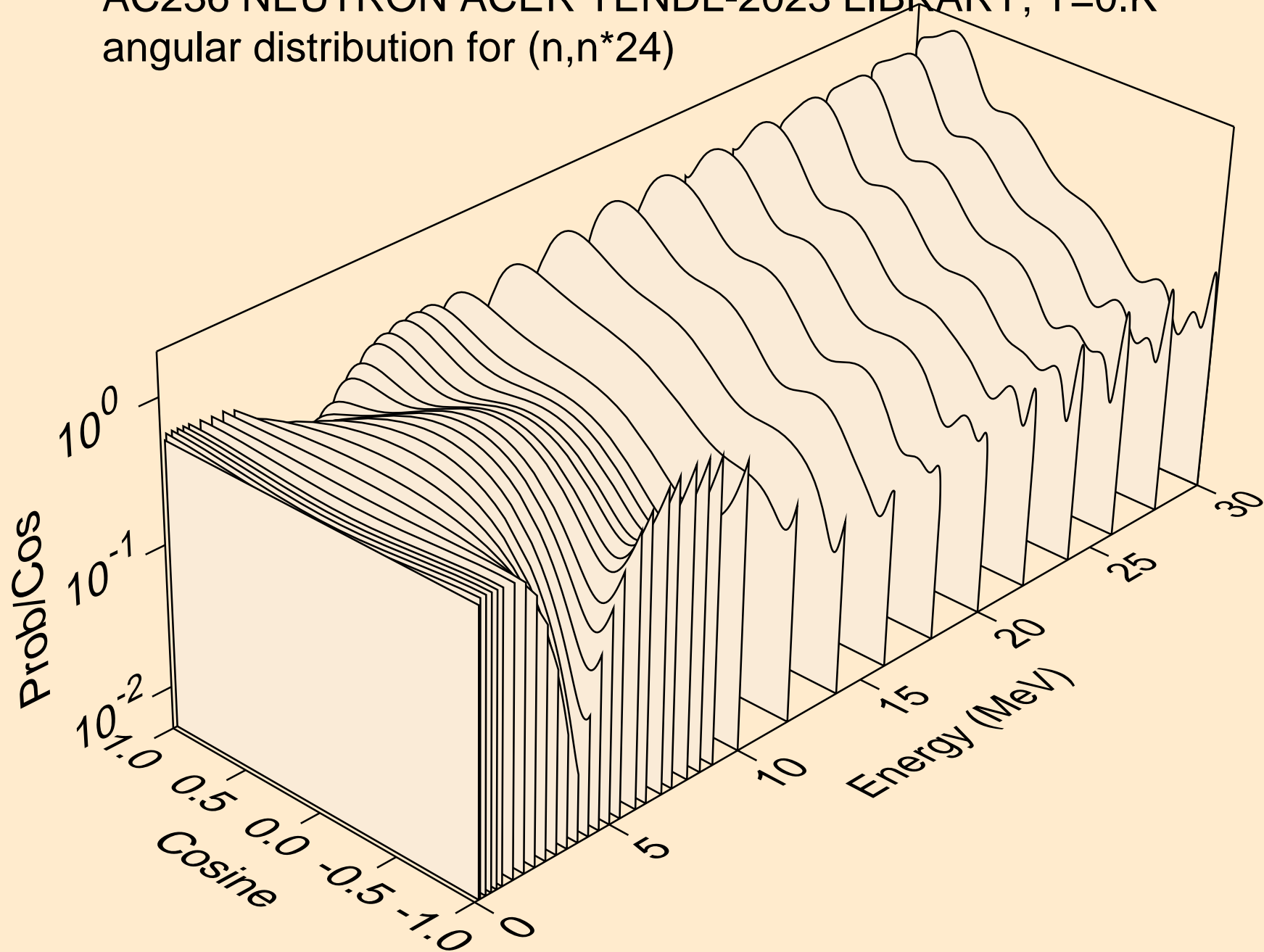

AC236 NEUTRON ACER TENDL-2023 LIBRARY; T=0.K
angular distribution for (n,n*25)

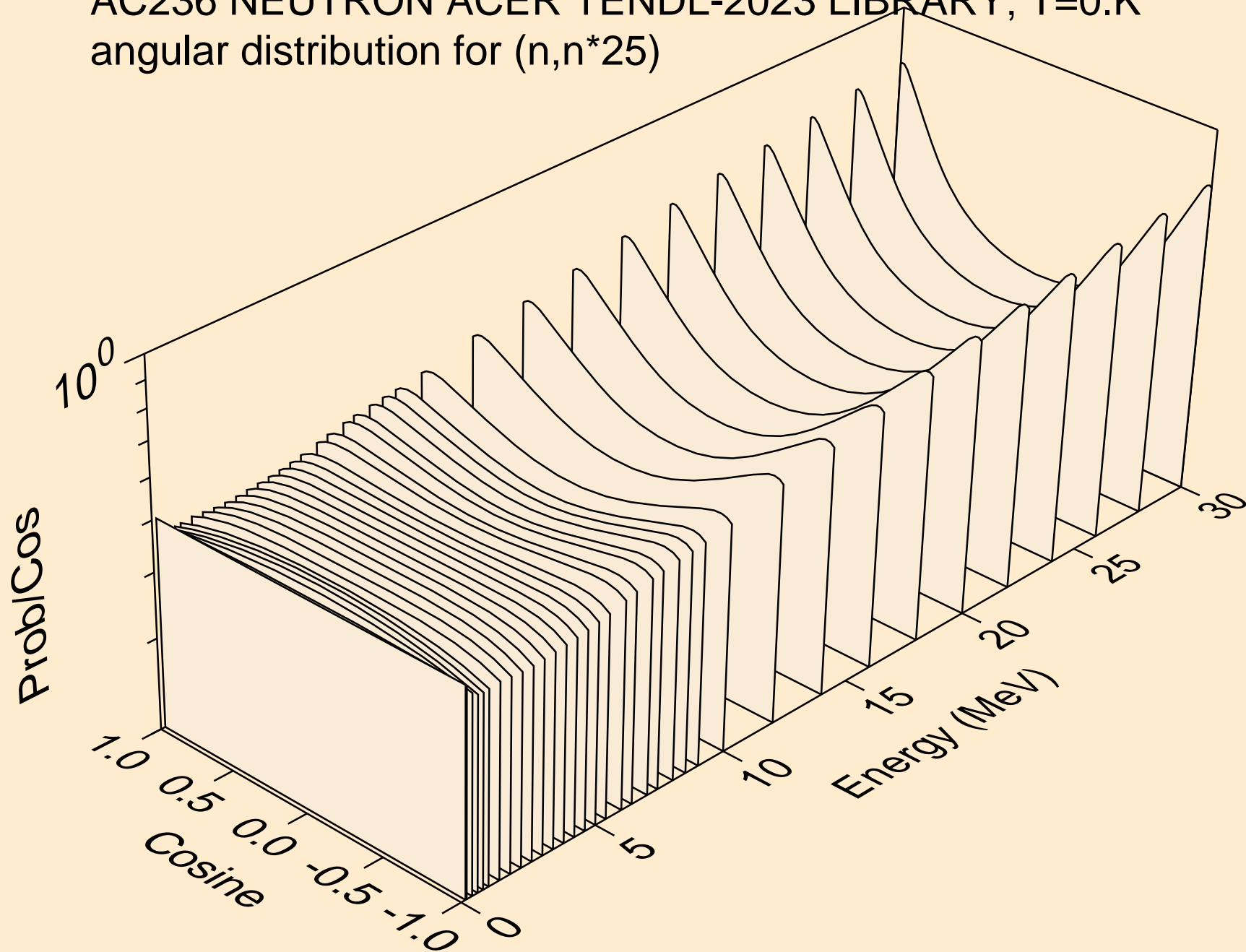

AC236 NEUTRON ACER TENDL-2023 LIBRARY; T=0.K
angular distribution for (n,n*26)

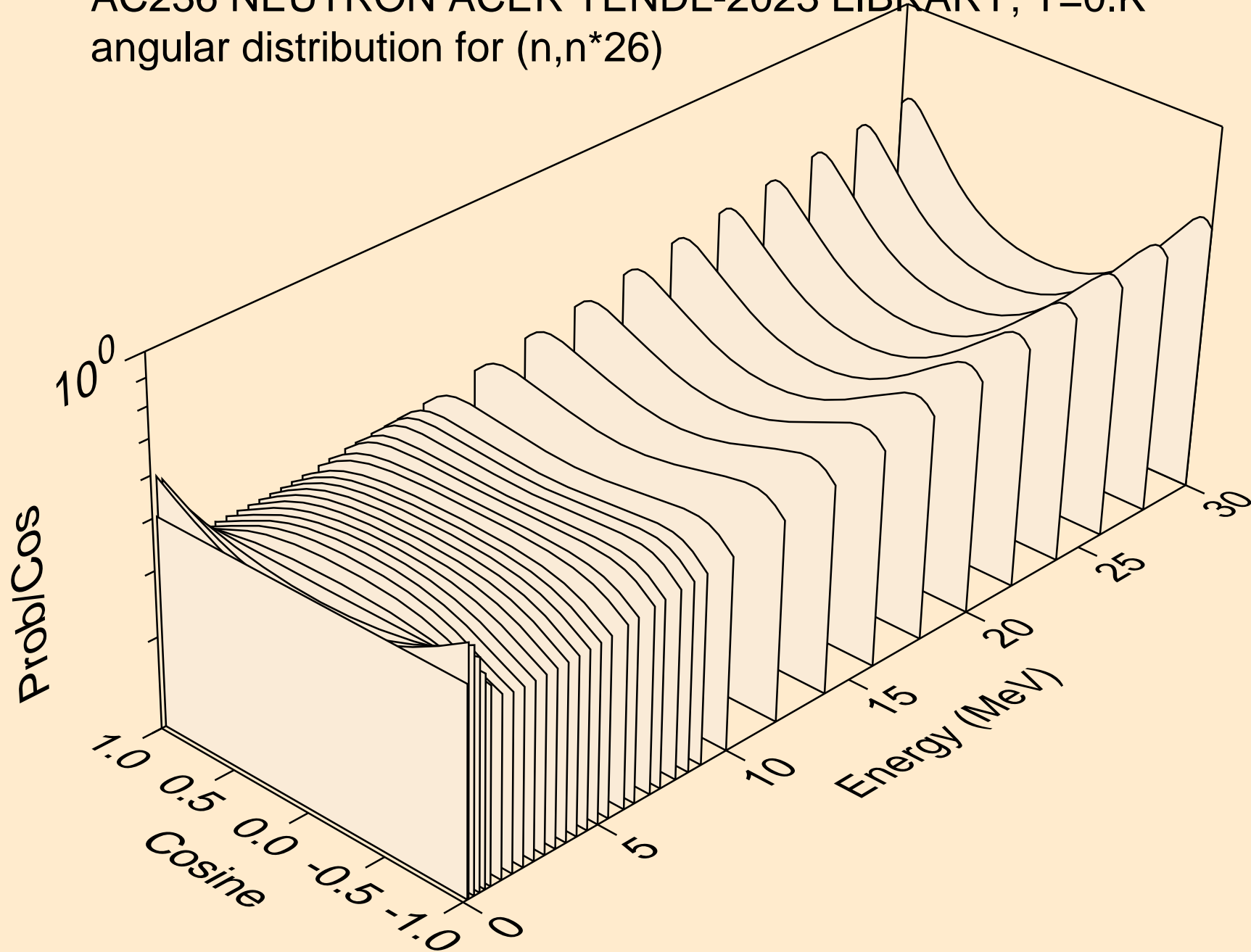

AC236 NEUTRON ACER TENDL-2023 LIBRARY; T=0.K
angular distribution for (n,n*27)

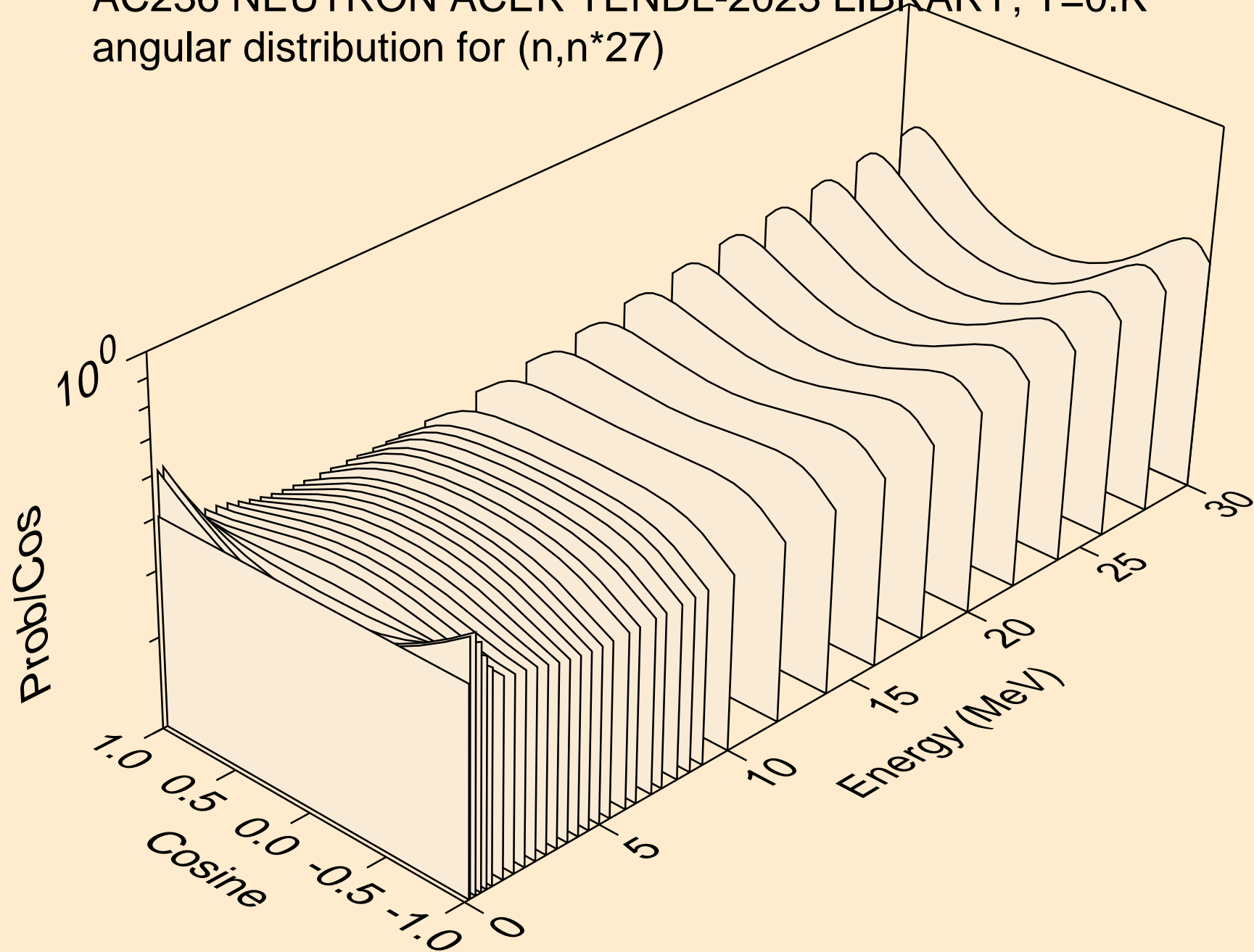

AC236 NEUTRON ACER TENDL-2023 LIBRARY; T=0.K
angular distribution for (n,n*28)

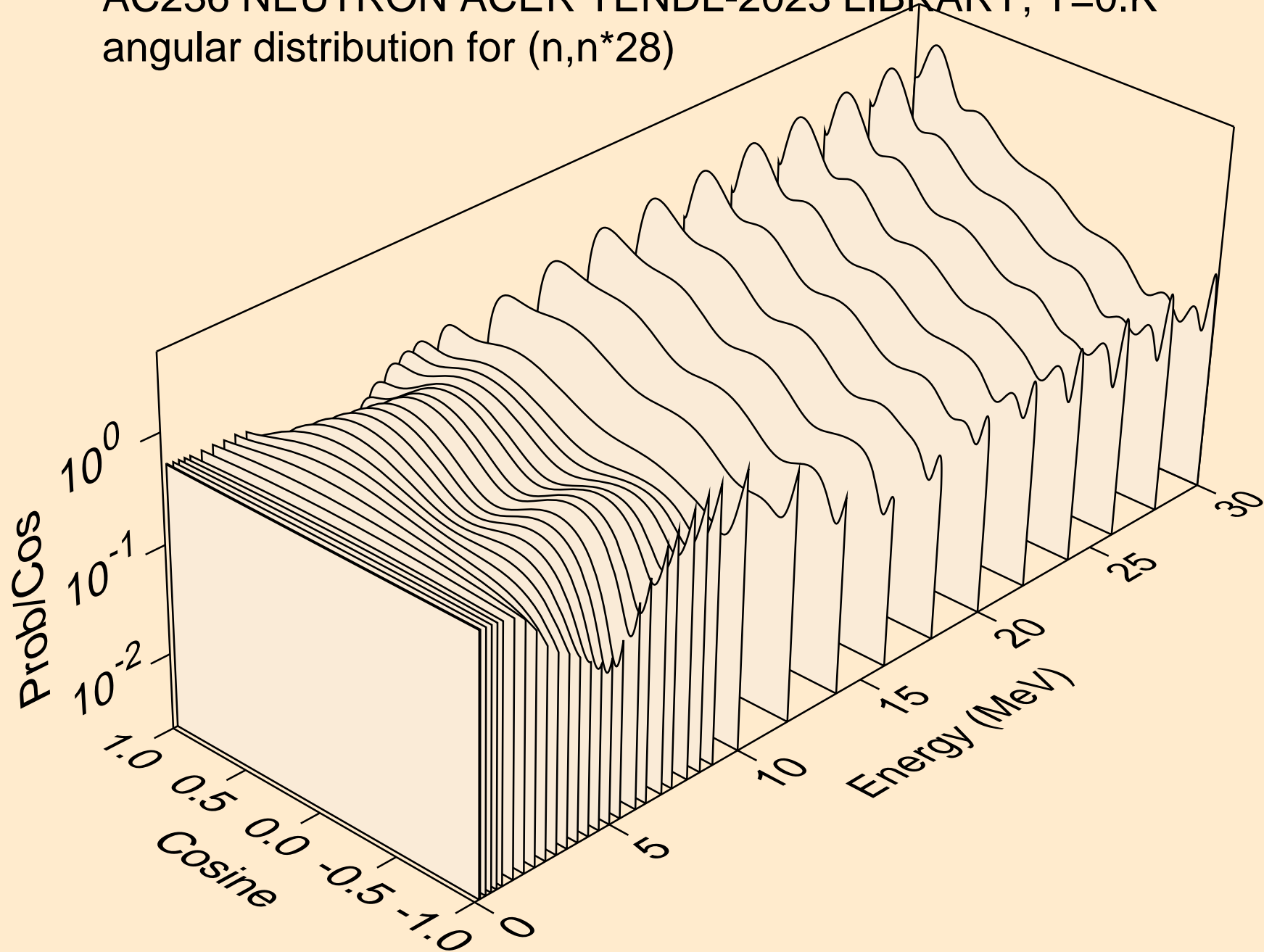

AC236 NEUTRON ACER TENDL-2023 LIBRARY; T=0.K
angular distribution for (n,n*29)

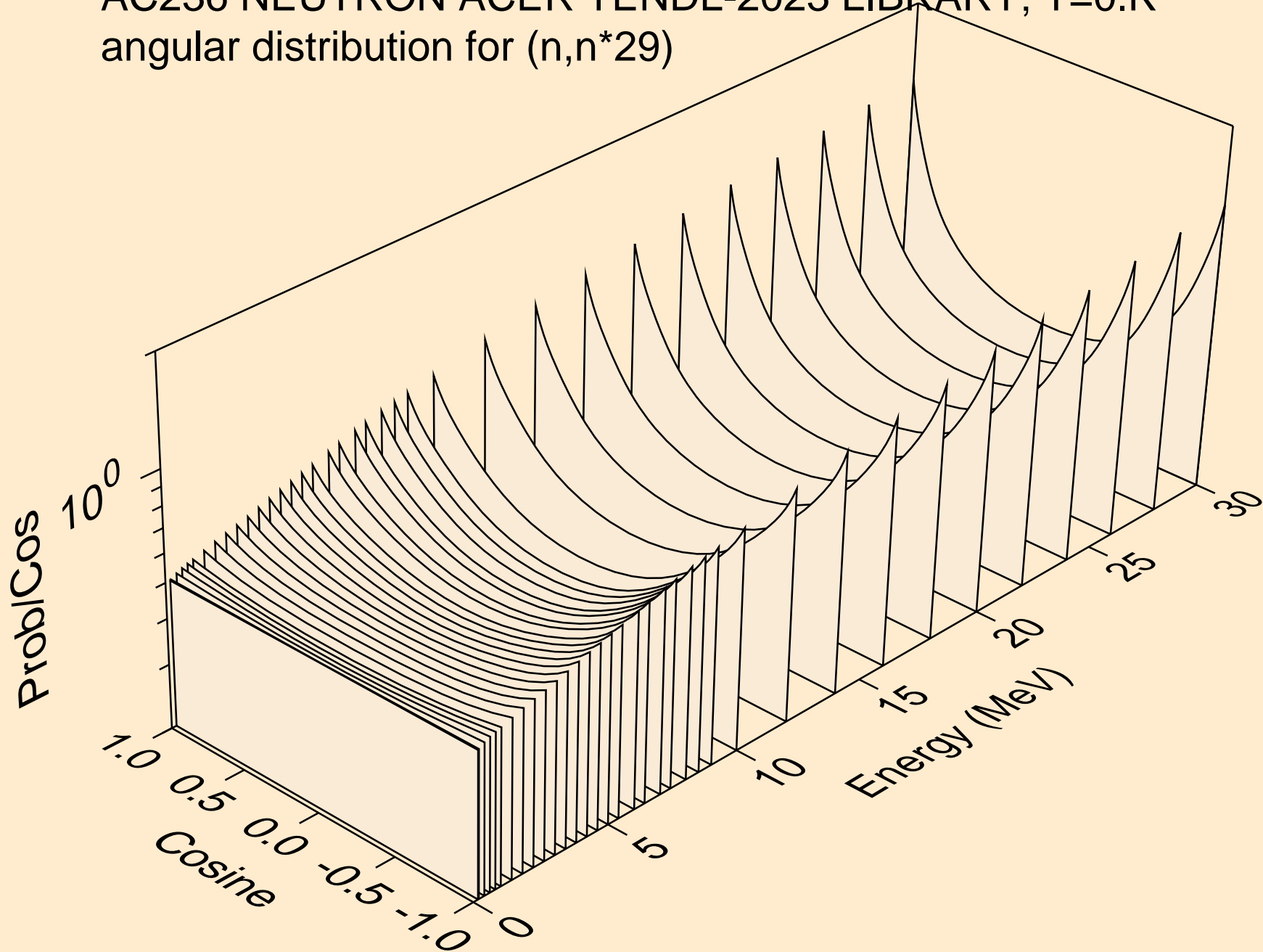

AC236 NEUTRON ACER TENDL-2023 LIBRARY; T=0.K
angular distribution for (n,n*30)

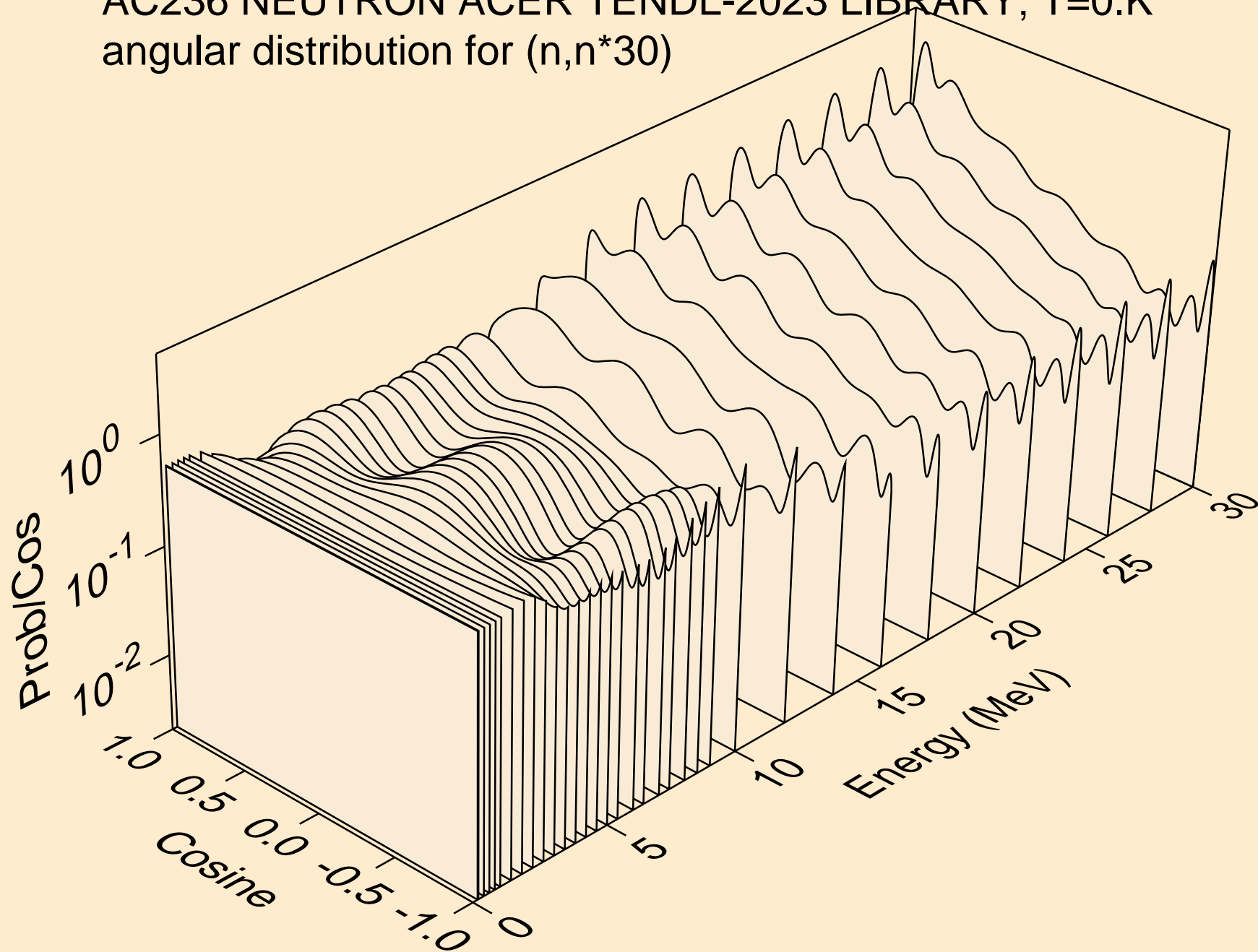

AC236 NEUTRON ACER TENDL-2023 LIBRARY; T=0.K

Total fission nubar

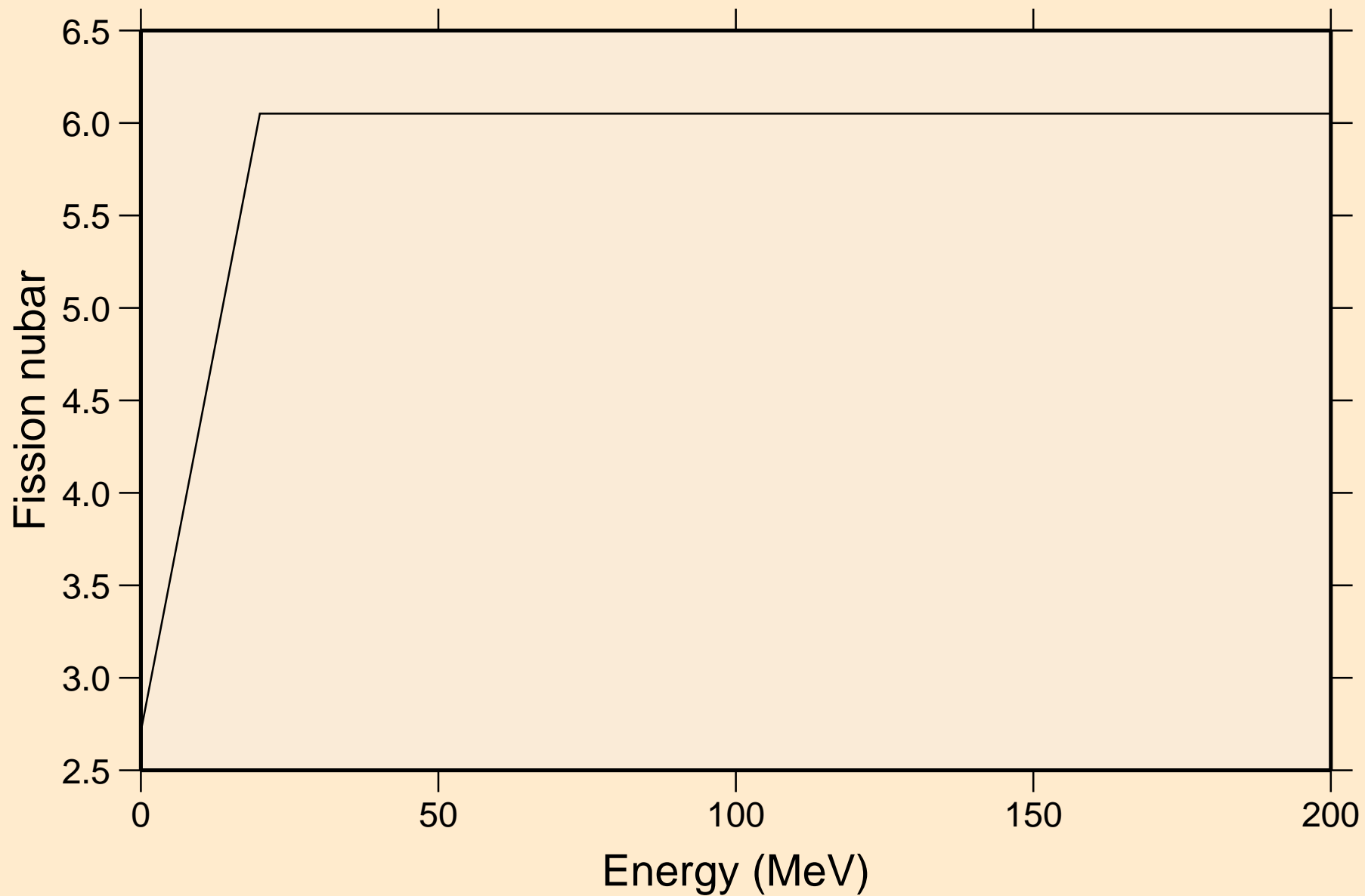

AC236 NEUTRON ACER TENDL-2023 LIBRARY; T=0.K
Neutron emission for (n,x)

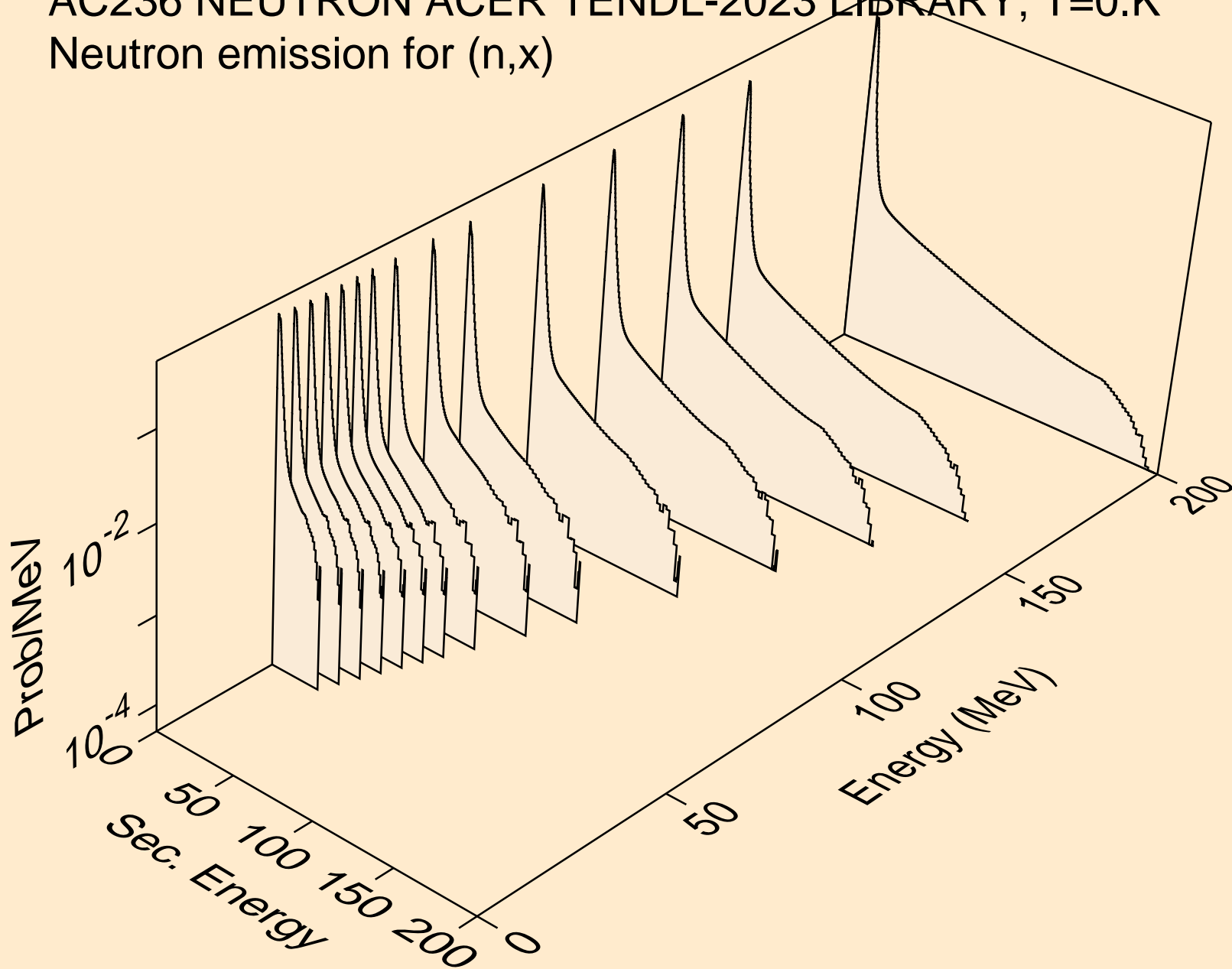

AC236 NEUTRON ACER TENDL-2023 LIBRARY; T=0.K
Neutron emission for (n,2nd)

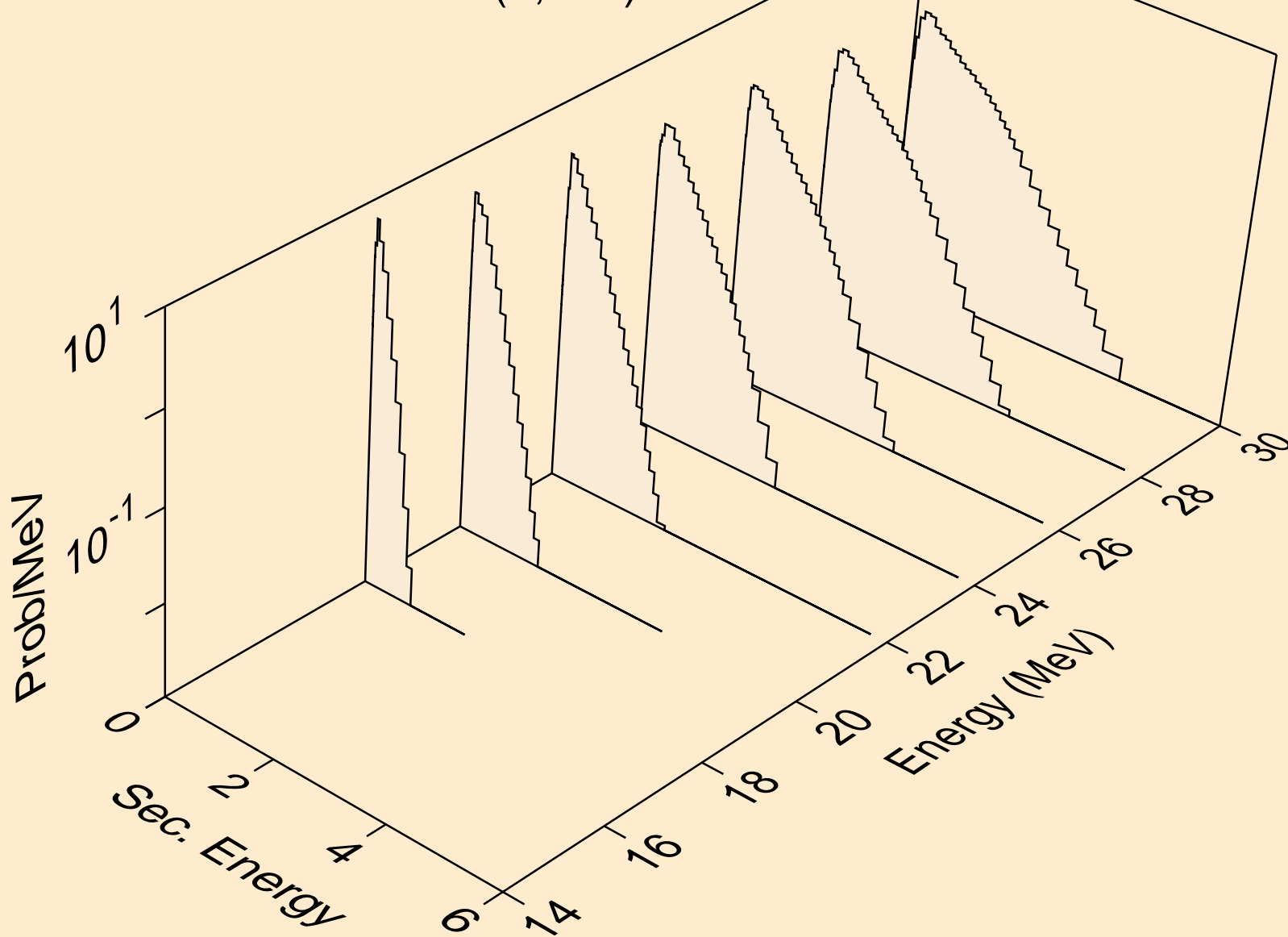

AC236 NEUTRON ACER TENDL-2023 LIBRARY; T=0.K
Neutron emission for (n,2n)

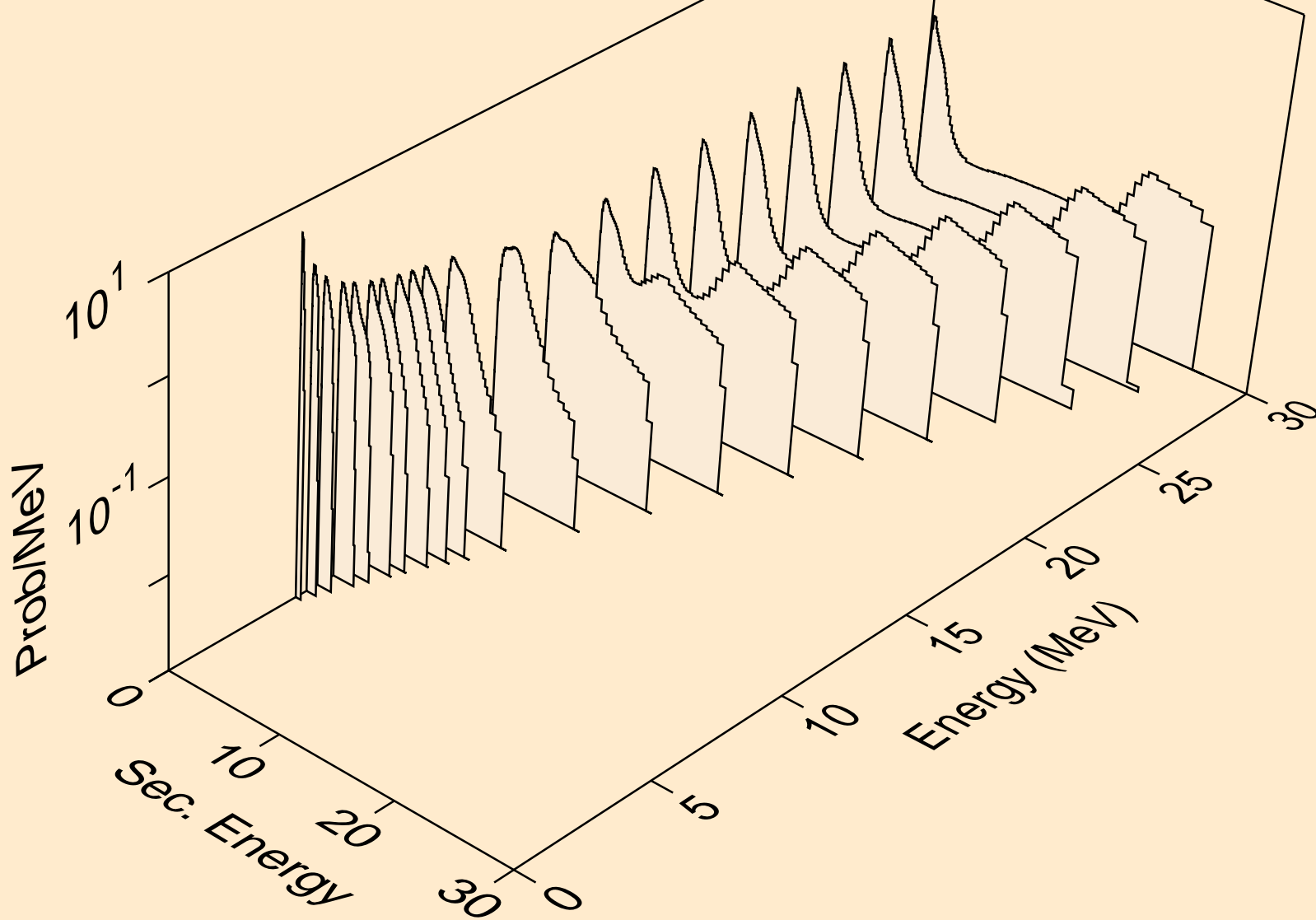

AC236 NEUTRON ACER TENDL-2023 LIBRARY; T=0.K
Neutron emission for (n,3n)

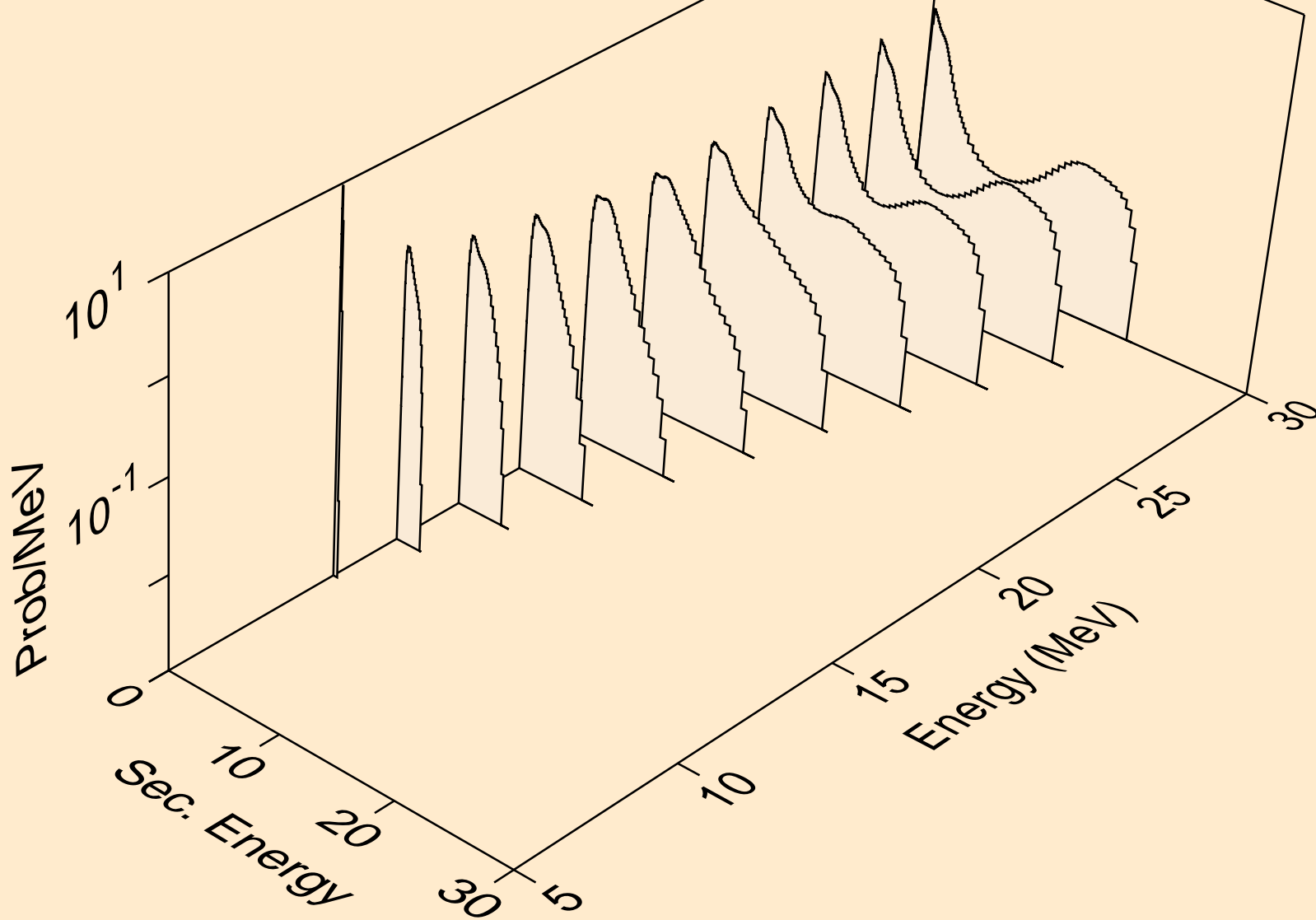

AC236 NEUTRON ACER TENDL-2023 LIBRARY; T=0.K
Neutron emission for fission

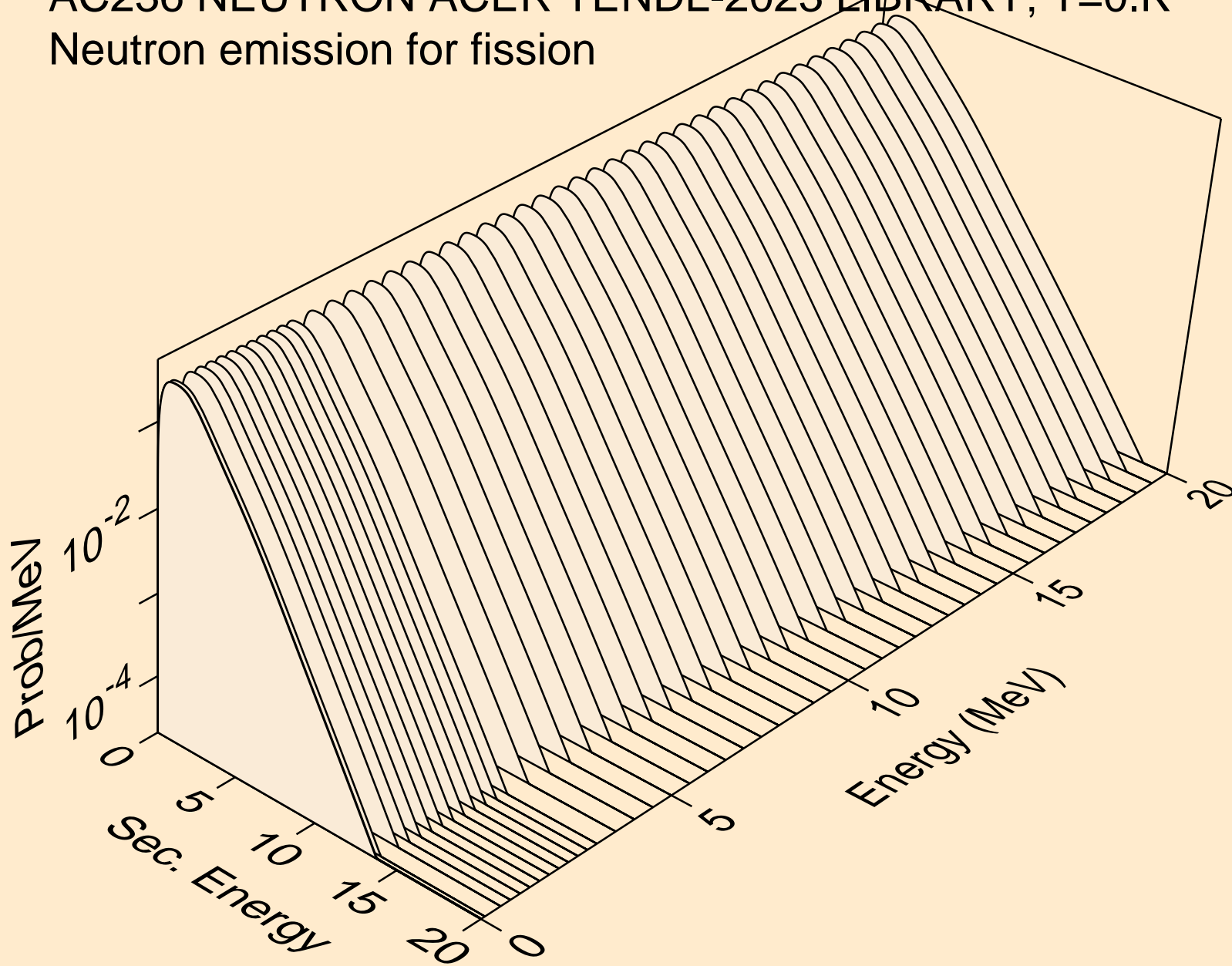

AC236 NEUTRON ACER TENDL-2023 LIBRARY; T=0.K
Neutron emission for (n,n*)a

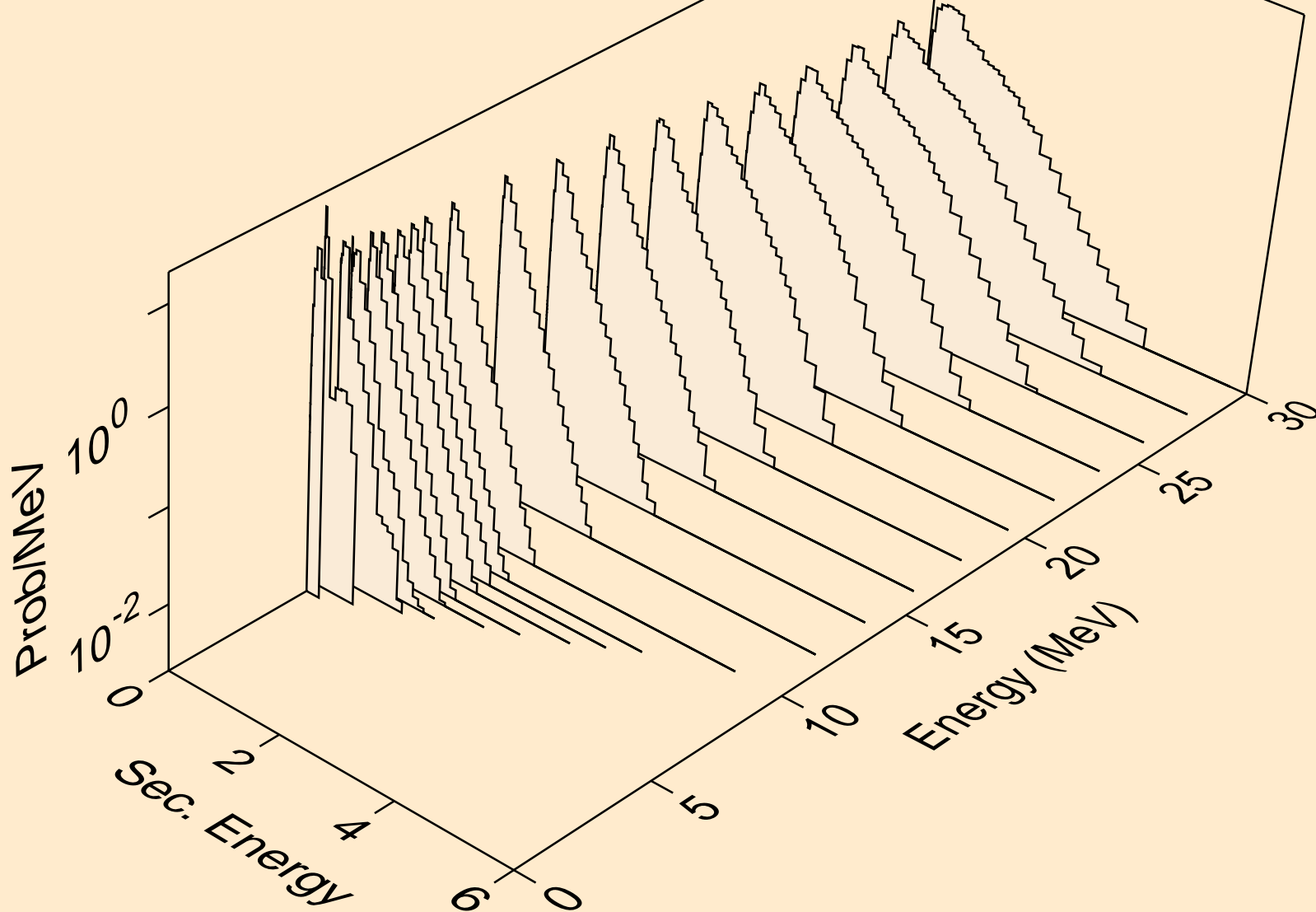

AC236 NEUTRON ACER TENDL-2023 LIBRARY; T=0.K
Neutron emission for (n,2n)a

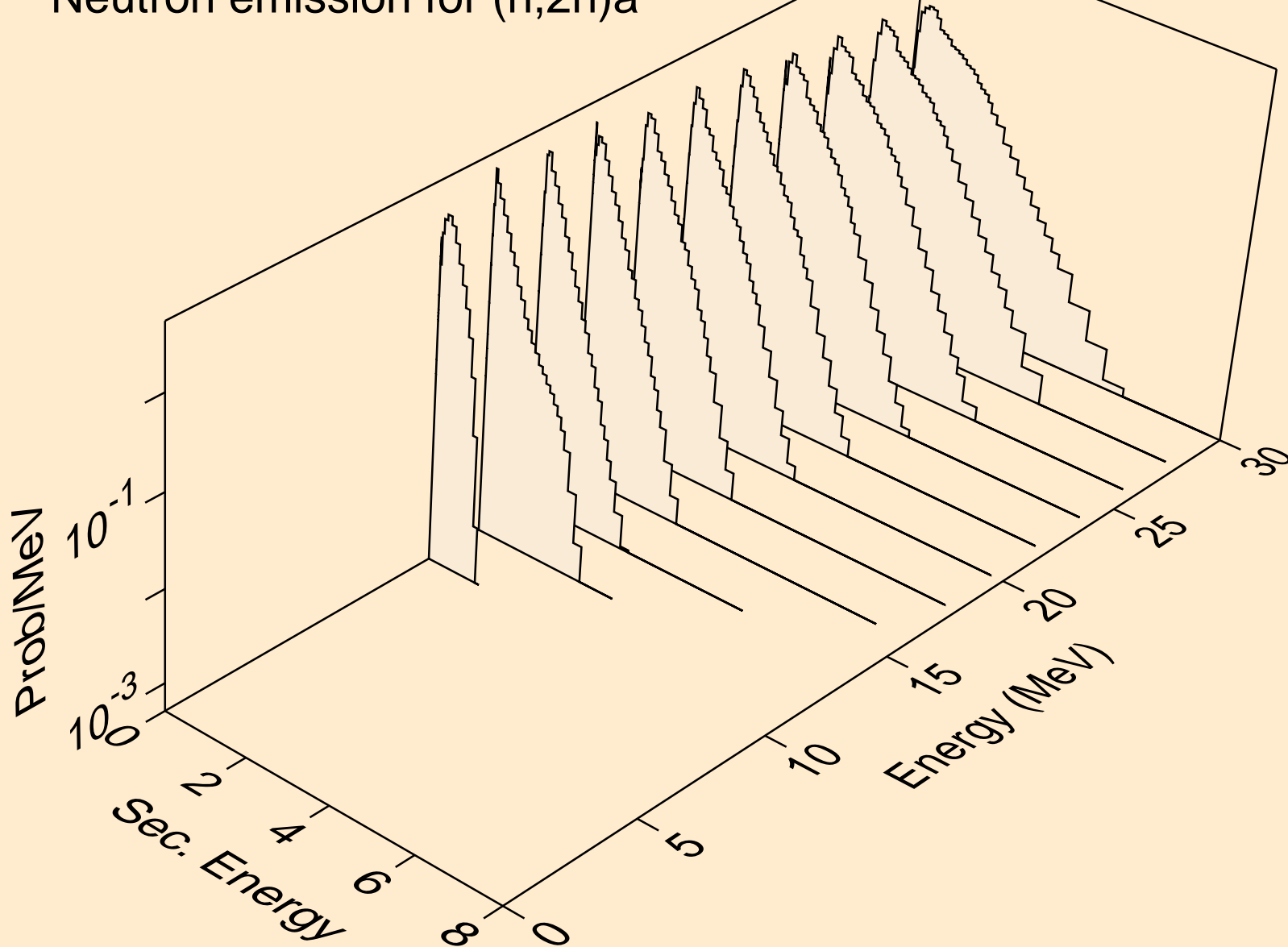

AC236 NEUTRON ACER TENDL-2023 LIBRARY; T=0.K
Neutron emission for (n,3n)a

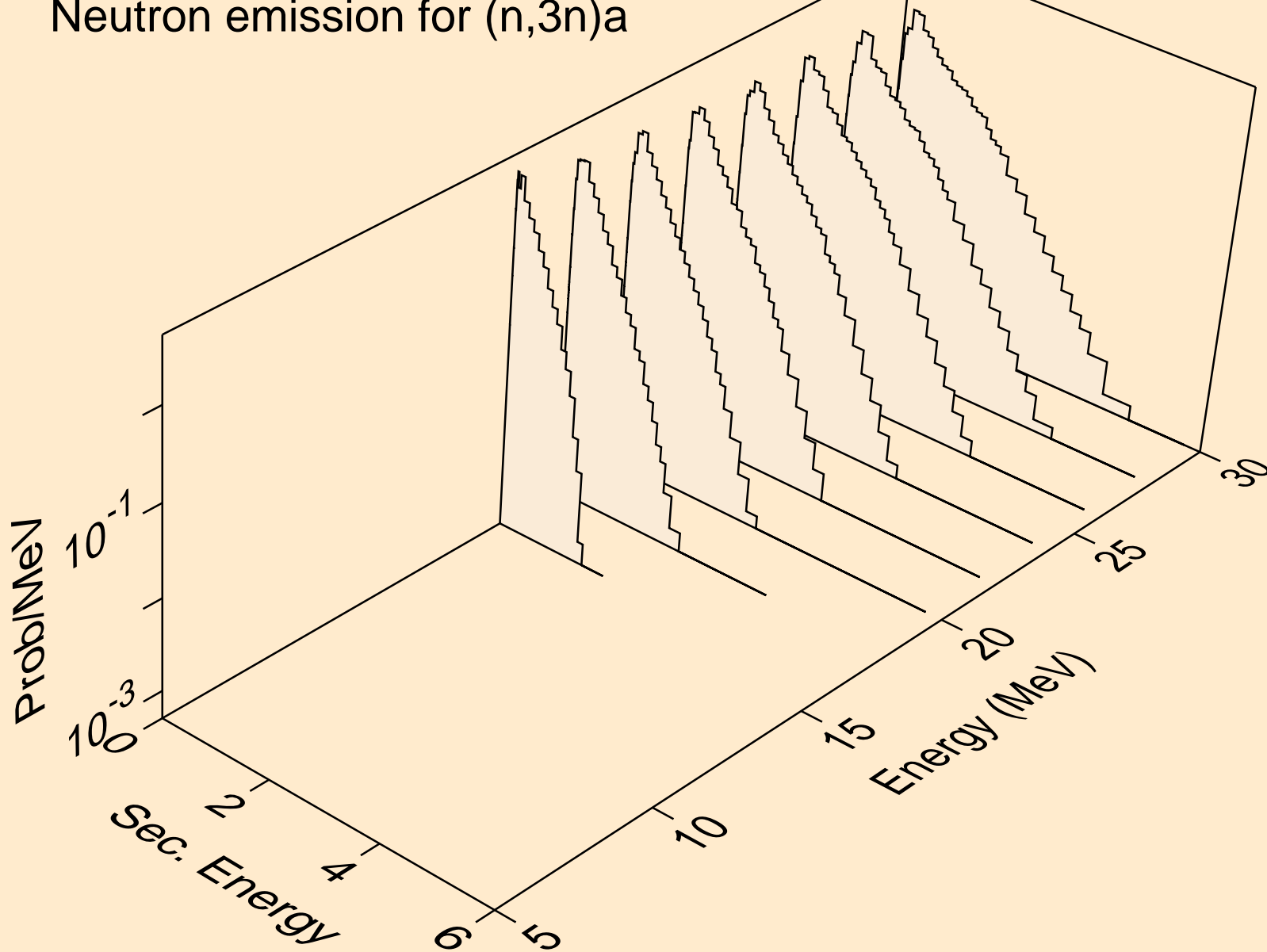

AC236 NEUTRON ACER TENDL-2023 LIBRARY; T=0.K
Neutron emission for (n,n*)p

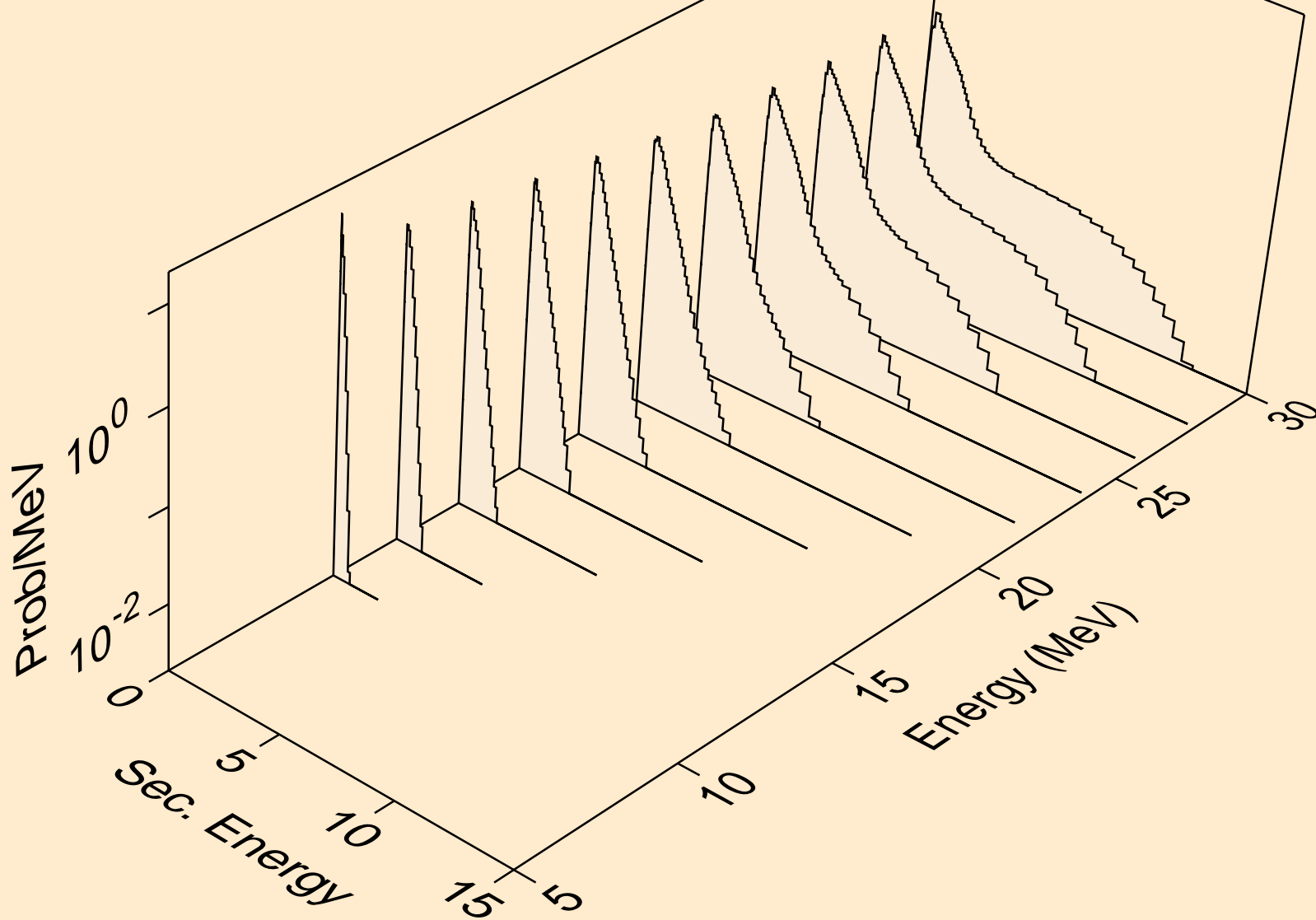

AC236 NEUTRON ACER TENDL-2023 LIBRARY; T=0.K
Neutron emission for (n,n*)d

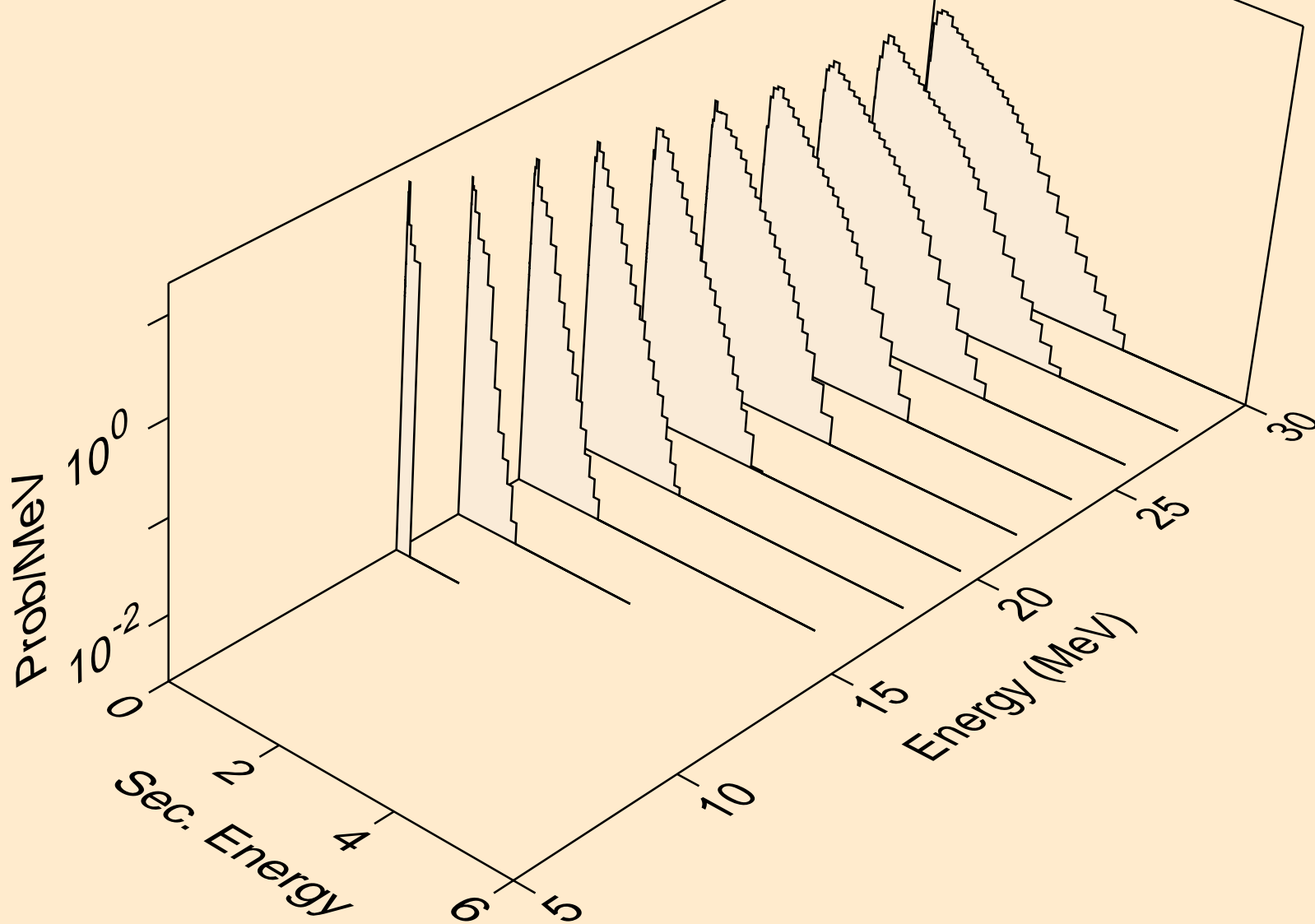

AC236 NEUTRON ACER TENDL-2023 LIBRARY; T=0.K
Neutron emission for (n,n*)t

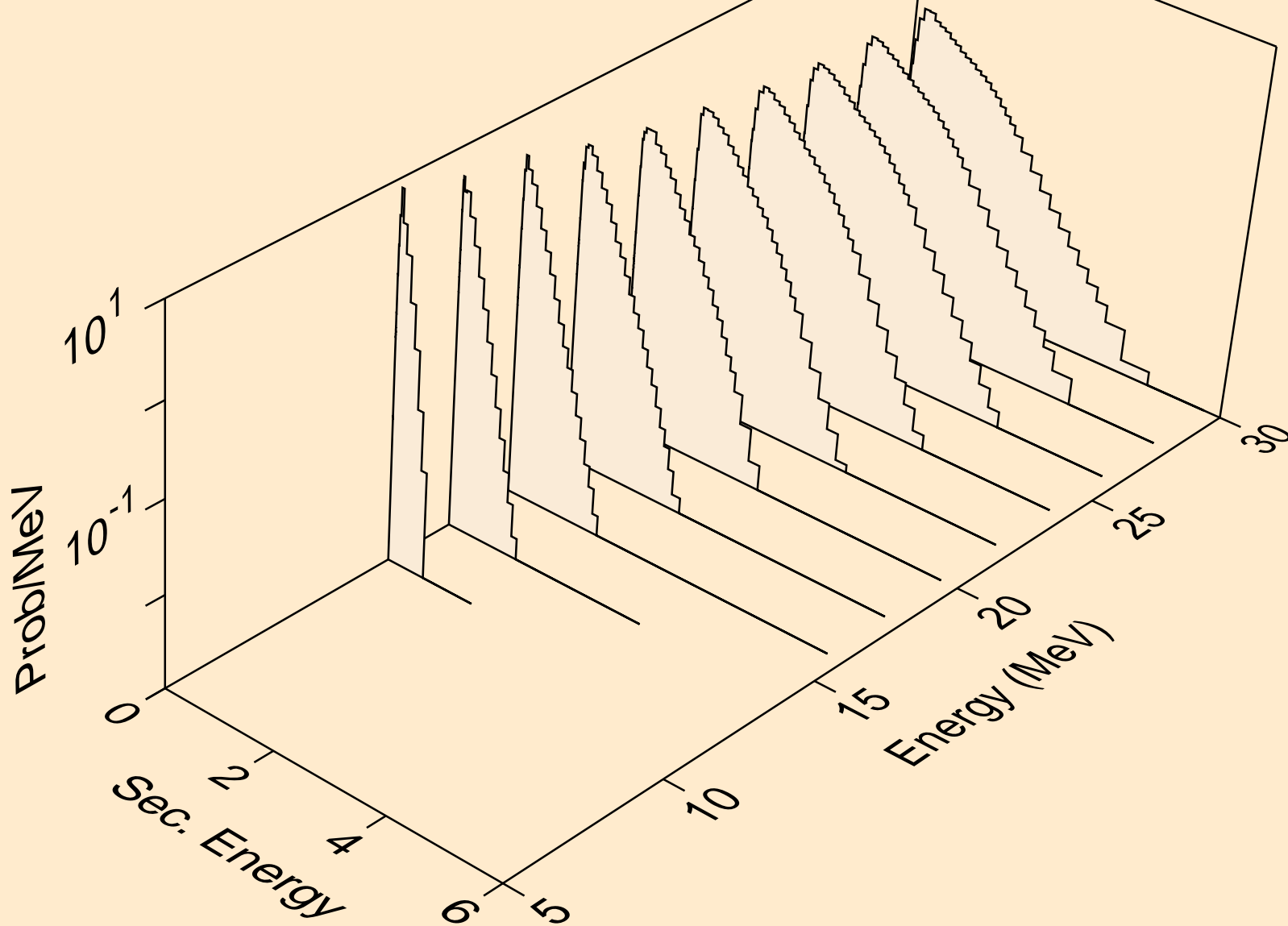

AC236 NEUTRON ACER TENDL-2023 LIBRARY; T=0.K
Neutron emission for (n,n*)he3

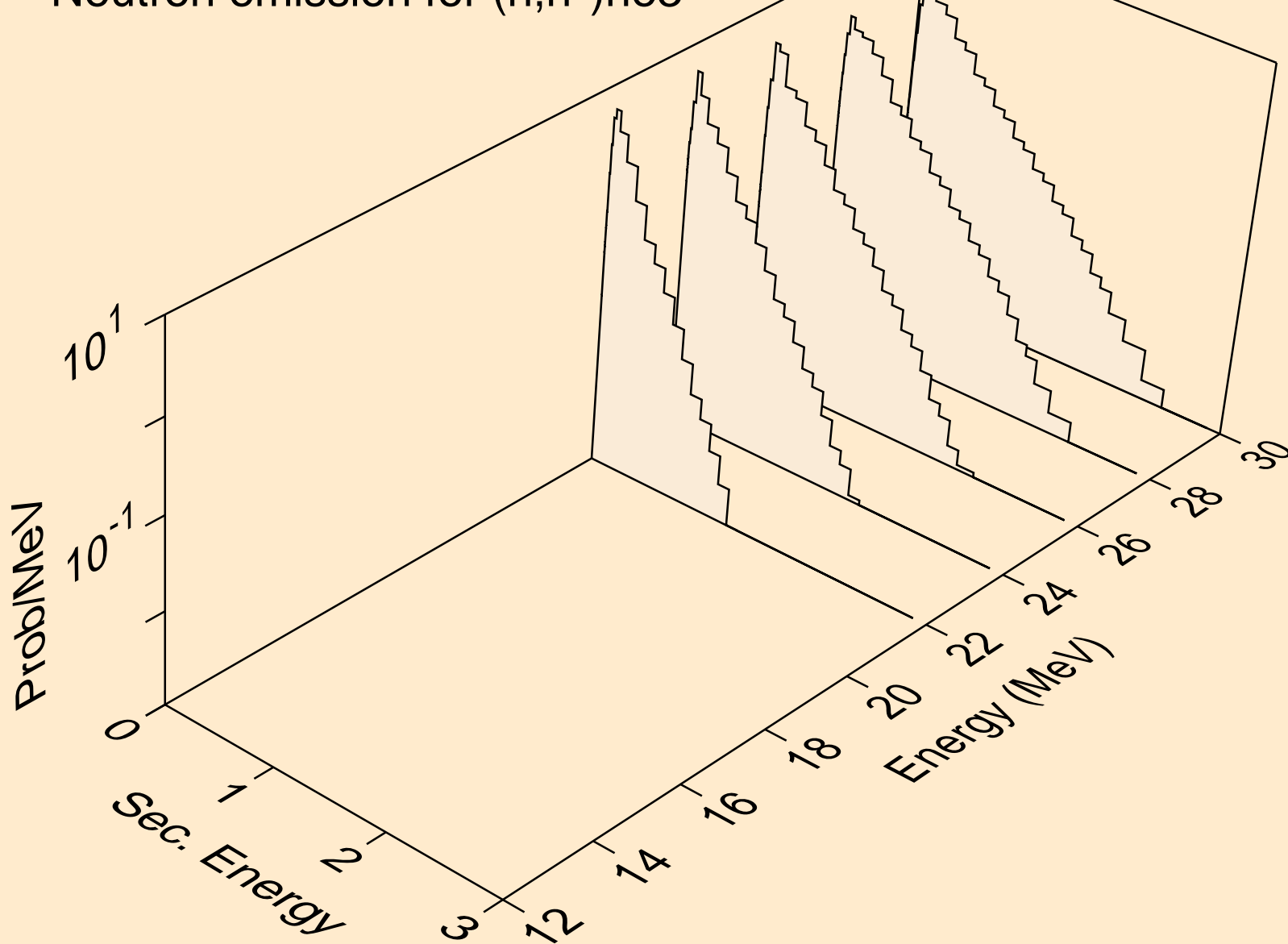

AC236 NEUTRON ACER TENDL-2023 LIBRARY; T=0.K
Neutron emission for (n,4n)

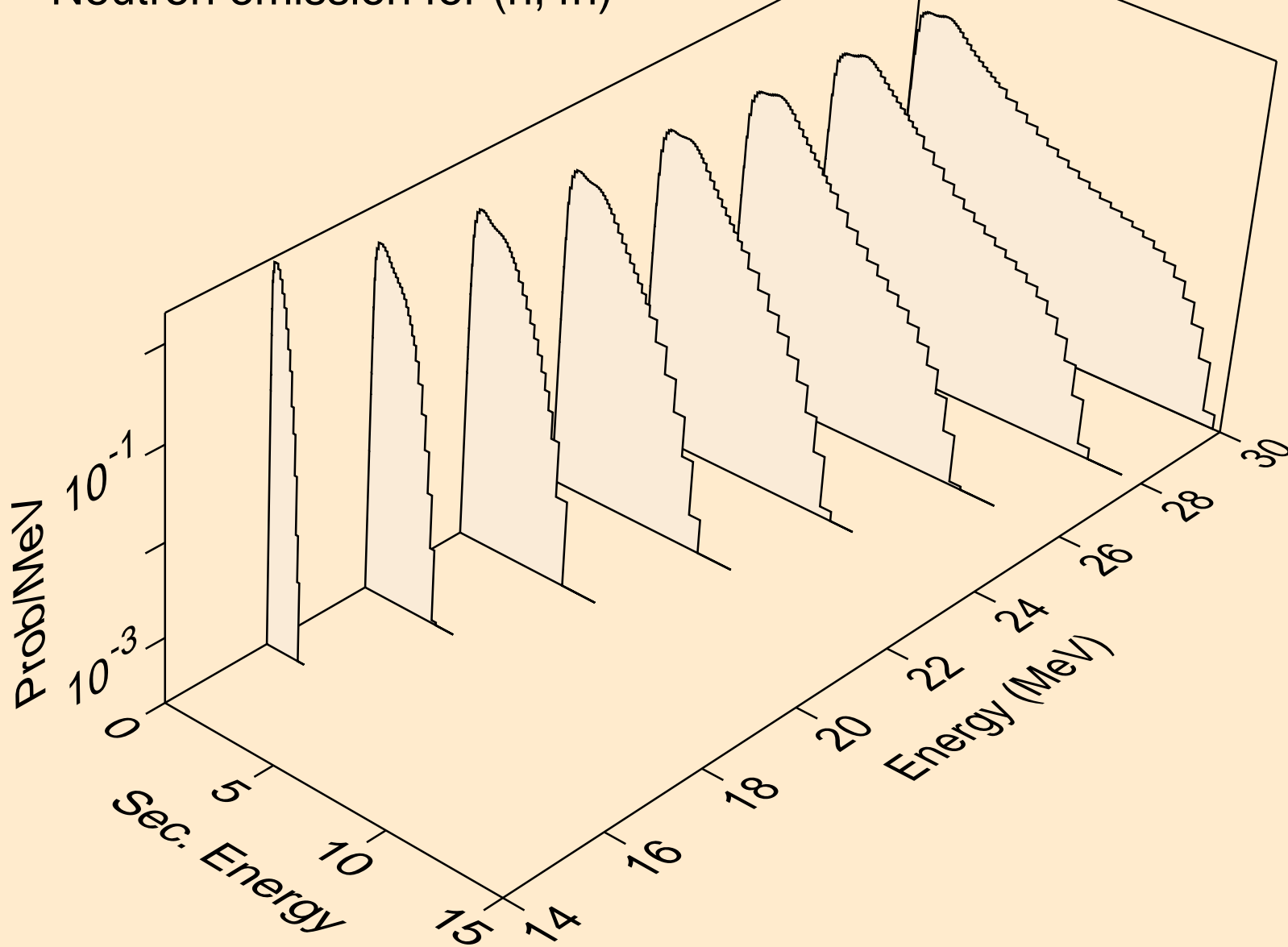

AC236 NEUTRON ACER TENDL-2023 LIBRARY; T=0.K
Neutron emission for (n,2np)

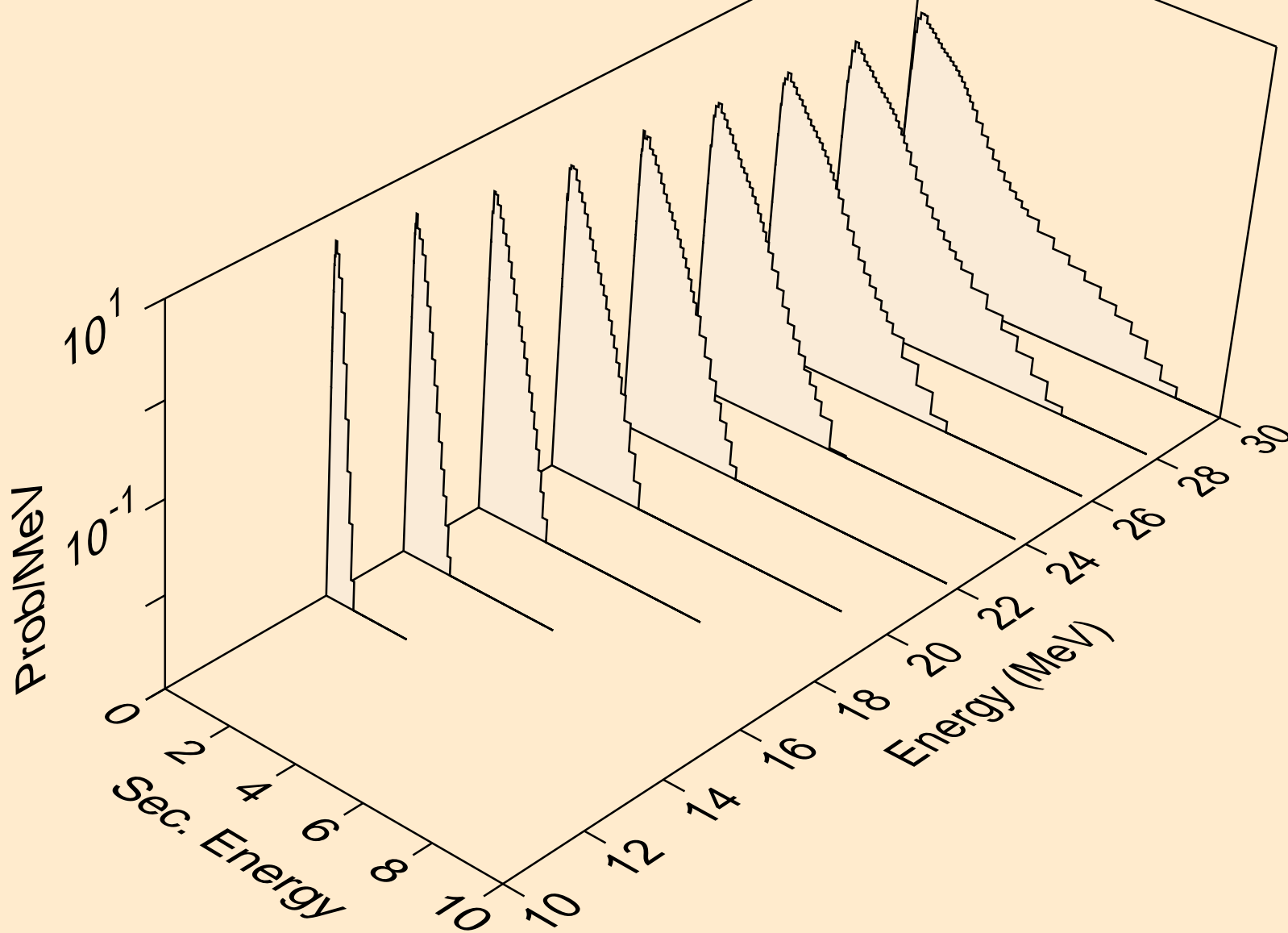

AC236 NEUTRON ACER TENDL-2023 LIBRARY; T=0.K
Neutron emission for (n,3np)

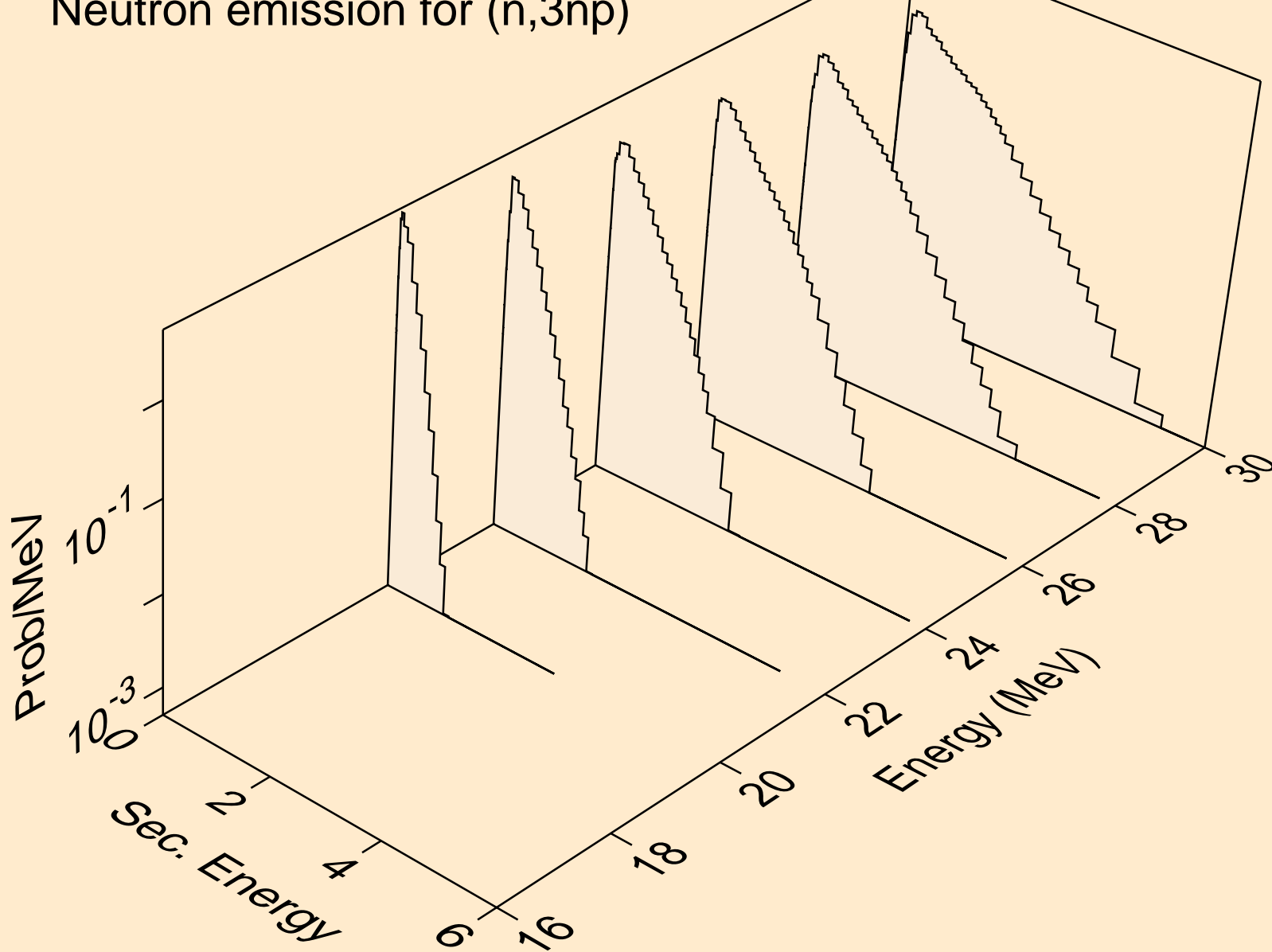

AC236 NEUTRON ACER TENDL-2023 LIBRARY; T=0.K
Neutron emission for (n,n*c)

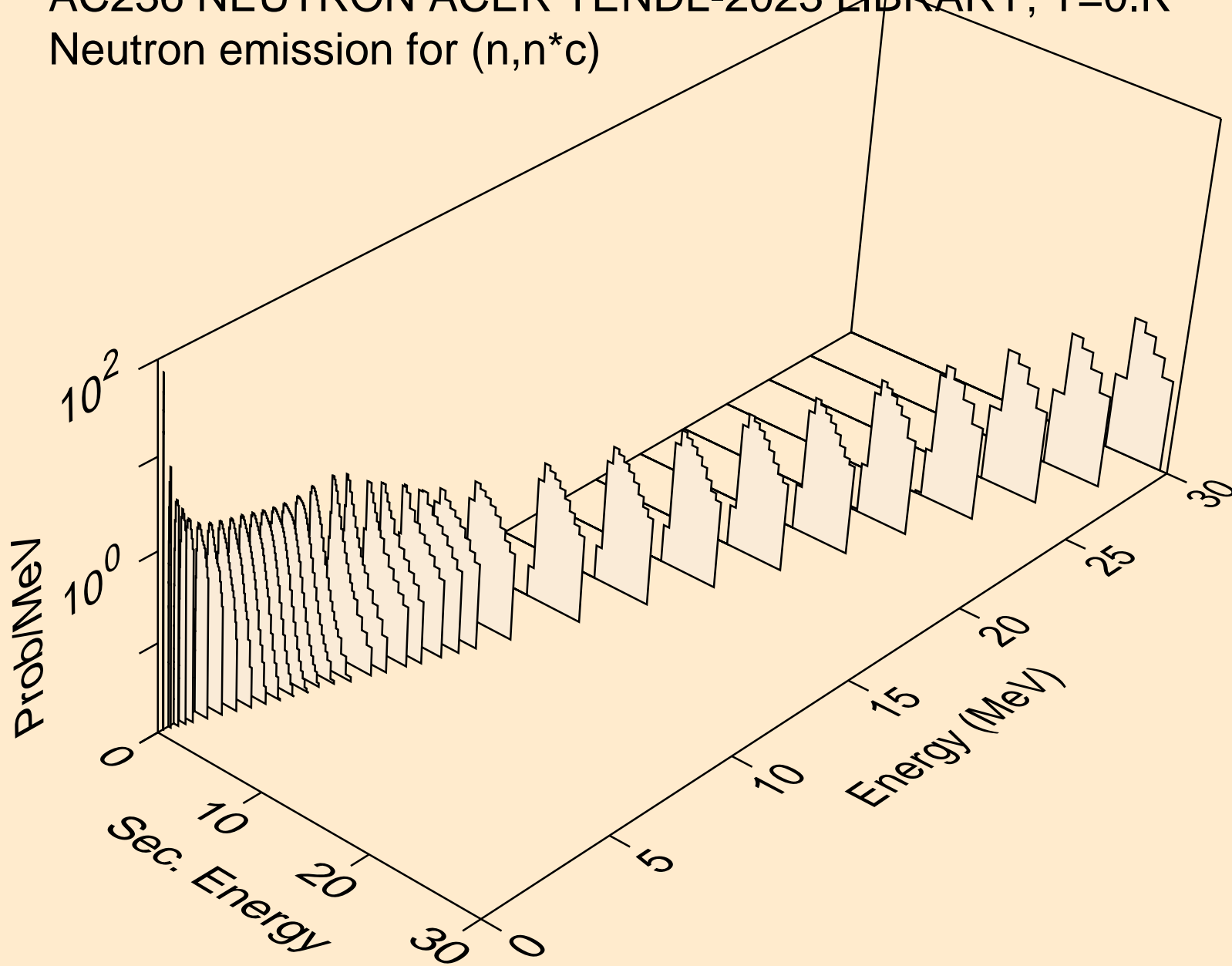

AC236 NEUTRON ACER TENDL-2023 LIBRARY; T=0.K

Delayed nubar

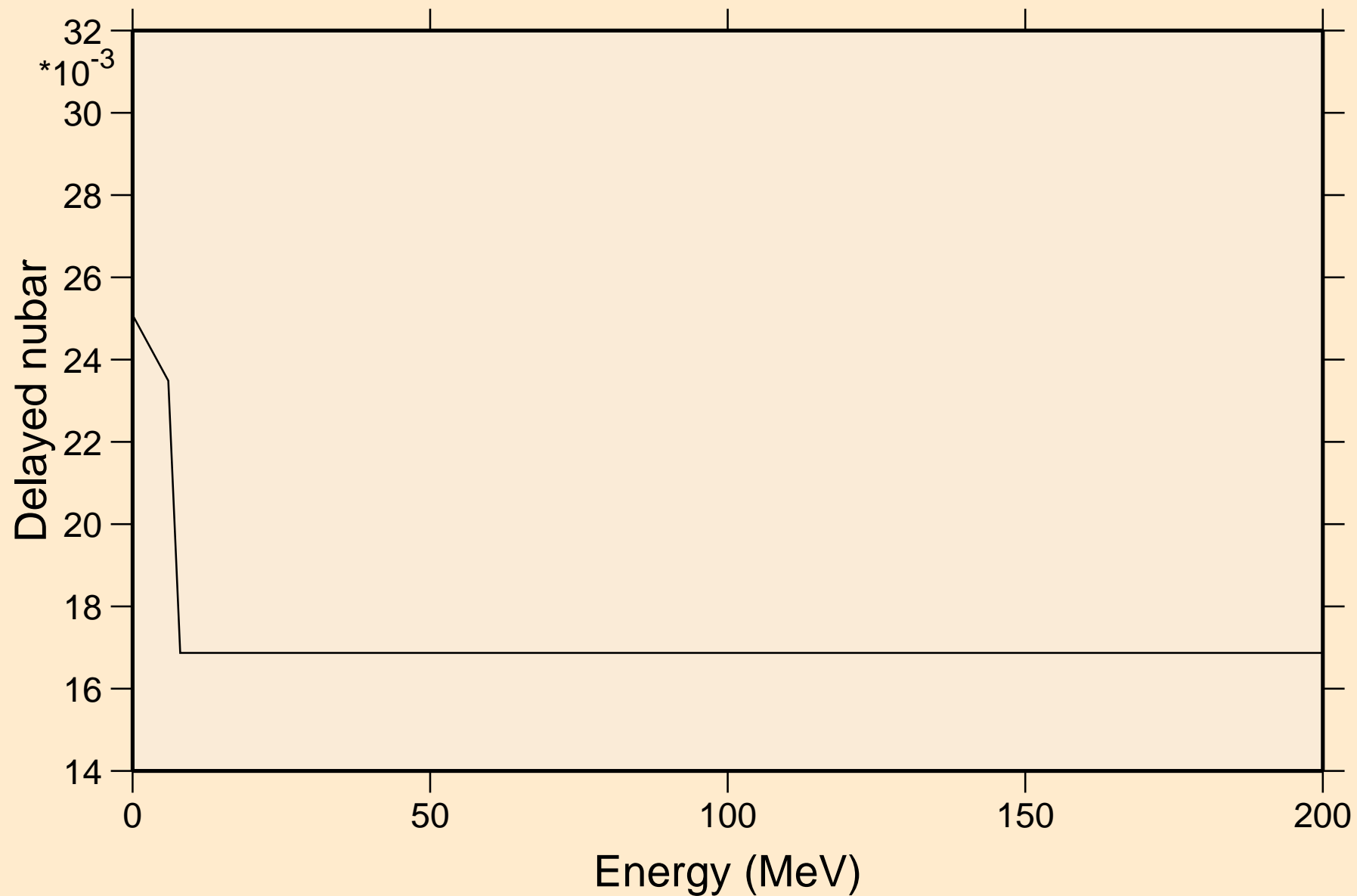

AC236 NEUTRON ACER TENDL-2023 LIBRARY; T=0.K

Delayed neutron spectra

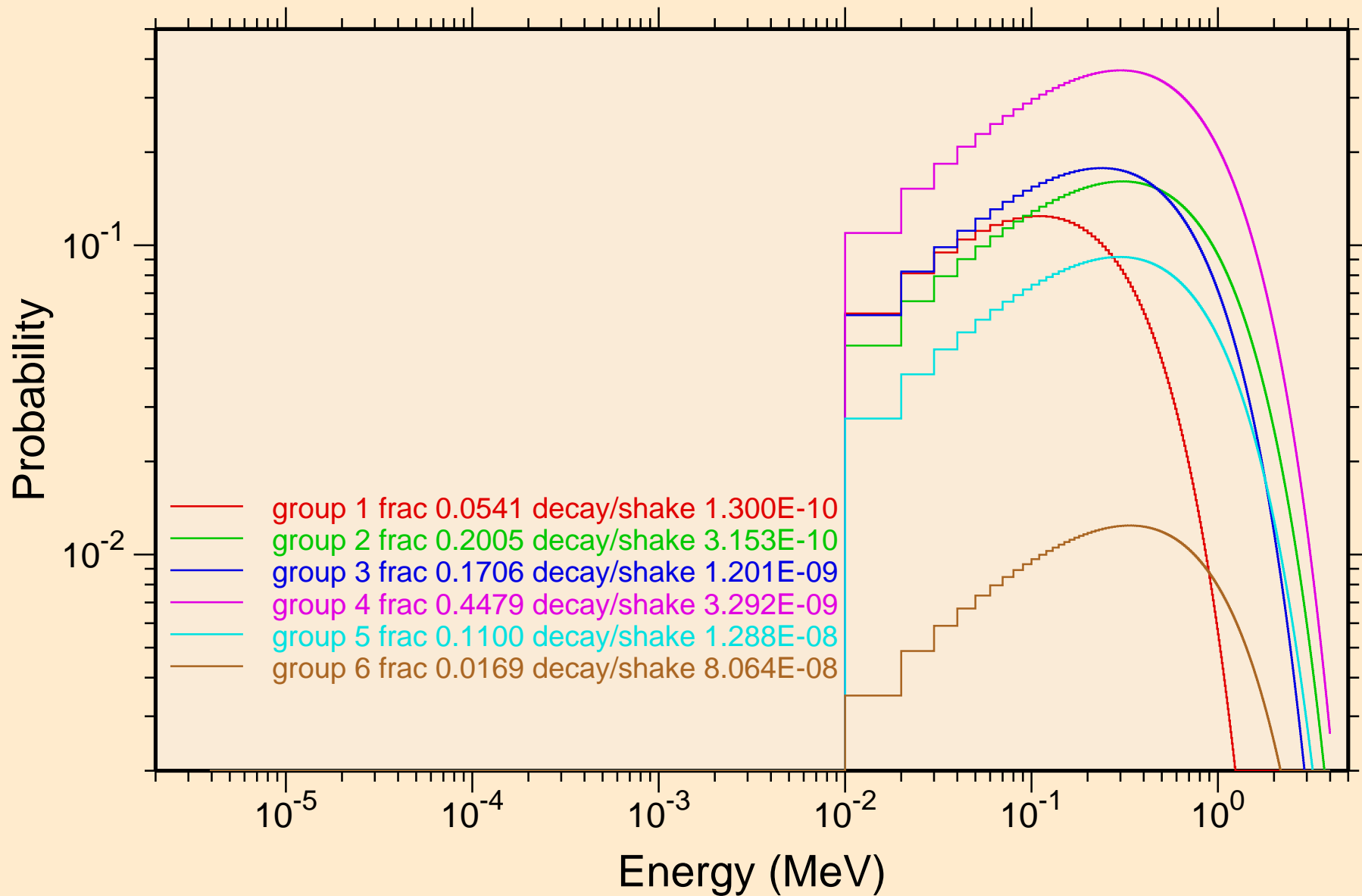

AC236 NEUTRON ACER TENDL-2023 LIBRARY; T=0.K
Photon emission for (n,x)

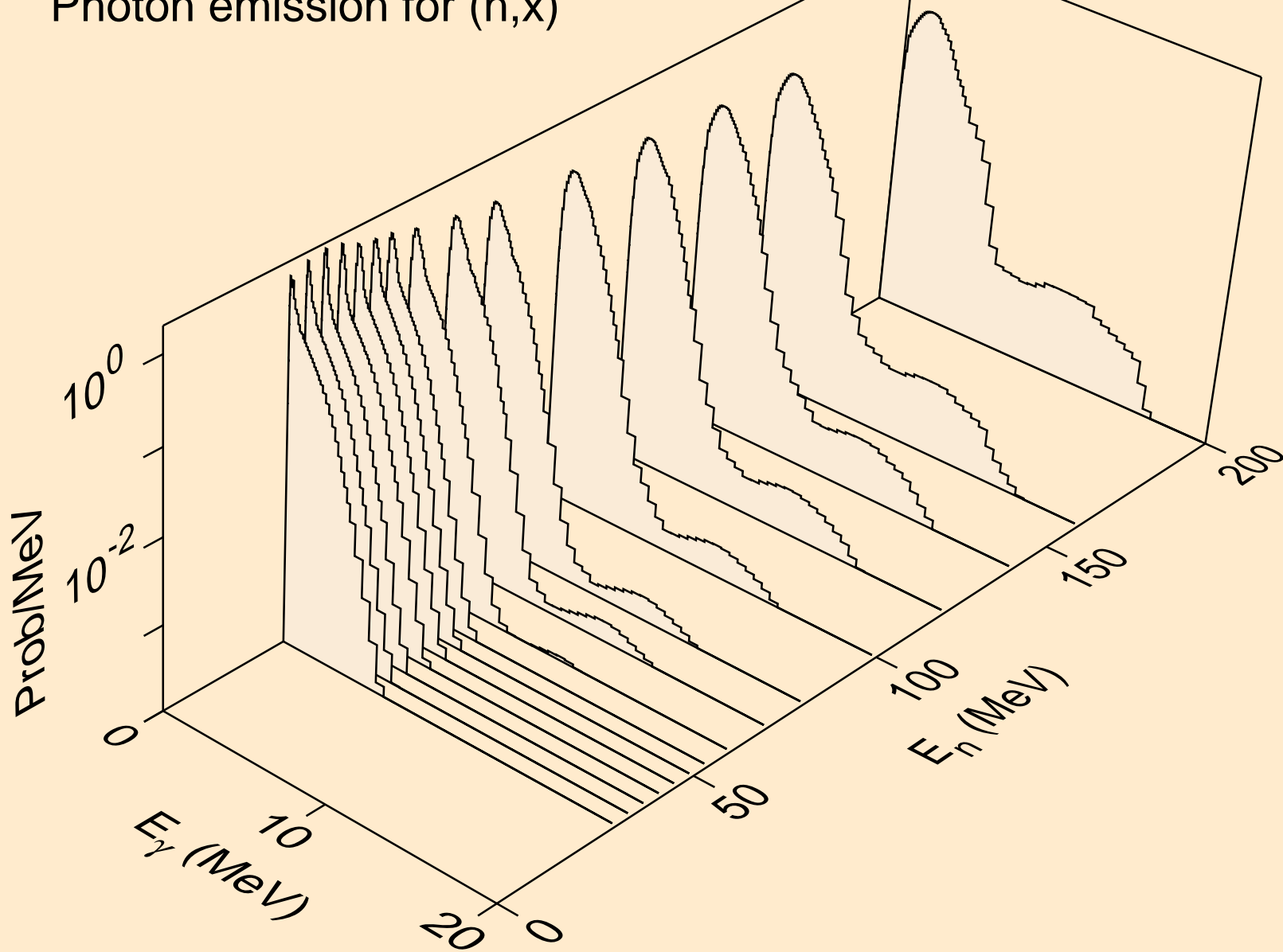

AC236 NEUTRON ACER TENDL-2023 LIBRARY; T=0.K
Photon emission for (n,2nd)

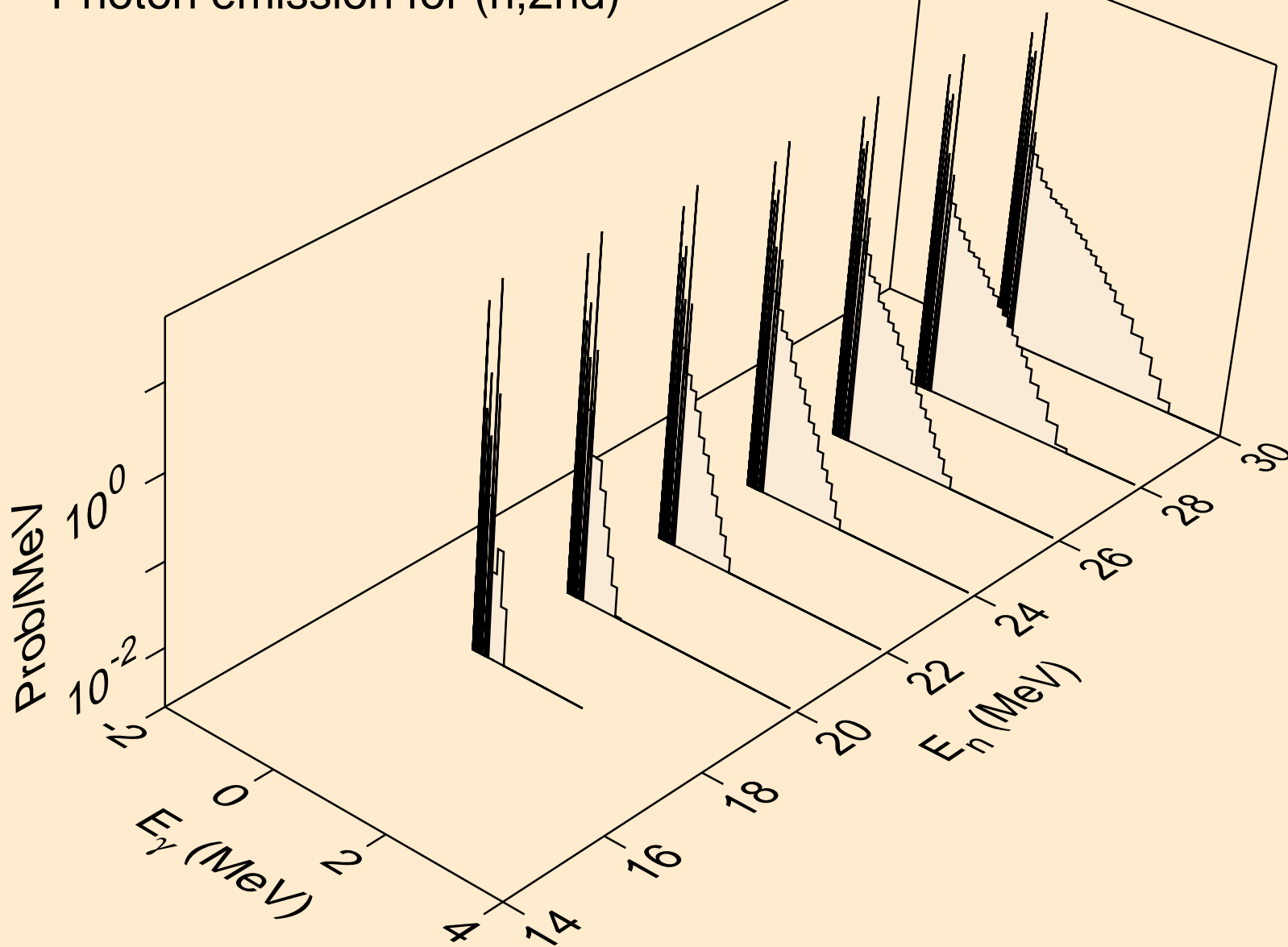

AC236 NEUTRON ACER TENDL-2023 LIBRARY; T=0.K
Photon emission for (n,2n)

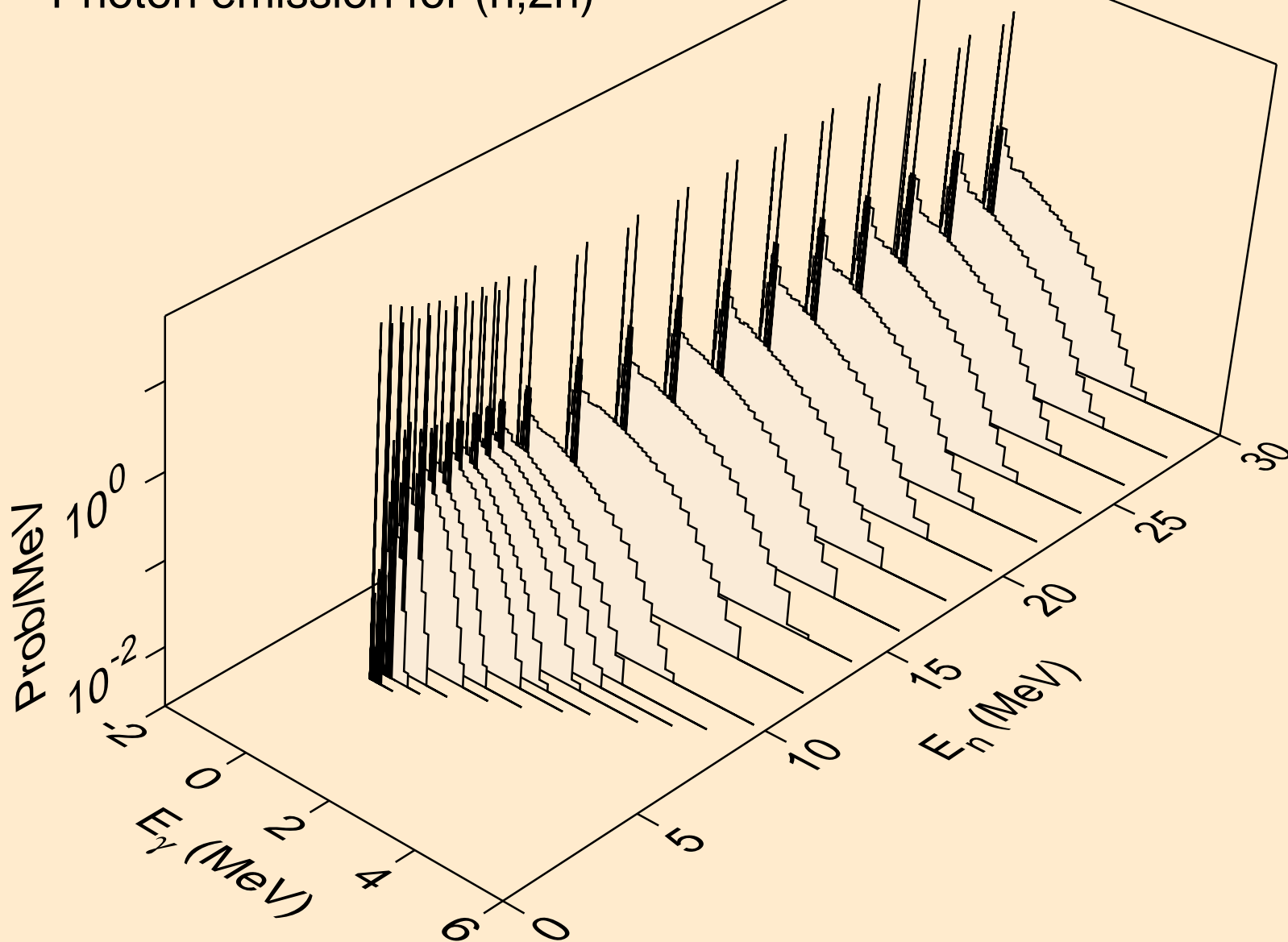

AC236 NEUTRON ACER TENDL-2023 LIBRARY; T=0.K
Photon emission for (n,3n)

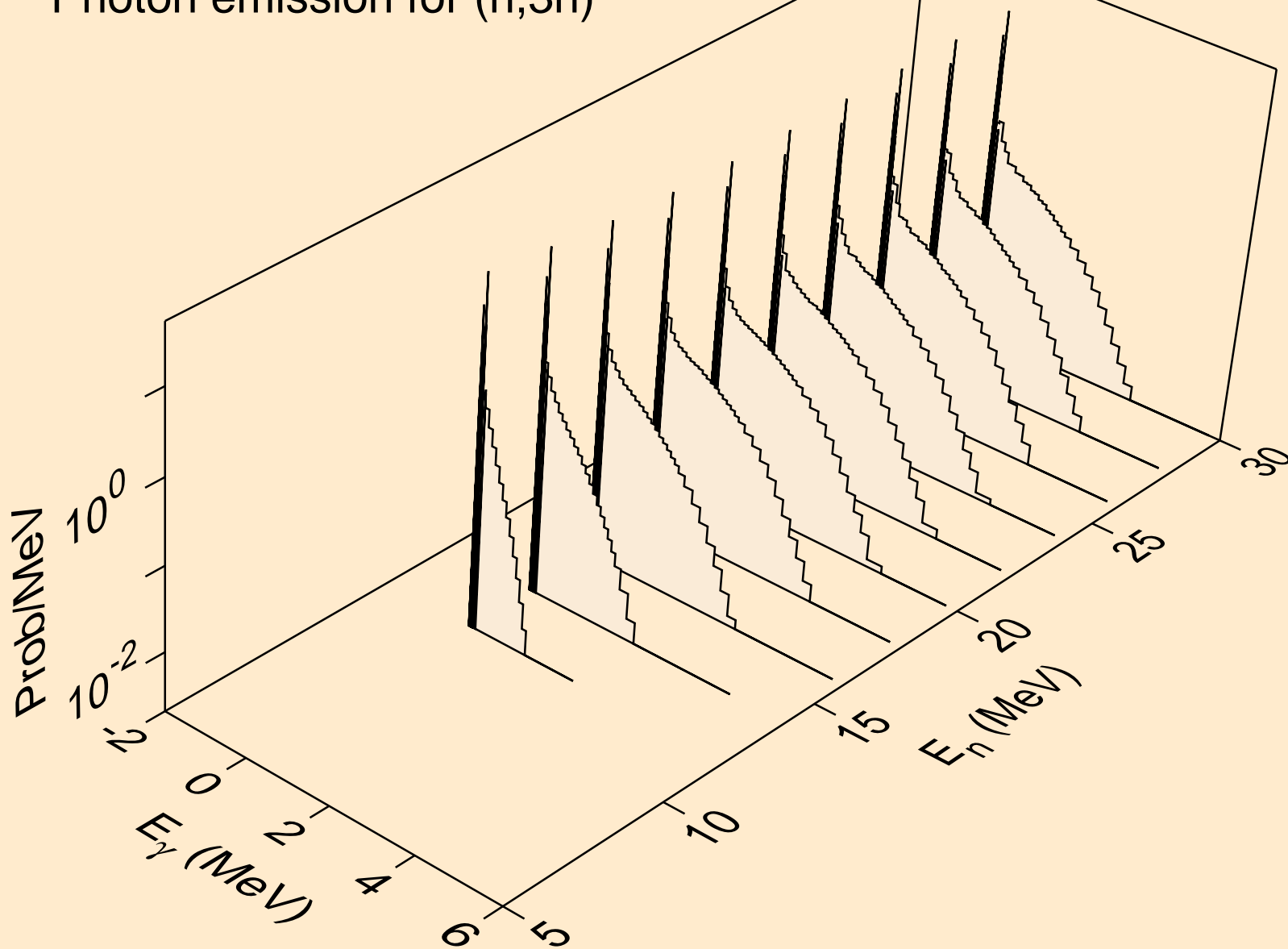

AC236 NEUTRON ACER TENDL-2023 LIBRARY; T=0.K
Photon emission for (n,n*)a

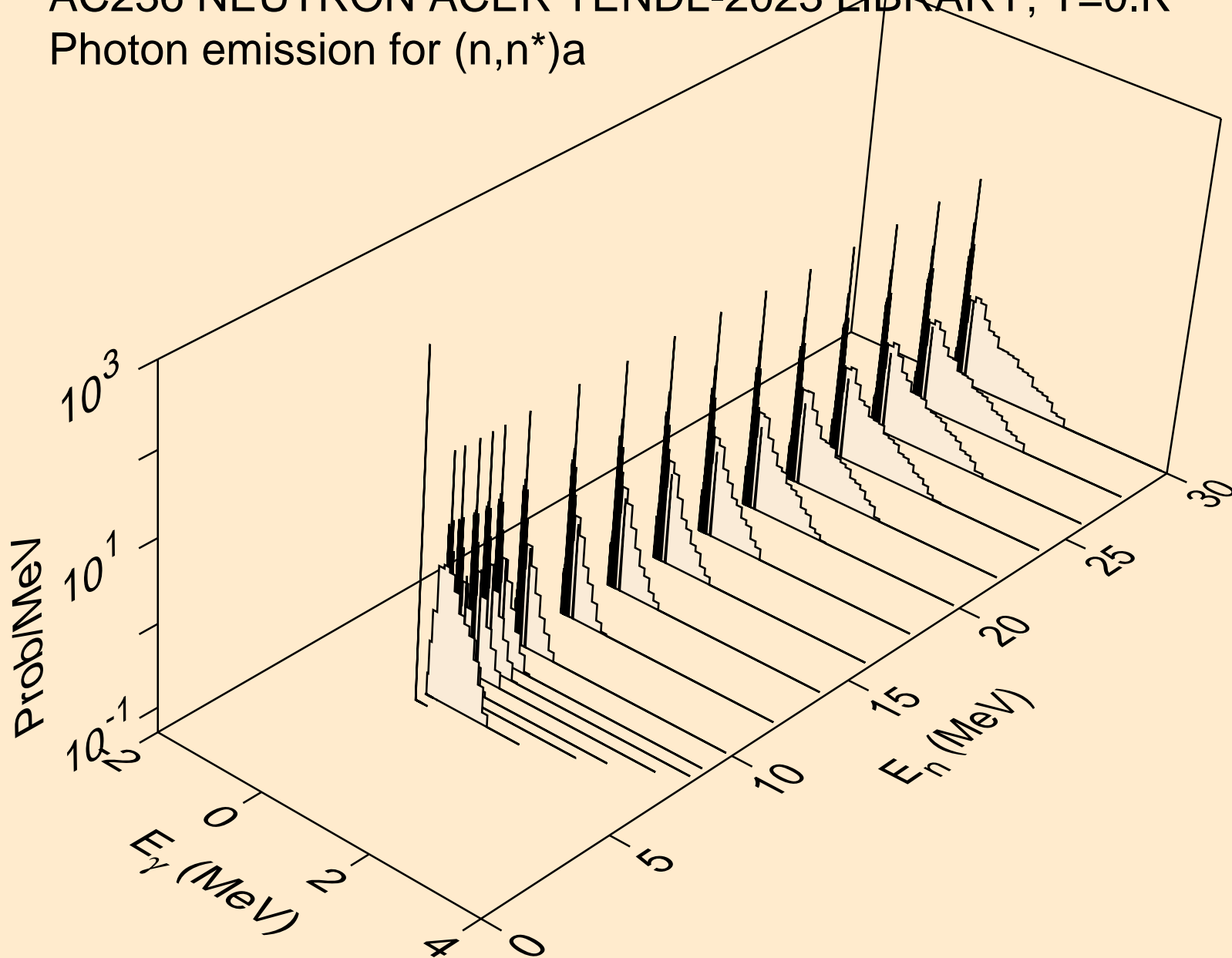

AC236 NEUTRON ACER TENDL-2023 LIBRARY; T=0.K
Photon emission for (n,2n) α

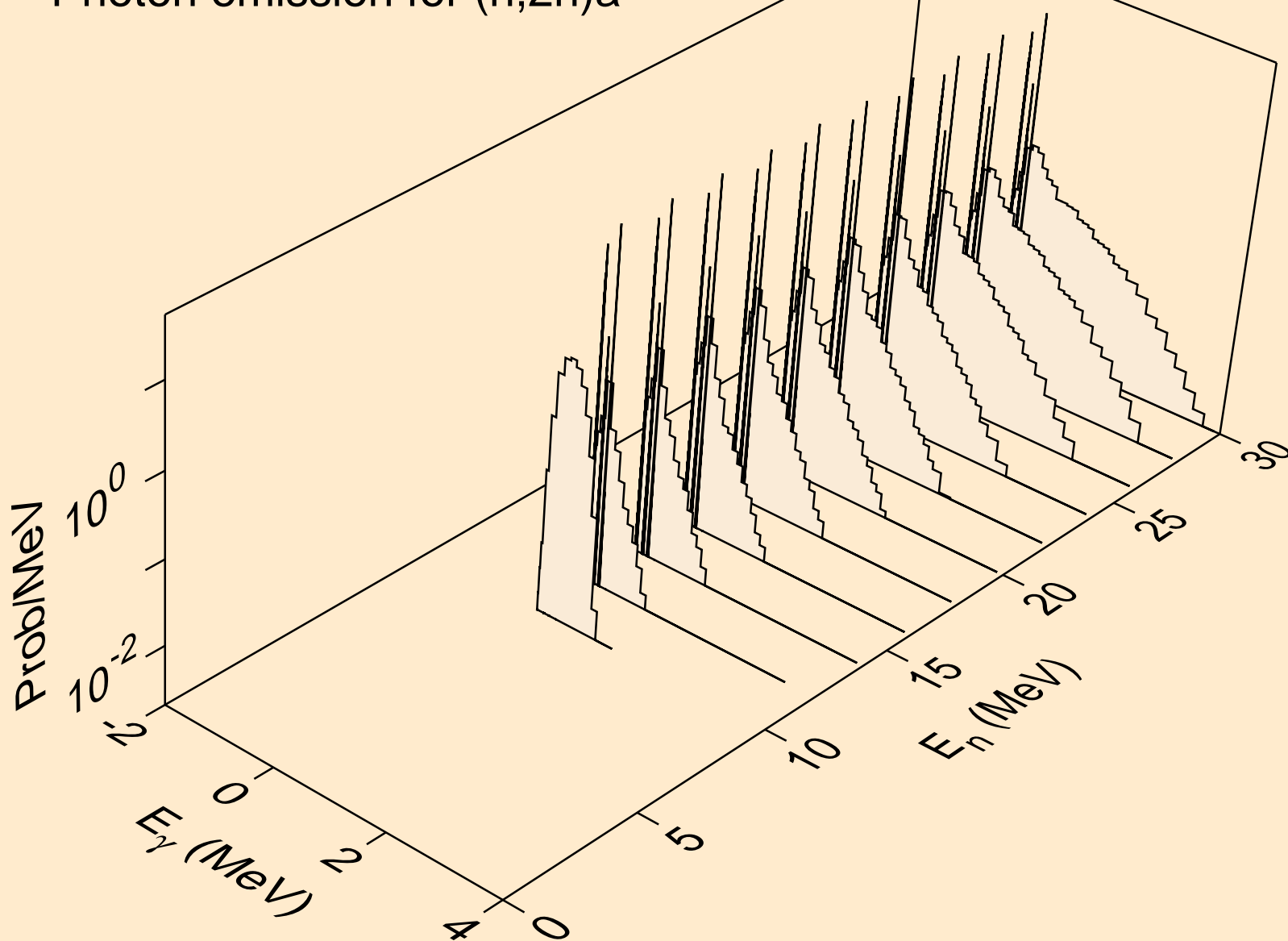

AC236 NEUTRON ACER TENDL-2023 LIBRARY; T=0.K
Photon emission for (n,3n)a

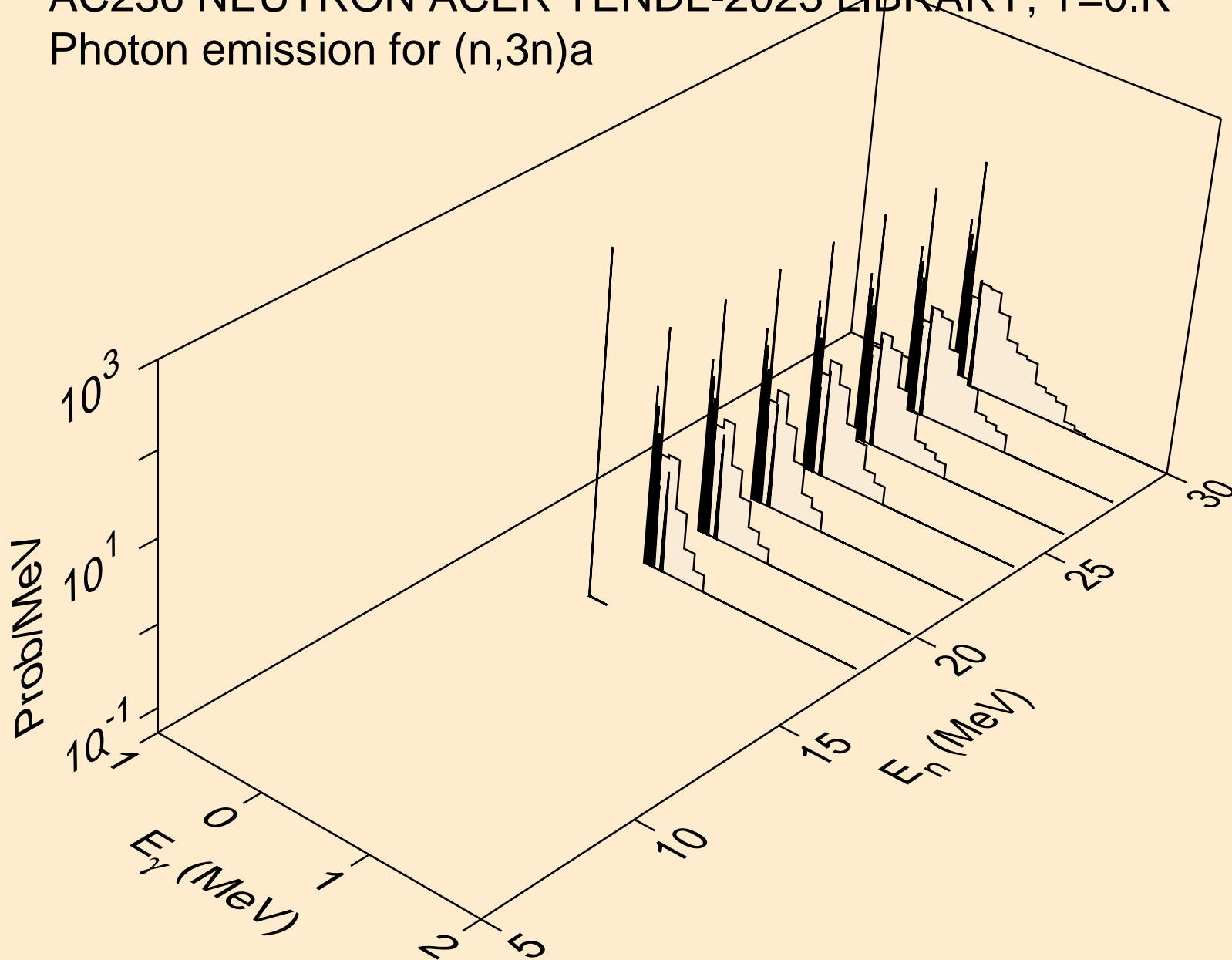

AC236 NEUTRON ACER TENDL-2023 LIBRARY; T=0.K
Photon emission for (n,n*)p

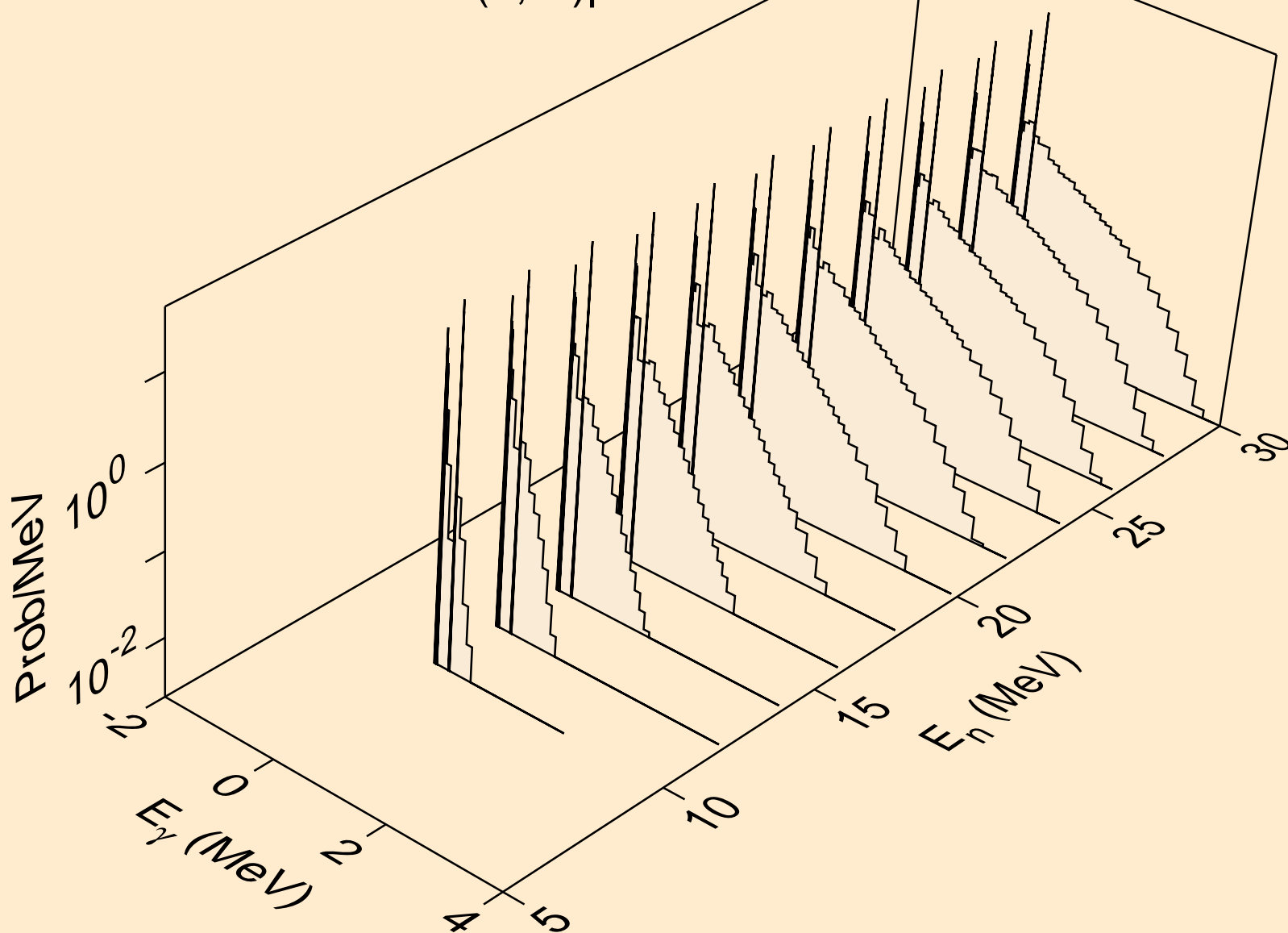

AC236 NEUTRON ACER TENDL-2023 LIBRARY; T=0.K
Photon emission for (n,n*)d

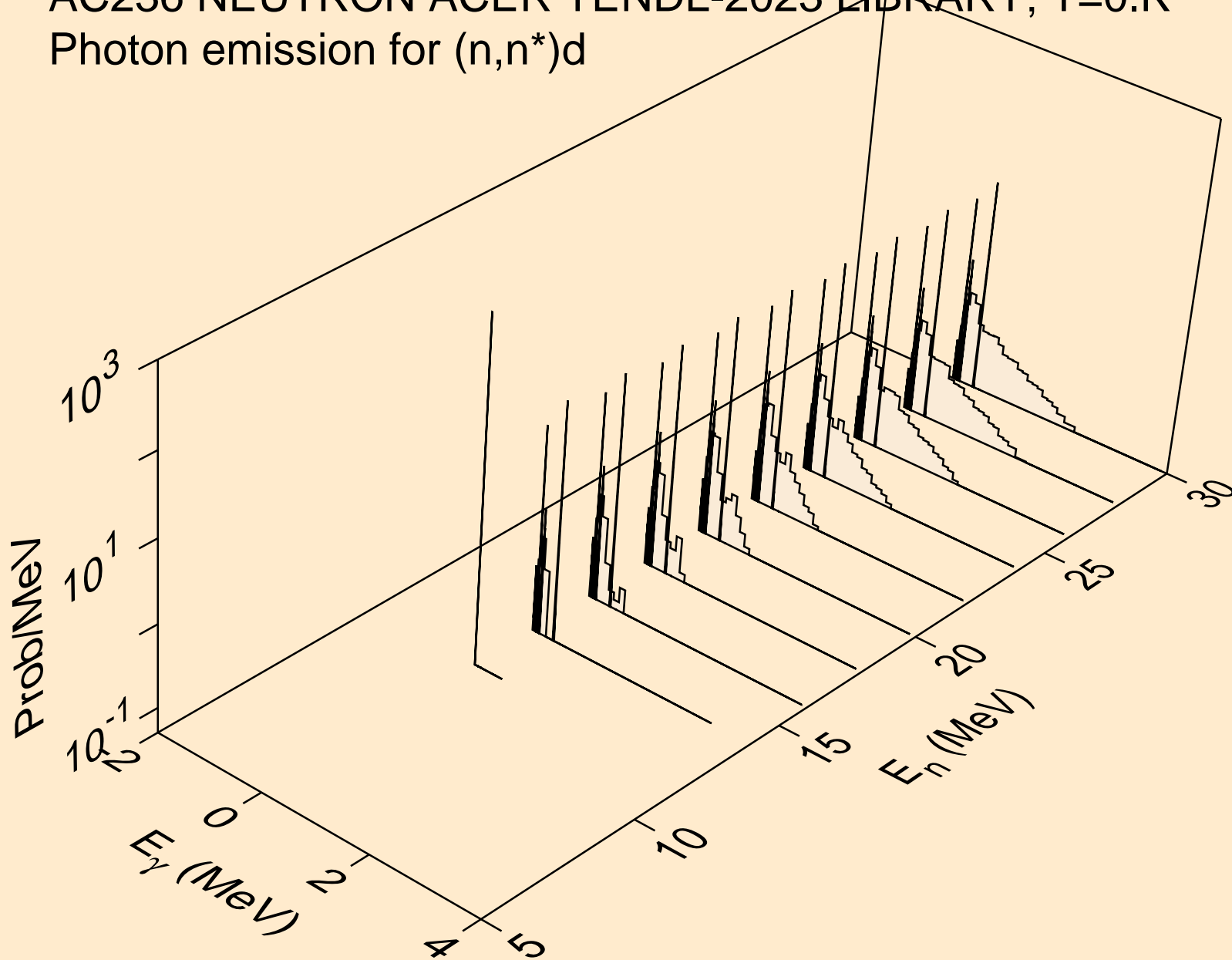

AC236 NEUTRON ACER TENDL-2023 LIBRARY; T=0.K
Photon emission for (n,n*)t

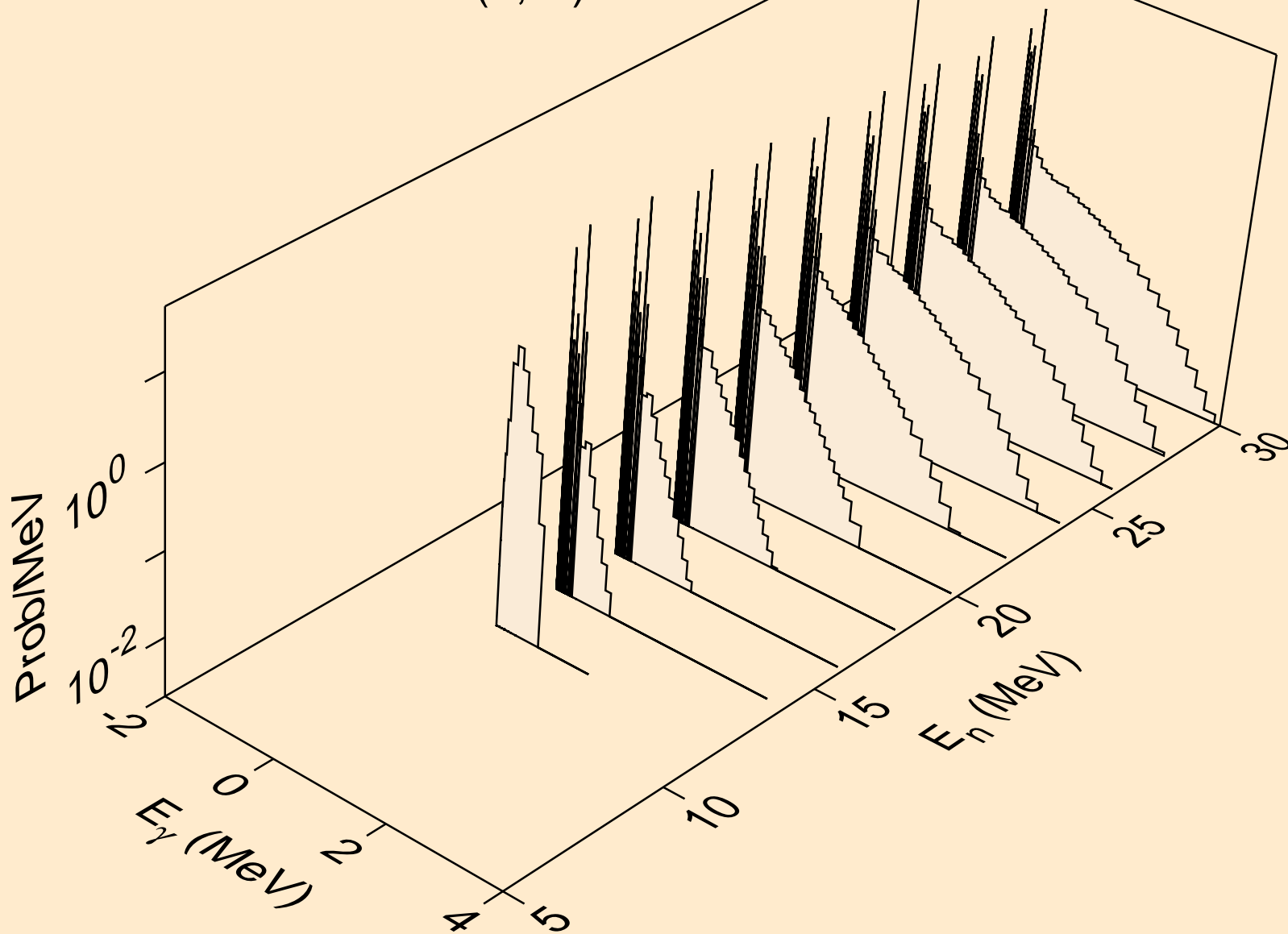

AC236 NEUTRON ACER TENDL-2023 LIBRARY; T=0.K
Photon emission for (n,n*)he3

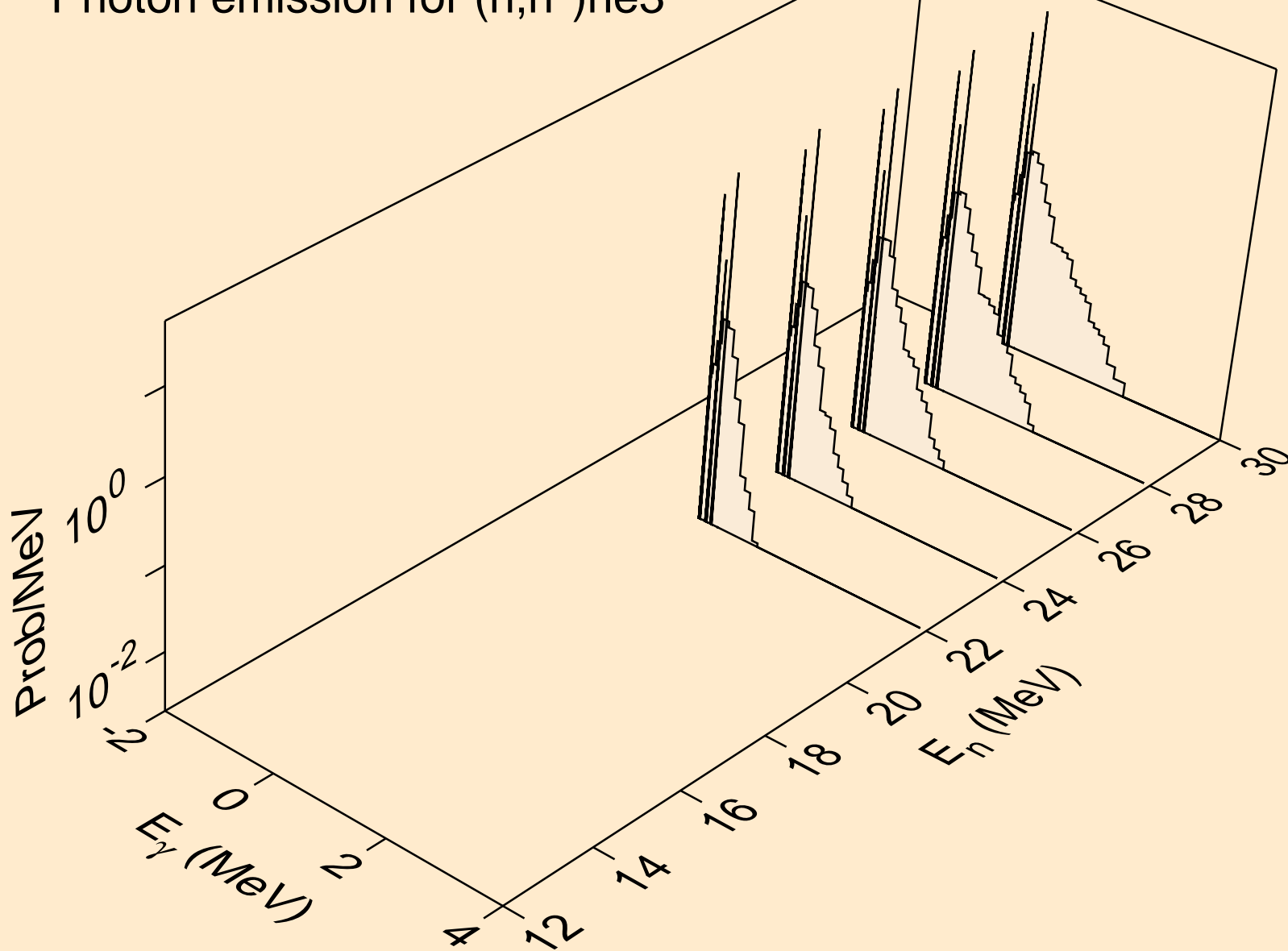

AC236 NEUTRON ACER TENDL-2023 LIBRARY; T=0.K
Photon emission for (n,4n)

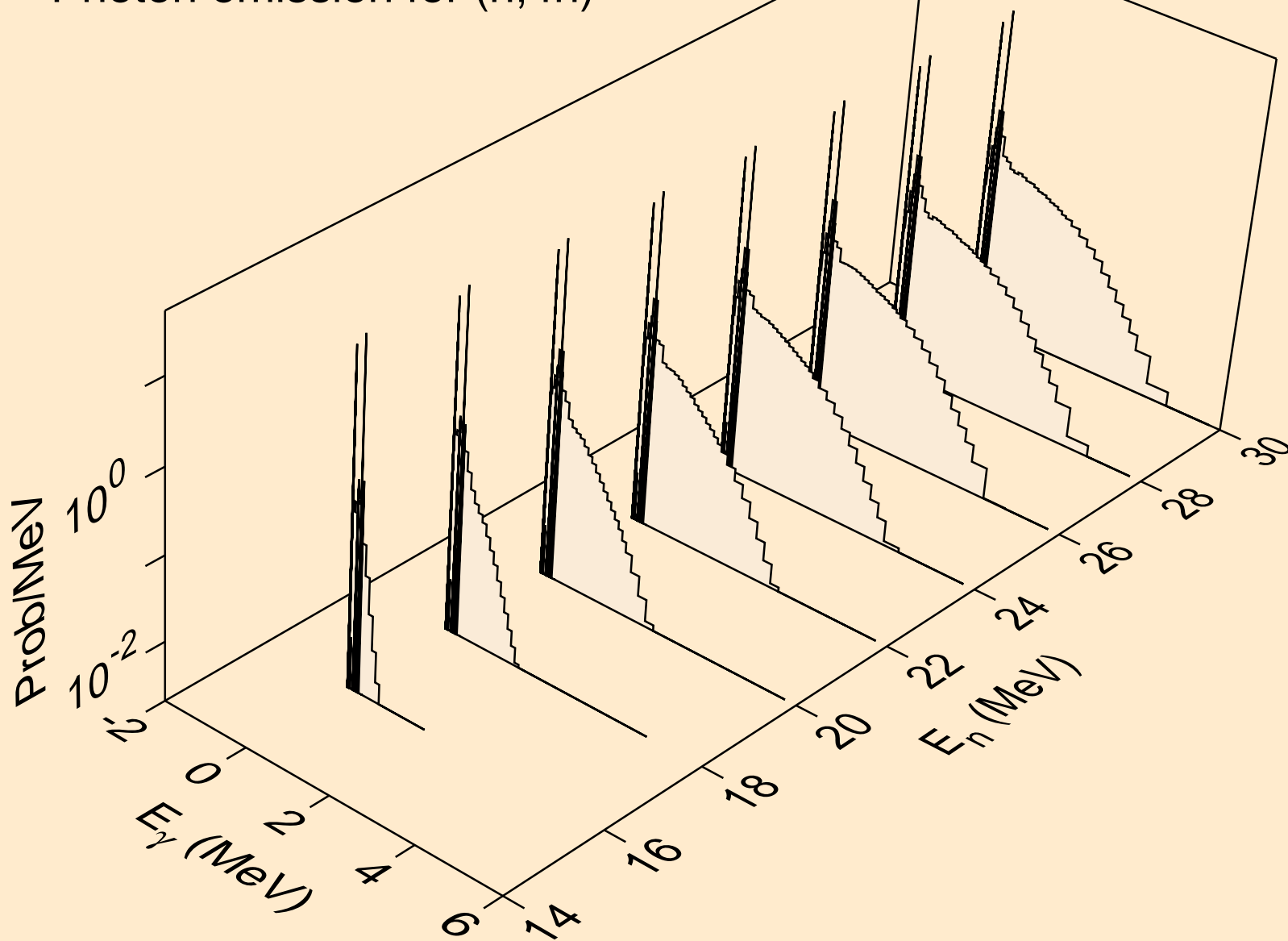

AC236 NEUTRON ACER TENDL-2023 LIBRARY; T=0.K
Photon emission for (n,2np)

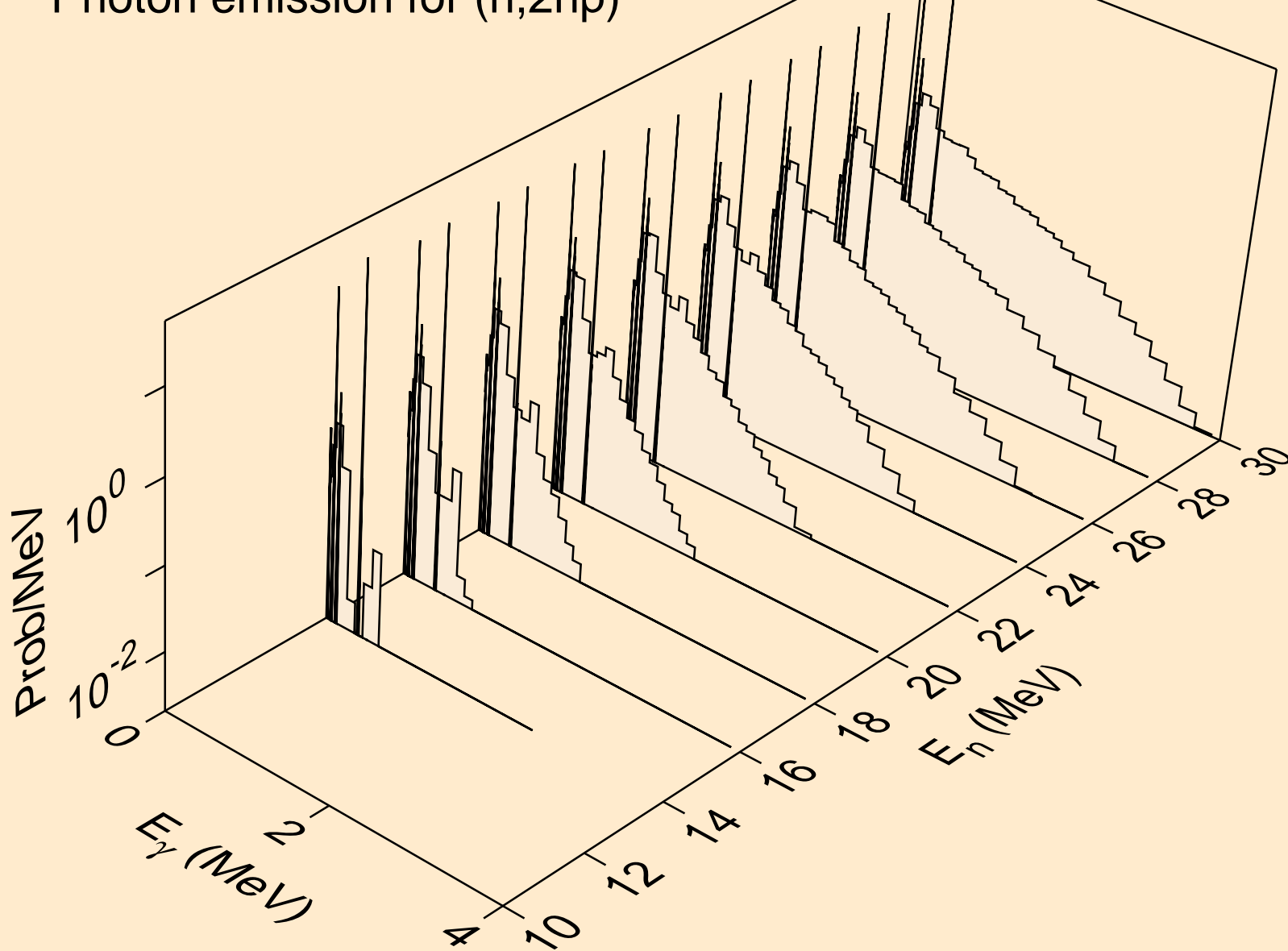

AC236 NEUTRON ACER TENDL-2023 LIBRARY; T=0.K
Photon emission for (n,3np)

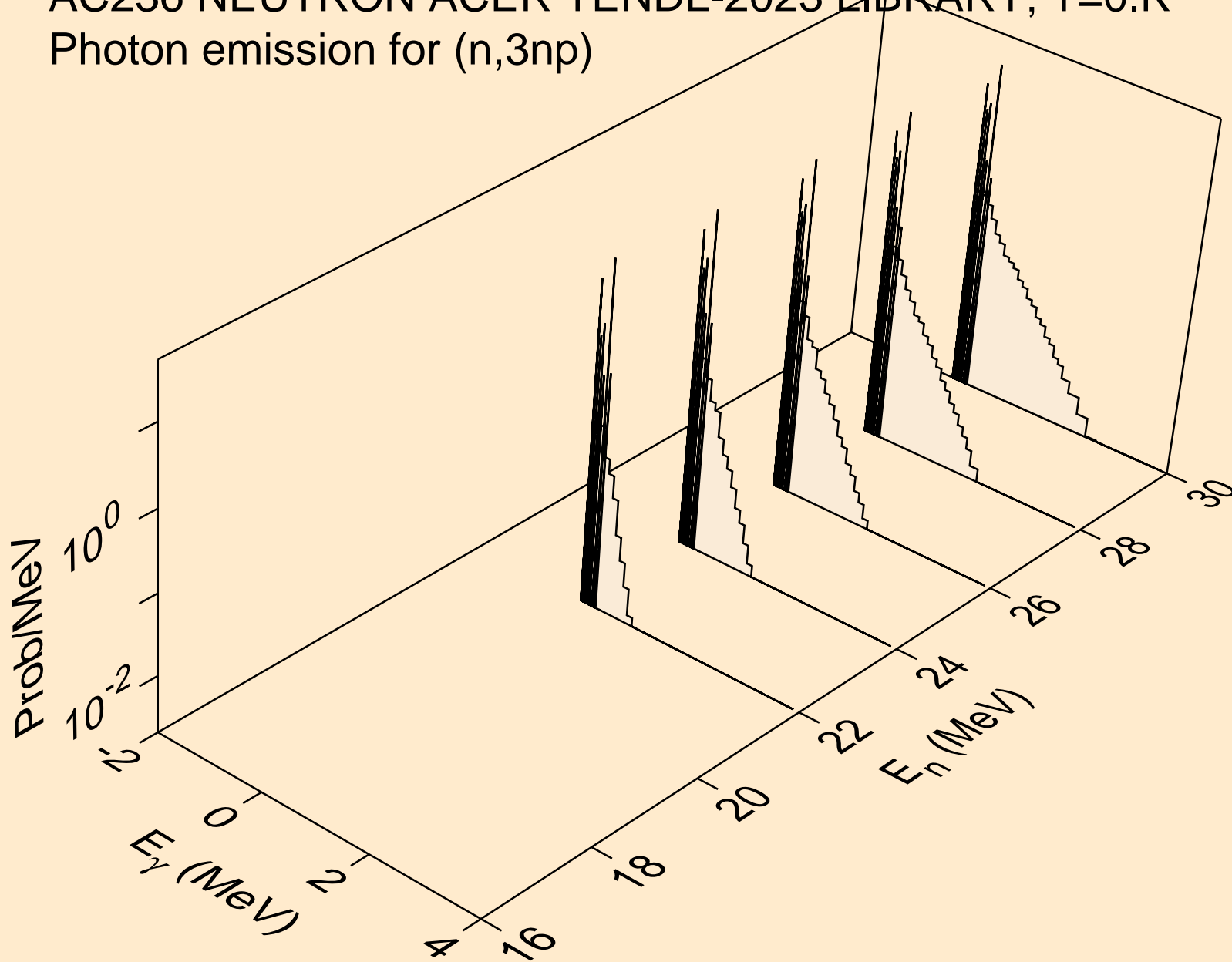

AC236 NEUTRON ACER TENDL-2023 LIBRARY; T=0.K
Photon emission for (n,n*c)

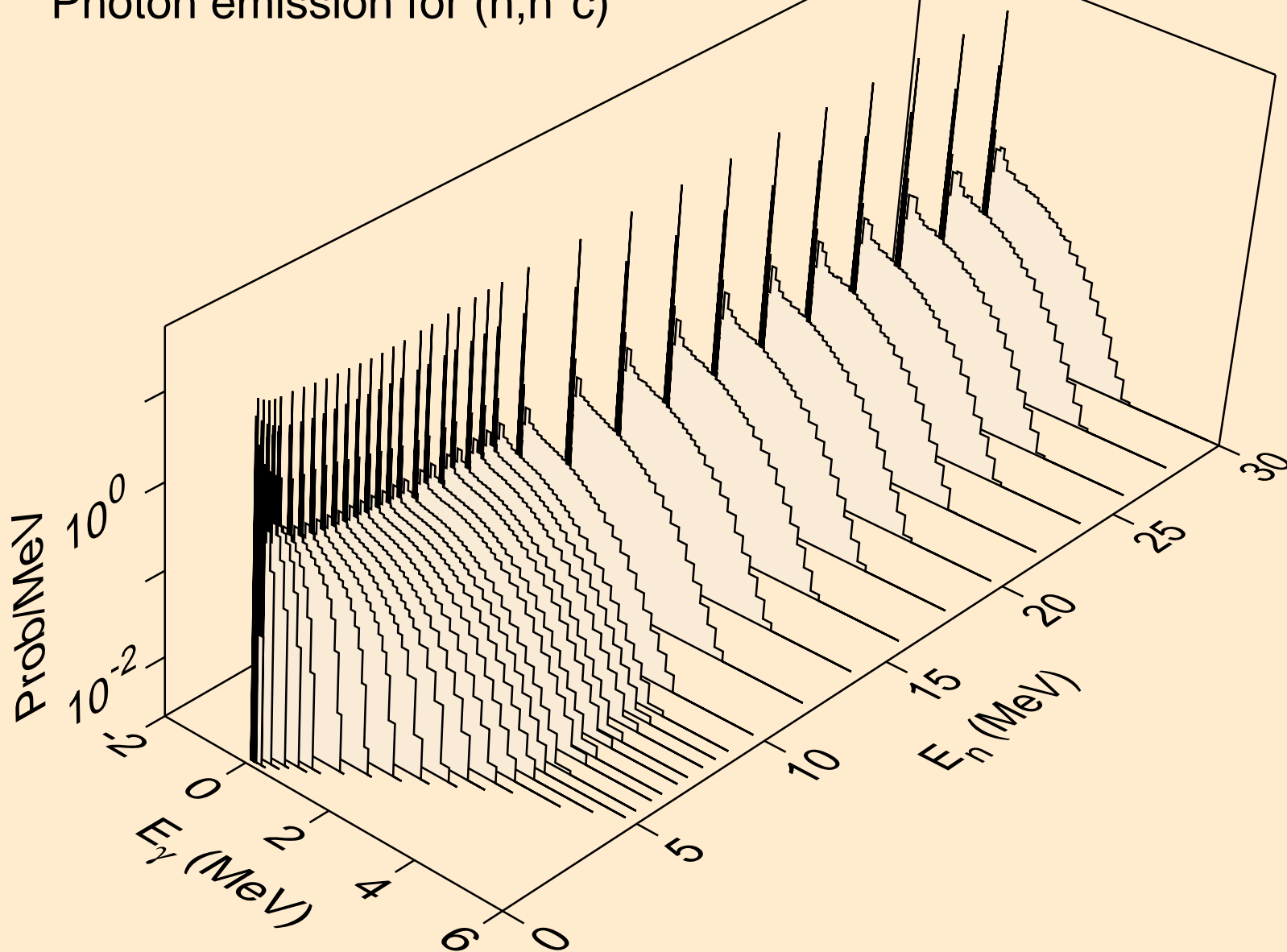

AC236 NEUTRON ACER TENDL-2023 LIBRARY; T=0.K
Photon emission for (n,gma)

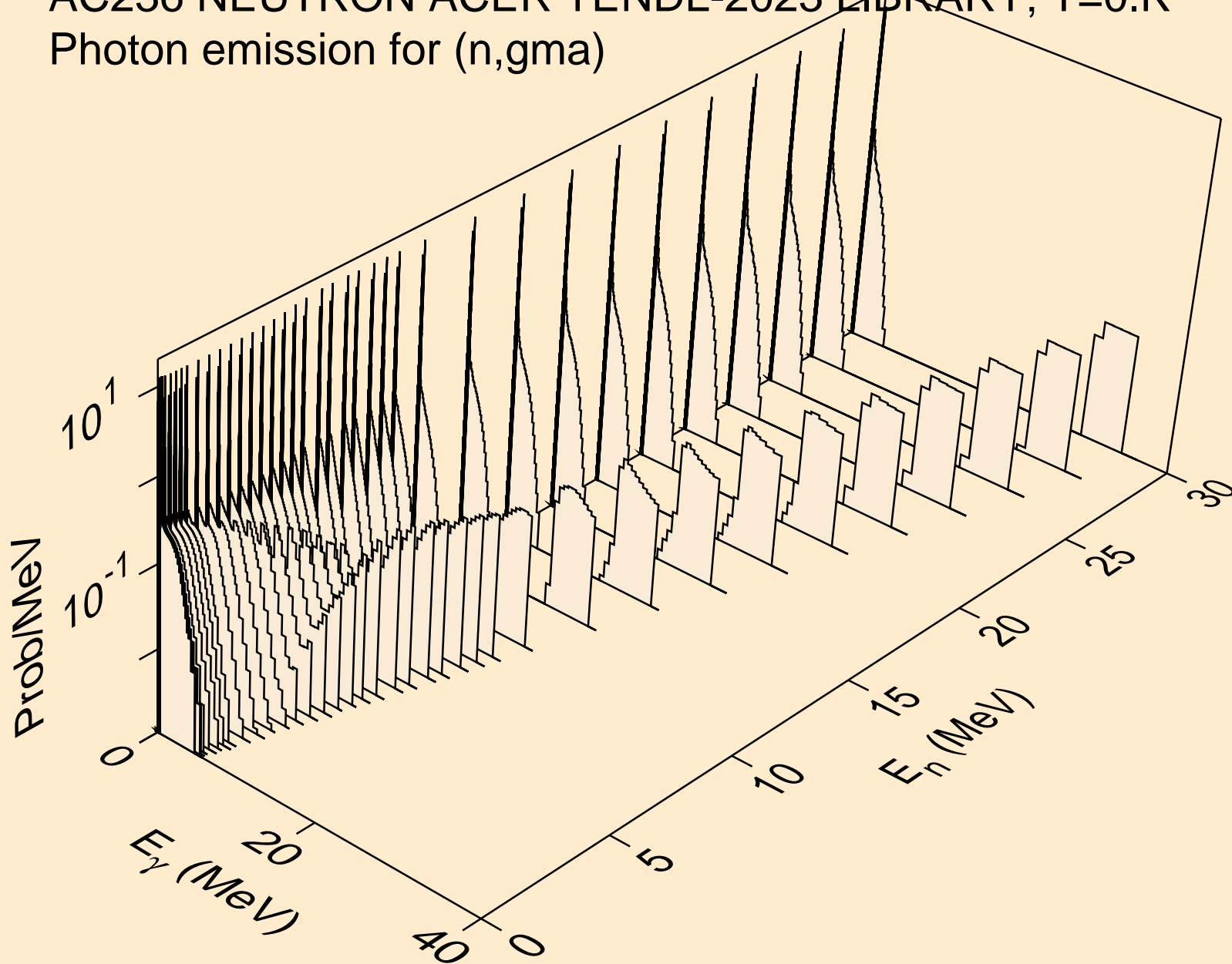

AC236 NEUTRON ACER TENDL-2023 LIBRARY; T=0.K
Photon emission for (n,p)

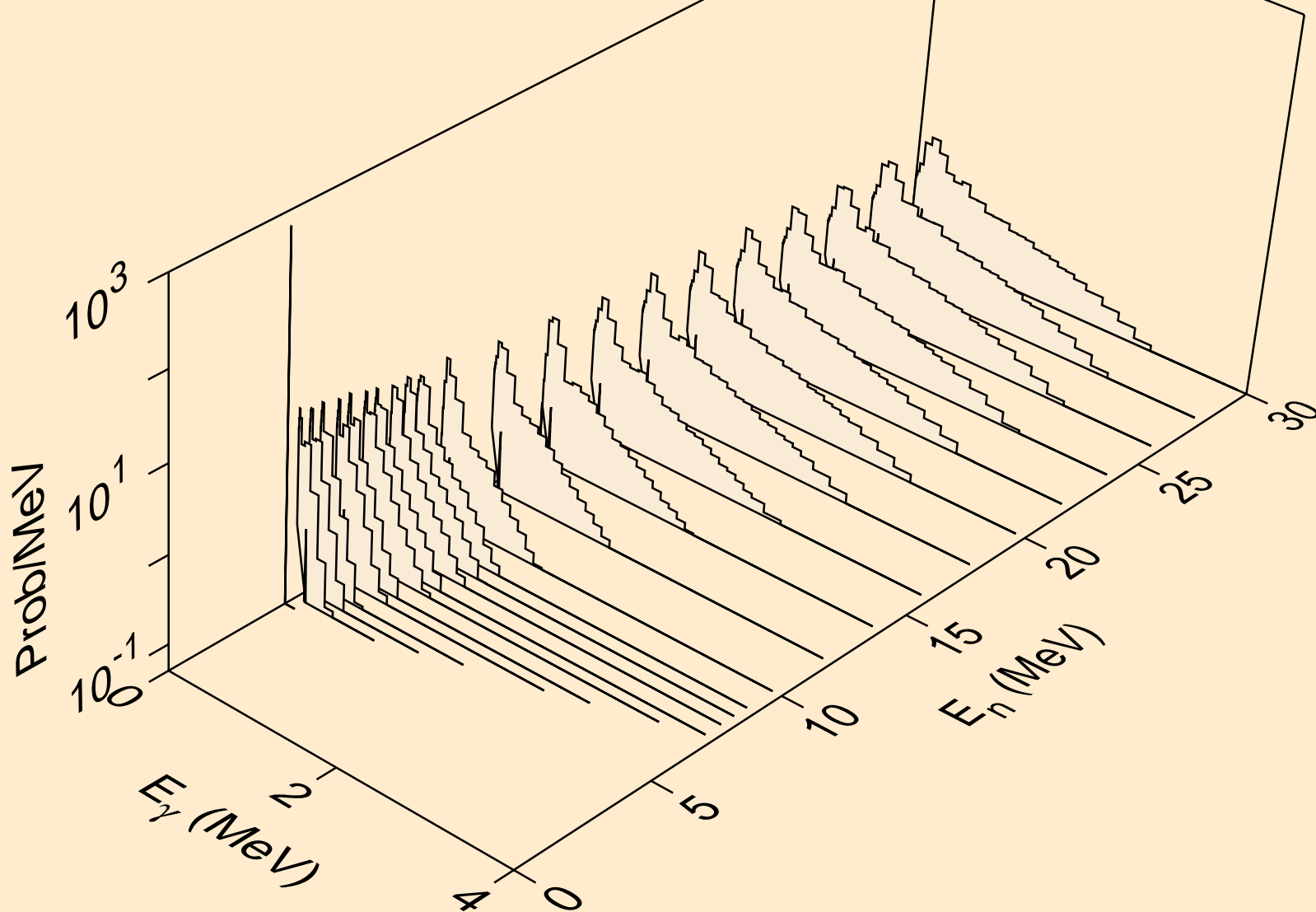

AC236 NEUTRON ACER TENDL-2023 LIBRARY; T=0.K
Photon emission for (n,d)

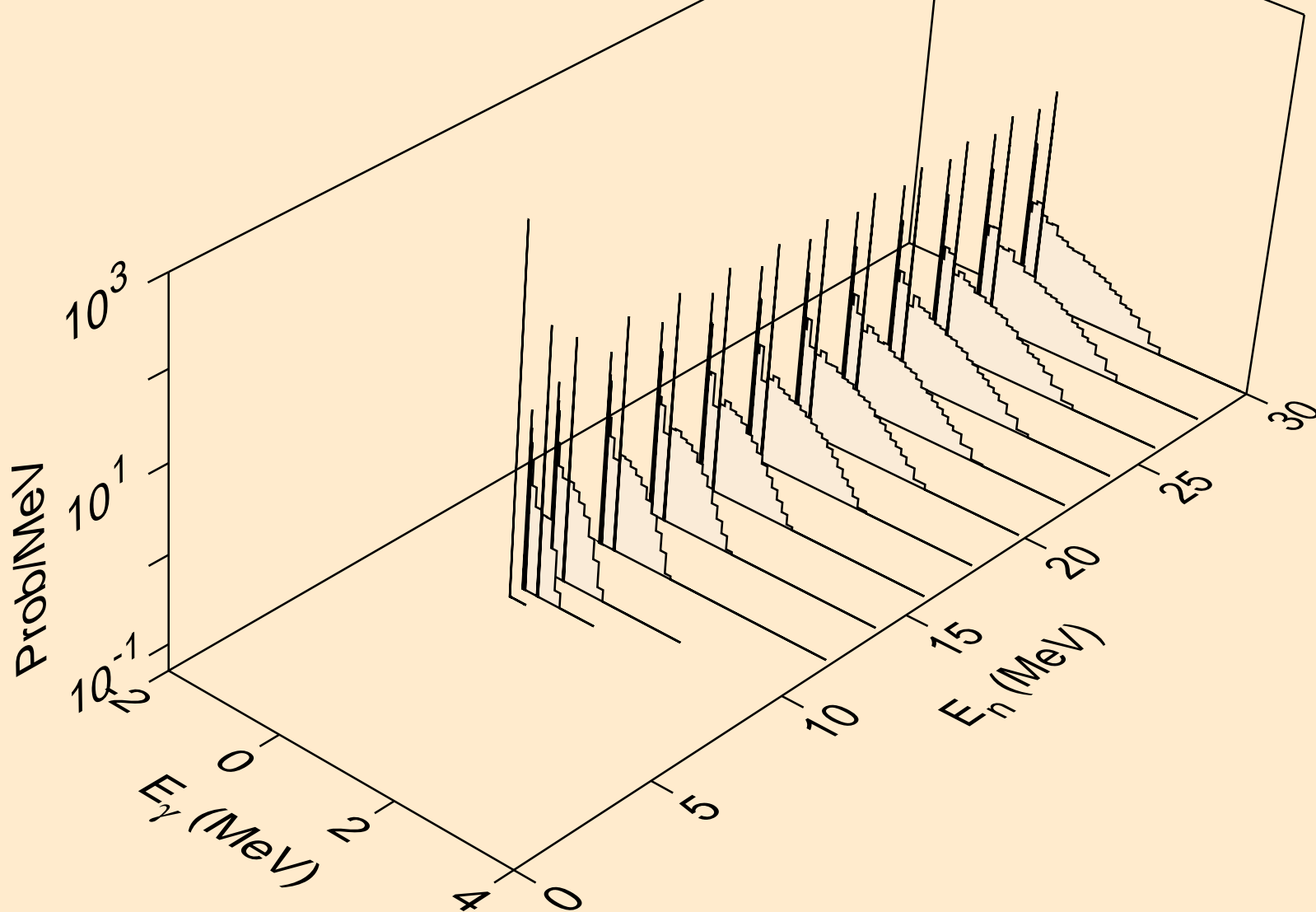

AC236 NEUTRON ACER TENDL-2023 LIBRARY; T=0.K
Photon emission for (n,t)

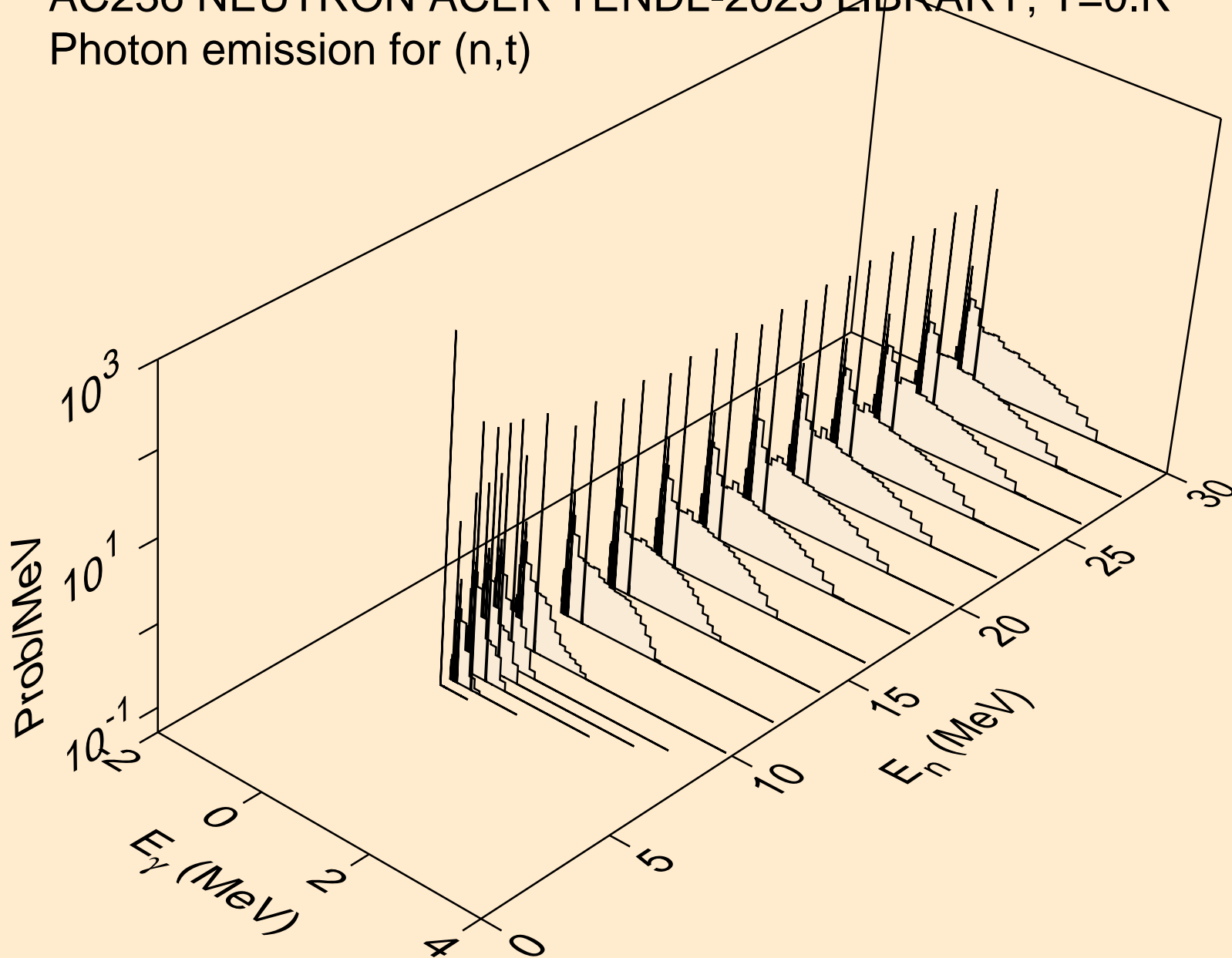

AC236 NEUTRON ACER TENDL-2023 LIBRARY; T=0.K
Photon emission for (n,he3)

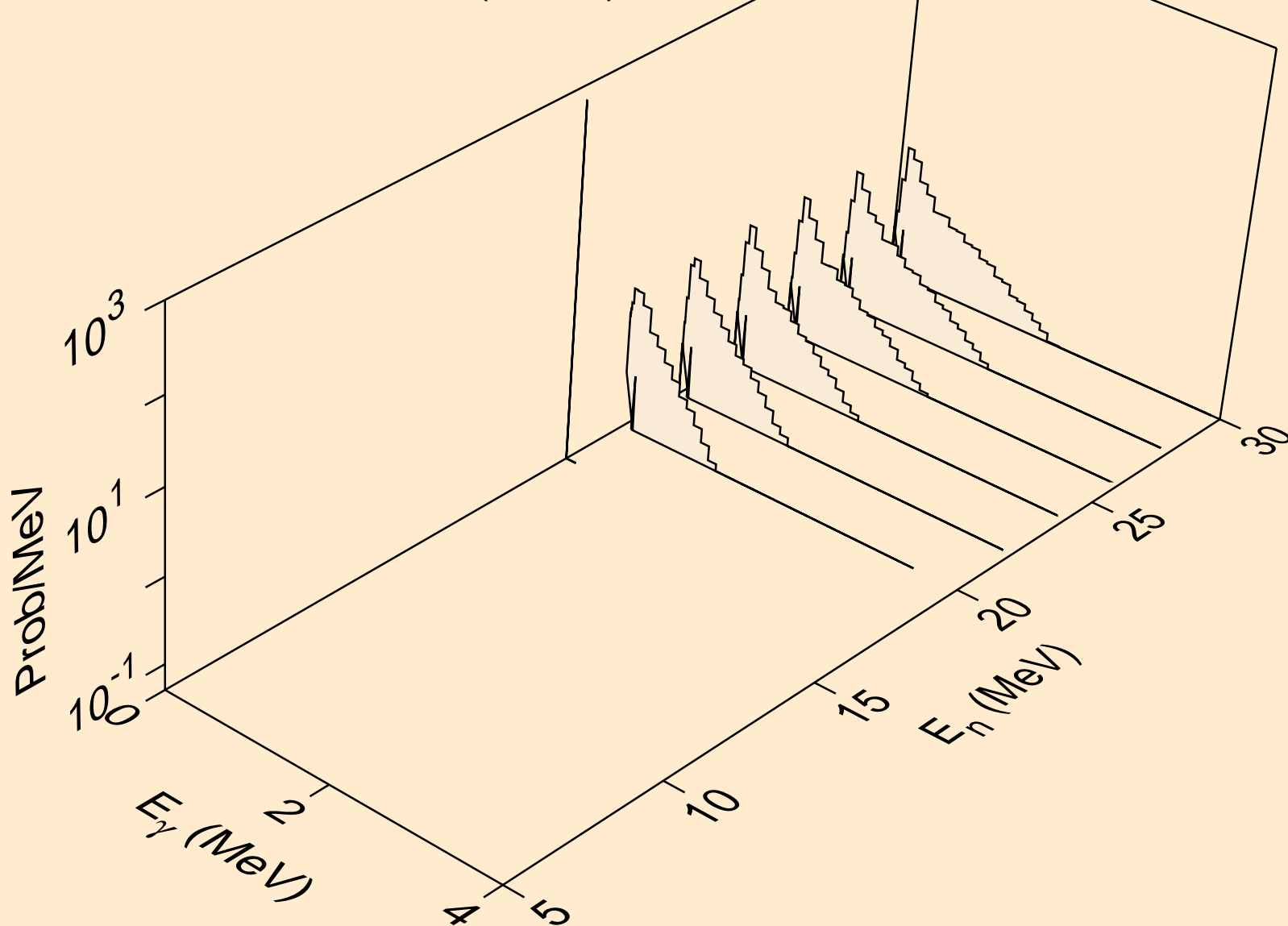

AC236 NEUTRON ACER TENDL-2023 LIBRARY; T=0.K
Photon emission for (n,a)

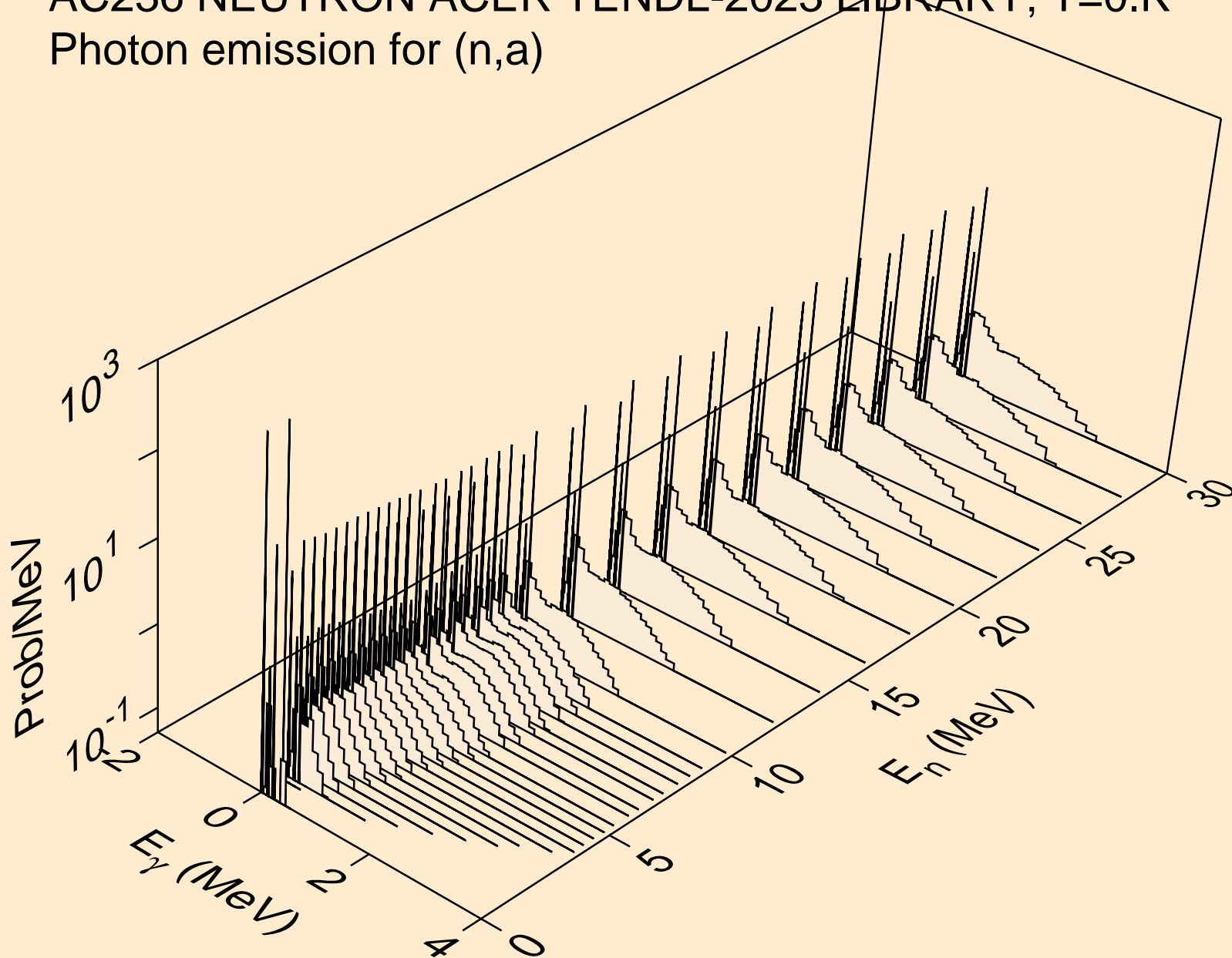

AC236 NEUTRON ACER TENDL-2023 LIBRARY; T=0.K
Photon emission for (n,2p)

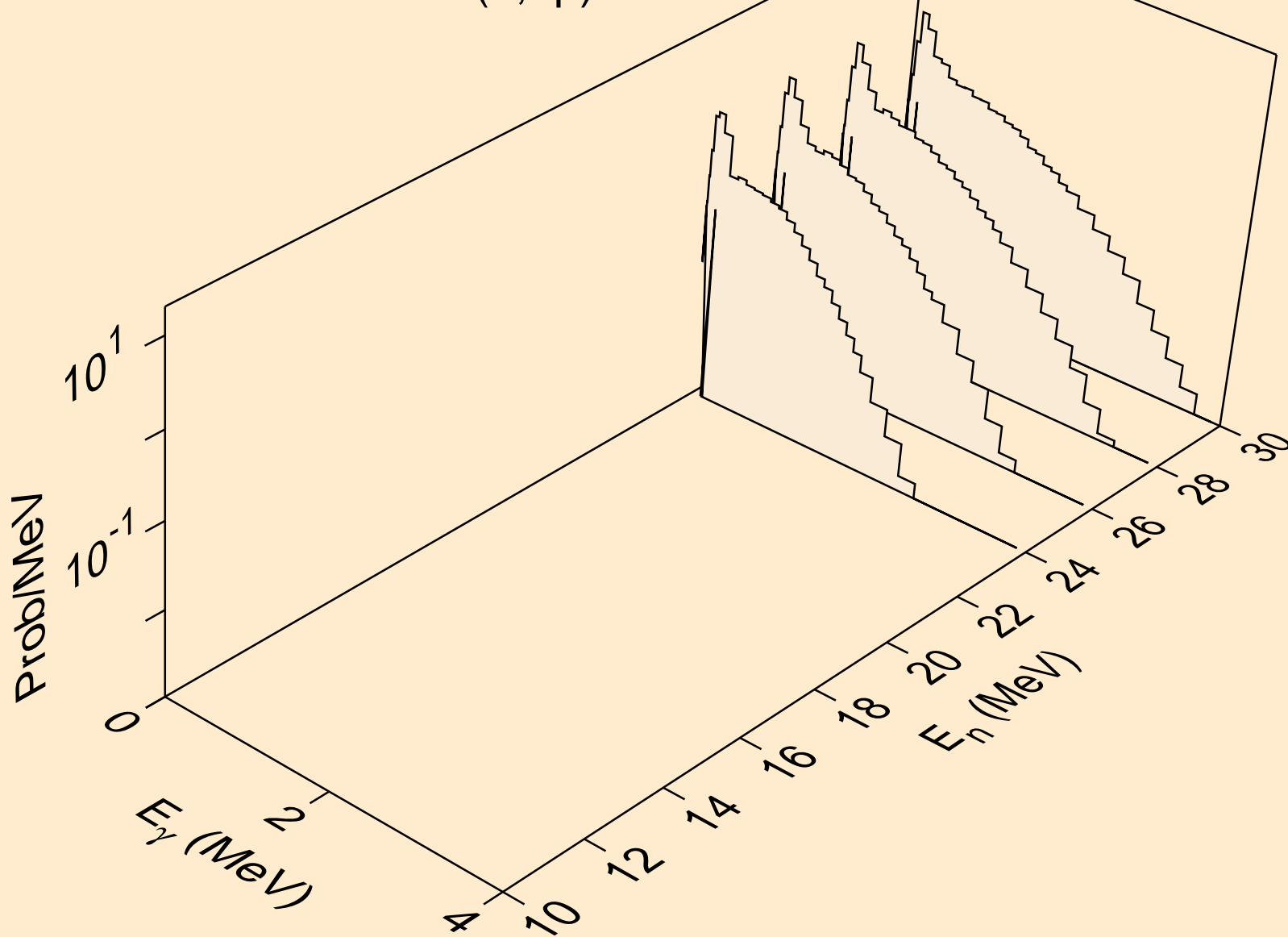

AC236 NEUTRON ACER TENDL-2023 LIBRARY; T=0.K
thermal capture photon spectrum

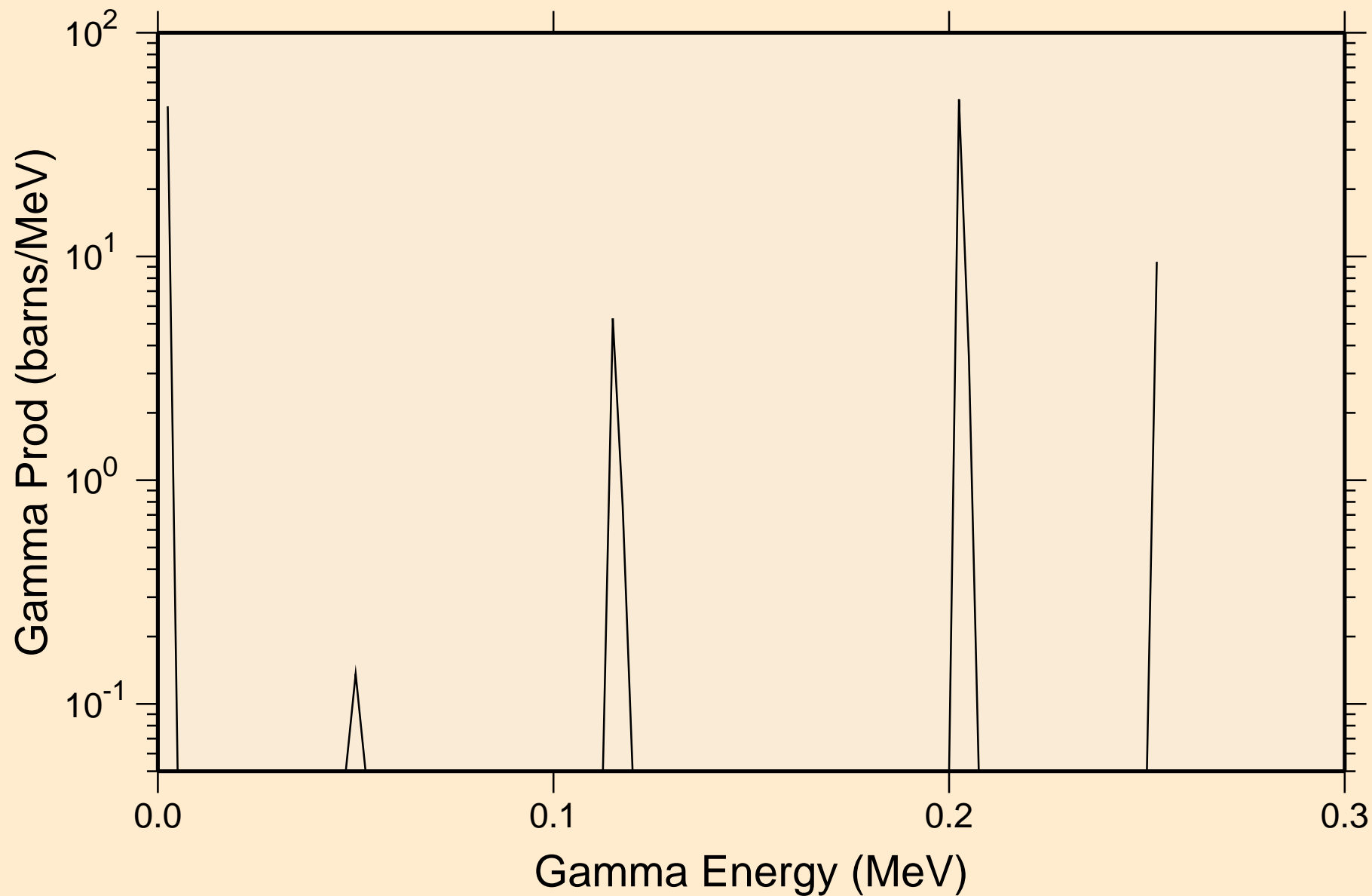

AC236 NEUTRON ACER TENDL-2023 LIBRARY; T=0.K
14 MeV photon spectrum

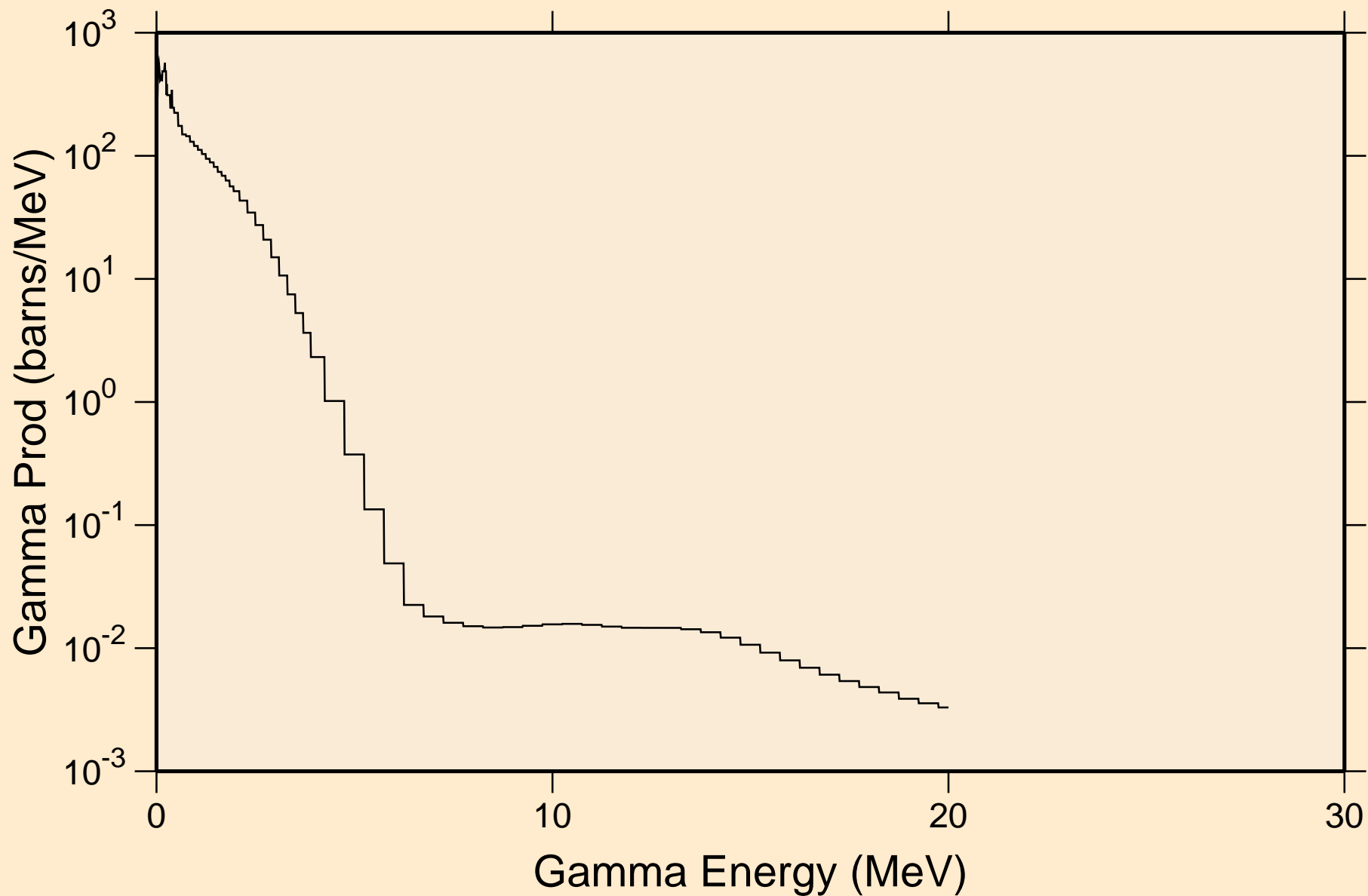

AC236 NEUTRON ACER TENDL-2023 LIBRARY; T=0.K
Particle heating contributions

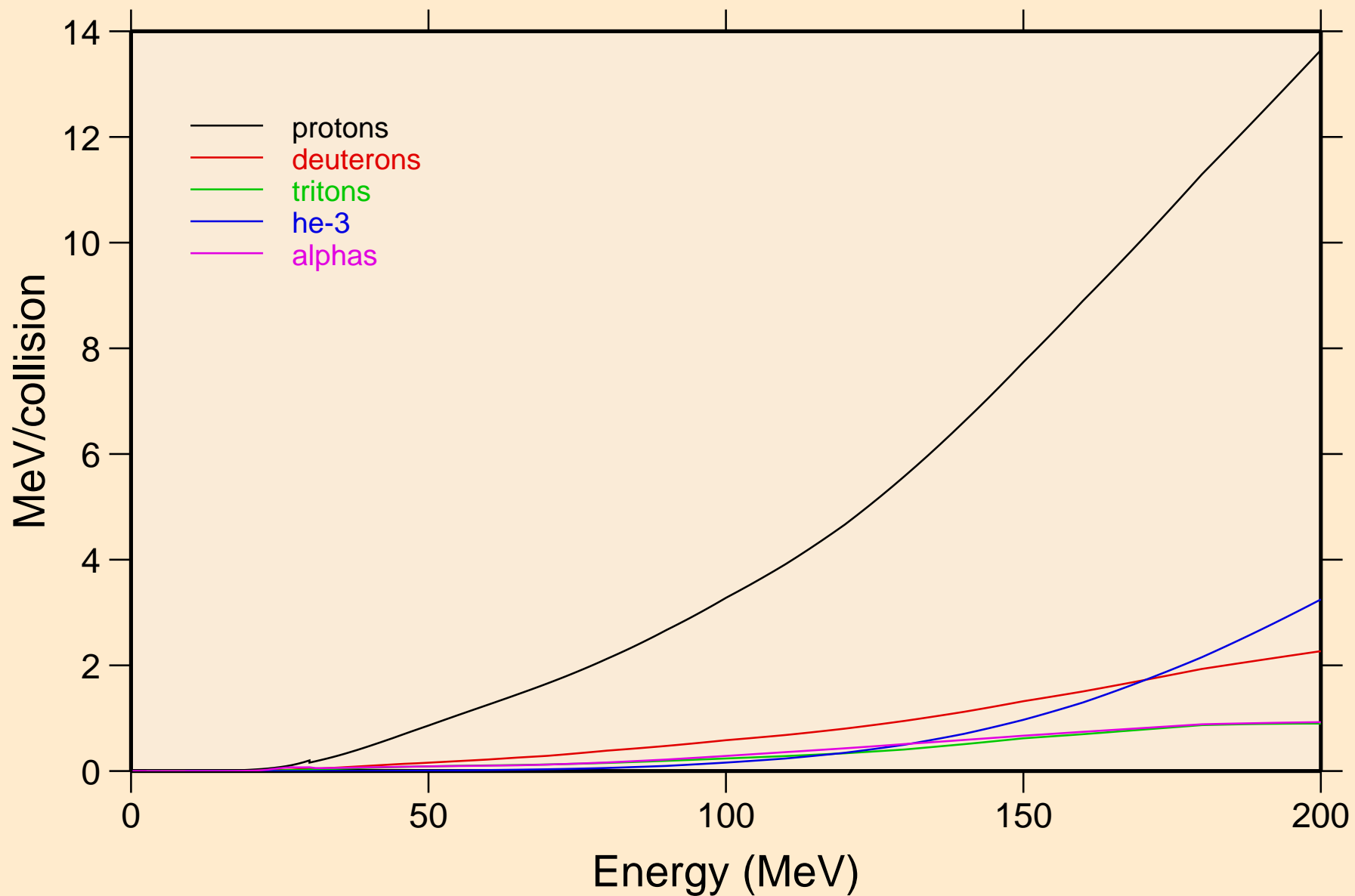

AC236 NEUTRON ACER TENDL-2023 LIBRARY; T=0.K
Recoil Heating

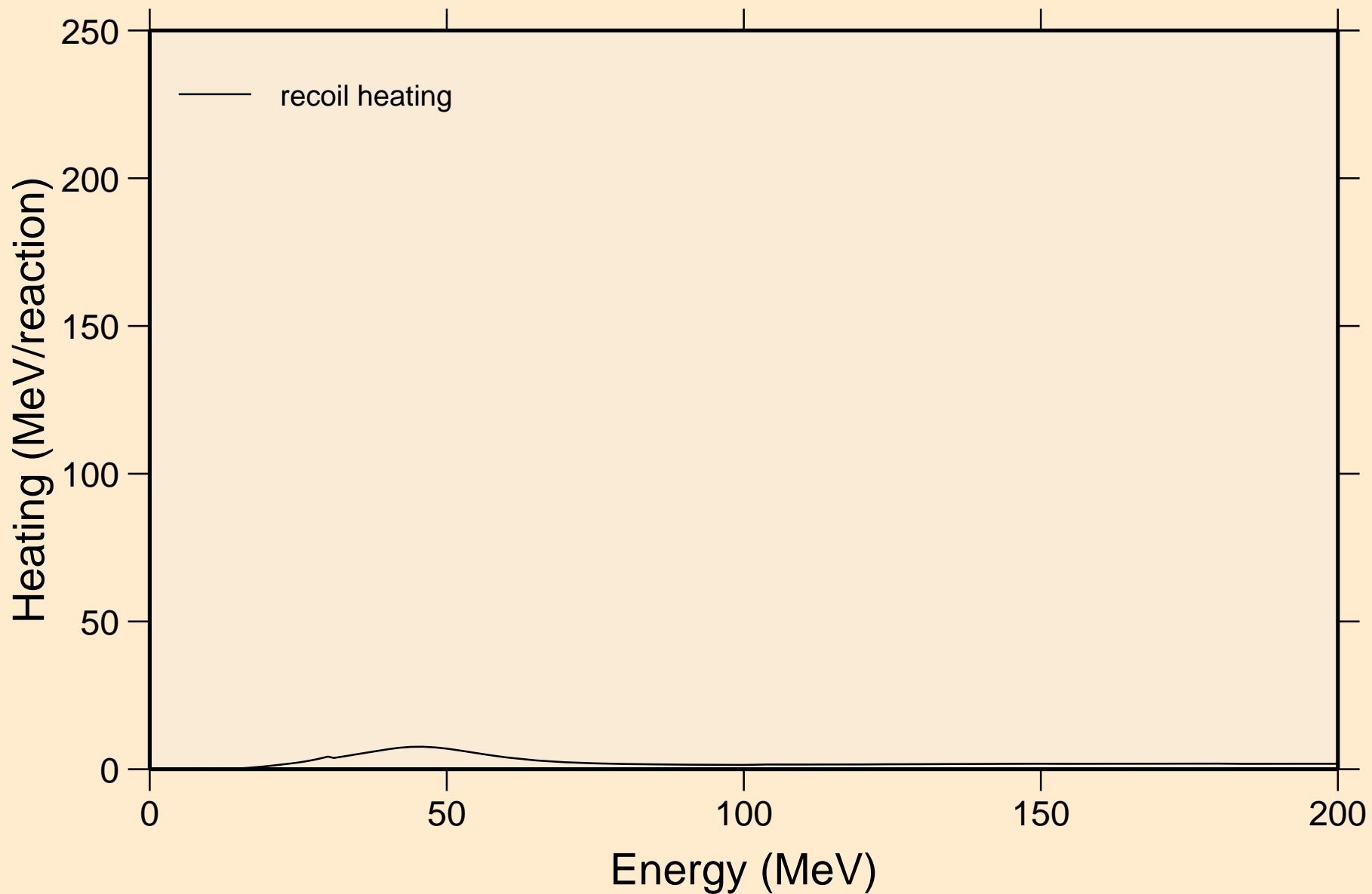

AC236 NEUTRON ACER TENDL-2023 LIBRARY; T=0.K
Particle production cross sections

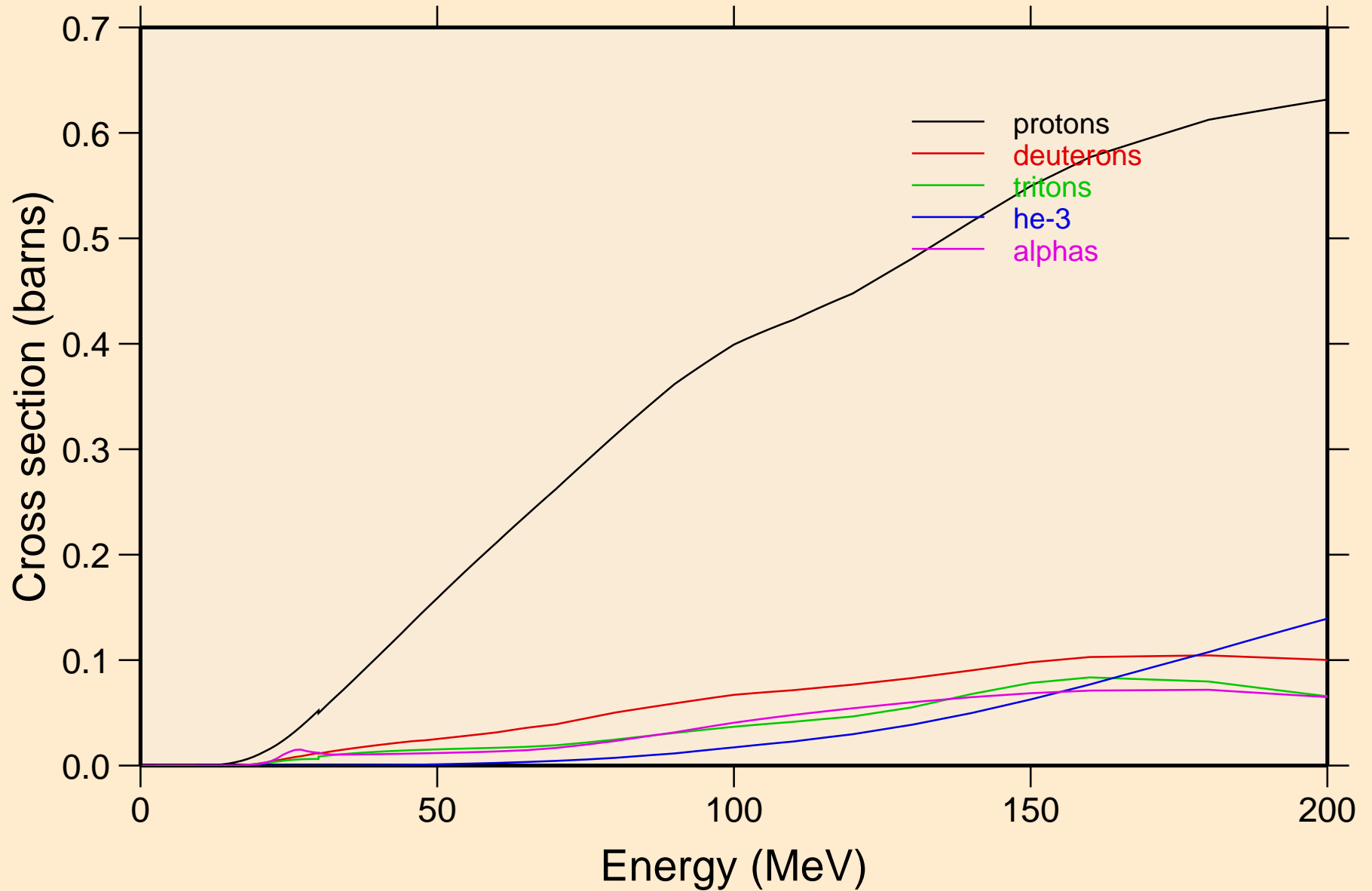

AC236 NEUTRON ACER TENDL-2023 LIBRARY; T=0.K
protons from (n,x)

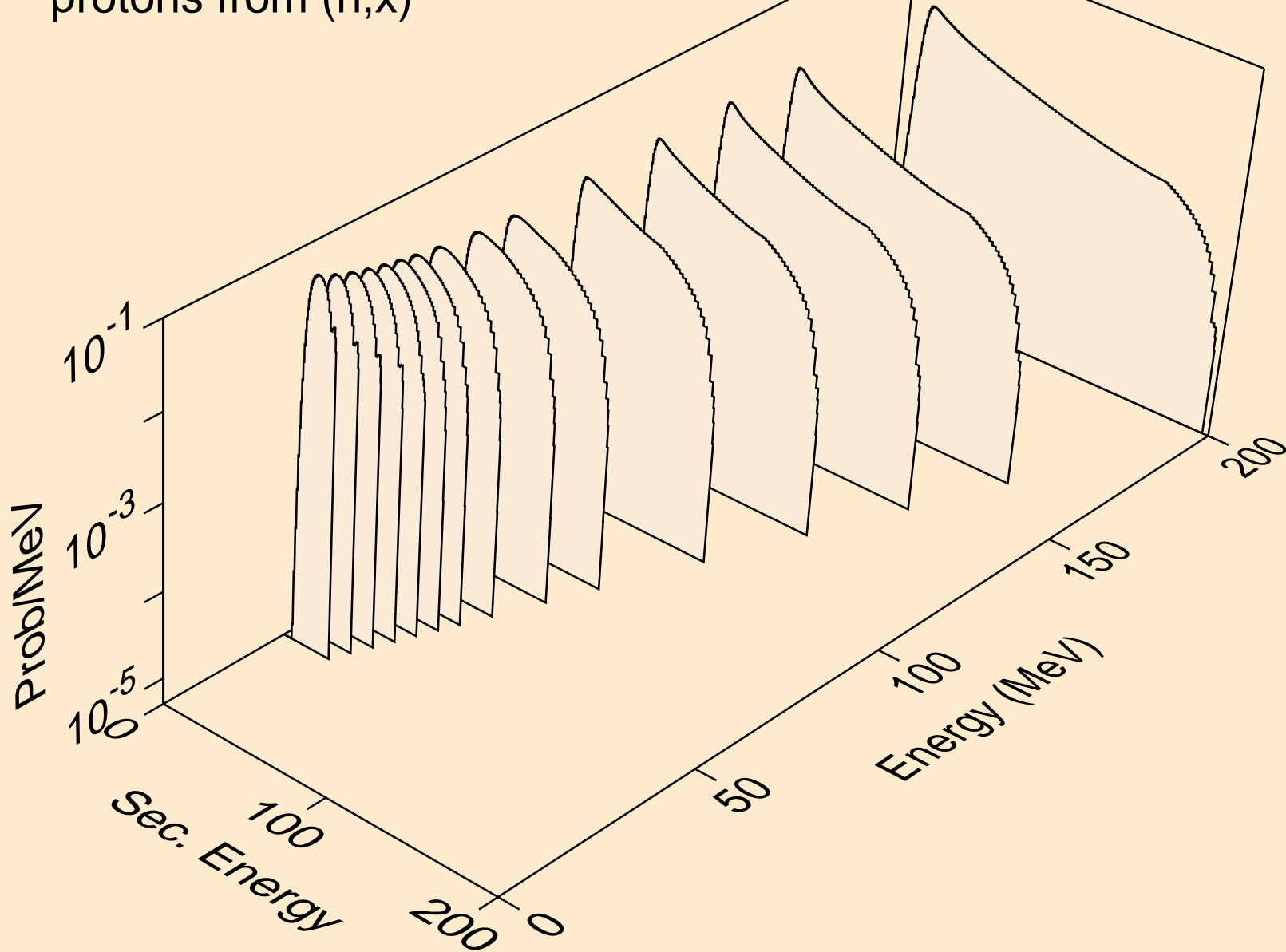

AC236 NEUTRON ACER TENDL-2023 LIBRARY; T=0.K
protons from (n,n*)p

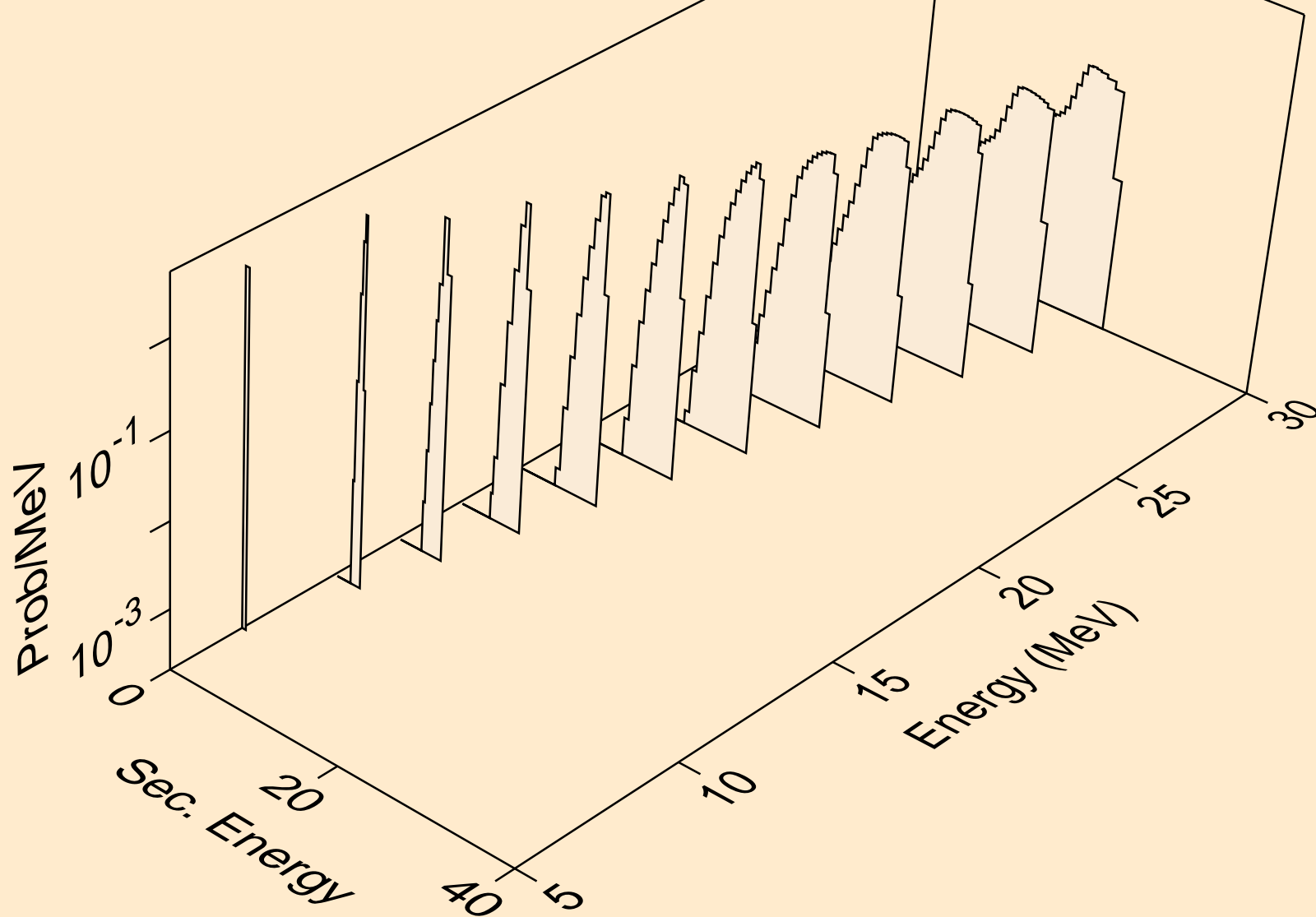

AC236 NEUTRON ACER TENDL-2023 LIBRARY; T=0.K
protons from (n,2np)

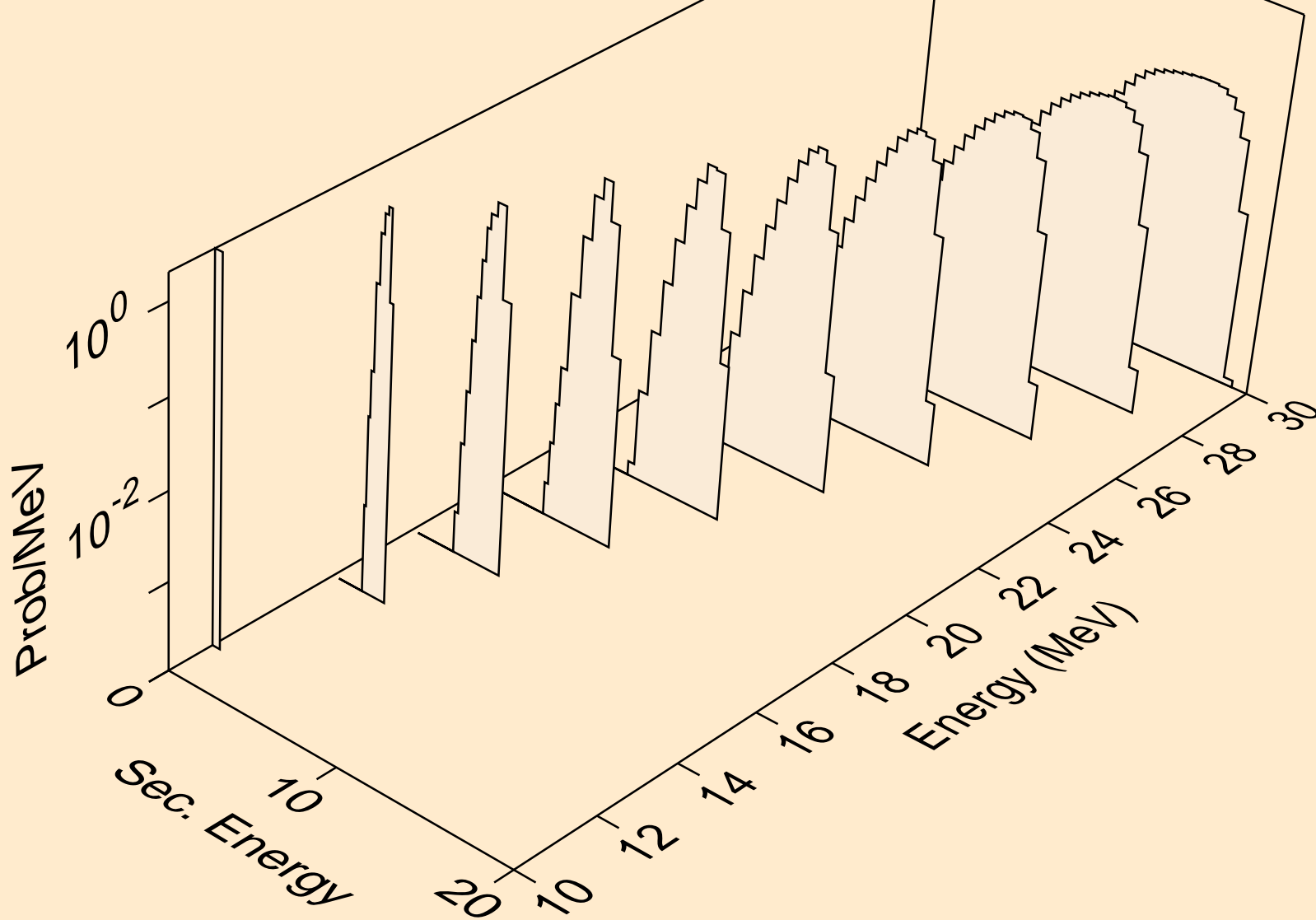

AC236 NEUTRON ACER TENDL-2023 LIBRARY; T=0.K
protons from (n,3np)

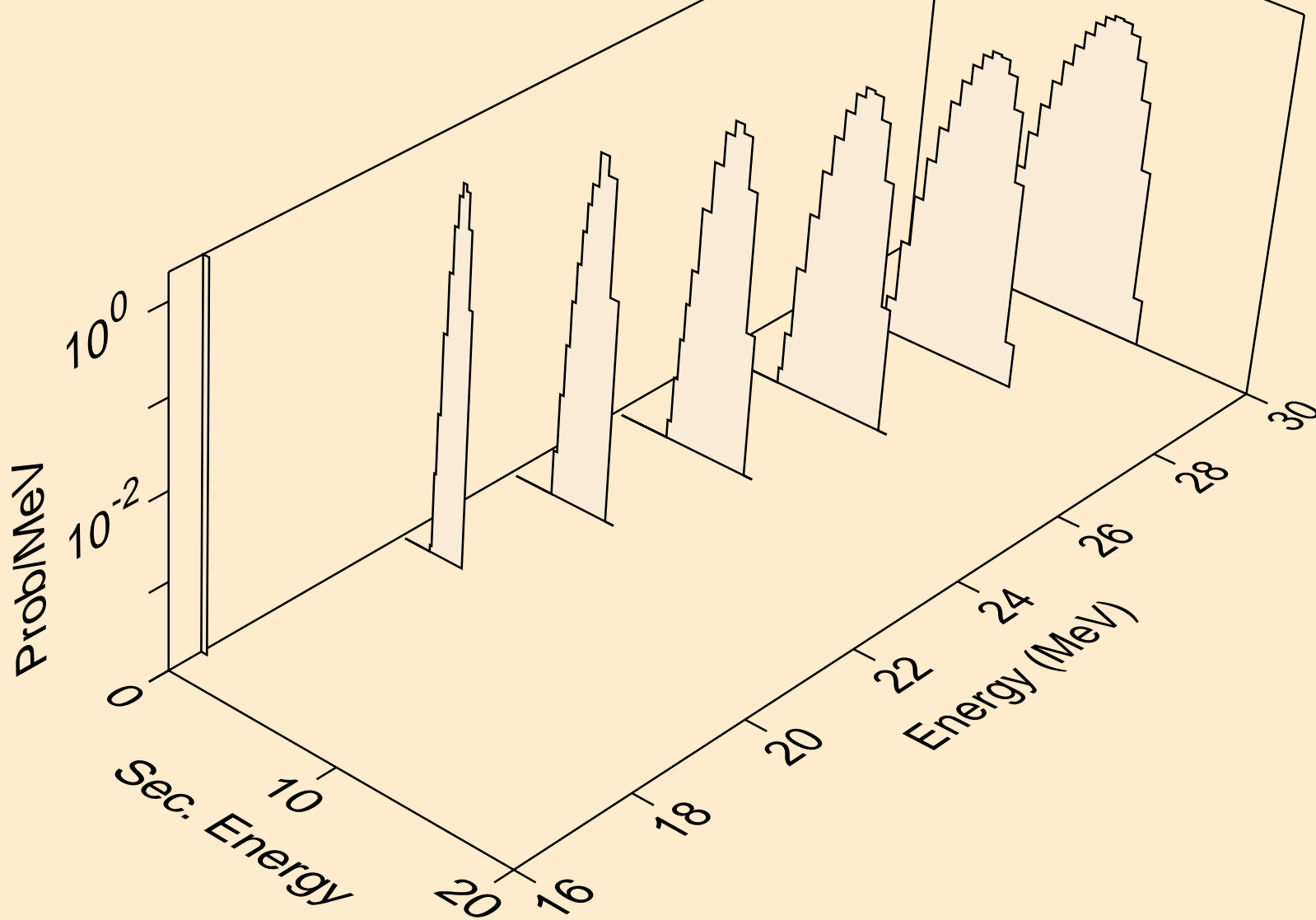

AC236 NEUTRON ACER TENDL-2023 LIBRARY; T=0.K
protons from (n,p)

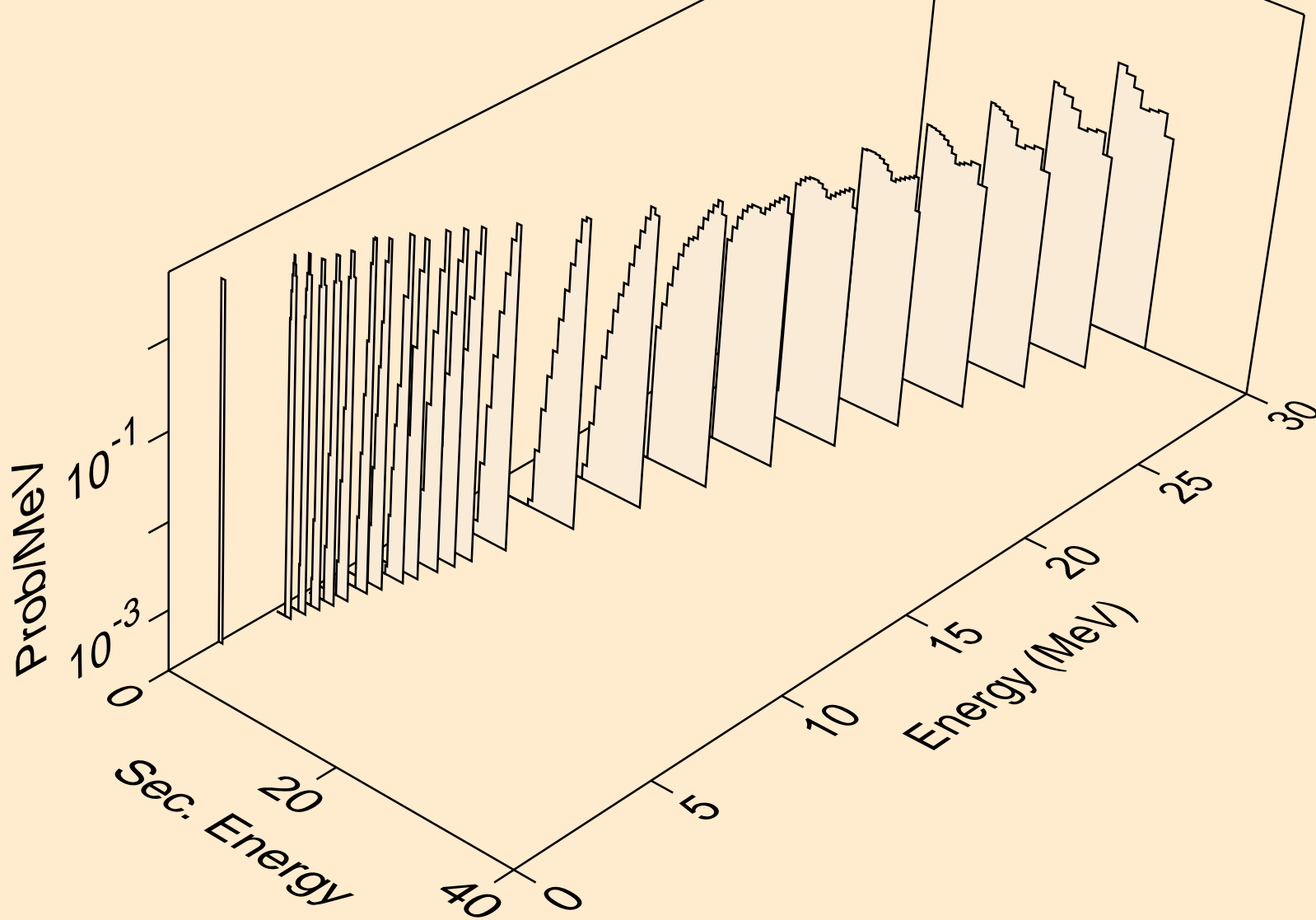

AC236 NEUTRON ACER TENDL-2023 LIBRARY; T=0.K
protons from (n,2p)

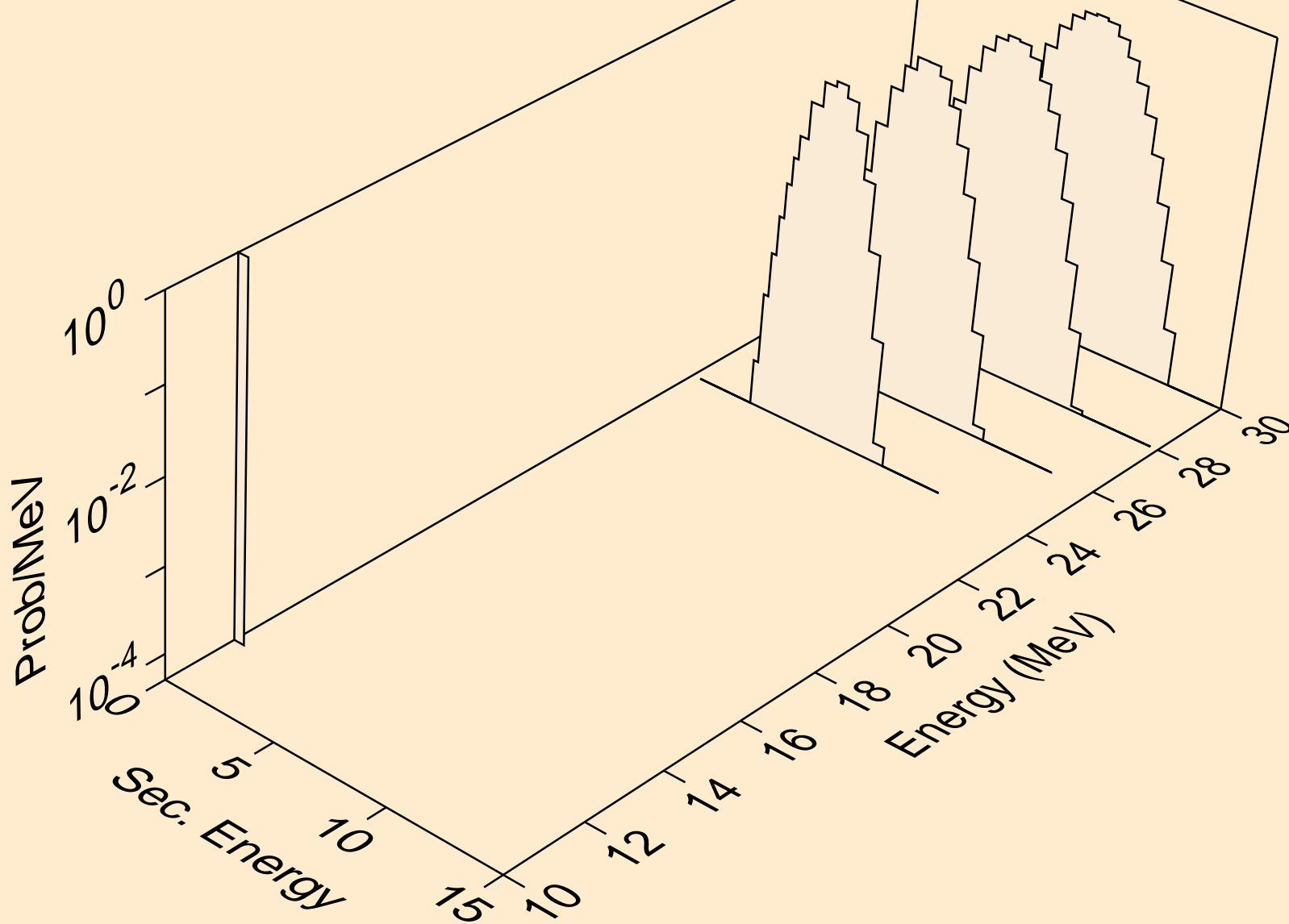

AC236 NEUTRON ACER TENDL-2023 LIBRARY; T=0.K
deuterons from (n,x)

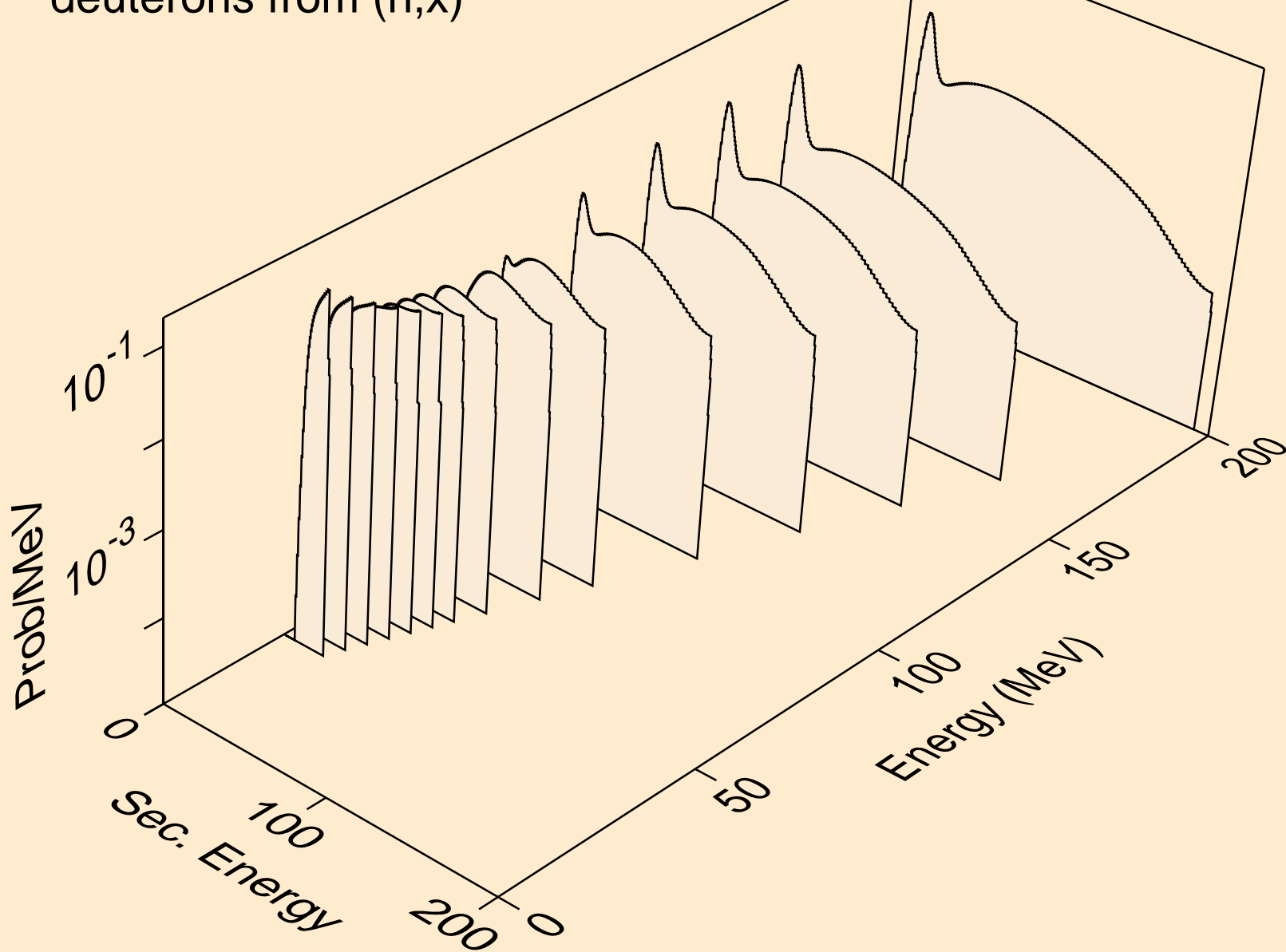

AC236 NEUTRON ACER TENDL-2023 LIBRARY; T=0.K
deuterons from (n,2nd)

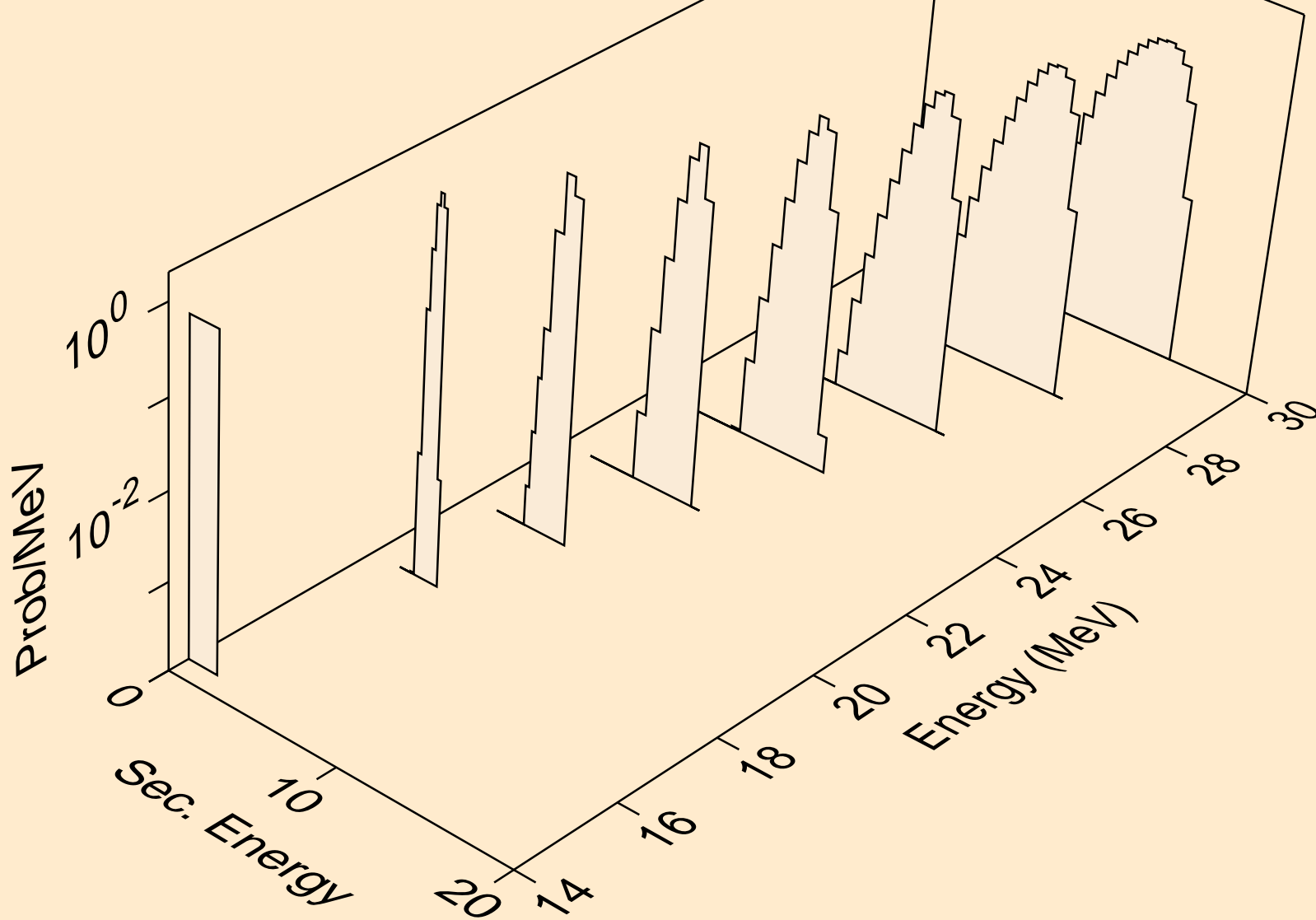

AC236 NEUTRON ACER TENDL-2023 LIBRARY; T=0.K
deuterons from (n,n*)d

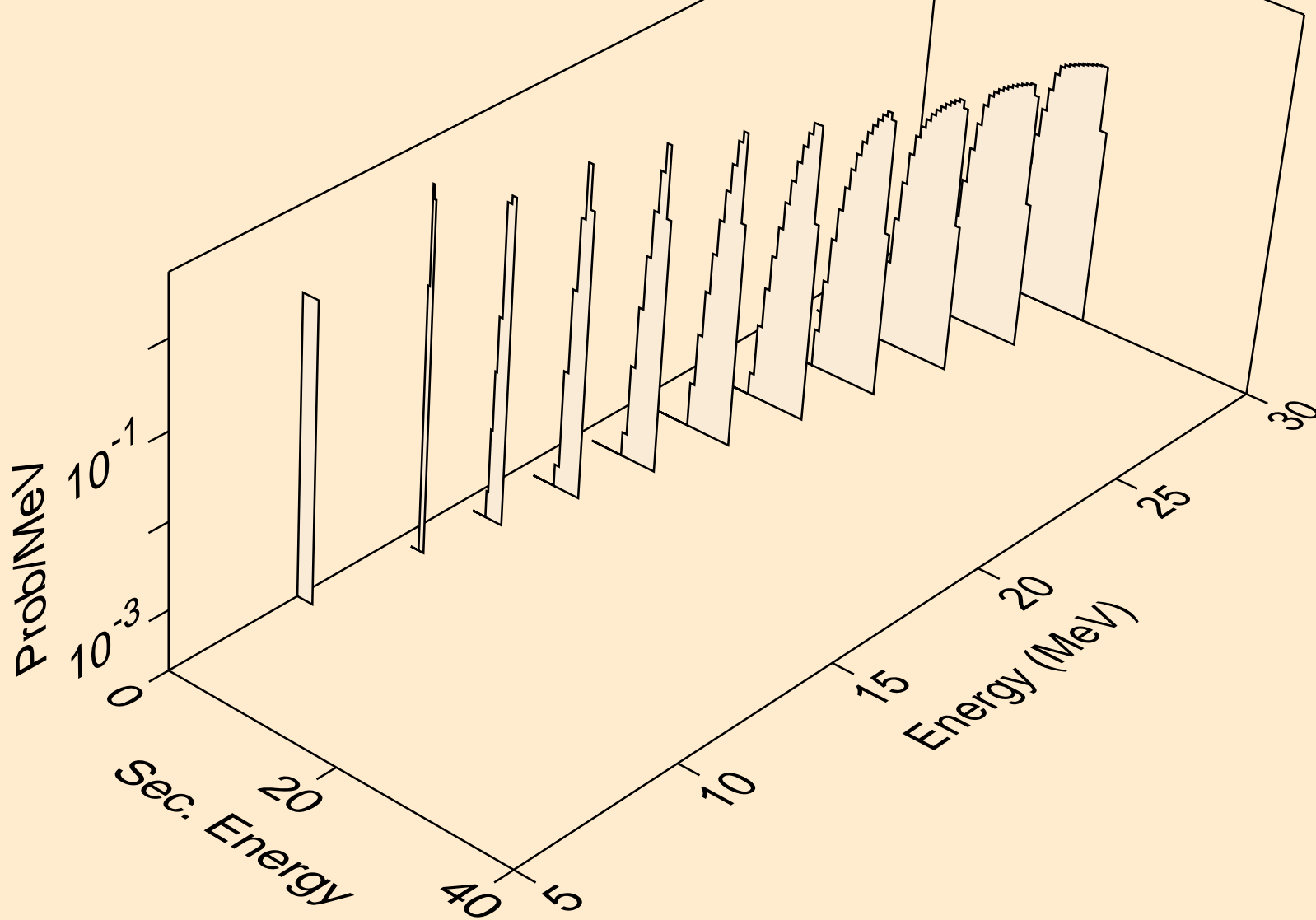

AC236 NEUTRON ACER TENDL-2023 LIBRARY; T=0.K
deuterons from (n,d)

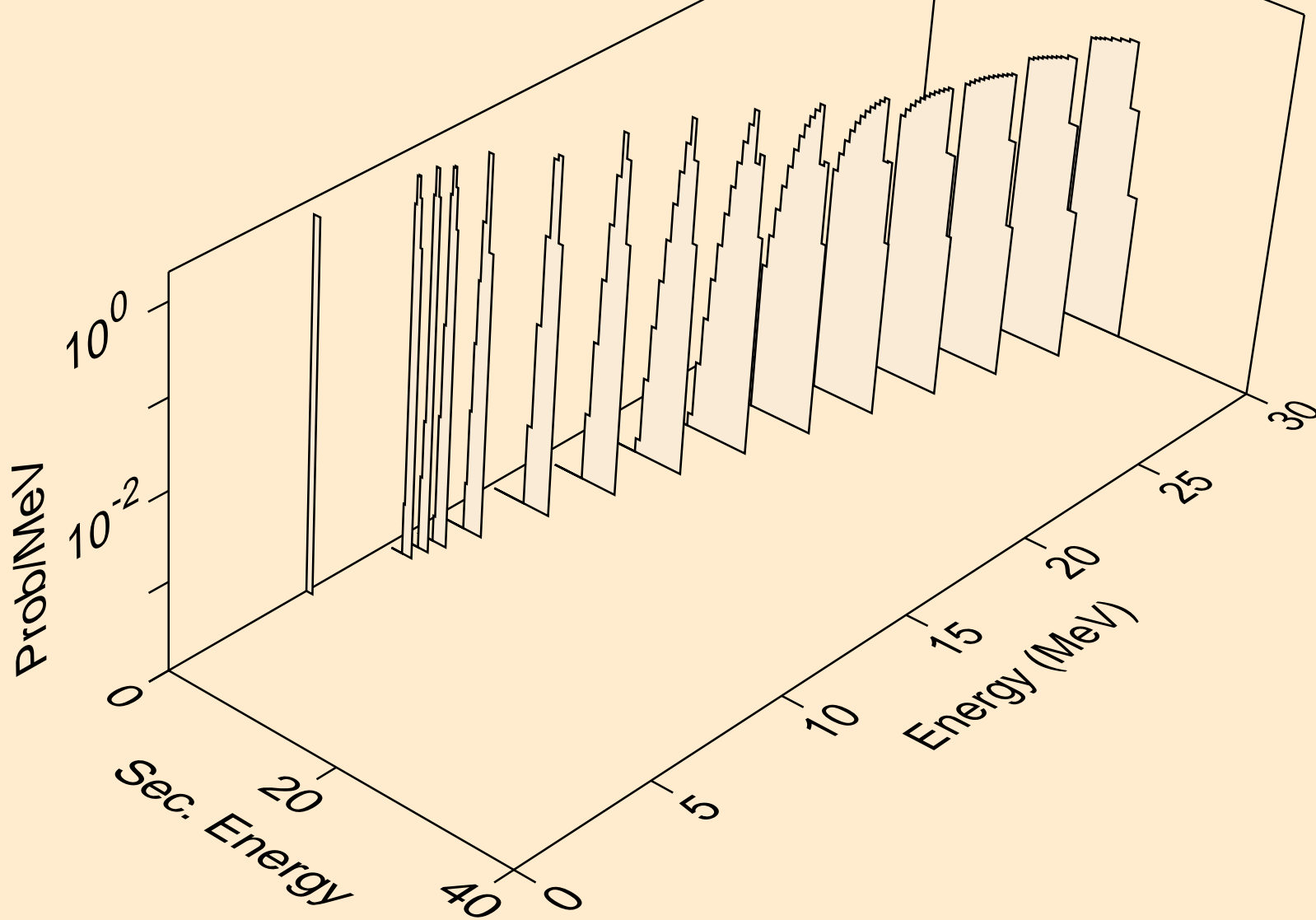

AC236 NEUTRON ACER TENDL-2023 LIBRARY; T=0.K
tritons from (n,x)

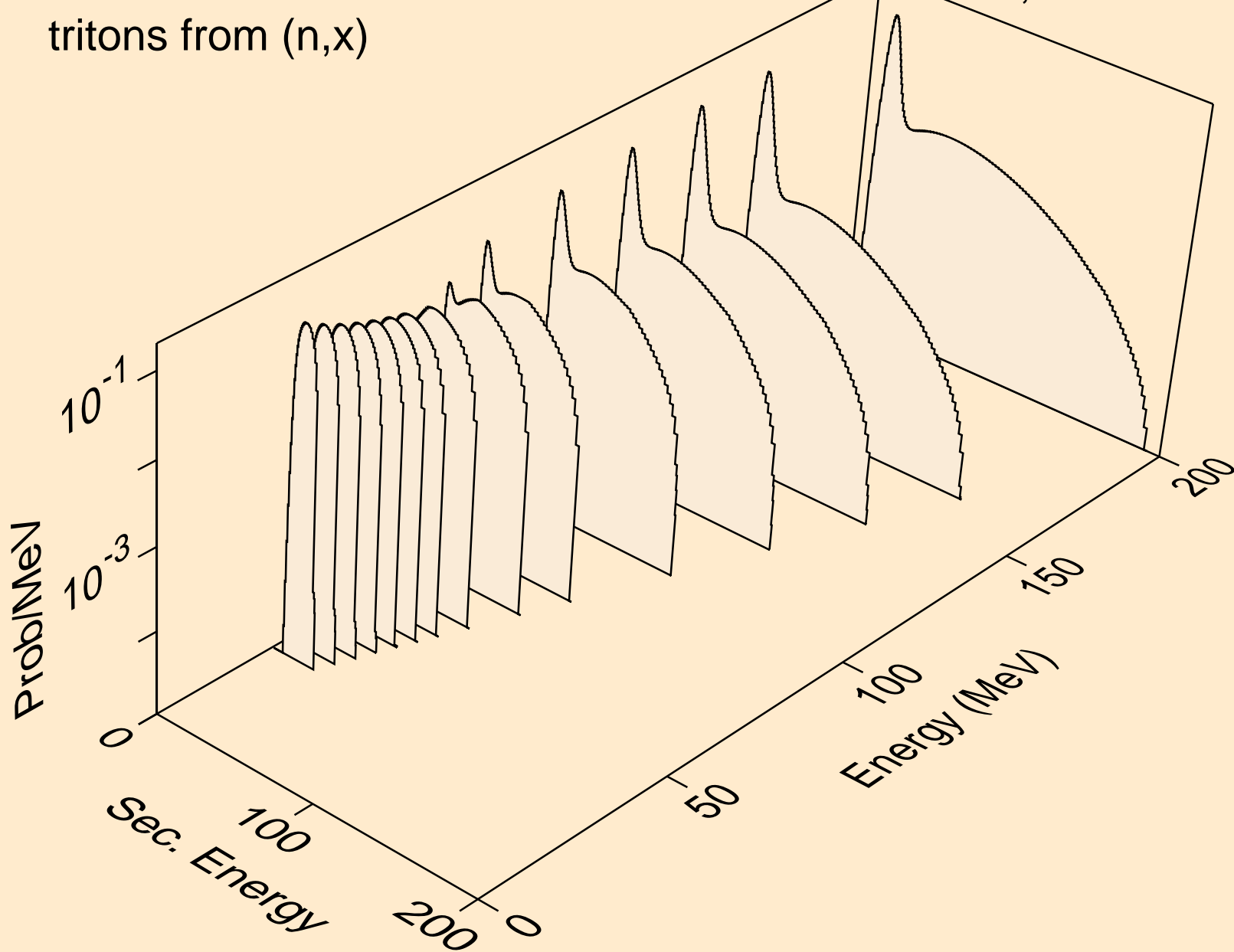

AC236 NEUTRON ACER TENDL-2023 LIBRARY; T=0.K
tritons from (n,n*)t

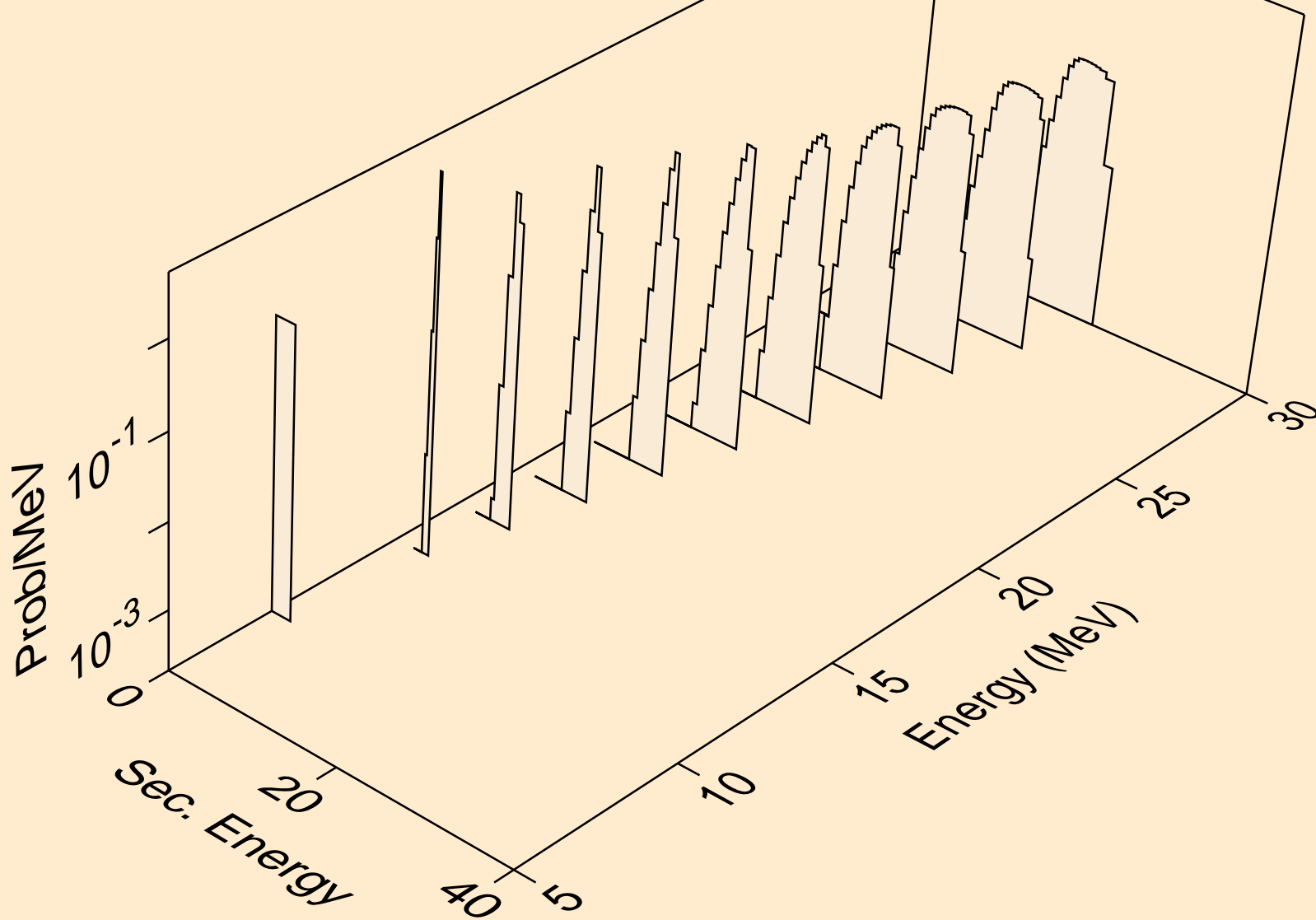

AC236 NEUTRON ACER TENDL-2023 LIBRARY; T=0.K
tritons from (n,t)

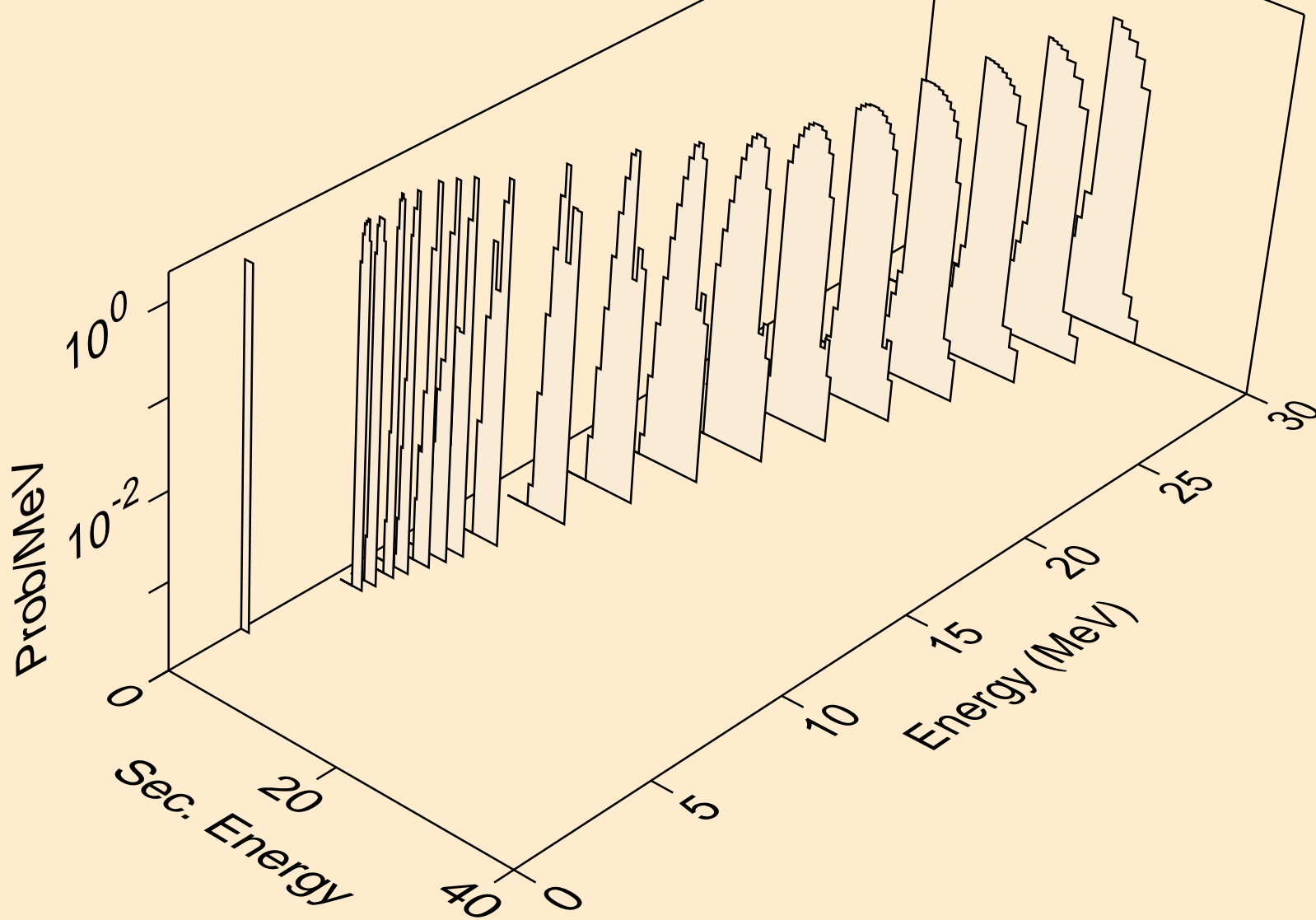

AC236 NEUTRON ACER TENDL-2023 LIBRARY; T=0.K
he3s from (n,x)

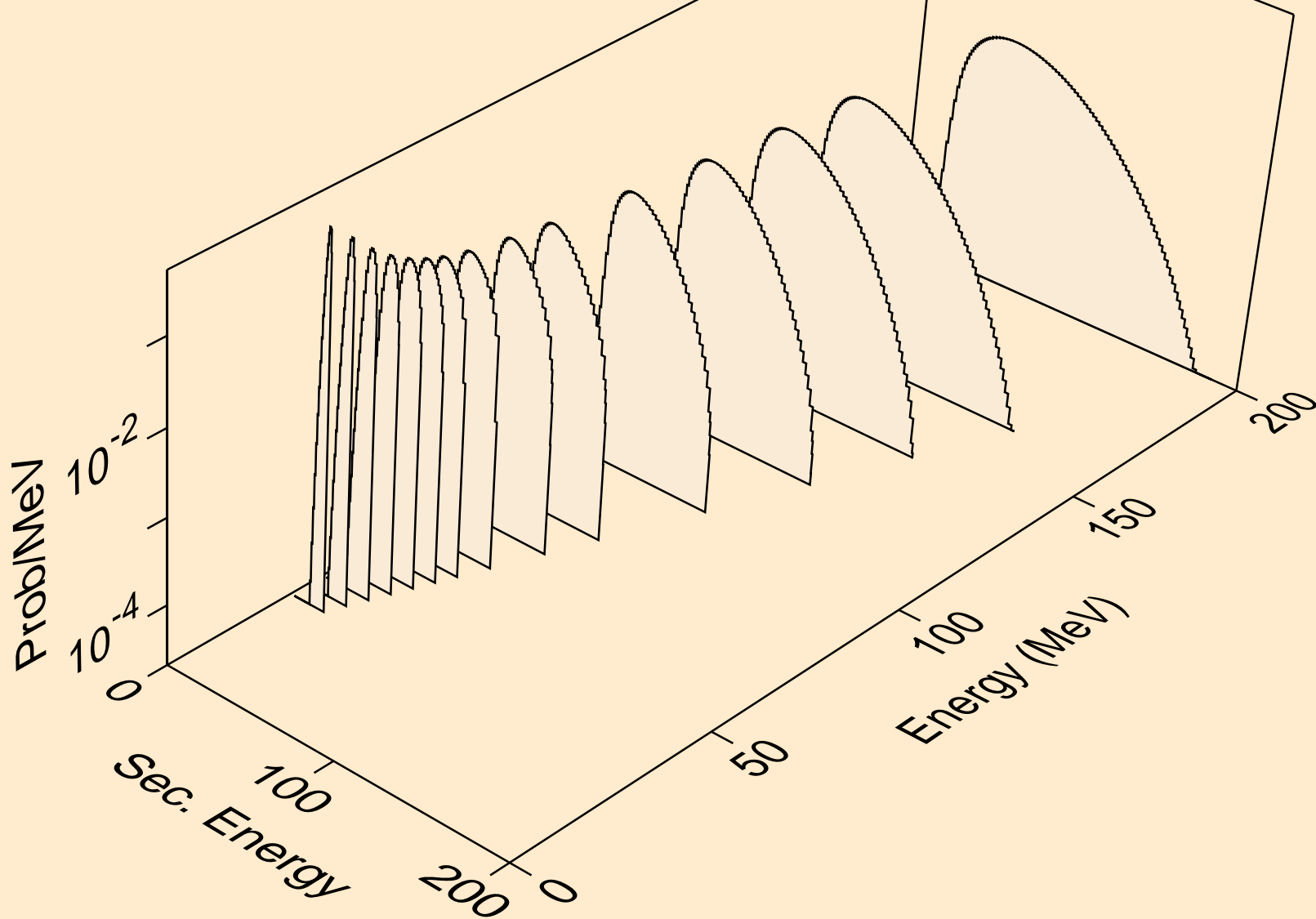

AC236 NEUTRON ACER TENDL-2023 LIBRARY; T=0.K
he3s from (n,n*)he3

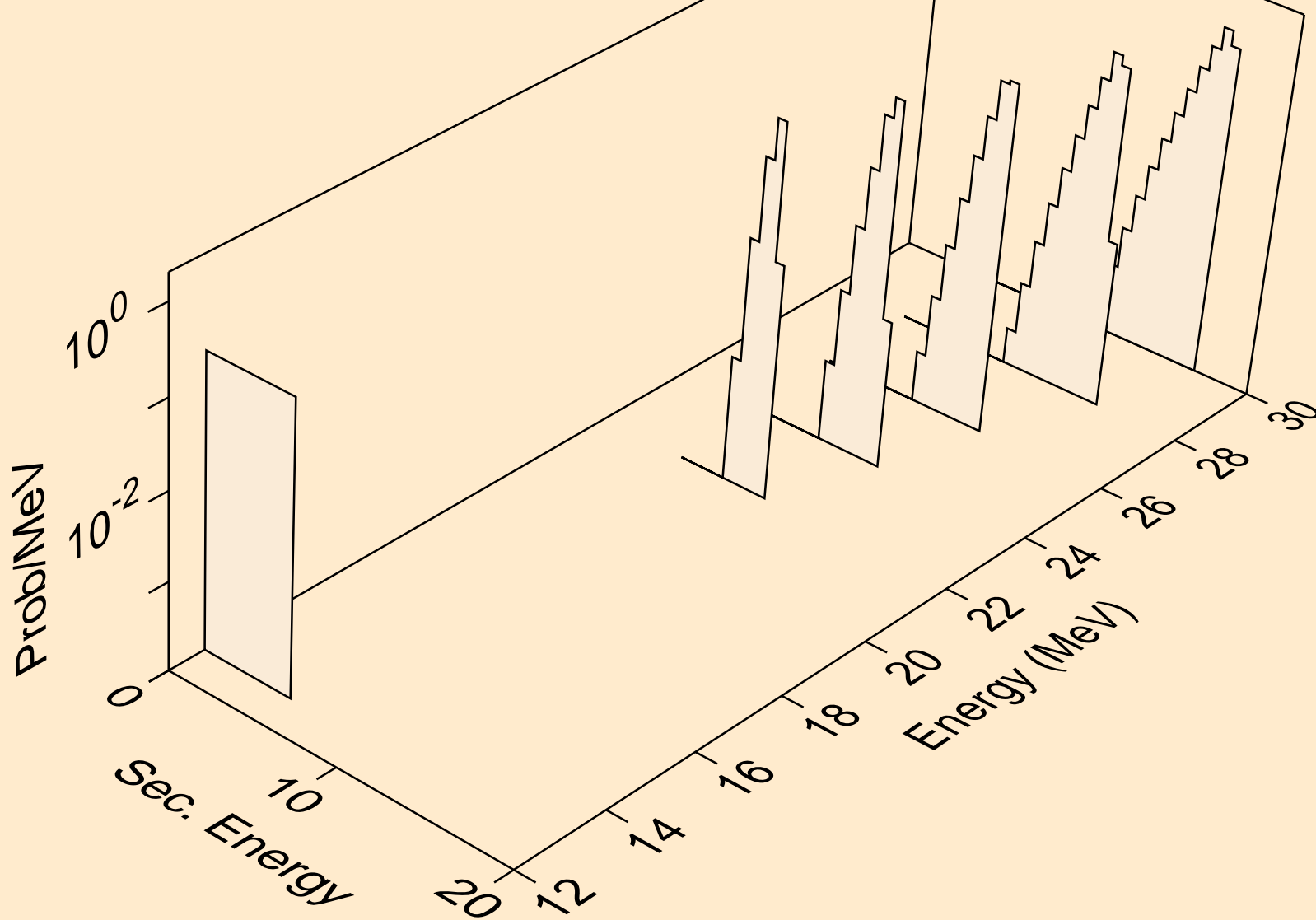

AC236 NEUTRON ACER TENDL-2023 LIBRARY; T=0.K
he3s from (n,he3)

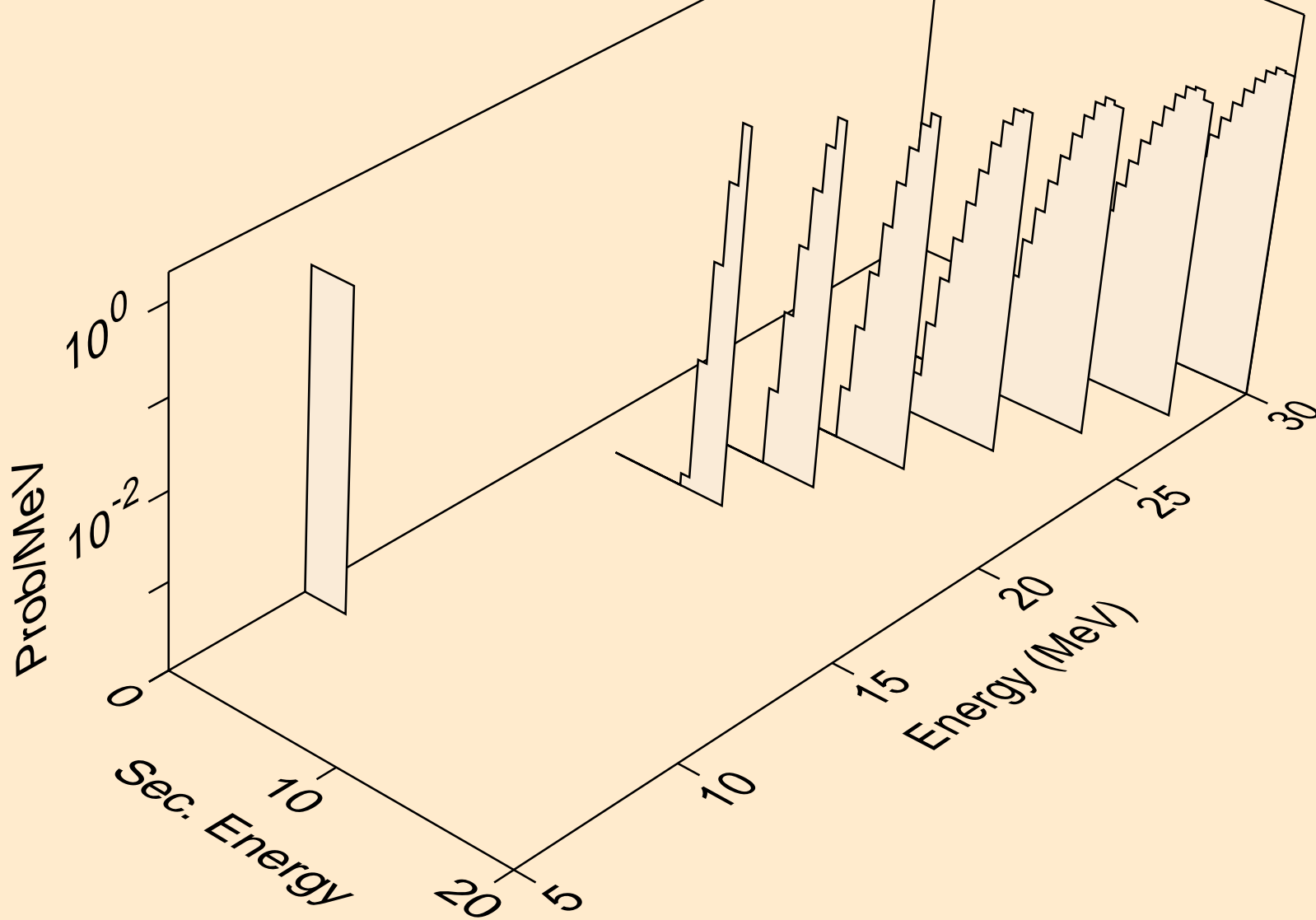

AC236 NEUTRON ACER TENDL-2023 LIBRARY; T=0.K
alphas from (n,x)

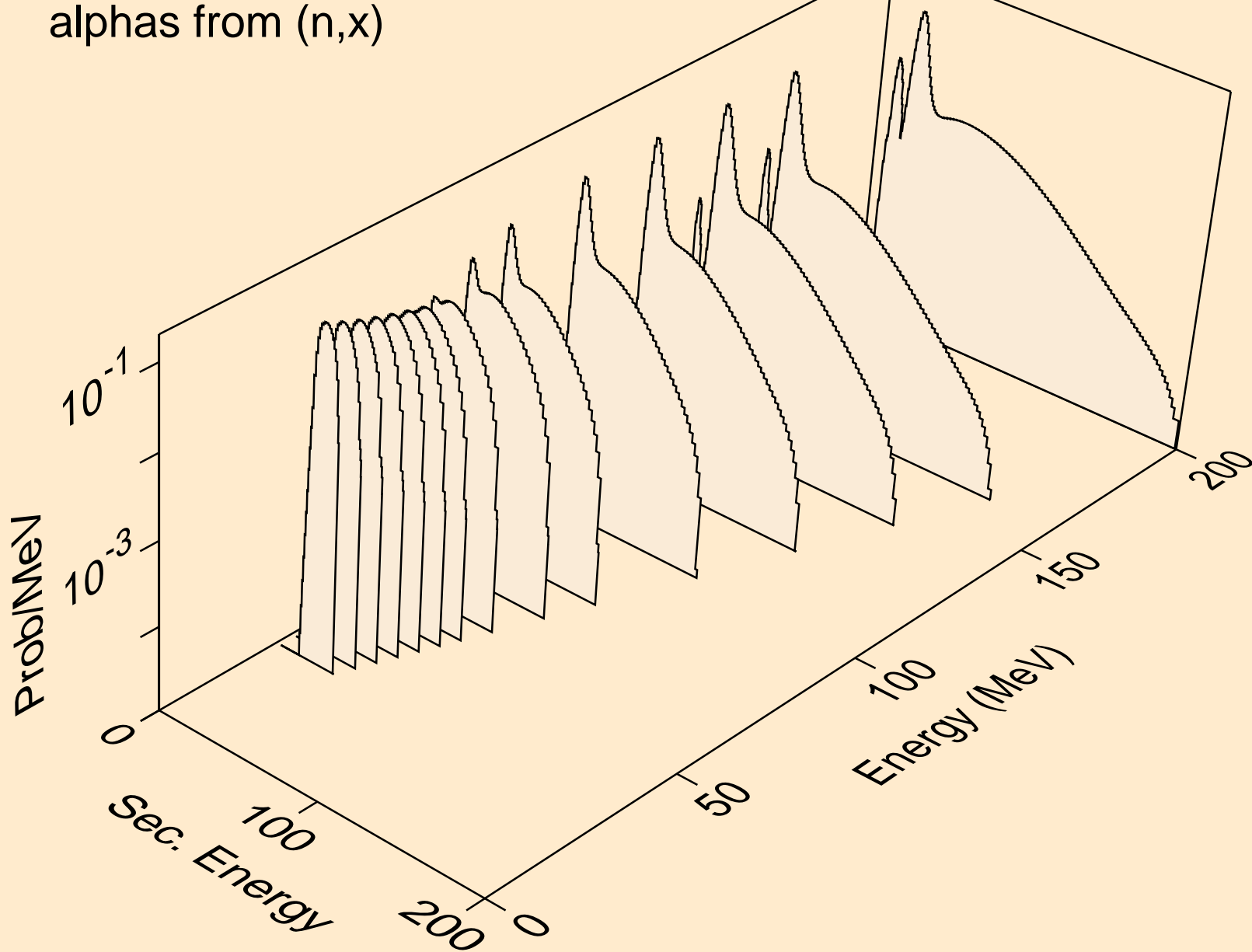

AC236 NEUTRON ACER TENDL-2023 LIBRARY; T=0.K
alphas from (n,n*)a

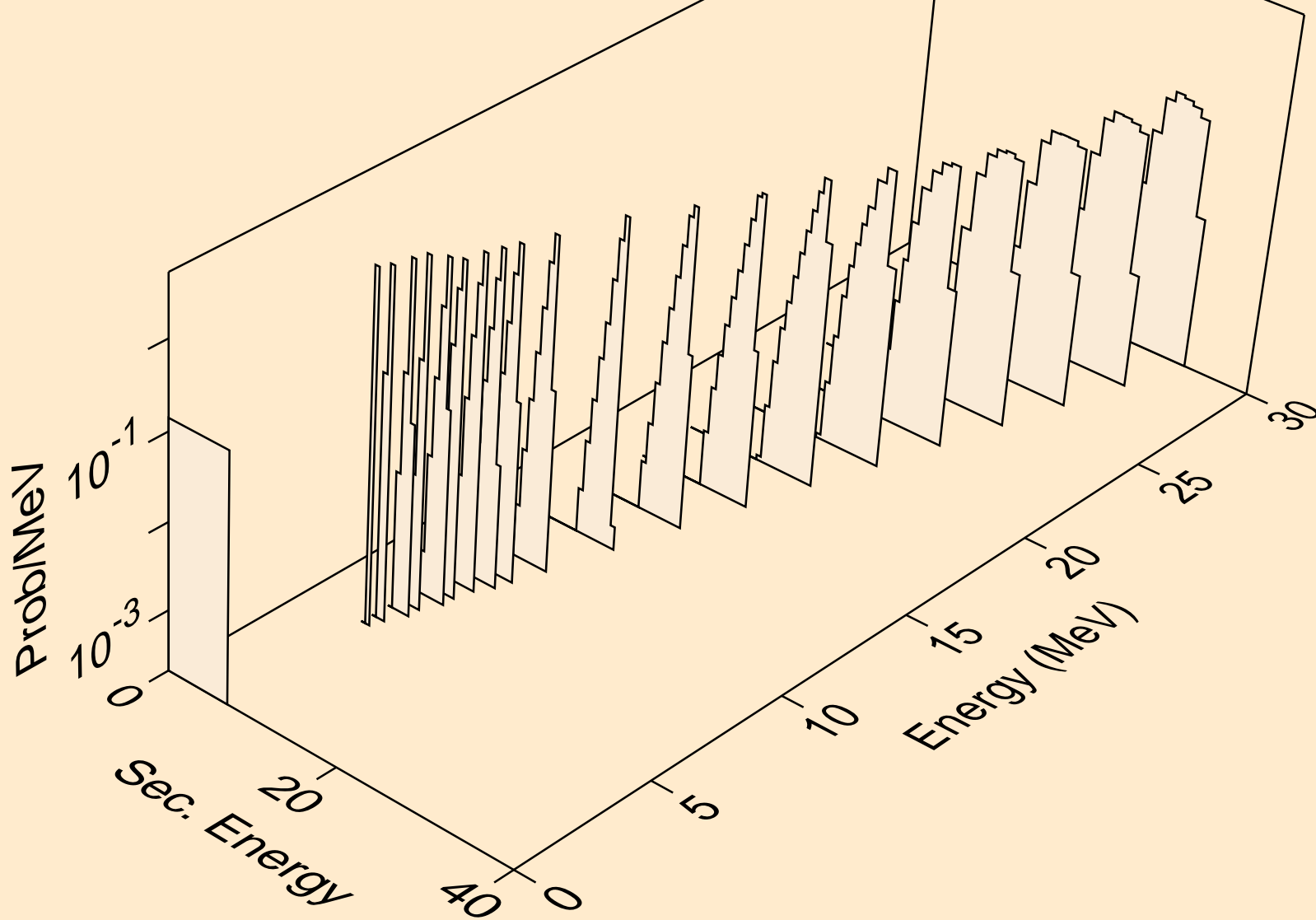

AC236 NEUTRON ACER TENDL-2023 LIBRARY; T=0.K
alphas from (n,2n)a

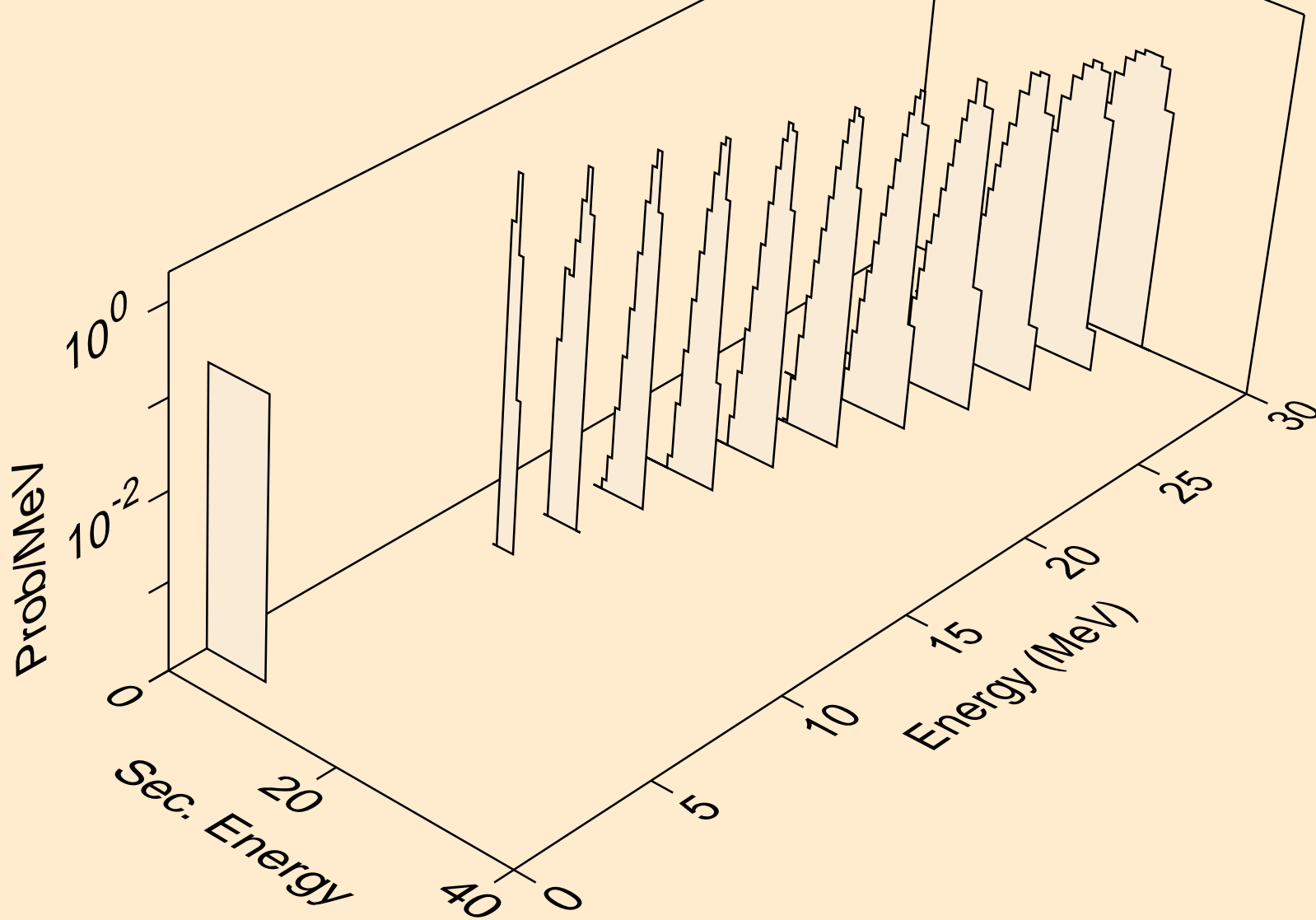

AC236 NEUTRON ACER TENDL-2023 LIBRARY; T=0.K
alphas from (n,3n)a

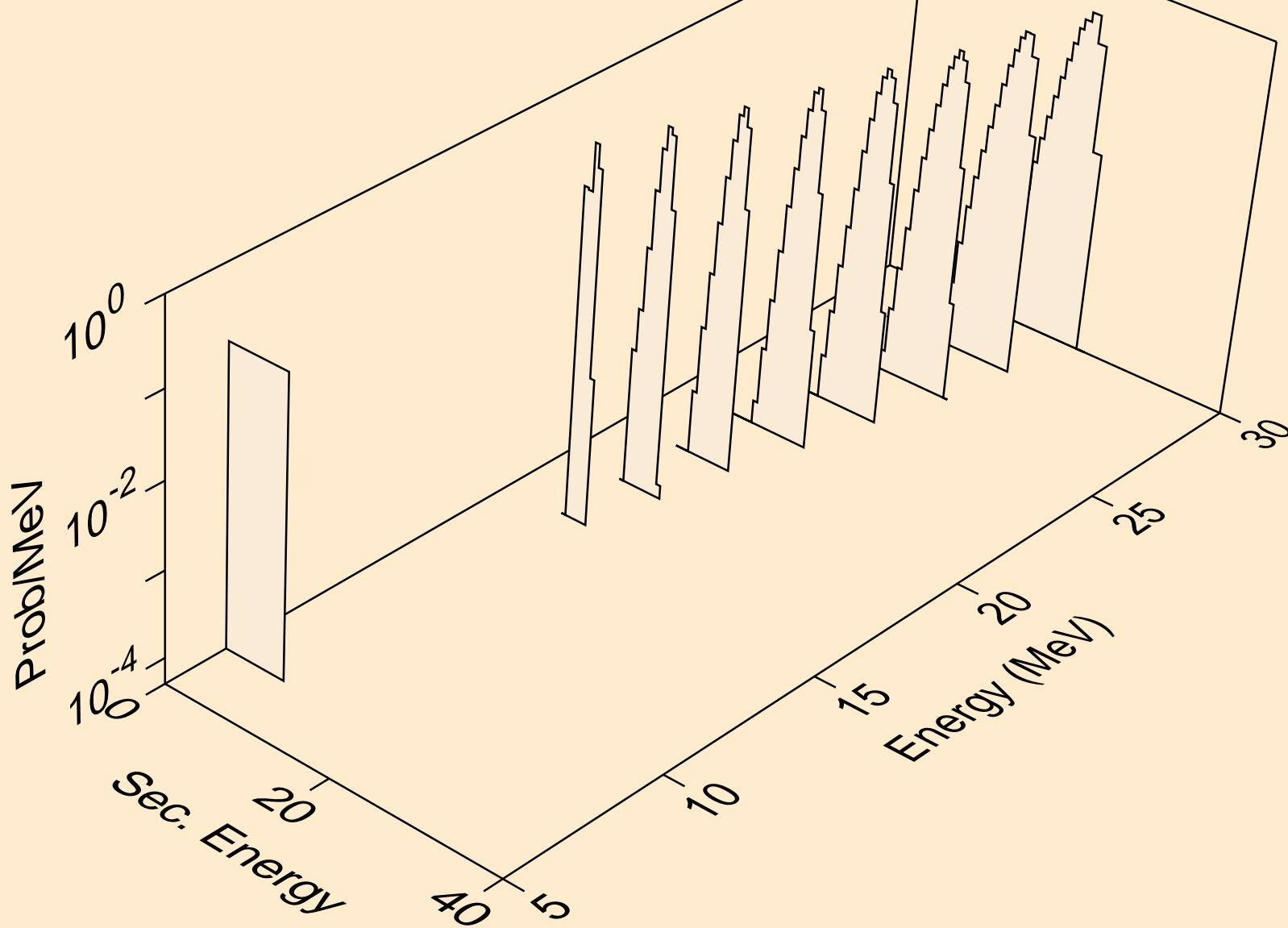

AC236 NEUTRON ACER TENDL-2023 LIBRARY; T=0.K
alphas from (n,a)

