

# AT228 NEUTRON ACER TENDL-2023 LIBRARY; T=0.K

## Principal cross sections

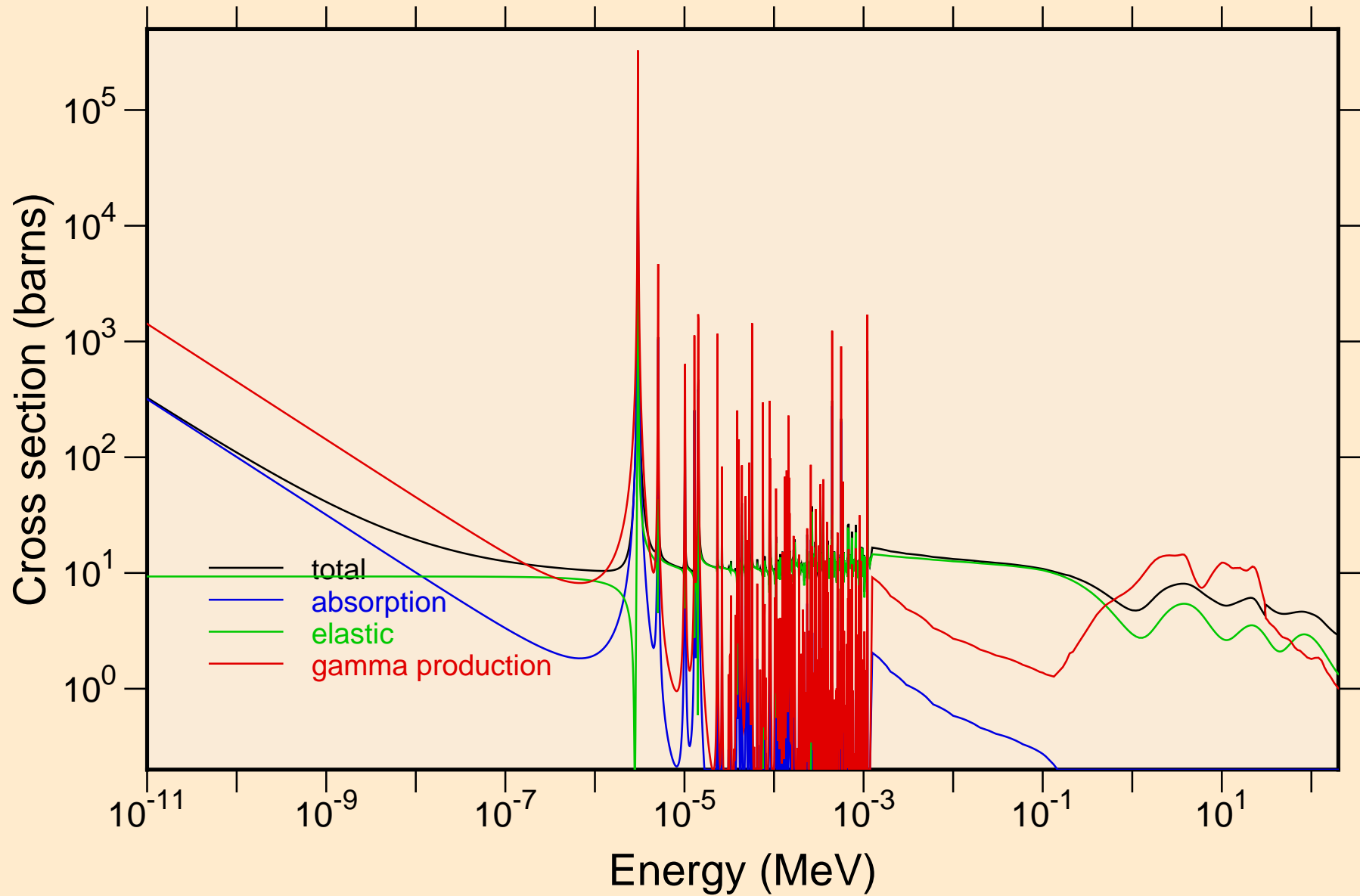

AT228 NEUTRON ACER TENDL-2023 LIBRARY; T=0.K  
resonance total cross section

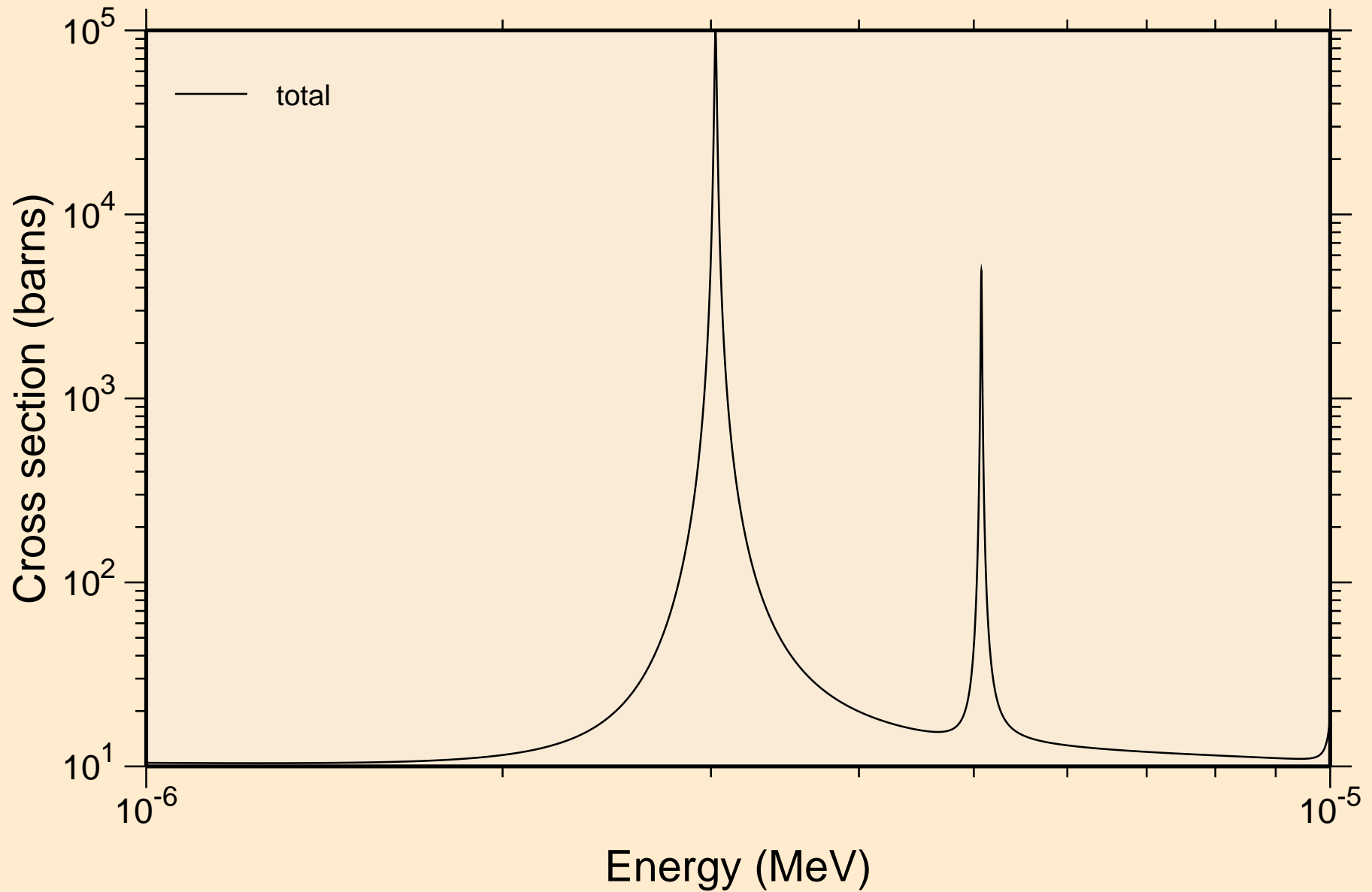

AT228 NEUTRON ACER TENDL-2023 LIBRARY; T=0.K  
resonance total cross section

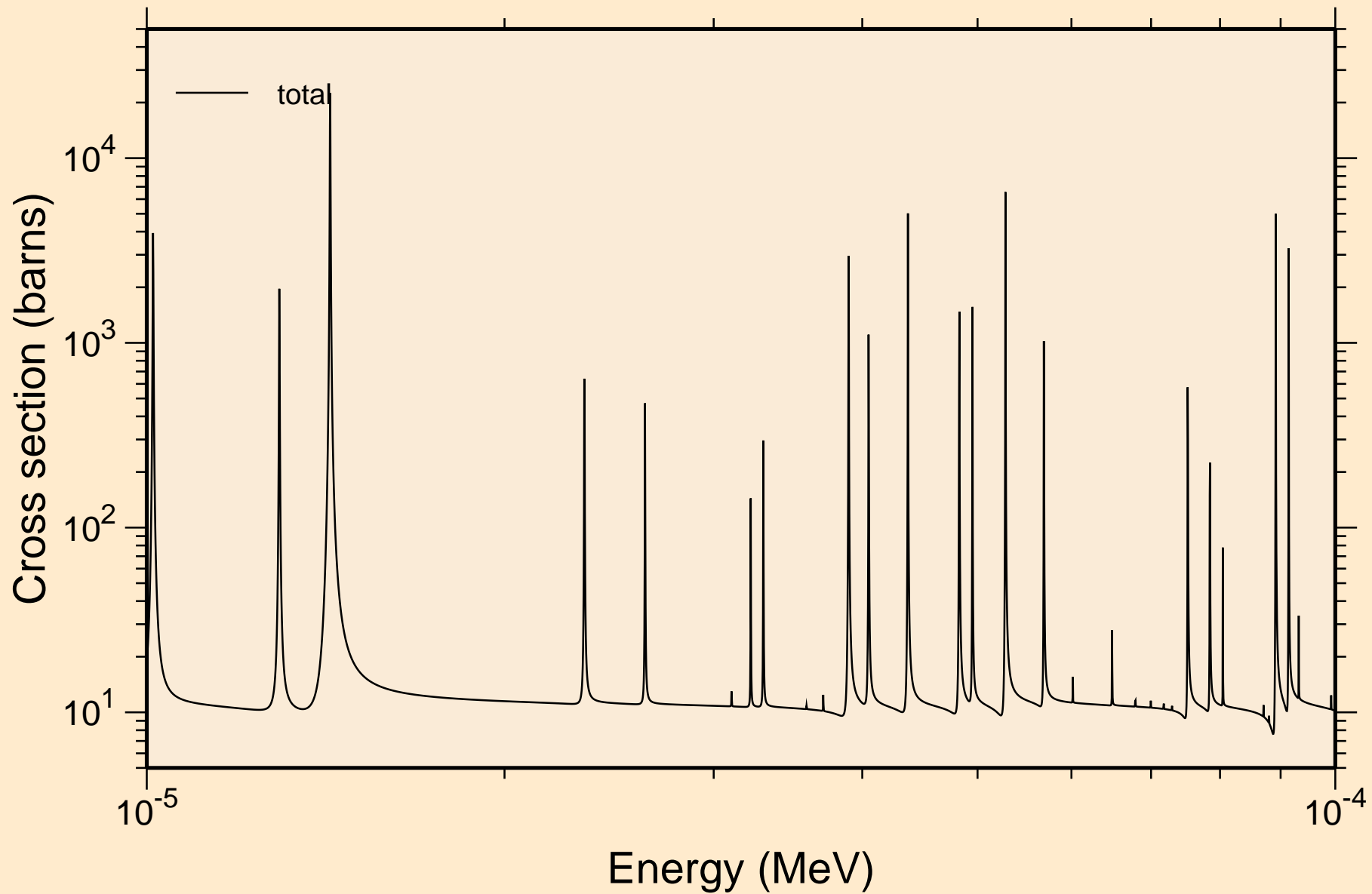

AT228 NEUTRON ACER TENDL-2023 LIBRARY; T=0.K  
resonance total cross section

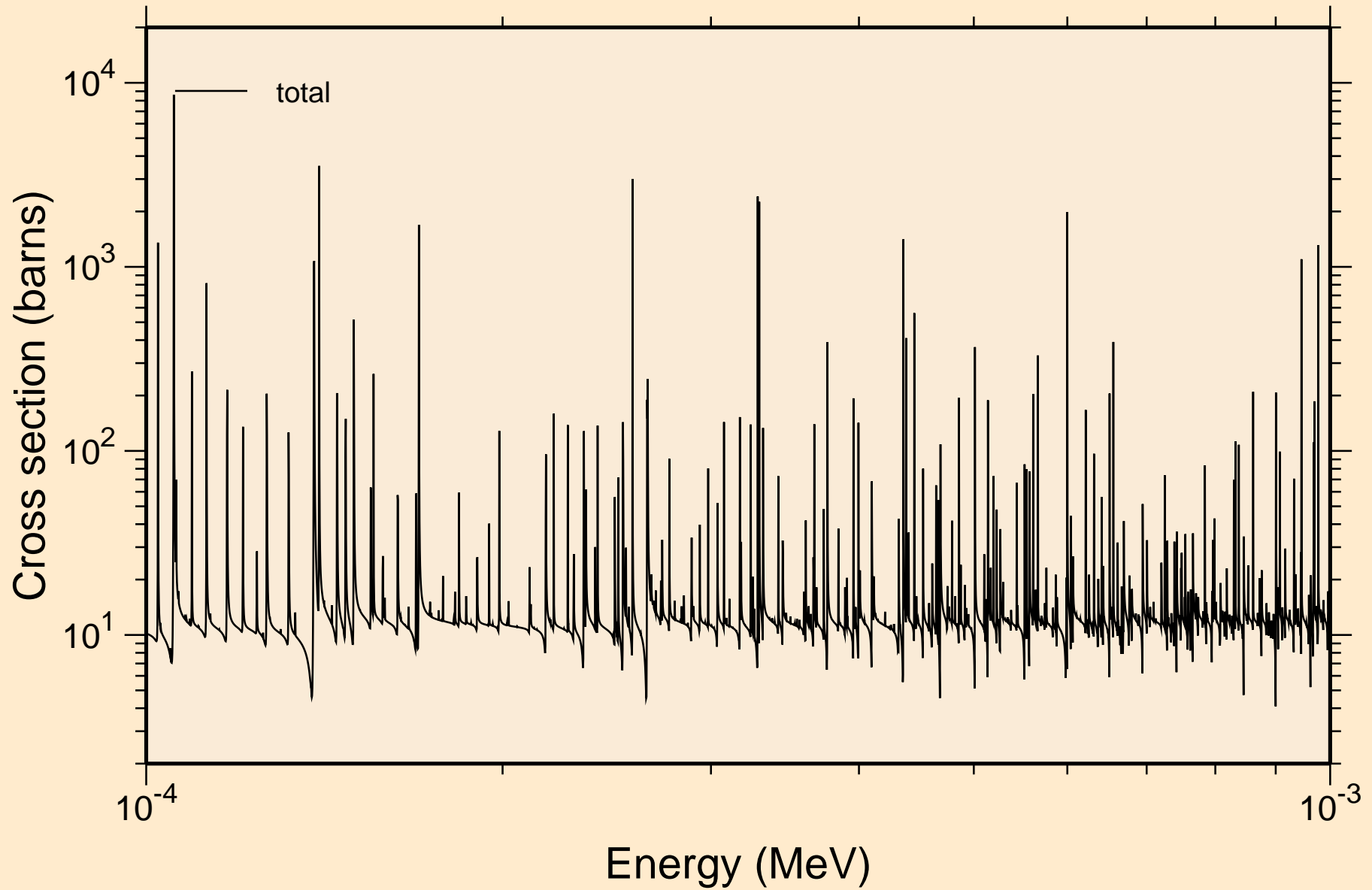

AT228 NEUTRON ACER TENDL-2023 LIBRARY; T=0.K  
resonance total cross section

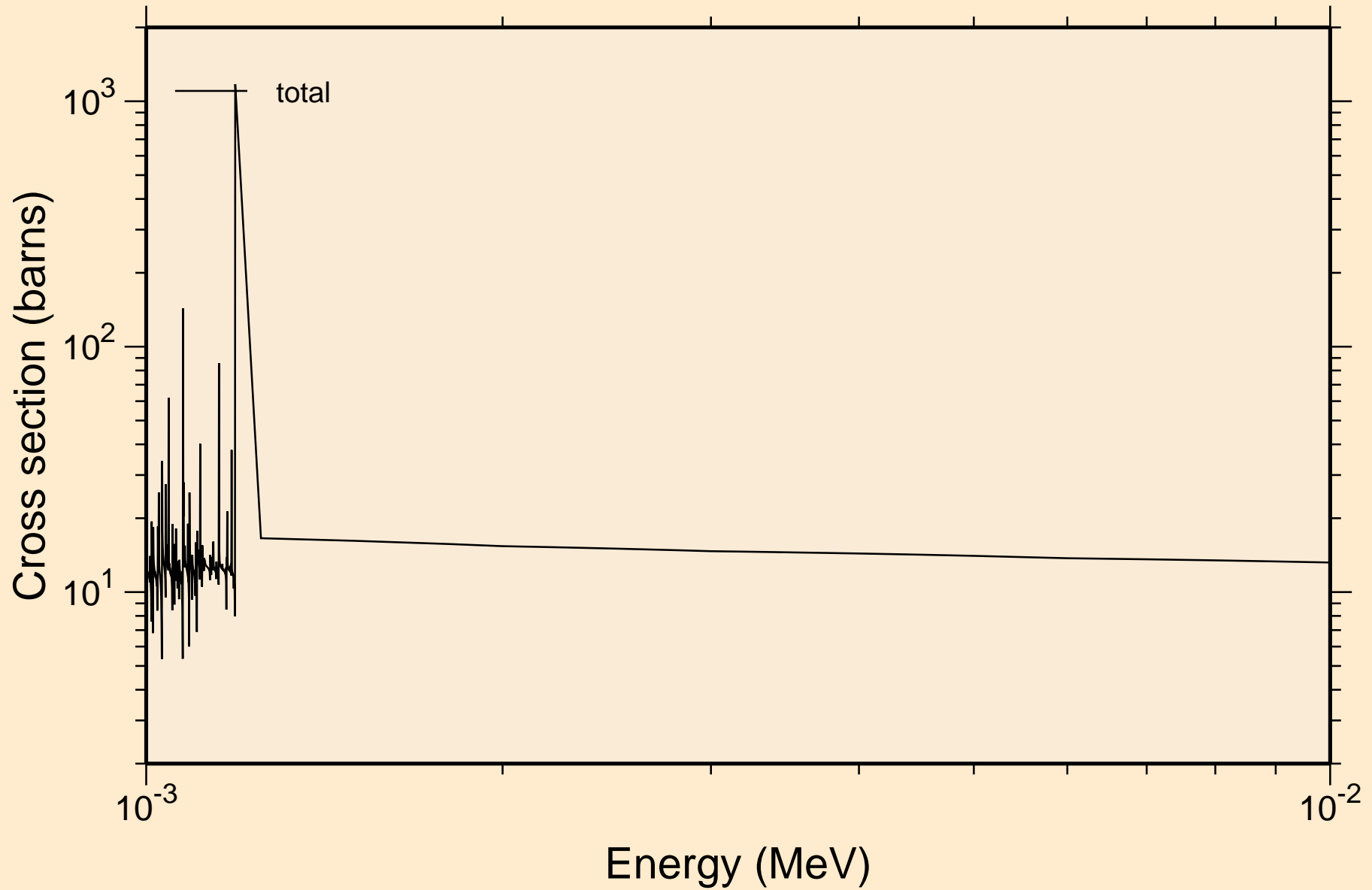

AT228 NEUTRON ACER TENDL-2023 LIBRARY; T=0.K  
resonance total cross section

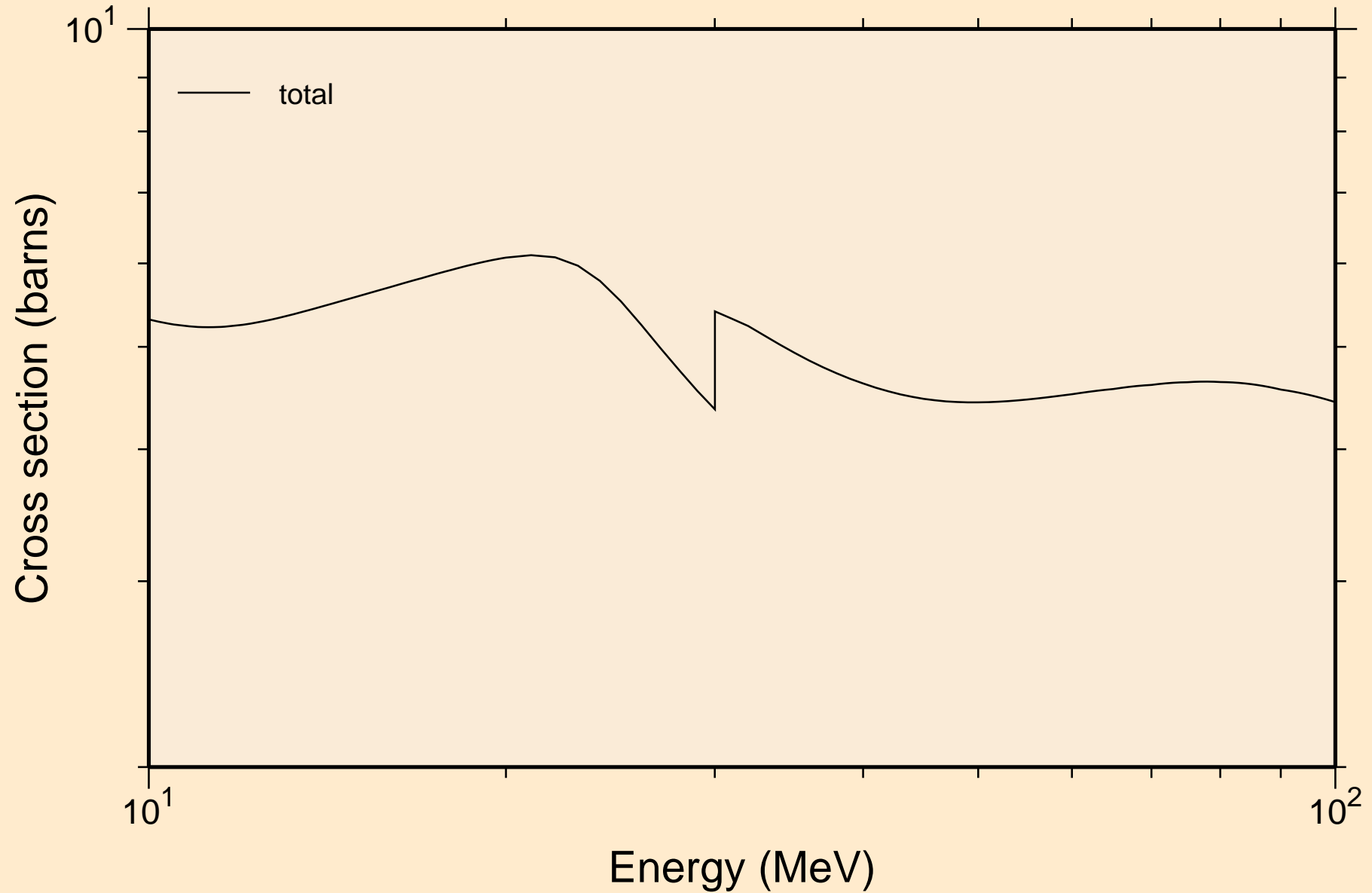

AT228 NEUTRON ACER TENDL-2023 LIBRARY; T=0.K  
resonance absorption cross sections

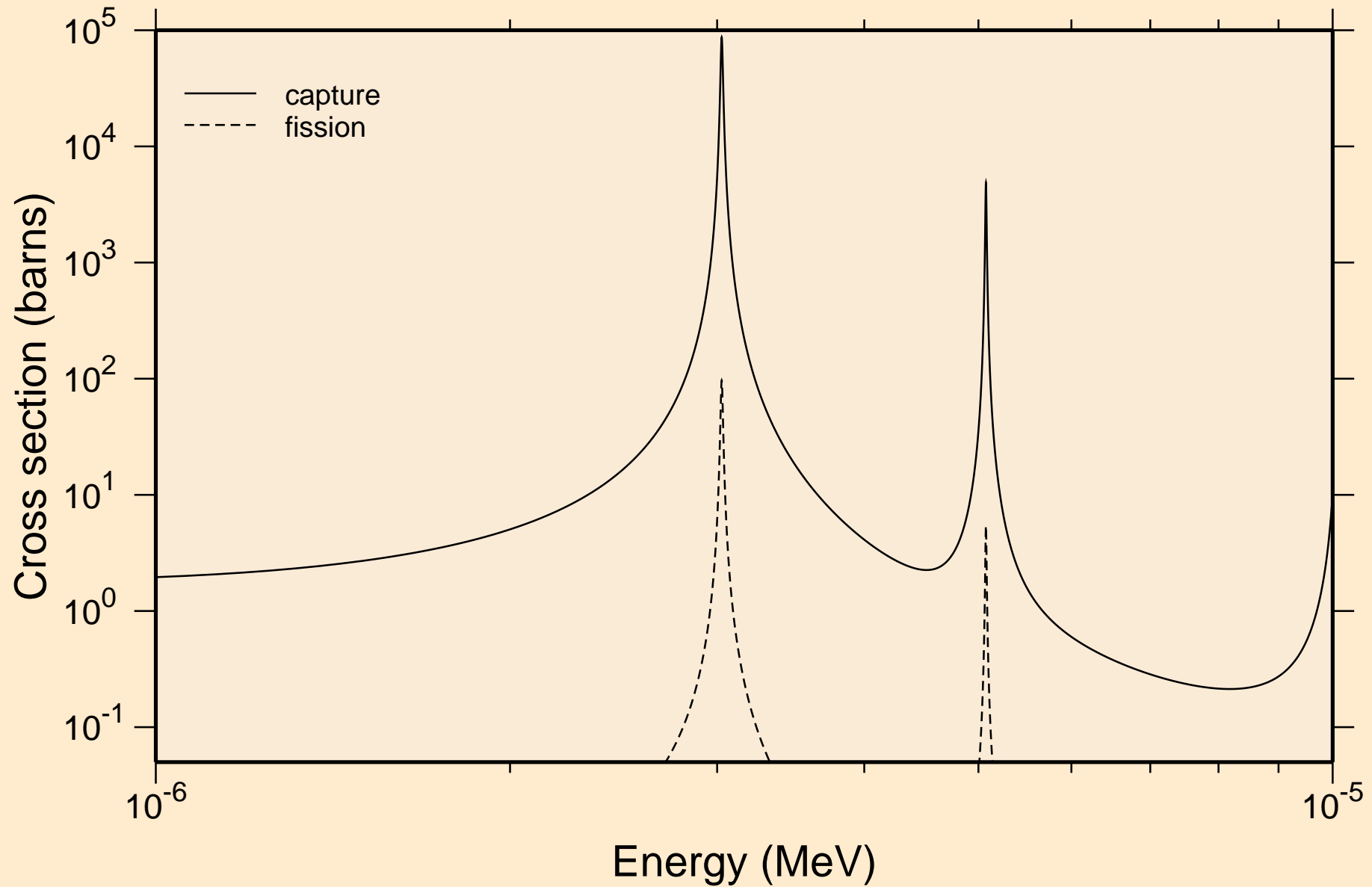

AT228 NEUTRON ACER TENDL-2023 LIBRARY; T=0.K  
resonance absorption cross sections

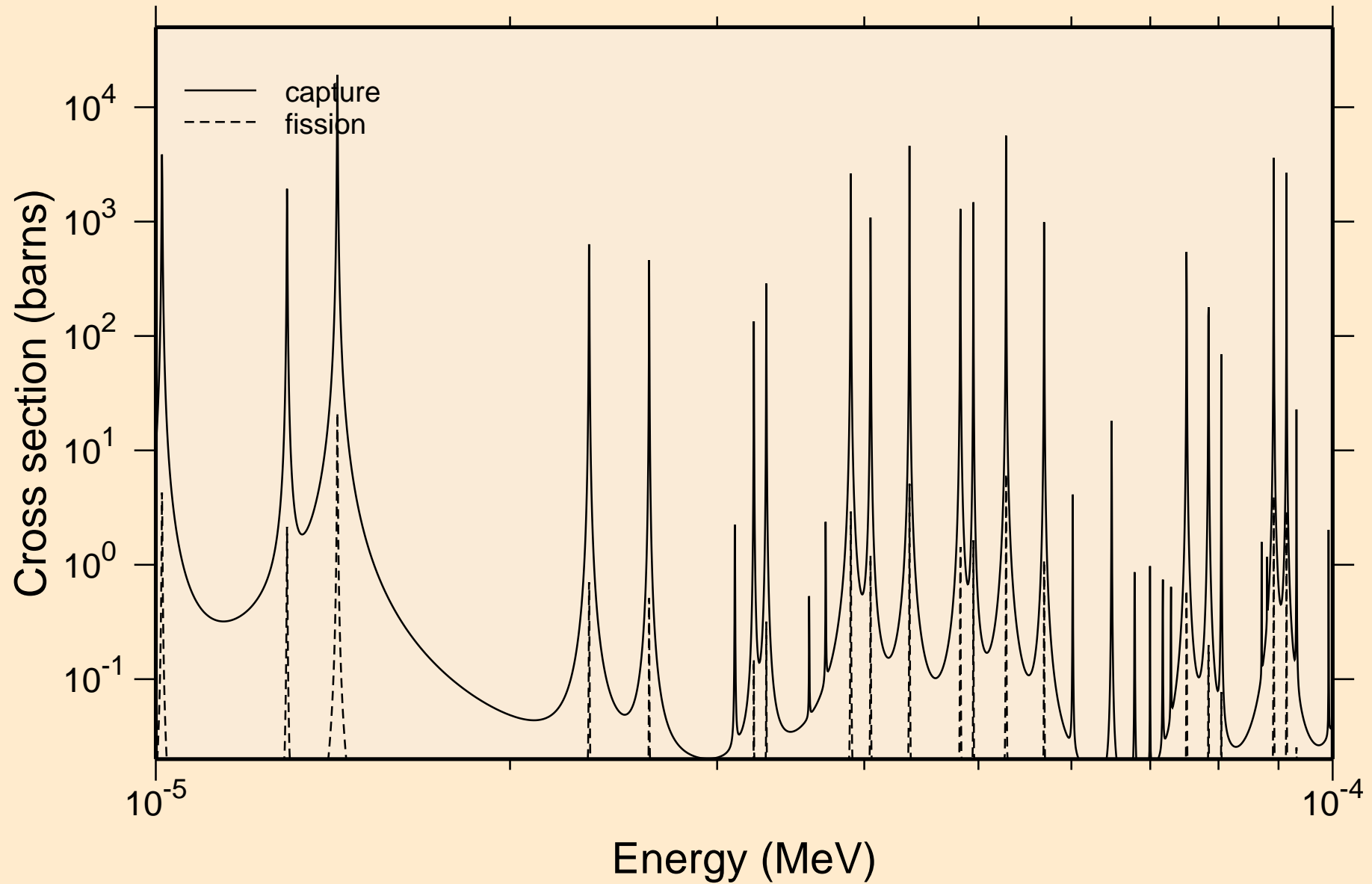

AT228 NEUTRON ACER TENDL-2023 LIBRARY; T=0.K  
resonance absorption cross sections

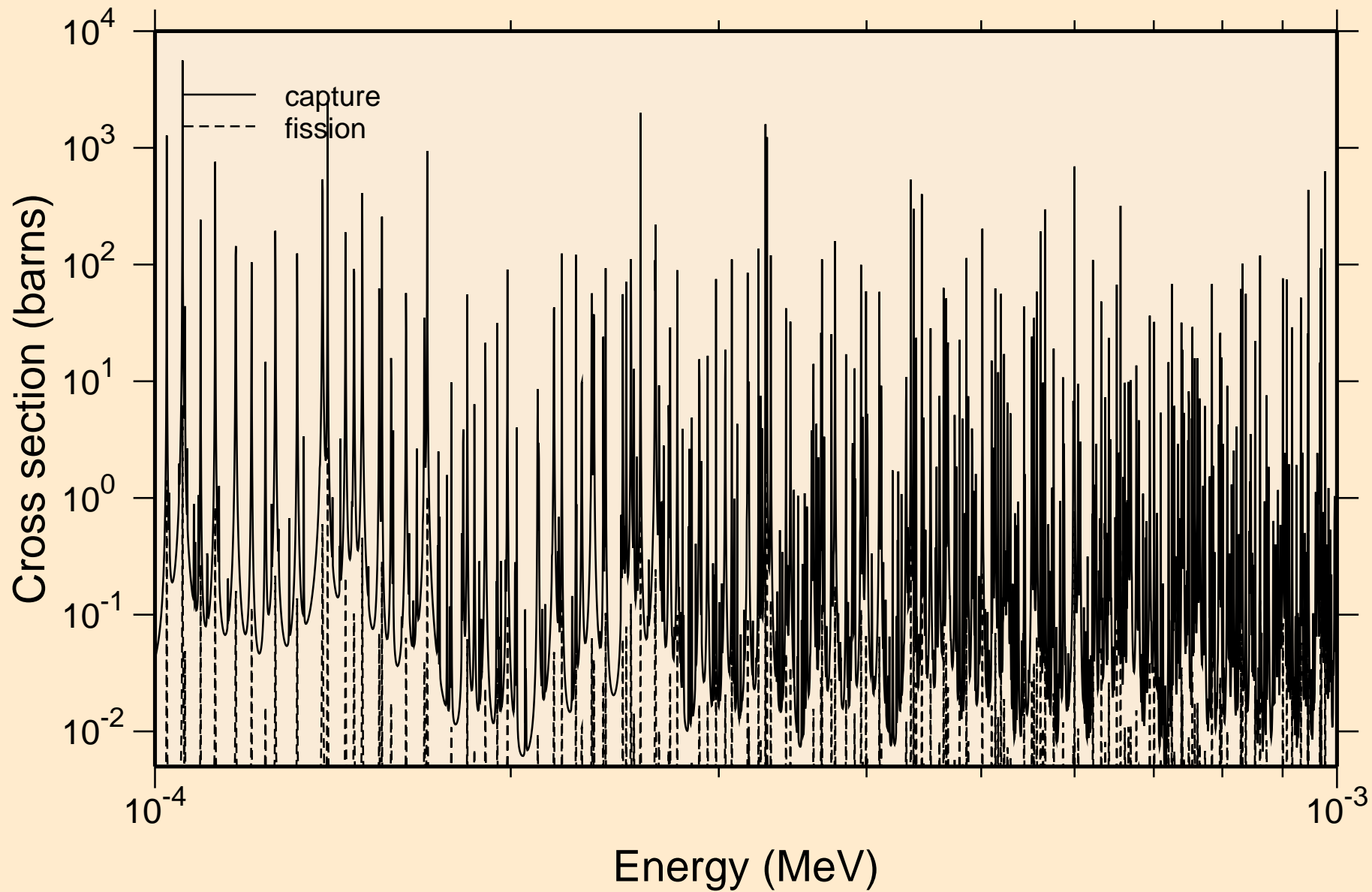

AT228 NEUTRON ACER TENDL-2023 LIBRARY; T=0.K  
resonance absorption cross sections

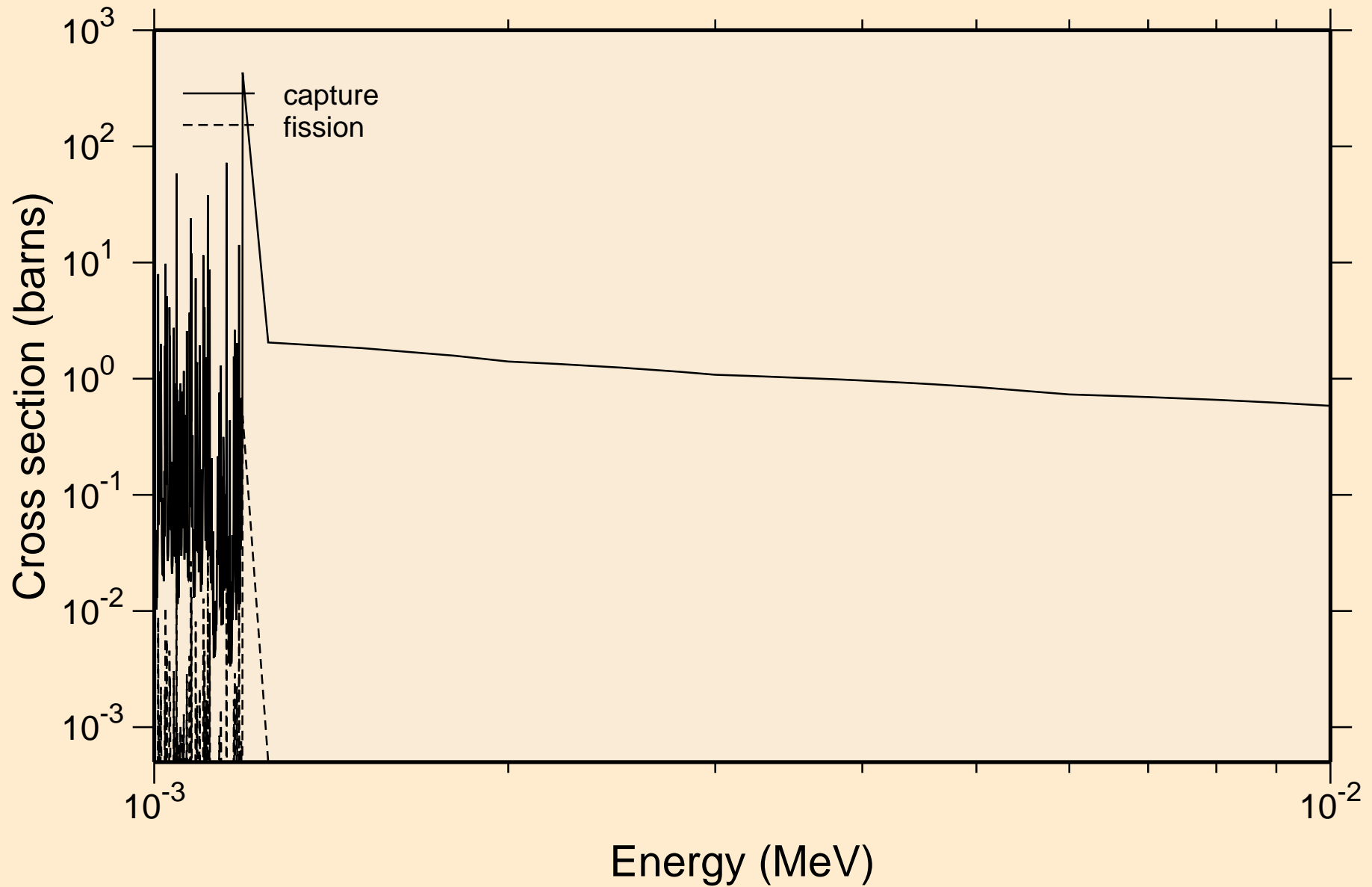

AT228 NEUTRON ACER TENDL-2023 LIBRARY; T=0.K  
resonance absorption cross sections

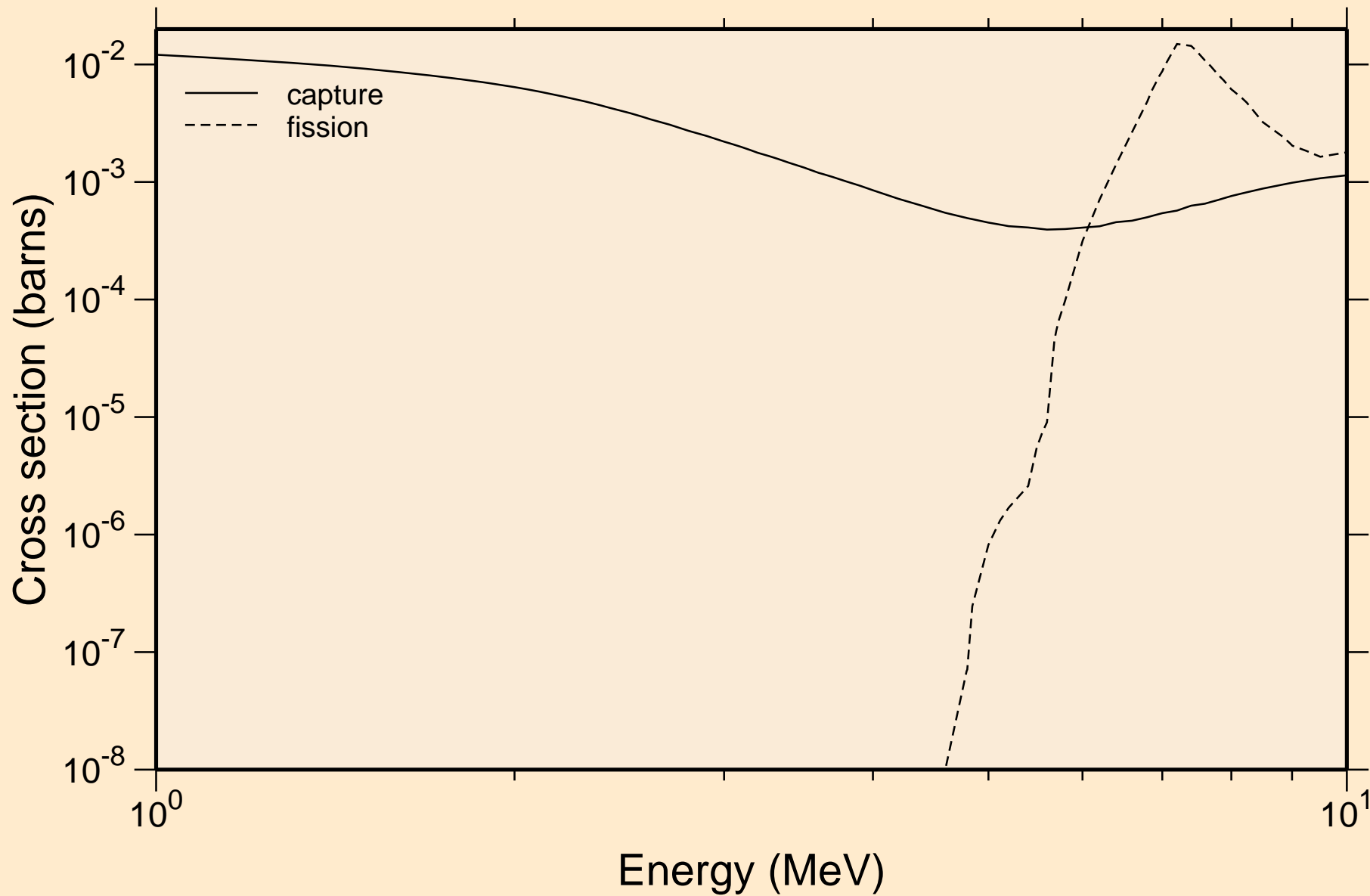

# AT228 NEUTRON ACER TENDL-2023 LIBRARY; T=0.K

## Heating

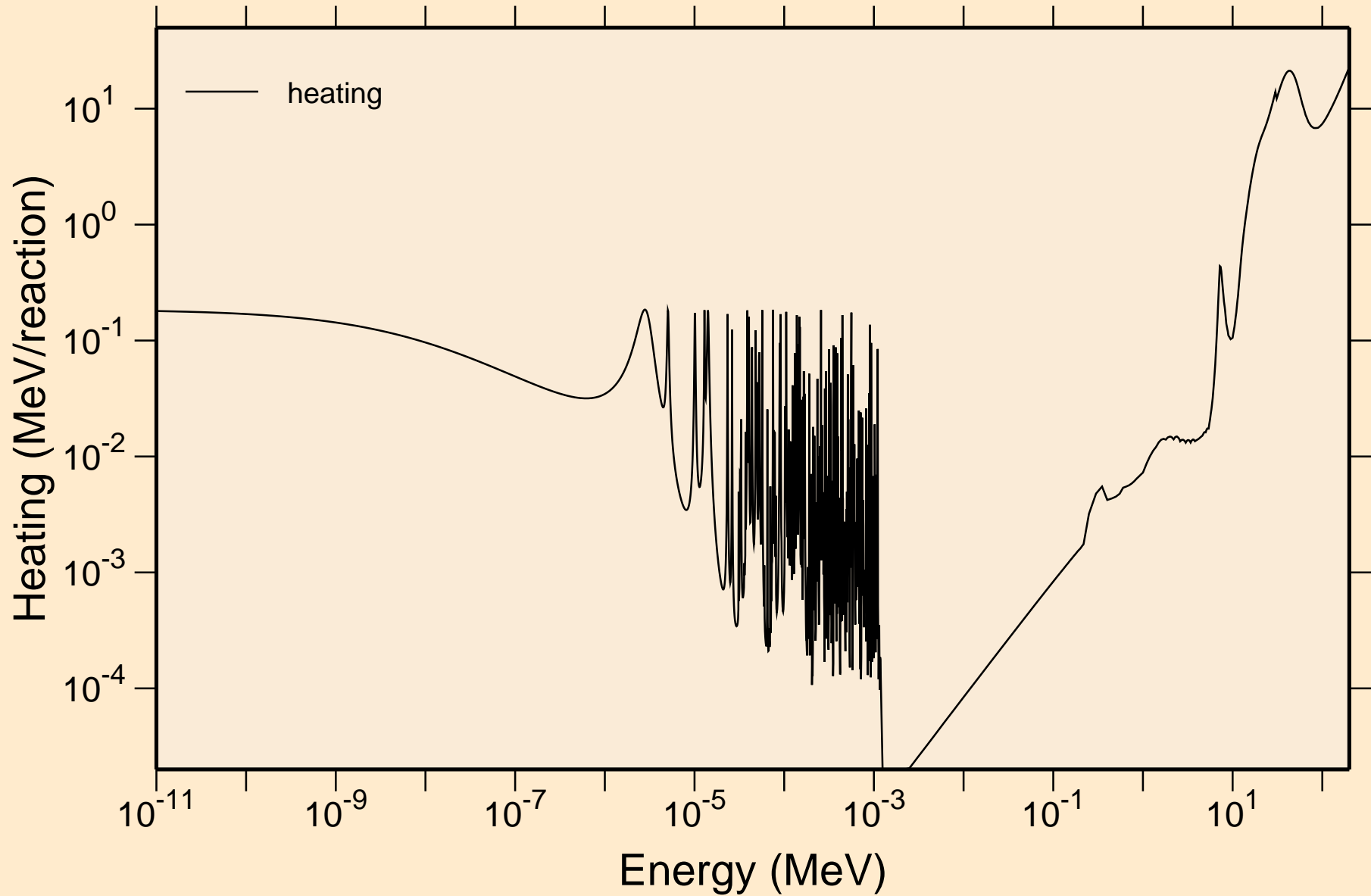

AT228 NEUTRON ACER TENDL-2023 LIBRARY; T=0.K  
Damage

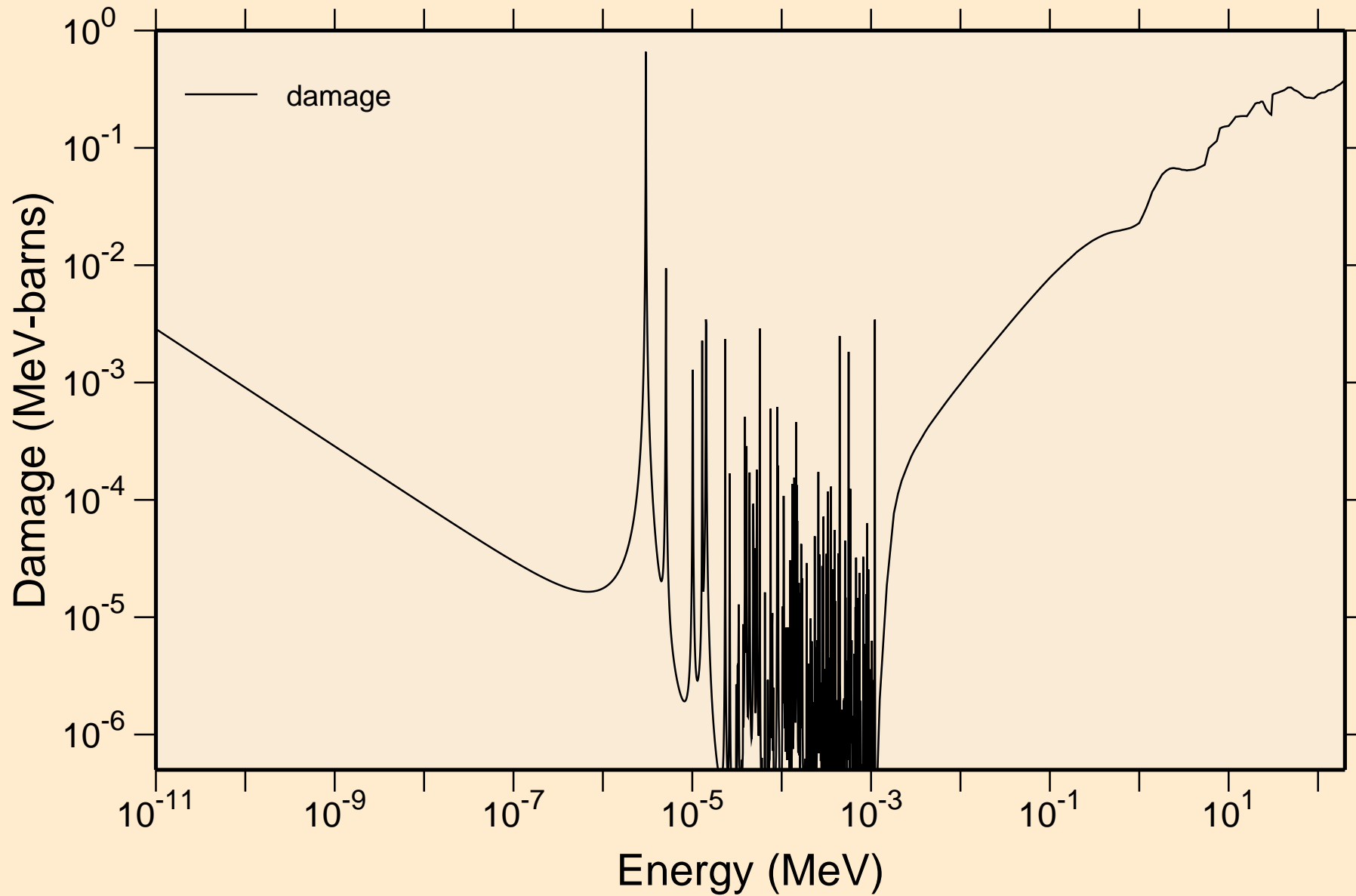

# AT228 NEUTRON ACER TENDL-2023 LIBRARY; T=0.K

## Non-threshold reactions

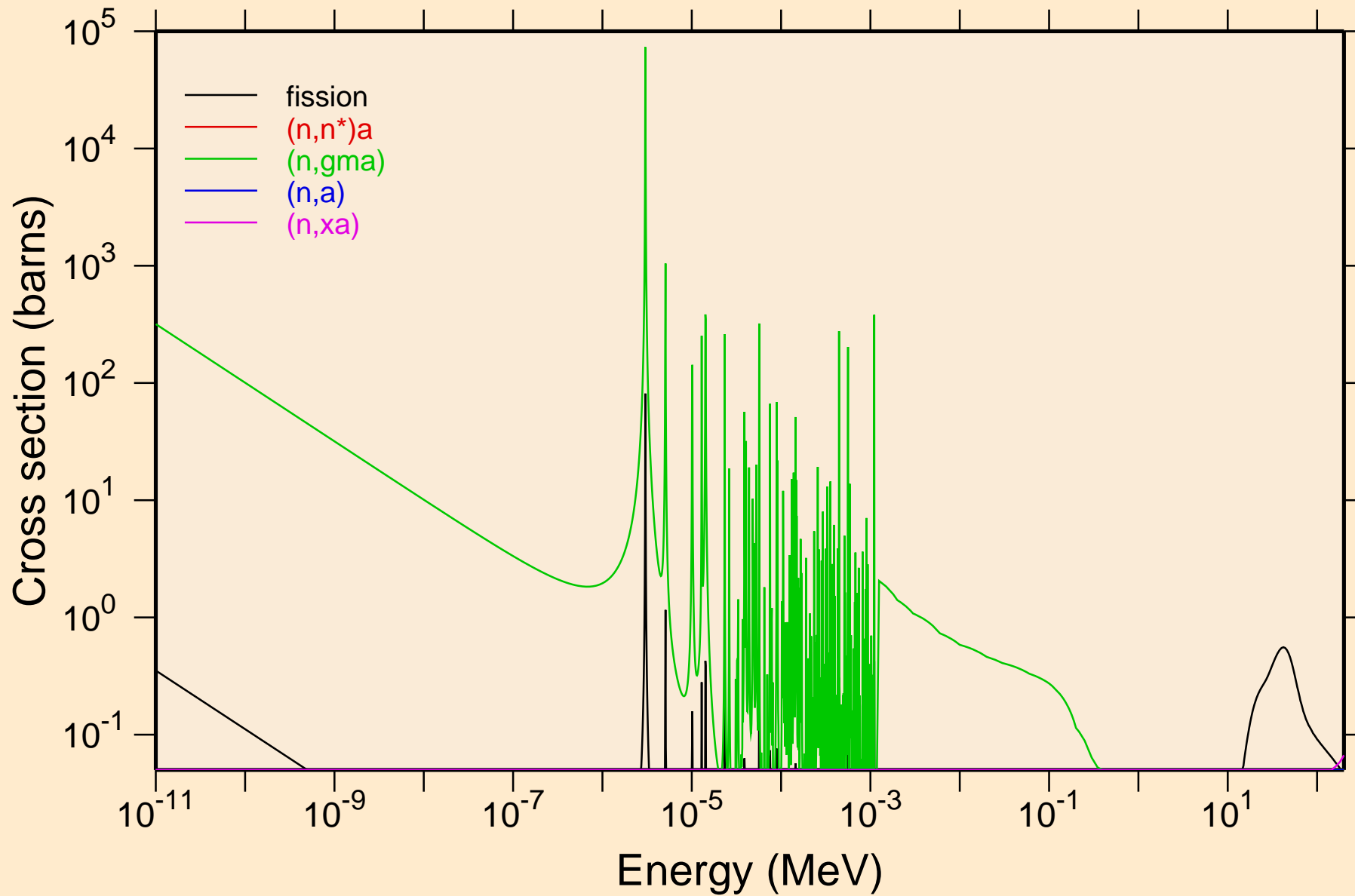

# AT228 NEUTRON ACER TENDL-2023 LIBRARY; T=0.K

## Principal cross sections

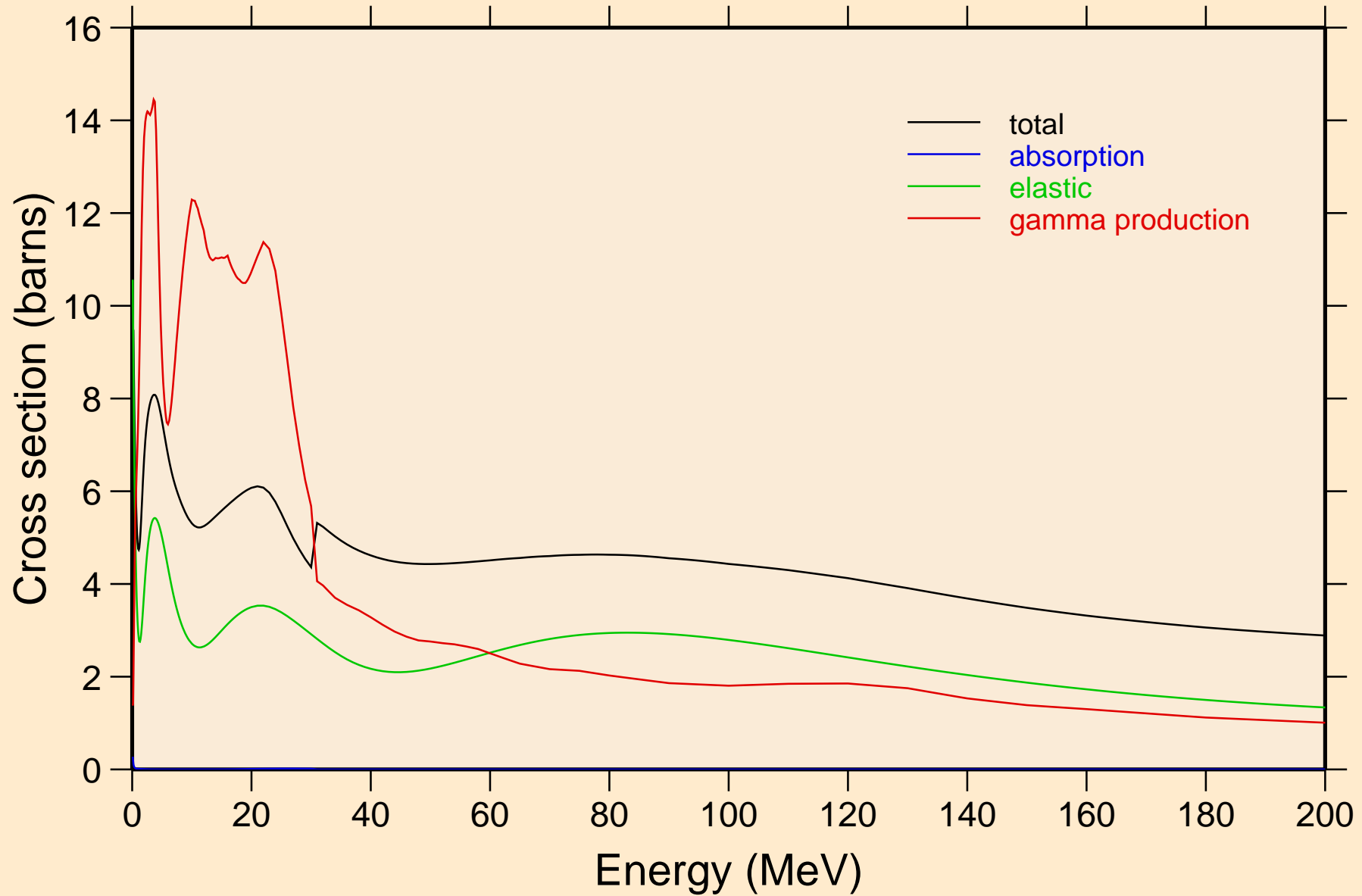

AT228 NEUTRON ACER TENDL-2023 LIBRARY; T=0.K

Heating

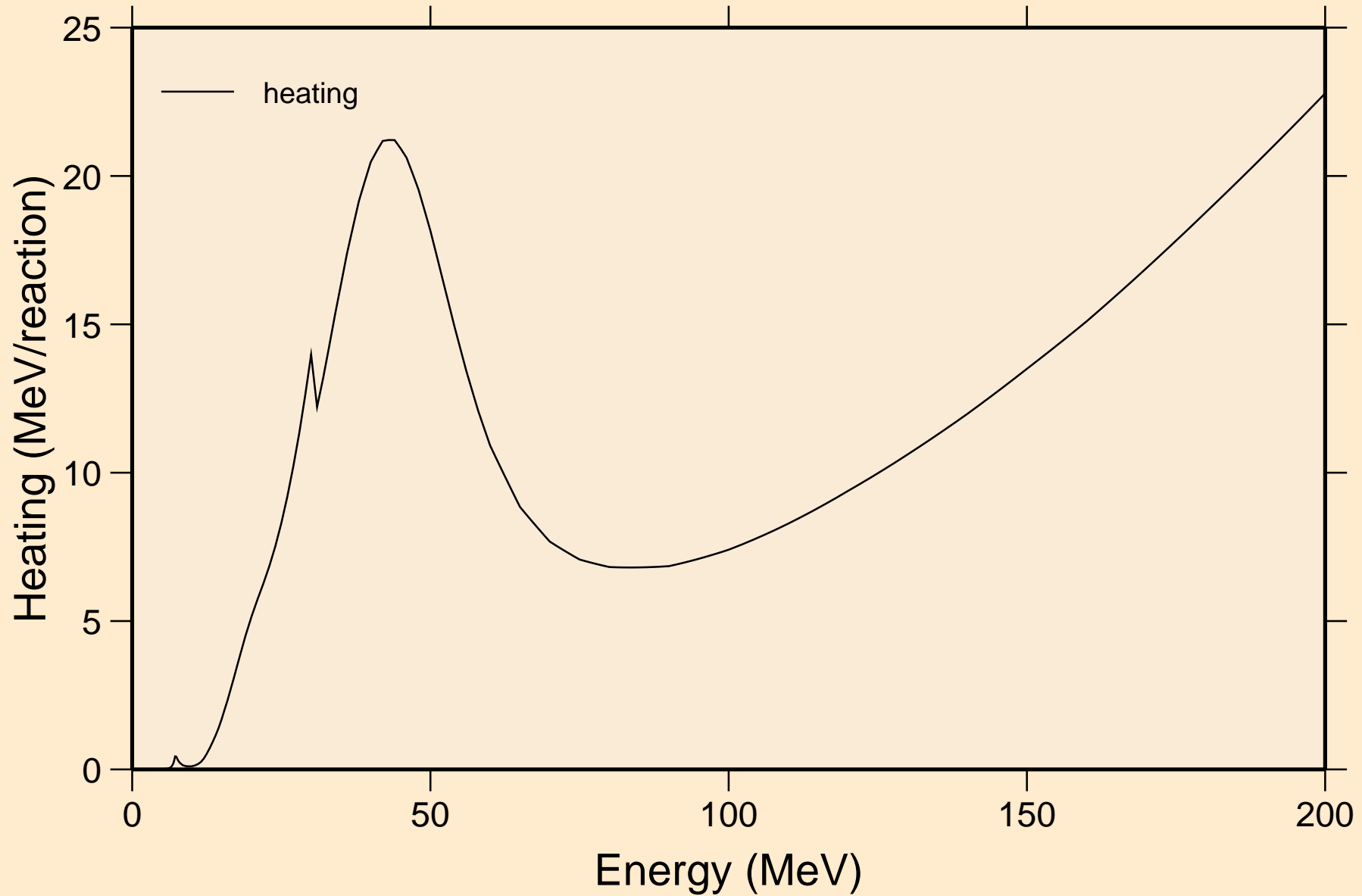

AT228 NEUTRON ACER TENDL-2023 LIBRARY; T=0.K  
Damage

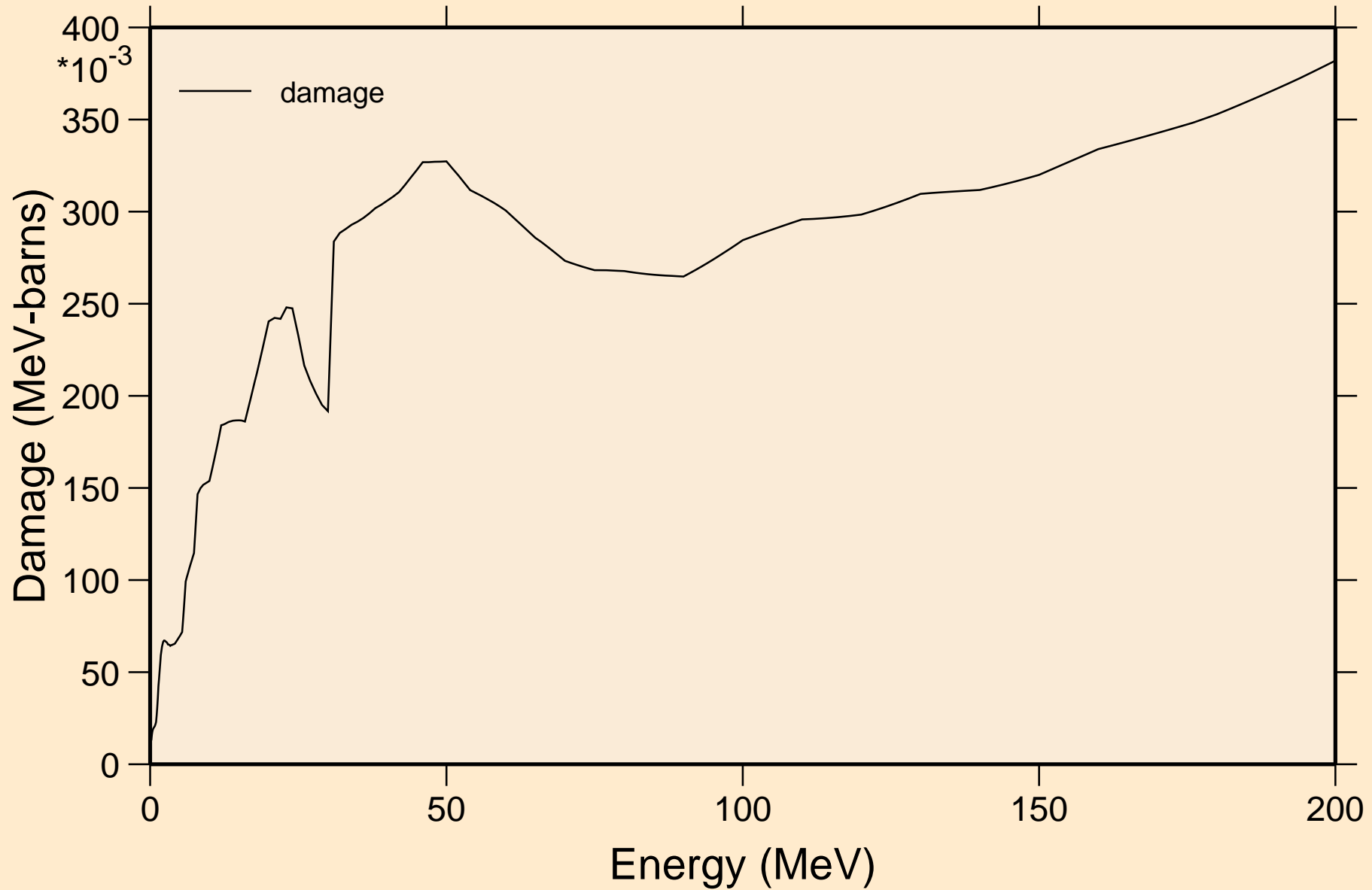

AT228 NEUTRON ACER TENDL-2023 LIBRARY; T=0.K  
Non-threshold reactions

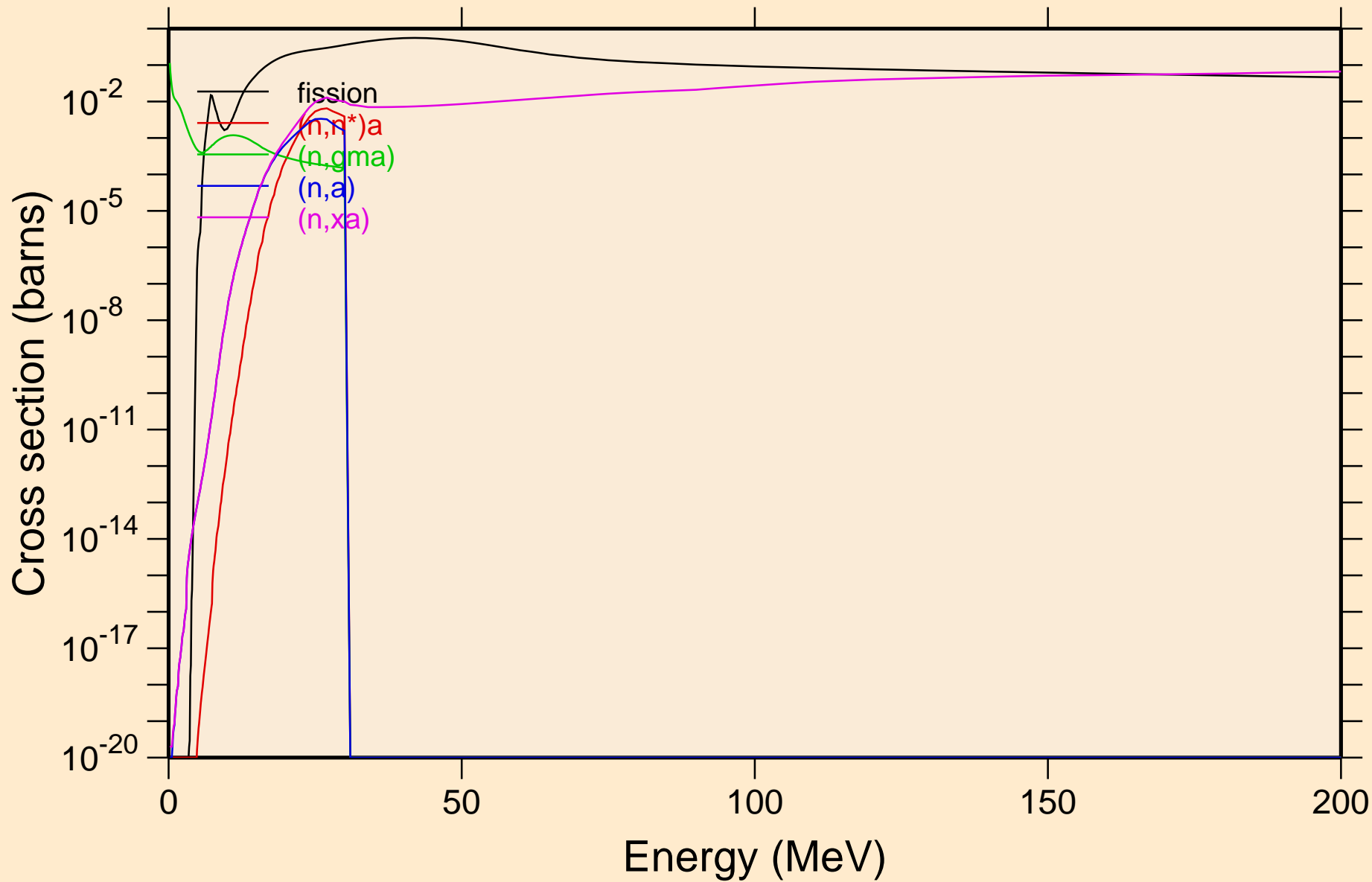

AT228 NEUTRON ACER TENDL-2023 LIBRARY; T=0.K  
Inelastic levels

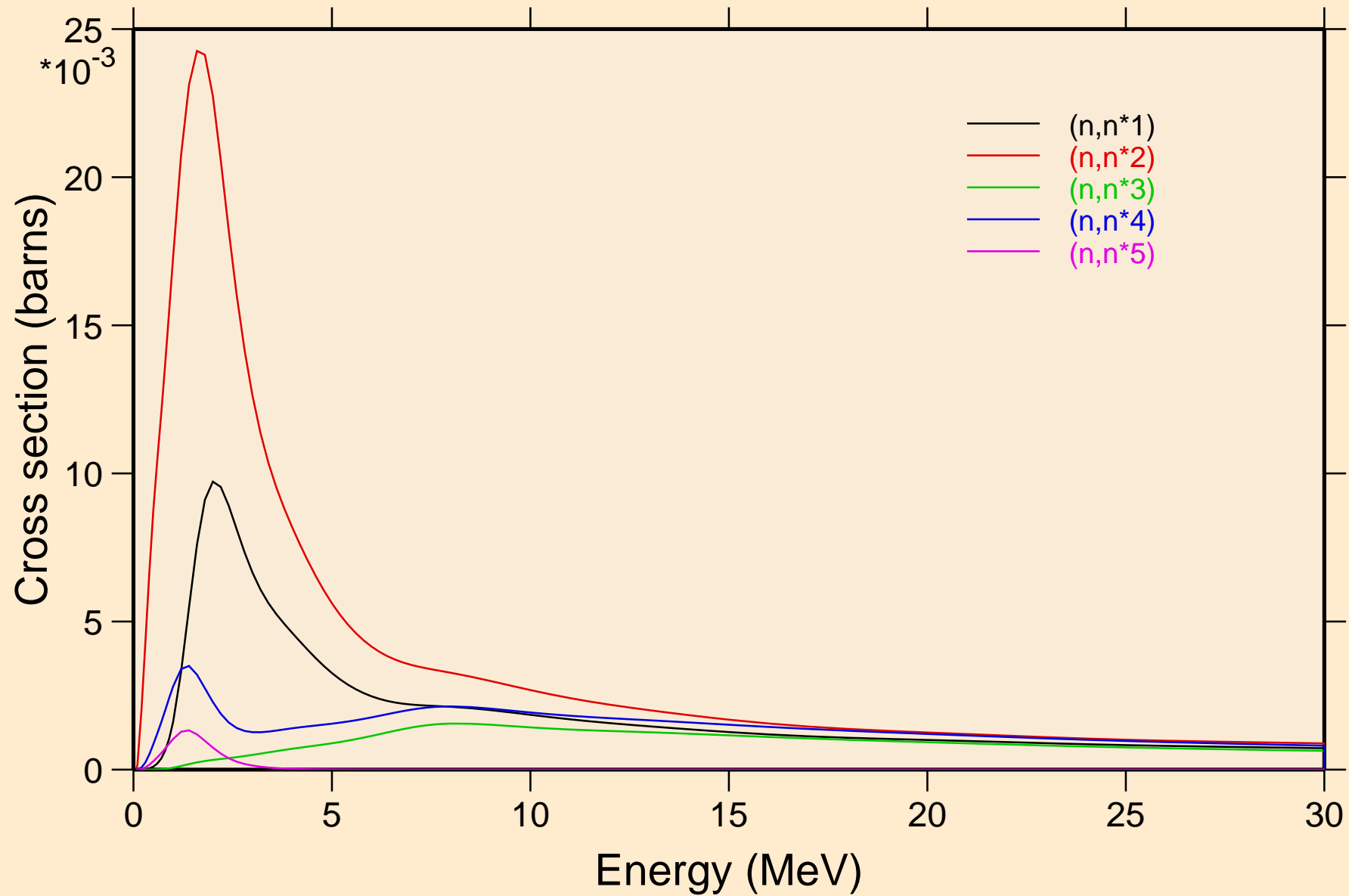

AT228 NEUTRON ACER TENDL-2023 LIBRARY; T=0.K  
Inelastic levels

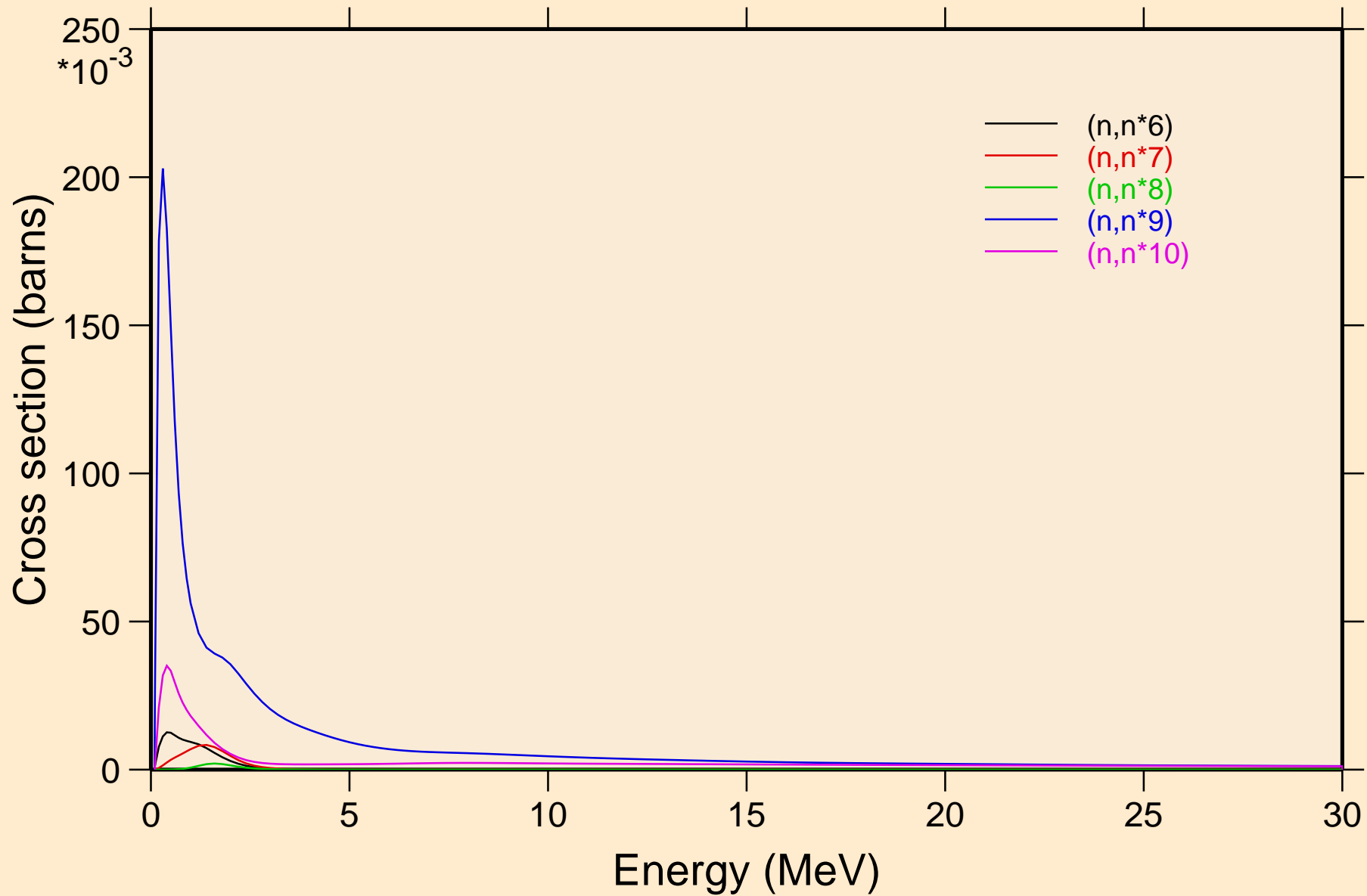

AT228 NEUTRON ACER TENDL-2023 LIBRARY; T=0.K  
Inelastic levels

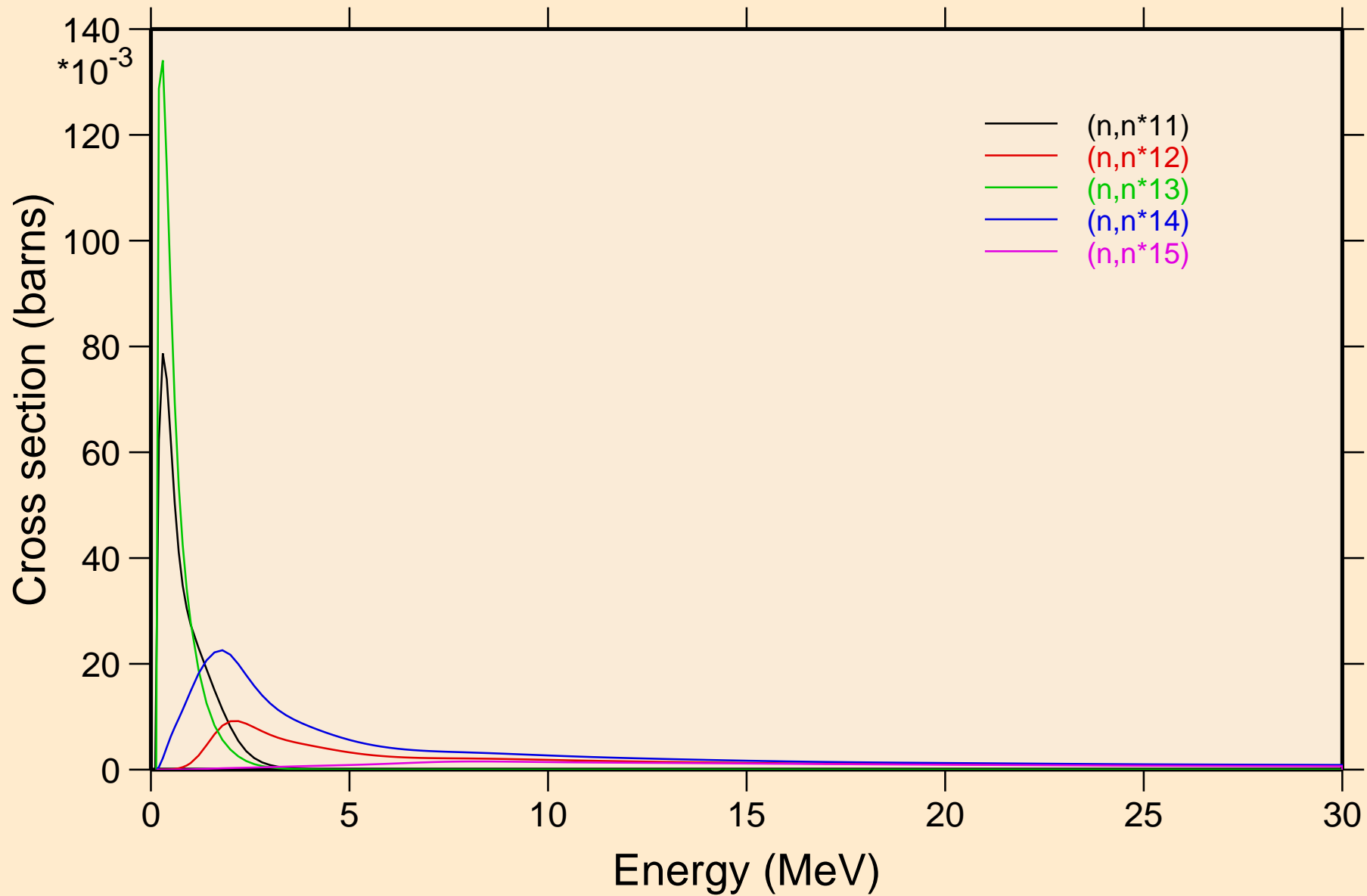

AT228 NEUTRON ACER TENDL-2023 LIBRARY; T=0.K  
Inelastic levels

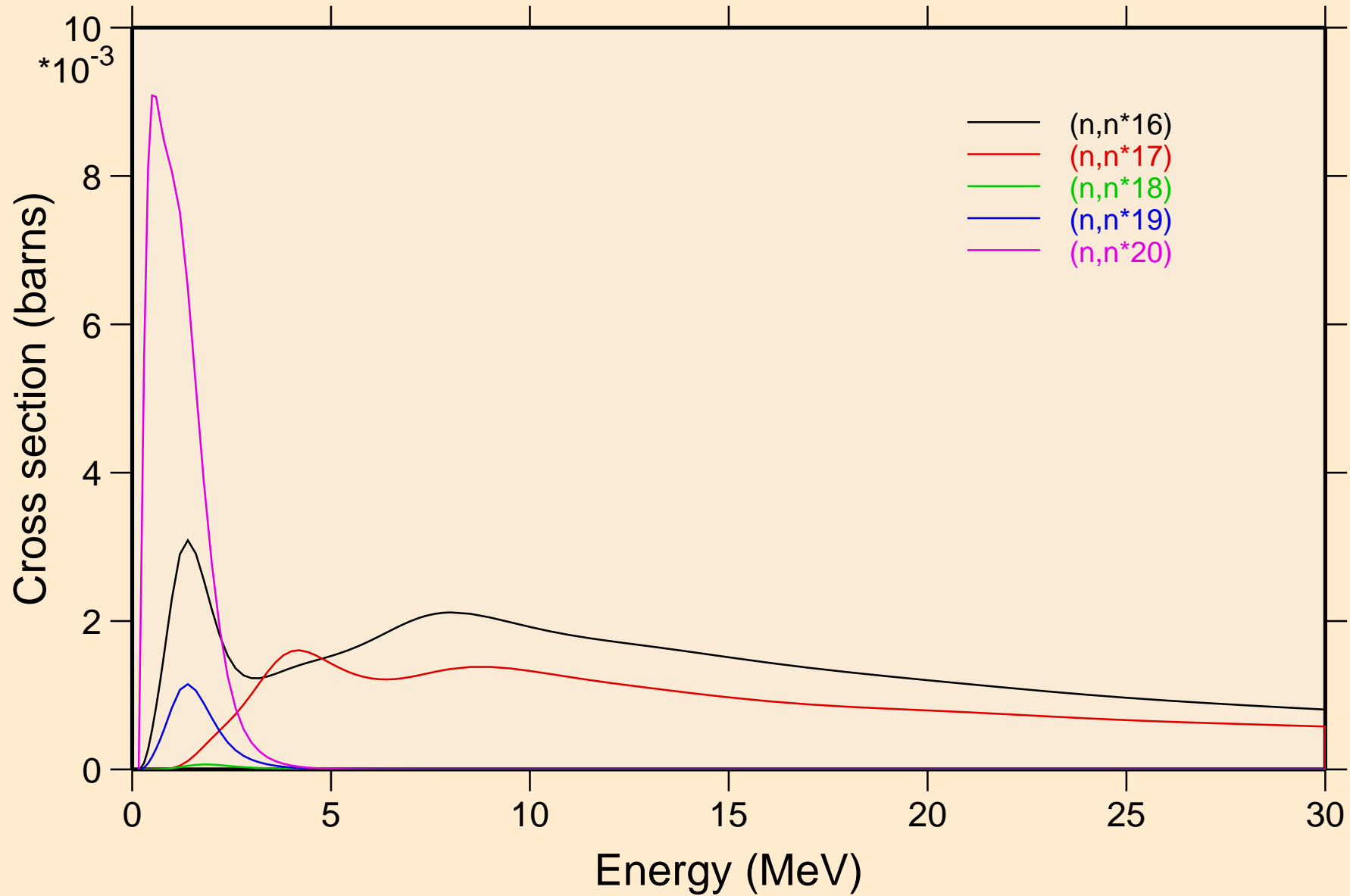

AT228 NEUTRON ACER TENDL-2023 LIBRARY; T=0.K  
Inelastic levels

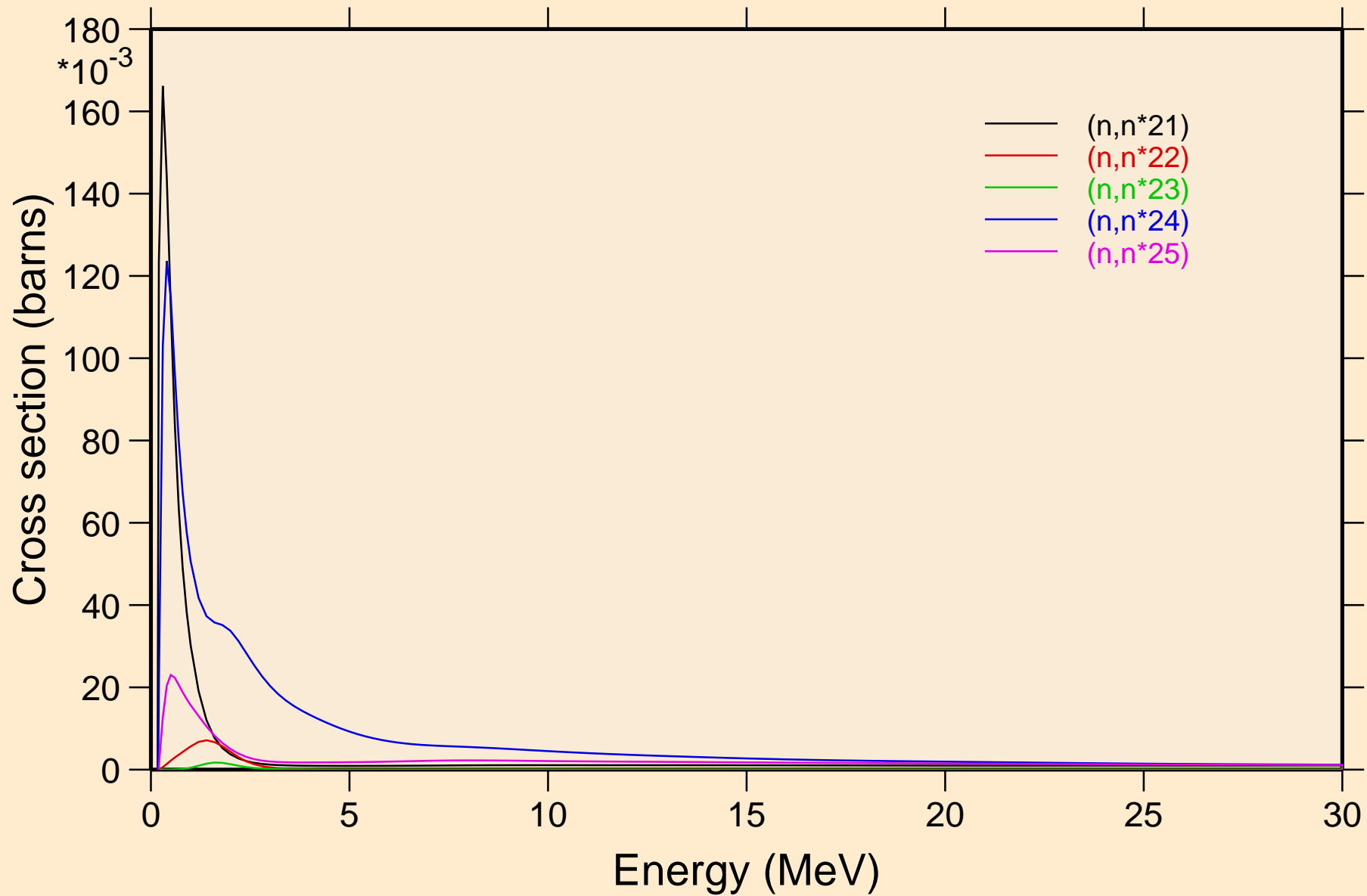

AT228 NEUTRON ACER TENDL-2023 LIBRARY; T=0.K  
Inelastic levels

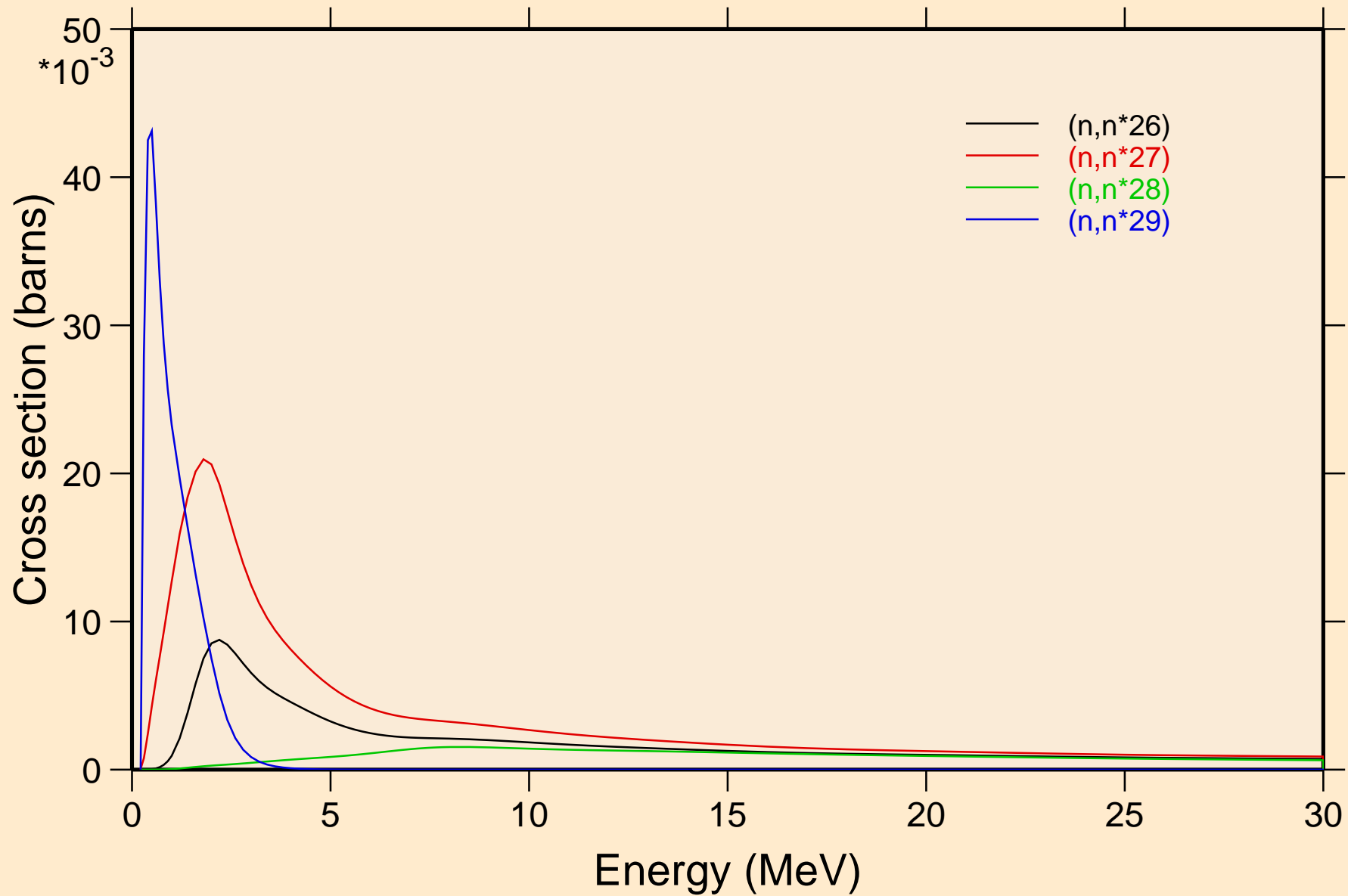

# AT228 NEUTRON ACER TENDL-2023 LIBRARY; T=0.K

## Threshold reactions

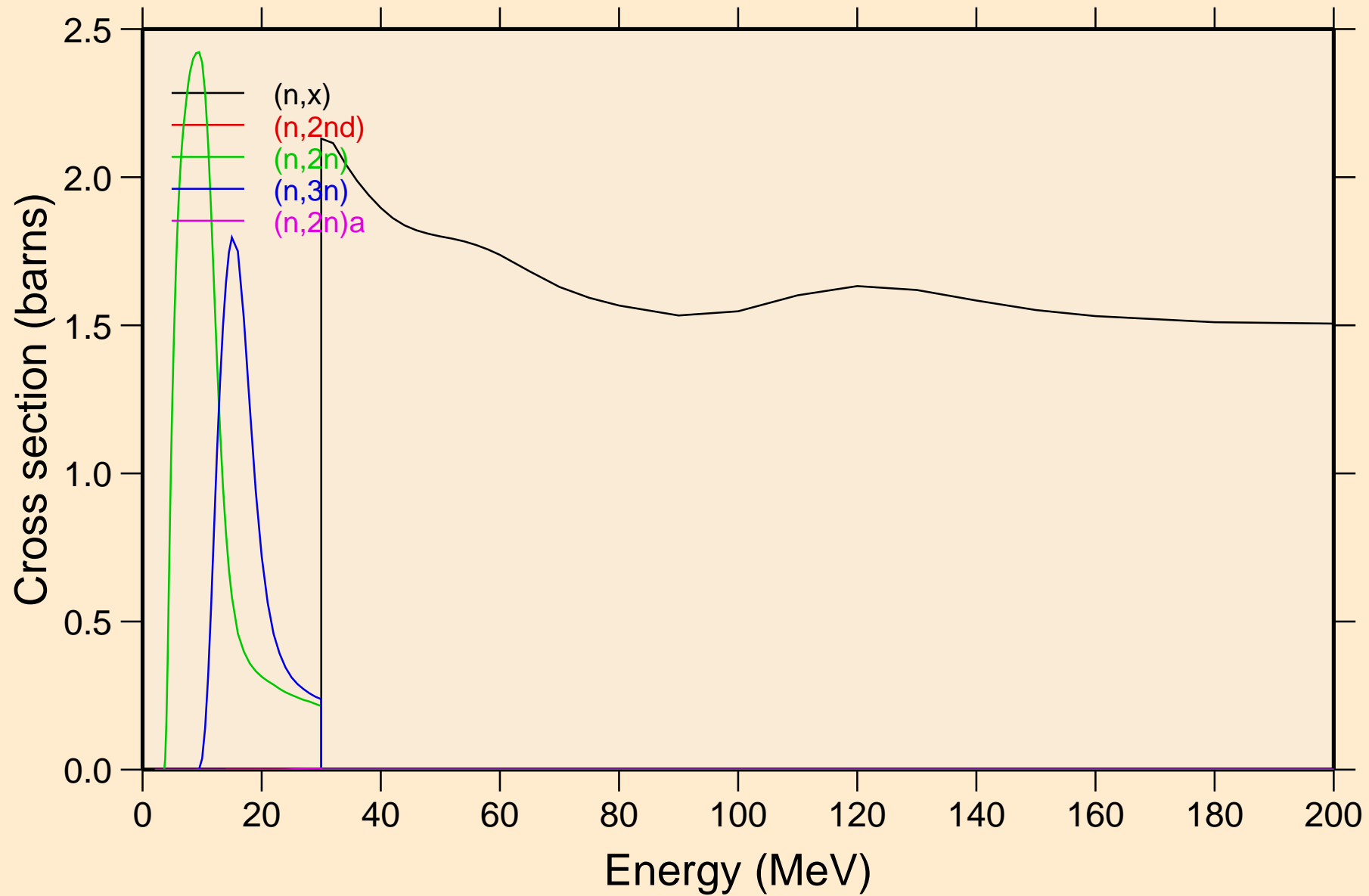

AT228 NEUTRON ACER TENDL-2023 LIBRARY; T=0.K  
Threshold reactions

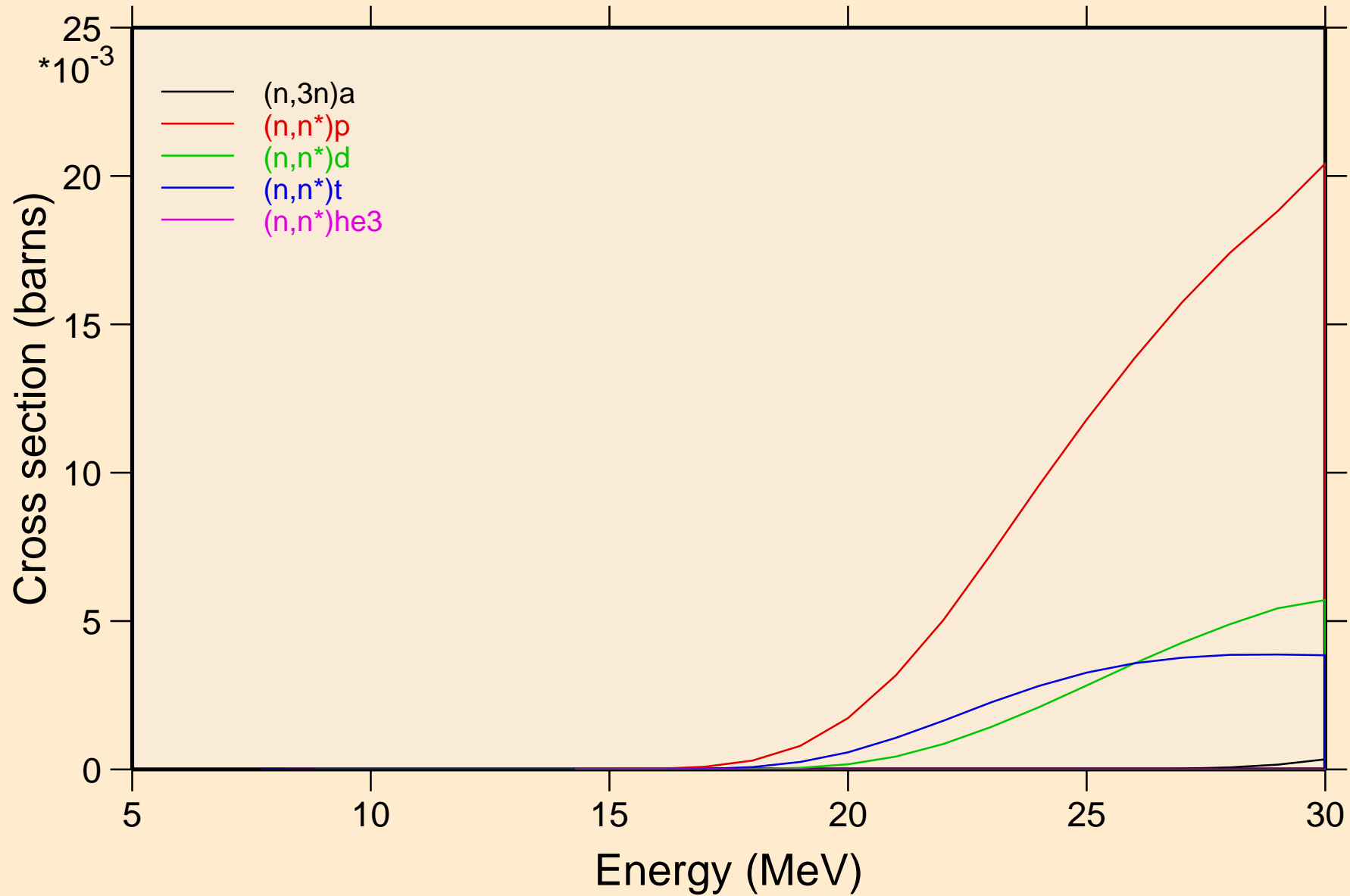

AT228 NEUTRON ACER TENDL-2023 LIBRARY; T=0.K  
Threshold reactions

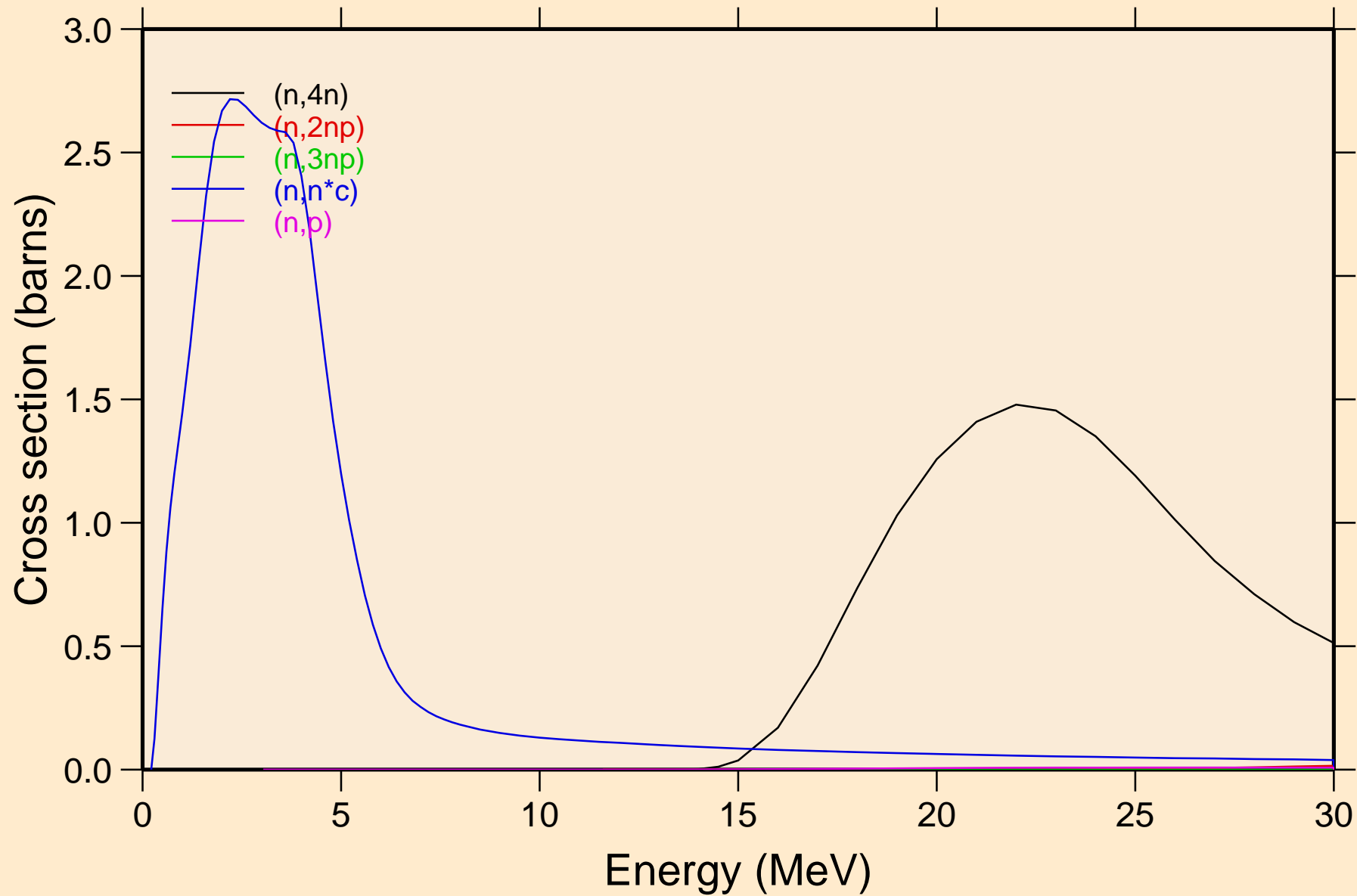

AT228 NEUTRON ACER TENDL-2023 LIBRARY; T=0.K  
Threshold reactions

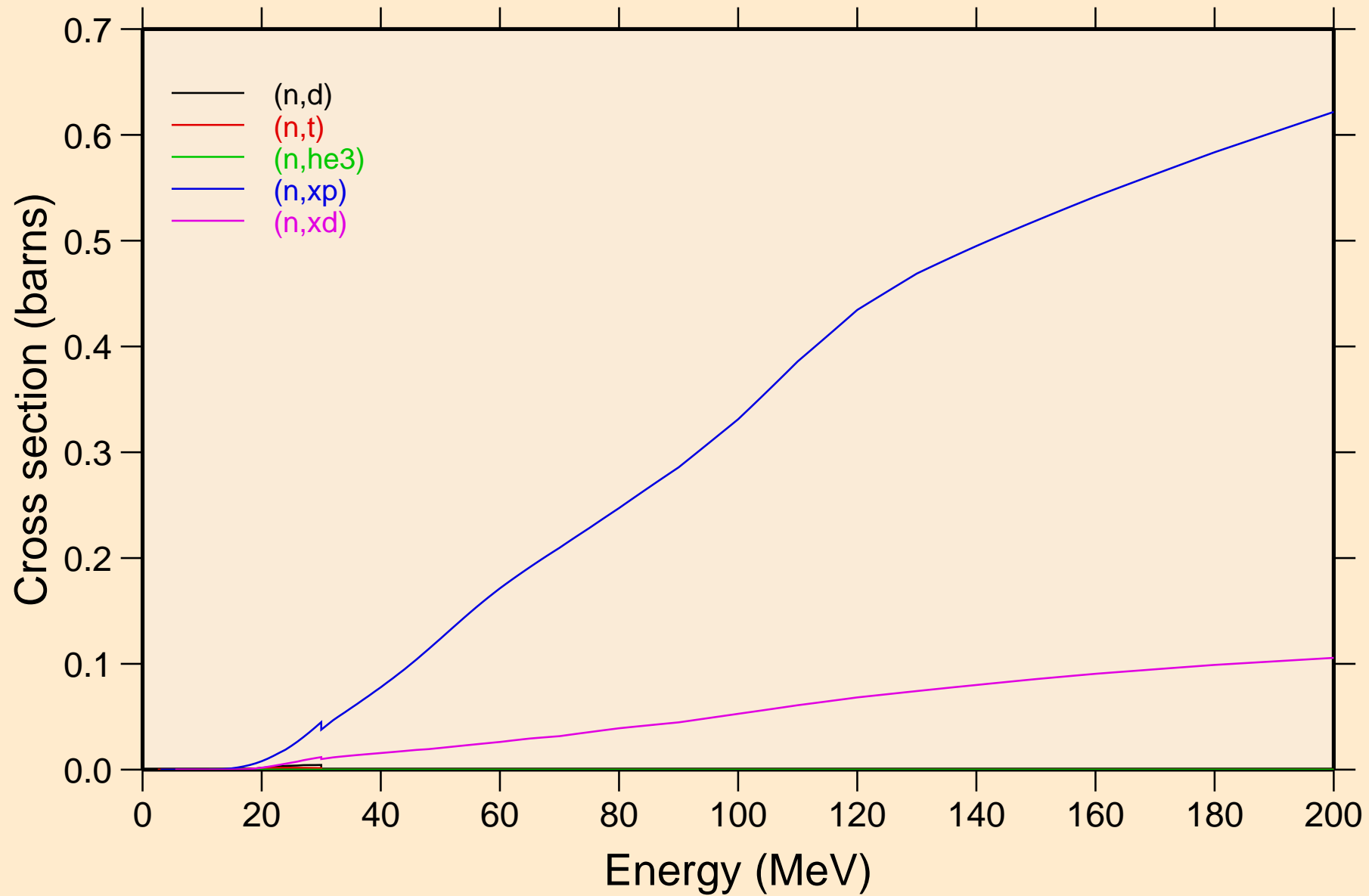

AT228 NEUTRON ACER TENDL-2023 LIBRARY; T=0.K  
Threshold reactions

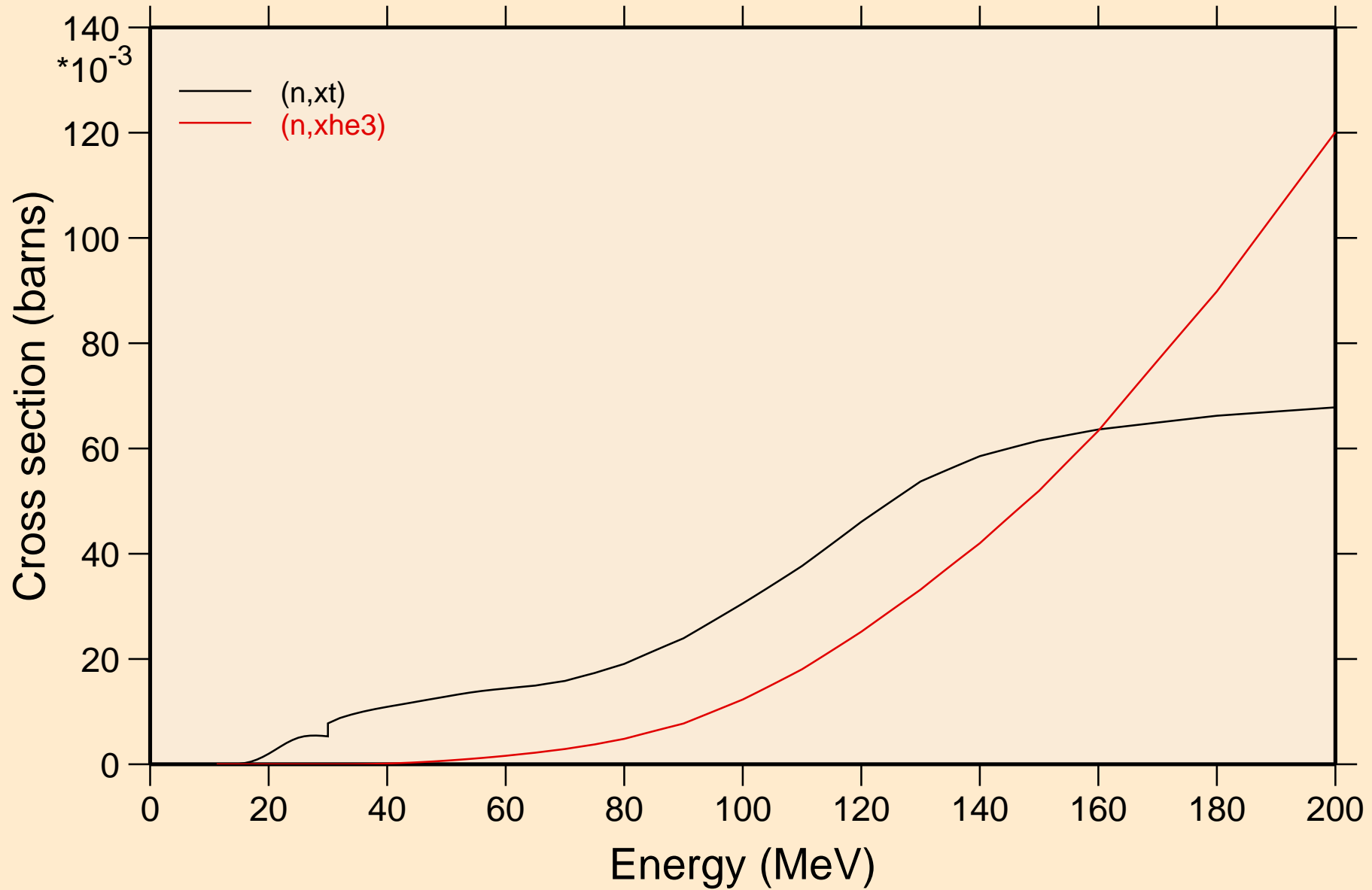

AT228 NEUTRON ACER TENDL-2023 LIBRARY; T=0.K  
angular distribution for elastic

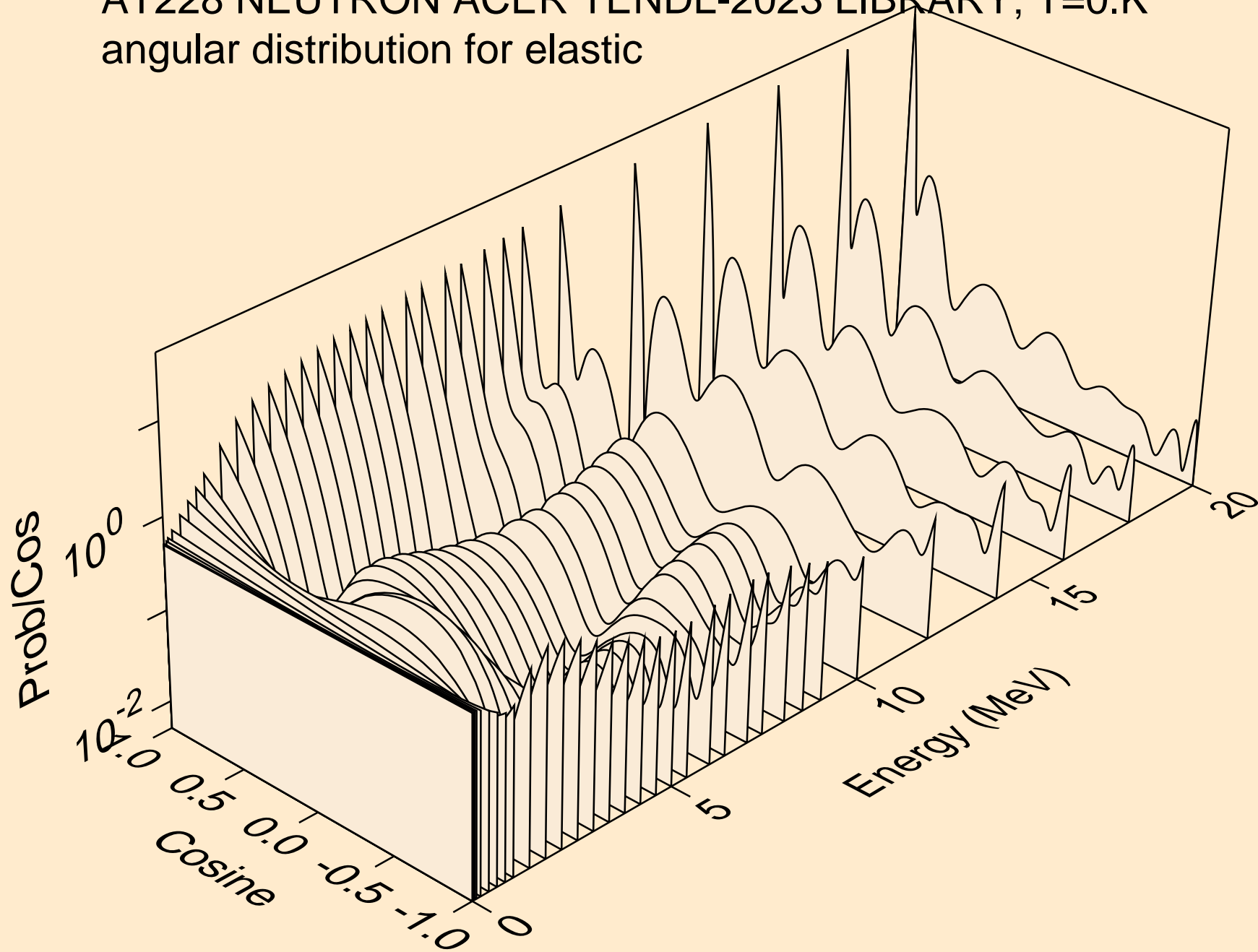

AT228 NEUTRON ACER TENDL-2023 LIBRARY; T=0.K  
angular distribution for elastic

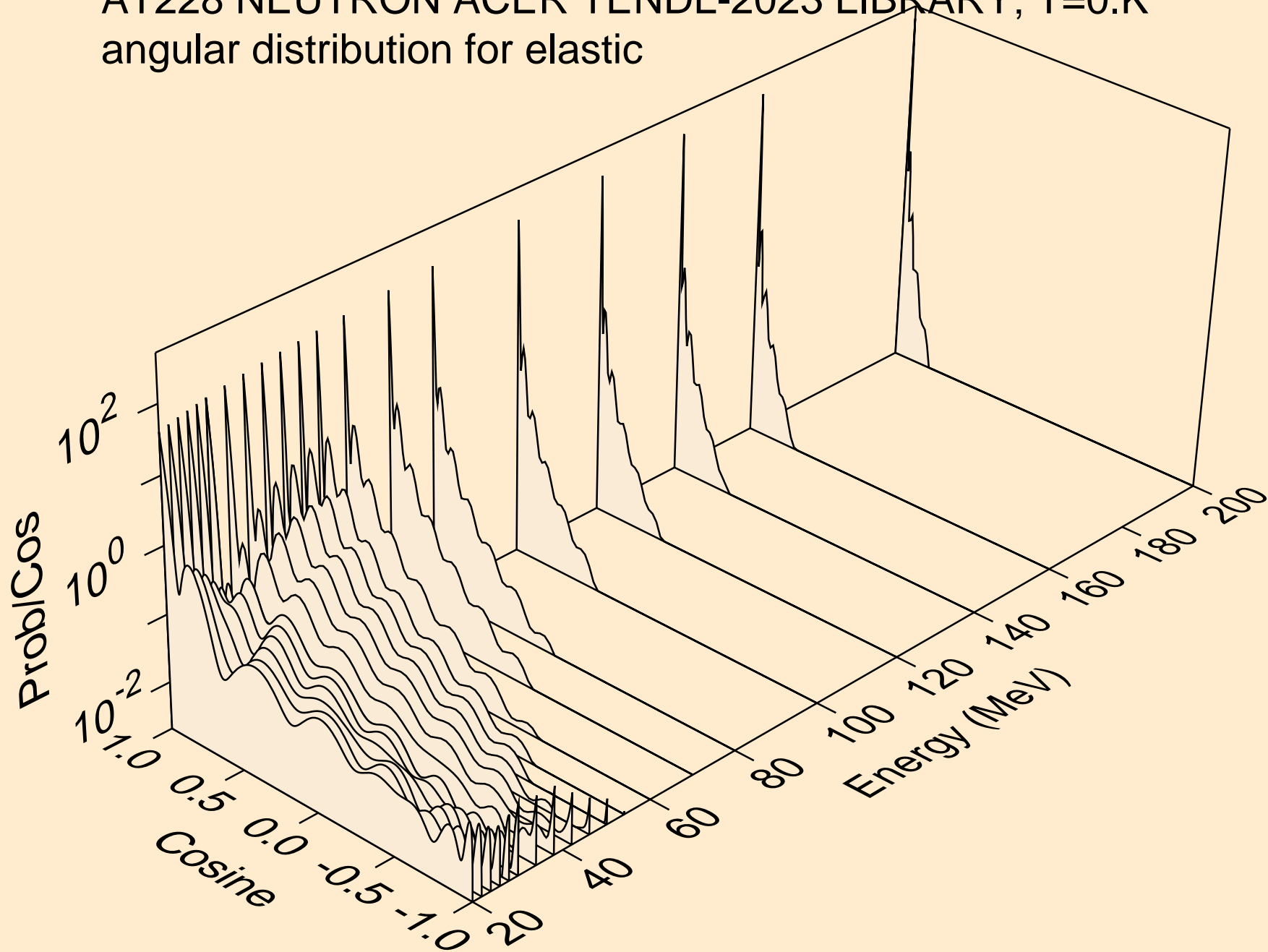

AT228 NEUTRON ACER TENDL-2023 LIBRARY; T=0.K  
angular distribution for (n,n\*1)

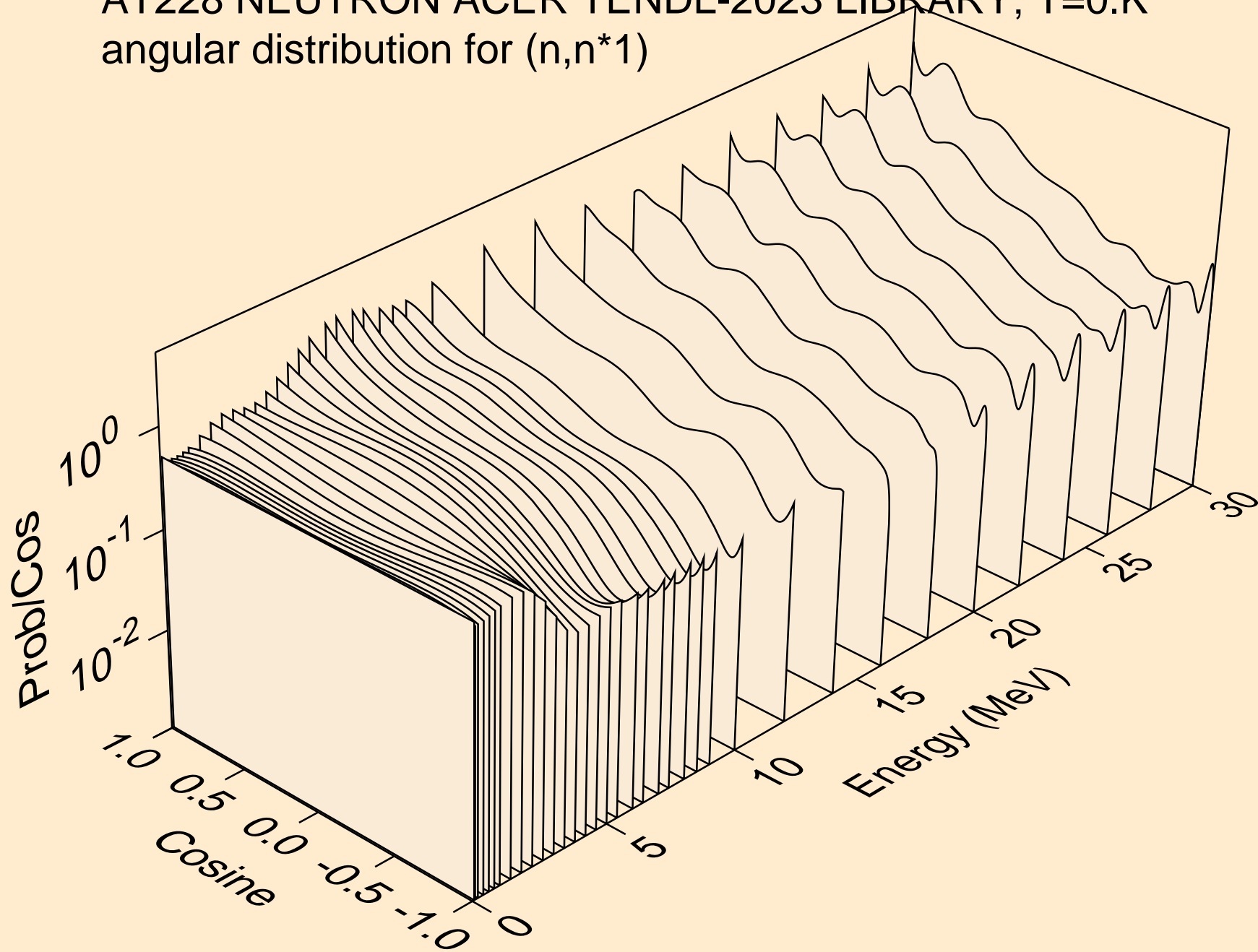

AT228 NEUTRON ACER TENDL-2023 LIBRARY; T=0.K  
angular distribution for (n,n\*2)

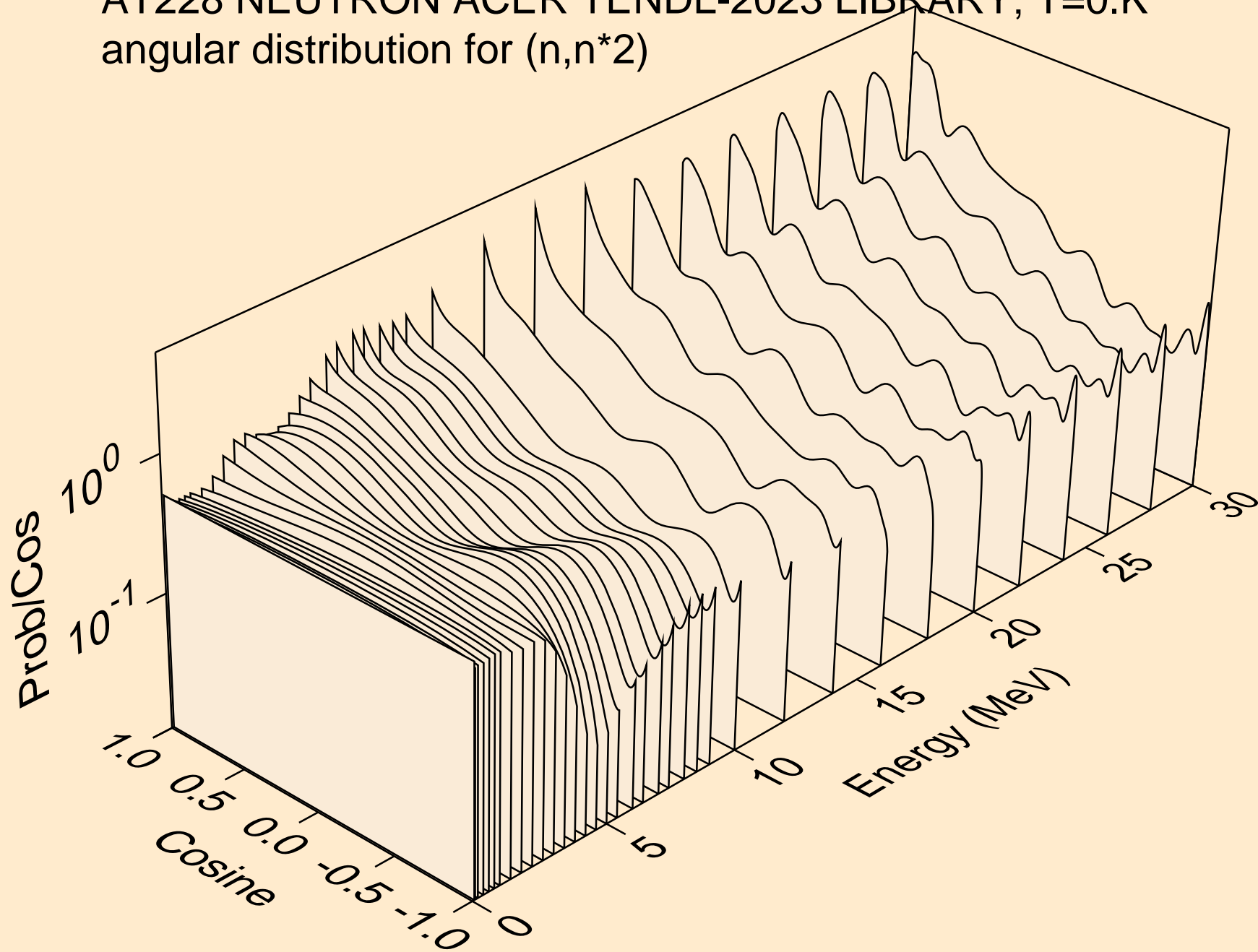

AT228 NEUTRON ACER TENDL-2023 LIBRARY; T=0.K  
angular distribution for (n,n\*3)

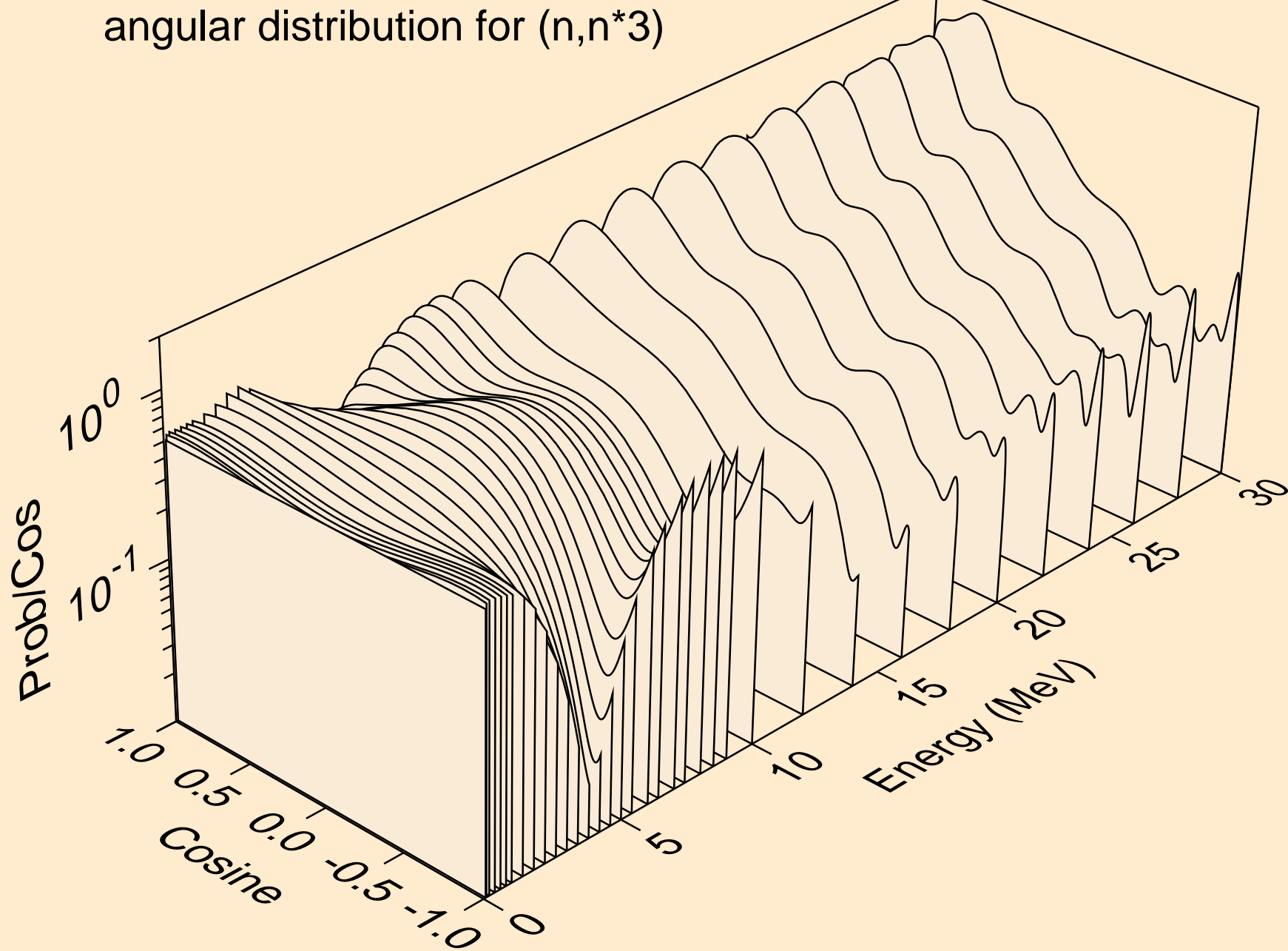

AT228 NEUTRON ACER TENDL-2023 LIBRARY; T=0.K  
angular distribution for (n,n\*4)

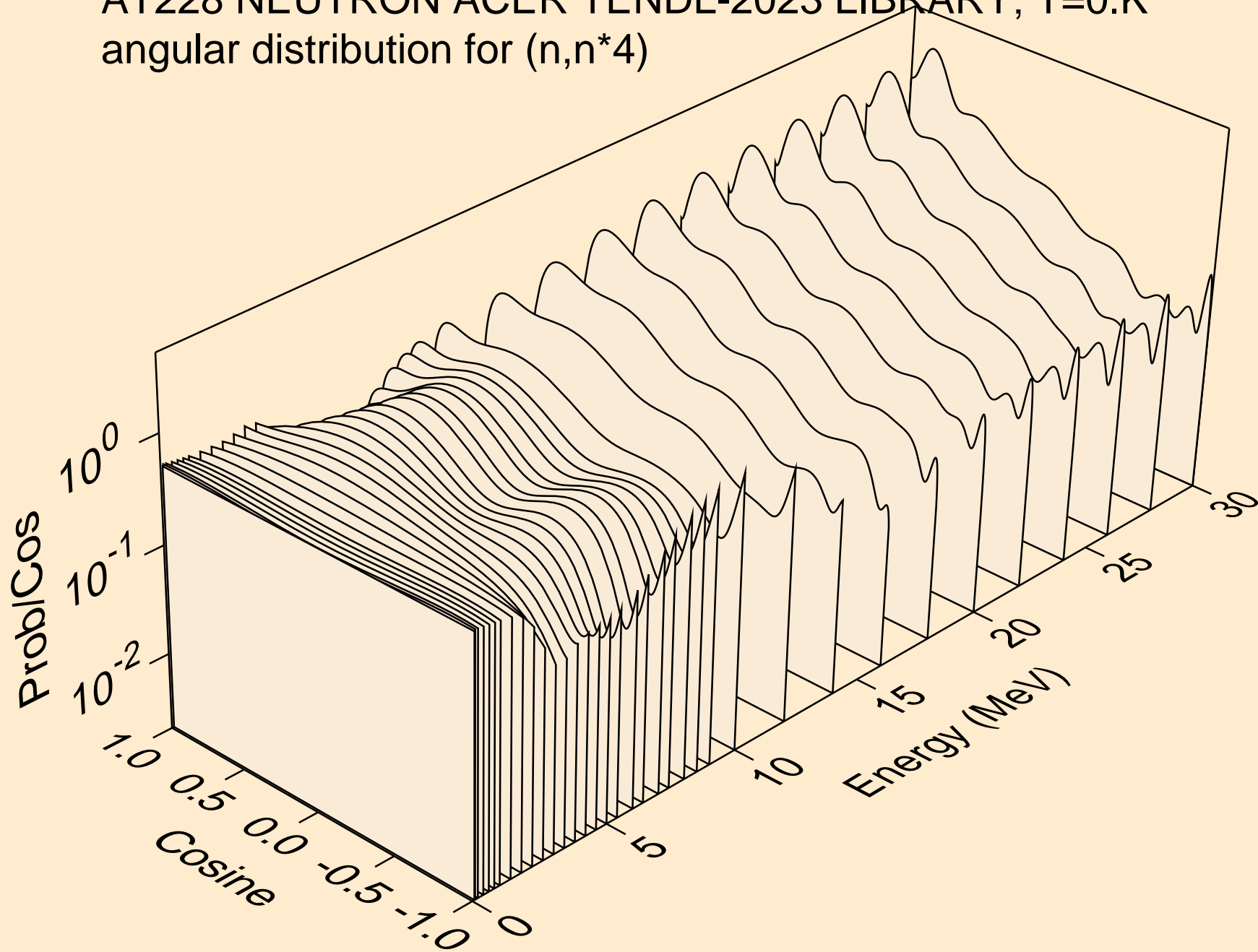

AT228 NEUTRON ACER TENDL-2023 LIBRARY; T=0.K  
angular distribution for (n,n\*5)

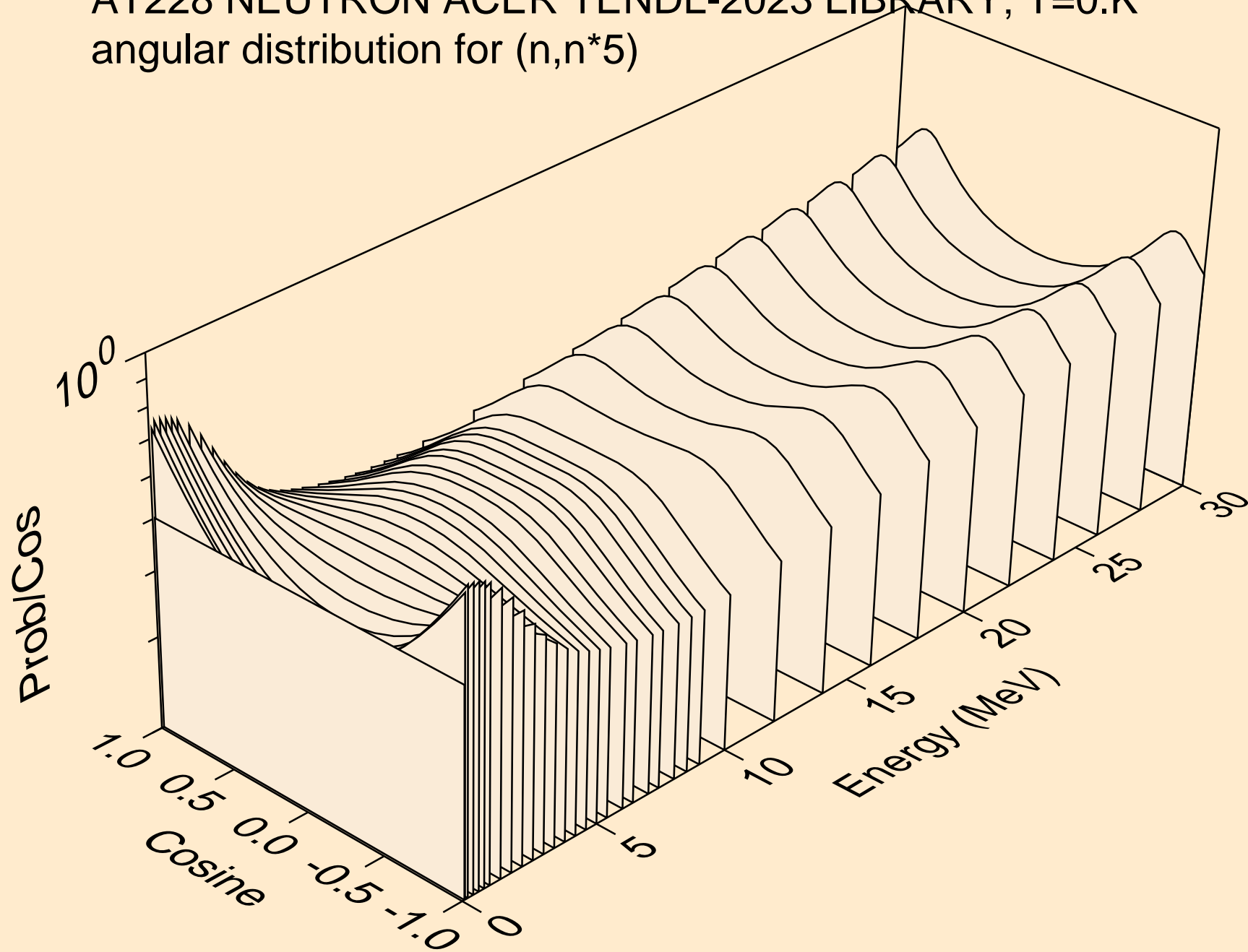

AT228 NEUTRON ACER TENDL-2023 LIBRARY; T=0.K  
angular distribution for (n,n\*6)

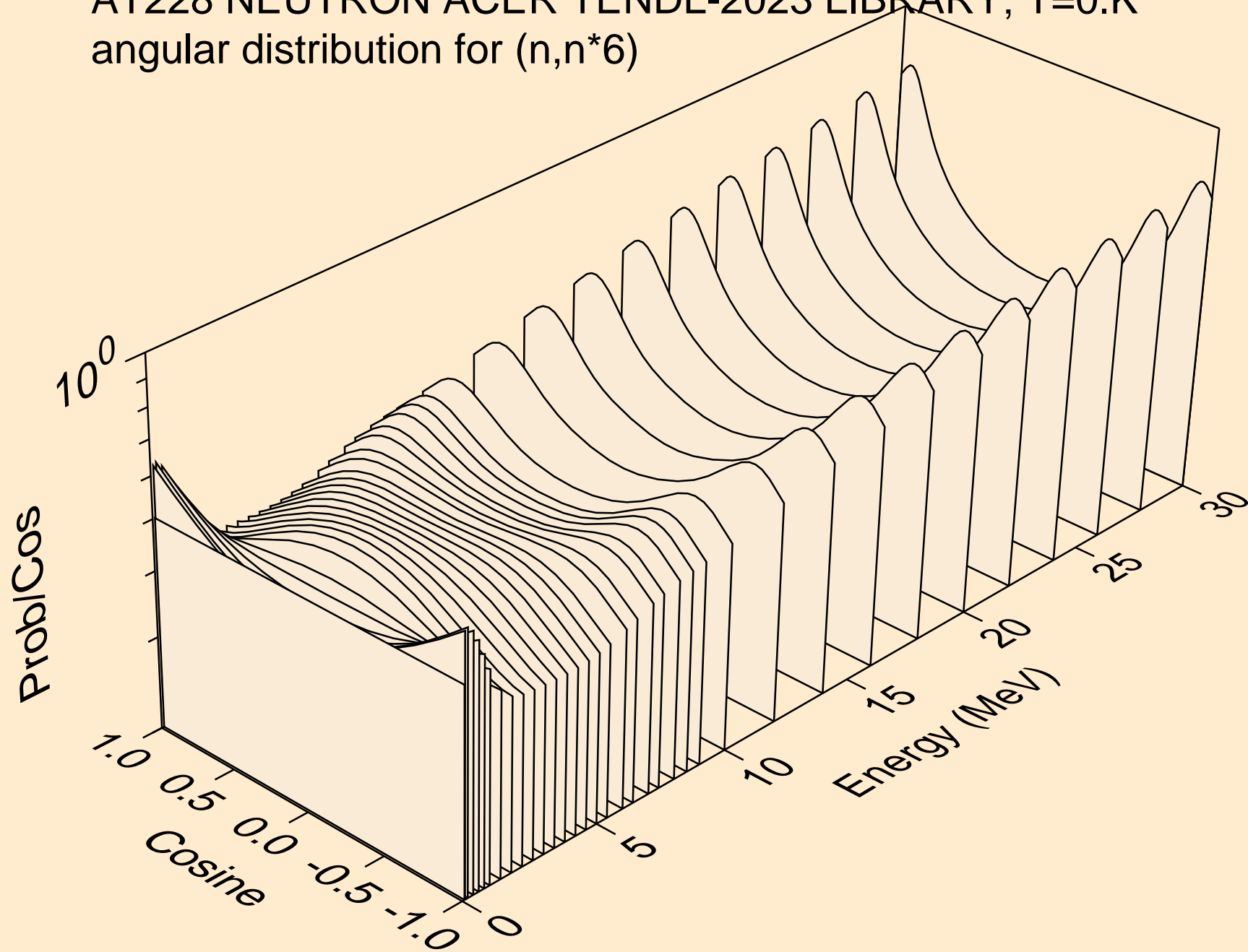

AT228 NEUTRON ACER TENDL-2023 LIBRARY; T=0.K  
angular distribution for (n,n\*7)

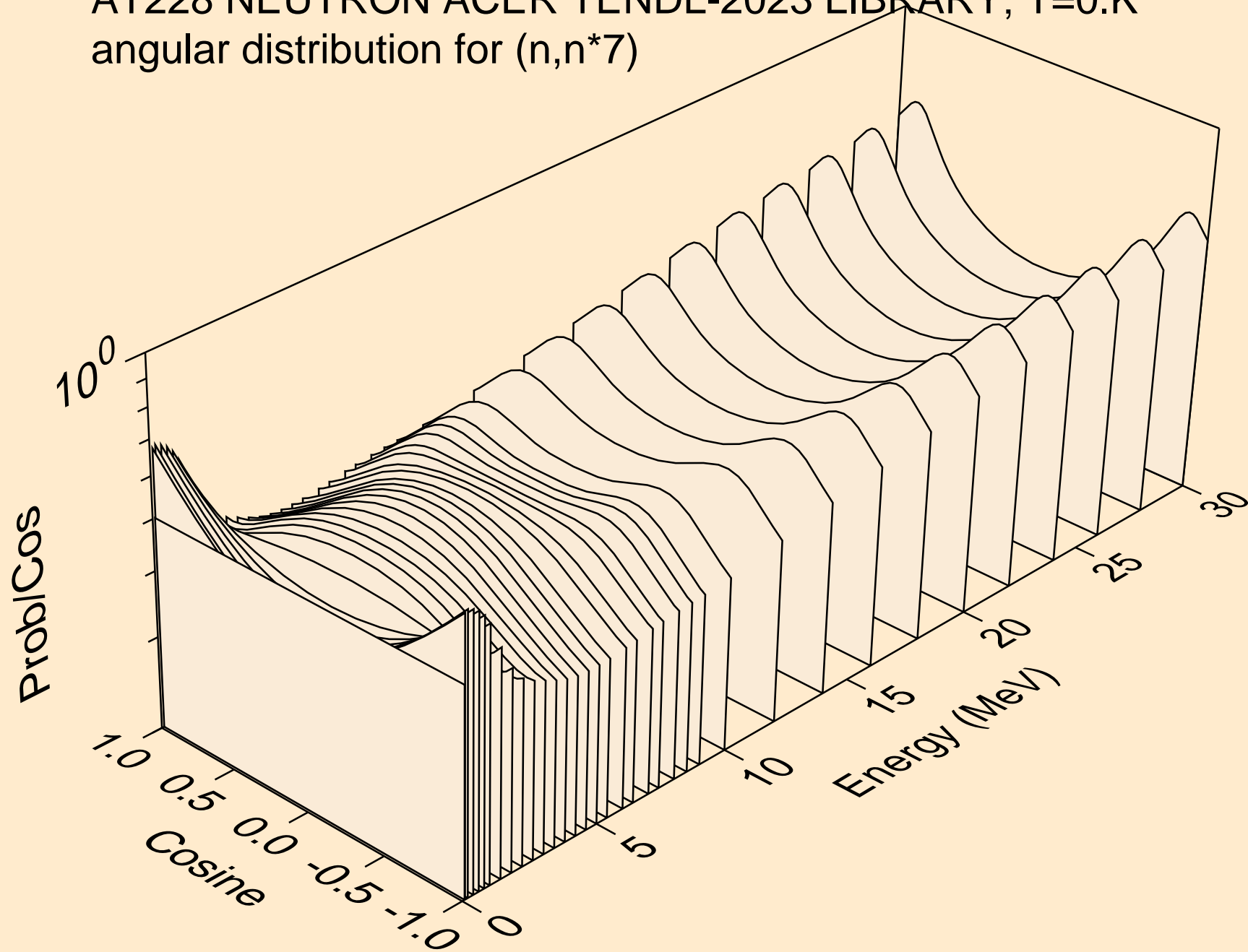

AT228 NEUTRON ACER TENDL-2023 LIBRARY; T=0.K  
angular distribution for (n,n\*8)

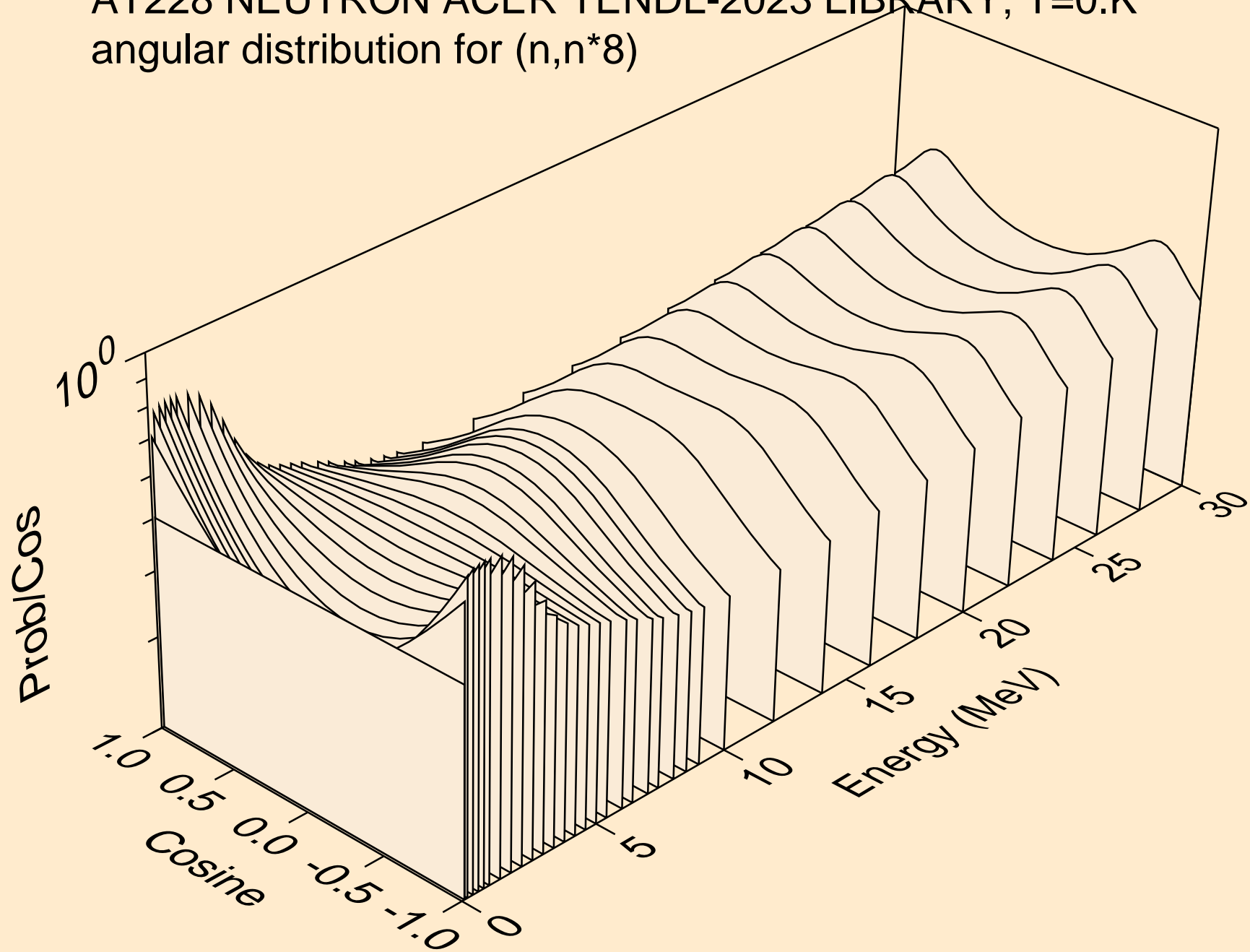

AT228 NEUTRON ACER TENDL-2023 LIBRARY; T=0.K  
angular distribution for (n,n\*9)

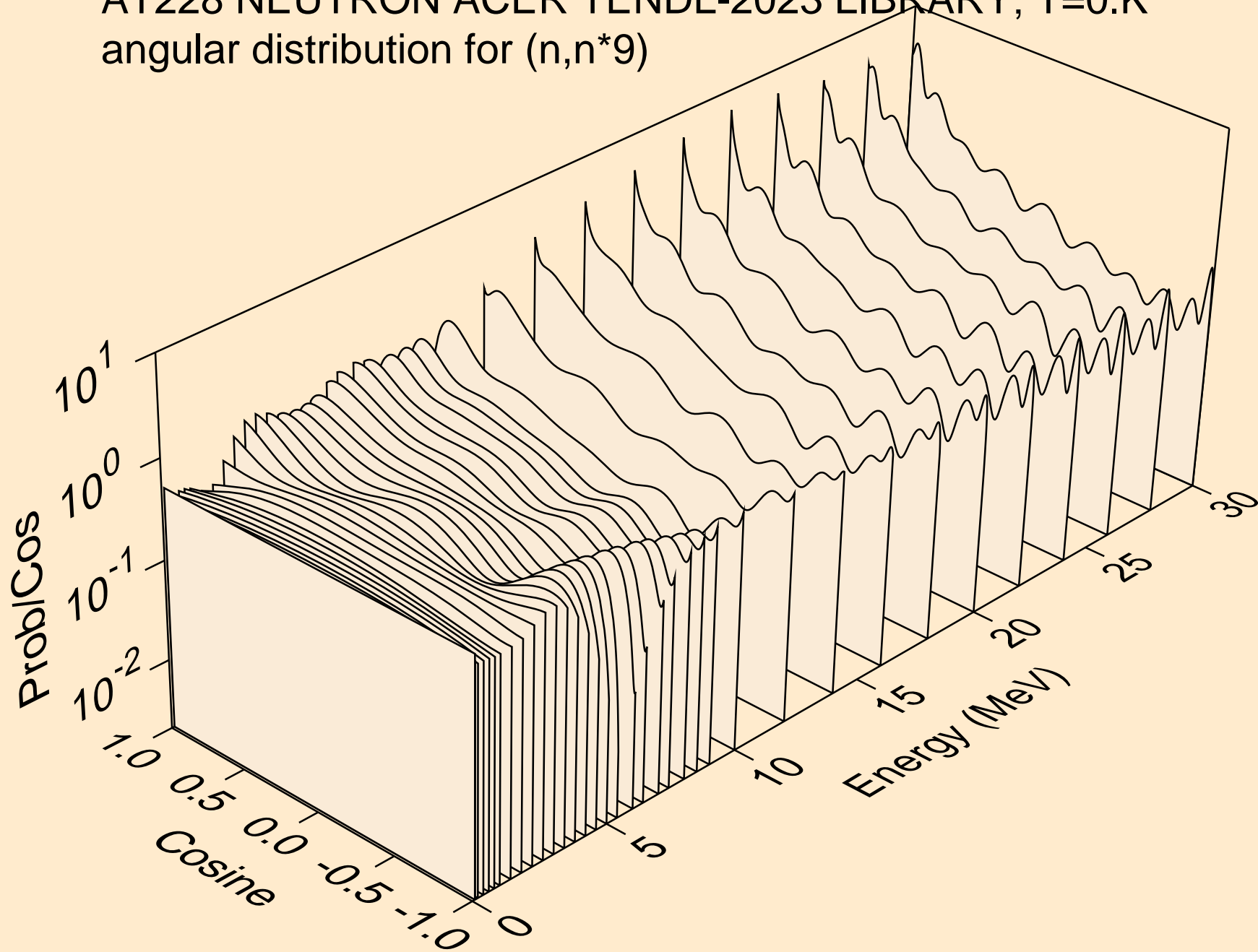

AT228 NEUTRON ACER TENDL-2023 LIBRARY; T=0.K  
angular distribution for (n,n\*10)

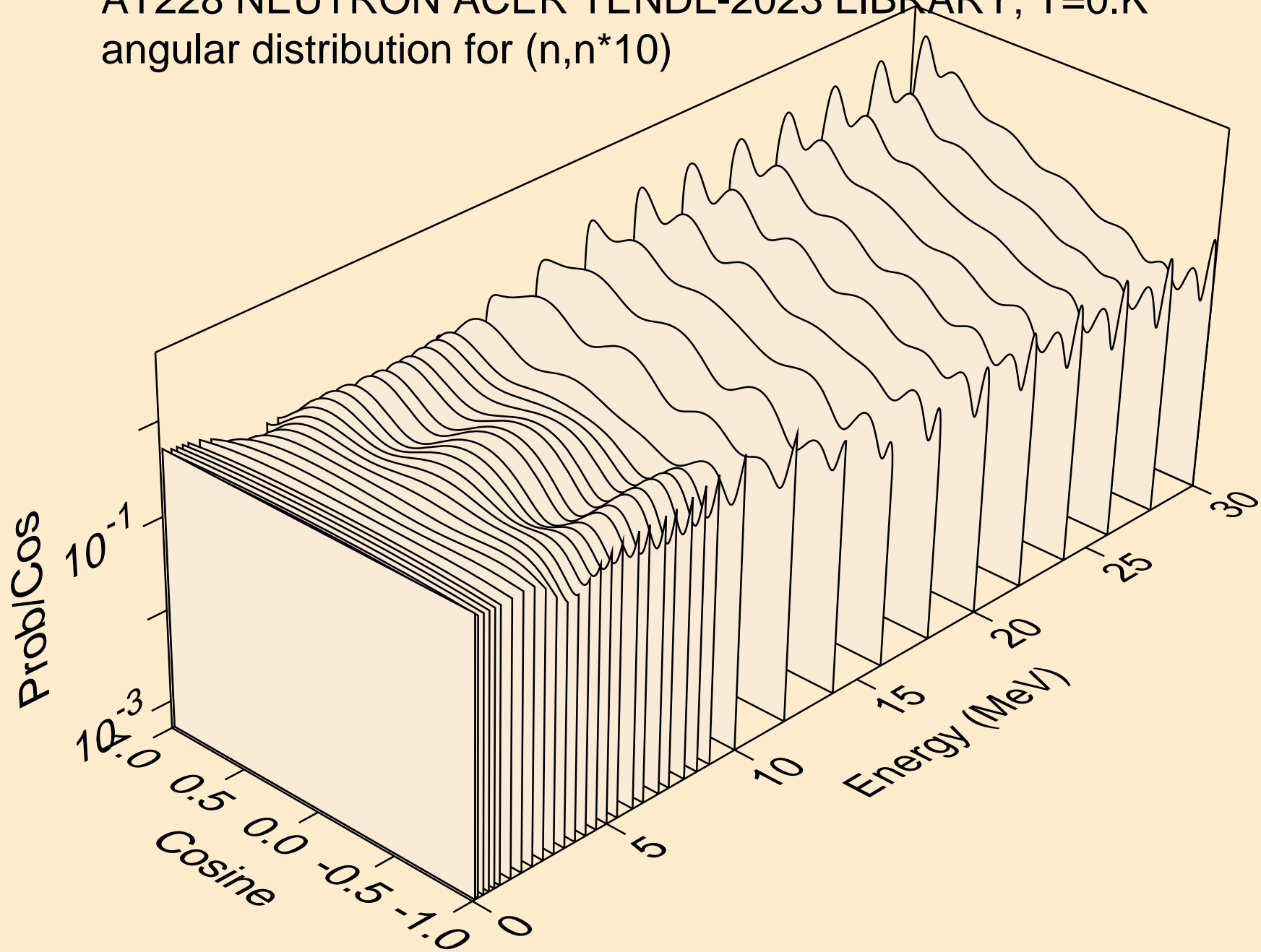

AT228 NEUTRON ACER TENDL-2023 LIBRARY; T=0.K  
angular distribution for (n,n\*11)

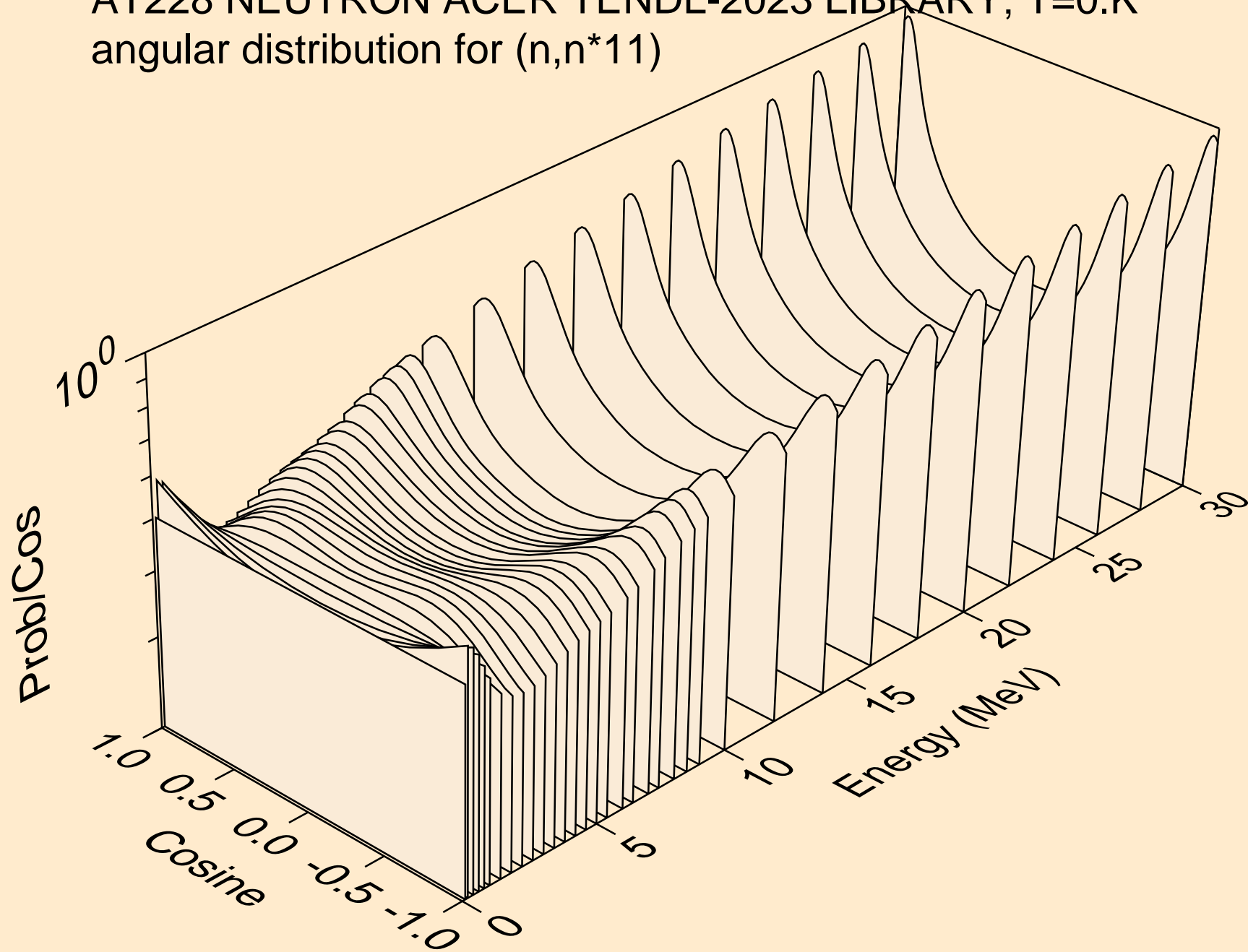

AT228 NEUTRON ACER TENDL-2023 LIBRARY; T=0.K  
angular distribution for (n,n\*12)

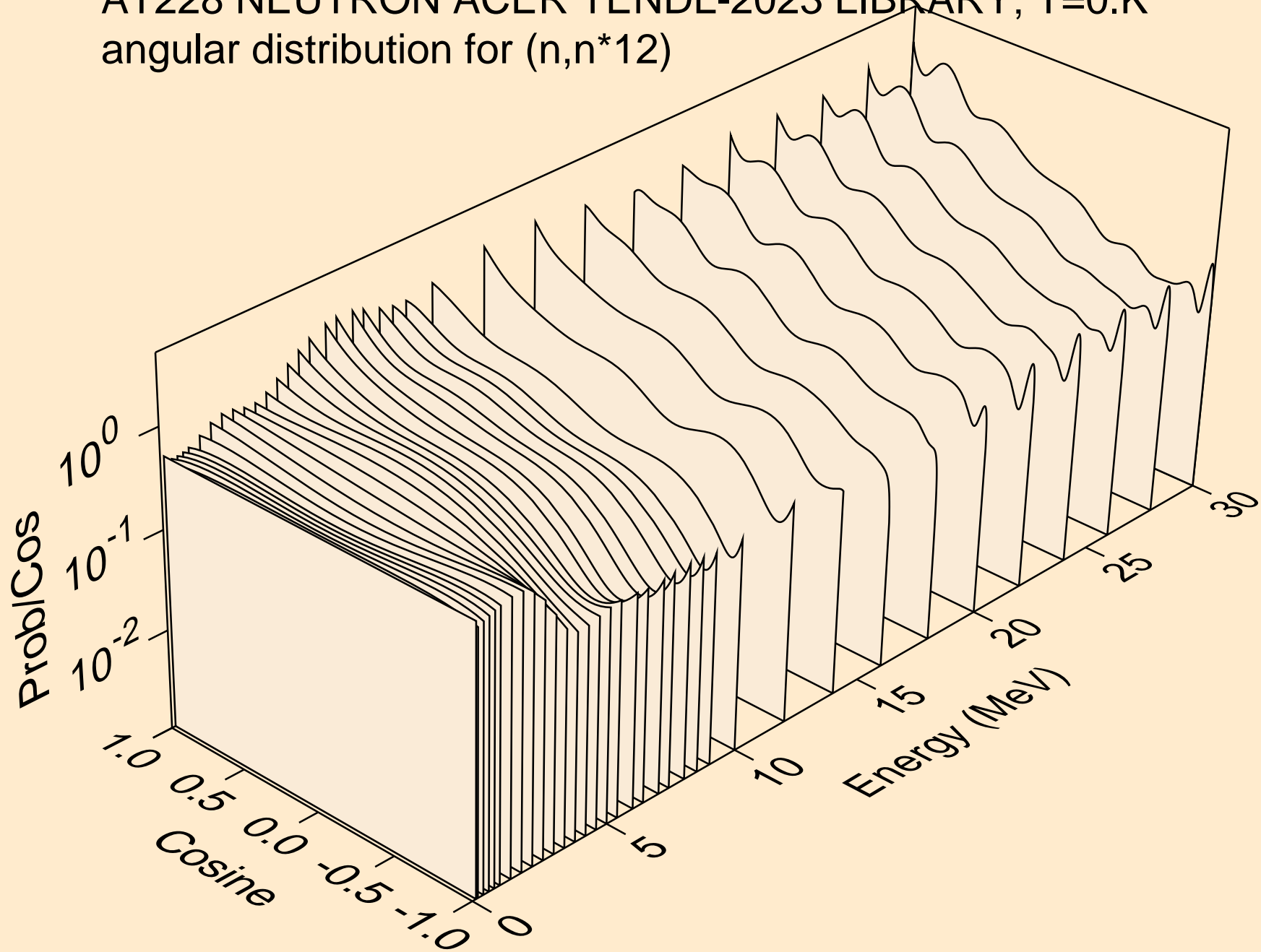

AT228 NEUTRON ACER TENDL-2023 LIBRARY; T=0.K  
angular distribution for (n,n\*13)

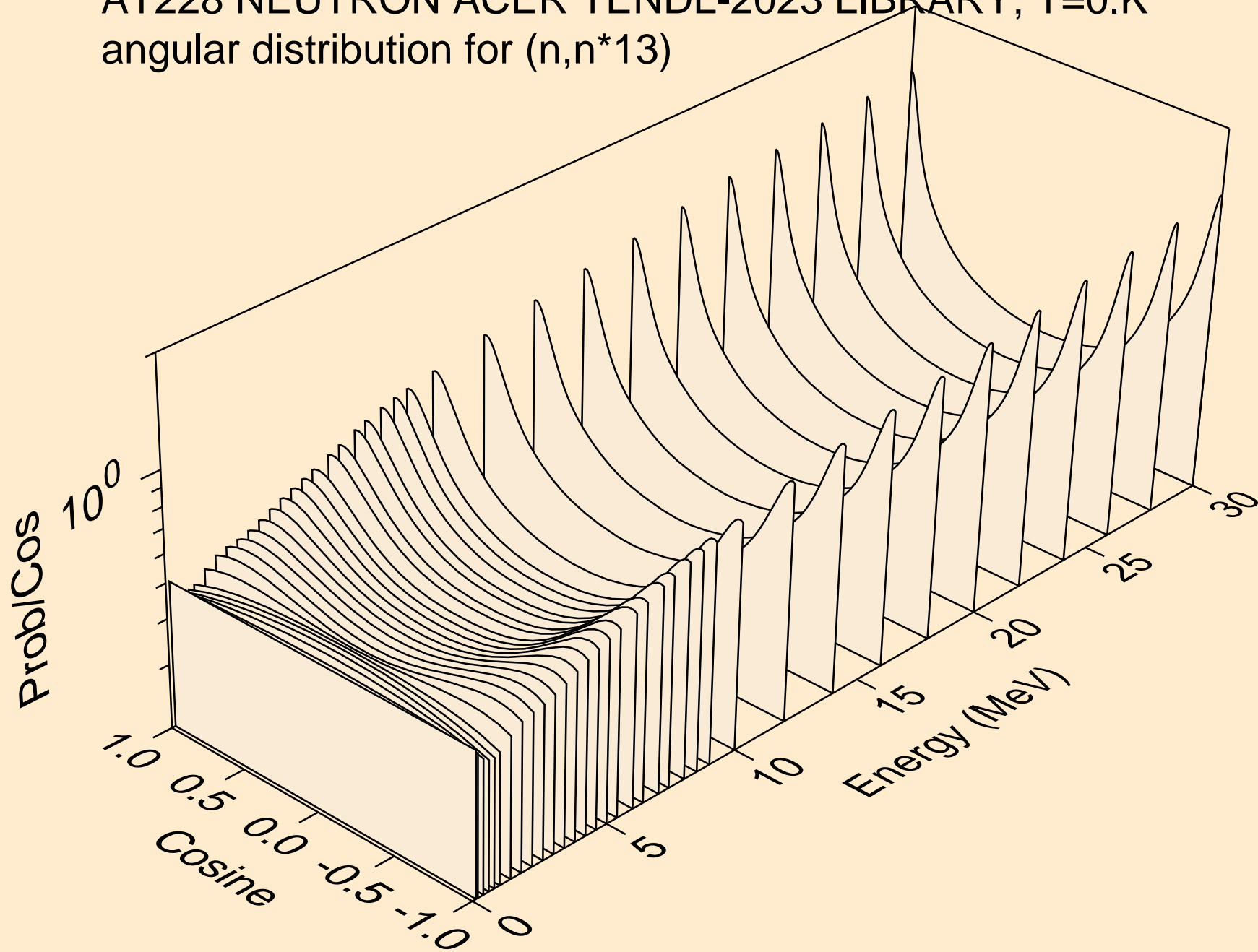

AT228 NEUTRON ACER TENDL-2023 LIBRARY; T=0.K  
angular distribution for (n,n\*14)

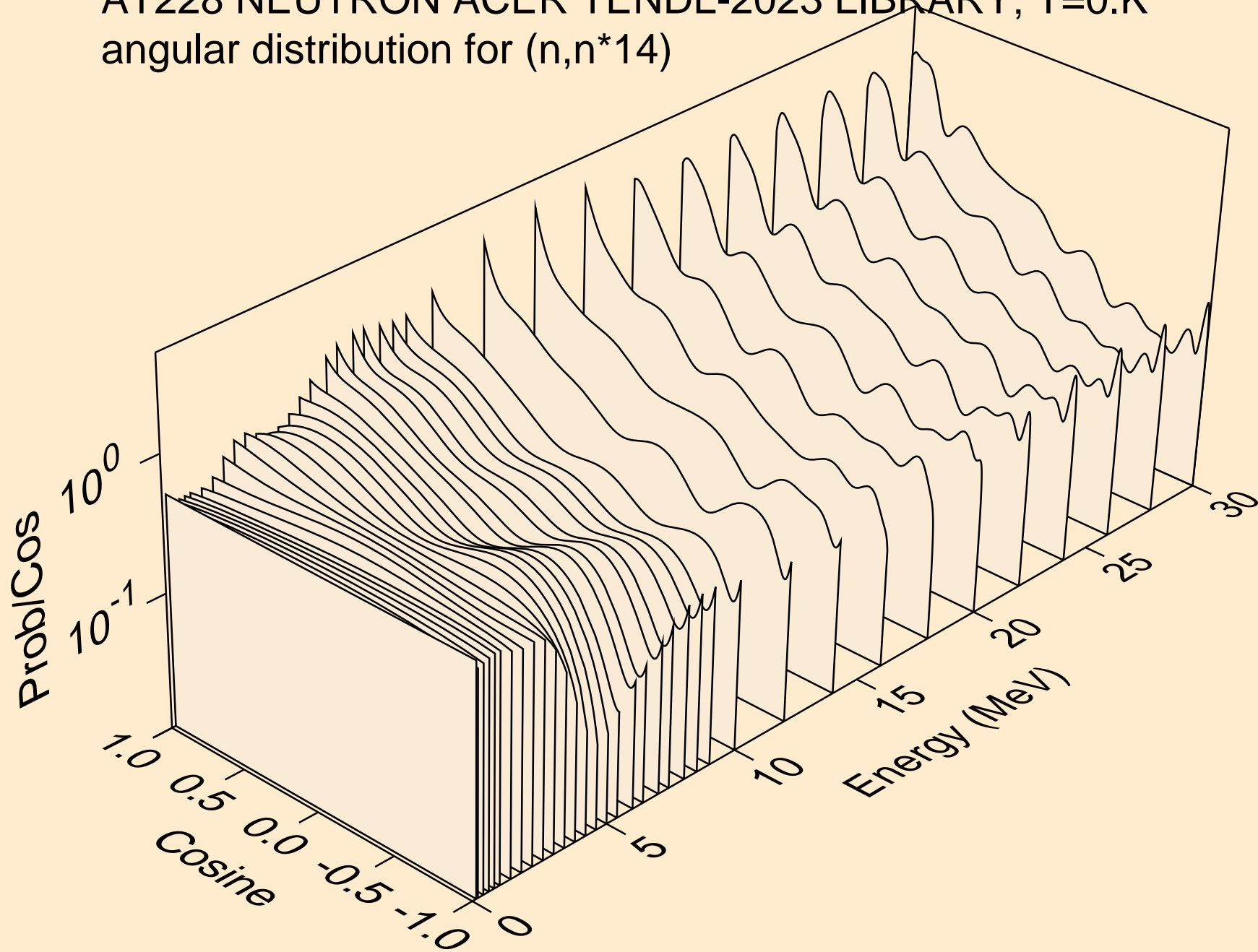

AT228 NEUTRON ACER TENDL-2023 LIBRARY; T=0.K  
angular distribution for (n,n\*15)

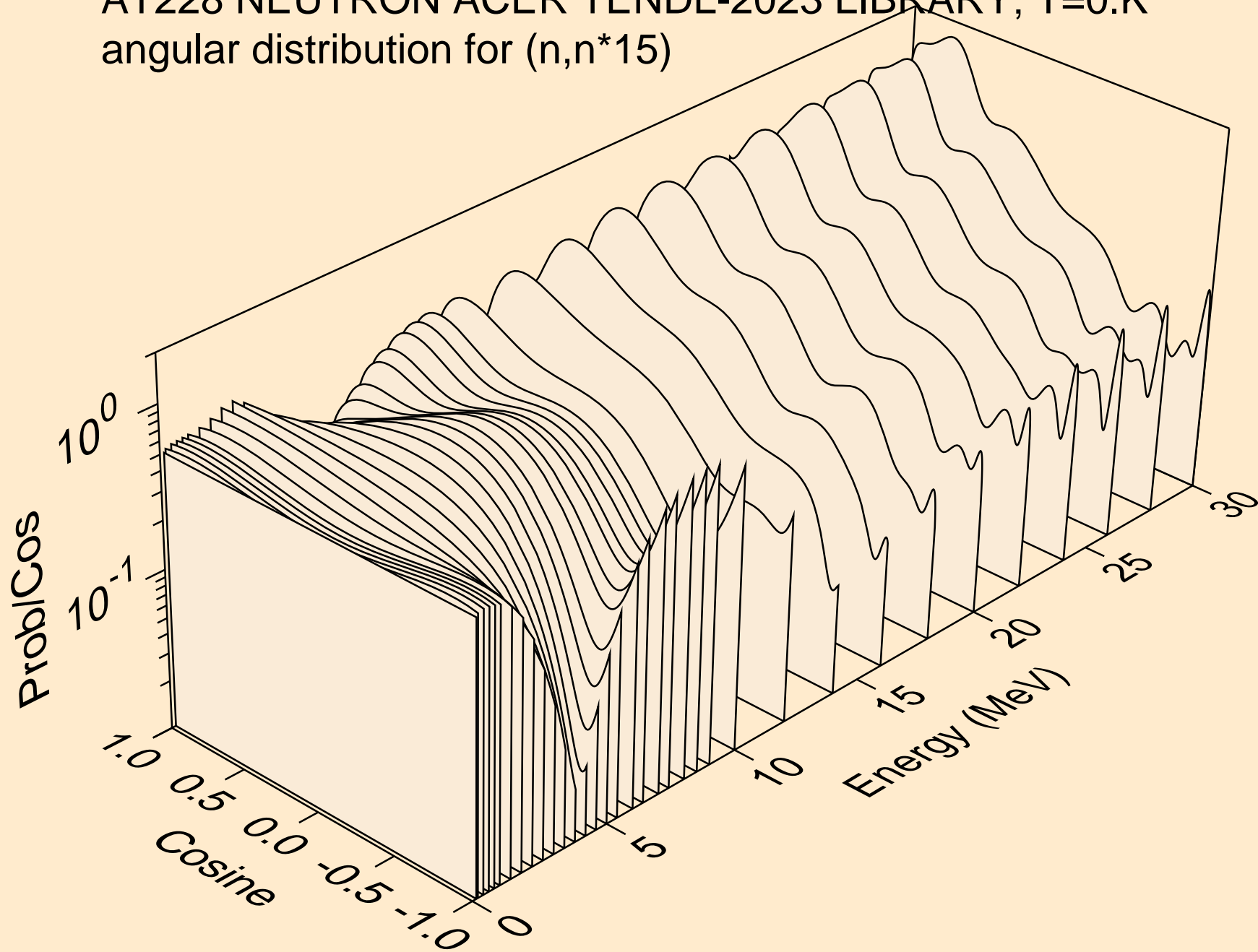

AT228 NEUTRON ACER TENDL-2023 LIBRARY; T=0.K  
angular distribution for (n,n\*16)

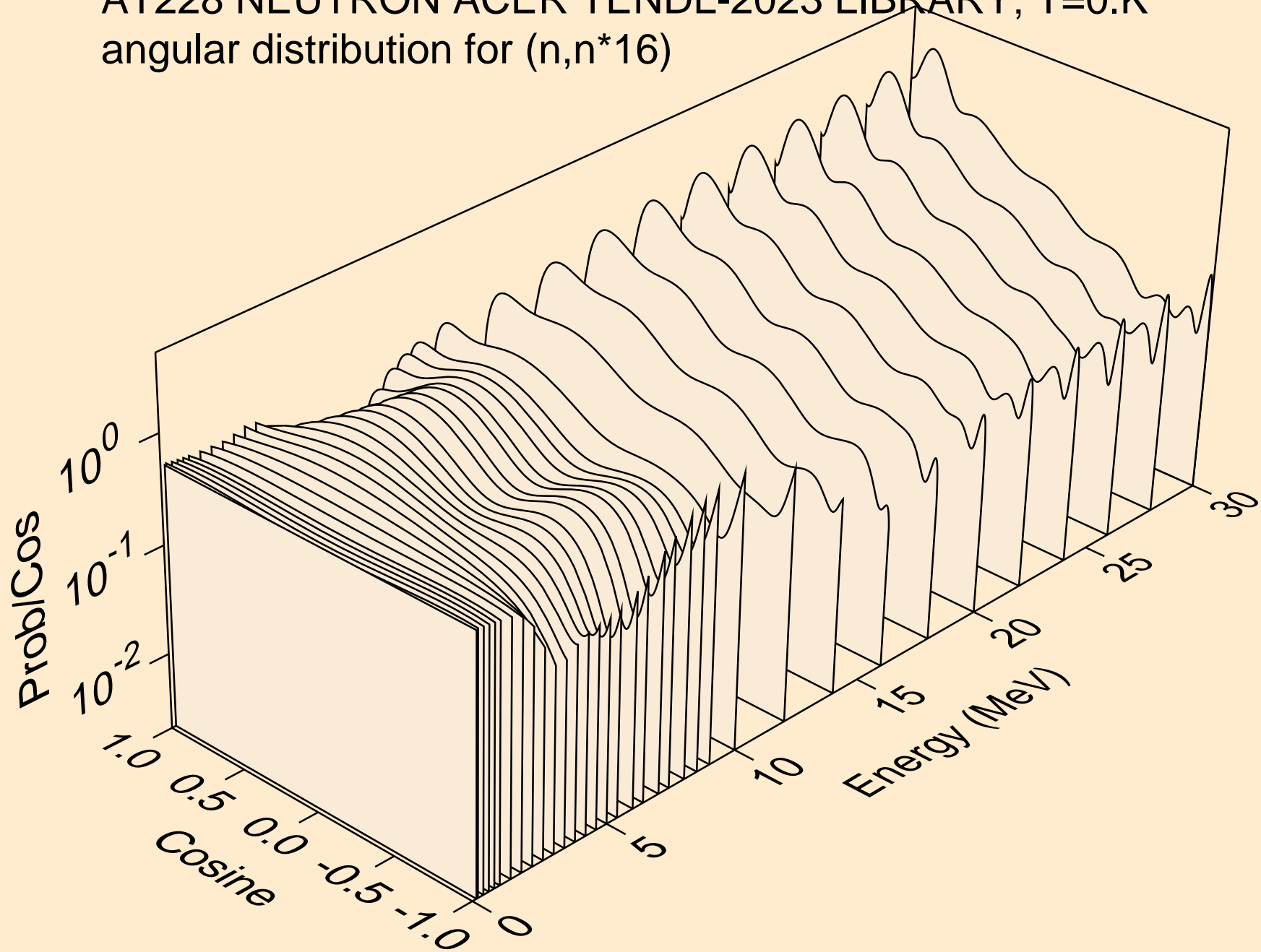

AT228 NEUTRON ACER TENDL-2023 LIBRARY; T=0.K  
angular distribution for (n,n\*17)

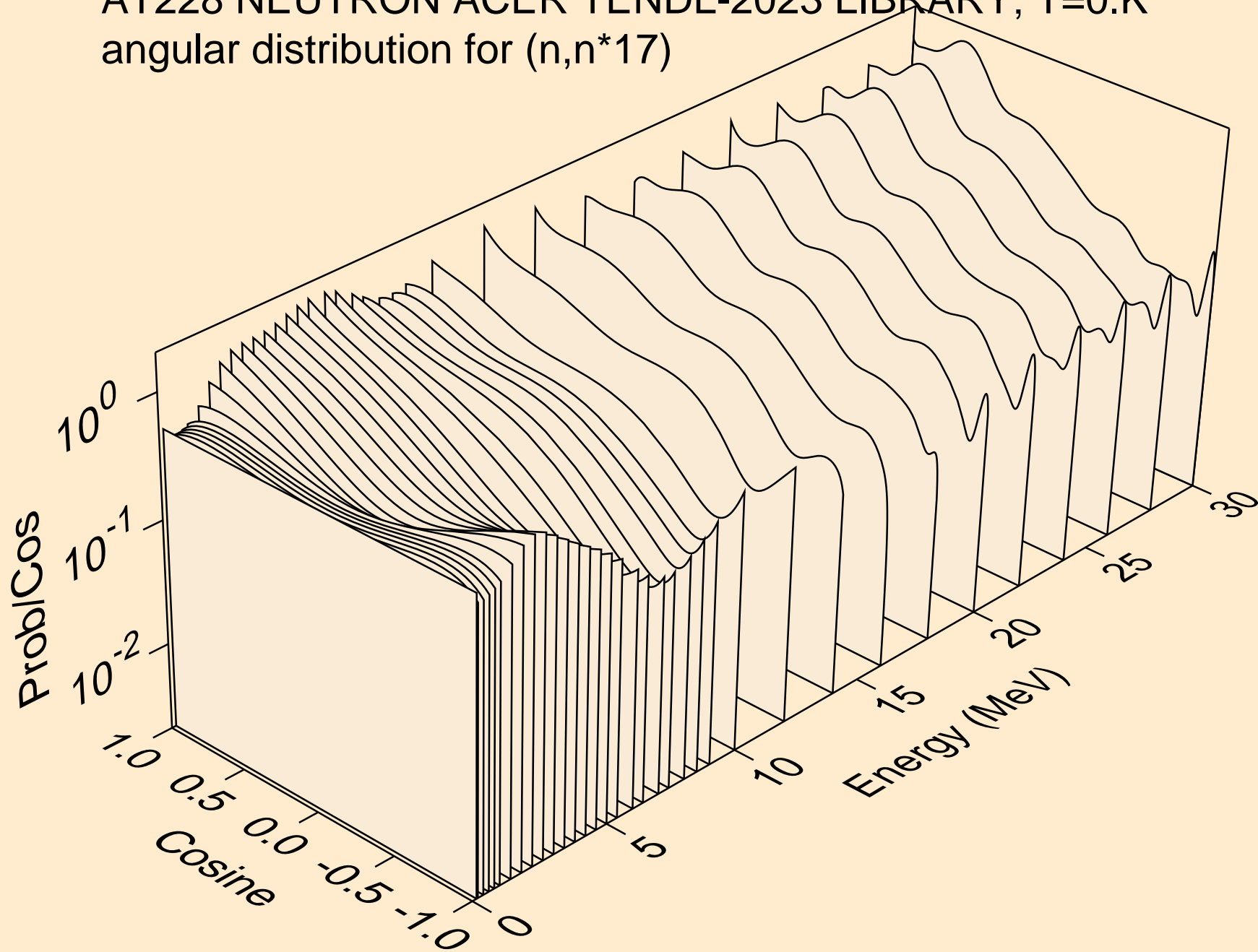

AT228 NEUTRON ACER TENDL-2023 LIBRARY; T=0.K  
angular distribution for (n,n\*18)

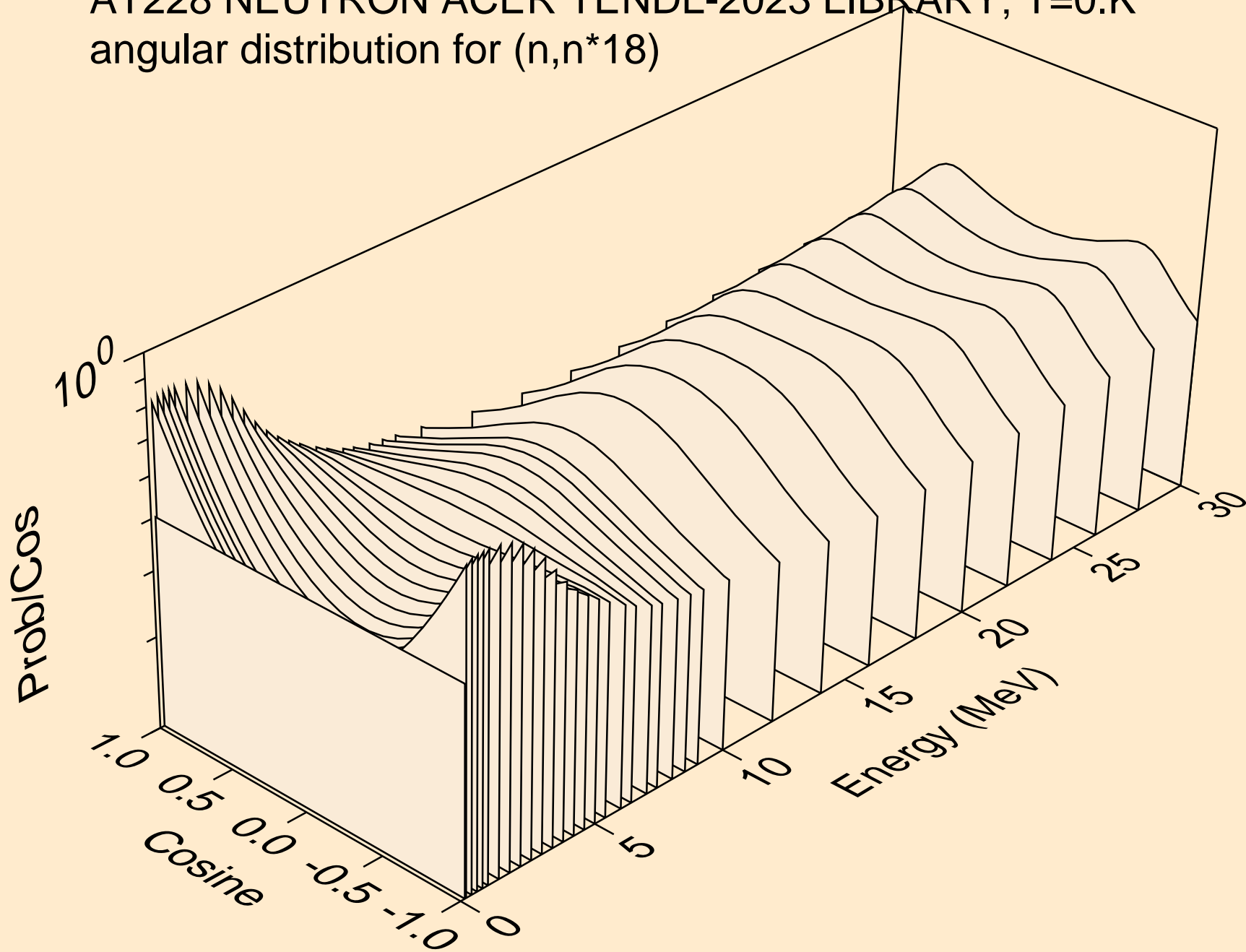

AT228 NEUTRON ACER TENDL-2023 LIBRARY; T=0.K  
angular distribution for (n,n\*19)

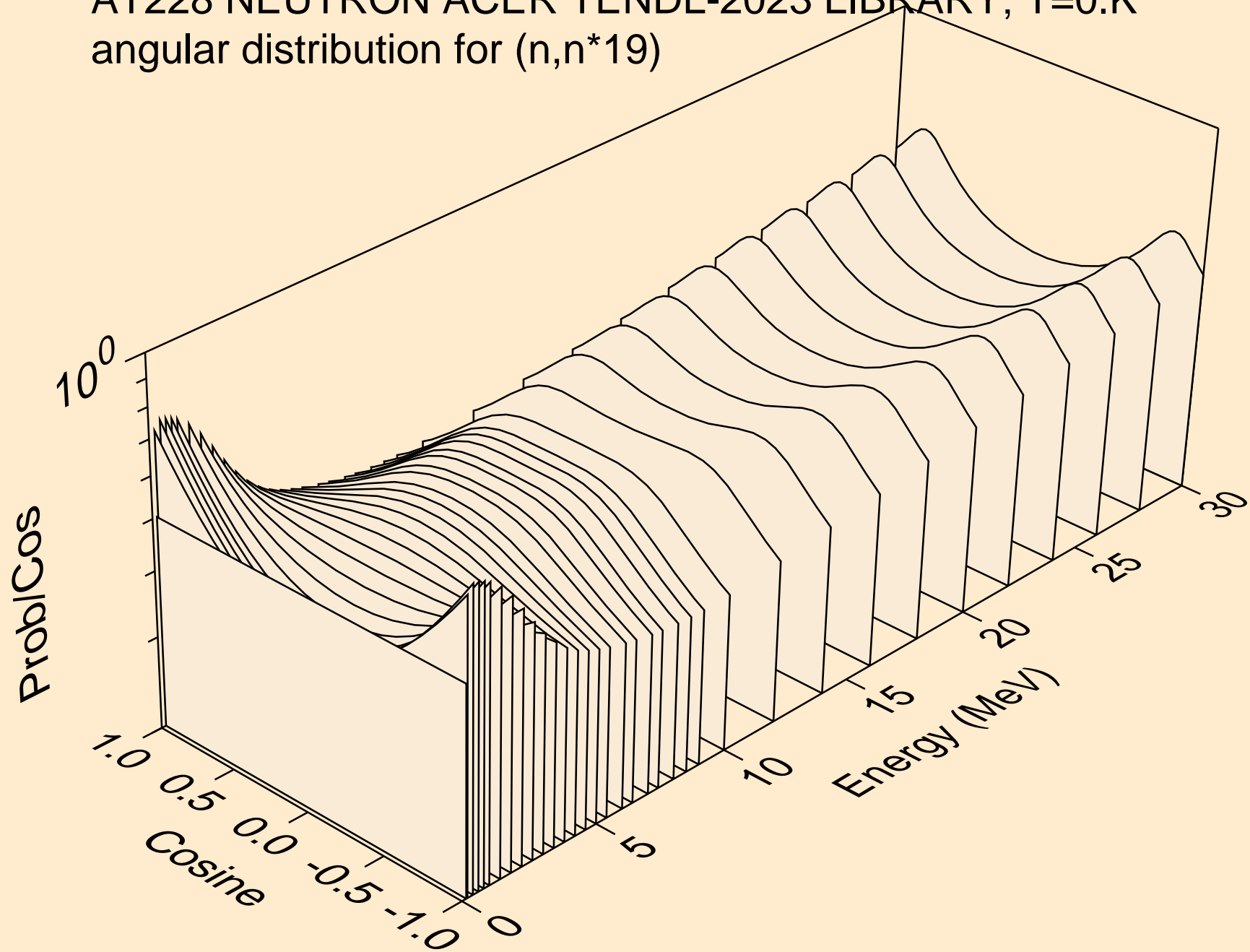

AT228 NEUTRON ACER TENDL-2023 LIBRARY; T=0.K  
angular distribution for (n,n\*20)

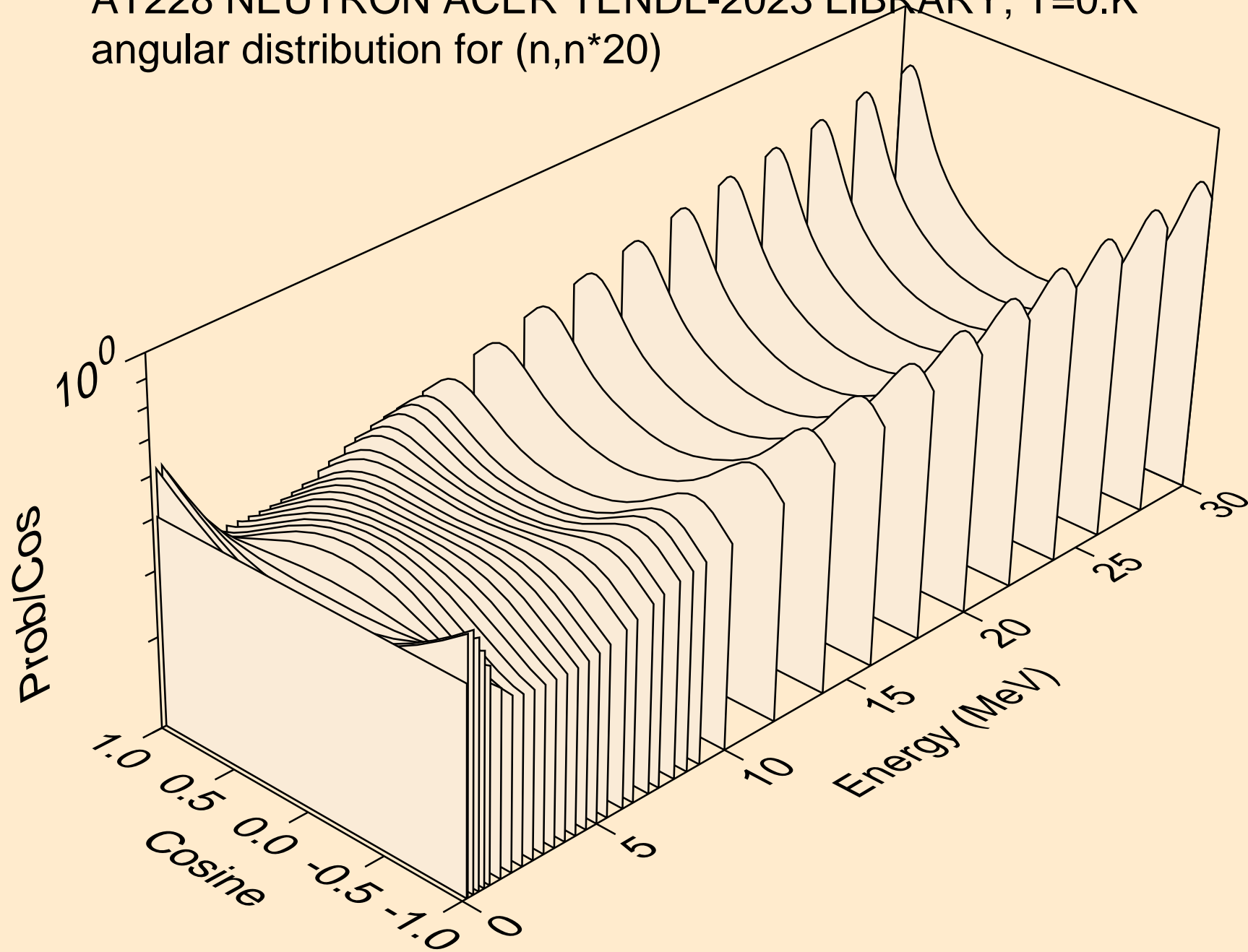

AT228 NEUTRON ACER TENDL-2023 LIBRARY; T=0.K  
angular distribution for (n,n\*21)

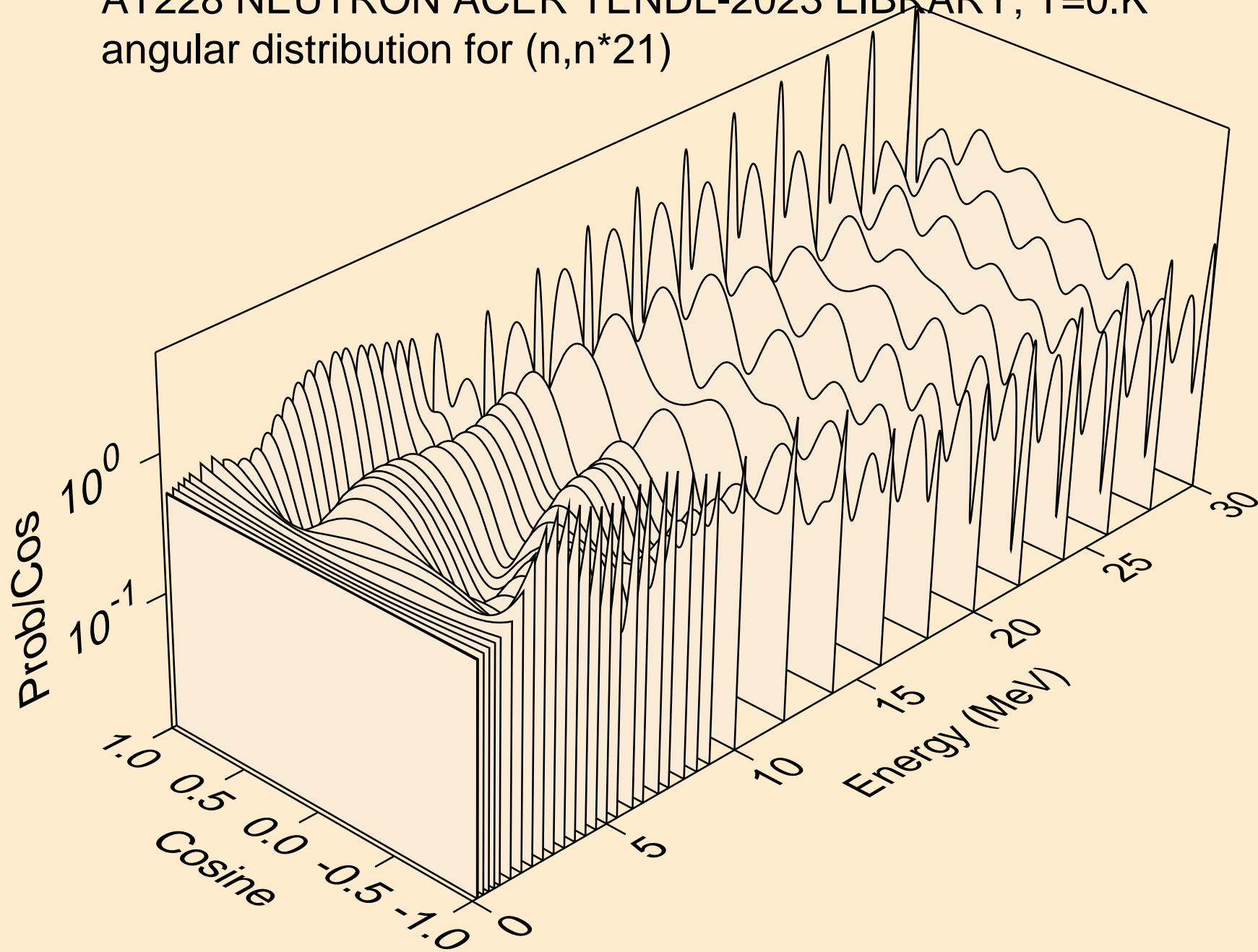

AT228 NEUTRON ACER TENDL-2023 LIBRARY; T=0.K  
angular distribution for (n,n\*22)

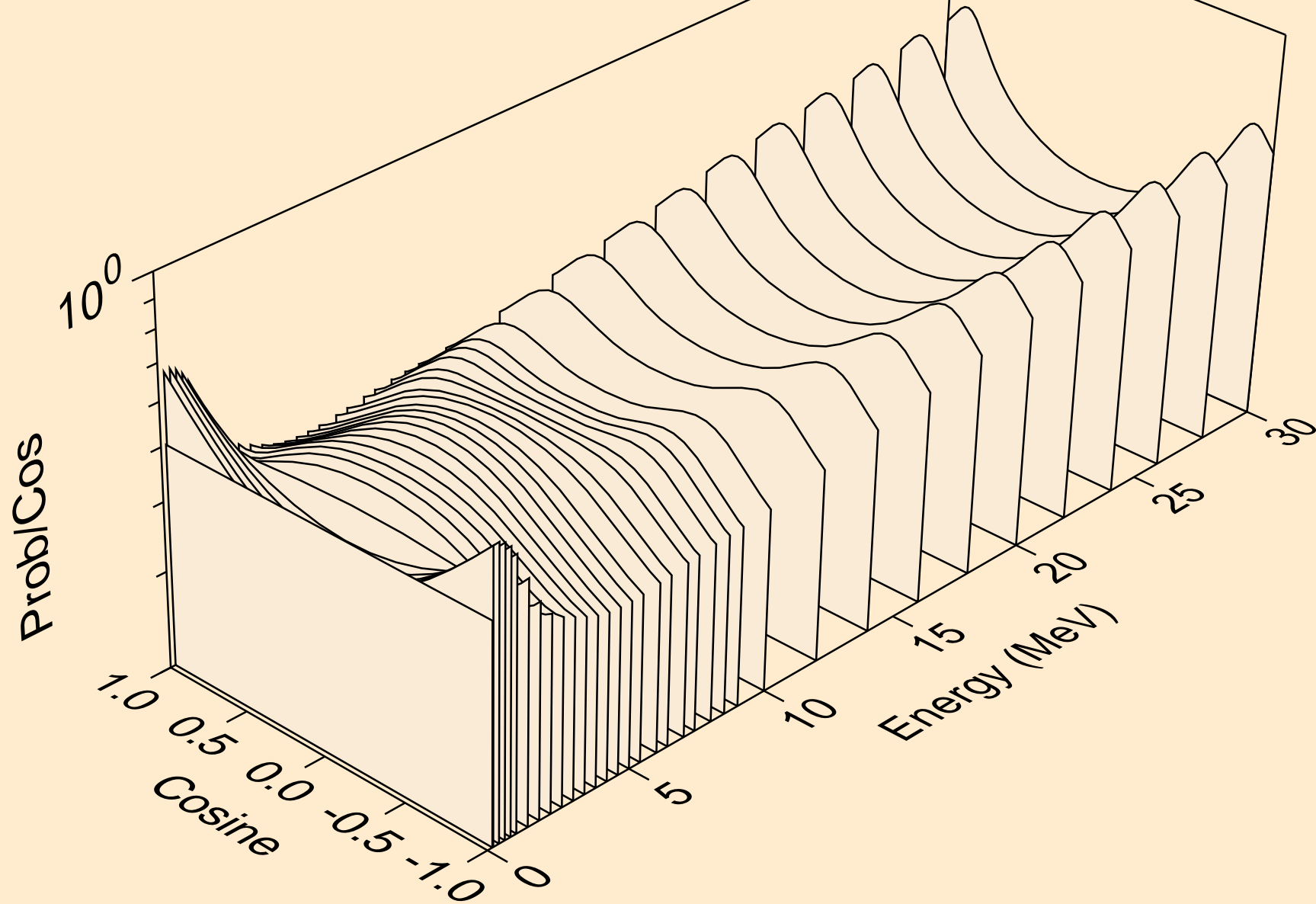

AT228 NEUTRON ACER TENDL-2023 LIBRARY; T=0.K  
angular distribution for (n,n\*23)

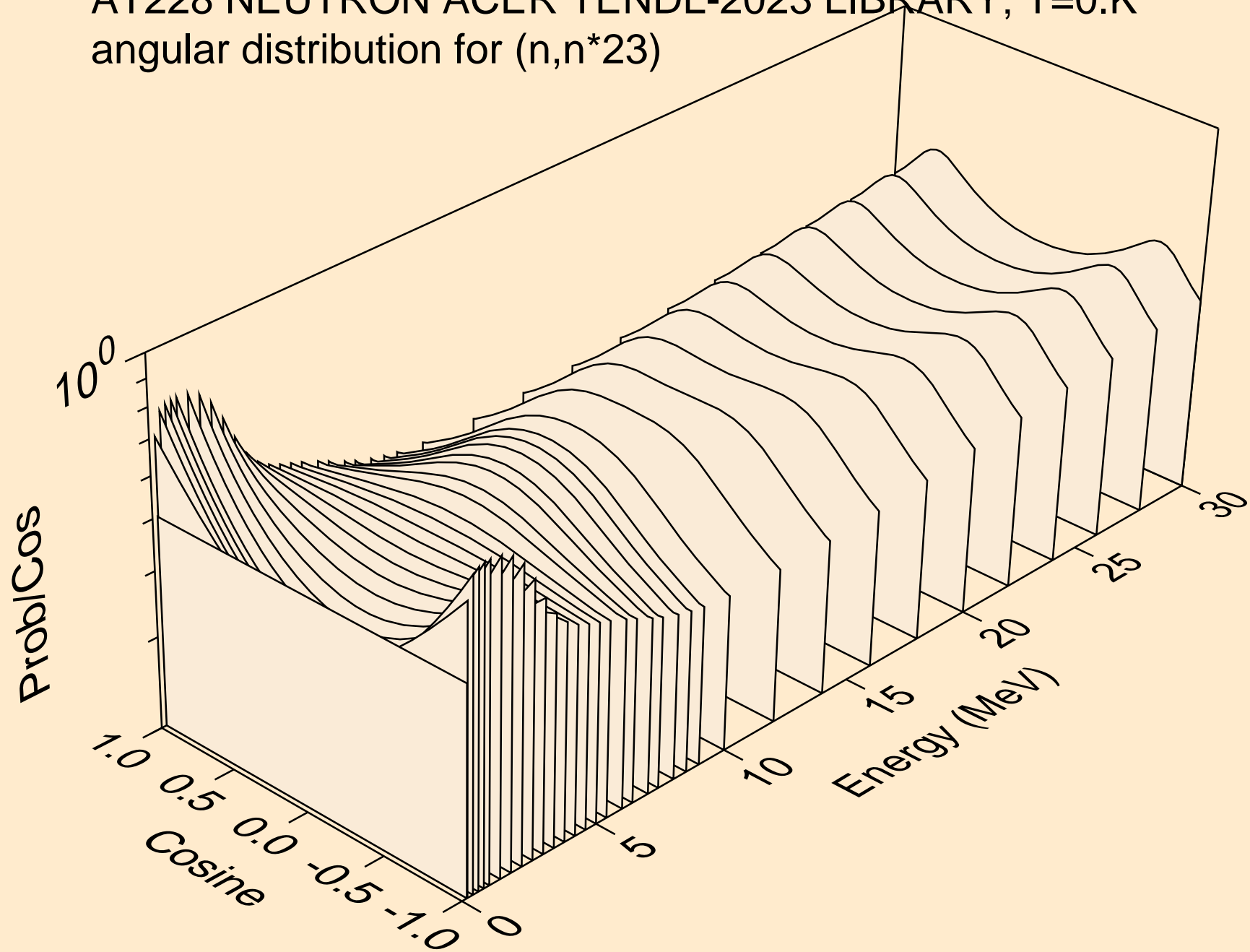

AT228 NEUTRON ACER TENDL-2023 LIBRARY; T=0.K  
angular distribution for (n,n\*24)

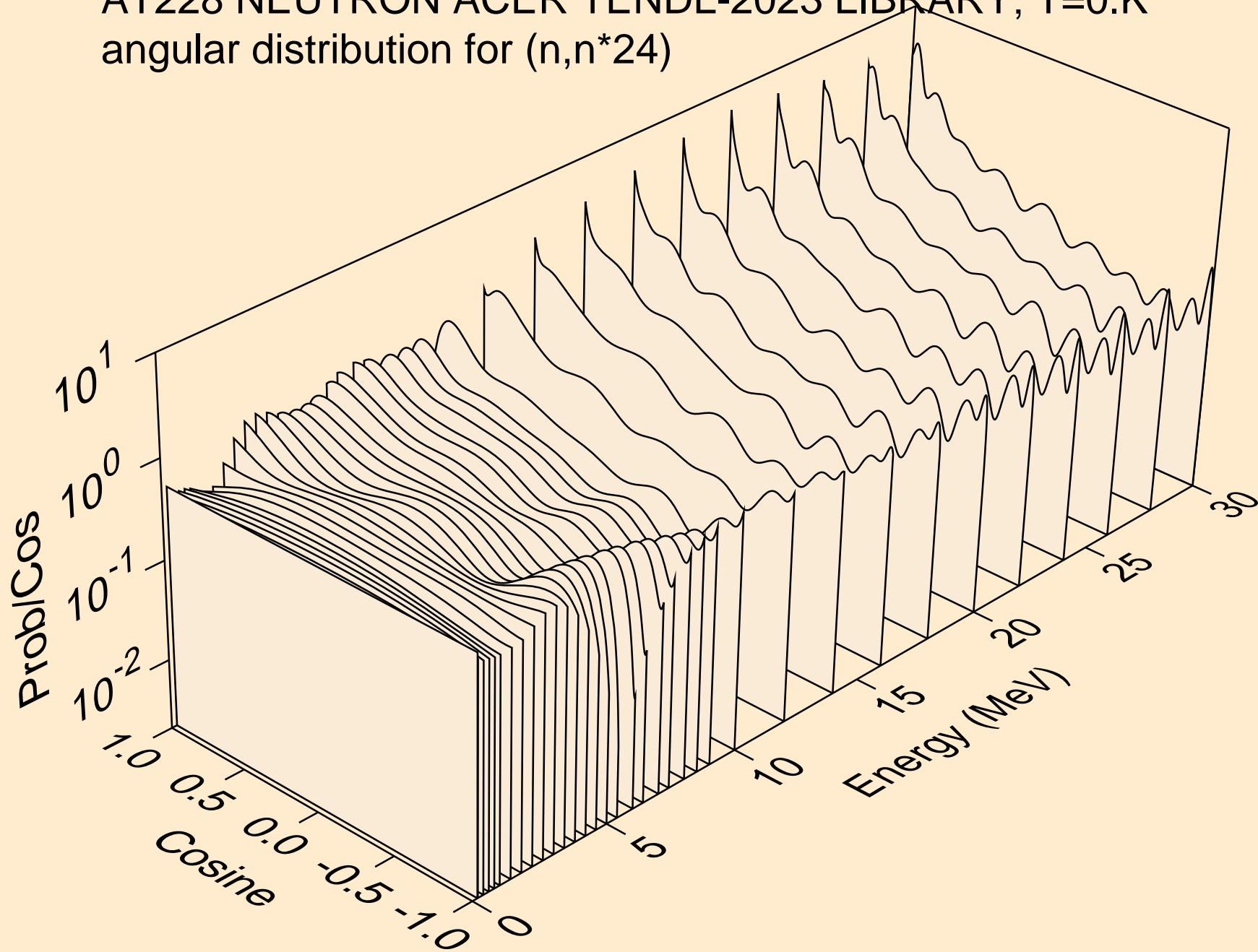

AT228 NEUTRON ACER TENDL-2023 LIBRARY; T=0.K  
angular distribution for (n,n\*25)

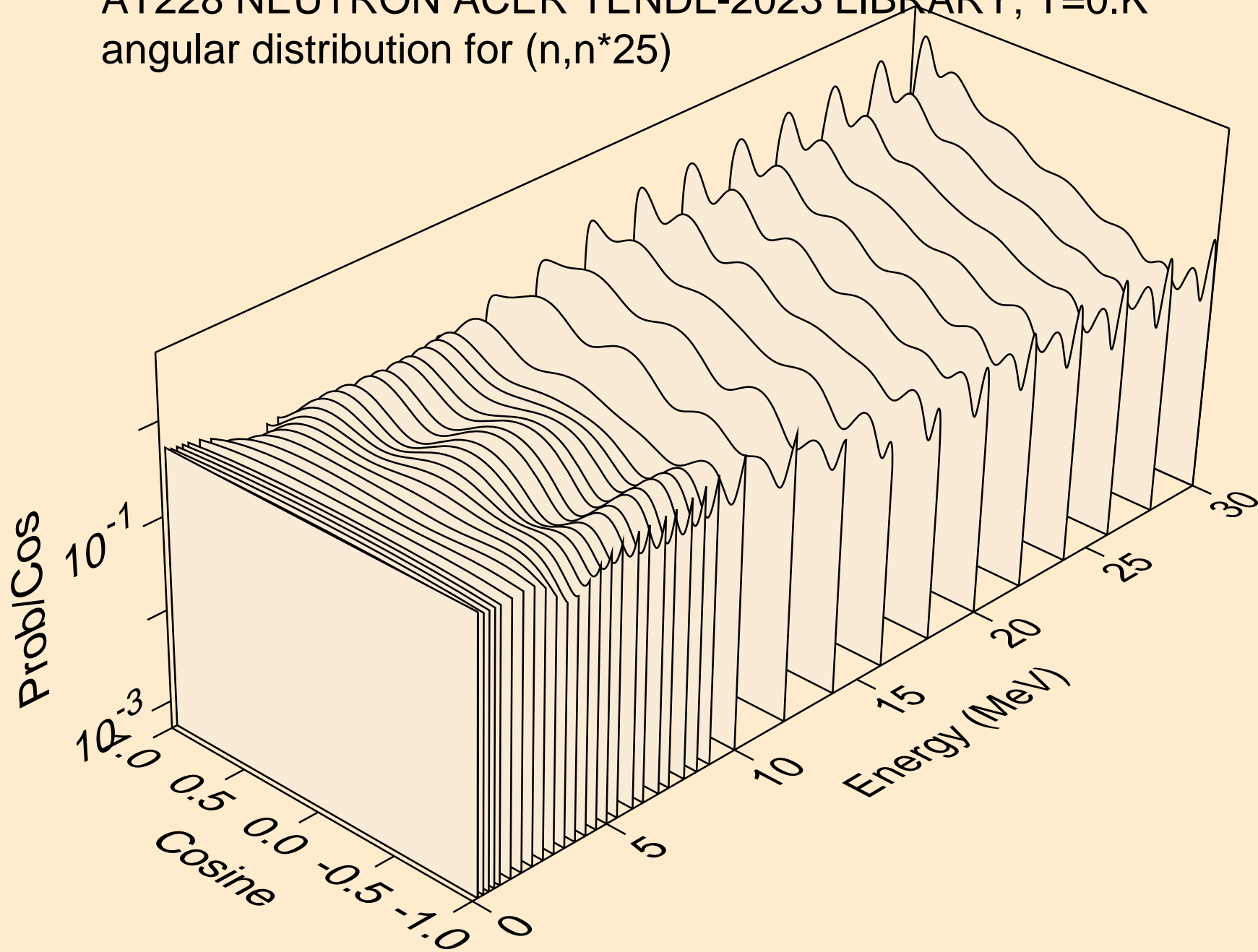

AT228 NEUTRON ACER TENDL-2023 LIBRARY; T=0.K  
angular distribution for (n,n\*26)

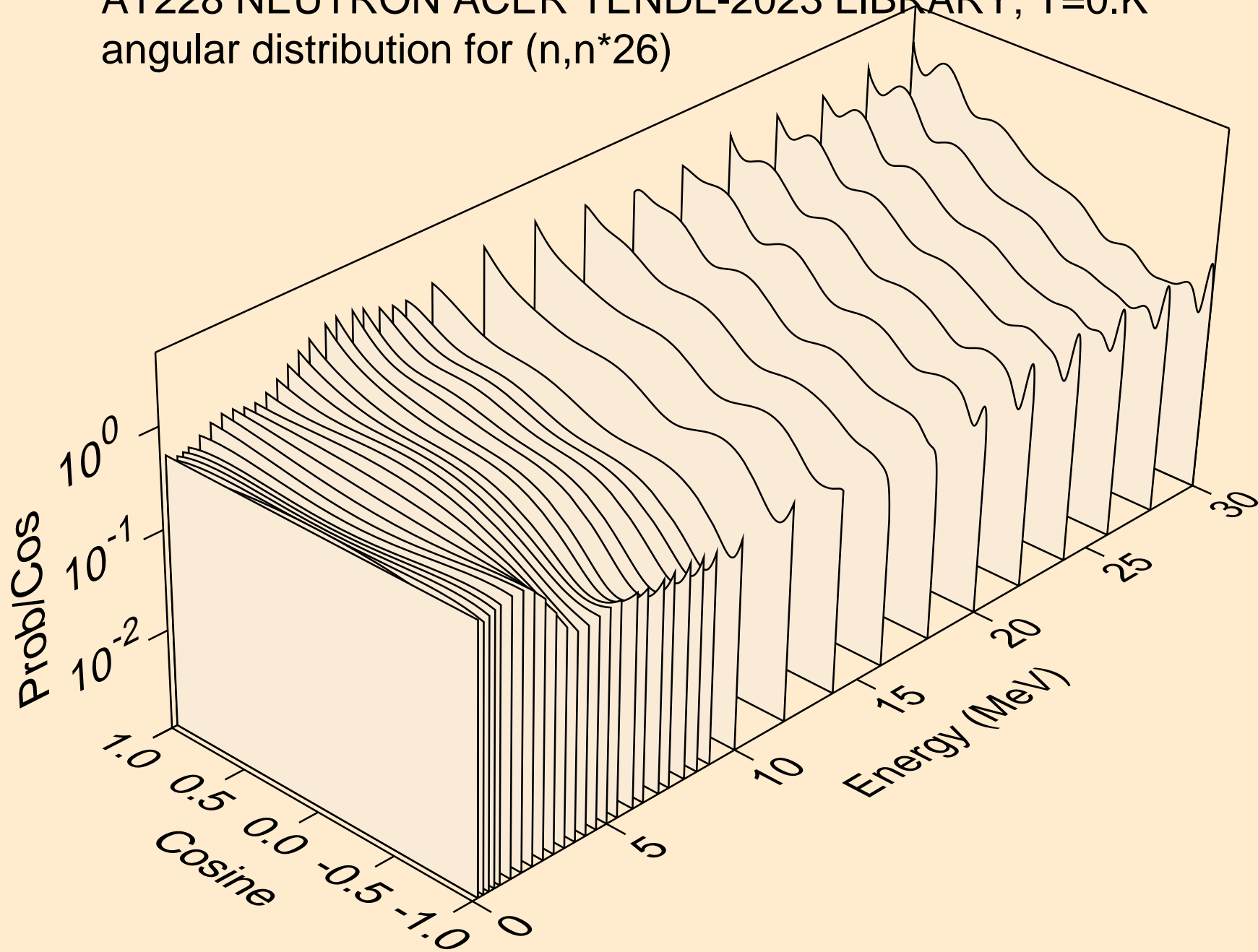

AT228 NEUTRON ACER TENDL-2023 LIBRARY; T=0.K  
angular distribution for (n,n\*27)

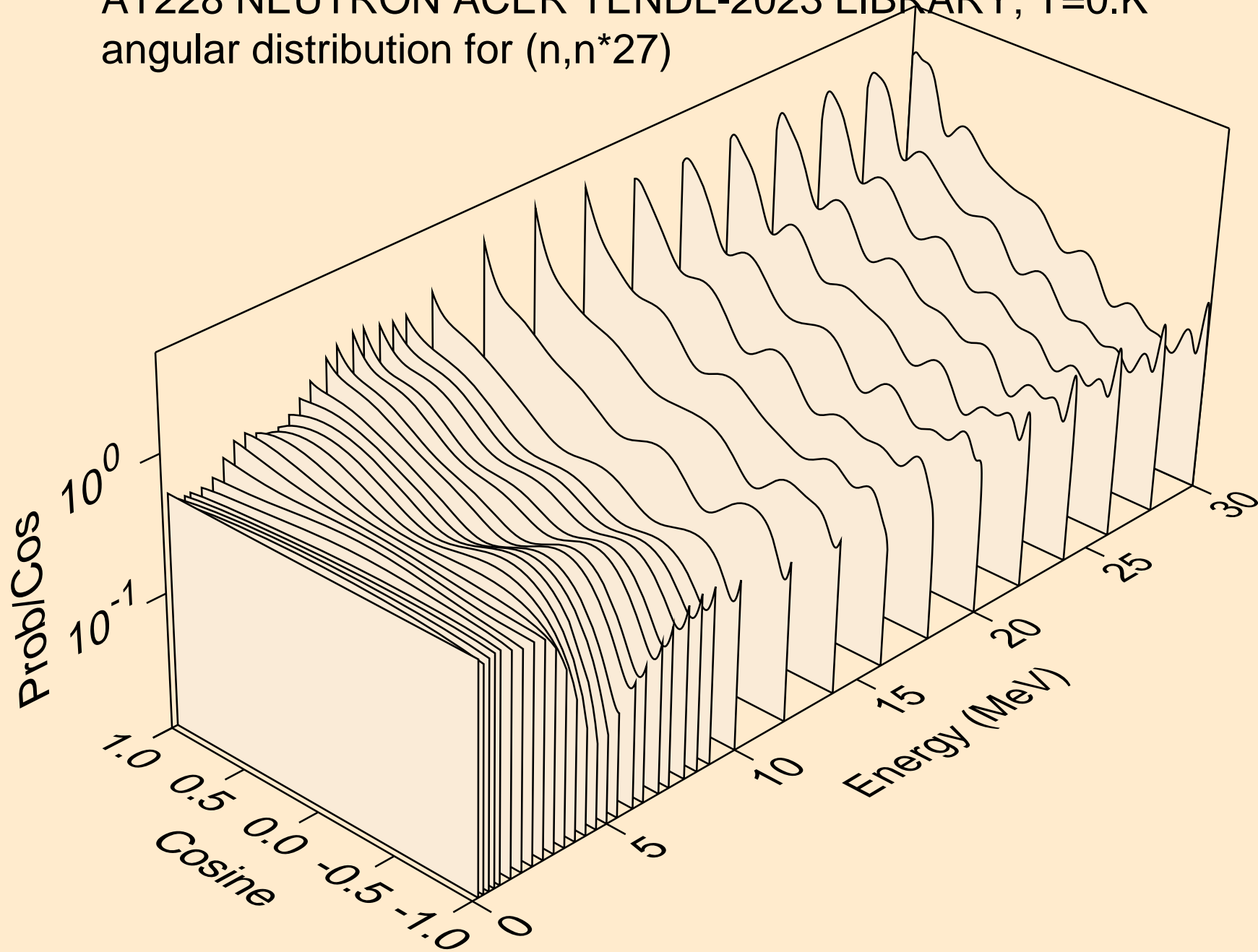

AT228 NEUTRON ACER TENDL-2023 LIBRARY; T=0.K  
angular distribution for (n,n\*28)

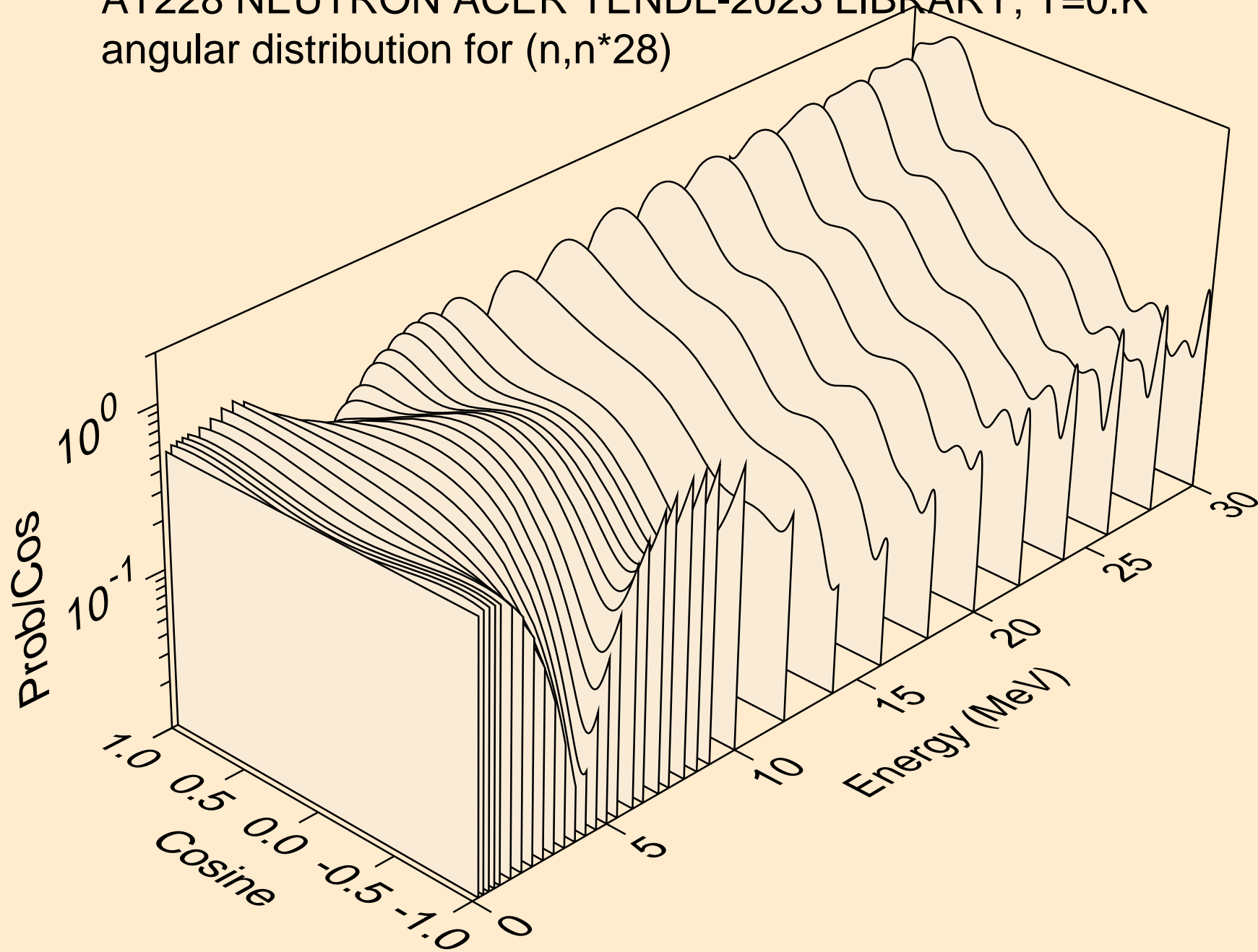

AT228 NEUTRON ACER TENDL-2023 LIBRARY; T=0.K  
angular distribution for (n,n\*29)

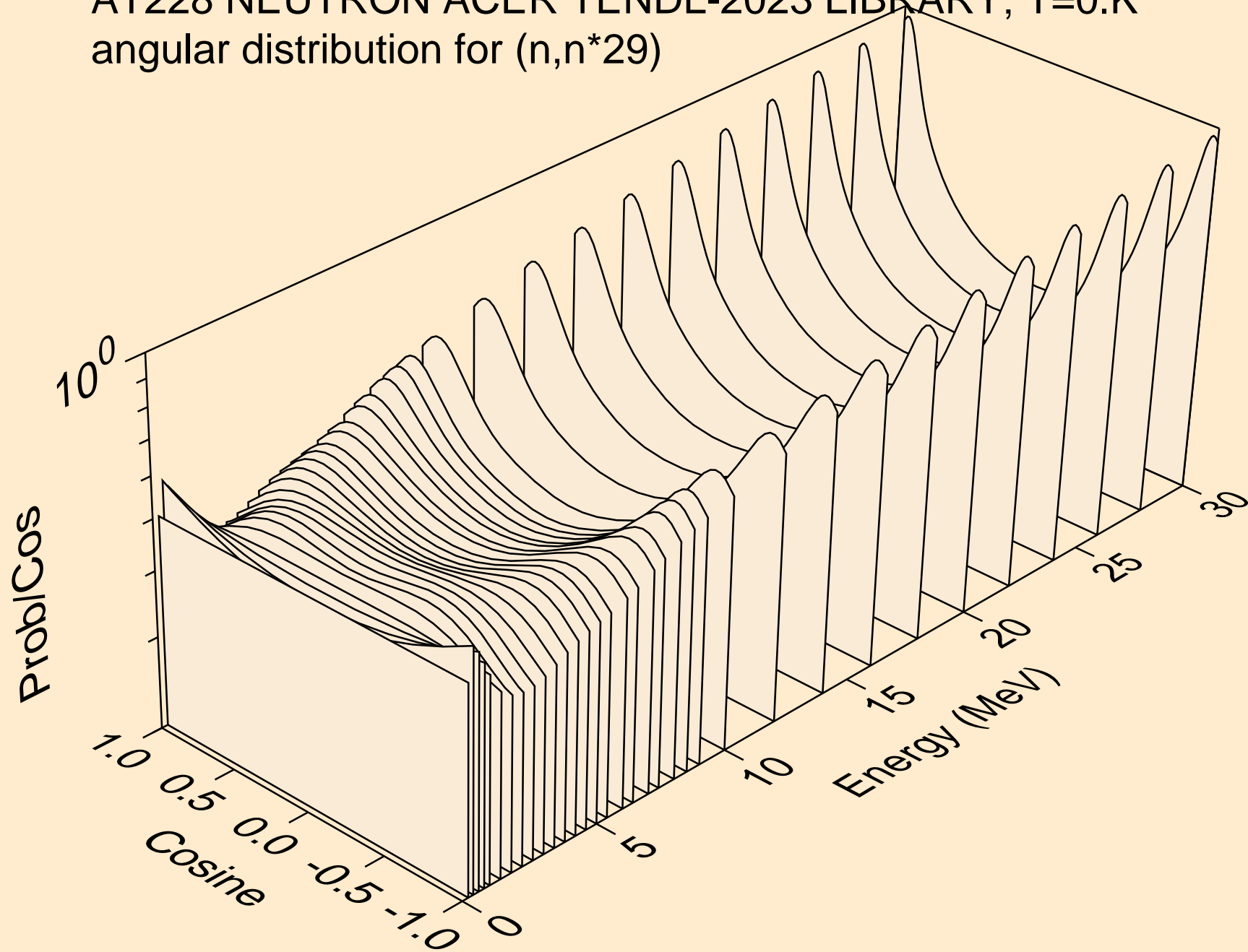

AT228 NEUTRON ACER TENDL-2023 LIBRARY; T=0.K

Total fission nubar

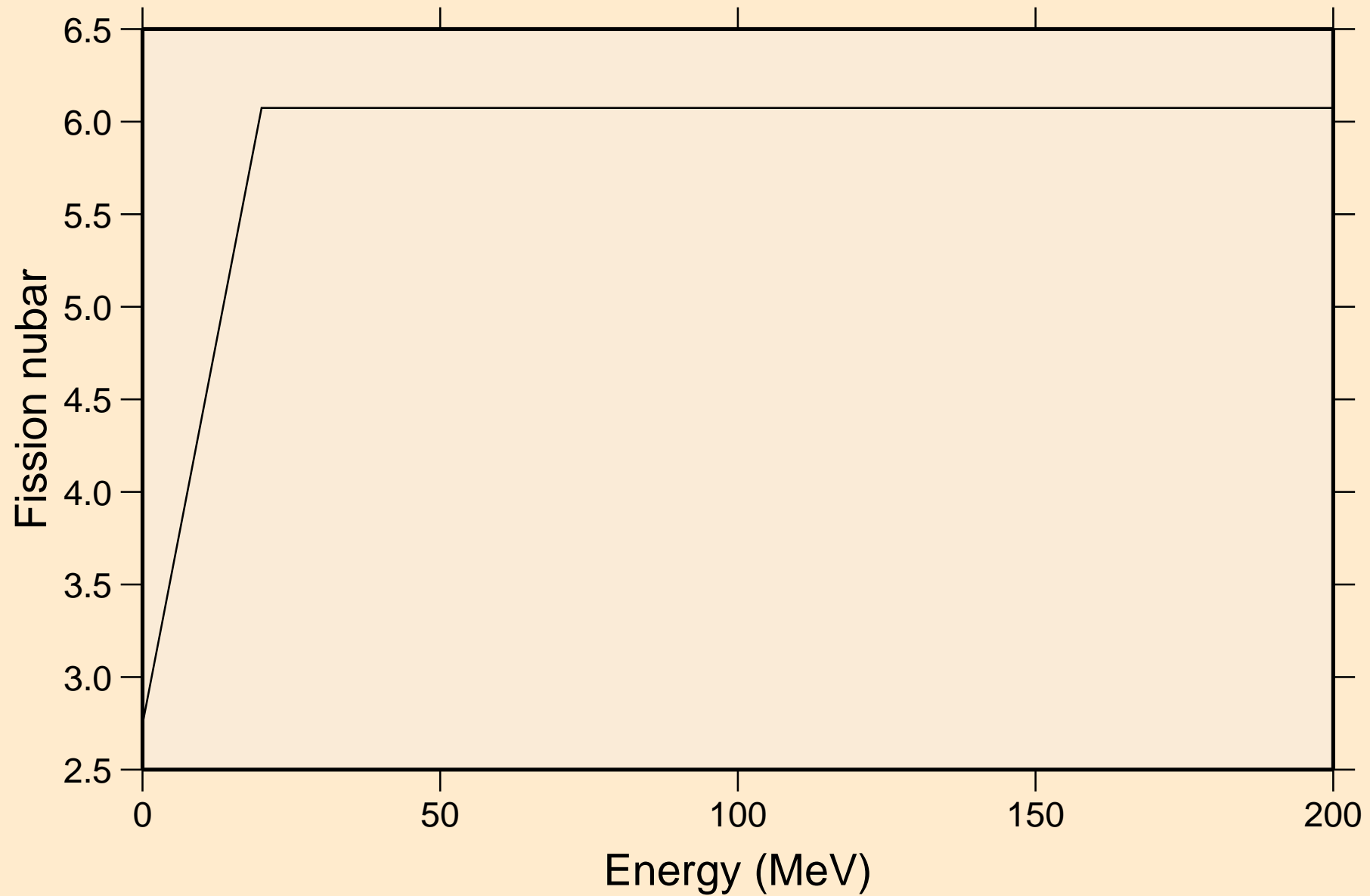

AT228 NEUTRON ACER TENDL-2023 LIBRARY; T=0.K  
Neutron emission for (n,x)

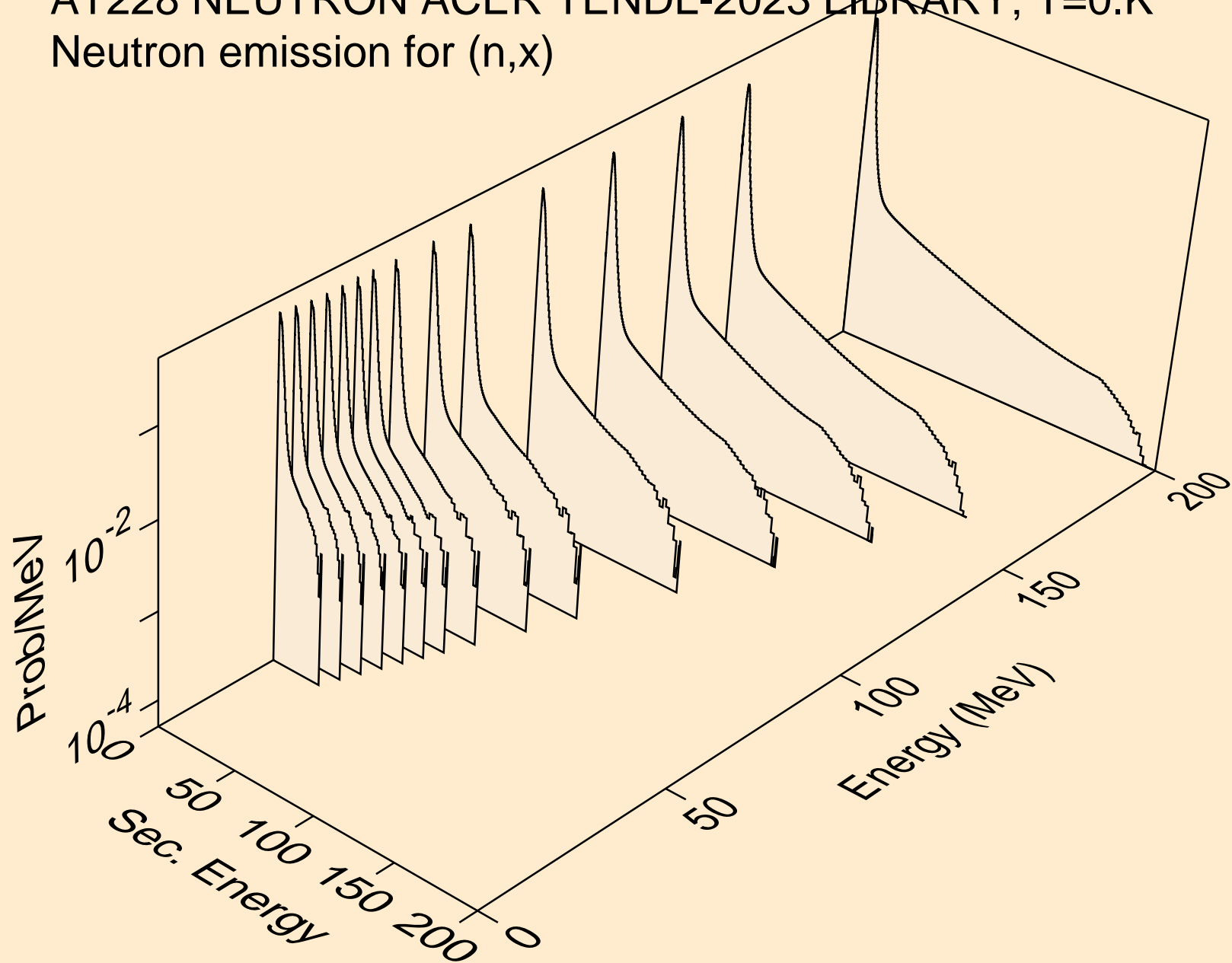

AT228 NEUTRON ACER TENDL-2023 LIBRARY; T=0.K  
Neutron emission for (n,2nd)

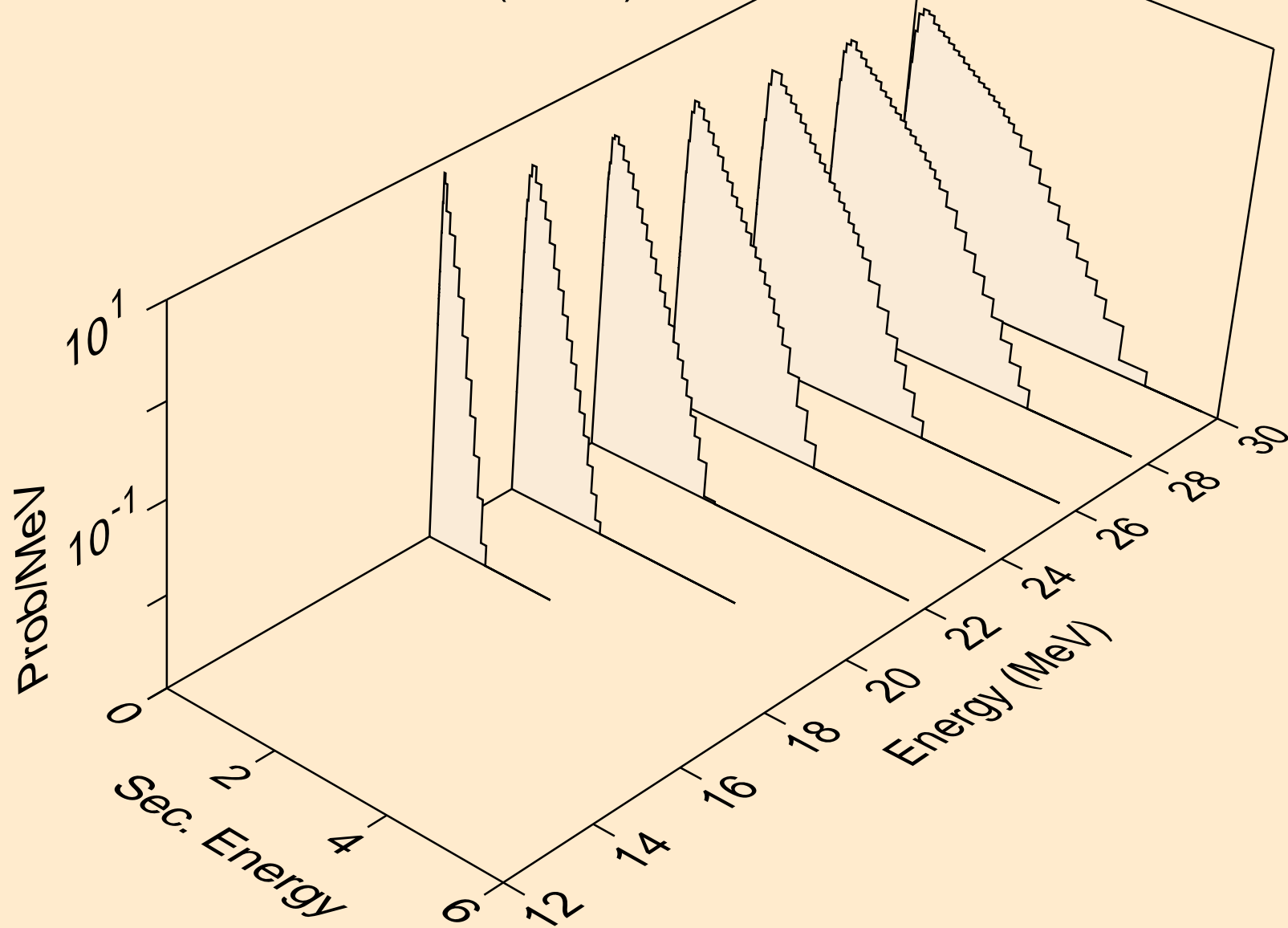

AT228 NEUTRON ACER TENDL-2023 LIBRARY; T=0.K  
Neutron emission for (n,2n)

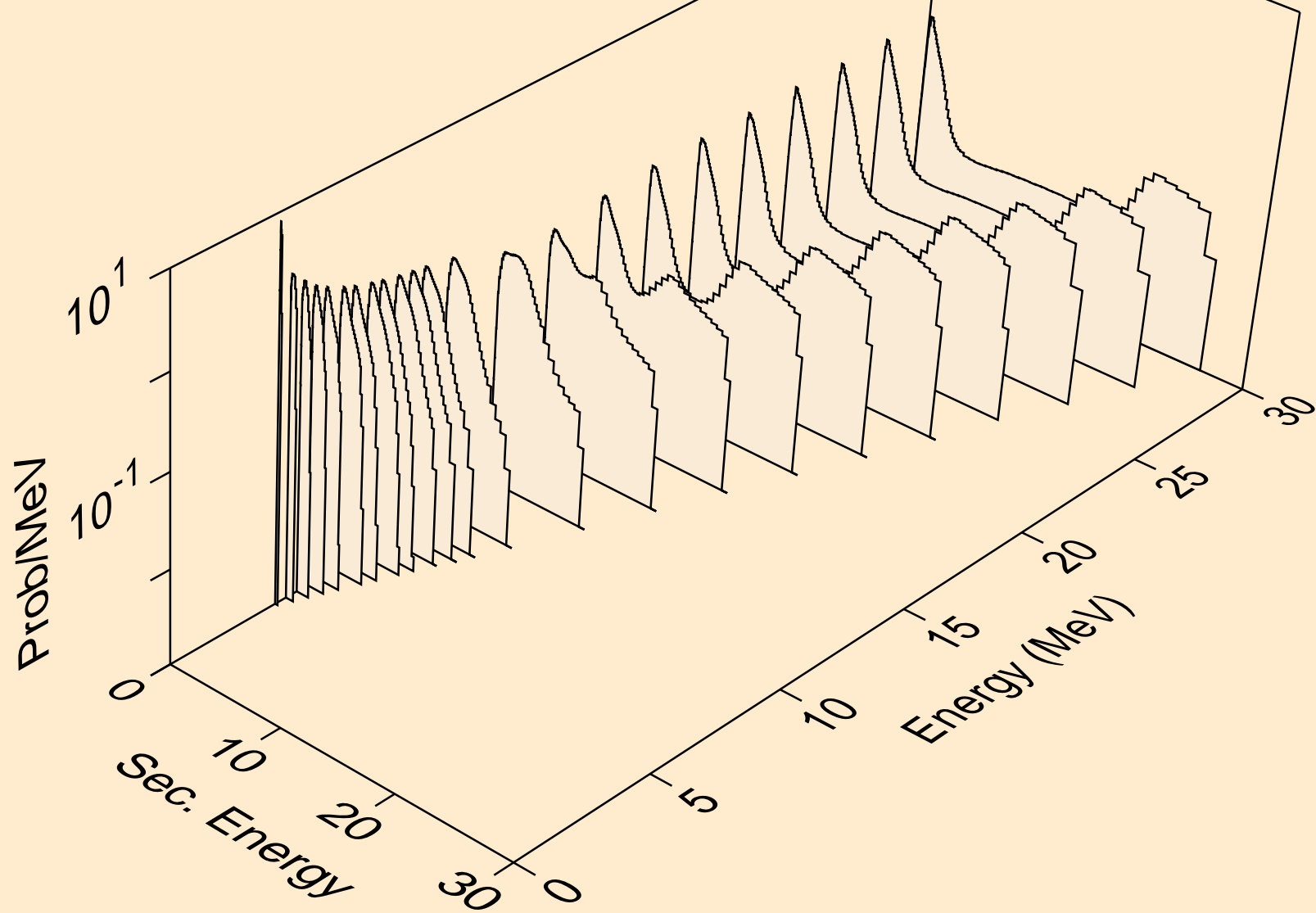

AT228 NEUTRON ACER TENDL-2023 LIBRARY; T=0.K  
Neutron emission for (n,3n)

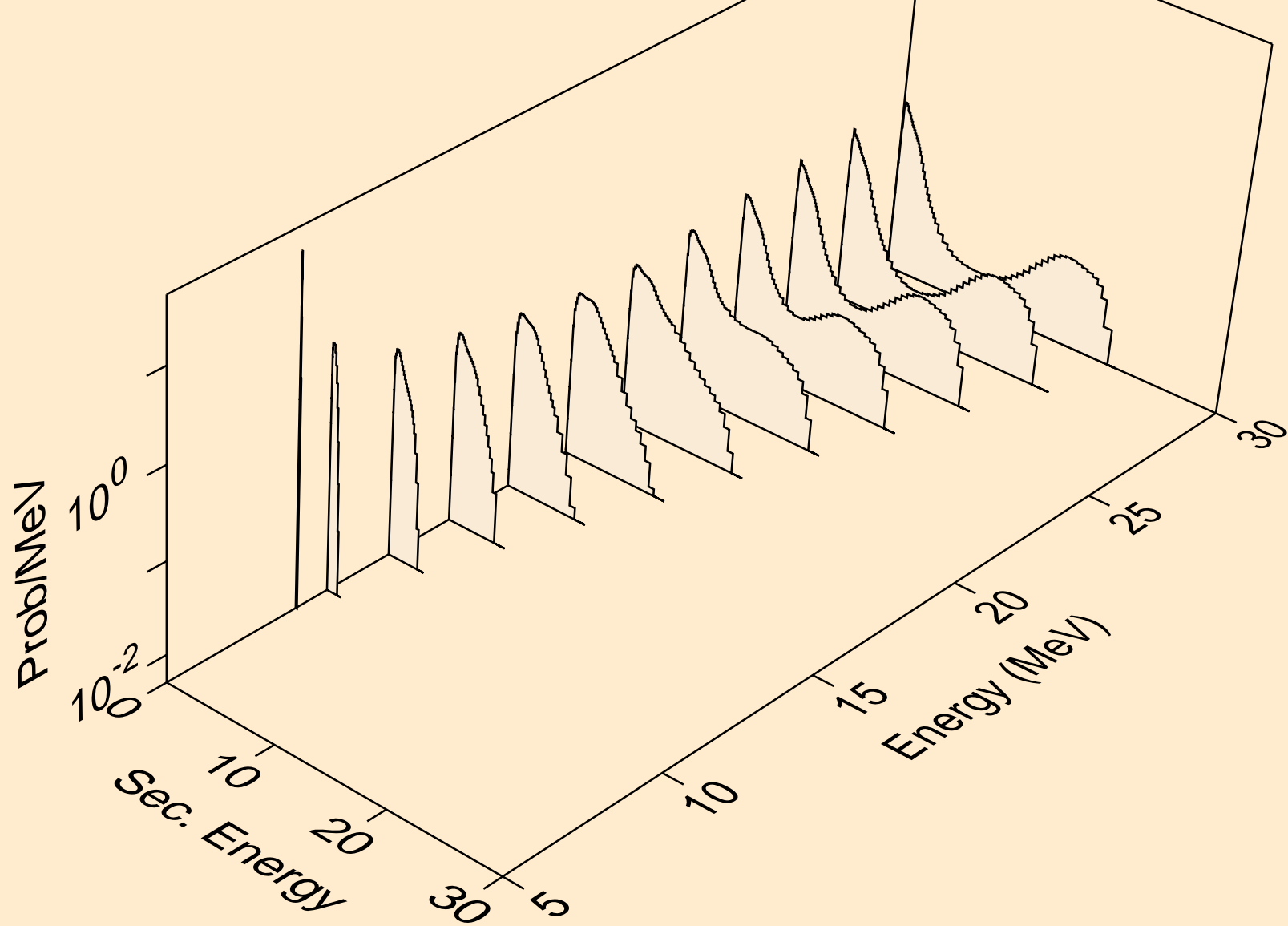

AT228 NEUTRON ACER TENDL-2023 LIBRARY; T=0.K  
Neutron emission for fission

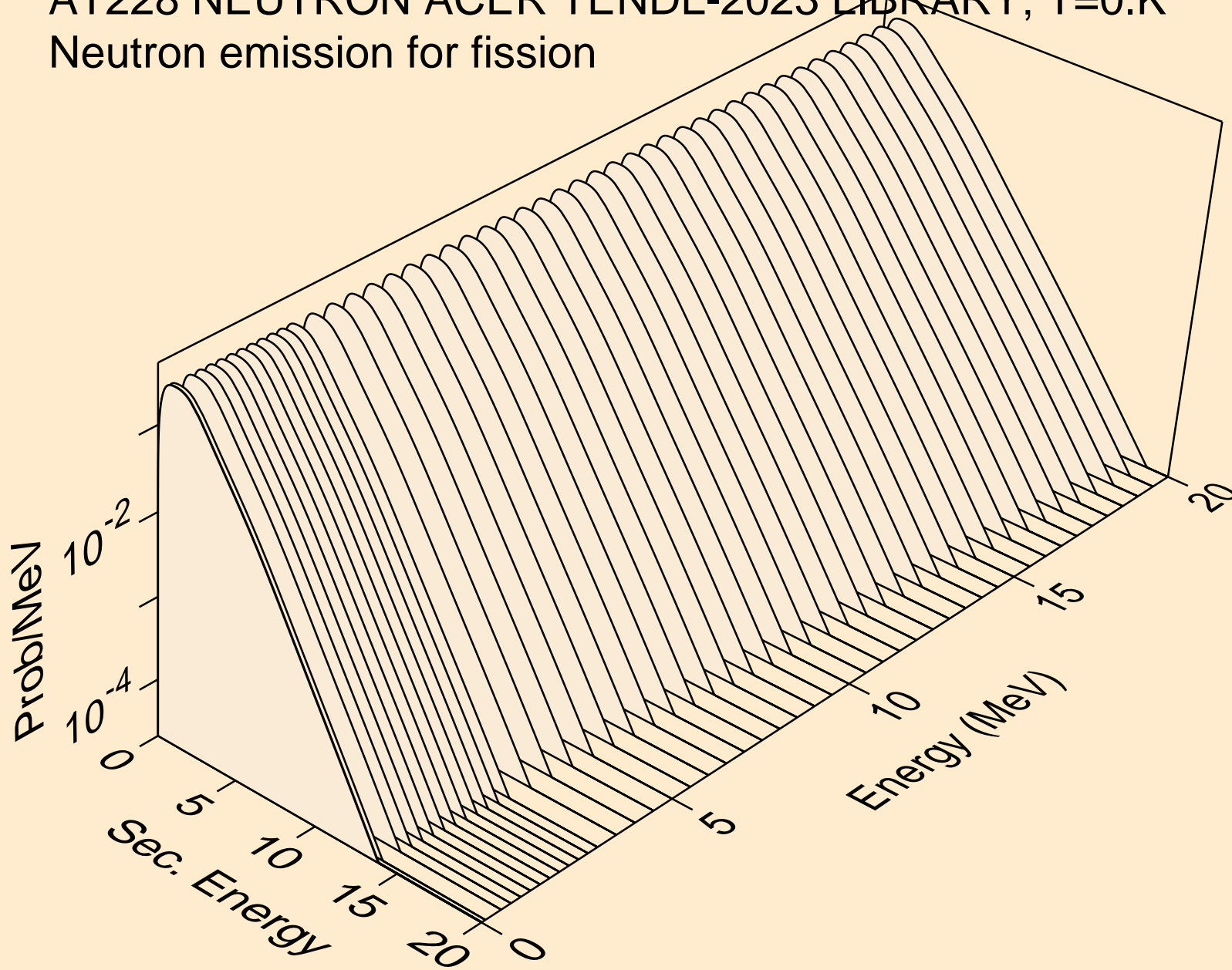

AT228 NEUTRON ACER TENDL-2023 LIBRARY; T=0.K  
Neutron emission for (n,n\*)a

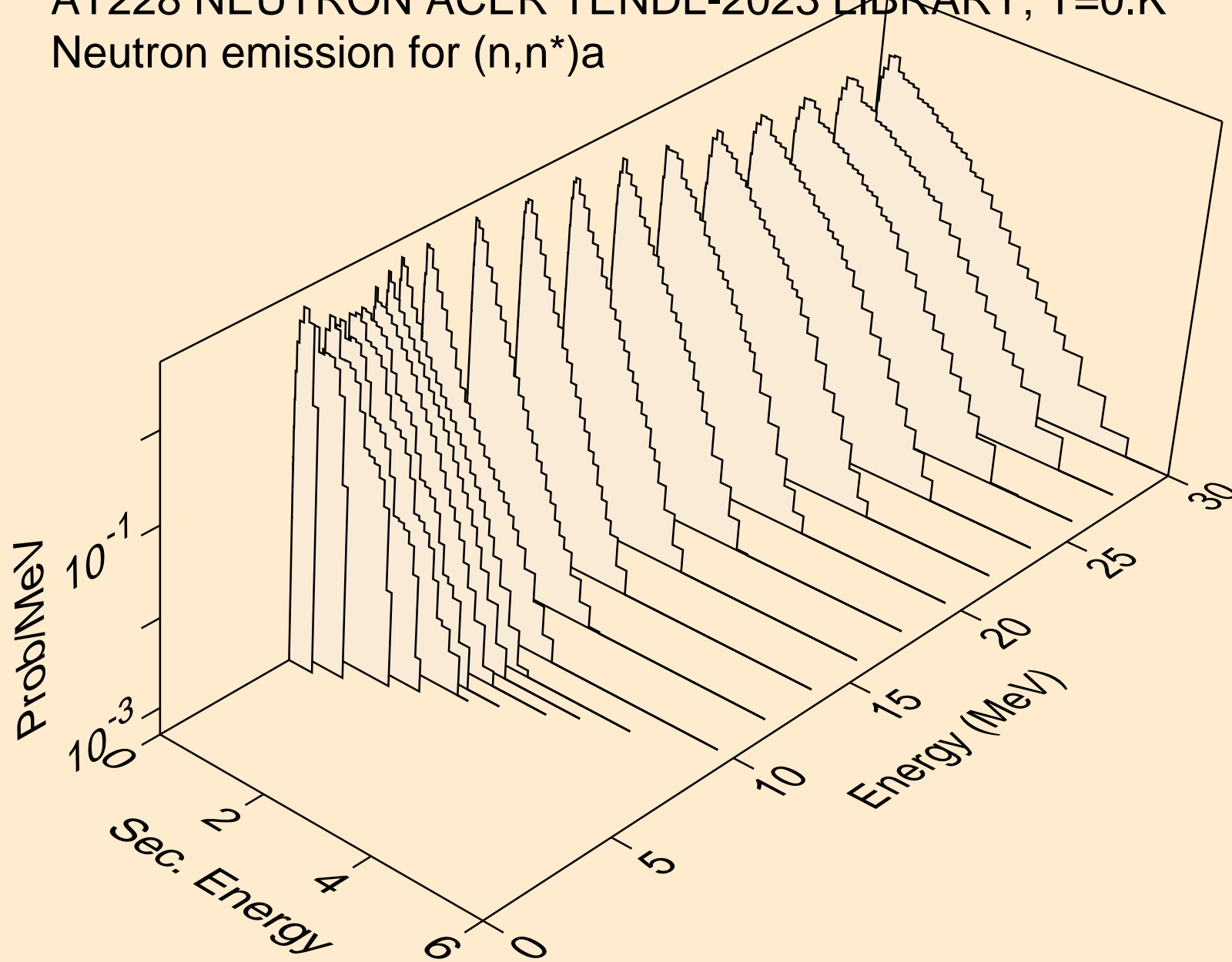

AT228 NEUTRON ACER TENDL-2023 LIBRARY; T=0.K  
Neutron emission for (n,2n)a

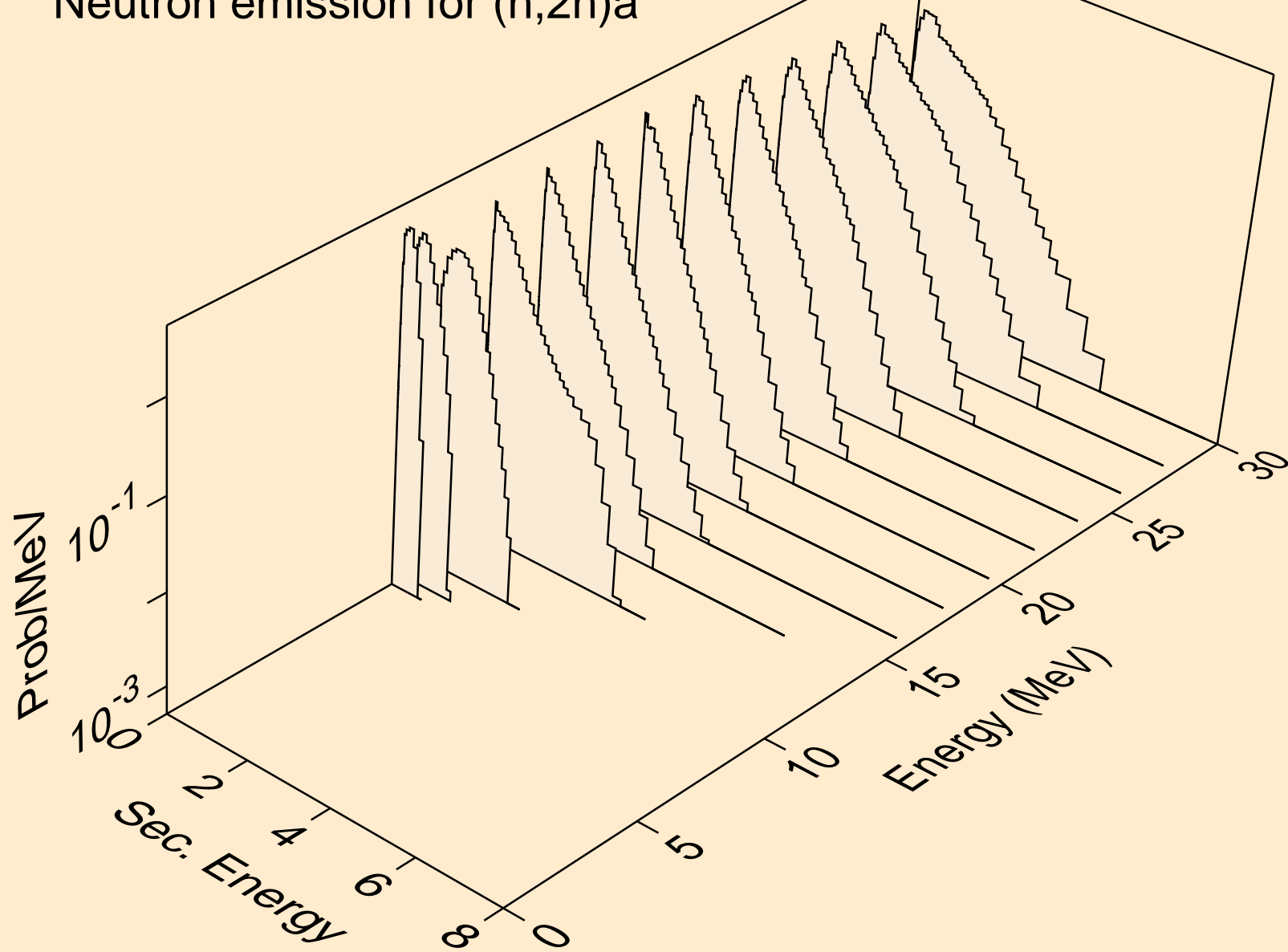

AT228 NEUTRON ACER TENDL-2023 LIBRARY; T=0.K  
Neutron emission for (n,3n)a

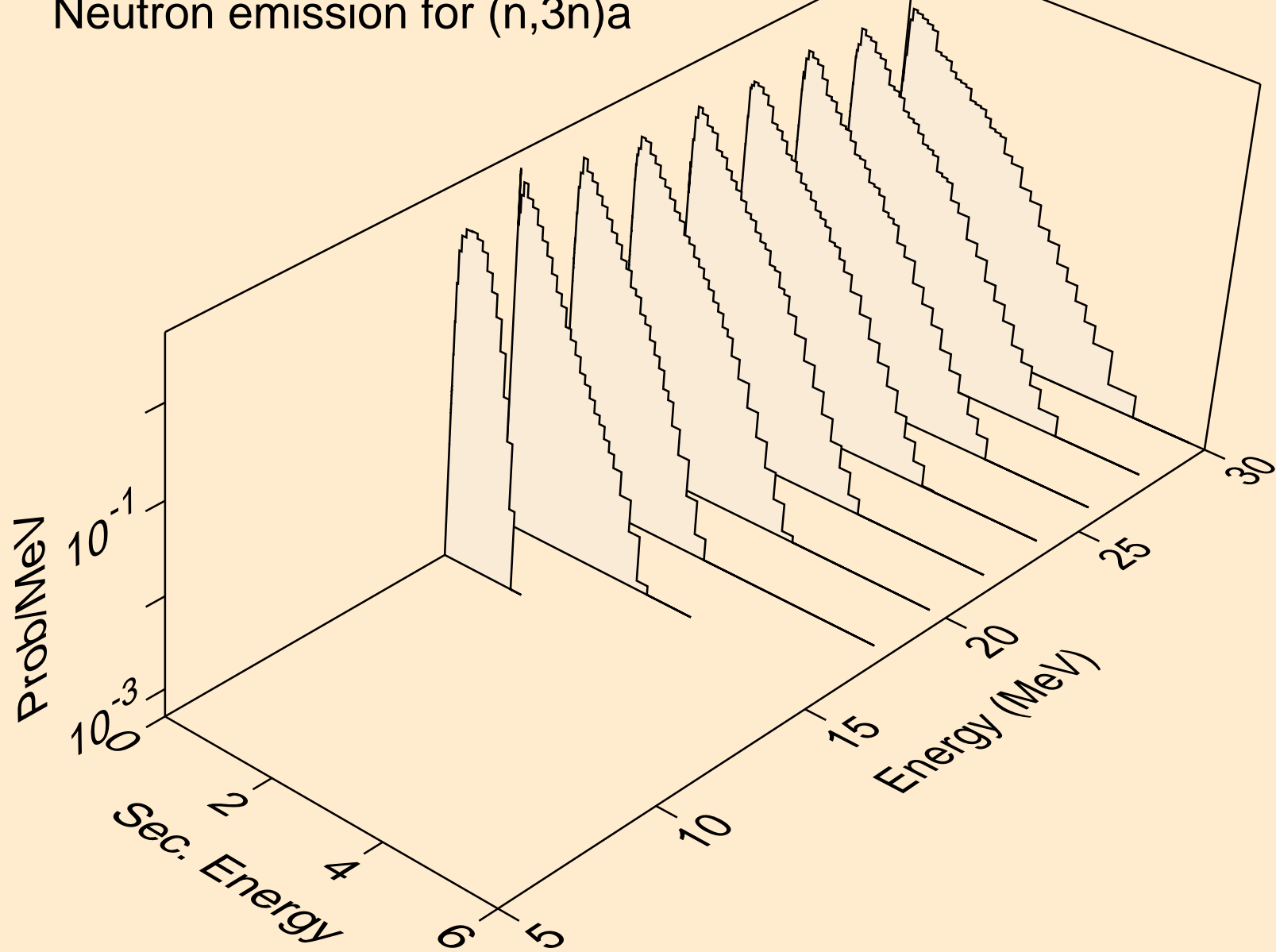

AT228 NEUTRON ACER TENDL-2023 LIBRARY; T=0.K  
Neutron emission for (n,n\*)p

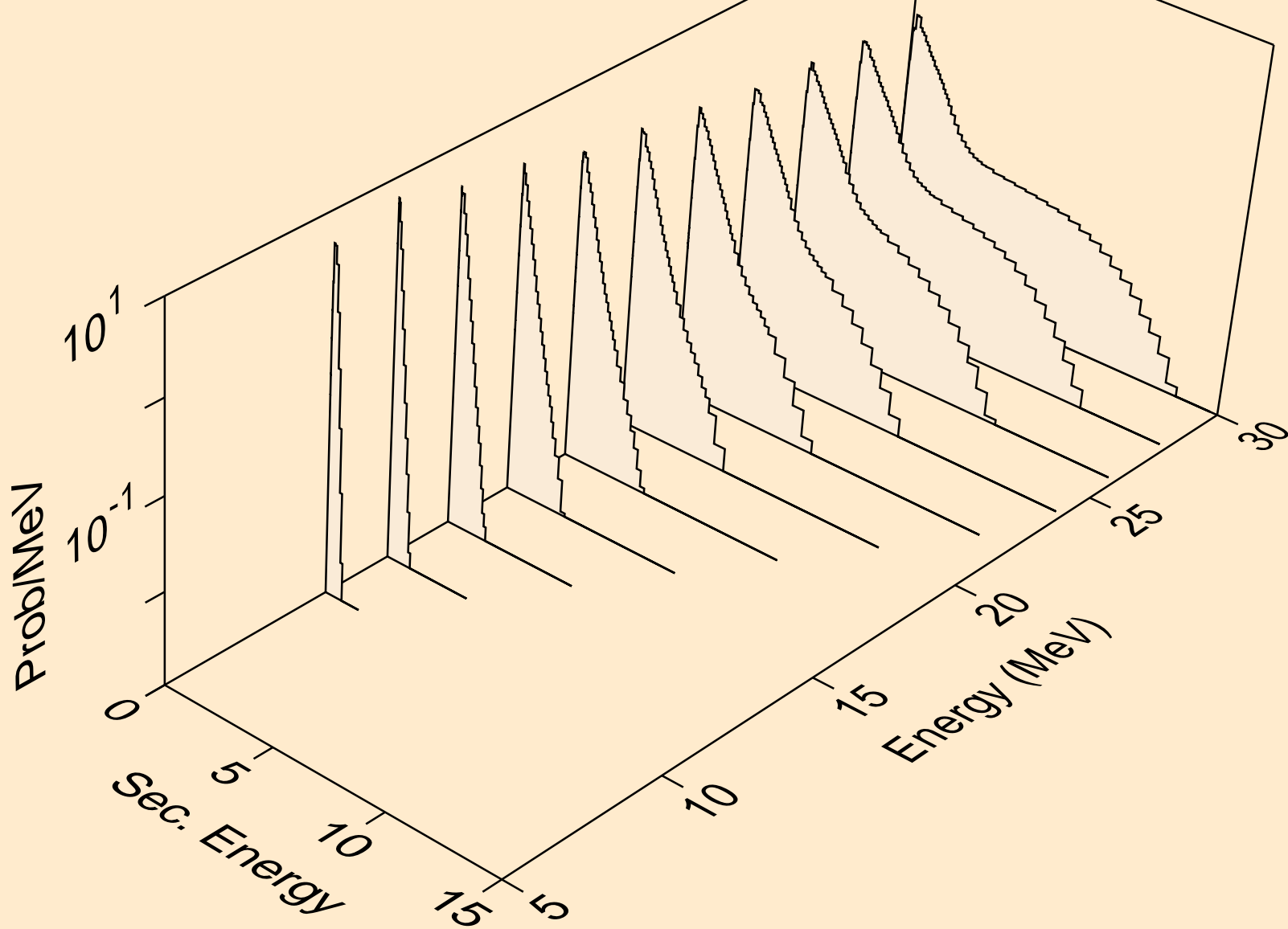

AT228 NEUTRON ACER TENDL-2023 LIBRARY; T=0.K  
Neutron emission for (n,n\*)d

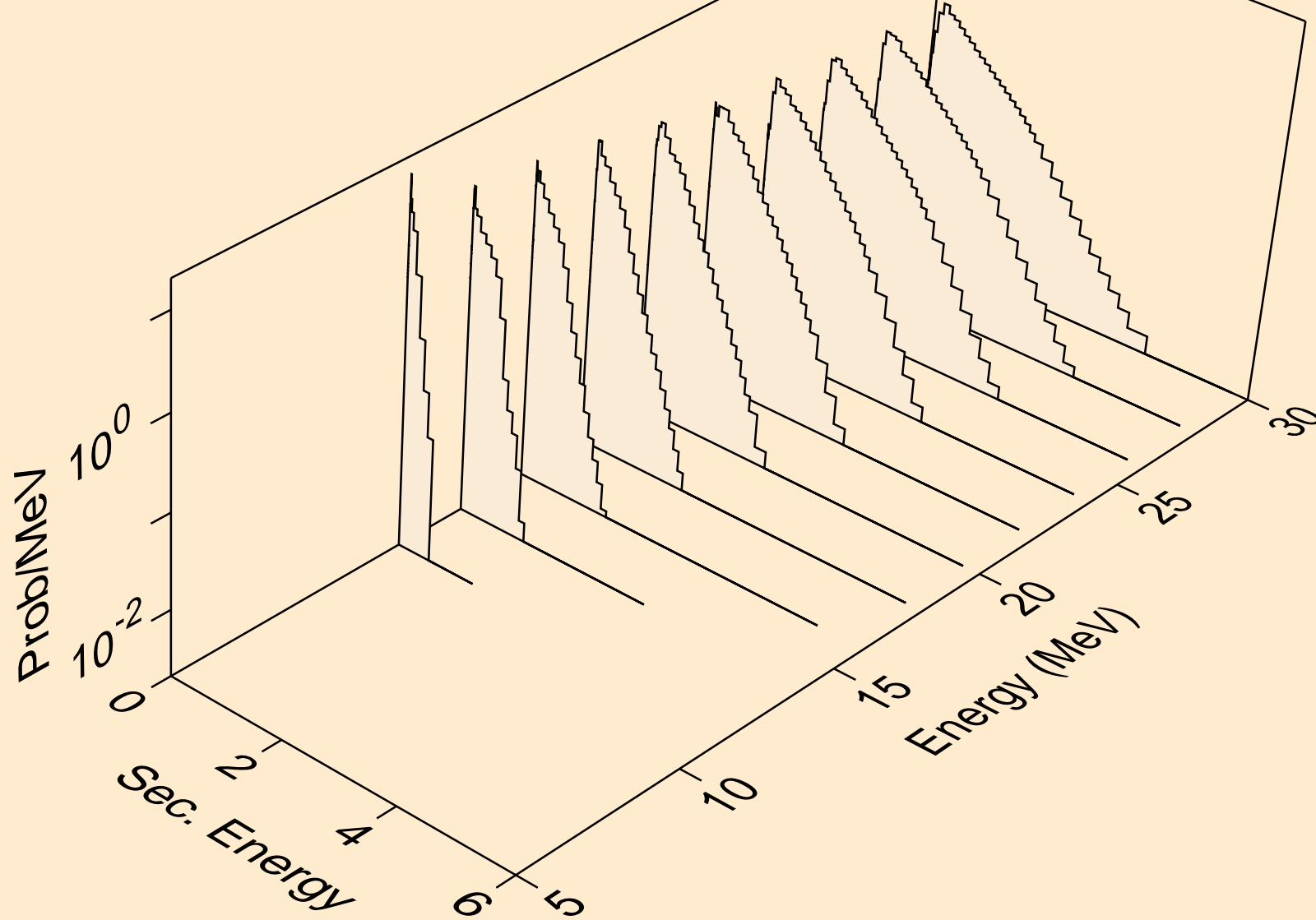

AT228 NEUTRON ACER TENDL-2023 LIBRARY; T=0.K  
Neutron emission for (n,n\*)t

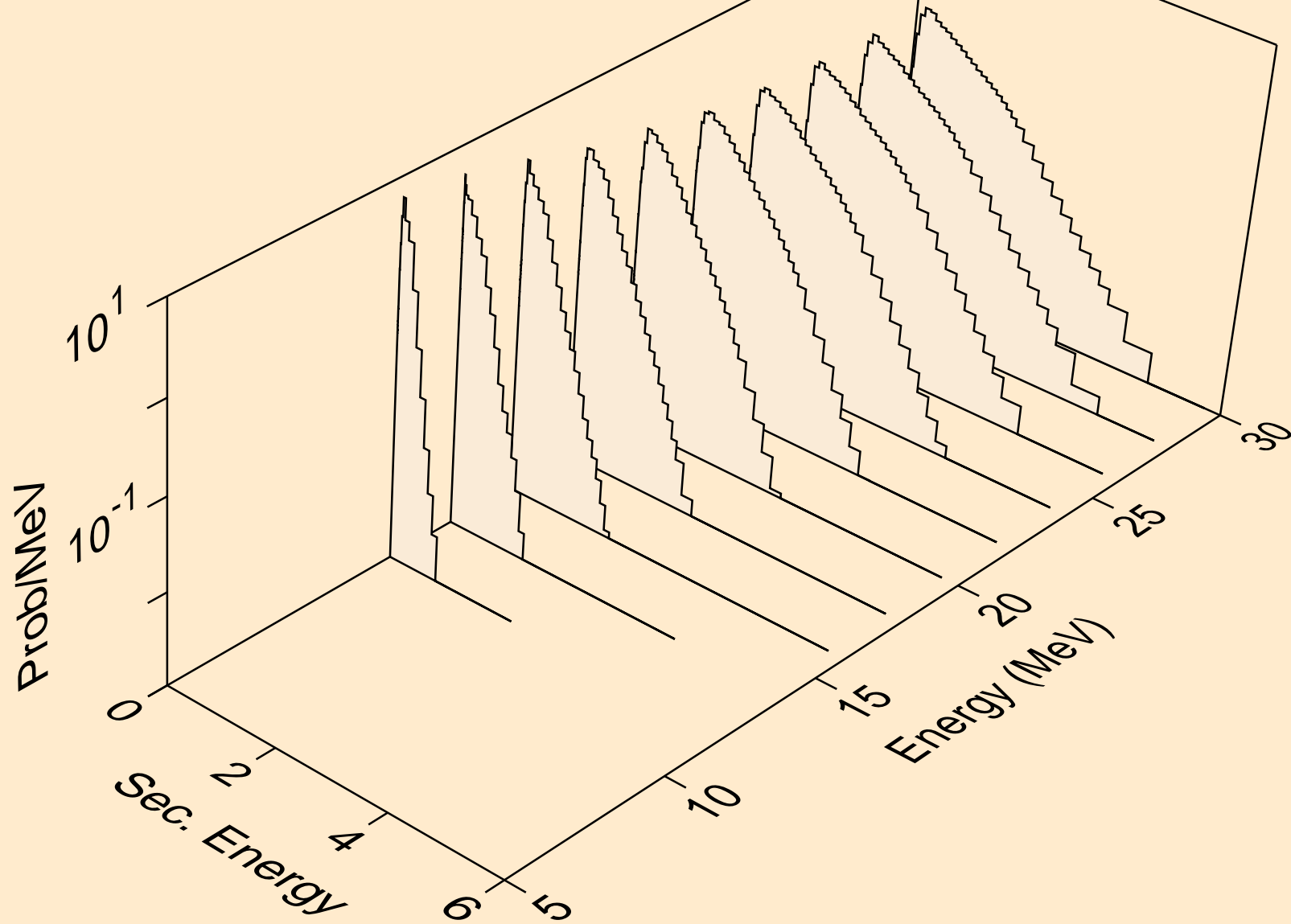

AT228 NEUTRON ACER TENDL-2023 LIBRARY; T=0.K  
Neutron emission for (n,n\*)he3

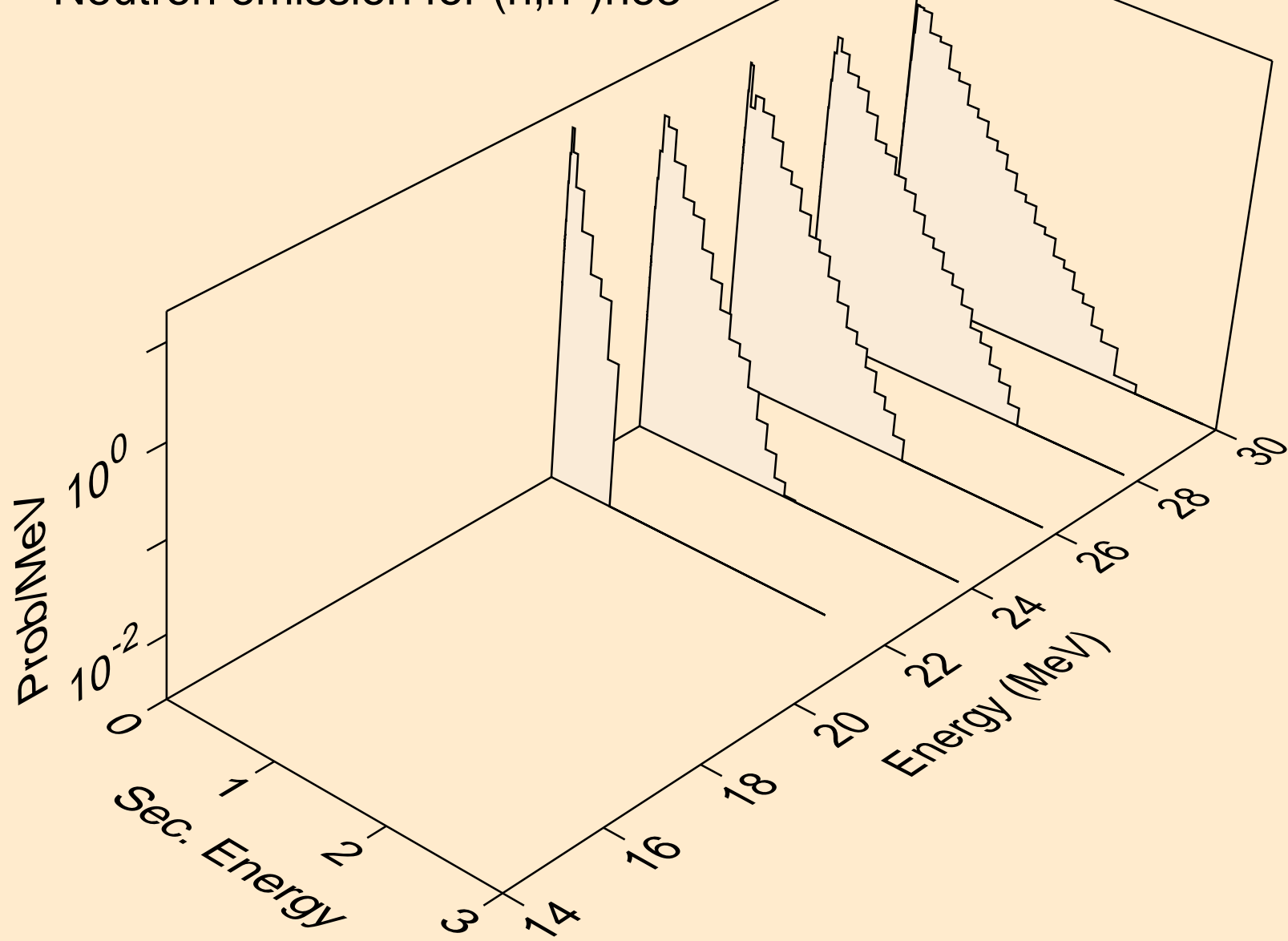

AT228 NEUTRON ACER TENDL-2023 LIBRARY; T=0.K  
Neutron emission for (n,4n)

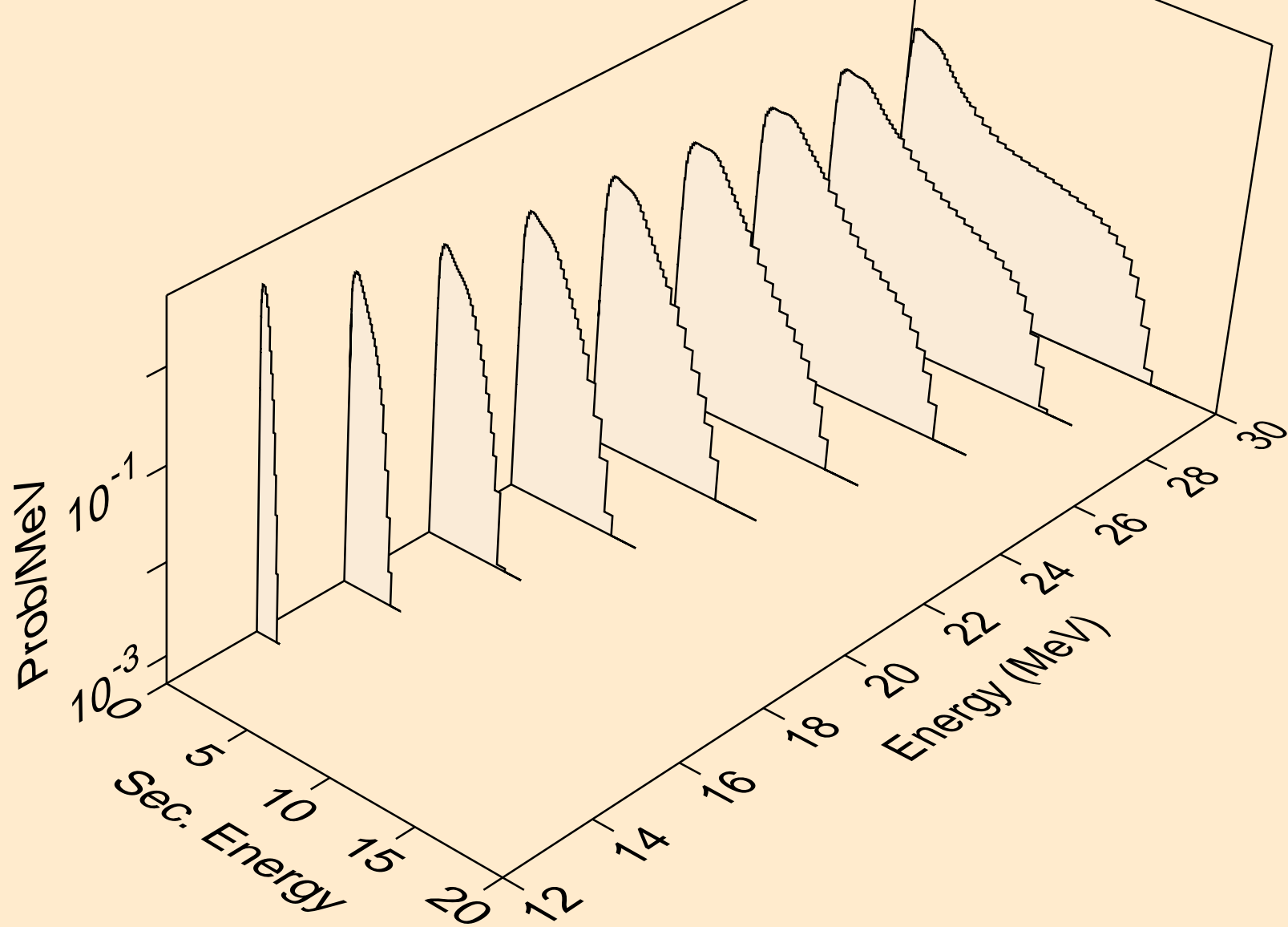

AT228 NEUTRON ACER TENDL-2023 LIBRARY; T=0.K  
Neutron emission for (n,2np)

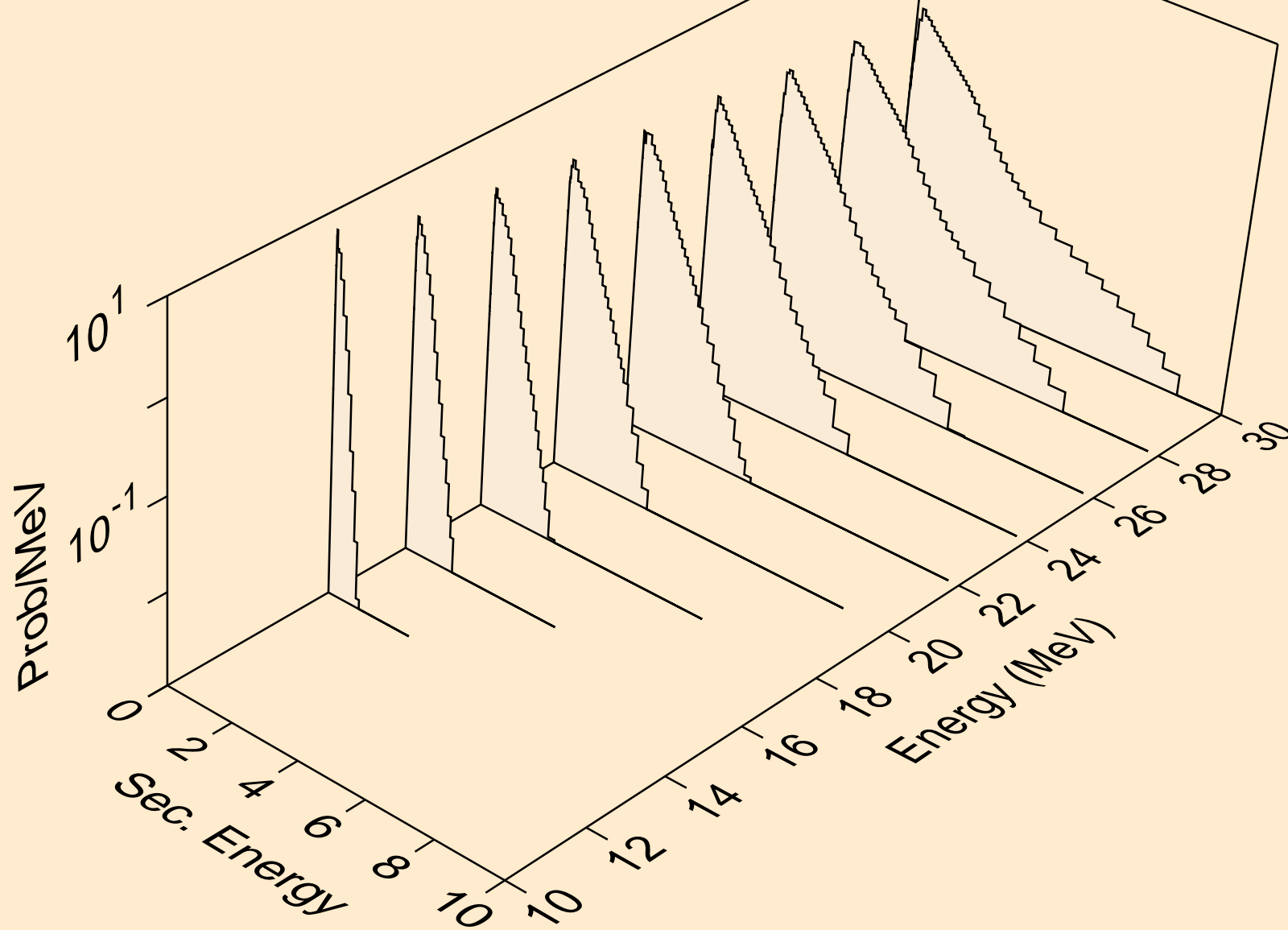

AT228 NEUTRON ACER TENDL-2023 LIBRARY; T=0.K  
Neutron emission for (n,3np)

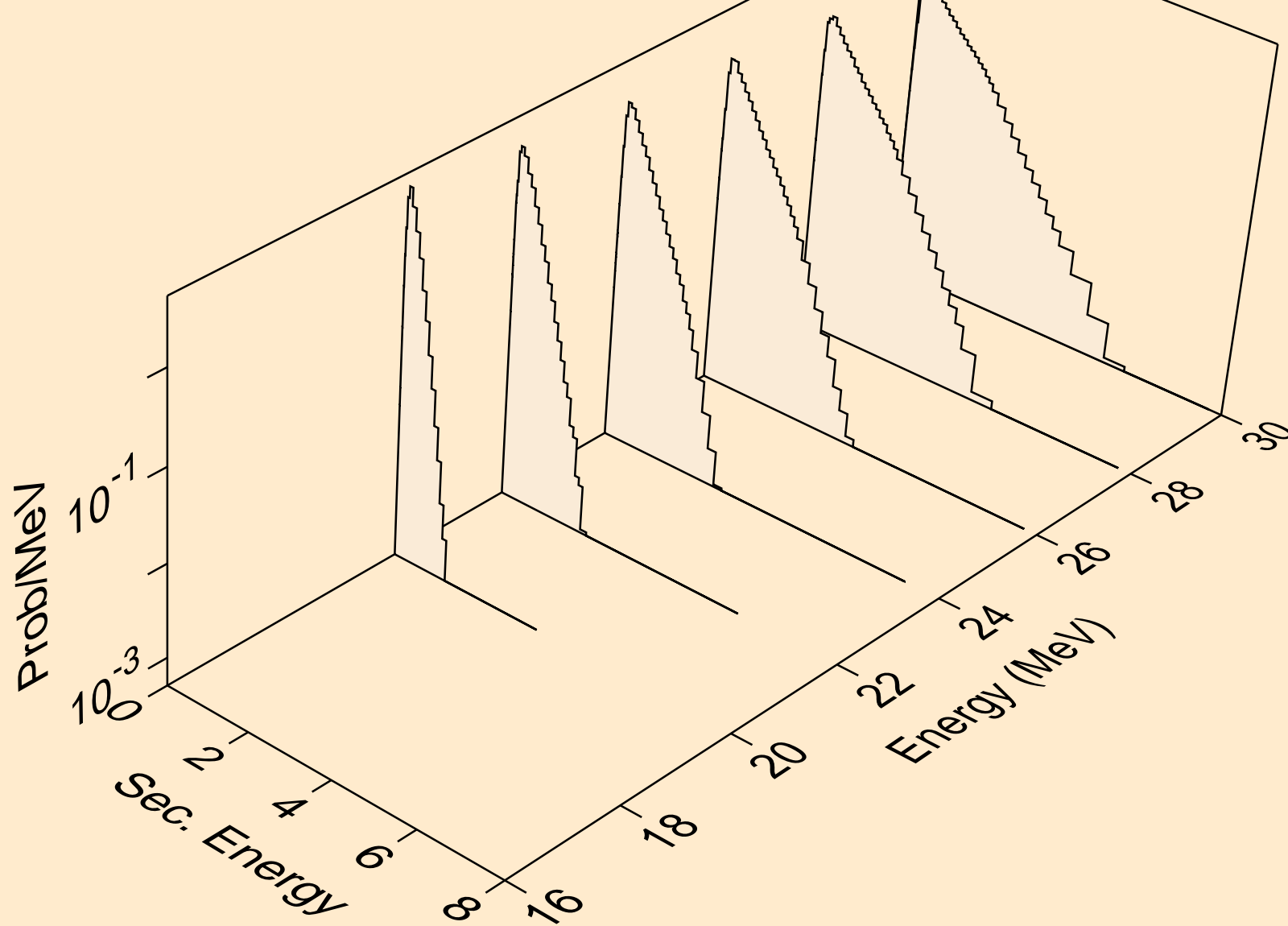

AT228 NEUTRON ACER TENDL-2023 LIBRARY; T=0.K  
Neutron emission for (n,n\*c)

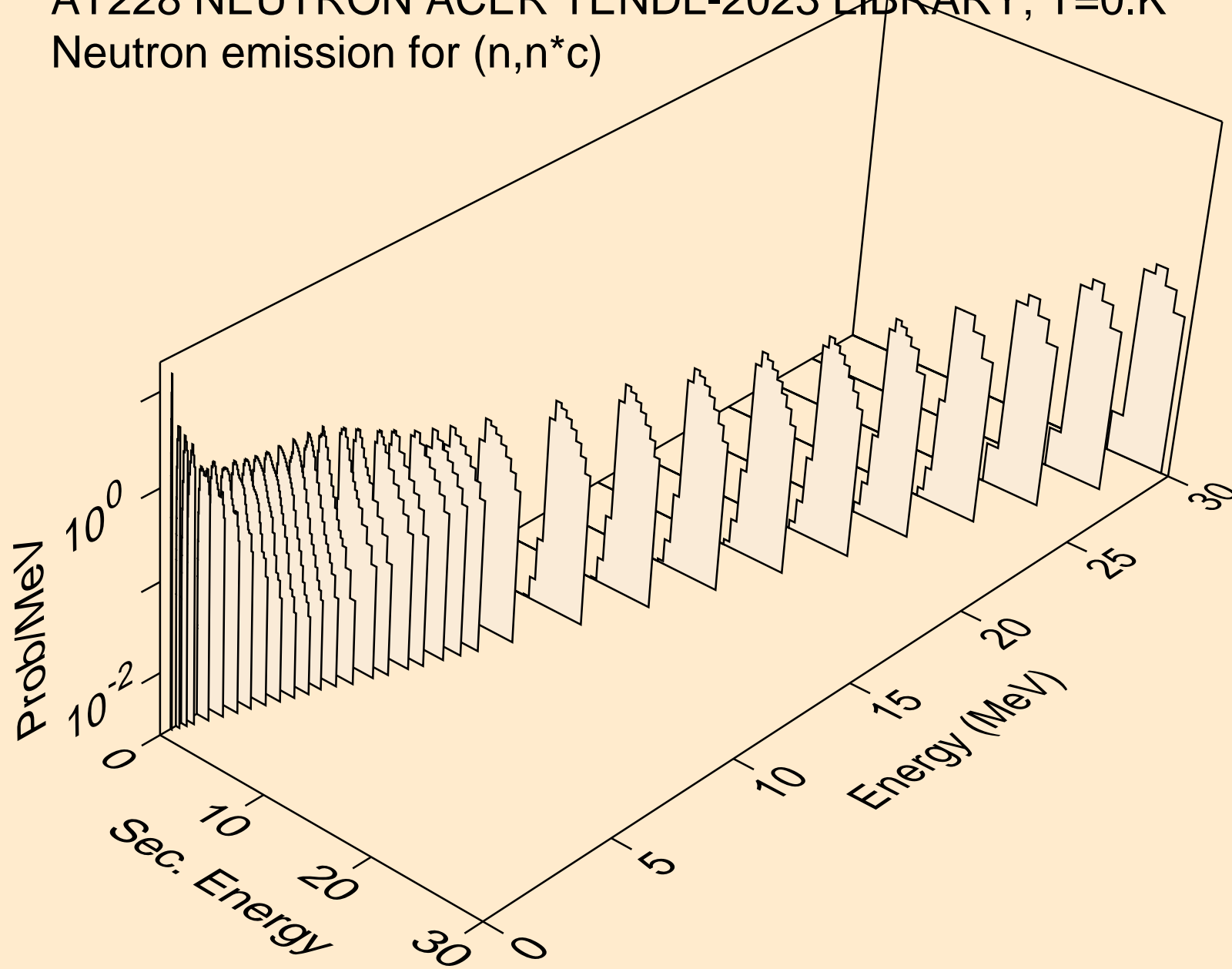

# AT228 NEUTRON ACER TENDL-2023 LIBRARY; T=0.K

## Delayed nubar

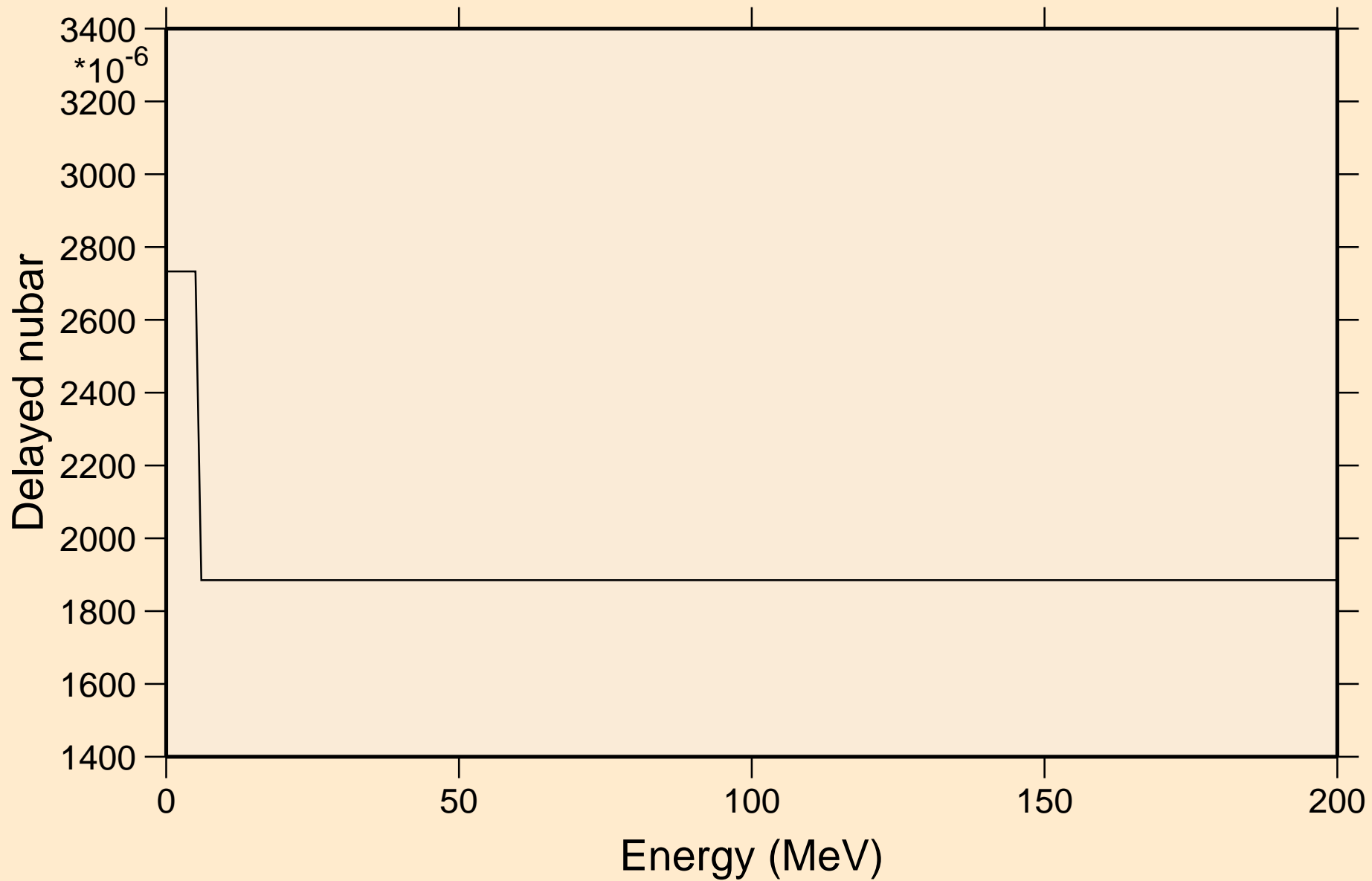

# AT228 NEUTRON ACER TENDL-2023 LIBRARY; T=0.K

## Delayed neutron spectra

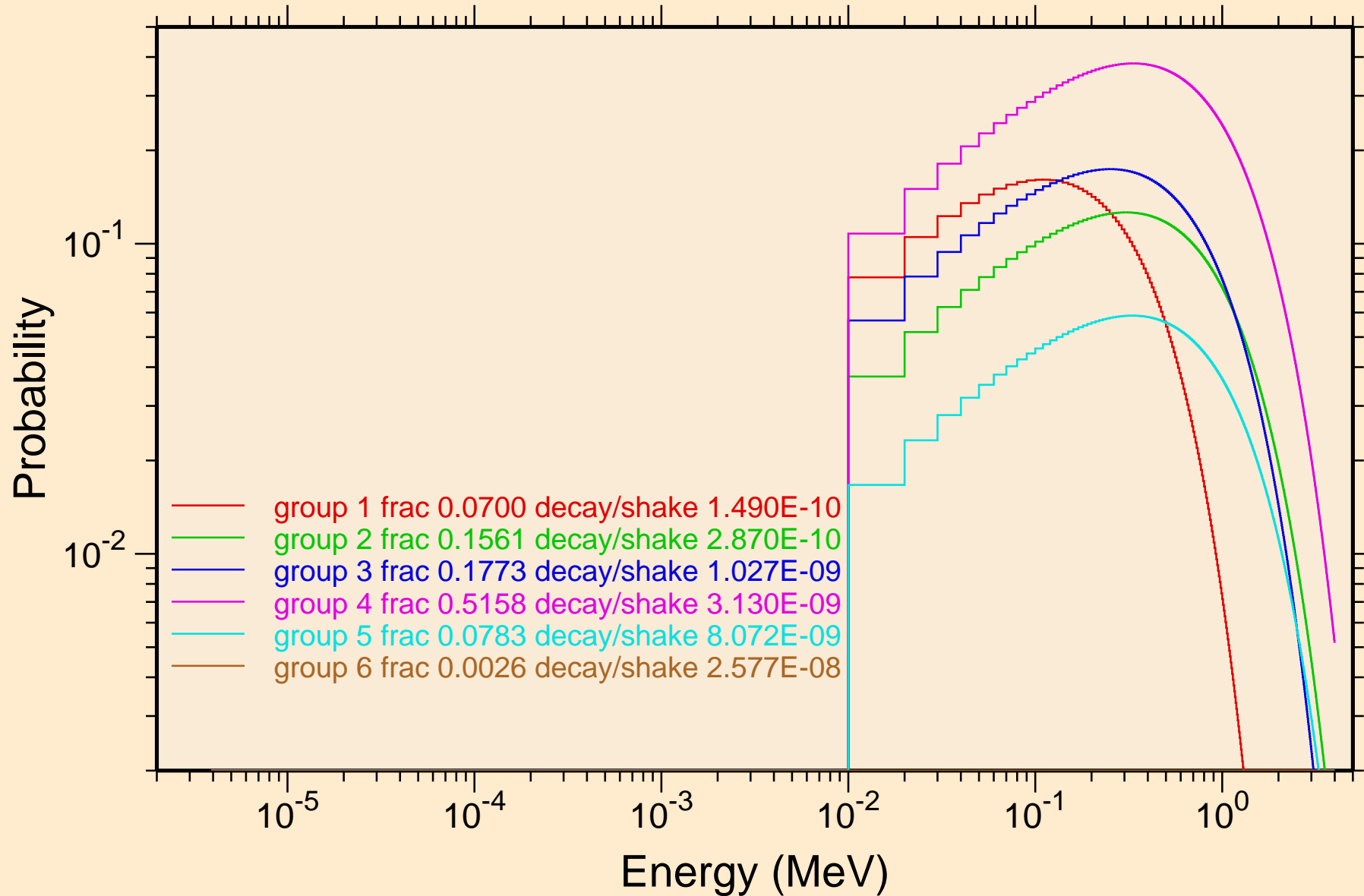

AT228 NEUTRON ACER TENDL-2023 LIBRARY; T=0.K  
Photon emission for (n,x)

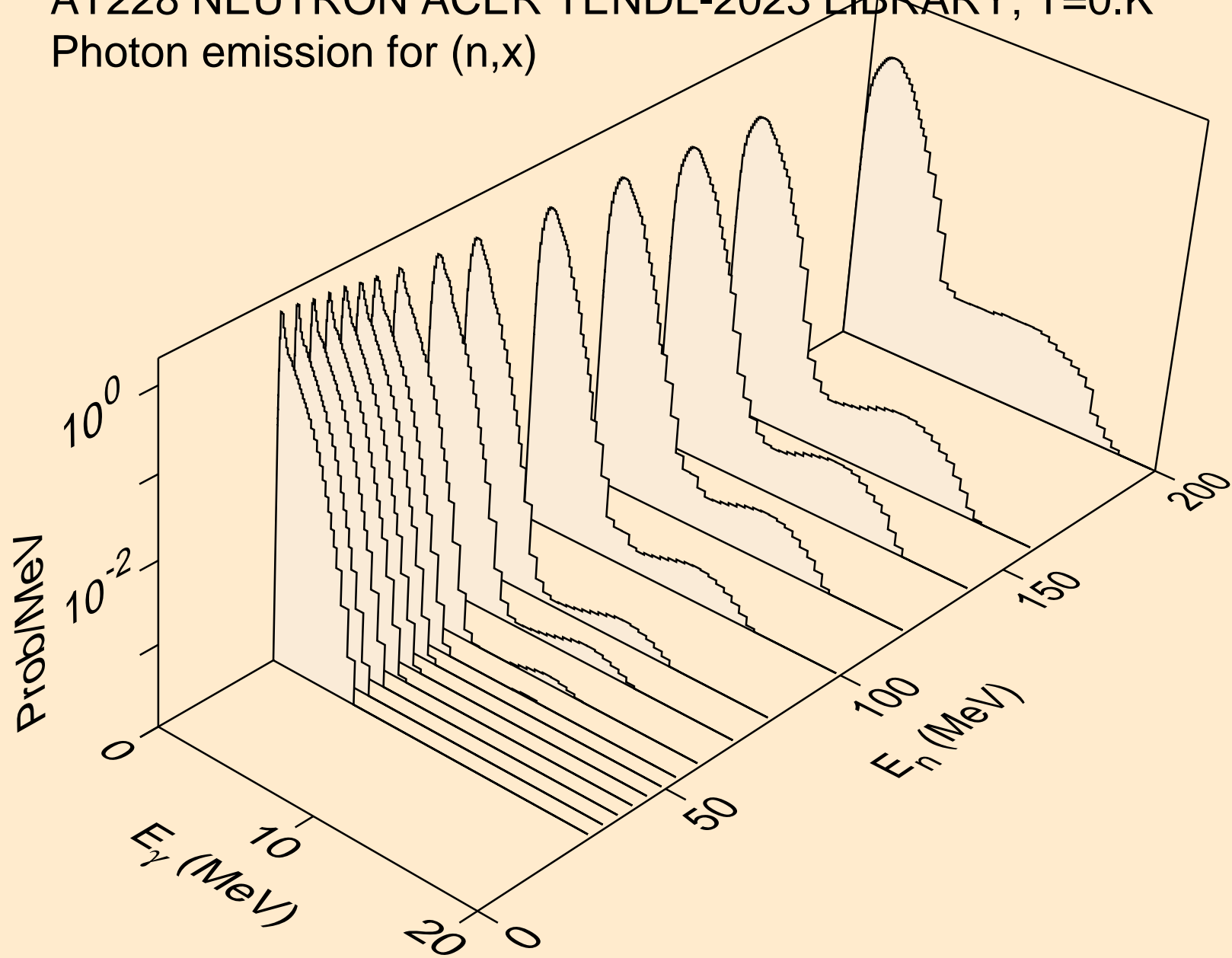

AT228 NEUTRON ACER TENDL-2023 LIBRARY; T=0.K  
Photon emission for (n,2nd)

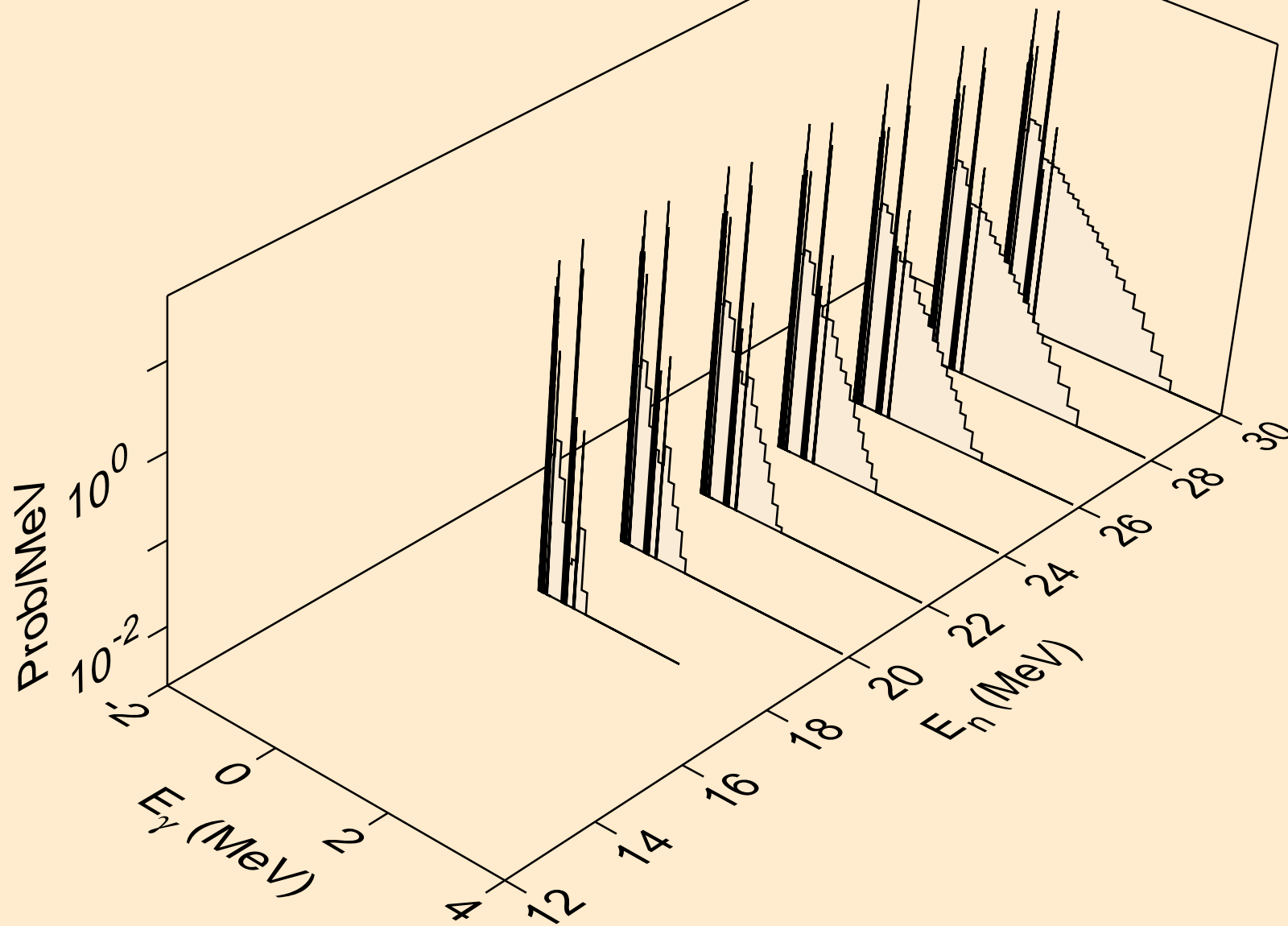

AT228 NEUTRON ACER TENDL-2023 LIBRARY; T=0.K  
Photon emission for (n,2n)

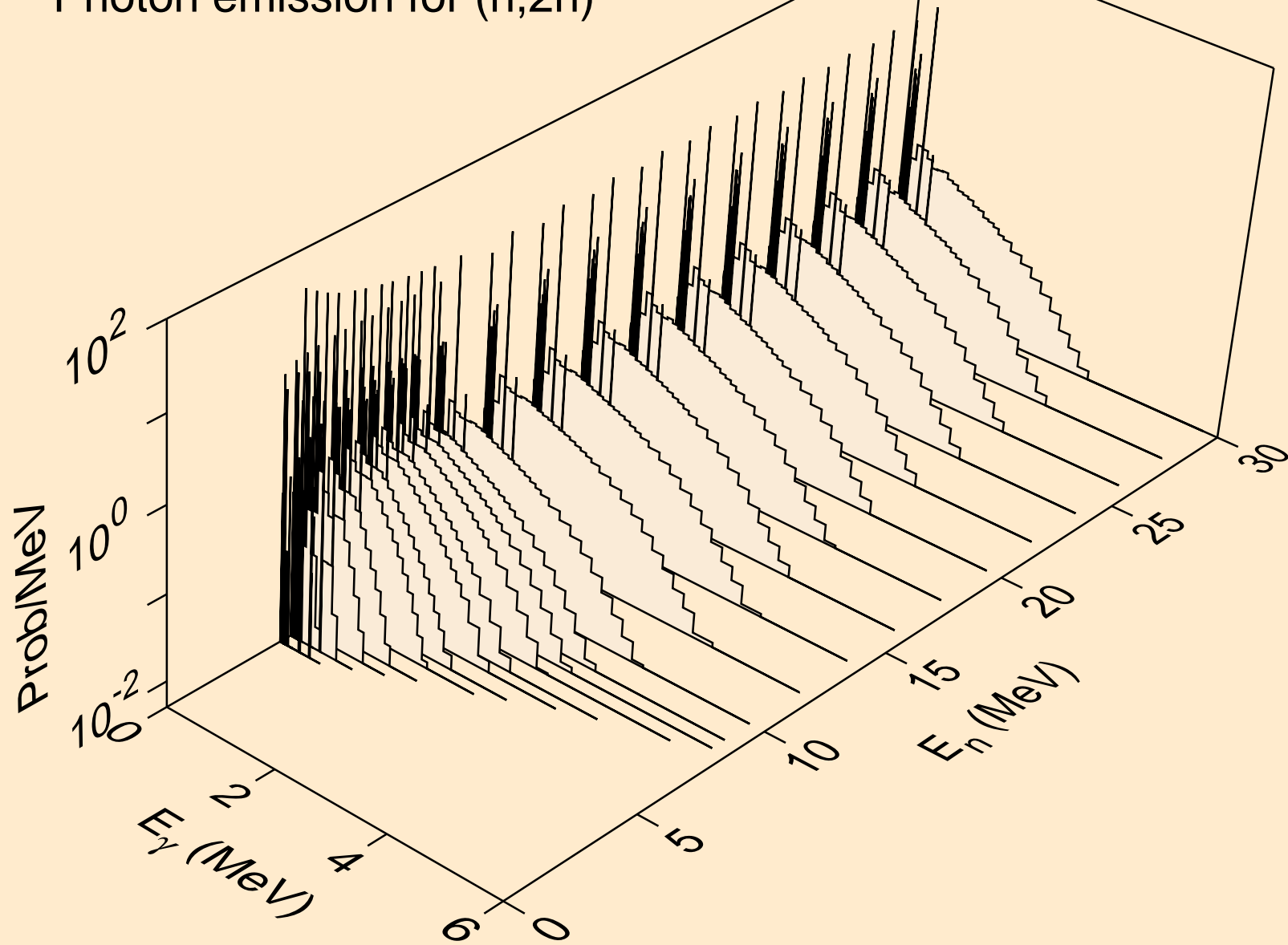

AT228 NEUTRON ACER TENDL-2023 LIBRARY; T=0.K  
Photon emission for (n,3n)

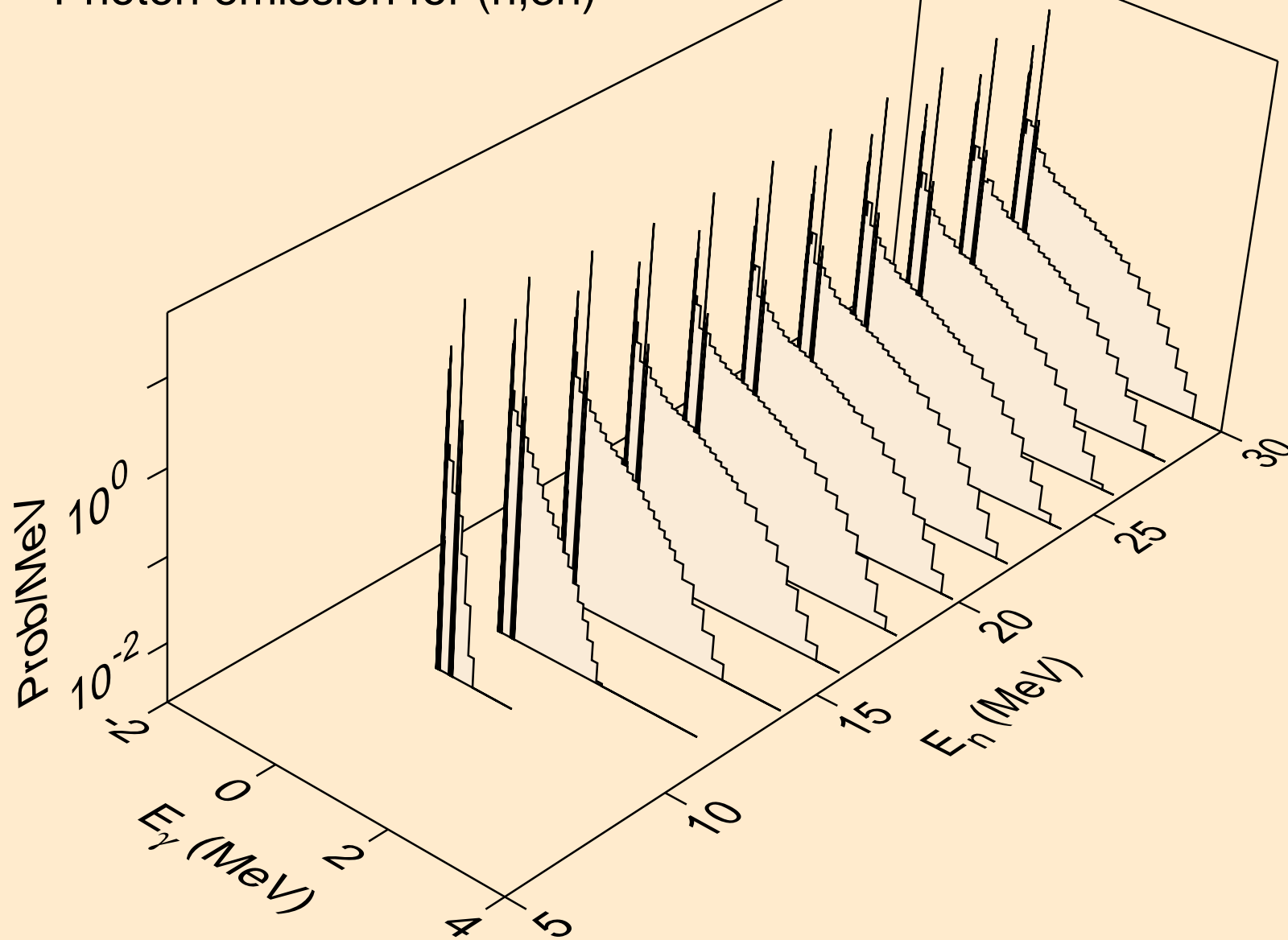

AT228 NEUTRON ACER TENDL-2023 LIBRARY; T=0.K  
Photon emission for (n,n\*)a

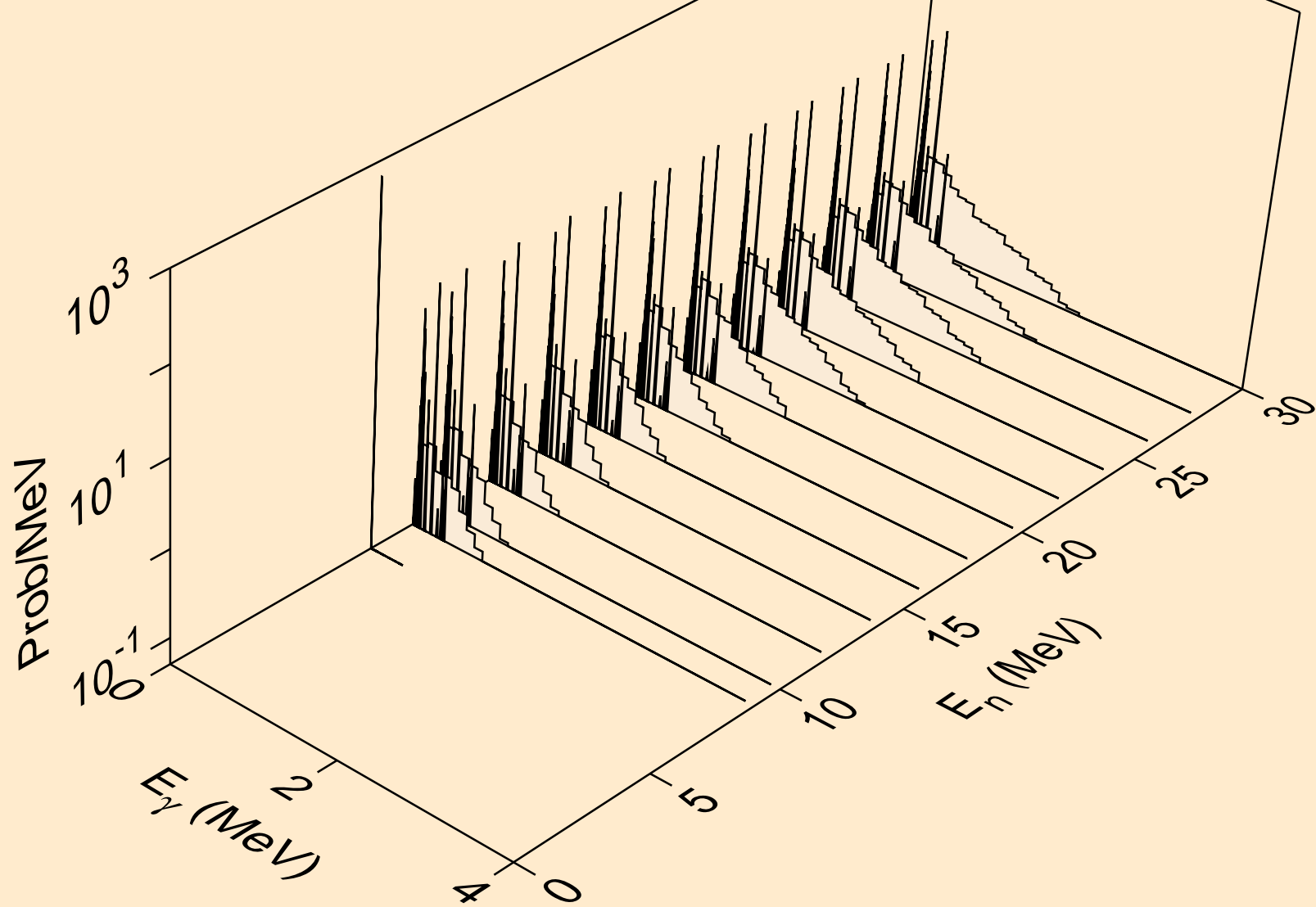

AT228 NEUTRON ACER TENDL-2023 LIBRARY; T=0.K  
Photon emission for (n,2n)a

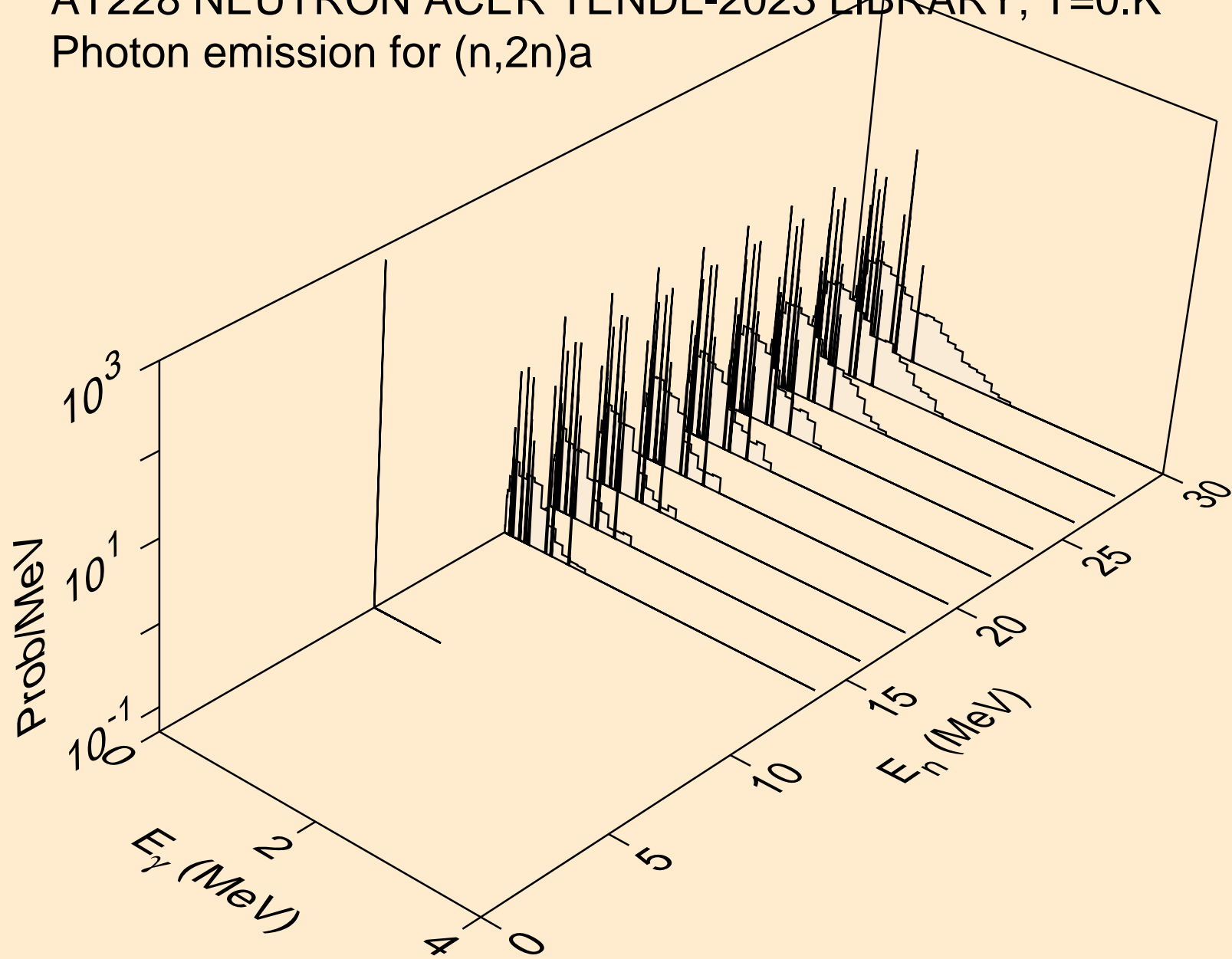

AT228 NEUTRON ACER TENDL-2023 LIBRARY; T=0.K  
Photon emission for (n,3n)a

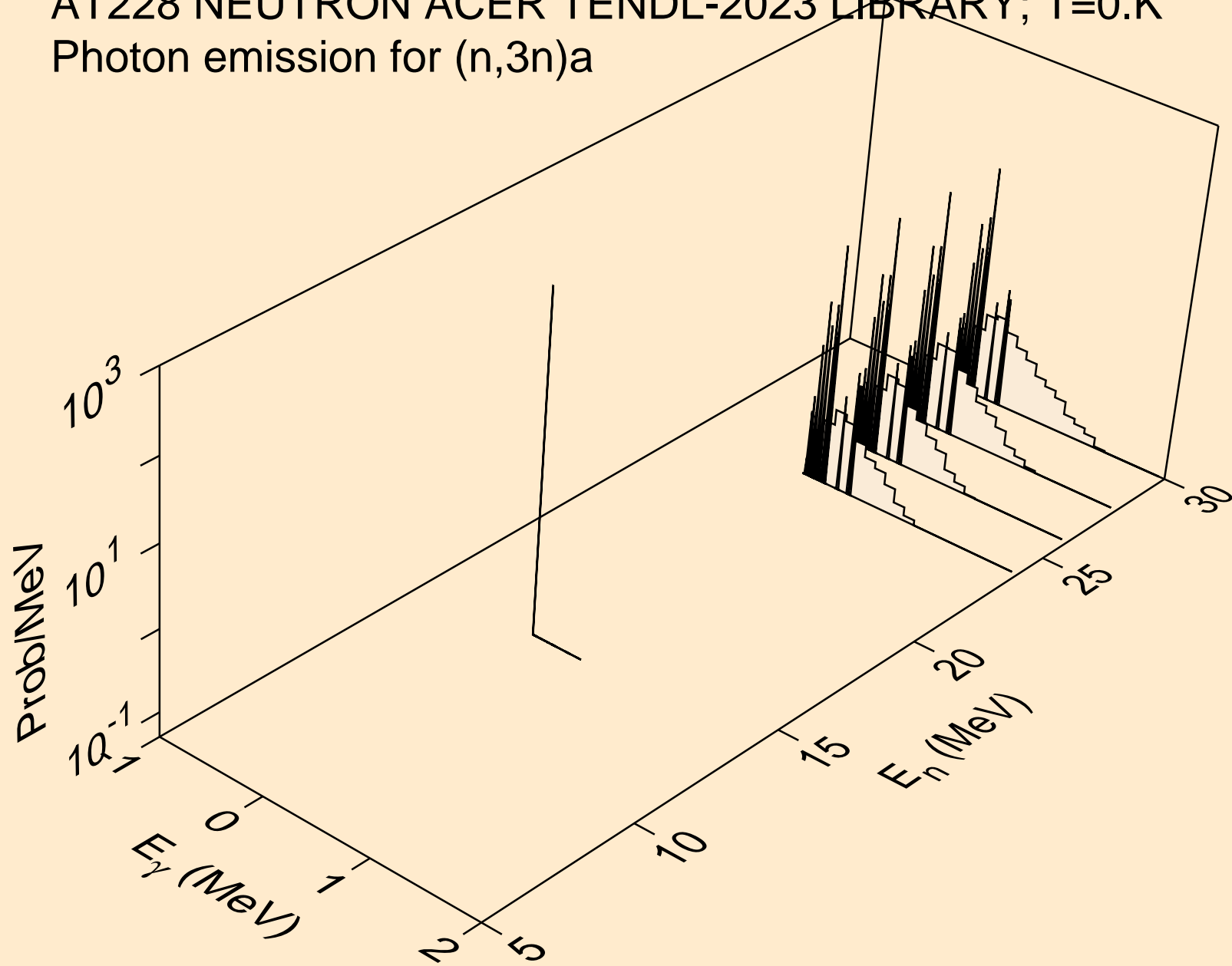

AT228 NEUTRON ACER TENDL-2023 LIBRARY; T=0.K  
Photon emission for (n,n\*)p

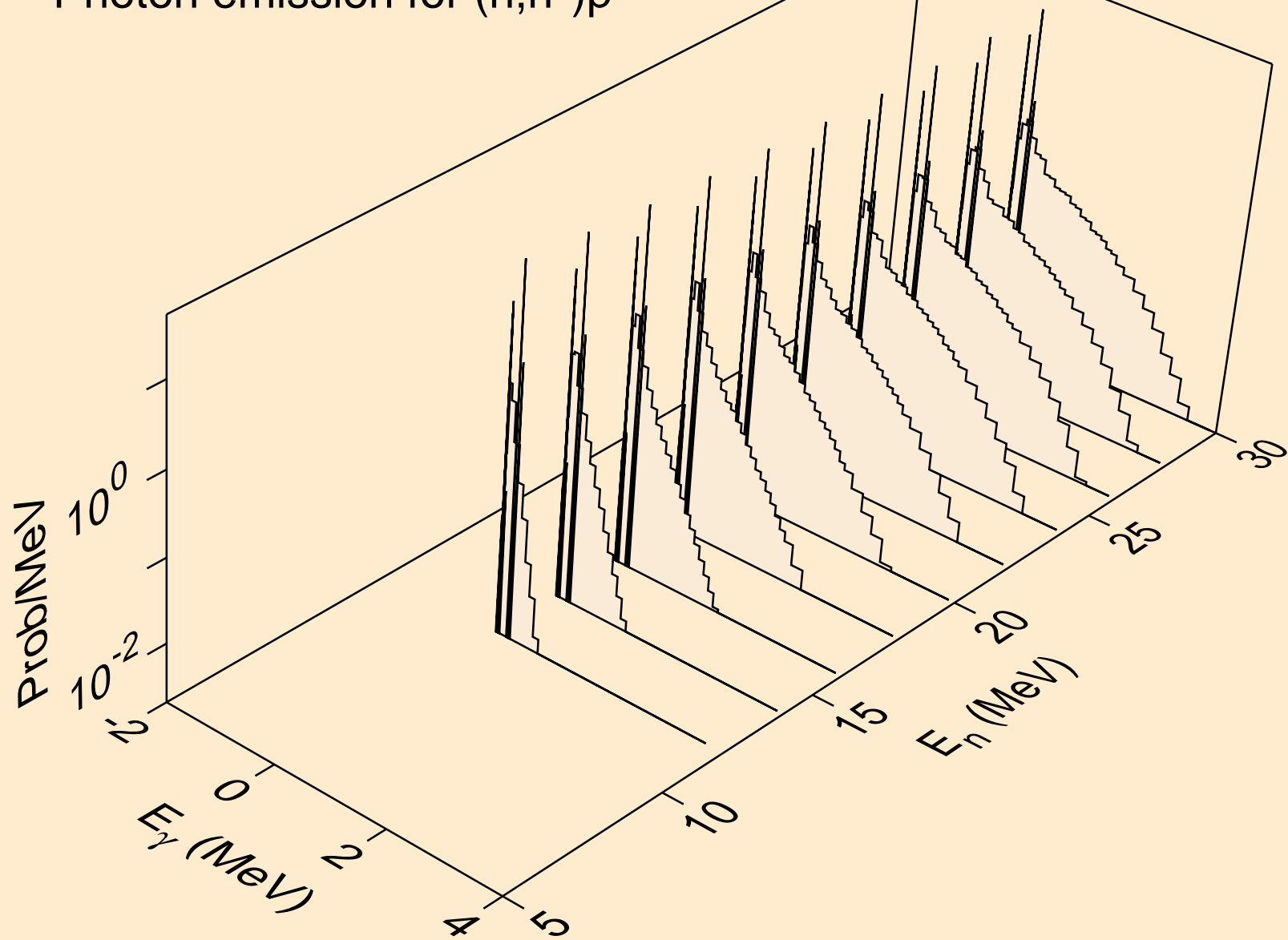

AT228 NEUTRON ACER TENDL-2023 LIBRARY; T=0.K  
Photon emission for (n,n\*)d

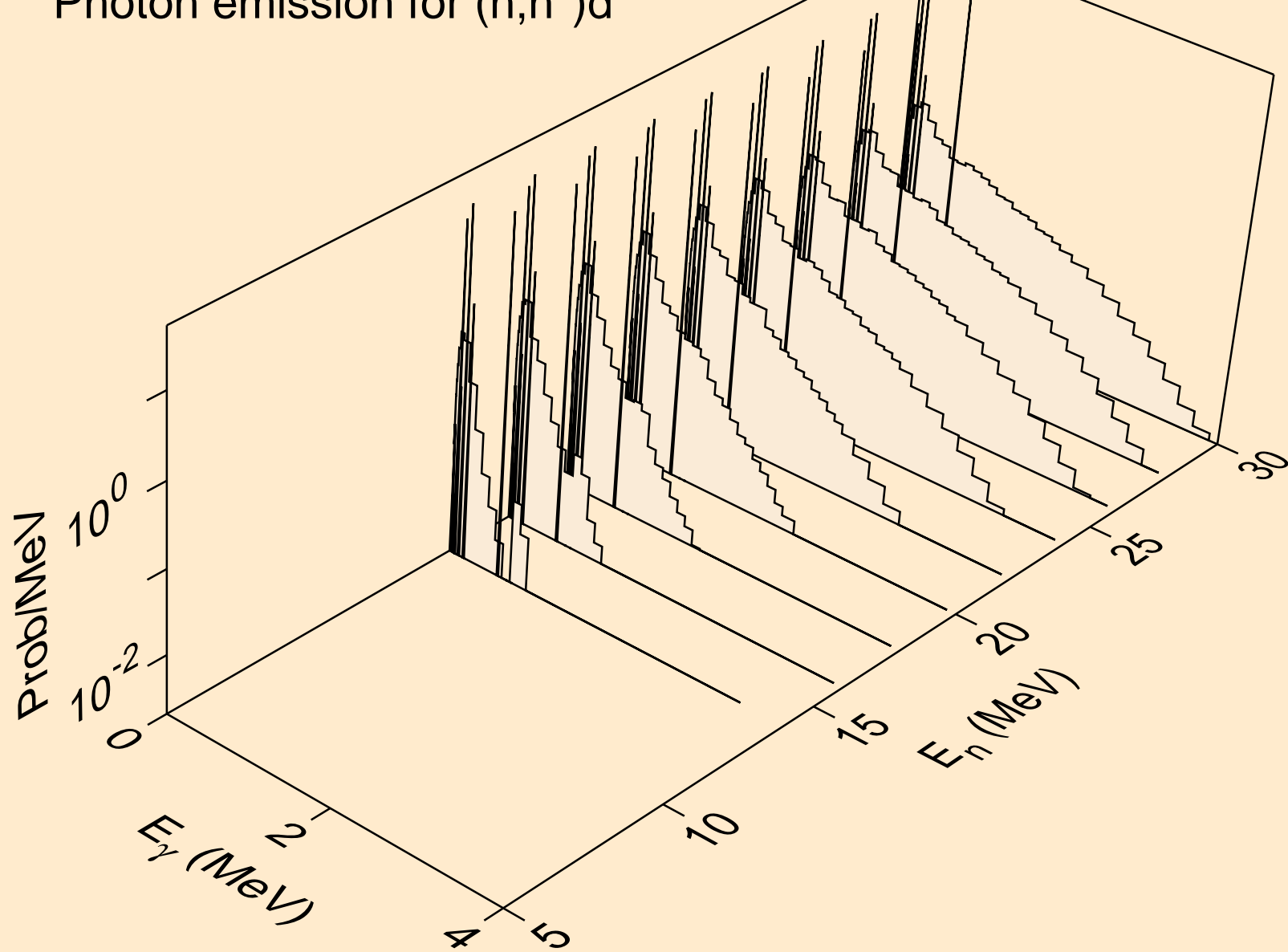

AT228 NEUTRON ACER TENDL-2023 LIBRARY; T=0.K  
Photon emission for (n,n\*)t

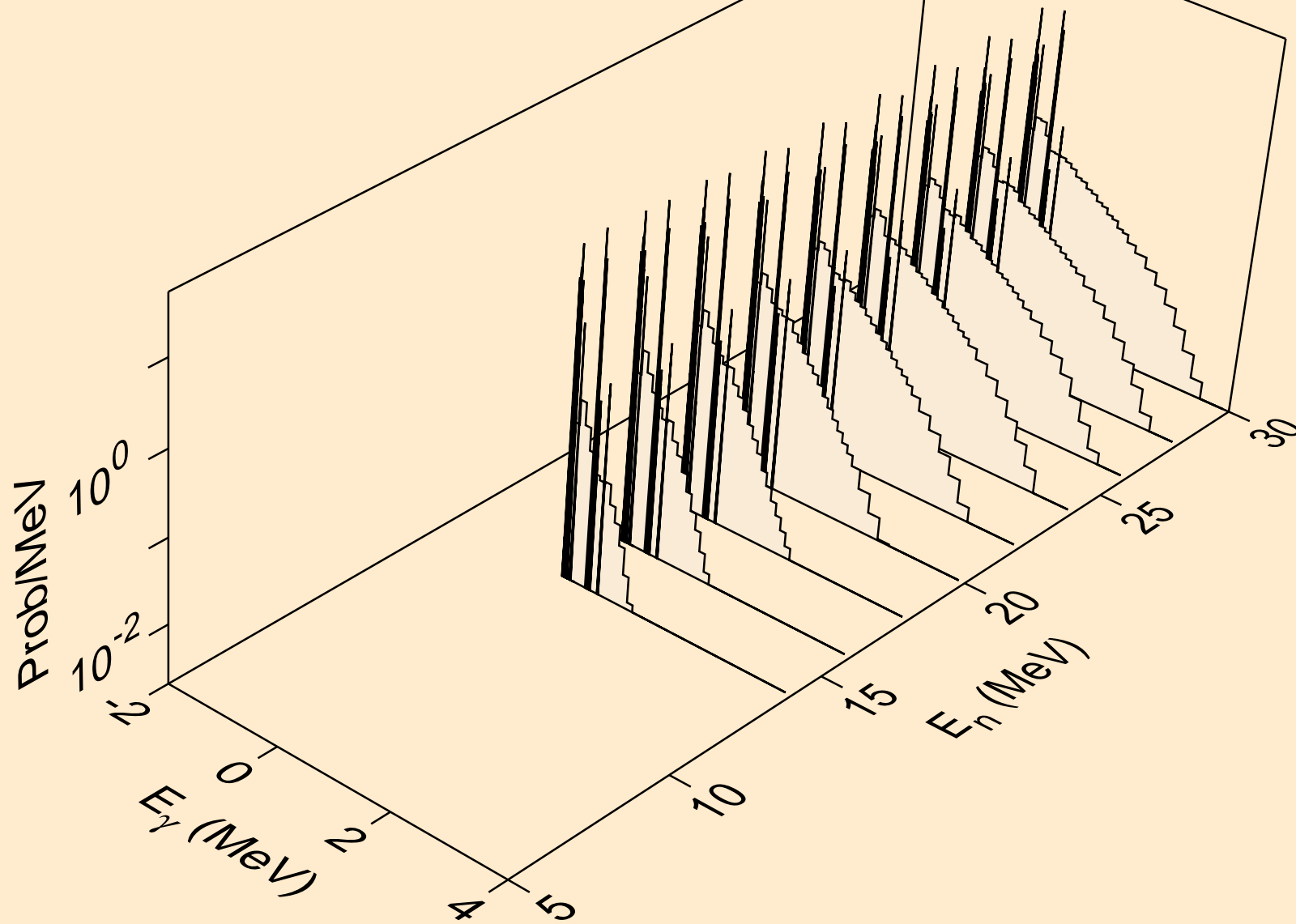

AT228 NEUTRON ACER TENDL-2023 LIBRARY; T=0.K  
Photon emission for (n,n\*)he3

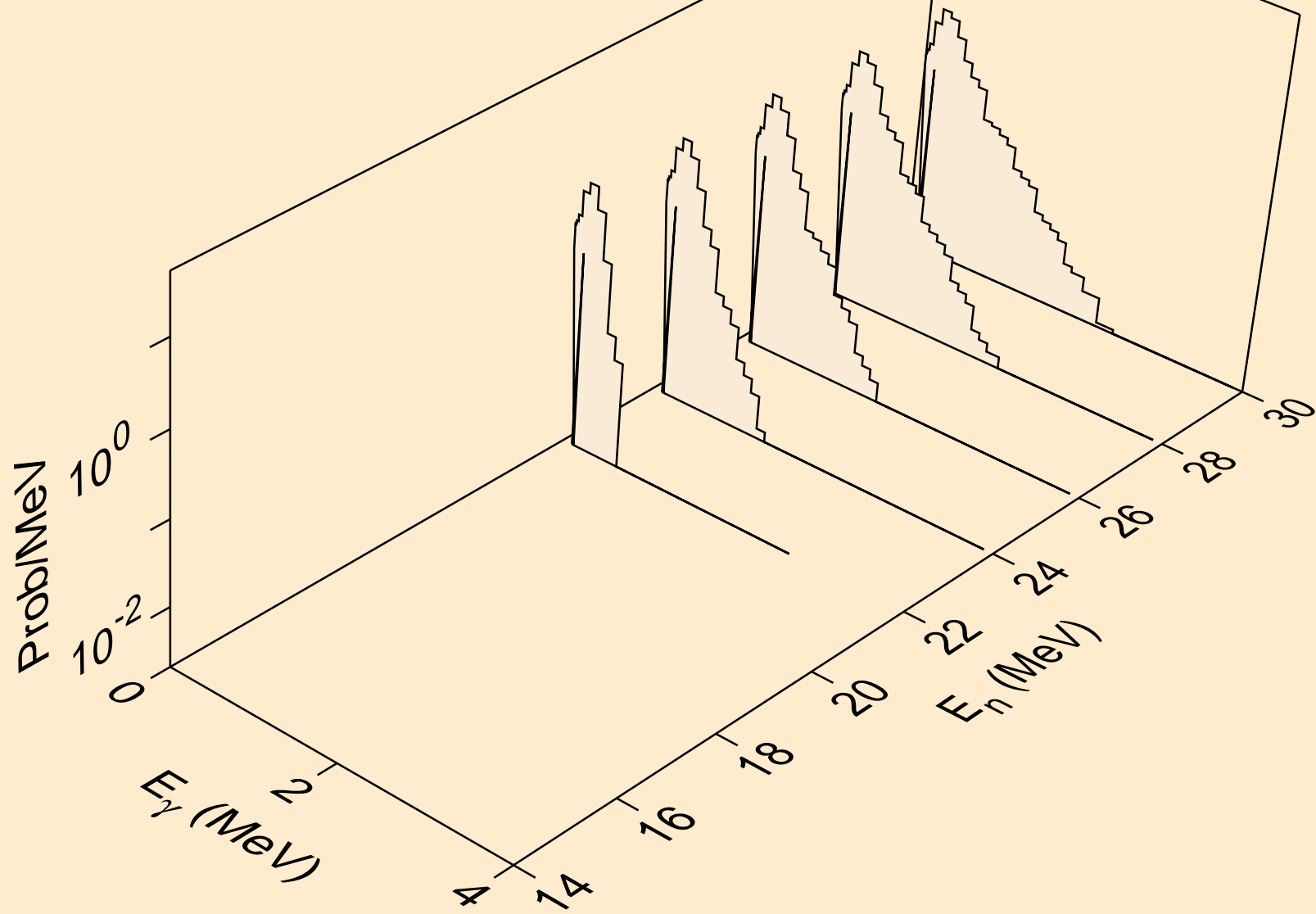

AT228 NEUTRON ACER TENDL-2023 LIBRARY; T=0.K  
Photon emission for (n,4n)

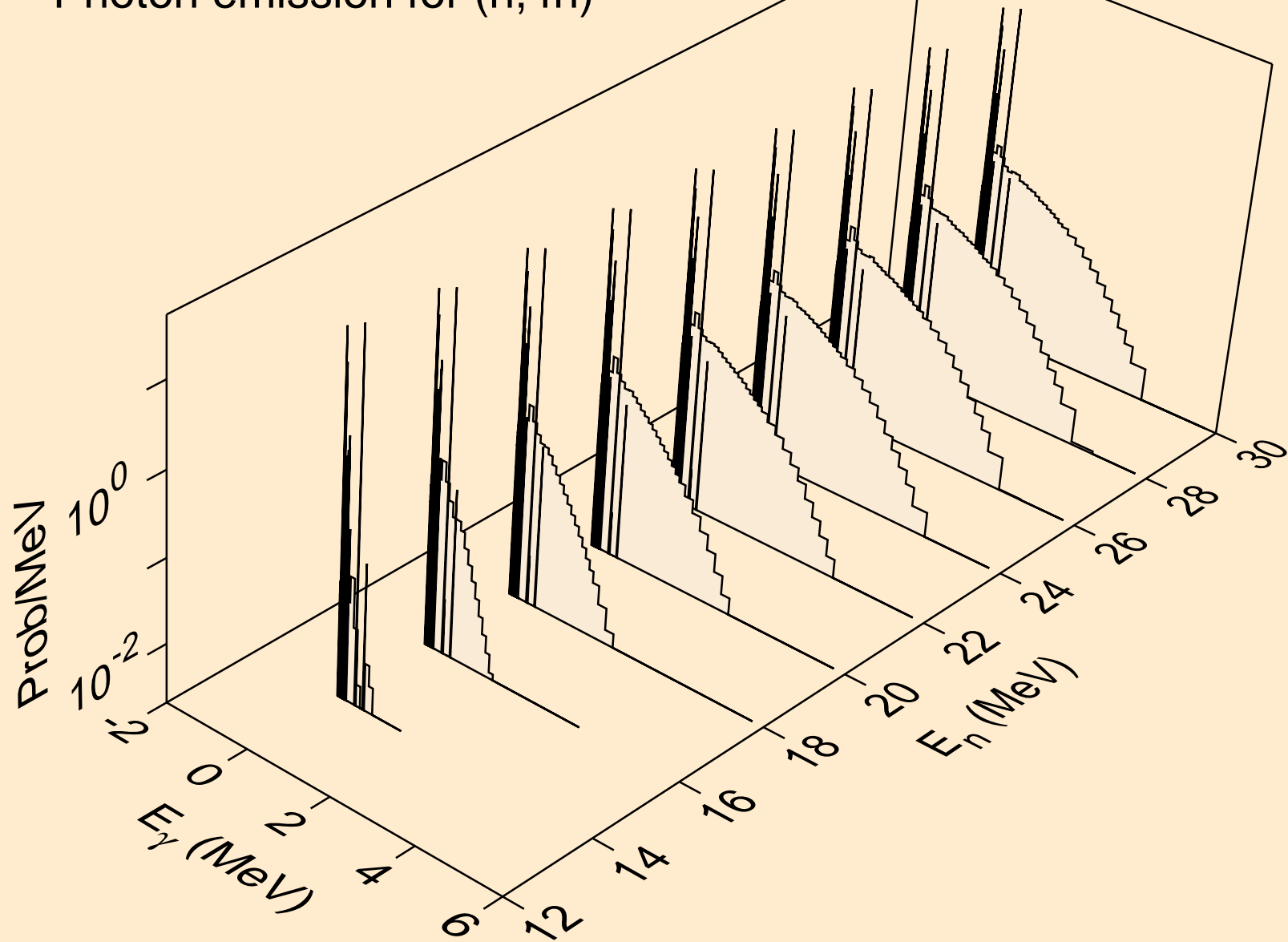

AT228 NEUTRON ACER TENDL-2023 LIBRARY; T=0.K  
Photon emission for (n,2np)

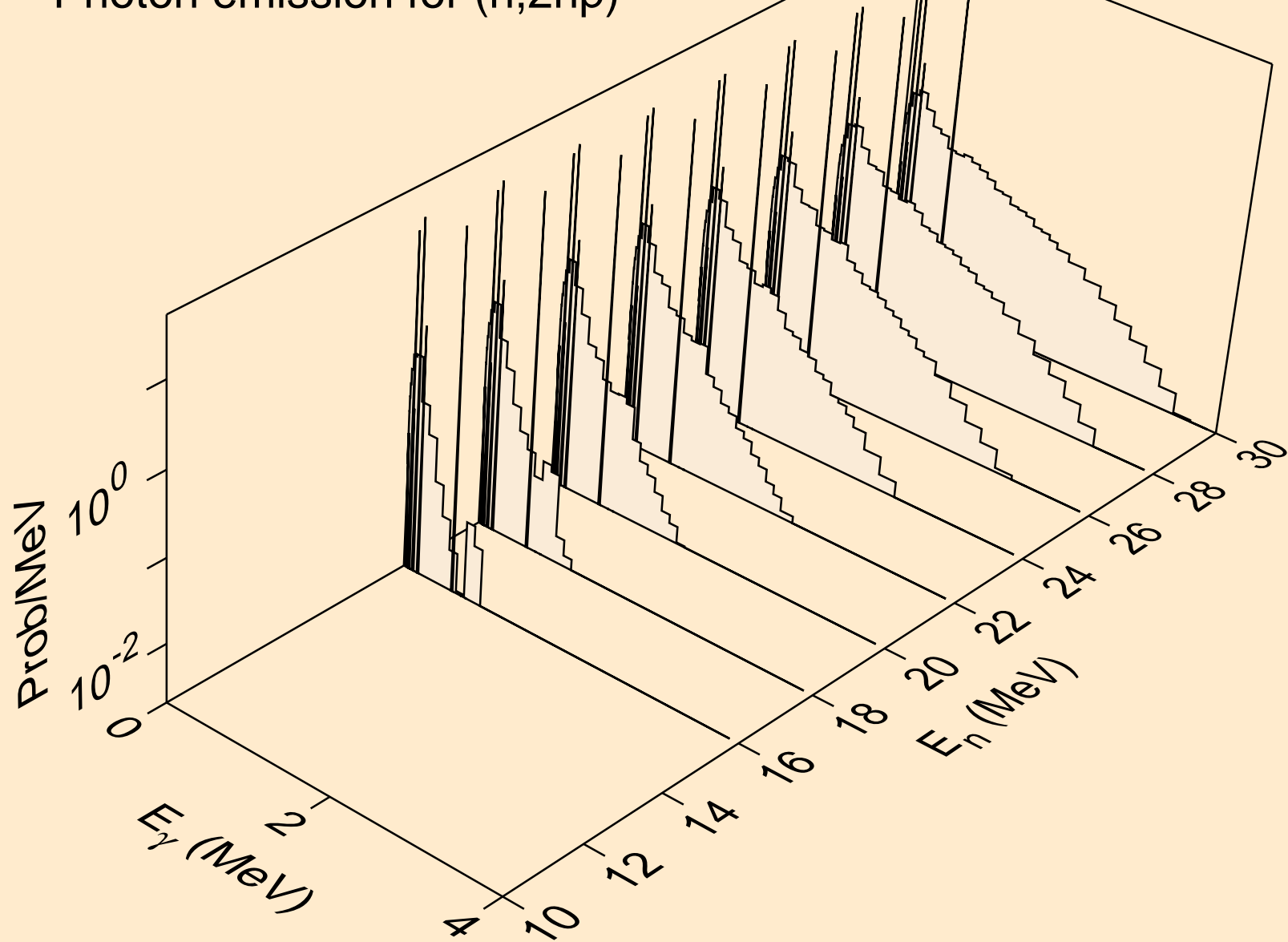

AT228 NEUTRON ACER TENDL-2023 LIBRARY; T=0.K  
Photon emission for (n,3np)

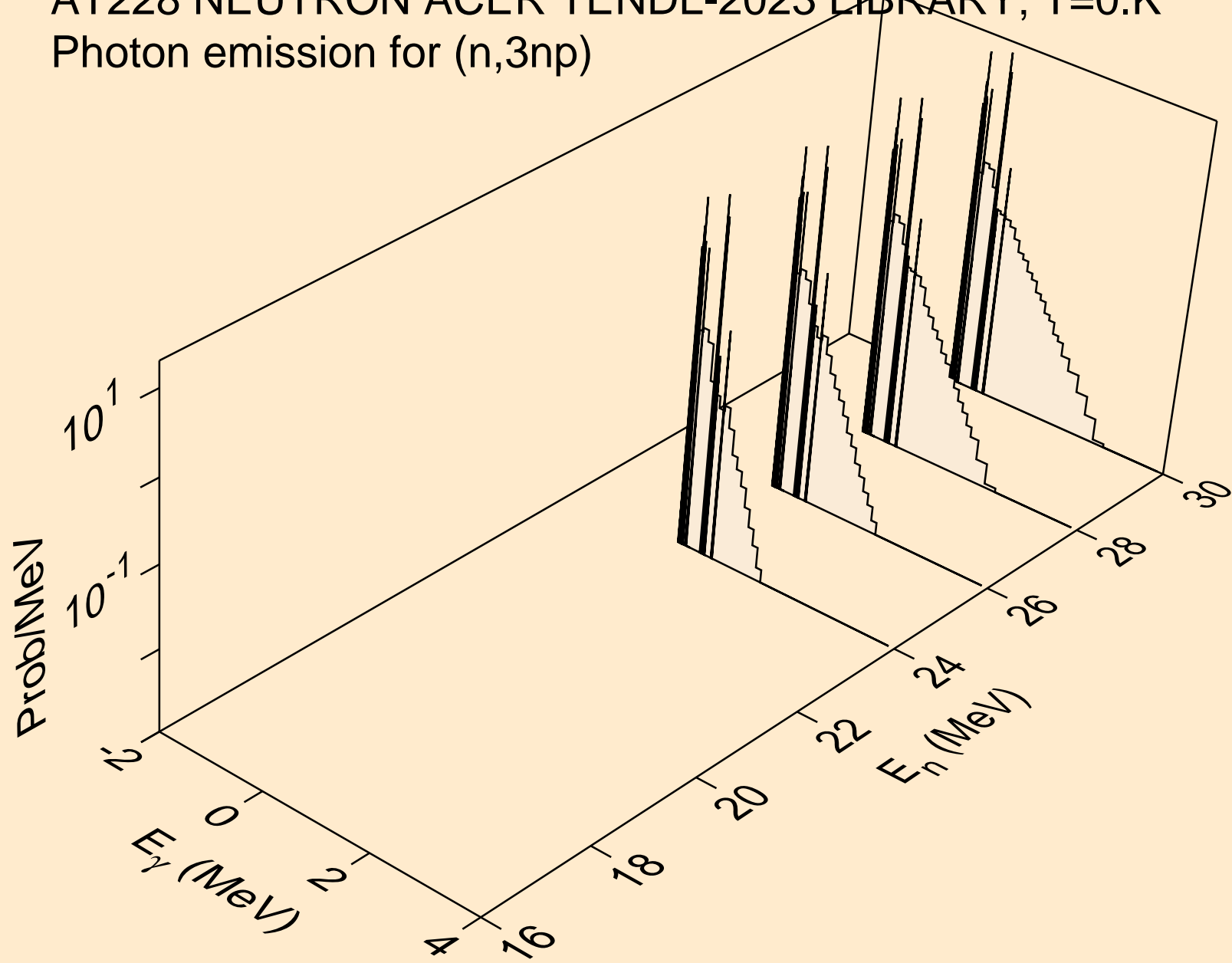

AT228 NEUTRON ACER TENDL-2023 LIBRARY; T=0.K  
Photon emission for (n,n\*c)

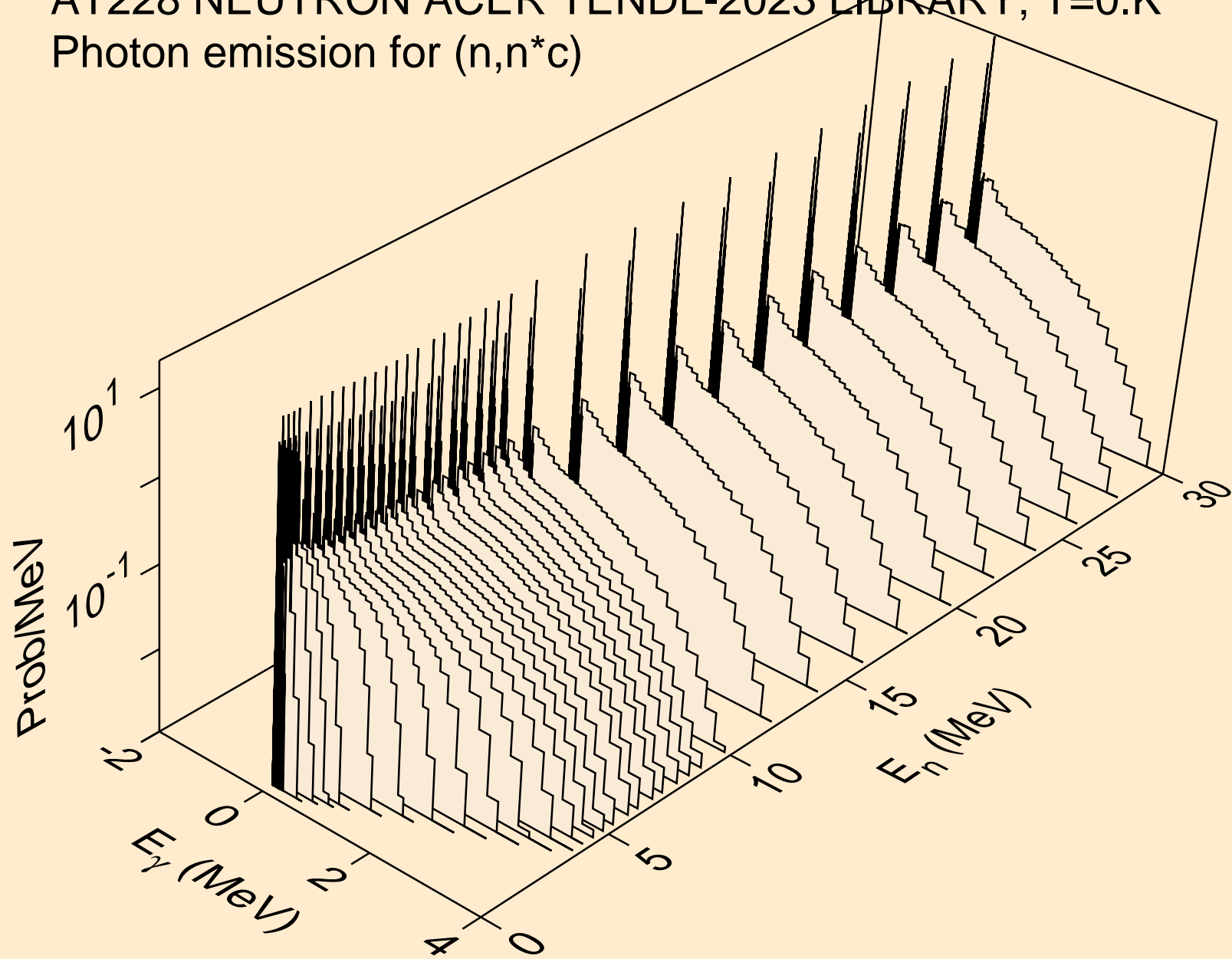

AT228 NEUTRON ACER TENDL-2023 LIBRARY; T=0.K  
Photon emission for (n,gma)

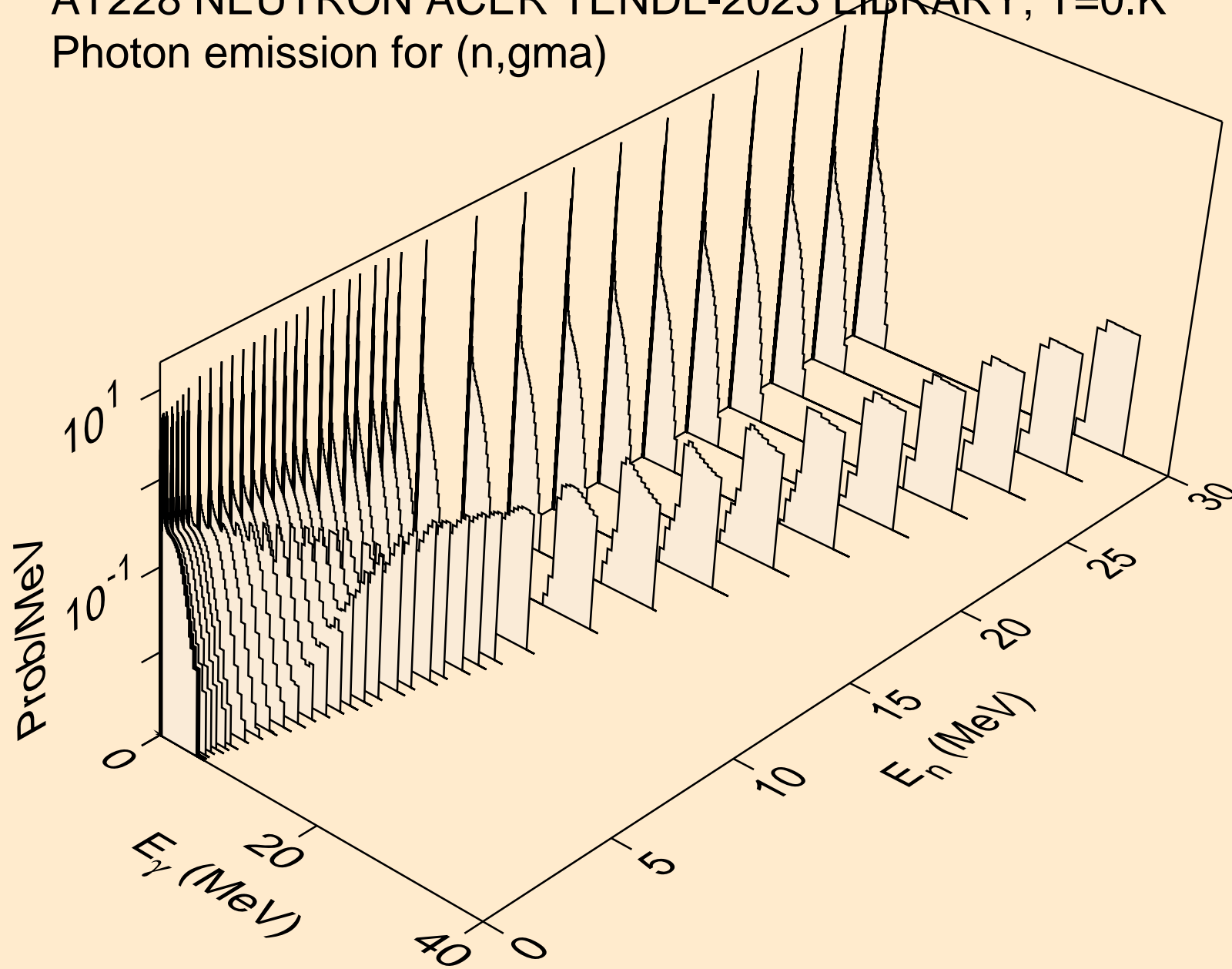

AT228 NEUTRON ACER TENDL-2023 LIBRARY; T=0.K  
Photon emission for (n,p)

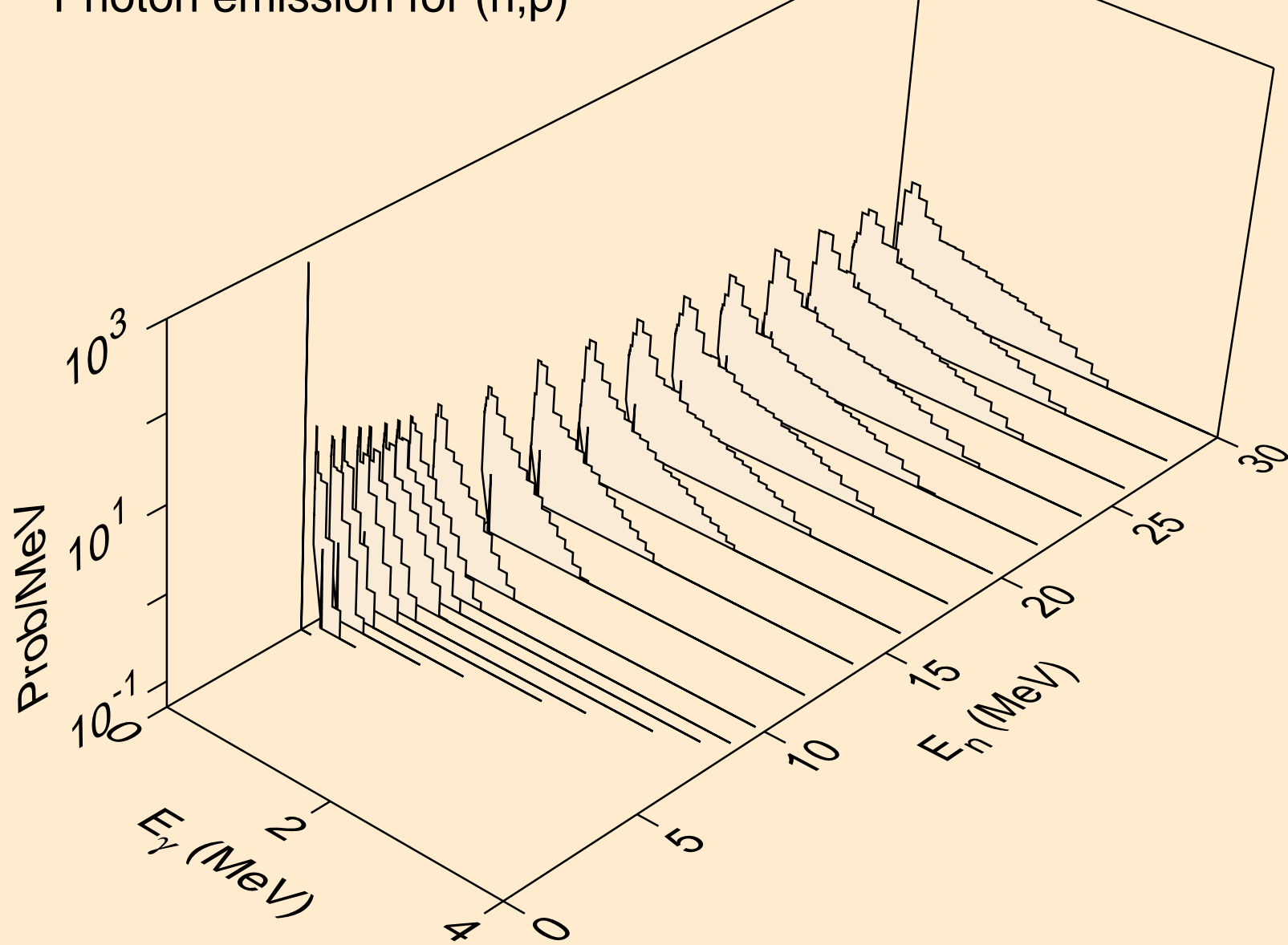

AT228 NEUTRON ACER TENDL-2023 LIBRARY; T=0.K  
Photon emission for (n,d)

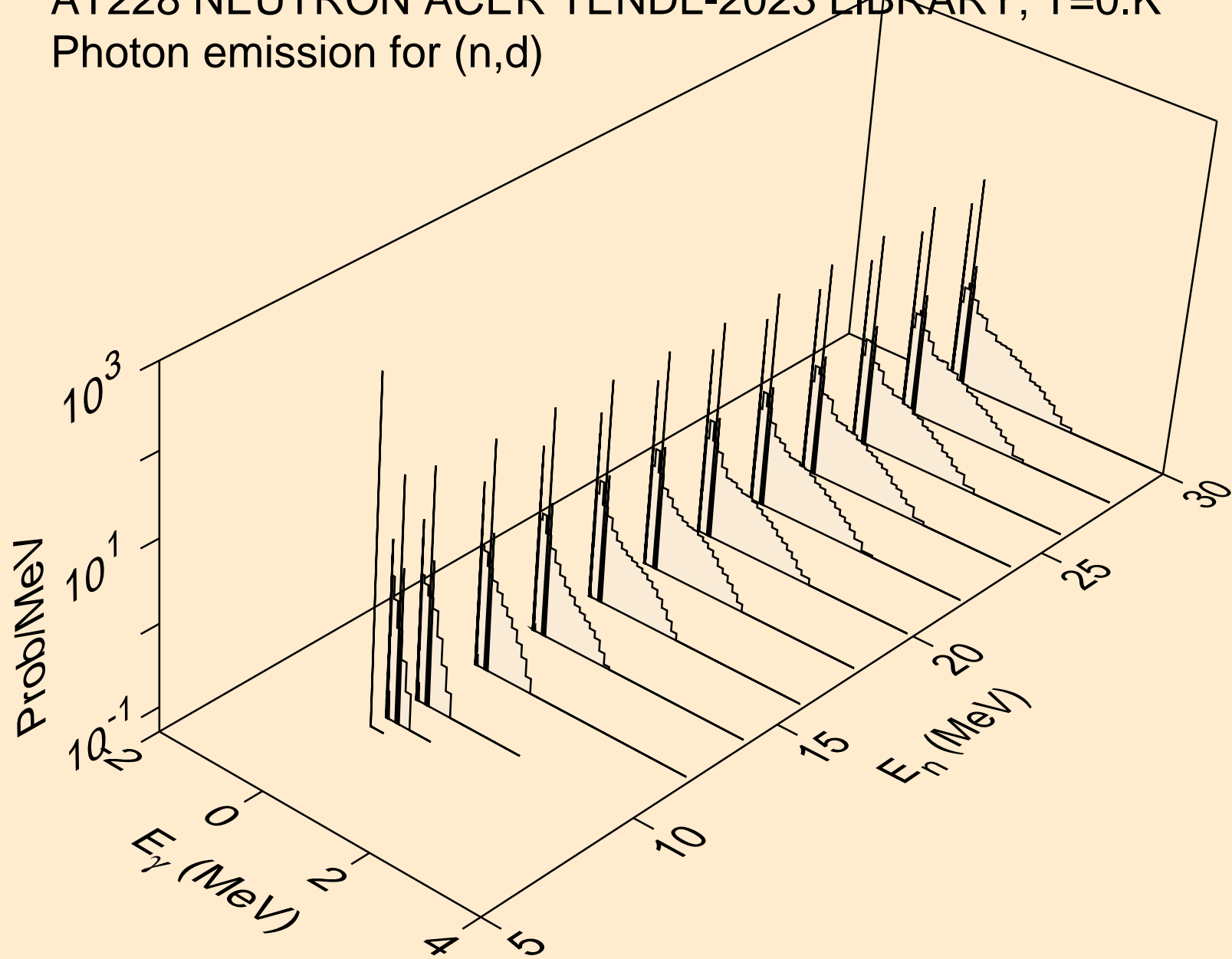

AT228 NEUTRON ACER TENDL-2023 LIBRARY; T=0.K  
Photon emission for (n,t)

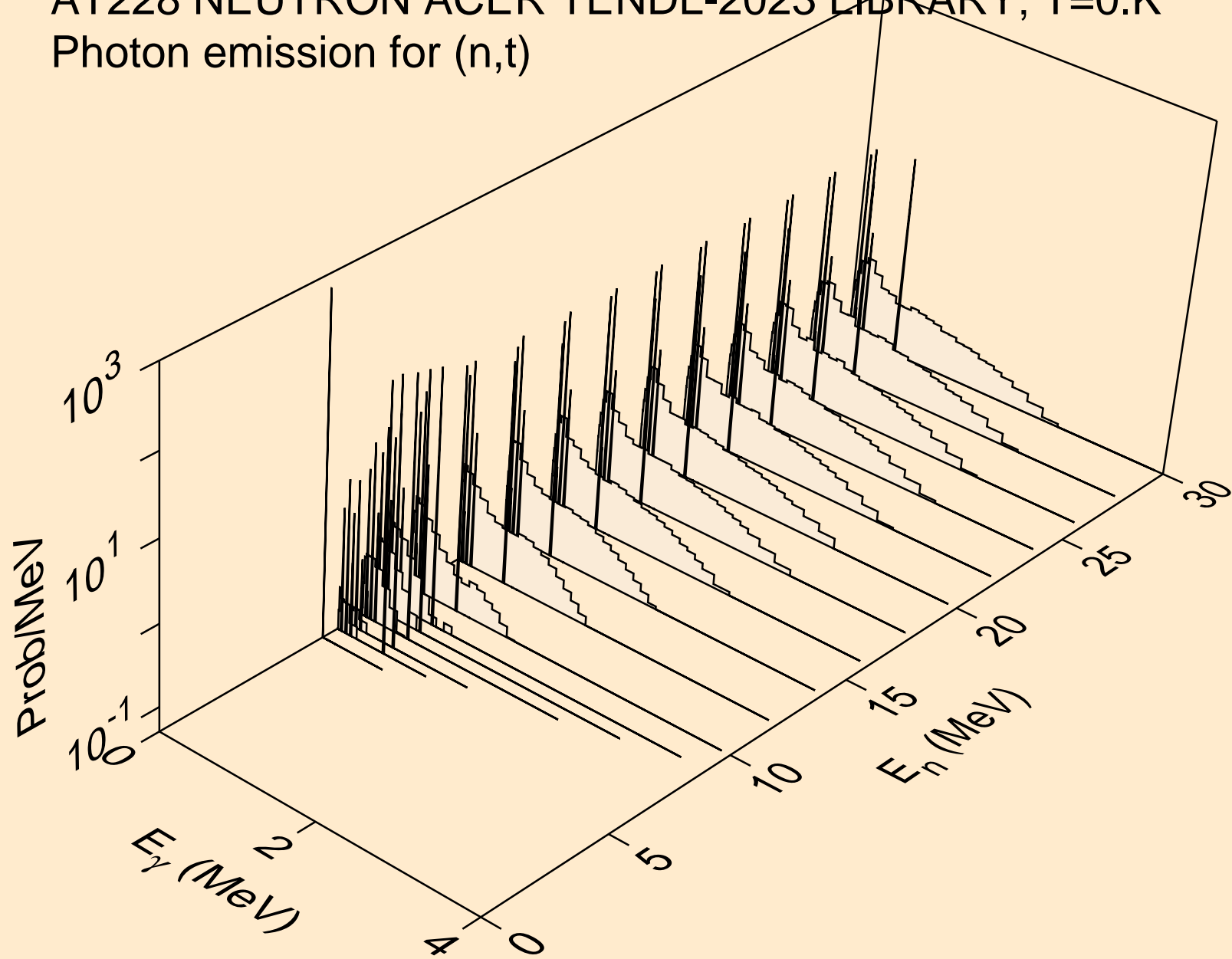

AT228 NEUTRON ACER TENDL-2023 LIBRARY; T=0.K  
Photon emission for (n,he3)

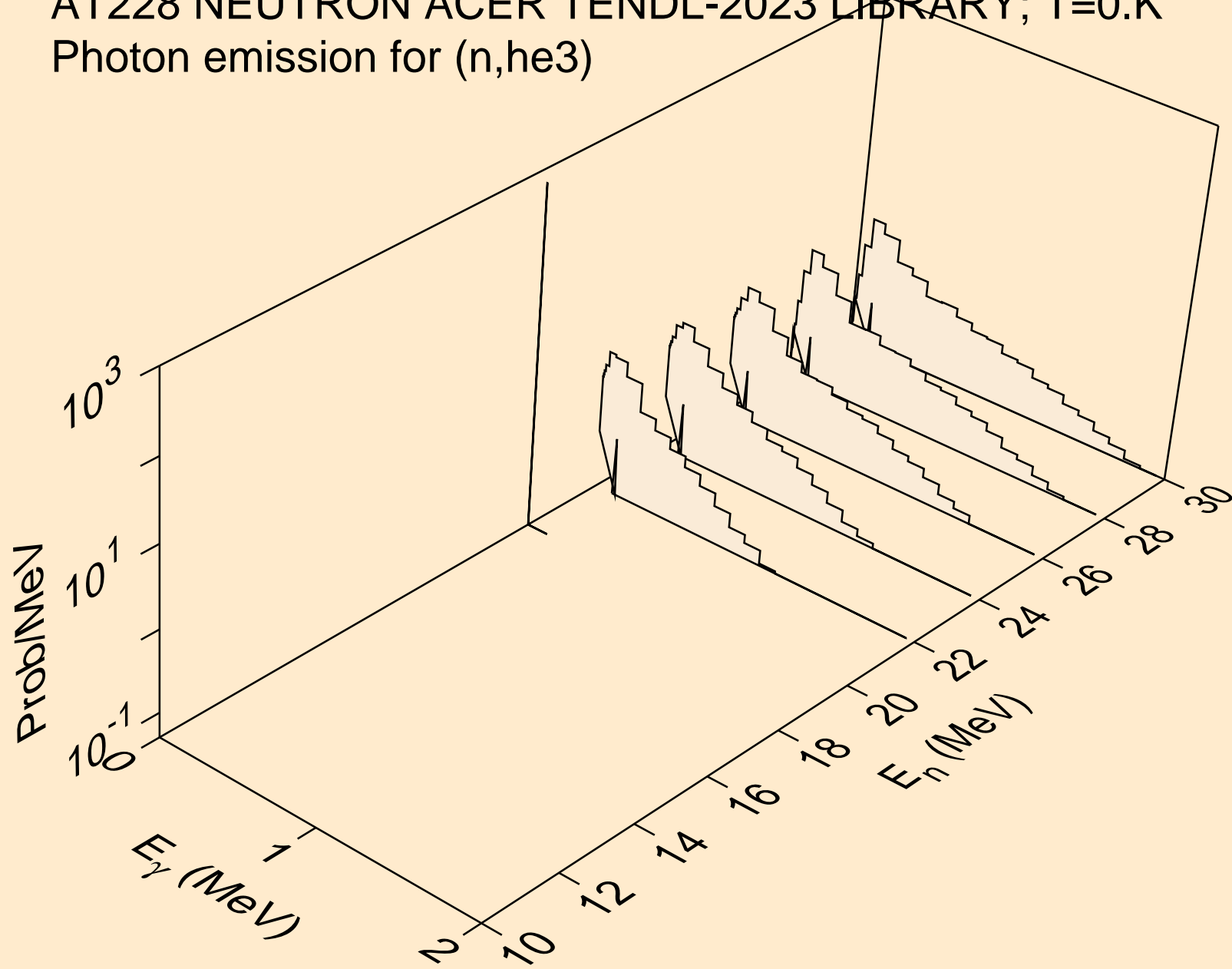

AT228 NEUTRON ACER TENDL-2023 LIBRARY; T=0.K  
Photon emission for (n,a)

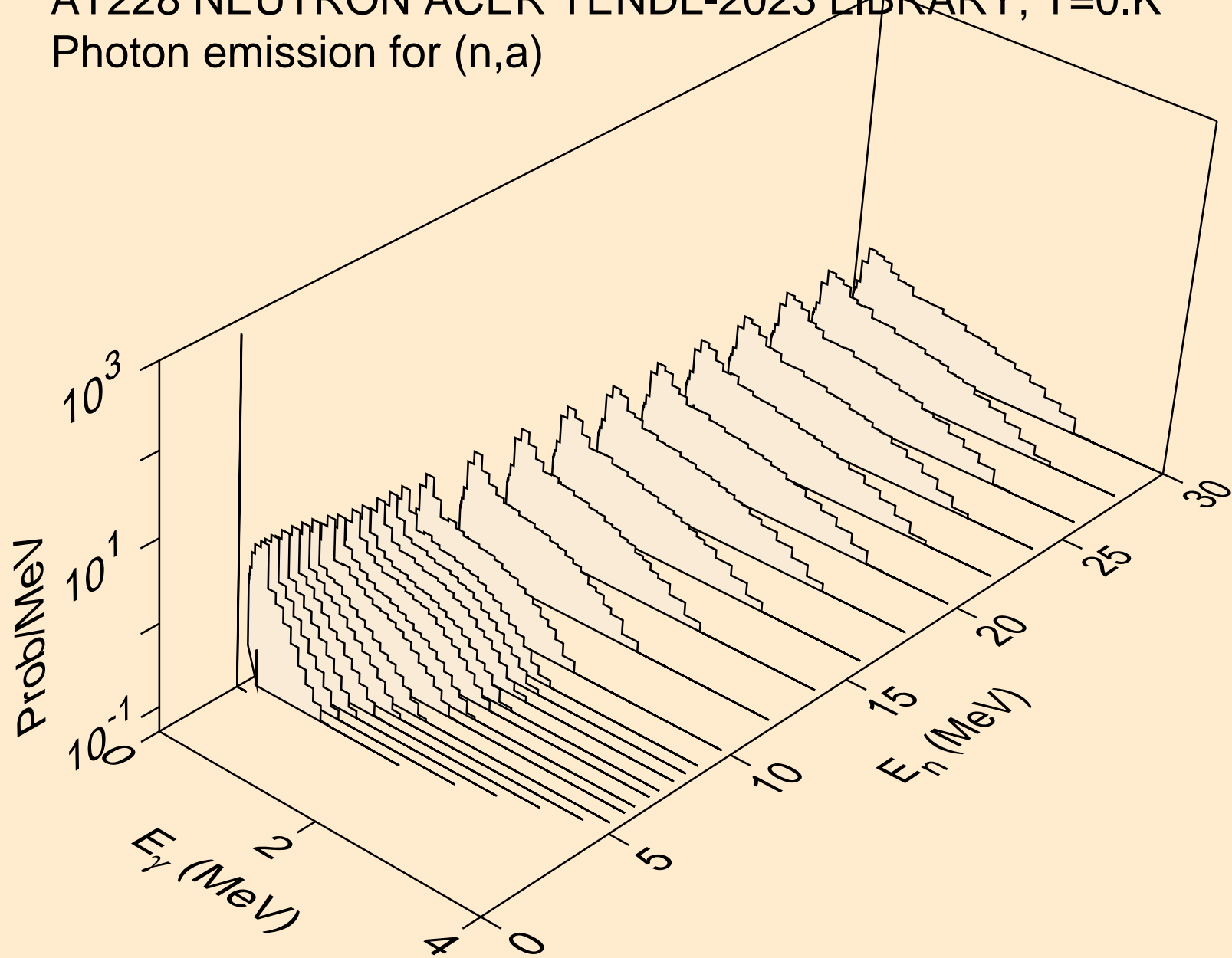

AT228 NEUTRON ACER TENDL-2023 LIBRARY; T=0.K  
thermal capture photon spectrum

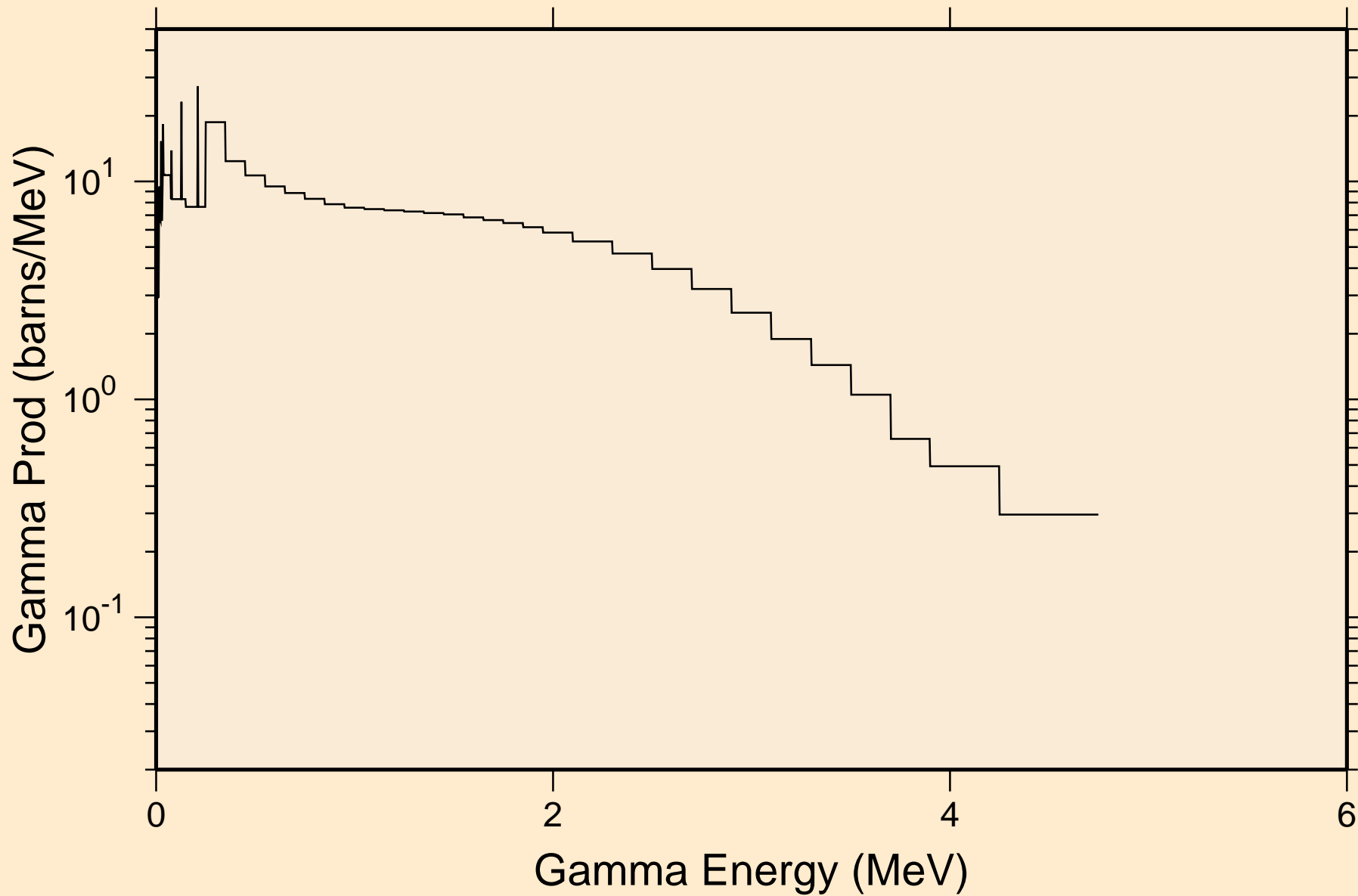

AT228 NEUTRON ACER TENDL-2023 LIBRARY; T=0.K  
14 MeV photon spectrum

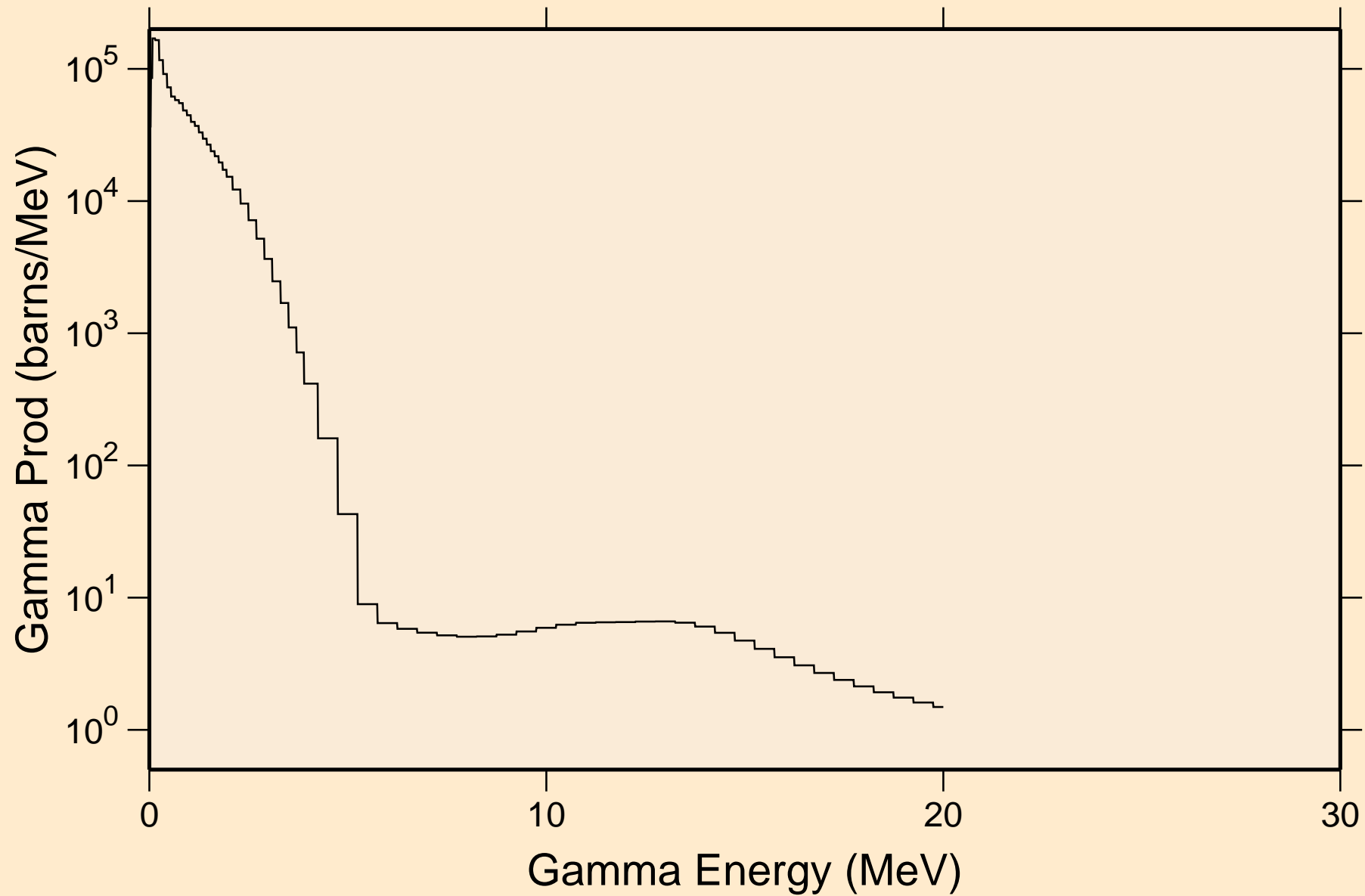

# AT228 NEUTRON ACER TENDL-2023 LIBRARY; T=0.K

## Particle heating contributions

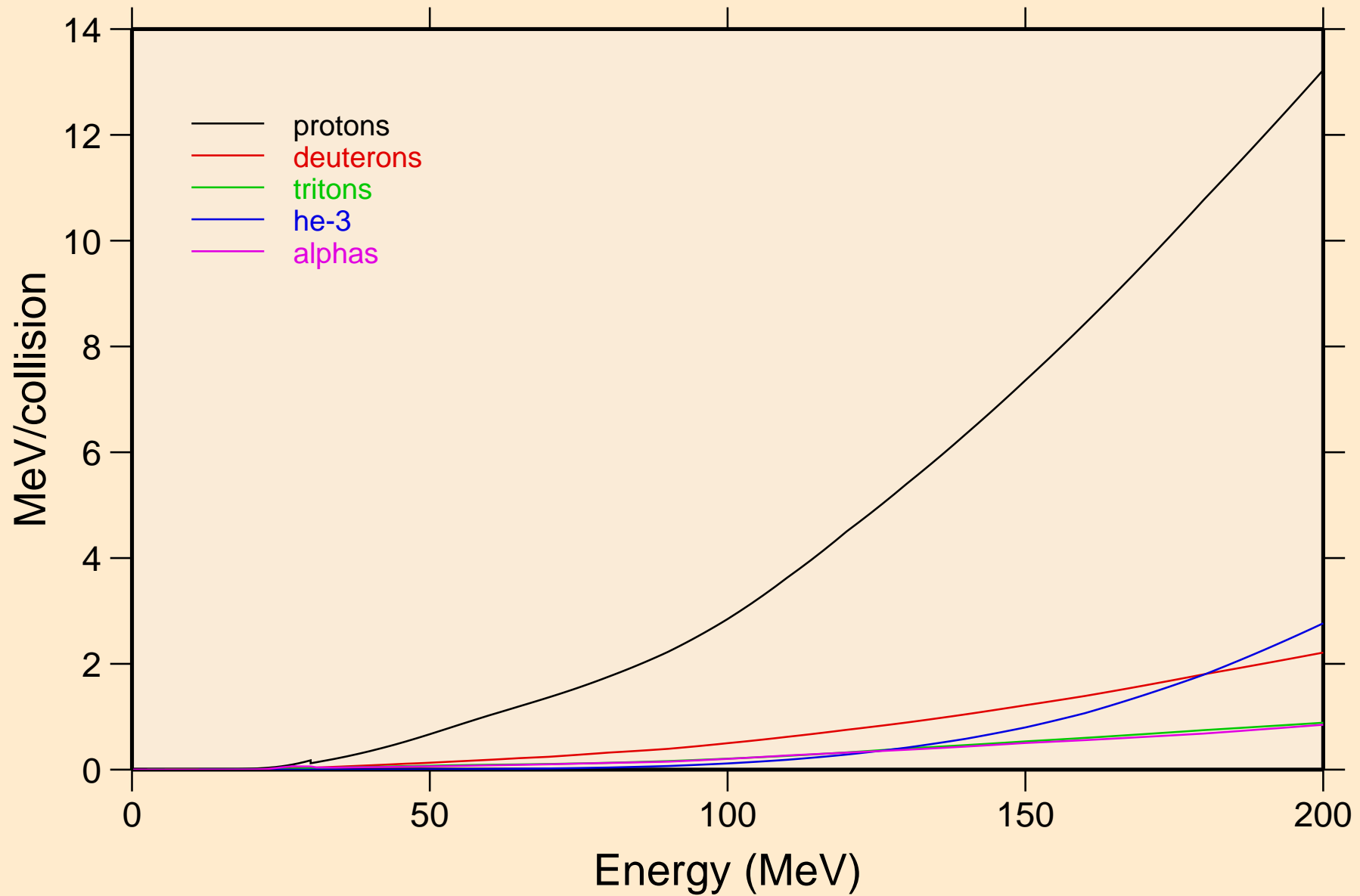

AT228 NEUTRON ACER TENDL-2023 LIBRARY; T=0.K  
Recoil Heating

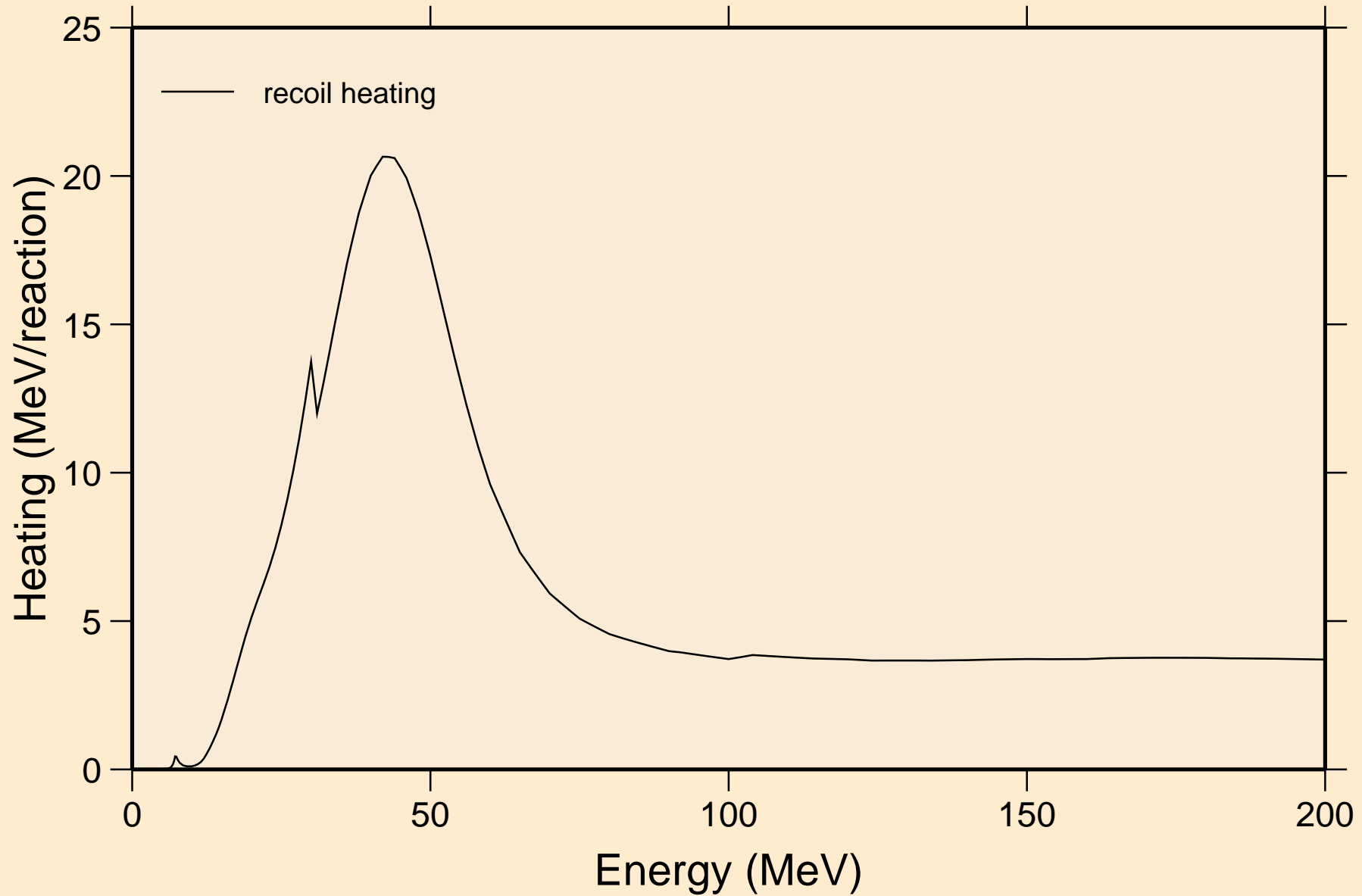

AT228 NEUTRON ACER TENDL-2023 LIBRARY; T=0.K  
Particle production cross sections

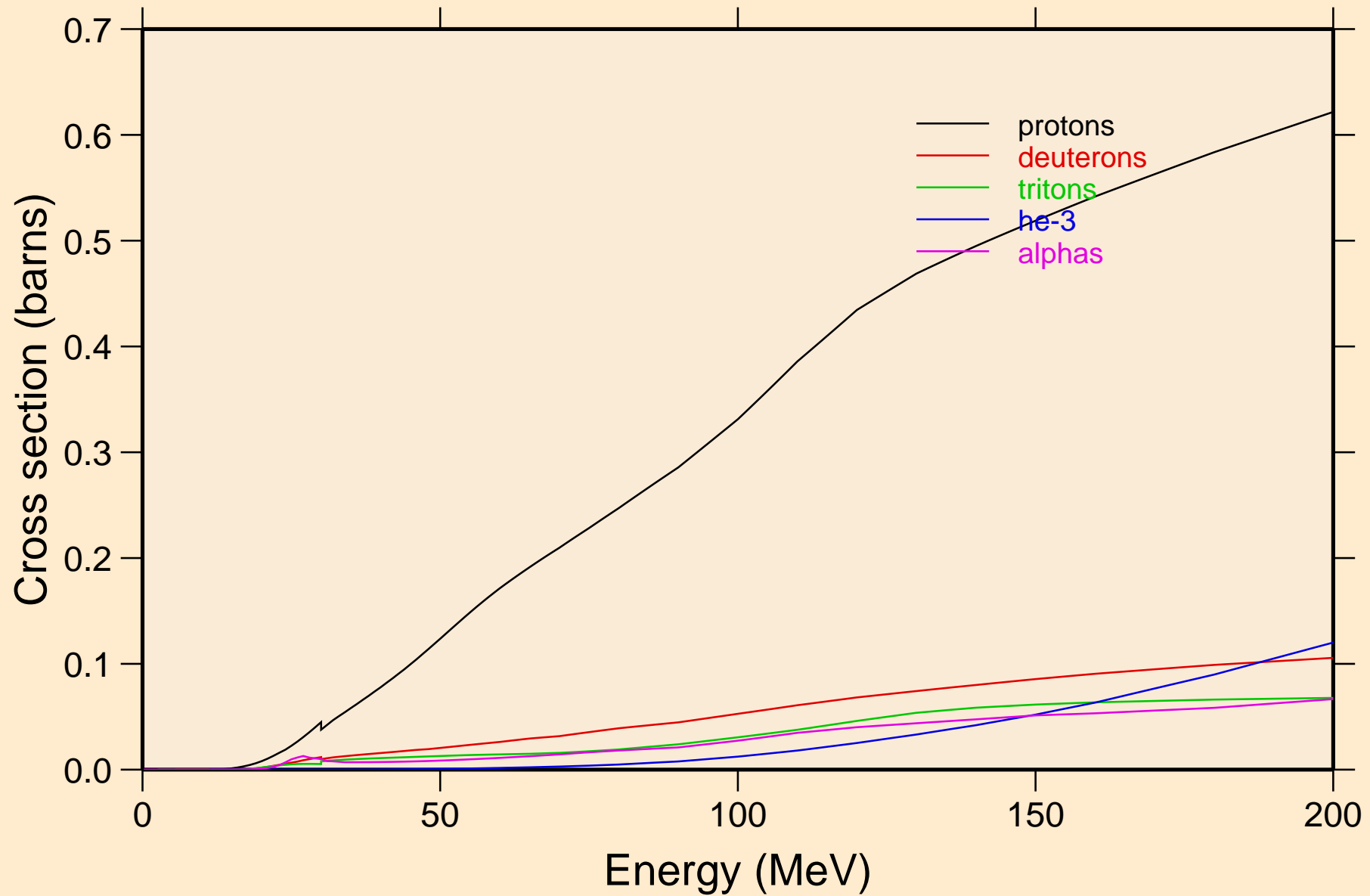

AT228 NEUTRON ACER TENDL-2023 LIBRARY; T=0.K  
protons from (n,x)

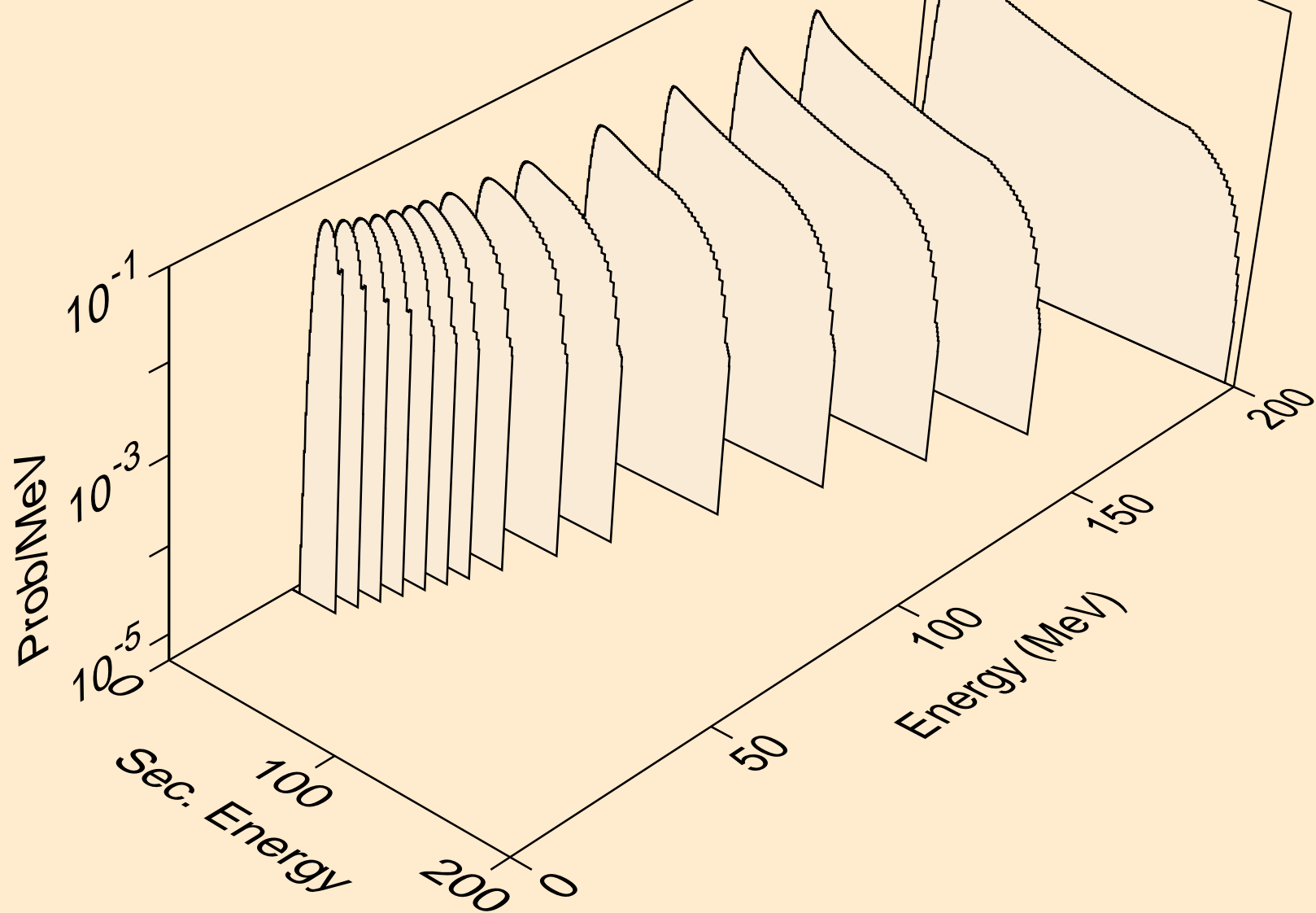

AT228 NEUTRON ACER TENDL-2023 LIBRARY; T=0.K  
protons from (n,n\*)p

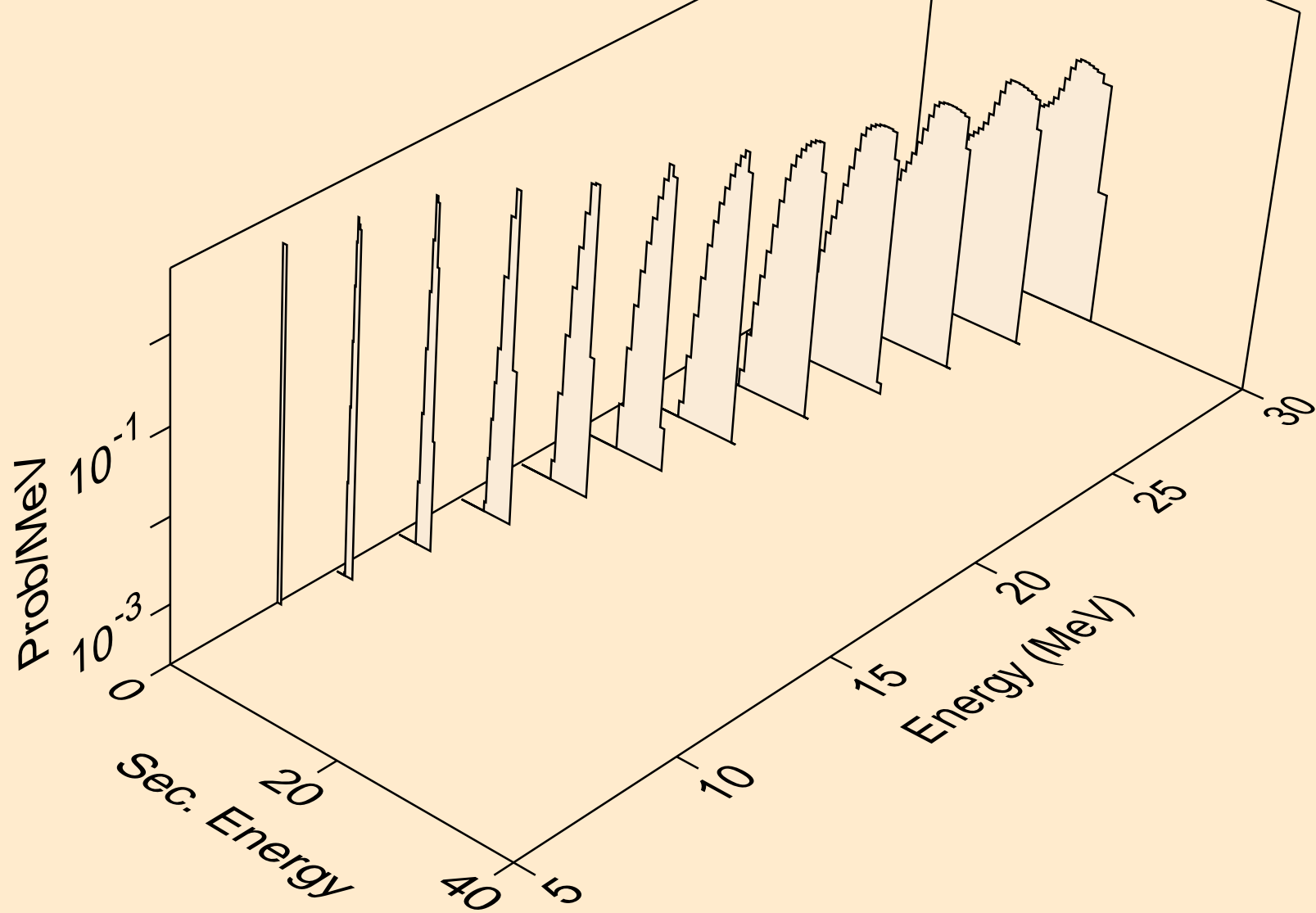

AT228 NEUTRON ACER TENDL-2023 LIBRARY; T=0.K  
protons from (n,2np)

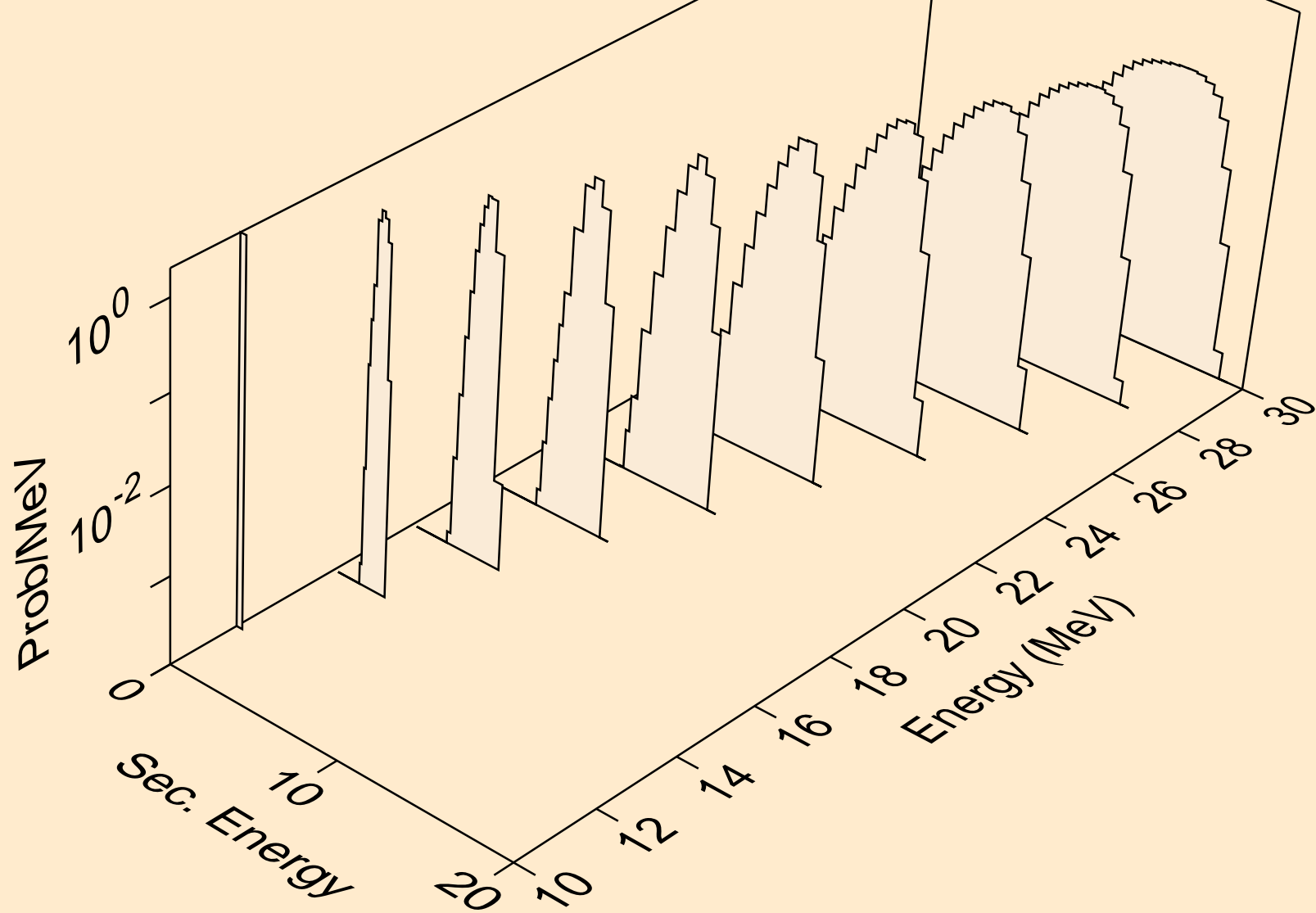

AT228 NEUTRON ACER TENDL-2023 LIBRARY; T=0.K  
protons from (n,3np)

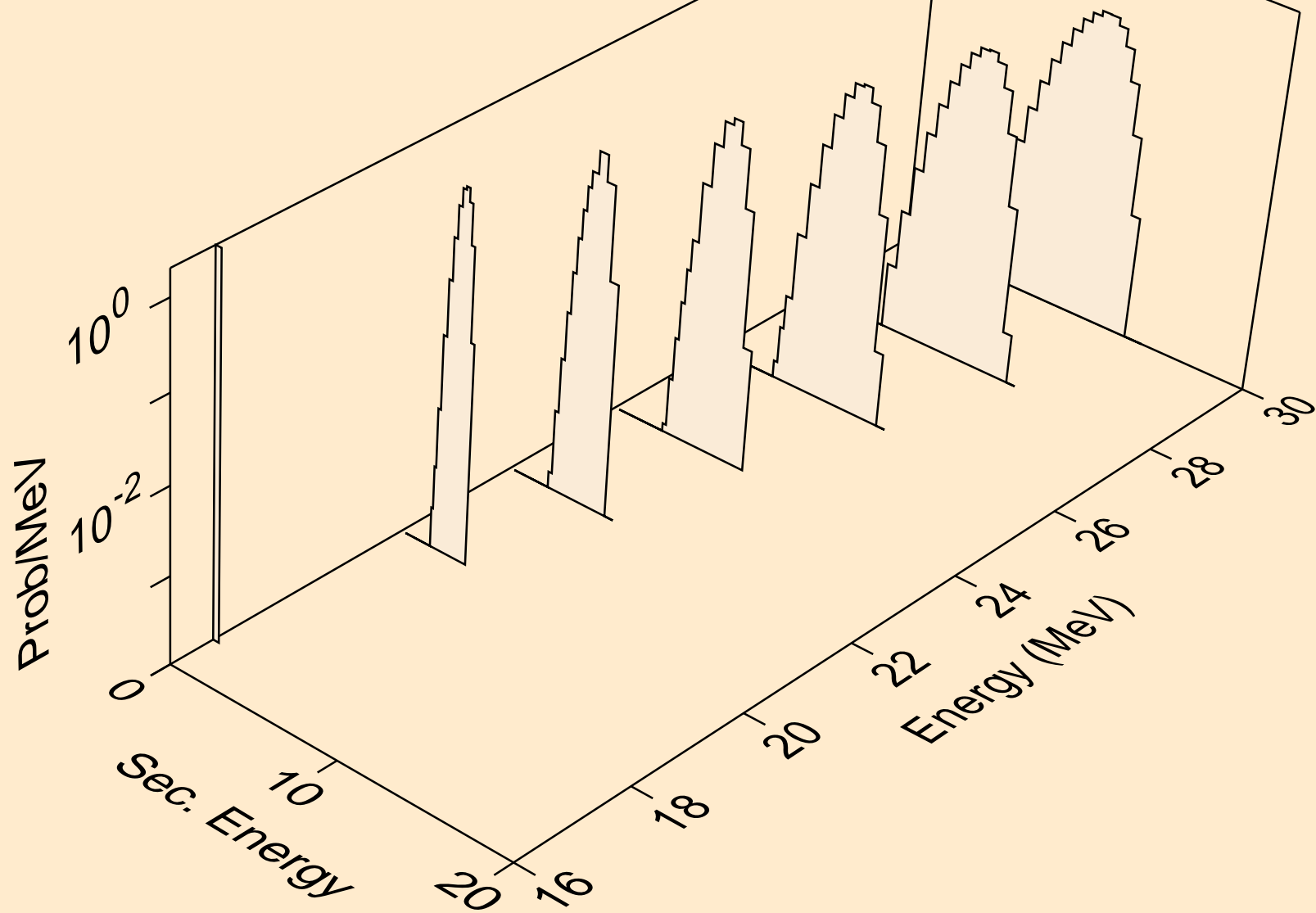

AT228 NEUTRON ACER TENDL-2023 LIBRARY; T=0.K  
protons from (n,p)

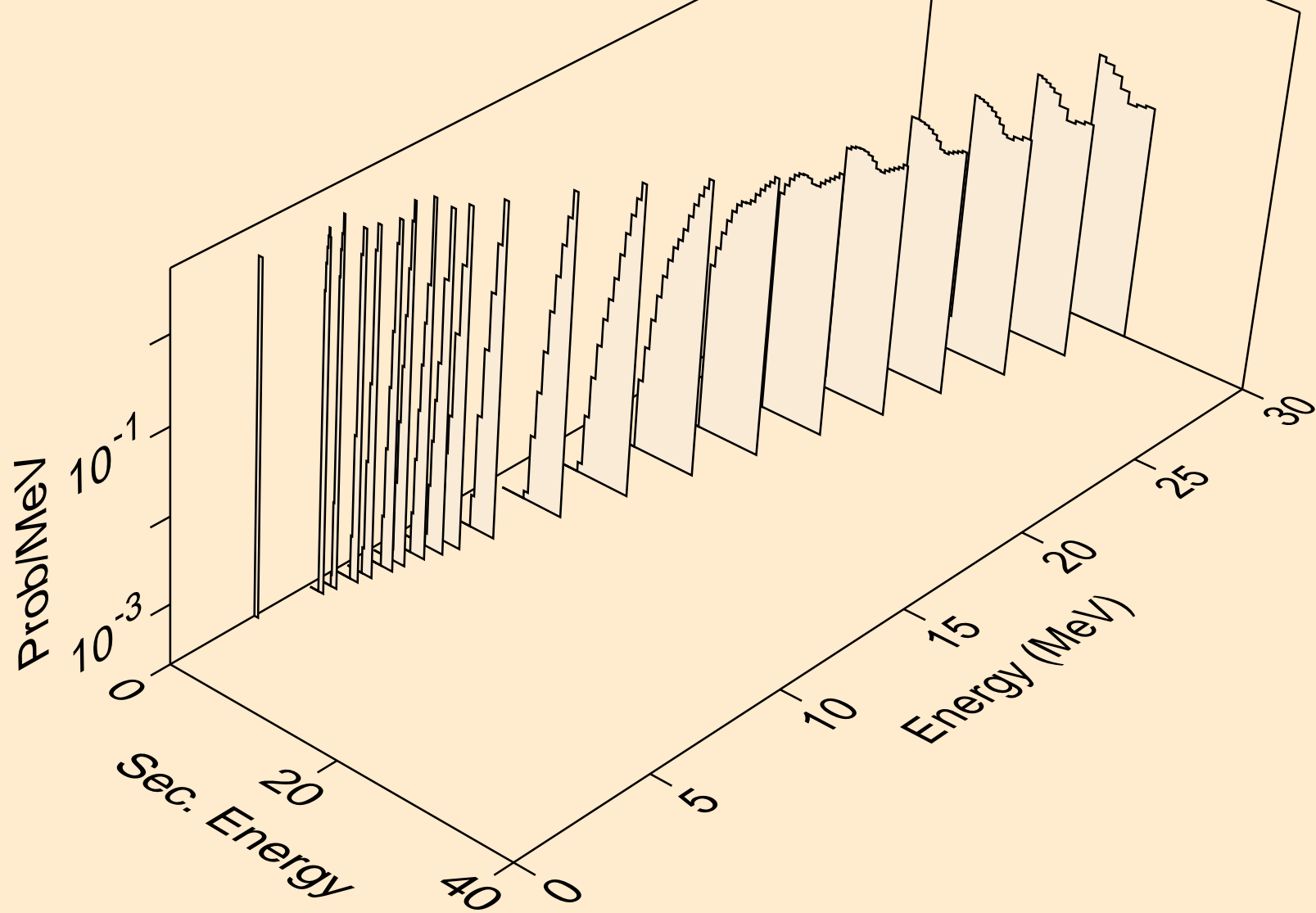

AT228 NEUTRON ACER TENDL-2023 LIBRARY; T=0.K  
deuterons from (n,x)

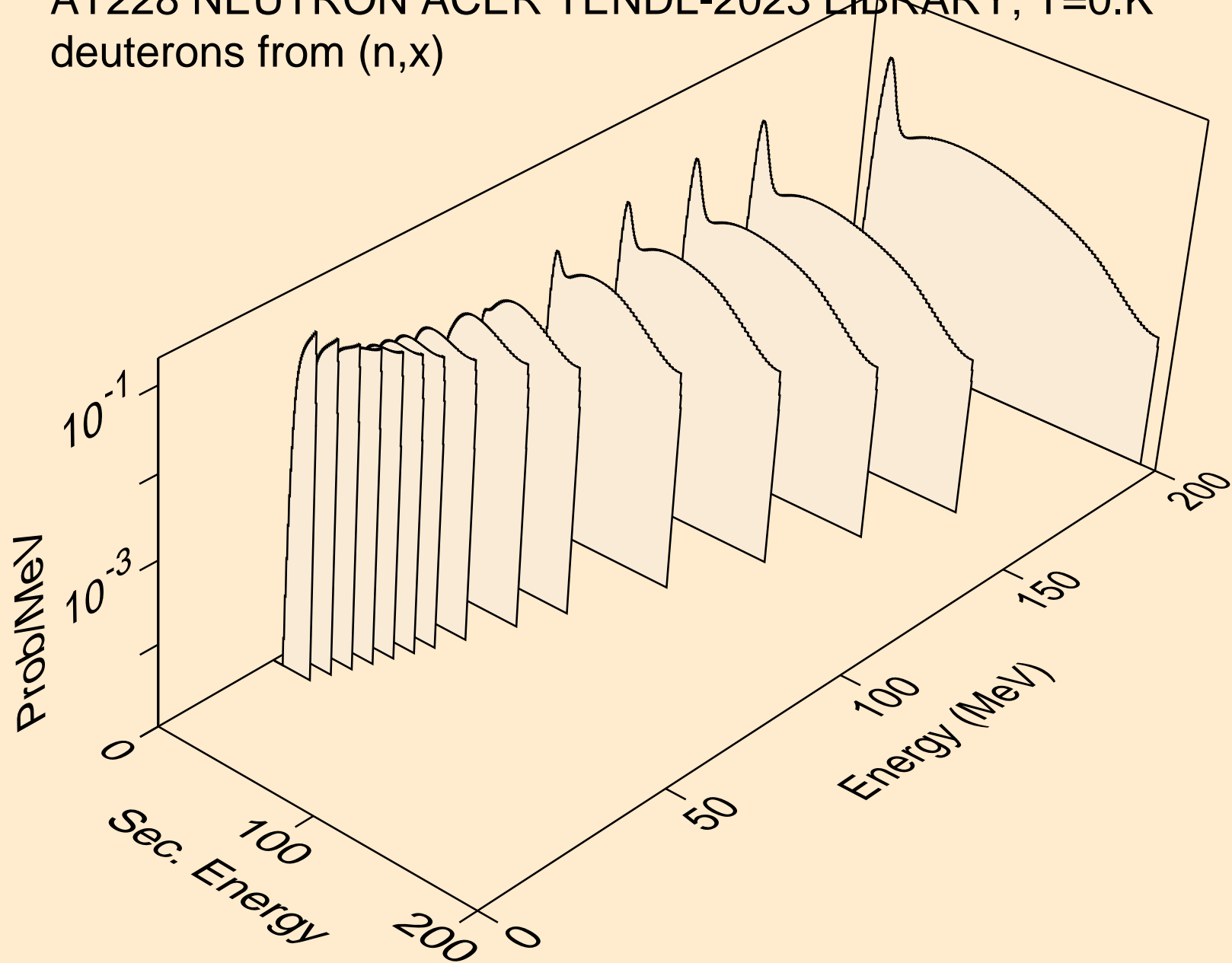

AT228 NEUTRON ACER TENDL-2023 LIBRARY; T=0.K  
deuterons from (n,2nd)

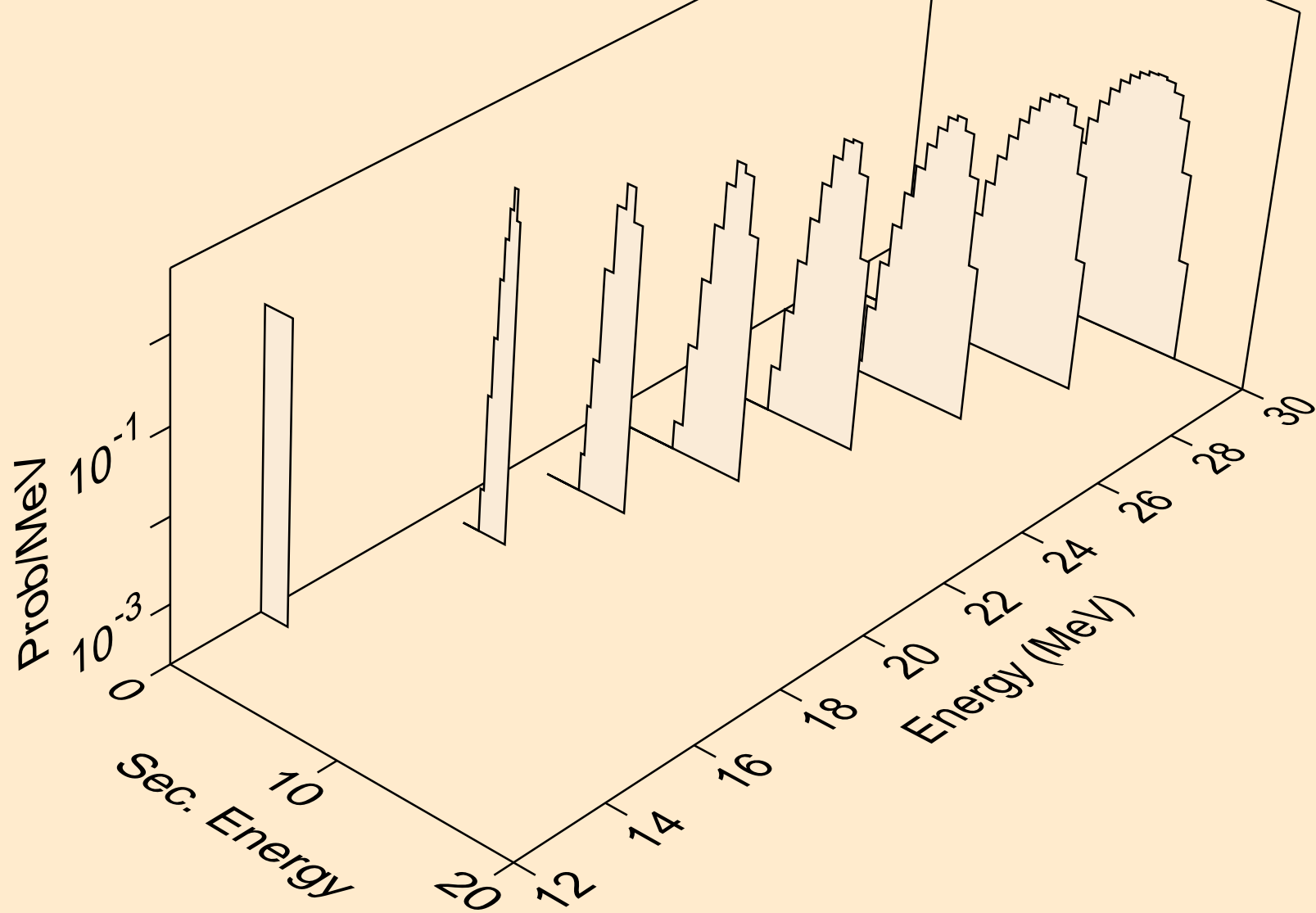

AT228 NEUTRON ACER TENDL-2023 LIBRARY; T=0.K  
deuterons from (n,n\*)d

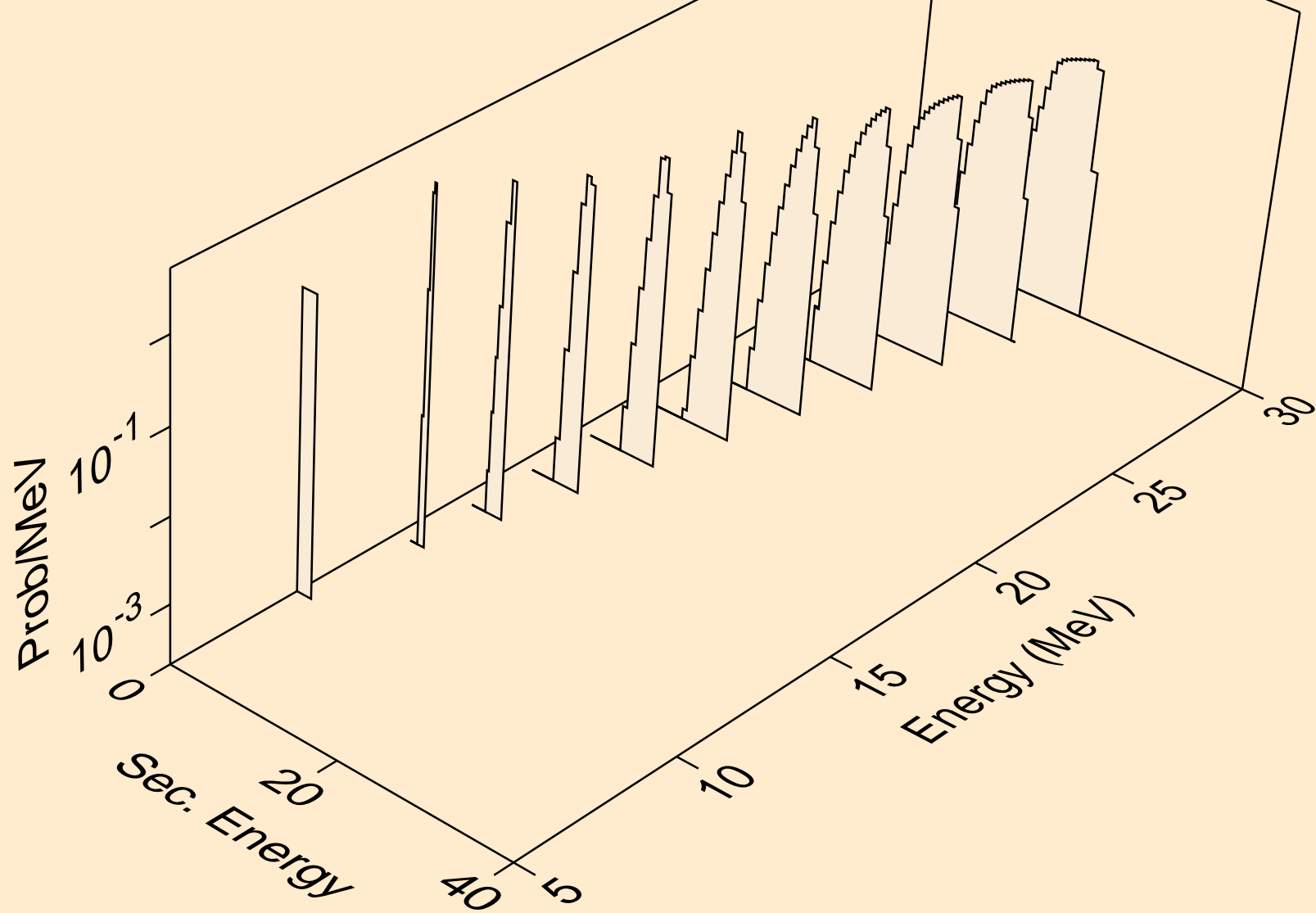

AT228 NEUTRON ACER TENDL-2023 LIBRARY; T=0.K  
deuterons from (n,d)

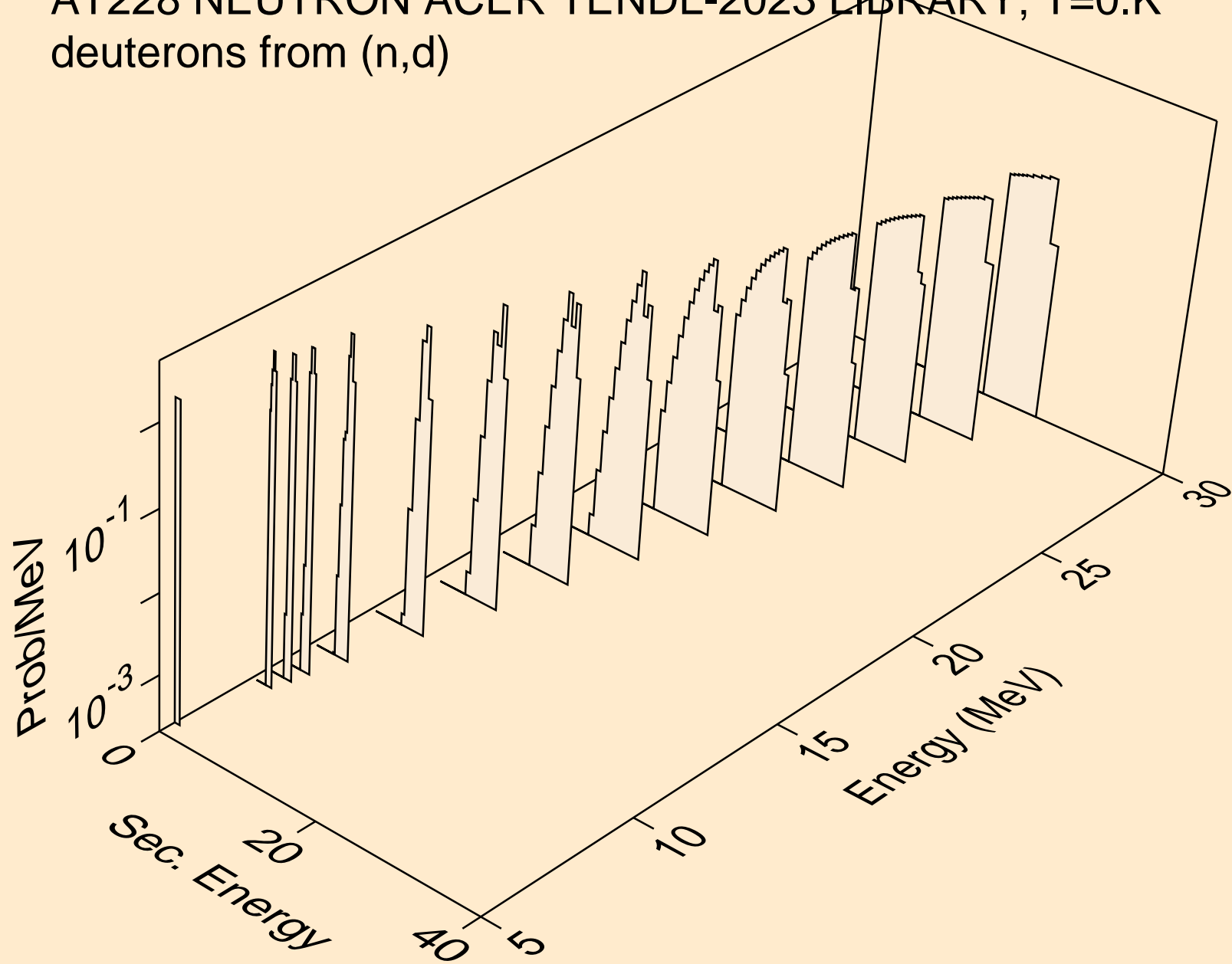

AT228 NEUTRON ACER TENDL-2023 LIBRARY; T=0.K  
tritons from (n,x)

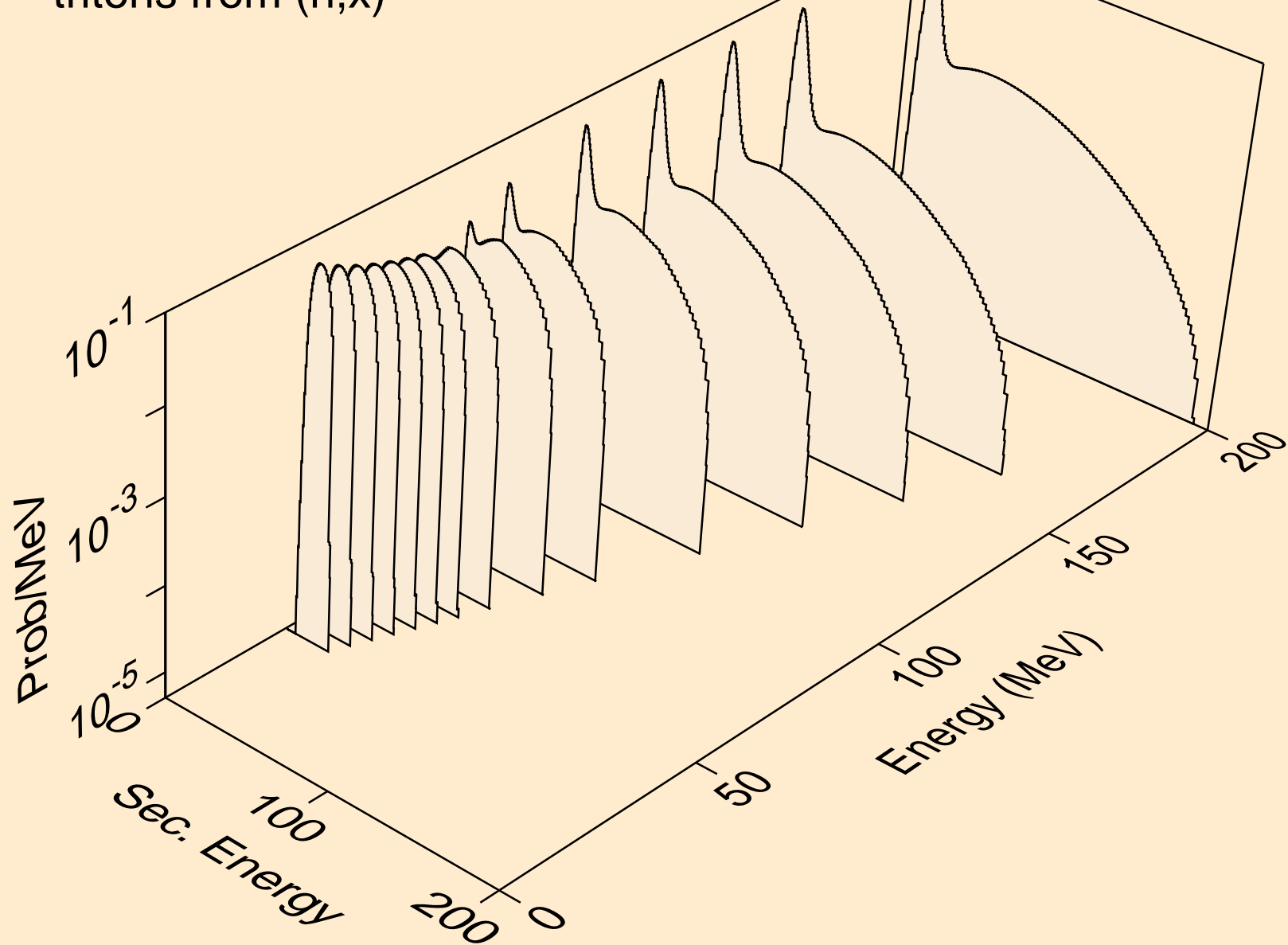

AT228 NEUTRON ACER TENDL-2023 LIBRARY; T=0.K  
tritons from (n,n\*)t

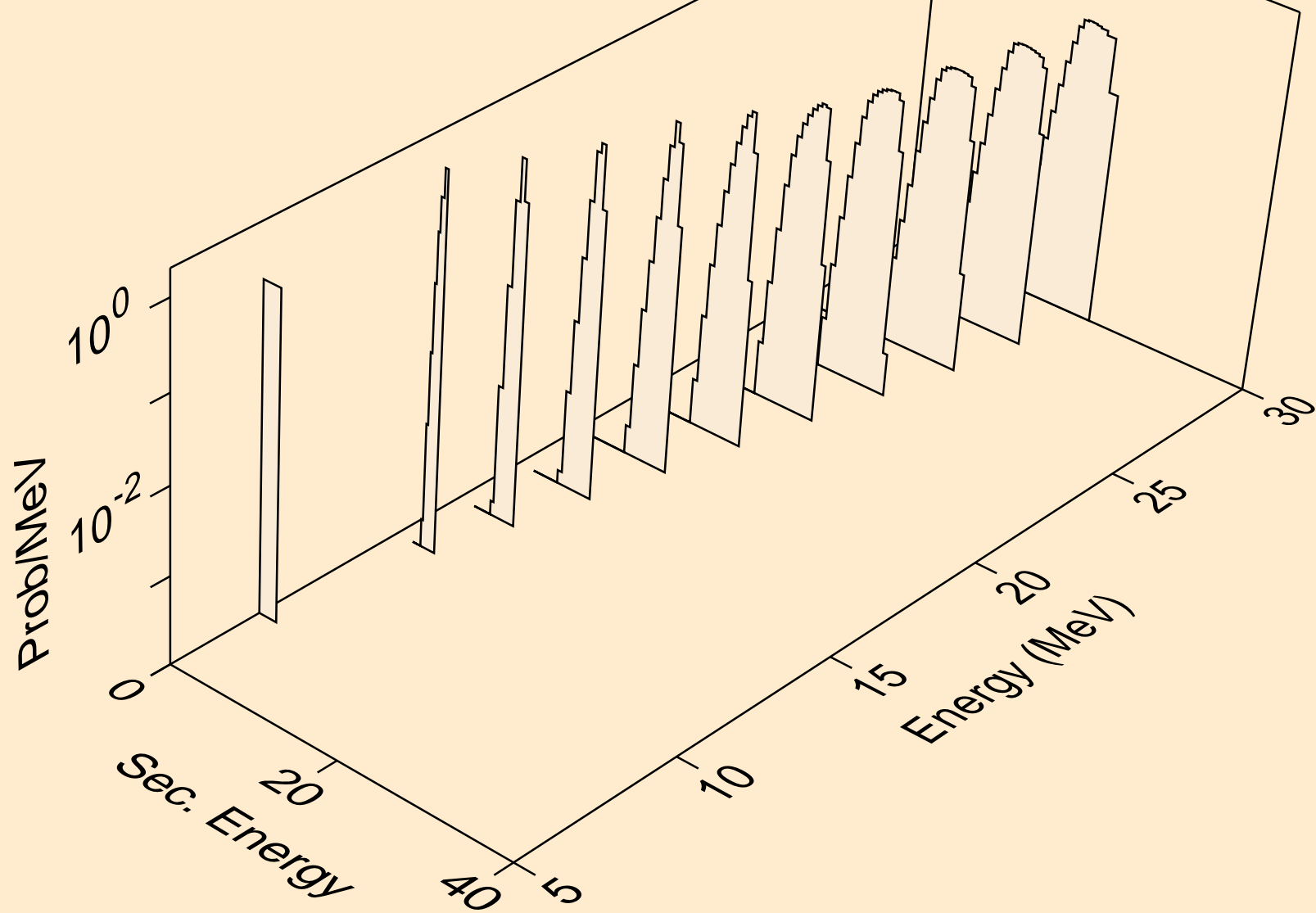

AT228 NEUTRON ACER TENDL-2023 LIBRARY; T=0.K  
tritons from (n,t)

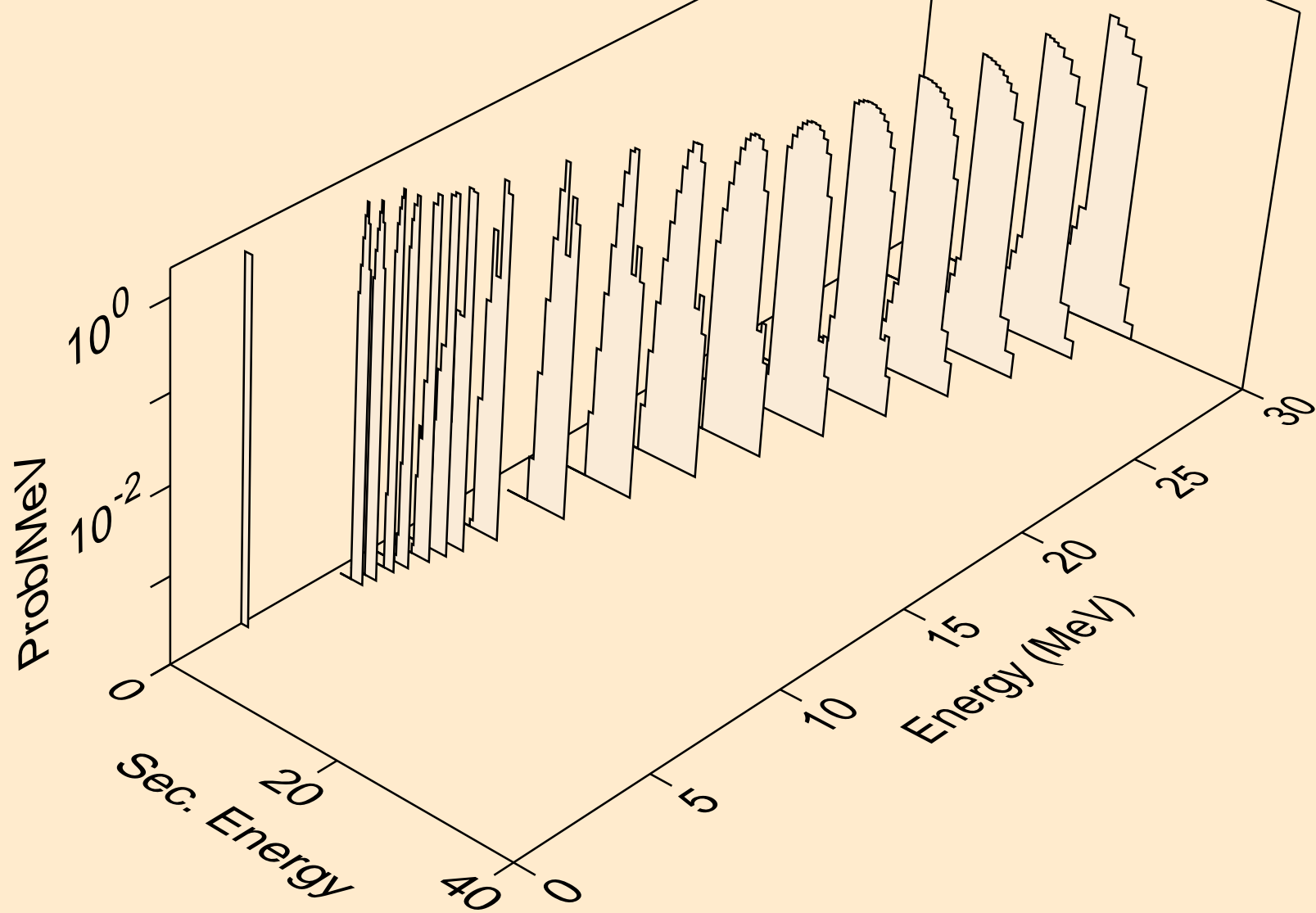

AT228 NEUTRON ACER TENDL-2023 LIBRARY; T=0.K  
he3s from (n,x)

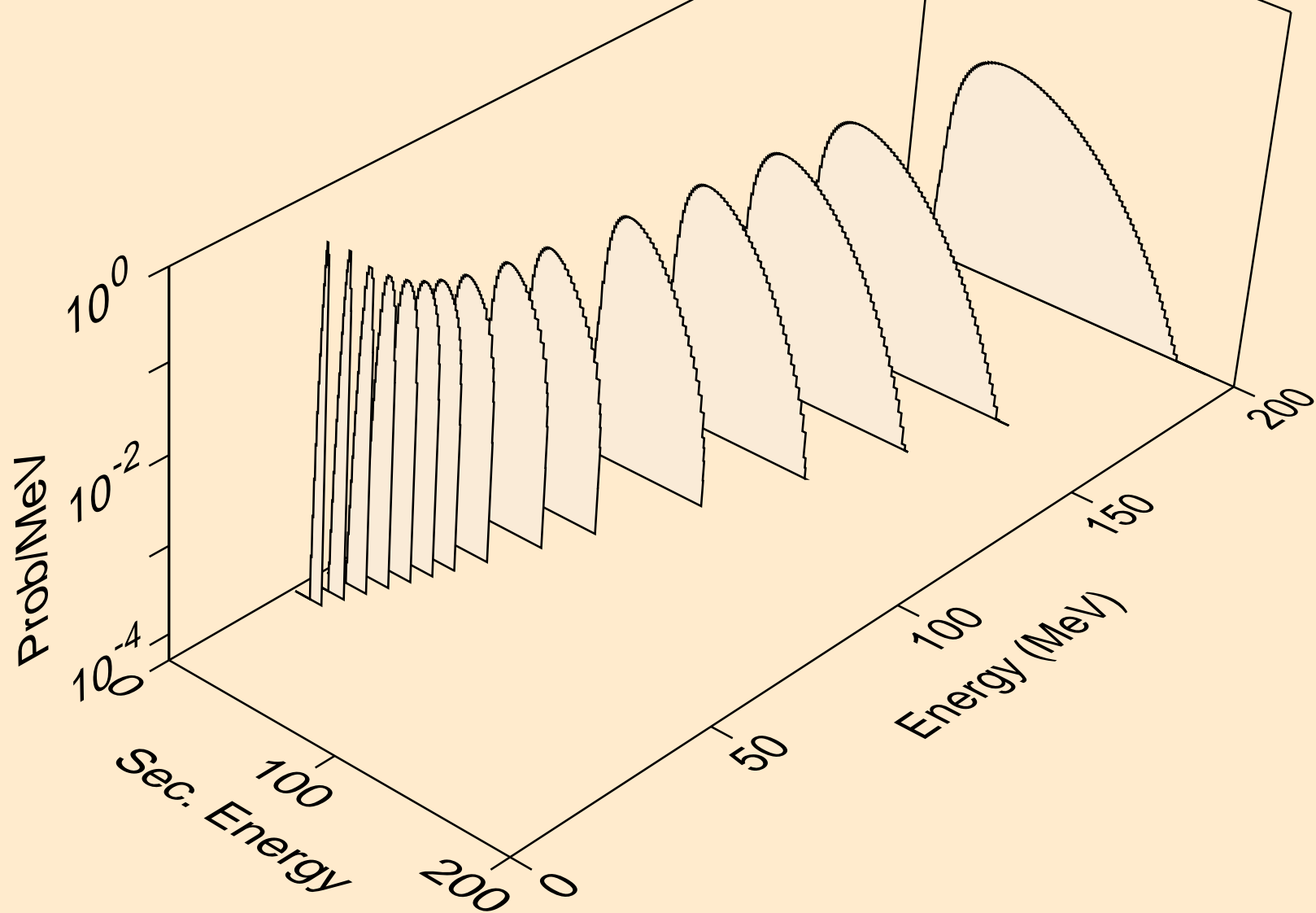

AT228 NEUTRON ACER TENDL-2023 LIBRARY; T=0.K  
he3s from (n,n\*)he3

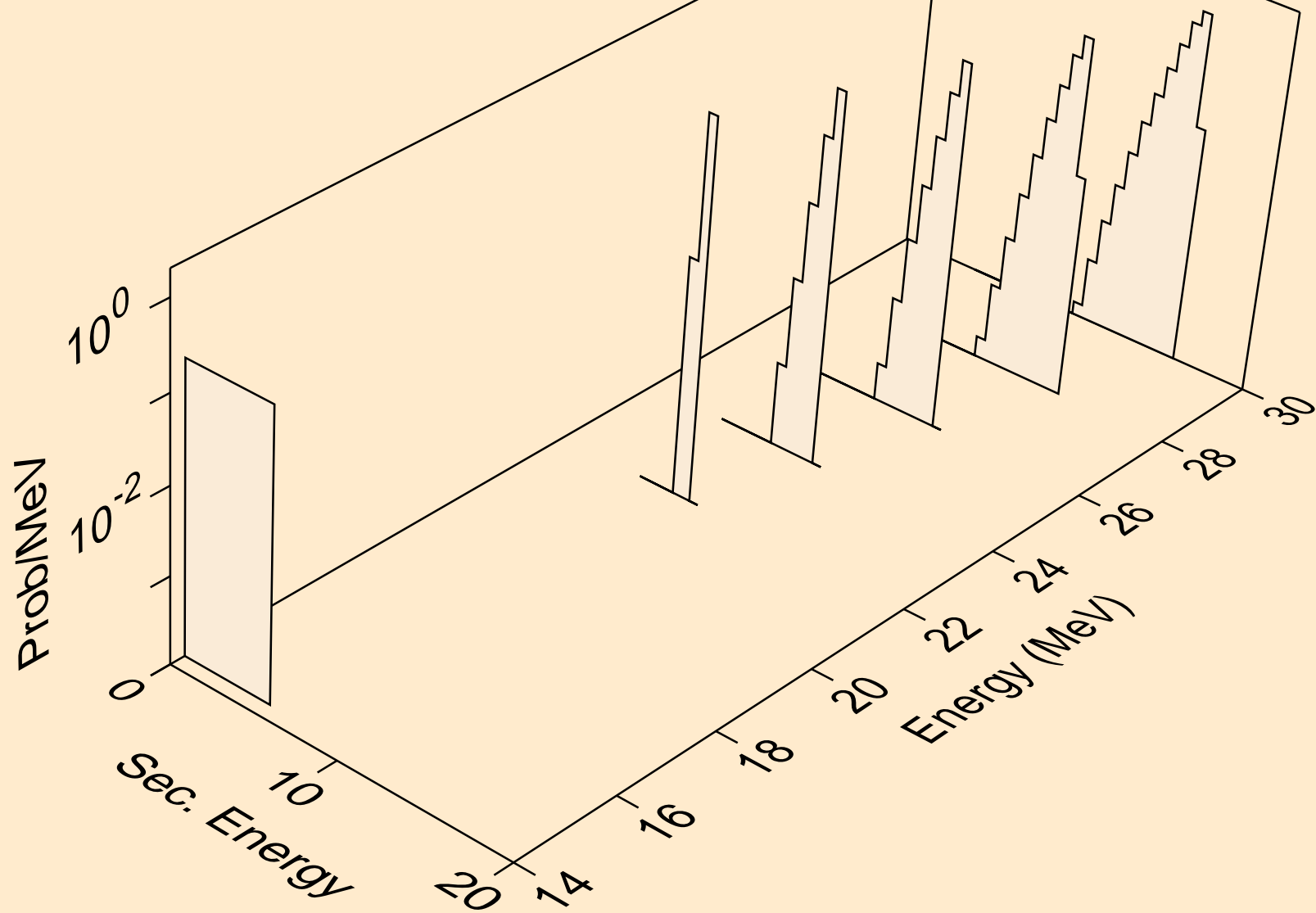

AT228 NEUTRON ACER TENDL-2023 LIBRARY; T=0.K  
he3s from (n,he3)

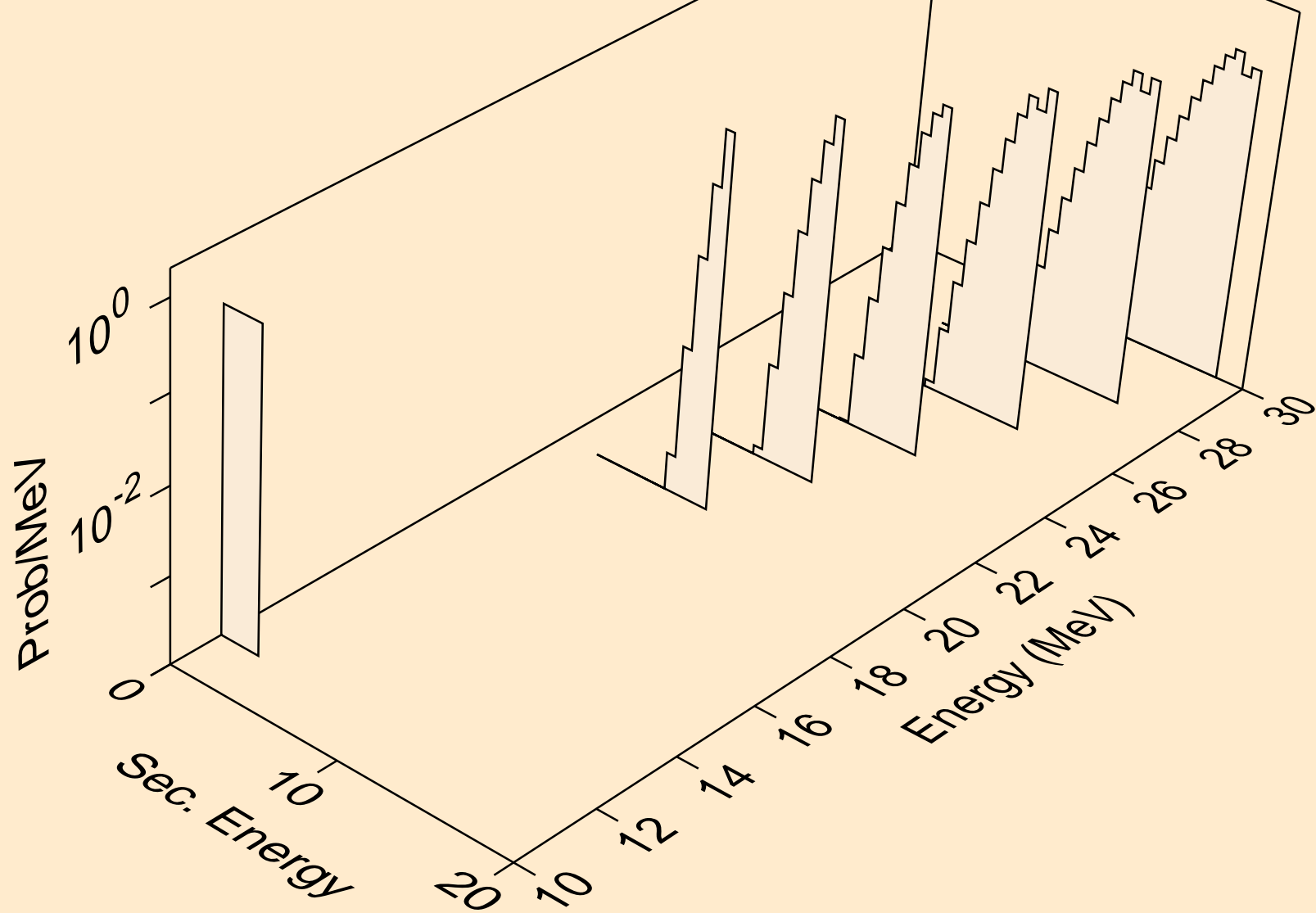

AT228 NEUTRON ACER TENDL-2023 LIBRARY; T=0.K  
alphas from (n,x)

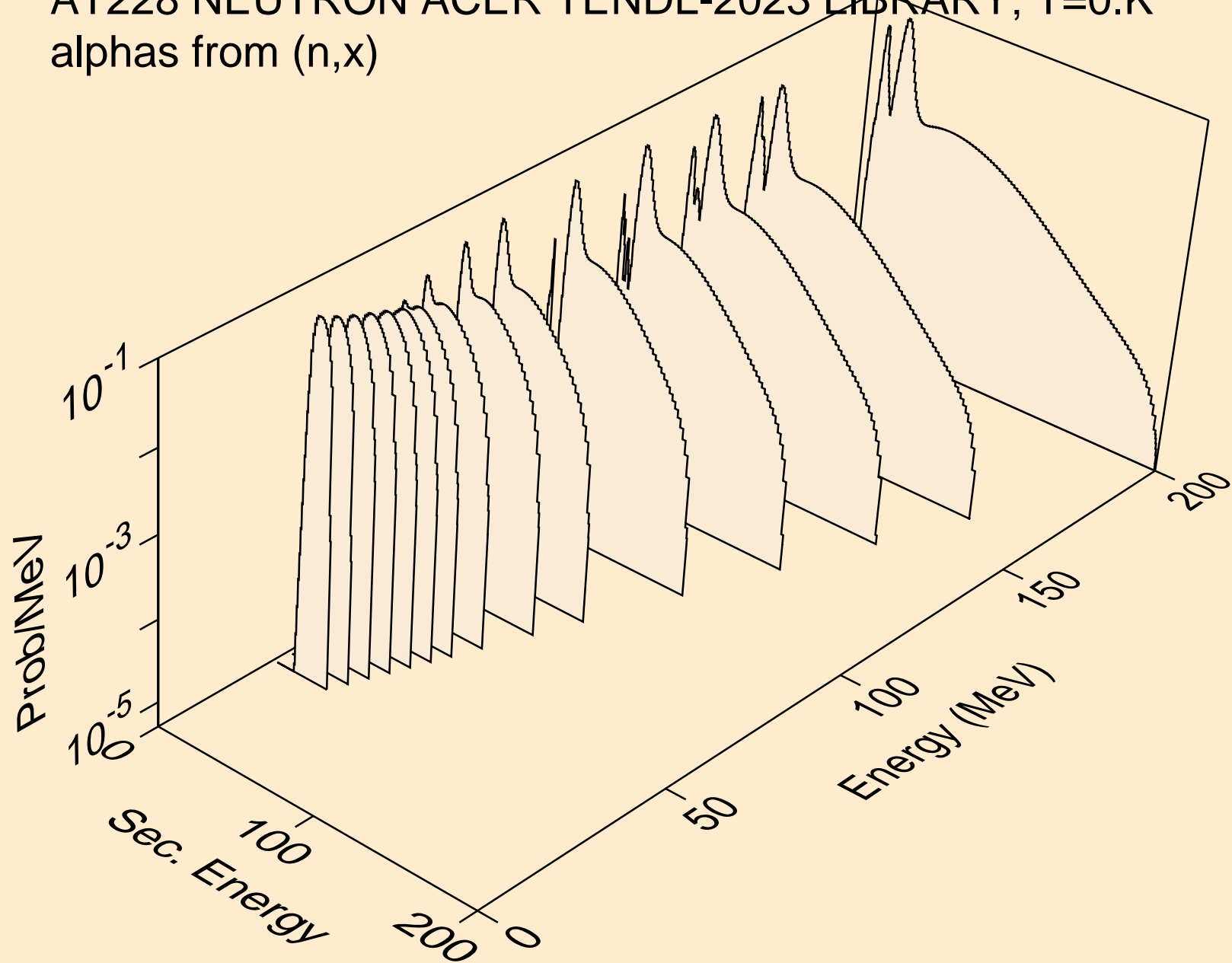

AT228 NEUTRON ACER TENDL-2023 LIBRARY; T=0.K  
alphas from (n,n\*)a

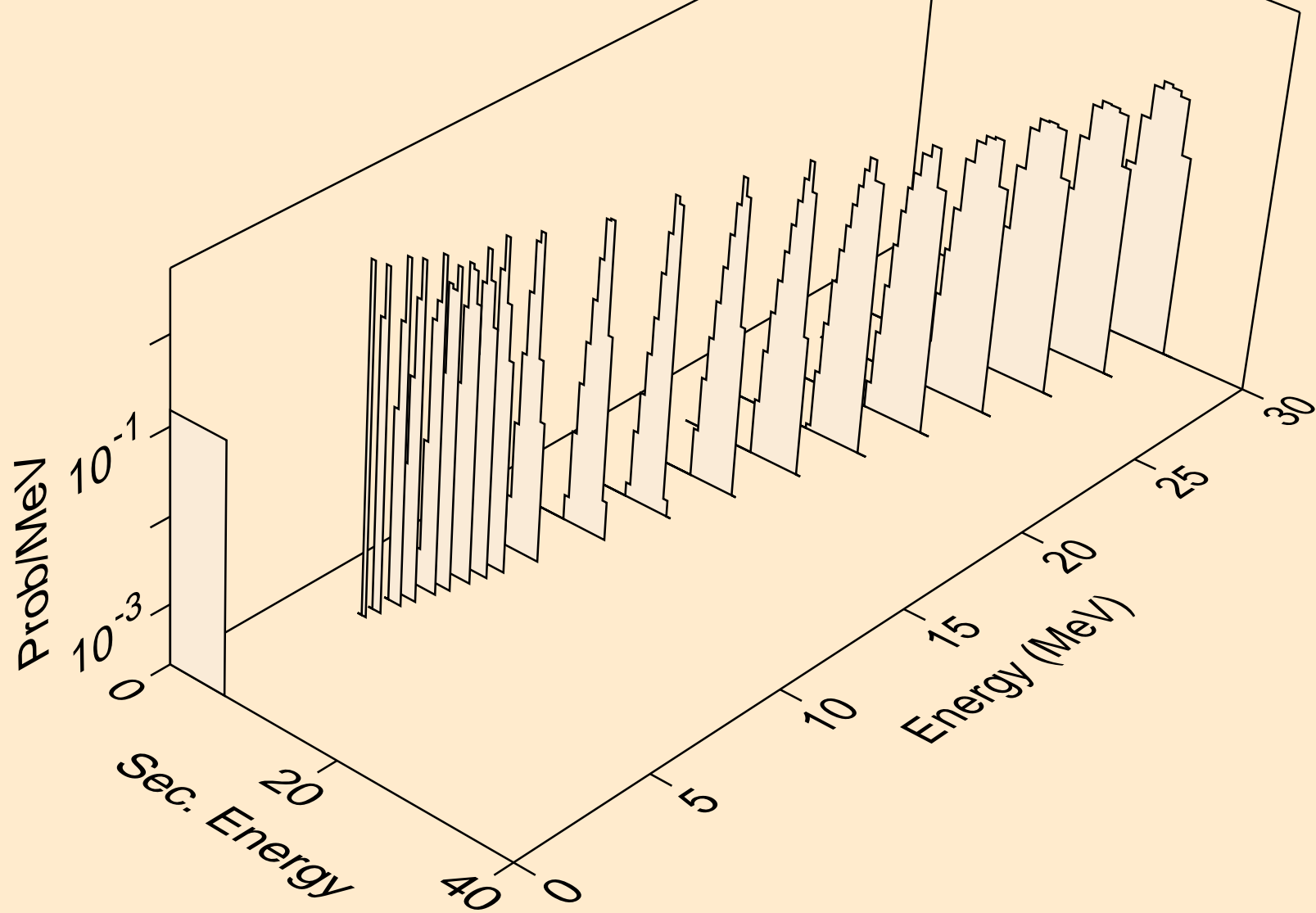

AT228 NEUTRON ACER TENDL-2023 LIBRARY; T=0.K  
alphas from (n,2n)a

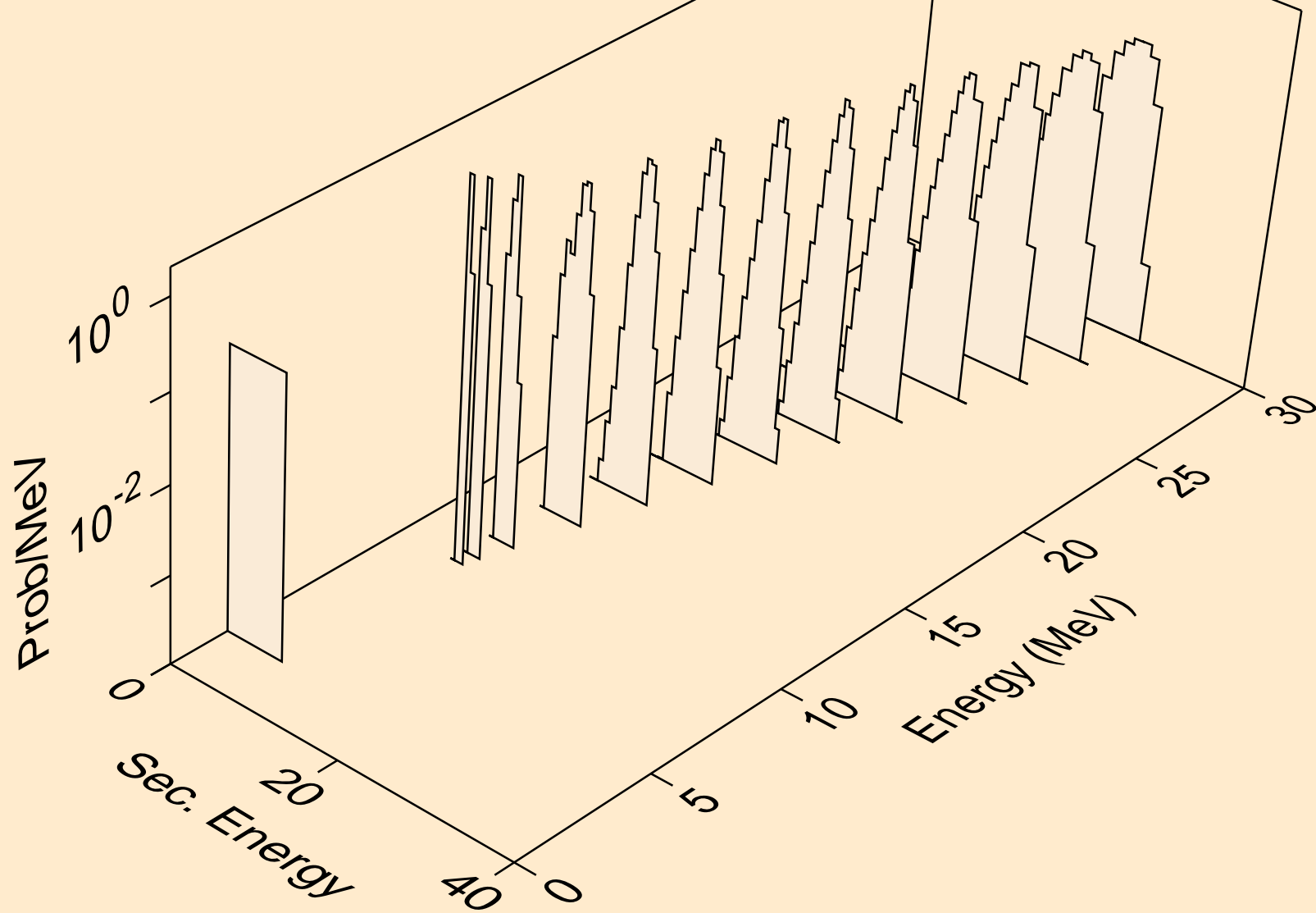

AT228 NEUTRON ACER TENDL-2023 LIBRARY; T=0.K  
alphas from (n,3n)a

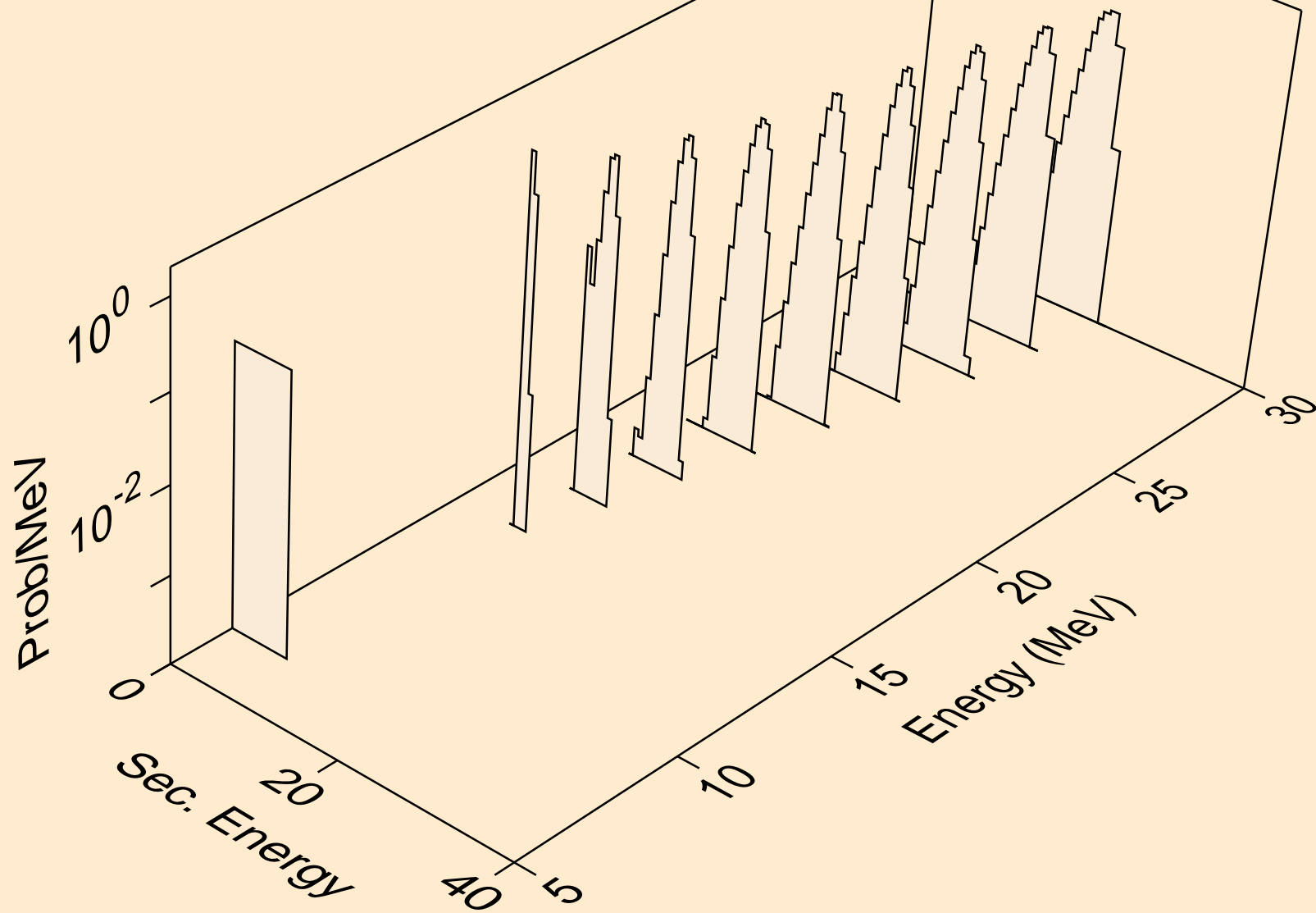

AT228 NEUTRON ACER TENDL-2023 LIBRARY; T=0.K  
alphas from (n,a)

