

BA133M NEUTRON ACER TENDL-2023 LIBRARY; T=0.K

Principal cross sections

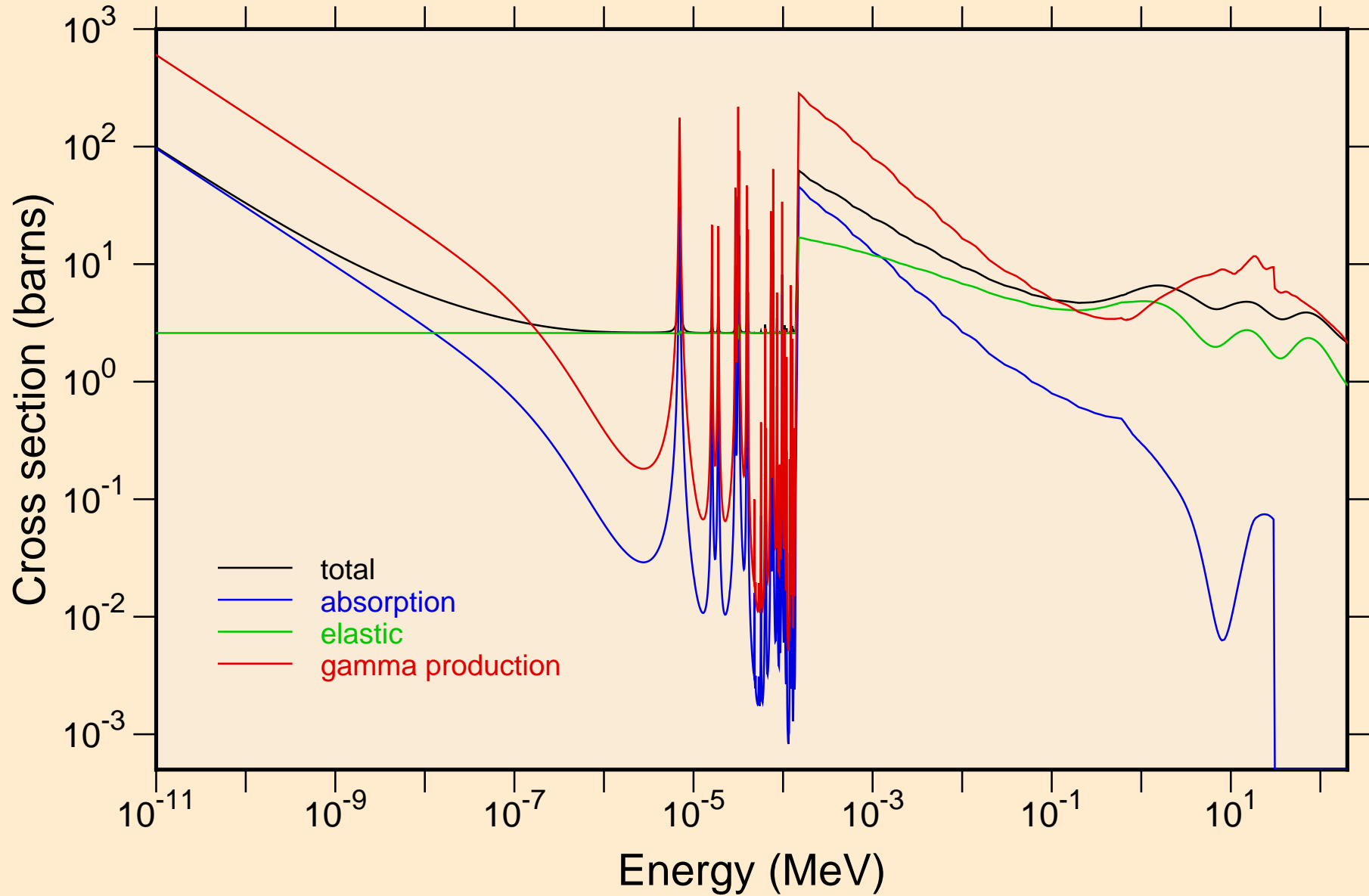

BA133M NEUTRON ACER TENDL-2023 LIBRARY; T=0.K
resonance total cross section

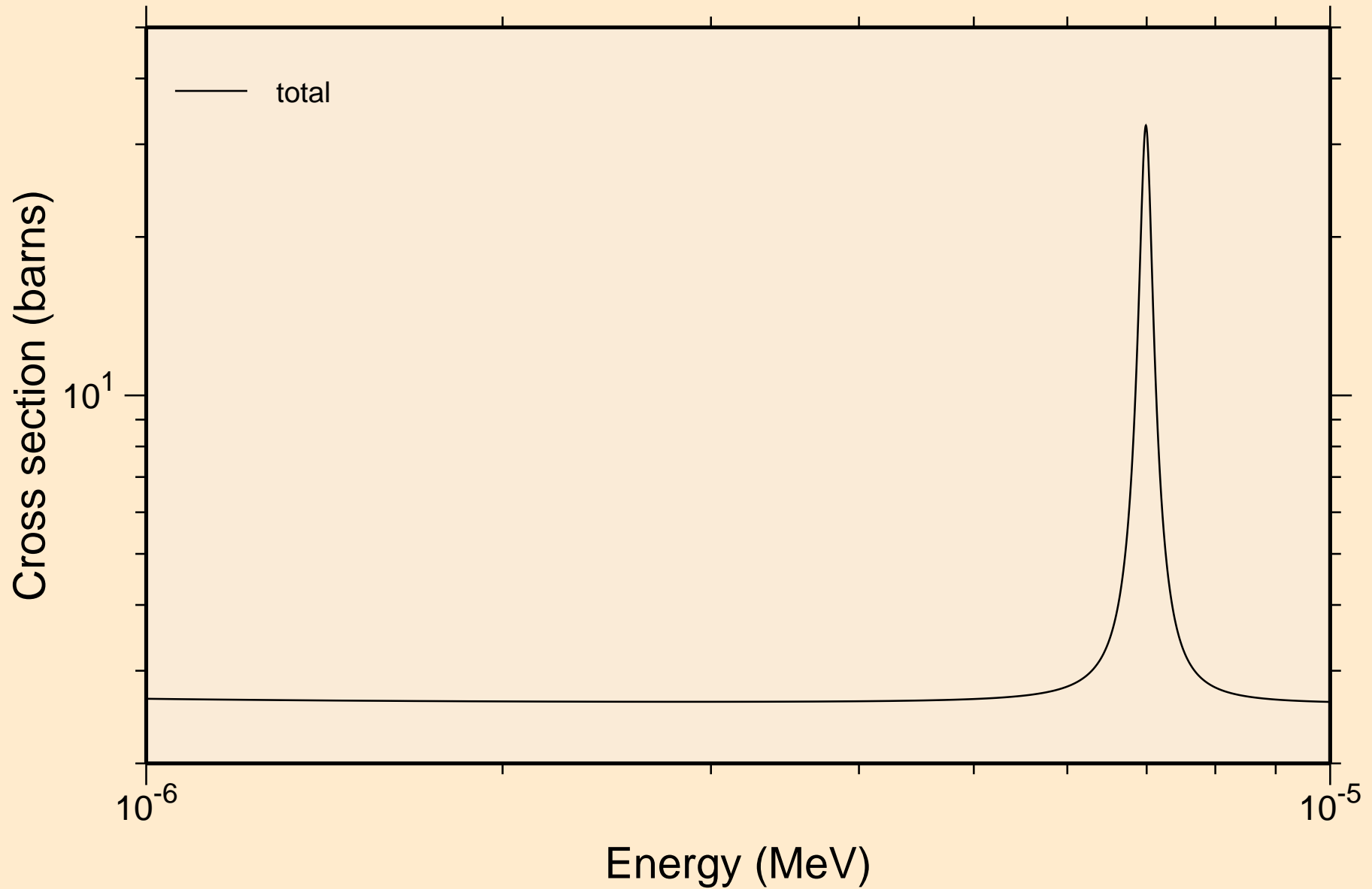

BA133M NEUTRON ACER TENDL-2023 LIBRARY; T=0.K
resonance total cross section

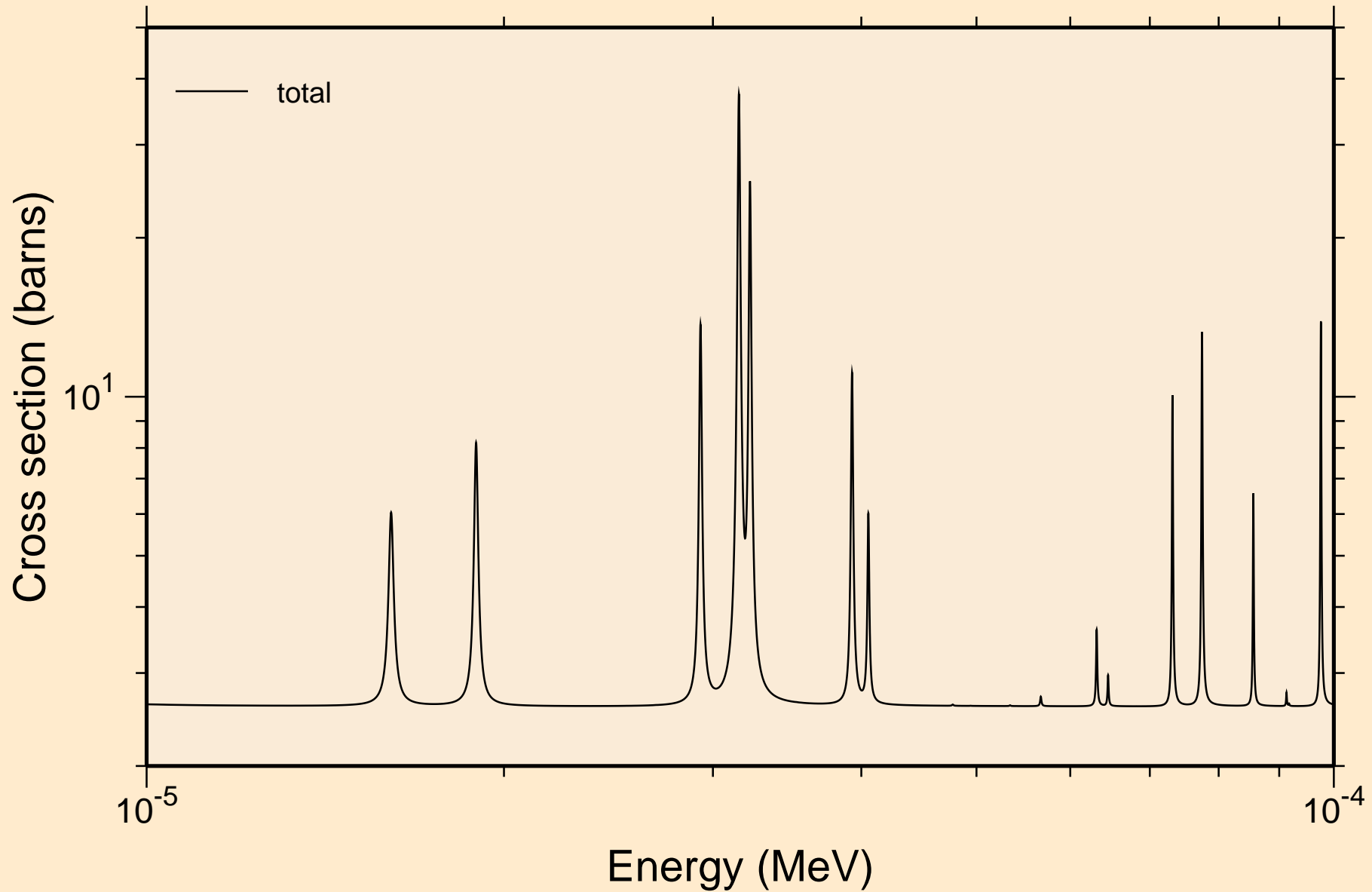

BA133M NEUTRON ACER TENDL-2023 LIBRARY; T=0.K
resonance total cross section

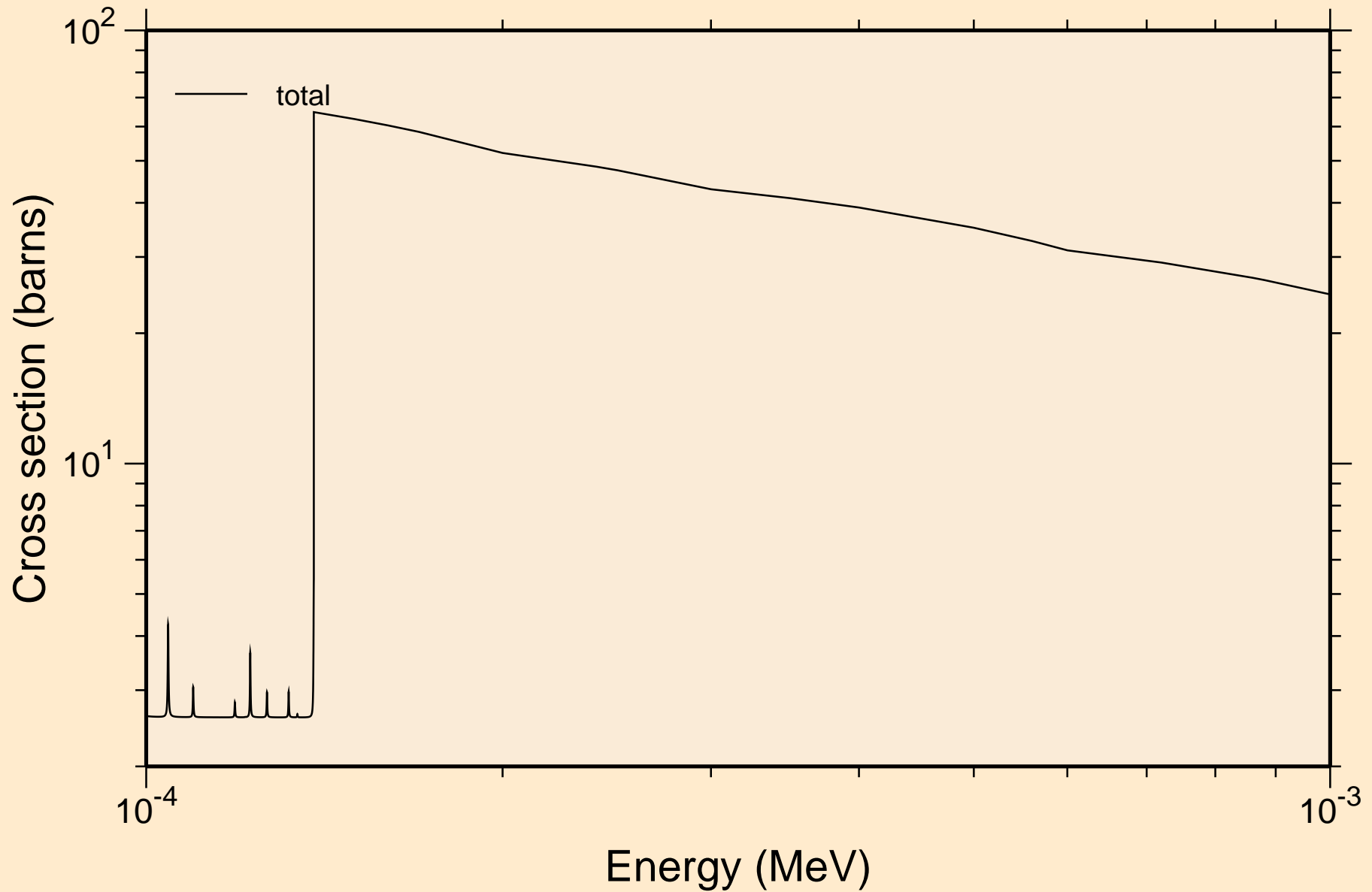

B̄A133M NEUTRON ACER TENDL-2023 LIBRARY; T=0.K
resonance total cross section

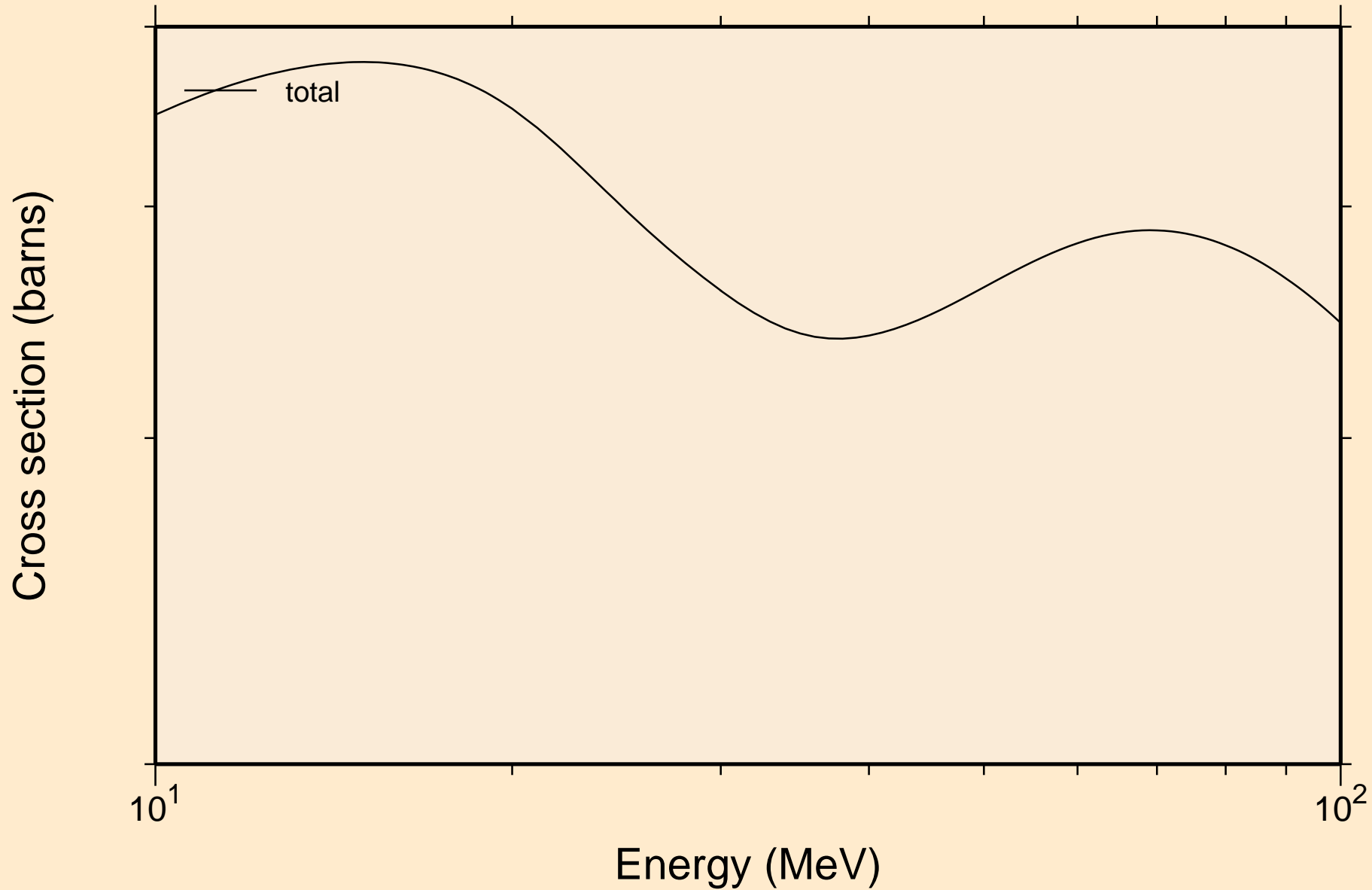

BA133M NEUTRON ACER TENDL-2023 LIBRARY; T=0.K
resonance absorption cross sections

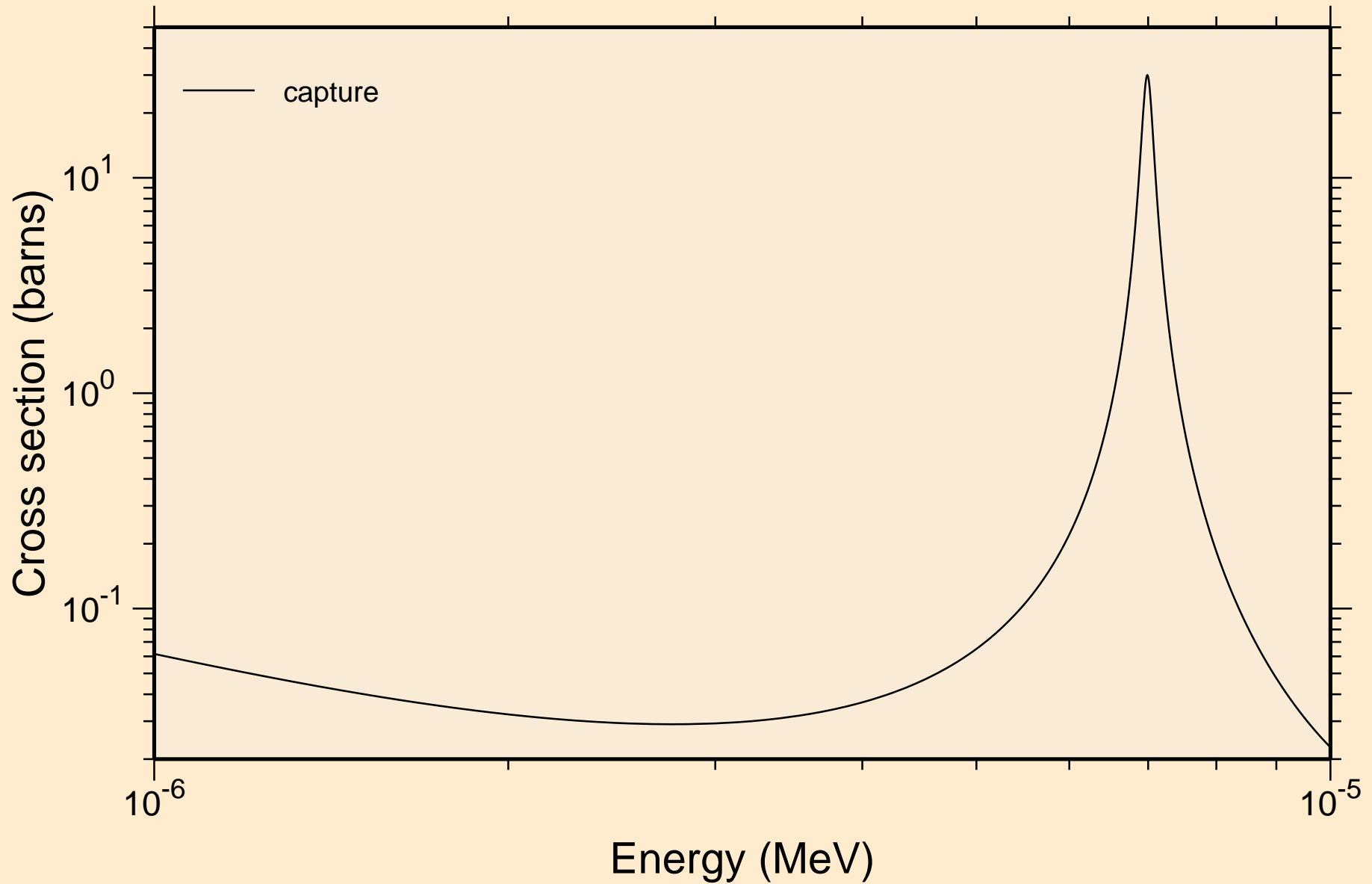

BA133M NEUTRON ACER TENDL-2023 LIBRARY; T=0.K
resonance absorption cross sections

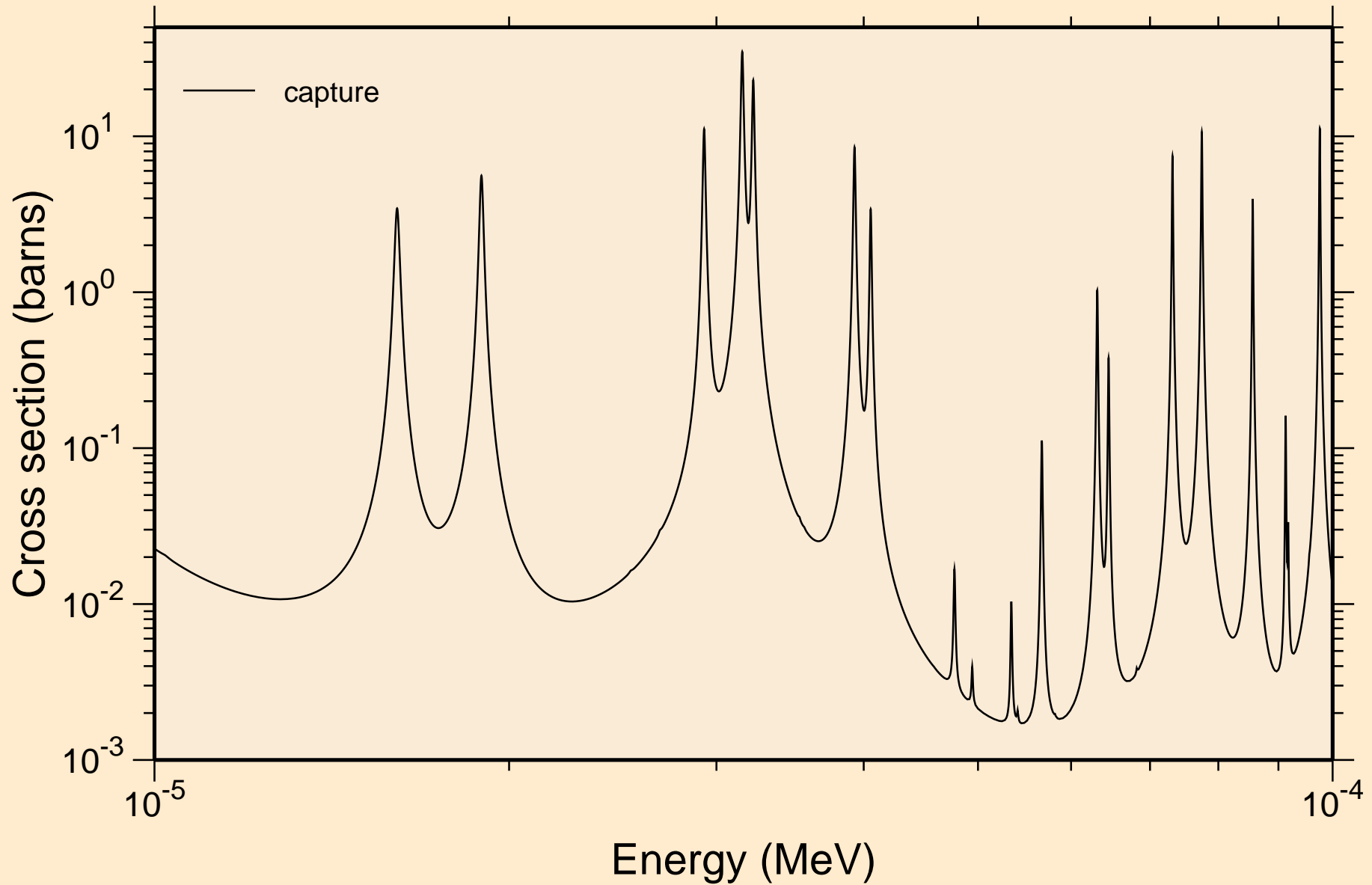

BA133M NEUTRON ACER TENDL-2023 LIBRARY; T=0.K
resonance absorption cross sections

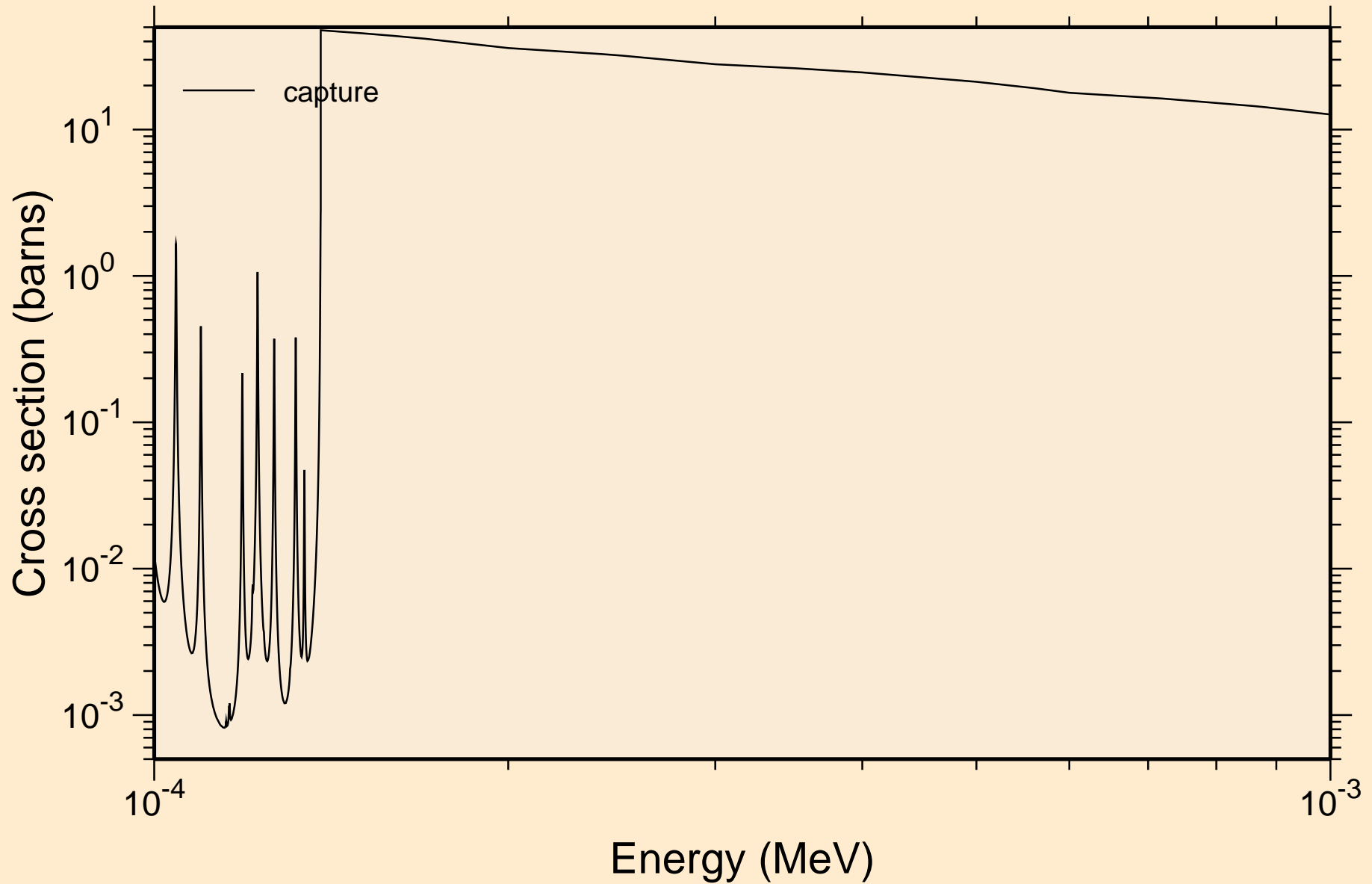

BA133M NEUTRON ACER TENDL-2023 LIBRARY; T=0.K
resonance absorption cross sections

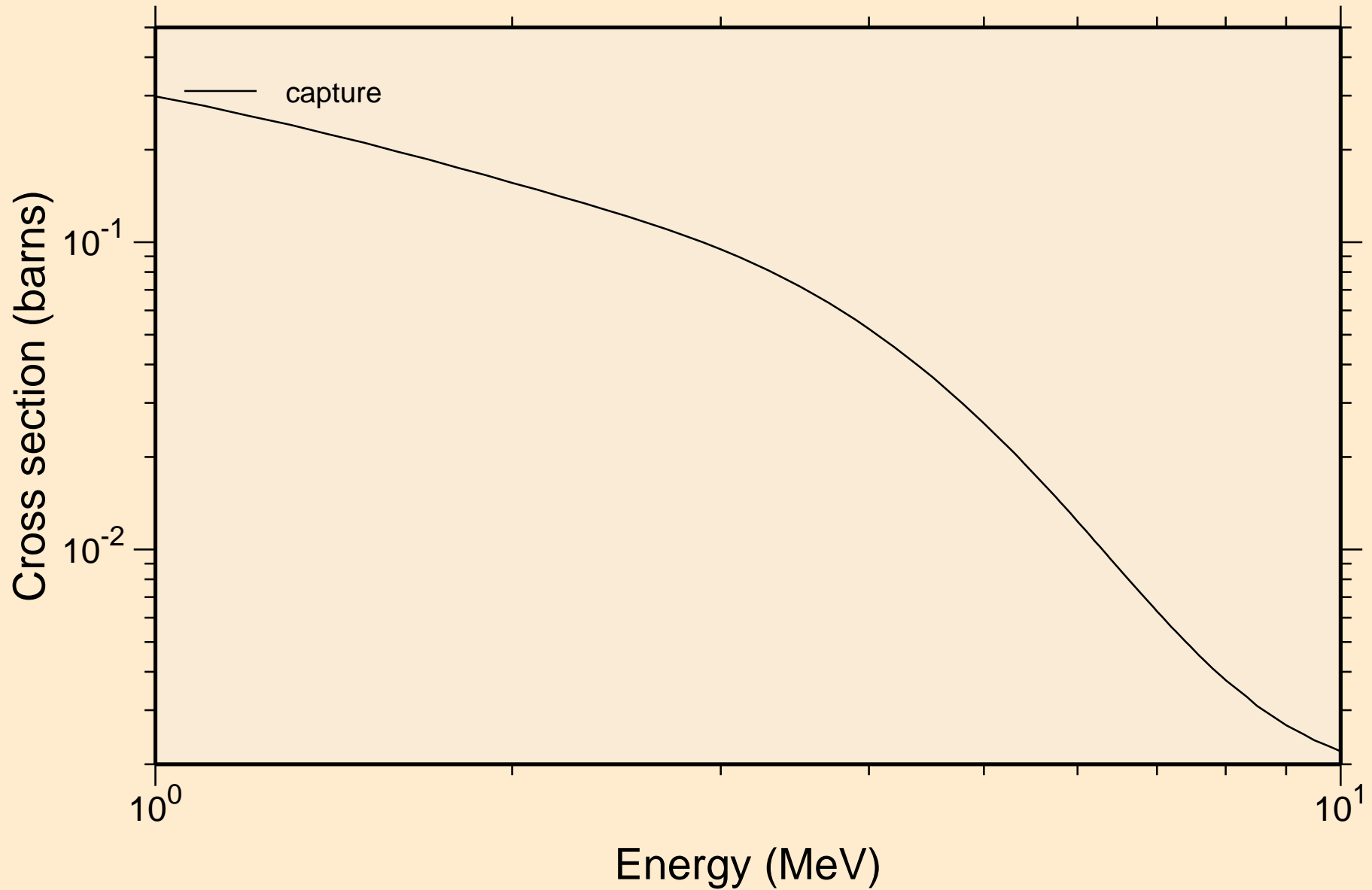

BA133M NEUTRON ACER TENDL-2023 LIBRARY; T=0.K
Heating

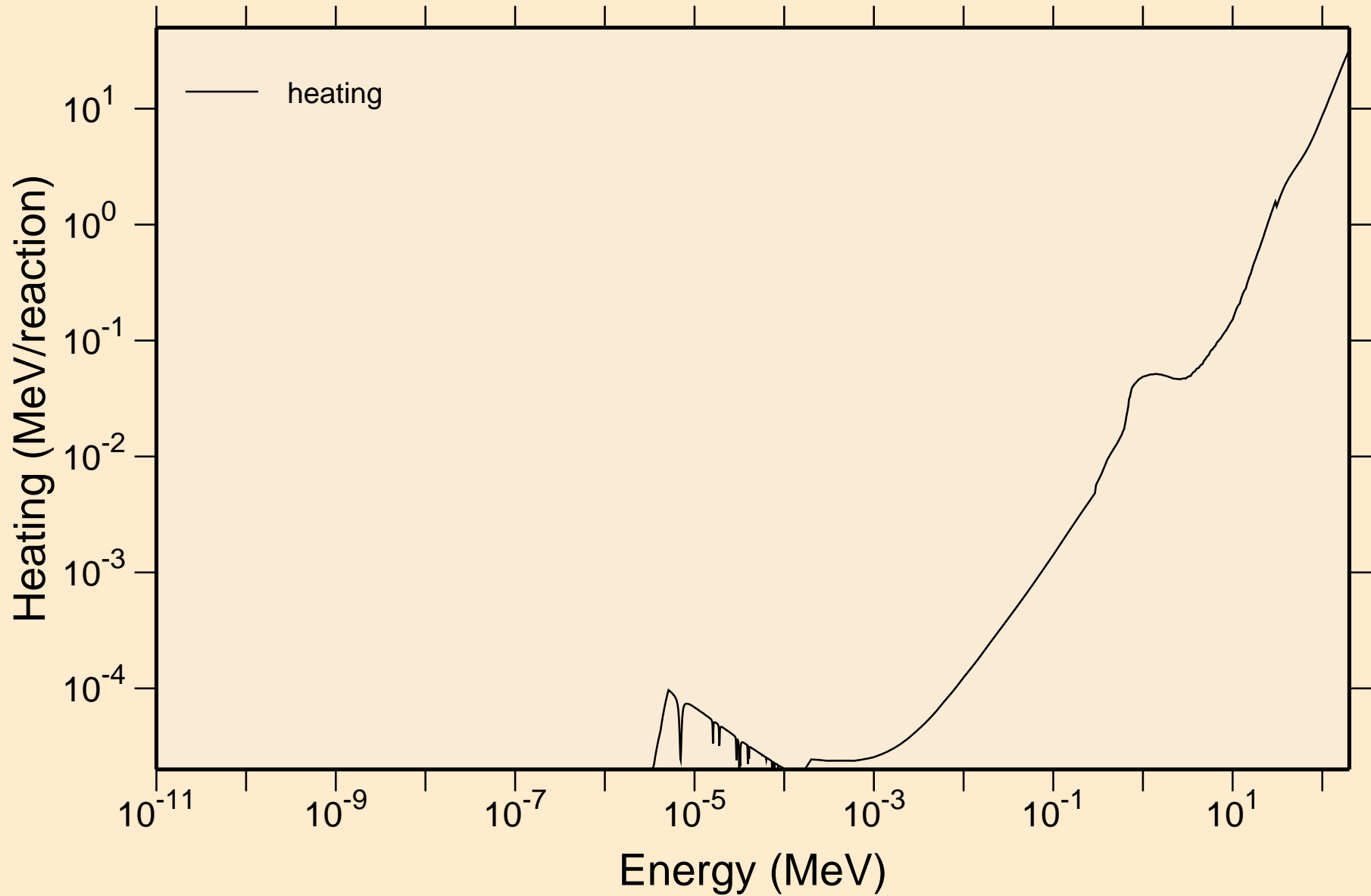

BA133M NEUTRON ACER TENDL-2023 LIBRARY; T=0.K
Damage

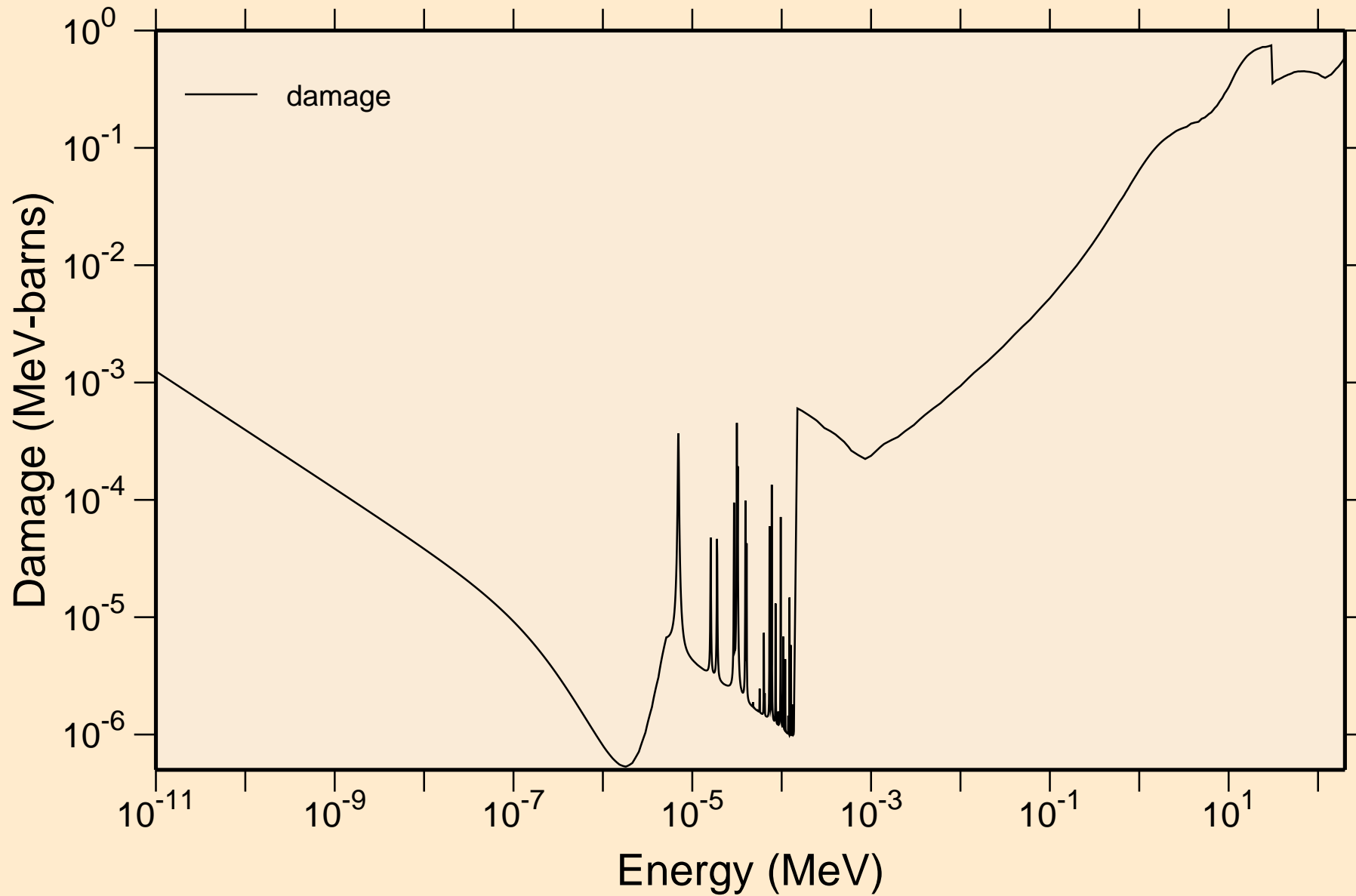

BA133M NEUTRON ACER TENDL-2023 LIBRARY; T=0.K
Non-threshold reactions

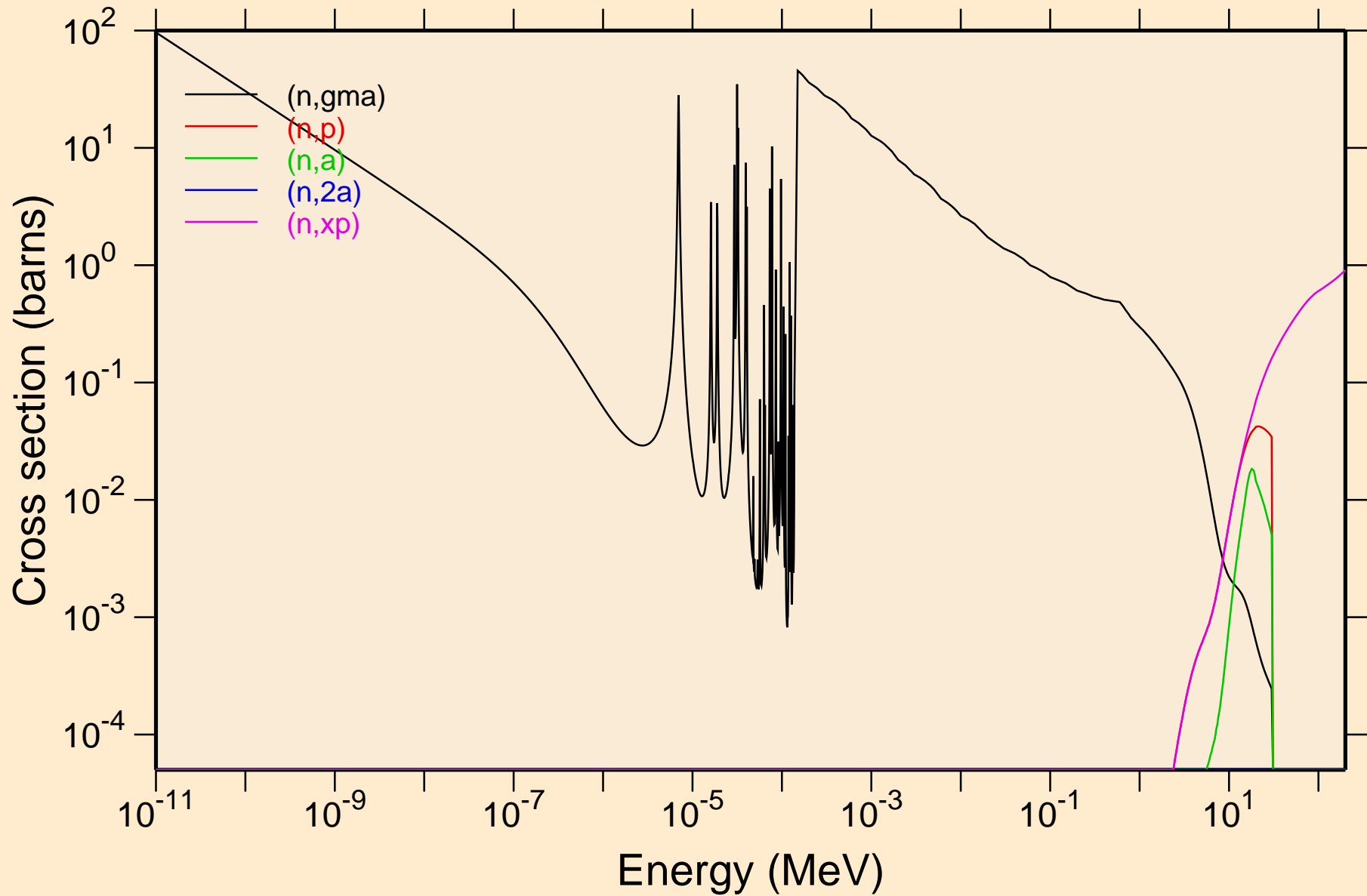

BA133M NEUTRON ACER TENDL-2023 LIBRARY; T=0.K
Non-threshold reactions

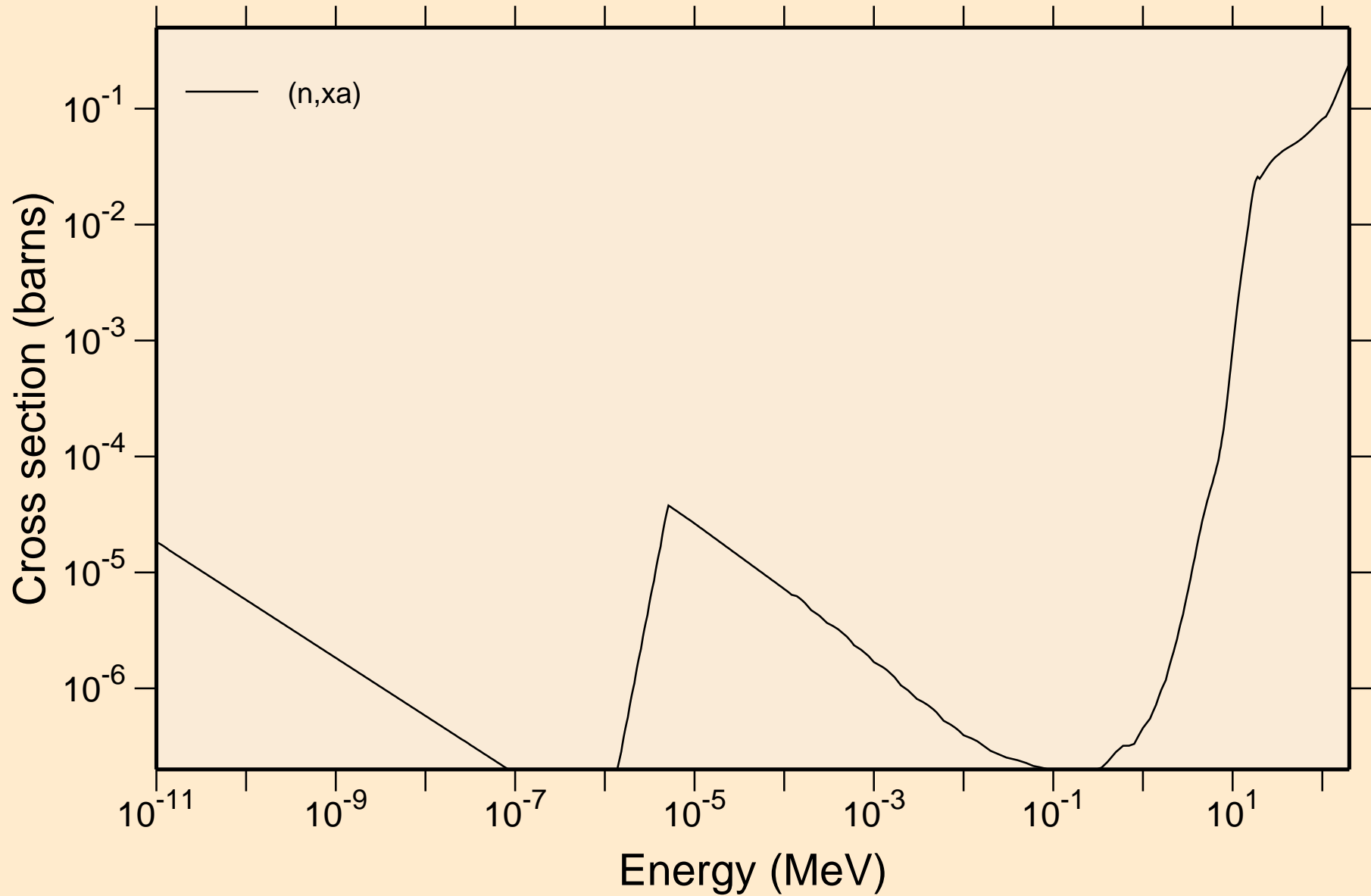

BA133M NEUTRON ACER TENDL-2023 LIBRARY; T=0.K

Principal cross sections

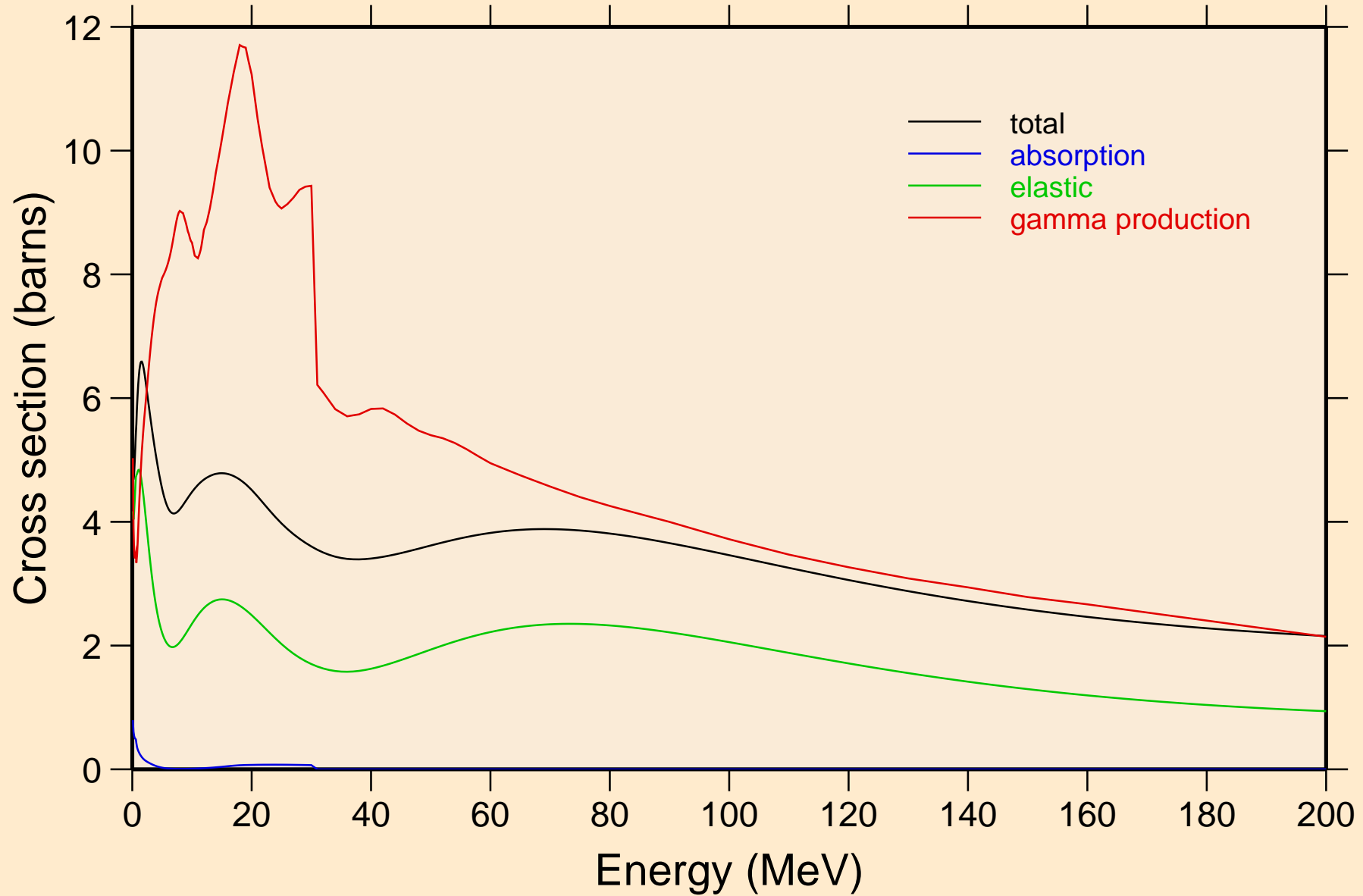

BA133M NEUTRON ACER TENDL-2023 LIBRARY; T=0.K

Heating

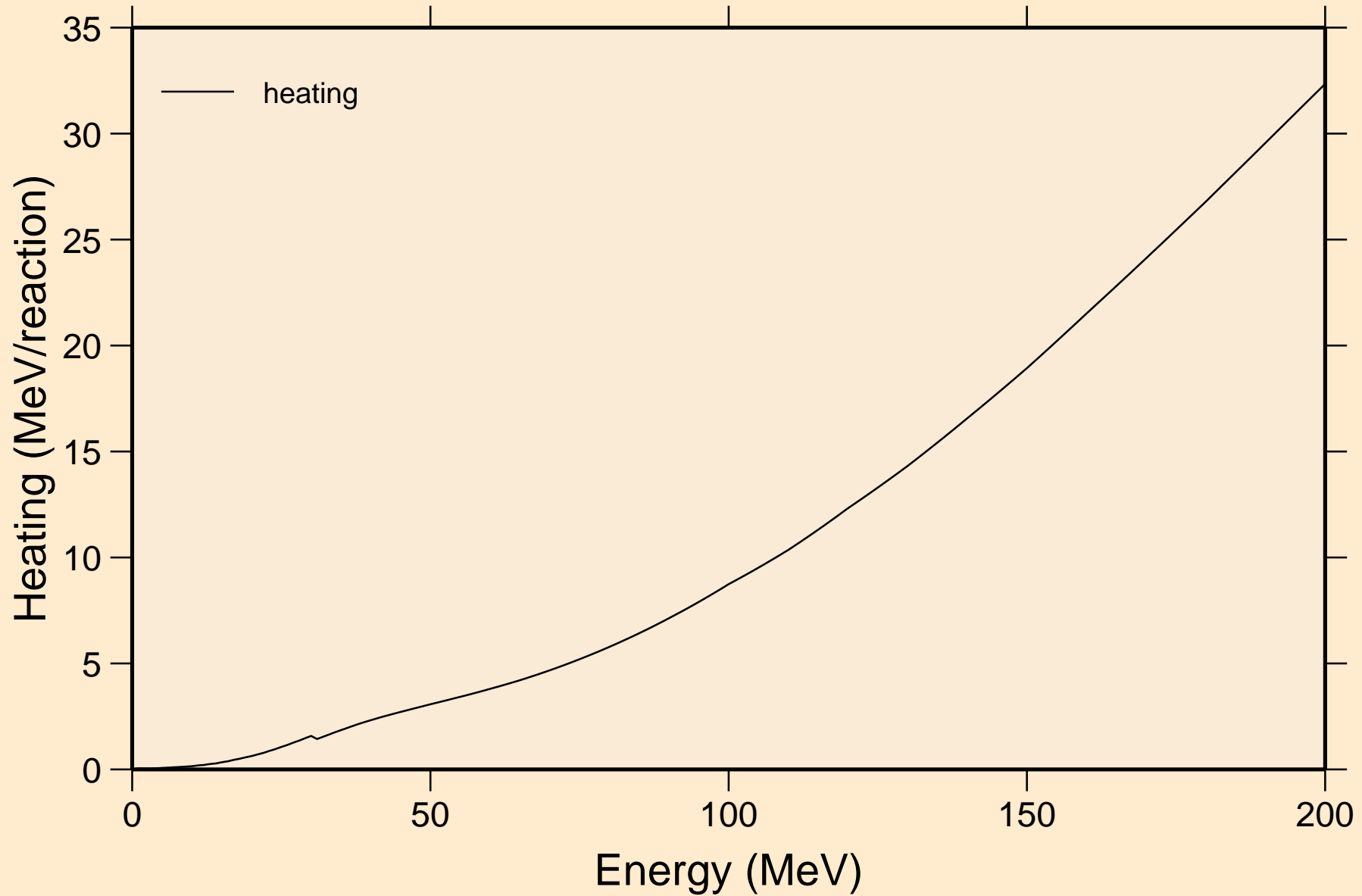

BA133M NEUTRON ACER TENDL-2023 LIBRARY; T=0.K
Damage

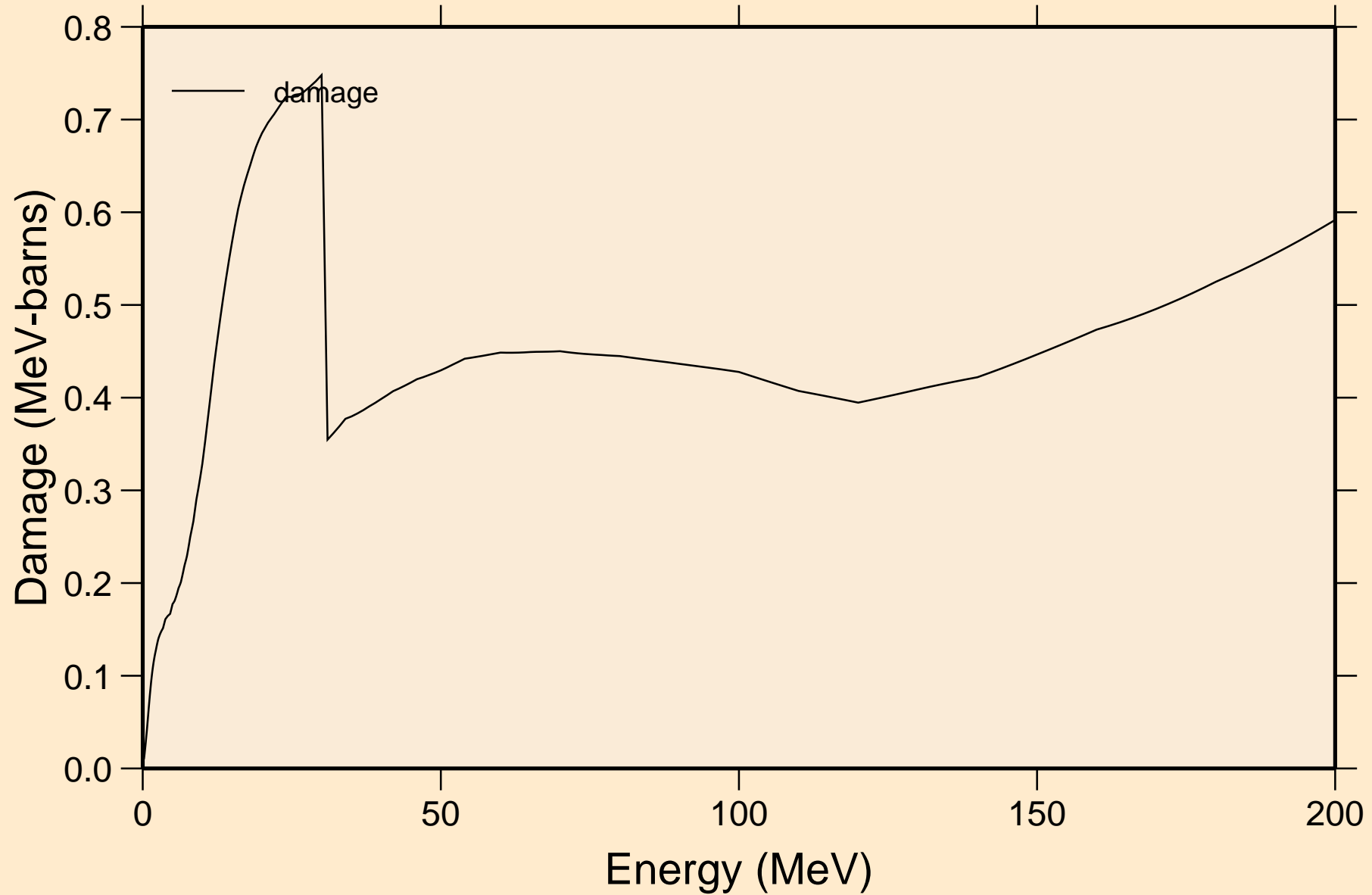

BA133M NEUTRON ACER TENDL-2023 LIBRARY; T=0.K
Non-threshold reactions

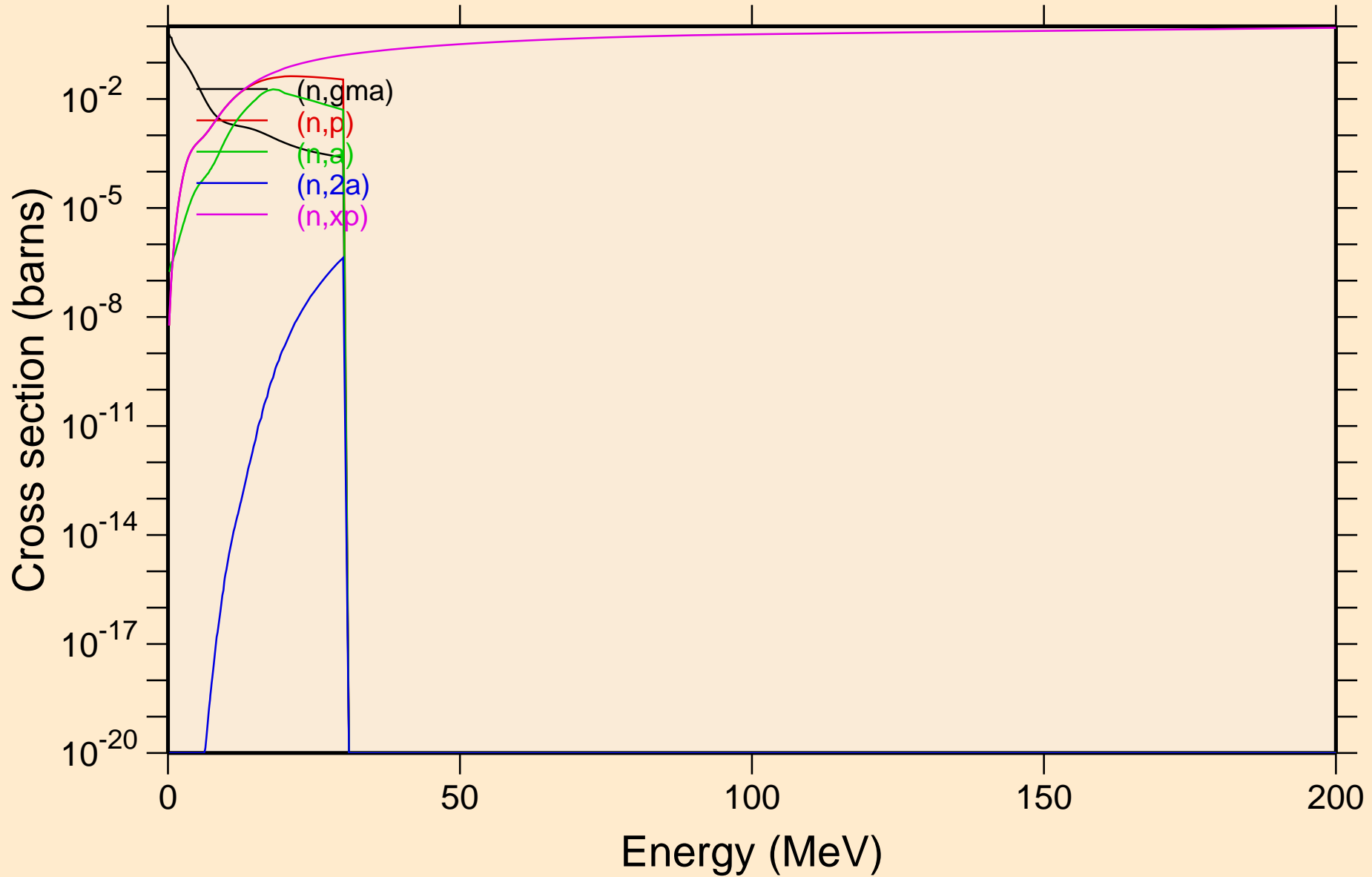

BA133M NEUTRON ACER TENDL-2023 LIBRARY; T=0.K
Non-threshold reactions

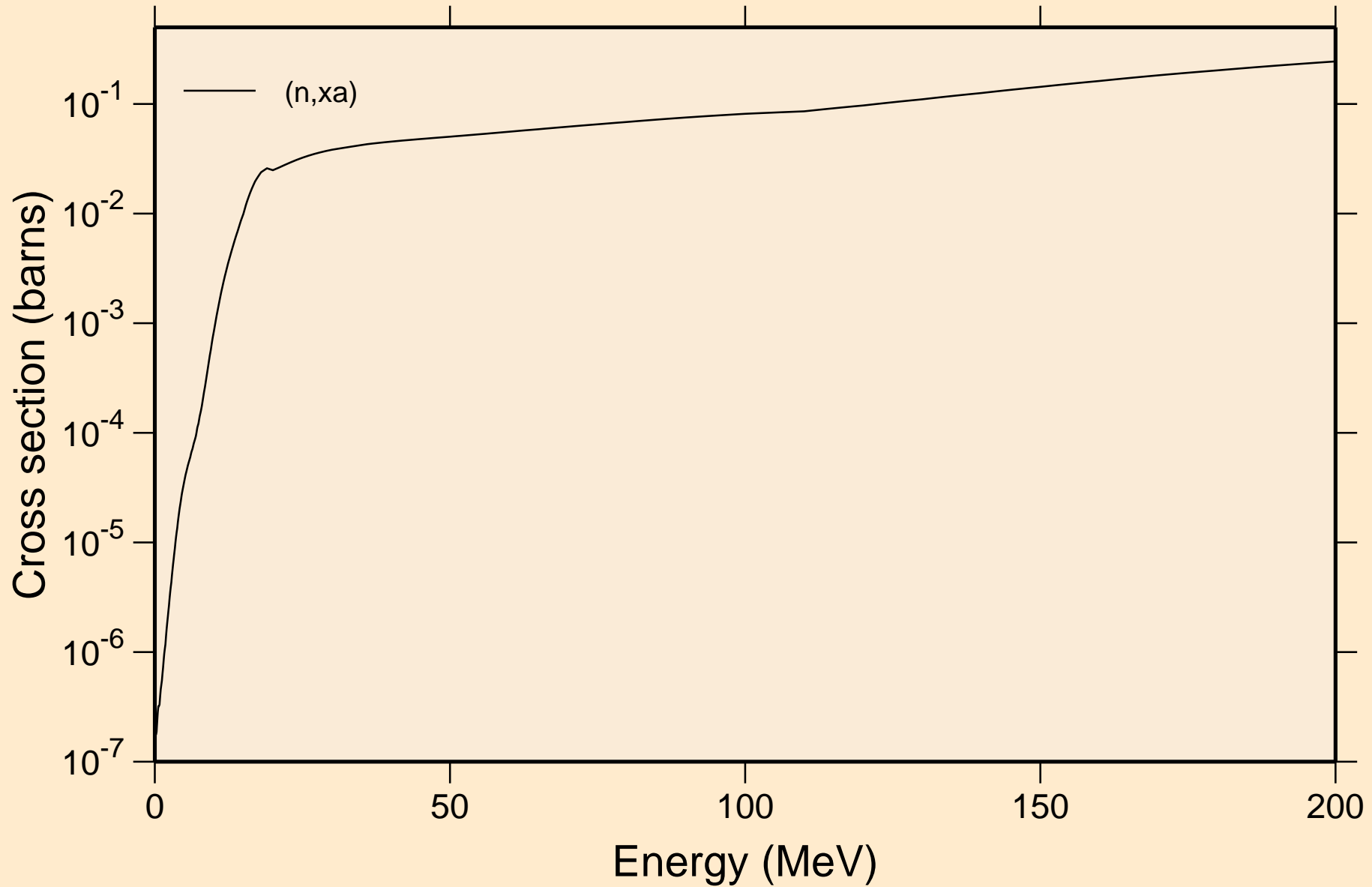

BA133M NEUTRON ACER TENDL-2023 LIBRARY; T=0.K
Inelastic levels

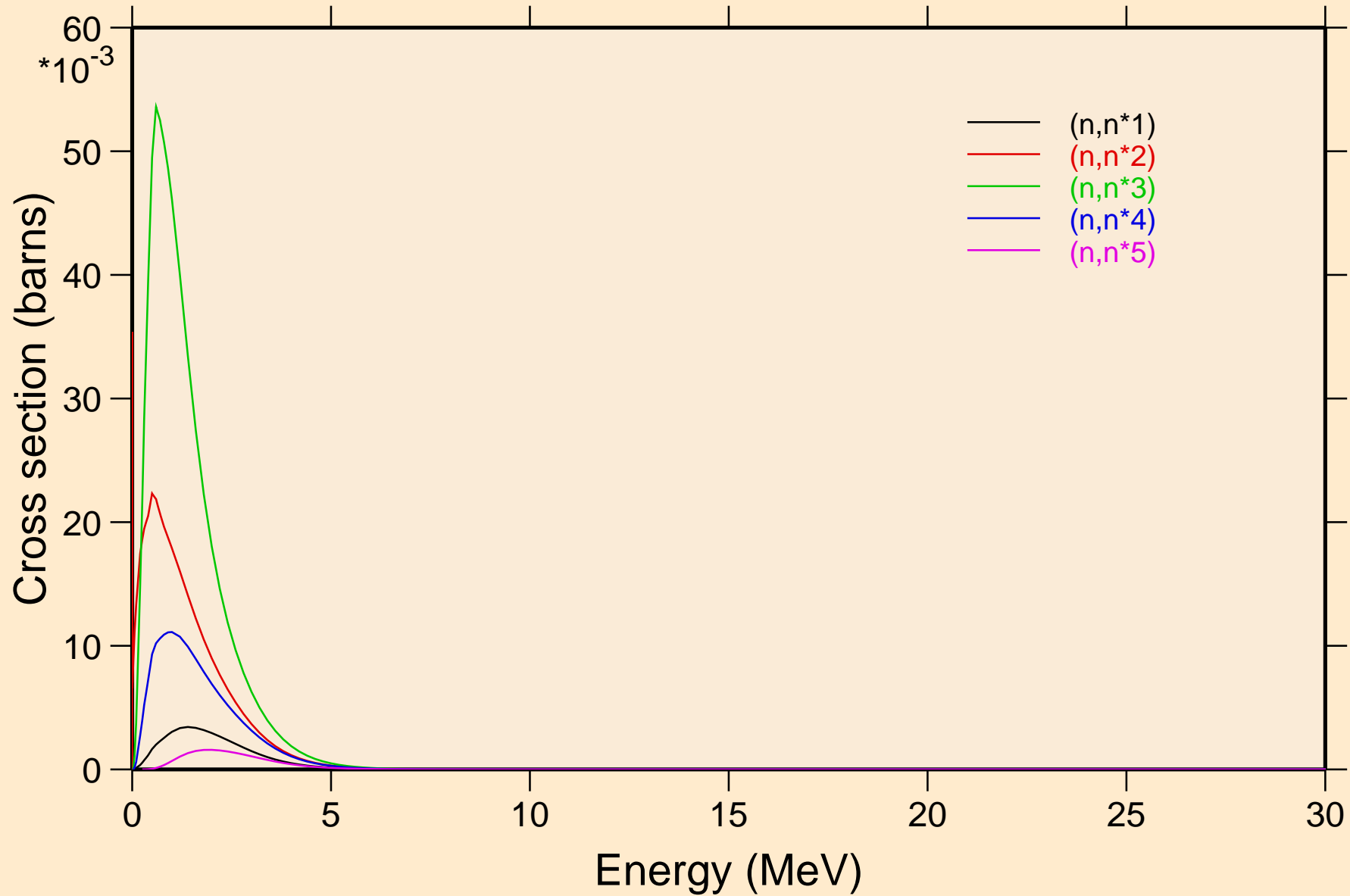

BA133M NEUTRON ACER TENDL-2023 LIBRARY; T=0.K
Inelastic levels

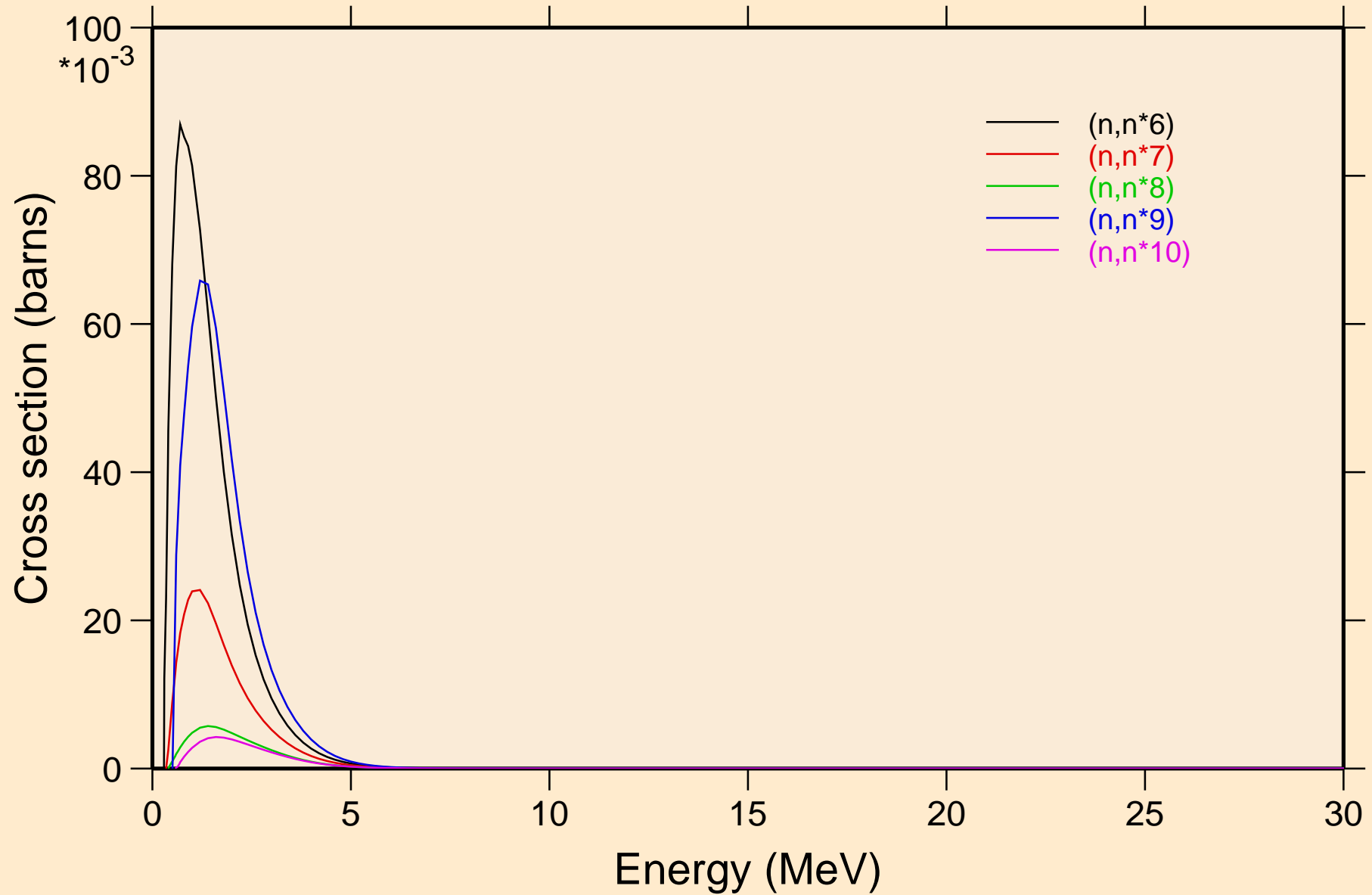

BA133M NEUTRON ACER TENDL-2023 LIBRARY; T=0.K
Inelastic levels

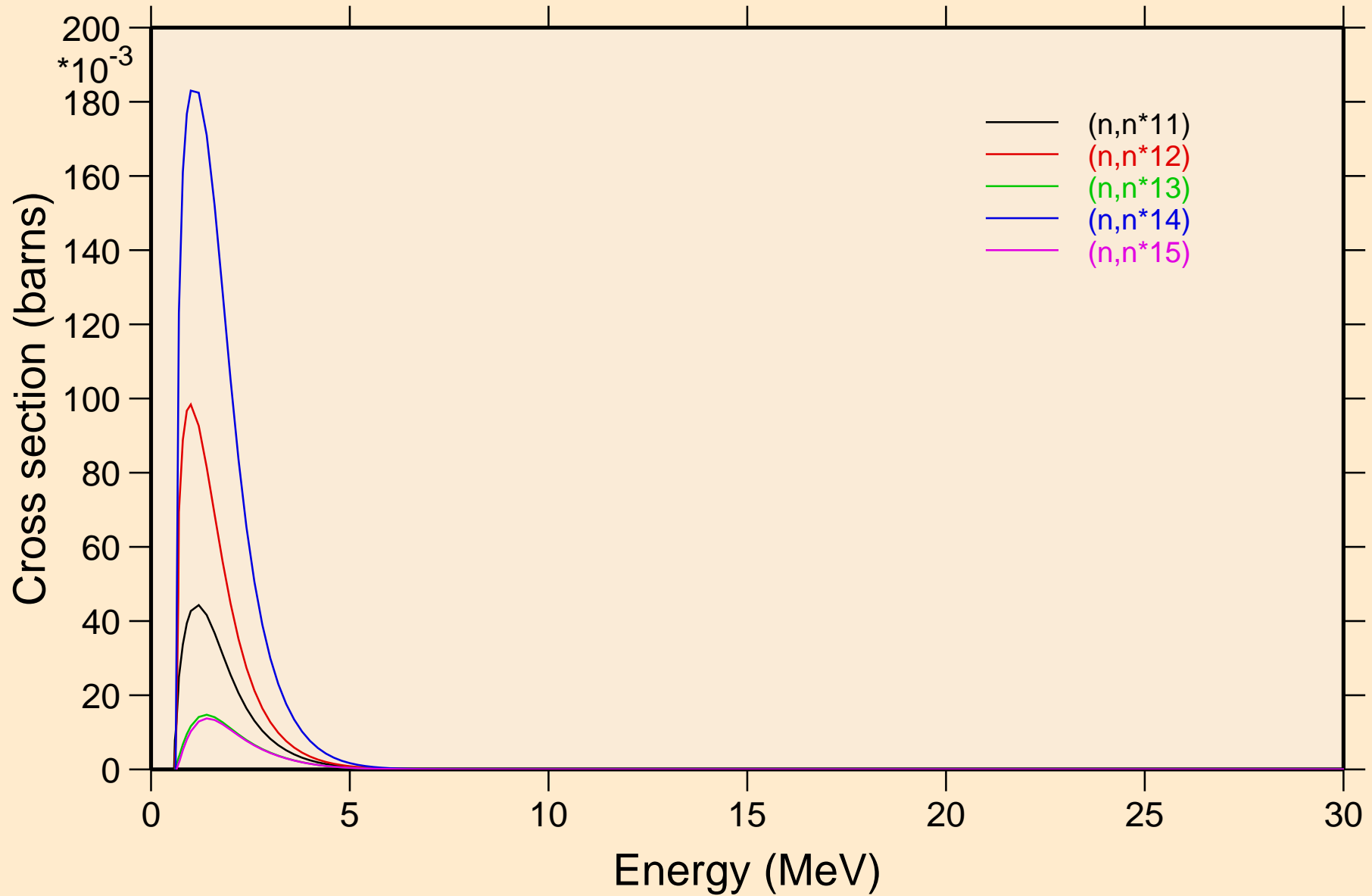

BA133M NEUTRON ACER TENDL-2023 LIBRARY; T=0.K
Inelastic levels

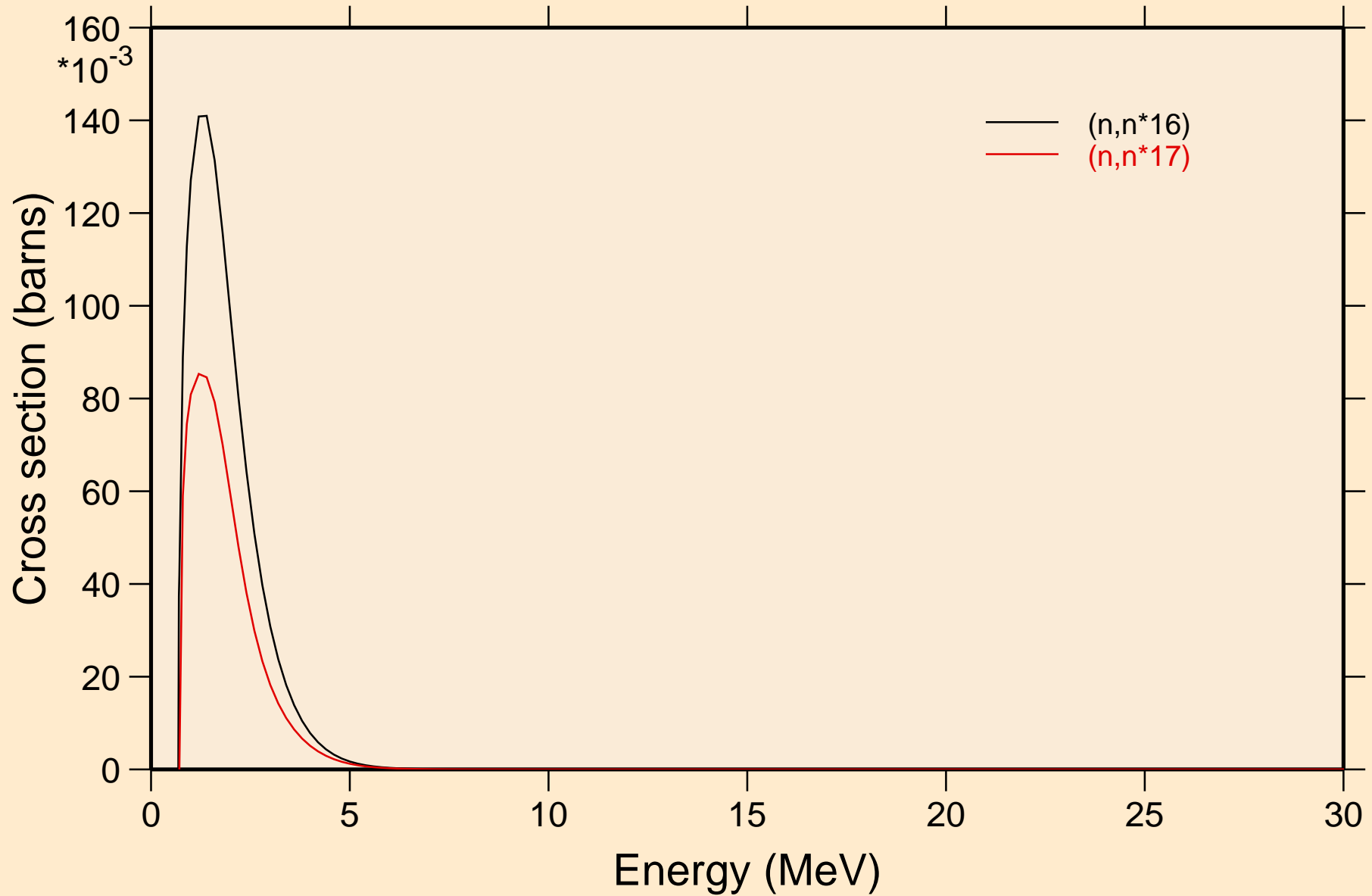

BA133M NEUTRON ACER TENDL-2023 LIBRARY; T=0.K
Threshold reactions

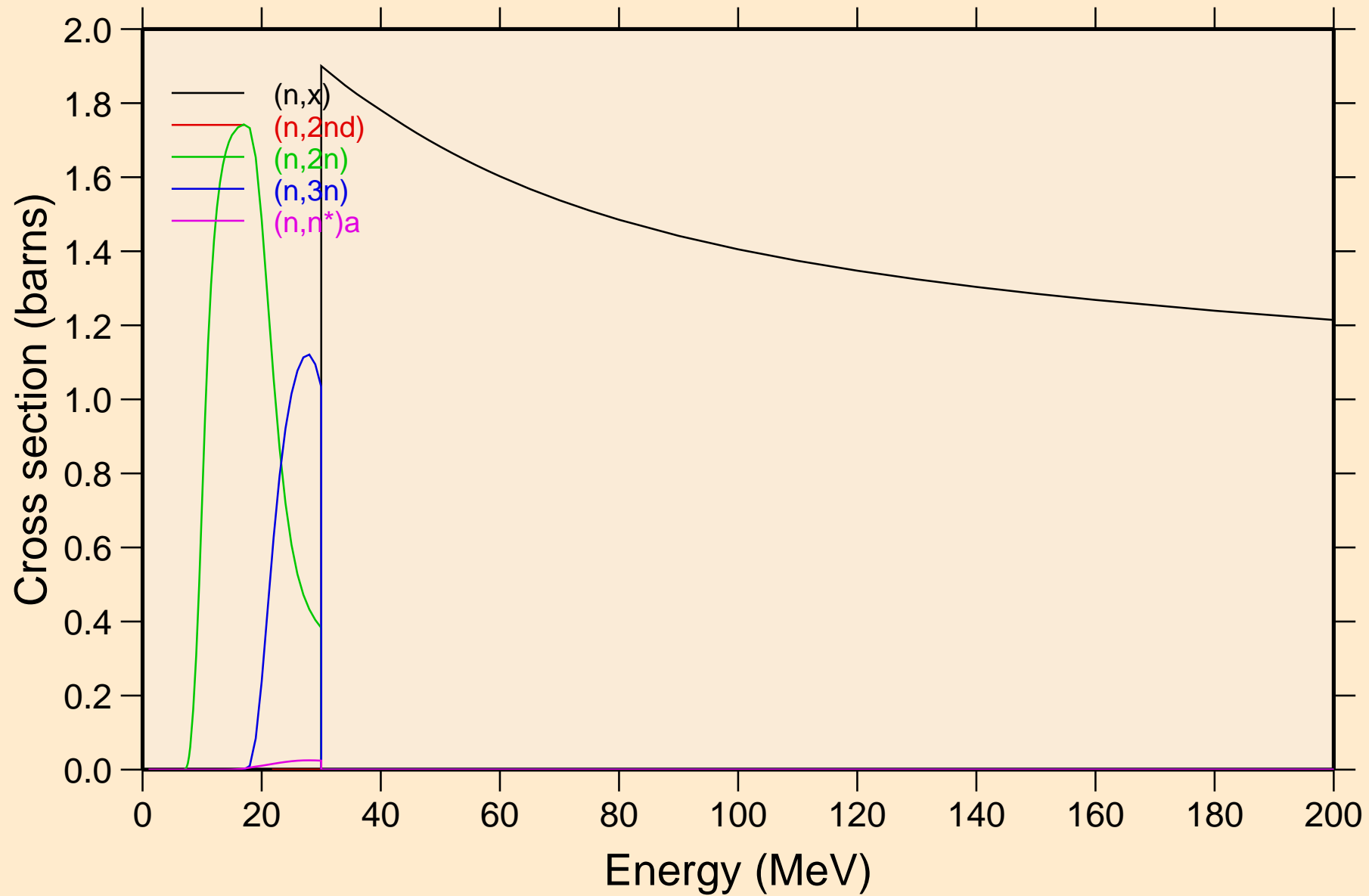

BA133M NEUTRON ACER TENDL-2023 LIBRARY; T=0.K
Threshold reactions

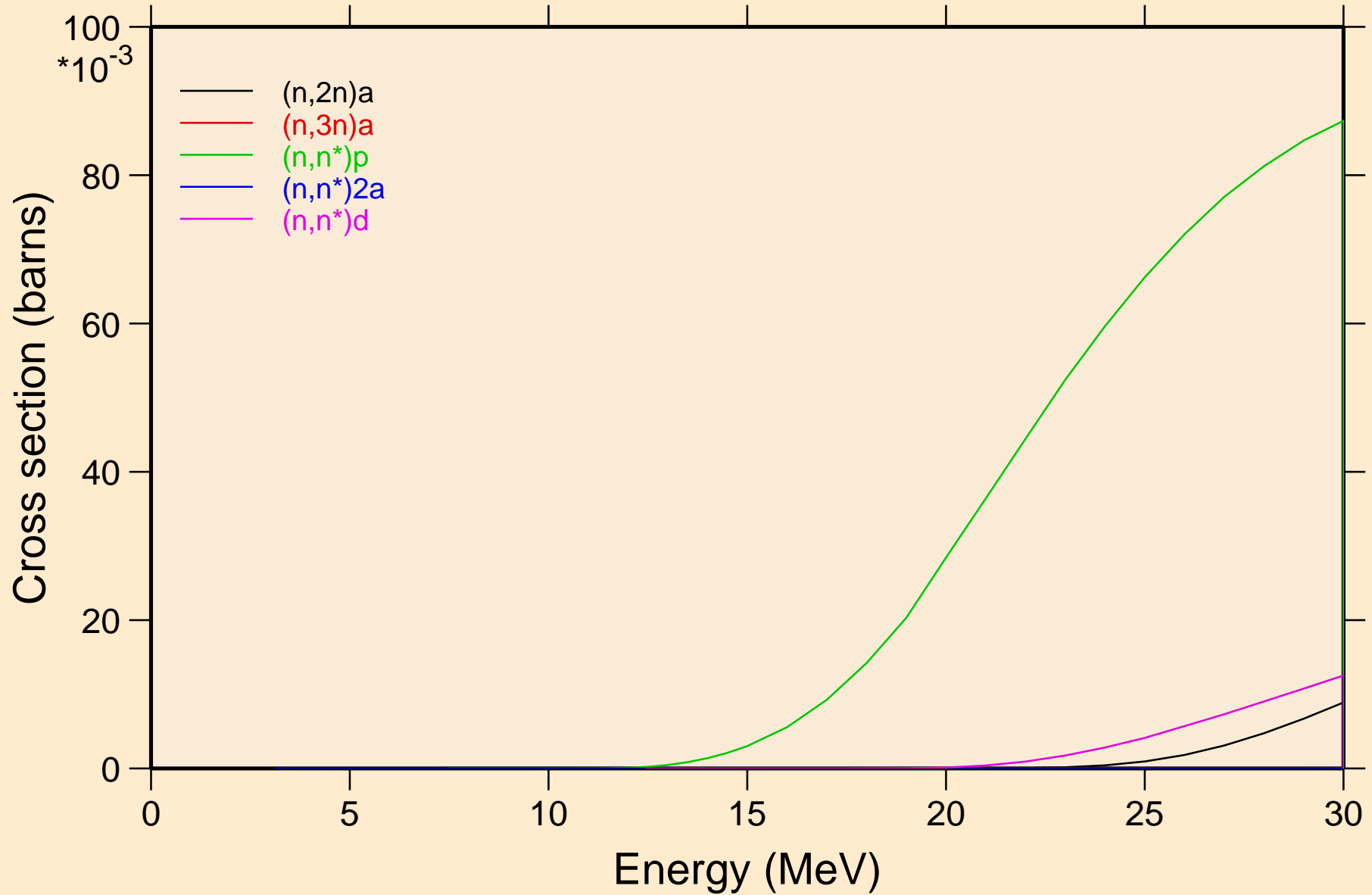

BA133M NEUTRON ACER TENDL-2023 LIBRARY; T=0.K
Threshold reactions

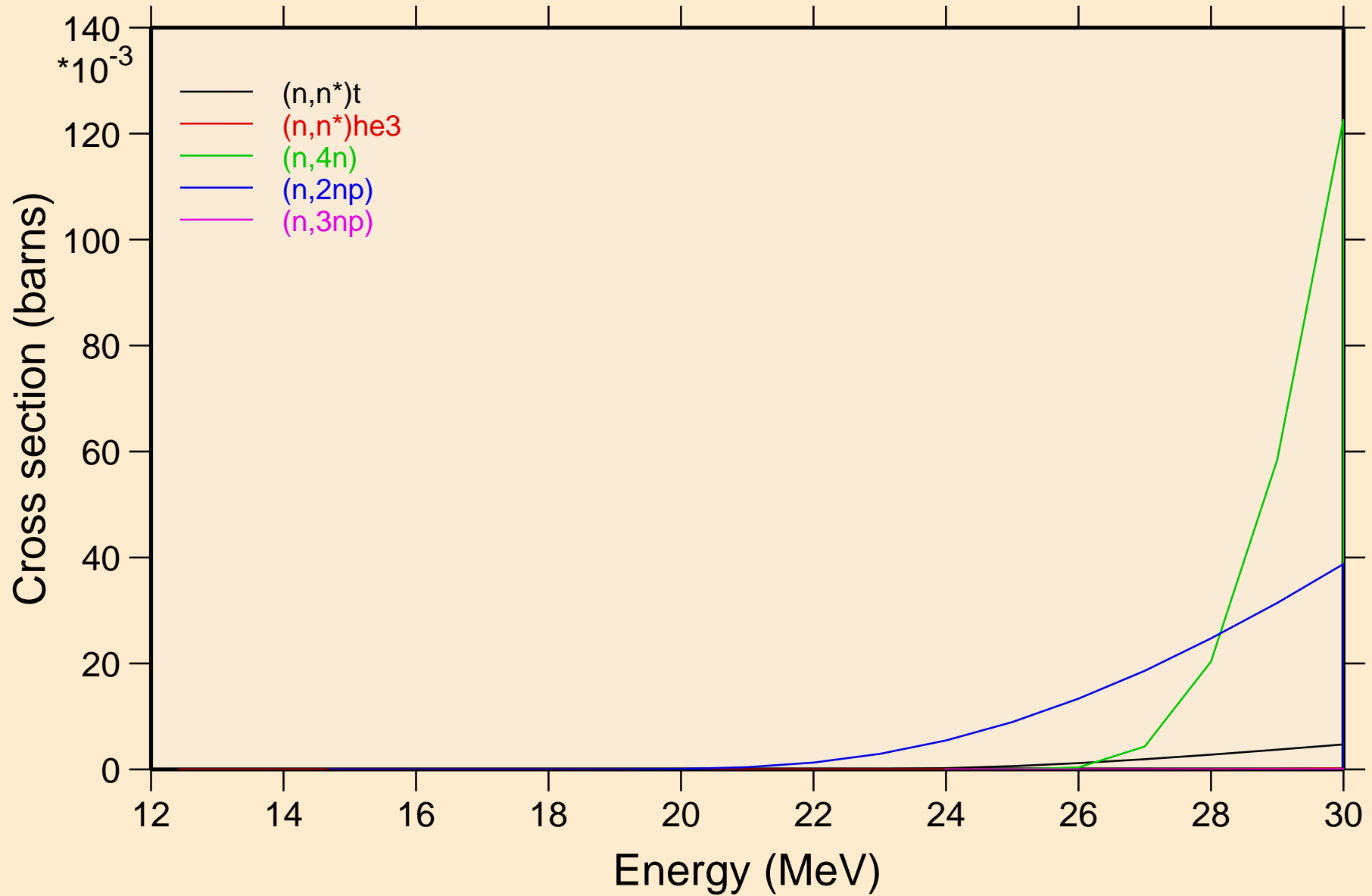

BA133M NEUTRON ACER TENDL-2023 LIBRARY; T=0.K
Threshold reactions

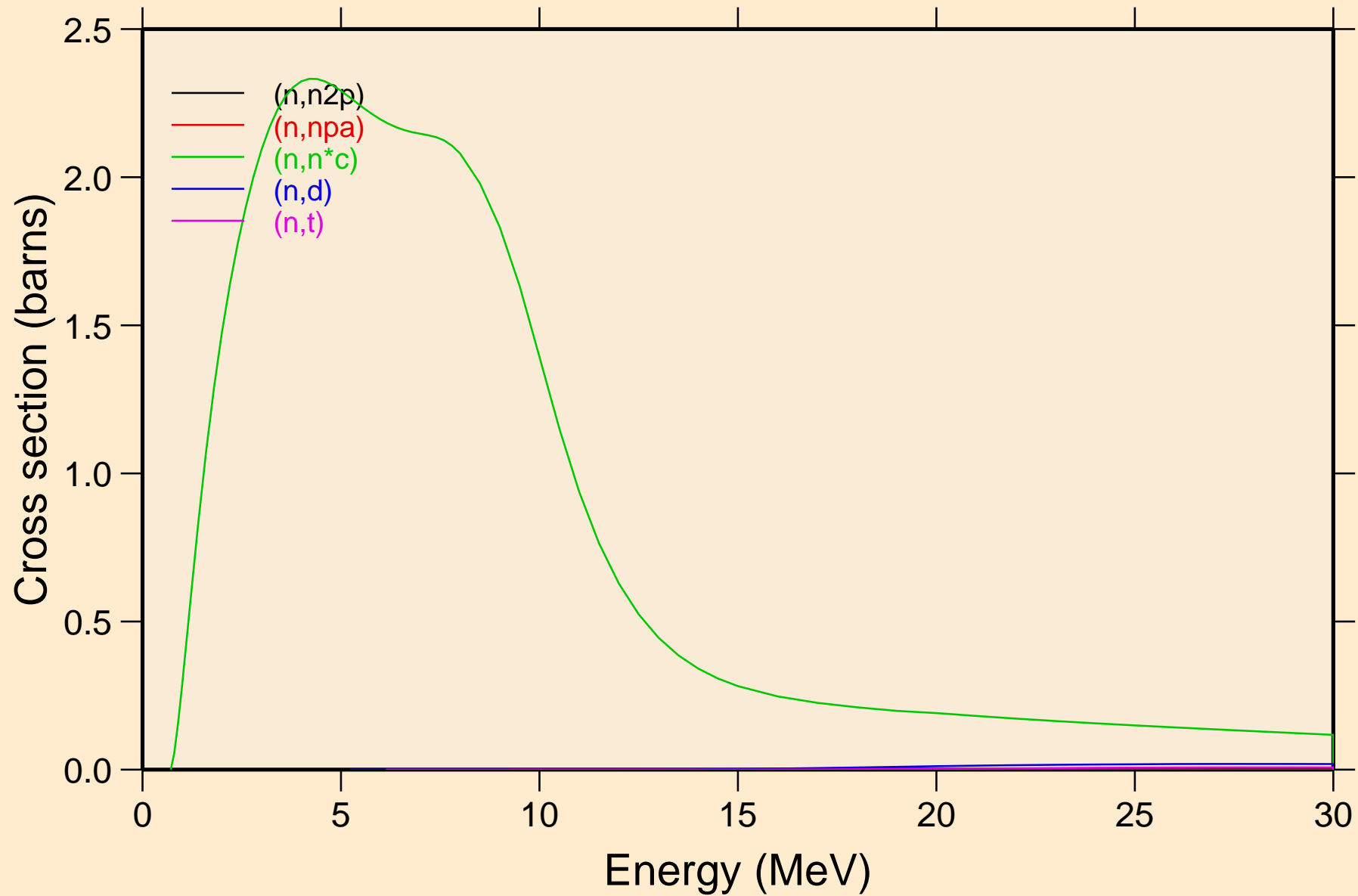

BA133M NEUTRON ACER TENDL-2023 LIBRARY; T=0.K
Threshold reactions

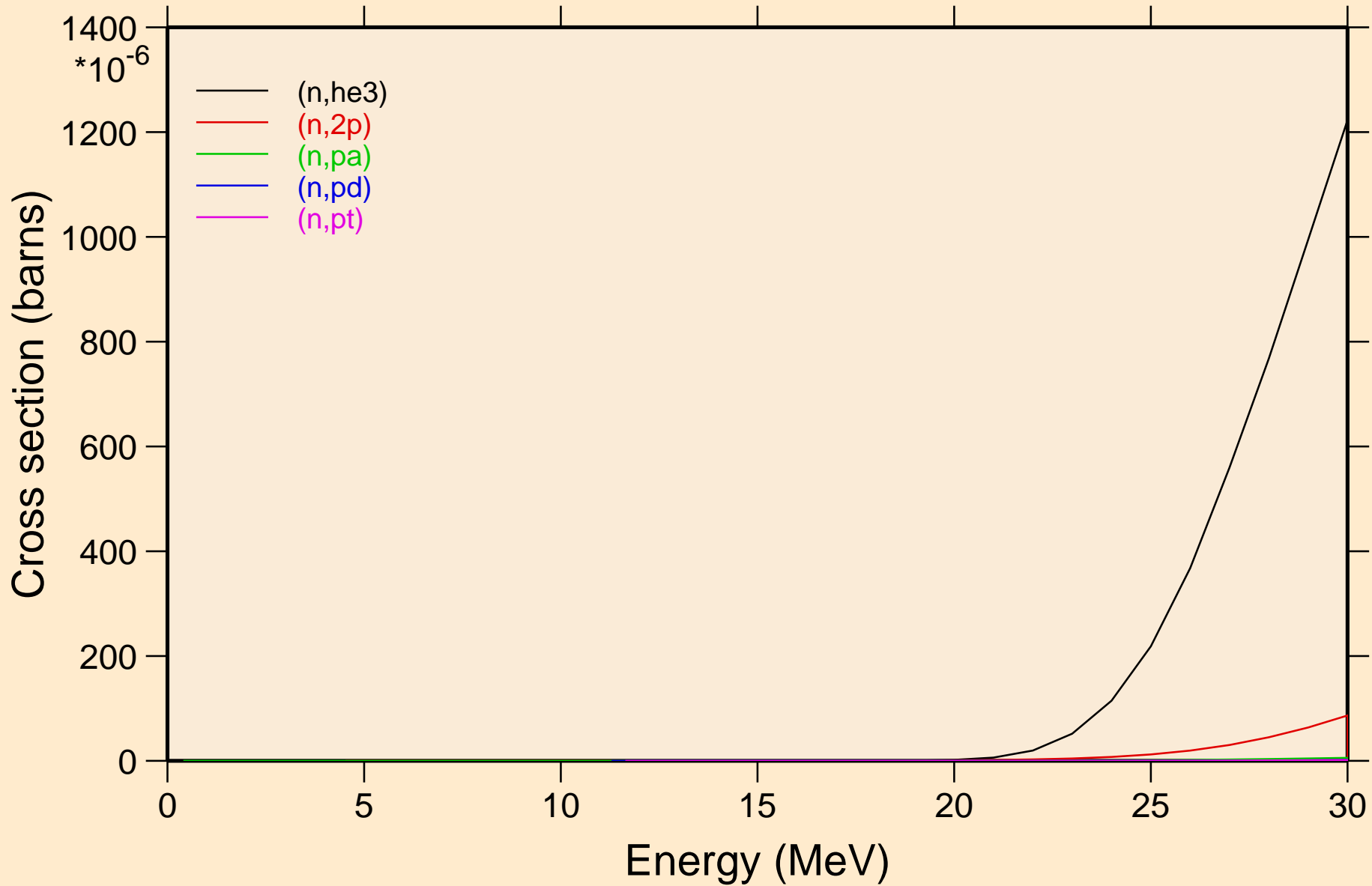

BA133M NEUTRON ACER TENDL-2023 LIBRARY; T=0.K
Threshold reactions

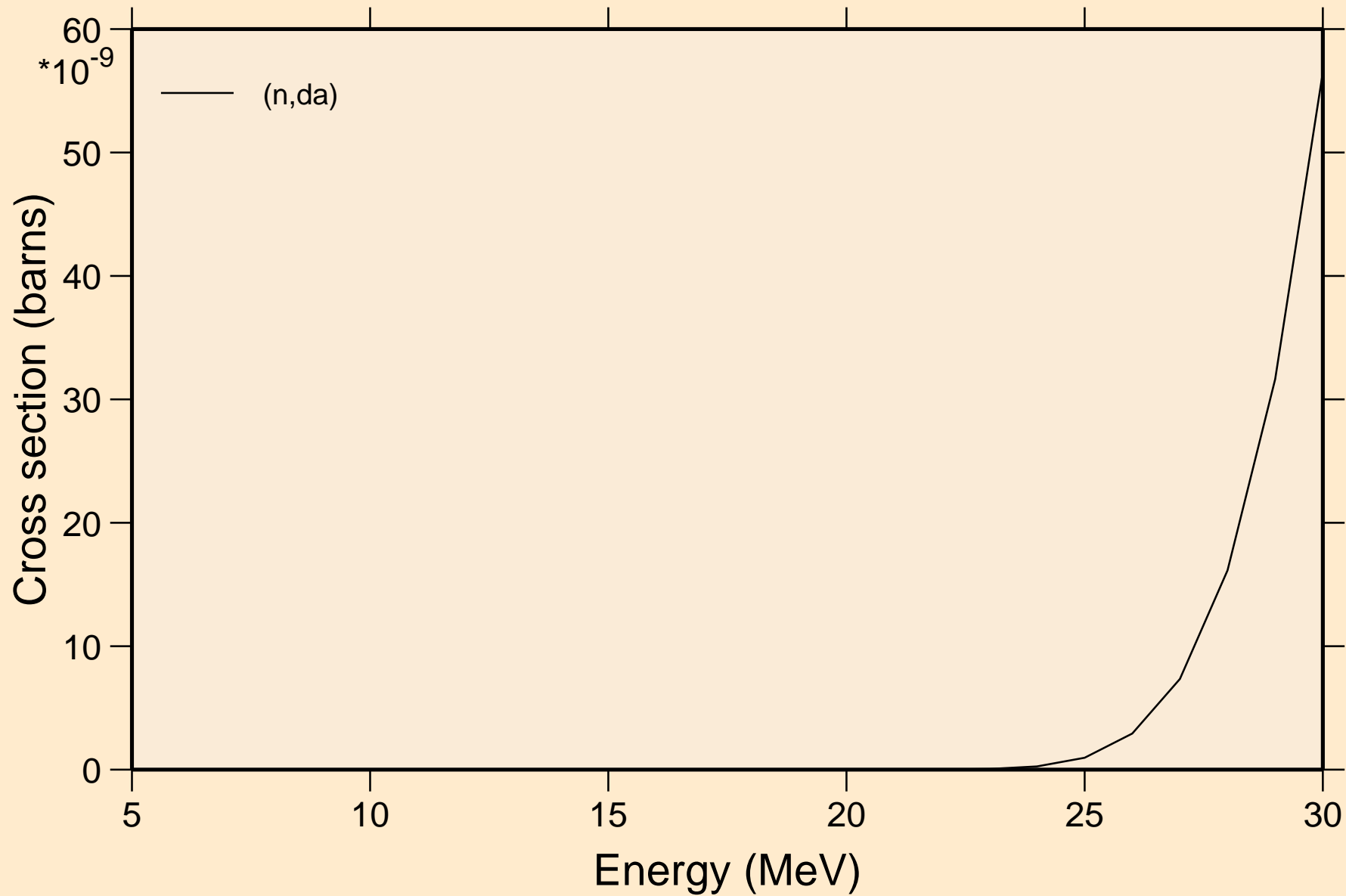

BA133M NEUTRON ACER TENDL-2023 LIBRARY; T=0.K
Threshold reactions

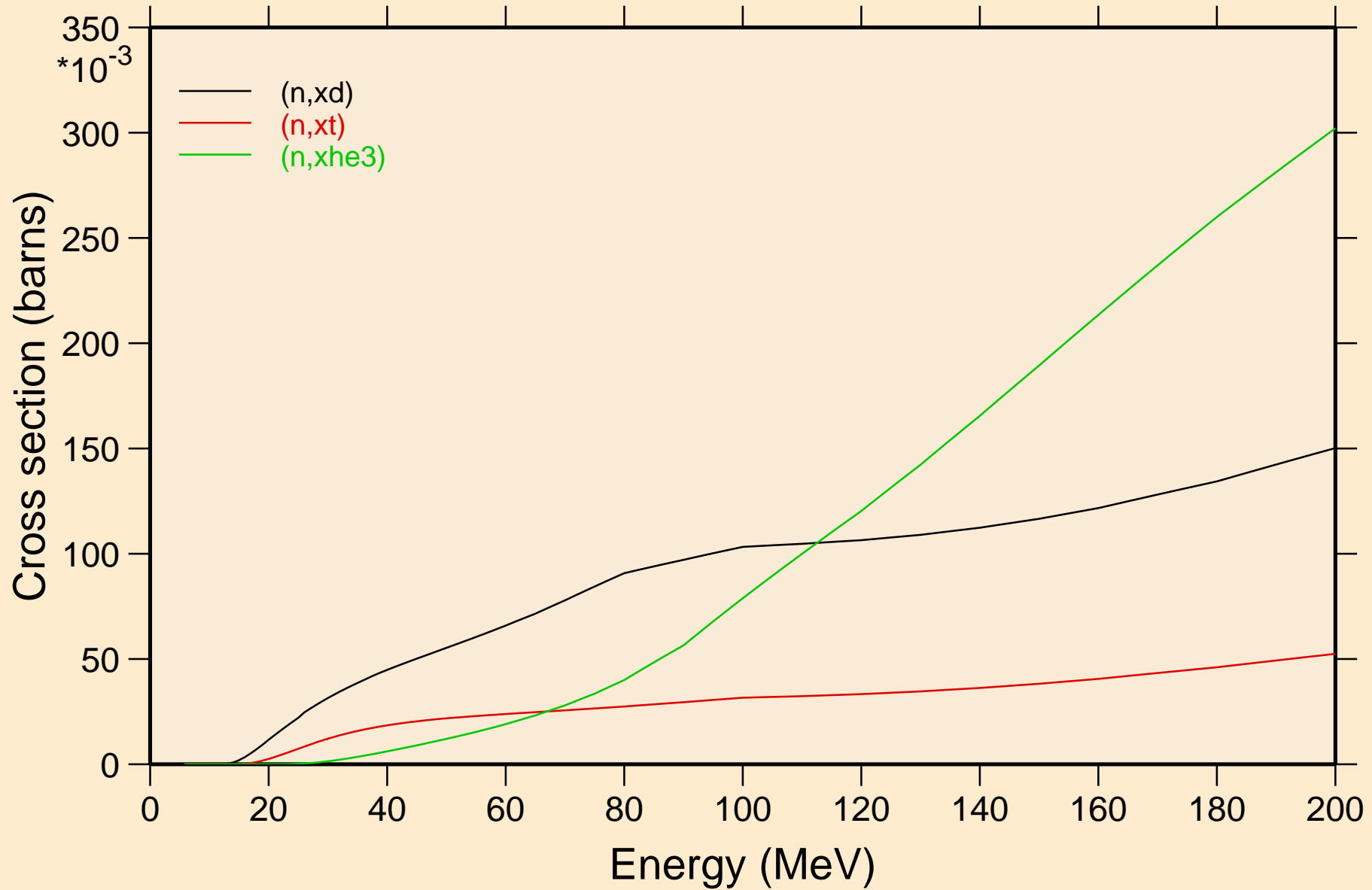

BA133M NEUTRON ACER TENDL-2023 LIBRARY; T=0.K
angular distribution for elastic

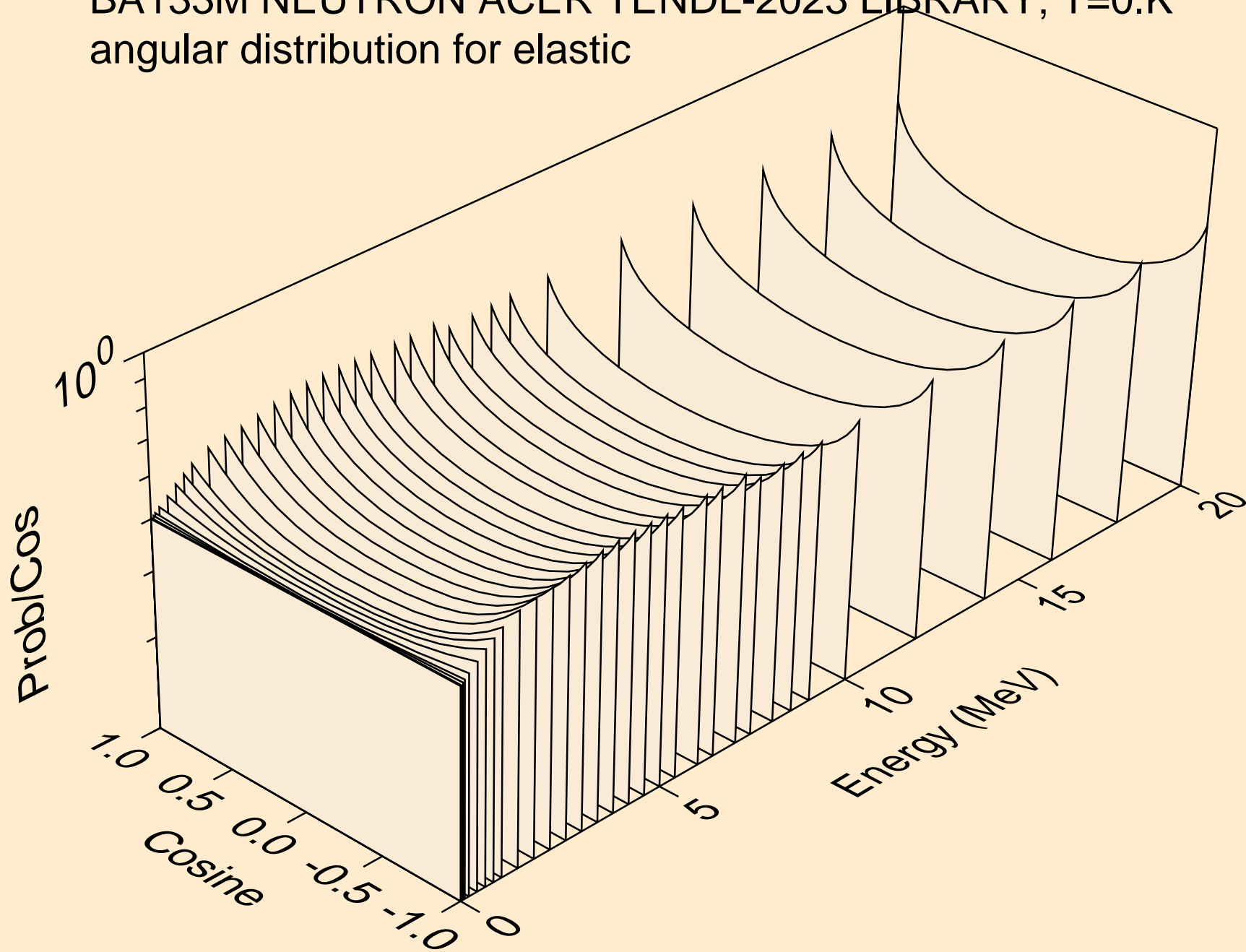

BA133M NEUTRON ACER TENDL-2023 LIBRARY; T=0.K
angular distribution for elastic

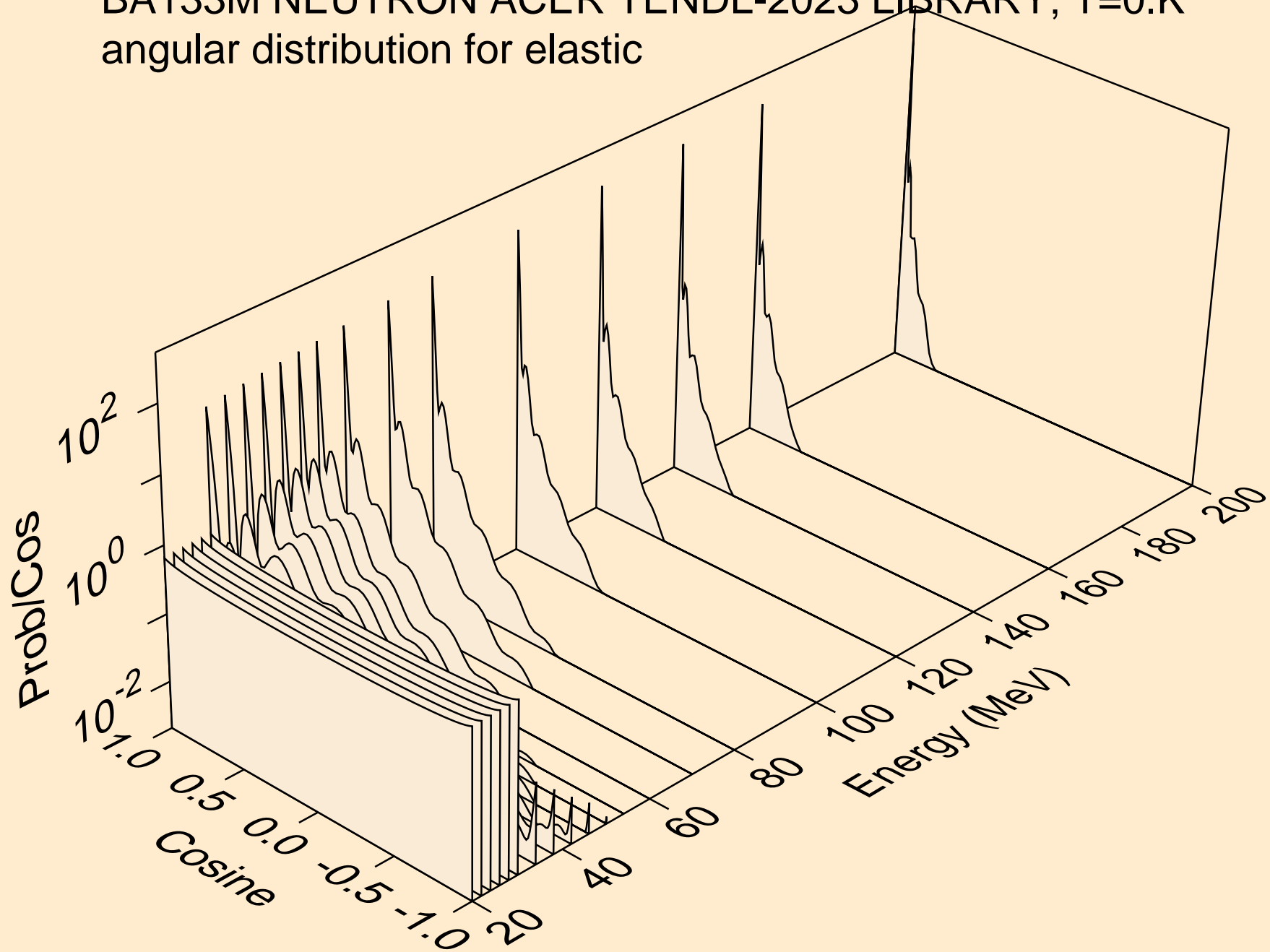

BA133M NEUTRON ACER TENDL-2023 LIBRARY; T=0.K
angular distribution for (n,n*1)

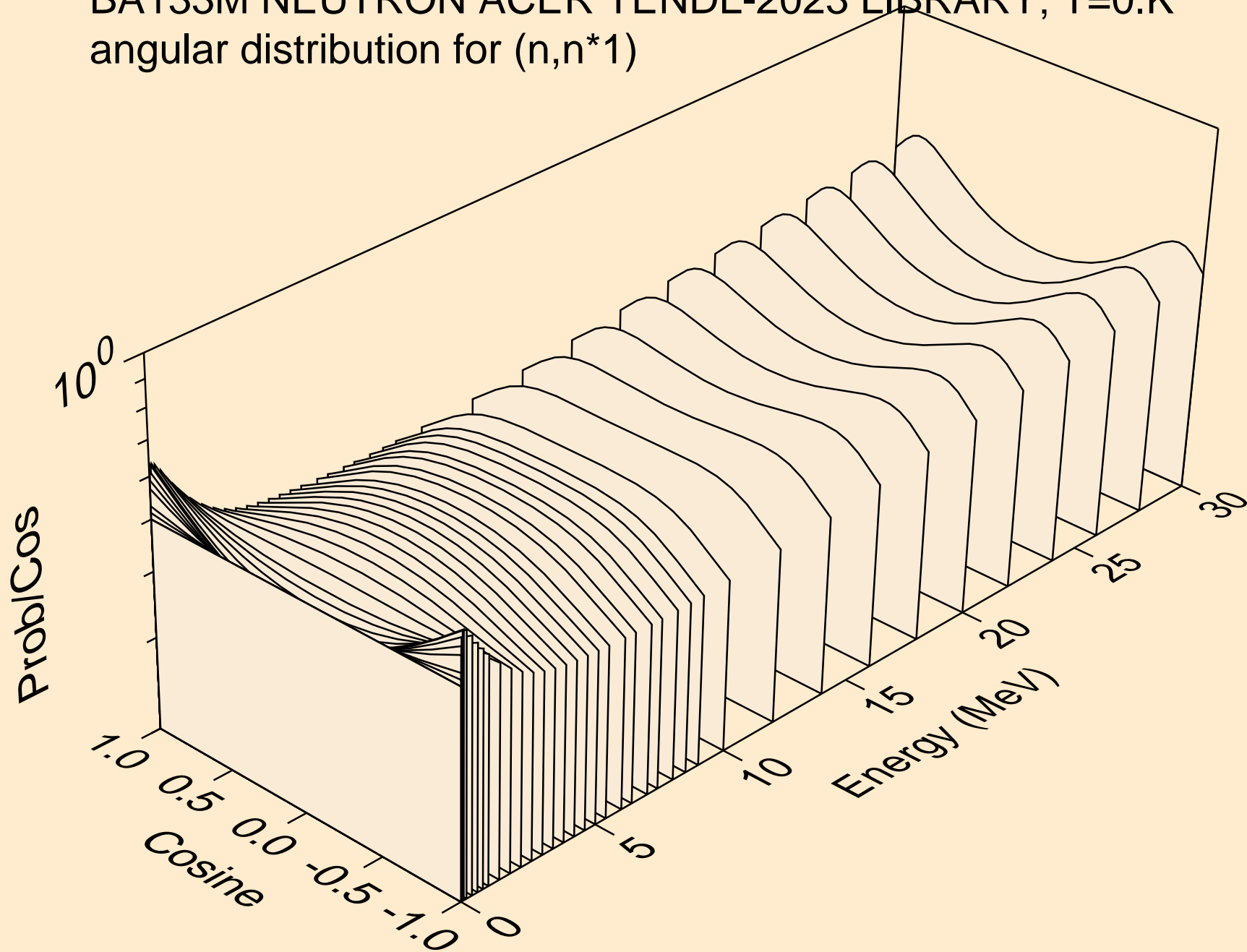

BA133M NEUTRON ACER TENDL-2023 LIBRARY; T=0.K
angular distribution for (n,n*2)

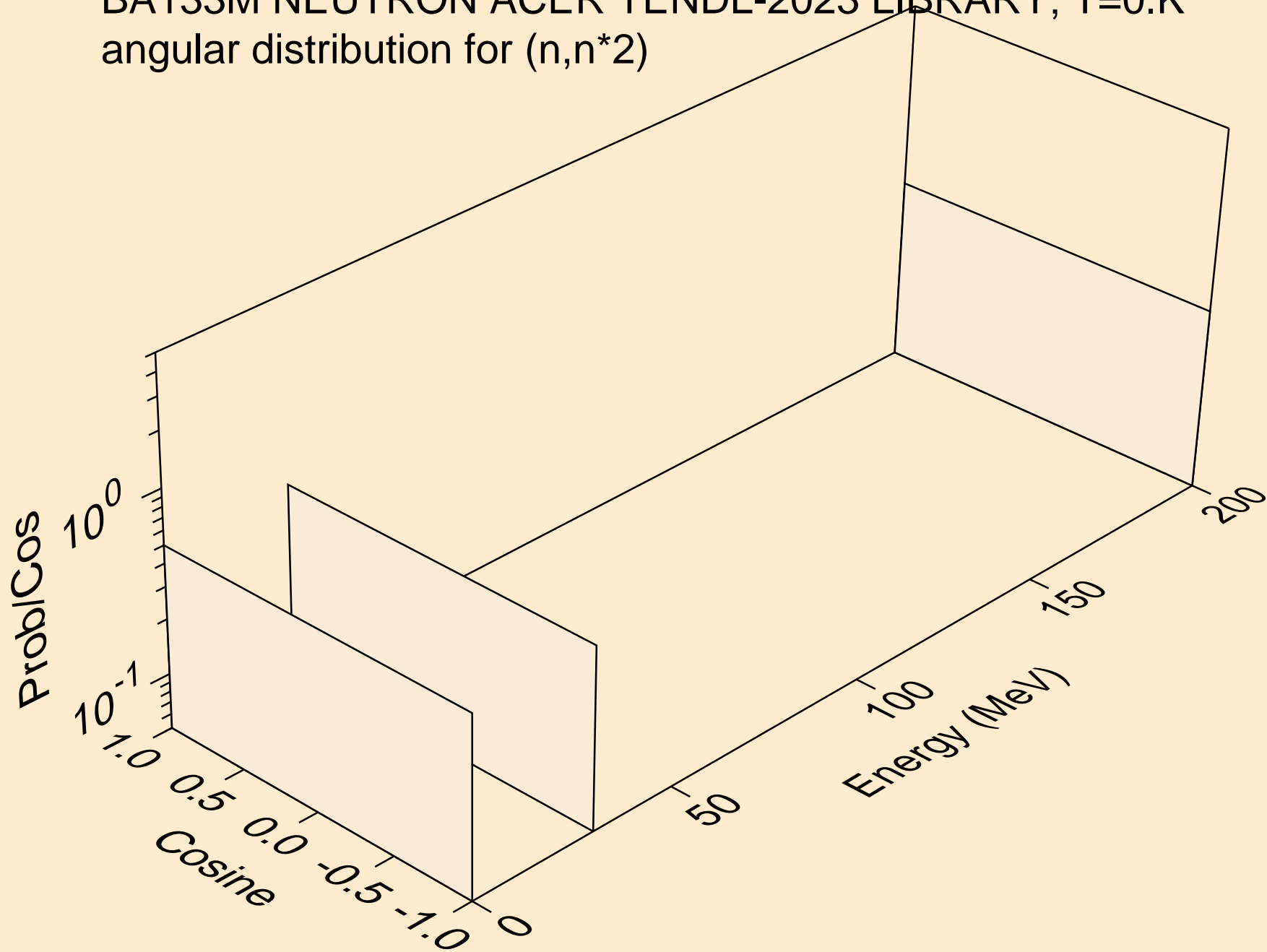

BA133M NEUTRON ACER TENDL-2023 LIBRARY; T=0.K
angular distribution for (n,n*3)

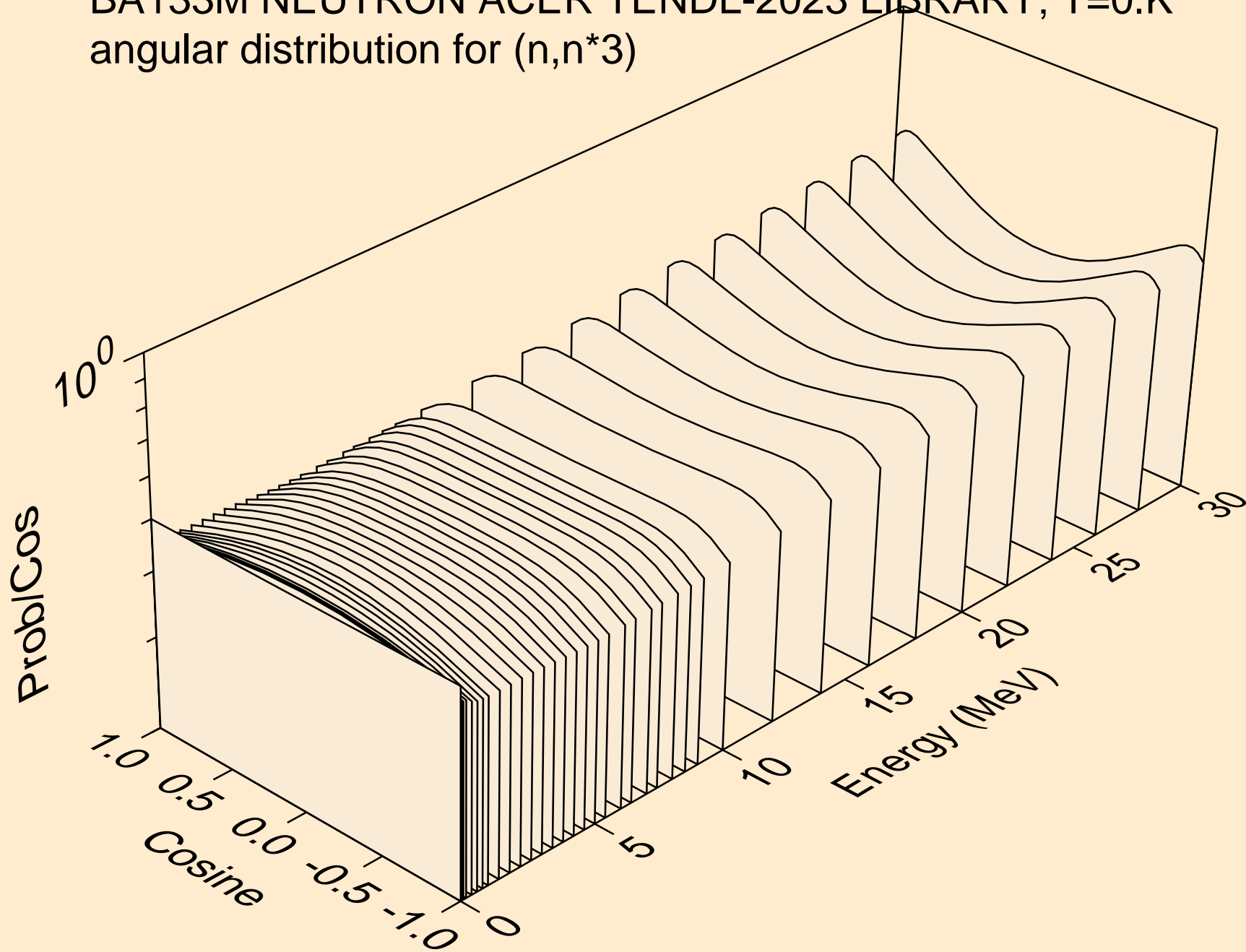

BA133M NEUTRON ACER TENDL-2023 LIBRARY; T=0.K
angular distribution for (n,n*4)

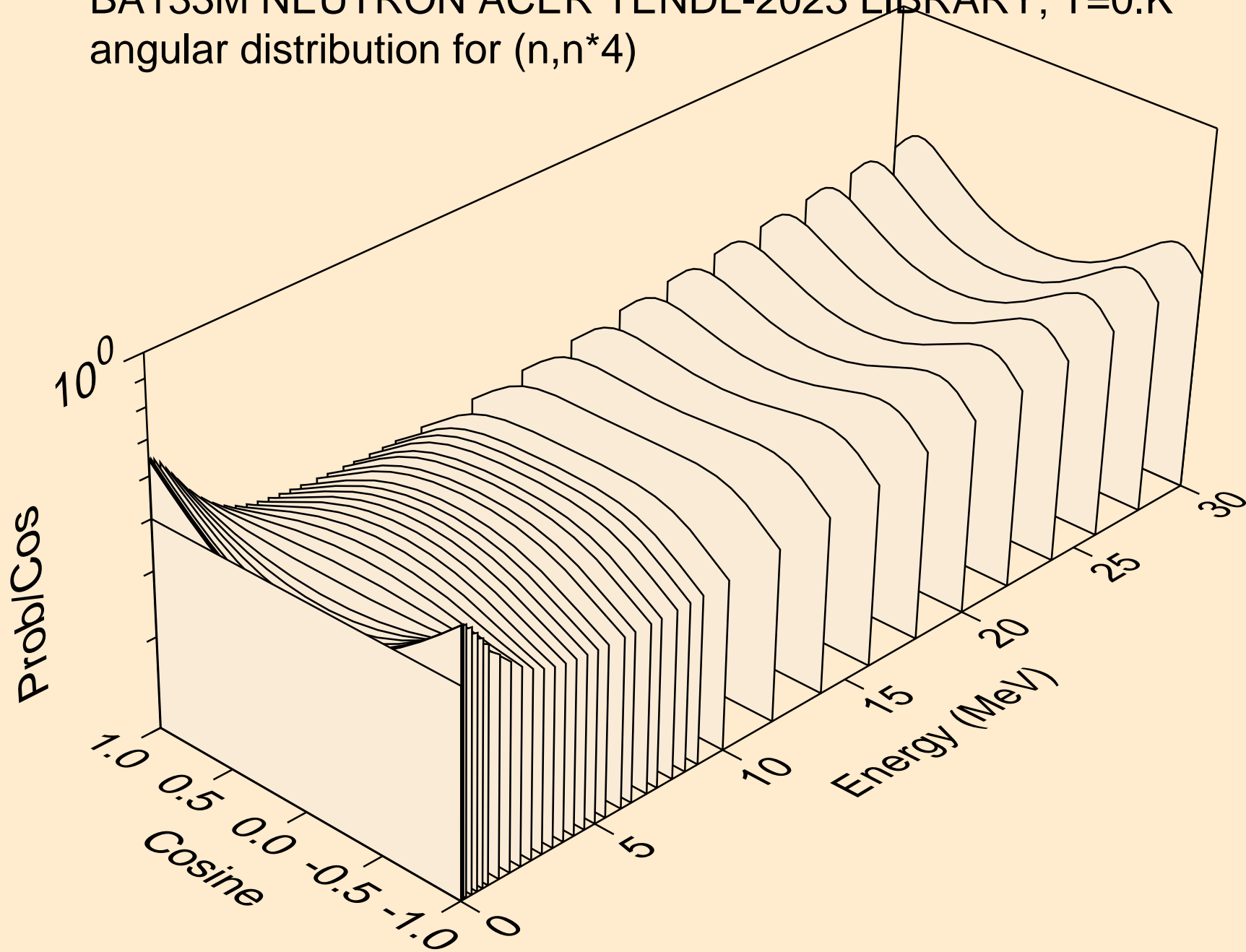

BA133M NEUTRON ACER TENDL-2023 LIBRARY; T=0.K
angular distribution for (n,n*5)

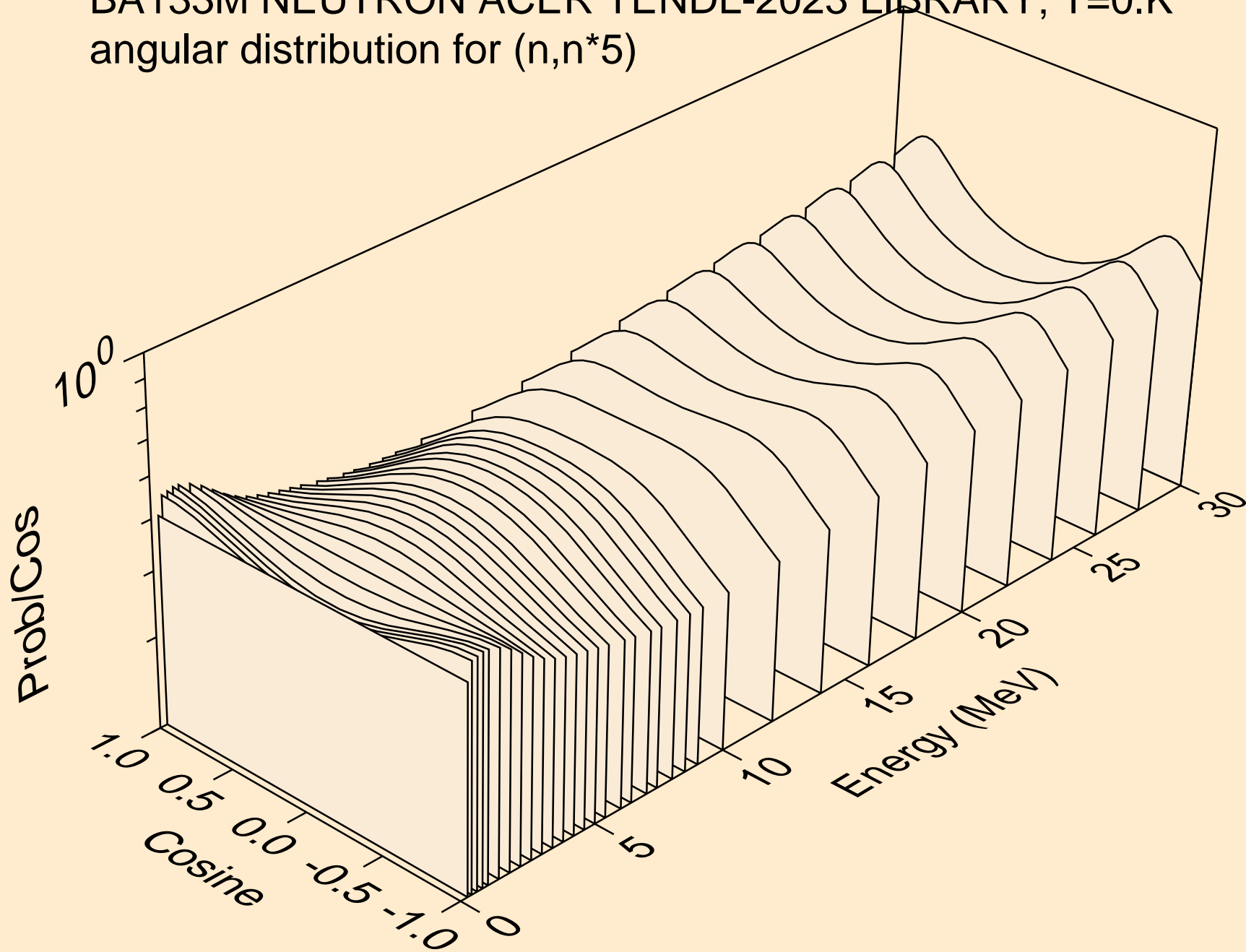

BA133M NEUTRON ACER TENDL-2023 LIBRARY; T=0.K
angular distribution for (n,n*6)

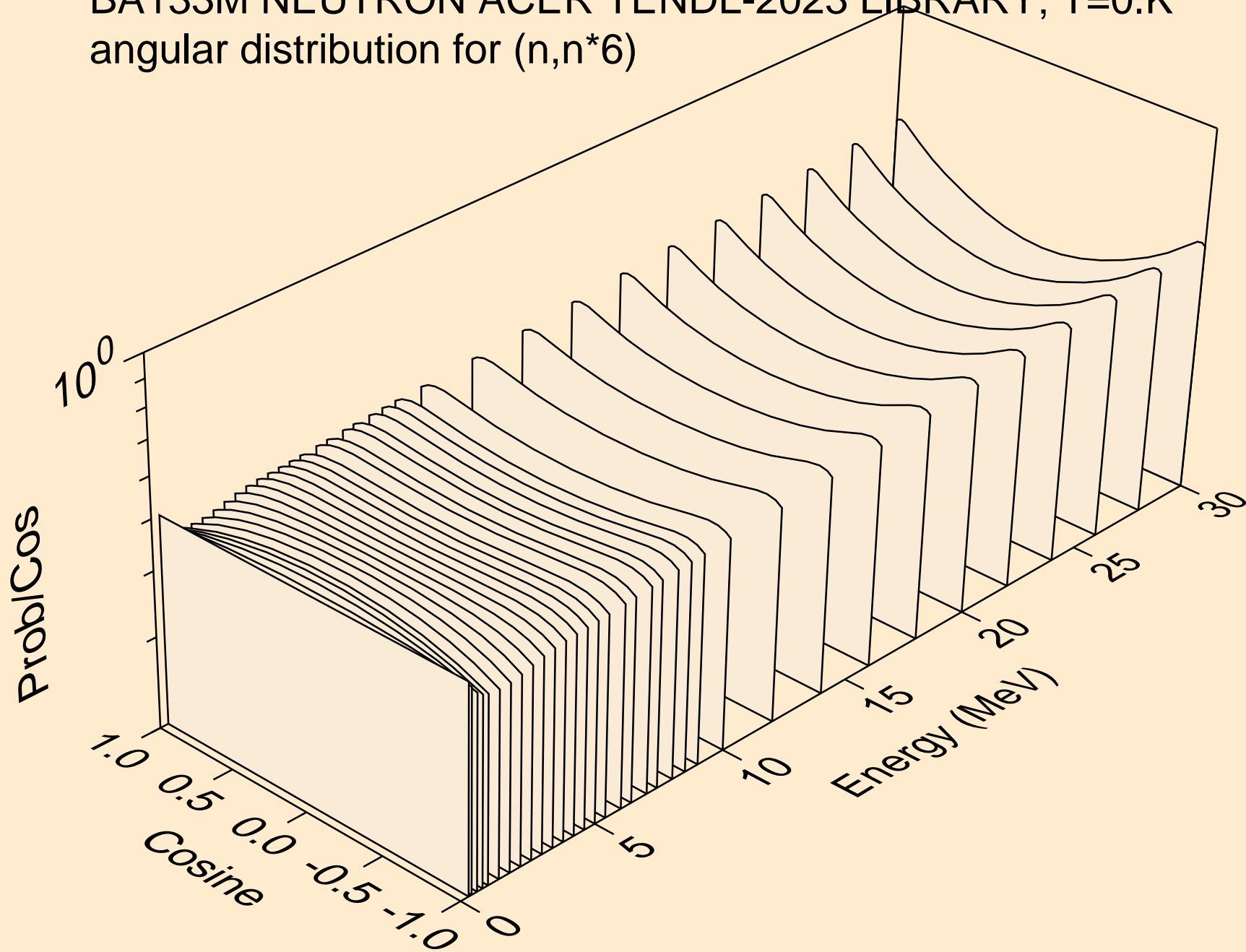

BA133M NEUTRON ACER TENDL-2023 LIBRARY; T=0.K
angular distribution for (n,n*7)

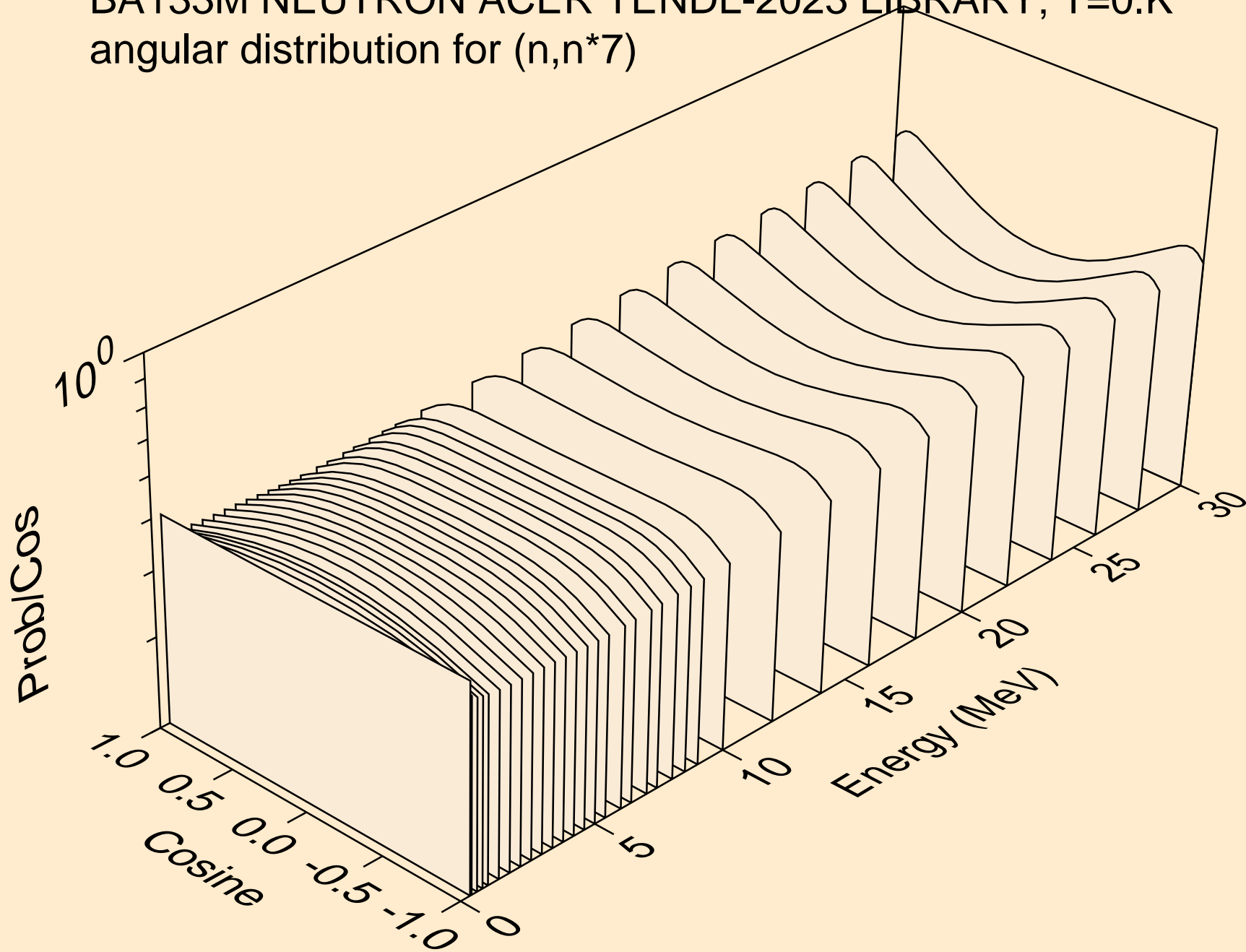

BA133M NEUTRON ACER TENDL-2023 LIBRARY; T=0.K
angular distribution for (n,n*8)

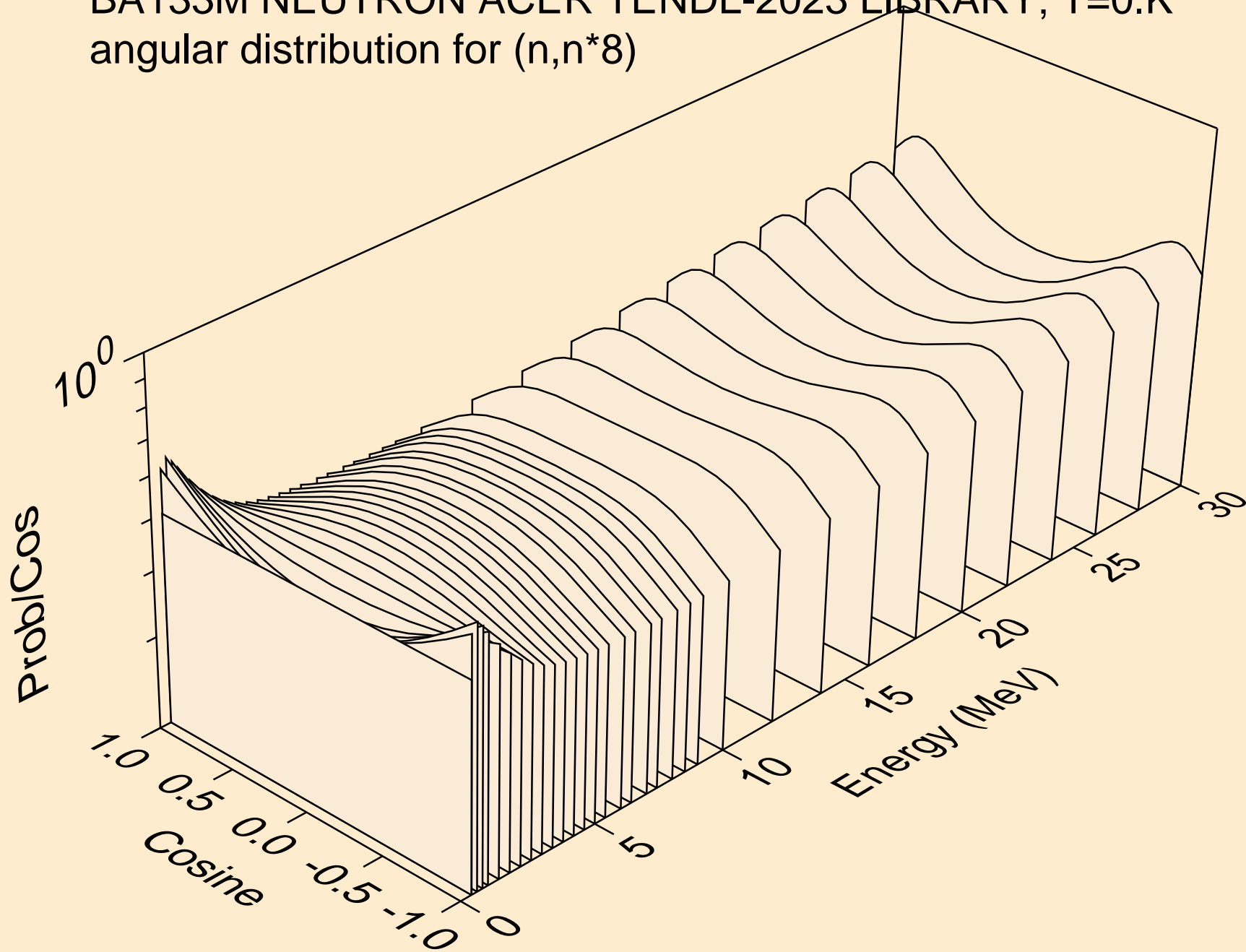

BA133M NEUTRON ACER TENDL-2023 LIBRARY; T=0.K
angular distribution for (n,n*9)

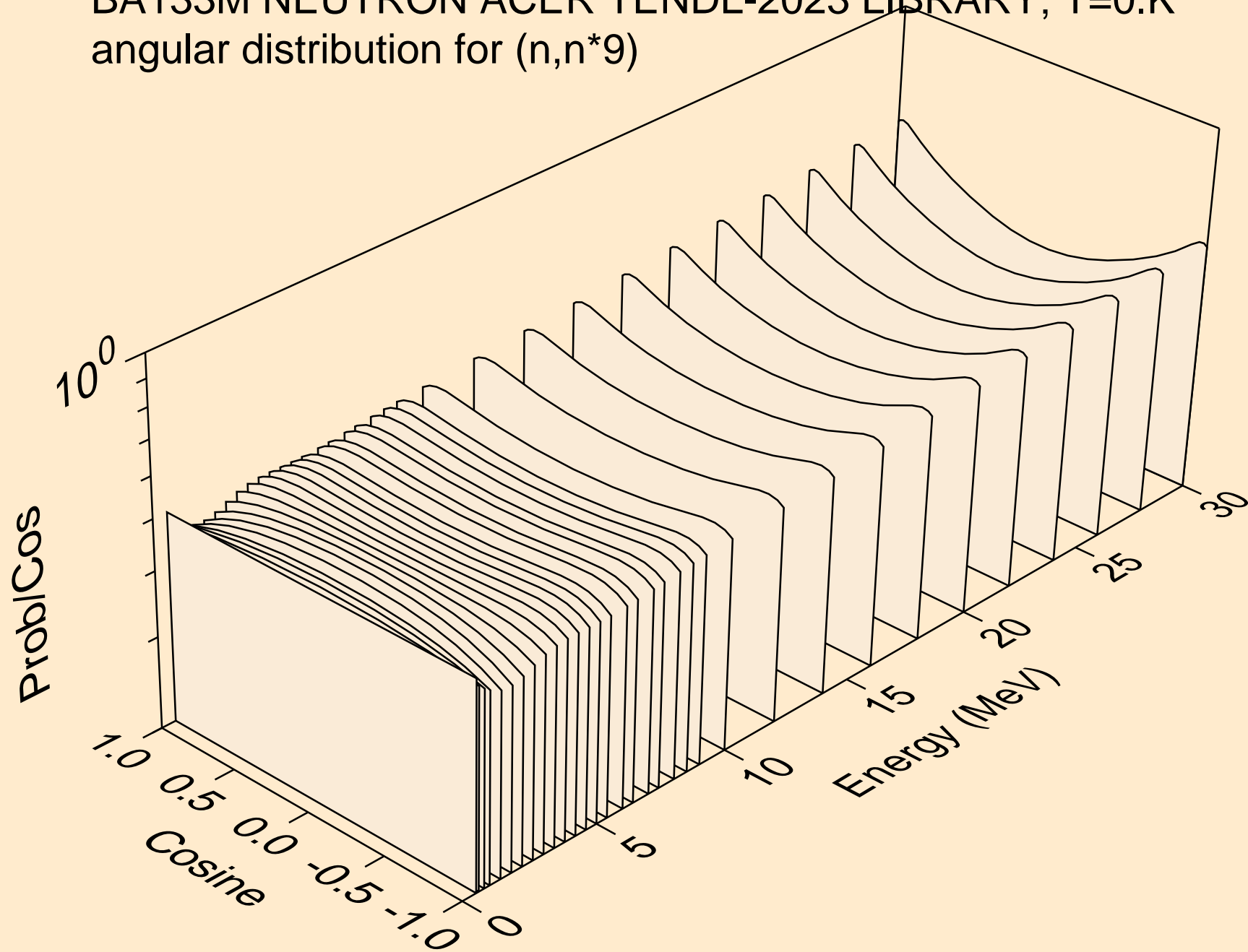

BA133M NEUTRON ACER TENDL-2023 LIBRARY; T=0.K
angular distribution for (n,n*10)

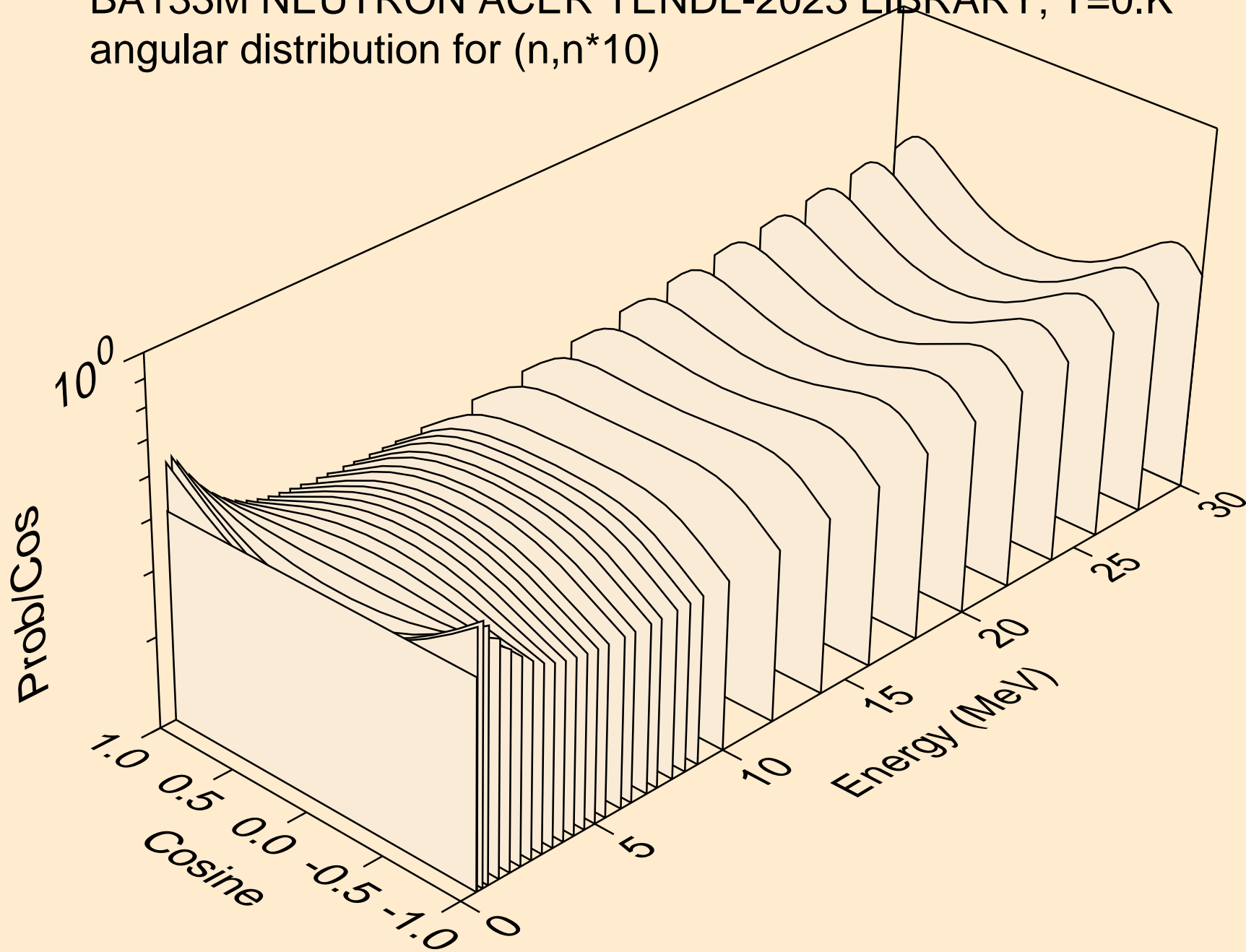

BA133M NEUTRON ACER TENDL-2023 LIBRARY; T=0.K
angular distribution for (n,n*11)

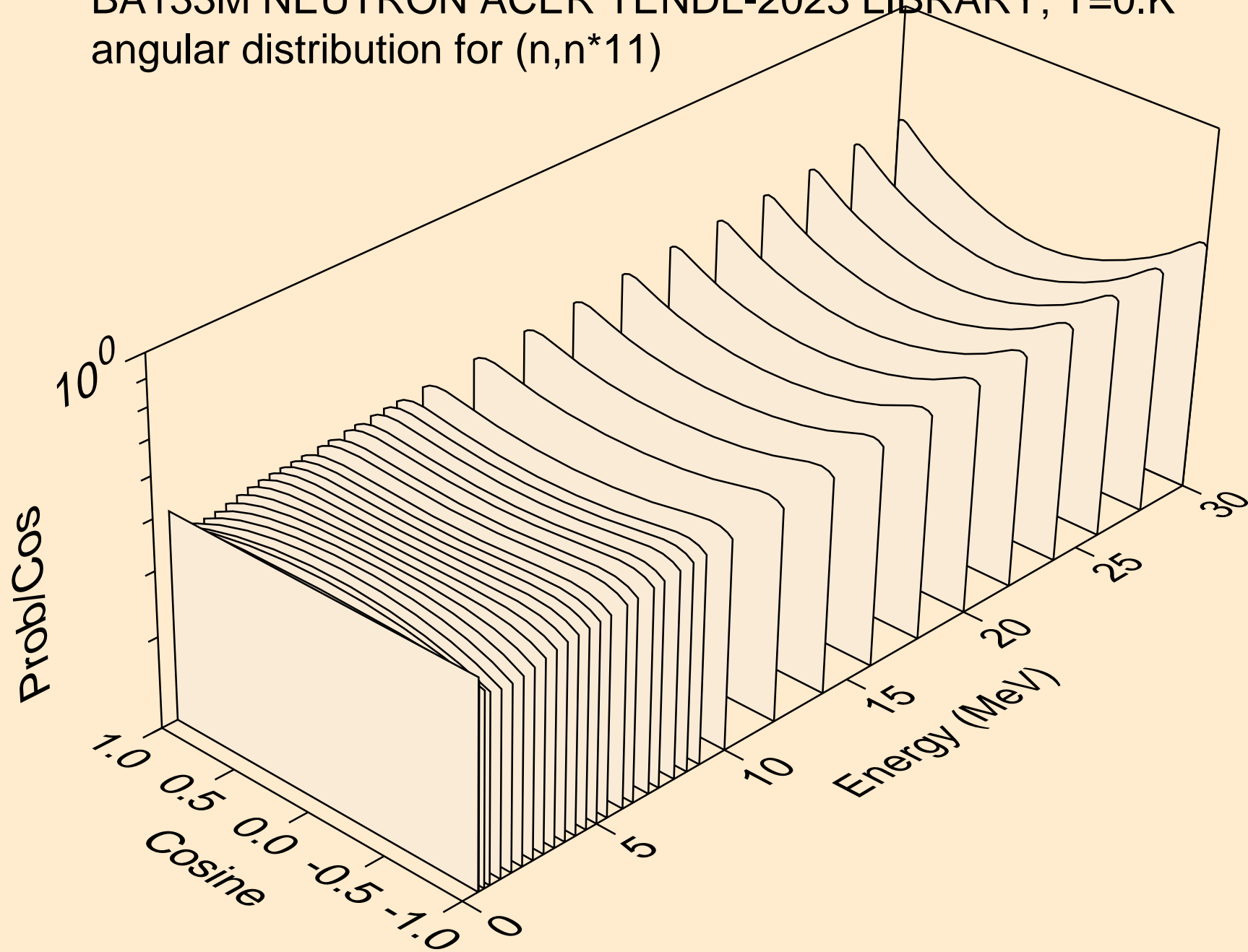

BA133M NEUTRON ACER TENDL-2023 LIBRARY; T=0.K
angular distribution for (n,n*12)

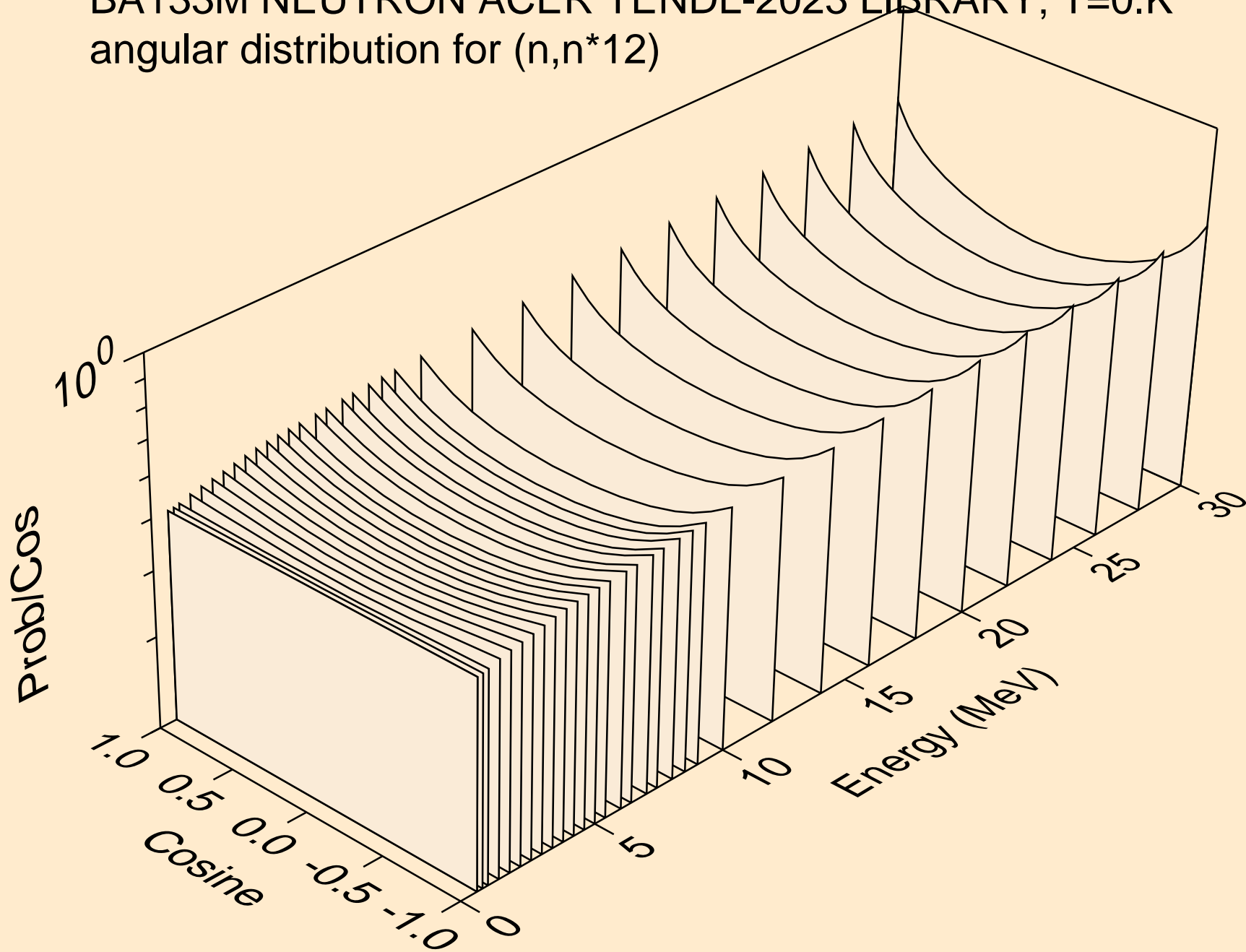

BA133M NEUTRON ACER TENDL-2023 LIBRARY; T=0.K
angular distribution for (n,n*13)

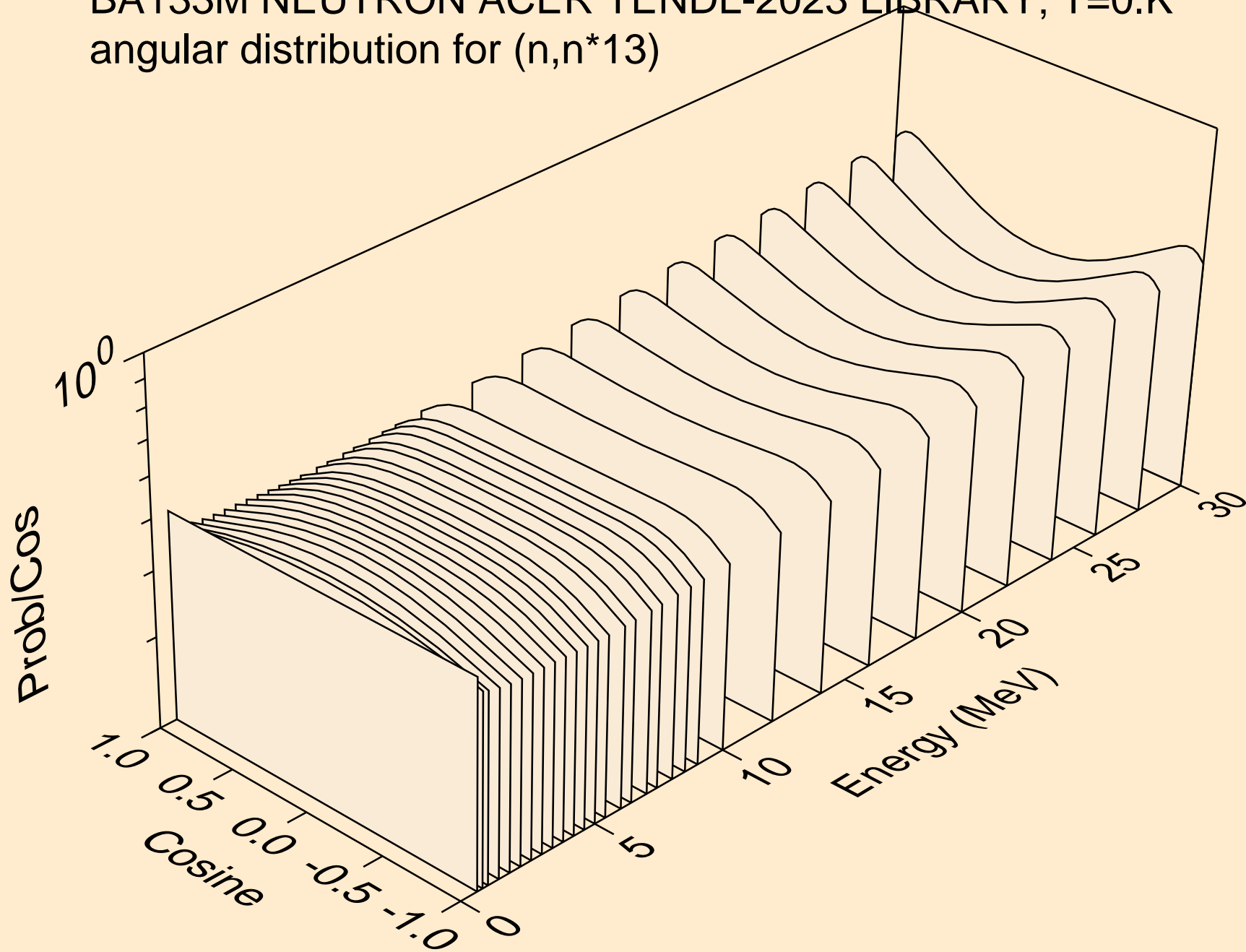

BA133M NEUTRON ACER TENDL-2023 LIBRARY; T=0.K
angular distribution for (n,n*14)

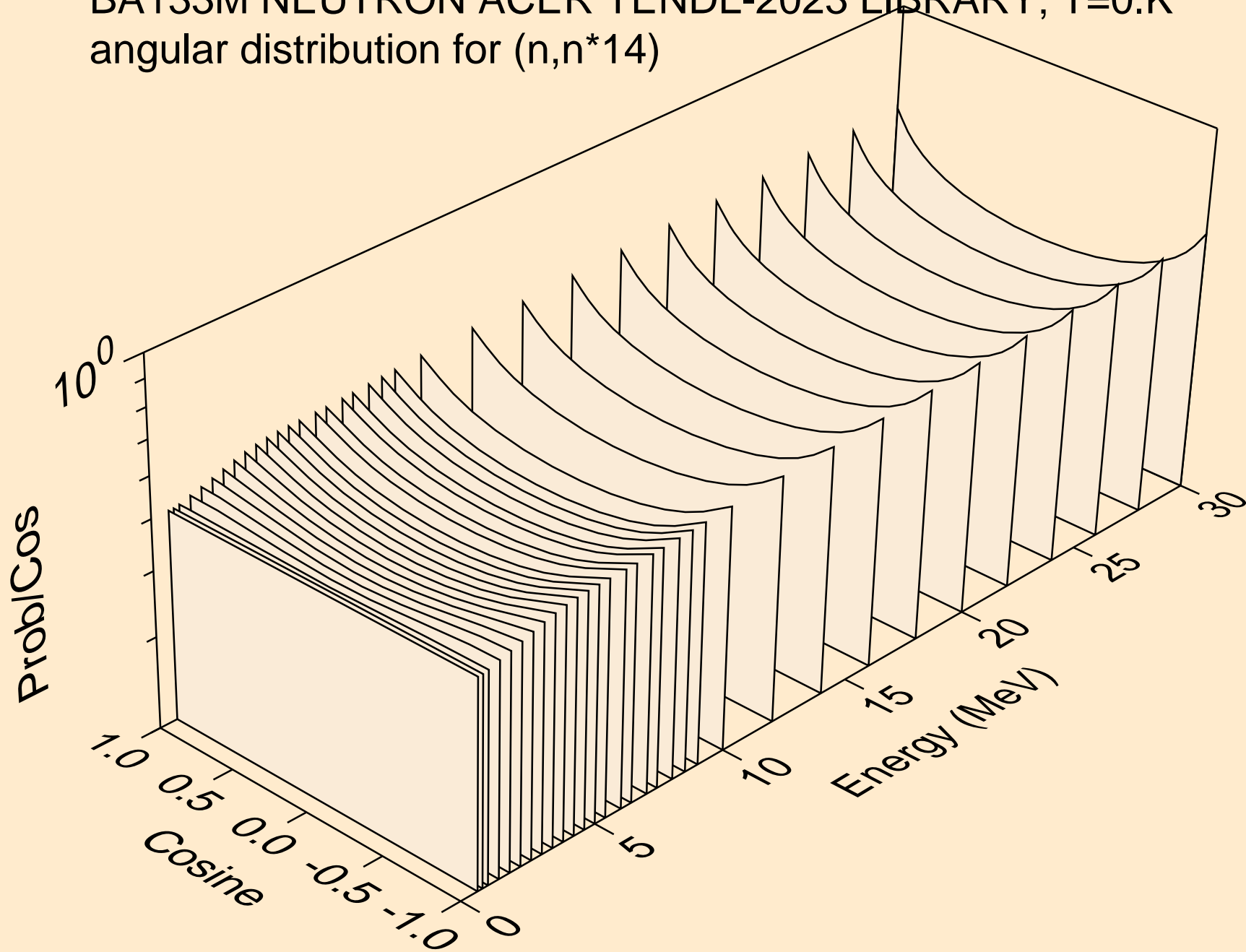

BA133M NEUTRON ACER TENDL-2023 LIBRARY; T=0.K
angular distribution for (n,n*15)

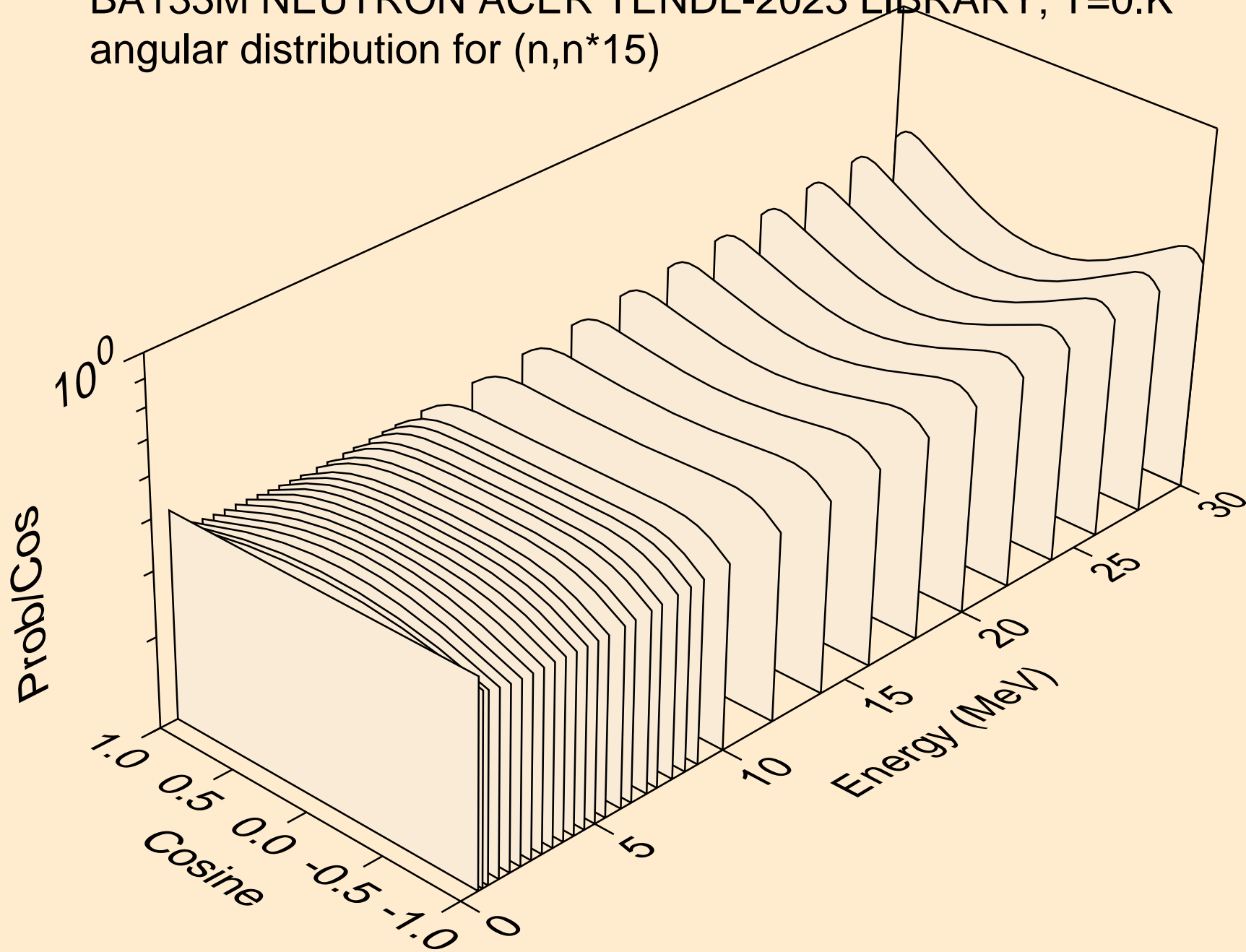

BA133M NEUTRON ACER TENDL-2023 LIBRARY; T=0.K
angular distribution for (n,n*16)

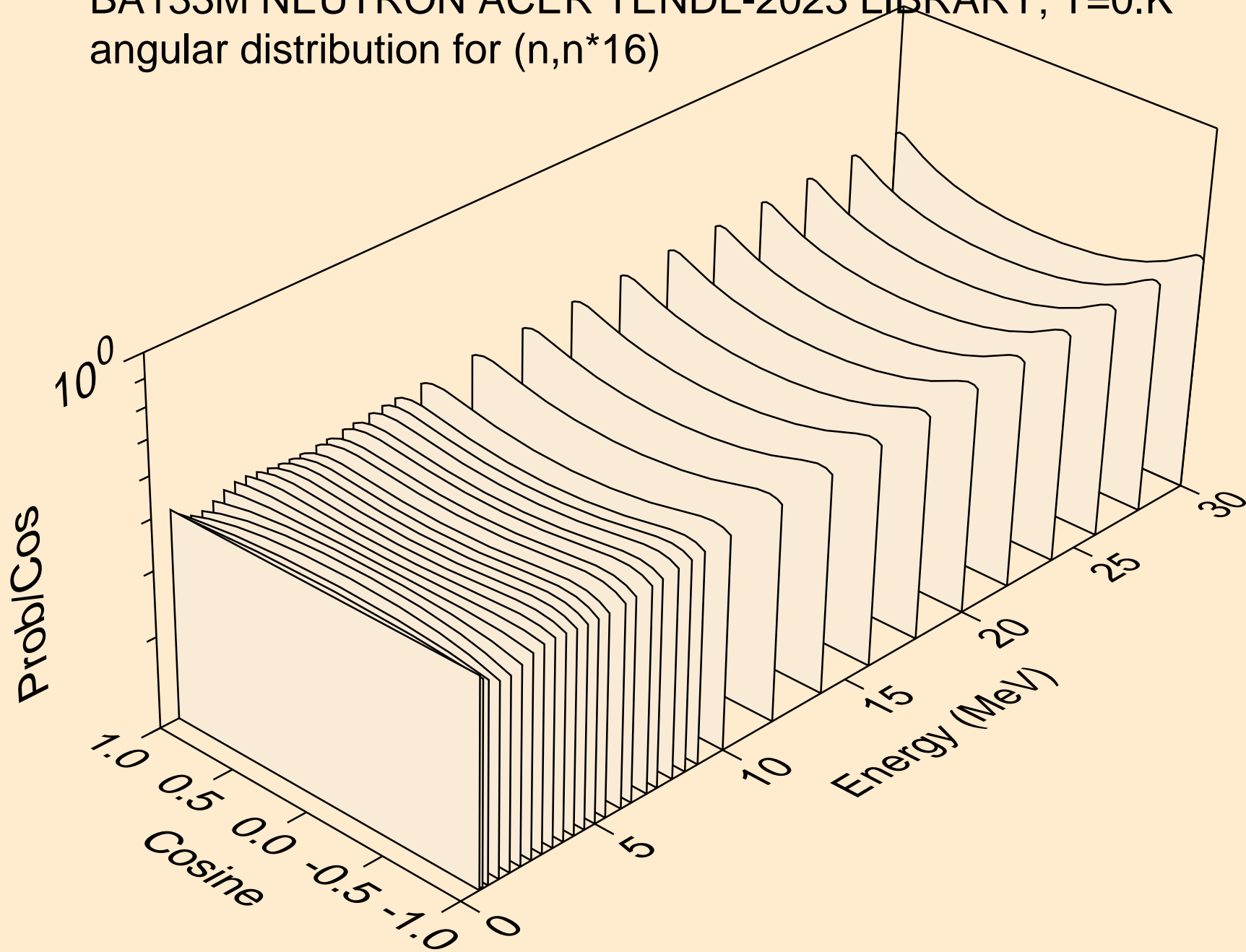

BA133M NEUTRON ACER TENDL-2023 LIBRARY; T=0.K
angular distribution for (n,n*17)

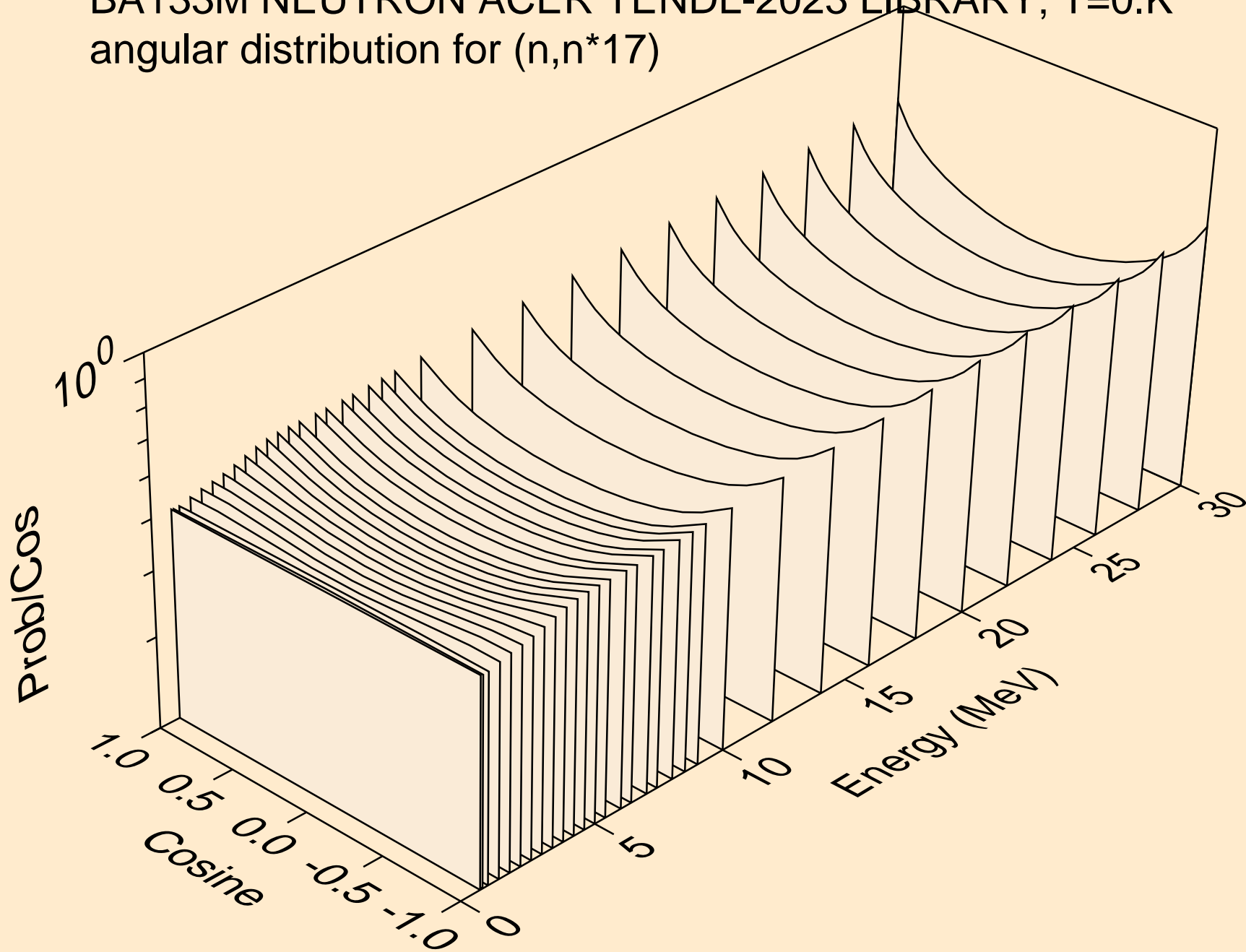

BA133M NEUTRON ACER TENDL-2023 LIBRARY; T=0.K
Neutron emission for (n,x)

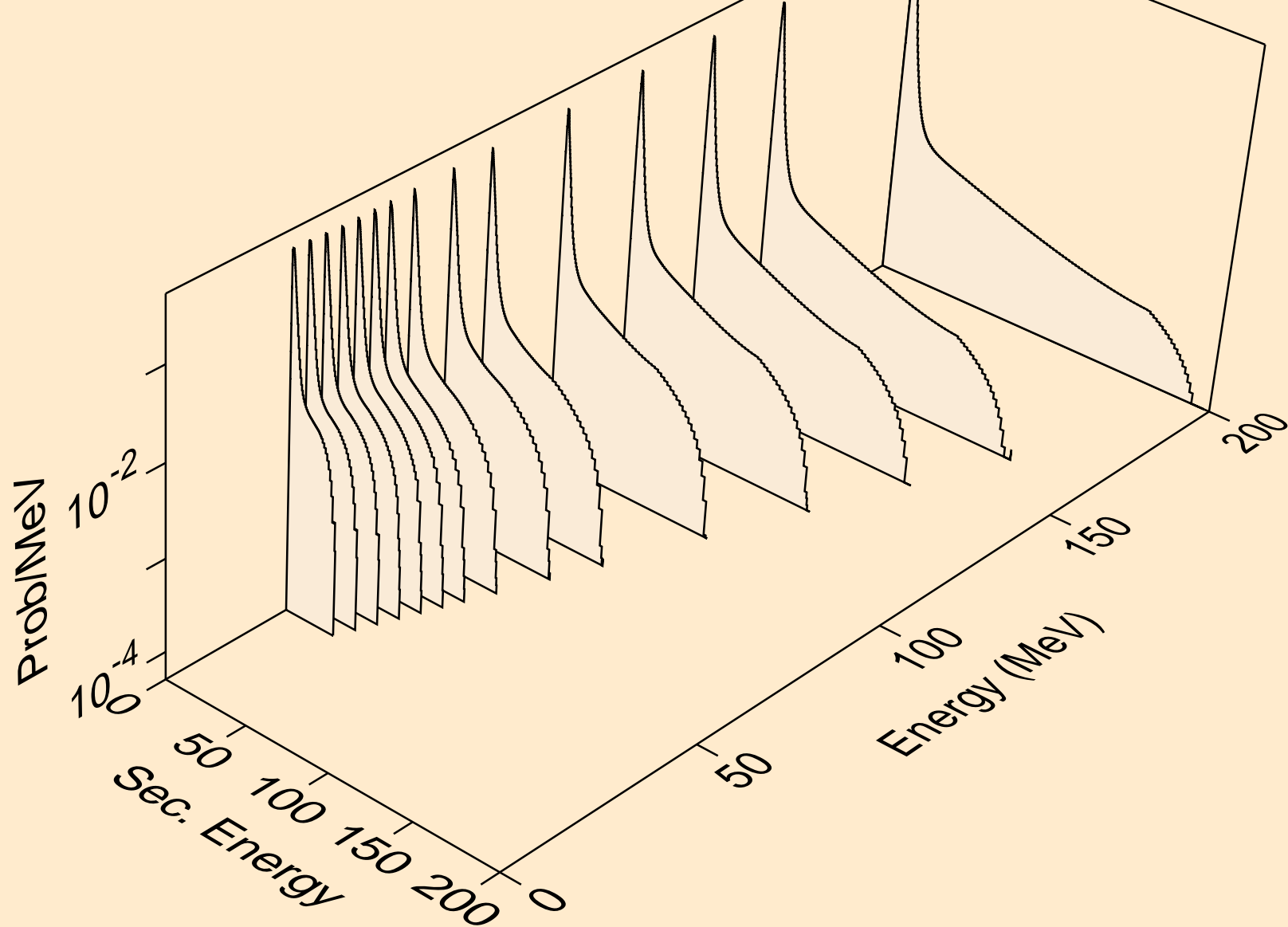

BA133M NEUTRON ACER TENDL-2023 LIBRARY; T=0.K
Neutron emission for (n,2nd)

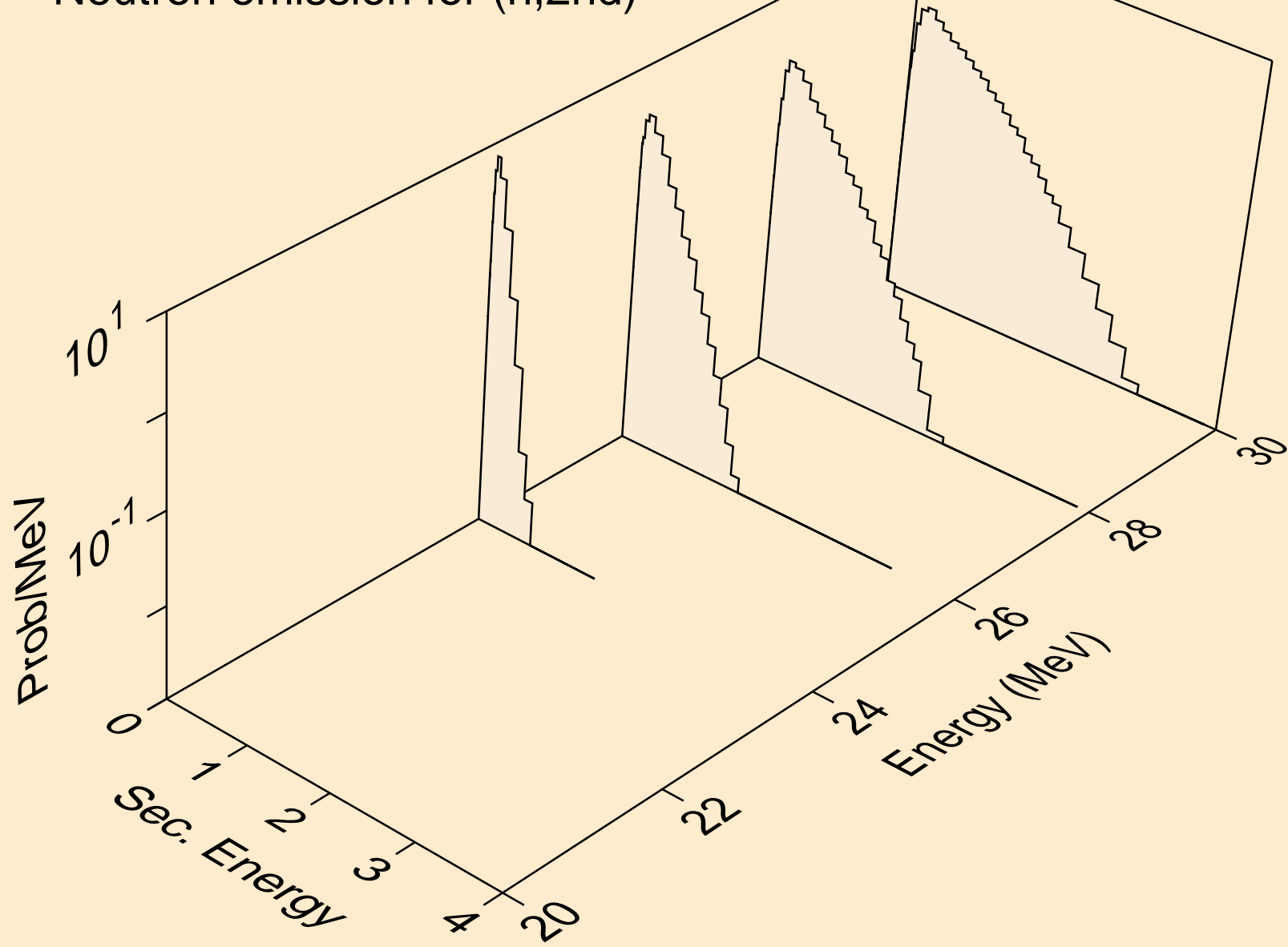

BA133M NEUTRON ACER TENDL-2023 LIBRARY; T=0.K
Neutron emission for (n,2n)

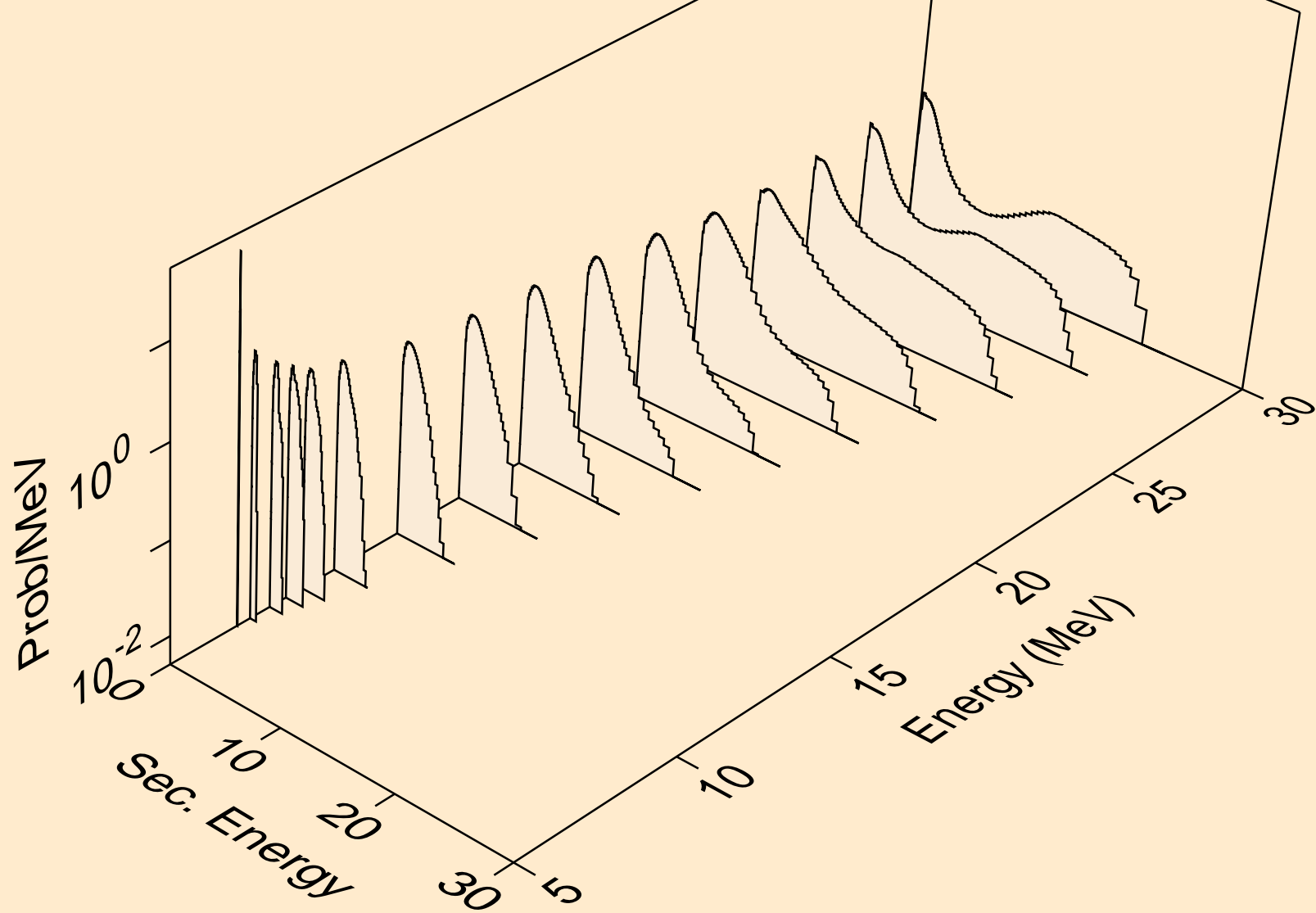

BA133M NEUTRON ACER TENDL-2023 LIBRARY; T=0.K
Neutron emission for (n,3n)

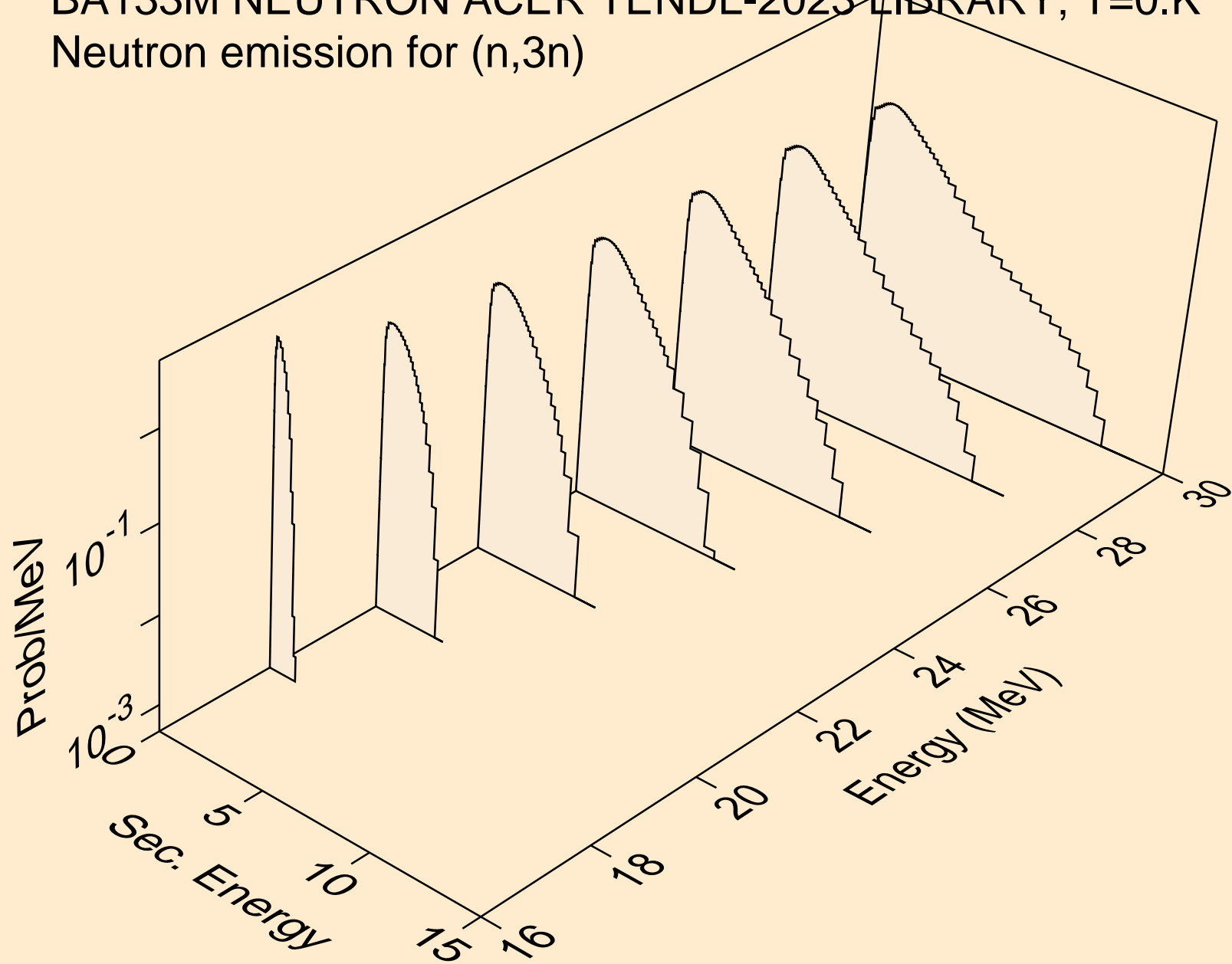

BA133M NEUTRON ACER TENDL-2023 LIBRARY; T=0.K
Neutron emission for (n,n*)a

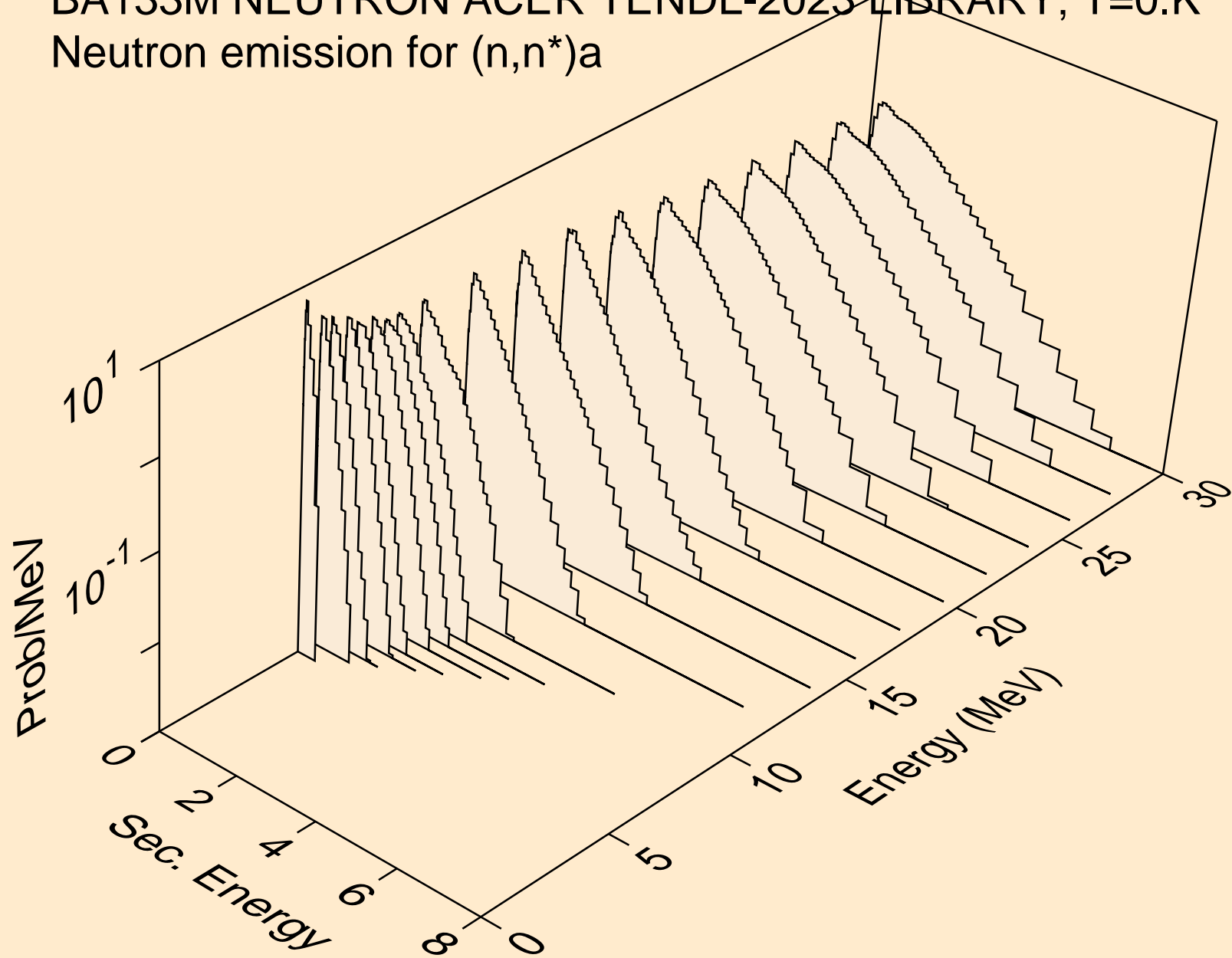

BA133M NEUTRON ACER TENDL-2023 LIBRARY; T=0.K
Neutron emission for (n,2n)a

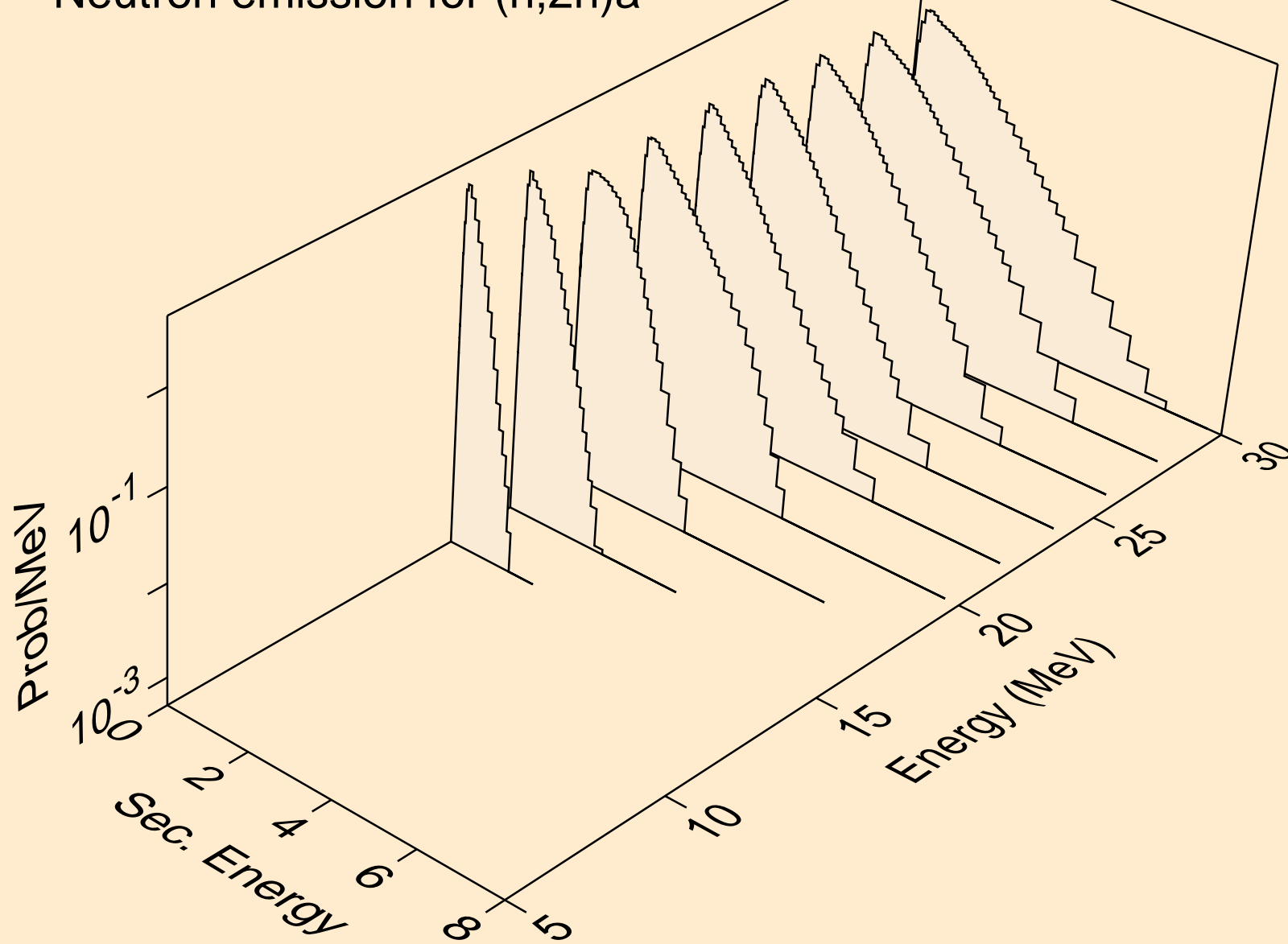

BA133M NEUTRON ACER TENDL-2023 LIBRARY; T=0.K
Neutron emission for (n,3n)a

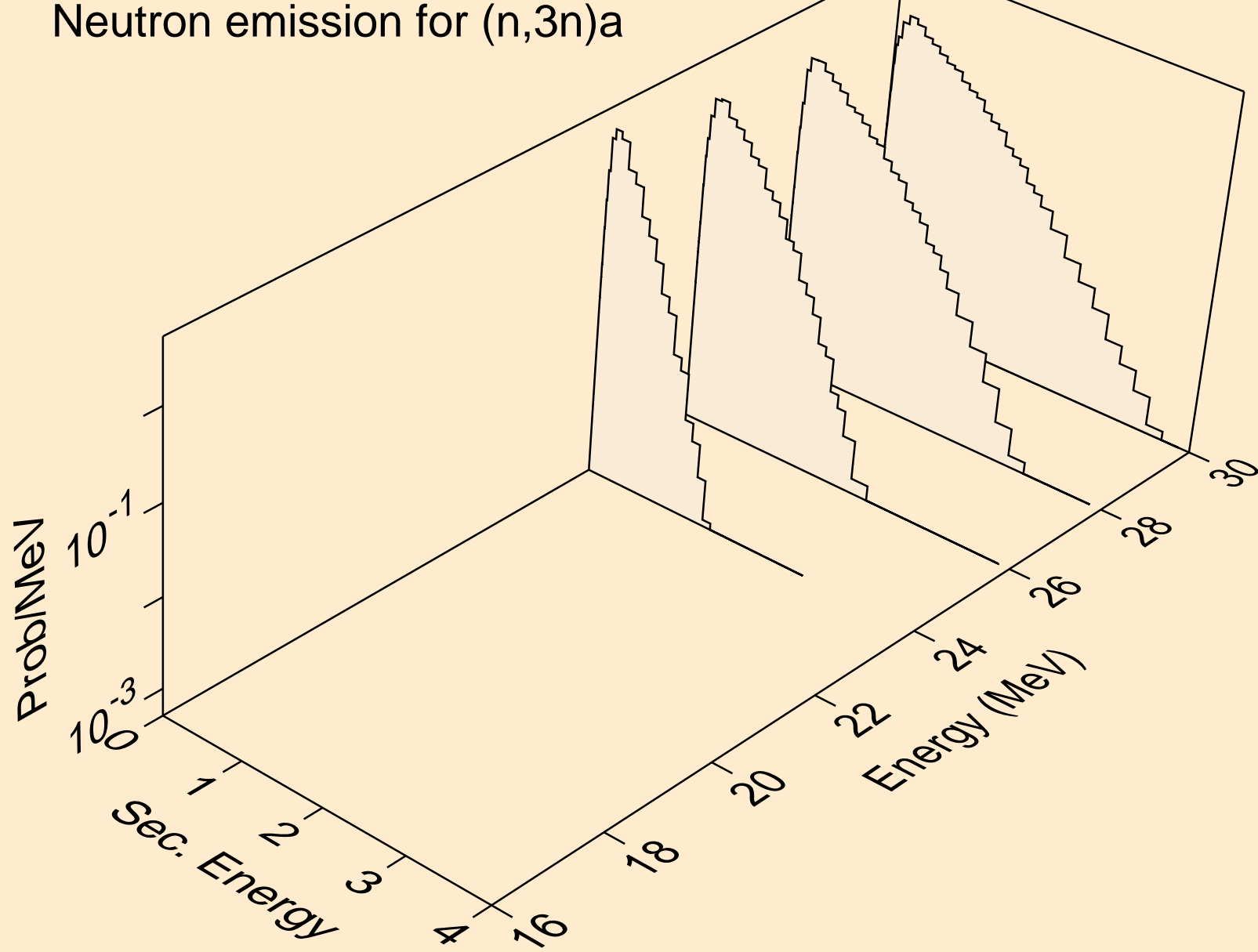

BA133M NEUTRON ACER TENDL-2023 LIBRARY; T=0.K
Neutron emission for (n,n*)p

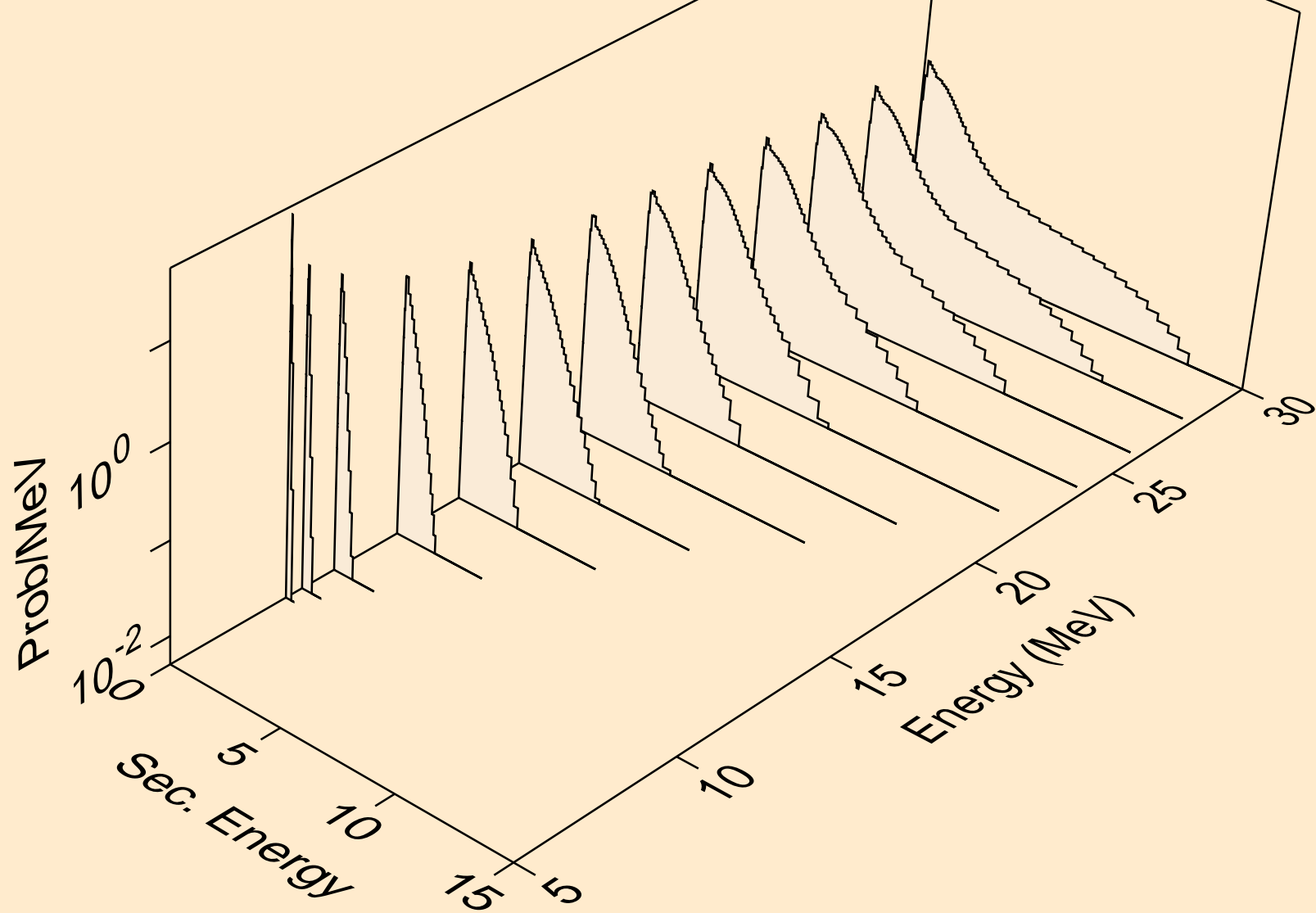

BA133M NEUTRON ACER TENDL-2023 LIBRARY; T=0.K
Neutron emission for (n,n*)2a

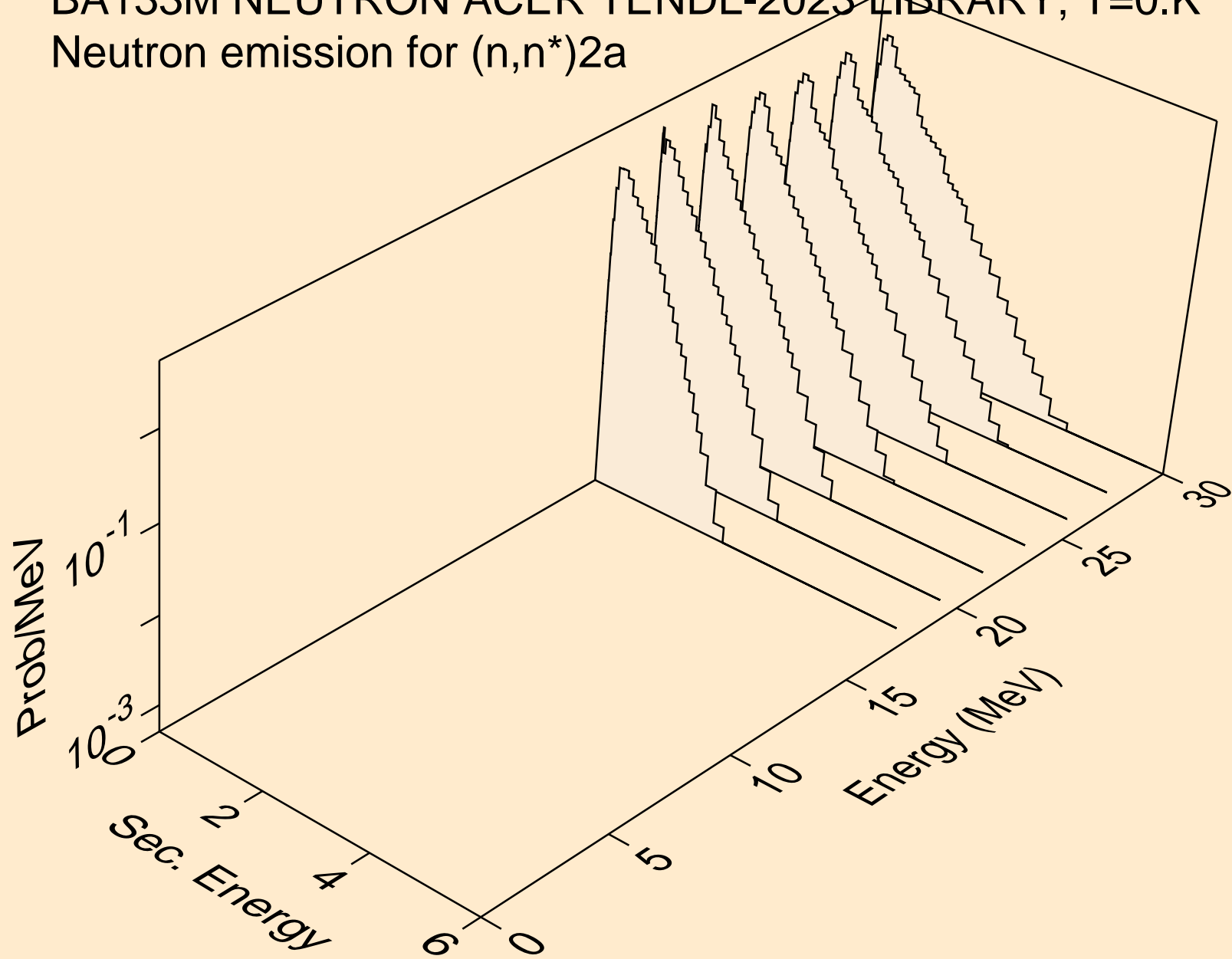

BA133M NEUTRON ACER TENDL-2023 LIBRARY; T=0.K
Neutron emission for (n,n*)d

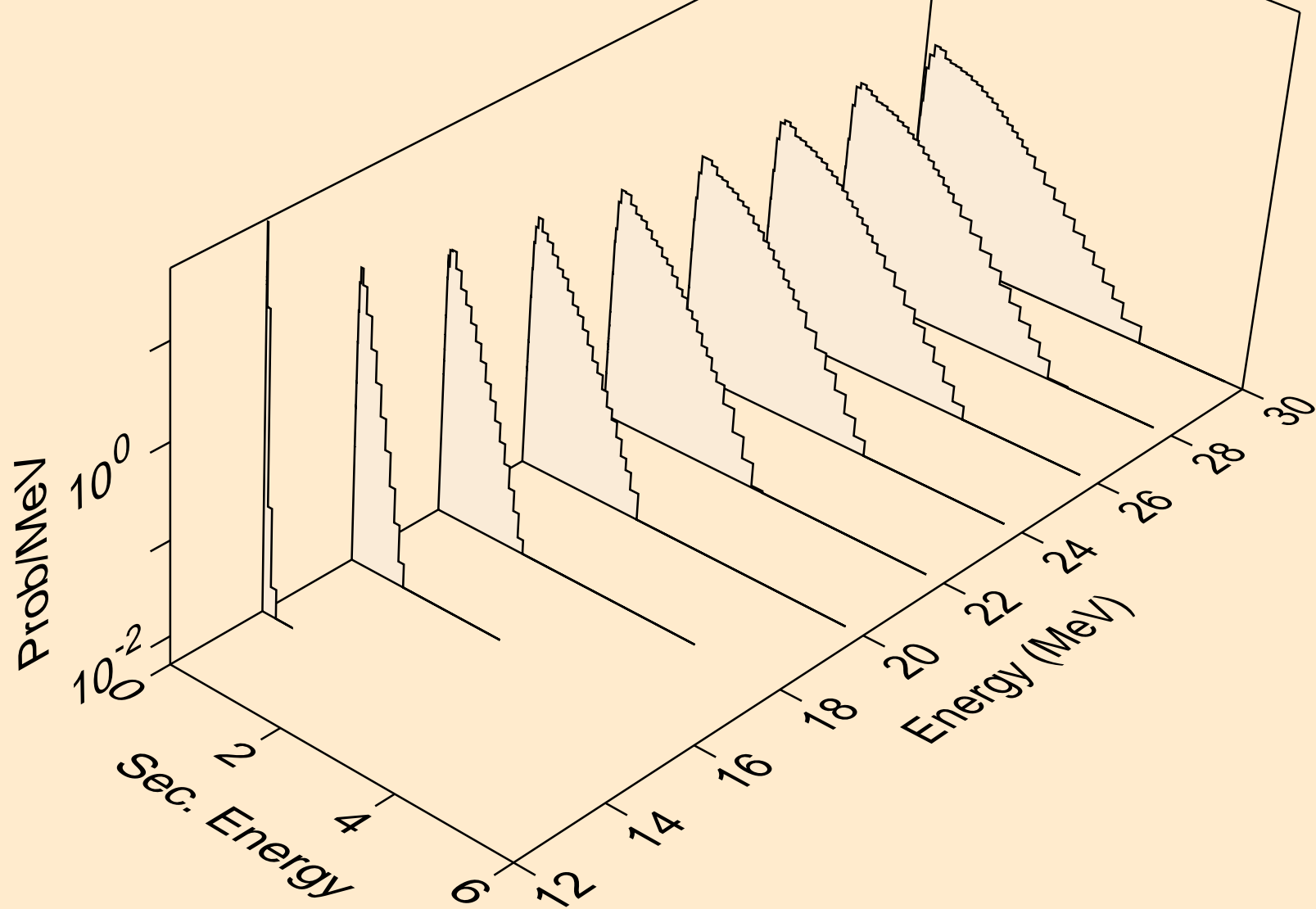

BA133M NEUTRON ACER TENDL-2023 LIBRARY; T=0.K
Neutron emission for (n,n*)t

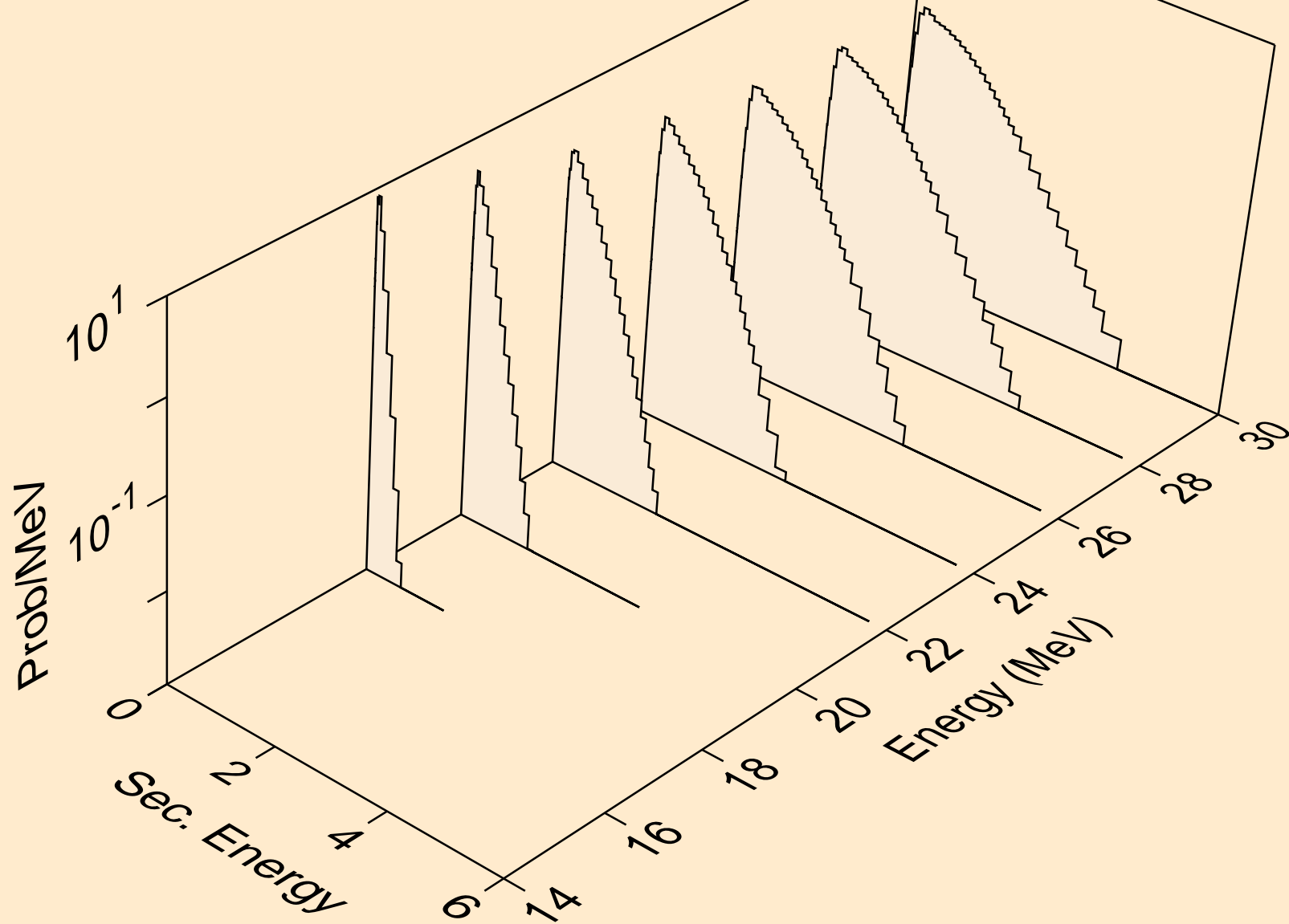

BA133M NEUTRON ACER TENDL-2023 LIBRARY; T=0.K
Neutron emission for (n,n*)he3

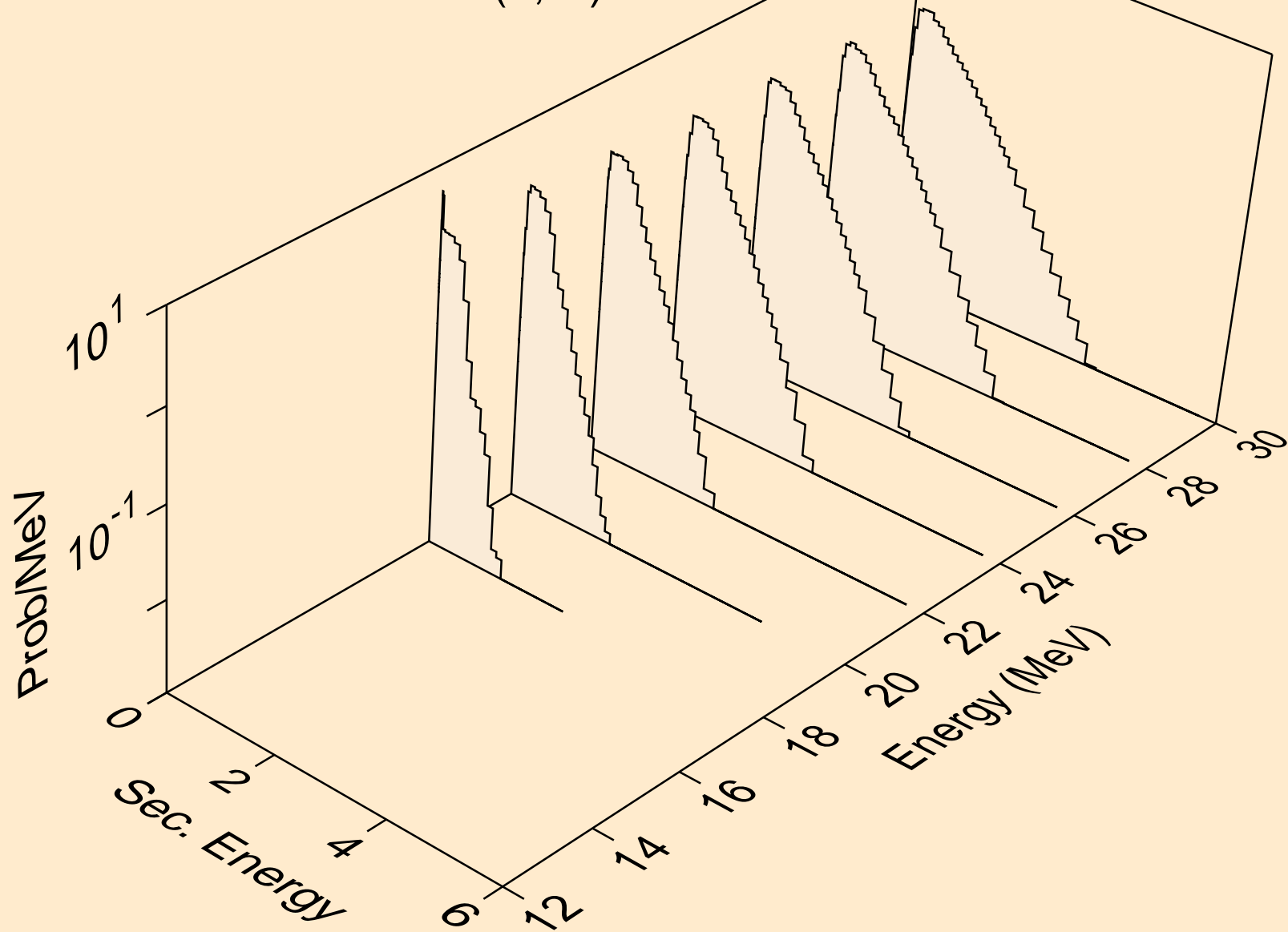

BA133M NEUTRON ACER TENDL-2023 LIBRARY; T=0.K
Neutron emission for (n,4n)

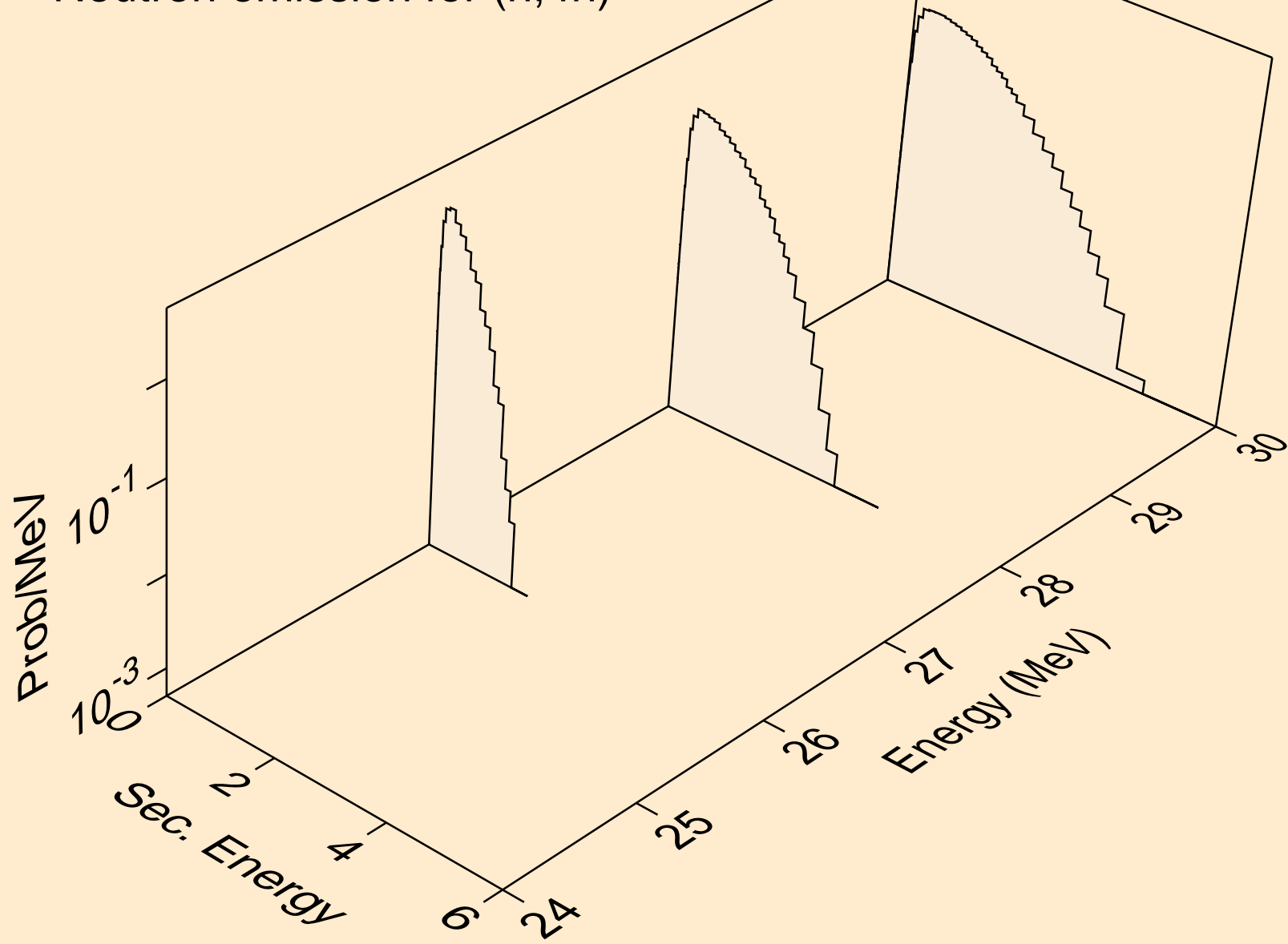

BA133M NEUTRON ACER TENDL-2023 LIBRARY; T=0.K
Neutron emission for (n,2np)

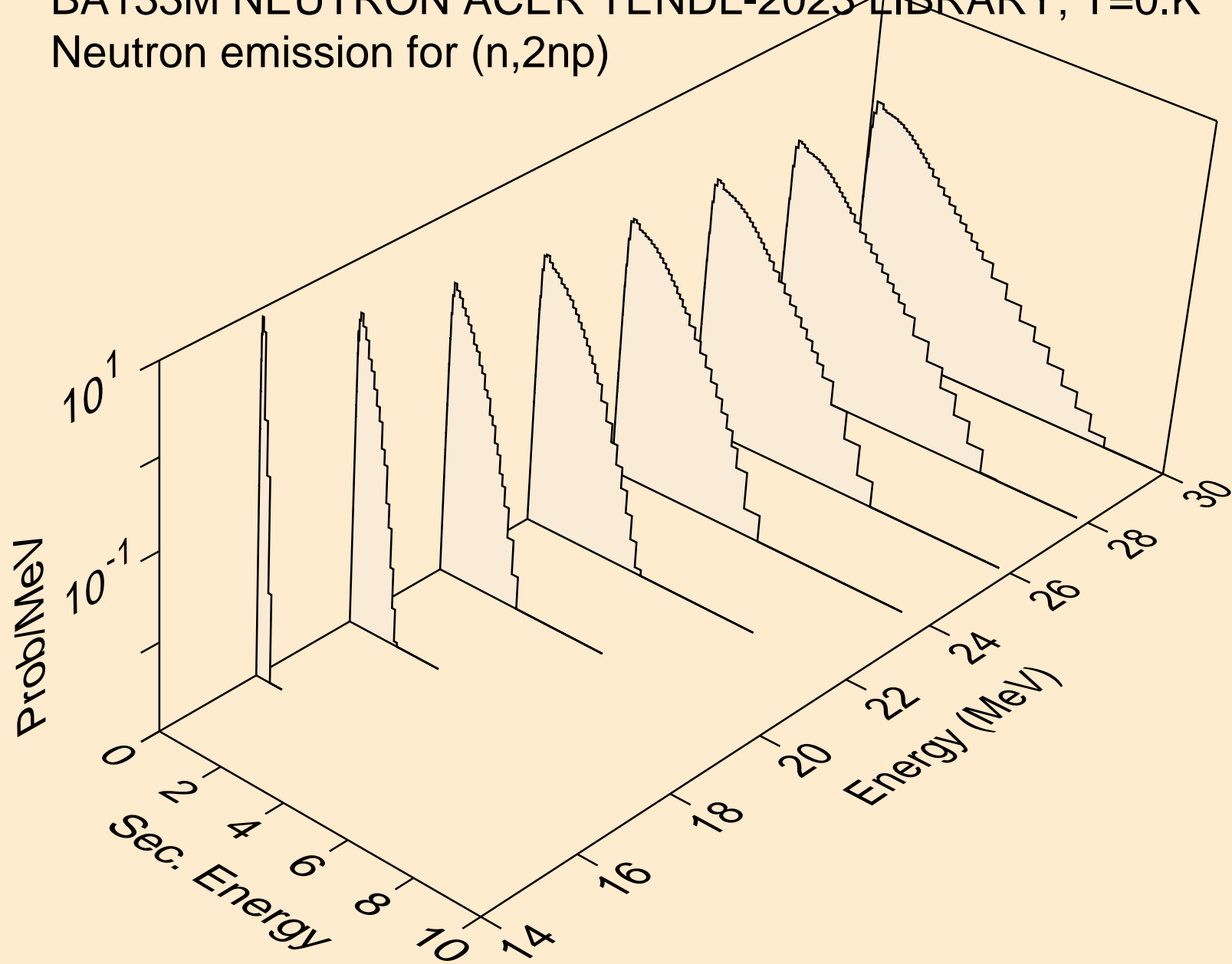

BA133M NEUTRON ACER TENDL-2023 LIBRARY; T=0.K
Neutron emission for (n,3np)

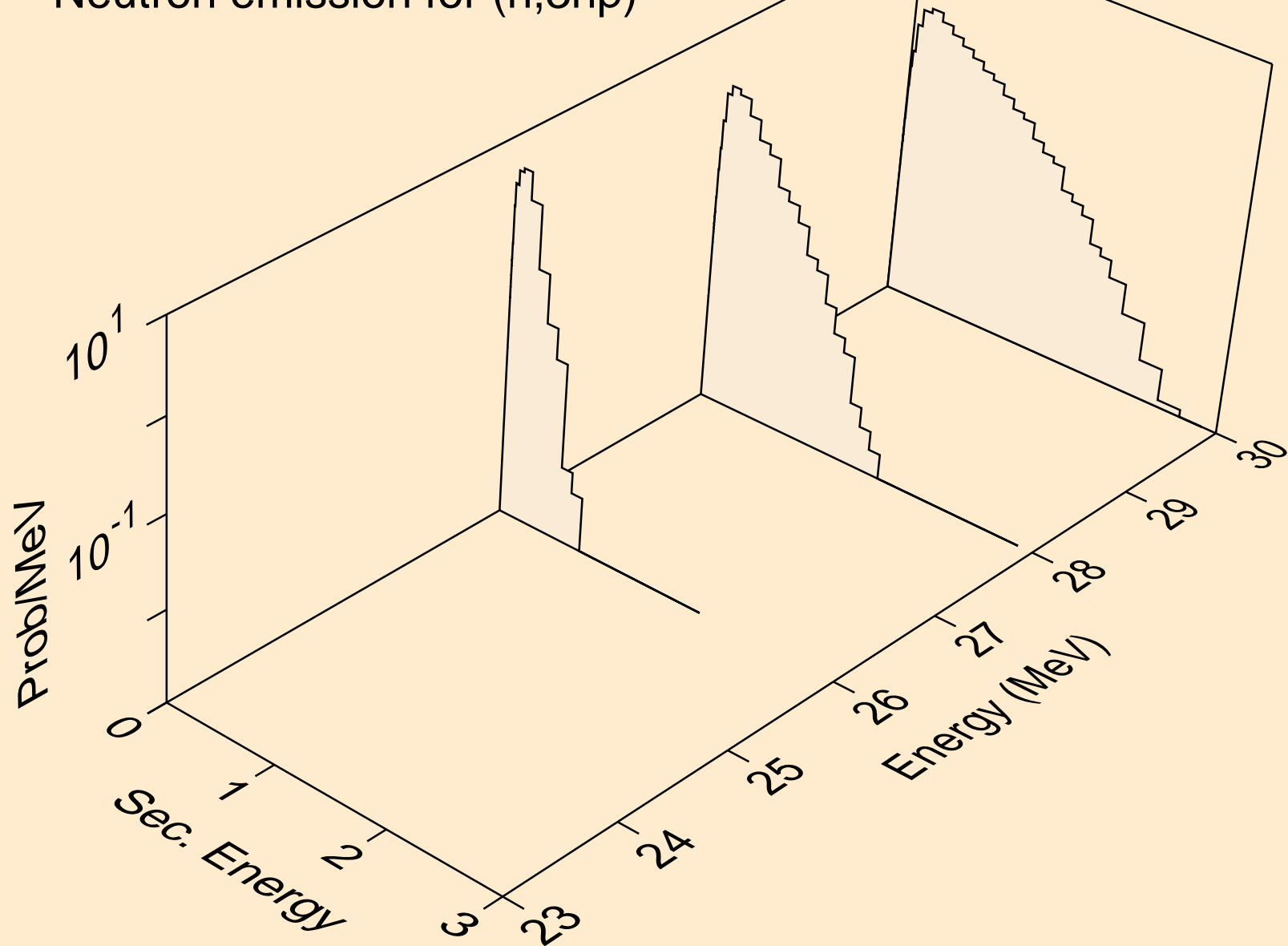

BA133M NEUTRON ACER TENDL-2023 LIBRARY; T=0.K
Neutron emission for (n,n2p)

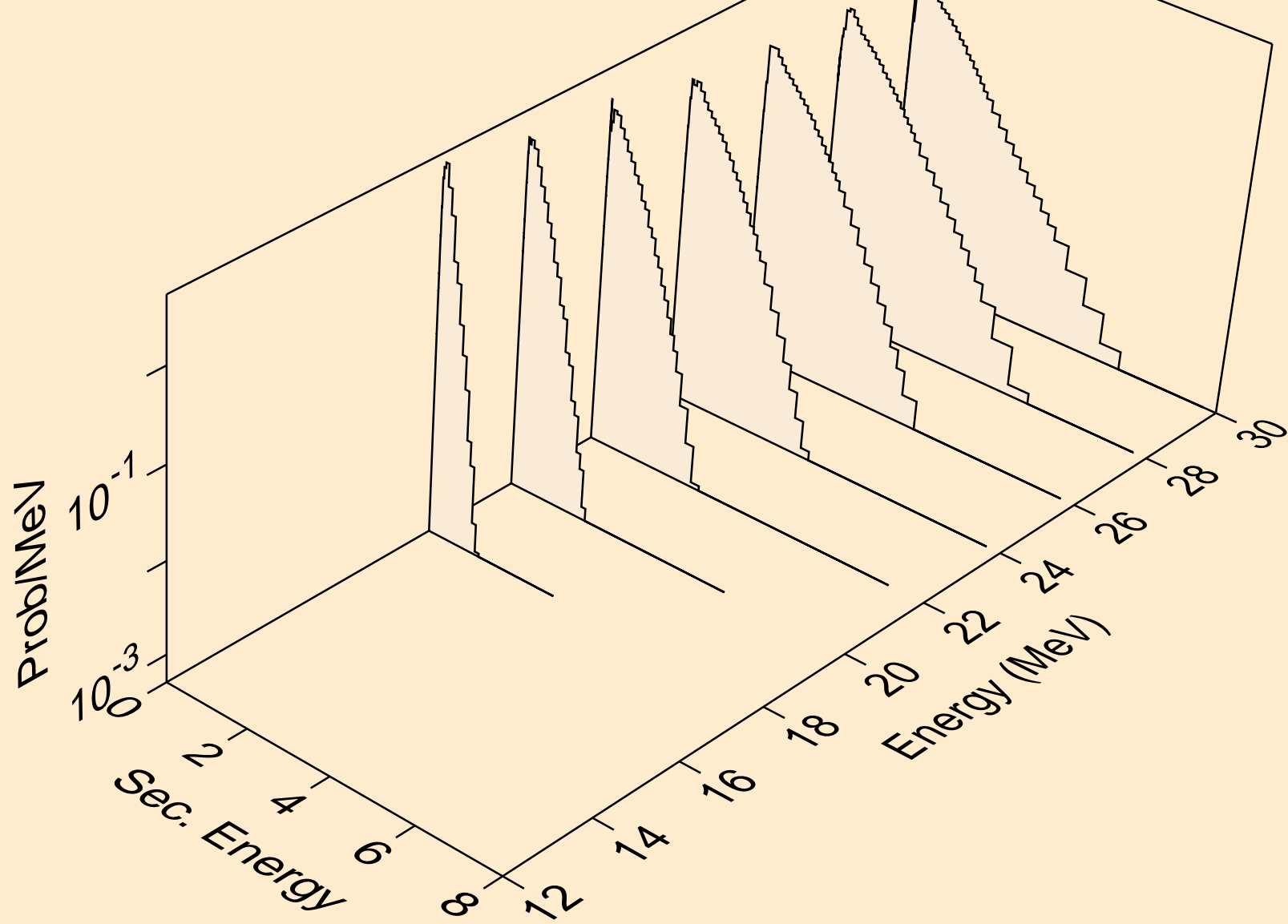

BA133M NEUTRON ACER TENDL-2023 LIBRARY; T=0.K
Neutron emission for (n,npa)

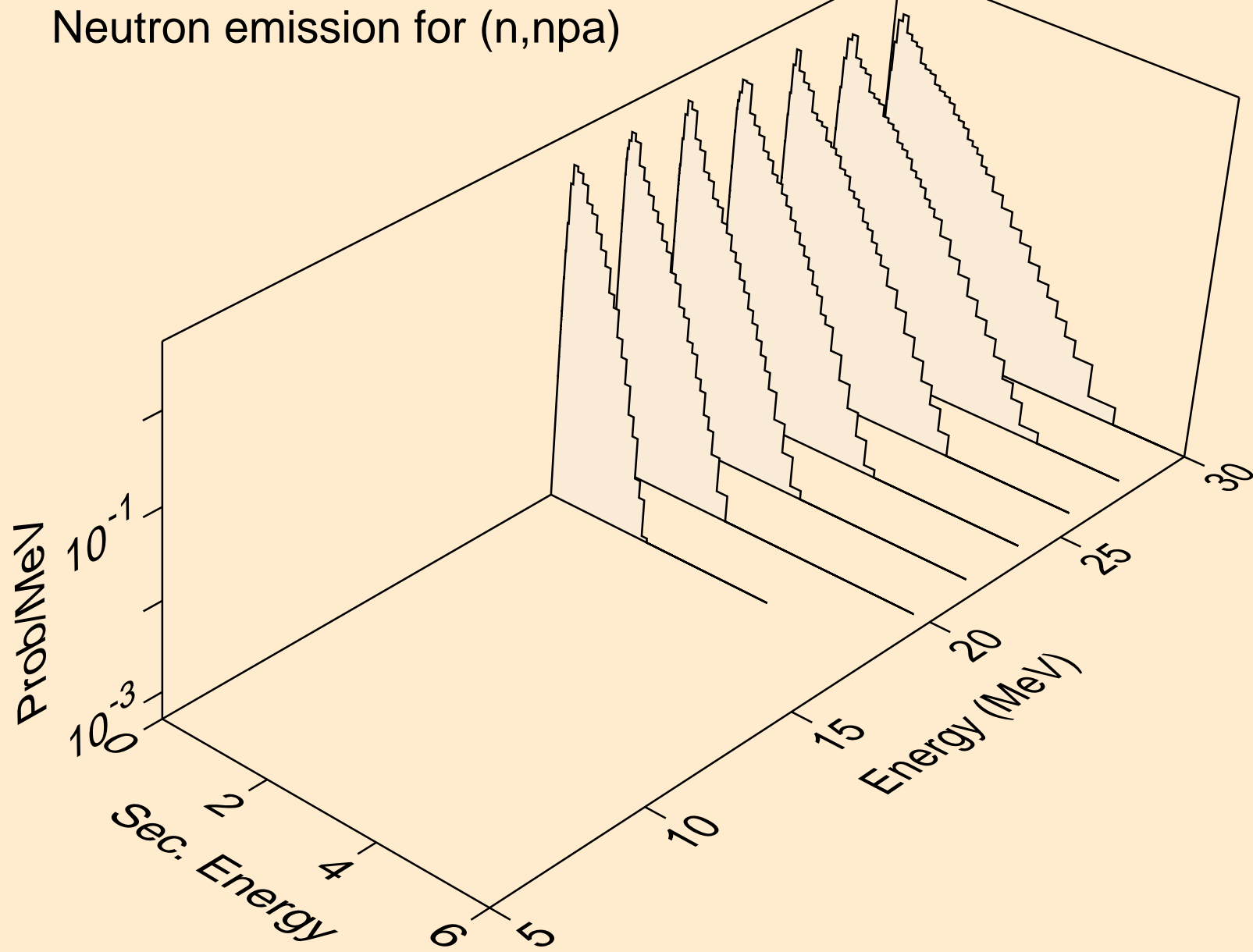

BA133M NEUTRON ACER TENDL-2023 LIBRARY; T=0.K
Neutron emission for (n,n*c)

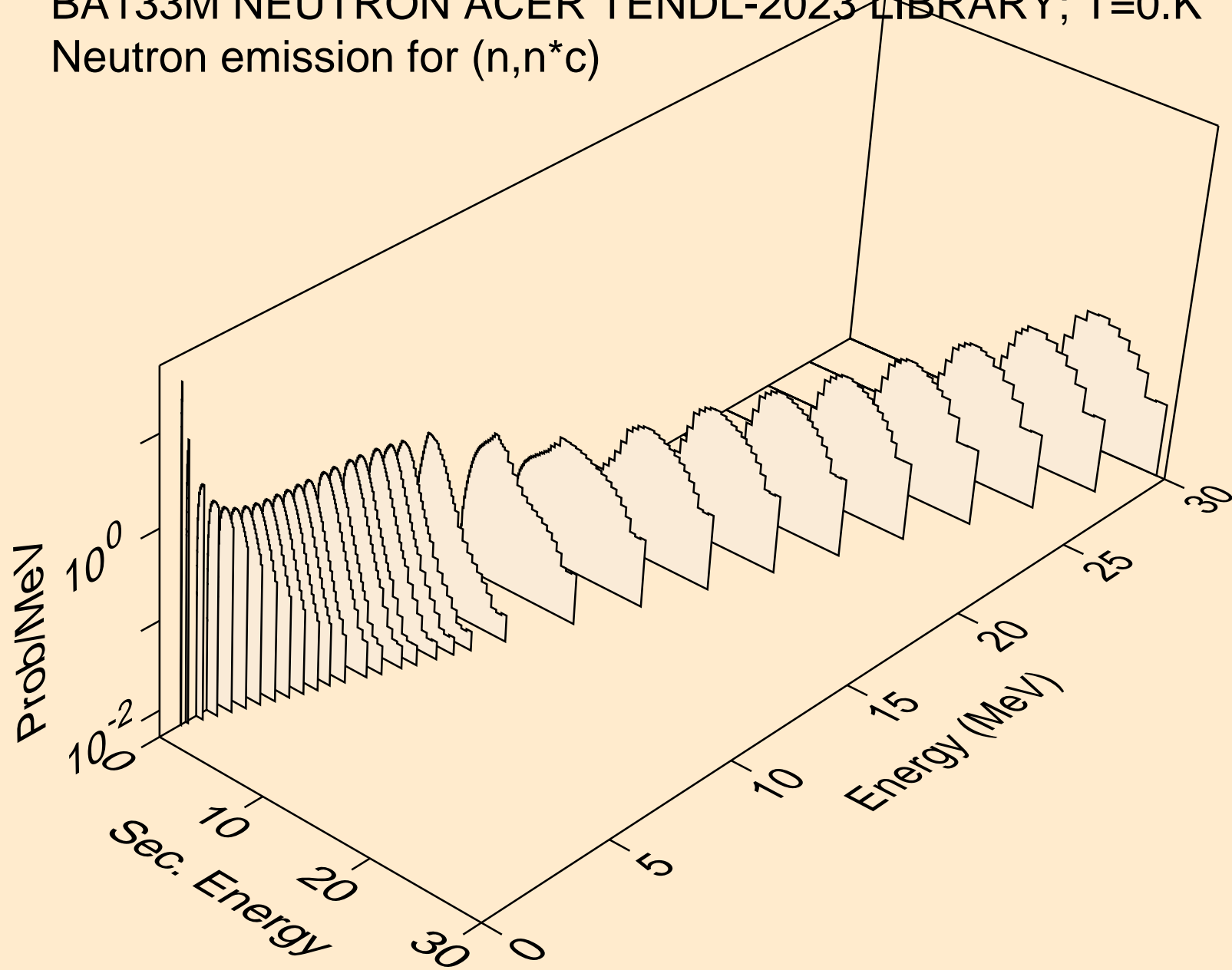

BA133M NEUTRON ACER TENDL-2023 LIBRARY; T=0.K
Photon emission for (n,x)

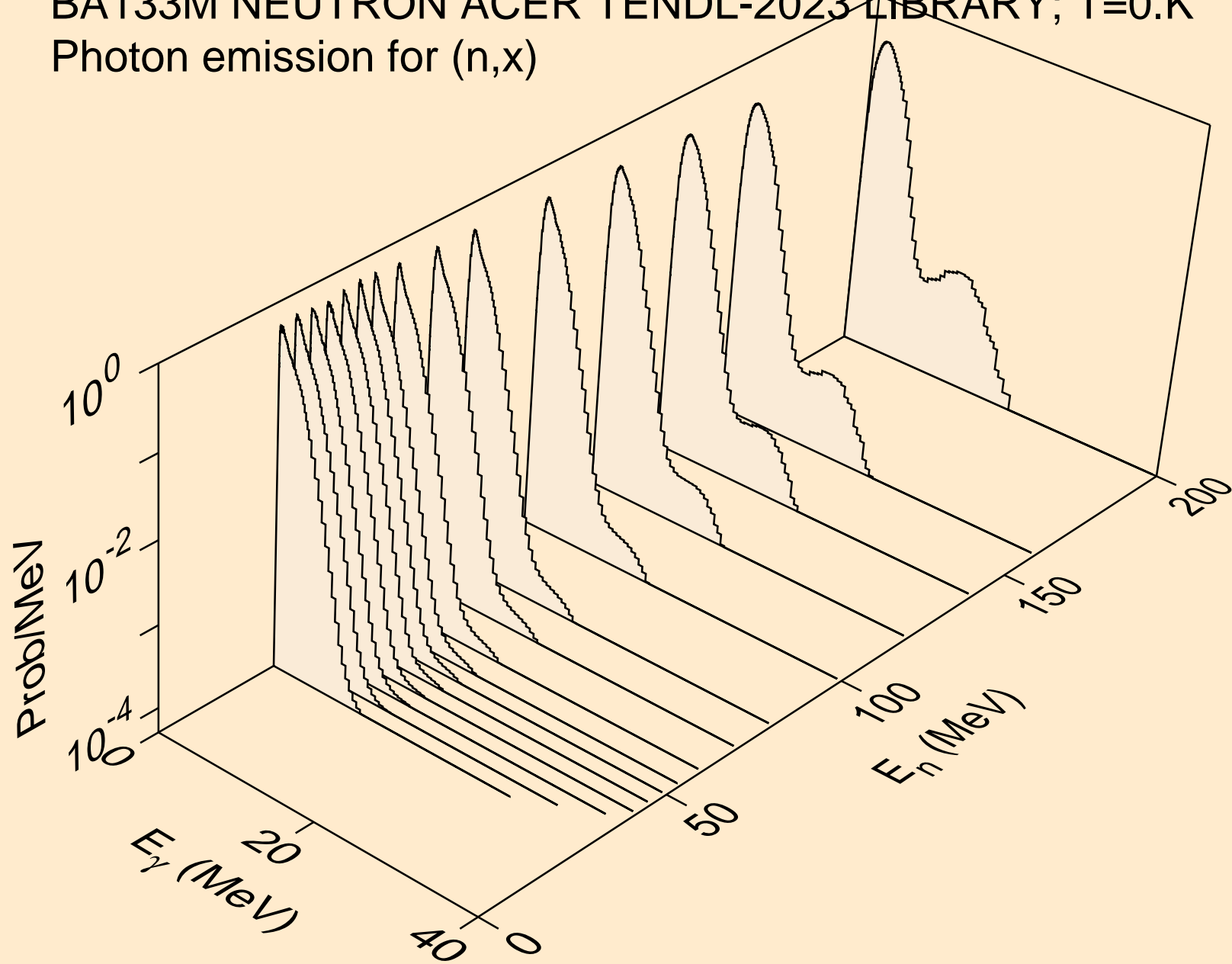

BA133M NEUTRON ACER TENDL-2023 LIBRARY; T=0.K
Photon emission for (n,2nd)

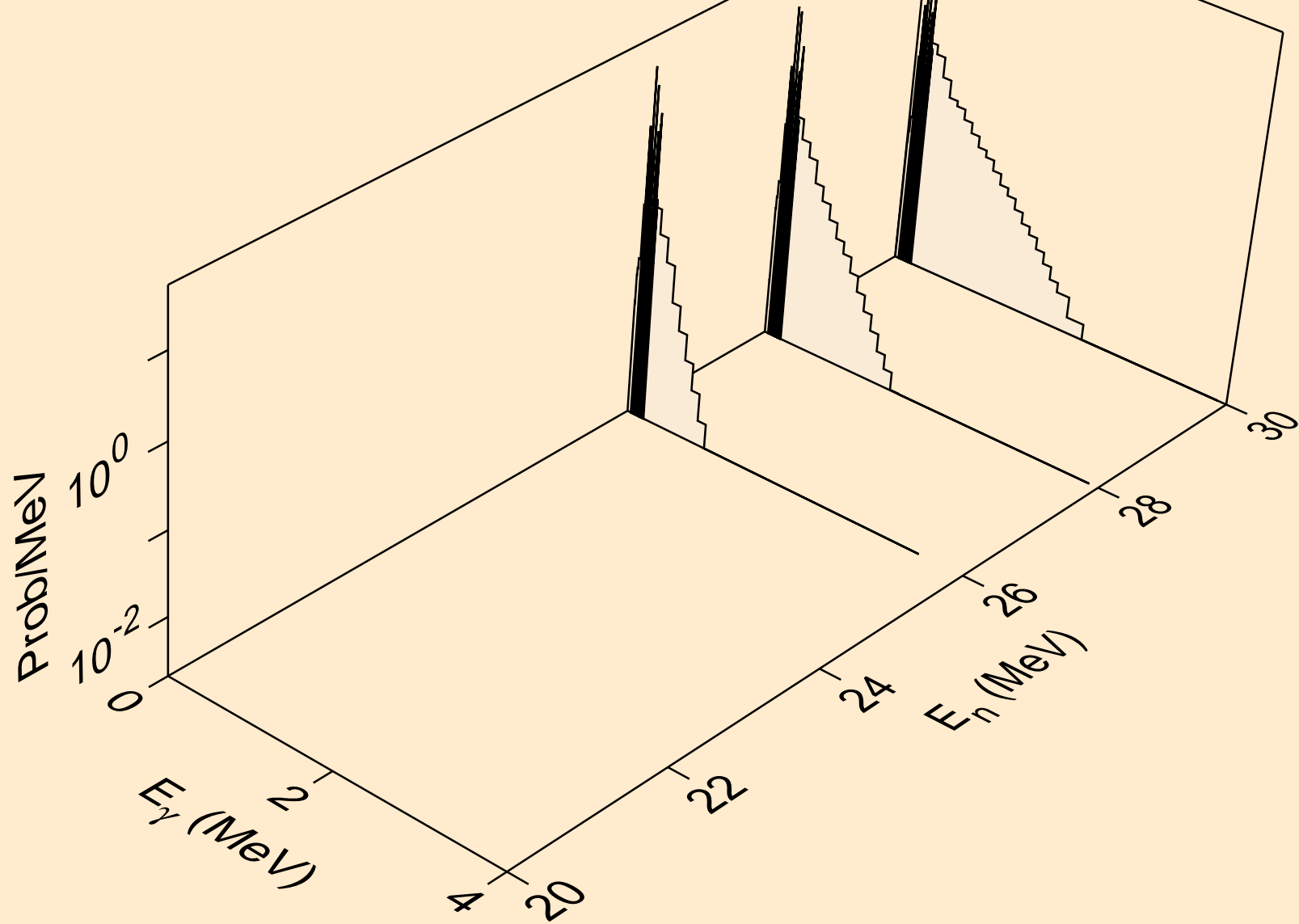

BA133M NEUTRON ACER TENDL-2023 LIBRARY; T=0.K
Photon emission for (n,2n)

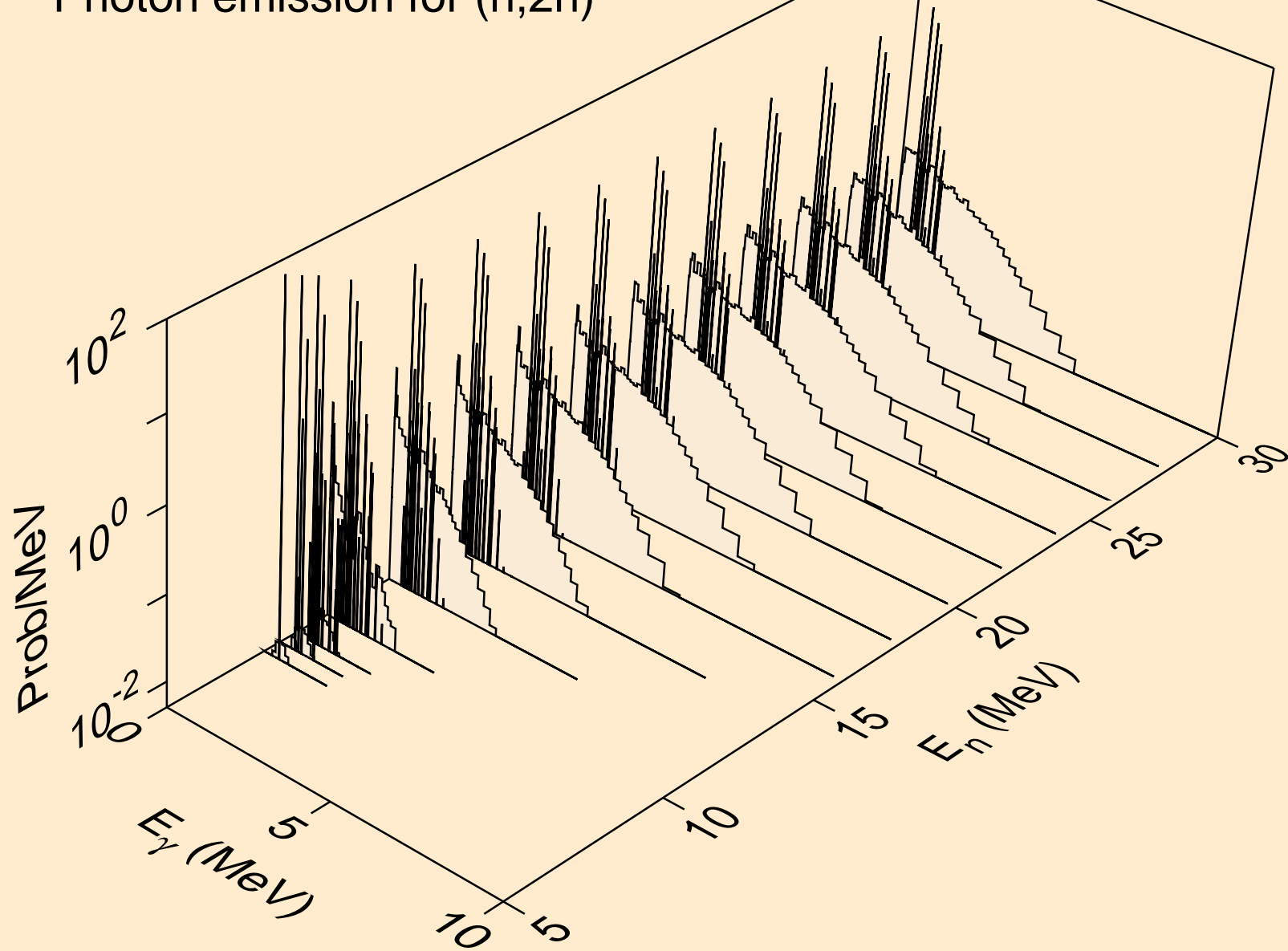

BA133M NEUTRON ACER TENDL-2023 LIBRARY; T=0.K
Photon emission for (n,3n)

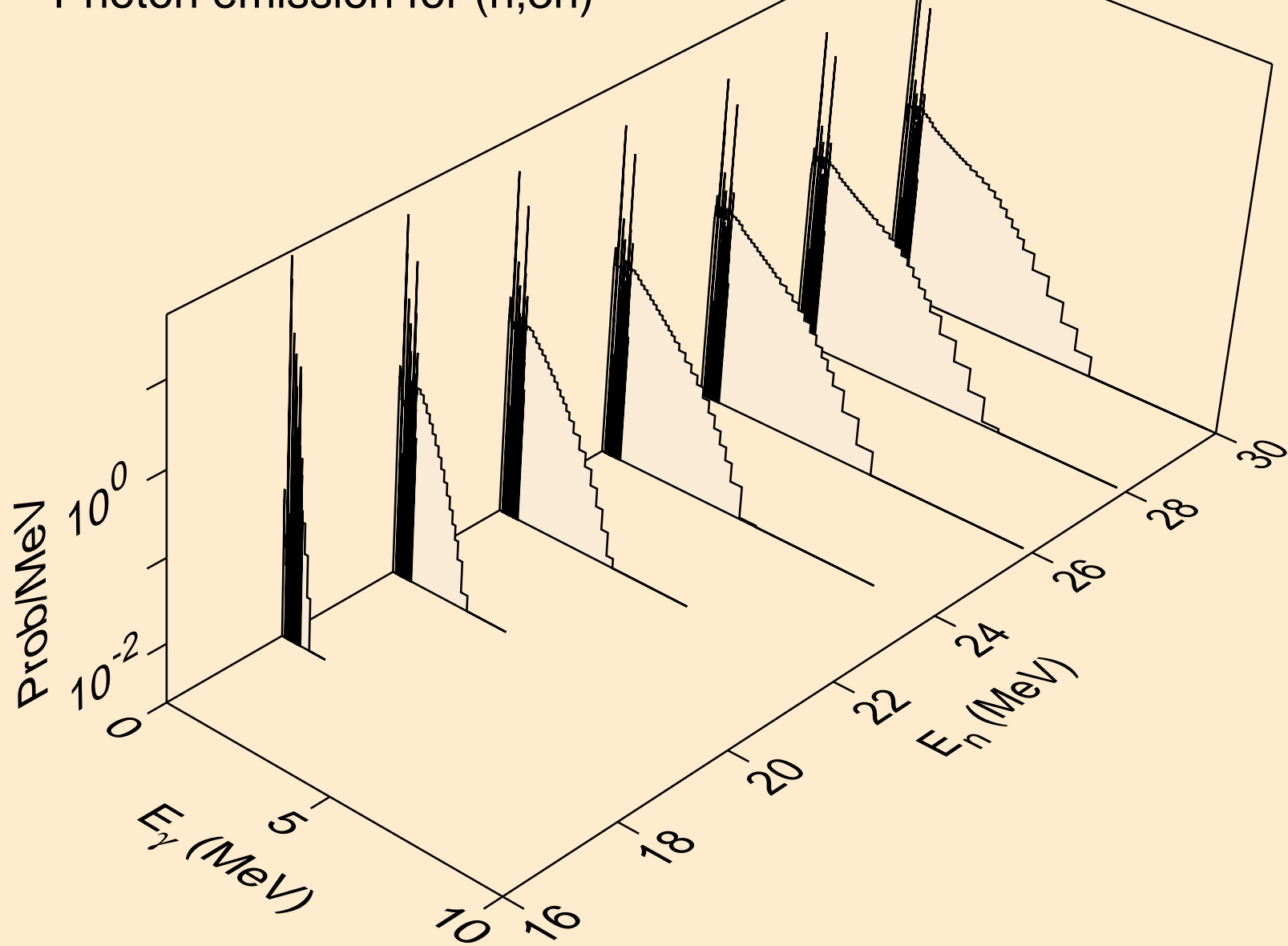

BA133M NEUTRON ACER TENDL-2023 LIBRARY; T=0.K
Photon emission for (n,n*)a

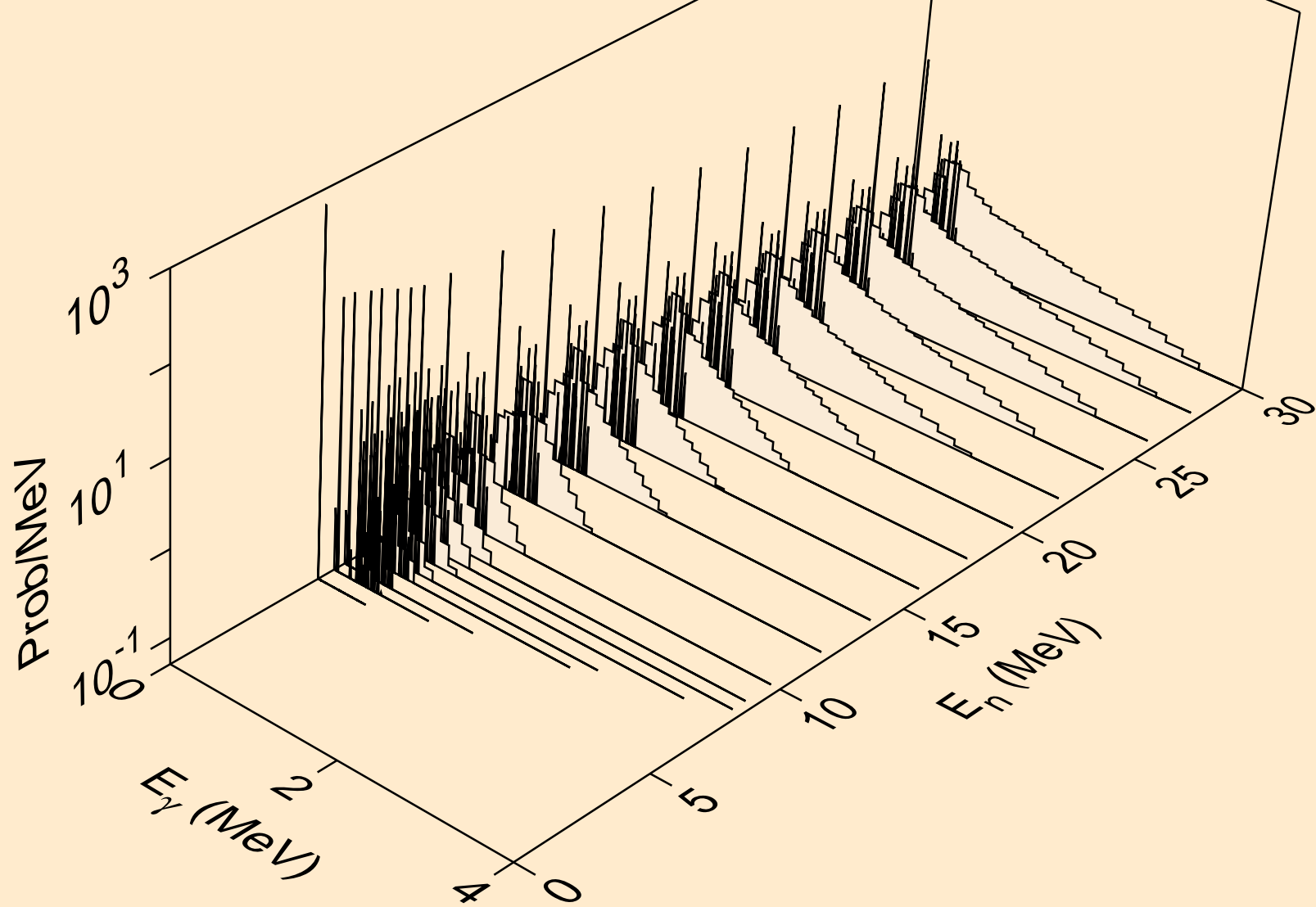

BA133M NEUTRON ACER TENDL-2023 LIBRARY; T=0.K
Photon emission for (n,2n)a

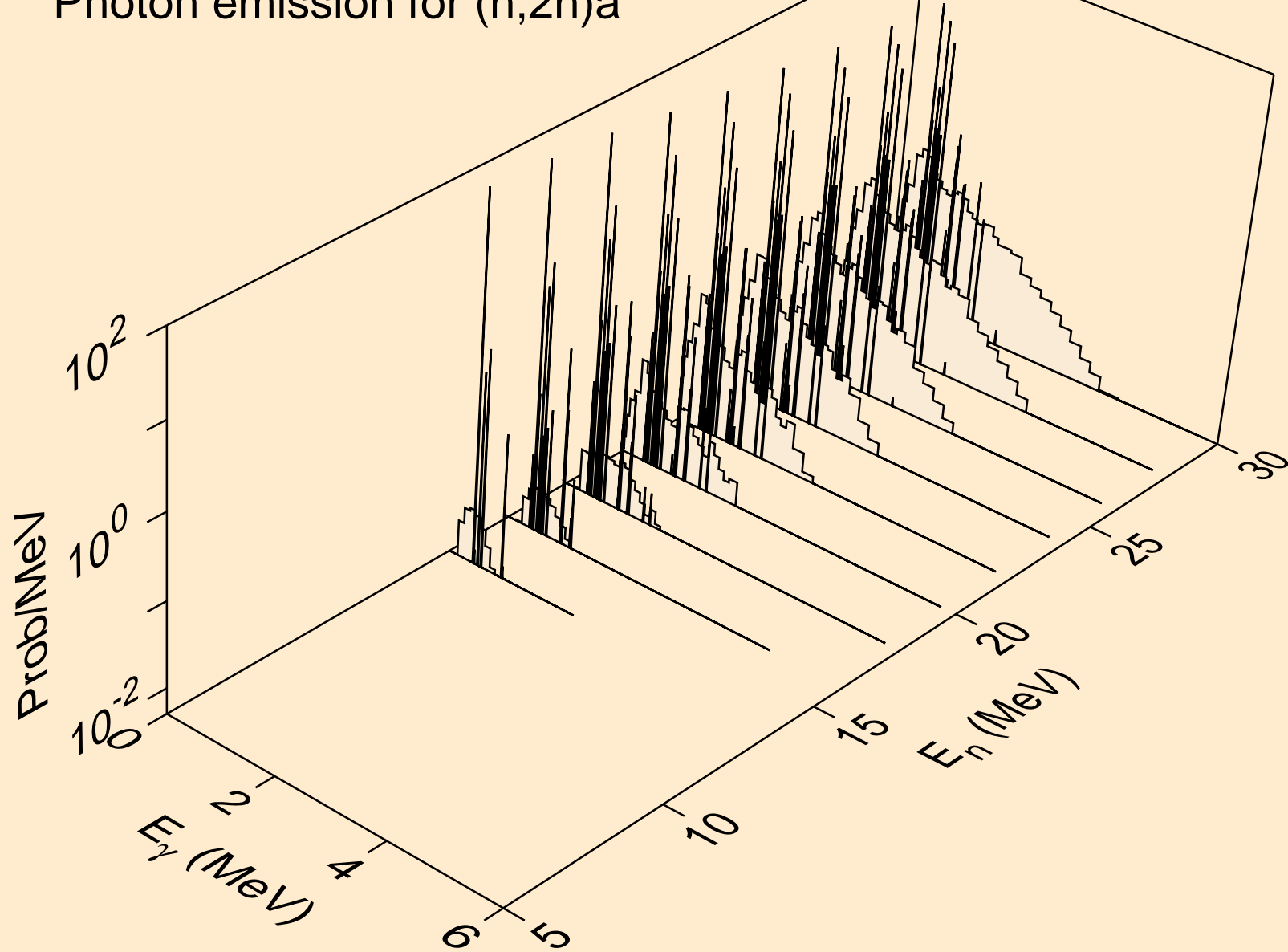

BA133M NEUTRON ACER TENDL-2023 LIBRARY; T=0.K
Photon emission for (n,3n)a

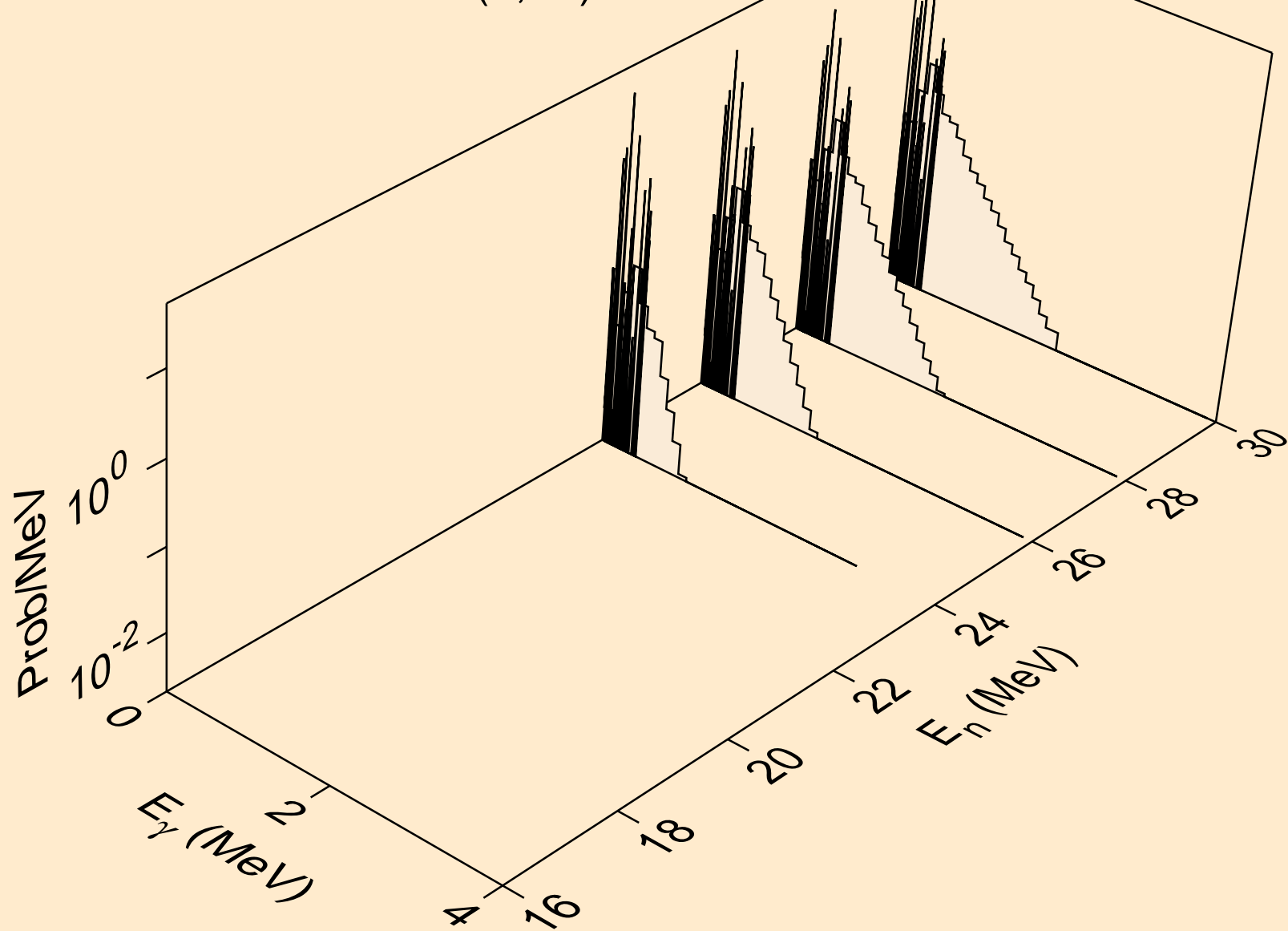

BA133M NEUTRON ACER TENDL-2023 LIBRARY; T=0.K
Photon emission for (n,n*)p

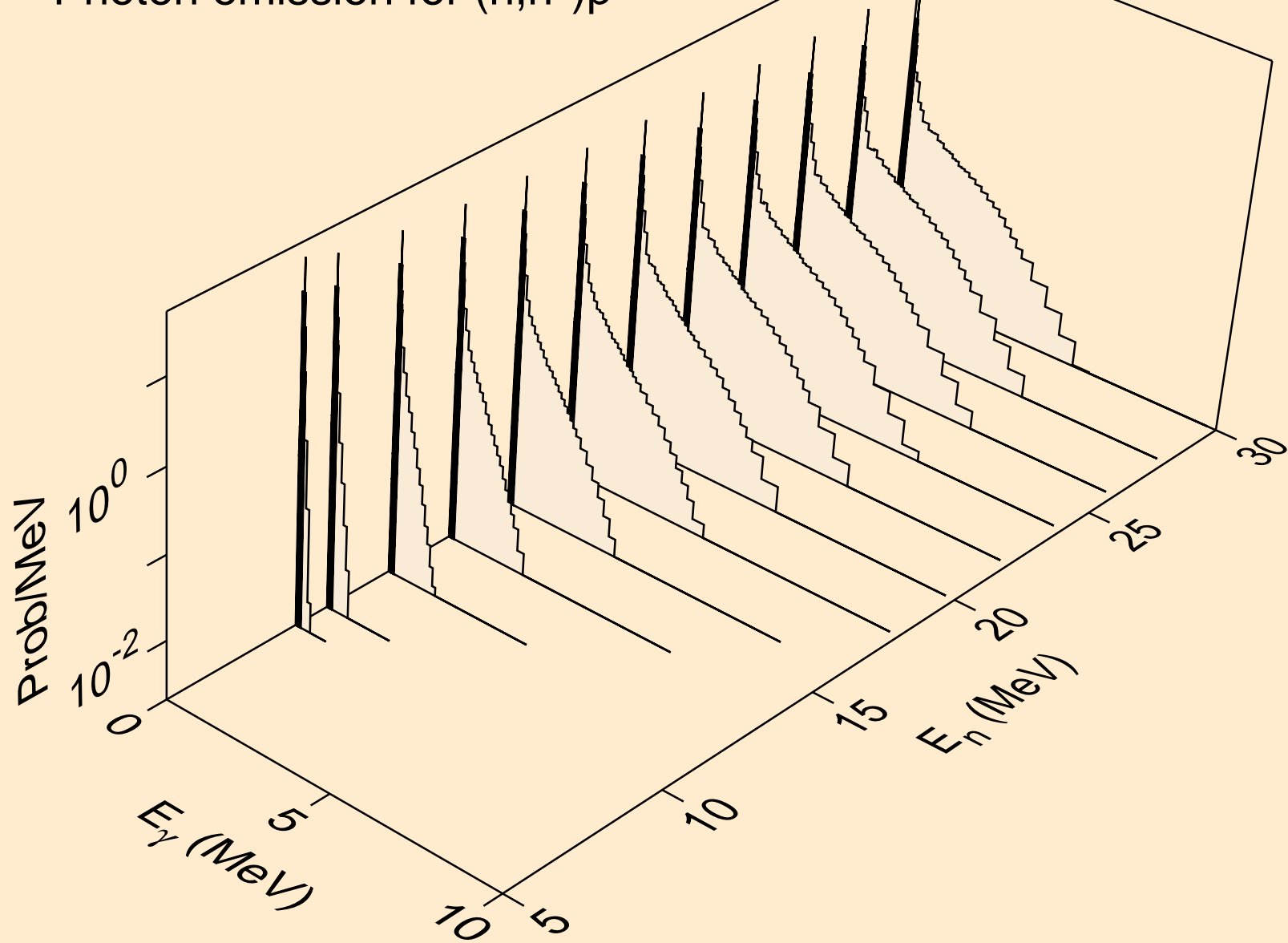

BA133M NEUTRON ACER TENDL-2023 LIBRARY; T=0.K
Photon emission for (n,n*)2a

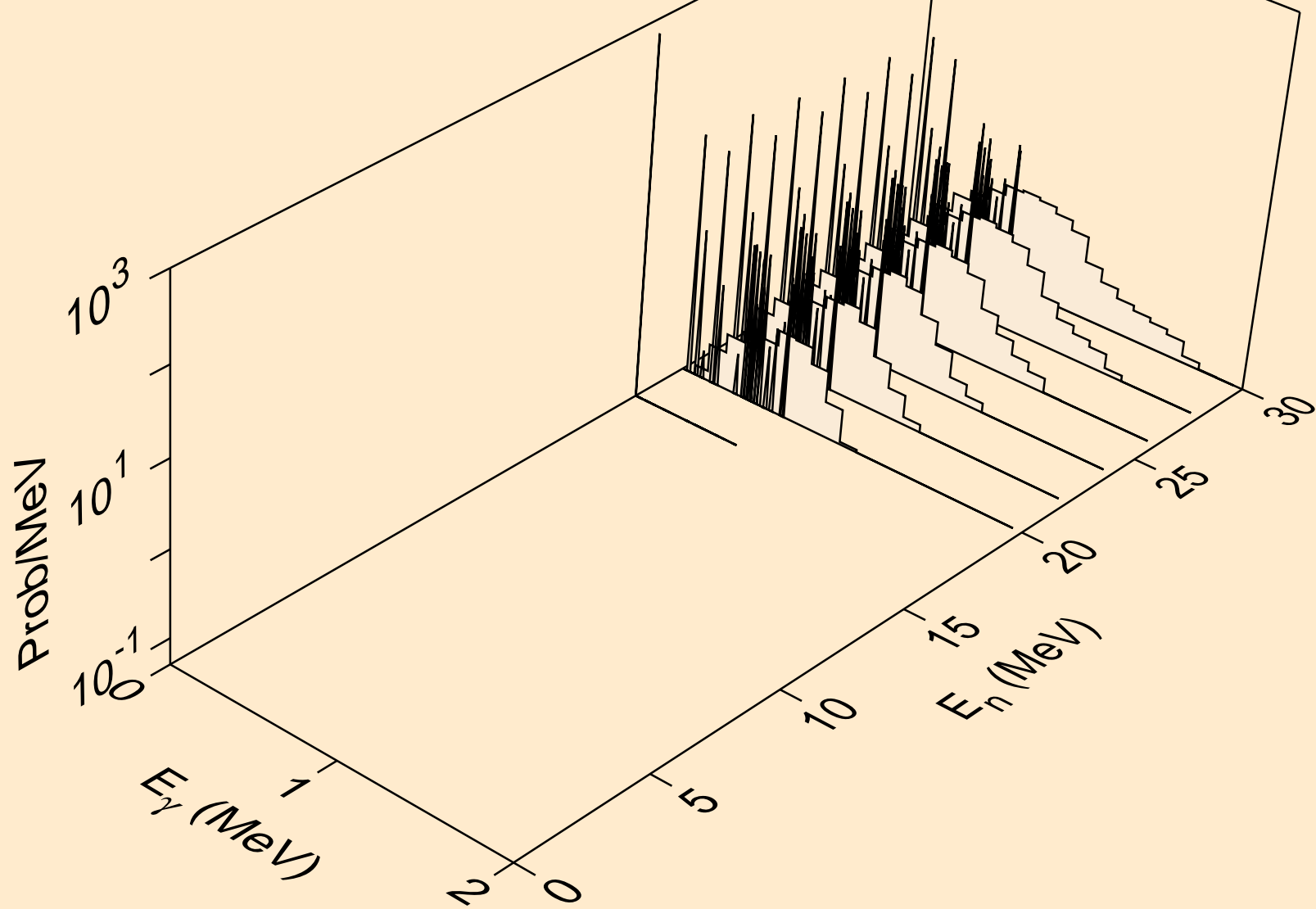

BA133M NEUTRON ACER TENDL-2023 LIBRARY; T=0.K
Photon emission for (n,n*)d

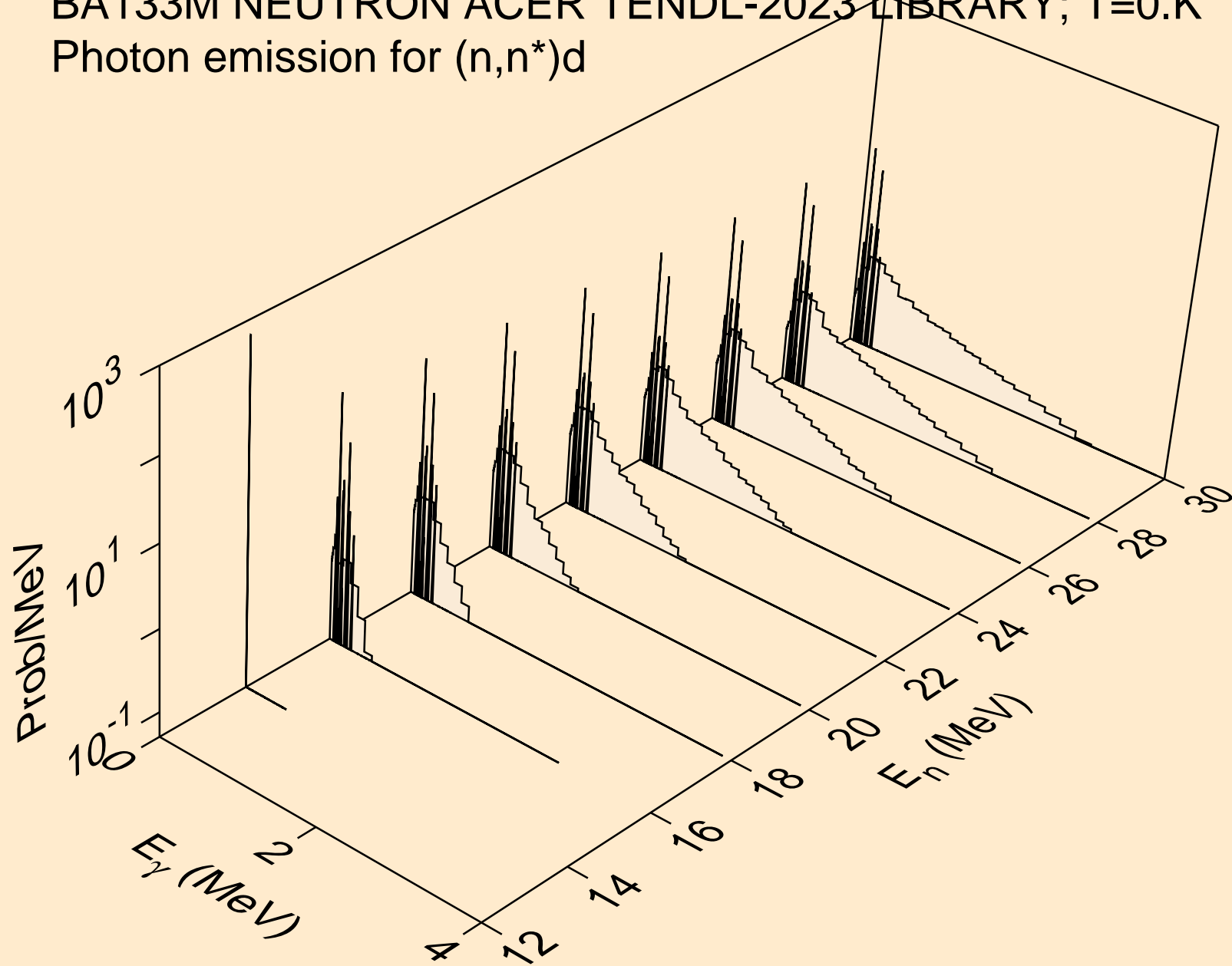

BA133M NEUTRON ACER TENDL-2023 LIBRARY; T=0.K
Photon emission for (n,n*)t

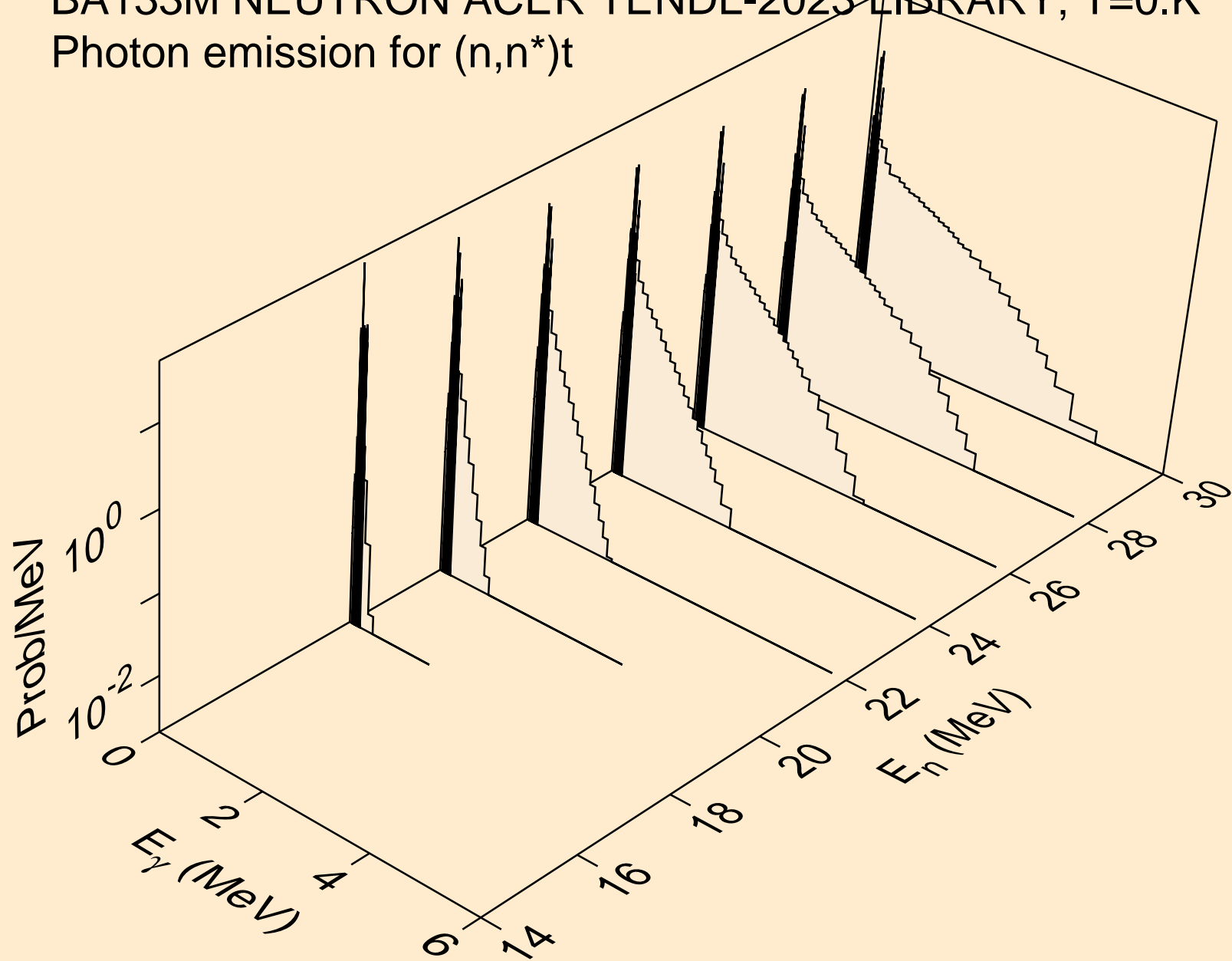

BA133M NEUTRON ACER TENDL-2023 LIBRARY; T=0.K
Photon emission for (n,n*)he3

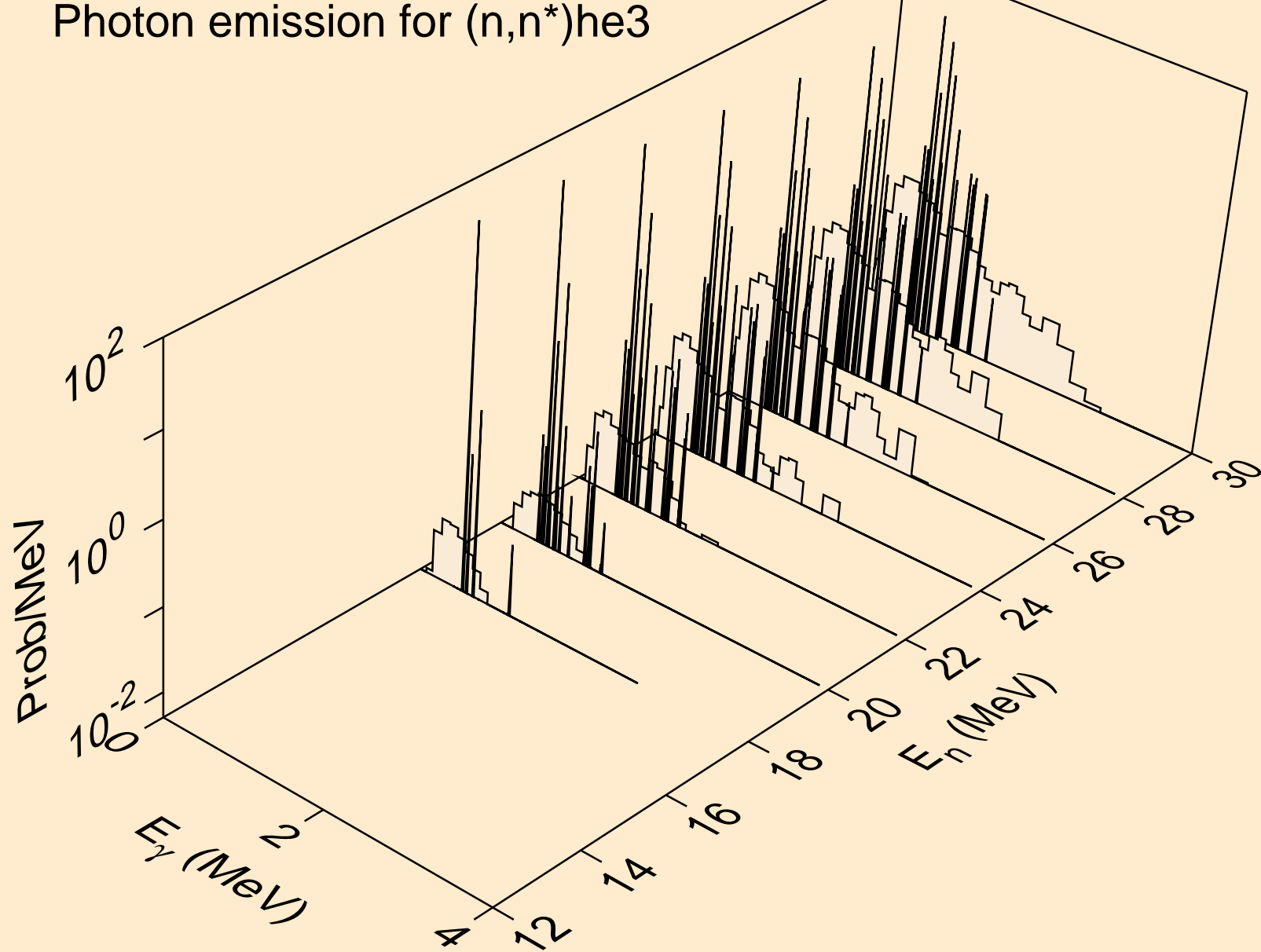

BA133M NEUTRON ACER TENDL-2023 LIBRARY; T=0.K
Photon emission for (n,4n)

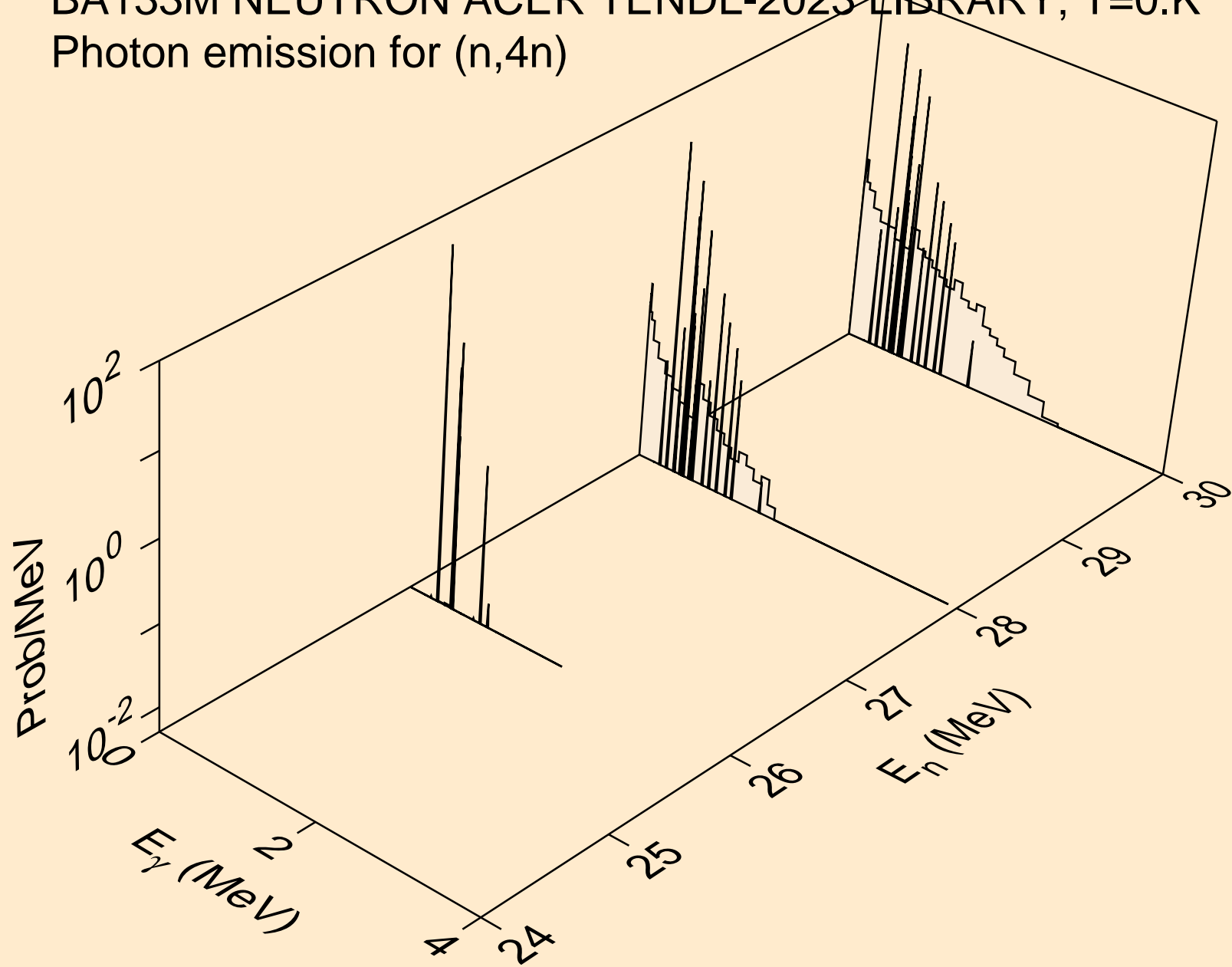

BA133M NEUTRON ACER TENDL-2023 LIBRARY; T=0.K
Photon emission for (n,2np)

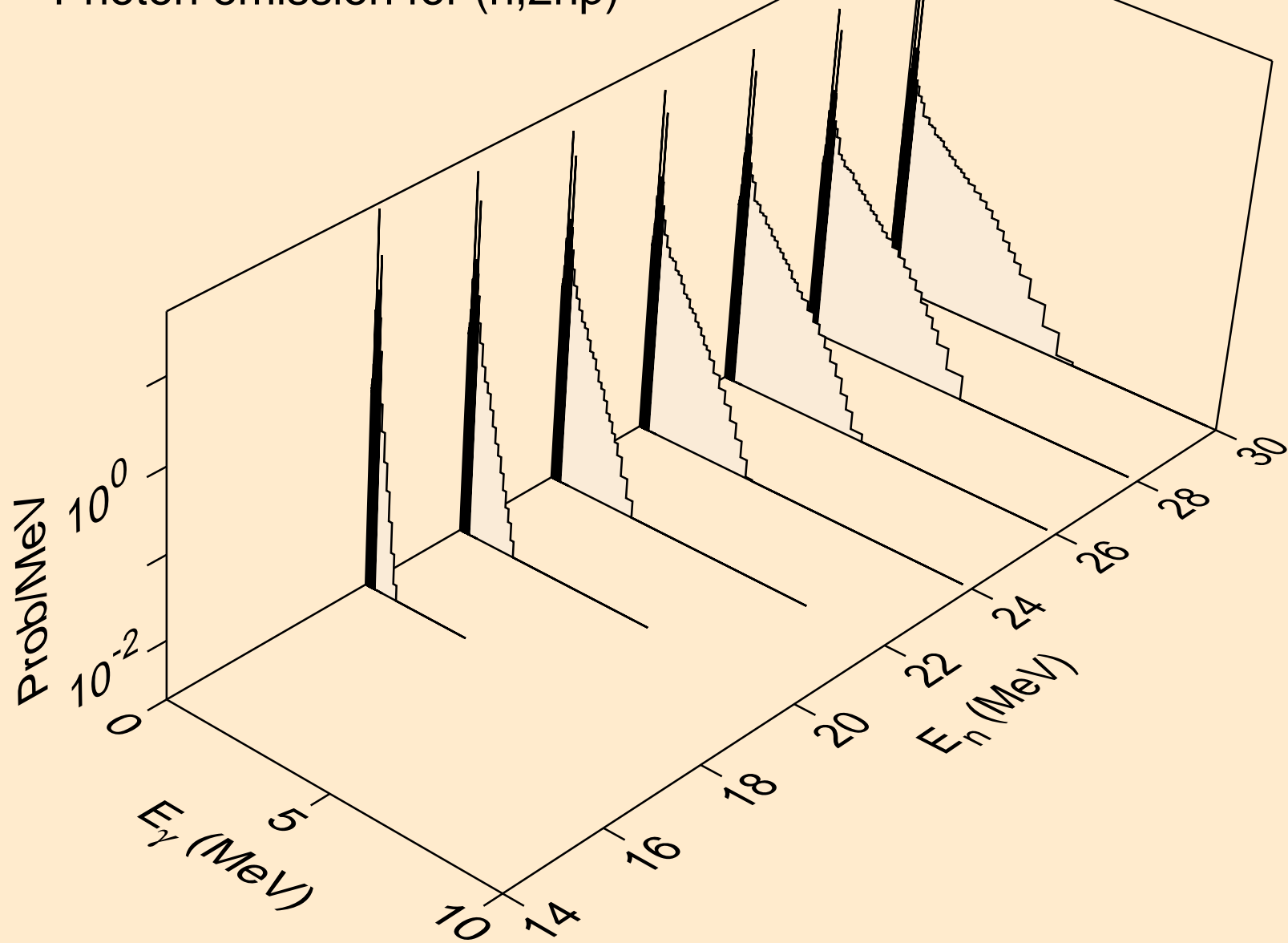

BA133M NEUTRON ACER TENDL-2023 LIBRARY; T=0.K
Photon emission for (n,3np)

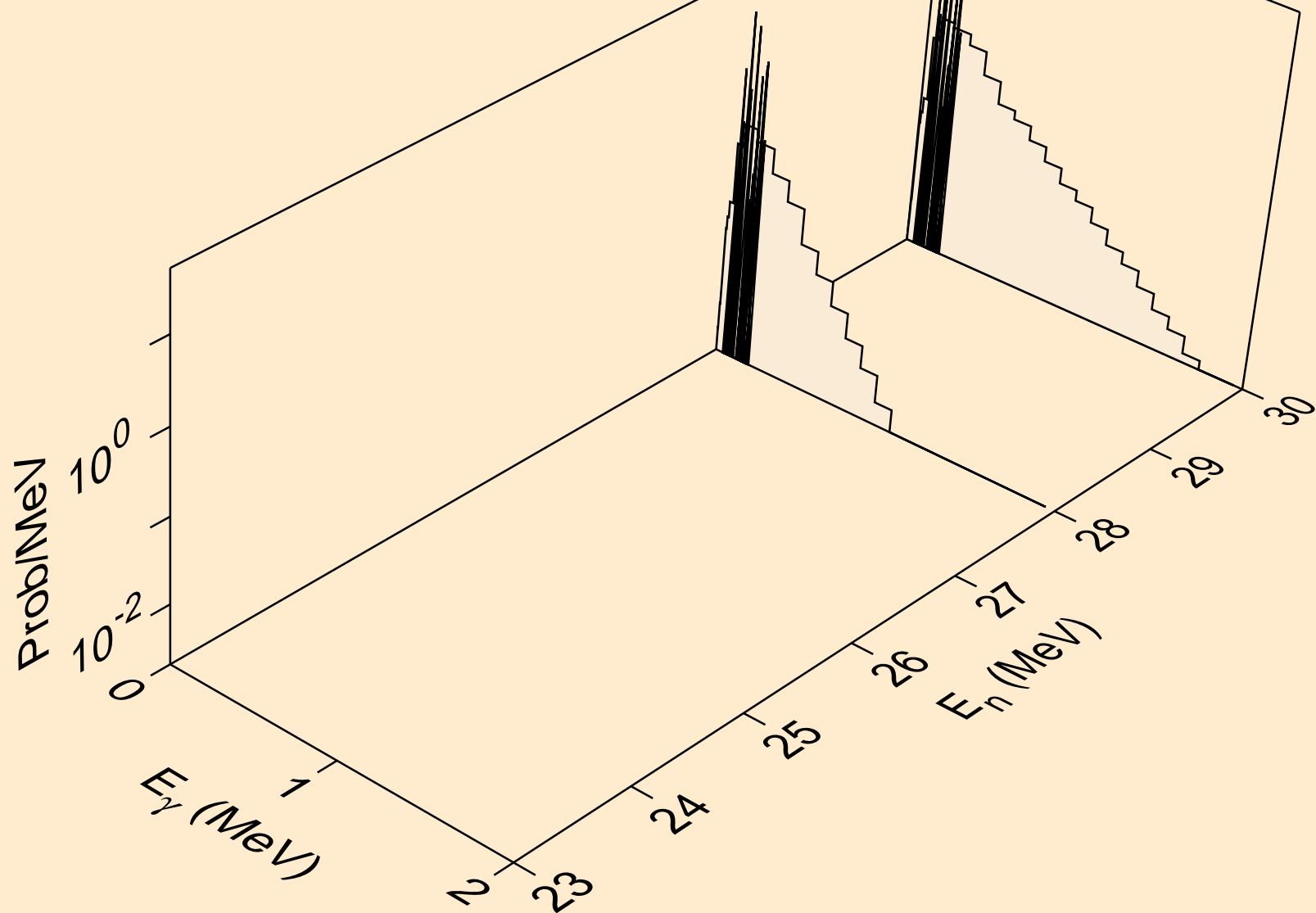

BA133M NEUTRON ACER TENDL-2023 LIBRARY; T=0.K
Photon emission for (n,n2p)

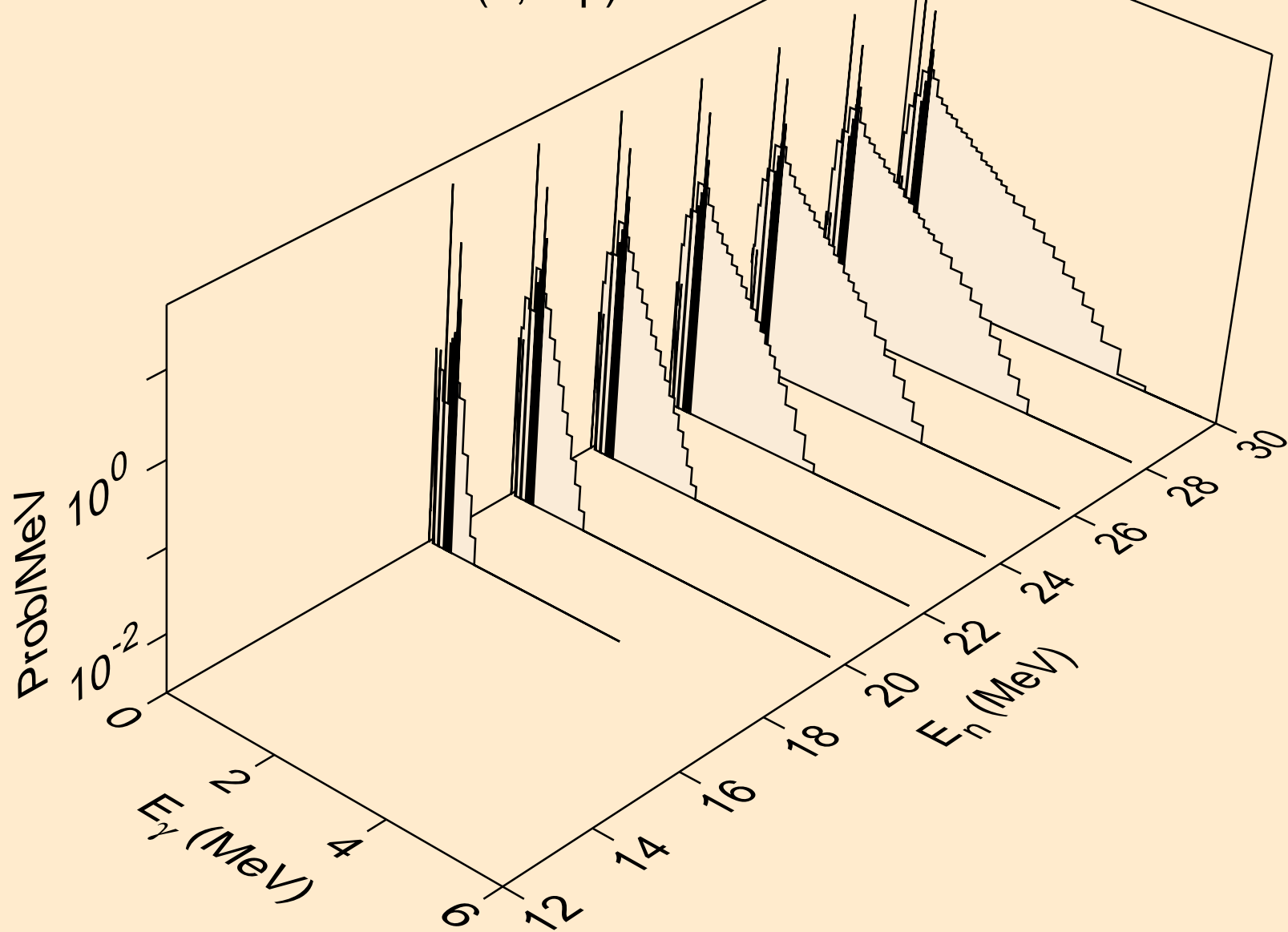

BA133M NEUTRON ACER TENDL-2023 LIBRARY; T=0.K
Photon emission for (n,npa)

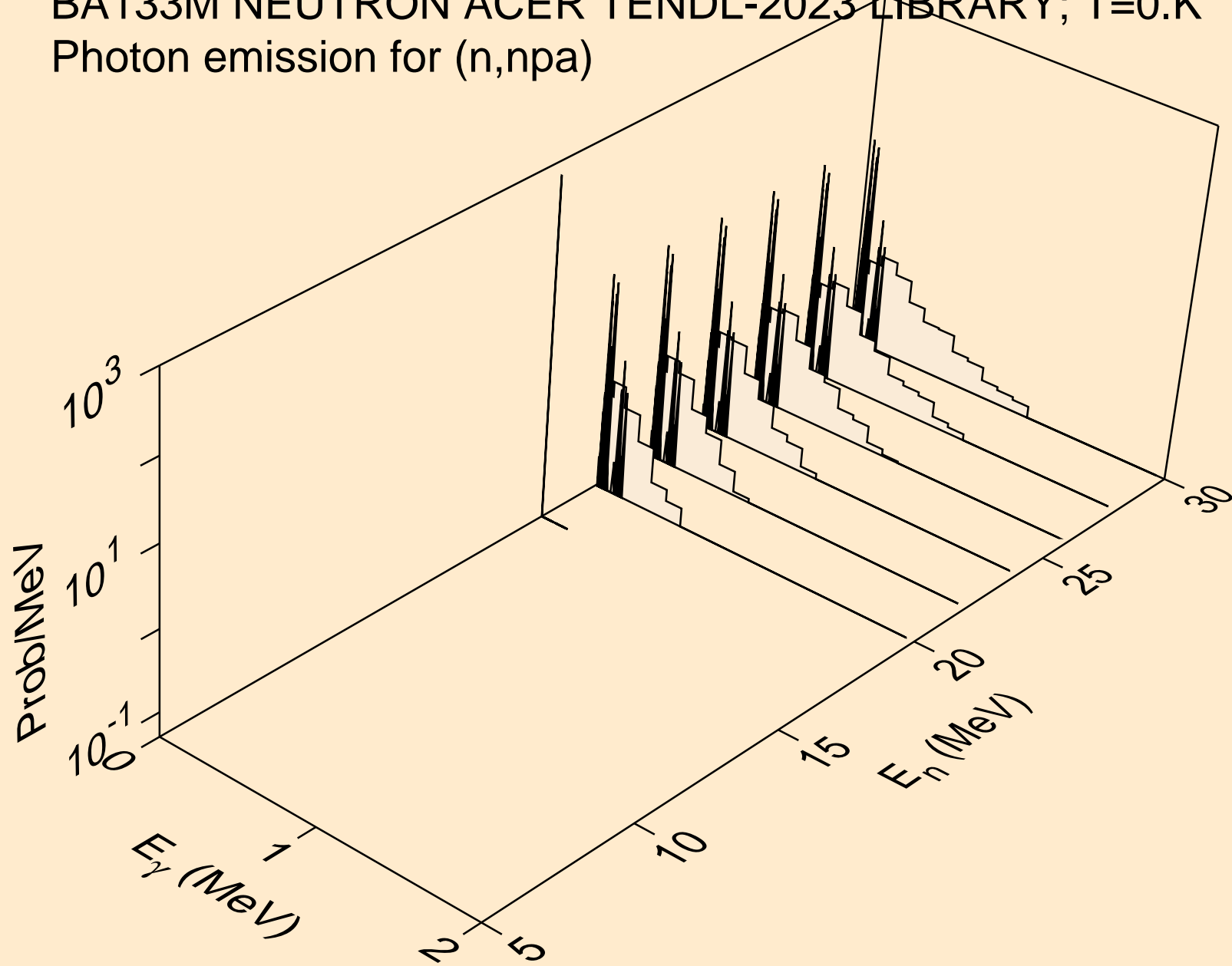

BA133M NEUTRON ACER TENDL-2023 LIBRARY; T=0.K
Photon emission for (n,n*1)

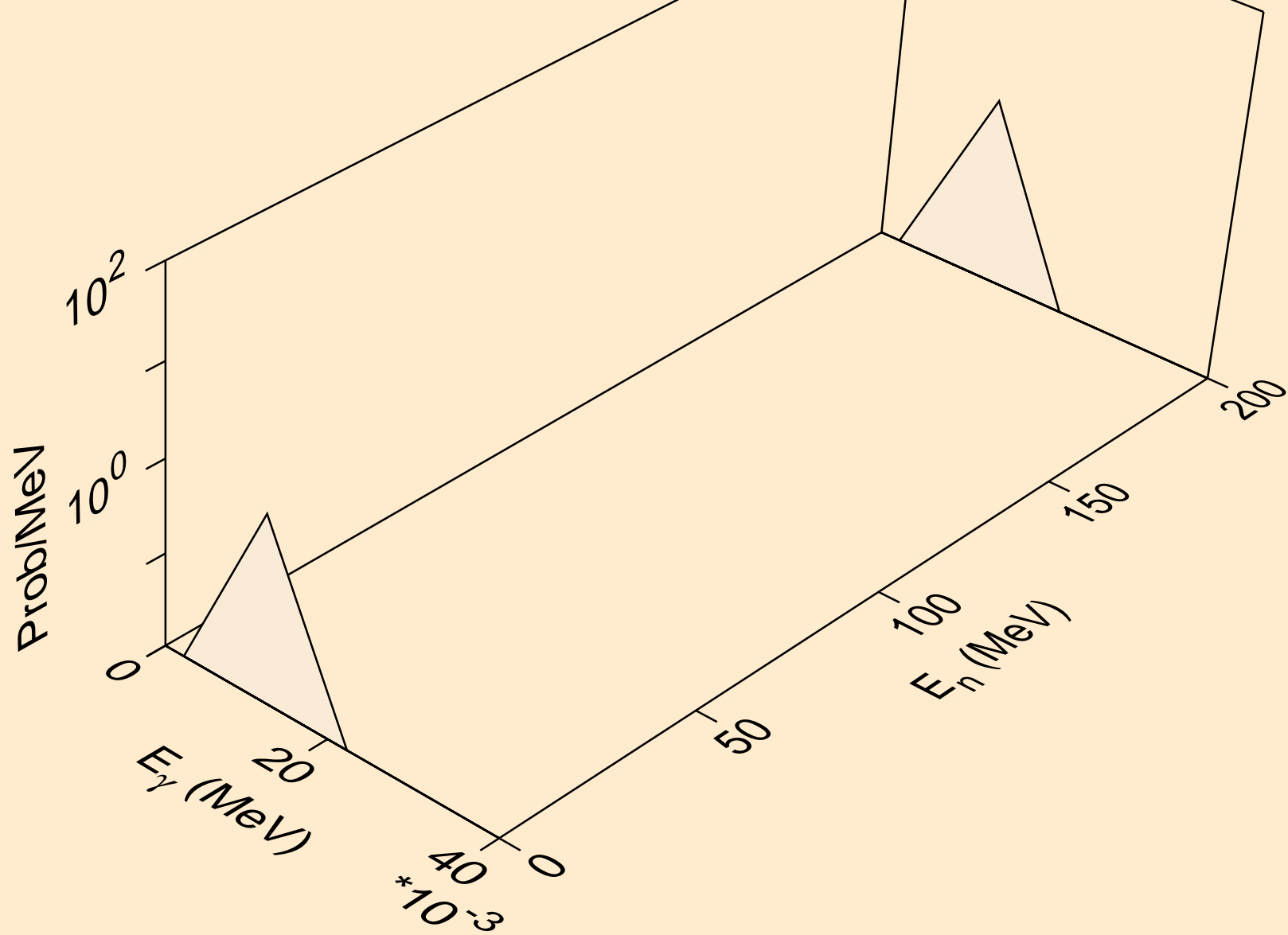

BA133M NEUTRON ACER TENDL-2023 LIBRARY; T=0.K
Photon emission for (n,n*3)

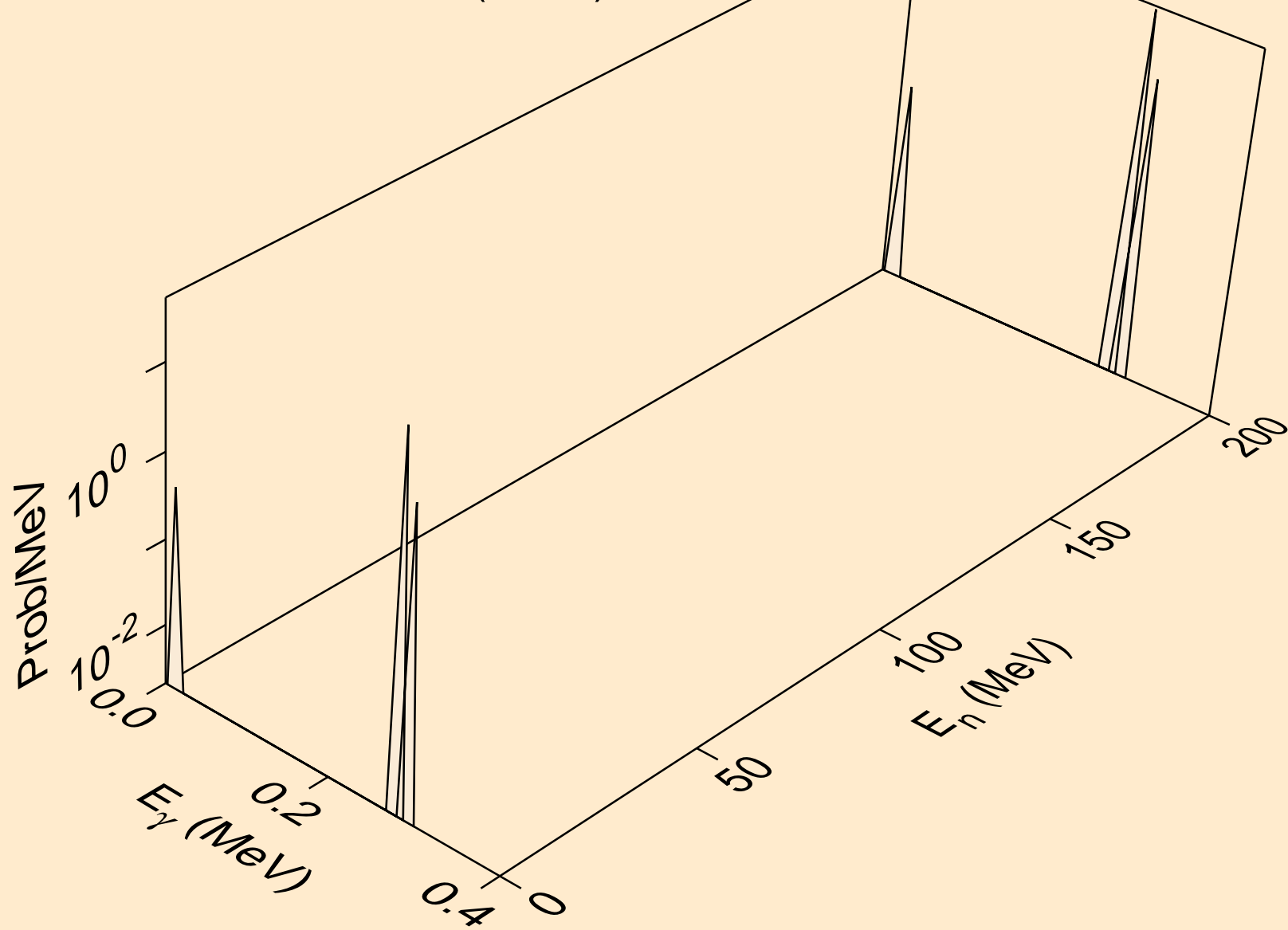

BA133M NEUTRON ACER TENDL-2023 LIBRARY; T=0.K
Photon emission for (n,n*4)

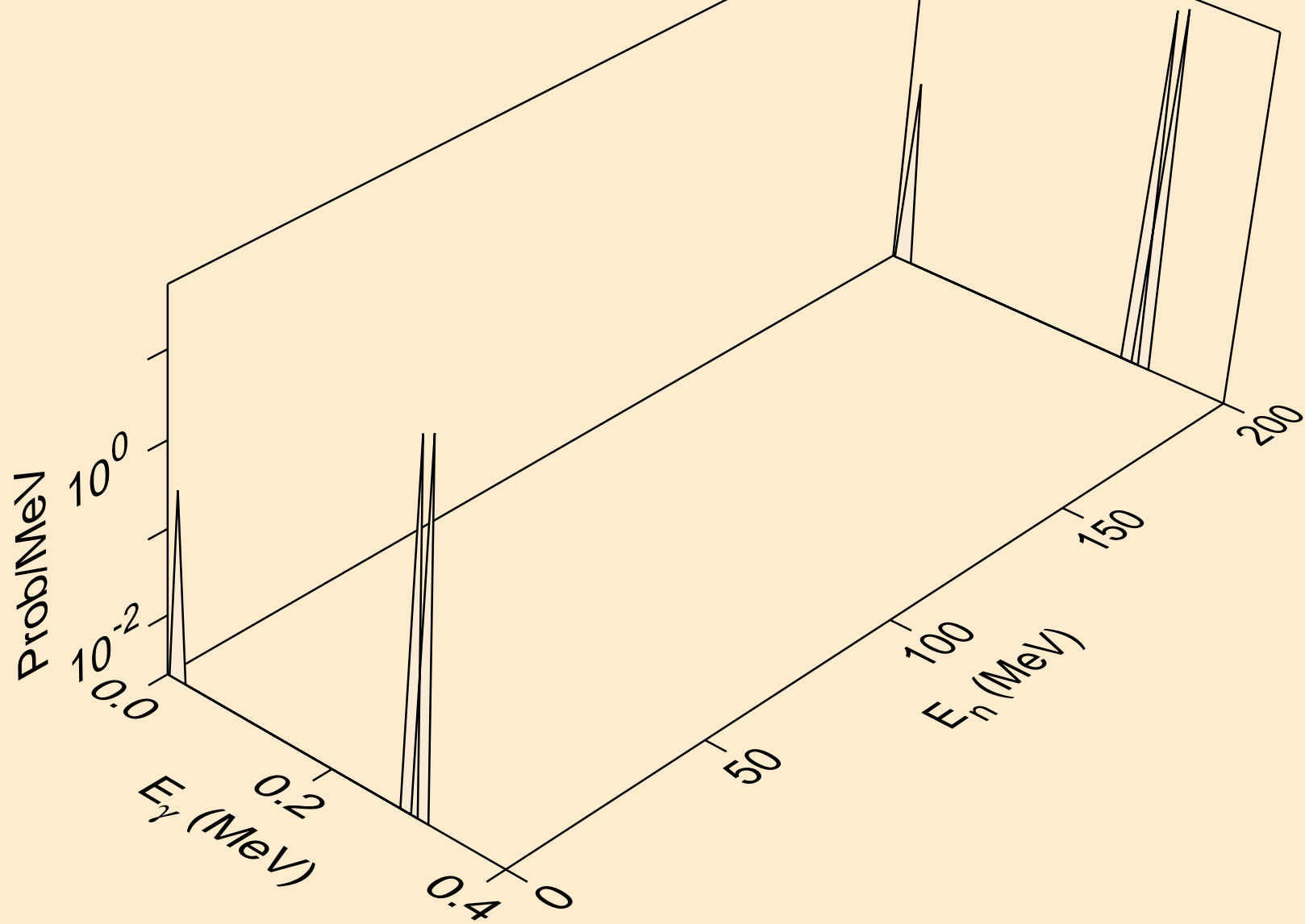

BA133M NEUTRON ACER TENDL-2023 LIBRARY; T=0.K
Photon emission for (n,n*5)

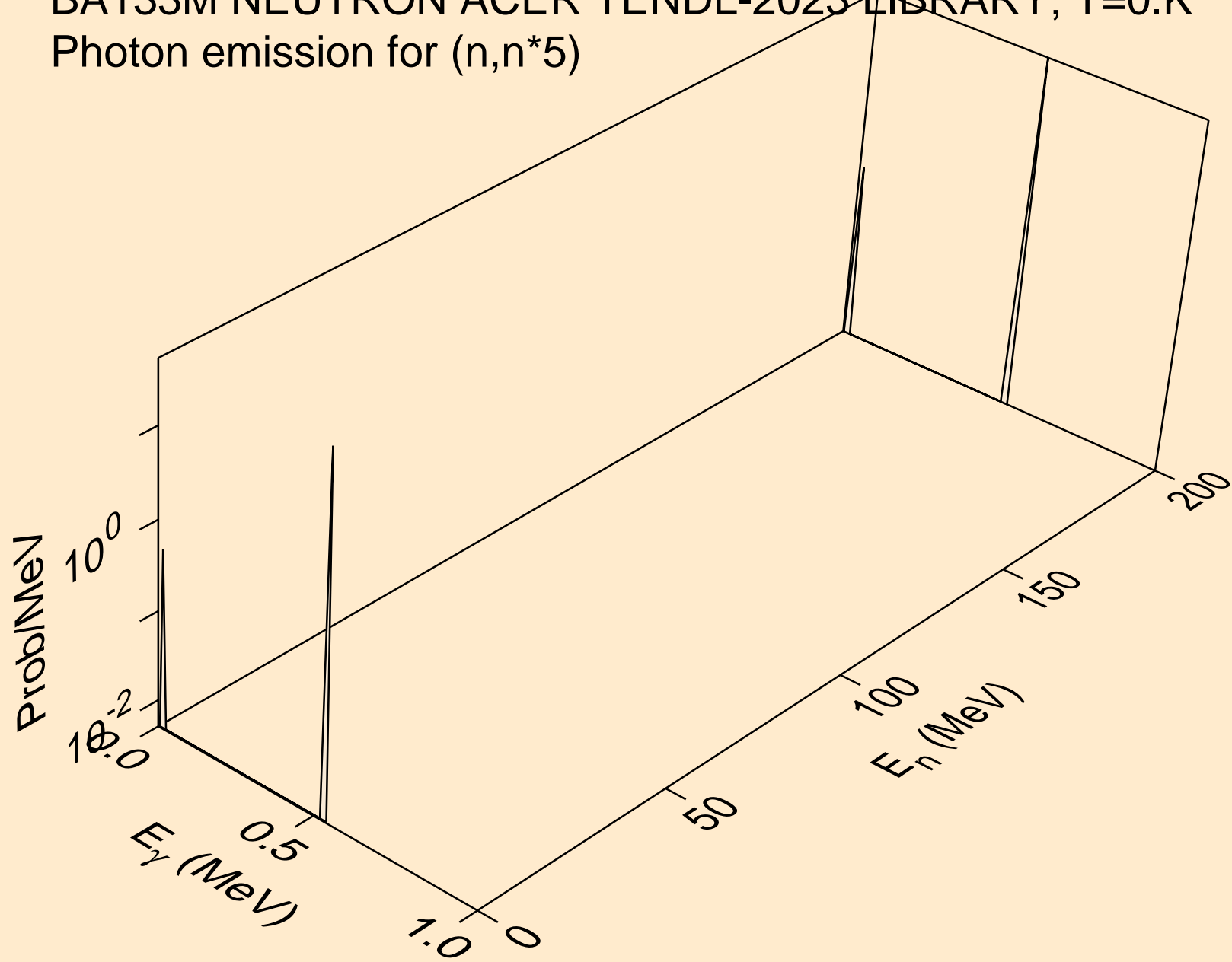

BA133M NEUTRON ACER TENDL-2023 LIBRARY; T=0.K
Photon emission for (n,n*6)

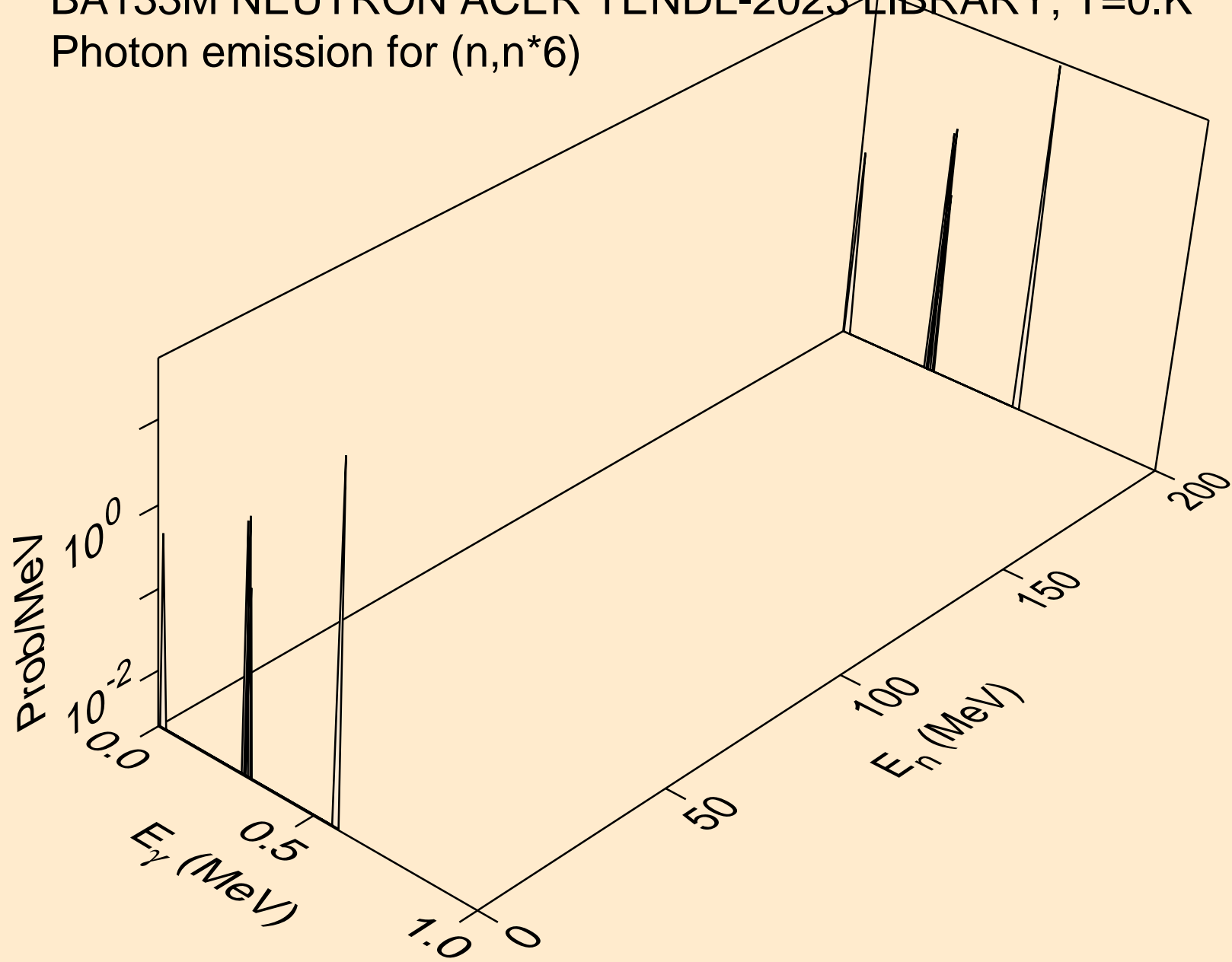

BA133M NEUTRON ACER TENDL-2023 LIBRARY; T=0.K
Photon emission for (n,n*7)

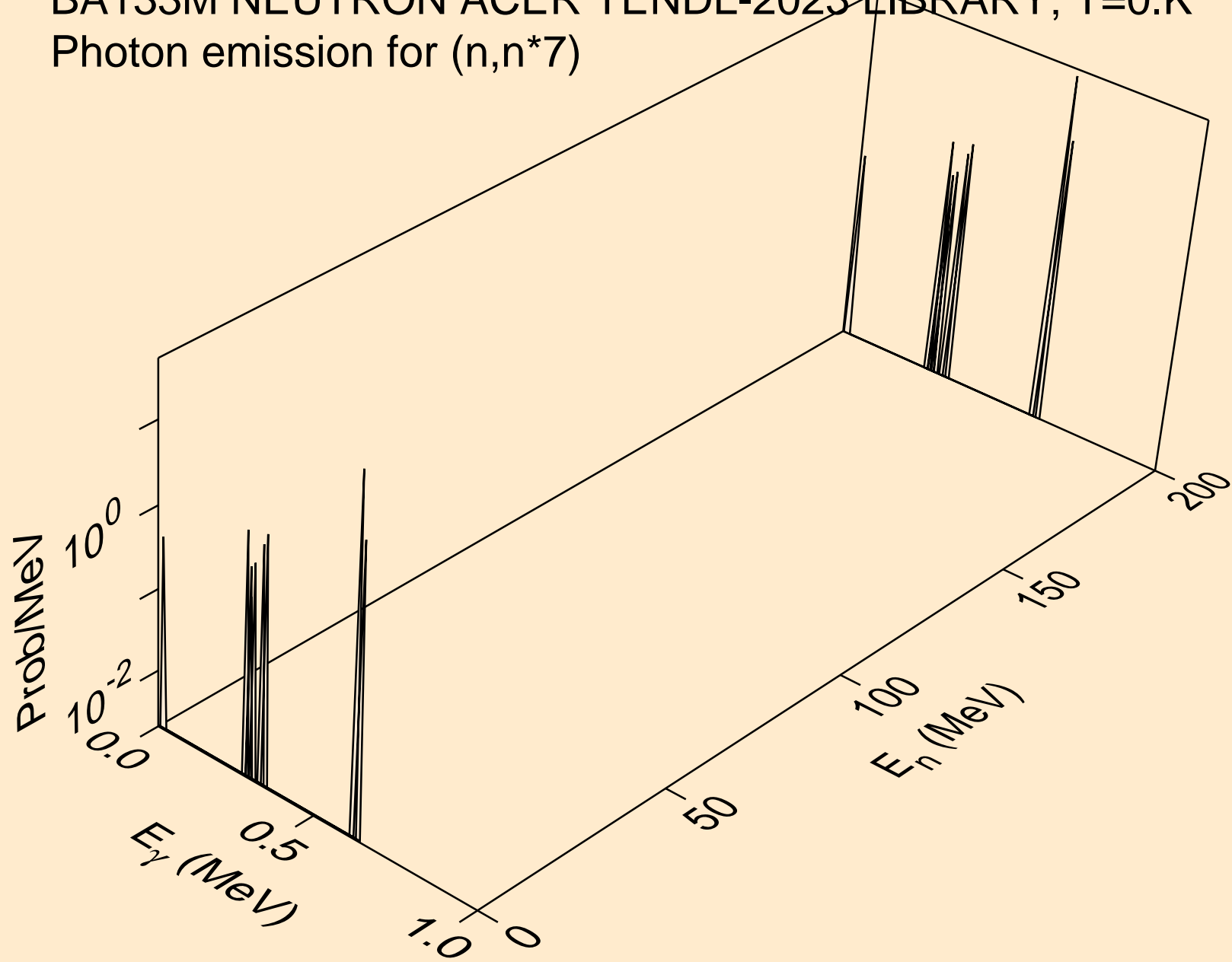

BA133M NEUTRON ACER TENDL-2023 LIBRARY; T=0.K
Photon emission for (n,n*8)

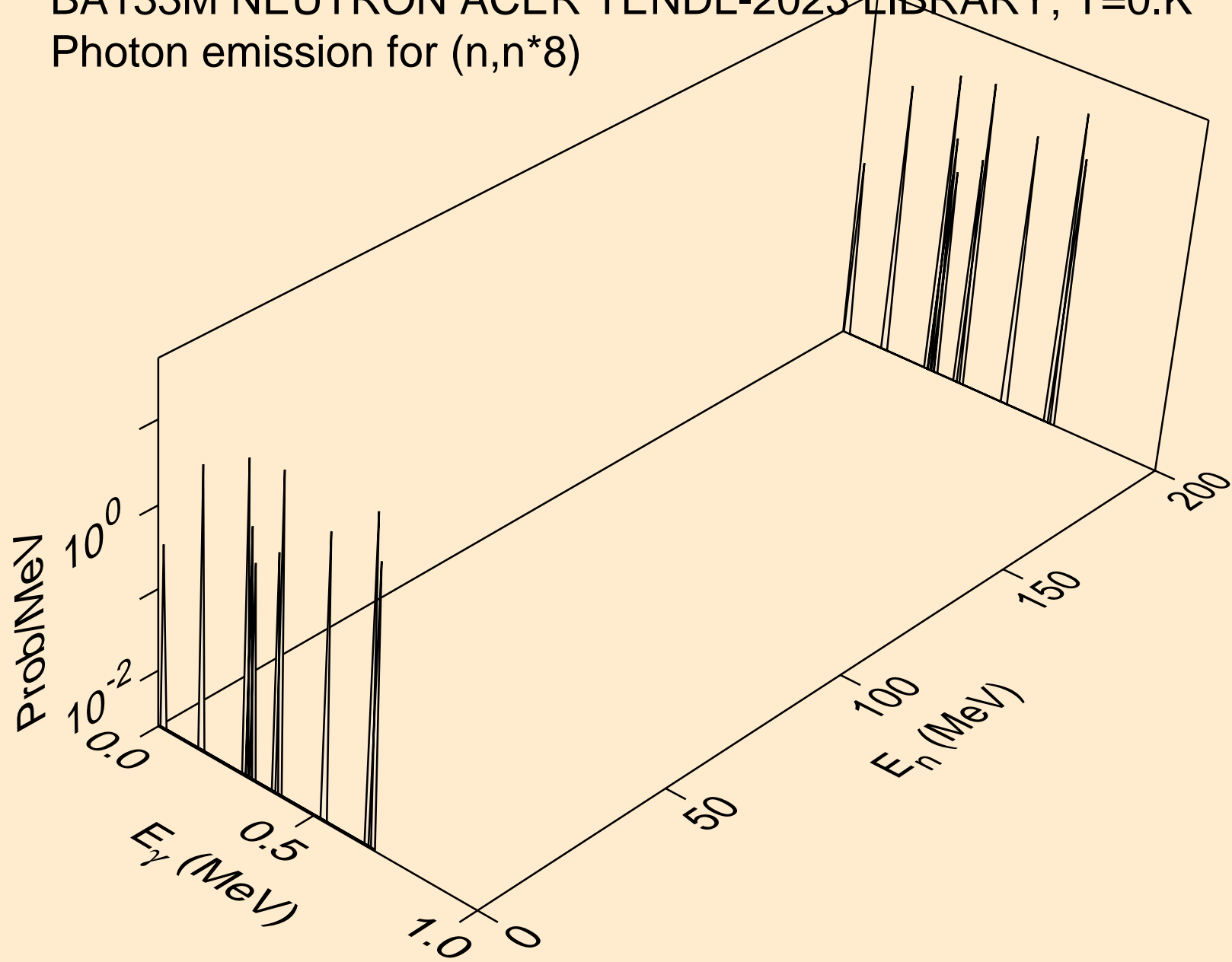

BA133M NEUTRON ACER TENDL-2023 LIBRARY; T=0.K
Photon emission for (n,n*9)

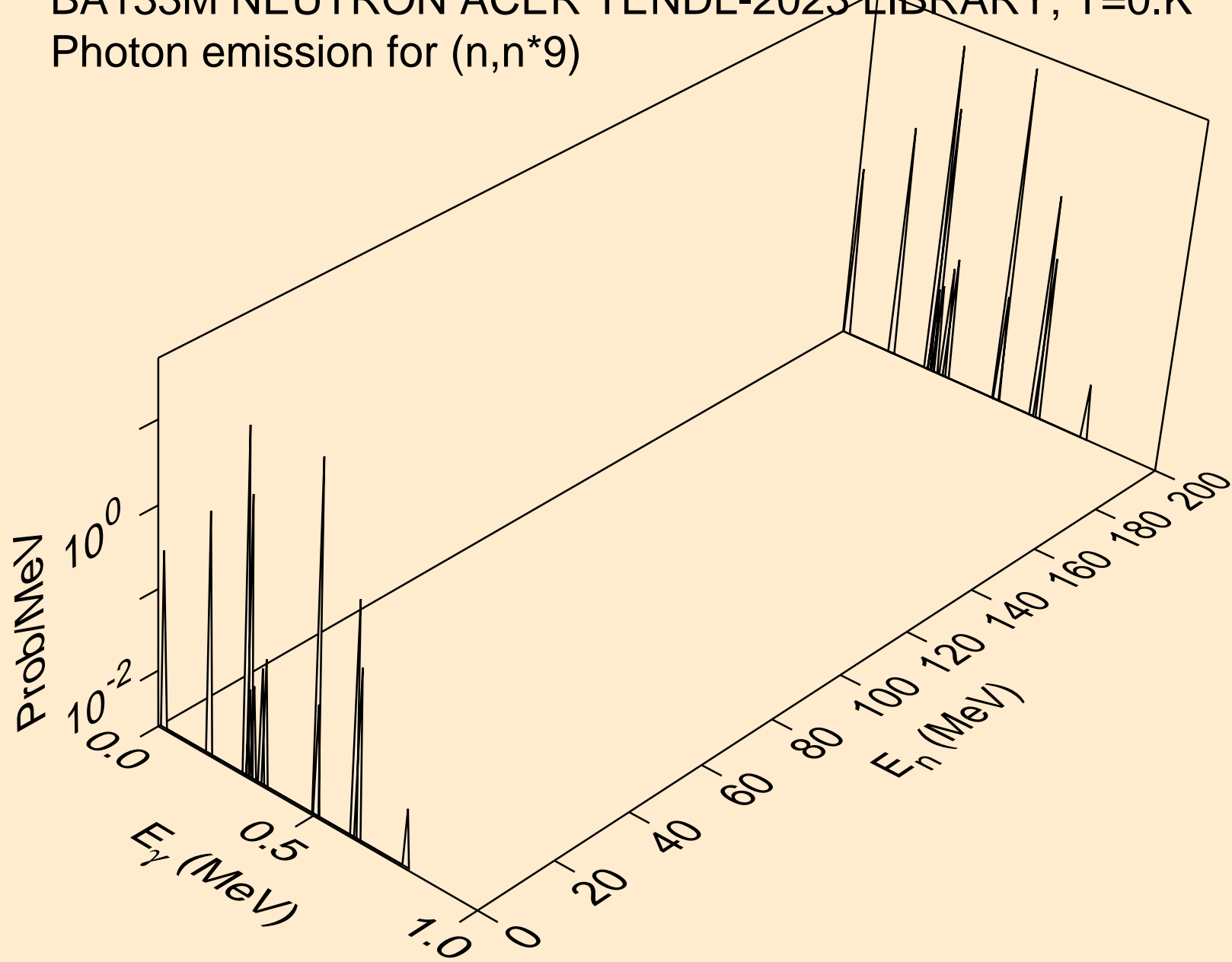

BA133M NEUTRON ACER TENDL-2023 LIBRARY; T=0.K
Photon emission for (n,n*10)

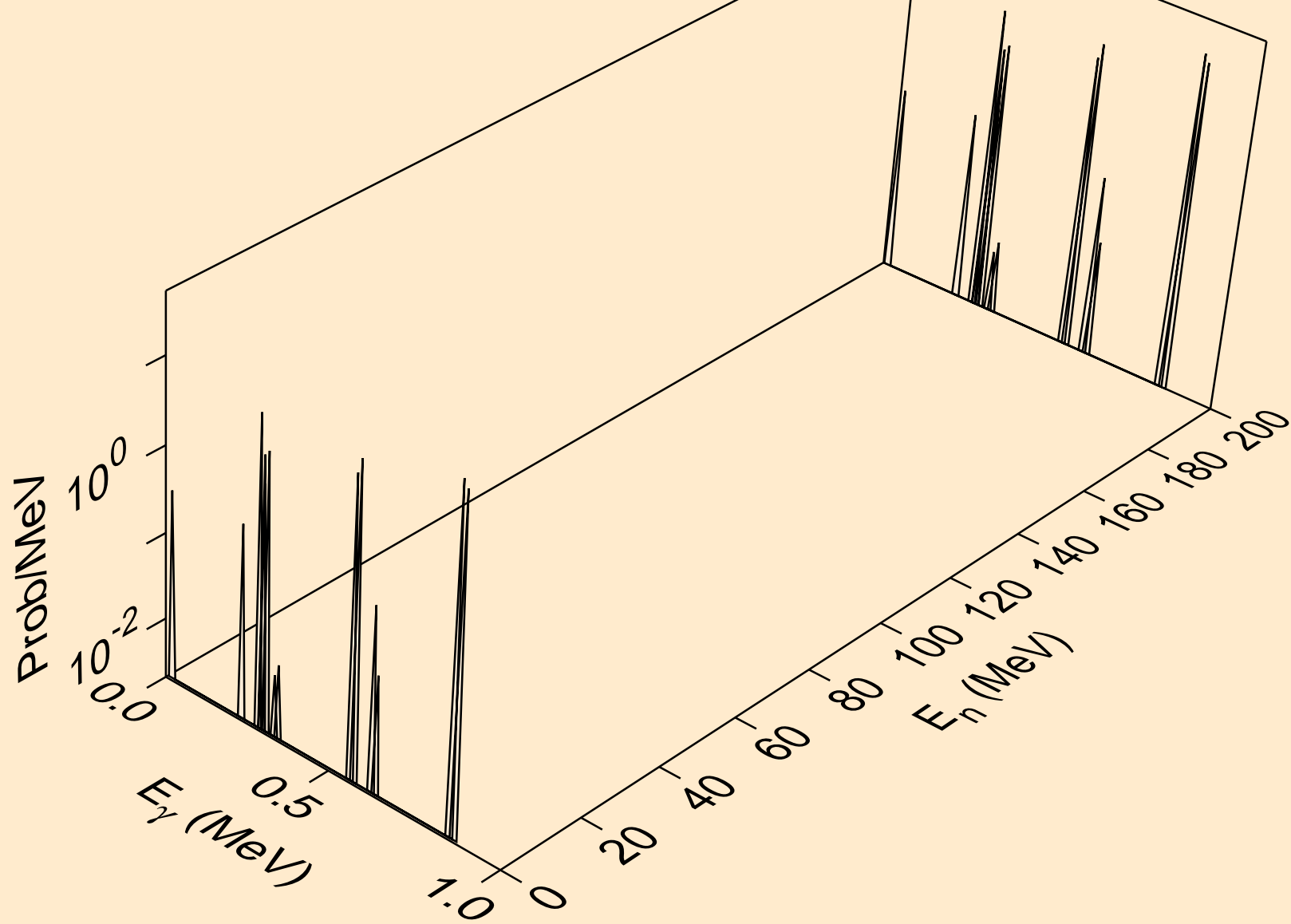

BA133M NEUTRON ACER TENDL-2023 LIBRARY; T=0.K
Photon emission for (n,n*11)

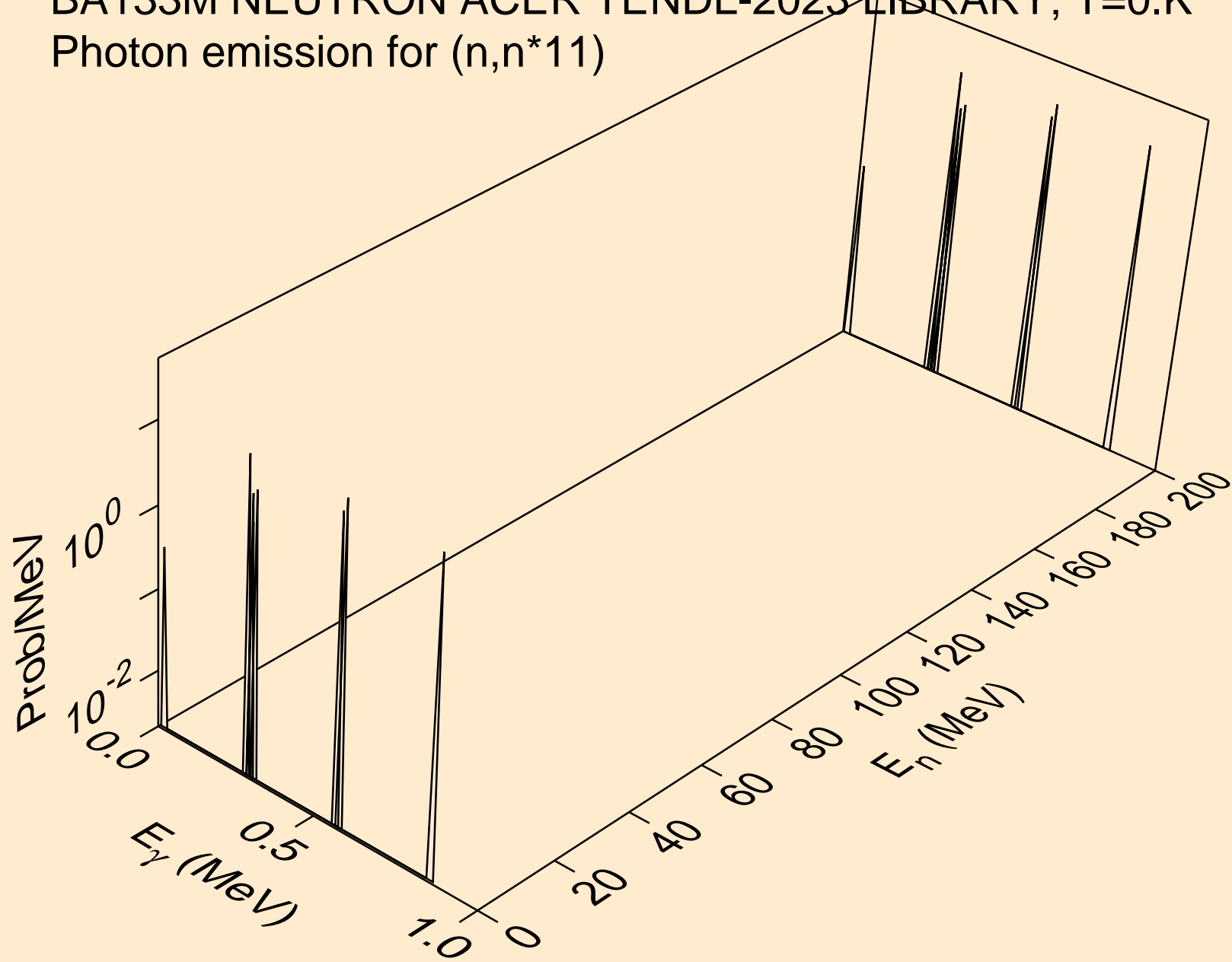

BA133M NEUTRON ACER TENDL-2023 LIBRARY; T=0.K
Photon emission for (n,n*12)

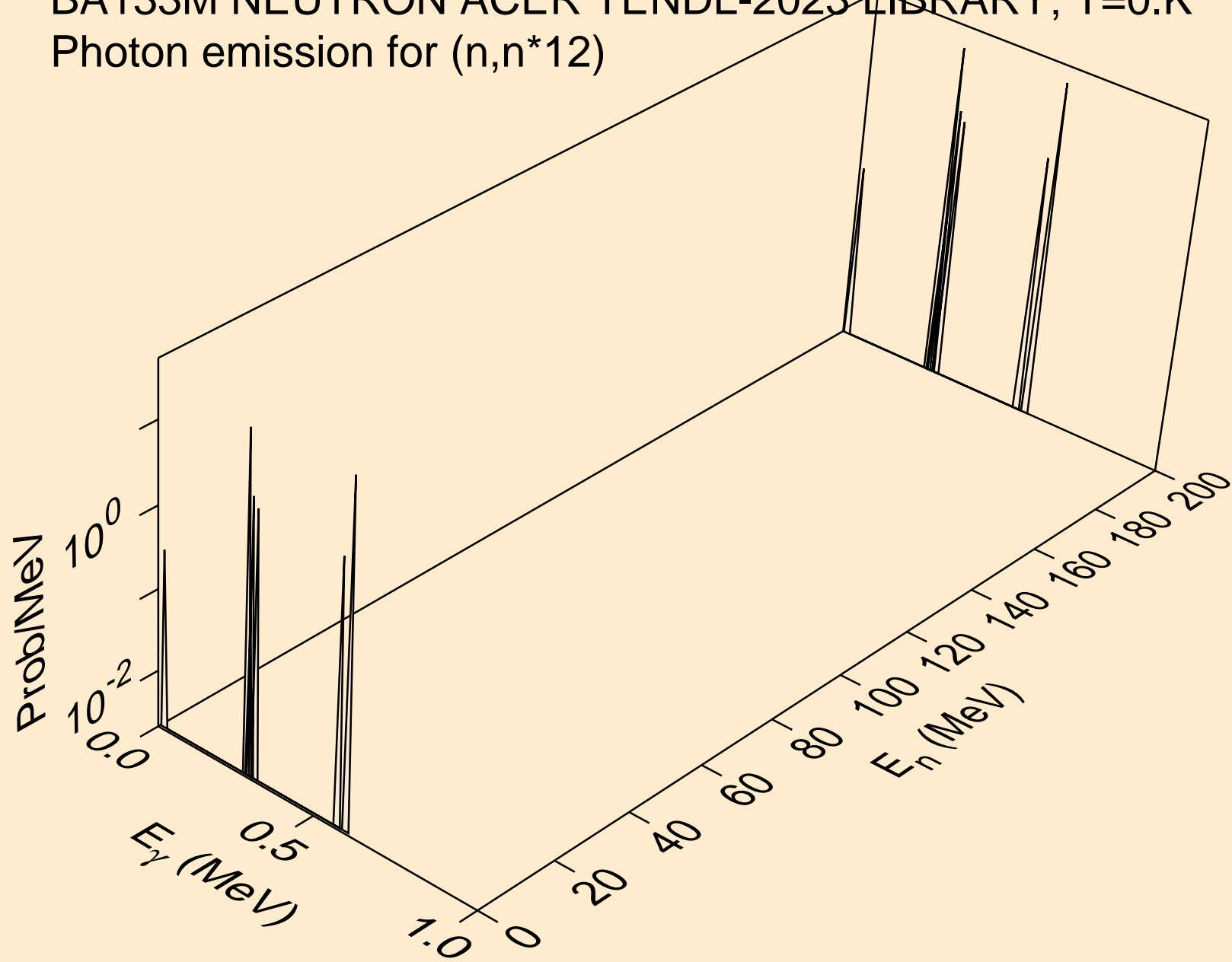

BA133M NEUTRON ACER TENDL-2023 LIBRARY; T=0.K
Photon emission for (n,n*13)

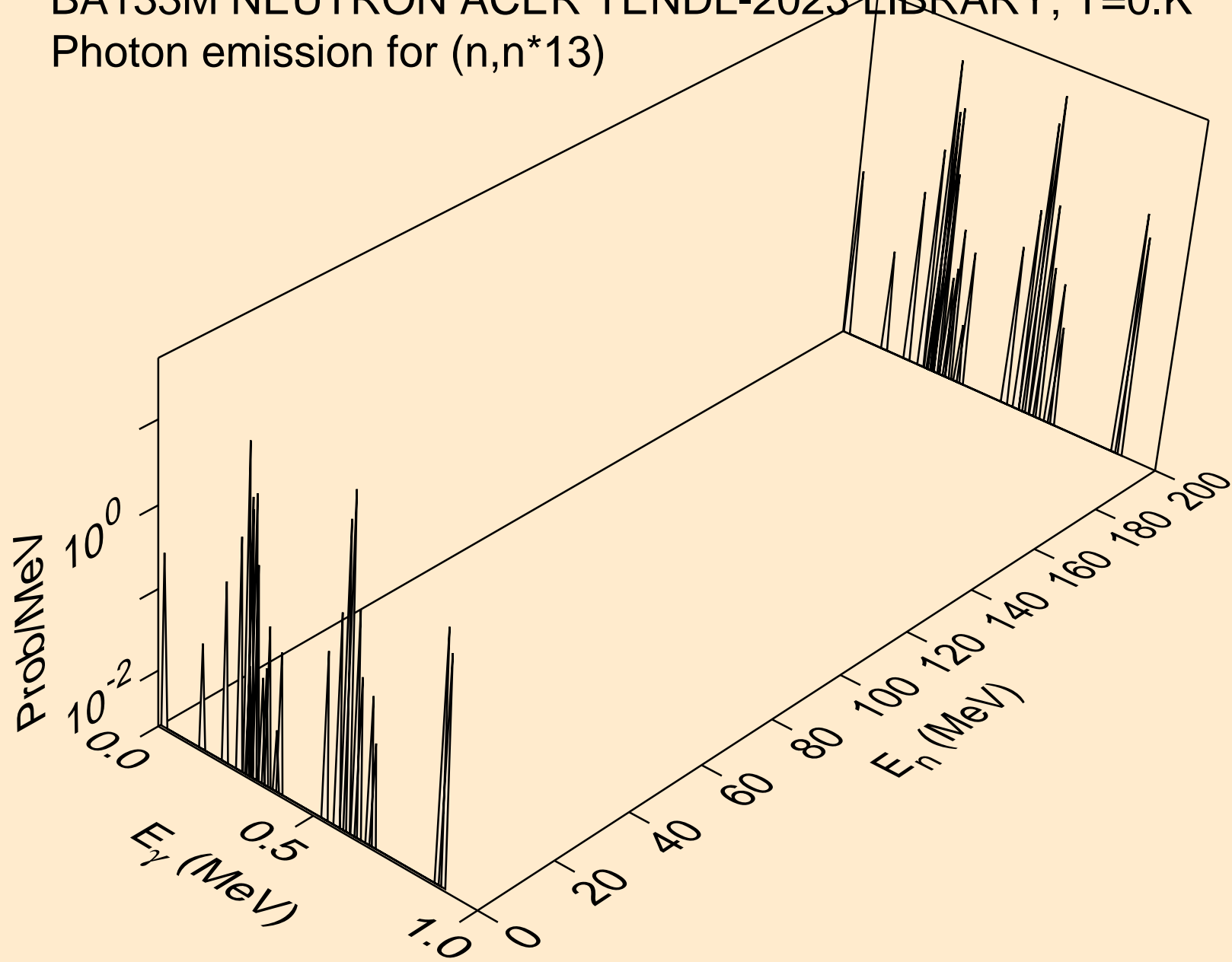

BA133M NEUTRON ACER TENDL-2023 LIBRARY; T=0.K
Photon emission for (n,n*14)

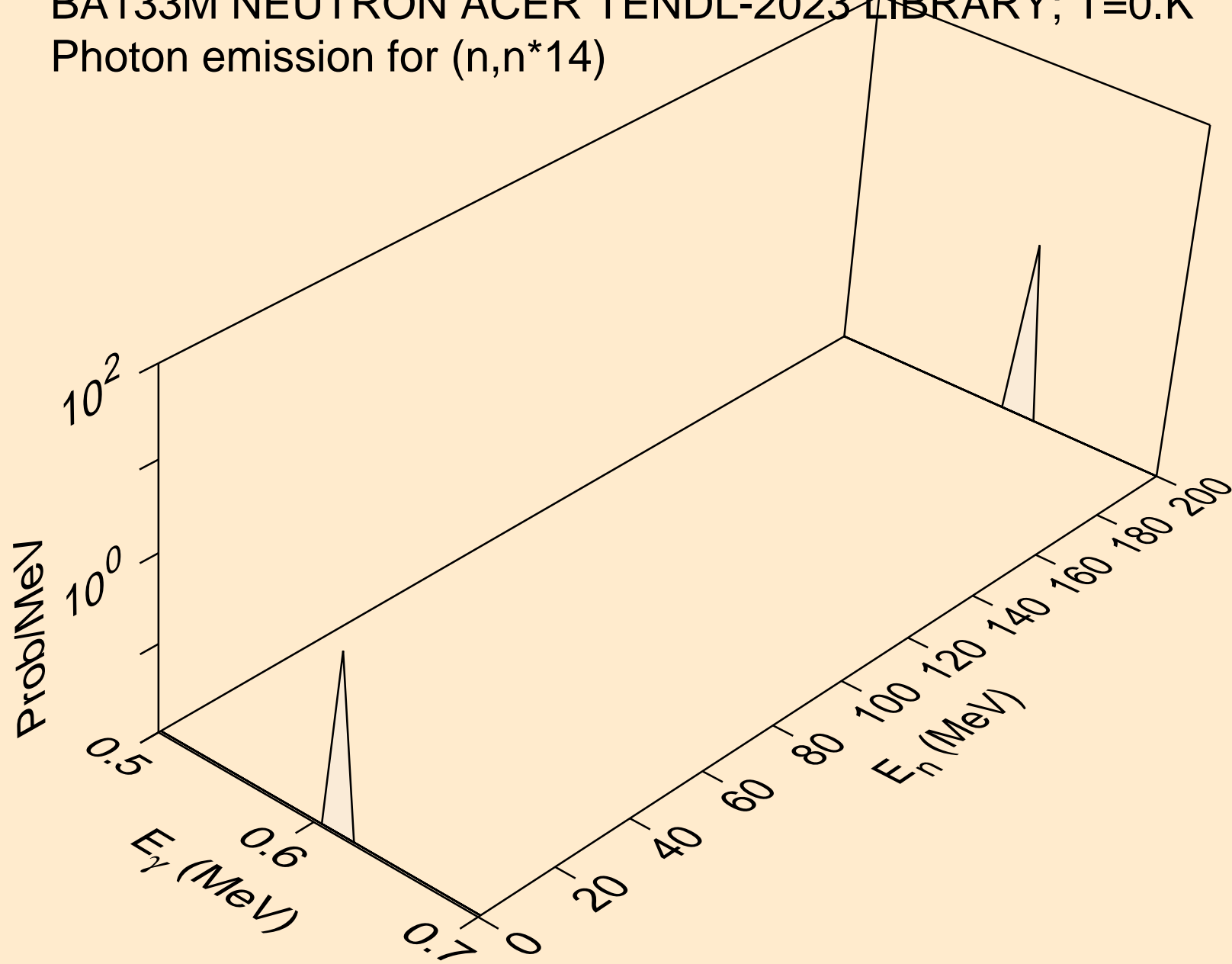

BA133M NEUTRON ACER TENDL-2023 LIBRARY; T=0.K
Photon emission for (n,n*15)

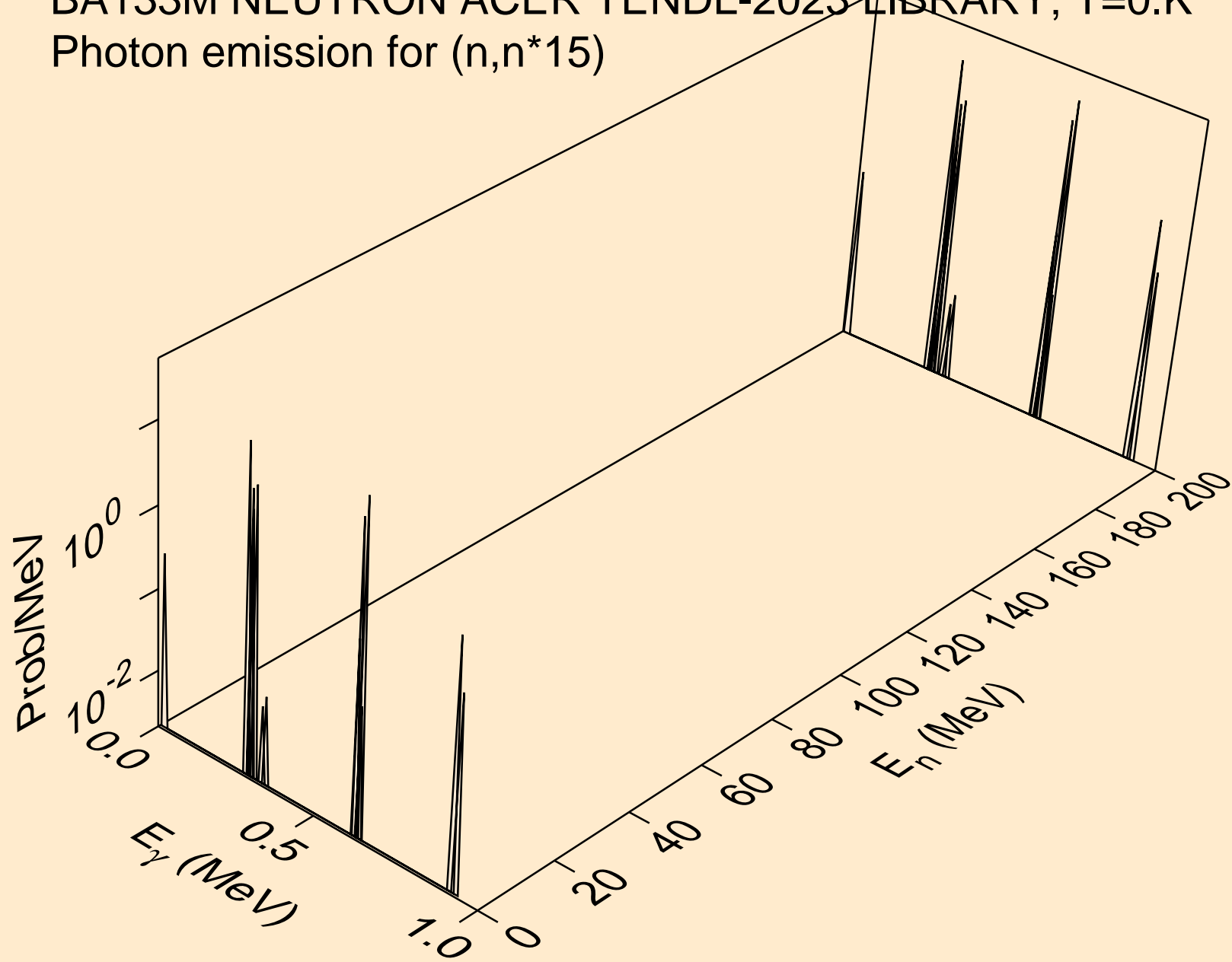

BA133M NEUTRON ACER TENDL-2023 LIBRARY; T=0.K
Photon emission for (n,n*16)

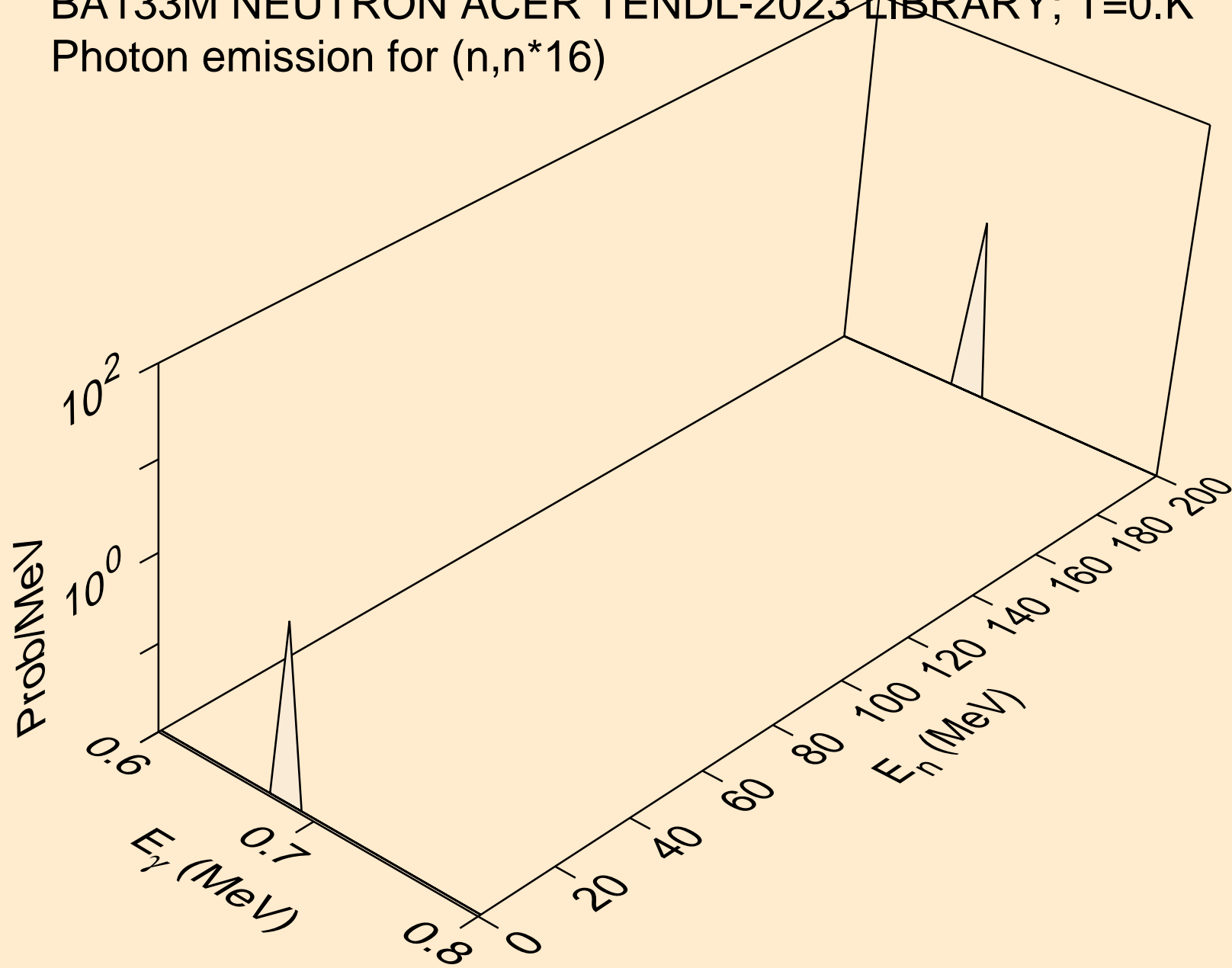

BA133M NEUTRON ACER TENDL-2023 LIBRARY; T=0.K
Photon emission for (n,n*17)

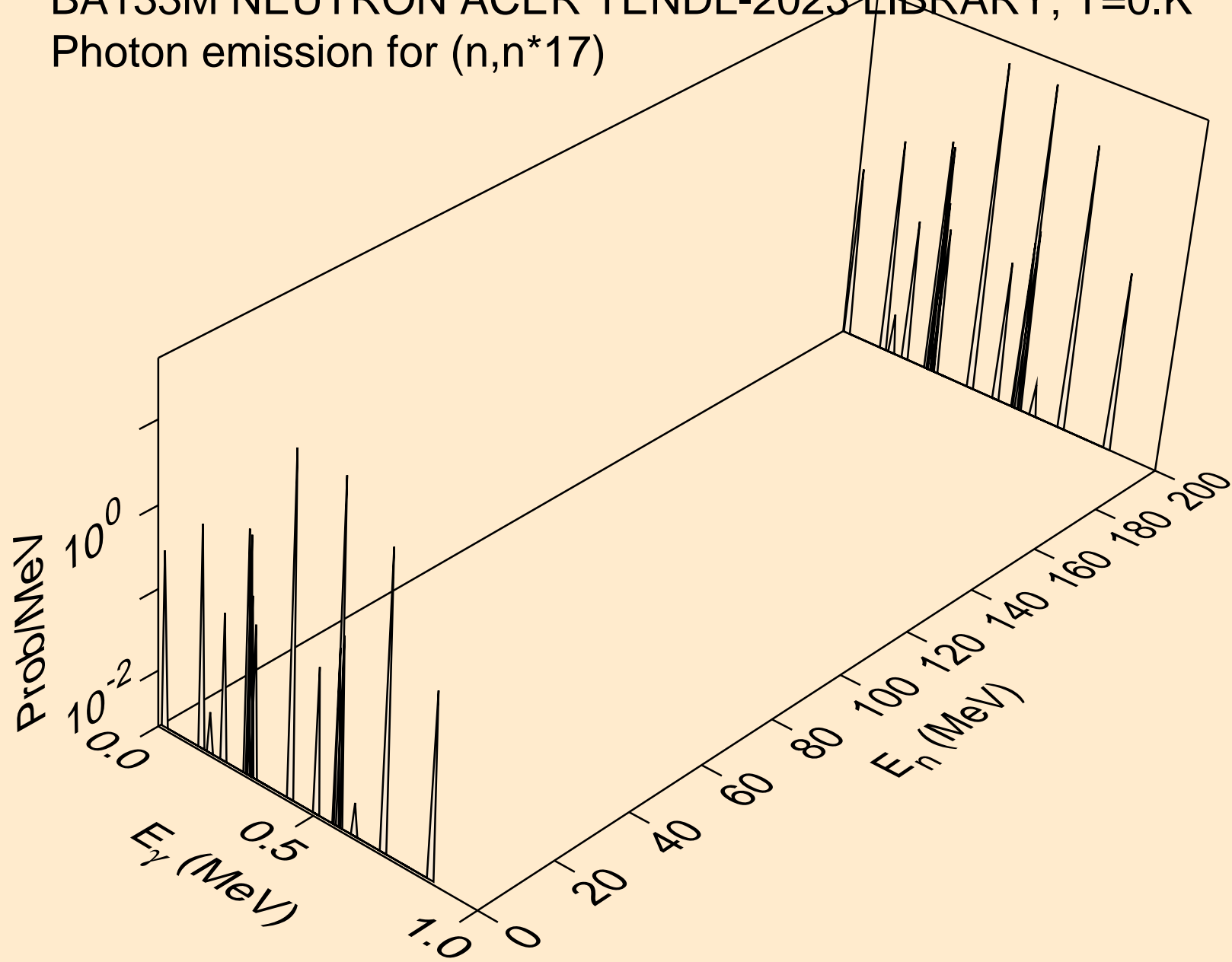

BA133M NEUTRON ACER TENDL-2023 LIBRARY; T=0.K
Photon emission for (n,n*c)

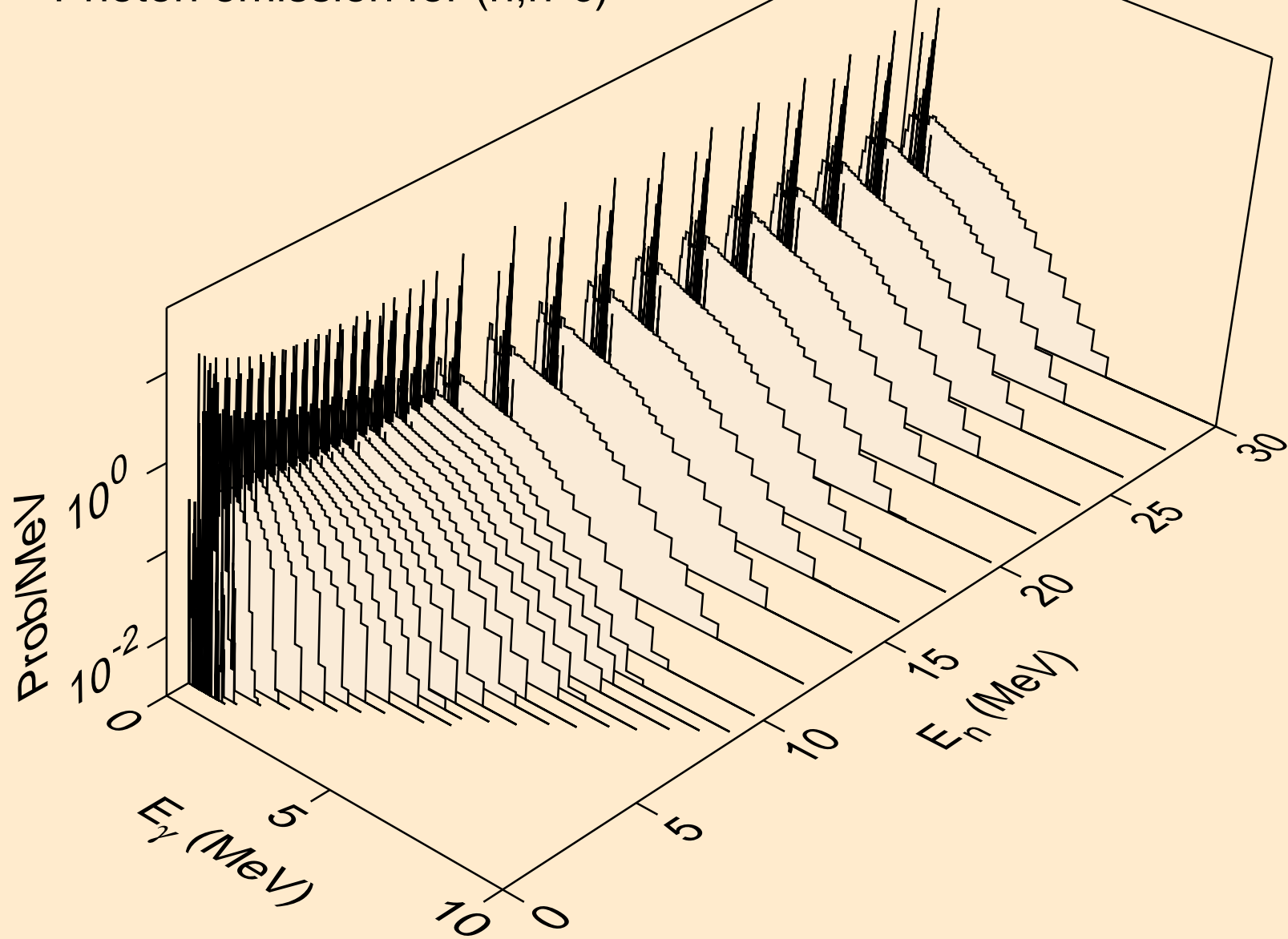

BA133M NEUTRON ACER TENDL-2023 LIBRARY; T=0.K
Photon emission for (n,gma)

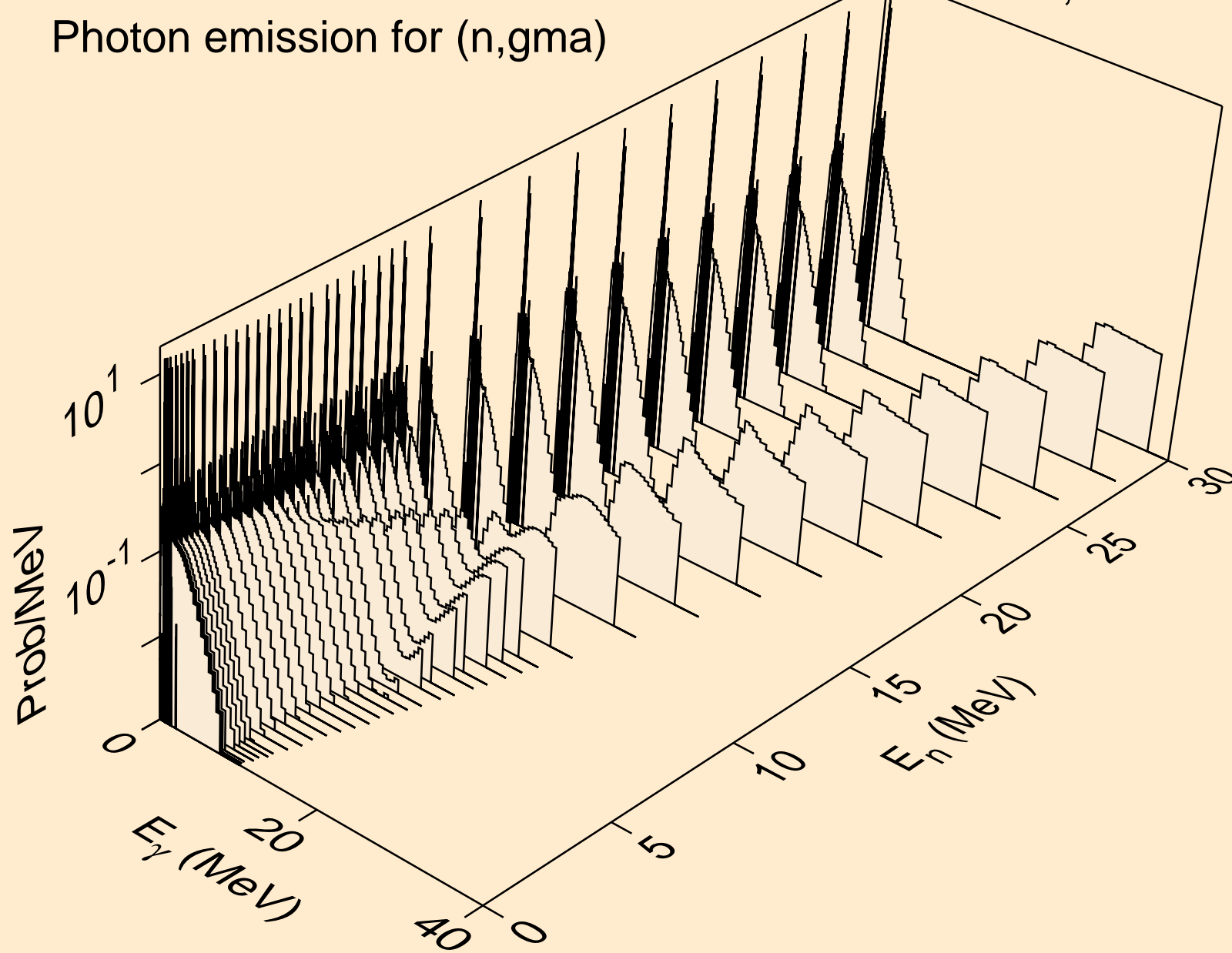

BA133M NEUTRON ACER TENDL-2023 LIBRARY; T=0.K
Photon emission for (n,p)

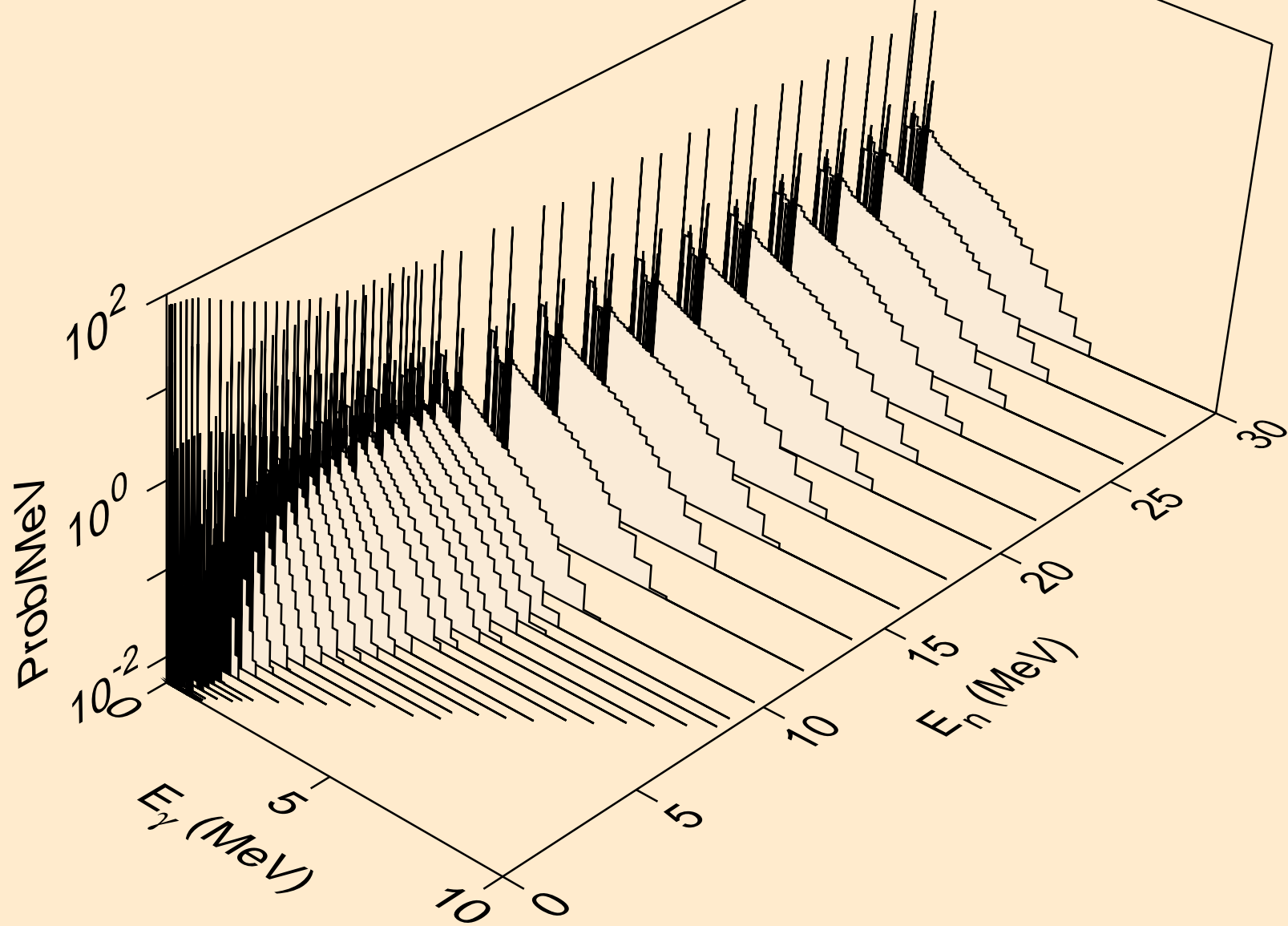

BA133M NEUTRON ACER TENDL-2023 LIBRARY; T=0.K
Photon emission for (n,d)

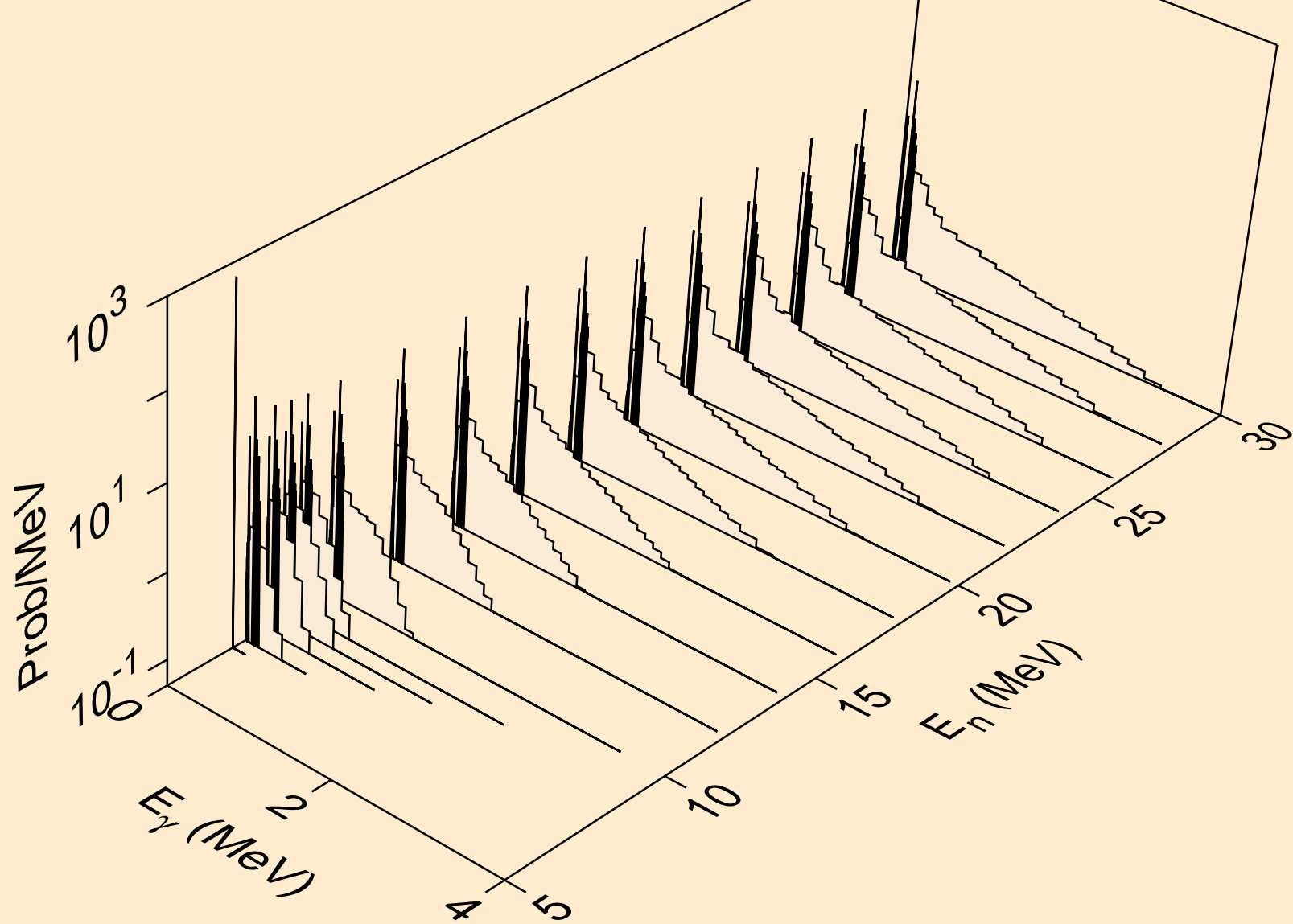

BA133M NEUTRON ACER TENDL-2023 LIBRARY; T=0.K
Photon emission for (n,t)

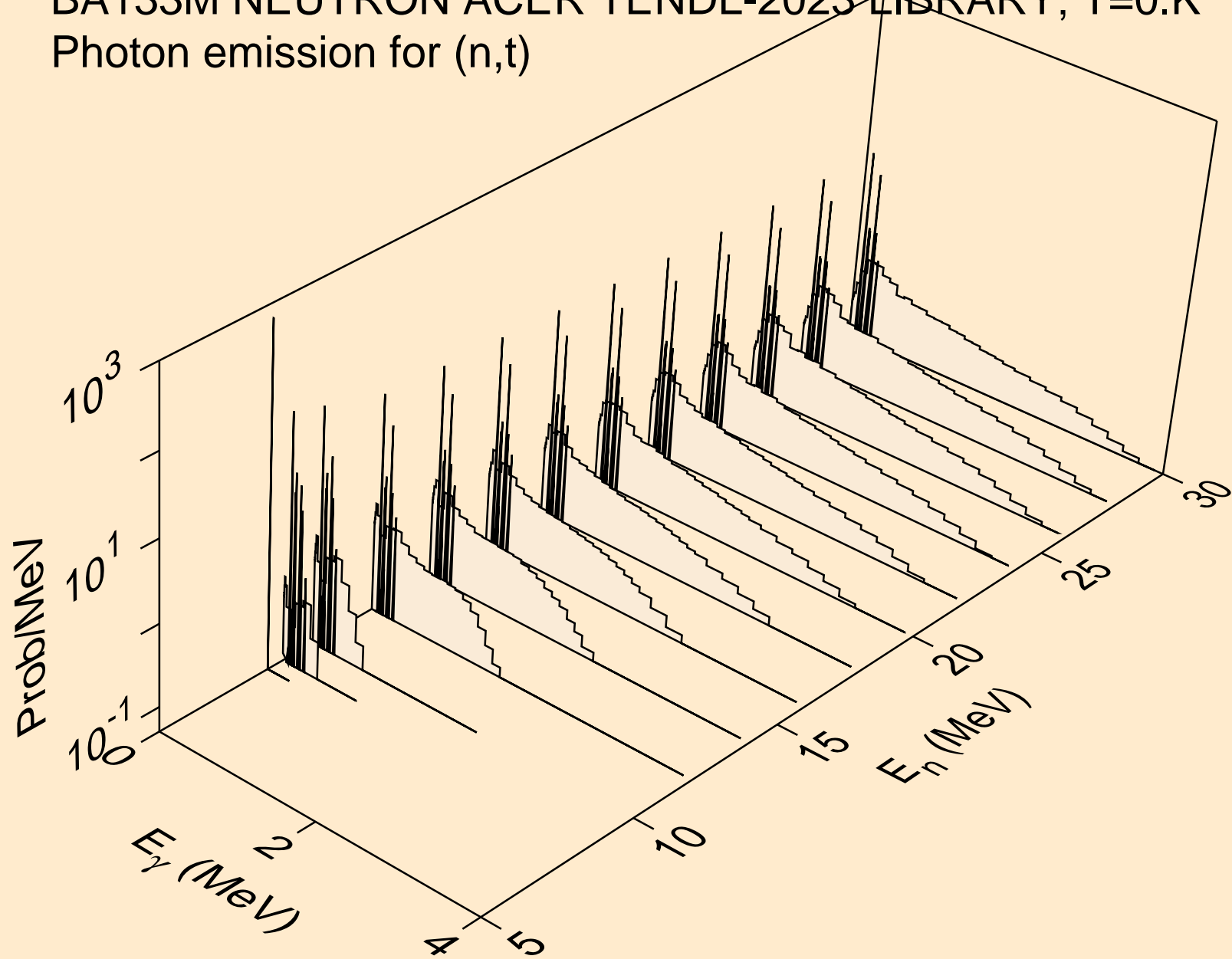

BA133M NEUTRON ACER TENDL-2023 LIBRARY; T=0.K
Photon emission for (n,he3)

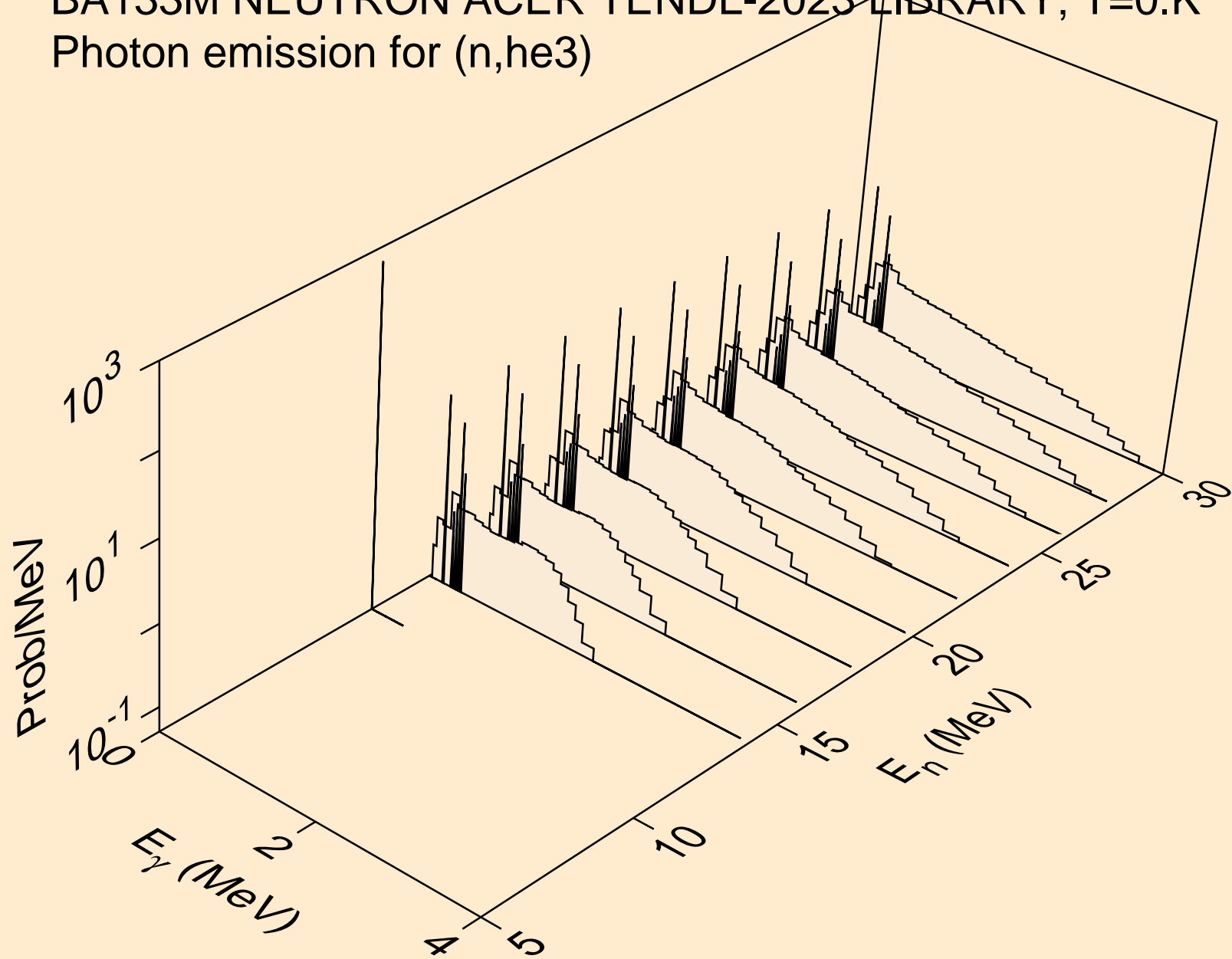

BA133M NEUTRON ACER TENDL-2023 LIBRARY; T=0.K
Photon emission for (n,a)

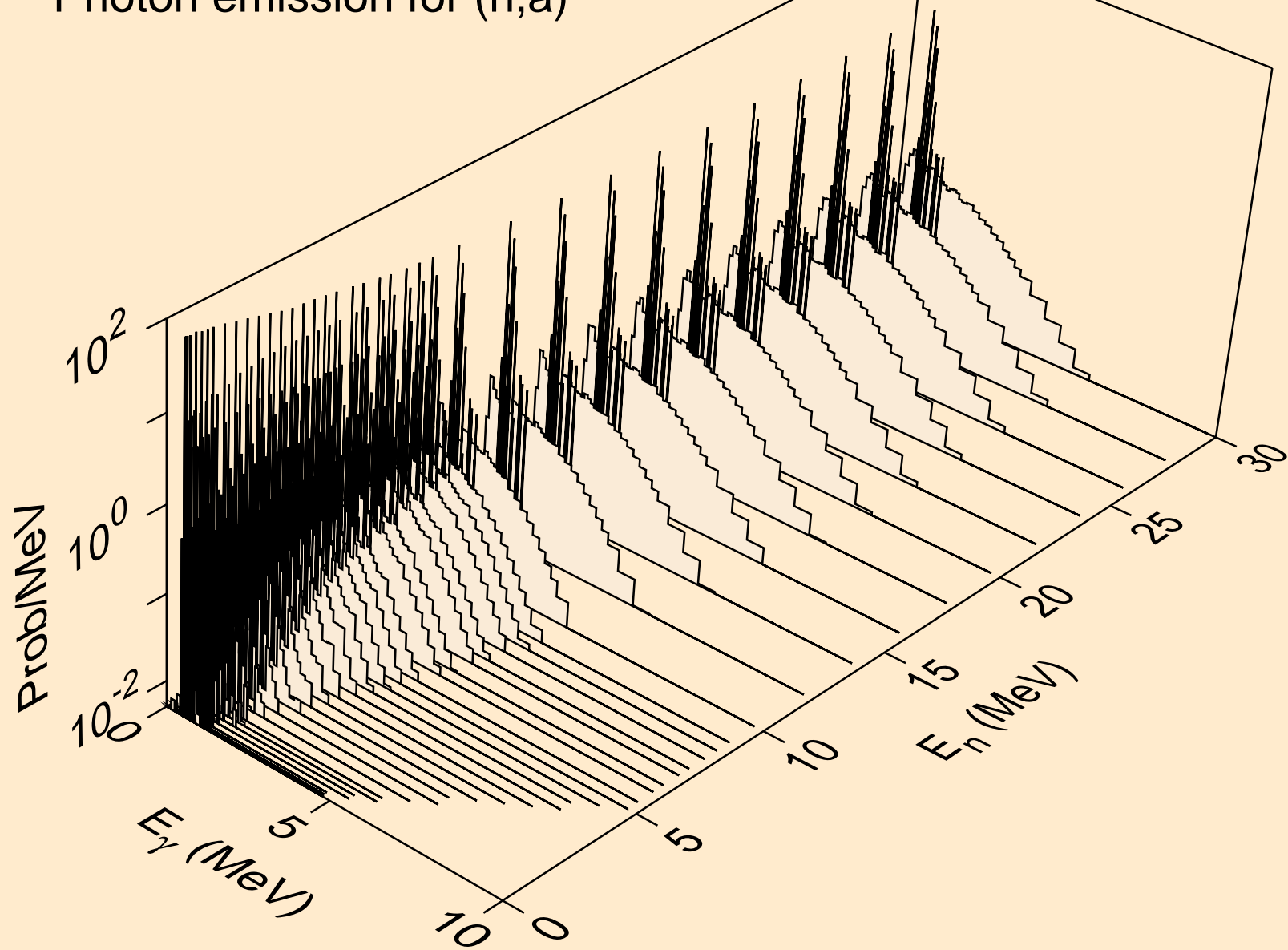

BA133M NEUTRON ACER TENDL-2023 LIBRARY; T=0.K
Photon emission for (n,2a)

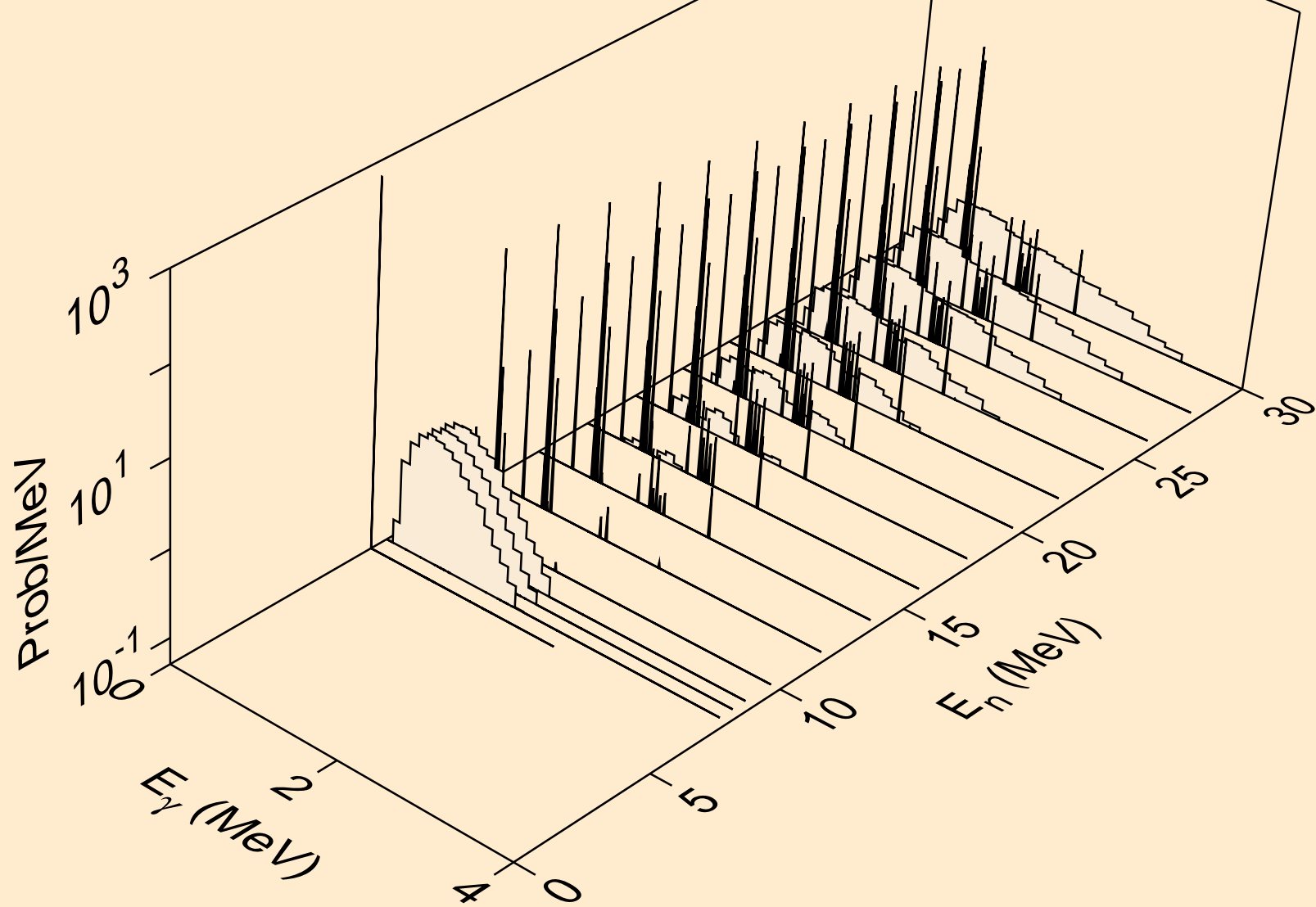

BA133M NEUTRON ACER TENDL-2023 LIBRARY; T=0.K
Photon emission for (n,2p)

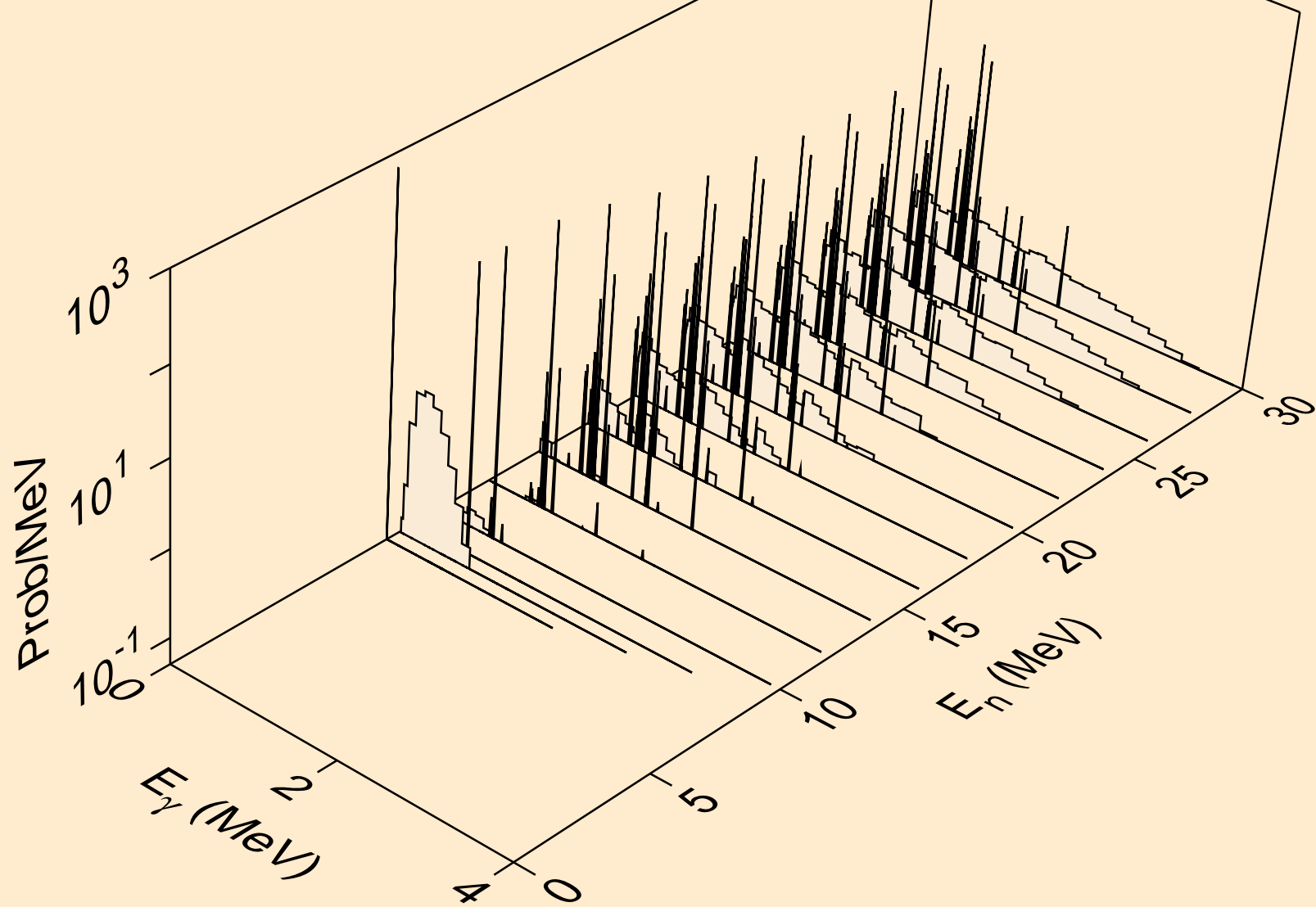

BA133M NEUTRON ACER TENDL-2023 LIBRARY; T=0.K
Photon emission for (n,p α)

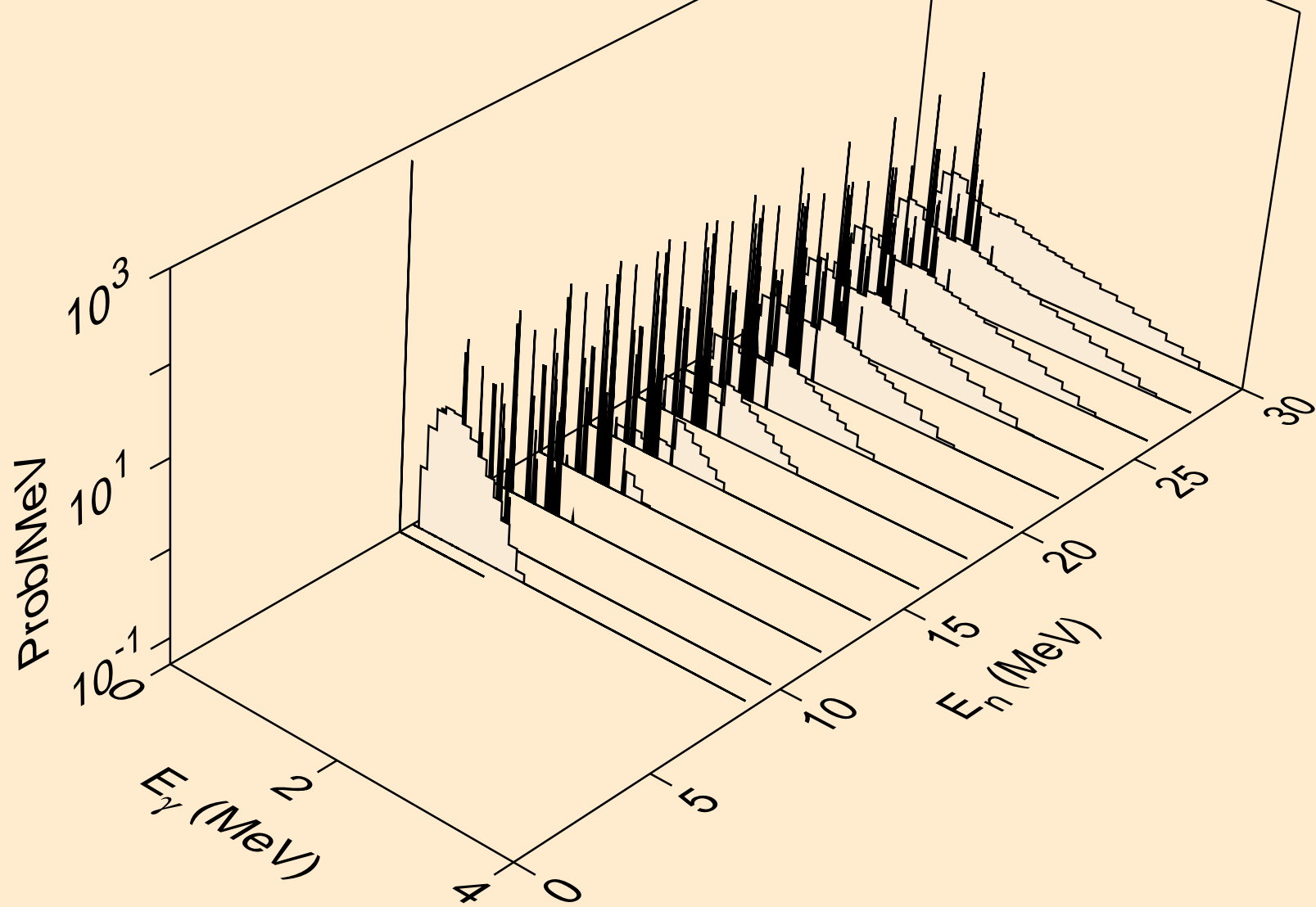

BA133M NEUTRON ACER TENDL-2023 LIBRARY; T=0.K
Photon emission for (n,pd)

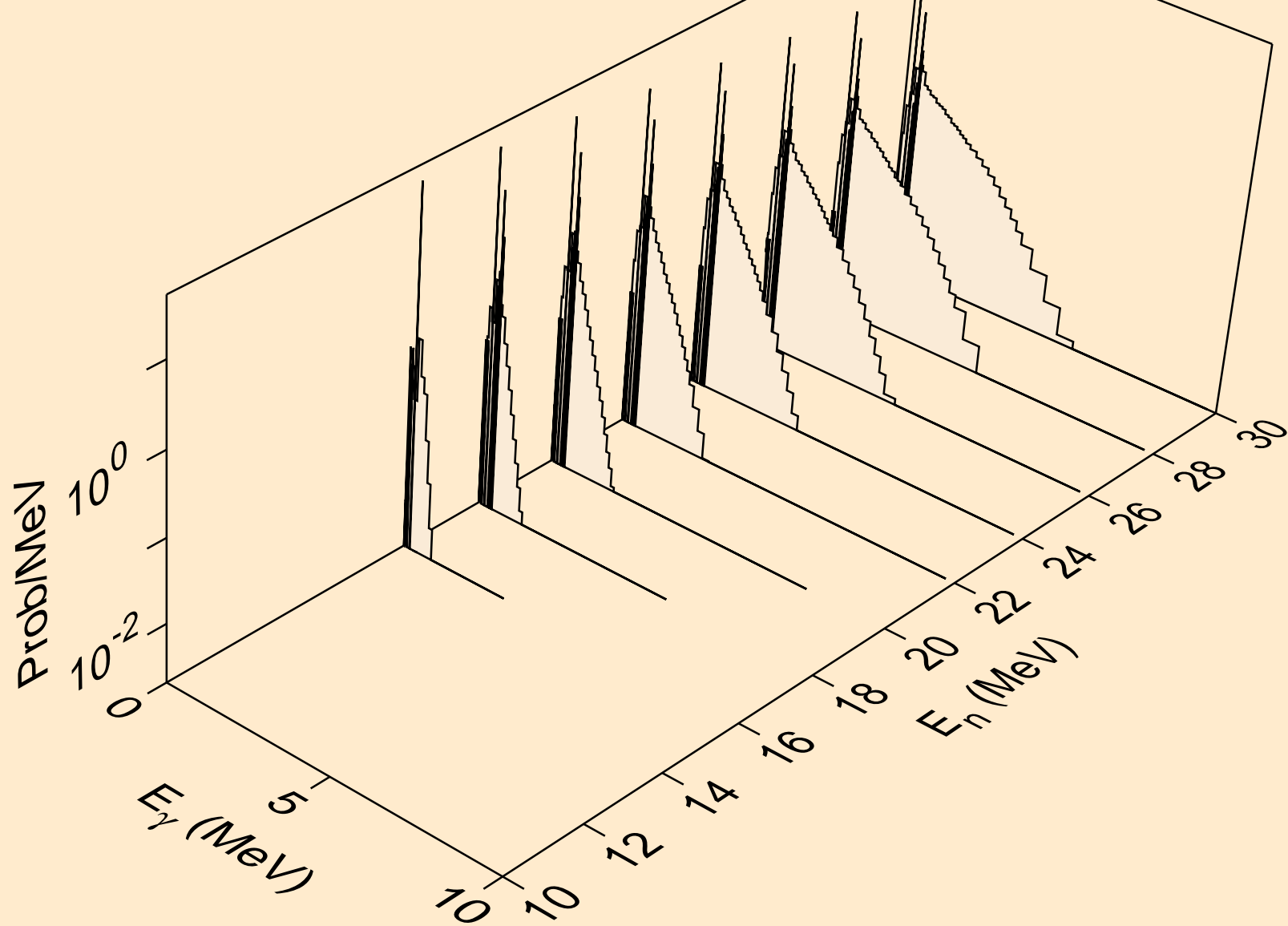

BA133M NEUTRON ACER TENDL-2023 LIBRARY; T=0.K
Photon emission for (n,pt)

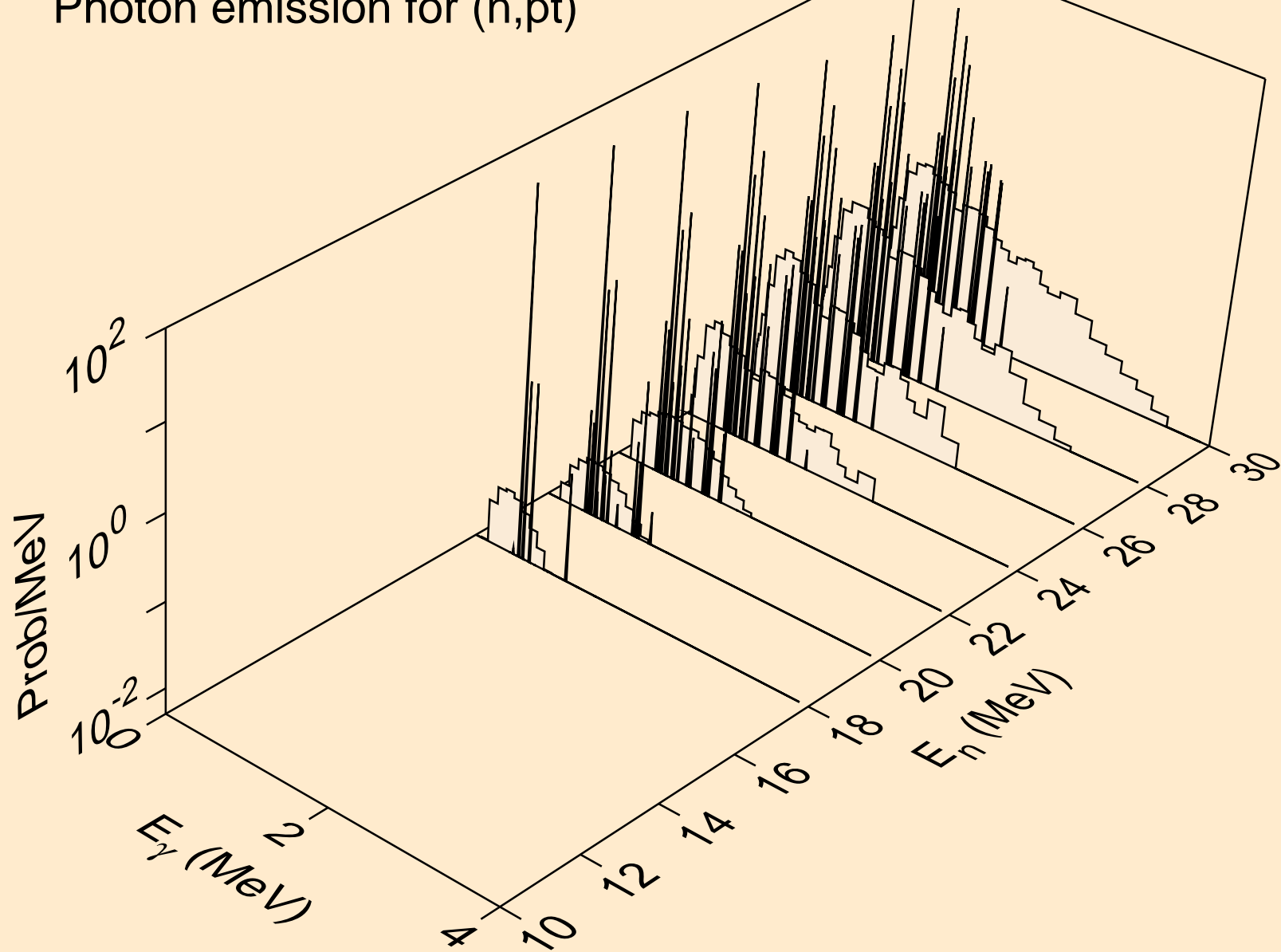

BA133M NEUTRON ACER TENDL-2023 LIBRARY; T=0.K
Photon emission for (n,da)

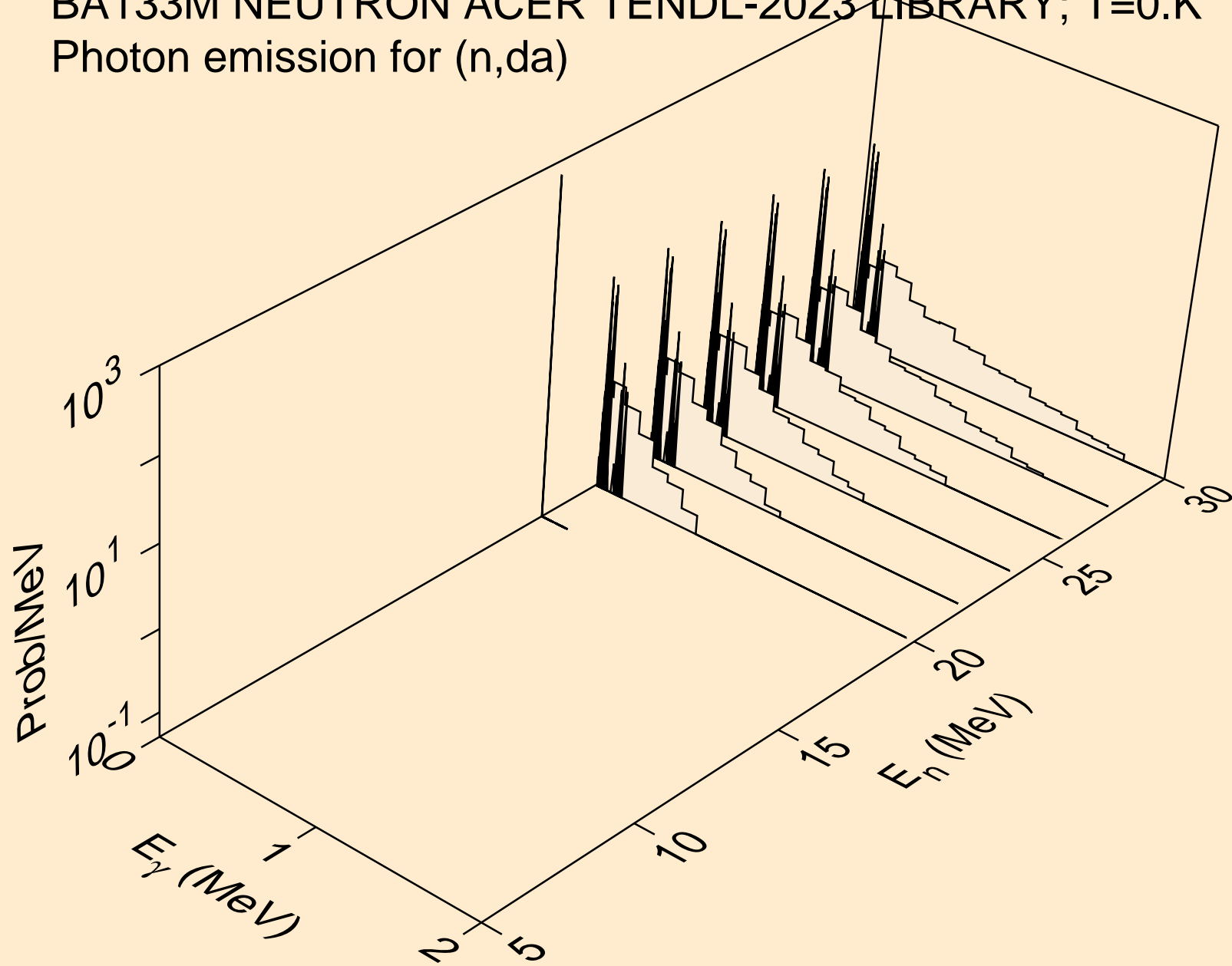

BA133M NEUTRON ACER TENDL-2023 LIBRARY; T=0.K
thermal capture photon spectrum

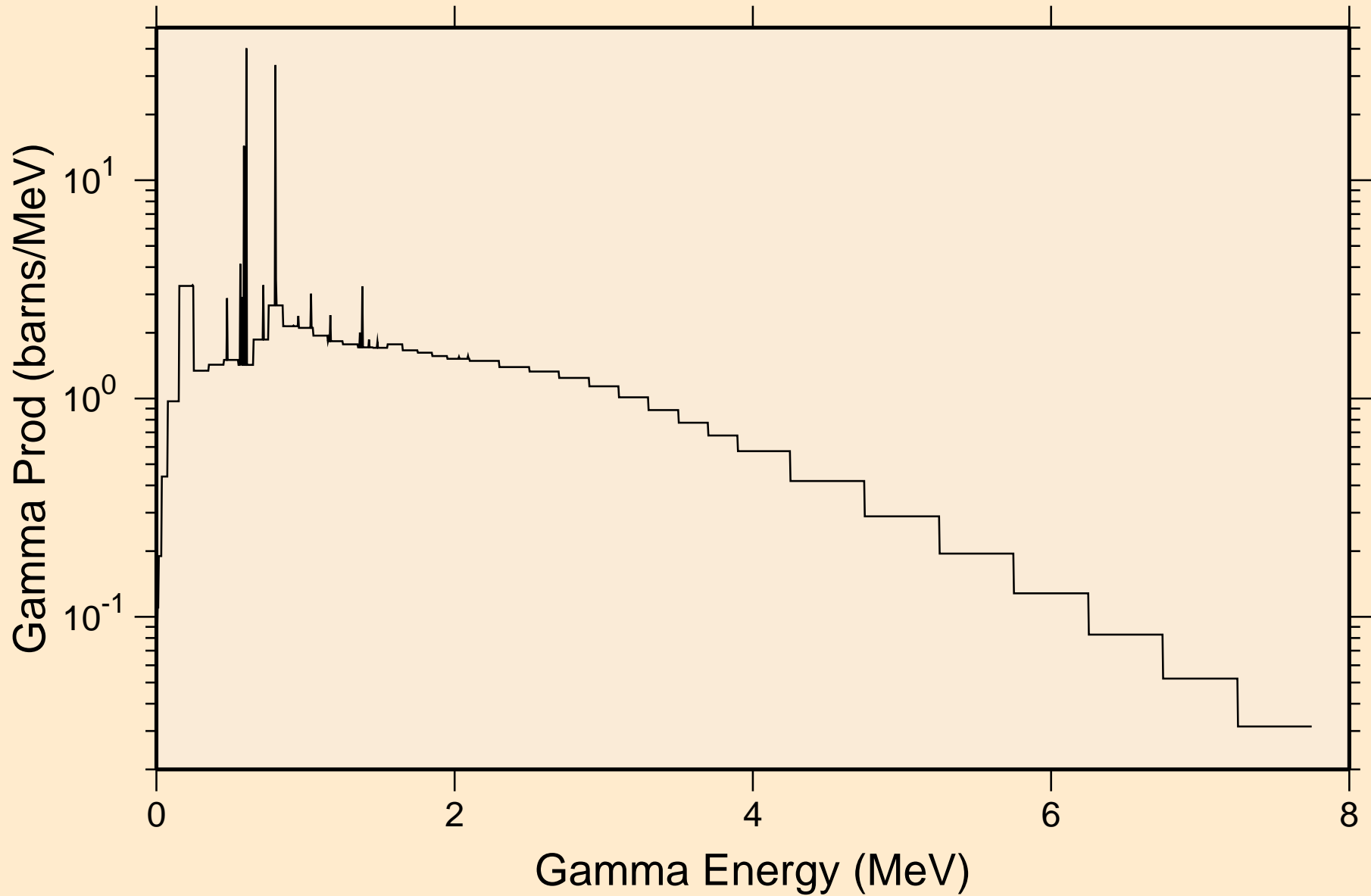

BA133M NEUTRON ACER TENDL-2023 LIBRARY; T=0.K
14 MeV photon spectrum

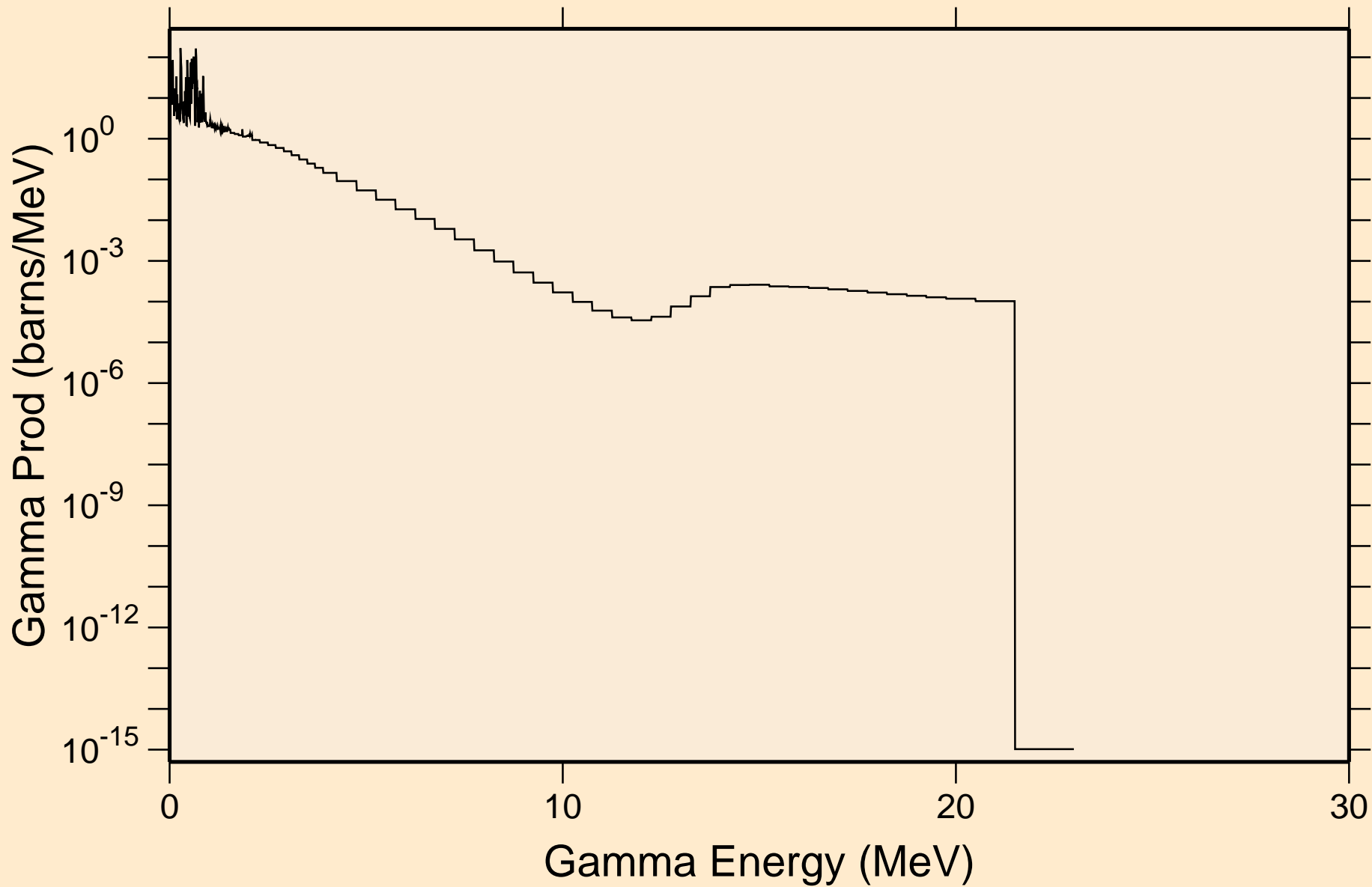

BA133M NEUTRON ACER TENDL-2023 LIBRARY; T=0.K

Particle heating contributions

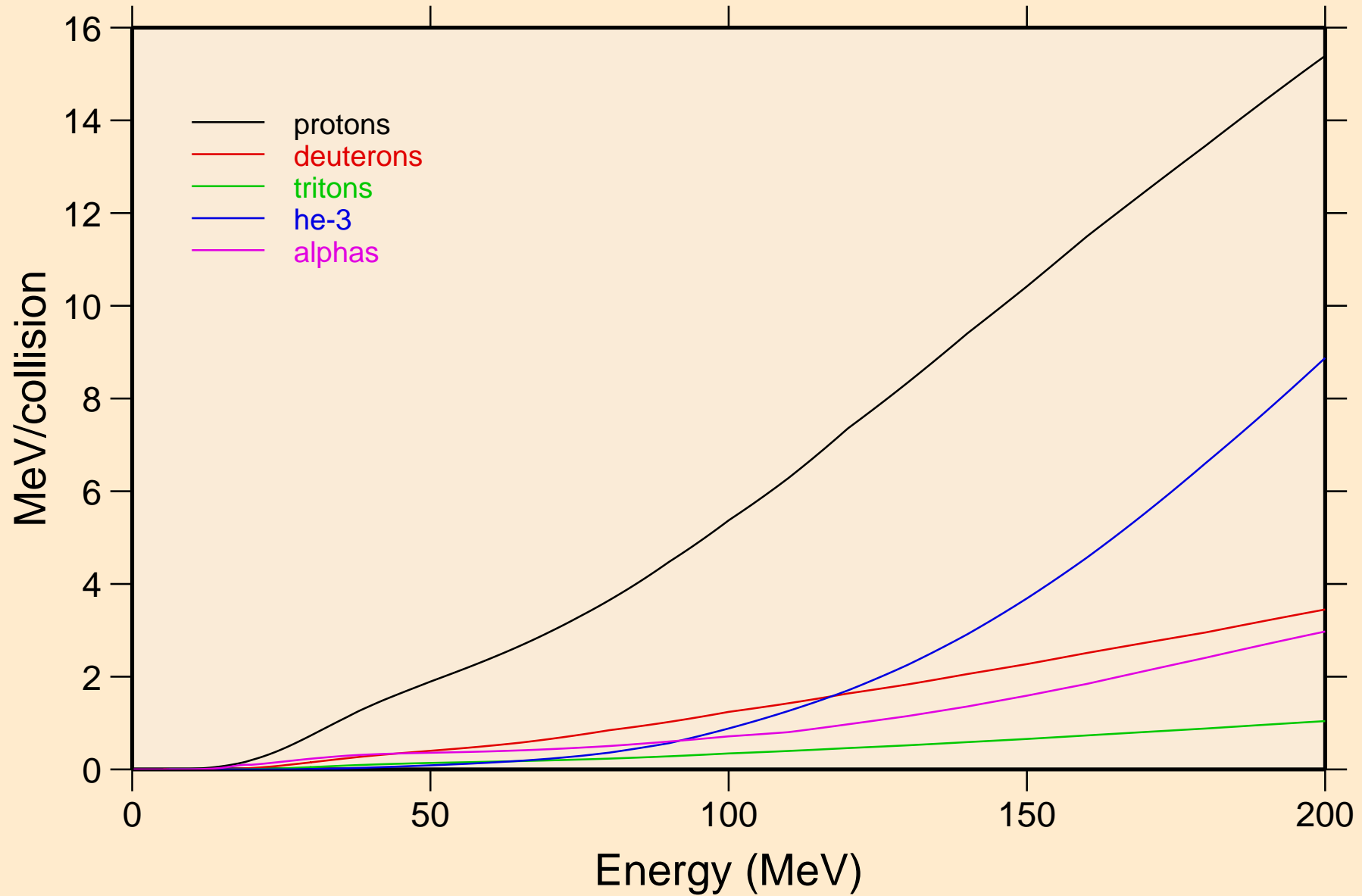

BA133M NEUTRON ACER TENDL-2023 LIBRARY; T=0.K
Recoil Heating

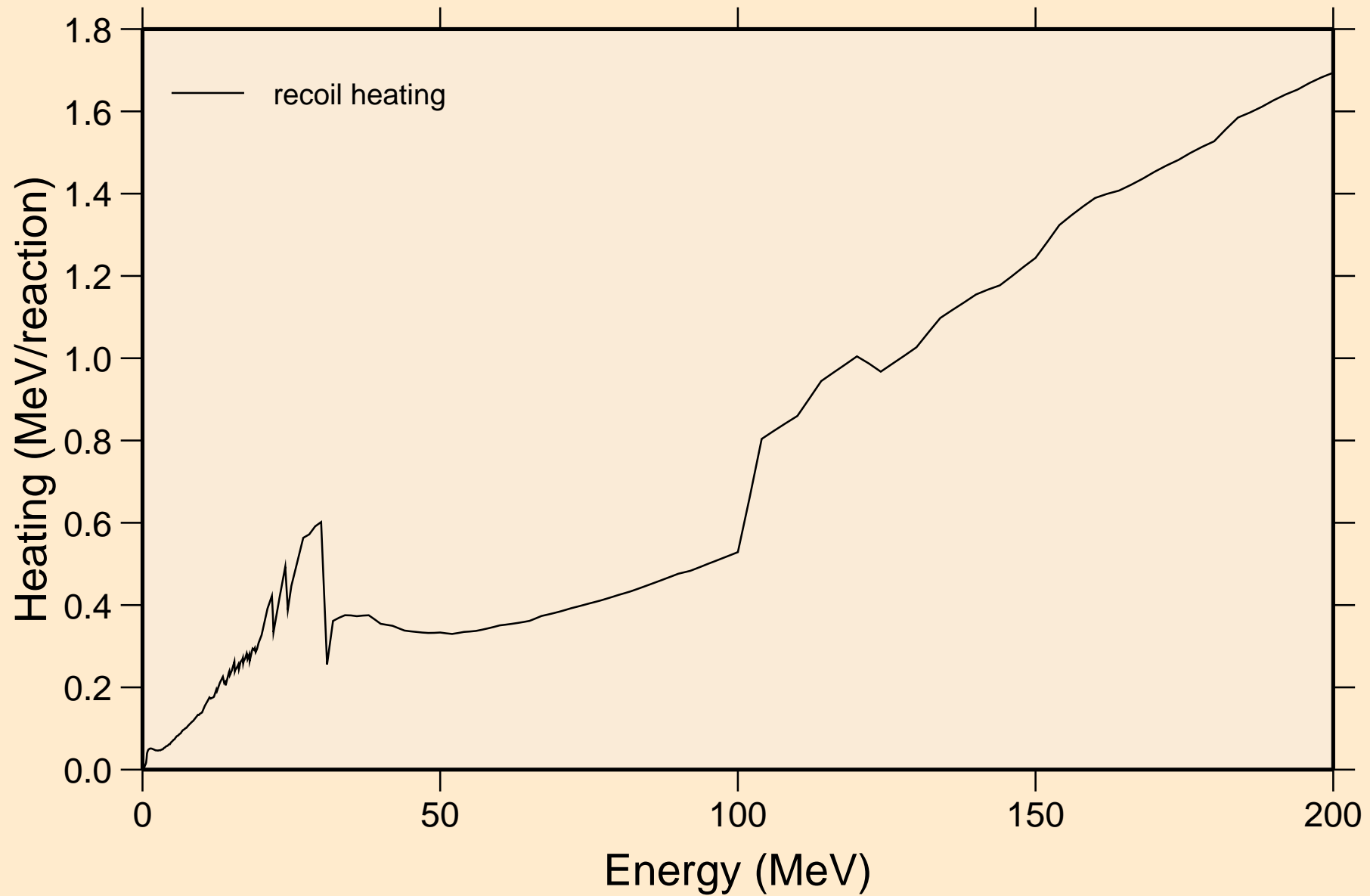

BA133M NEUTRON ACER TENDL-2023 LIBRARY; T=0.K
Particle production cross sections

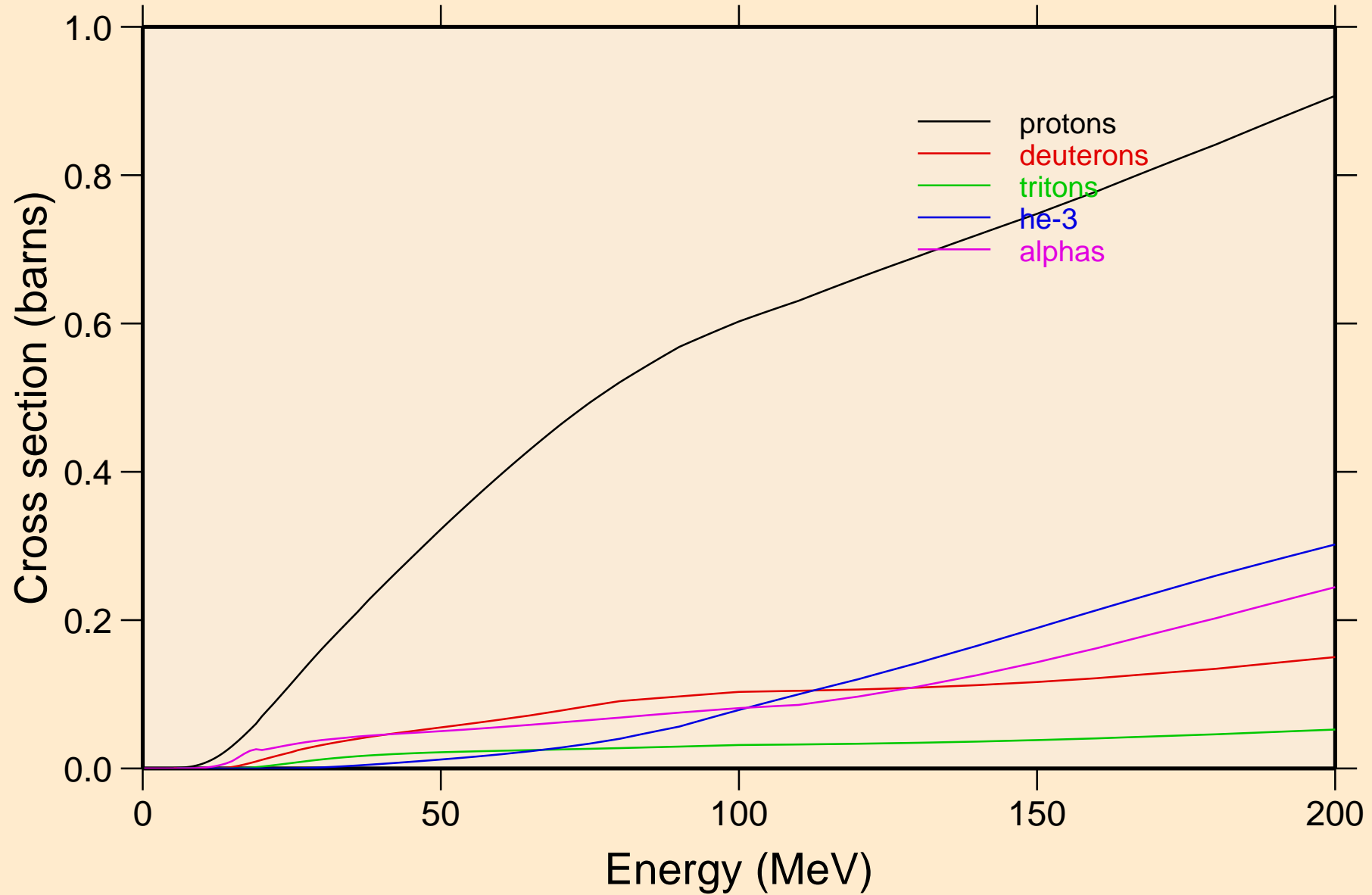

BA133M NEUTRON ACER TENDL-2023 LIBRARY; T=0.K
protons from (n,x)

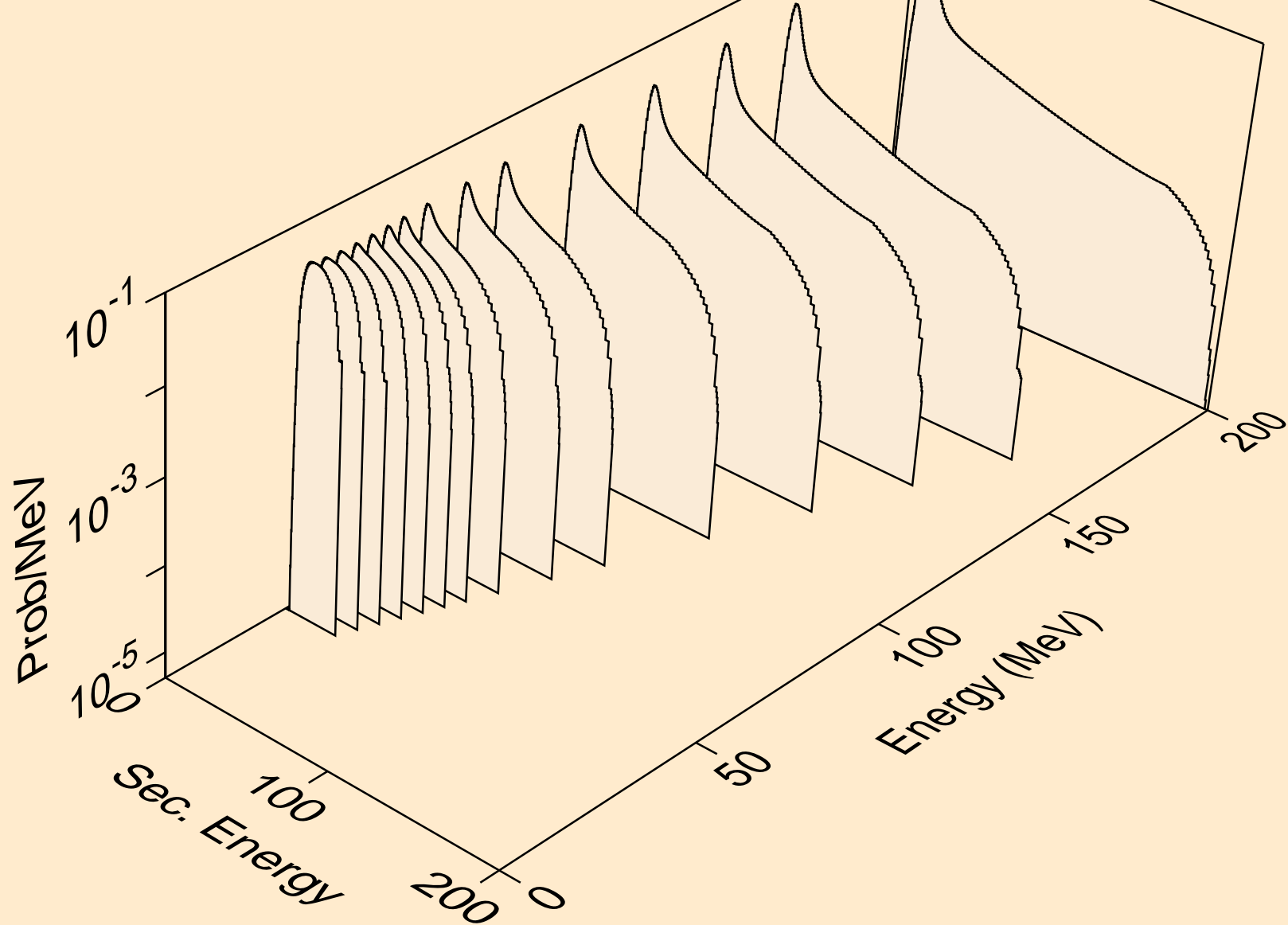

BA133M NEUTRON ACER TENDL-2023 LIBRARY; T=0.K
protons from (n,n*)p

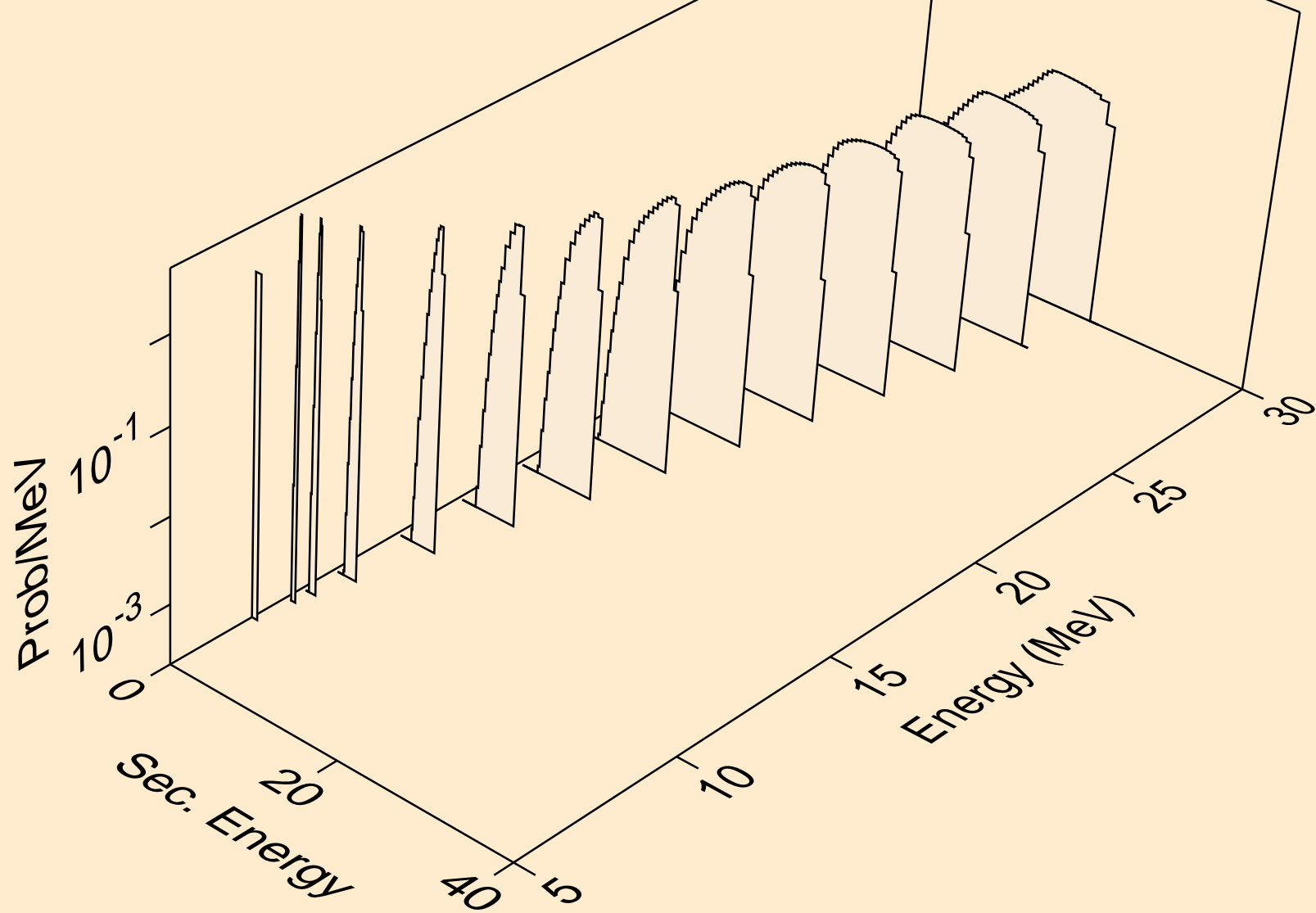

BA133M NEUTRON ACER TENDL-2023 LIBRARY; T=0.K
protons from (n,2np)

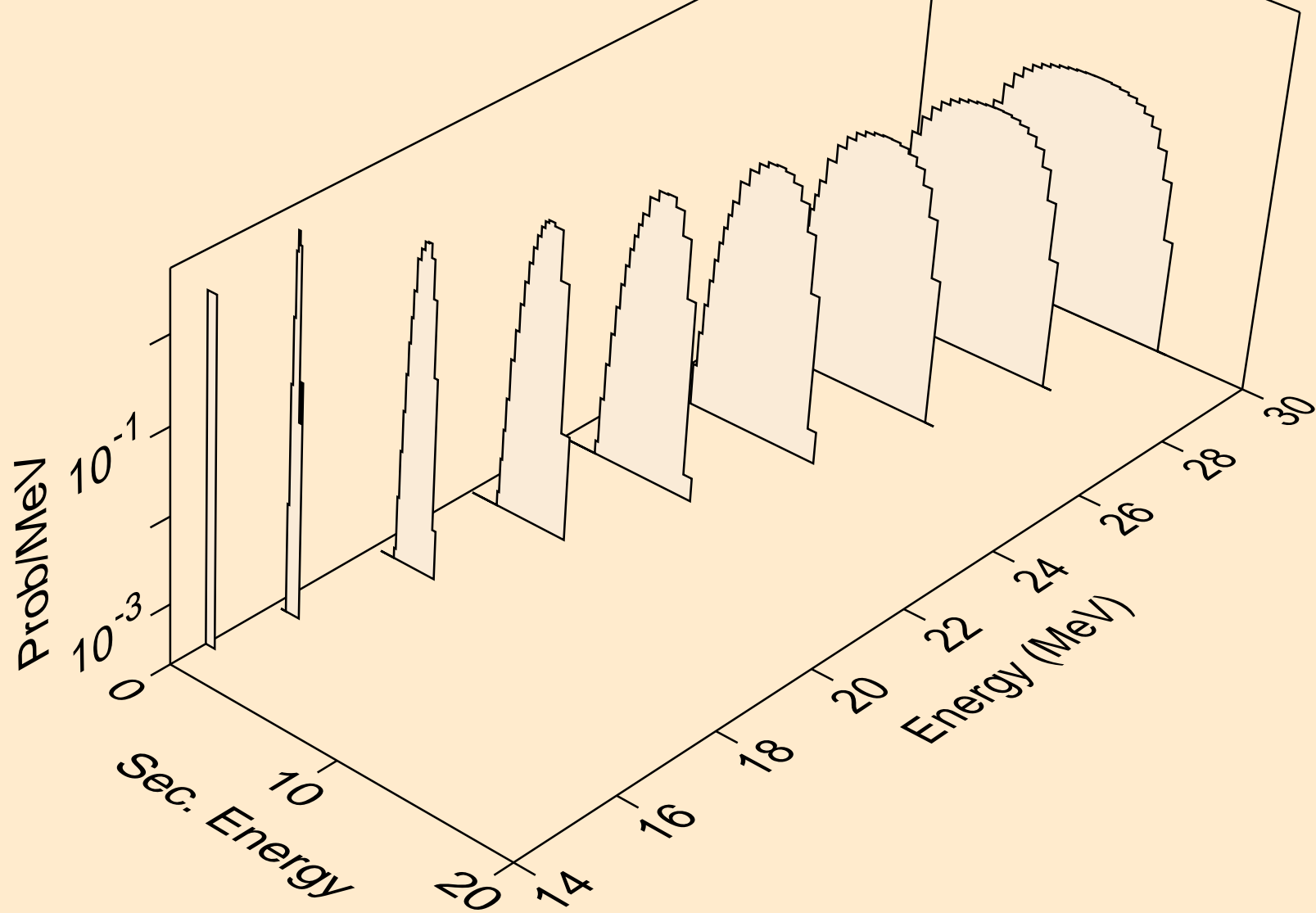

BA133M NEUTRON ACER TENDL-2023 LIBRARY; T=0.K
protons from (n,3np)

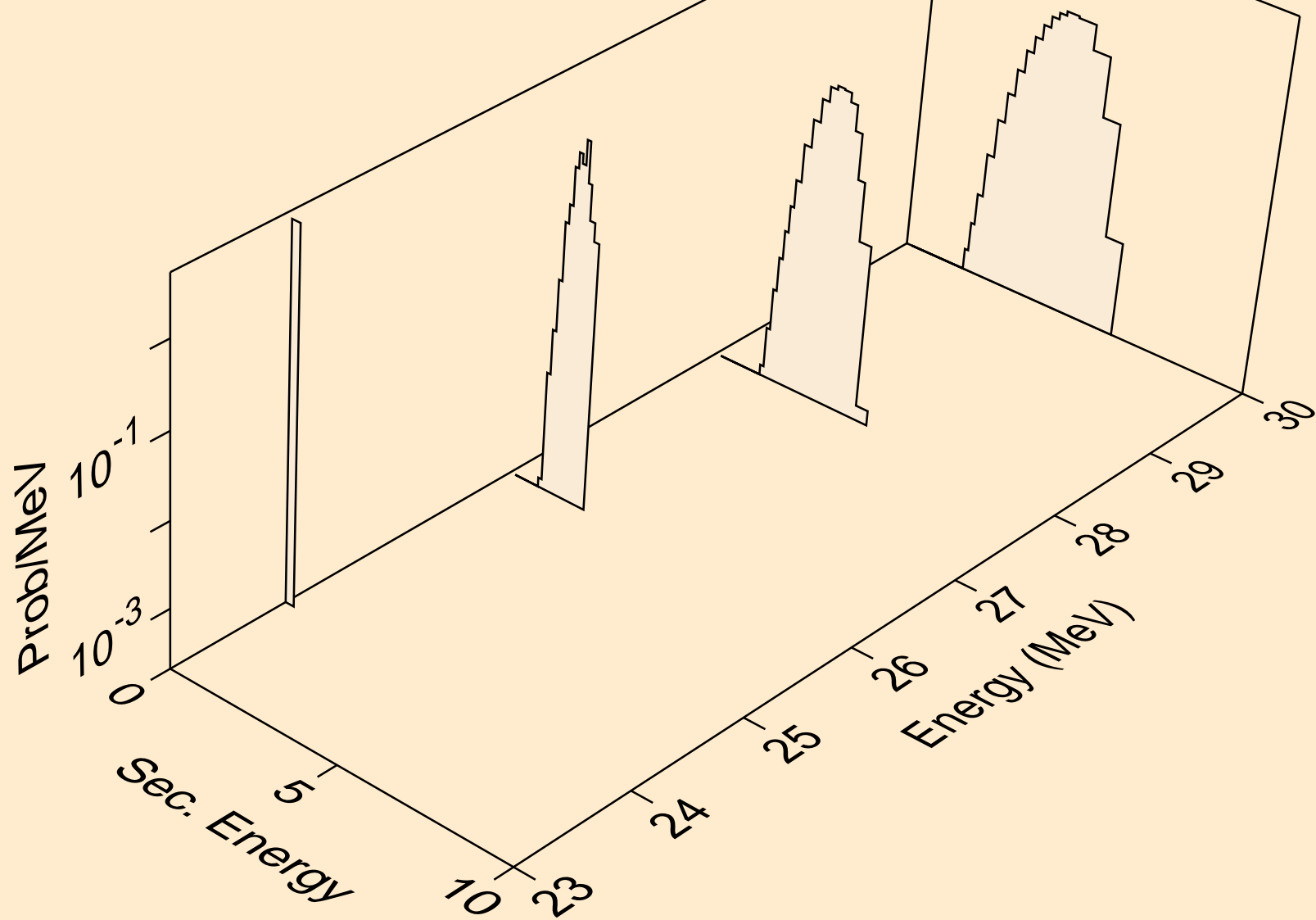

BA133M NEUTRON ACER TENDL-2023 LIBRARY; T=0.K
protons from (n,n2p)

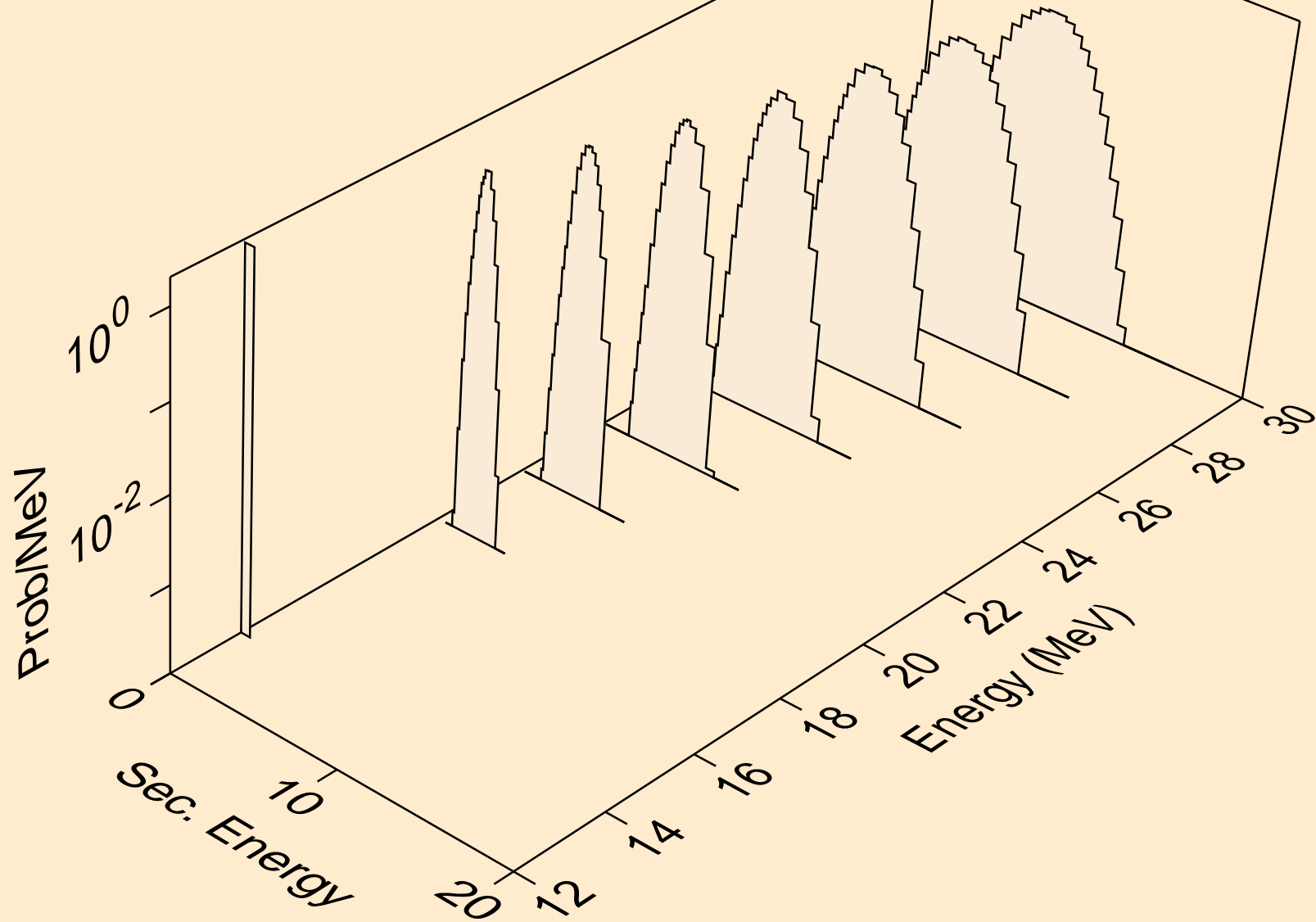

BA133M NEUTRON ACER TENDL-2023 LIBRARY; T=0.K
protons from (n,npa)

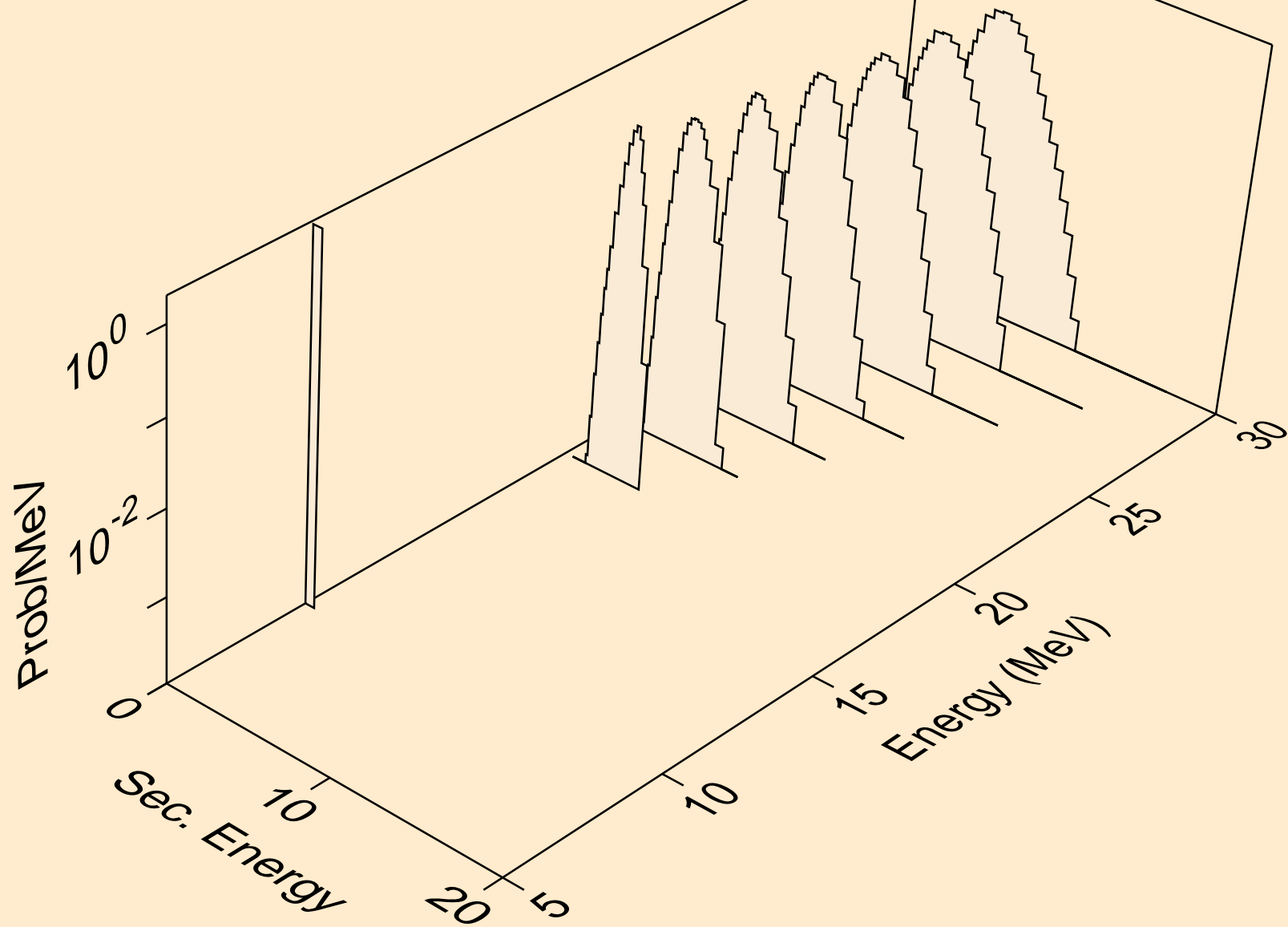

BA133M NEUTRON ACER TENDL-2023 LIBRARY; T=0.K
protons from (n,p)

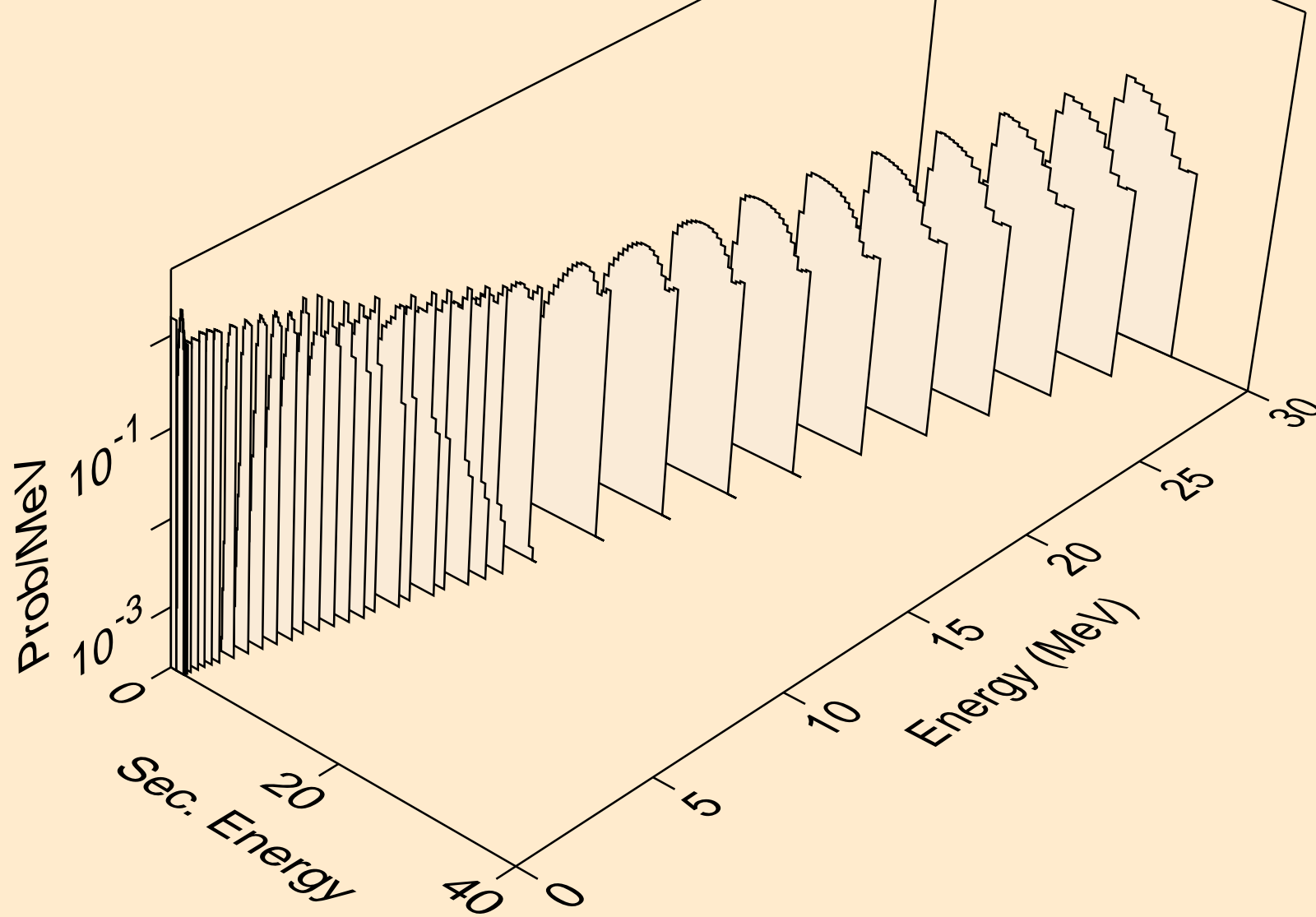

BA133M NEUTRON ACER TENDL-2023 LIBRARY; T=0.K
protons from (n,2p)

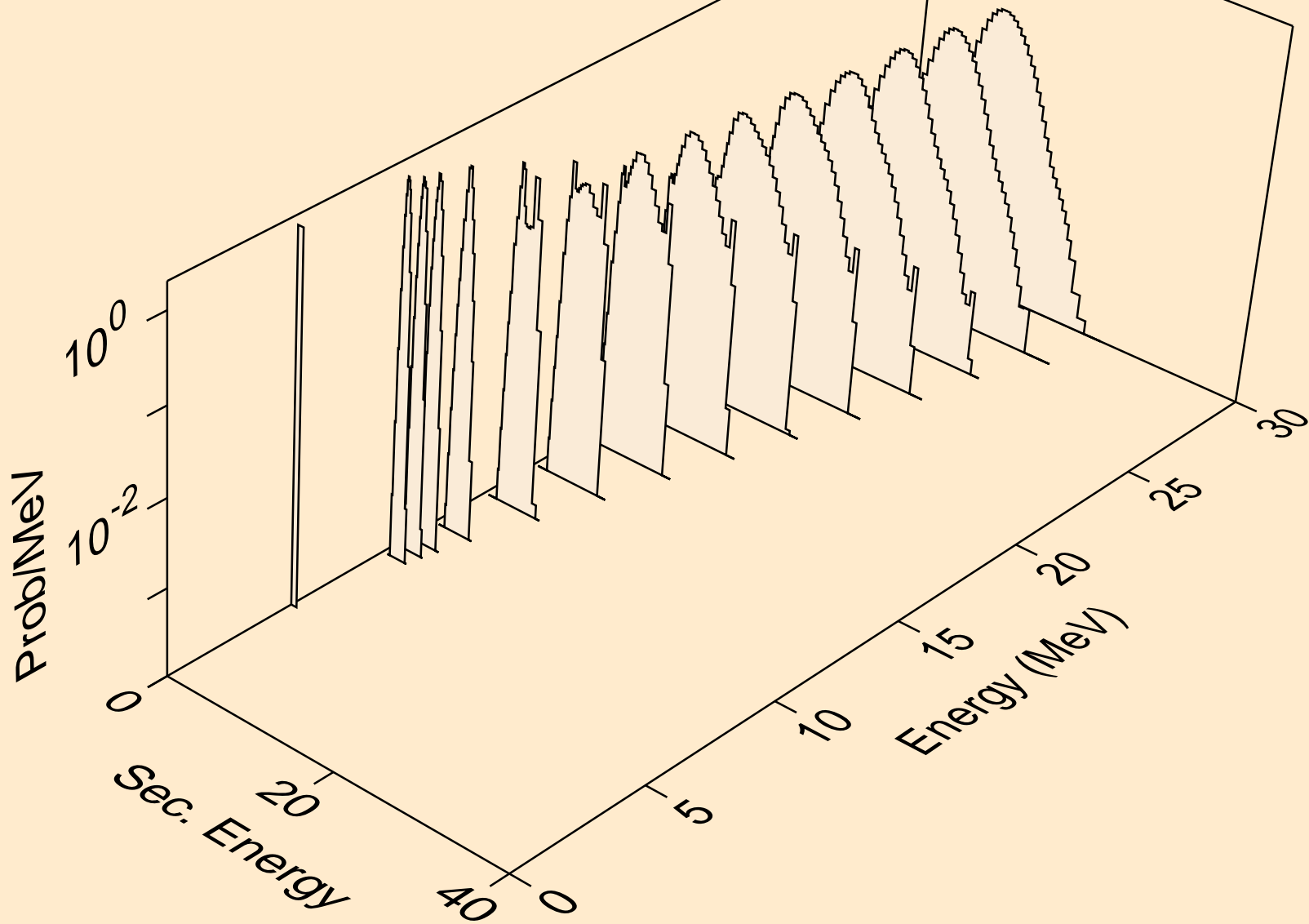

BA133M NEUTRON ACER TENDL-2023 LIBRARY; T=0.K
protons from (n,p)

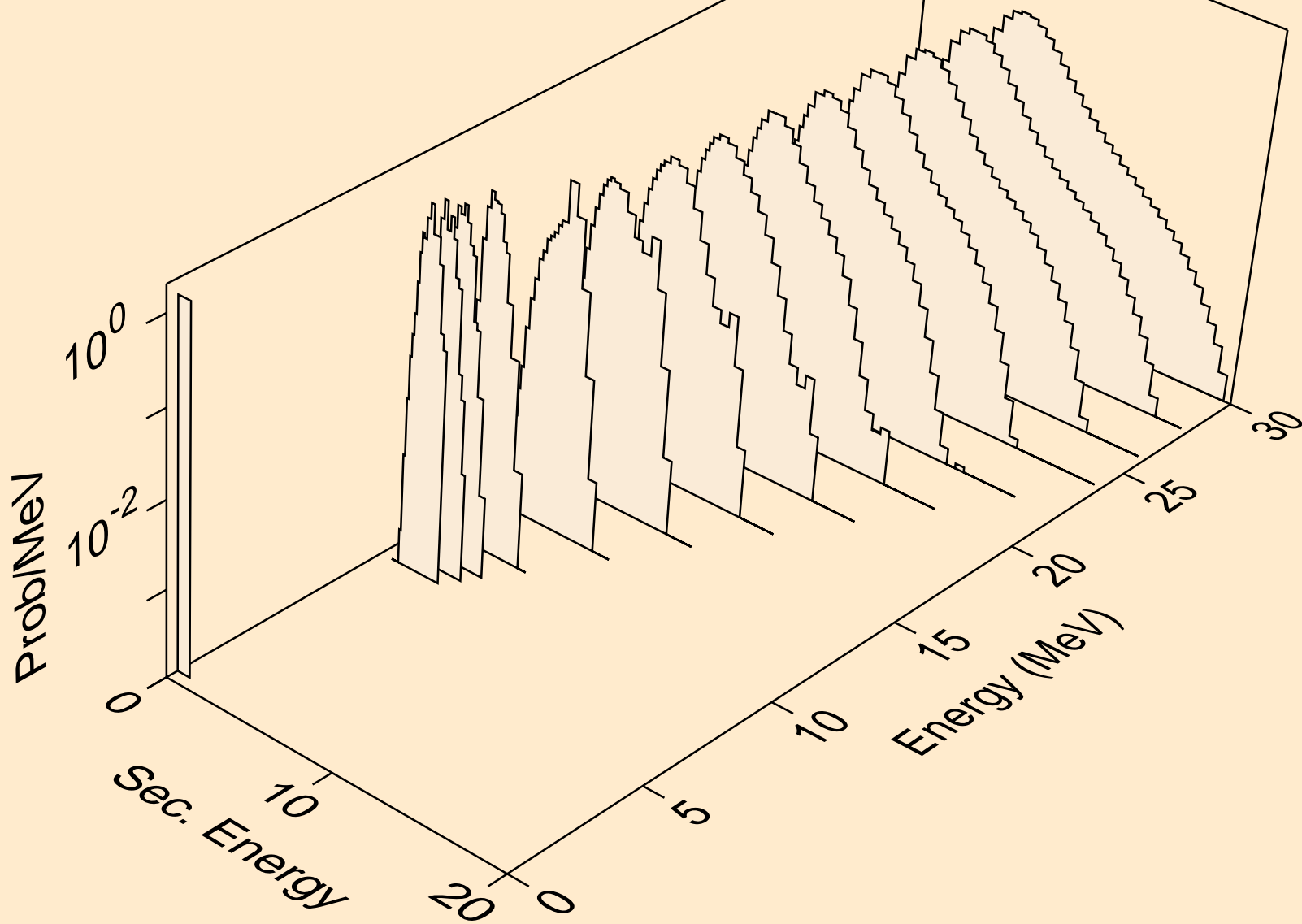

BA133M NEUTRON ACER TENDL-2023 LIBRARY; T=0.K
protons from (n,pd)

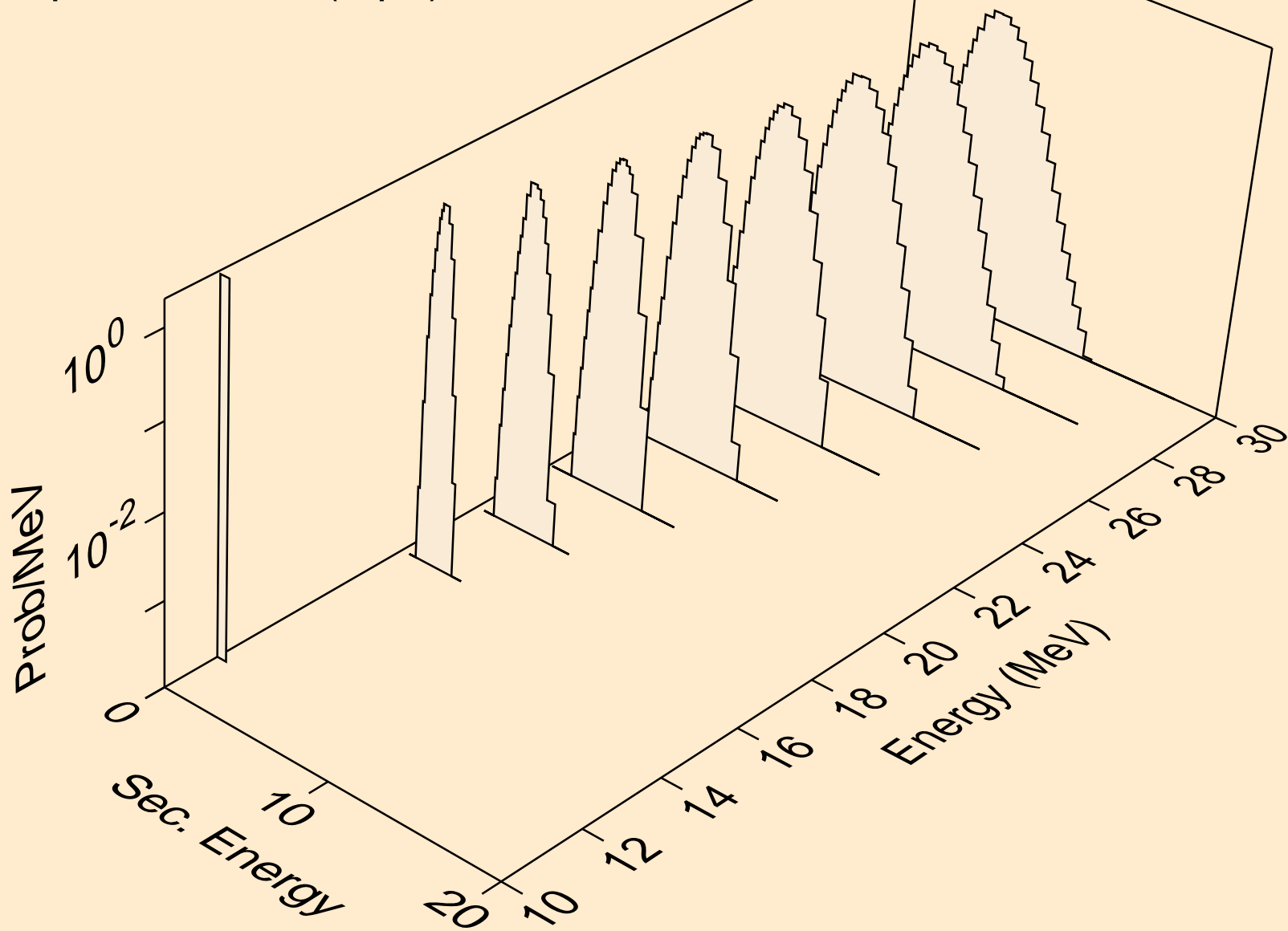

BA133M NEUTRON ACER TENDL-2023 LIBRARY; T=0.K
protons from (n,pt)

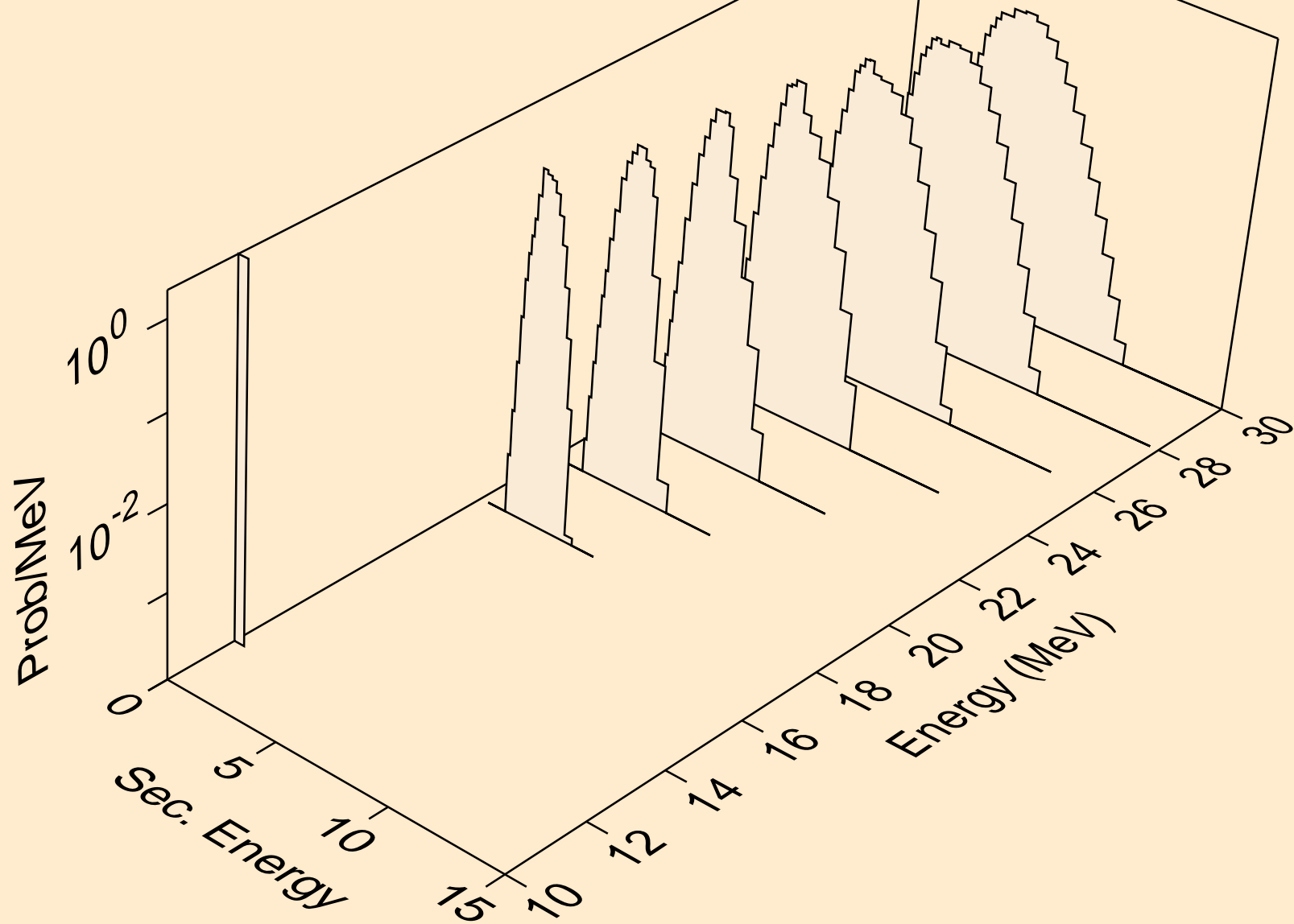

BA133M NEUTRON ACER TENDL-2023 LIBRARY; T=0.K
deuterons from (n,x)

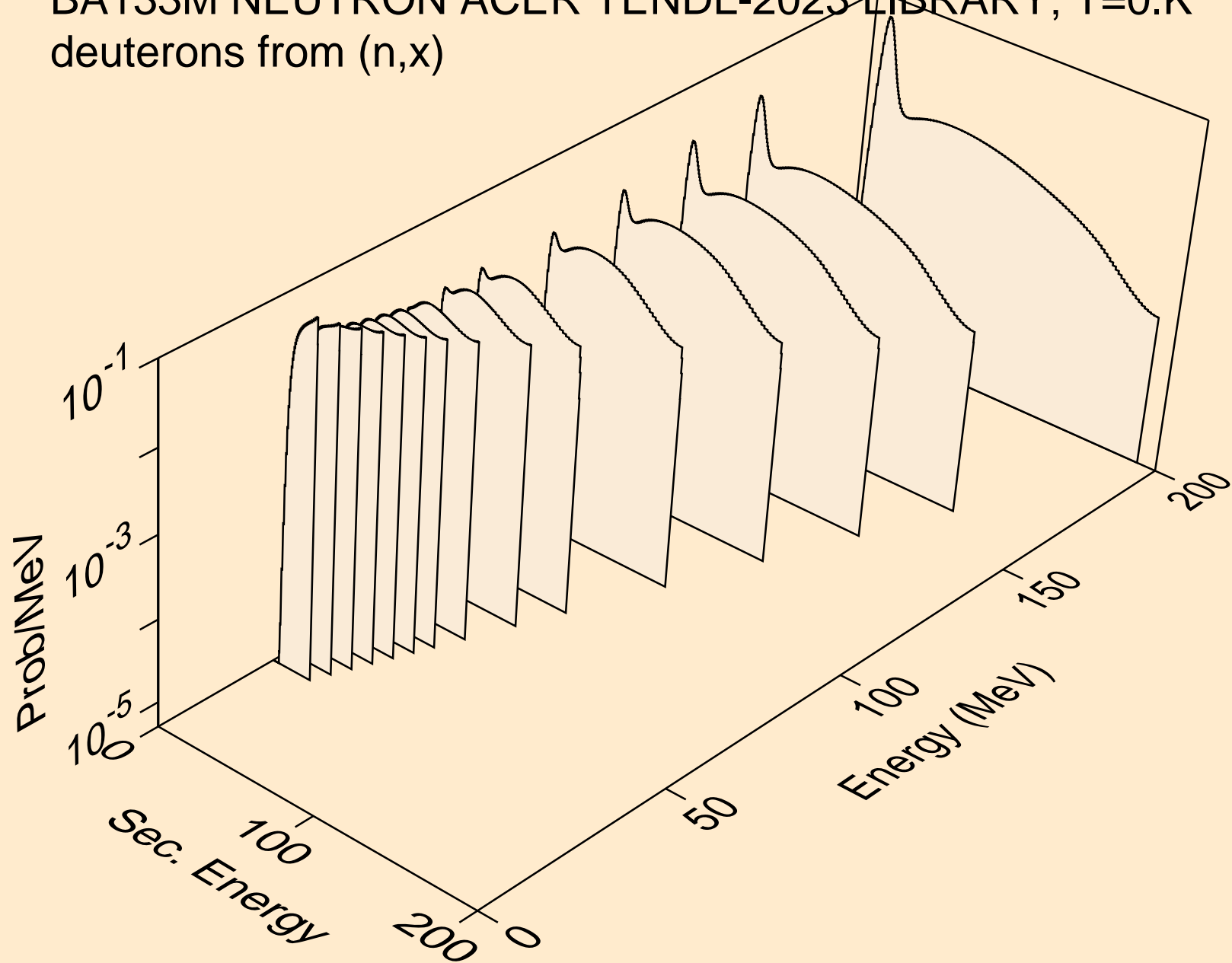

BA133M NEUTRON ACER TENDL-2023 LIBRARY; T=0.K
deuterons from (n,2nd)

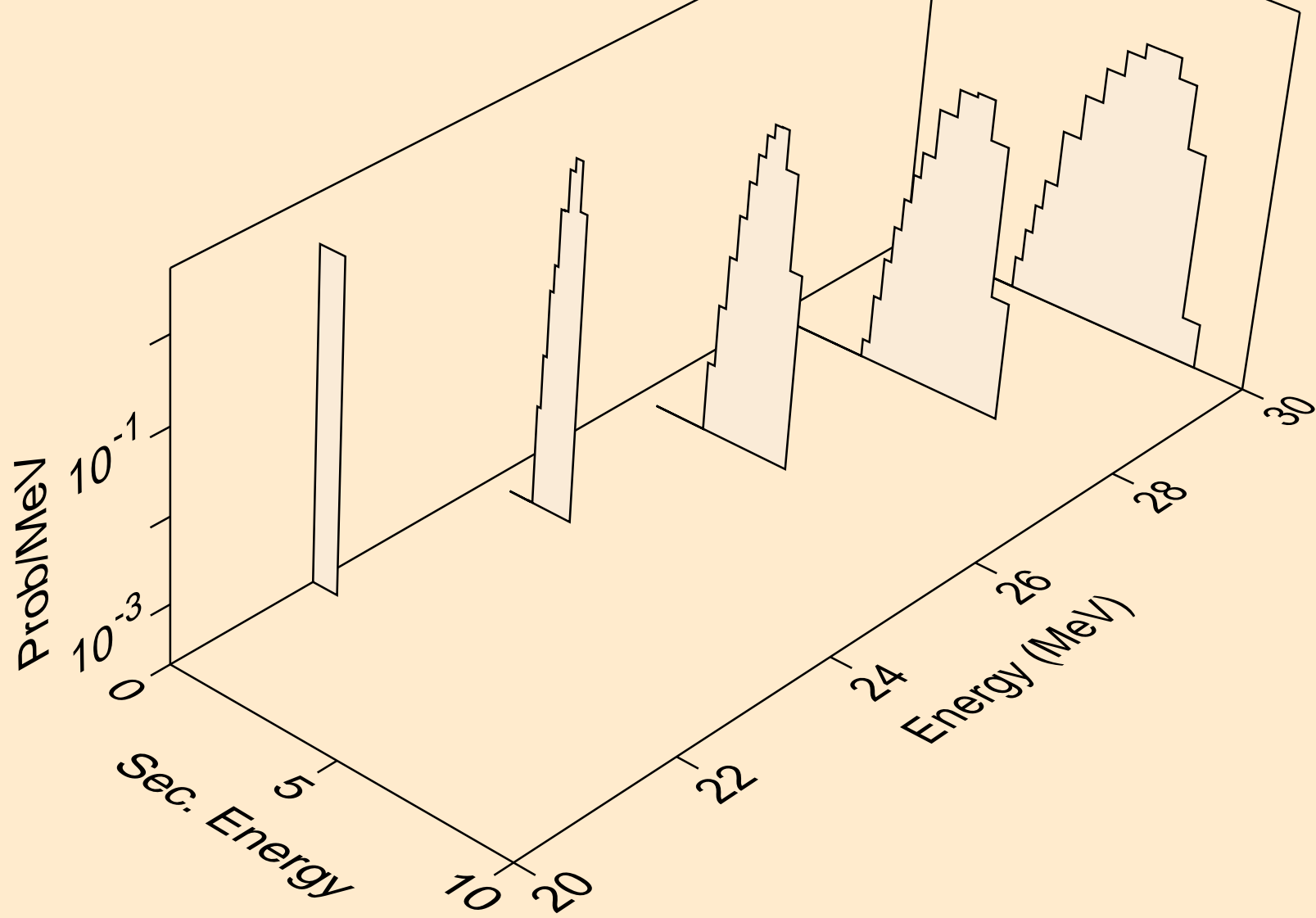

BA133M NEUTRON ACER TENDL-2023 LIBRARY; T=0.K
deuterons from (n,n*)d

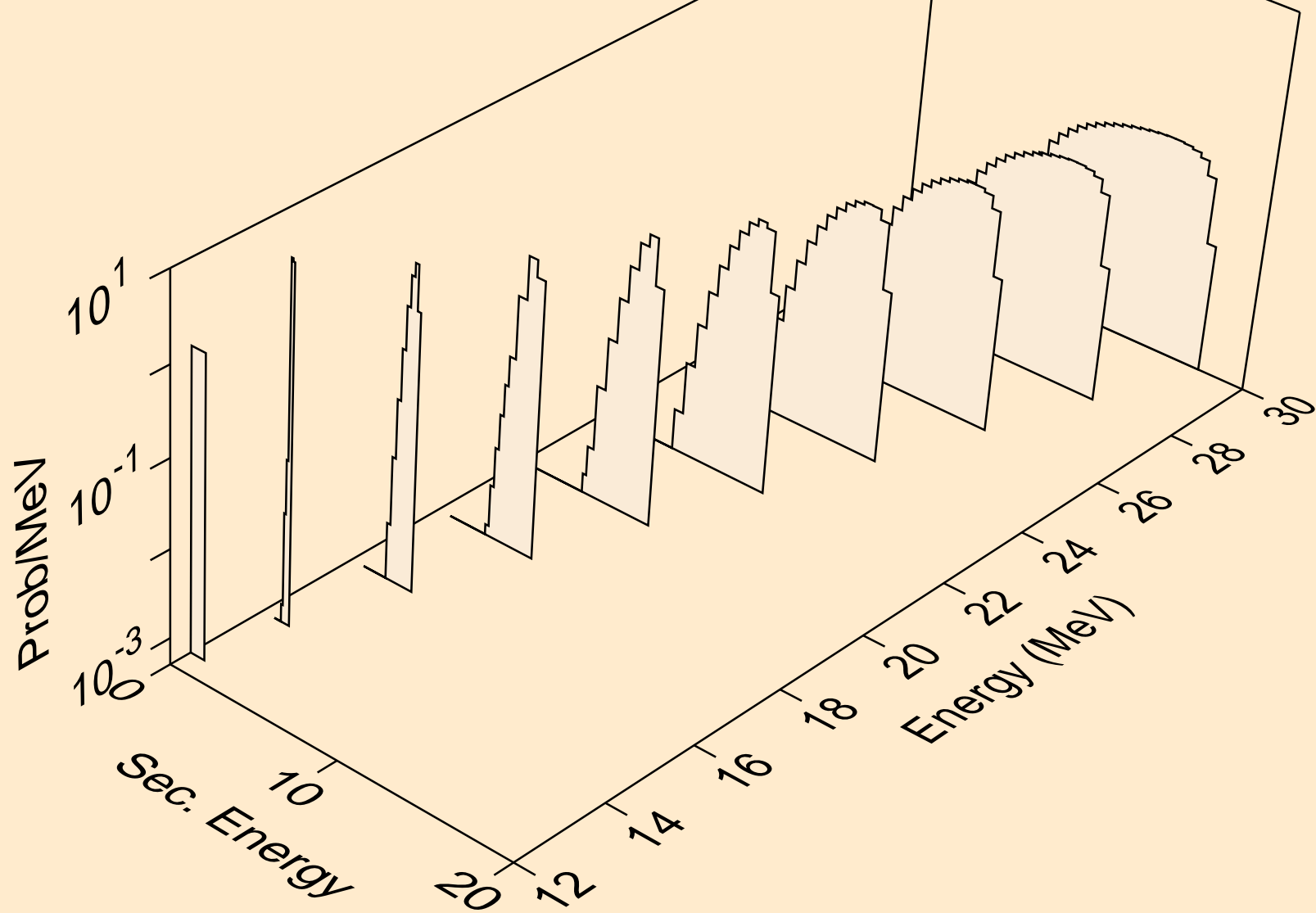

BA133M NEUTRON ACER TENDL-2023 LIBRARY; T=0.K
deuterons from (n,d)

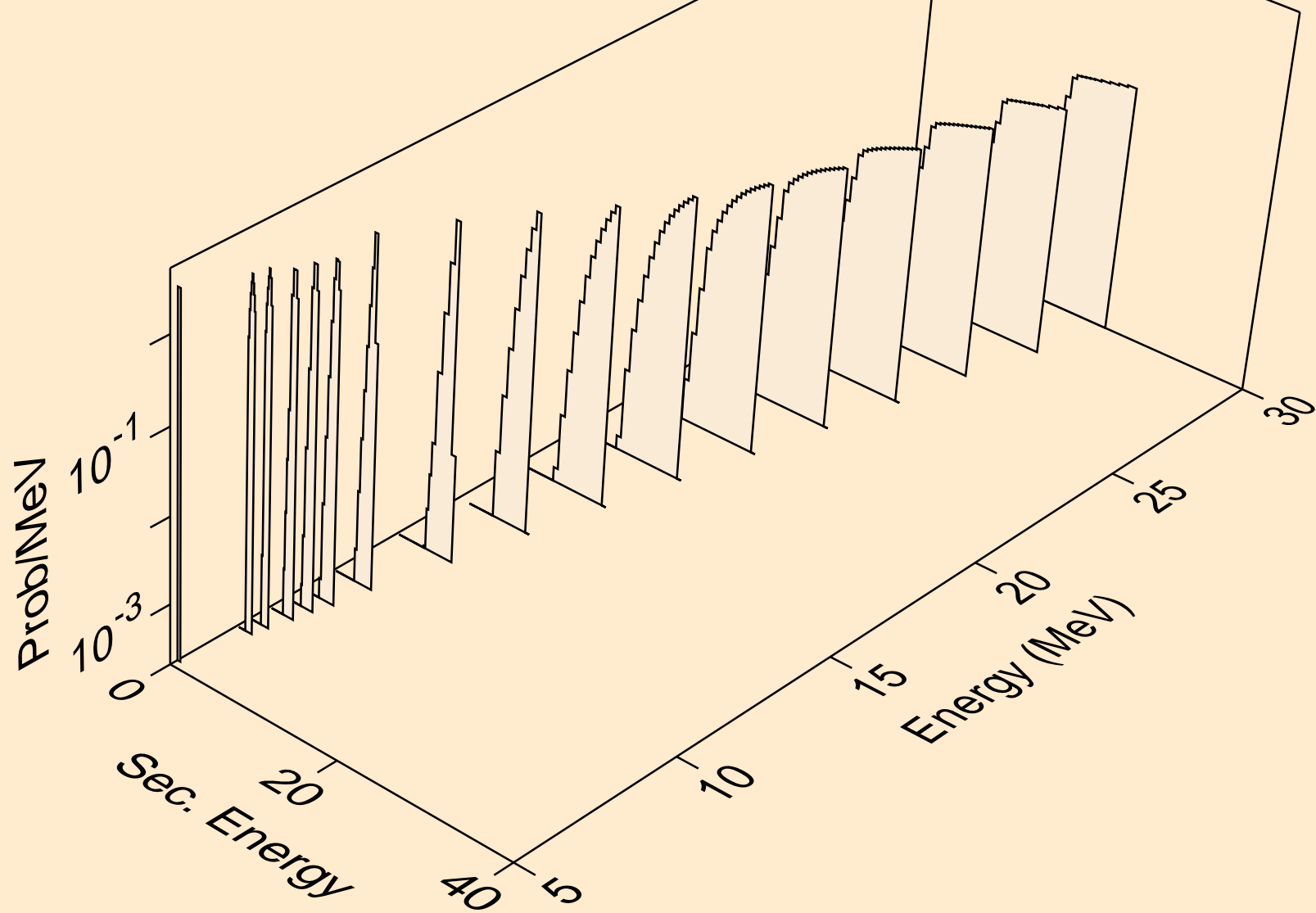

BA133M NEUTRON ACER TENDL-2023 LIBRARY; T=0.K
deuterons from (n,pd)

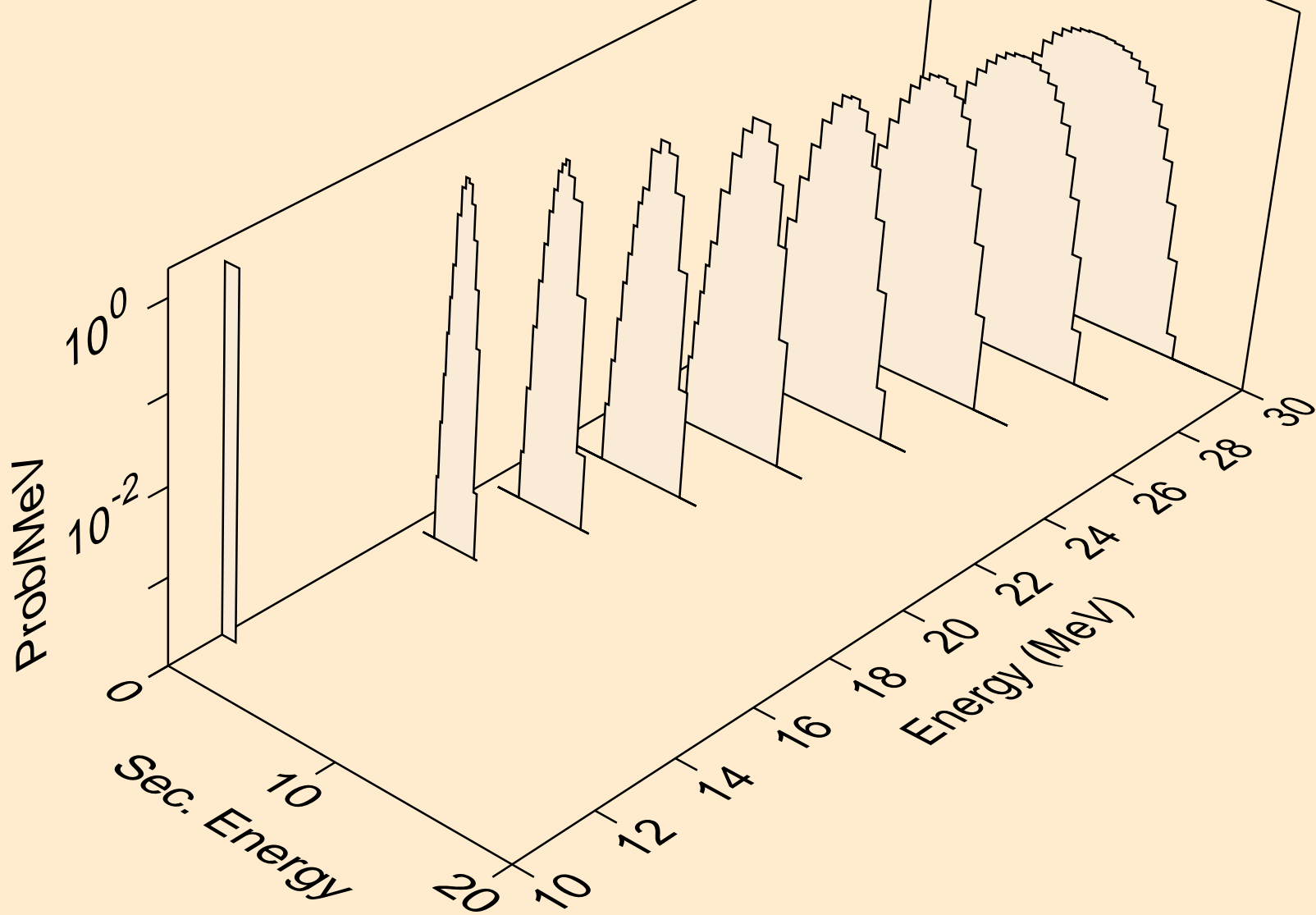

BA133M NEUTRON ACER TENDL-2023 LIBRARY; T=0.K
deuterons from (n,da)

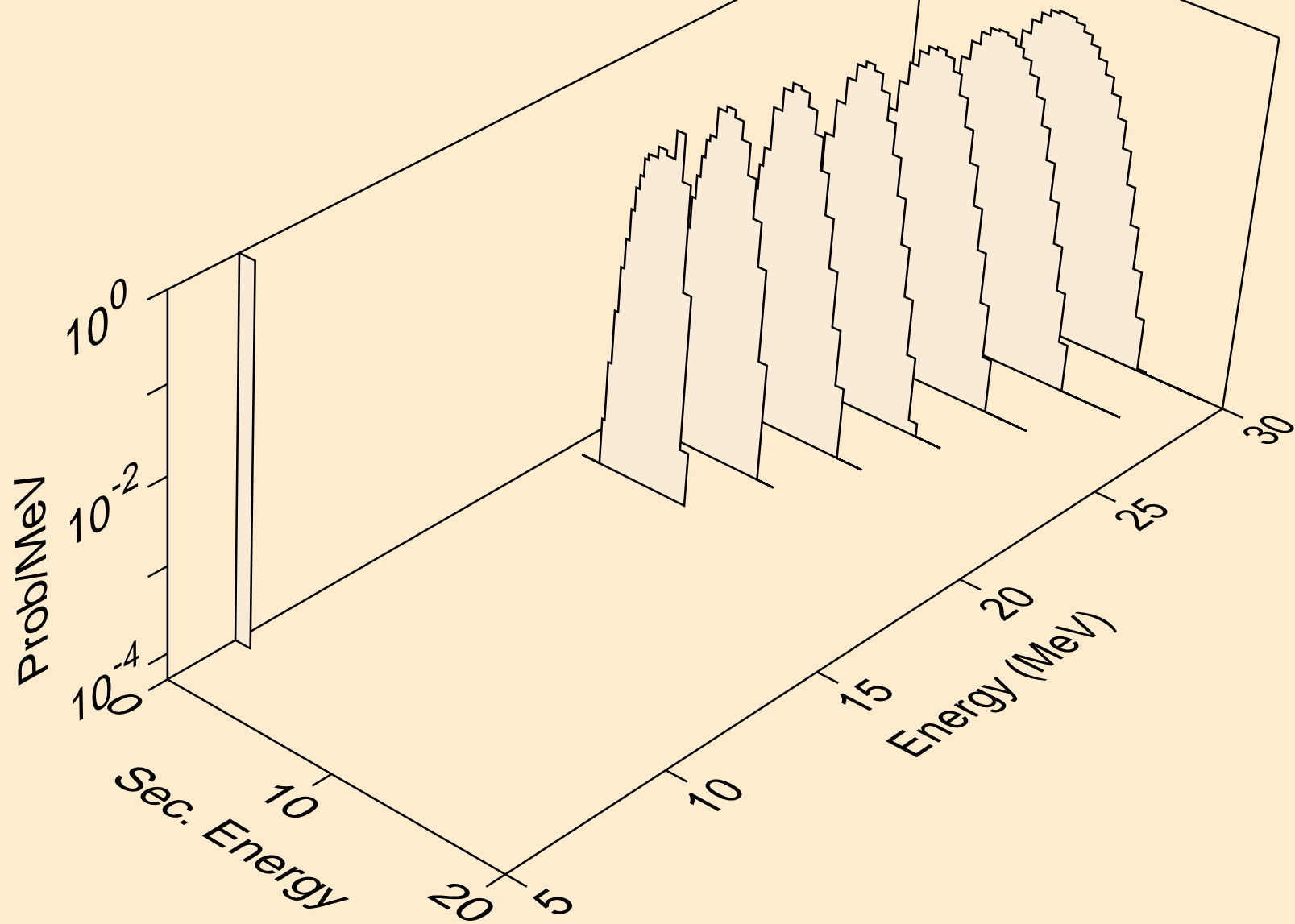

BA133M NEUTRON ACER TENDL-2023 LIBRARY; T=0.K
tritons from (n,x)

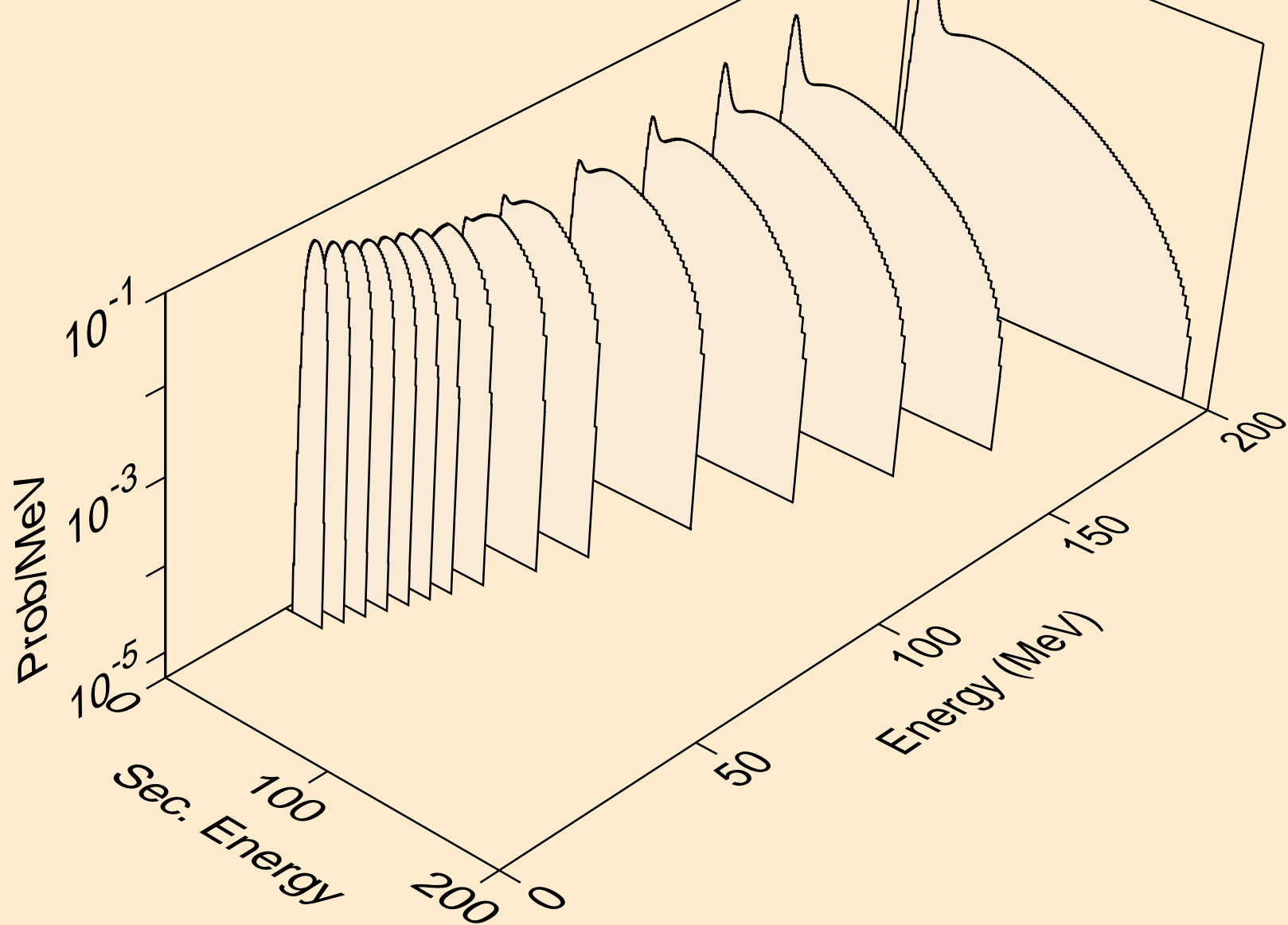

BA133M NEUTRON ACER TENDL-2023 LIBRARY; T=0.K
tritons from (n,n*)t

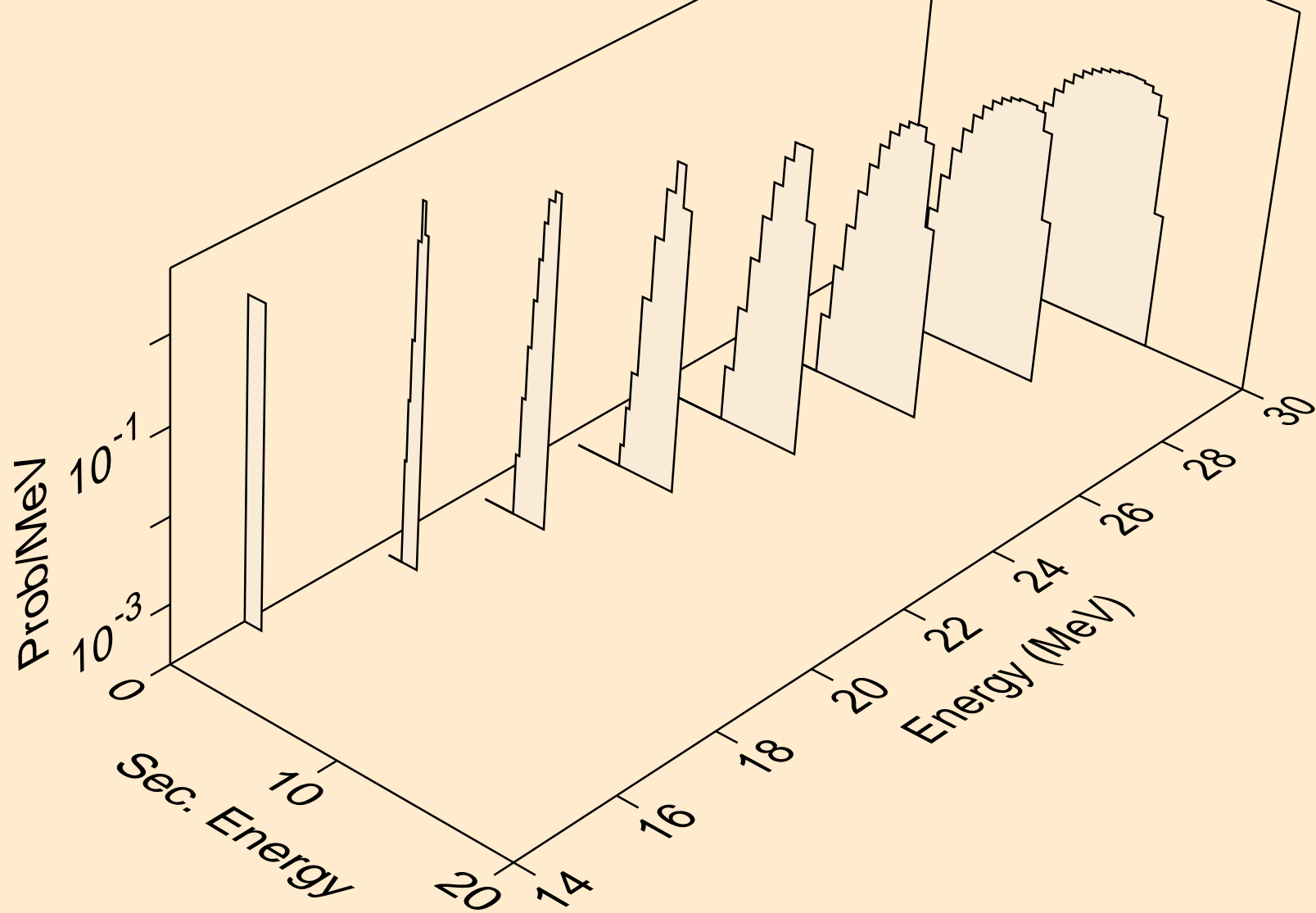

BA133M NEUTRON ACER TENDL-2023 LIBRARY; T=0.K
tritons from (n,t)

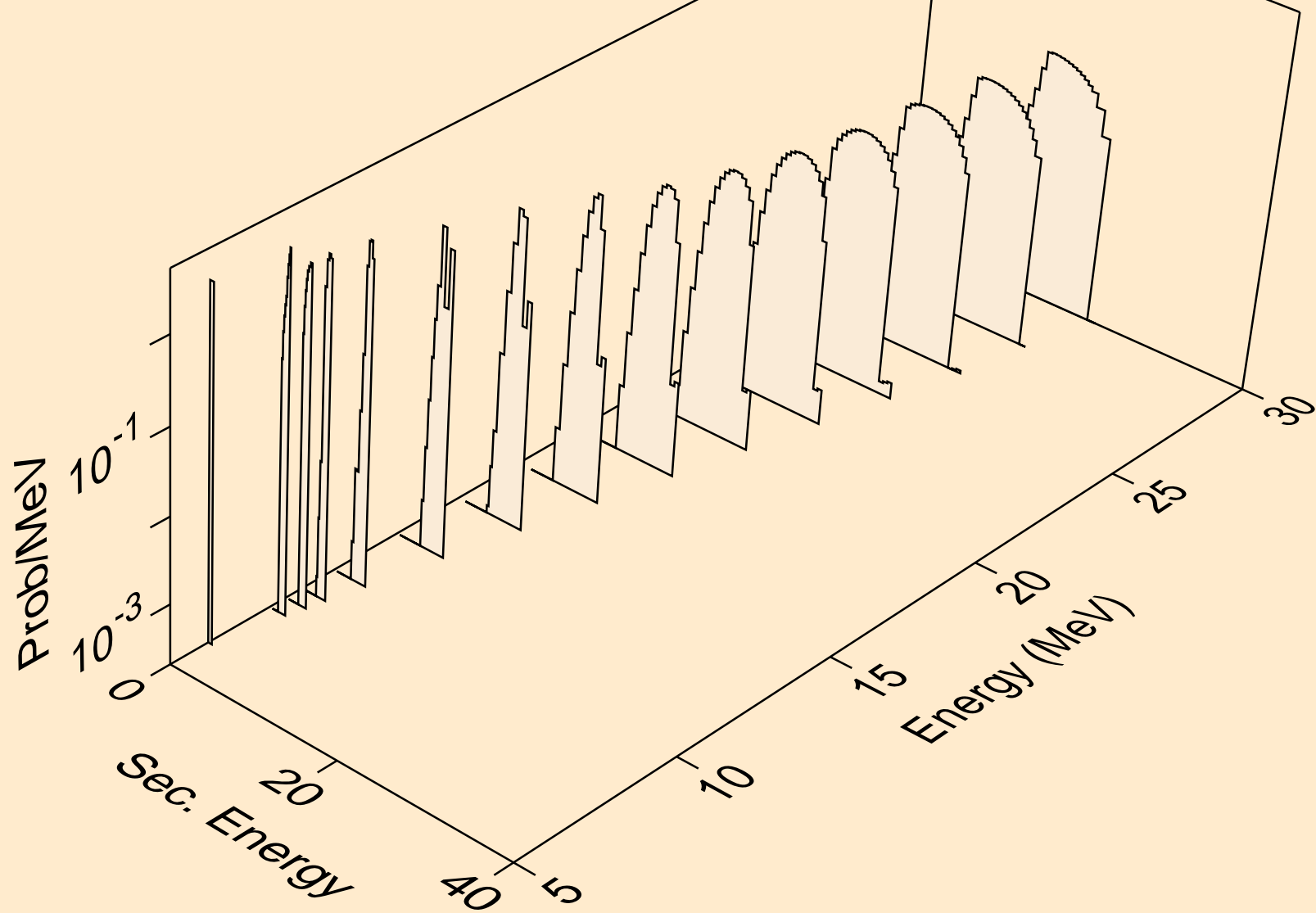

BA133M NEUTRON ACER TENDL-2023 LIBRARY; T=0.K
tritons from (n,pt)

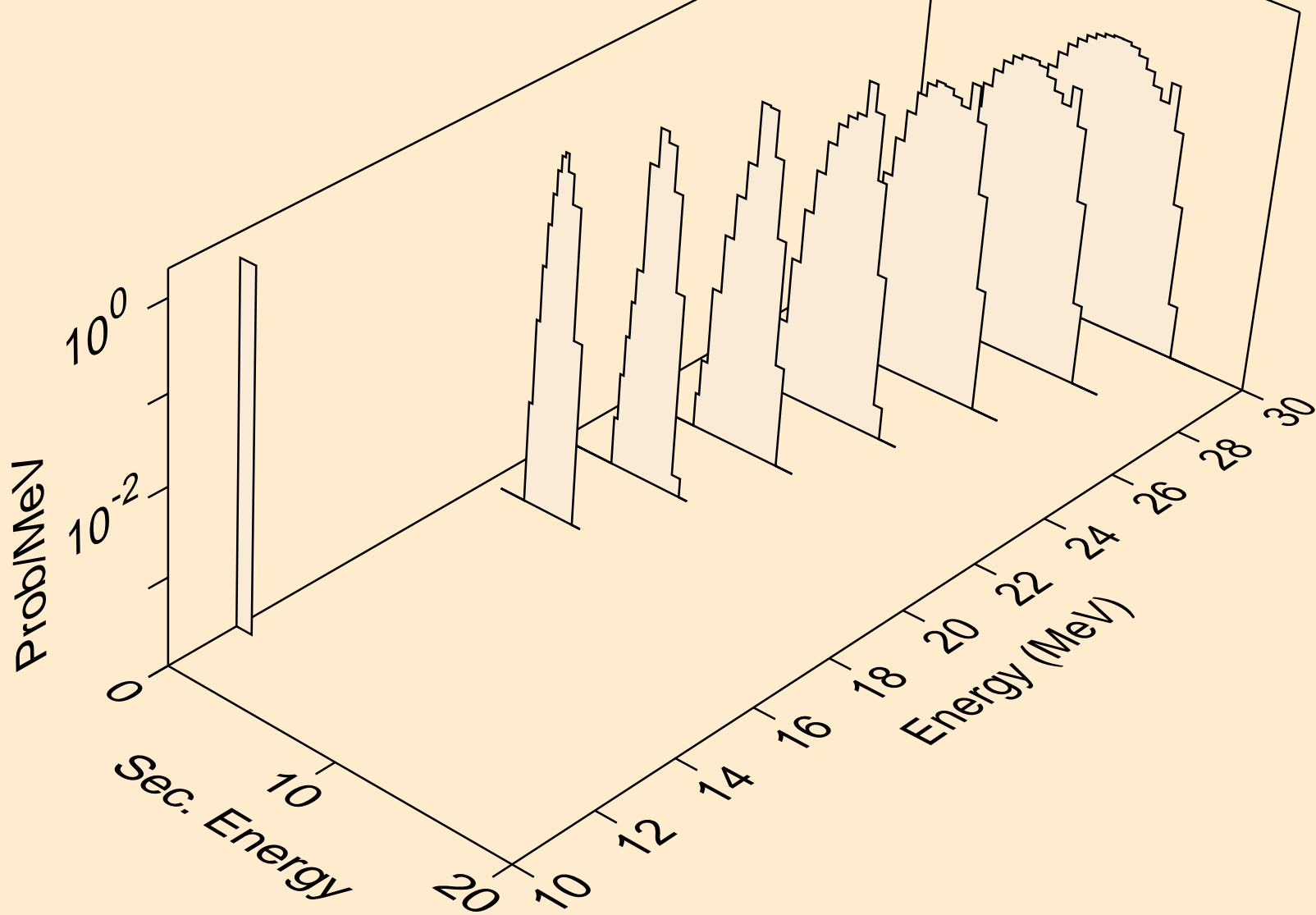

BA133M NEUTRON ACER TENDL-2023 LIBRARY; T=0.K
he3s from (n,x)

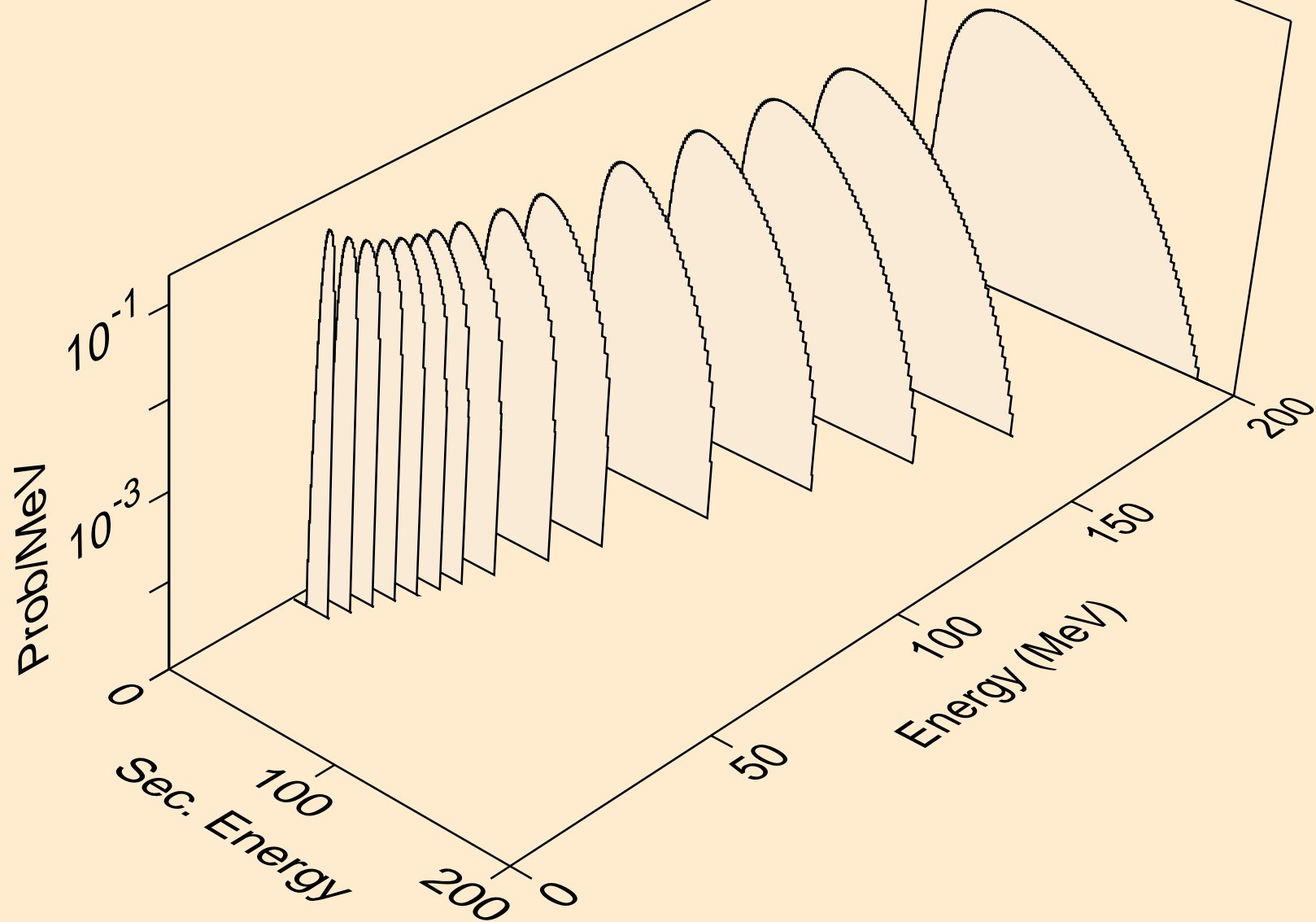

BA133M NEUTRON ACER TENDL-2023 LIBRARY; T=0.K
he3s from (n,n*)he3

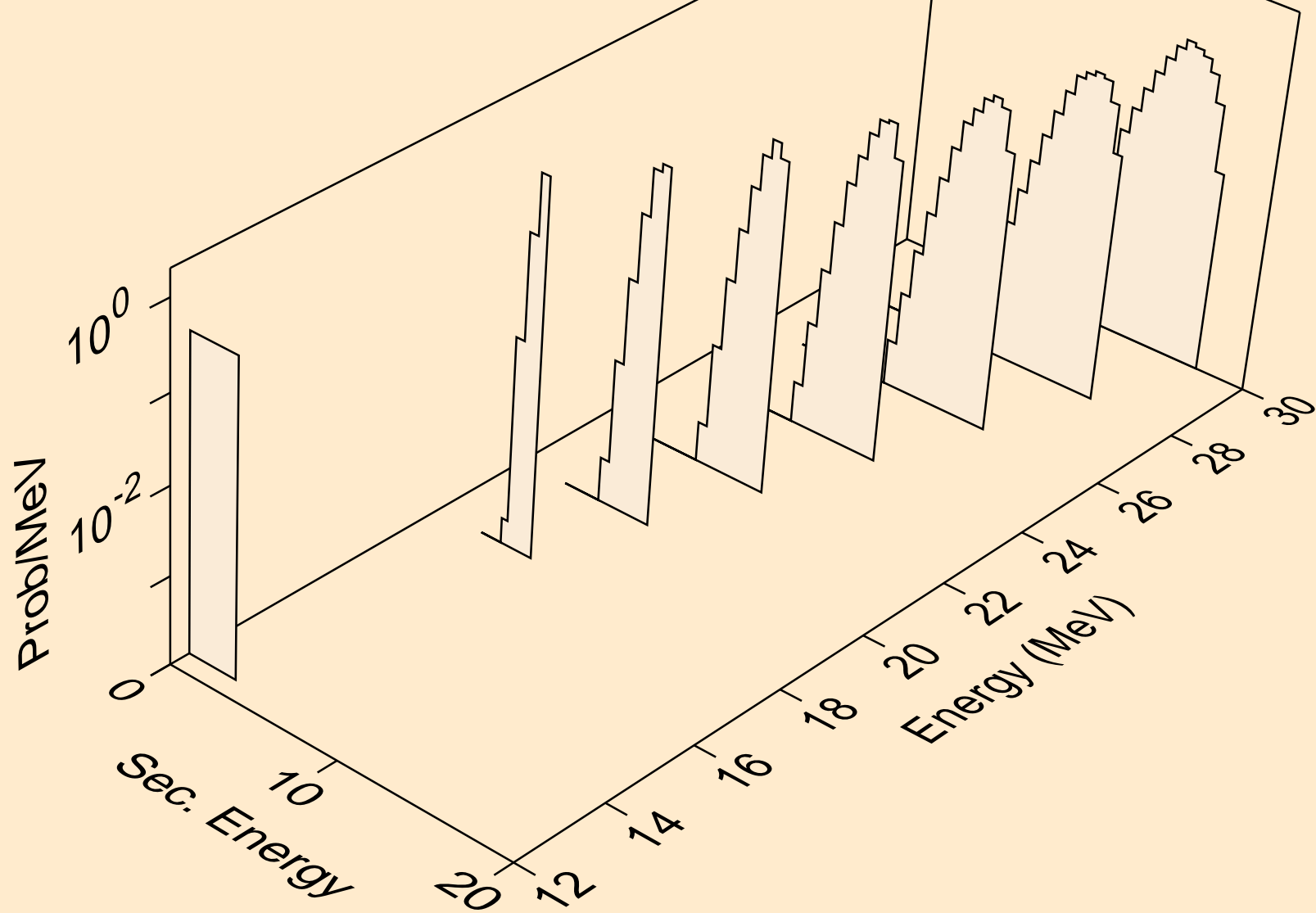

BA133M NEUTRON ACER TENDL-2023 LIBRARY; T=0.K
he3s from (n,he3)

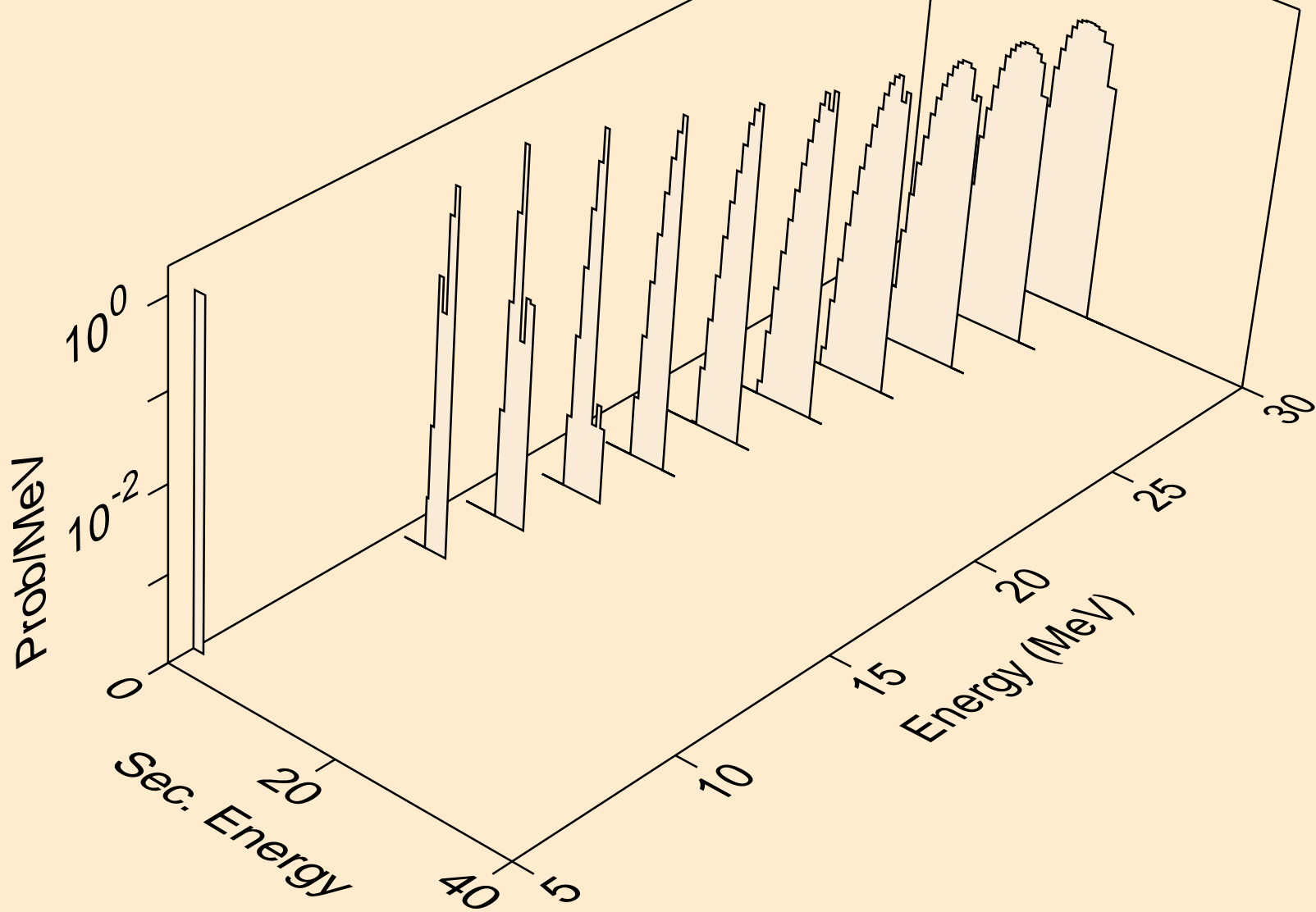

BA133M NEUTRON ACER TENDL-2023 LIBRARY; T=0.K
alphas from (n,x)

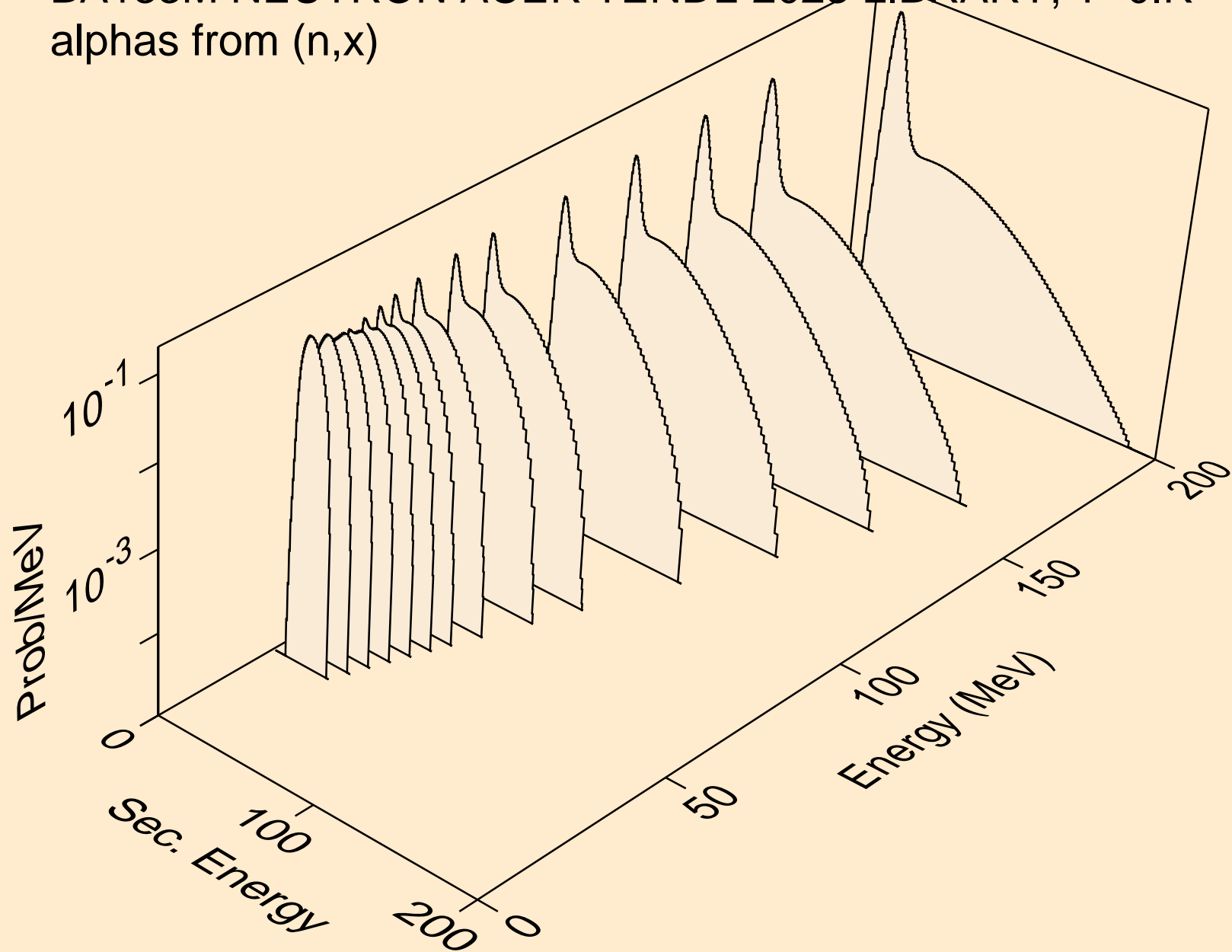

BA133M NEUTRON ACER TENDL-2023 LIBRARY; T=0.K
alphas from (n,n*)a

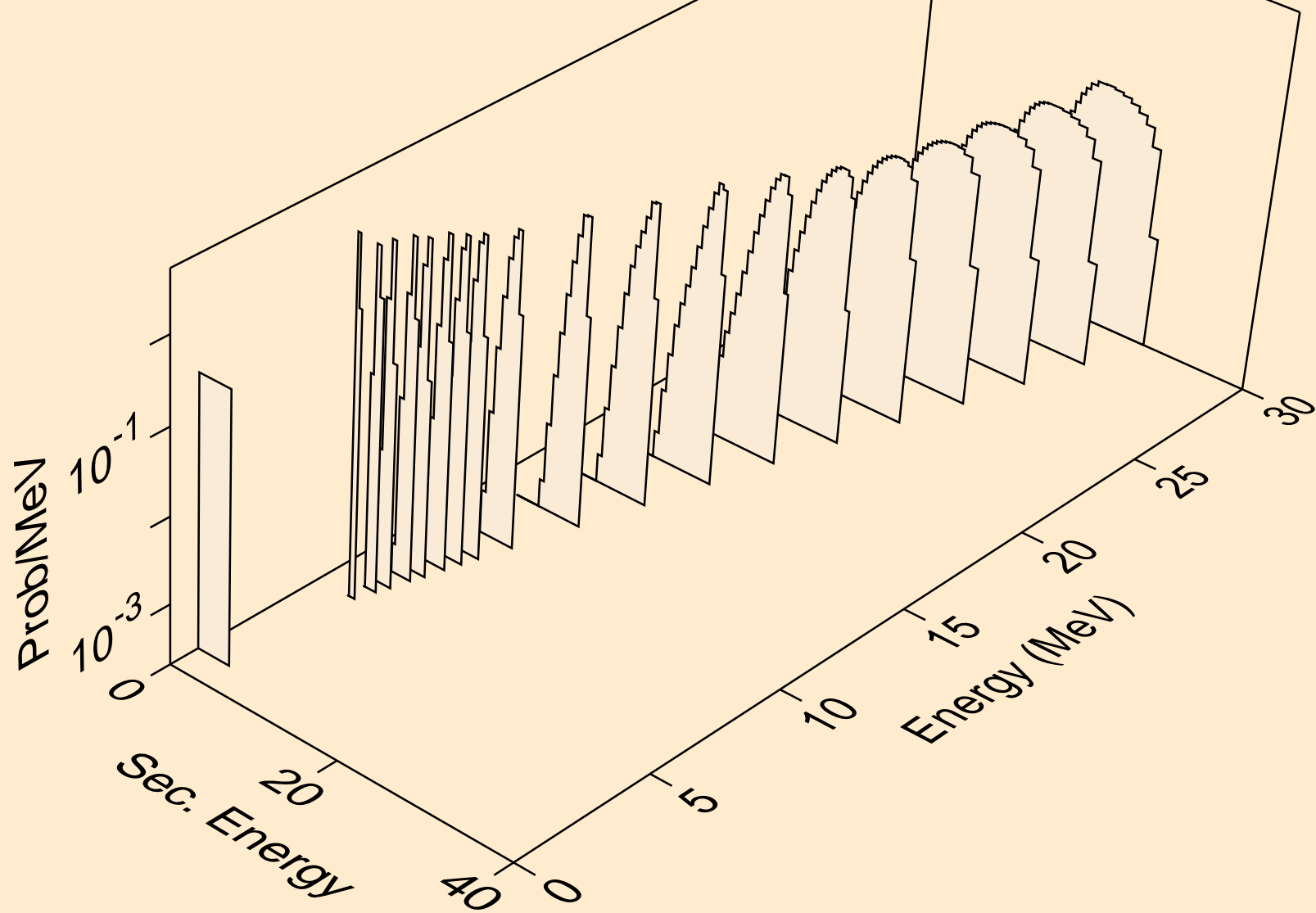

BA133M NEUTRON ACER TENDL-2023 LIBRARY; T=0.K
alphas from (n,2n)a

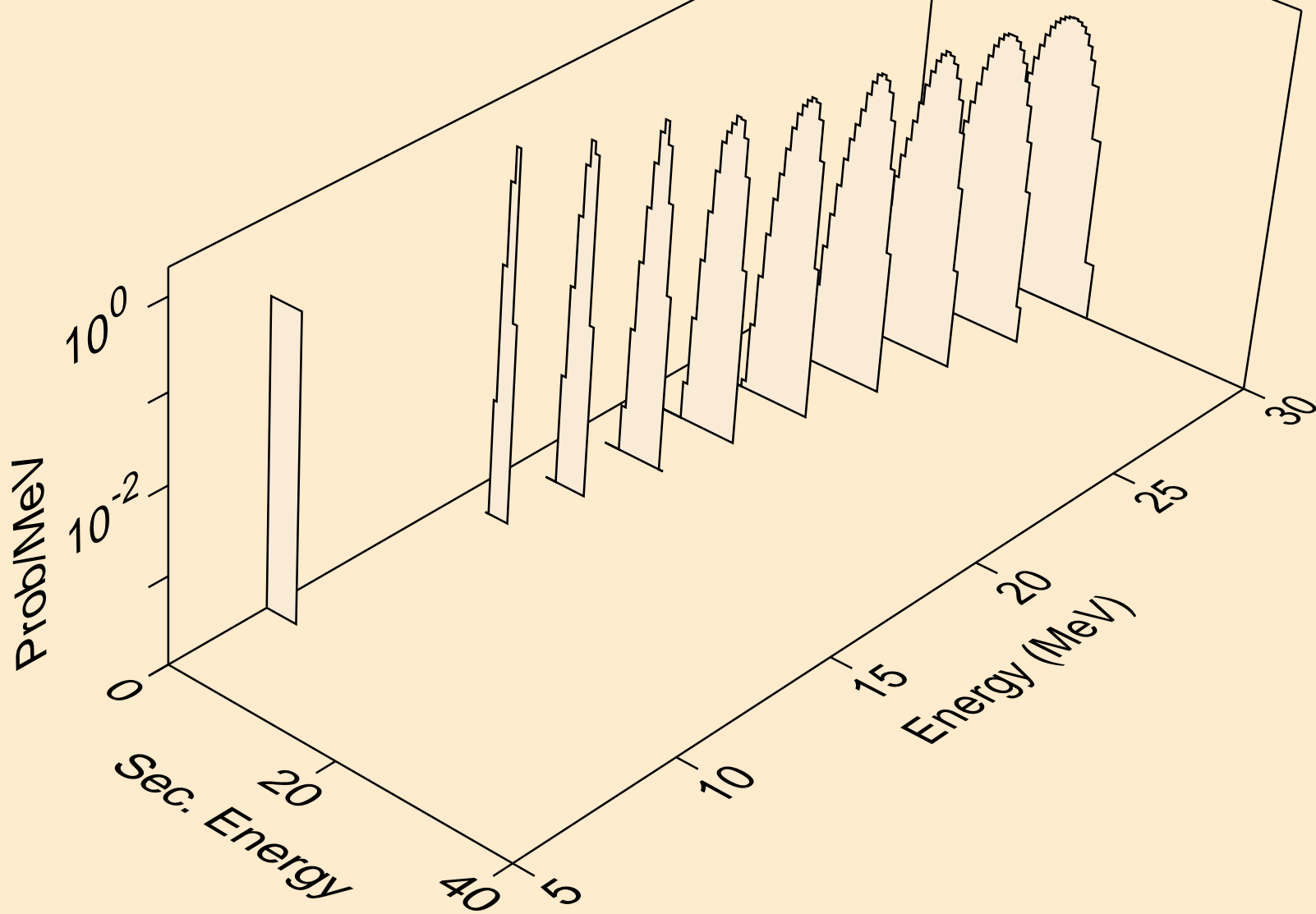

BA133M NEUTRON ACER TENDL-2023 LIBRARY; T=0.K
alphas from (n,3n)a

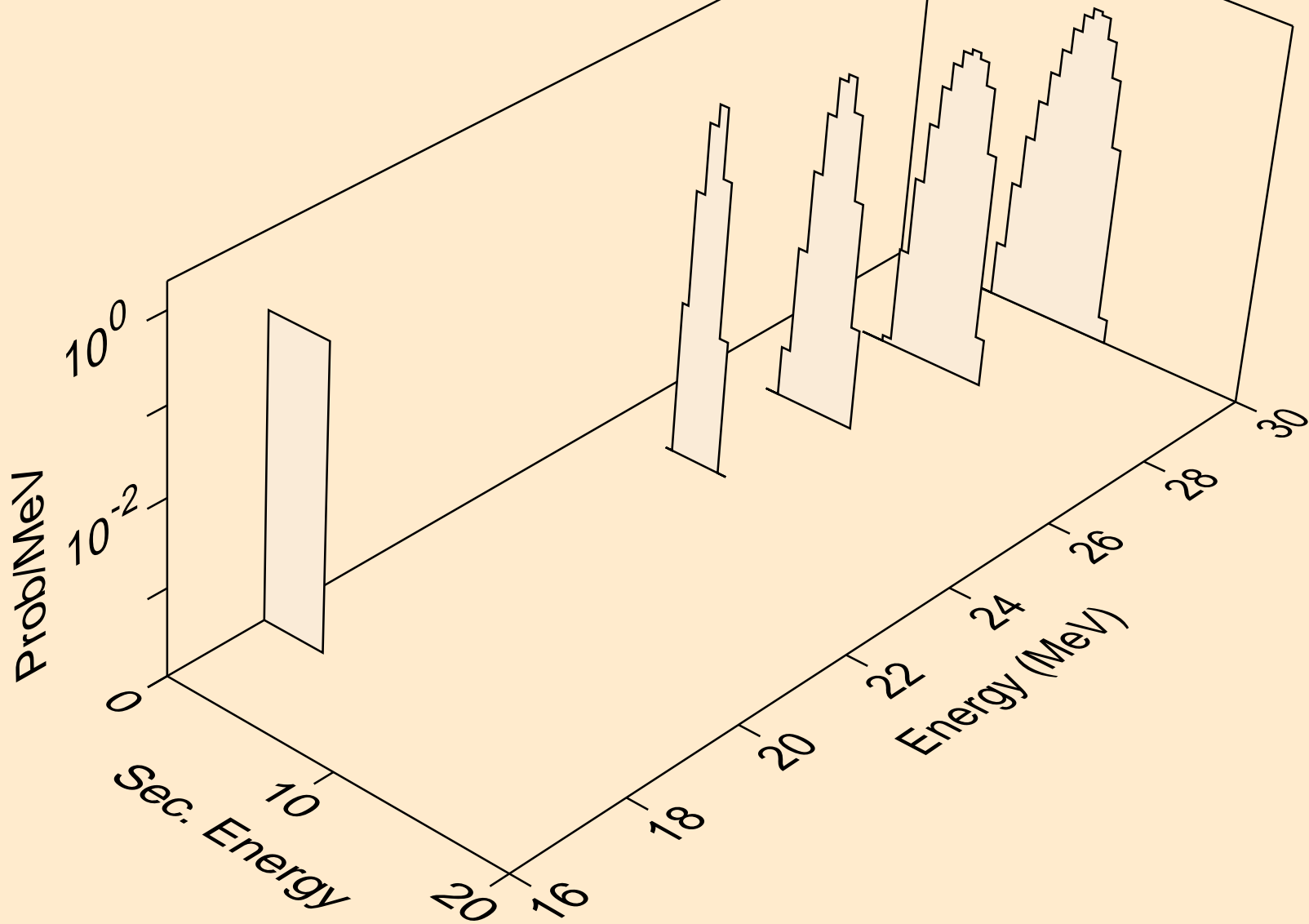

BA133M NEUTRON ACER TENDL-2023 LIBRARY; T=0.K
alphas from (n,n*)2a

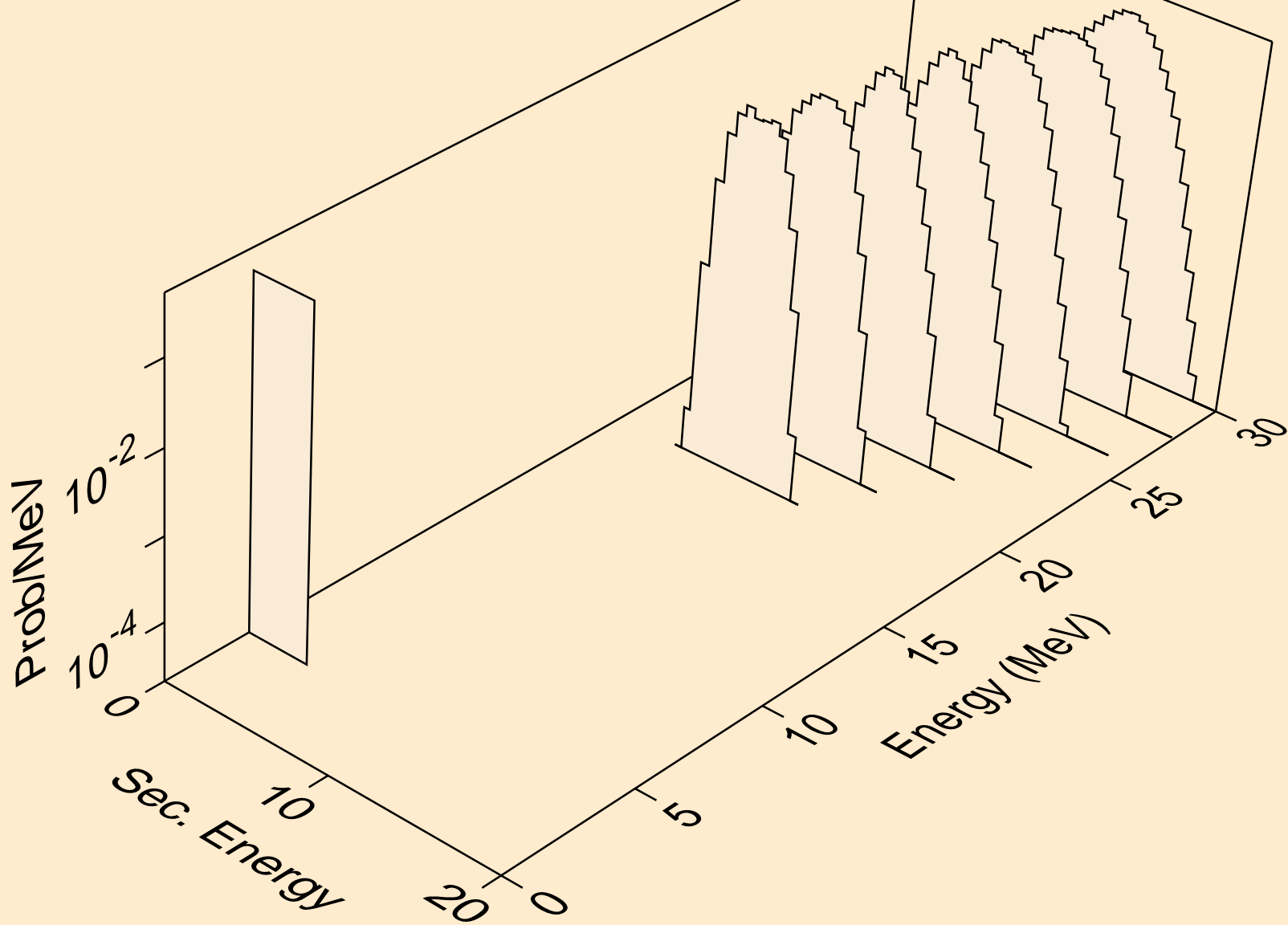

BA133M NEUTRON ACER TENDL-2023 LIBRARY; T=0.K
alphas from (n,npa)

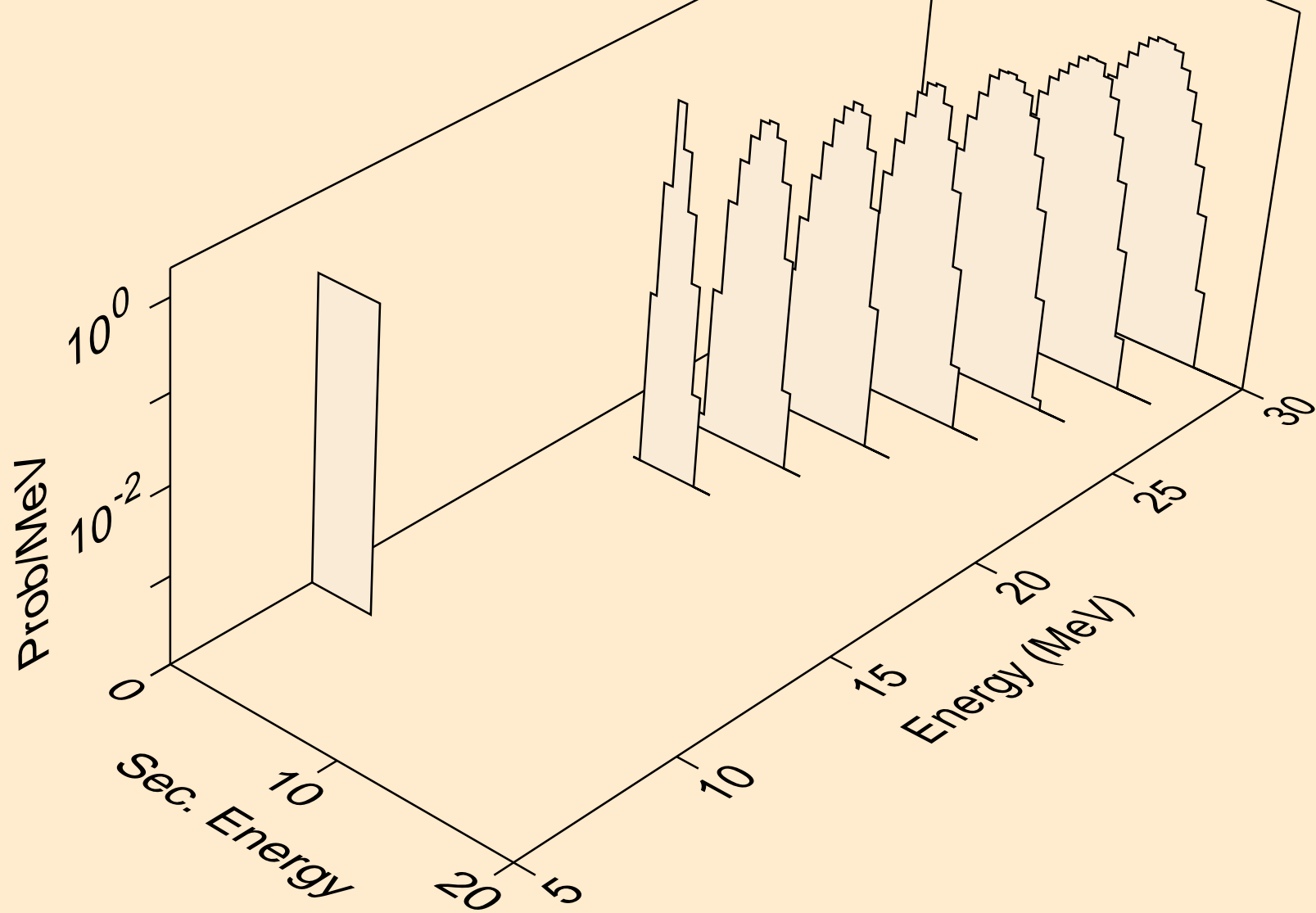

BA133M NEUTRON ACER TENDL-2023 LIBRARY; T=0.K
alphas from (n,a)

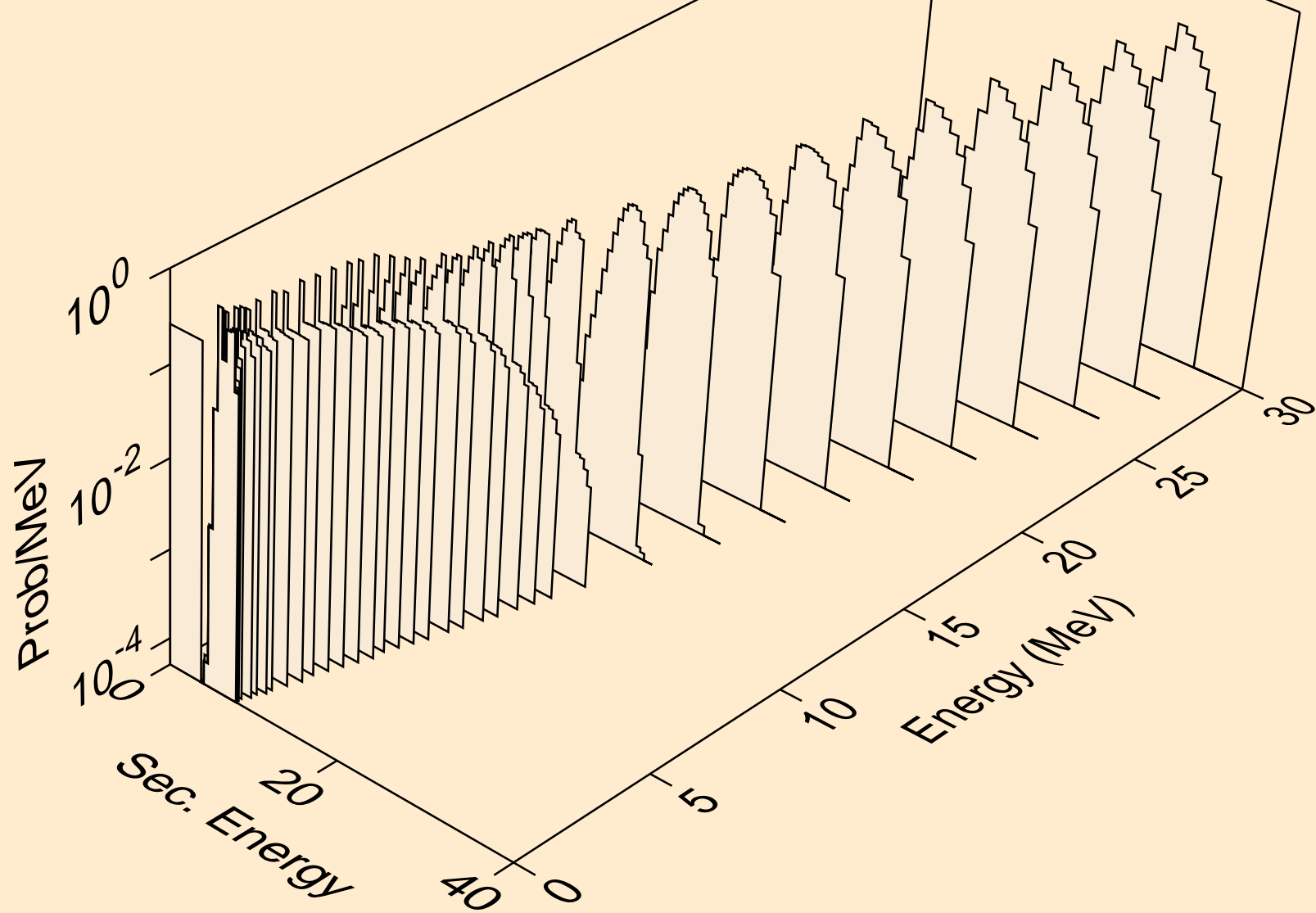

BA133M NEUTRON ACER TENDL-2023 LIBRARY; T=0.K
alphas from (n,2a)

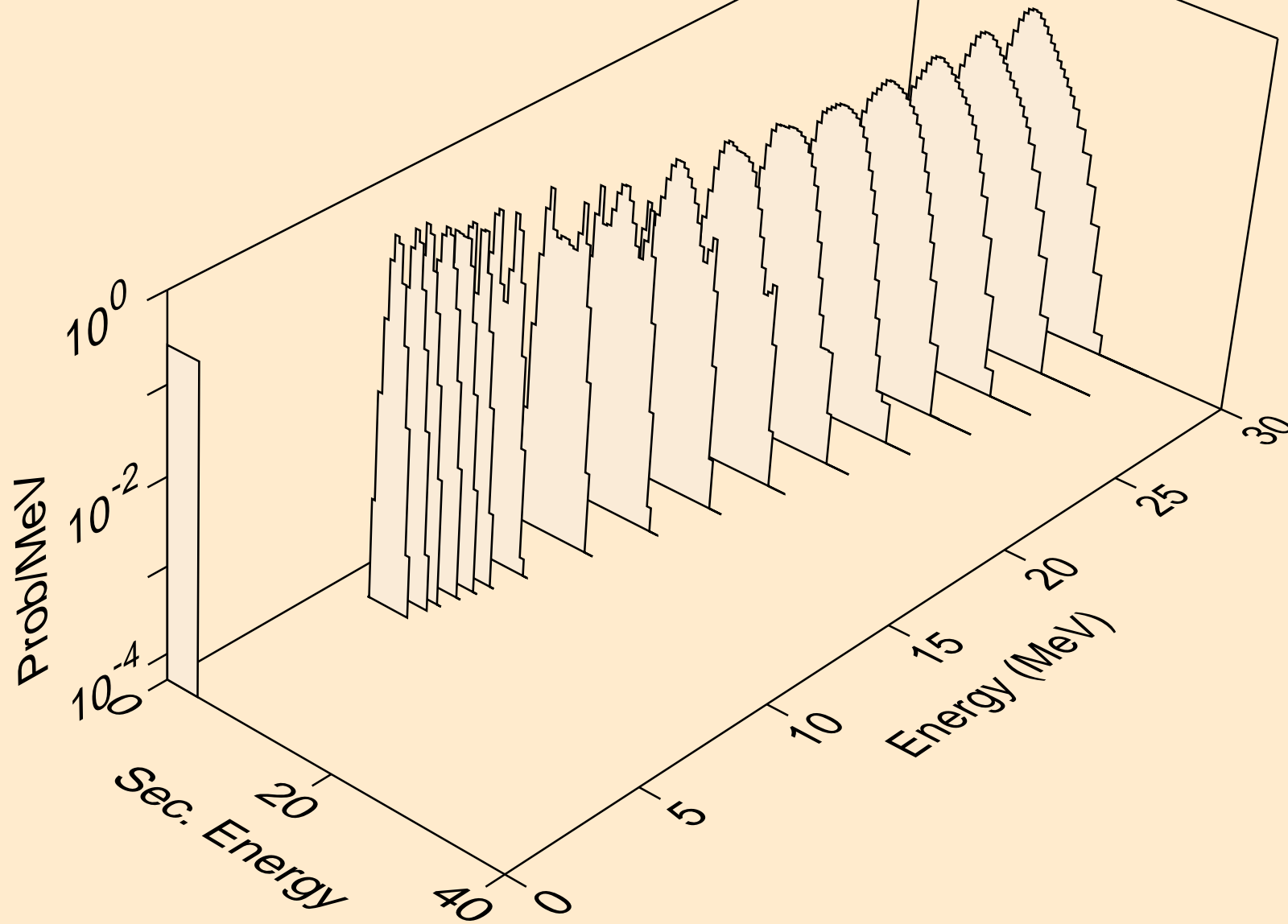

BA133M NEUTRON ACER TENDL-2023 LIBRARY; T=0.K
alphas from (n,p)

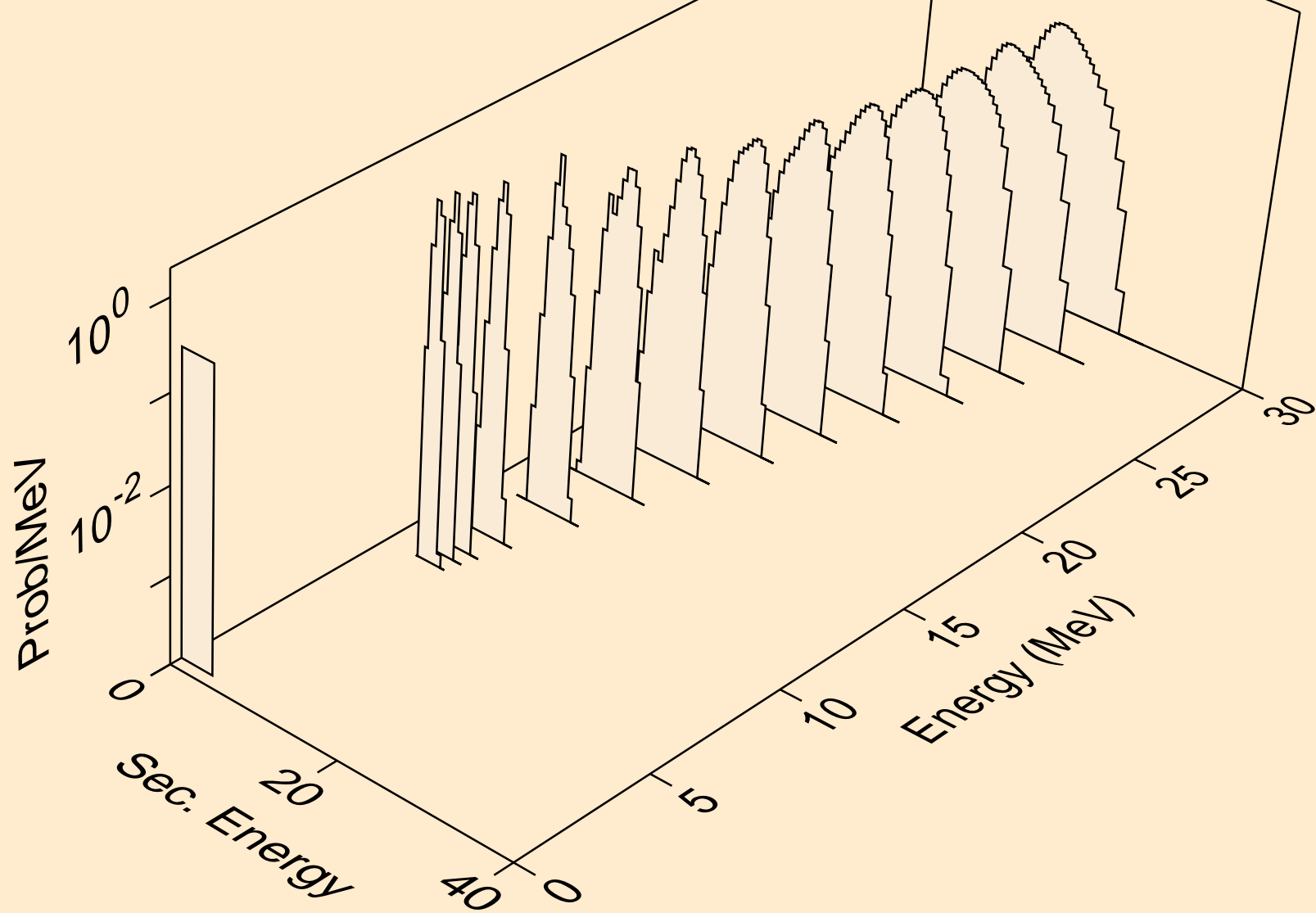

BA133M NEUTRON ACER TENDL-2023 LIBRARY; T=0.K
alphas from (n,da)

