

# BE010 NEUTRON ACER TENDL-2023 LIBRARY; T=0.K

## Principal cross sections

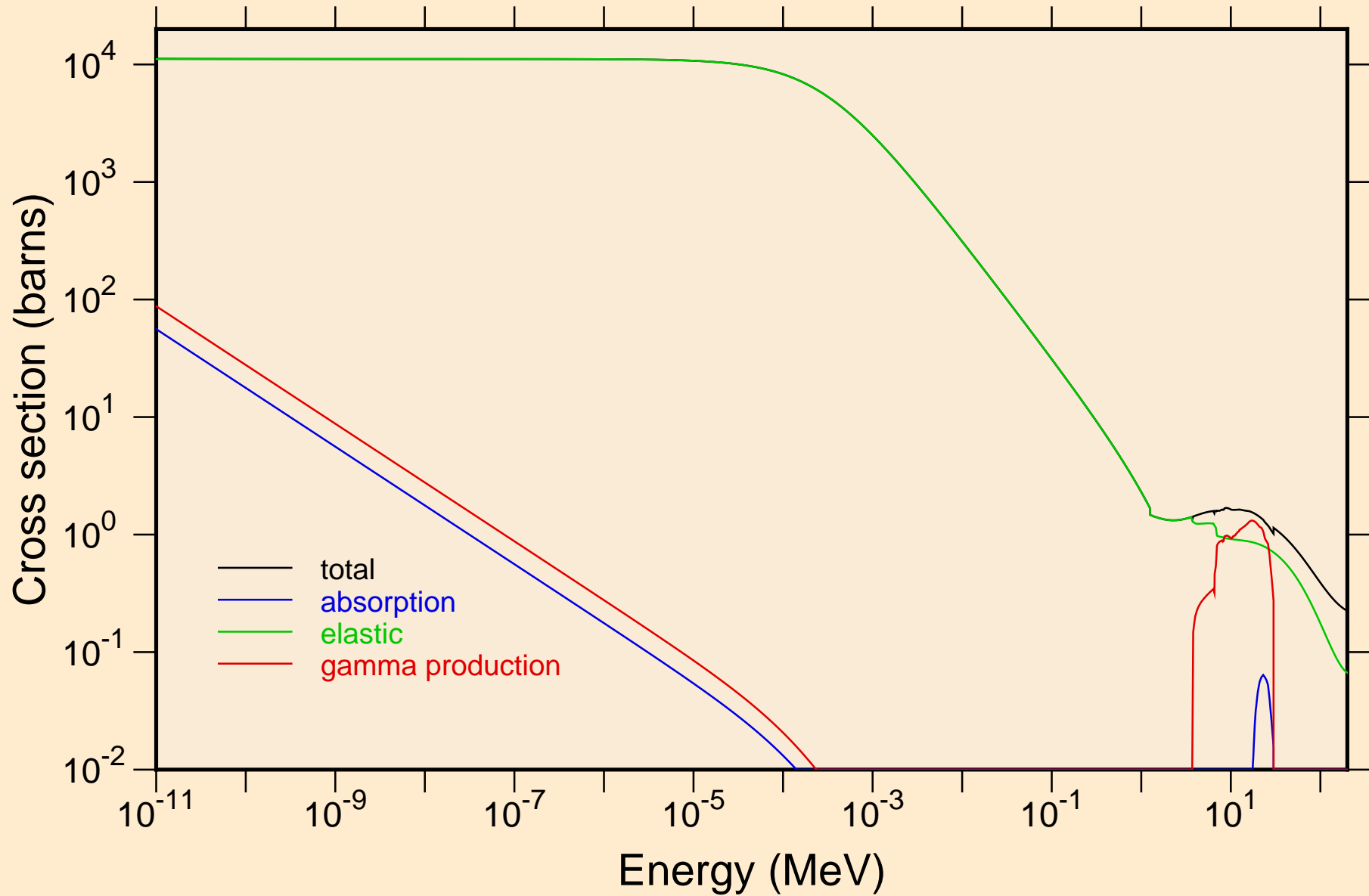

BE010 NEUTRON ACER TENDL-2023 LIBRARY; T=0.K  
Heating

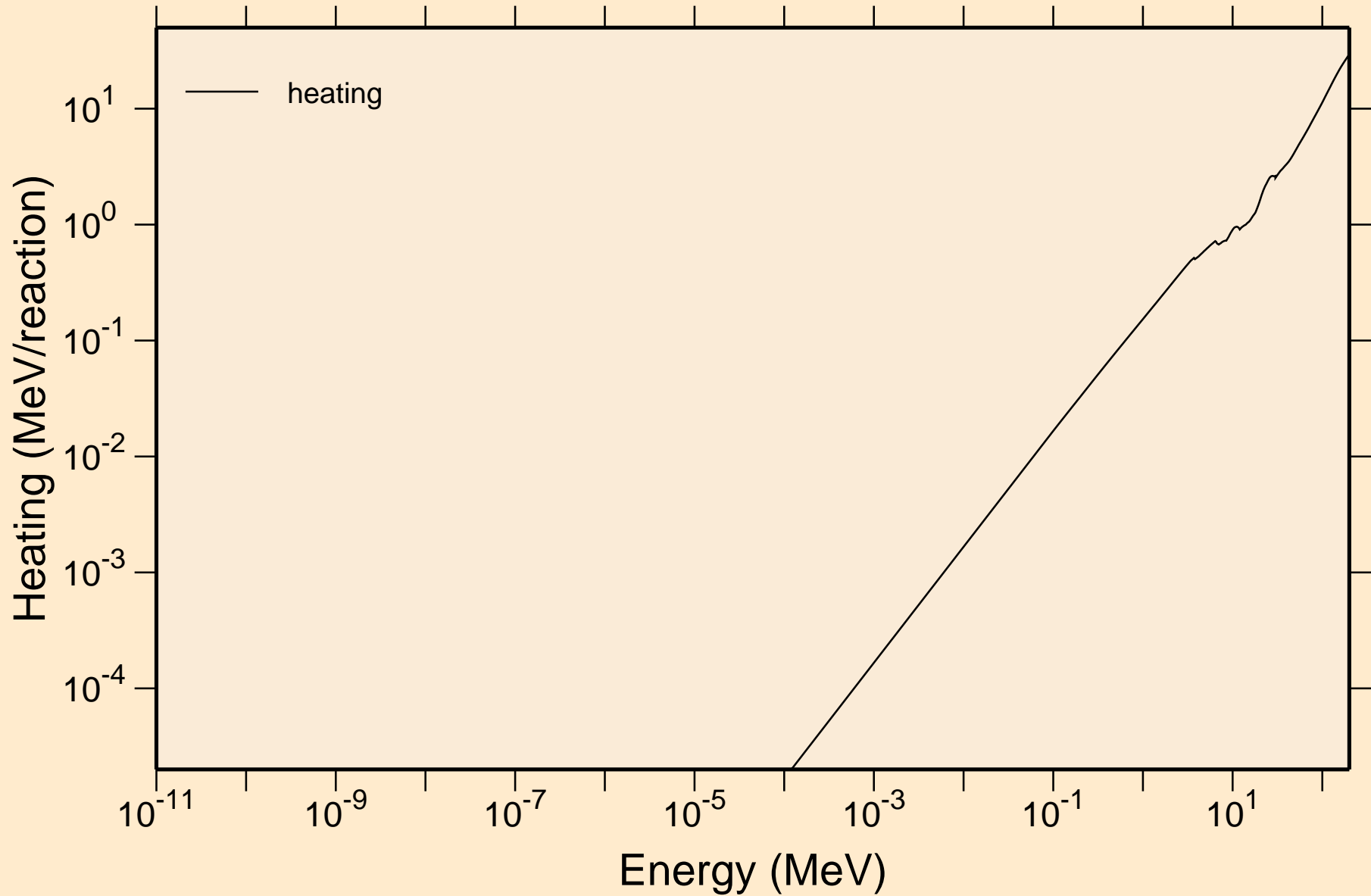

BE010 NEUTRON ACER TENDL-2023 LIBRARY; T=0.K  
Damage

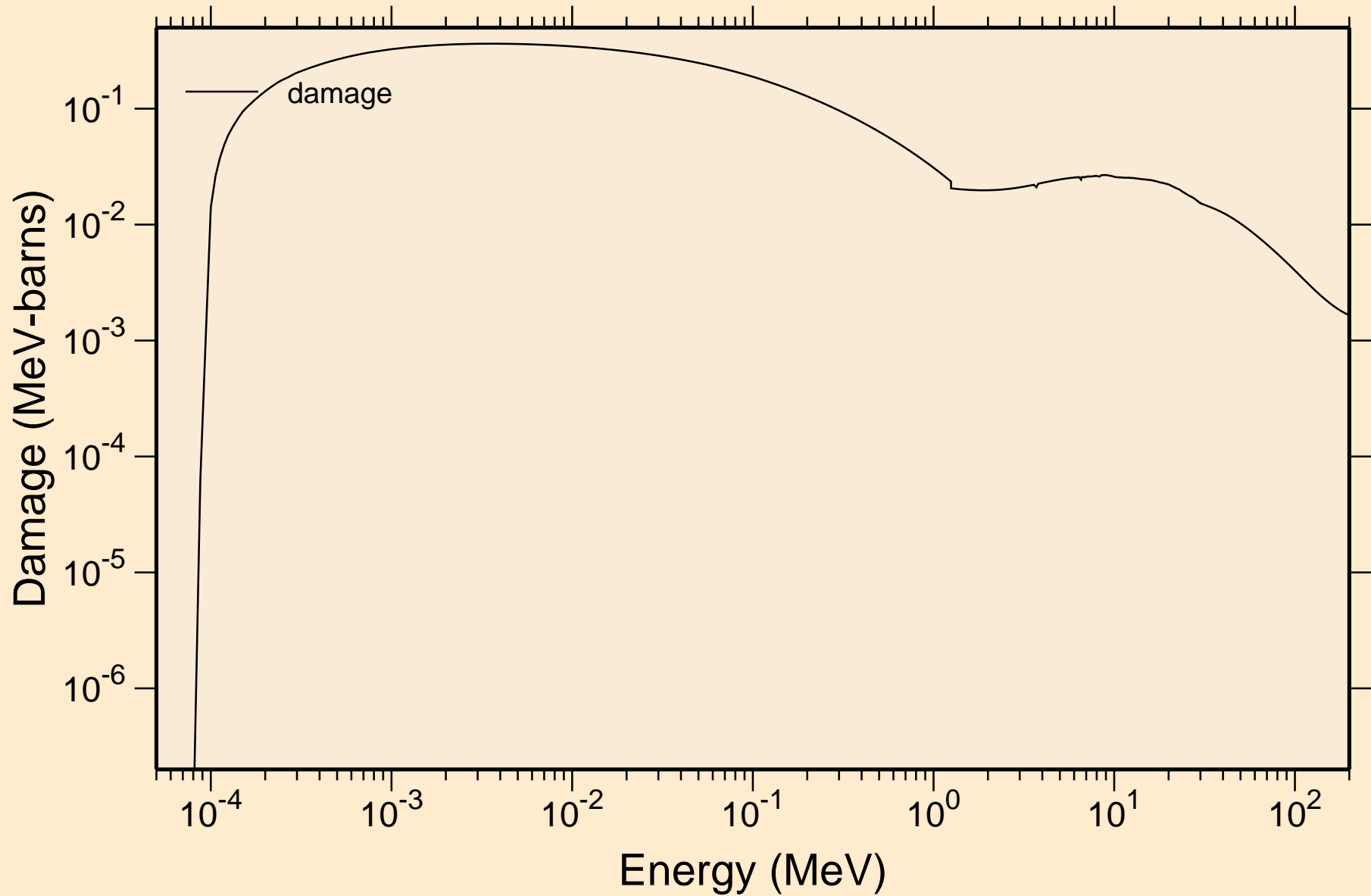

BE010 NEUTRON ACER TENDL-2023 LIBRARY; T=0.K  
Non-threshold reactions

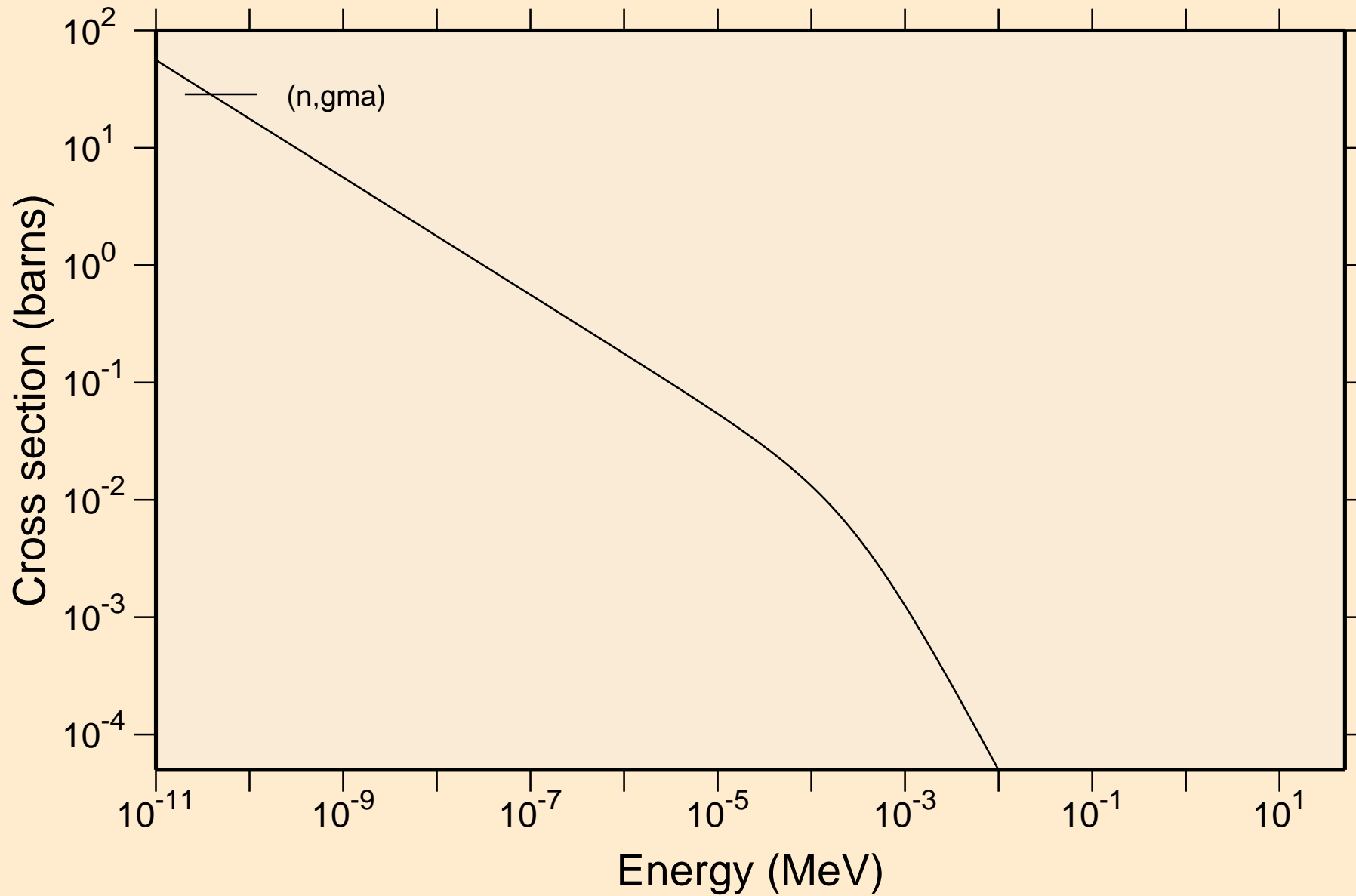

# BE010 NEUTRON ACER TENDL-2023 LIBRARY; T=0.K

## Principal cross sections

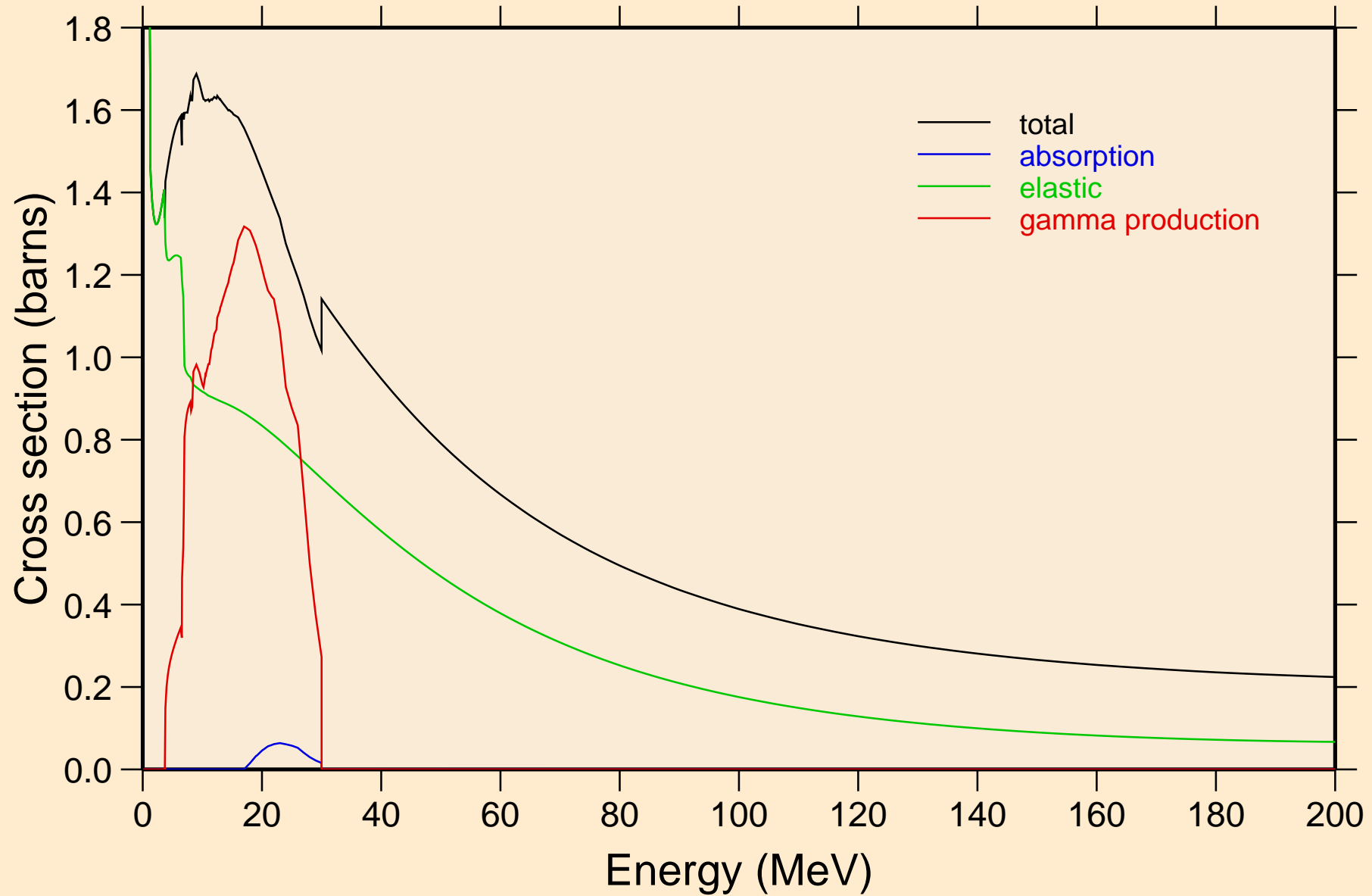

# BE010 NEUTRON ACER TENDL-2023 LIBRARY; T=0.K

## Heating

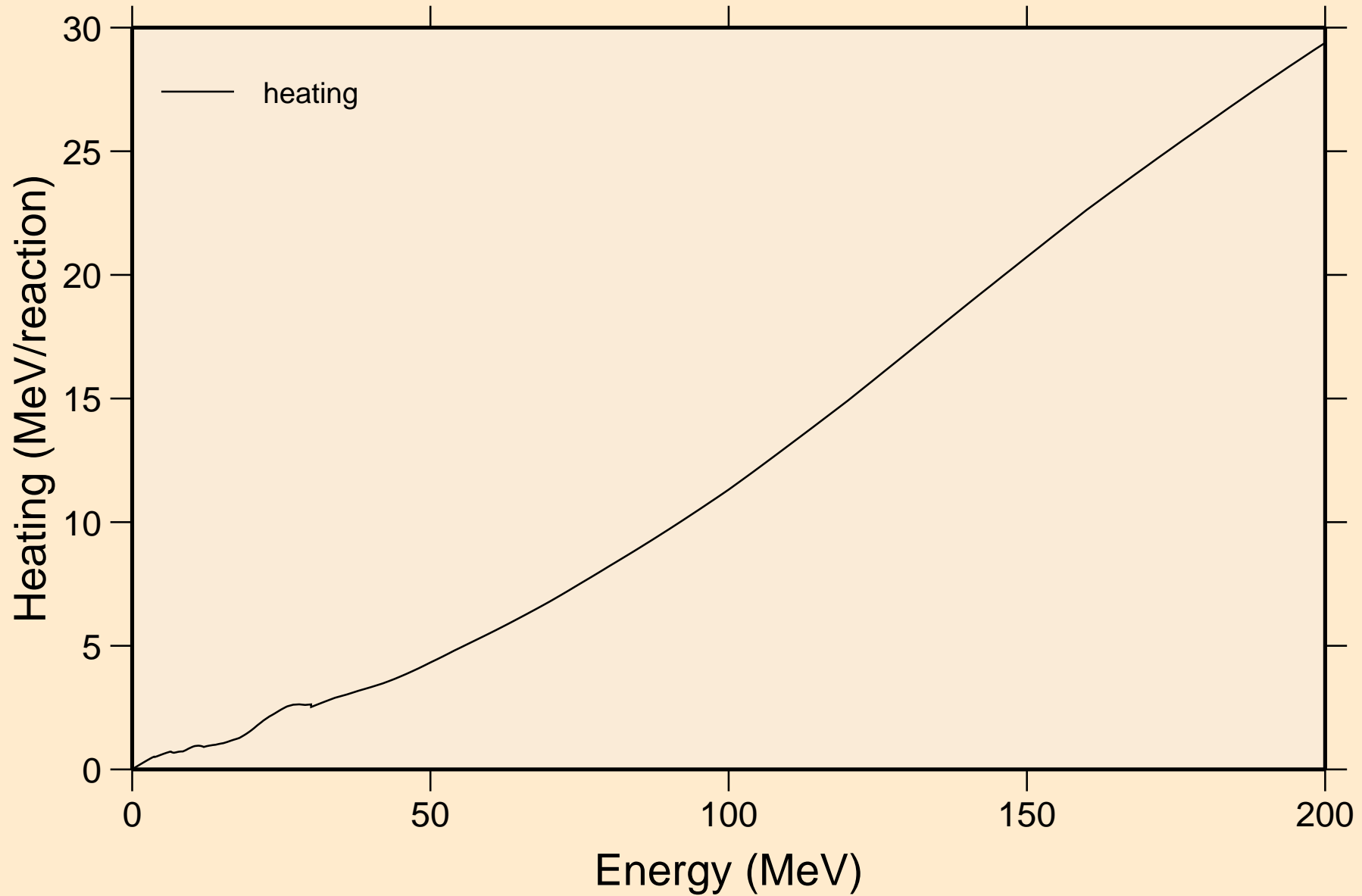

# BE010 NEUTRON ACER TENDL-2023 LIBRARY; T=0.K

## Damage

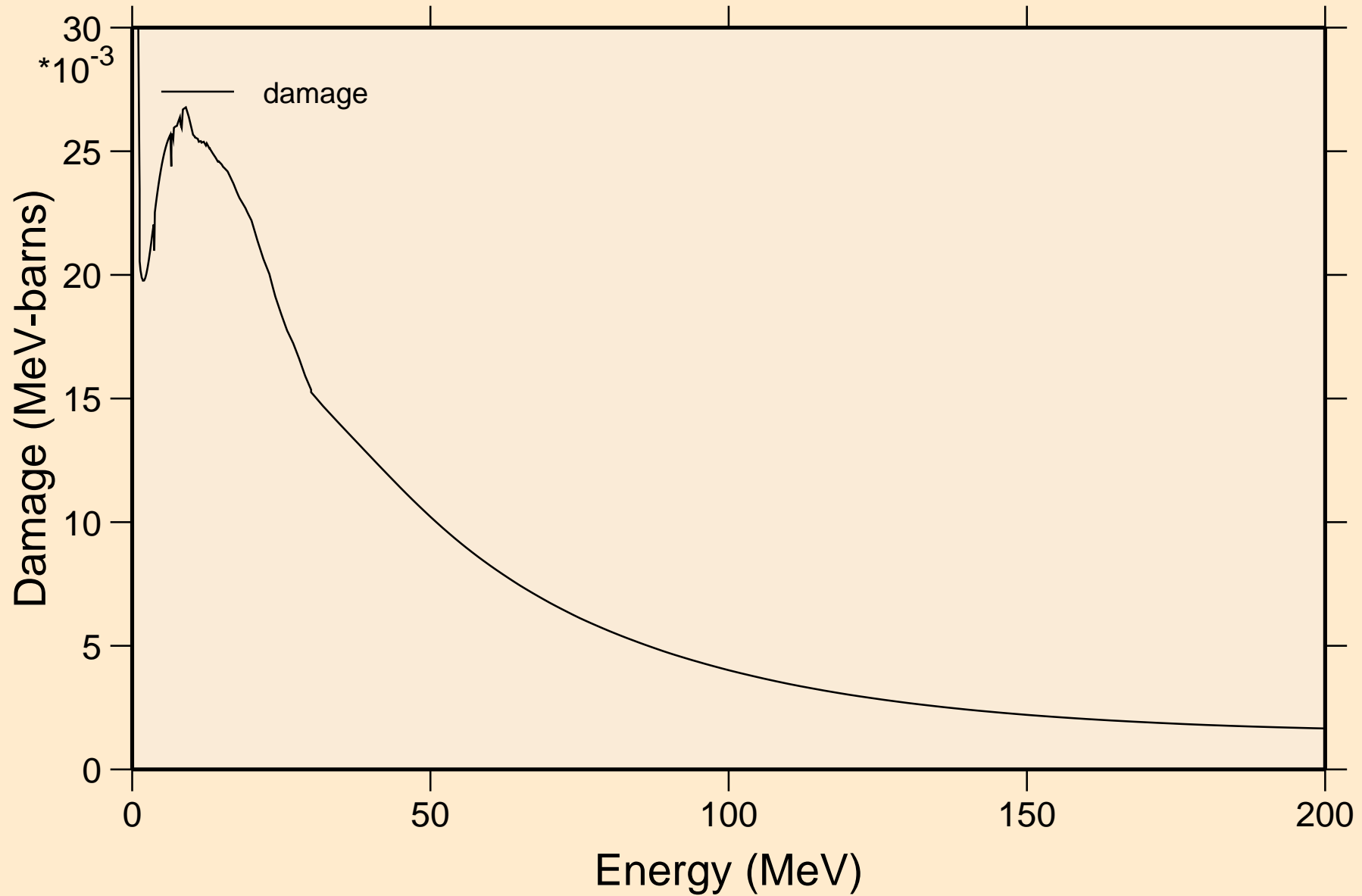

BE010 NEUTRON ACER TENDL-2023 LIBRARY; T=0.K  
Non-threshold reactions

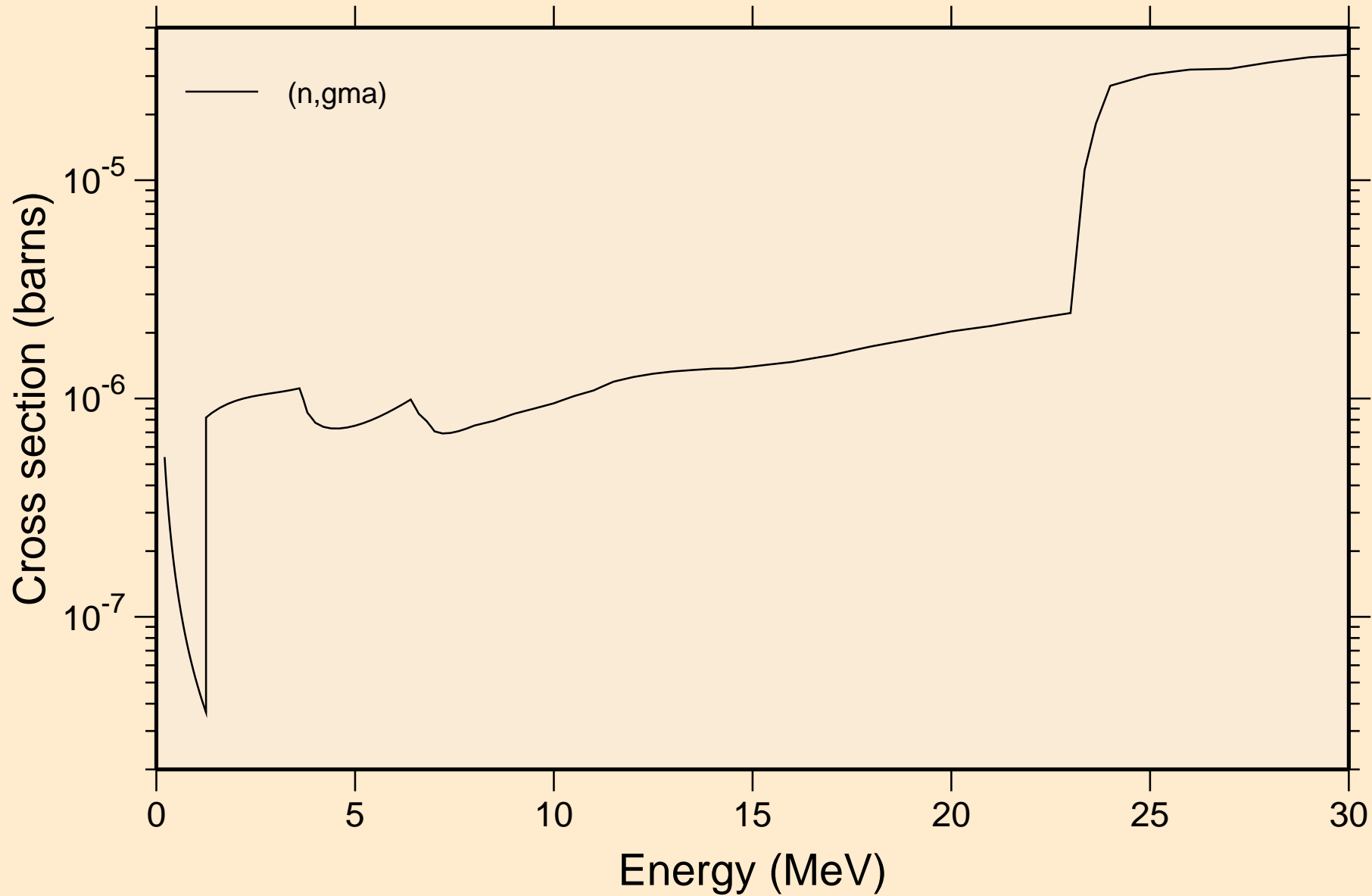

BE010 NEUTRON ACER TENDL-2023 LIBRARY; T=0.K  
Inelastic levels

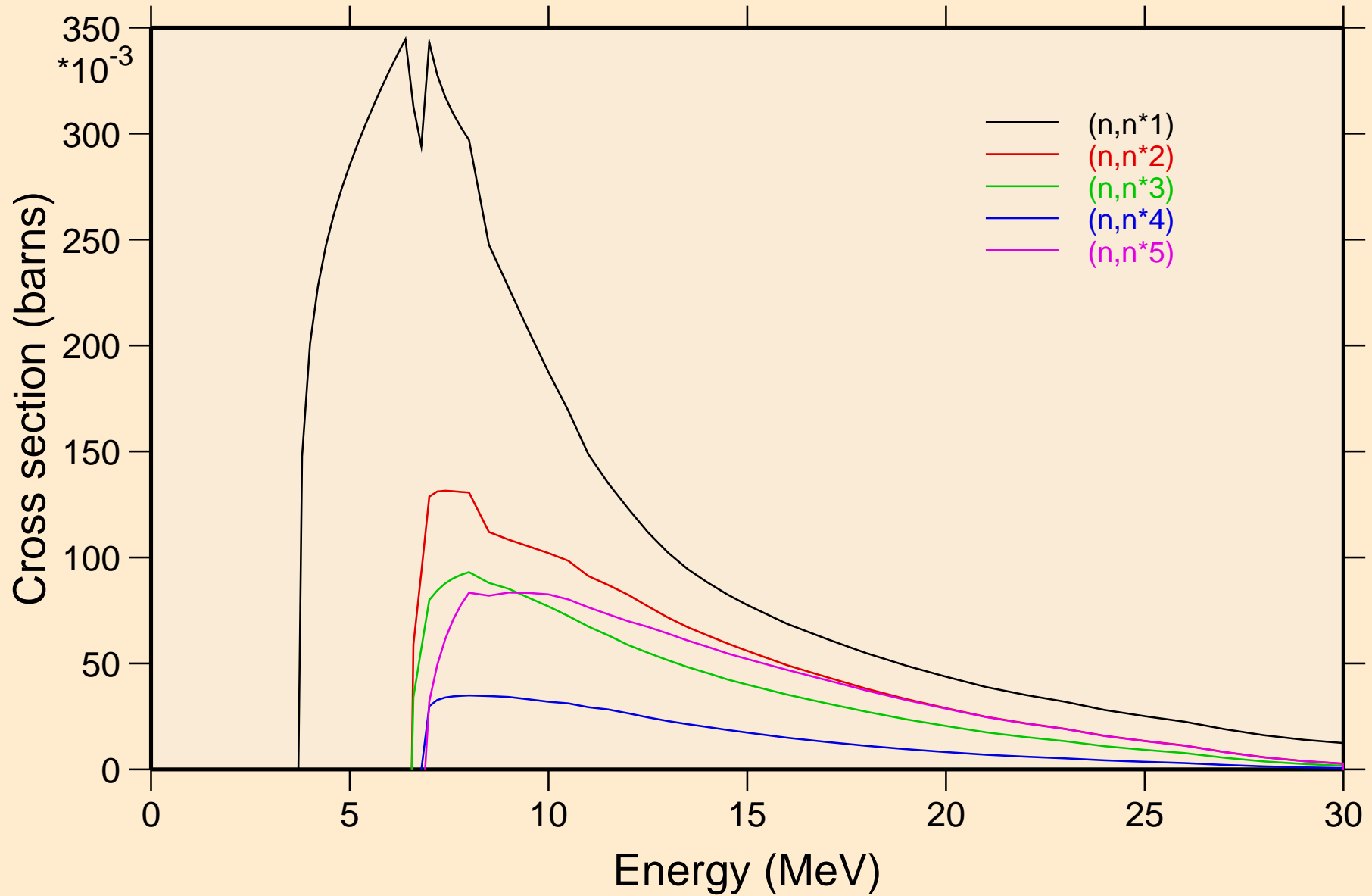

BE010 NEUTRON ACER TENDL-2023 LIBRARY; T=0.K  
Inelastic levels

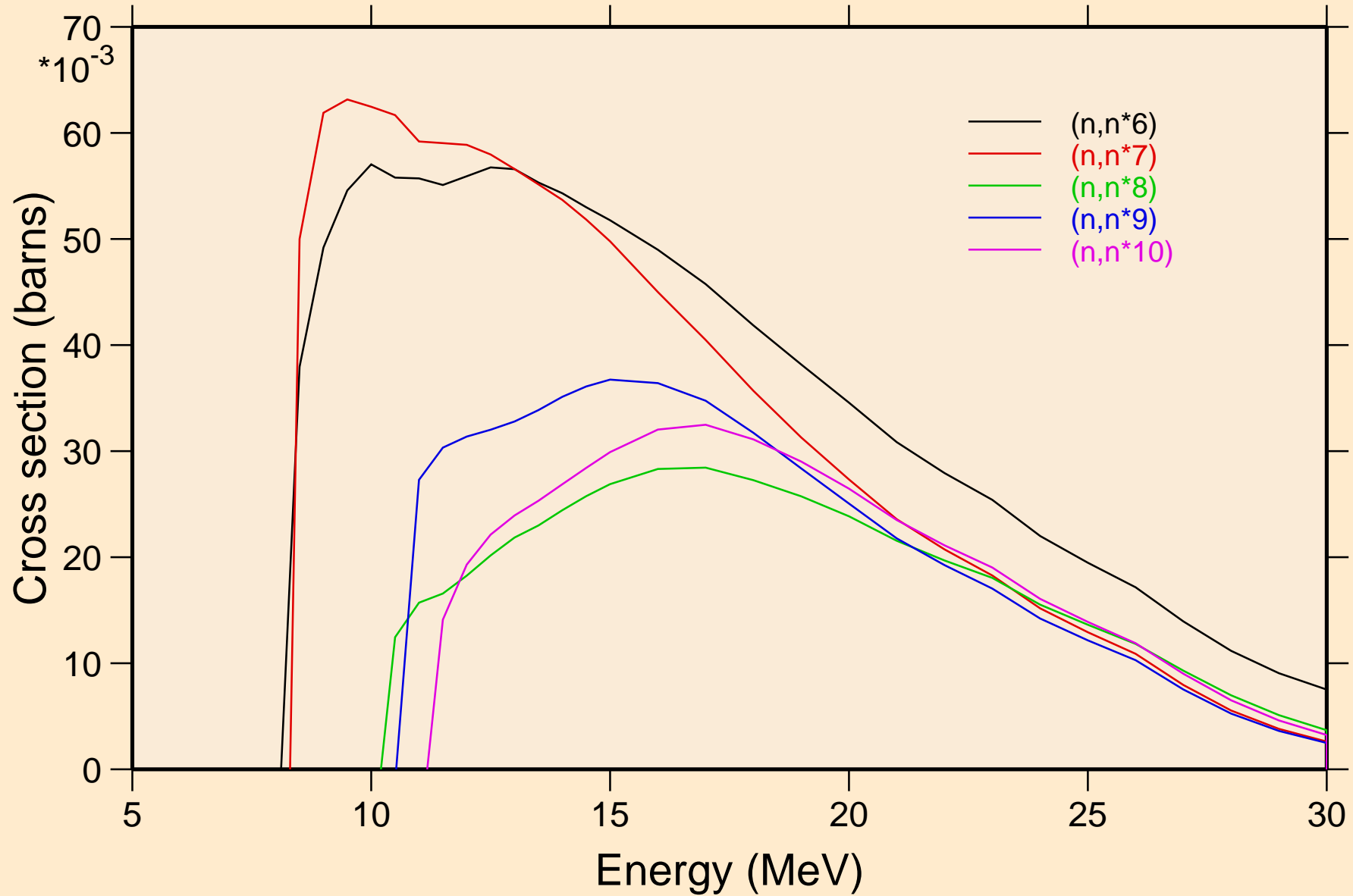

BE010 NEUTRON ACER TENDL-2023 LIBRARY; T=0.K  
Inelastic levels

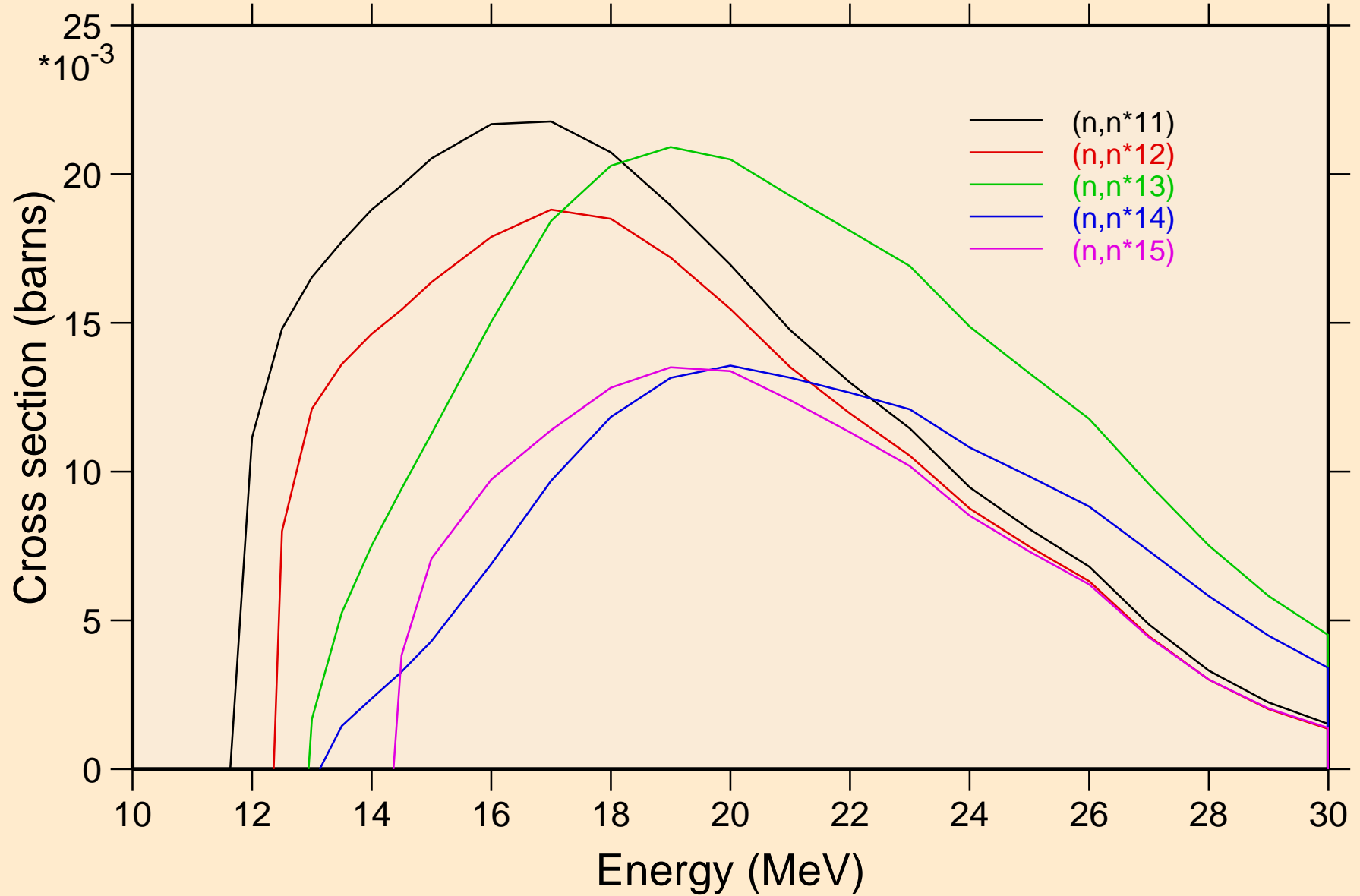

BE010 NEUTRON ACER TENDL-2023 LIBRARY; T=0.K  
Inelastic levels

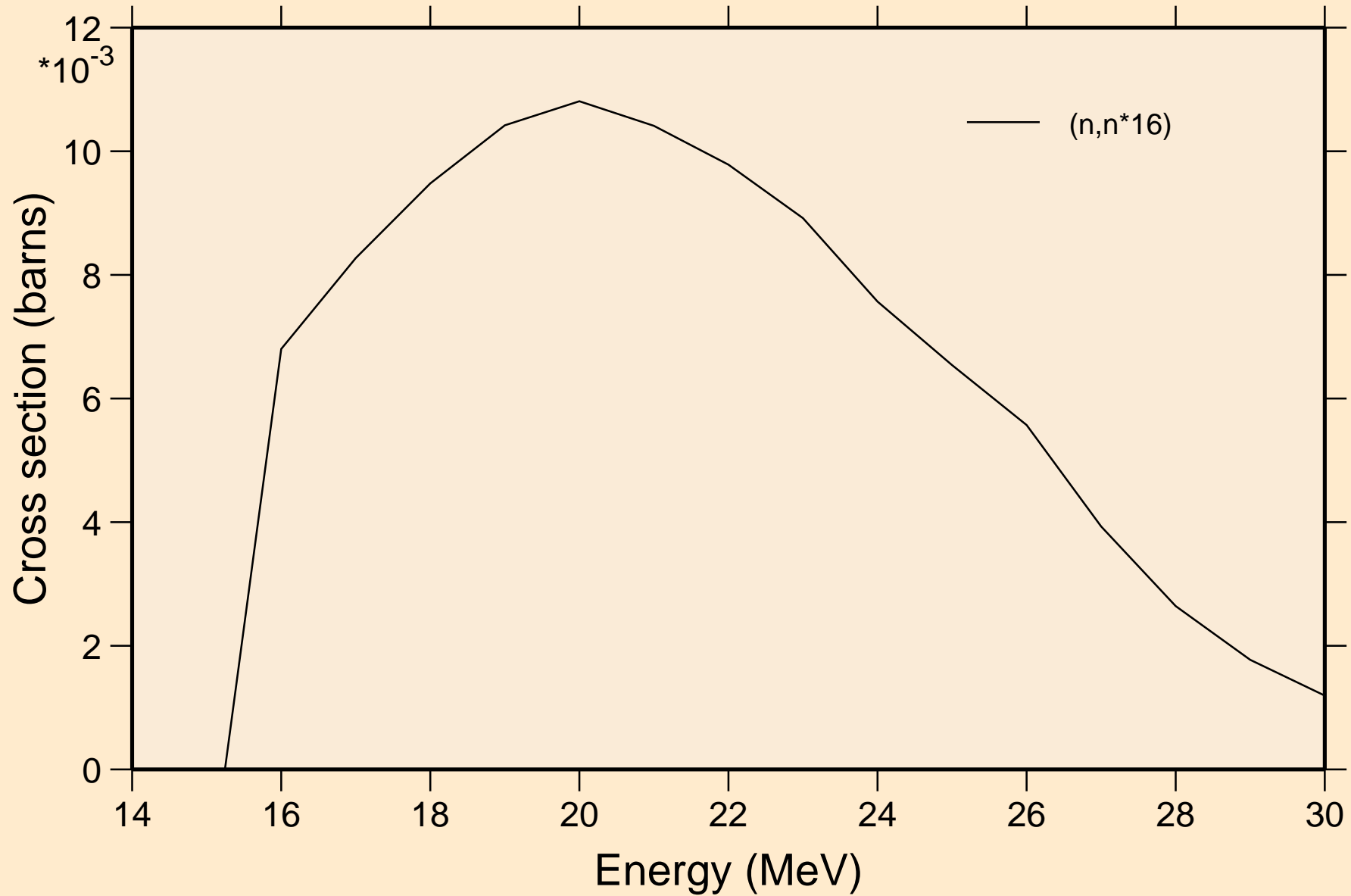

BE010 NEUTRON ACER TENDL-2023 LIBRARY; T=0.K  
Threshold reactions

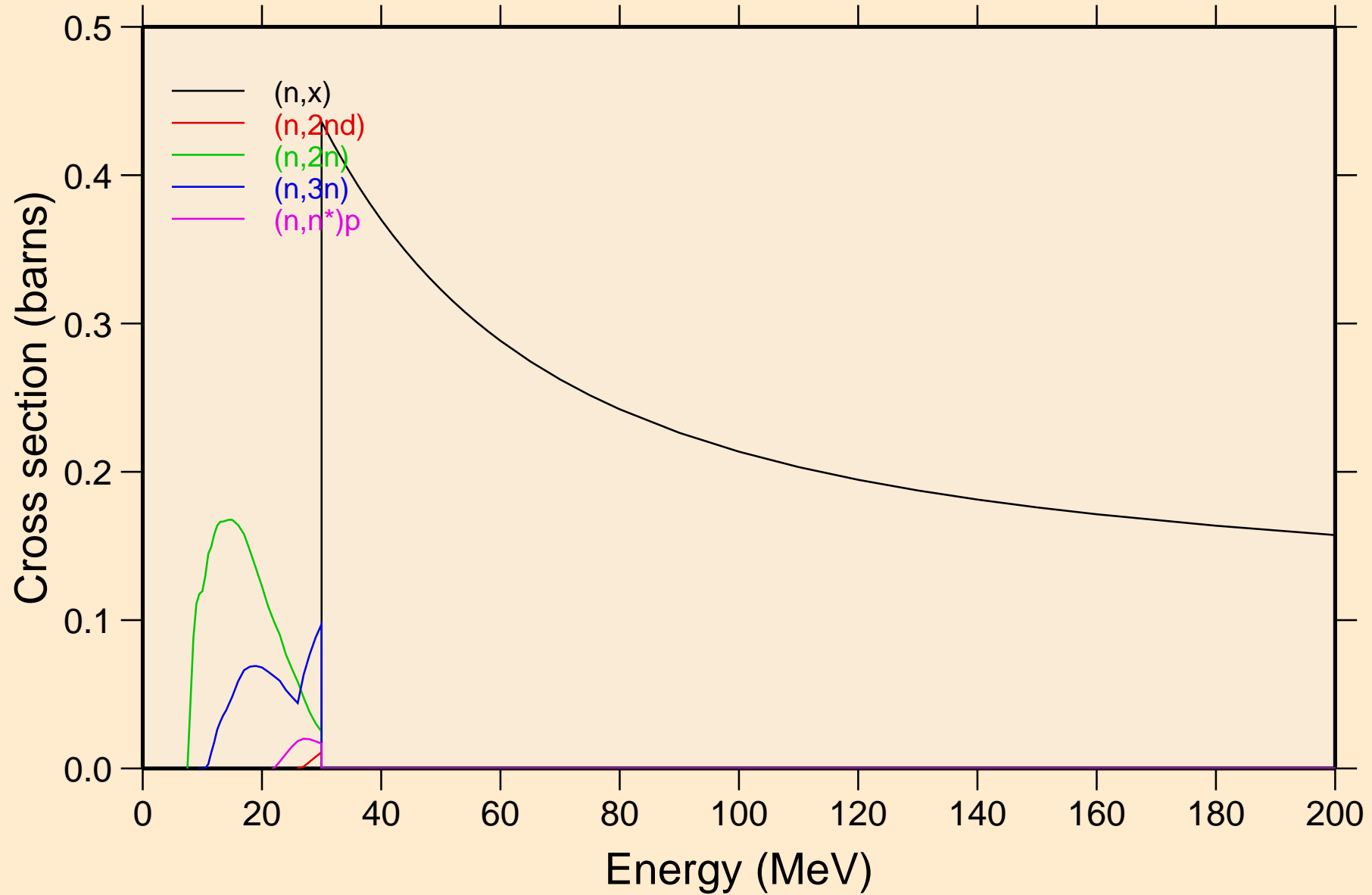

BE010 NEUTRON ACER TENDL-2023 LIBRARY; T=0.K  
Threshold reactions

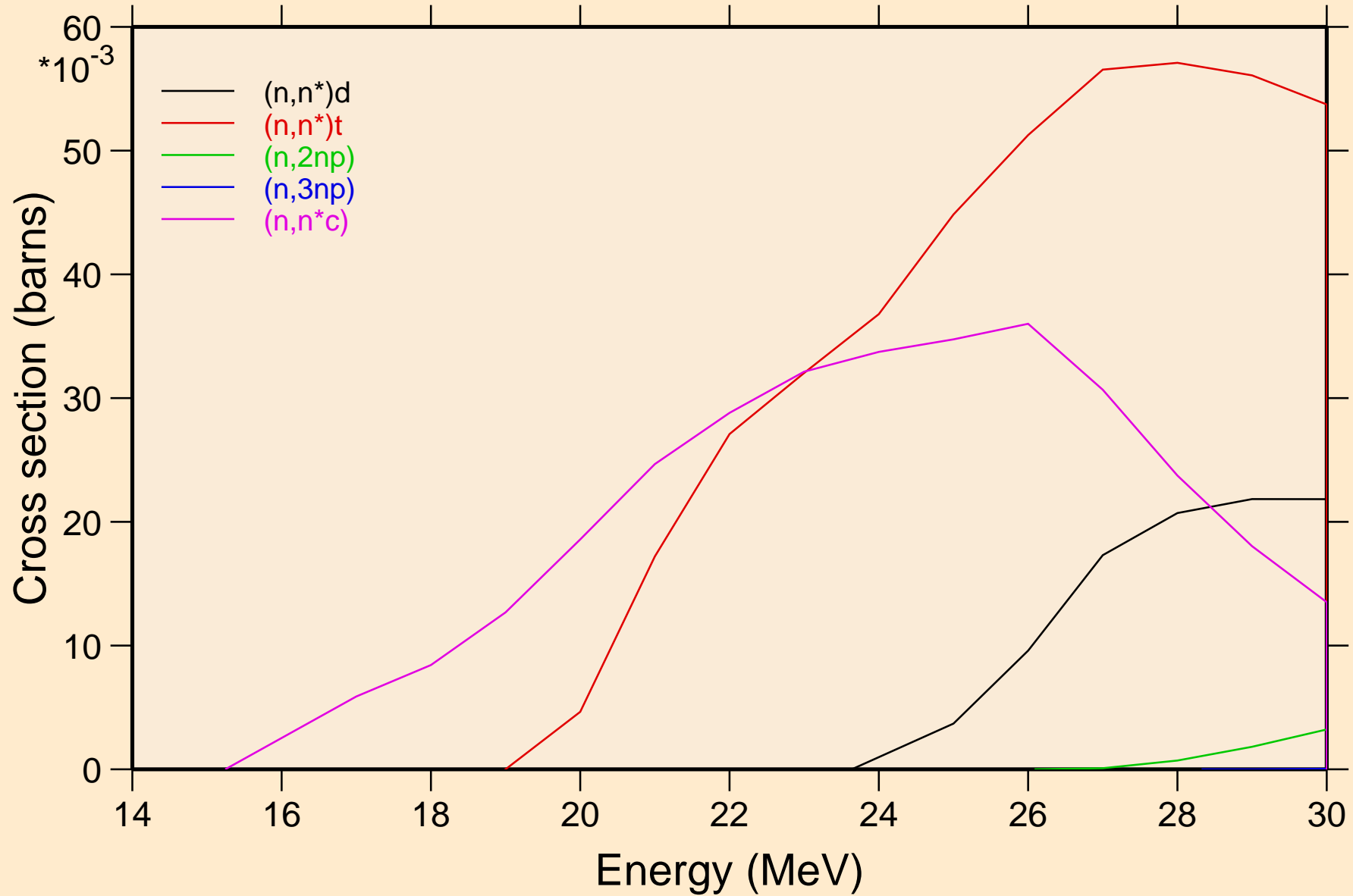

BE010 NEUTRON ACER TENDL-2023 LIBRARY; T=0.K  
Threshold reactions

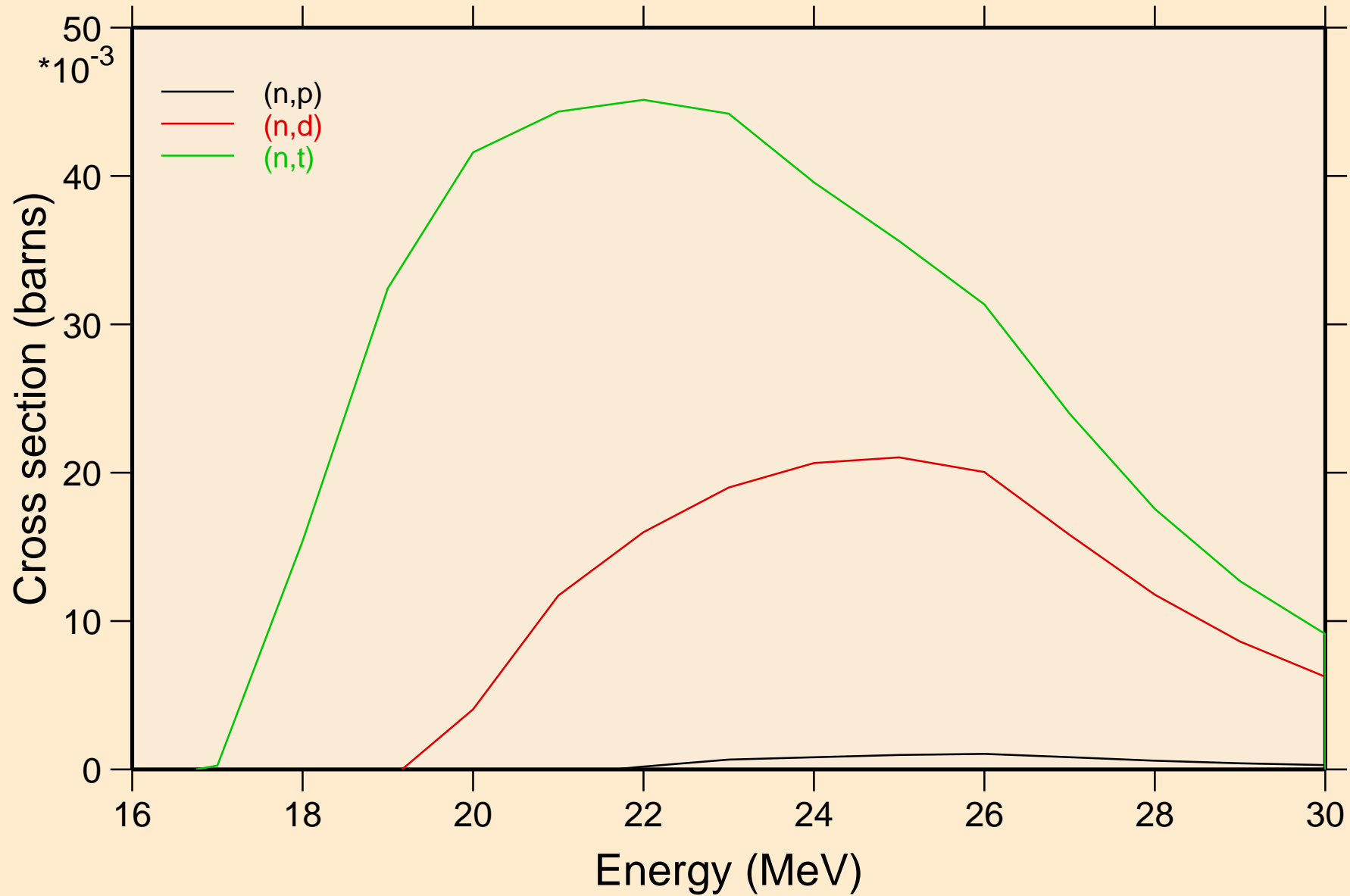

BE010 NEUTRON ACER TENDL-2023 LIBRARY; T=0.K  
Threshold reactions

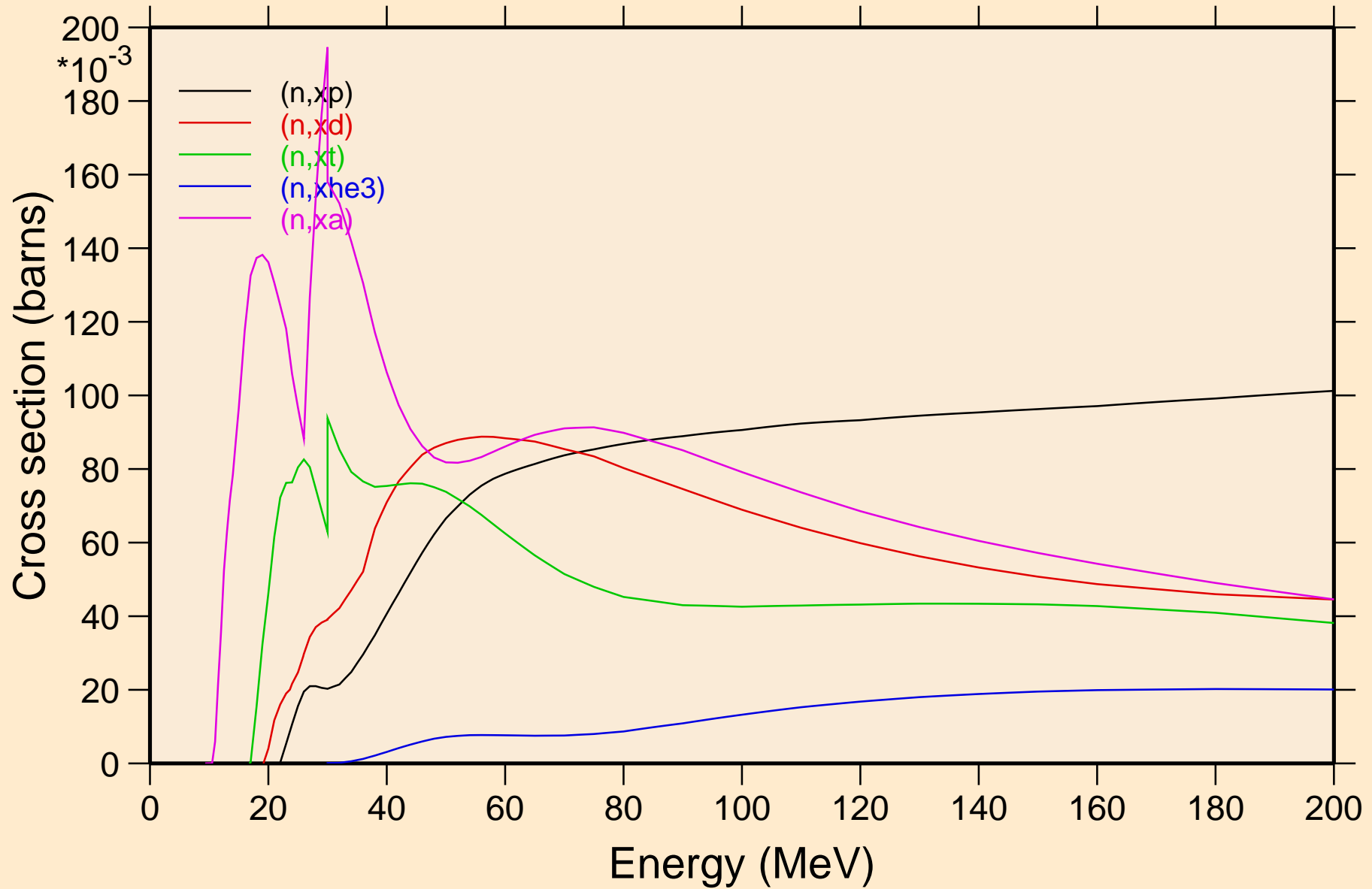

BE010 NEUTRON ACER TENDL-2023 LIBRARY; T=0.K  
angular distribution for elastic

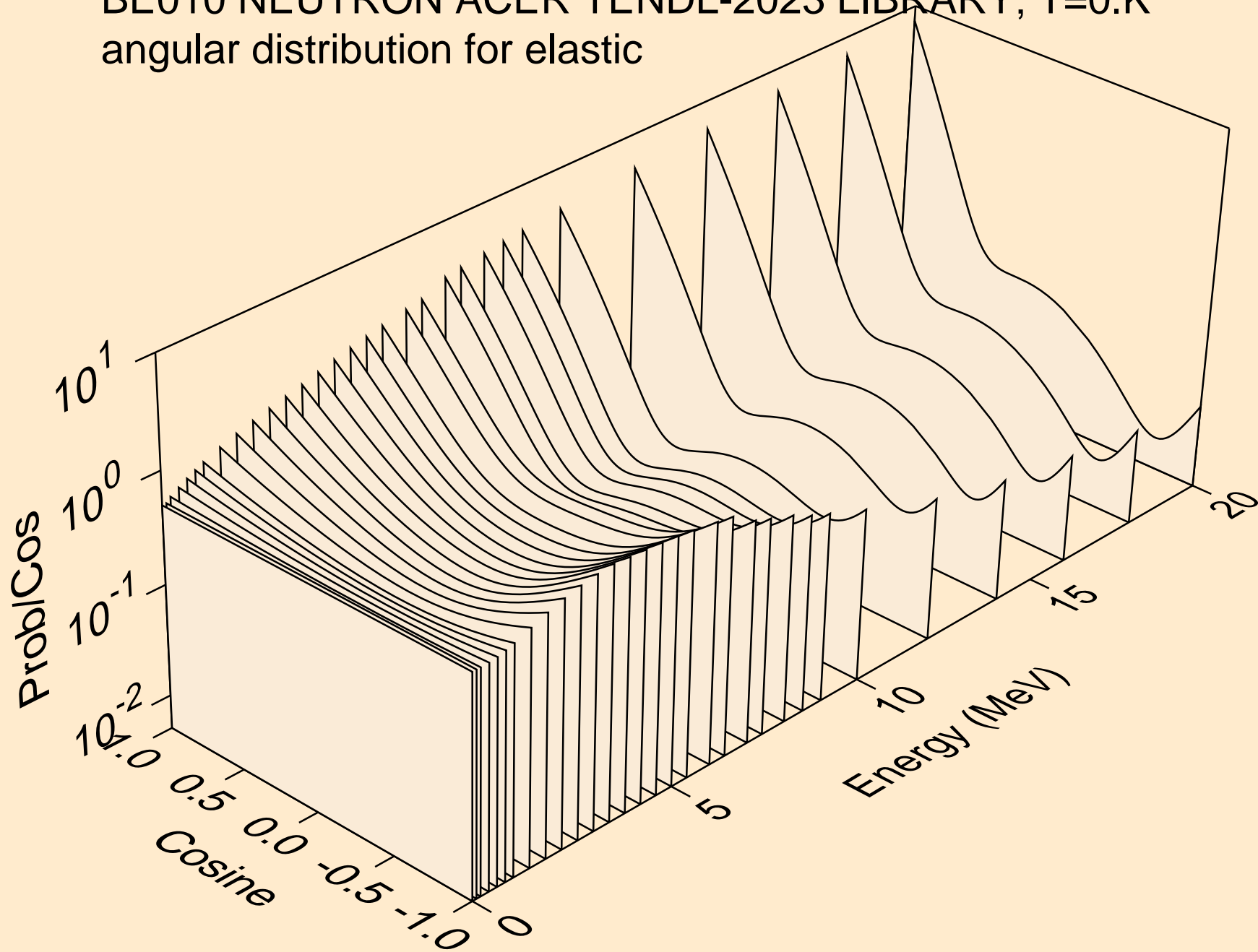

BE010 NEUTRON ACER TENDL-2023 LIBRARY; T=0.K  
angular distribution for elastic

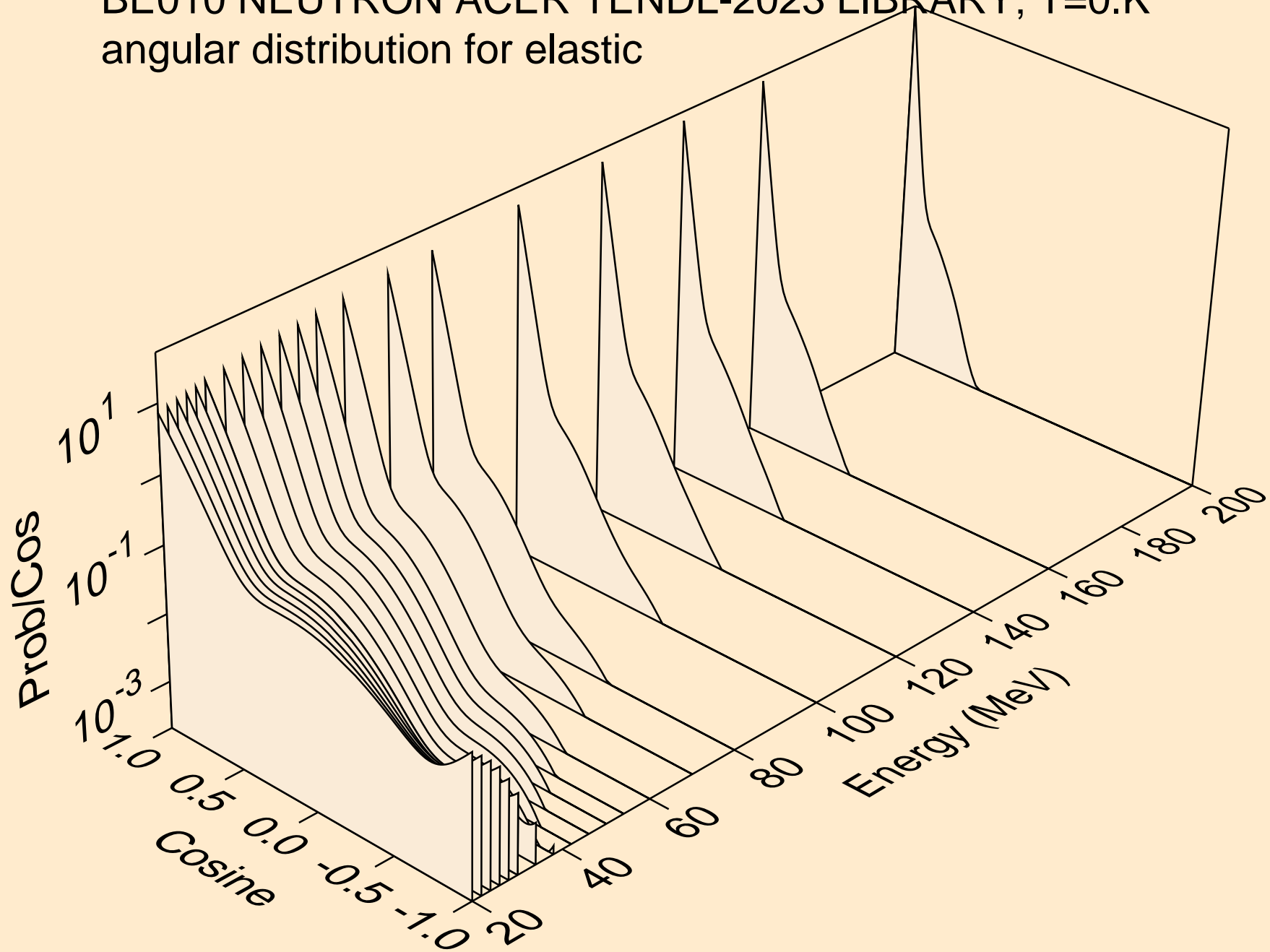

BE010 NEUTRON ACER TENDL-2023 LIBRARY; T=0.K  
angular distribution for (n,n\*1)

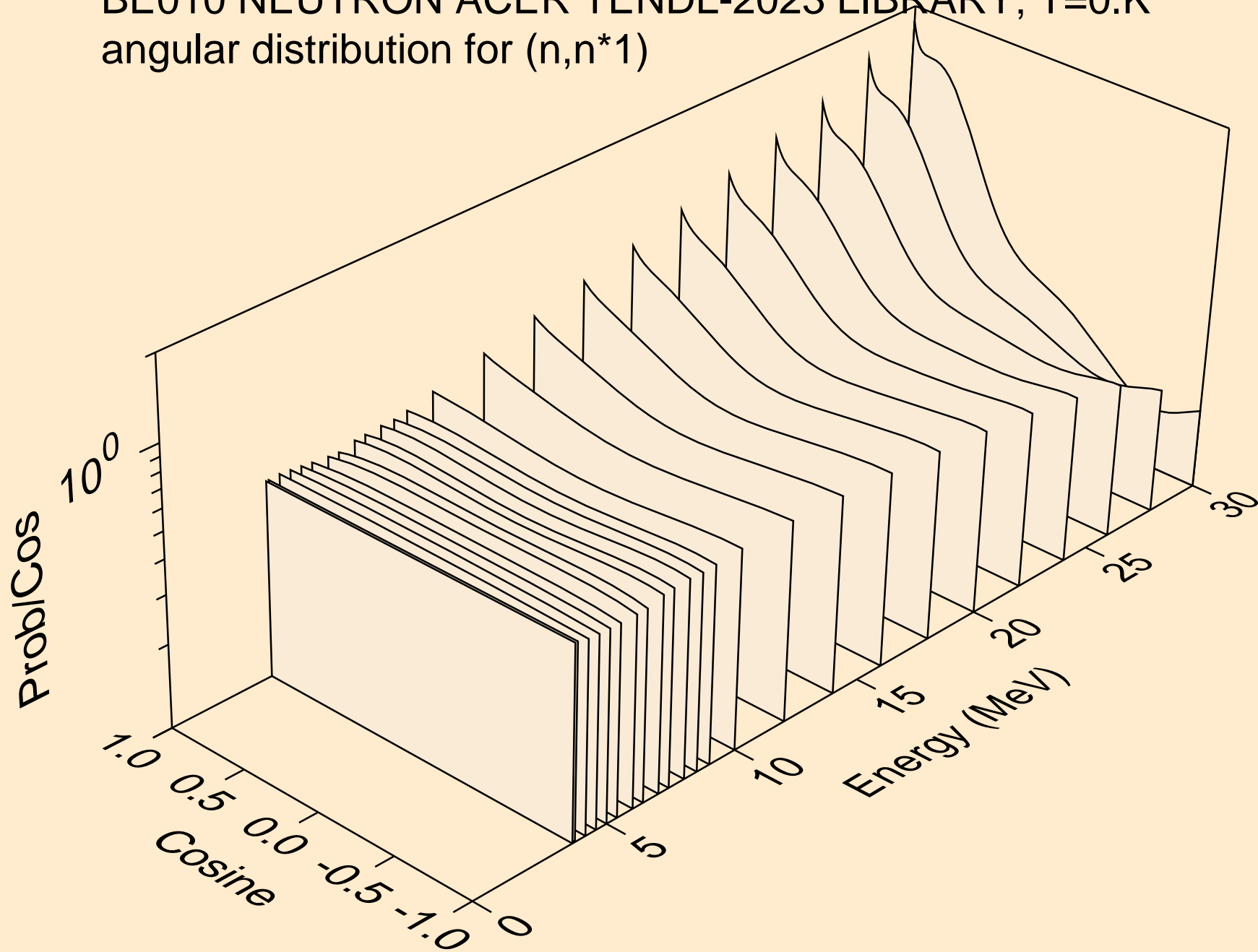

BE010 NEUTRON ACER TENDL-2023 LIBRARY; T=0.K  
angular distribution for (n,n\*2)

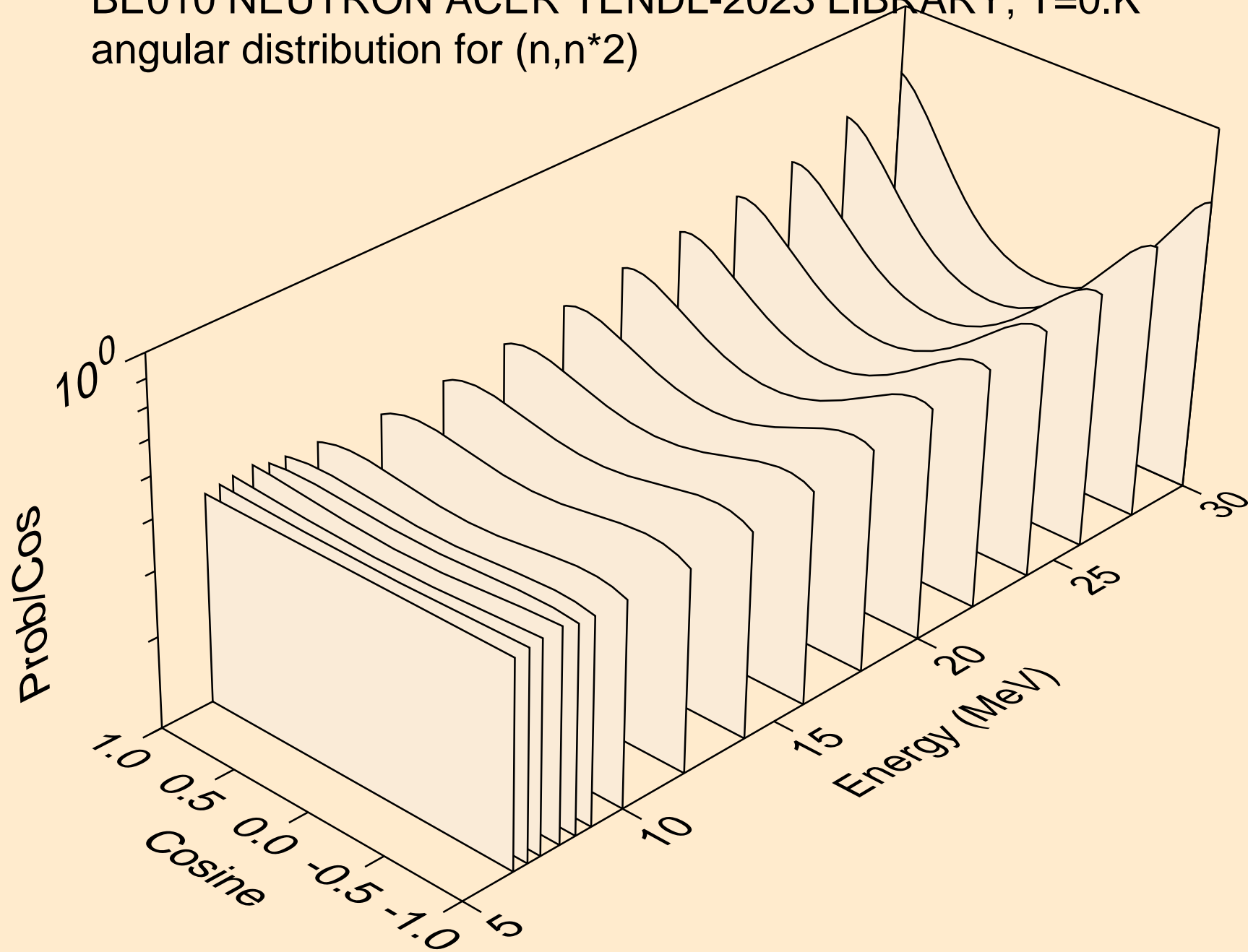

BE010 NEUTRON ACER TENDL-2023 LIBRARY; T=0.K  
angular distribution for (n,n\*3)

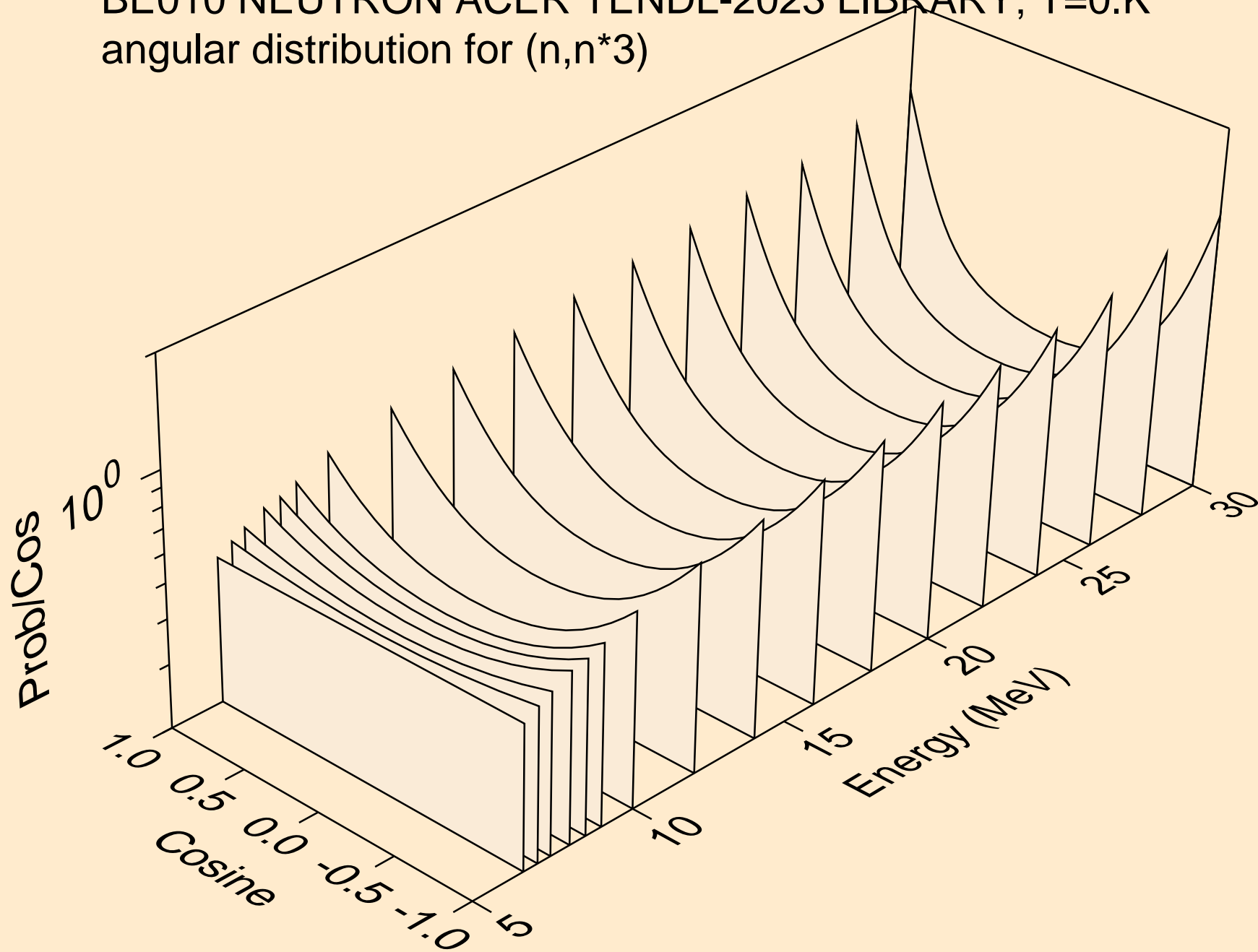

BE010 NEUTRON ACER TENDL-2023 LIBRARY; T=0.K  
angular distribution for (n,n\*4)

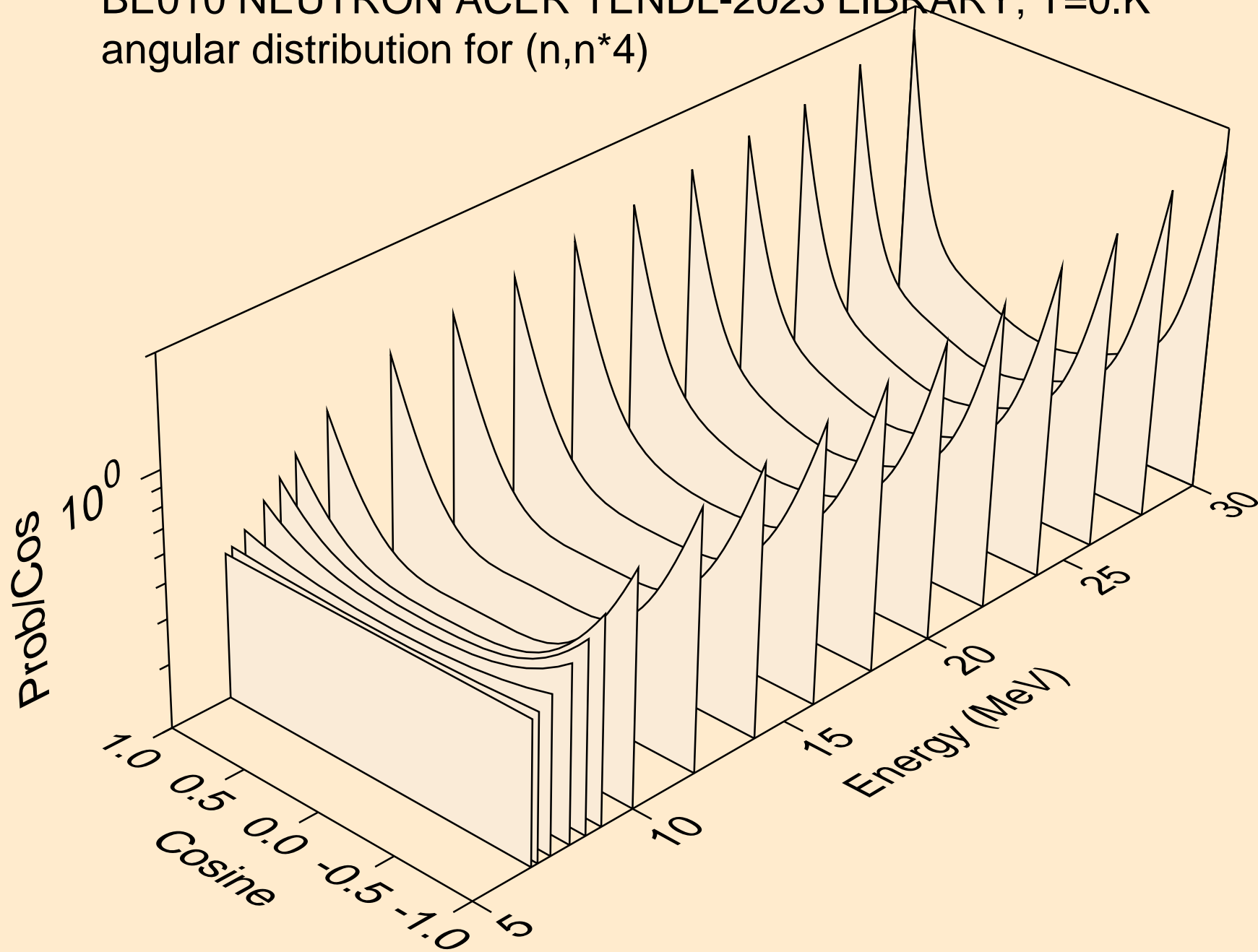

BE010 NEUTRON ACER TENDL-2023 LIBRARY; T=0.K  
angular distribution for (n,n\*5)

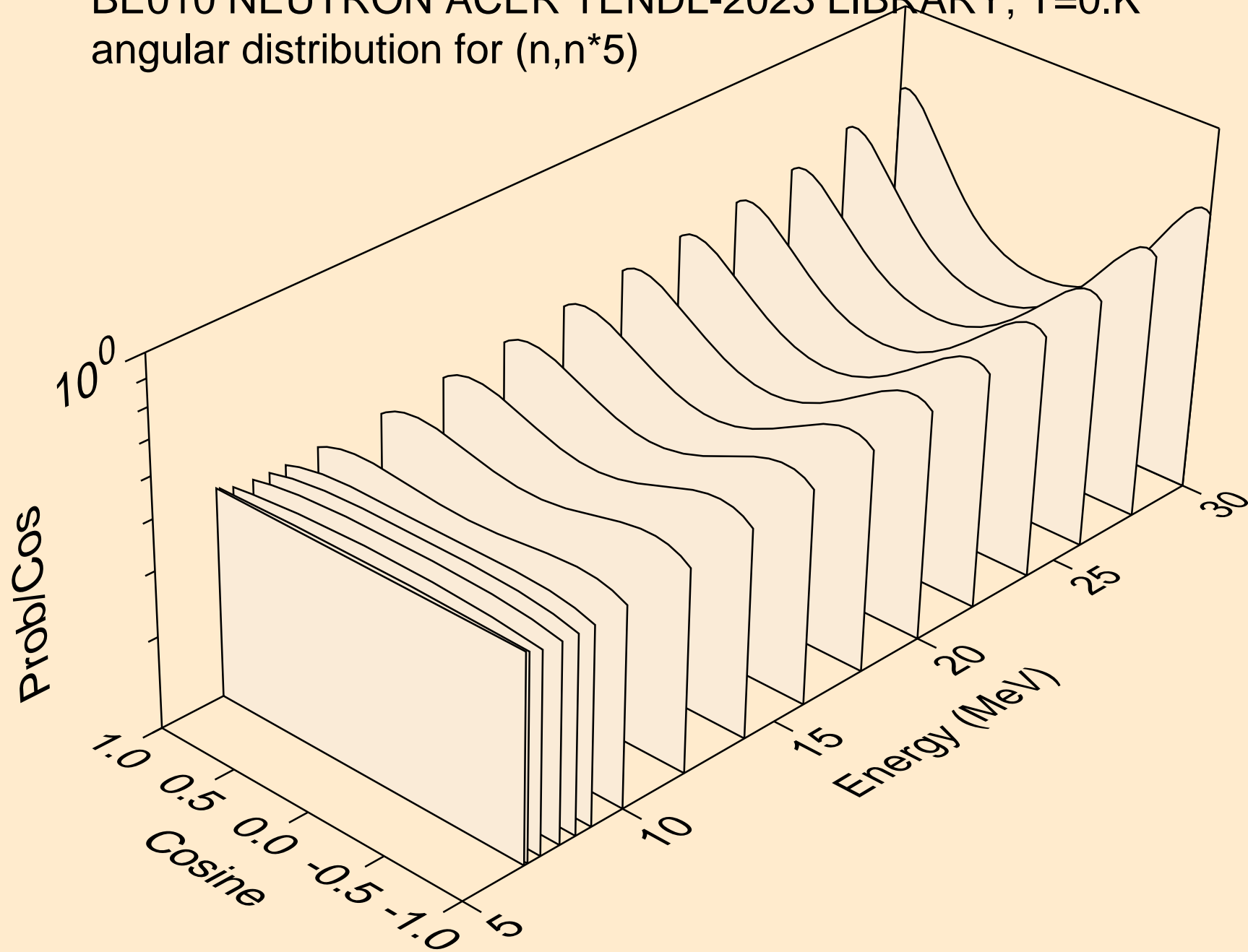

BE010 NEUTRON ACER TENDL-2023 LIBRARY; T=0.K  
angular distribution for (n,n\*6)

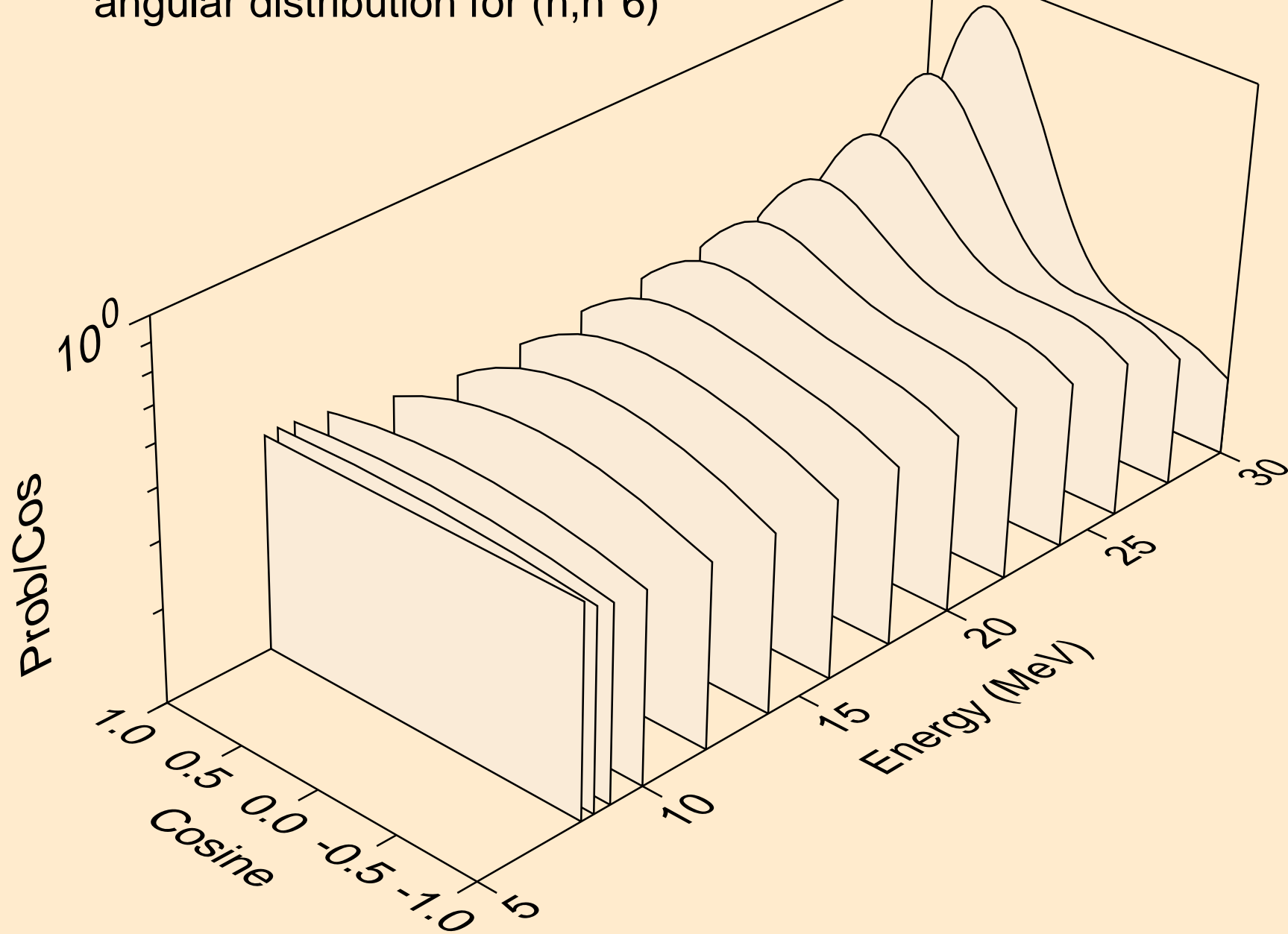

BE010 NEUTRON ACER TENDL-2023 LIBRARY; T=0.K  
angular distribution for (n,n\*7)

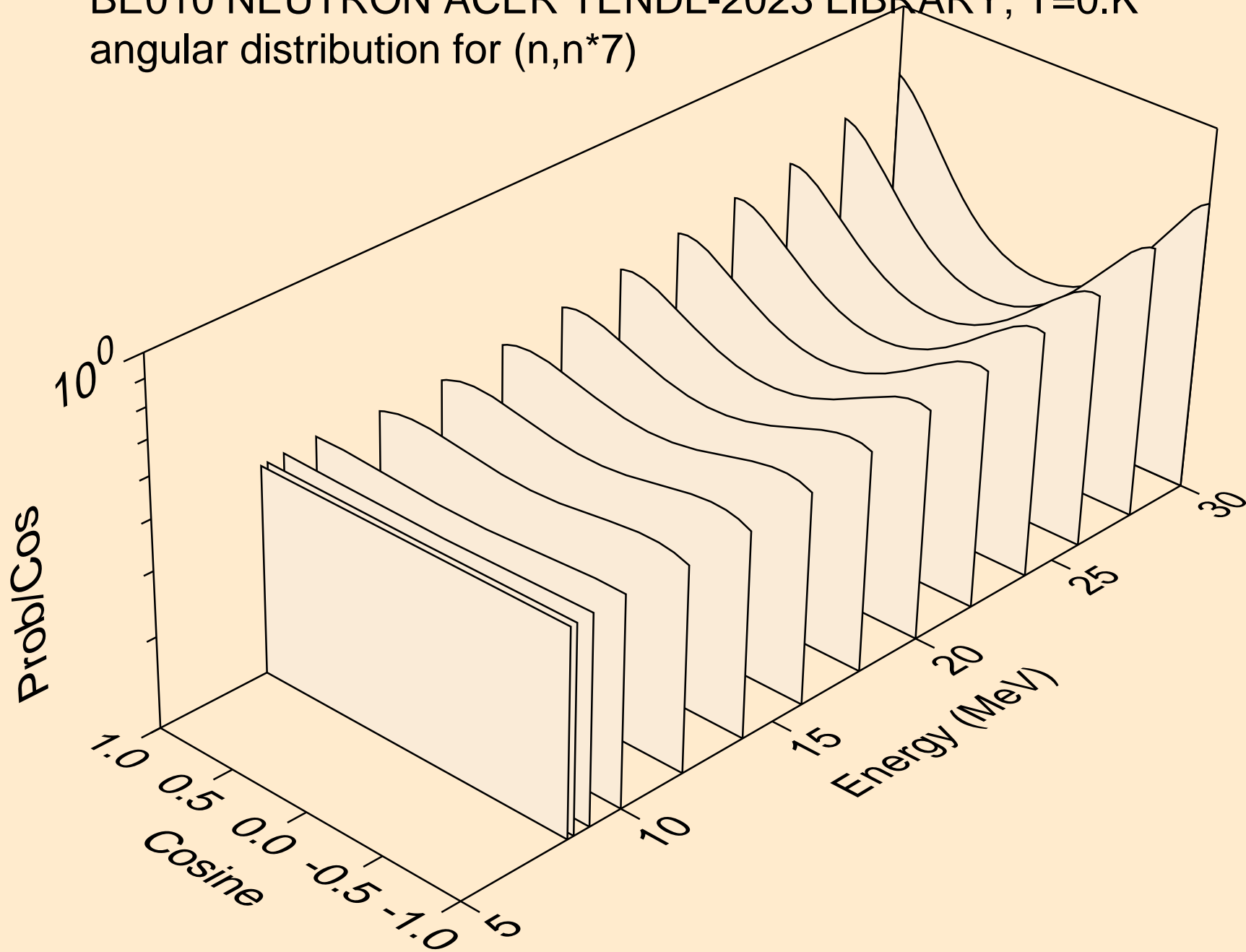

BE010 NEUTRON ACER TENDL-2023 LIBRARY; T=0.K  
angular distribution for (n,n\*8)

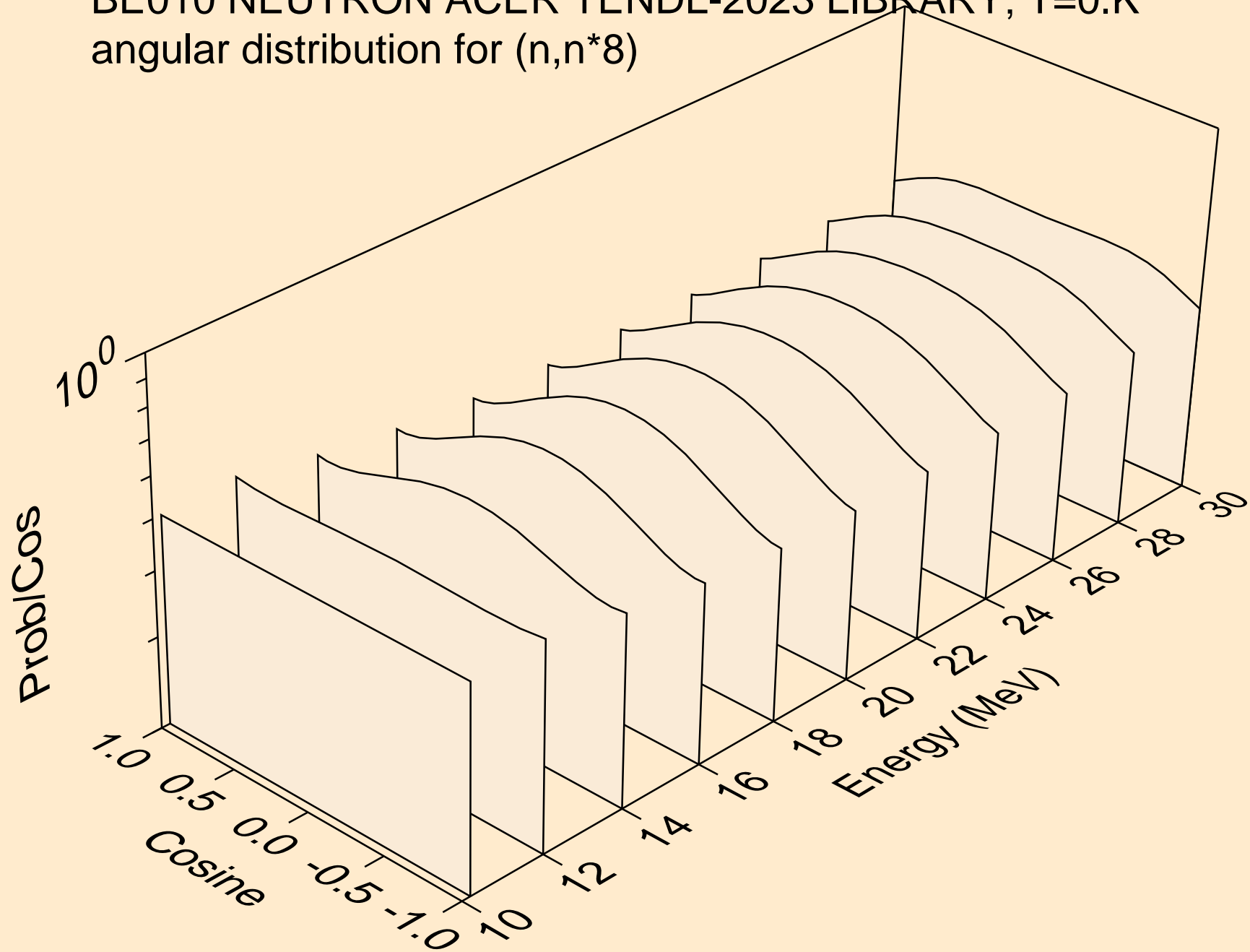

BE010 NEUTRON ACER TENDL-2023 LIBRARY; T=0.K  
angular distribution for (n,n\*9)

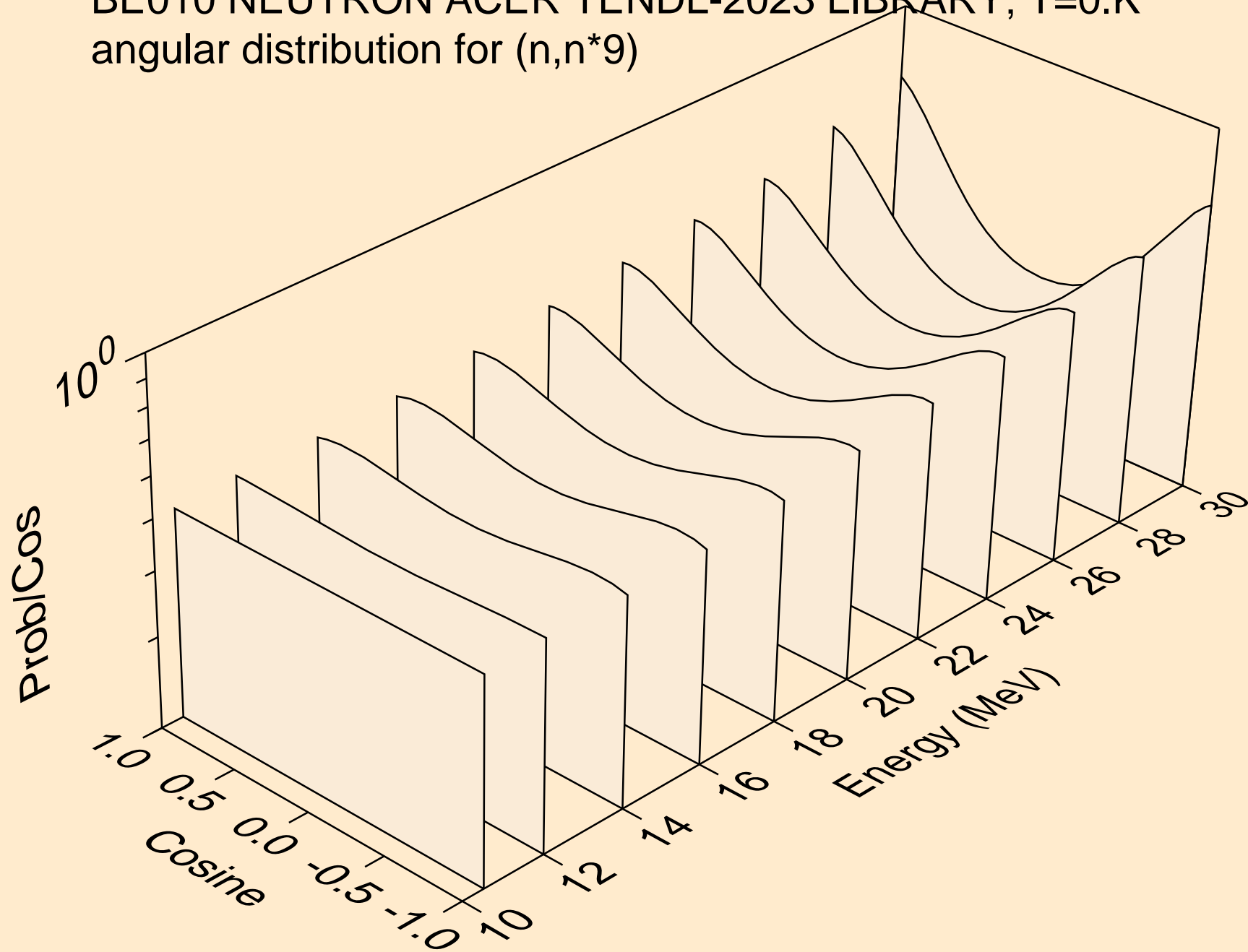

BE010 NEUTRON ACER TENDL-2023 LIBRARY; T=0.K  
angular distribution for (n,n\*10)

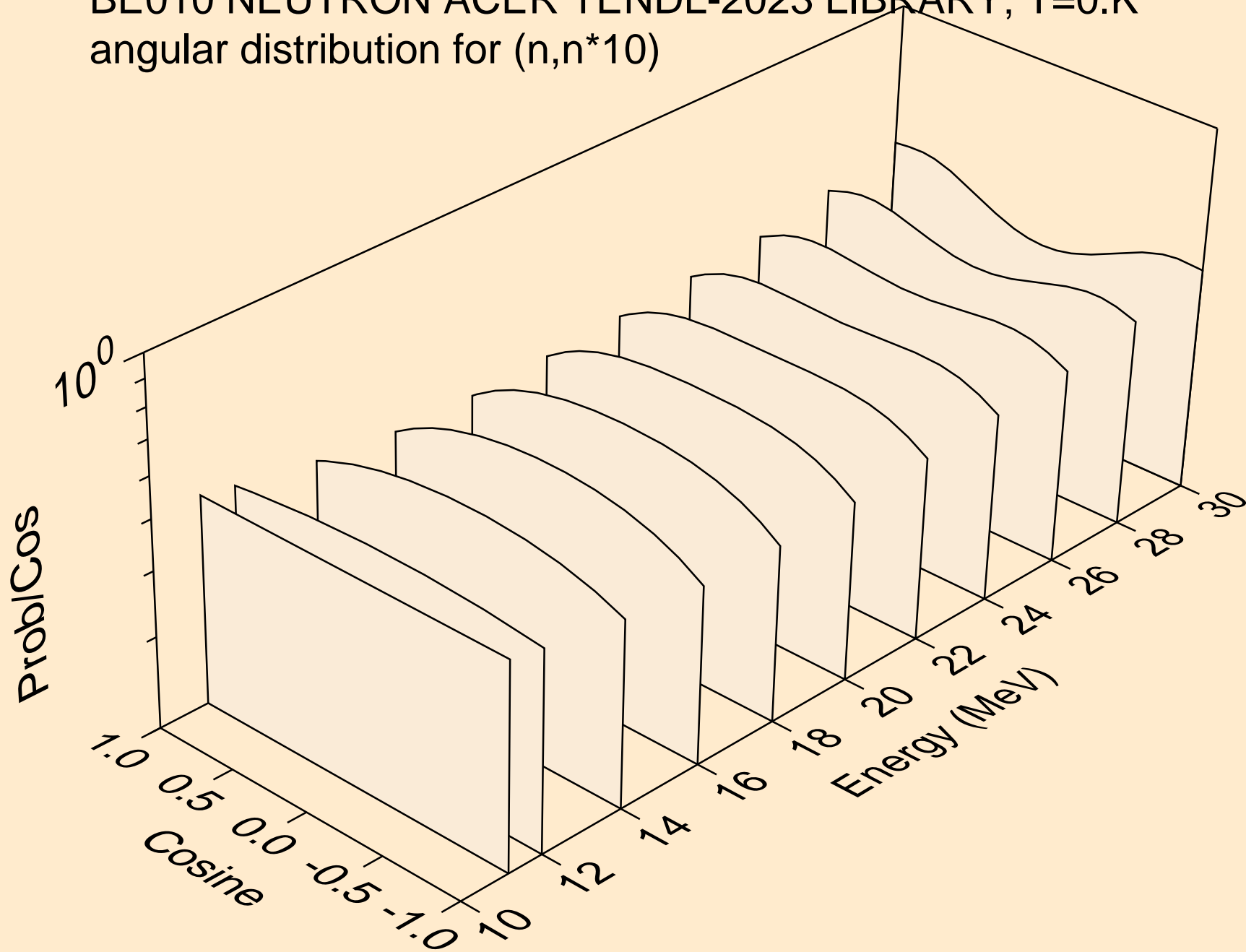

BE010 NEUTRON ACER TENDL-2023 LIBRARY; T=0.K  
angular distribution for (n,n\*11)

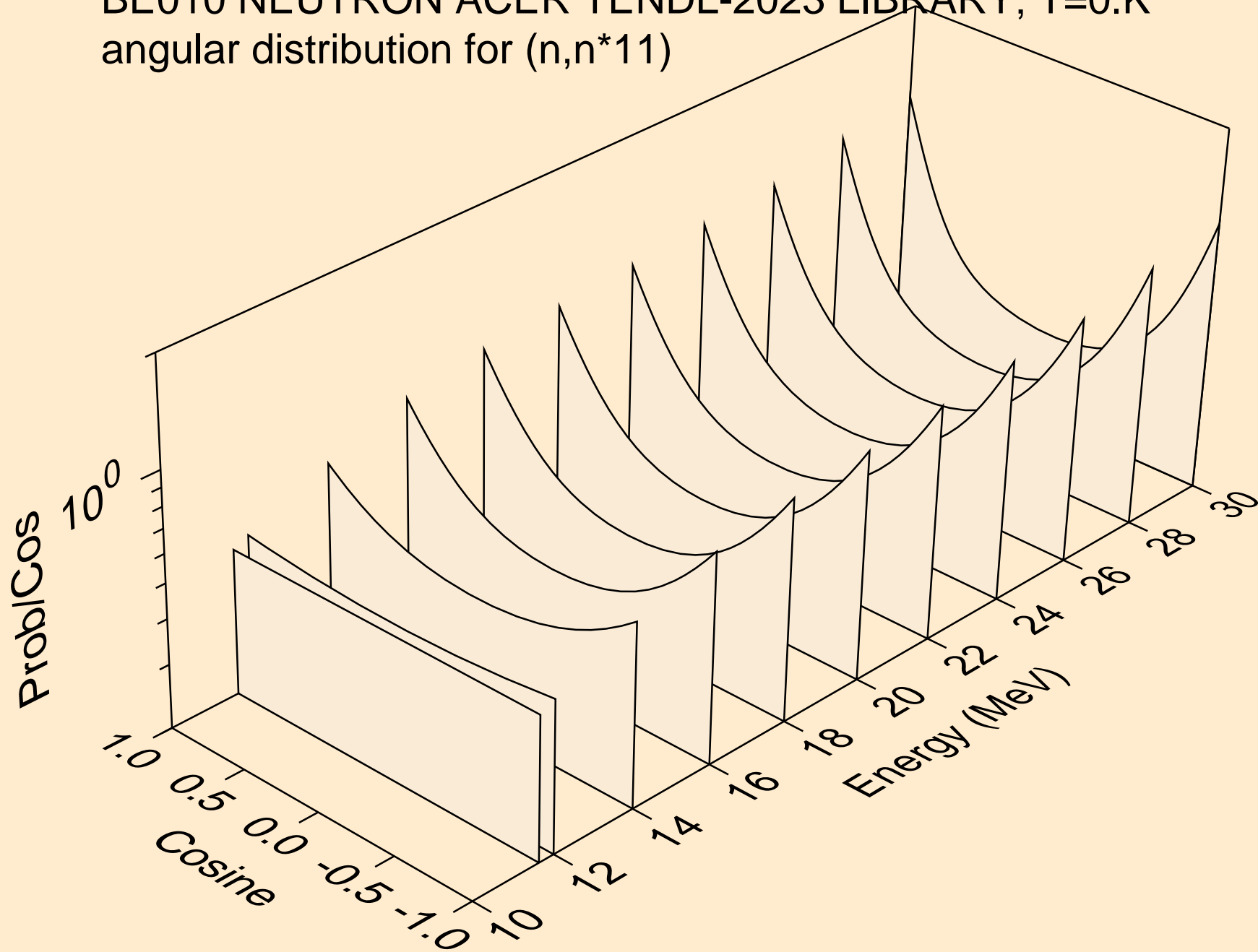

BE010 NEUTRON ACER TENDL-2023 LIBRARY; T=0.K  
angular distribution for (n,n\*12)

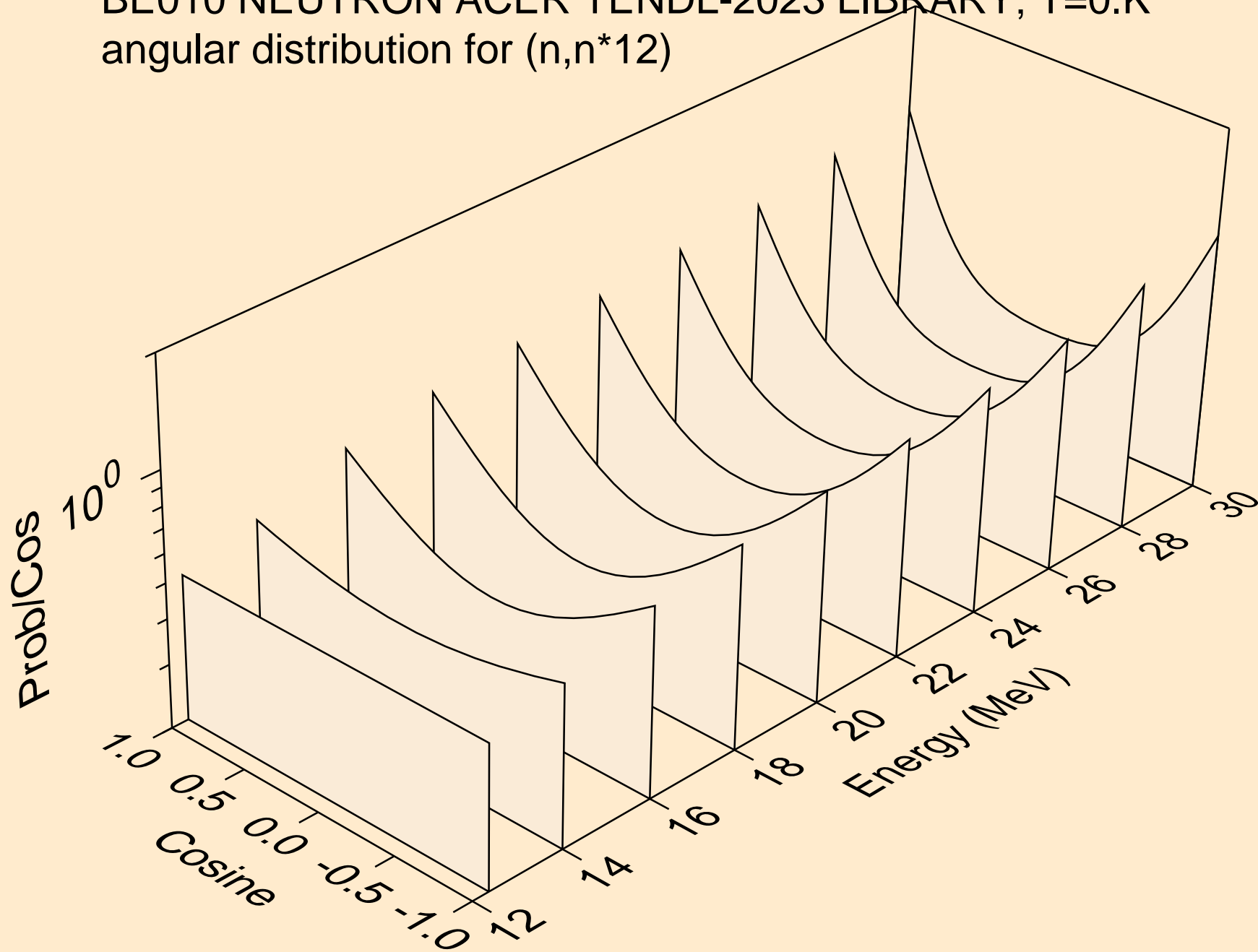

BE010 NEUTRON ACER TENDL-2023 LIBRARY; T=0.K  
angular distribution for (n,n\*13)

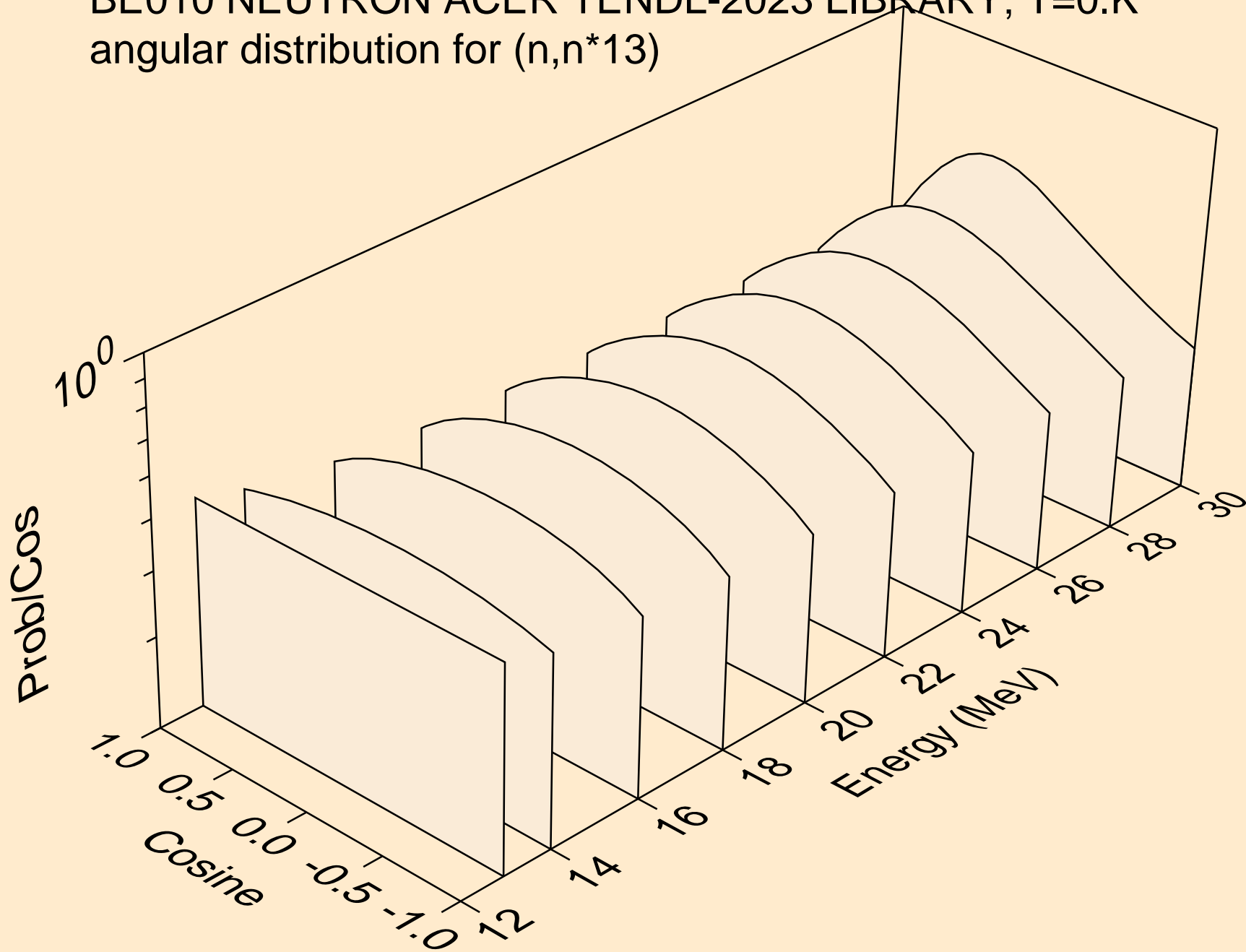

BE010 NEUTRON ACER TENDL-2023 LIBRARY; T=0.K  
angular distribution for (n,n\*14)

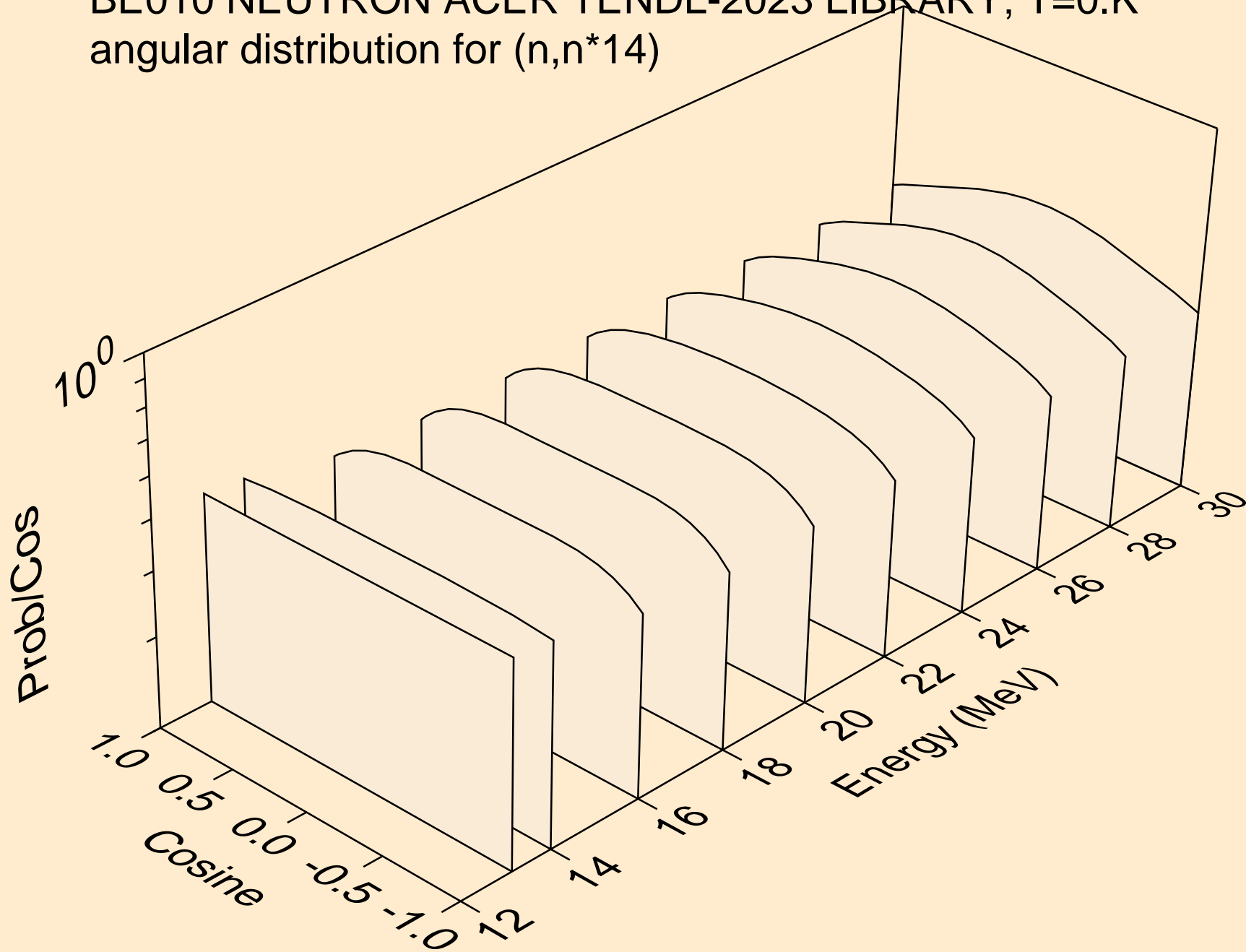

BE010 NEUTRON ACER TENDL-2023 LIBRARY; T=0.K  
angular distribution for (n,n\*15)

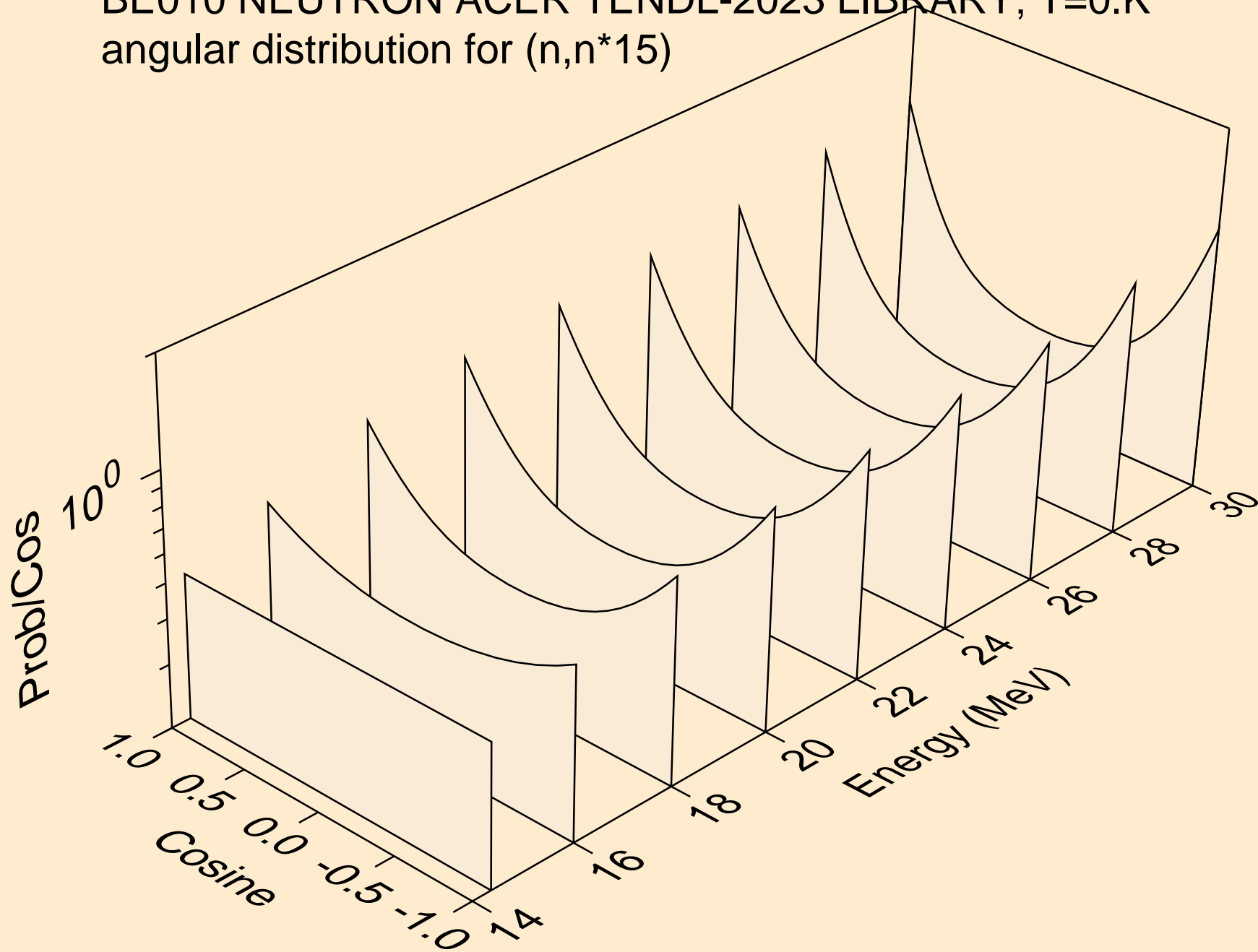

BE010 NEUTRON ACER TENDL-2023 LIBRARY; T=0.K  
angular distribution for (n,n\*16)

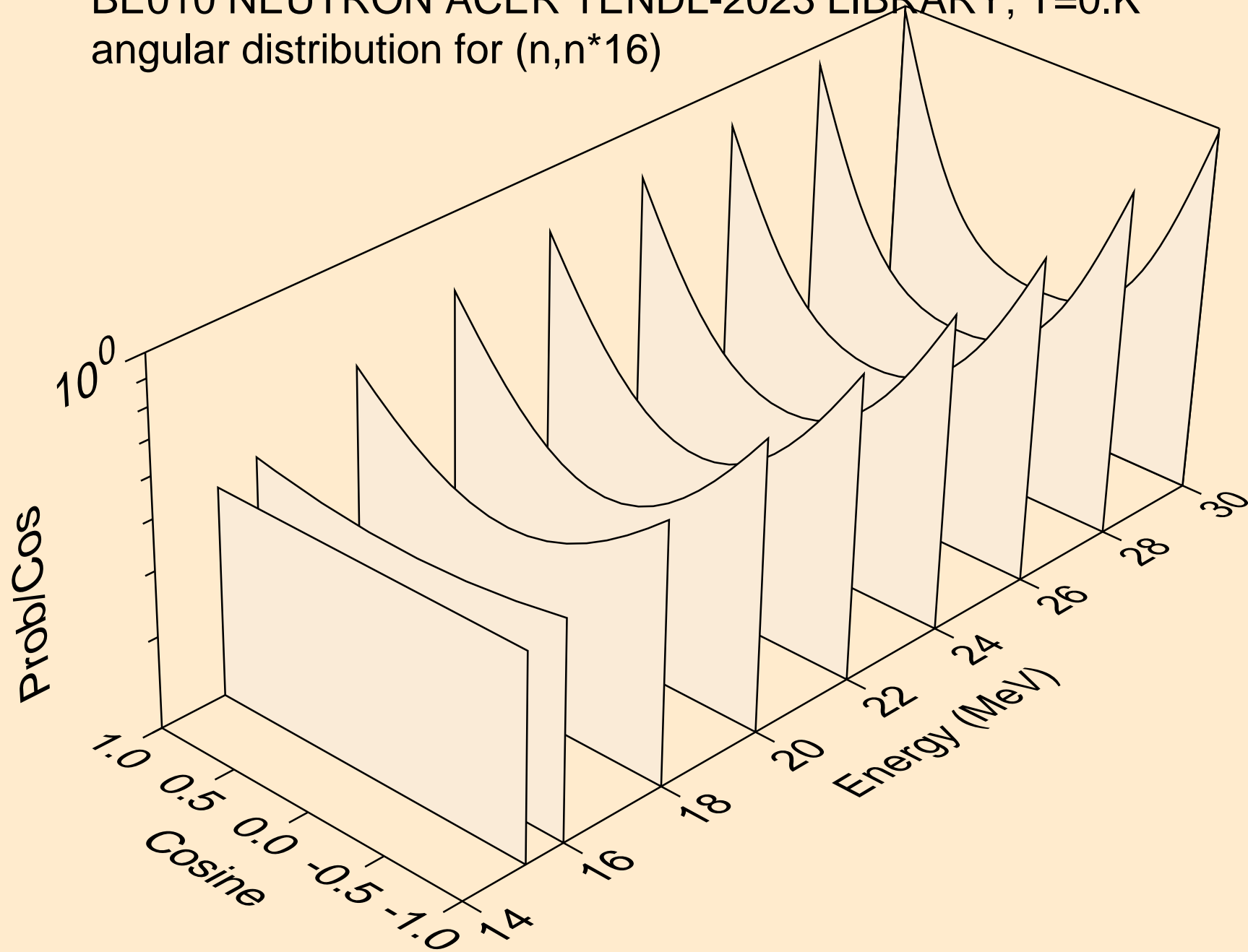

BE010 NEUTRON ACER TENDL-2023 LIBRARY; T=0.K  
Neutron emission for (n,x)

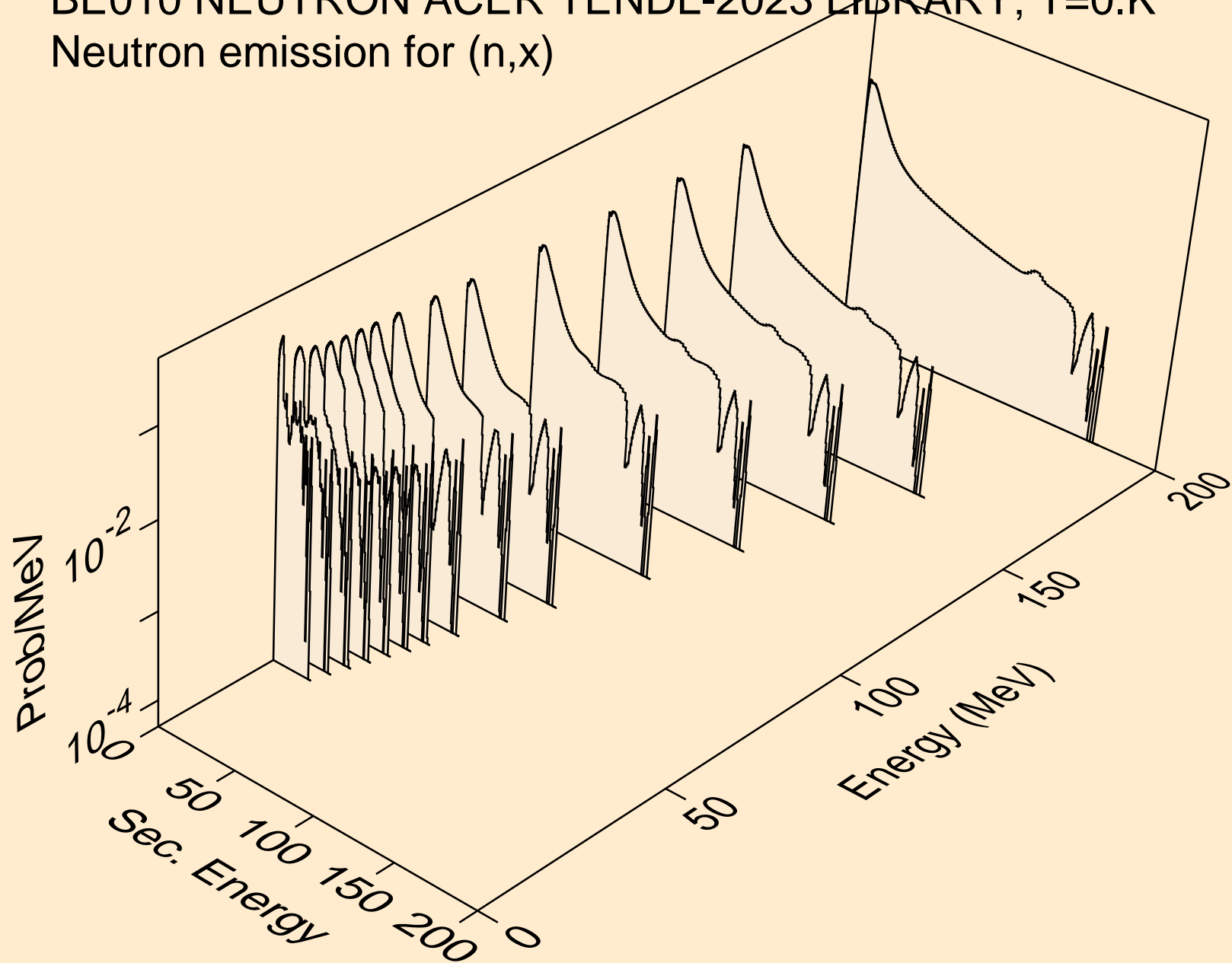

BE010 NEUTRON ACER TENDL-2023 LIBRARY; T=0.K  
Neutron emission for (n,2nd)

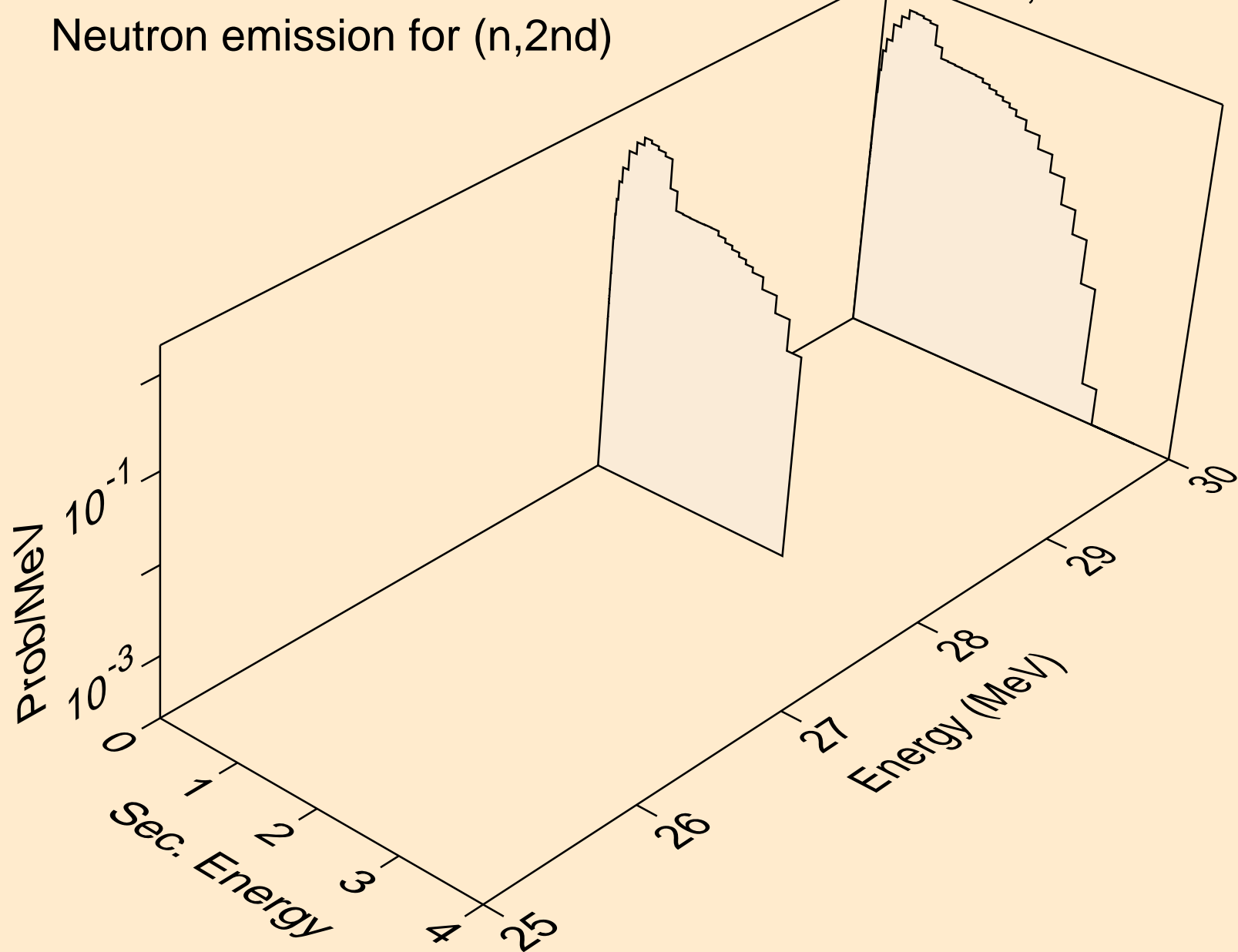

BE010 NEUTRON ACER TENDL-2023 LIBRARY; T=0.K  
Neutron emission for (n,2n)

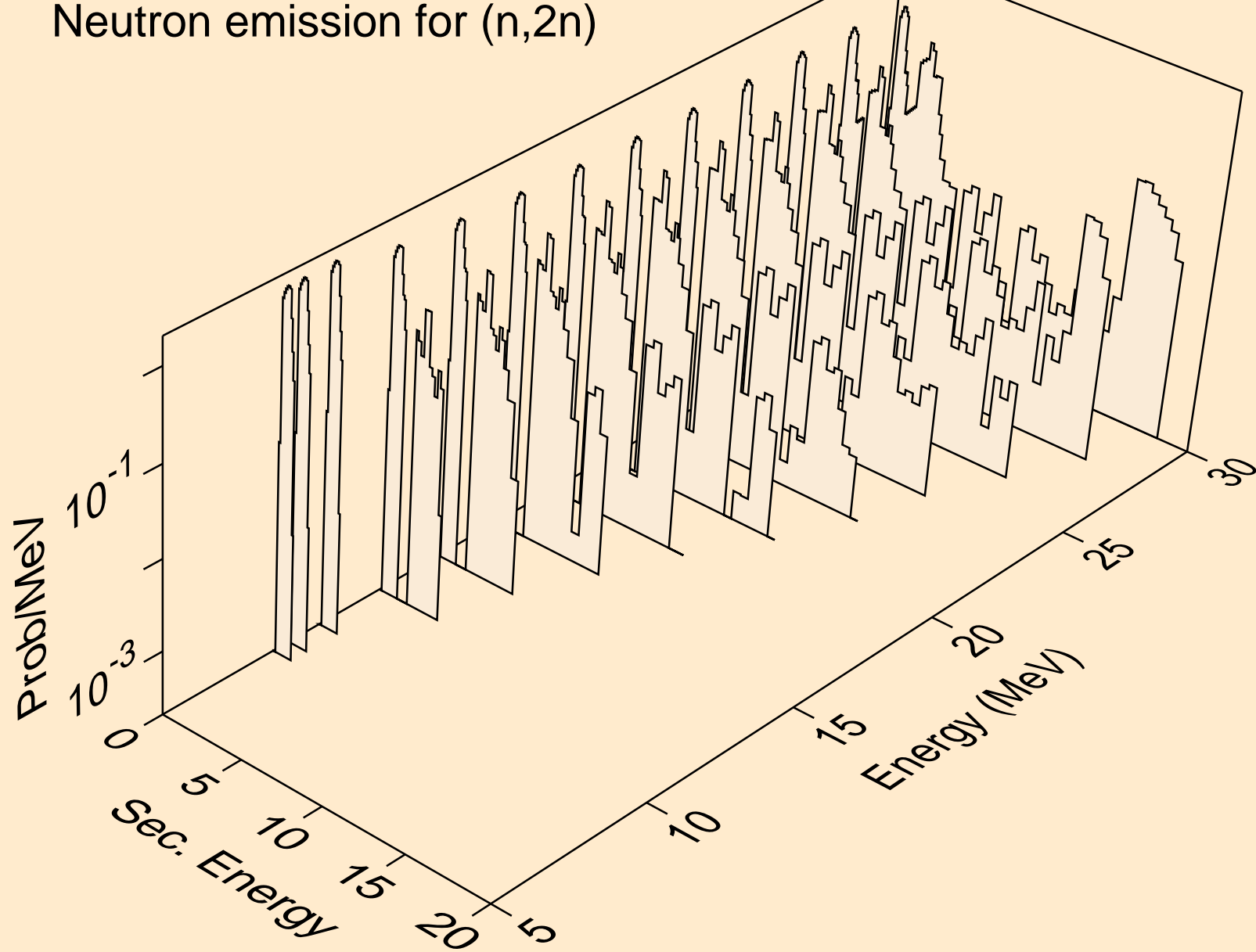

BE010 NEUTRON ACER TENDL-2023 LIBRARY; T=0.K  
Neutron emission for (n,3n)

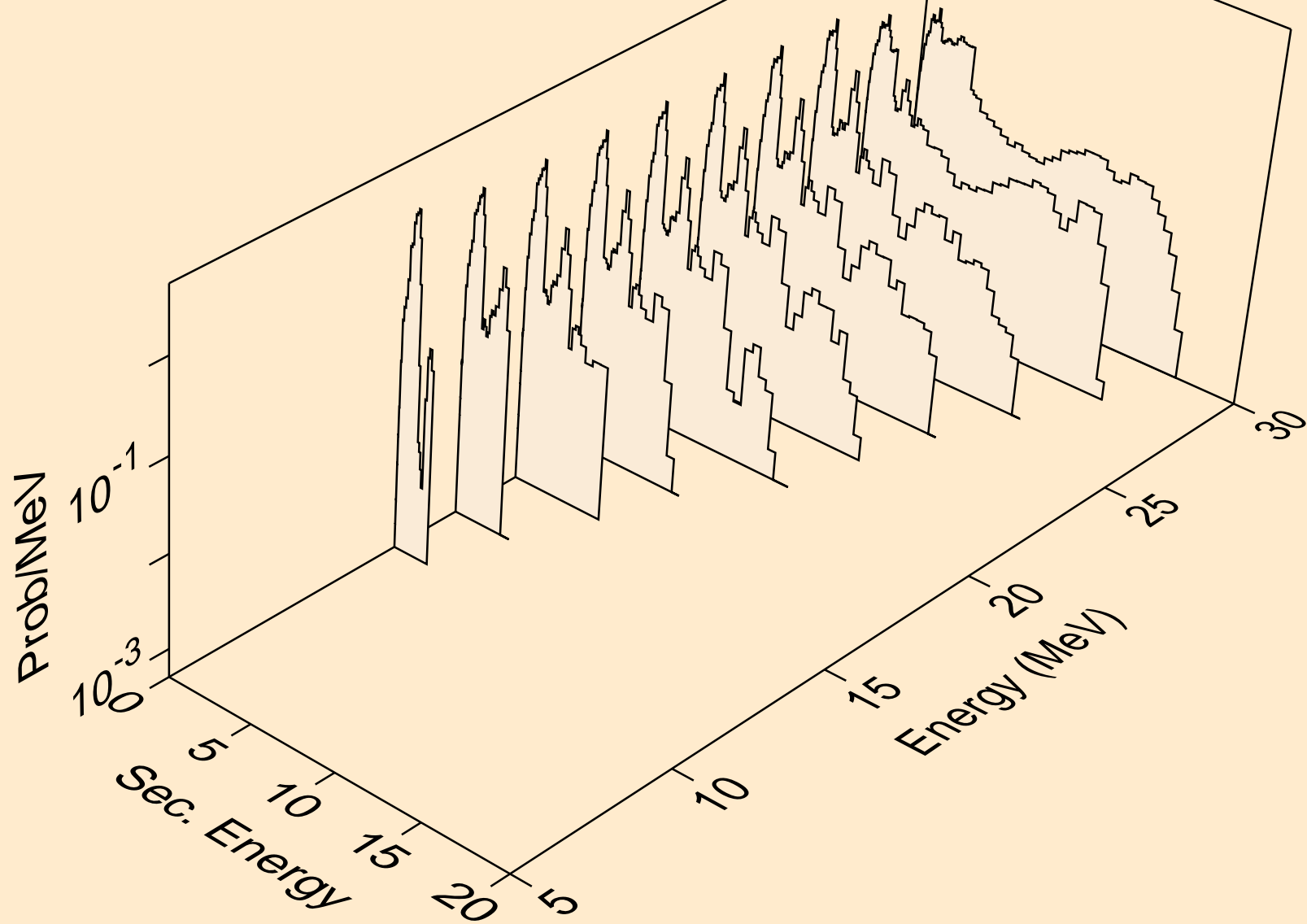

BE010 NEUTRON ACER TENDL-2023 LIBRARY; T=0.K  
Neutron emission for (n,n\*)p

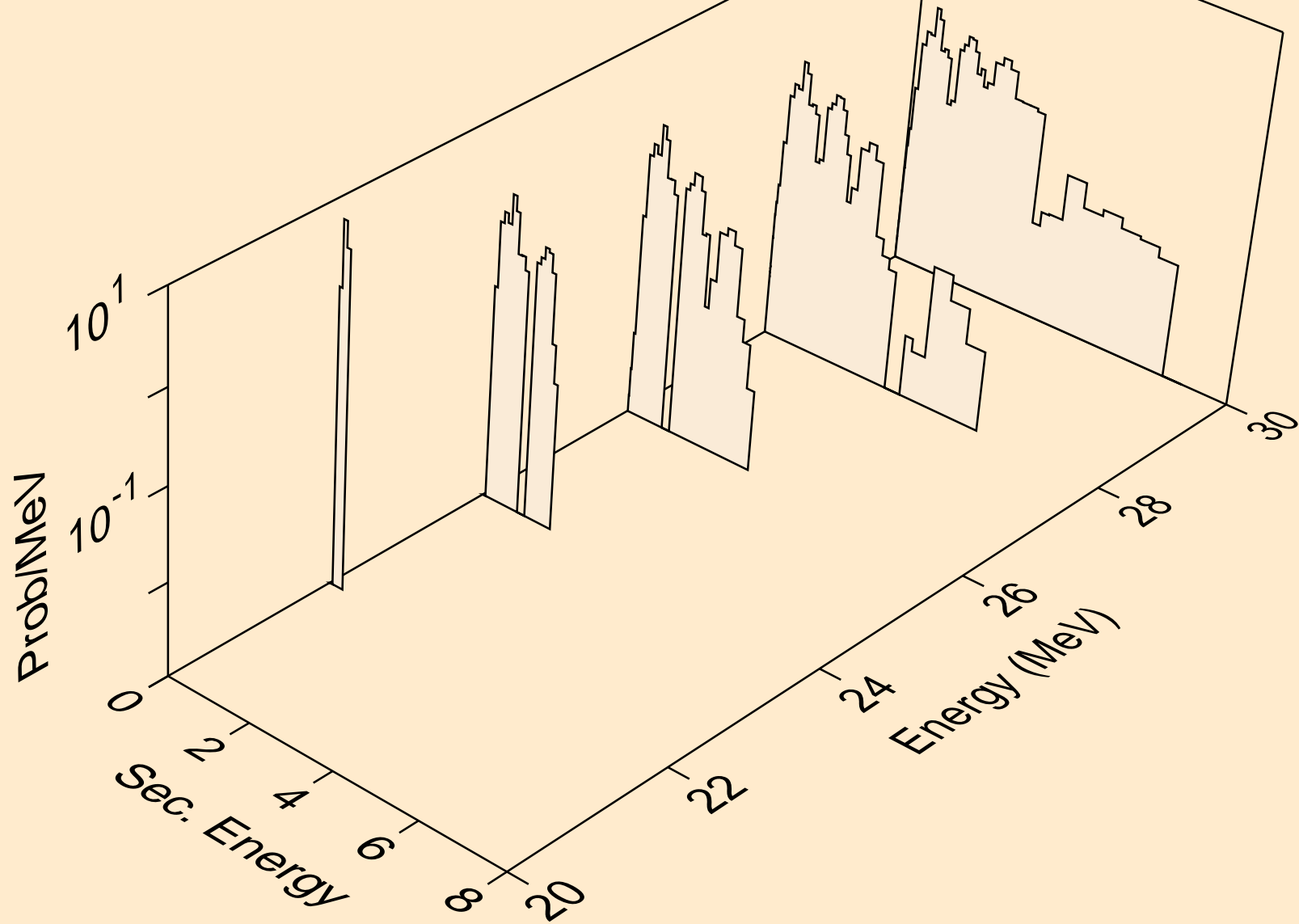

BE010 NEUTRON ACER TENDL-2023 LIBRARY; T=0.K  
Neutron emission for (n,n\*)d

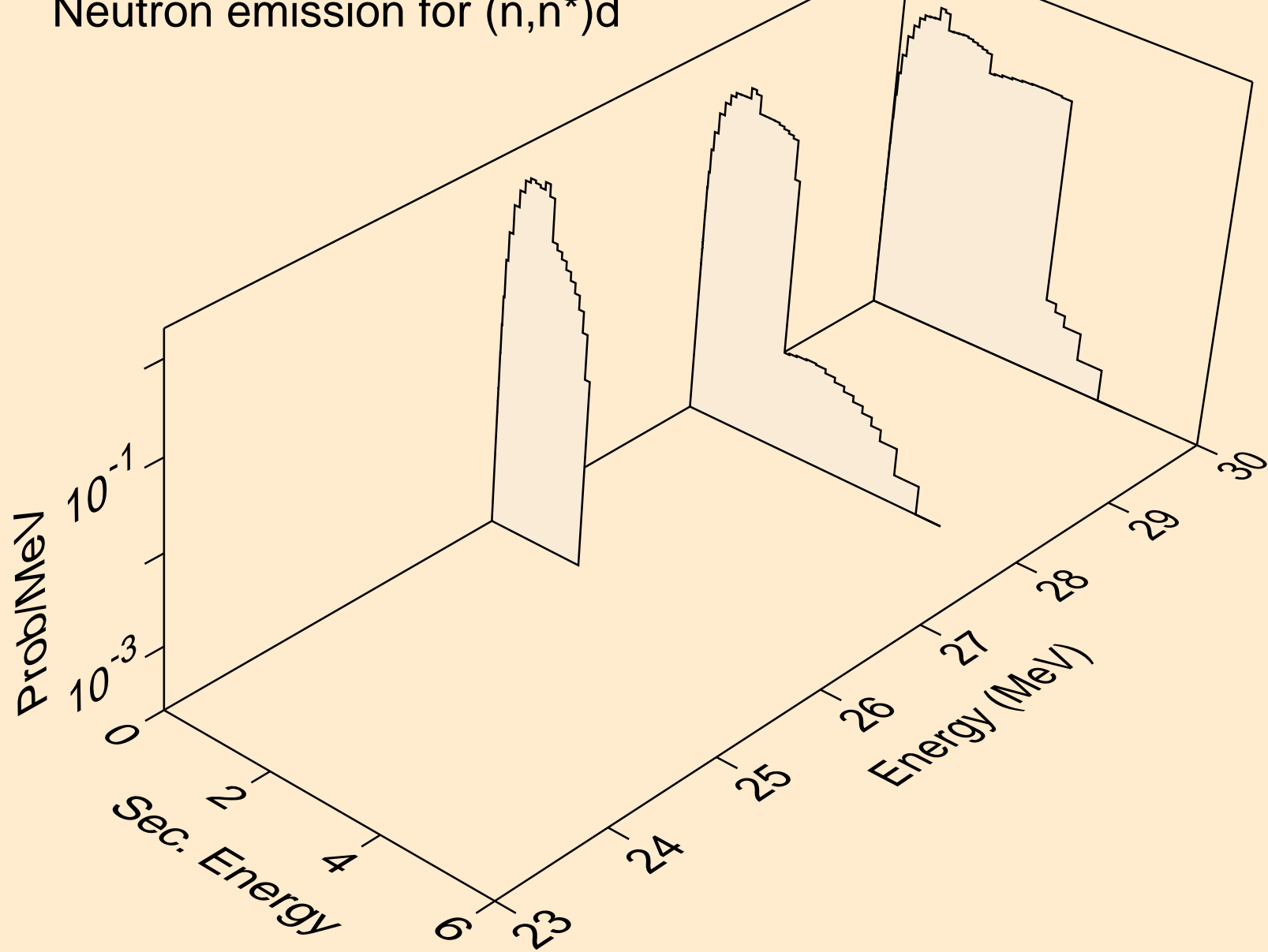

BE010 NEUTRON ACER TENDL-2023 LIBRARY; T=0.K  
Neutron emission for (n,n\*)t

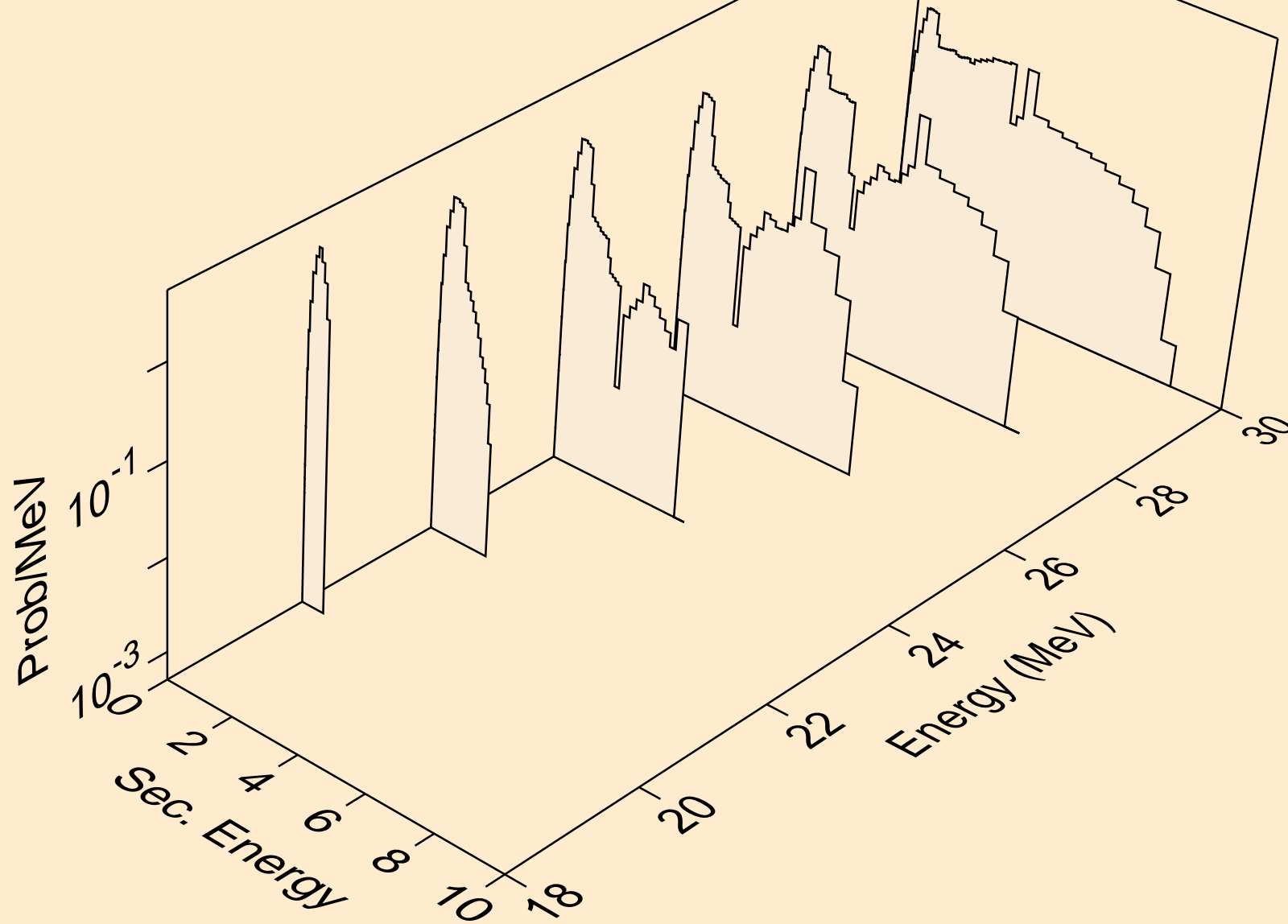

BE010 NEUTRON ACER TENDL-2023 LIBRARY; T=0.K  
Neutron emission for (n,2np)

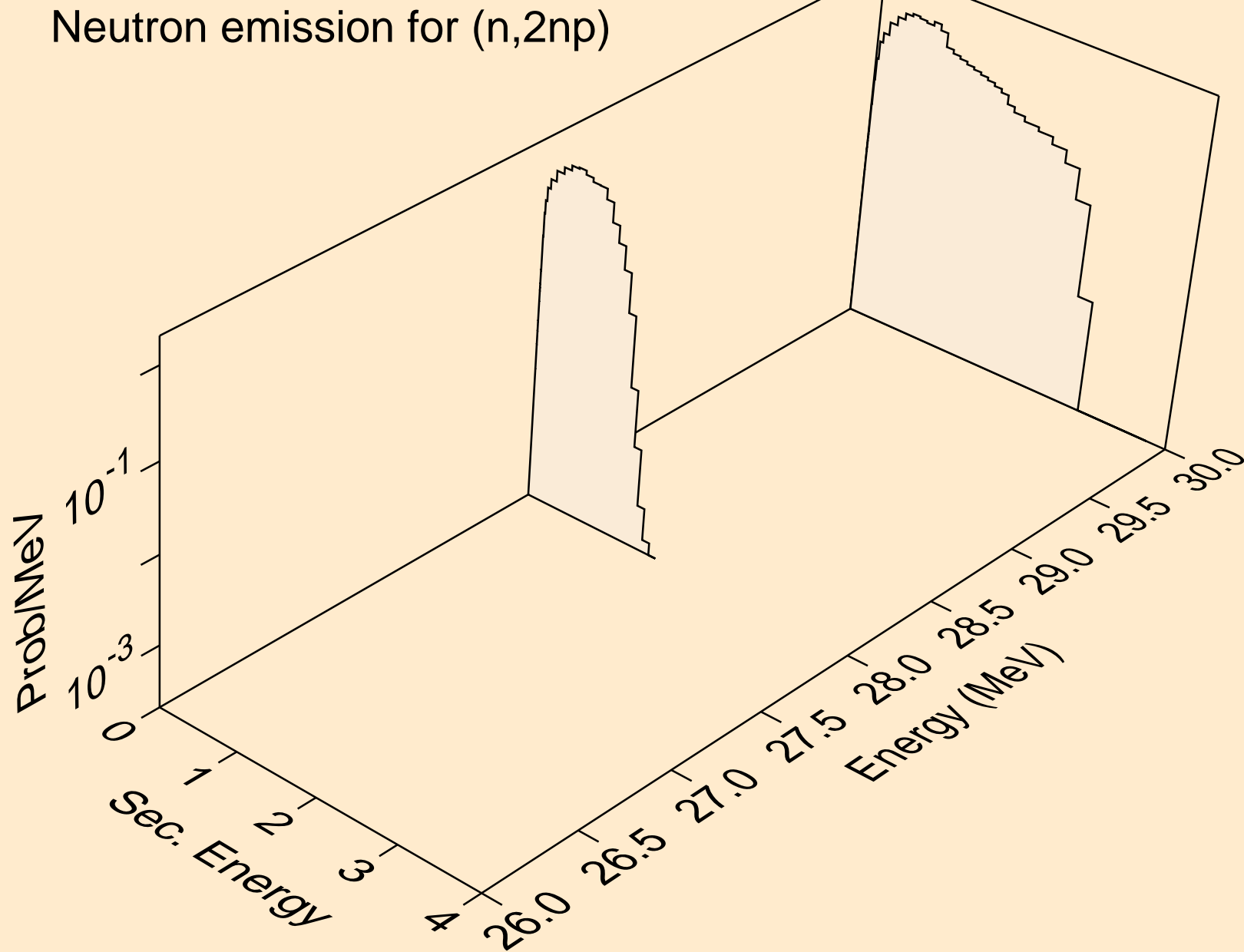

BE010 NEUTRON ACER TENDL-2023 LIBRARY; T=0.K  
Neutron emission for (n,3np)

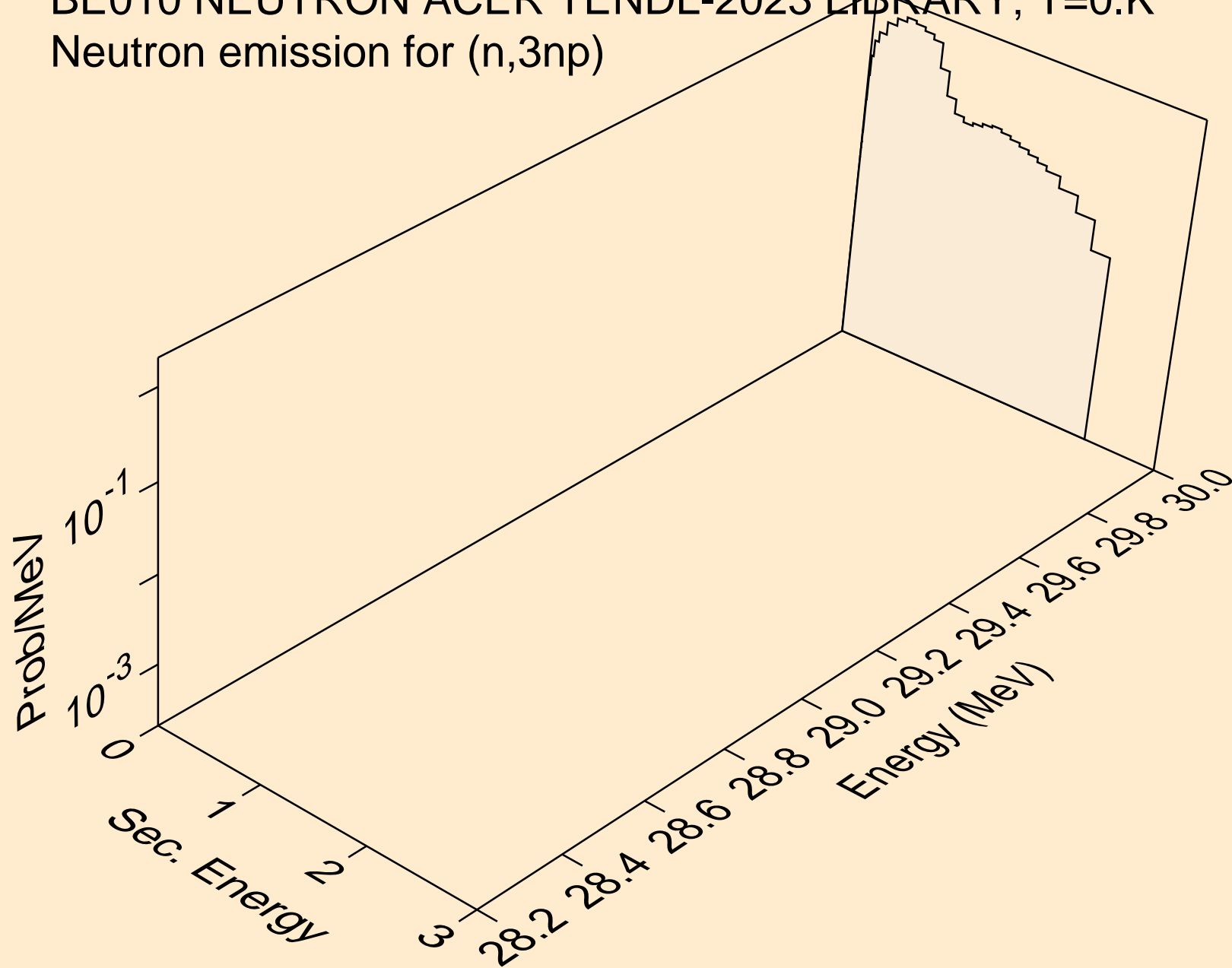

BE010 NEUTRON ACER TENDL-2023 LIBRARY; T=0.K  
Photon emission for (n,x)

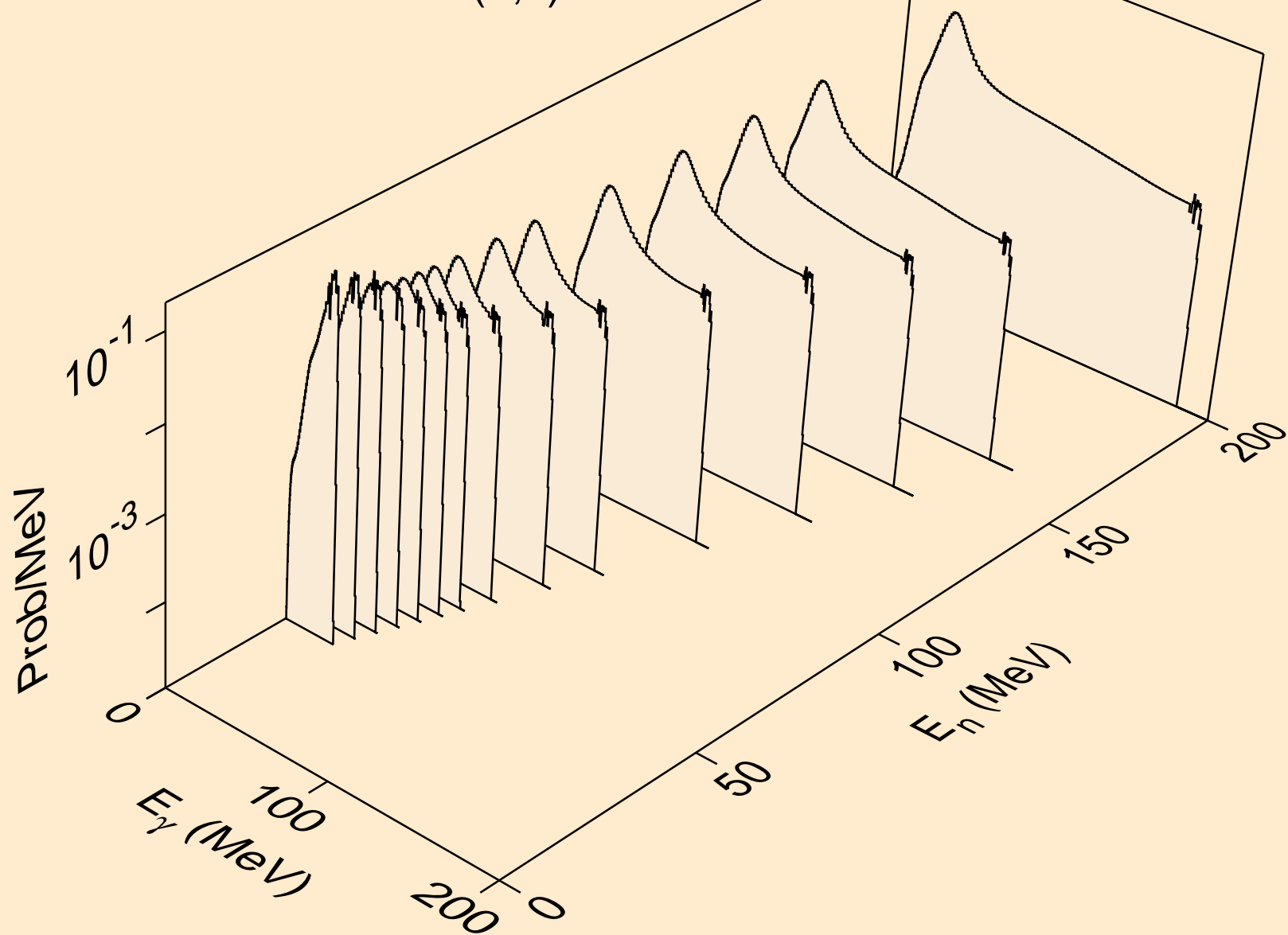

BE010 NEUTRON ACER TENDL-2023 LIBRARY; T=0.K  
Photon emission for (n,2nd)

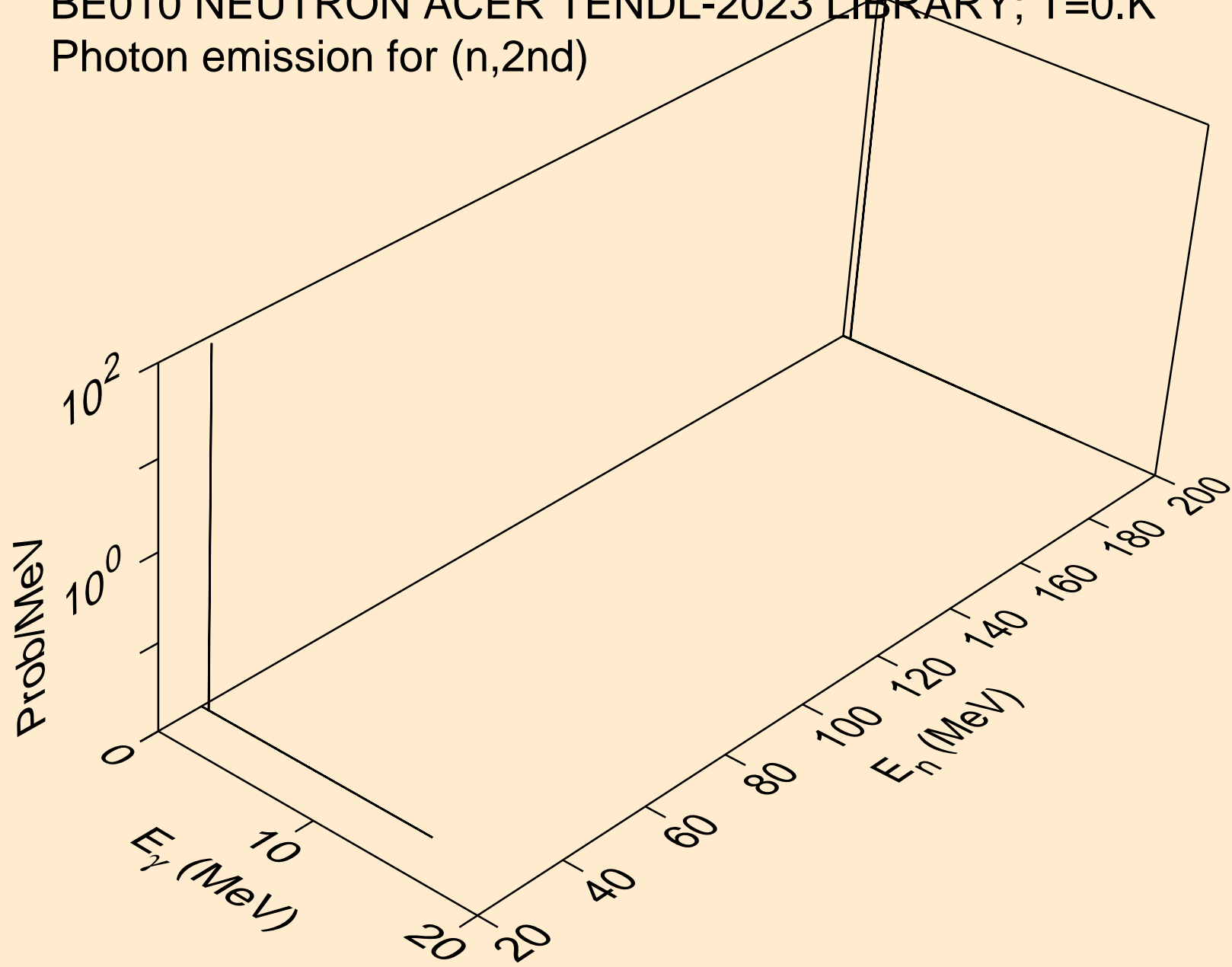

BE010 NEUTRON ACER TENDL-2023 LIBRARY; T=0.K  
Photon emission for (n,2n)

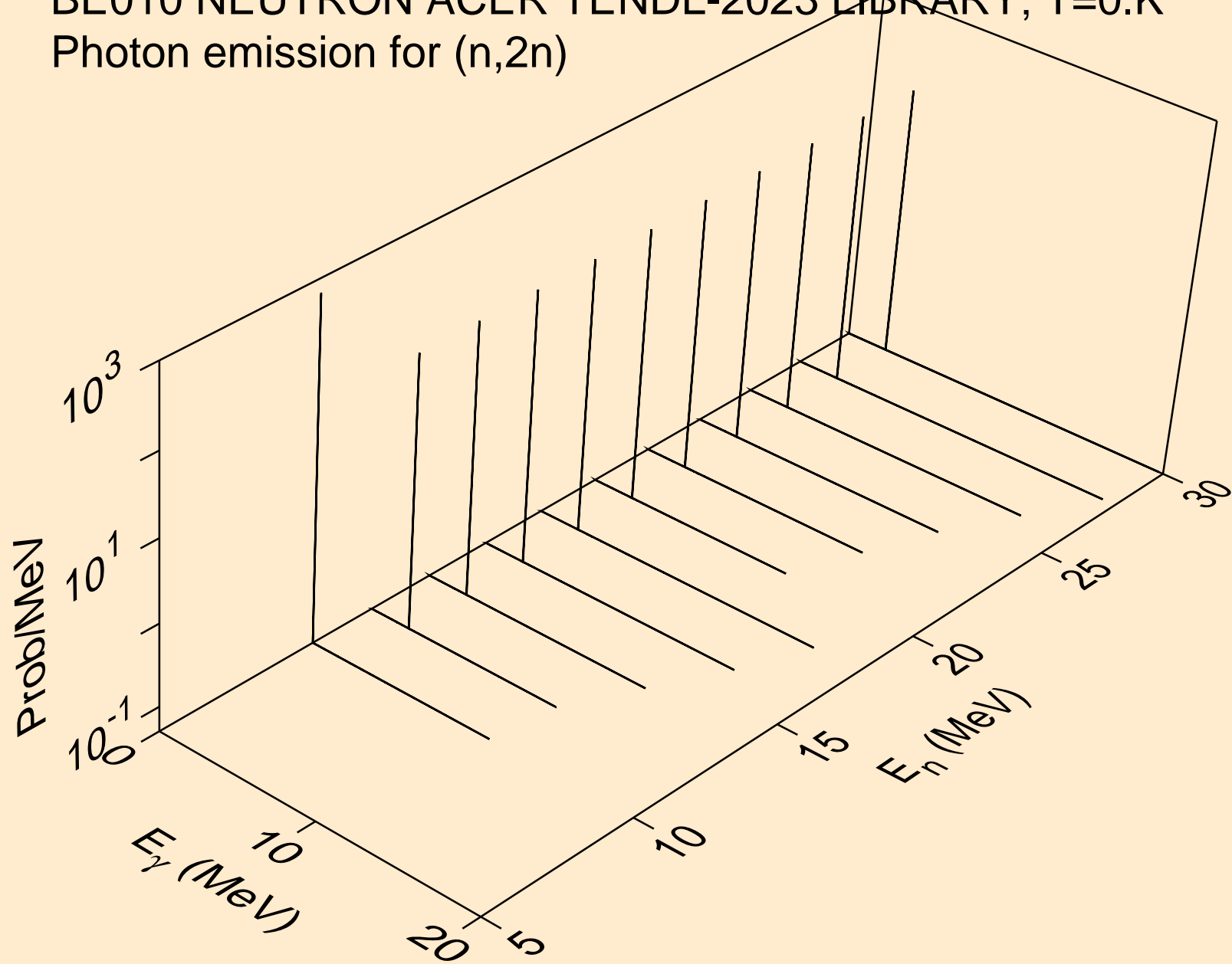

BE010 NEUTRON ACER TENDL-2023 LIBRARY; T=0.K  
Photon emission for (n,3n)

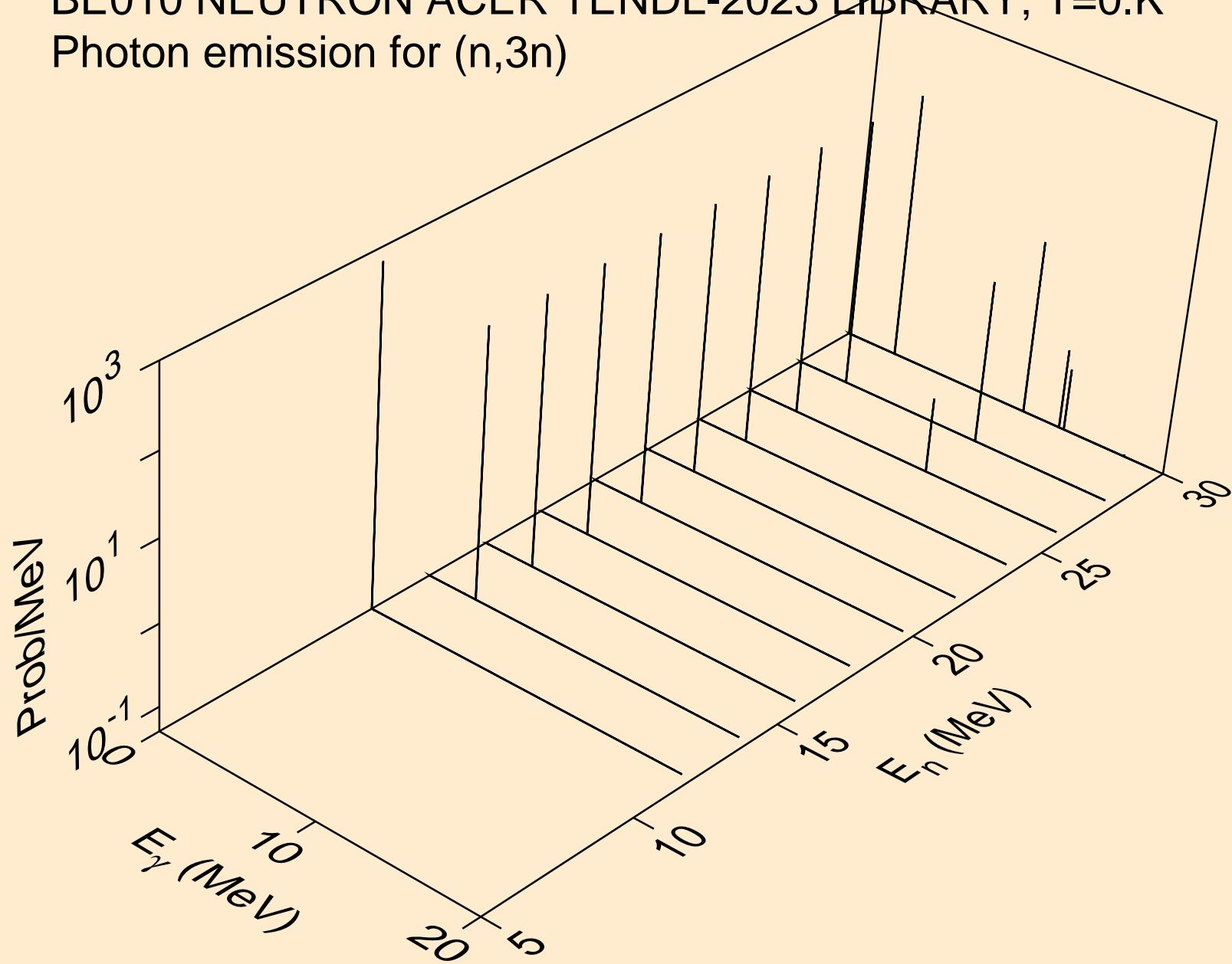

BE010 NEUTRON ACER TENDL-2023 LIBRARY; T=0.K  
Photon emission for (n,n\*)p

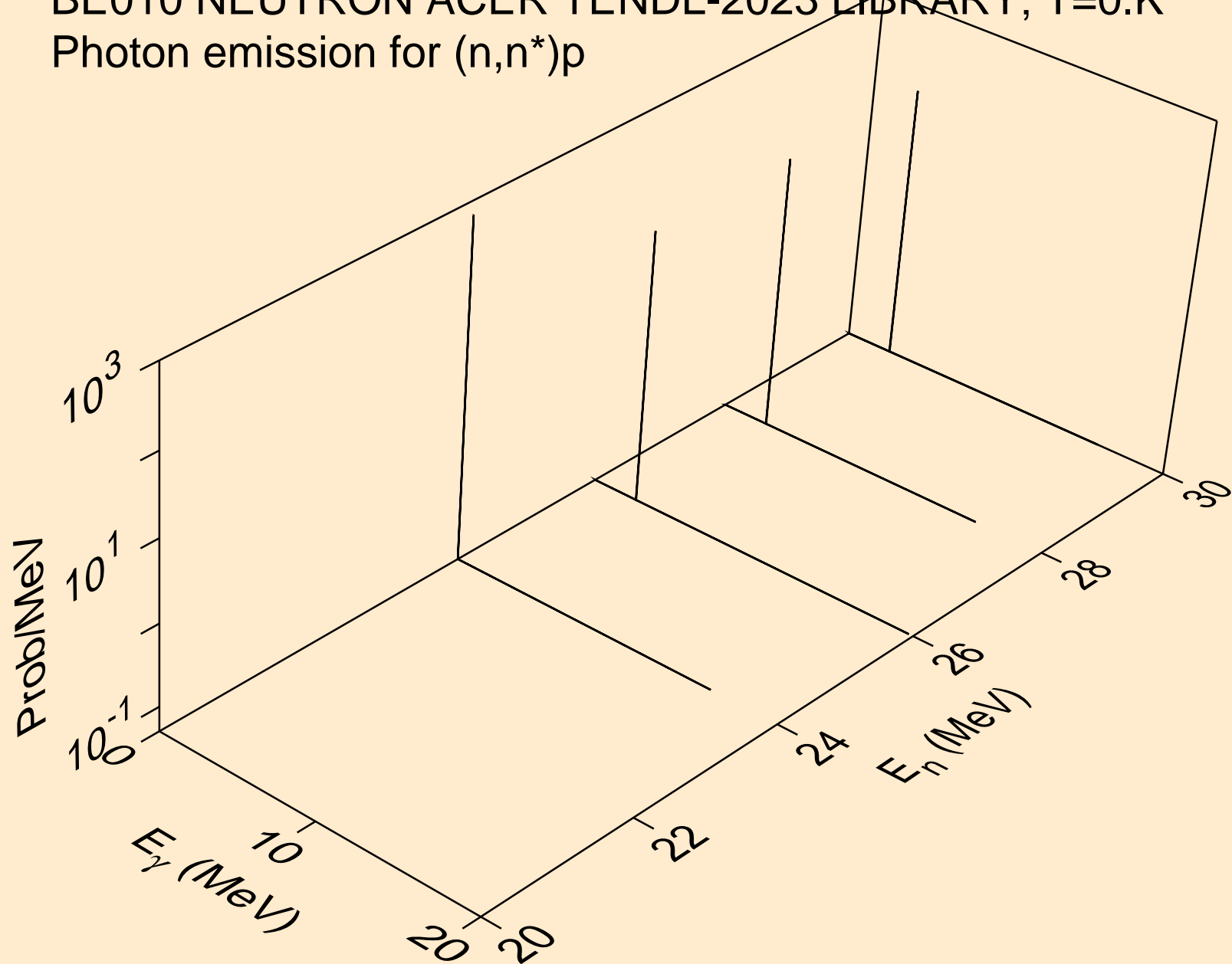

BE010 NEUTRON ACER TENDL-2023 LIBRARY; T=0.K  
Photon emission for (n,n\*)d

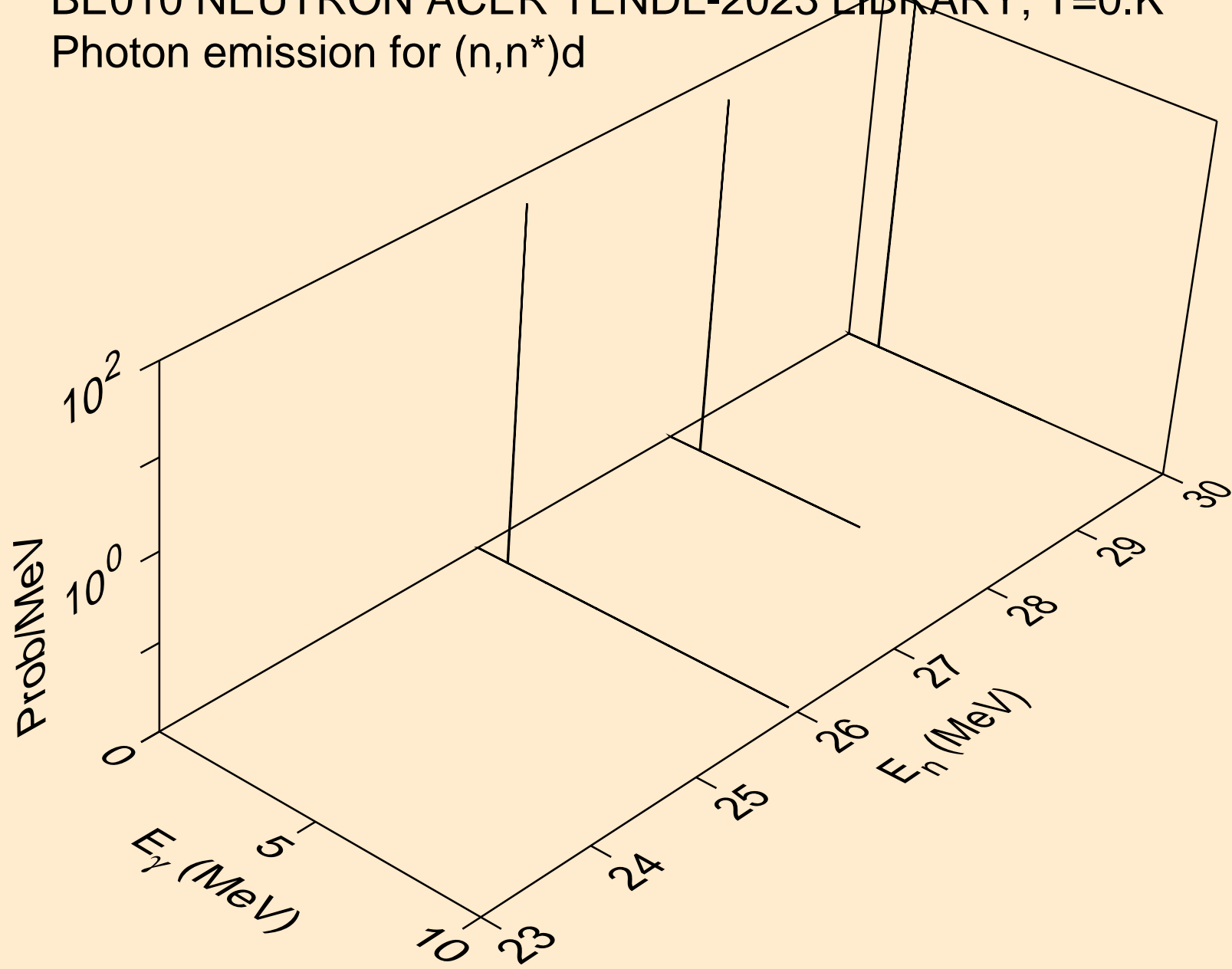

BE010 NEUTRON ACER TENDL-2023 LIBRARY; T=0.K  
Photon emission for (n,n\*)t

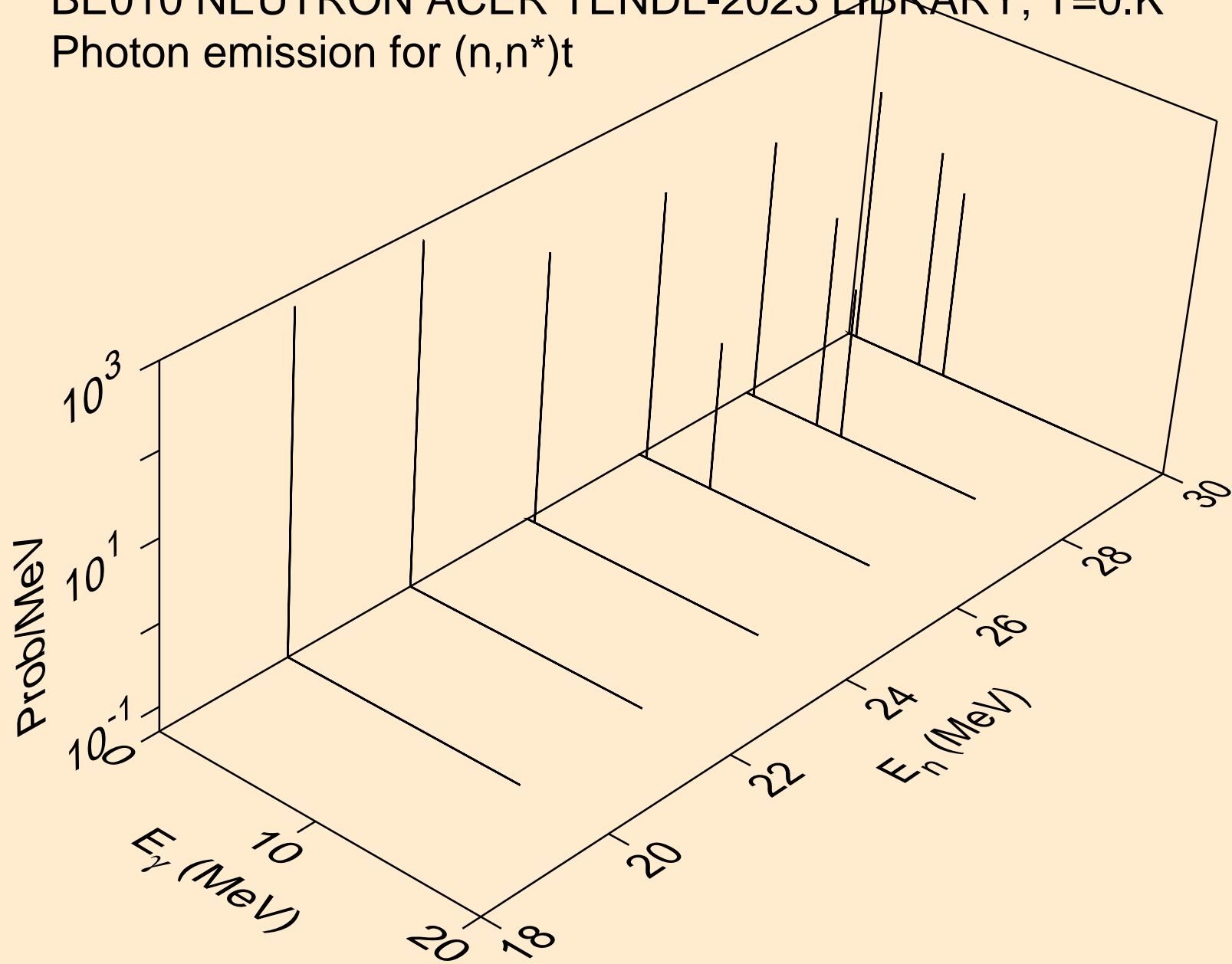

BE010 NEUTRON ACER TENDL-2023 LIBRARY; T=0.K  
Photon emission for (n,2np)

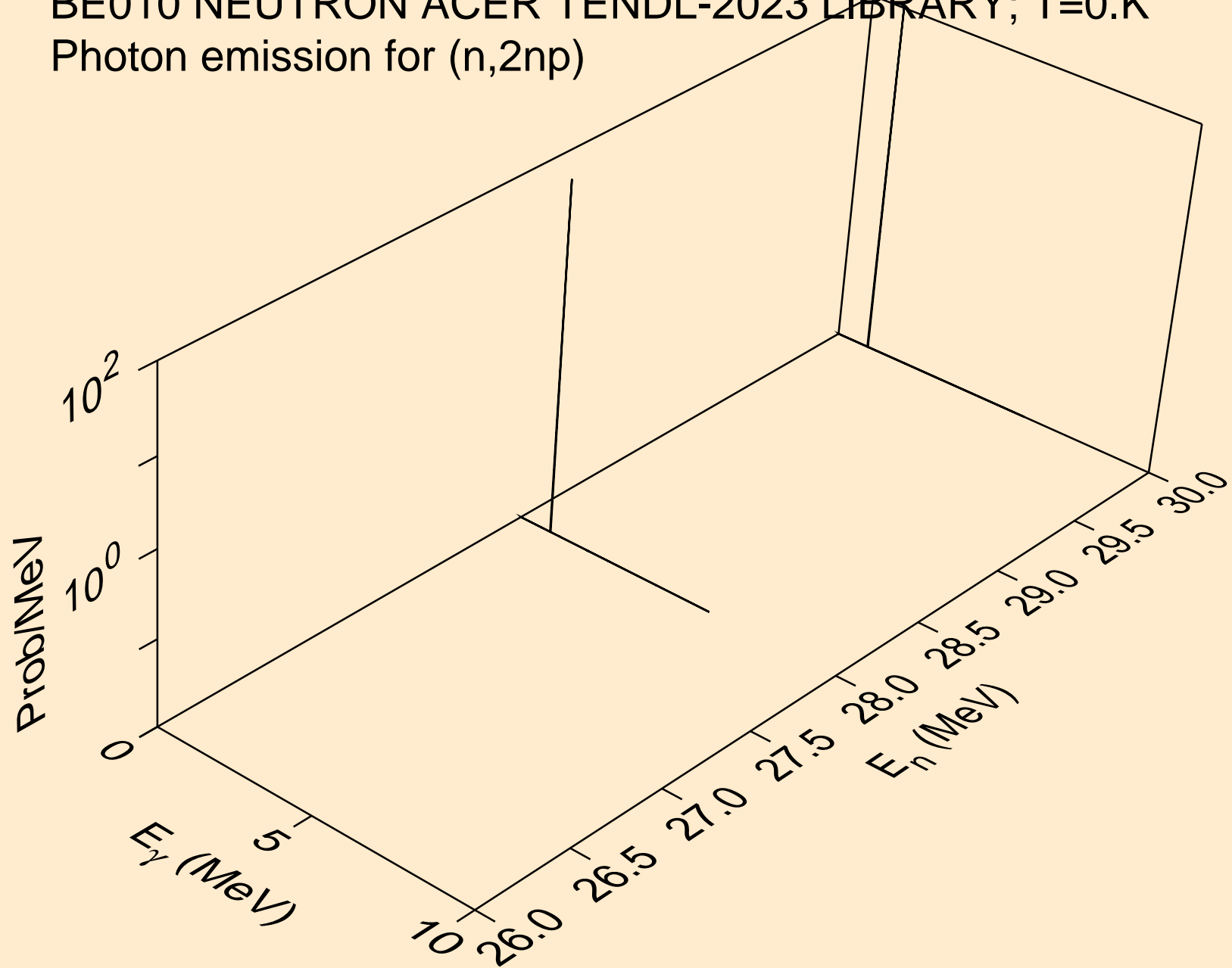

BE010 NEUTRON ACER TENDL-2023 LIBRARY; T=0.K  
Photon emission for (n,3np)

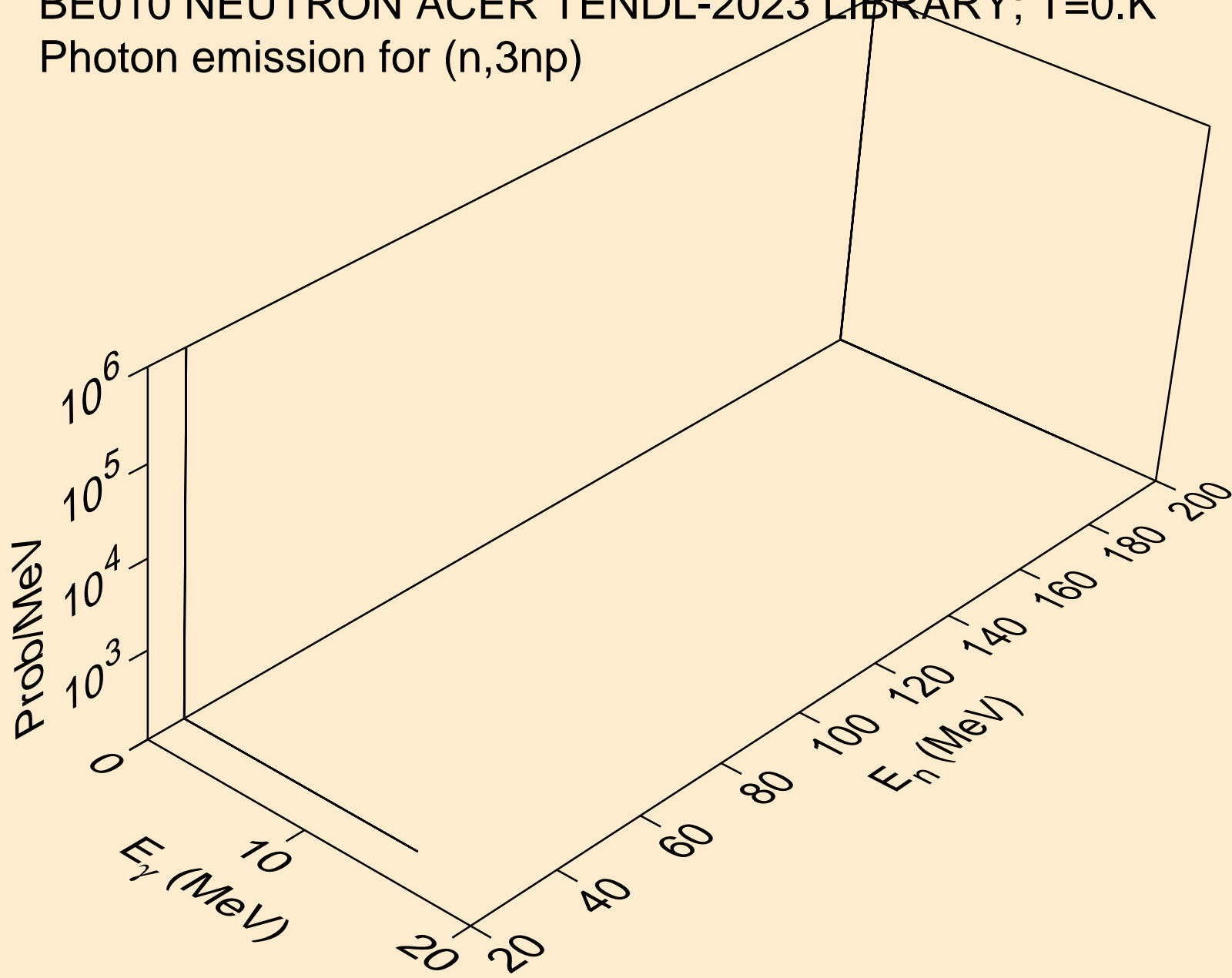

BE010 NEUTRON ACER TENDL-2023 LIBRARY; T=0.K  
Photon emission for (n,n\*c)

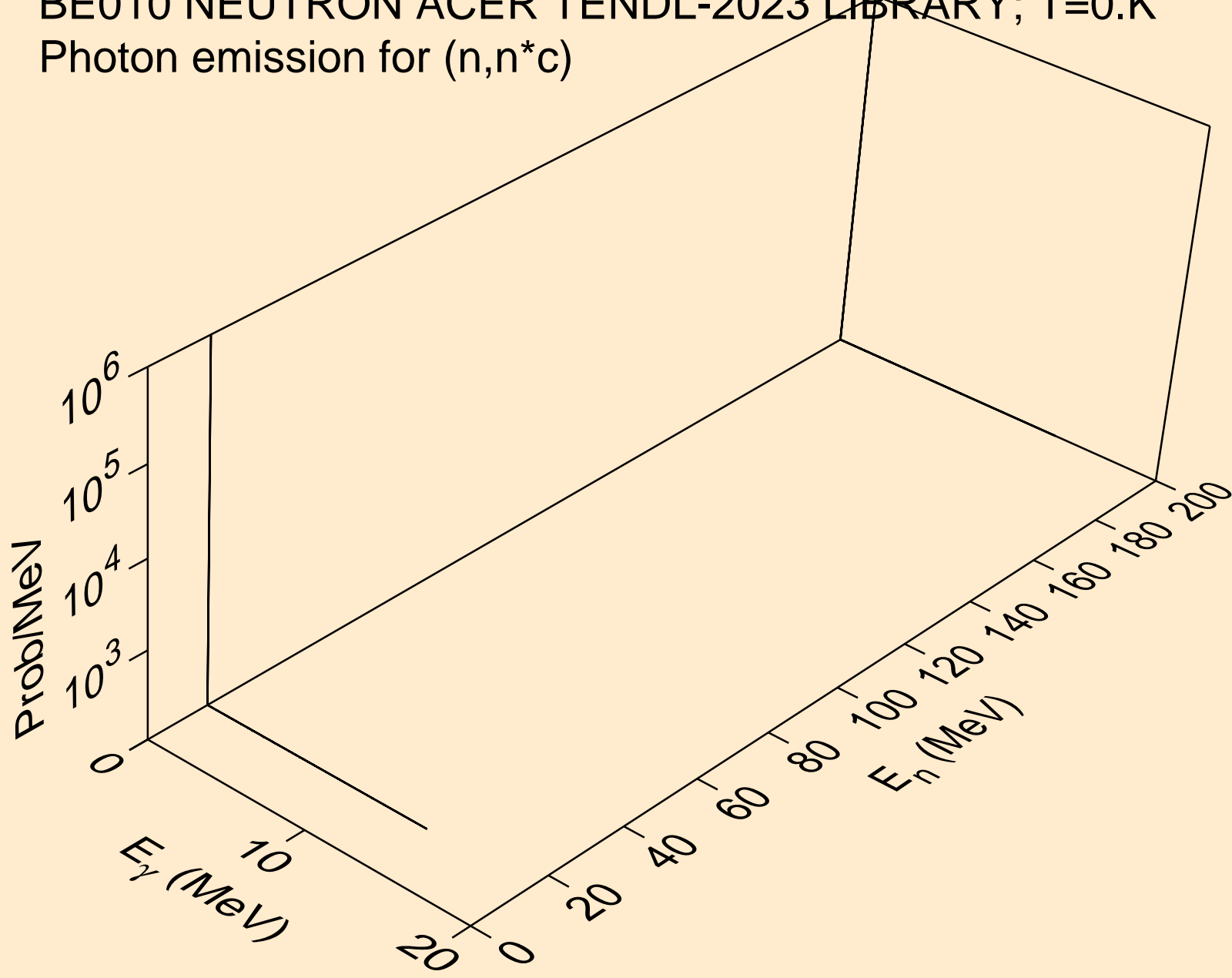

BE010 NEUTRON ACER TENDL-2023 LIBRARY; T=0.K  
Photon emission for (n,gma)

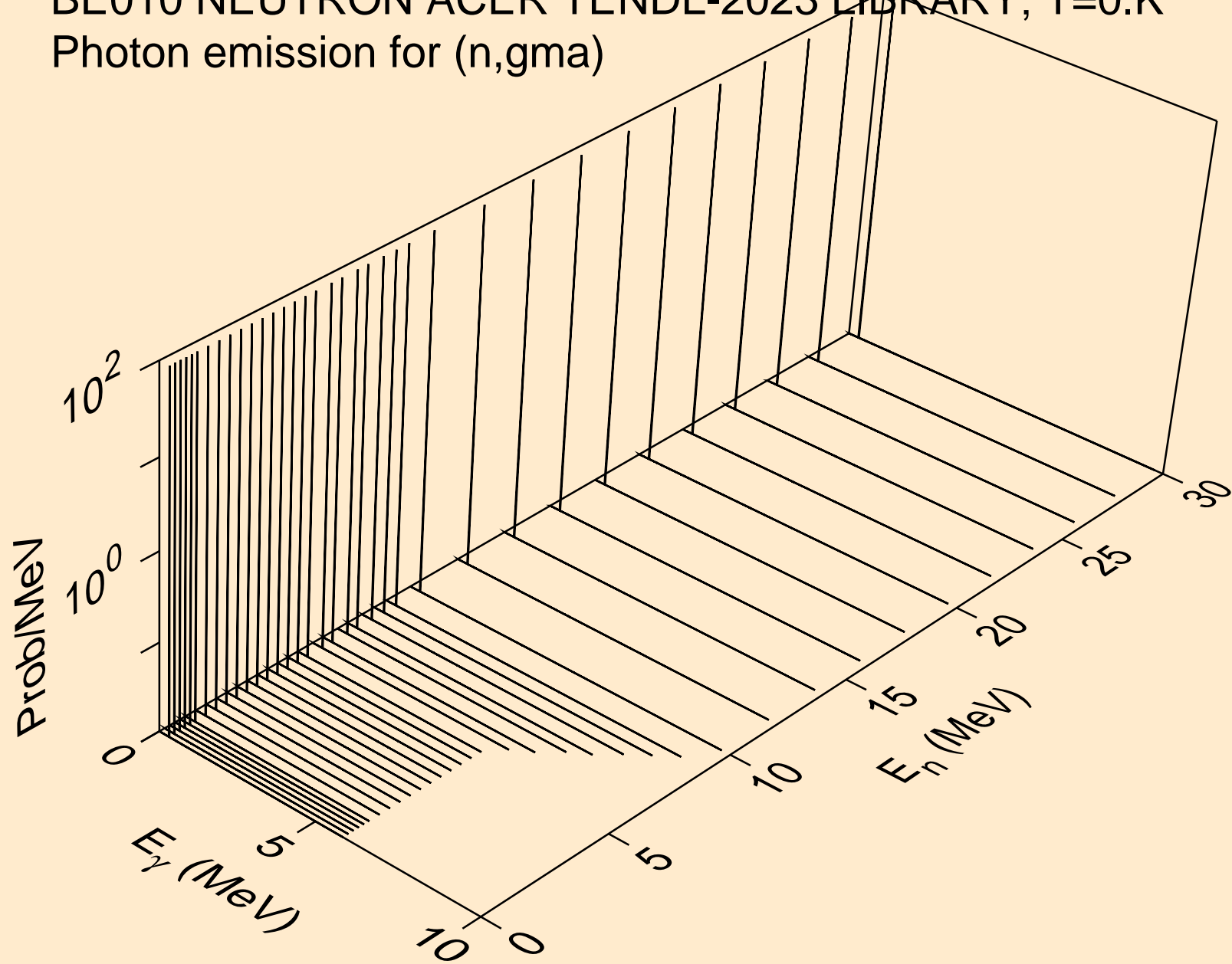

BE010 NEUTRON ACER TENDL-2023 LIBRARY; T=0.K  
Photon emission for (n,p)

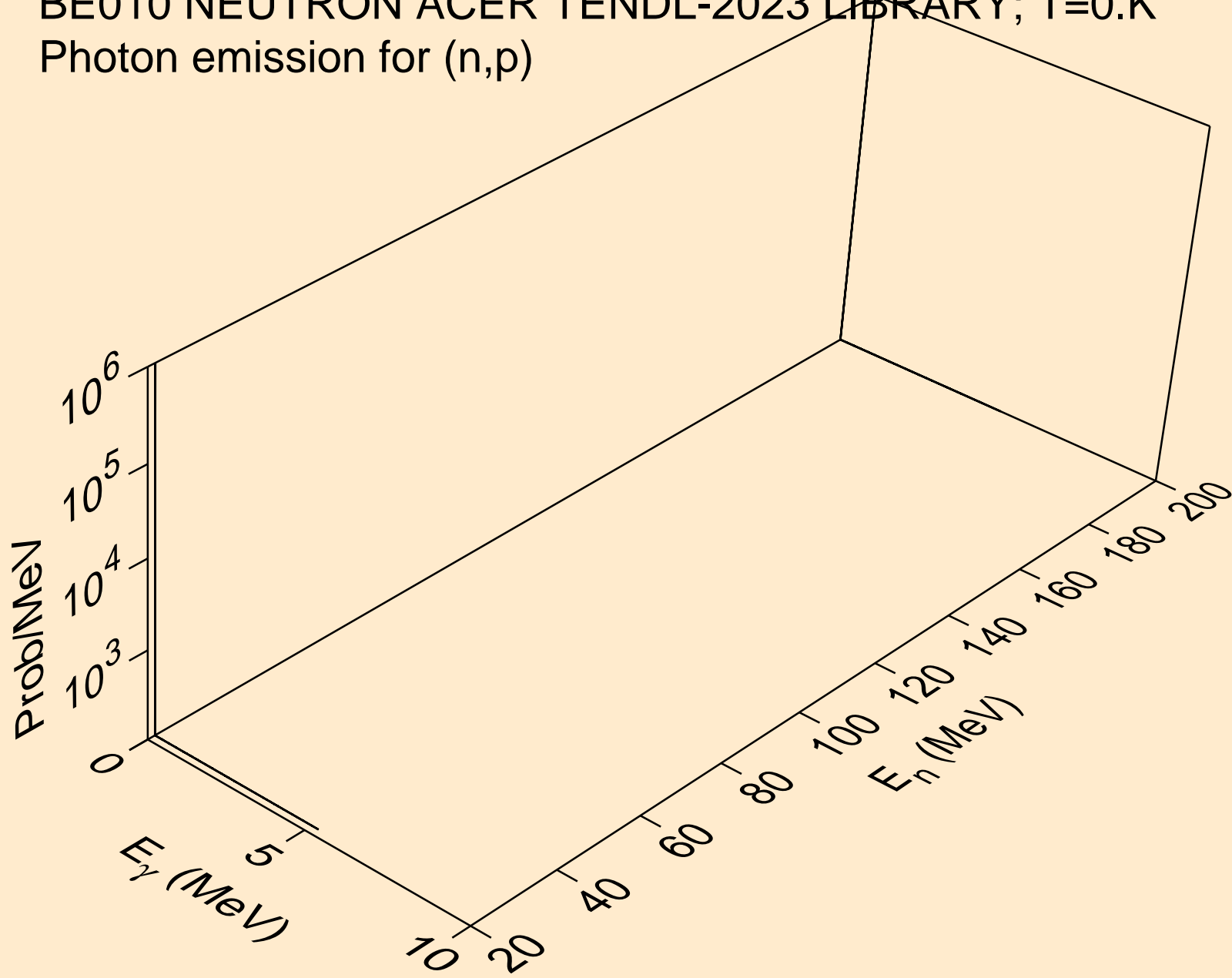

BE010 NEUTRON ACER TENDL-2023 LIBRARY; T=0.K  
Photon emission for (n,d)

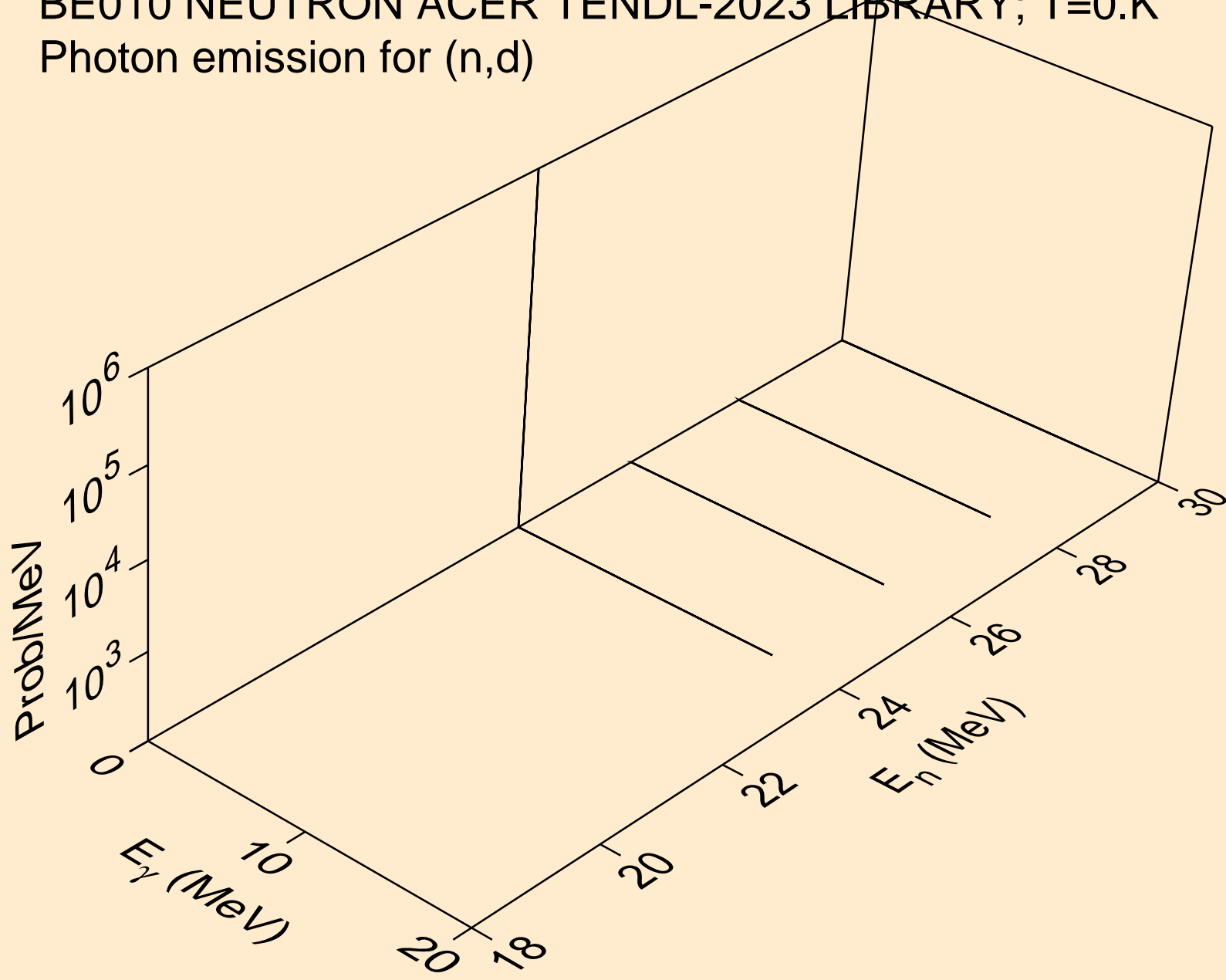

BE010 NEUTRON ACER TENDL-2023 LIBRARY; T=0.K  
Photon emission for (n,t)

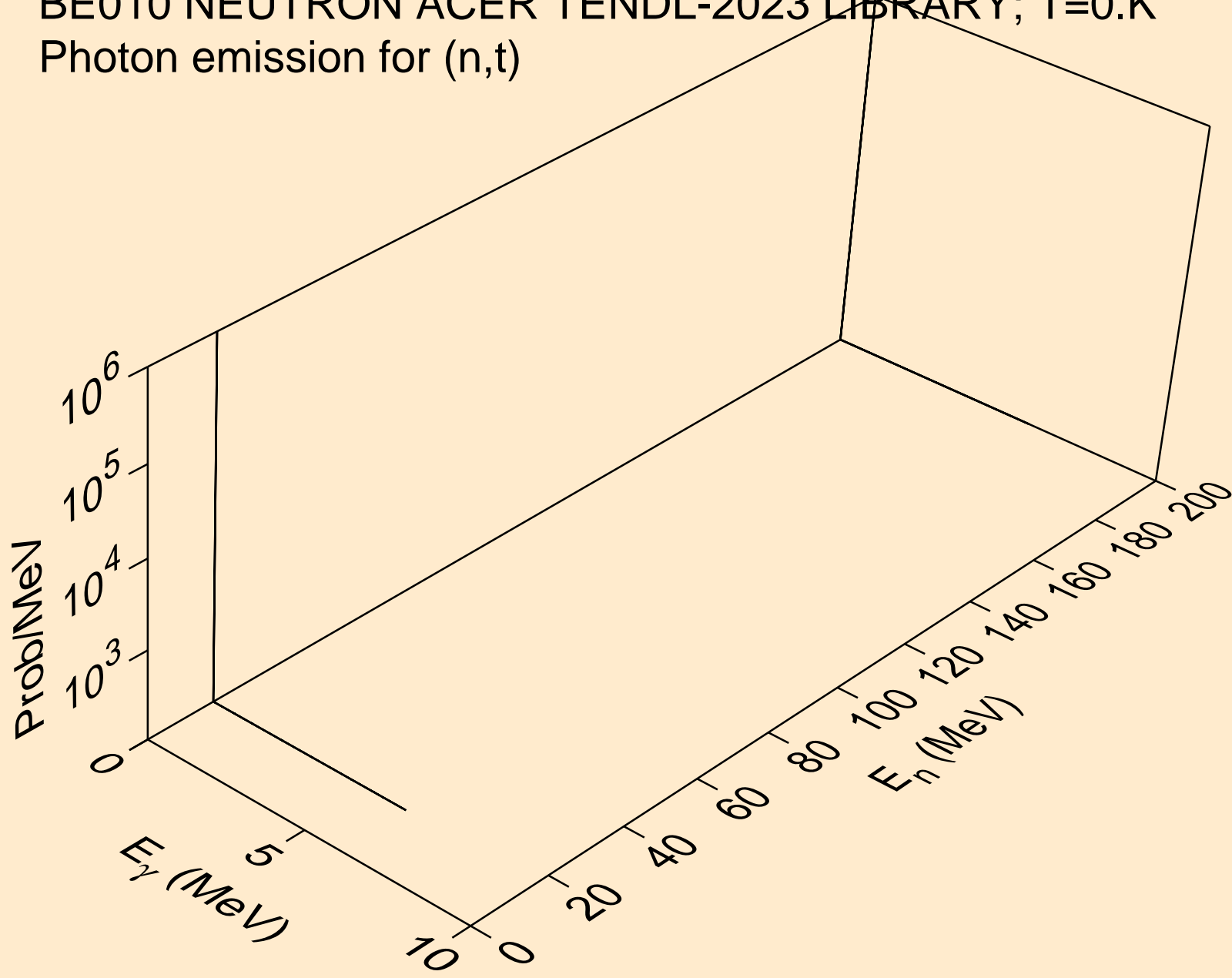

BE010 NEUTRON ACER TENDL-2023 LIBRARY; T=0.K  
thermal capture photon spectrum

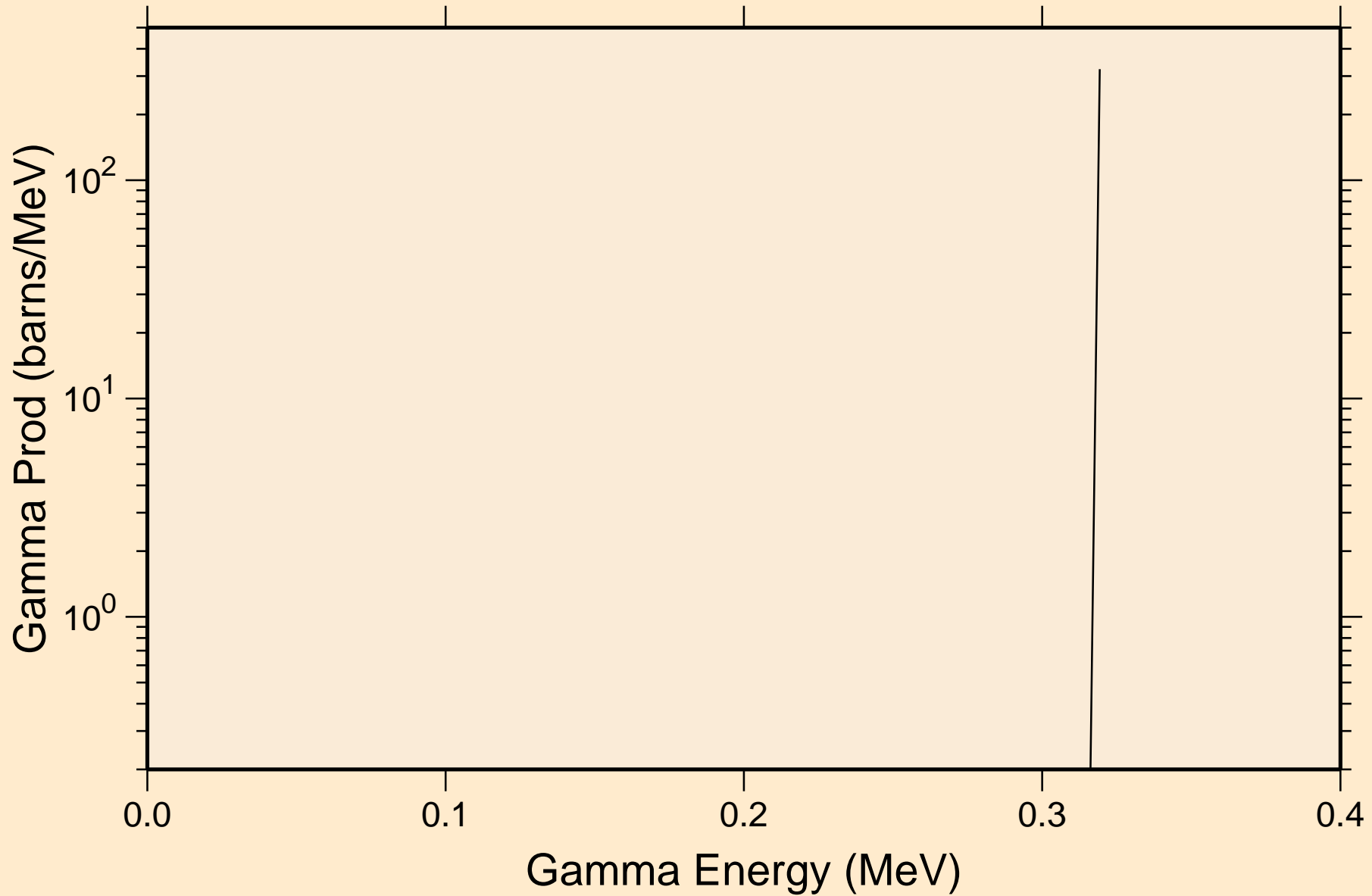

BE010 NEUTRON ACER TENDL-2023 LIBRARY; T=0.K  
14 MeV photon spectrum

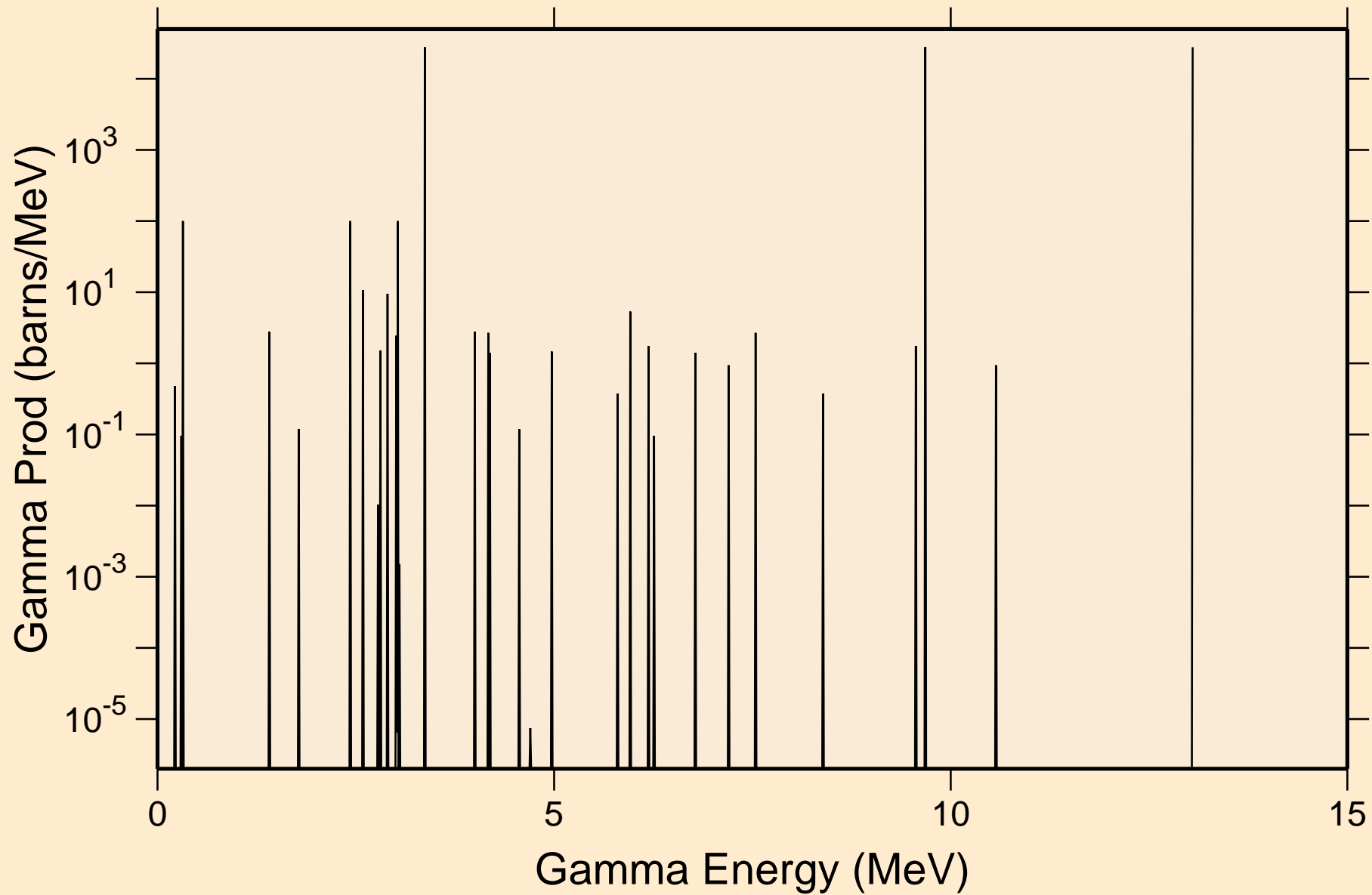

BE010 NEUTRON ACER TENDL-2023 LIBRARY; T=0.K  
Particle heating contributions

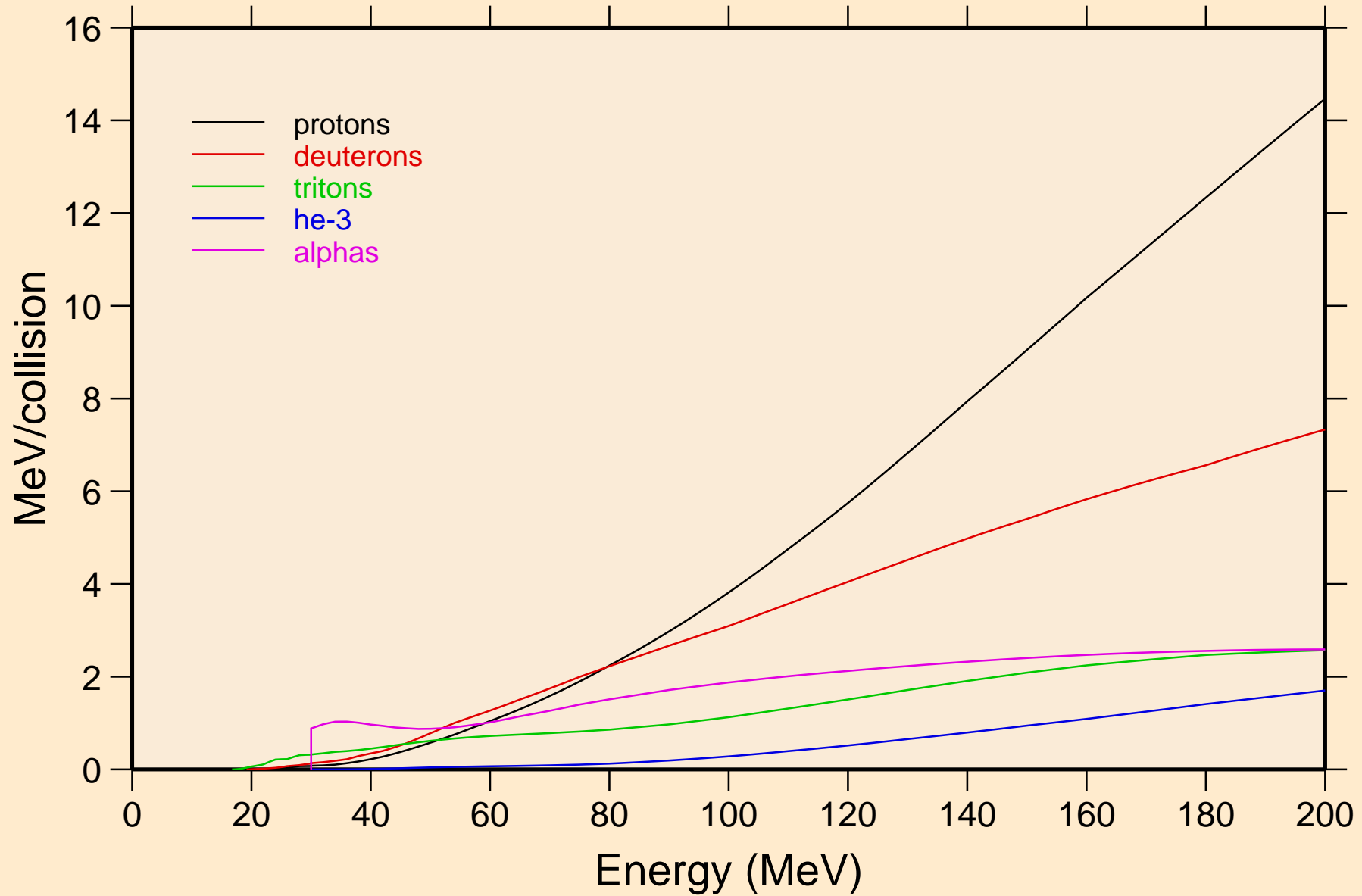

BE010 NEUTRON ACER TENDL-2023 LIBRARY; T=0.K  
Recoil Heating

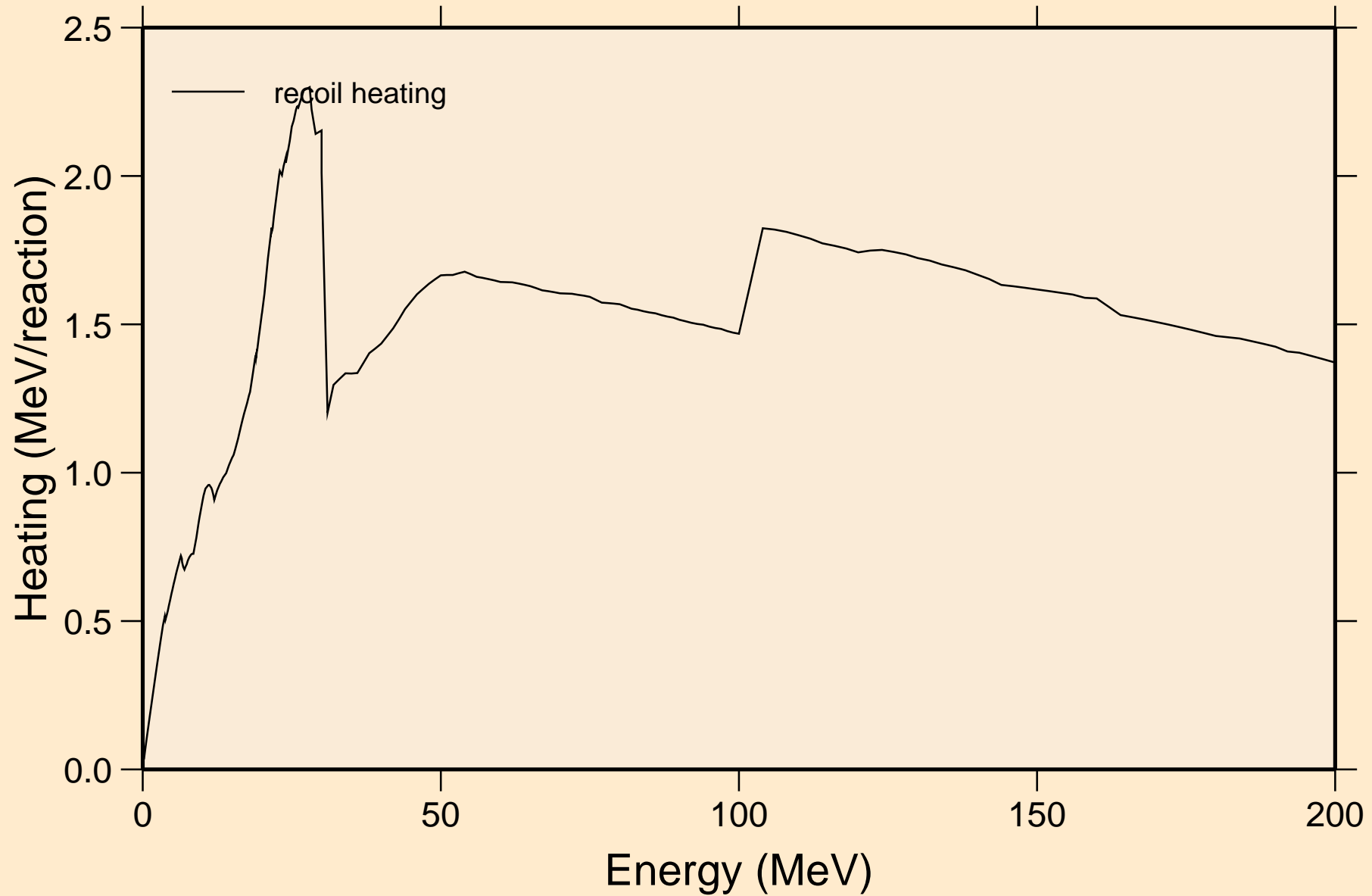

# BE010 NEUTRON ACER TENDL-2023 LIBRARY; T=0.K

## Particle production cross sections

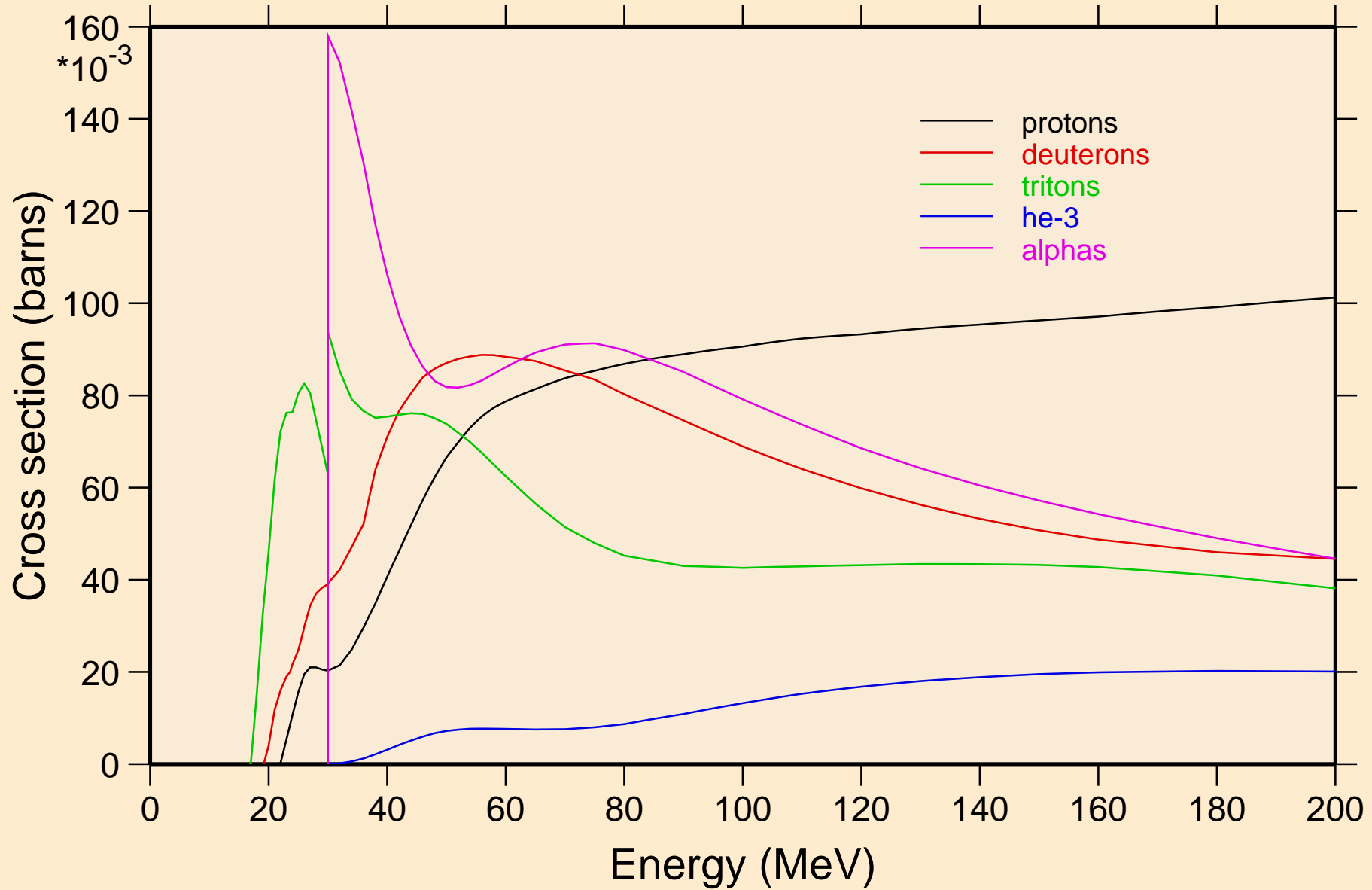

BE010 NEUTRON ACER TENDL-2023 LIBRARY; T=0.K  
protons from (n,x)

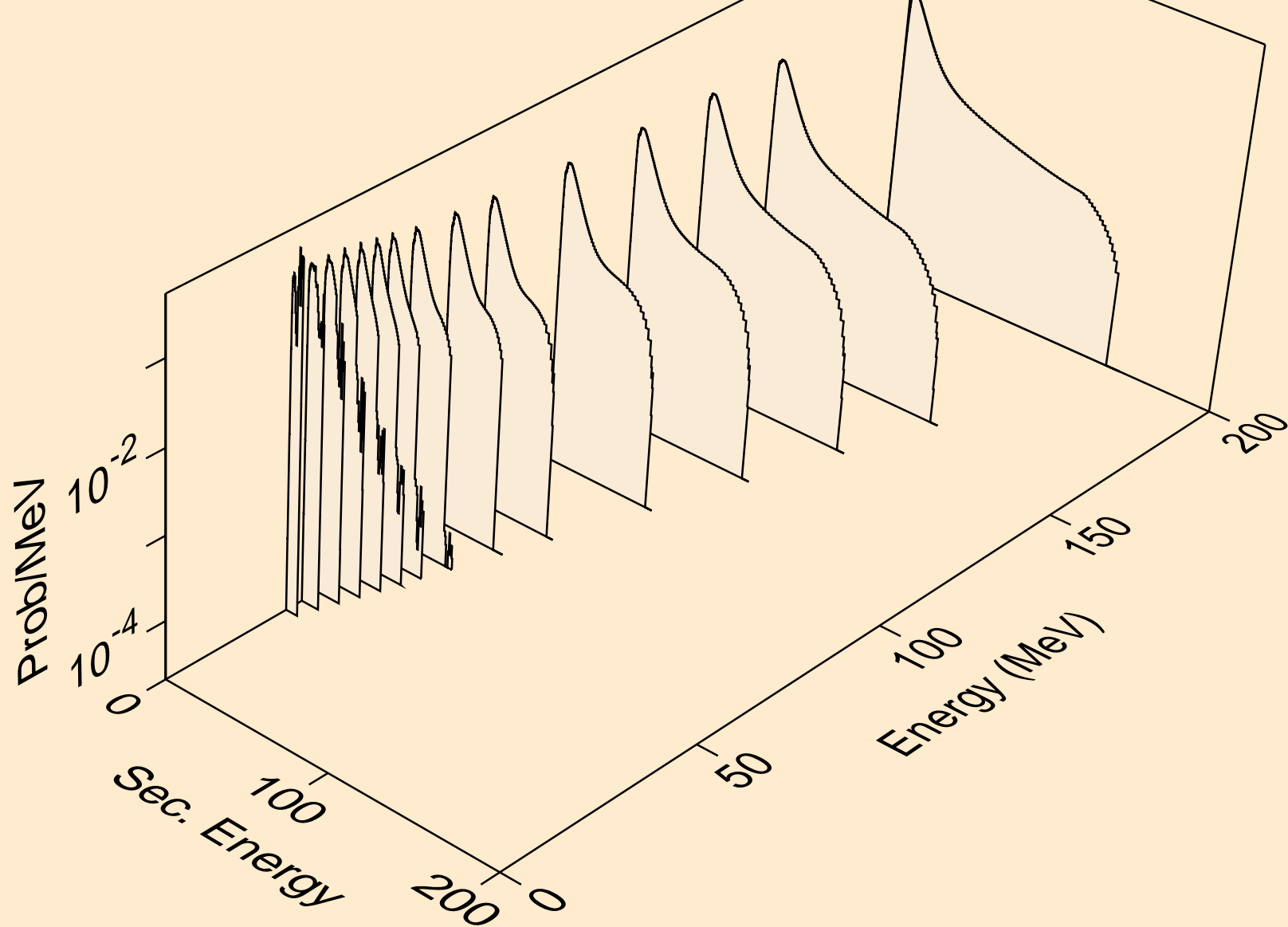

BE010 NEUTRON ACER TENDL-2023 LIBRARY; T=0.K  
protons from (n,n\*)p

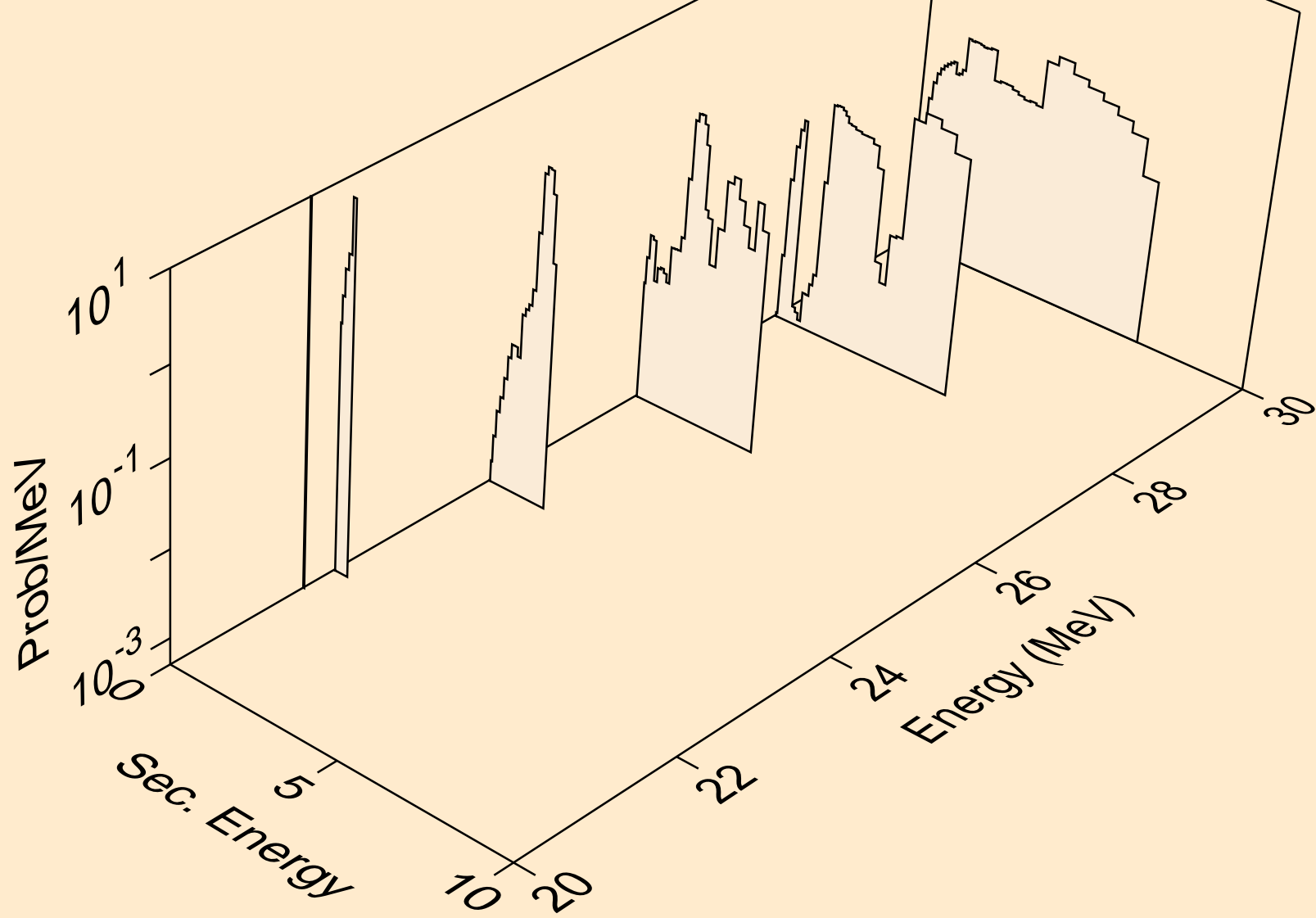

BE010 NEUTRON ACER TENDL-2023 LIBRARY; T=0.K  
protons from (n,2np)

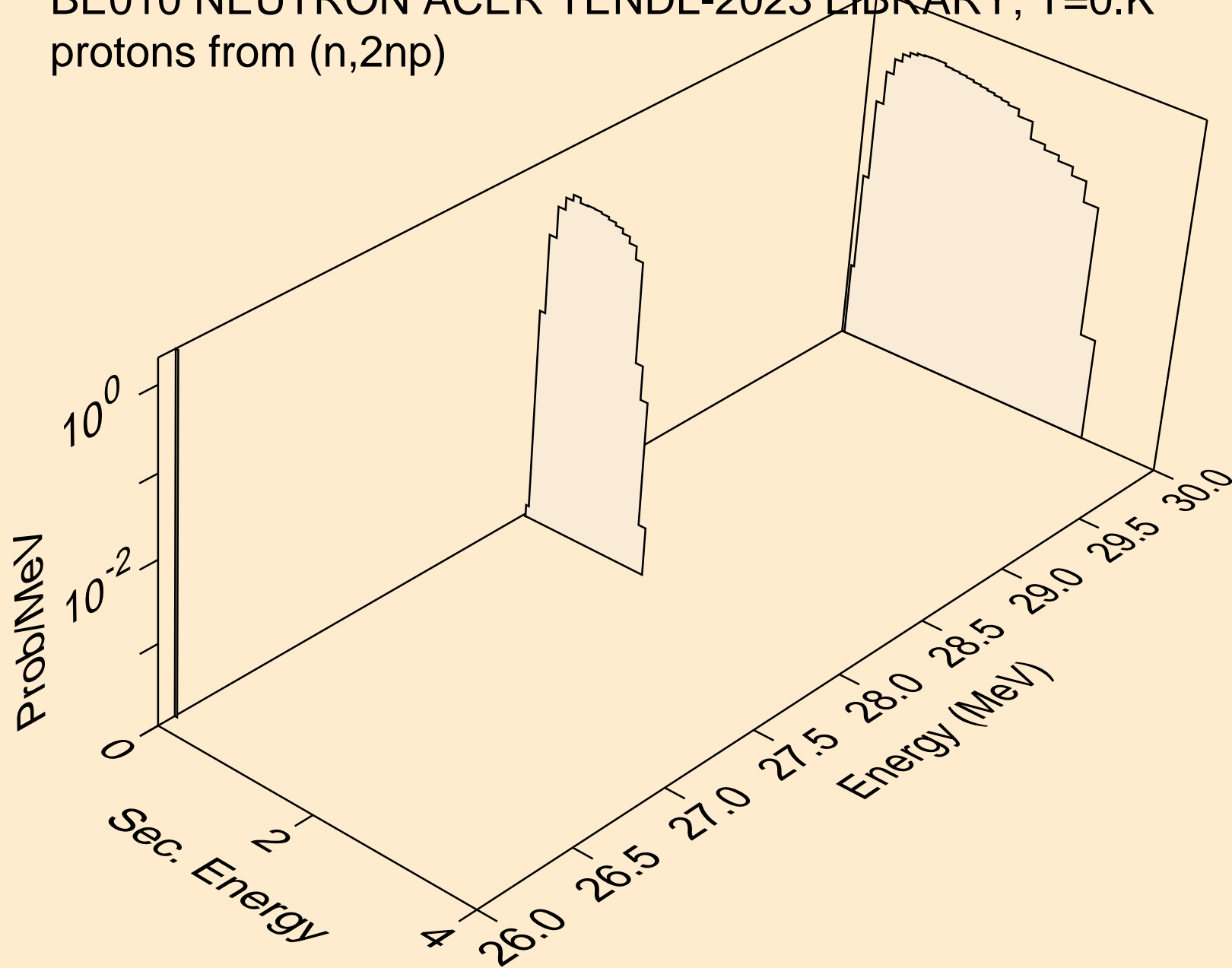

BE010 NEUTRON ACER TENDL-2023 LIBRARY; T=0.K  
protons from (n,3np)

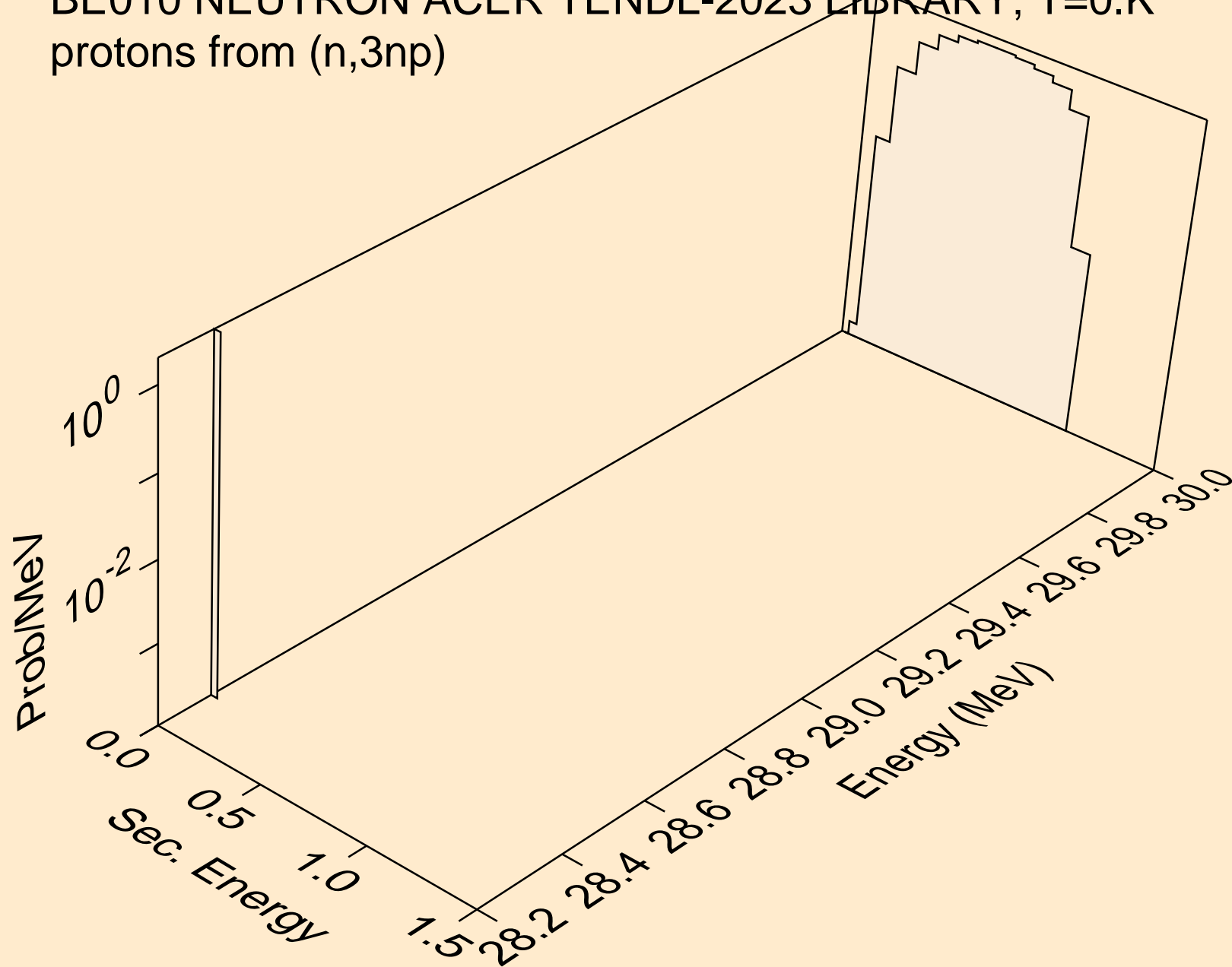

BE010 NEUTRON ACER TENDL-2023 LIBRARY; T=0.K  
protons from (n,p)

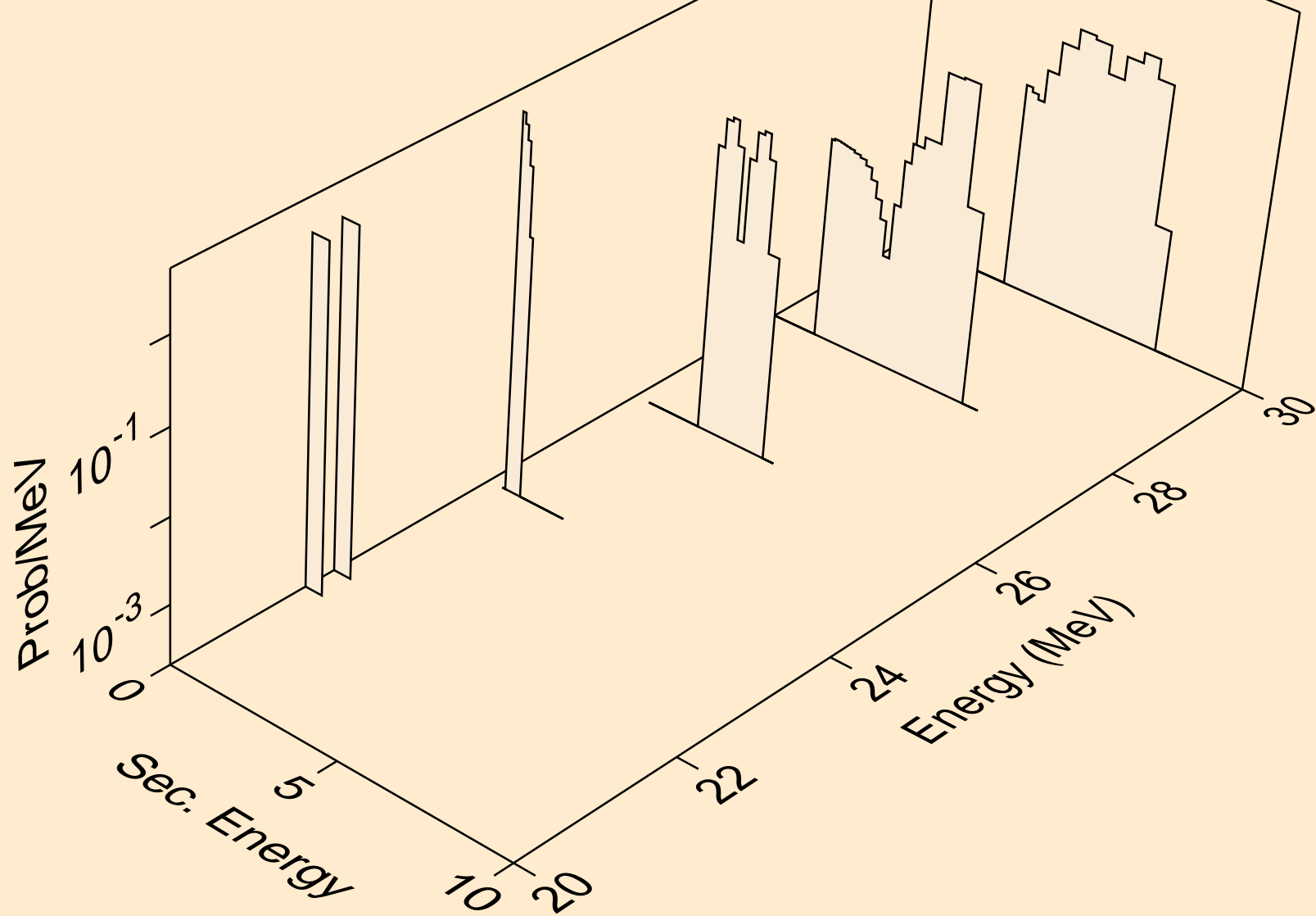

BE010 NEUTRON ACER TENDL-2023 LIBRARY; T=0.K  
deuterons from (n,x)

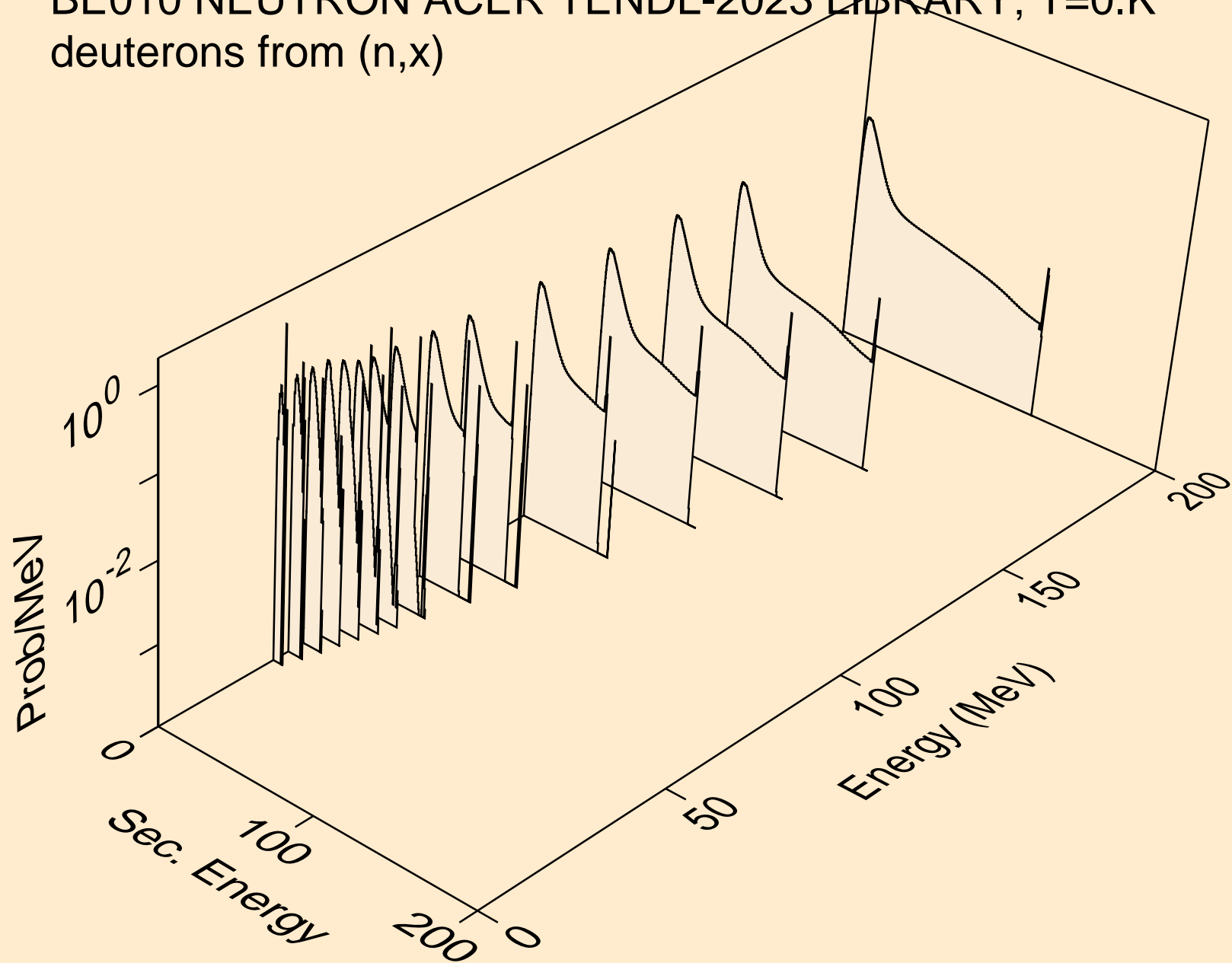

BE010 NEUTRON ACER TENDL-2023 LIBRARY; T=0.K  
deuterons from (n,2nd)

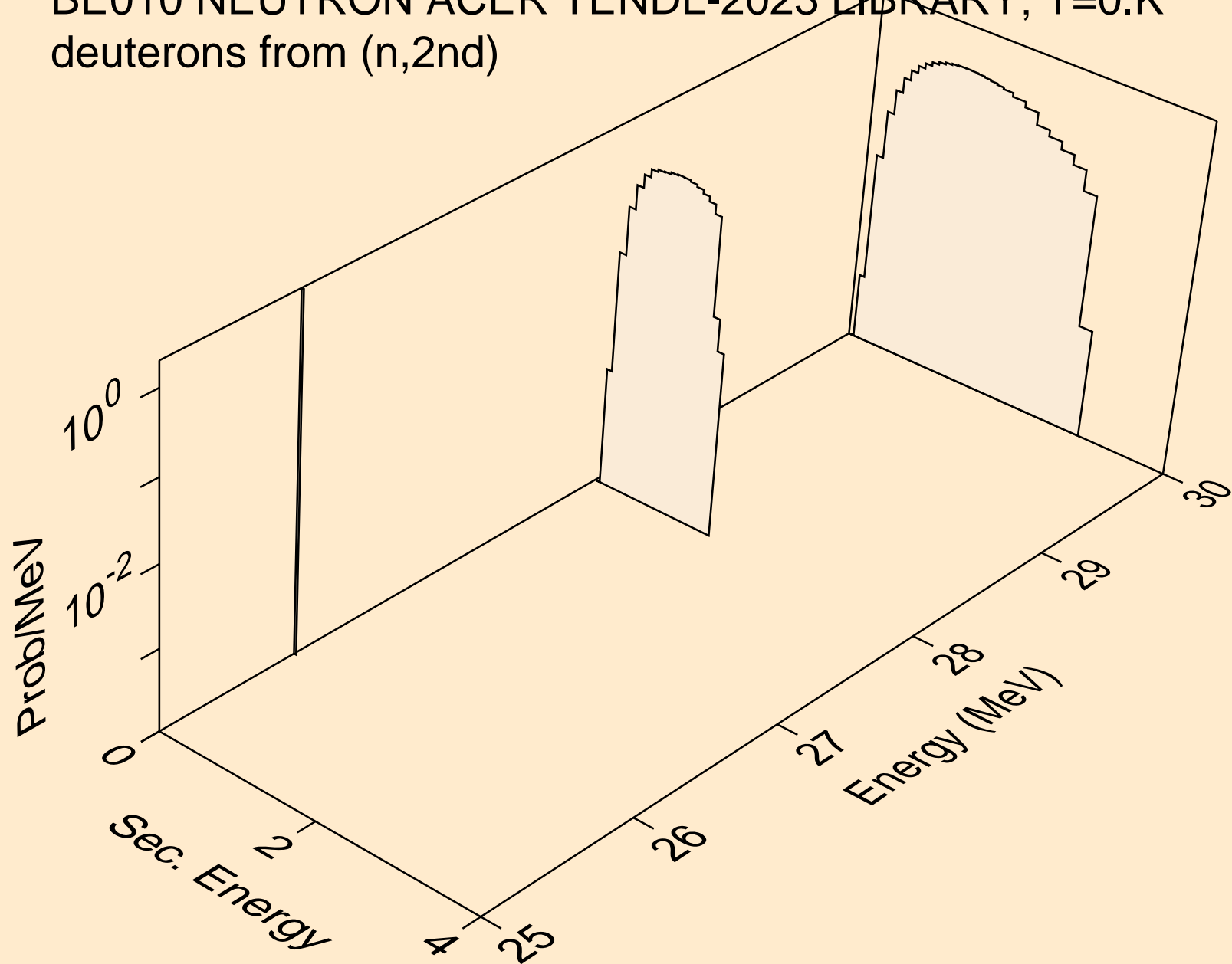

BE010 NEUTRON ACER TENDL-2023 LIBRARY; T=0.K  
deuterons from (n,n\*)d

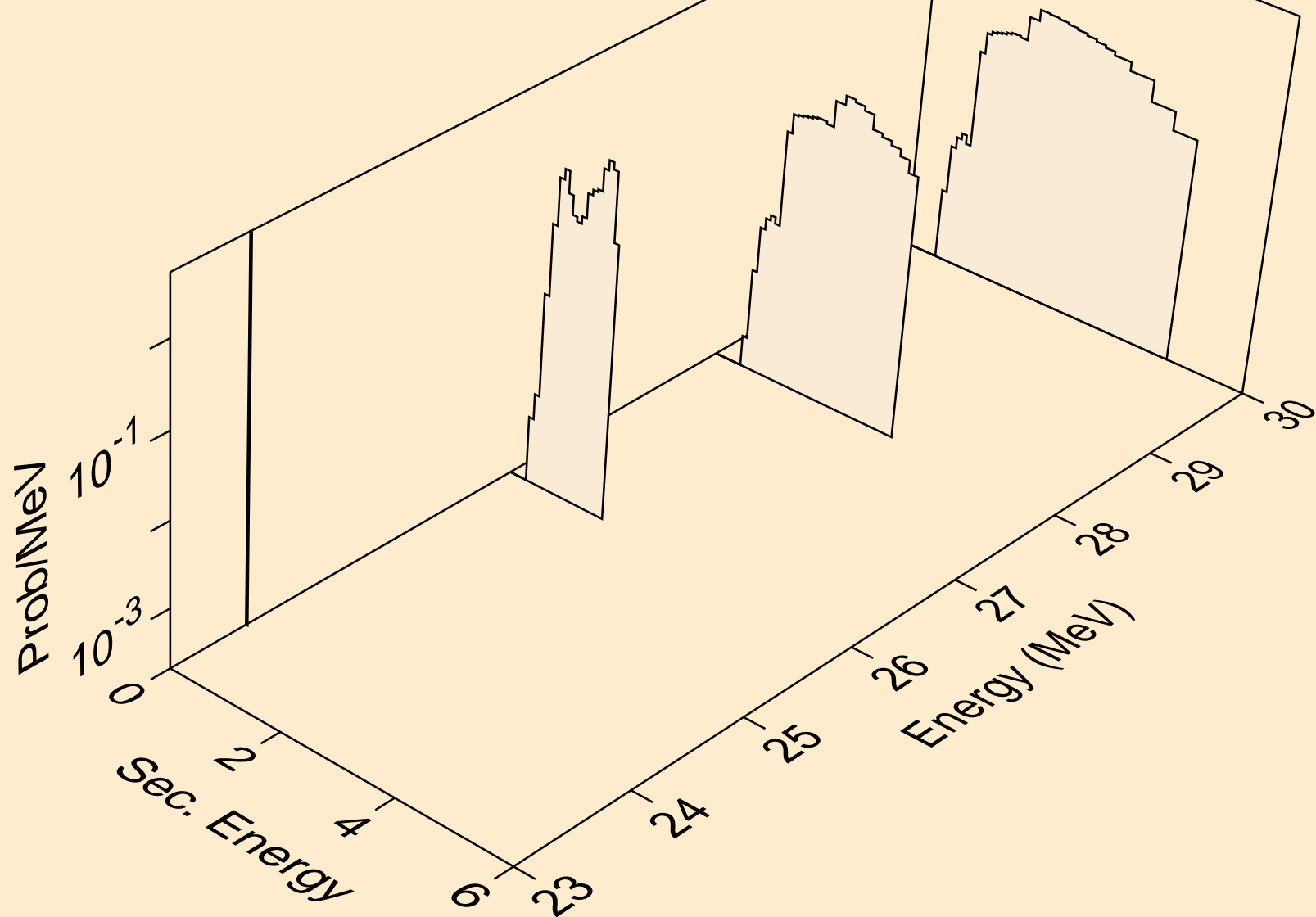

BE010 NEUTRON ACER TENDL-2023 LIBRARY; T=0.K  
deuterons from (n,d)

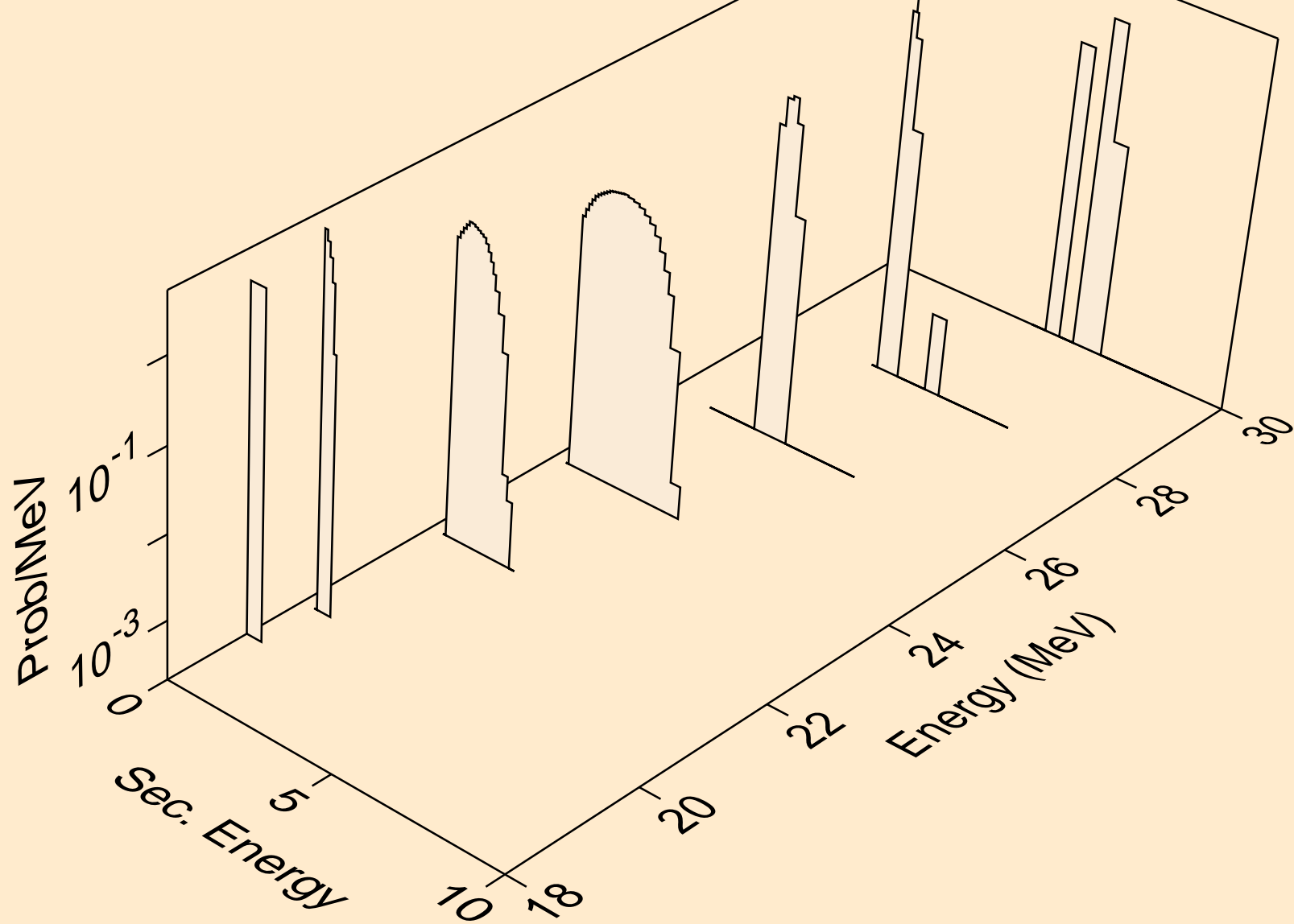

BE010 NEUTRON ACER TENDL-2023 LIBRARY; T=0.K  
tritons from (n,x)

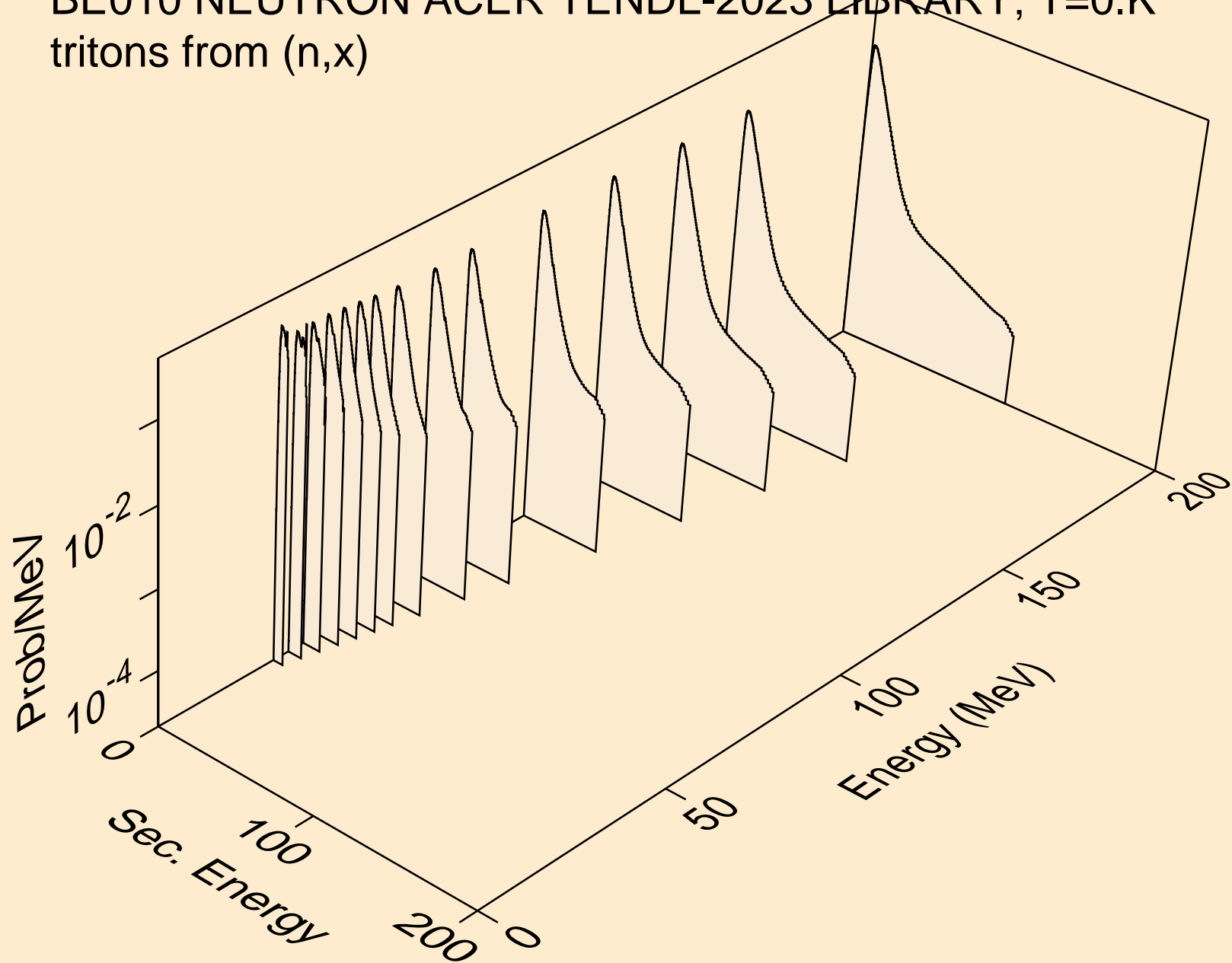

BE010 NEUTRON ACER TENDL-2023 LIBRARY; T=0.K  
tritons from (n,n\*)t

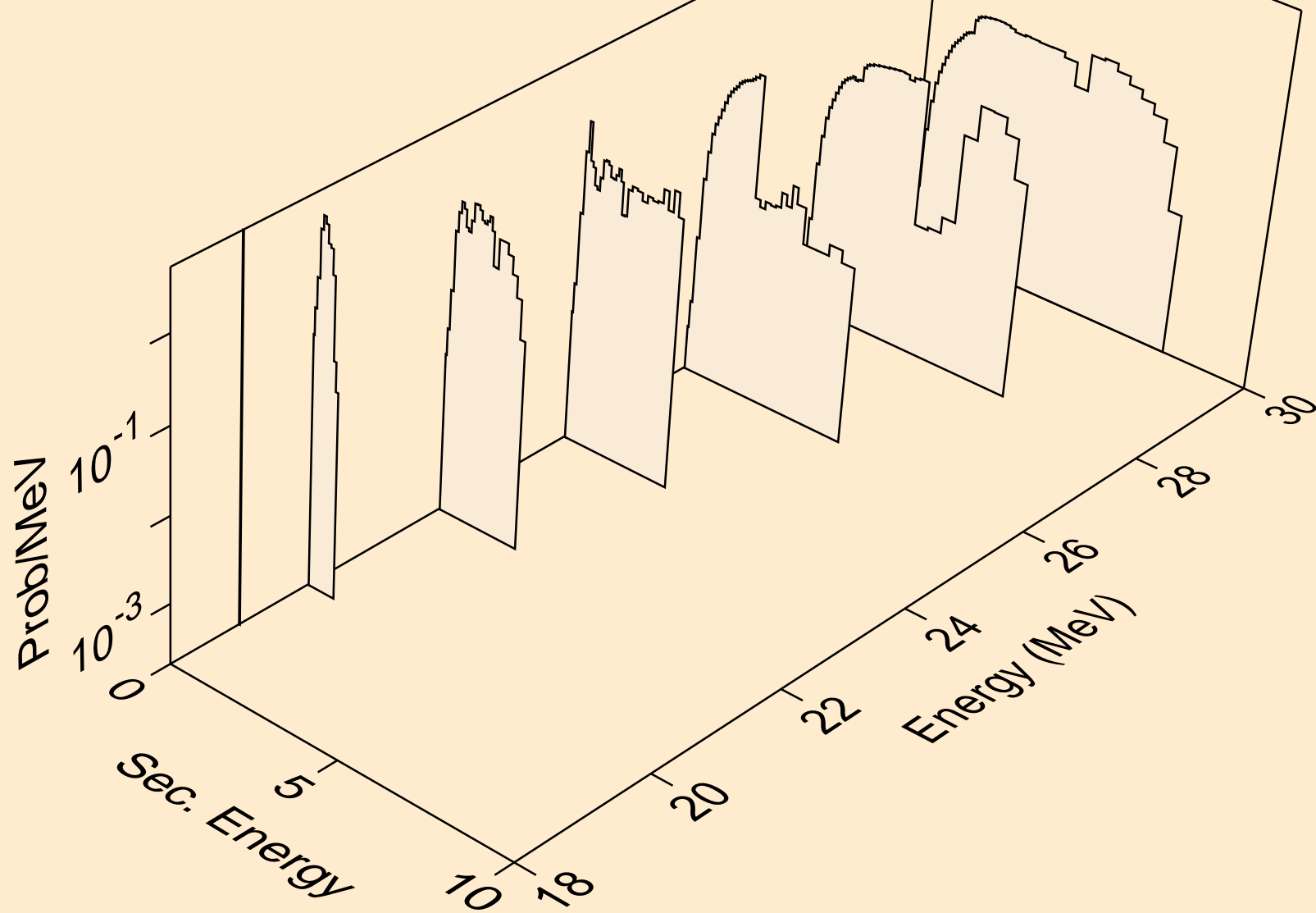

BE010 NEUTRON ACER TENDL-2023 LIBRARY; T=0.K  
tritons from (n,t)

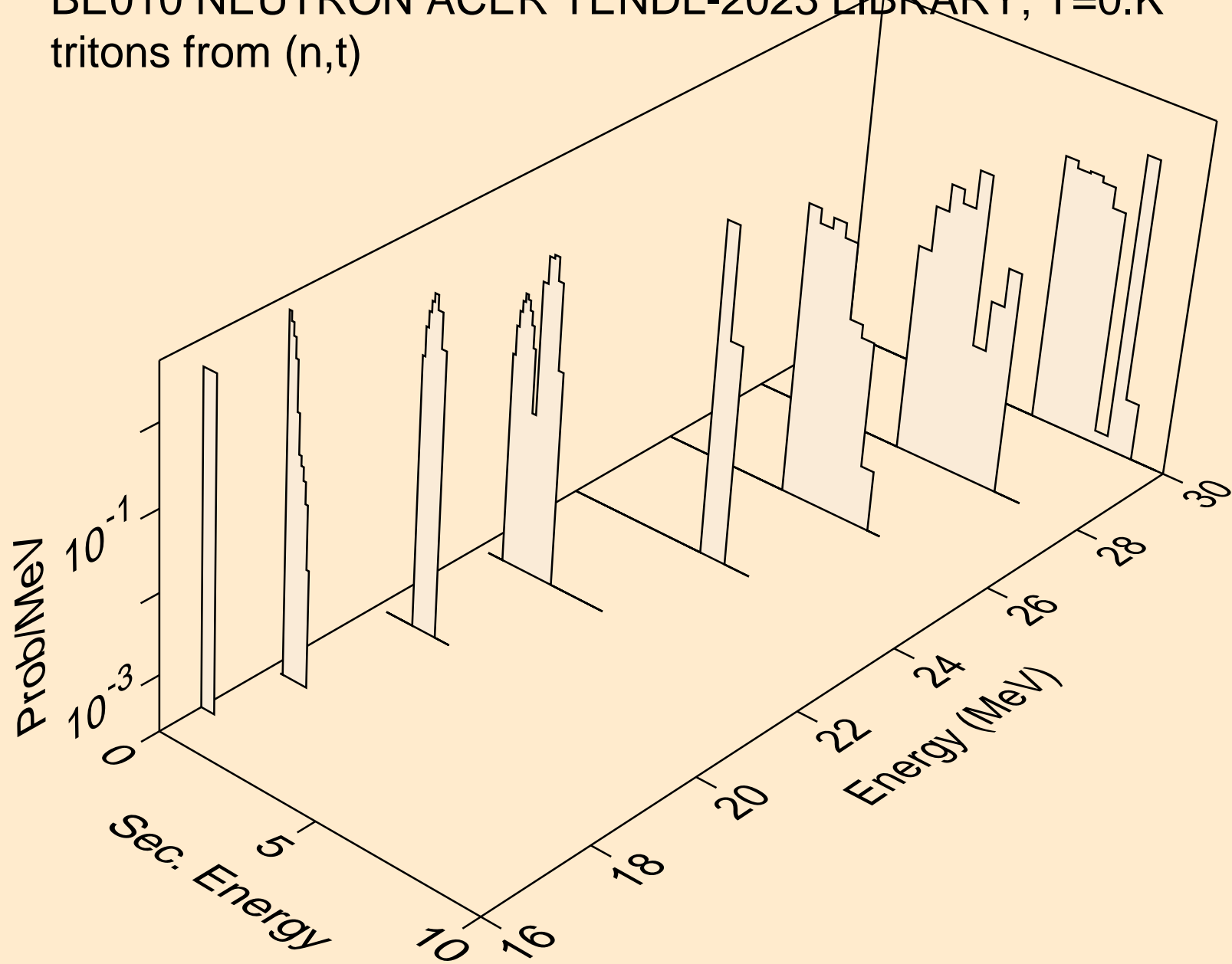

BE010 NEUTRON ACER TENDL-2023 LIBRARY; T=0.K  
he3s from (n,x)

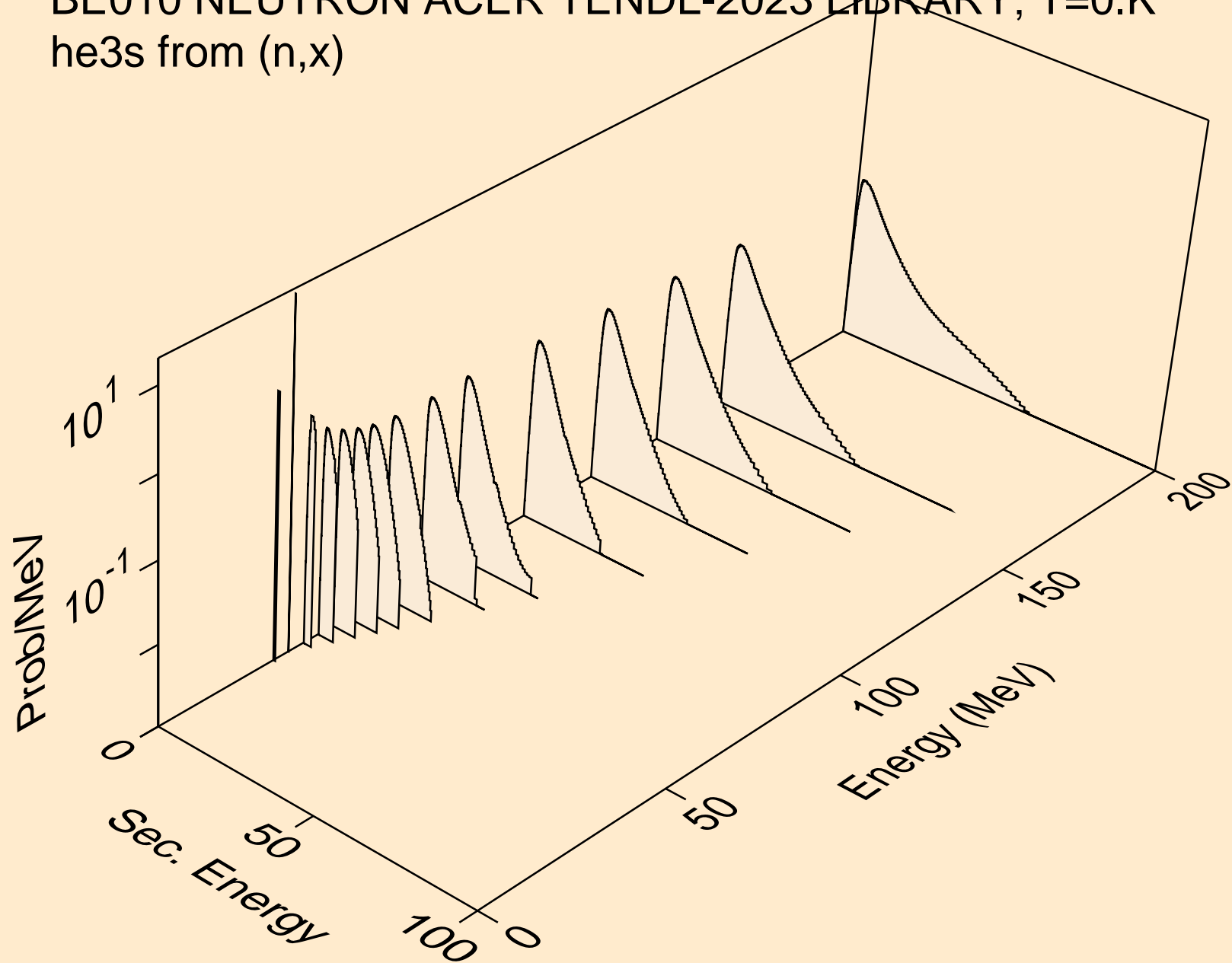

BE010 NEUTRON ACER TENDL-2023 LIBRARY; T=0.K  
alphas from (n,x)

