

# CD105 NEUTRON ACER TENDL-2023 LIBRARY; T=0.K

## Principal cross sections

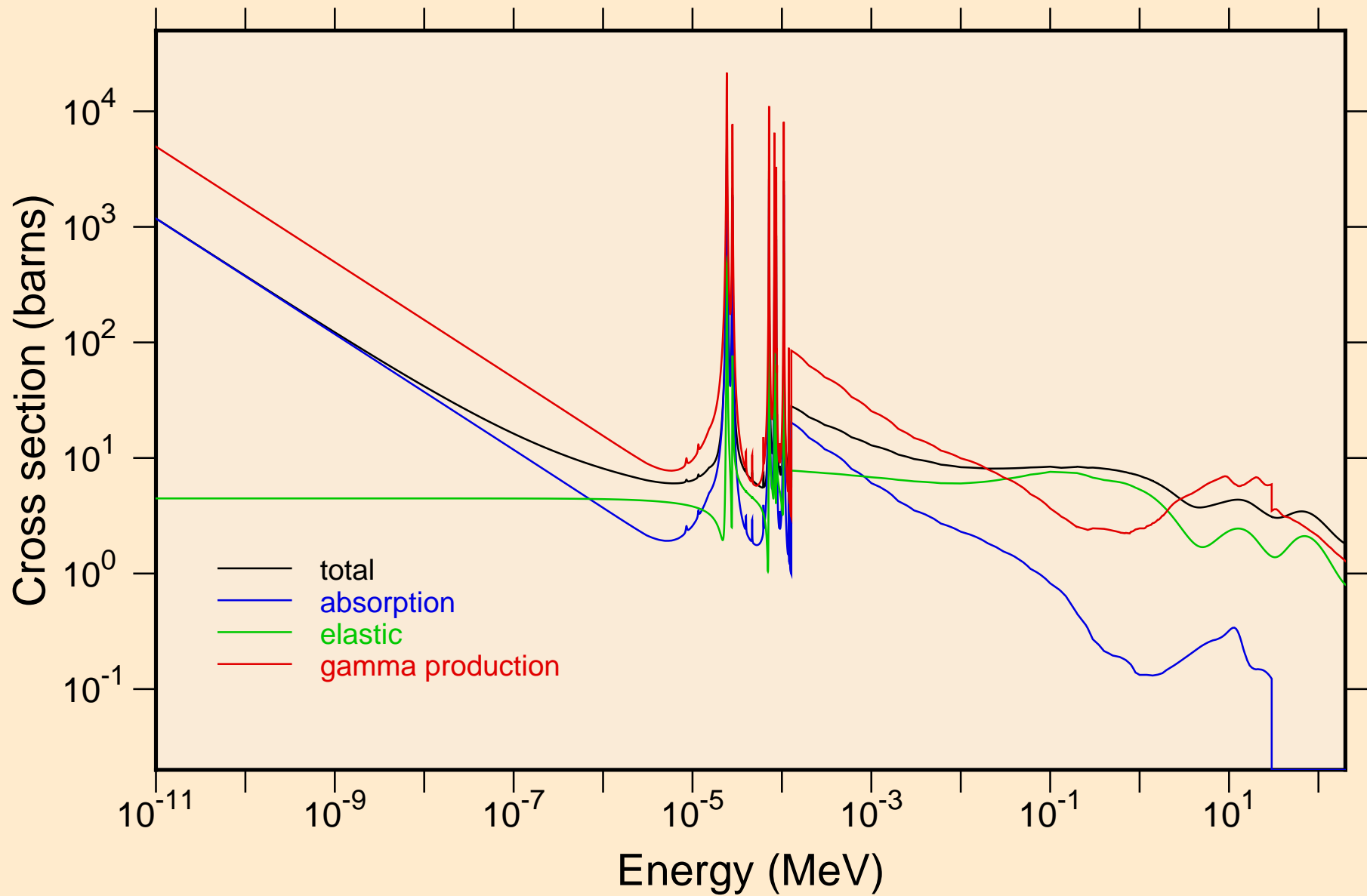

CD105 NEUTRON ACER TENDL-2023 LIBRARY; T=0.K  
resonance total cross section

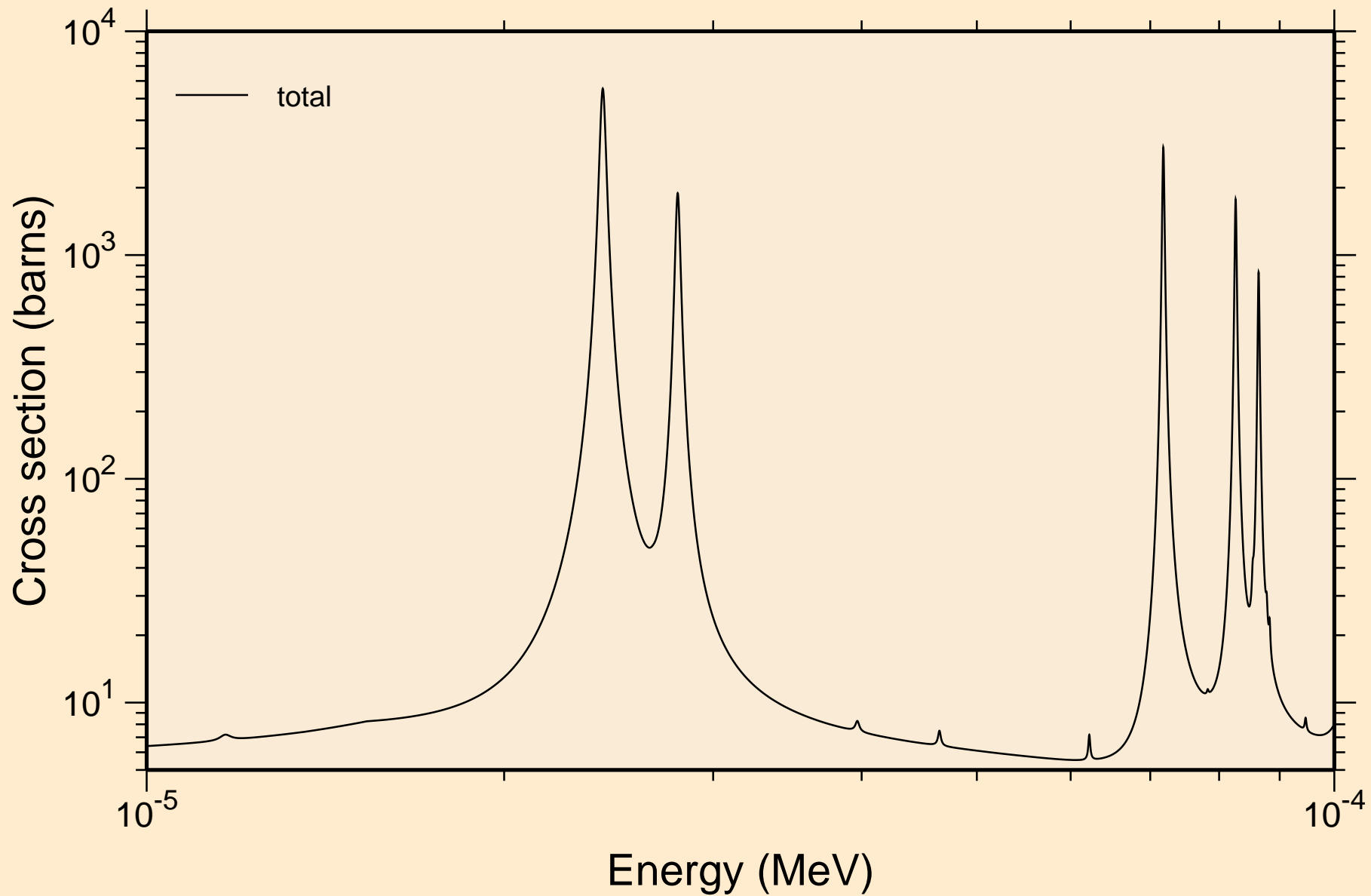

CD105 NEUTRON ACER TENDL-2023 LIBRARY; T=0.K  
resonance total cross section

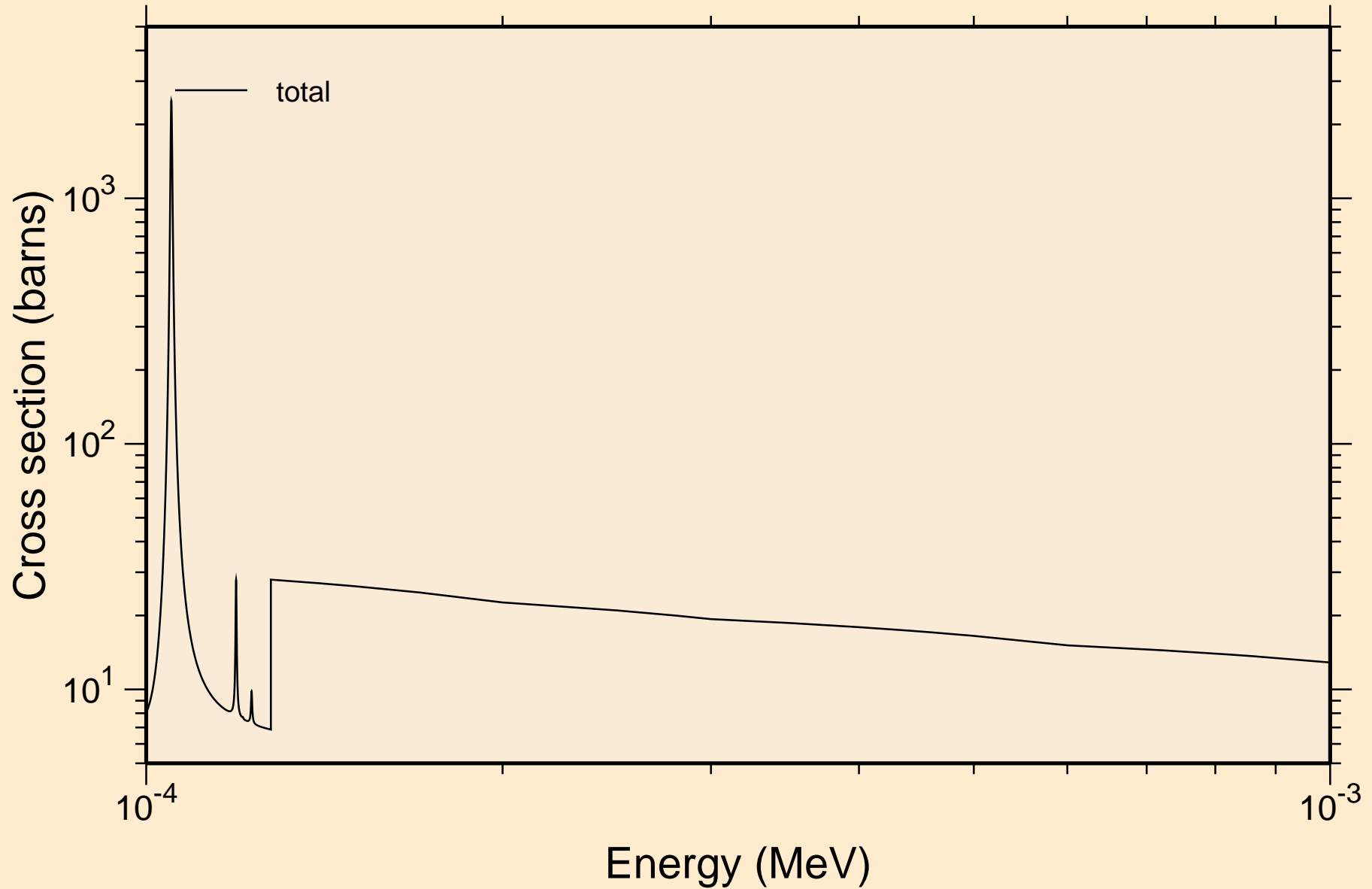

CD105 NEUTRON ACER TENDL-2023 LIBRARY; T=0.K  
resonance total cross section

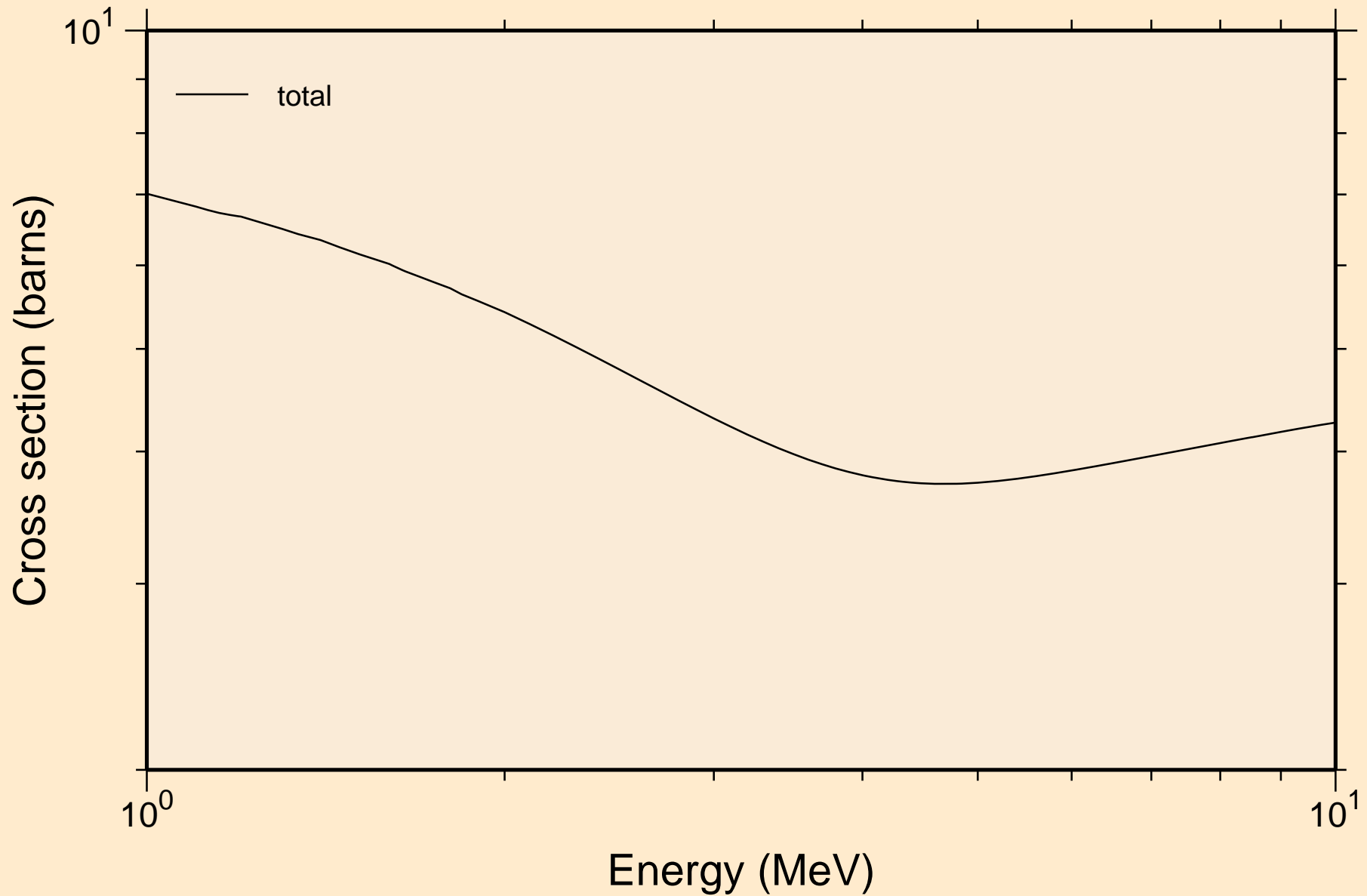

CD105 NEUTRON ACER TENDL-2023 LIBRARY; T=0.K  
resonance absorption cross sections

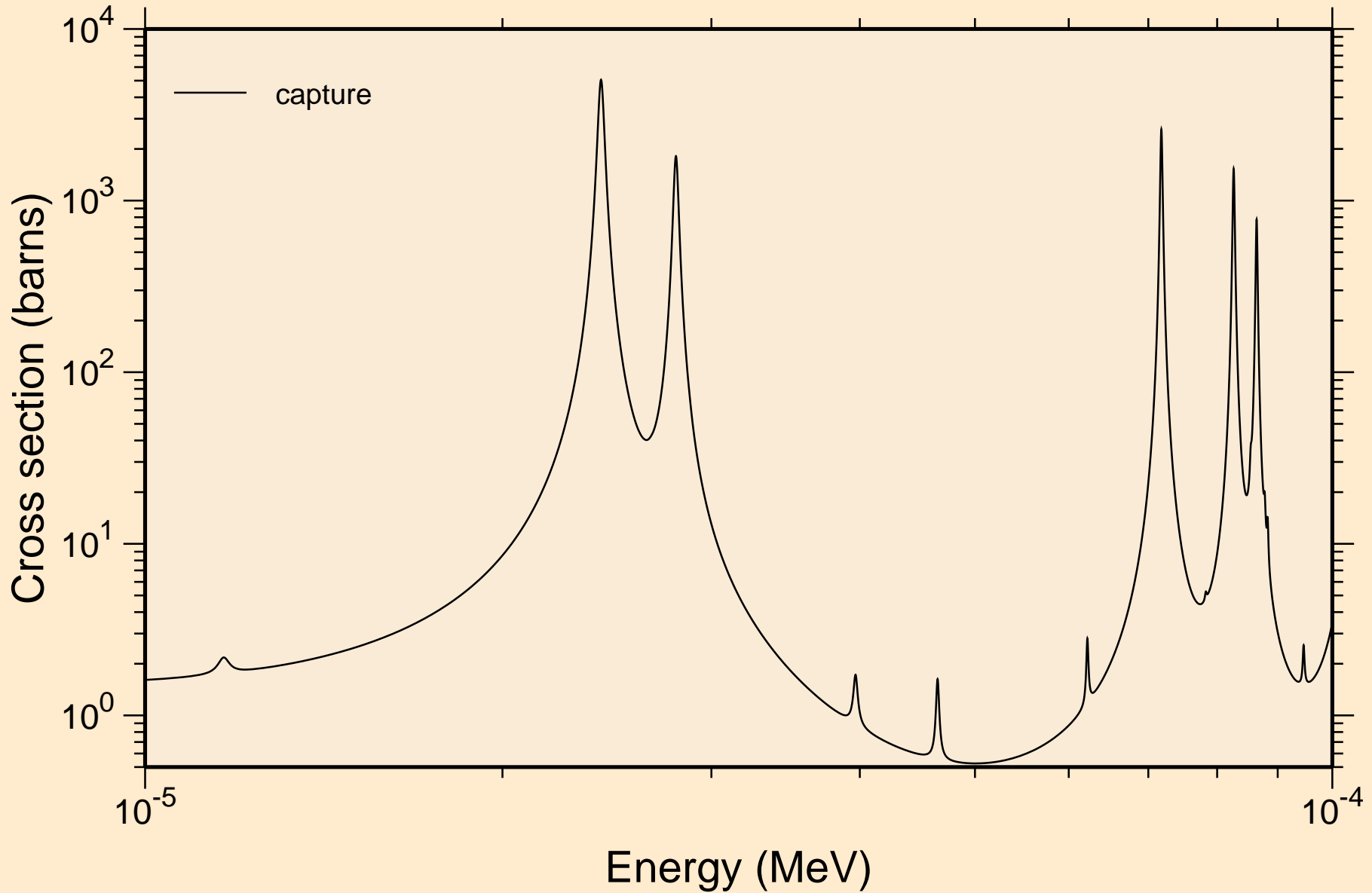

CD105 NEUTRON ACER TENDL-2023 LIBRARY; T=0.K  
resonance absorption cross sections

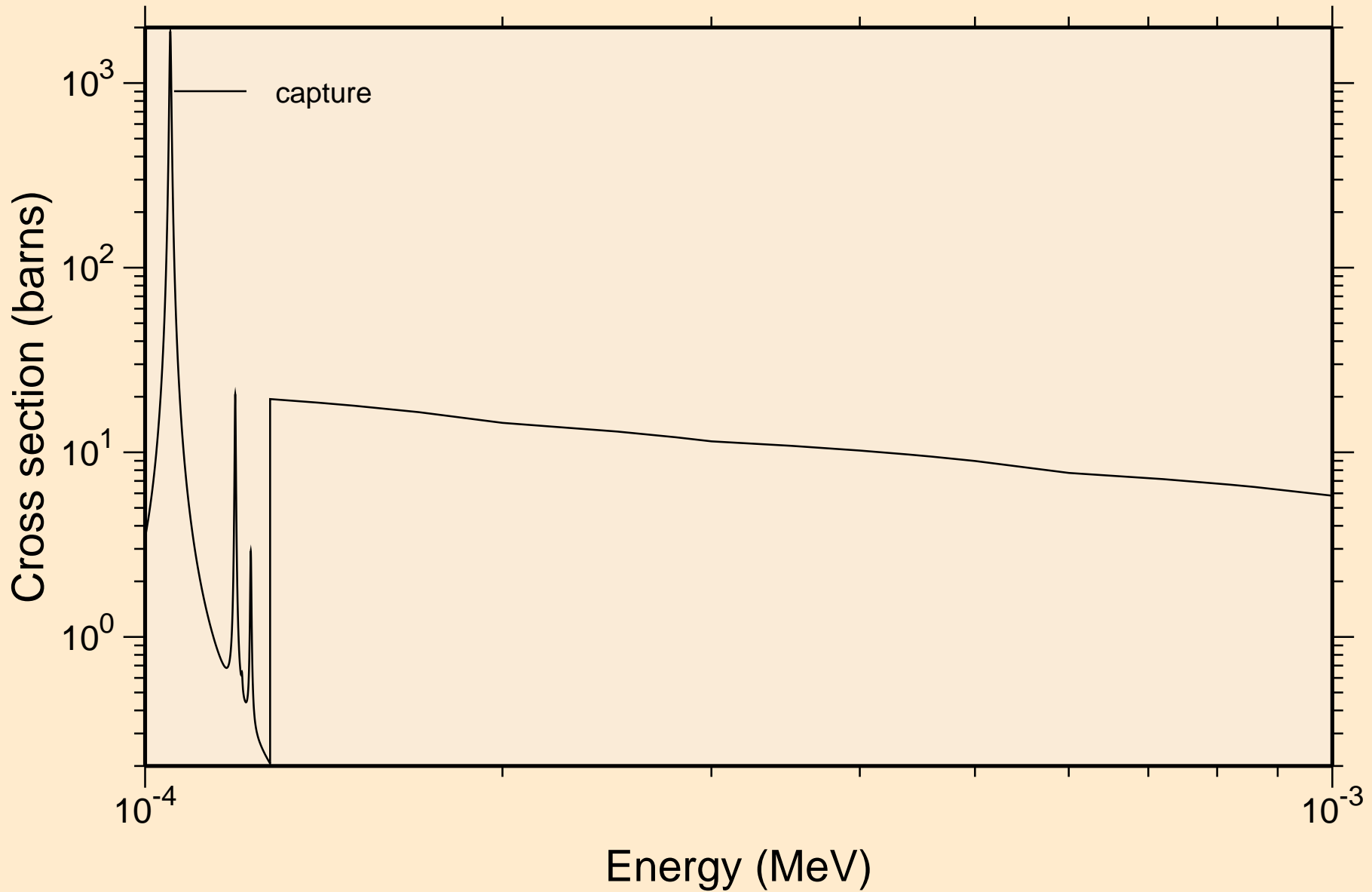

CD105 NEUTRON ACER TENDL-2023 LIBRARY; T=0.K  
resonance absorption cross sections

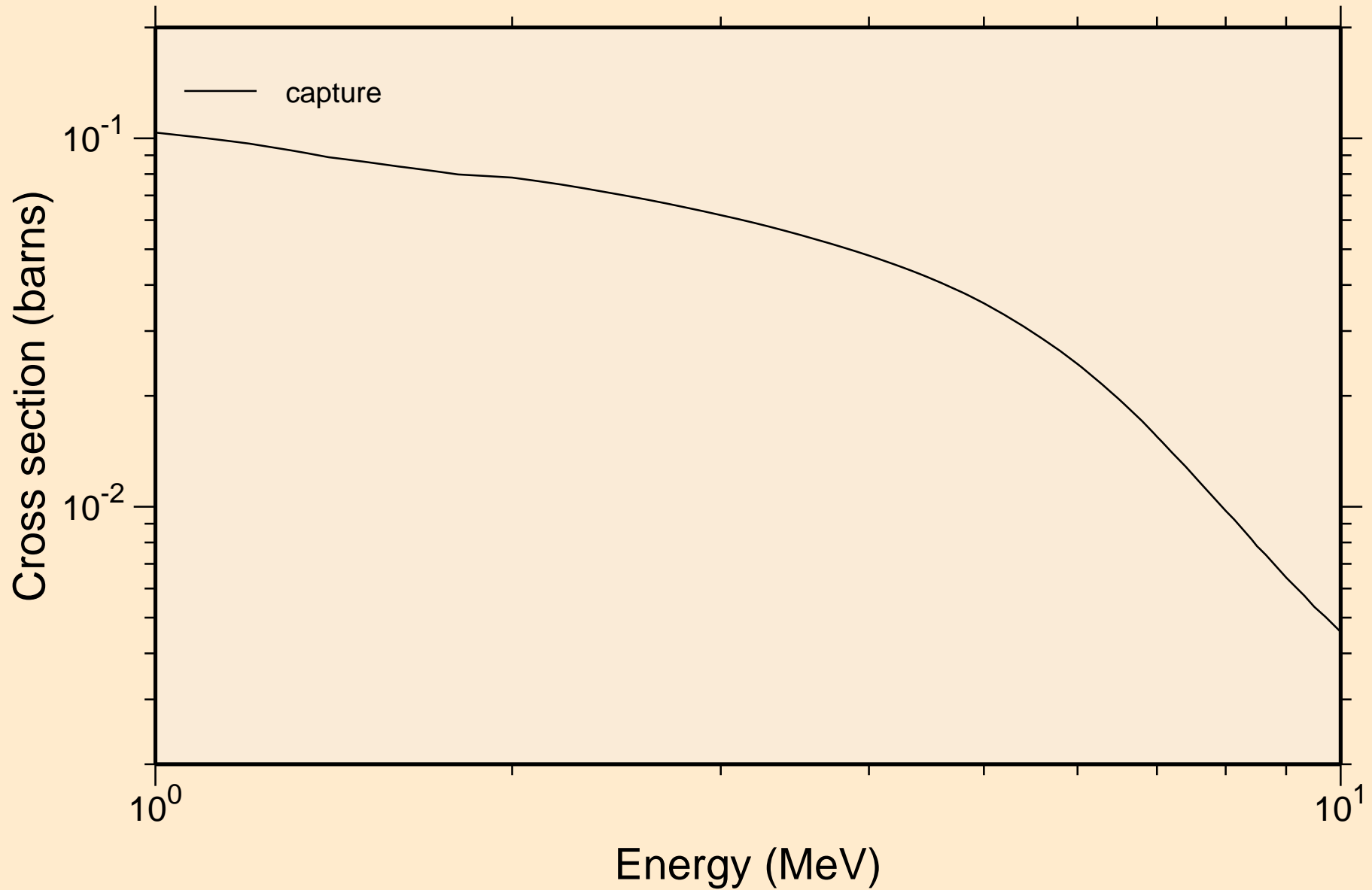

# CD105 NEUTRON ACER TENDL-2023 LIBRARY; T=0.K

## Heating

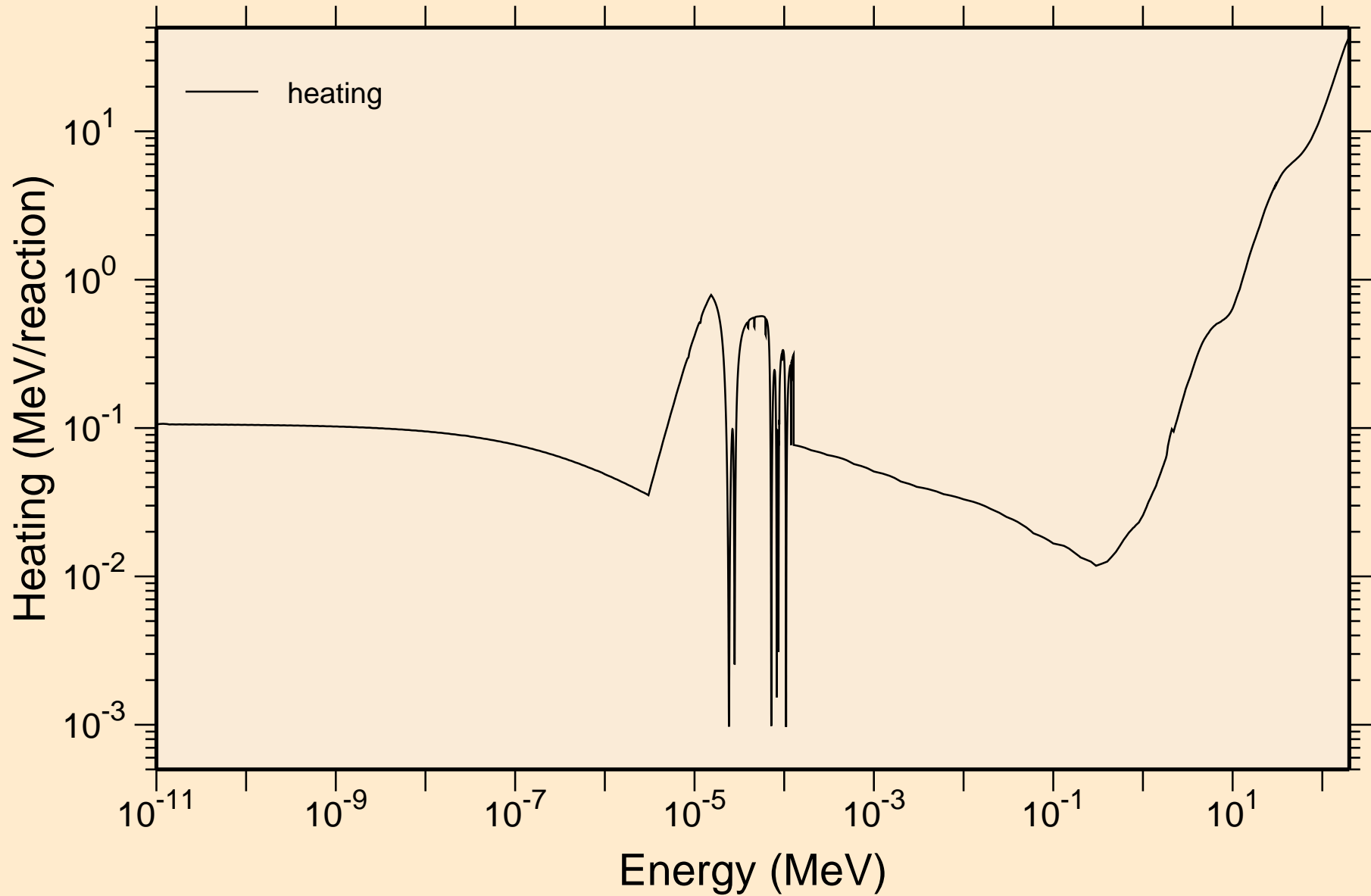

# CD105 NEUTRON ACER TENDL-2023 LIBRARY; T=0.K

## Damage

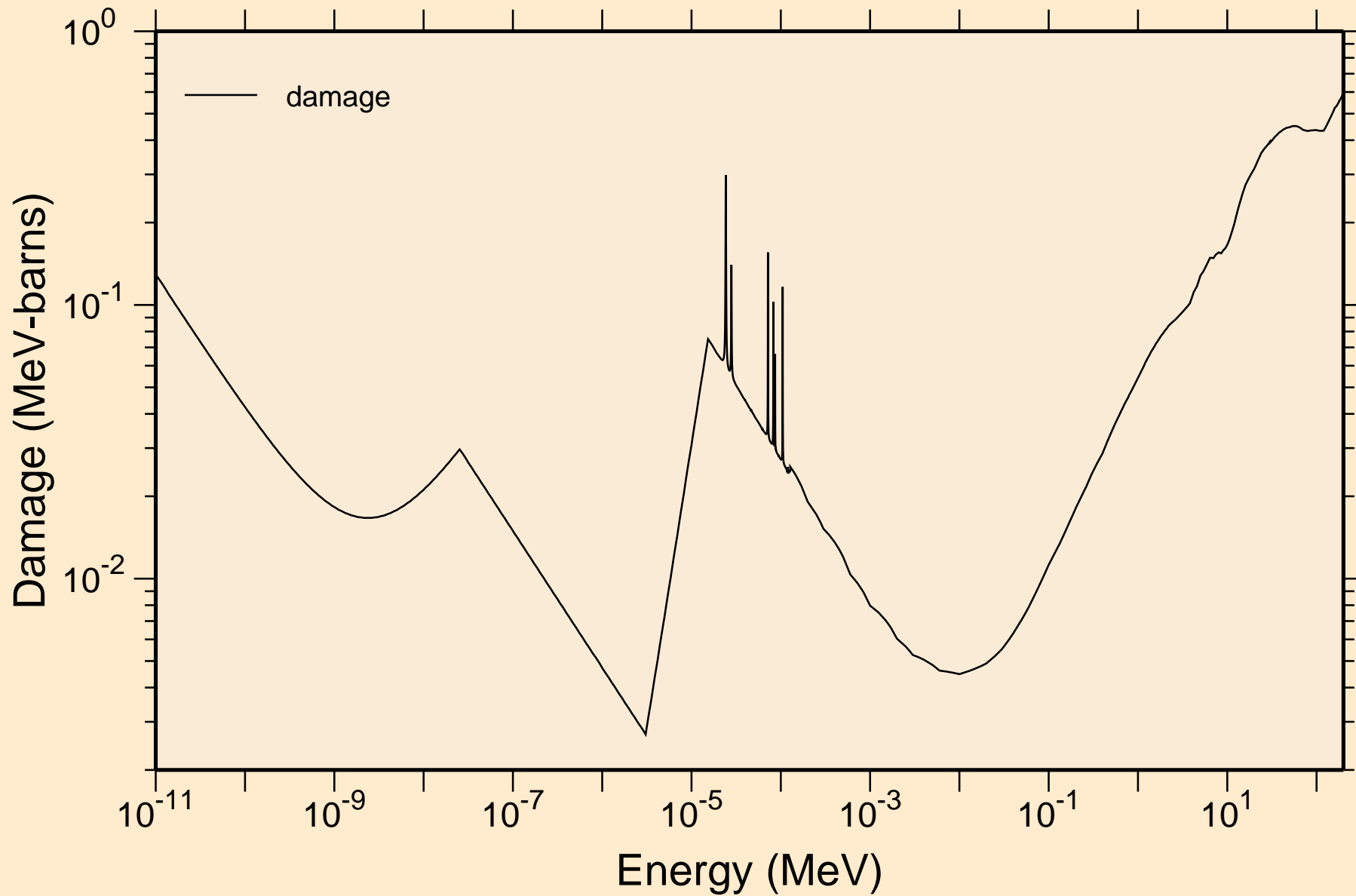

# CD105 NEUTRON ACER TENDL-2023 LIBRARY; T=0.K

## Non-threshold reactions

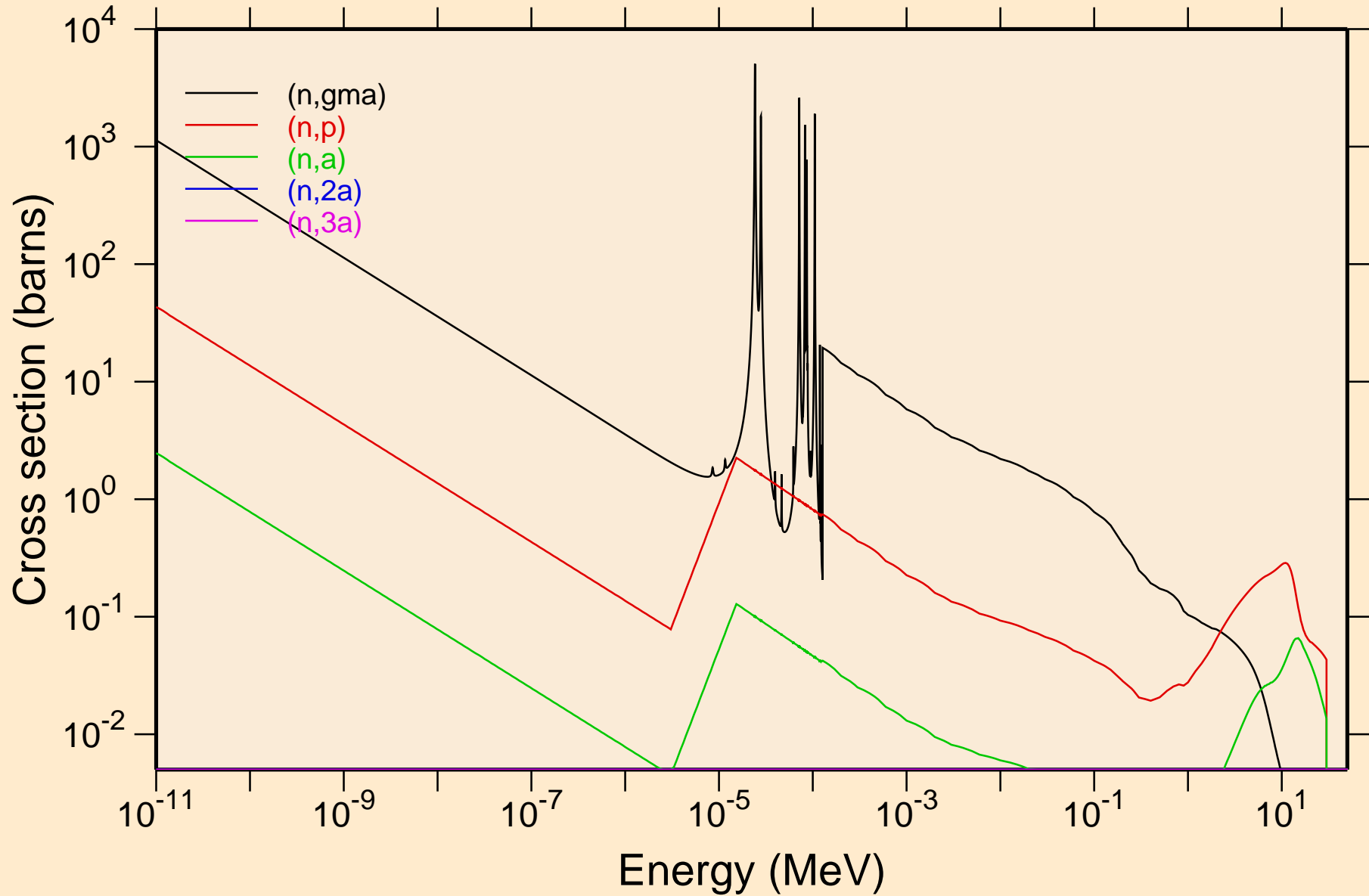

CD105 NEUTRON ACER TENDL-2023 LIBRARY; T=0.K  
Non-threshold reactions

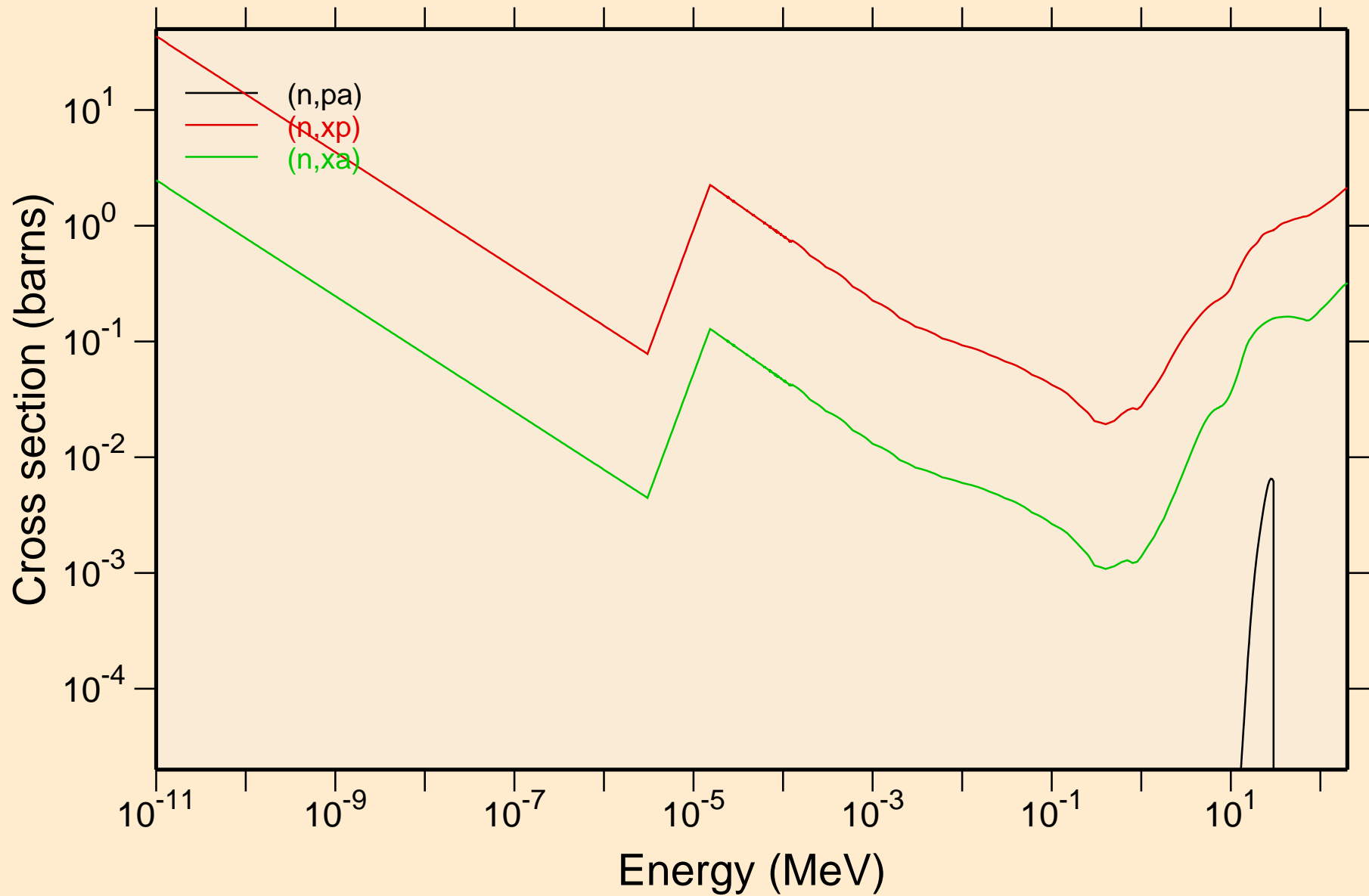

# CD105 NEUTRON ACER TENDL-2023 LIBRARY; T=0.K

## Principal cross sections

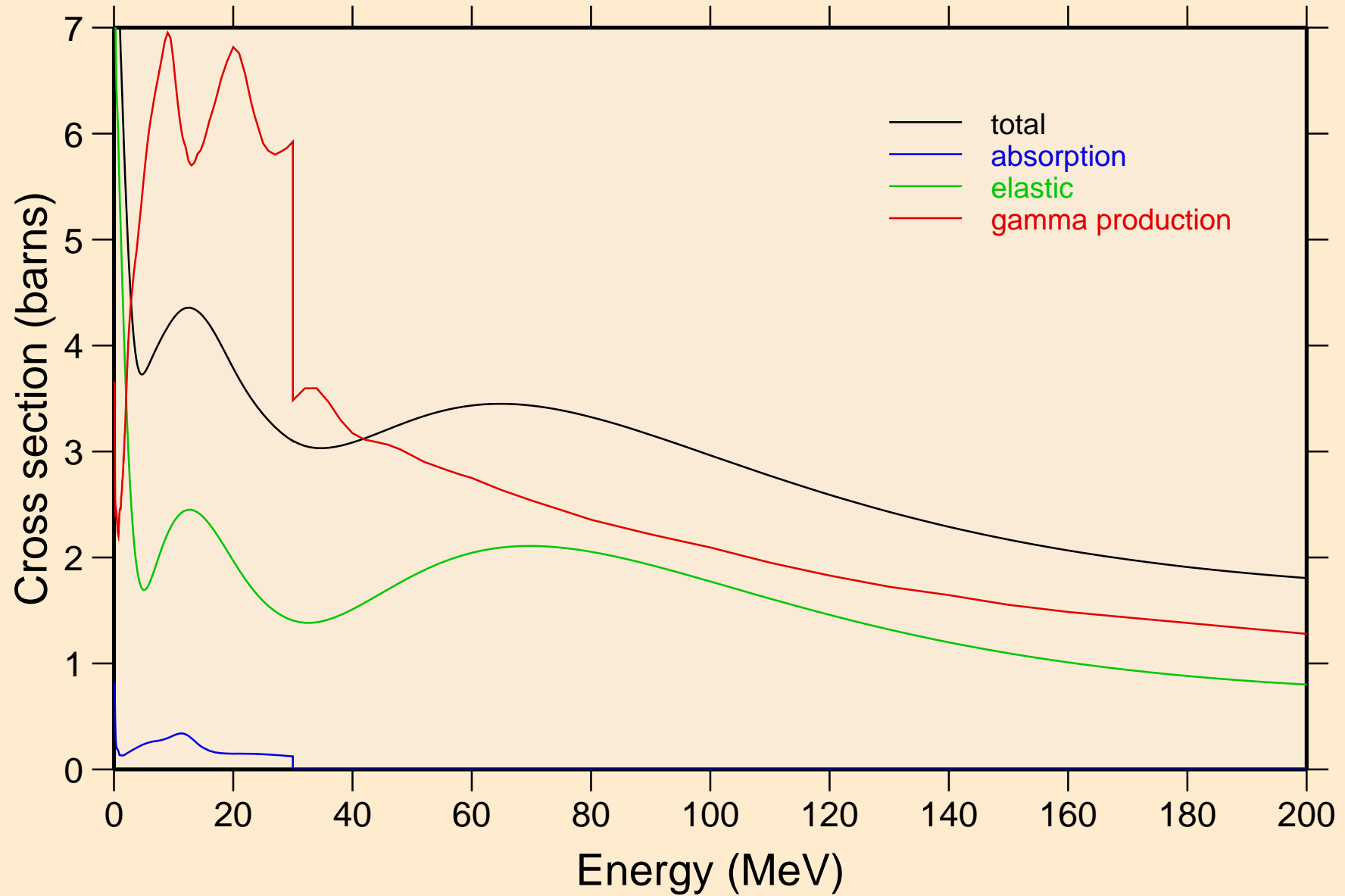

# CD105 NEUTRON ACER TENDL-2023 LIBRARY; T=0.K

## Heating

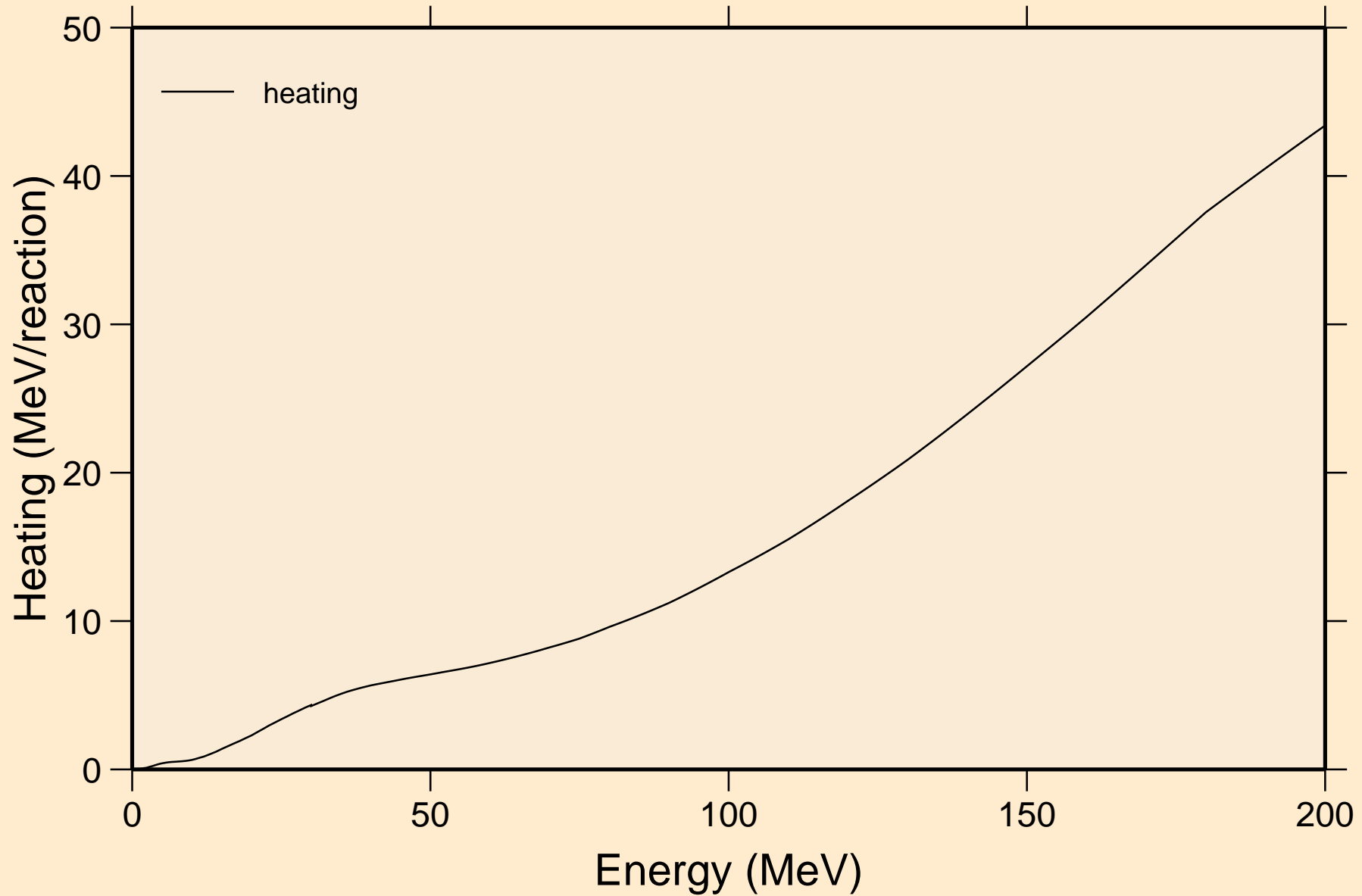

# CD105 NEUTRON ACER TENDL-2023 LIBRARY; T=0.K

## Damage

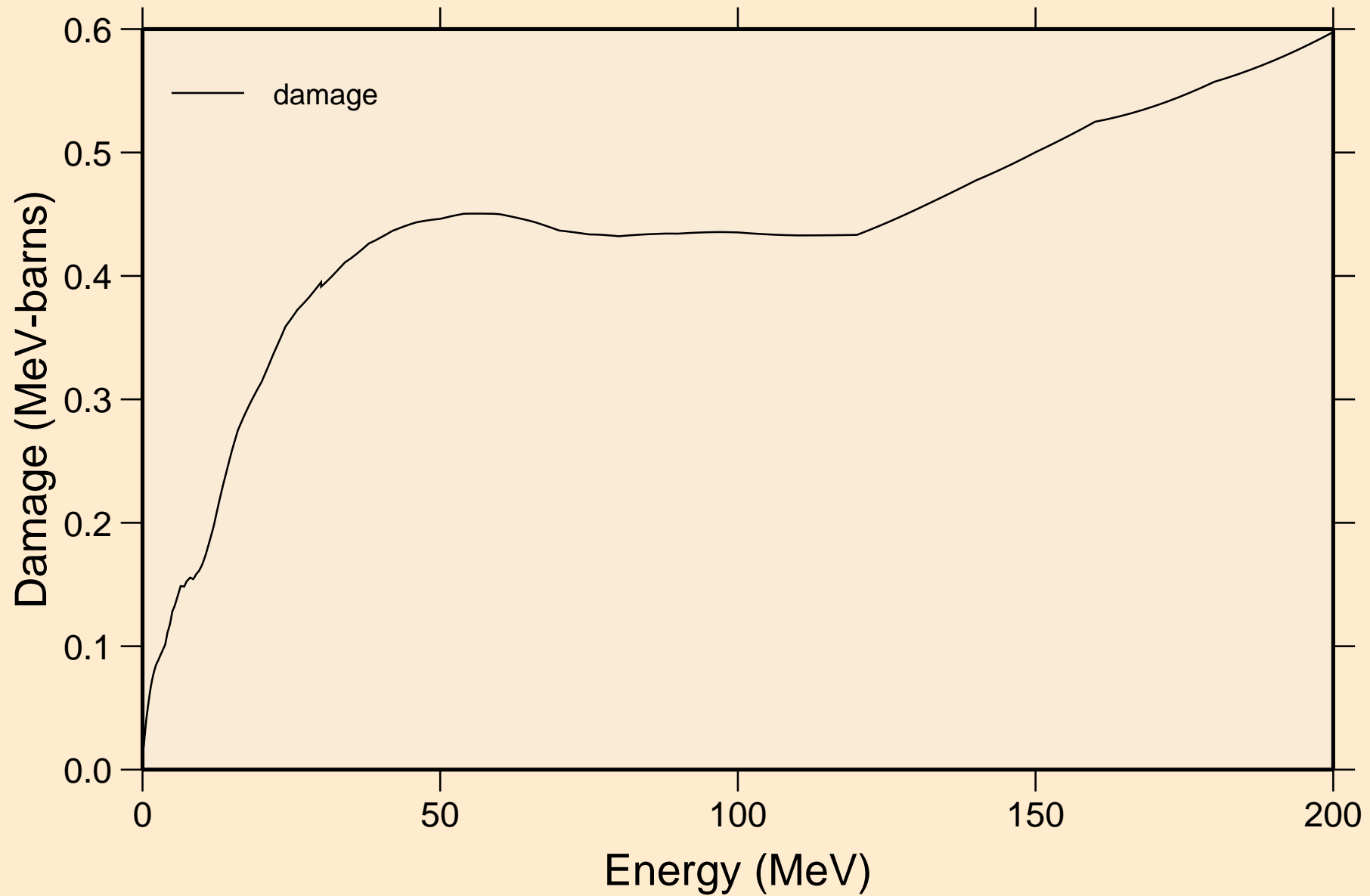

# CD105 NEUTRON ACER TENDL-2023 LIBRARY; T=0.K

## Non-threshold reactions

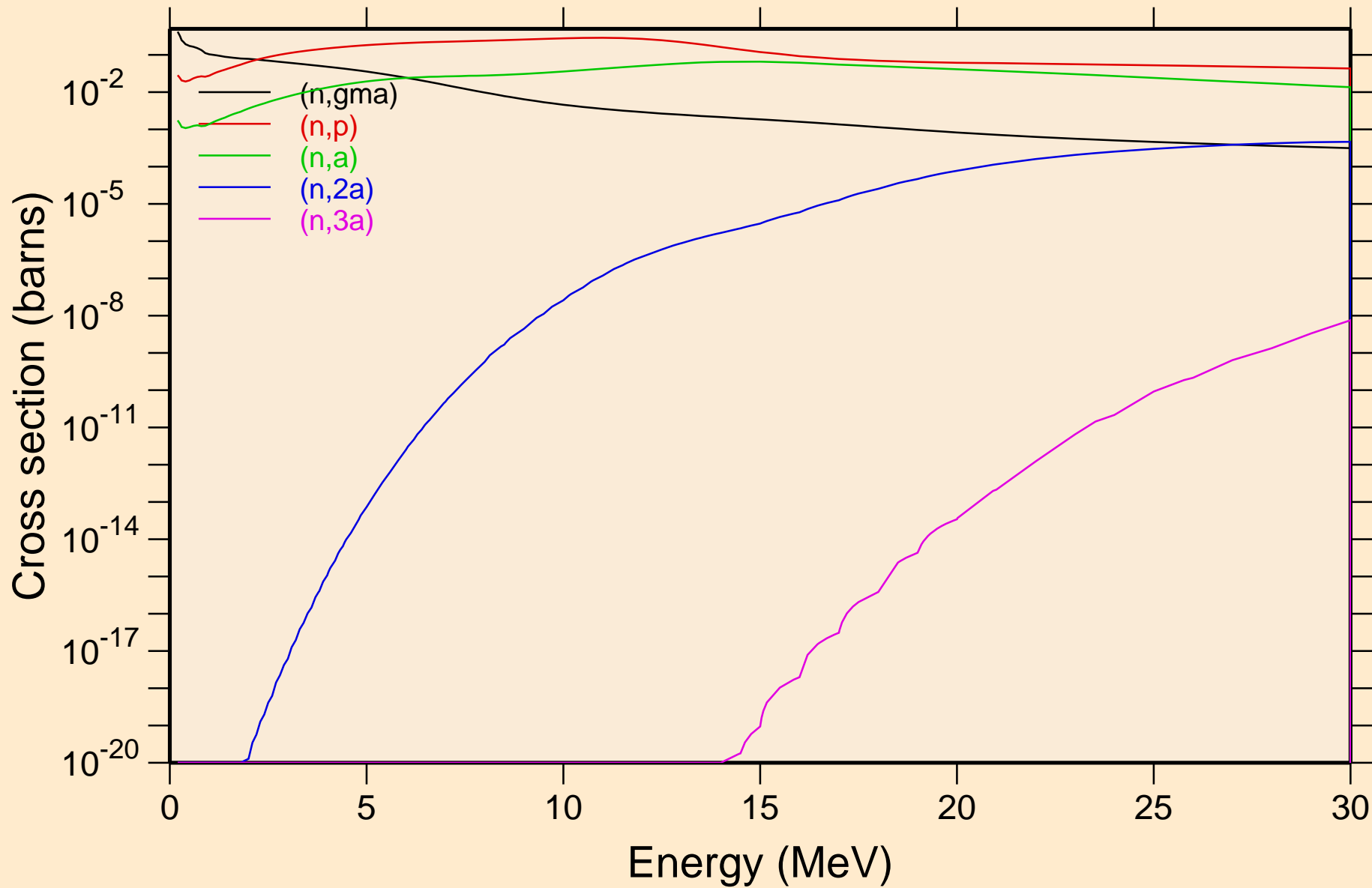

# CD105 NEUTRON ACER TENDL-2023 LIBRARY; T=0.K

## Non-threshold reactions

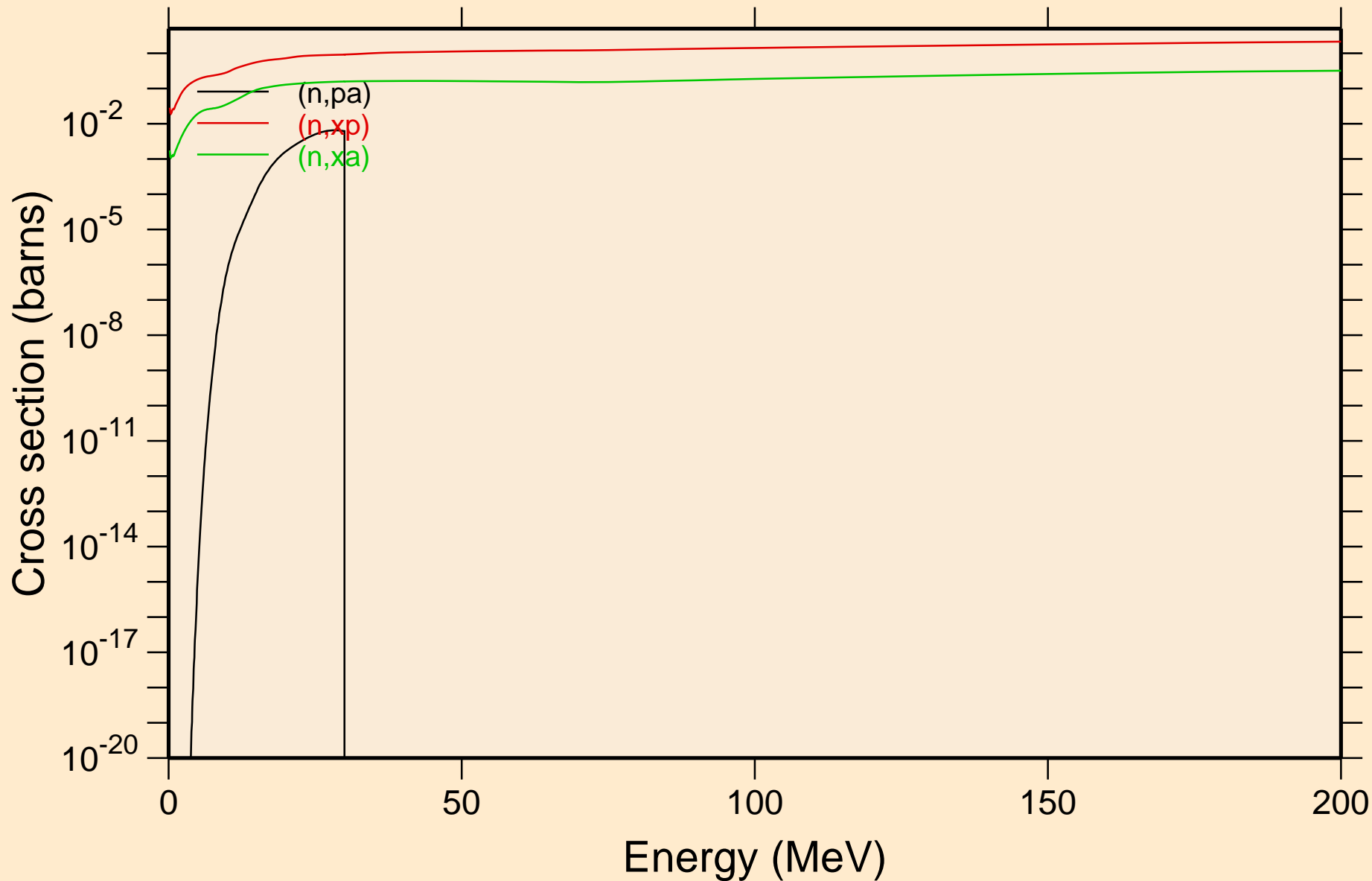

CD105 NEUTRON ACER TENDL-2023 LIBRARY; T=0.K  
Inelastic levels

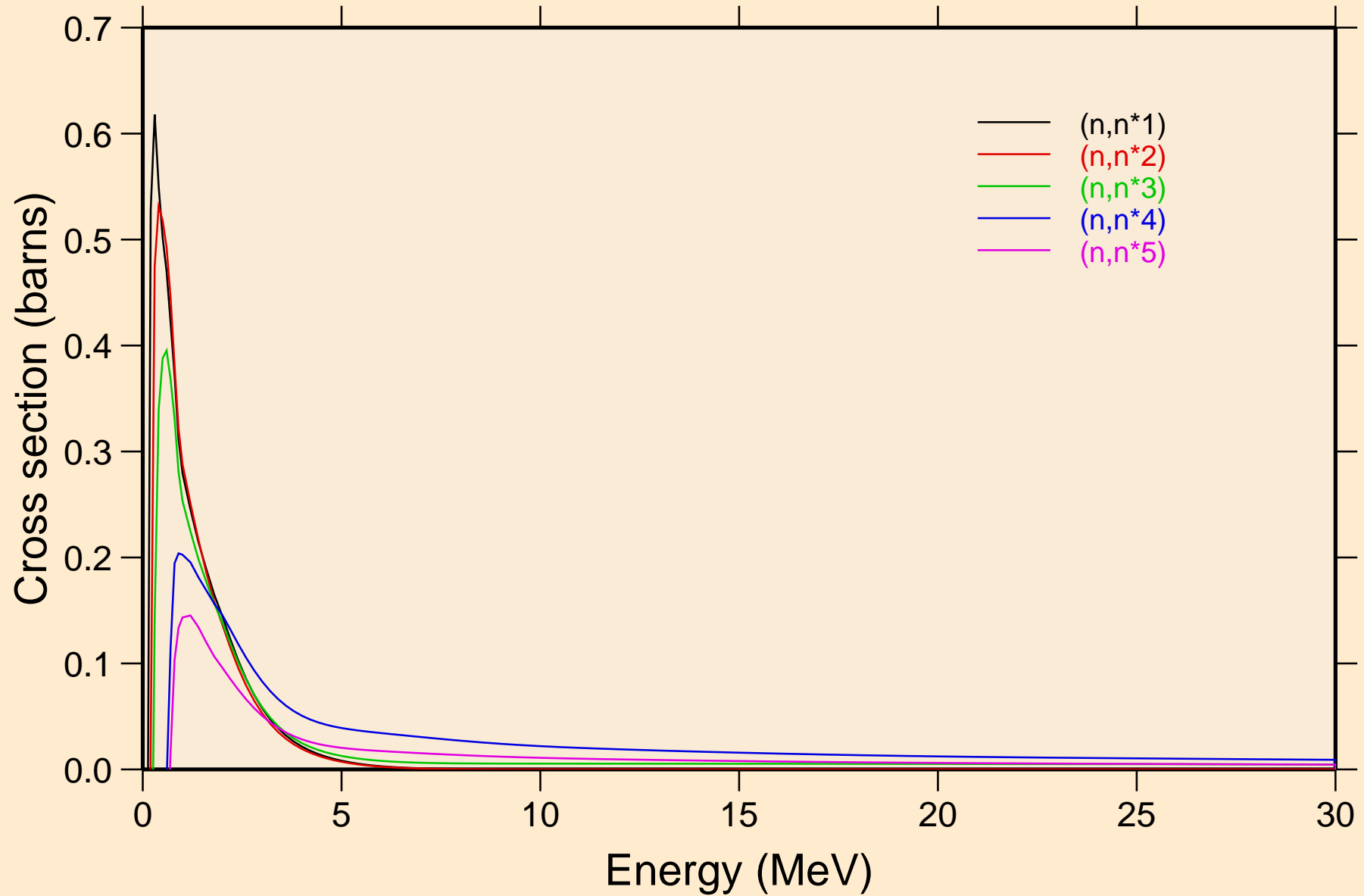

# CD105 NEUTRON ACER TENDL-2023 LIBRARY; T=0.K

## Inelastic levels

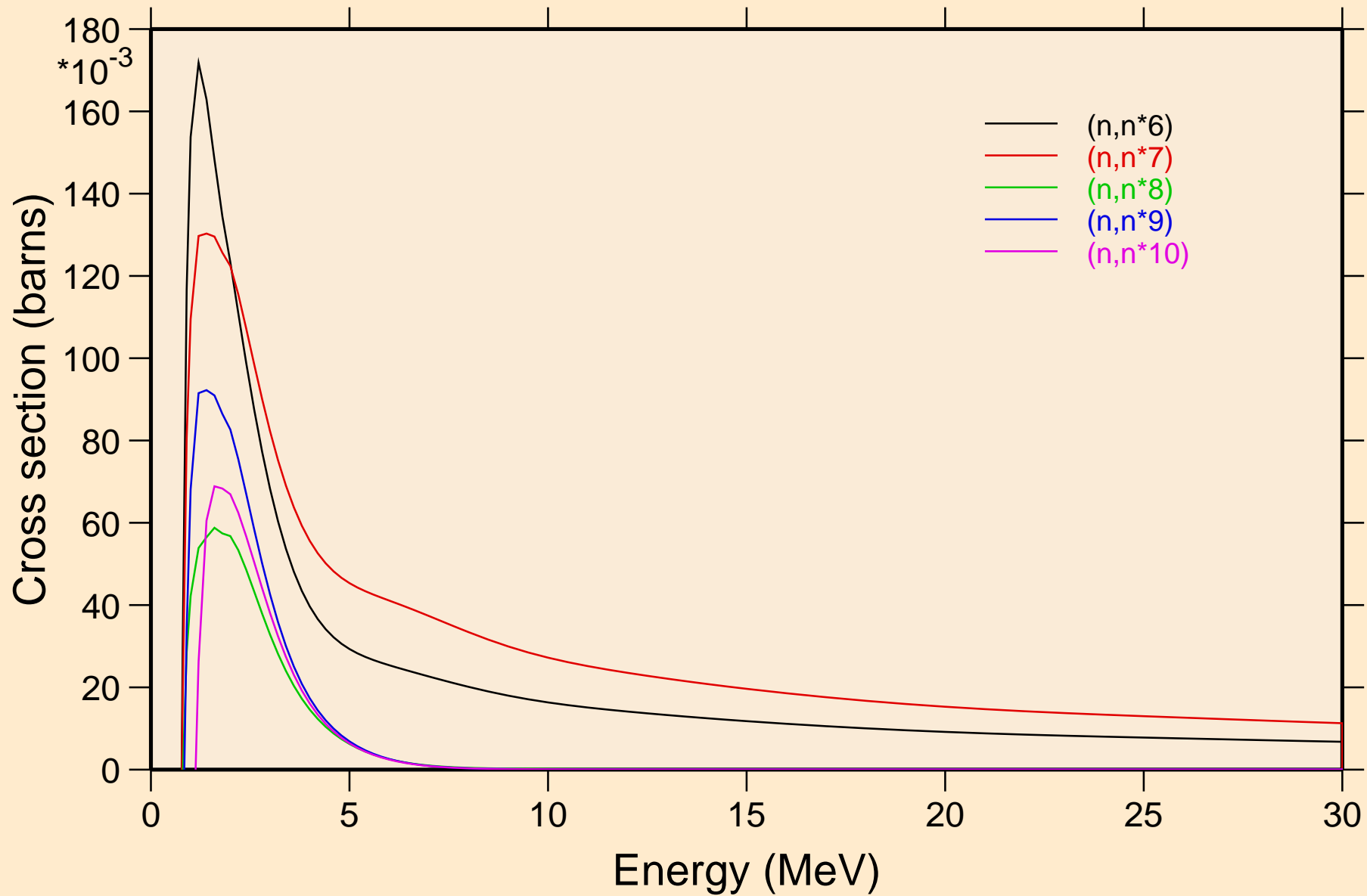

CD105 NEUTRON ACER TENDL-2023 LIBRARY; T=0.K  
Inelastic levels

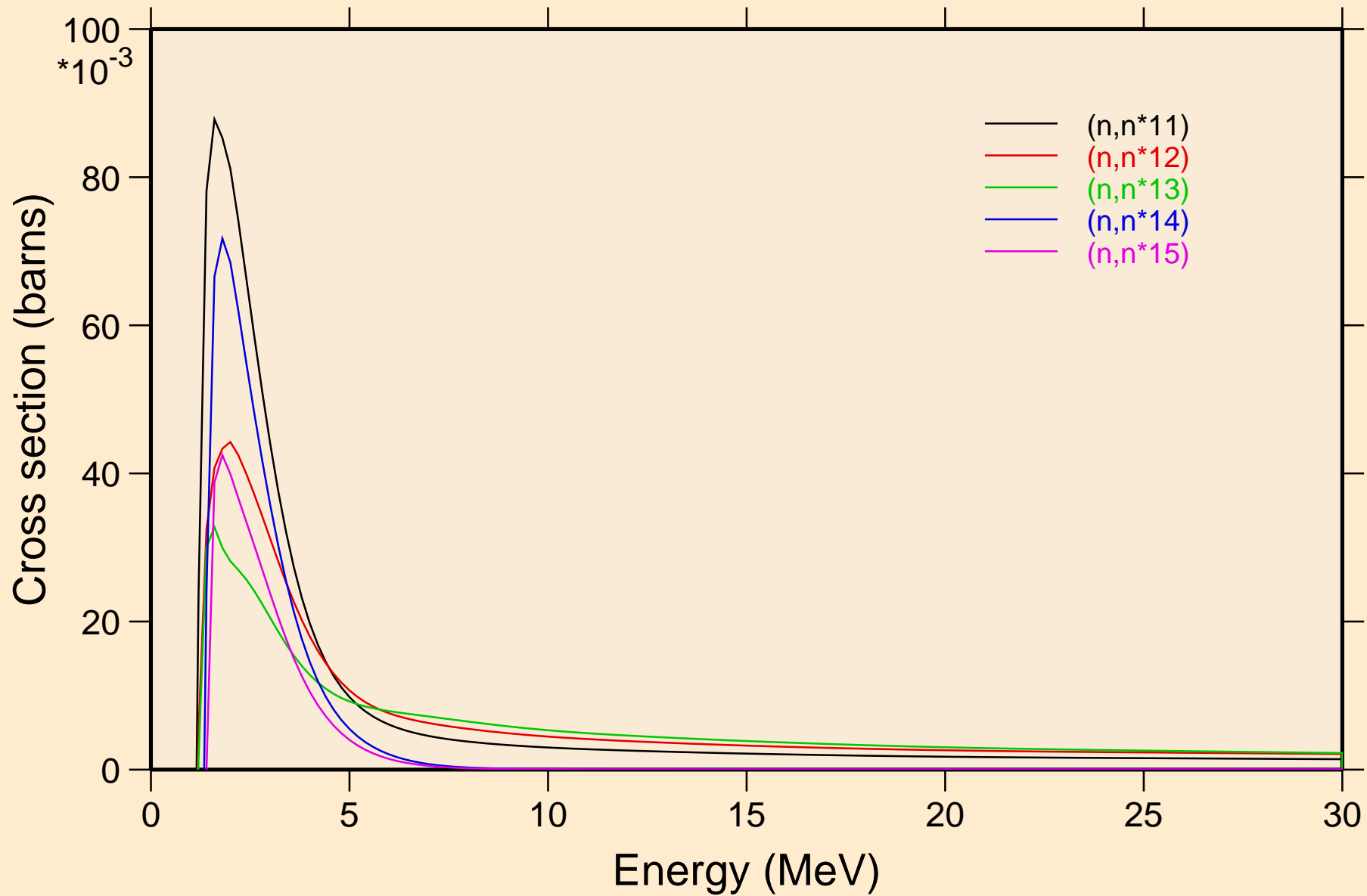

CD105 NEUTRON ACER TENDL-2023 LIBRARY; T=0.K  
Inelastic levels

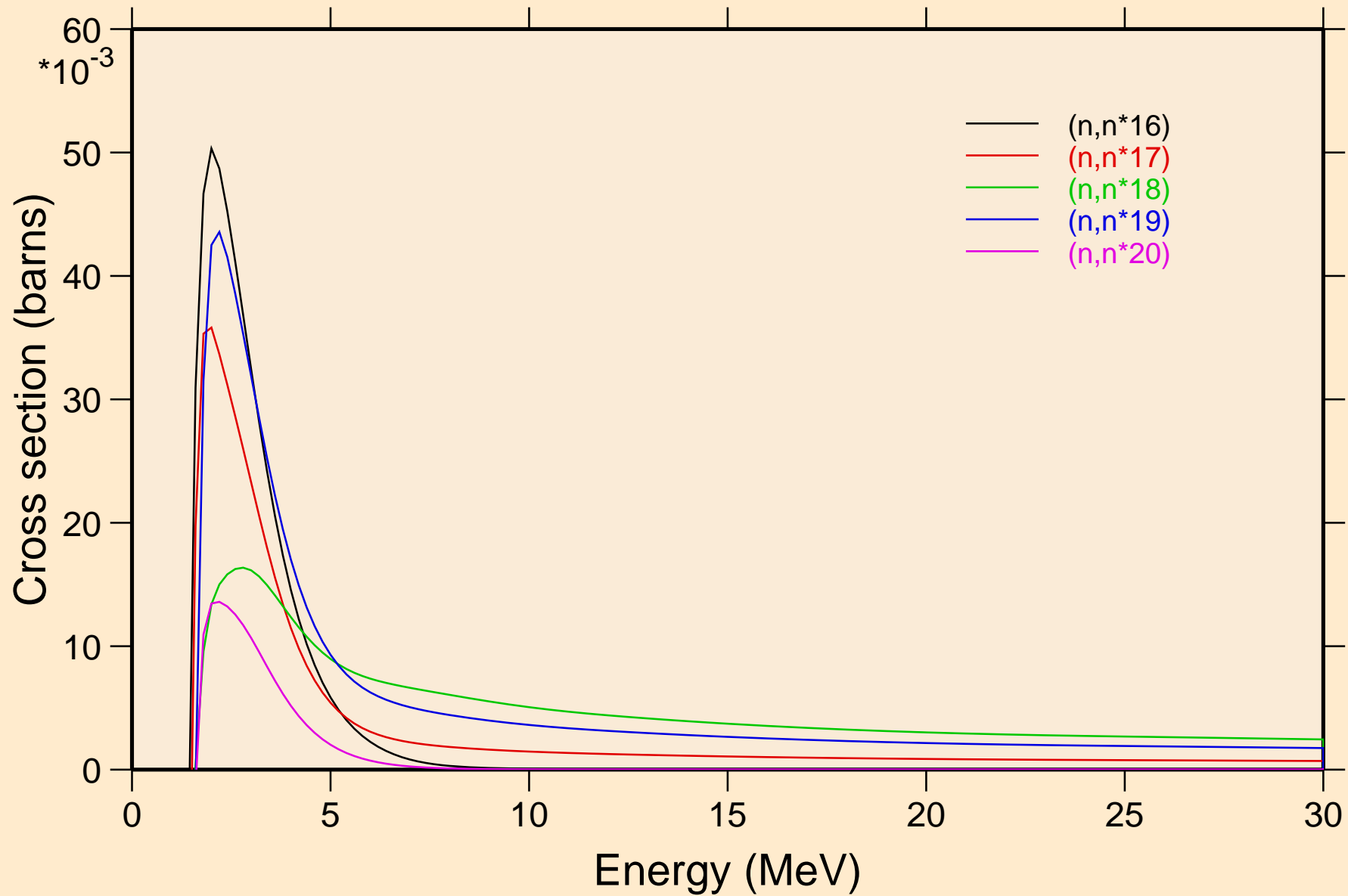

# CD105 NEUTRON ACER TENDL-2023 LIBRARY; T=0.K

## Inelastic levels

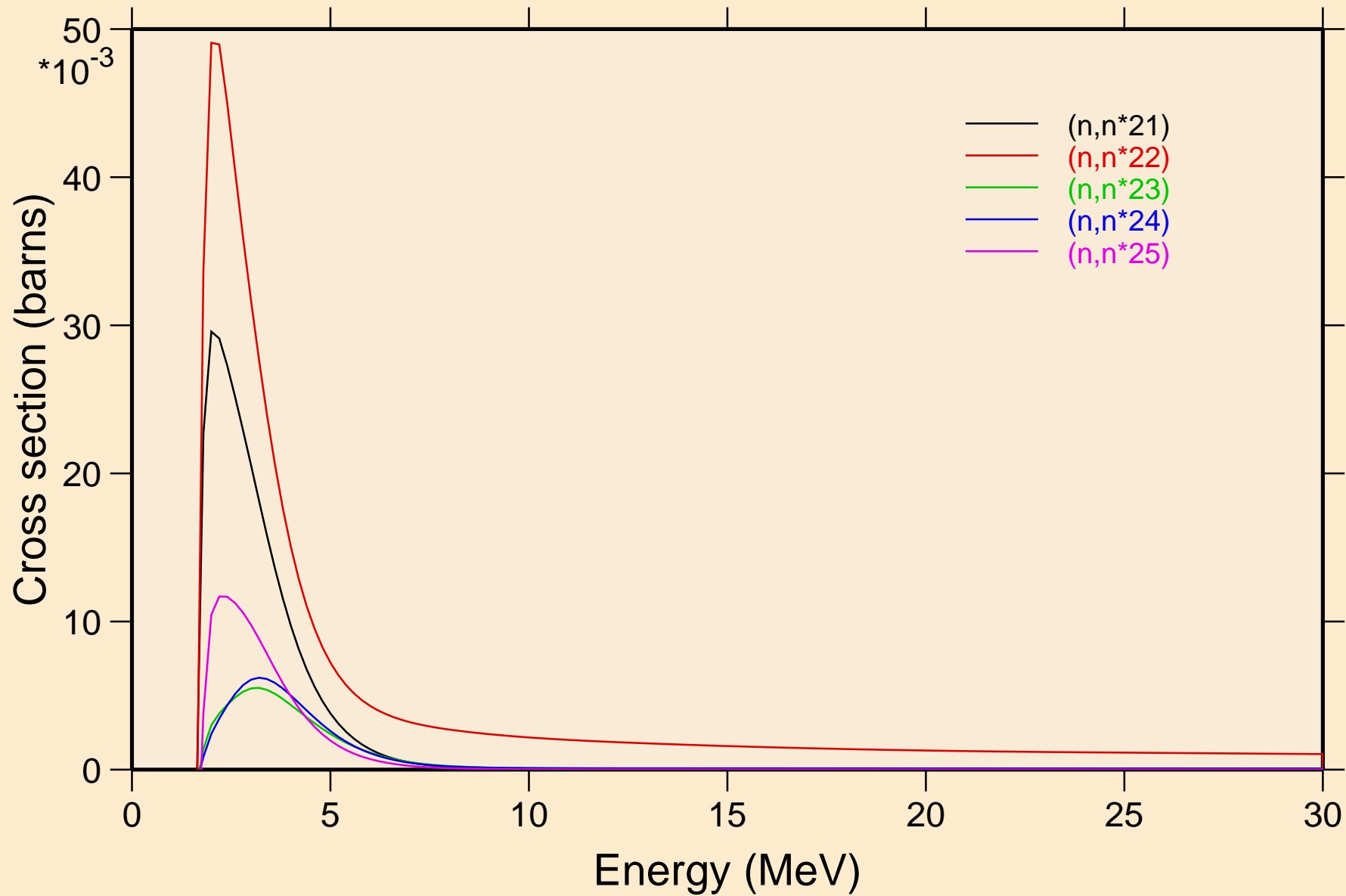

CD105 NEUTRON ACER TENDL-2023 LIBRARY; T=0.K  
Inelastic levels

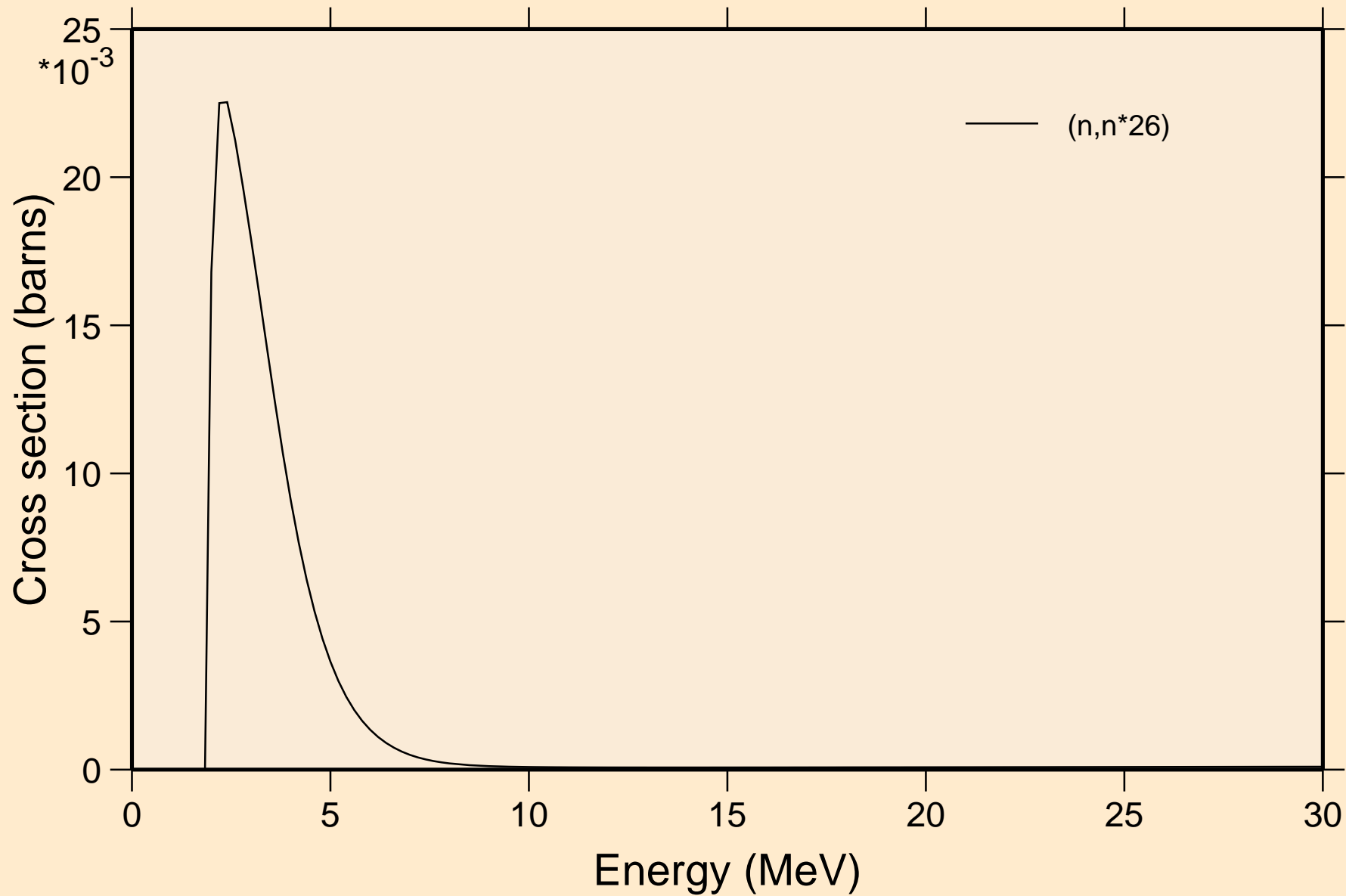

# CD105 NEUTRON ACER TENDL-2023 LIBRARY; T=0.K

## Threshold reactions

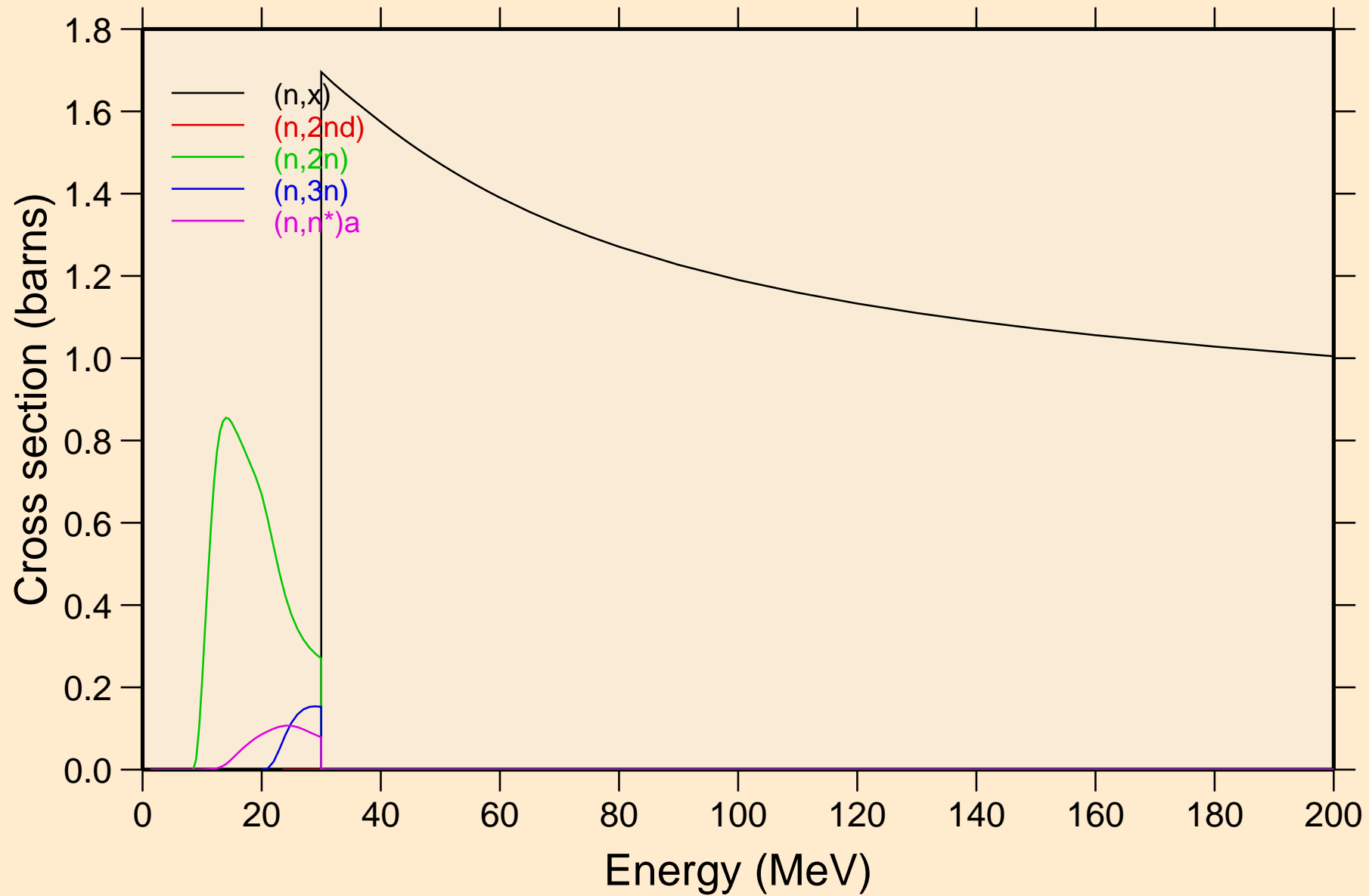

# CD105 NEUTRON ACER TENDL-2023 LIBRARY; T=0.K

## Threshold reactions

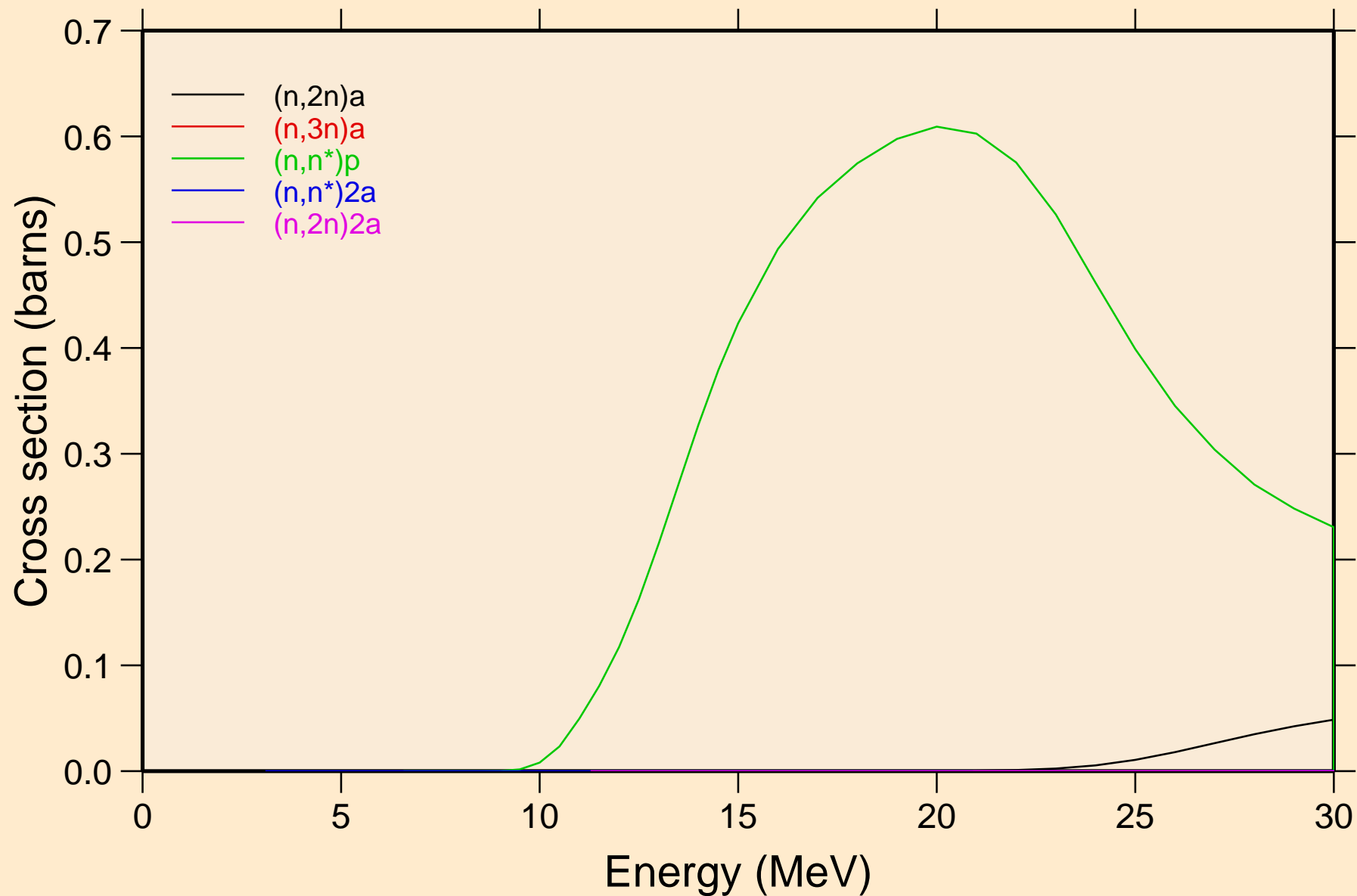

# CD105 NEUTRON ACER TENDL-2023 LIBRARY; T=0.K

## Threshold reactions

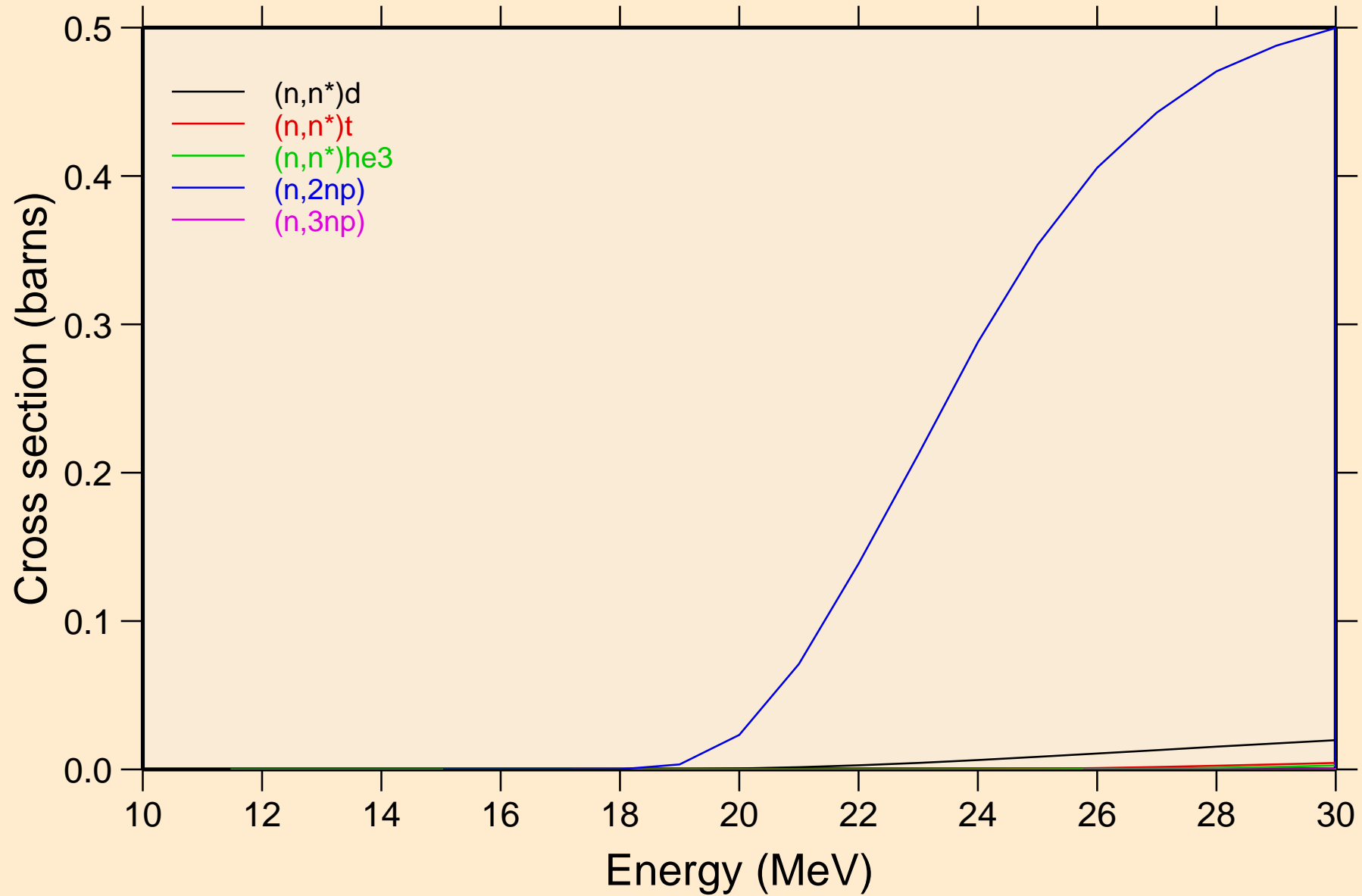

# CD105 NEUTRON ACER TENDL-2023 LIBRARY; T=0.K

## Threshold reactions

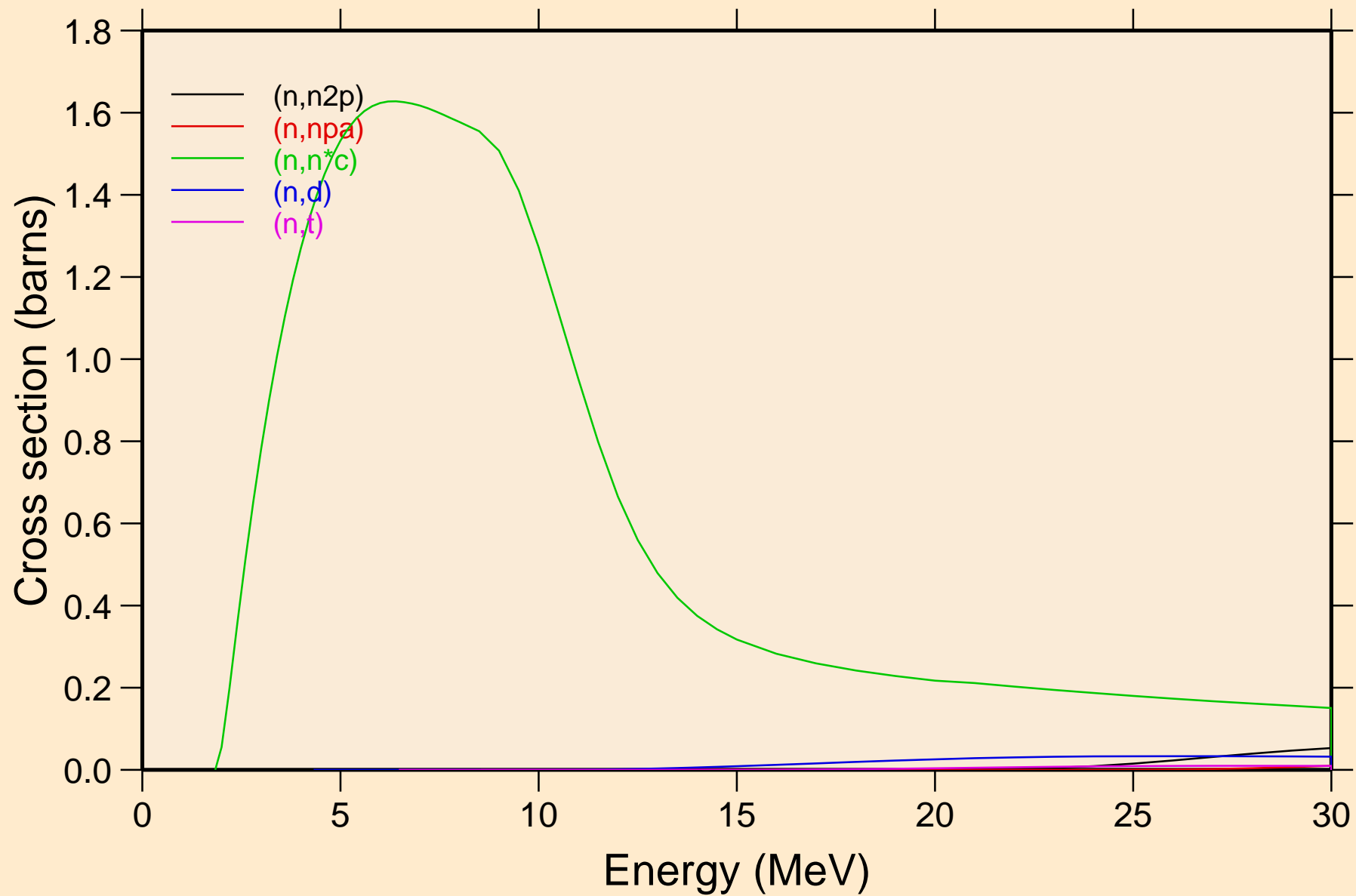

# CD105 NEUTRON ACER TENDL-2023 LIBRARY; T=0.K

## Threshold reactions

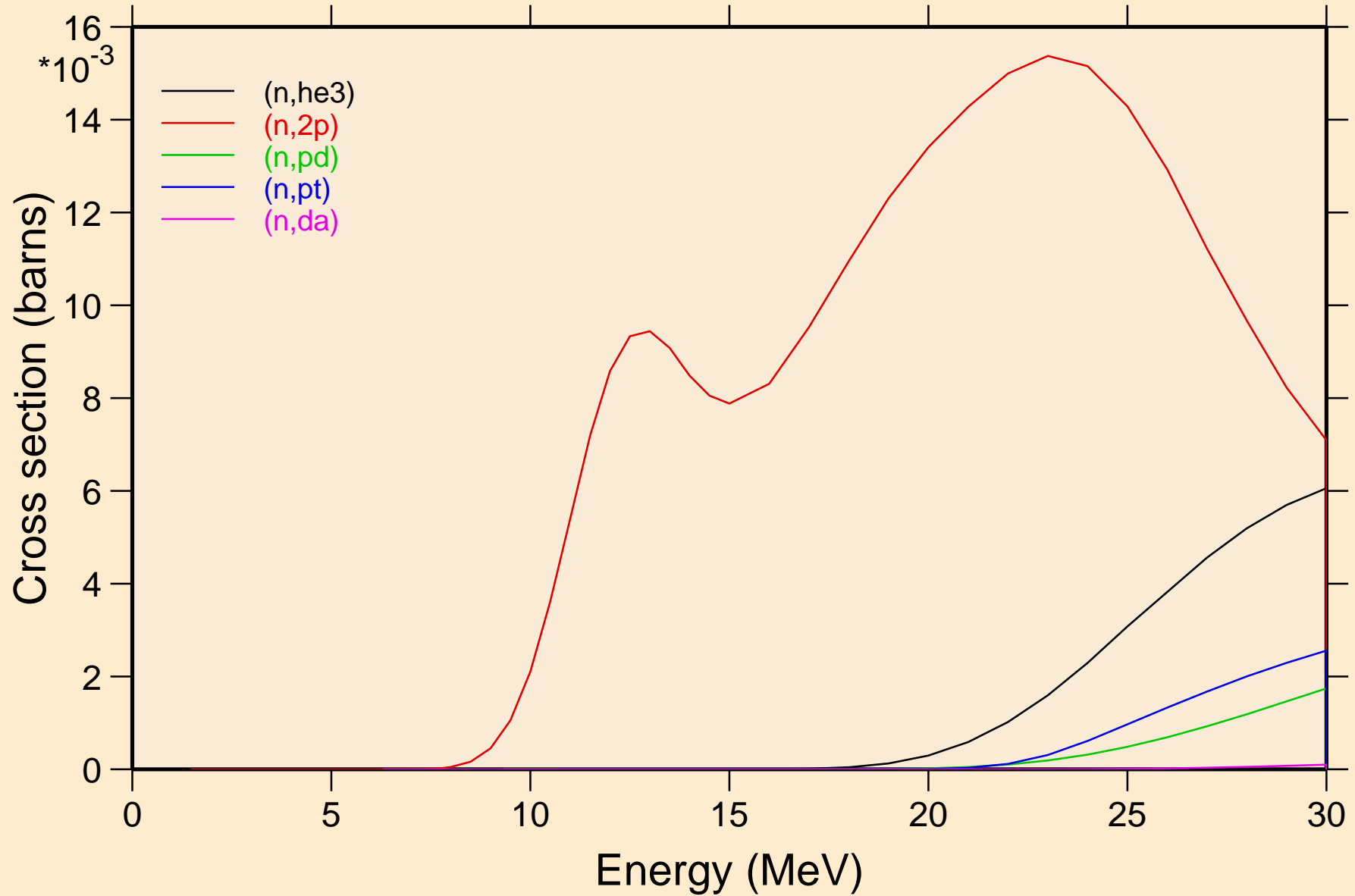

# CD105 NEUTRON ACER TENDL-2023 LIBRARY; T=0.K

## Threshold reactions

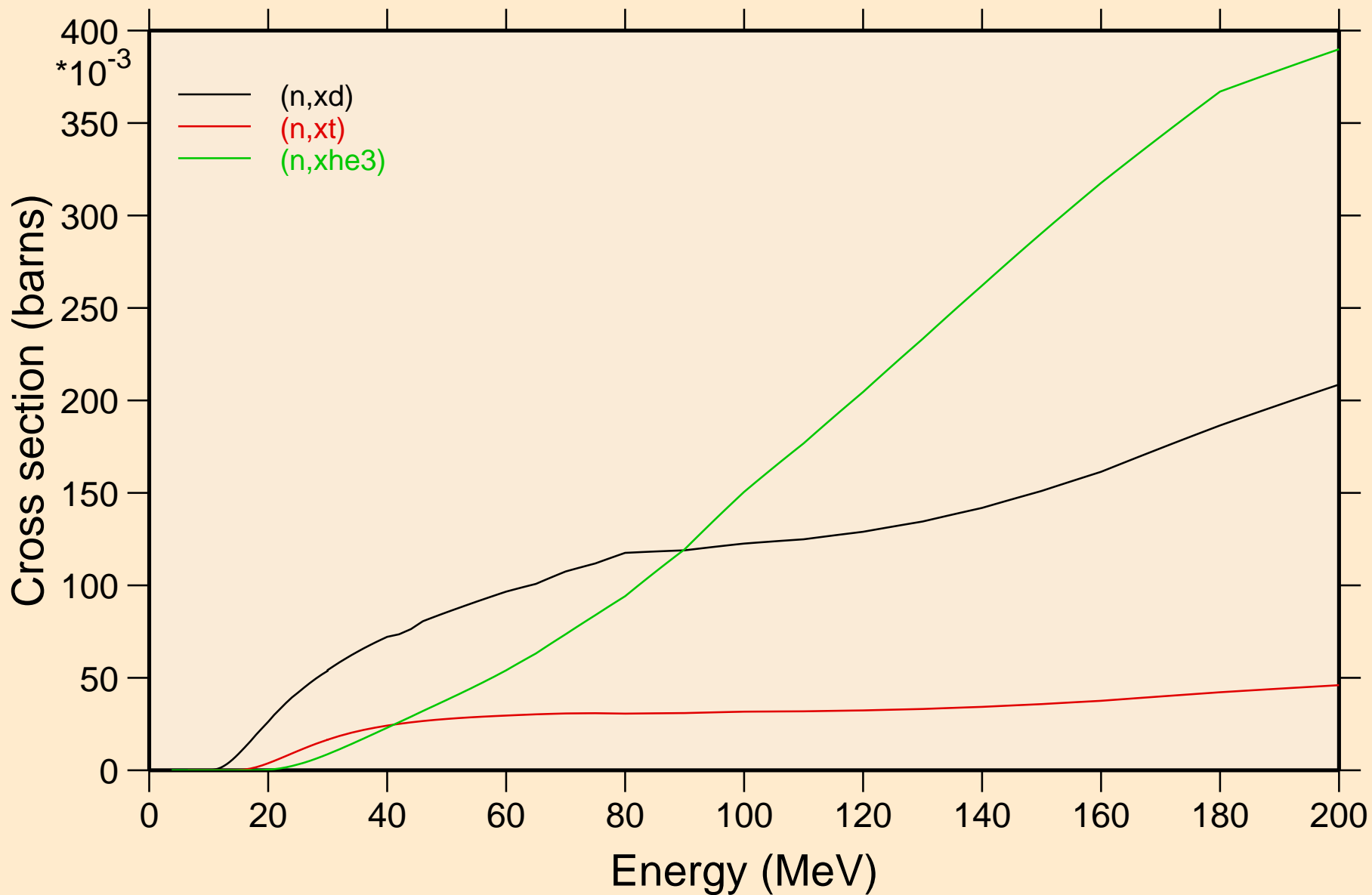

CD105 NEUTRON ACER TENDL-2023 LIBRARY; T=0.K  
angular distribution for elastic

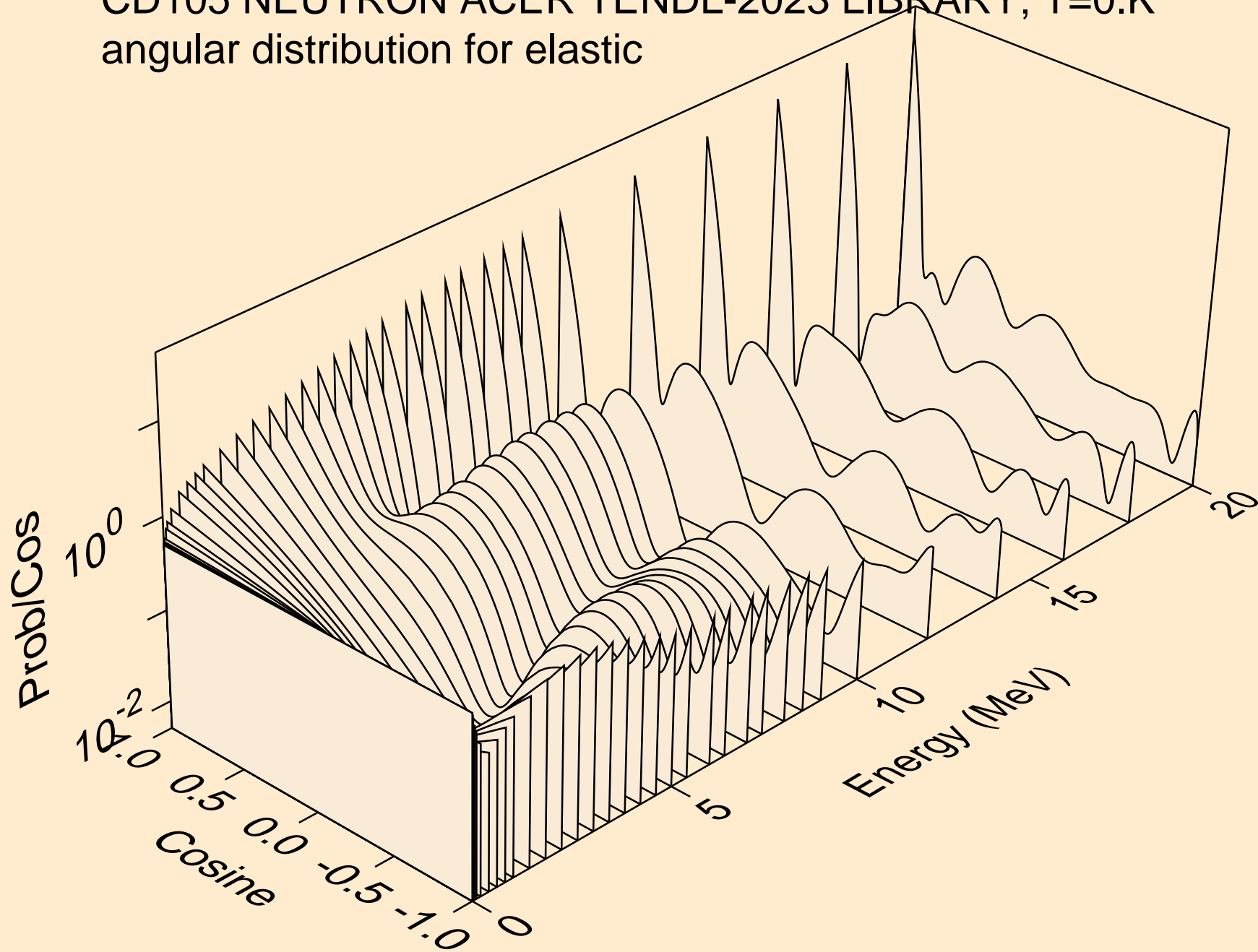

CD105 NEUTRON ACER TENDL-2023 LIBRARY; T=0.K  
angular distribution for elastic

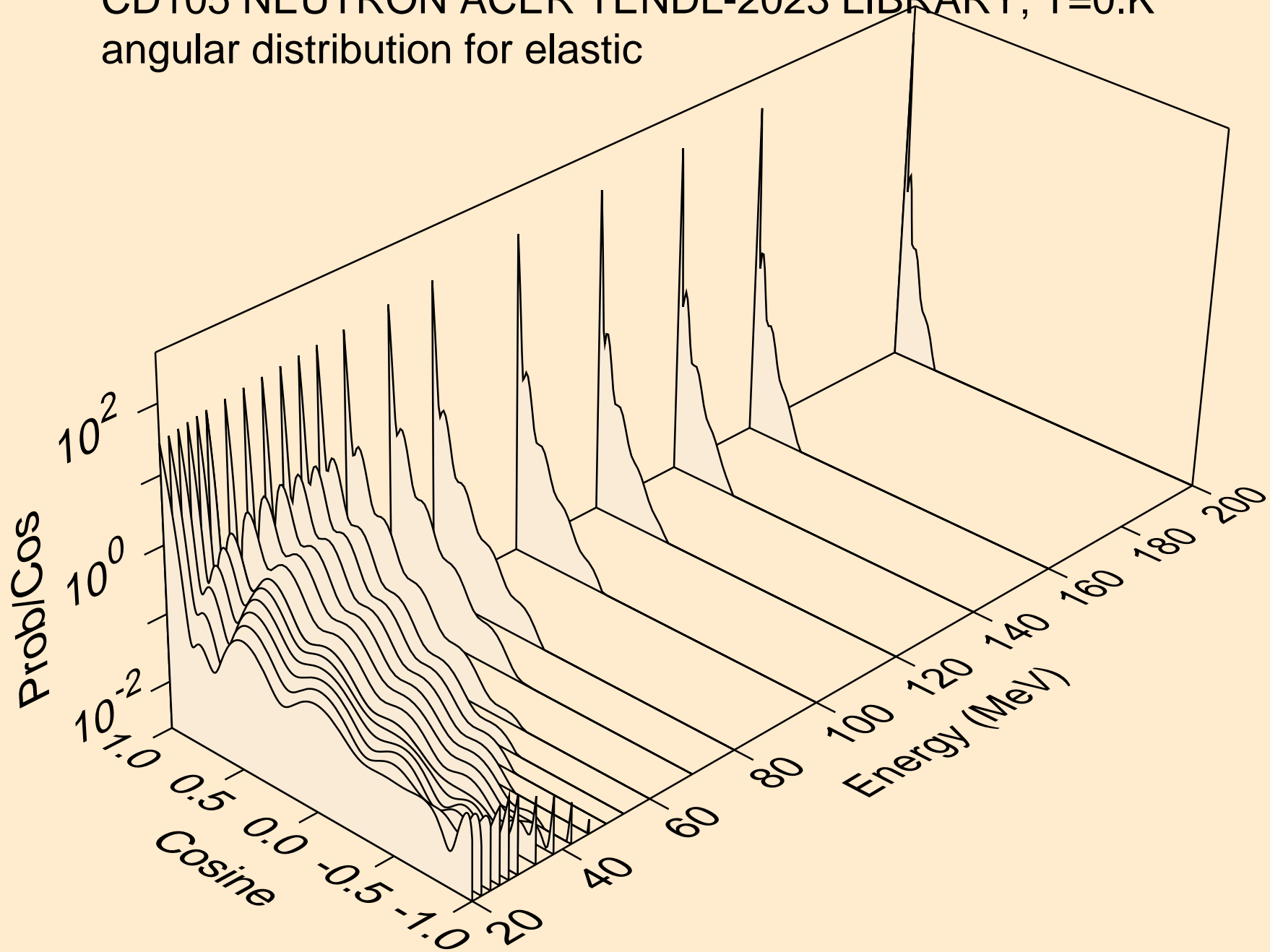

CD105 NEUTRON ACER TENDL-2023 LIBRARY; T=0.K  
angular distribution for (n,n\*1)

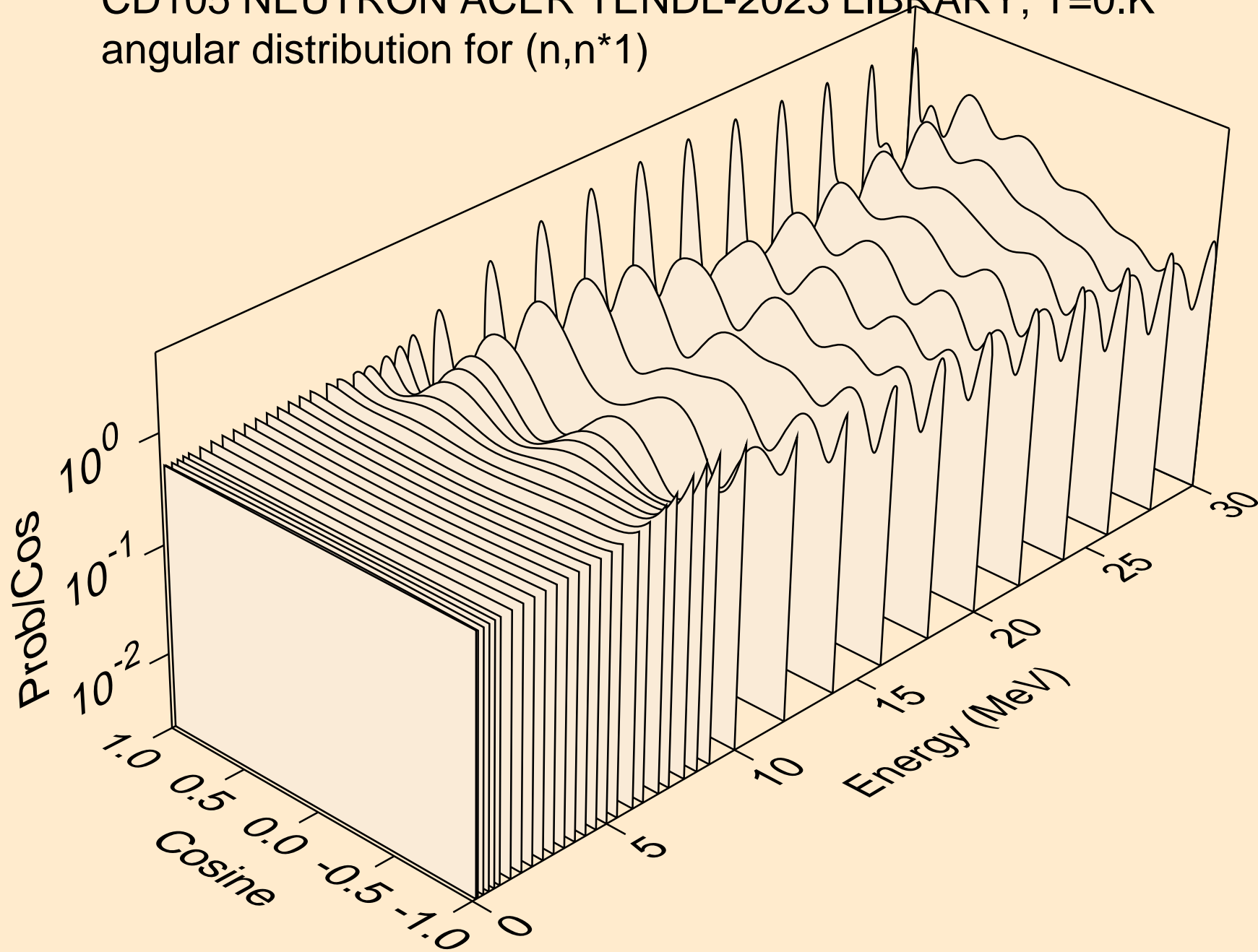

CD105 NEUTRON ACER TENDL-2023 LIBRARY; T=0.K  
angular distribution for (n,n\*2)

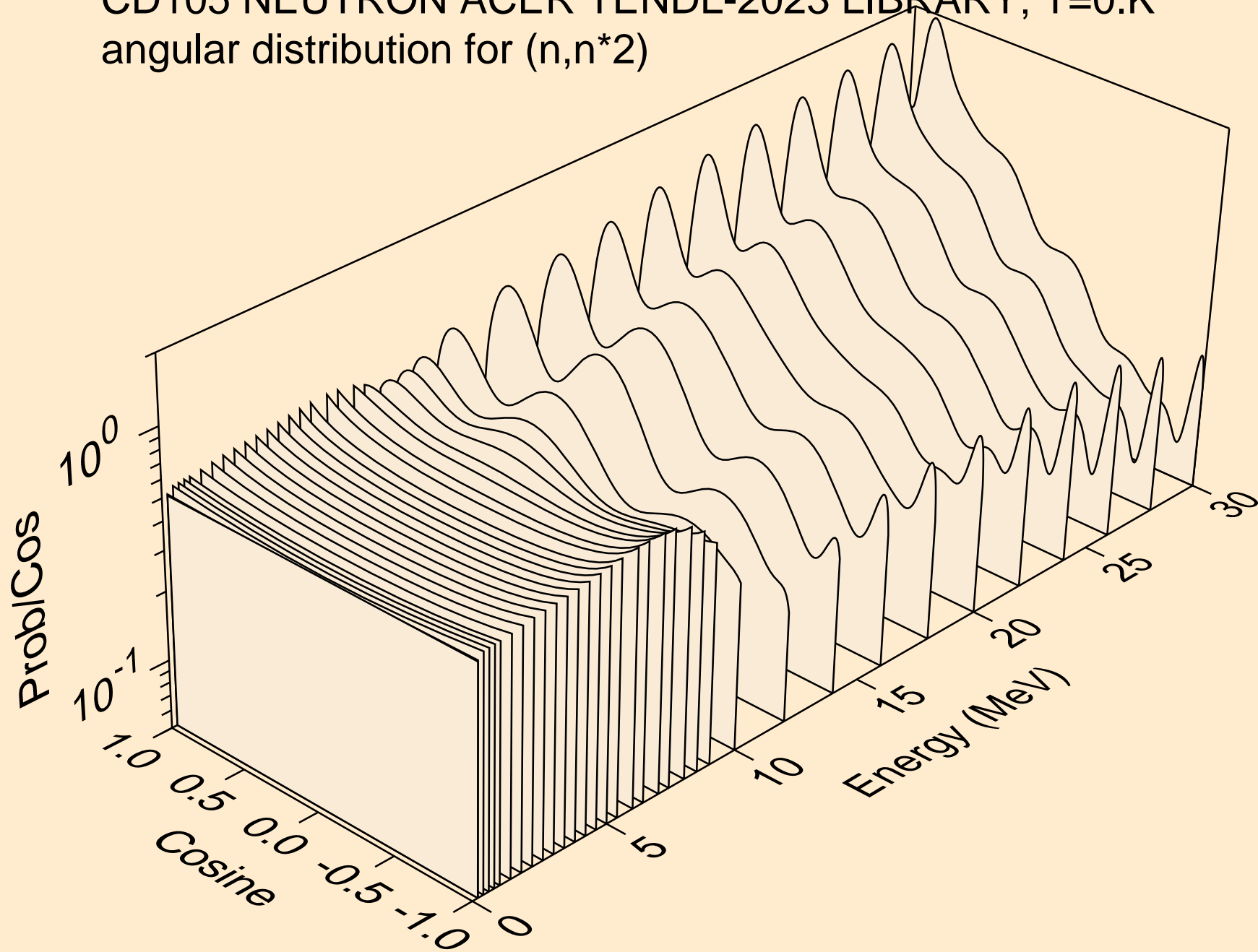

CD105 NEUTRON ACER TENDL-2023 LIBRARY; T=0.K  
angular distribution for (n,n\*3)

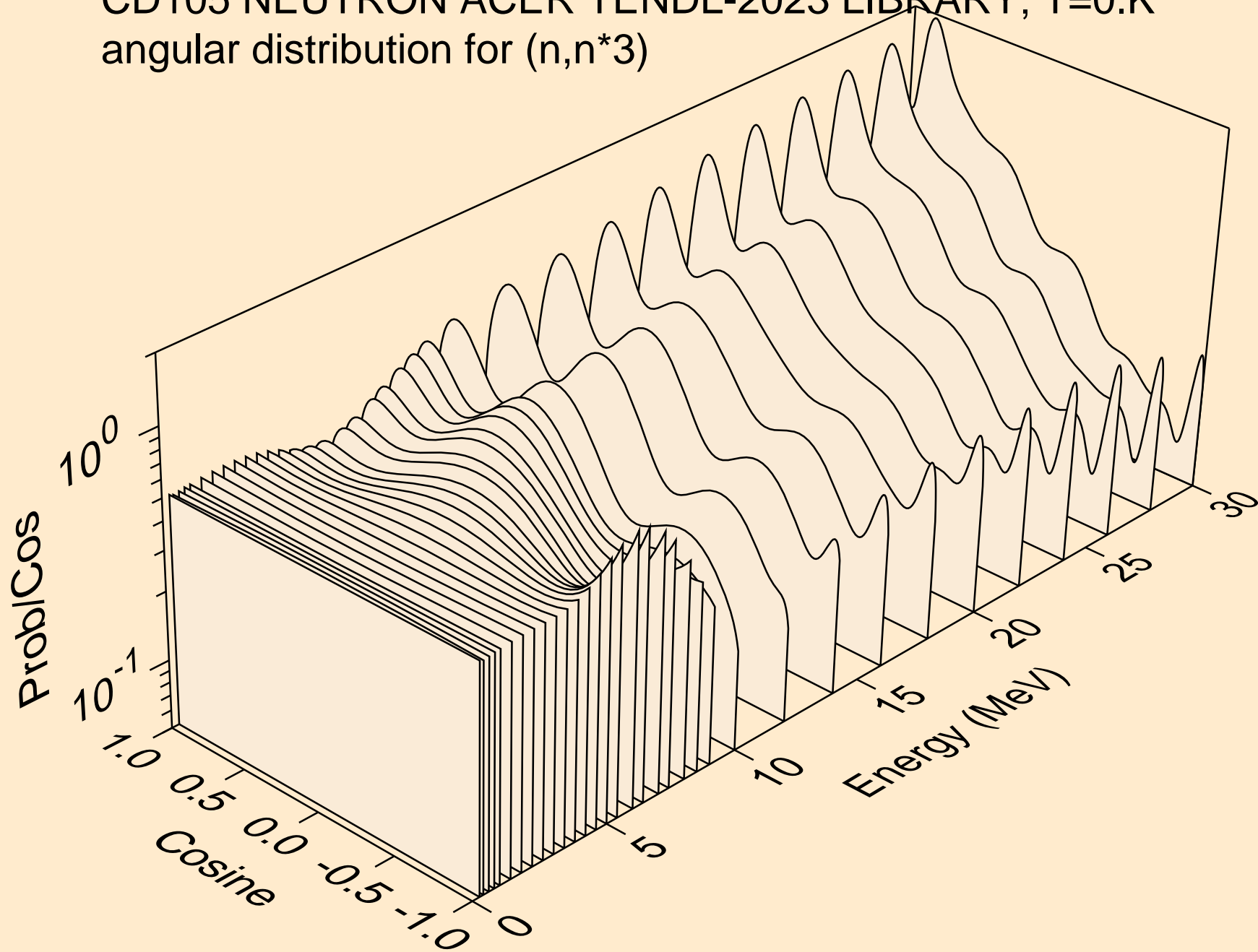

CD105 NEUTRON ACER TENDL-2023 LIBRARY; T=0.K  
angular distribution for (n,n\*4)

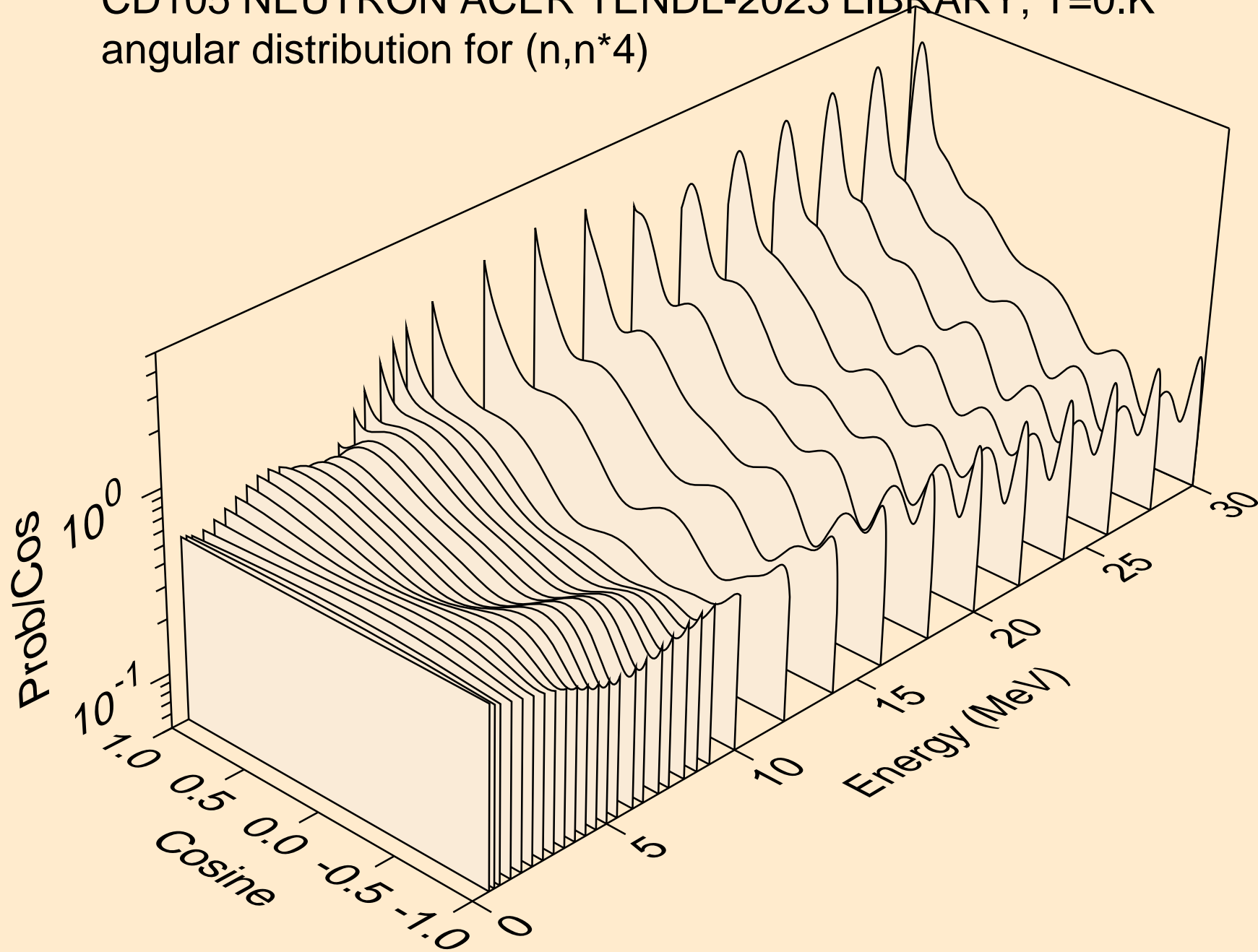

CD105 NEUTRON ACER TENDL-2023 LIBRARY; T=0.K  
angular distribution for (n,n\*5)

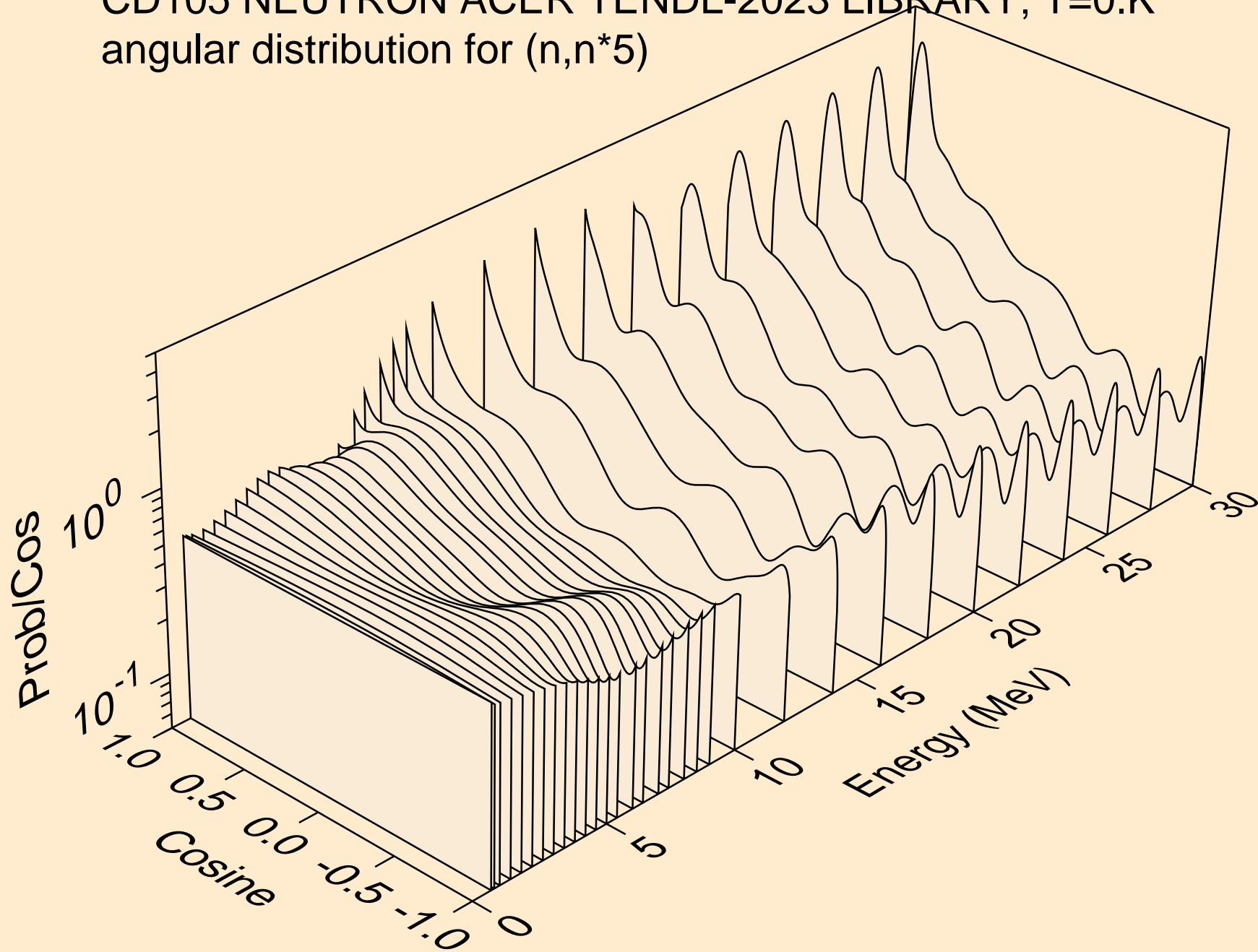

CD105 NEUTRON ACER TENDL-2023 LIBRARY; T=0.K  
angular distribution for (n,n\*6)

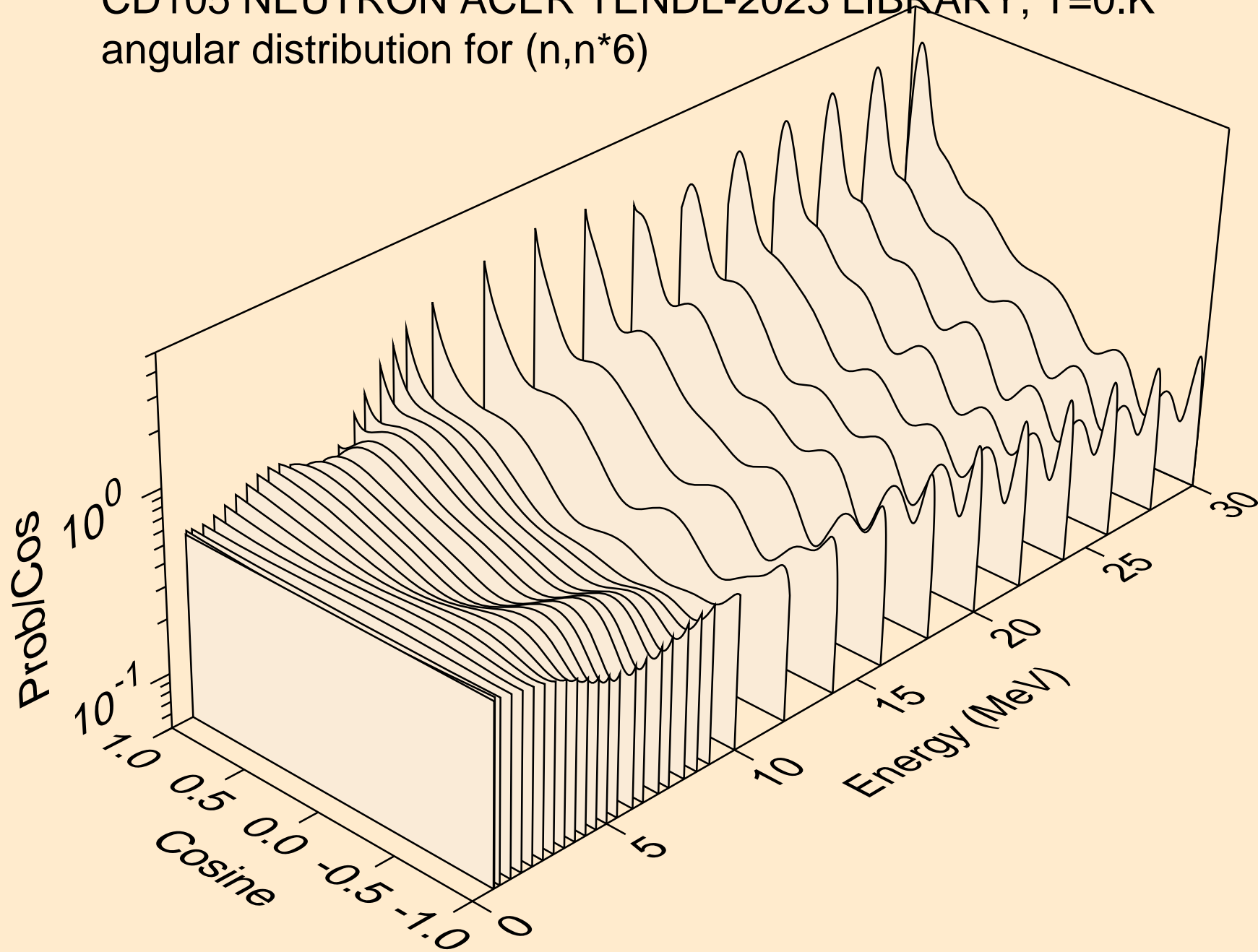

CD105 NEUTRON ACER TENDL-2023 LIBRARY; T=0.K  
angular distribution for (n,n\*7)

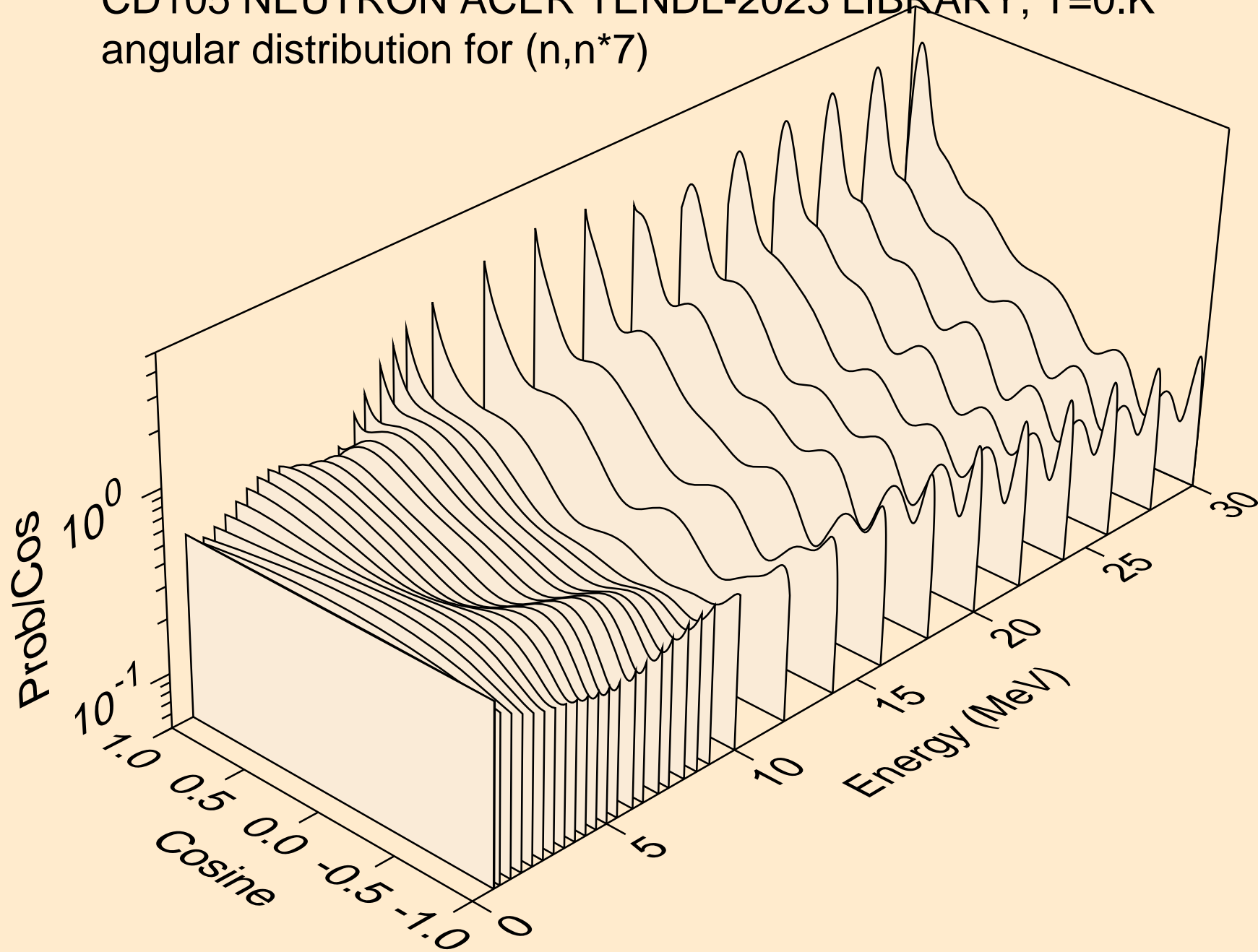

CD105 NEUTRON ACER TENDL-2023 LIBRARY; T=0.K  
angular distribution for (n,n\*8)

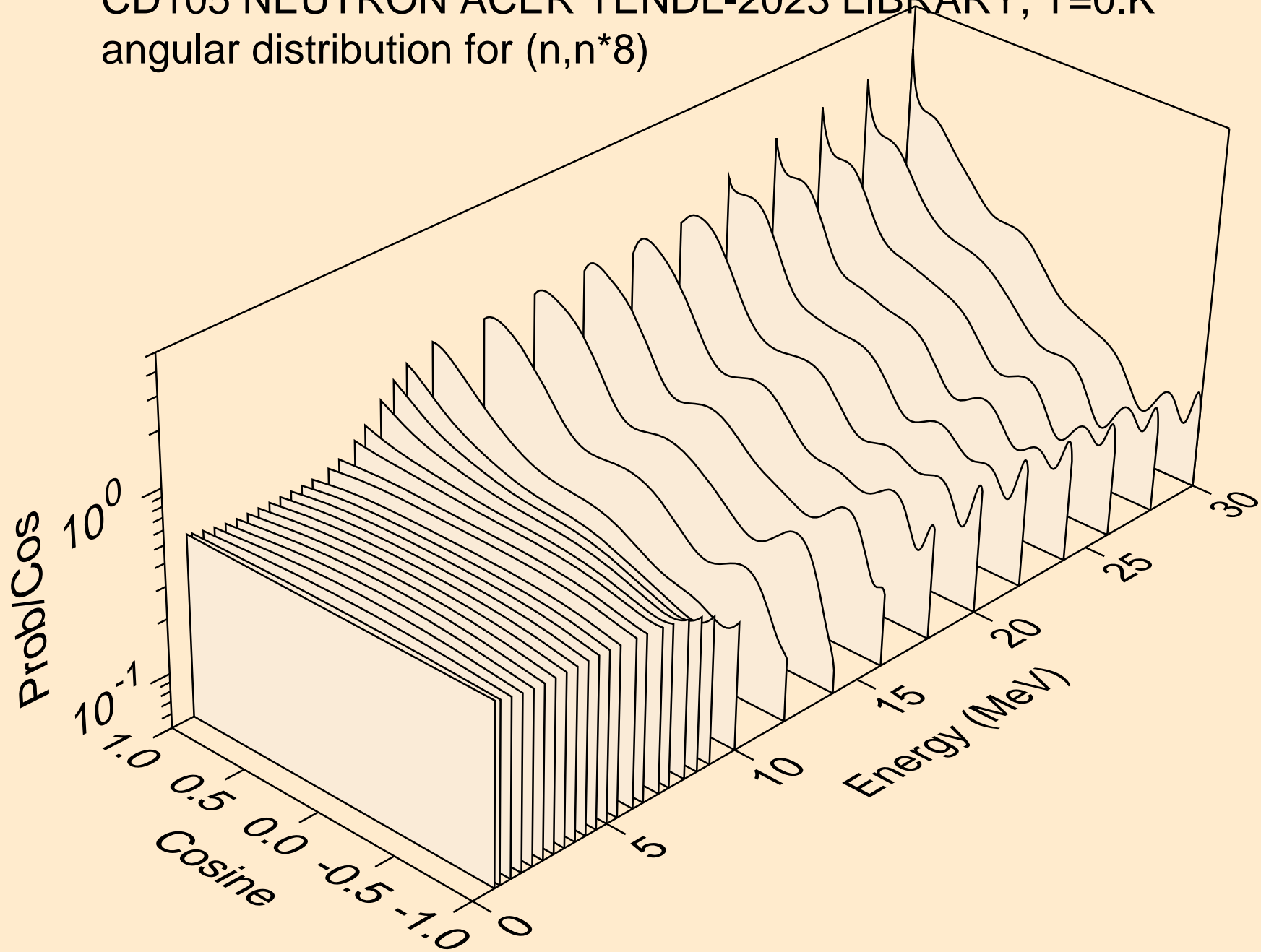

CD105 NEUTRON ACER TENDL-2023 LIBRARY; T=0.K  
angular distribution for (n,n\*9)

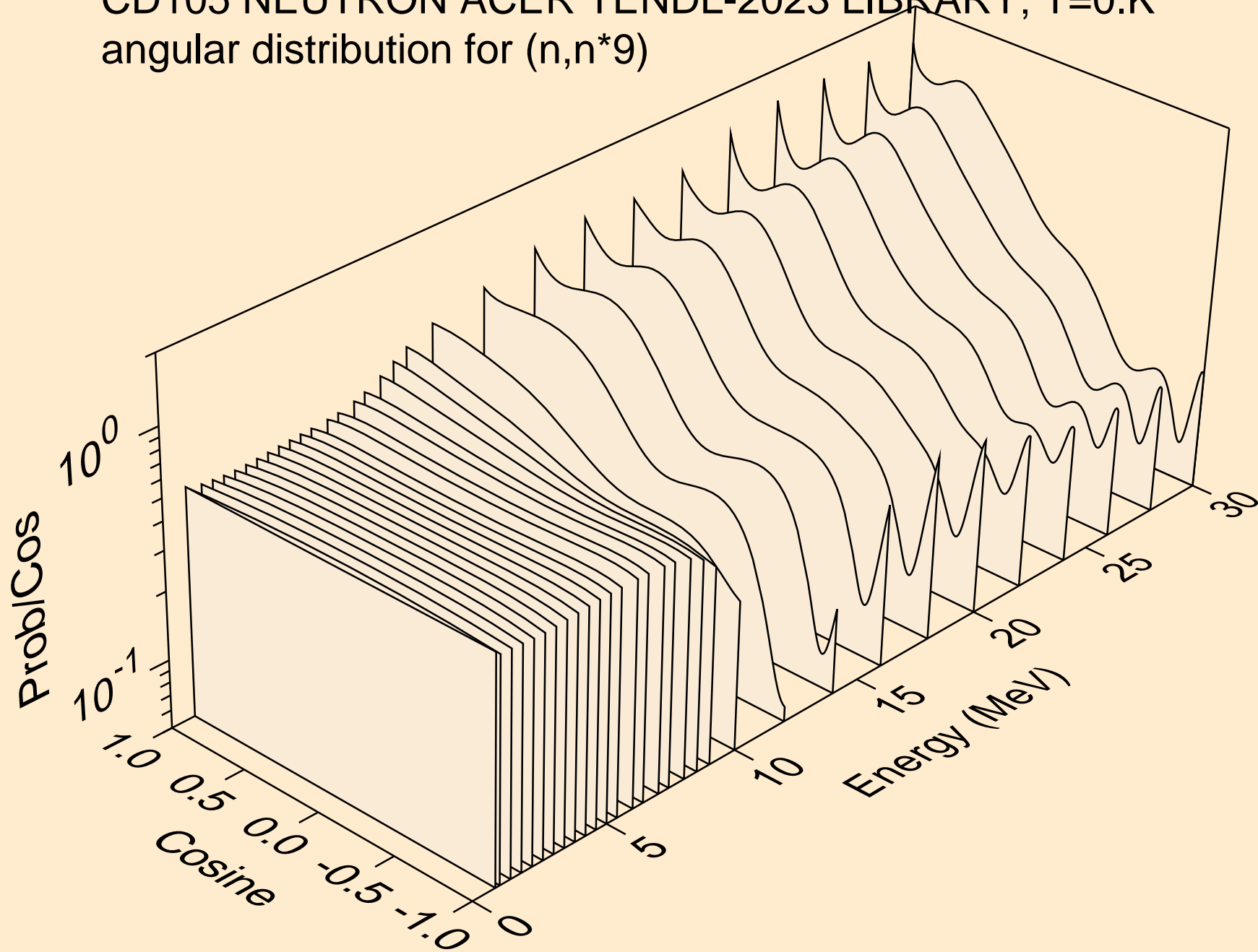

CD105 NEUTRON ACER TENDL-2023 LIBRARY; T=0.K  
angular distribution for (n,n\*10)

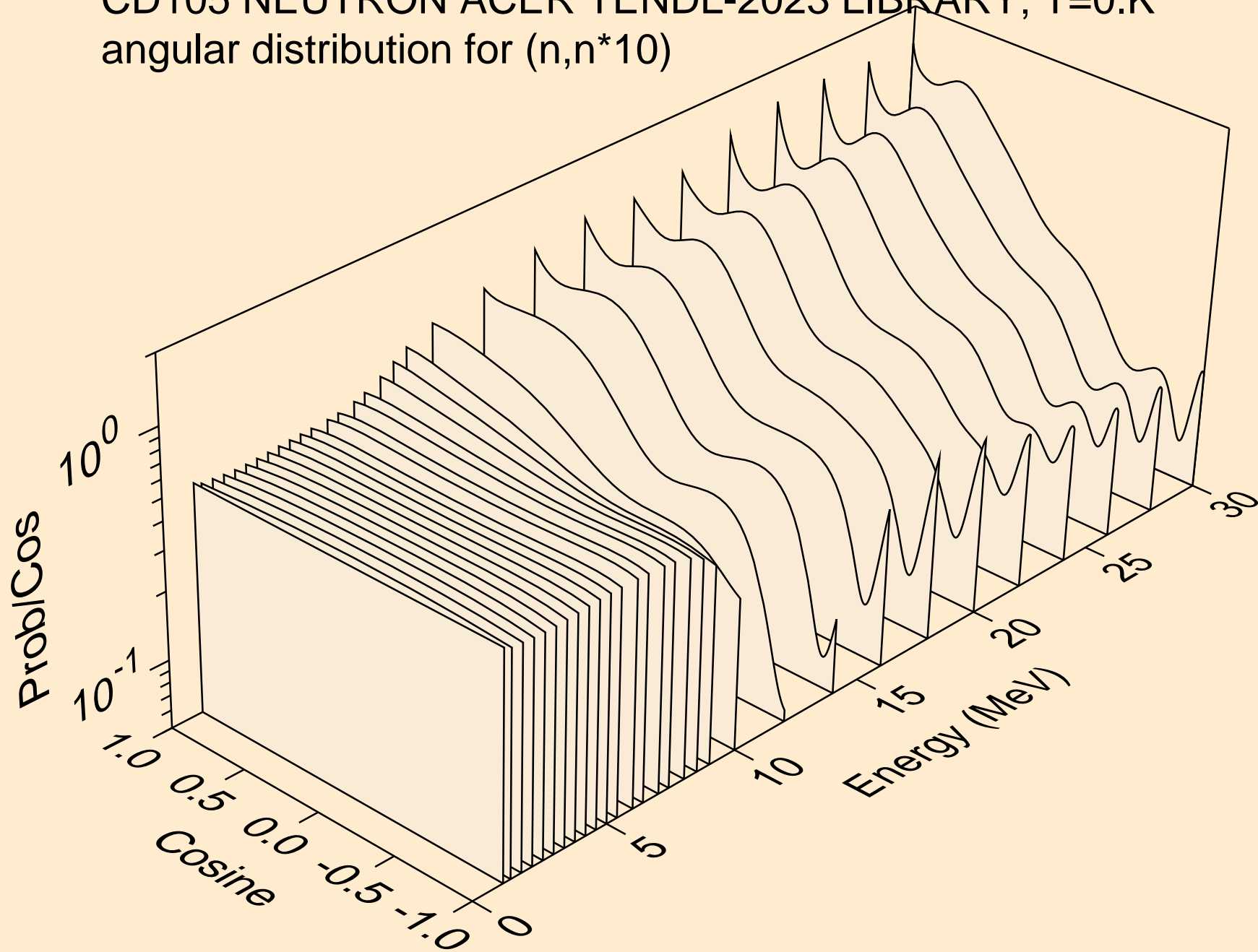

CD105 NEUTRON ACER TENDL-2023 LIBRARY; T=0.K  
angular distribution for (n,n\*11)

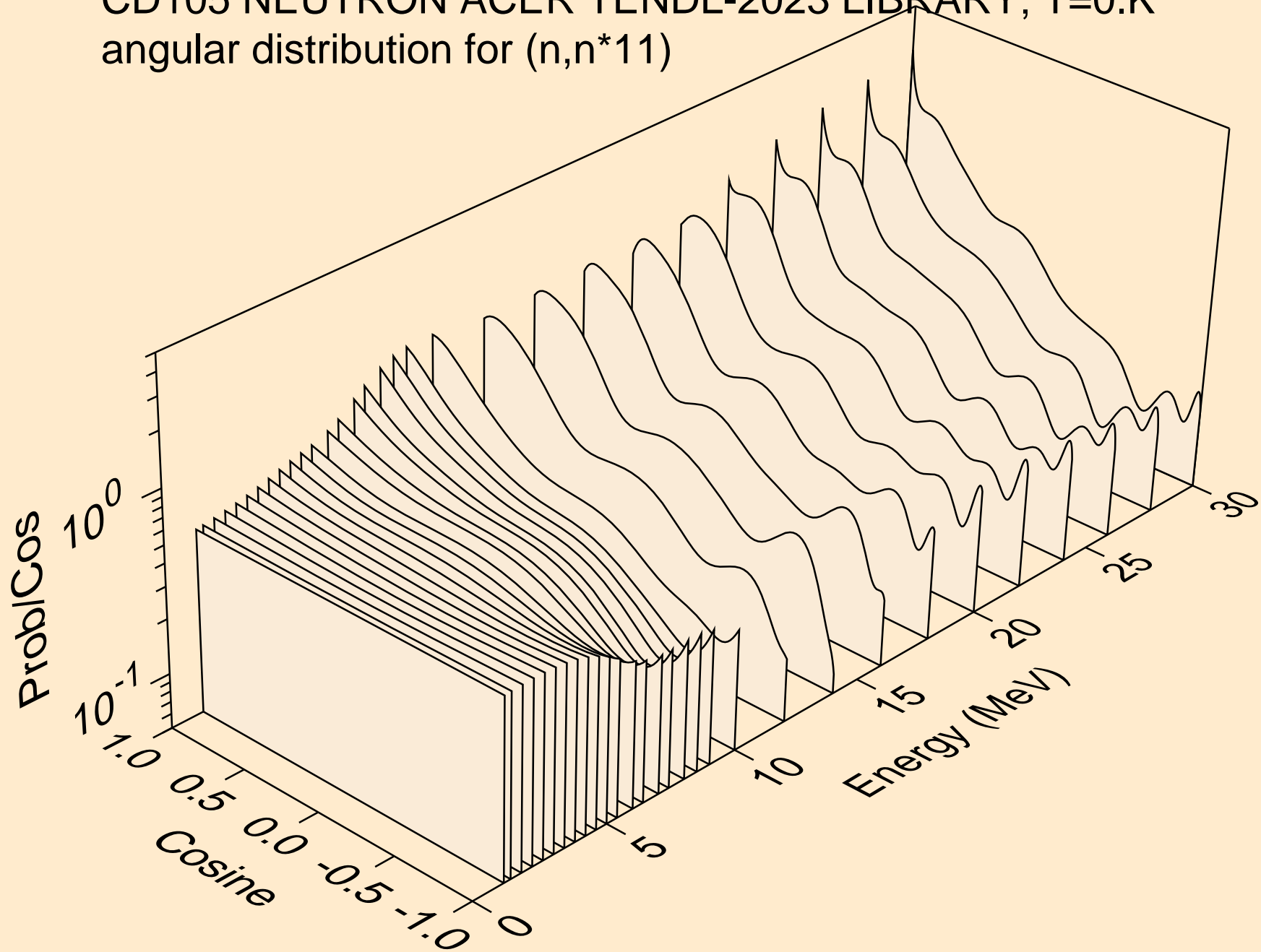

CD105 NEUTRON ACER TENDL-2023 LIBRARY; T=0.K  
angular distribution for (n,n\*12)

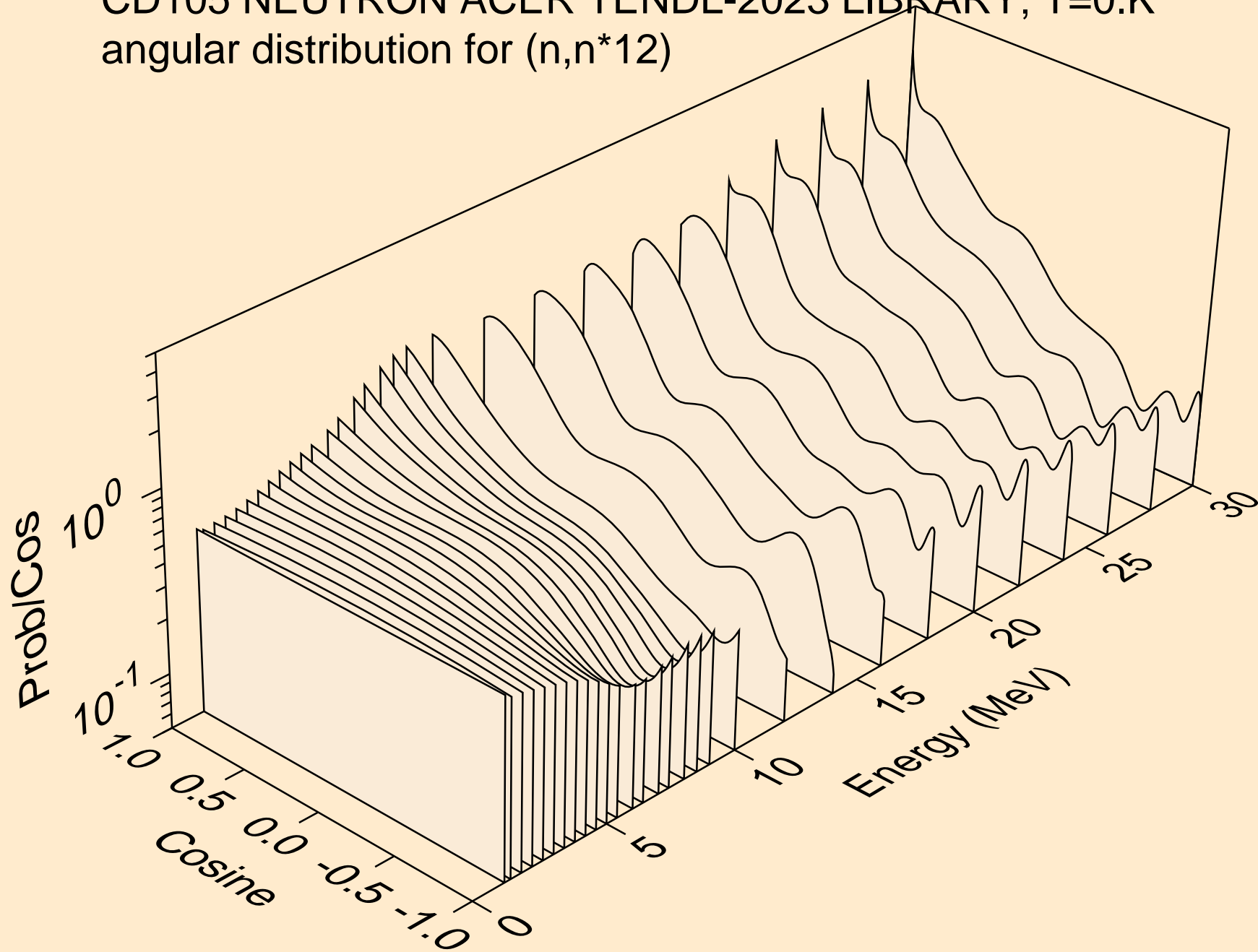

CD105 NEUTRON ACER TENDL-2023 LIBRARY; T=0.K  
angular distribution for (n,n\*13)

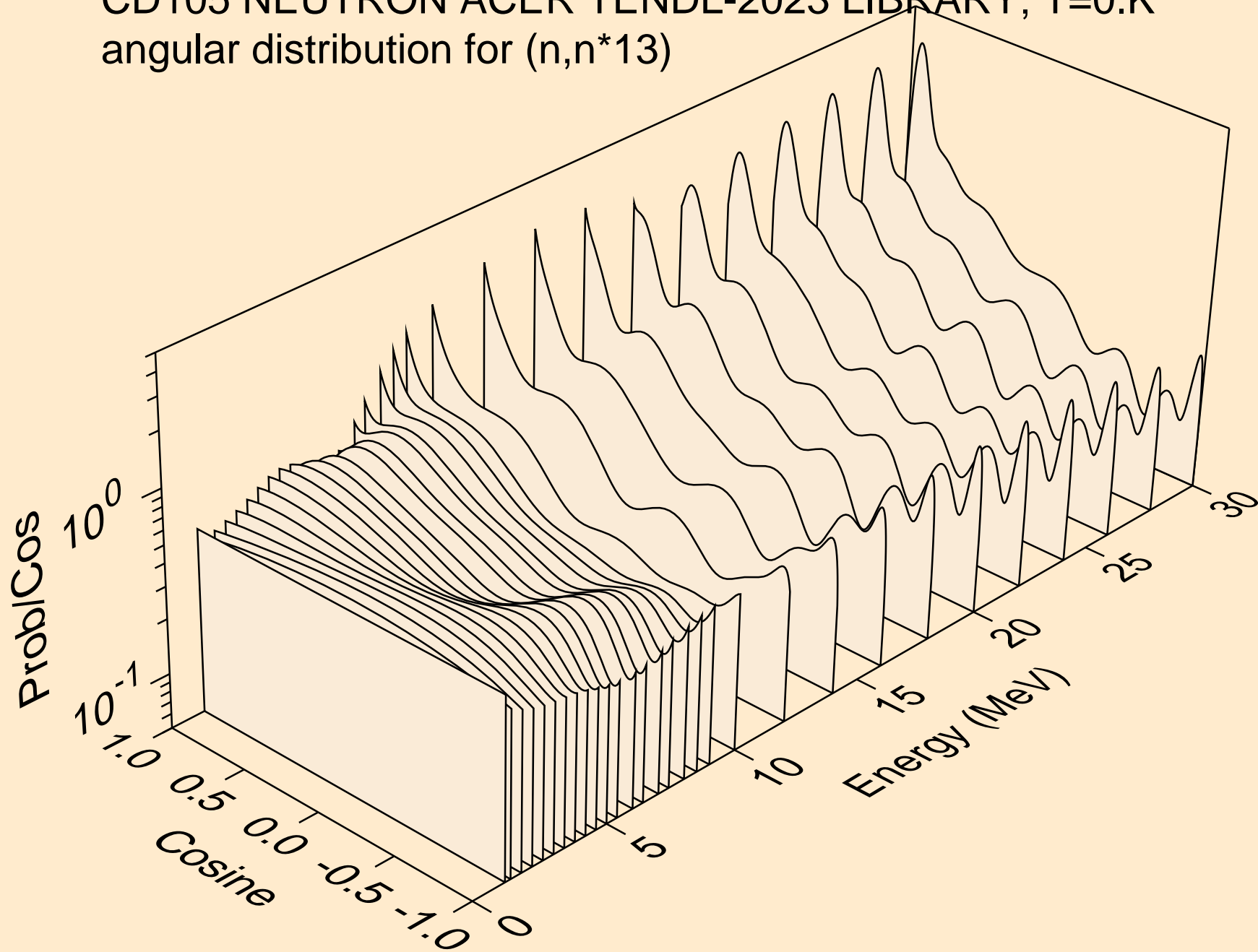

CD105 NEUTRON ACER TENDL-2023 LIBRARY; T=0.K  
angular distribution for (n,n\*14)

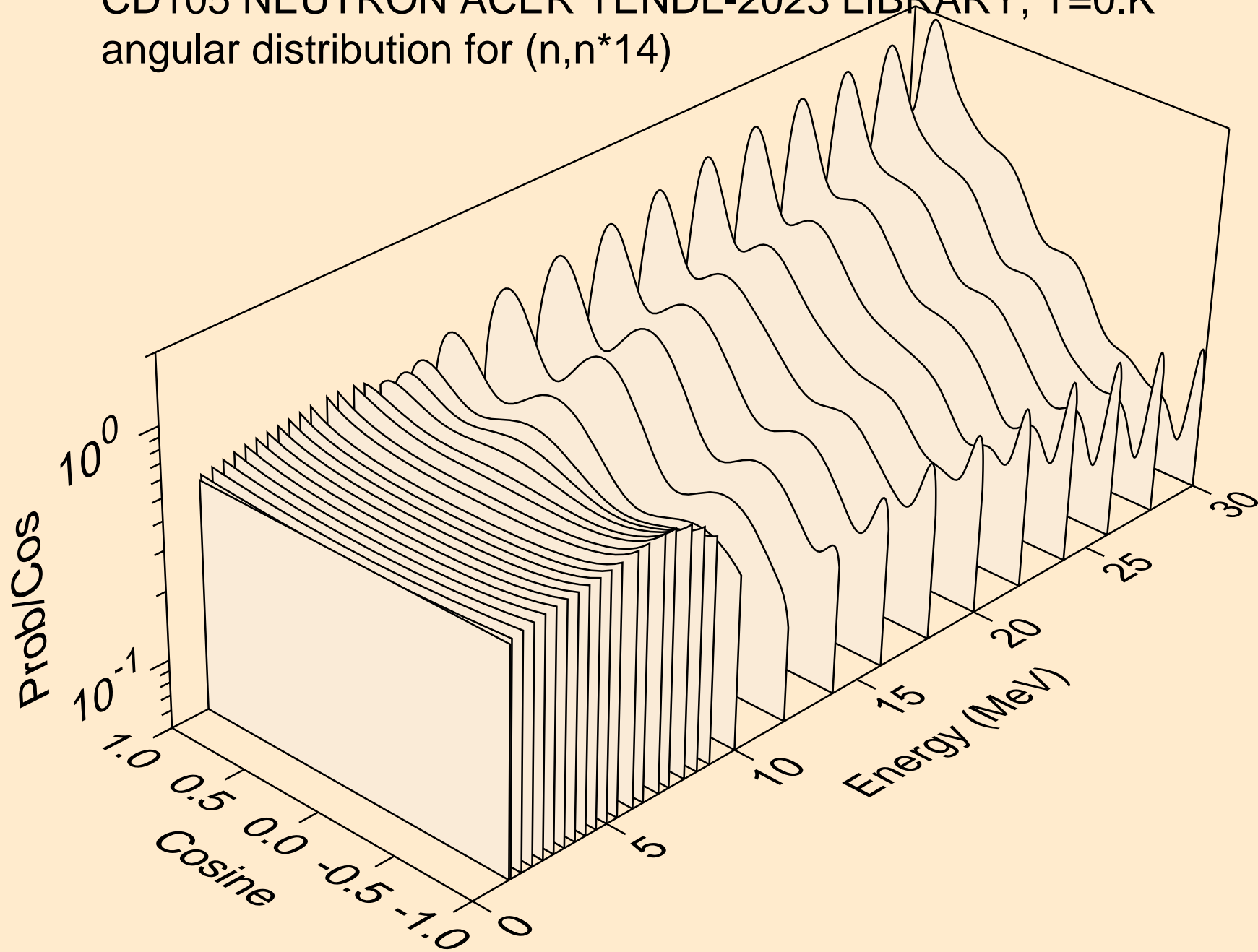

CD105 NEUTRON ACER TENDL-2023 LIBRARY; T=0.K  
angular distribution for (n,n\*15)

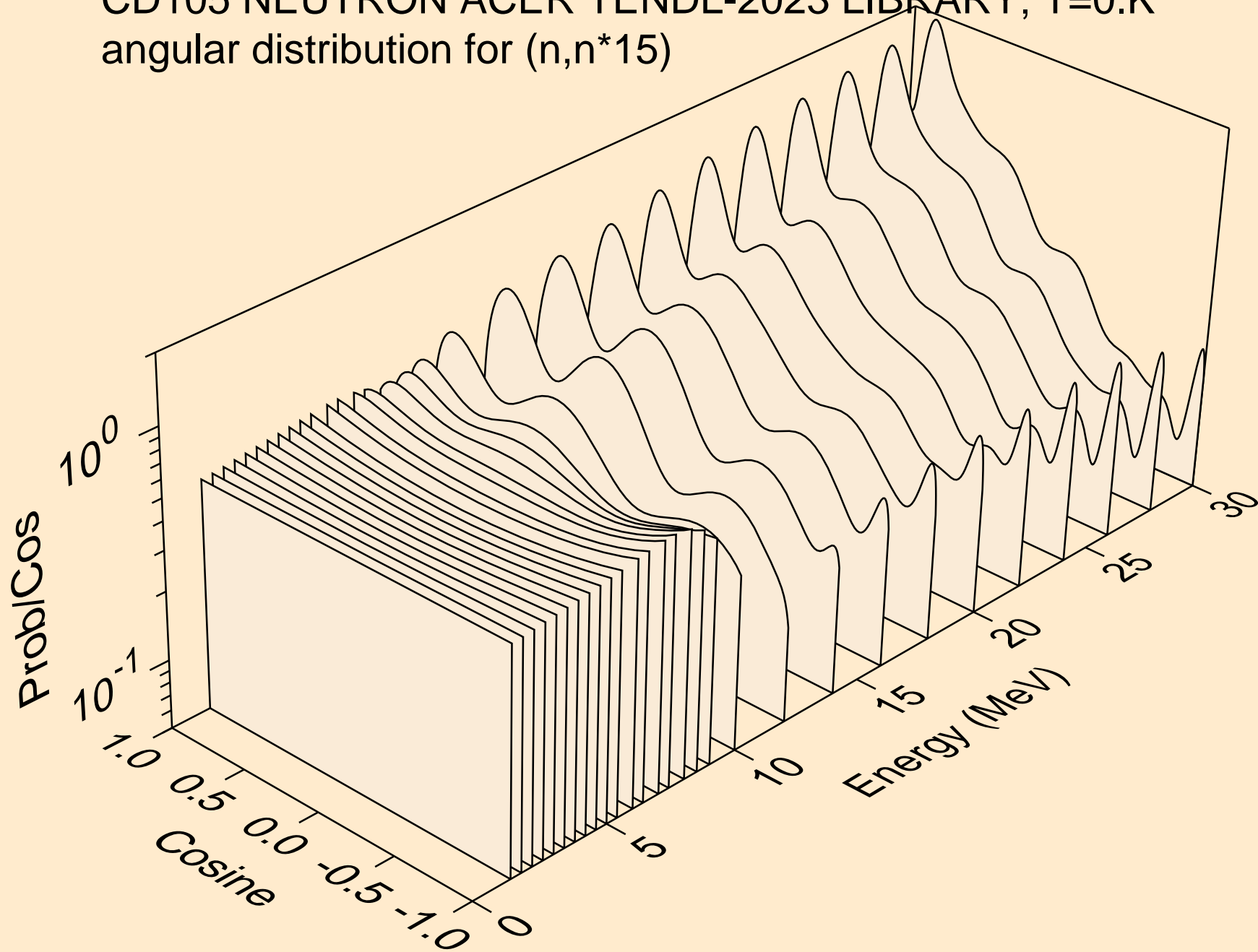

CD105 NEUTRON ACER TENDL-2023 LIBRARY; T=0.K  
angular distribution for (n,n\*16)

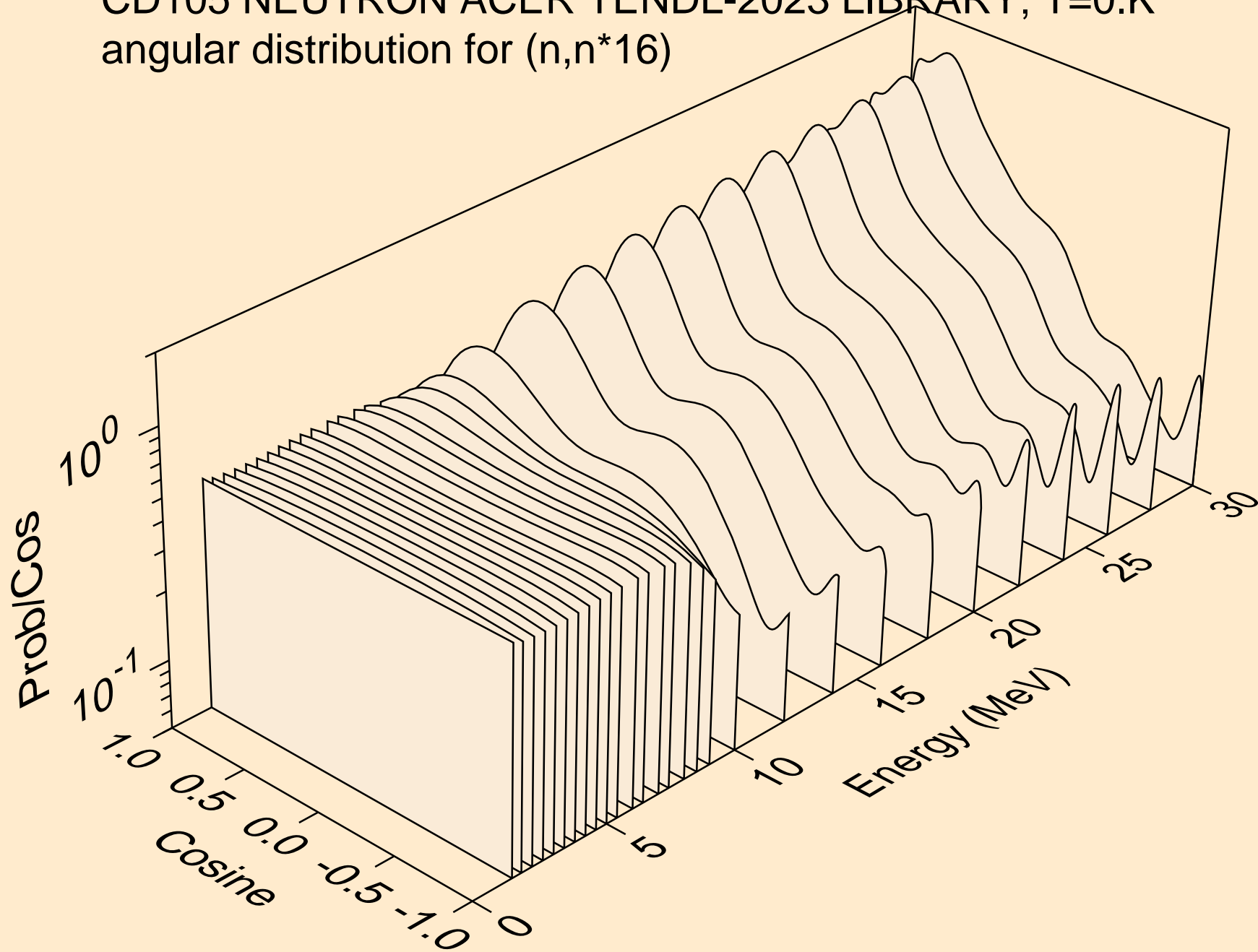

CD105 NEUTRON ACER TENDL-2023 LIBRARY; T=0.K  
angular distribution for (n,n\*17)

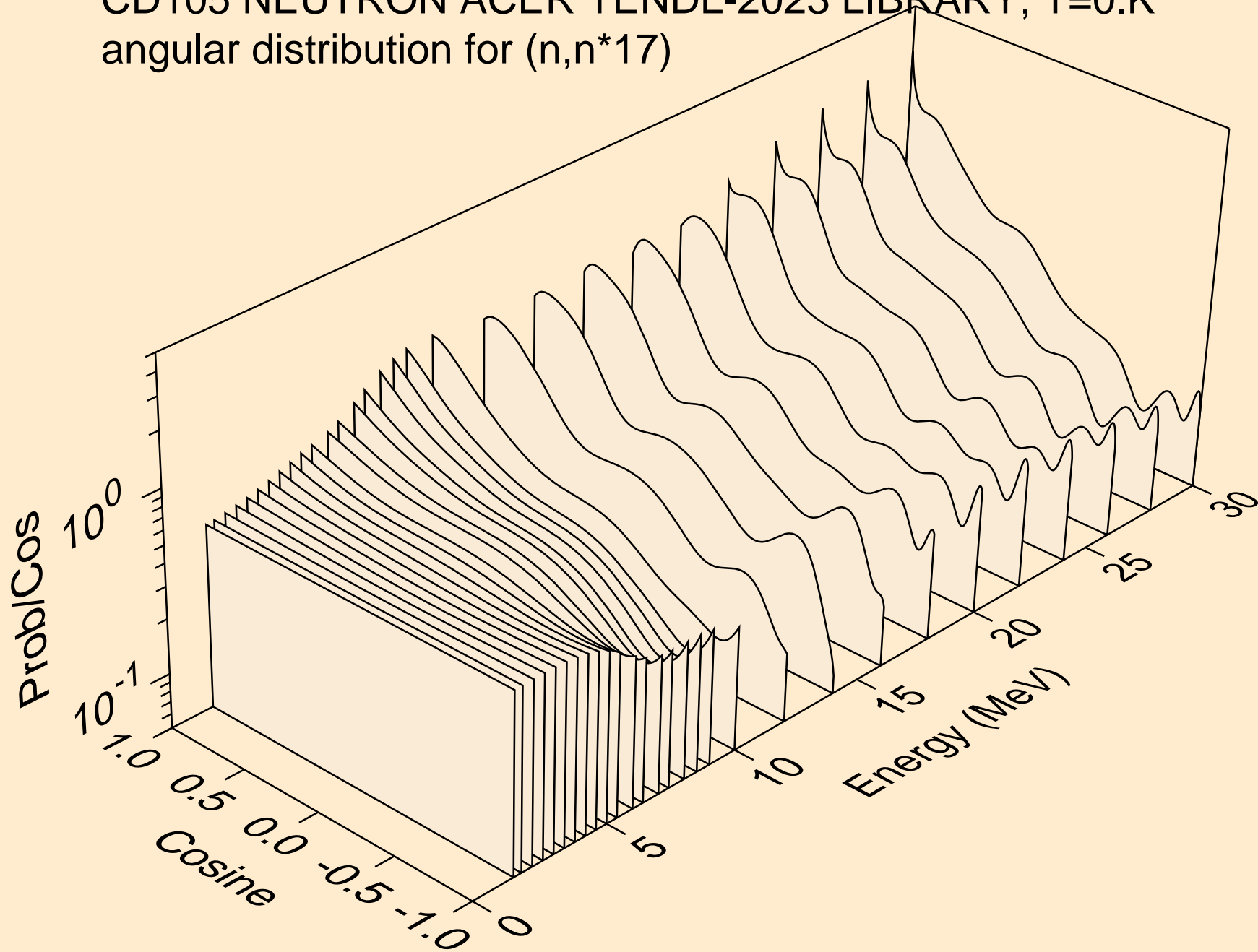

CD105 NEUTRON ACER TENDL-2023 LIBRARY; T=0.K  
angular distribution for (n,n\*18)

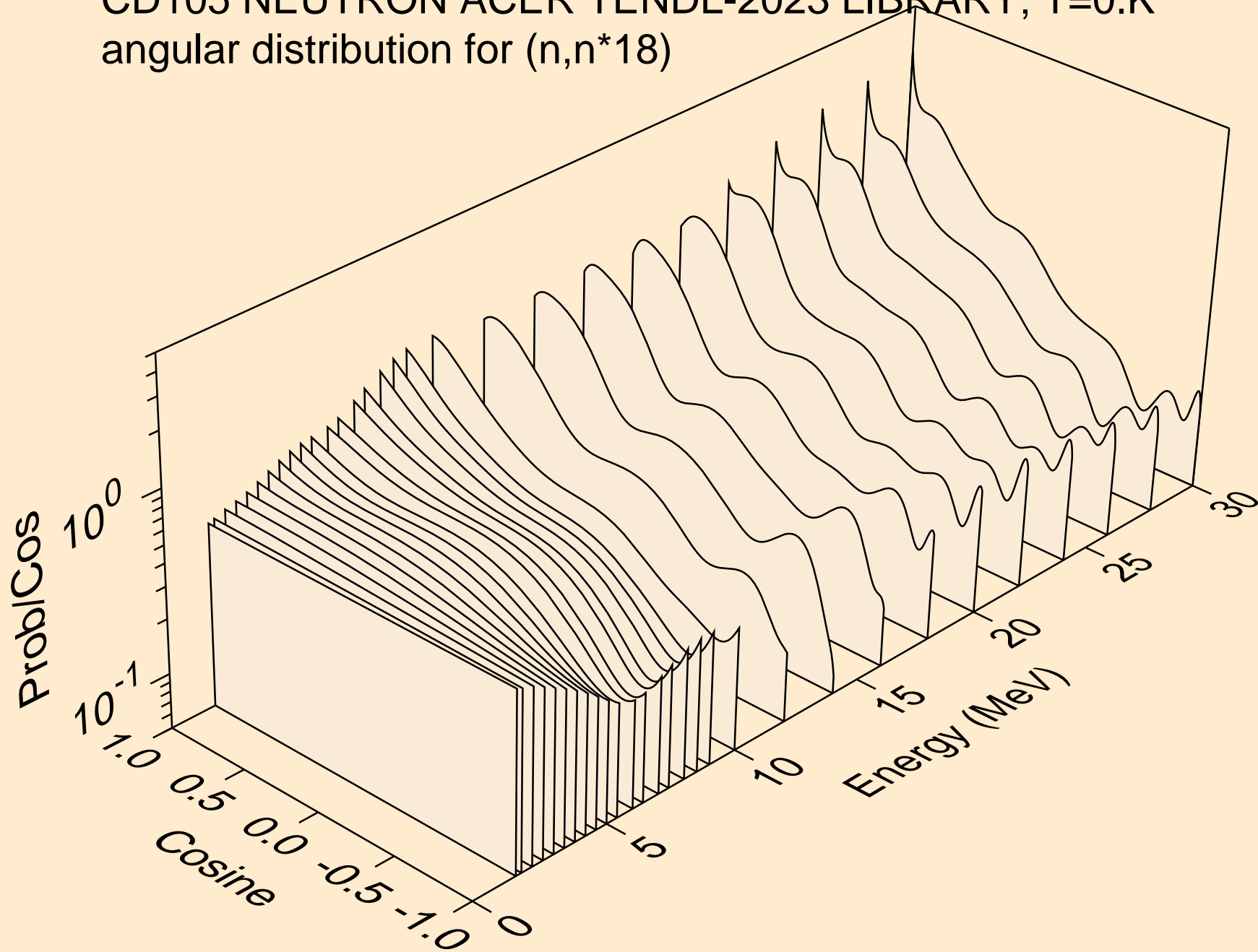

CD105 NEUTRON ACER TENDL-2023 LIBRARY; T=0.K  
angular distribution for (n,n\*19)

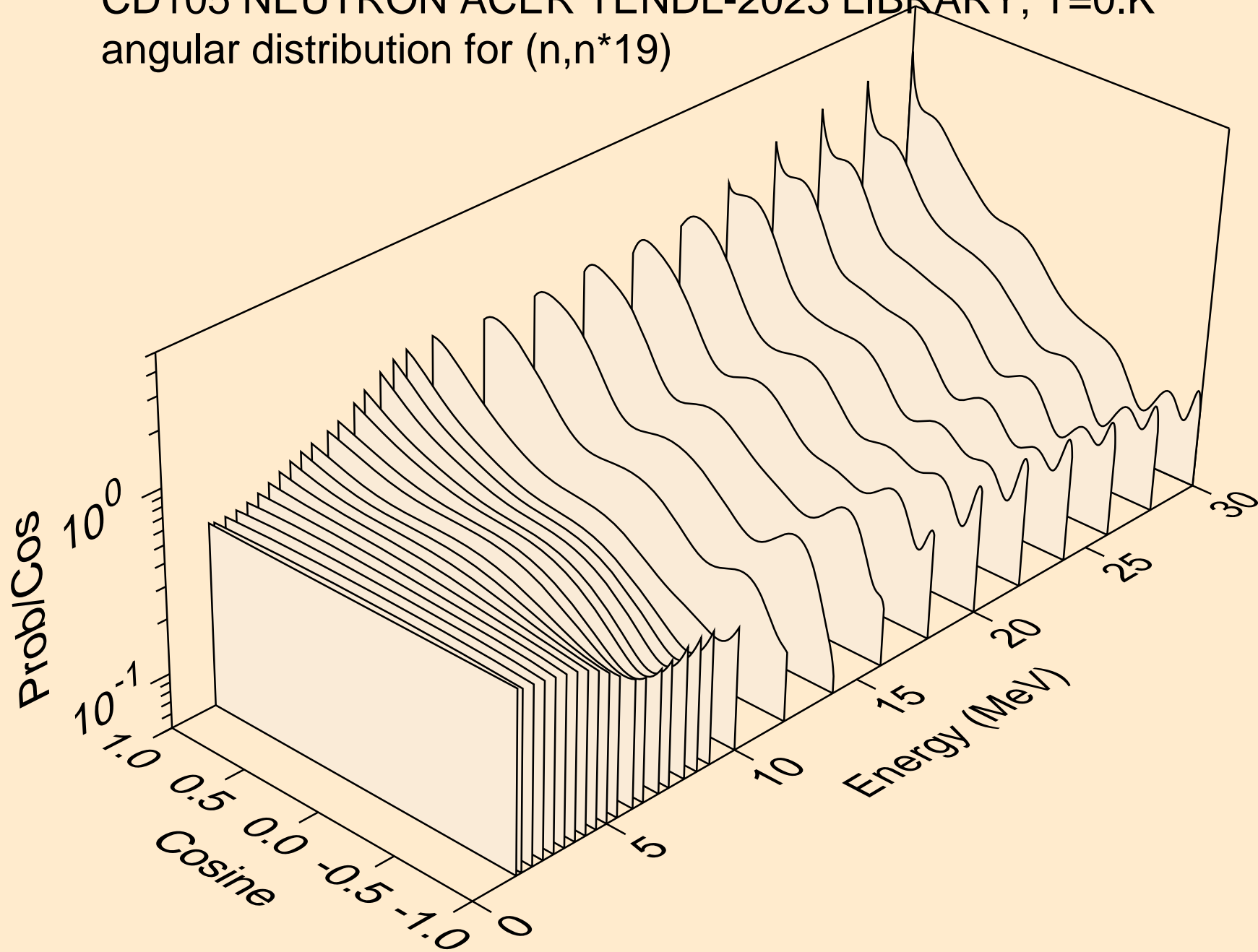

CD105 NEUTRON ACER TENDL-2023 LIBRARY; T=0.K  
angular distribution for (n,n\*20)

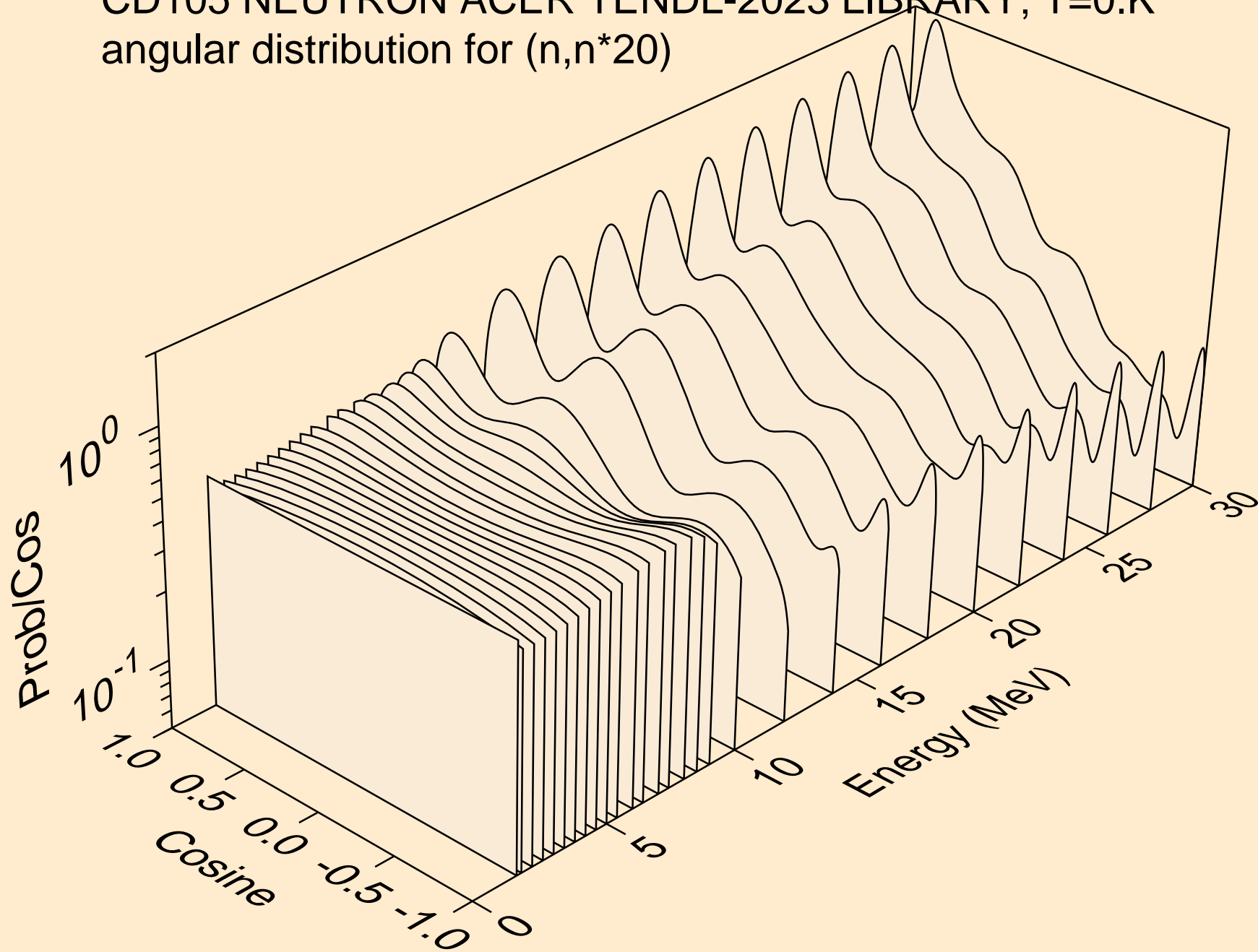

CD105 NEUTRON ACER TENDL-2023 LIBRARY; T=0.K  
angular distribution for (n,n\*21)

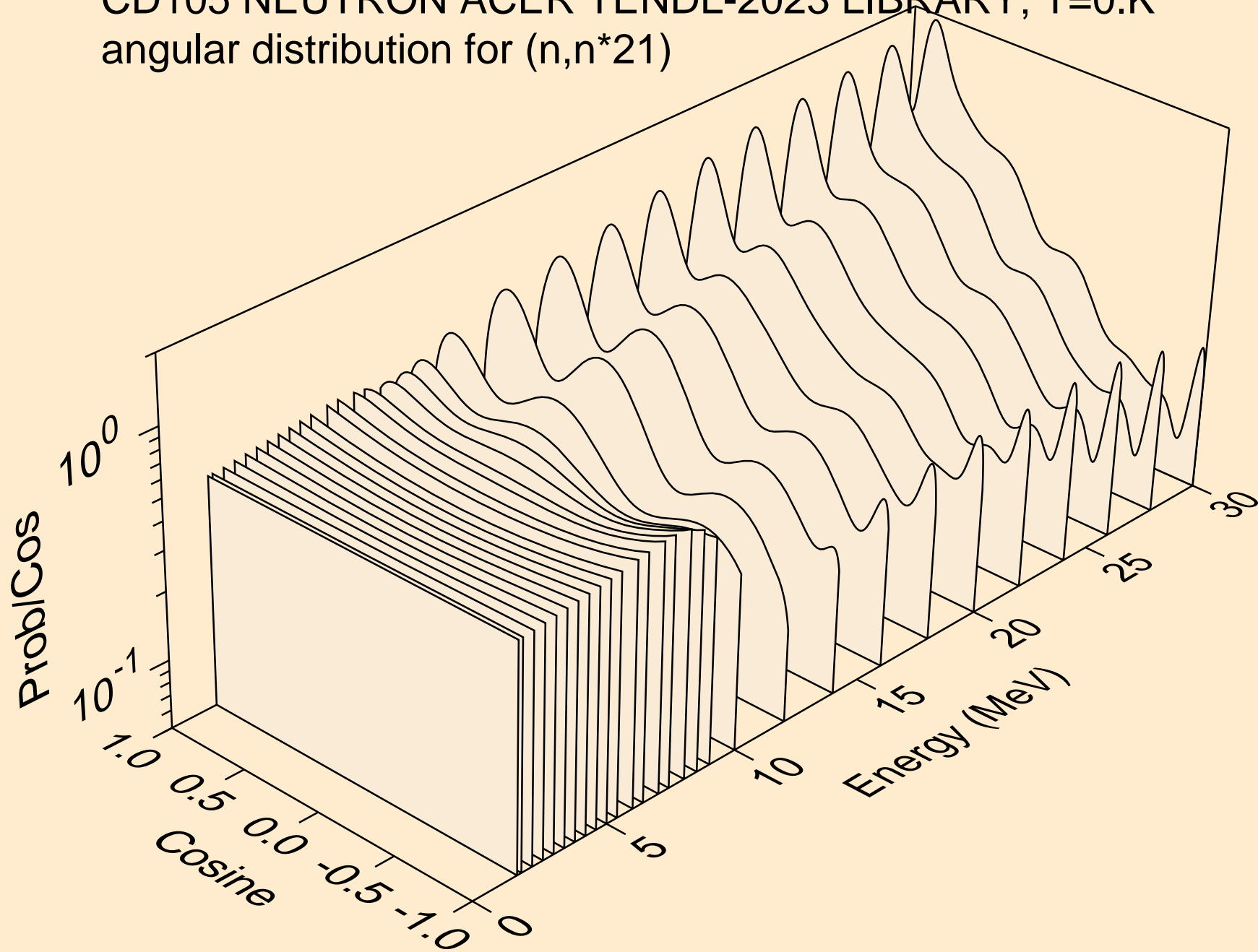

CD105 NEUTRON ACER TENDL-2023 LIBRARY; T=0.K  
angular distribution for (n,n\*22)

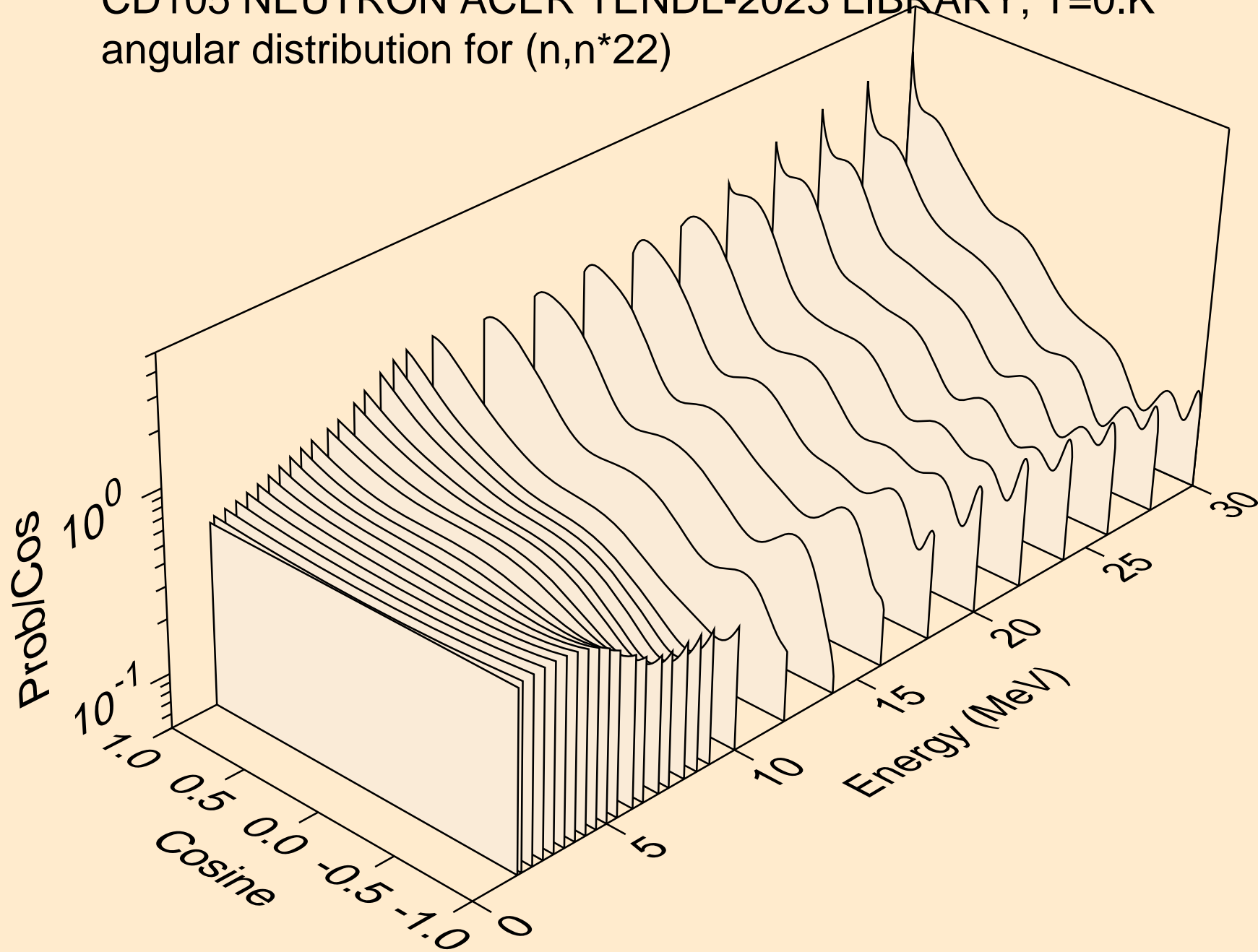

CD105 NEUTRON ACER TENDL-2023 LIBRARY; T=0.K  
angular distribution for (n,n\*23)

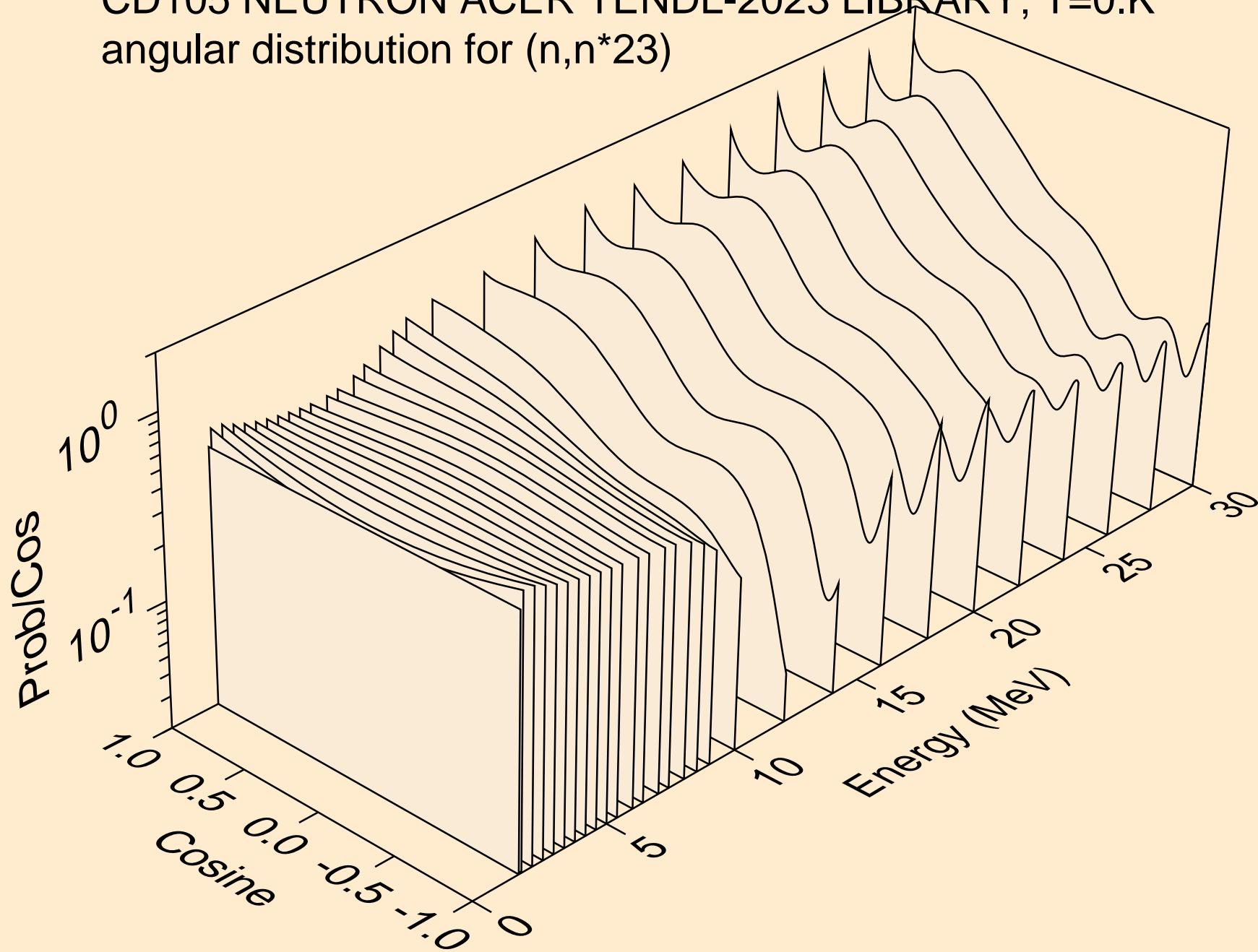

CD105 NEUTRON ACER TENDL-2023 LIBRARY; T=0.K  
angular distribution for (n,n\*24)

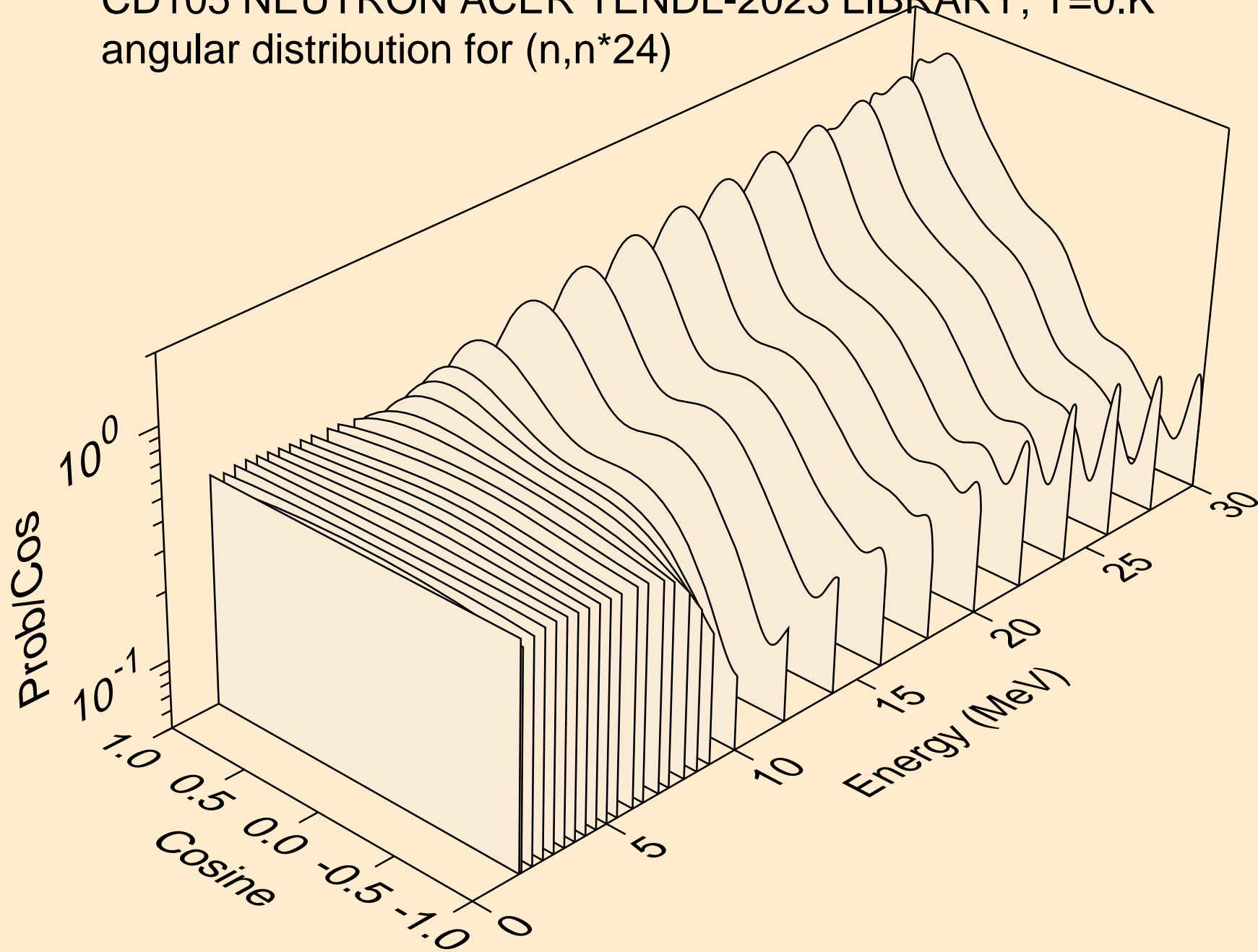

CD105 NEUTRON ACER TENDL-2023 LIBRARY; T=0.K  
angular distribution for (n,n\*25)

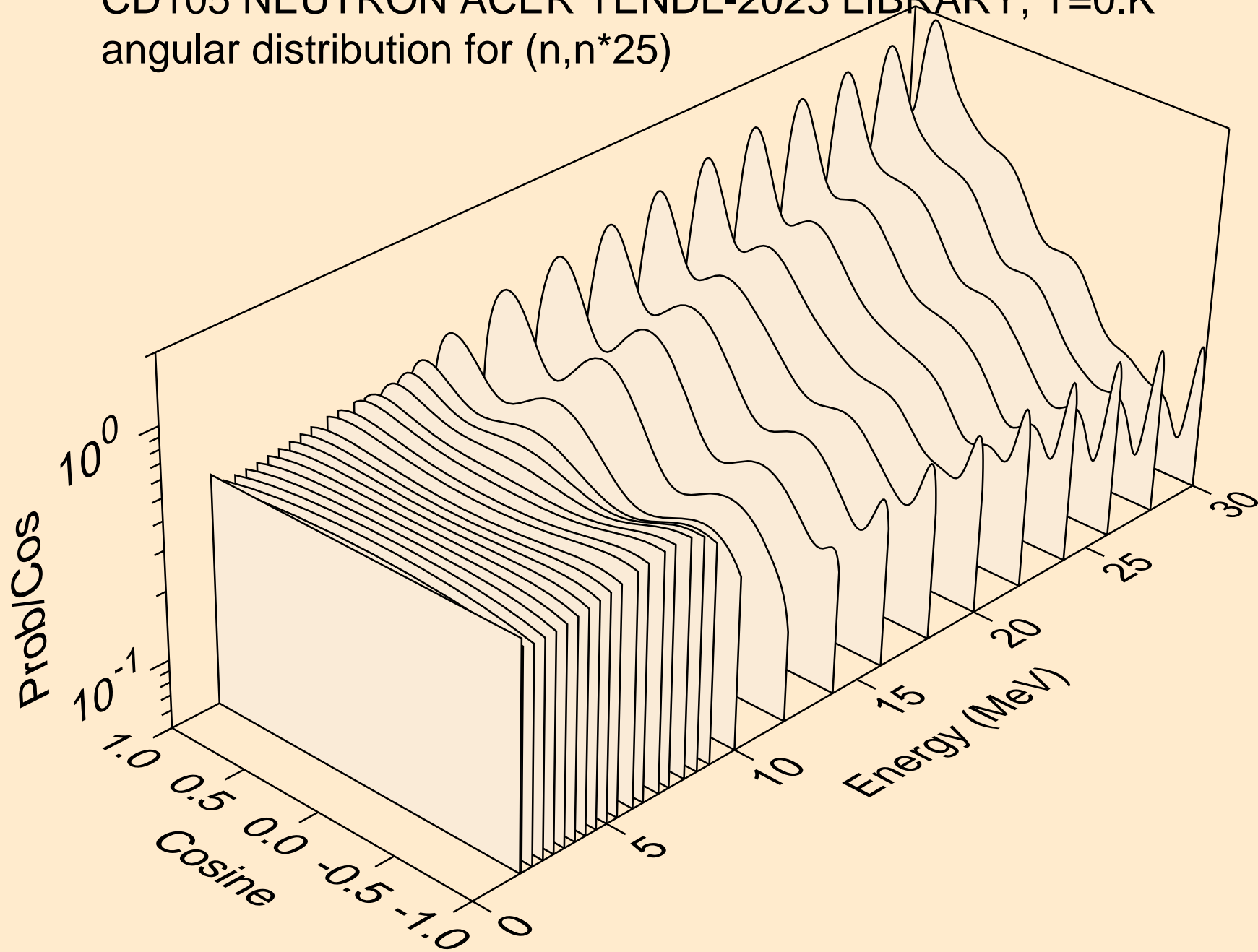

CD105 NEUTRON ACER TENDL-2023 LIBRARY; T=0.K  
angular distribution for (n,n\*26)

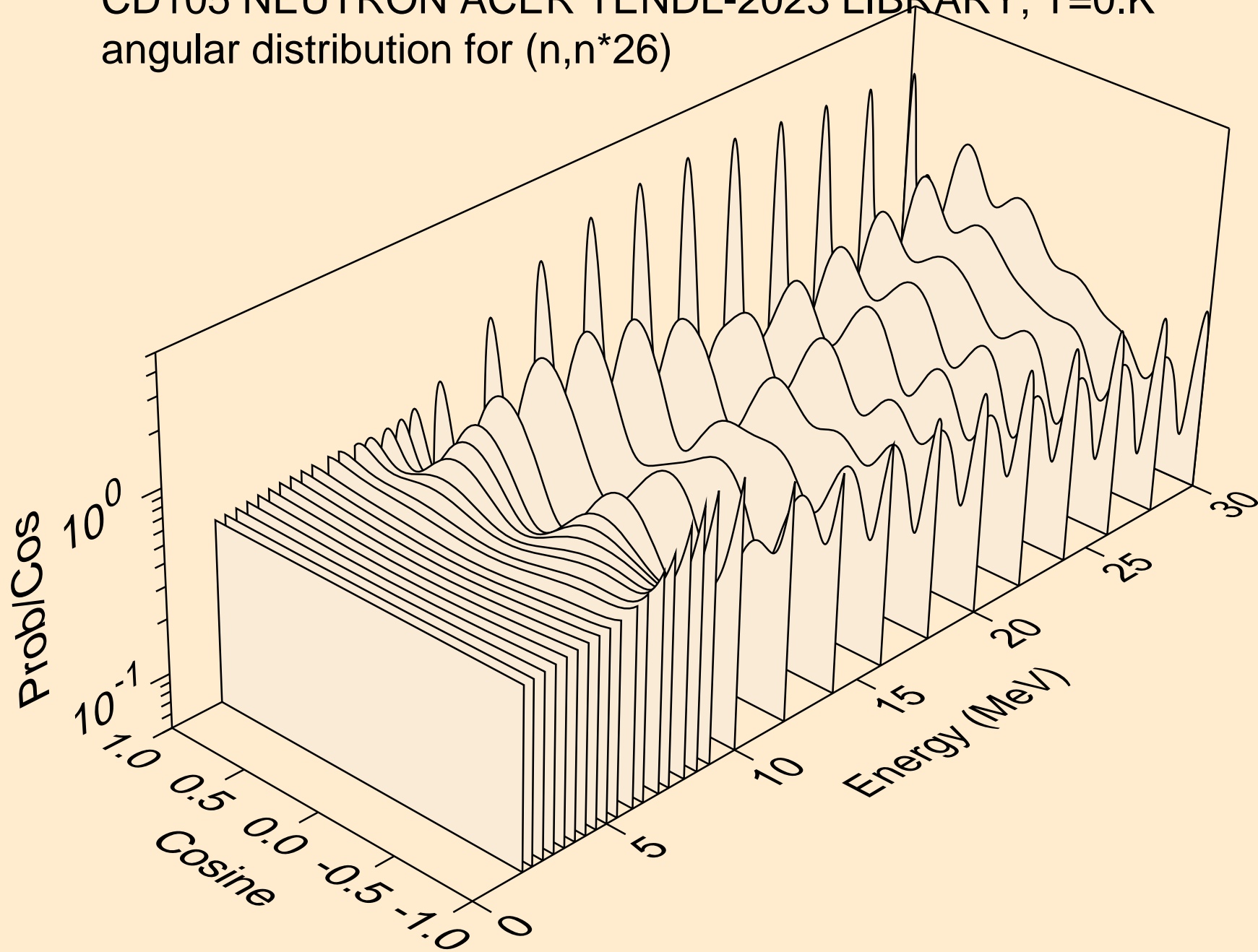

CD105 NEUTRON ACER TENDL-2023 LIBRARY; T=0.K  
Neutron emission for (n,x)

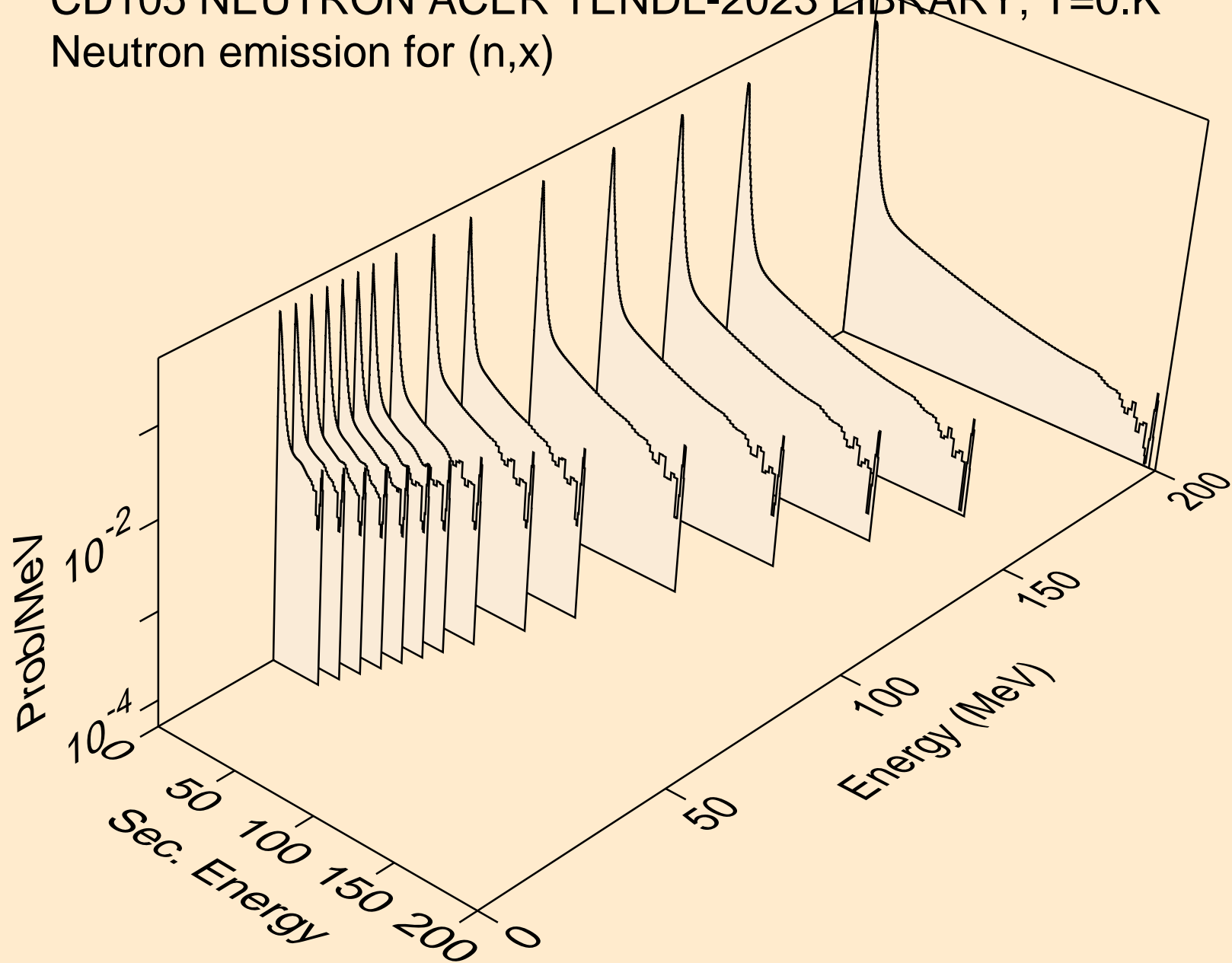

CD105 NEUTRON ACER TENDL-2023 LIBRARY; T=0.K  
Neutron emission for (n,2nd)

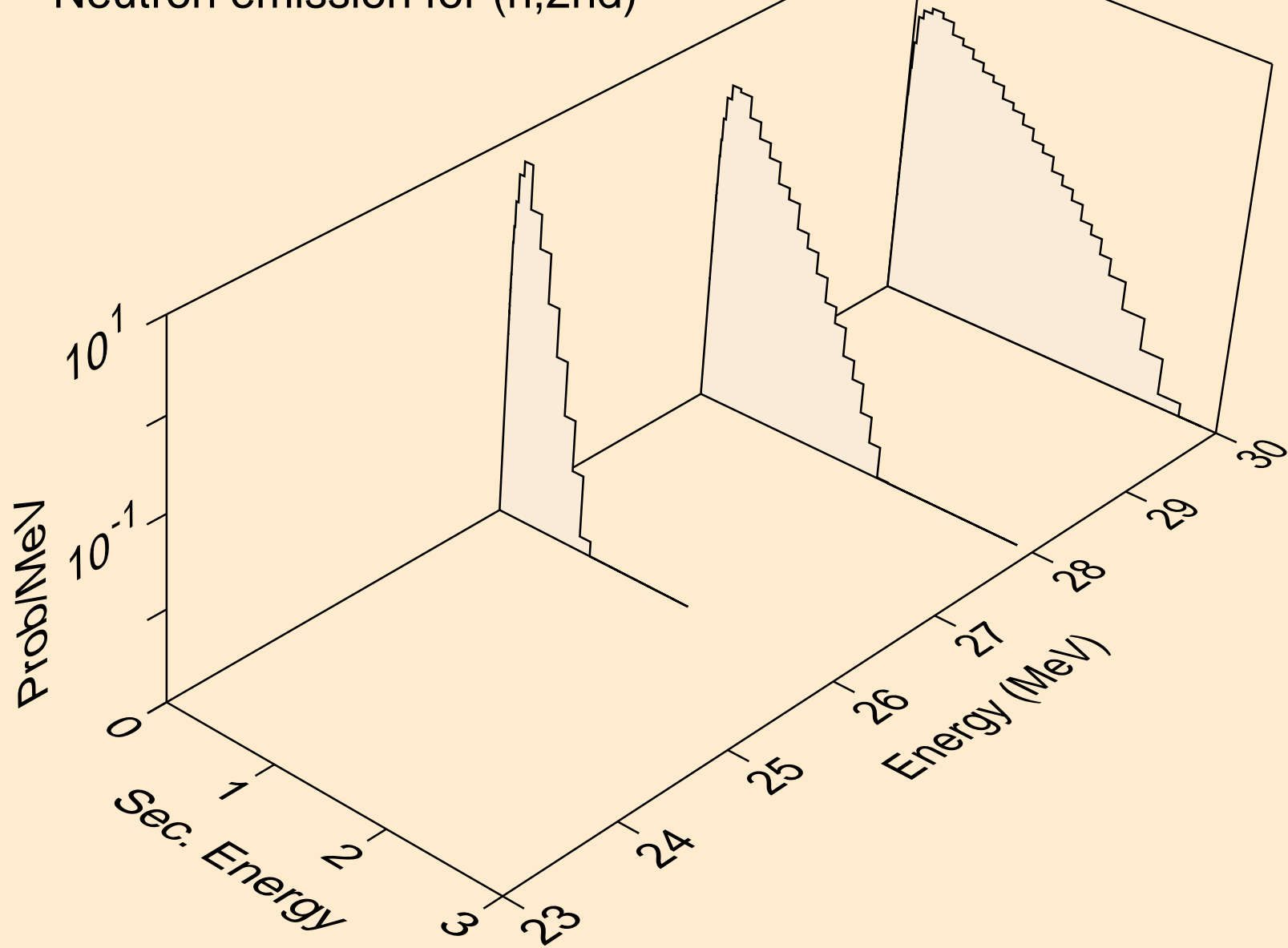

CD105 NEUTRON ACER TENDL-2023 LIBRARY; T=0.K  
Neutron emission for (n,2n)

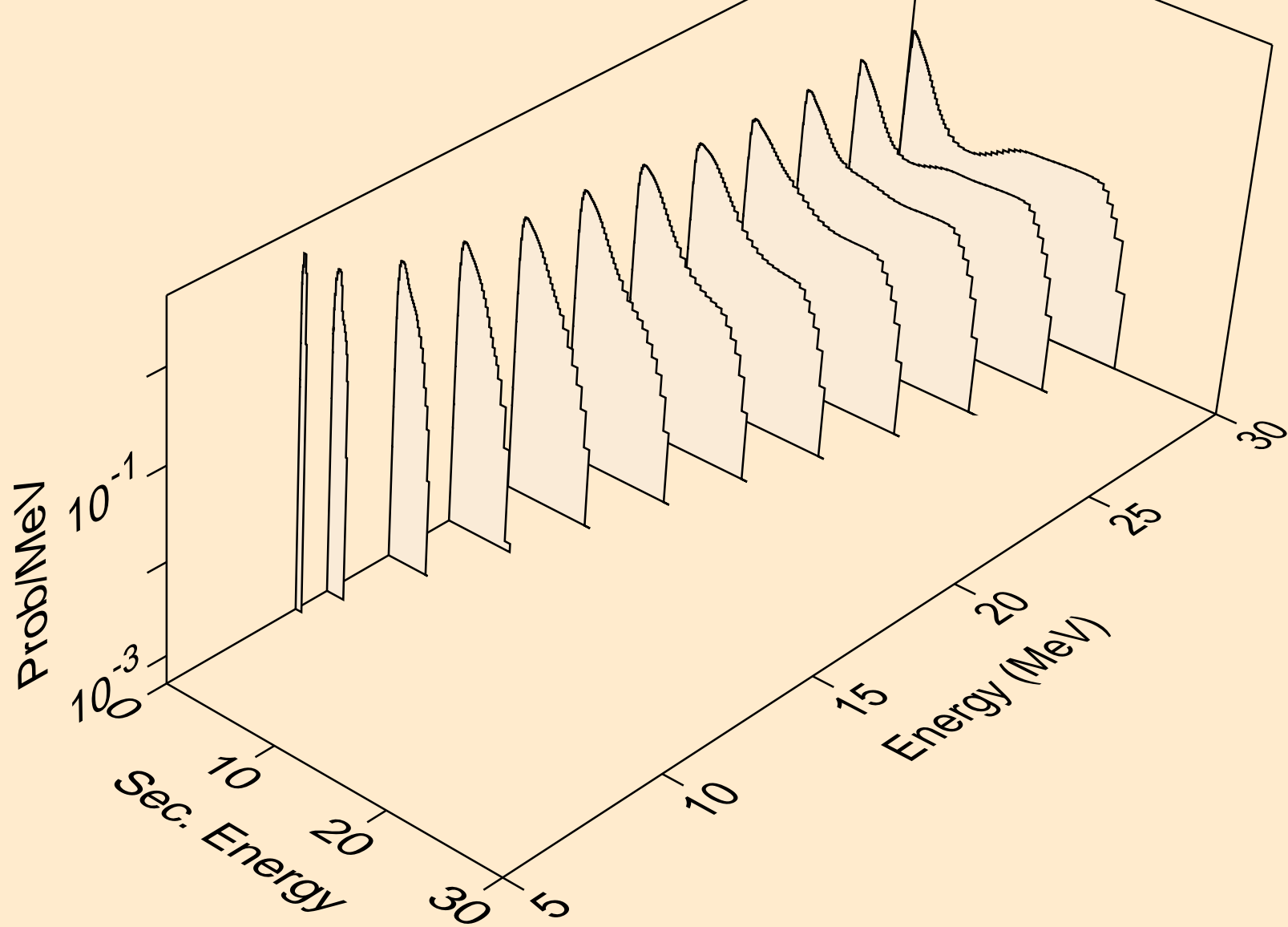

CD105 NEUTRON ACER TENDL-2023 LIBRARY; T=0.K  
Neutron emission for (n,3n)

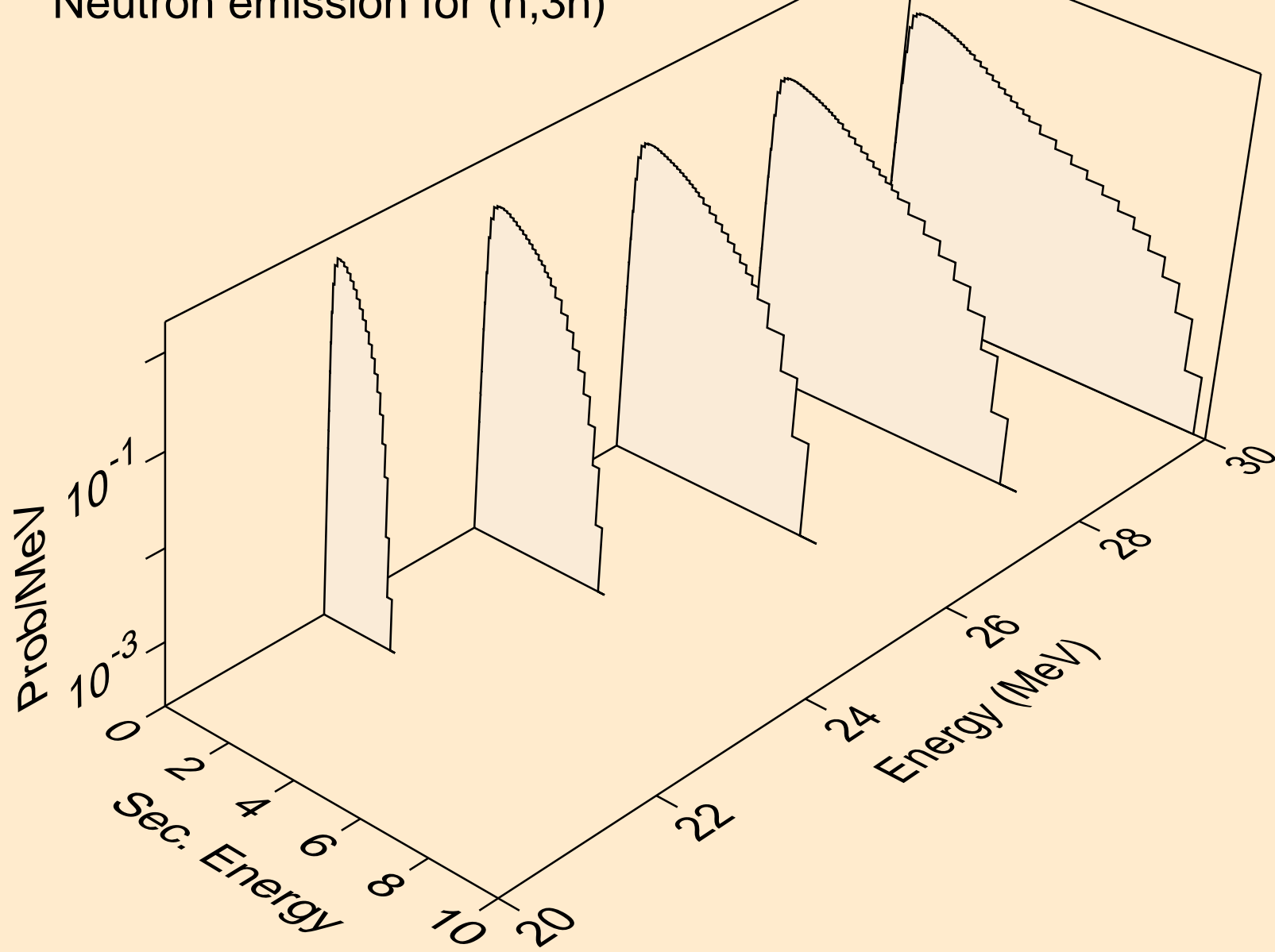

CD105 NEUTRON ACER TENDL-2023 LIBRARY; T=0.K  
Neutron emission for (n,n\*)a

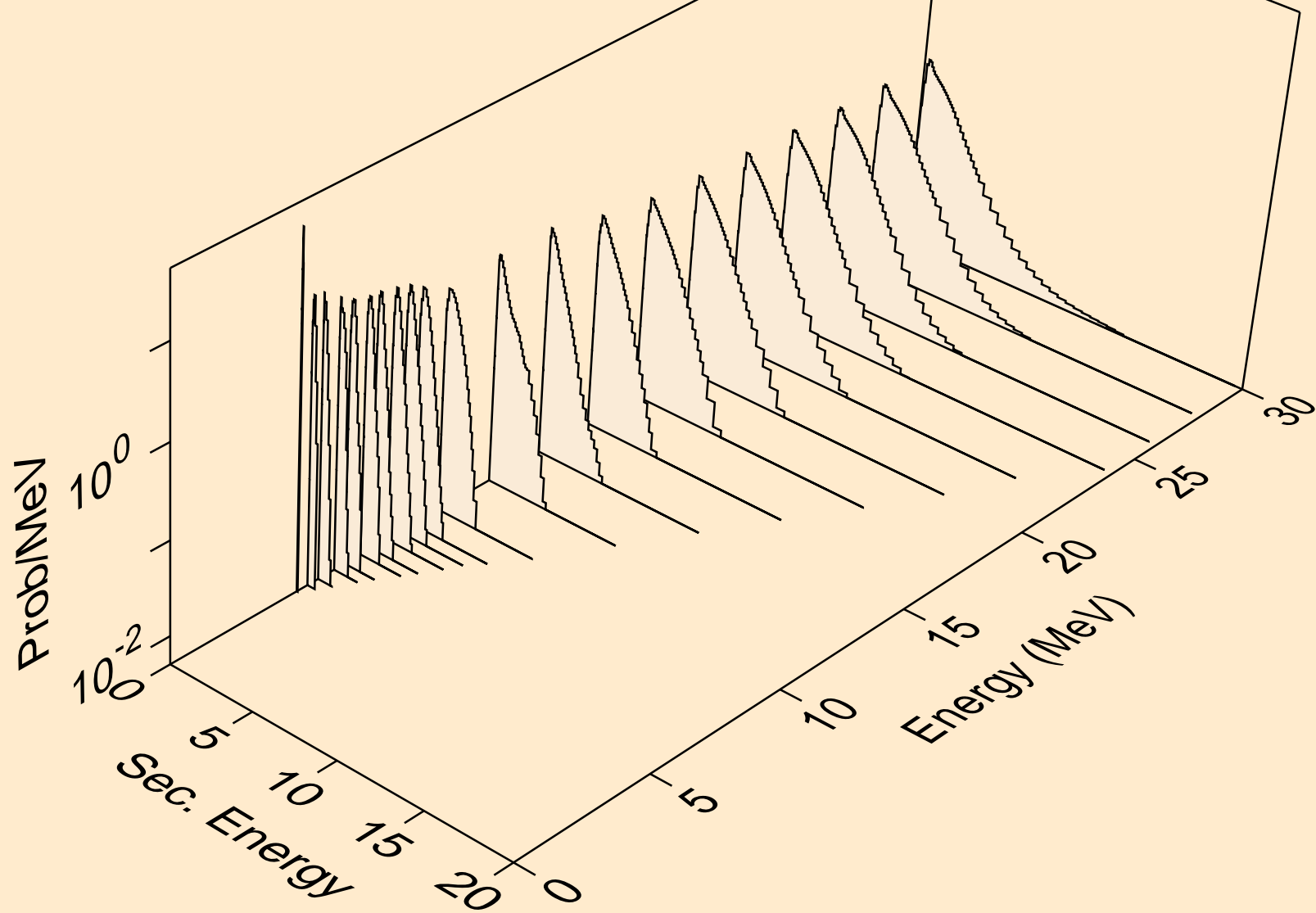

CD105 NEUTRON ACER TENDL-2023 LIBRARY; T=0.K  
Neutron emission for (n,2n)a

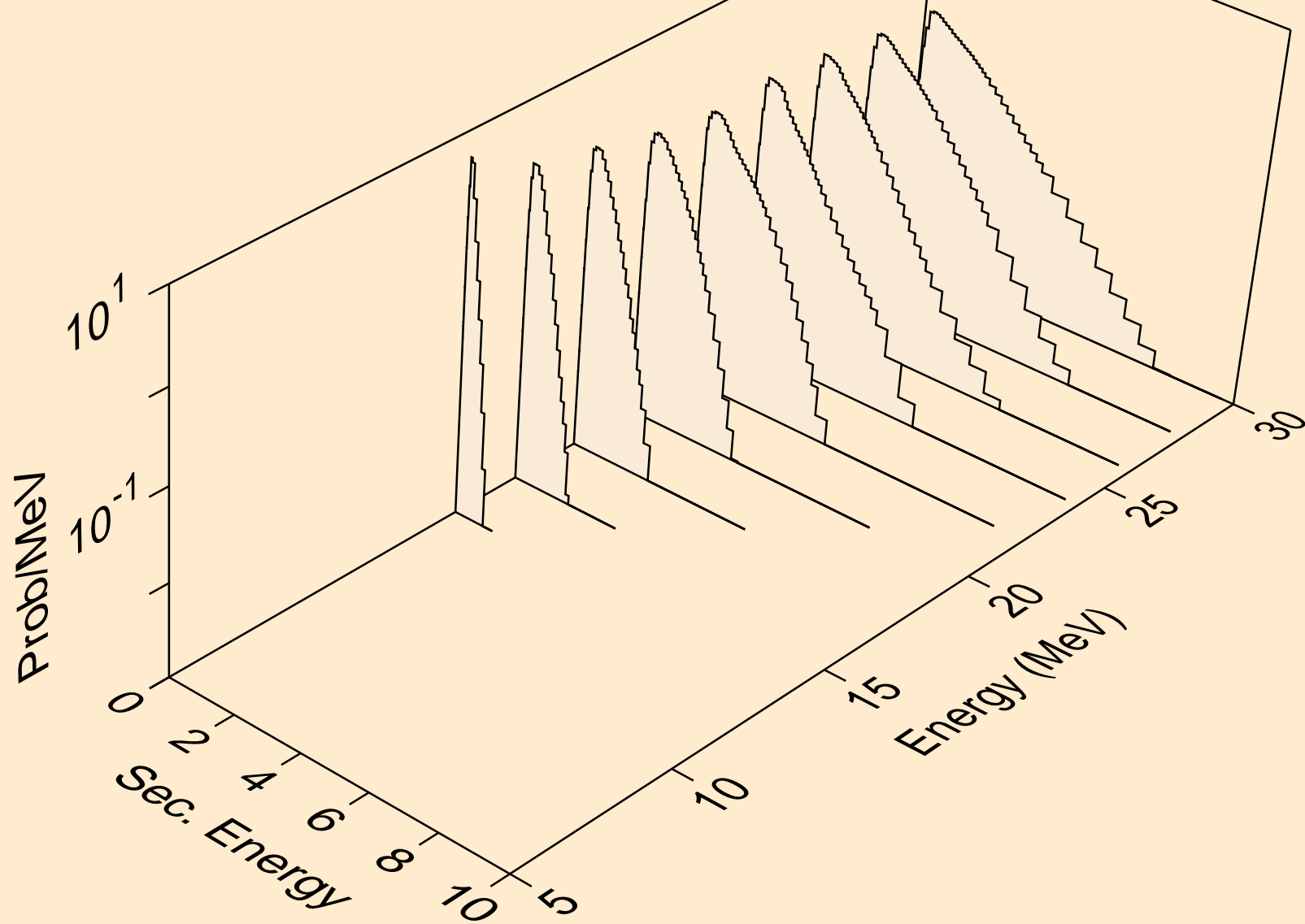

CD105 NEUTRON ACER TENDL-2023 LIBRARY; T=0.K  
Neutron emission for (n,3n)a

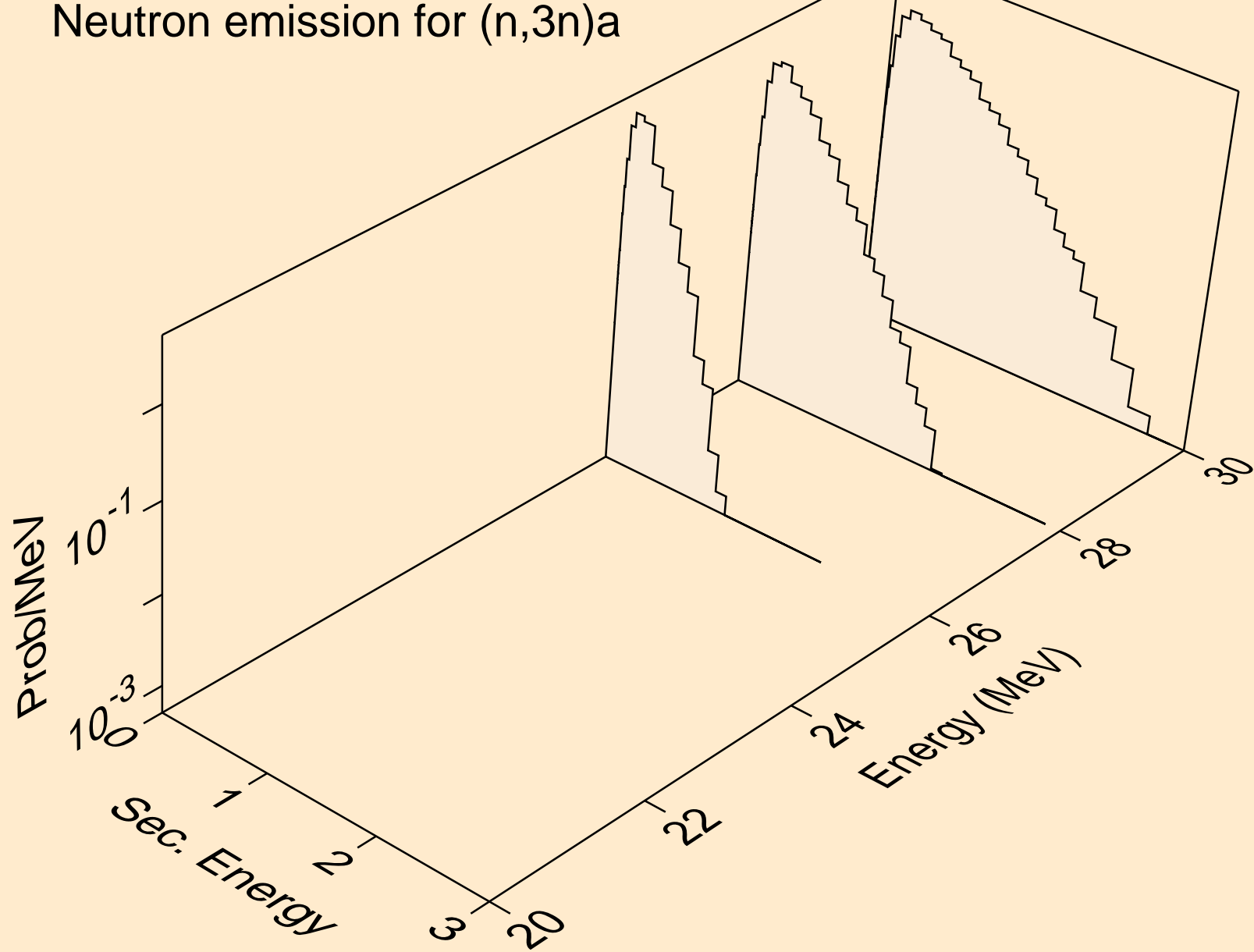

CD105 NEUTRON ACER TENDL-2023 LIBRARY; T=0.K  
Neutron emission for (n,n\*)p

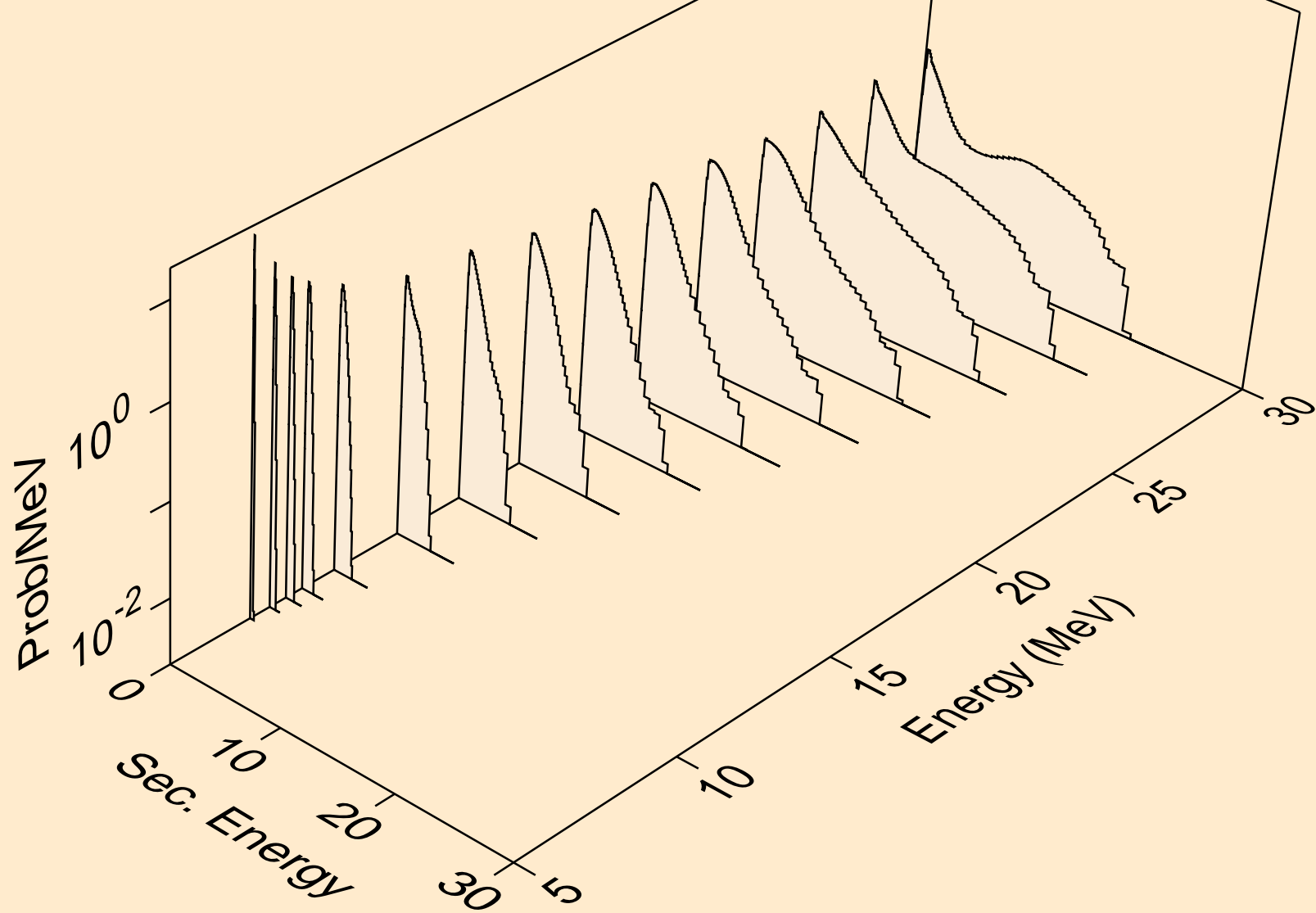

CD105 NEUTRON ACER TENDL-2023 LIBRARY; T=0.K  
Neutron emission for (n,n\*)2a

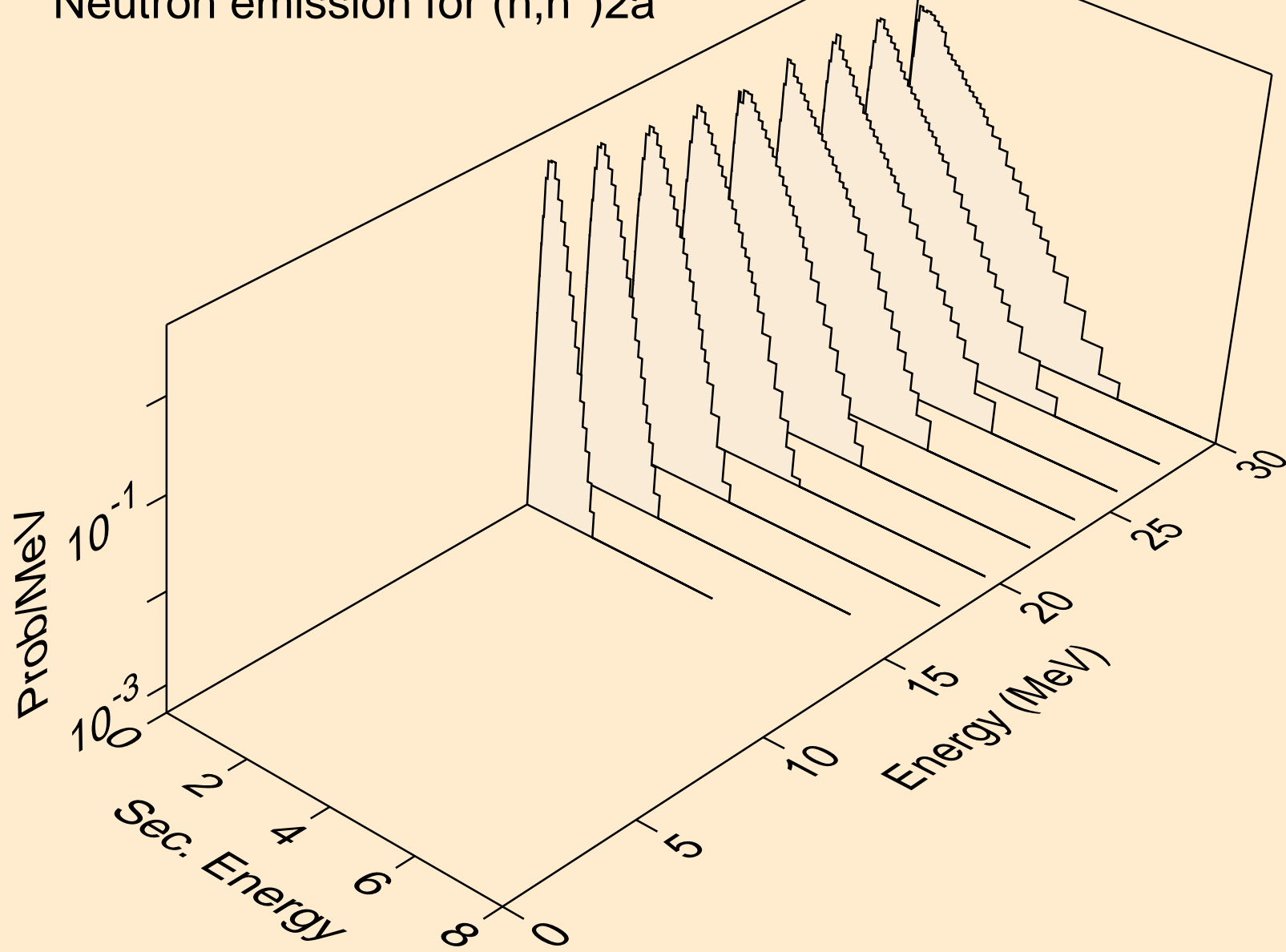

CD105 NEUTRON ACER TENDL-2023 LIBRARY; T=0.K  
Neutron emission for (n,2n)2a

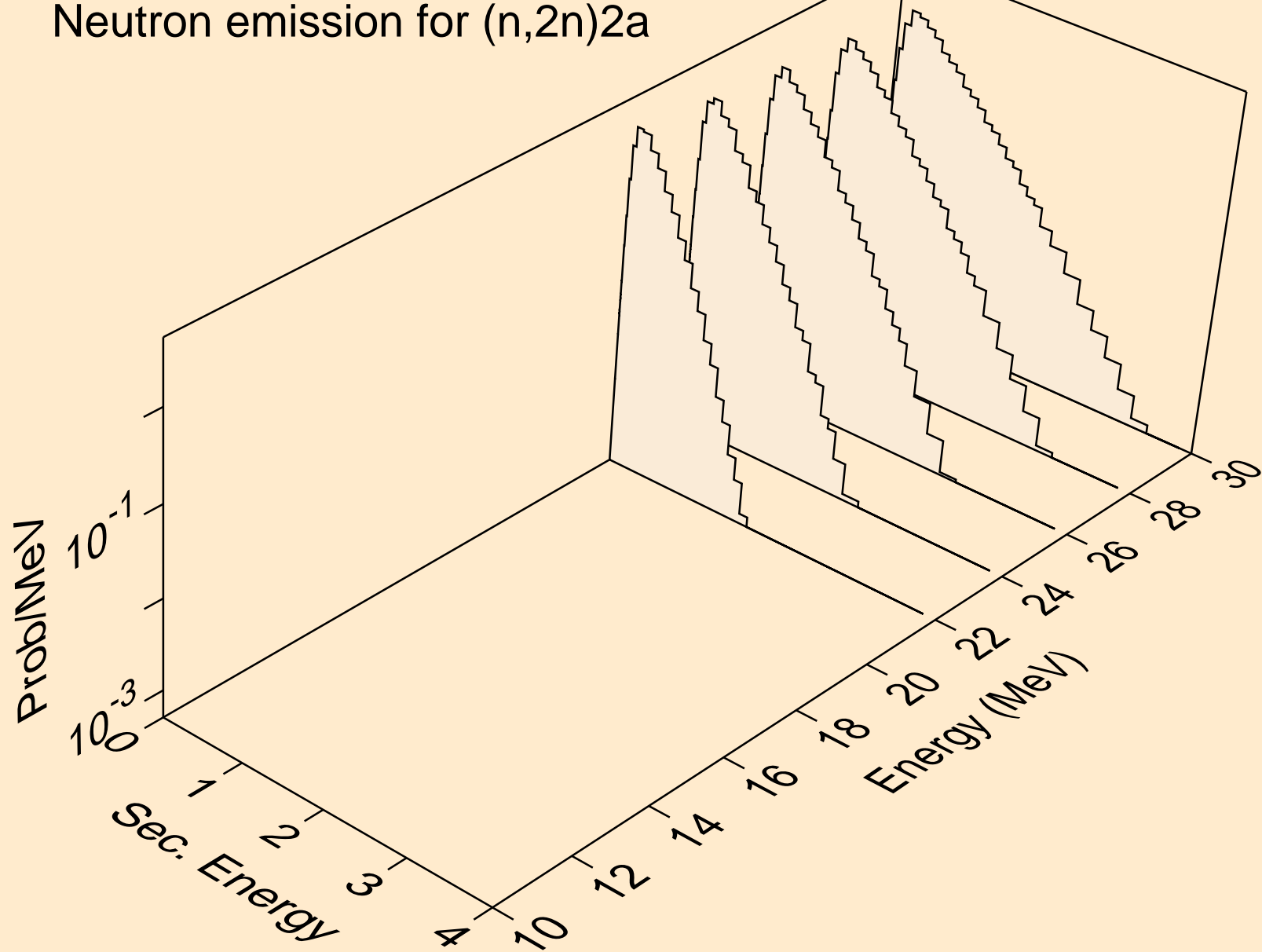

CD105 NEUTRON ACER TENDL-2023 LIBRARY; T=0.K  
Neutron emission for (n,n\*)d

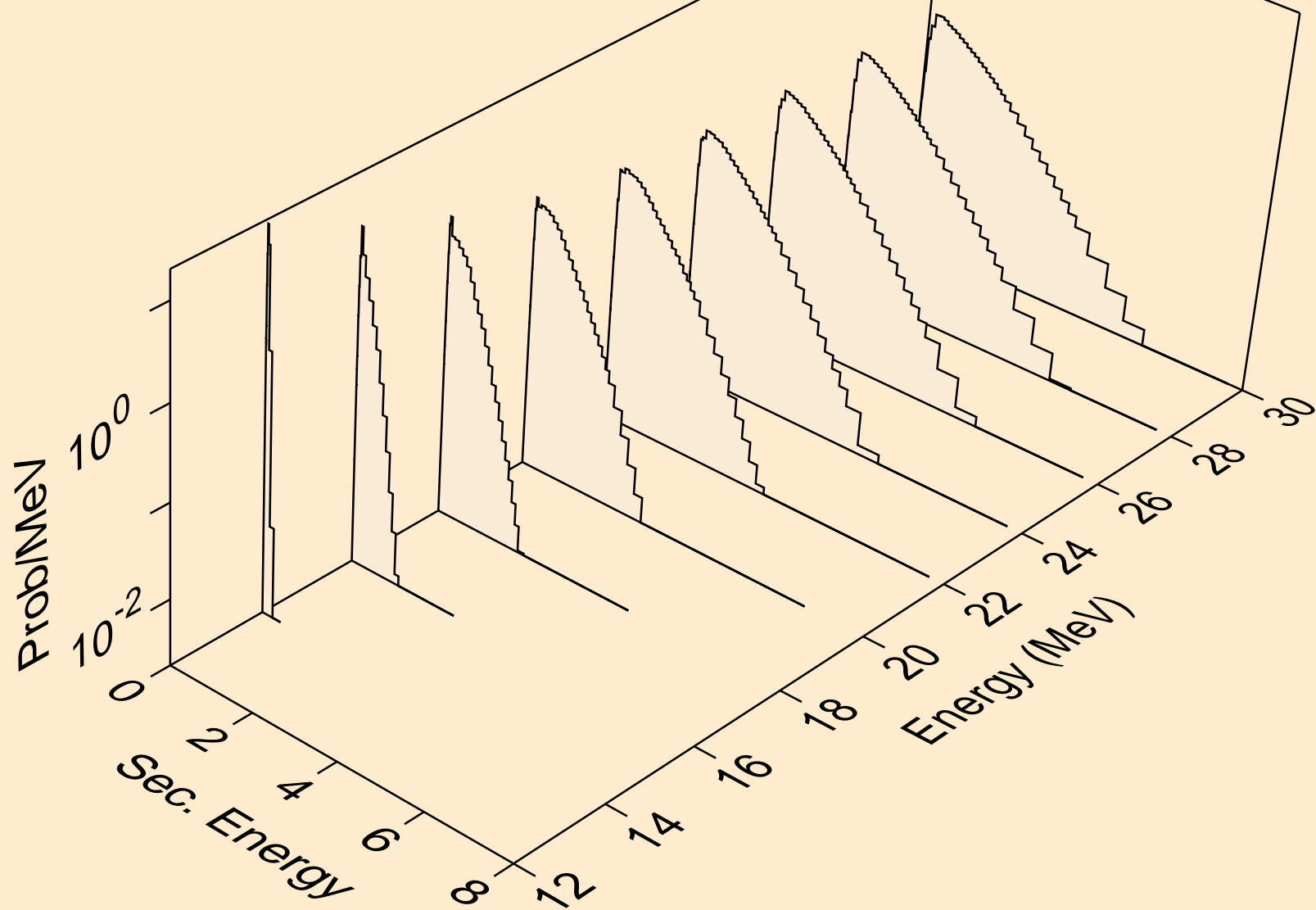

CD105 NEUTRON ACER TENDL-2023 LIBRARY; T=0.K  
Neutron emission for (n,n\*)t

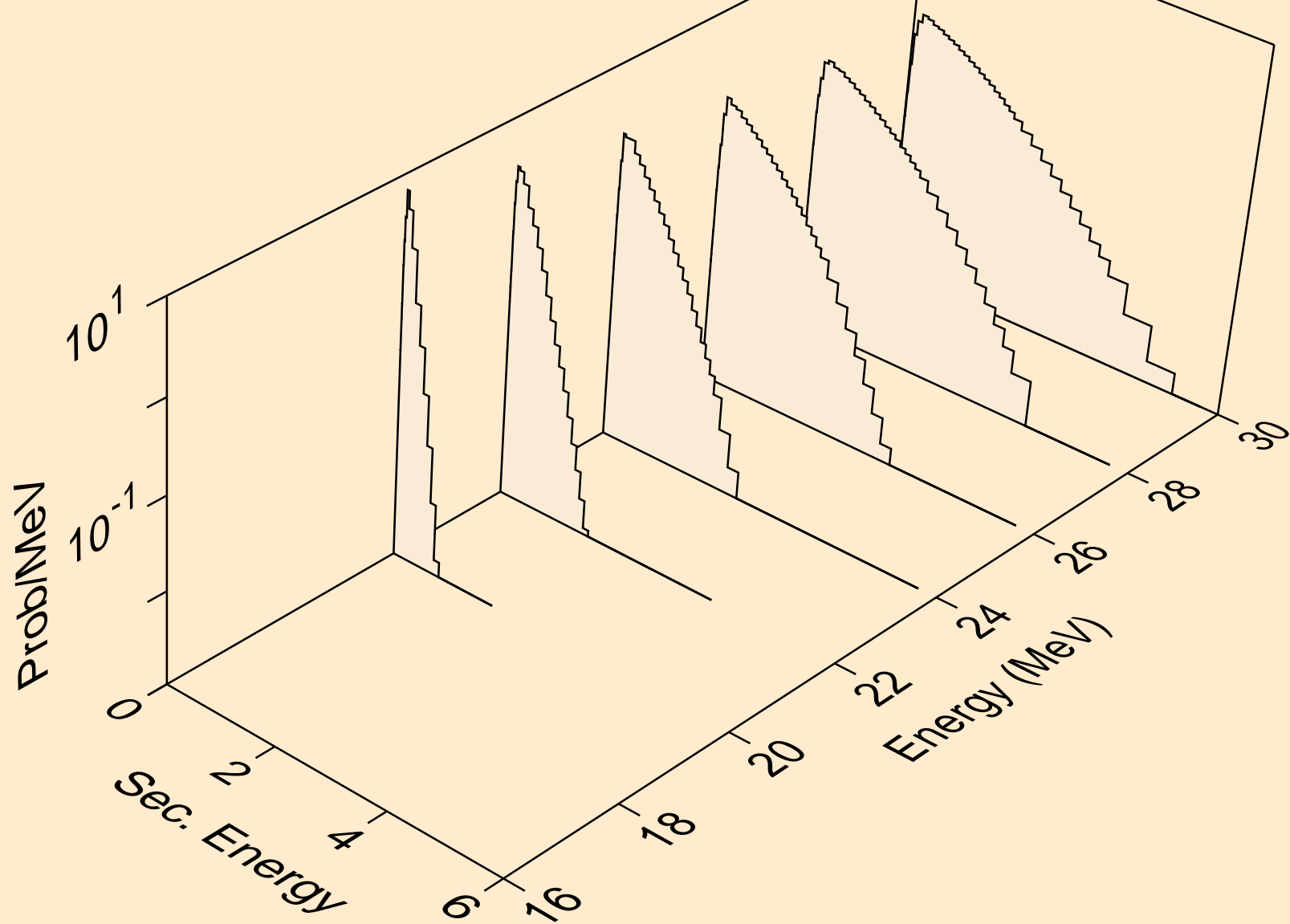

CD105 NEUTRON ACER TENDL-2023 LIBRARY; T=0.K  
Neutron emission for (n,n\*)he3

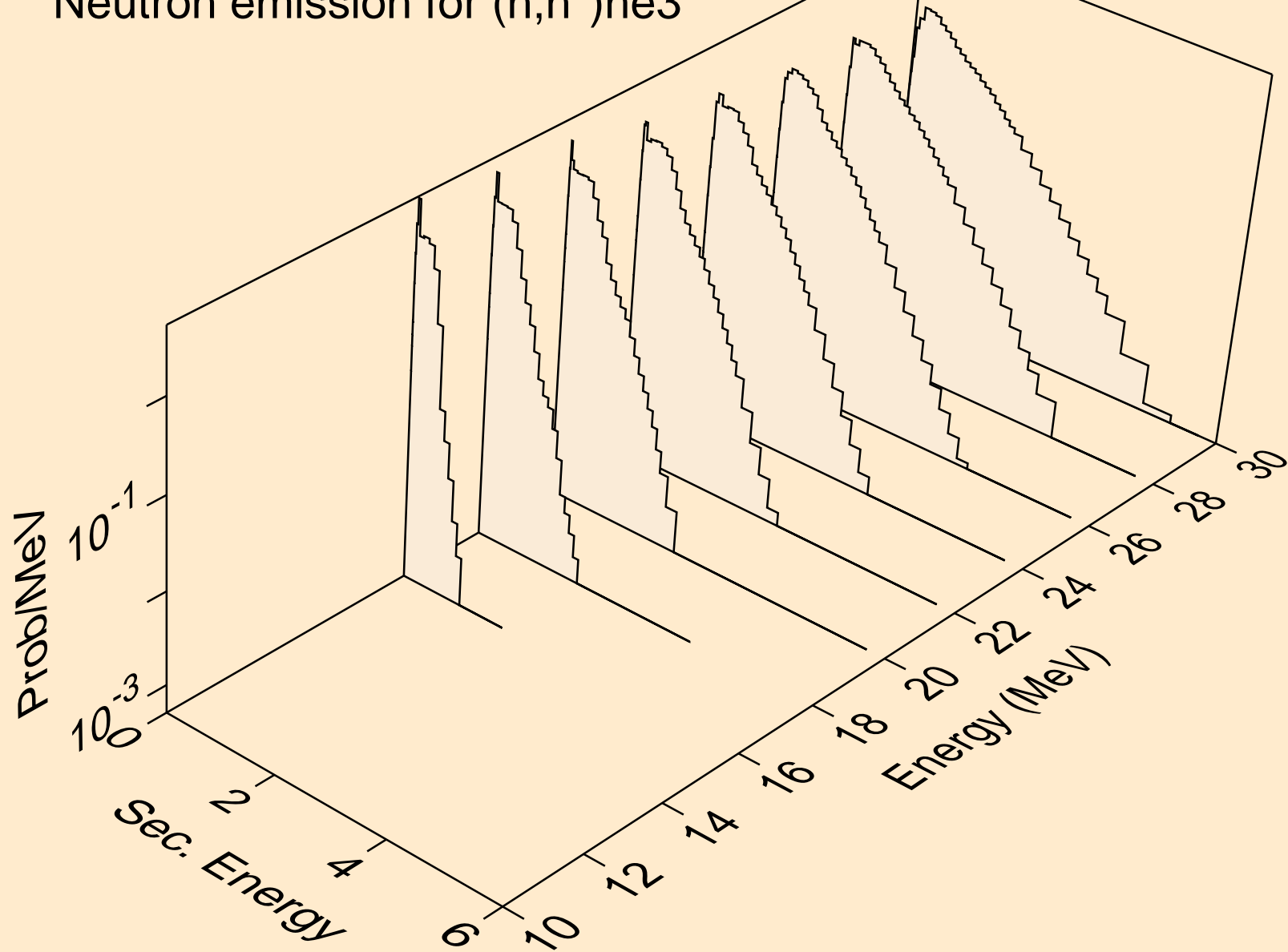

CD105 NEUTRON ACER TENDL-2023 LIBRARY; T=0.K  
Neutron emission for (n,2np)

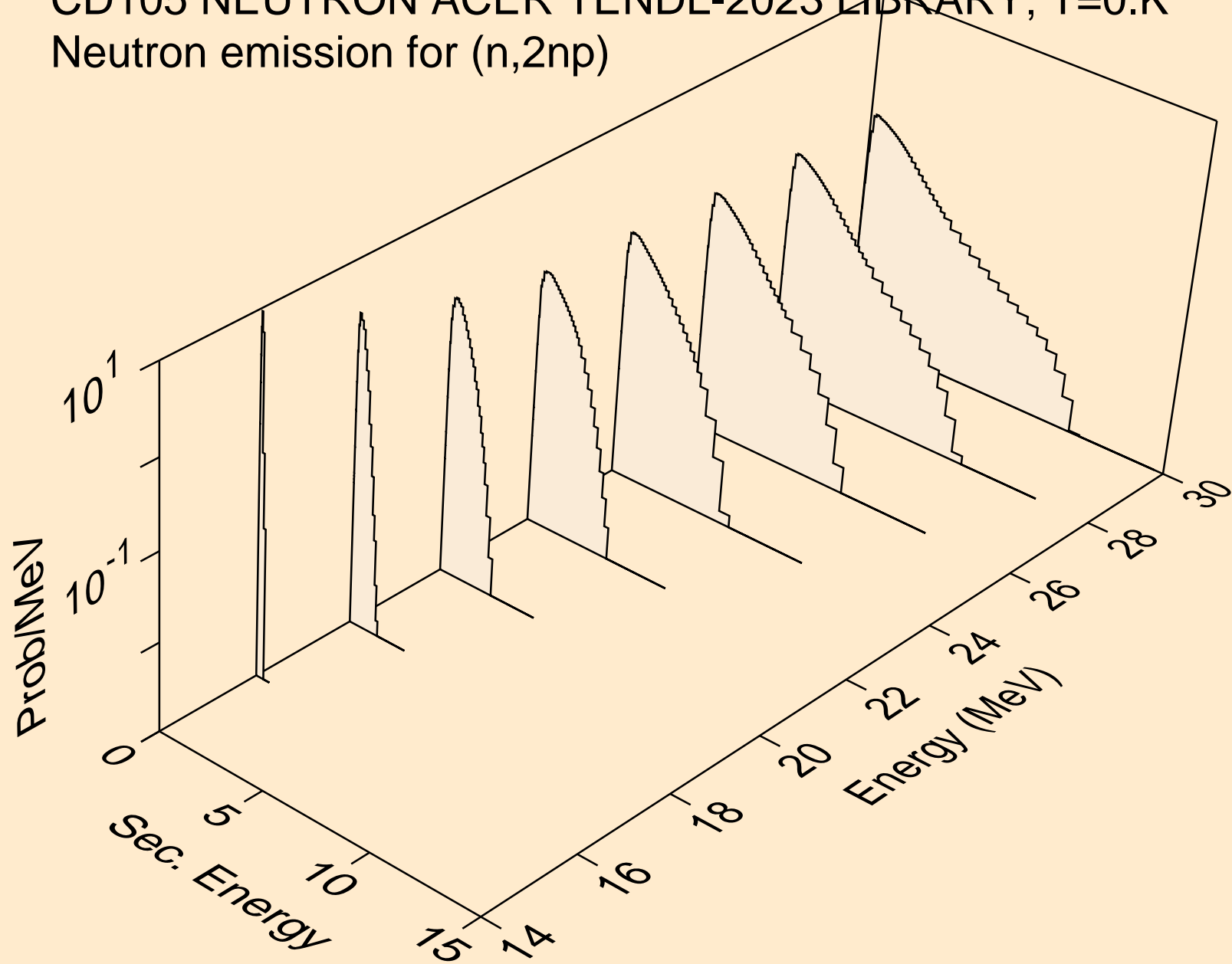

CD105 NEUTRON ACER TENDL-2023 LIBRARY; T=0.K  
Neutron emission for (n,3np)

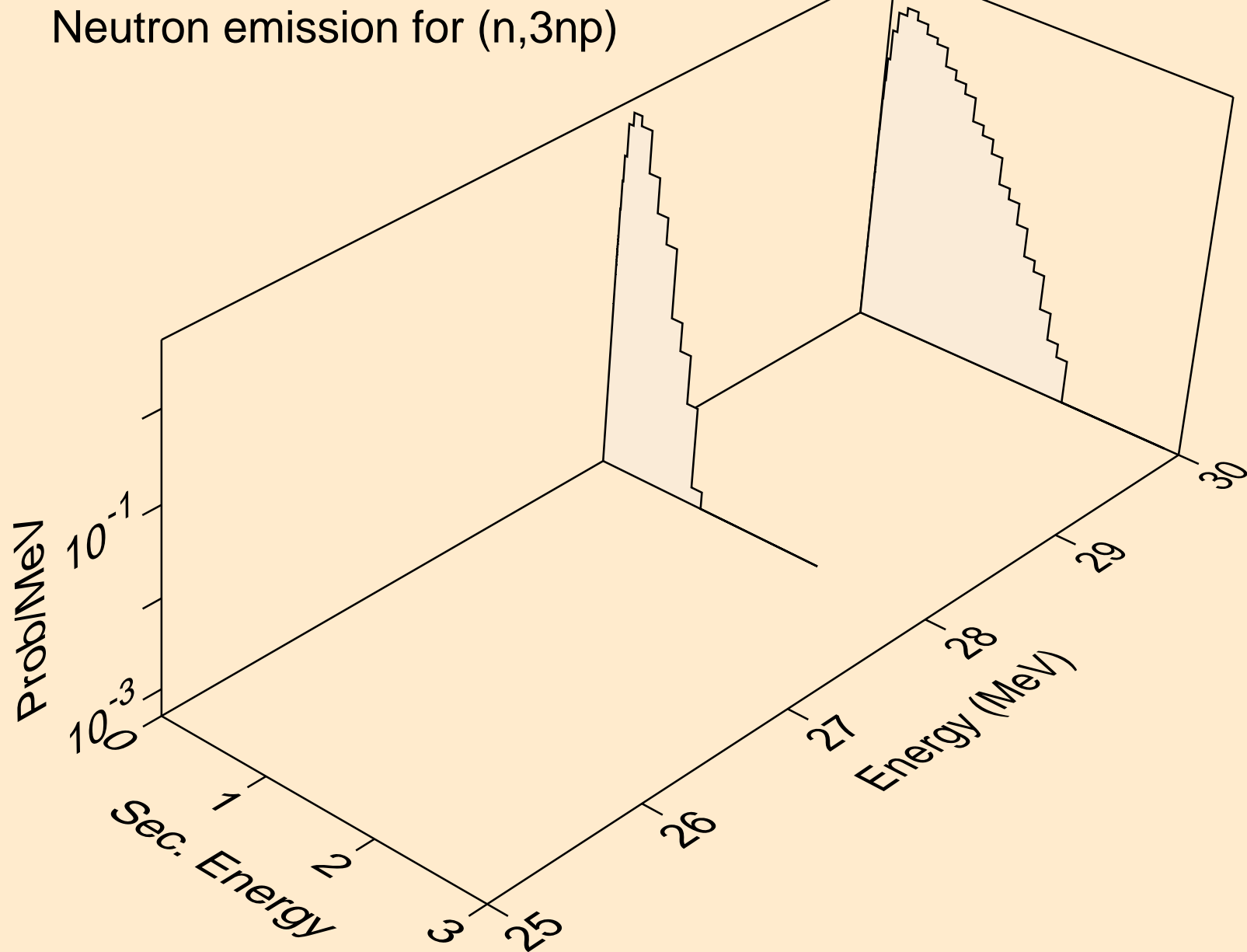

CD105 NEUTRON ACER TENDL-2023 LIBRARY; T=0.K  
Neutron emission for (n,n2p)

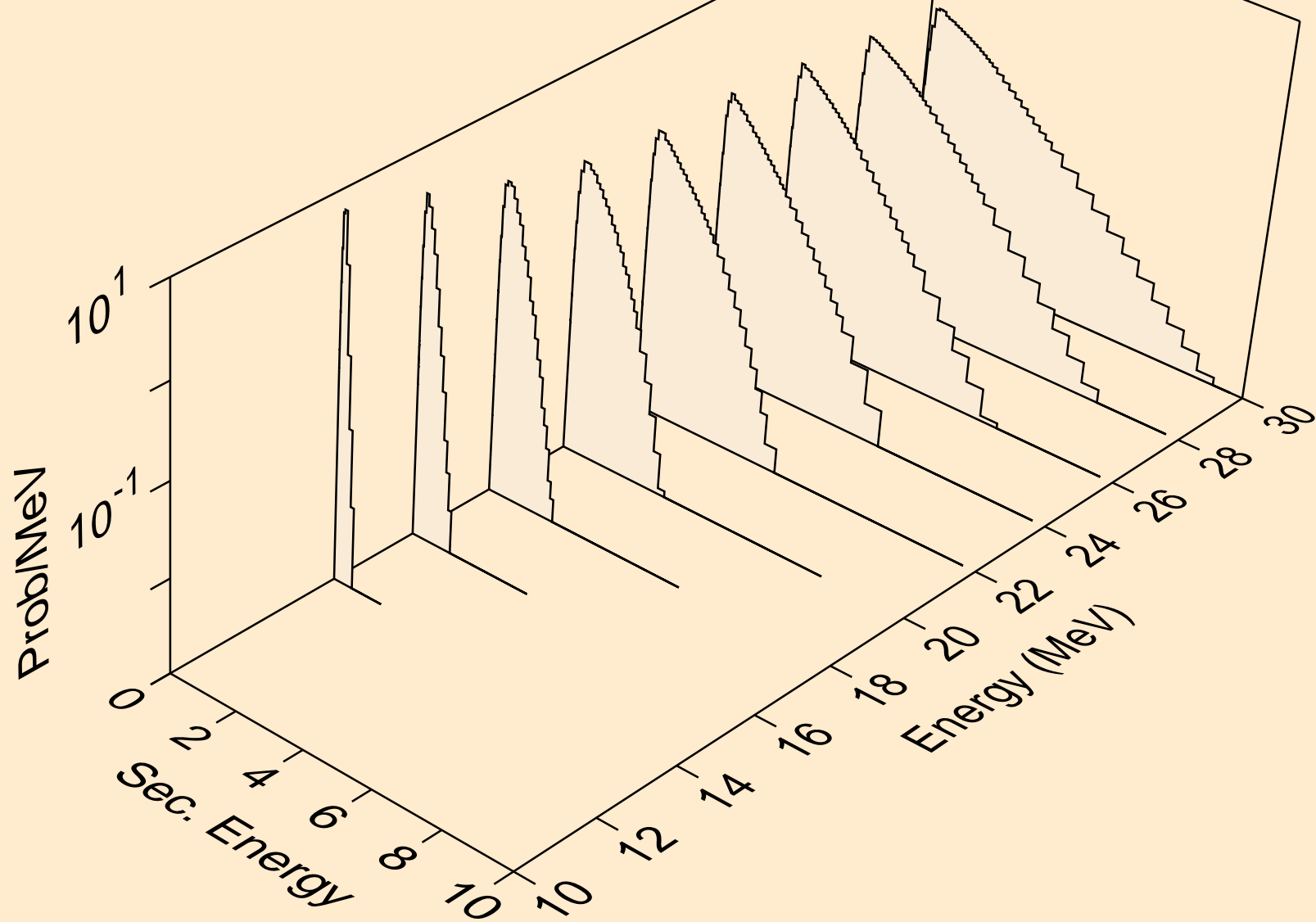

CD105 NEUTRON ACER TENDL-2023 LIBRARY; T=0.K  
Neutron emission for (n,npa)

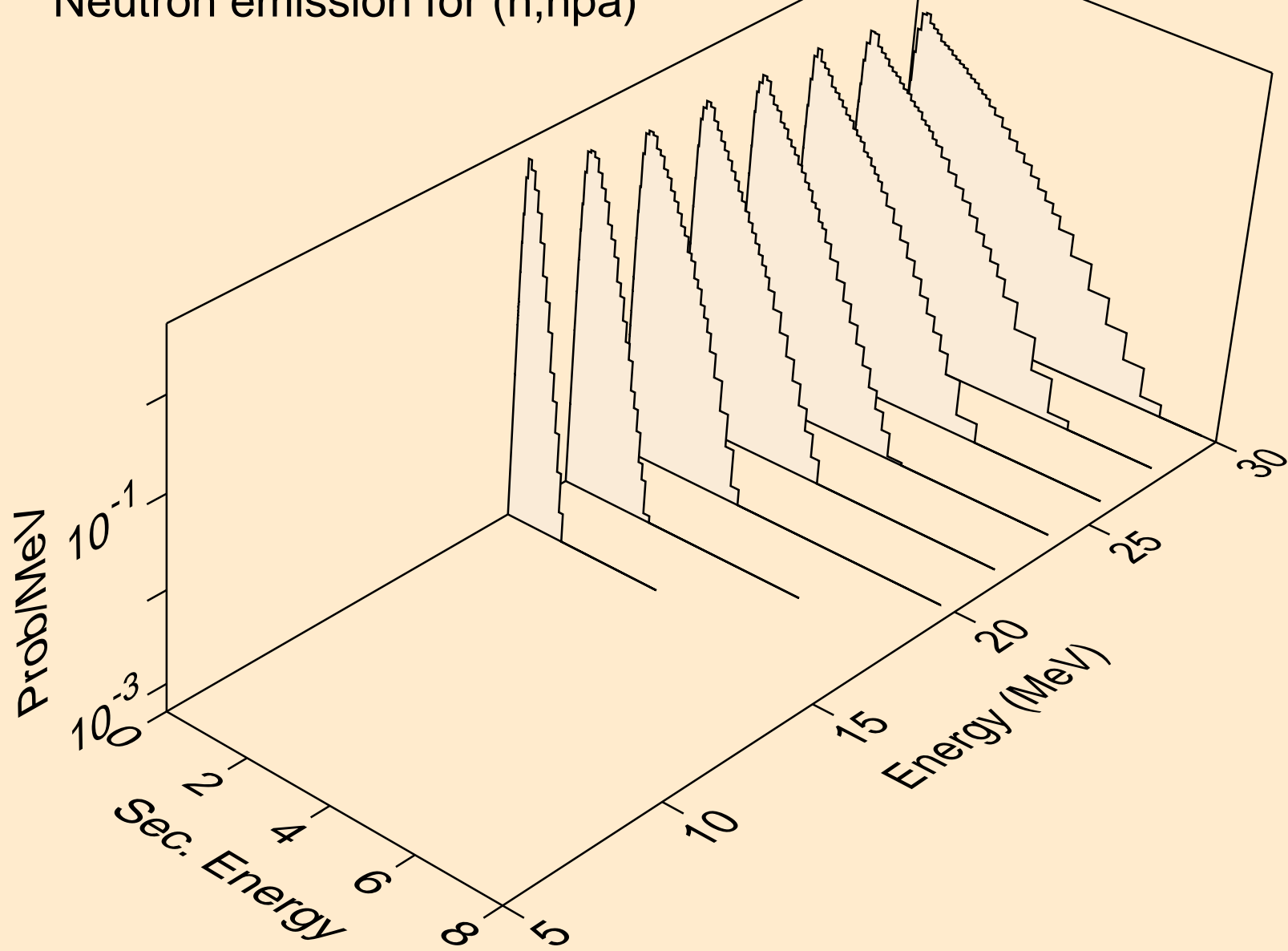

CD105 NEUTRON ACER TENDL-2023 LIBRARY; T=0.K  
Neutron emission for (n,n\*c)

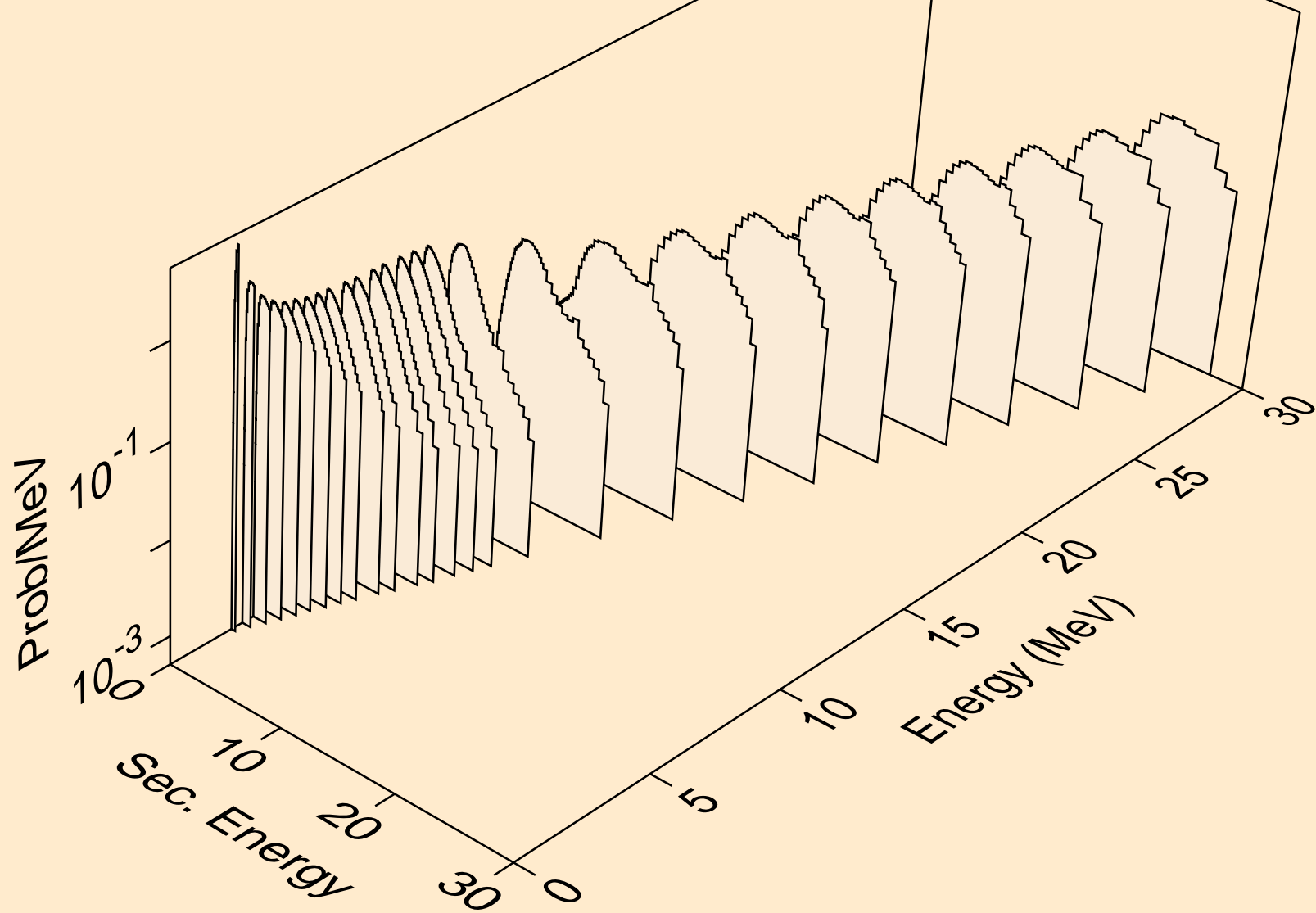

CD105 NEUTRON ACER TENDL-2023 LIBRARY; T=0.K  
Photon emission for (n,x)

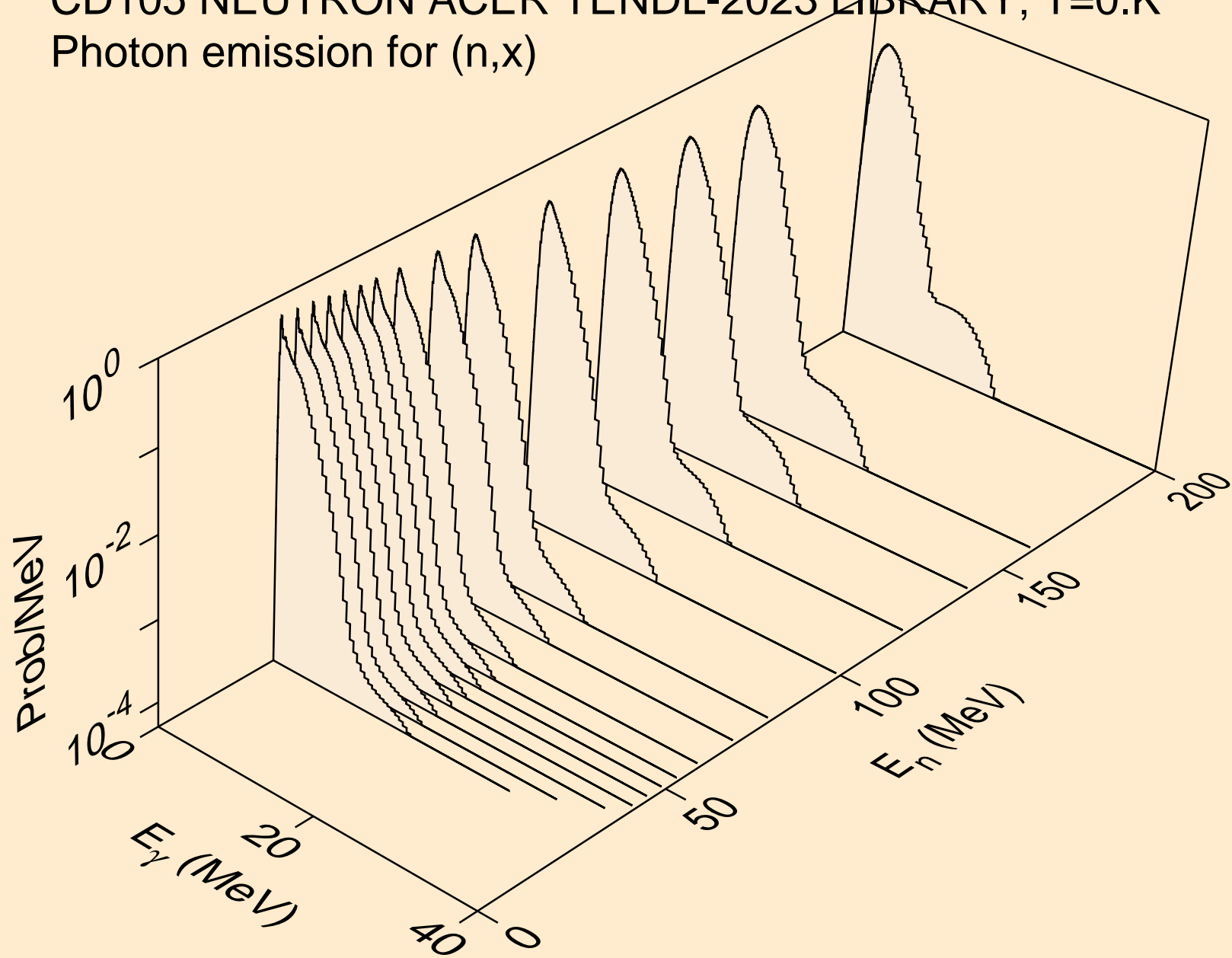

CD105 NEUTRON ACER TENDL-2023 LIBRARY; T=0.K  
Photon emission for (n,2nd)

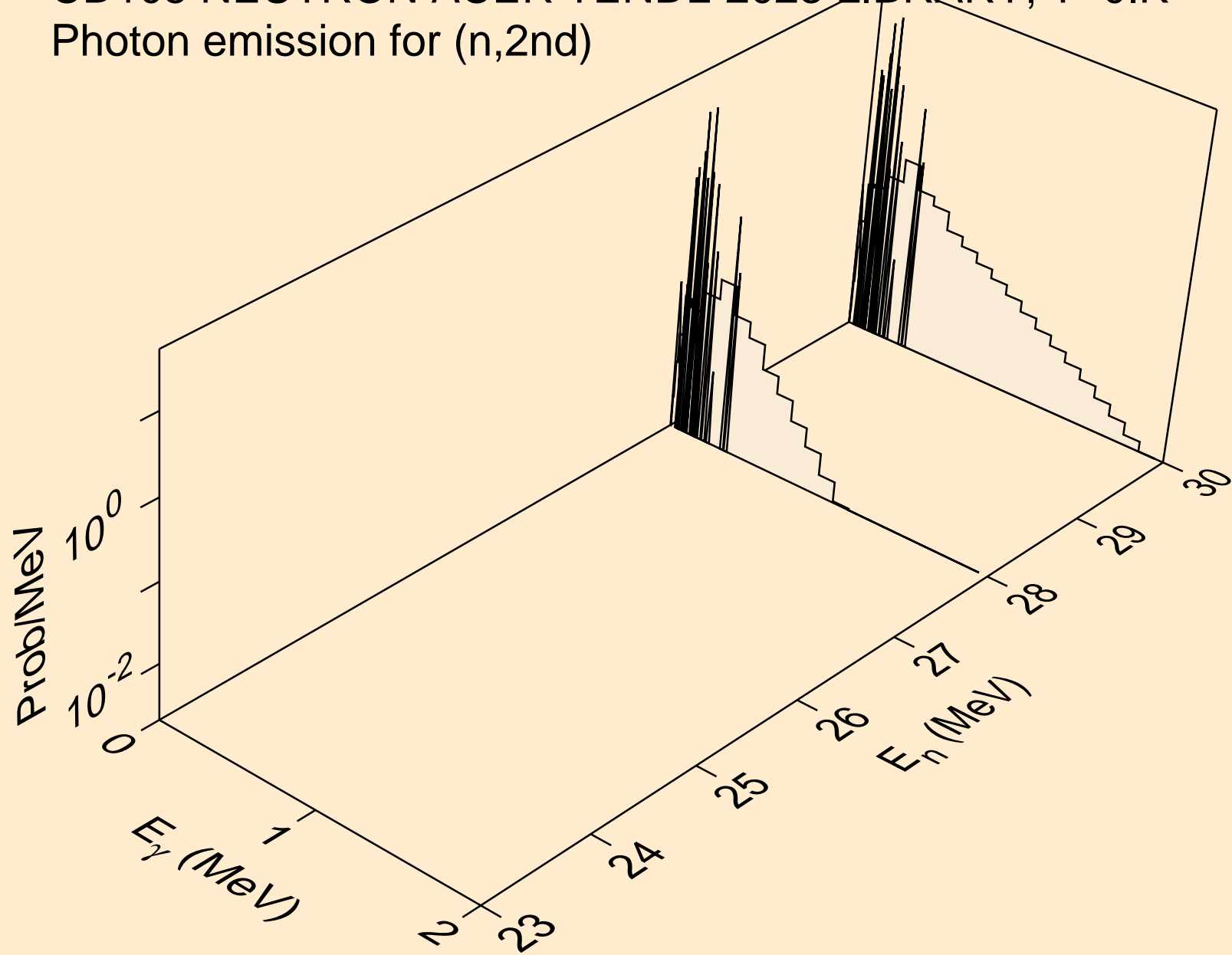

CD105 NEUTRON ACER TENDL-2023 LIBRARY; T=0.K  
Photon emission for (n,2n)

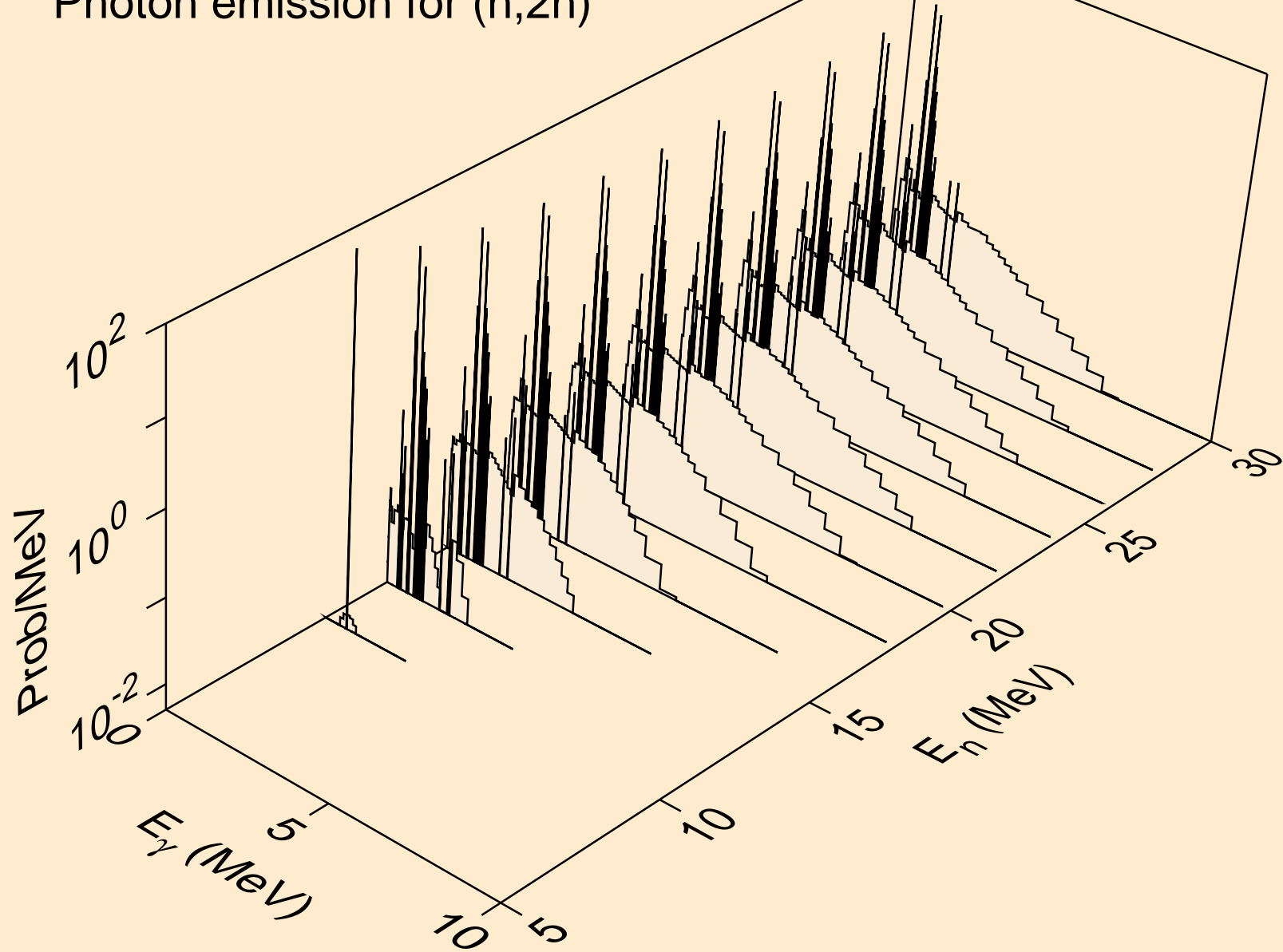

CD105 NEUTRON ACER TENDL-2023 LIBRARY; T=0.K  
Photon emission for (n,3n)

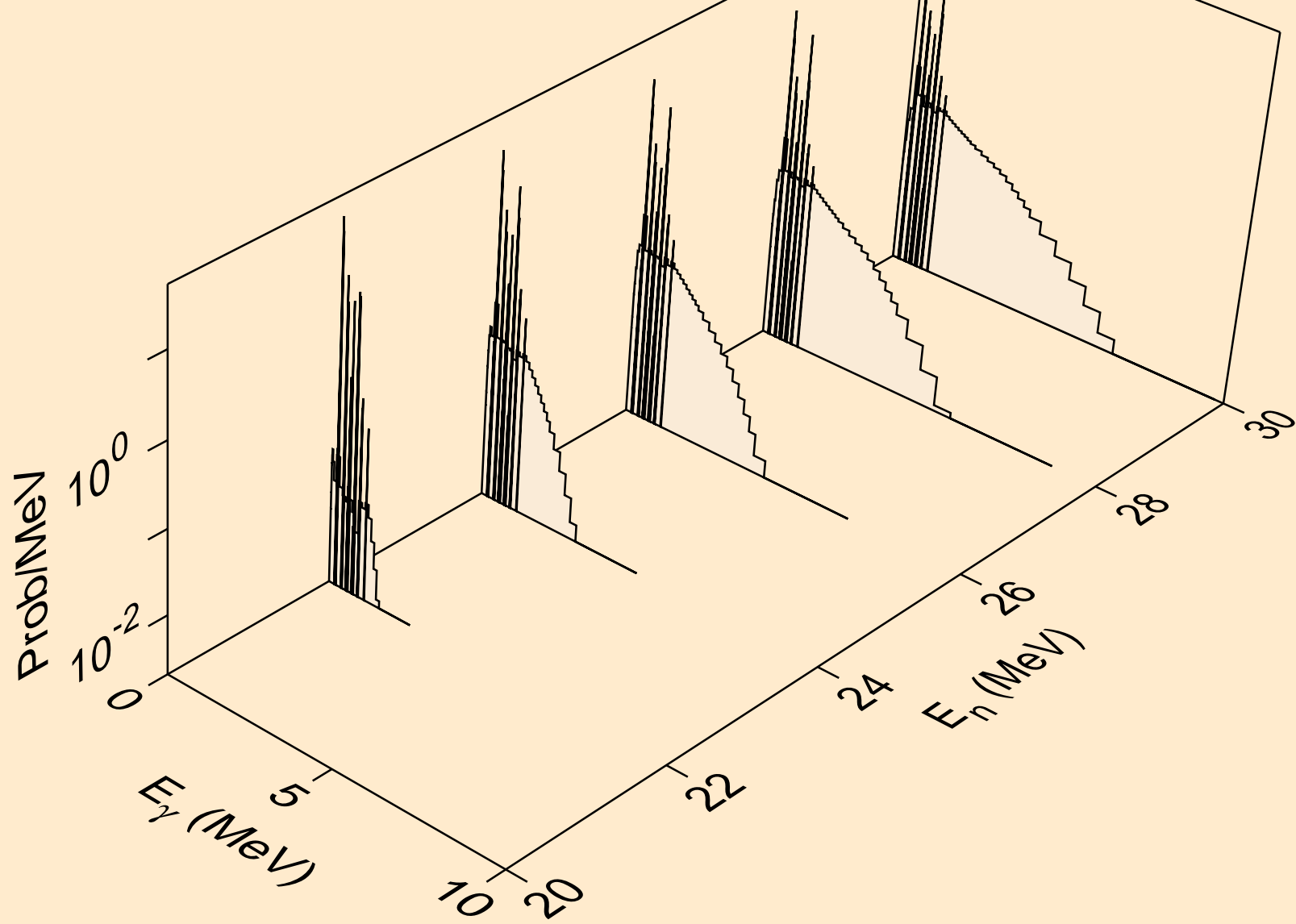

CD105 NEUTRON ACER TENDL-2023 LIBRARY; T=0.K  
Photon emission for (n,n\*)a

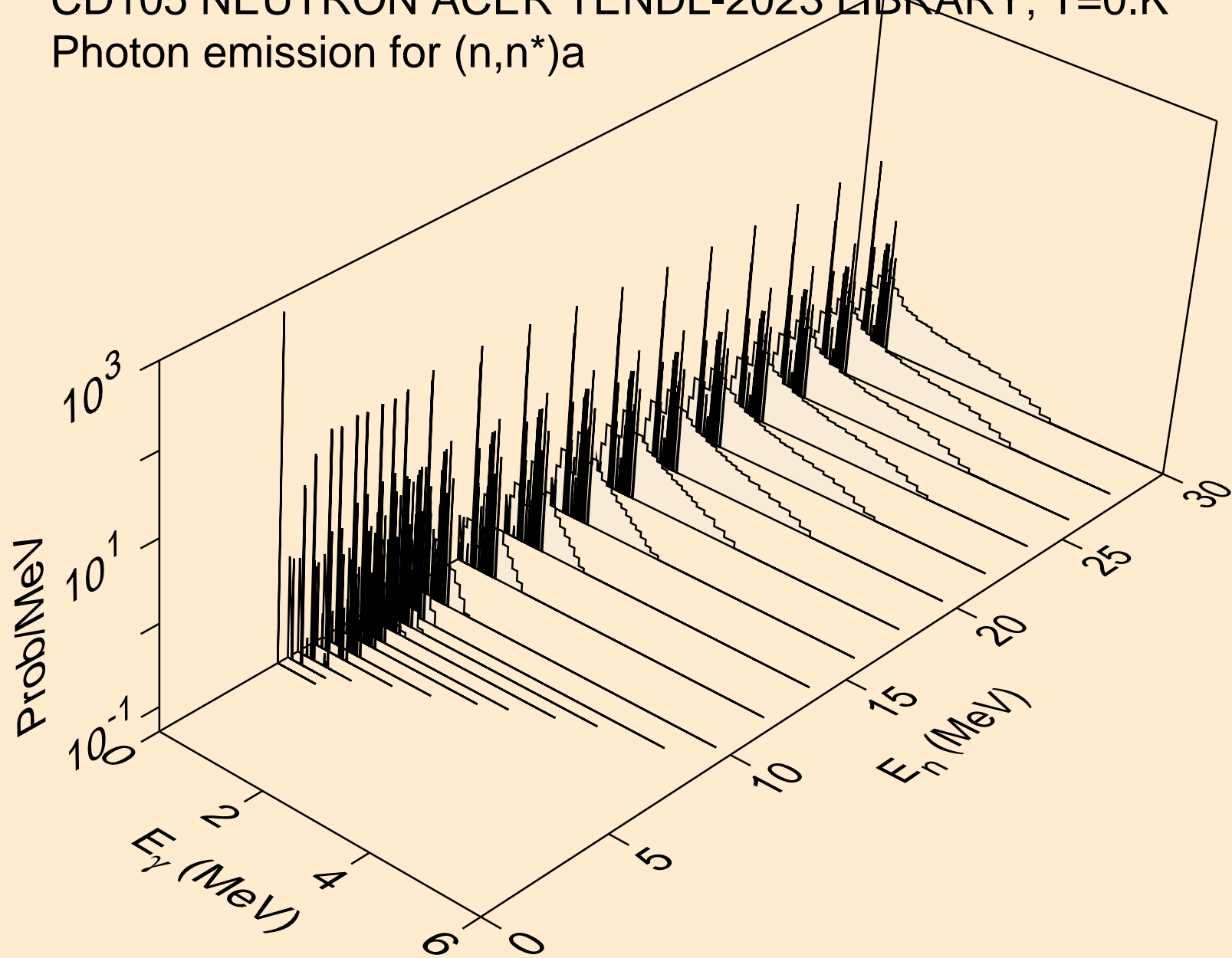

CD105 NEUTRON ACER TENDL-2023 LIBRARY; T=0.K  
Photon emission for (n,2n)a

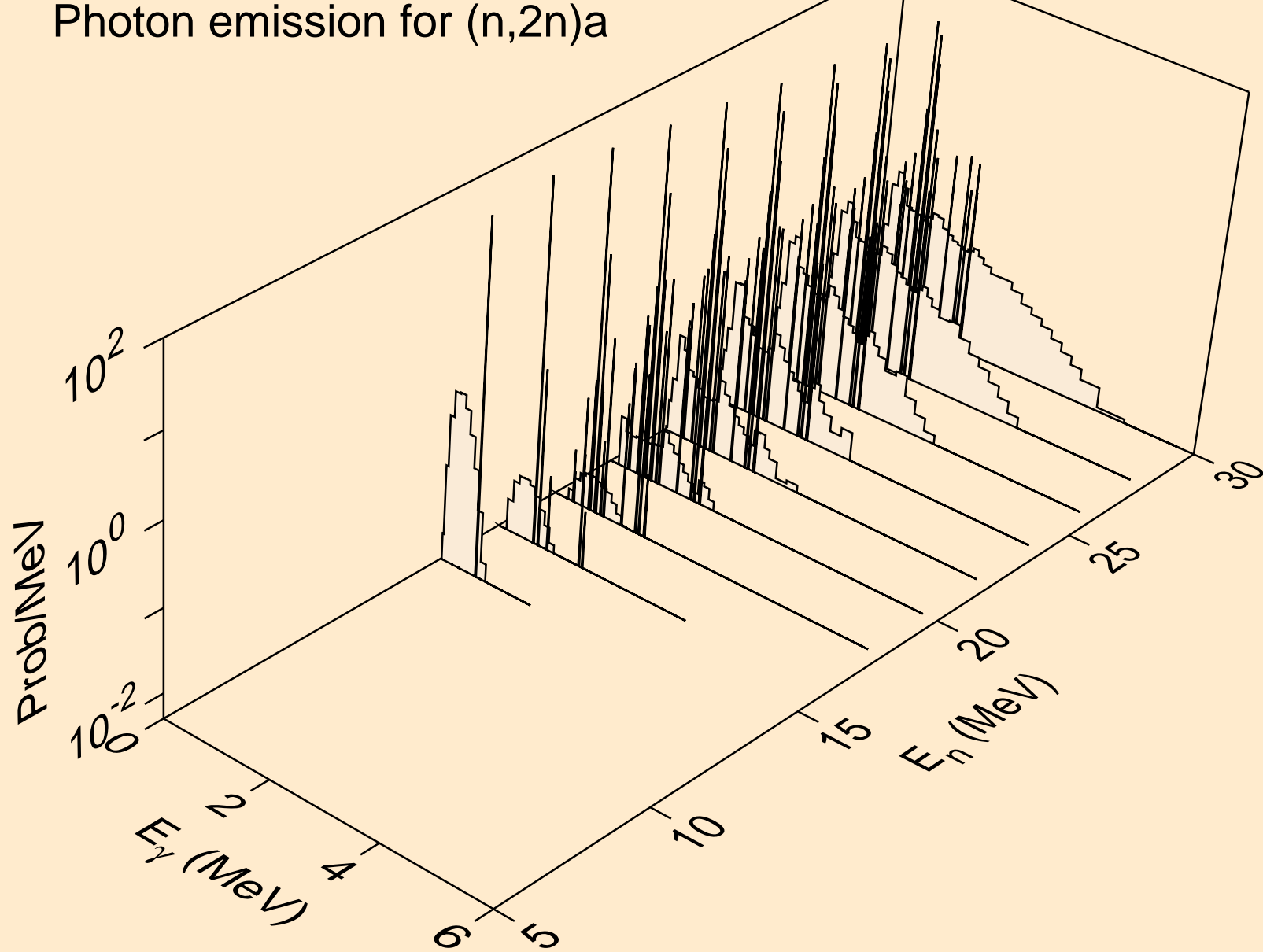

CD105 NEUTRON ACER TENDL-2023 LIBRARY; T=0.K  
Photon emission for (n,3n)a

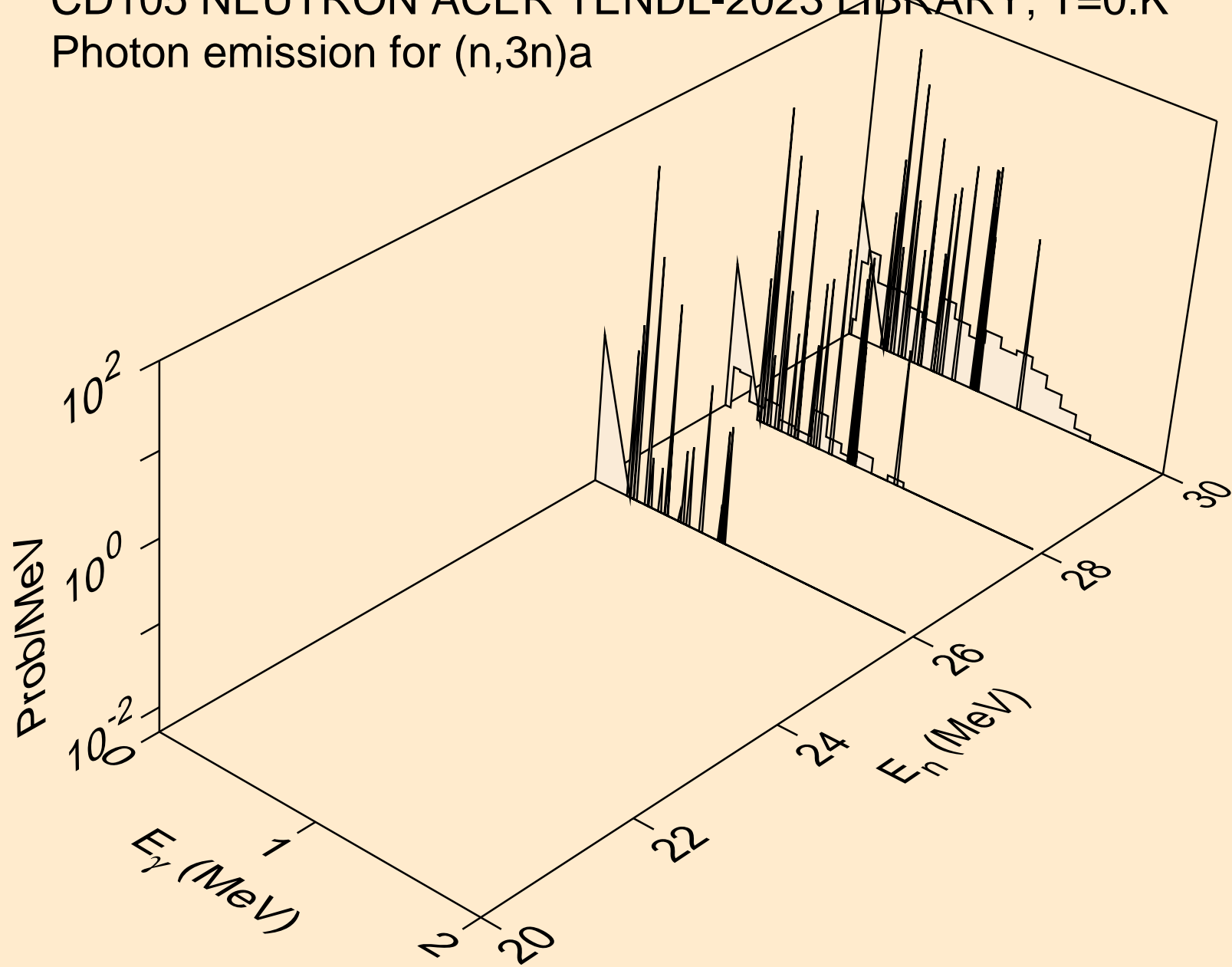

CD105 NEUTRON ACER TENDL-2023 LIBRARY; T=0.K  
Photon emission for (n,n\*)p

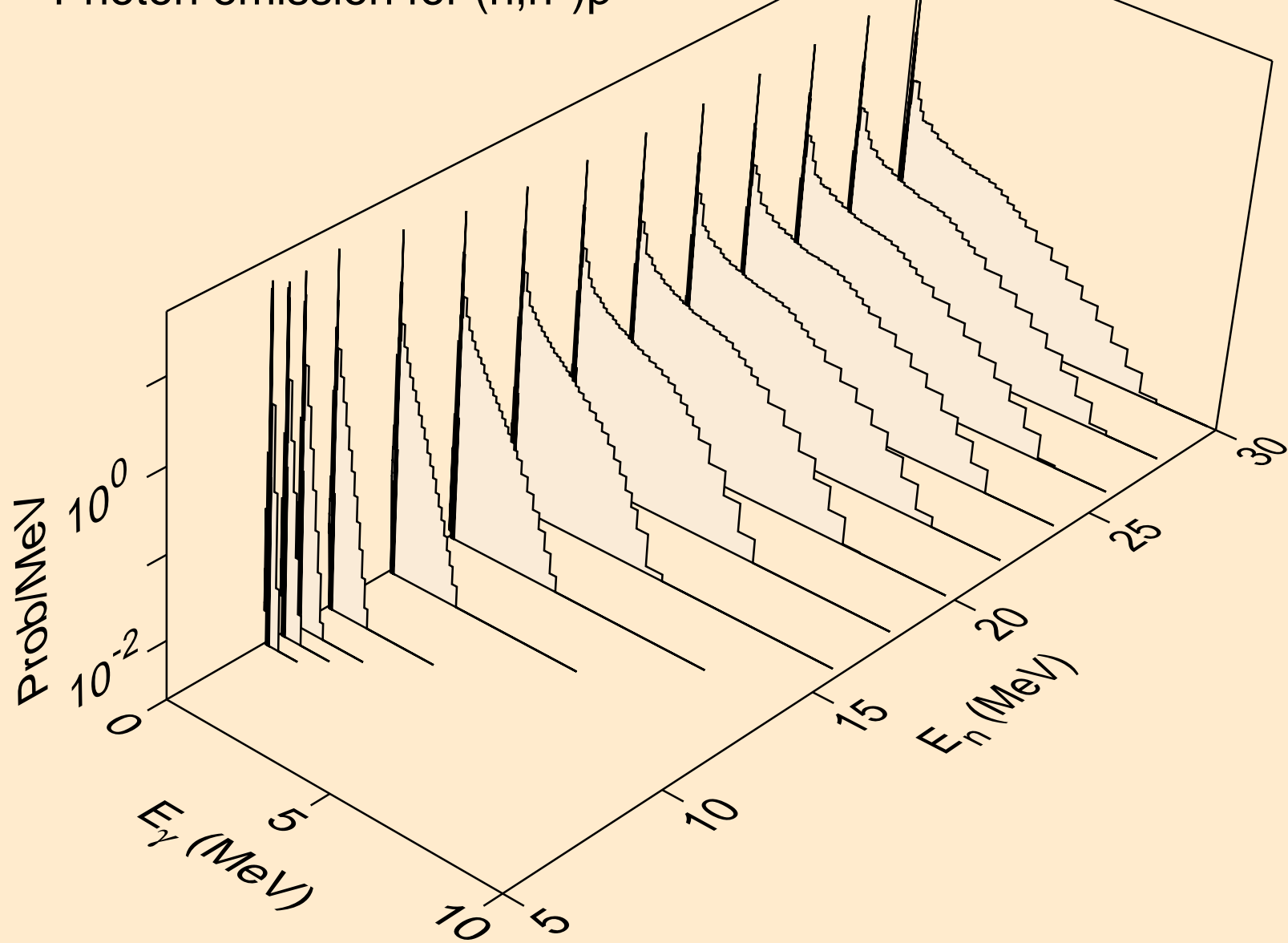

CD105 NEUTRON ACER TENDL-2023 LIBRARY; T=0.K  
Photon emission for (n,n\*)2a

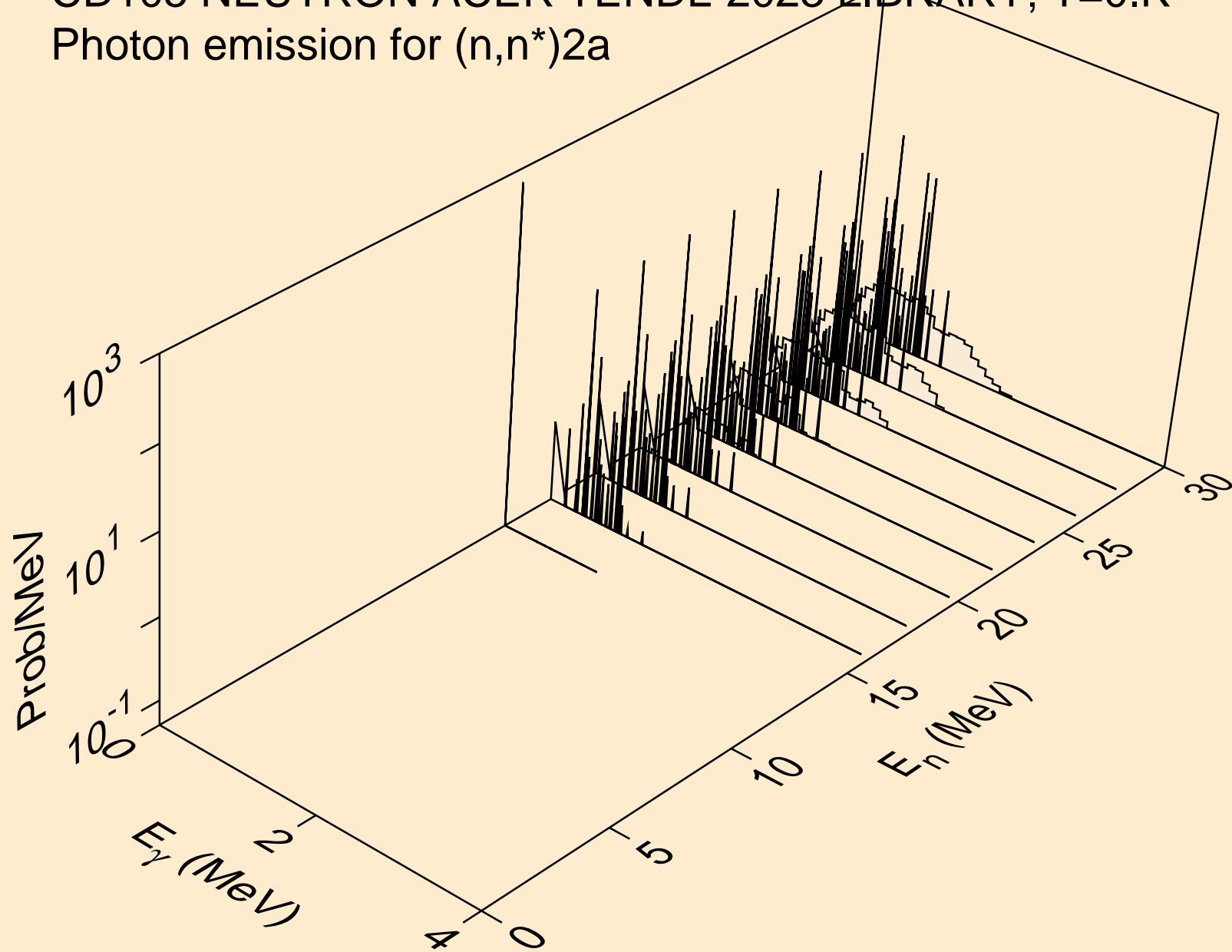

CD105 NEUTRON ACER TENDL-2023 LIBRARY; T=0.K  
Photon emission for (n,2n)2a

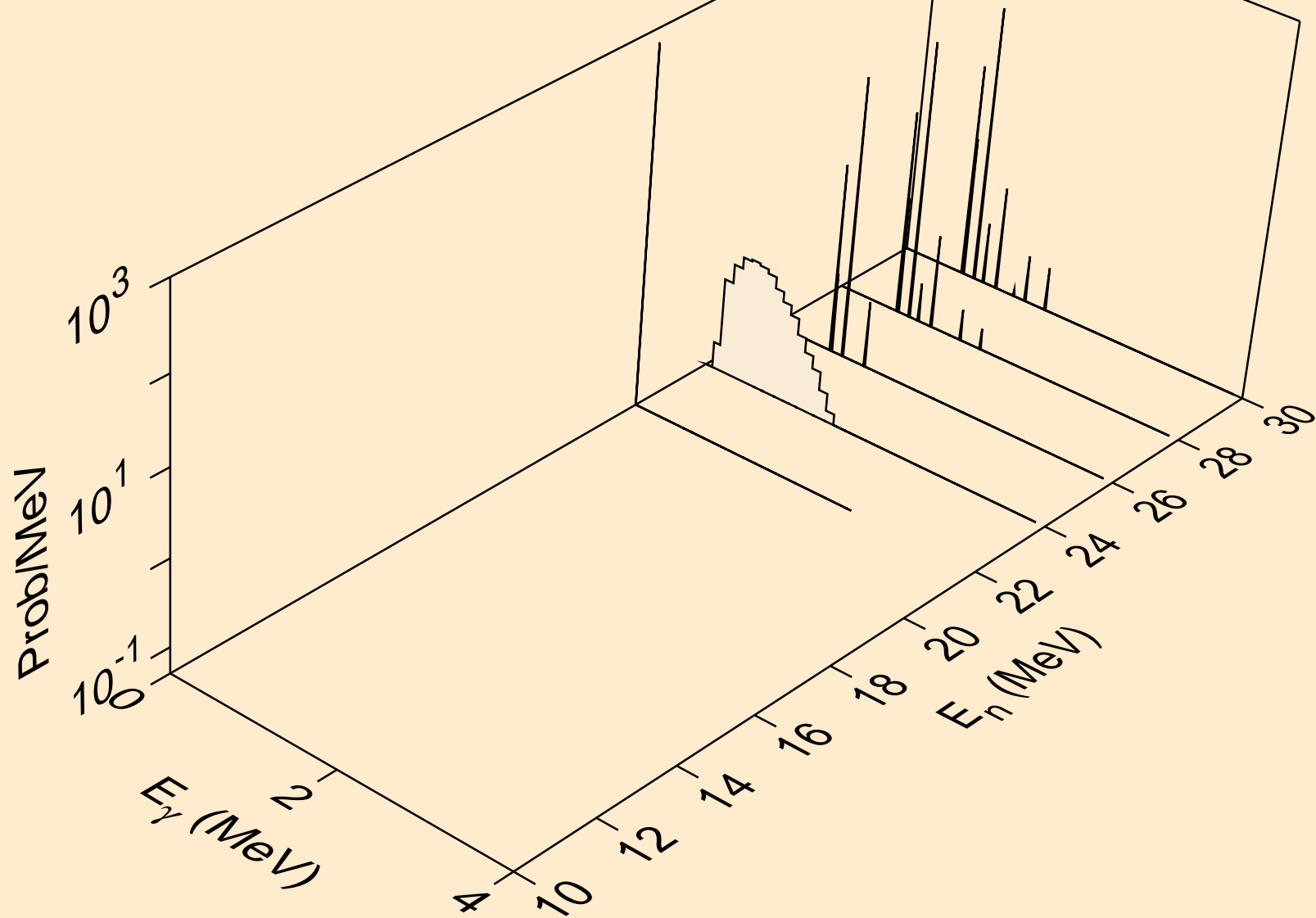

CD105 NEUTRON ACER TENDL-2023 LIBRARY; T=0.K  
Photon emission for (n,n\*)d

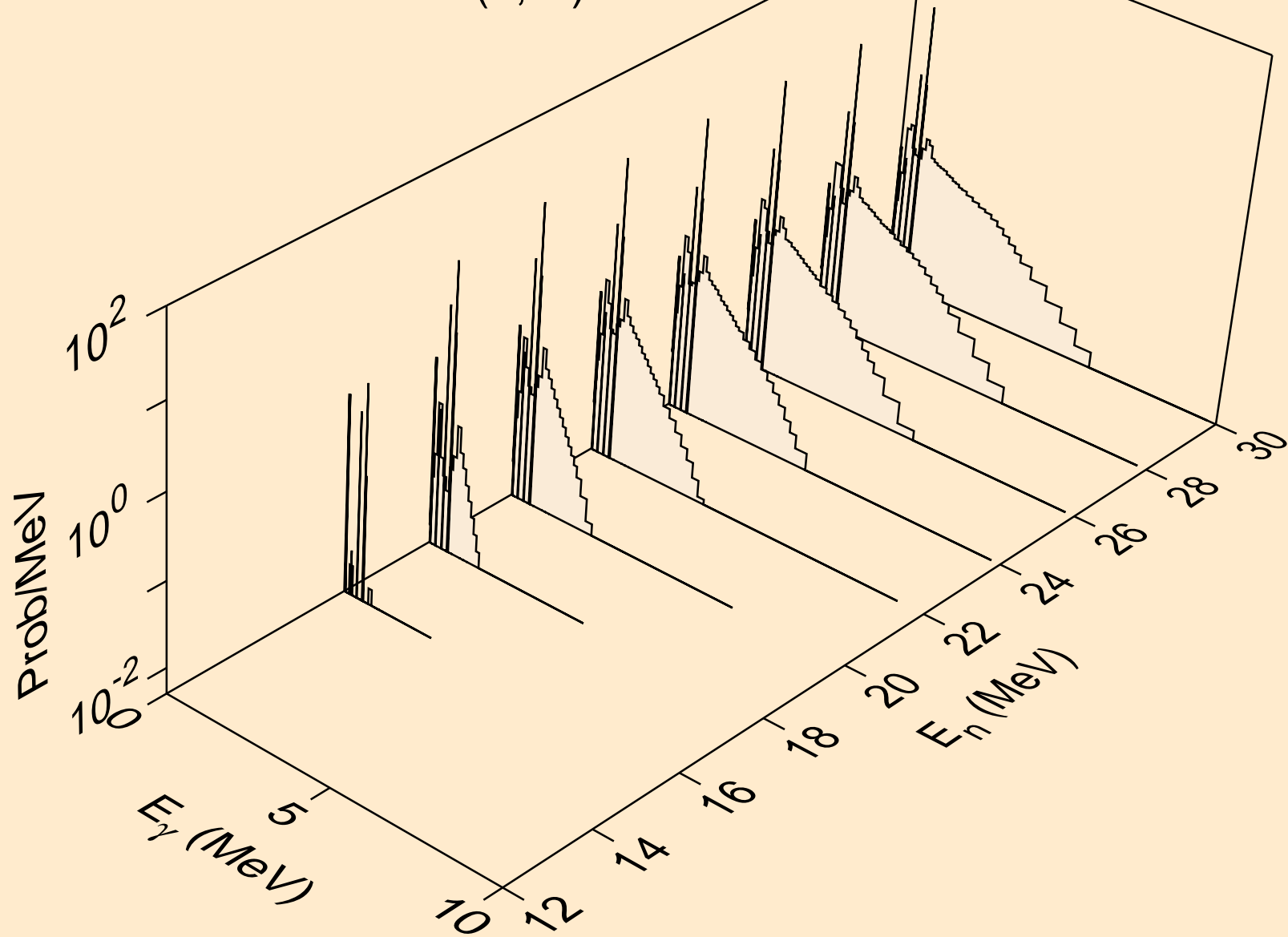

CD105 NEUTRON ACER TENDL-2023 LIBRARY; T=0.K  
Photon emission for (n,n\*)t

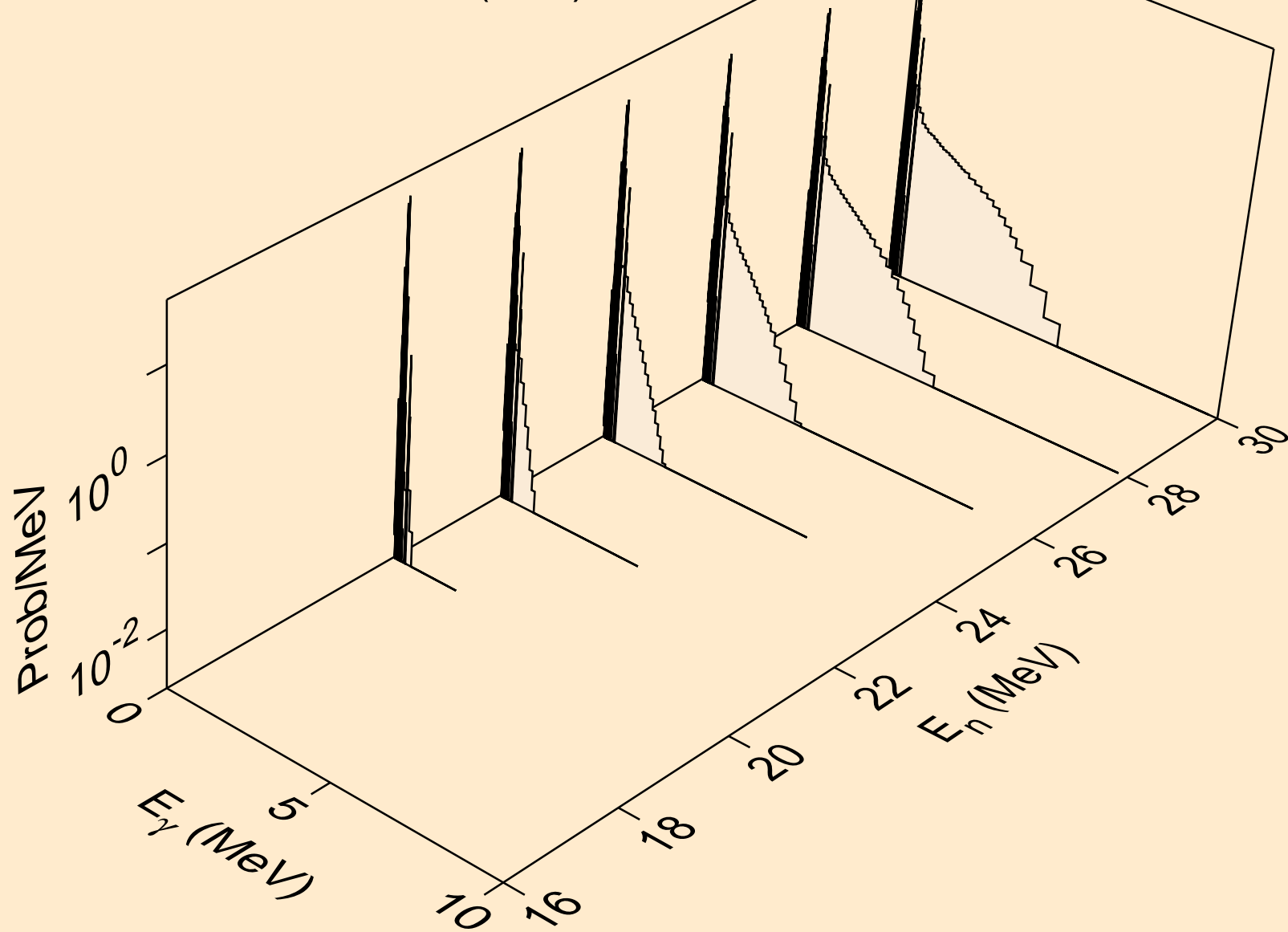

CD105 NEUTRON ACER TENDL-2023 LIBRARY; T=0.K  
Photon emission for (n,n\*)he3

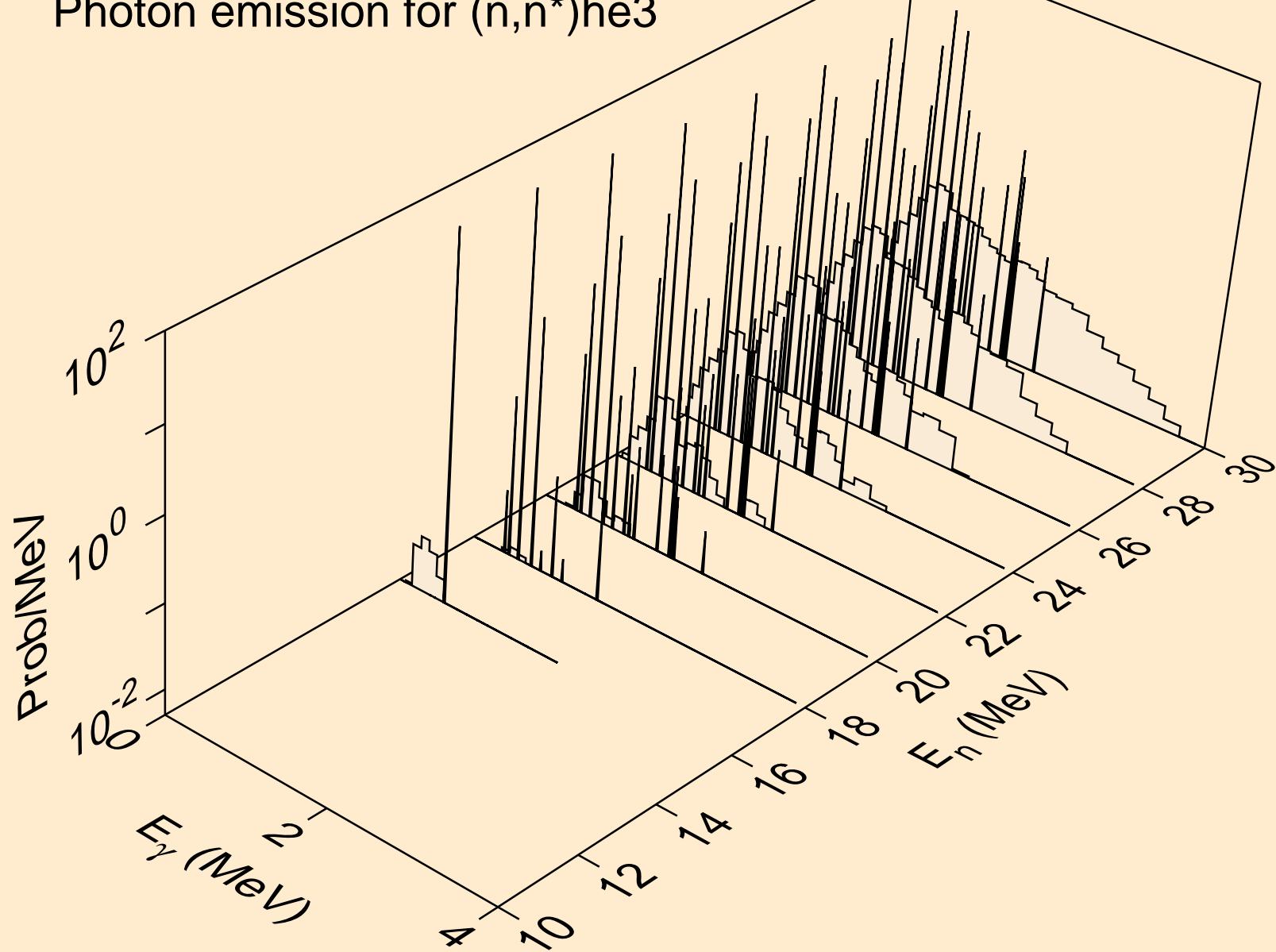

CD105 NEUTRON ACER TENDL-2023 LIBRARY; T=0.K  
Photon emission for (n,2np)

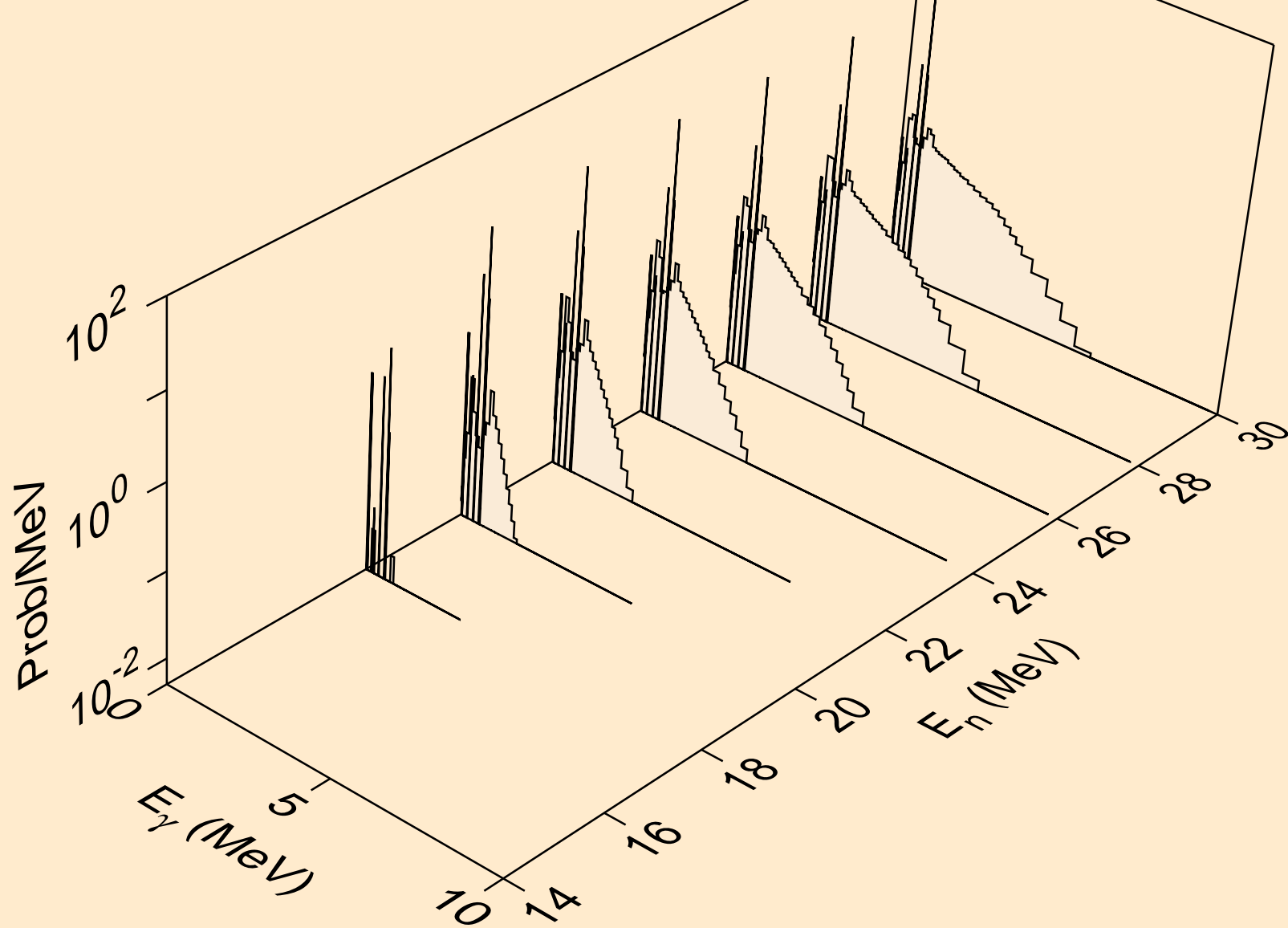

CD105 NEUTRON ACER TENDL-2023 LIBRARY; T=0.K  
Photon emission for (n,3np)

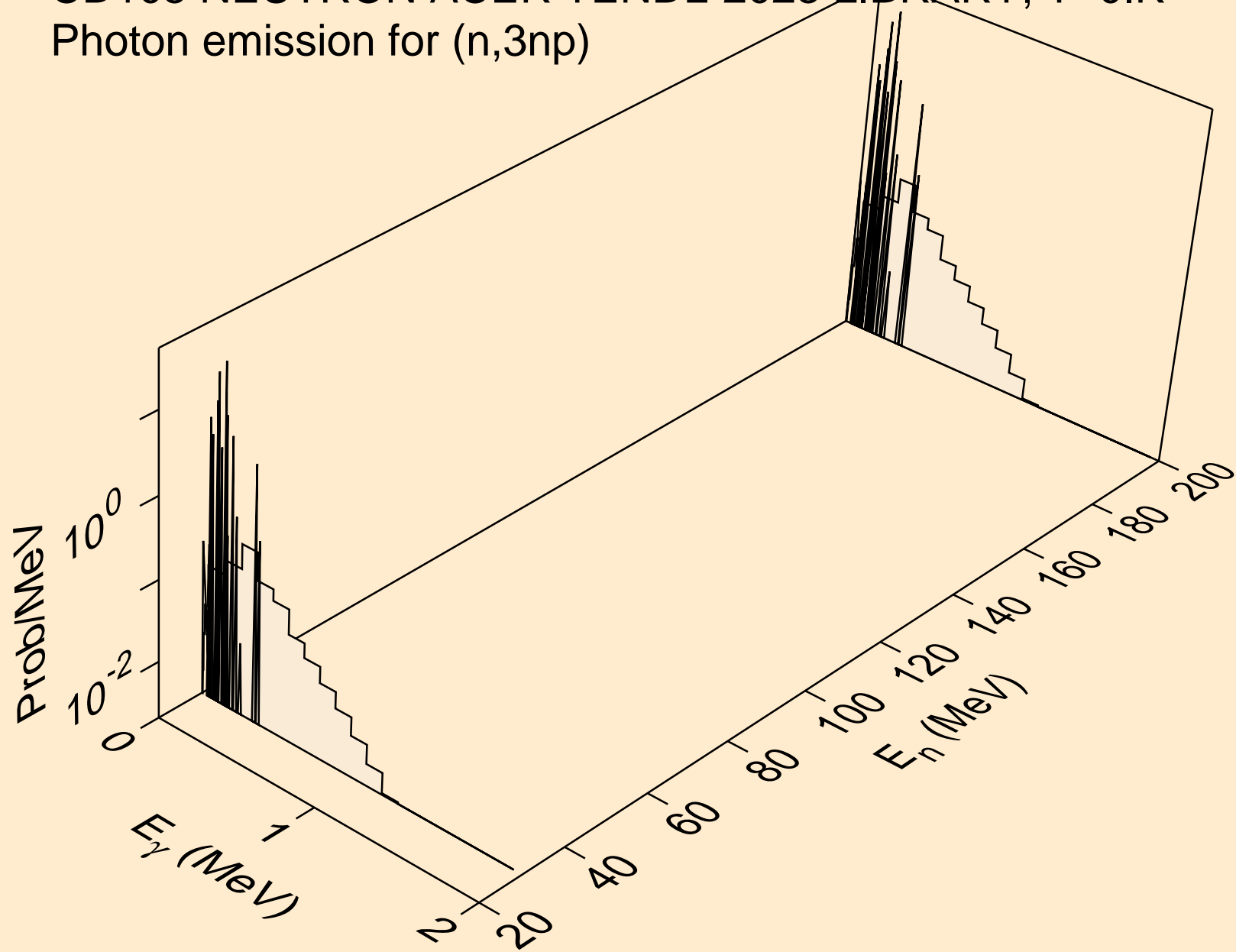

CD105 NEUTRON ACER TENDL-2023 LIBRARY; T=0.K  
Photon emission for (n,n2p)

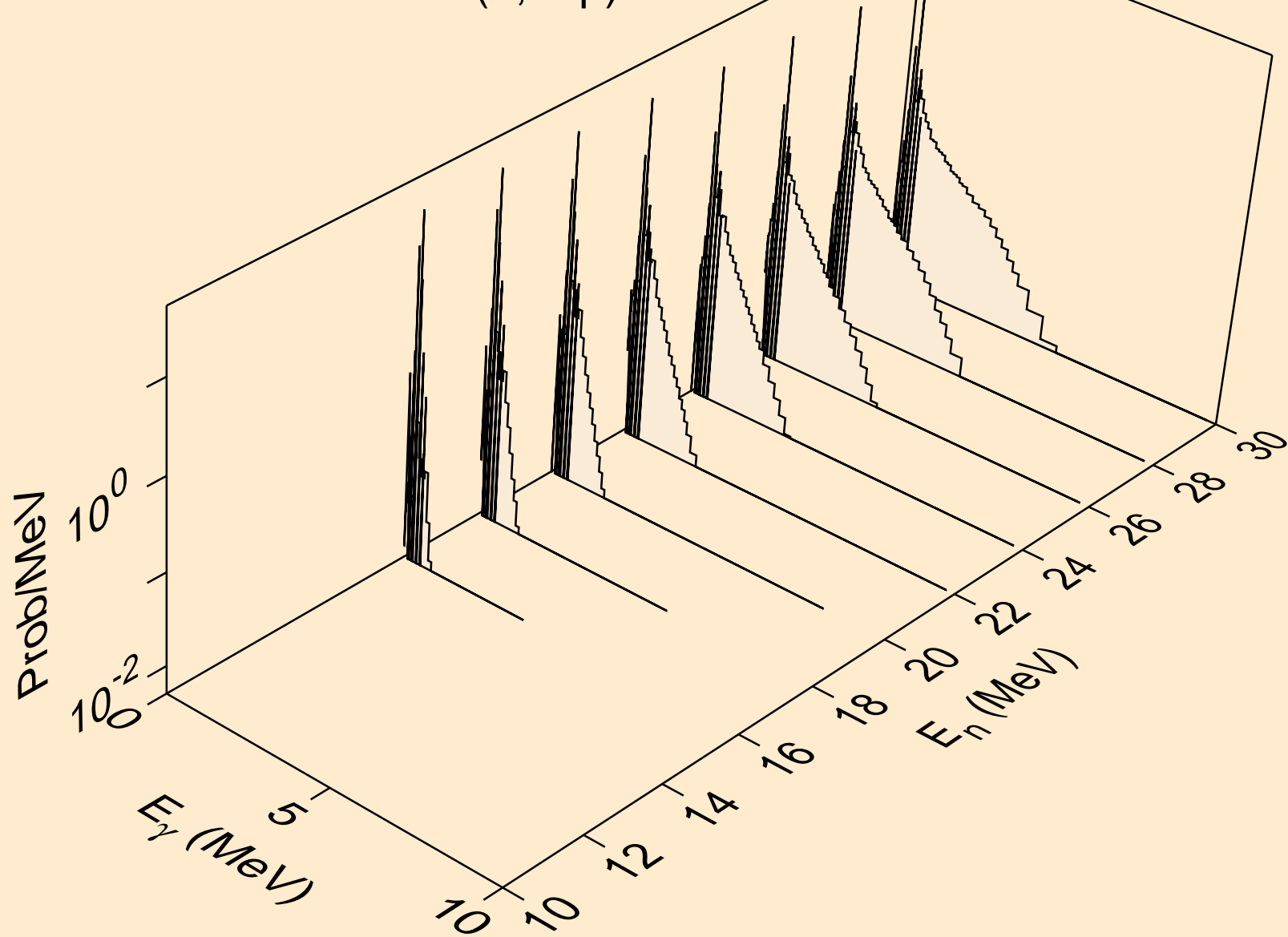

CD105 NEUTRON ACER TENDL-2023 LIBRARY; T=0.K  
Photon emission for (n,npa)

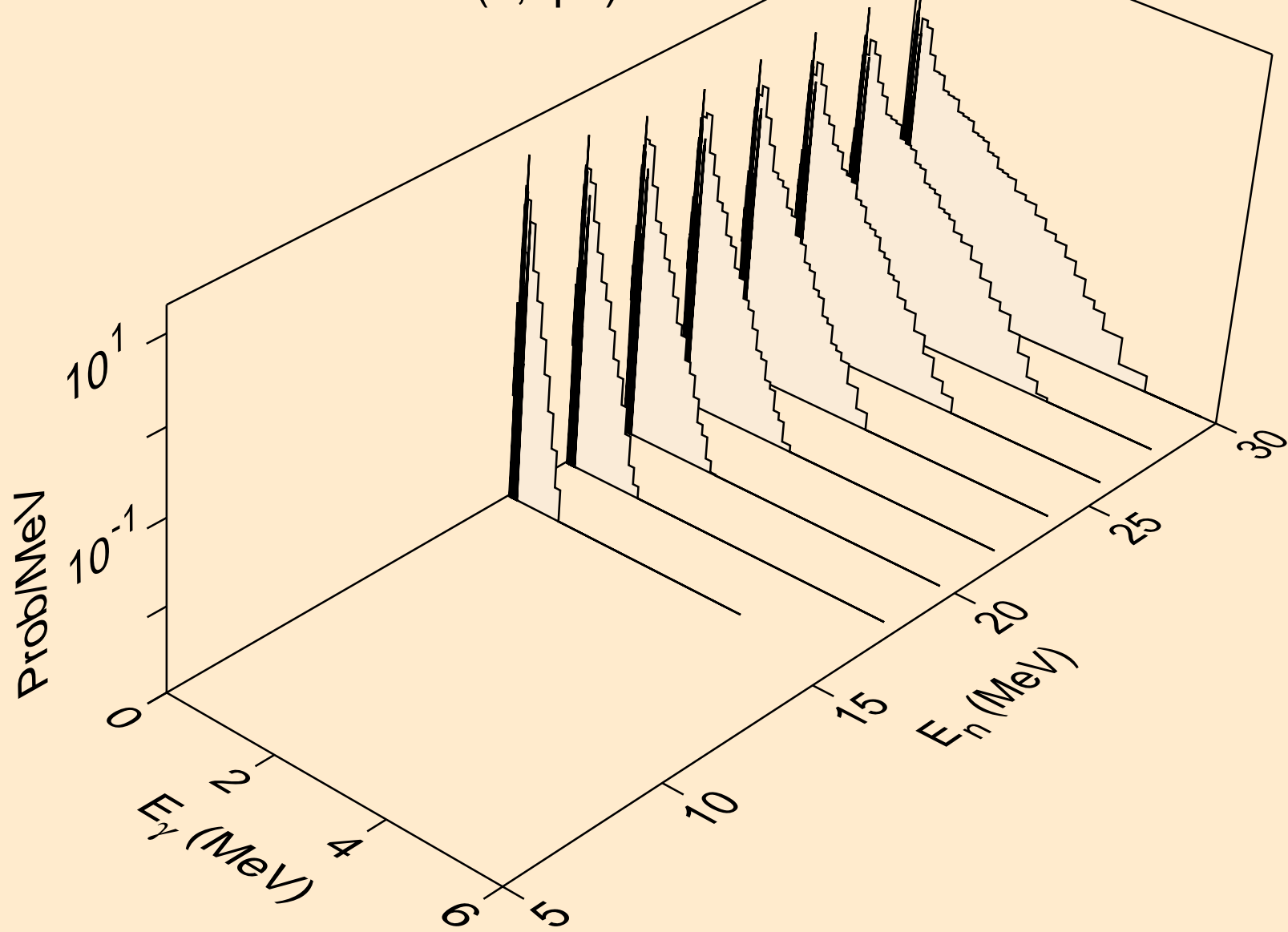

CD105 NEUTRON ACER TENDL-2023 LIBRARY; T=0.K  
Photon emission for (n,n\*c)

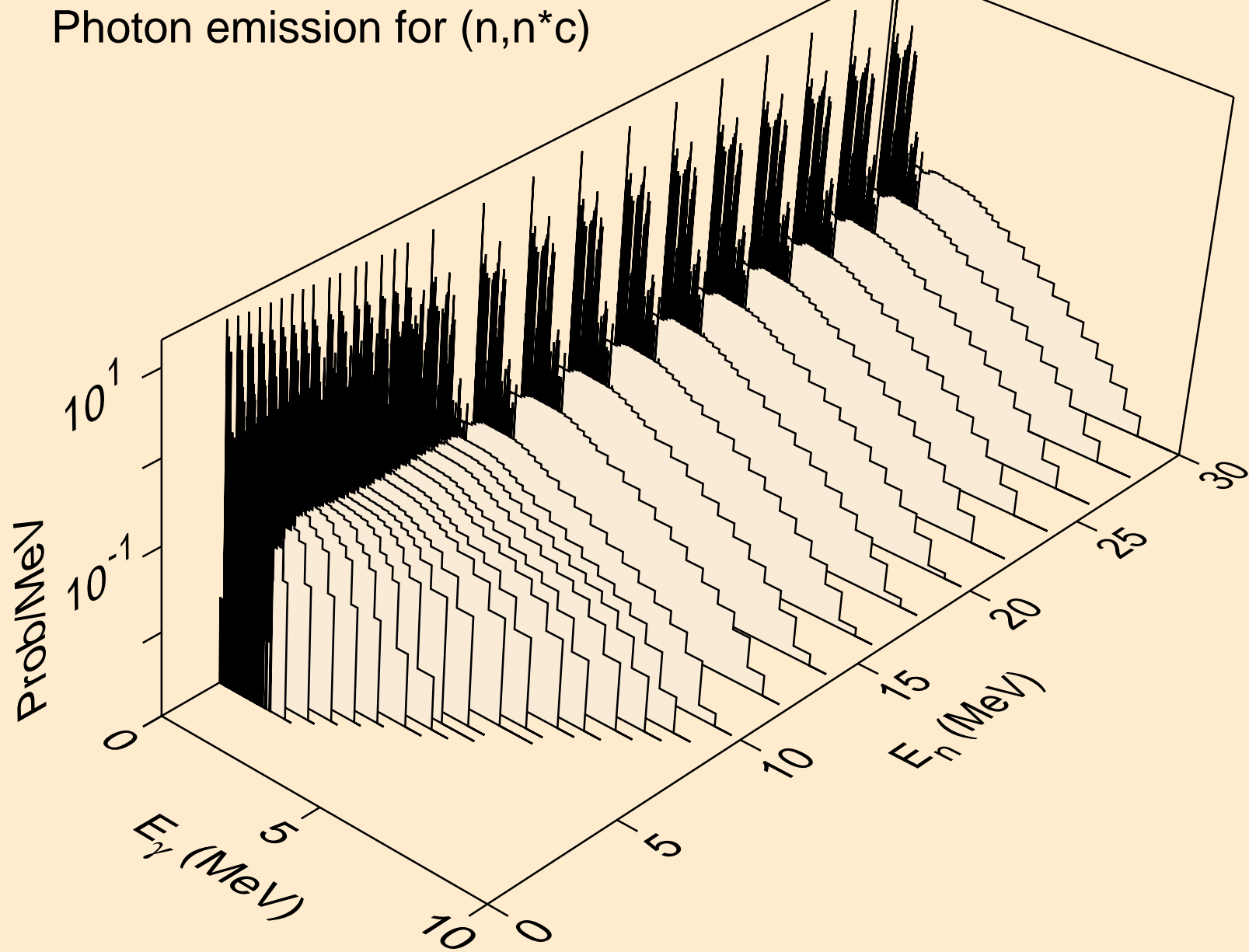

CD105 NEUTRON ACER TENDL-2023 LIBRARY; T=0.K  
Photon emission for (n,gma)

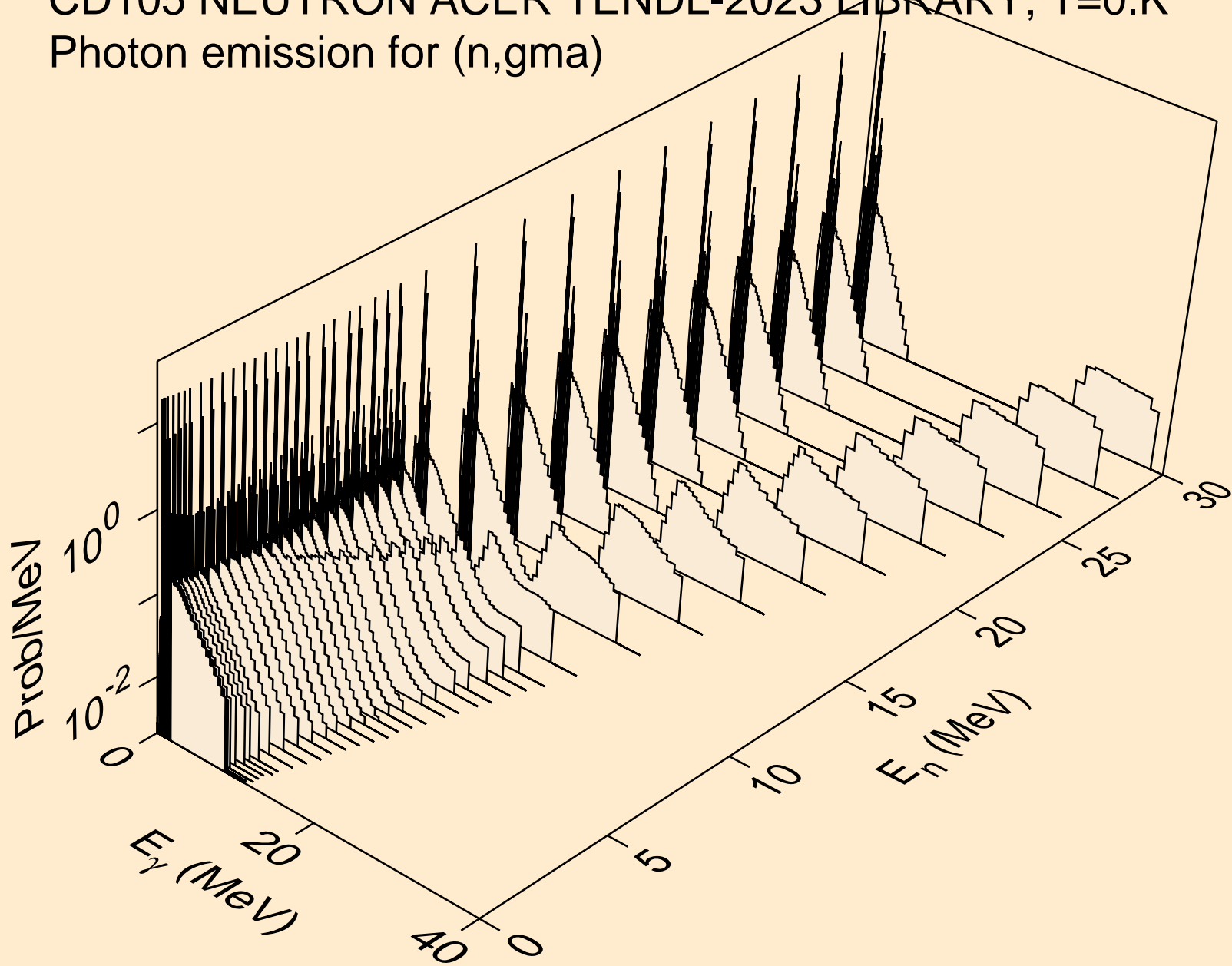

CD105 NEUTRON ACER TENDL-2023 LIBRARY; T=0.K  
Photon emission for (n,p)

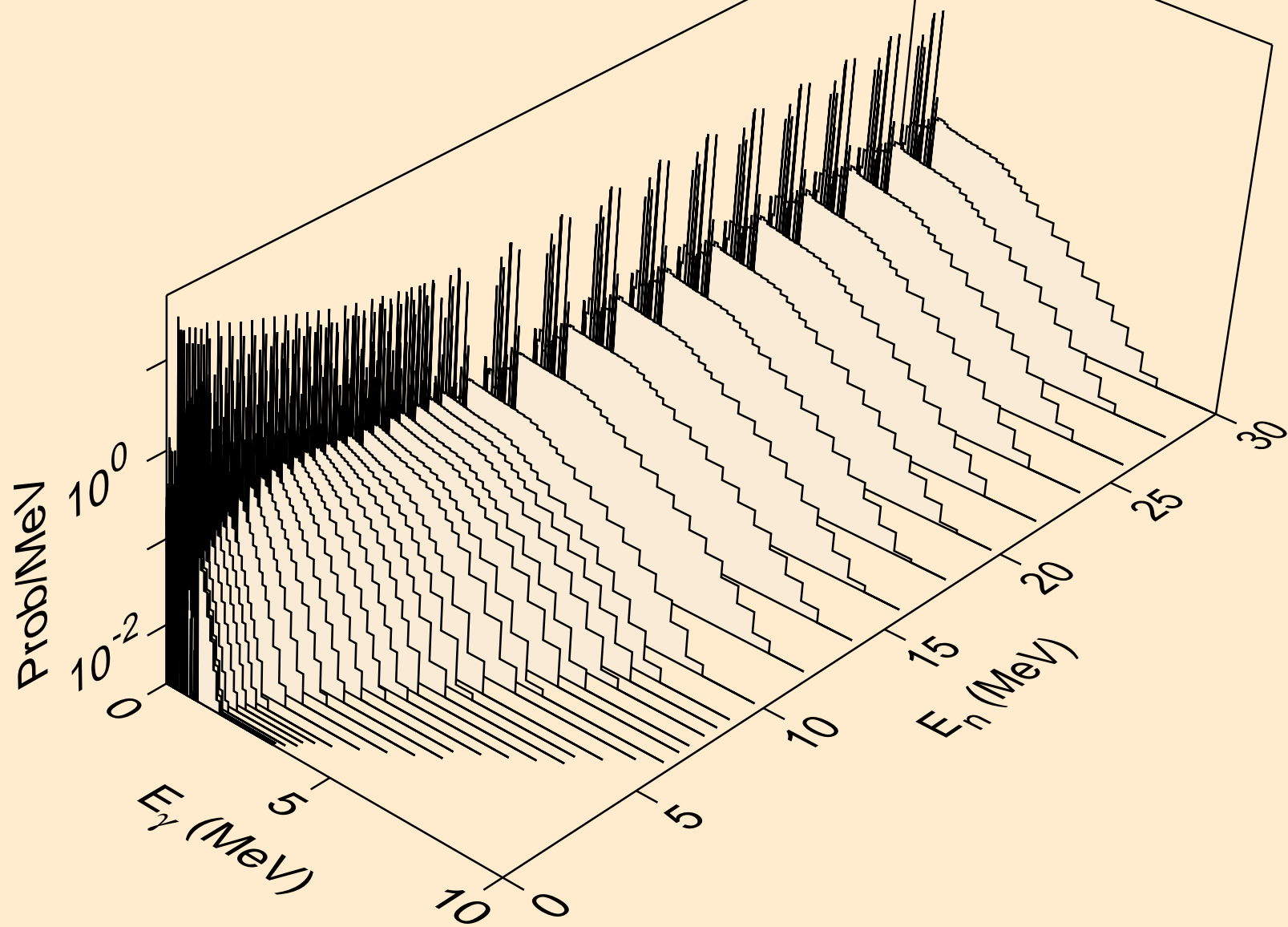

CD105 NEUTRON ACER TENDL-2023 LIBRARY; T=0.K  
Photon emission for (n,d)

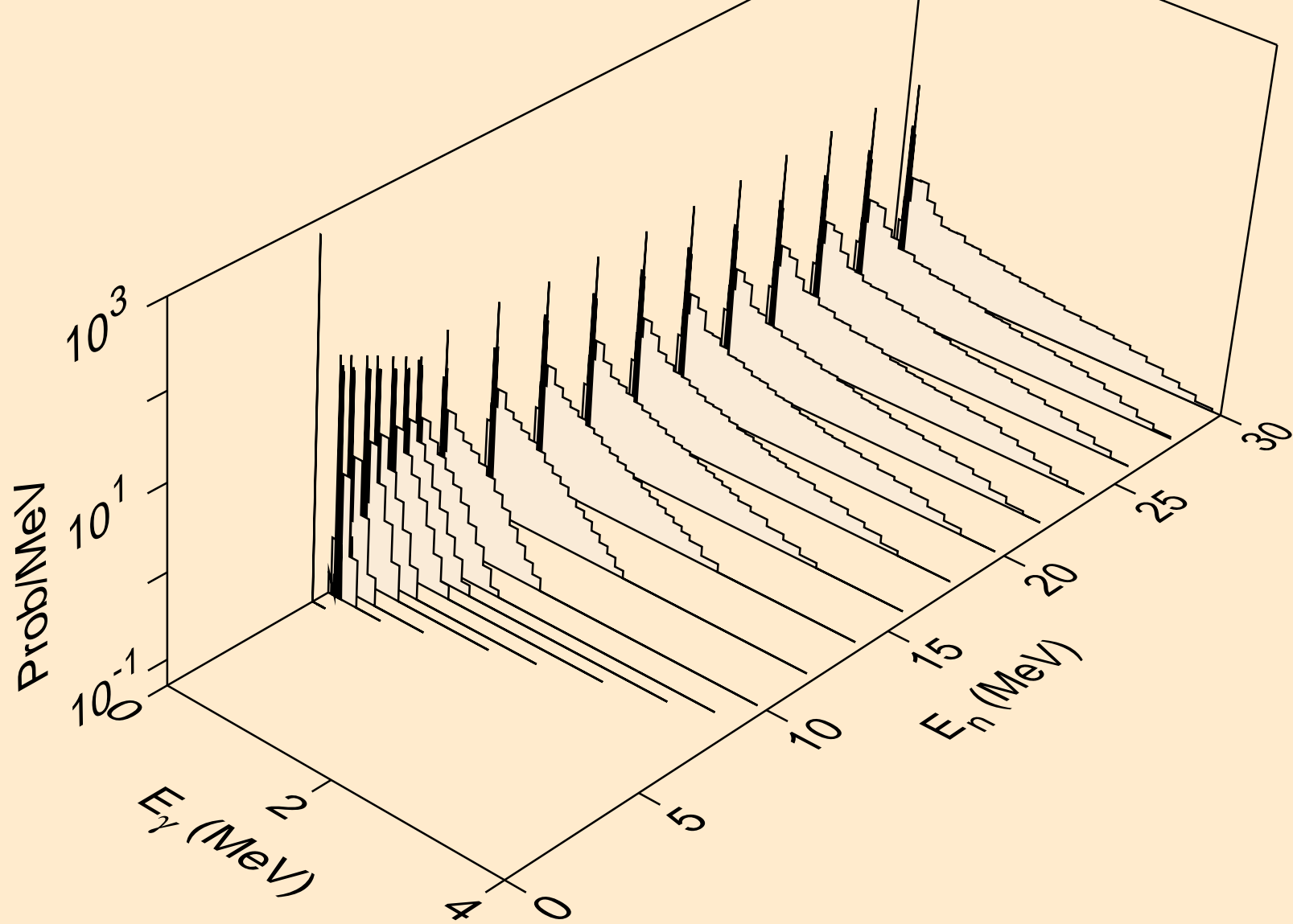

CD105 NEUTRON ACER TENDL-2023 LIBRARY; T=0.K  
Photon emission for (n,t)

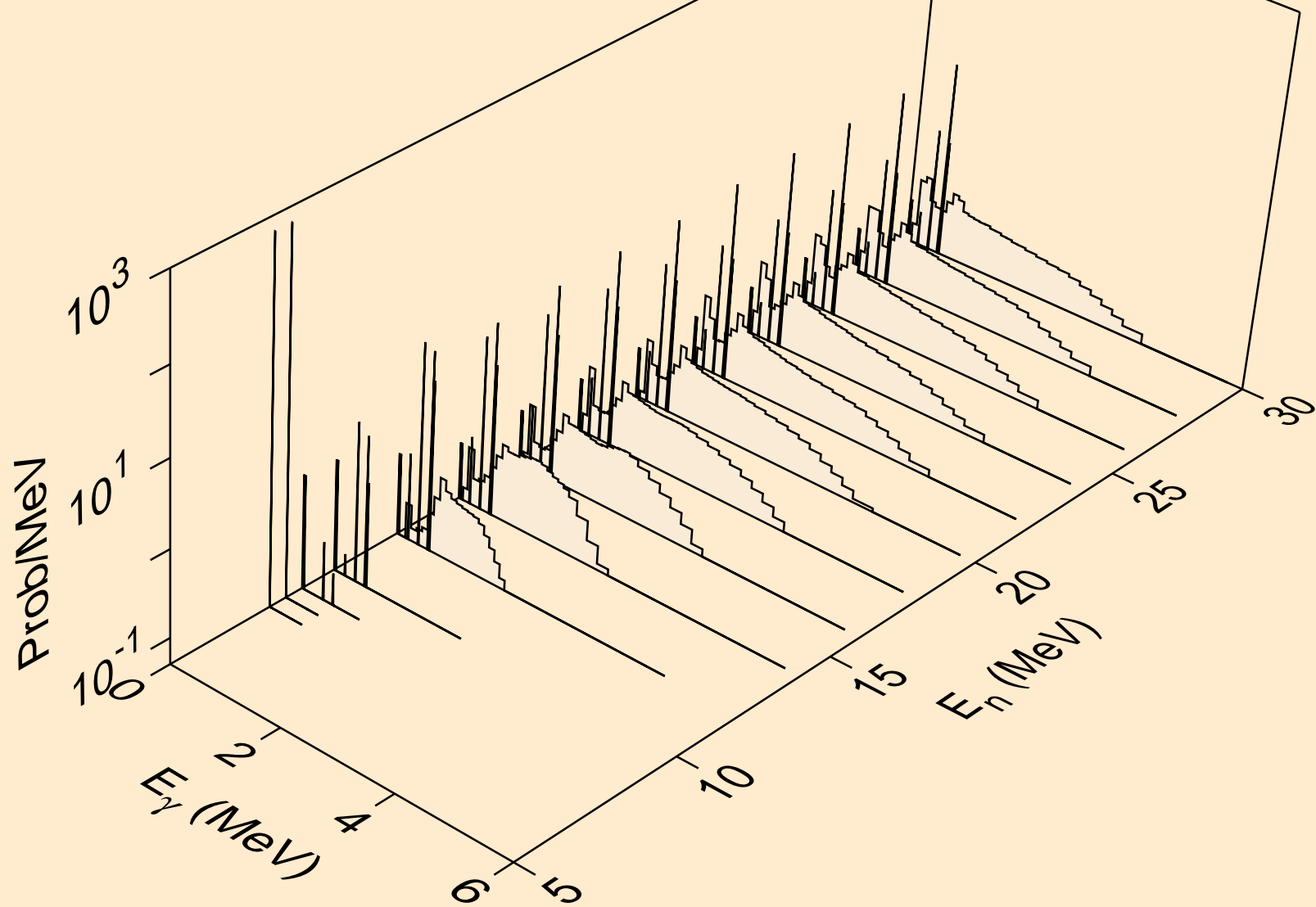

CD105 NEUTRON ACER TENDL-2023 LIBRARY; T=0.K  
Photon emission for (n,he3)

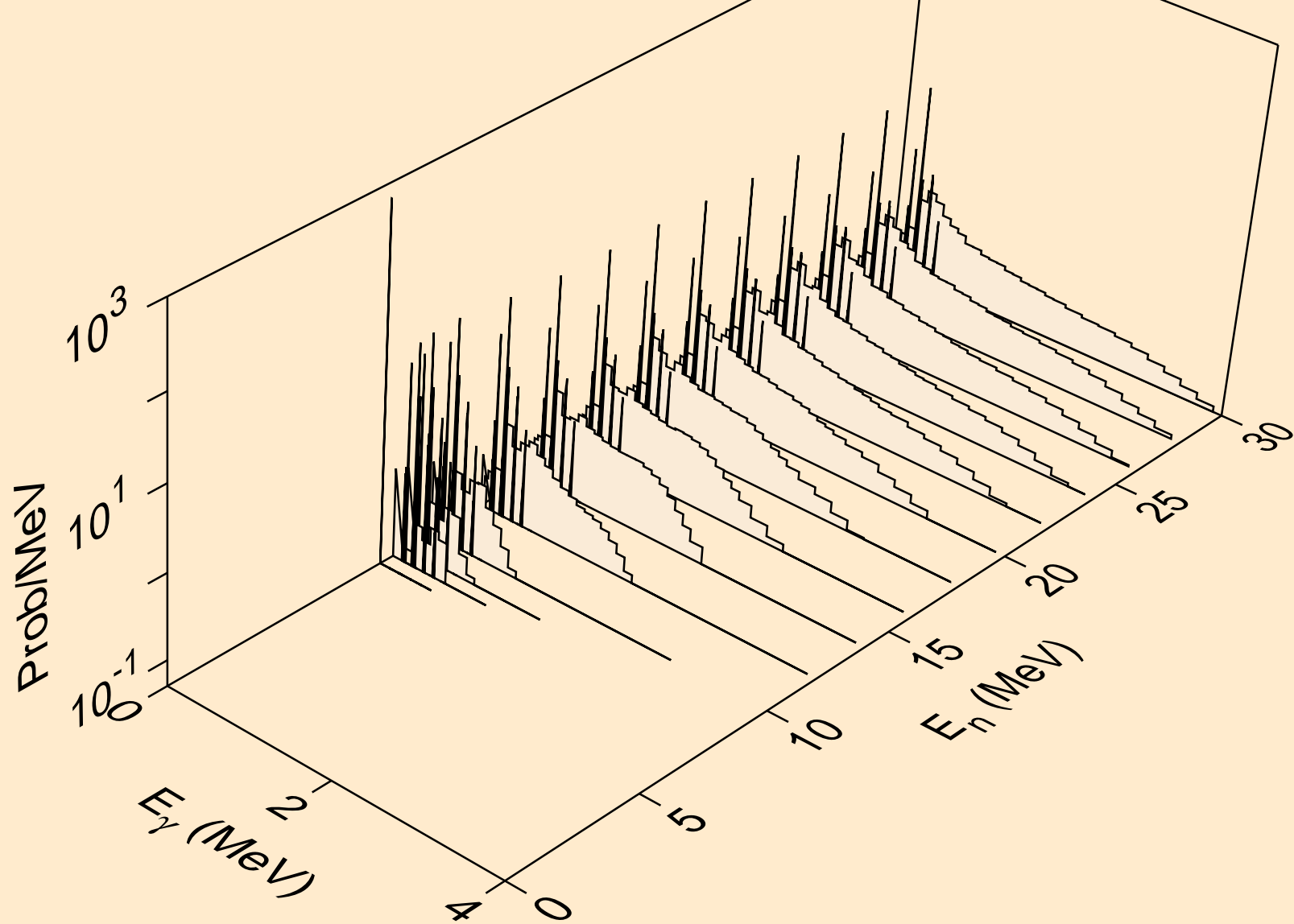

CD105 NEUTRON ACER TENDL-2023 LIBRARY; T=0.K  
Photon emission for (n,a)

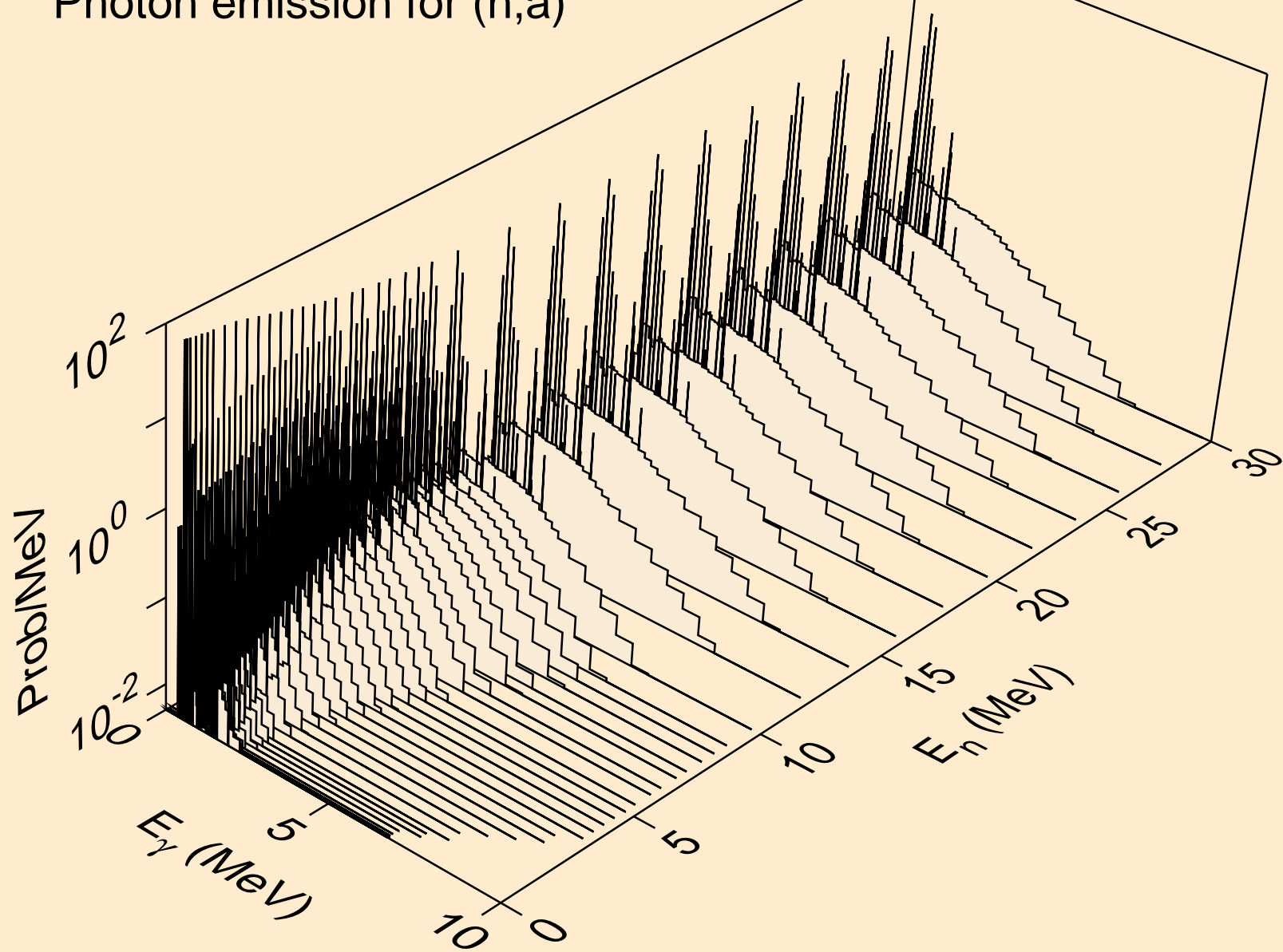

CD105 NEUTRON ACER TENDL-2023 LIBRARY; T=0.K  
Photon emission for (n,2a)

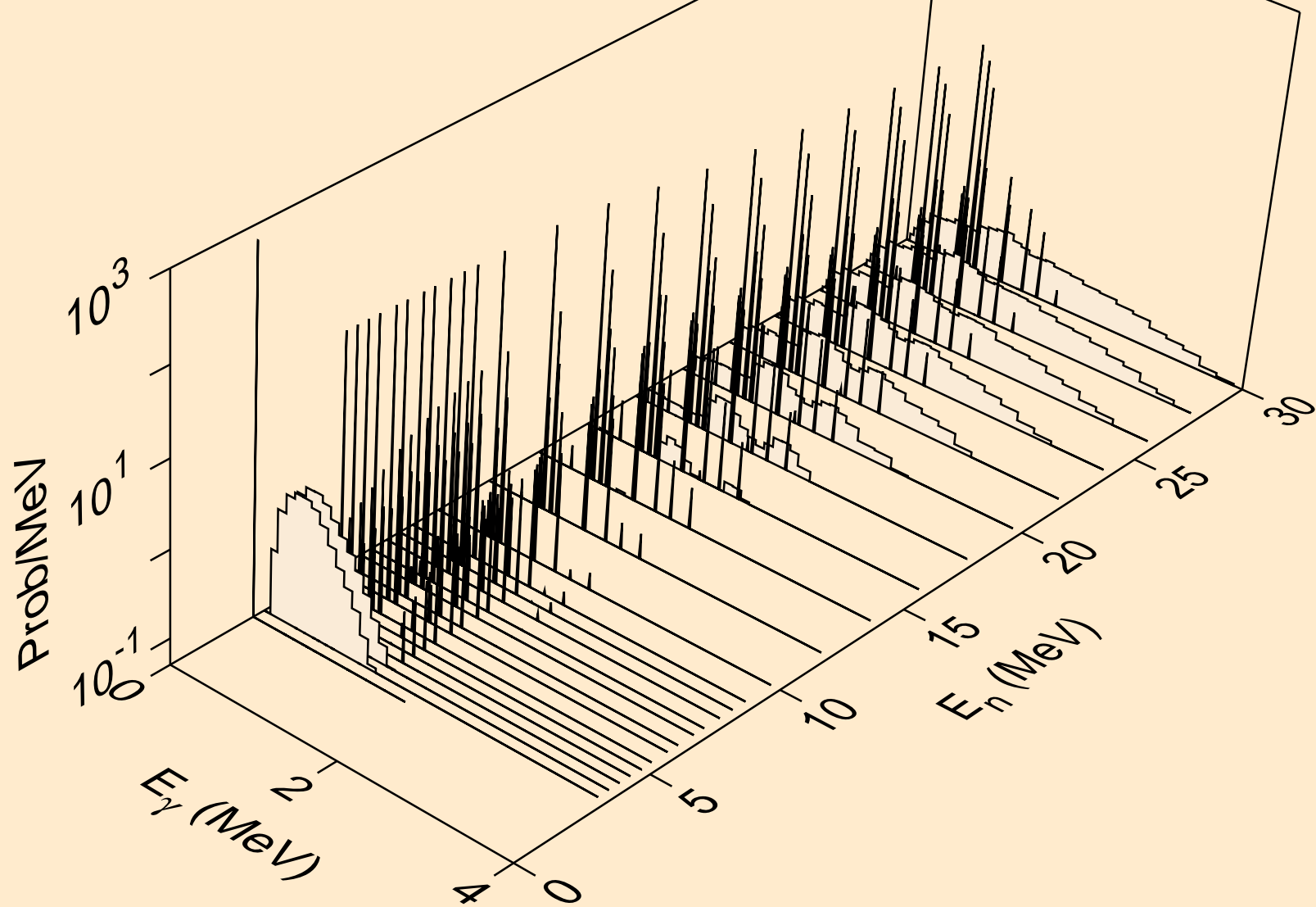

CD105 NEUTRON ACER TENDL-2023 LIBRARY; T=0.K  
Photon emission for (n,3a)

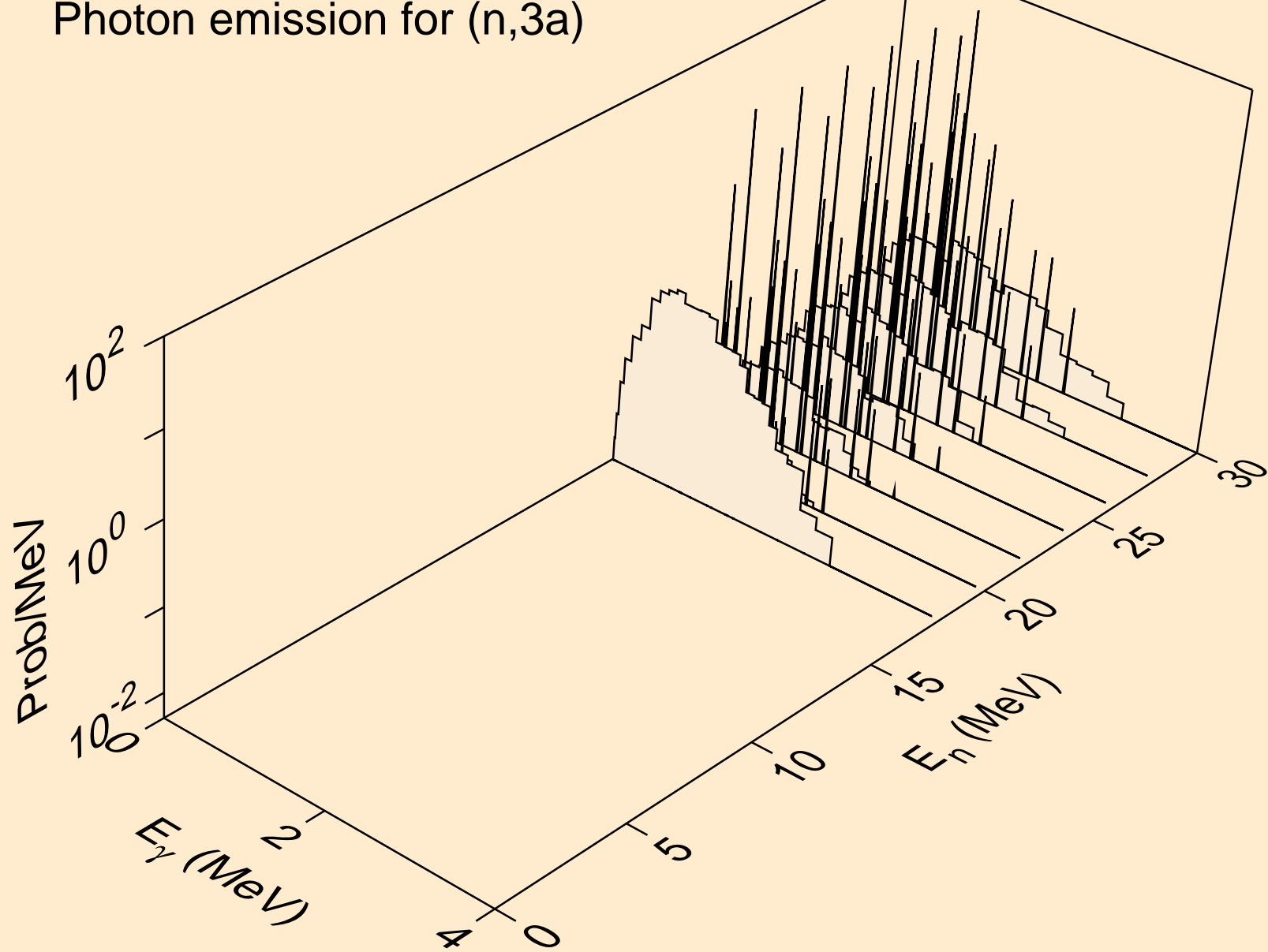

CD105 NEUTRON ACER TENDL-2023 LIBRARY; T=0.K  
Photon emission for (n,2p)

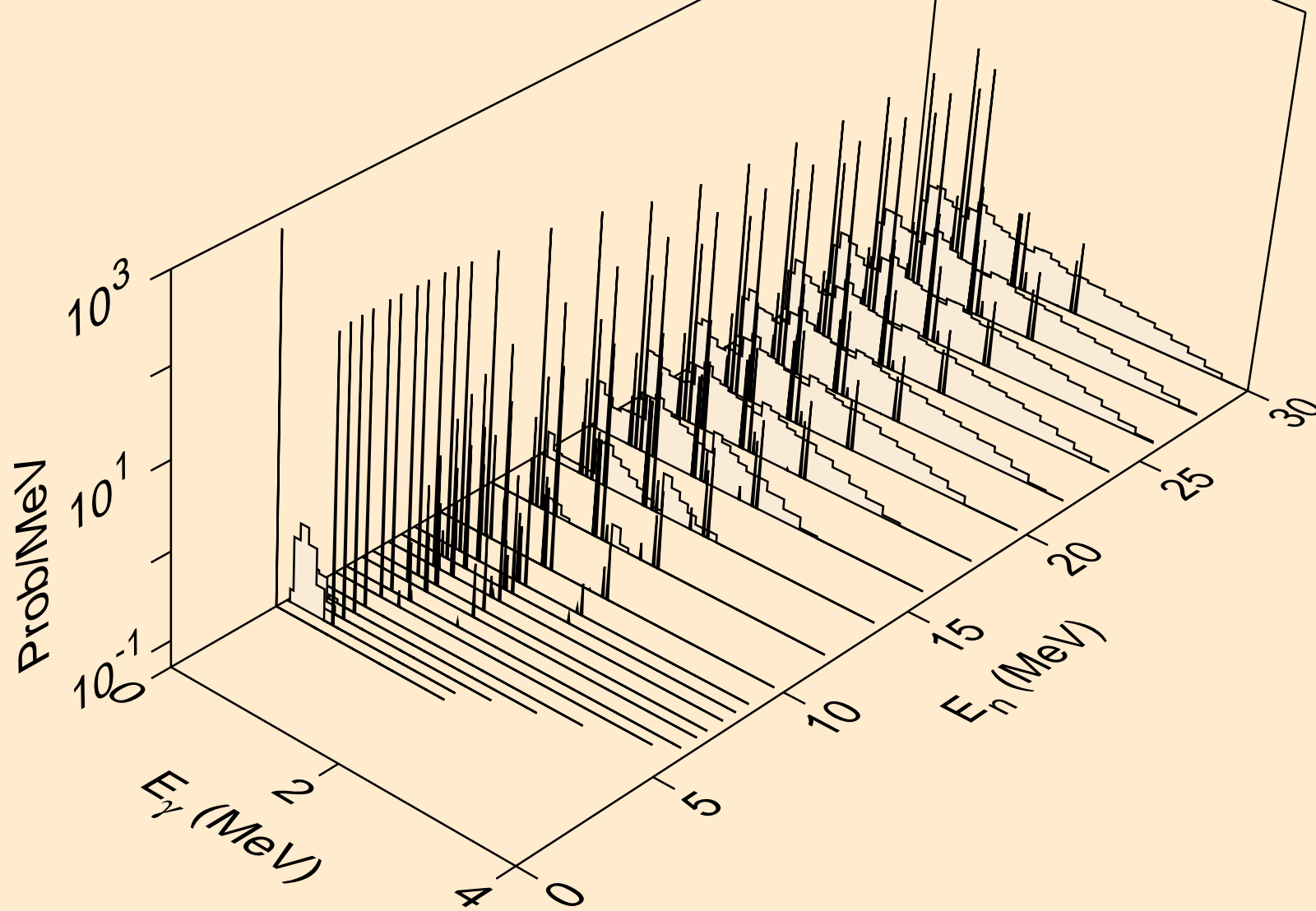

CD105 NEUTRON ACER TENDL-2023 LIBRARY; T=0.K  
Photon emission for (n,p)

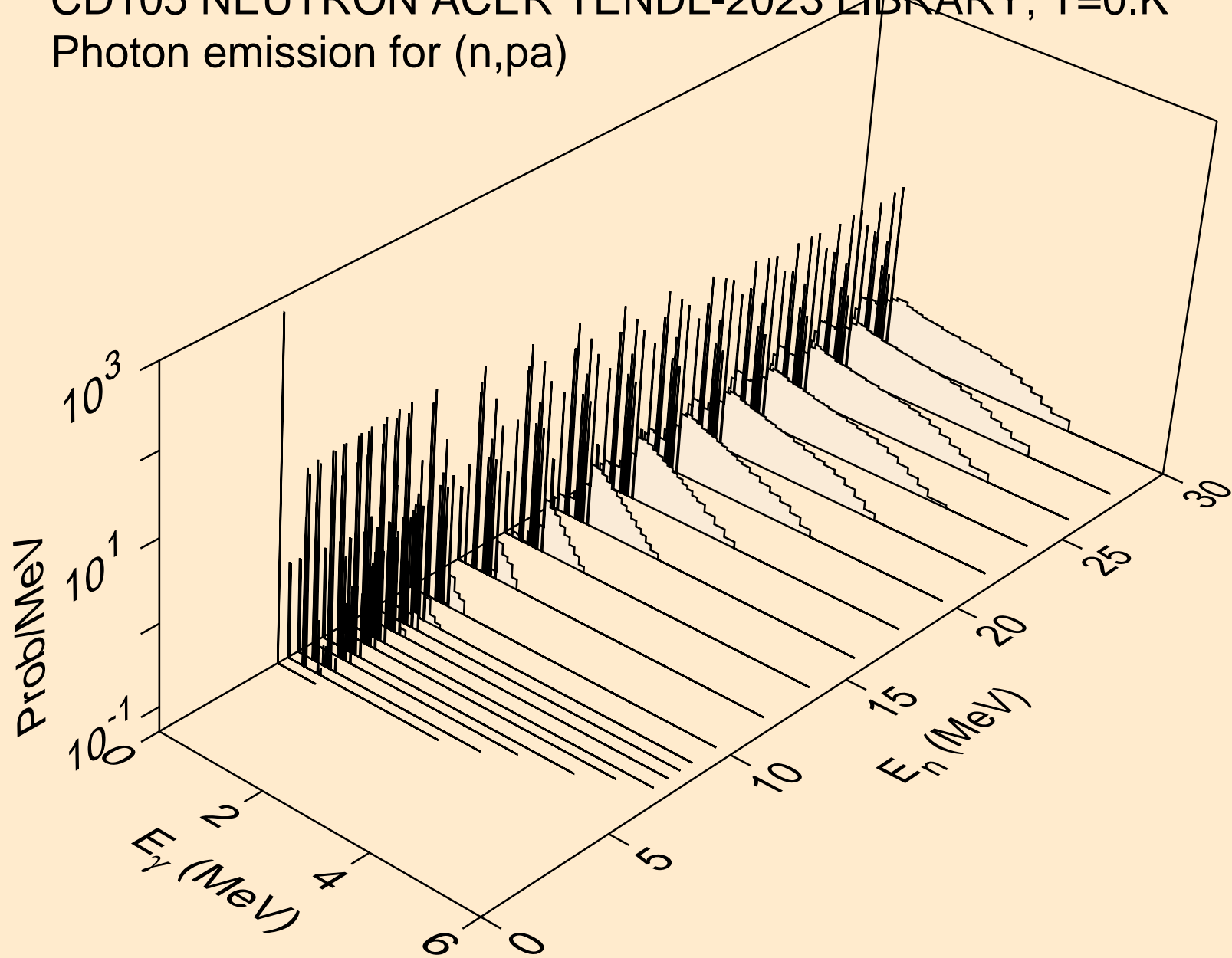

CD105 NEUTRON ACER TENDL-2023 LIBRARY; T=0.K  
Photon emission for (n,pd)

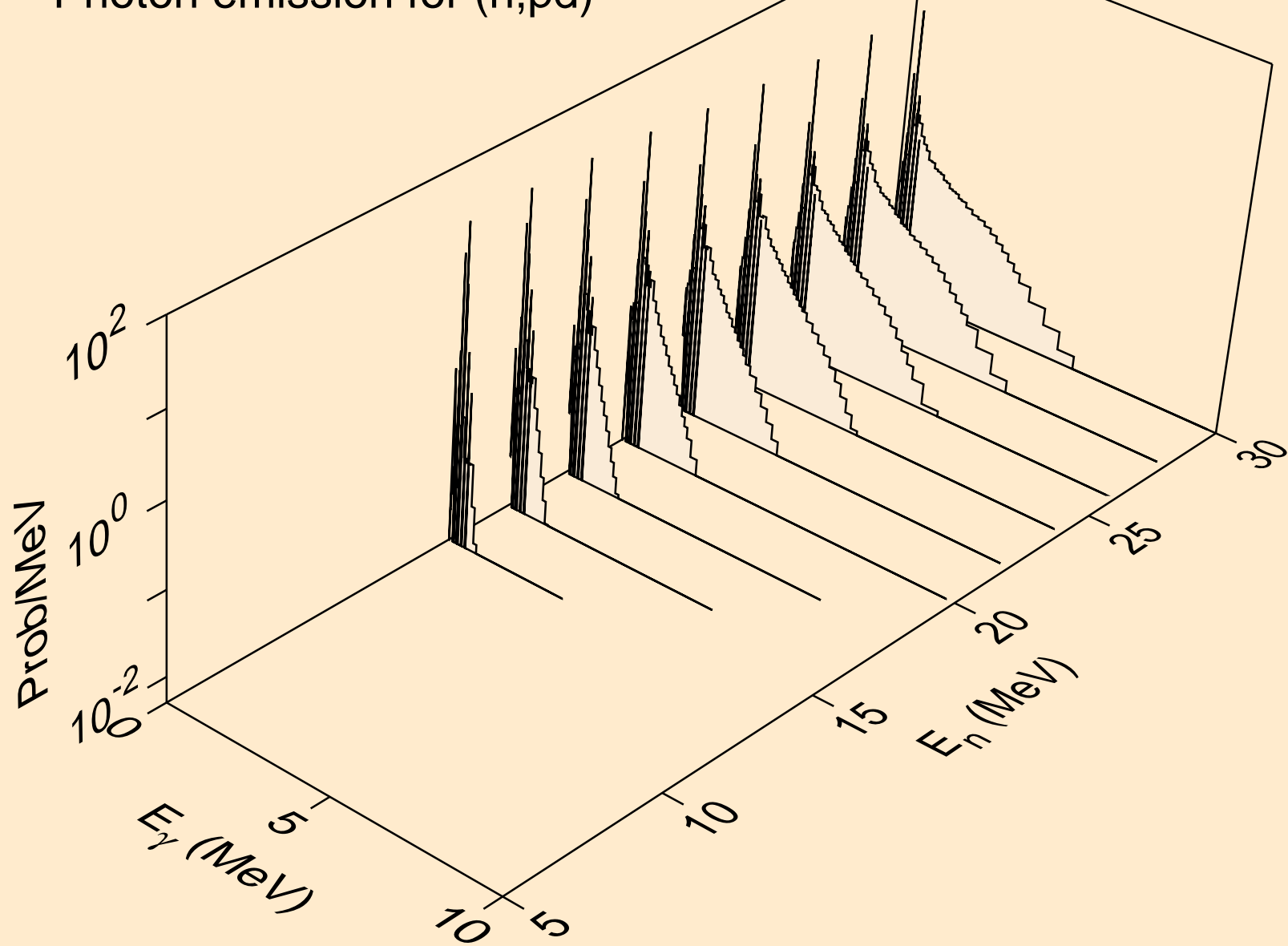

CD105 NEUTRON ACER TENDL-2023 LIBRARY; T=0.K  
Photon emission for (n,pt)

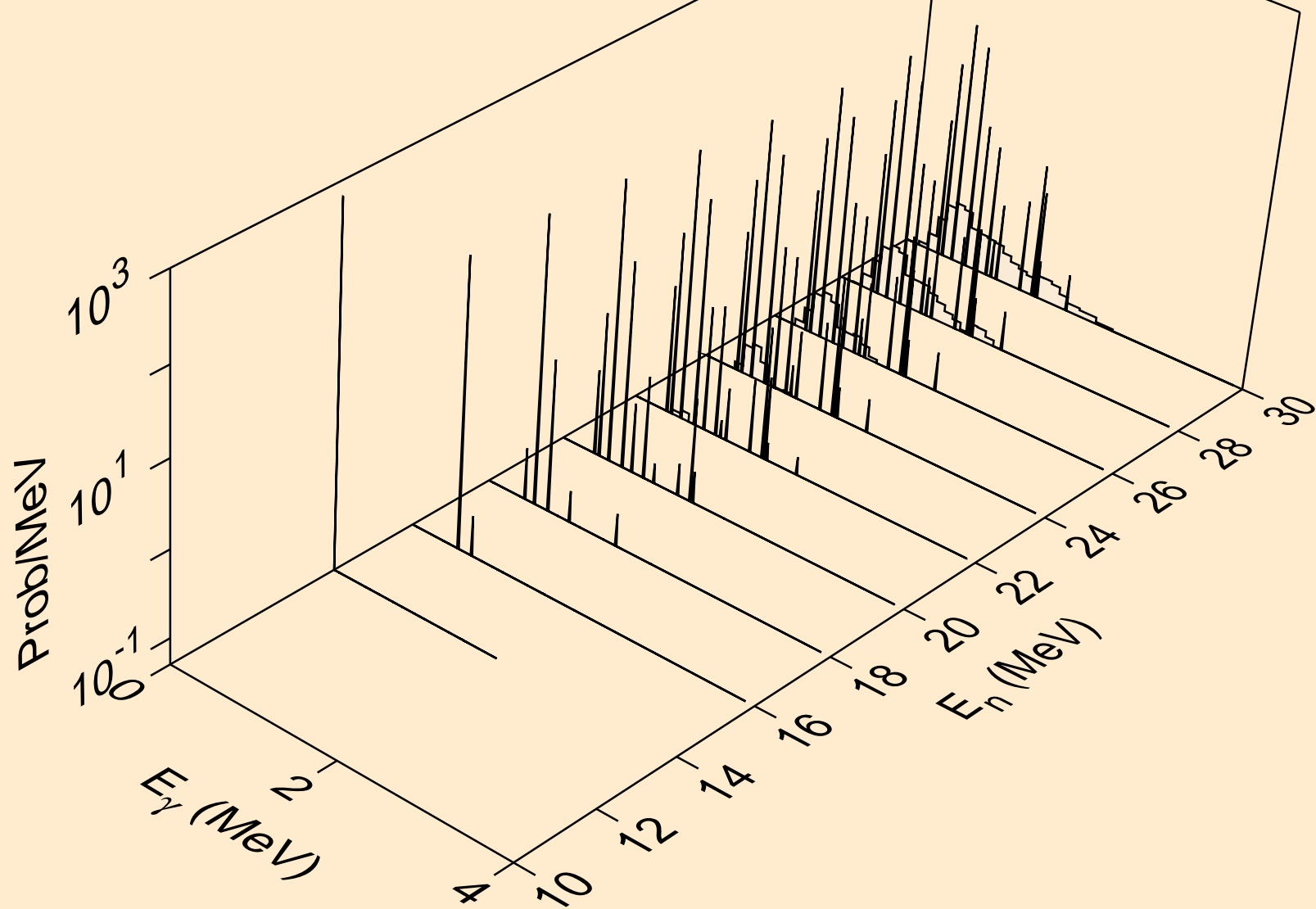

CD105 NEUTRON ACER TENDL-2023 LIBRARY; T=0.K  
Photon emission for (n,da)

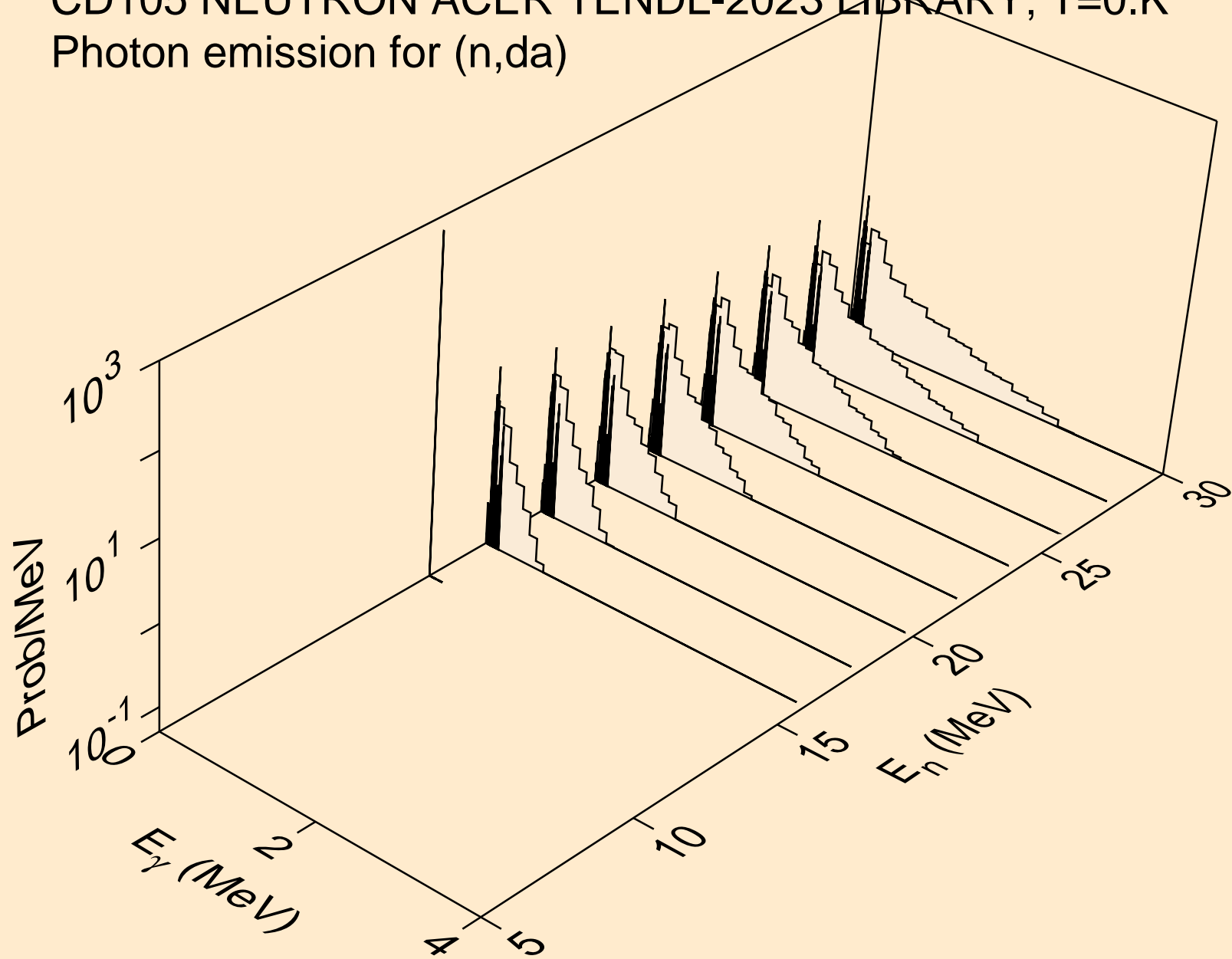

CD105 NEUTRON ACER TENDL-2023 LIBRARY; T=0.K  
thermal capture photon spectrum

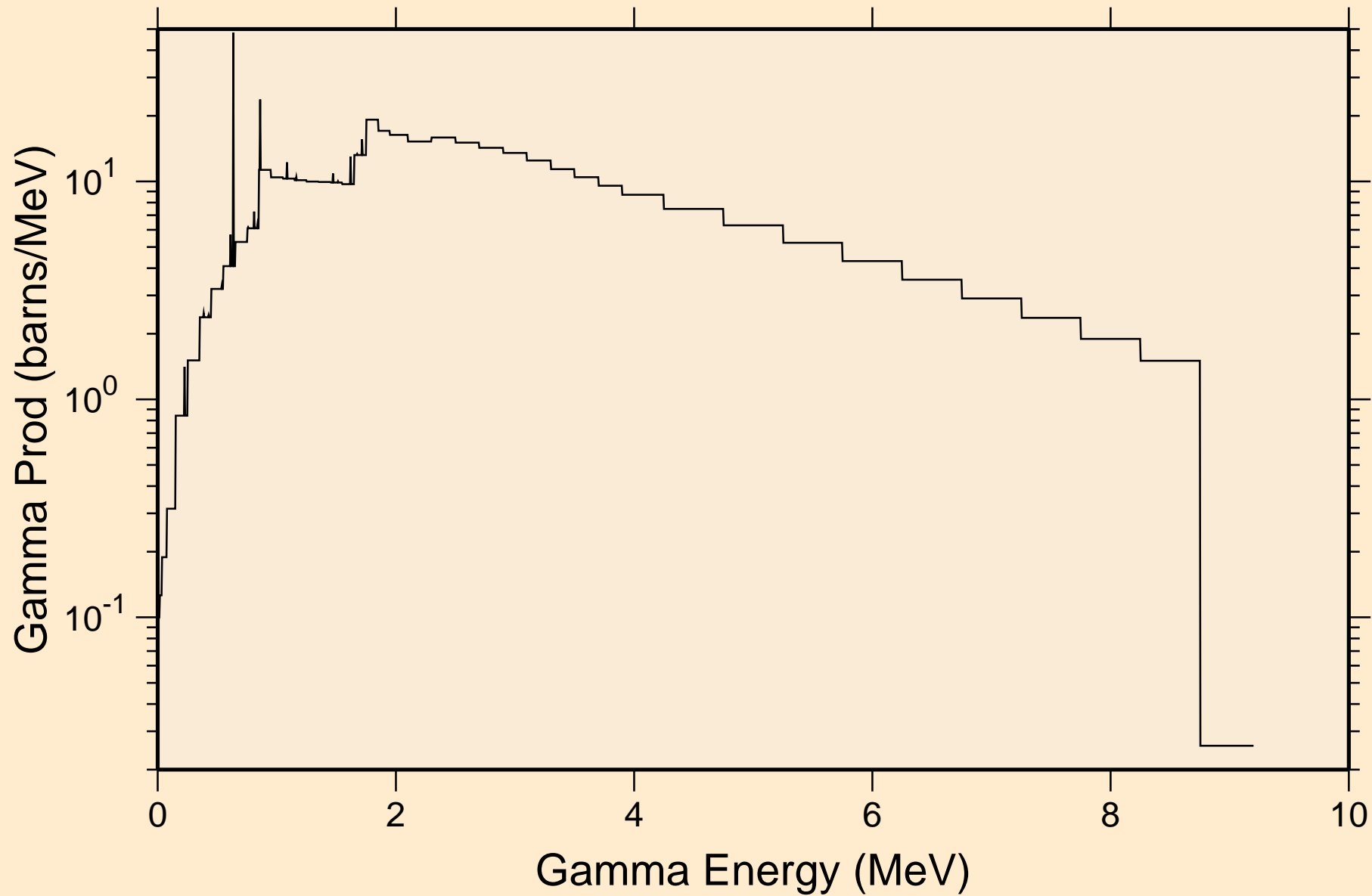

CD105 NEUTRON ACER TENDL-2023 LIBRARY; T=0.K  
14 MeV photon spectrum

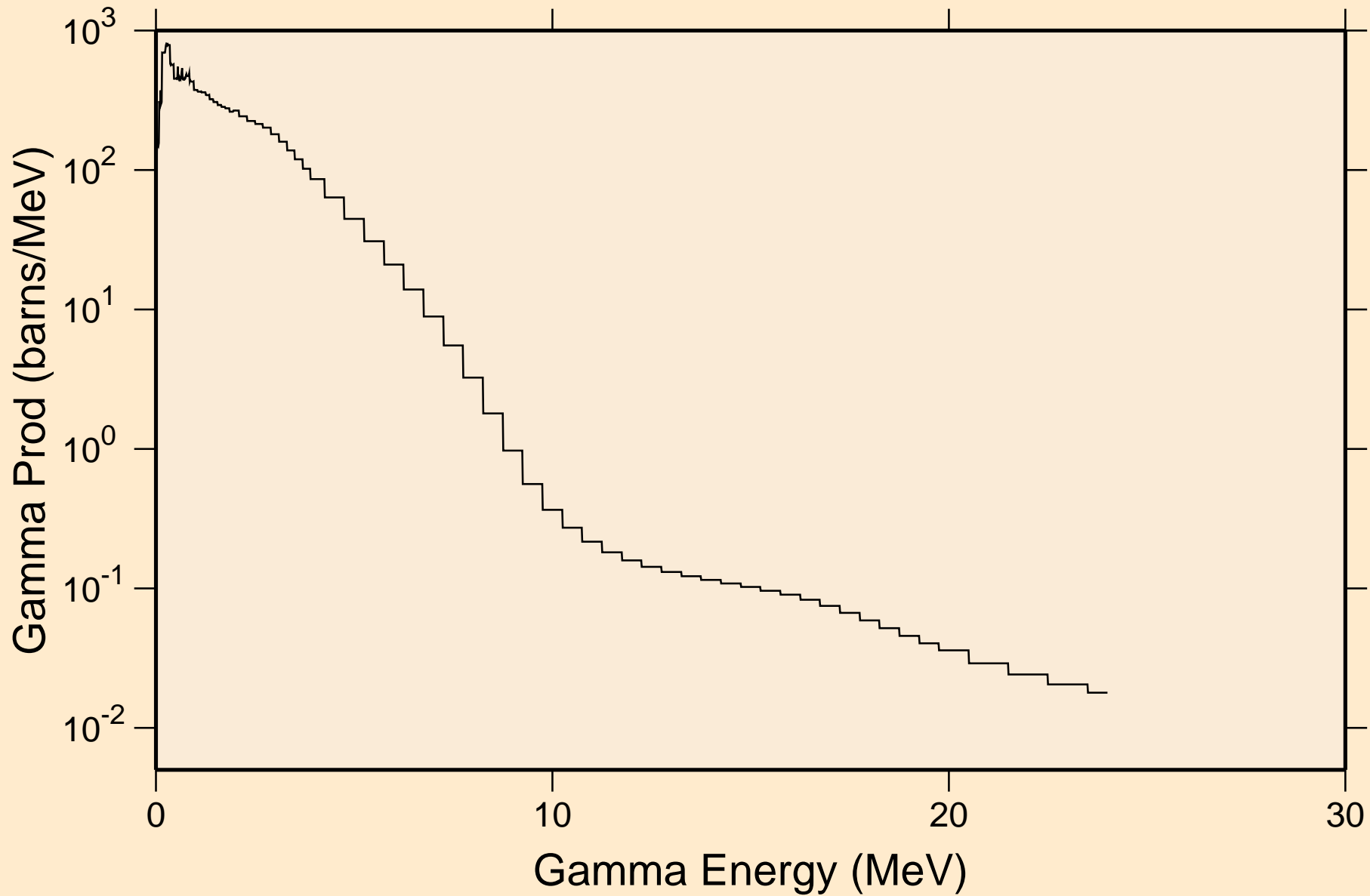

# CD105 NEUTRON ACER TENDL-2023 LIBRARY; T=0.K

## Particle heating contributions

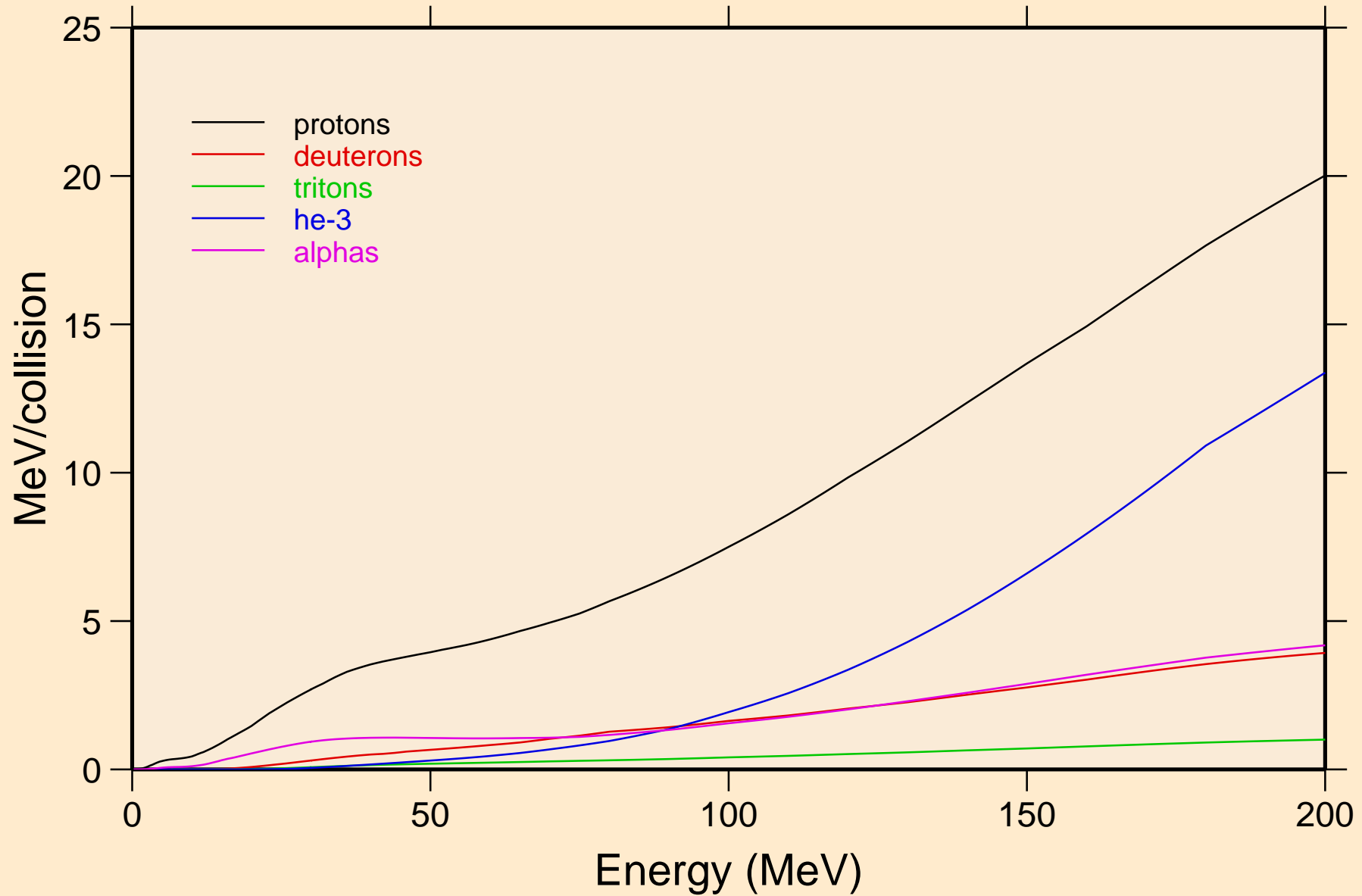

# CD105 NEUTRON ACER TENDL-2023 LIBRARY; T=0.K

## Recoil Heating

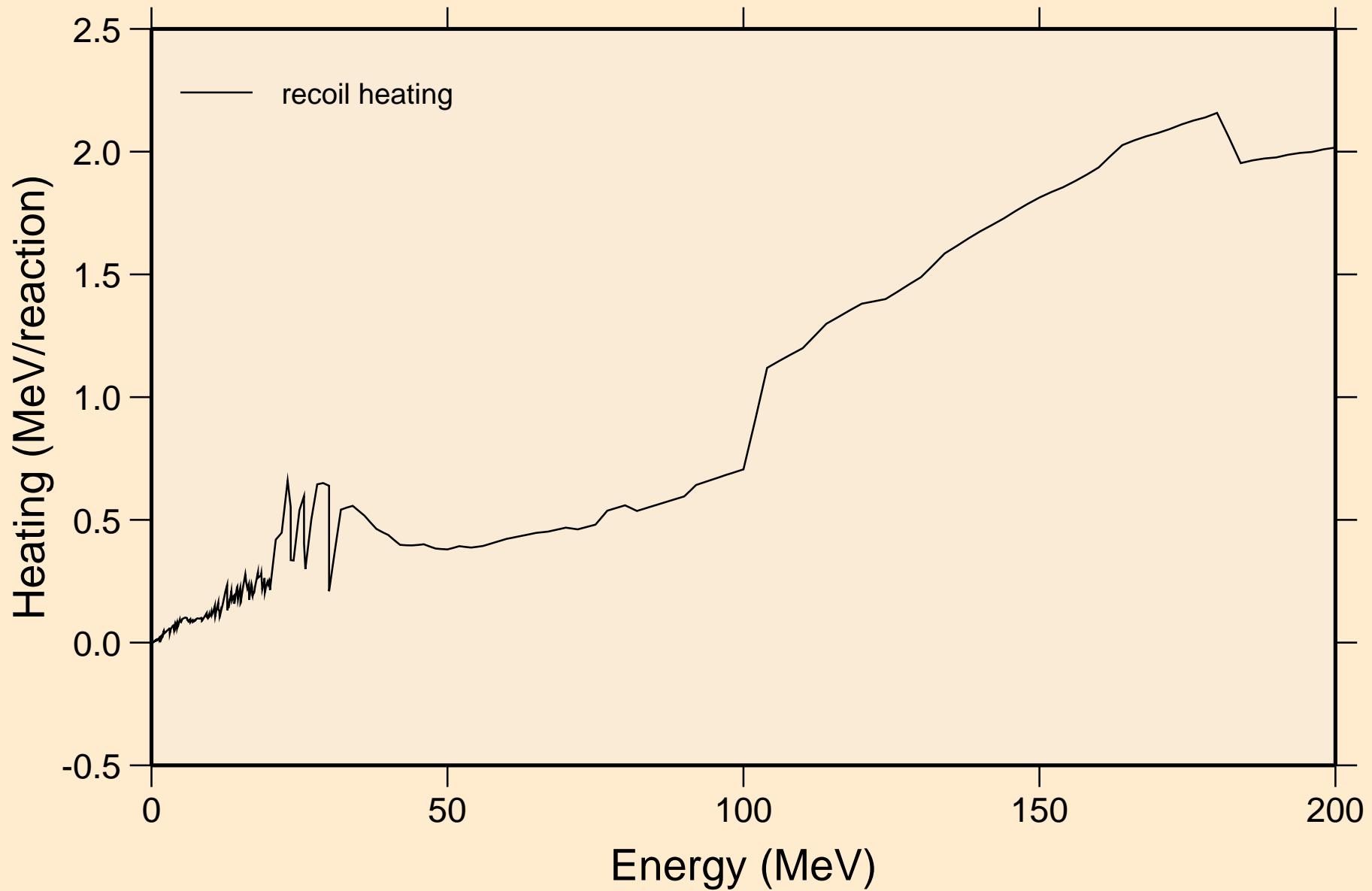

# CD105 NEUTRON ACER TENDL-2023 LIBRARY; T=0.K

## Particle production cross sections

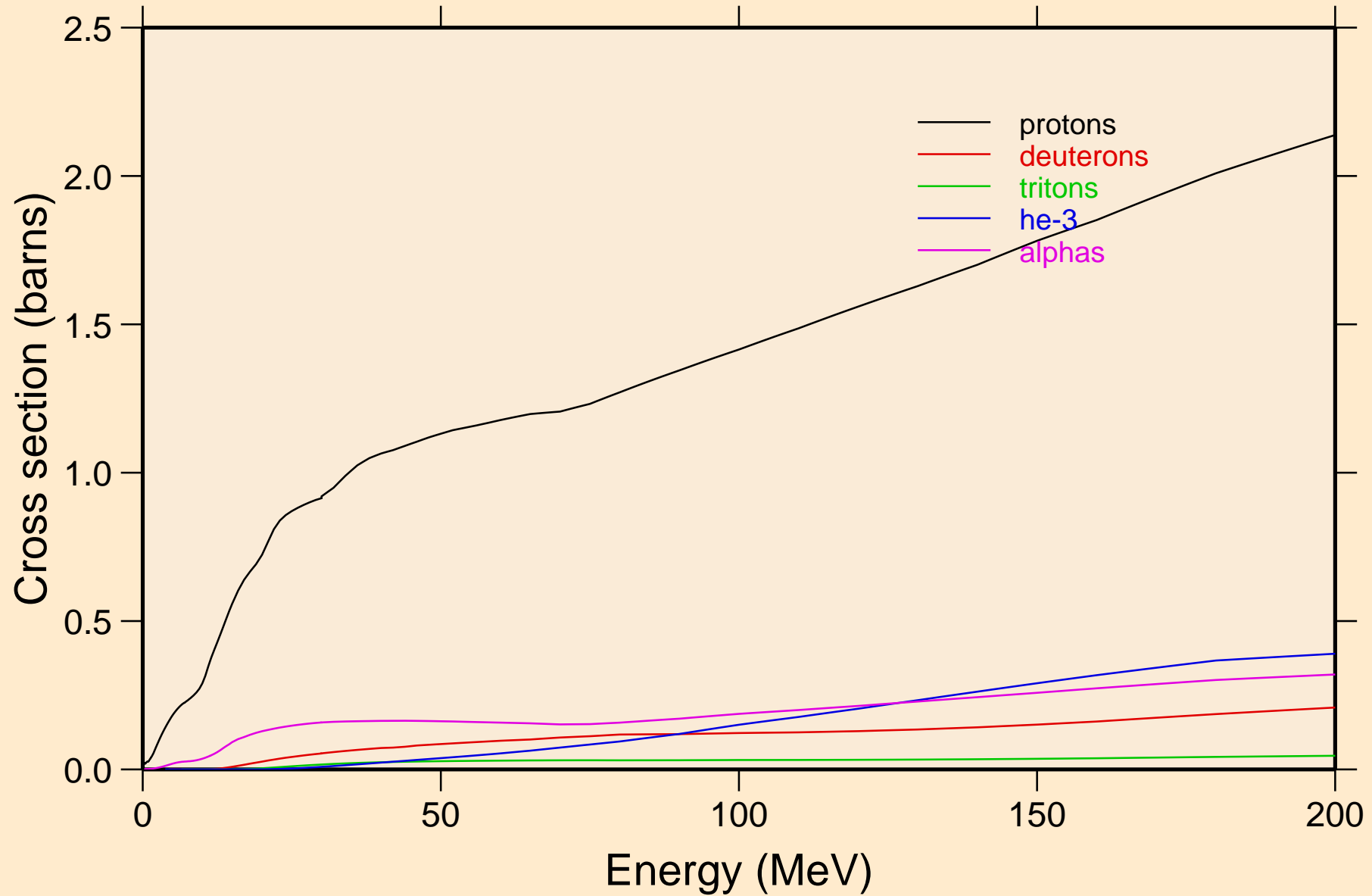

CD105 NEUTRON ACER TENDL-2023 LIBRARY; T=0.K  
protons from (n,x)

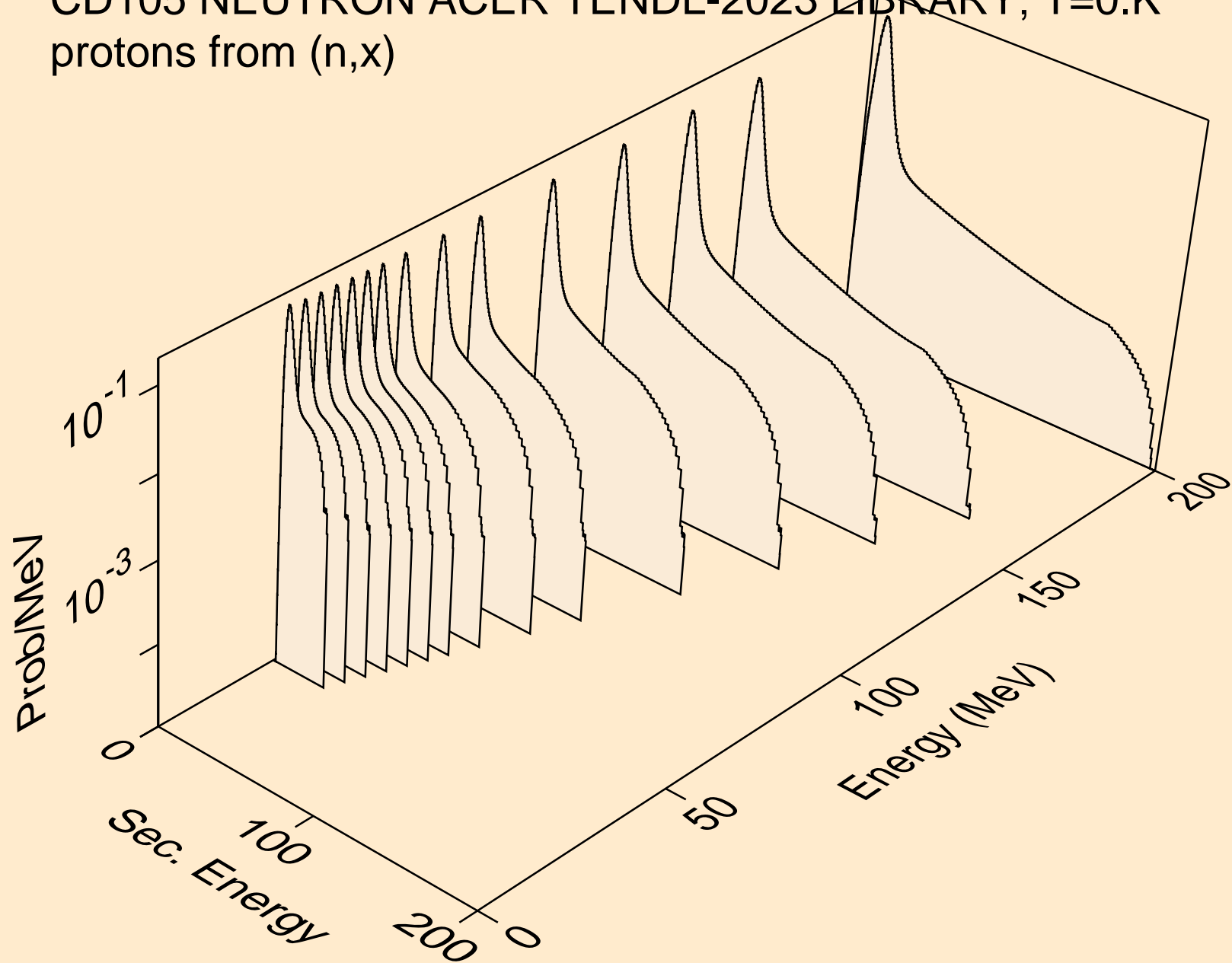

CD105 NEUTRON ACER TENDL-2023 LIBRARY; T=0.K  
protons from (n,n\*)p

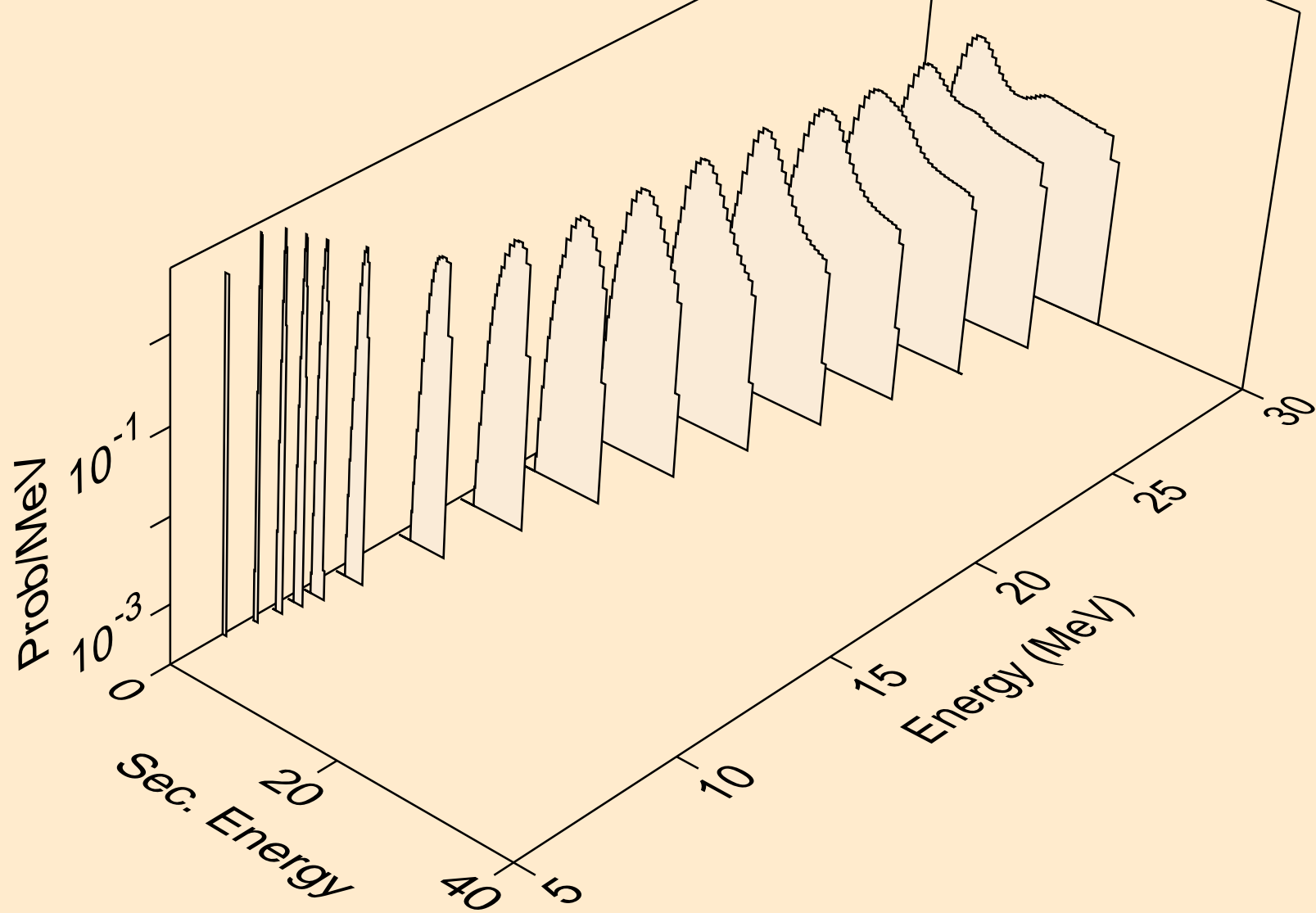

CD105 NEUTRON ACER TENDL-2023 LIBRARY; T=0.K  
protons from (n,2np)

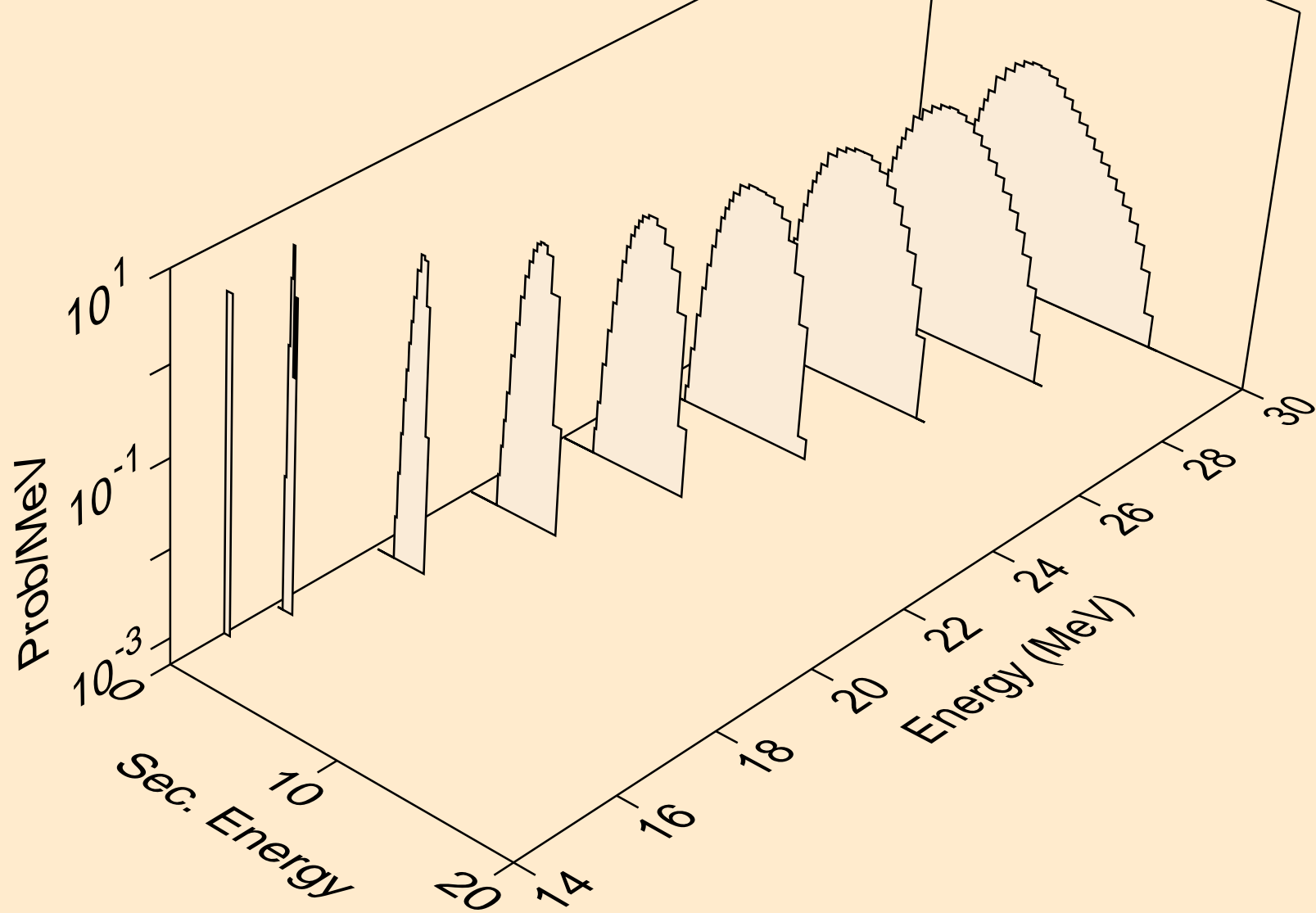

CD105 NEUTRON ACER TENDL-2023 LIBRARY; T=0.K  
protons from (n,3np)

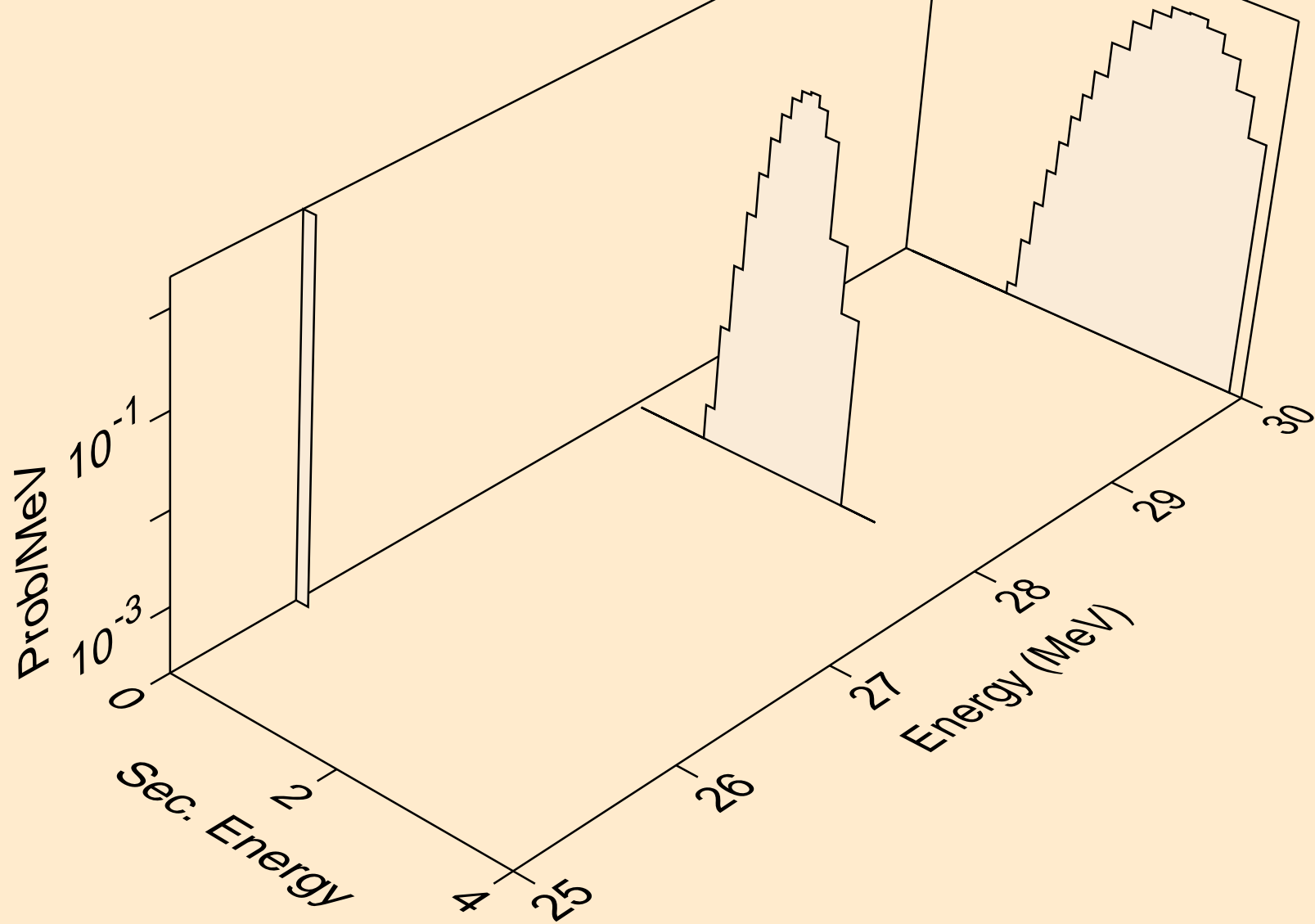

CD105 NEUTRON ACER TENDL-2023 LIBRARY; T=0.K  
protons from (n,n2p)

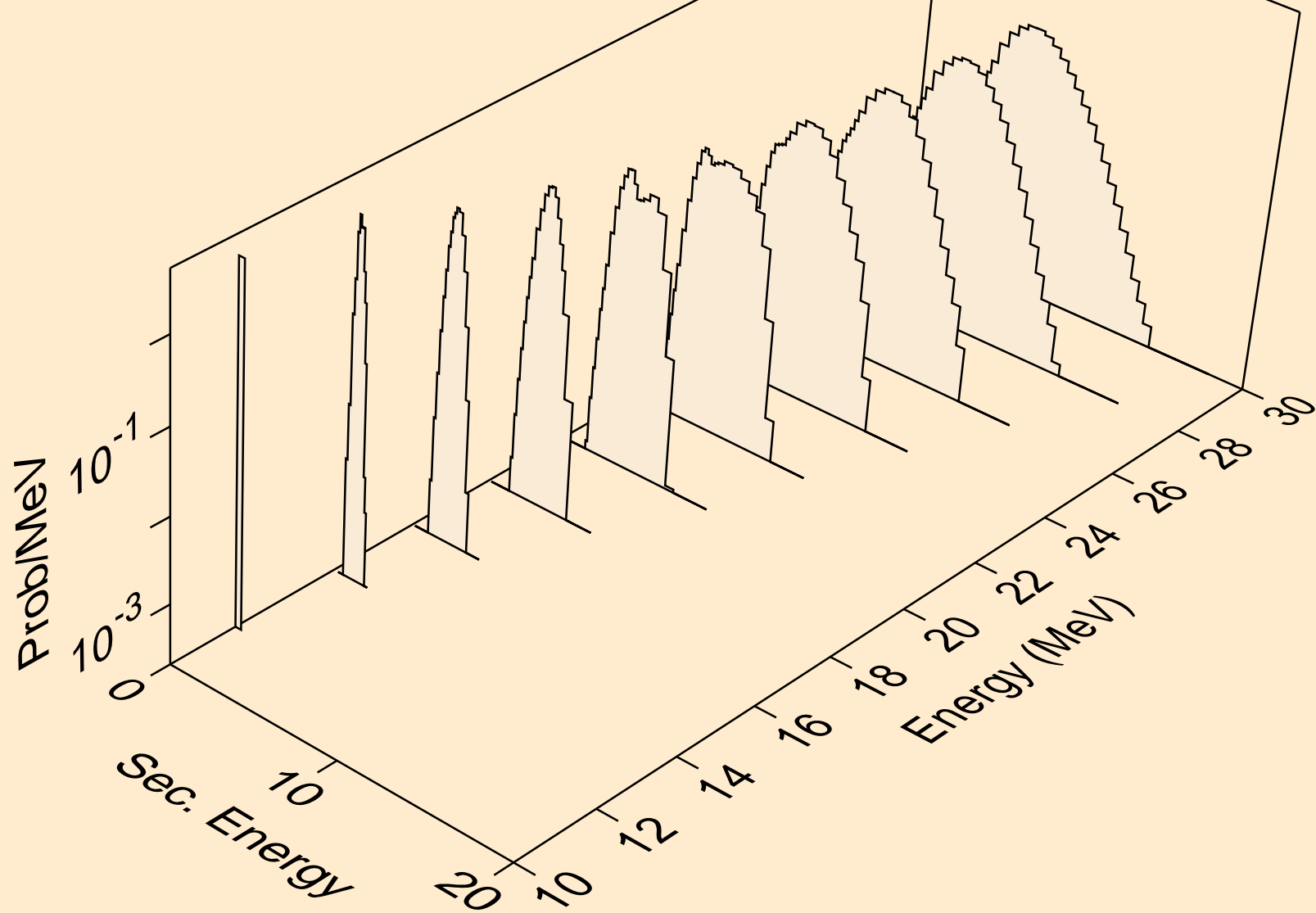

CD105 NEUTRON ACER TENDL-2023 LIBRARY; T=0.K  
protons from (n,npa)

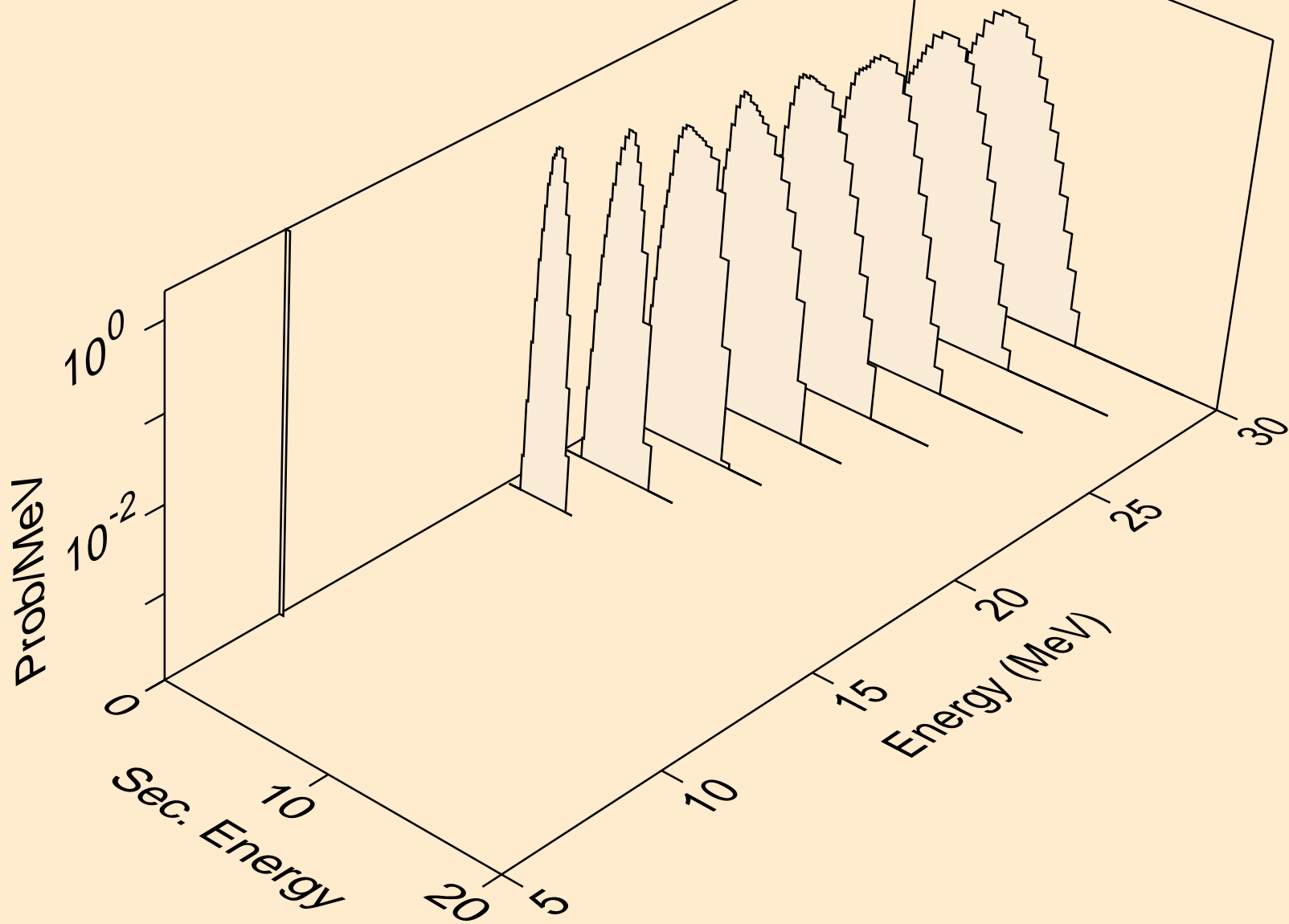

CD105 NEUTRON ACER TENDL-2023 LIBRARY; T=0.K  
protons from (n,p)

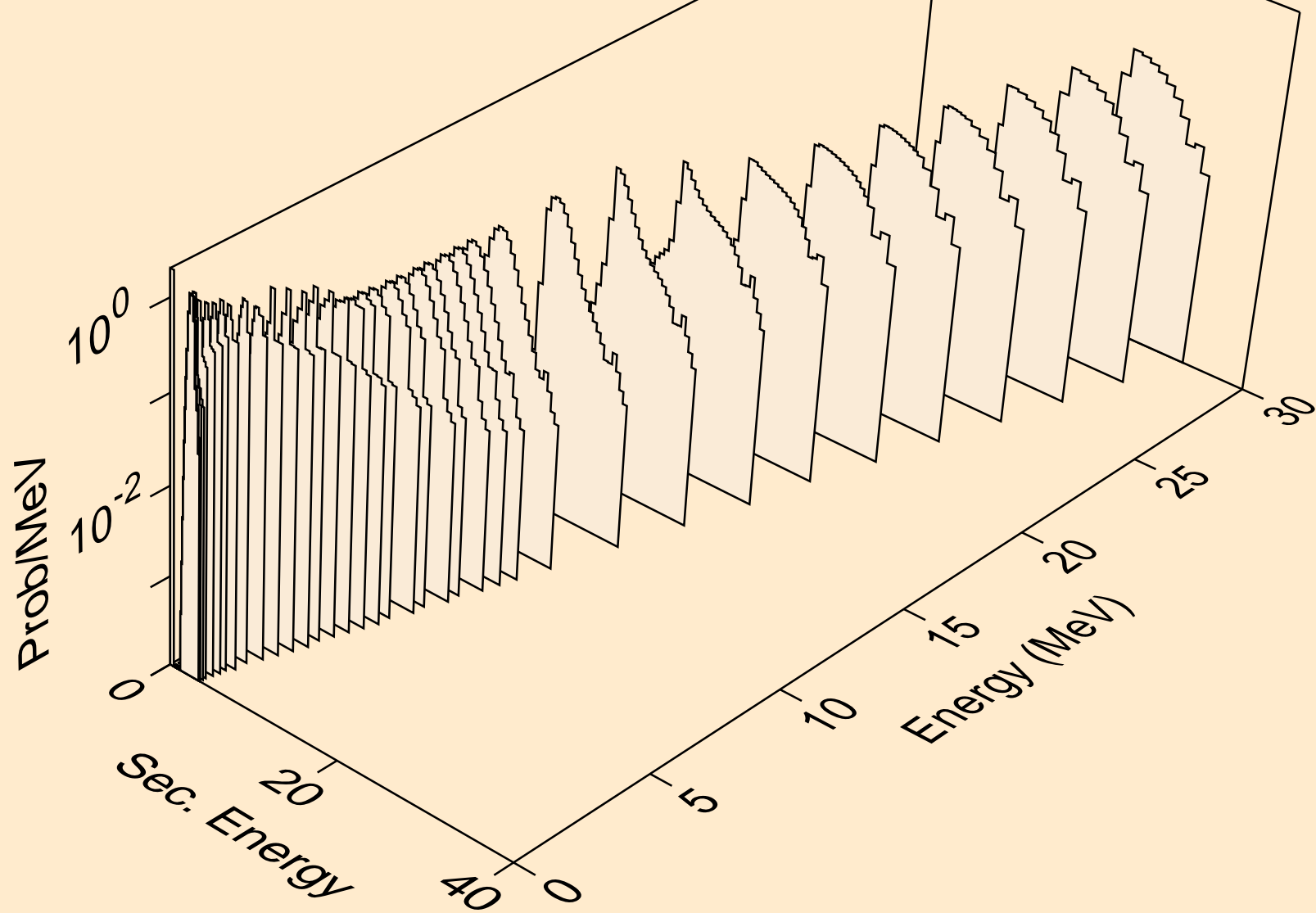

CD105 NEUTRON ACER TENDL-2023 LIBRARY; T=0.K  
protons from (n,2p)

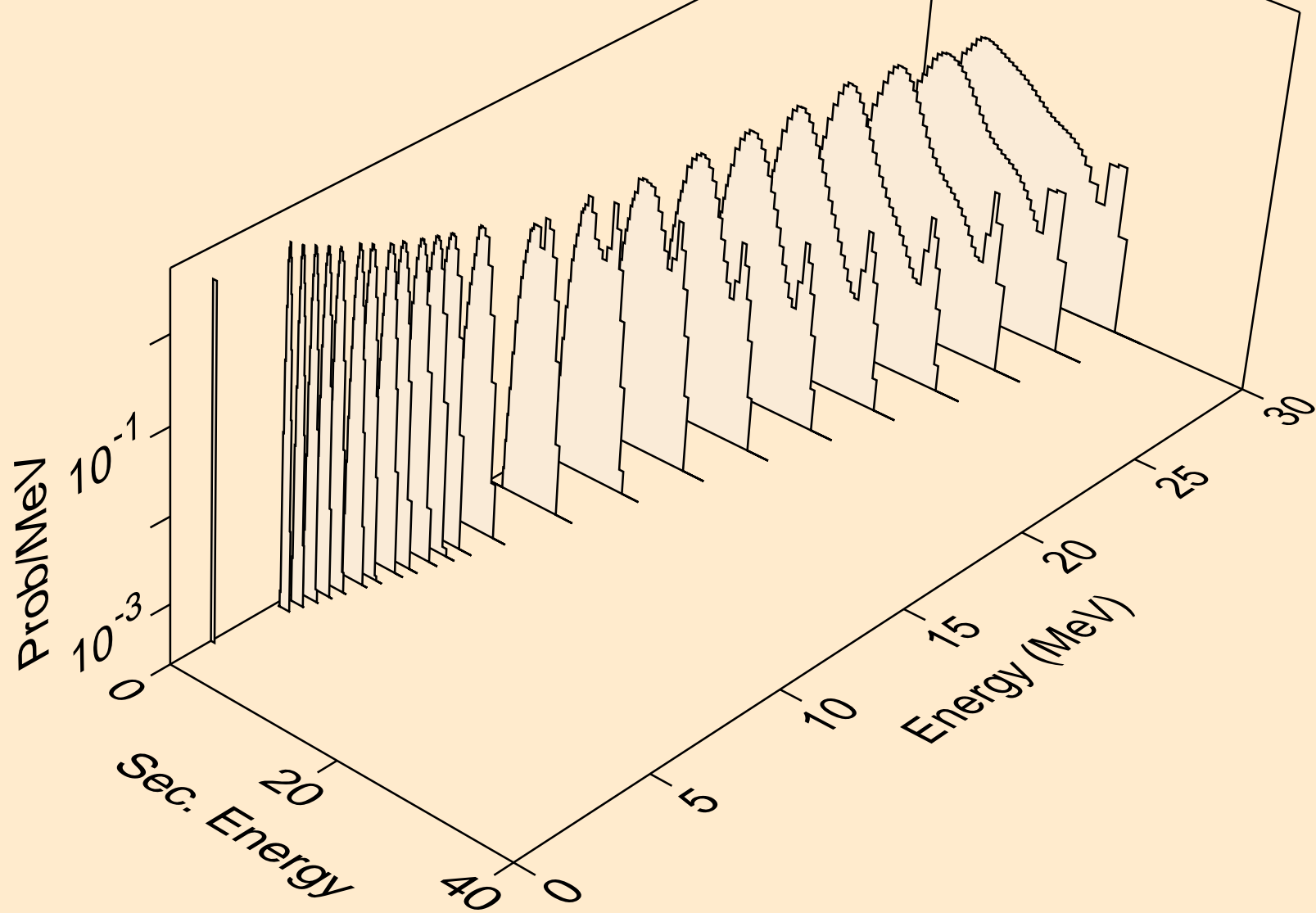

CD105 NEUTRON ACER TENDL-2023 LIBRARY; T=0.K  
protons from (n,p)

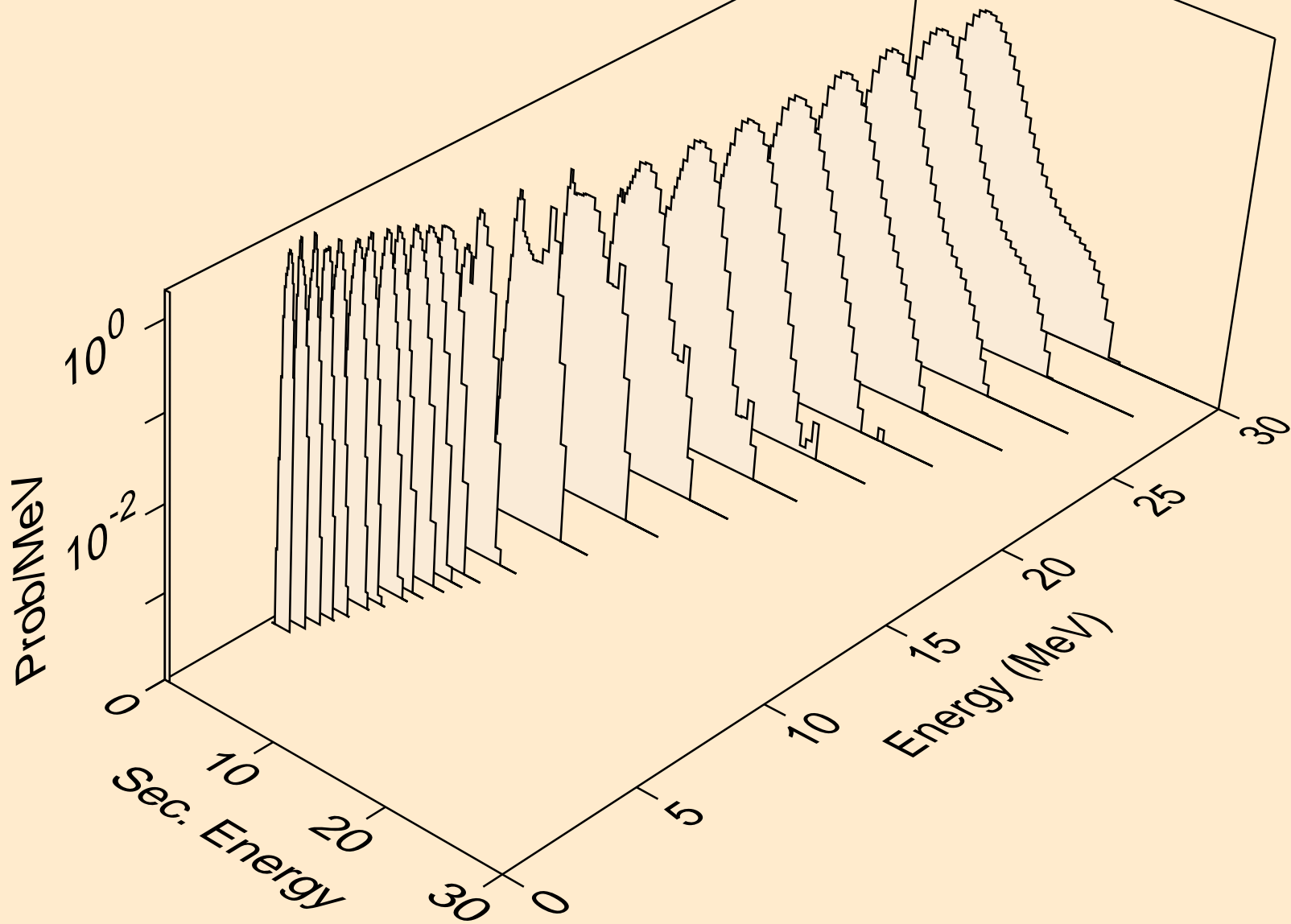

CD105 NEUTRON ACER TENDL-2023 LIBRARY; T=0.K  
protons from (n,pd)

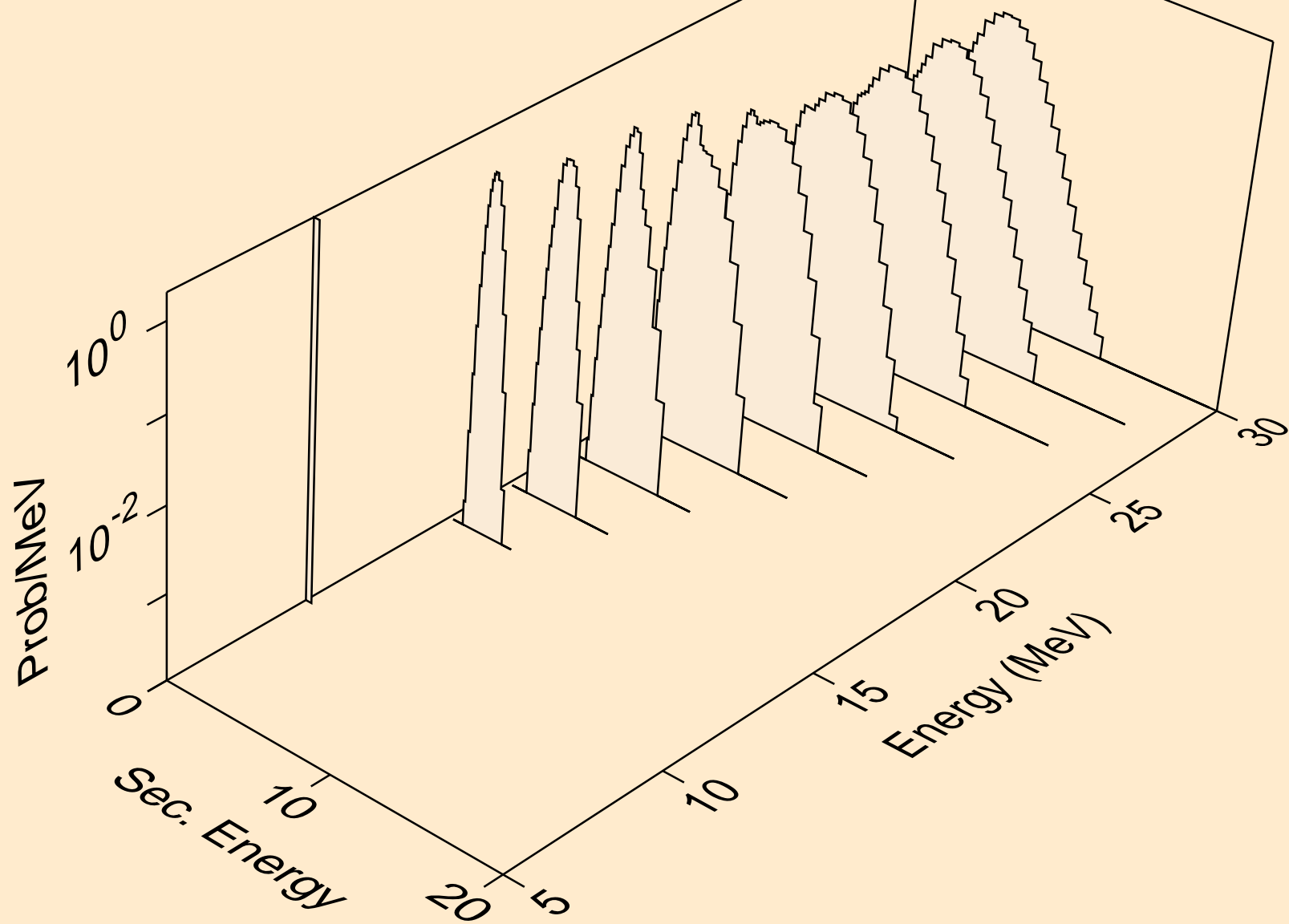

CD105 NEUTRON ACER TENDL-2023 LIBRARY; T=0.K  
protons from (n,pt)

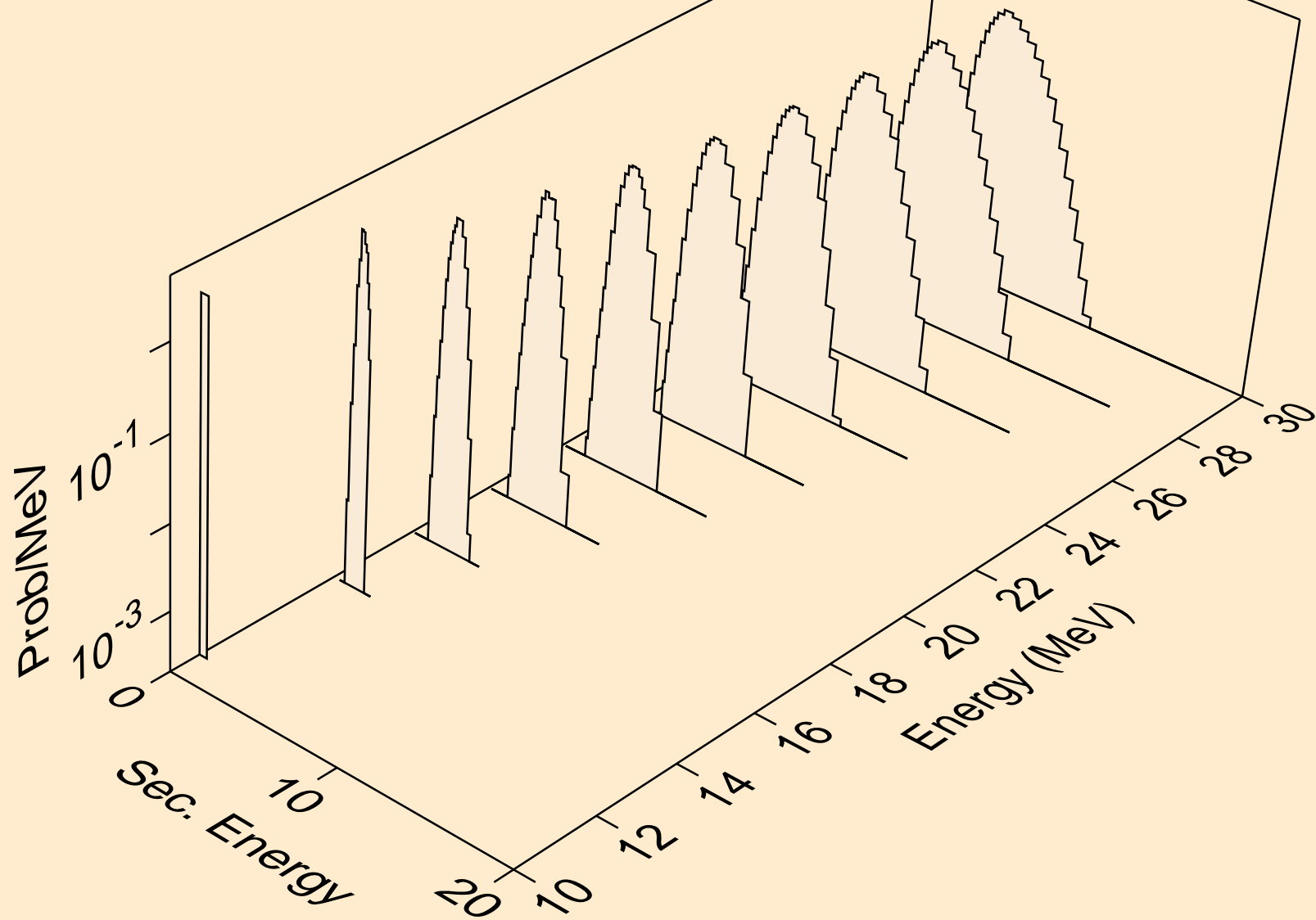

CD105 NEUTRON ACER TENDL-2023 LIBRARY; T=0.K  
deuterons from (n,x)

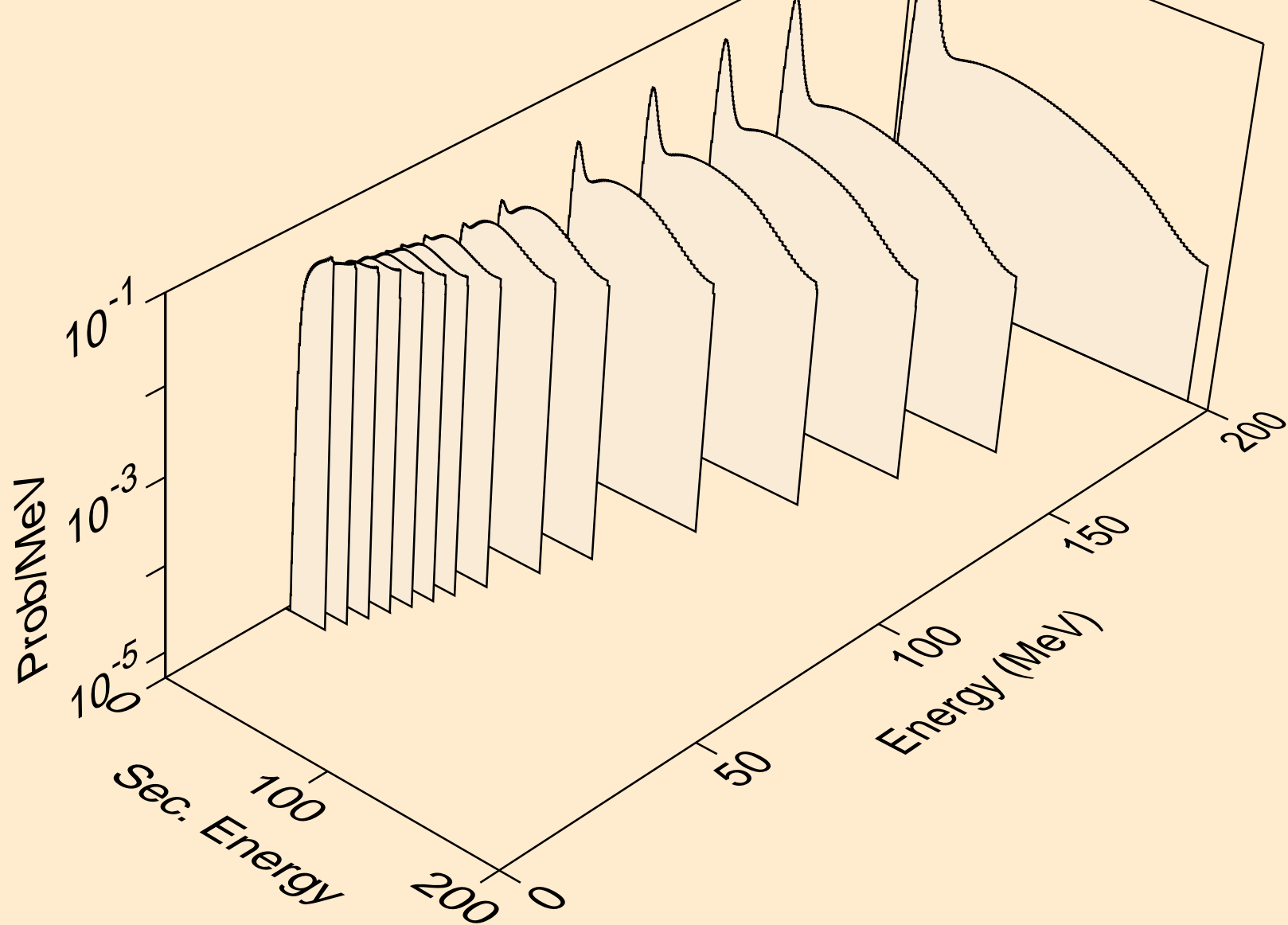

CD105 NEUTRON ACER TENDL-2023 LIBRARY; T=0.K  
deuterons from (n,2nd)

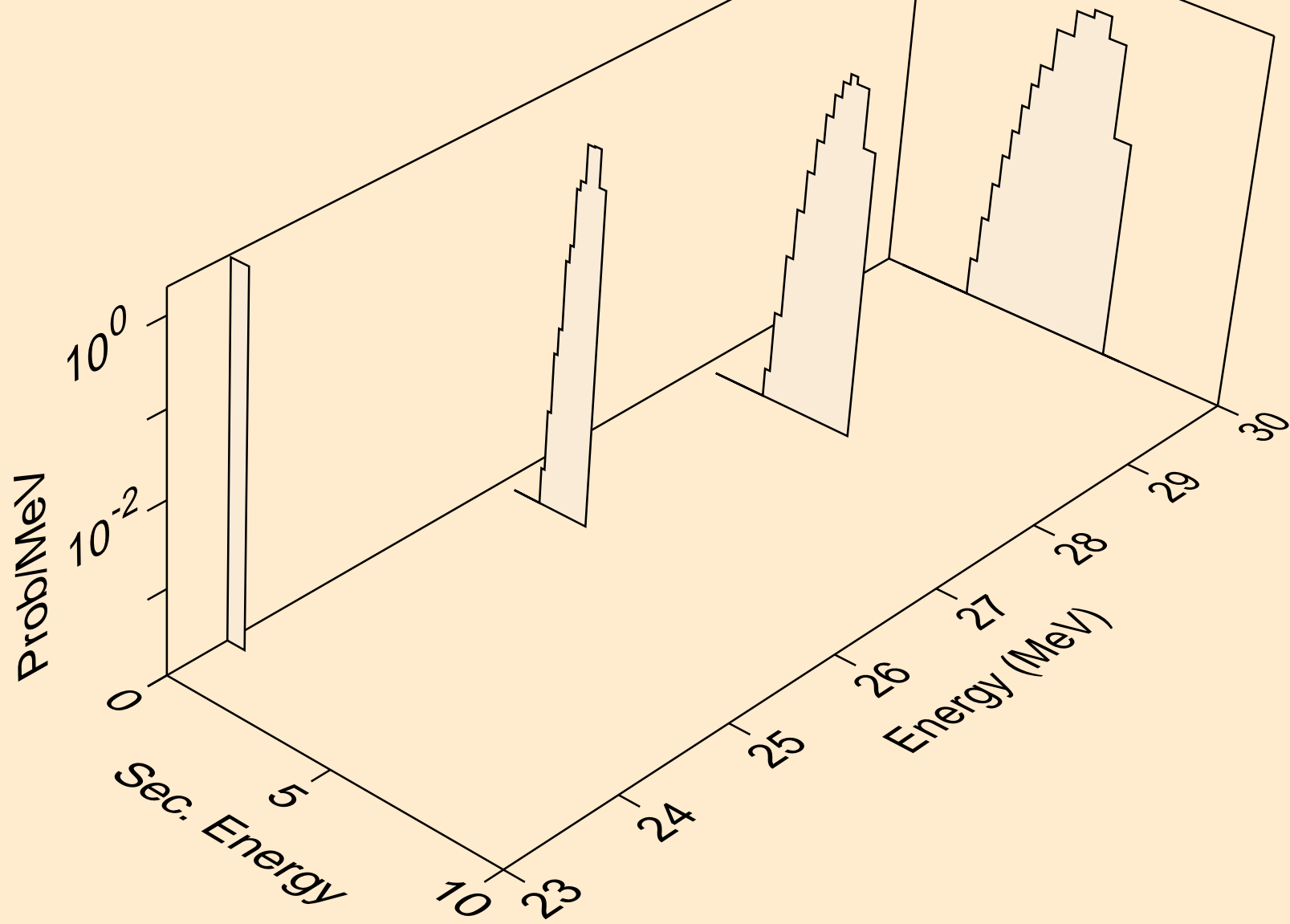

CD105 NEUTRON ACER TENDL-2023 LIBRARY; T=0.K  
deuterons from (n,n\*)d

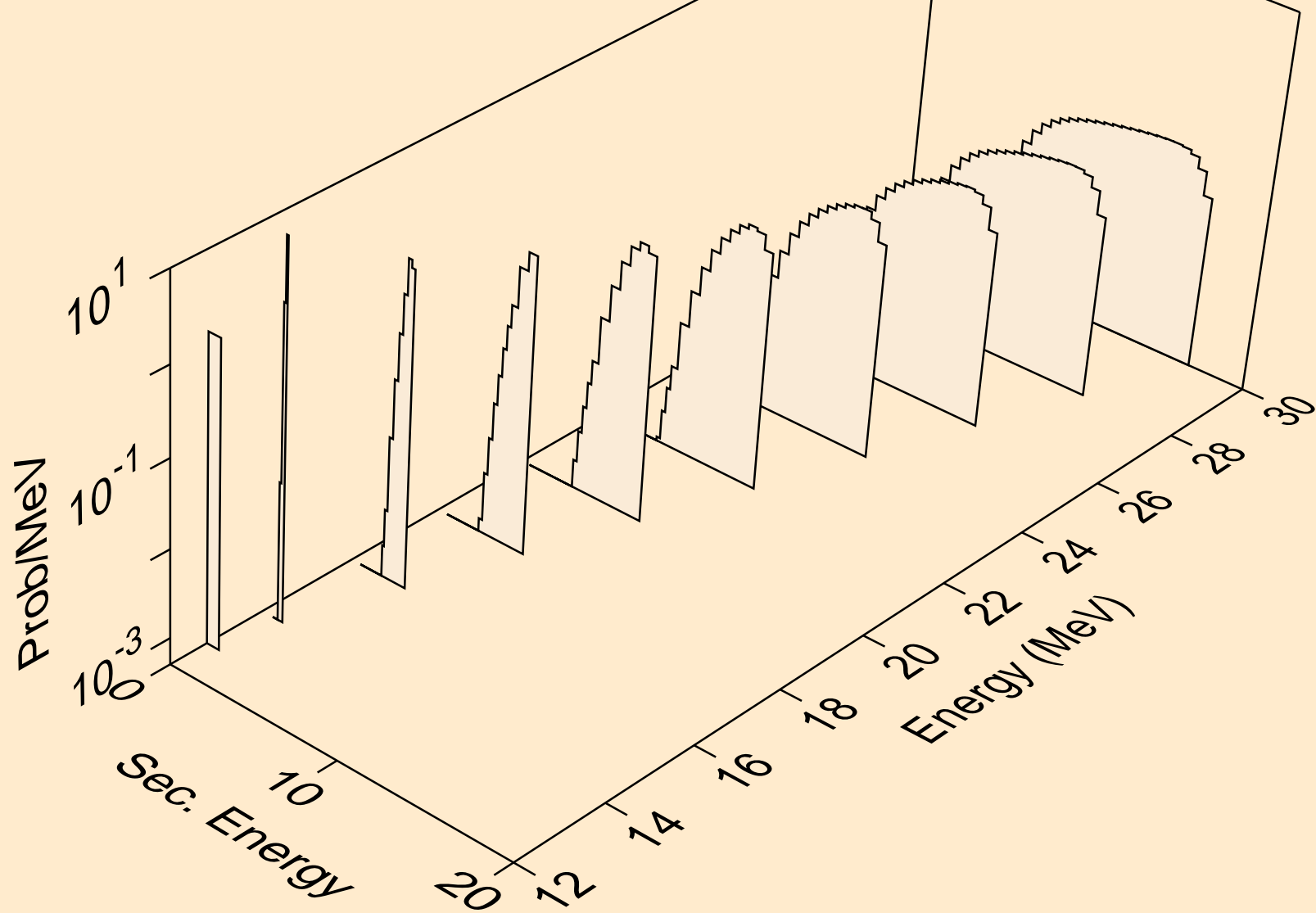

CD105 NEUTRON ACER TENDL-2023 LIBRARY; T=0.K  
deuterons from (n,d)

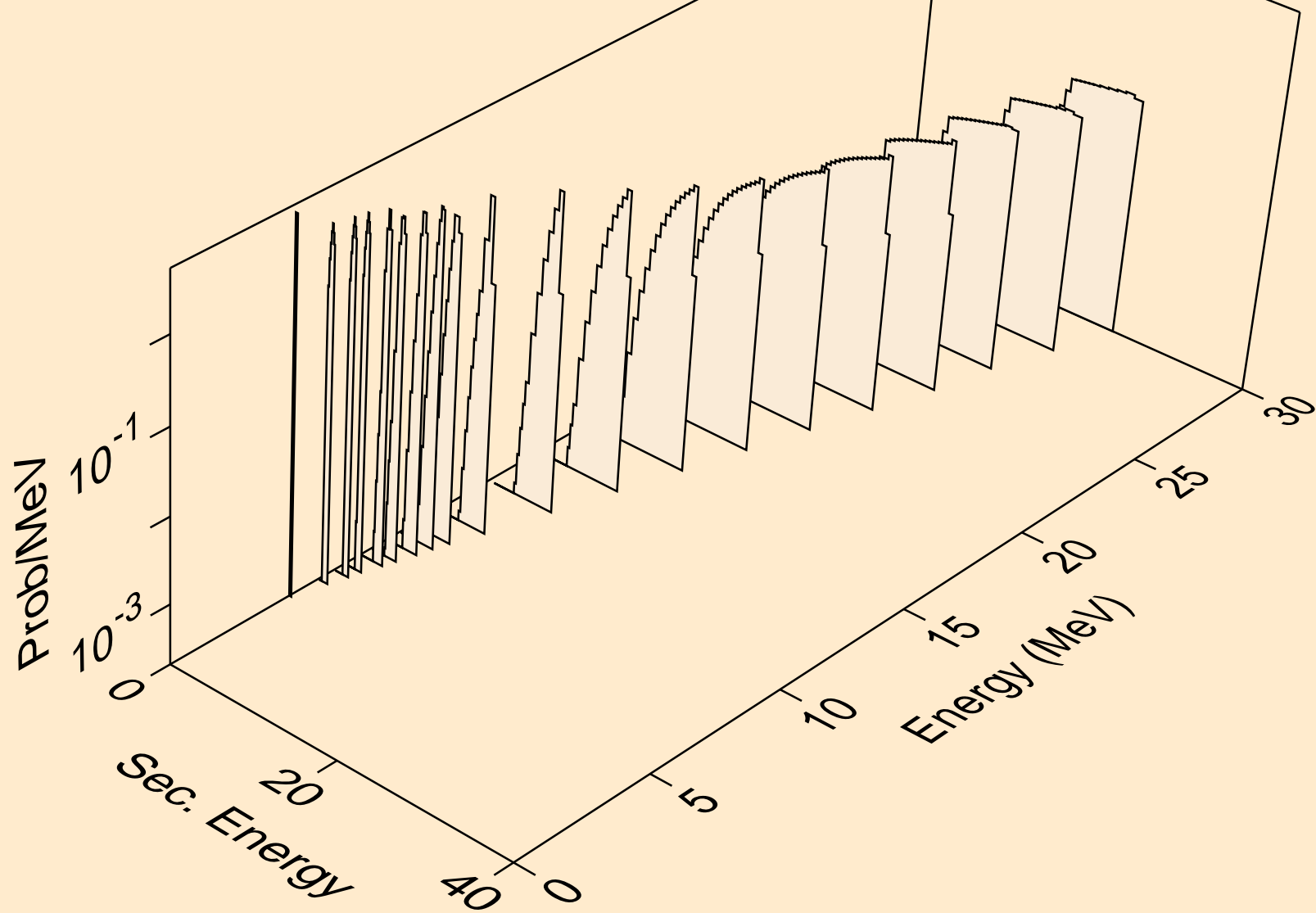

CD105 NEUTRON ACER TENDL-2023 LIBRARY; T=0.K  
deuterons from (n,pd)

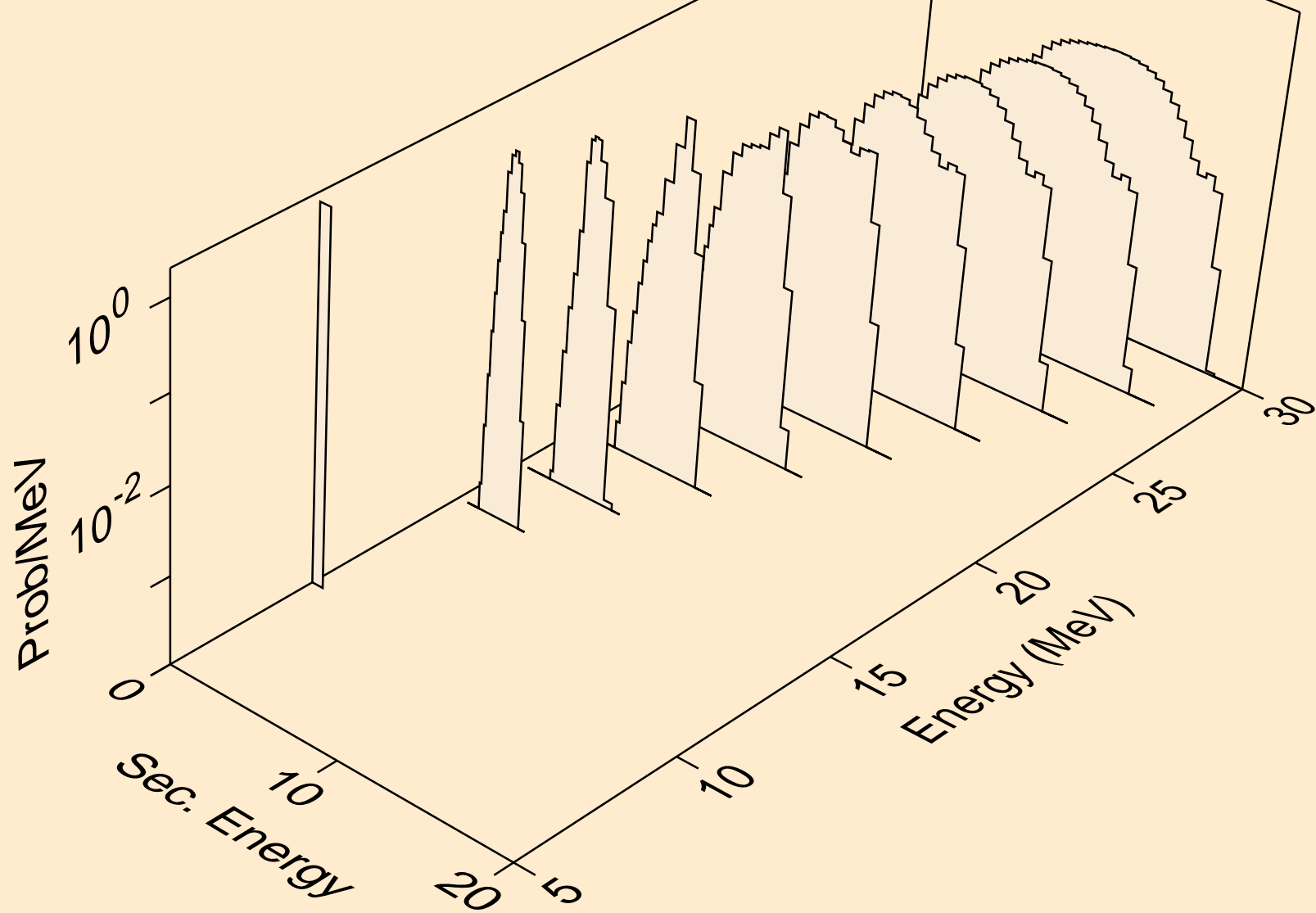

CD105 NEUTRON ACER TENDL-2023 LIBRARY; T=0.K  
deuterons from (n,da)

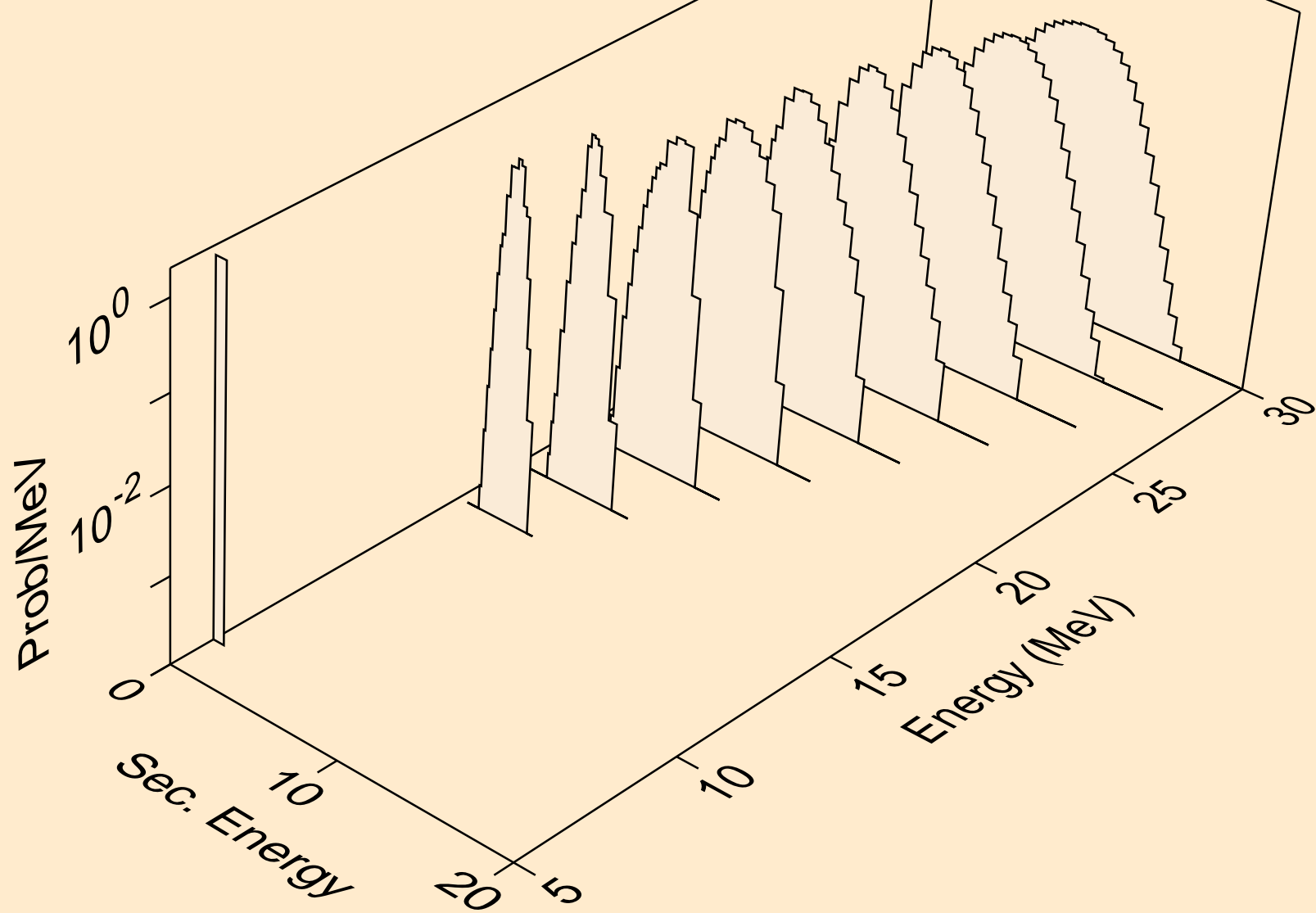

CD105 NEUTRON ACER TENDL-2023 LIBRARY; T=0.K  
tritons from (n,x)

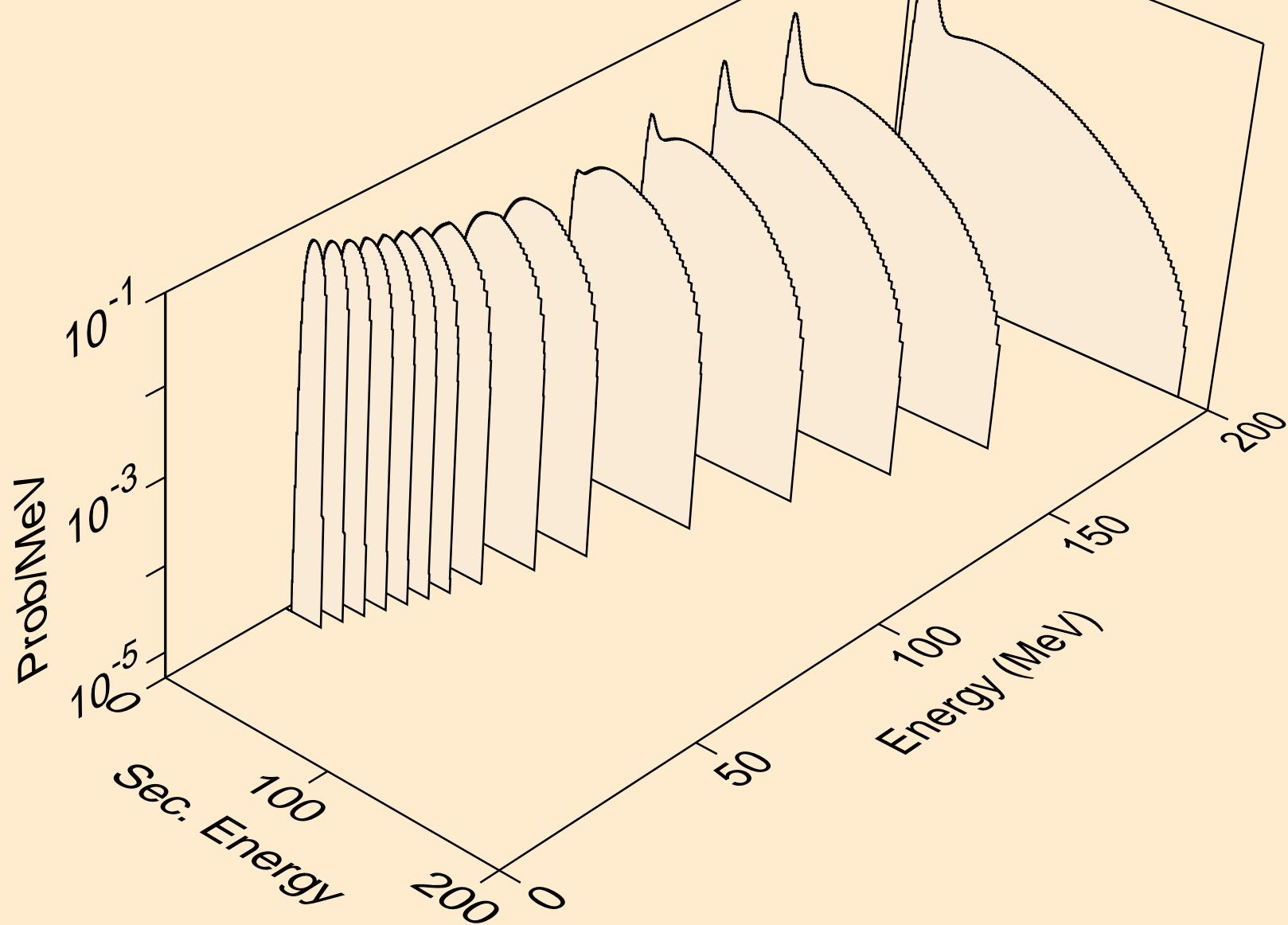

CD105 NEUTRON ACER TENDL-2023 LIBRARY; T=0.K  
tritons from (n,n\*)t

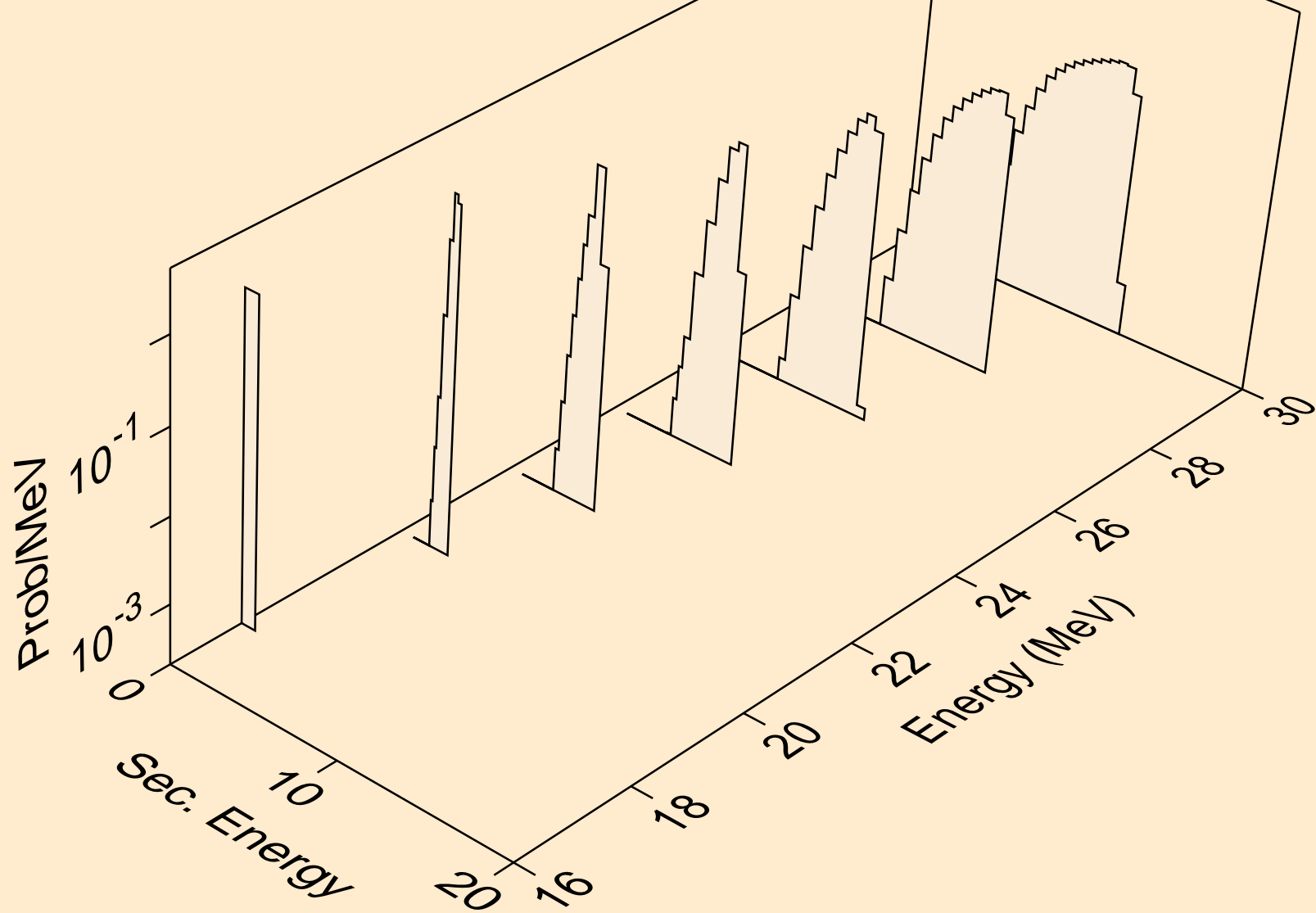

CD105 NEUTRON ACER TENDL-2023 LIBRARY; T=0.K  
tritons from (n,t)

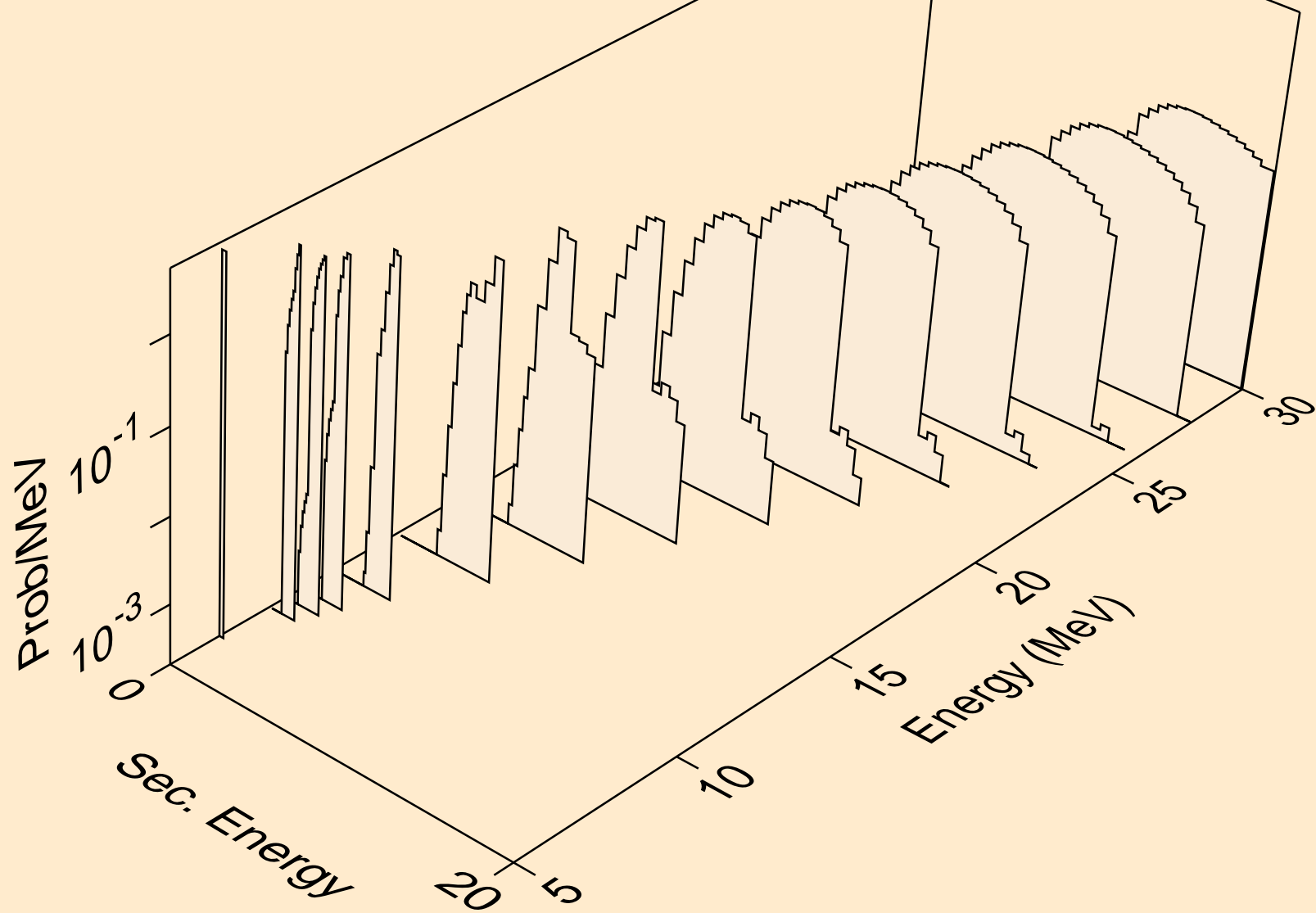

CD105 NEUTRON ACER TENDL-2023 LIBRARY; T=0.K  
tritons from (n,pt)

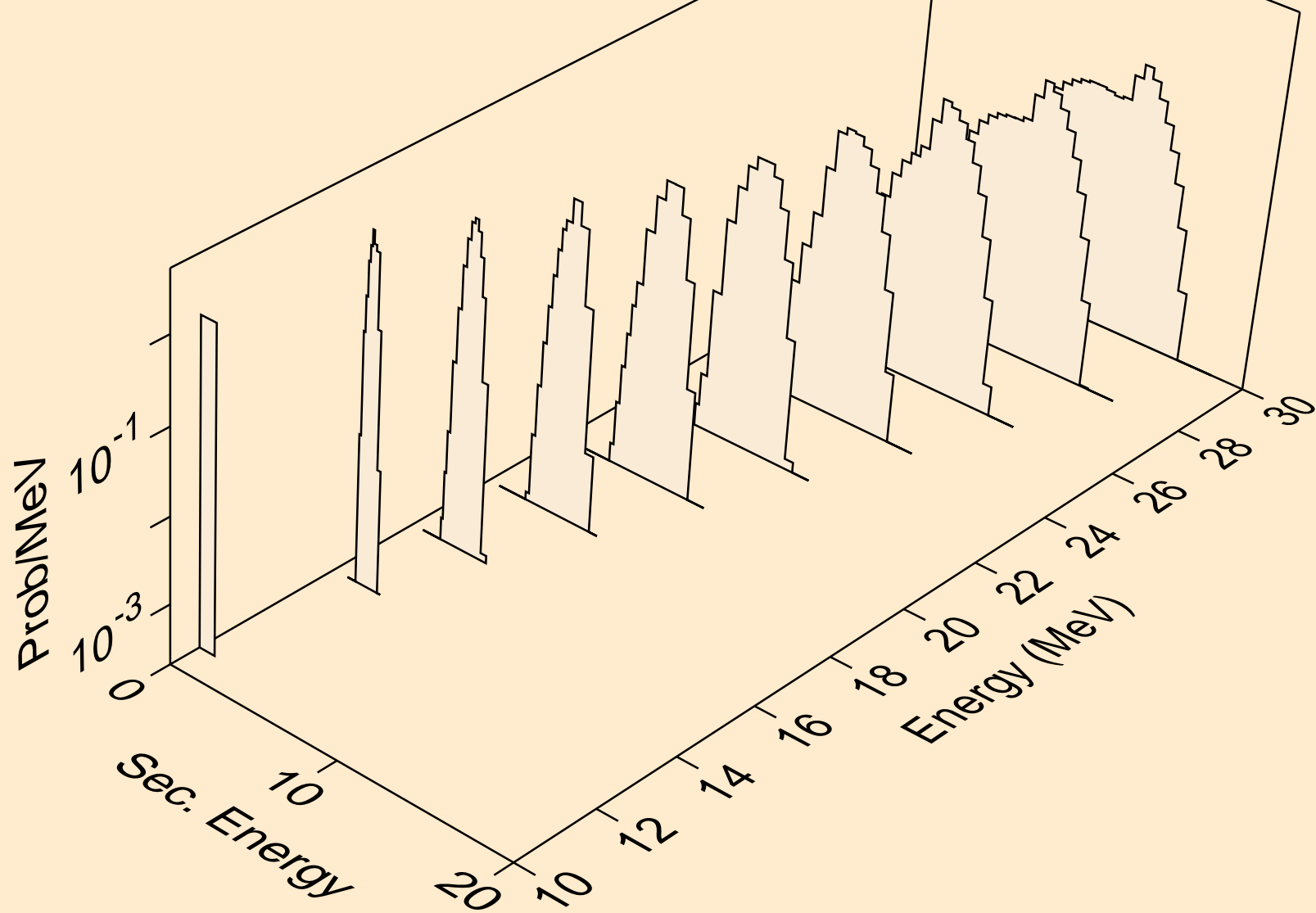

CD105 NEUTRON ACER TENDL-2023 LIBRARY; T=0.K  
he3s from (n,x)

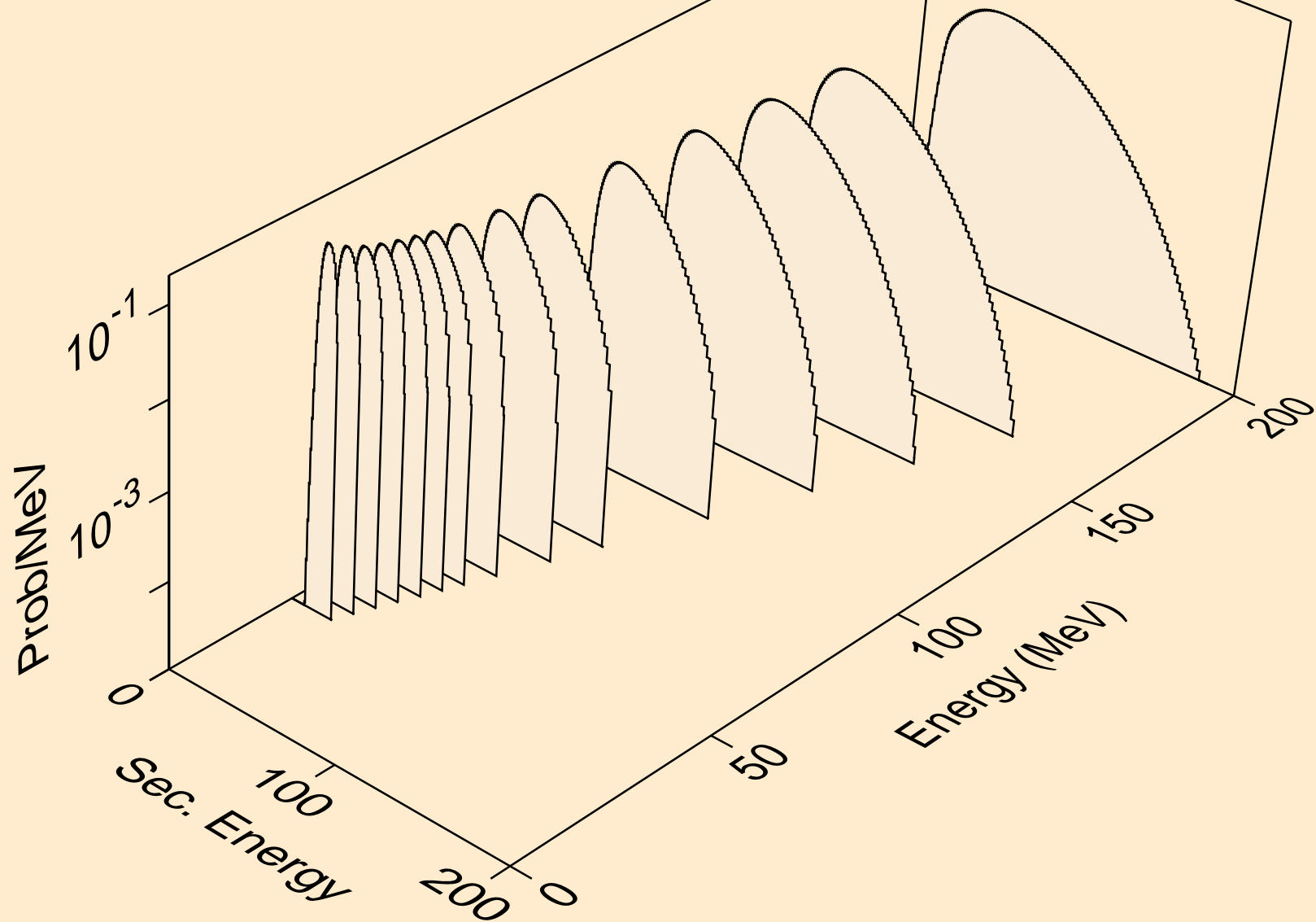

CD105 NEUTRON ACER TENDL-2023 LIBRARY; T=0.K  
he3s from (n,n\*)he3

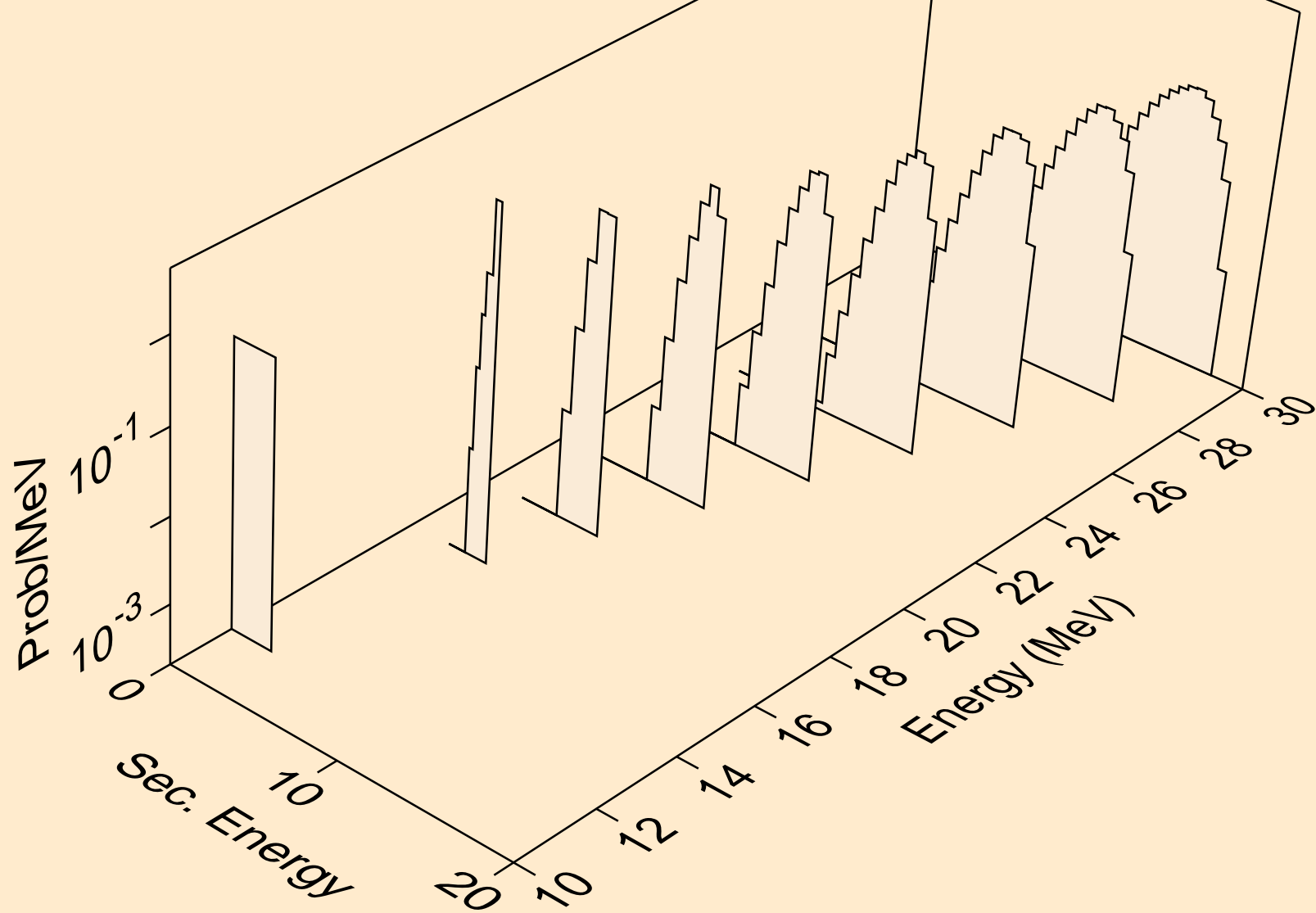

CD105 NEUTRON ACER TENDL-2023 LIBRARY; T=0.K  
he3s from (n,he3)

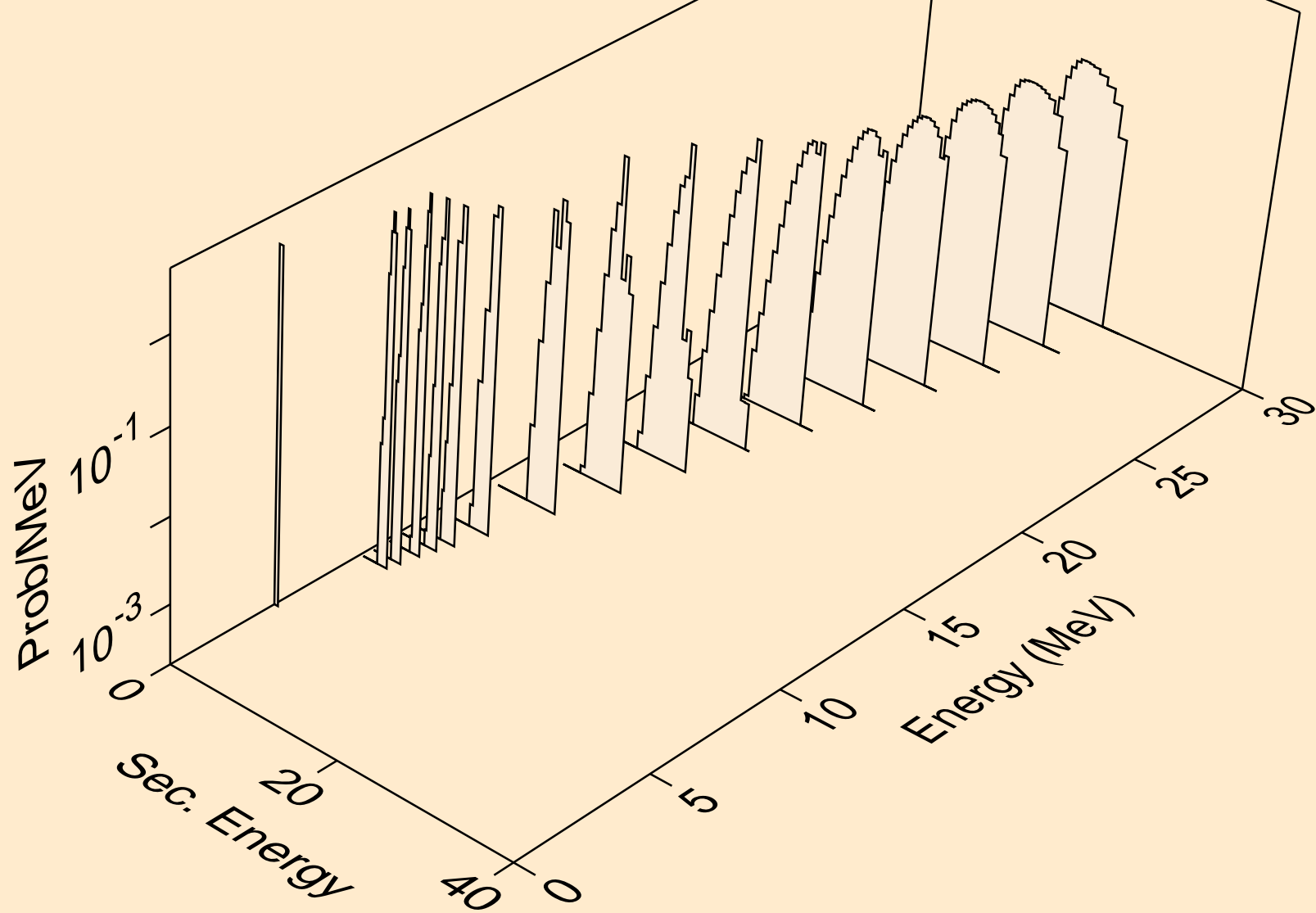

CD105 NEUTRON ACER TENDL-2023 LIBRARY; T=0.K  
alphas from (n,x)

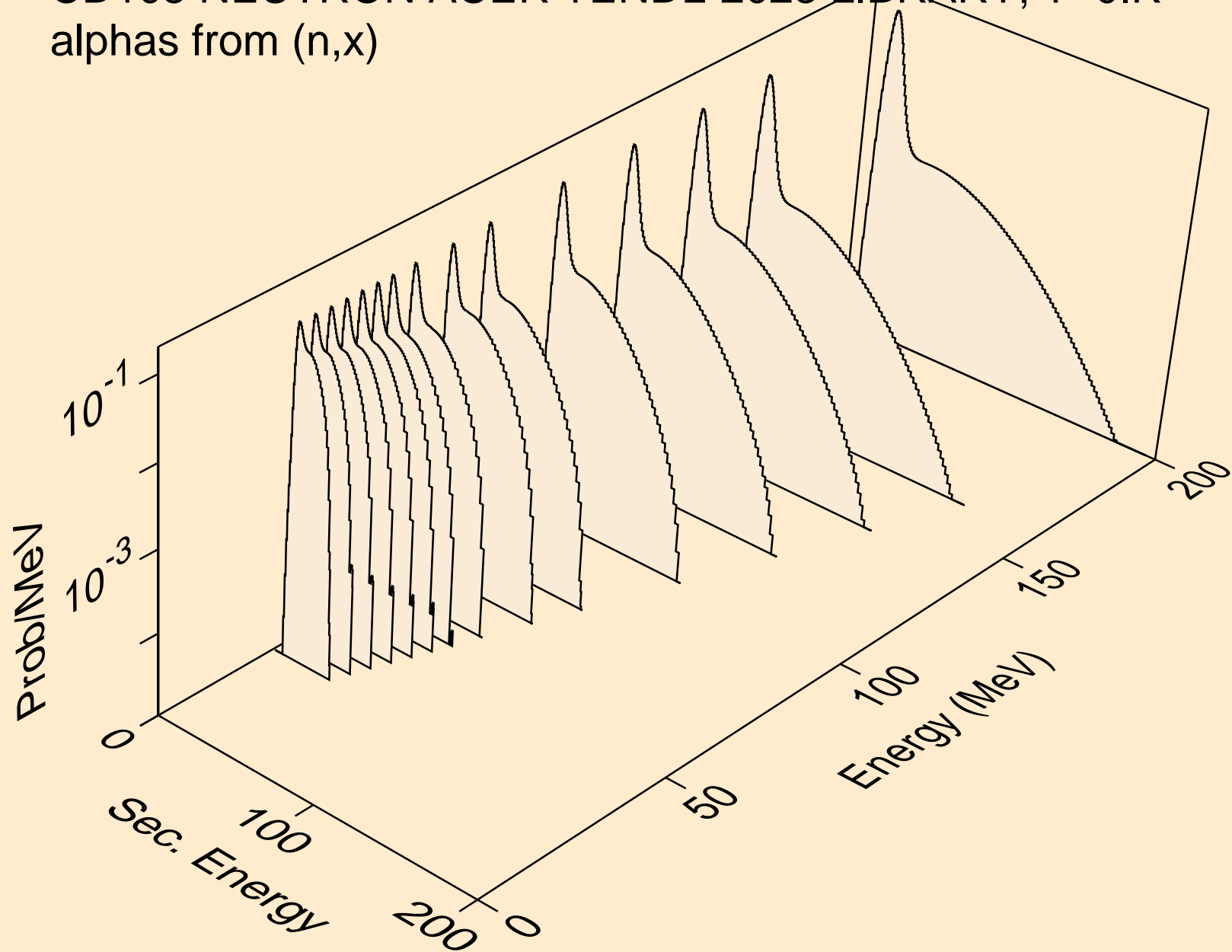

CD105 NEUTRON ACER TENDL-2023 LIBRARY; T=0.K  
alphas from (n,n\*)a

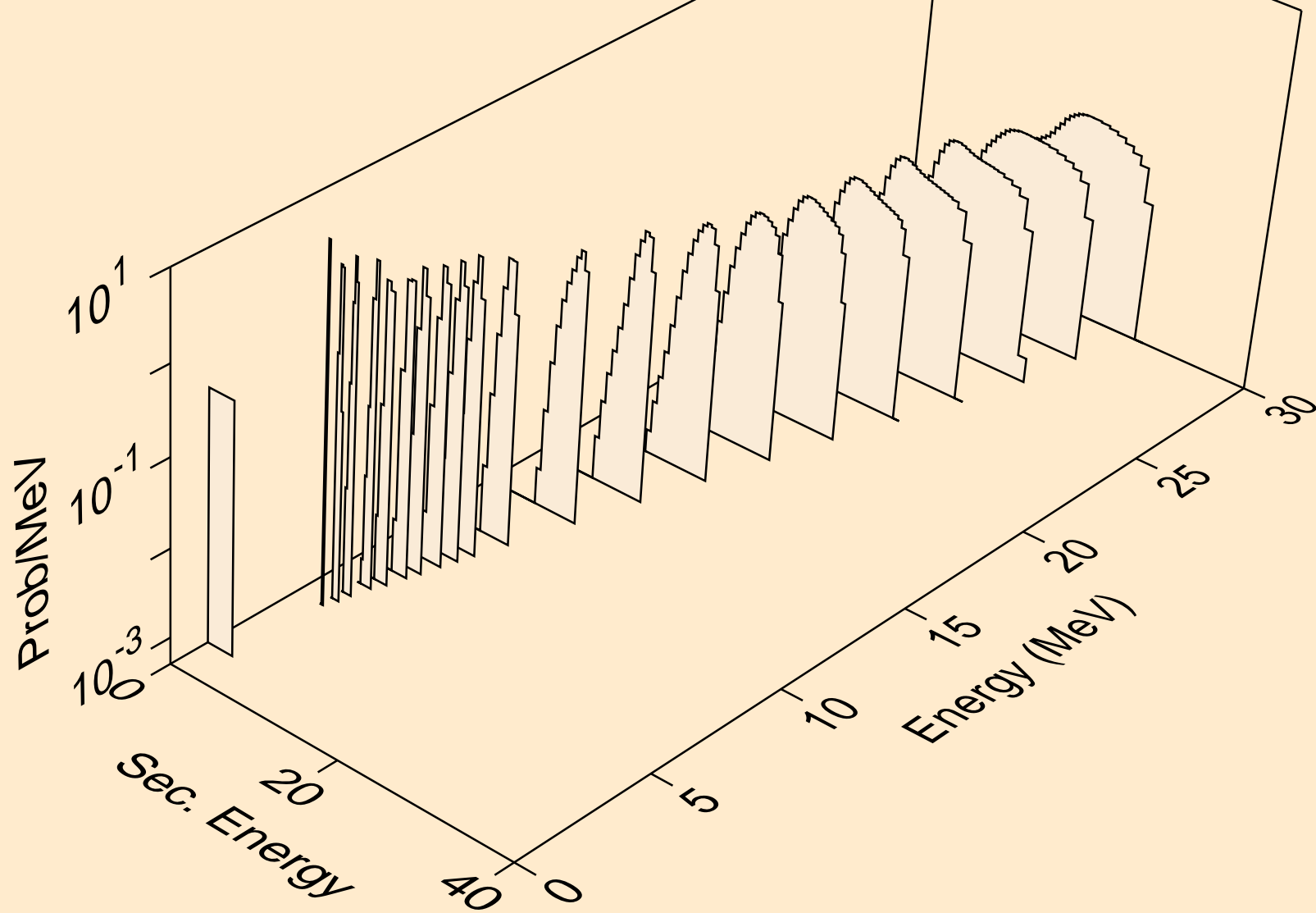

CD105 NEUTRON ACER TENDL-2023 LIBRARY; T=0.K  
alphas from (n,2n)a

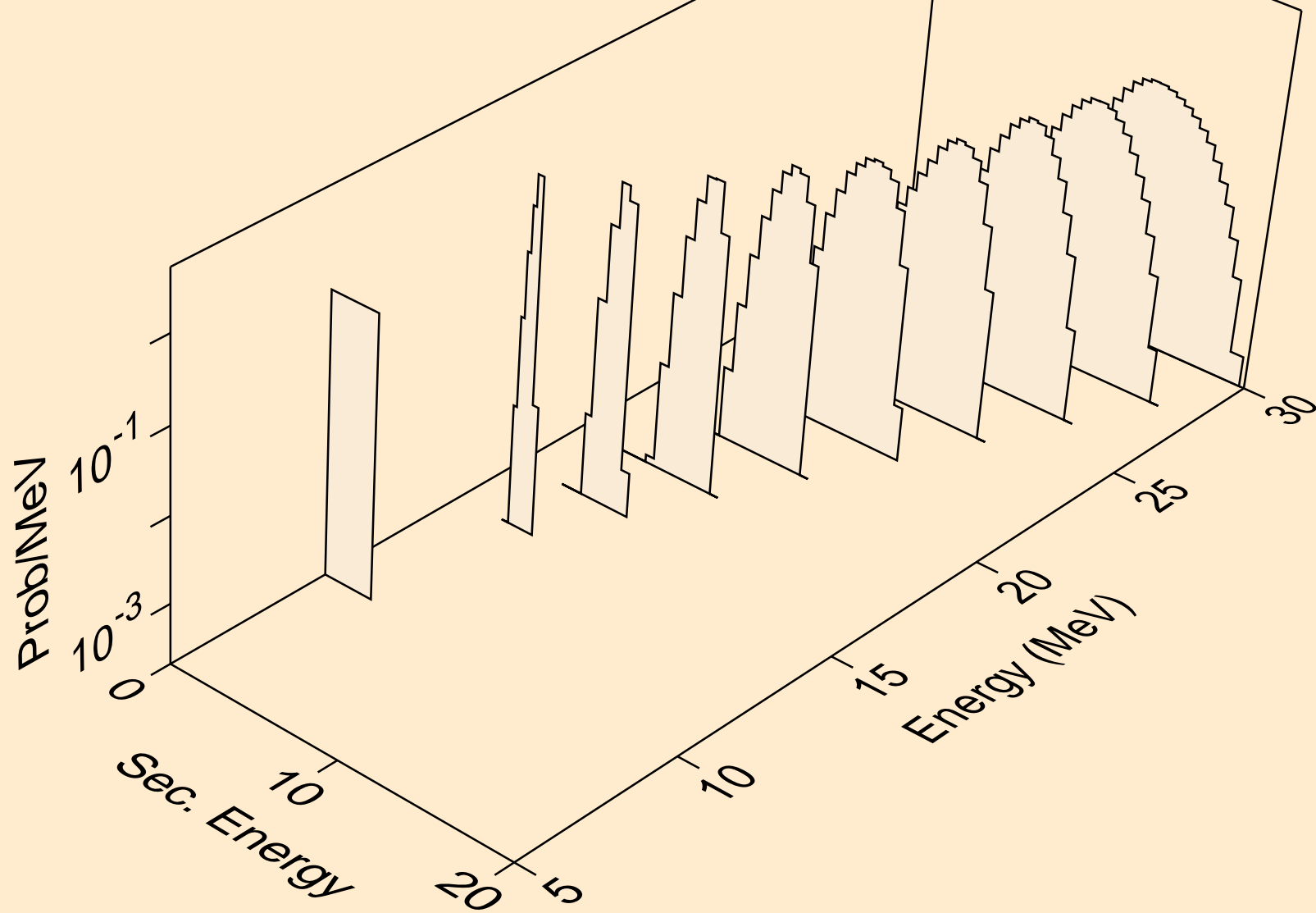

CD105 NEUTRON ACER TENDL-2023 LIBRARY; T=0.K  
alphas from (n,3n)a

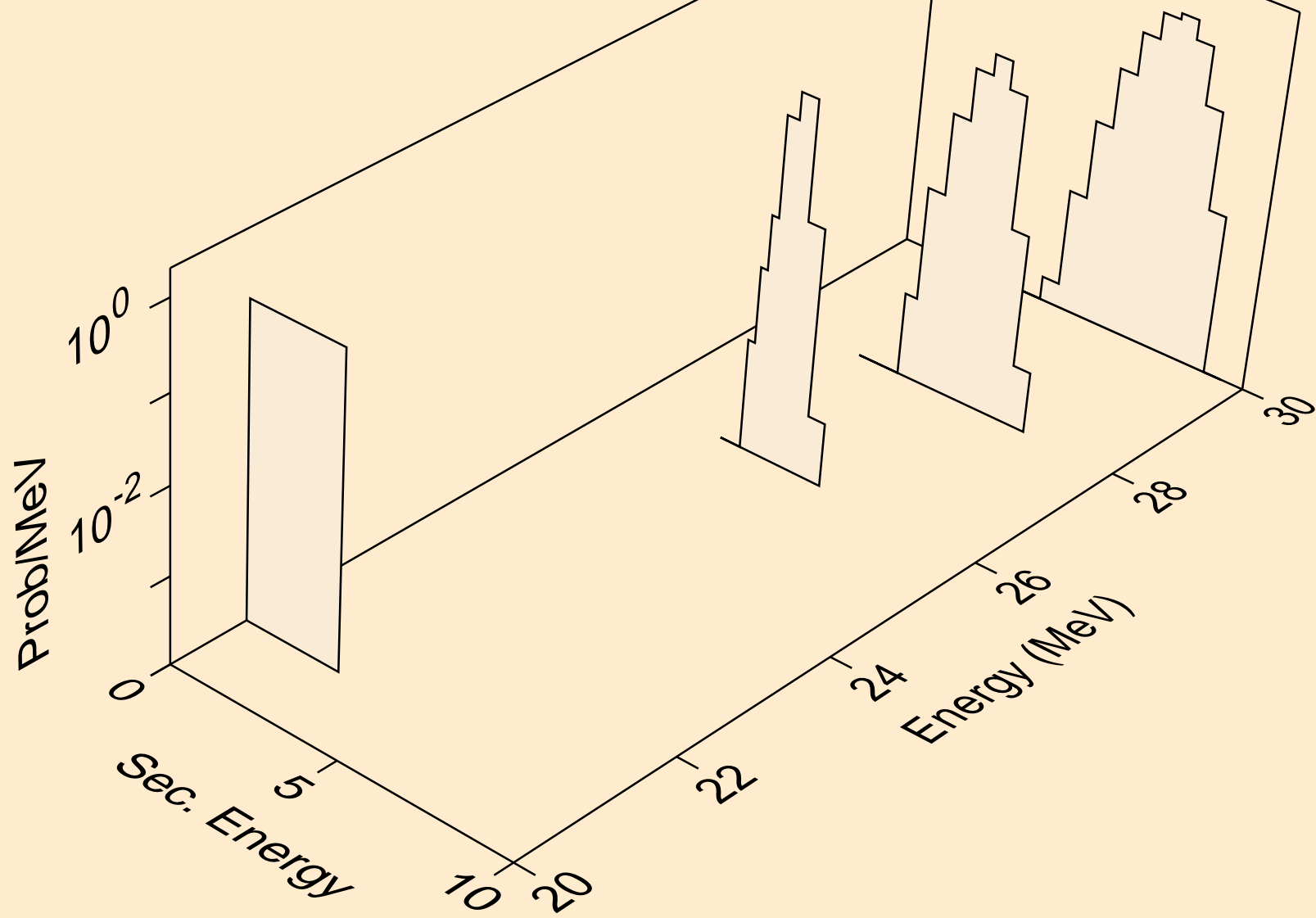

CD105 NEUTRON ACER TENDL-2023 LIBRARY; T=0.K  
alphas from (n,n\*)2a

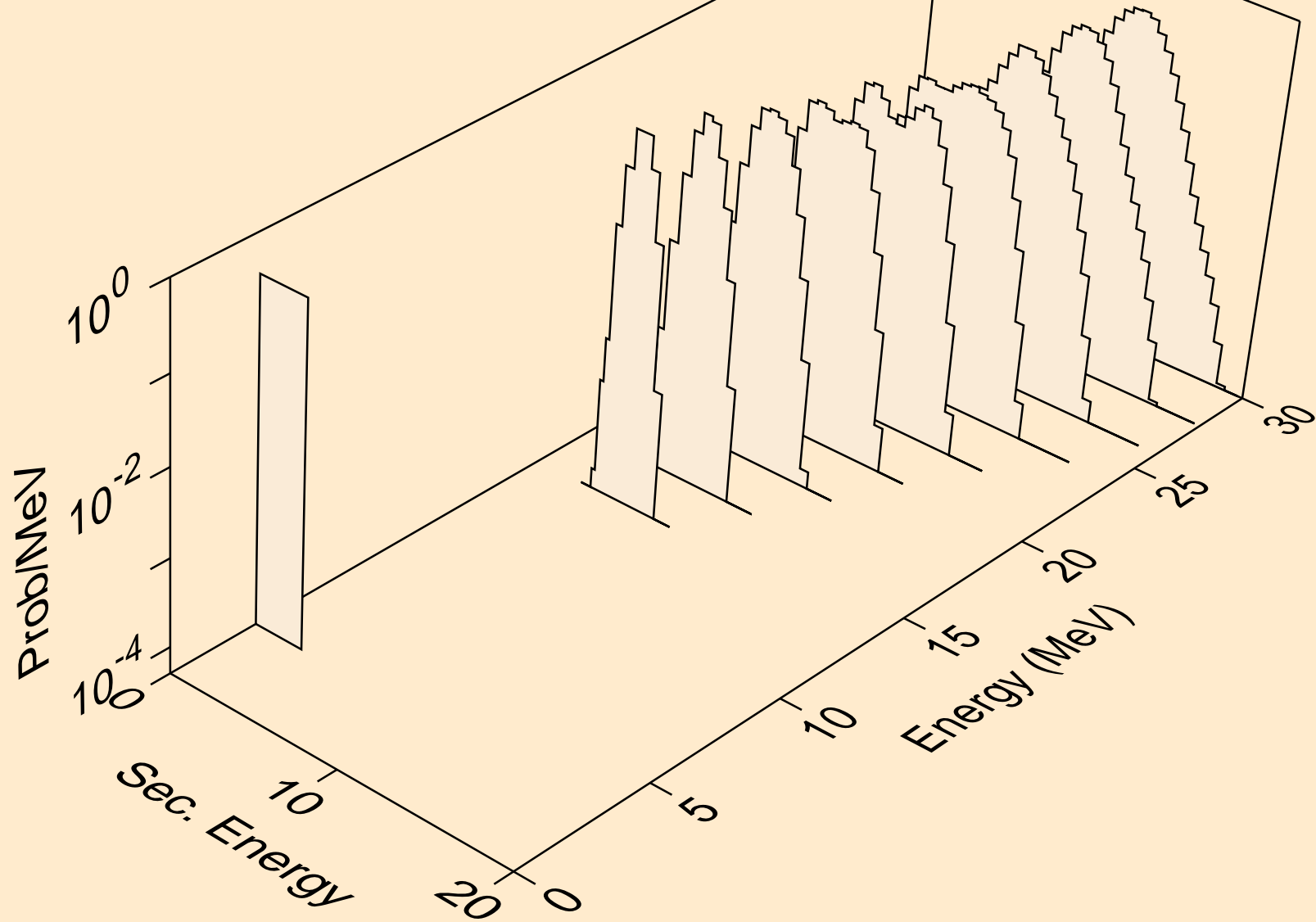

CD105 NEUTRON ACER TENDL-2023 LIBRARY; T=0.K  
alphas from (n,2n)2a

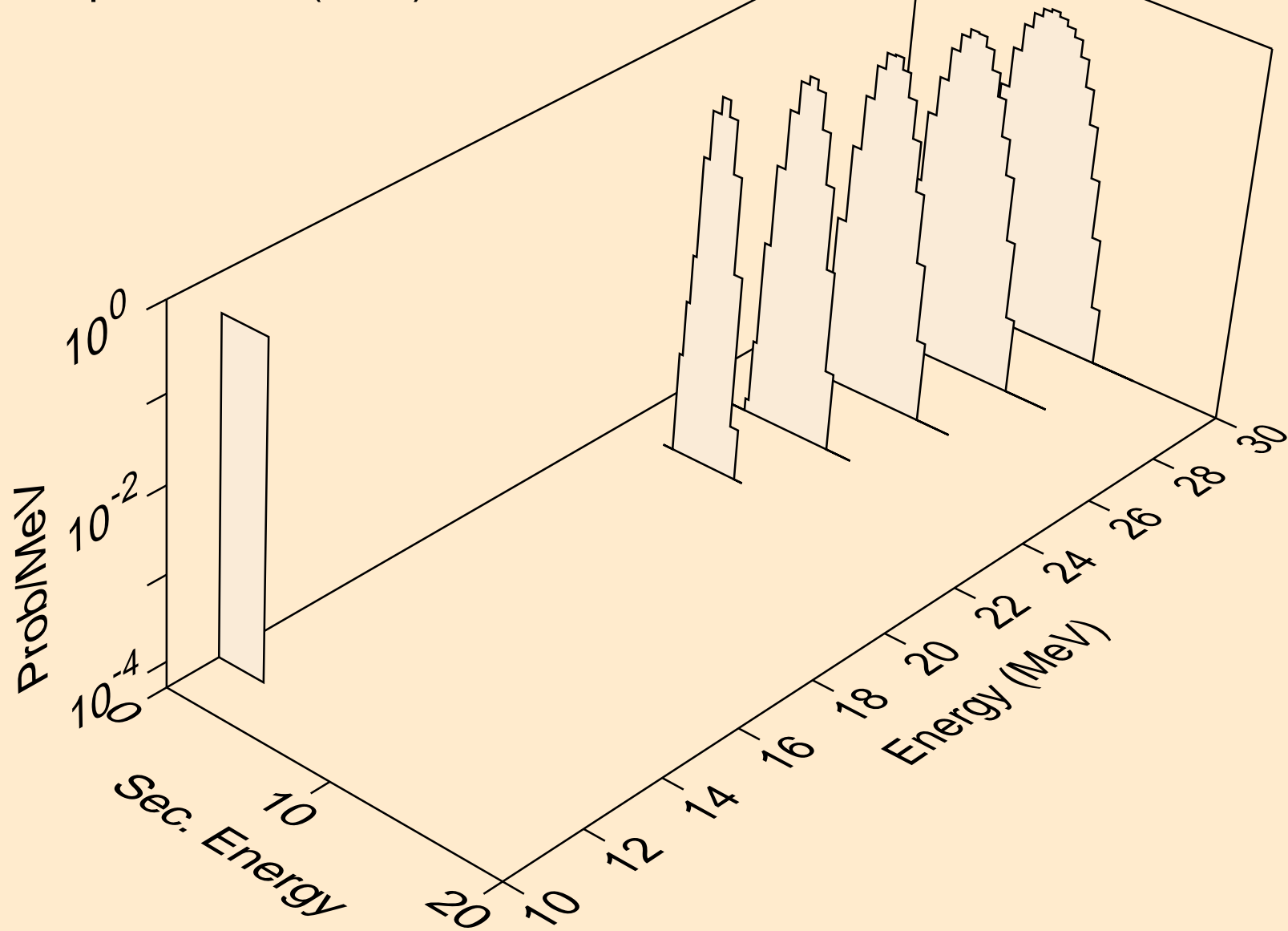

CD105 NEUTRON ACER TENDL-2023 LIBRARY; T=0.K  
alphas from (n,npa)

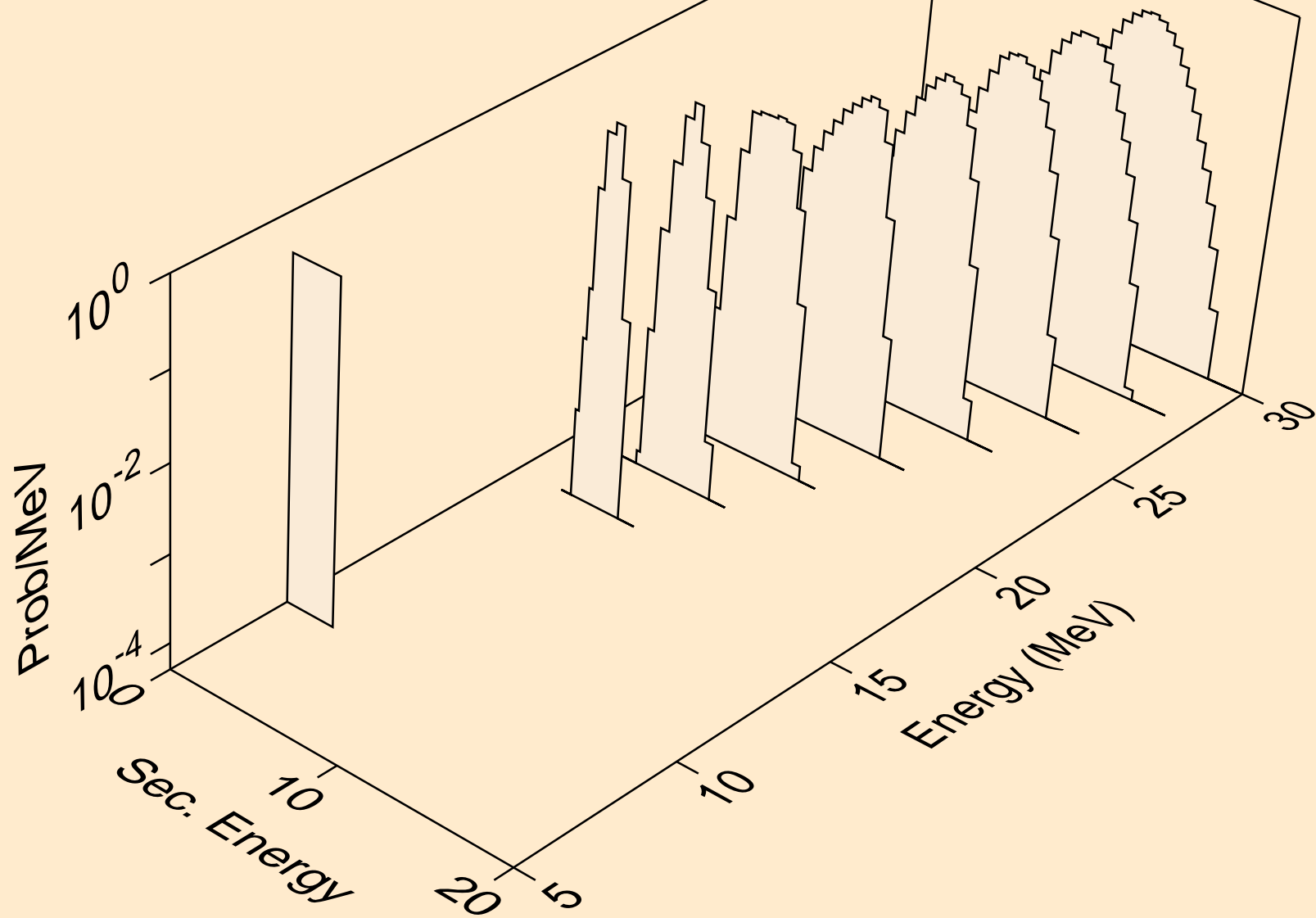

CD105 NEUTRON ACER TENDL-2023 LIBRARY; T=0.K  
alphas from (n,a)

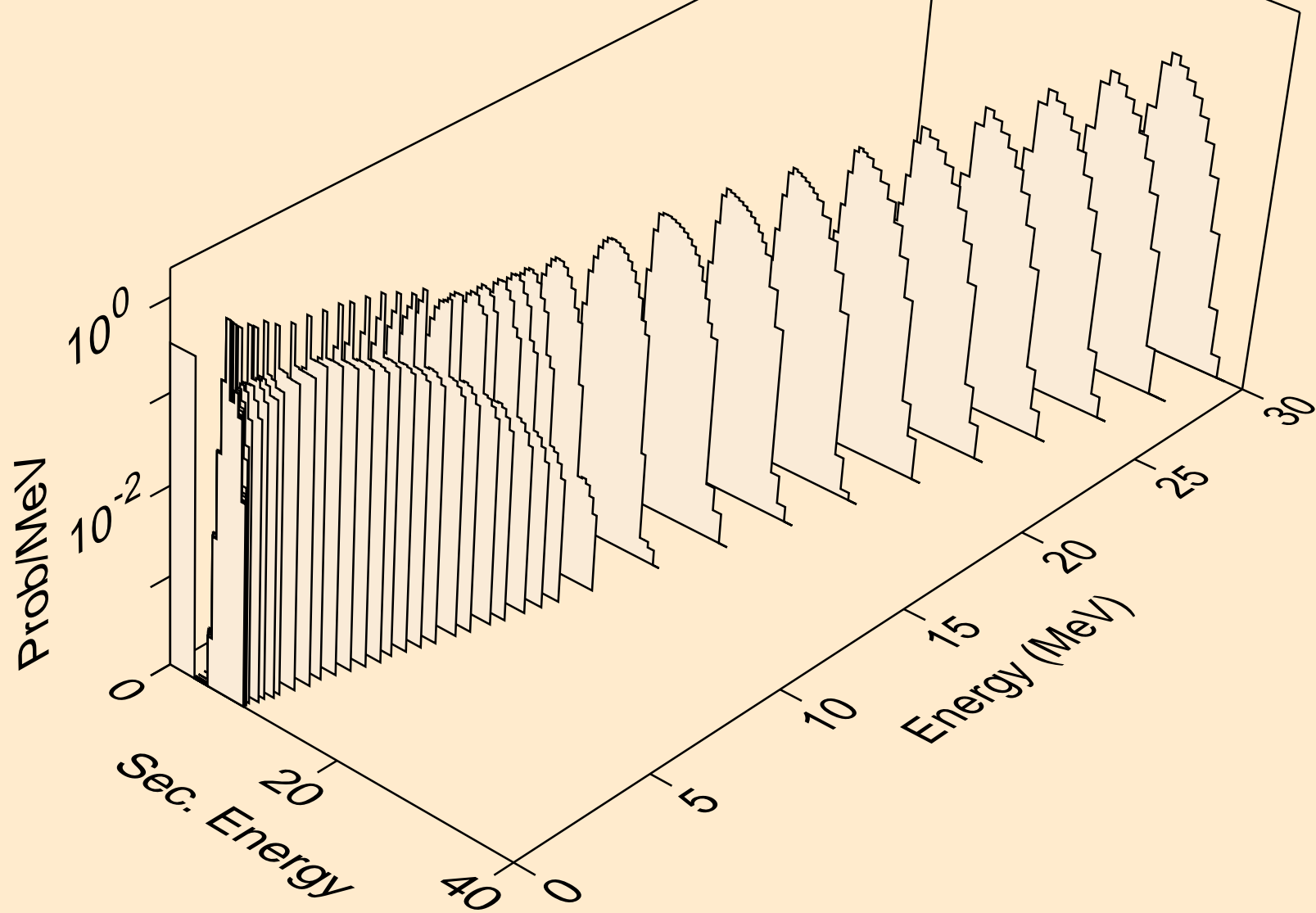

CD105 NEUTRON ACER TENDL-2023 LIBRARY; T=0.K  
alphas from (n,2a)

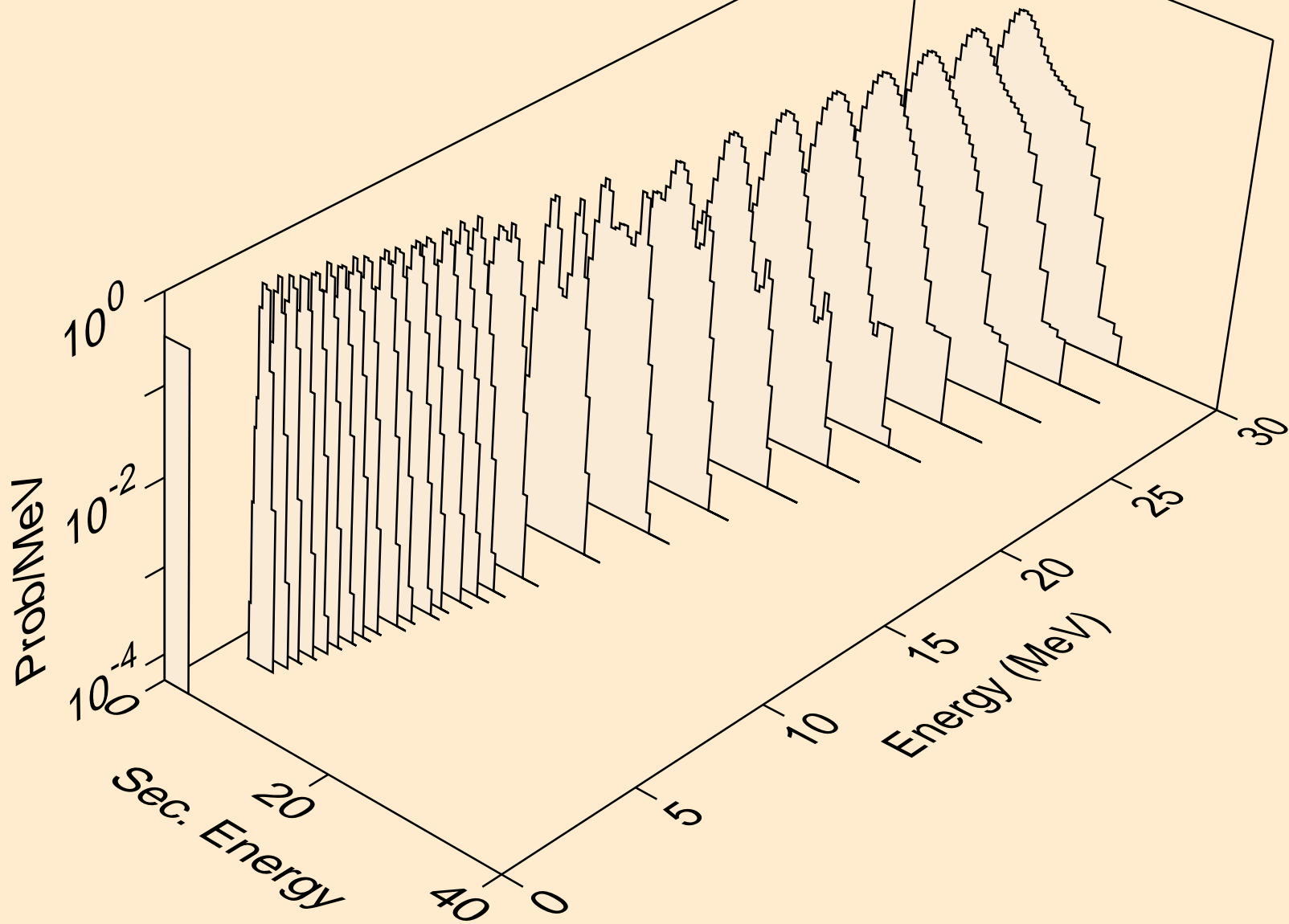

CD105 NEUTRON ACER TENDL-2023 LIBRARY; T=0.K  
alphas from (n,3a)

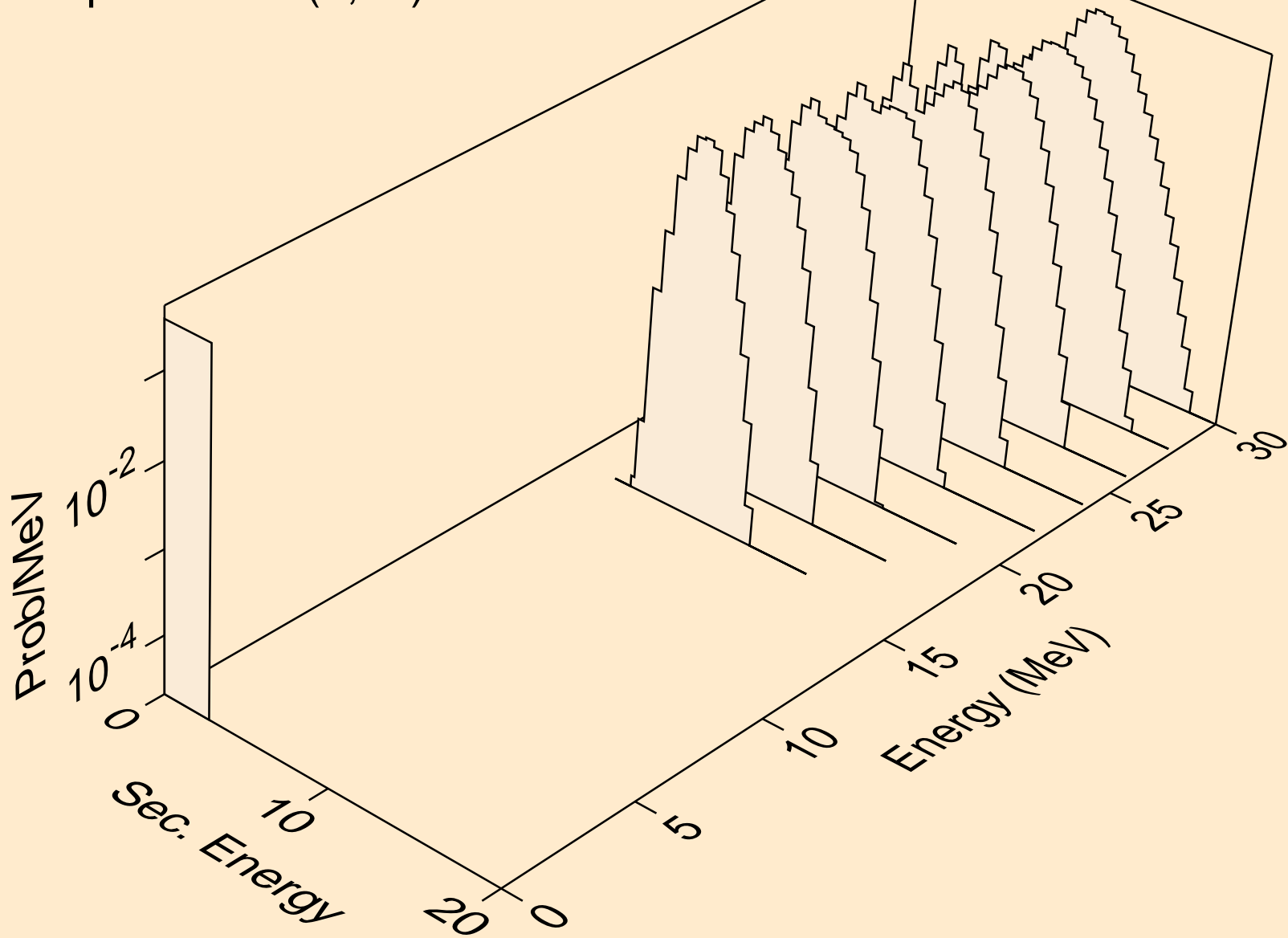

CD105 NEUTRON ACER TENDL-2023 LIBRARY; T=0.K  
alphas from (n,pa)

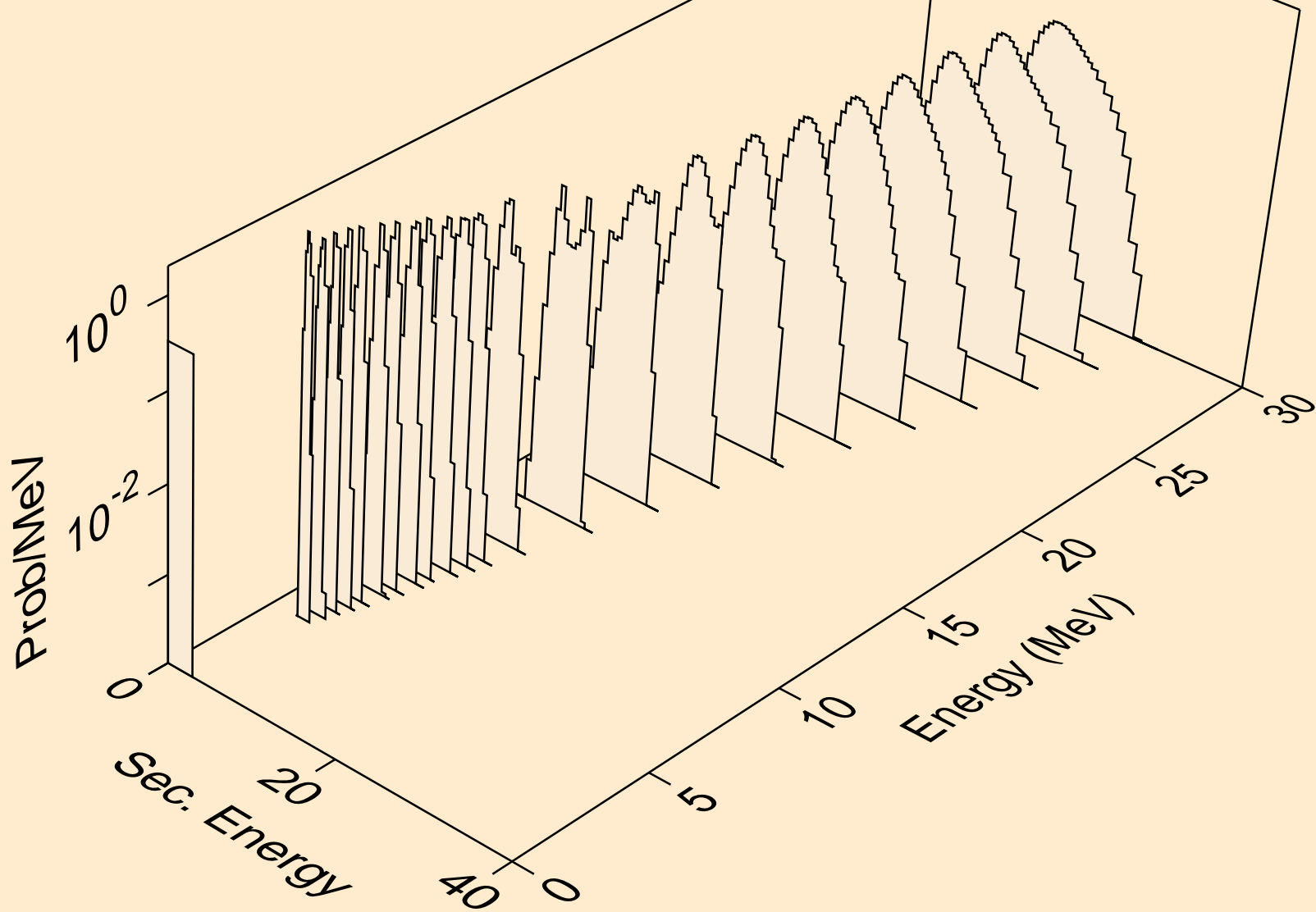

CD105 NEUTRON ACER TENDL-2023 LIBRARY; T=0.K  
alphas from (n,da)

