

DS283 NEUTRON ACER TENDL-2023 LIBRARY; T=0.K

Principal cross sections

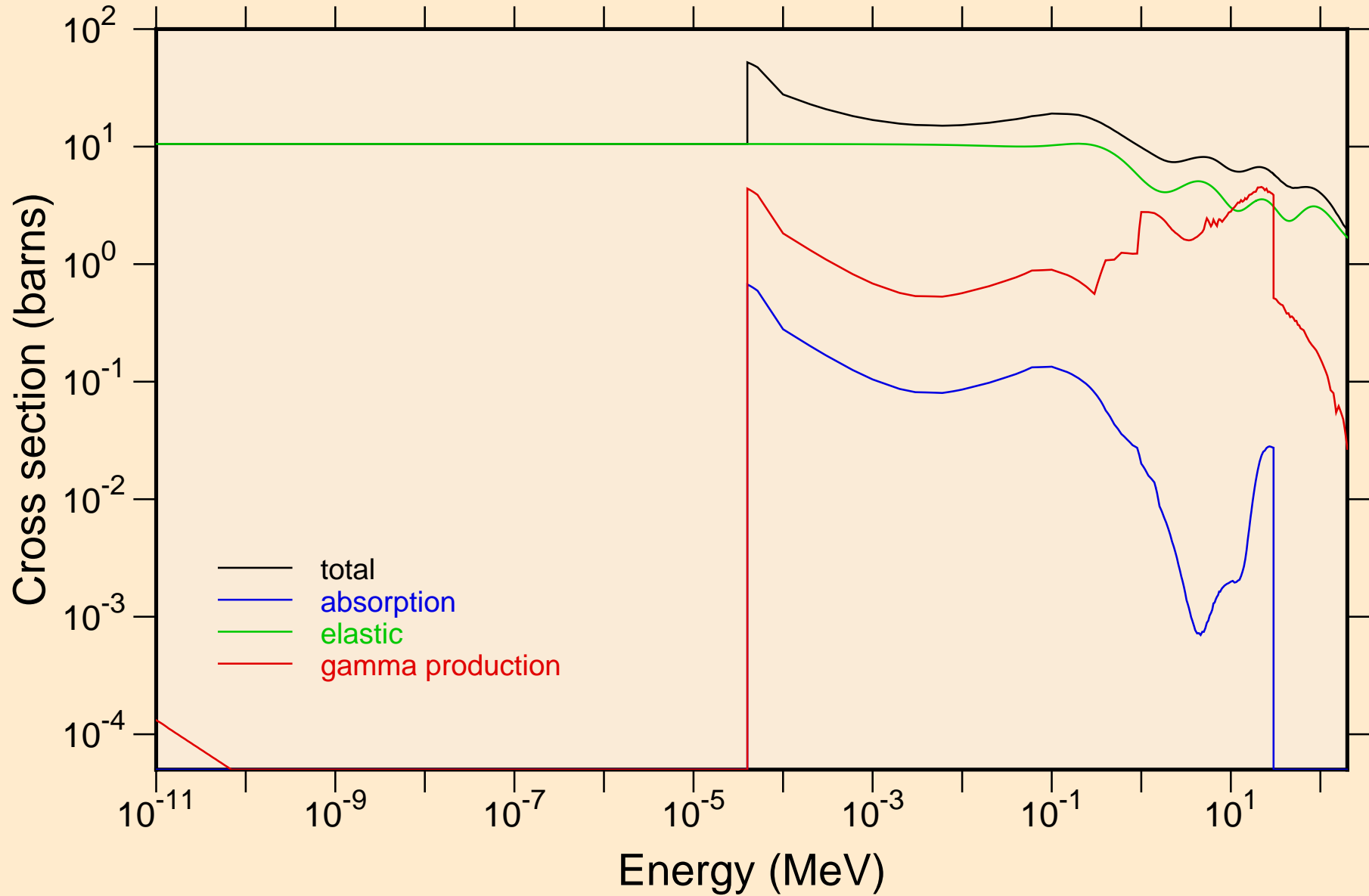

DS283 NEUTRON ACER TENDL-2023 LIBRARY; T=0.K

Heating

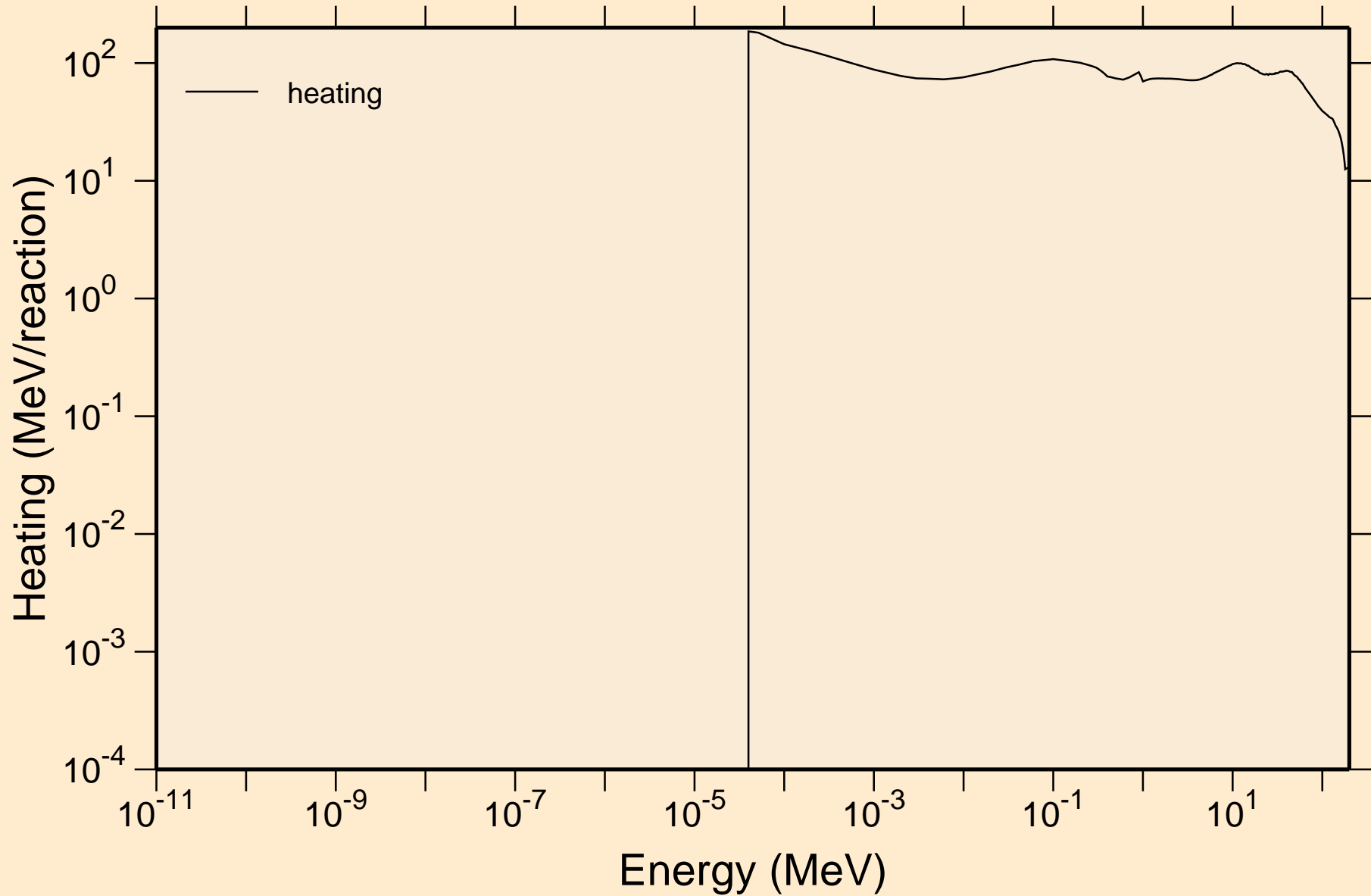

DS283 NEUTRON ACER TENDL-2023 LIBRARY; T=0.K
Damage

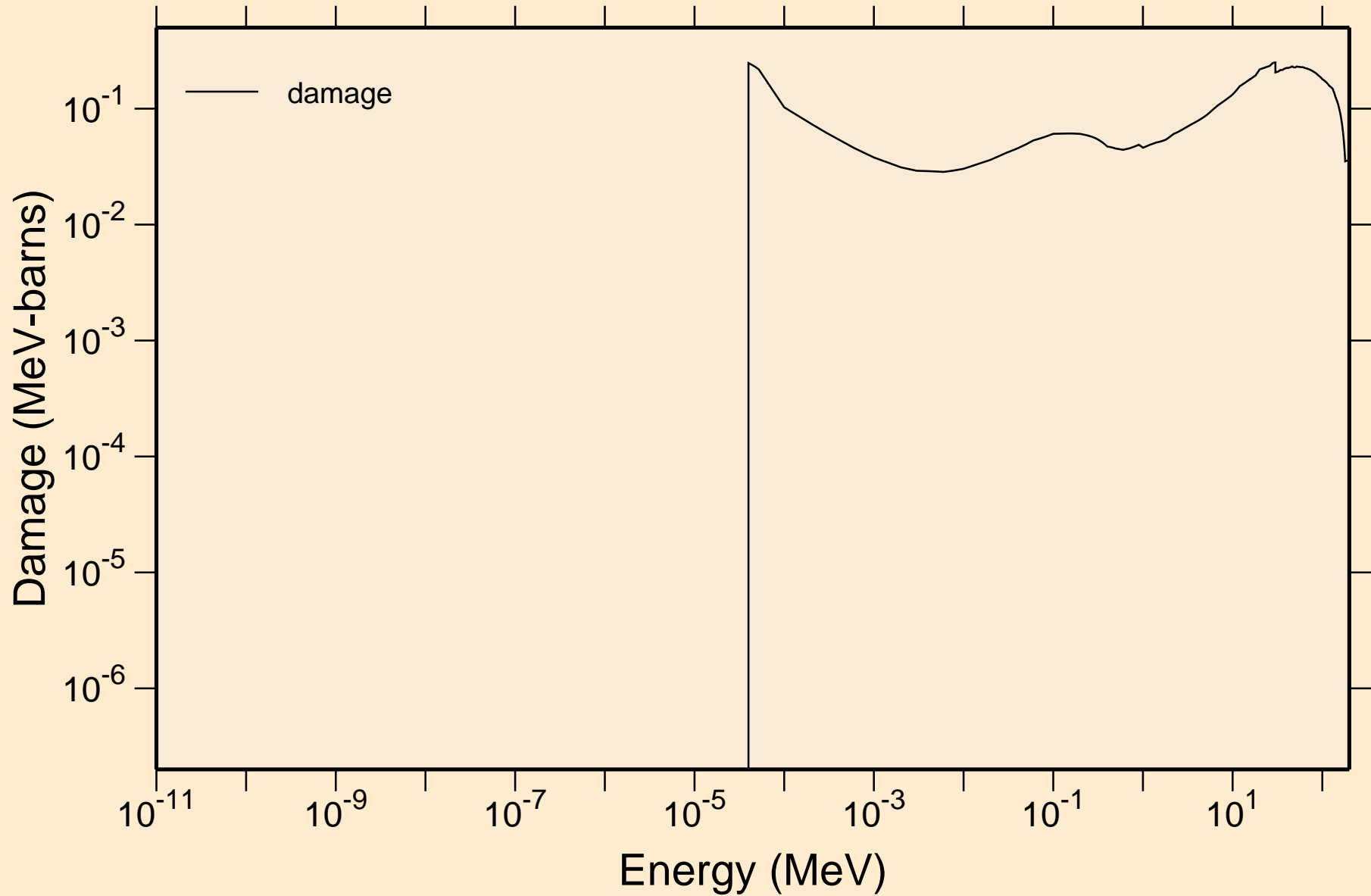

DS283 NEUTRON ACER TENDL-2023 LIBRARY; T=0.K
Non-threshold reactions

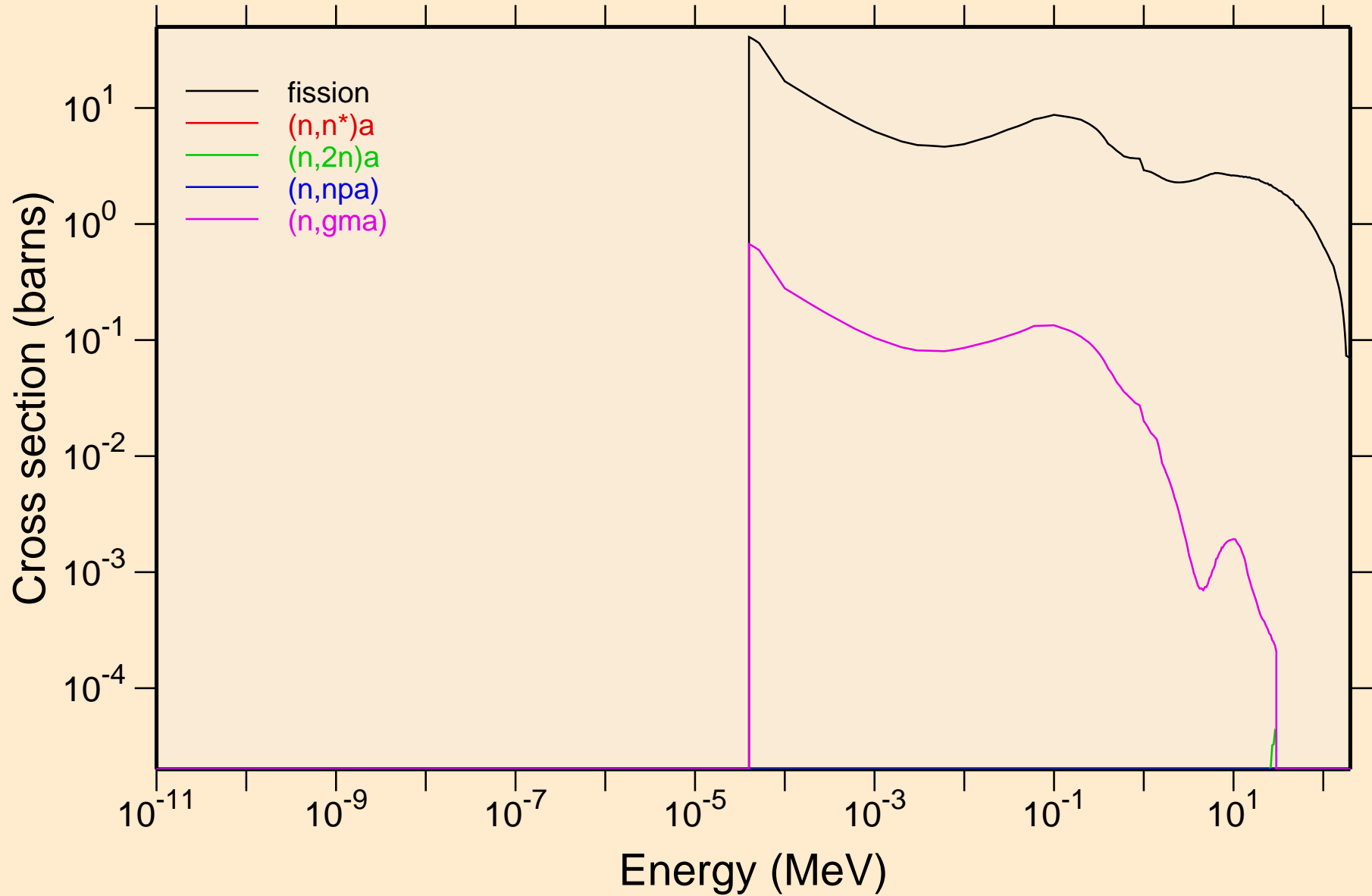

DS283 NEUTRON ACER TENDL-2023 LIBRARY; T=0.K
Non-threshold reactions

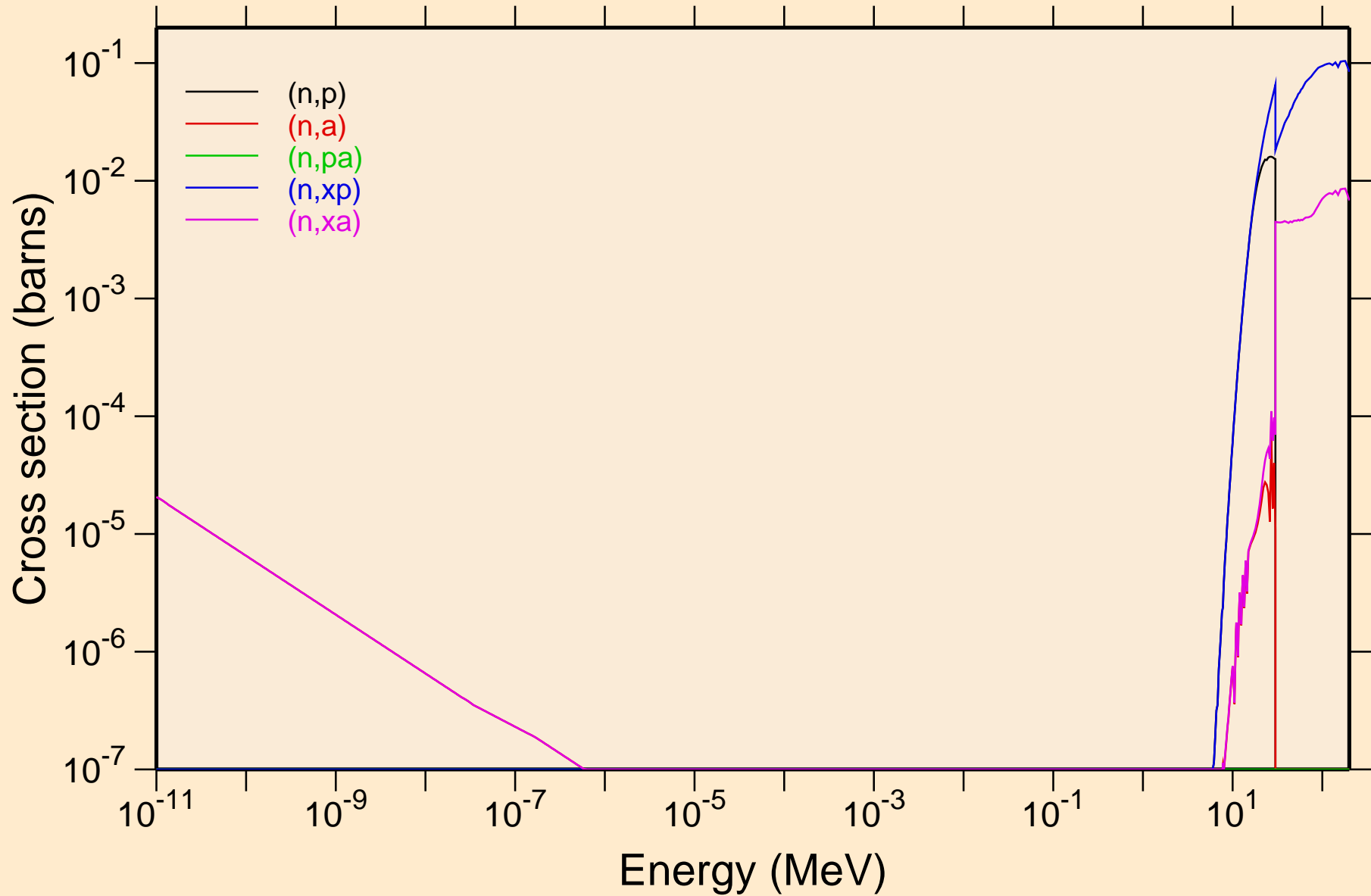

DS283 NEUTRON ACER TENDL-2023 LIBRARY; T=0.K

Principal cross sections

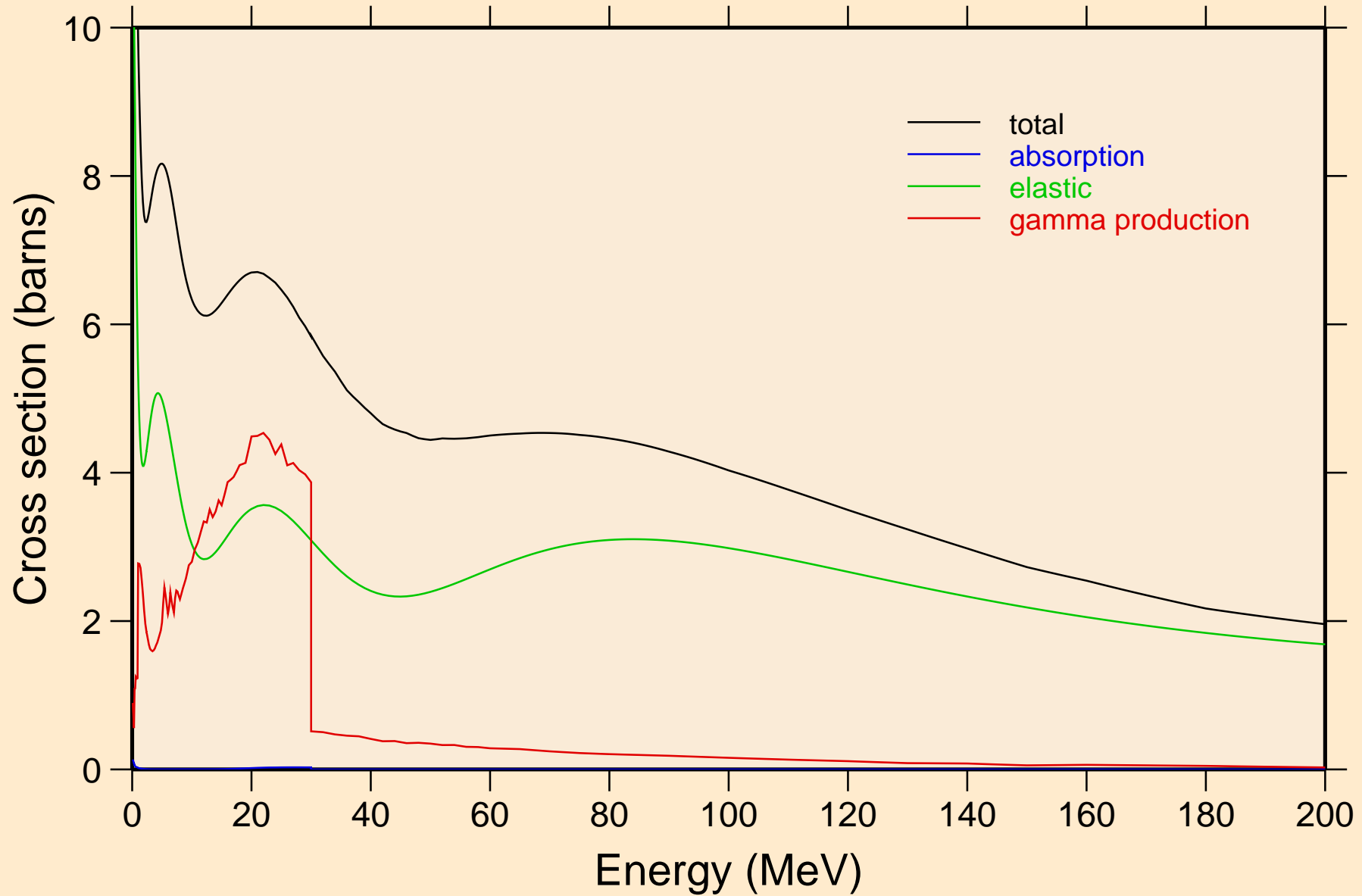

DS283 NEUTRON ACER TENDL-2023 LIBRARY; T=0.K

Heating

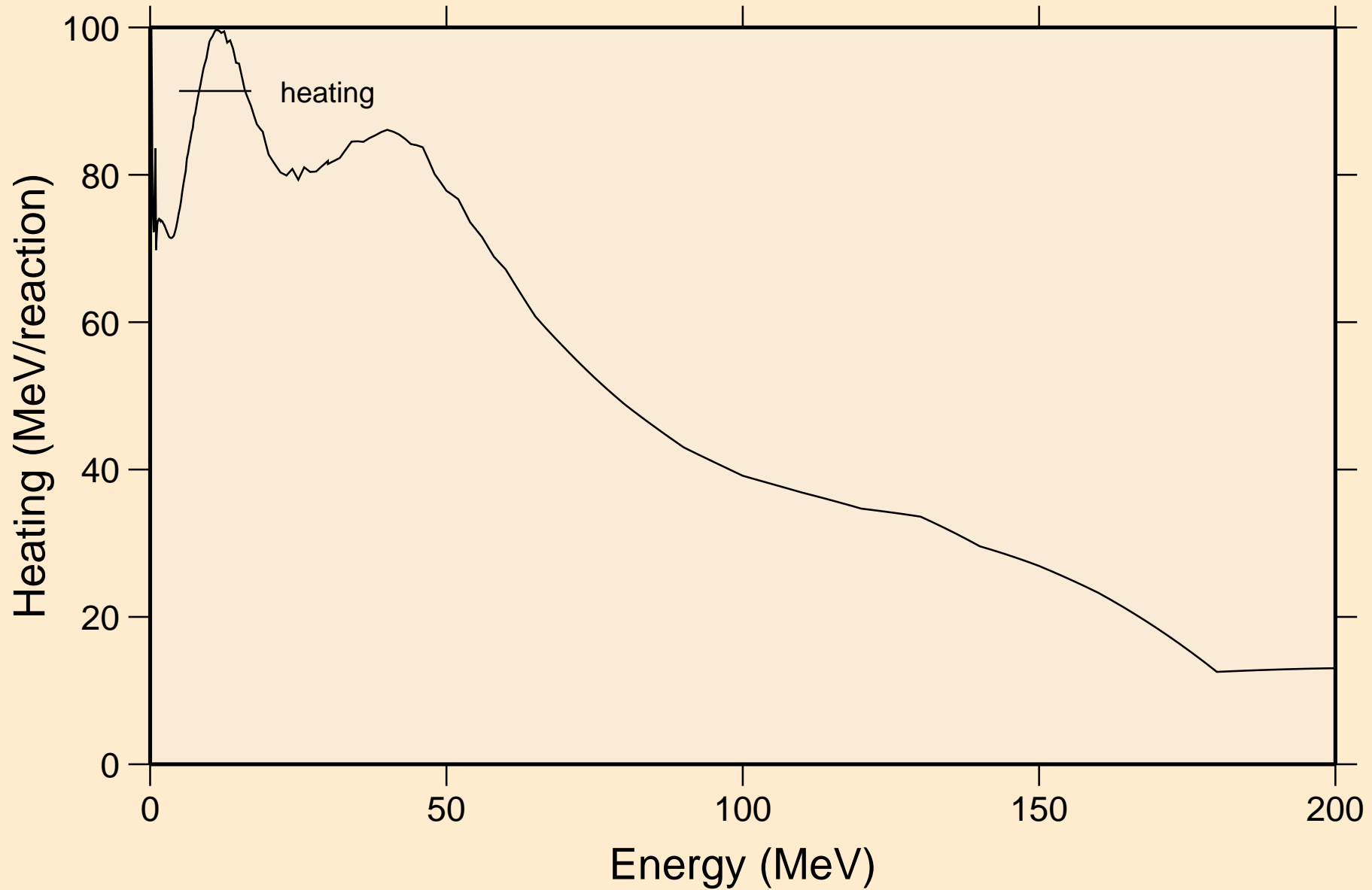

DS283 NEUTRON ACER TENDL-2023 LIBRARY; T=0.K

Damage

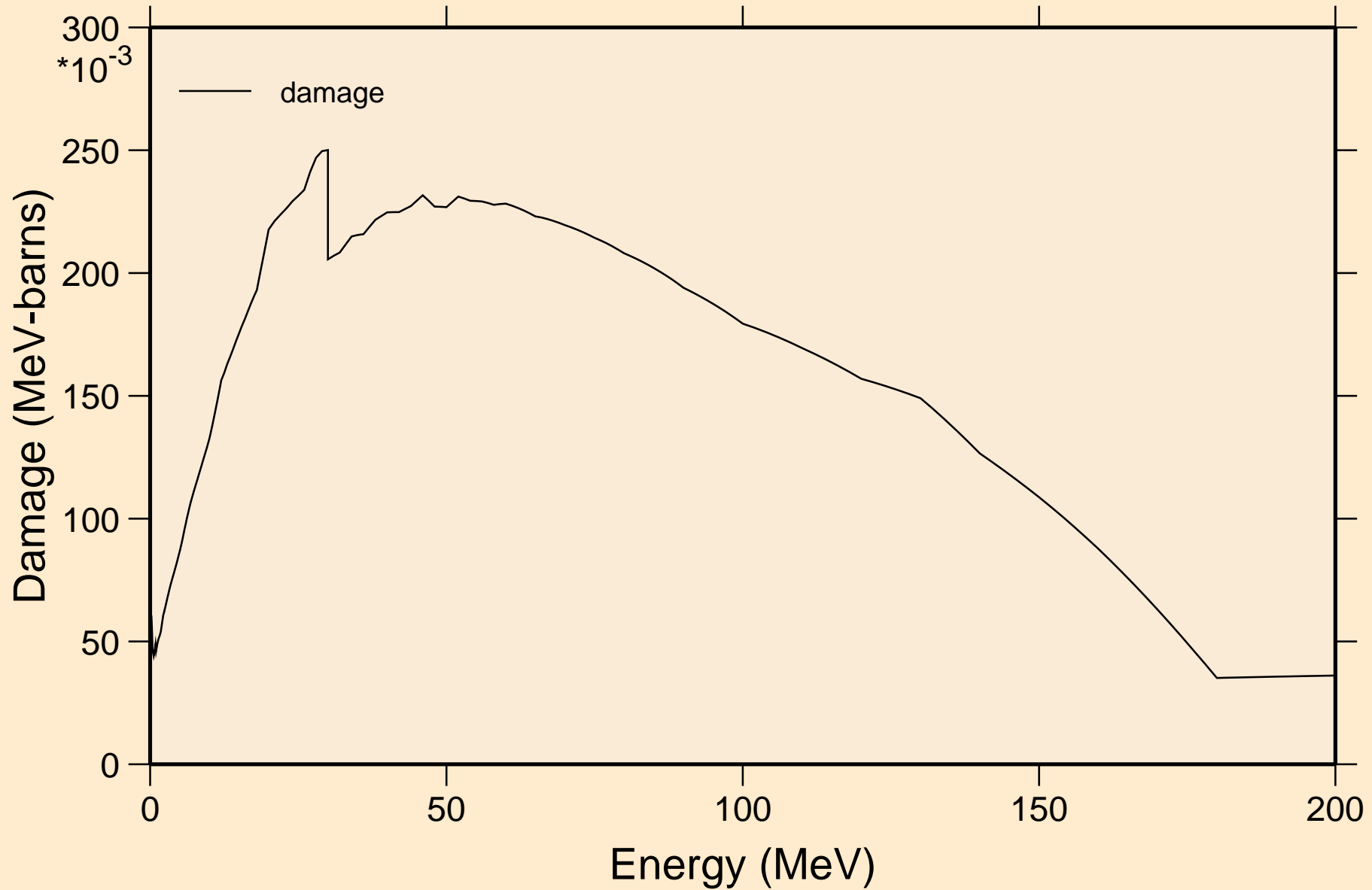

DS283 NEUTRON ACER TENDL-2023 LIBRARY; T=0.K

Non-threshold reactions

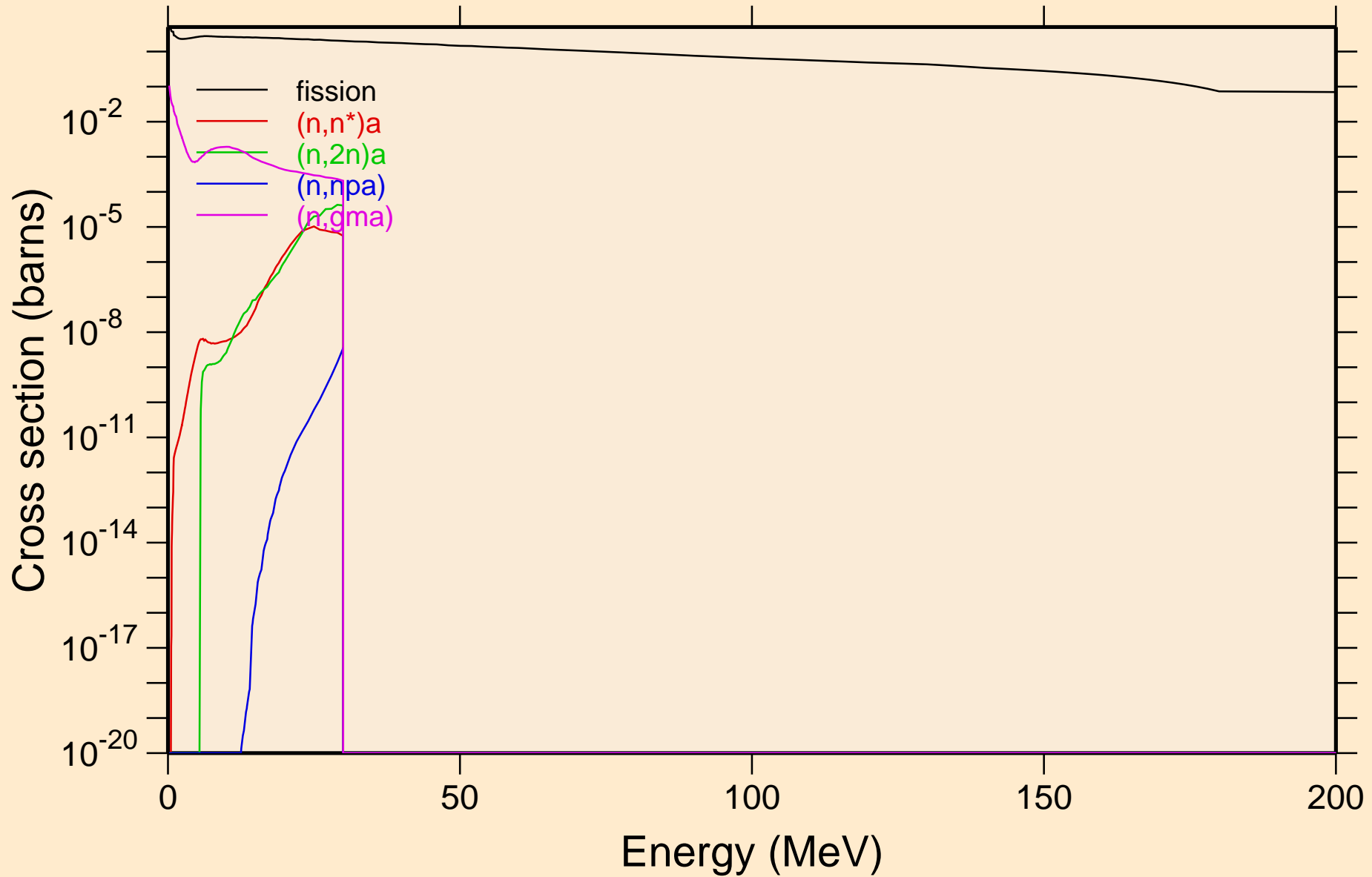

DS283 NEUTRON ACER TENDL-2023 LIBRARY; T=0.K

Non-threshold reactions

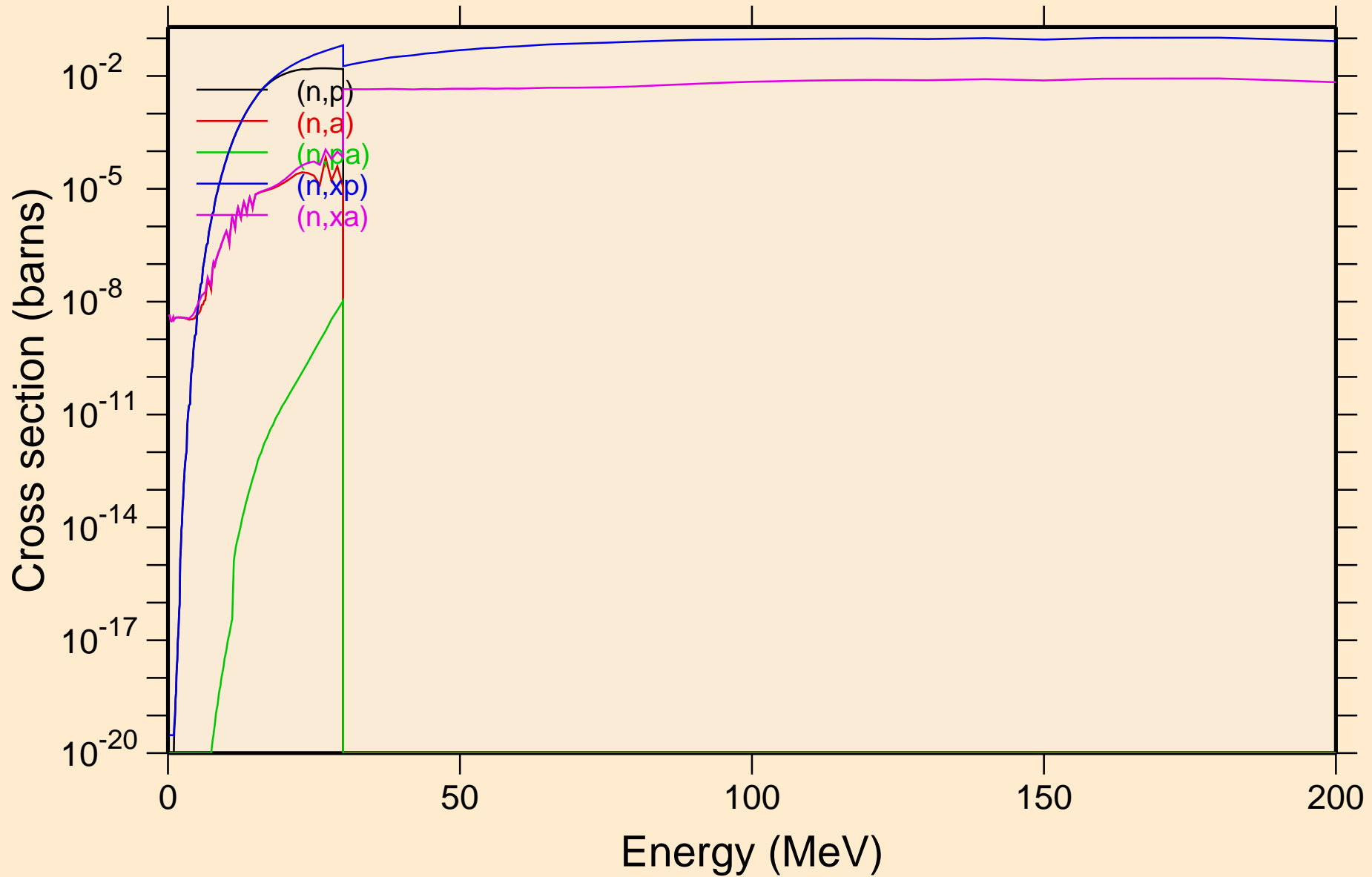

DS283 NEUTRON ACER TENDL-2023 LIBRARY; T=0.K
Inelastic levels

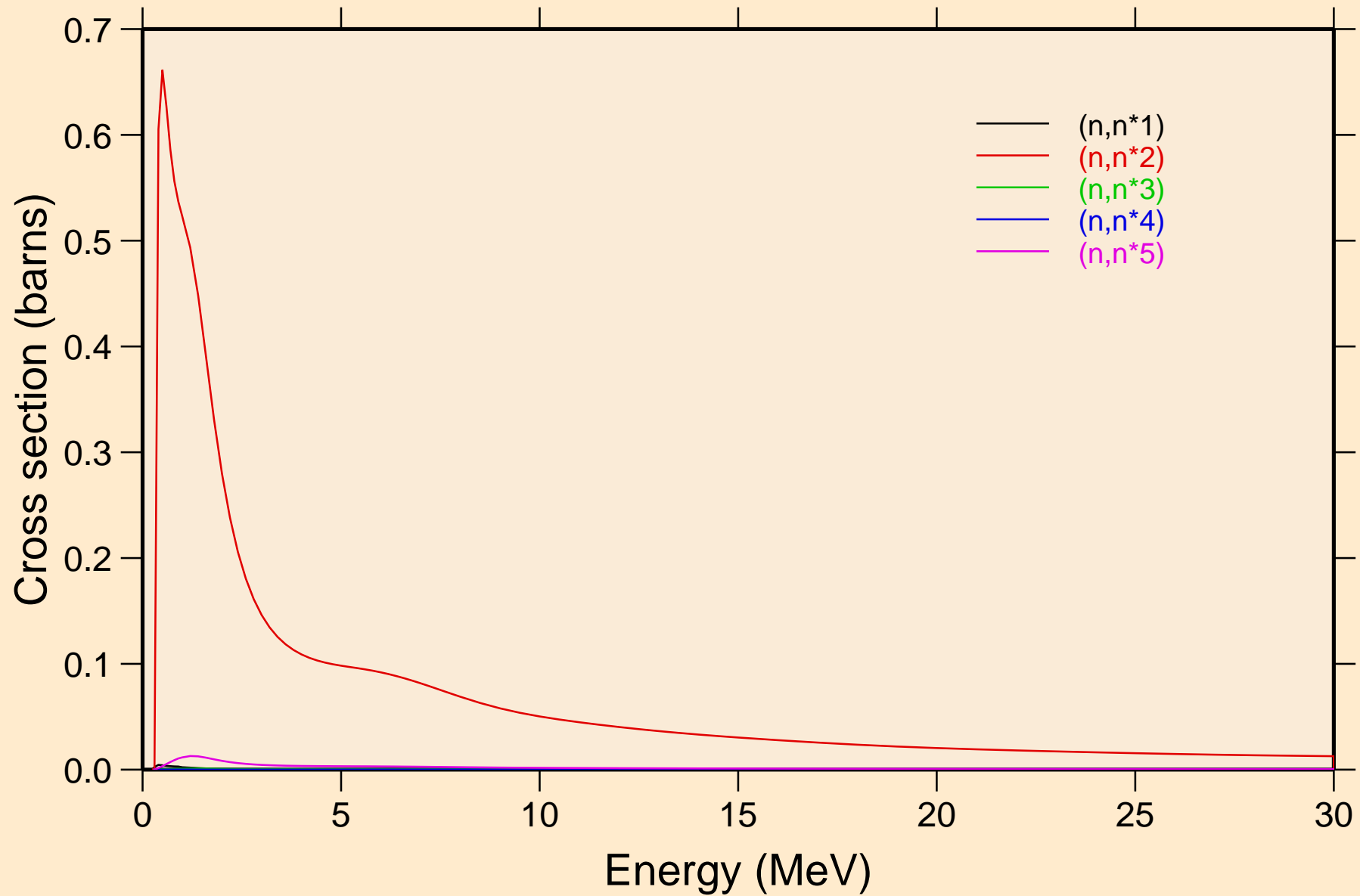

DS283 NEUTRON ACER TENDL-2023 LIBRARY; T=0.K
Inelastic levels

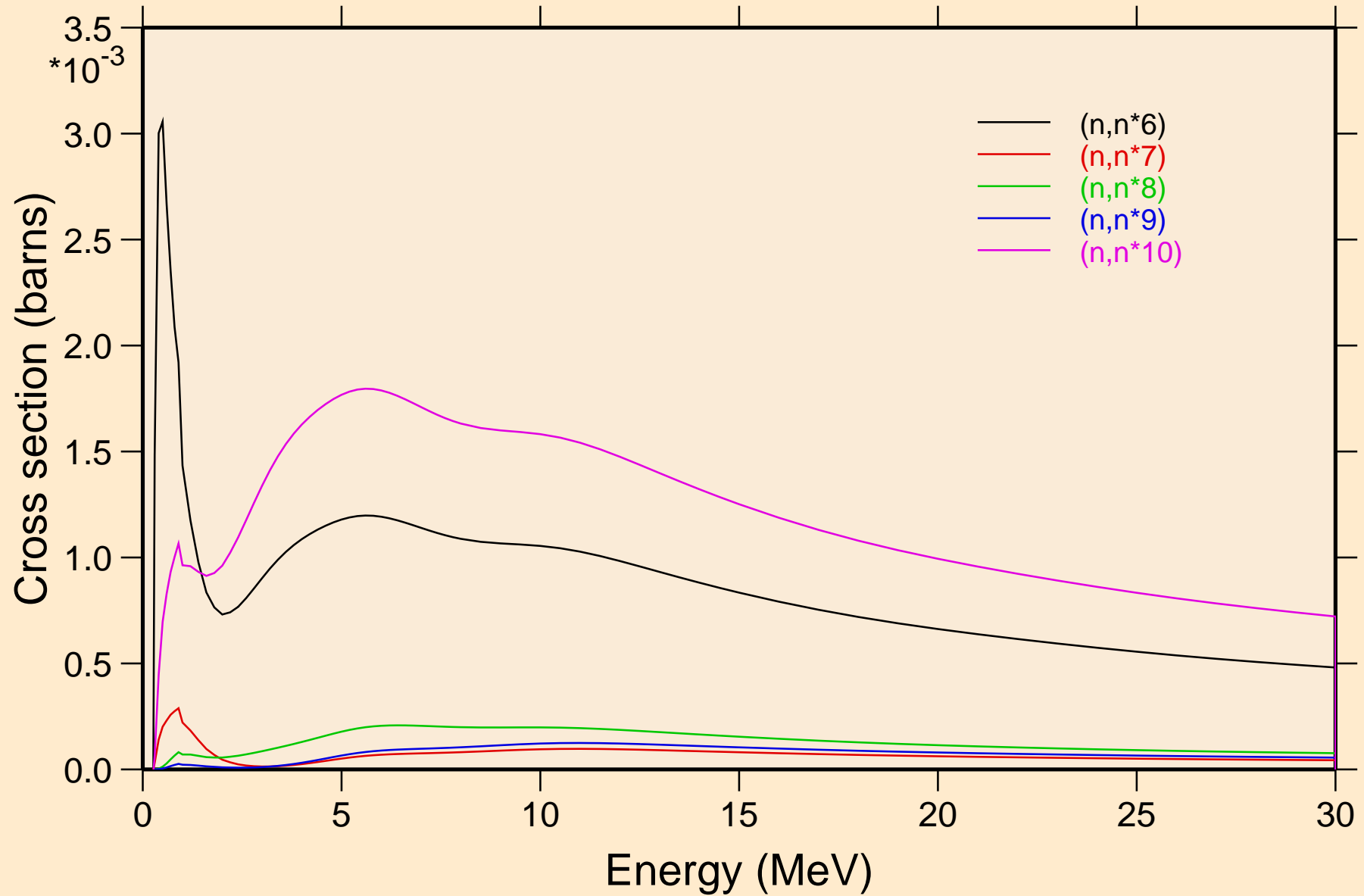

DS283 NEUTRON ACER TENDL-2023 LIBRARY; T=0.K
Inelastic levels

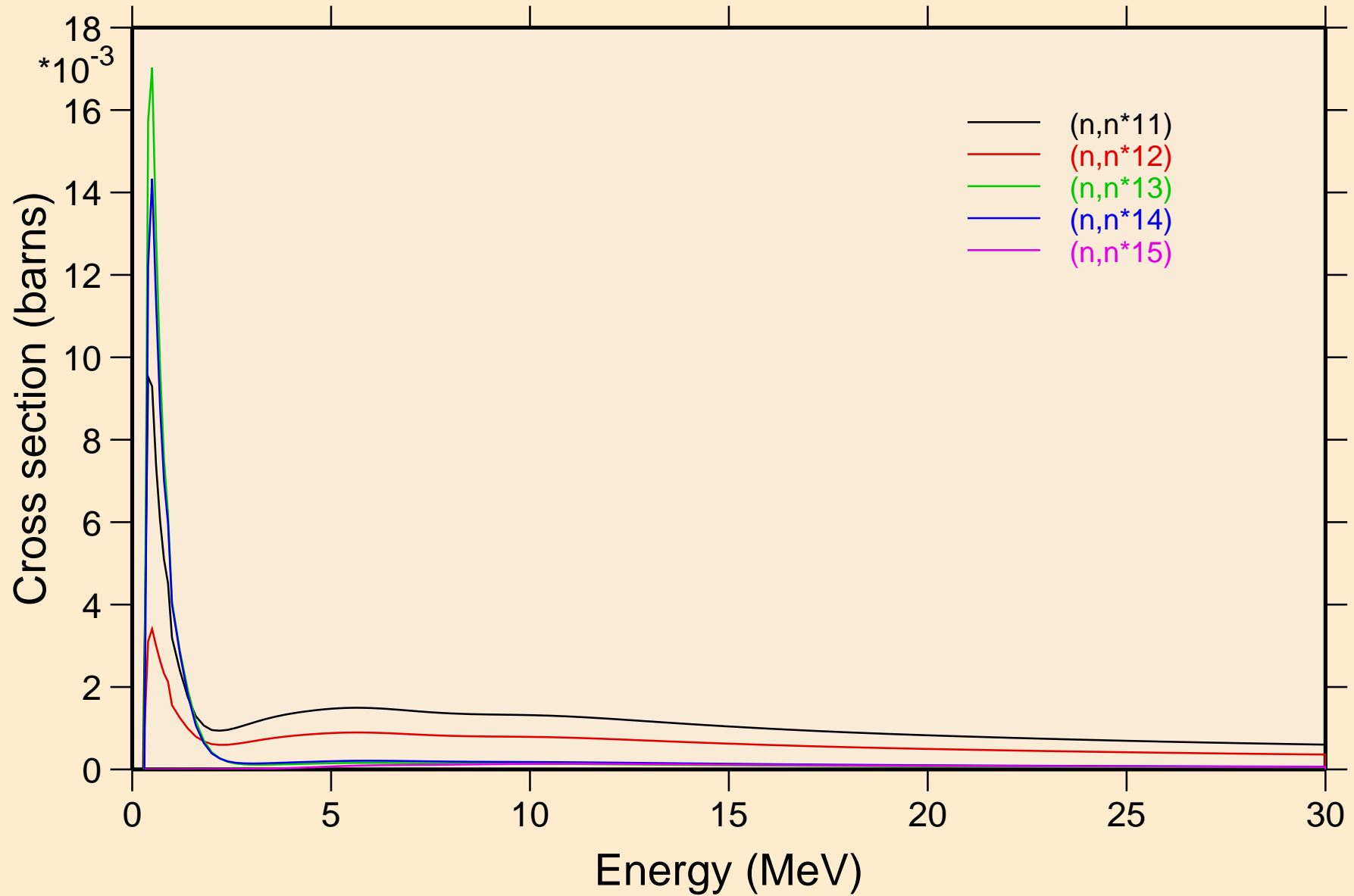

DS283 NEUTRON ACER TENDL-2023 LIBRARY; T=0.K
Inelastic levels

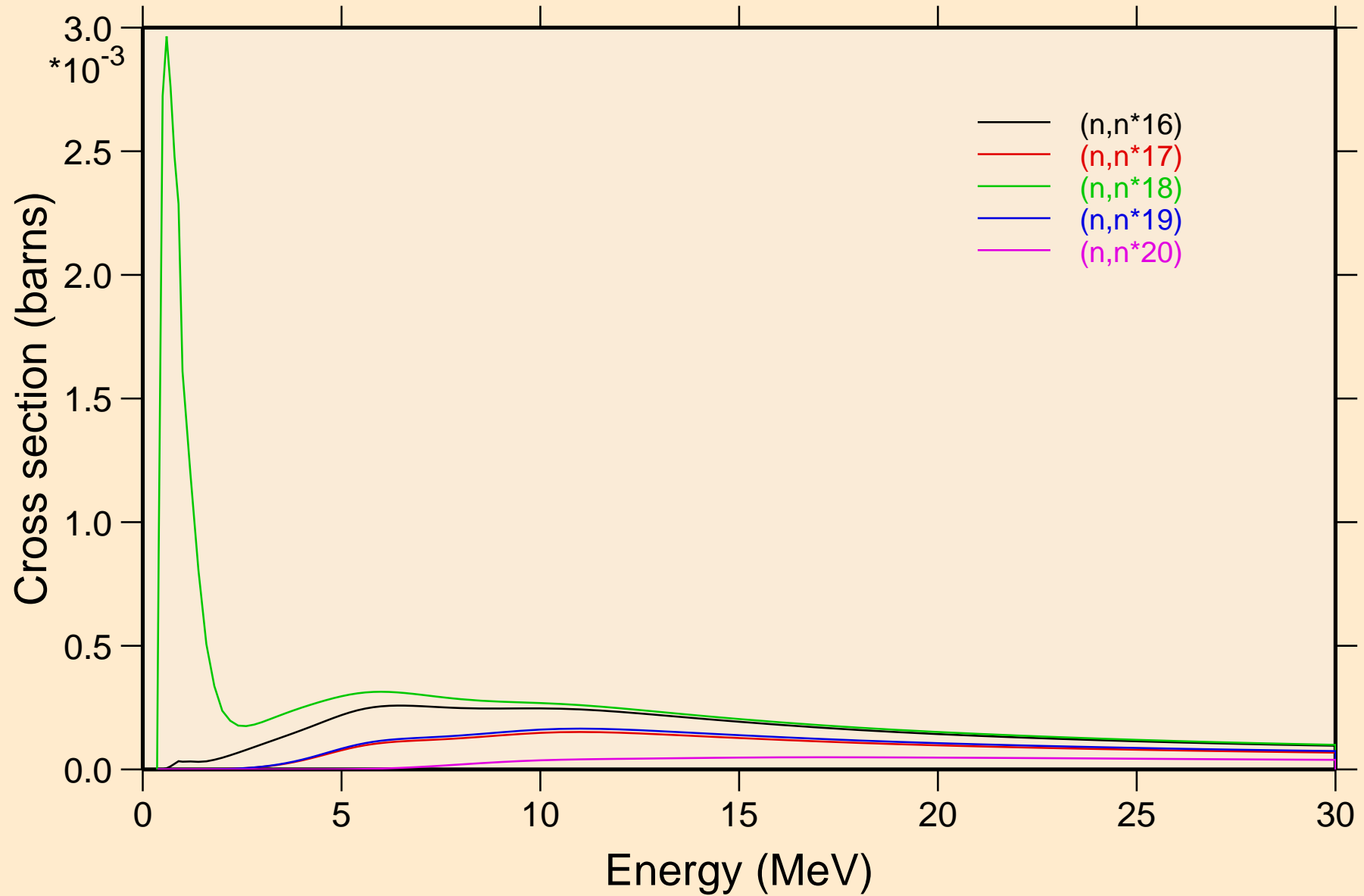

DS283 NEUTRON ACER TENDL-2023 LIBRARY; T=0.K
Inelastic levels

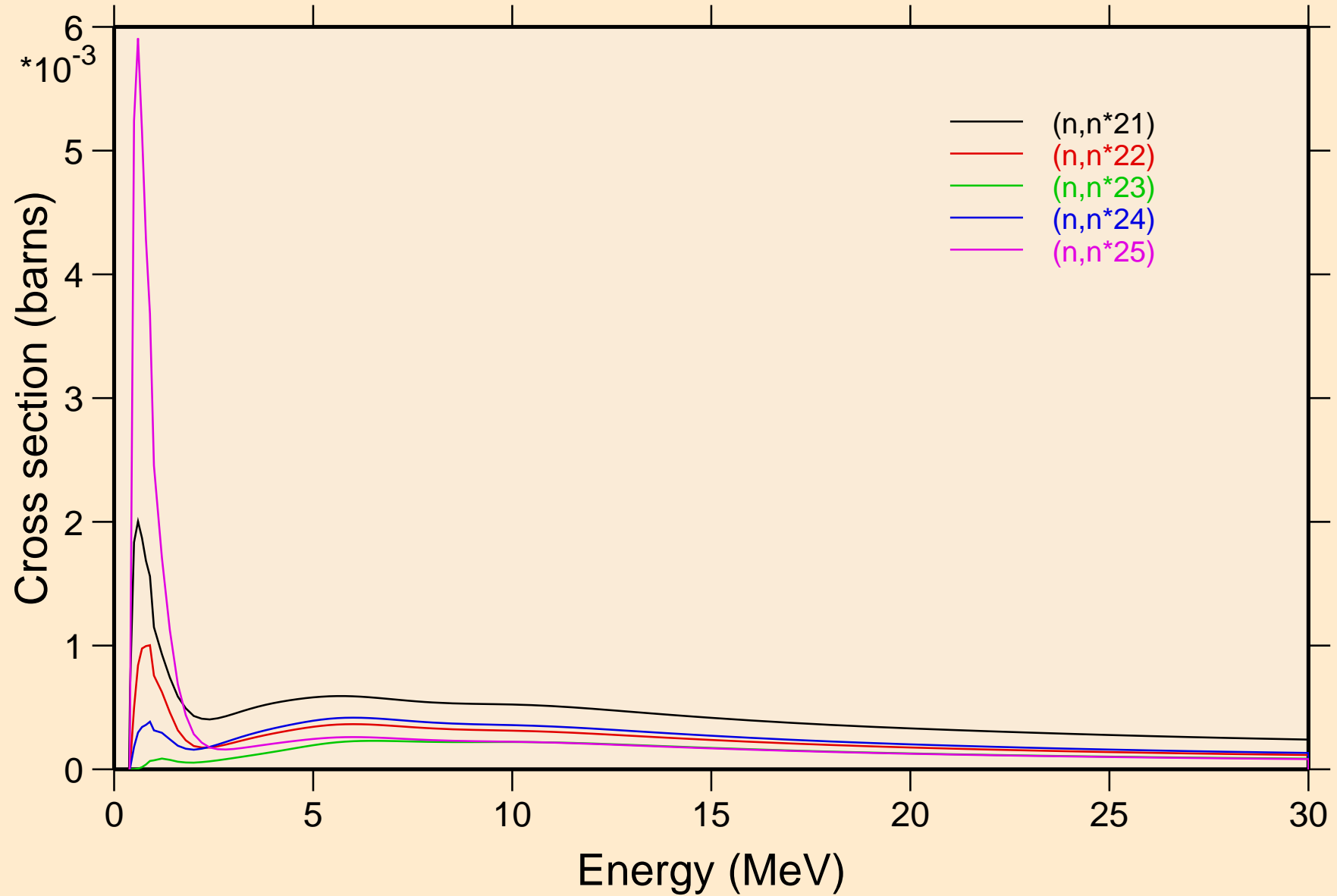

DS283 NEUTRON ACER TENDL-2023 LIBRARY; T=0.K
Inelastic levels

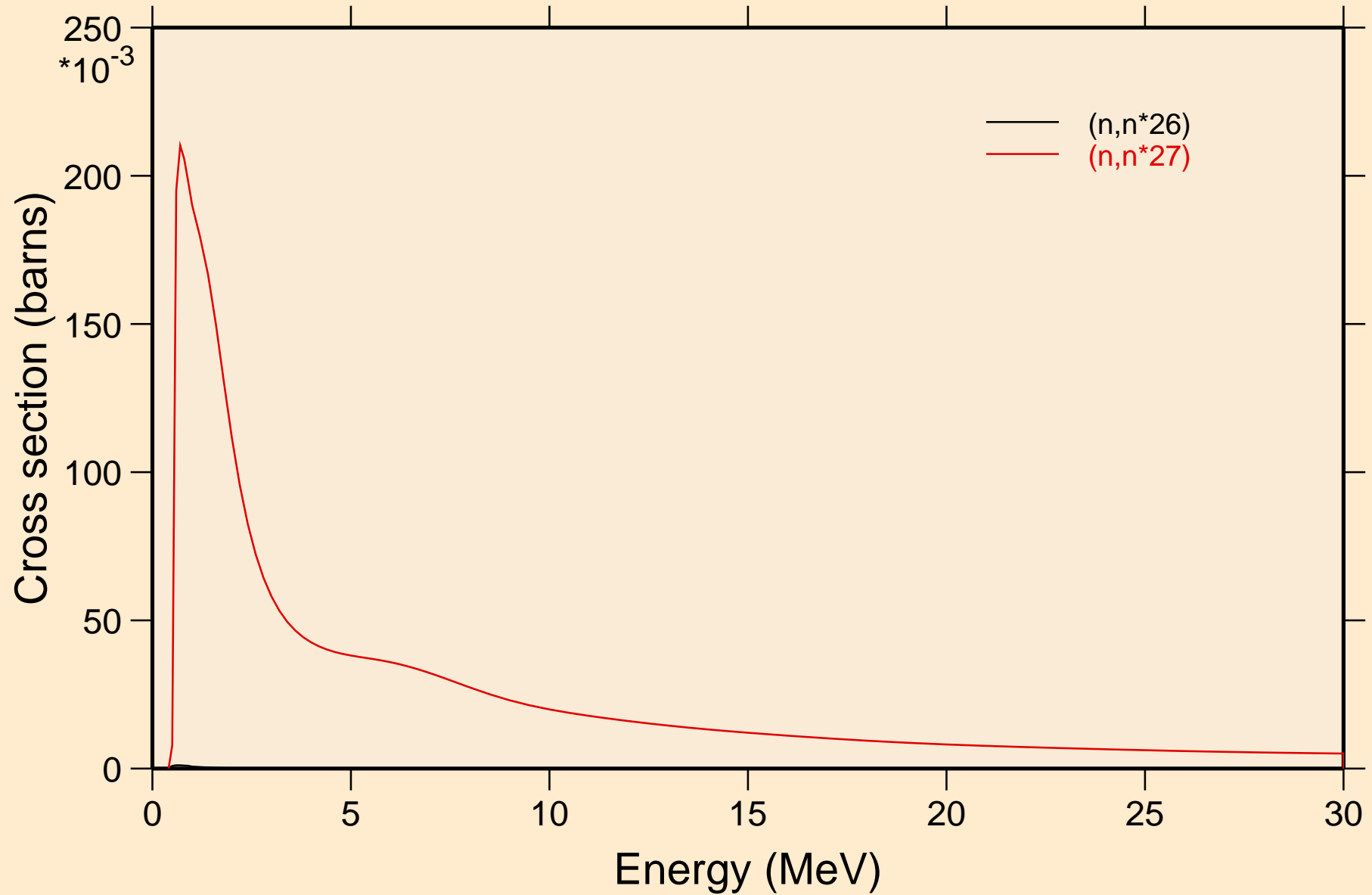

DS283 NEUTRON ACER TENDL-2023 LIBRARY; T=0.K
Threshold reactions

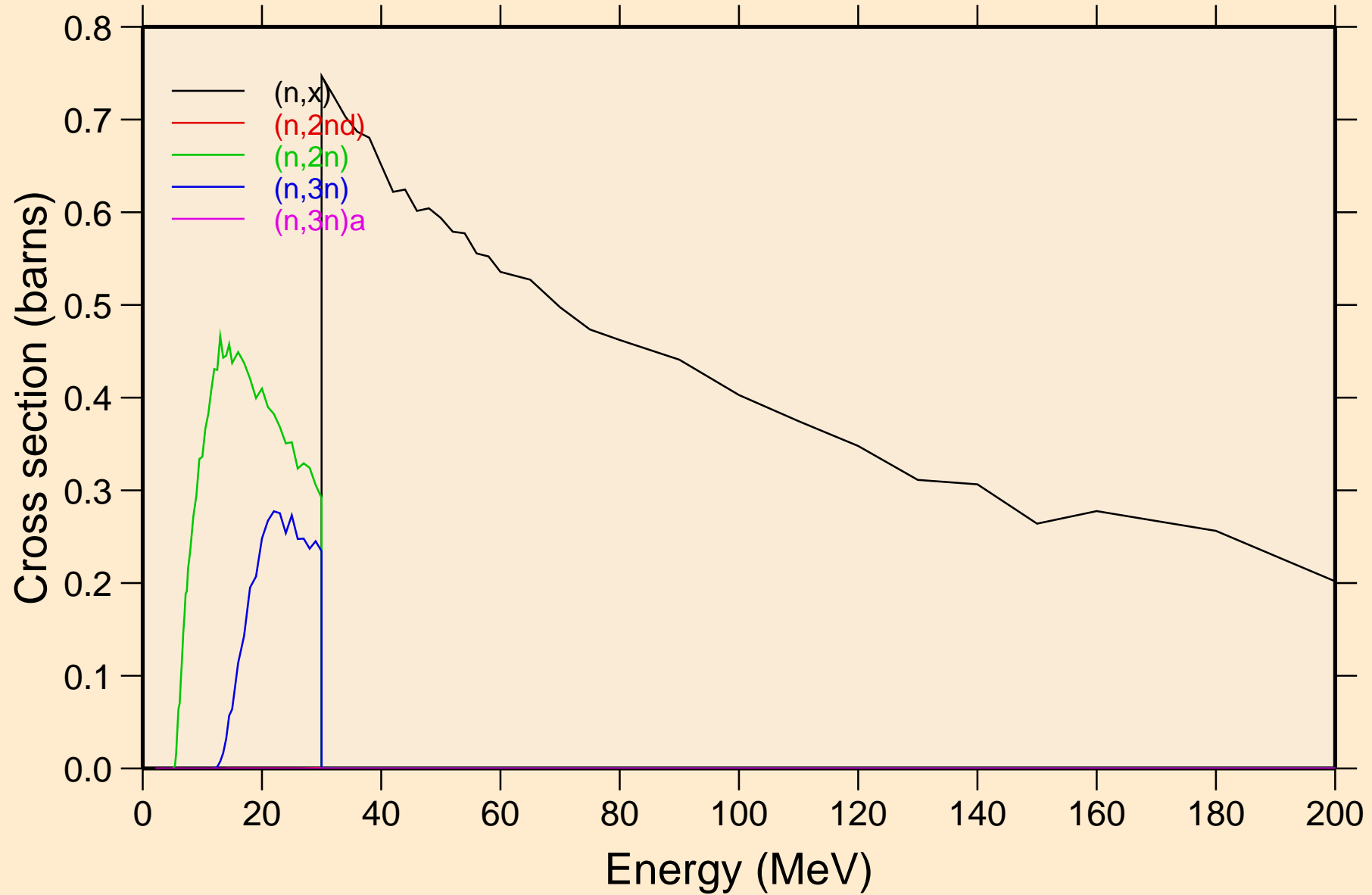

DS283 NEUTRON ACER TENDL-2023 LIBRARY; T=0.K
Threshold reactions

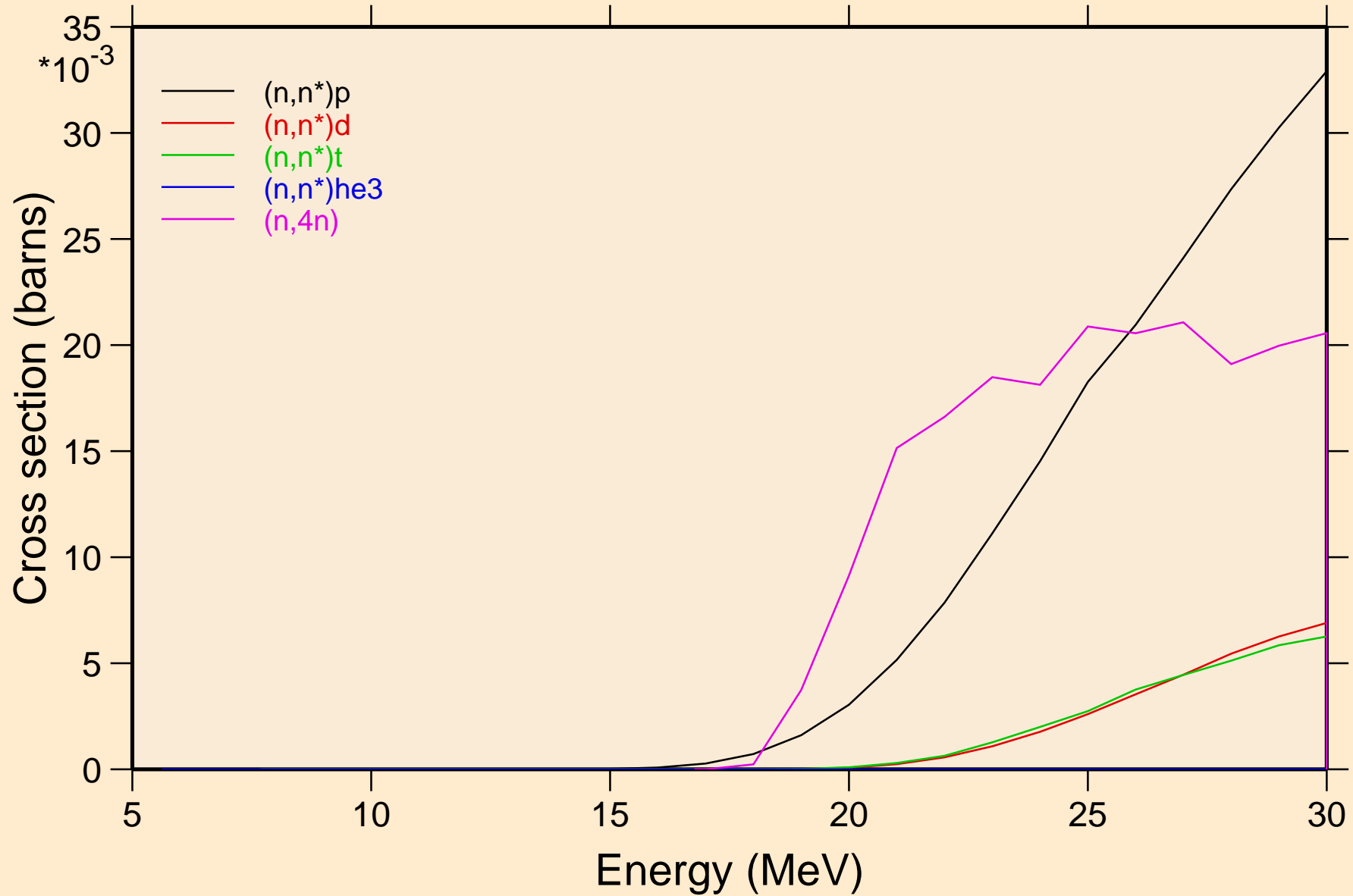

DS283 NEUTRON ACER TENDL-2023 LIBRARY; T=0.K

Threshold reactions

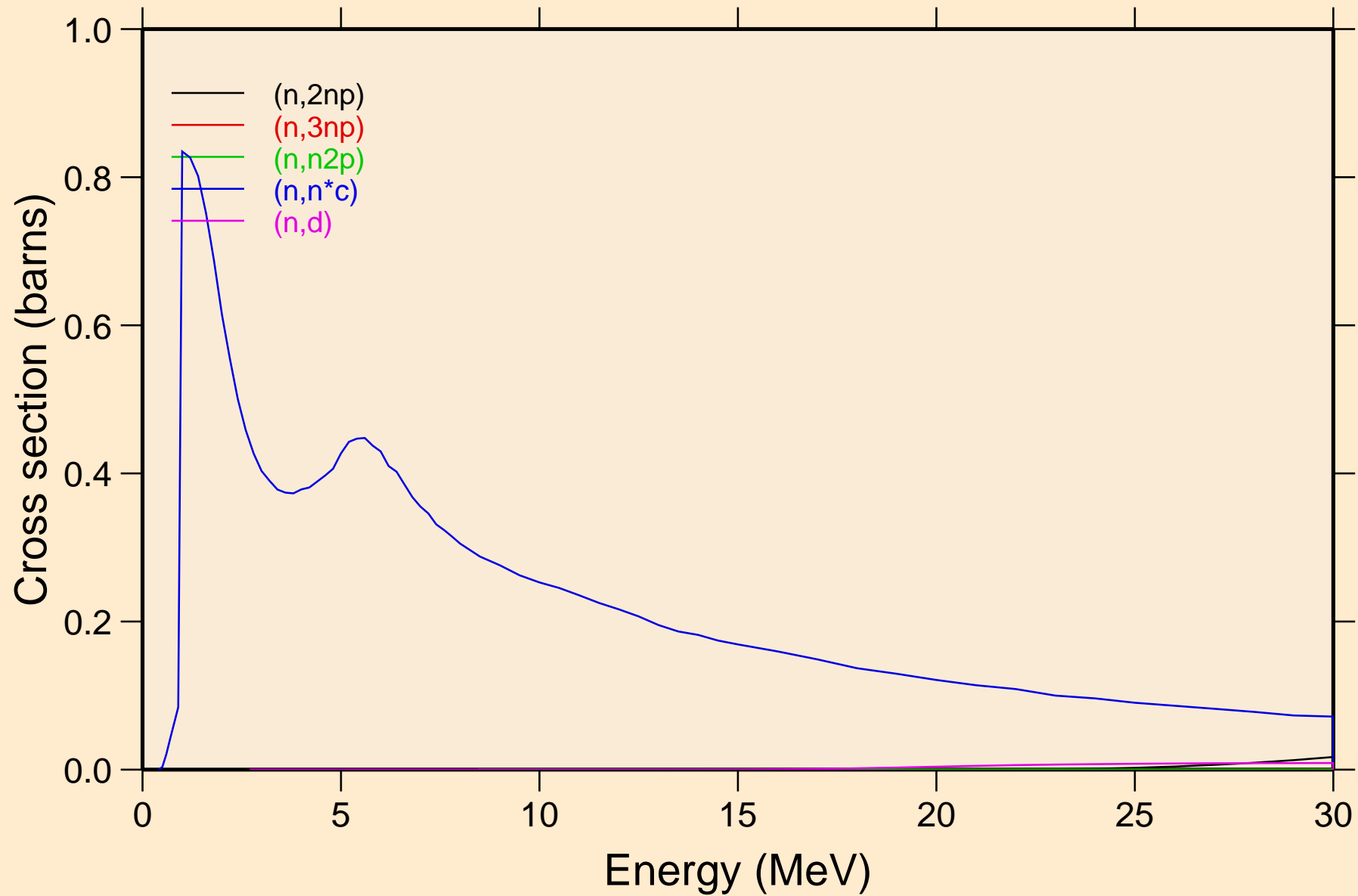

DS283 NEUTRON ACER TENDL-2023 LIBRARY; T=0.K
Threshold reactions

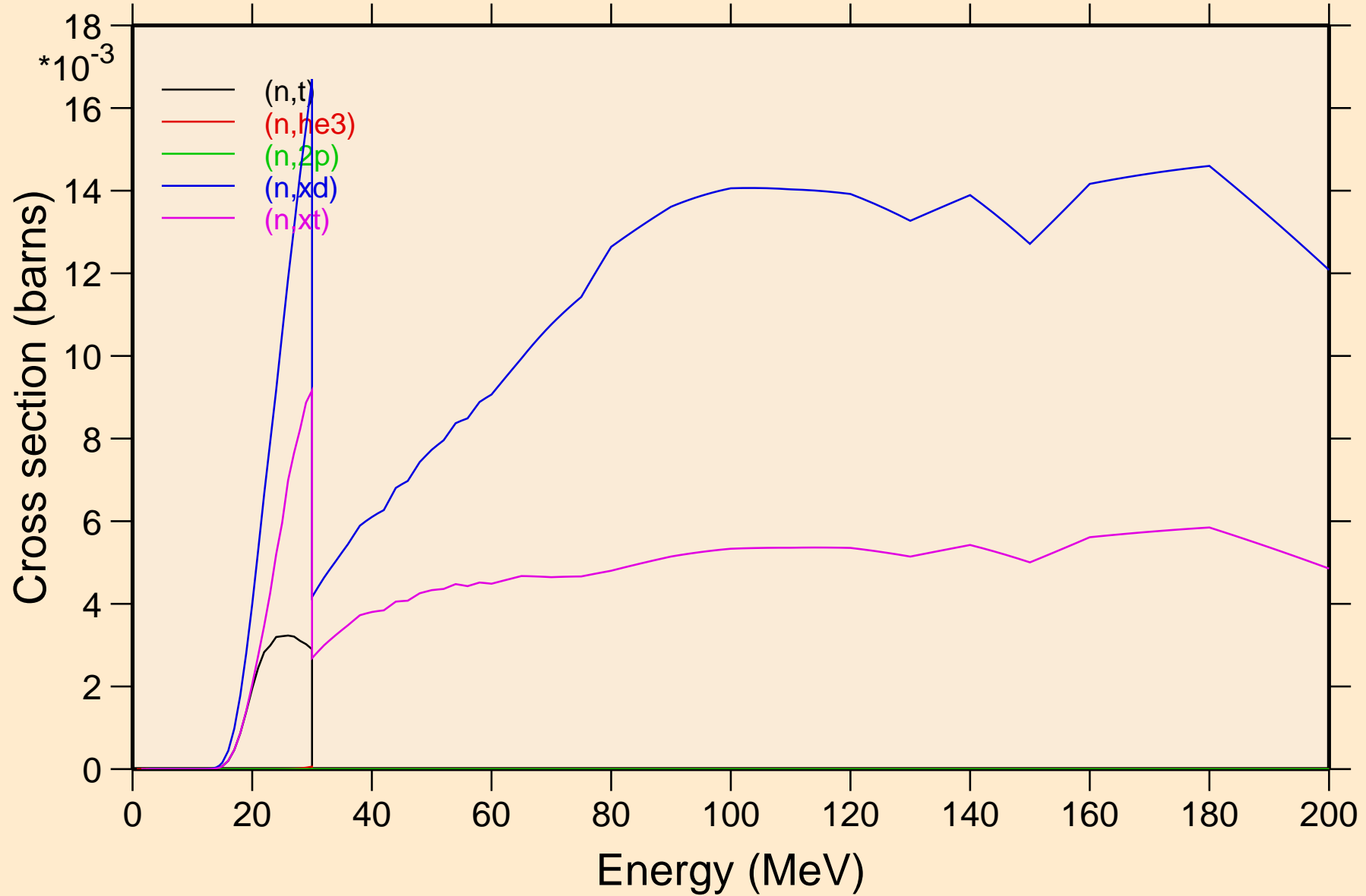

DS283 NEUTRON ACER TENDL-2023 LIBRARY; T=0.K
Threshold reactions

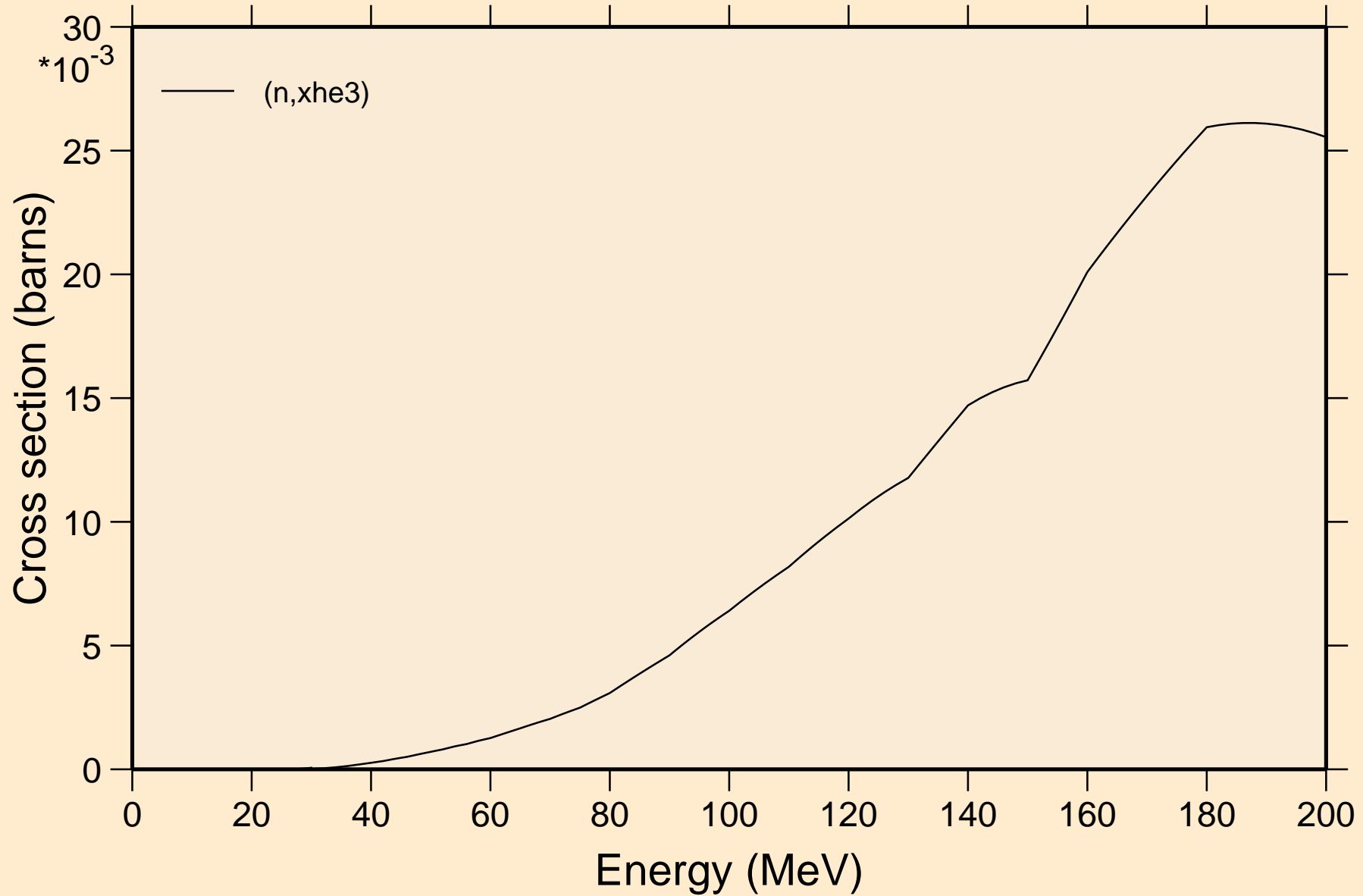

DS283 NEUTRON ACER TENDL-2023 LIBRARY; T=0.K
angular distribution for elastic

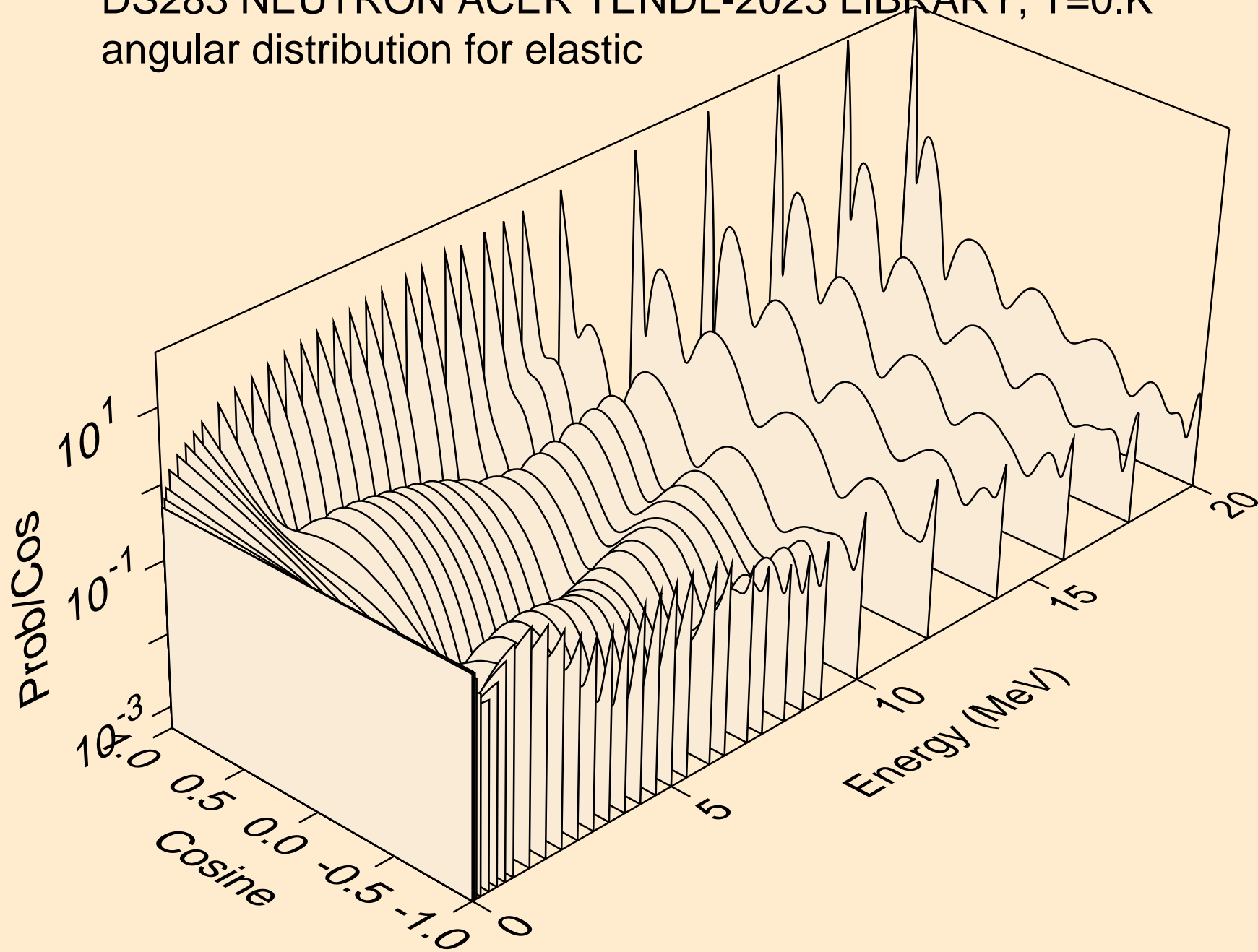

DS283 NEUTRON ACER TENDL-2023 LIBRARY; T=0.K
angular distribution for elastic

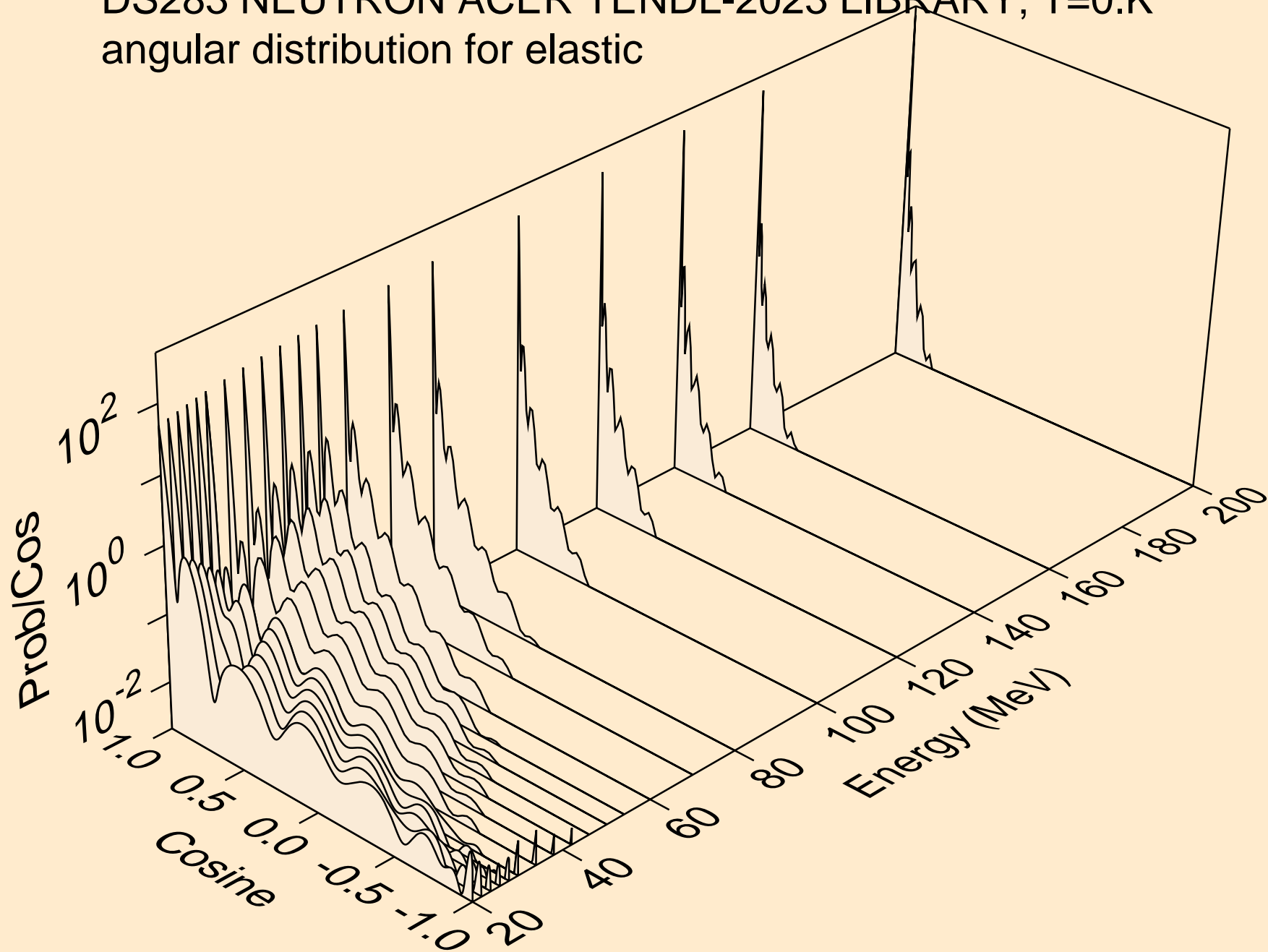

DS283 NEUTRON ACER TENDL-2023 LIBRARY; T=0.K
angular distribution for (n,n*1)

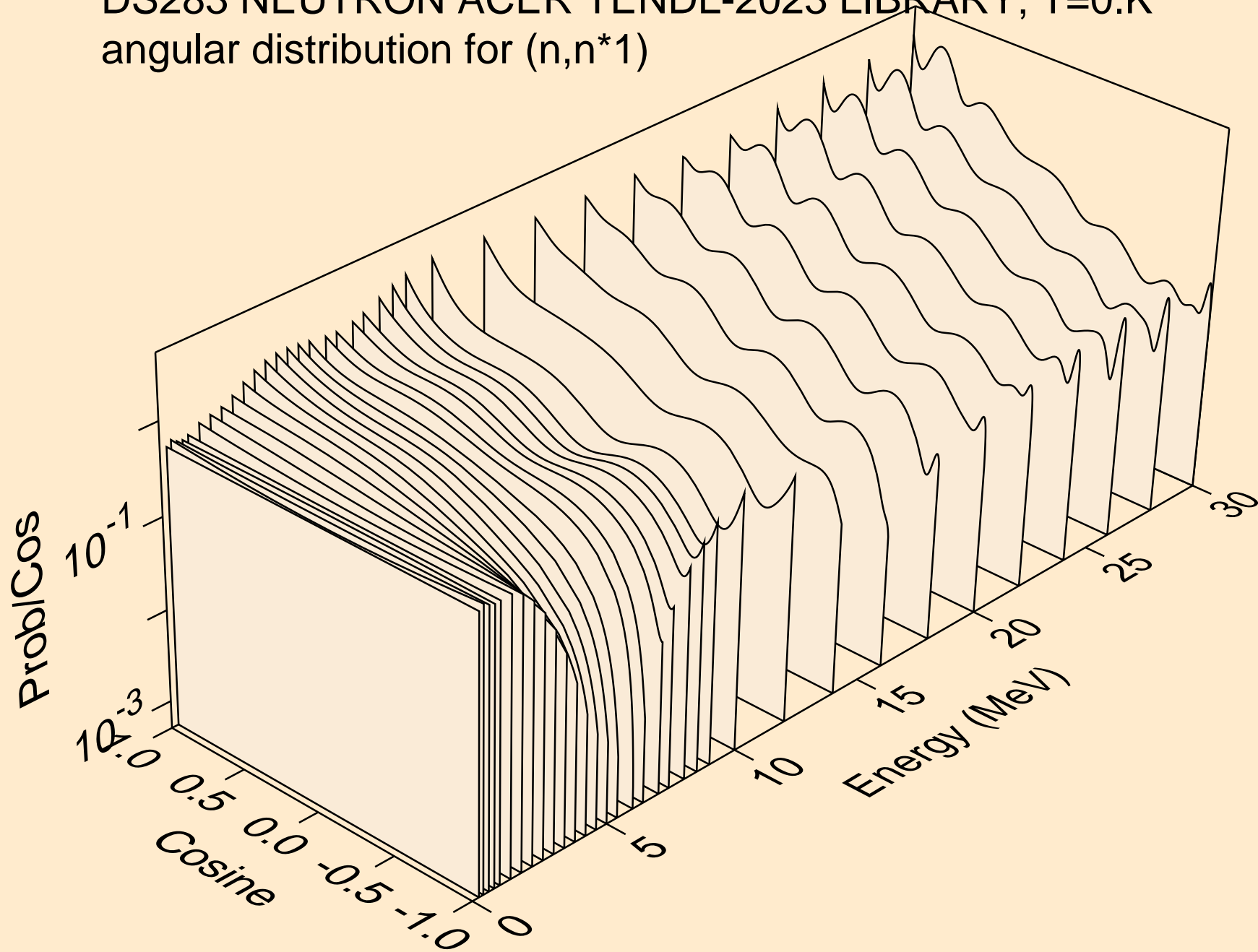

DS283 NEUTRON ACER TENDL-2023 LIBRARY; T=0.K
angular distribution for (n,n*2)

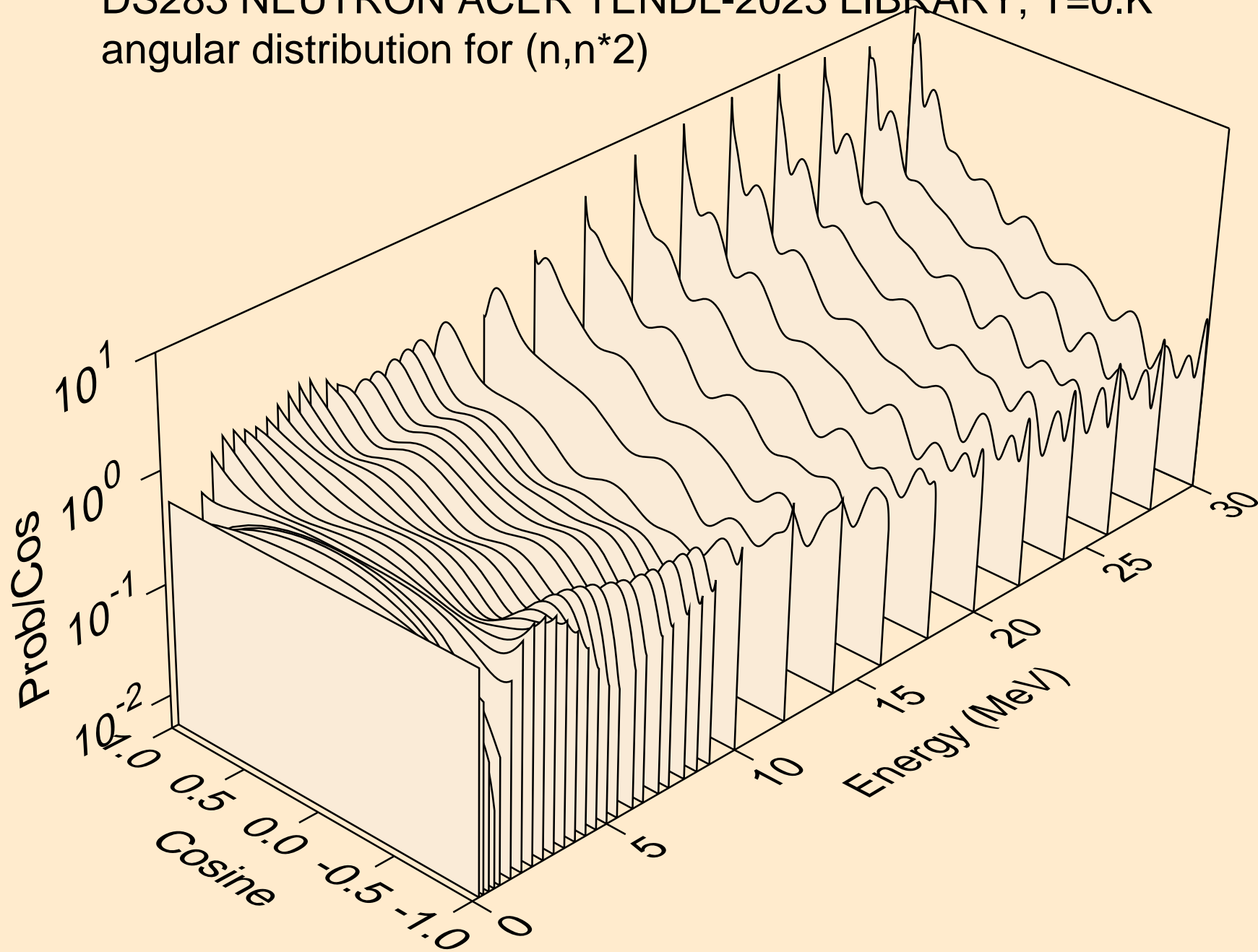

DS283 NEUTRON ACER TENDL-2023 LIBRARY; T=0.K
angular distribution for (n,n*3)

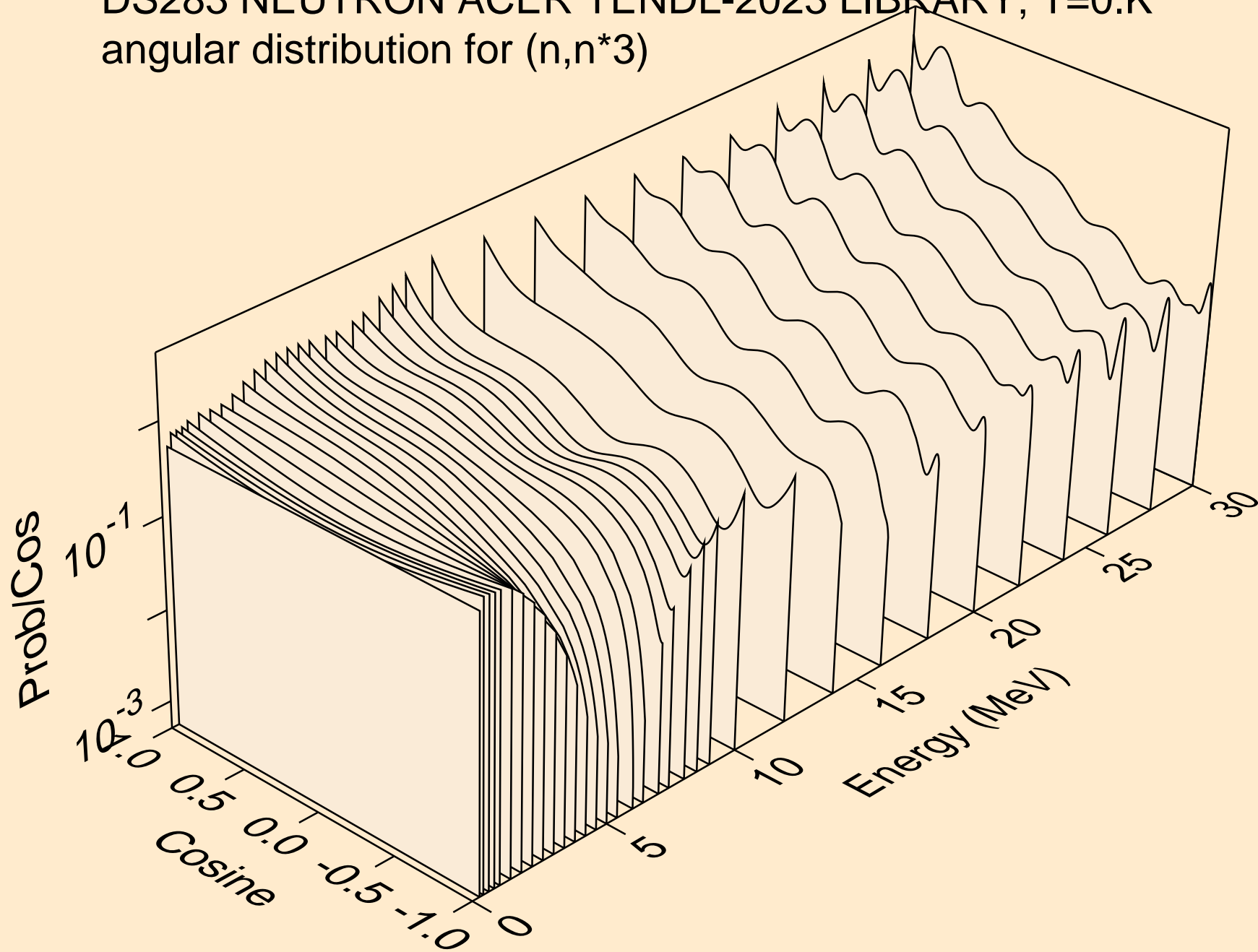

DS283 NEUTRON ACER TENDL-2023 LIBRARY; T=0.K
angular distribution for (n,n*4)

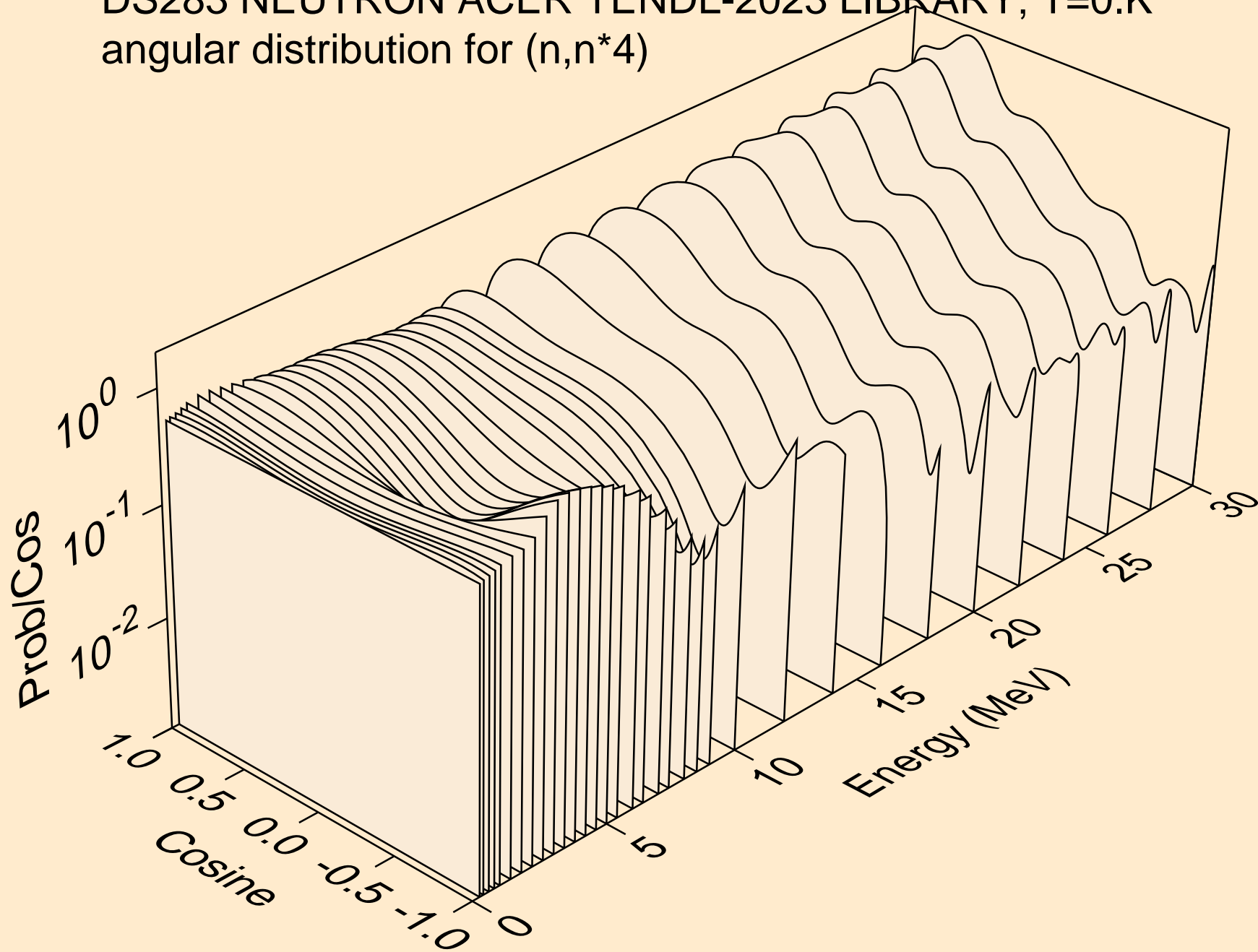

DS283 NEUTRON ACER TENDL-2023 LIBRARY; T=0.K
angular distribution for (n,n*5)

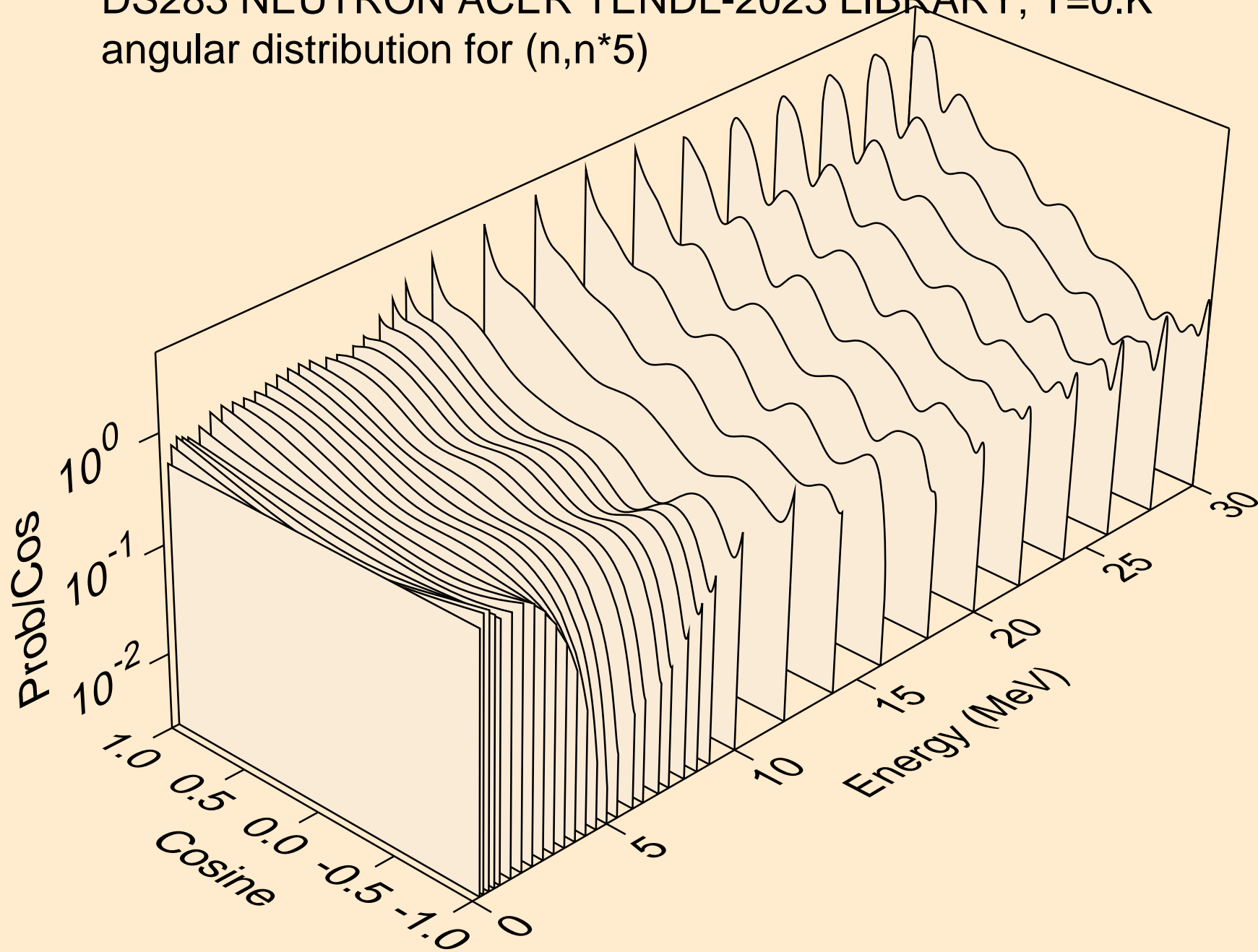

DS283 NEUTRON ACER TENDL-2023 LIBRARY; T=0.K
angular distribution for (n,n*6)

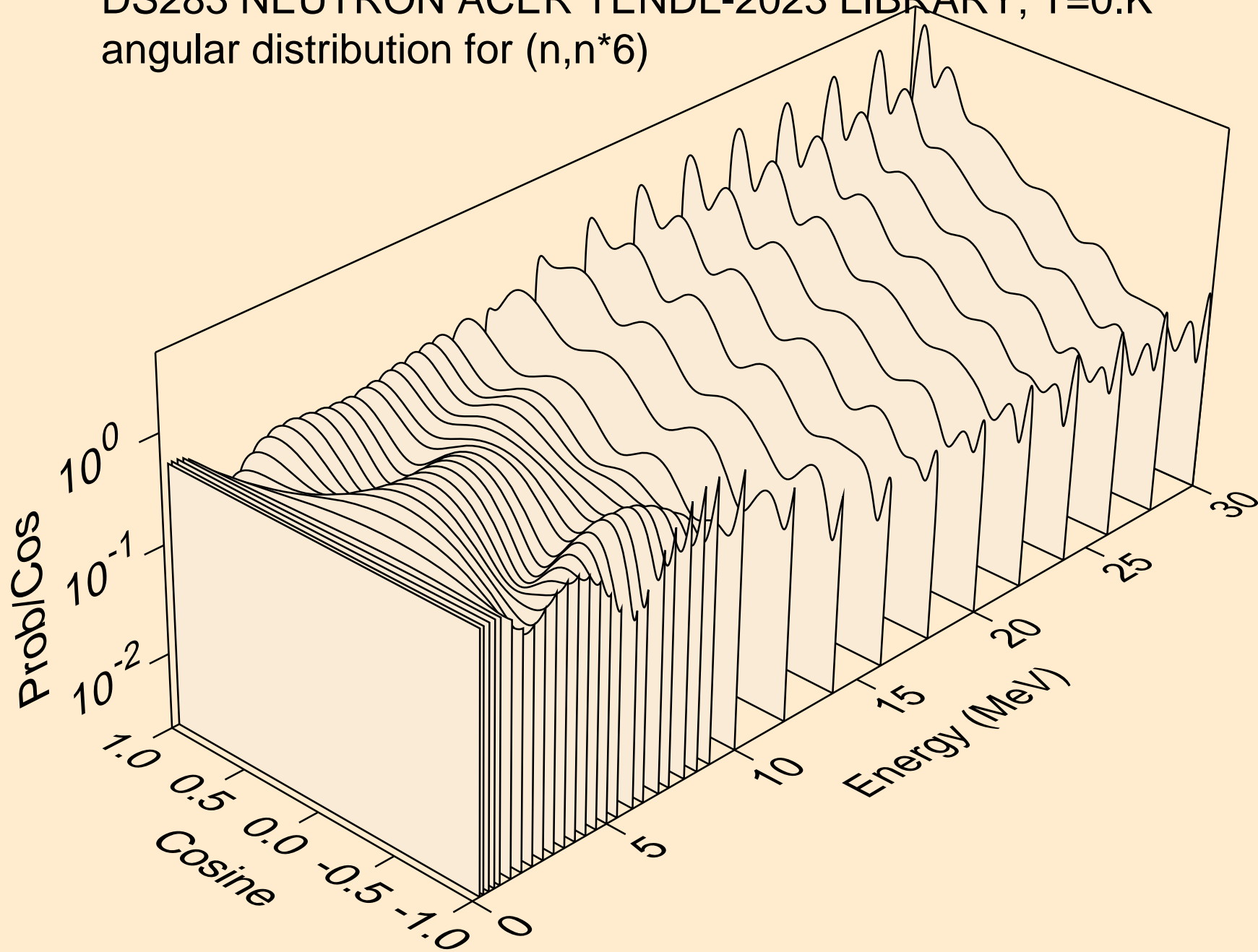

DS283 NEUTRON ACER TENDL-2023 LIBRARY; T=0.K
angular distribution for (n,n*7)

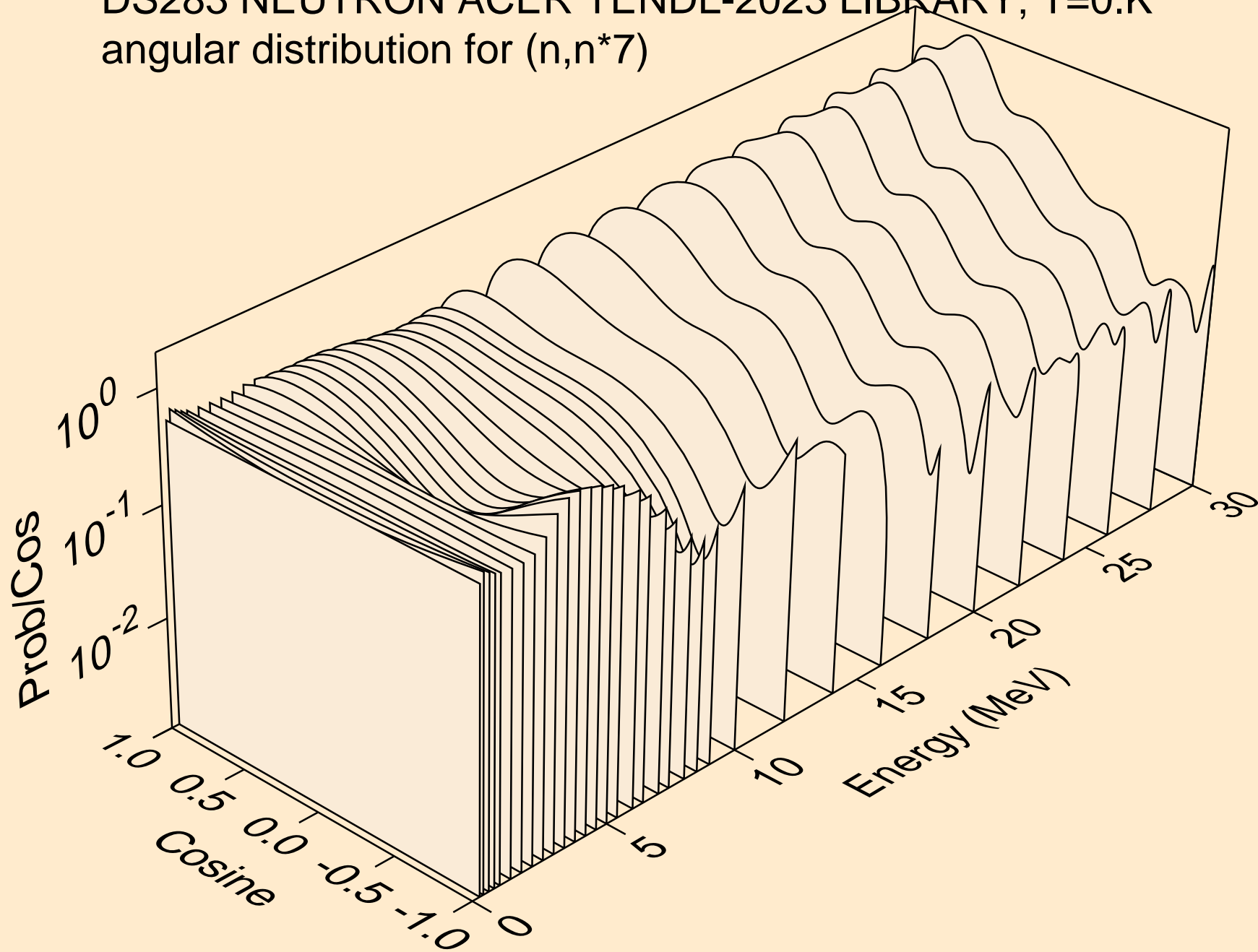

DS283 NEUTRON ACER TENDL-2023 LIBRARY; T=0.K
angular distribution for (n,n*8)

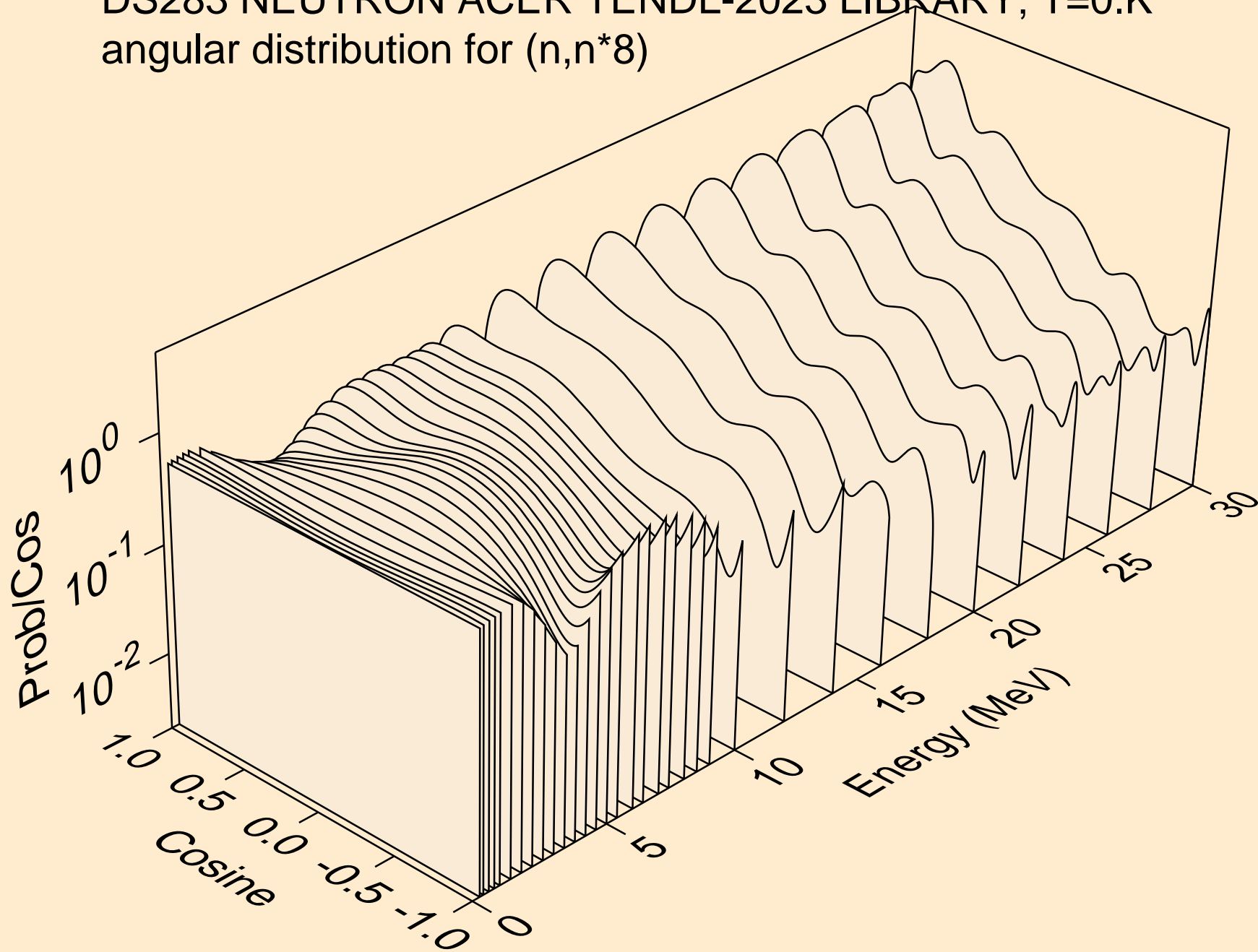

DS283 NEUTRON ACER TENDL-2023 LIBRARY; T=0.K
angular distribution for (n,n*9)

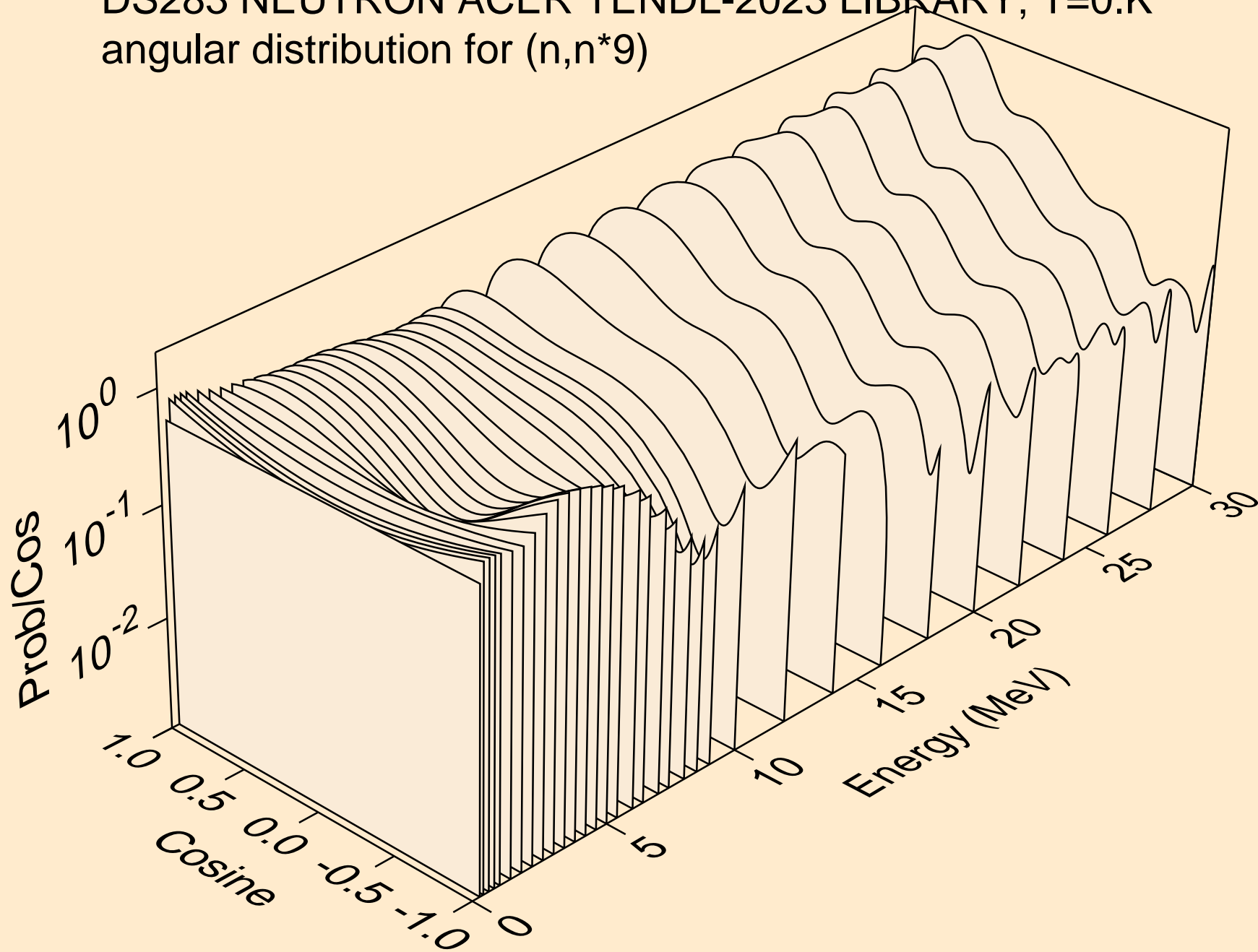

DS283 NEUTRON ACER TENDL-2023 LIBRARY; T=0.K
angular distribution for (n,n*10)

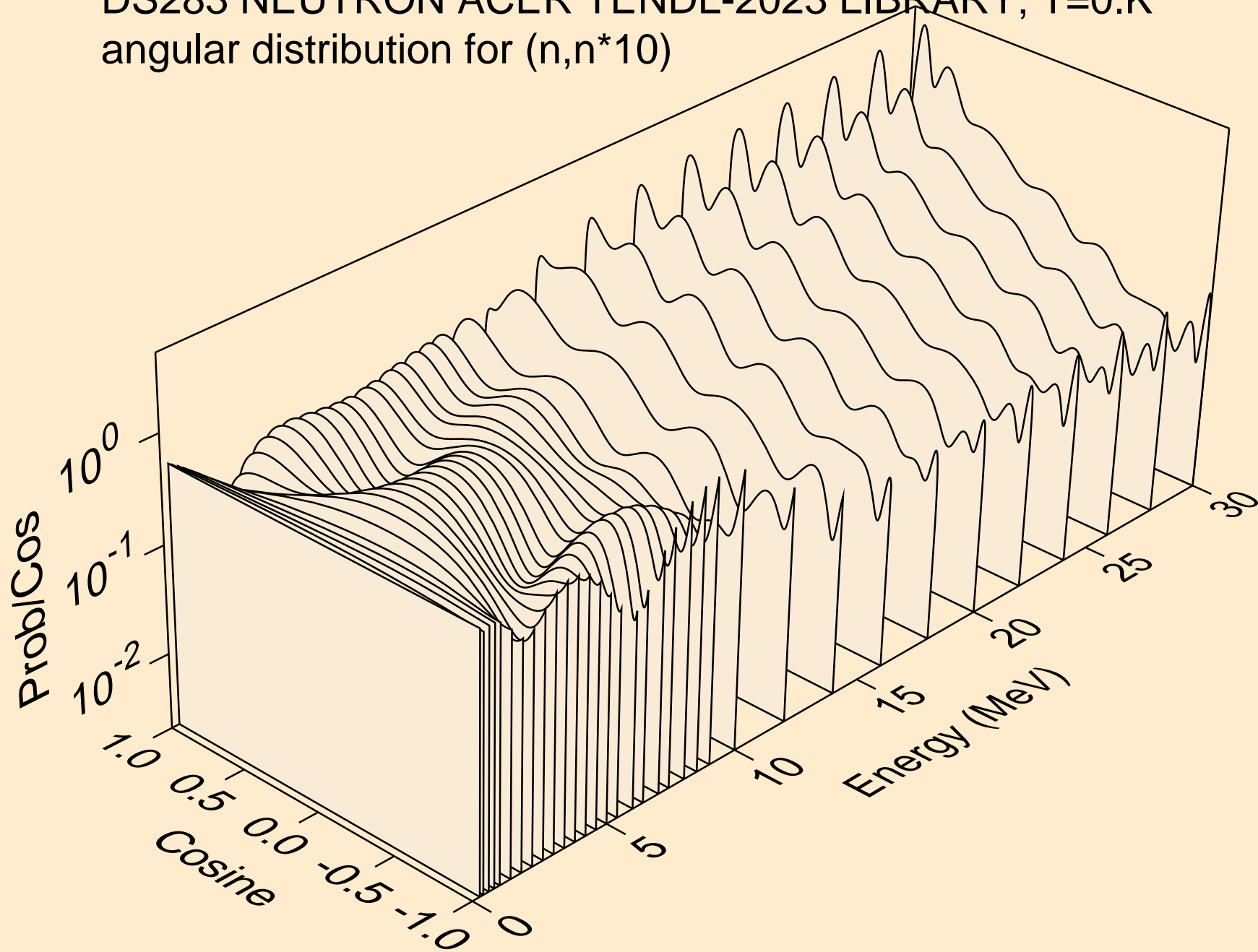

DS283 NEUTRON ACER TENDL-2023 LIBRARY; T=0.K
angular distribution for (n,n*11)

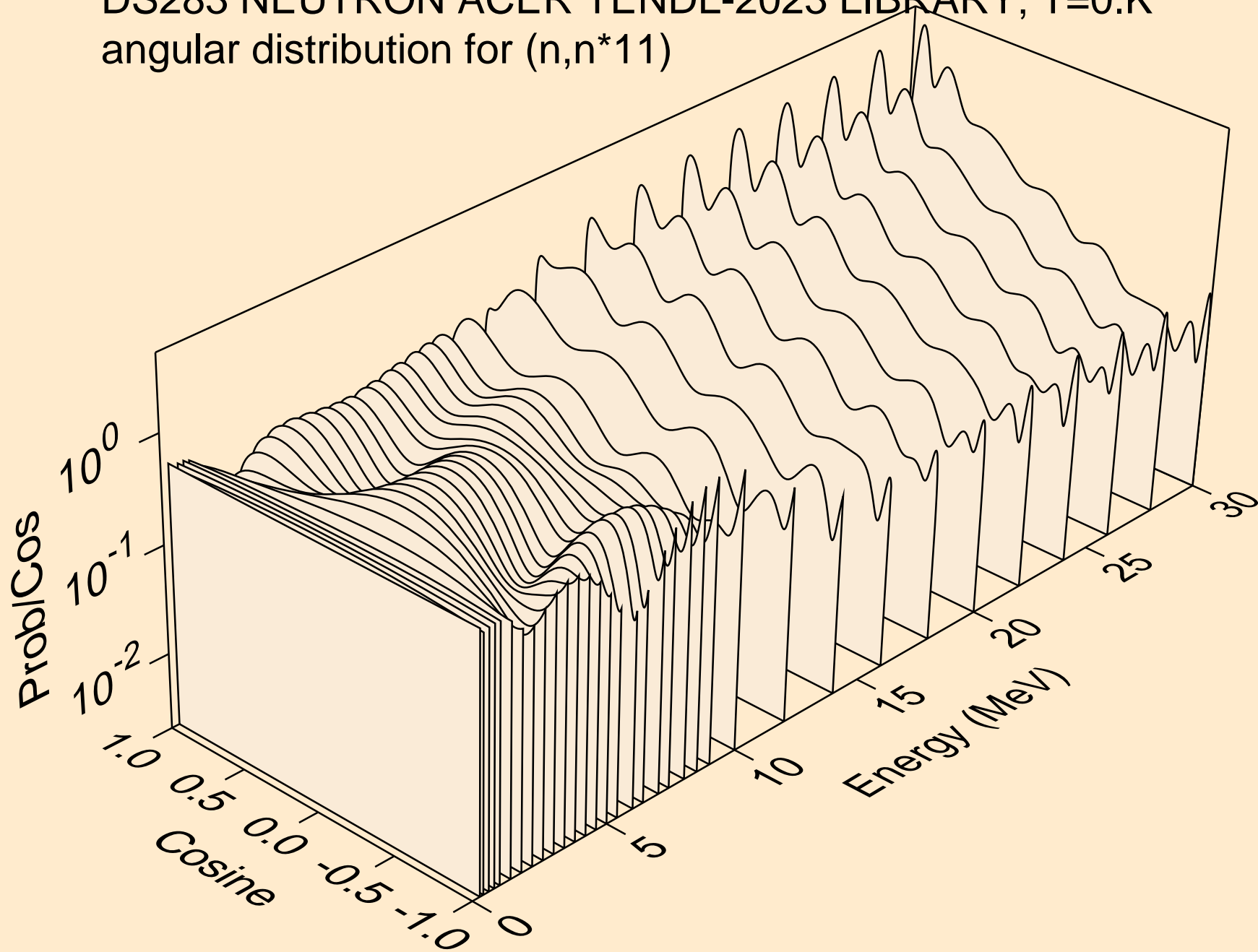

DS283 NEUTRON ACER TENDL-2023 LIBRARY; T=0.K
angular distribution for (n,n*12)

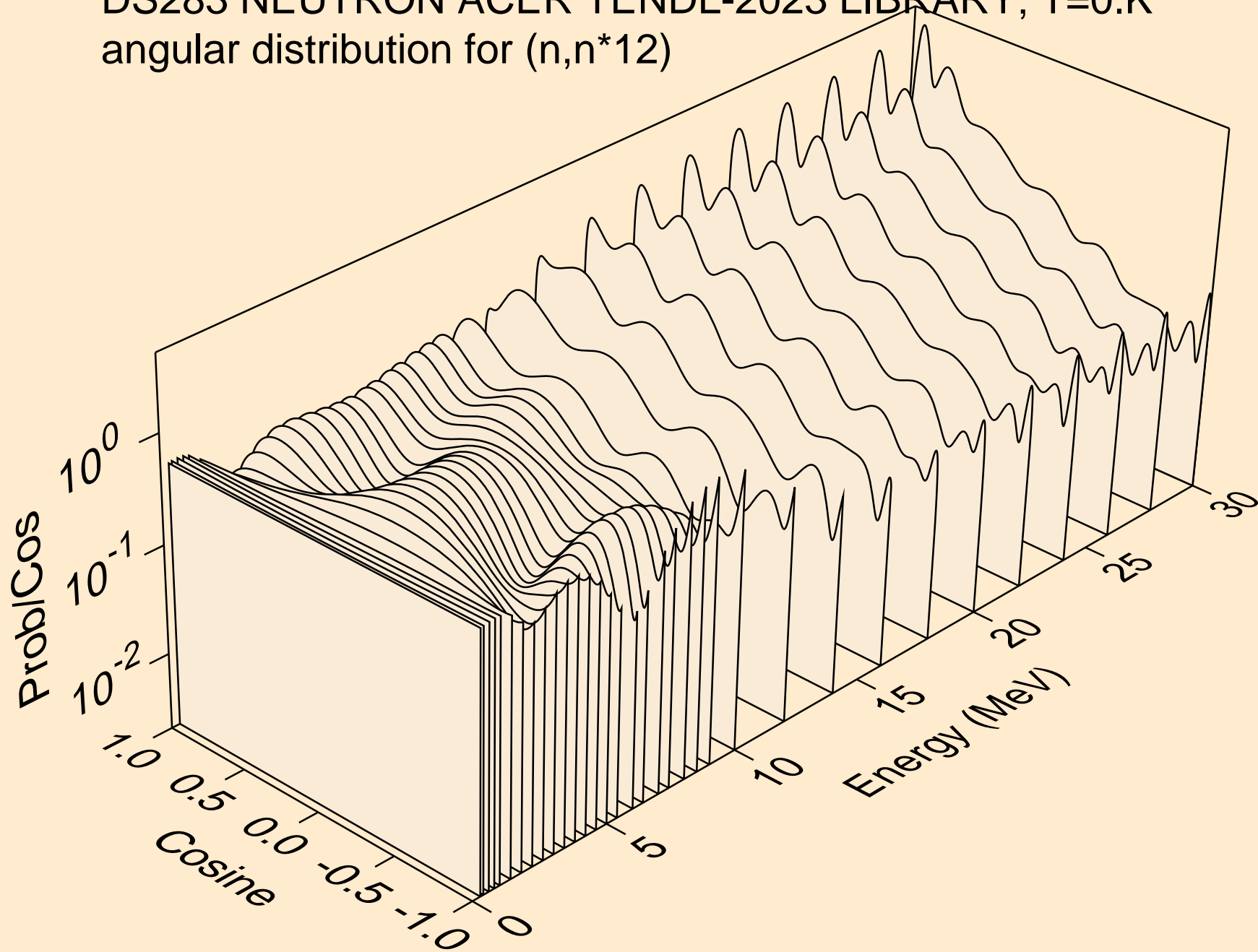

DS283 NEUTRON ACER TENDL-2023 LIBRARY; T=0.K
angular distribution for (n,n*13)

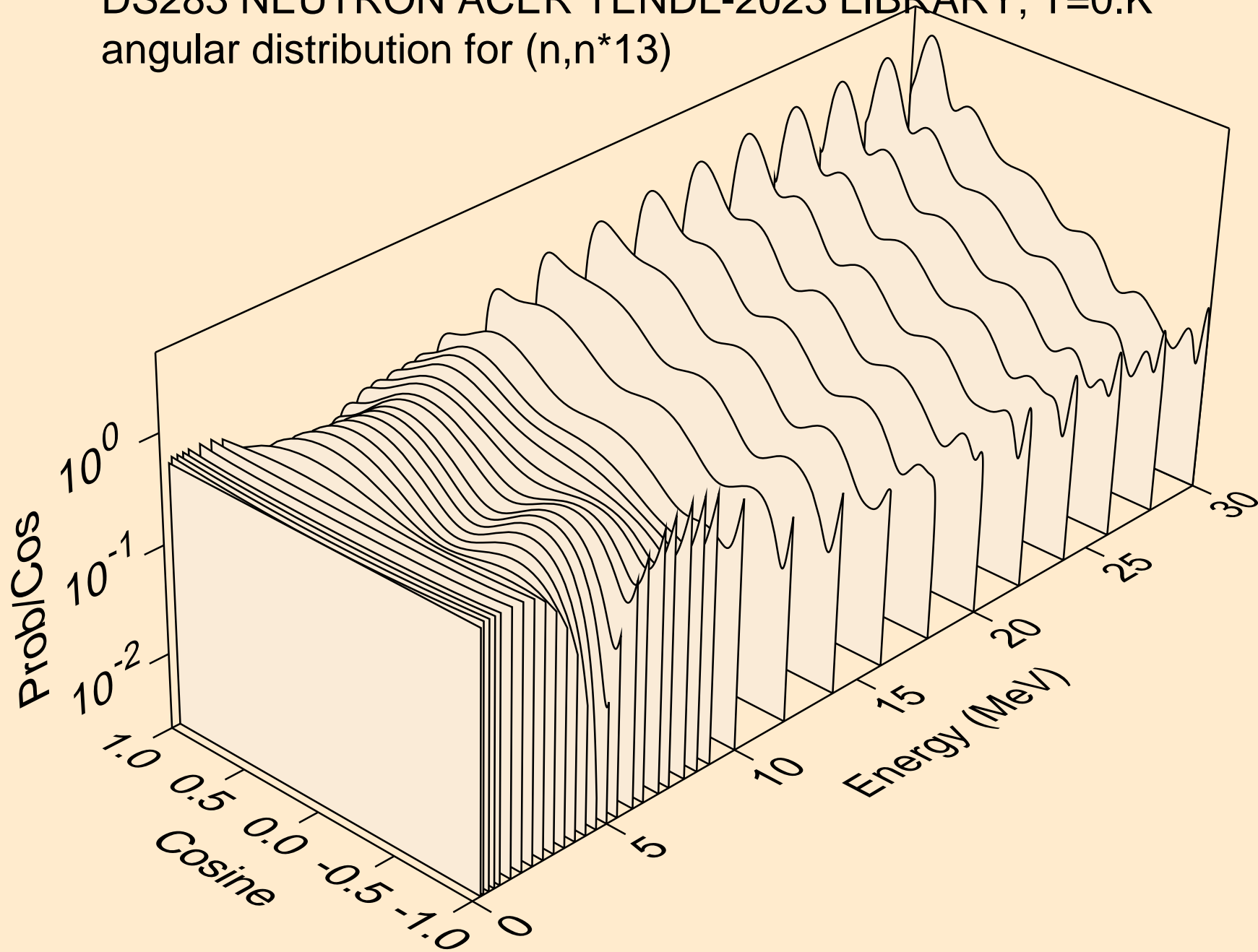

DS283 NEUTRON ACER TENDL-2023 LIBRARY; T=0.K
angular distribution for (n,n*14)

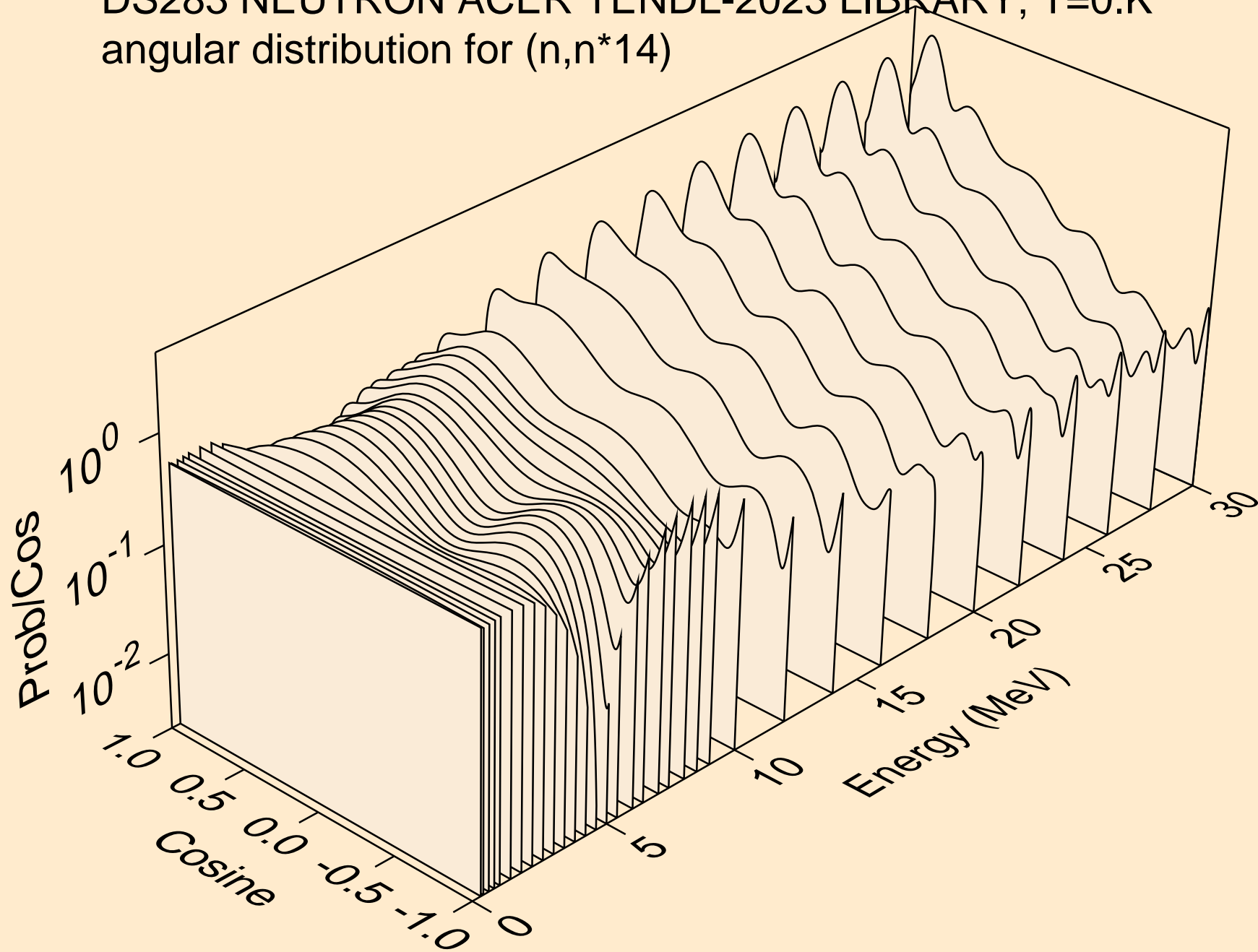

DS283 NEUTRON ACER TENDL-2023 LIBRARY; T=0.K
angular distribution for (n,n*15)

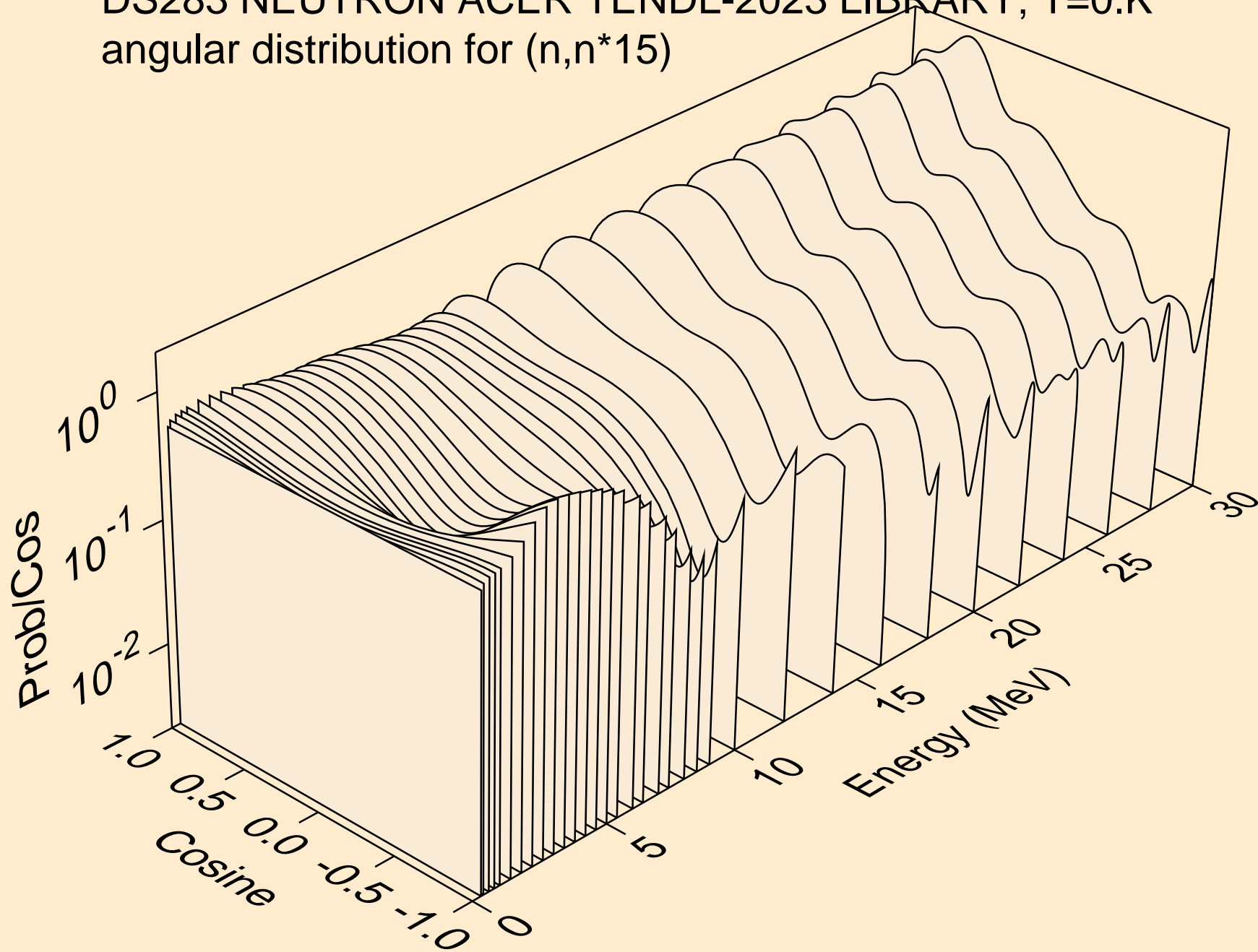

DS283 NEUTRON ACER TENDL-2023 LIBRARY; T=0.K
angular distribution for (n,n*16)

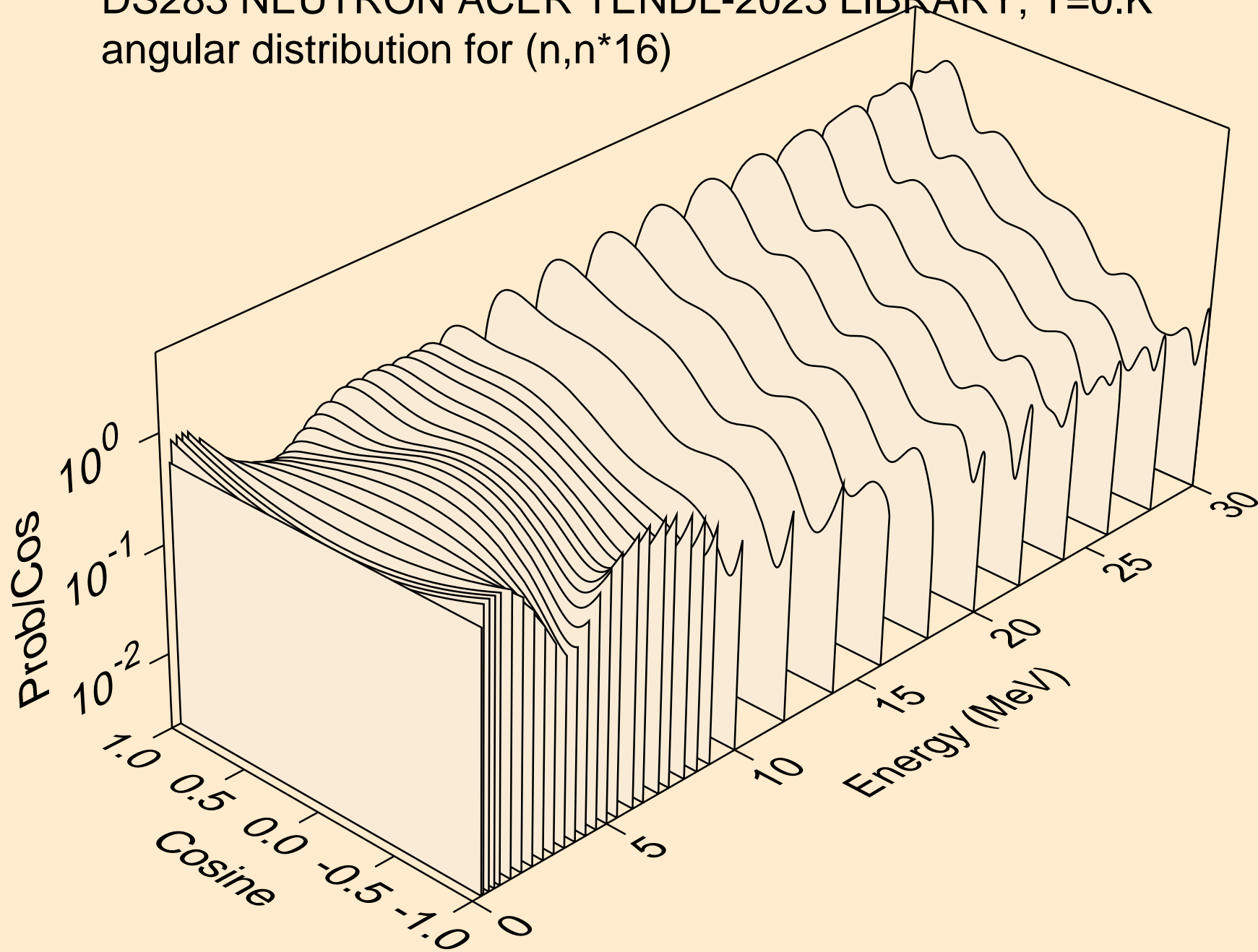

DS283 NEUTRON ACER TENDL-2023 LIBRARY; T=0.K
angular distribution for (n,n*17)

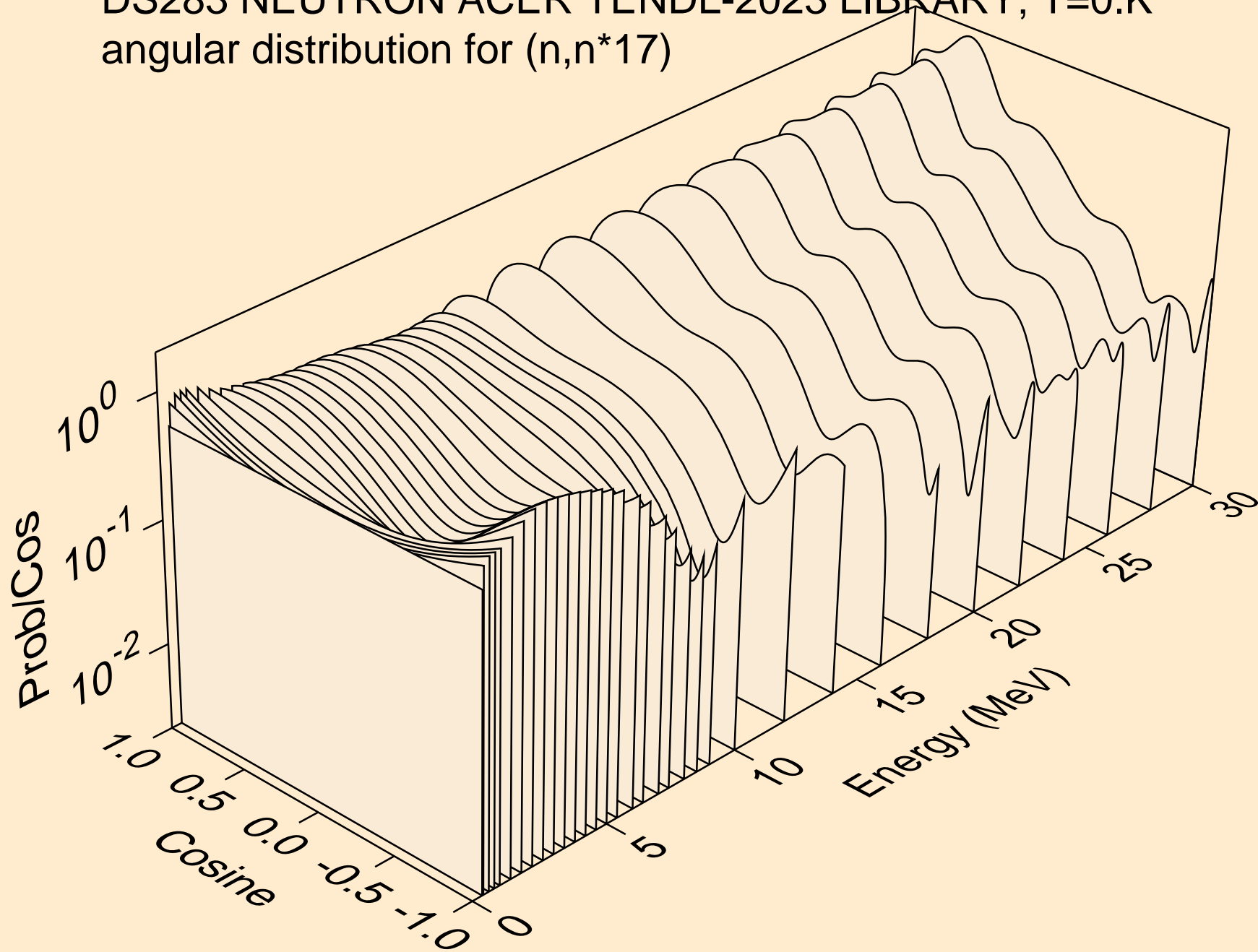

DS283 NEUTRON ACER TENDL-2023 LIBRARY; T=0.K
angular distribution for (n,n*18)

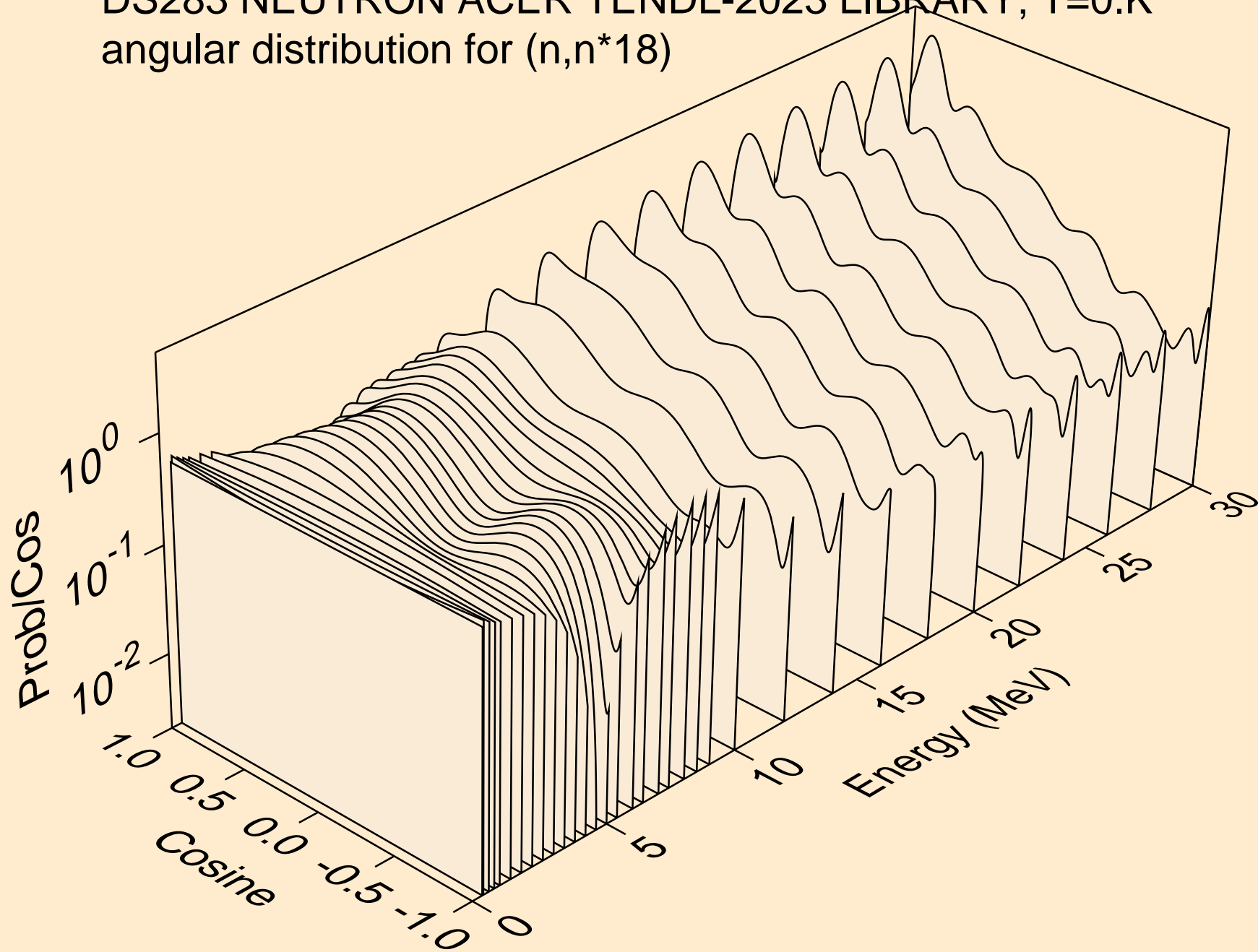

DS283 NEUTRON ACER TENDL-2023 LIBRARY; T=0.K
angular distribution for (n,n*19)

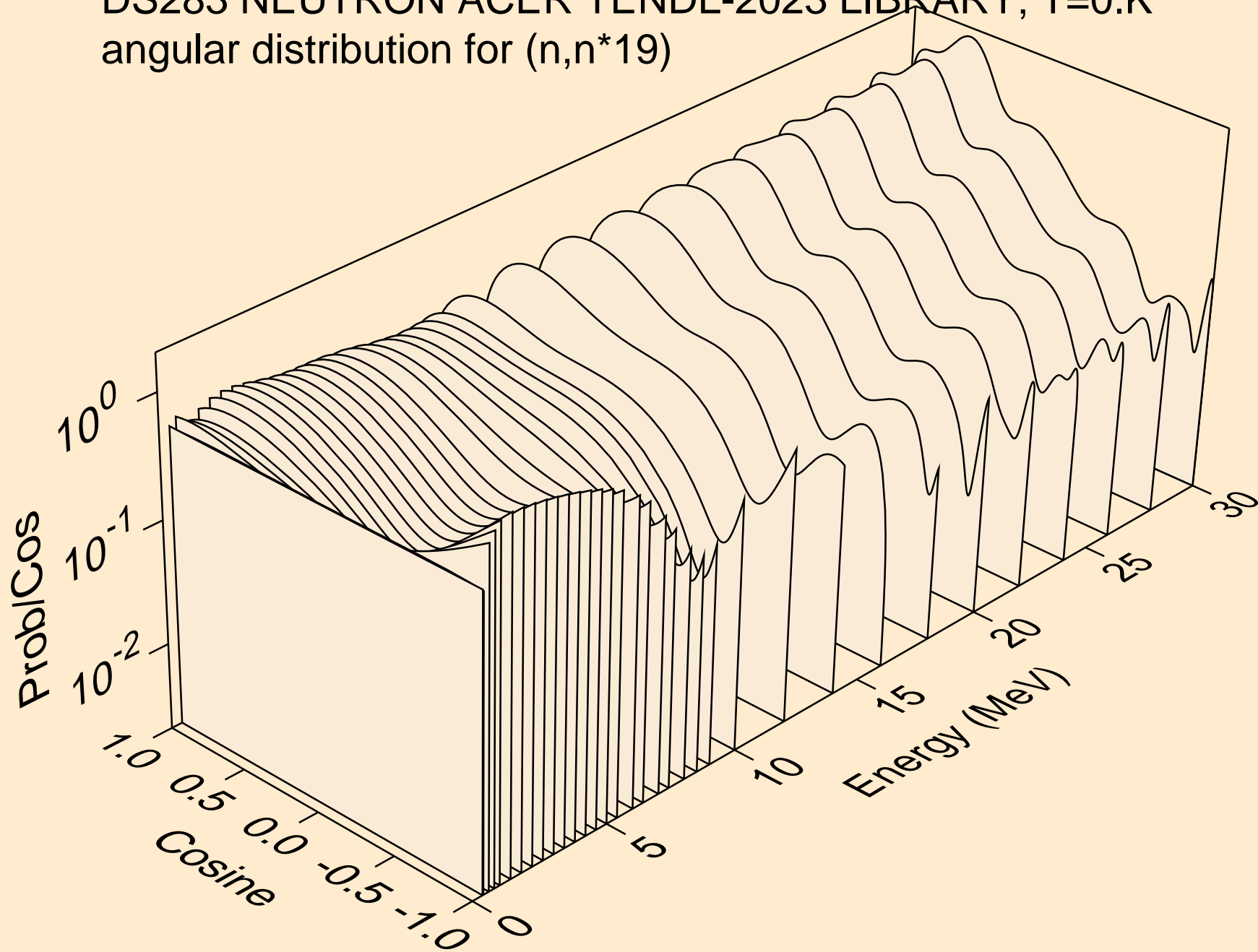

DS283 NEUTRON ACER TENDL-2023 LIBRARY; T=0.K
angular distribution for (n,n*20)

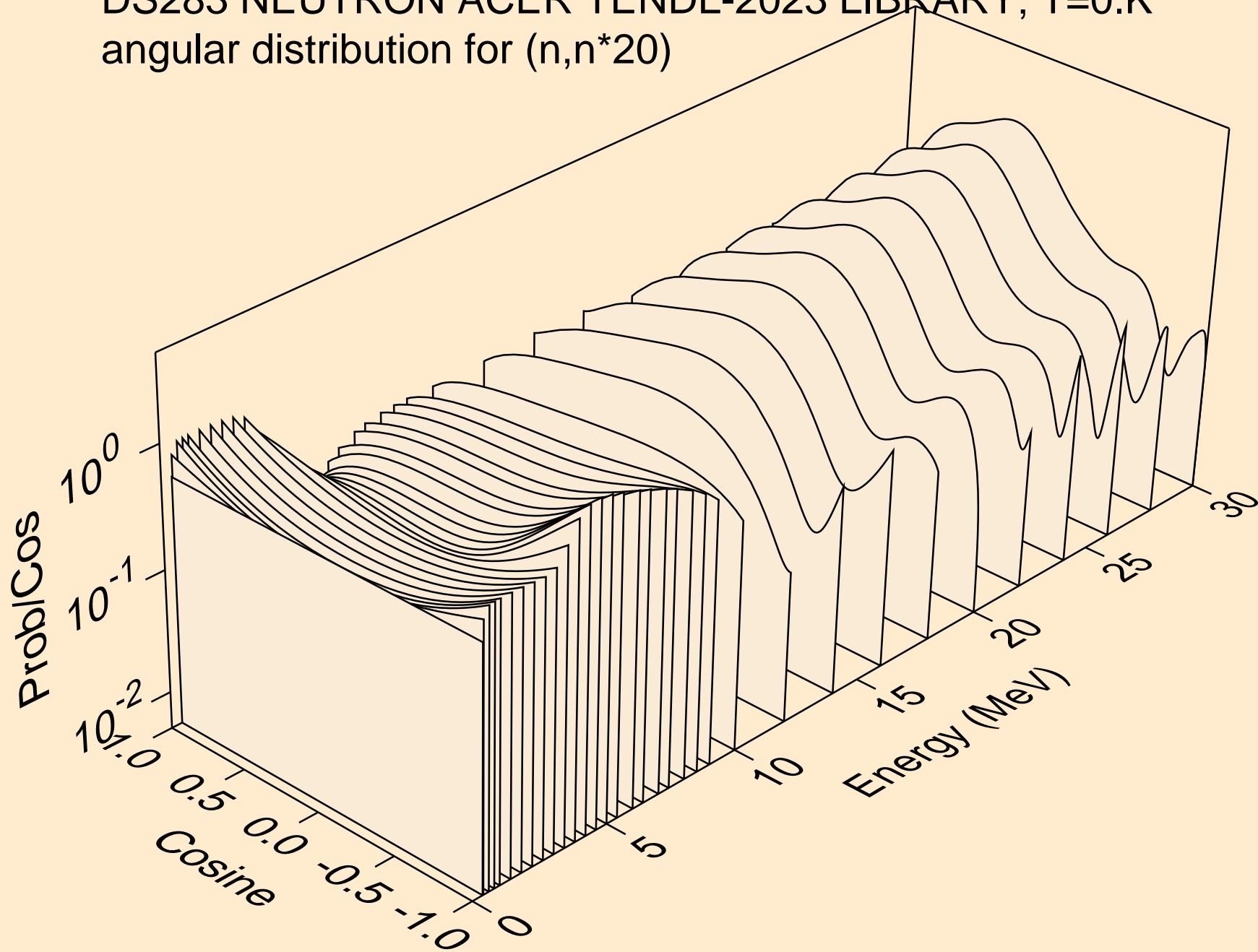

DS283 NEUTRON ACER TENDL-2023 LIBRARY; T=0.K
angular distribution for (n,n*21)

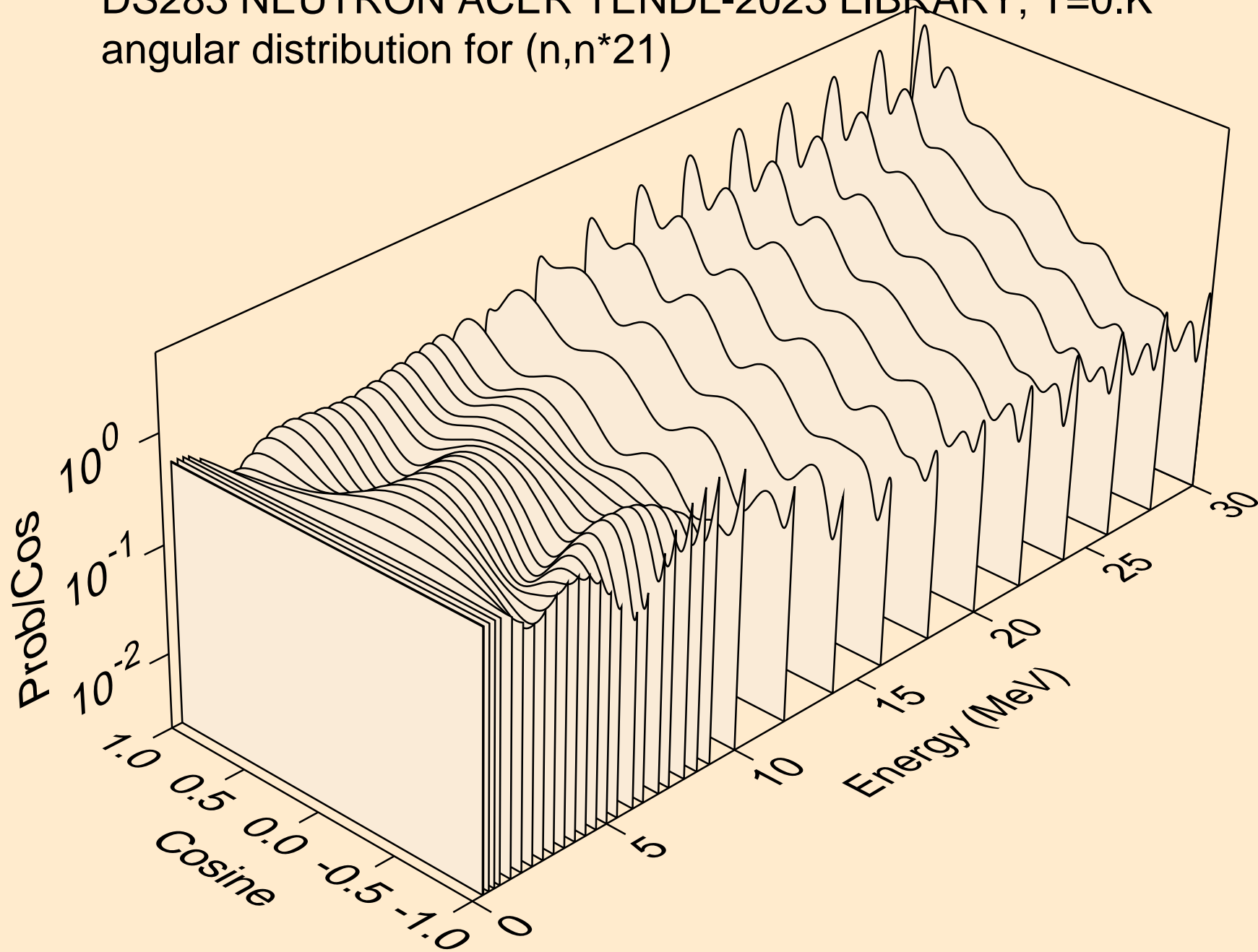

DS283 NEUTRON ACER TENDL-2023 LIBRARY; T=0.K
angular distribution for (n,n*22)

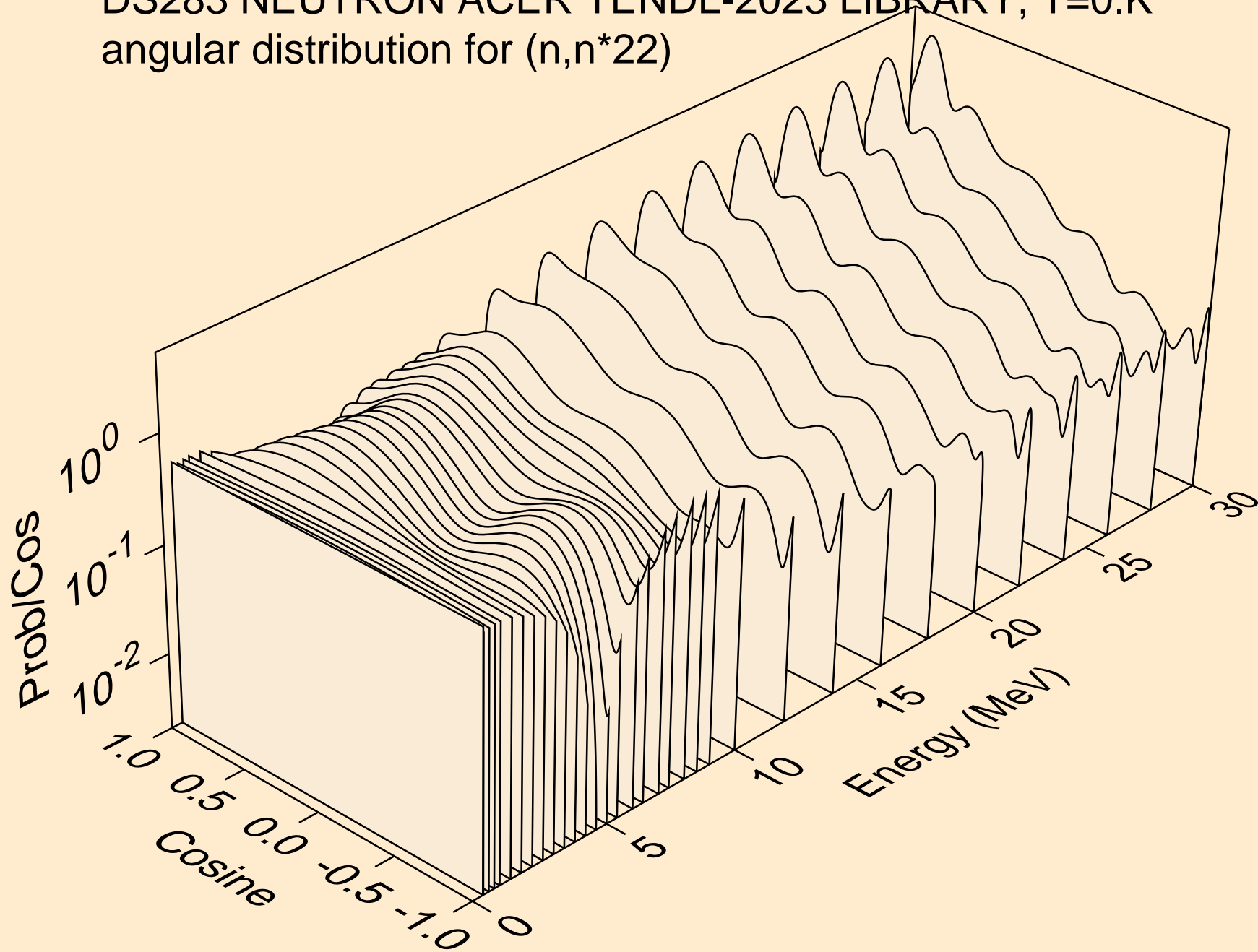

DS283 NEUTRON ACER TENDL-2023 LIBRARY; T=0.K
angular distribution for (n,n*23)

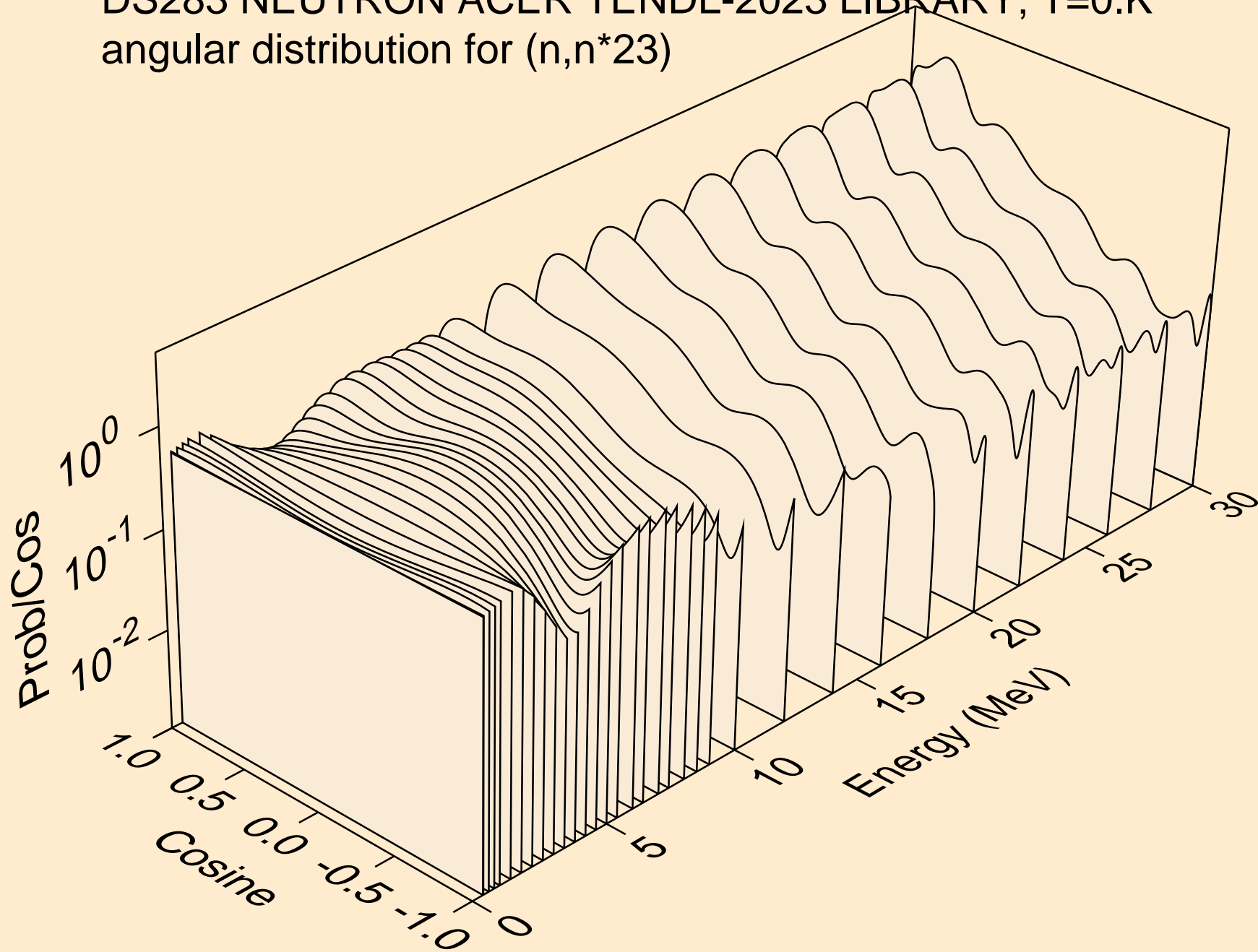

DS283 NEUTRON ACER TENDL-2023 LIBRARY; T=0.K
angular distribution for (n,n*24)

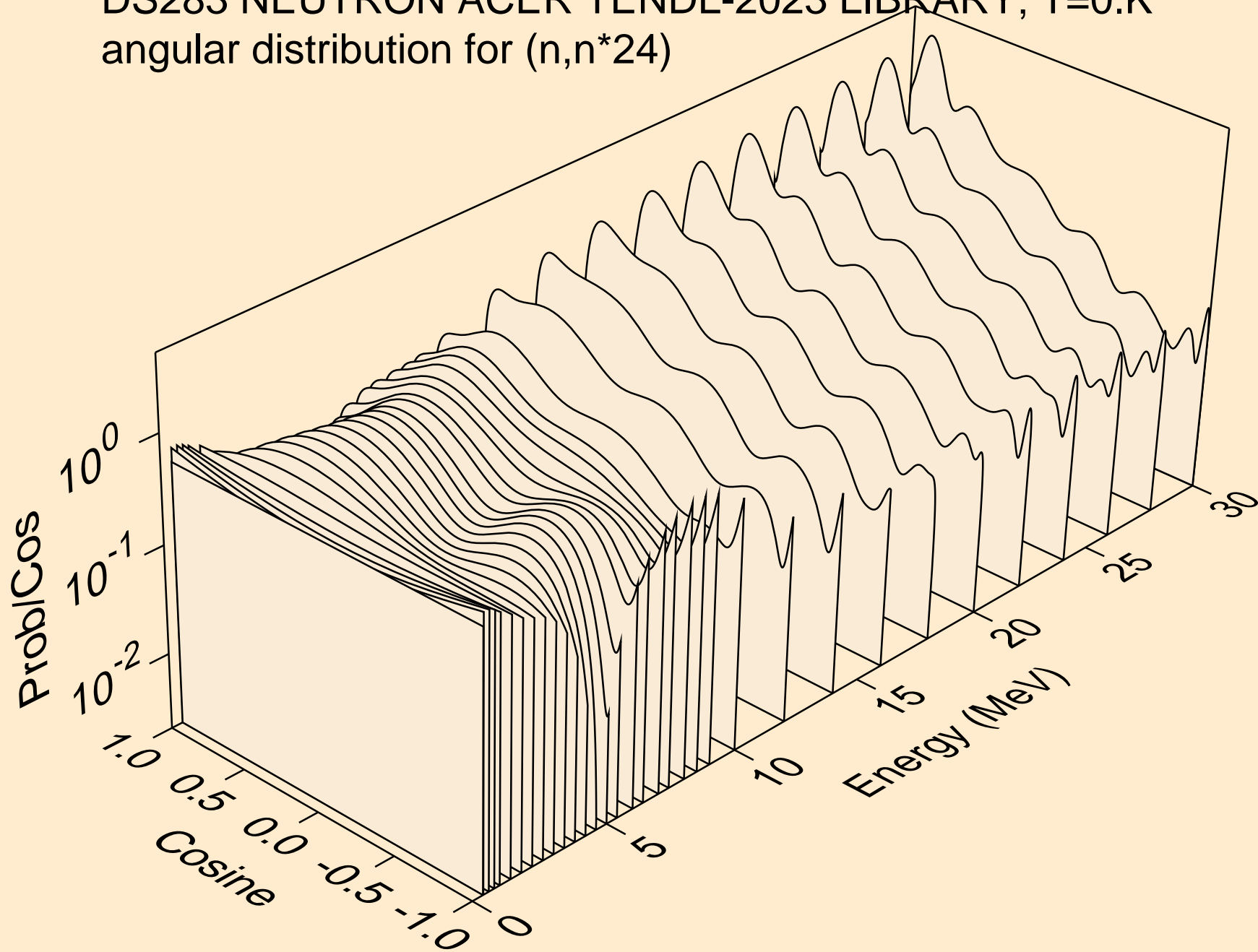

DS283 NEUTRON ACER TENDL-2023 LIBRARY; T=0.K
angular distribution for (n,n*25)

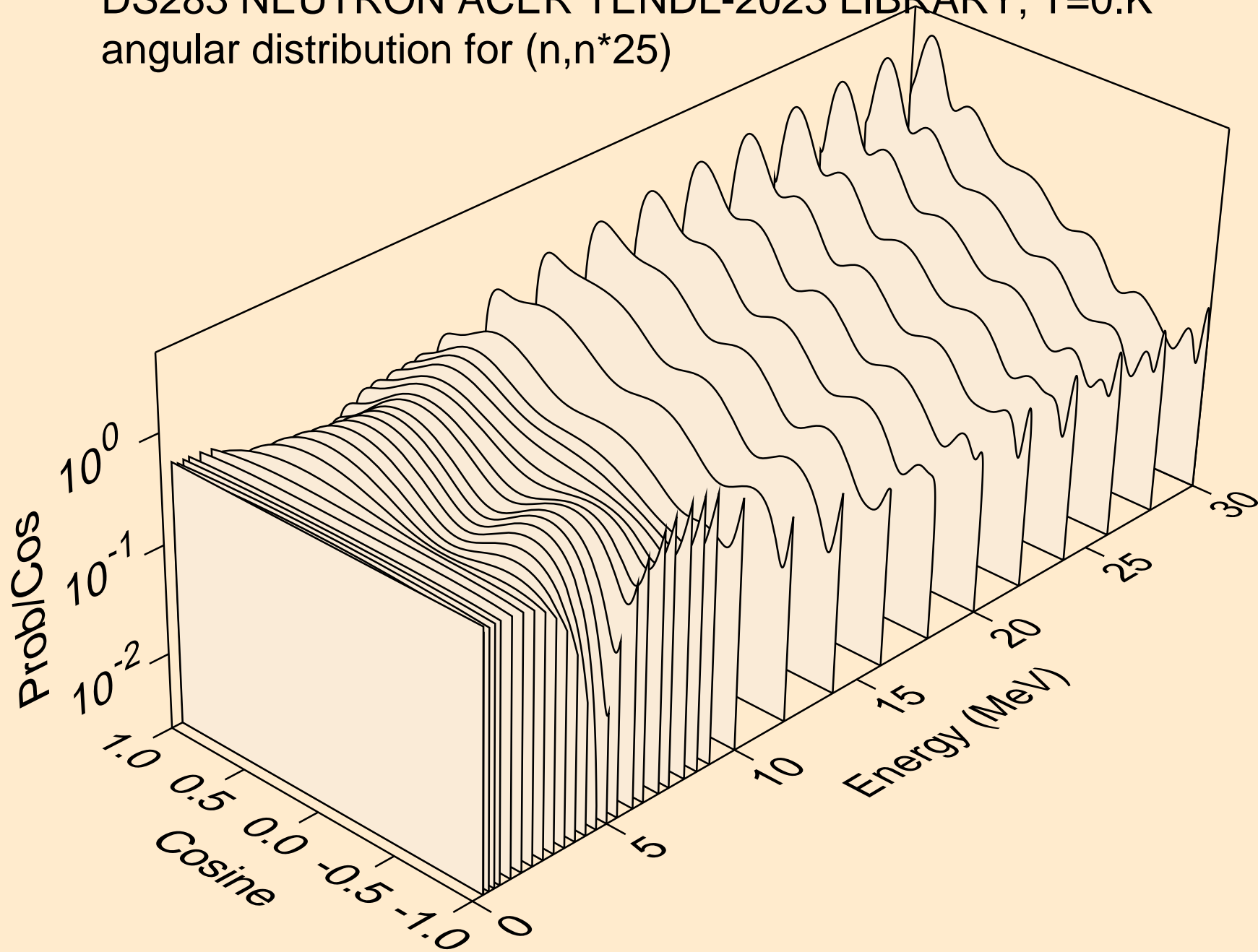

DS283 NEUTRON ACER TENDL-2023 LIBRARY; T=0.K
angular distribution for (n,n*26)

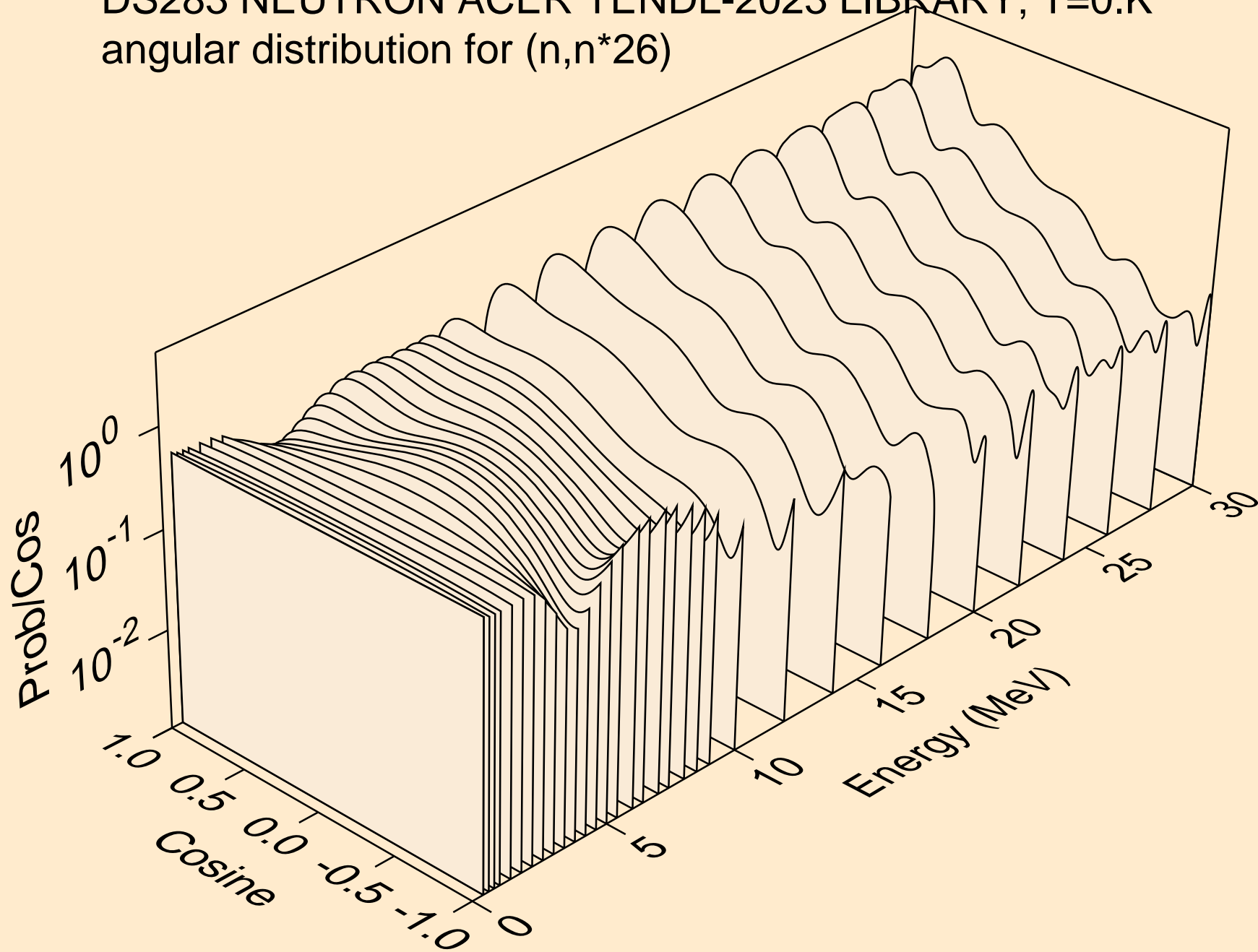

DS283 NEUTRON ACER TENDL-2023 LIBRARY; T=0.K
angular distribution for (n,n*27)

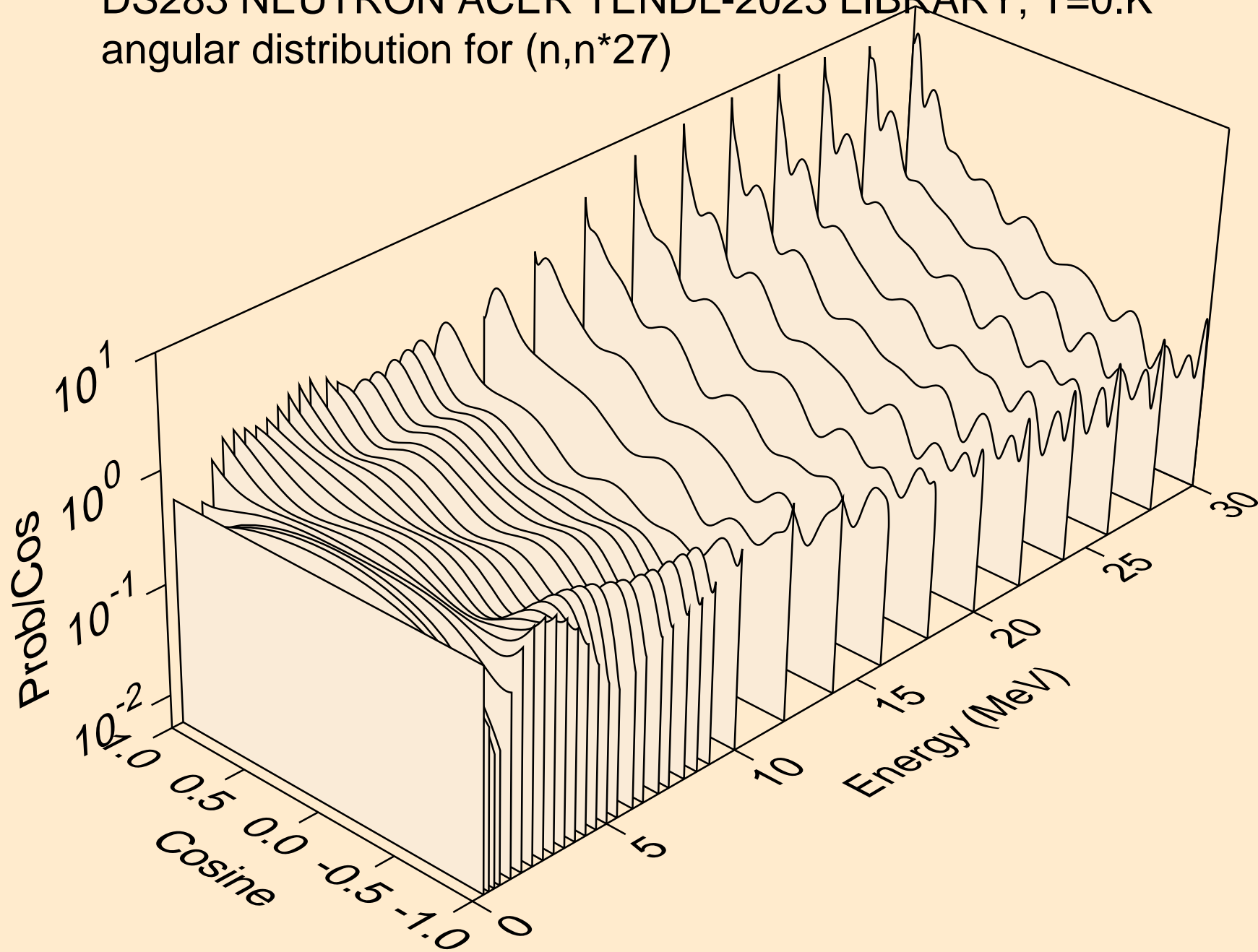

DS283 NEUTRON ACER TENDL-2023 LIBRARY; T=0.K

Total fission nubar

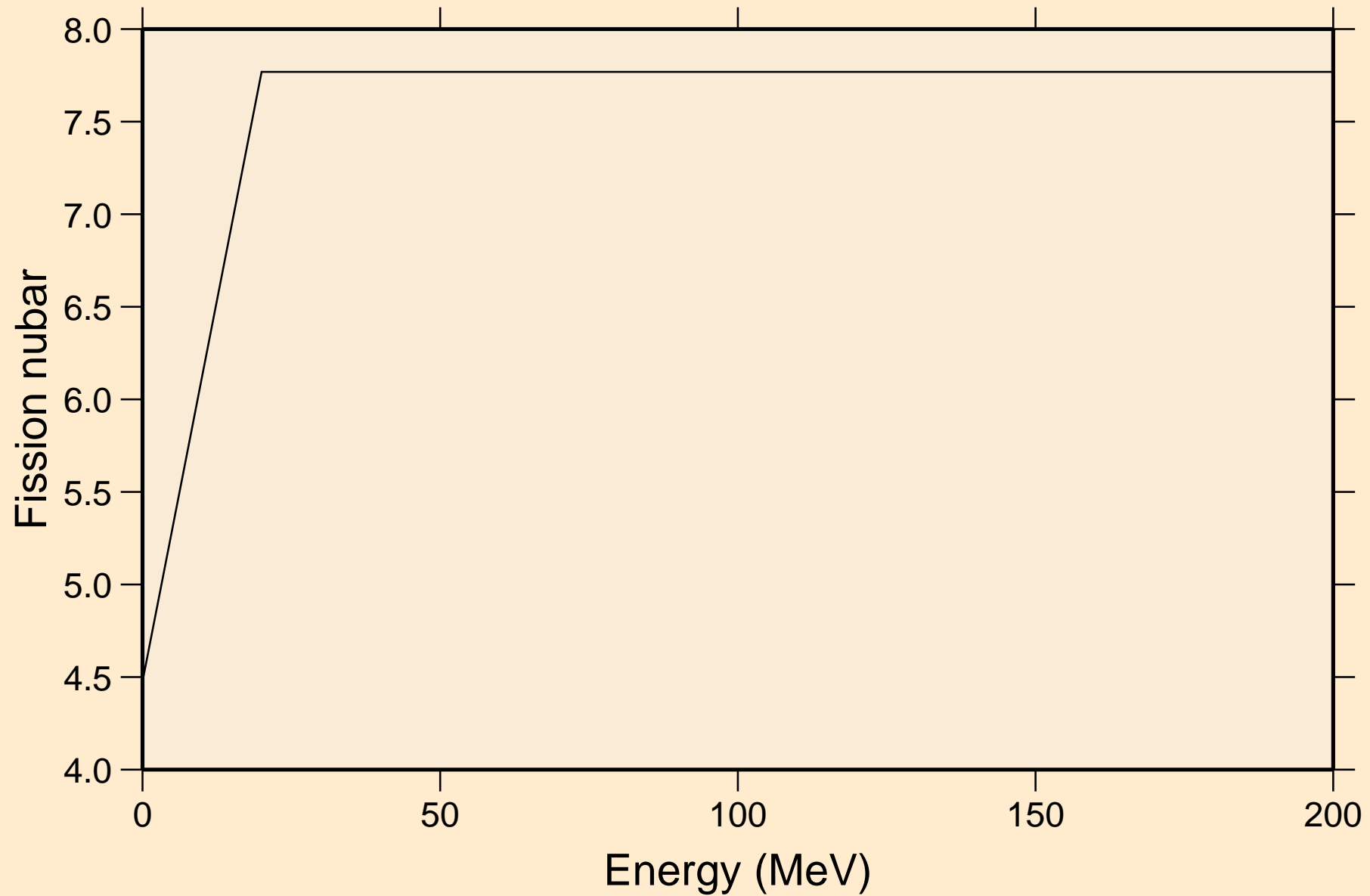

DS283 NEUTRON ACER TENDL-2023 LIBRARY; T=0.K
Neutron emission for (n,x)

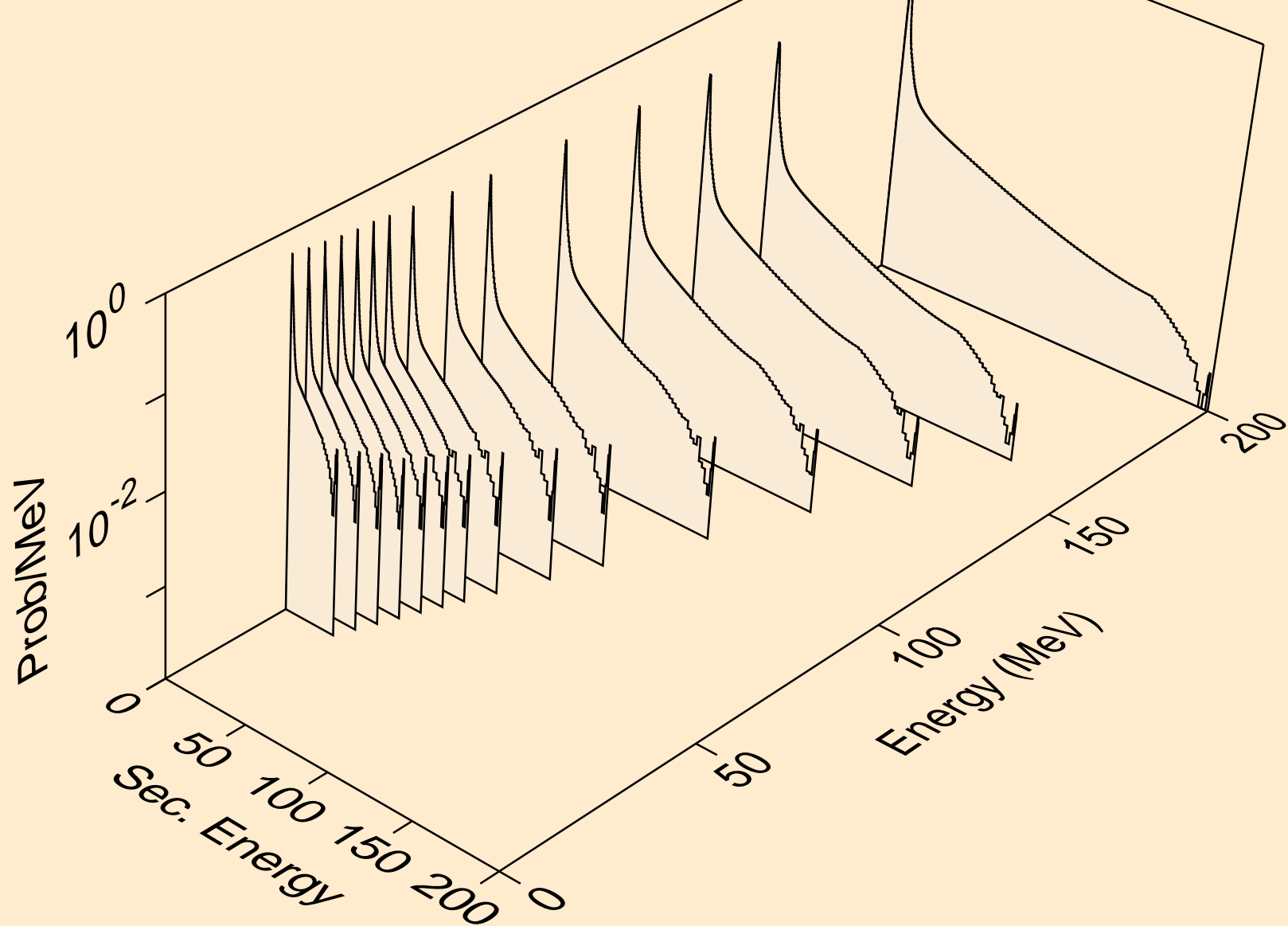

DS283 NEUTRON ACER TENDL-2023 LIBRARY; T=0.K
Neutron emission for (n,2nd)

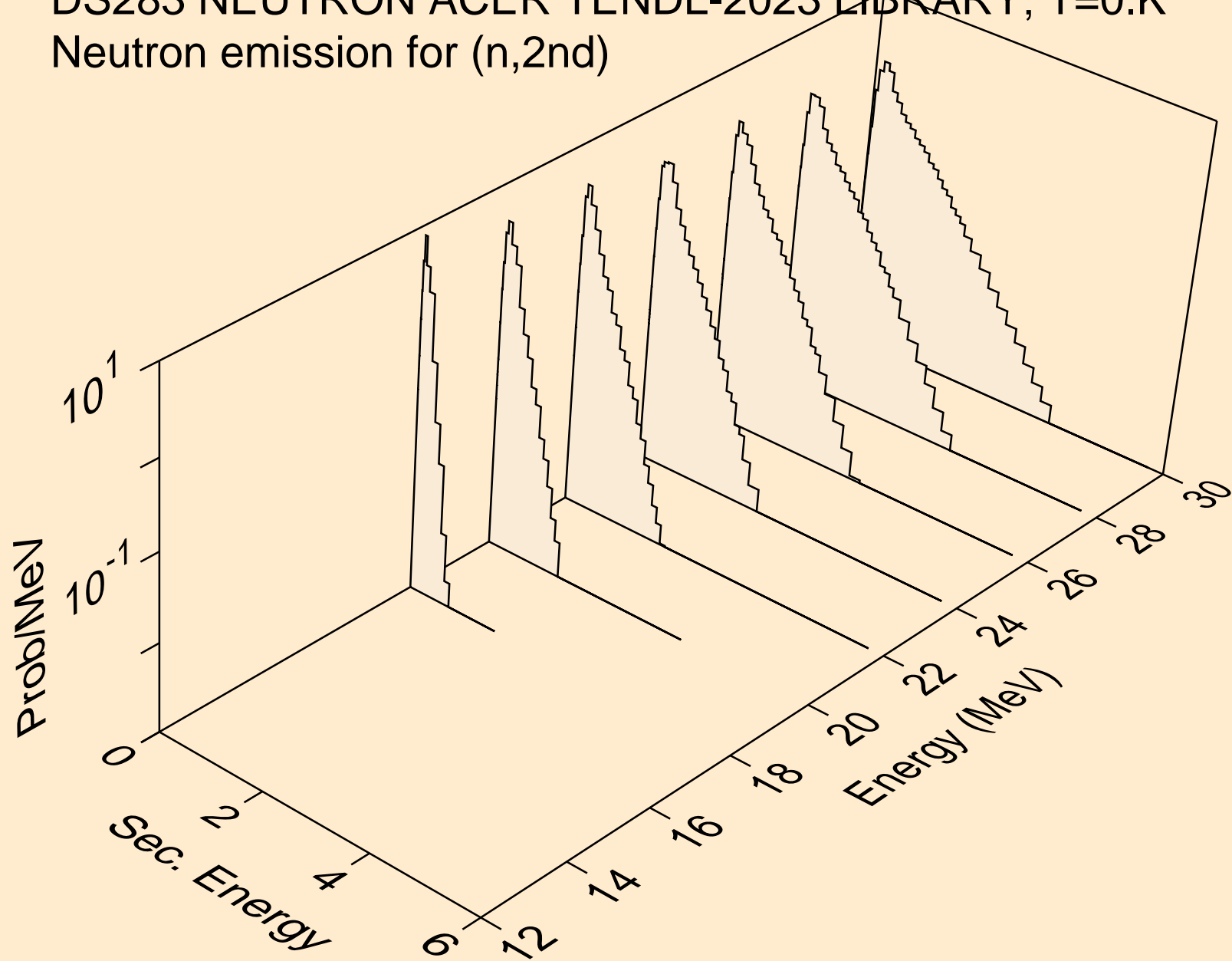

DS283 NEUTRON ACER TENDL-2023 LIBRARY; T=0.K
Neutron emission for (n,2n)

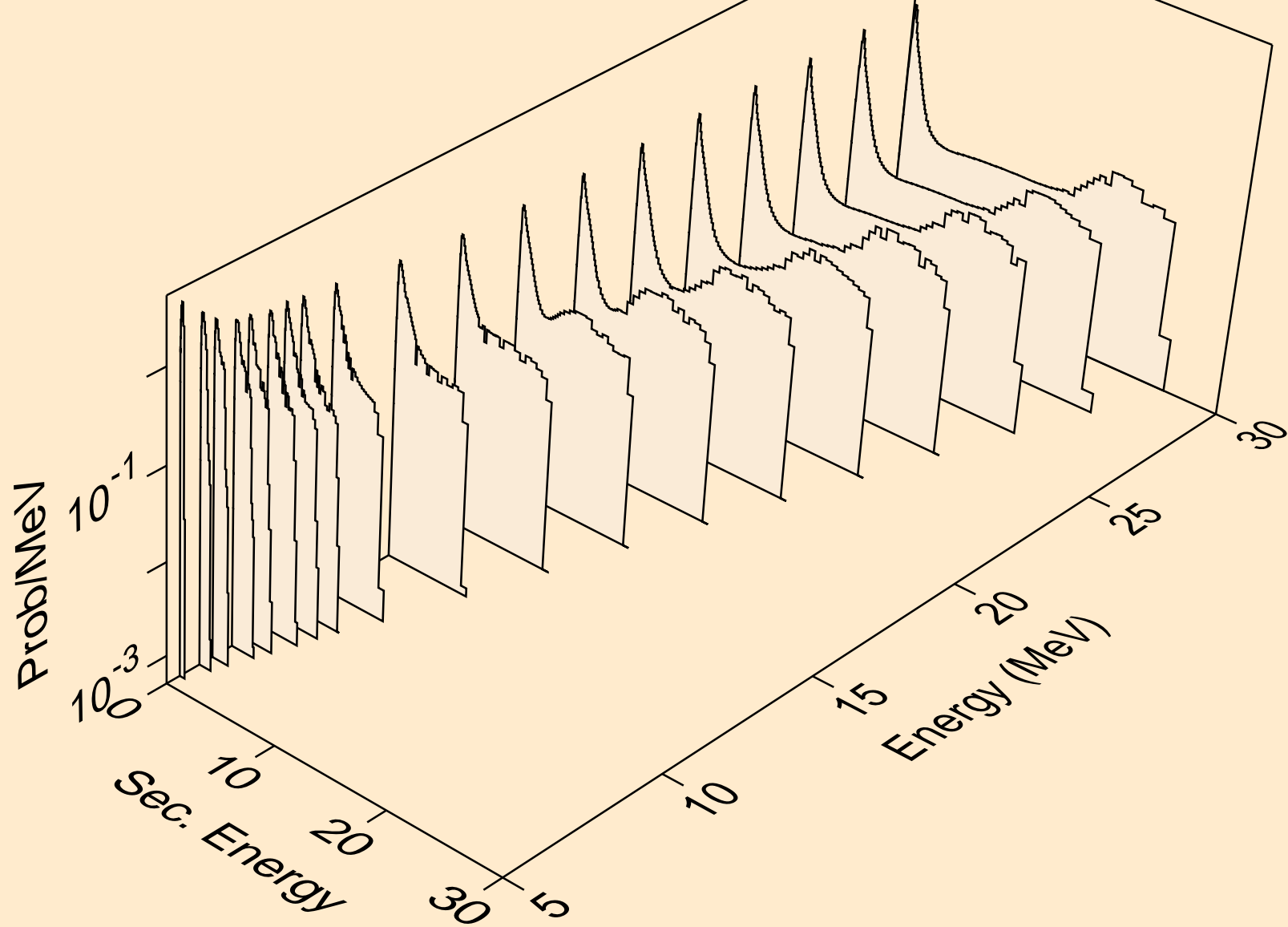

DS283 NEUTRON ACER TENDL-2023 LIBRARY; T=0.K
Neutron emission for (n,3n)

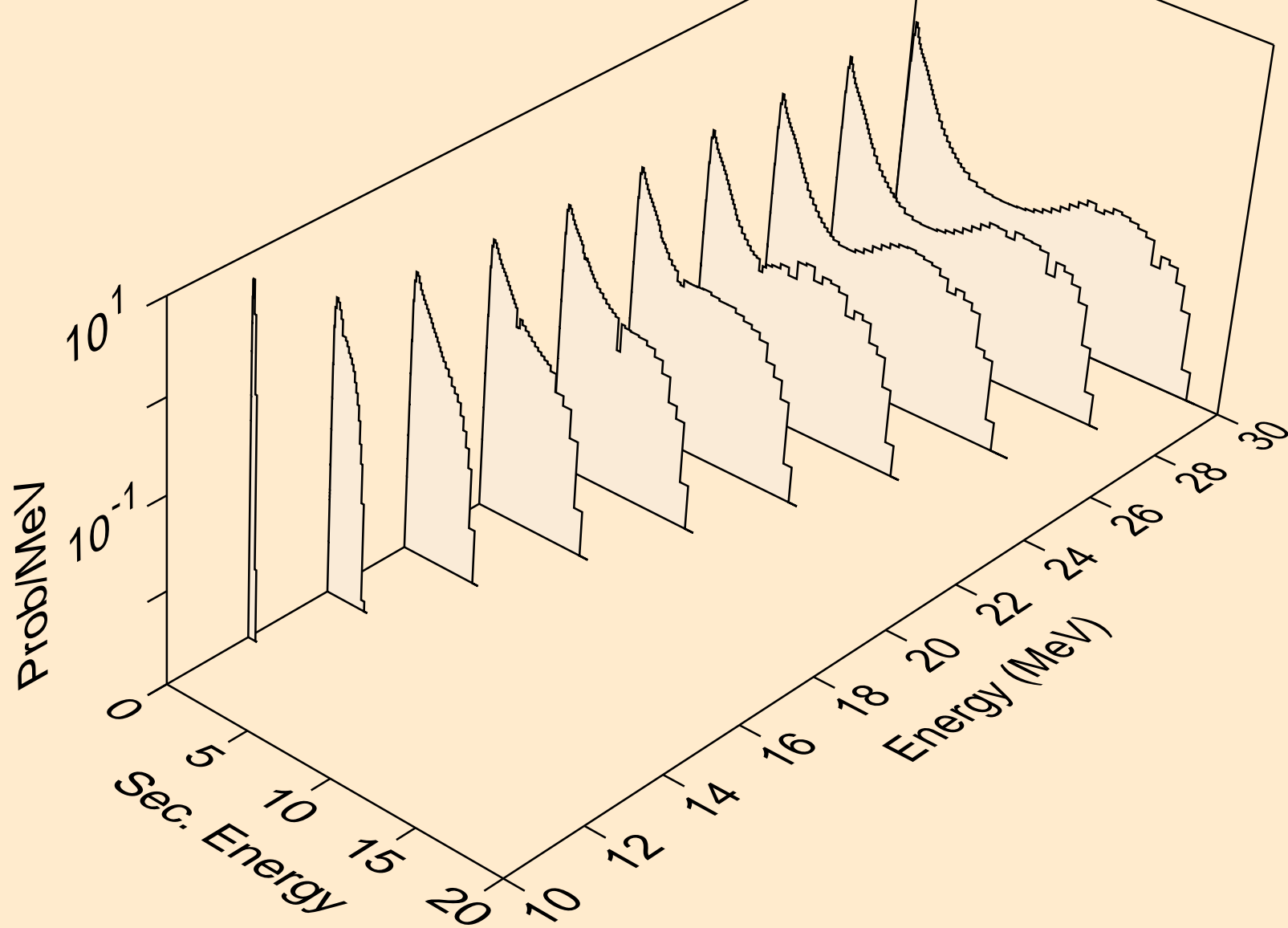

DS283 NEUTRON ACER TENDL-2023 LIBRARY; T=0.K
Neutron emission for fission

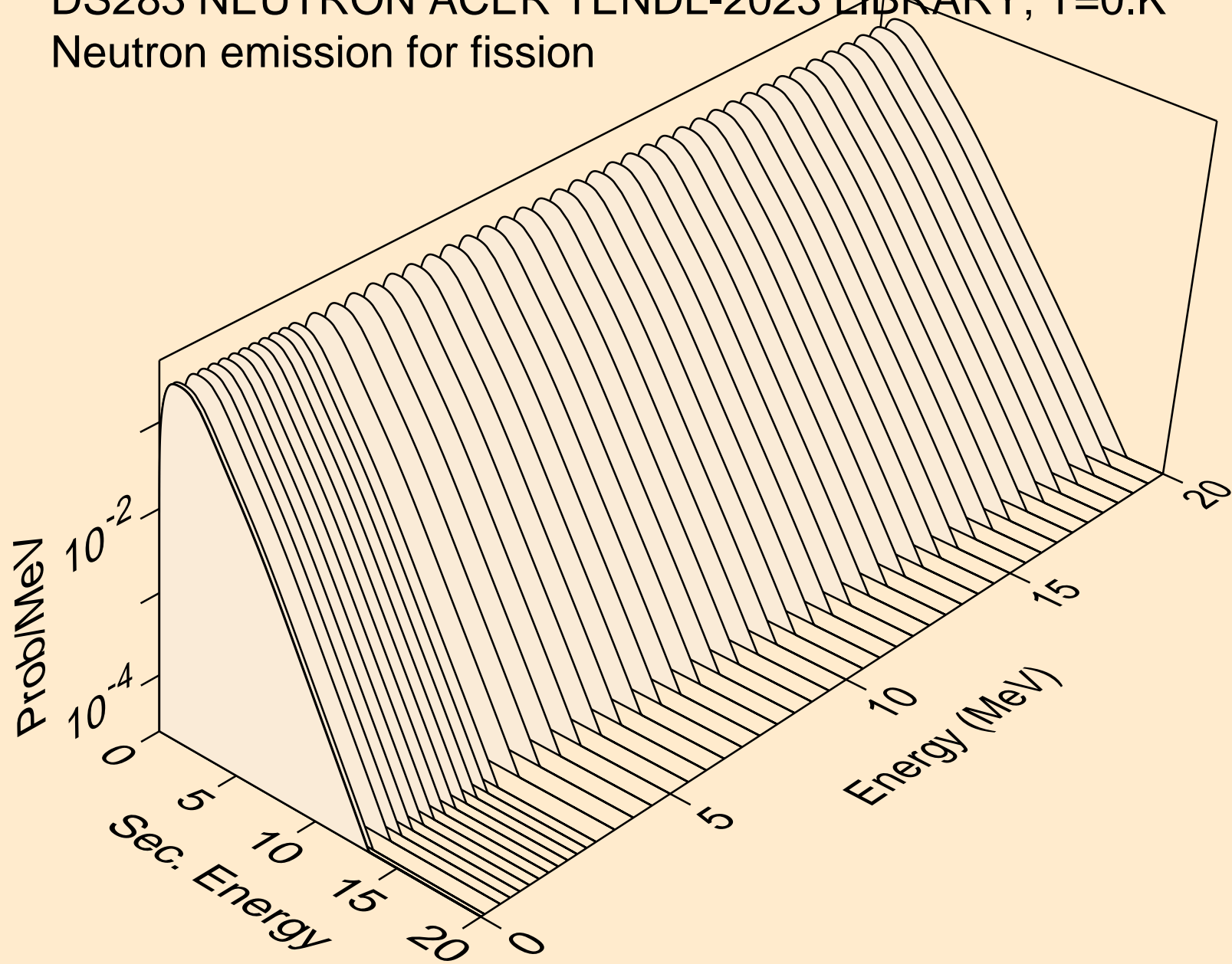

DS283 NEUTRON ACER TENDL-2023 LIBRARY; T=0.K
Neutron emission for (n,n*)a

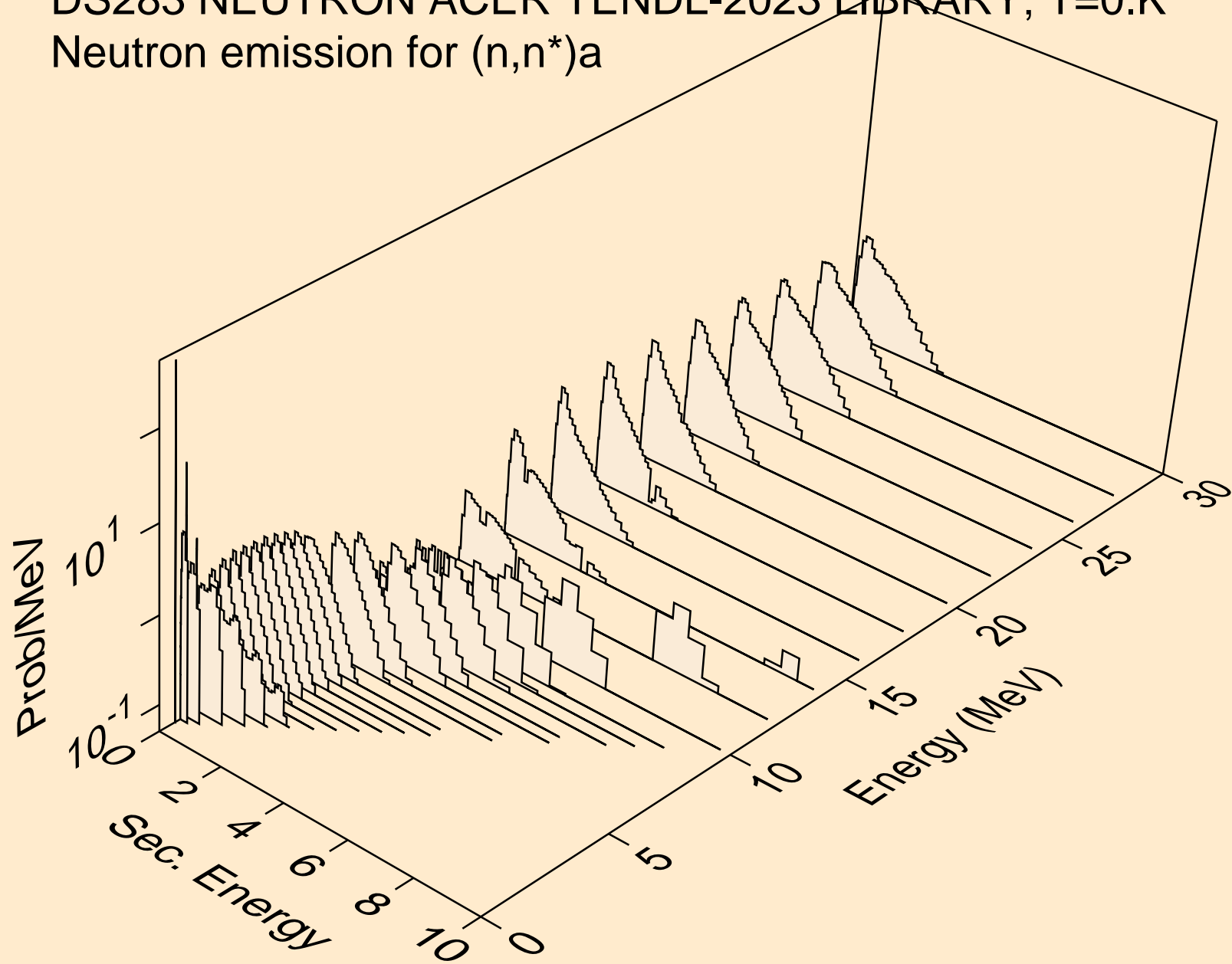

DS283 NEUTRON ACER TENDL-2023 LIBRARY; T=0.K
Neutron emission for (n,2n)a

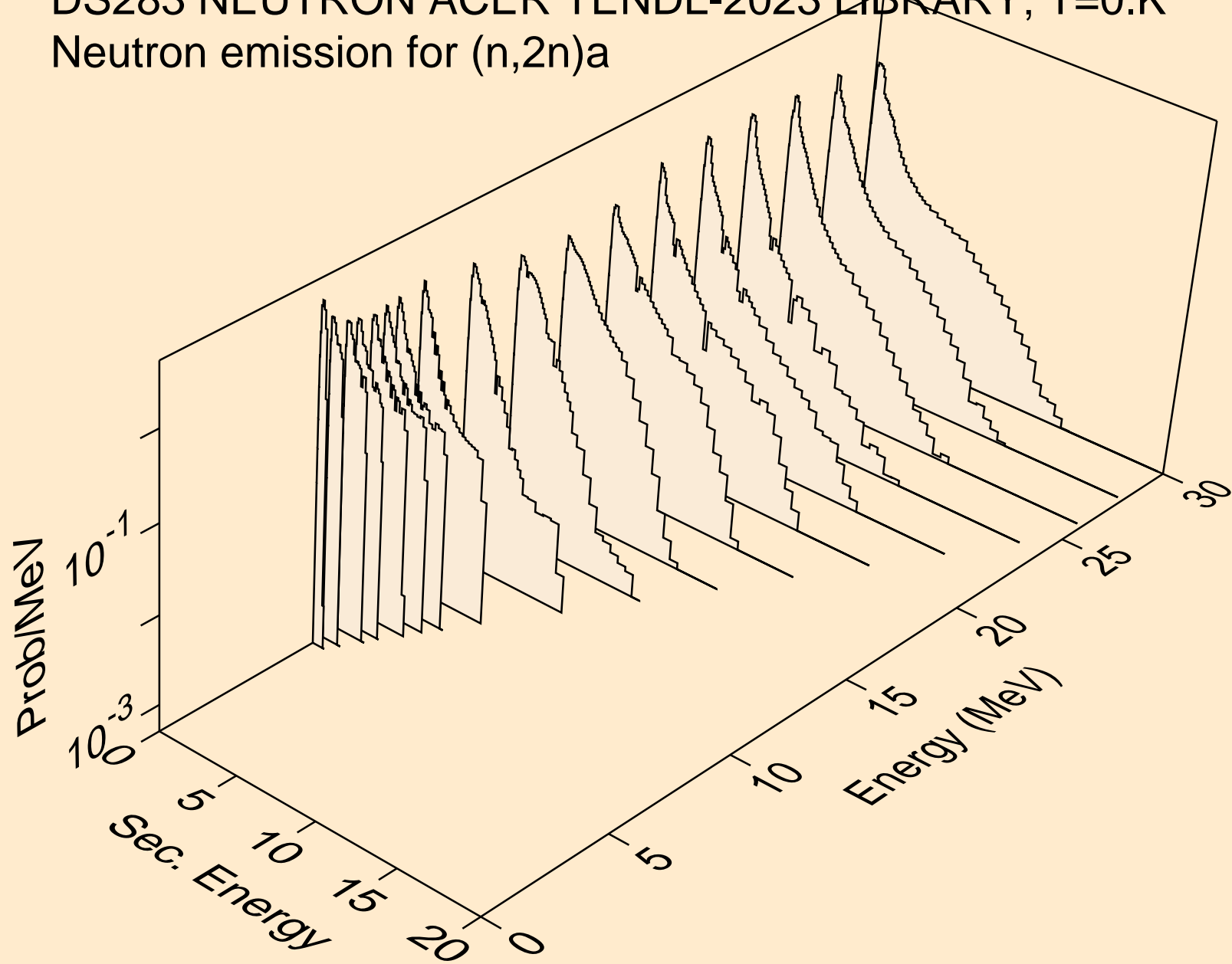

DS283 NEUTRON ACER TENDL-2023 LIBRARY; T=0.K
Neutron emission for (n,3n)a

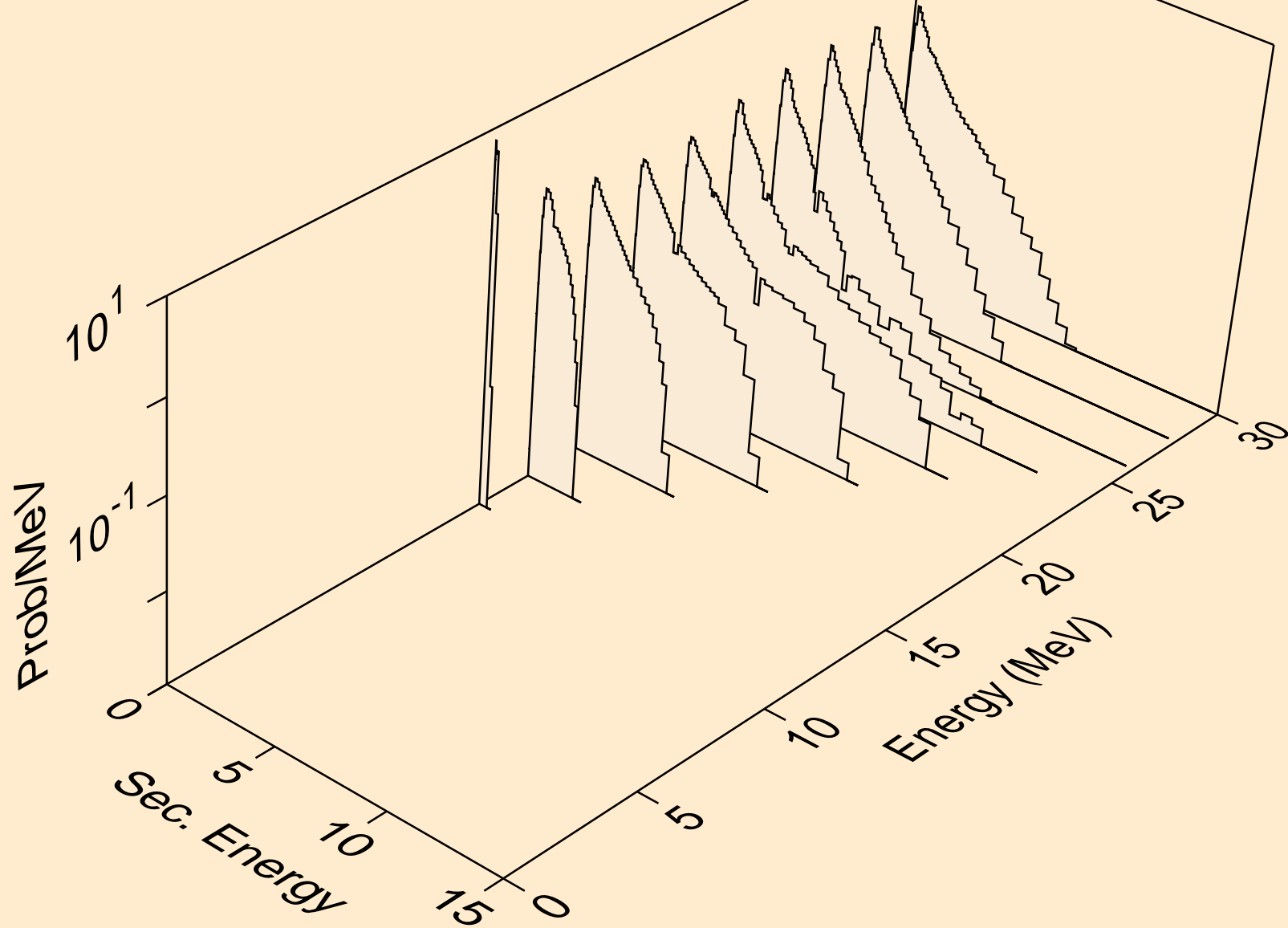

DS283 NEUTRON ACER TENDL-2023 LIBRARY; T=0.K
Neutron emission for (n,n*)p

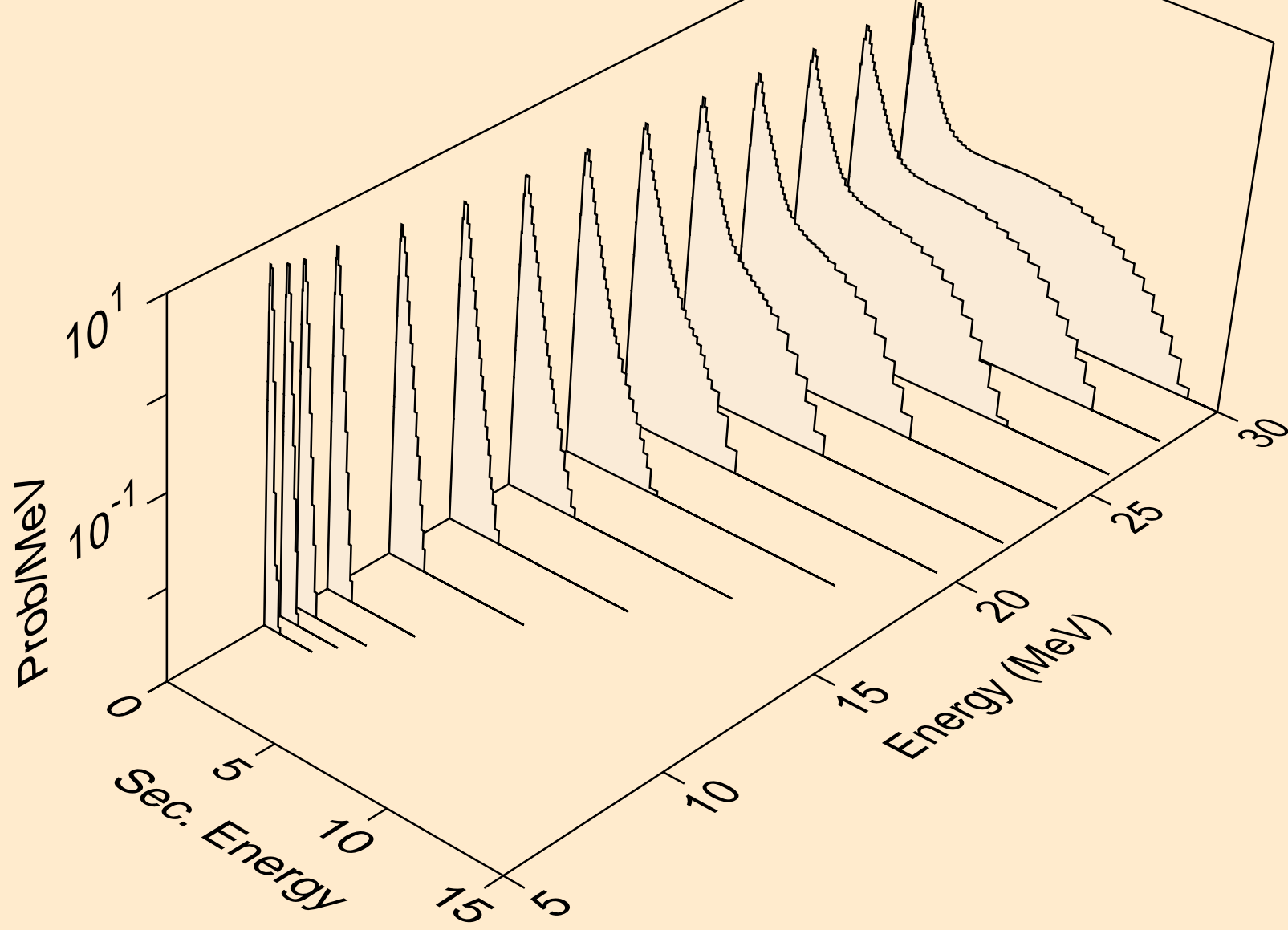

DS283 NEUTRON ACER TENDL-2023 LIBRARY; T=0.K
Neutron emission for (n,n*)d

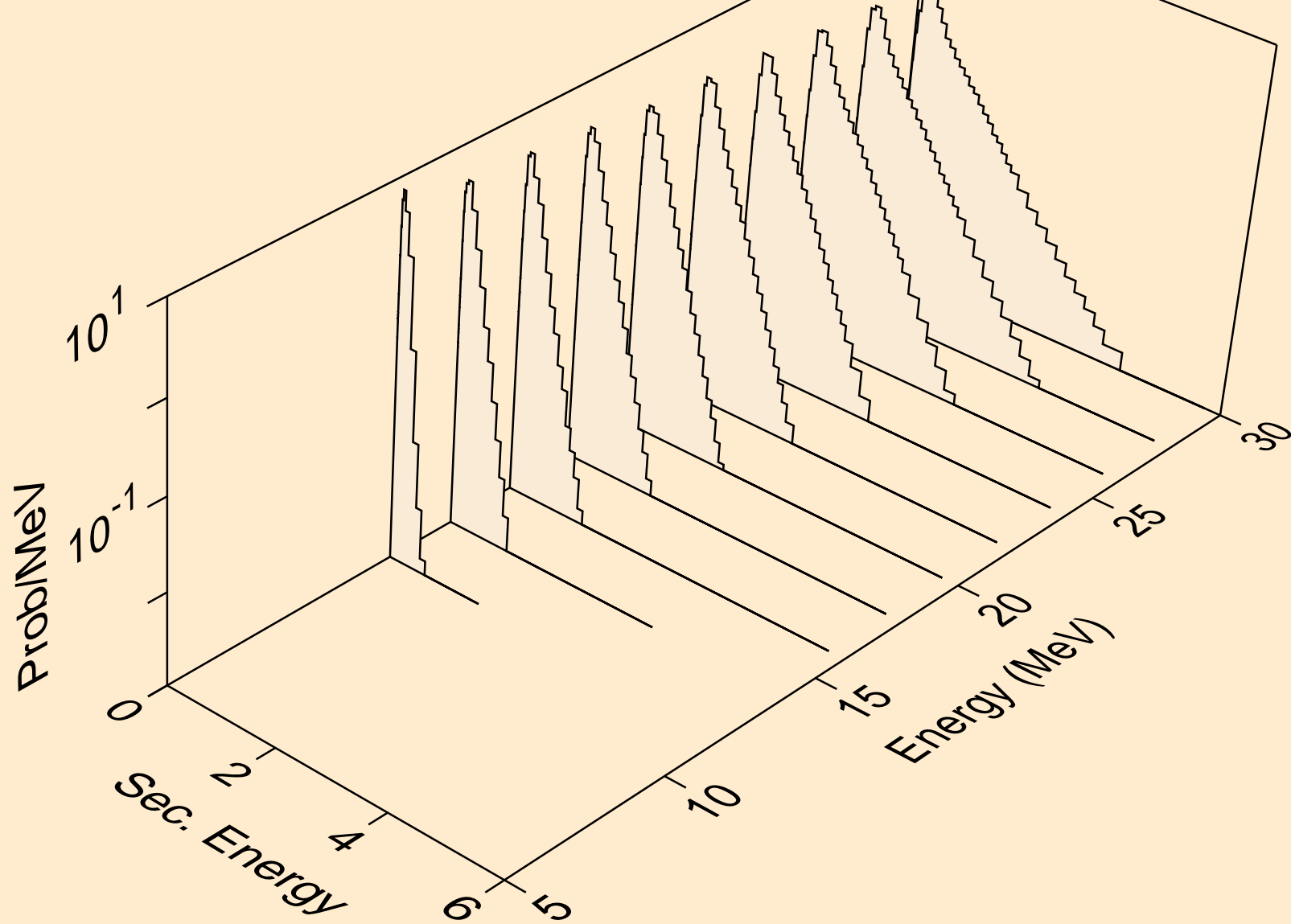

DS283 NEUTRON ACER TENDL-2023 LIBRARY; T=0.K
Neutron emission for (n,n*)t

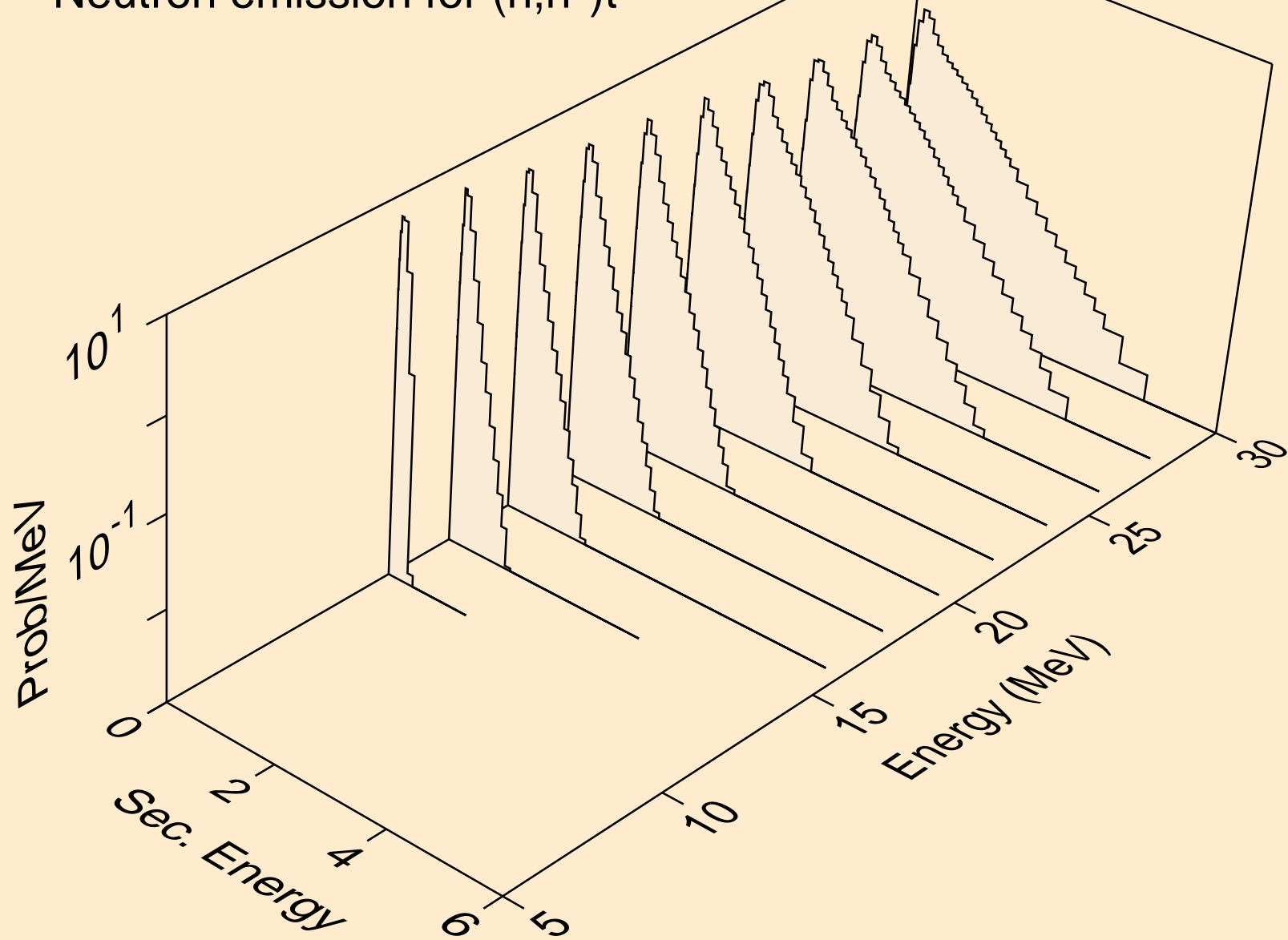

DS283 NEUTRON ACER TENDL-2023 LIBRARY; T=0.K
Neutron emission for (n,n*)he3

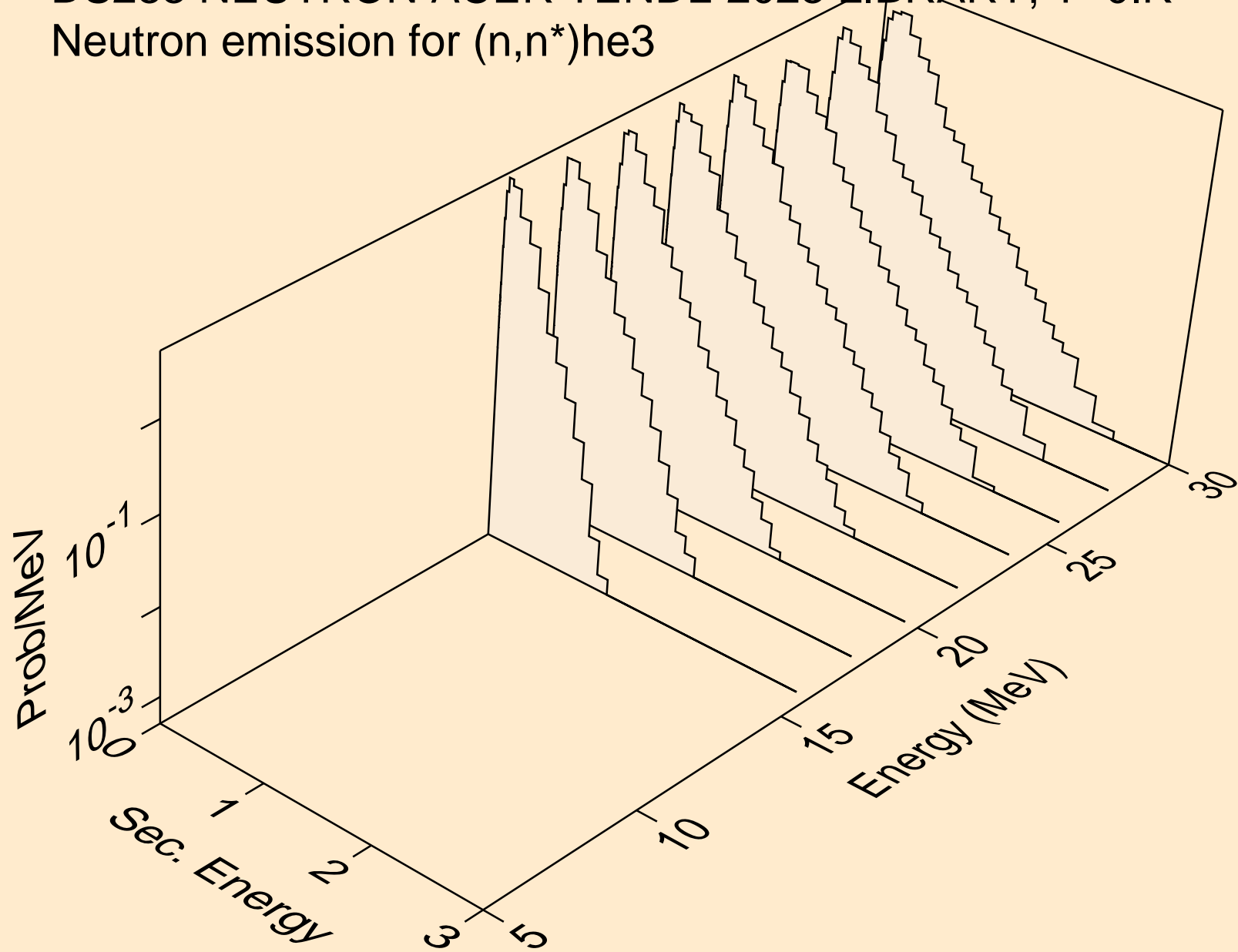

DS283 NEUTRON ACER TENDL-2023 LIBRARY; T=0.K
Neutron emission for (n,4n)

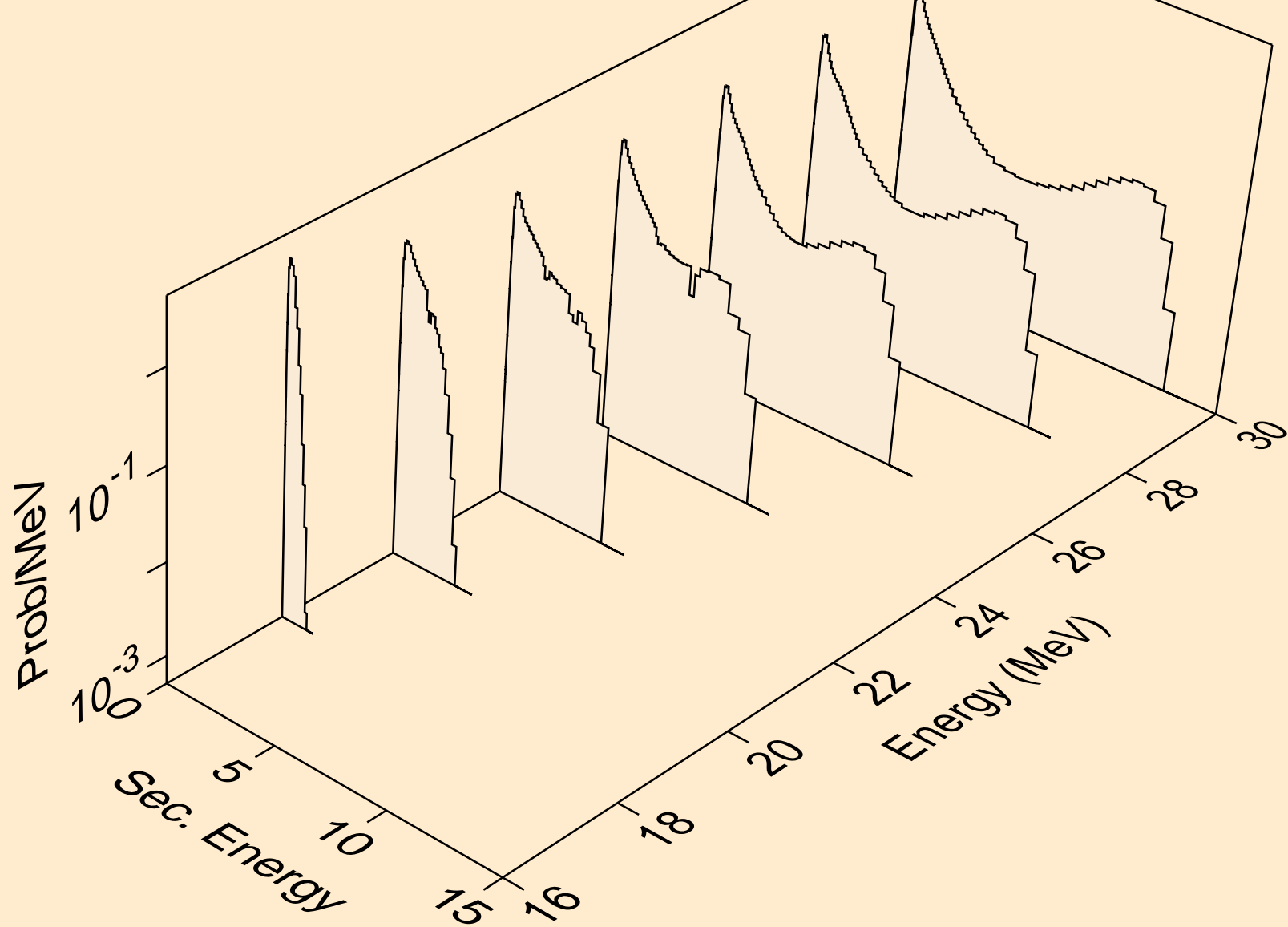

DS283 NEUTRON ACER TENDL-2023 LIBRARY; T=0.K
Neutron emission for (n,2np)

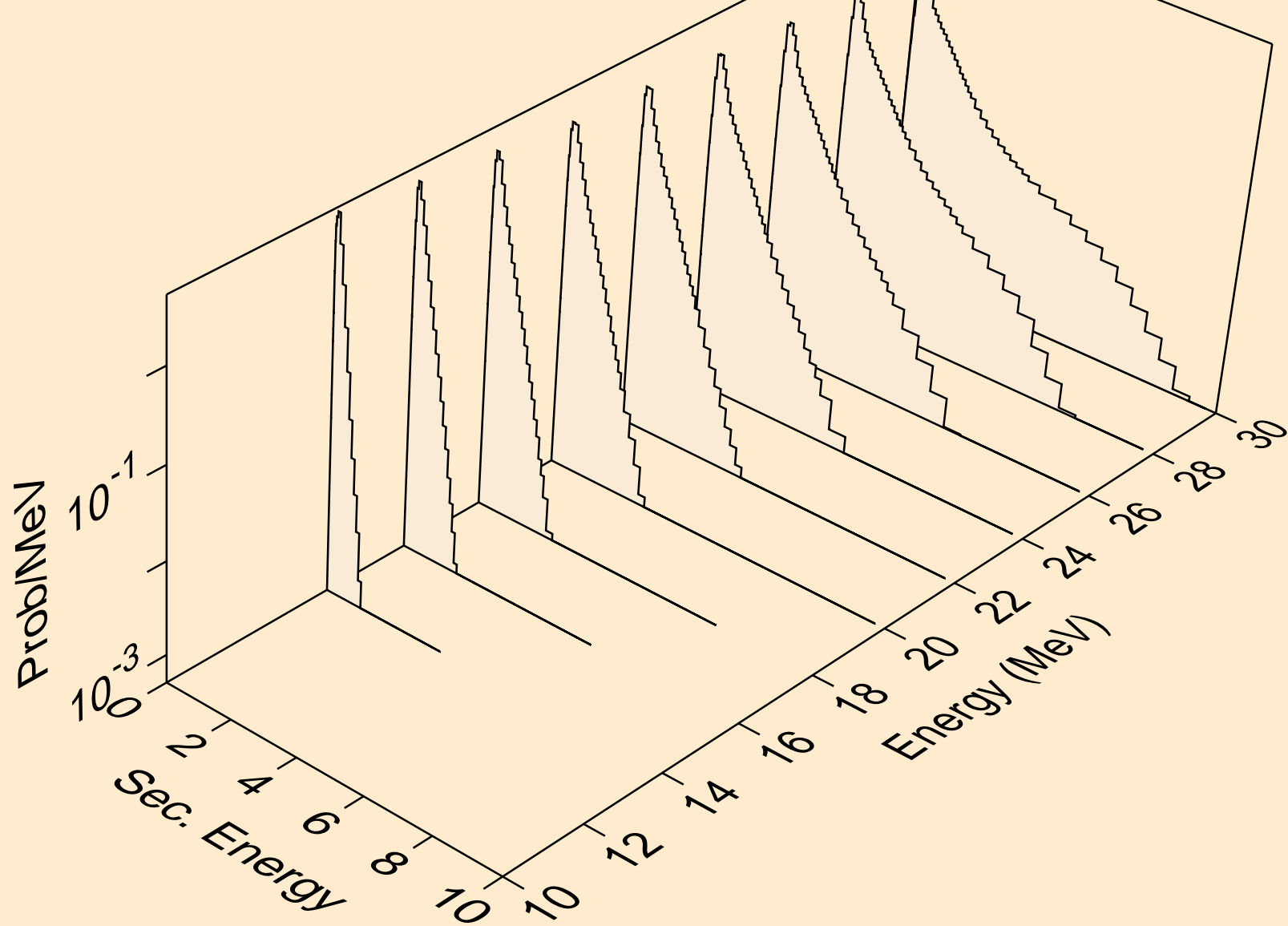

DS283 NEUTRON ACER TENDL-2023 LIBRARY; T=0.K
Neutron emission for (n,3np)

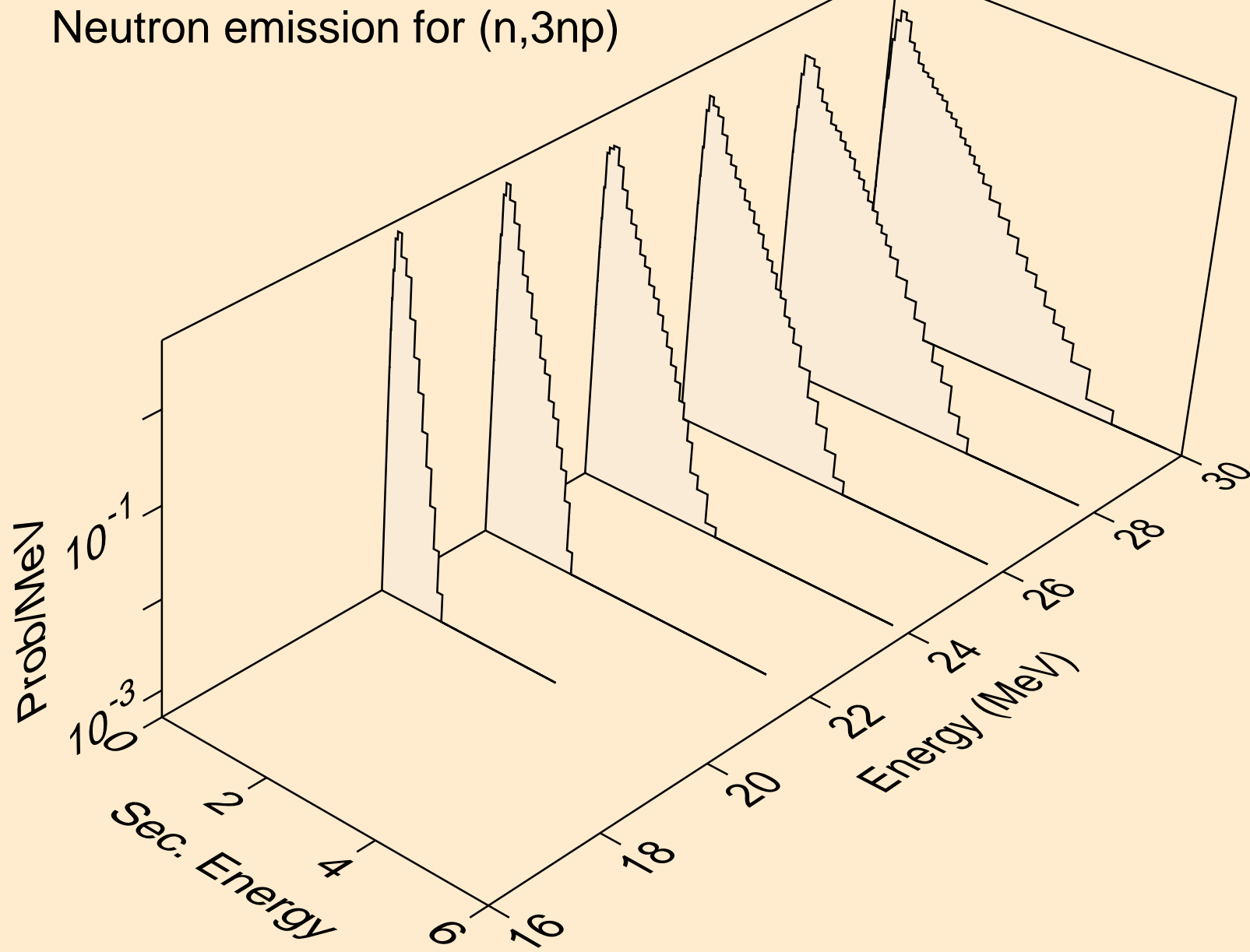

DS283 NEUTRON ACER TENDL-2023 LIBRARY; T=0.K
Neutron emission for (n,n2p)

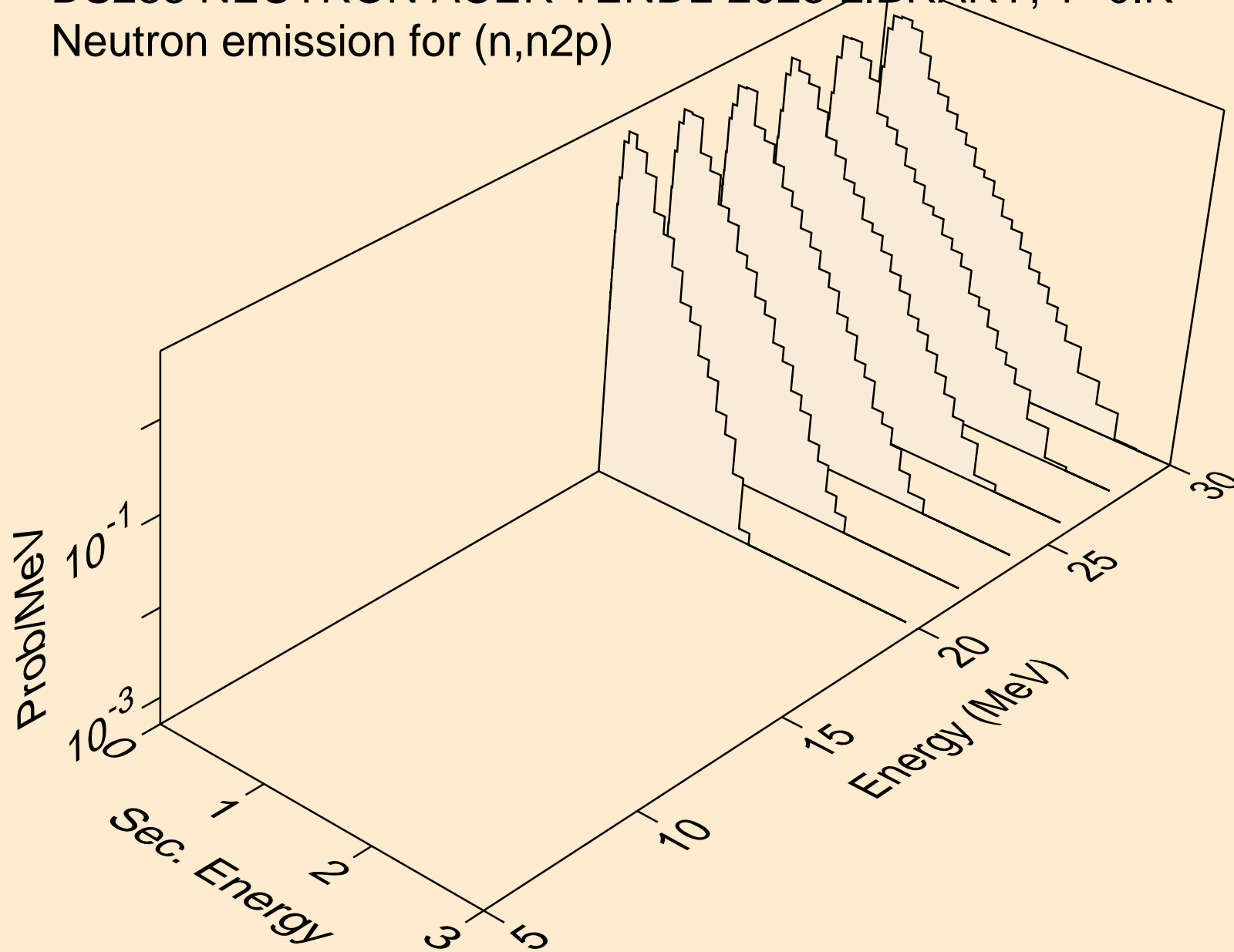

DS283 NEUTRON ACER TENDL-2023 LIBRARY; T=0.K
Neutron emission for (n,npa)

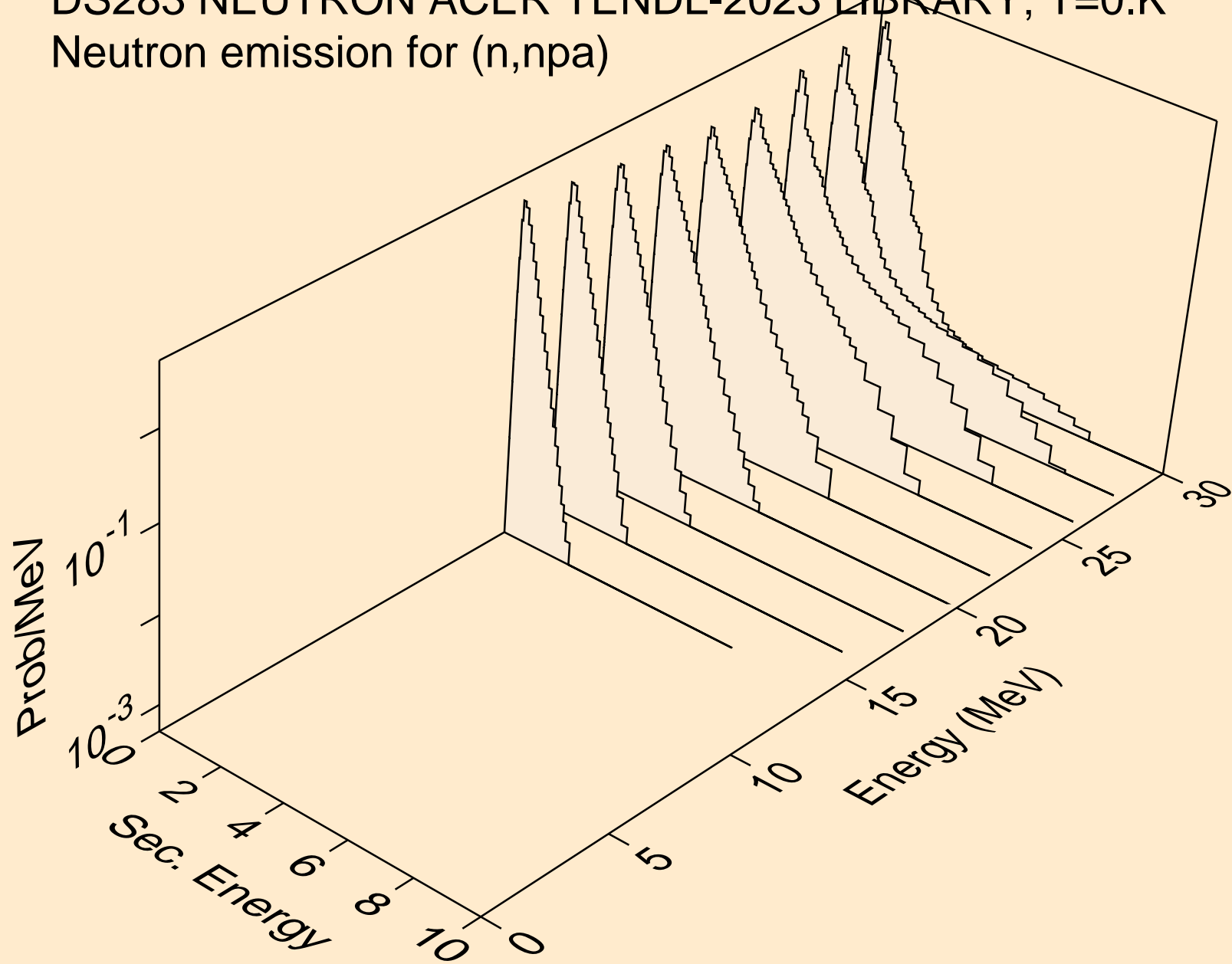

DS283 NEUTRON ACER TENDL-2023 LIBRARY; T=0.K
Neutron emission for (n,n*c)

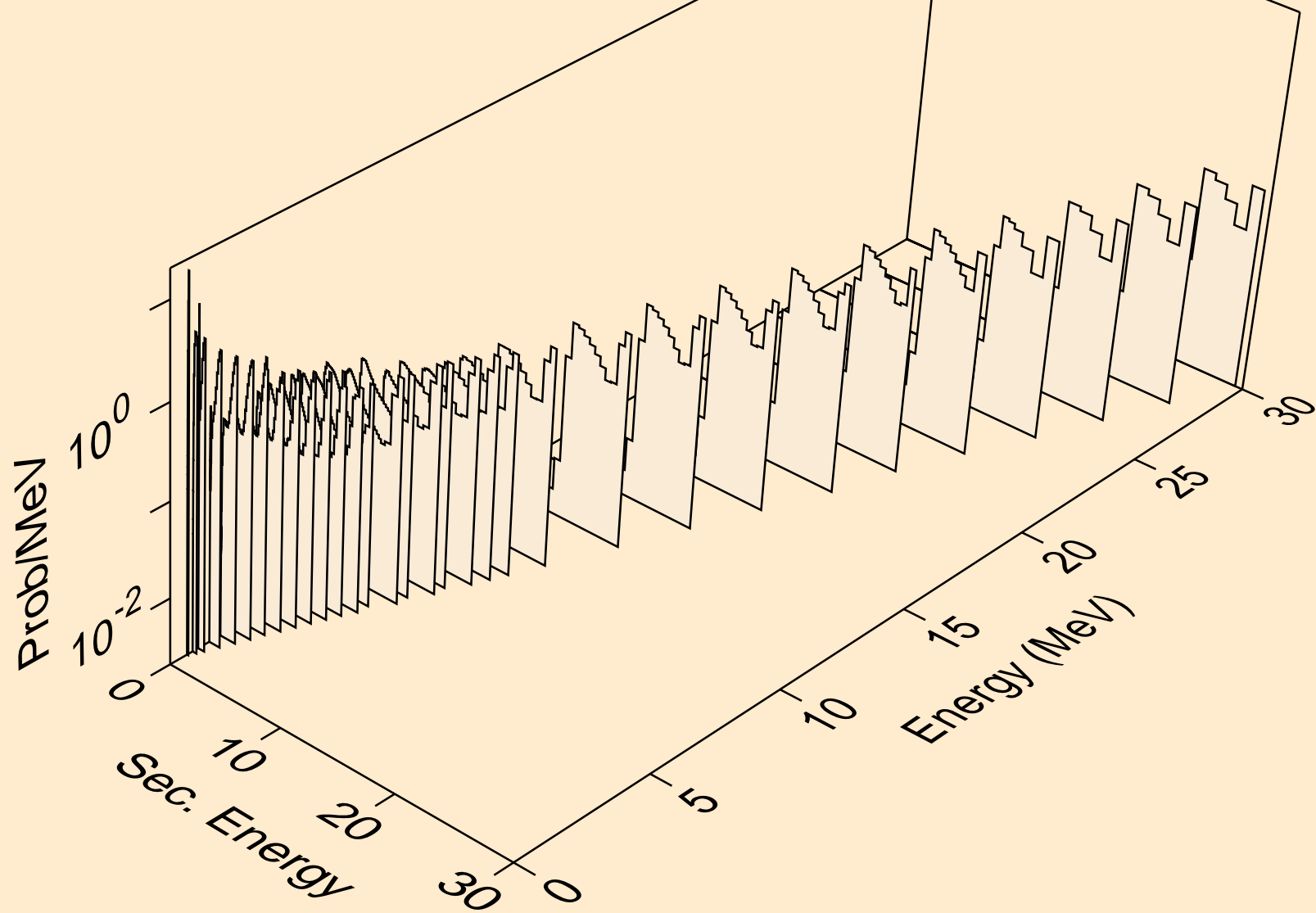

DS283 NEUTRON ACER TENDL-2023 LIBRARY; T=0.K

Delayed nubar

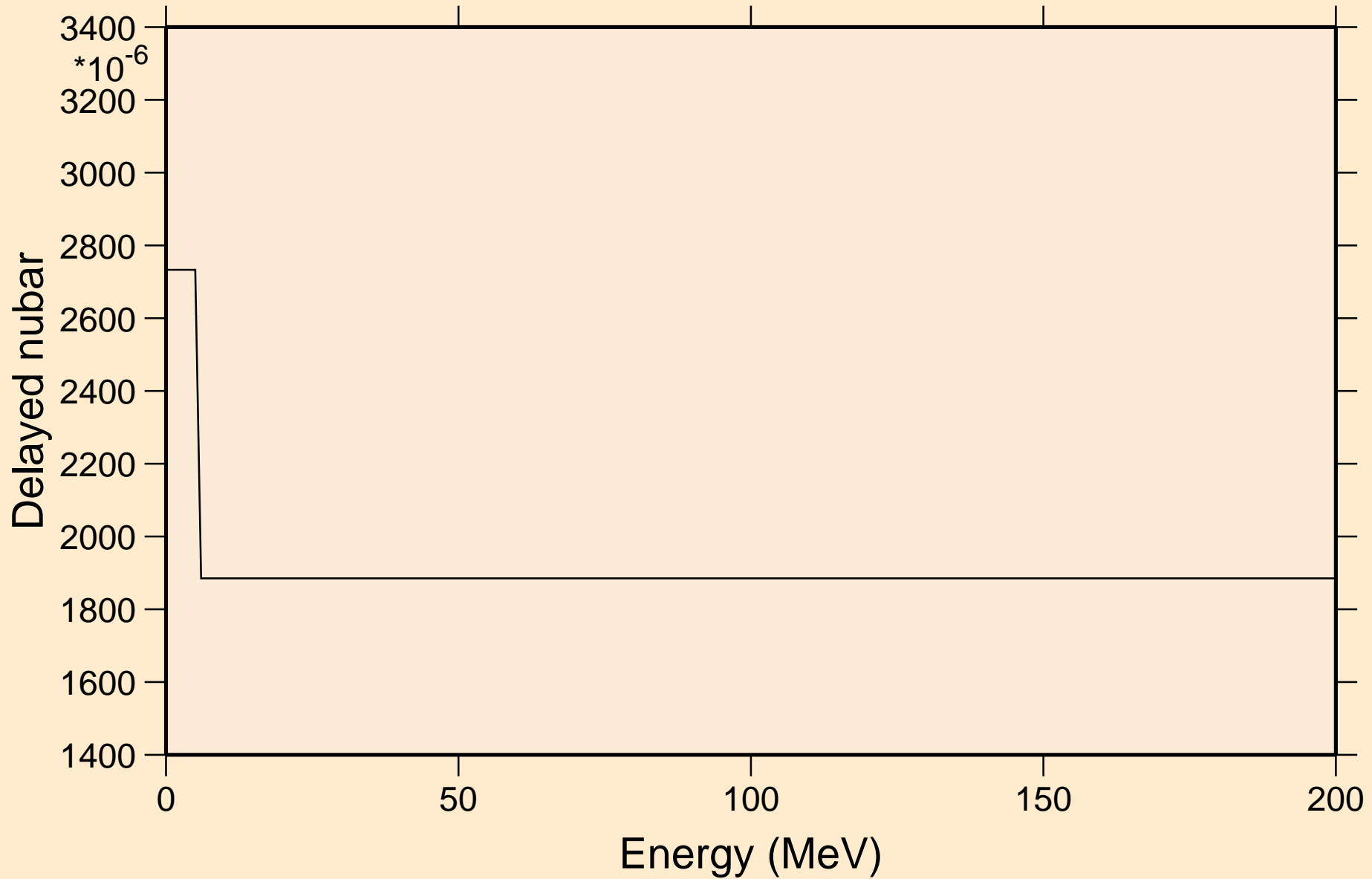

DS283 NEUTRON ACER TENDL-2023 LIBRARY; T=0.K
Delayed neutron spectra

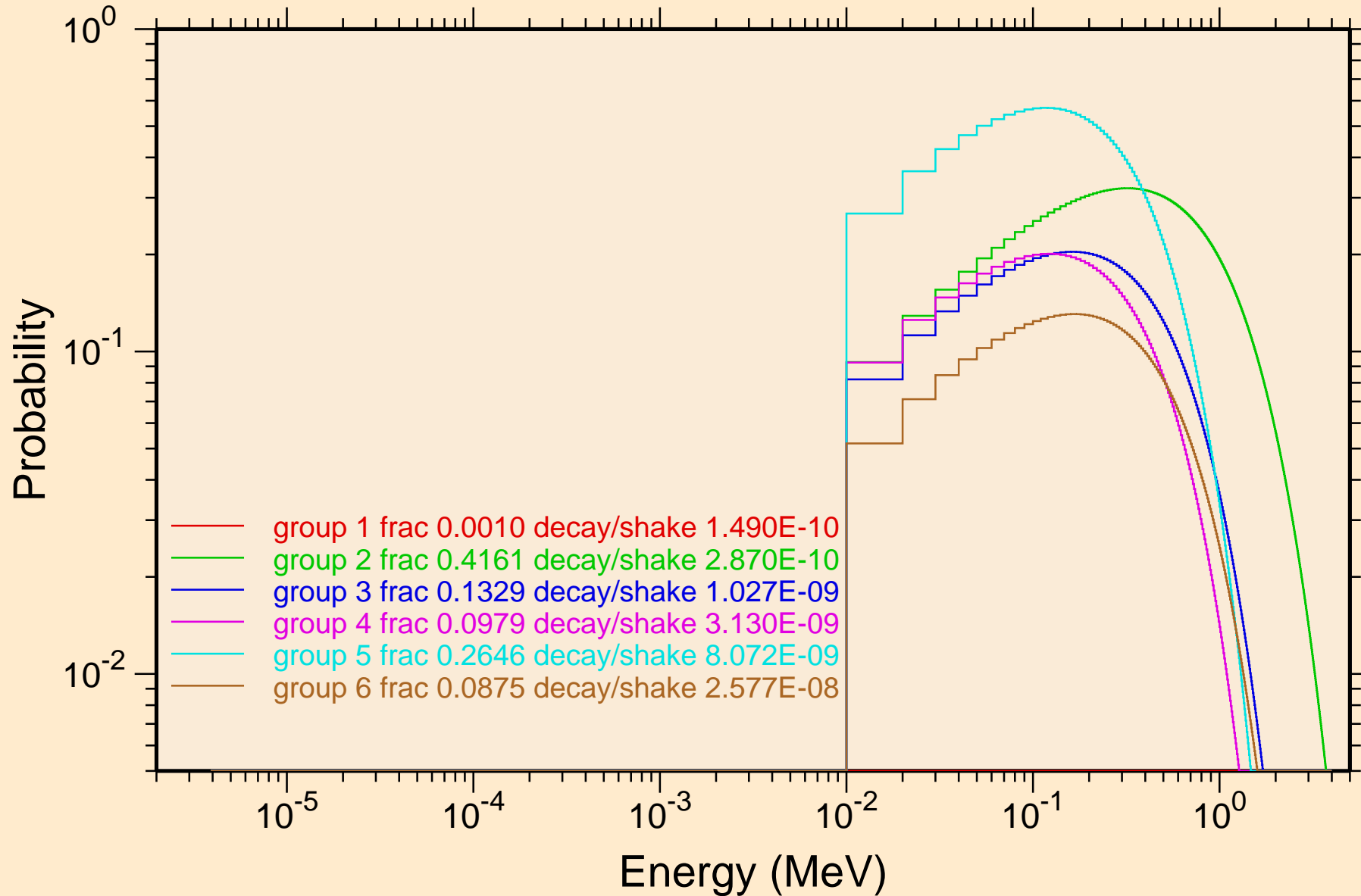

DS283 NEUTRON ACER TENDL-2023 LIBRARY; T=0.K
Photon emission for (n,x)

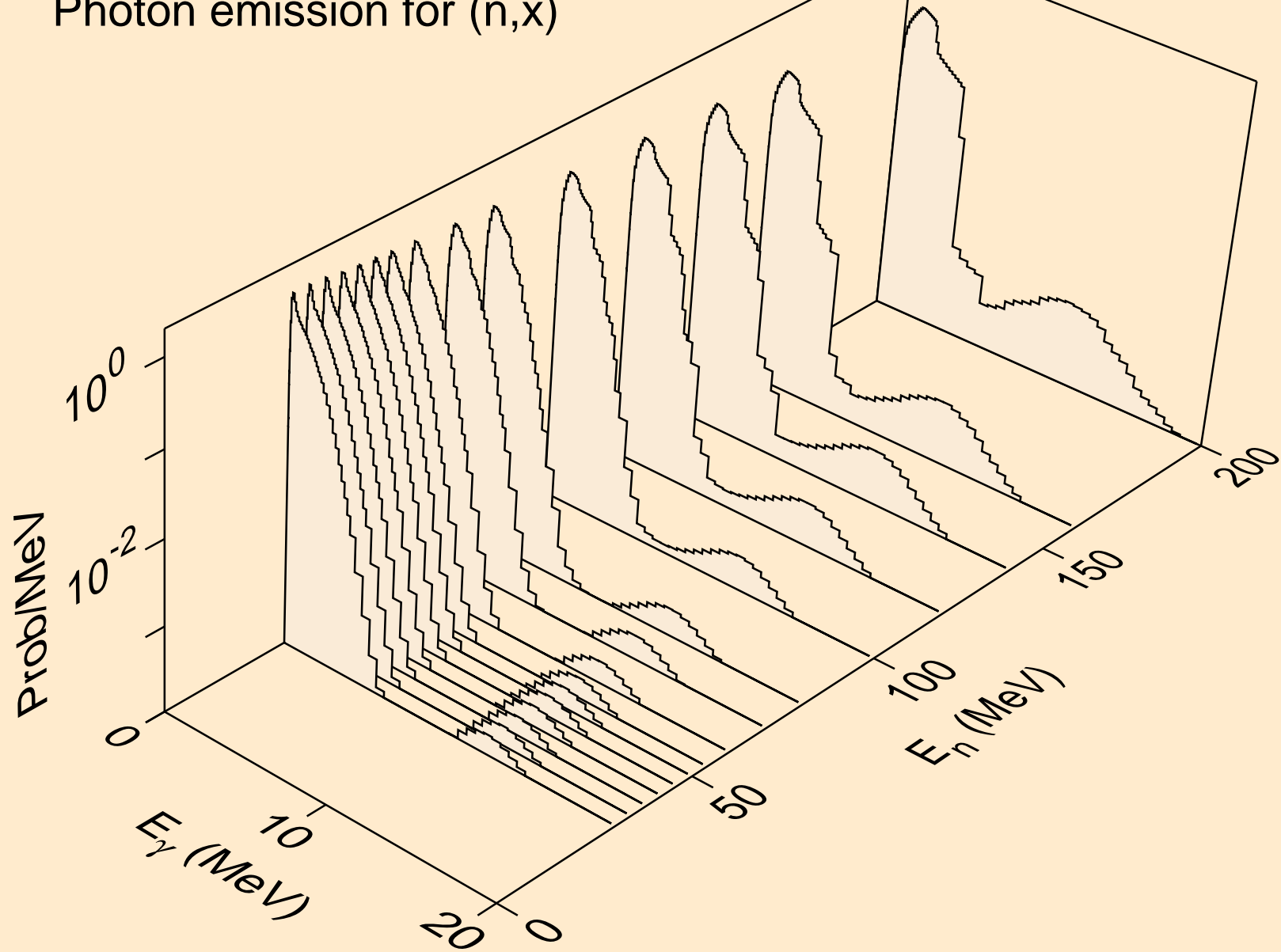

DS283 NEUTRON ACER TENDL-2023 LIBRARY; T=0.K
Photon emission for (n,2nd)

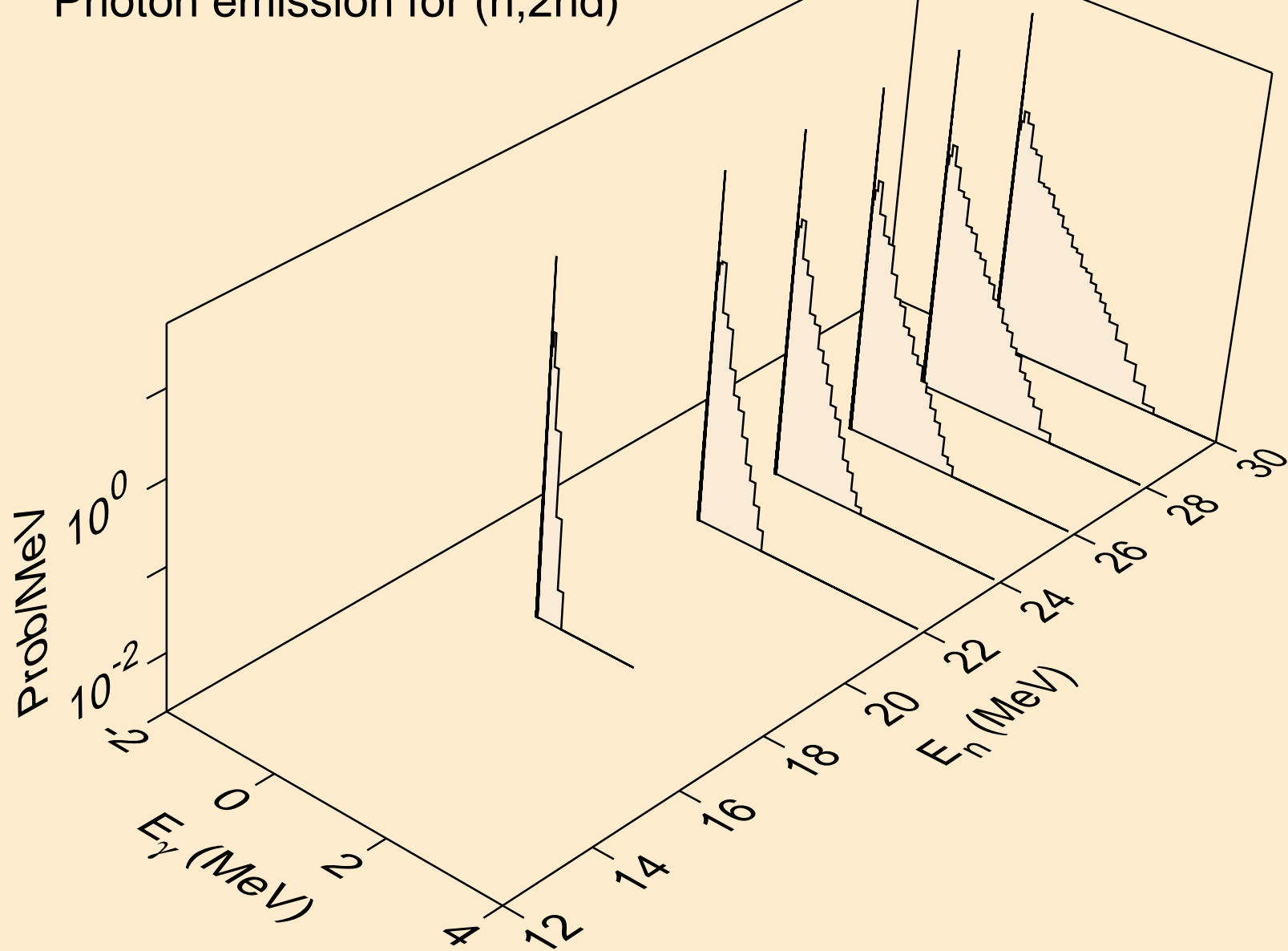

DS283 NEUTRON ACER TENDL-2023 LIBRARY; T=0.K
Photon emission for (n,2n)

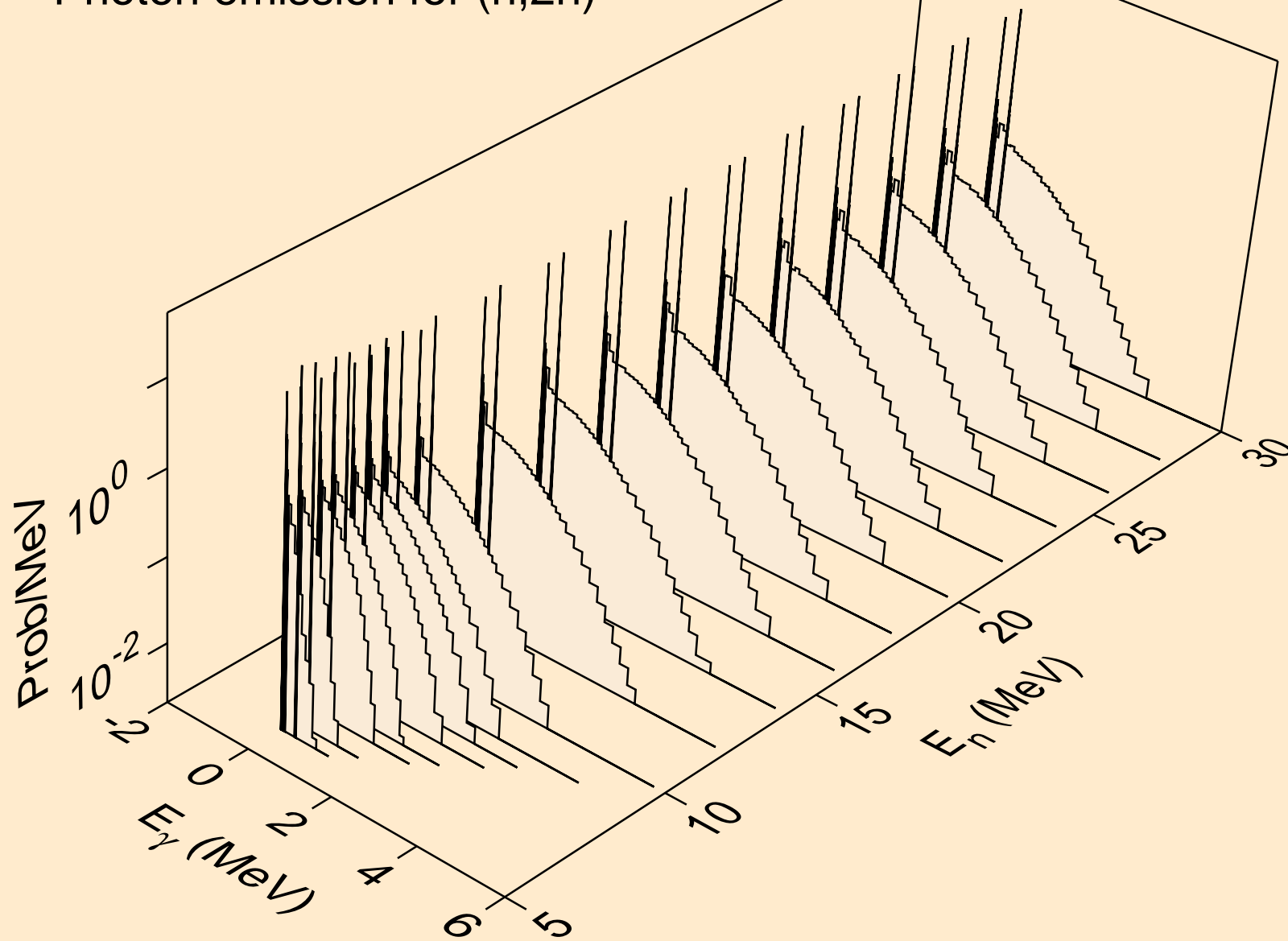

DS283 NEUTRON ACER TENDL-2023 LIBRARY; T=0.K
Photon emission for (n,3n)

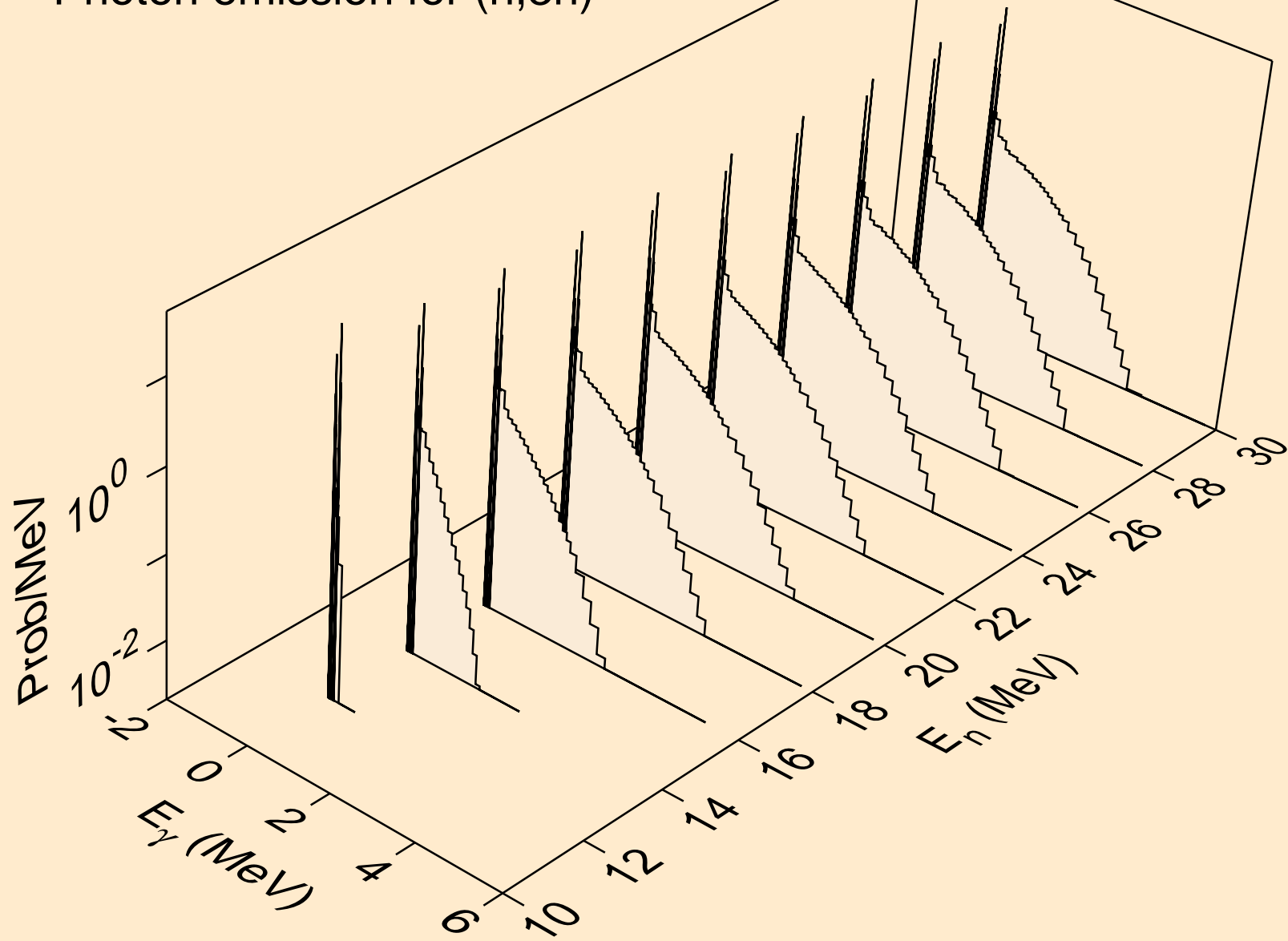

DS283 NEUTRON ACER TENDL-2023 LIBRARY; T=0.K
Photon emission for (n,n*)a

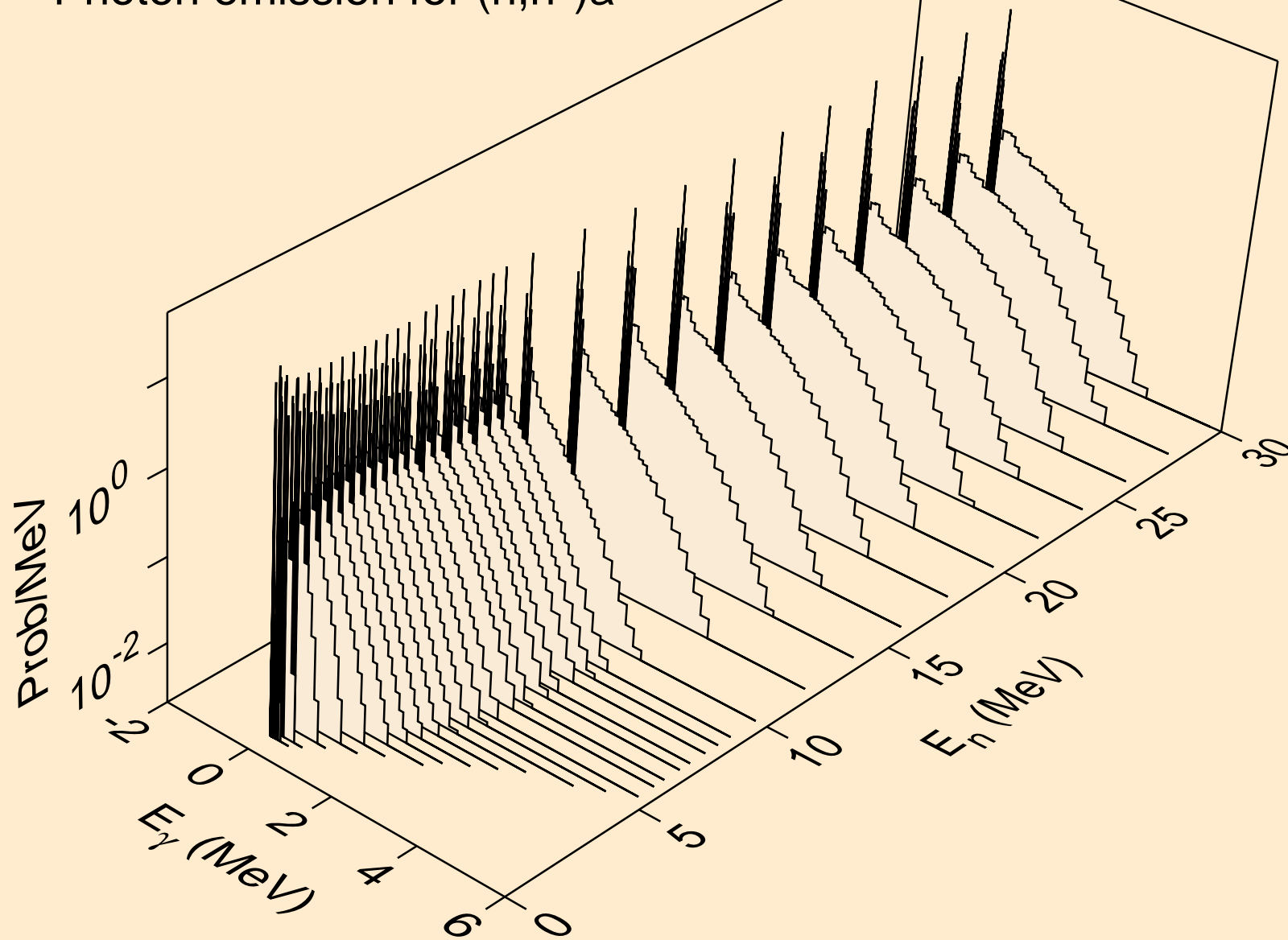

DS283 NEUTRON ACER TENDL-2023 LIBRARY; T=0.K
Photon emission for (n,2n)a

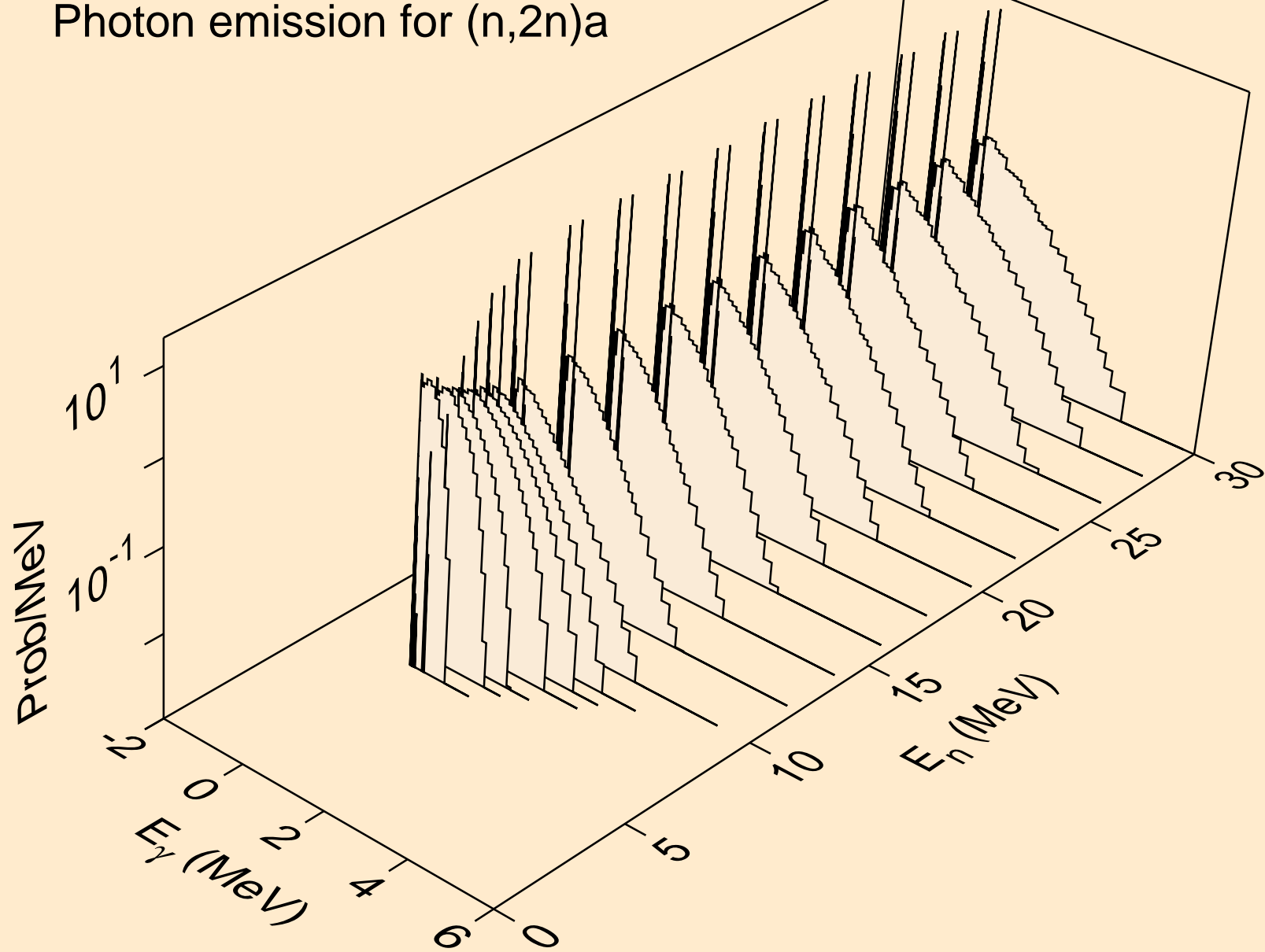

DS283 NEUTRON ACER TENDL-2023 LIBRARY; T=0.K
Photon emission for (n,3n)a

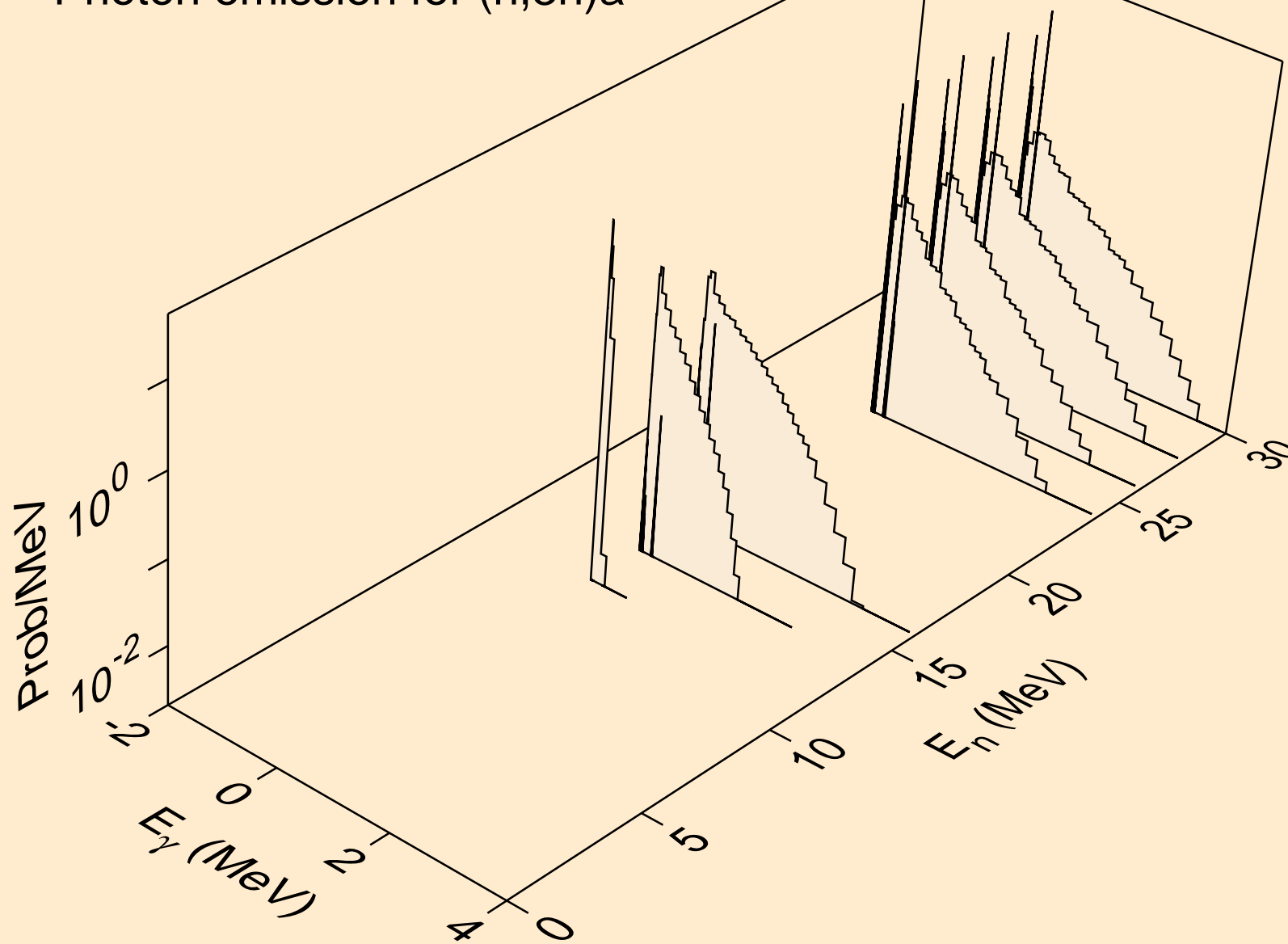

DS283 NEUTRON ACER TENDL-2023 LIBRARY; T=0.K
Photon emission for (n,n*)p

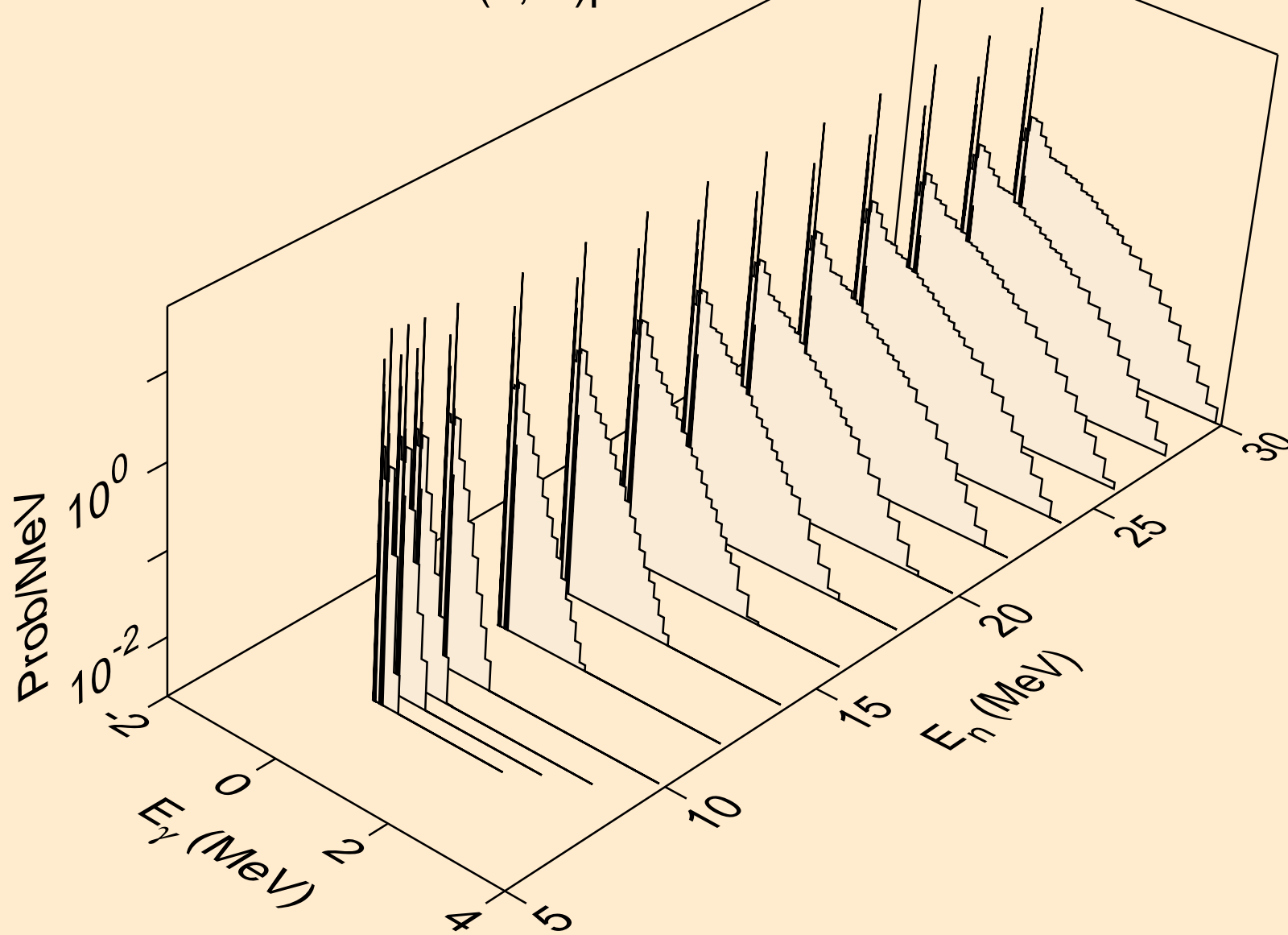

DS283 NEUTRON ACER TENDL-2023 LIBRARY; T=0.K
Photon emission for (n,n*)d

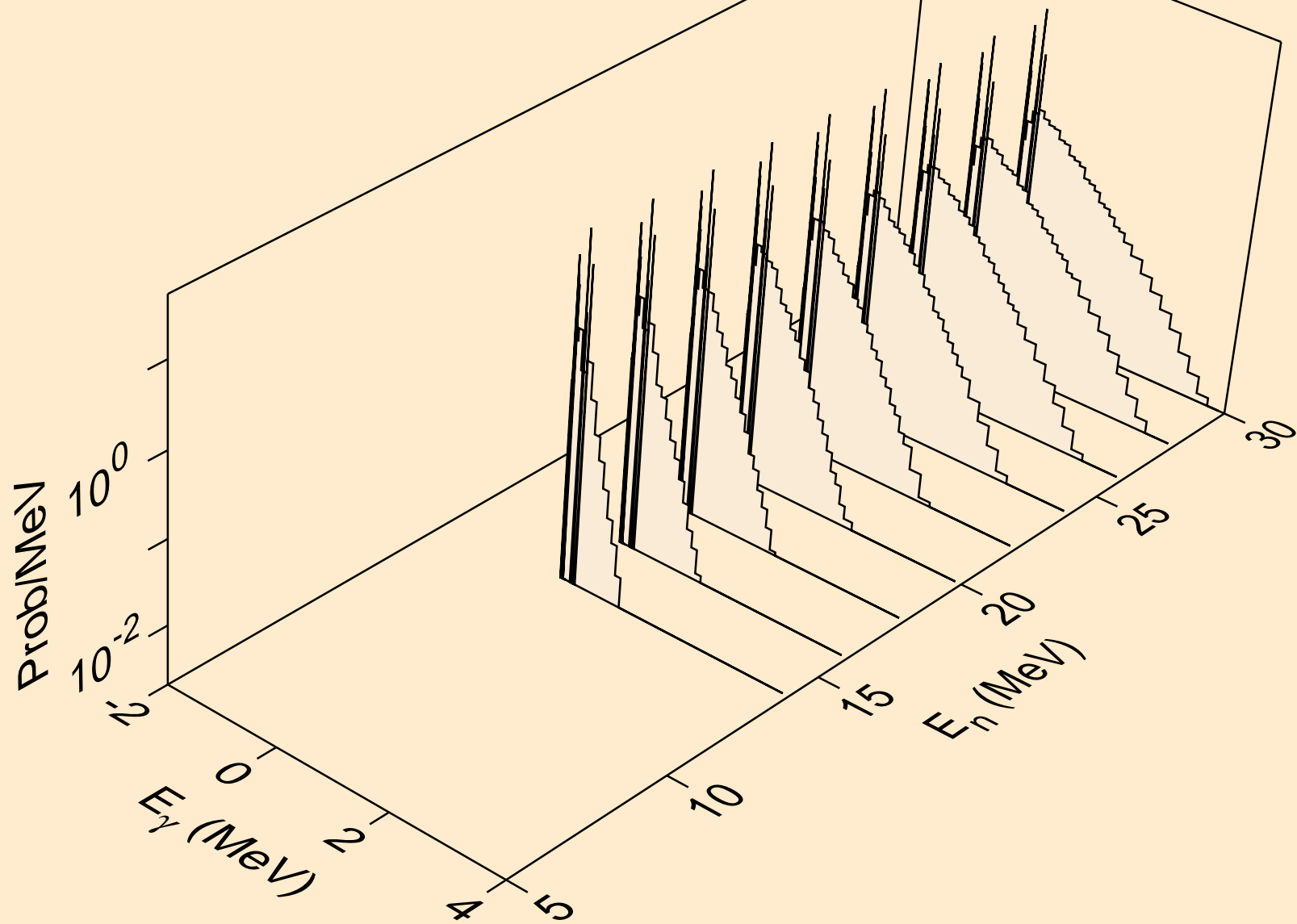

DS283 NEUTRON ACER TENDL-2023 LIBRARY; T=0.K
Photon emission for (n,n*)t

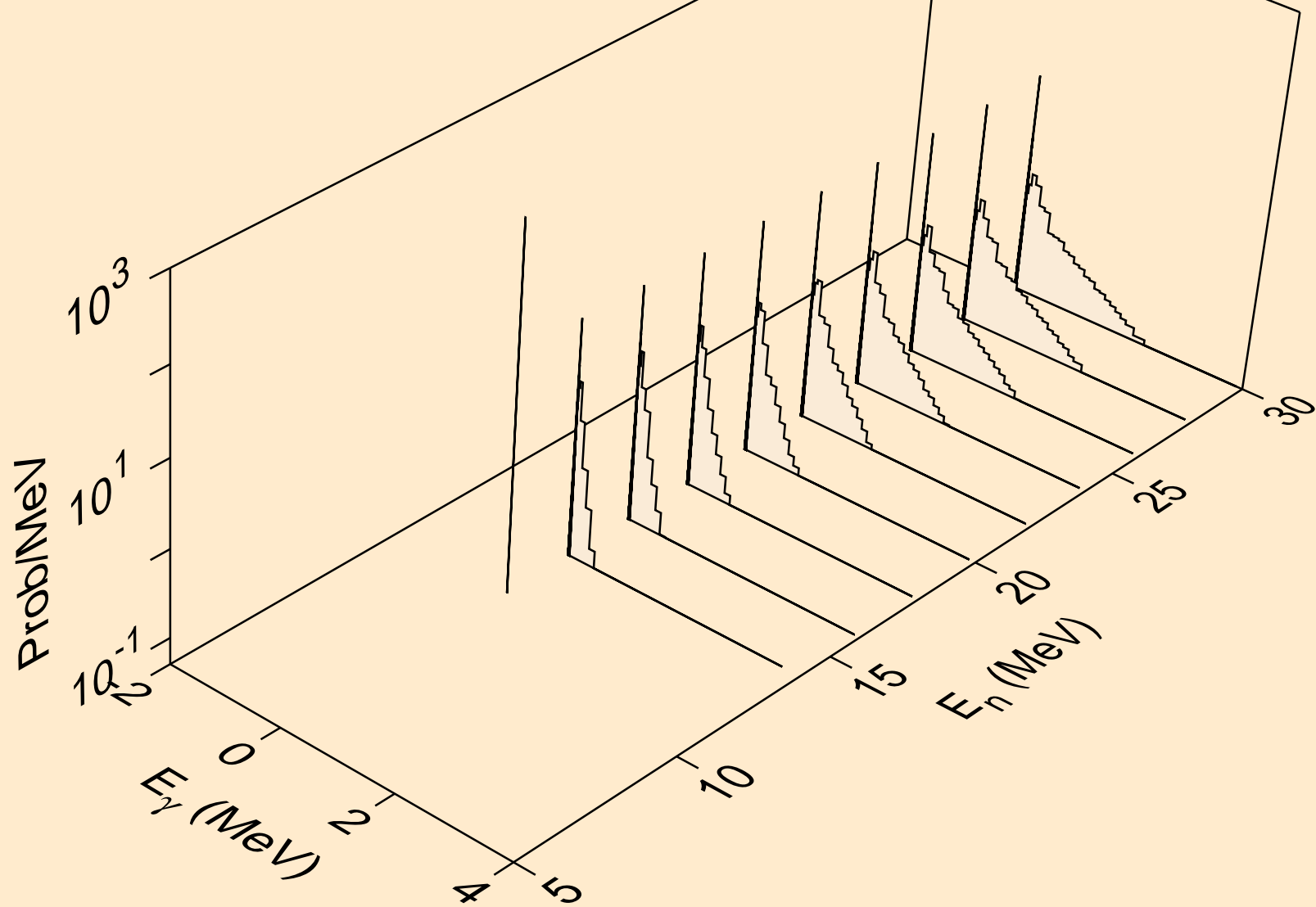

DS283 NEUTRON ACER TENDL-2023 LIBRARY; T=0.K
Photon emission for (n,n*)he3

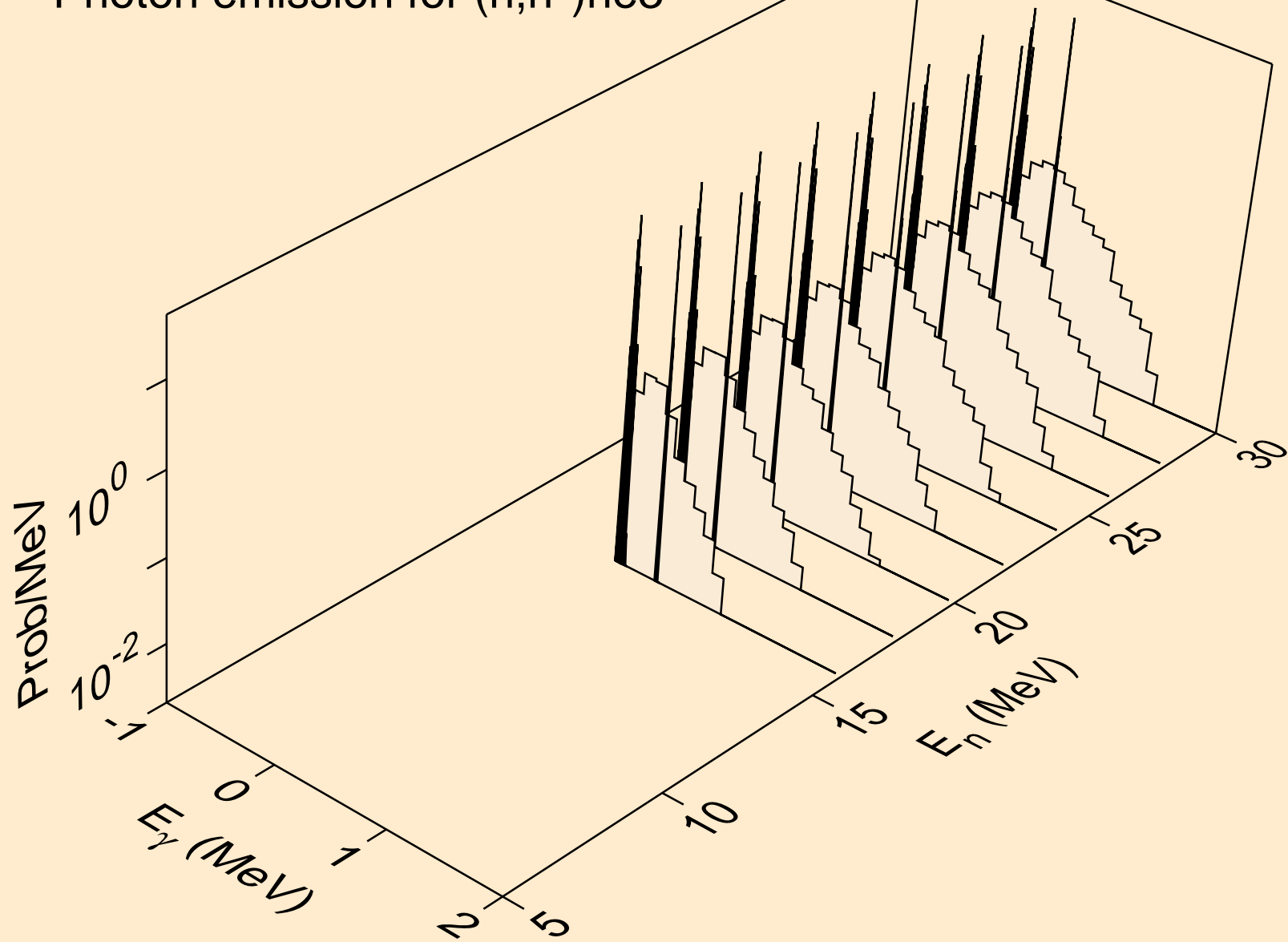

DS283 NEUTRON ACER TENDL-2023 LIBRARY; T=0.K
Photon emission for (n,4n)

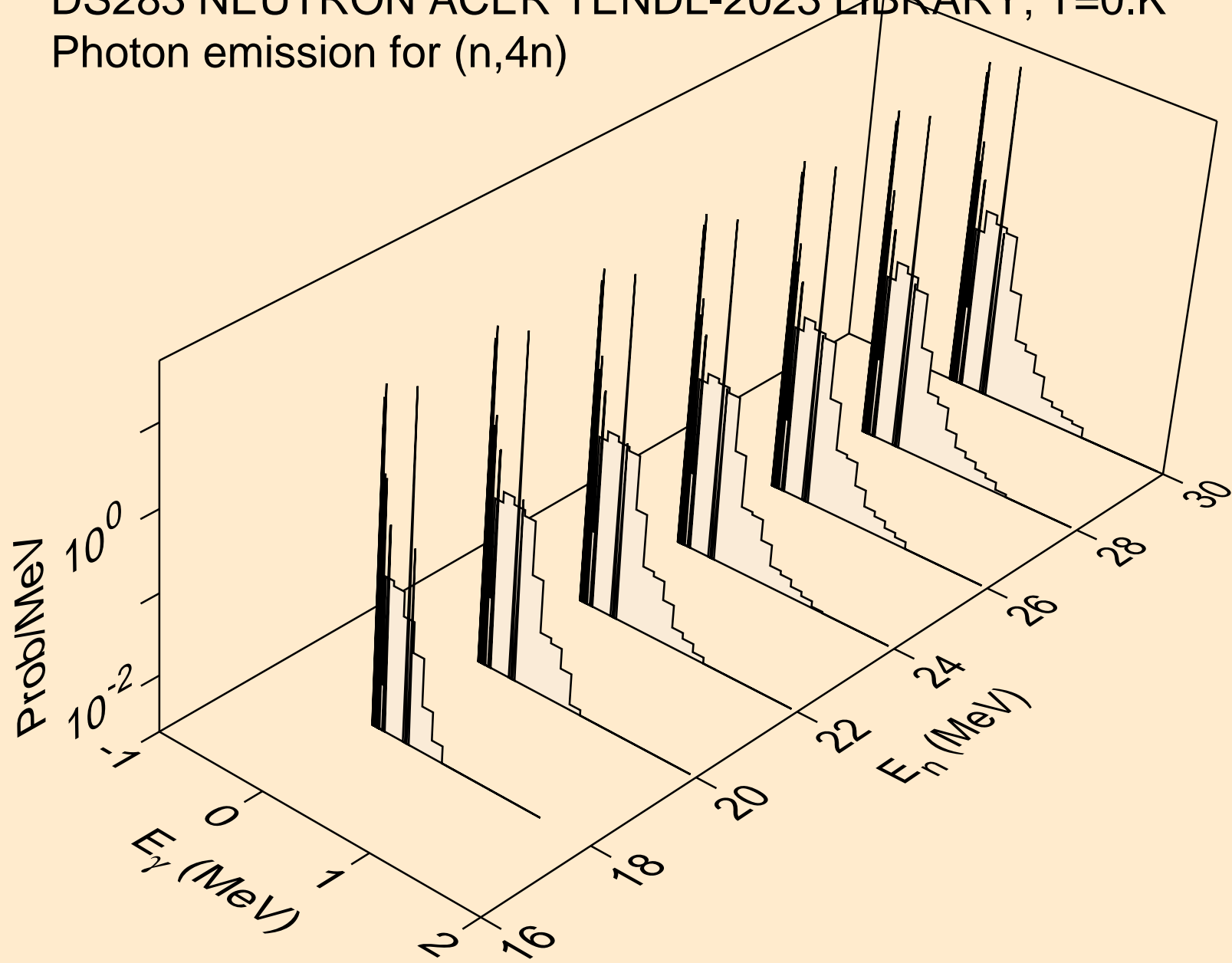

DS283 NEUTRON ACER TENDL-2023 LIBRARY; T=0.K
Photon emission for (n,2np)

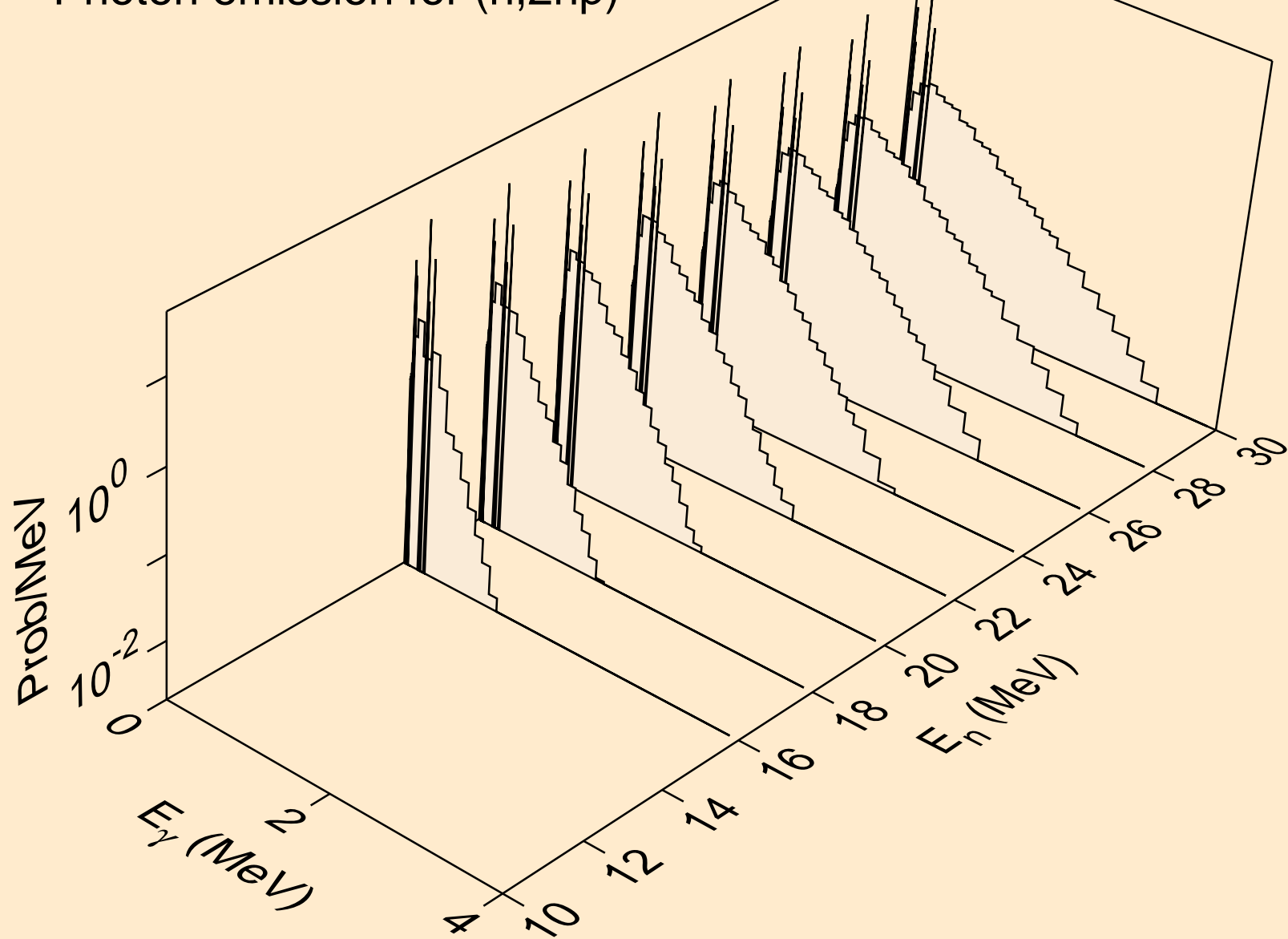

DS283 NEUTRON ACER TENDL-2023 LIBRARY; T=0.K
Photon emission for (n,3np)

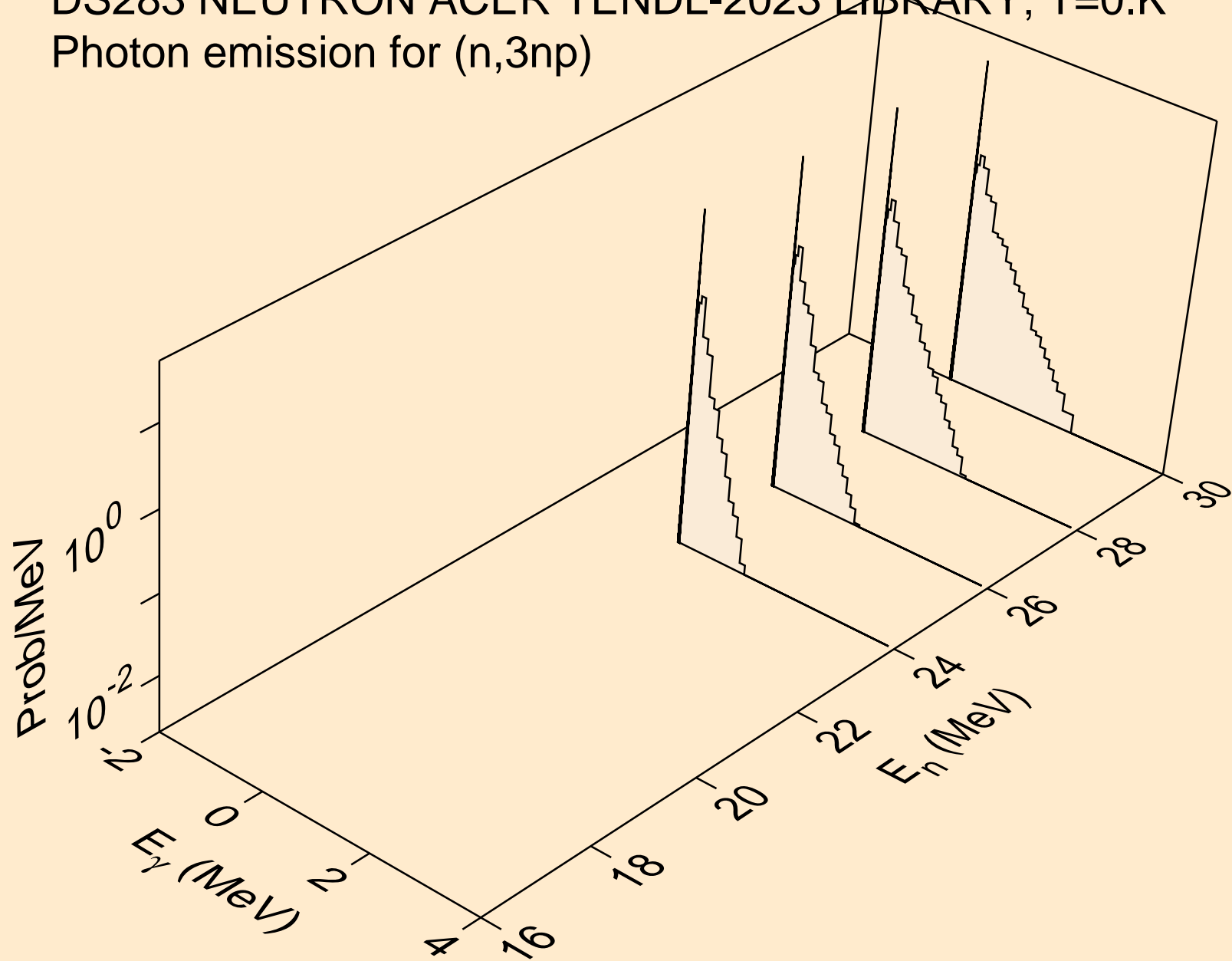

DS283 NEUTRON ACER TENDL-2023 LIBRARY; T=0.K
Photon emission for (n,n2p)

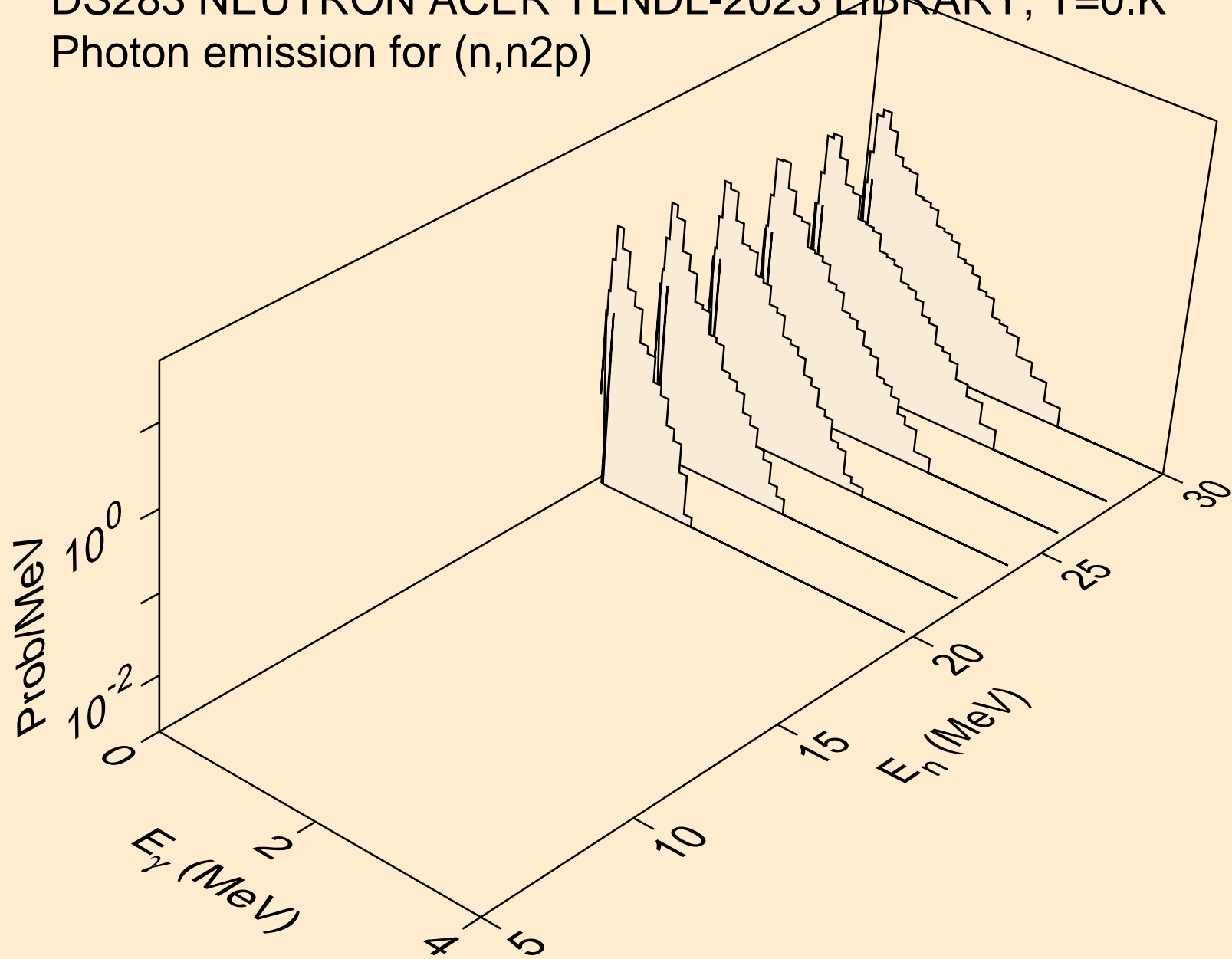

DS283 NEUTRON ACER TENDL-2023 LIBRARY; T=0.K
Photon emission for (n,npa)

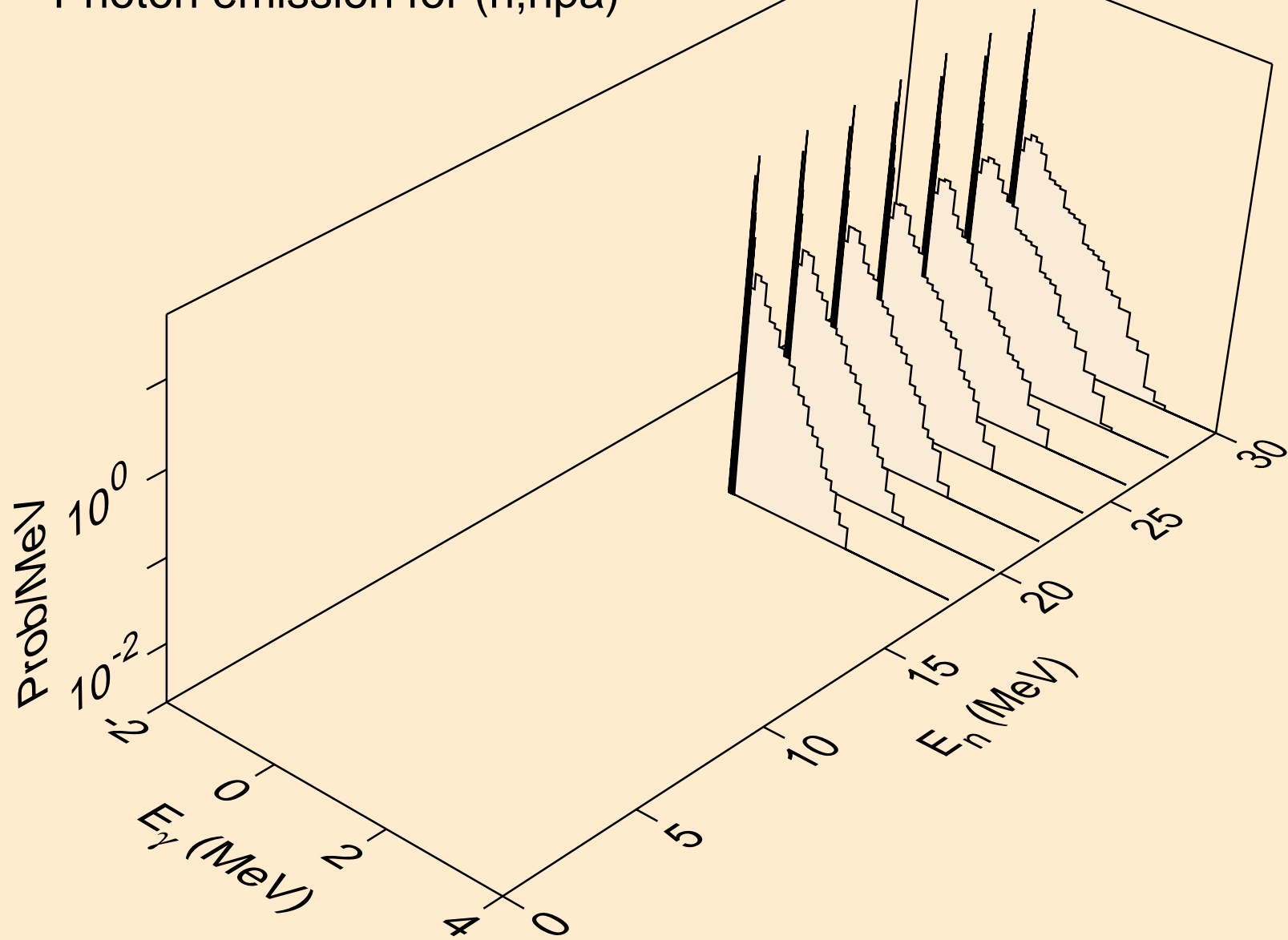

DS283 NEUTRON ACER TENDL-2023 LIBRARY; T=0.K
Photon emission for (n,n*c)

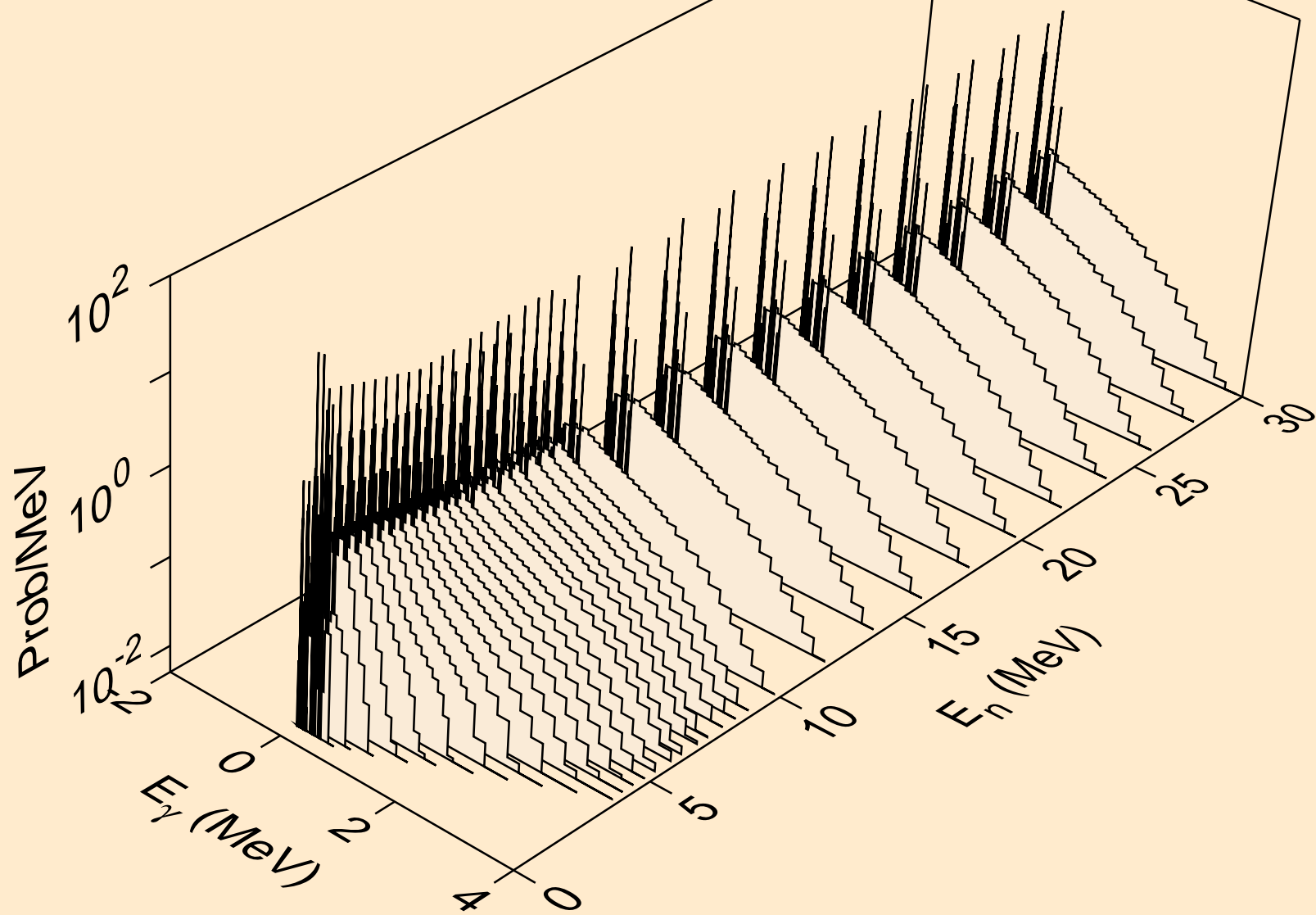

DS283 NEUTRON ACER TENDL-2023 LIBRARY; T=0.K
Photon emission for (n,gma)

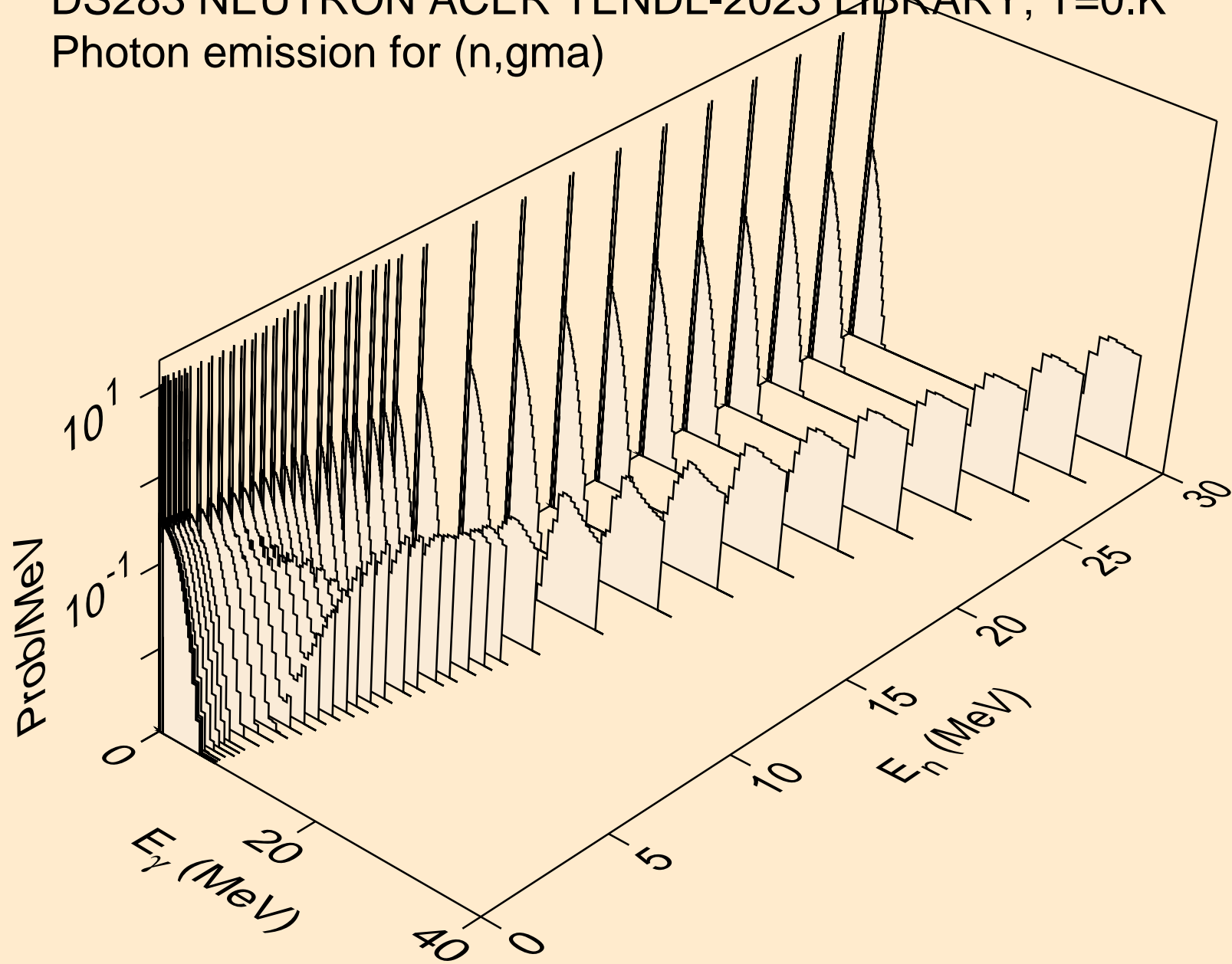

DS283 NEUTRON ACER TENDL-2023 LIBRARY; T=0.K
Photon emission for (n,p)

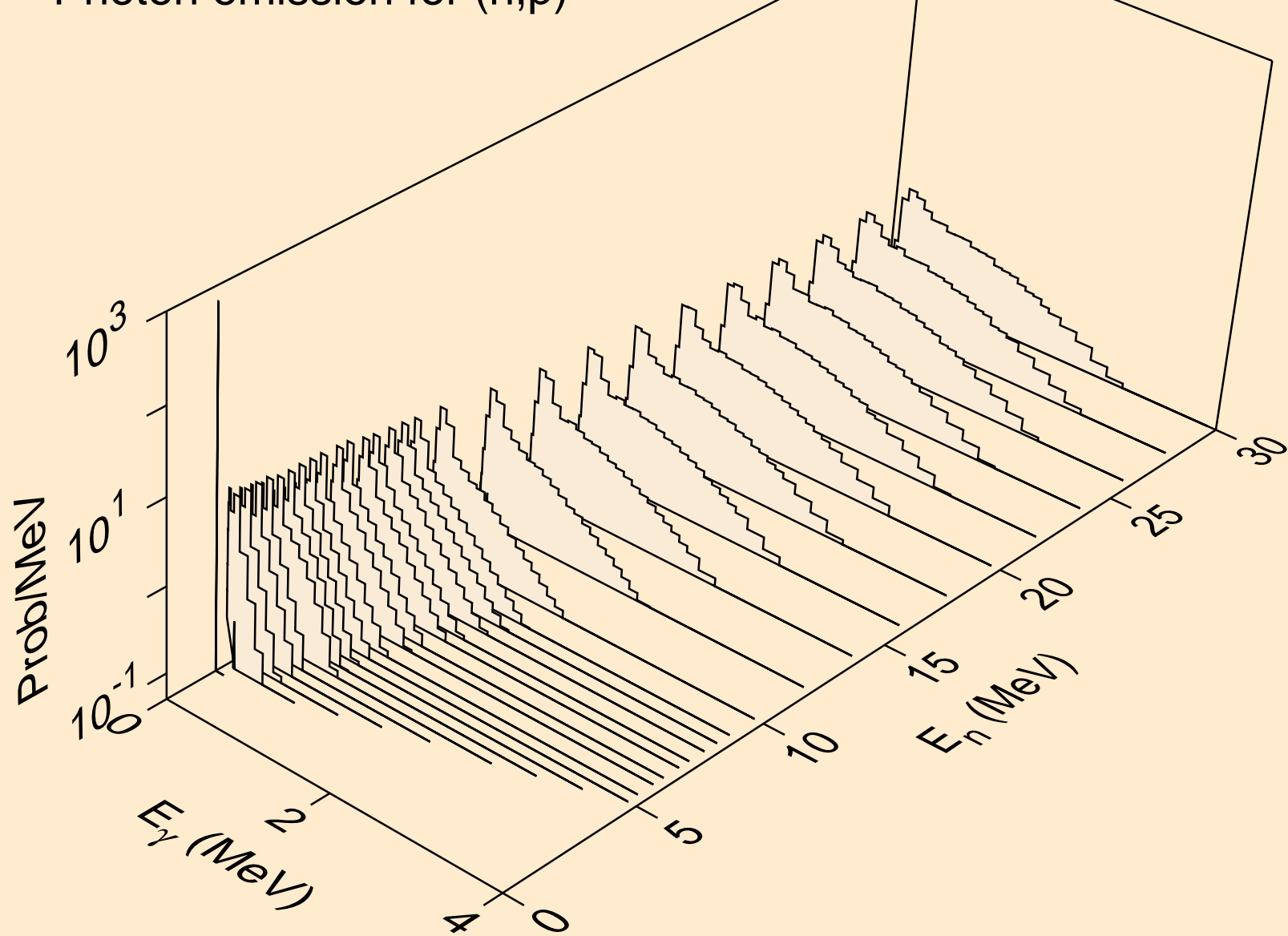

DS283 NEUTRON ACER TENDL-2023 LIBRARY; T=0.K
Photon emission for (n,d)

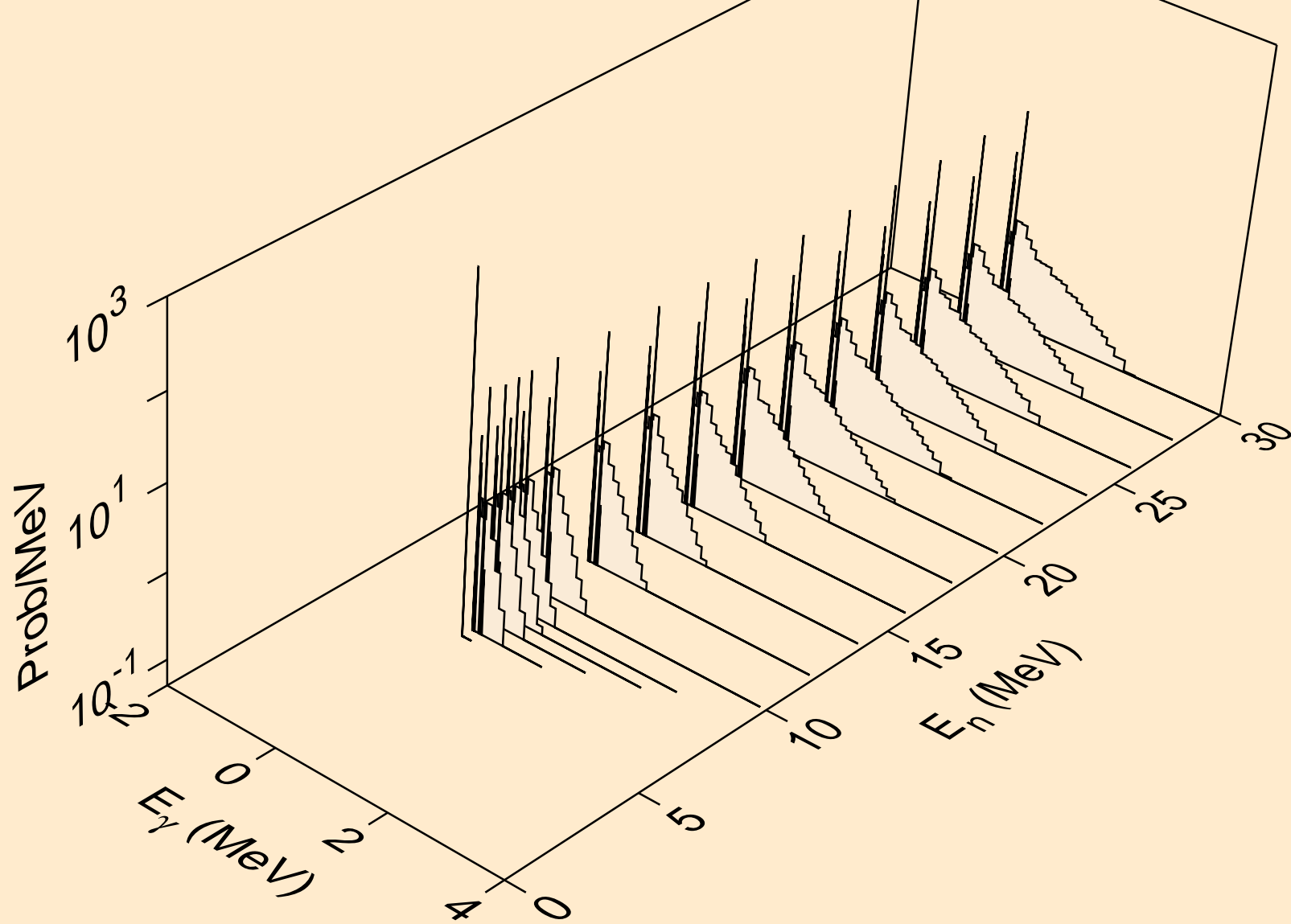

DS283 NEUTRON ACER TENDL-2023 LIBRARY; T=0.K
Photon emission for (n,t)

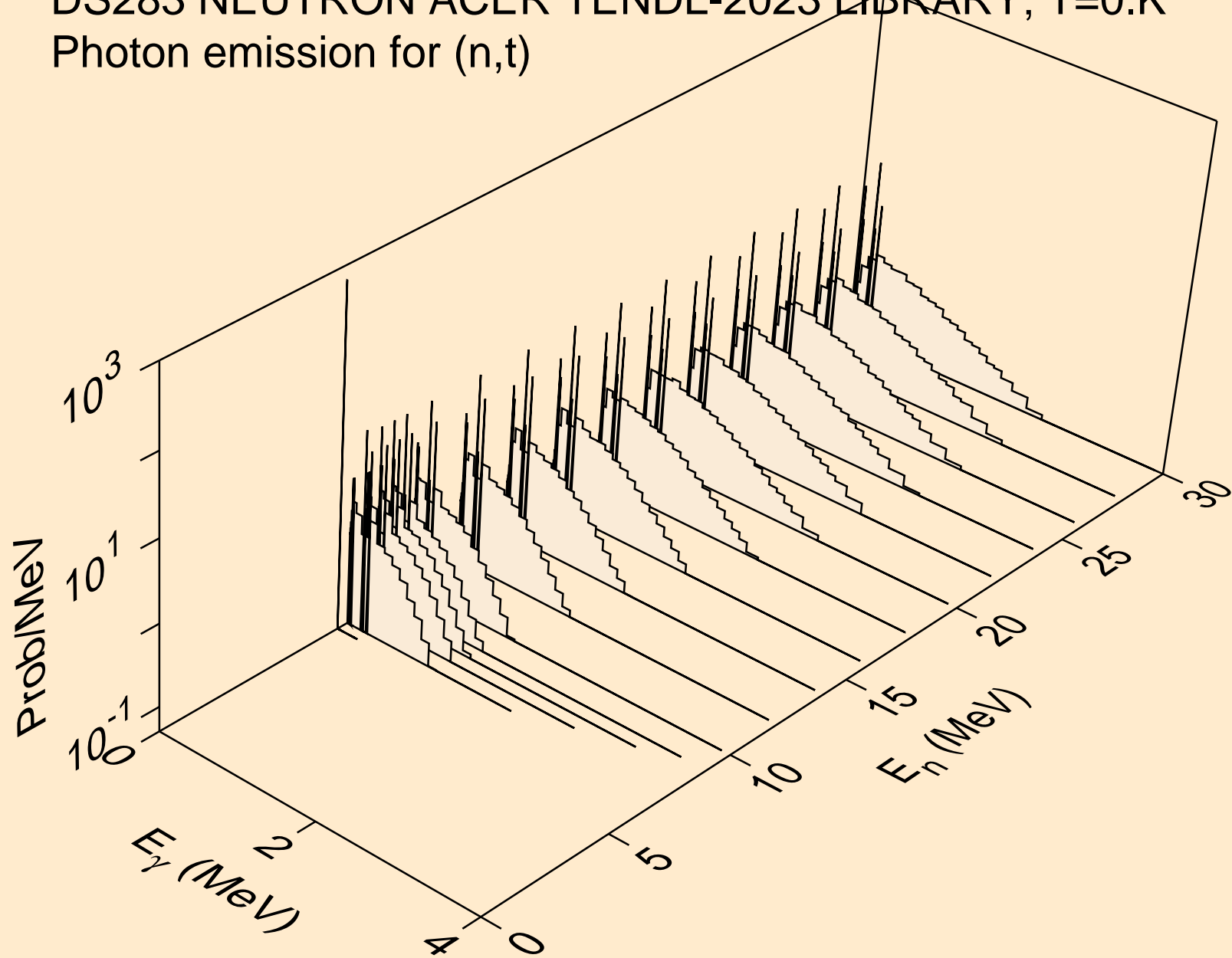

DS283 NEUTRON ACER TENDL-2023 LIBRARY; T=0.K
Photon emission for (n,he3)

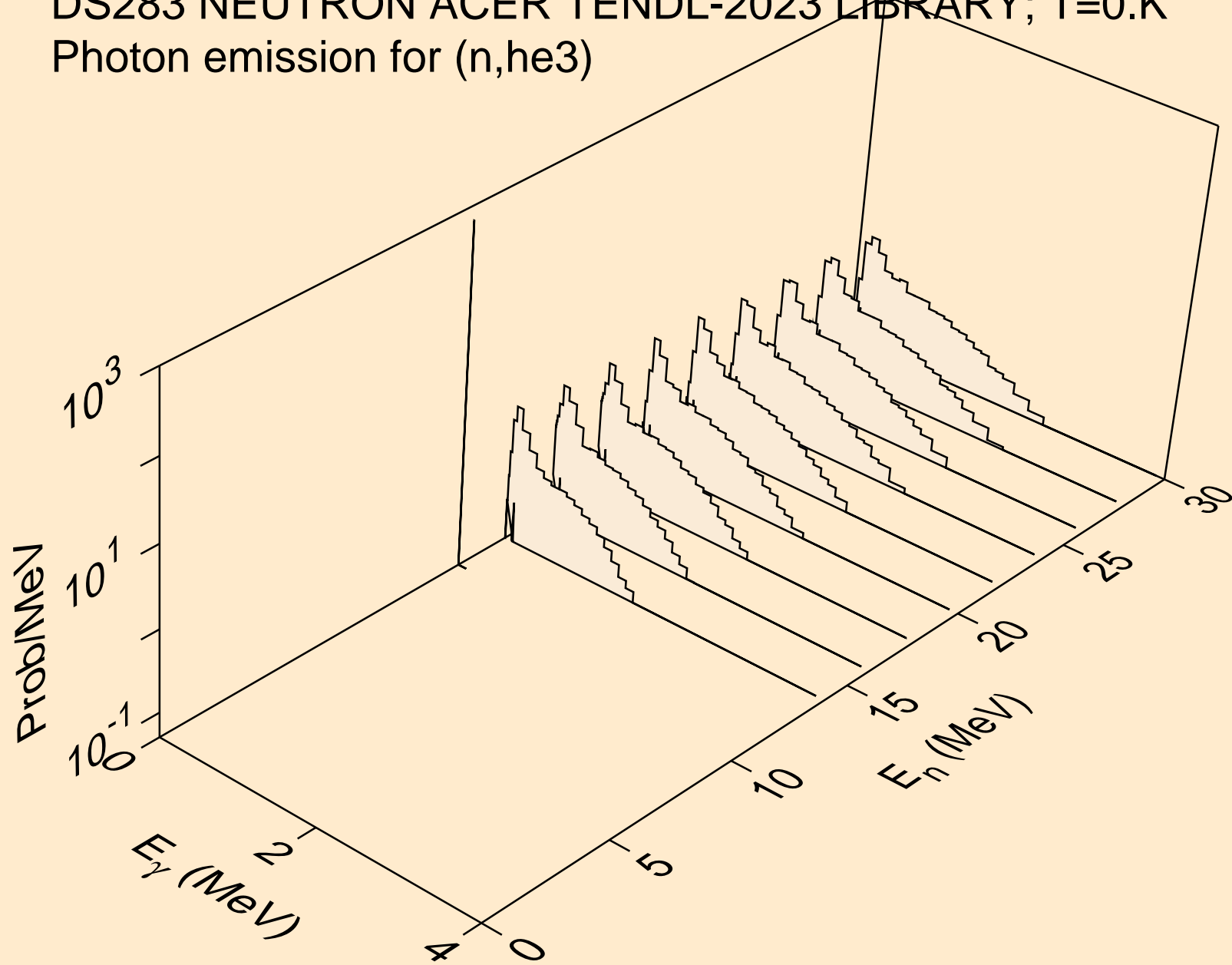

DS283 NEUTRON ACER TENDL-2023 LIBRARY; T=0.K
Photon emission for (n,a)

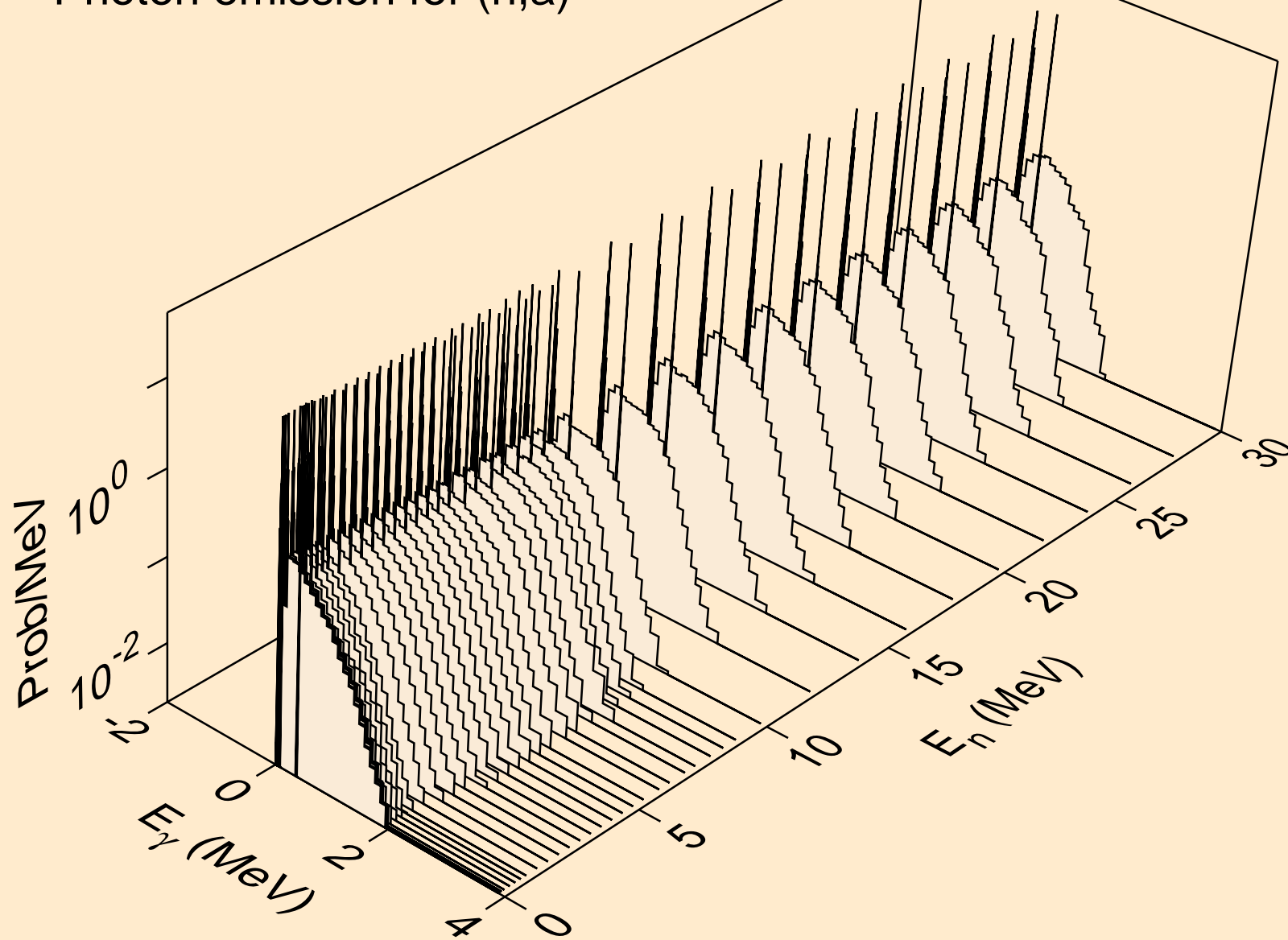

DS283 NEUTRON ACER TENDL-2023 LIBRARY; T=0.K
Photon emission for (n,2p)

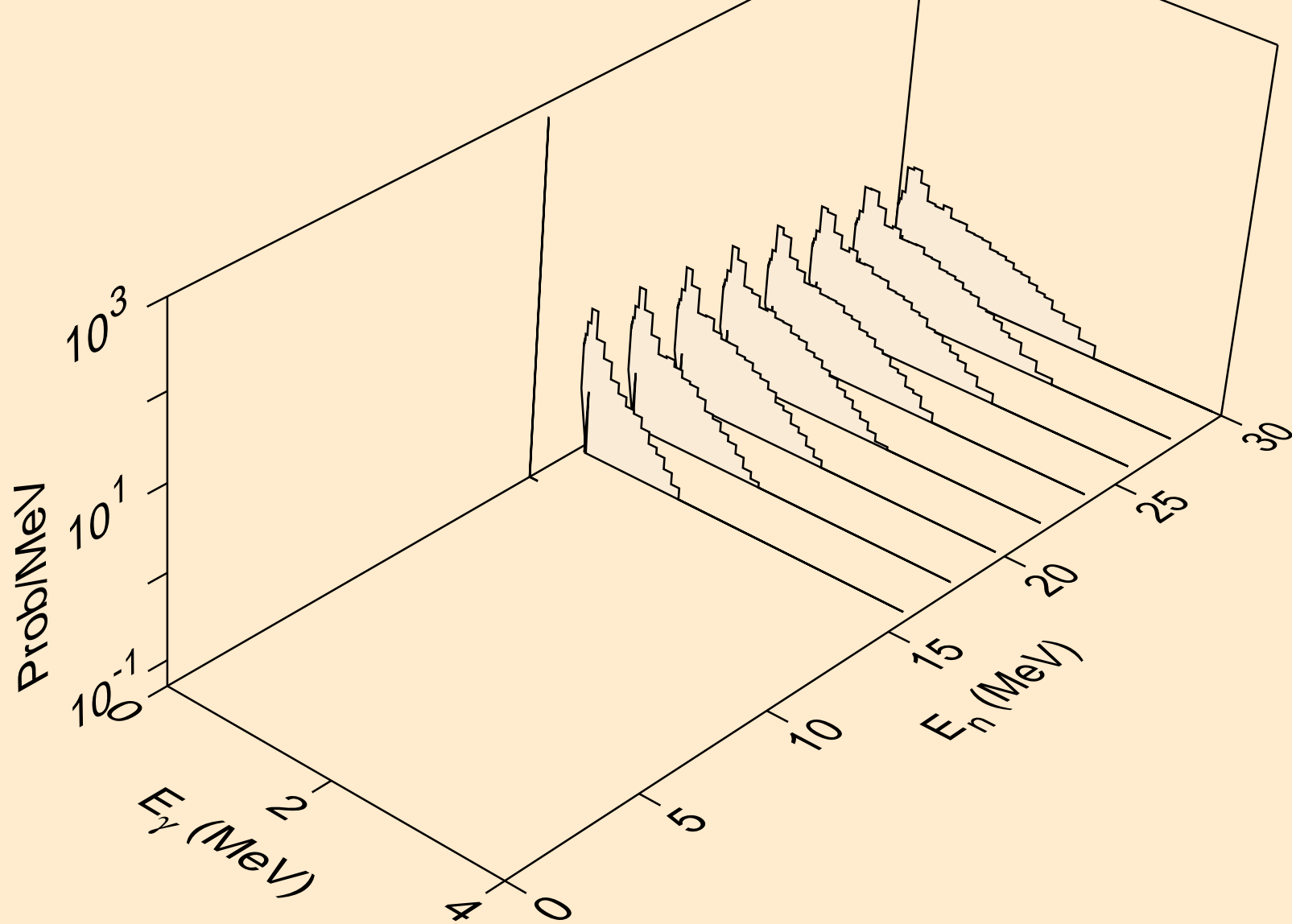

DS283 NEUTRON ACER TENDL-2023 LIBRARY; T=0.K
Photon emission for (n,p α)

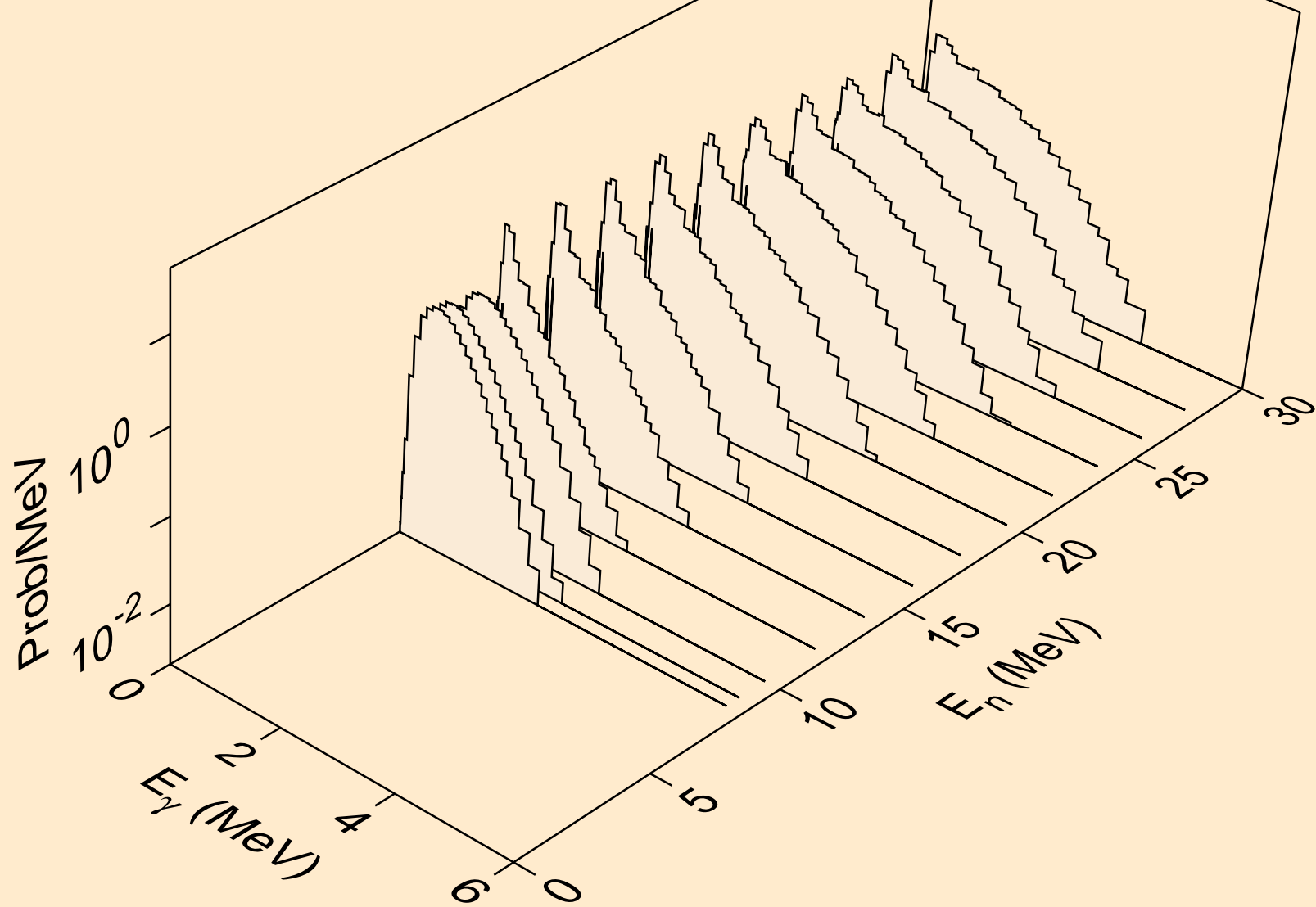

DS283 NEUTRON ACER TENDL-2023 LIBRARY; T=0.K
thermal capture photon spectrum

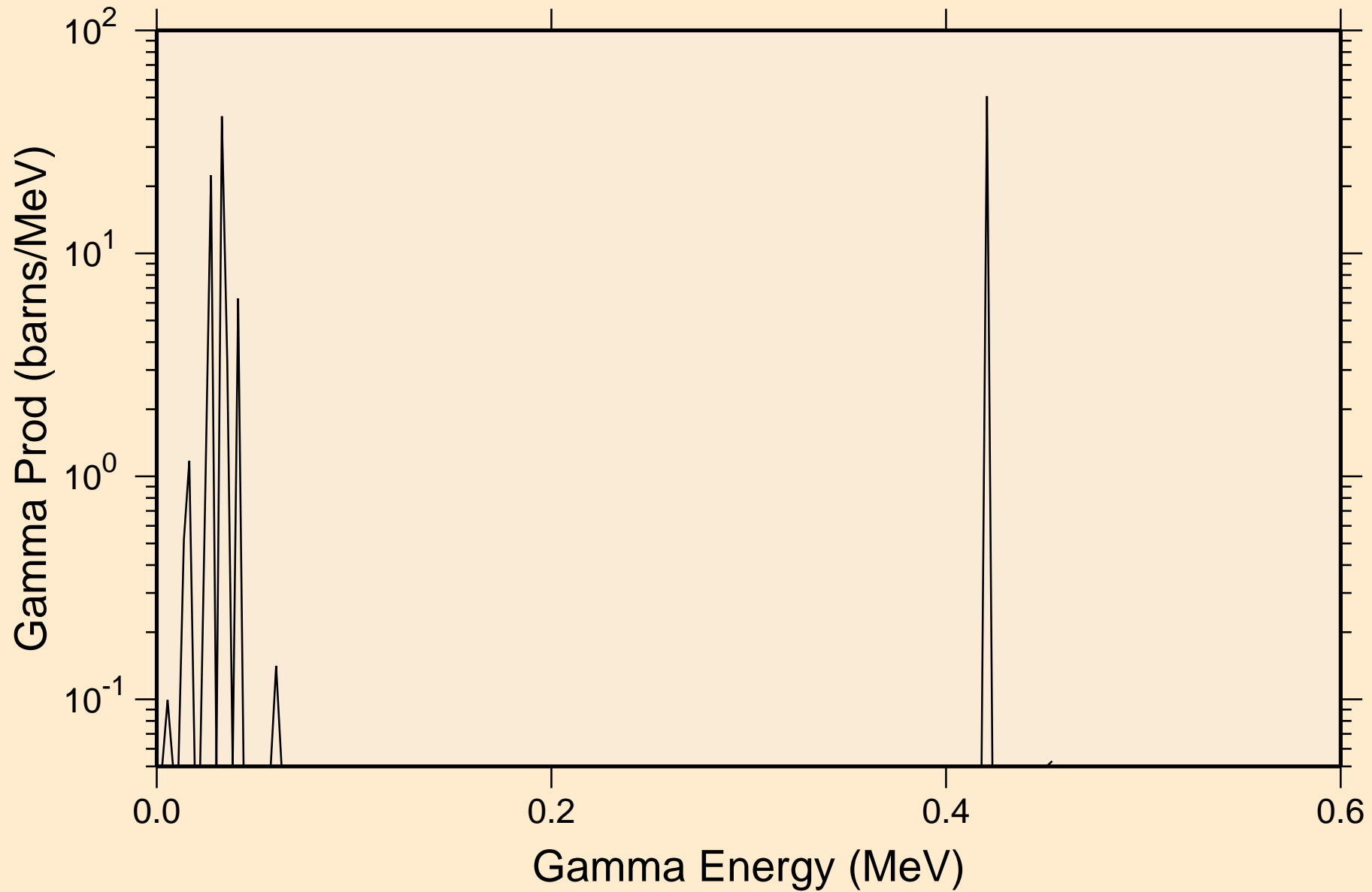

DS283 NEUTRON ACER TENDL-2023 LIBRARY; T=0.K
14 MeV photon spectrum

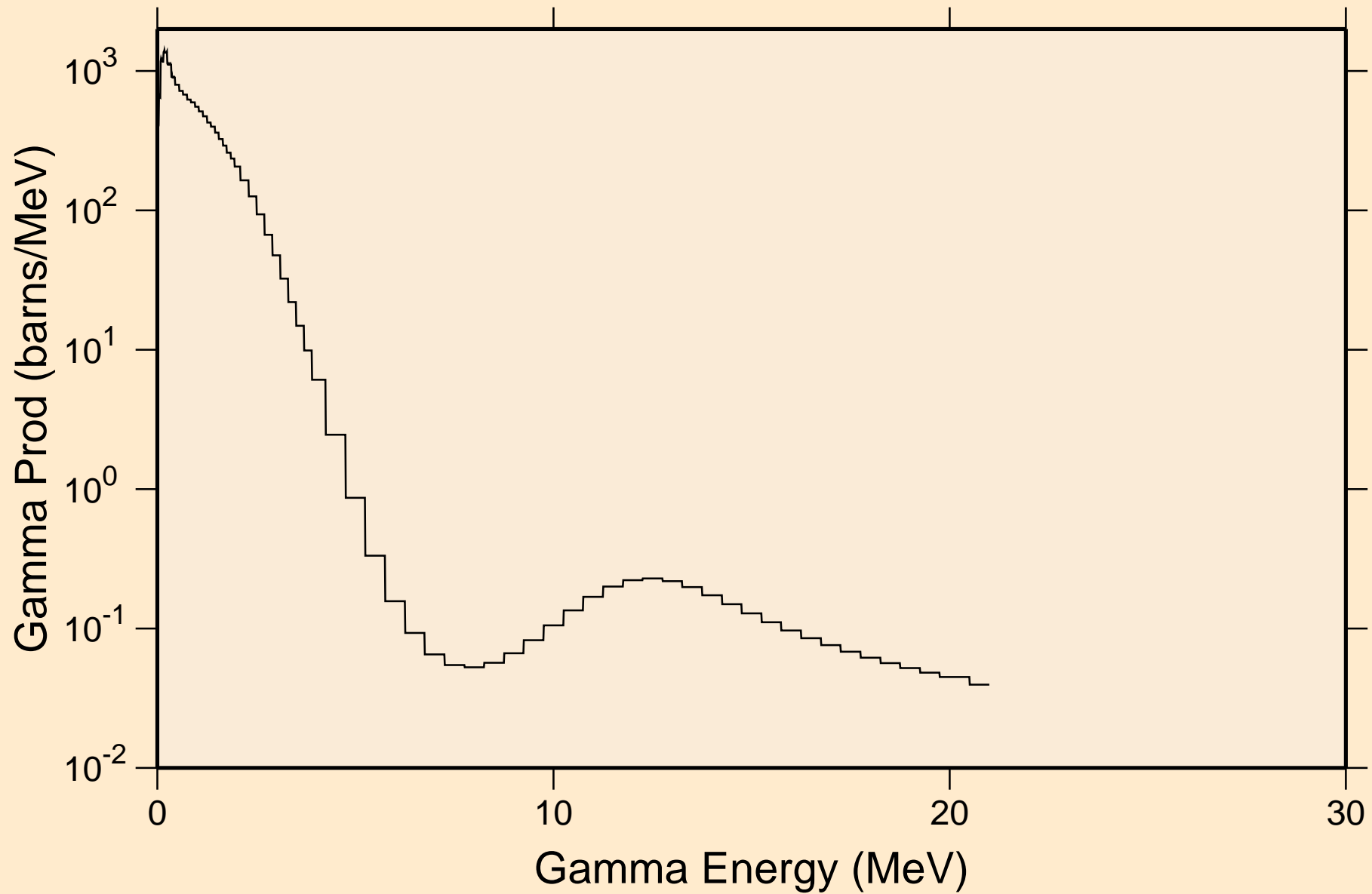

DS283 NEUTRON ACER TENDL-2023 LIBRARY; T=0.K

Particle heating contributions

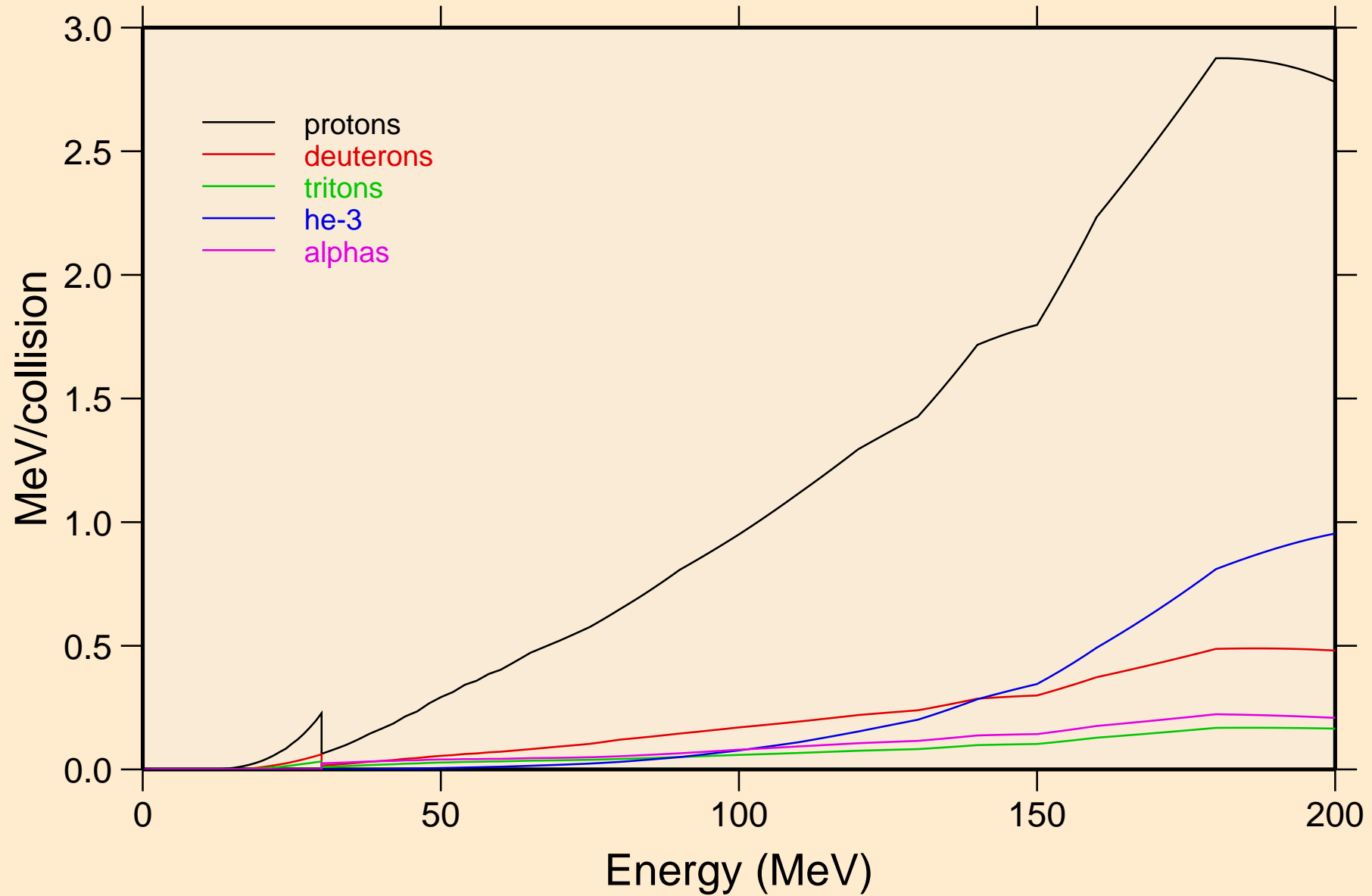

DS283 NEUTRON ACER TENDL-2023 LIBRARY; T=0.K
Recoil Heating

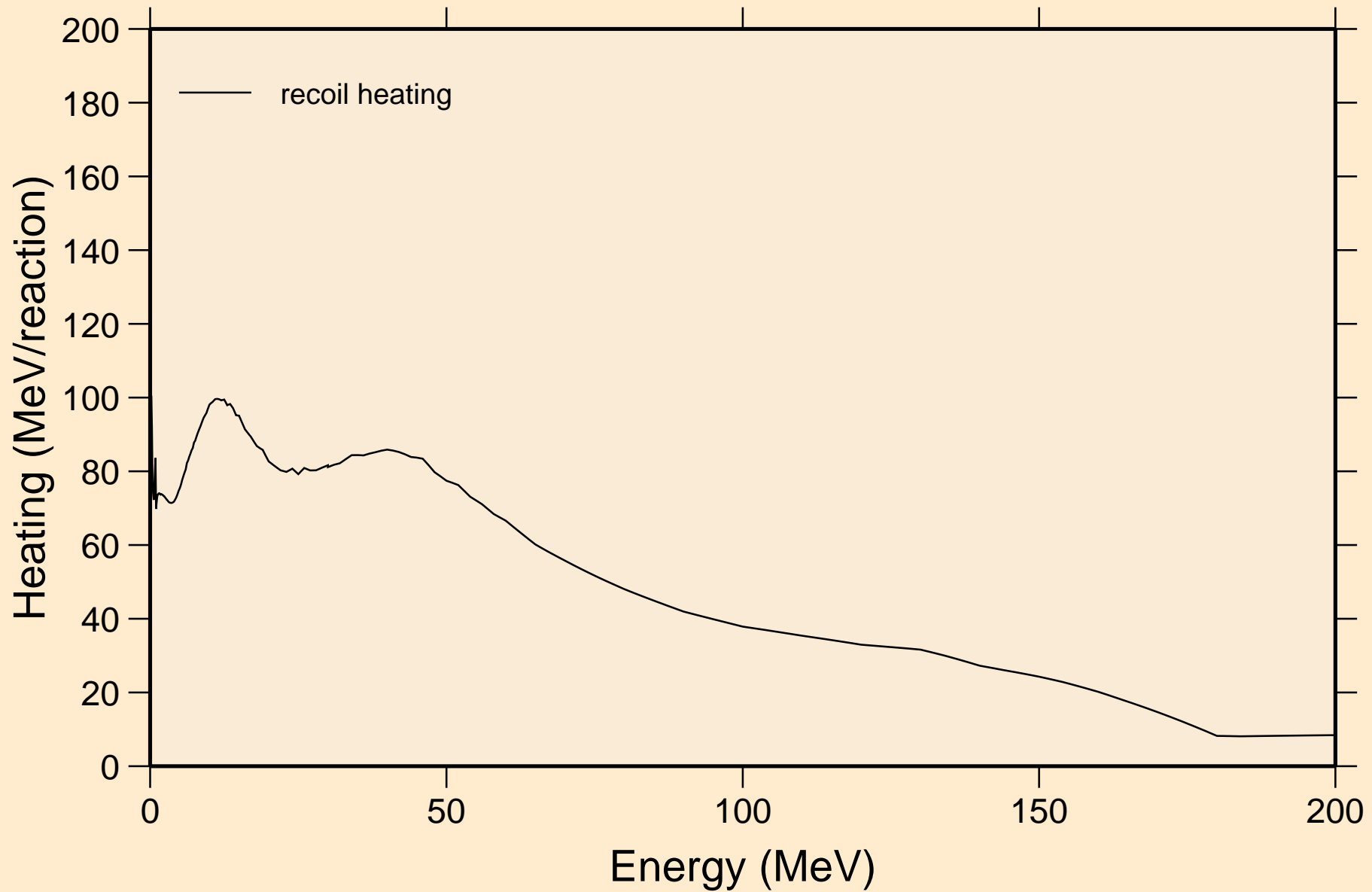

DS283 NEUTRON ACER TENDL-2023 LIBRARY; T=0.K

Particle production cross sections

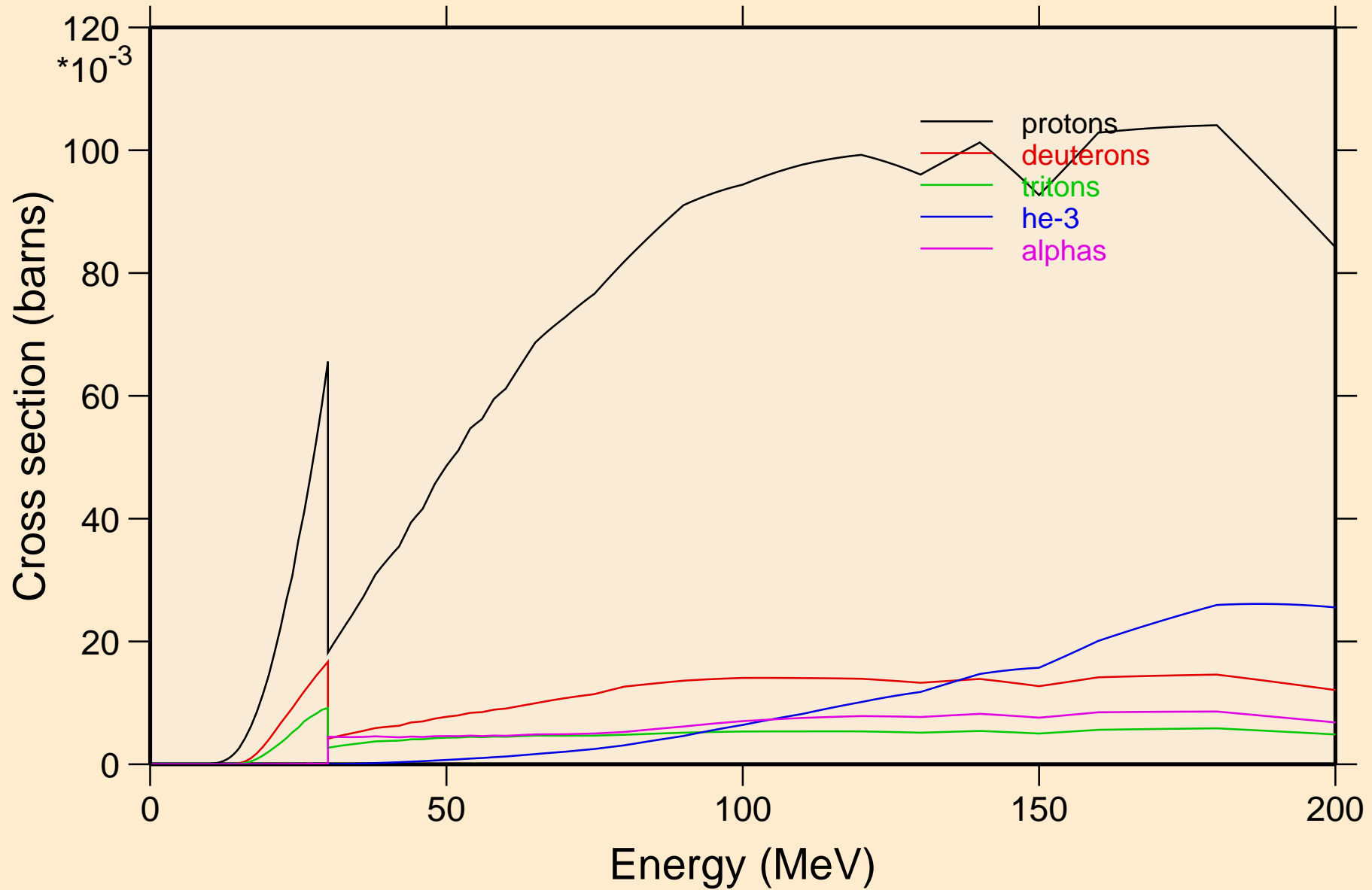

DS283 NEUTRON ACER TENDL-2023 LIBRARY; T=0.K
protons from (n,x)

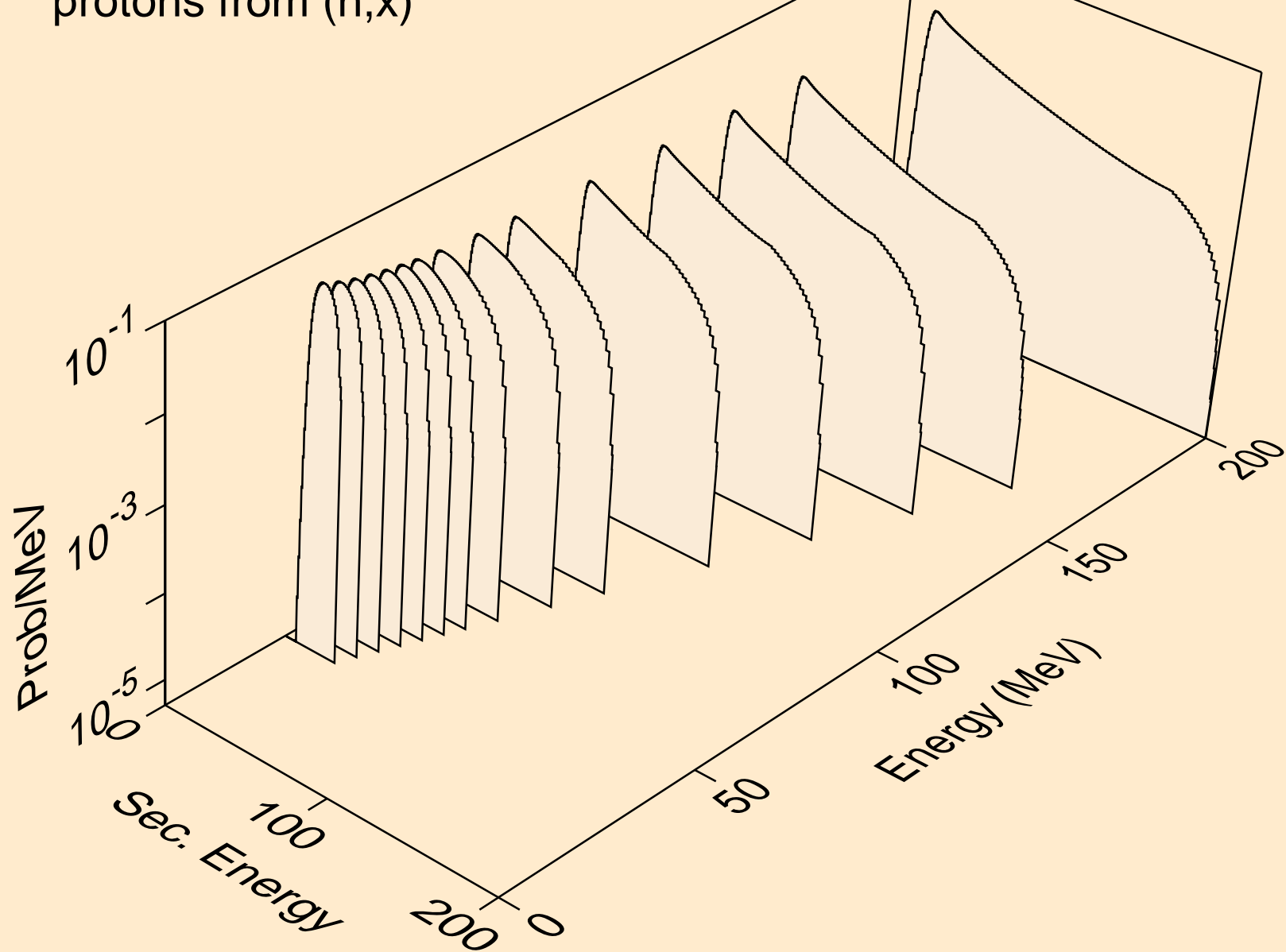

DS283 NEUTRON ACER TENDL-2023 LIBRARY; T=0.K
protons from (n,n*)p

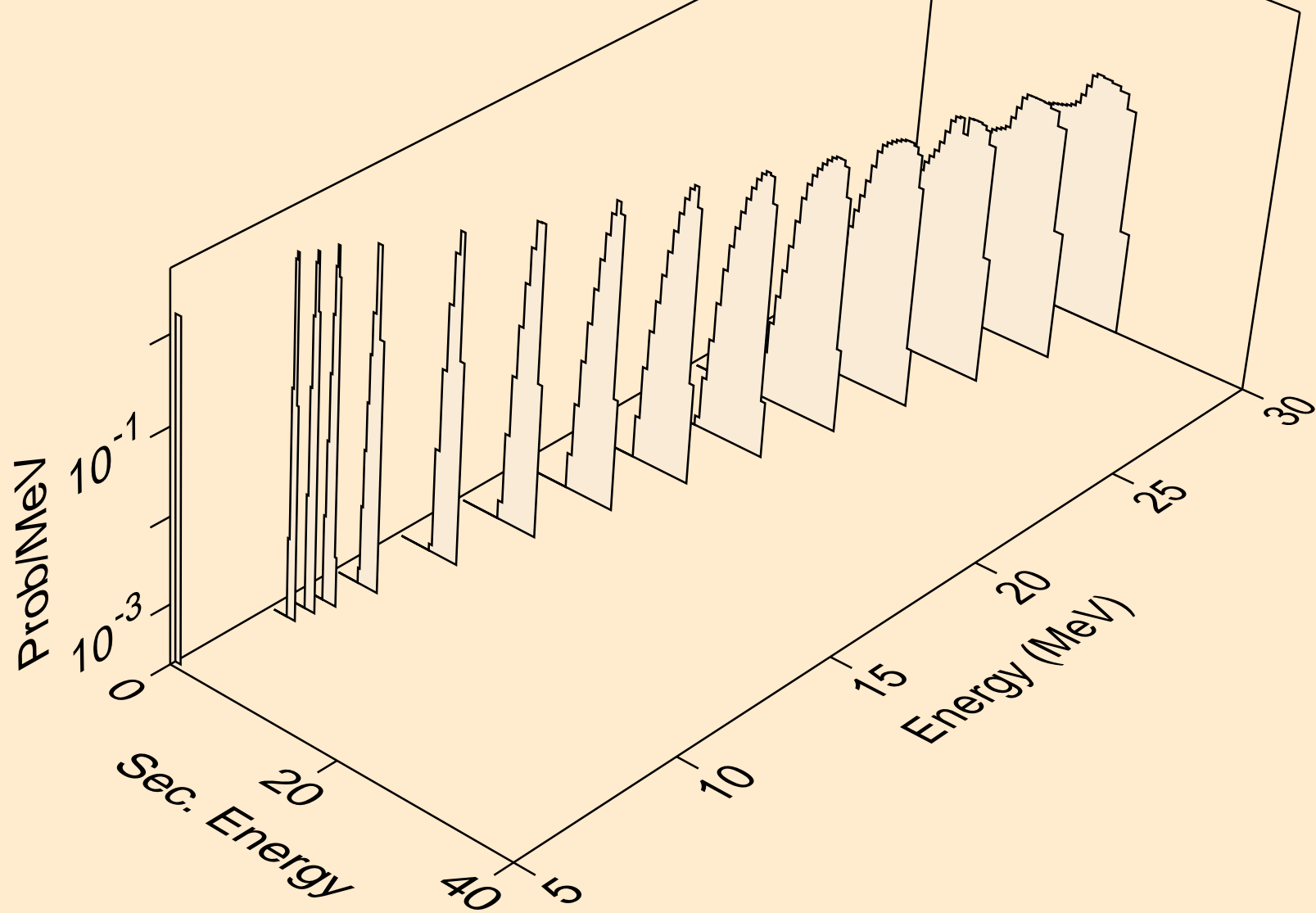

DS283 NEUTRON ACER TENDL-2023 LIBRARY; T=0.K
protons from (n,2np)

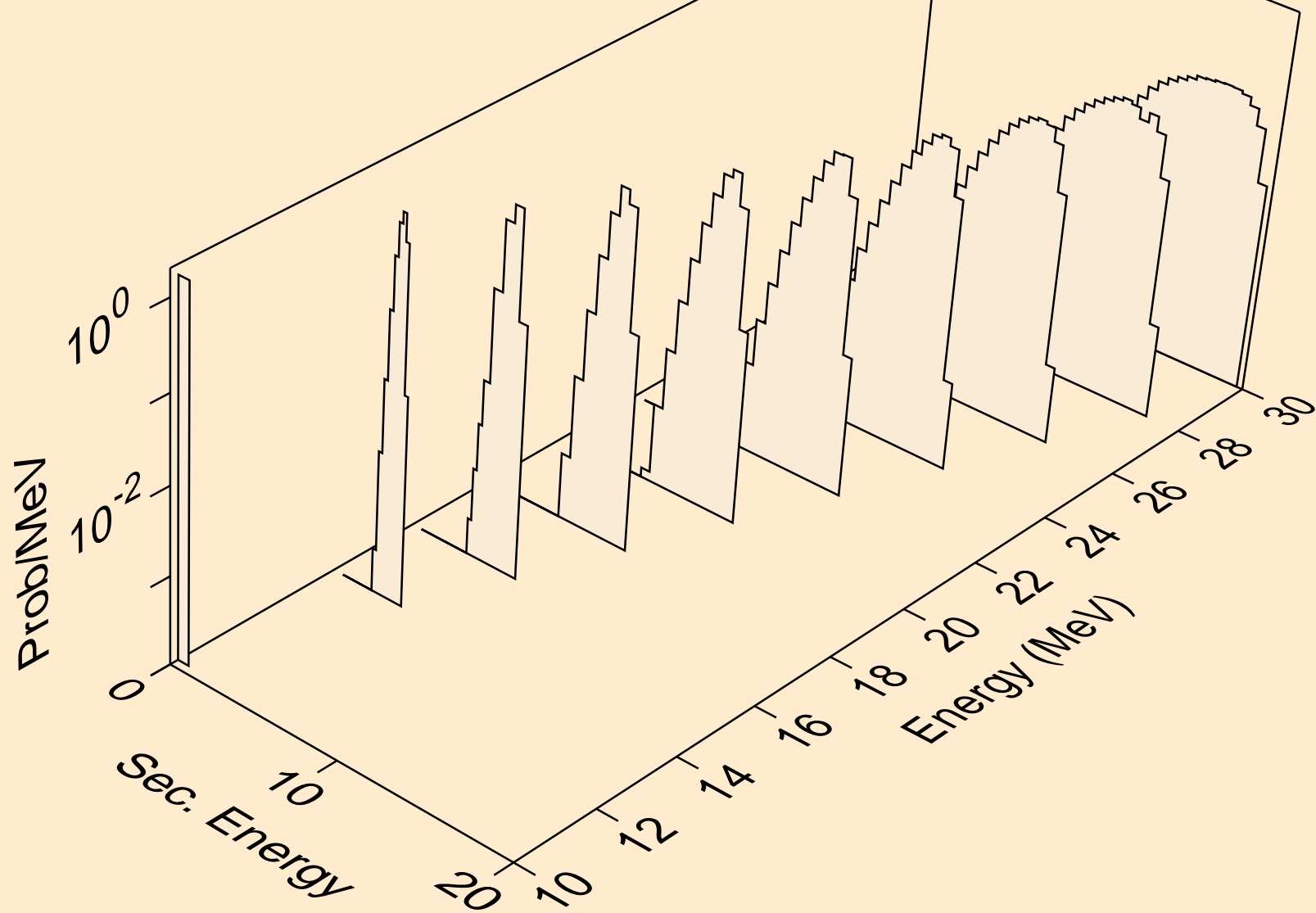

DS283 NEUTRON ACER TENDL-2023 LIBRARY; T=0.K
protons from (n,3np)

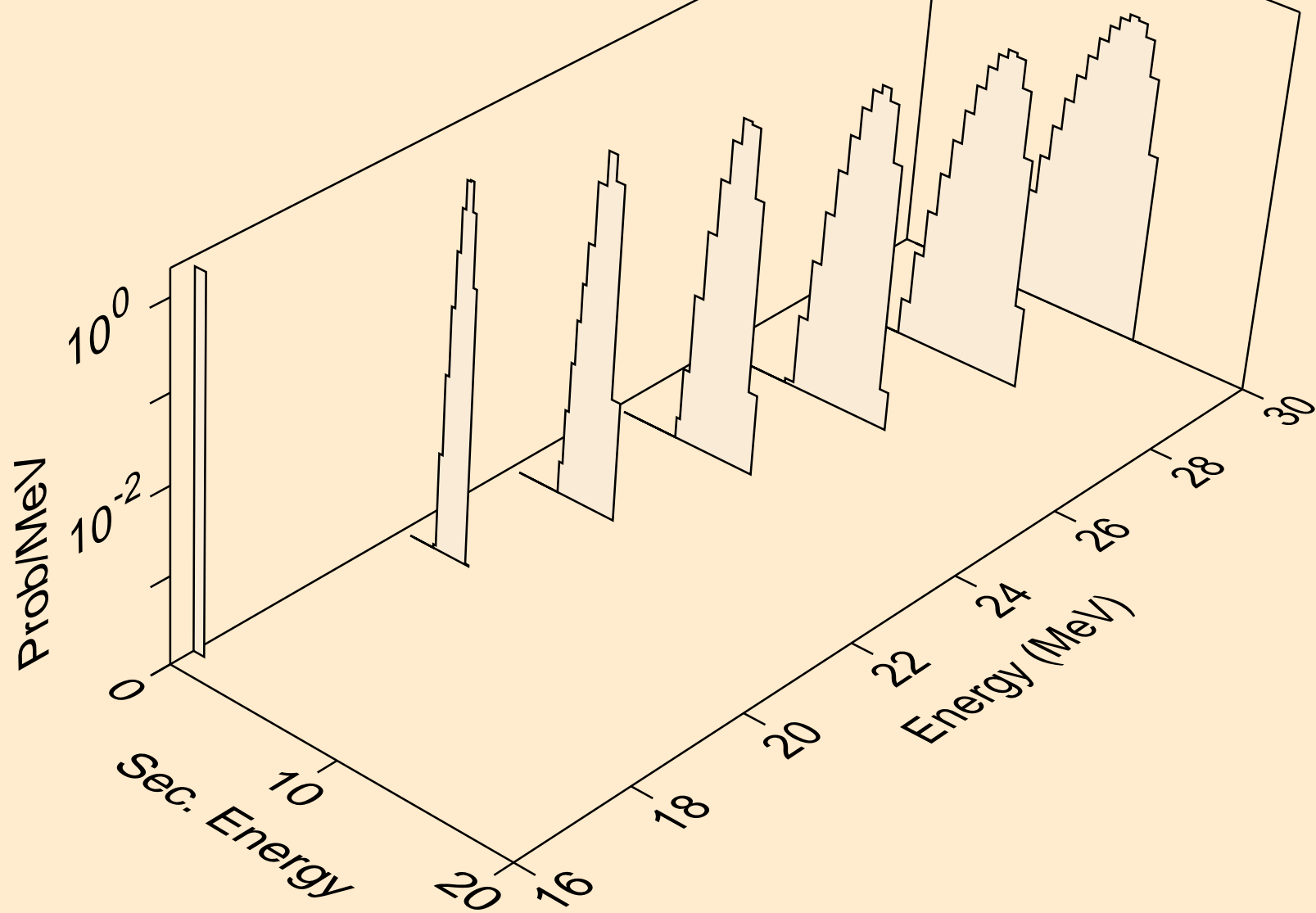

DS283 NEUTRON ACER TENDL-2023 LIBRARY; T=0.K
protons from (n,n2p)

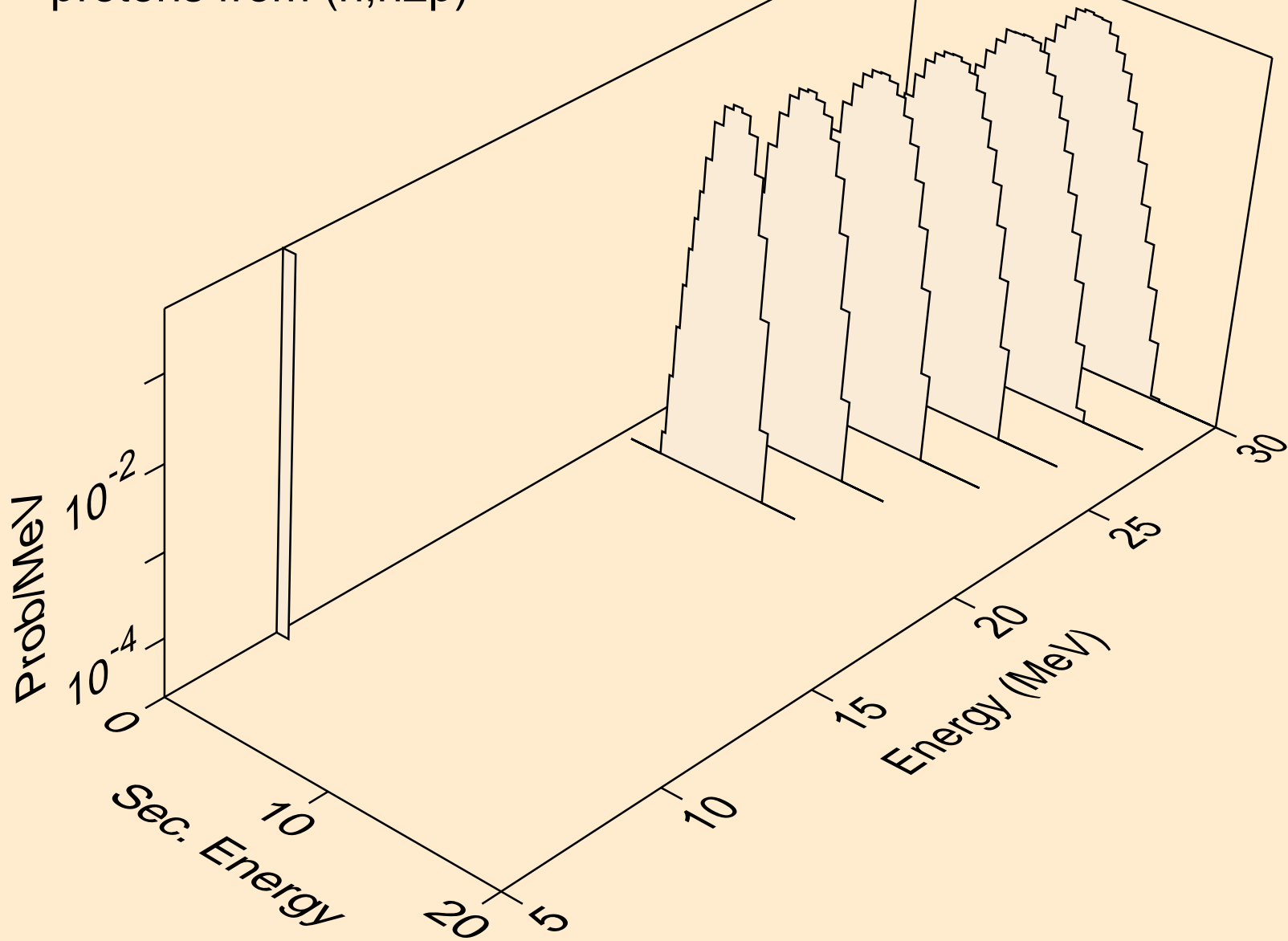

DS283 NEUTRON ACER TENDL-2023 LIBRARY; T=0.K
protons from (n,npa)

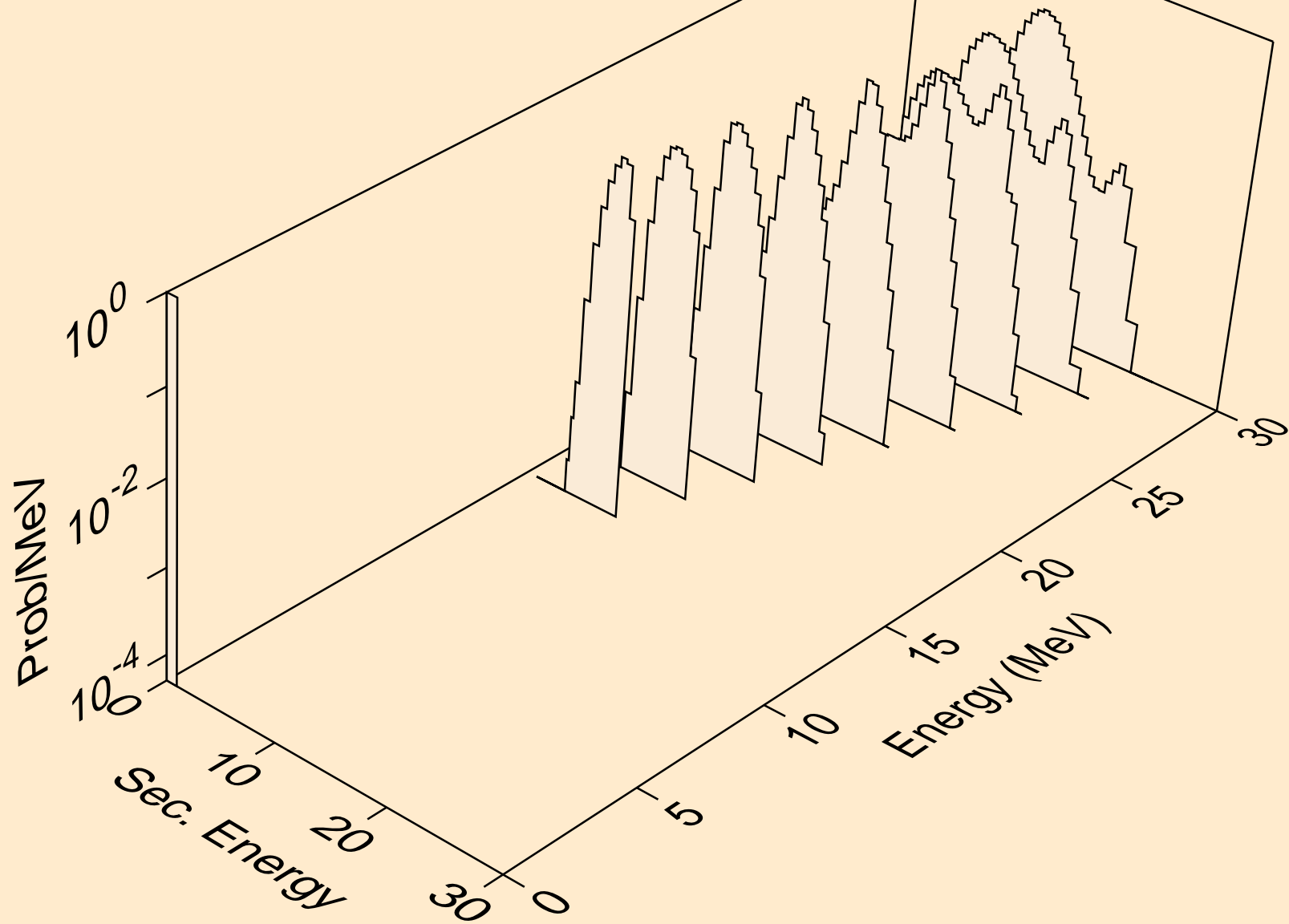

DS283 NEUTRON ACER TENDL-2023 LIBRARY; T=0.K
protons from (n,p)

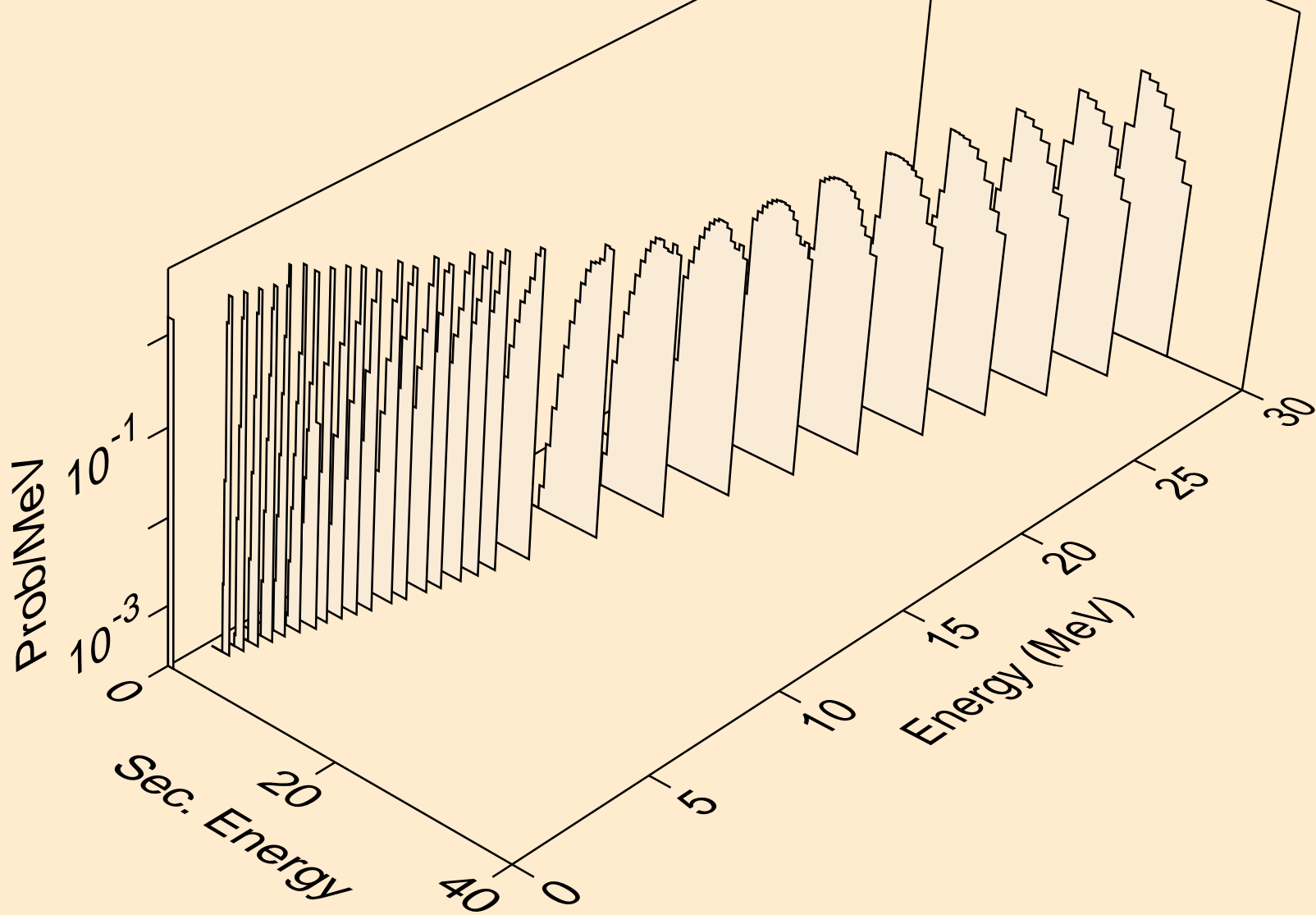

DS283 NEUTRON ACER TENDL-2023 LIBRARY; T=0.K
protons from (n,2p)

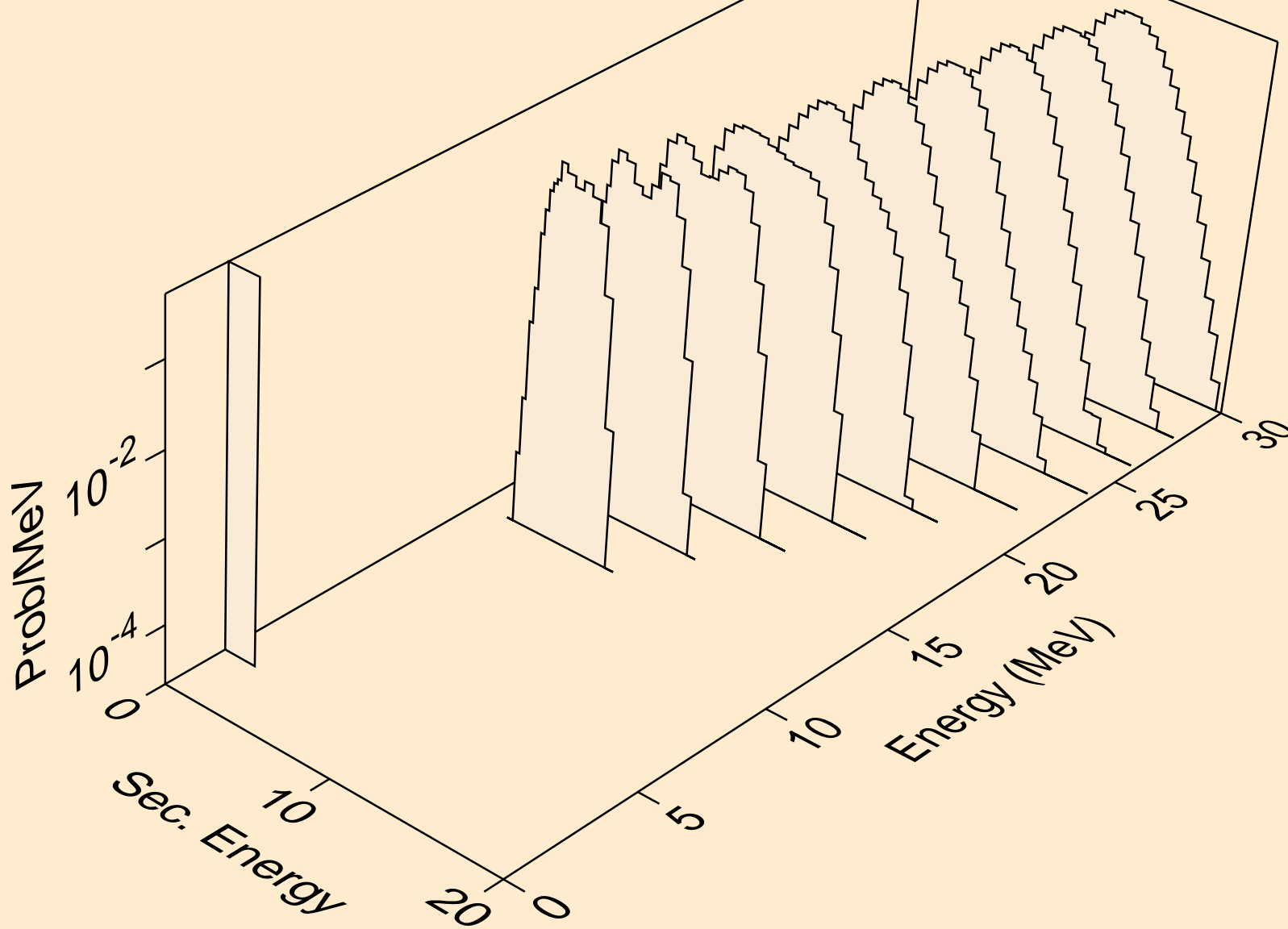

DS283 NEUTRON ACER TENDL-2023 LIBRARY; T=0.K
protons from (n,p)

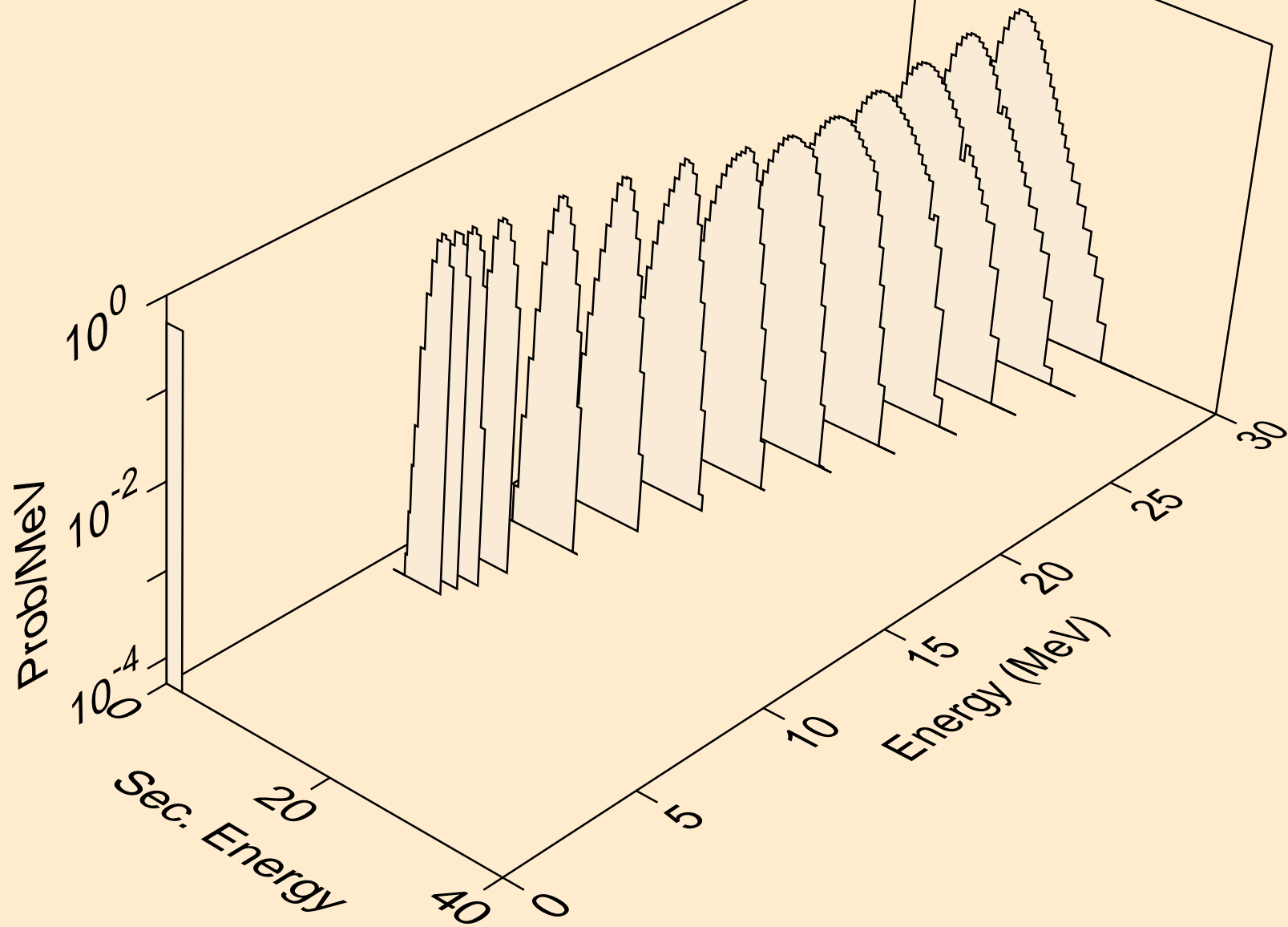

DS283 NEUTRON ACER TENDL-2023 LIBRARY; T=0.K
deuterons from (n,x)

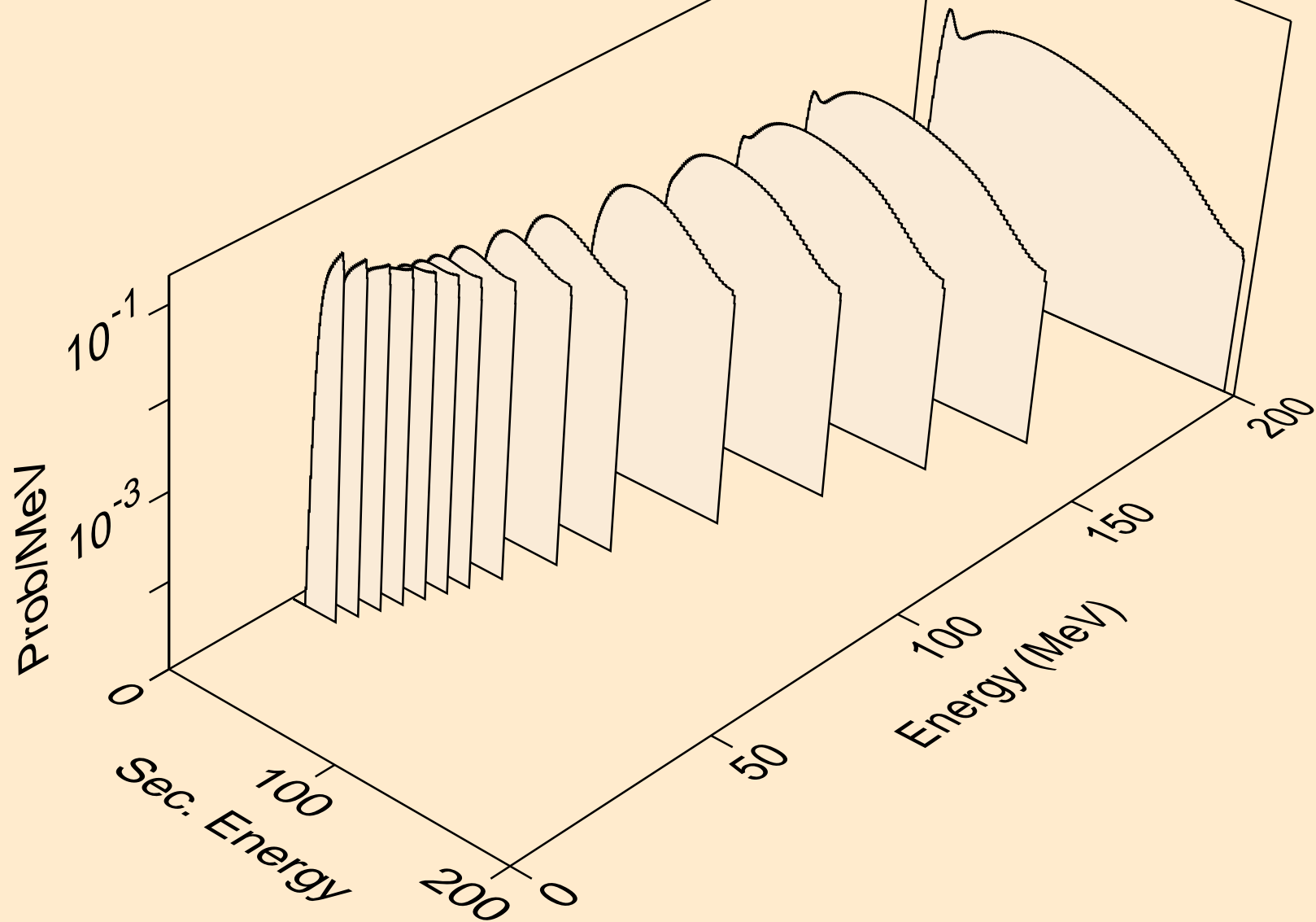

DS283 NEUTRON ACER TENDL-2023 LIBRARY; T=0.K
deuterons from (n,2nd)

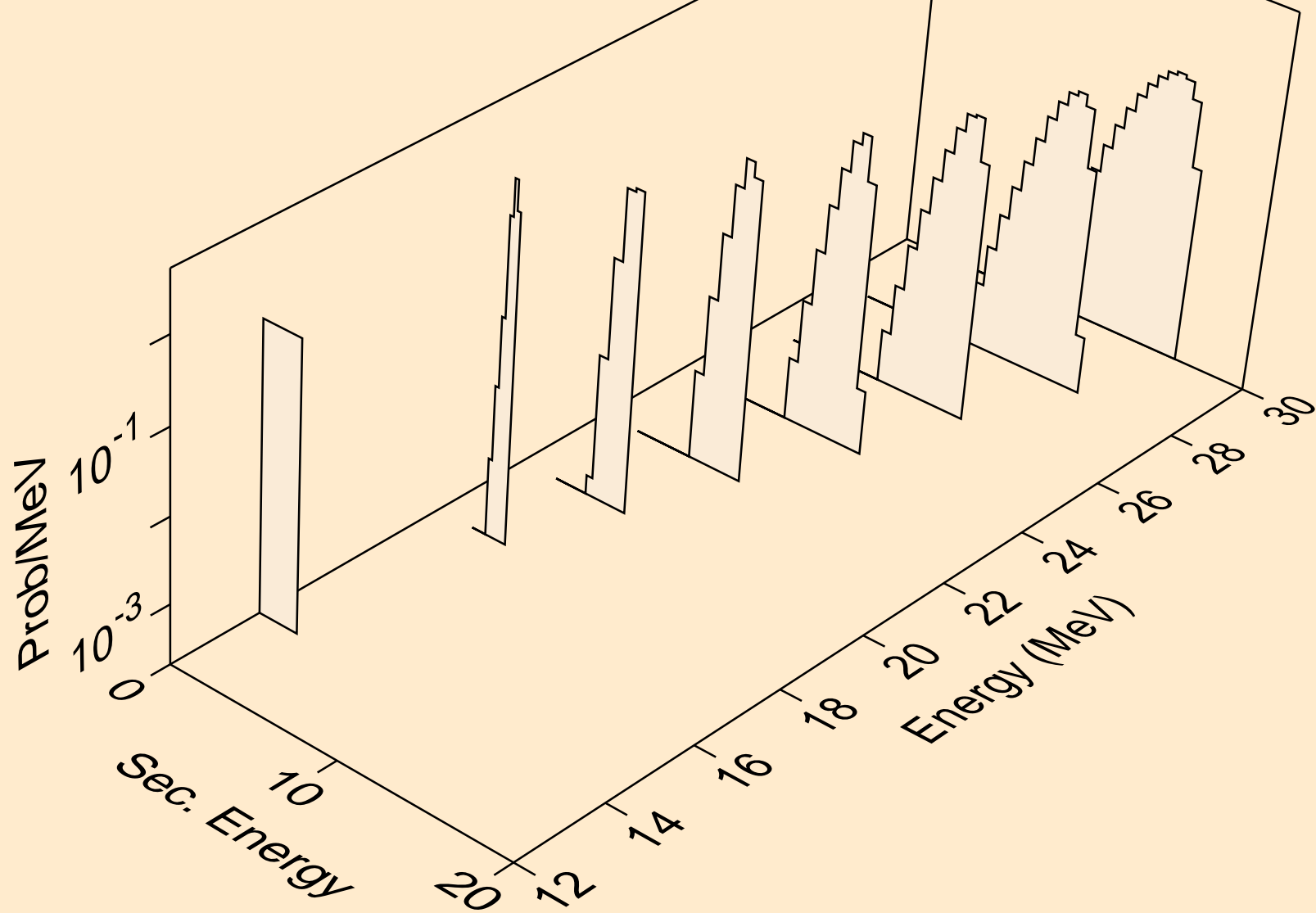

DS283 NEUTRON ACER TENDL-2023 LIBRARY; T=0.K
deuterons from (n,n*)d

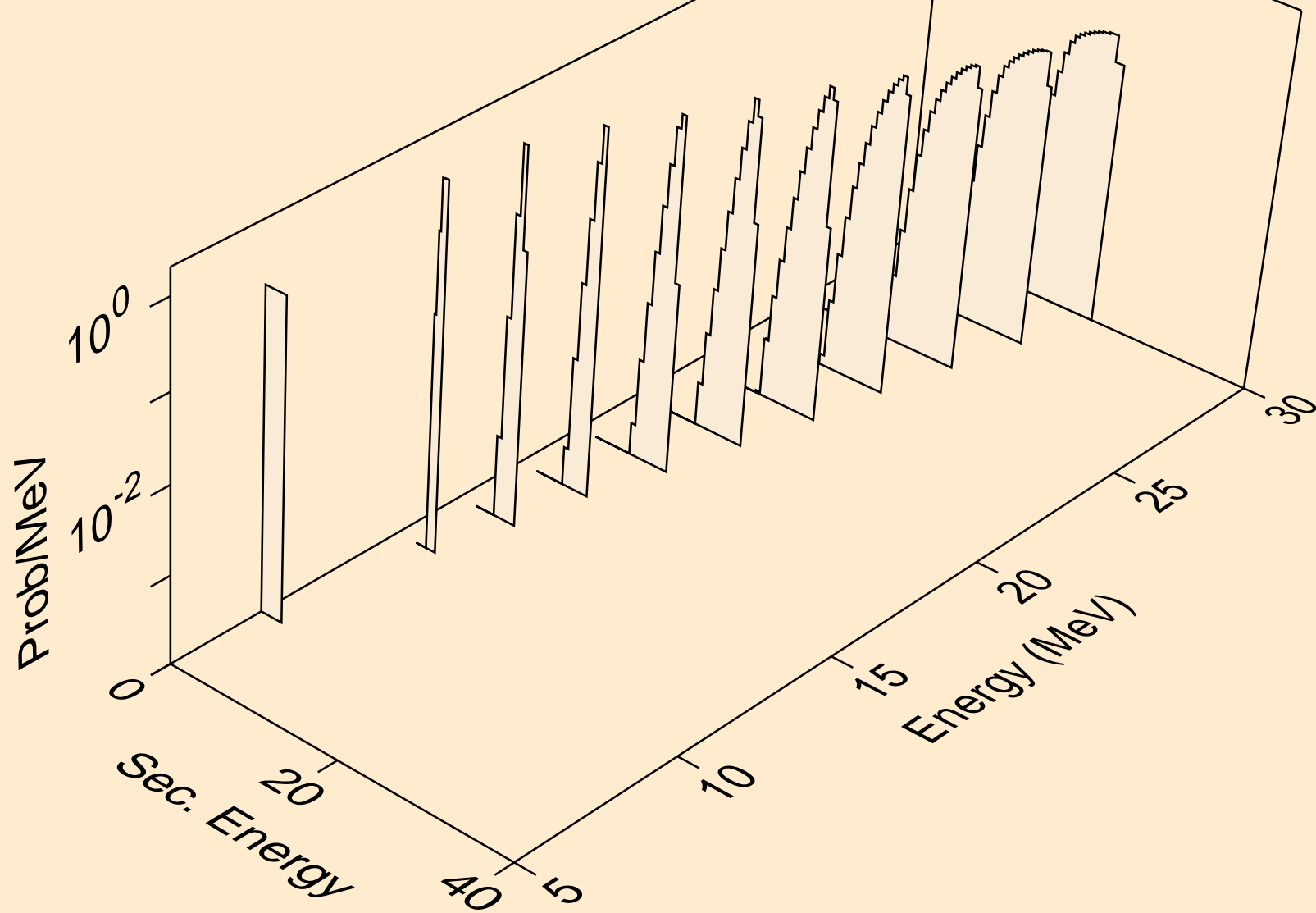

DS283 NEUTRON ACER TENDL-2023 LIBRARY; T=0.K
deuterons from (n,d)

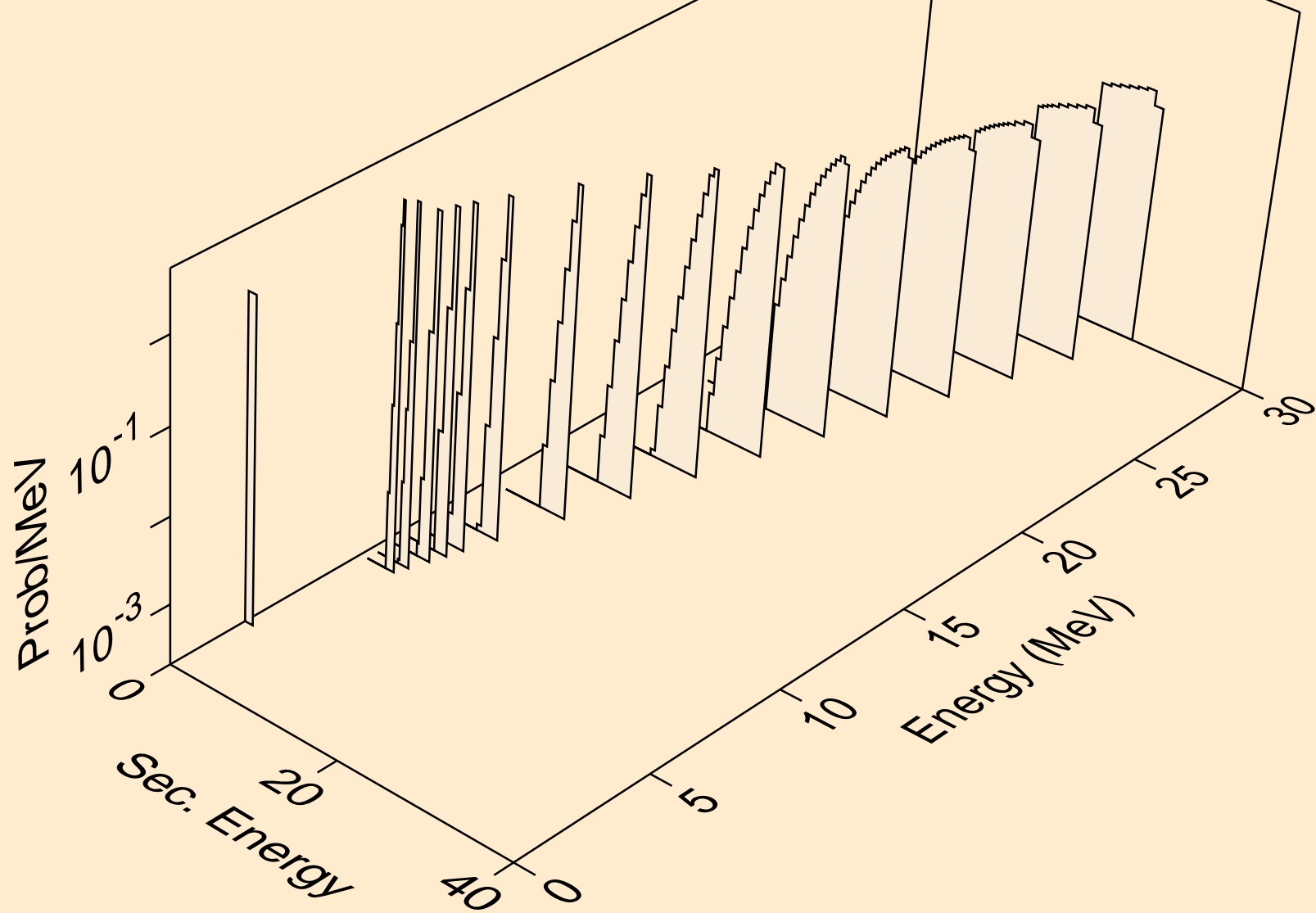

DS283 NEUTRON ACER TENDL-2023 LIBRARY; T=0.K
tritons from (n,x)

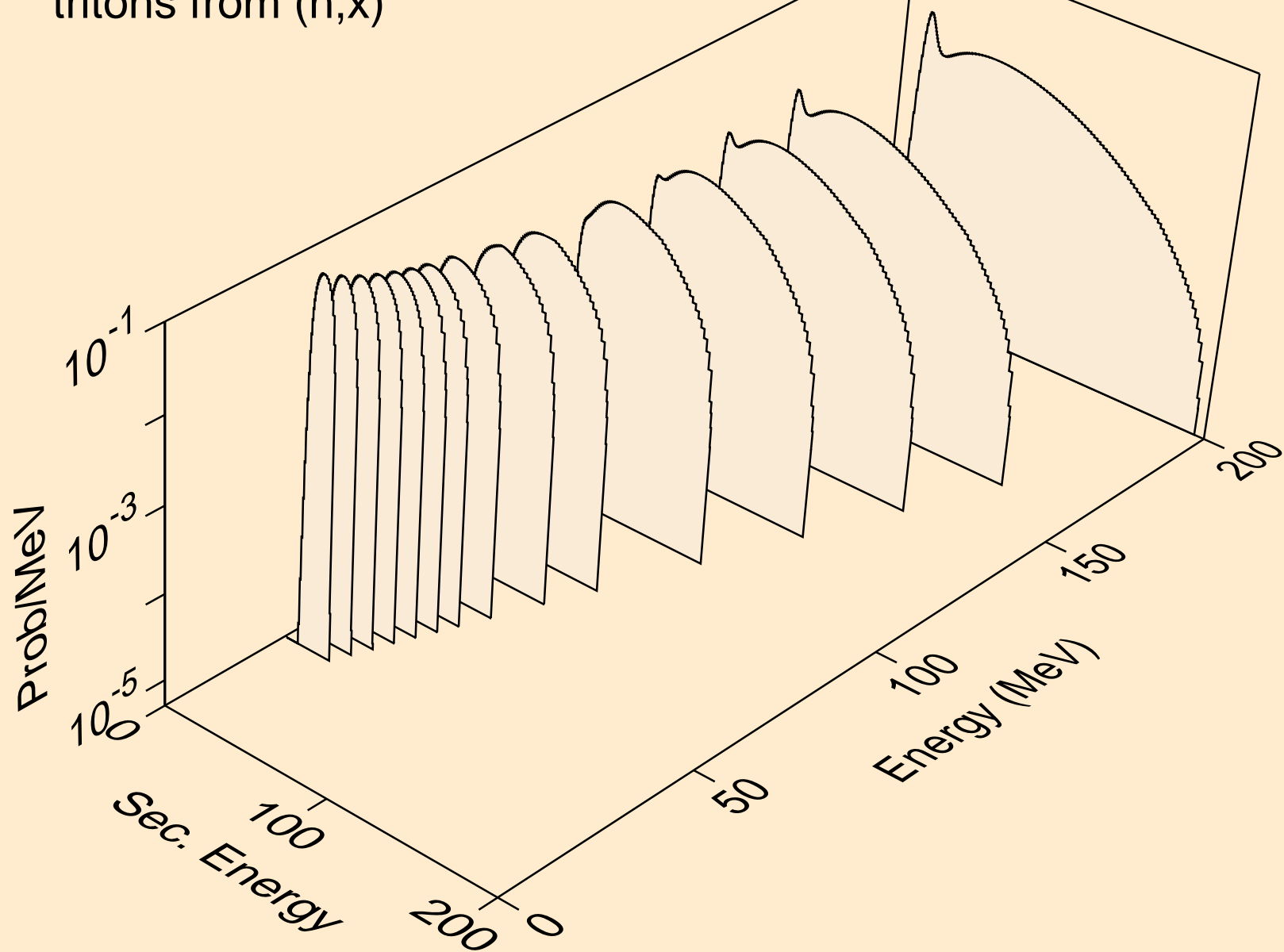

DS283 NEUTRON ACER TENDL-2023 LIBRARY; T=0.K
tritons from (n,n*)t

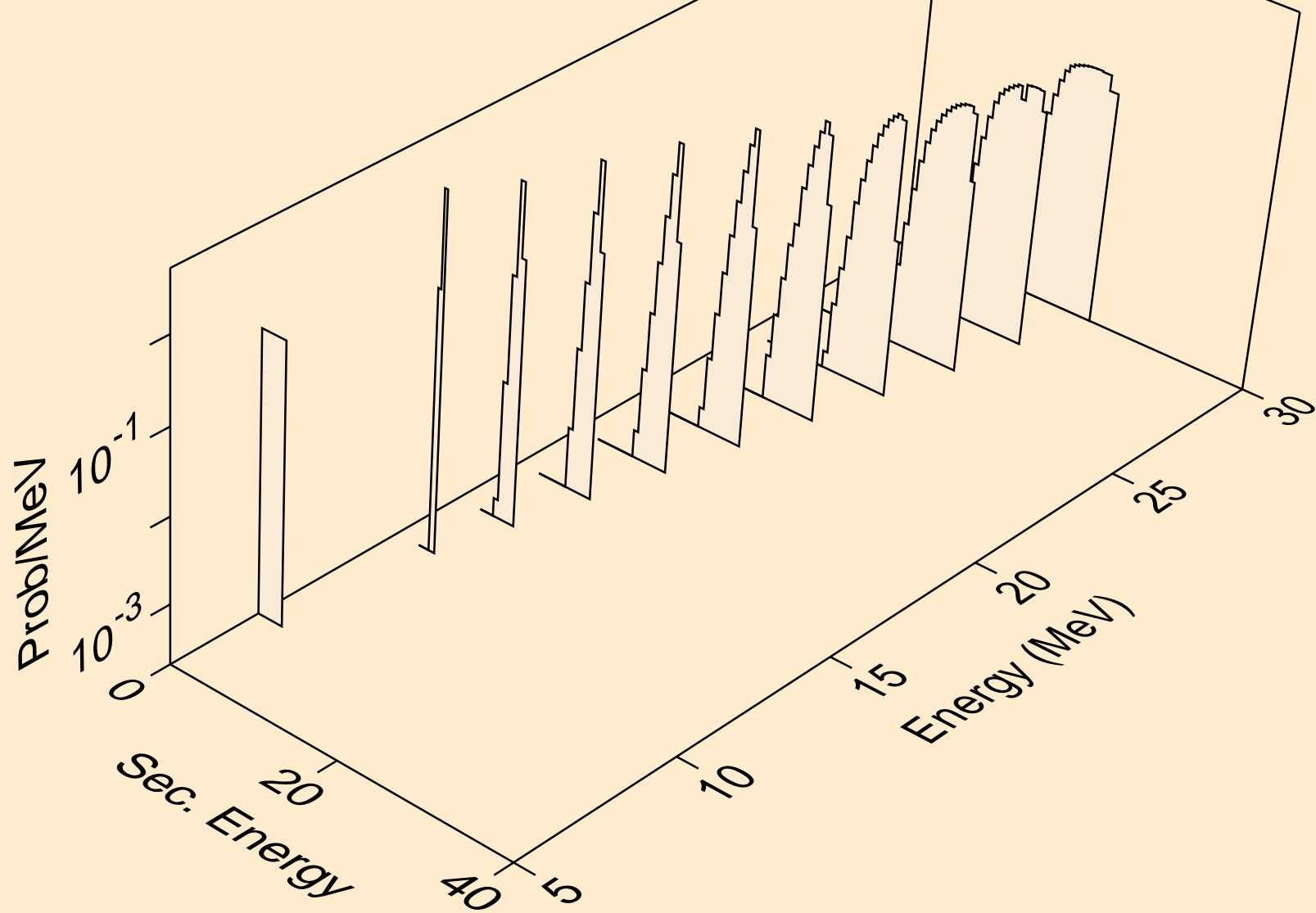

DS283 NEUTRON ACER TENDL-2023 LIBRARY; T=0.K
tritons from (n,t)

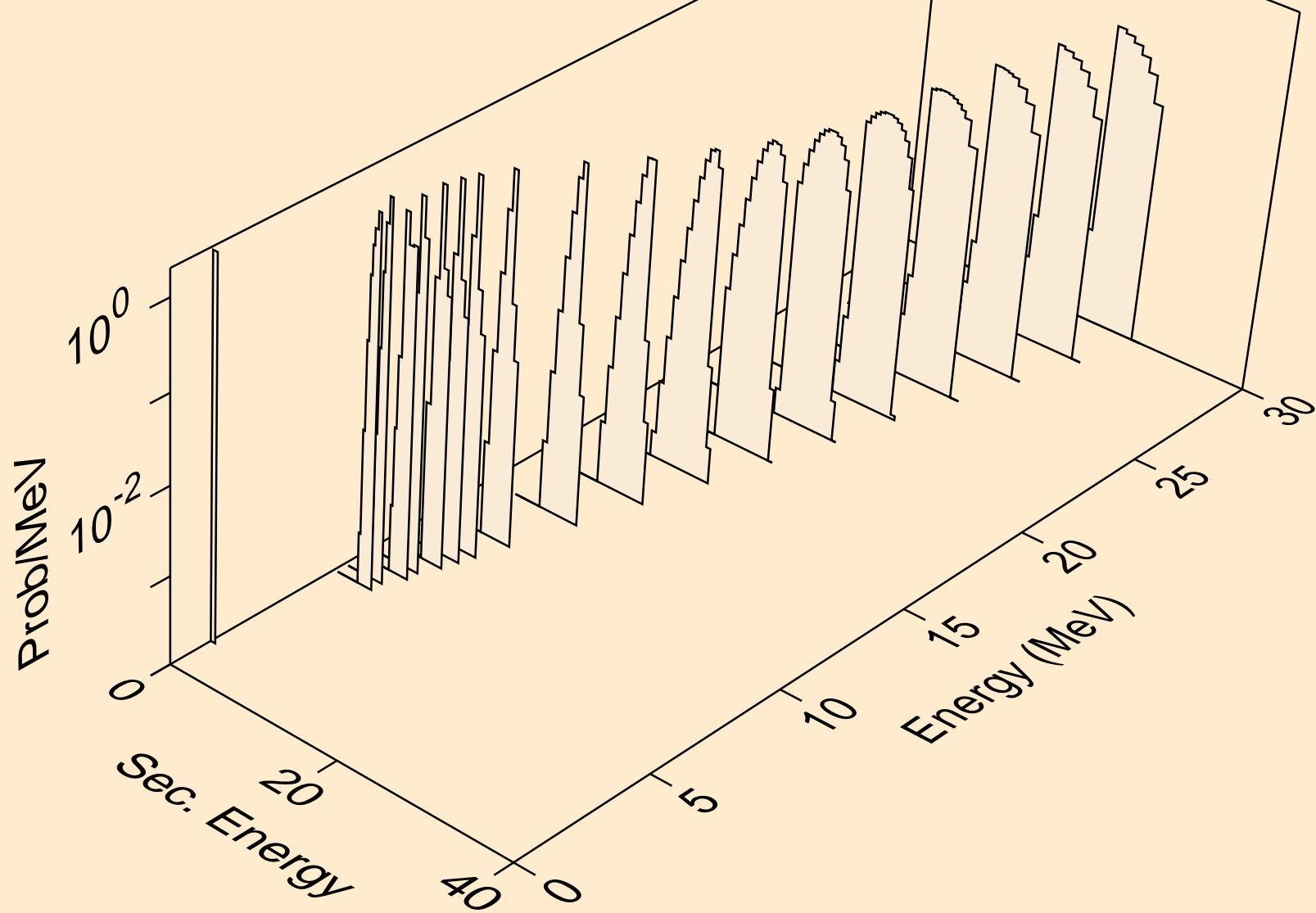

DS283 NEUTRON ACER TENDL-2023 LIBRARY; T=0.K
he3s from (n,x)

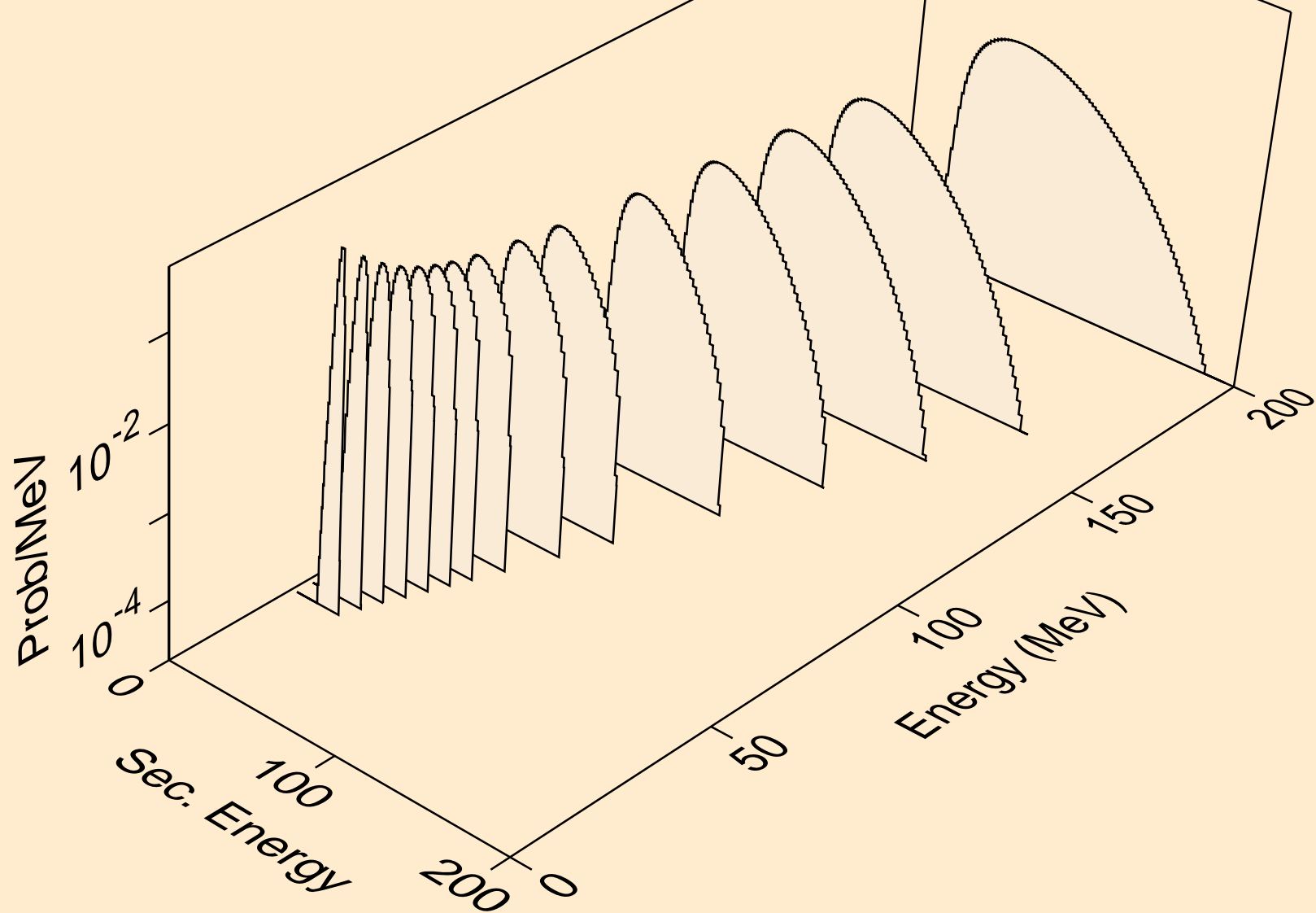

DS283 NEUTRON ACER TENDL-2023 LIBRARY; T=0.K
he3s from (n,n*)he3

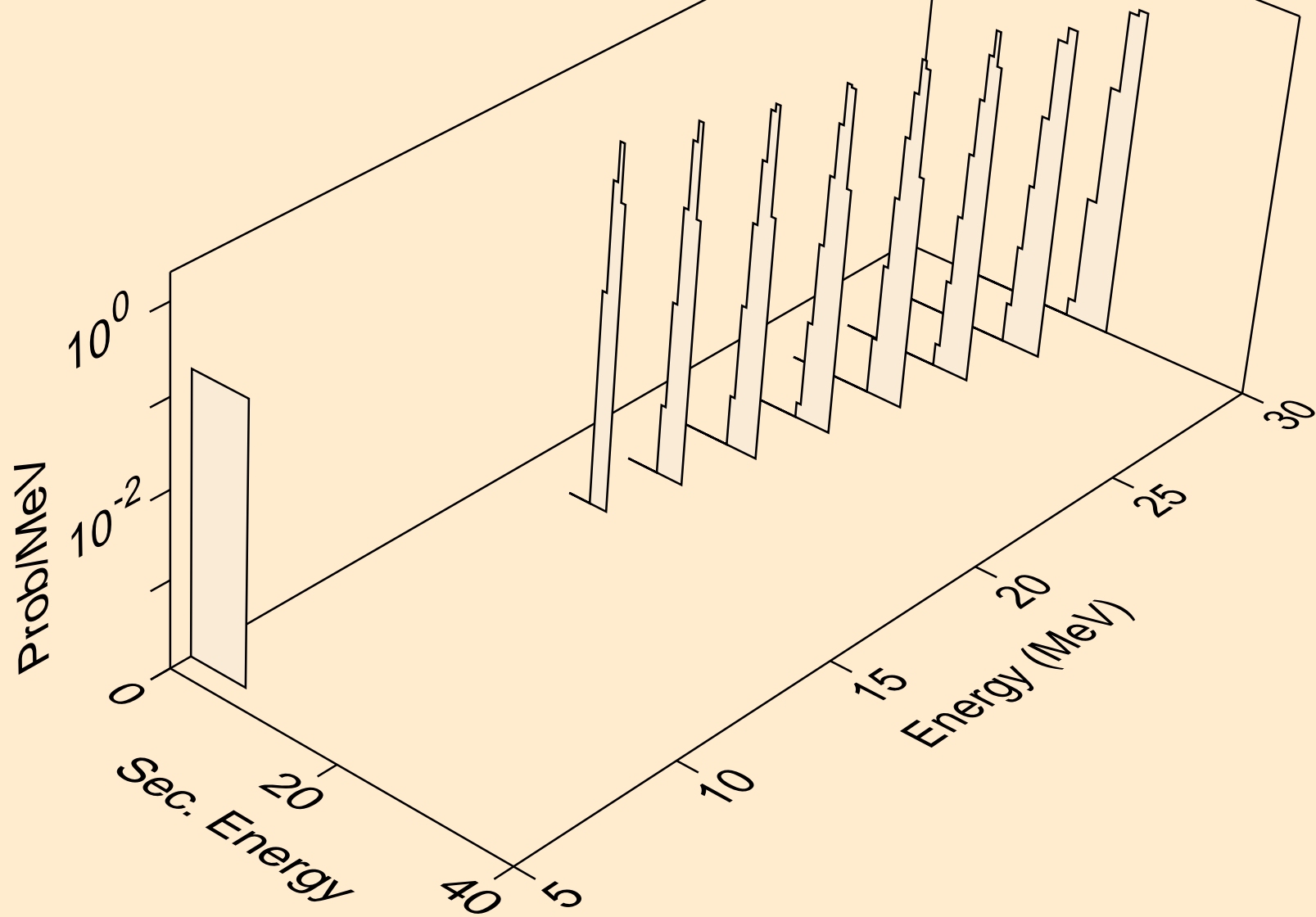

DS283 NEUTRON ACER TENDL-2023 LIBRARY; T=0.K
he3s from (n,he3)

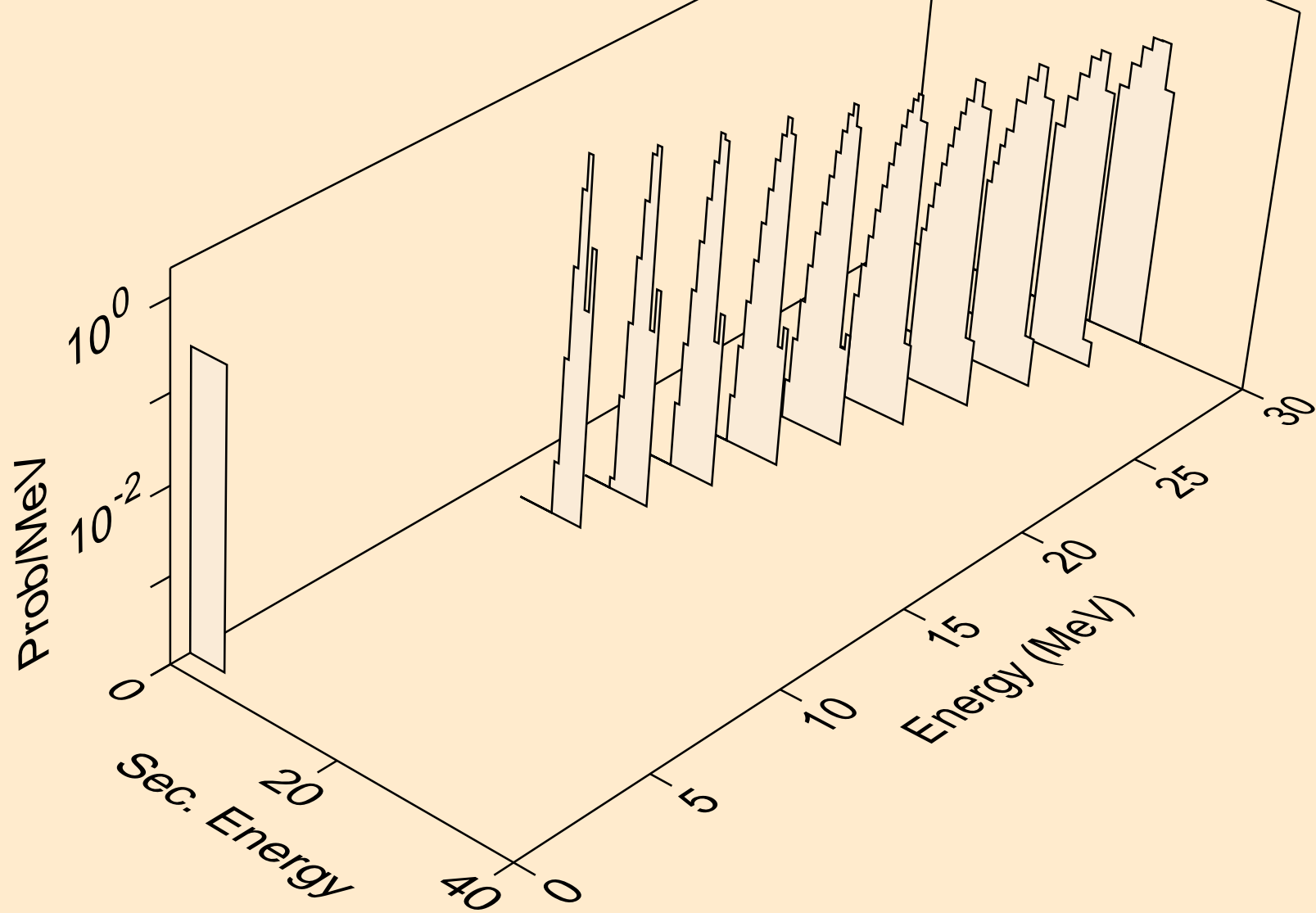

DS283 NEUTRON ACER TENDL-2023 LIBRARY; T=0.K
alphas from (n,x)

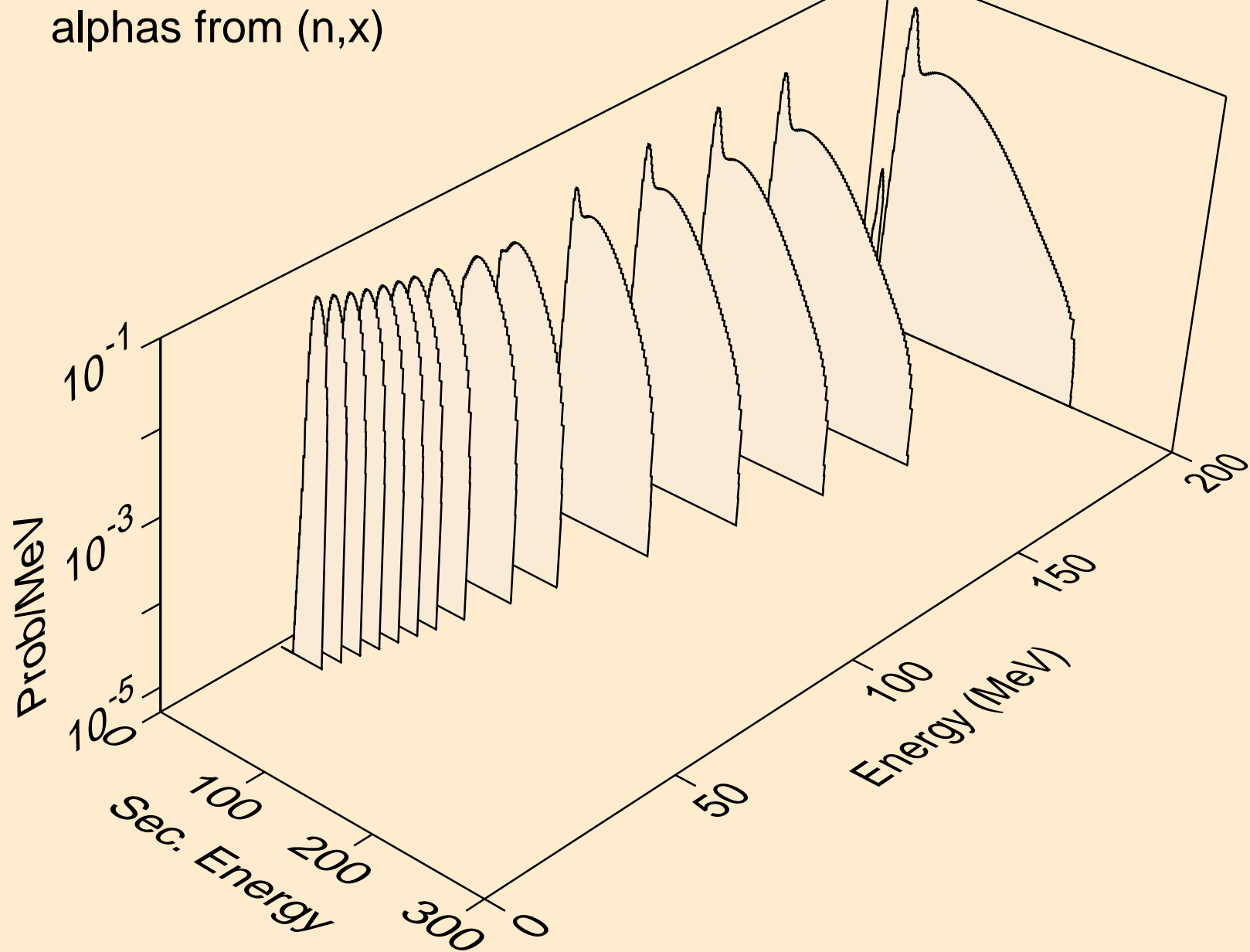

DS283 NEUTRON ACER TENDL-2023 LIBRARY; T=0.K
alphas from (n,n*)a

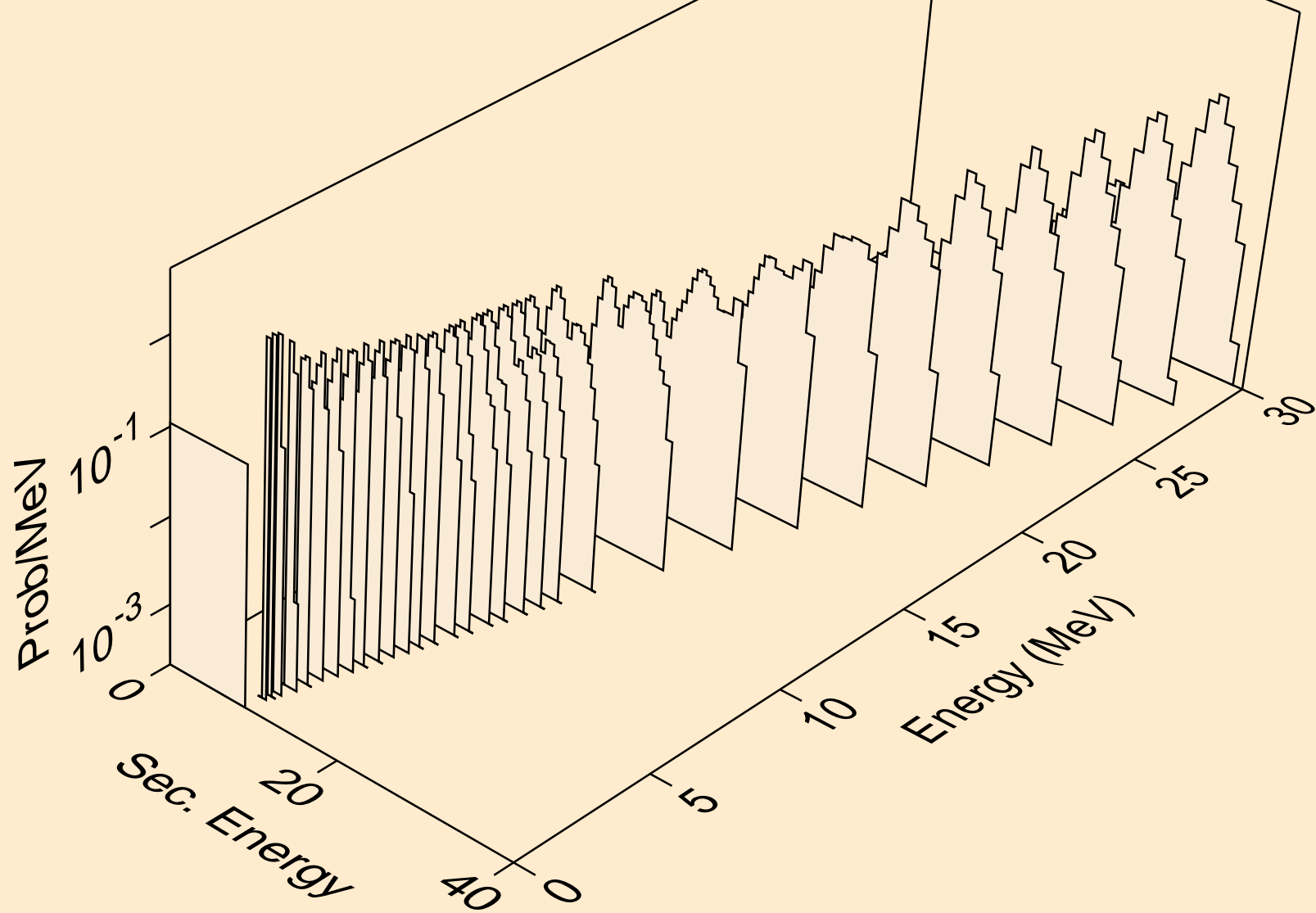

DS283 NEUTRON ACER TENDL-2023 LIBRARY; T=0.K
alphas from (n,2n)a

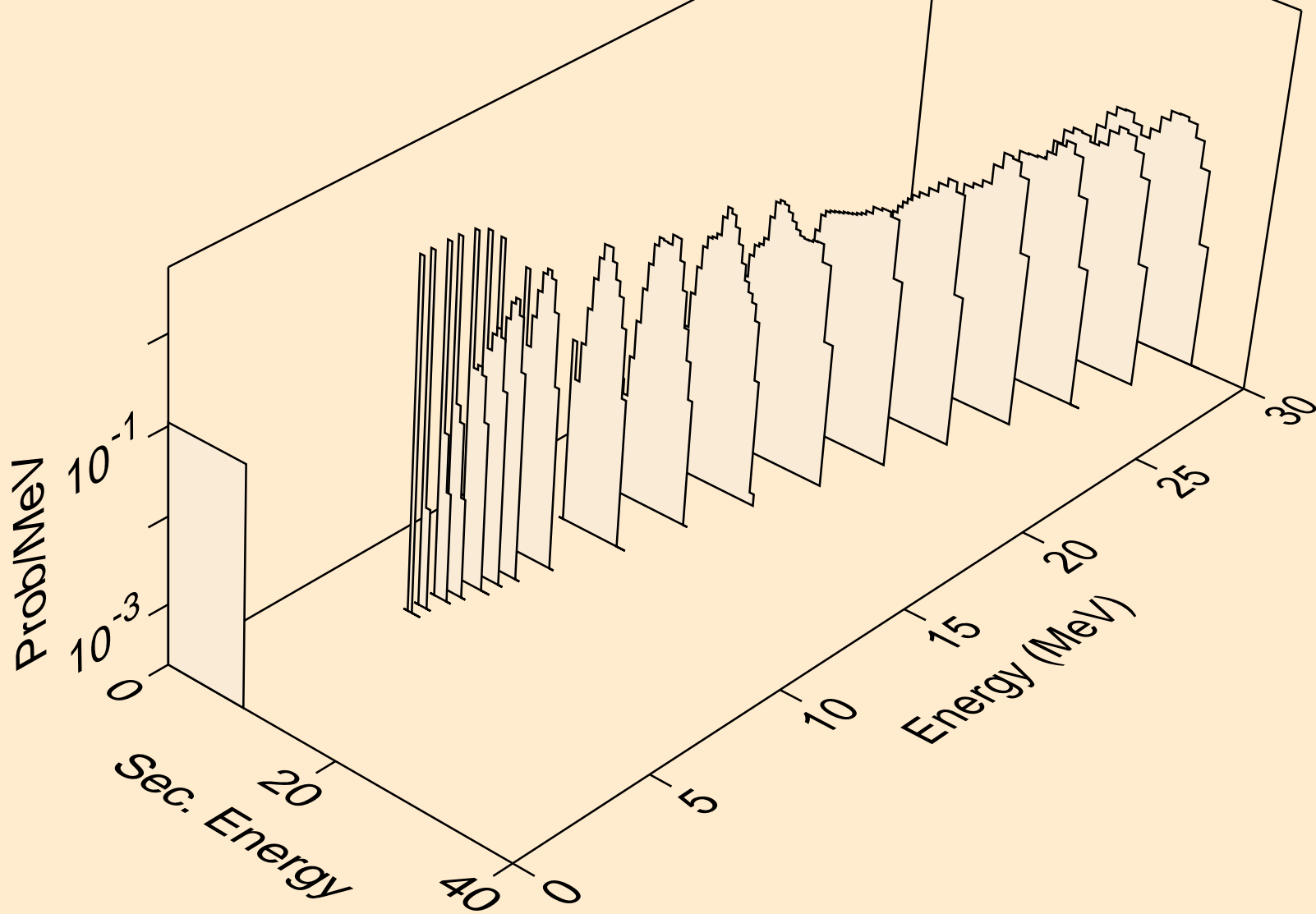

DS283 NEUTRON ACER TENDL-2023 LIBRARY; T=0.K
alphas from (n,3n)a

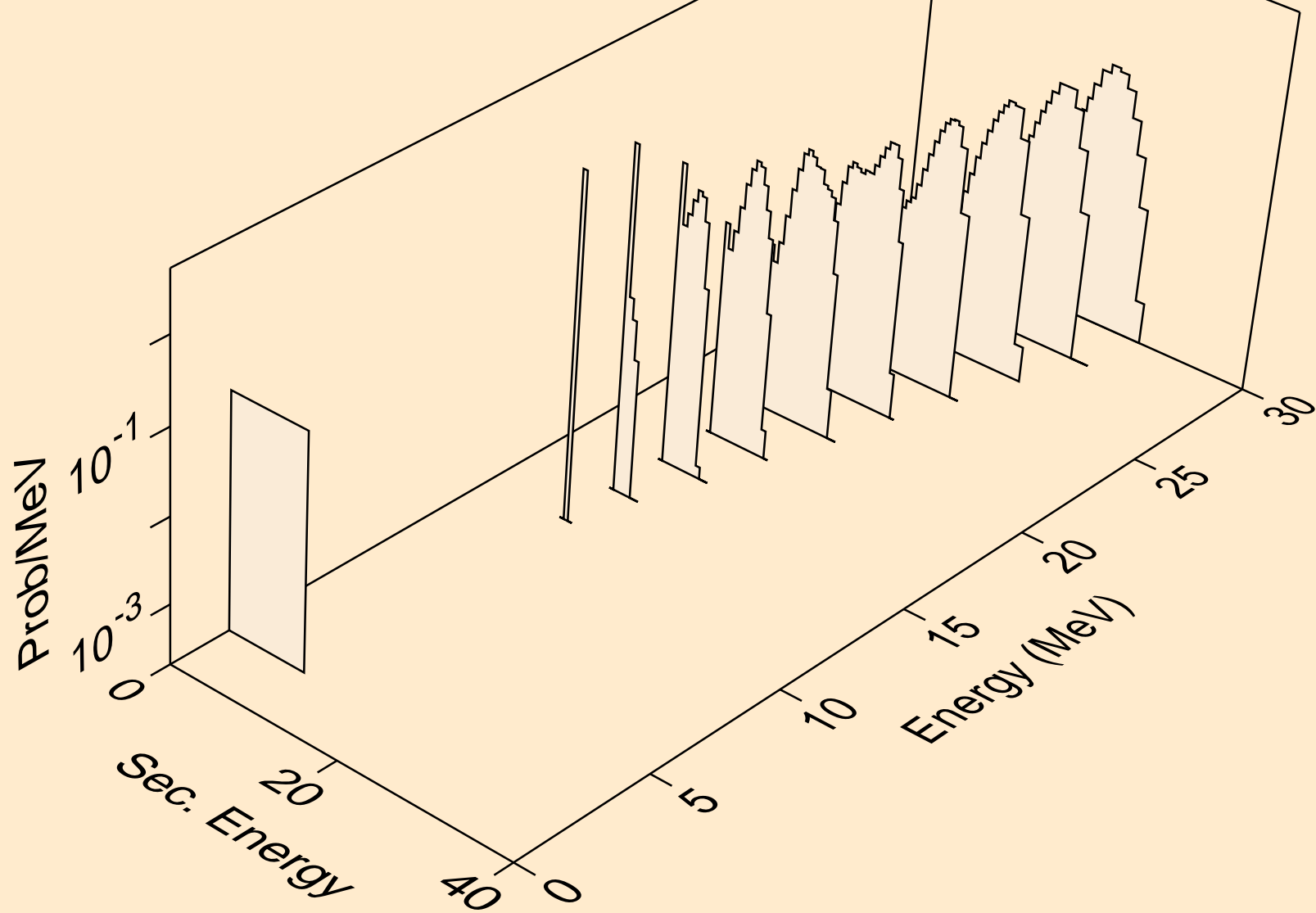

DS283 NEUTRON ACER TENDL-2023 LIBRARY; T=0.K
alphas from (n,npa)

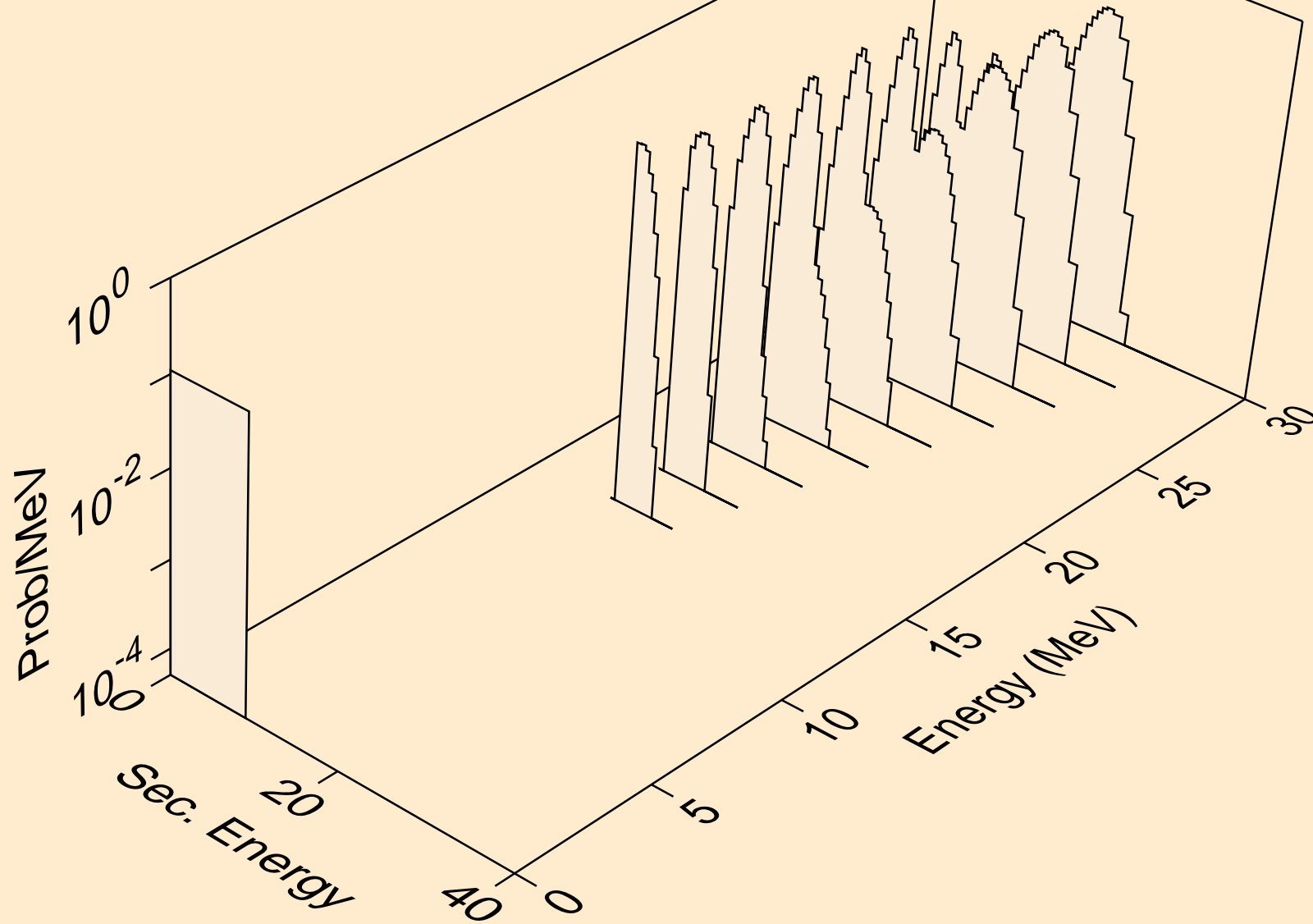

DS283 NEUTRON ACER TENDL-2023 LIBRARY; T=0.K
alphas from (n,a)

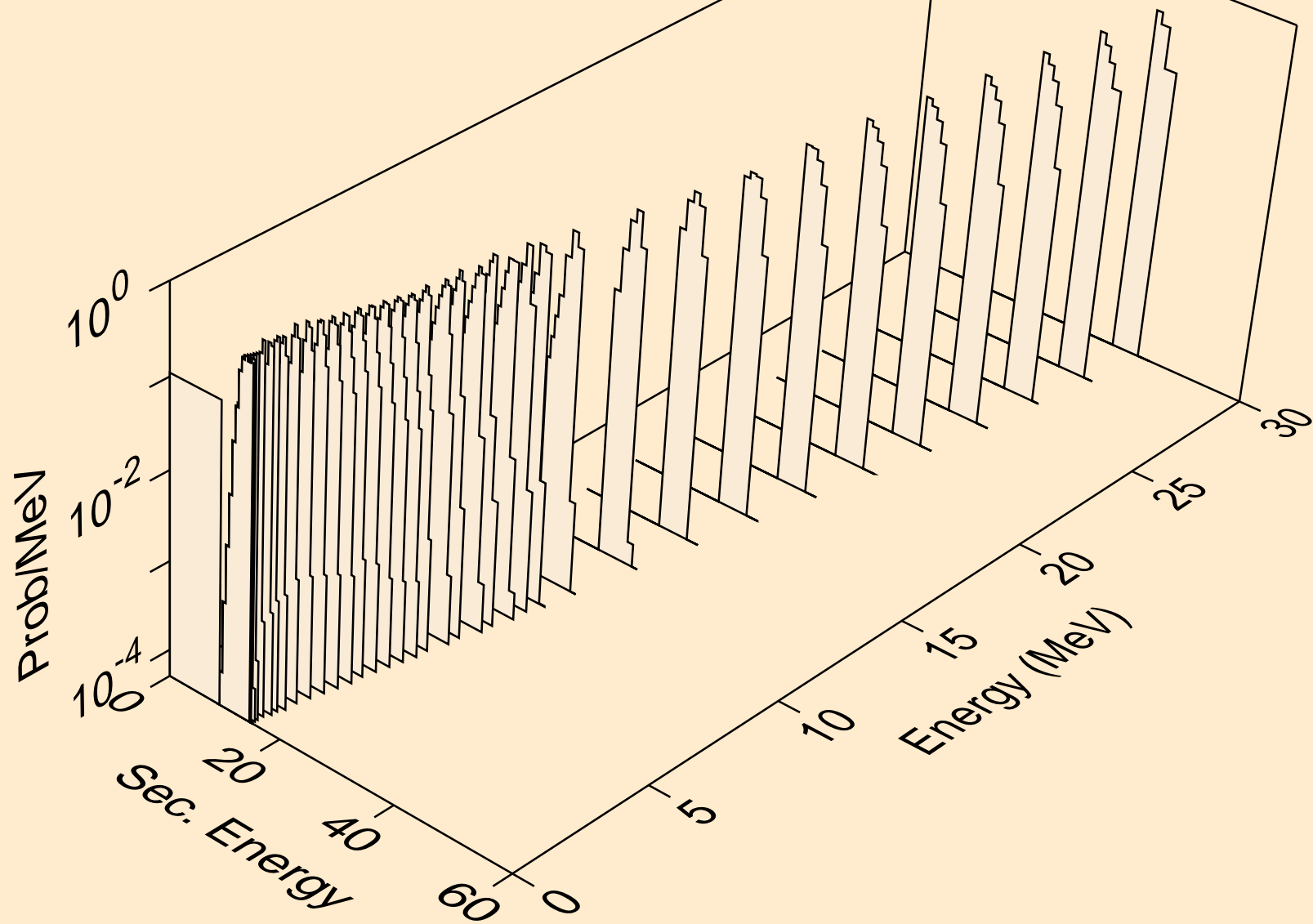

DS283 NEUTRON ACER TENDL-2023 LIBRARY; T=0.K
alphas from (n,pa)

