

# EU152M NEUTRON ACER TENDL-2023 LIBRARY; T=0.K

## Principal cross sections

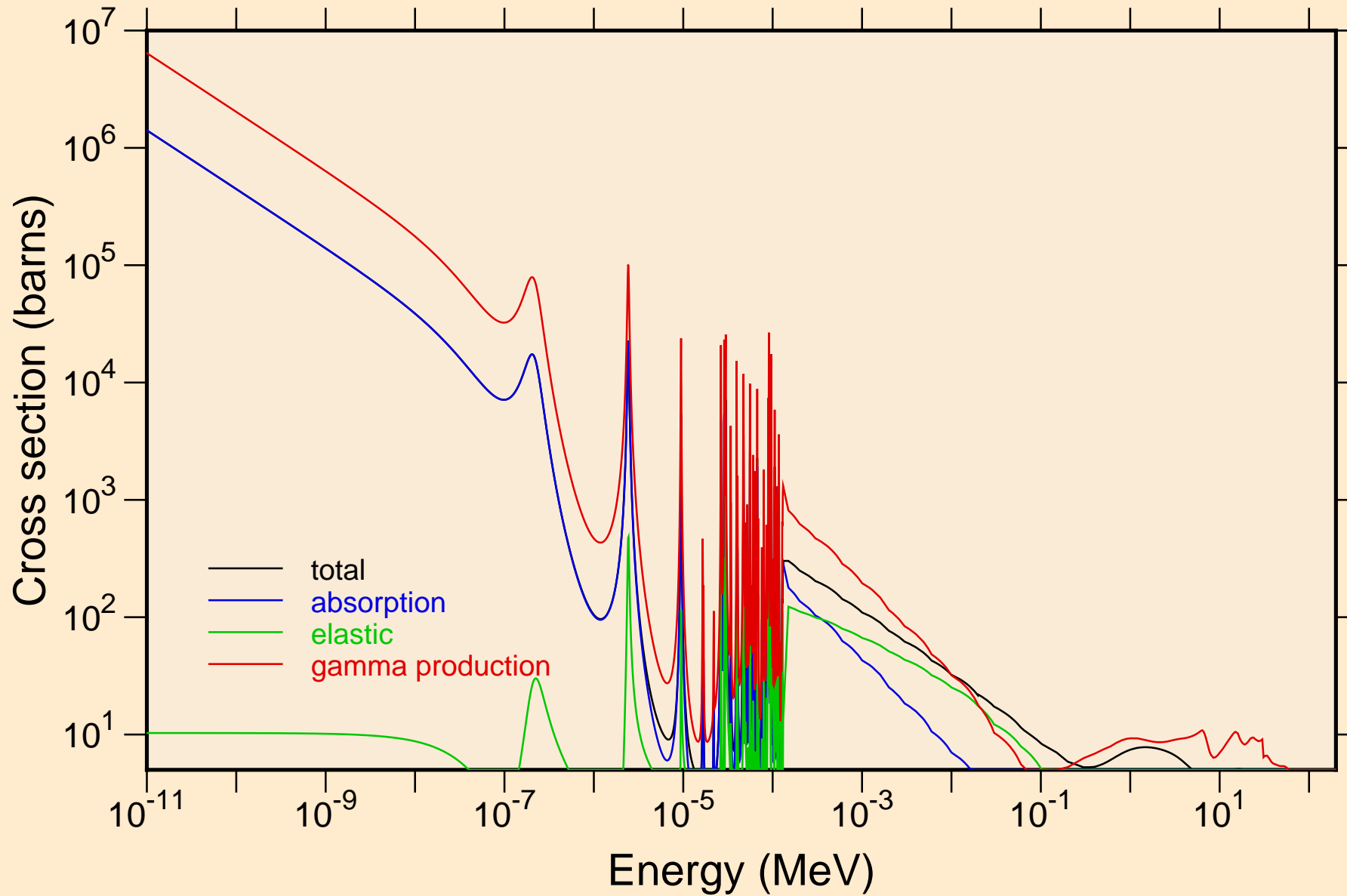

EU152M NEUTRON ACER TENDL-2023 LIBRARY; T=0.K  
resonance total cross section

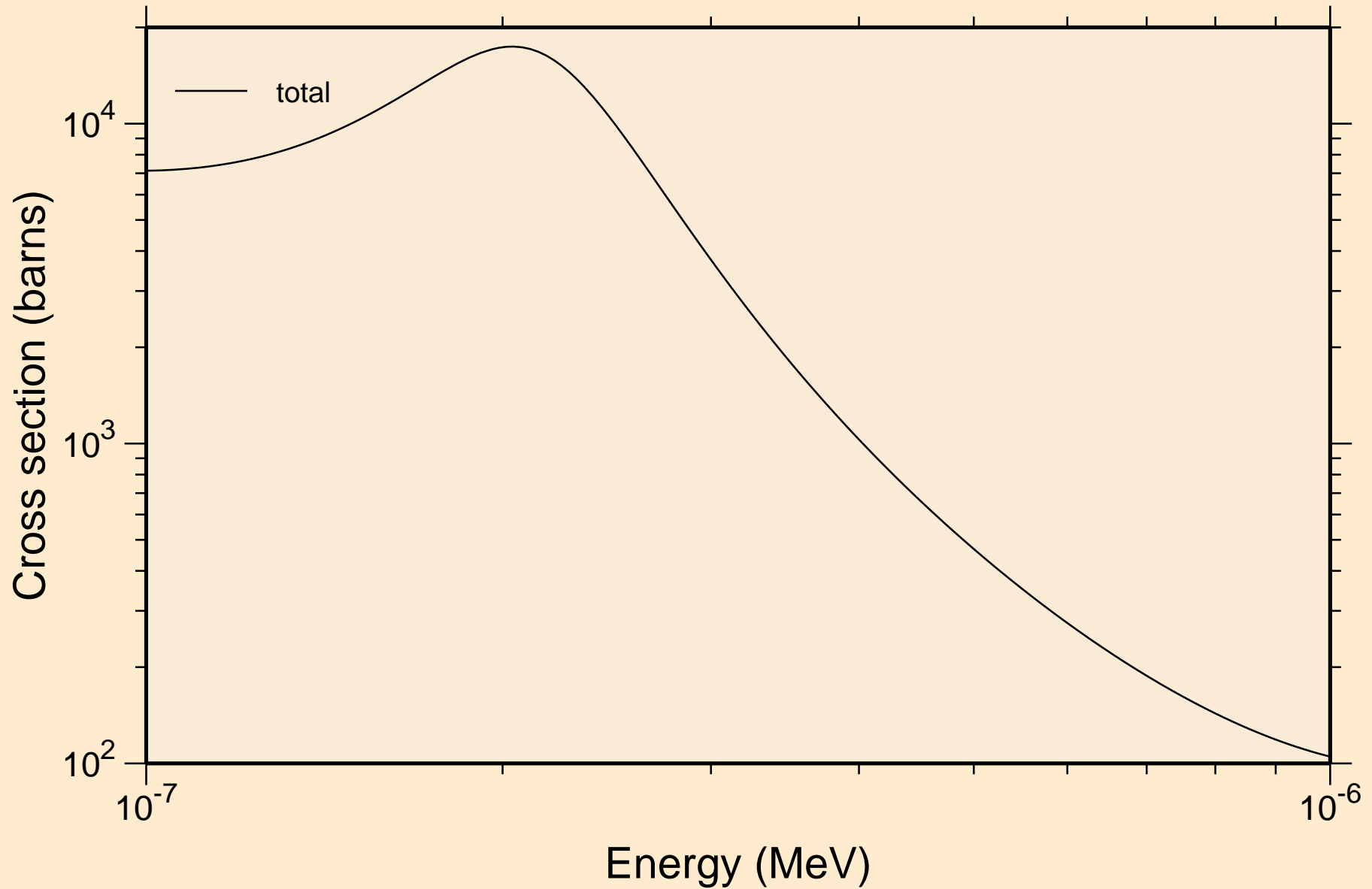

EU152M NEUTRON ACER TENDL-2023 LIBRARY; T=0.K  
resonance total cross section

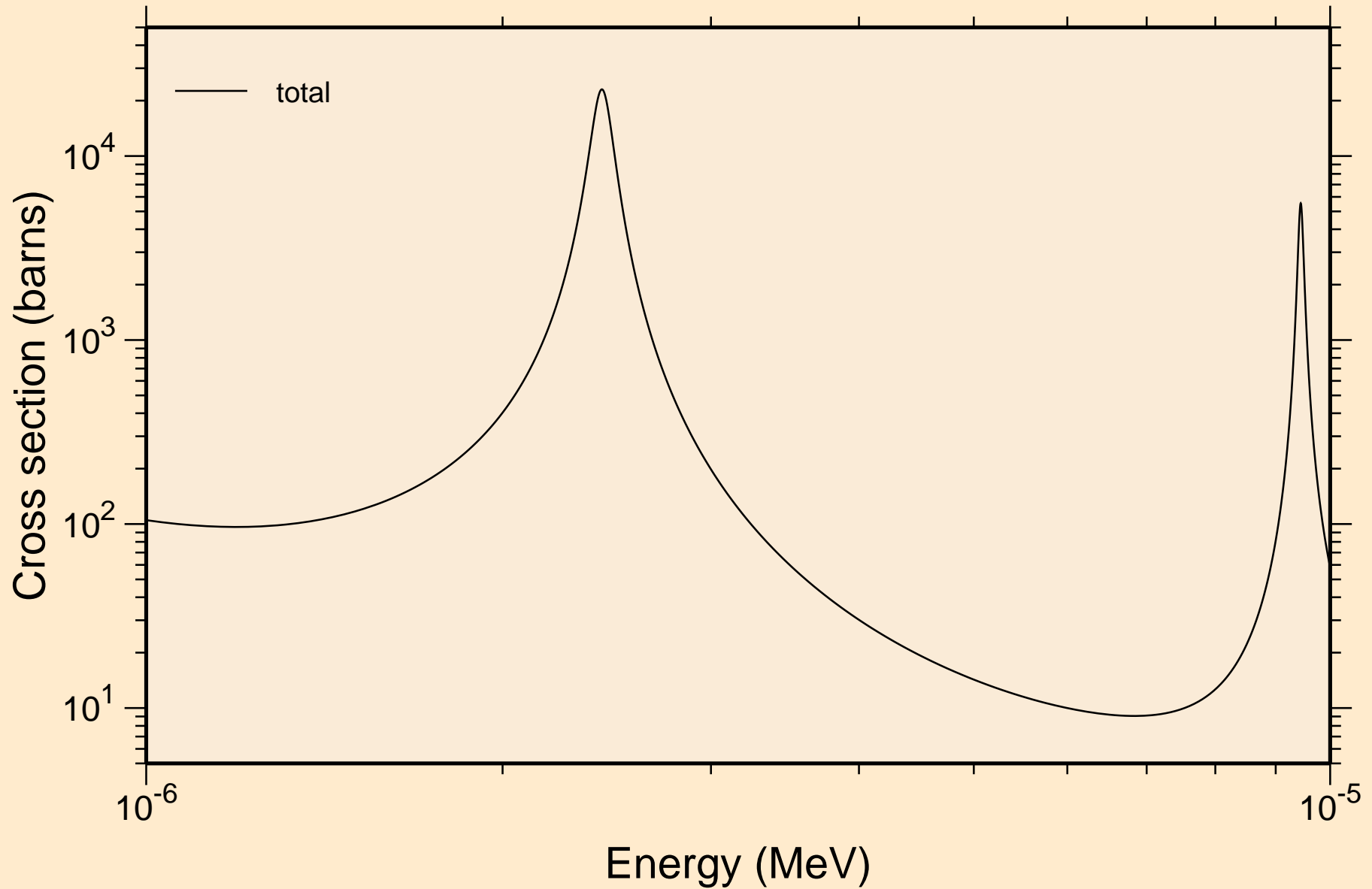

EU152M NEUTRON ACER TENDL-2023 LIBRARY; T=0.K  
resonance total cross section

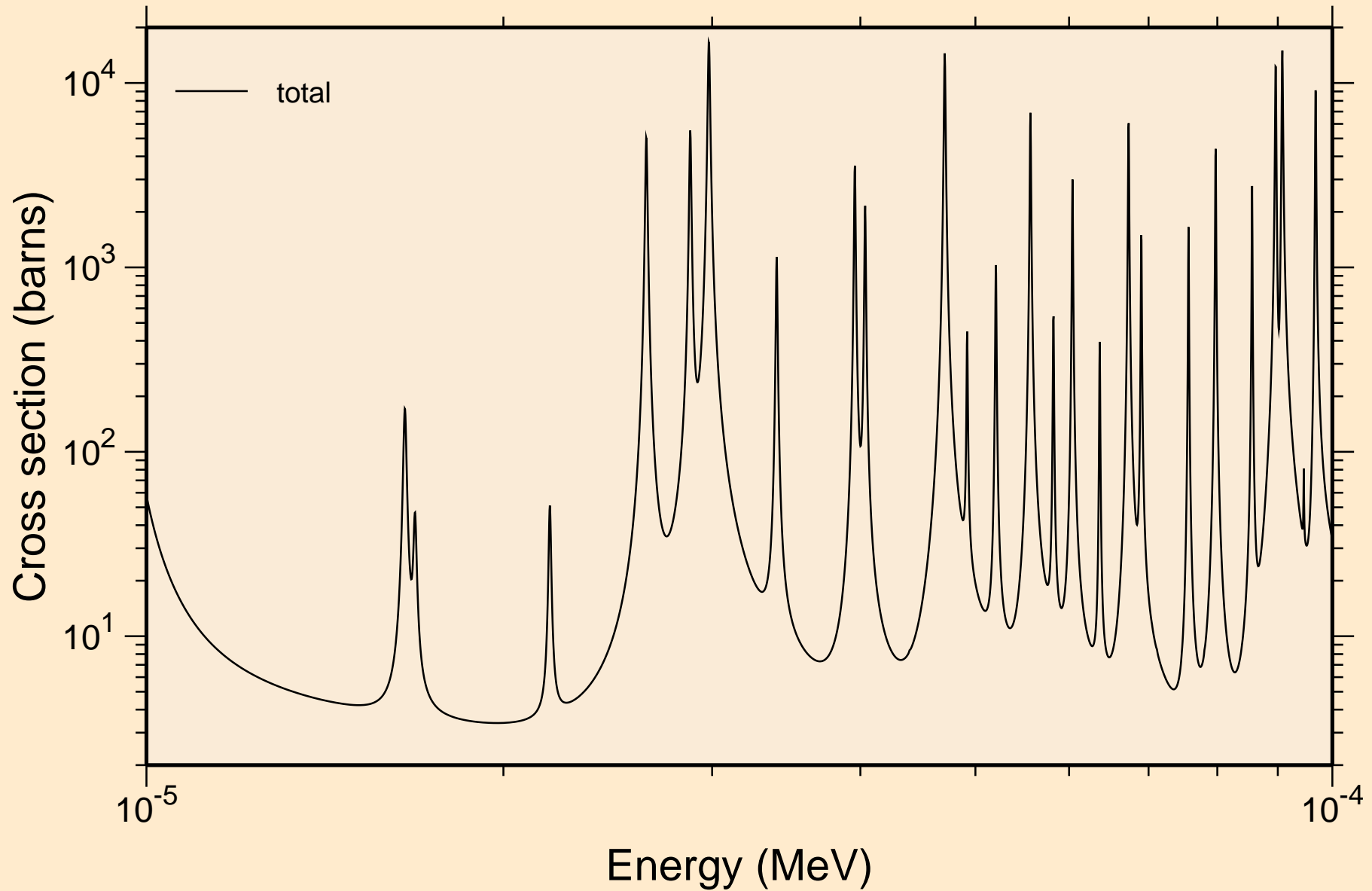

EU152M NEUTRON ACER TENDL-2023 LIBRARY; T=0.K  
resonance total cross section

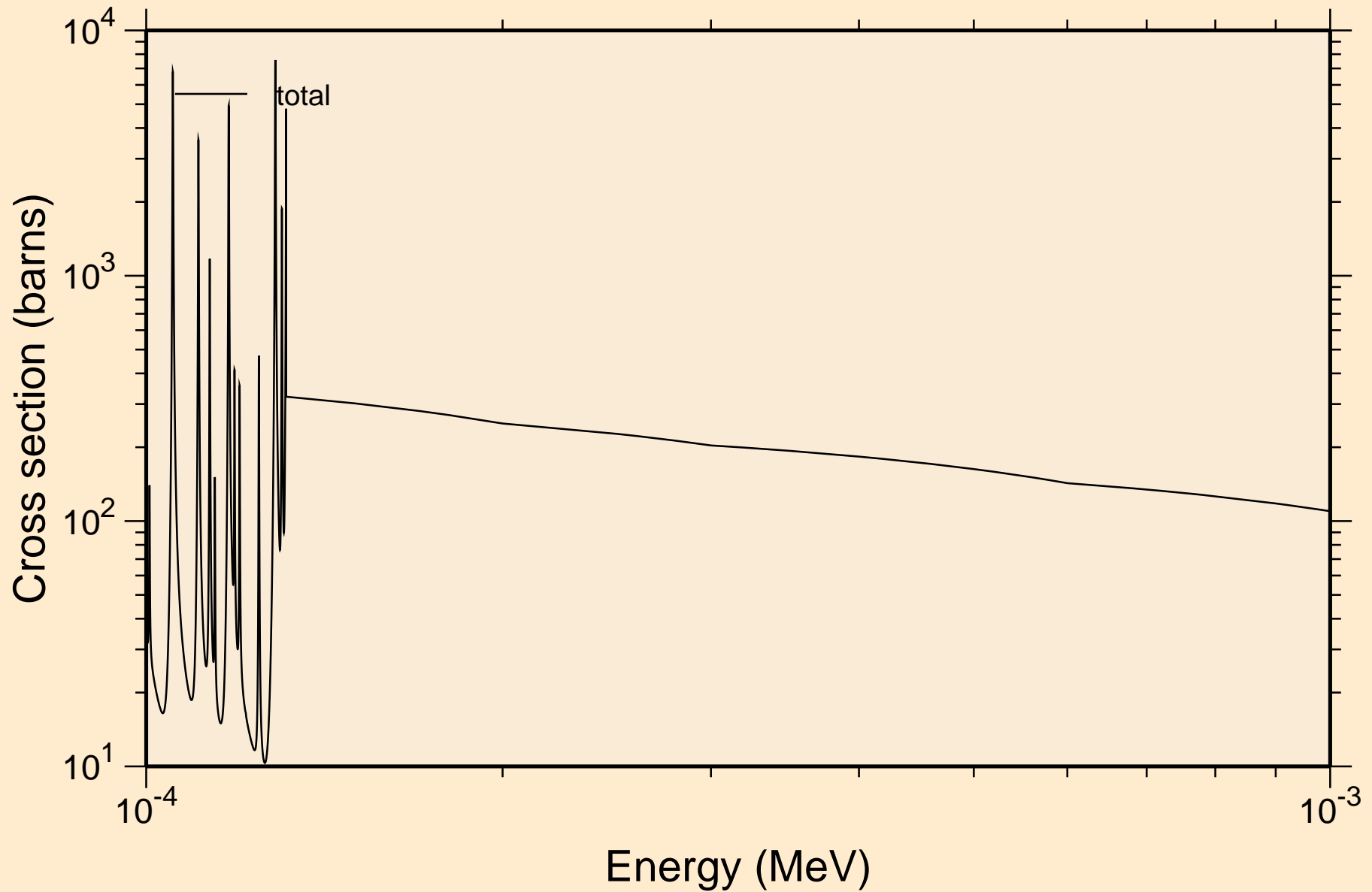

EU152M NEUTRON ACER TENDL-2023 LIBRARY; T=0.K  
resonance total cross section

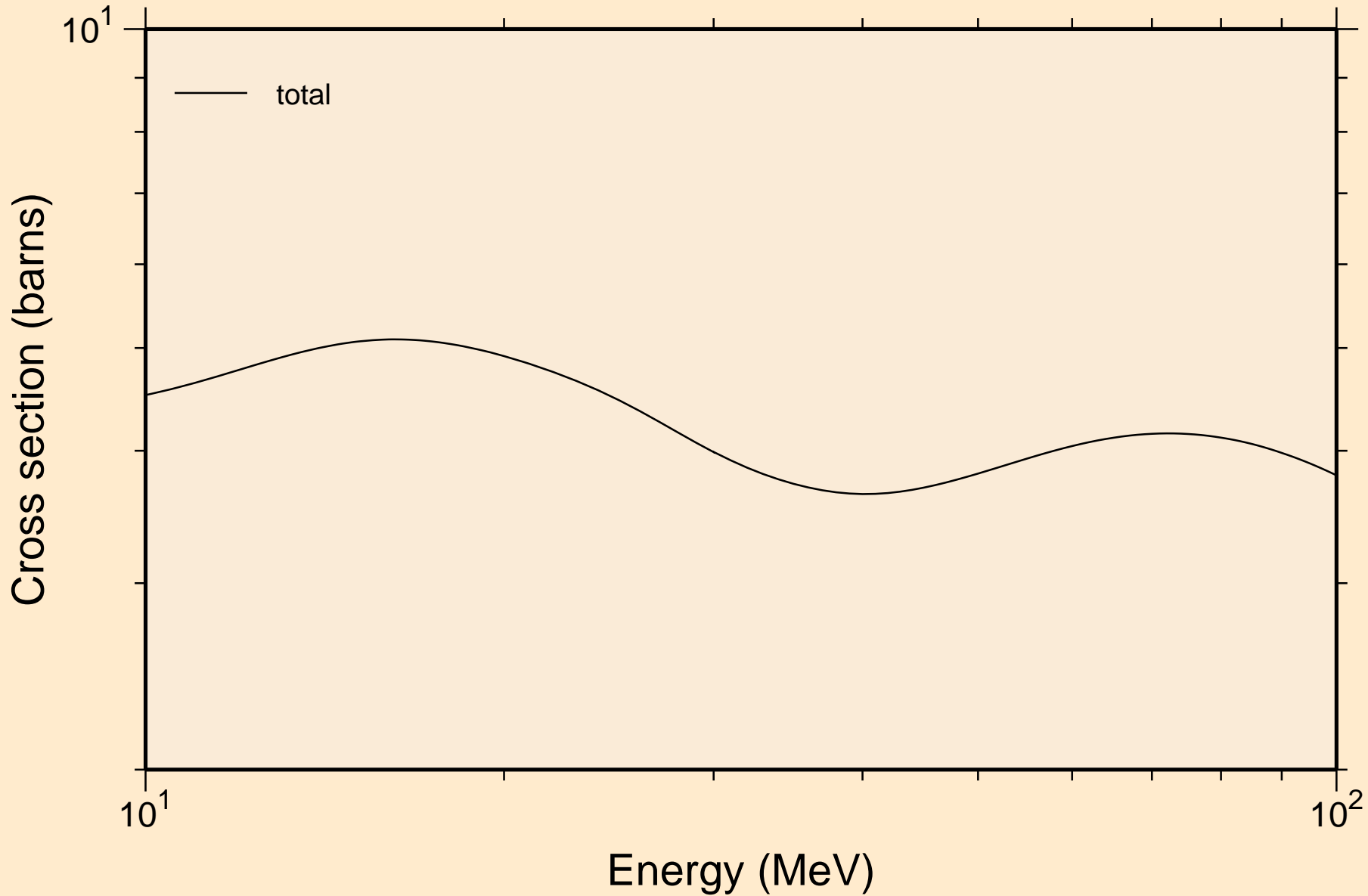

EU152M NEUTRON ACER TENDL-2023 LIBRARY; T=0.K  
resonance absorption cross sections

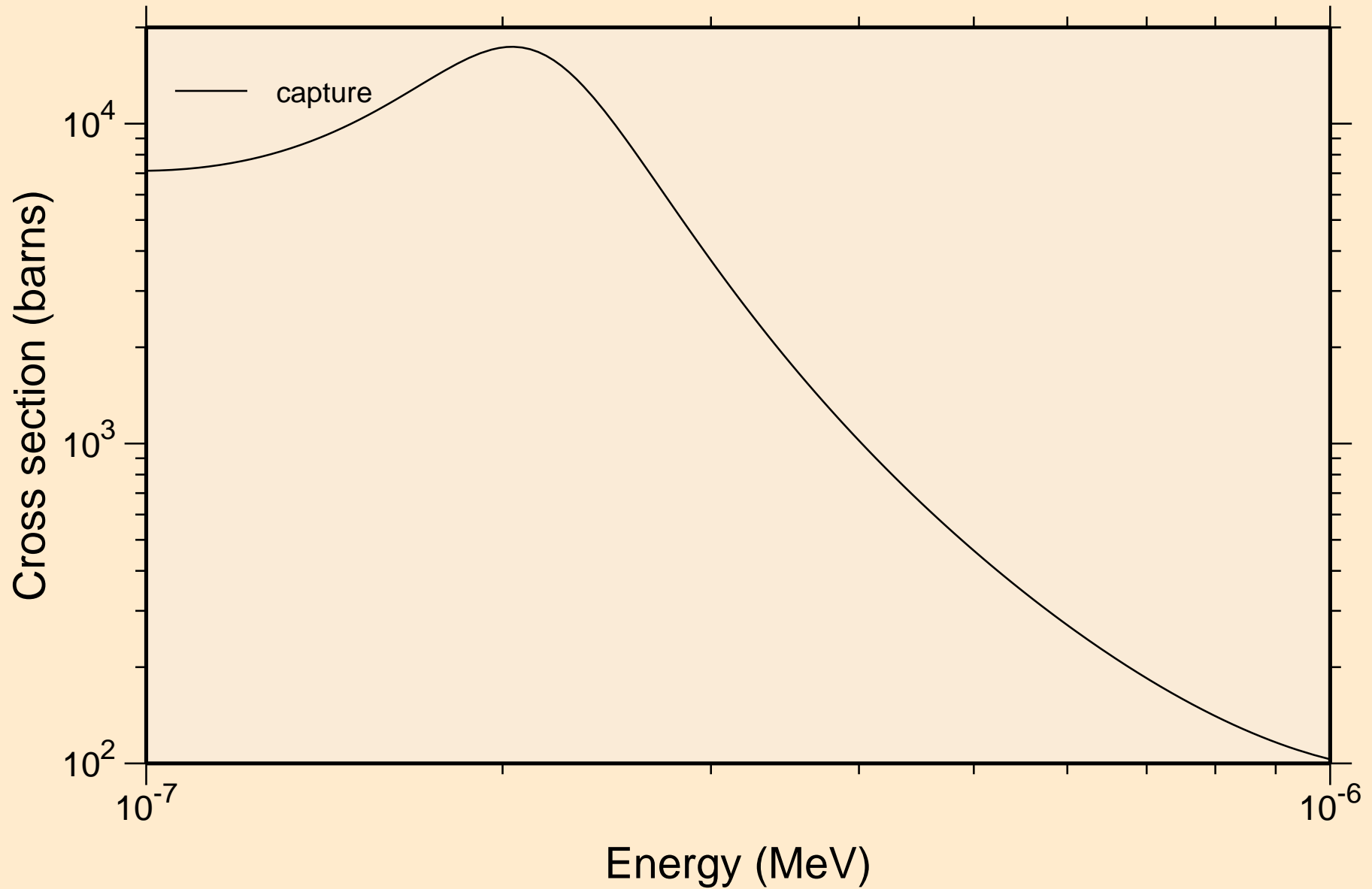

EU152M NEUTRON ACER TENDL-2023 LIBRARY; T=0.K  
resonance absorption cross sections

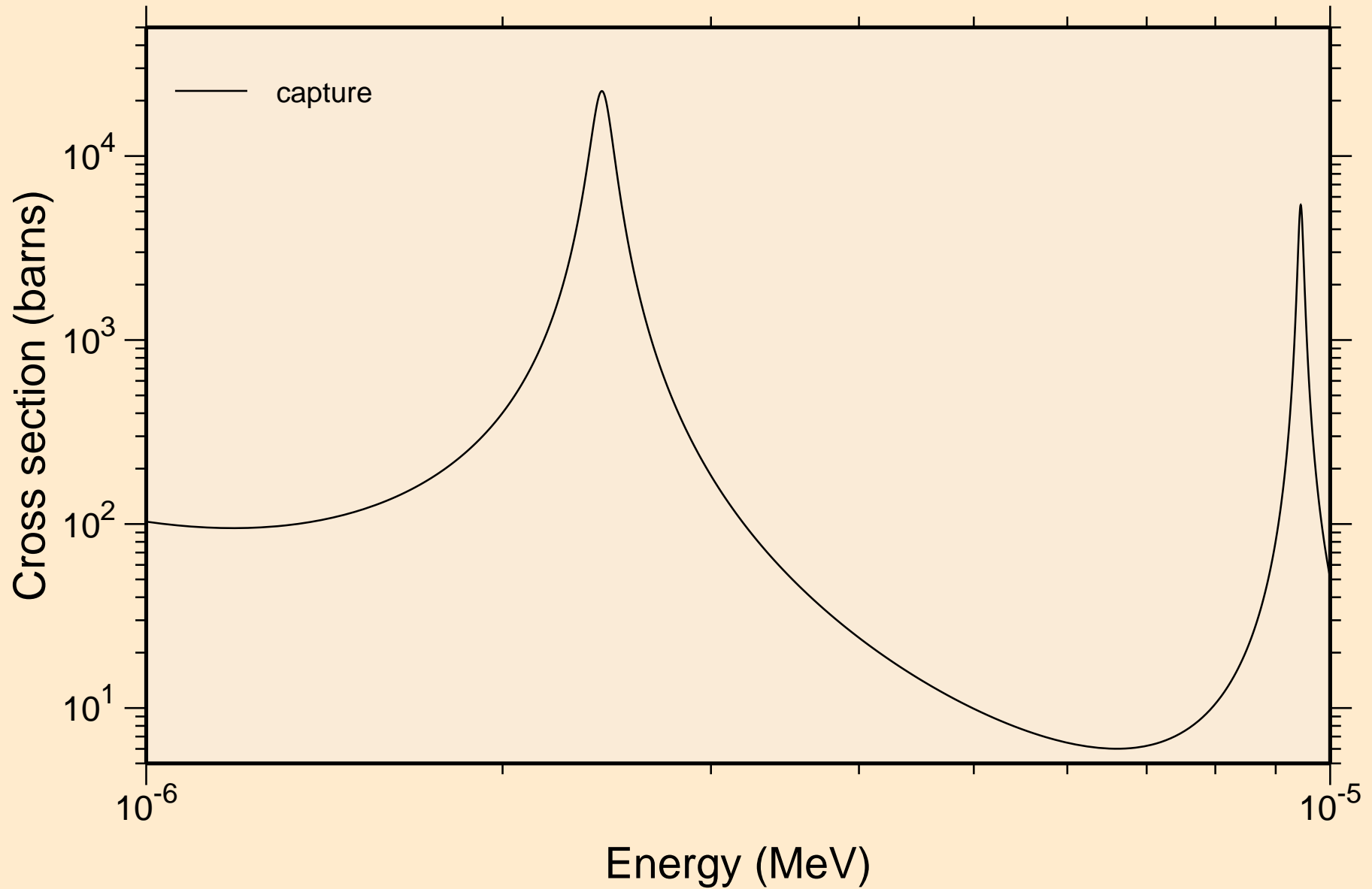

EU152M NEUTRON ACER TENDL-2023 LIBRARY; T=0.K  
resonance absorption cross sections

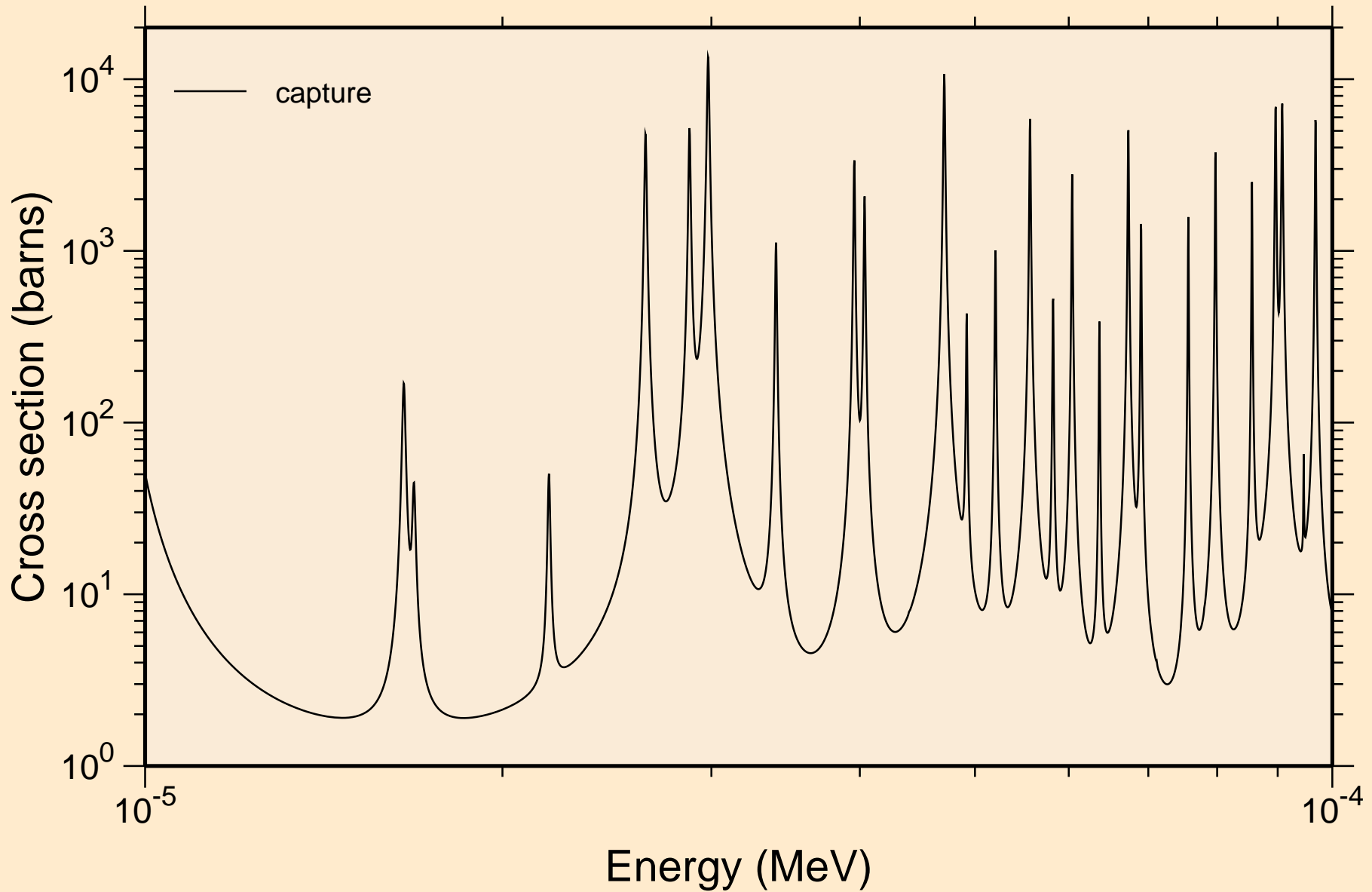

EU152M NEUTRON ACER TENDL-2023 LIBRARY; T=0.K  
resonance absorption cross sections

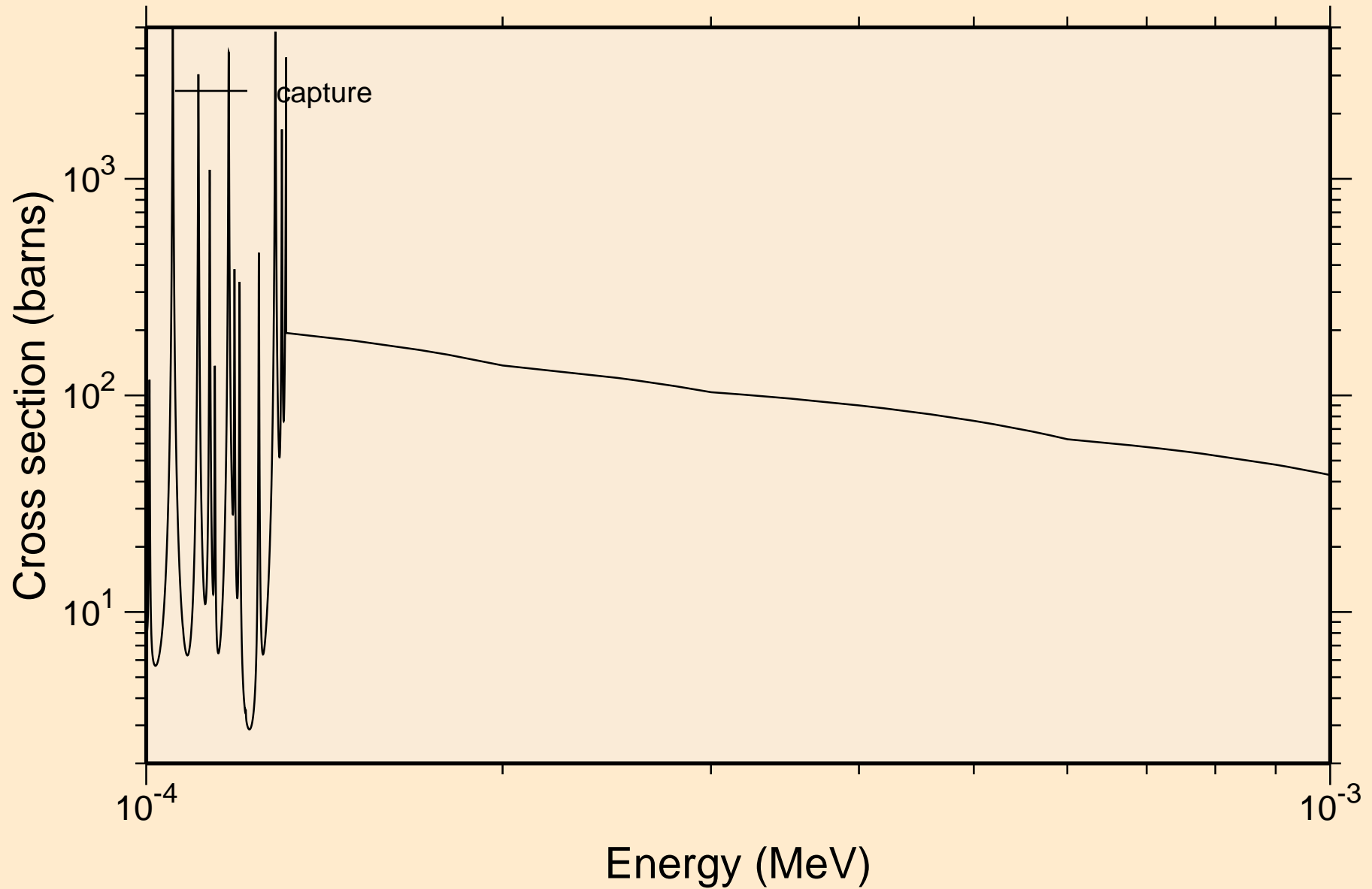

EU152M NEUTRON ACER TENDL-2023 LIBRARY; T=0.K  
resonance absorption cross sections

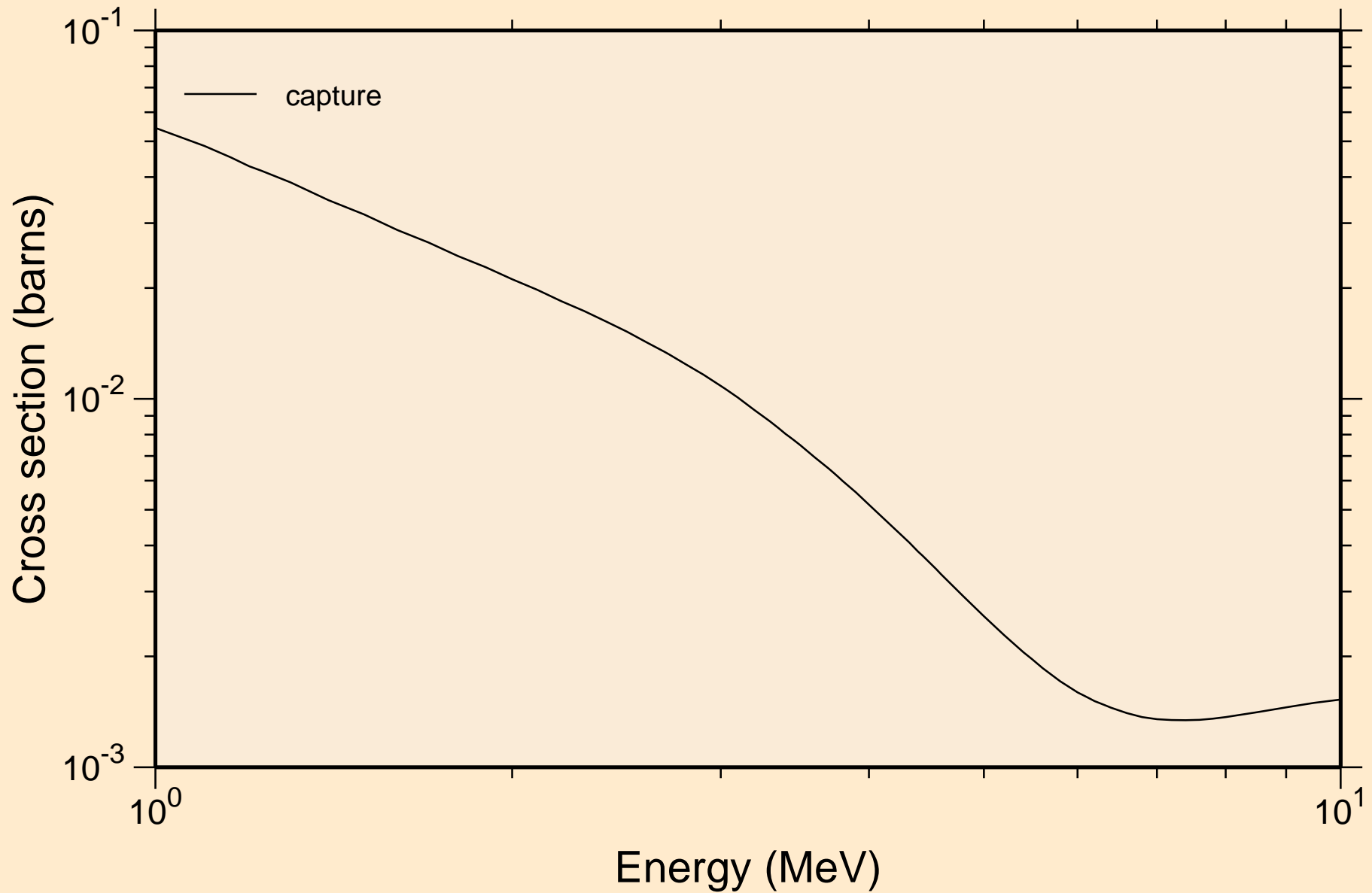

EU152M NEUTRON ACER TENDL-2023 LIBRARY; T=0.K  
Heating

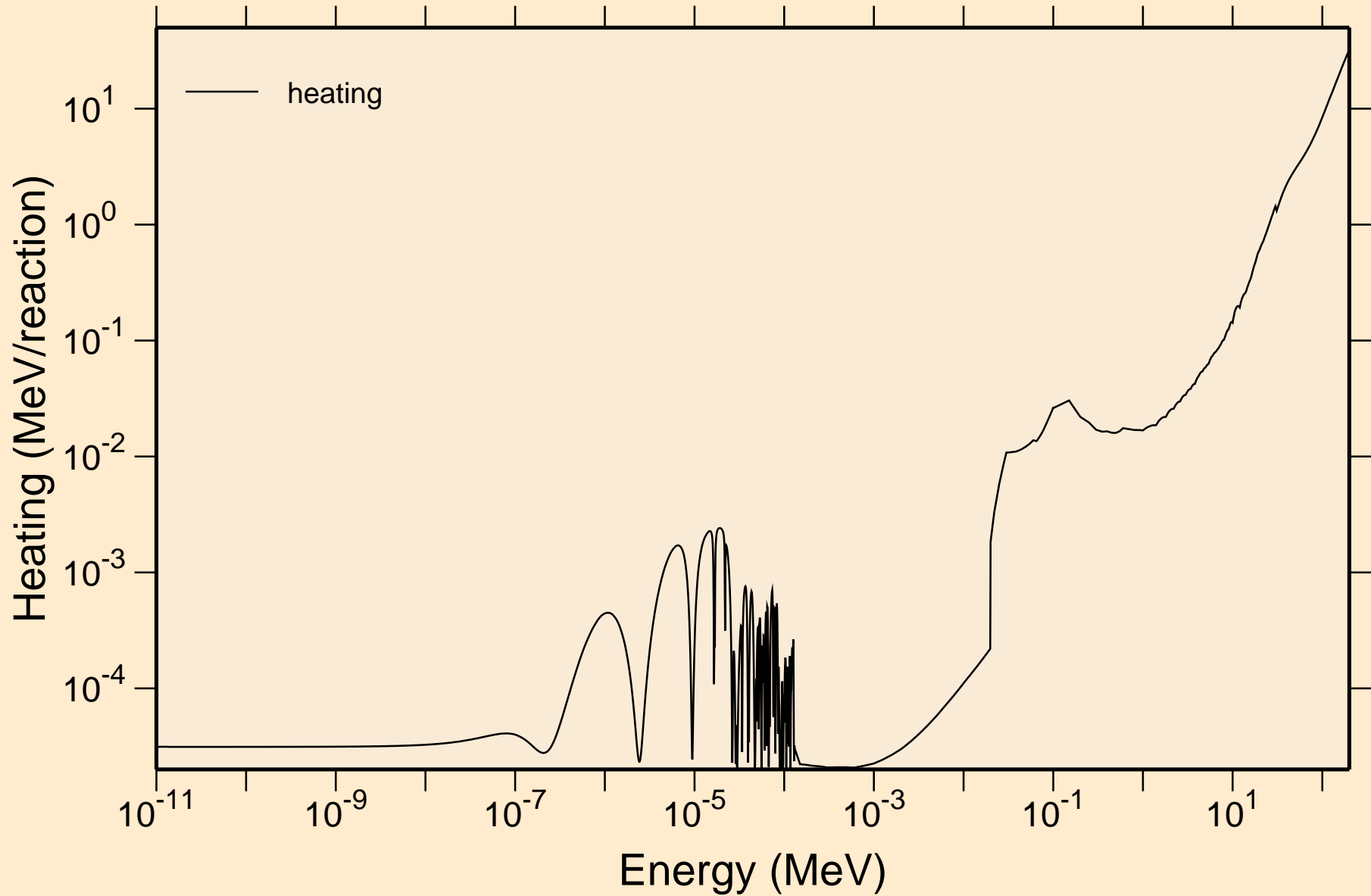

# EU152M NEUTRON ACER TENDL-2023 LIBRARY; T=0.K

## Damage

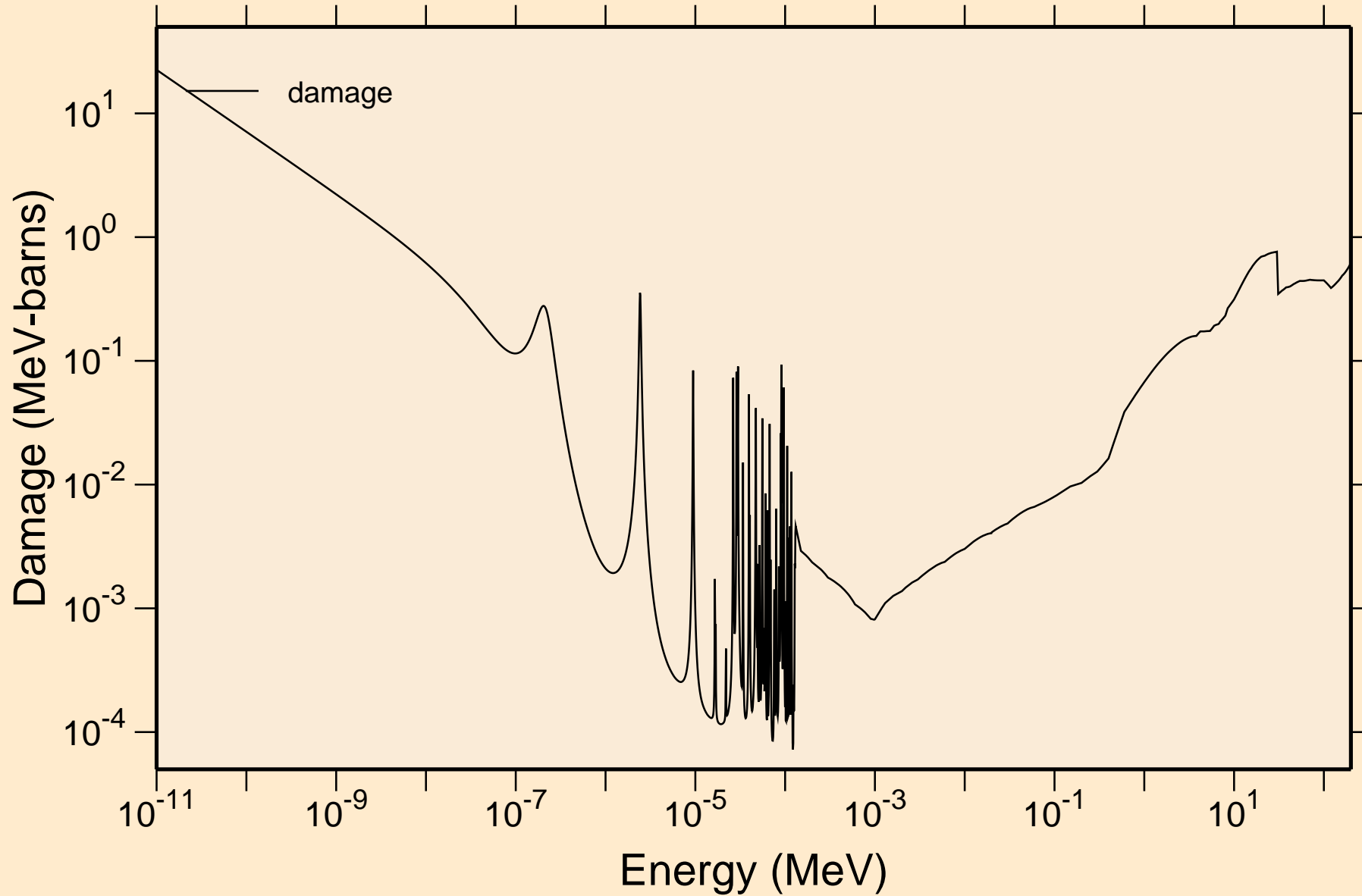

# EU152M NEUTRON ACER TENDL-2023 LIBRARY; T=0.K

## Non-threshold reactions

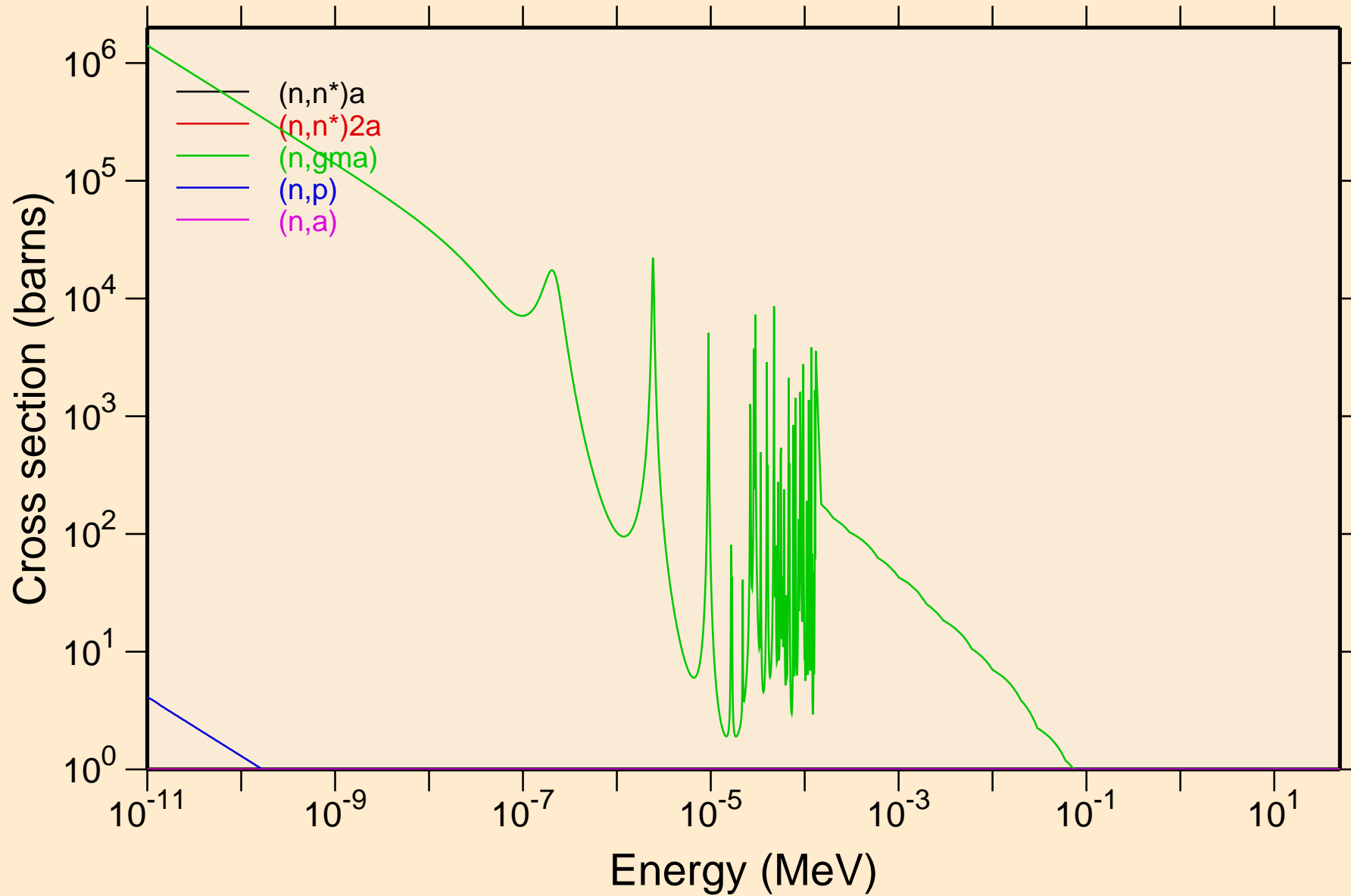

# EU152M NEUTRON ACER TENDL-2023 LIBRARY; T=0.K

## Non-threshold reactions

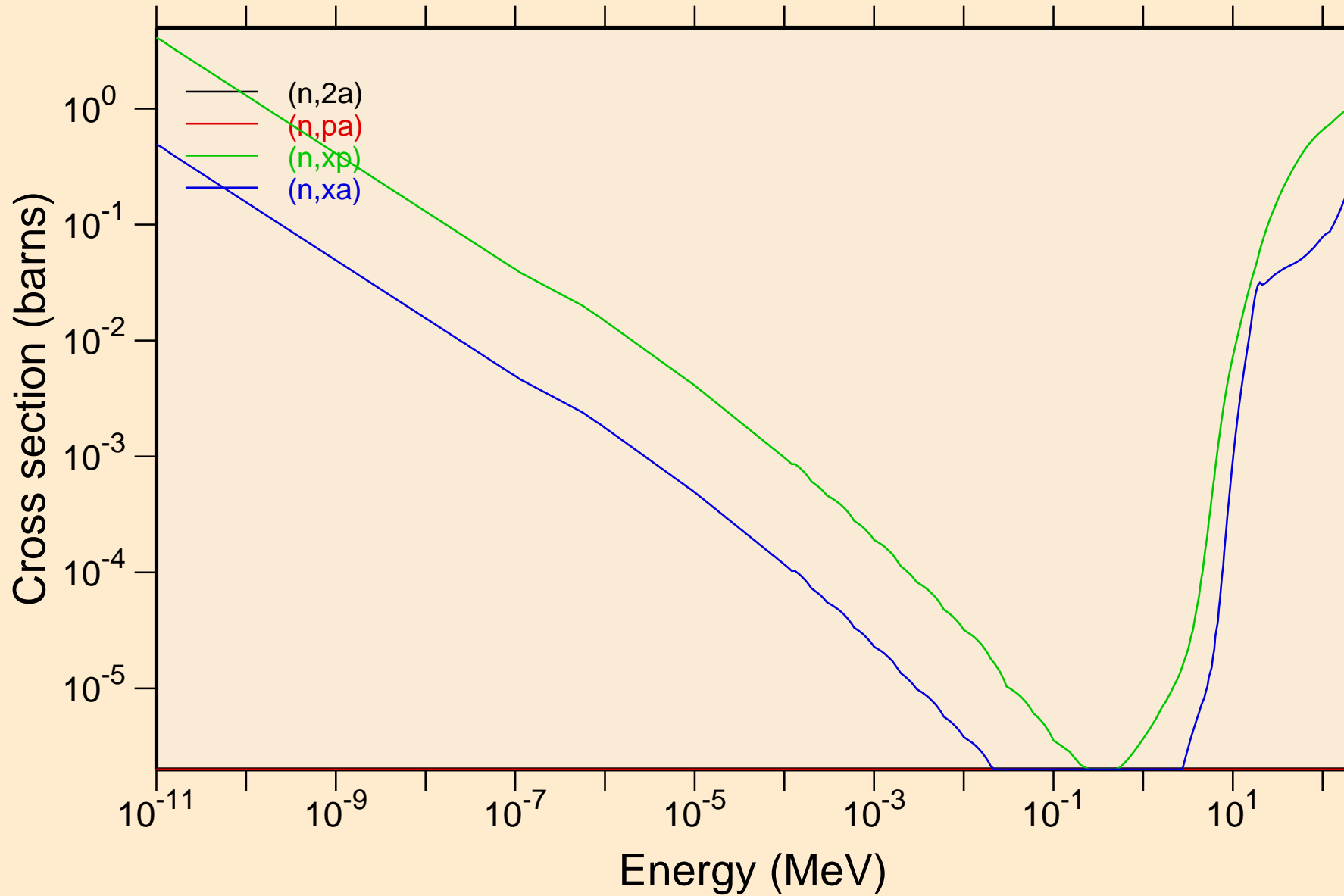

# EU152M NEUTRON ACER TENDL-2023 LIBRARY; T=0.K

## Principal cross sections

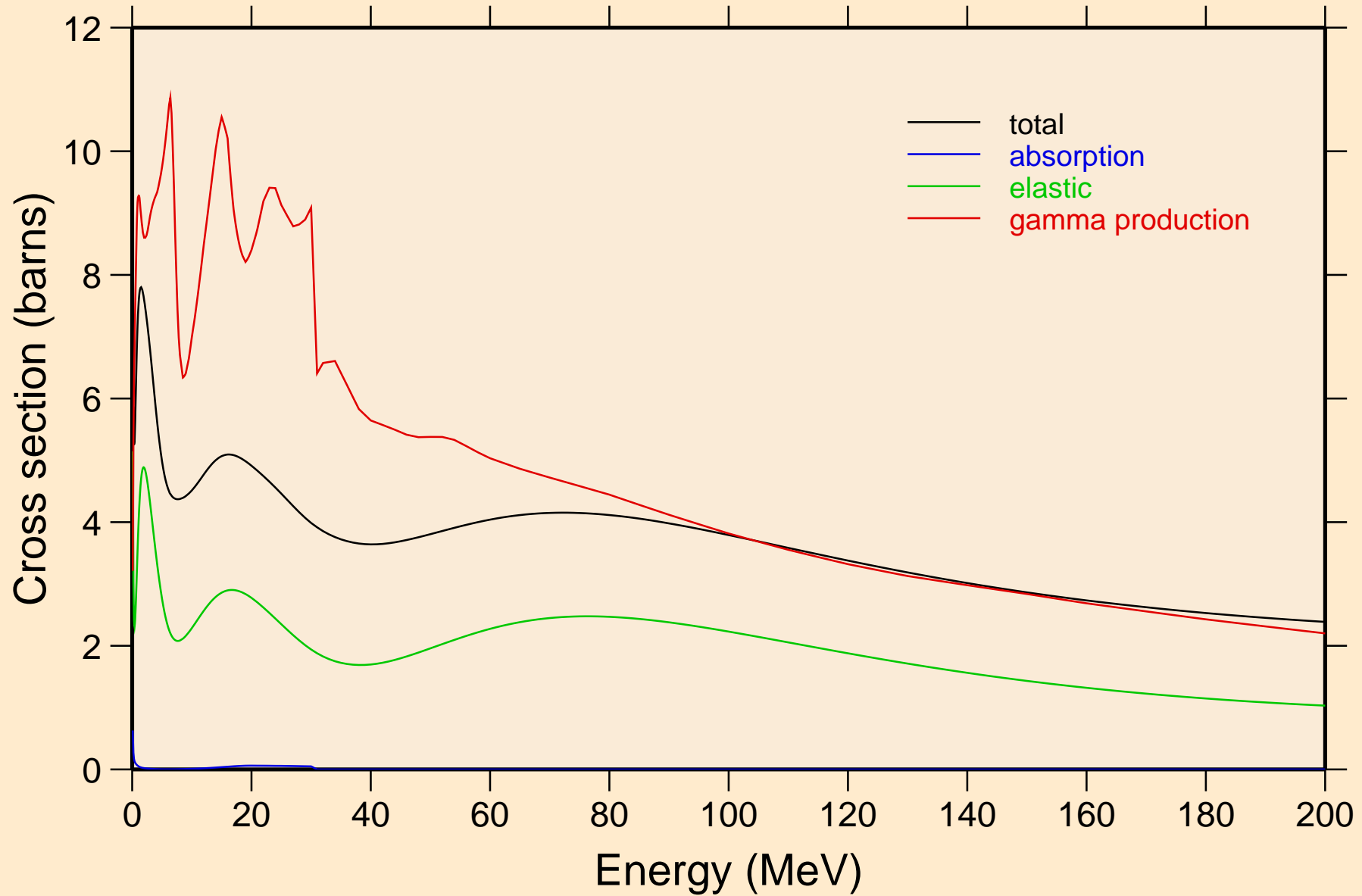

# EU152M NEUTRON ACER TENDL-2023 LIBRARY; T=0.K

## Heating

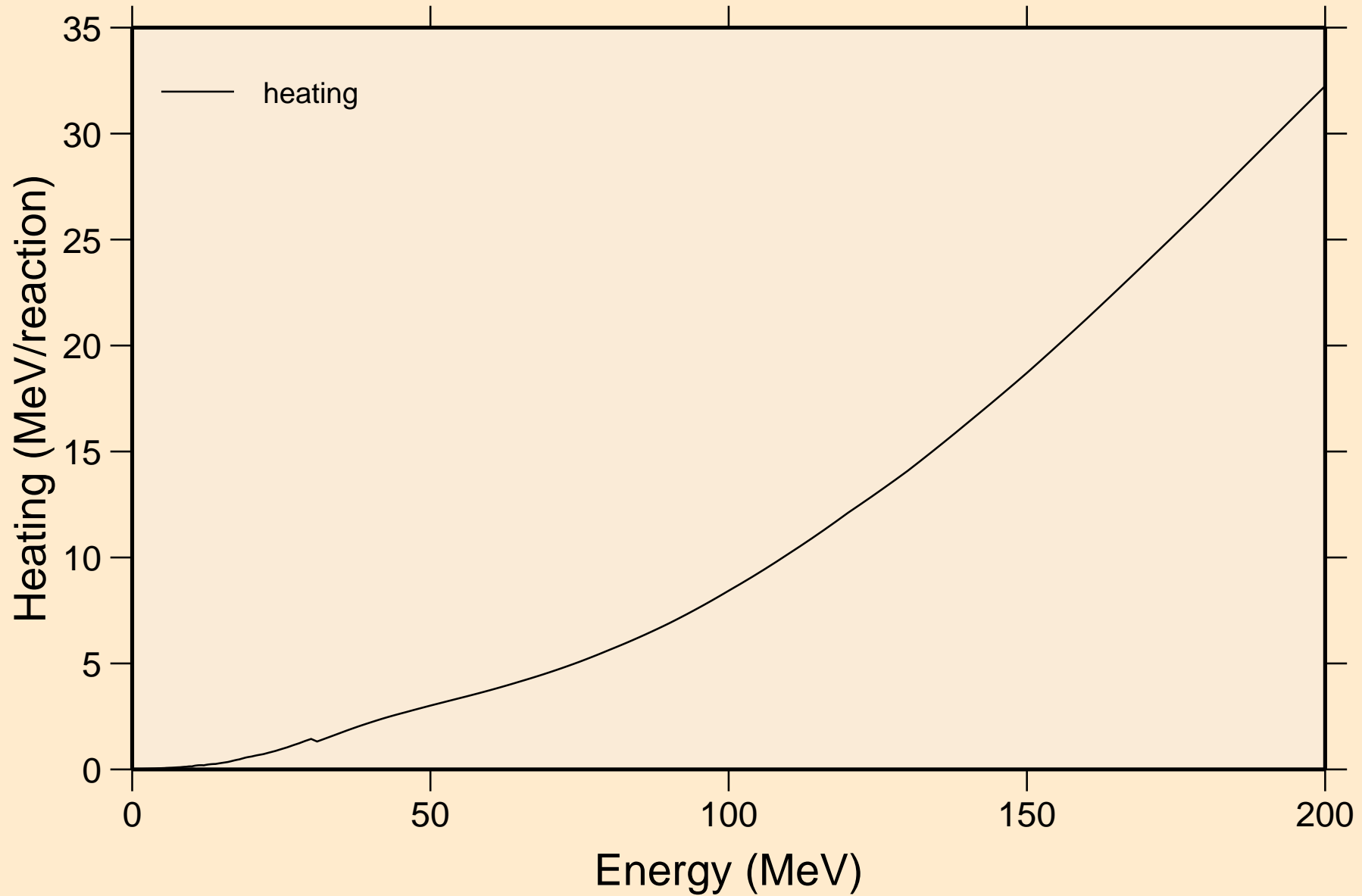

# EU152M NEUTRON ACER TENDL-2023 LIBRARY; T=0.K

## Damage

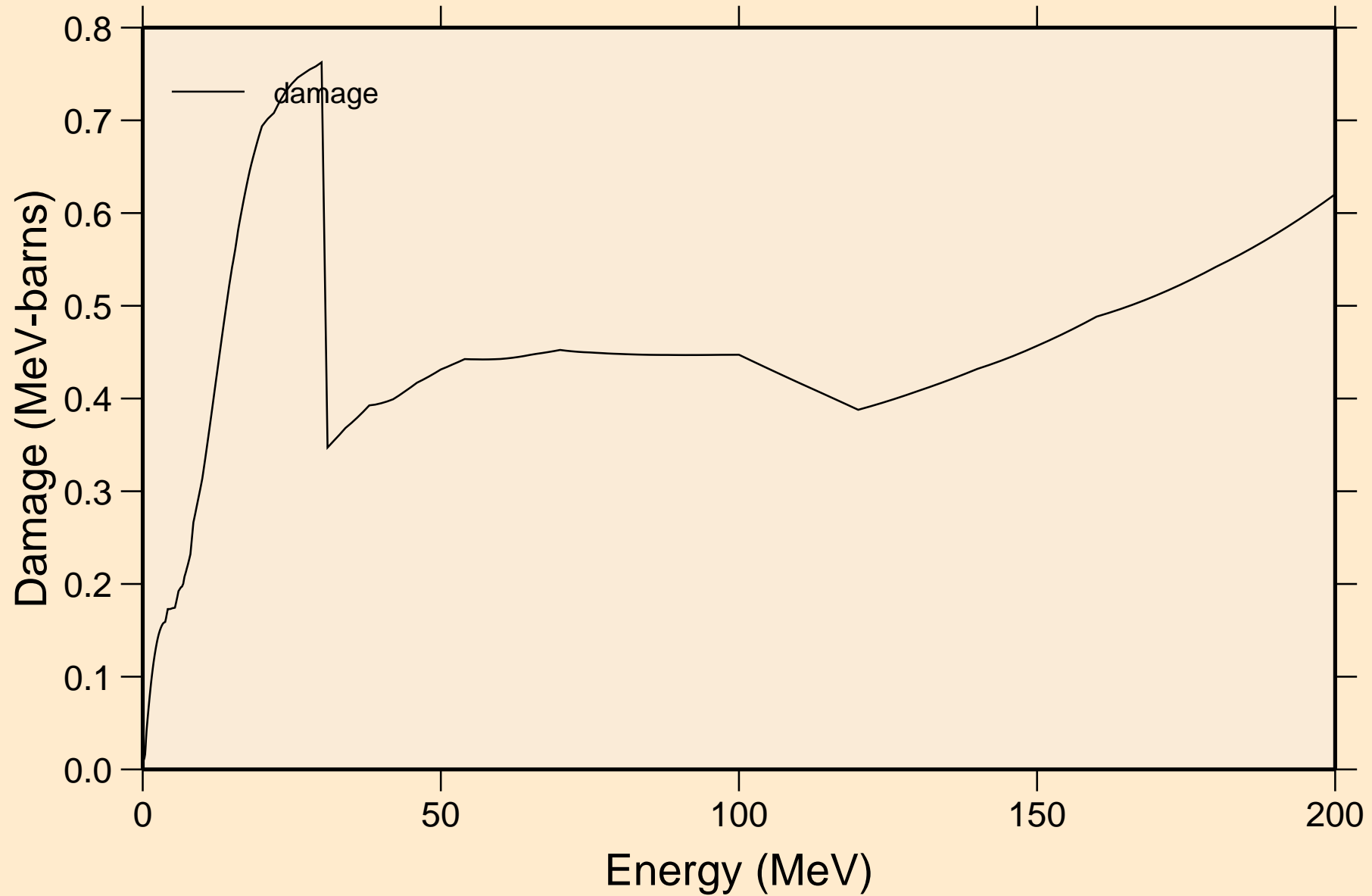

# EU152M NEUTRON ACER TENDL-2023 LIBRARY; T=0.K

## Non-threshold reactions

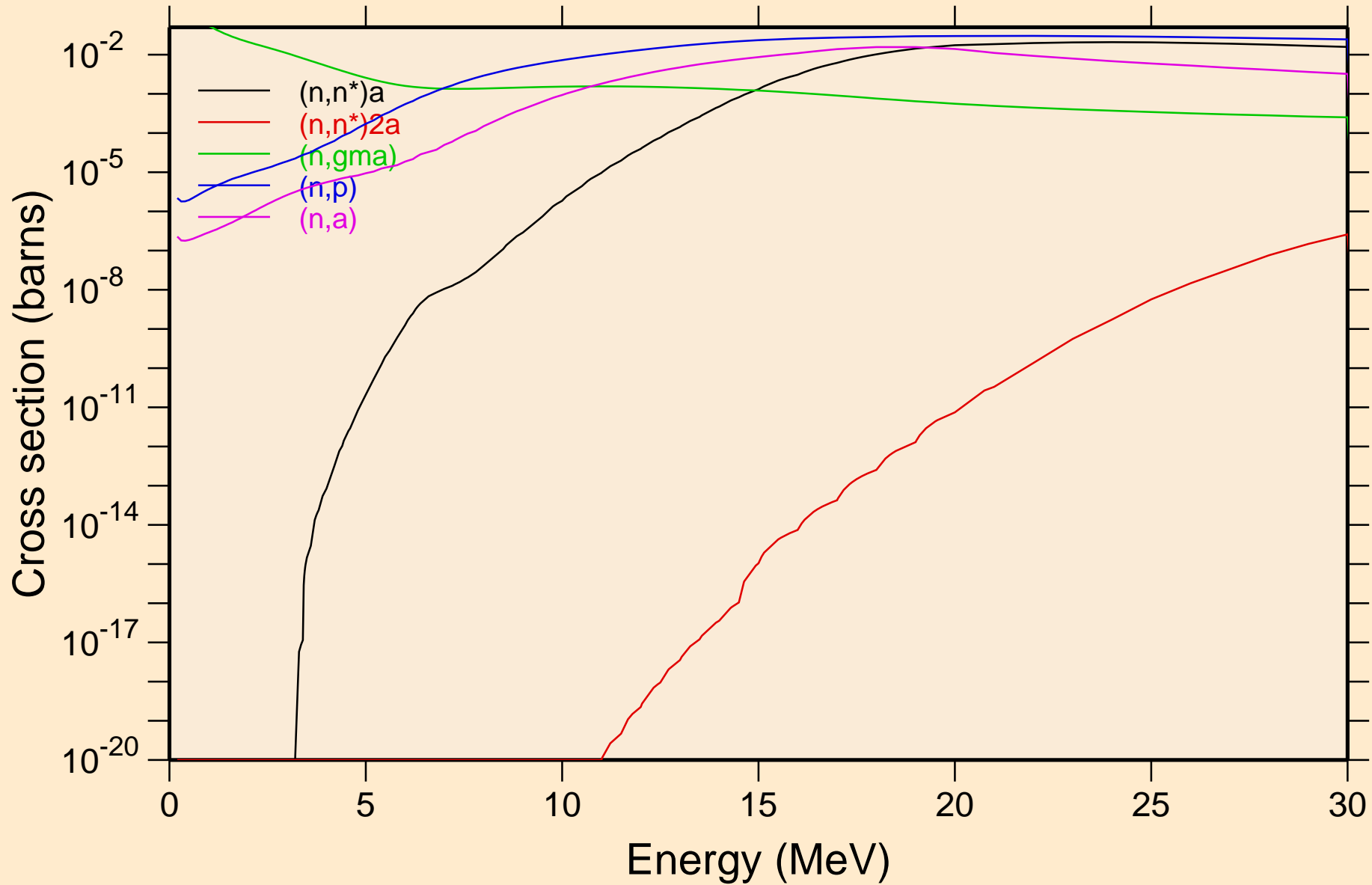

EU152M NEUTRON ACER TENDL-2023 LIBRARY; T=0.K  
Non-threshold reactions

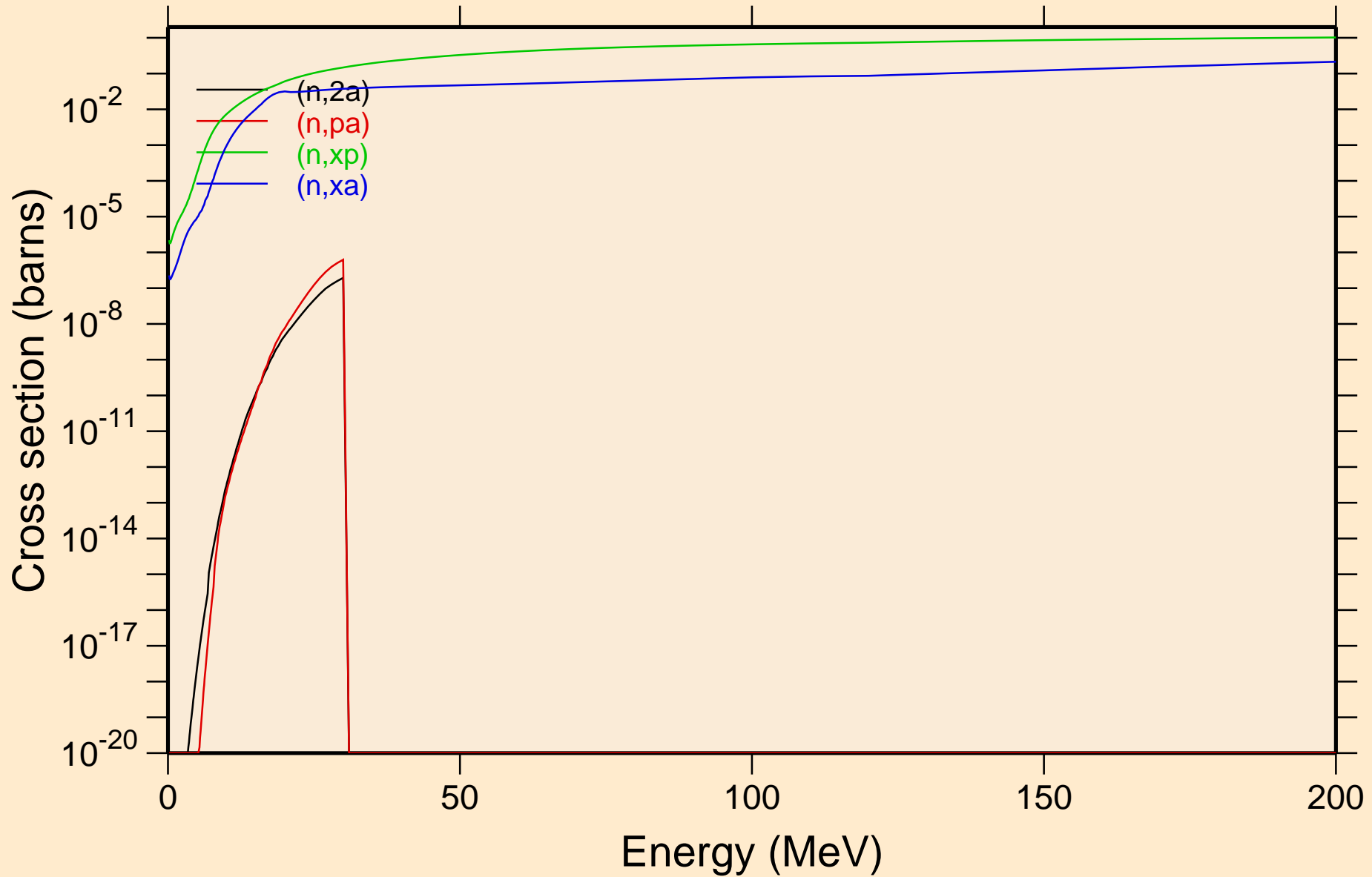

EU152M NEUTRON ACER TENDL-2023 LIBRARY; T=0.K  
Inelastic levels

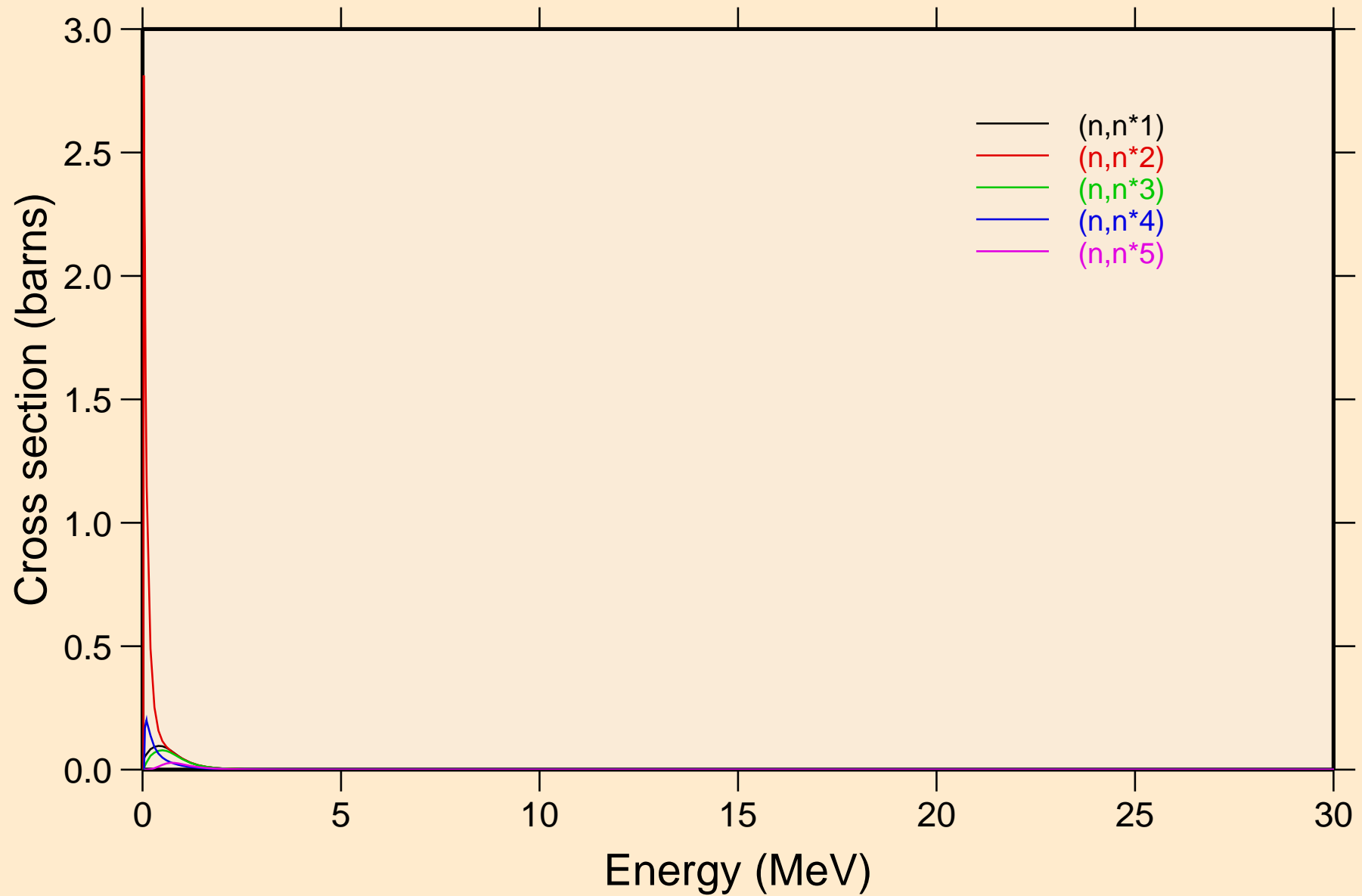

EU152M NEUTRON ACER TENDL-2023 LIBRARY; T=0.K  
Inelastic levels

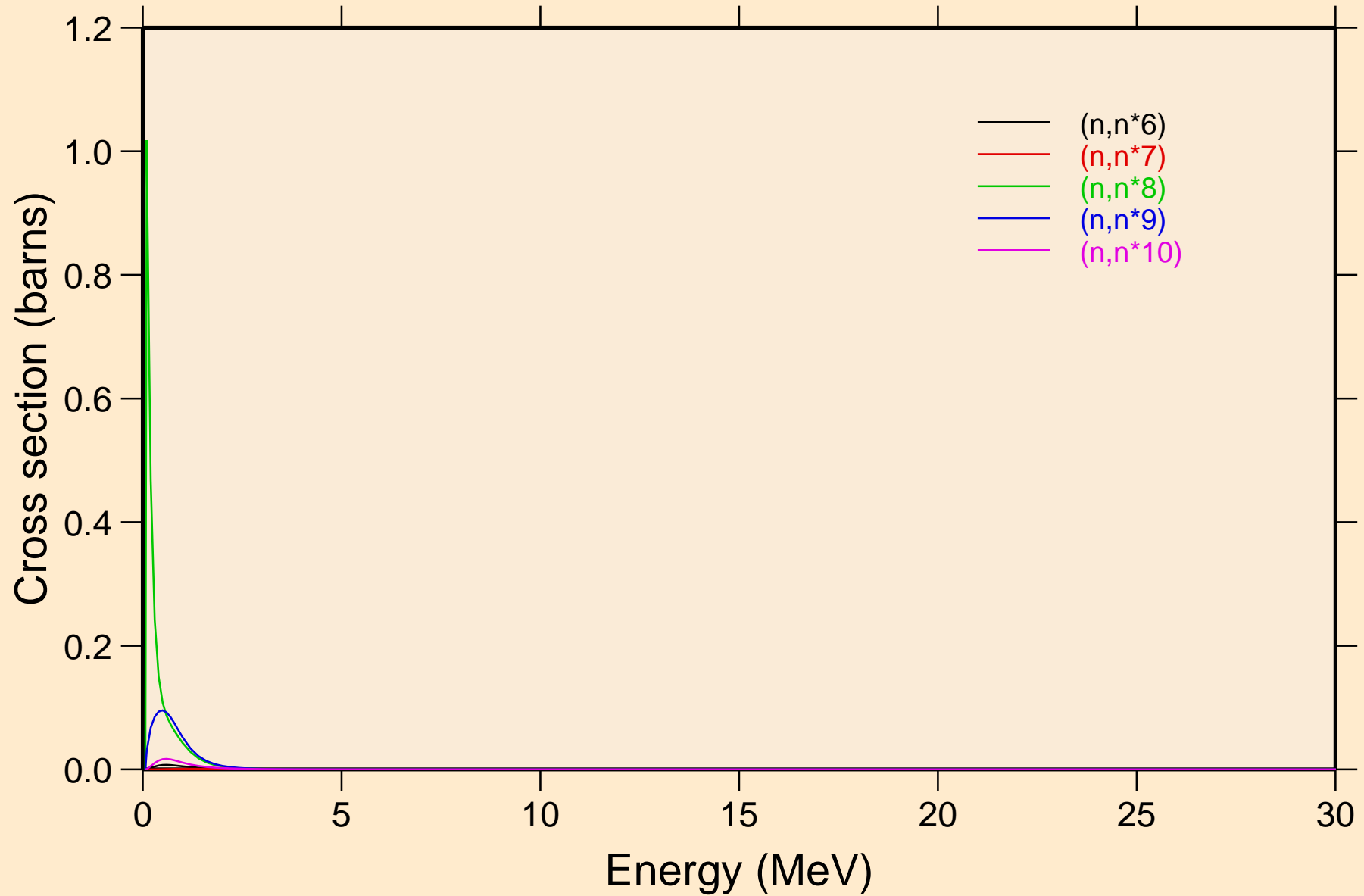

EU152M NEUTRON ACER TENDL-2023 LIBRARY; T=0.K  
Inelastic levels

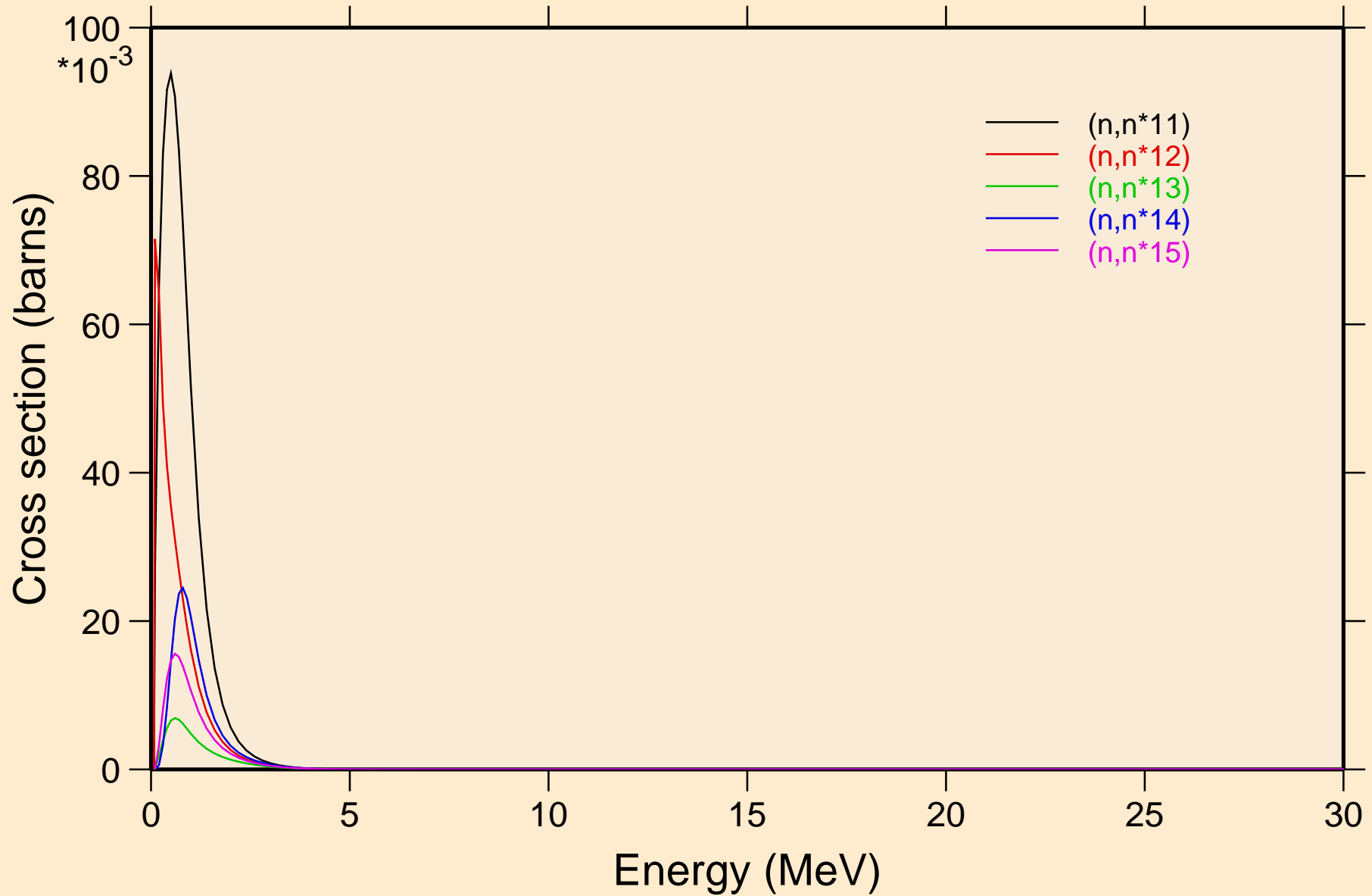

# EU152M NEUTRON ACER TENDL-2023 LIBRARY; T=0.K

## Threshold reactions

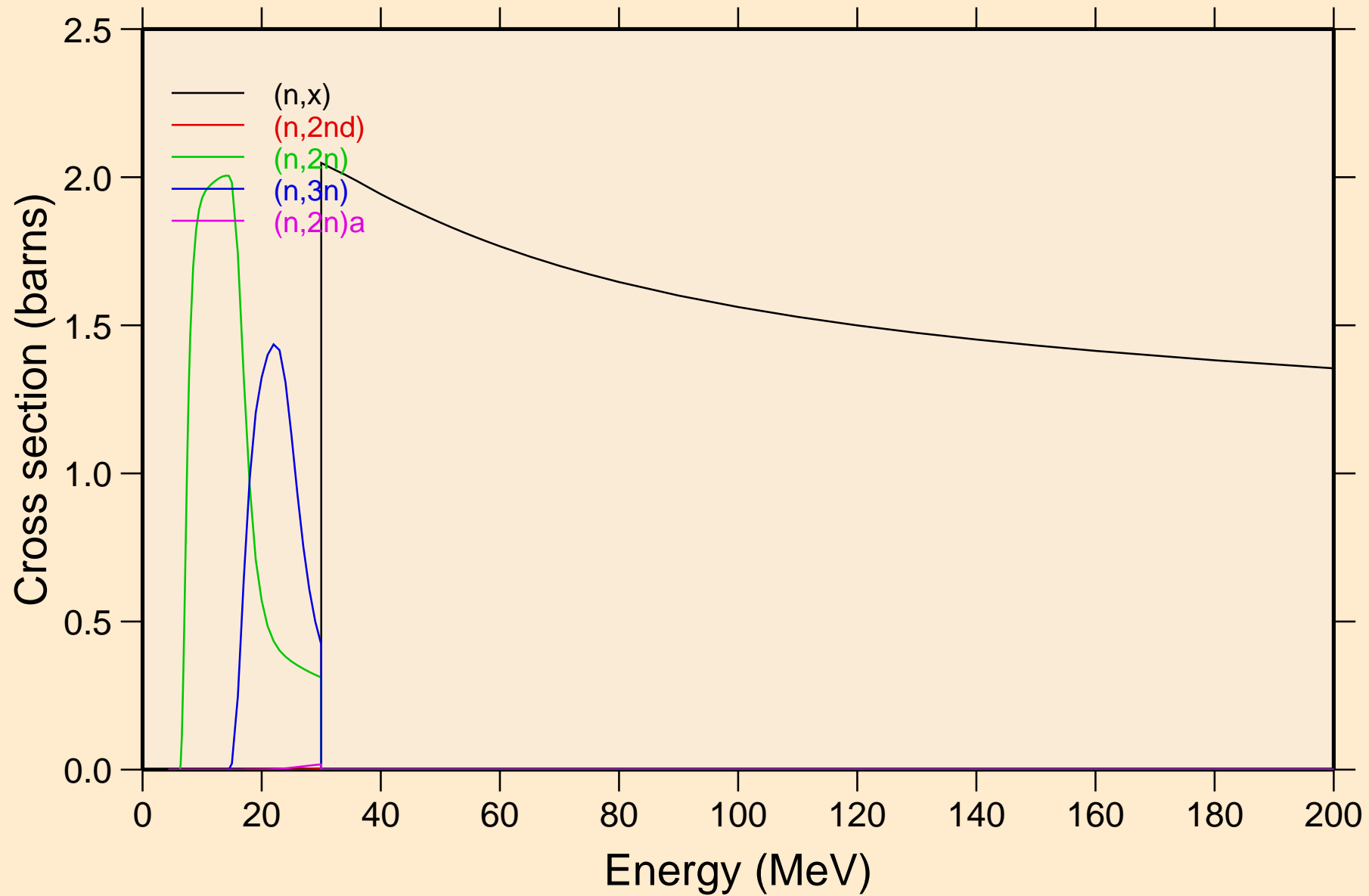

# EU152M NEUTRON ACER TENDL-2023 LIBRARY; T=0.K

## Threshold reactions

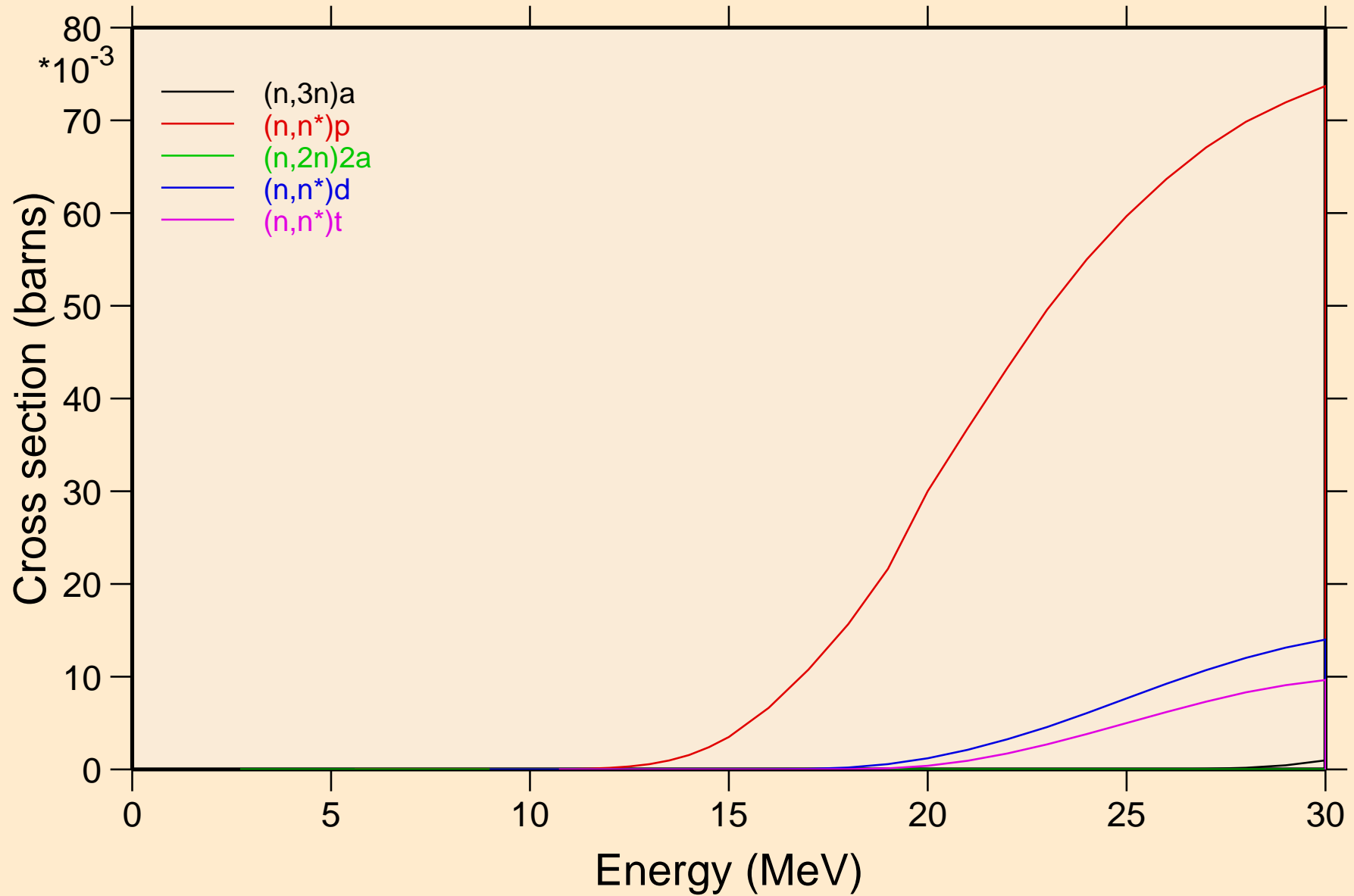

# EU152M NEUTRON ACER TENDL-2023 LIBRARY; T=0.K

## Threshold reactions

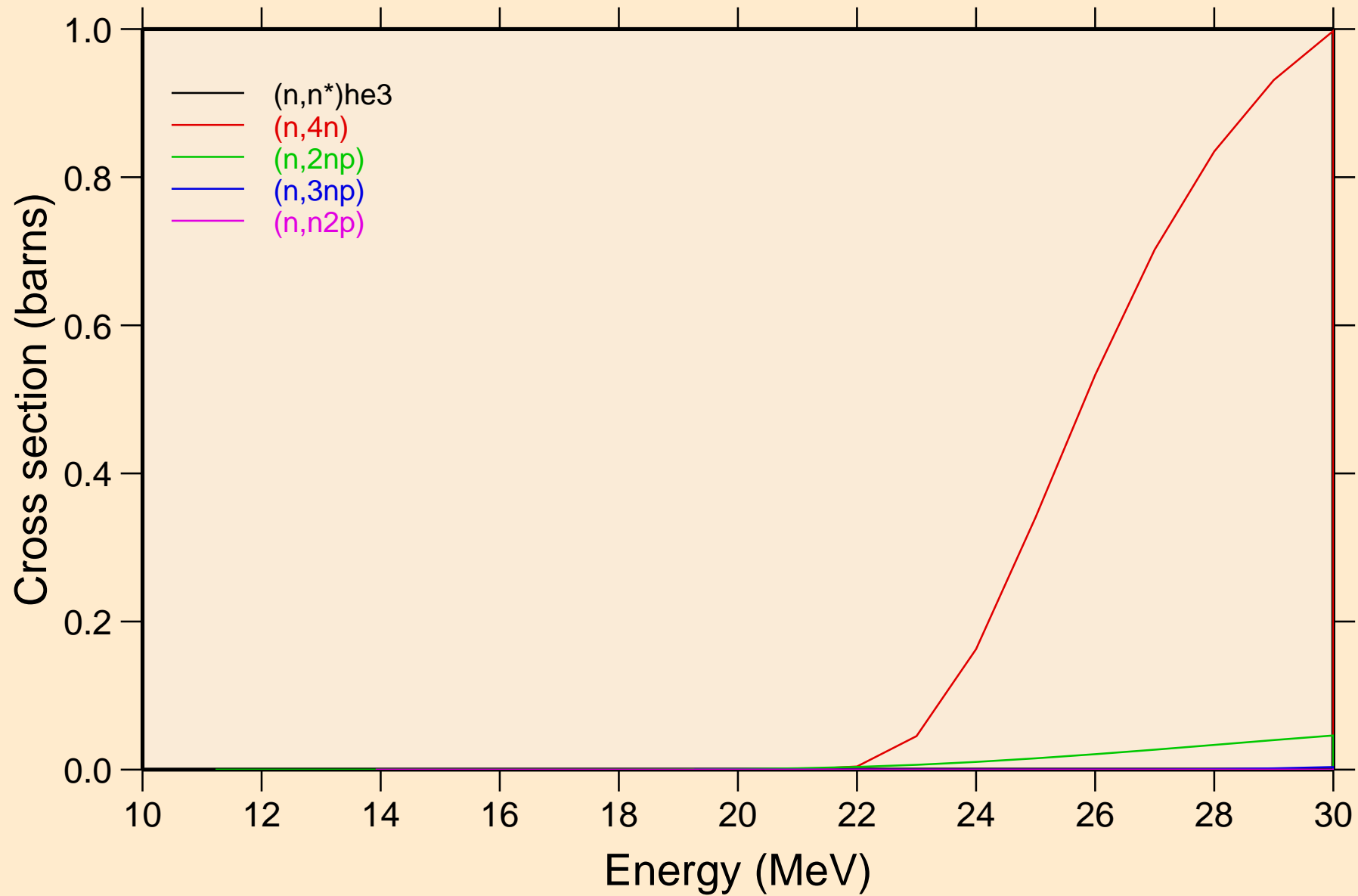

# EU152M NEUTRON ACER TENDL-2023 LIBRARY; T=0.K

## Threshold reactions

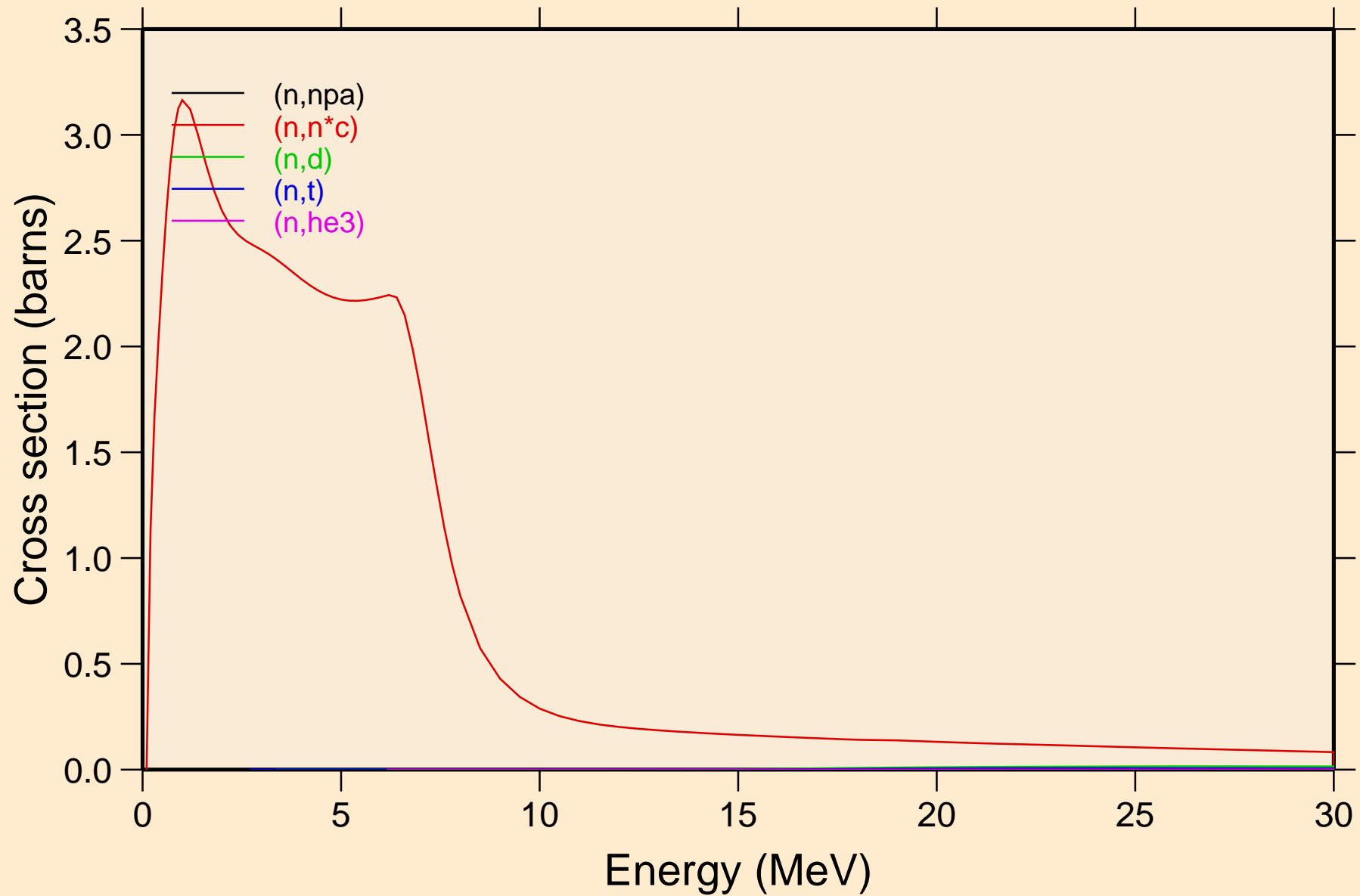

EU152M NEUTRON ACER TENDL-2023 LIBRARY; T=0.K  
Threshold reactions

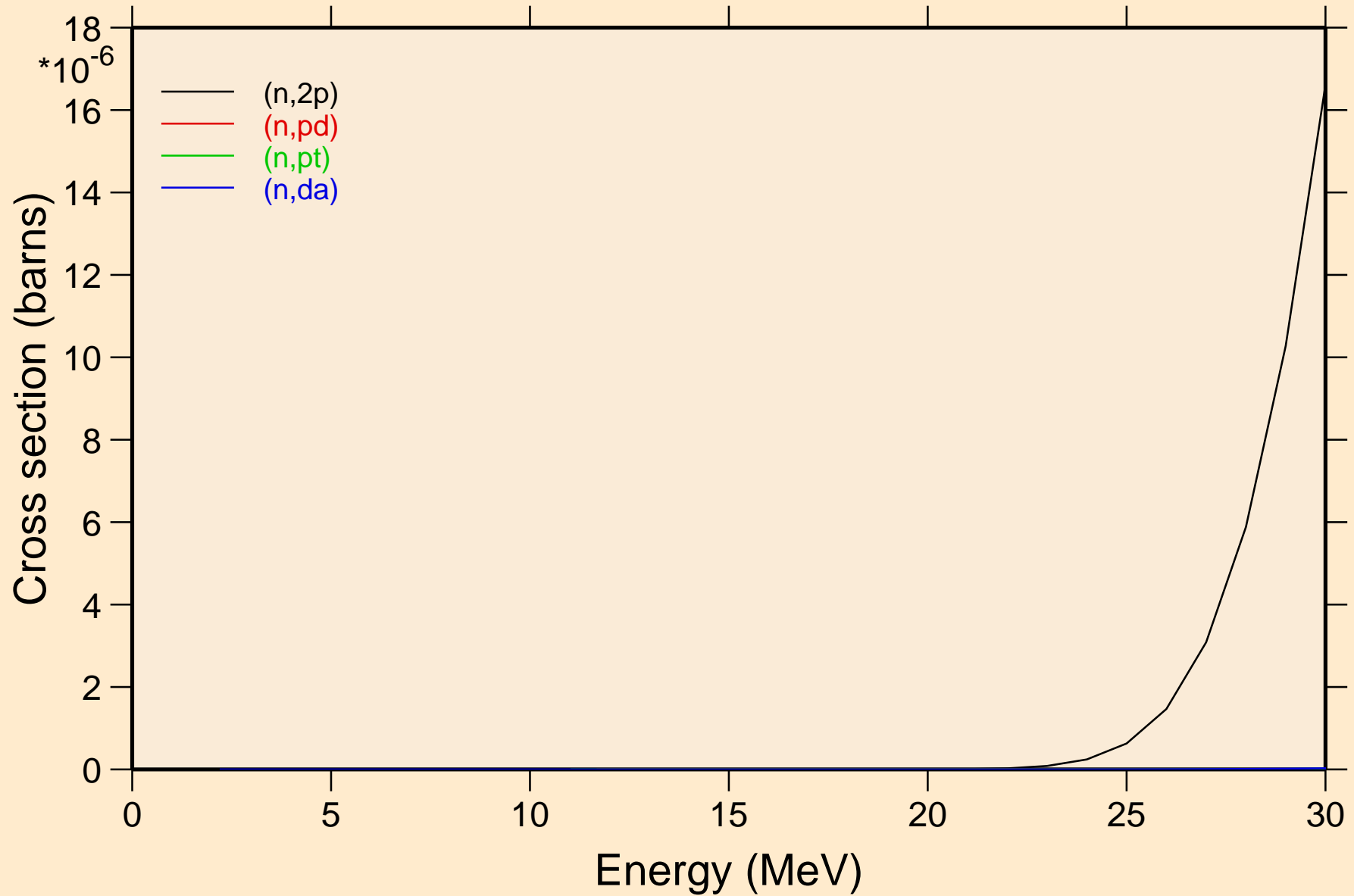

# EU152M NEUTRON ACER TENDL-2023 LIBRARY; T=0.K

## Threshold reactions

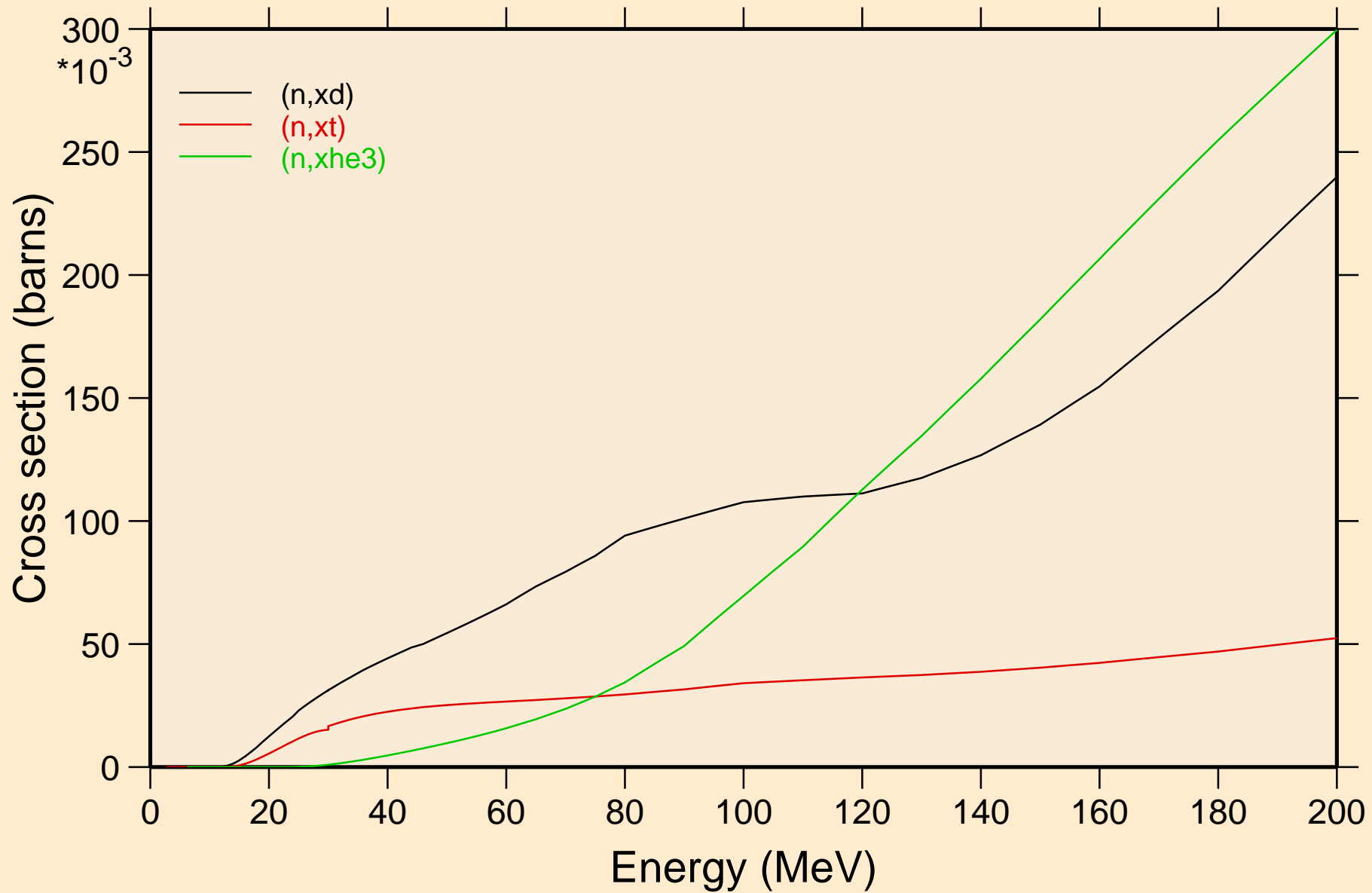

EU152M NEUTRON ACER TENDL-2023 LIBRARY; T=0.K  
angular distribution for elastic

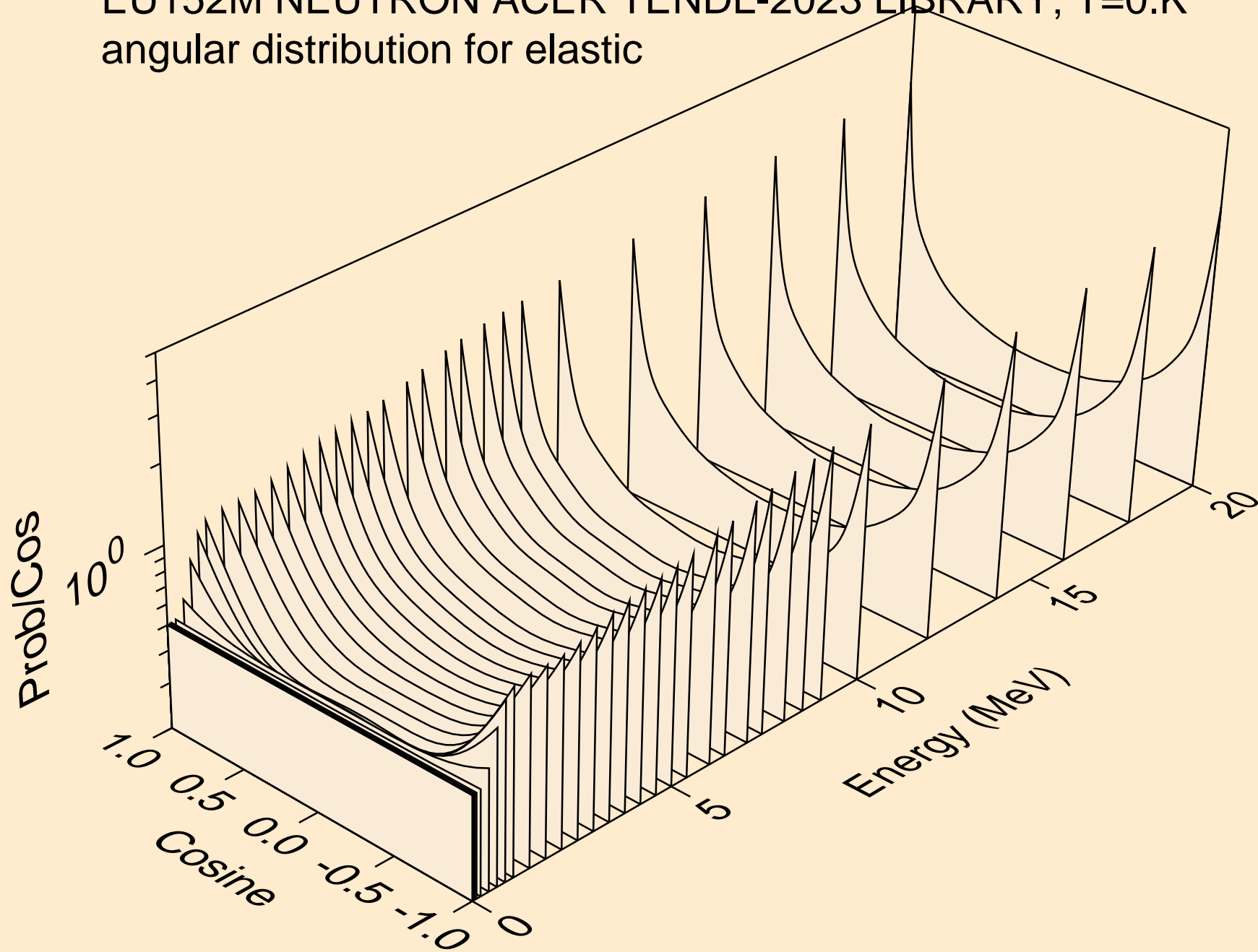

EU152M NEUTRON ACER TENDL-2023 LIBRARY; T=0.K  
angular distribution for elastic

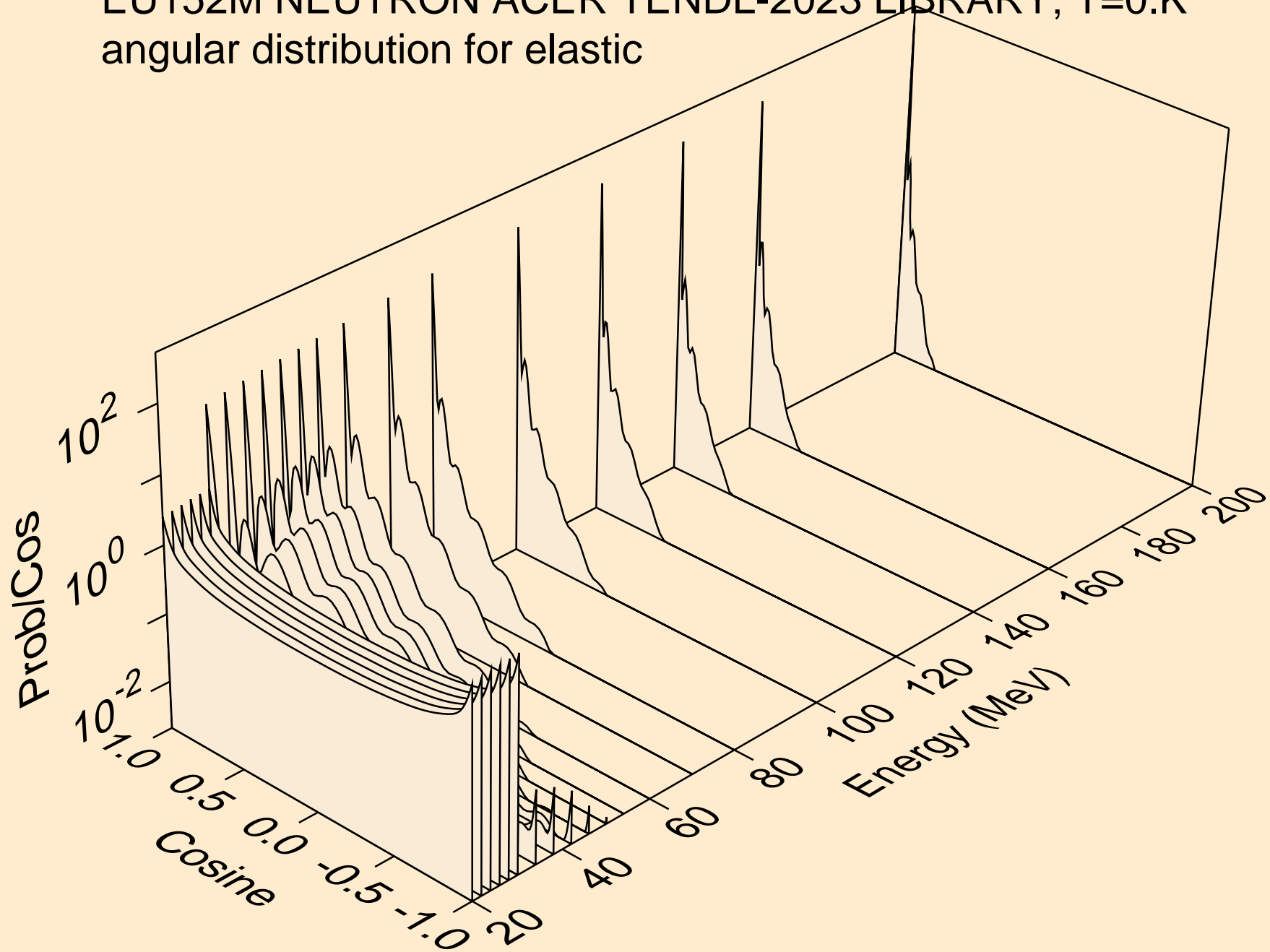

EU152M NEUTRON ACER TENDL-2023 LIBRARY; T=0.K  
angular distribution for (n,n\*1)

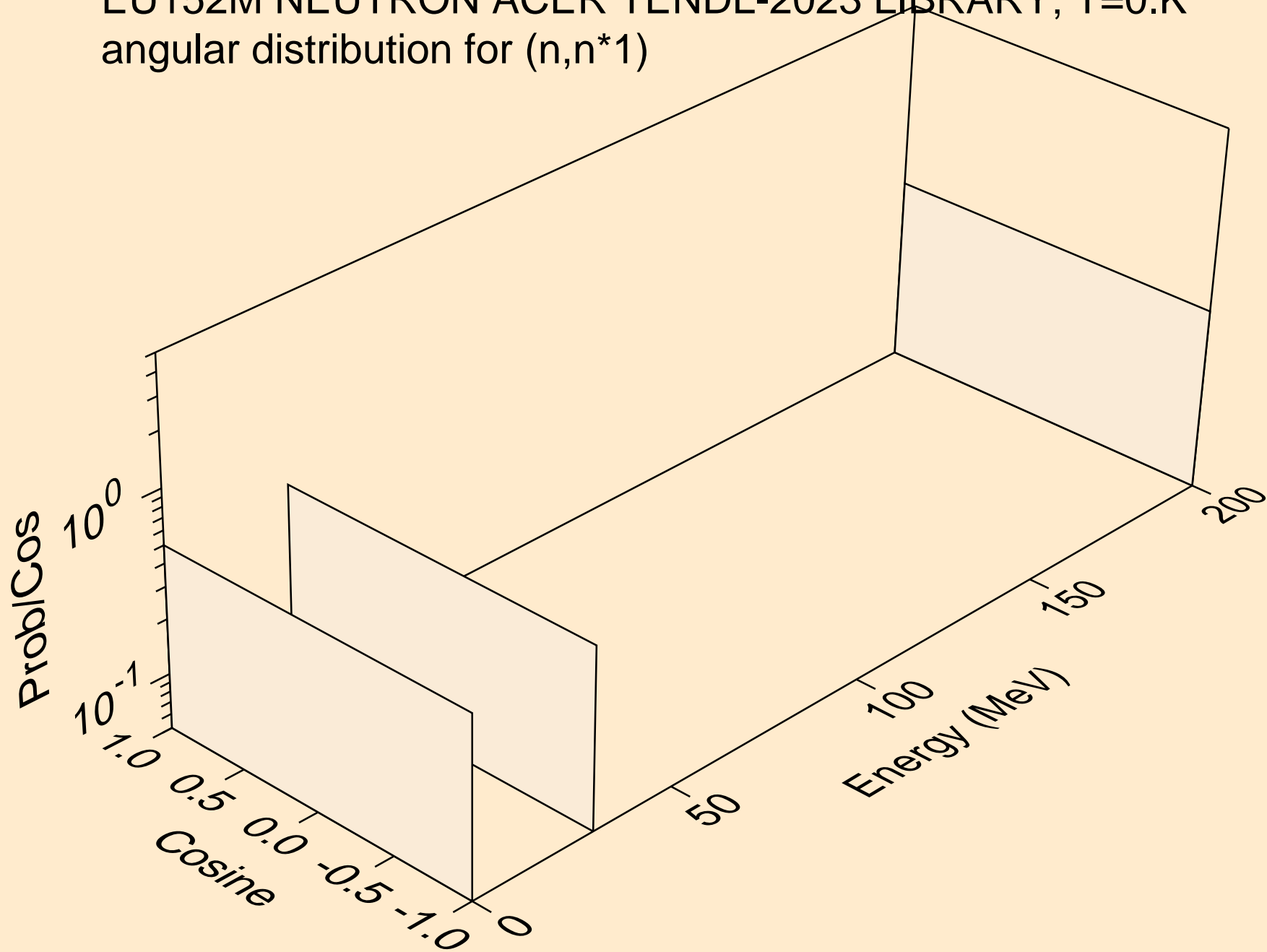

EU152M NEUTRON ACER TENDL-2023 LIBRARY; T=0.K  
angular distribution for (n,n\*2)

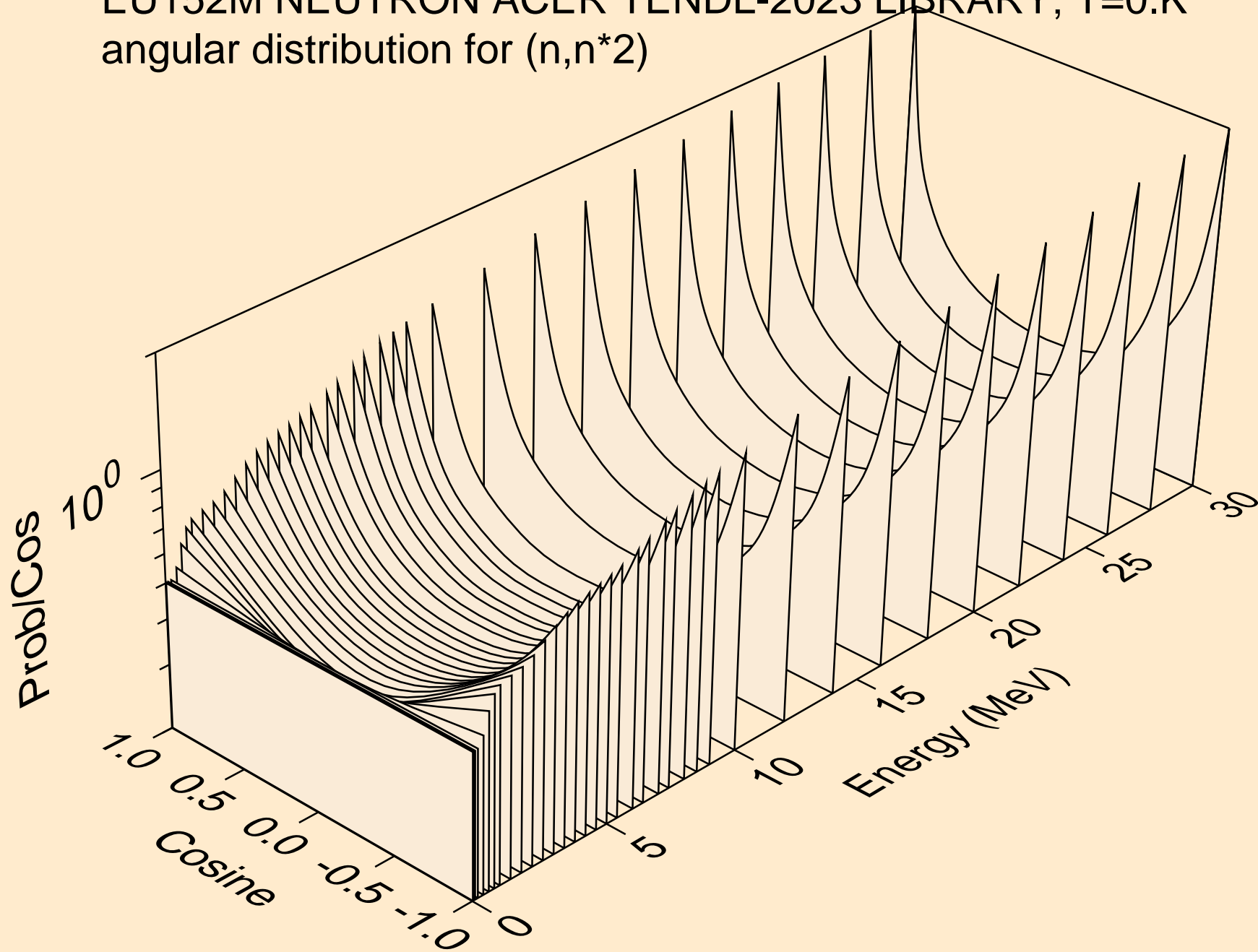

EU152M NEUTRON ACER TENDL-2023 LIBRARY; T=0.K  
angular distribution for (n,n\*3)

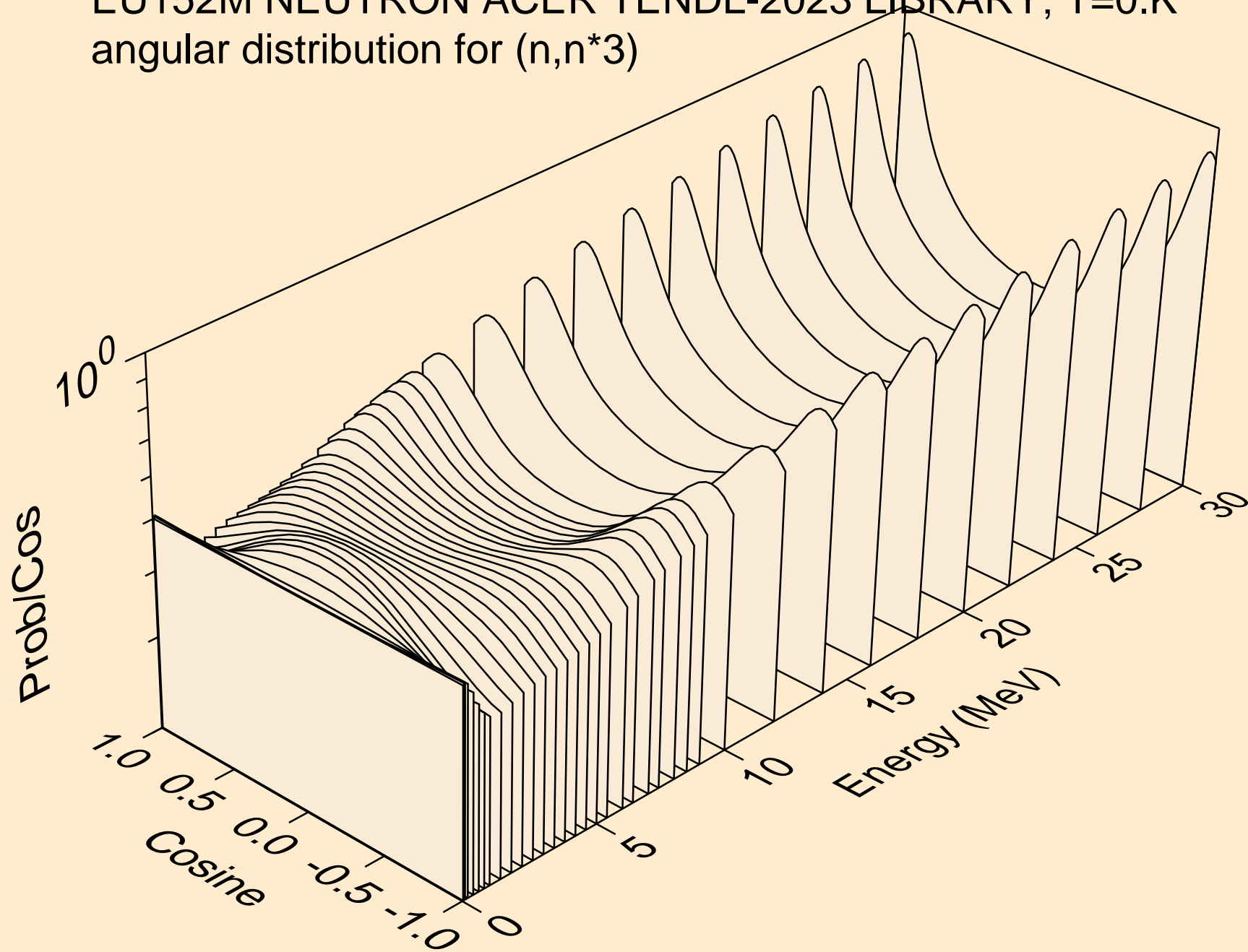

EU152M NEUTRON ACER TENDL-2023 LIBRARY; T=0.K  
angular distribution for (n,n\*4)

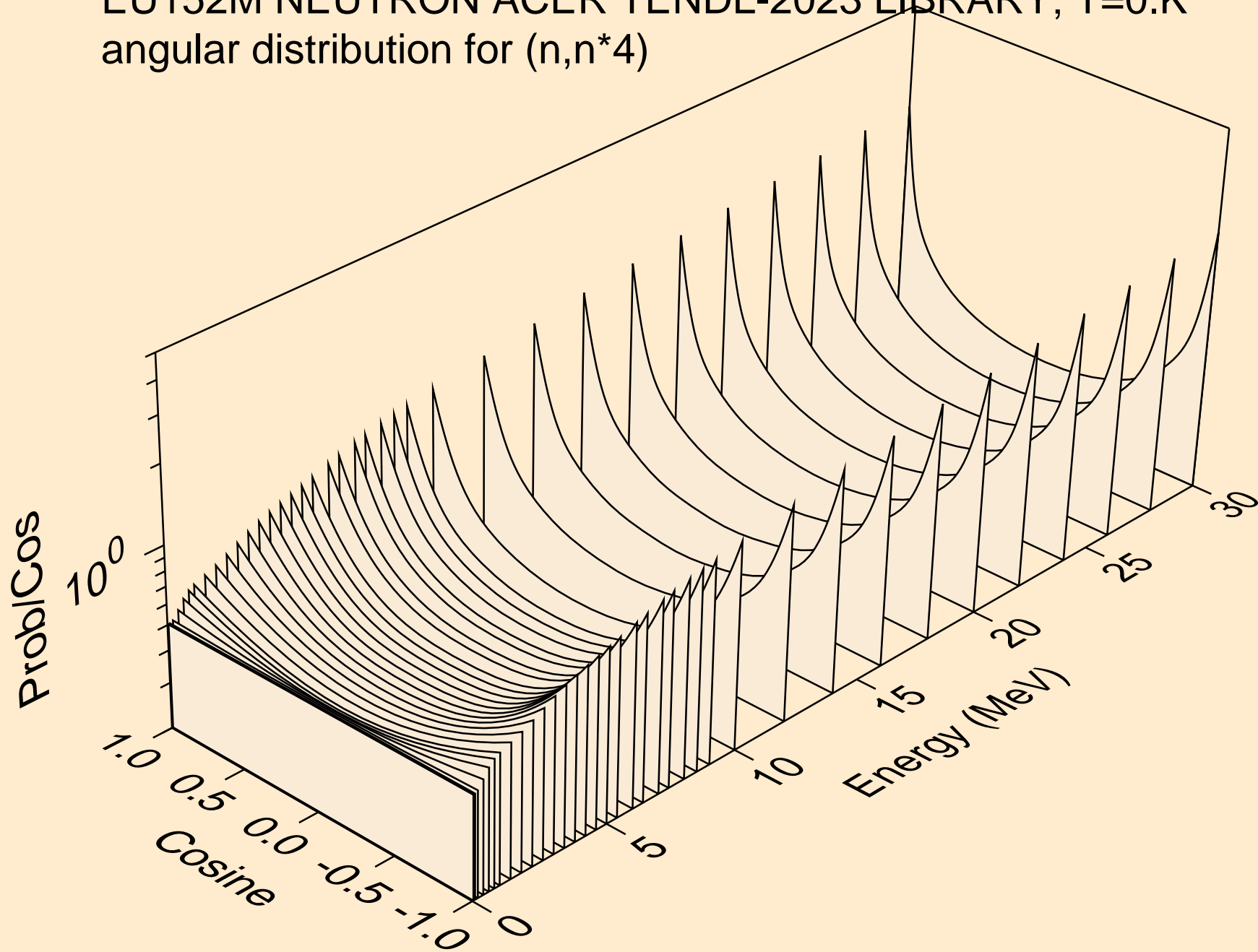

EU152M NEUTRON ACER TENDL-2023 LIBRARY; T=0.K  
angular distribution for (n,n\*5)

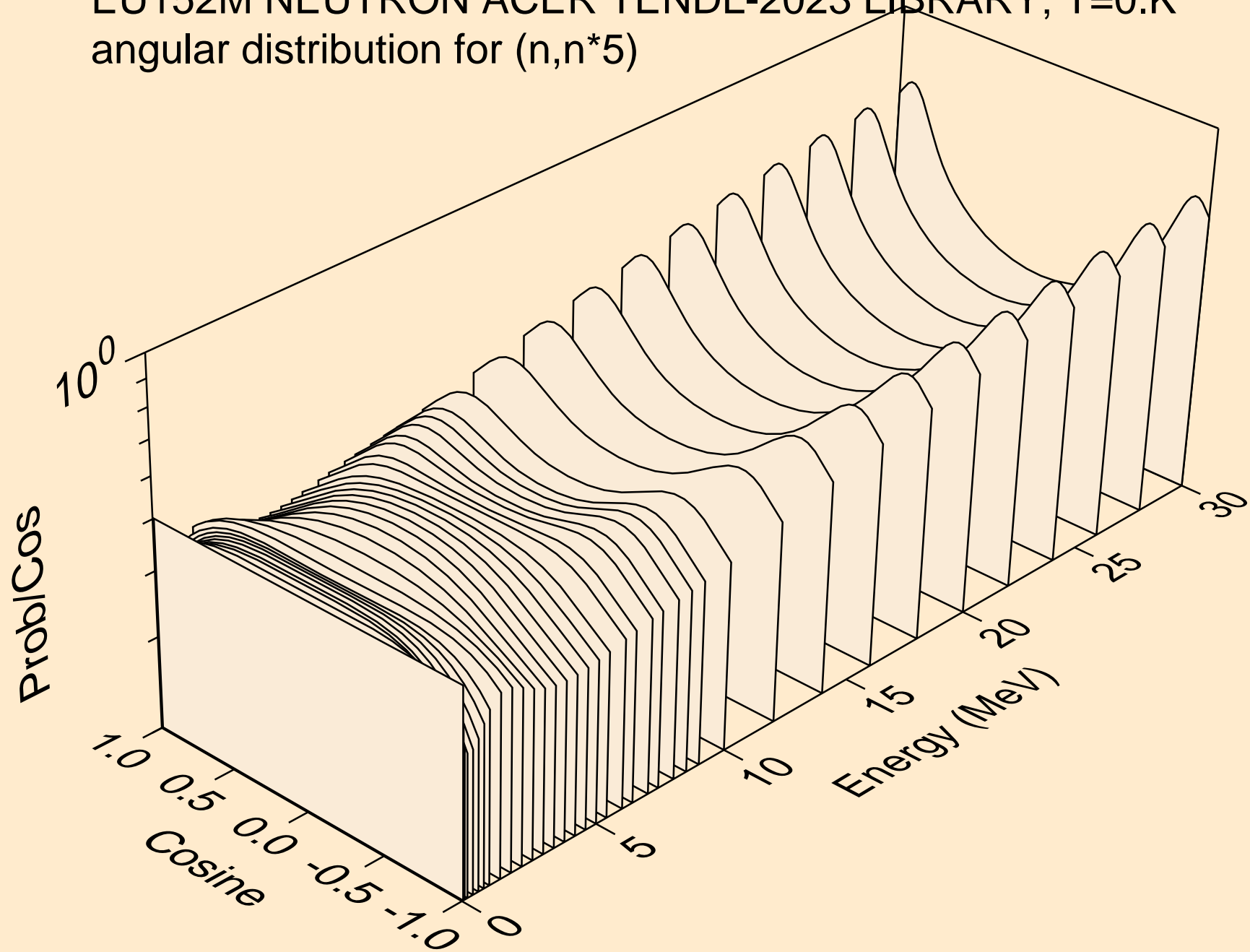

EU152M NEUTRON ACER TENDL-2023 LIBRARY; T=0.K  
angular distribution for (n,n\*6)

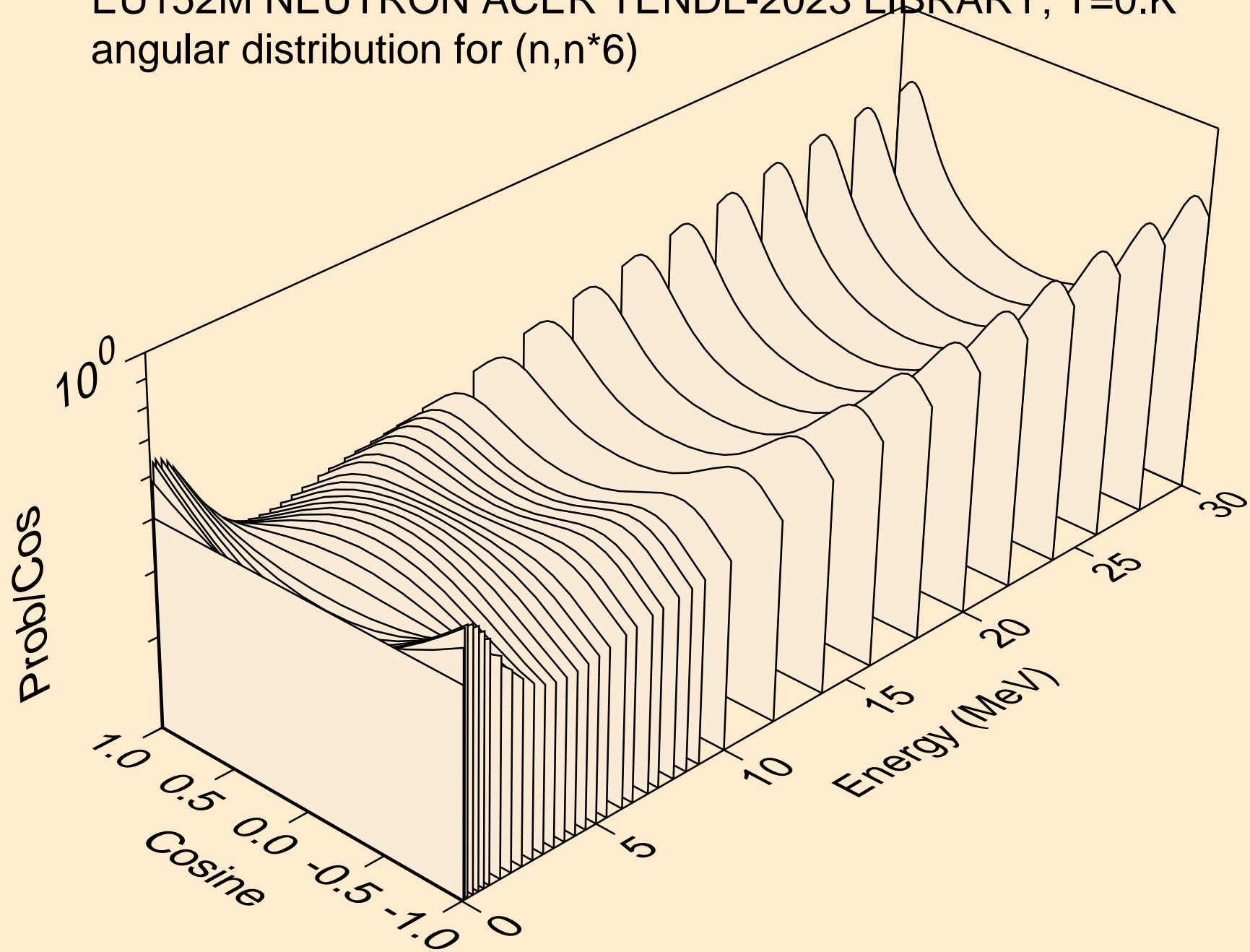

EU152M NEUTRON ACER TENDL-2023 LIBRARY; T=0.K  
angular distribution for (n,n\*7)

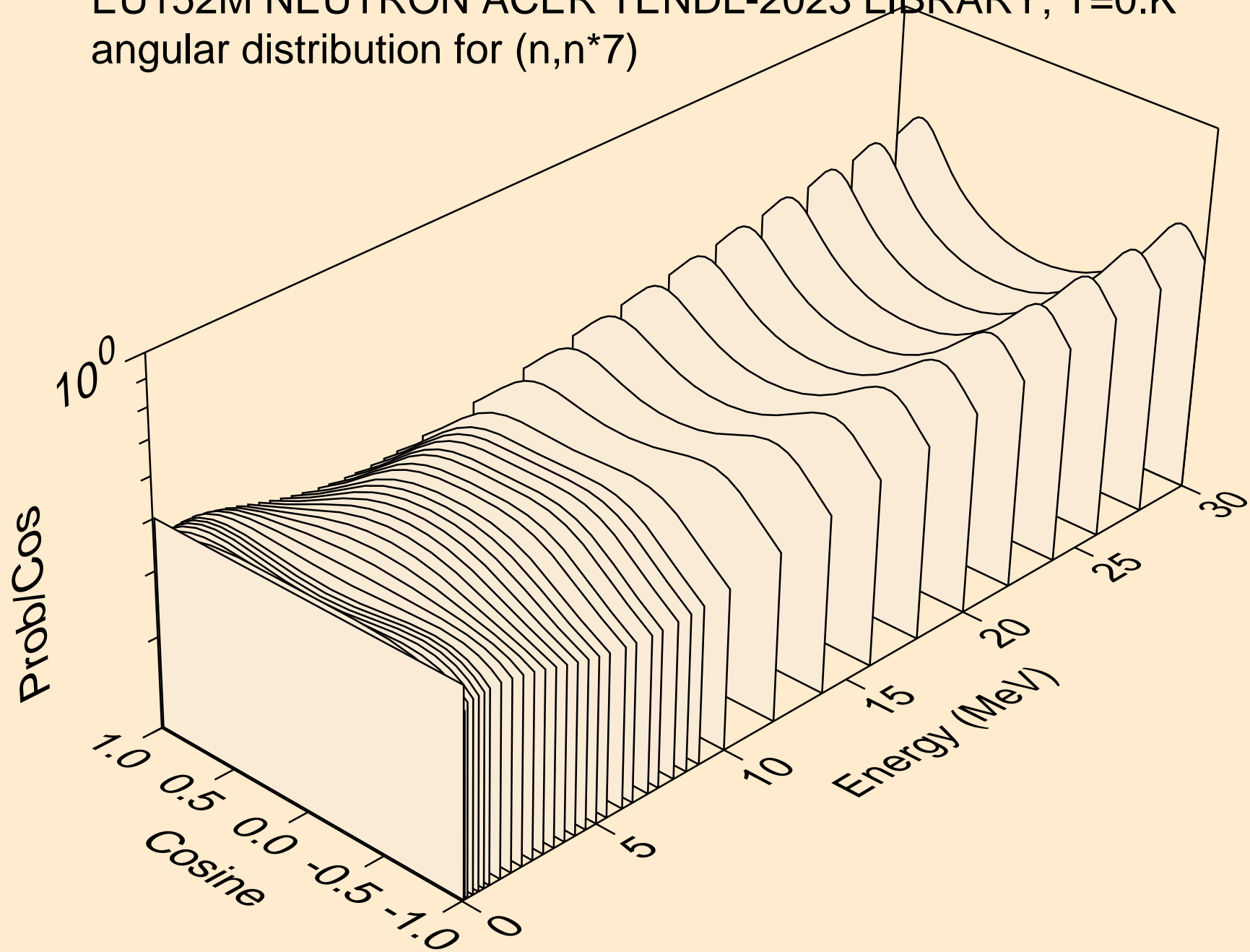

EU152M NEUTRON ACER TENDL-2023 LIBRARY; T=0.K  
angular distribution for (n,n\*8)

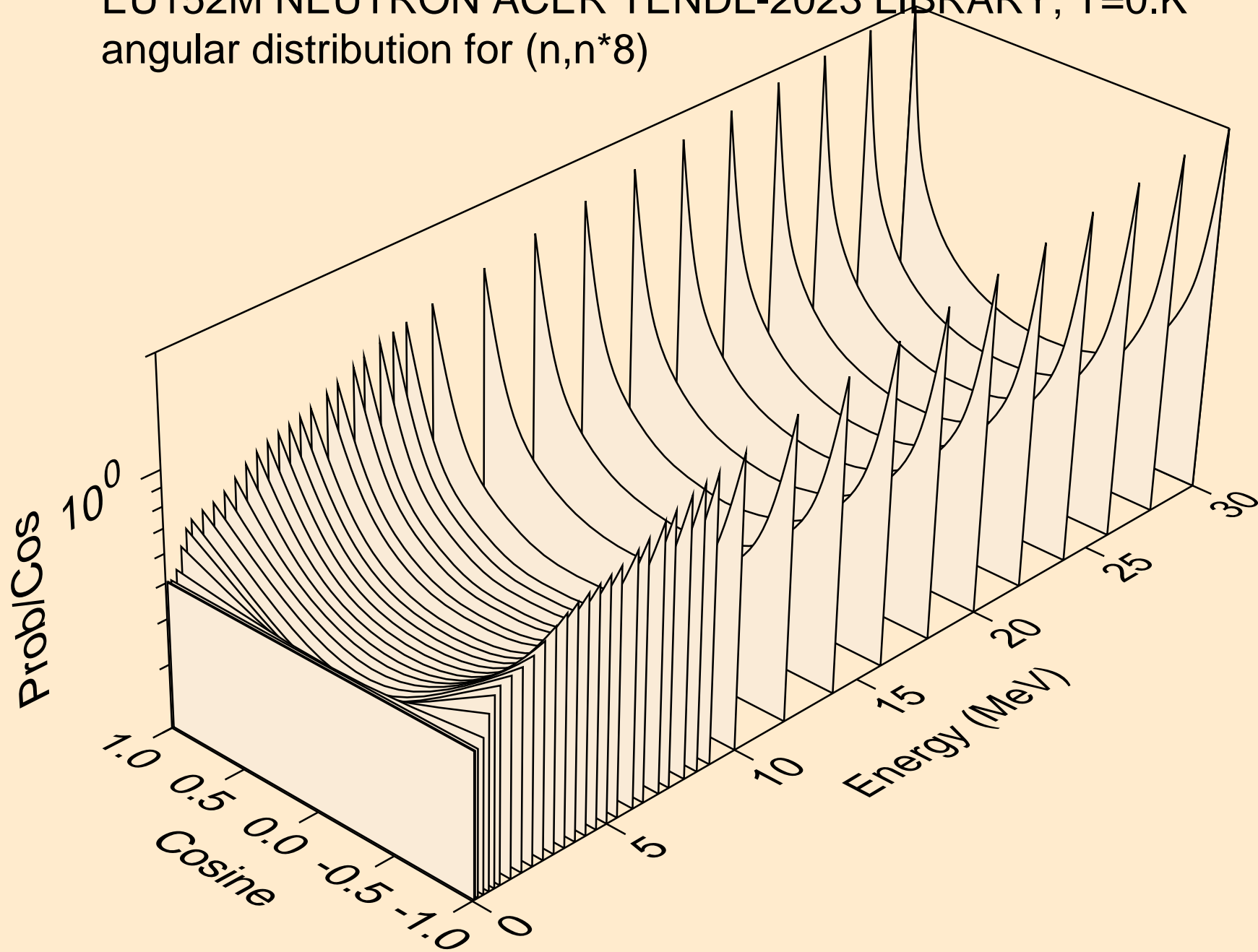

EU152M NEUTRON ACER TENDL-2023 LIBRARY; T=0.K  
angular distribution for (n,n\*9)

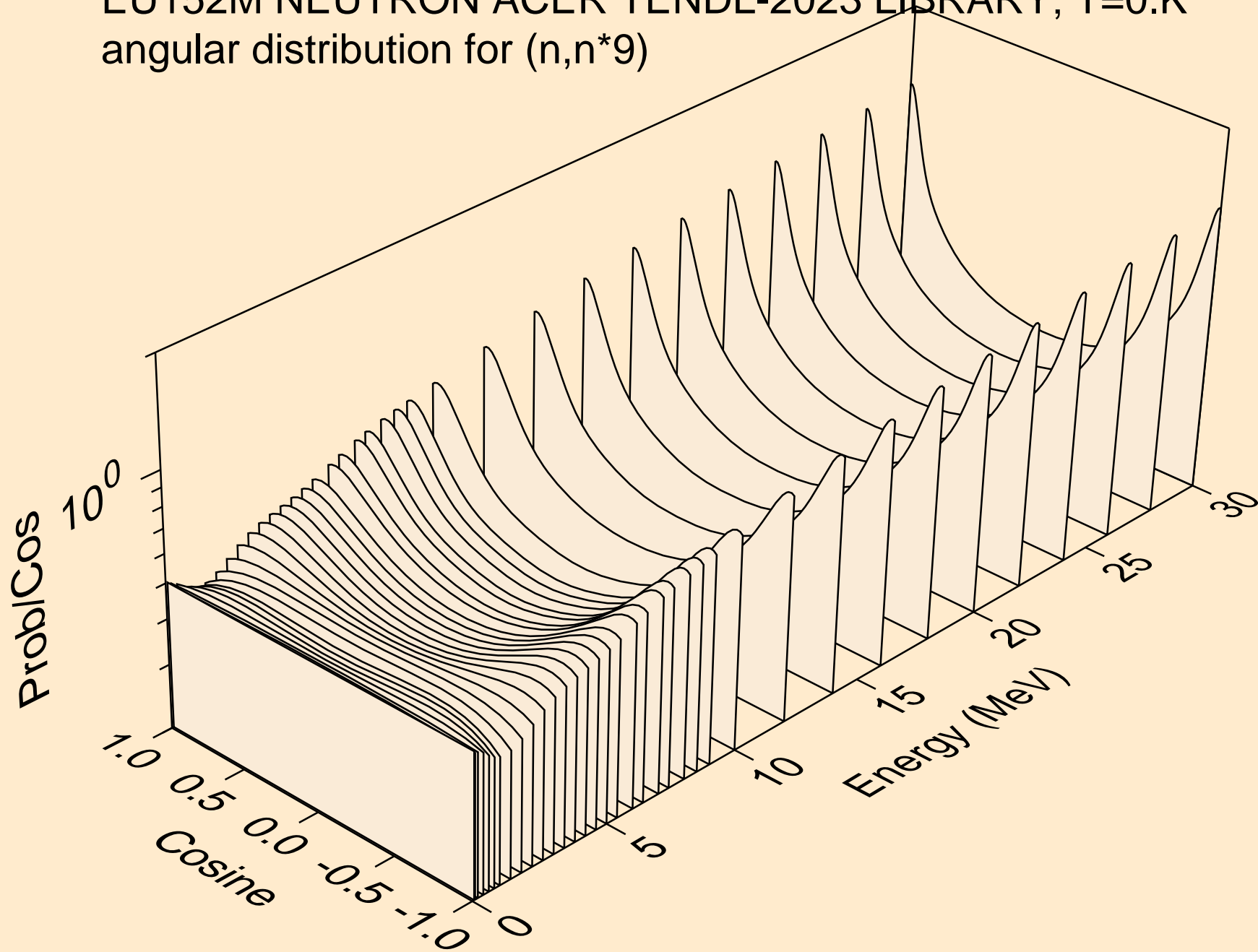

EU152M NEUTRON ACER TENDL-2023 LIBRARY; T=0.K  
angular distribution for (n,n\*10)

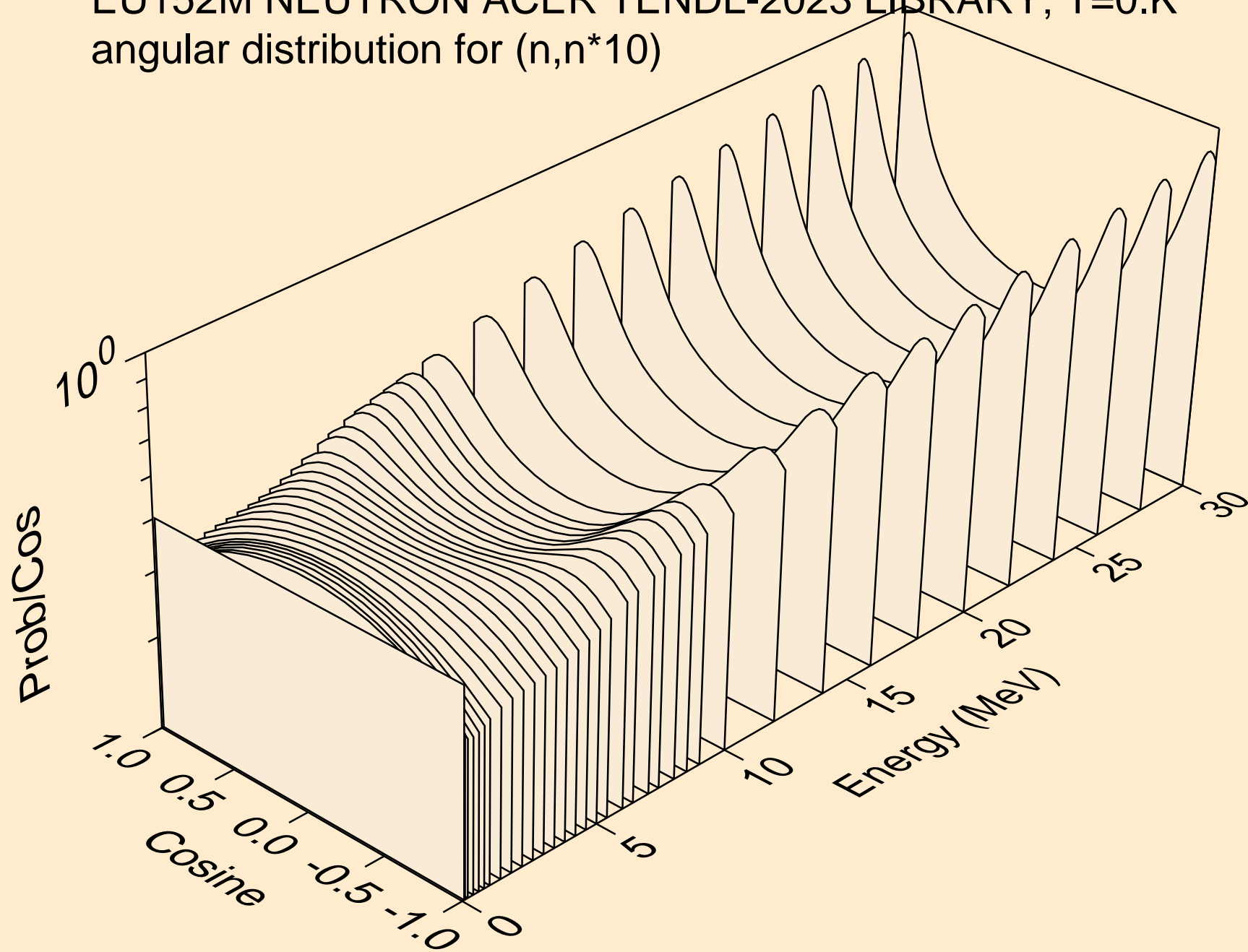

EU152M NEUTRON ACER TENDL-2023 LIBRARY; T=0.K  
angular distribution for (n,n\*11)

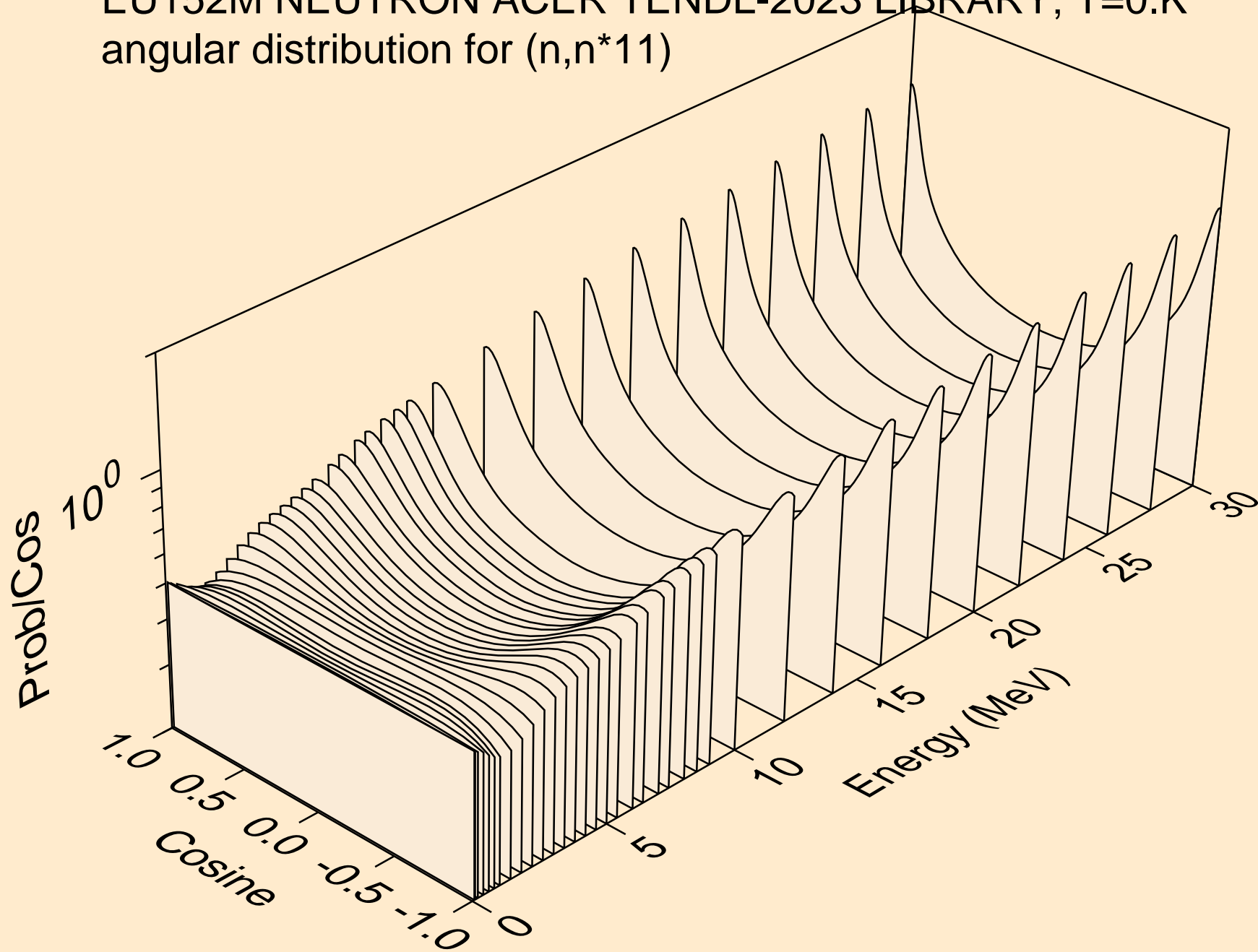

EU152M NEUTRON ACER TENDL-2023 LIBRARY; T=0.K  
angular distribution for (n,n\*12)

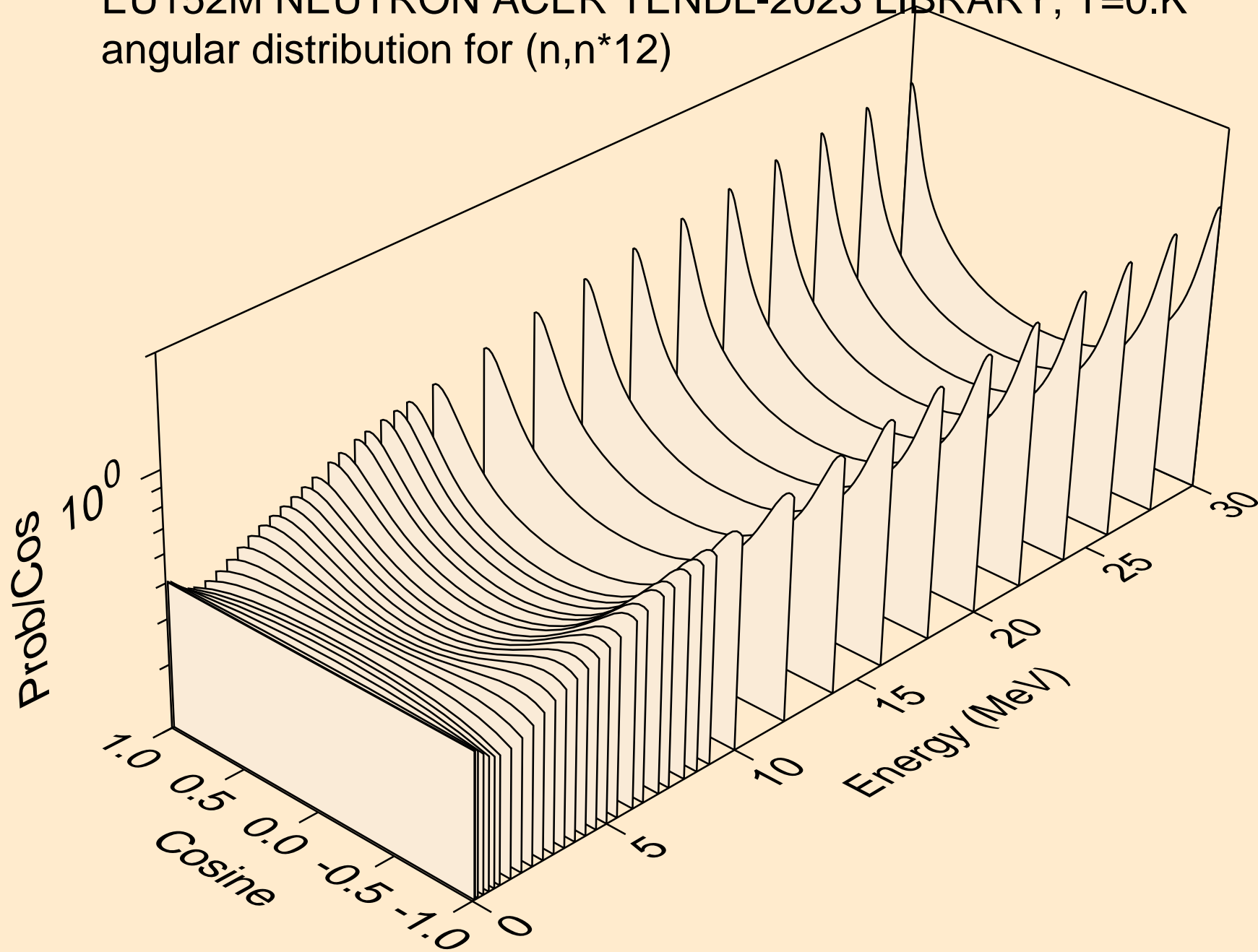

EU152M NEUTRON ACER TENDL-2023 LIBRARY; T=0.K  
angular distribution for (n,n\*13)

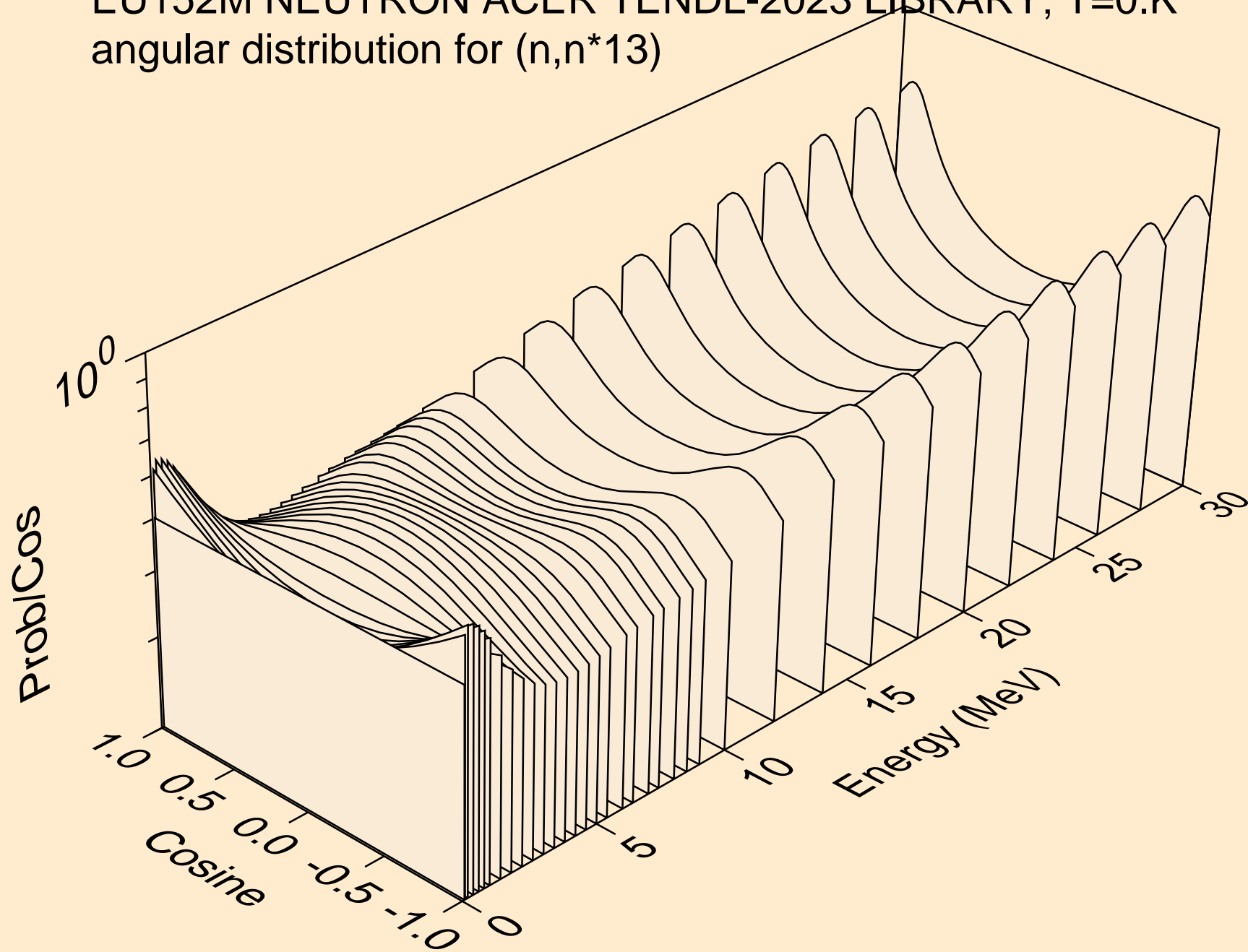

EU152M NEUTRON ACER TENDL-2023 LIBRARY; T=0.K  
angular distribution for (n,n\*14)

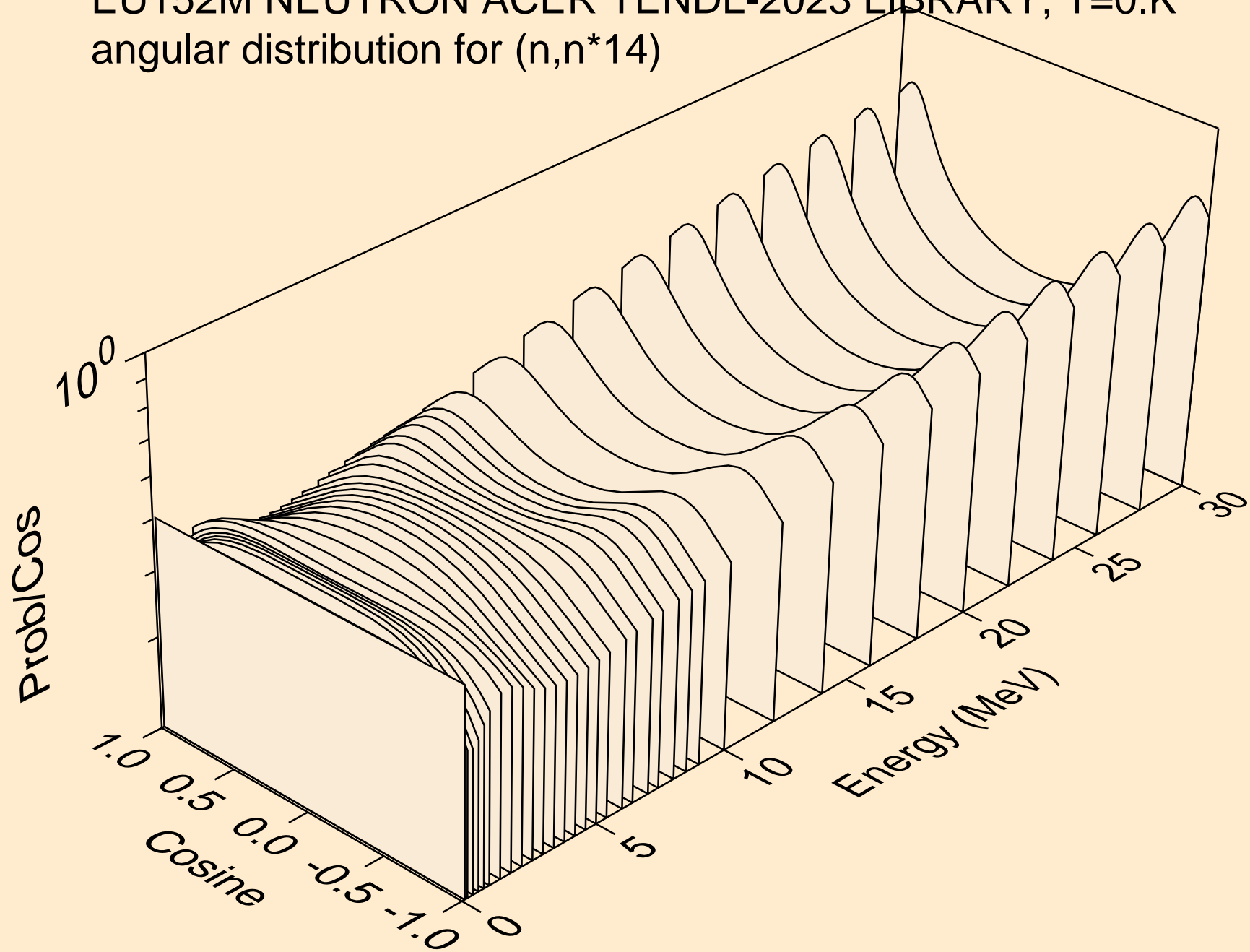

EU152M NEUTRON ACER TENDL-2023 LIBRARY; T=0.K  
angular distribution for (n,n\*15)

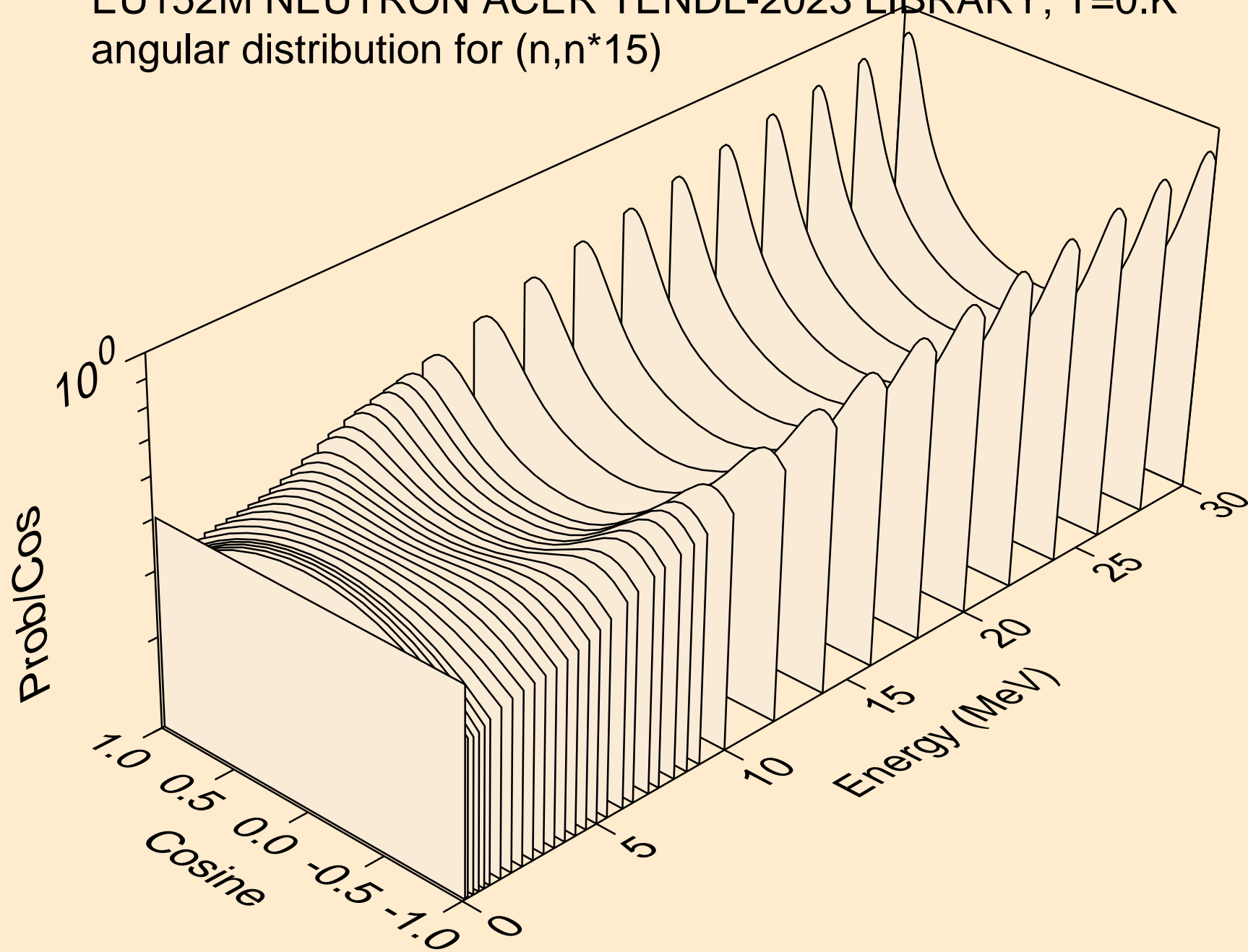

EU152M NEUTRON ACER TENDL-2023 LIBRARY; T=0.K  
Neutron emission for (n,x)

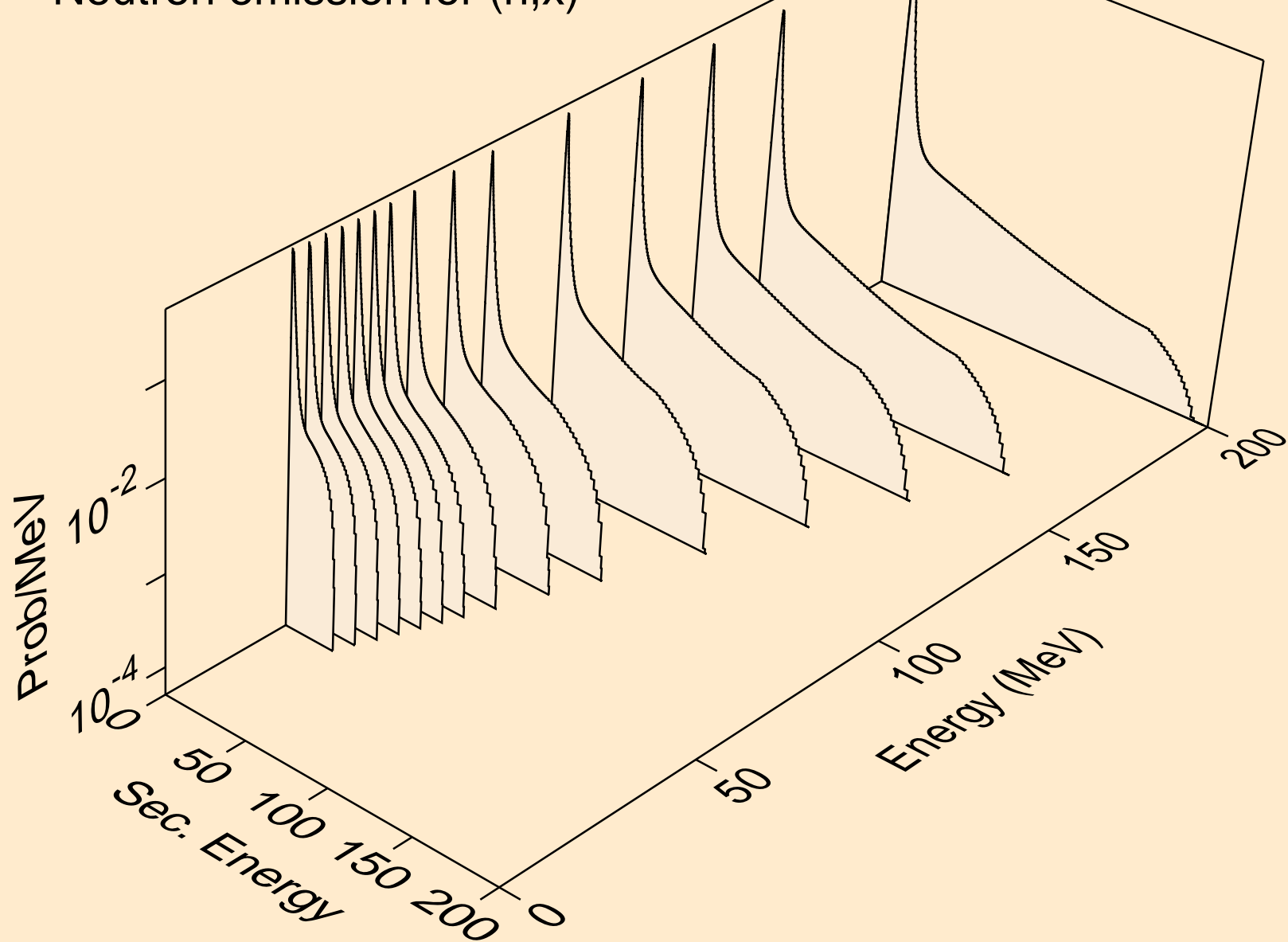

EU152M NEUTRON ACER TENDL-2023 LIBRARY; T=0.K  
Neutron emission for (n,2nd)

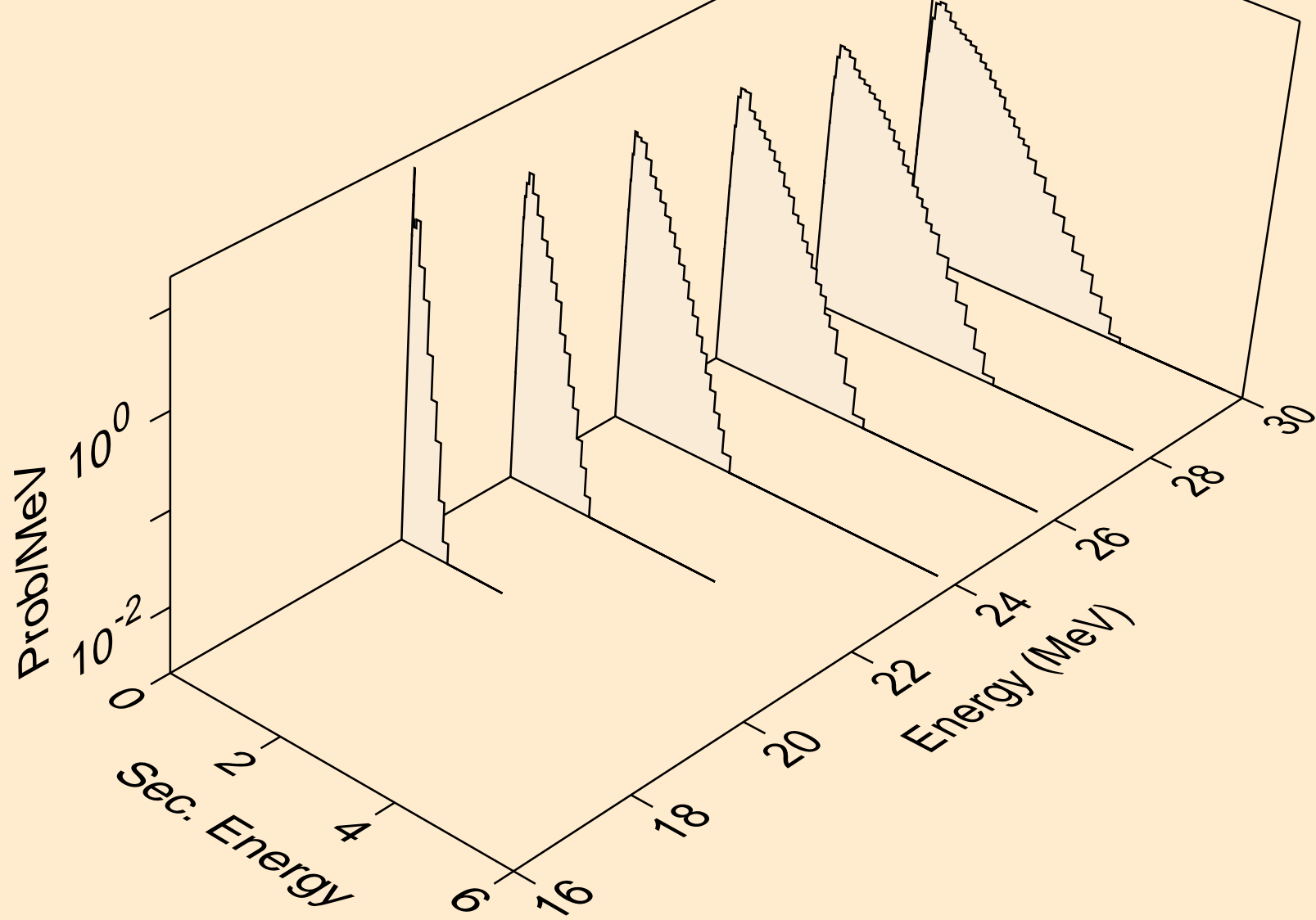

EU152M NEUTRON ACER TENDL-2023 LIBRARY; T=0.K  
Neutron emission for (n,2n)

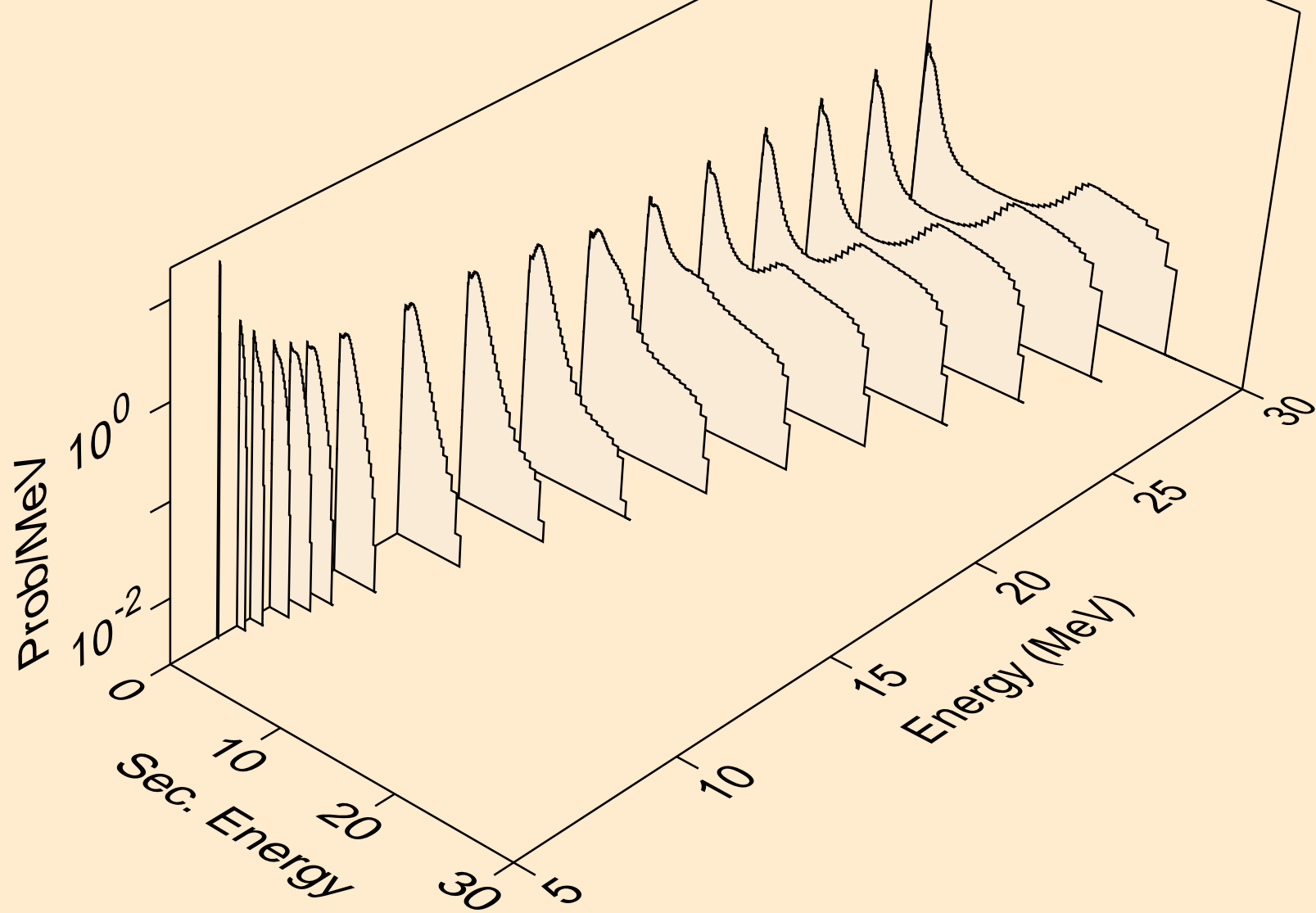

EU152M NEUTRON ACER TENDL-2023 LIBRARY; T=0.K  
Neutron emission for (n,3n)

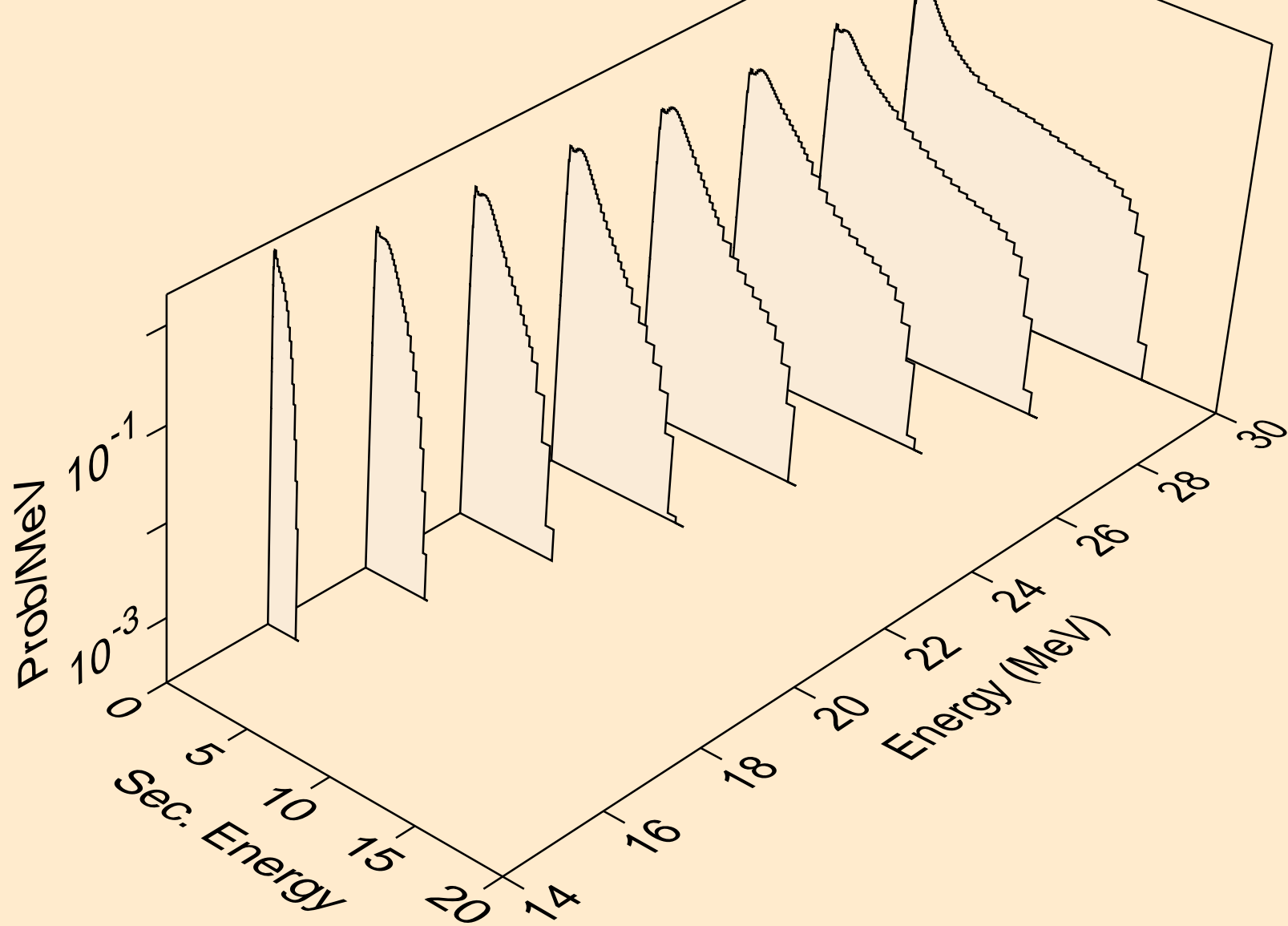

EU152M NEUTRON ACER TENDL-2023 LIBRARY; T=0.K  
Neutron emission for (n,n\*)a

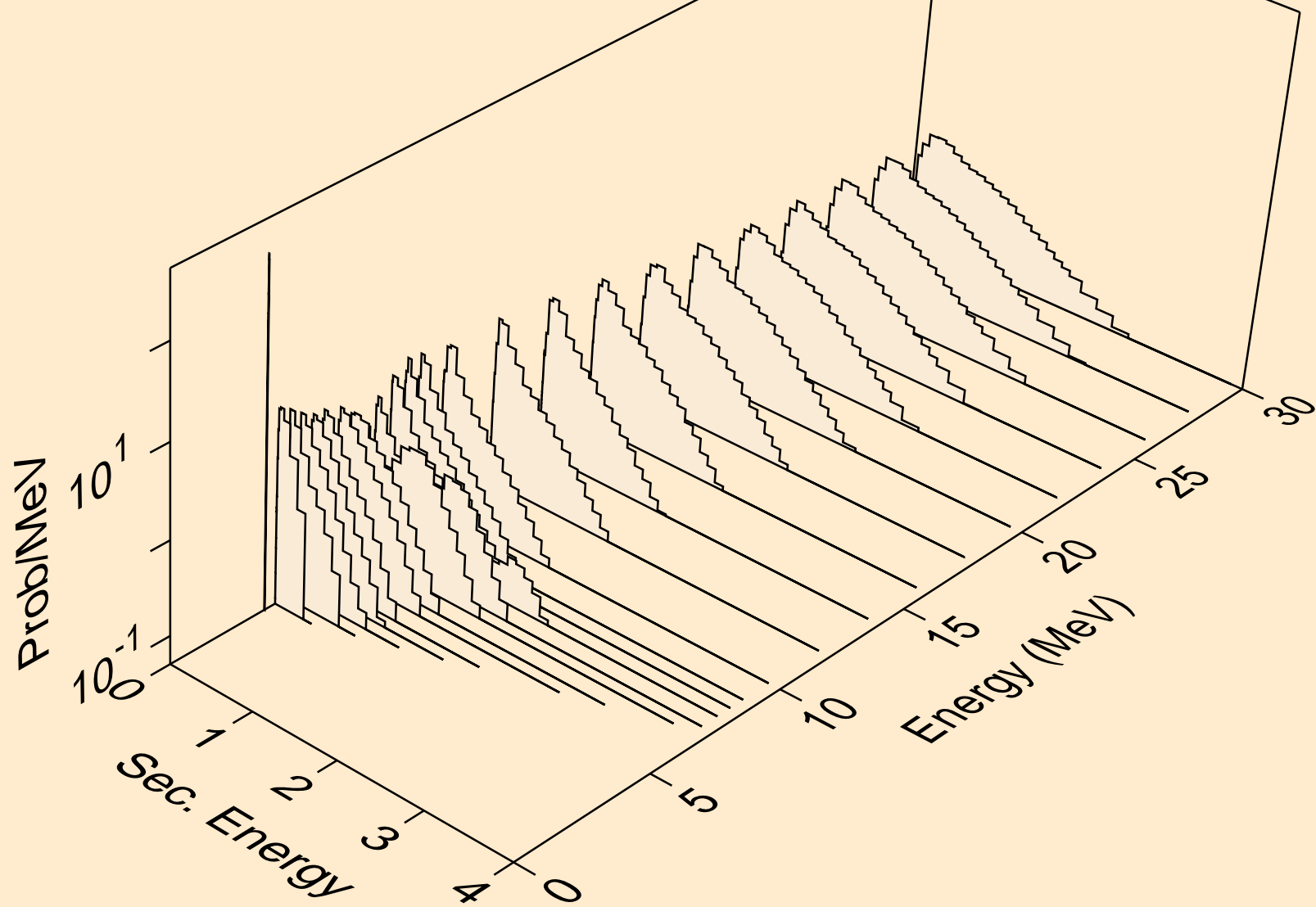

EU152M NEUTRON ACER TENDL-2023 LIBRARY; T=0.K  
Neutron emission for (n,2n)a

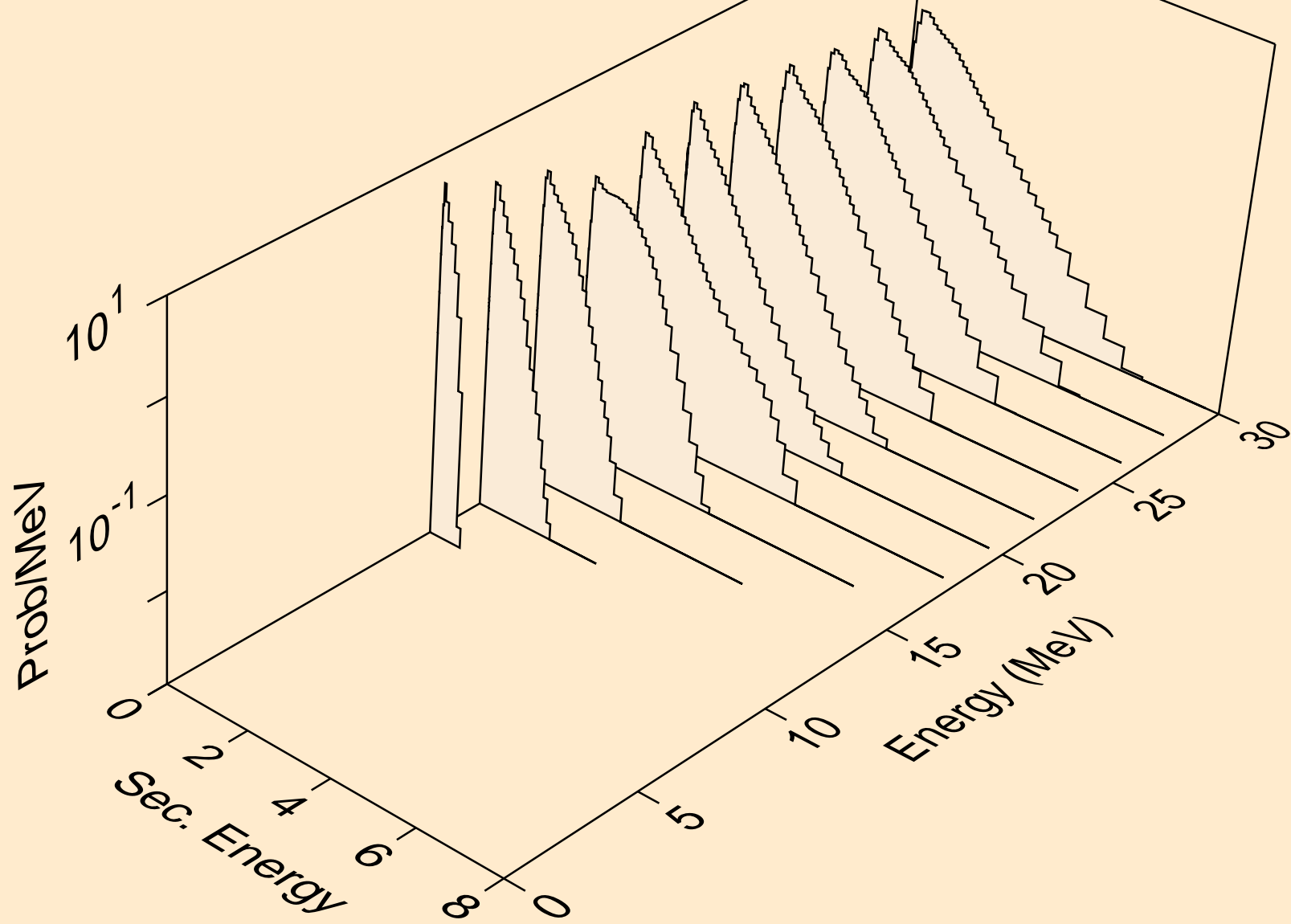

EU152M NEUTRON ACER TENDL-2023 LIBRARY; T=0.K  
Neutron emission for (n,3n)a

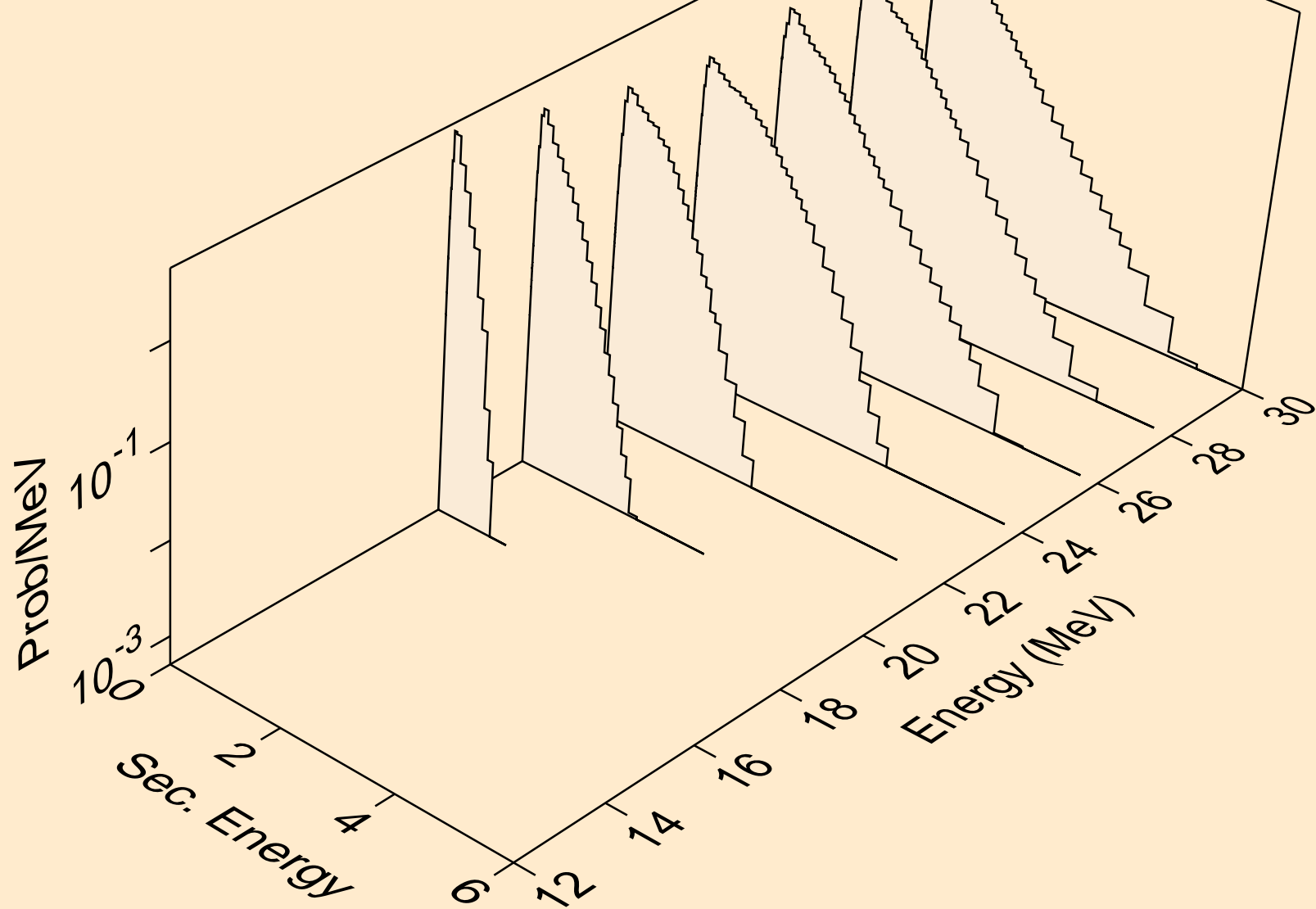

EU152M NEUTRON ACER TENDL-2023 LIBRARY; T=0.K  
Neutron emission for (n,n\*)p

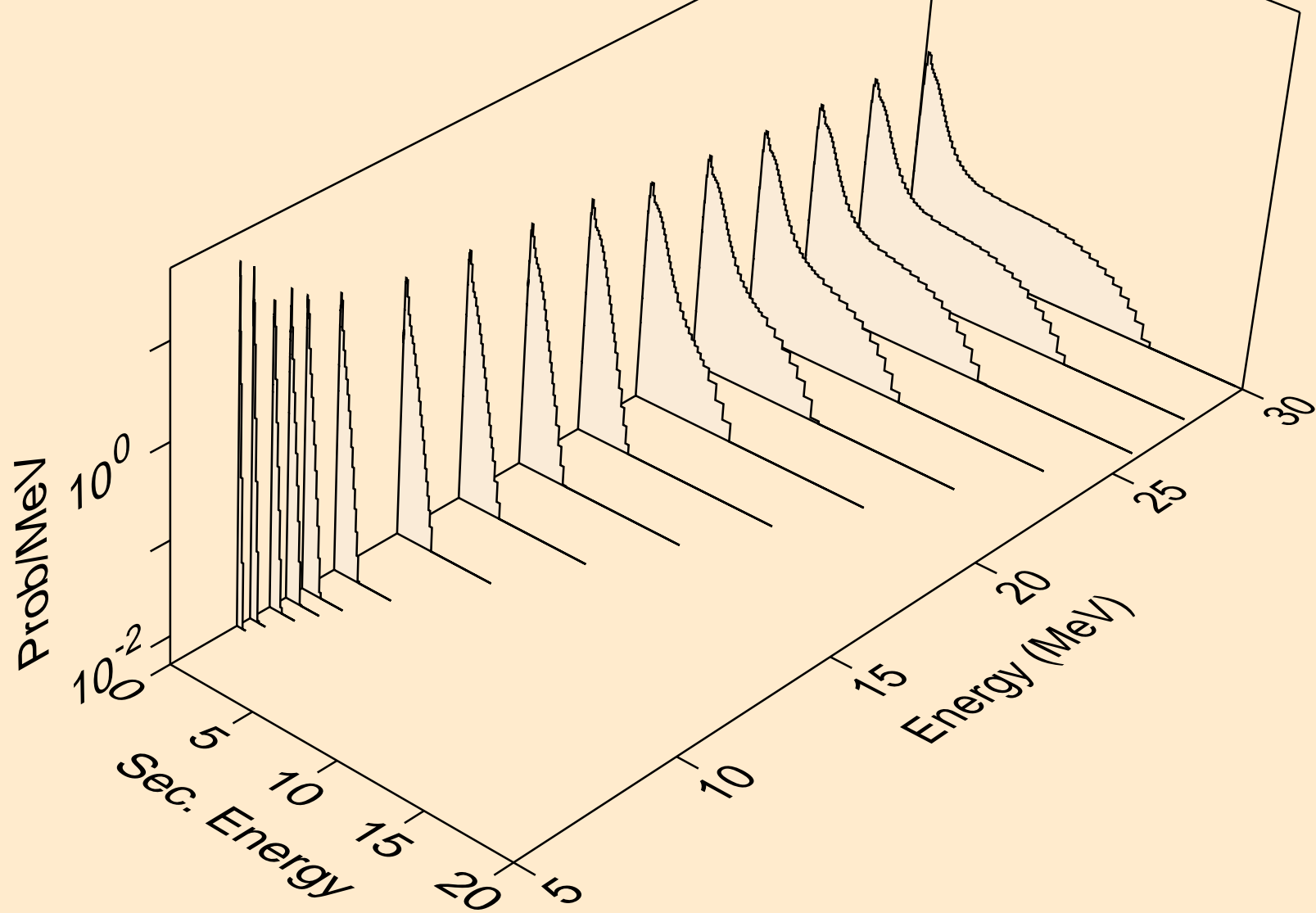

EU152M NEUTRON ACER TENDL-2023 LIBRARY; T=0.K  
Neutron emission for (n,n\*)2a

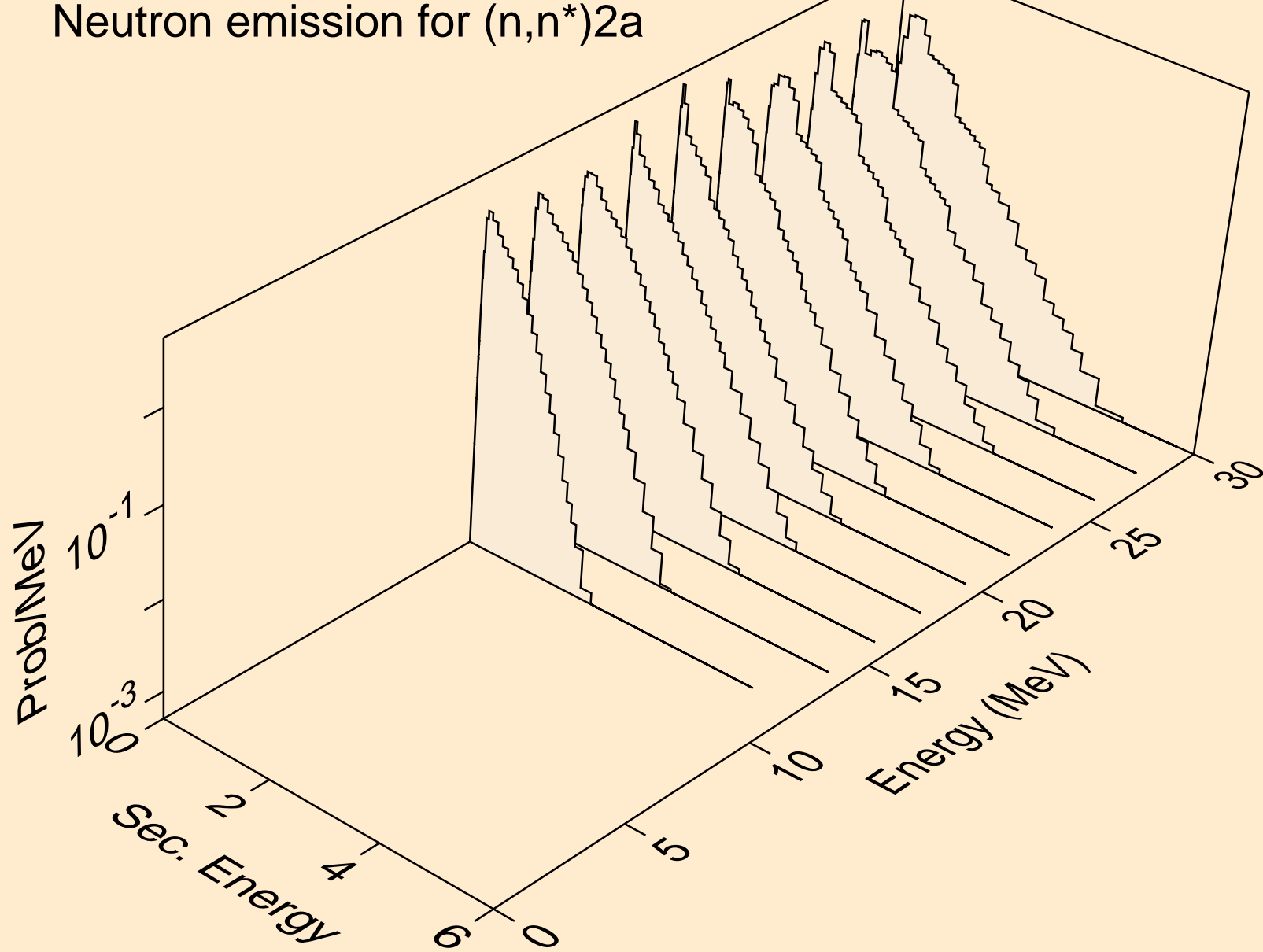

EU152M NEUTRON ACER TENDL-2023 LIBRARY; T=0.K  
Neutron emission for (n,2n)2a

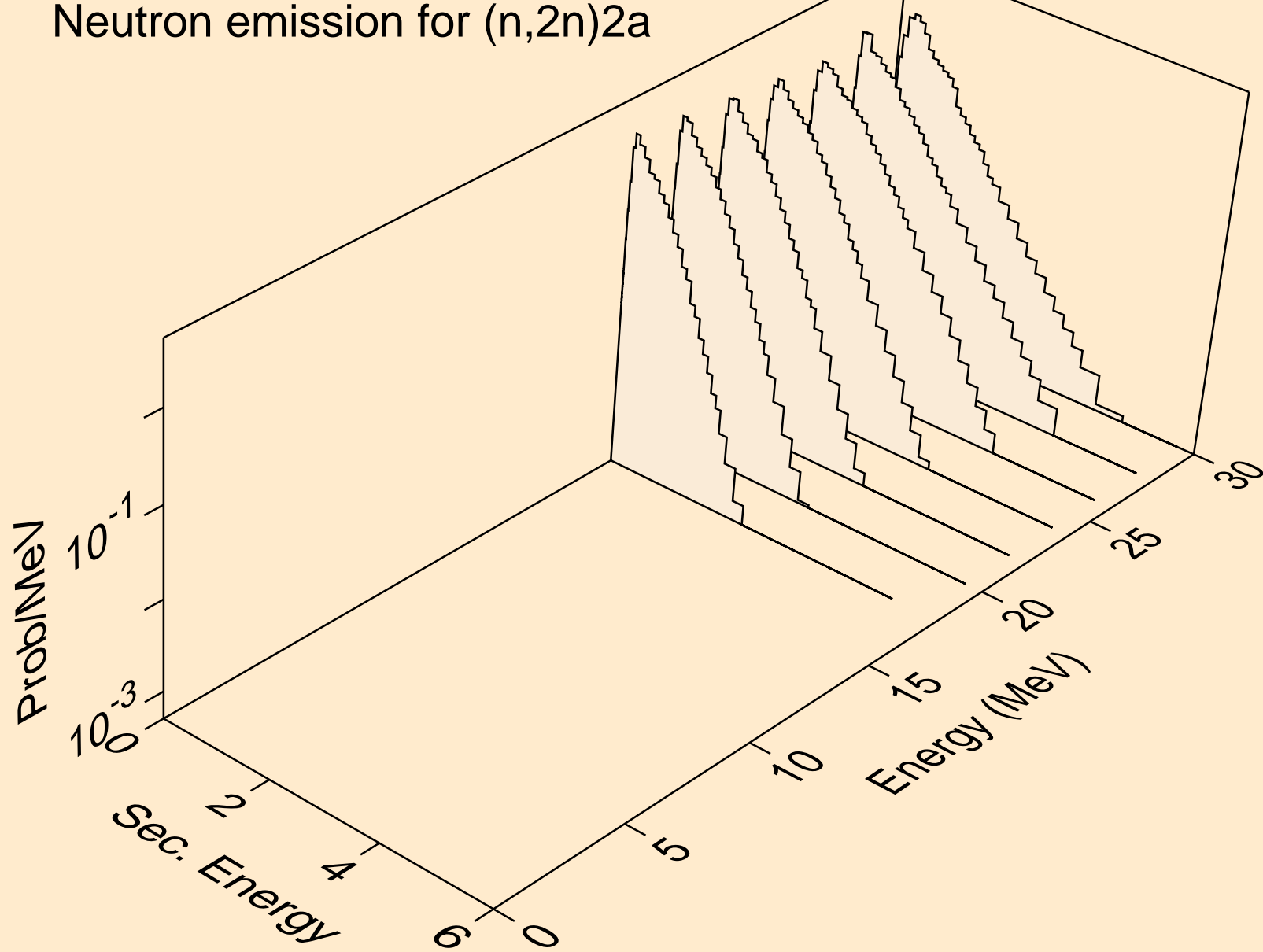

EU152M NEUTRON ACER TENDL-2023 LIBRARY; T=0.K  
Neutron emission for (n,n\*)d

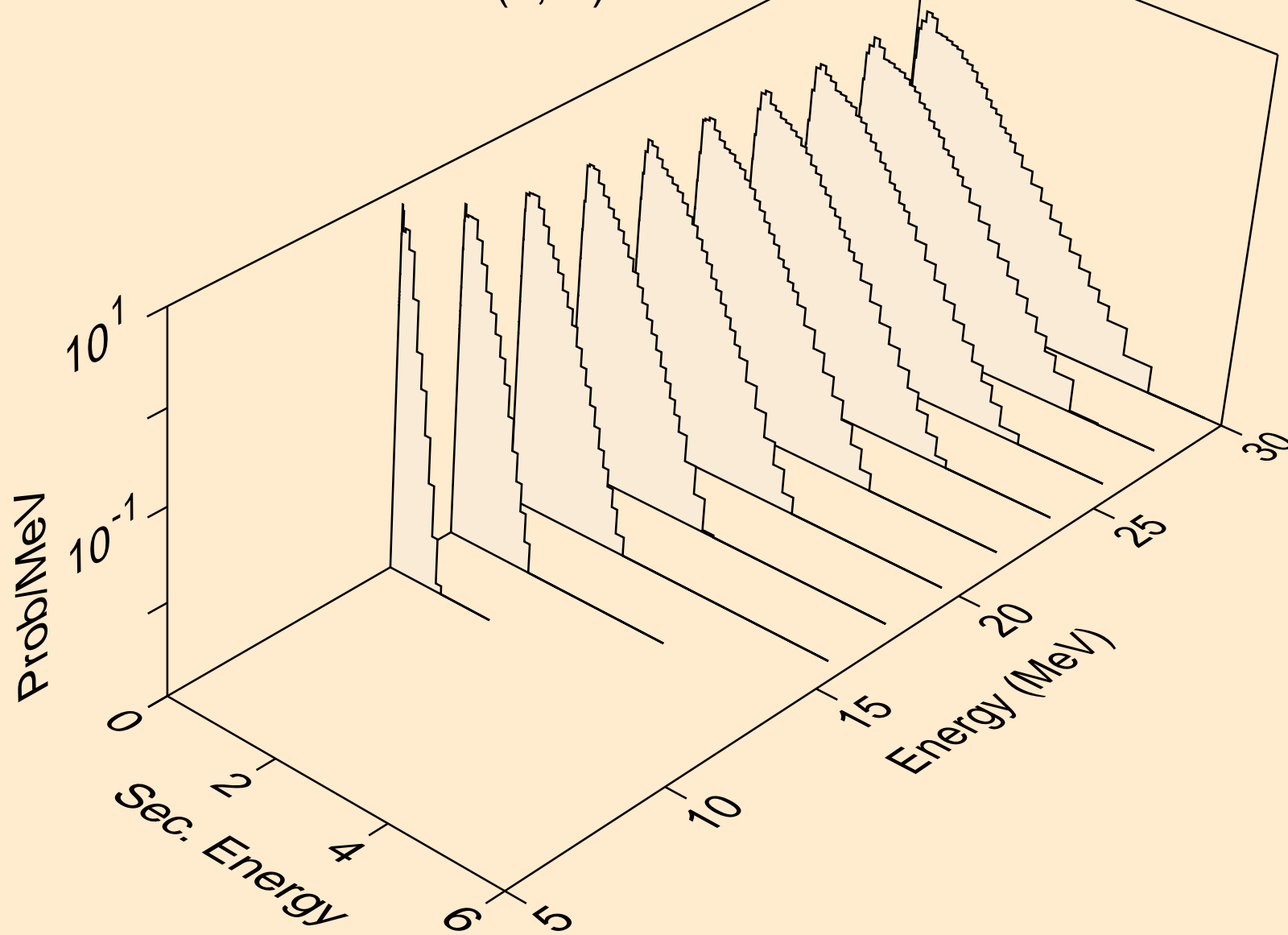

EU152M NEUTRON ACER TENDL-2023 LIBRARY; T=0.K  
Neutron emission for (n,n\*)t

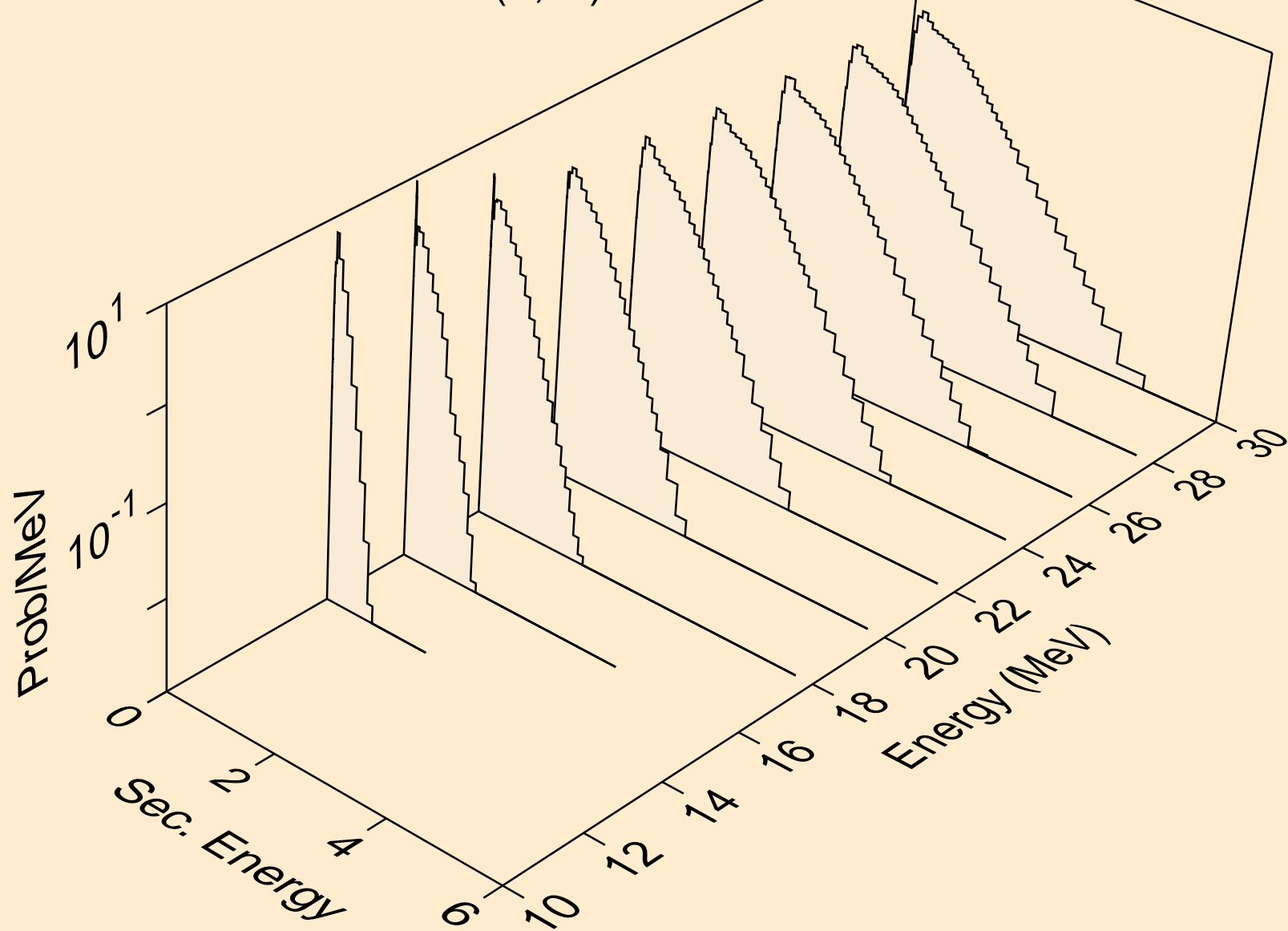

EU152M NEUTRON ACER TENDL-2023 LIBRARY; T=0.K  
Neutron emission for (n,n\*)he3

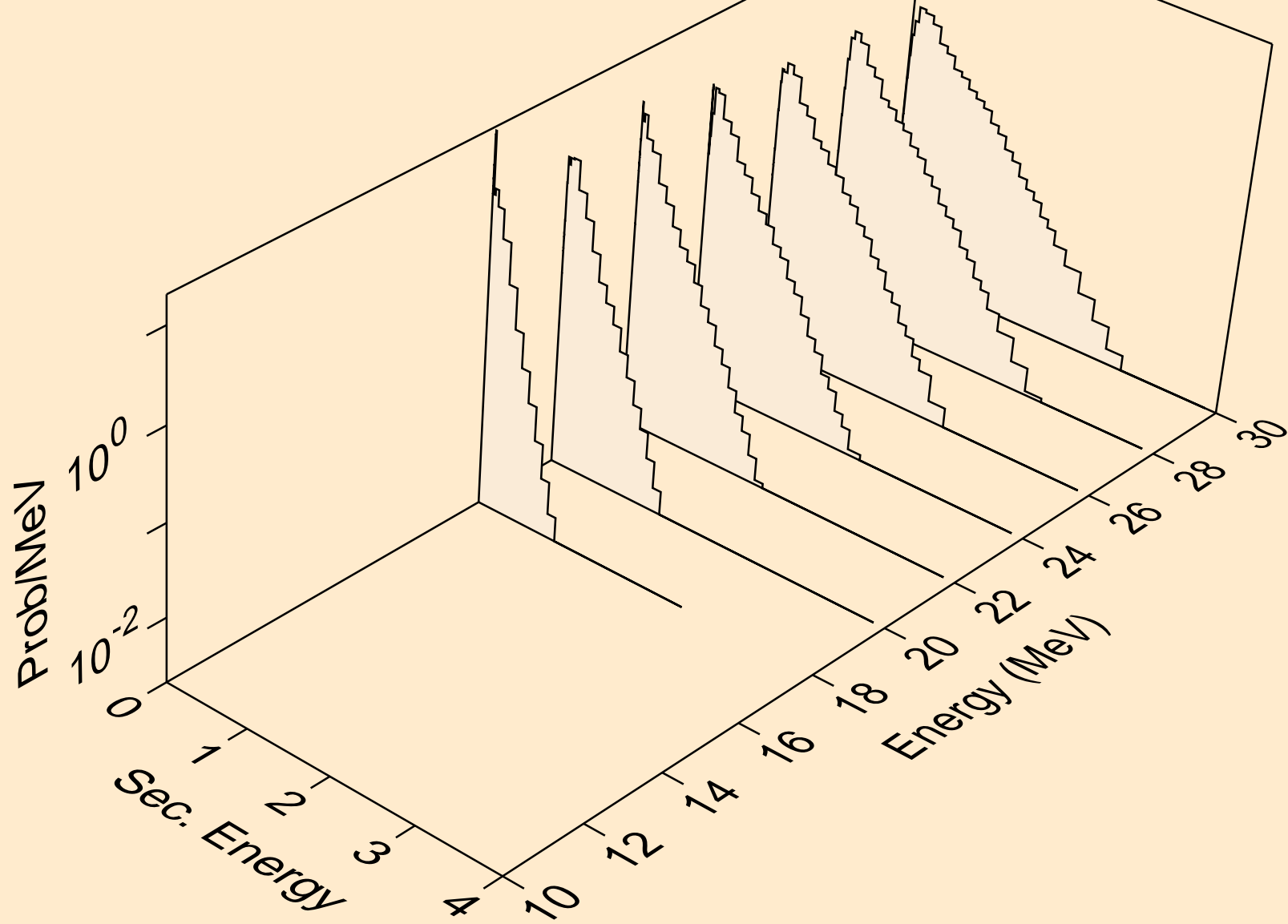

EU152M NEUTRON ACER TENDL-2023 LIBRARY; T=0.K  
Neutron emission for (n,4n)

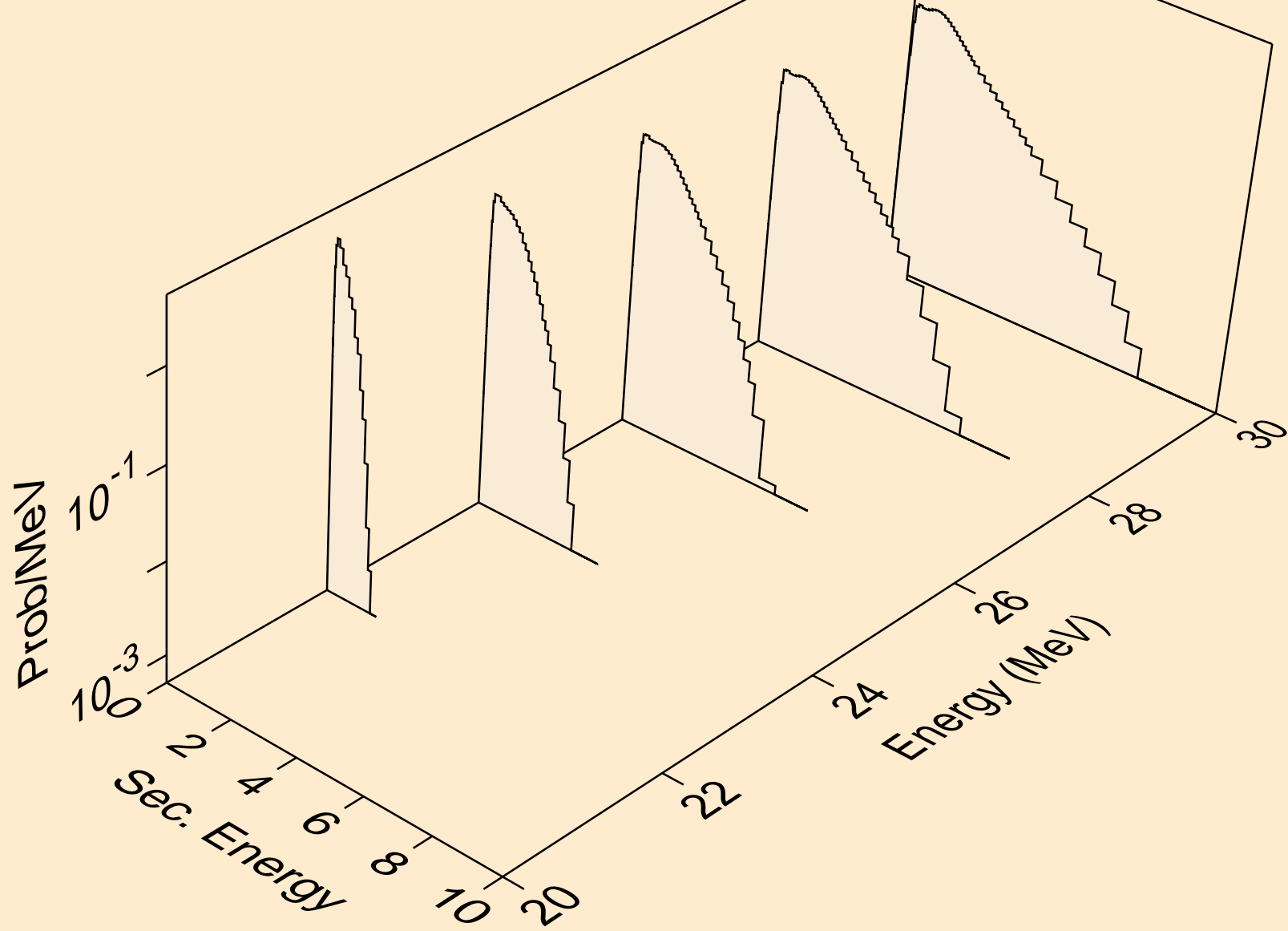

EU152M NEUTRON ACER TENDL-2023 LIBRARY; T=0.K  
Neutron emission for (n,2np)

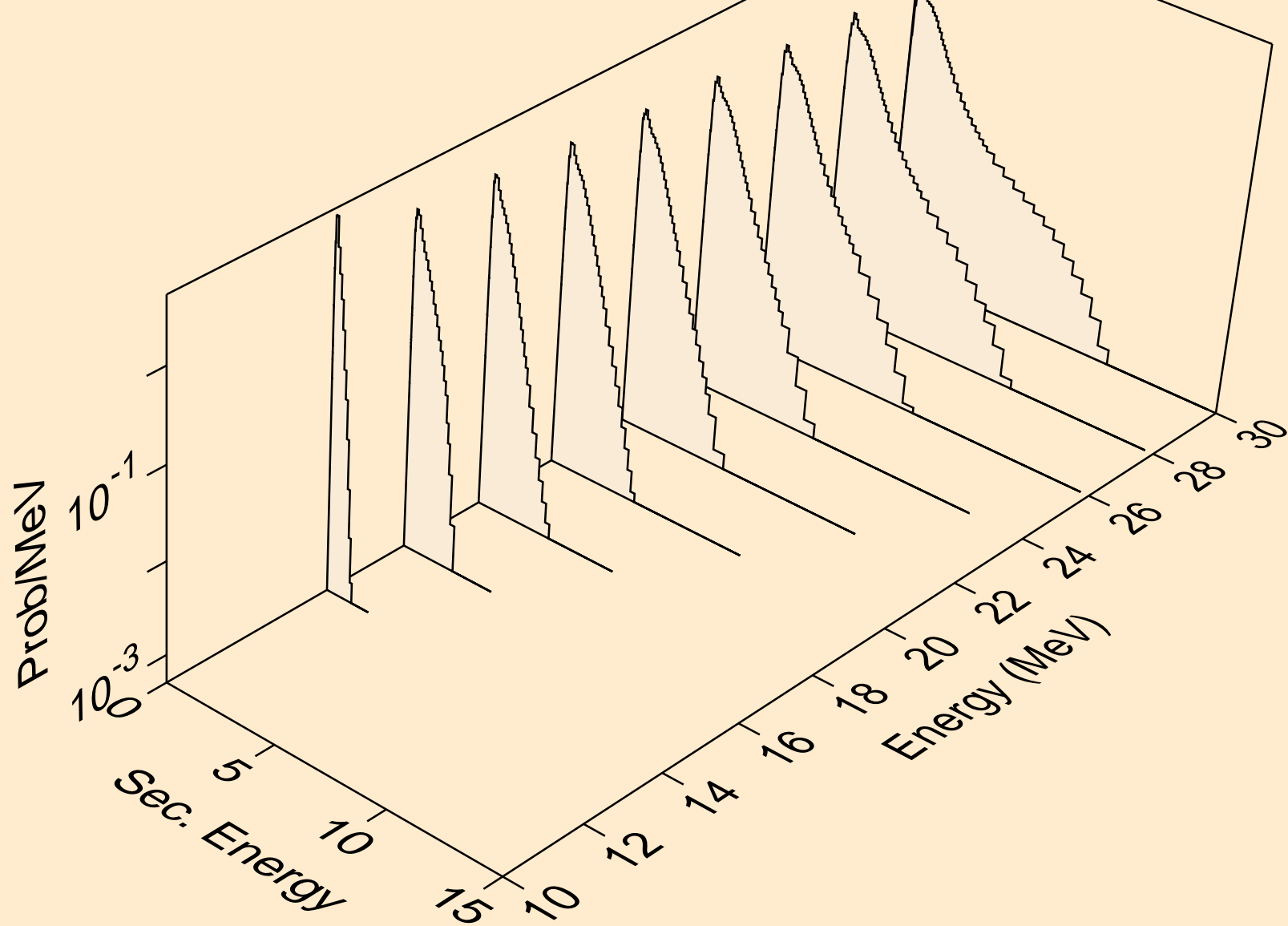

EU152M NEUTRON ACER TENDL-2023 LIBRARY; T=0.K  
Neutron emission for (n,3np)

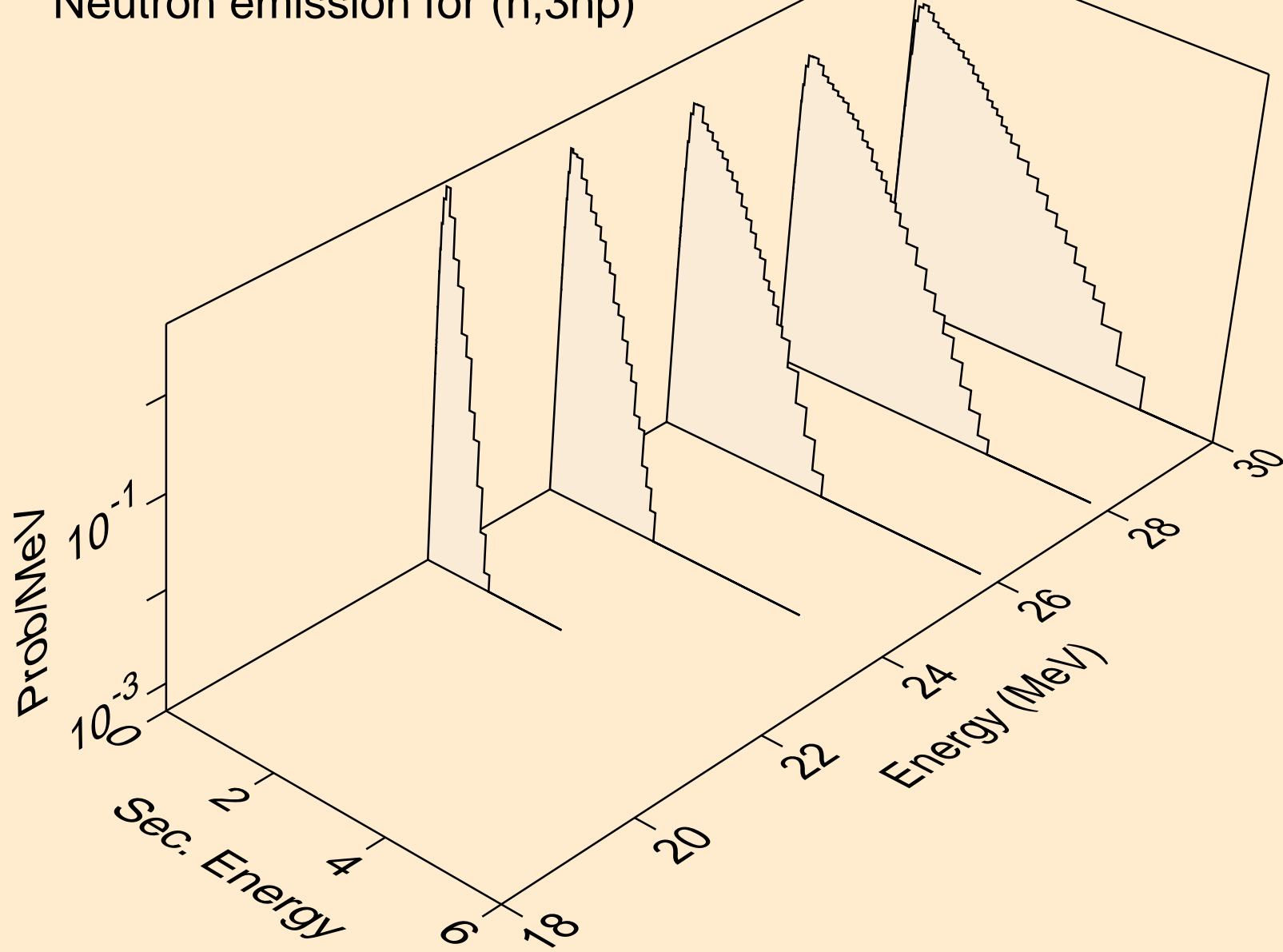

EU152M NEUTRON ACER TENDL-2023 LIBRARY; T=0.K  
Neutron emission for (n,n2p)

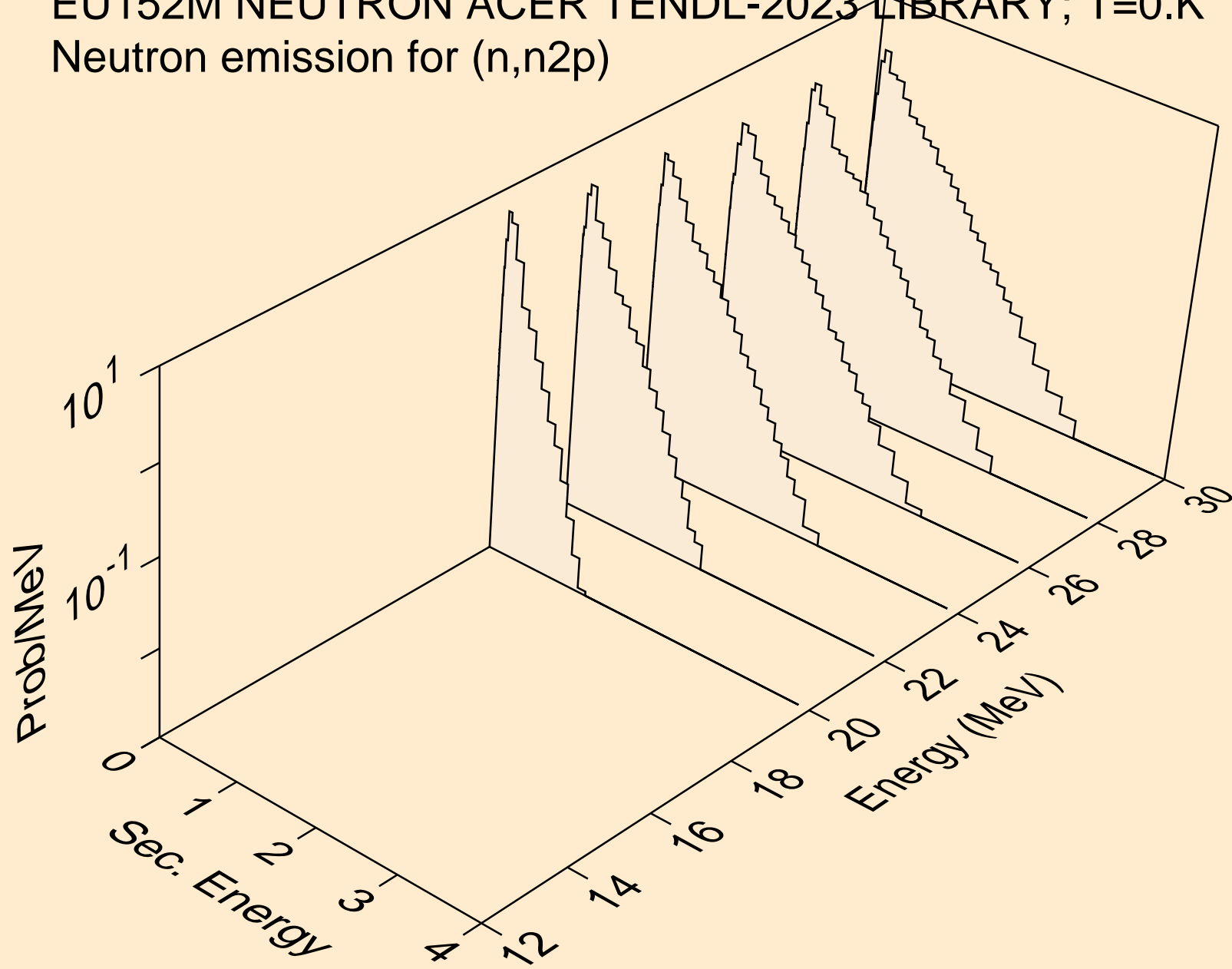

EU152M NEUTRON ACER TENDL-2023 LIBRARY; T=0.K  
Neutron emission for (n,npa)

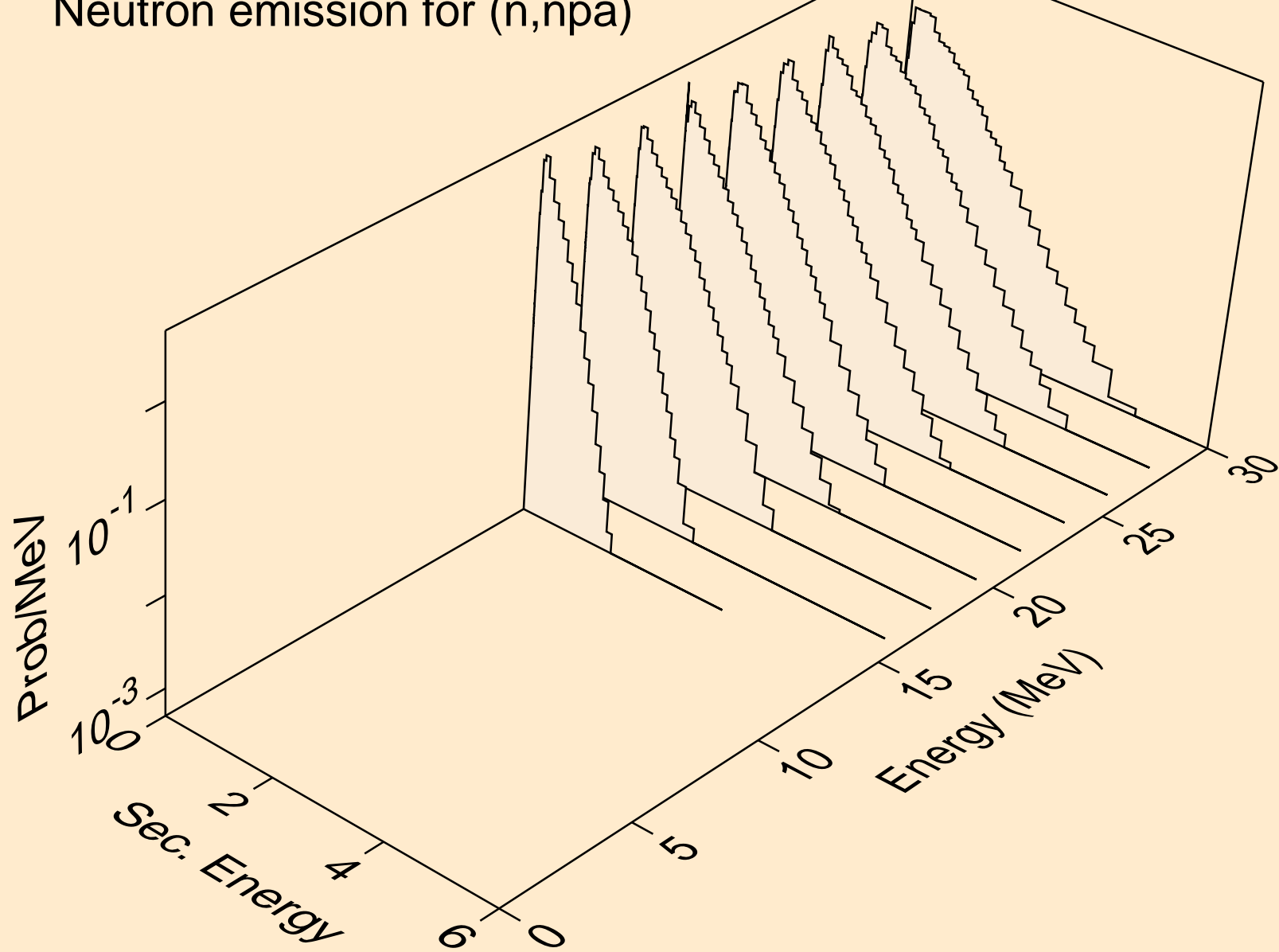

EU152M NEUTRON ACER TENDL-2023 LIBRARY; T=0.K  
Neutron emission for (n,n\*c)

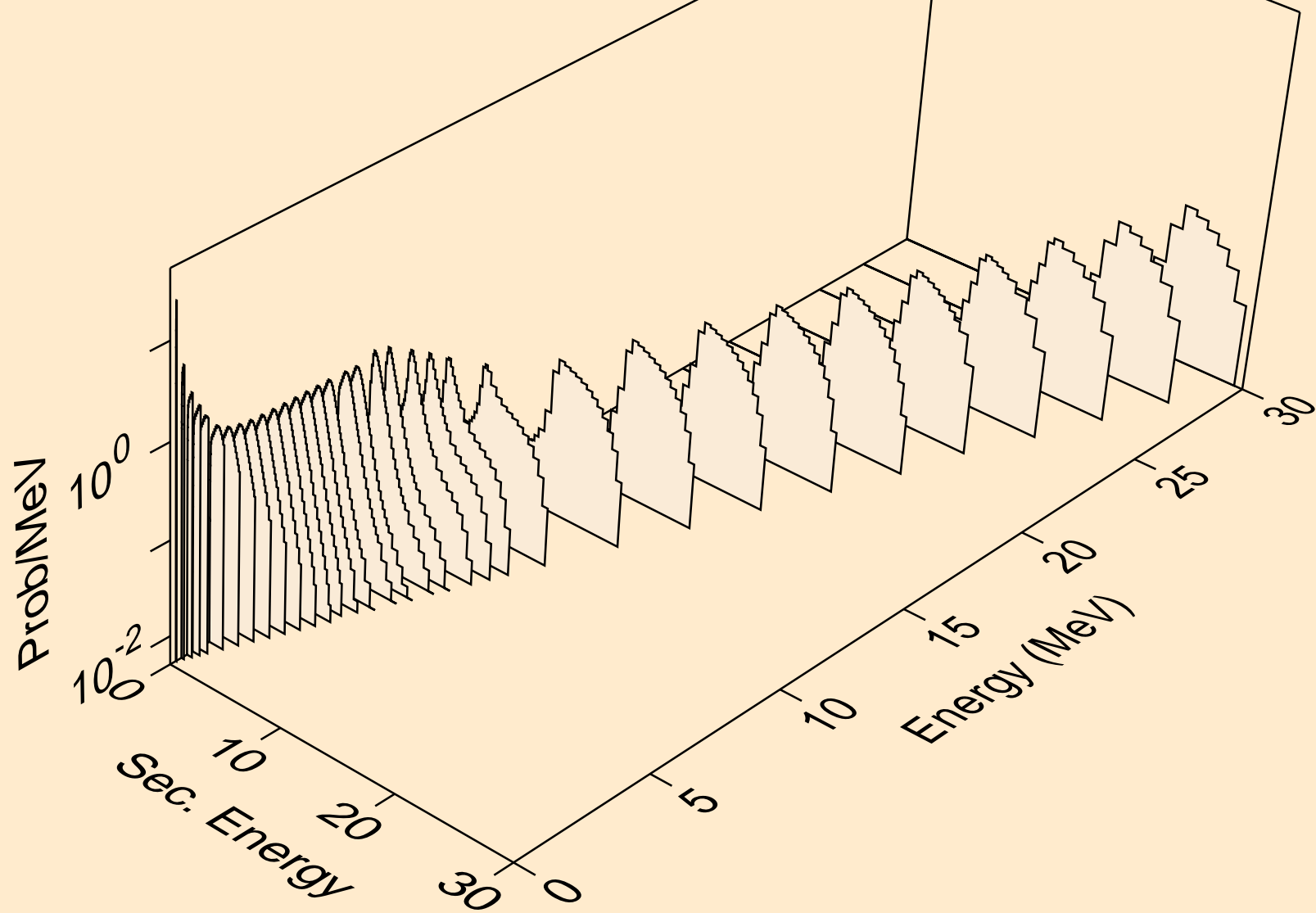

EU152M NEUTRON ACER TENDL-2023 LIBRARY; T=0.K  
Photon emission for (n,x)

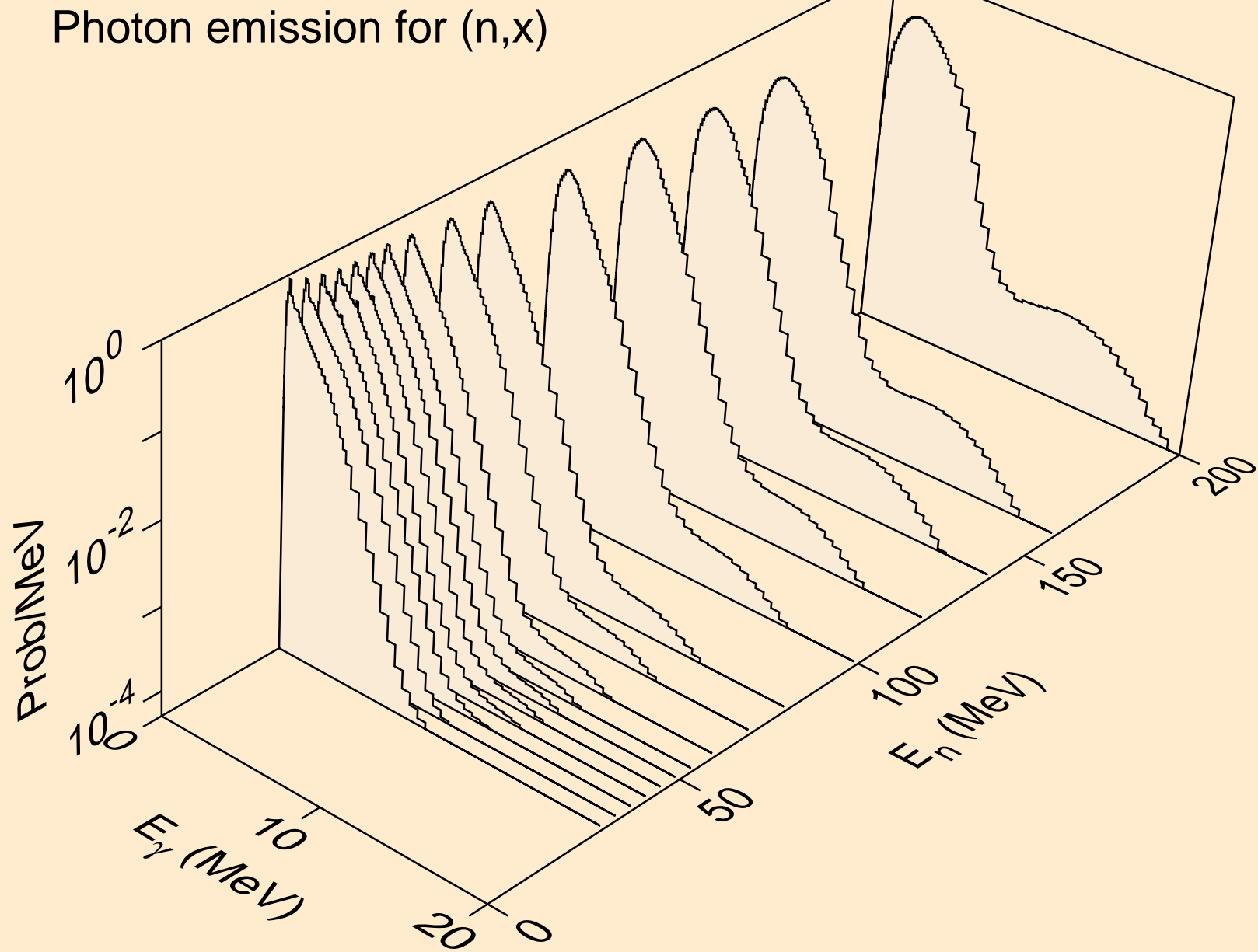

EU152M NEUTRON ACER TENDL-2023 LIBRARY; T=0.K  
Photon emission for (n,2nd)

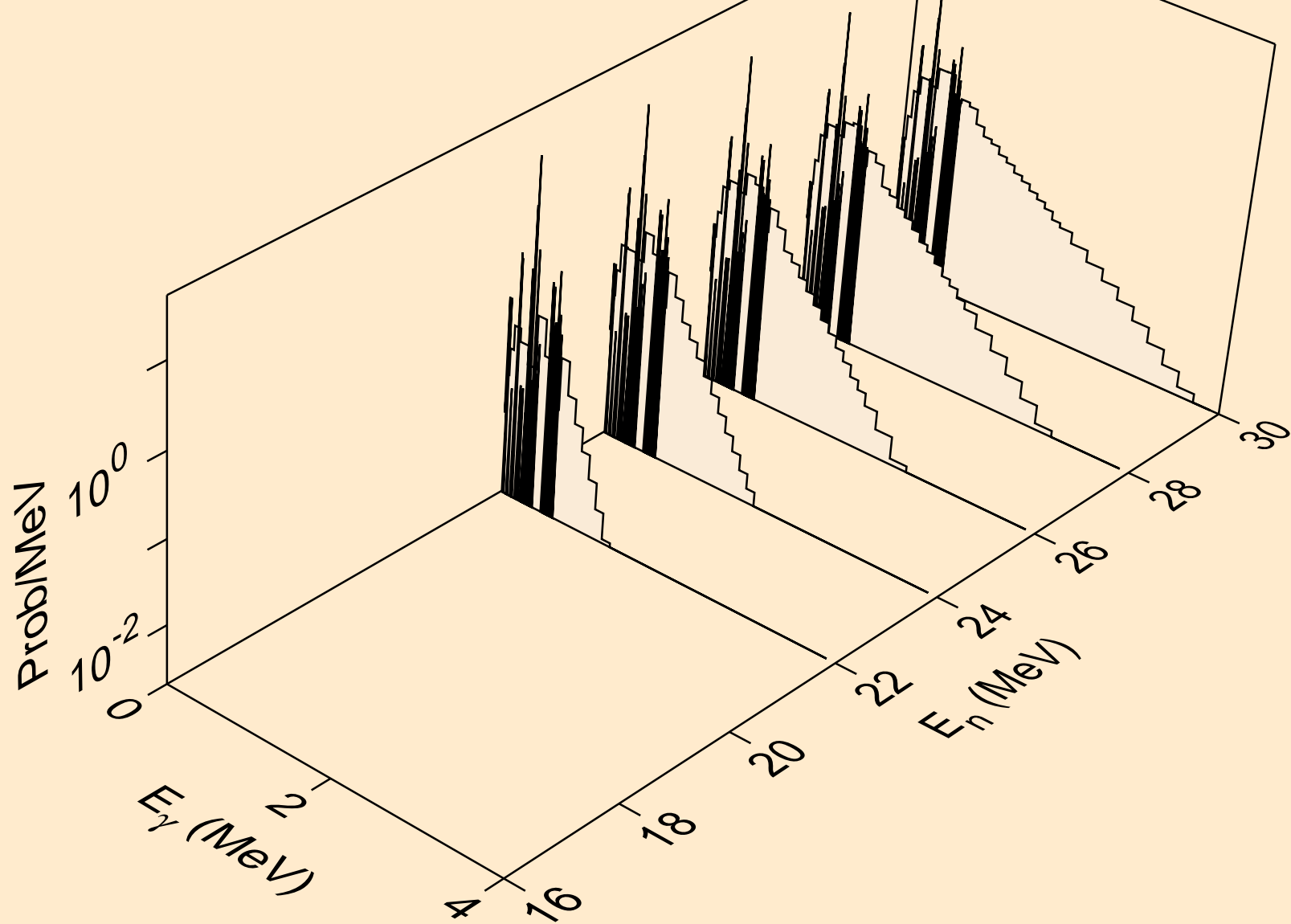

EU152M NEUTRON ACER TENDL-2023 LIBRARY; T=0.K  
Photon emission for (n,2n)

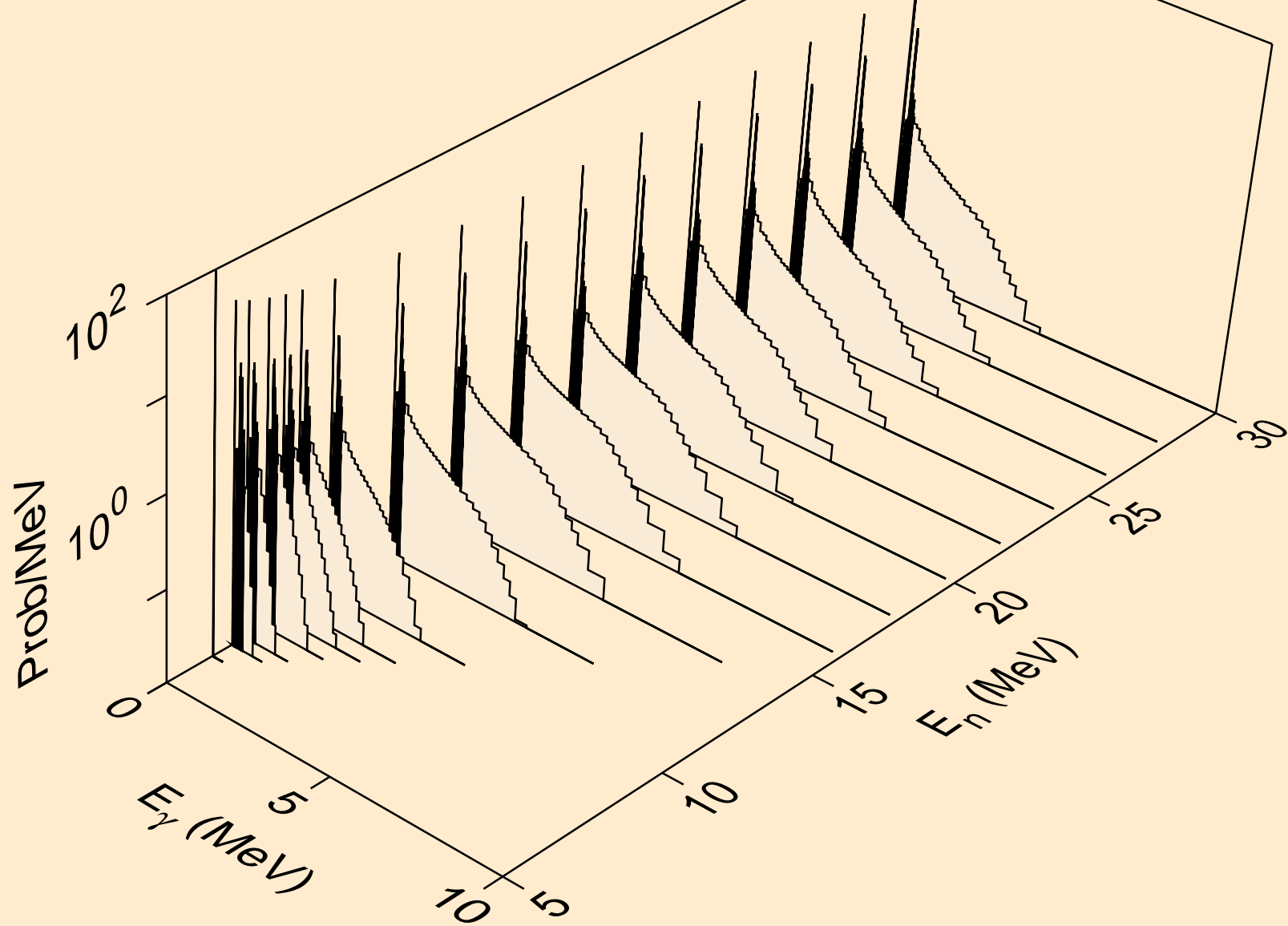

EU152M NEUTRON ACER TENDL-2023 LIBRARY; T=0.K  
Photon emission for (n,3n)

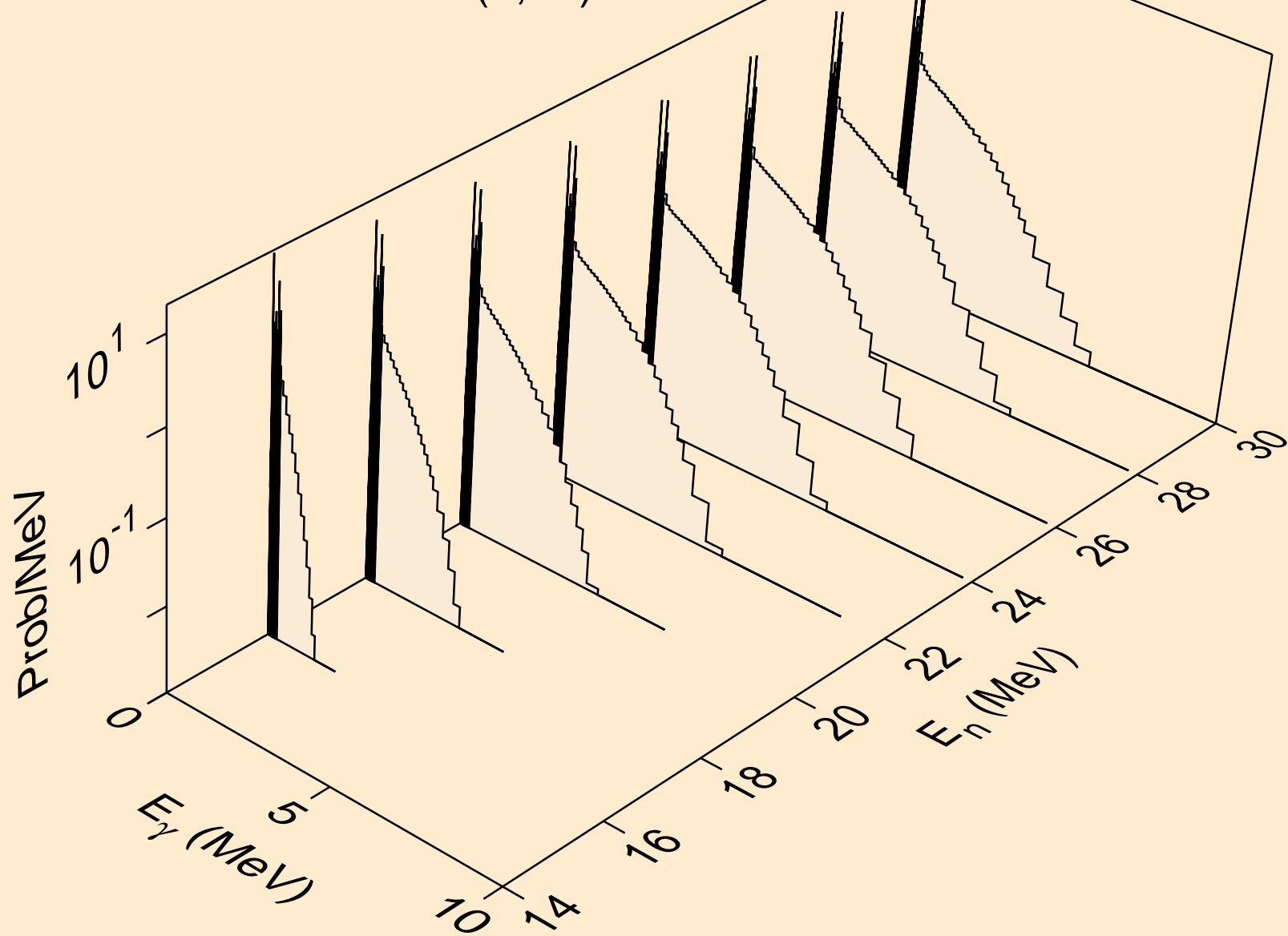

EU152M NEUTRON ACER TENDL-2023 LIBRARY; T=0.K  
Photon emission for (n,n\*)a

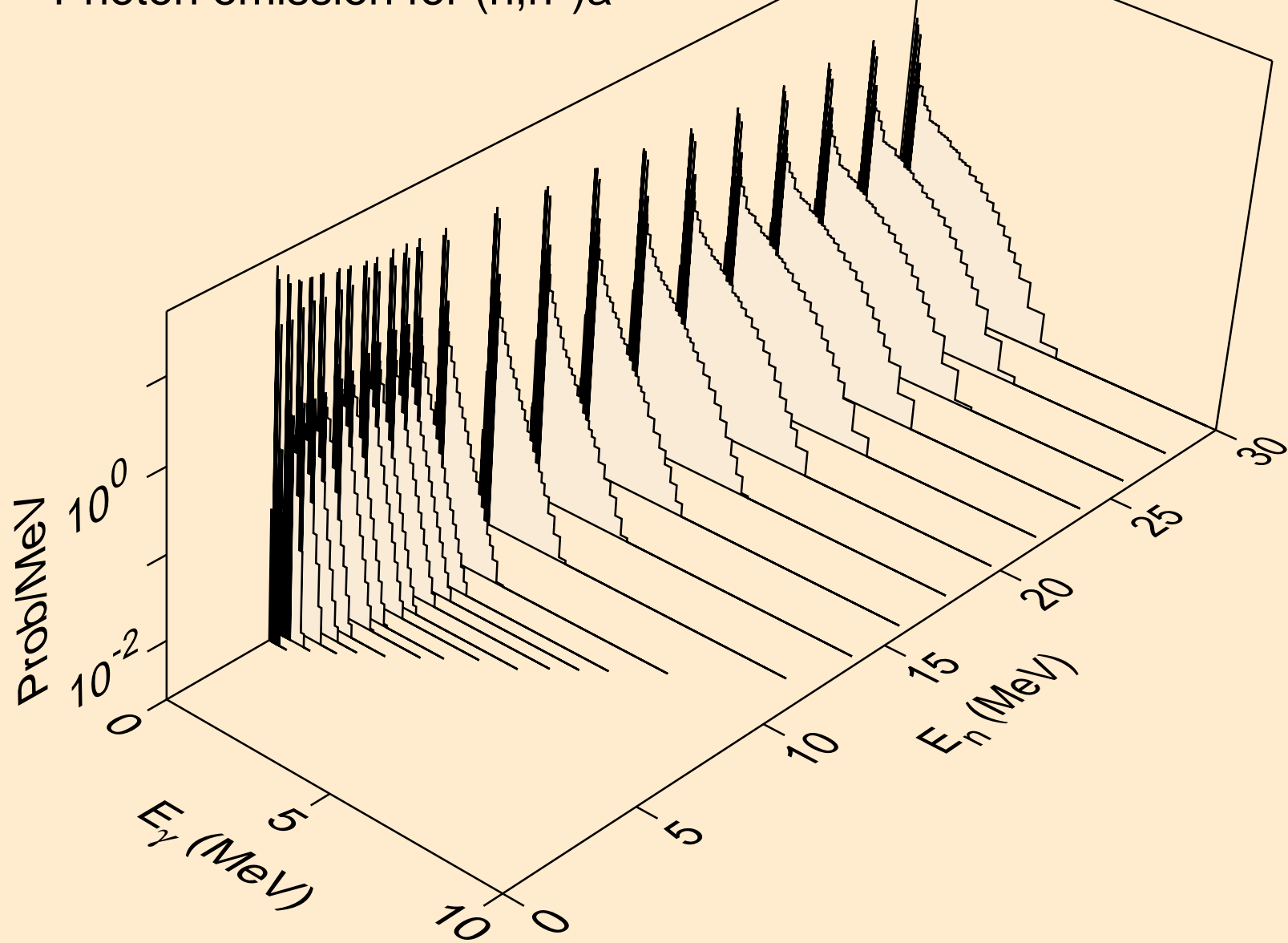

EU152M NEUTRON ACER TENDL-2023 LIBRARY; T=0.K  
Photon emission for (n,2n) $\alpha$

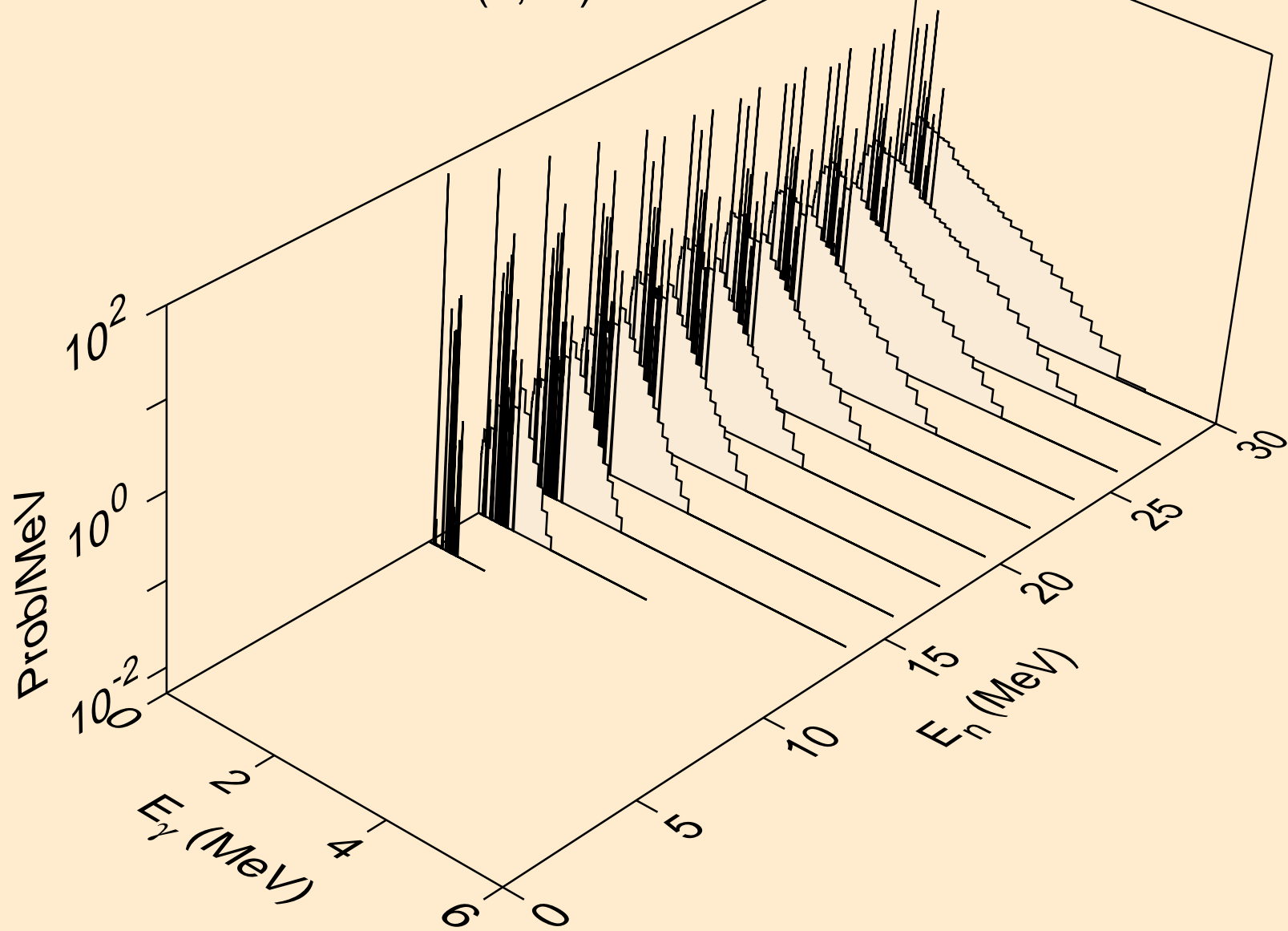

EU152M NEUTRON ACER TENDL-2023 LIBRARY; T=0.K  
Photon emission for (n,3n)a

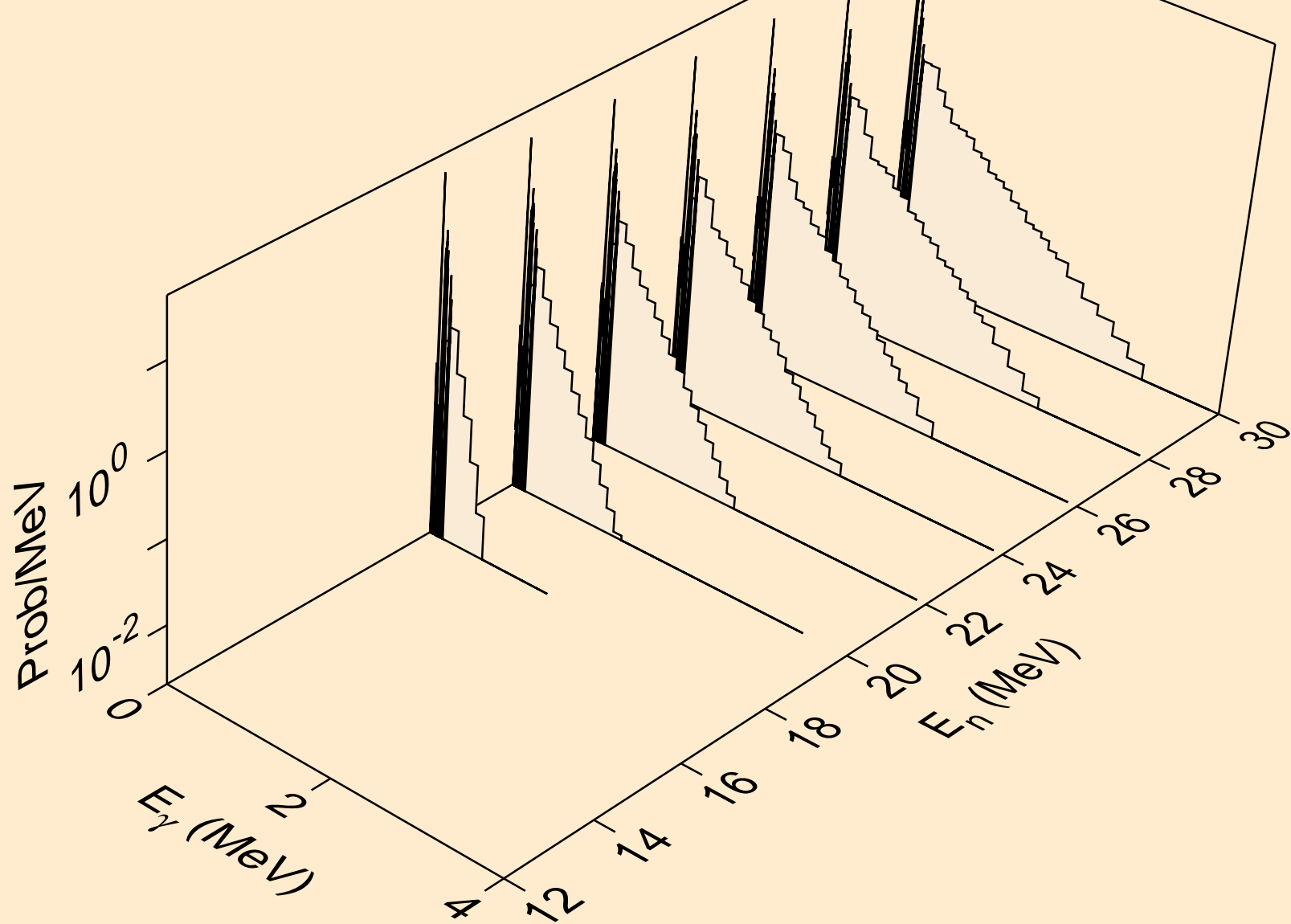

EU152M NEUTRON ACER TENDL-2023 LIBRARY; T=0.K  
Photon emission for (n,n\*)p

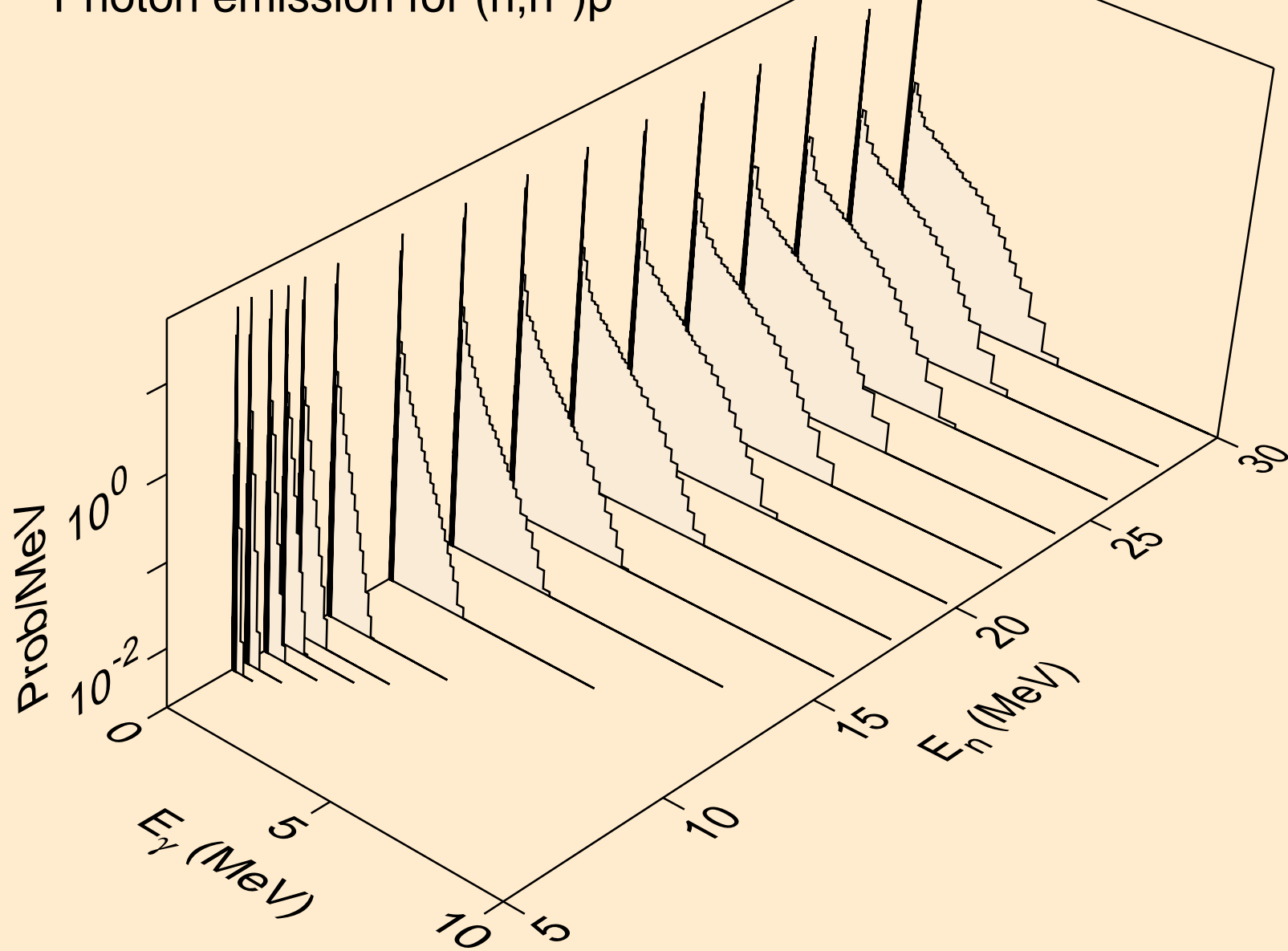

EU152M NEUTRON ACER TENDL-2023 LIBRARY; T=0.K  
Photon emission for (n,n\*)2a

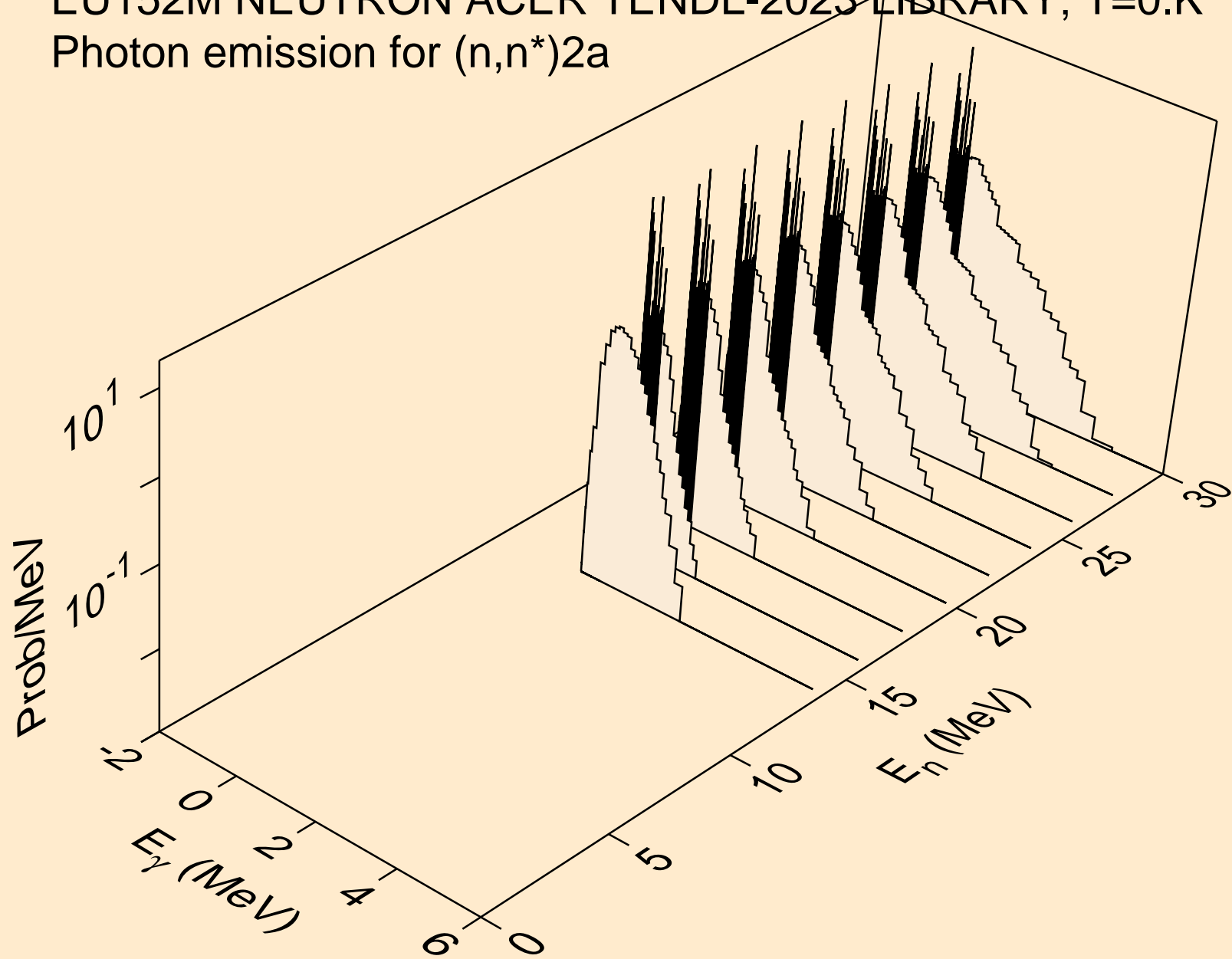

EU152M NEUTRON ACER TENDL-2023 LIBRARY; T=0.K  
Photon emission for (n,2n)2a

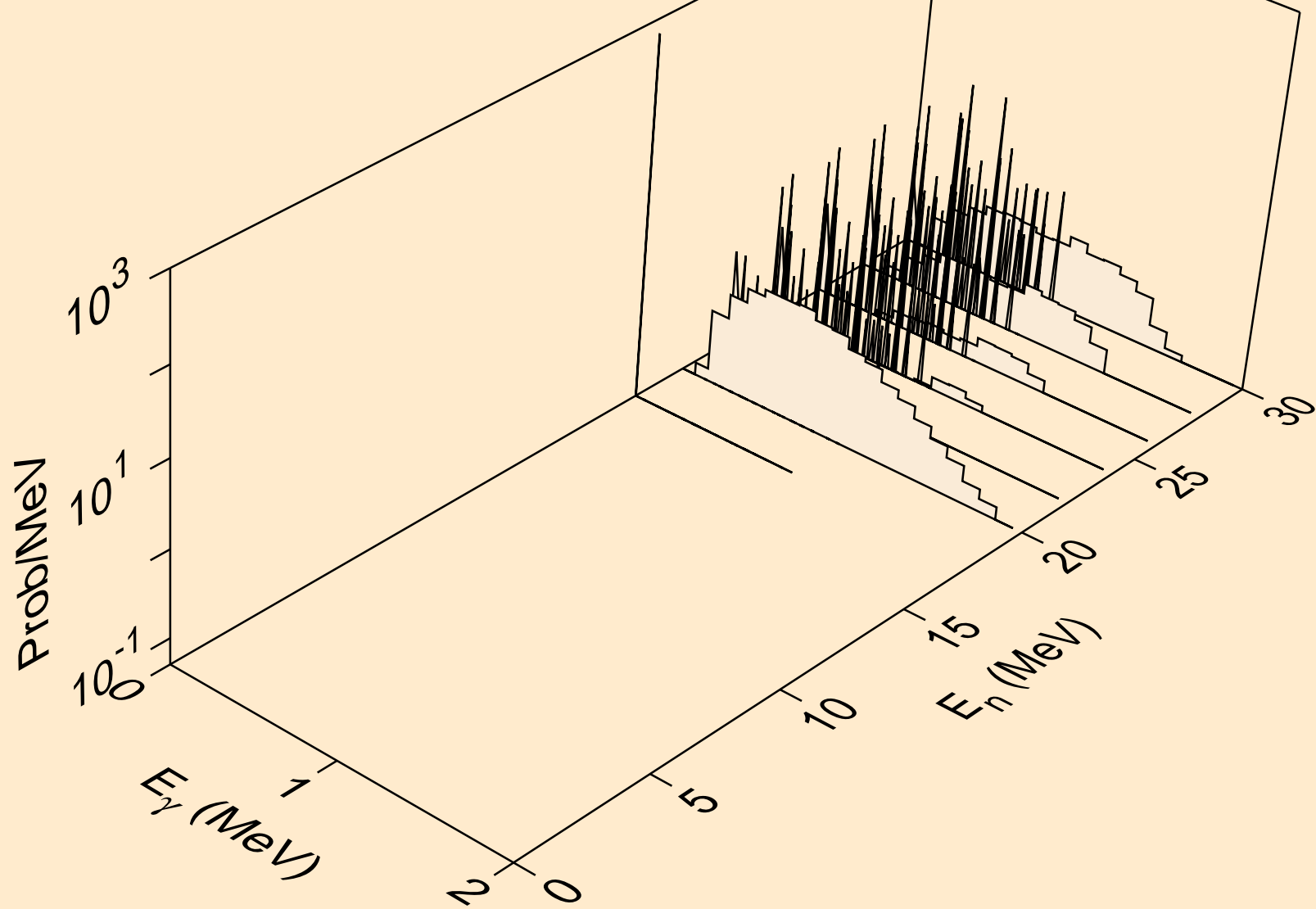

EU152M NEUTRON ACER TENDL-2023 LIBRARY; T=0.K  
Photon emission for (n,n\*)d

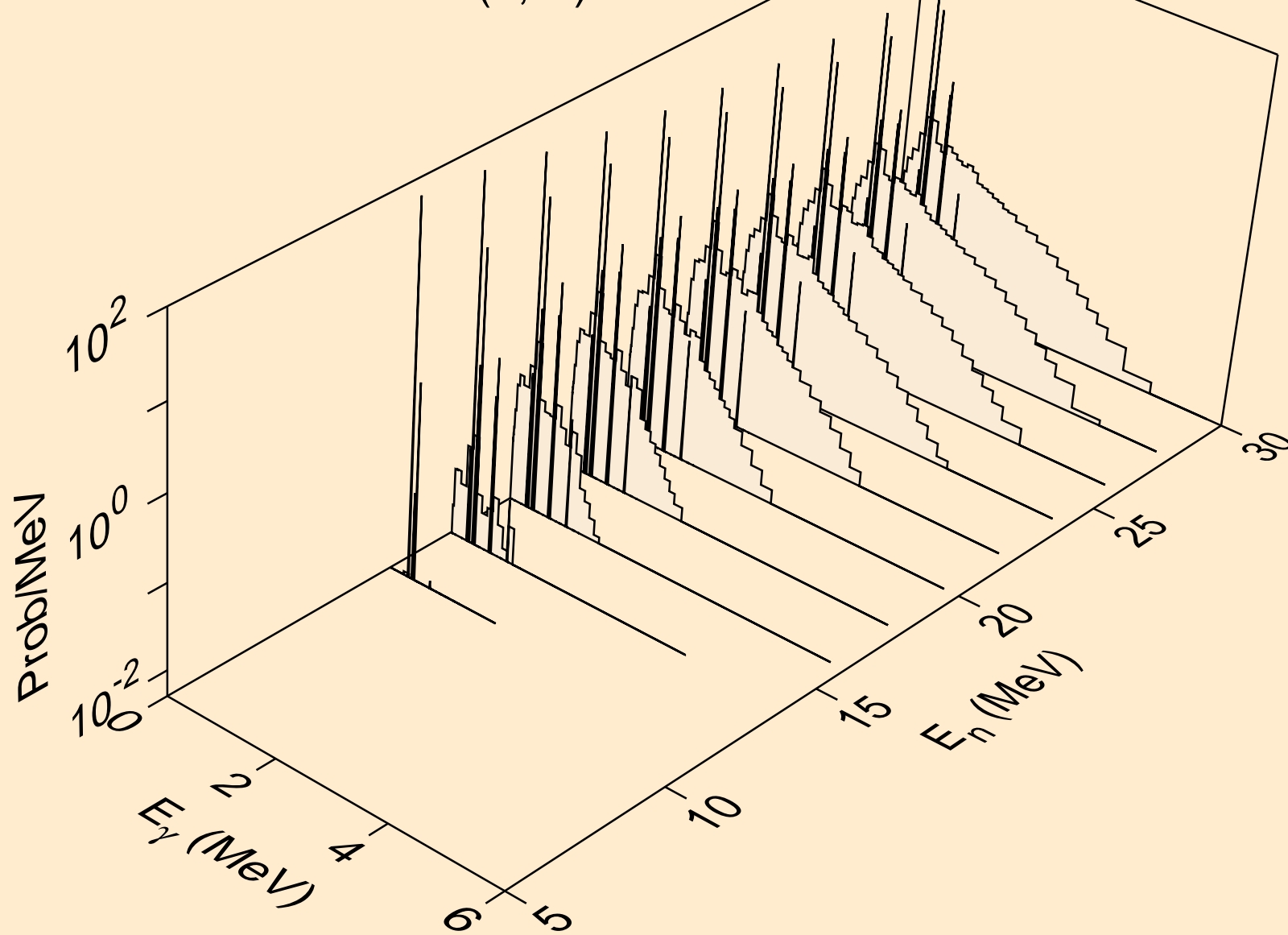

EU152M NEUTRON ACER TENDL-2023 LIBRARY; T=0.K  
Photon emission for (n,n\*)t

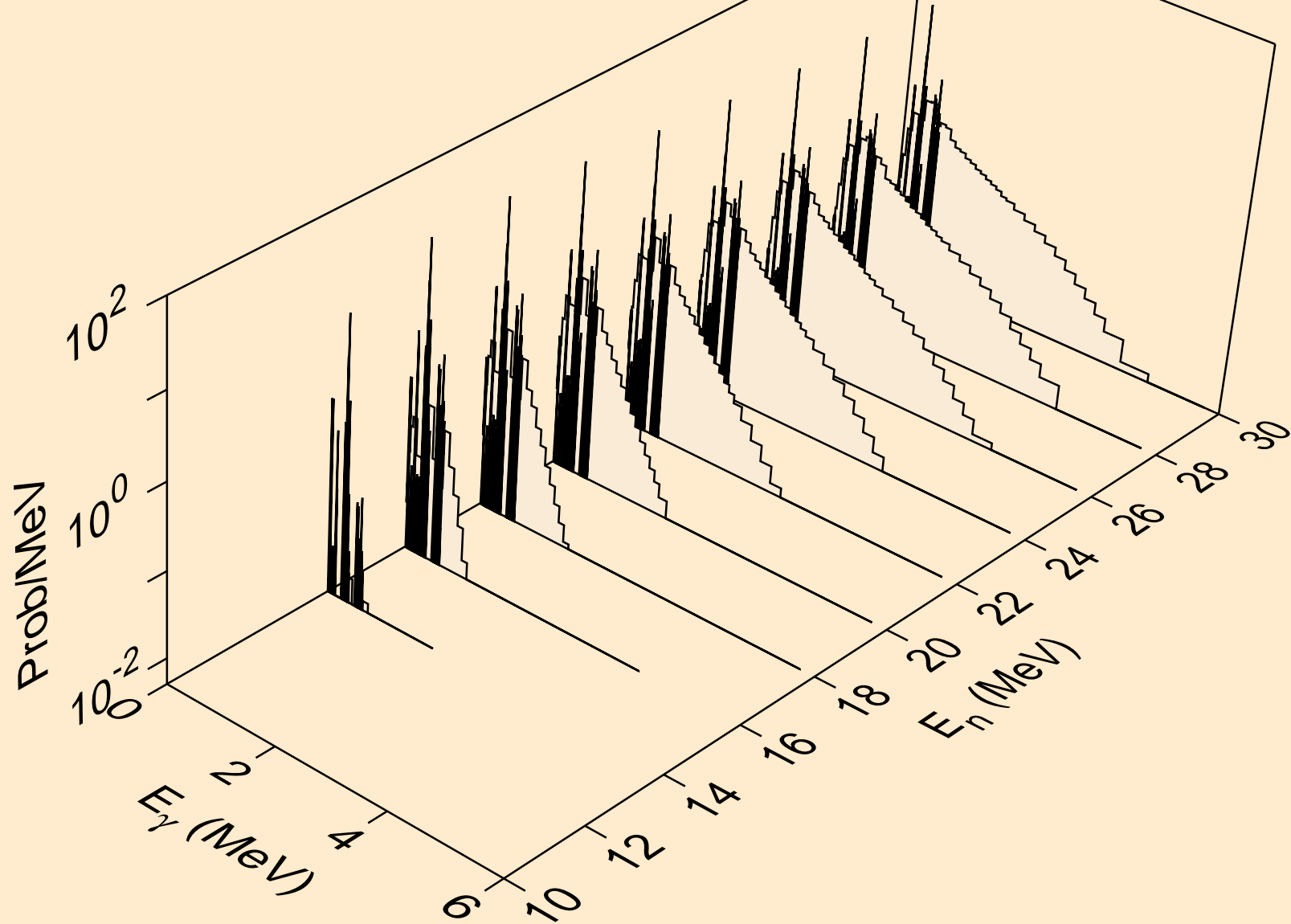

EU152M NEUTRON ACER TENDL-2023 LIBRARY; T=0.K  
Photon emission for (n,n\*)he3

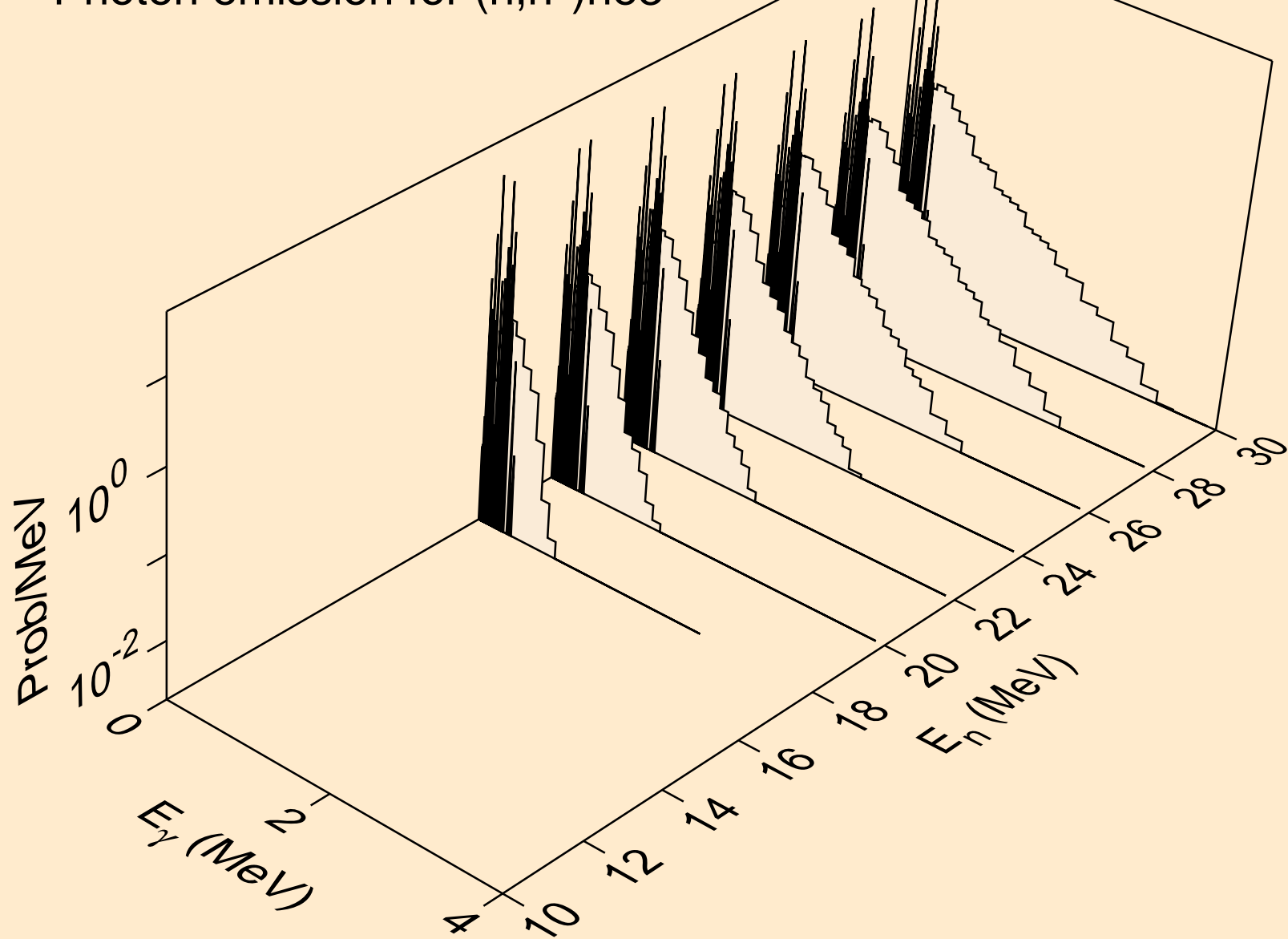

EU152M NEUTRON ACER TENDL-2023 LIBRARY; T=0.K  
Photon emission for (n,4n)

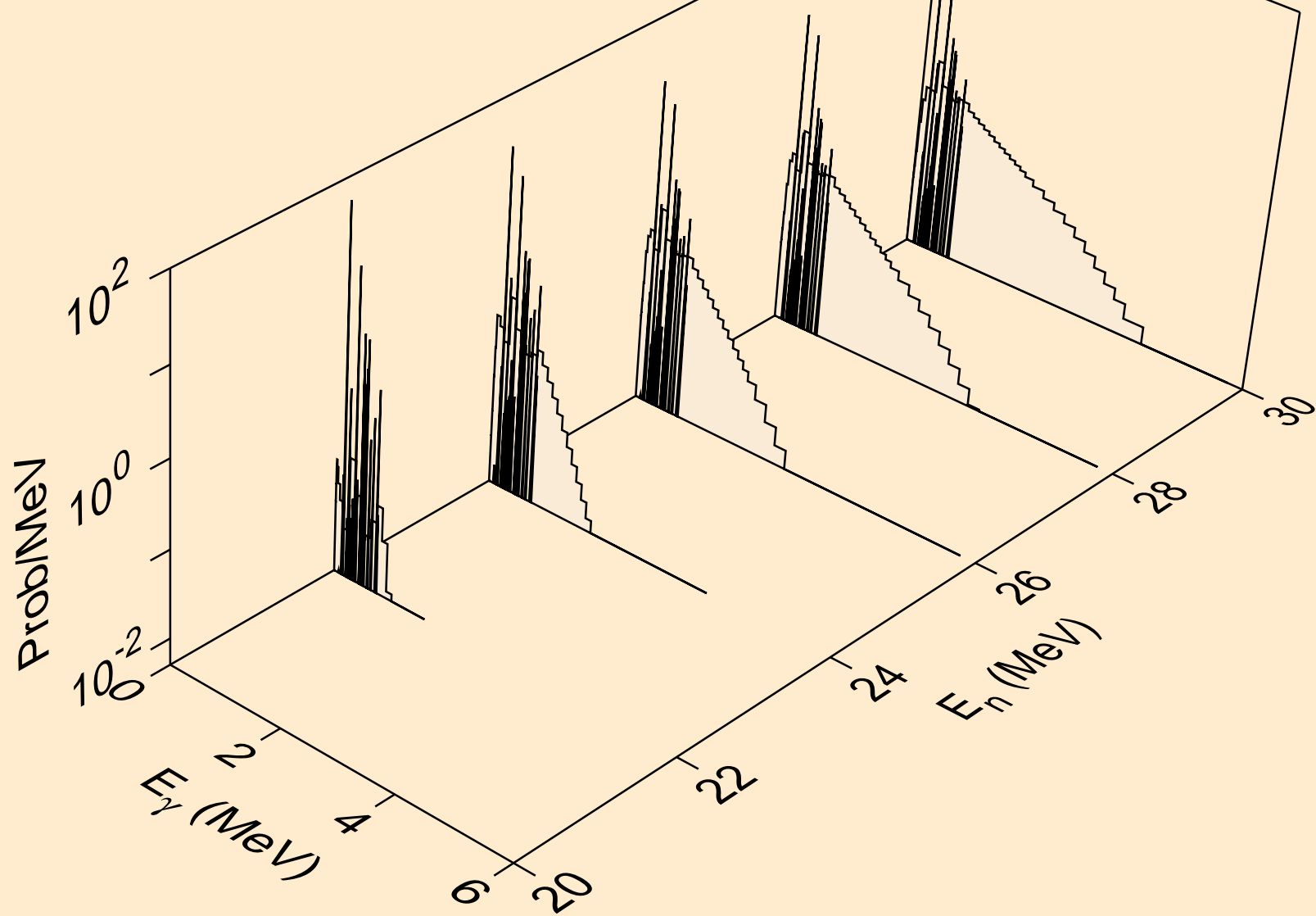

EU152M NEUTRON ACER TENDL-2023 LIBRARY; T=0.K  
Photon emission for (n,2np)

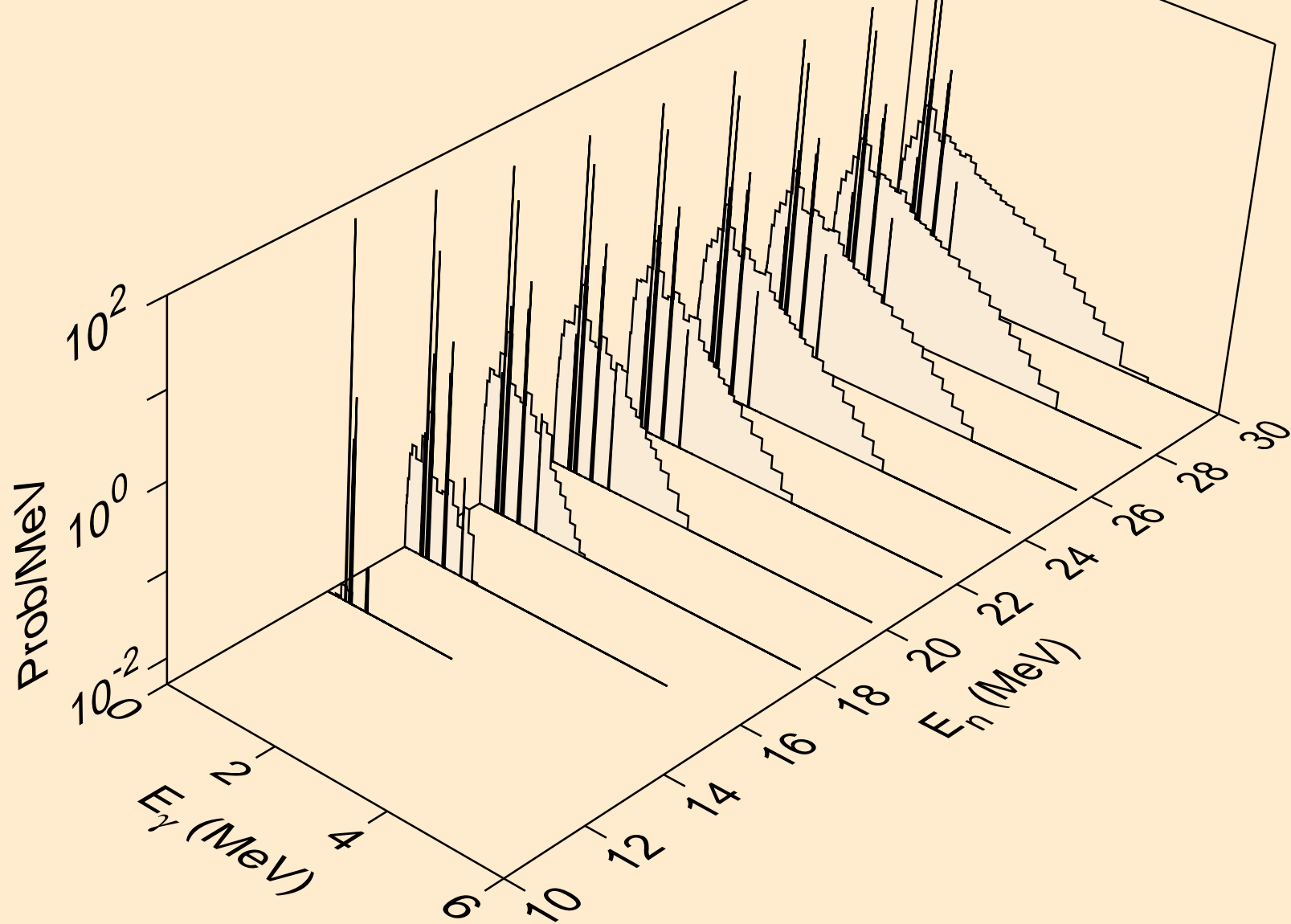

EU152M NEUTRON ACER TENDL-2023 LIBRARY; T=0.K  
Photon emission for (n,3np)

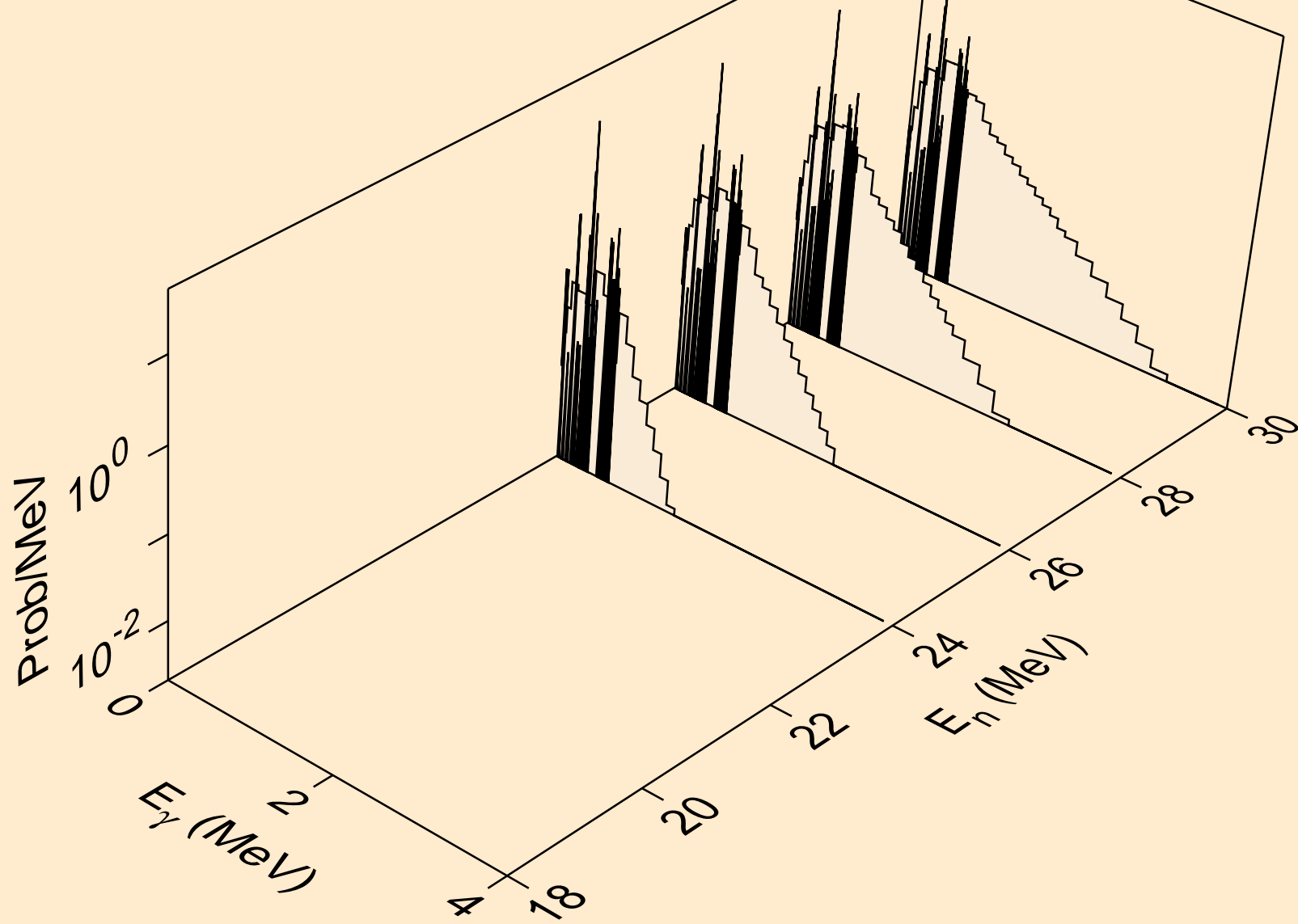

EU152M NEUTRON ACER TENDL-2023 LIBRARY; T=0.K  
Photon emission for (n,n2p)

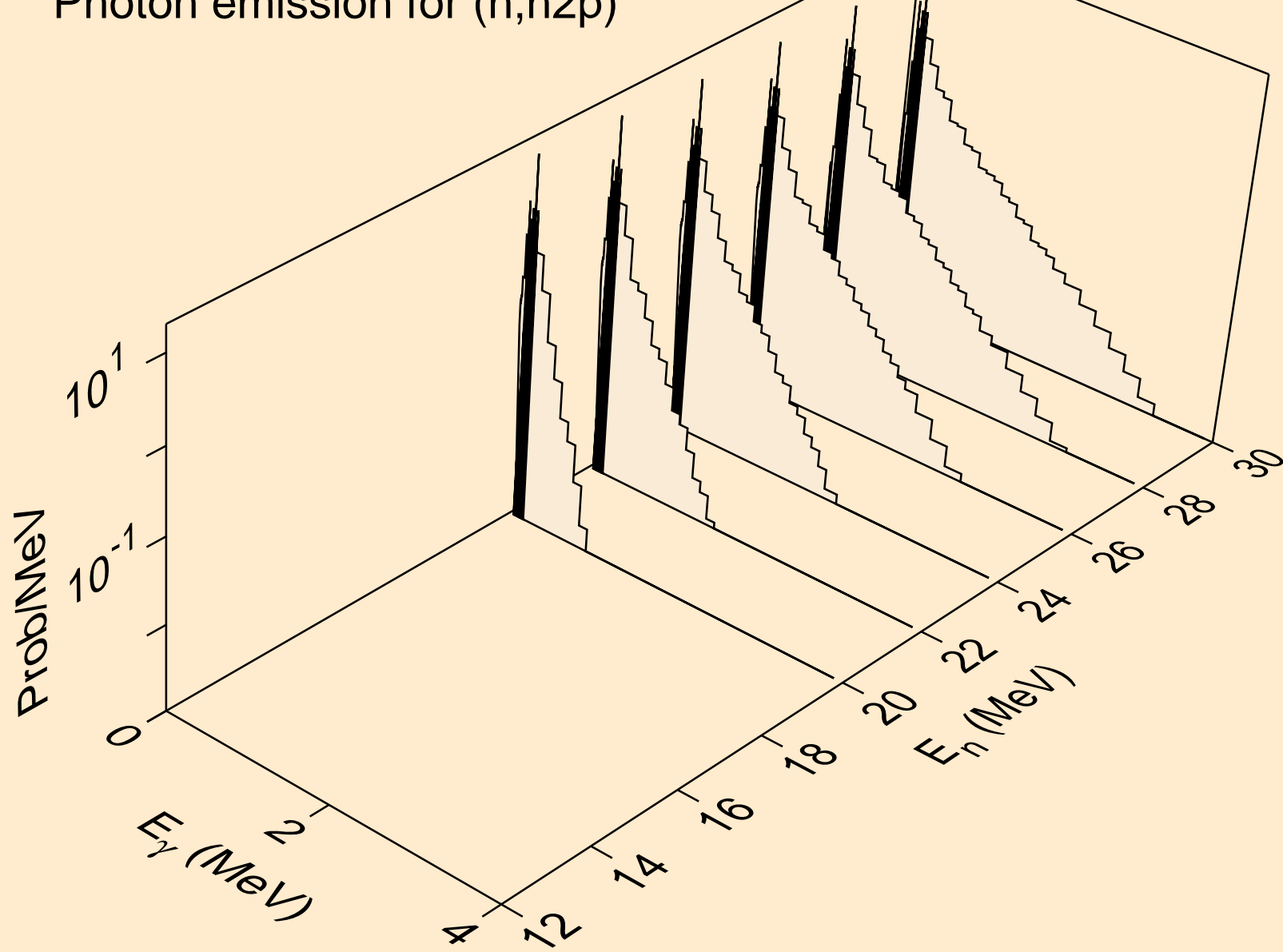

EU152M NEUTRON ACER TENDL-2023 LIBRARY; T=0.K  
Photon emission for (n,npa)

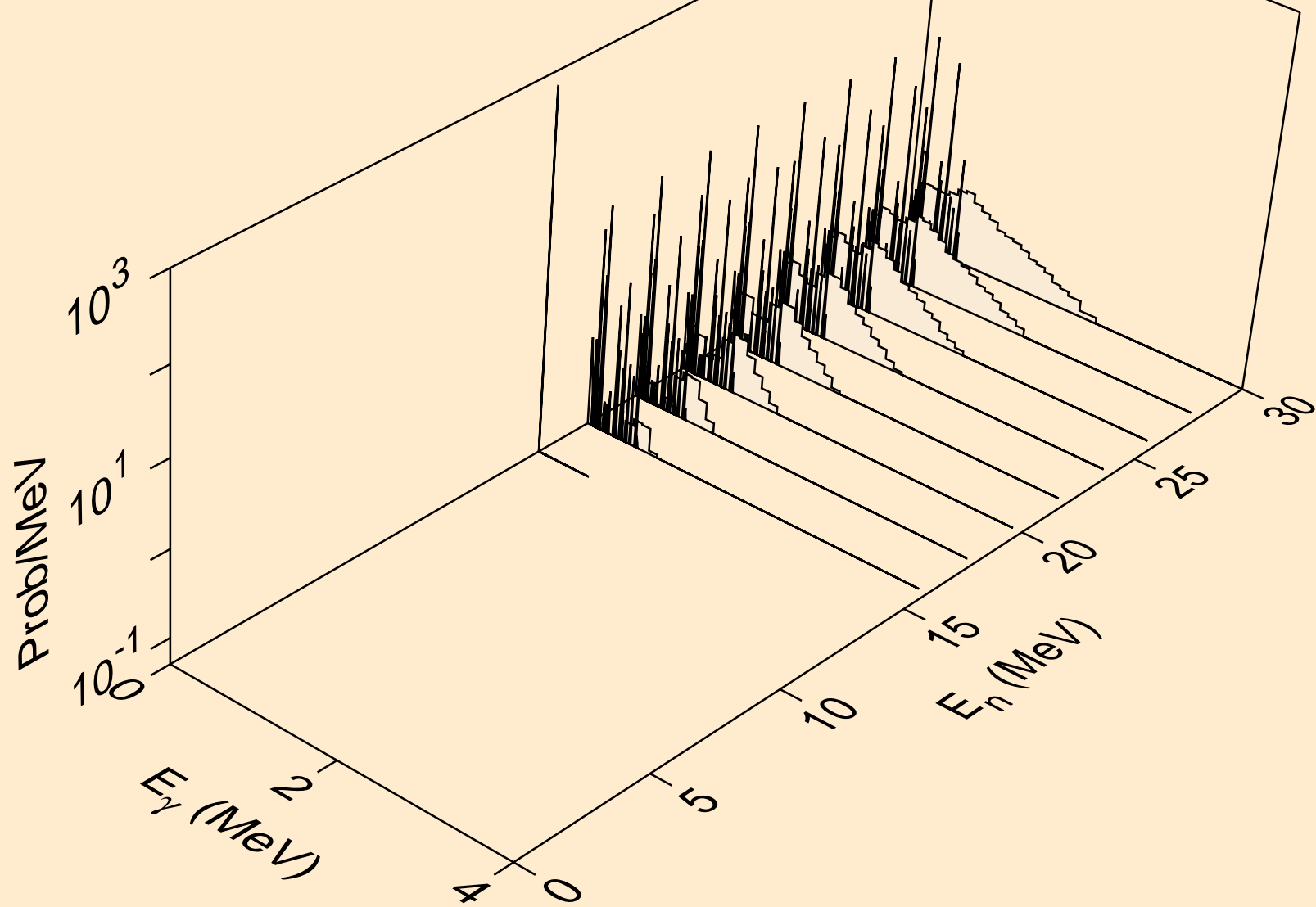

EU152M NEUTRON ACER TENDL-2023 LIBRARY; T=0.K  
Photon emission for (n,n\*2)

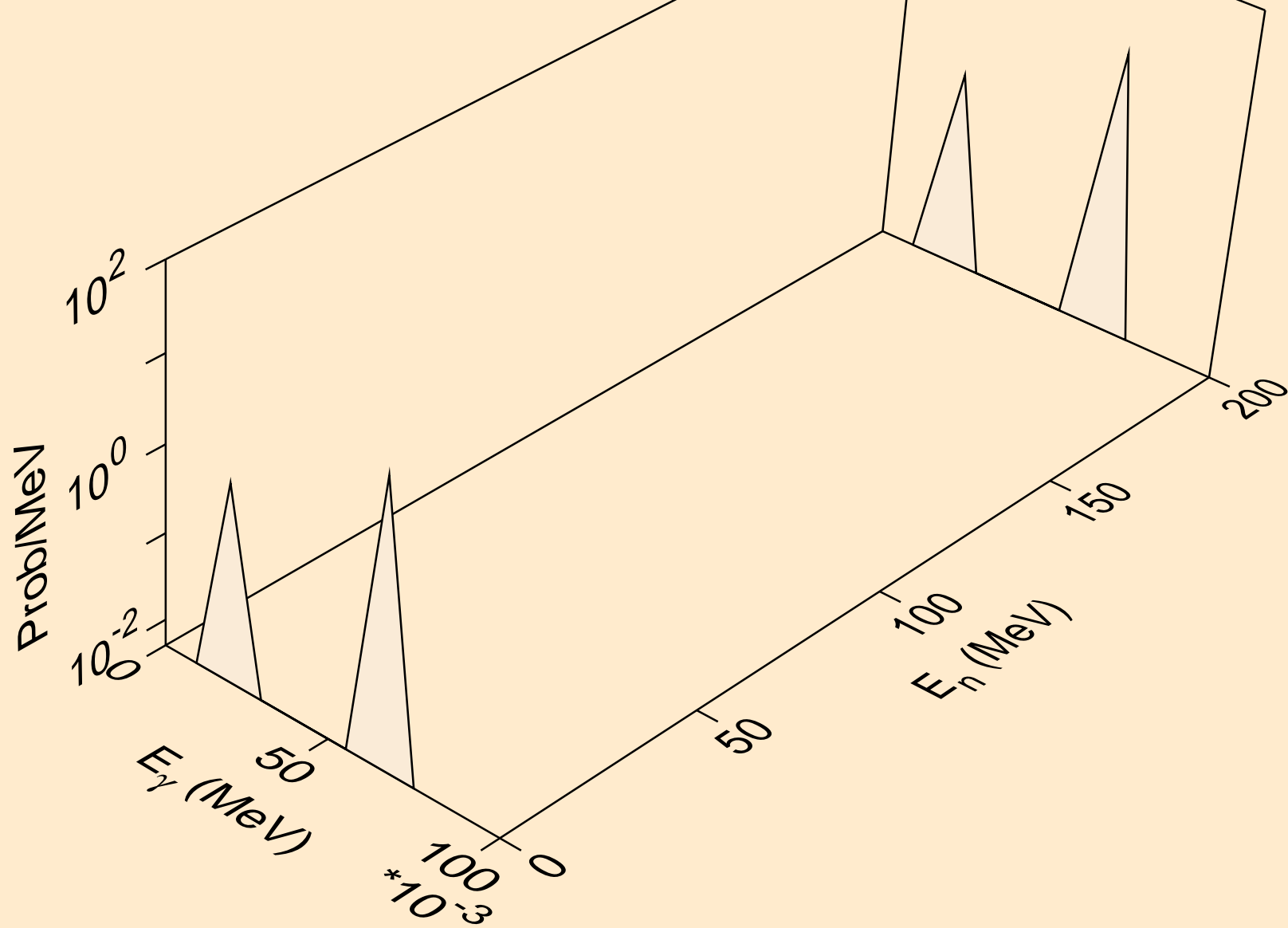

EU152M NEUTRON ACER TENDL-2023 LIBRARY; T=0.K  
Photon emission for (n,n\*3)

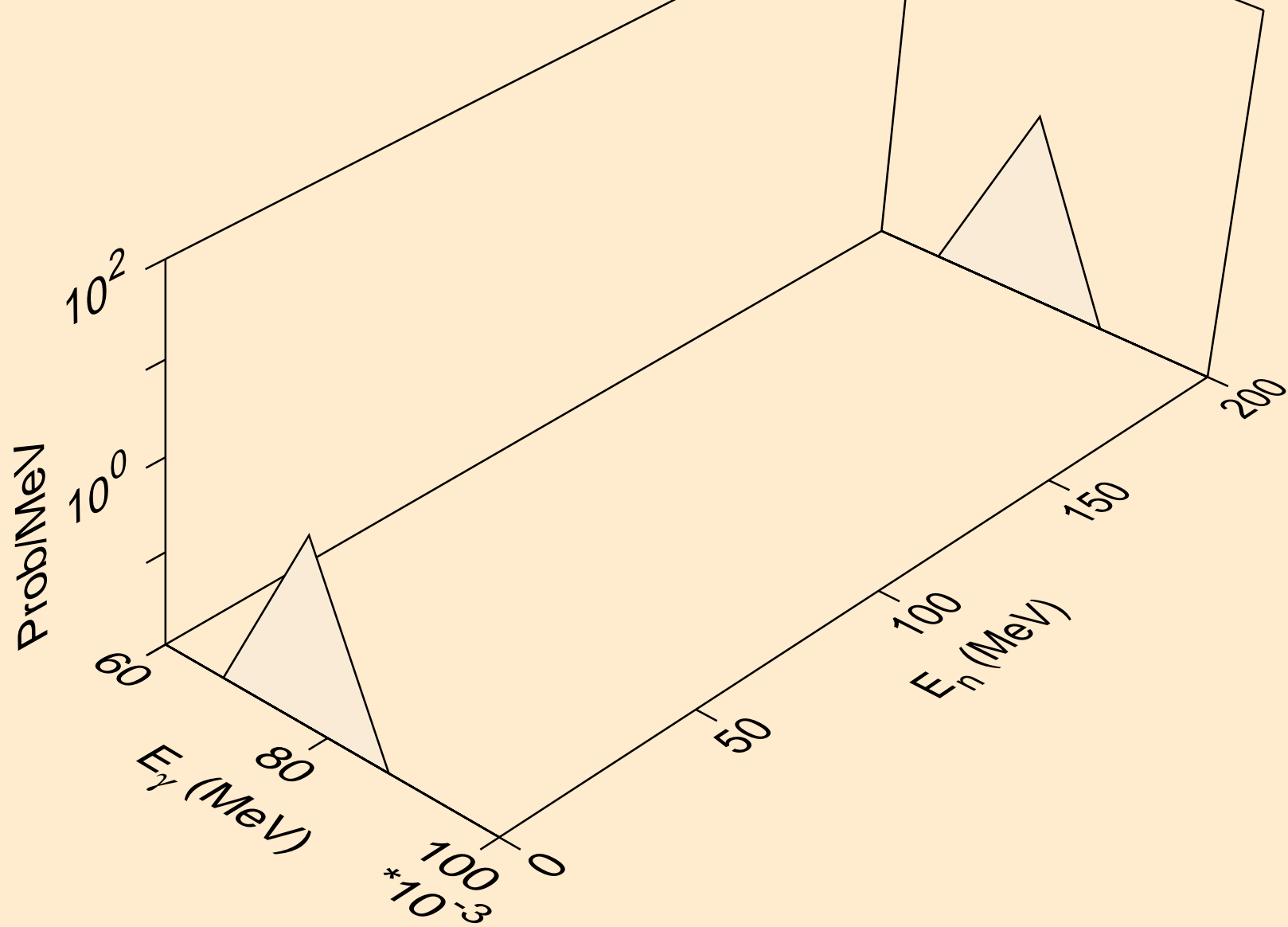

EU152M NEUTRON ACER TENDL-2023 LIBRARY; T=0.K  
Photon emission for (n,n\*4)

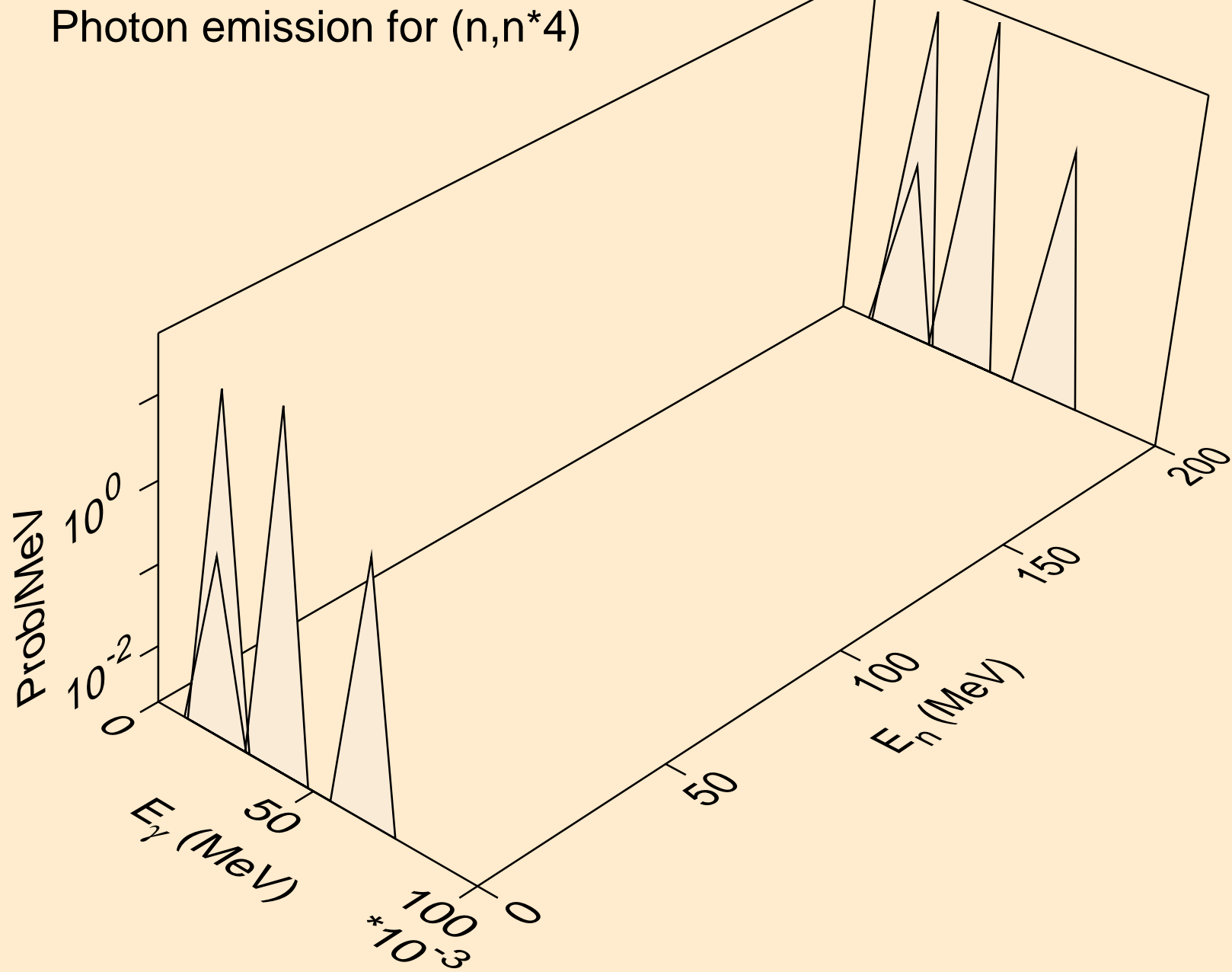

EU152M NEUTRON ACER TENDL-2023 LIBRARY; T=0.K  
Photon emission for (n,n\*5)

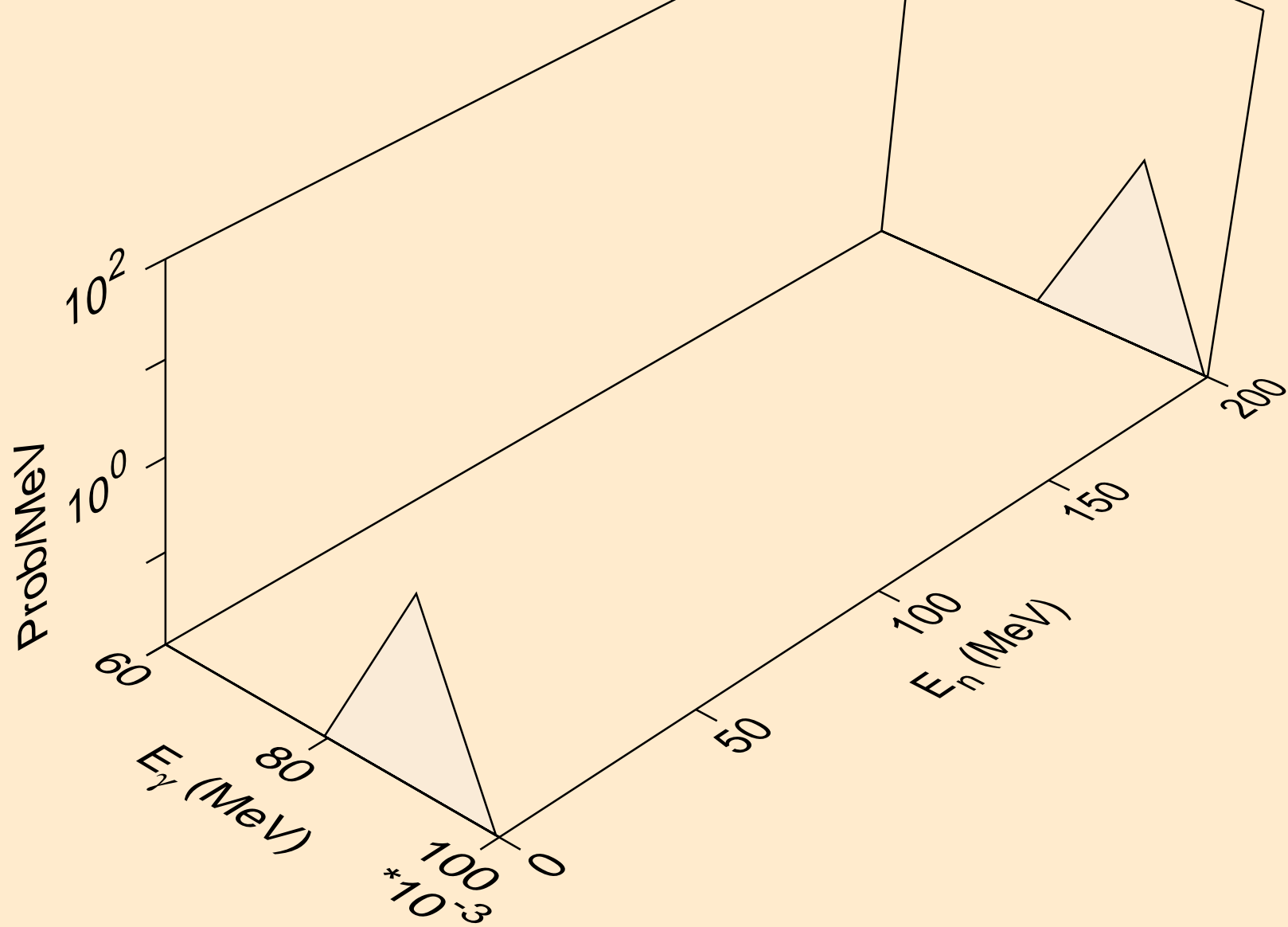

EU152M NEUTRON ACER TENDL-2023 LIBRARY; T=0.K  
Photon emission for (n,n\*6)

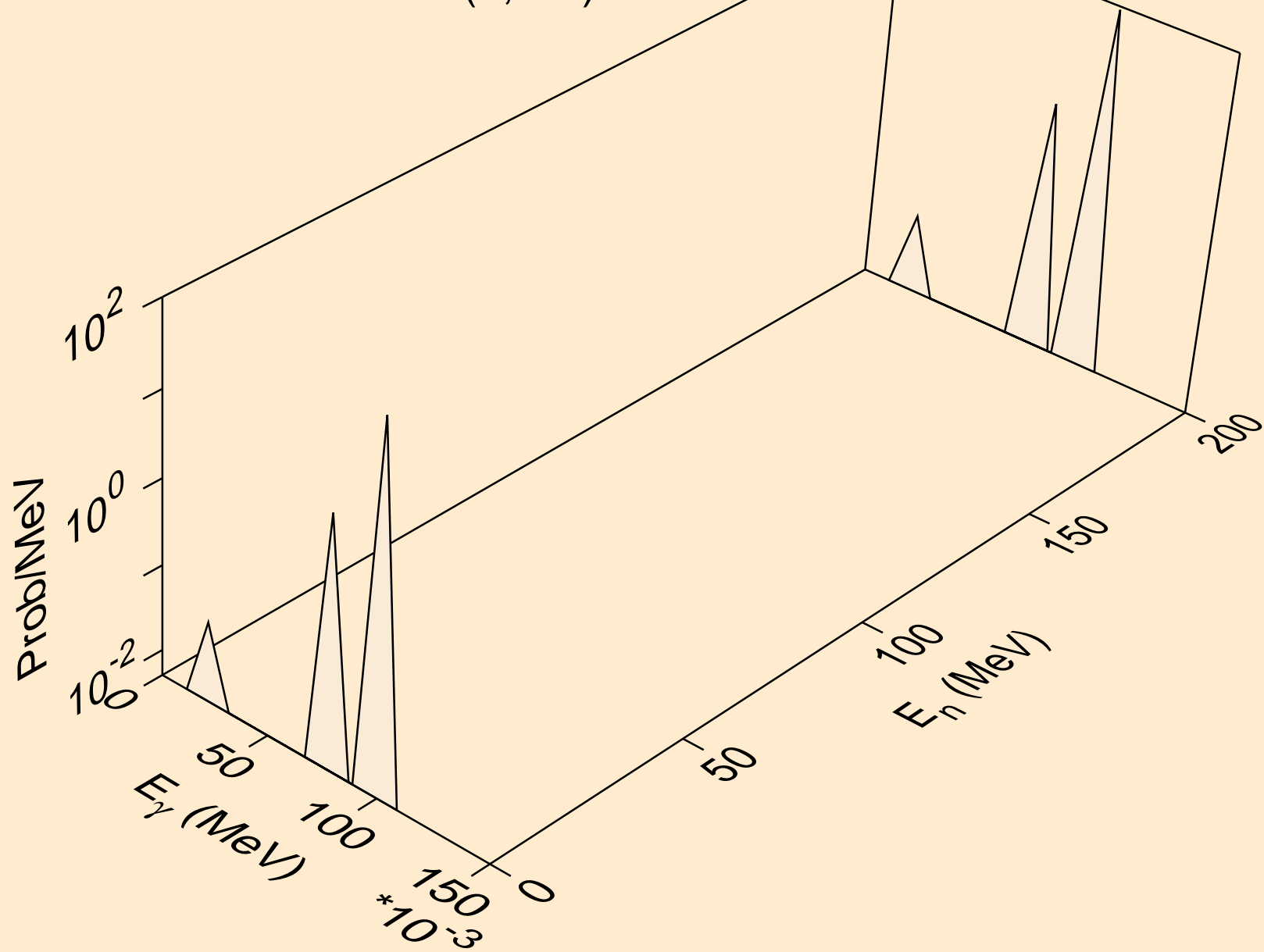

EU152M NEUTRON ACER TENDL-2023 LIBRARY; T=0.K  
Photon emission for (n,n\*7)

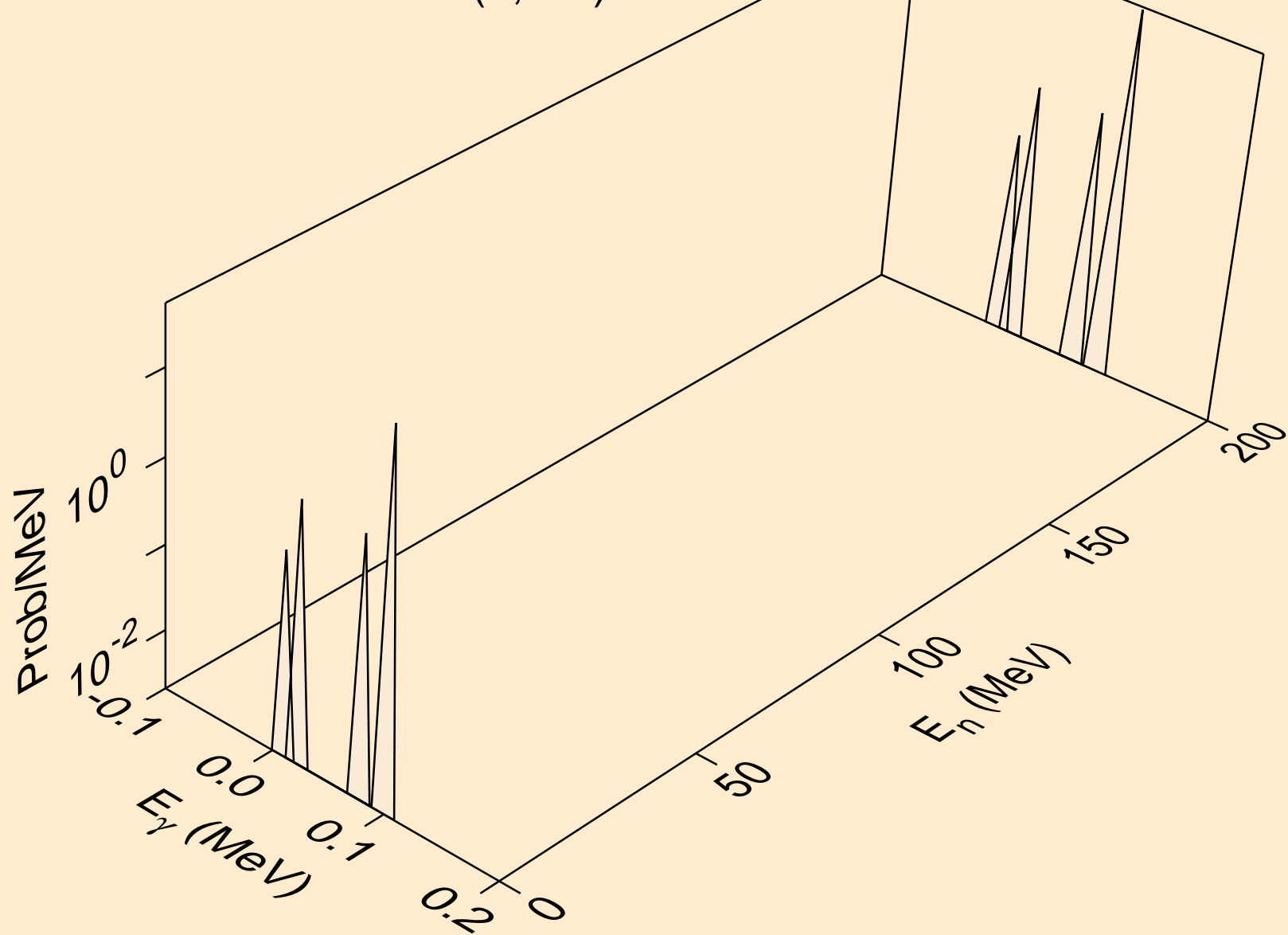

EU152M NEUTRON ACER TENDL-2023 LIBRARY; T=0.K  
Photon emission for (n,n\*8)

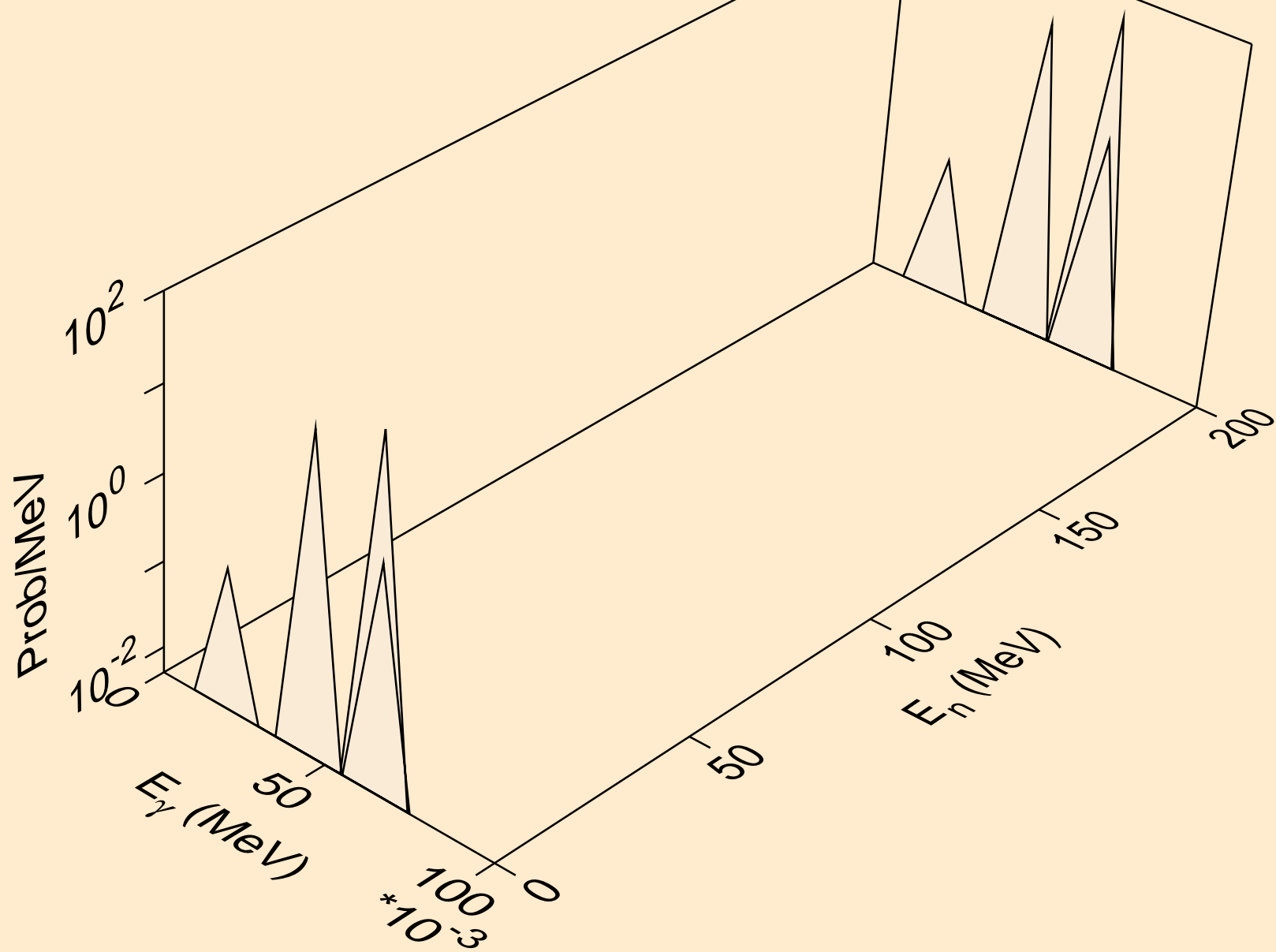

EU152M NEUTRON ACER TENDL-2023 LIBRARY; T=0.K  
Photon emission for (n,n\*9)

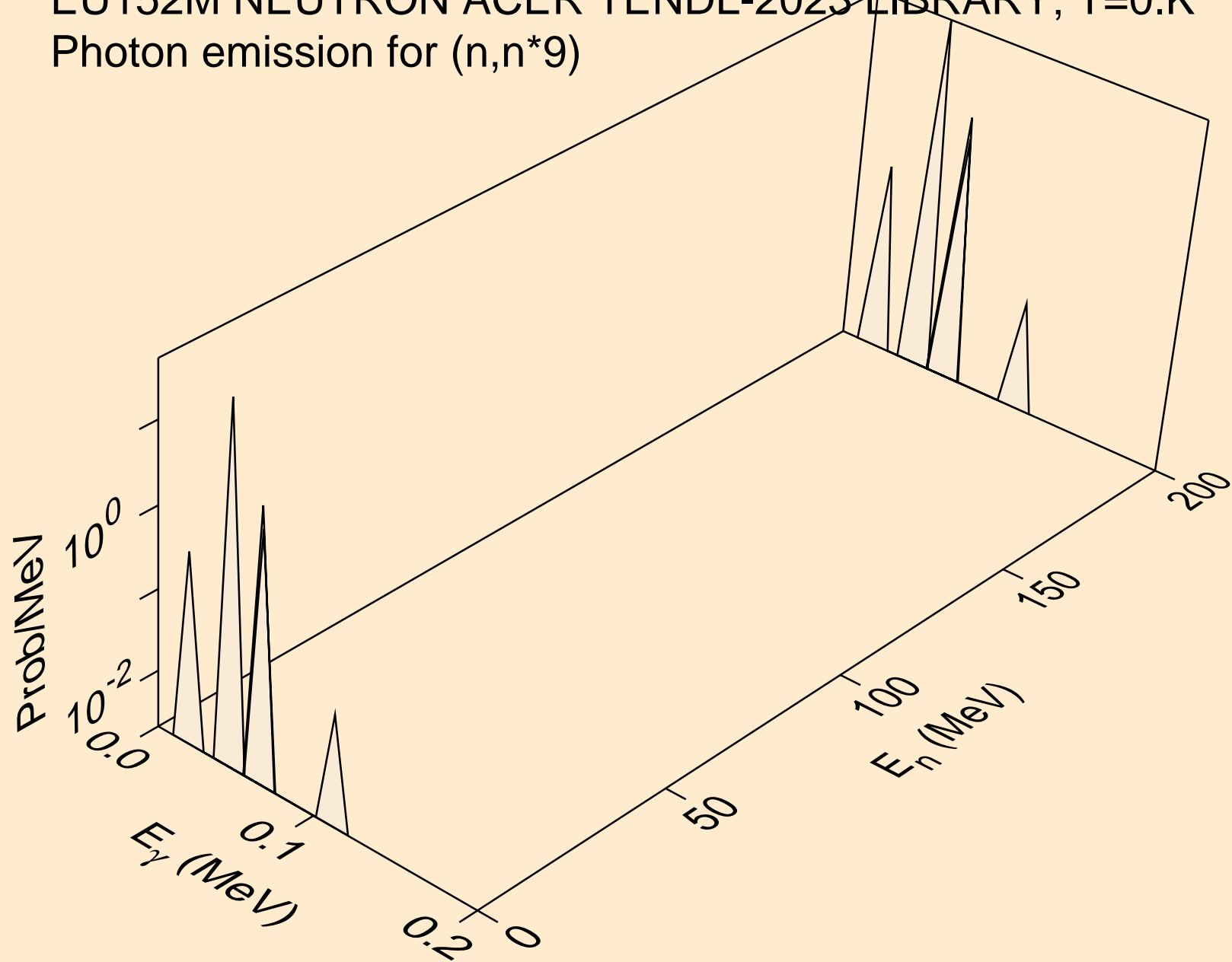

EU152M NEUTRON ACER TENDL-2023 LIBRARY; T=0.K  
Photon emission for (n,n\*10)

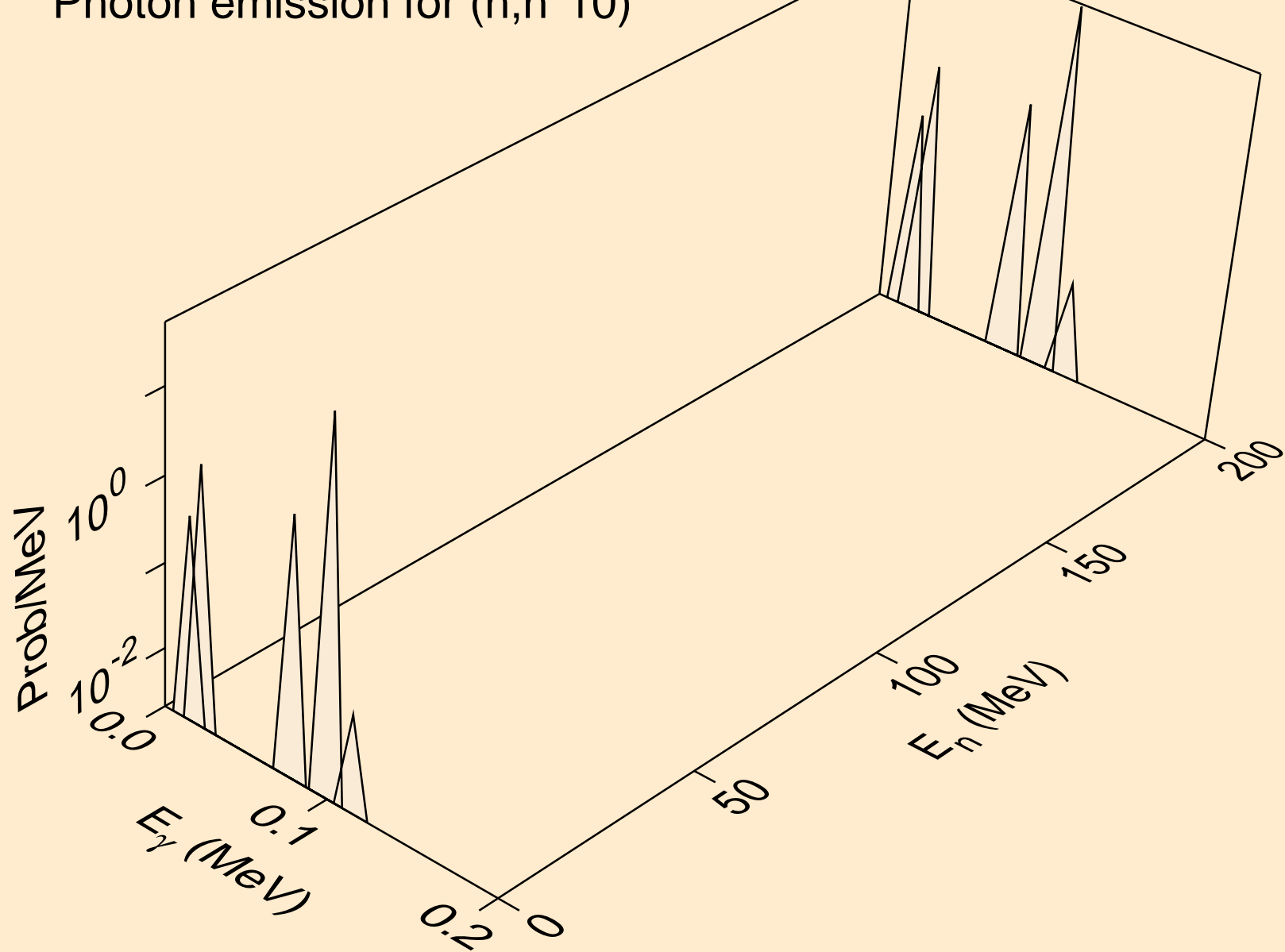

EU152M NEUTRON ACER TENDL-2023 LIBRARY; T=0.K  
Photon emission for (n,n\*11)

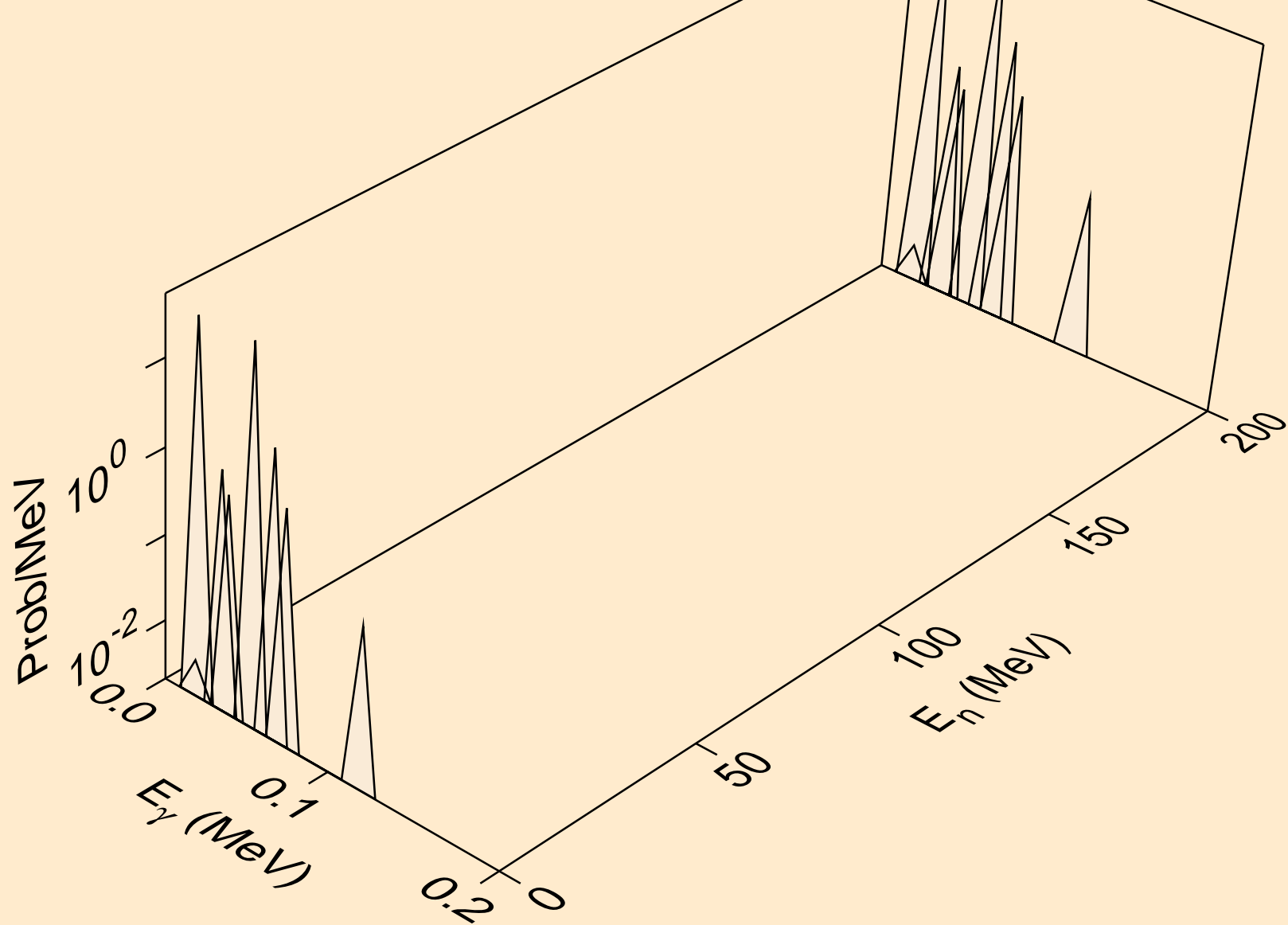

EU152M NEUTRON ACER TENDL-2023 LIBRARY; T=0.K  
Photon emission for (n,n\*12)

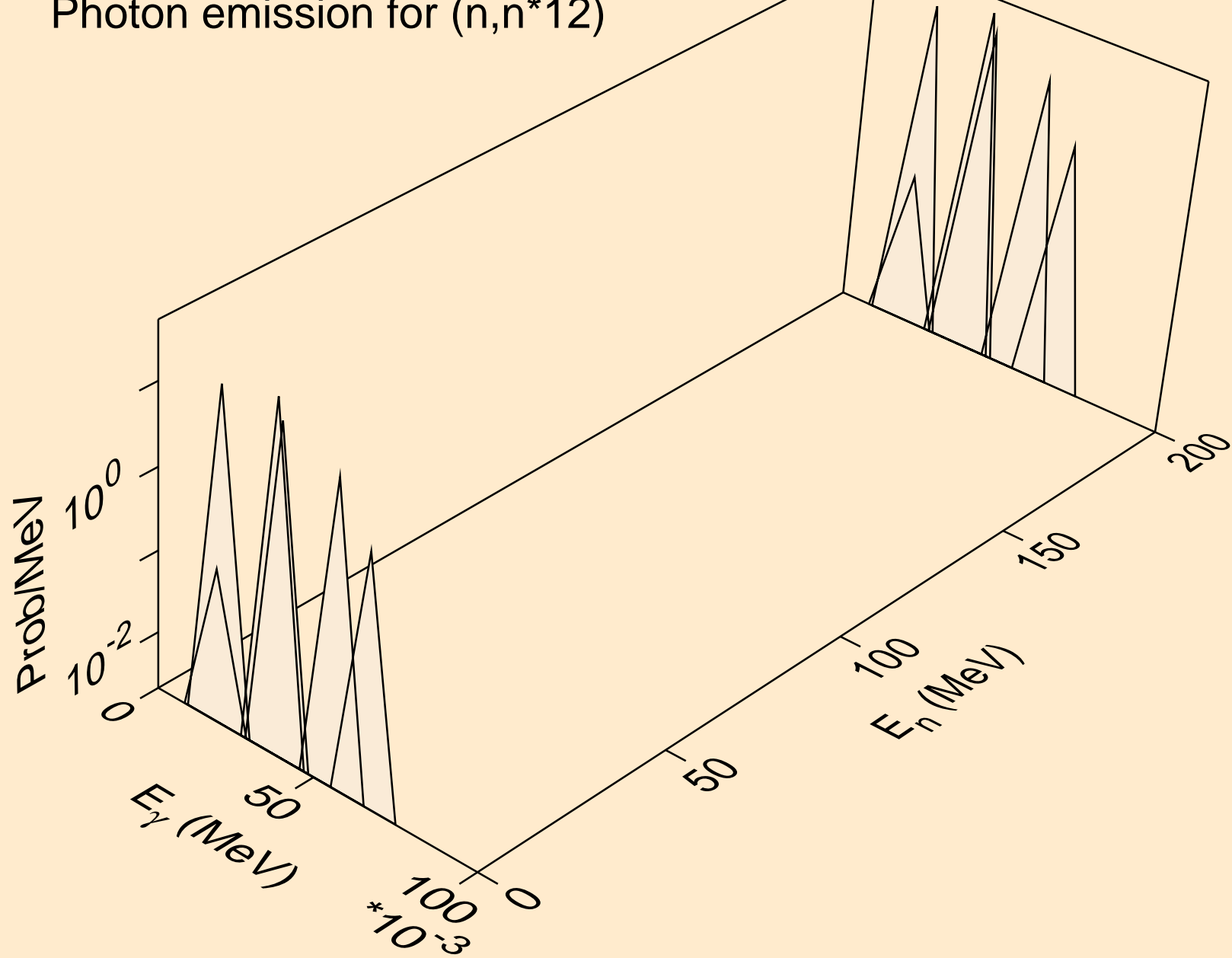

EU152M NEUTRON ACER TENDL-2023 LIBRARY; T=0.K  
Photon emission for (n,n\*13)

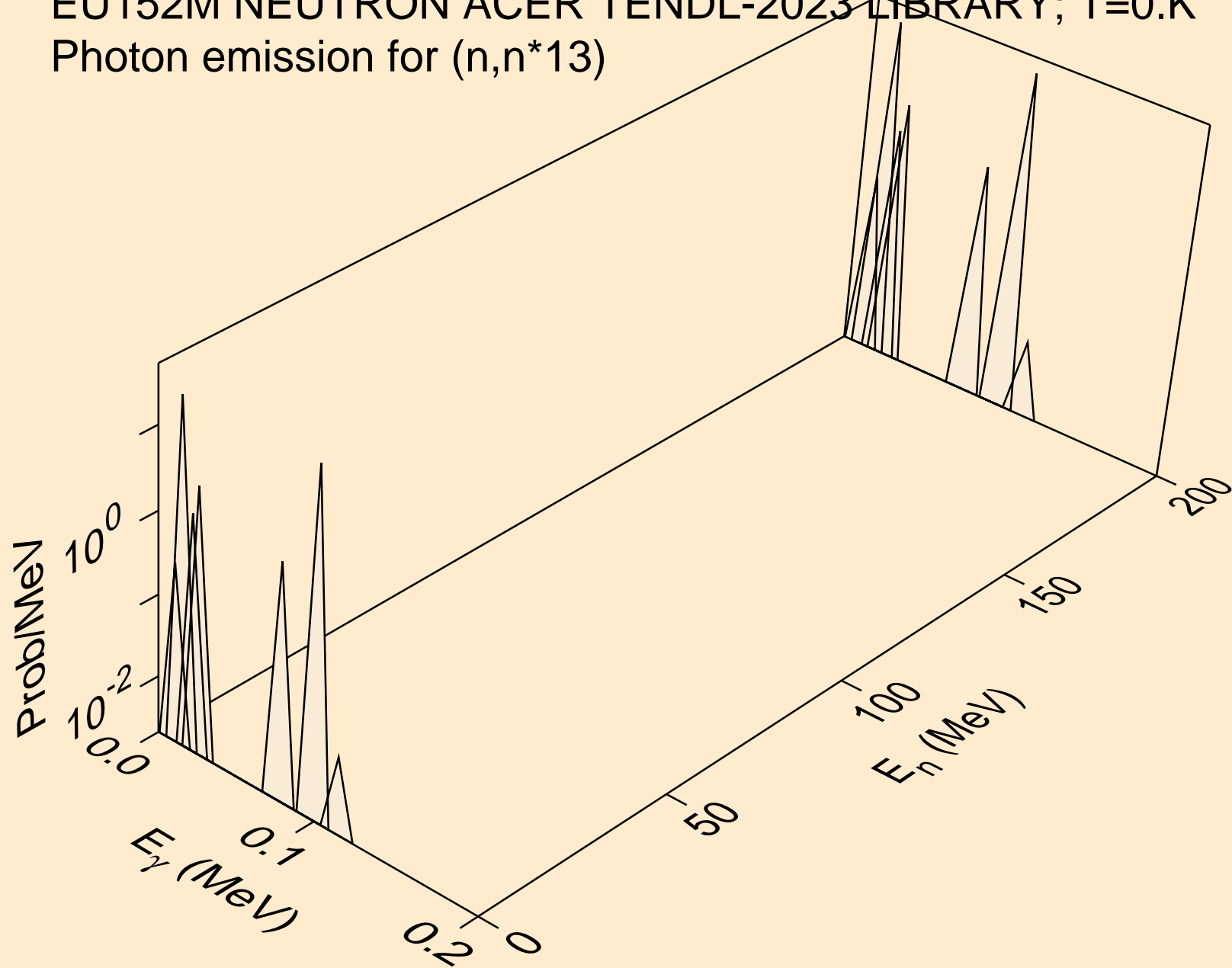

EU152M NEUTRON ACER TENDL-2023 LIBRARY; T=0.K  
Photon emission for (n,n\*14)

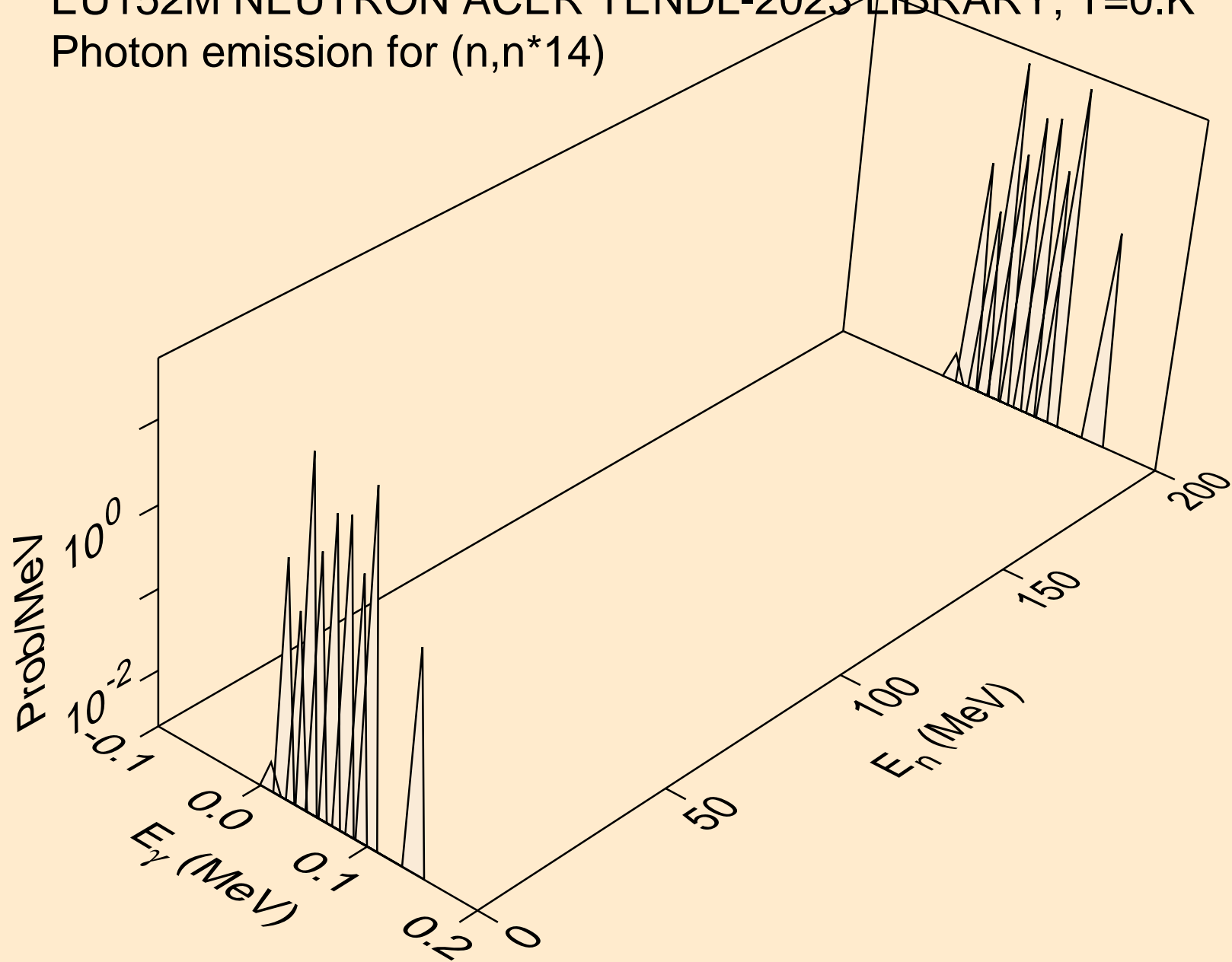

EU152M NEUTRON ACER TENDL-2023 LIBRARY; T=0.K  
Photon emission for (n,n\*15)

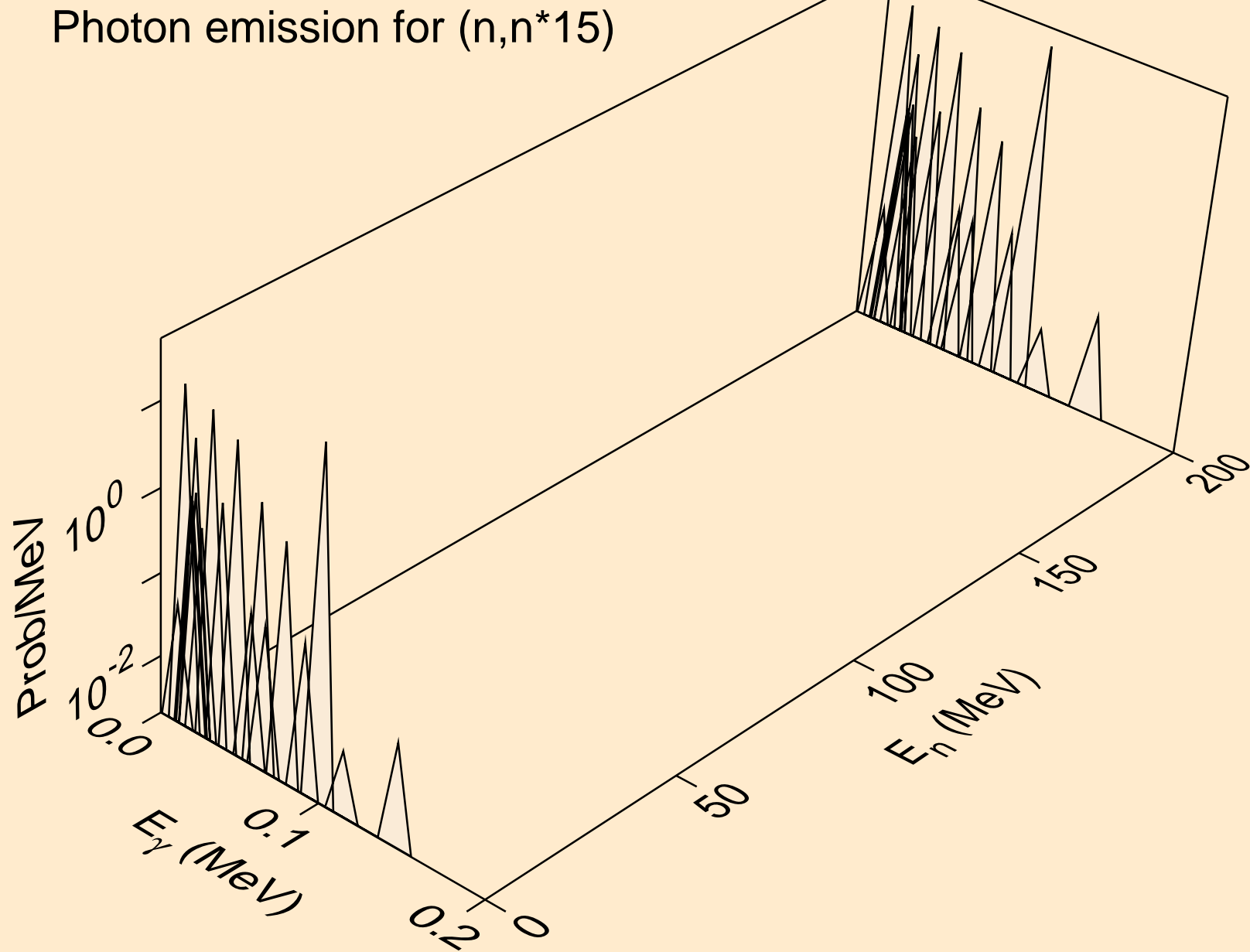

EU152M NEUTRON ACER TENDL-2023 LIBRARY; T=0.K  
Photon emission for (n,n\*c)

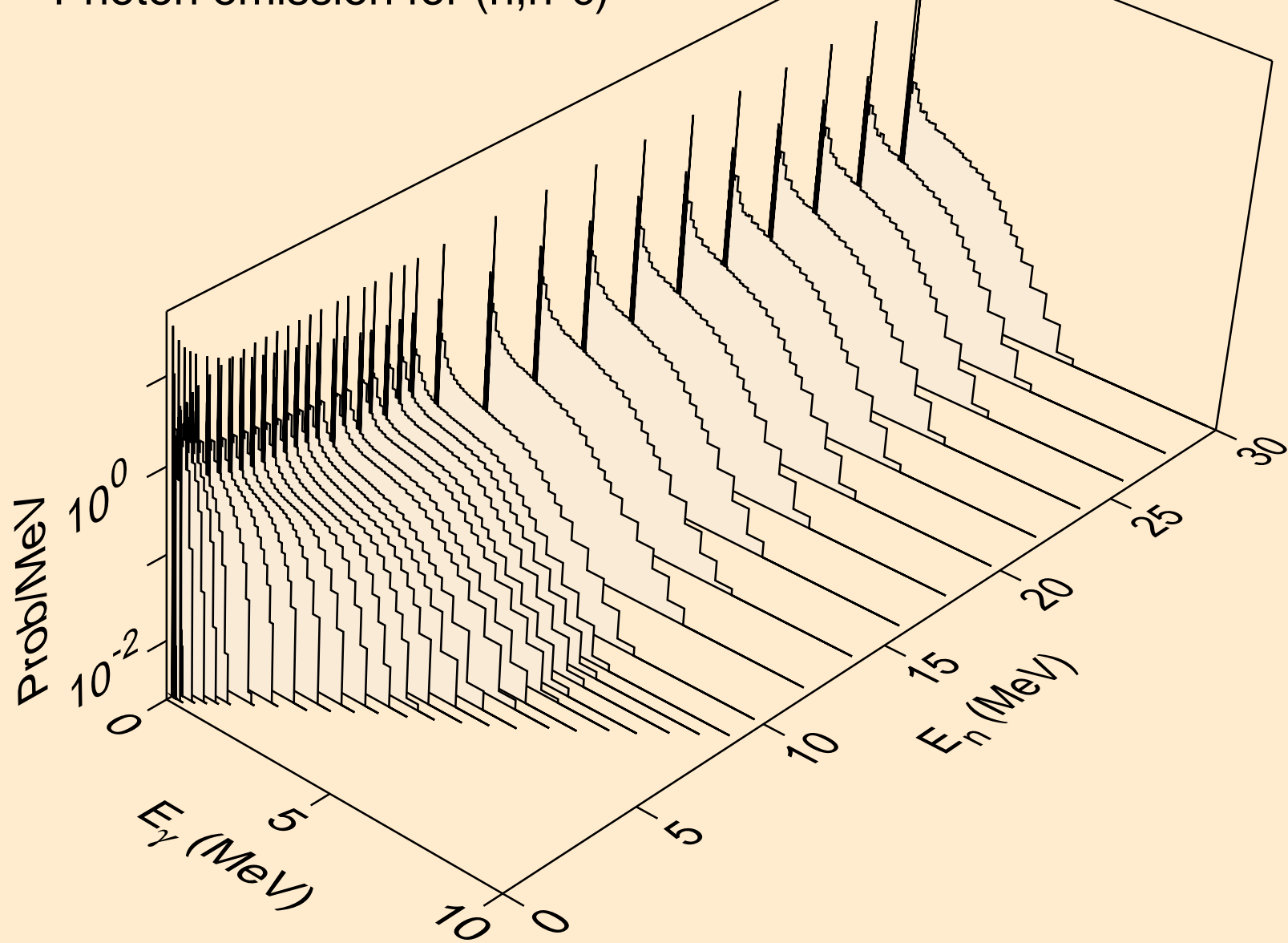

EU152M NEUTRON ACER TENDL-2023 LIBRARY; T=0.K  
Photon emission for (n,gma)

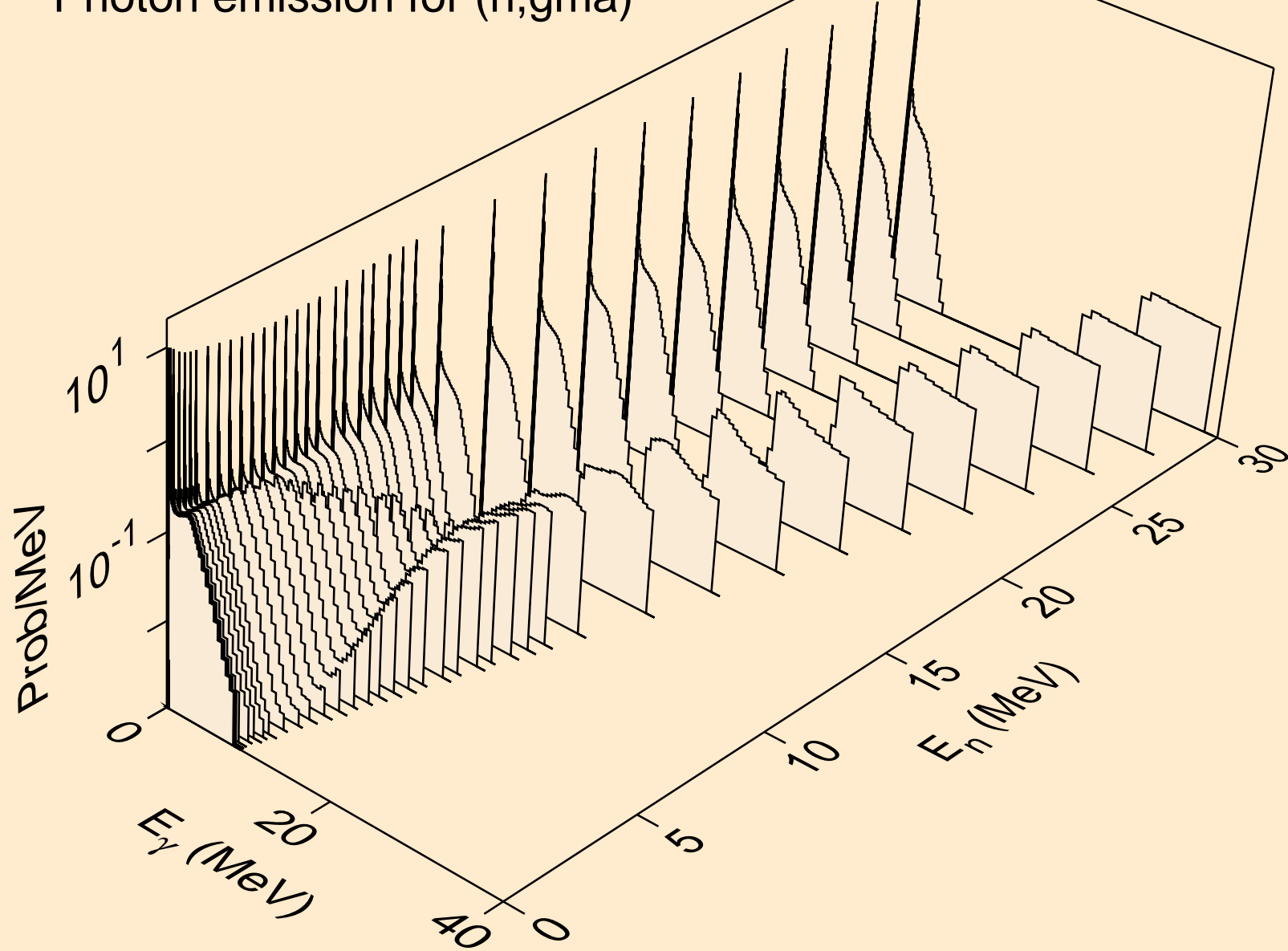

EU152M NEUTRON ACER TENDL-2023 LIBRARY; T=0.K  
Photon emission for (n,p)

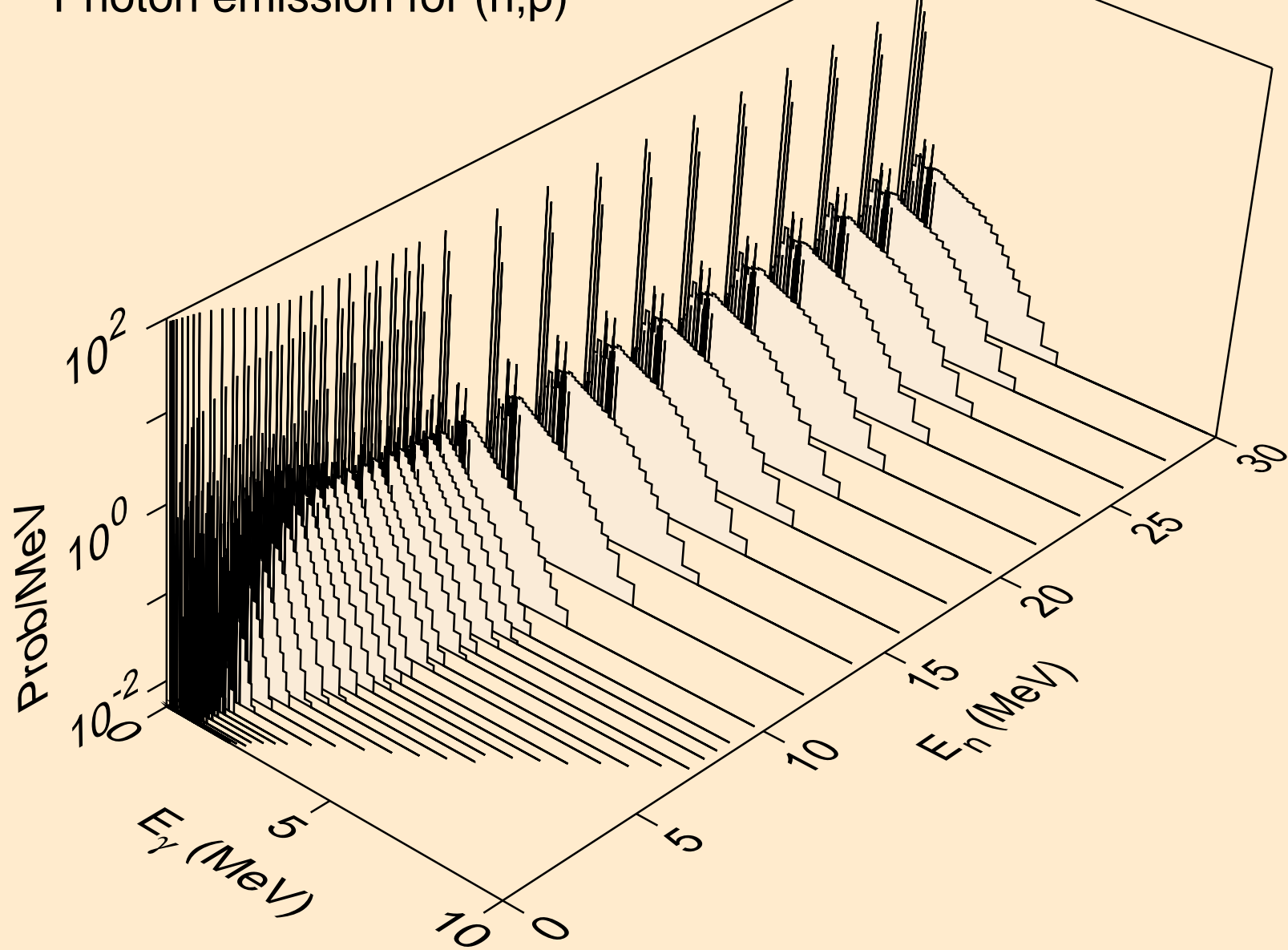

EU152M NEUTRON ACER TENDL-2023 LIBRARY; T=0.K  
Photon emission for (n,d)

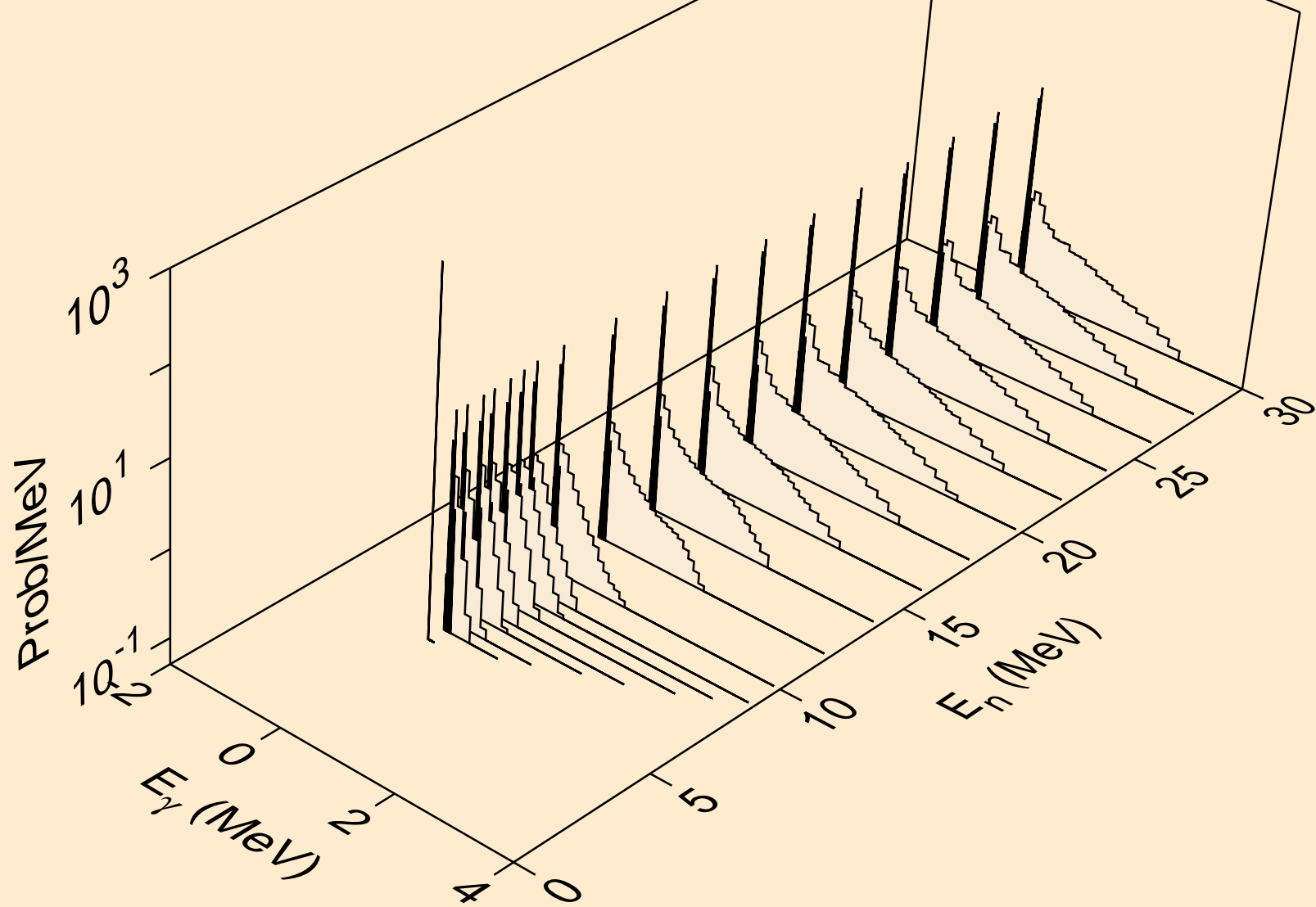

EU152M NEUTRON ACER TENDL-2023 LIBRARY; T=0.K  
Photon emission for (n,t)

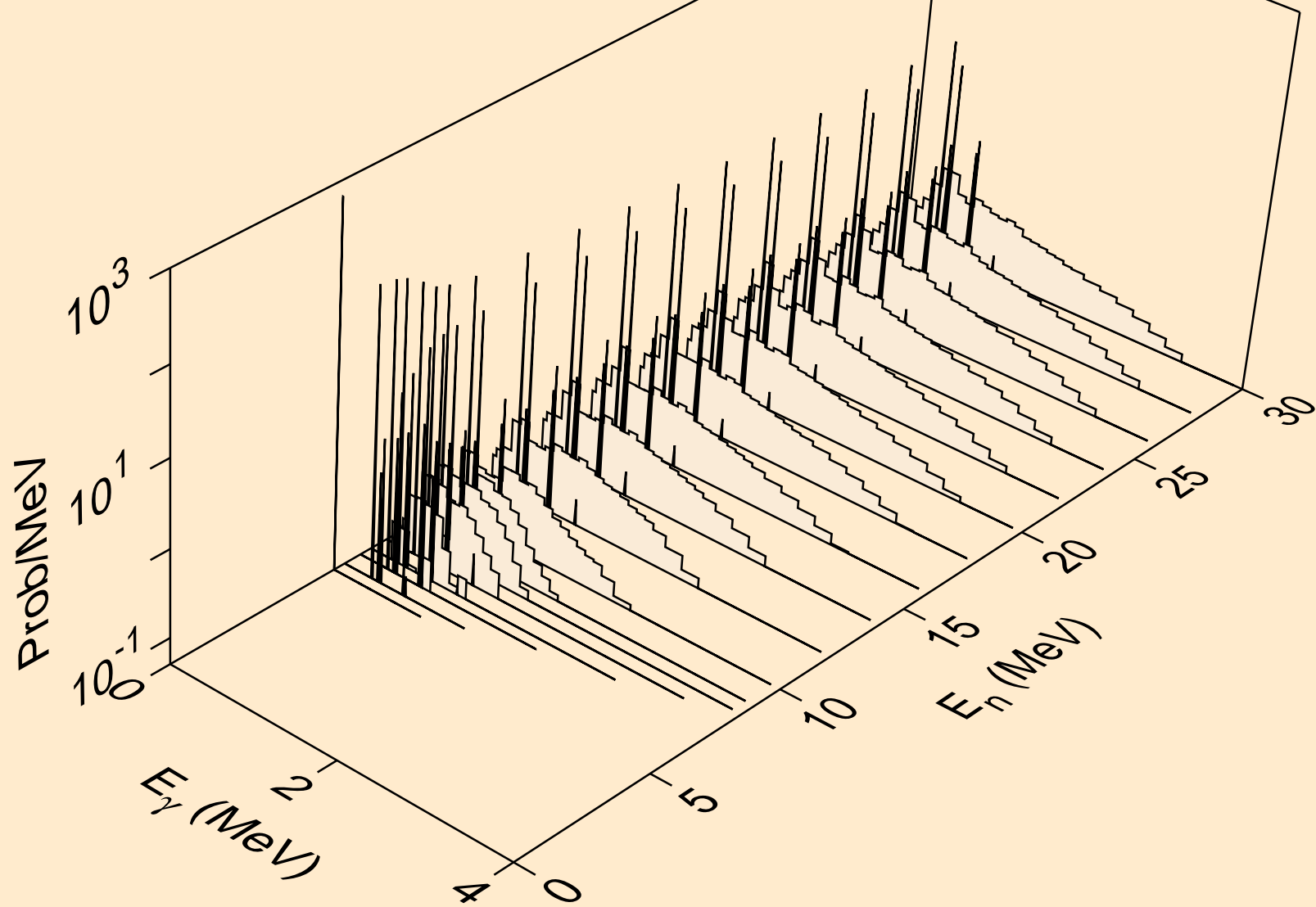

EU152M NEUTRON ACER TENDL-2023 LIBRARY; T=0.K  
Photon emission for (n,he3)

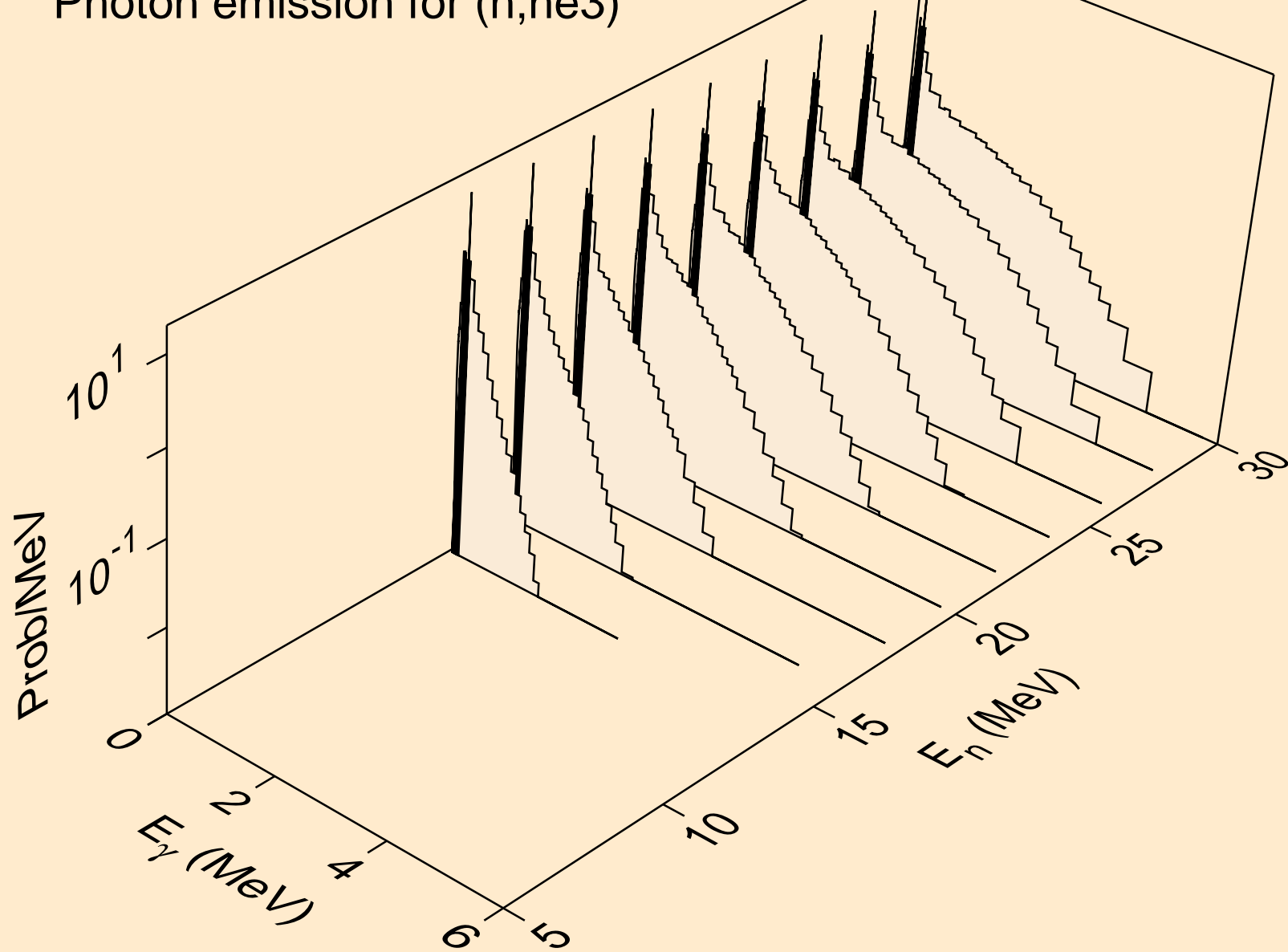

EU152M NEUTRON ACER TENDL-2023 LIBRARY; T=0.K  
Photon emission for (n,a)

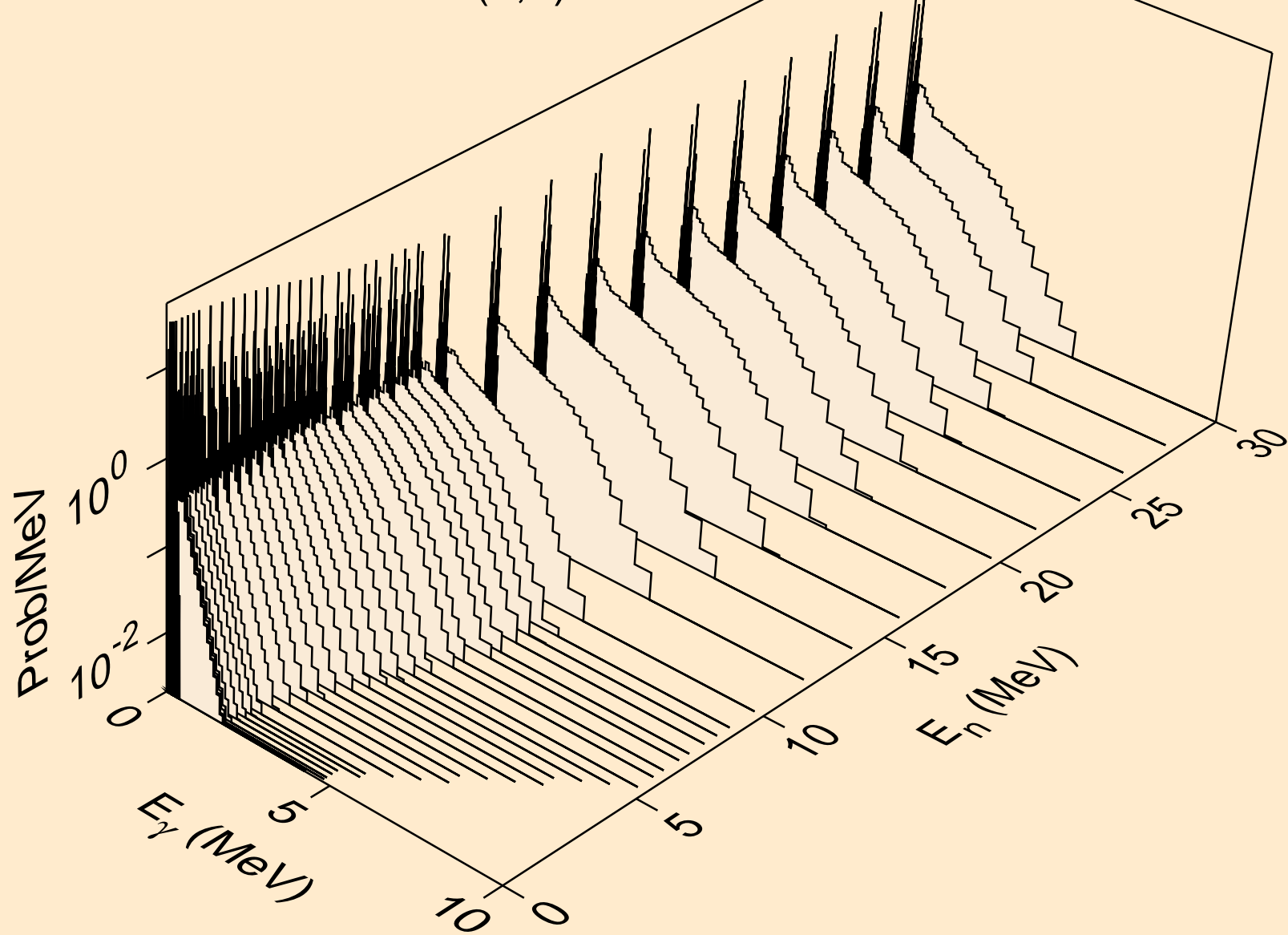

EU152M NEUTRON ACER TENDL-2023 LIBRARY; T=0.K  
Photon emission for (n,2a)

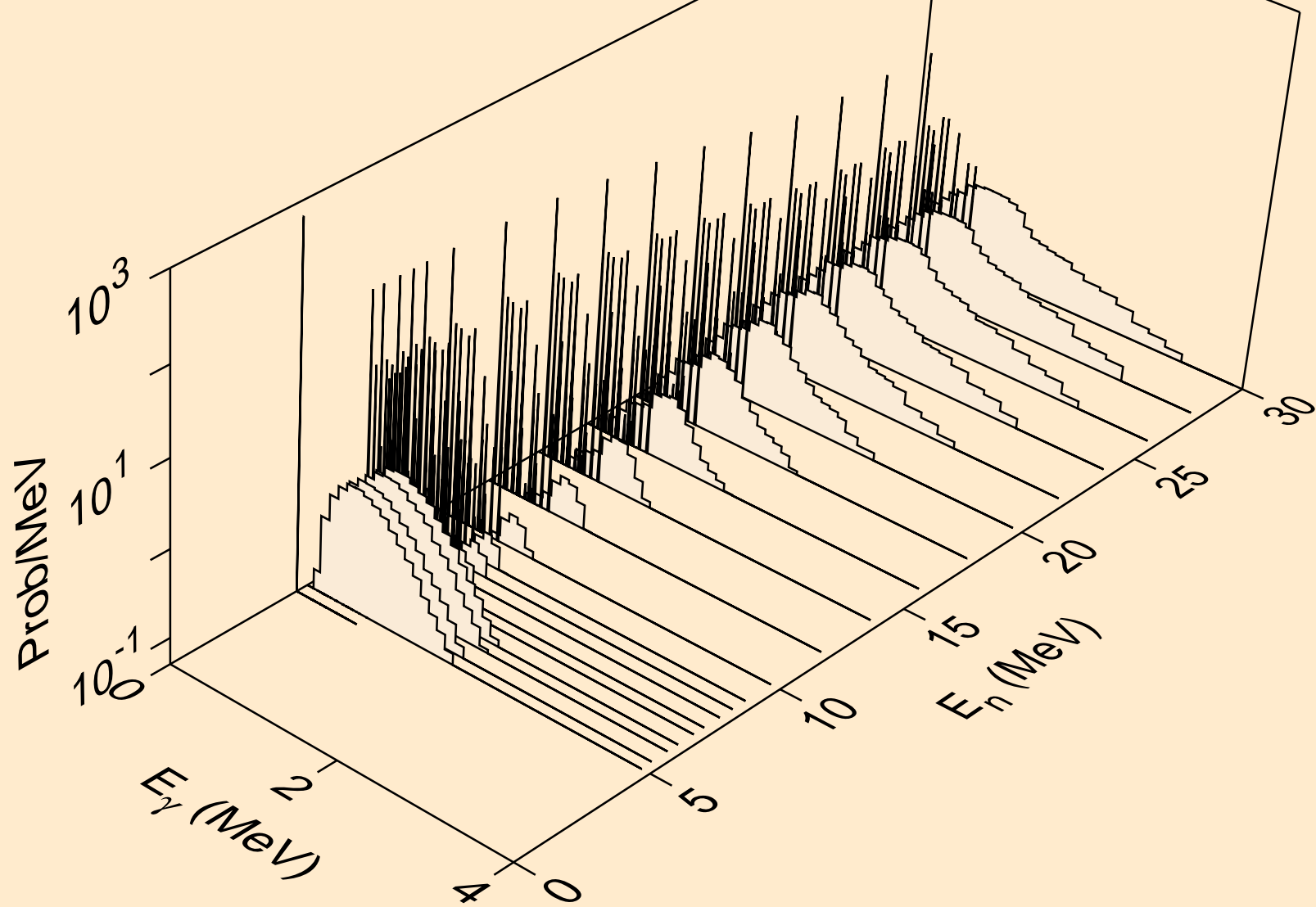

EU152M NEUTRON ACER TENDL-2023 LIBRARY; T=0.K  
Photon emission for (n,2p)

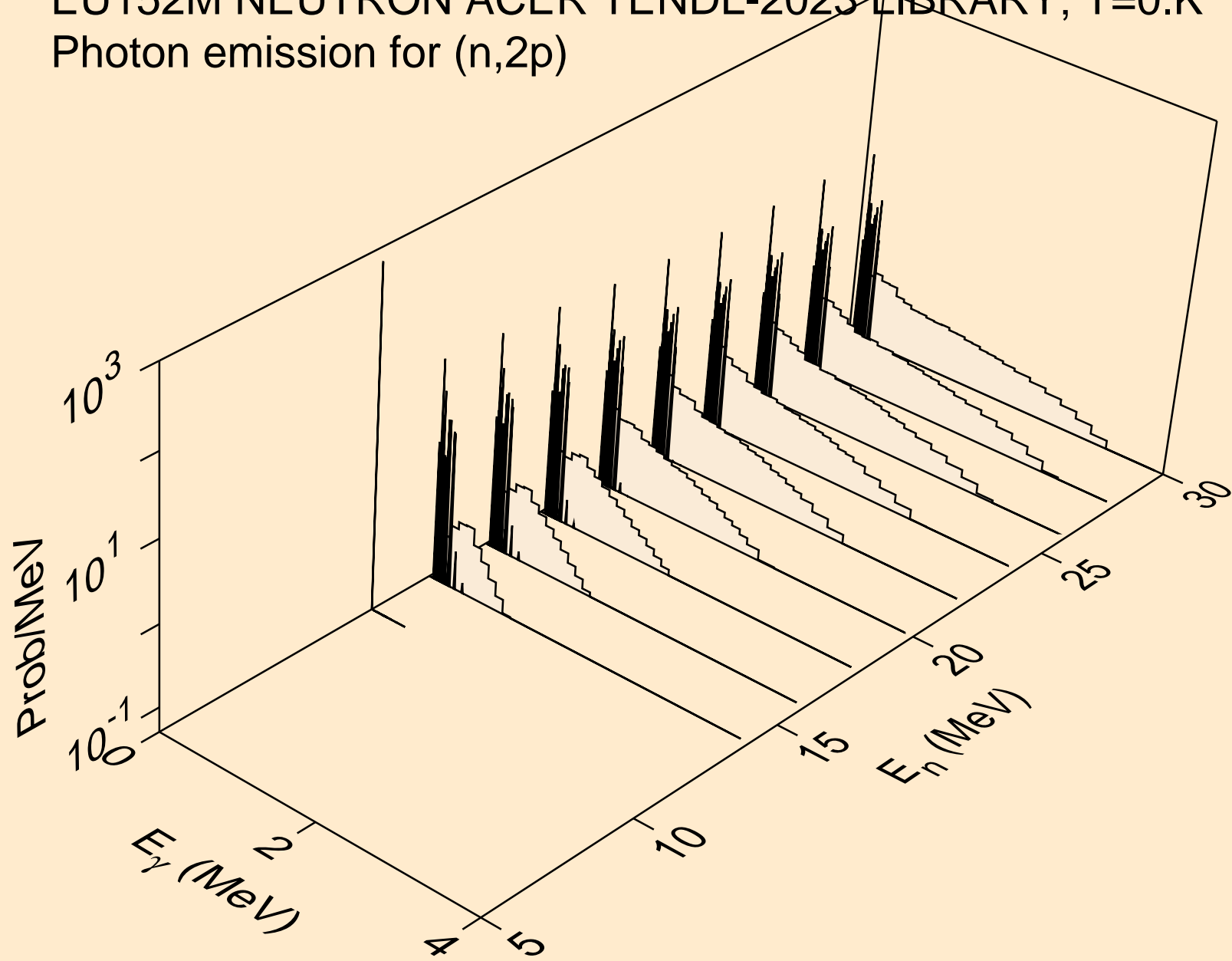

EU152M NEUTRON ACER TENDL-2023 LIBRARY; T=0.K  
Photon emission for (n,p $\alpha$ )

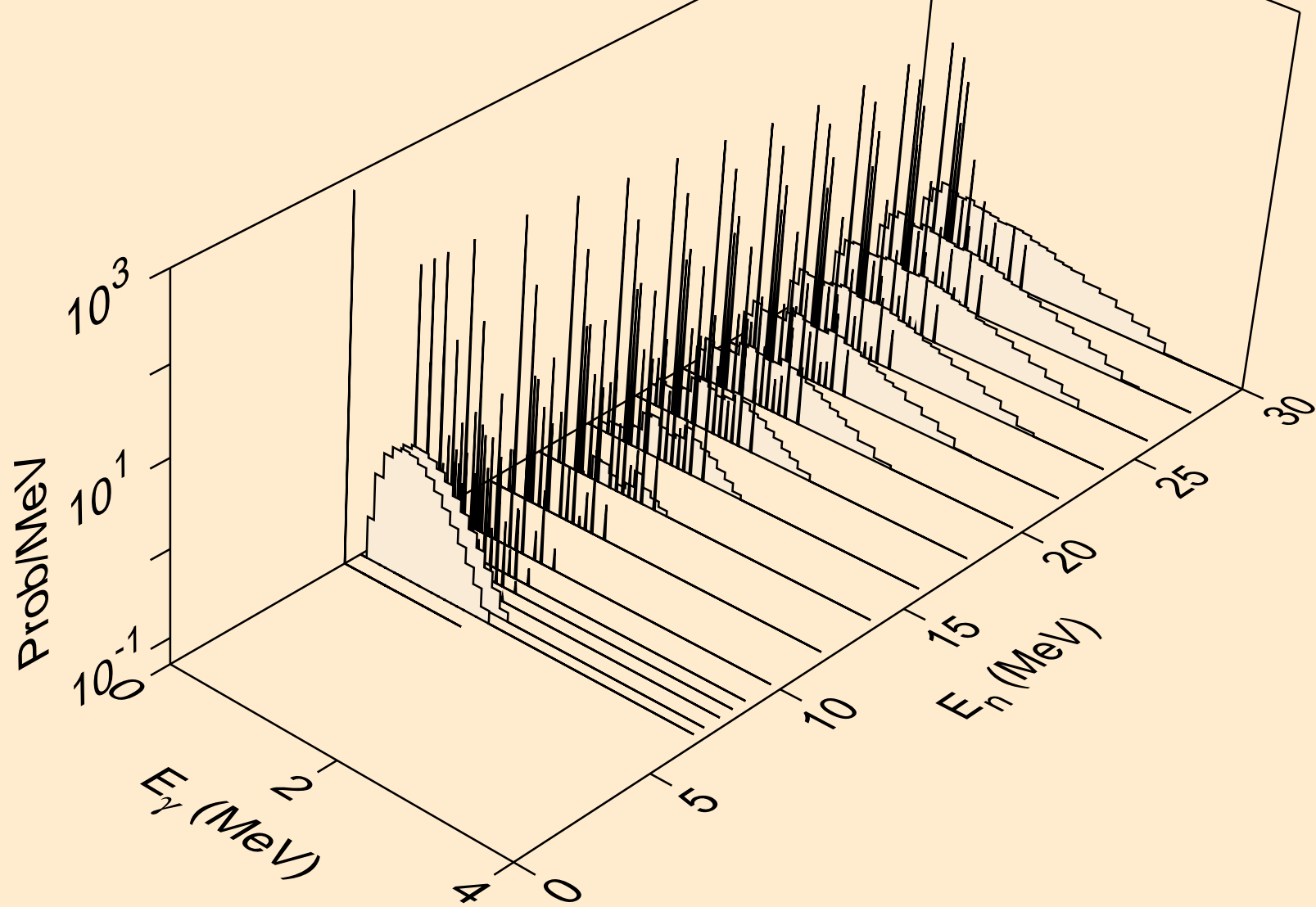

EU152M NEUTRON ACER TENDL-2023 LIBRARY; T=0.K  
Photon emission for (n,pd)

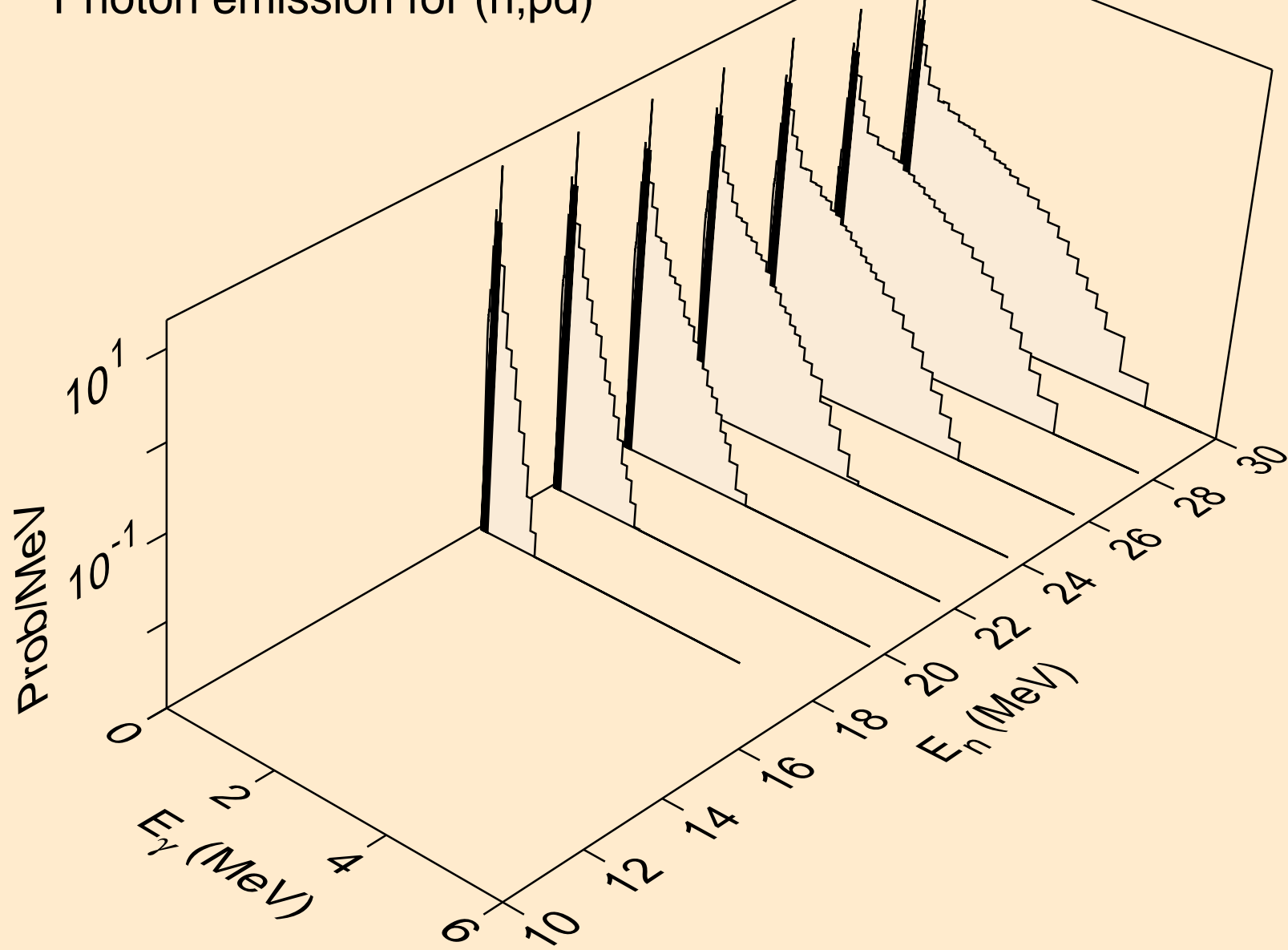

EU152M NEUTRON ACER TENDL-2023 LIBRARY; T=0.K  
Photon emission for (n,pt)

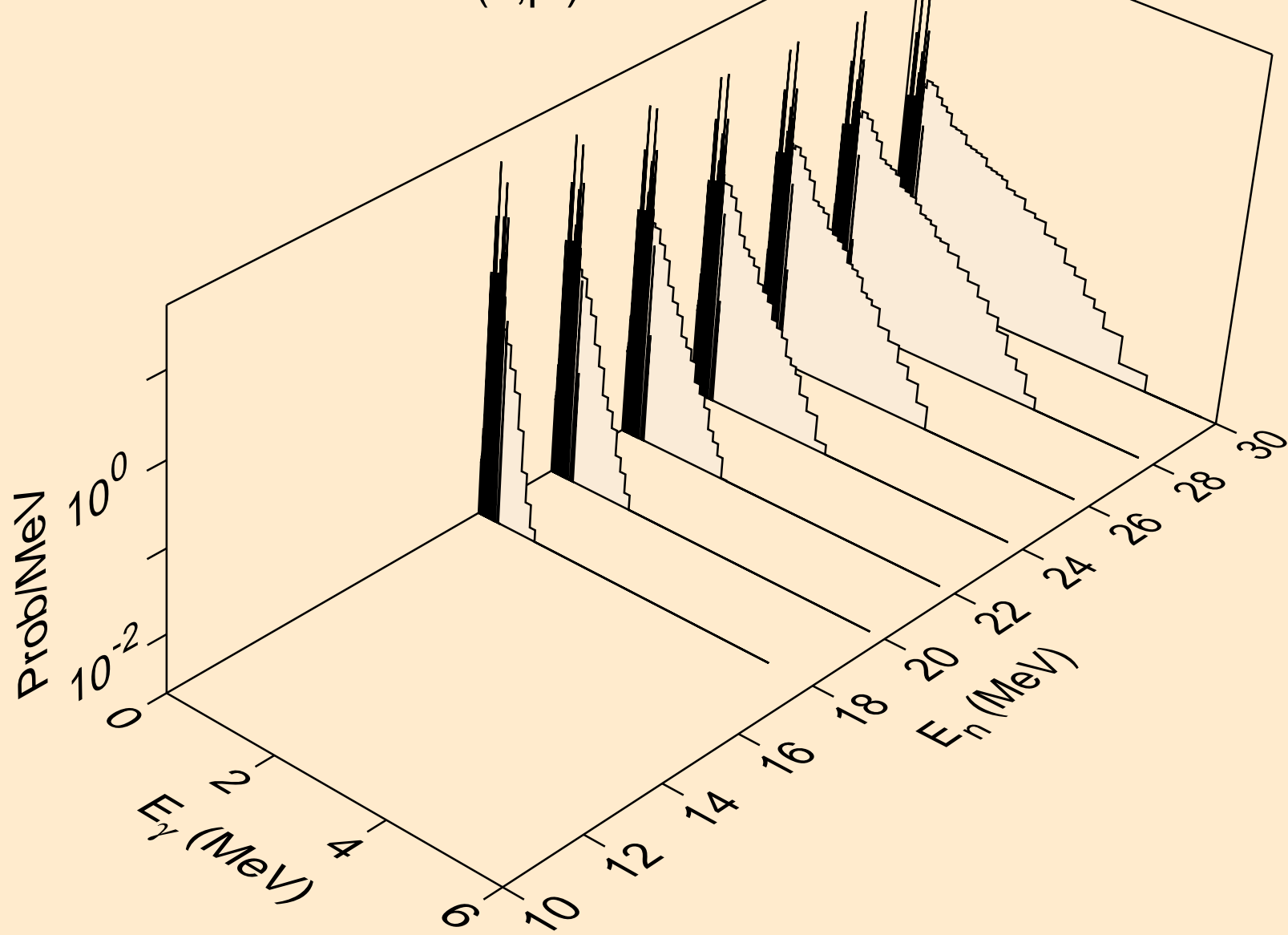

EU152M NEUTRON ACER TENDL-2023 LIBRARY; T=0.K  
Photon emission for (n,da)

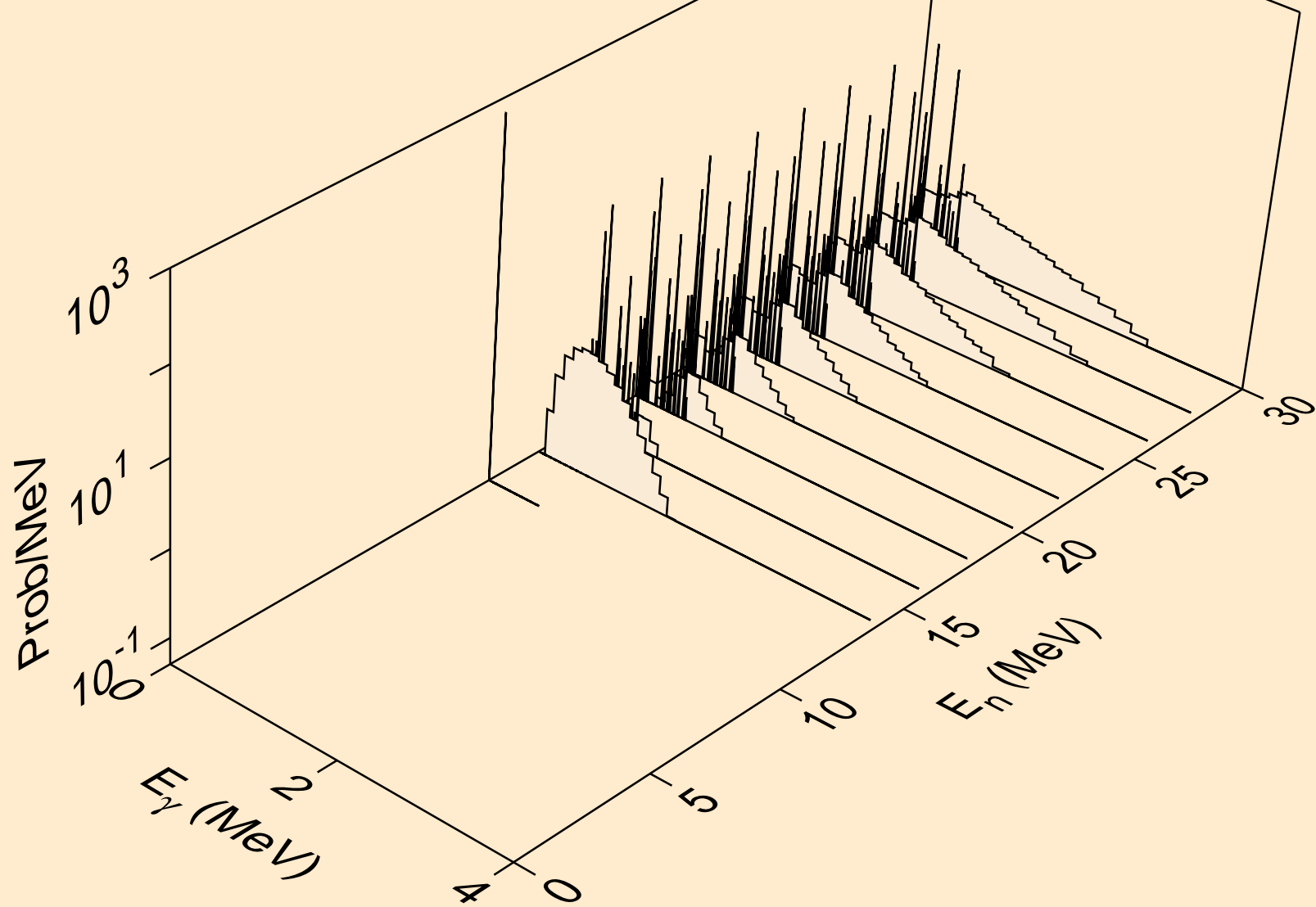

EU152M NEUTRON ACER TENDL-2023 LIBRARY; T=0.K  
thermal capture photon spectrum

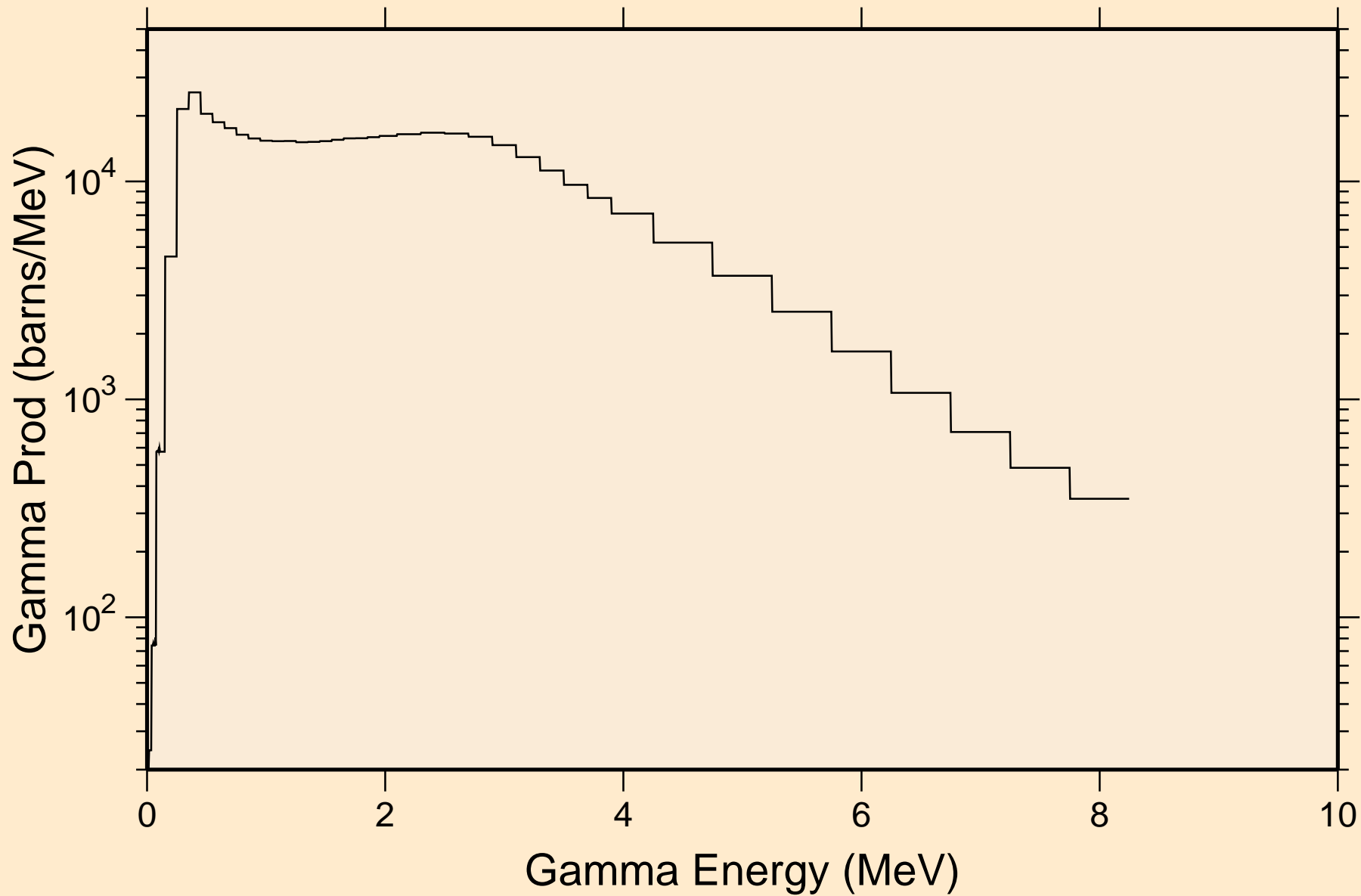

EU152M NEUTRON ACER TENDL-2023 LIBRARY; T=0.K  
14 MeV photon spectrum

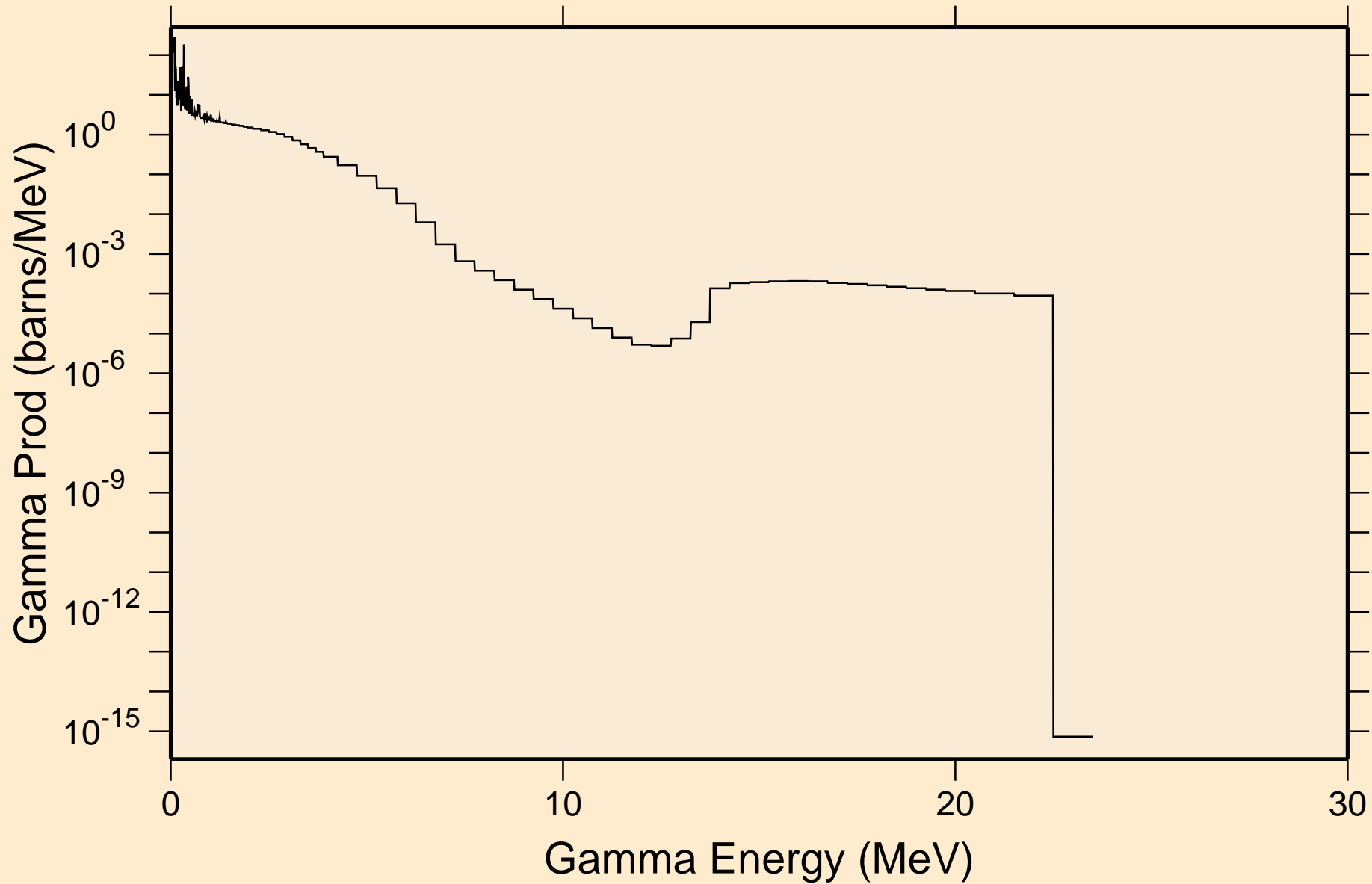

# EU152M NEUTRON ACER TENDL-2023 LIBRARY; T=0.K

## Particle heating contributions

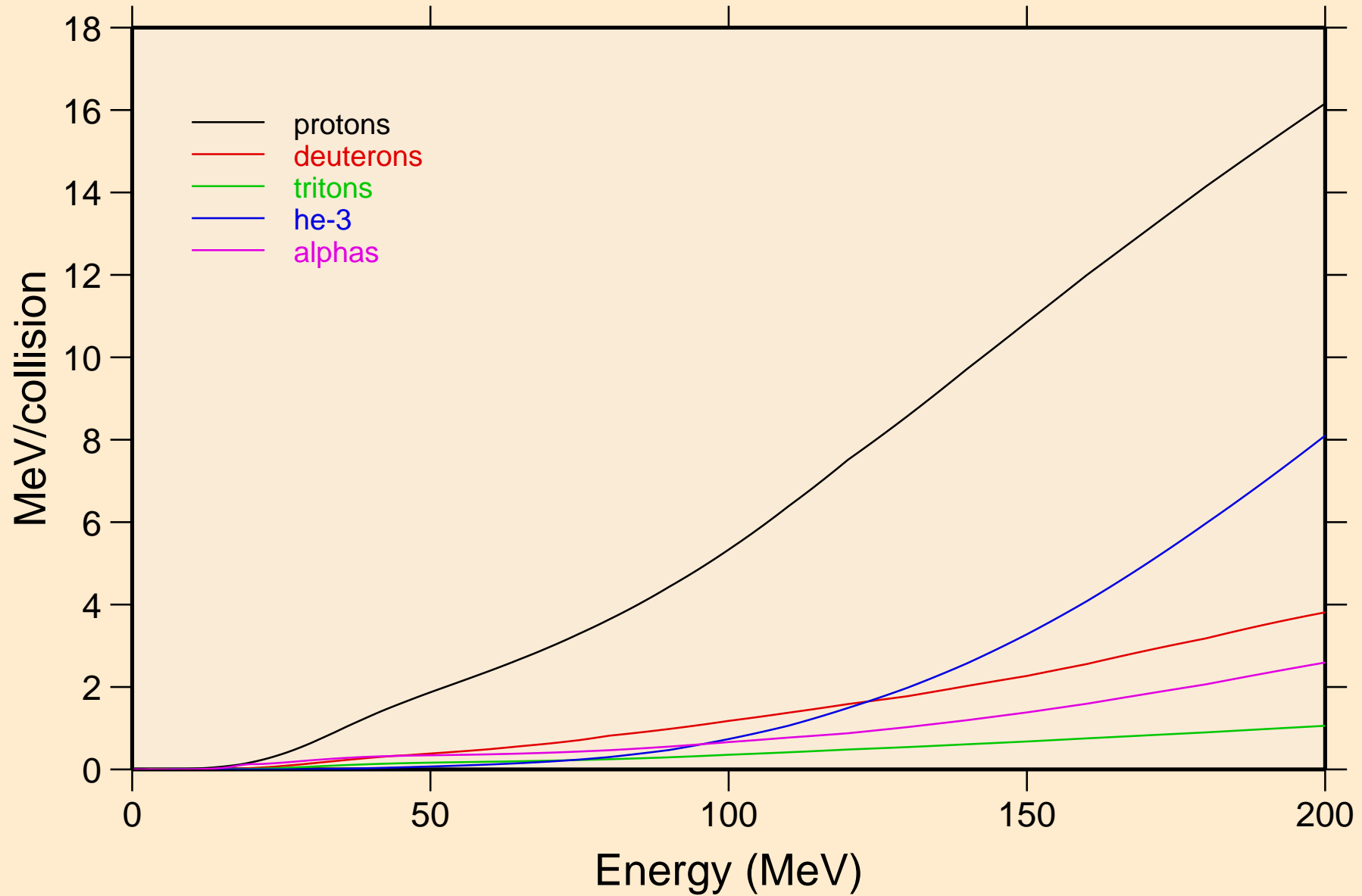

# EU152M NEUTRON ACER TENDL-2023 LIBRARY; T=0.K

## Recoil Heating

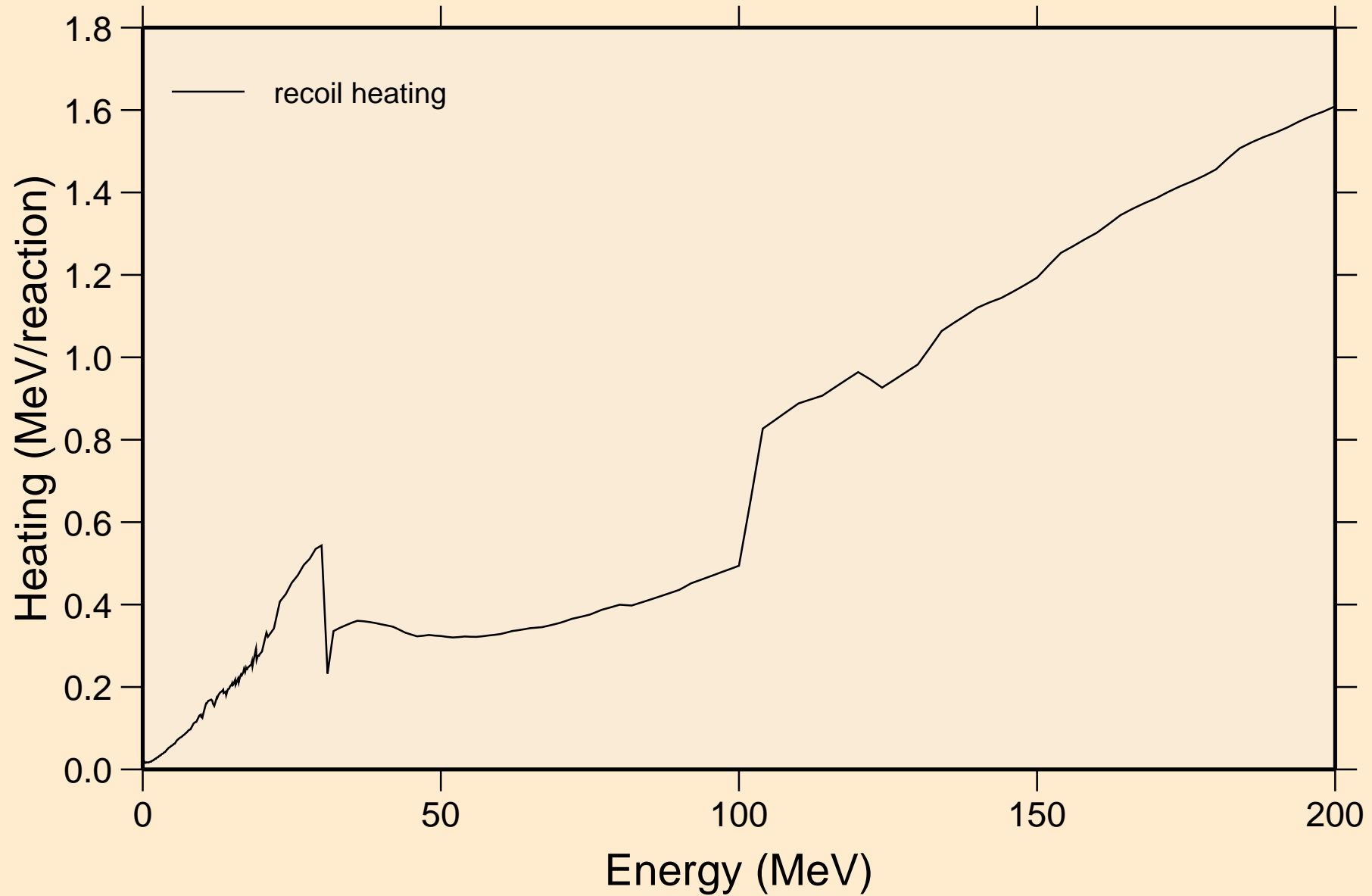

# EU152M NEUTRON ACER TENDL-2023 LIBRARY; T=0.K

## Particle production cross sections

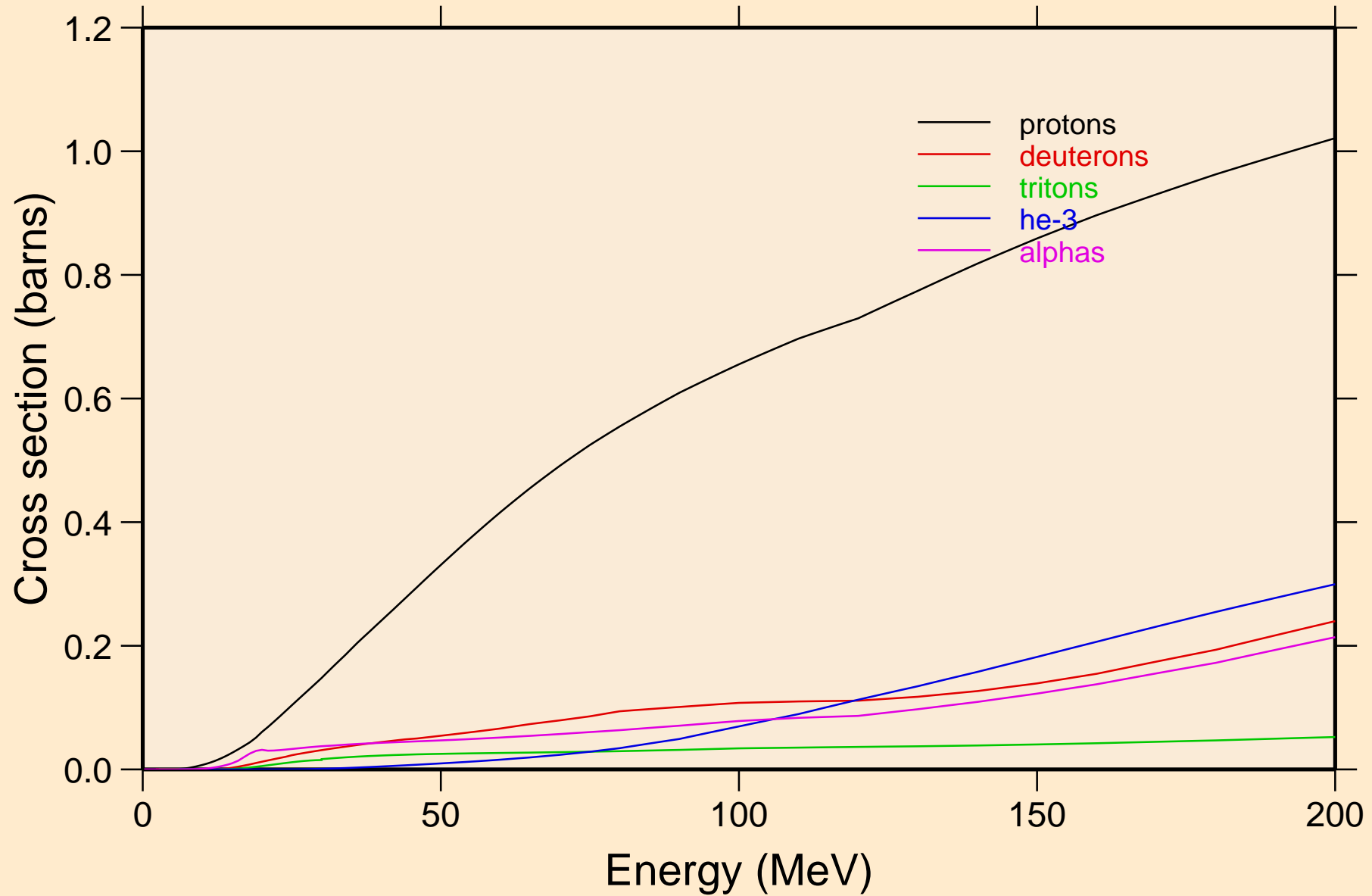

EU152M NEUTRON ACER TENDL-2023 LIBRARY; T=0.K  
protons from (n,x)

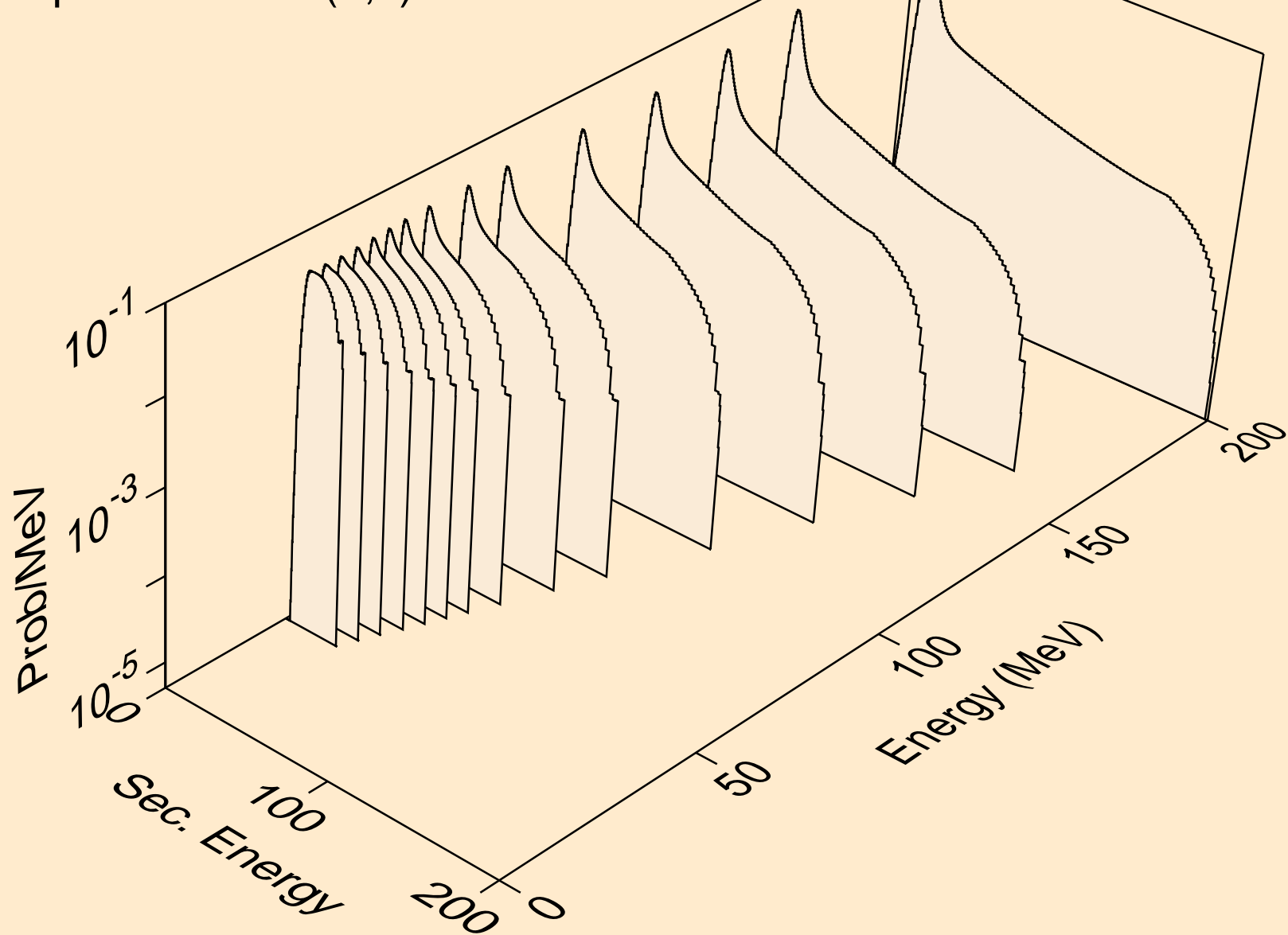

EU152M NEUTRON ACER TENDL-2023 LIBRARY; T=0.K  
protons from (n,n\*)p

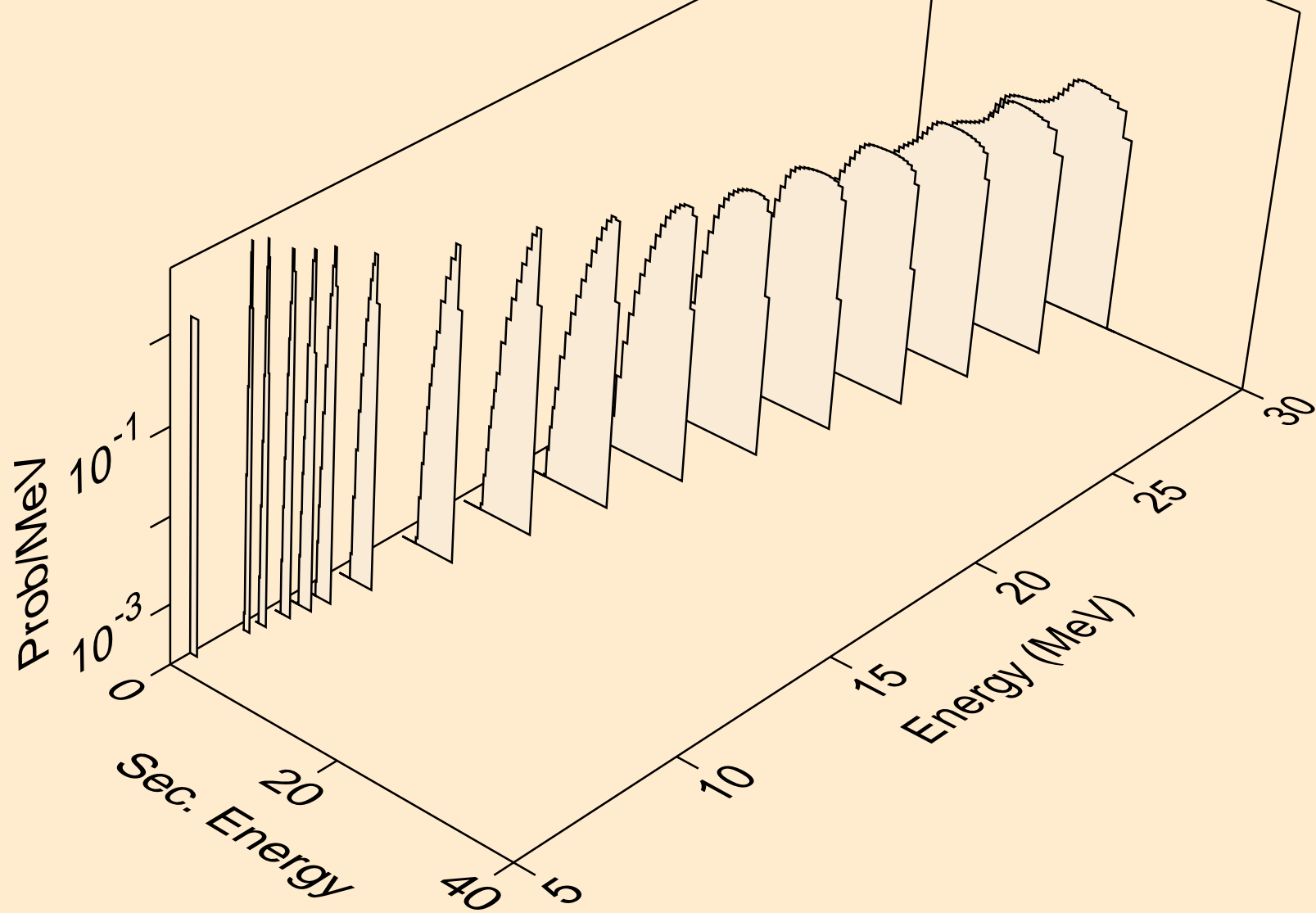

EU152M NEUTRON ACER TENDL-2023 LIBRARY; T=0.K  
protons from (n,2np)

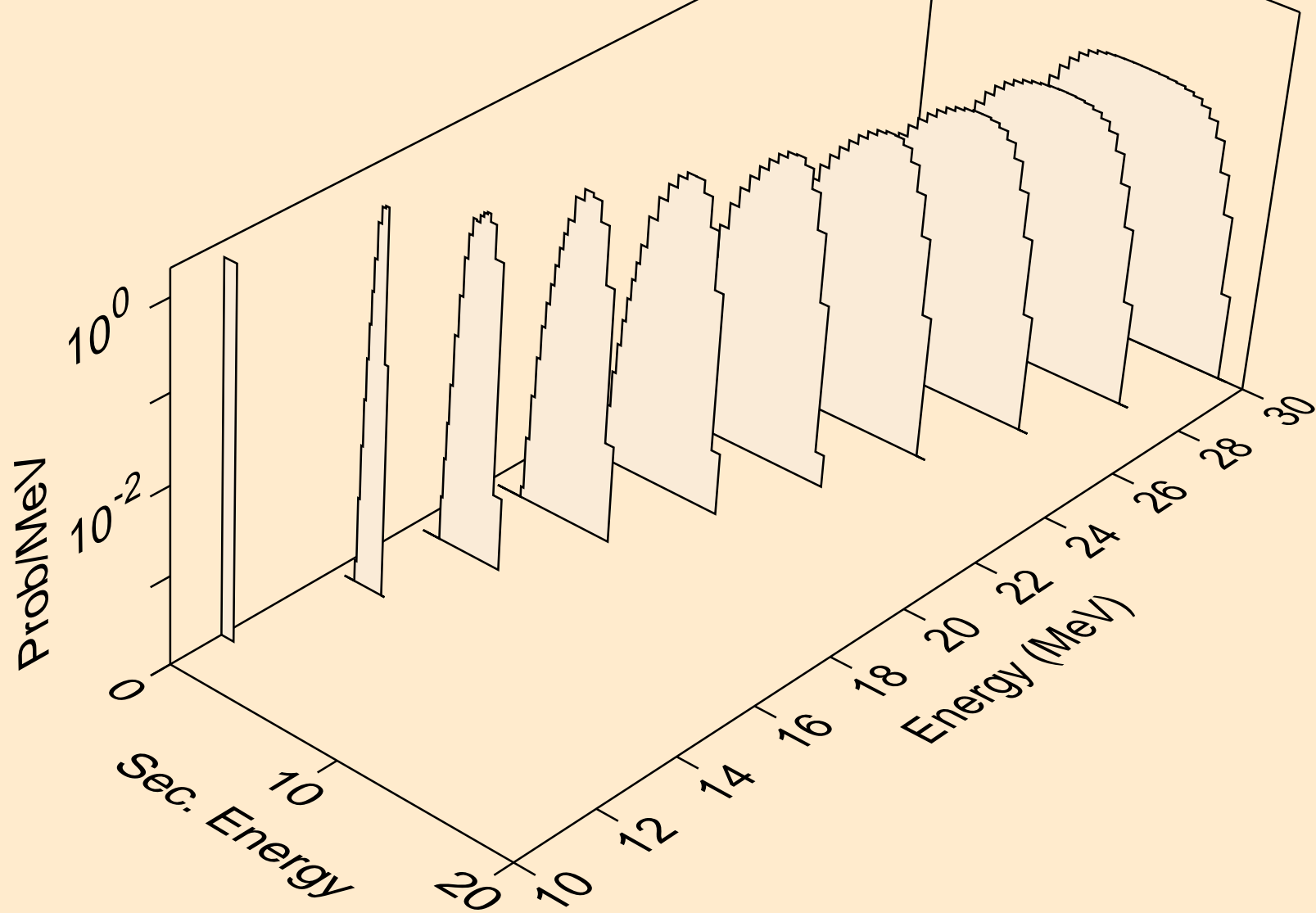

EU152M NEUTRON ACER TENDL-2023 LIBRARY; T=0.K  
protons from (n,3np)

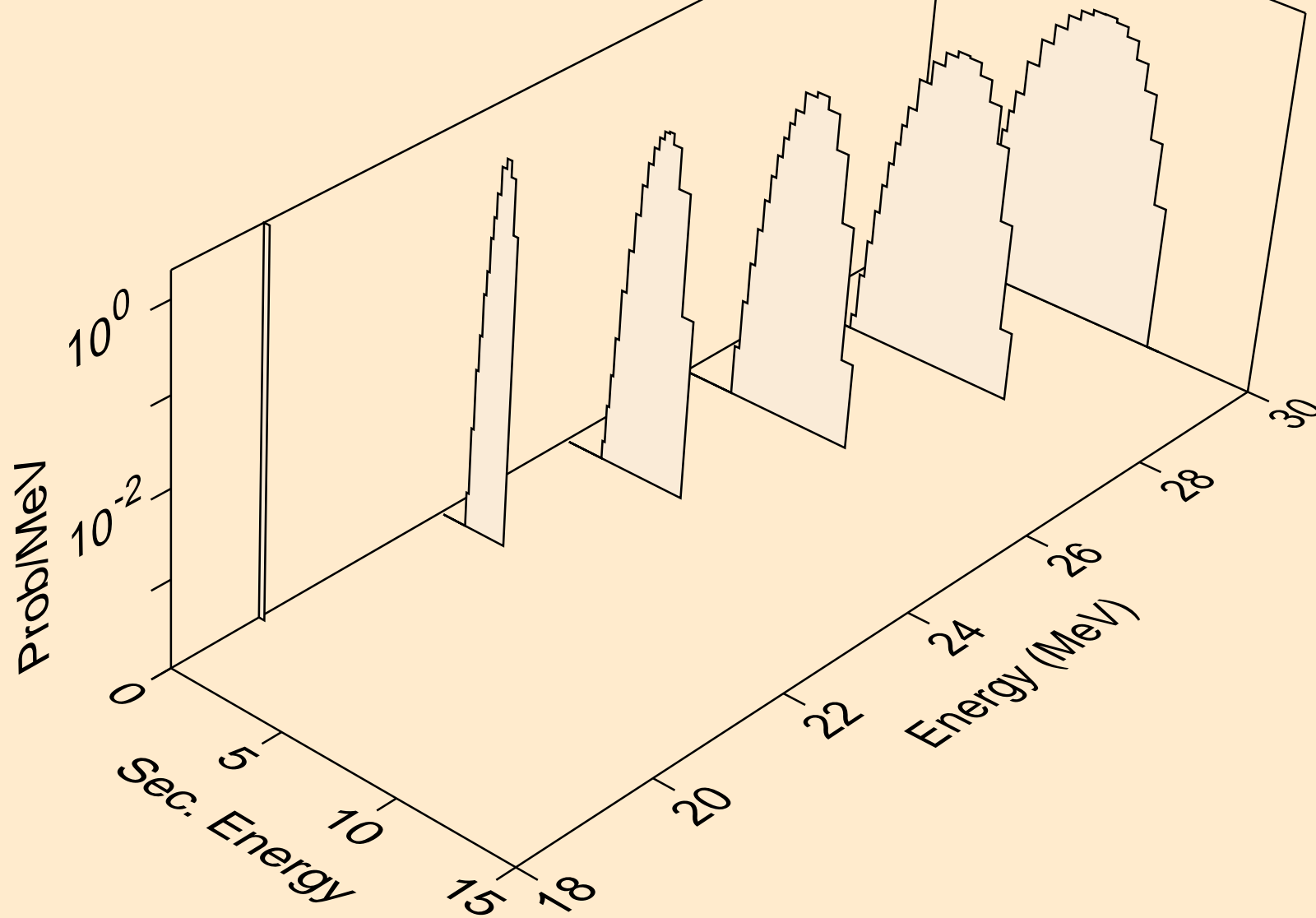

EU152M NEUTRON ACER TENDL-2023 LIBRARY; T=0.K  
protons from (n,n2p)

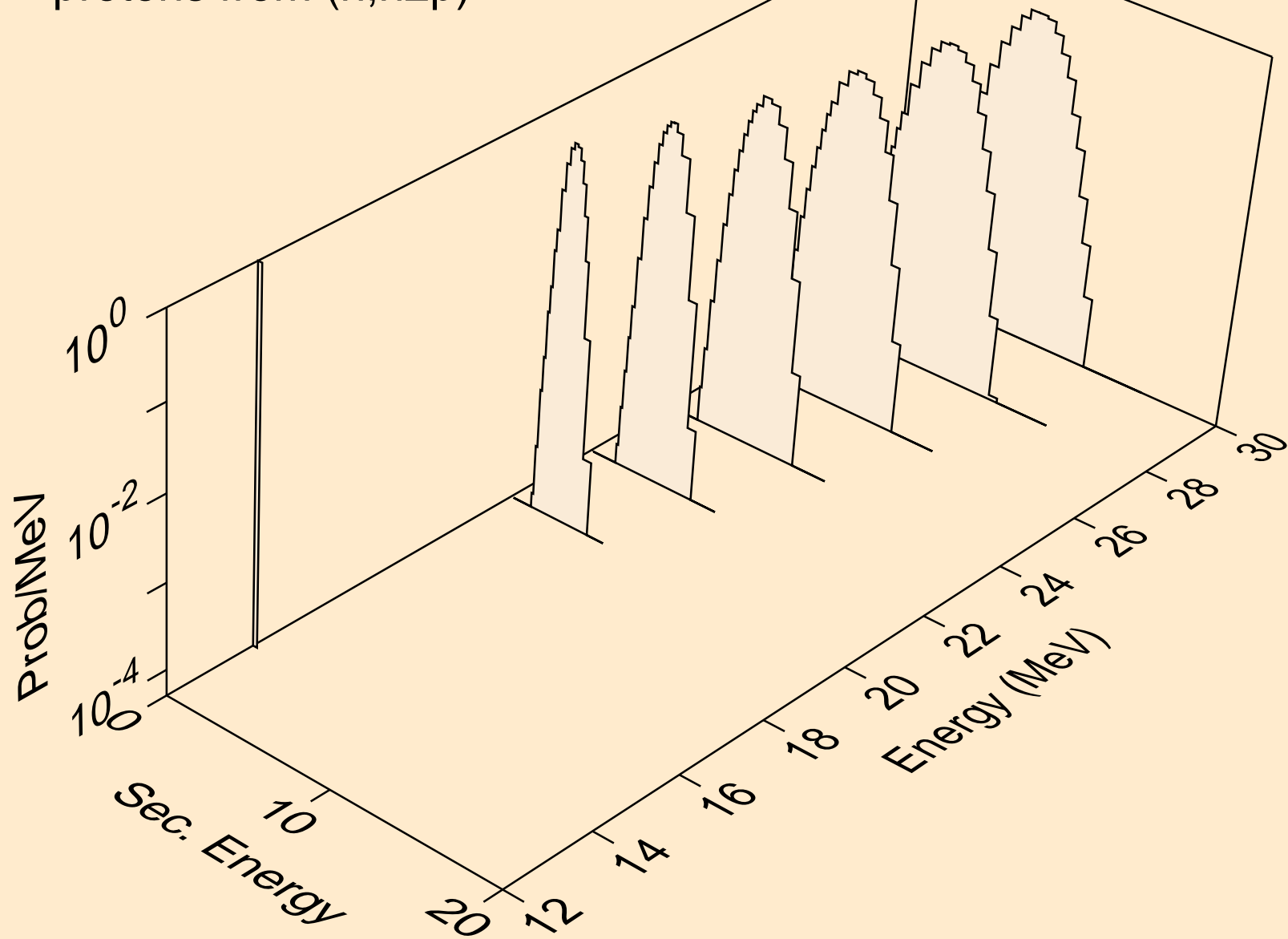

EU152M NEUTRON ACER TENDL-2023 LIBRARY; T=0.K  
protons from (n,npa)

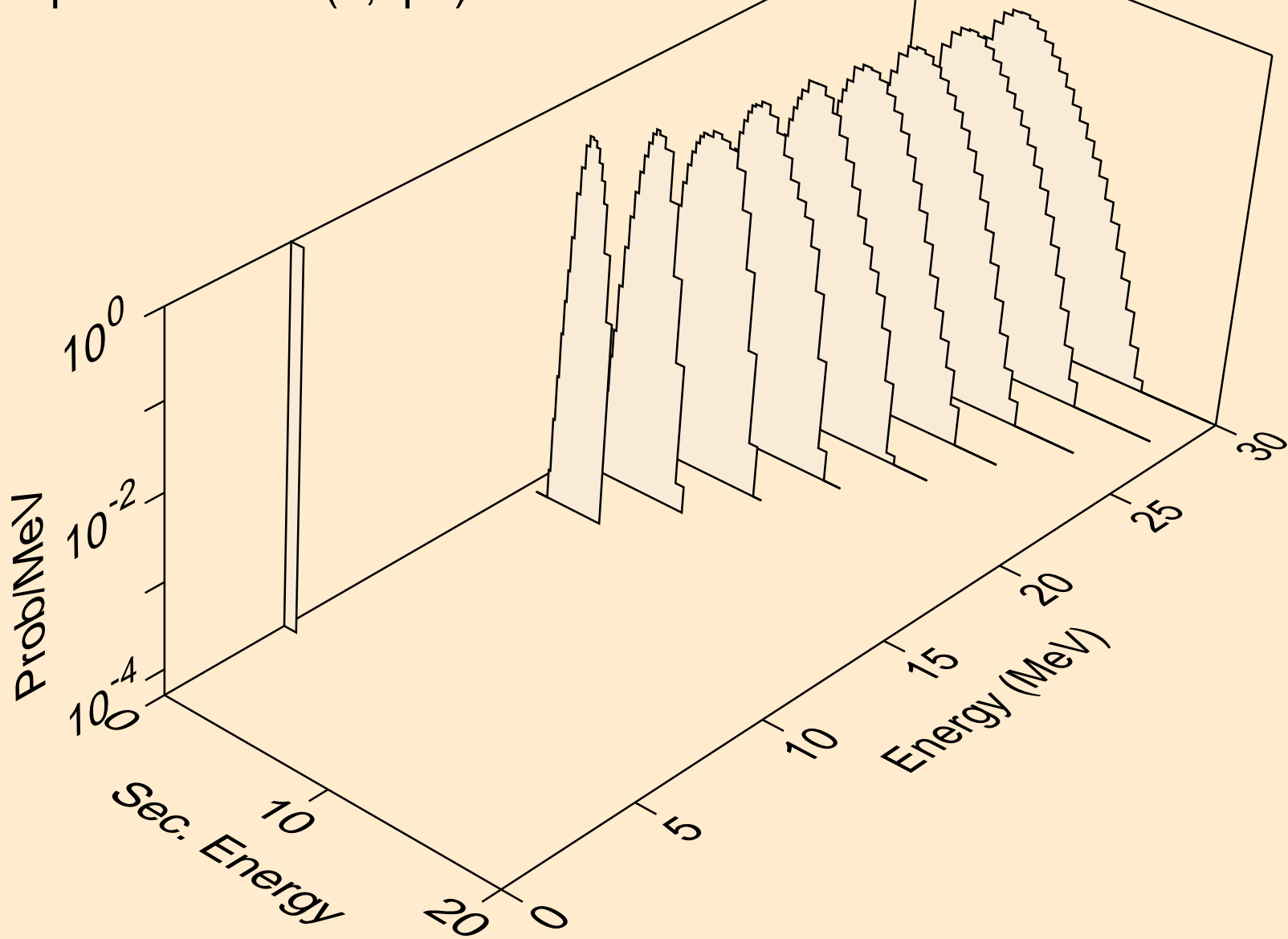

EU152M NEUTRON ACER TENDL-2023 LIBRARY; T=0.K  
protons from (n,p)

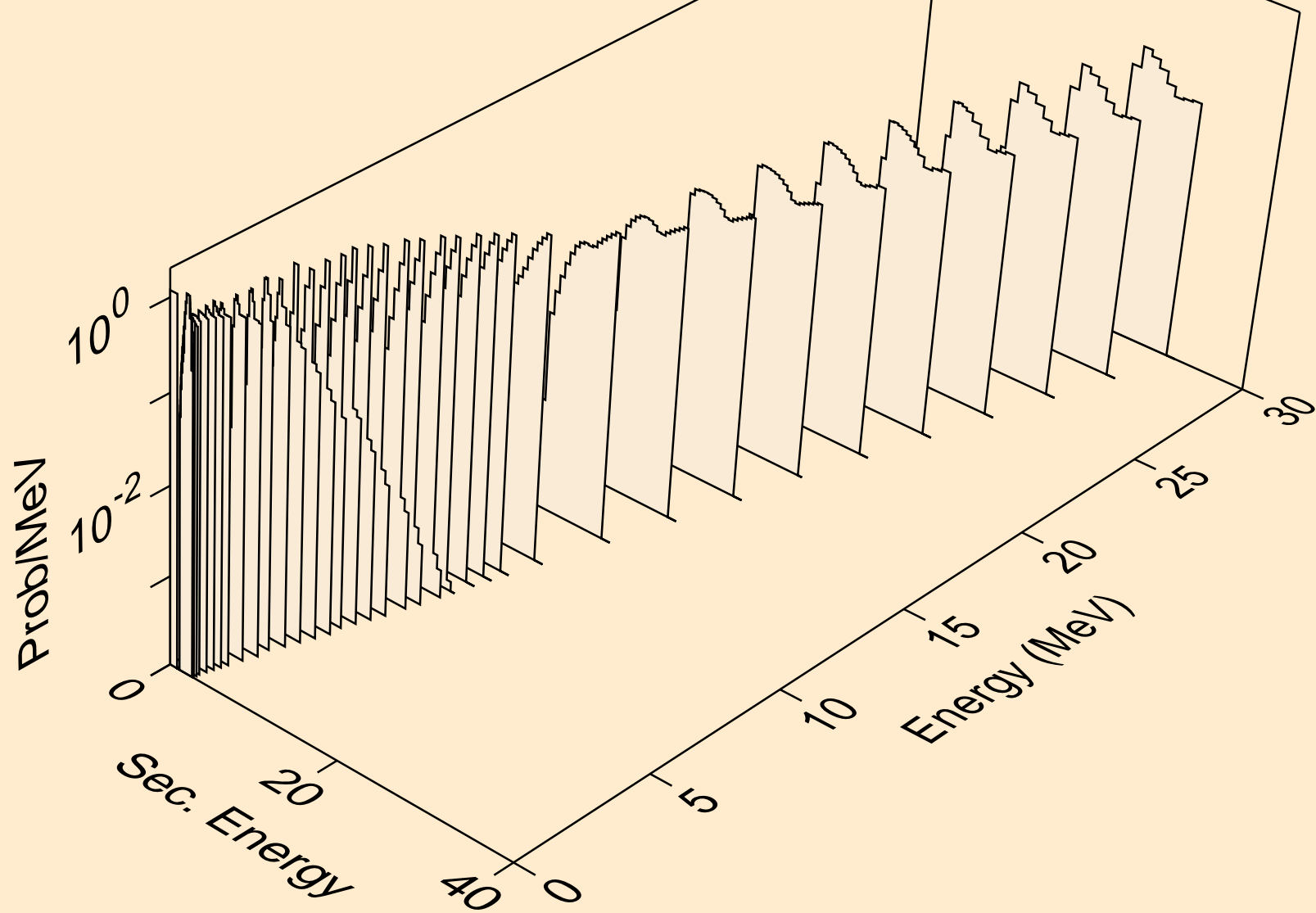

EU152M NEUTRON ACER TENDL-2023 LIBRARY; T=0.K  
protons from (n,2p)

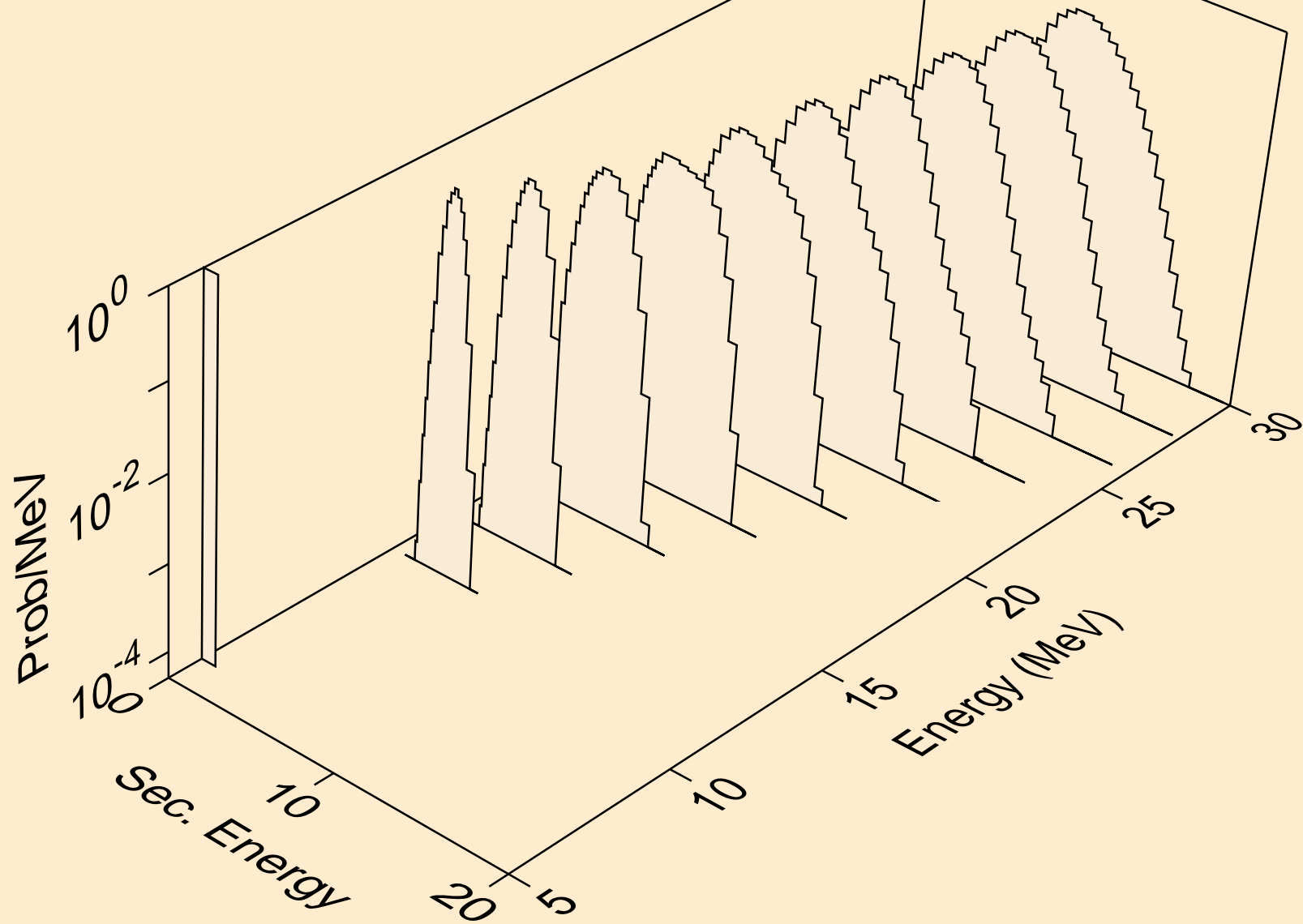

EU152M NEUTRON ACER TENDL-2023 LIBRARY; T=0.K  
protons from (n,p)

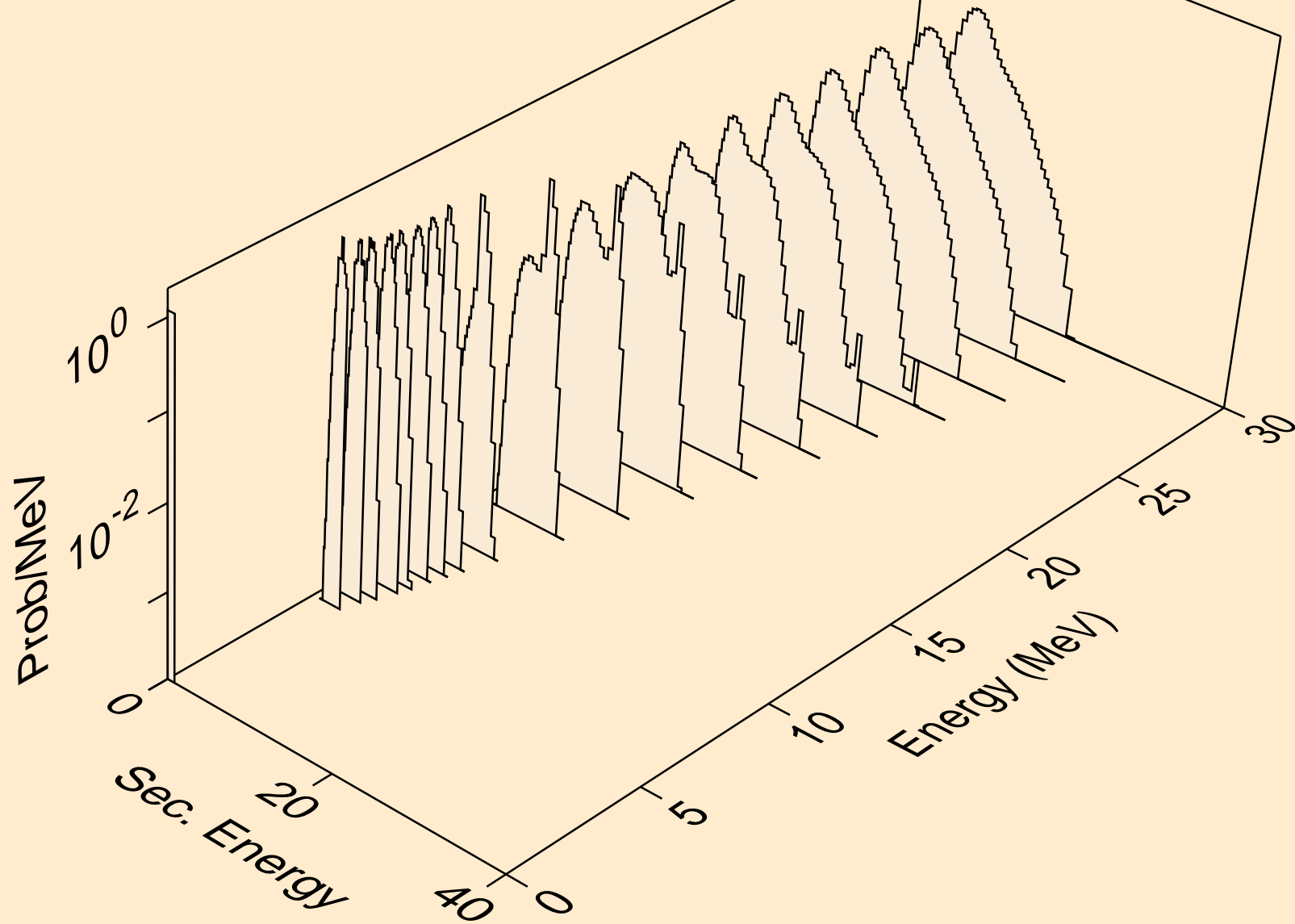

EU152M NEUTRON ACER TENDL-2023 LIBRARY; T=0.K  
protons from (n,pd)

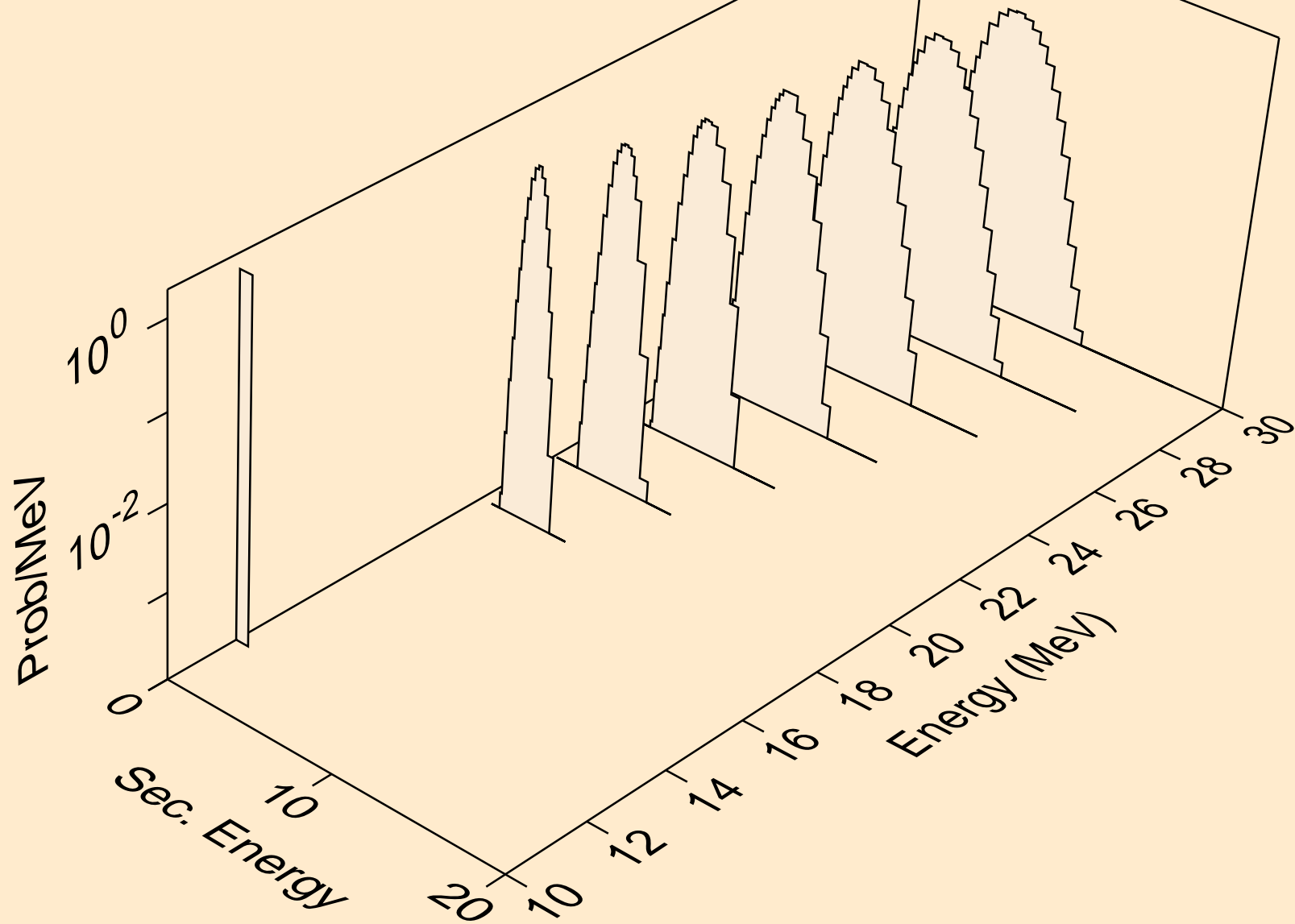

EU152M NEUTRON ACER TENDL-2023 LIBRARY; T=0.K  
protons from (n,pt)

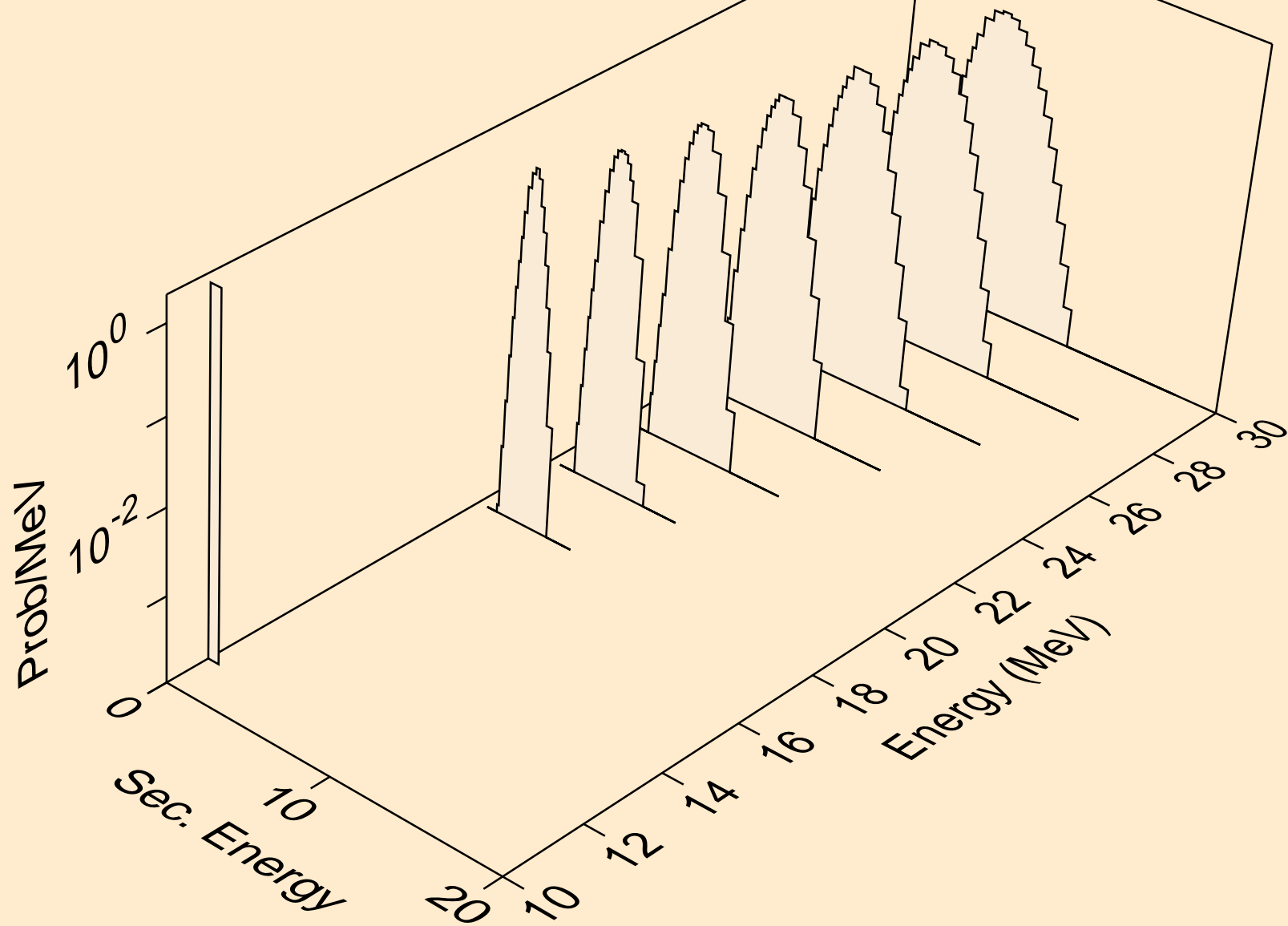

EU152M NEUTRON ACER TENDL-2023 LIBRARY; T=0.K  
deuterons from (n,x)

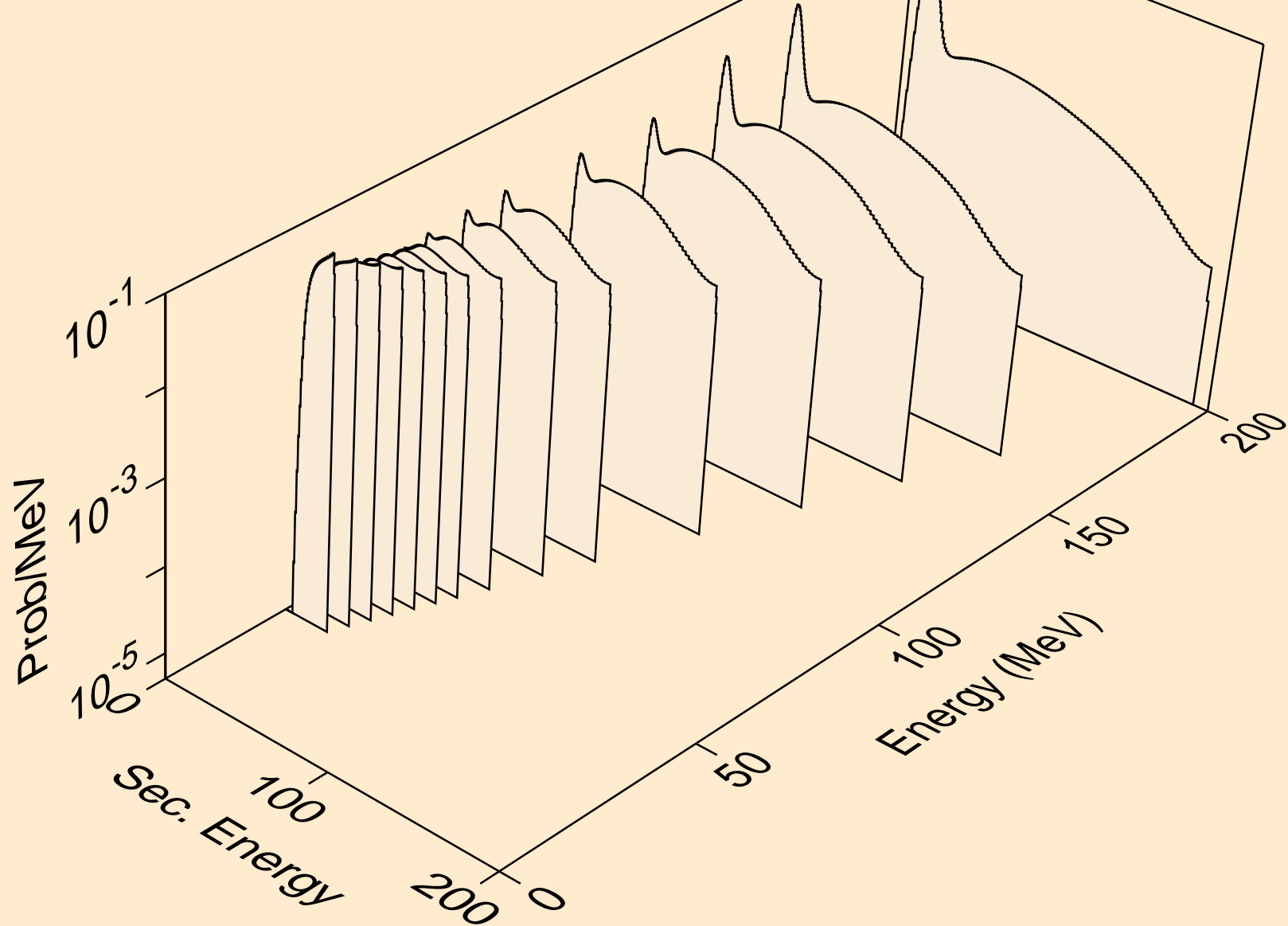

EU152M NEUTRON ACER TENDL-2023 LIBRARY; T=0.K  
deuterons from (n,2nd)

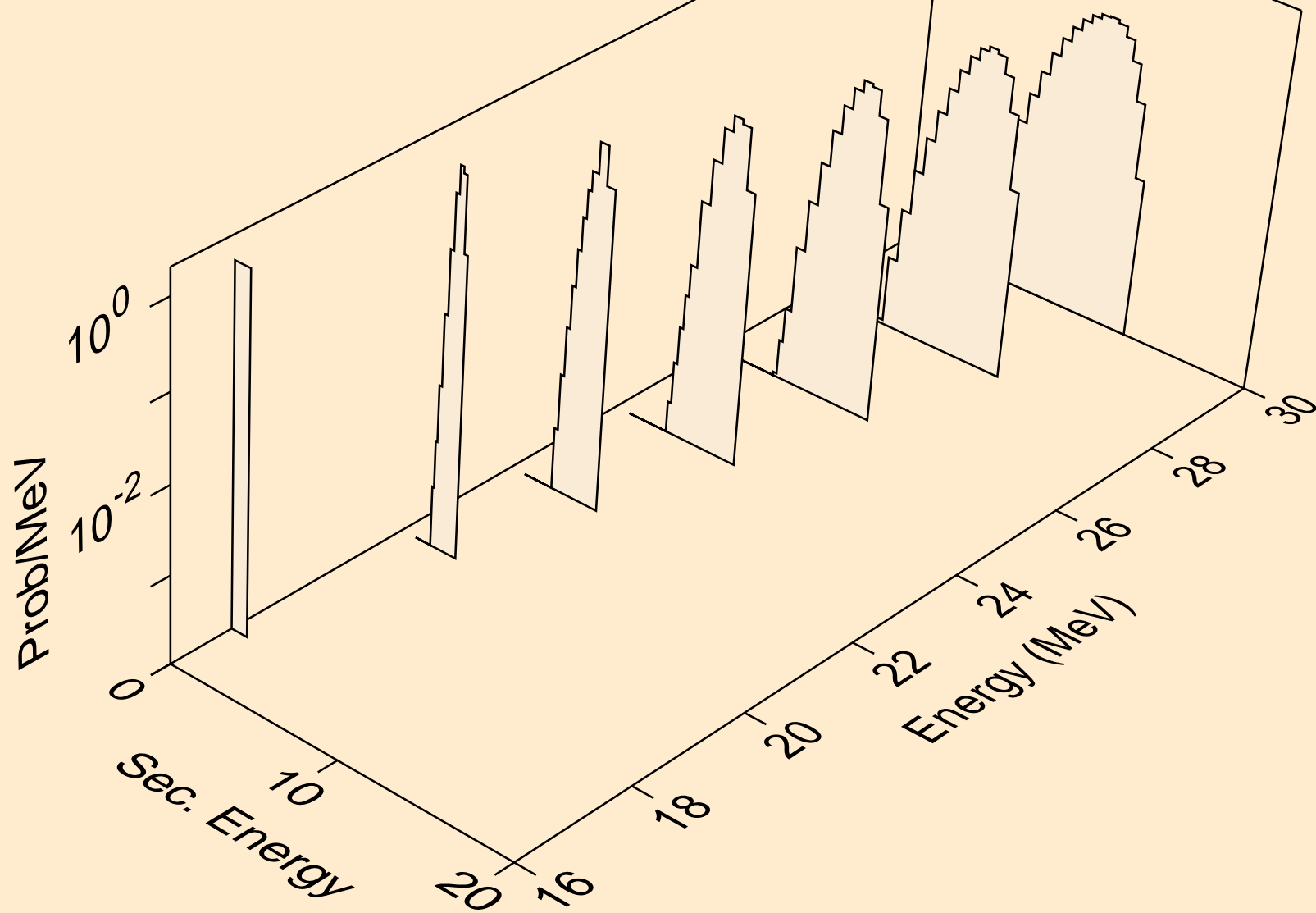

EU152M NEUTRON ACER TENDL-2023 LIBRARY; T=0.K  
deuterons from (n,n\*)d

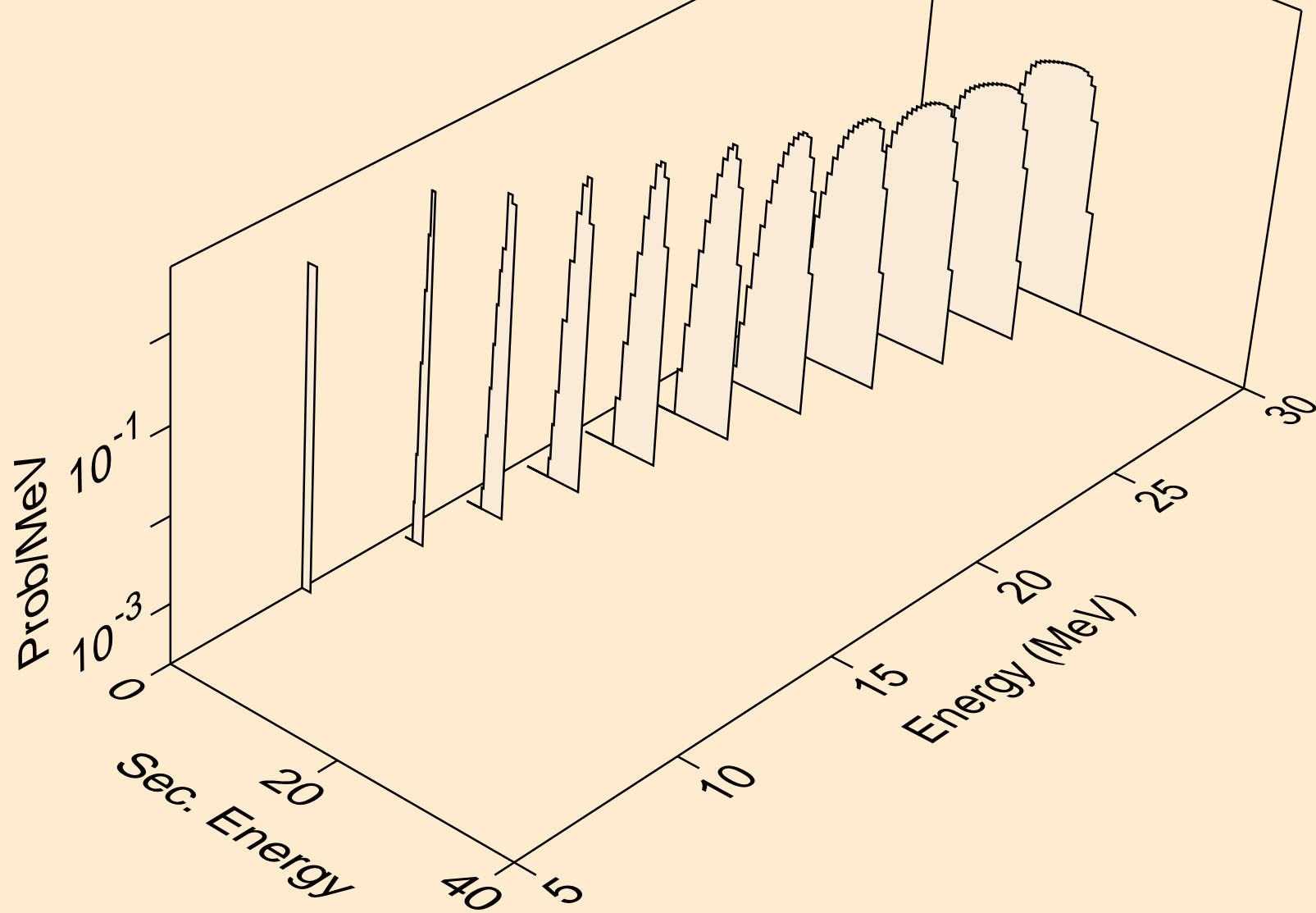

EU152M NEUTRON ACER TENDL-2023 LIBRARY; T=0.K  
deuterons from (n,d)

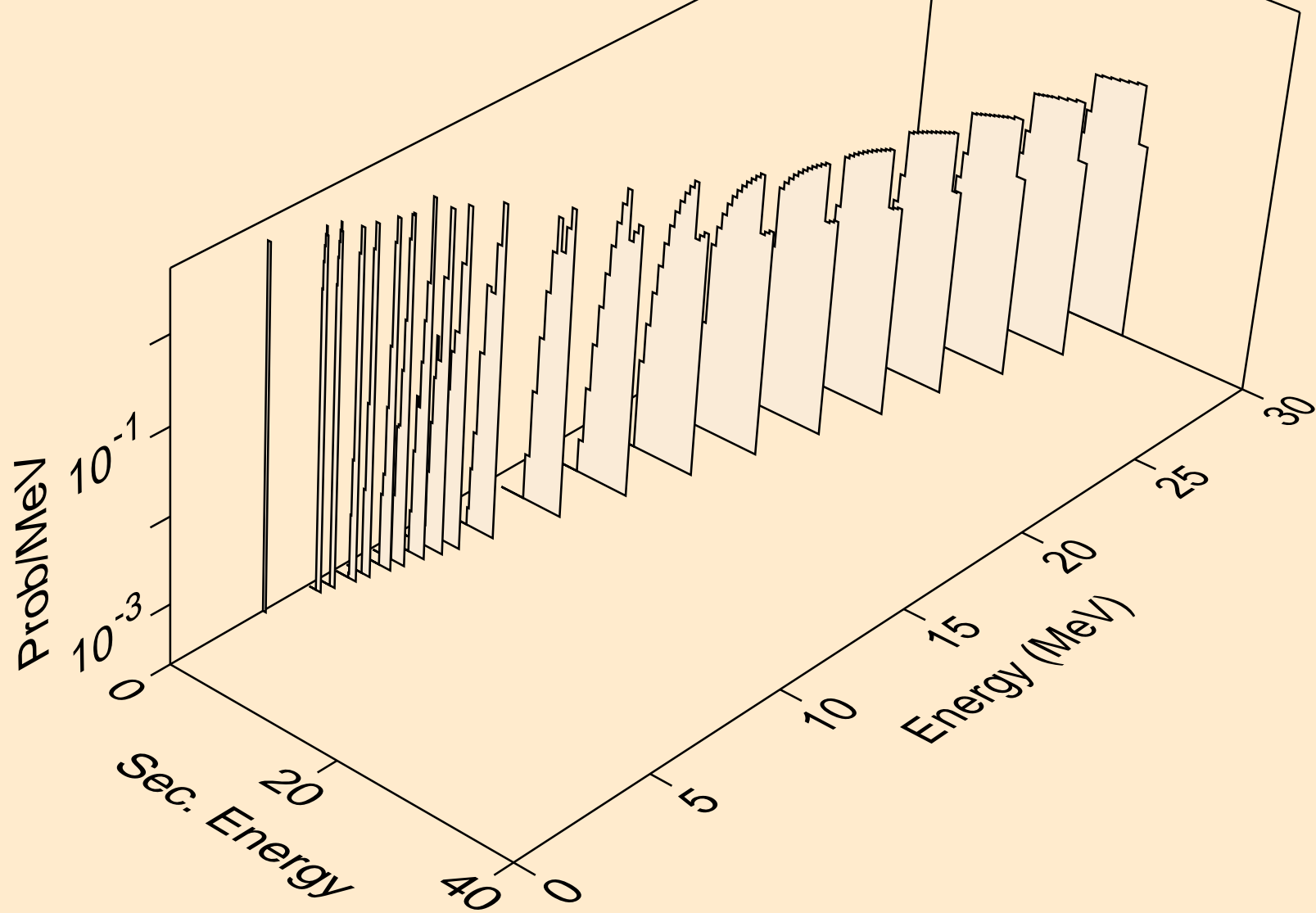

EU152M NEUTRON ACER TENDL-2023 LIBRARY; T=0.K  
deuterons from (n,pd)

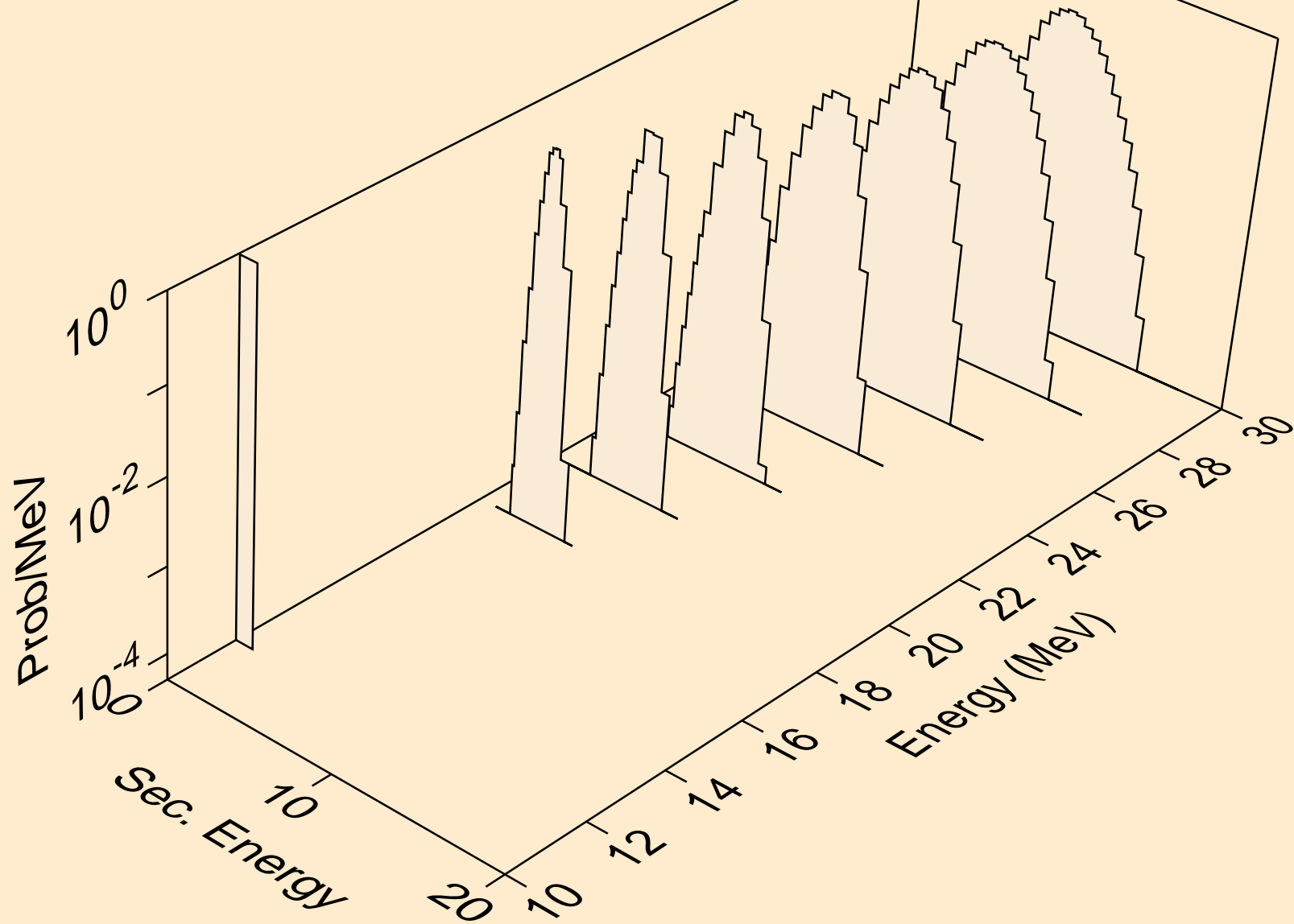

EU152M NEUTRON ACER TENDL-2023 LIBRARY; T=0.K  
deuterons from (n,da)

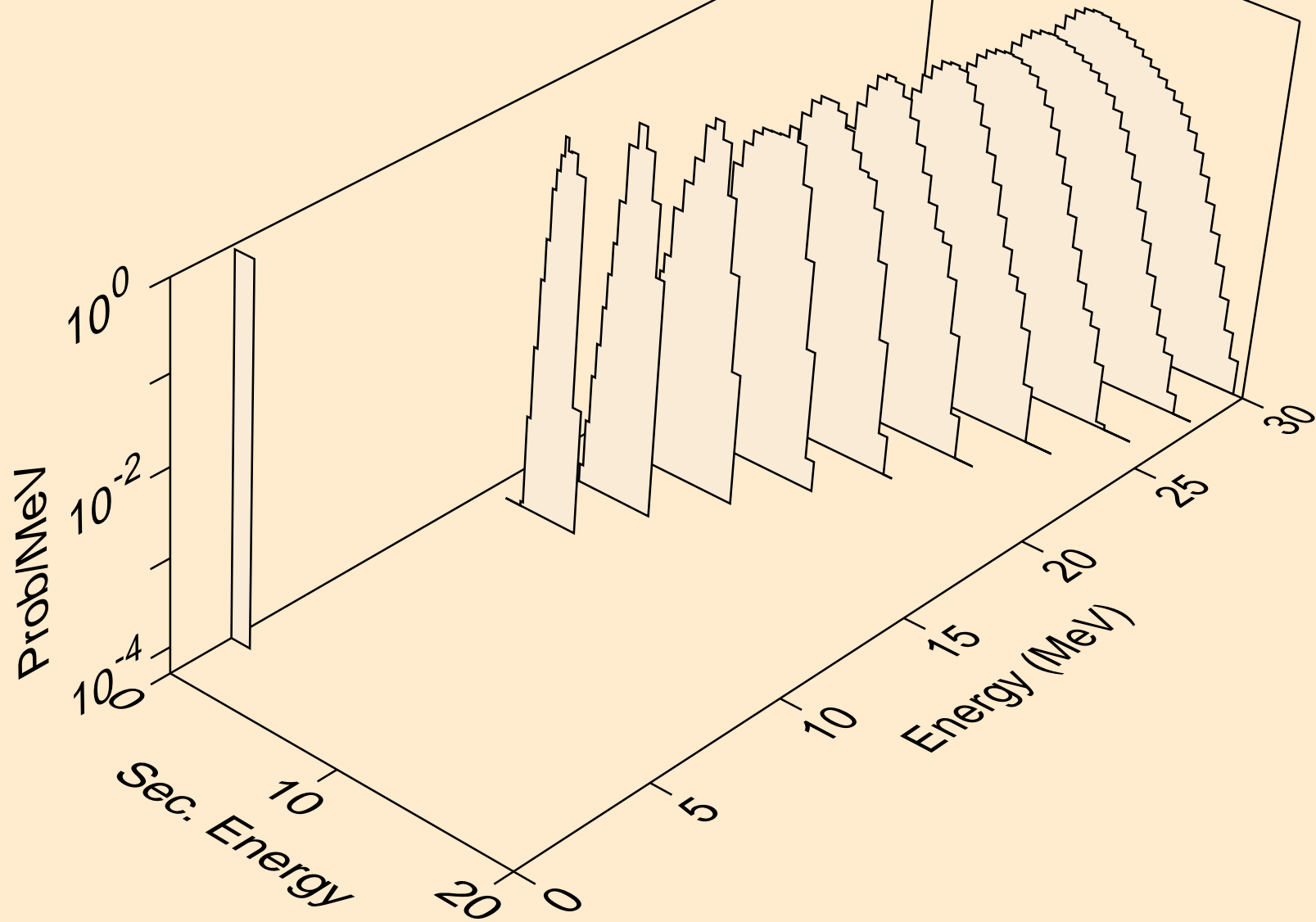

EU152M NEUTRON ACER TENDL-2023 LIBRARY; T=0.K  
tritons from (n,x)

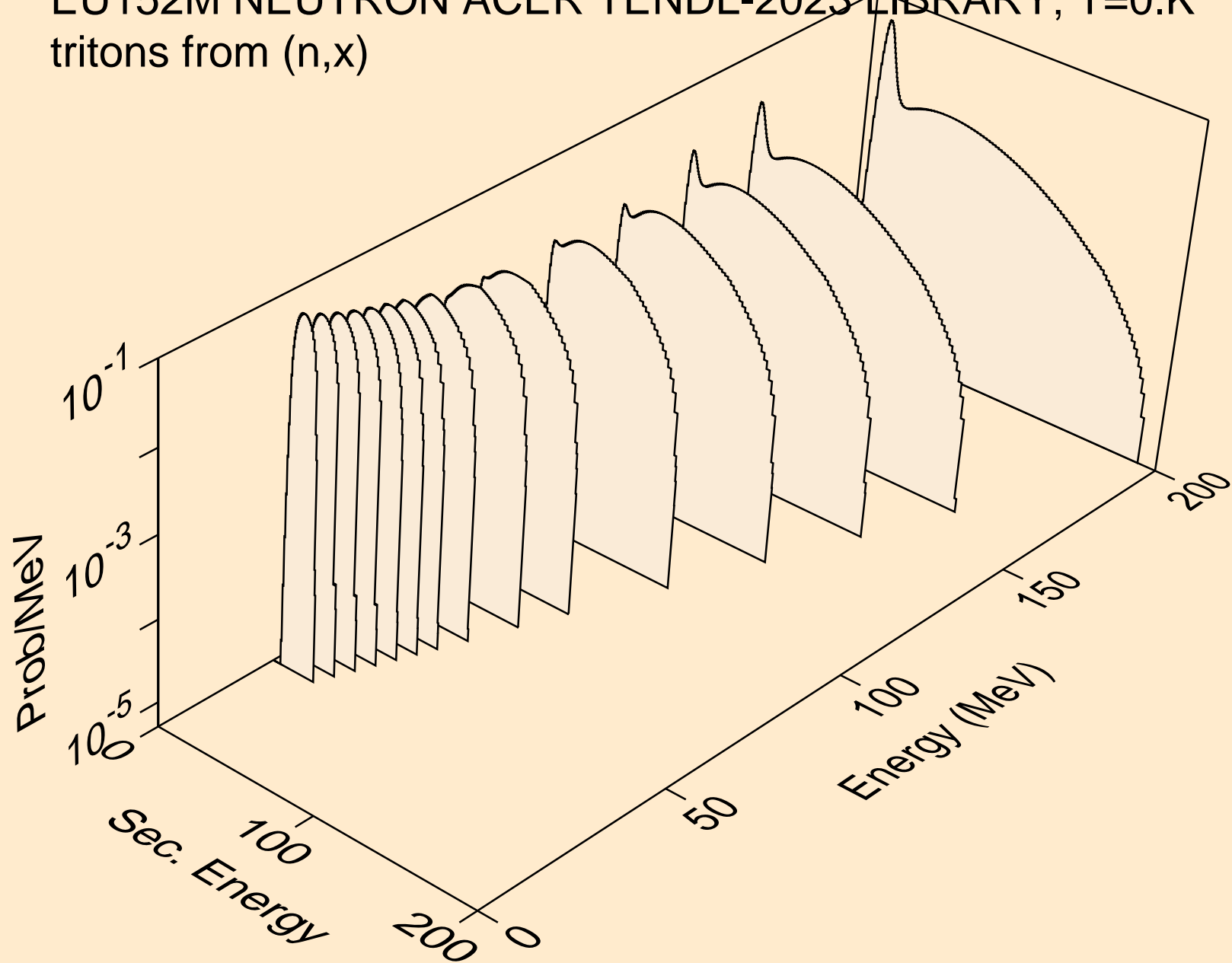

EU152M NEUTRON ACER TENDL-2023 LIBRARY; T=0.K  
tritons from (n,n\*)t

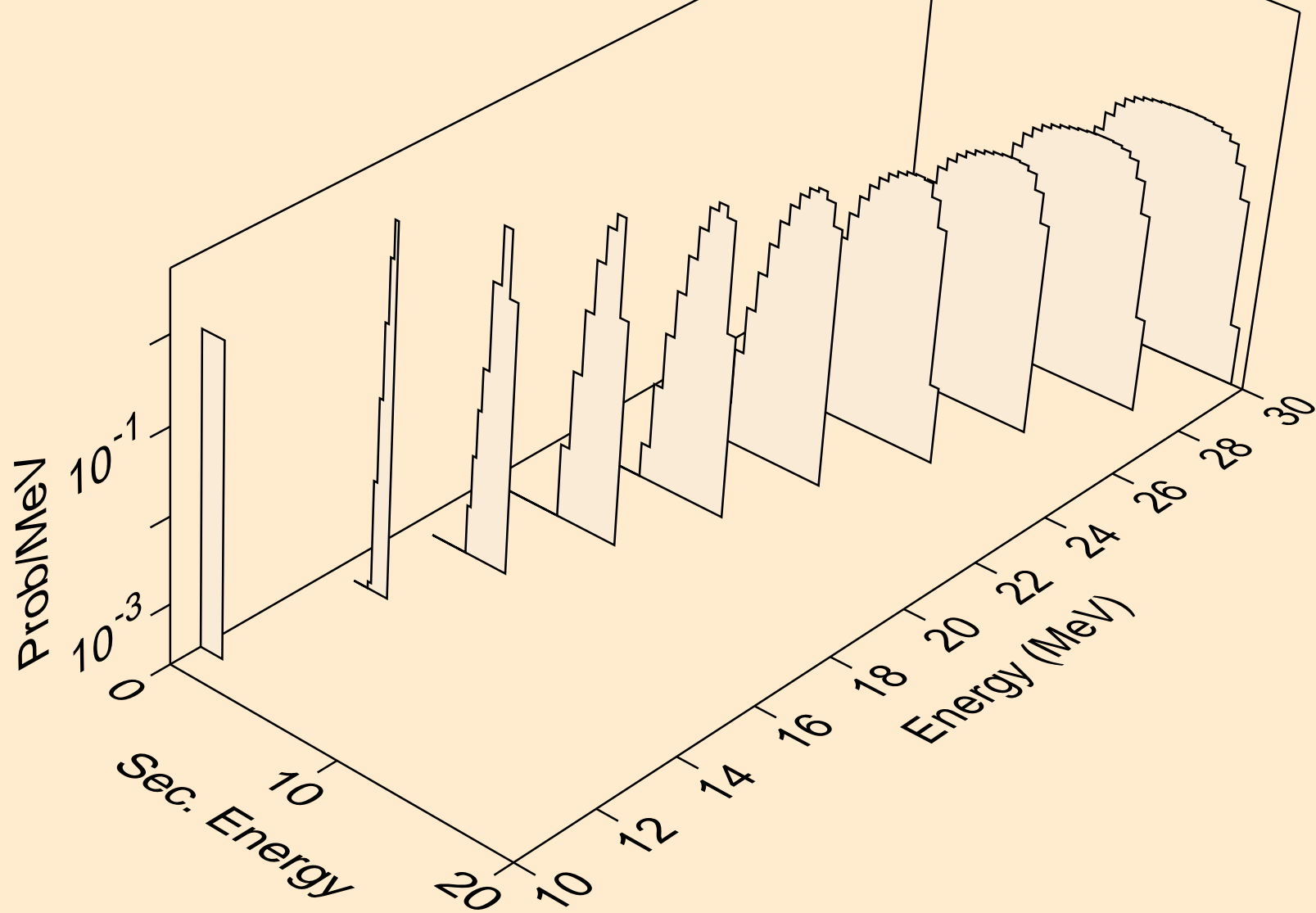

EU152M NEUTRON ACER TENDL-2023 LIBRARY; T=0.K  
tritons from (n,t)

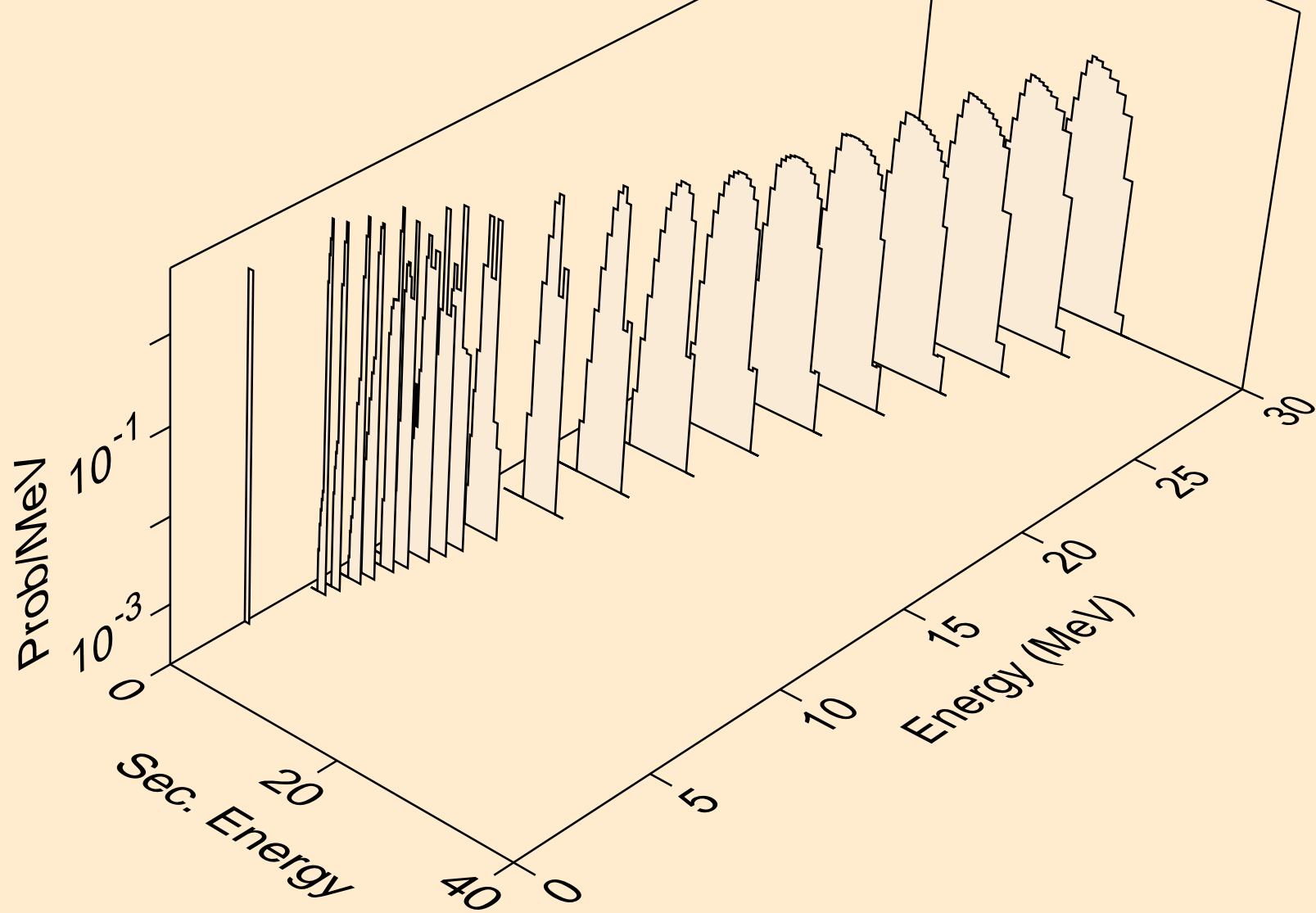

EU152M NEUTRON ACER TENDL-2023 LIBRARY; T=0.K  
tritons from (n,pt)

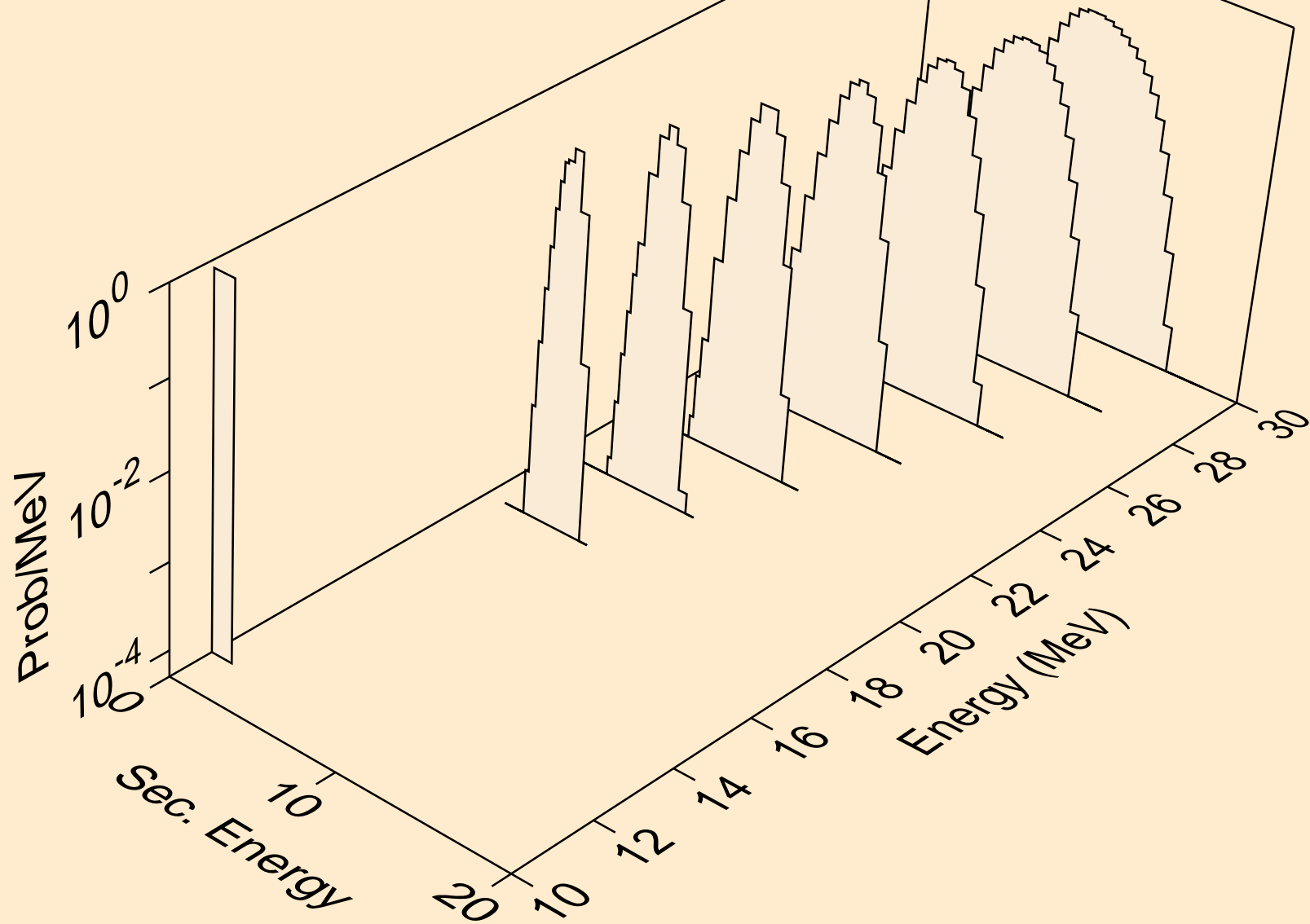

EU152M NEUTRON ACER TENDL-2023 LIBRARY; T=0.K  
he3s from (n,x)

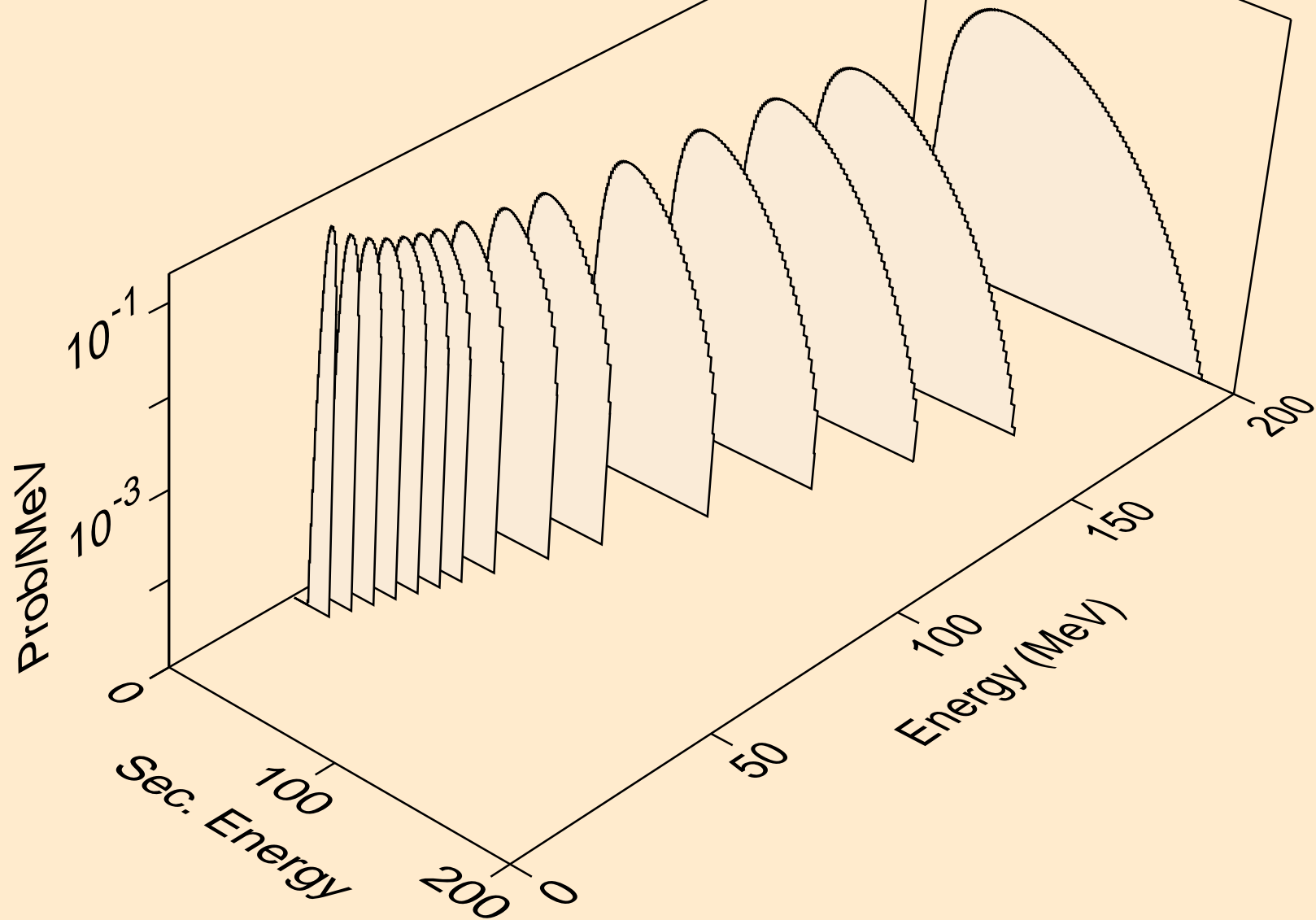

EU152M NEUTRON ACER TENDL-2023 LIBRARY; T=0.K  
he3s from (n,n\*)he3

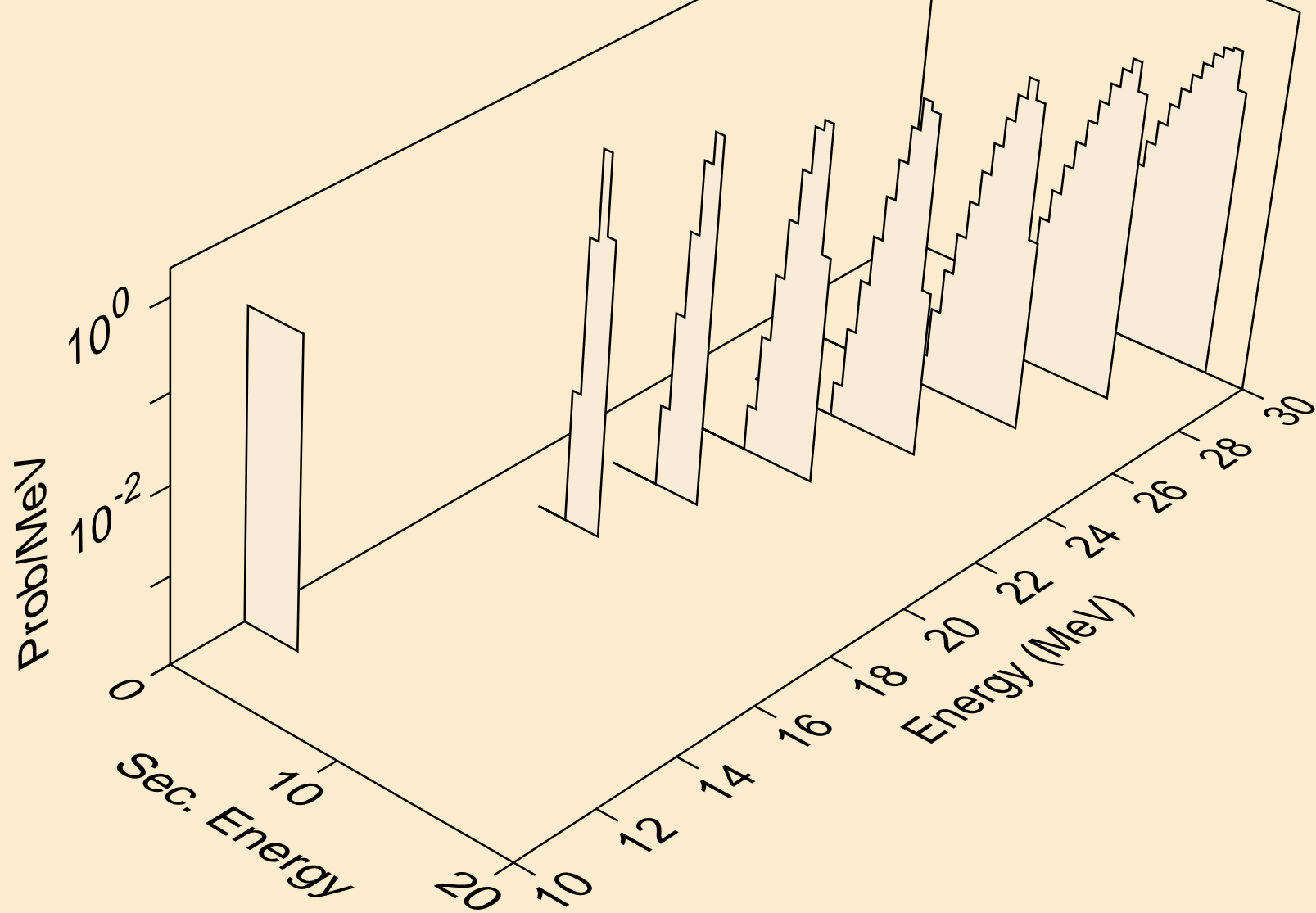

EU152M NEUTRON ACER TENDL-2023 LIBRARY; T=0.K  
he3s from (n,he3)

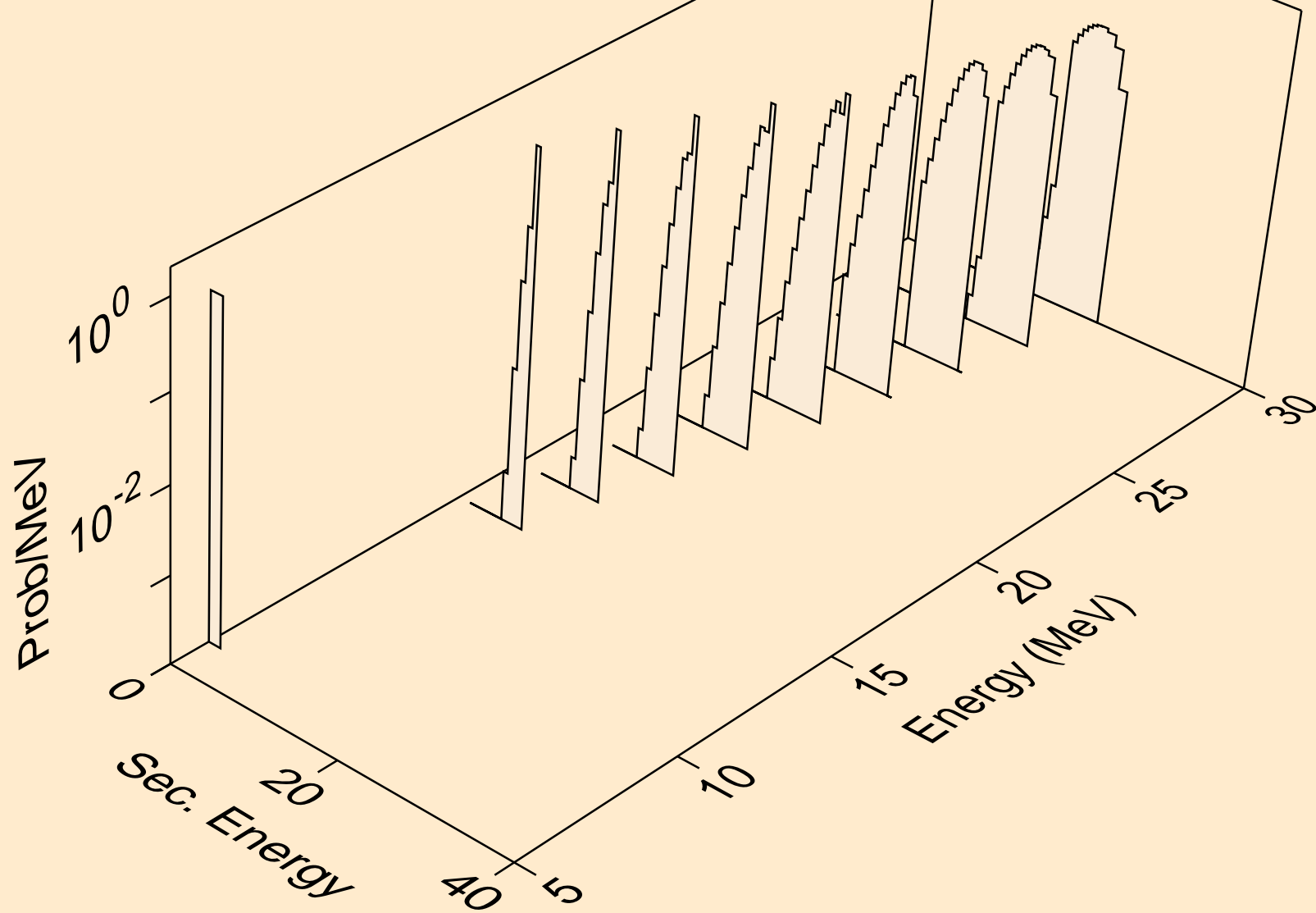

EU152M NEUTRON ACER TENDL-2023 LIBRARY; T=0.K  
alphas from (n,x)

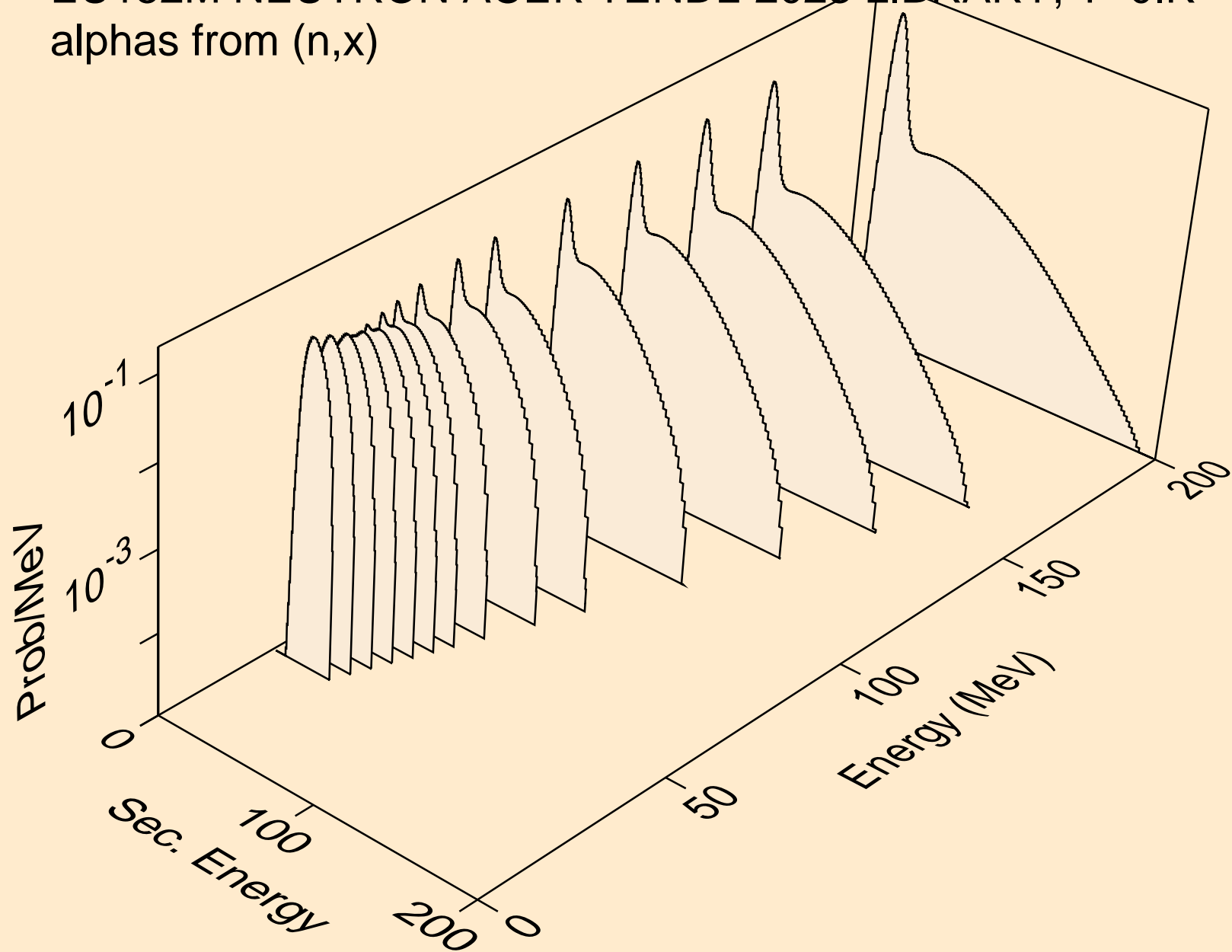

EU152M NEUTRON ACER TENDL-2023 LIBRARY; T=0.K  
alphas from (n,n\*)a

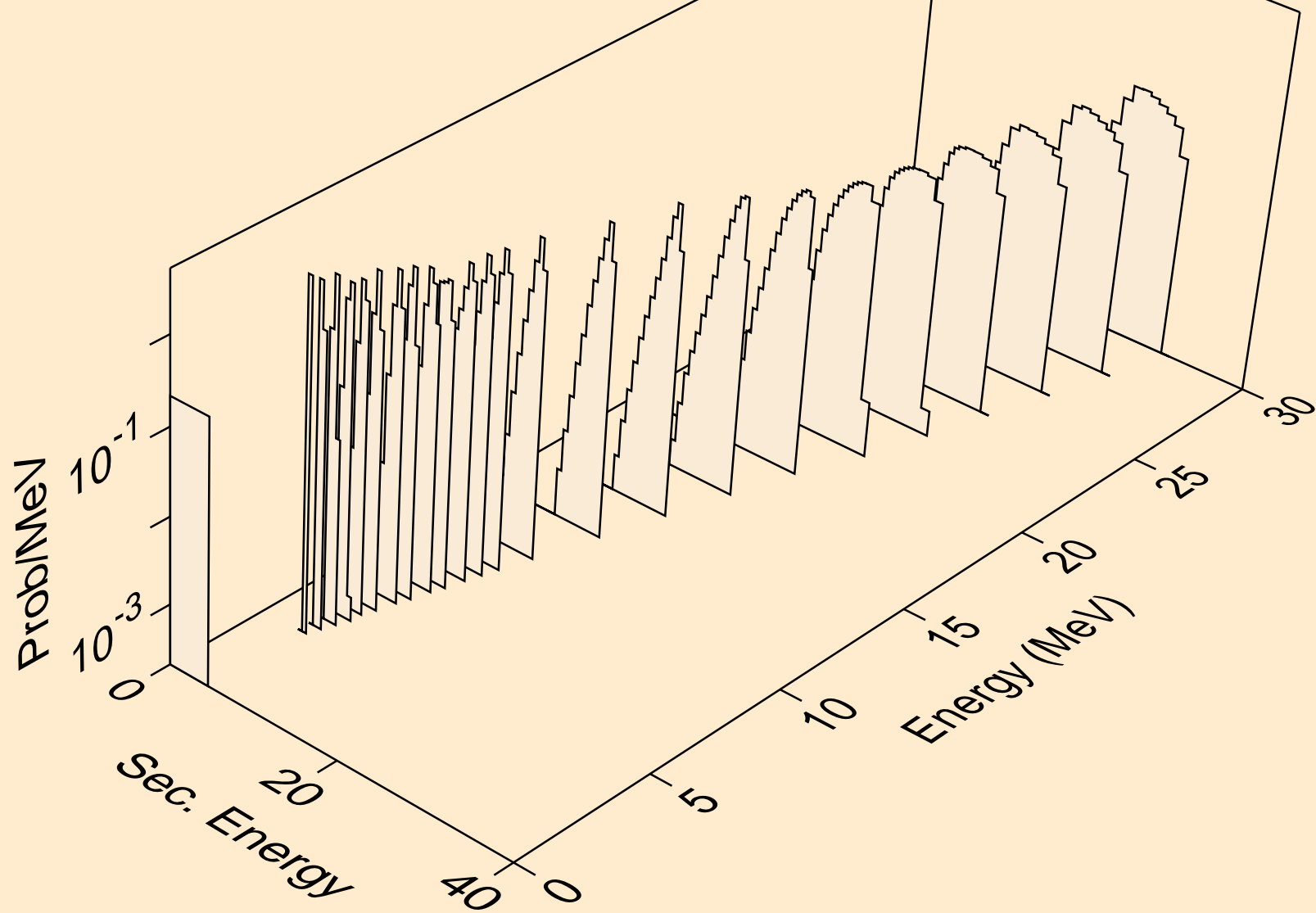

EU152M NEUTRON ACER TENDL-2023 LIBRARY; T=0.K  
alphas from (n,2n)a

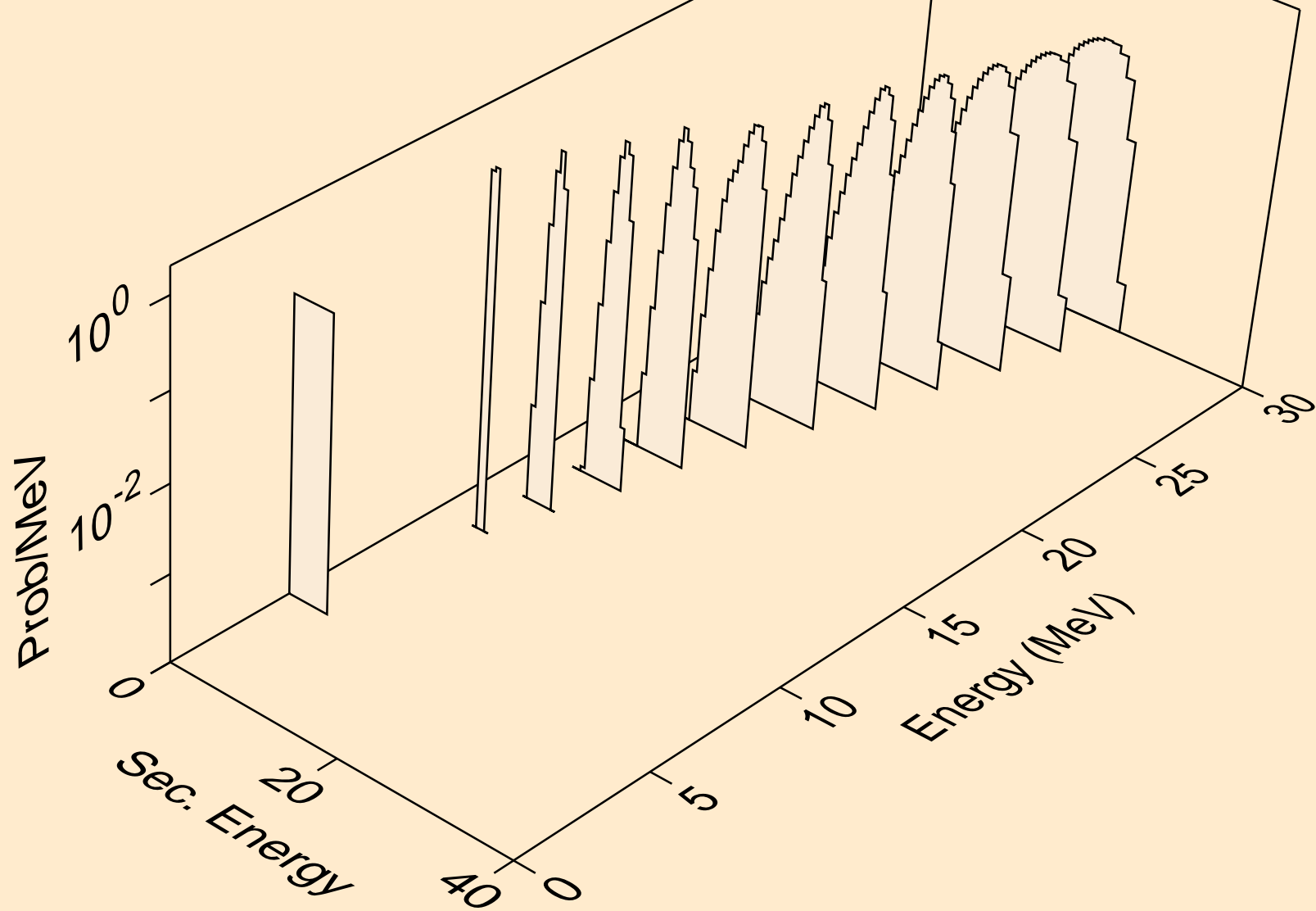

EU152M NEUTRON ACER TENDL-2023 LIBRARY; T=0.K  
alphas from (n,3n)a

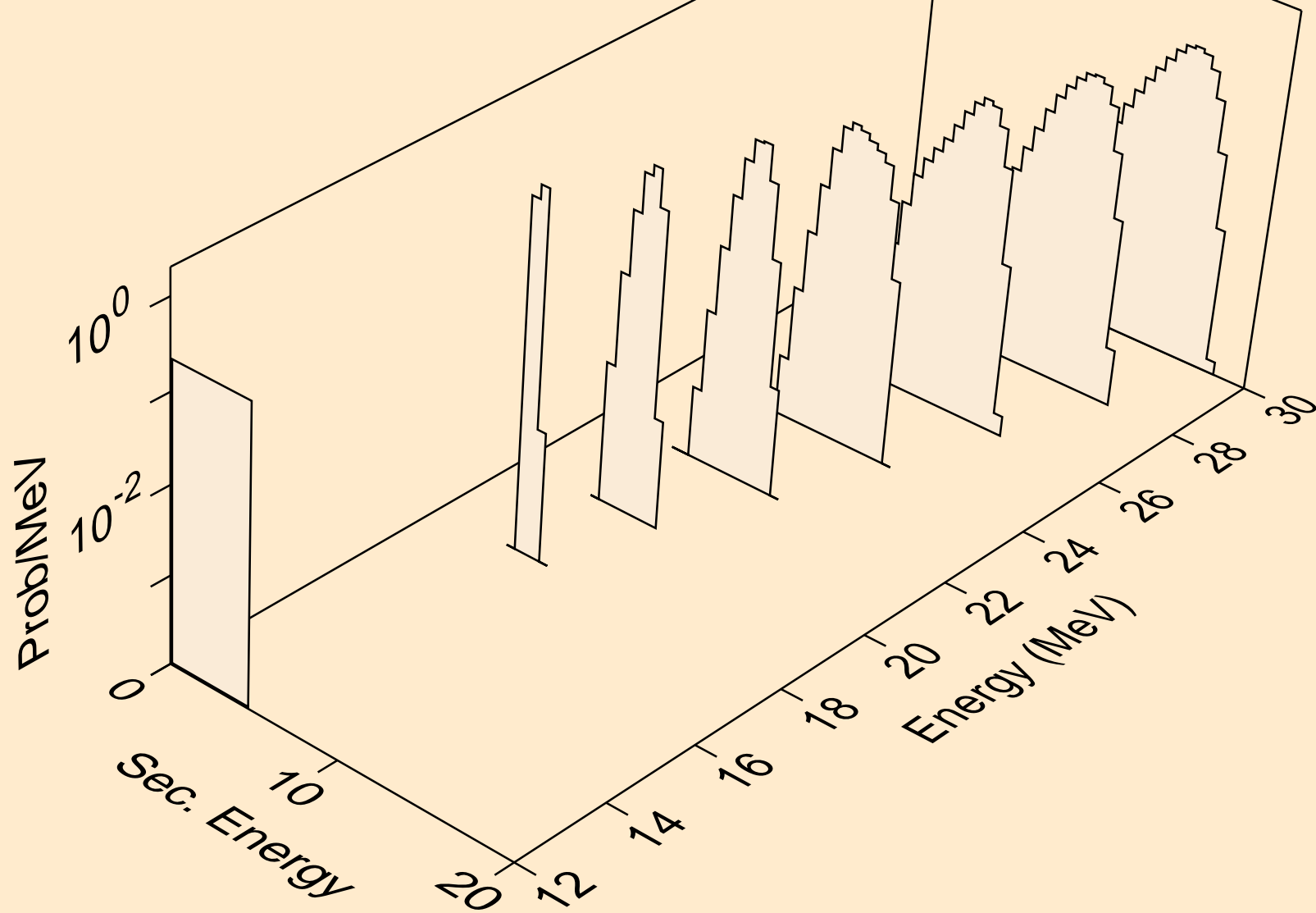

EU152M NEUTRON ACER TENDL-2023 LIBRARY; T=0.K  
alphas from (n,n\*)2a

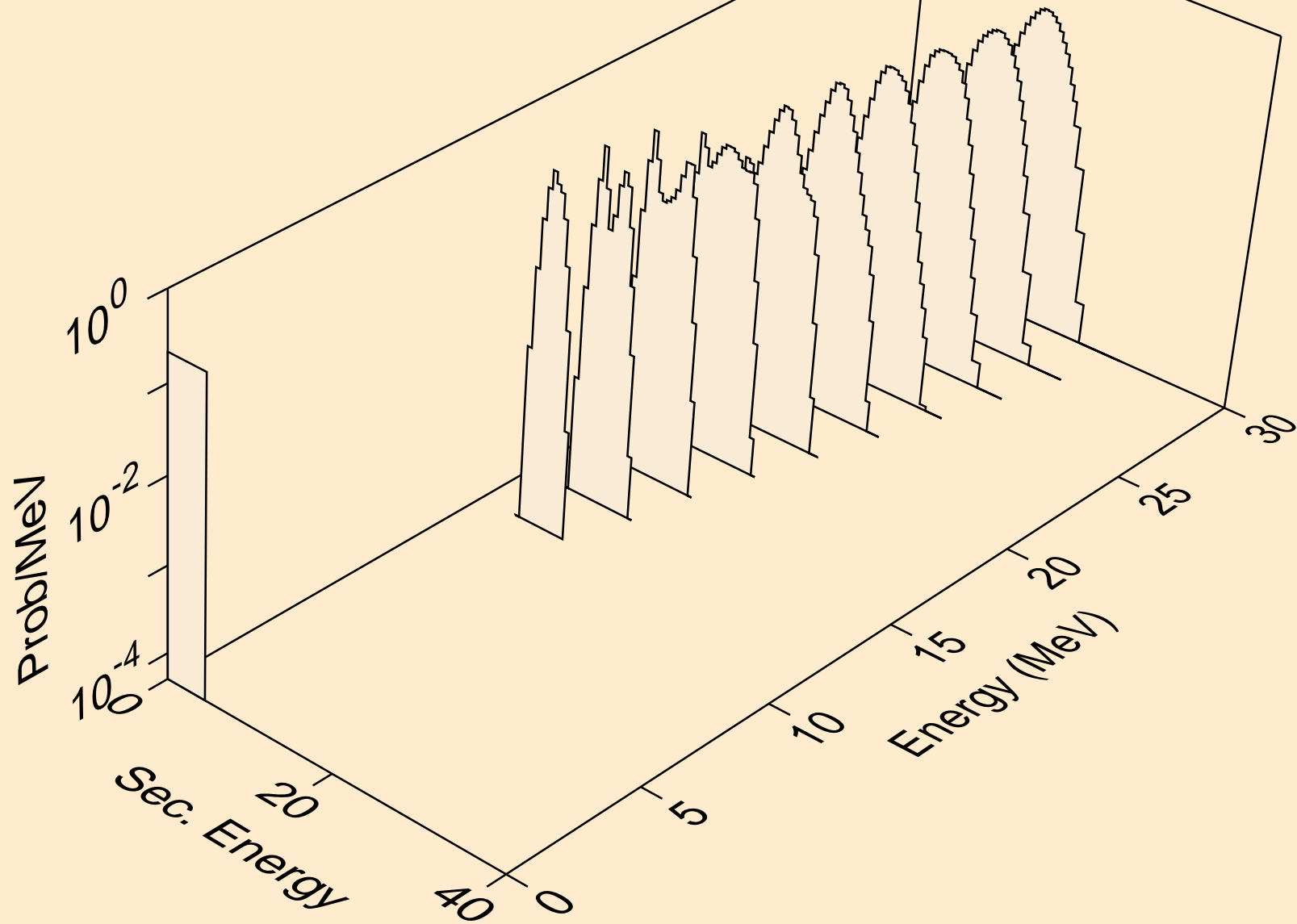

EU152M NEUTRON ACER TENDL-2023 LIBRARY; T=0.K  
alphas from (n,2n)2a

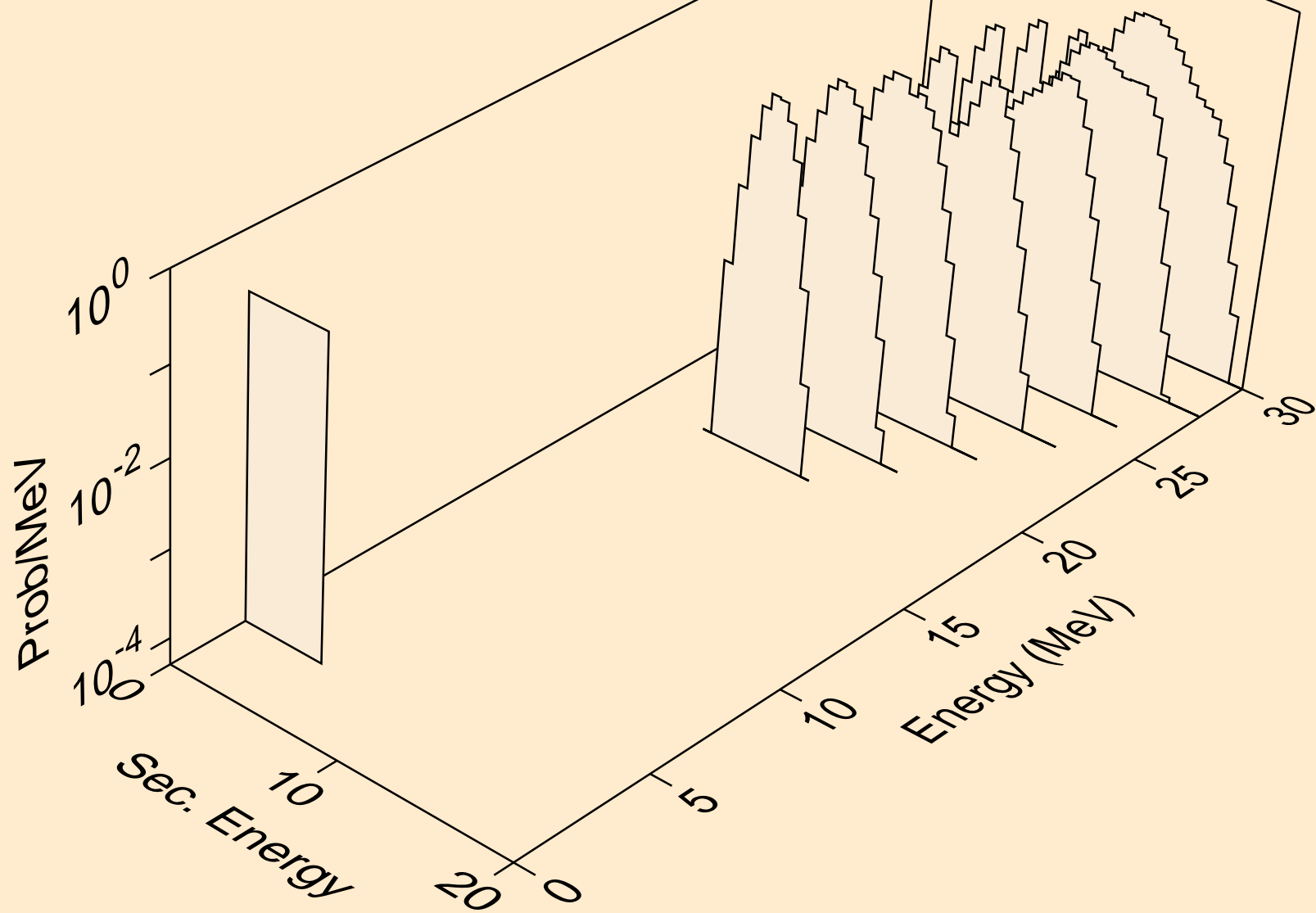

EU152M NEUTRON ACER TENDL-2023 LIBRARY; T=0.K  
alphas from (n,npa)

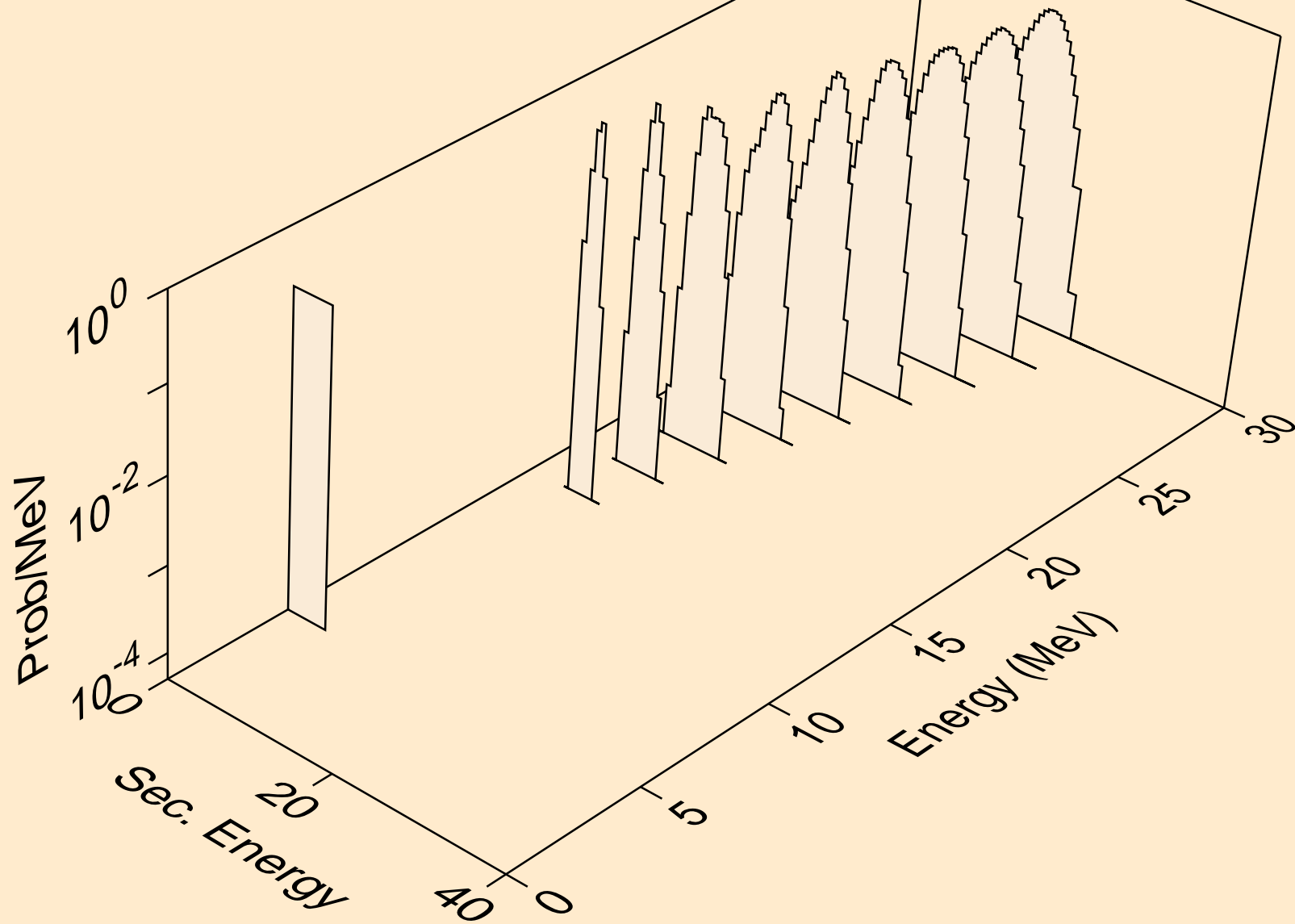

EU152M NEUTRON ACER TENDL-2023 LIBRARY; T=0.K  
alphas from (n,a)

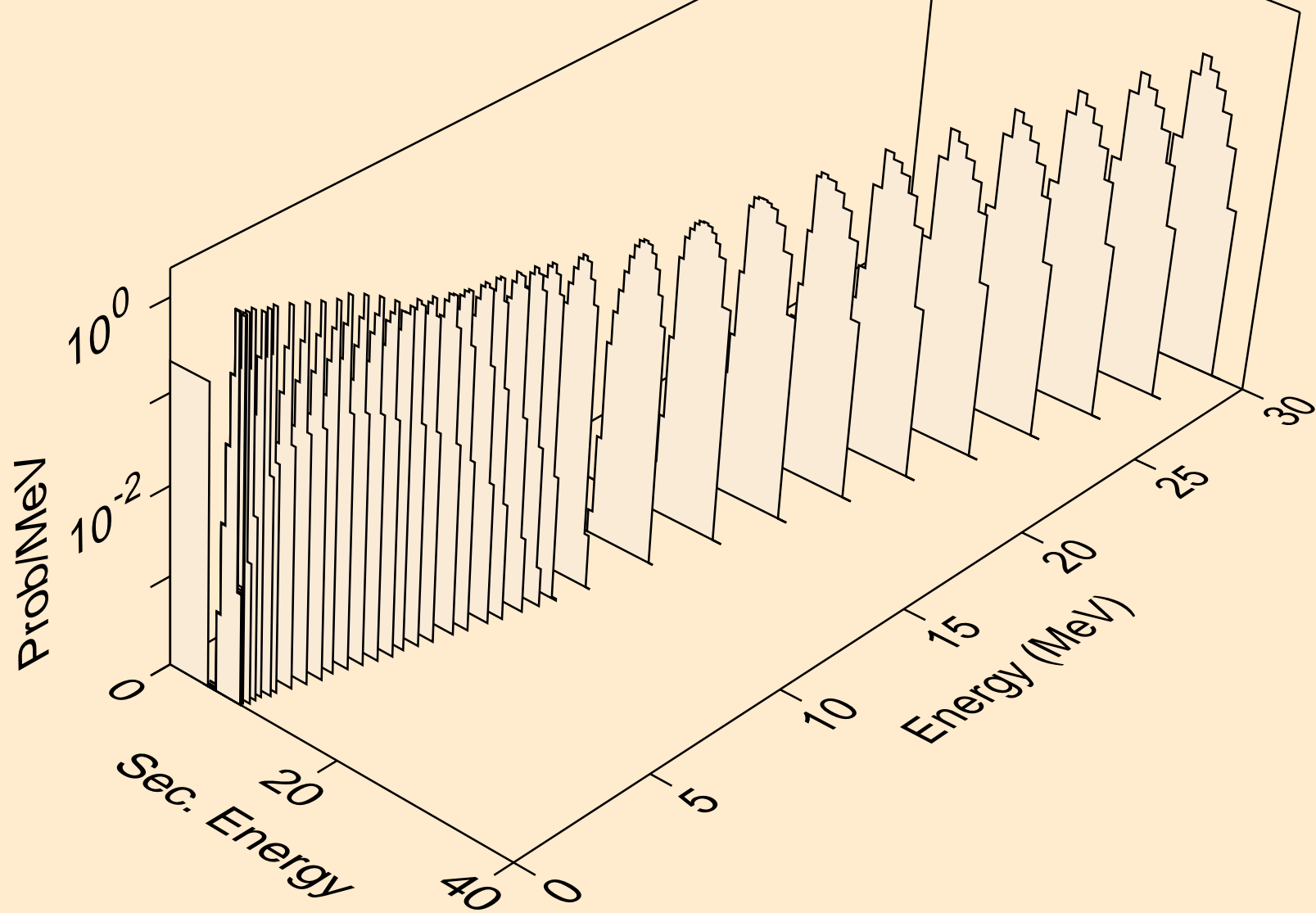

EU152M NEUTRON ACER TENDL-2023 LIBRARY; T=0.K  
alphas from (n,2a)

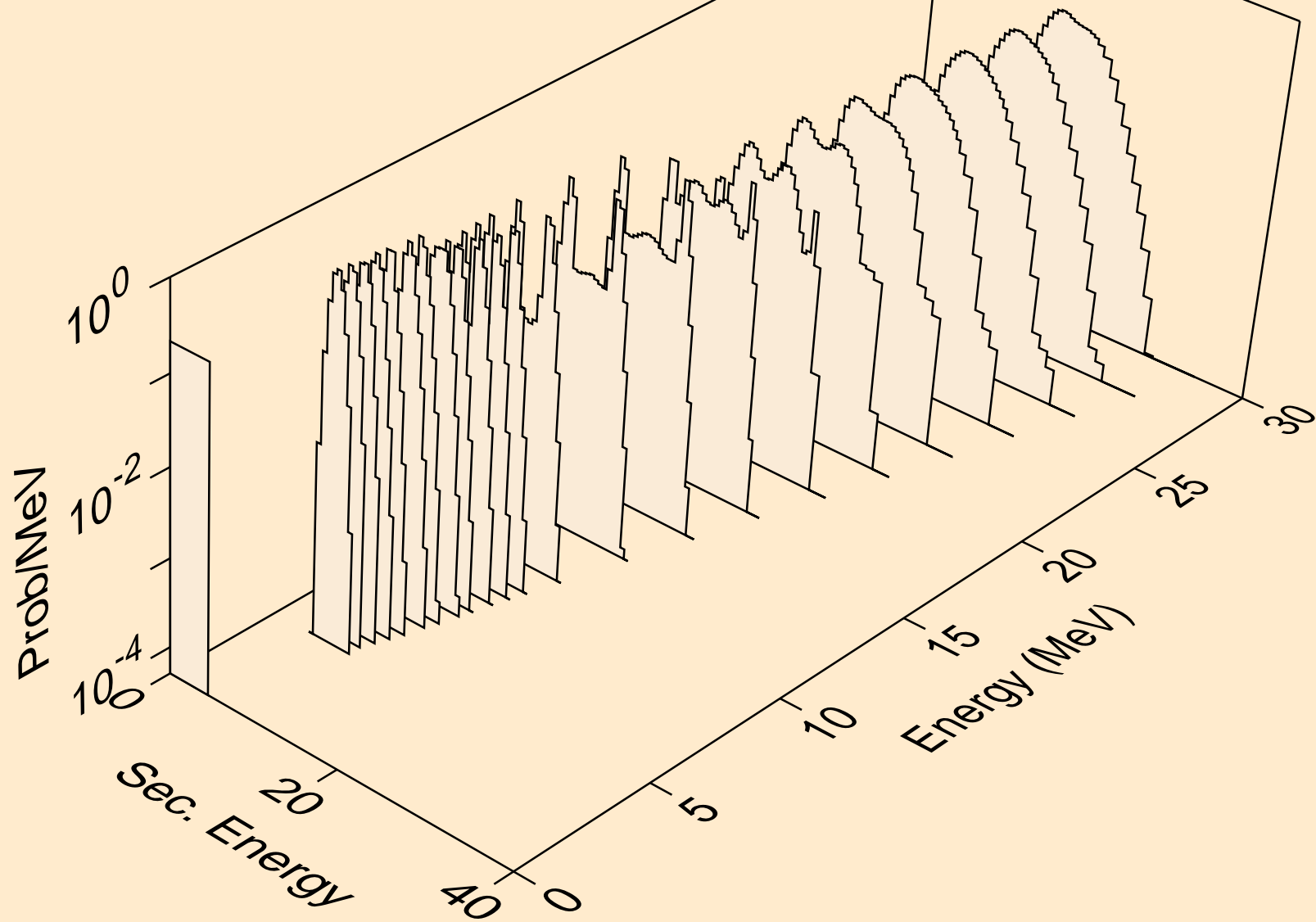

EU152M NEUTRON ACER TENDL-2023 LIBRARY; T=0.K  
alphas from (n,pa)

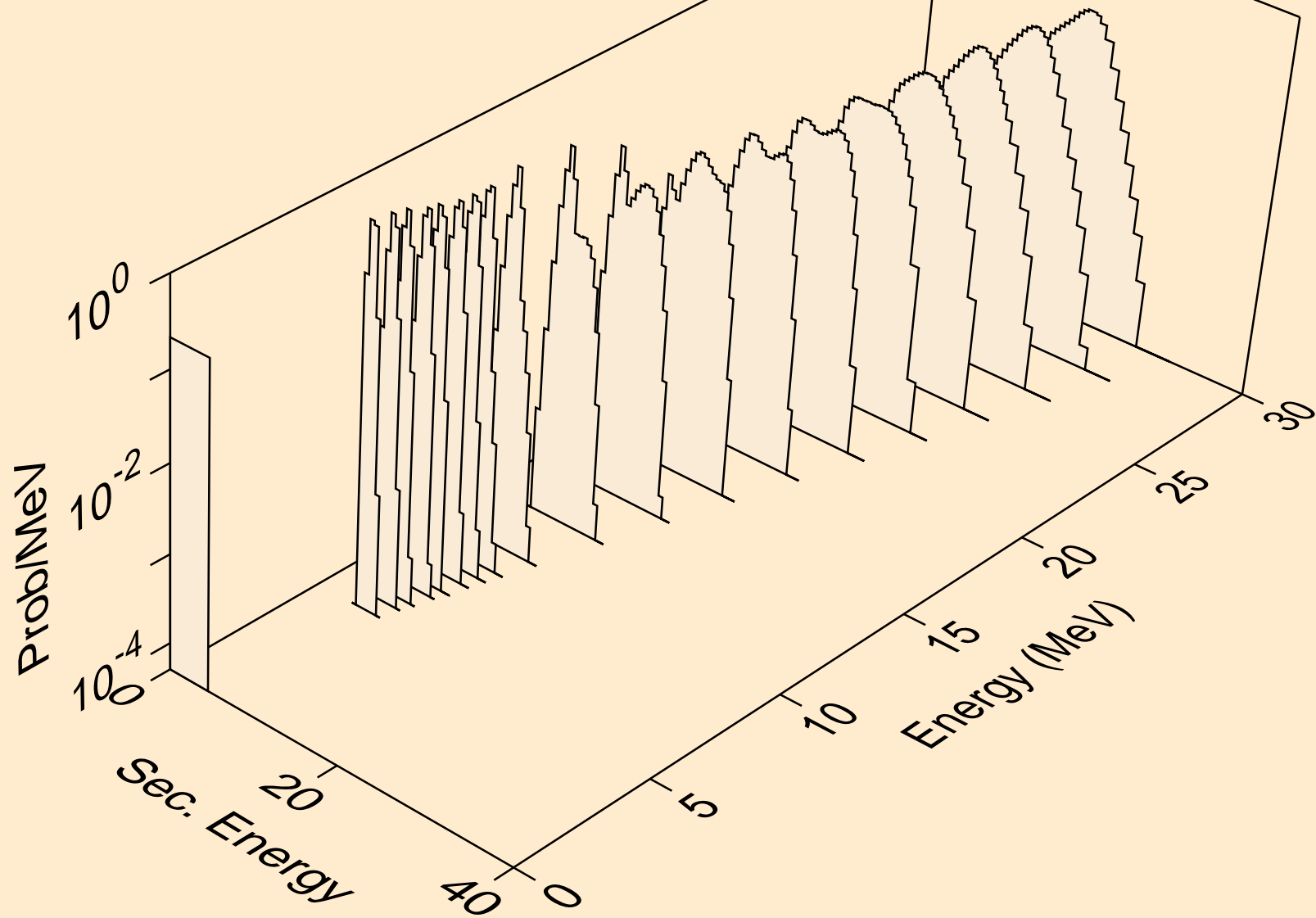

EU152M NEUTRON ACER TENDL-2023 LIBRARY; T=0.K  
alphas from (n,da)

