

GA072 NEUTRON ACER TENDL-2023 LIBRARY; T=0.K

Principal cross sections

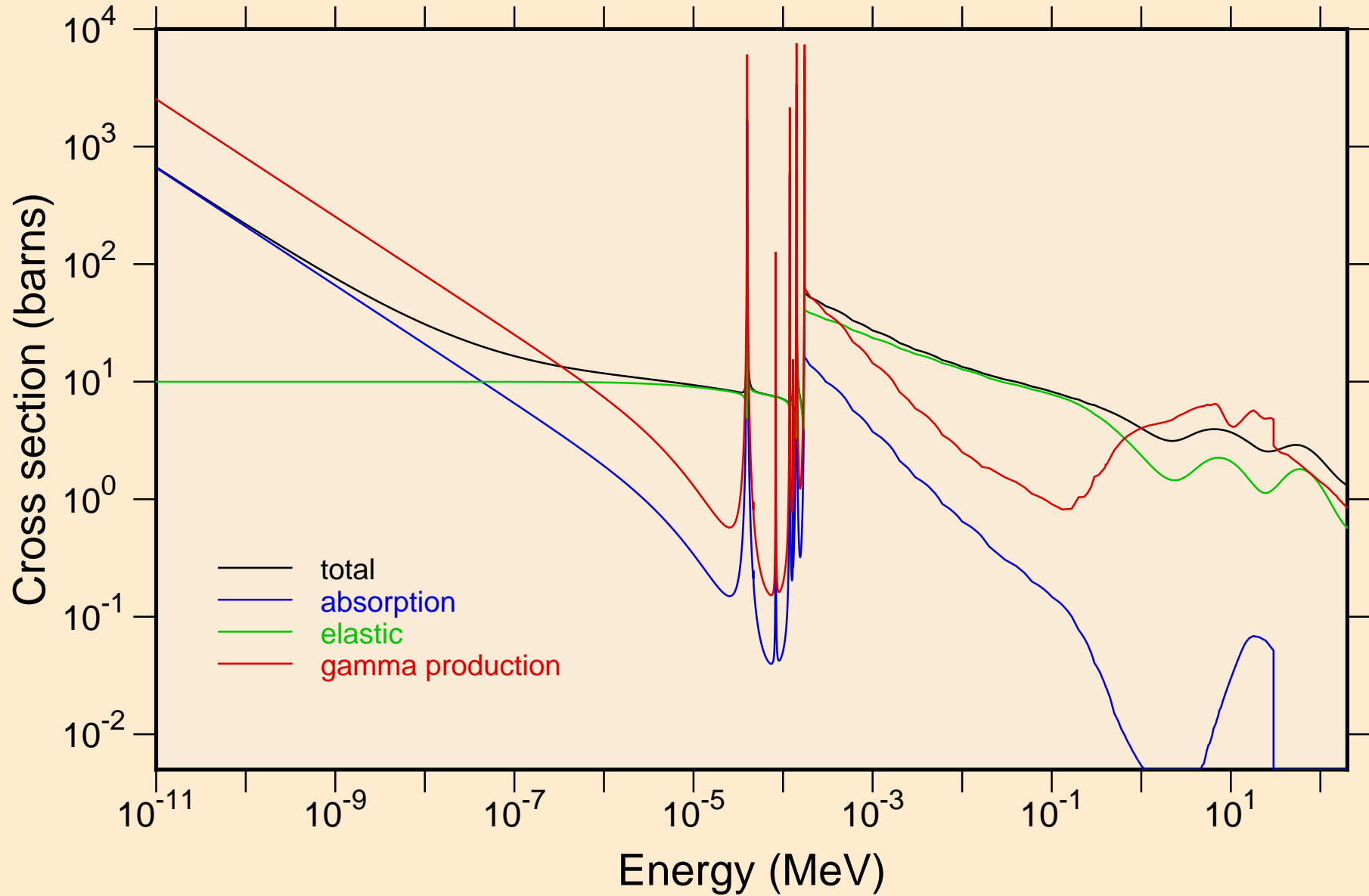

GA072 NEUTRON ACER TENDL-2023 LIBRARY; T=0.K
resonance total cross section

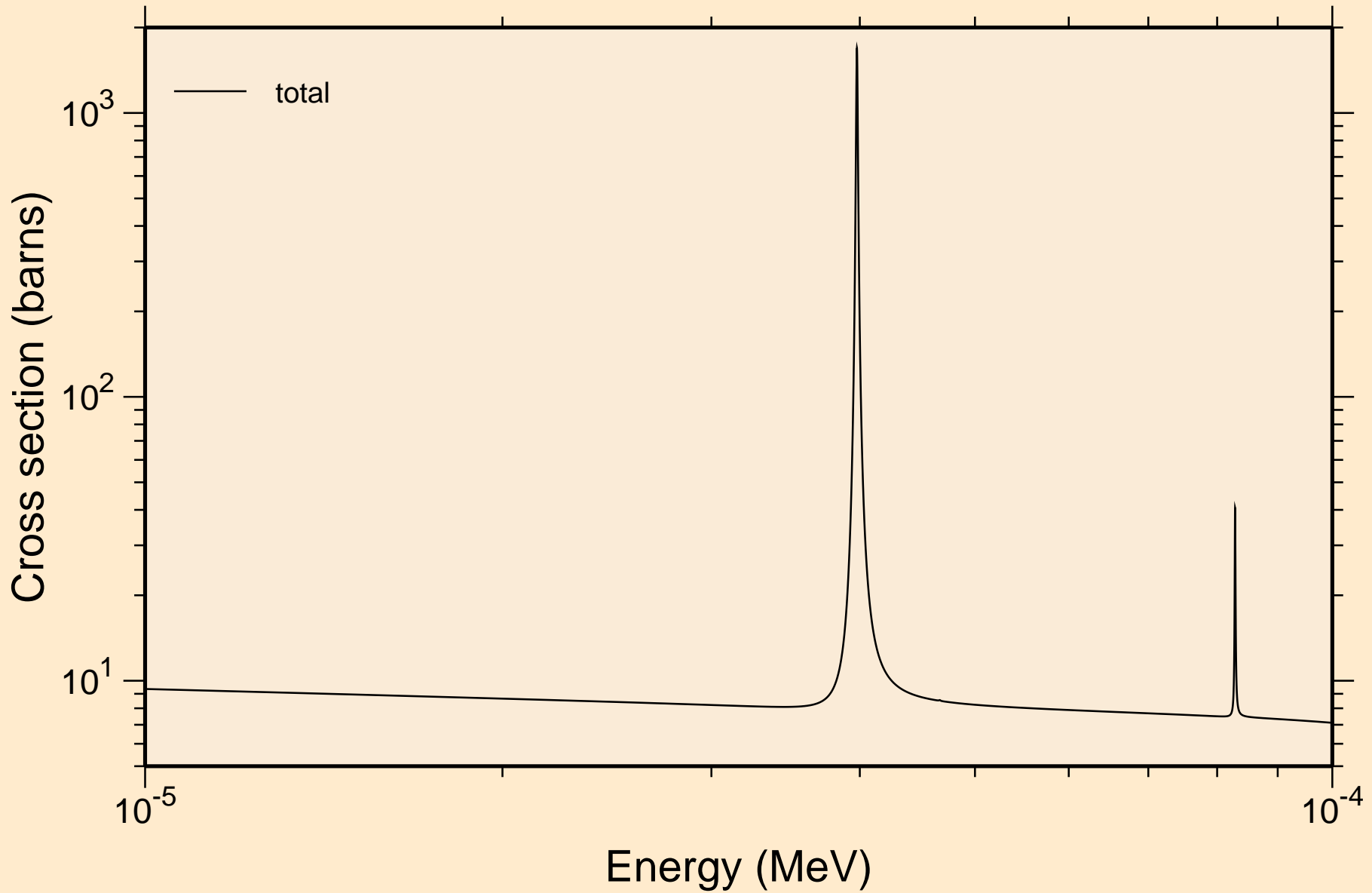

GA072 NEUTRON ACER TENDL-2023 LIBRARY; T=0.K
resonance total cross section

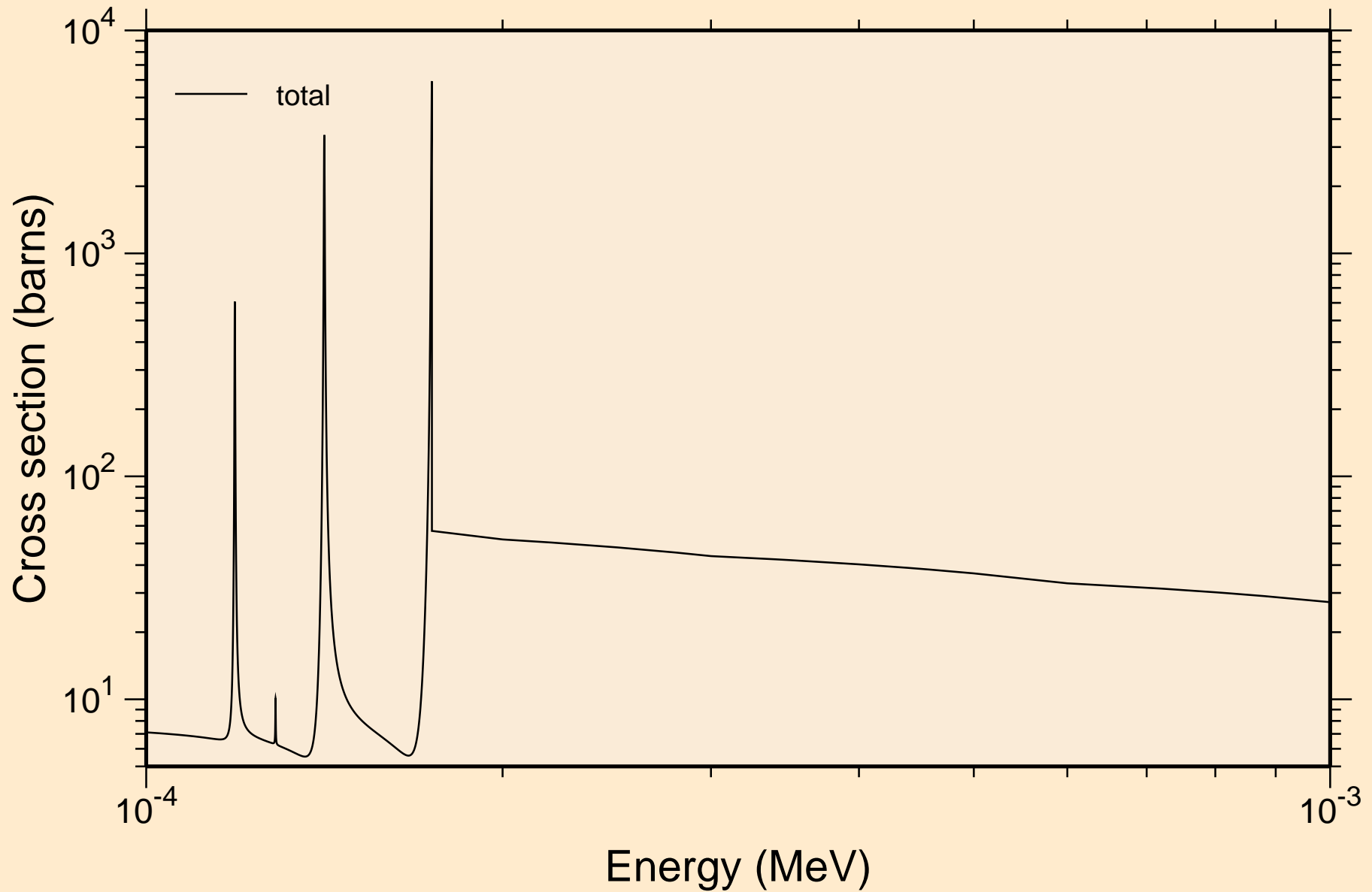

ḠA072 NEUTRON ACER TENDL-2023 LIBRARY; T=0.K
resonance total cross section

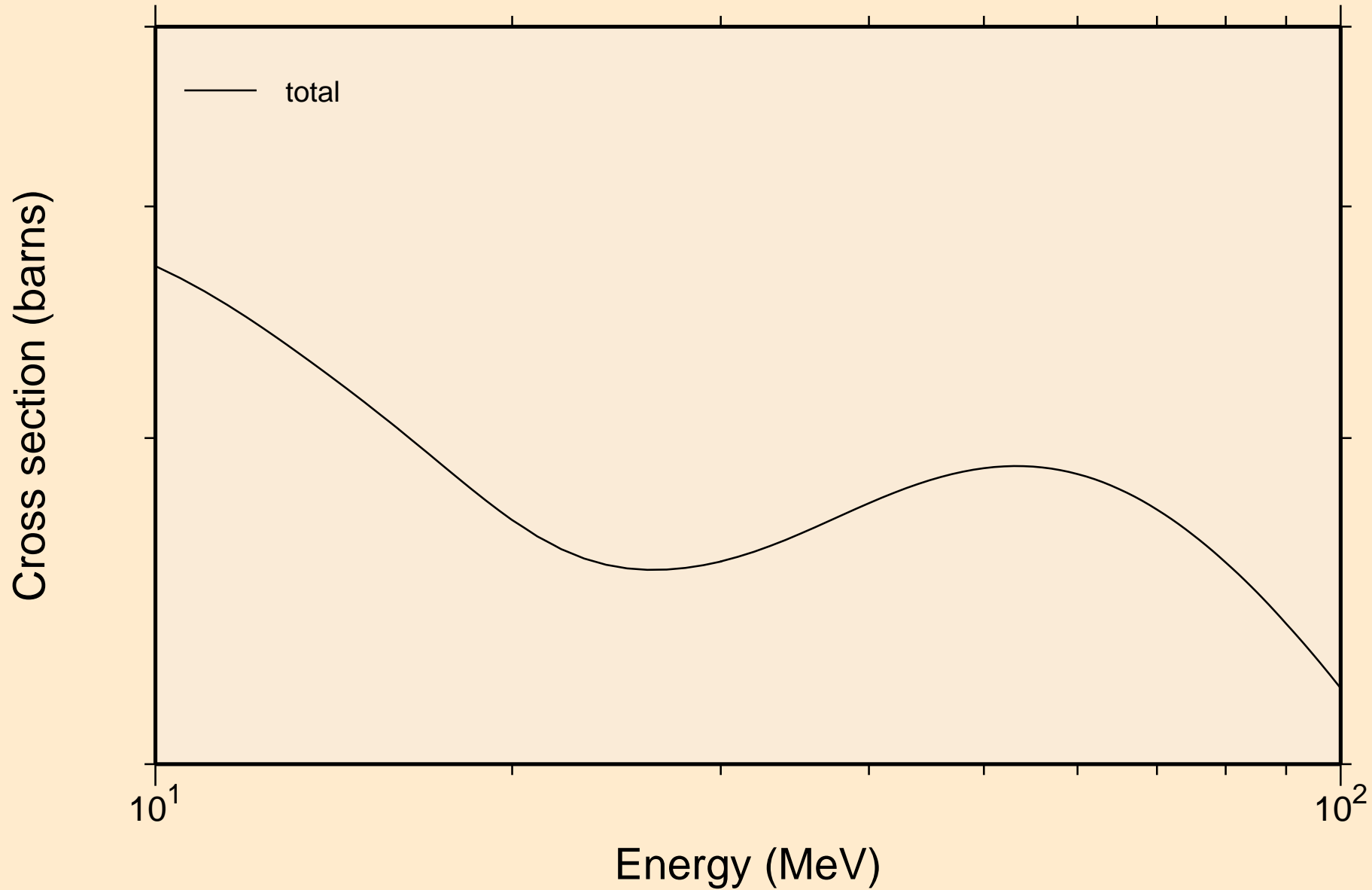

GA072 NEUTRON ACER TENDL-2023 LIBRARY; T=0.K
resonance absorption cross sections

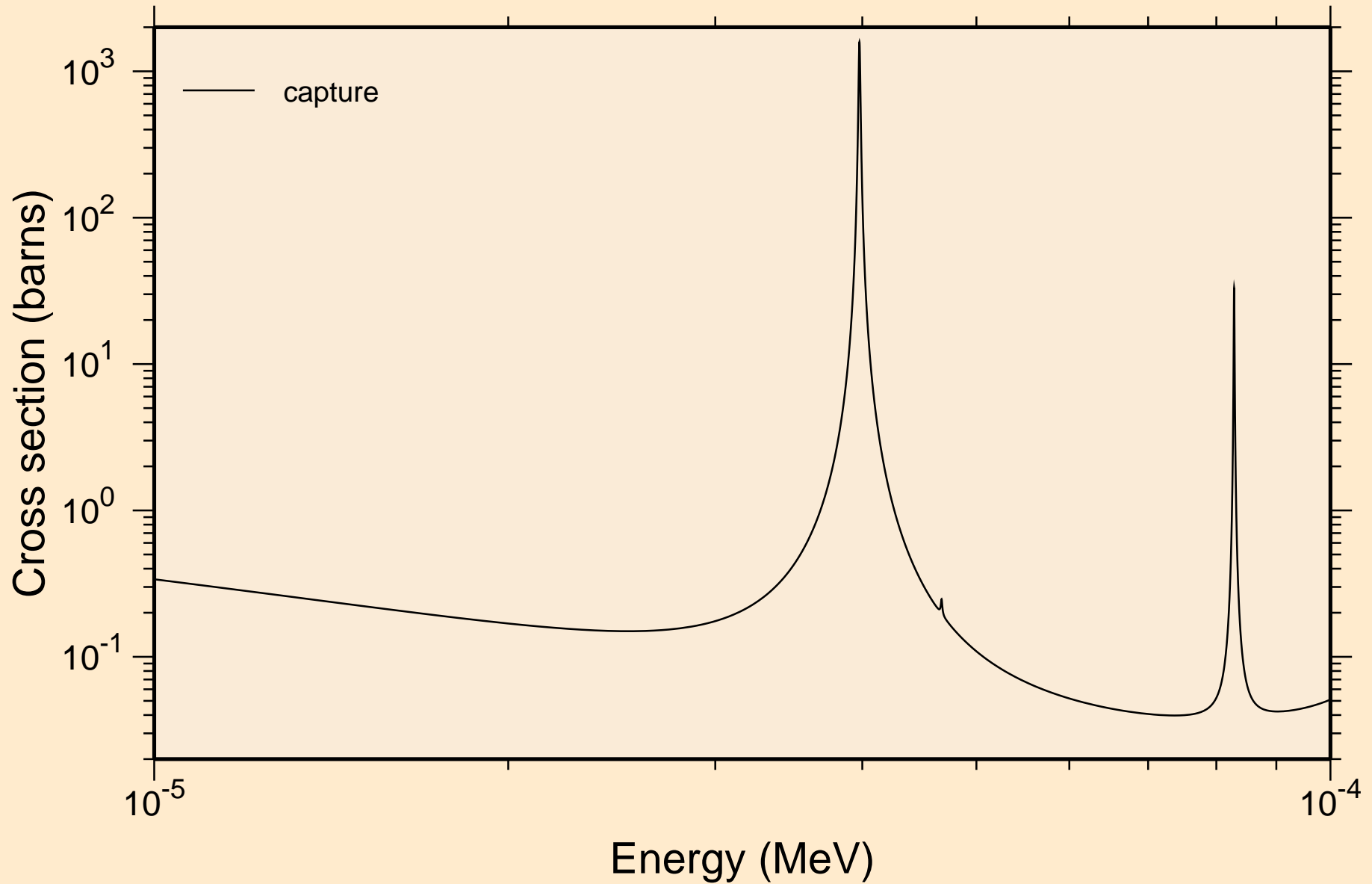

GA072 NEUTRON ACER TENDL-2023 LIBRARY; T=0.K
resonance absorption cross sections

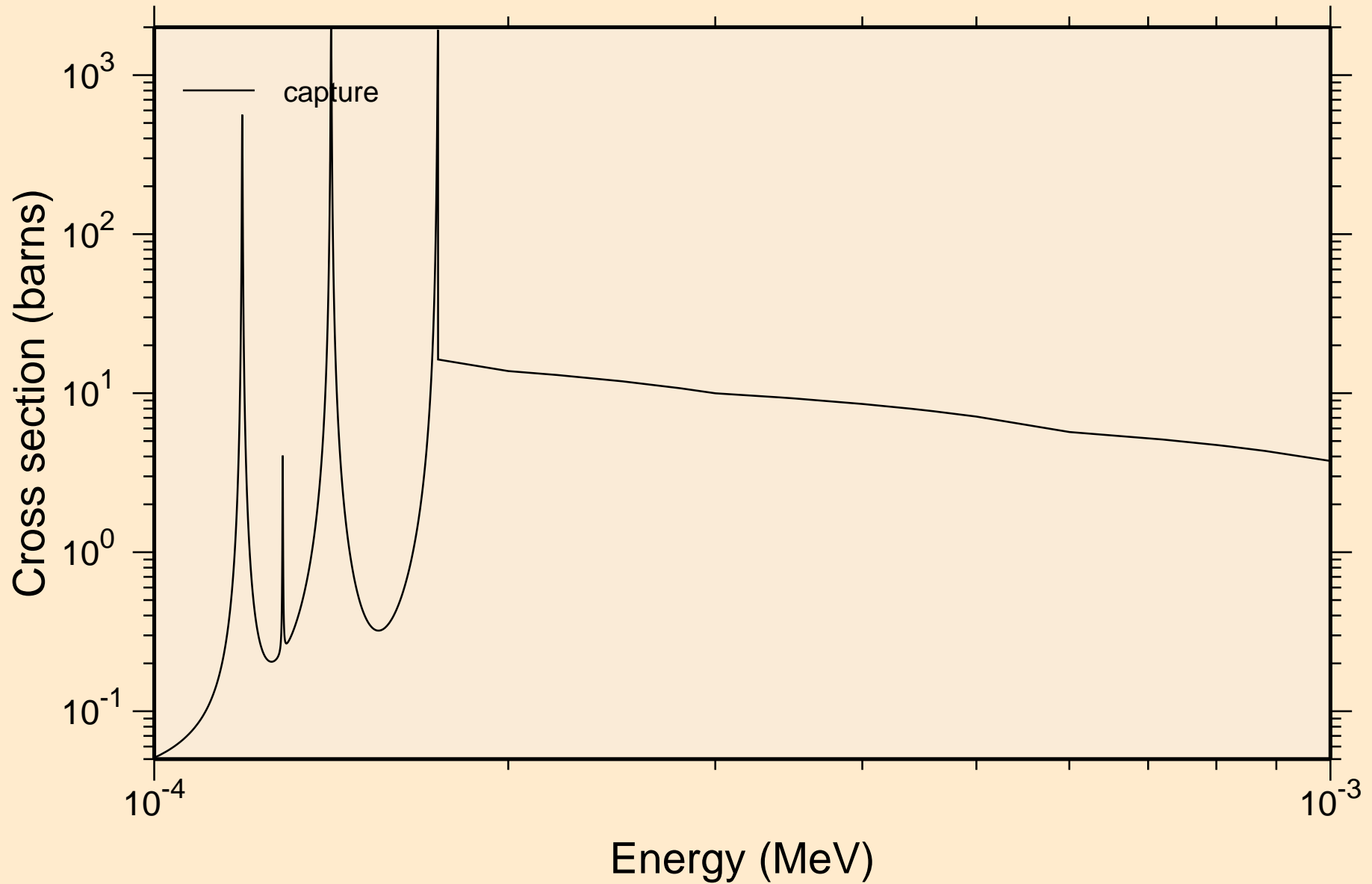

GA072 NEUTRON ACER TENDL-2023 LIBRARY; T=0.K
resonance absorption cross sections

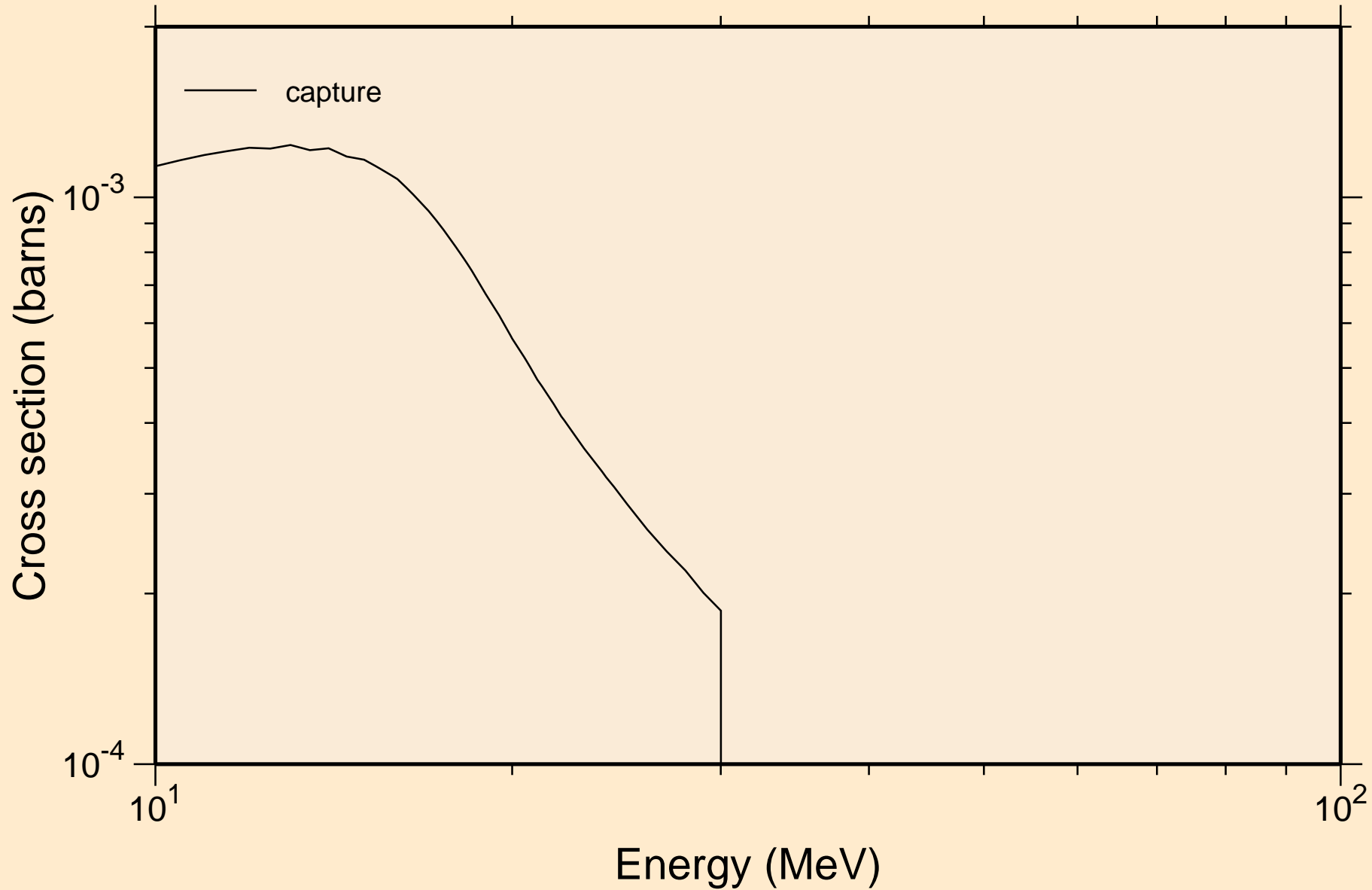

GA072 NEUTRON ACER TENDL-2023 LIBRARY; T=0.K

Heating

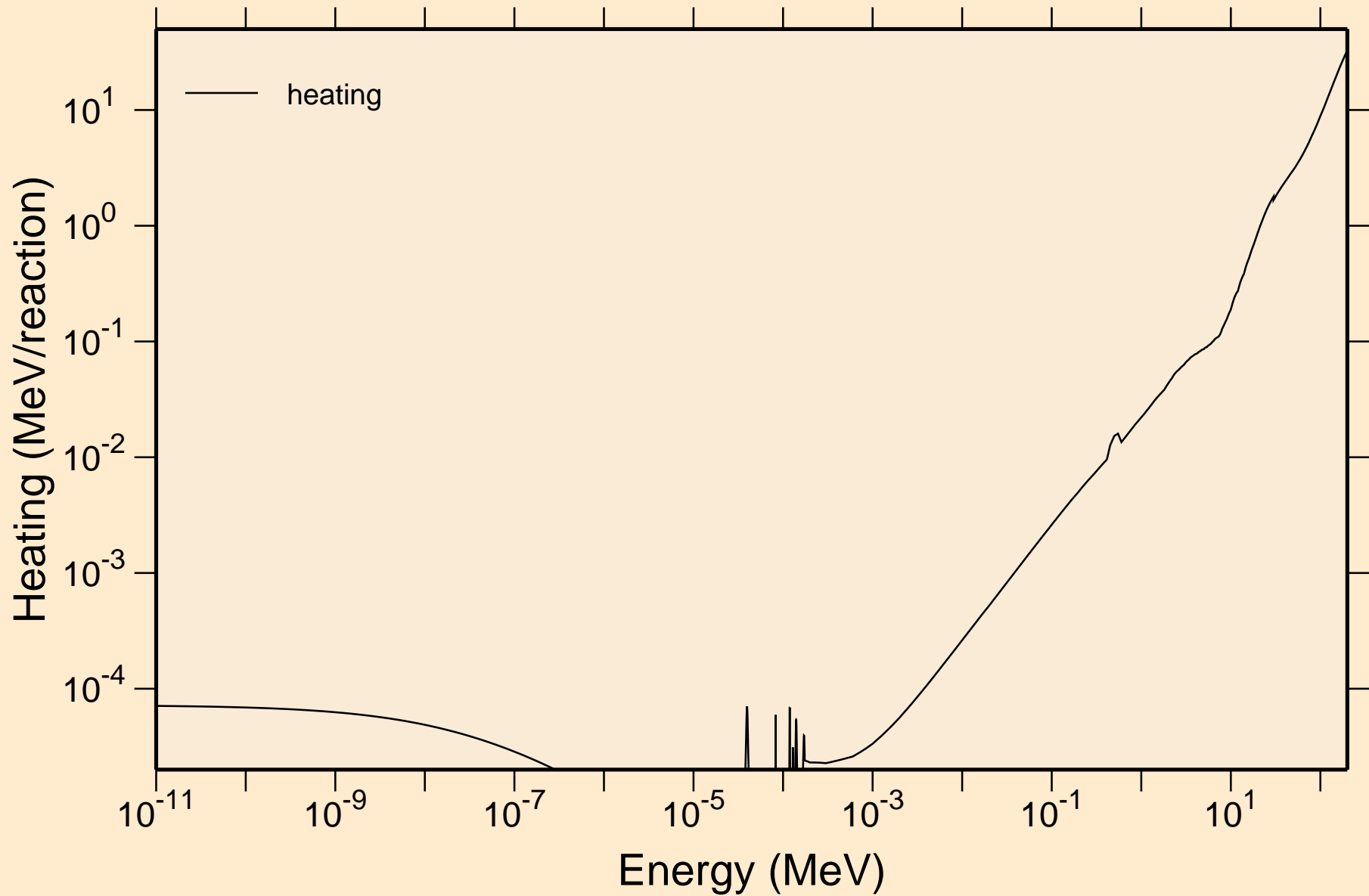

GA072 NEUTRON ACER TENDL-2023 LIBRARY; T=0.K

Damage

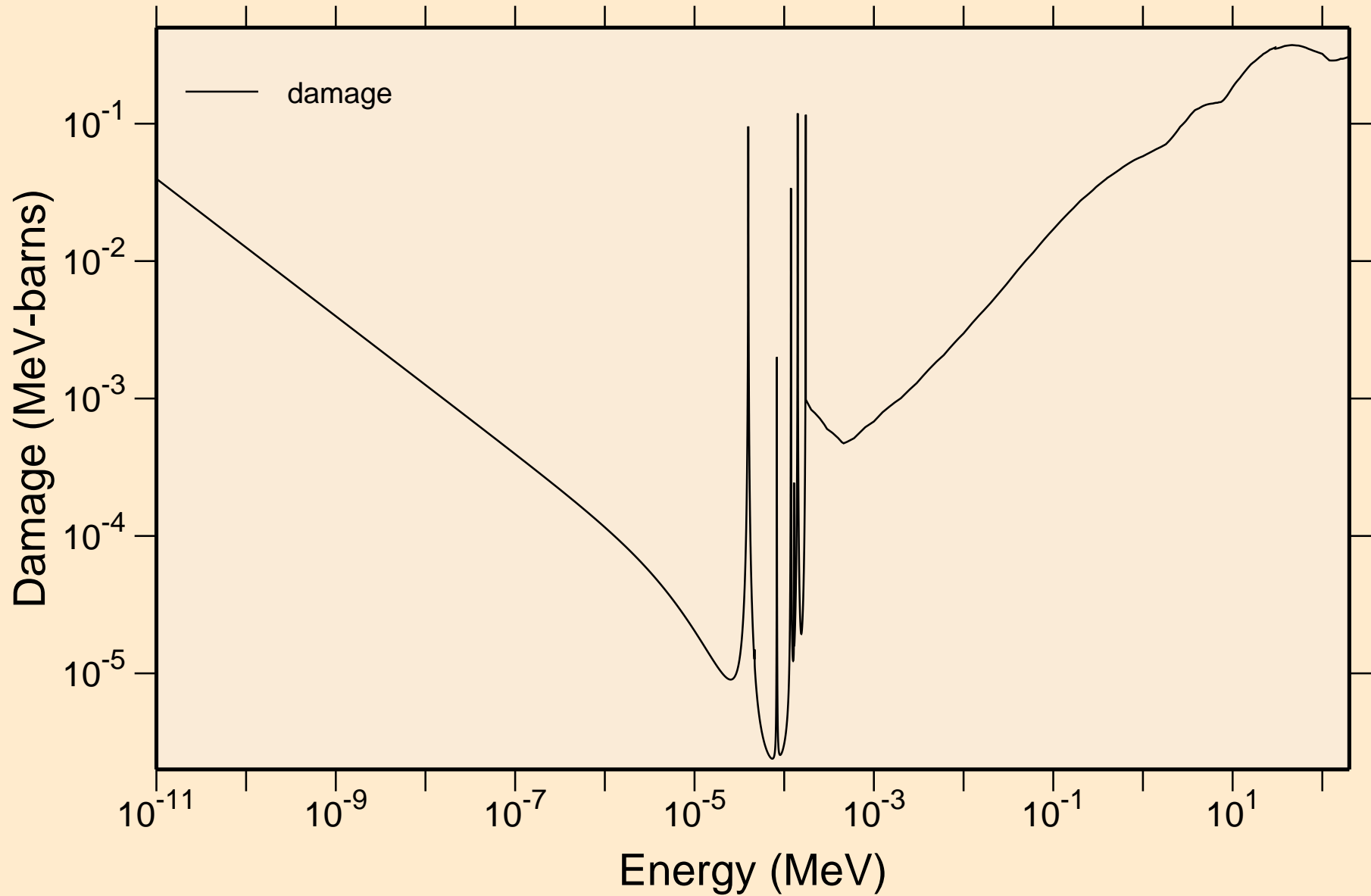

GA072 NEUTRON ACER TENDL-2023 LIBRARY; T=0.K
Non-threshold reactions

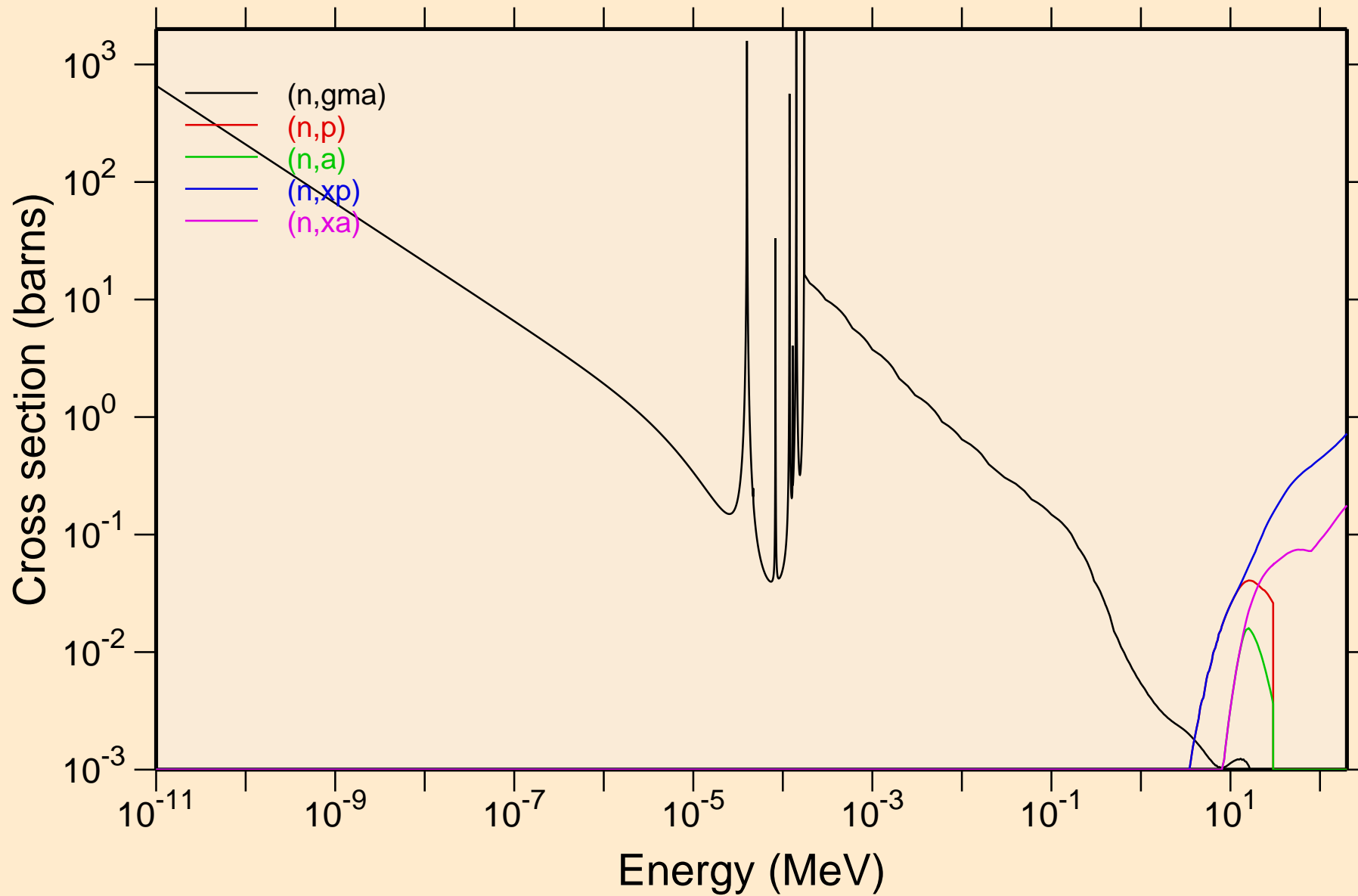

GA072 NEUTRON ACER TENDL-2023 LIBRARY; T=0.K

Principal cross sections

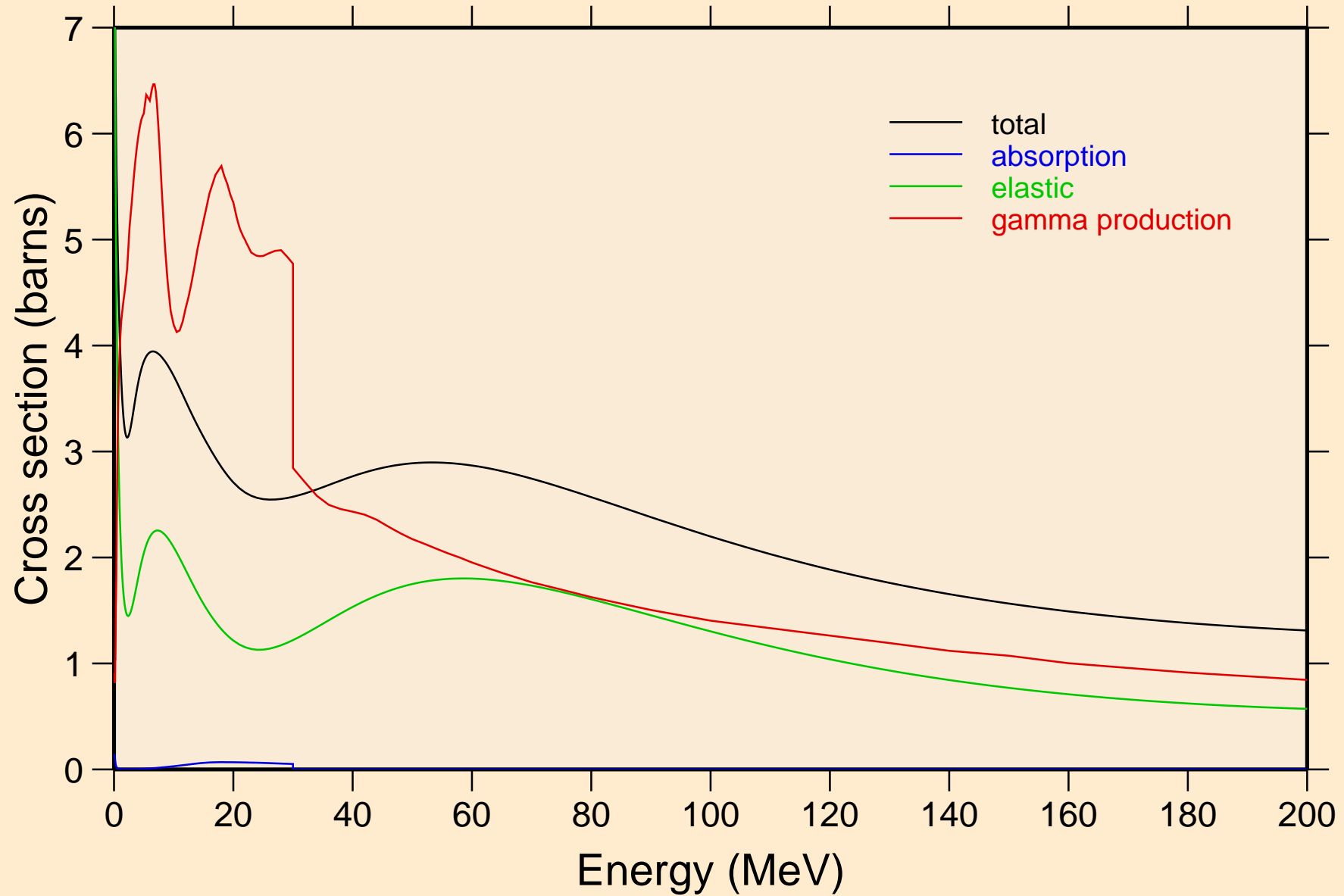

GA072 NEUTRON ACER TENDL-2023 LIBRARY; T=0.K

Heating

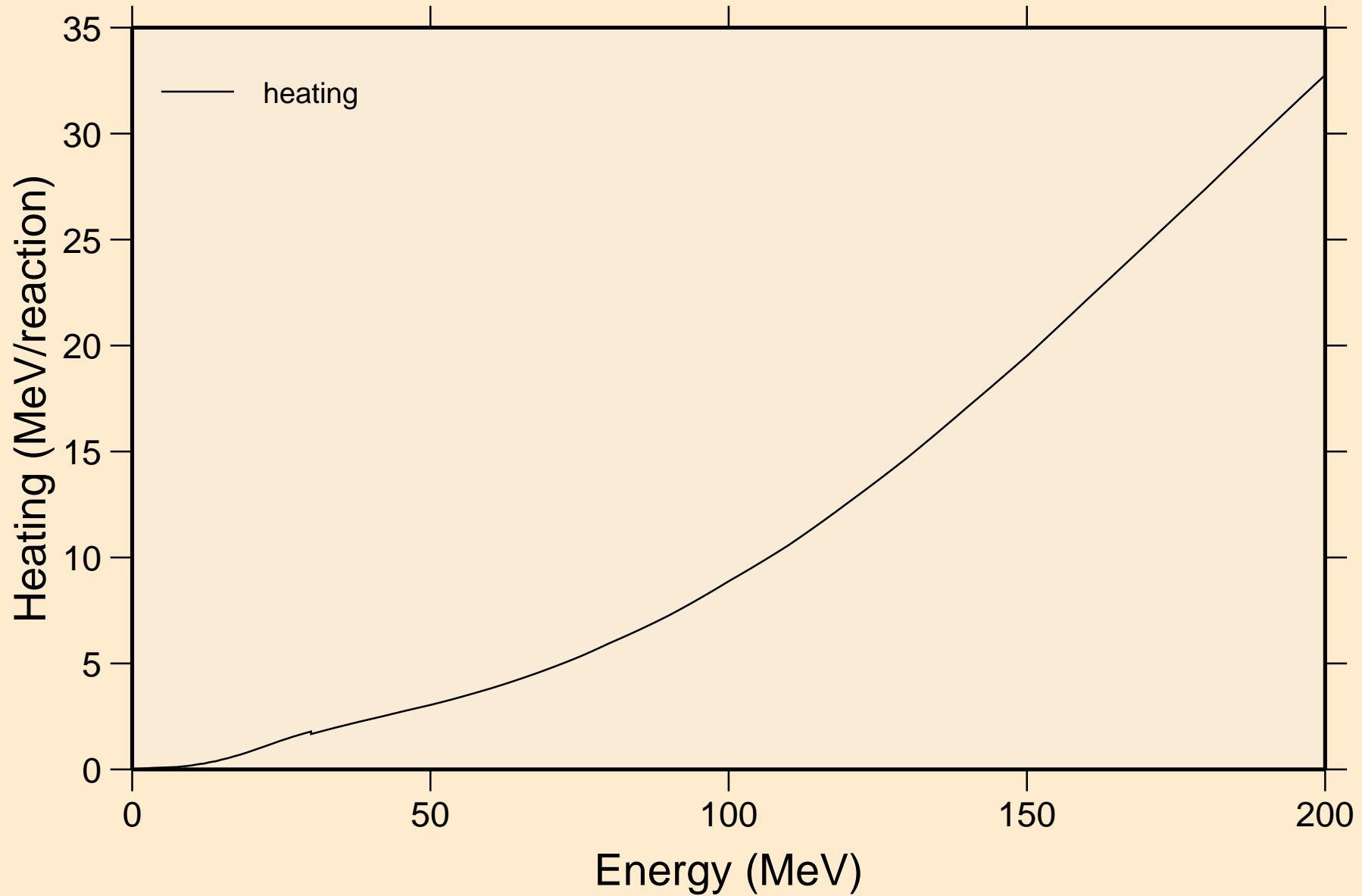

GA072 NEUTRON ACER TENDL-2023 LIBRARY; T=0.K

Damage

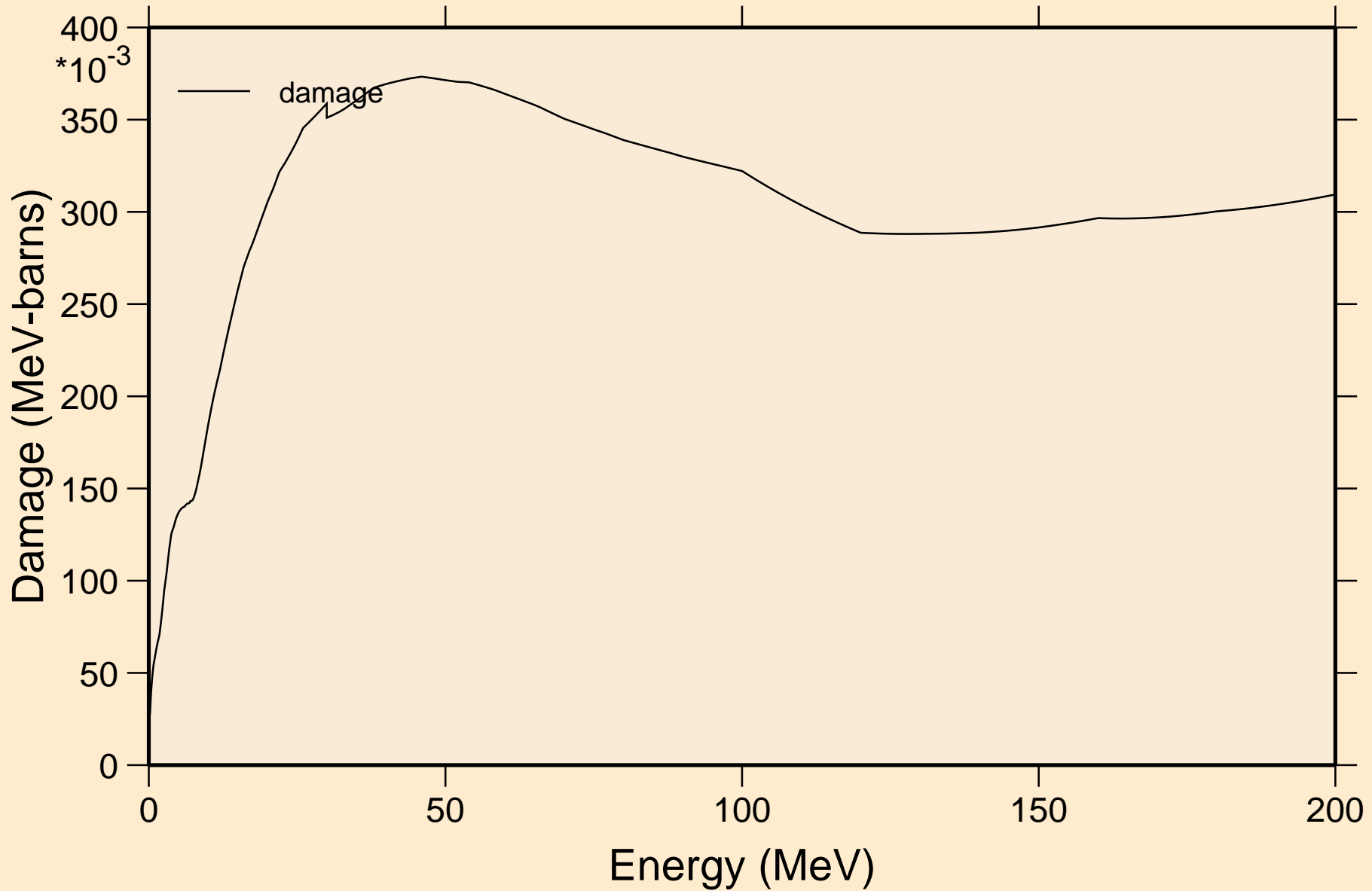

GA072 NEUTRON ACER TENDL-2023 LIBRARY; T=0.K
Non-threshold reactions

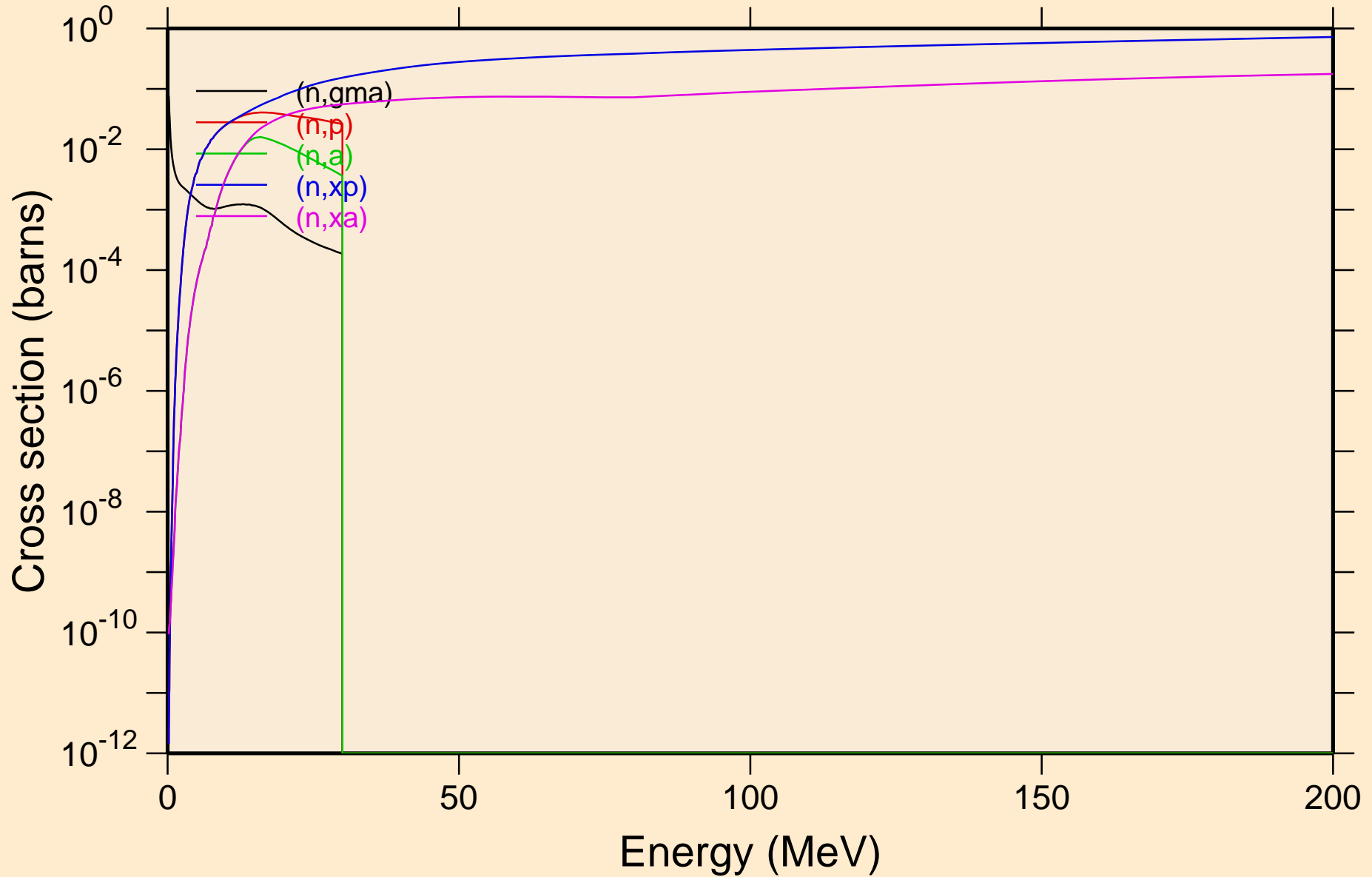

GA072 NEUTRON ACER TENDL-2023 LIBRARY; T=0.K
Inelastic levels

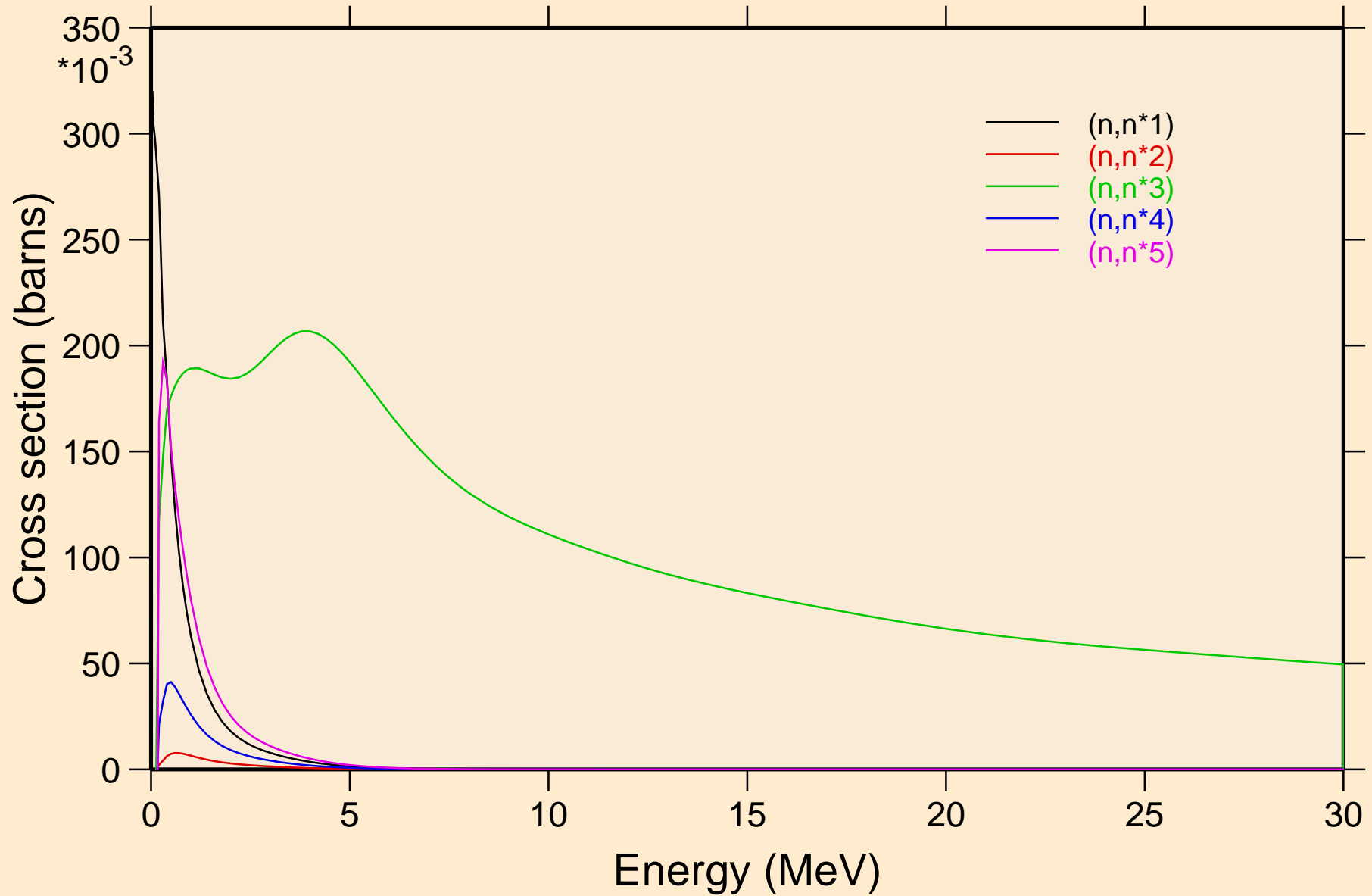

GA072 NEUTRON ACER TENDL-2023 LIBRARY; T=0.K

Inelastic levels

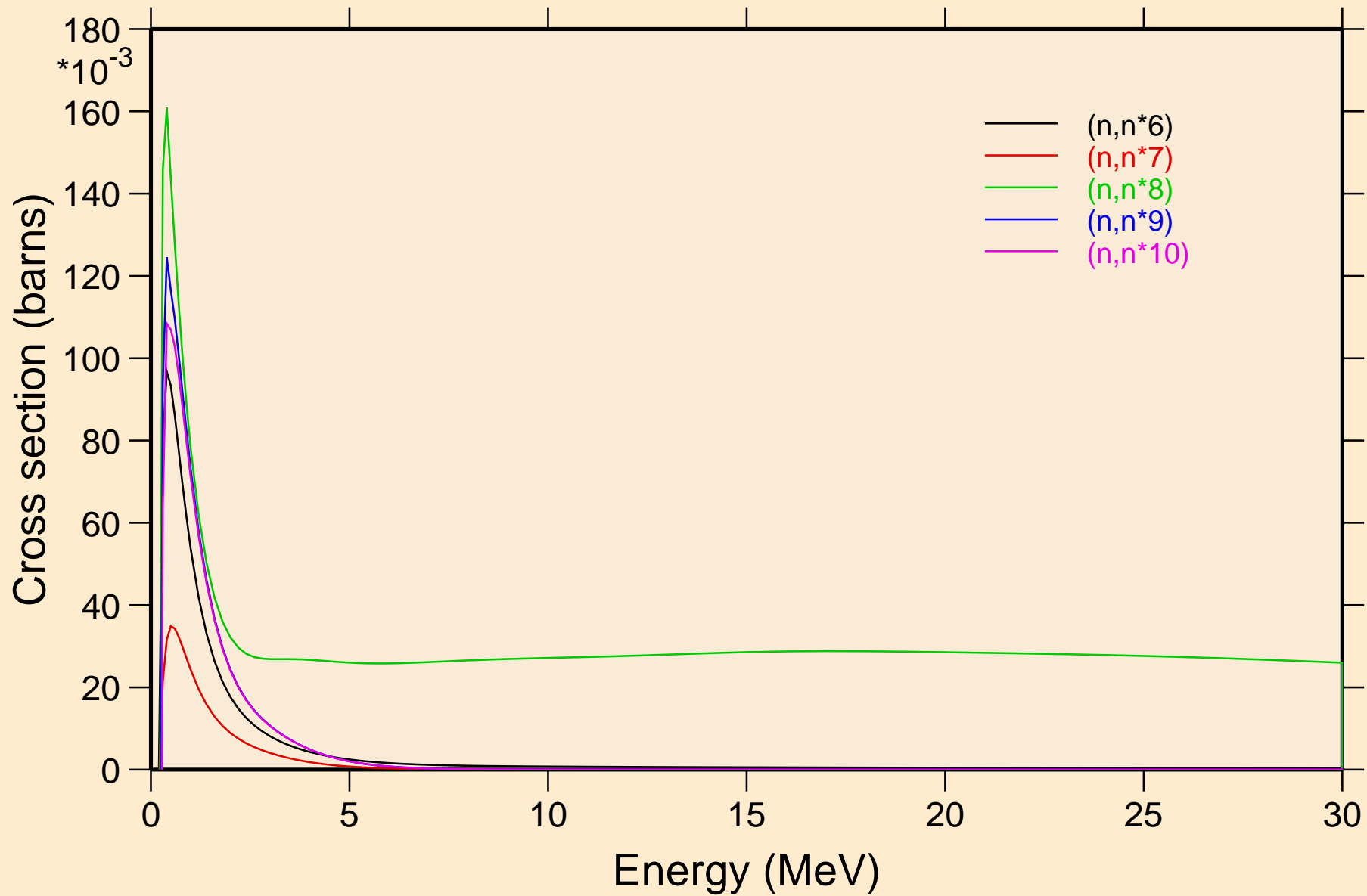

GA072 NEUTRON ACER TENDL-2023 LIBRARY; T=0.K

Inelastic levels

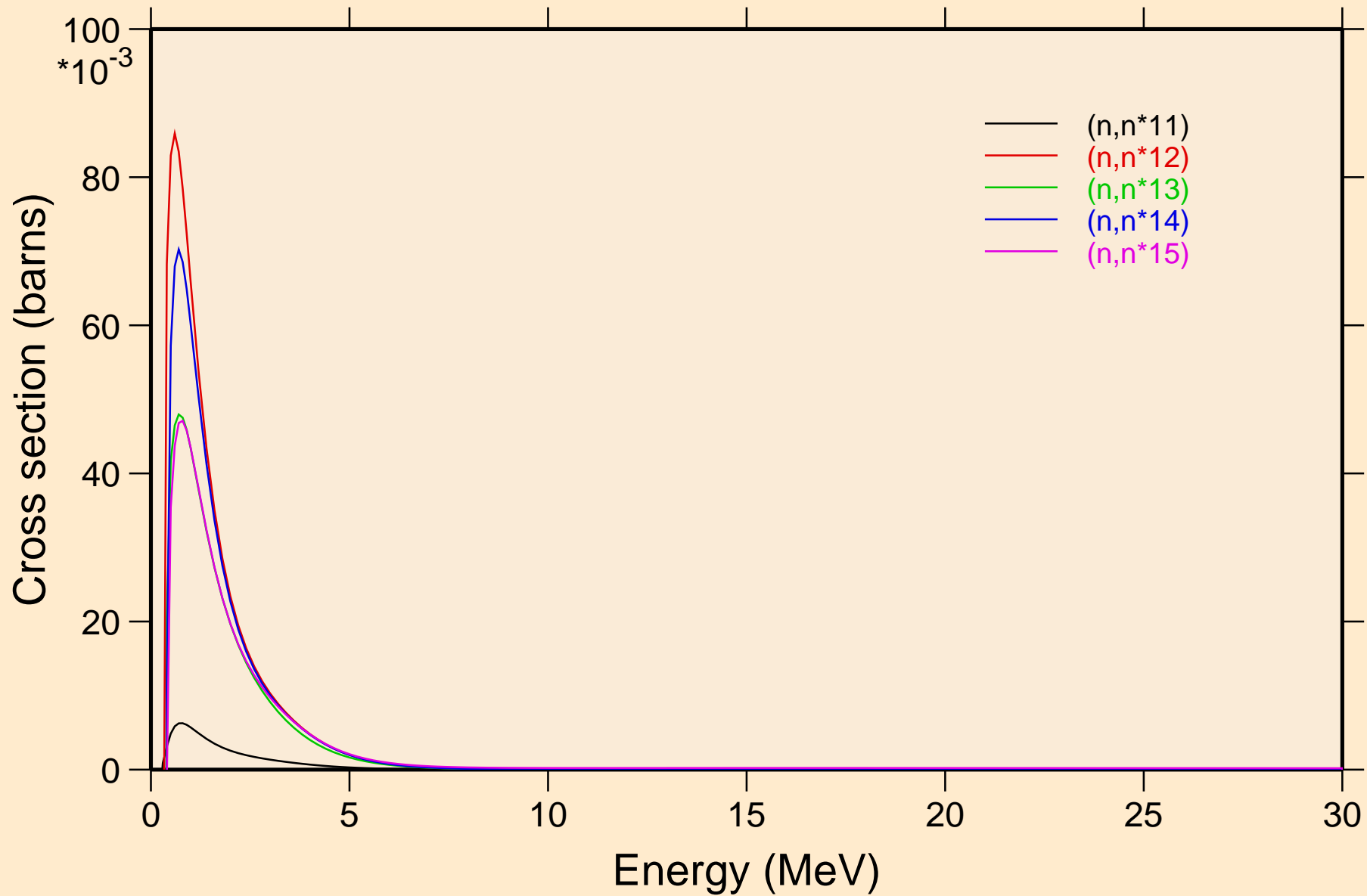

GA072 NEUTRON ACER TENDL-2023 LIBRARY; T=0.K
Inelastic levels

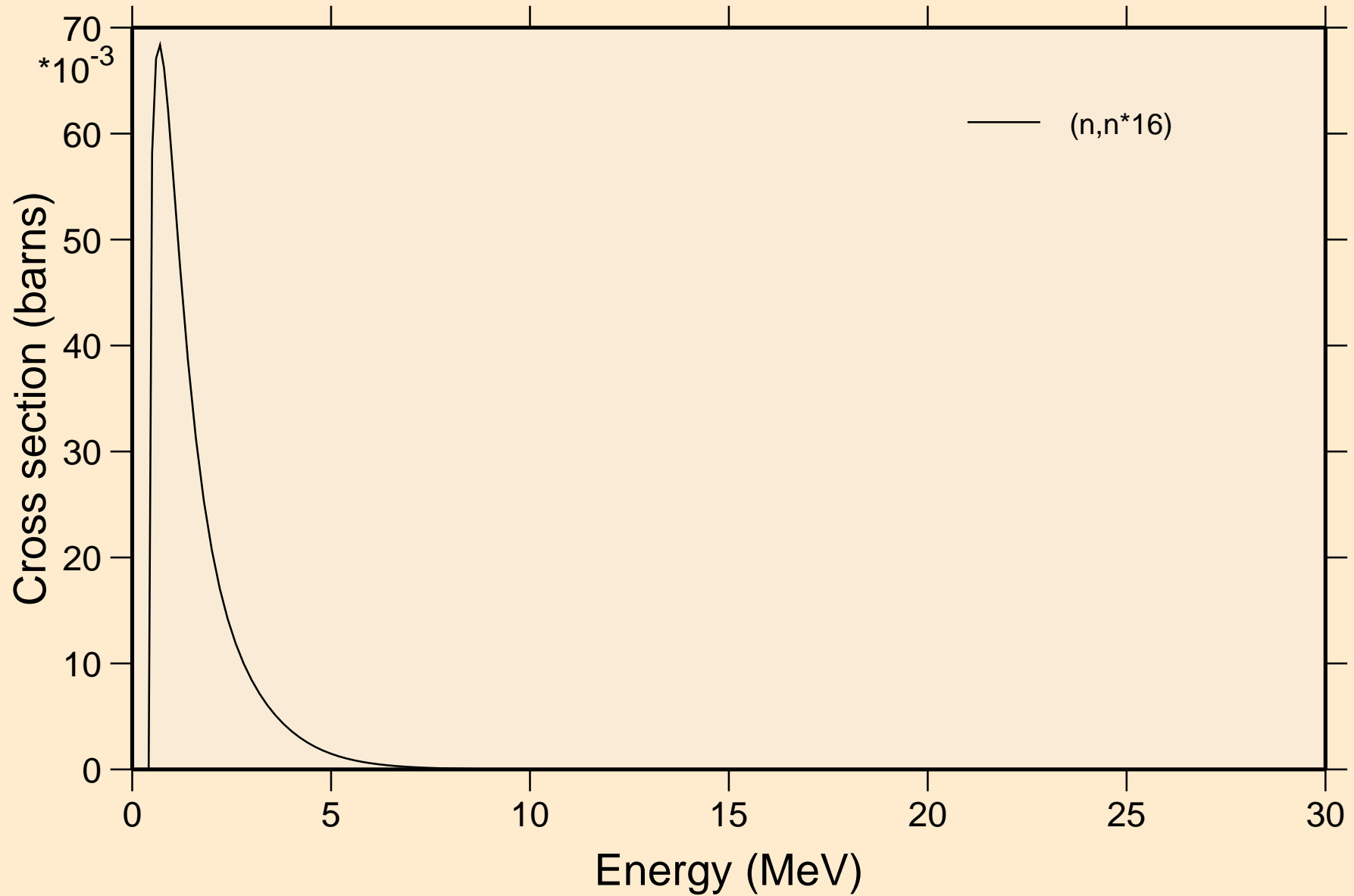

GA072 NEUTRON ACER TENDL-2023 LIBRARY; T=0.K
Threshold reactions

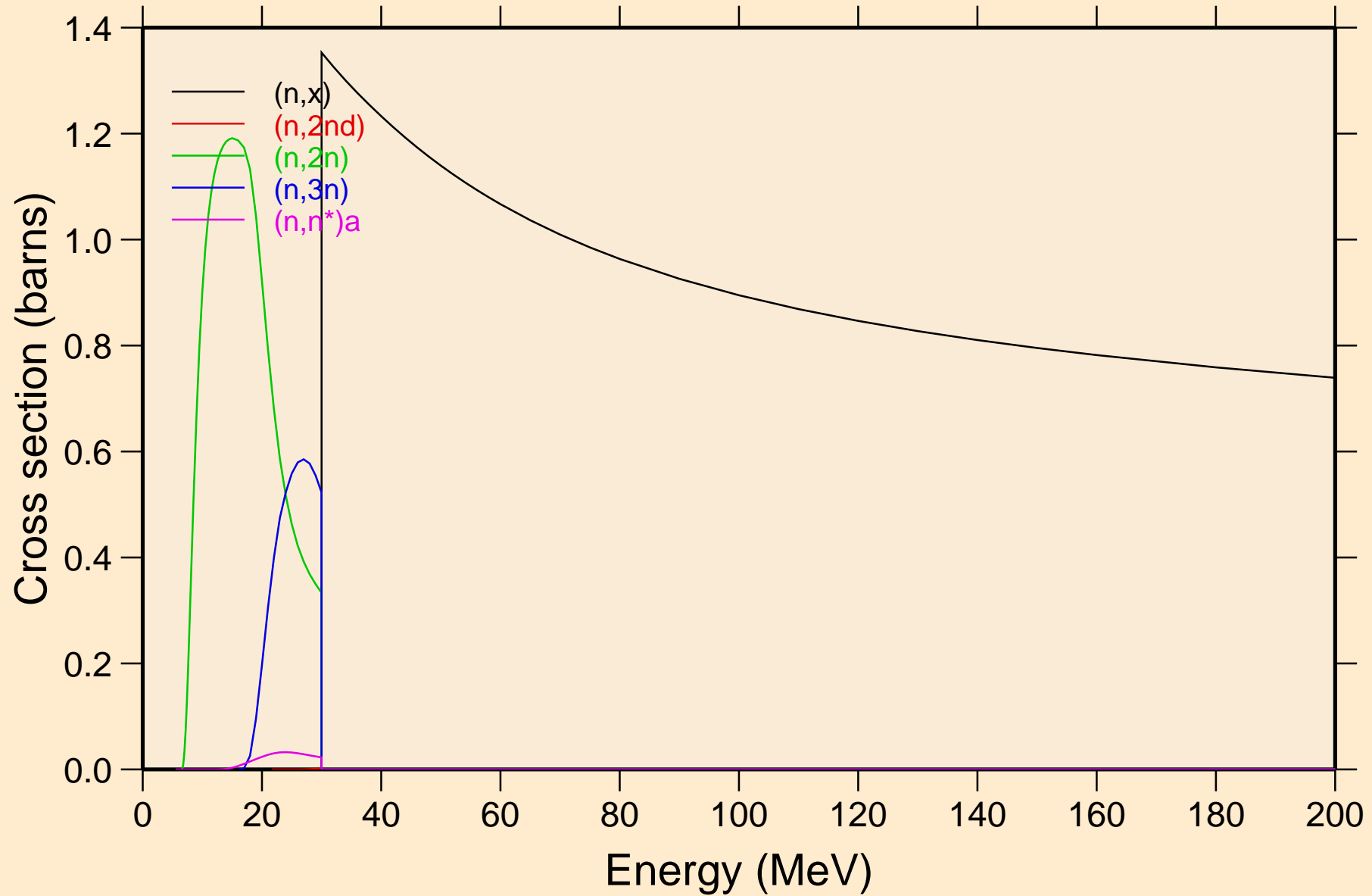

GA072 NEUTRON ACER TENDL-2023 LIBRARY; T=0.K
Threshold reactions

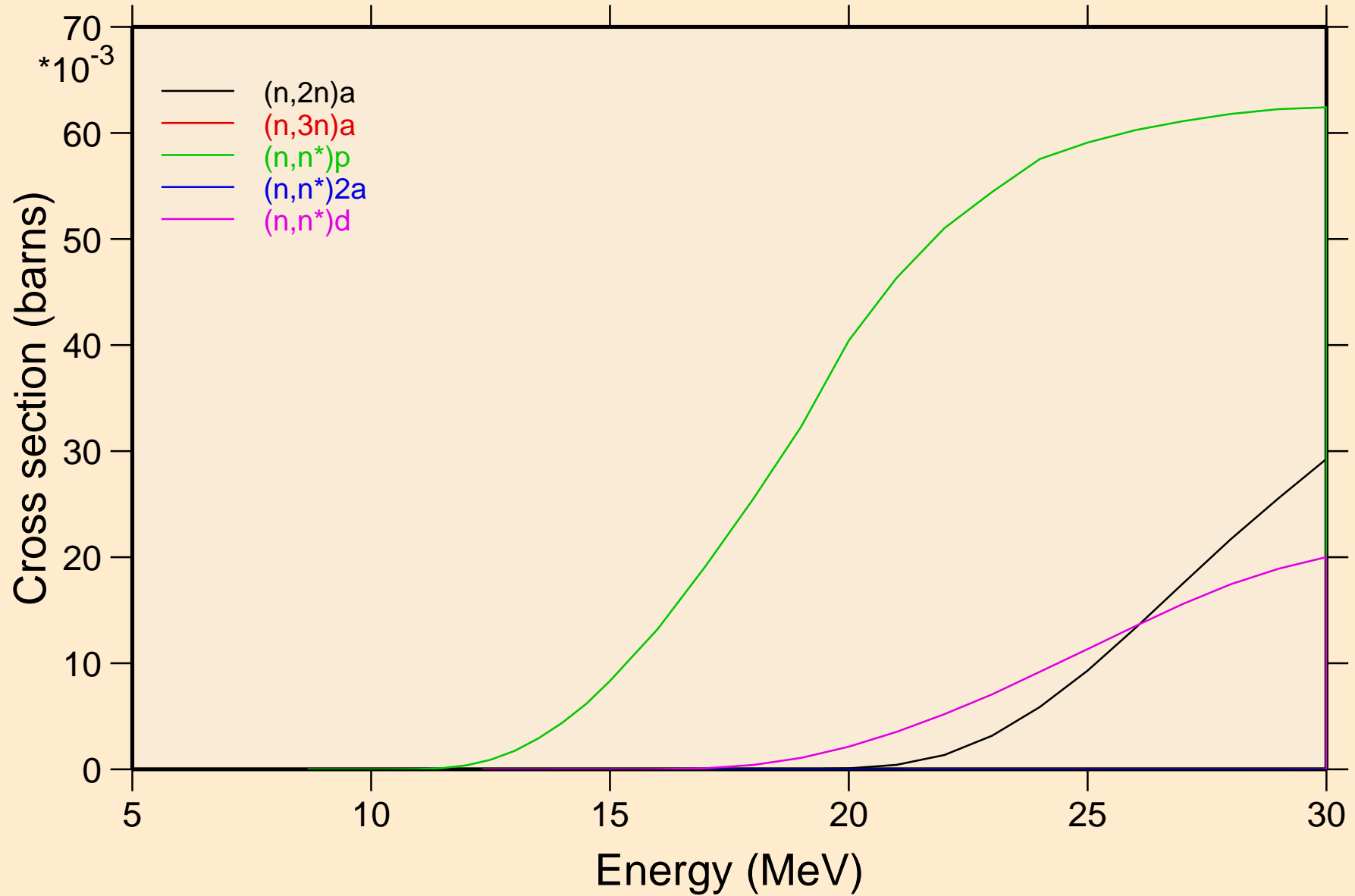

GA072 NEUTRON ACER TENDL-2023 LIBRARY; T=0.K

Threshold reactions

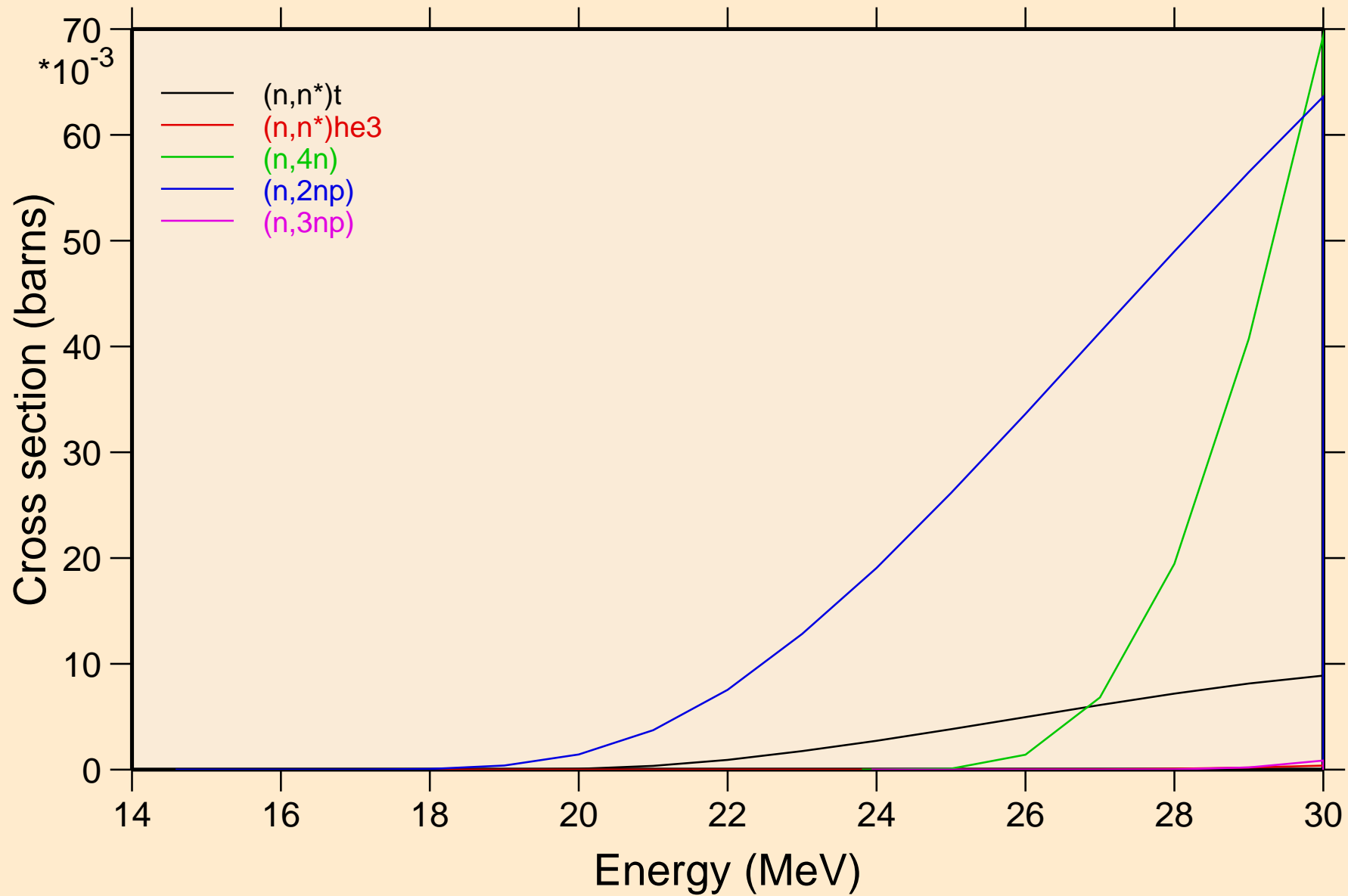

GA072 NEUTRON ACER TENDL-2023 LIBRARY; T=0.K
Threshold reactions

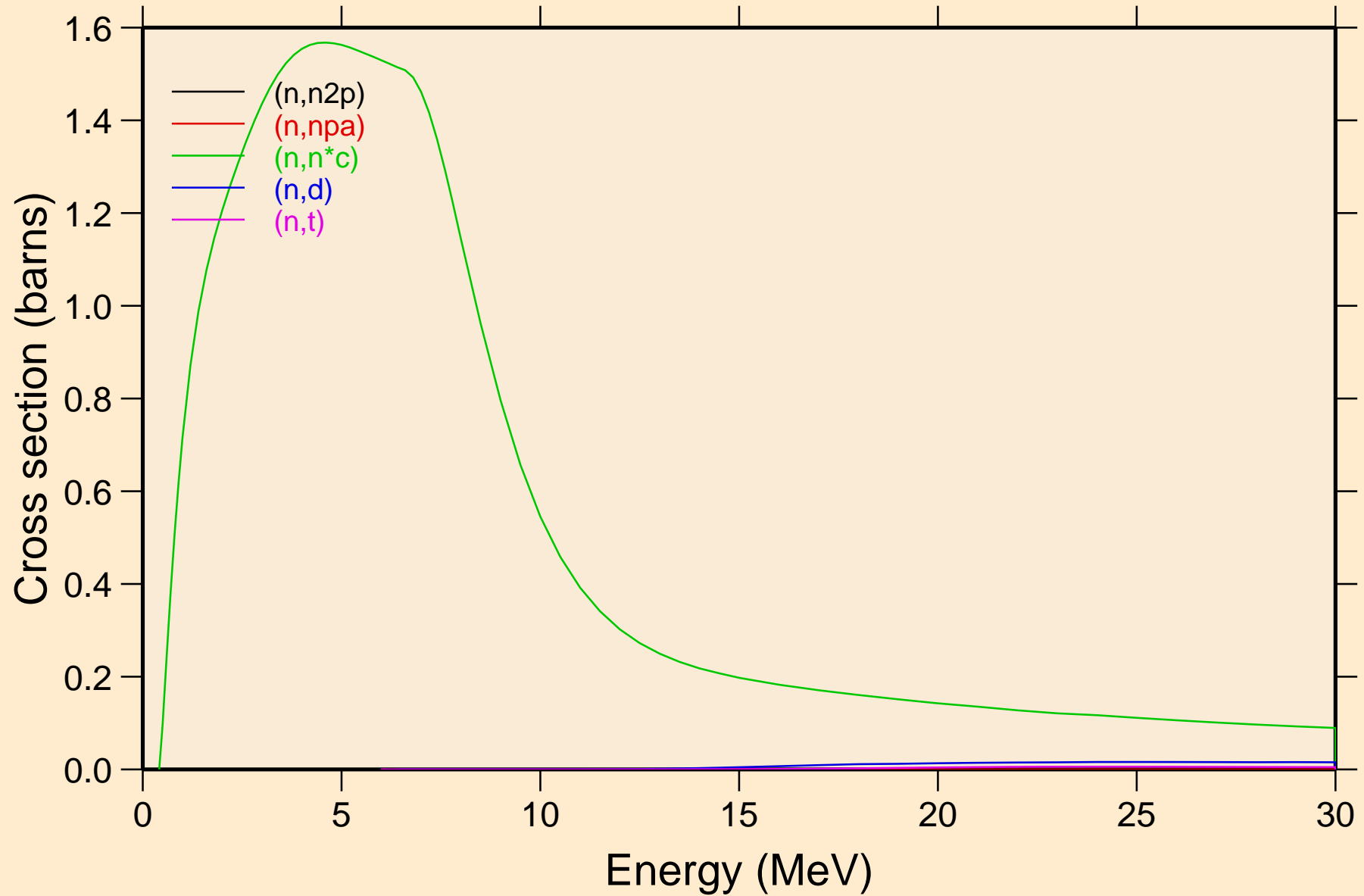

GA072 NEUTRON ACER TENDL-2023 LIBRARY; T=0.K

Threshold reactions

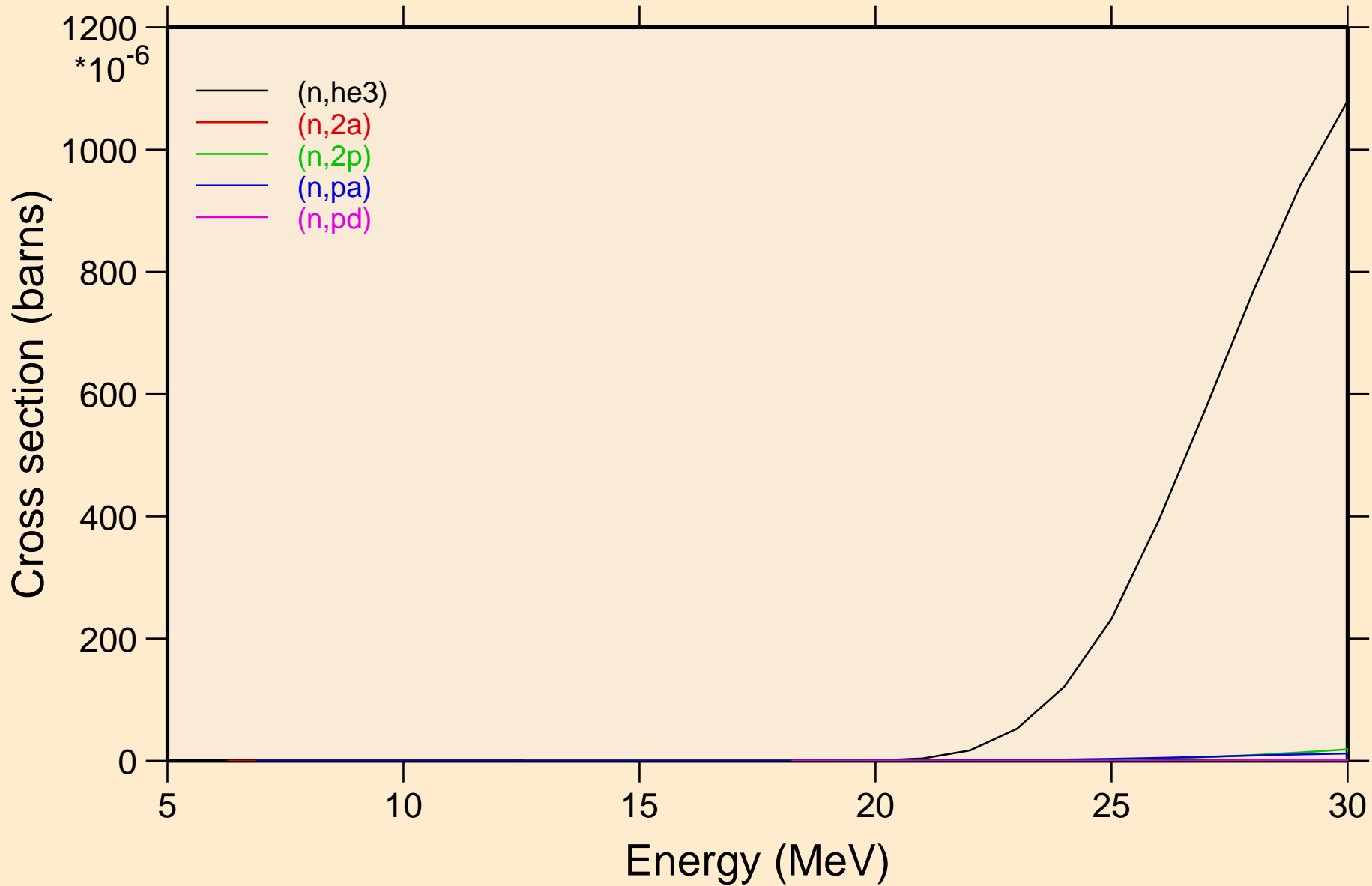

GA072 NEUTRON ACER TENDL-2023 LIBRARY; T=0.K

Threshold reactions

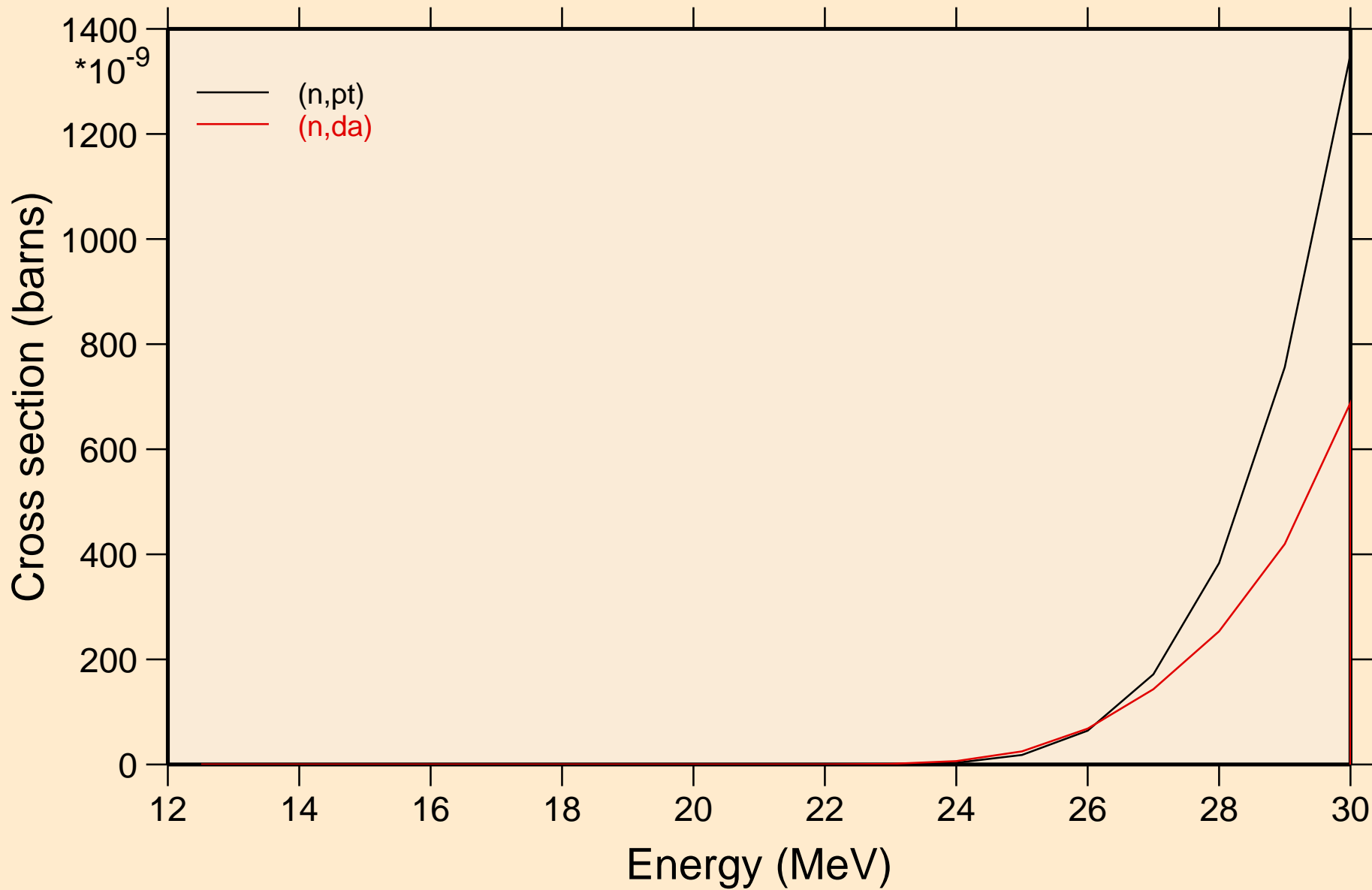

GA072 NEUTRON ACER TENDL-2023 LIBRARY; T=0.K

Threshold reactions

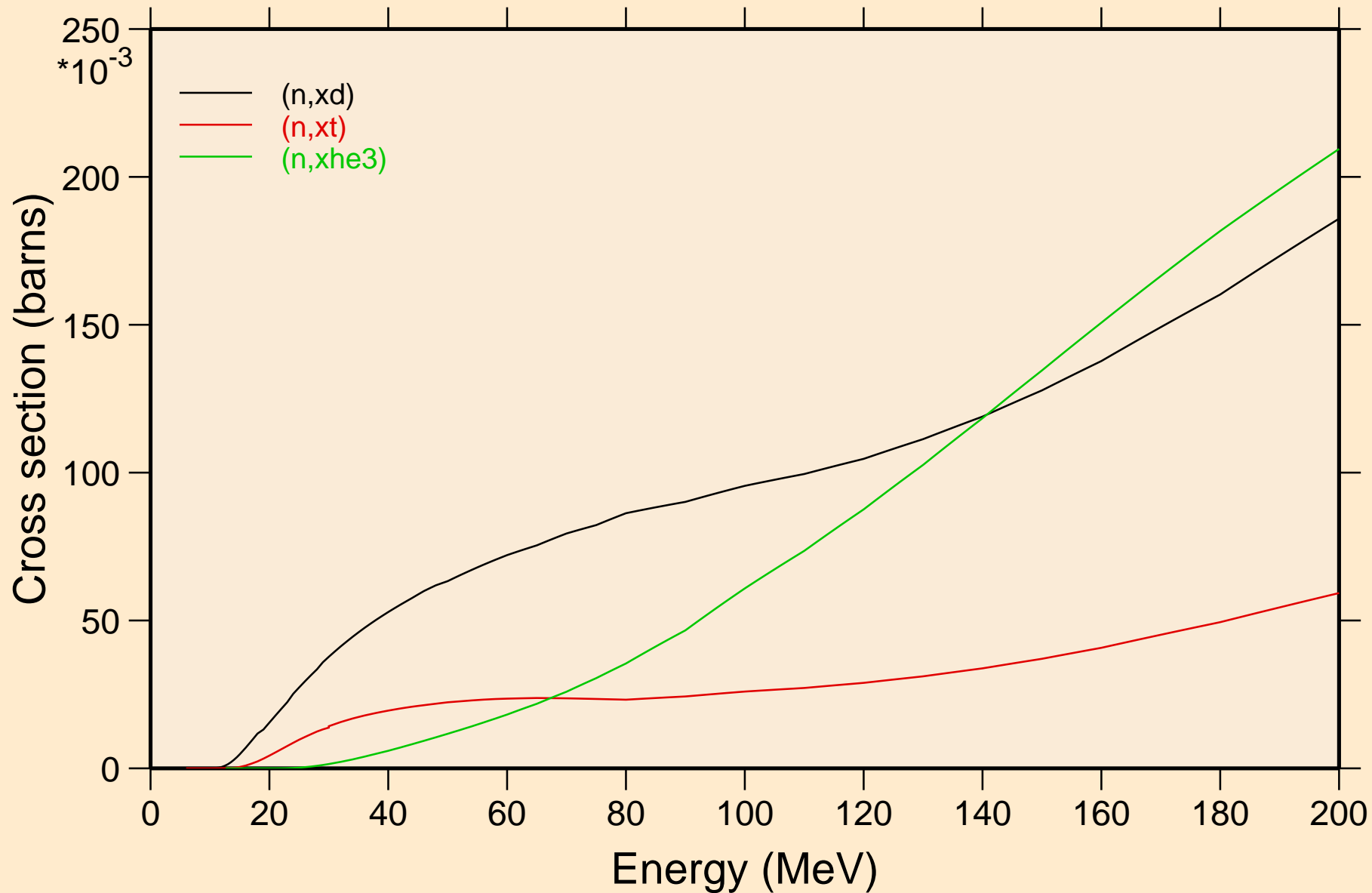

GA072 NEUTRON ACER TENDL-2023 LIBRARY; T=0.K
angular distribution for elastic

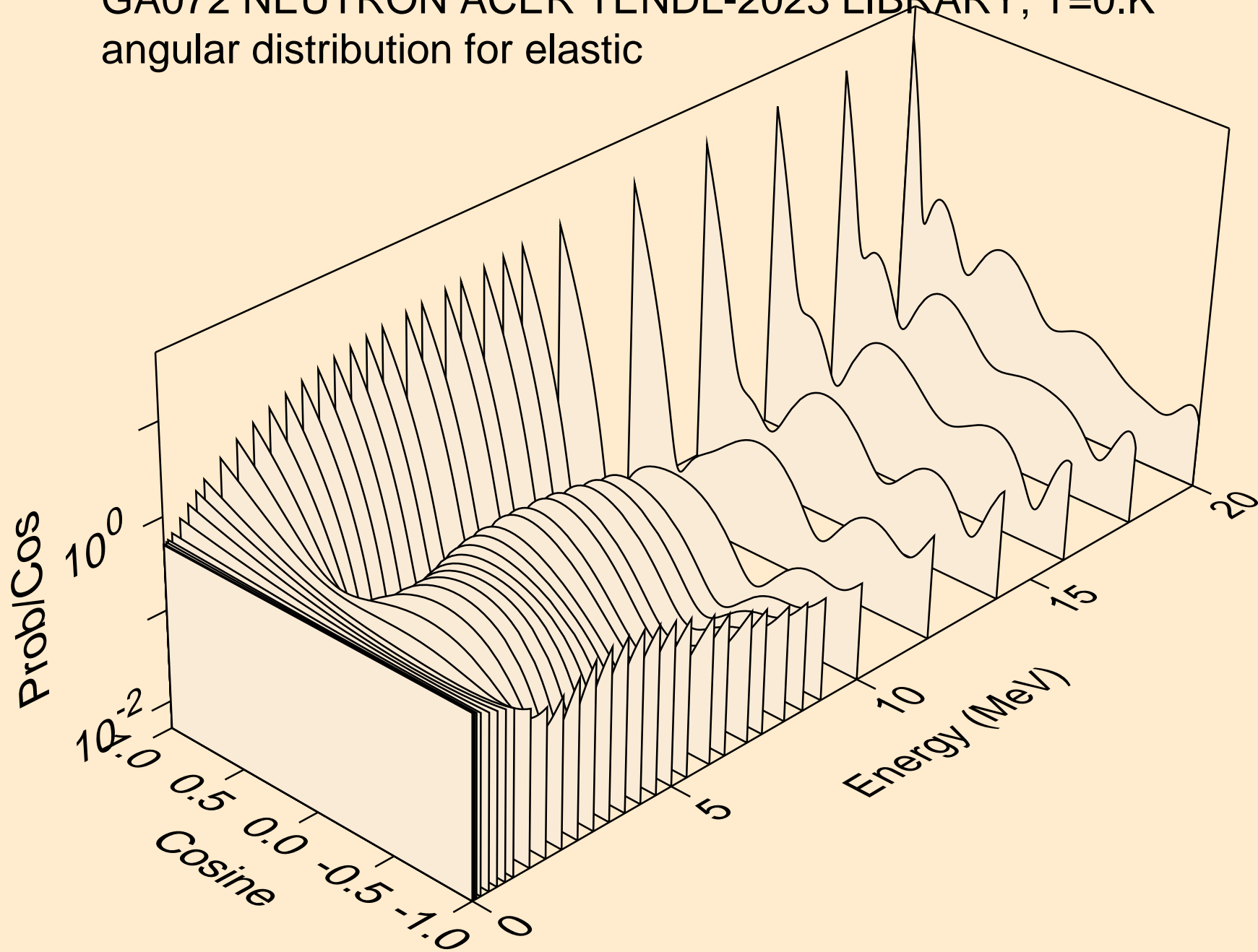

GA072 NEUTRON ACER TENDL-2023 LIBRARY; T=0.K
angular distribution for elastic

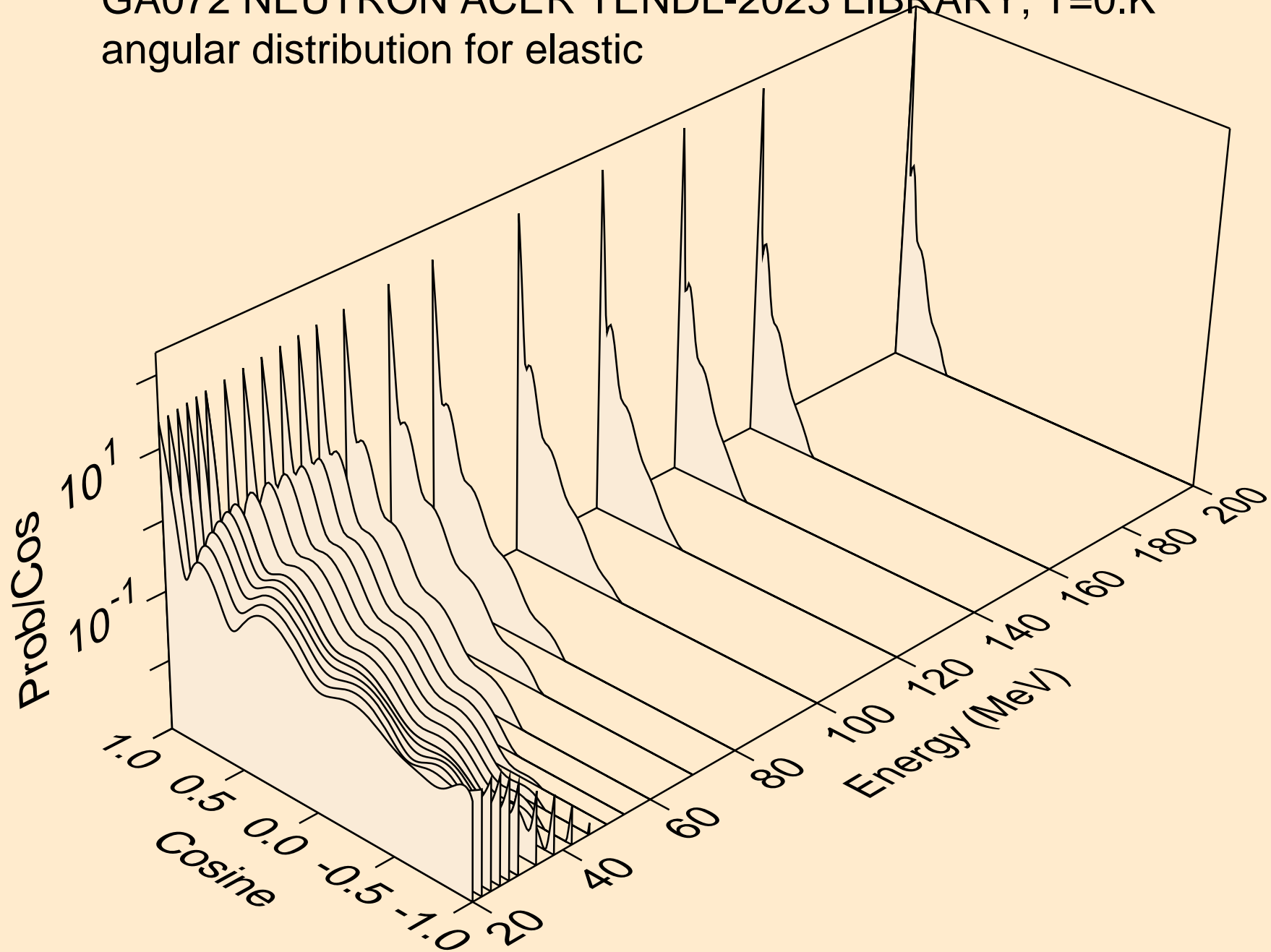

GA072 NEUTRON ACER TENDL-2023 LIBRARY; T=0.K
angular distribution for (n,n*1)

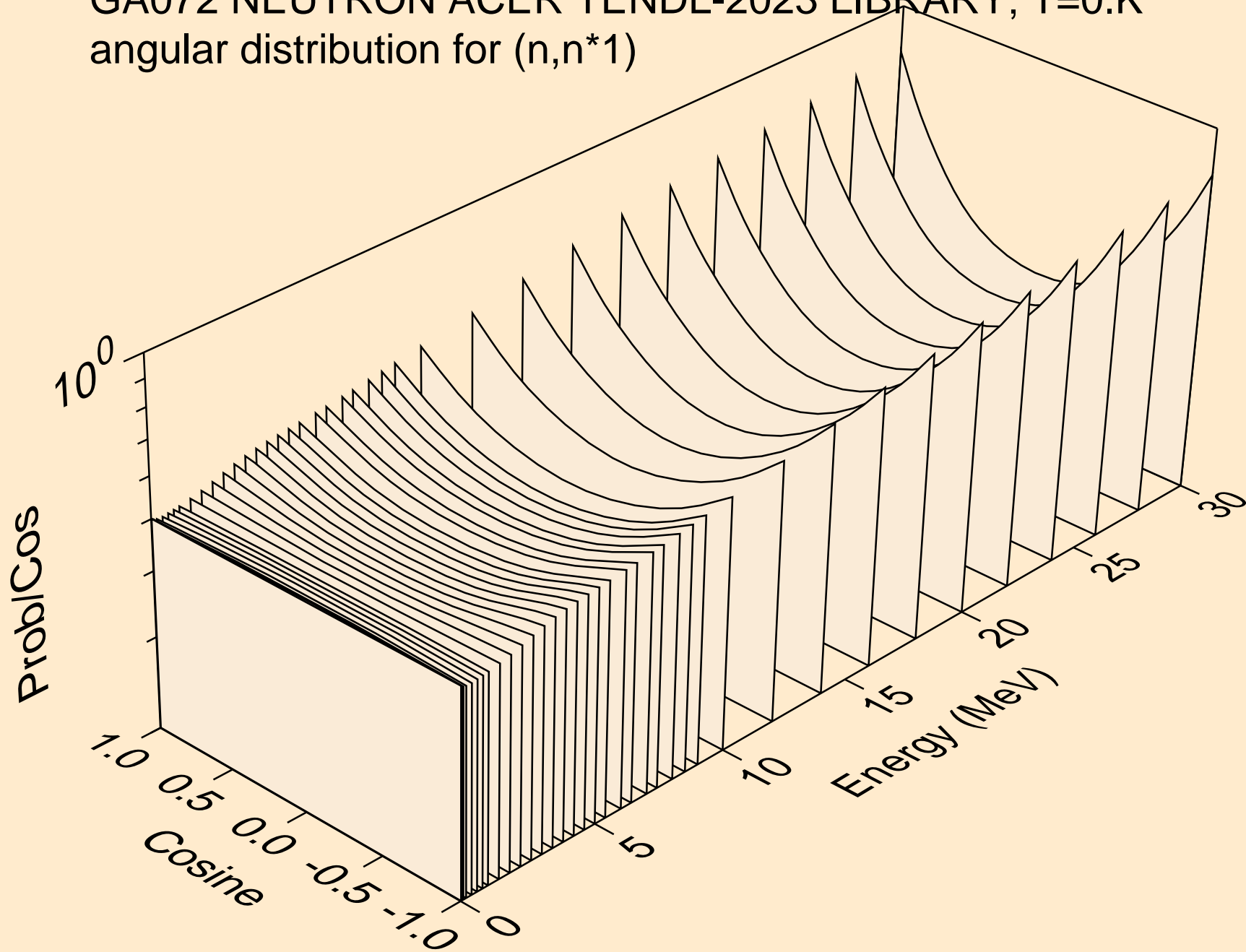

GA072 NEUTRON ACER TENDL-2023 LIBRARY; T=0.K
angular distribution for (n,n*2)

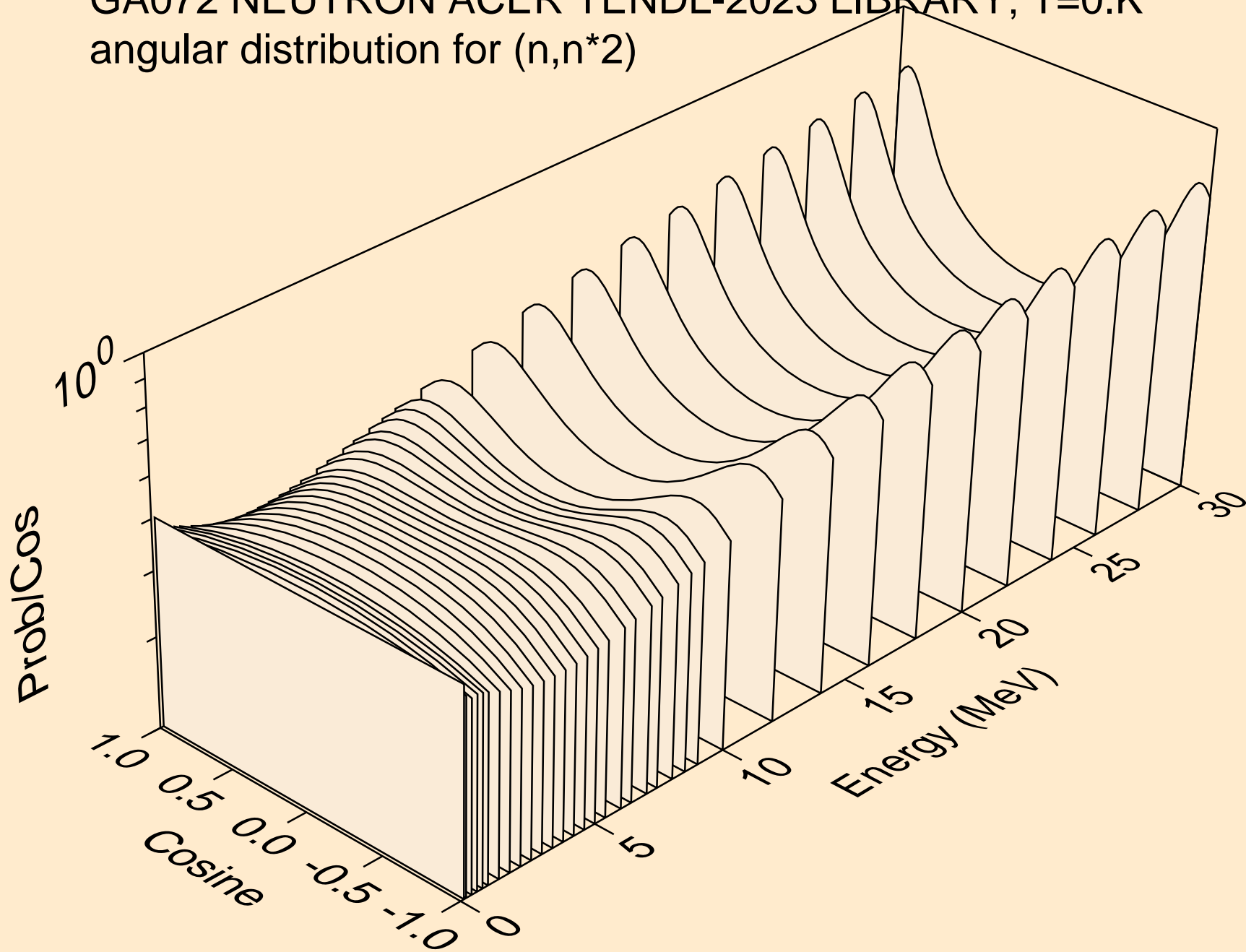

GA072 NEUTRON ACER TENDL-2023 LIBRARY; T=0.K
angular distribution for (n,n*3)

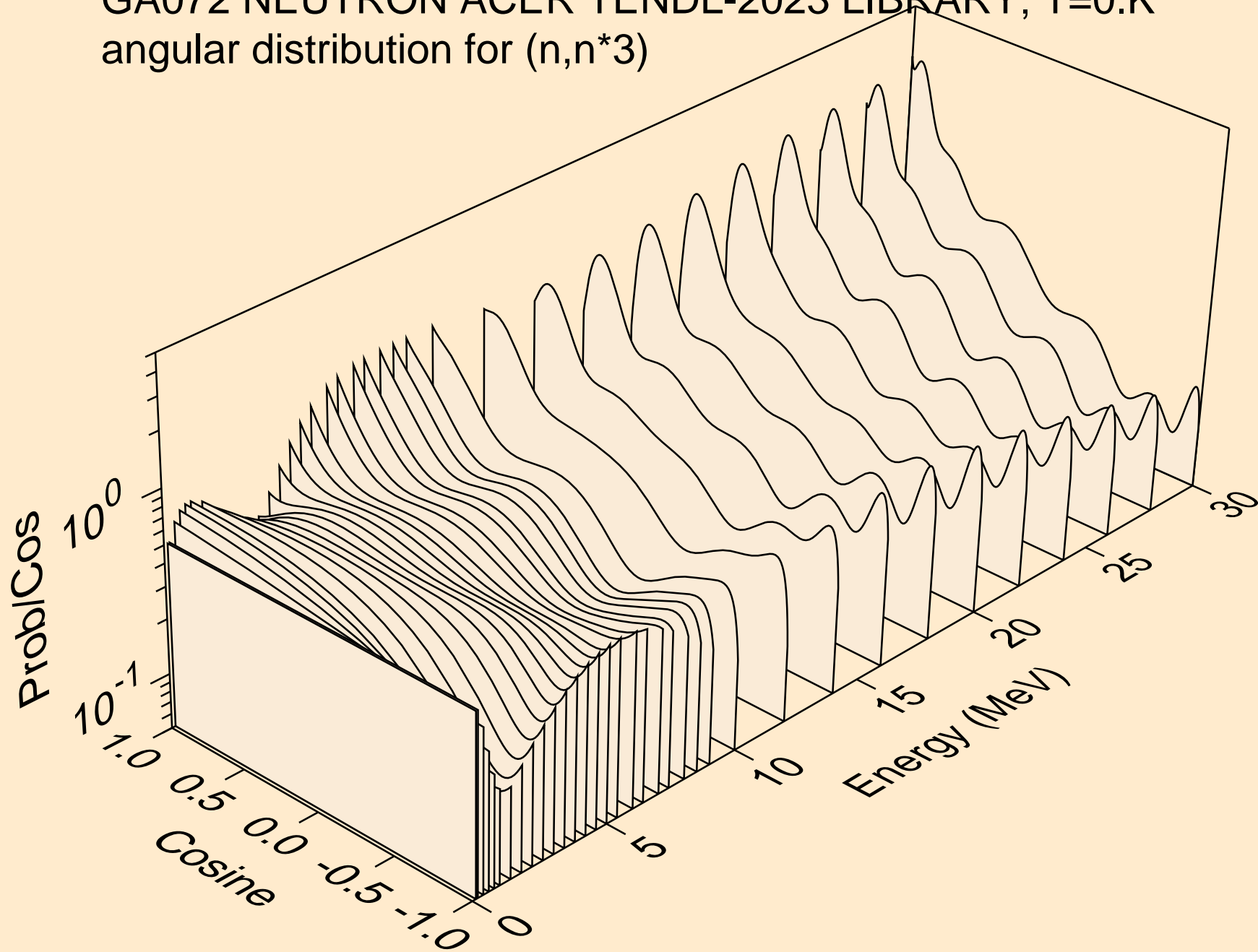

GA072 NEUTRON ACER TENDL-2023 LIBRARY; T=0.K
angular distribution for (n,n*4)

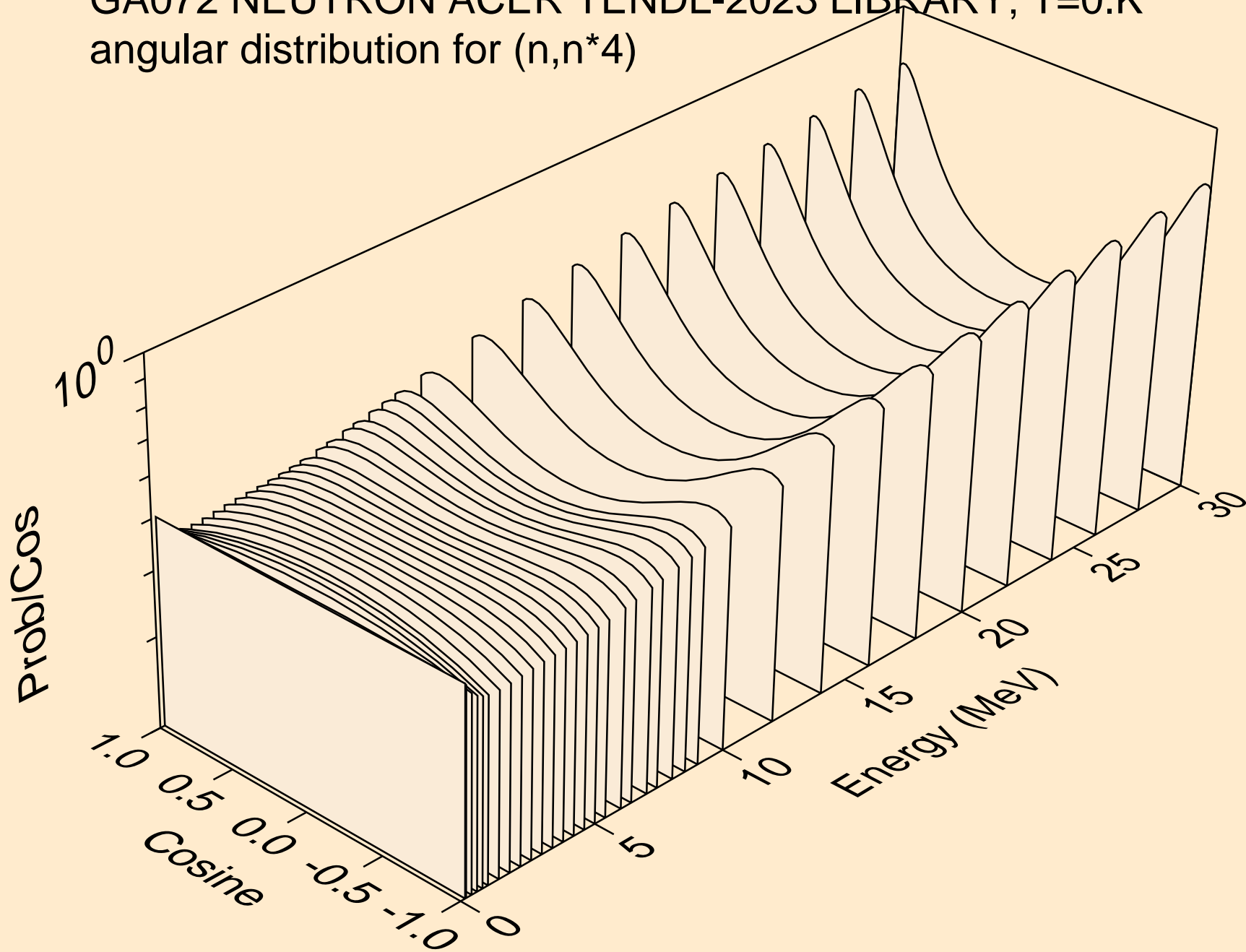

GA072 NEUTRON ACER TENDL-2023 LIBRARY; T=0.K
angular distribution for (n,n*5)

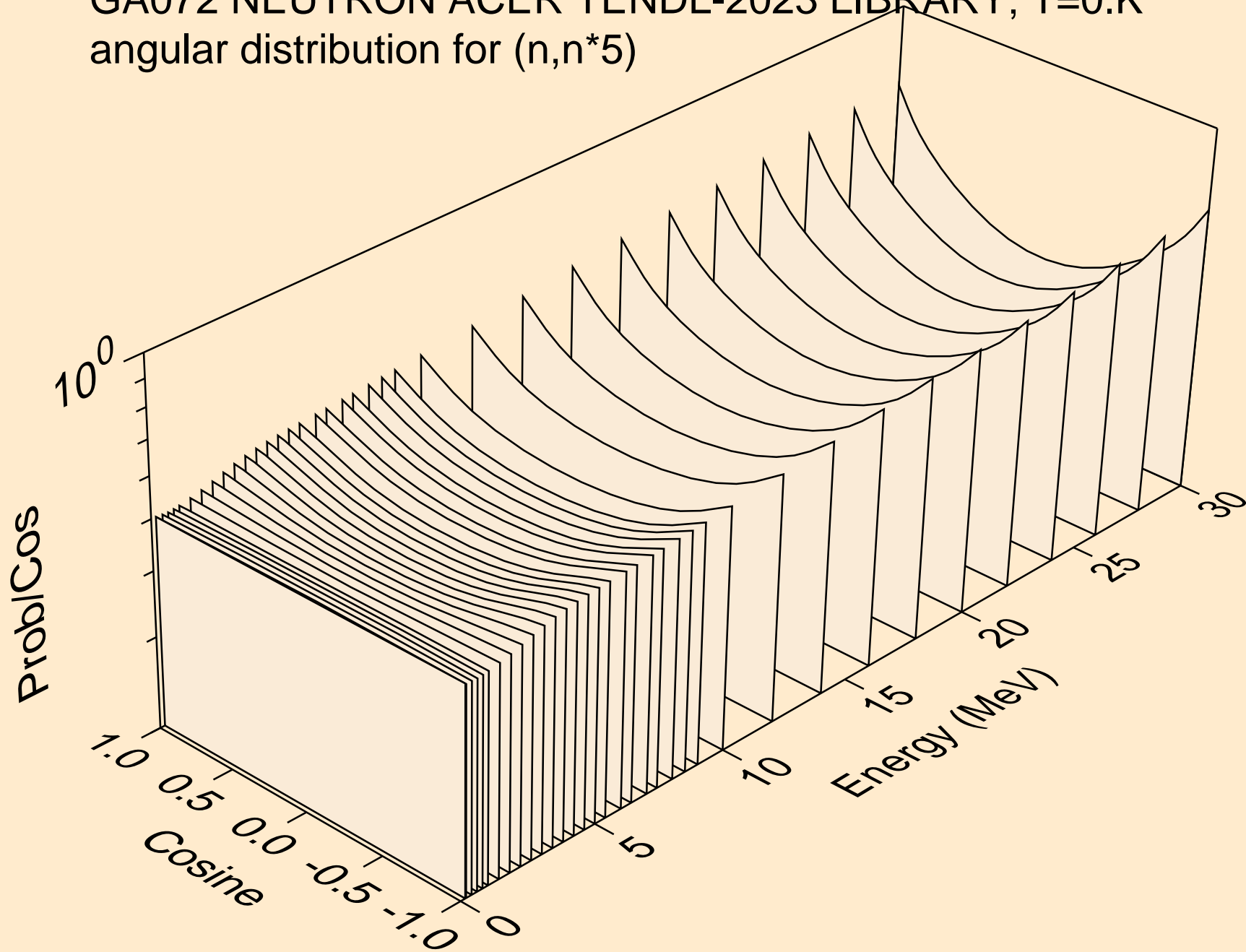

GA072 NEUTRON ACER TENDL-2023 LIBRARY; T=0.K
angular distribution for (n,n*6)

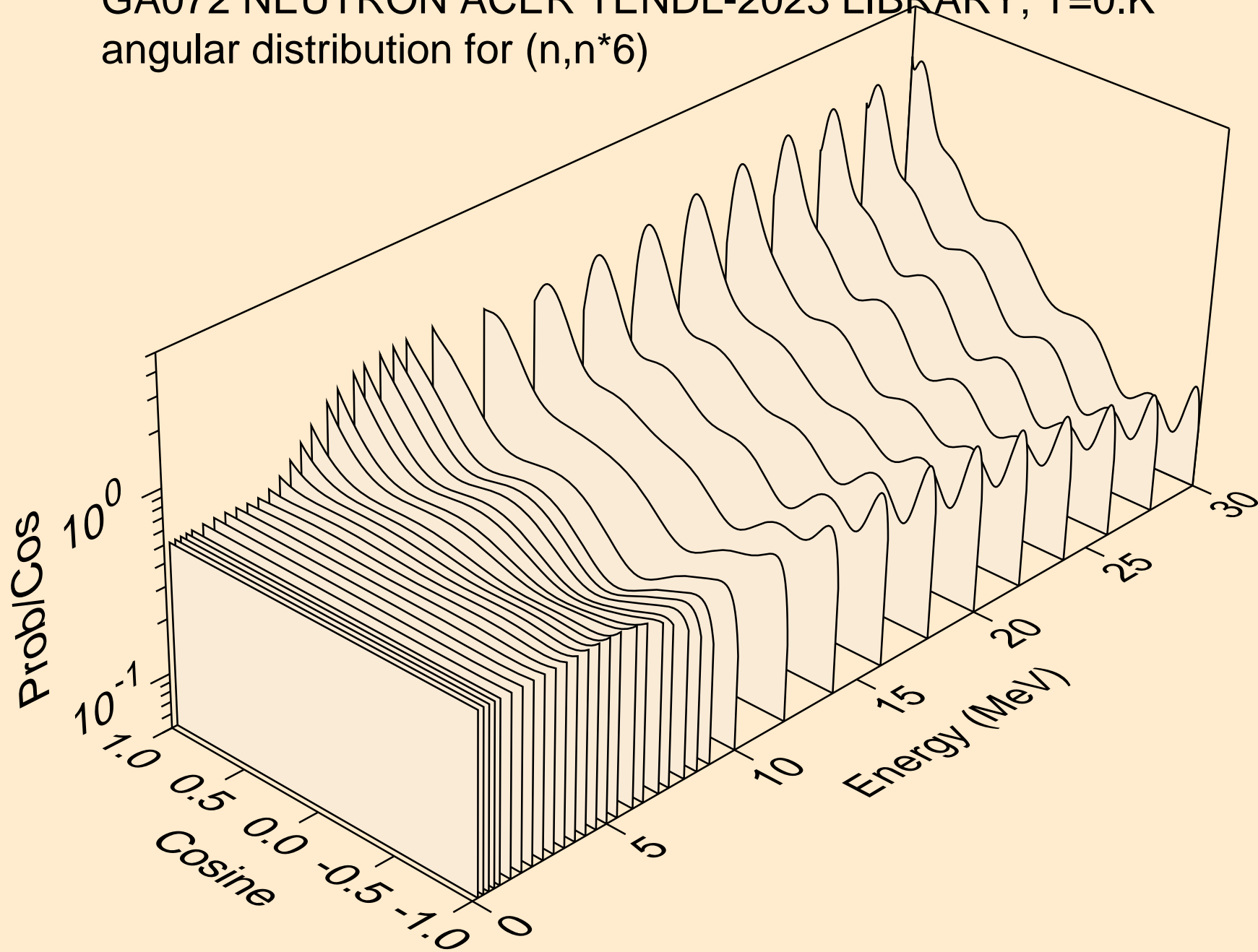

GA072 NEUTRON ACER TENDL-2023 LIBRARY; T=0.K
angular distribution for (n,n*7)

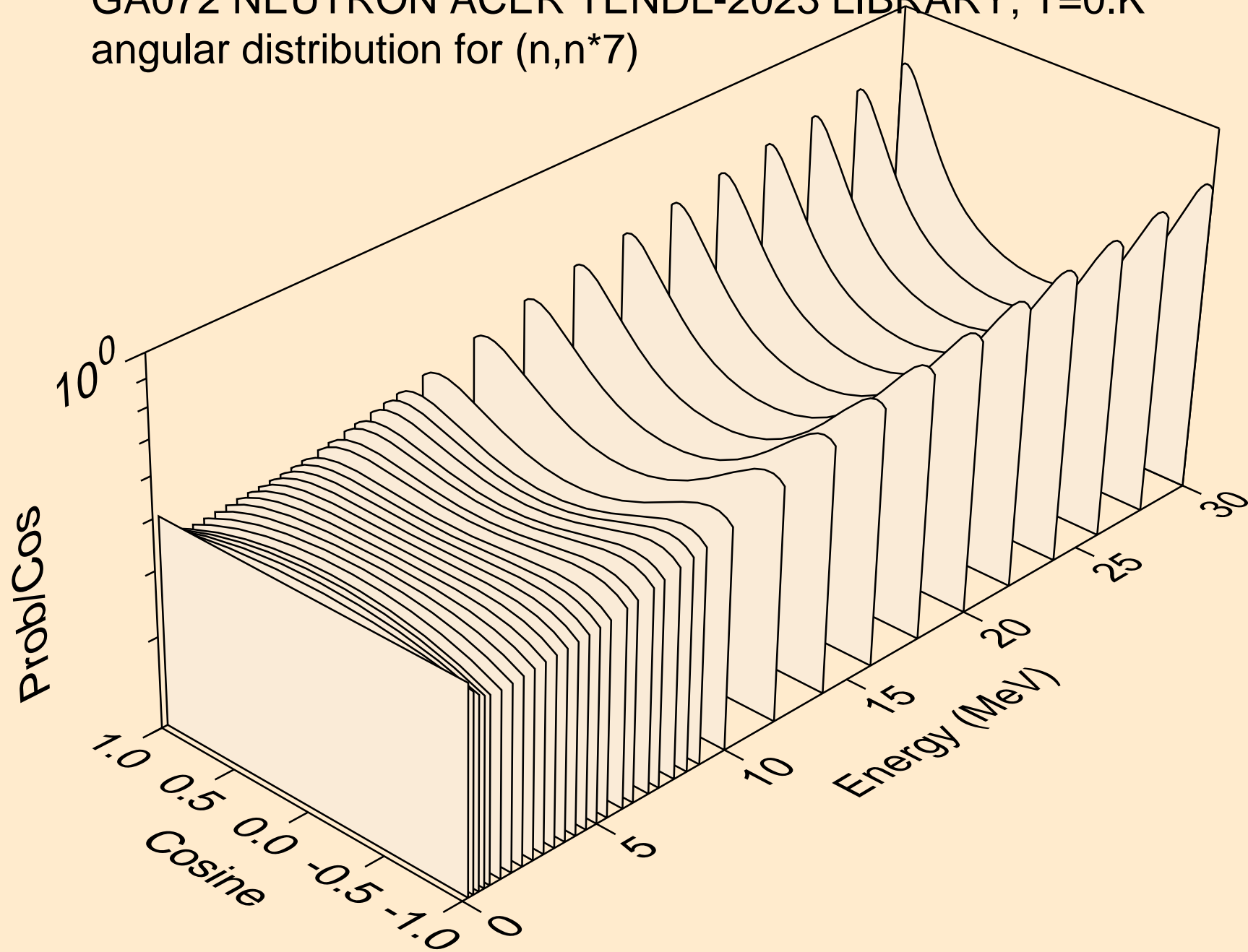

GA072 NEUTRON ACER TENDL-2023 LIBRARY; T=0.K
angular distribution for (n,n*8)

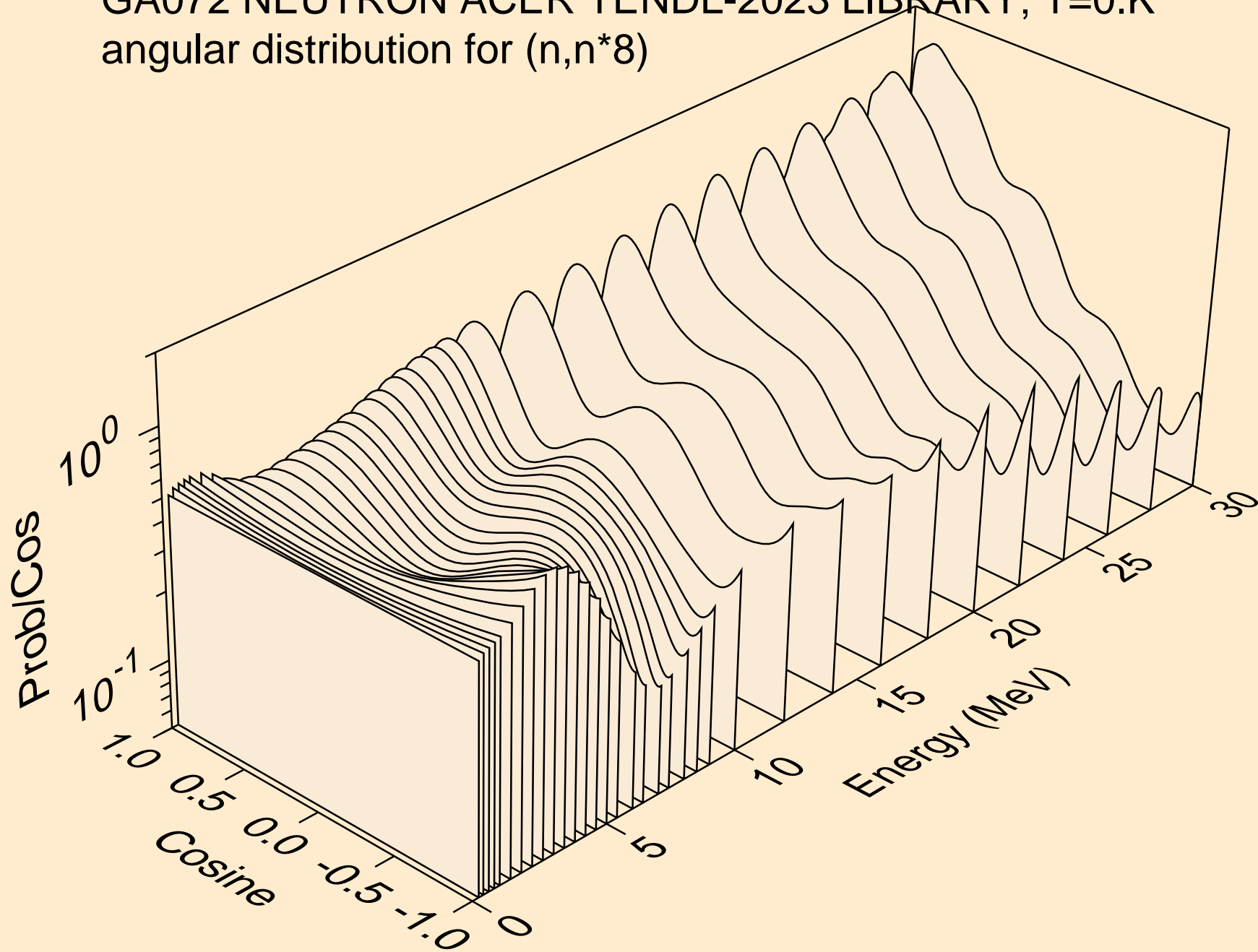

GA072 NEUTRON ACER TENDL-2023 LIBRARY; T=0.K
angular distribution for (n,n*9)

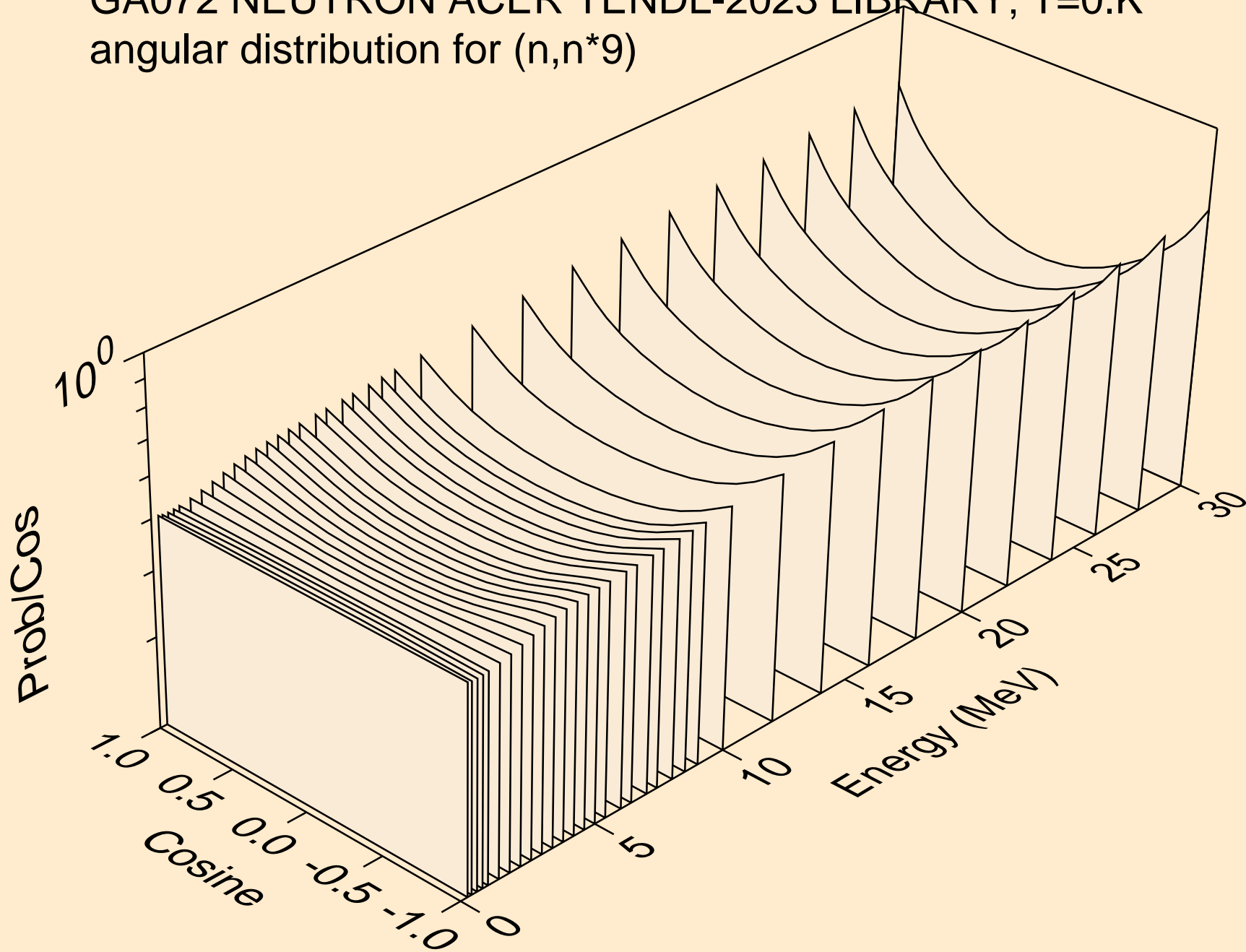

GA072 NEUTRON ACER TENDL-2023 LIBRARY; T=0.K
angular distribution for (n,n*10)

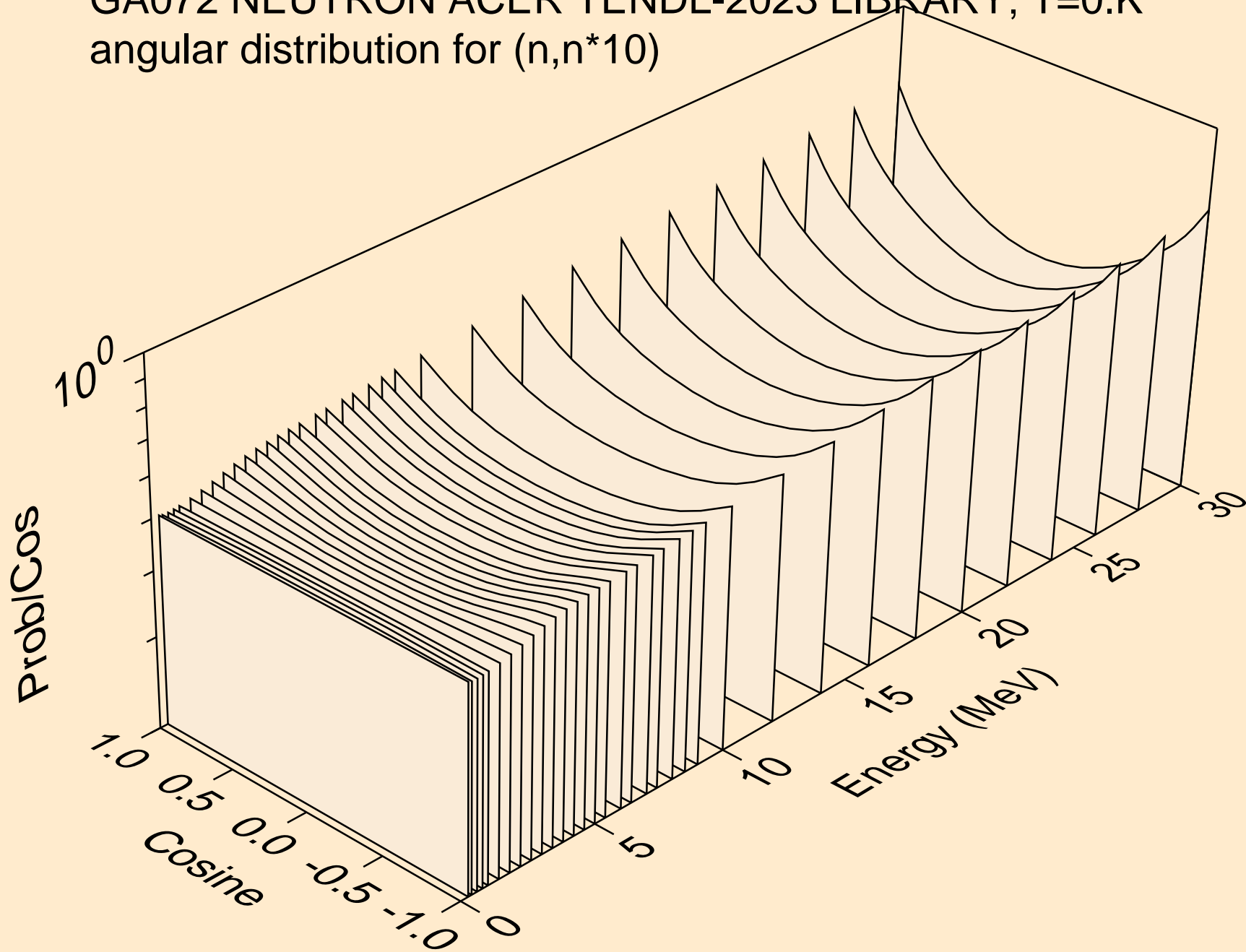

GA072 NEUTRON ACER TENDL-2023 LIBRARY; T=0.K
angular distribution for (n,n*11)

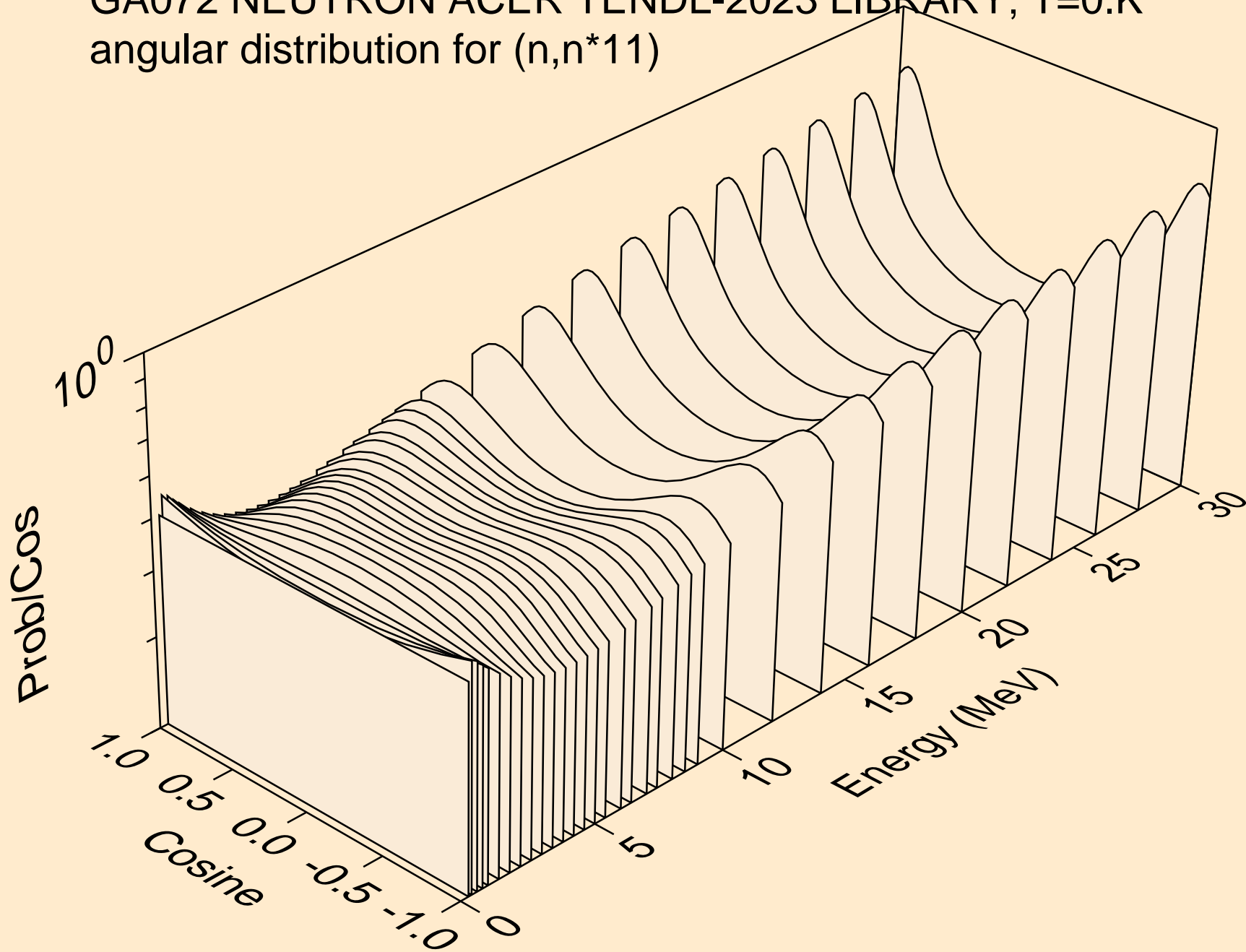

GA072 NEUTRON ACER TENDL-2023 LIBRARY; T=0.K
angular distribution for (n,n*12)

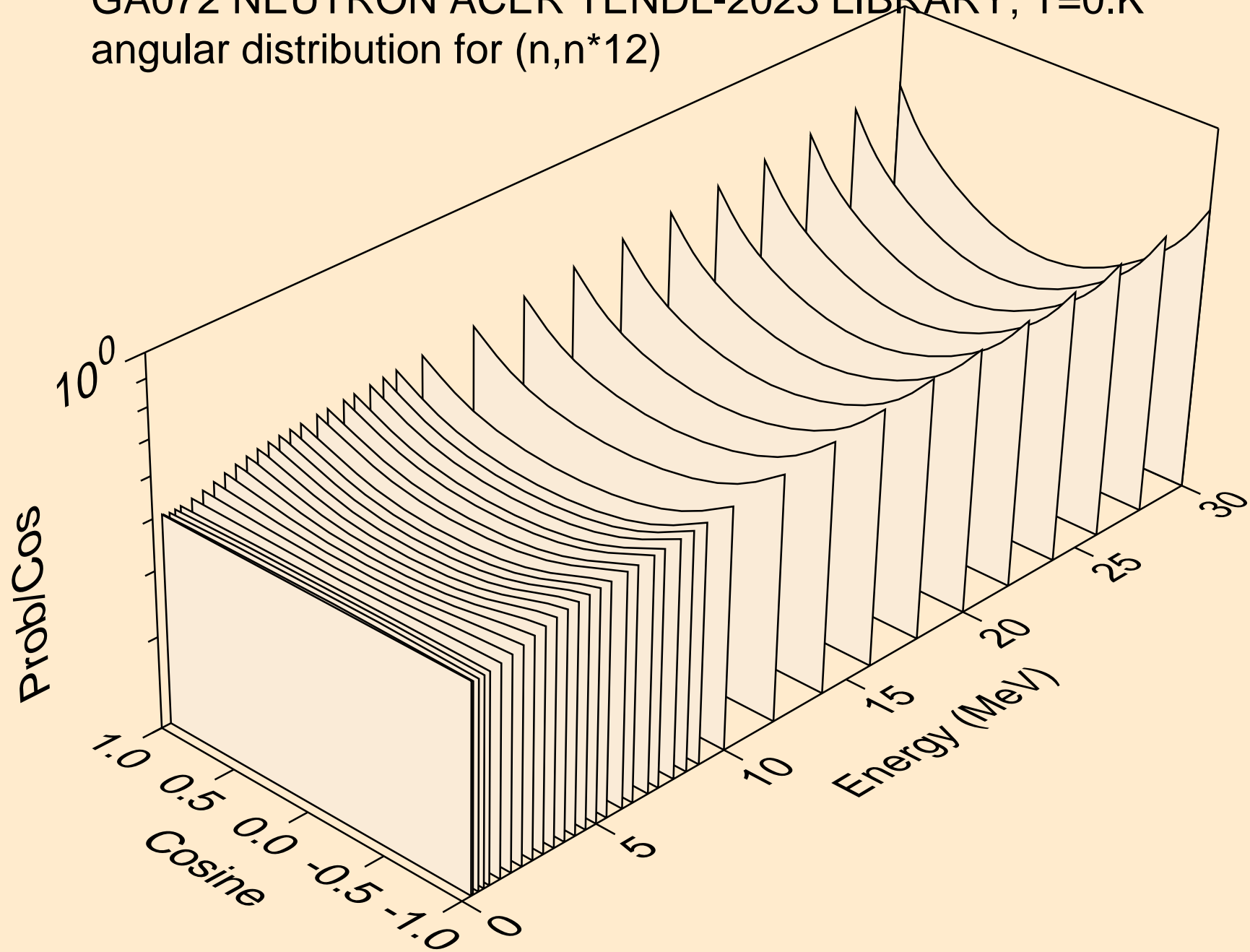

GA072 NEUTRON ACER TENDL-2023 LIBRARY; T=0.K
angular distribution for (n,n*13)

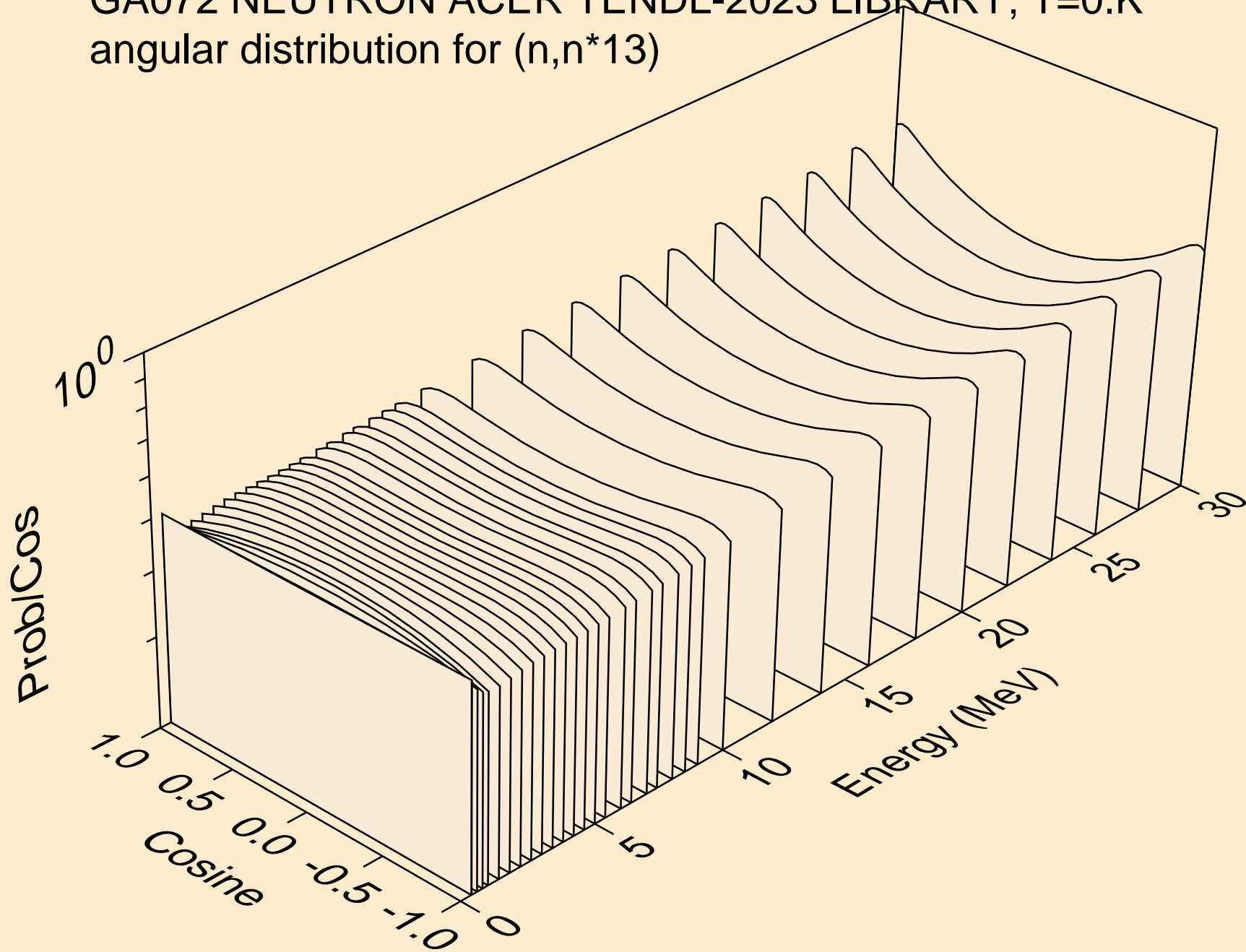

GA072 NEUTRON ACER TENDL-2023 LIBRARY; T=0.K
angular distribution for (n,n*14)

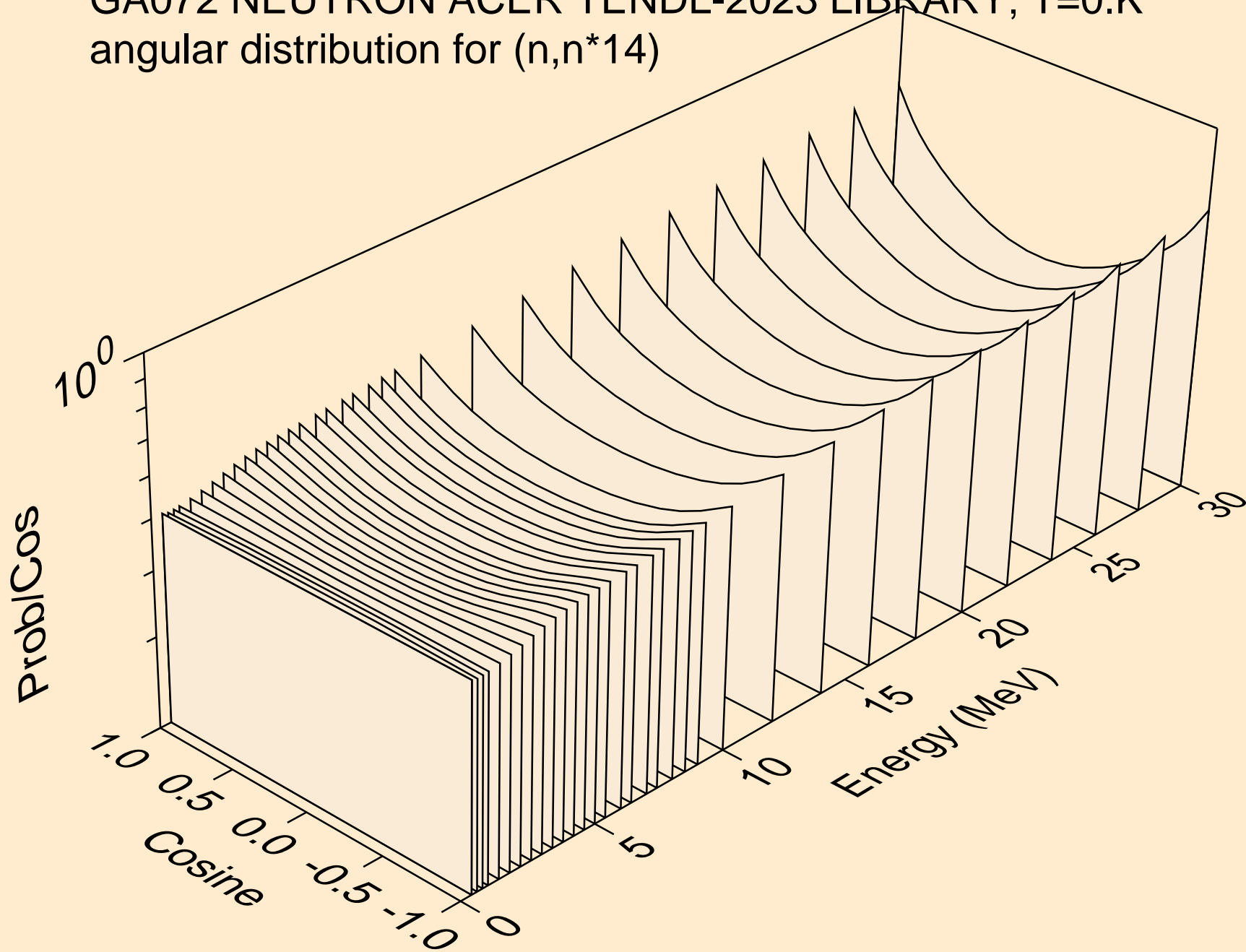

GA072 NEUTRON ACER TENDL-2023 LIBRARY; T=0.K
angular distribution for (n,n*15)

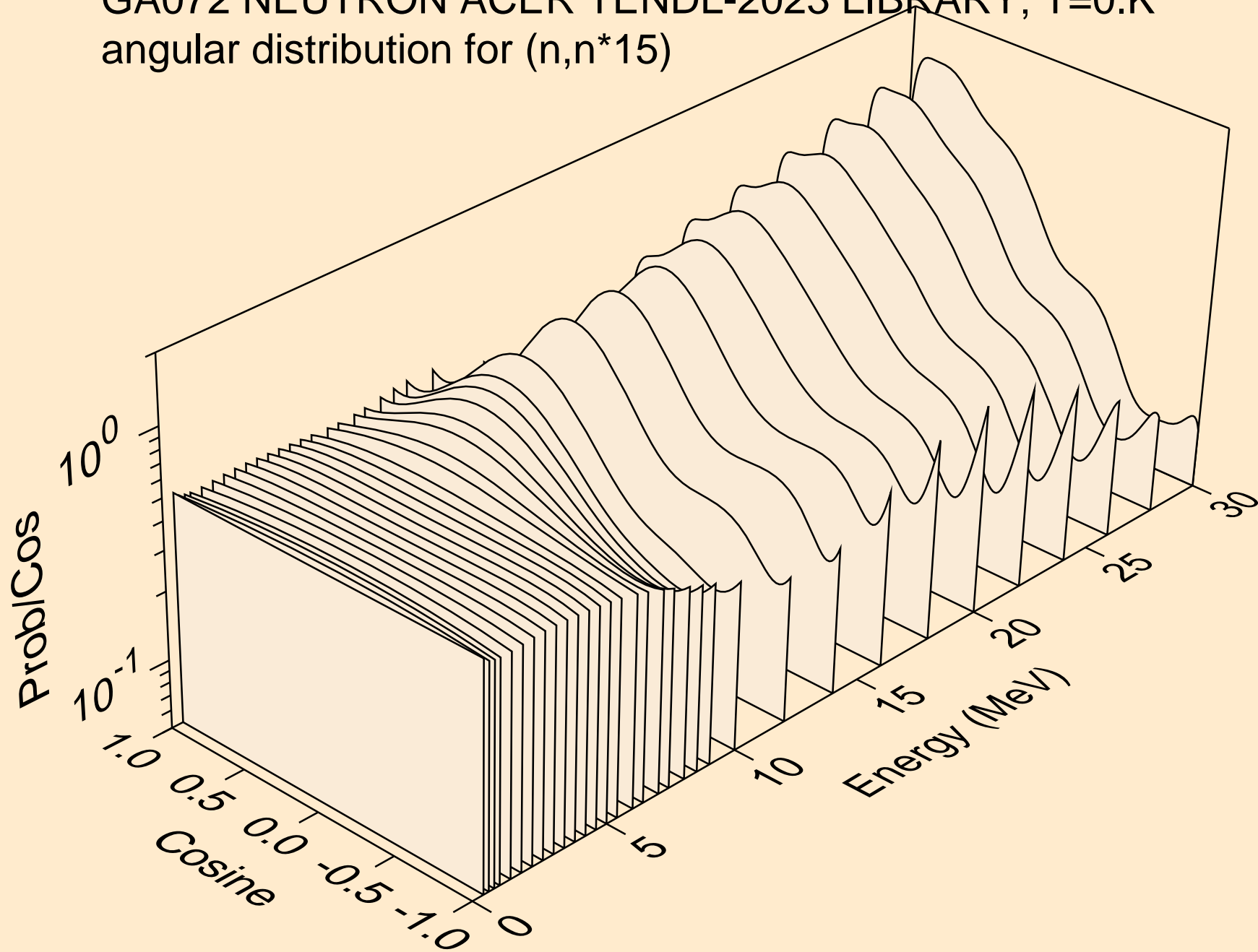

GA072 NEUTRON ACER TENDL-2023 LIBRARY; T=0.K
angular distribution for (n,n*16)

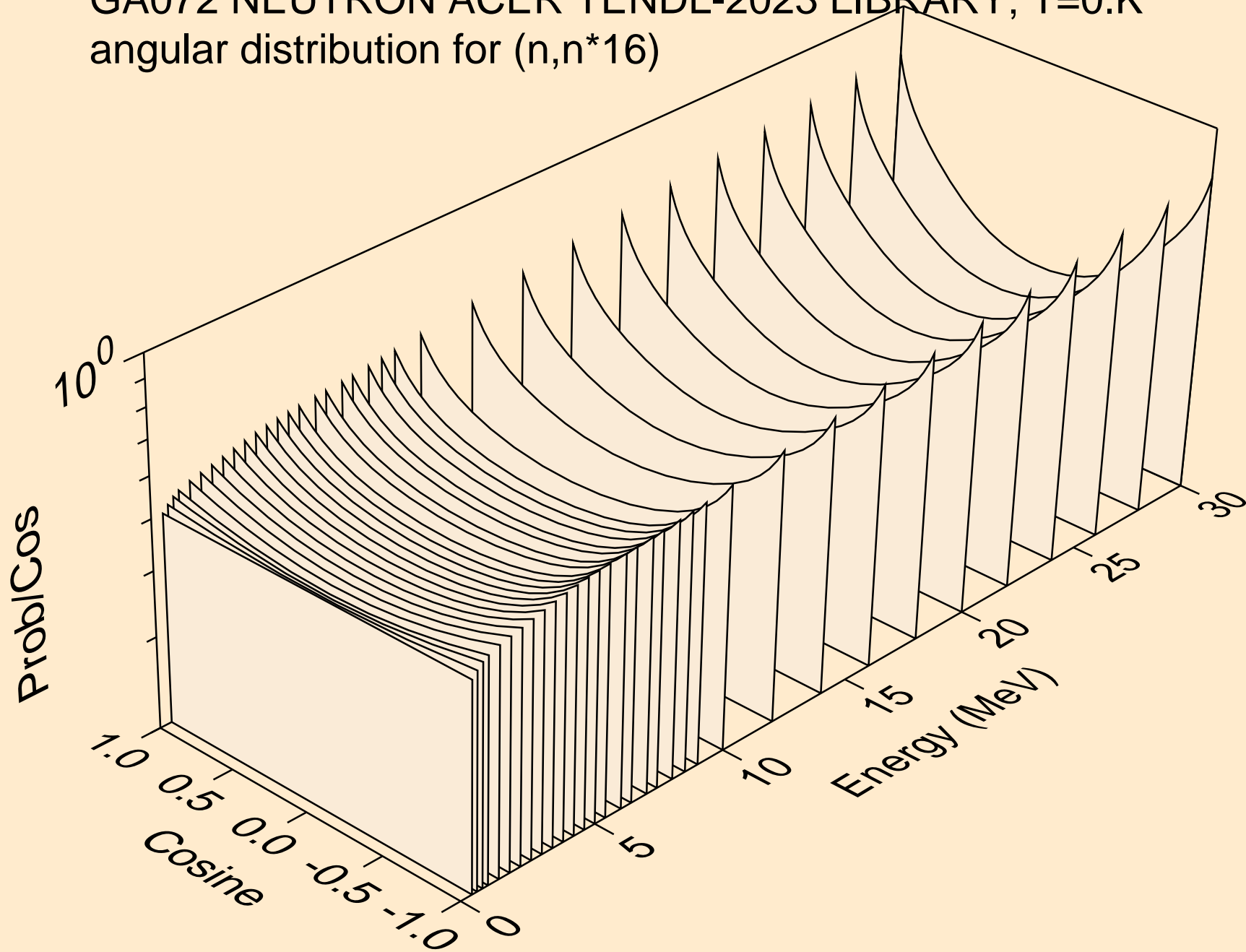

GA072 NEUTRON ACER TENDL-2023 LIBRARY; T=0.K
Neutron emission for (n,x)

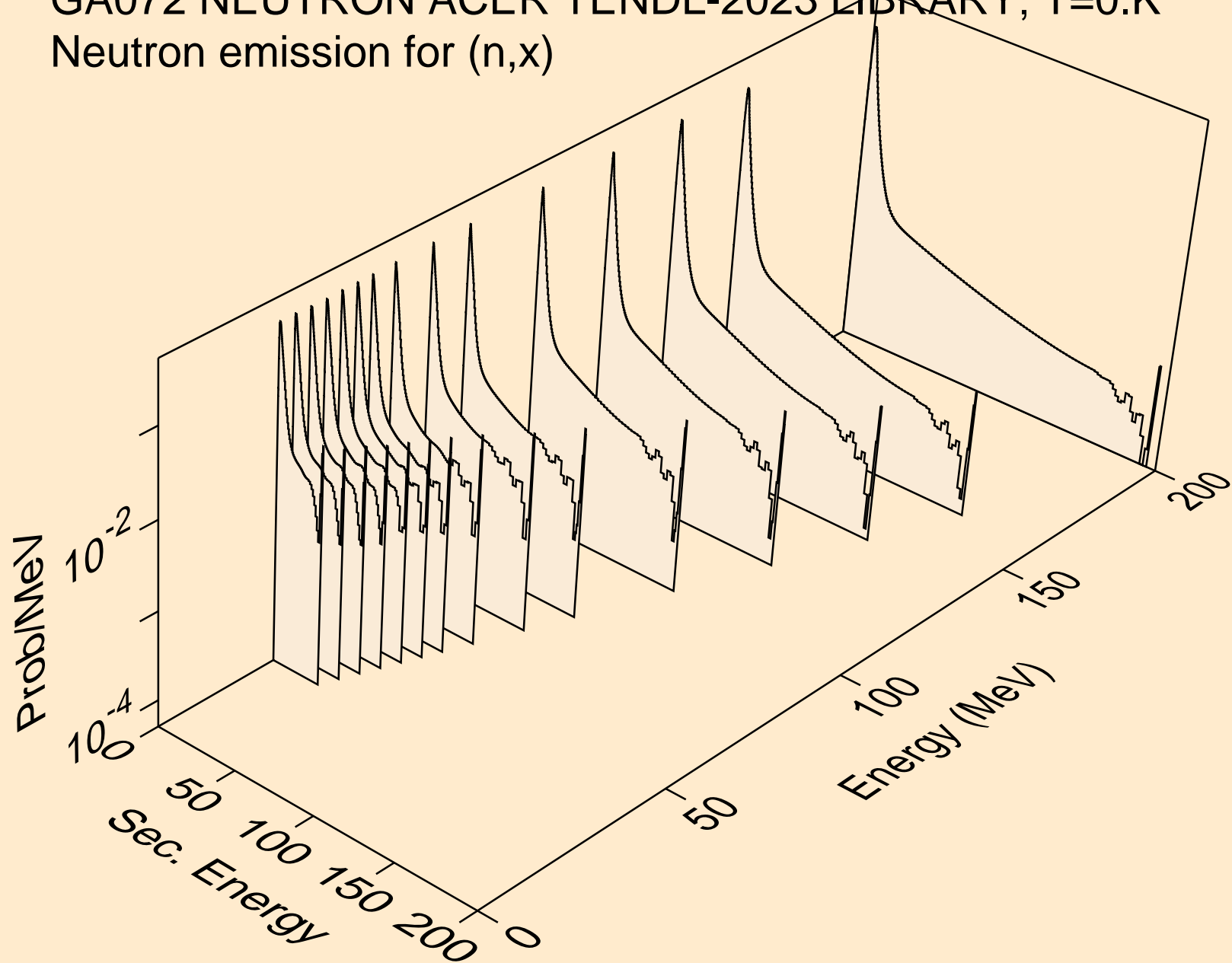

GA072 NEUTRON ACER TENDL-2023 LIBRARY; T=0.K
Neutron emission for (n,2nd)

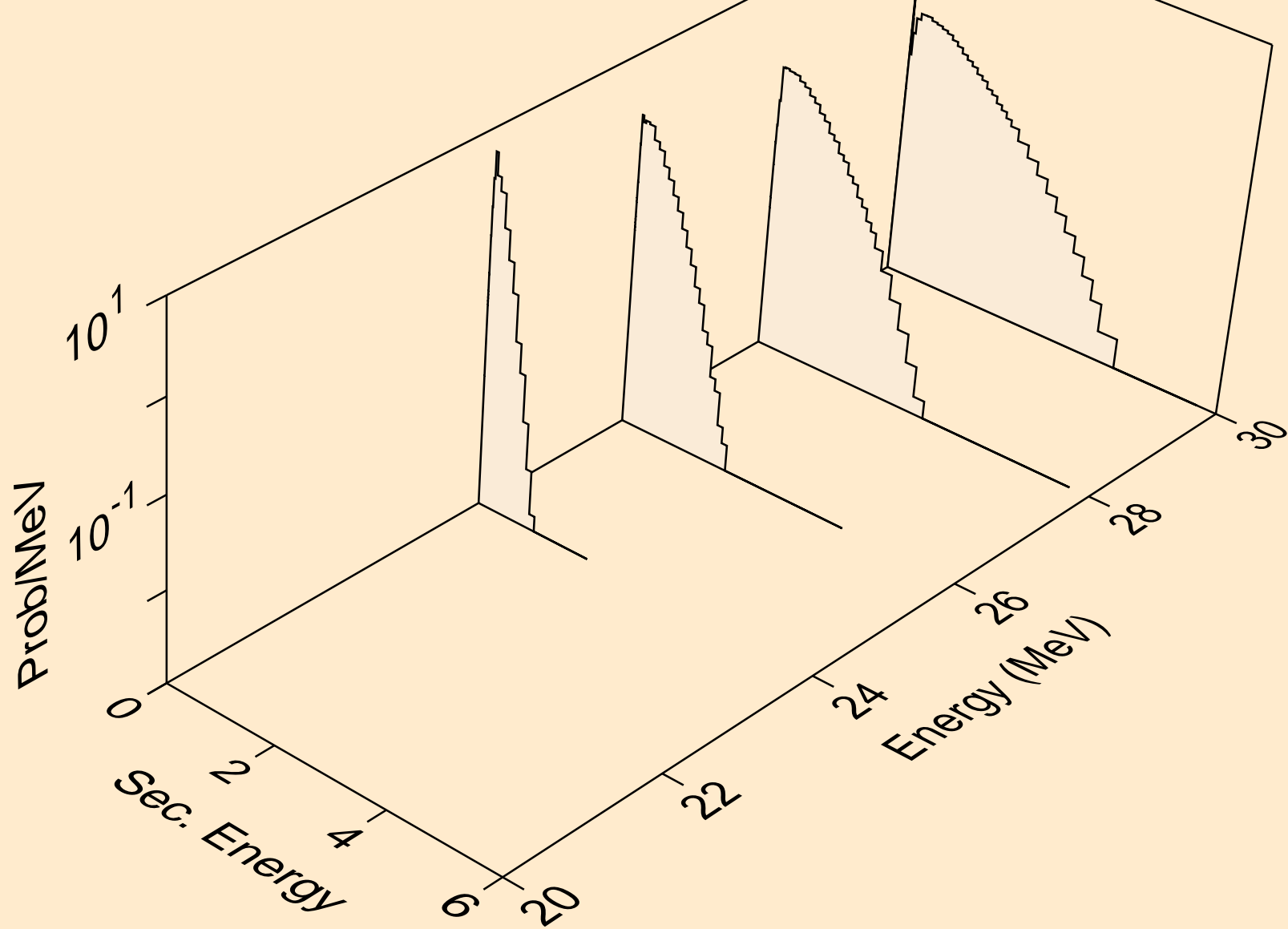

GA072 NEUTRON ACER TENDL-2023 LIBRARY; T=0.K
Neutron emission for (n,2n)

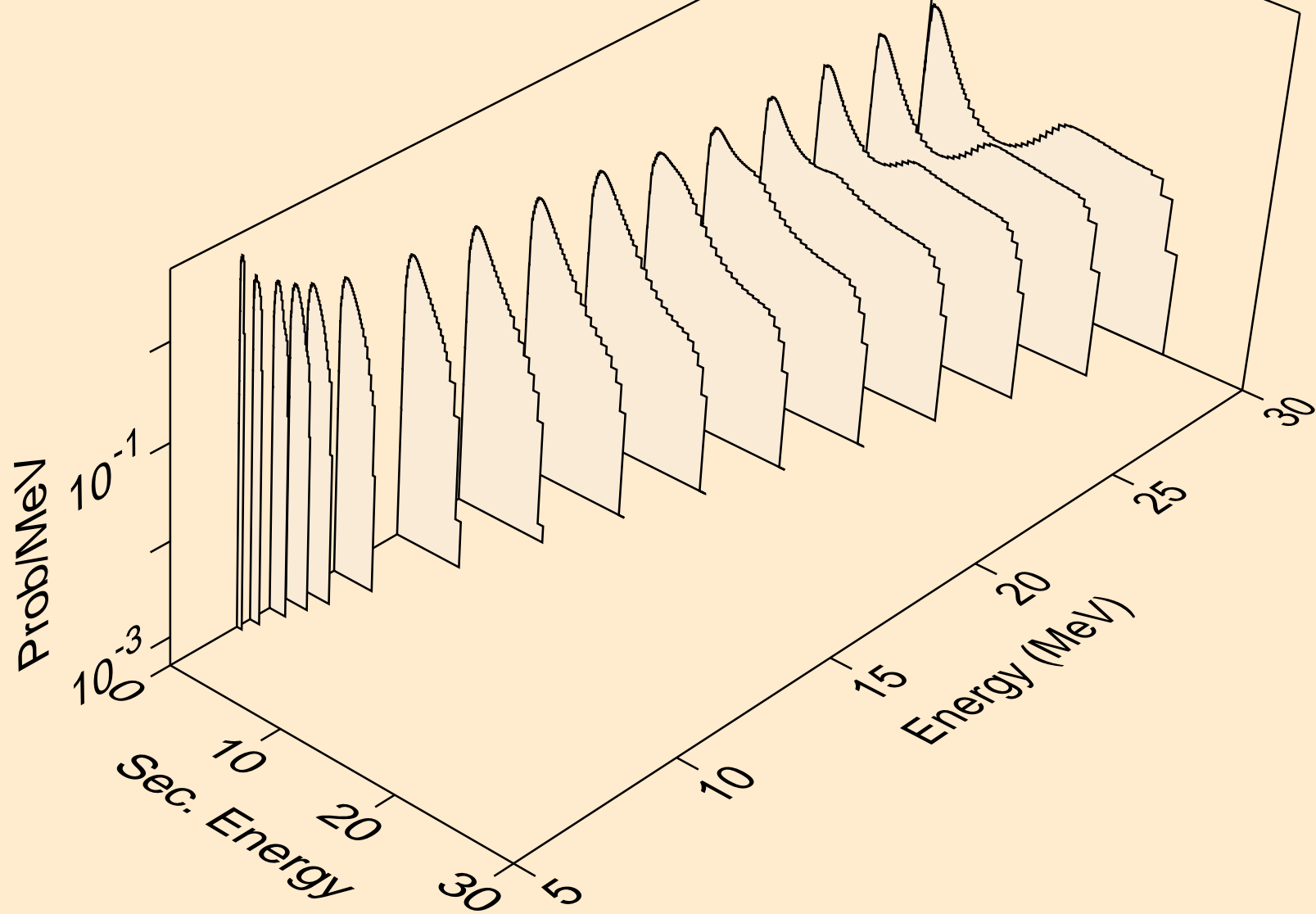

GA072 NEUTRON ACER TENDL-2023 LIBRARY; T=0.K
Neutron emission for (n,3n)

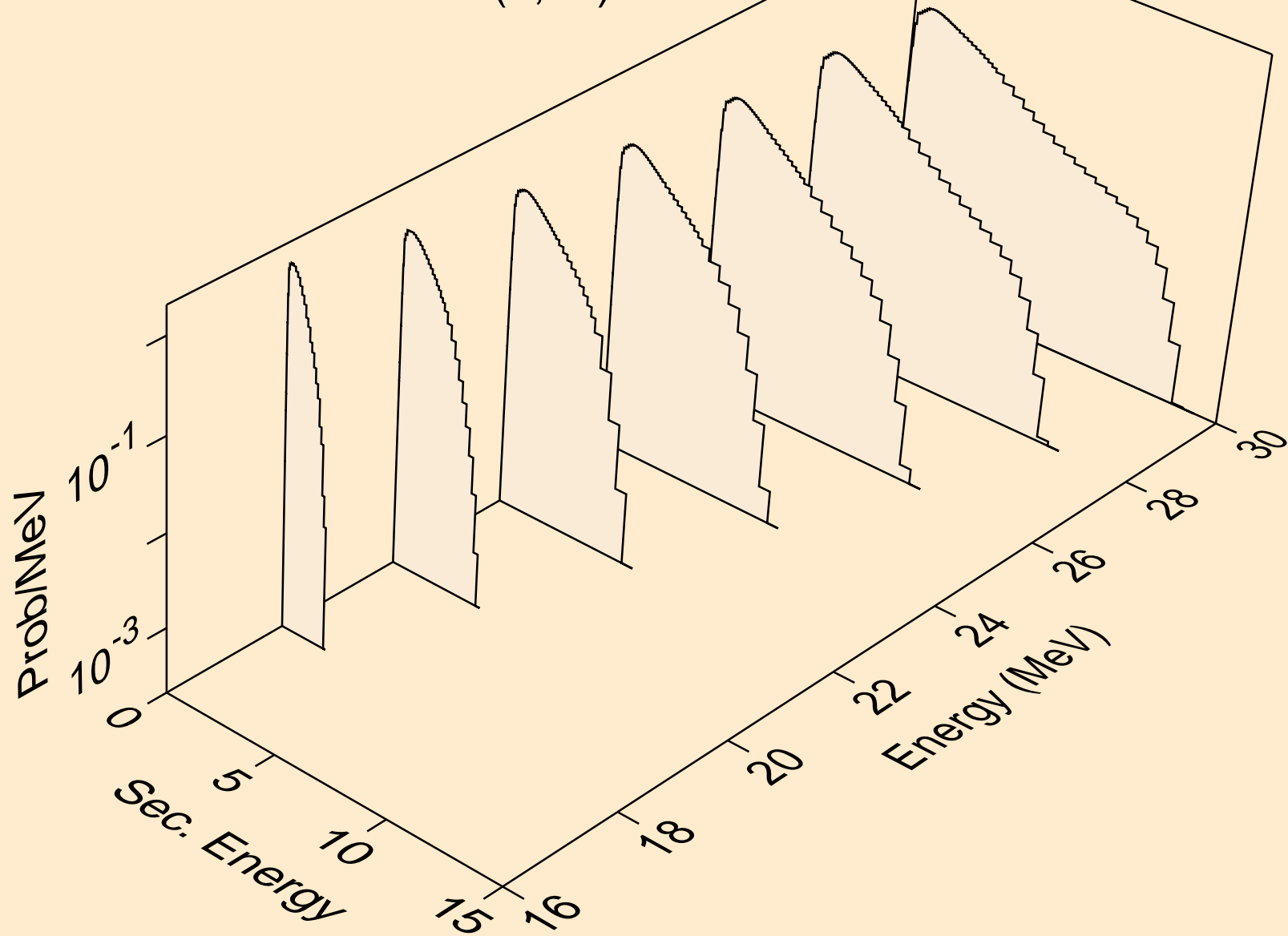

GA072 NEUTRON ACER TENDL-2023 LIBRARY; T=0.K
Neutron emission for (n,n*)a

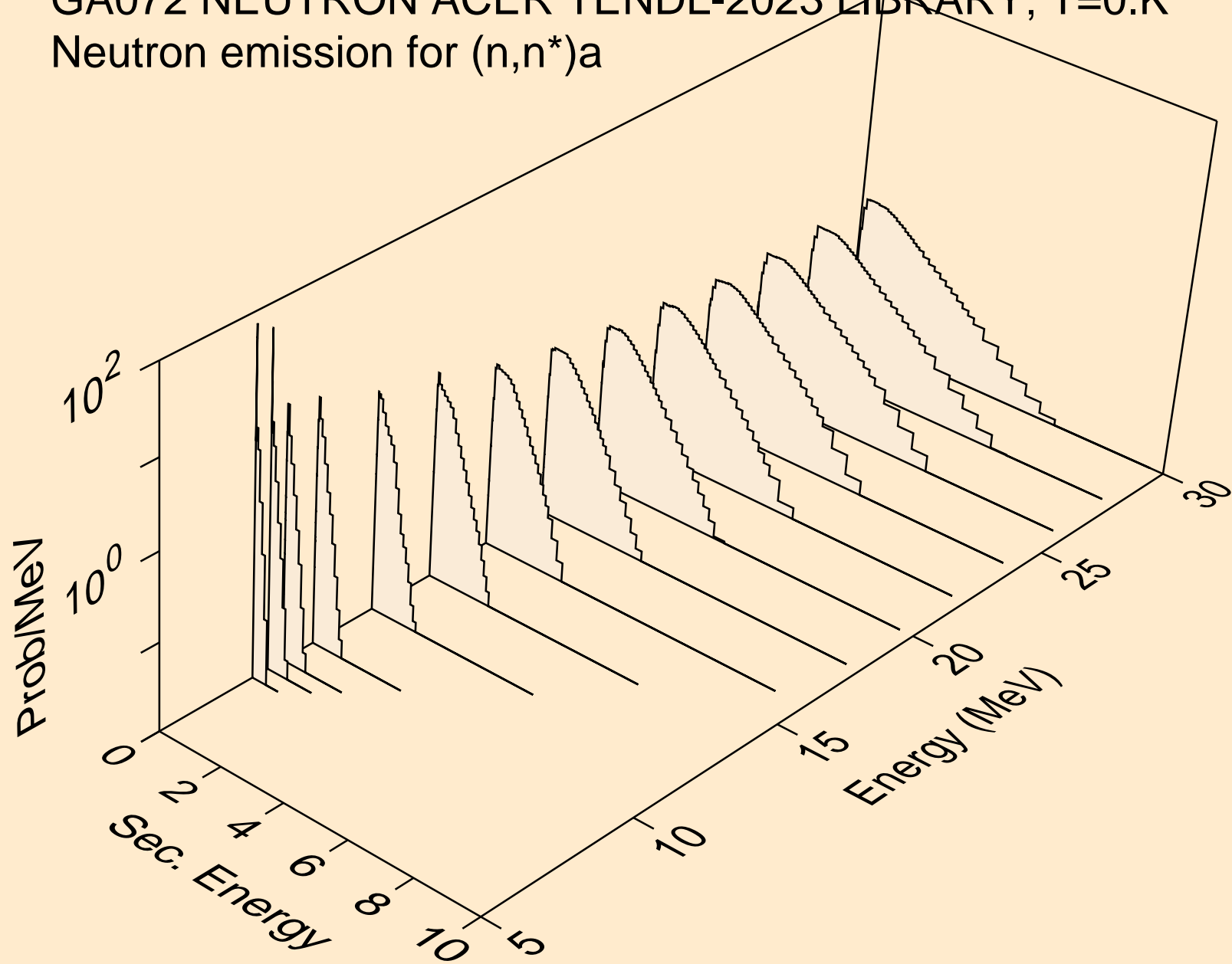

GA072 NEUTRON ACER TENDL-2023 LIBRARY; T=0.K
Neutron emission for (n,2n)a

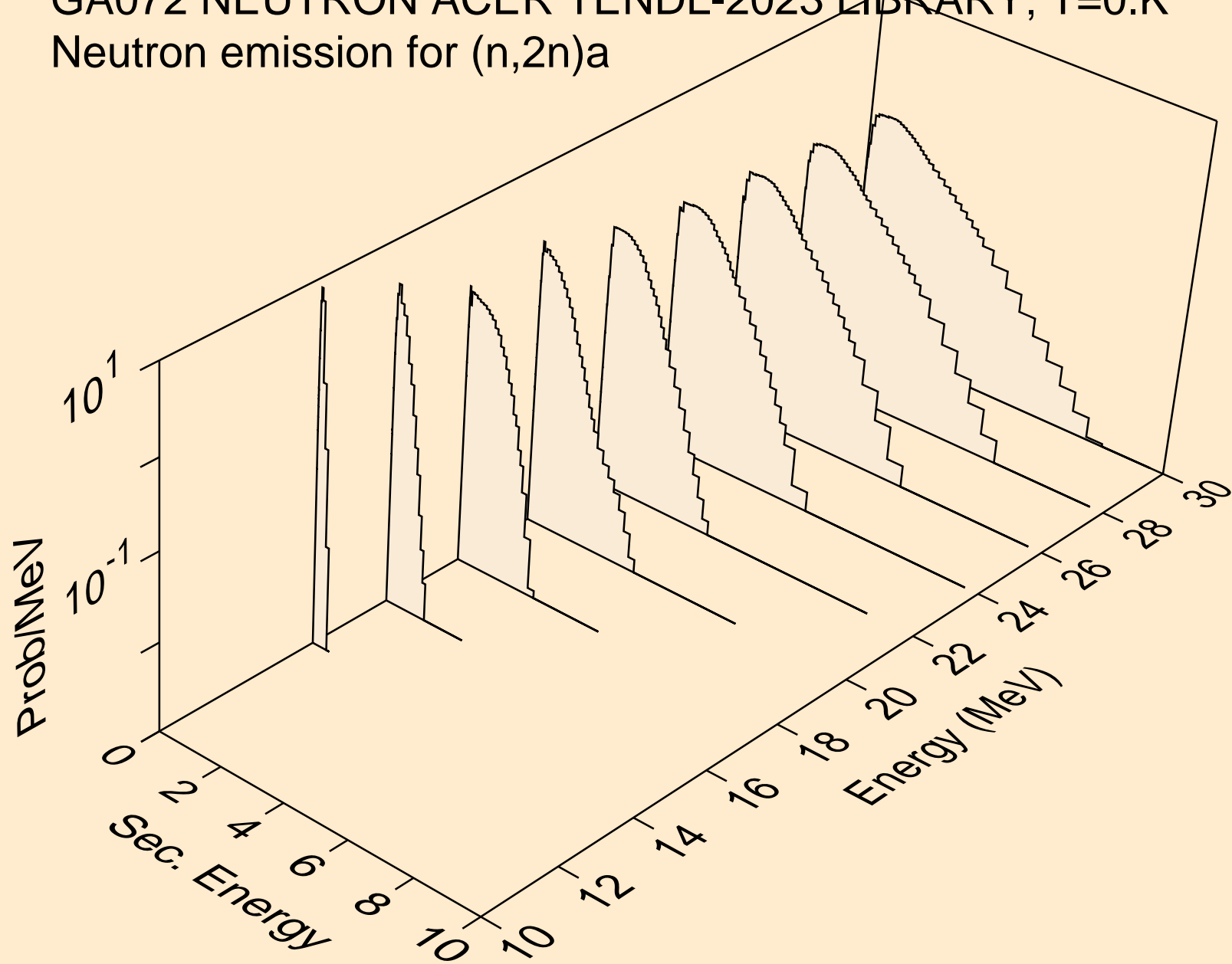

GA072 NEUTRON ACER TENDL-2023 LIBRARY; T=0.K
Neutron emission for (n,3n)a

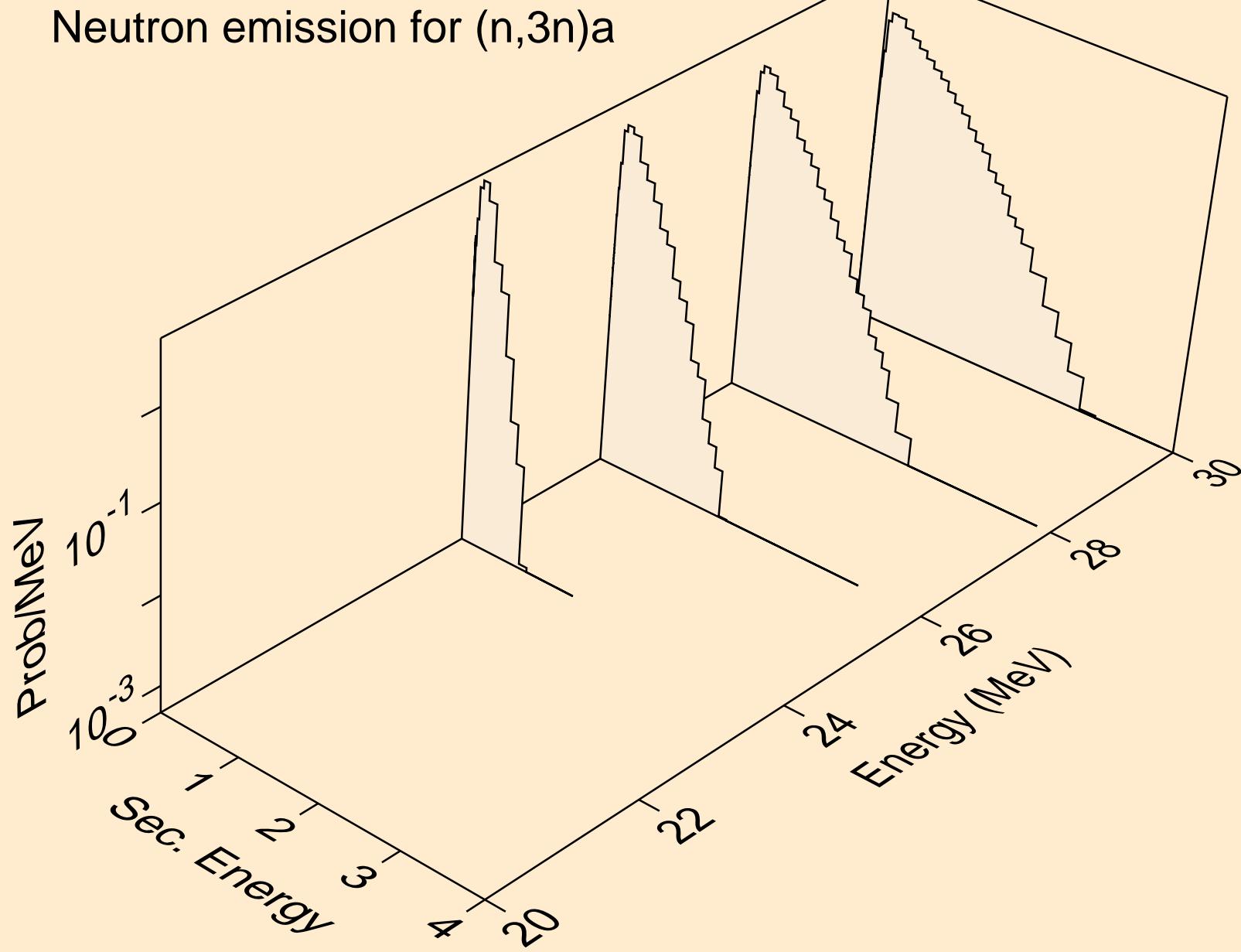

GA072 NEUTRON ACER TENDL-2023 LIBRARY; T=0.K
Neutron emission for (n,n*)p

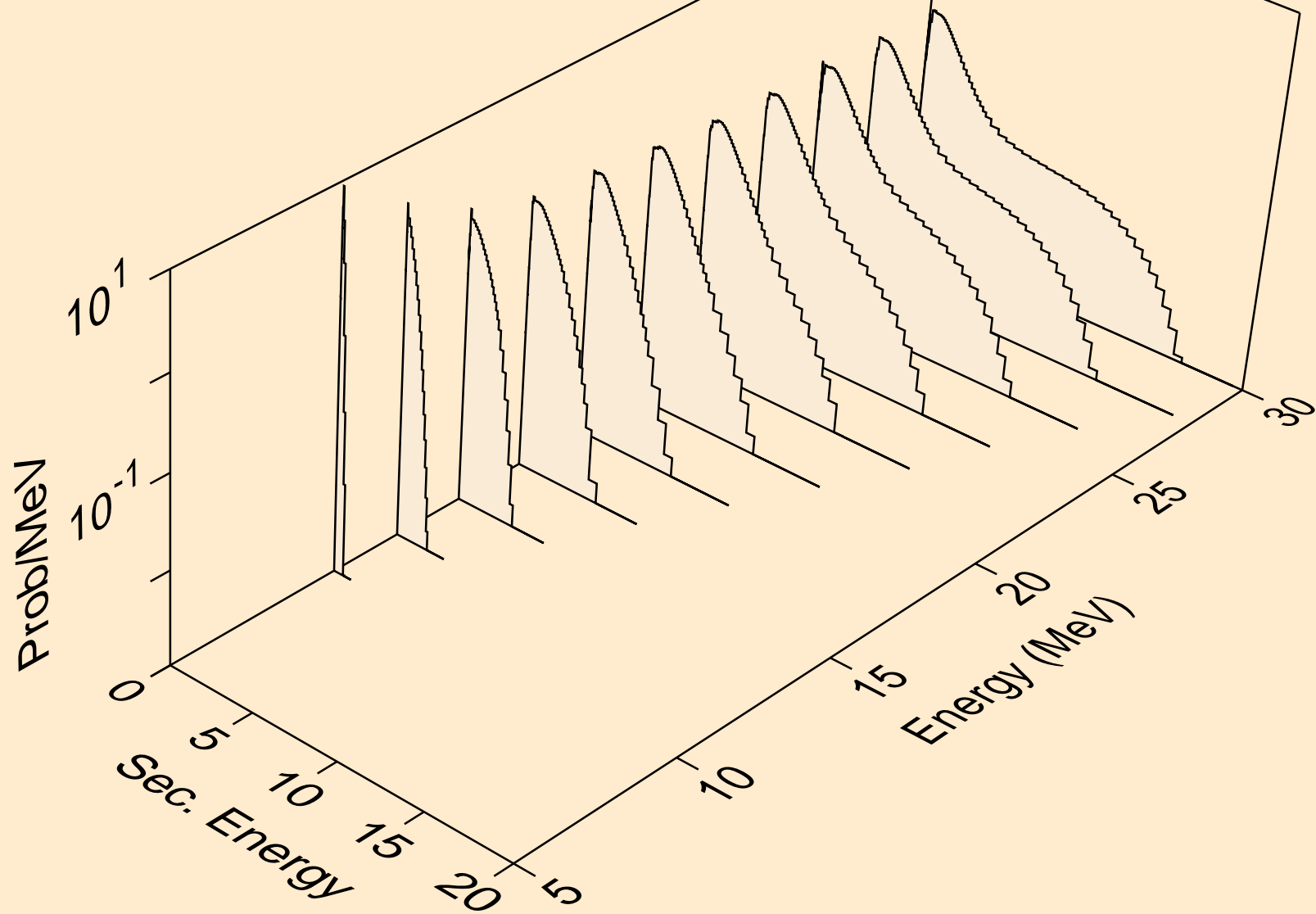

GA072 NEUTRON ACER TENDL-2023 LIBRARY; T=0.K
Neutron emission for (n,n*)2a

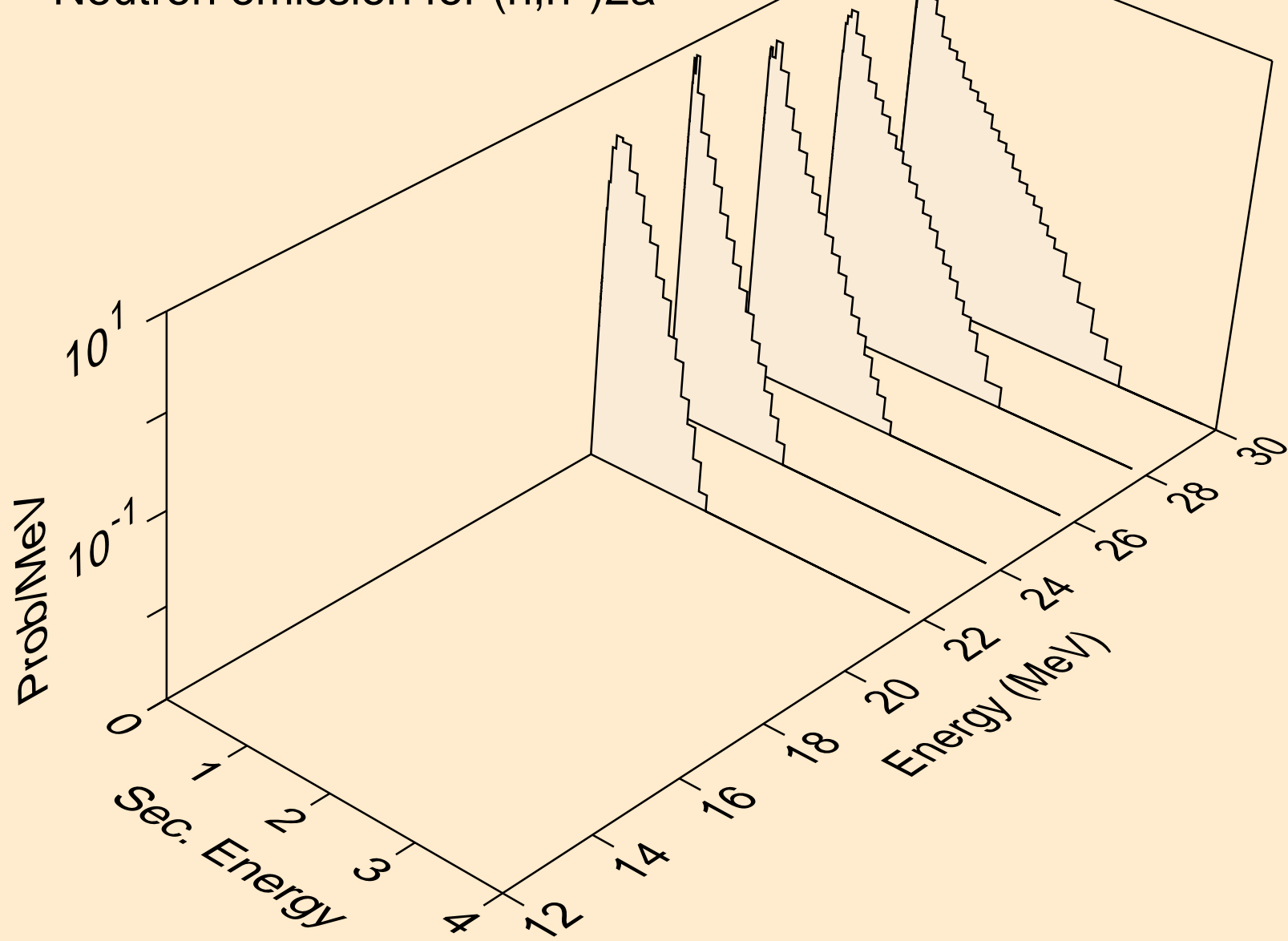

GA072 NEUTRON ACER TENDL-2023 LIBRARY; T=0.K
Neutron emission for (n,n*)d

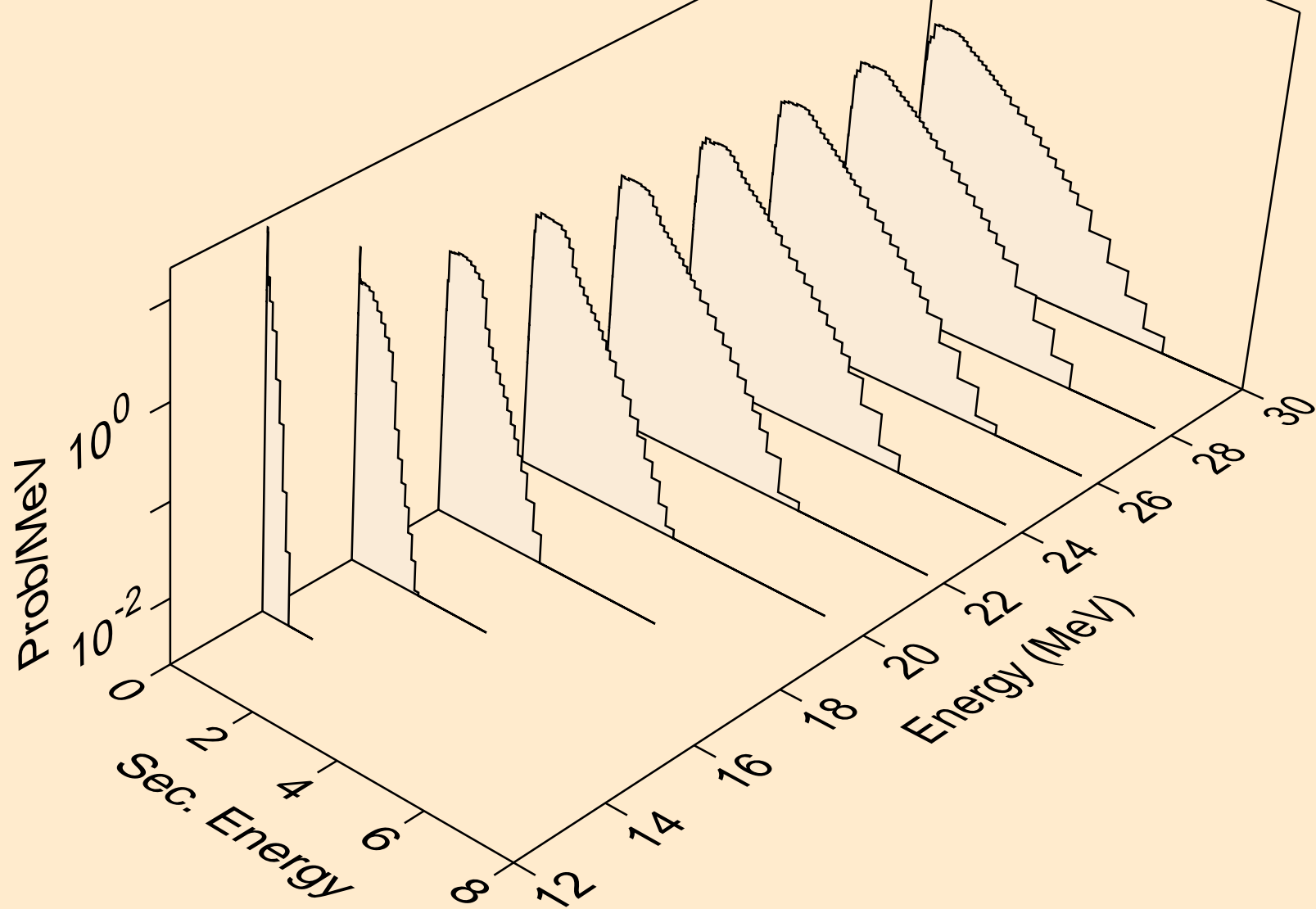

GA072 NEUTRON ACER TENDL-2023 LIBRARY; T=0.K
Neutron emission for (n,n*)t

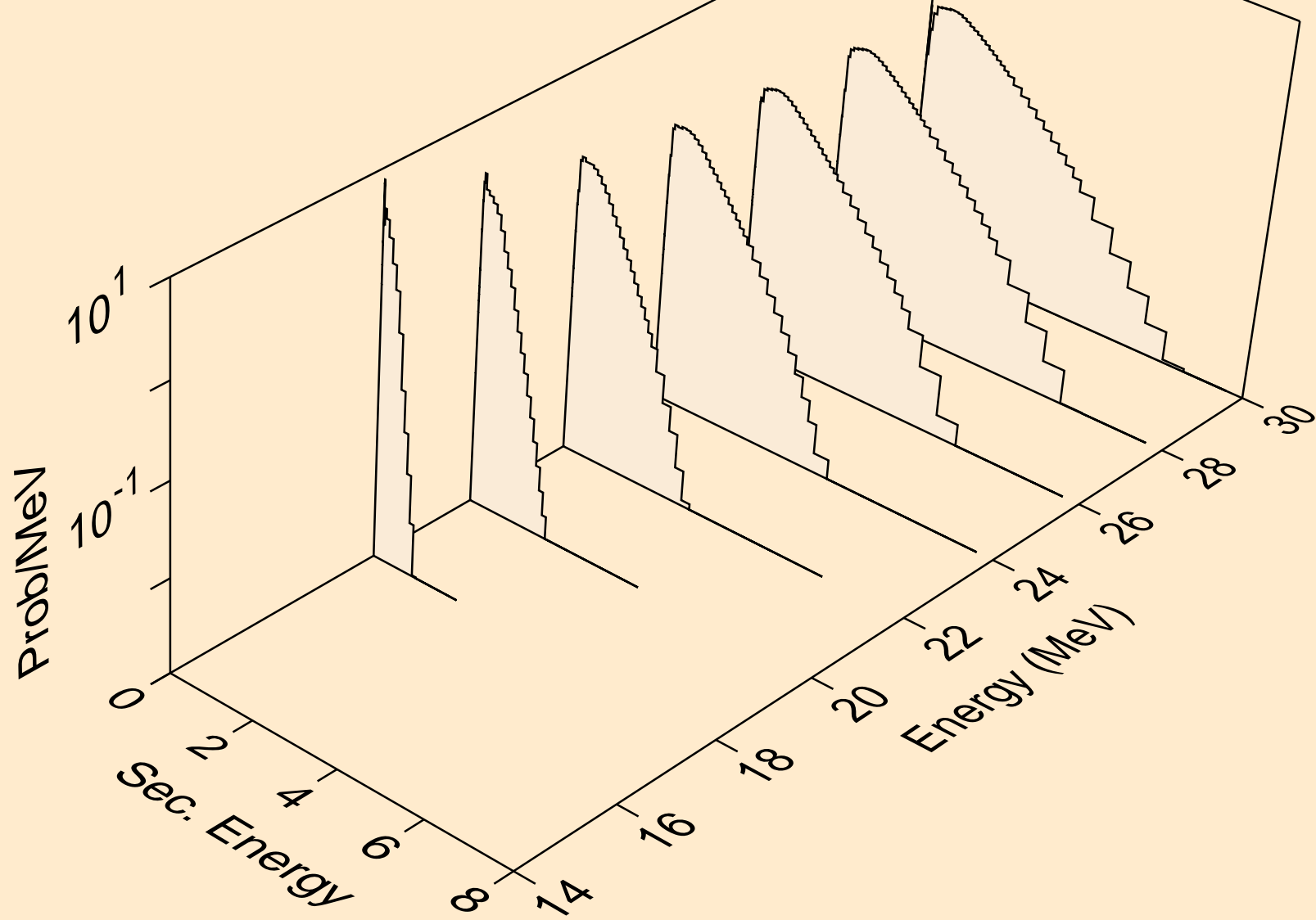

GA072 NEUTRON ACER TENDL-2023 LIBRARY; T=0.K
Neutron emission for (n,n*)he3

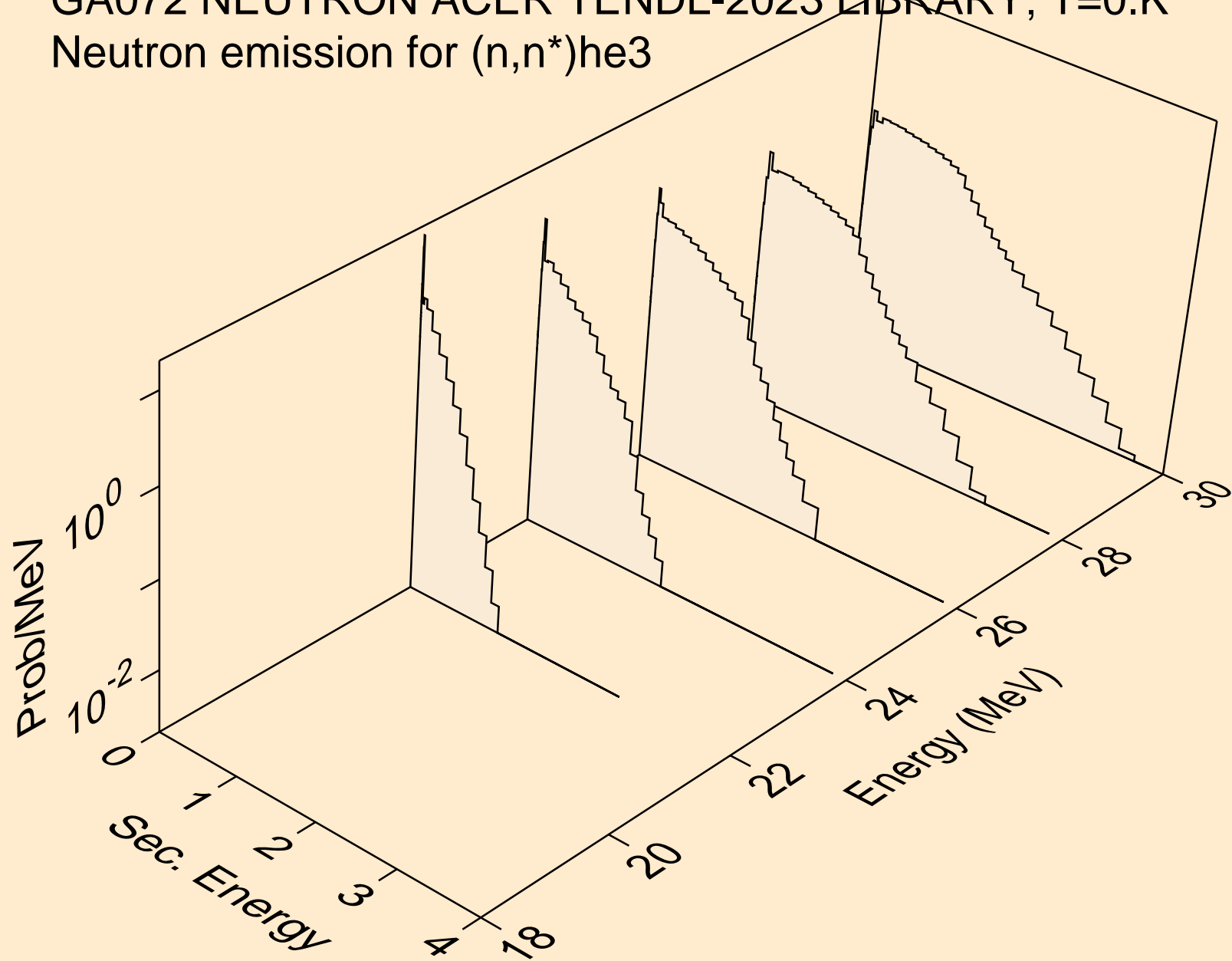

GA072 NEUTRON ACER TENDL-2023 LIBRARY; T=0.K
Neutron emission for (n,4n)

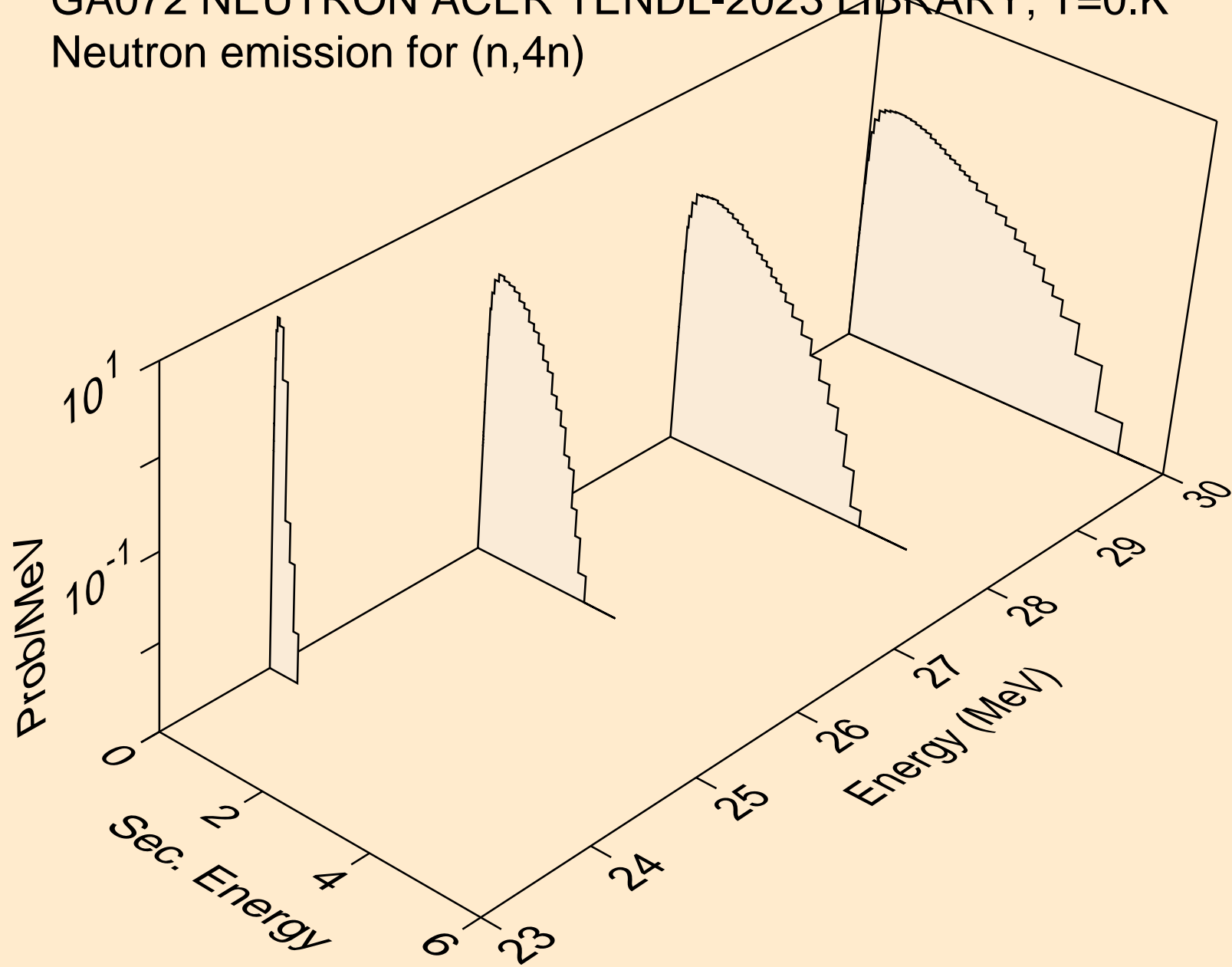

GA072 NEUTRON ACER TENDL-2023 LIBRARY; T=0.K
Neutron emission for (n,2np)

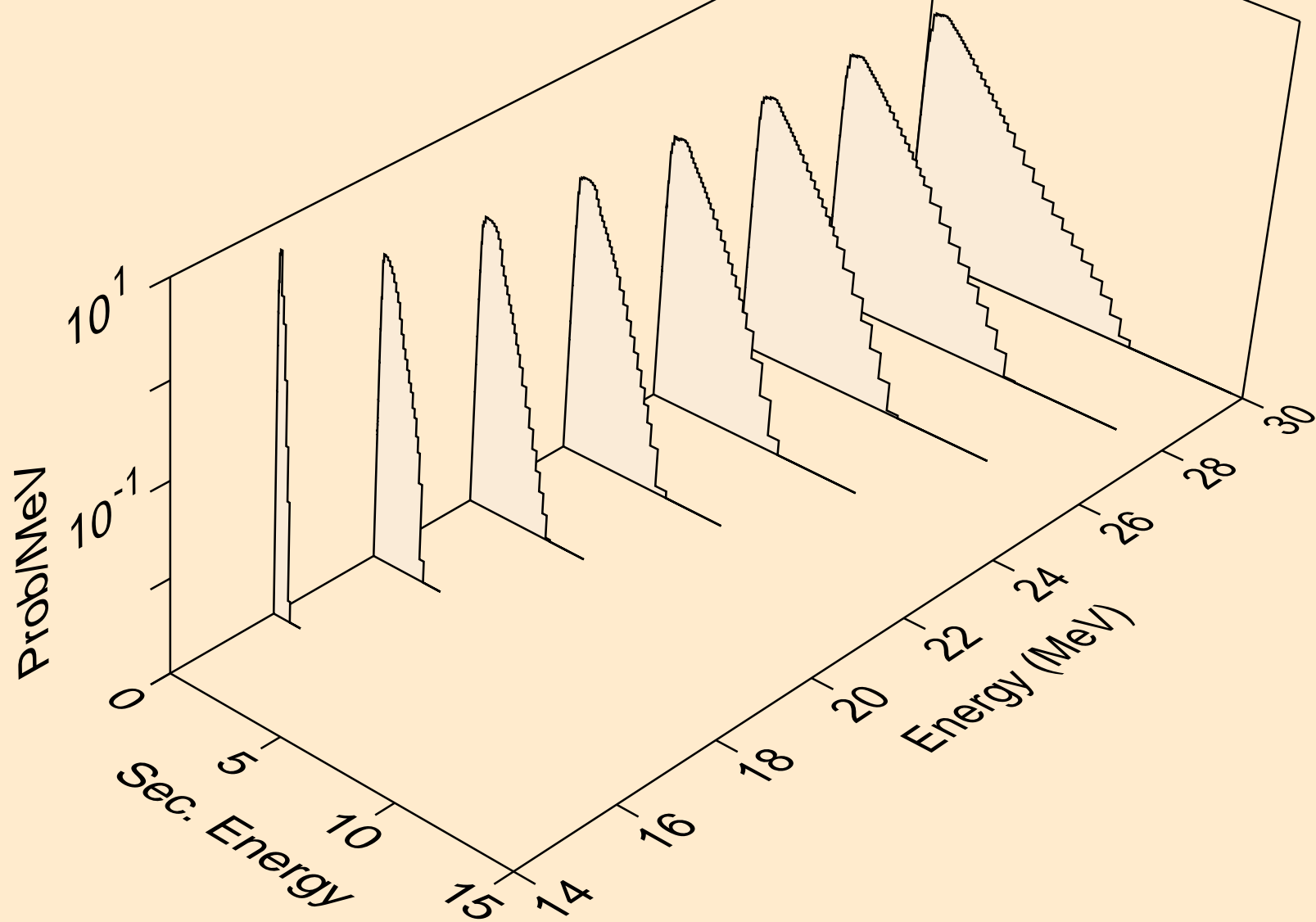

GA072 NEUTRON ACER TENDL-2023 LIBRARY; T=0.K
Neutron emission for (n,3np)

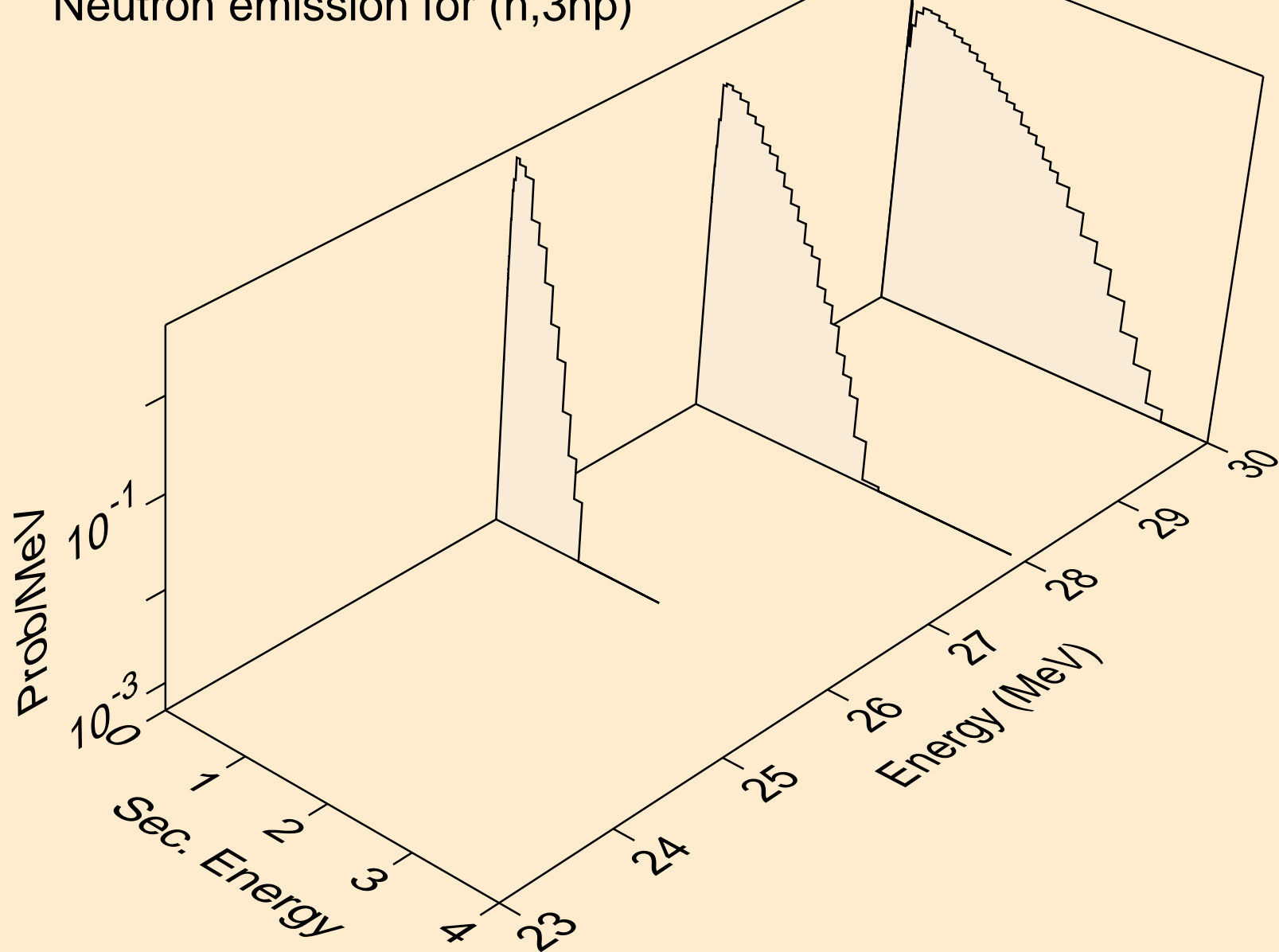

GA072 NEUTRON ACER TENDL-2023 LIBRARY; T=0.K
Neutron emission for (n,n2p)

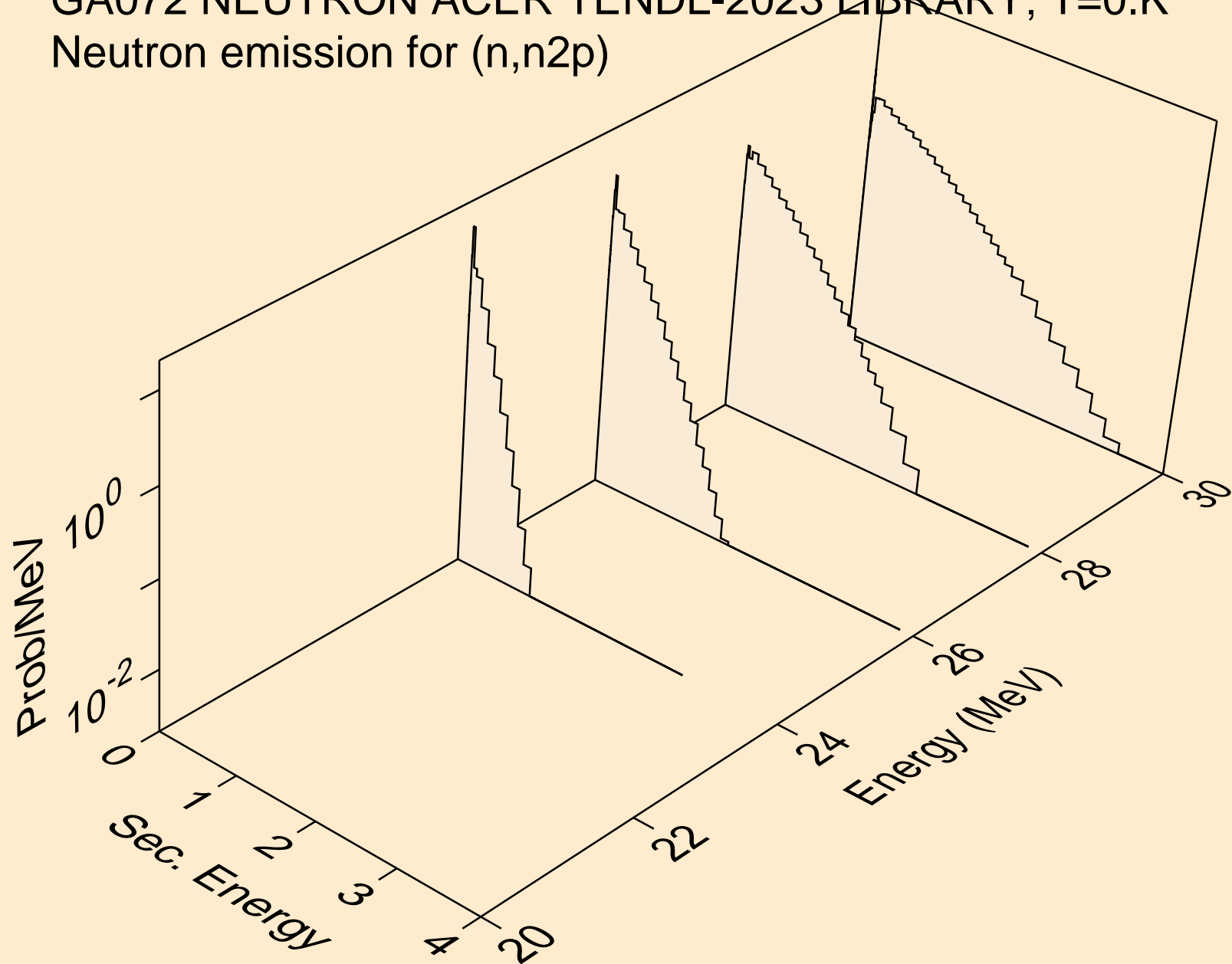

GA072 NEUTRON ACER TENDL-2023 LIBRARY; T=0.K
Neutron emission for (n,npa)

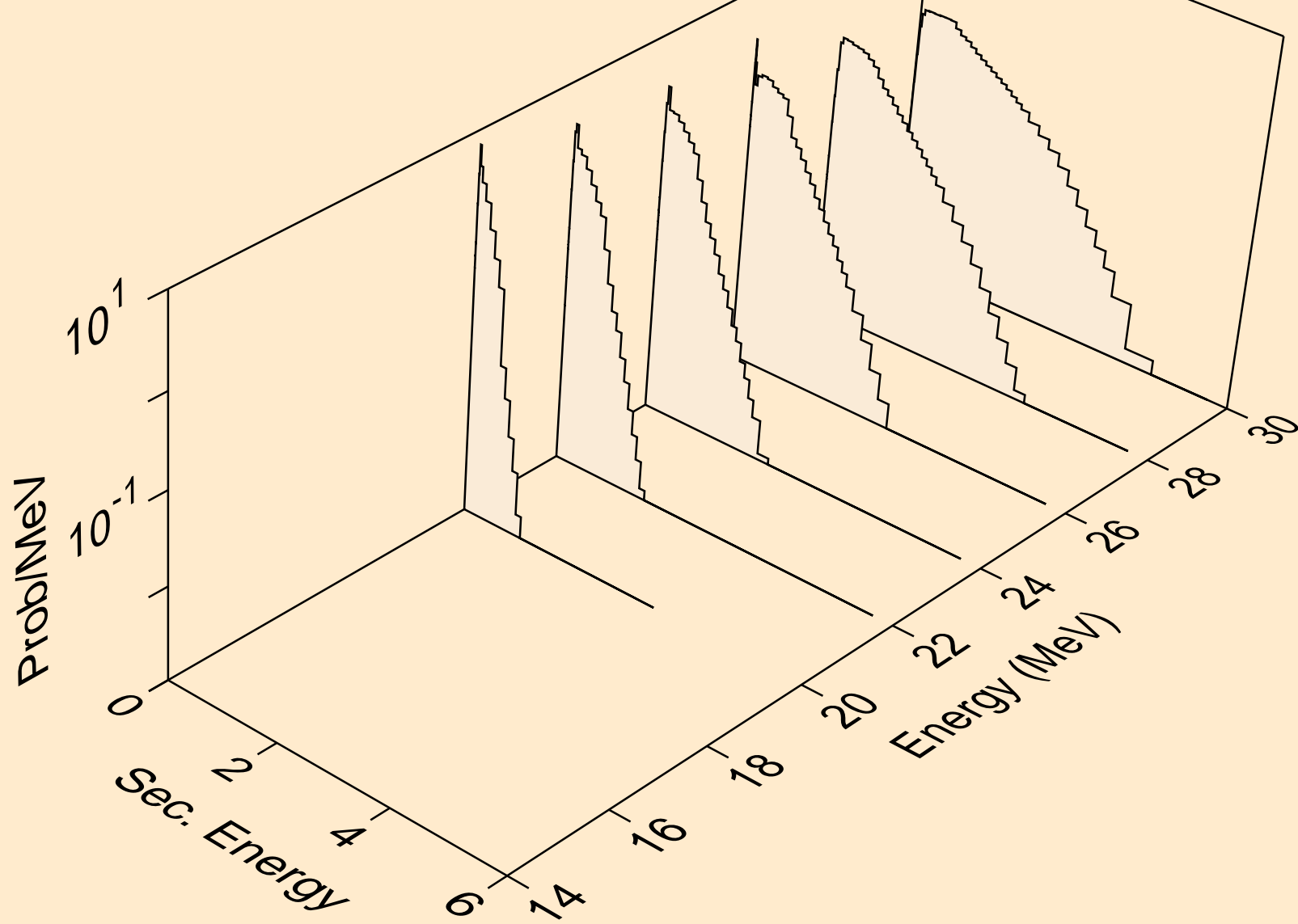

GA072 NEUTRON ACER TENDL-2023 LIBRARY; T=0.K
Neutron emission for (n,n*c)

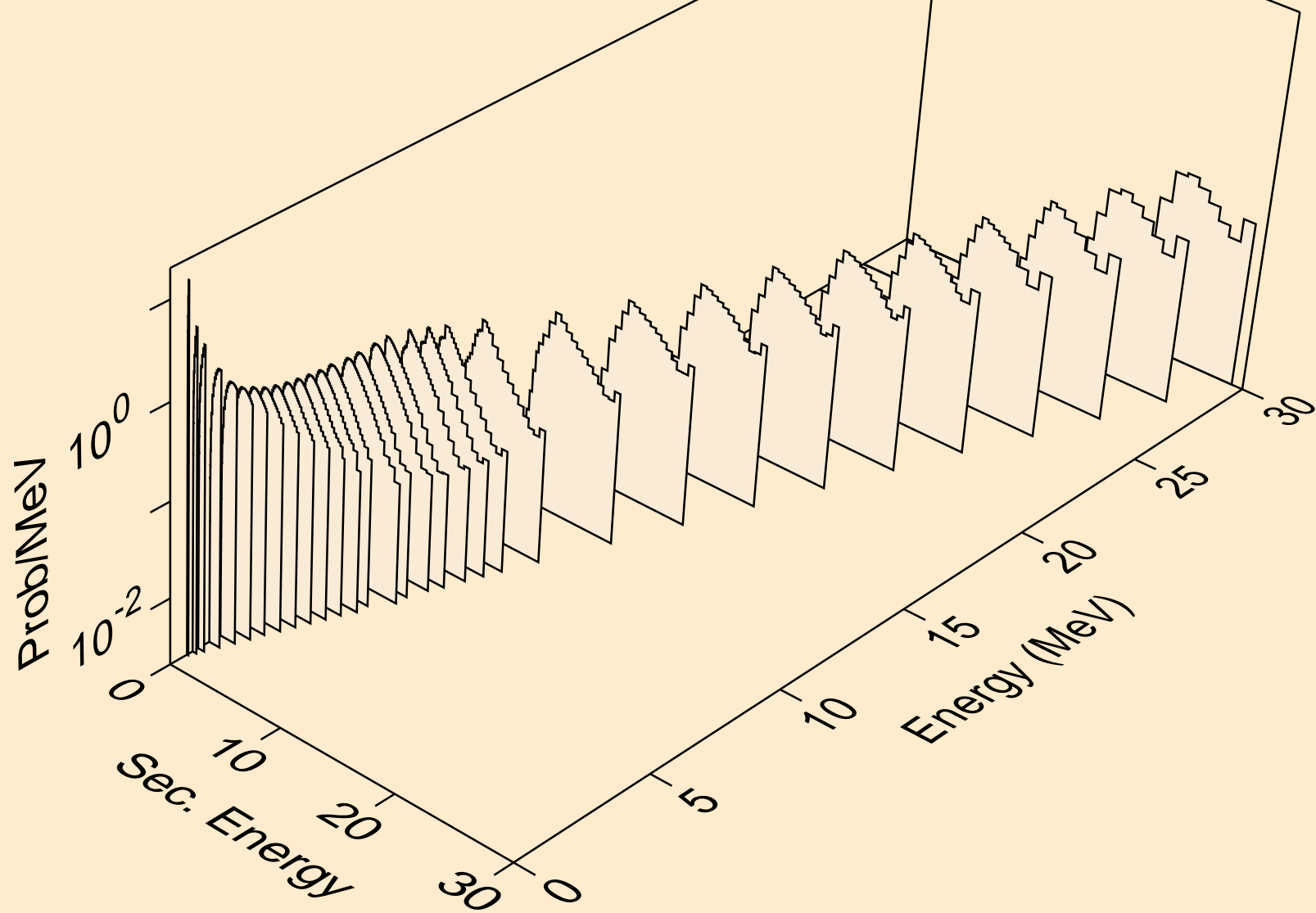

GA072 NEUTRON ACER TENDL-2023 LIBRARY; T=0.K
Photon emission for (n,x)

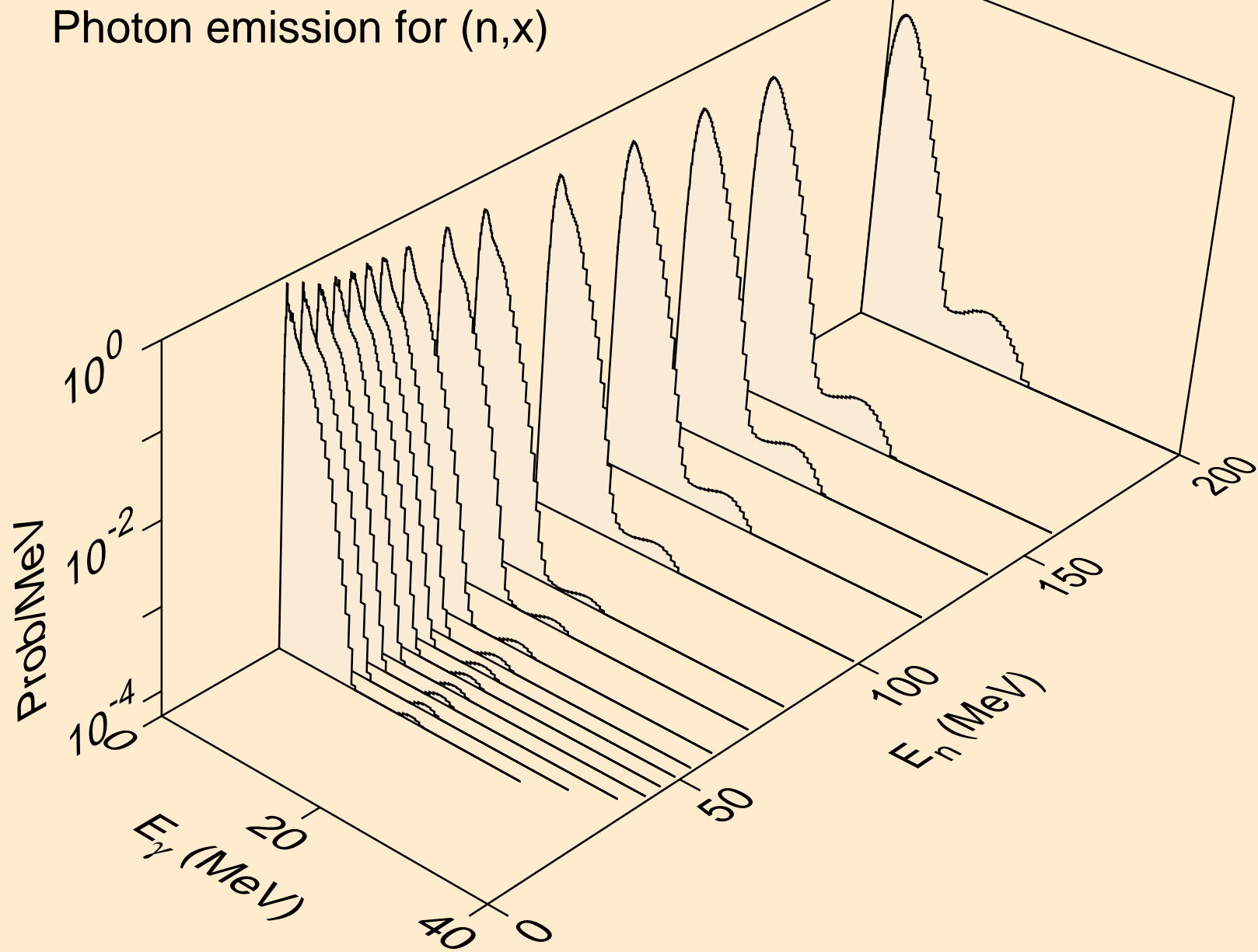

GA072 NEUTRON ACER TENDL-2023 LIBRARY; T=0.K
Photon emission for (n,2nd)

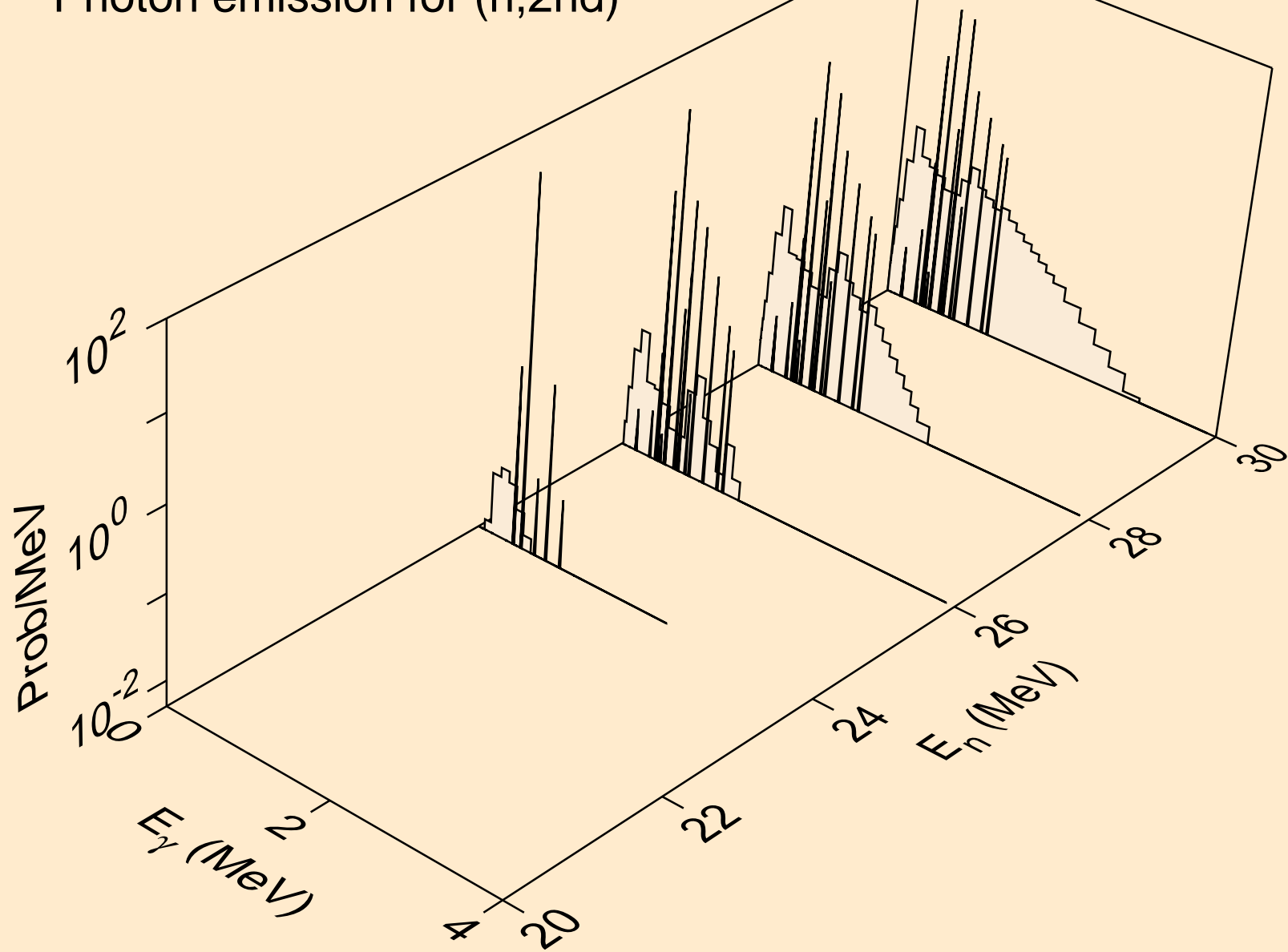

GA072 NEUTRON ACER TENDL-2023 LIBRARY; T=0.K
Photon emission for (n,2n)

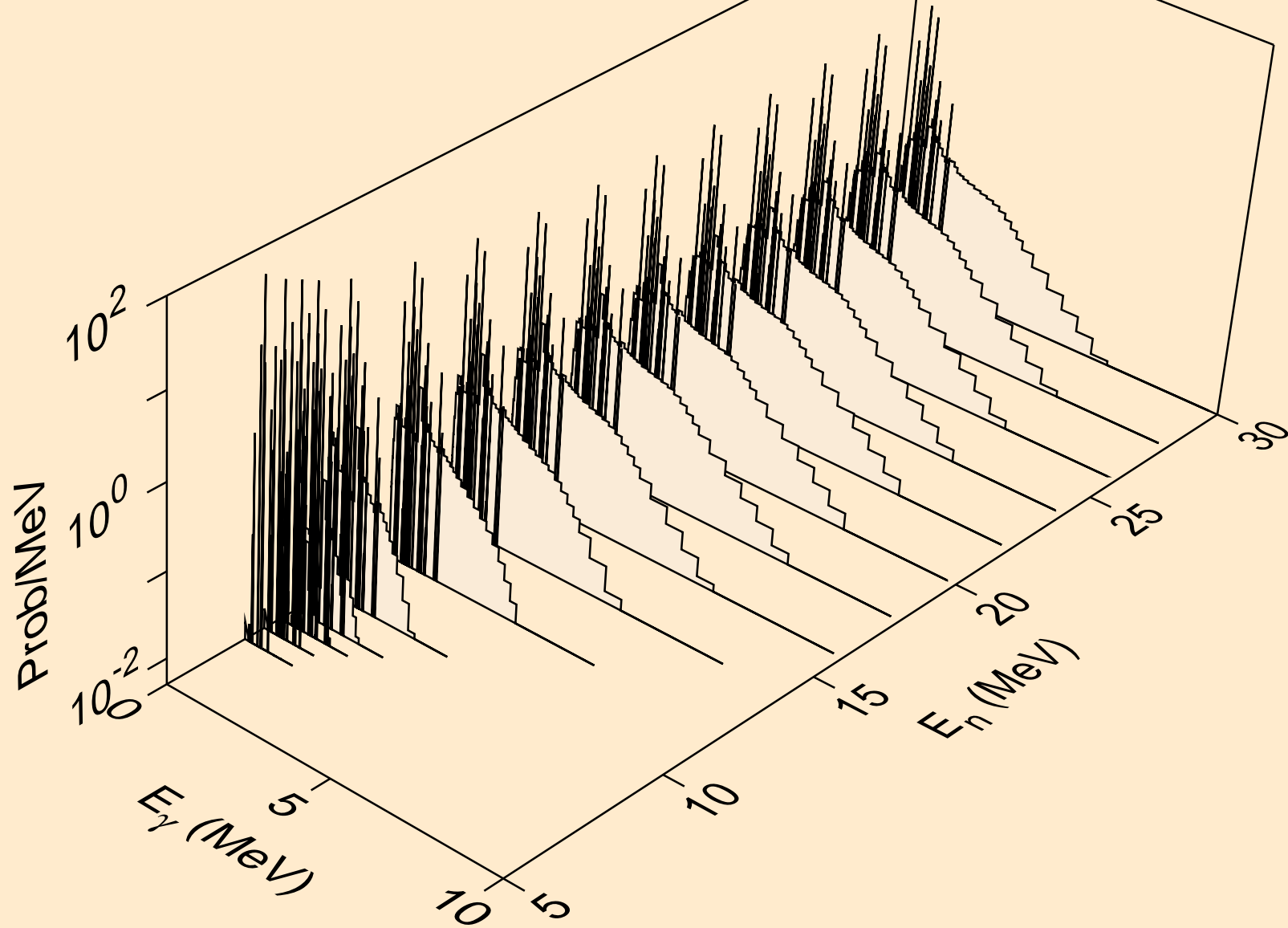

GA072 NEUTRON ACER TENDL-2023 LIBRARY; T=0.K
Photon emission for (n,3n)

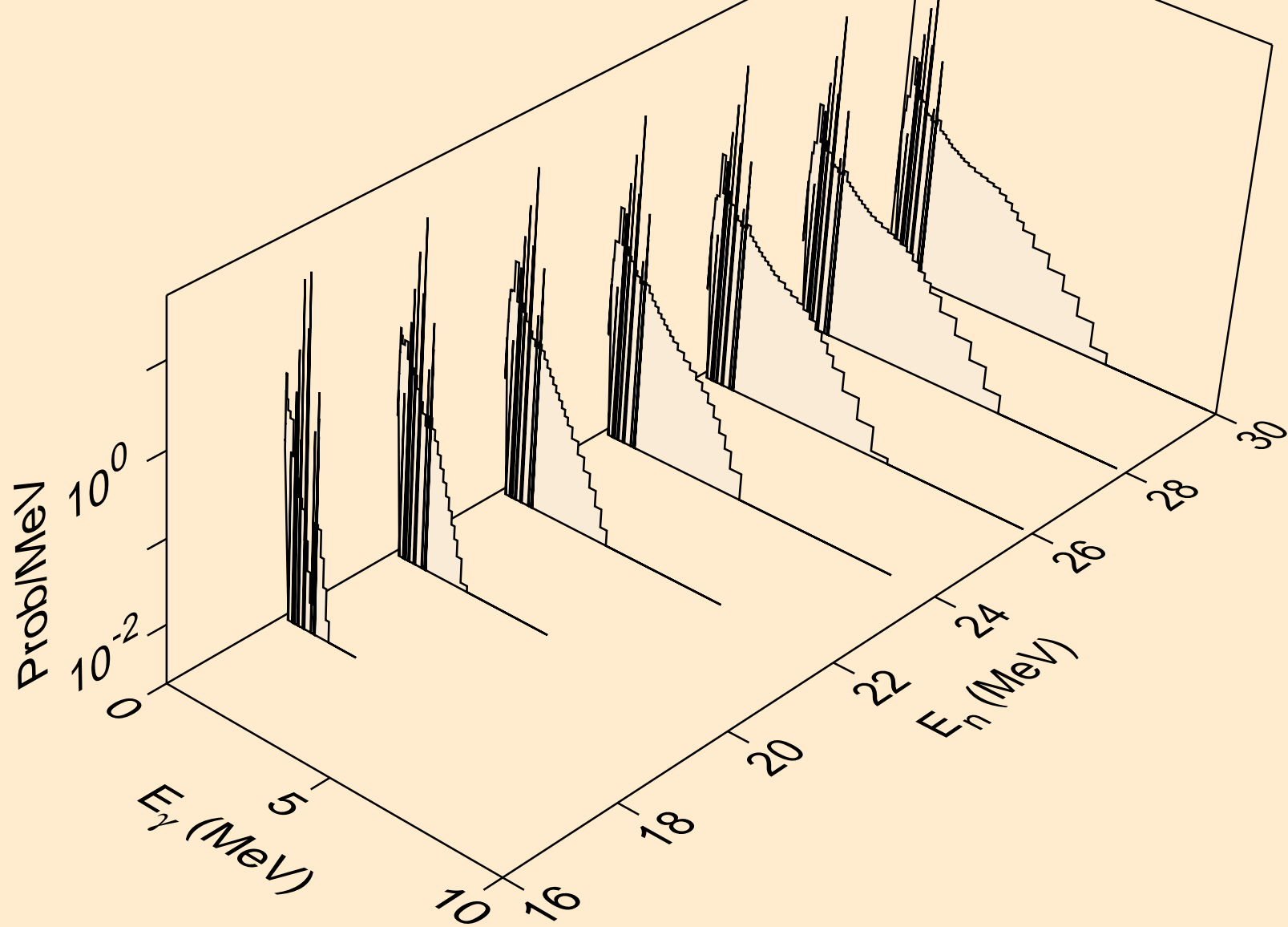

GA072 NEUTRON ACER TENDL-2023 LIBRARY; T=0.K
Photon emission for (n,n*)a

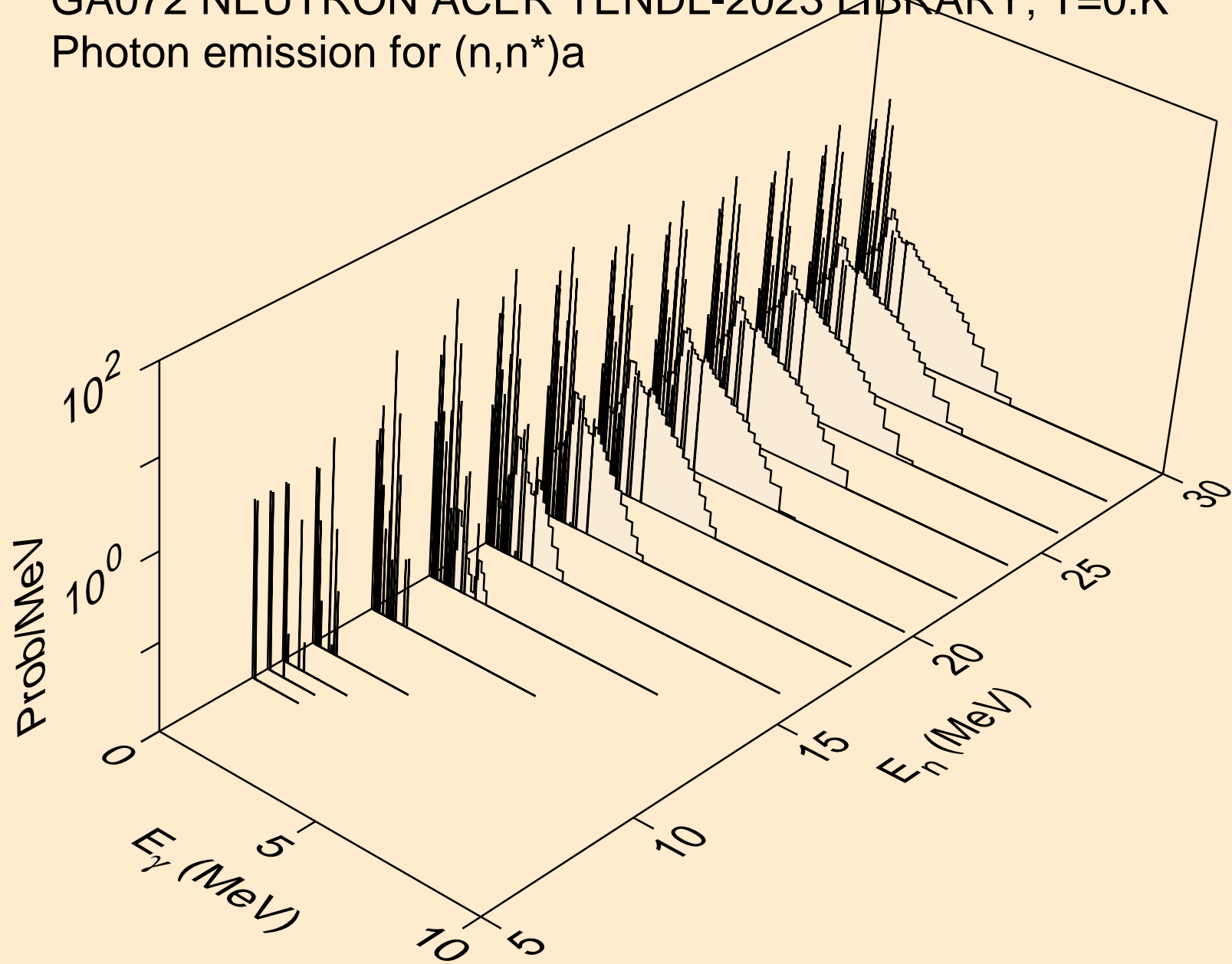

GA072 NEUTRON ACER TENDL-2023 LIBRARY; T=0.K
Photon emission for (n,2n)a

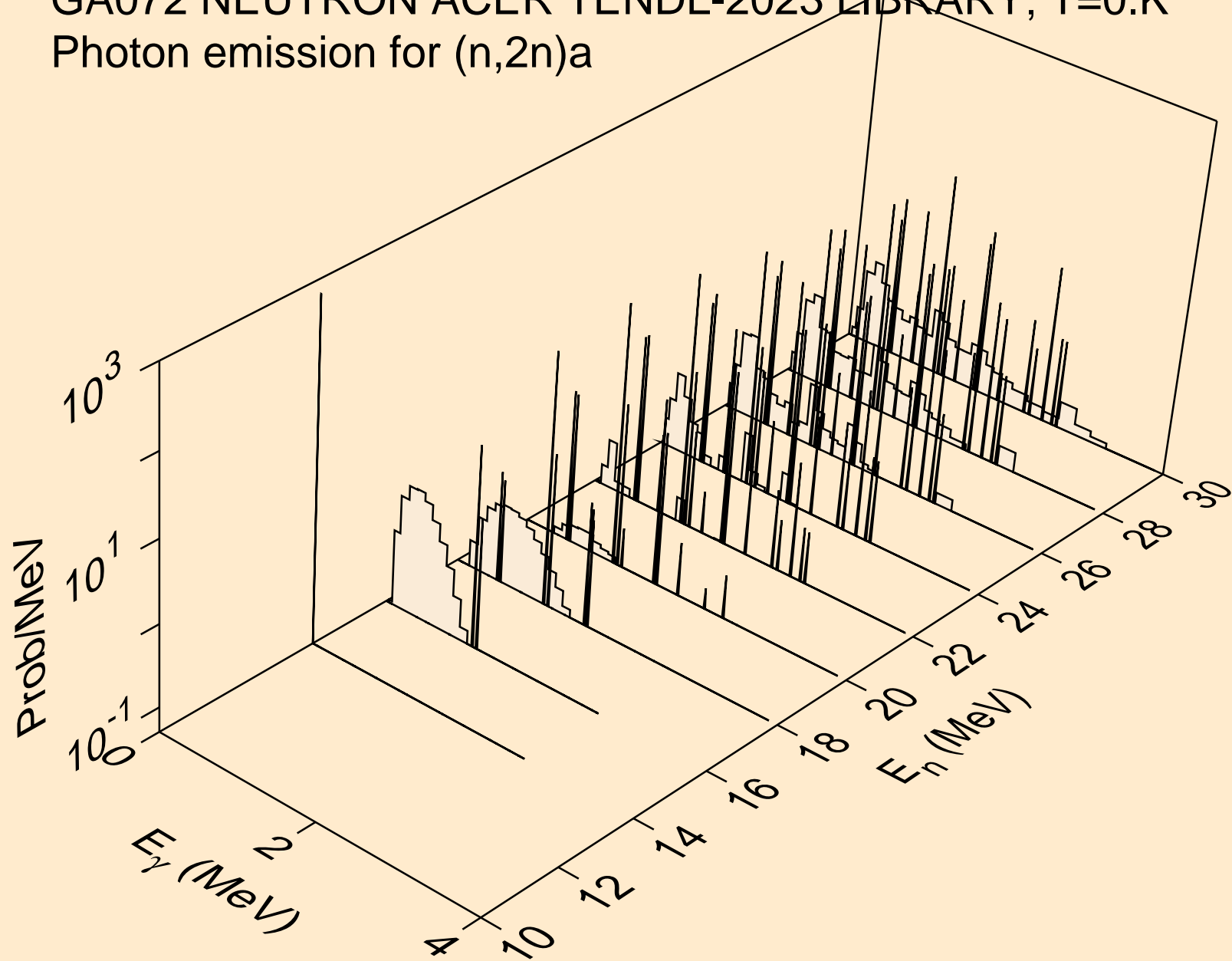

GA072 NEUTRON ACER TENDL-2023 LIBRARY; T=0.K
Photon emission for (n,3n)a

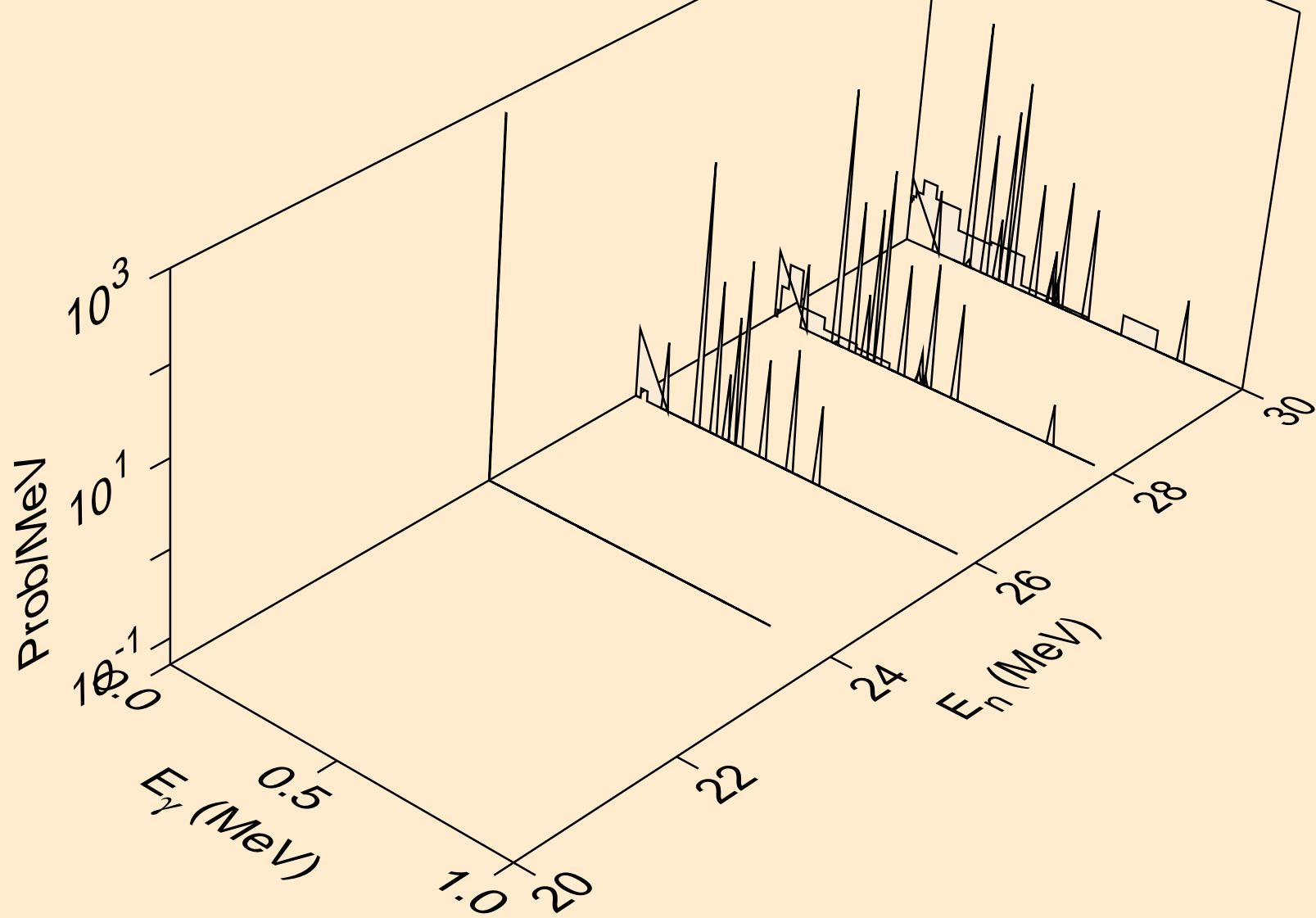

GA072 NEUTRON ACER TENDL-2023 LIBRARY; T=0.K
Photon emission for (n,n*)p

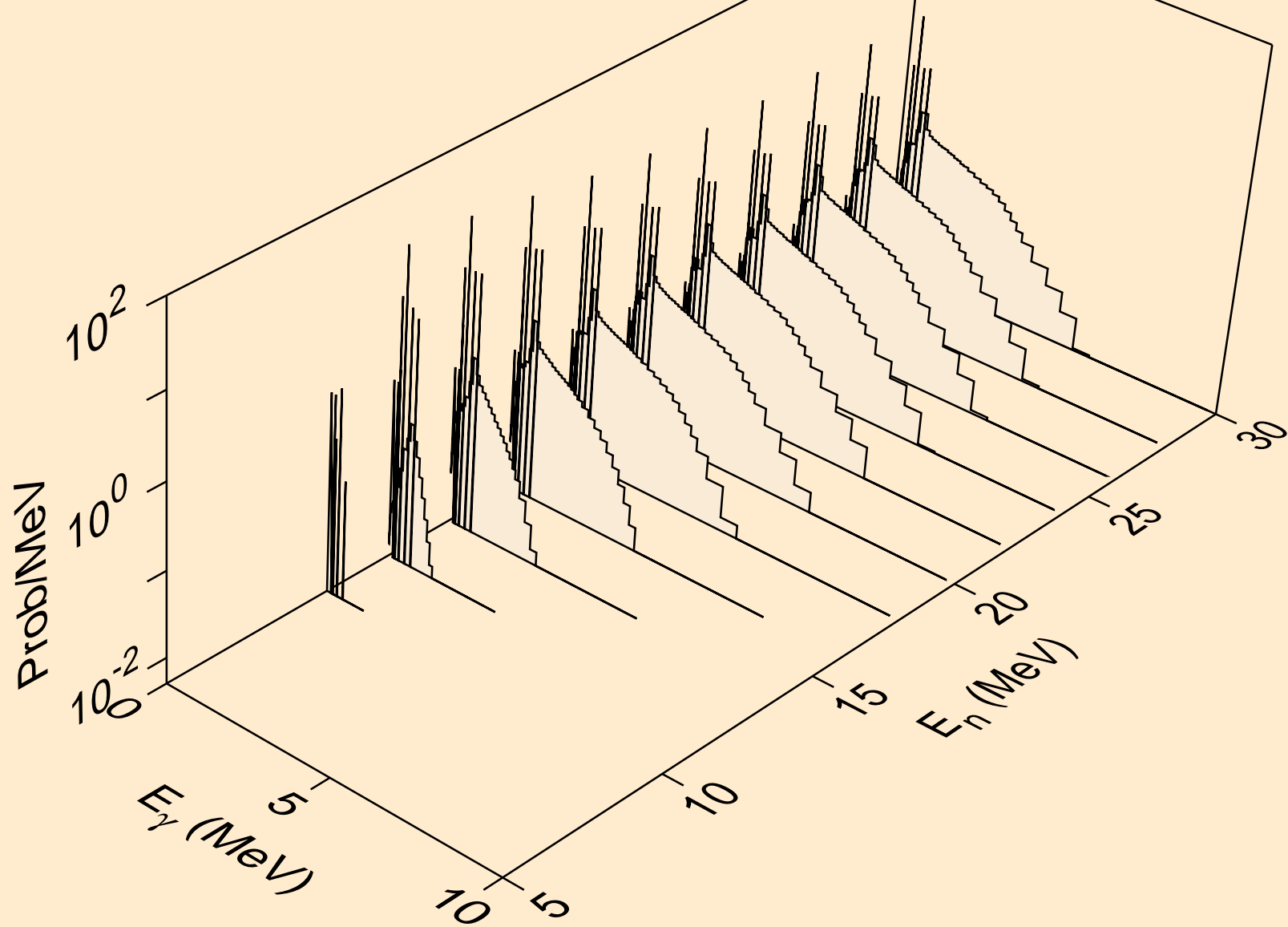

GA072 NEUTRON ACER TENDL-2023 LIBRARY; T=0.K
Photon emission for (n,n*)2a

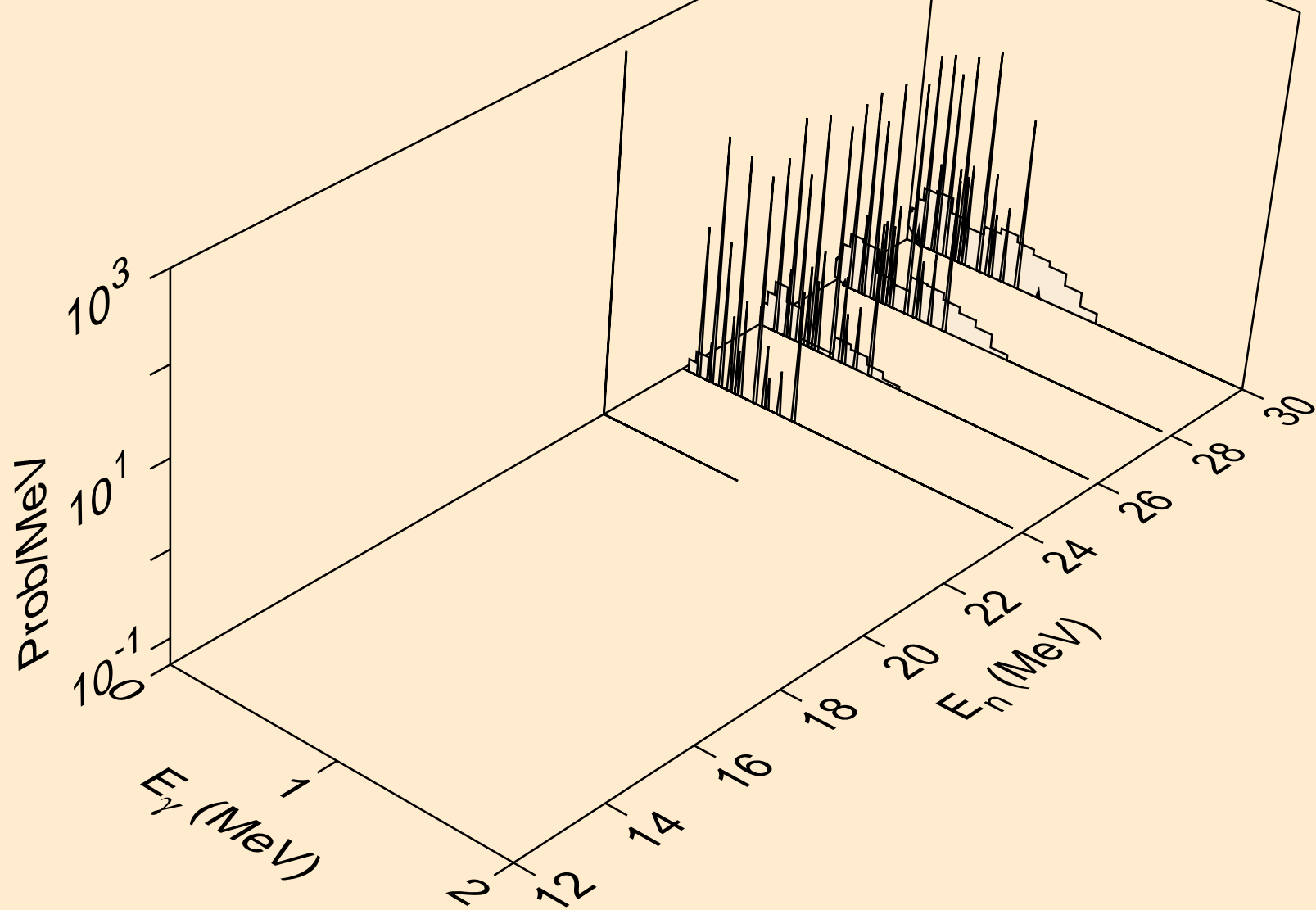

GA072 NEUTRON ACER TENDL-2023 LIBRARY; T=0.K
Photon emission for (n,n*)d

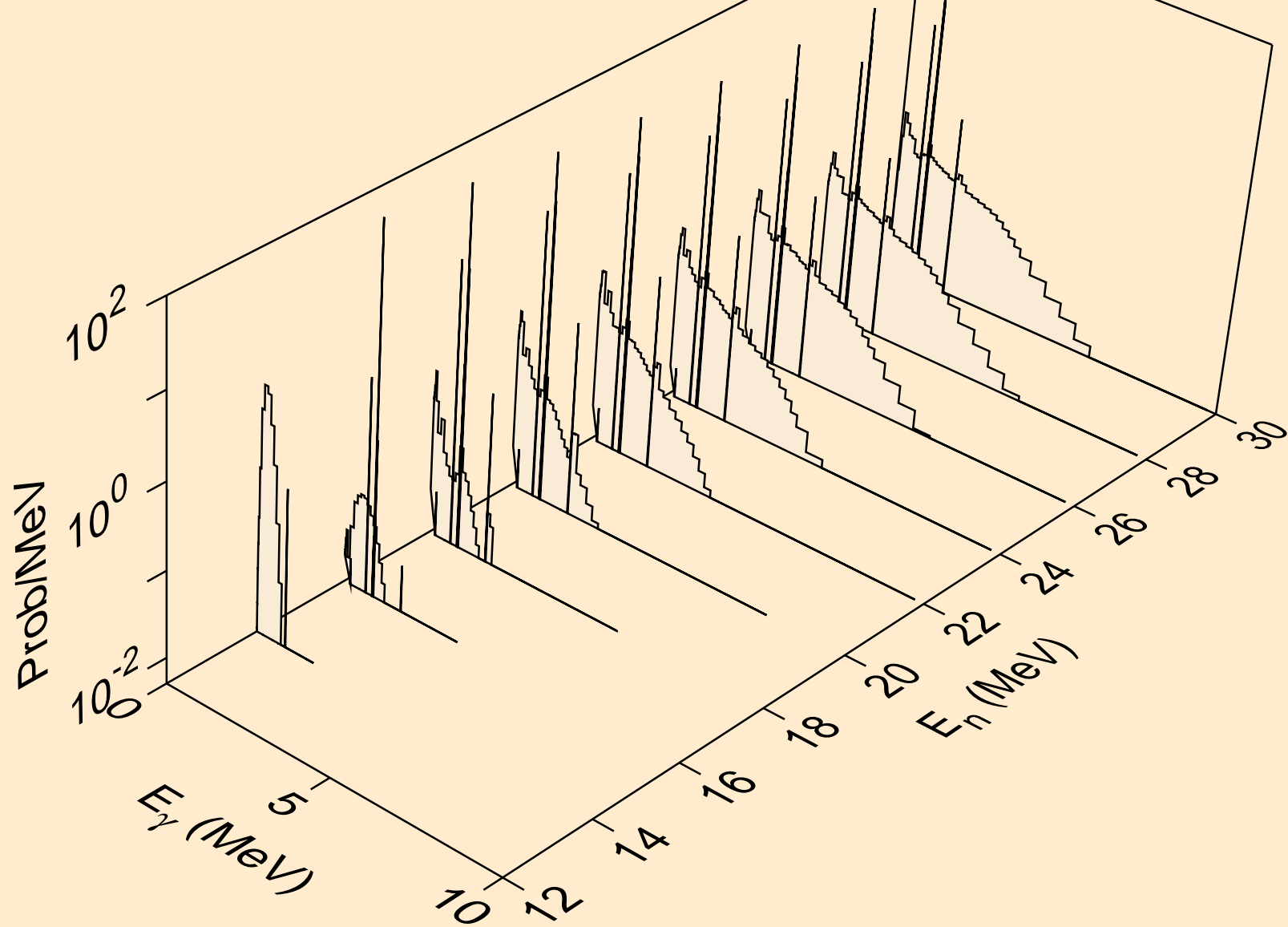

GA072 NEUTRON ACER TENDL-2023 LIBRARY; T=0.K
Photon emission for (n,n*)t

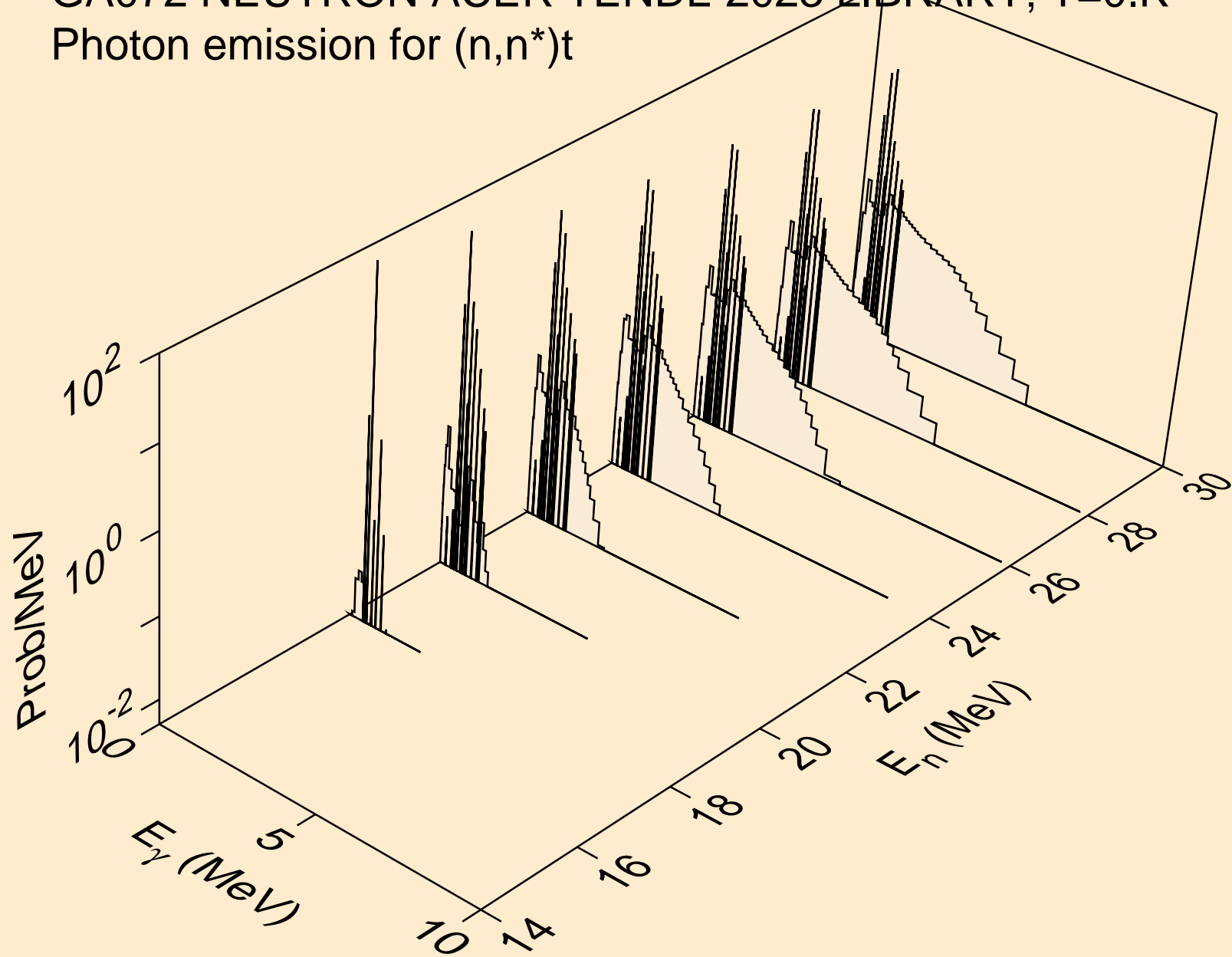

GA072 NEUTRON ACER TENDL-2023 LIBRARY; T=0.K
Photon emission for (n,n*)he3

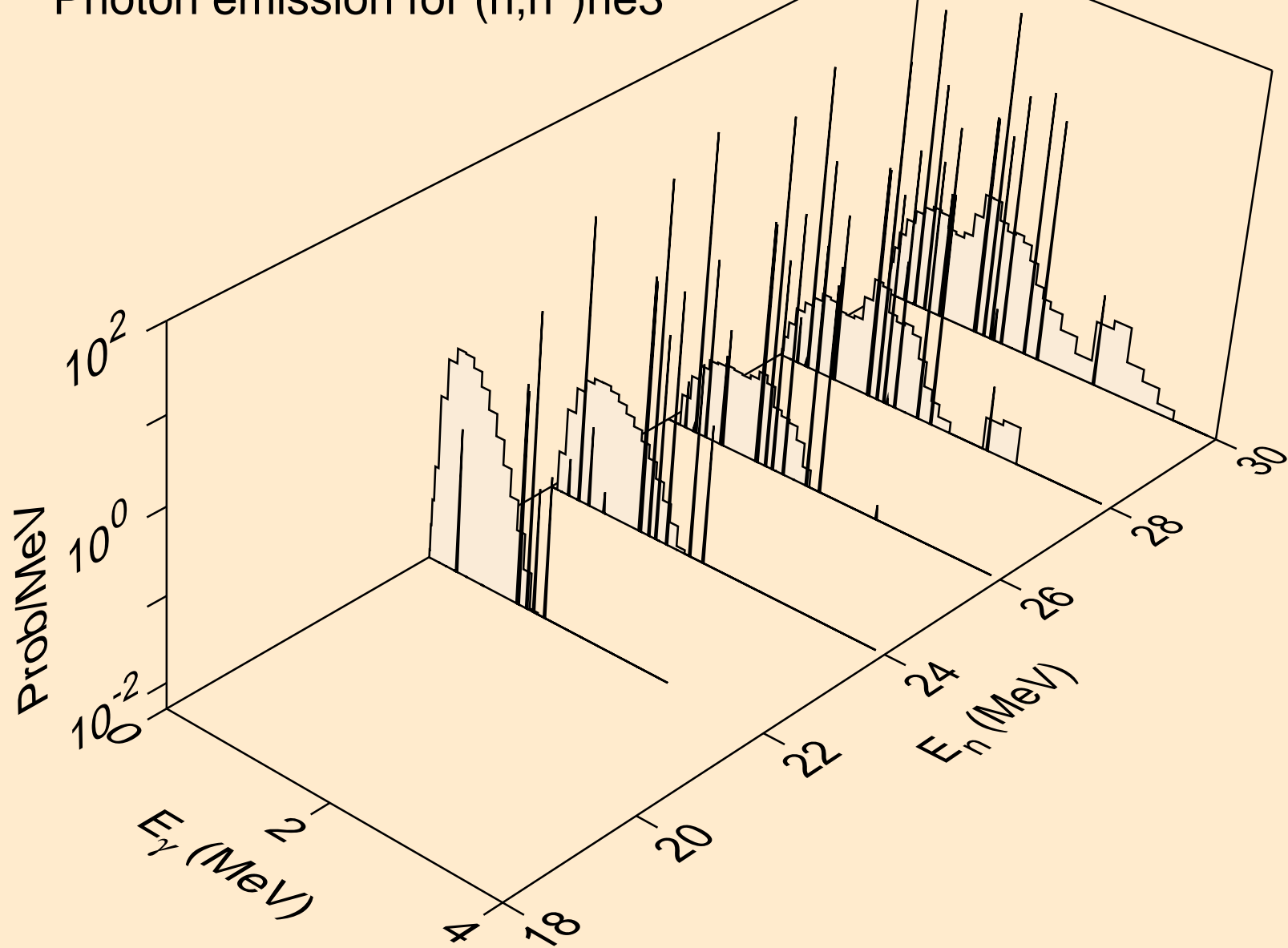

GA072 NEUTRON ACER TENDL-2023 LIBRARY; T=0.K
Photon emission for (n,4n)

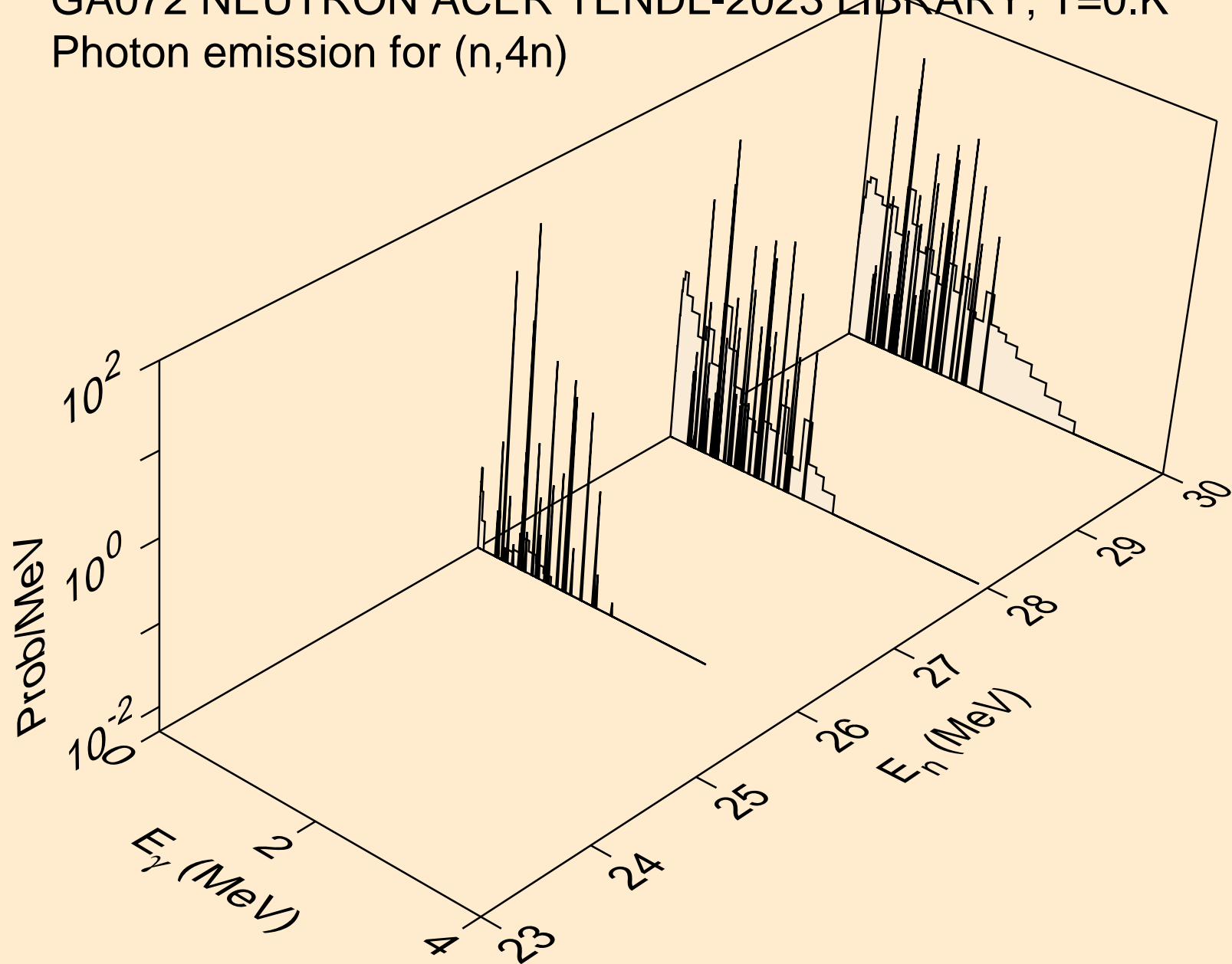

GA072 NEUTRON ACER TENDL-2023 LIBRARY; T=0.K
Photon emission for (n,2np)

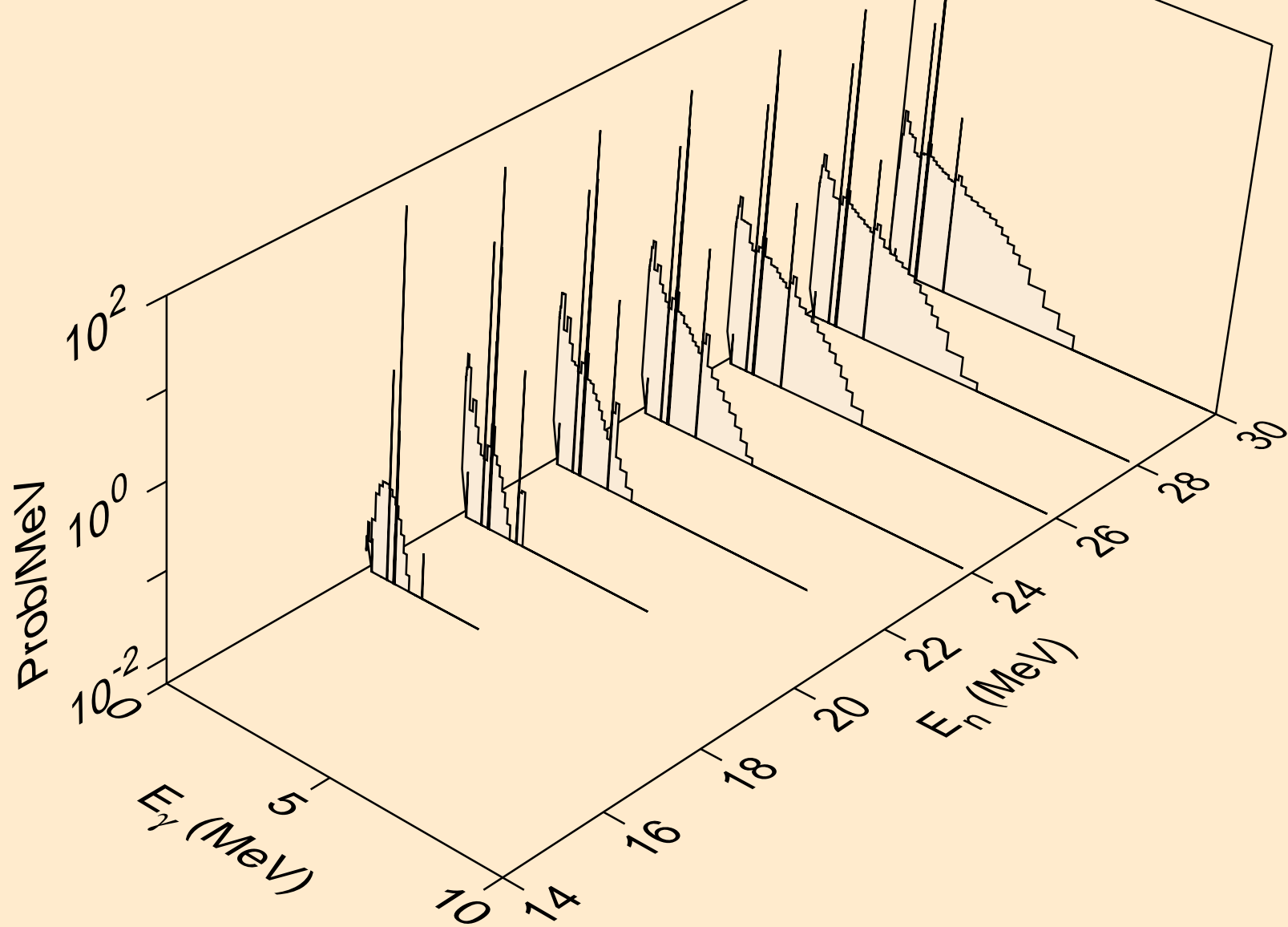

GA072 NEUTRON ACER TENDL-2023 LIBRARY; T=0.K
Photon emission for (n,3np)

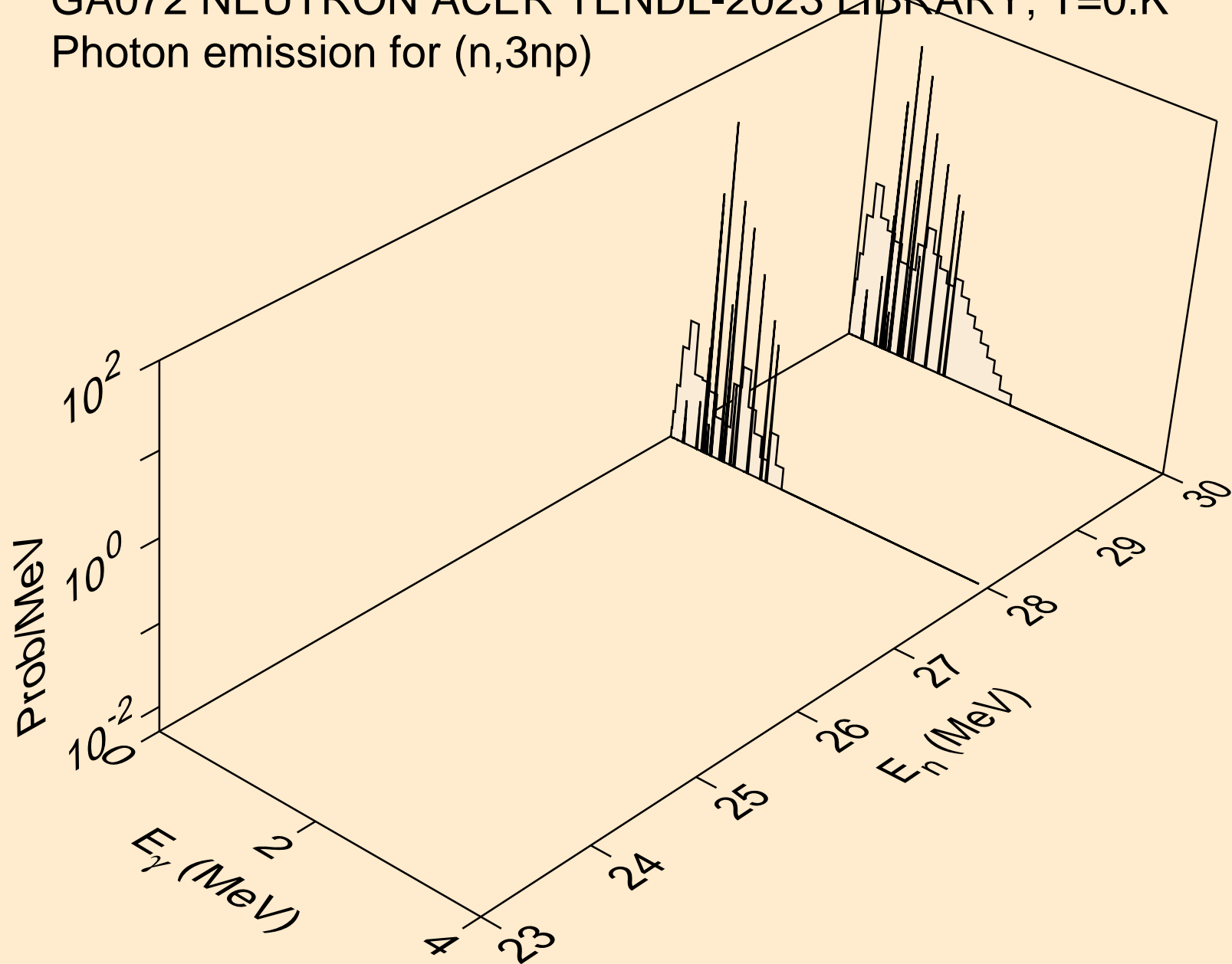

GA072 NEUTRON ACER TENDL-2023 LIBRARY; T=0.K
Photon emission for (n,n2p)

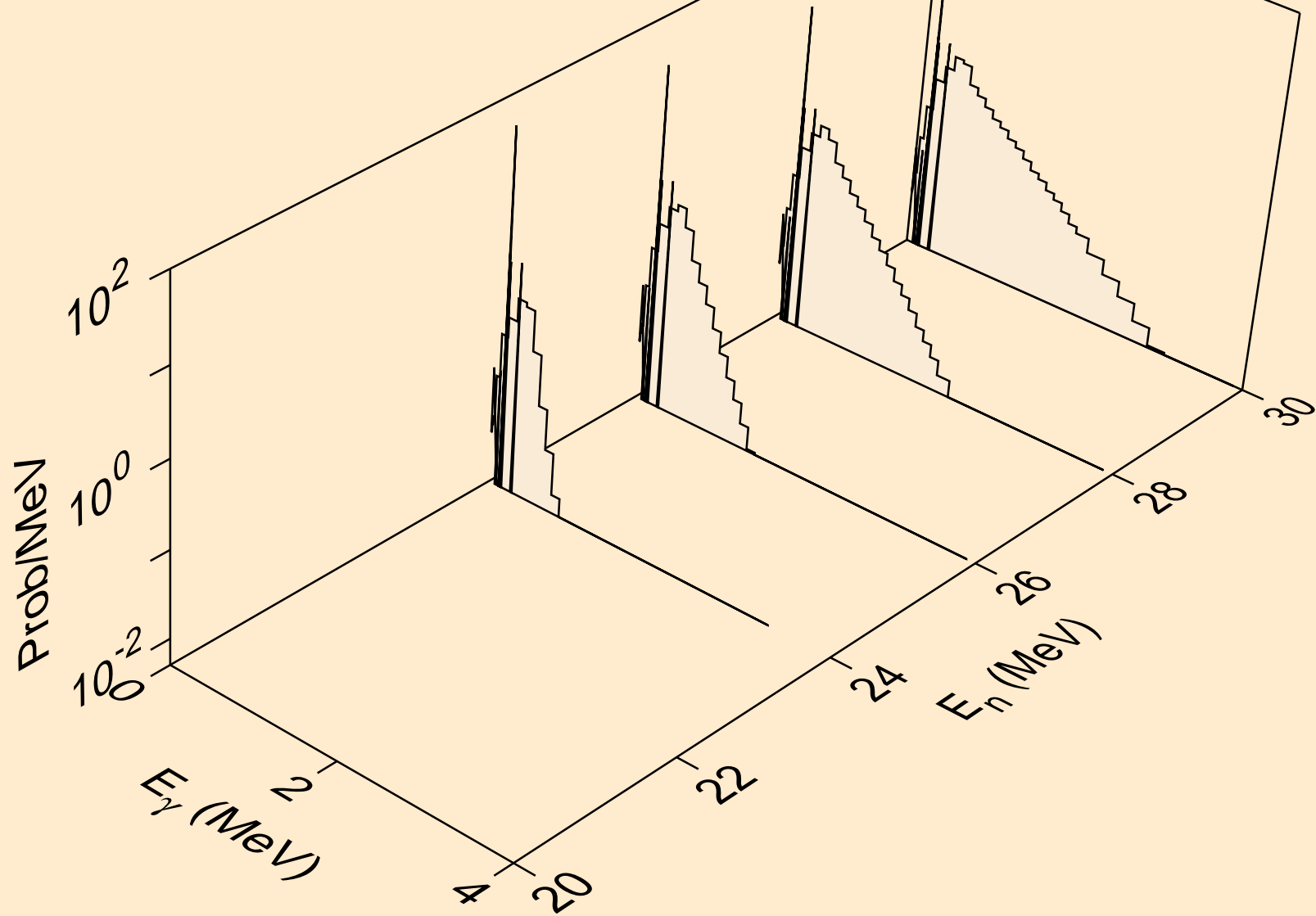

GA072 NEUTRON ACER TENDL-2023 LIBRARY; T=0.K
Photon emission for (n,npa)

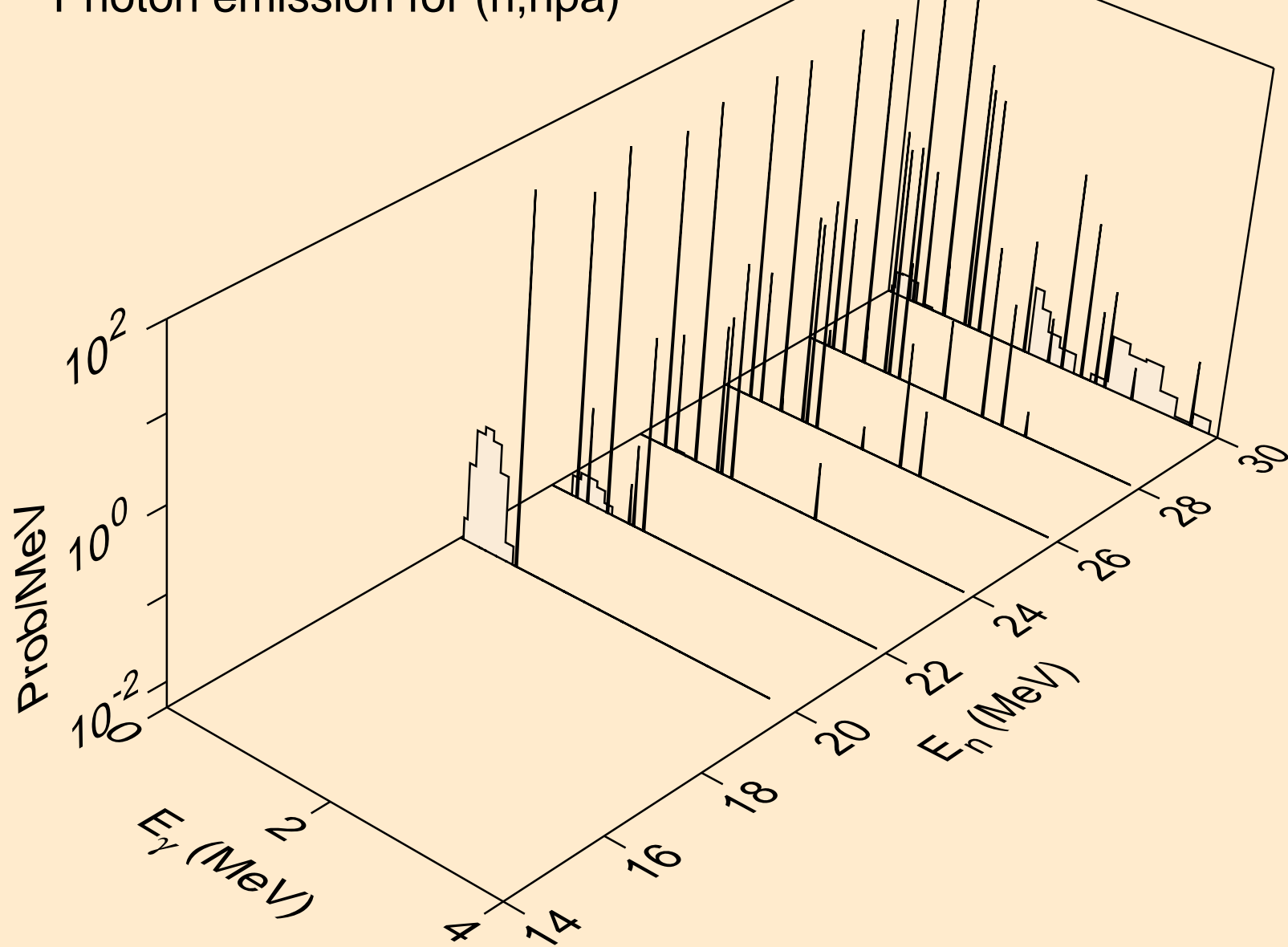

GA072 NEUTRON ACER TENDL-2023 LIBRARY; T=0.K
Photon emission for (n,n*c)

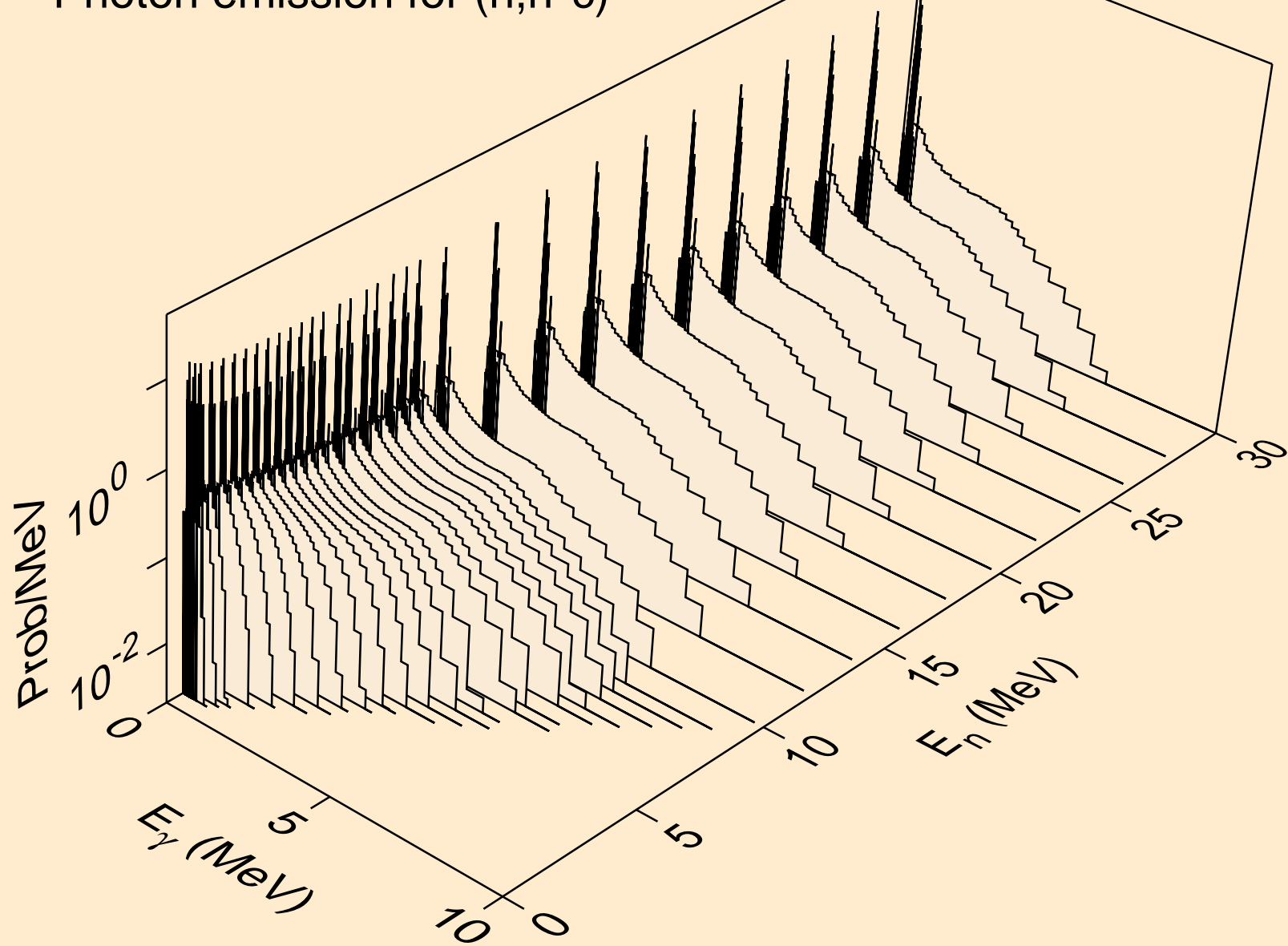

GA072 NEUTRON ACER TENDL-2023 LIBRARY; T=0.K
Photon emission for (n,gma)

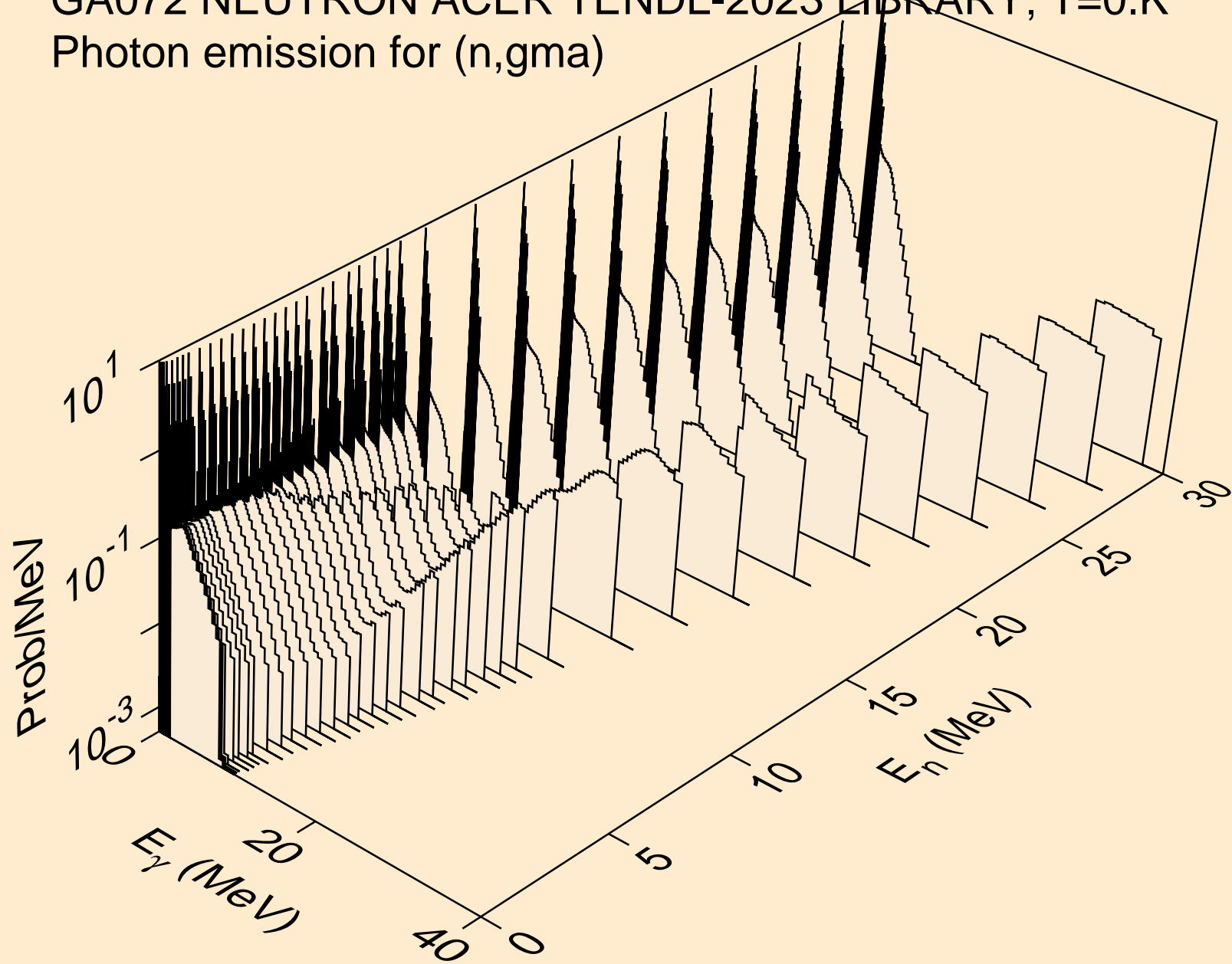

GA072 NEUTRON ACER TENDL-2023 LIBRARY; T=0.K
Photon emission for (n,p)

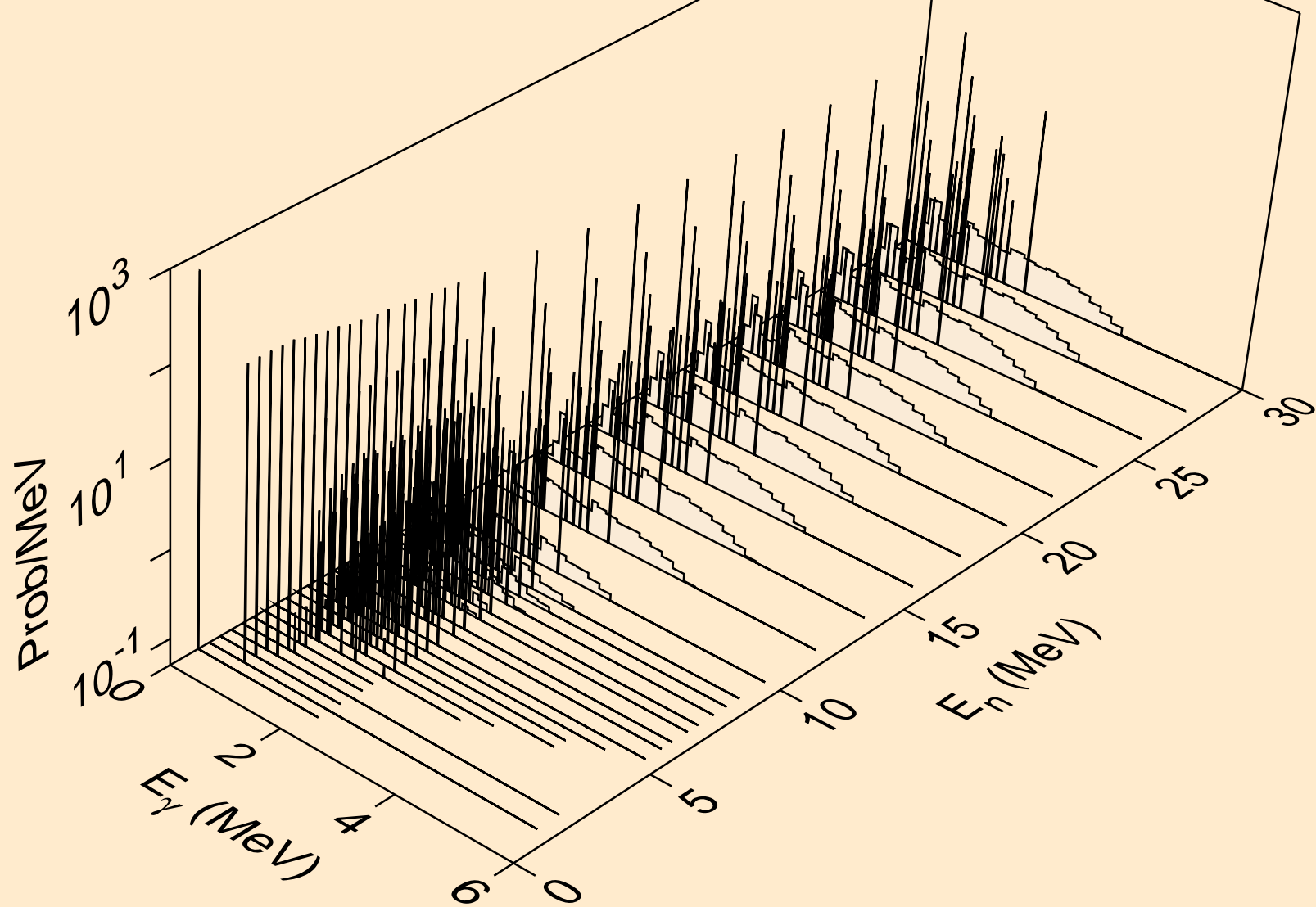

GA072 NEUTRON ACER TENDL-2023 LIBRARY; T=0.K
Photon emission for (n,d)

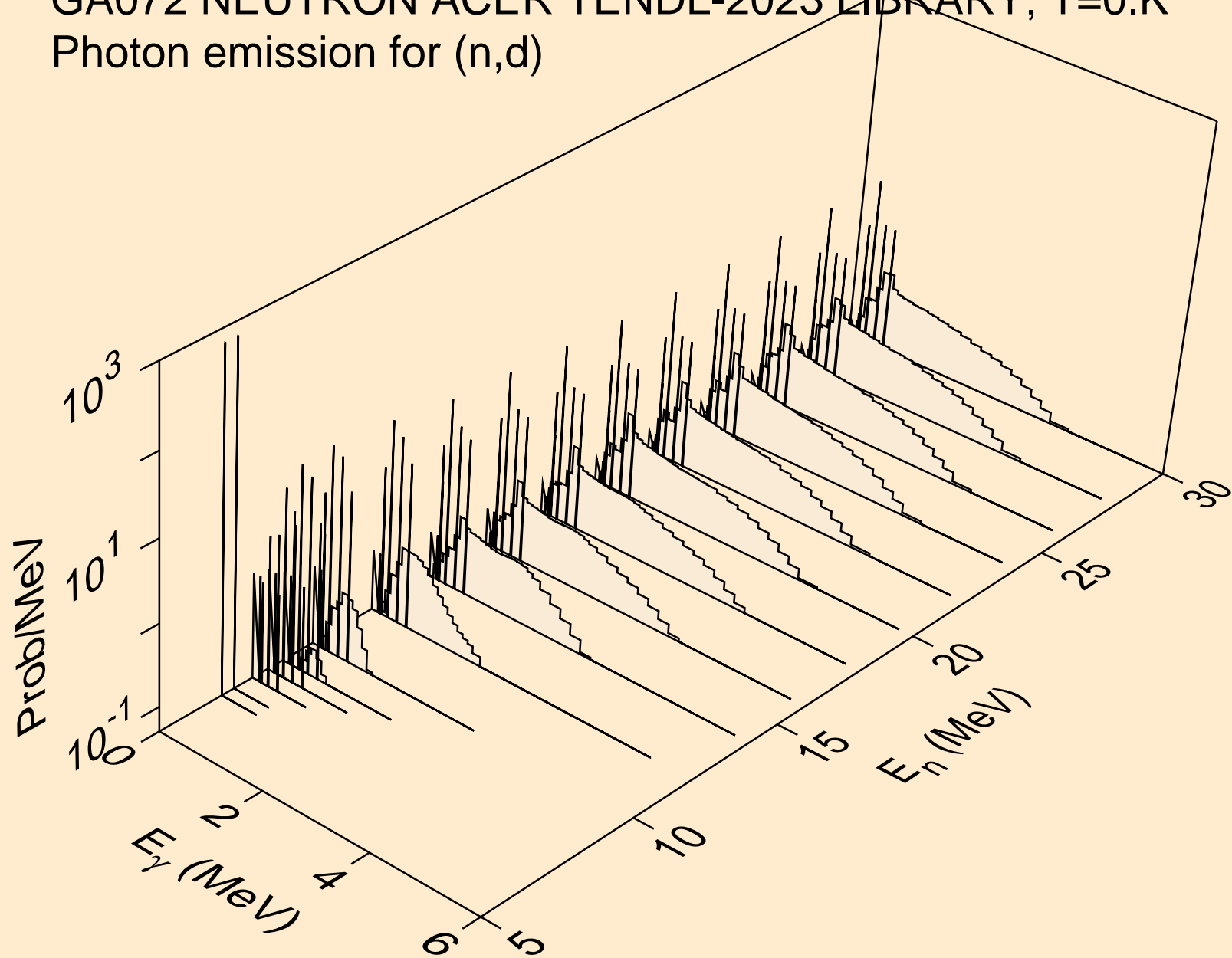

GA072 NEUTRON ACER TENDL-2023 LIBRARY; T=0.K
Photon emission for (n,t)

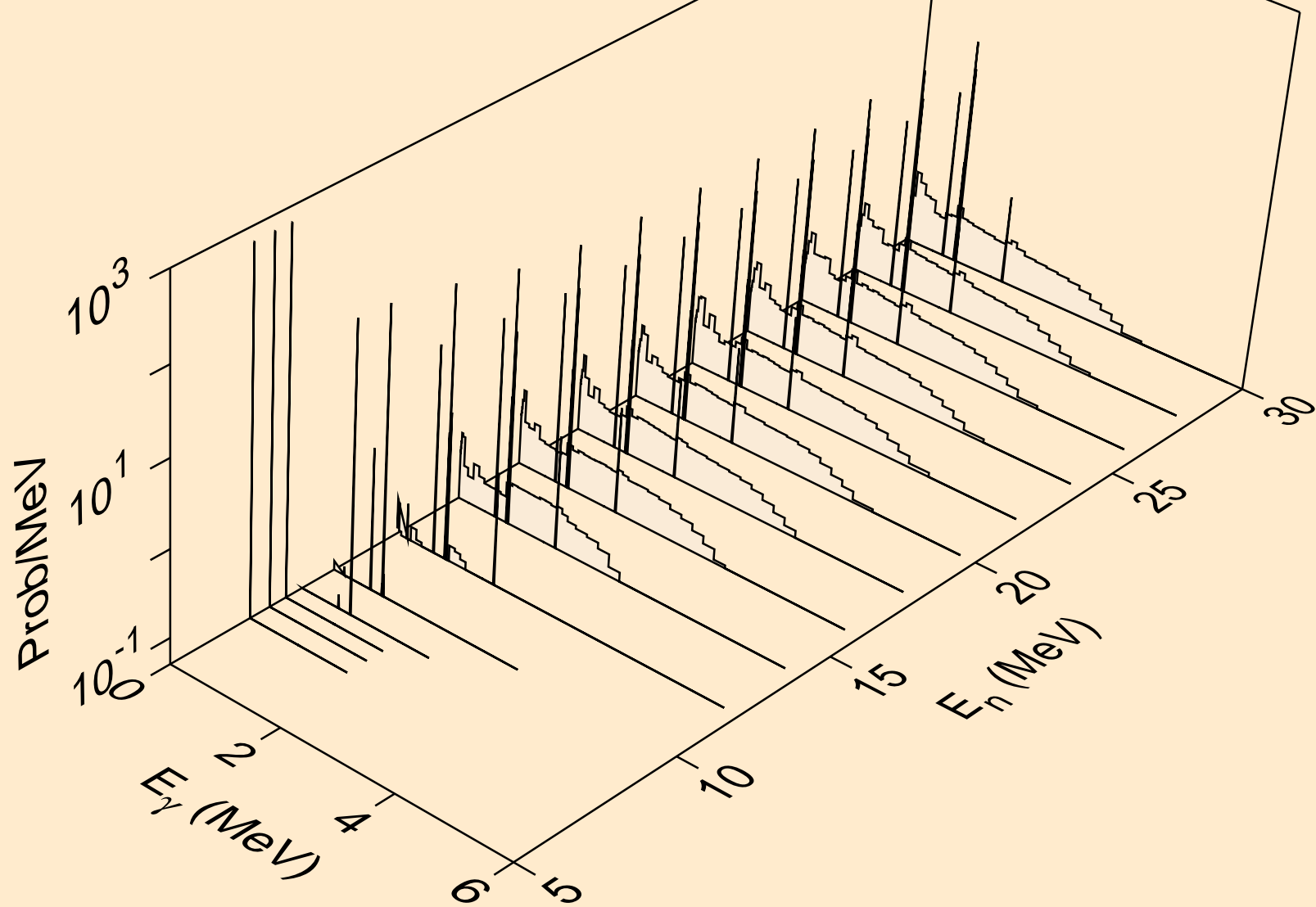

GA072 NEUTRON ACER TENDL-2023 LIBRARY; T=0.K
Photon emission for (n,he3)

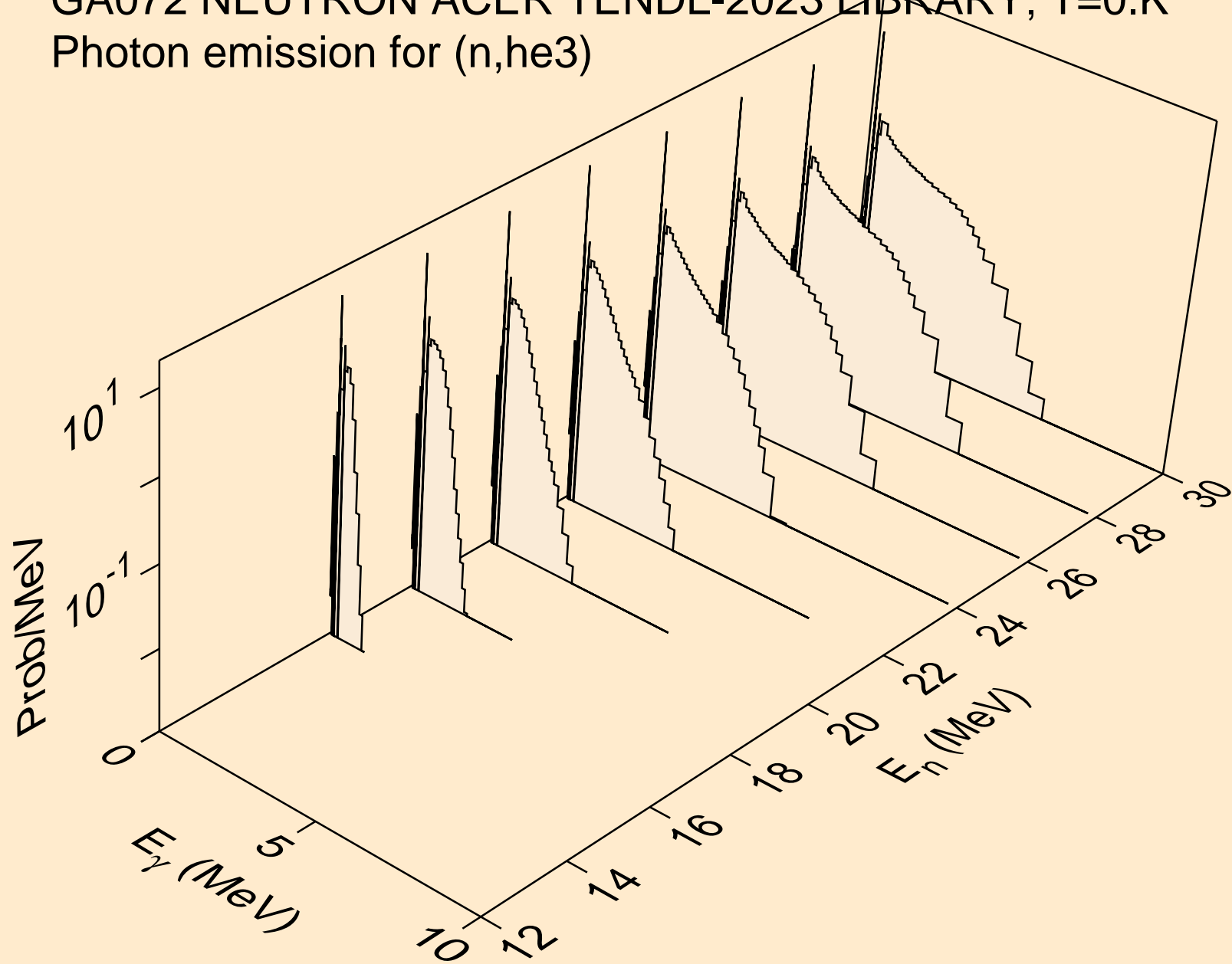

GA072 NEUTRON ACER TENDL-2023 LIBRARY; T=0.K
Photon emission for (n,a)

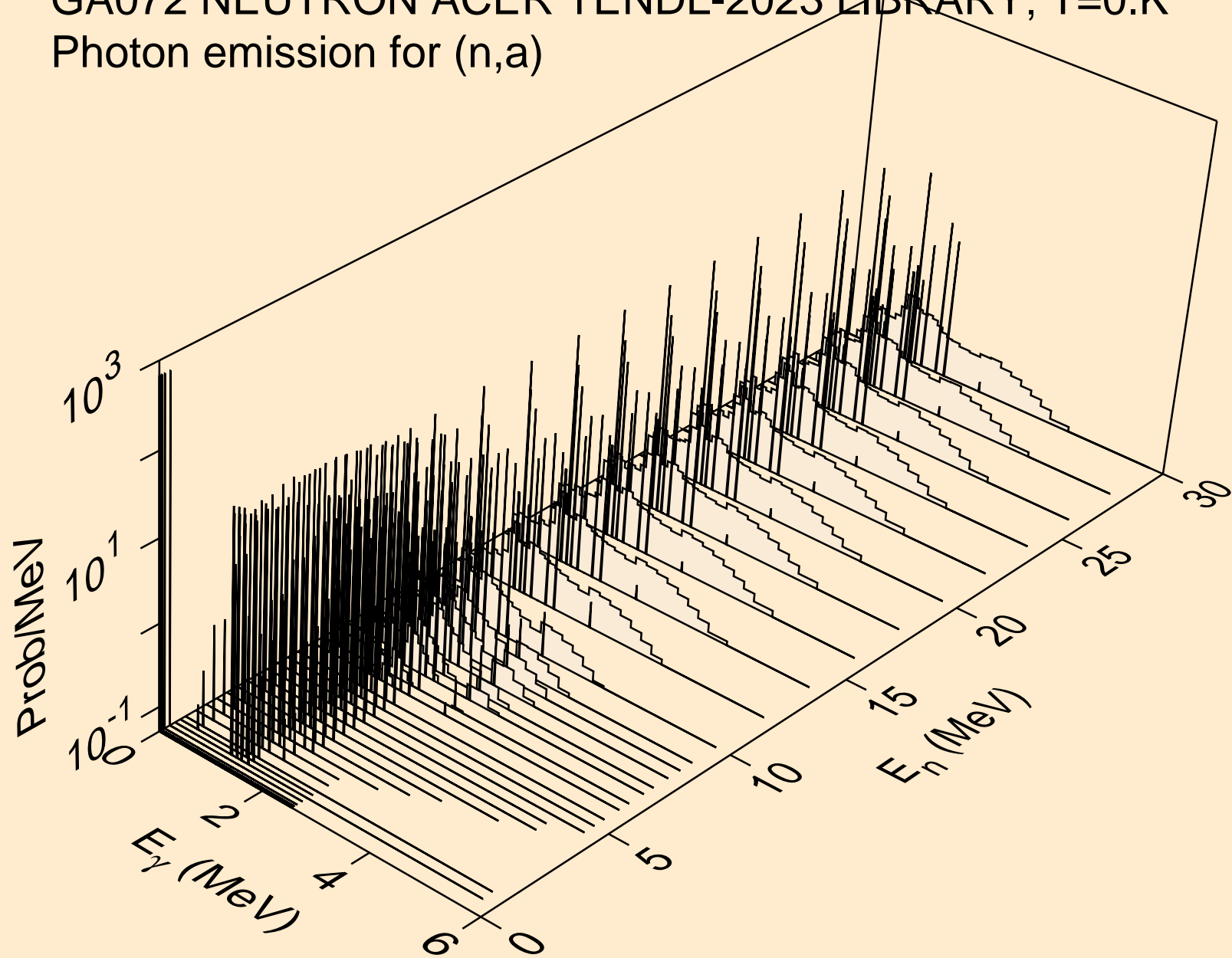

GA072 NEUTRON ACER TENDL-2023 LIBRARY; T=0.K
Photon emission for (n,2a)

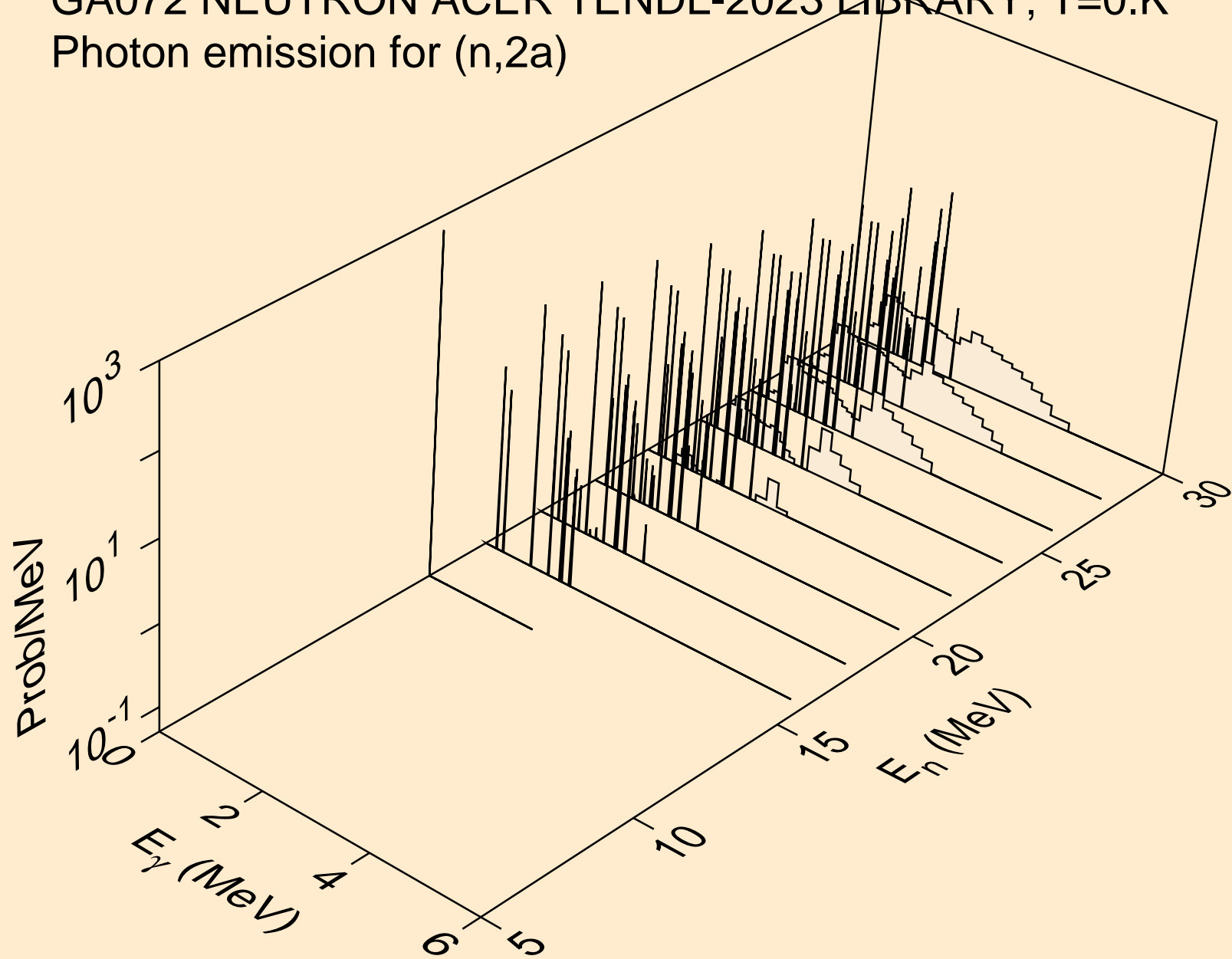

GA072 NEUTRON ACER TENDL-2023 LIBRARY; T=0.K
Photon emission for (n,2p)

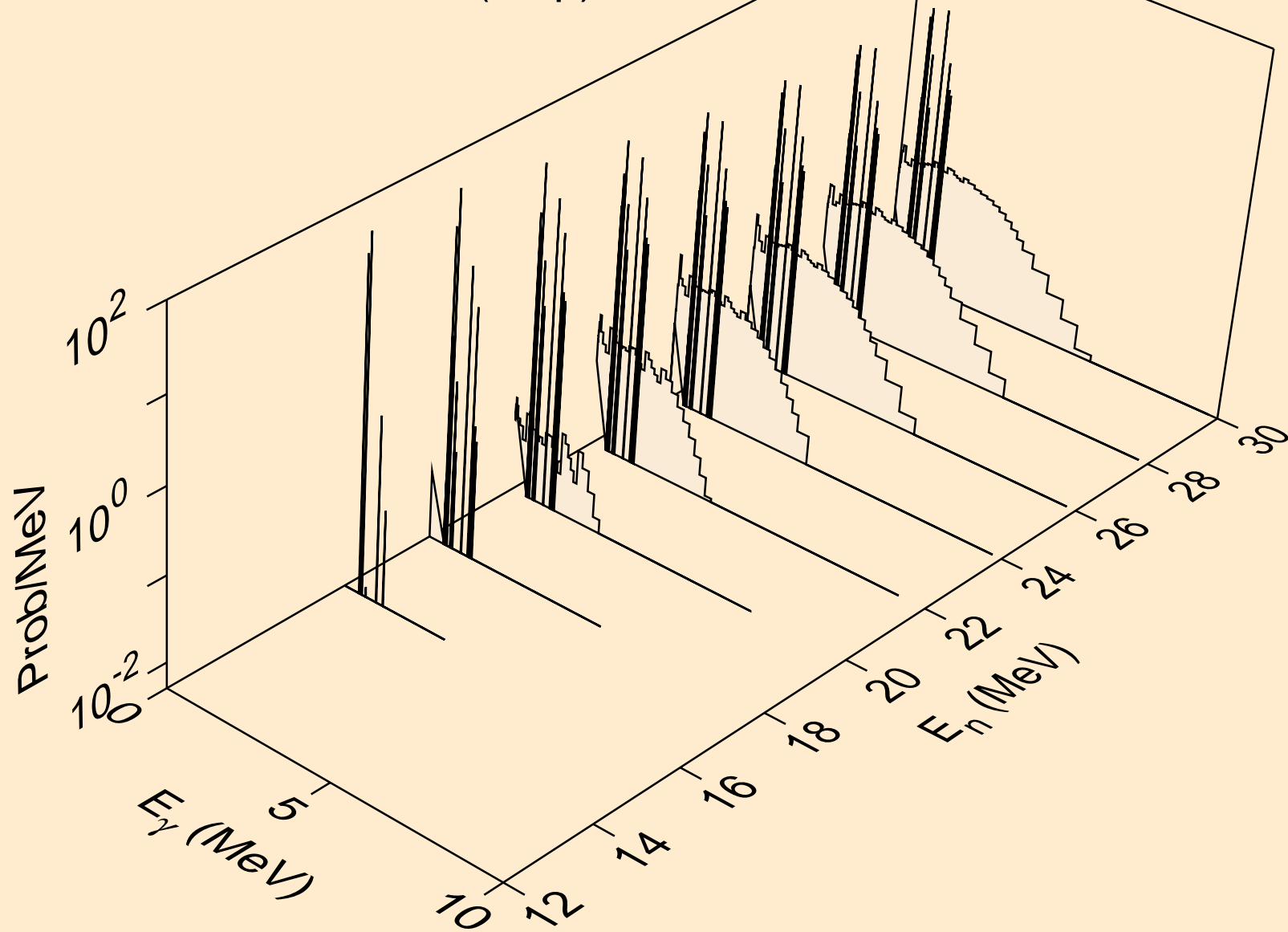

GA072 NEUTRON ACER TENDL-2023 LIBRARY; T=0.K
Photon emission for (n,p)

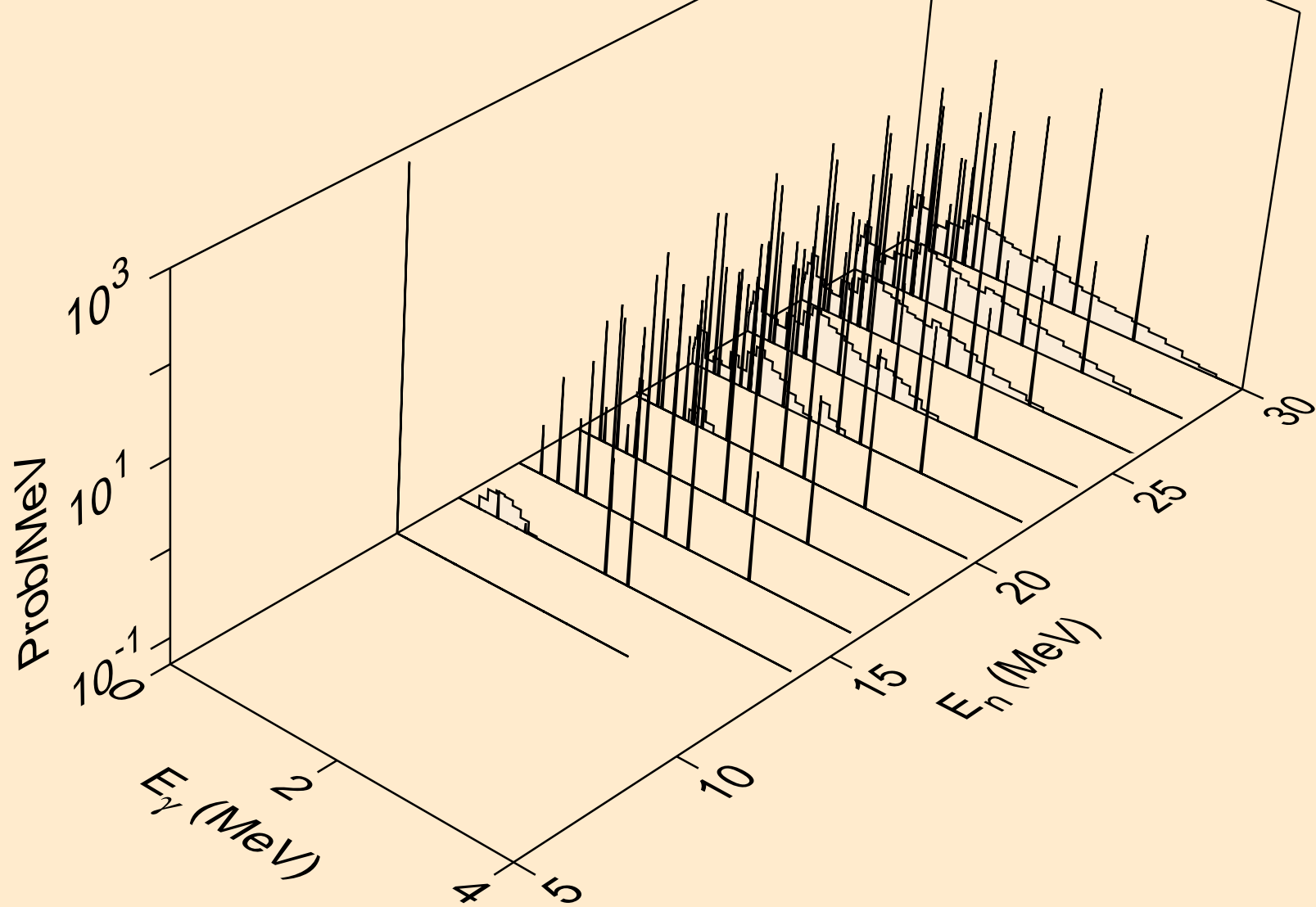

GA072 NEUTRON ACER TENDL-2023 LIBRARY; T=0.K
Photon emission for (n,pd)

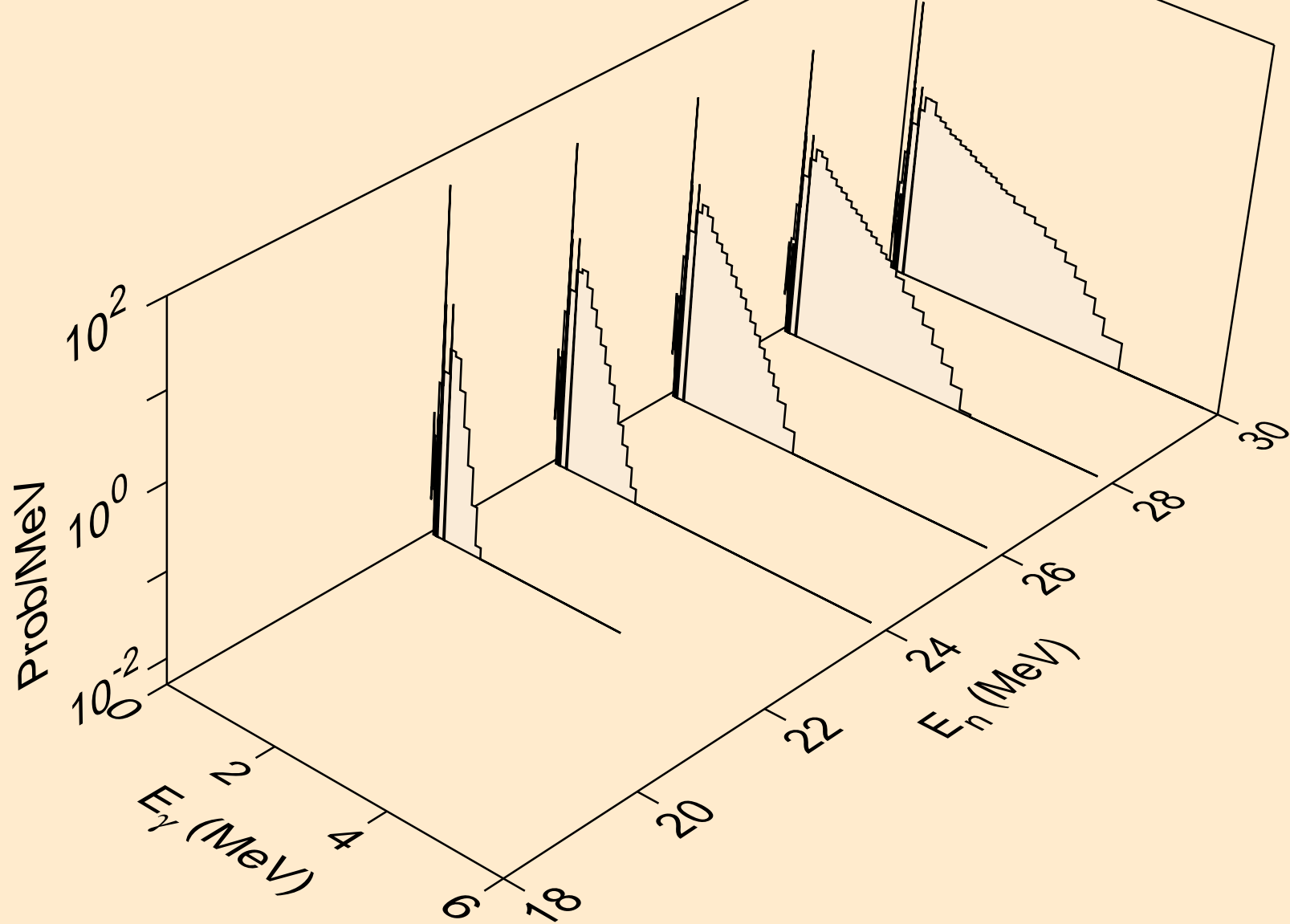

GA072 NEUTRON ACER TENDL-2023 LIBRARY; T=0.K
Photon emission for (n,pt)

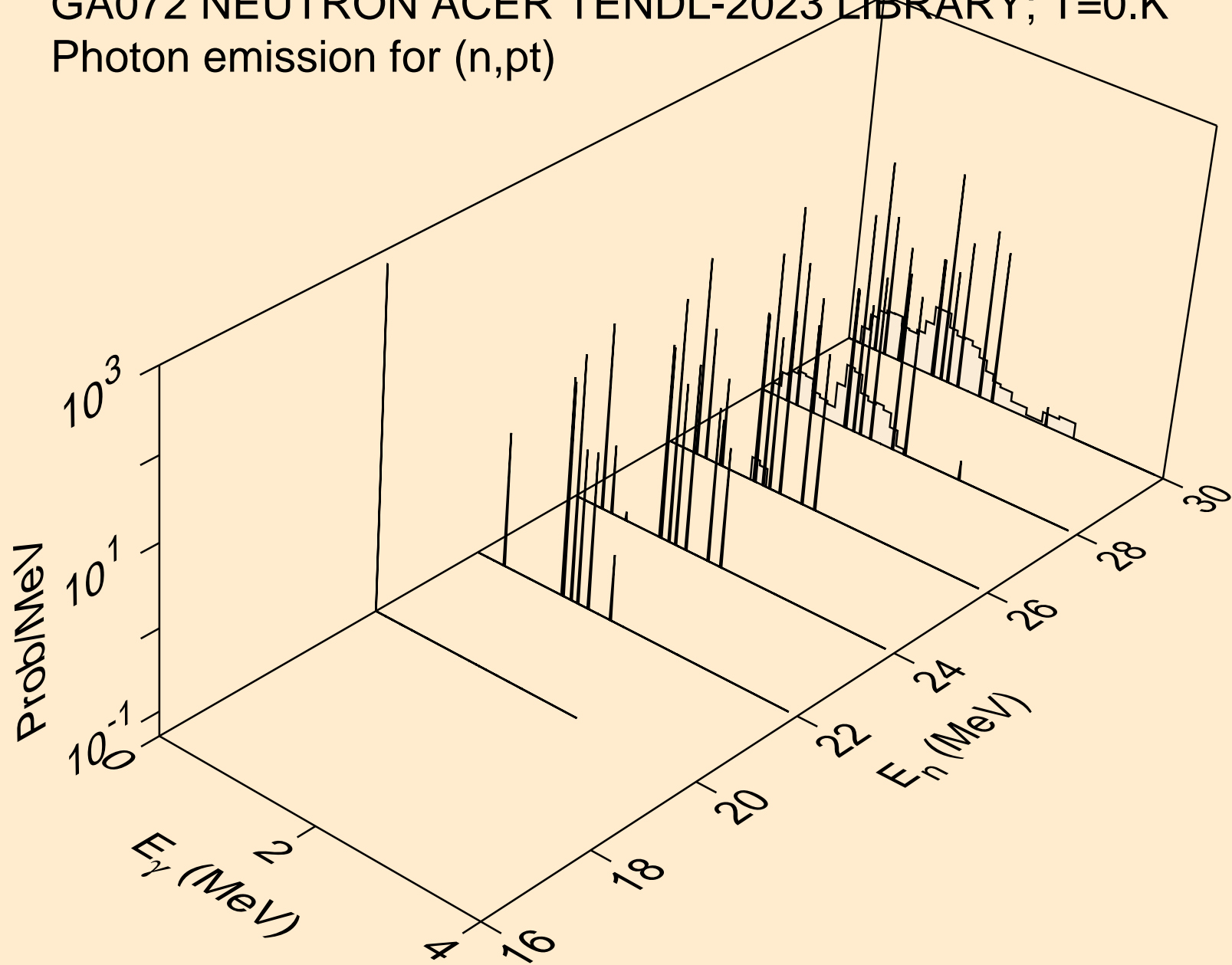

GA072 NEUTRON ACER TENDL-2023 LIBRARY; T=0.K
Photon emission for (n,da)

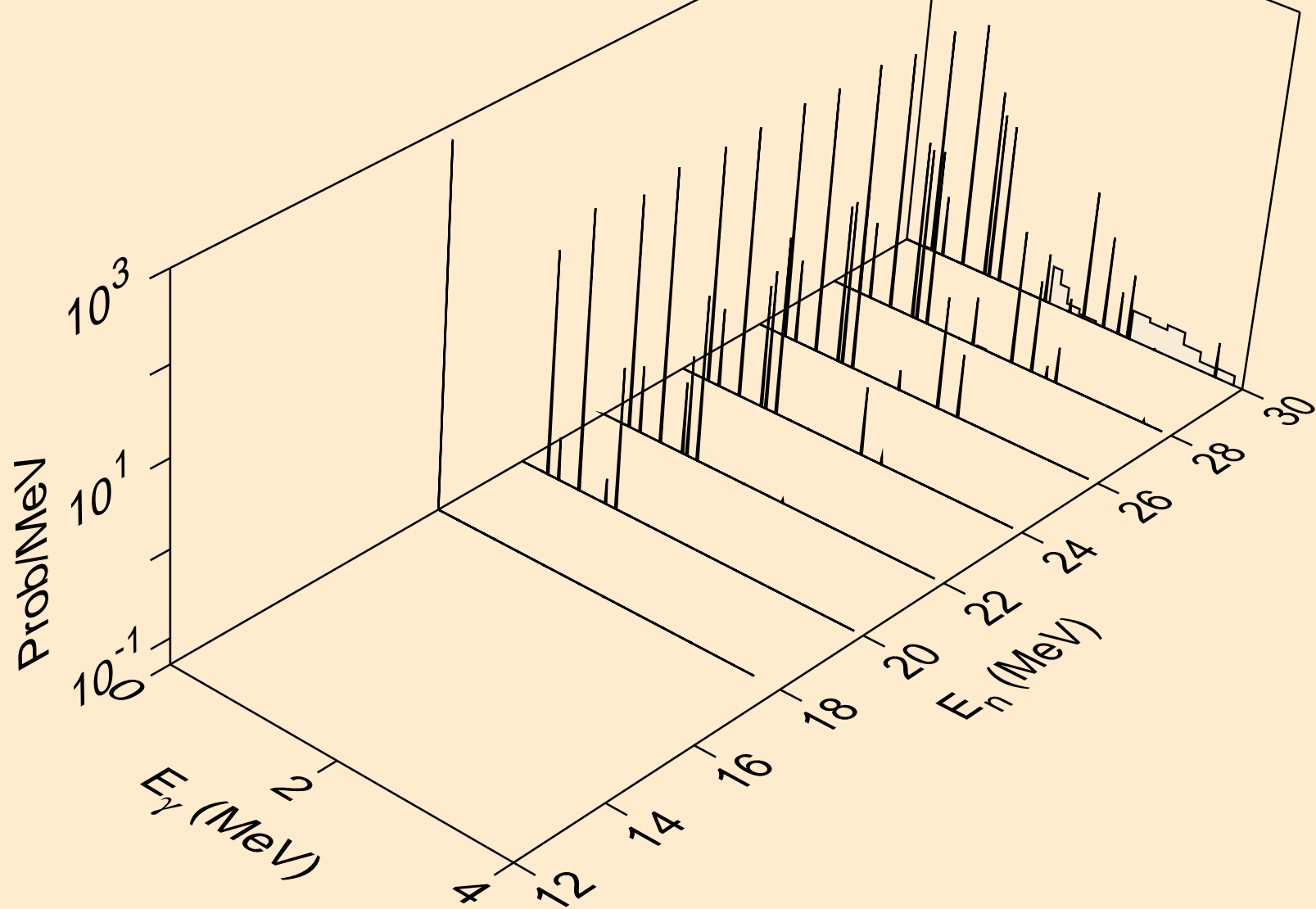

GA072 NEUTRON ACER TENDL-2023 LIBRARY; T=0.K
thermal capture photon spectrum

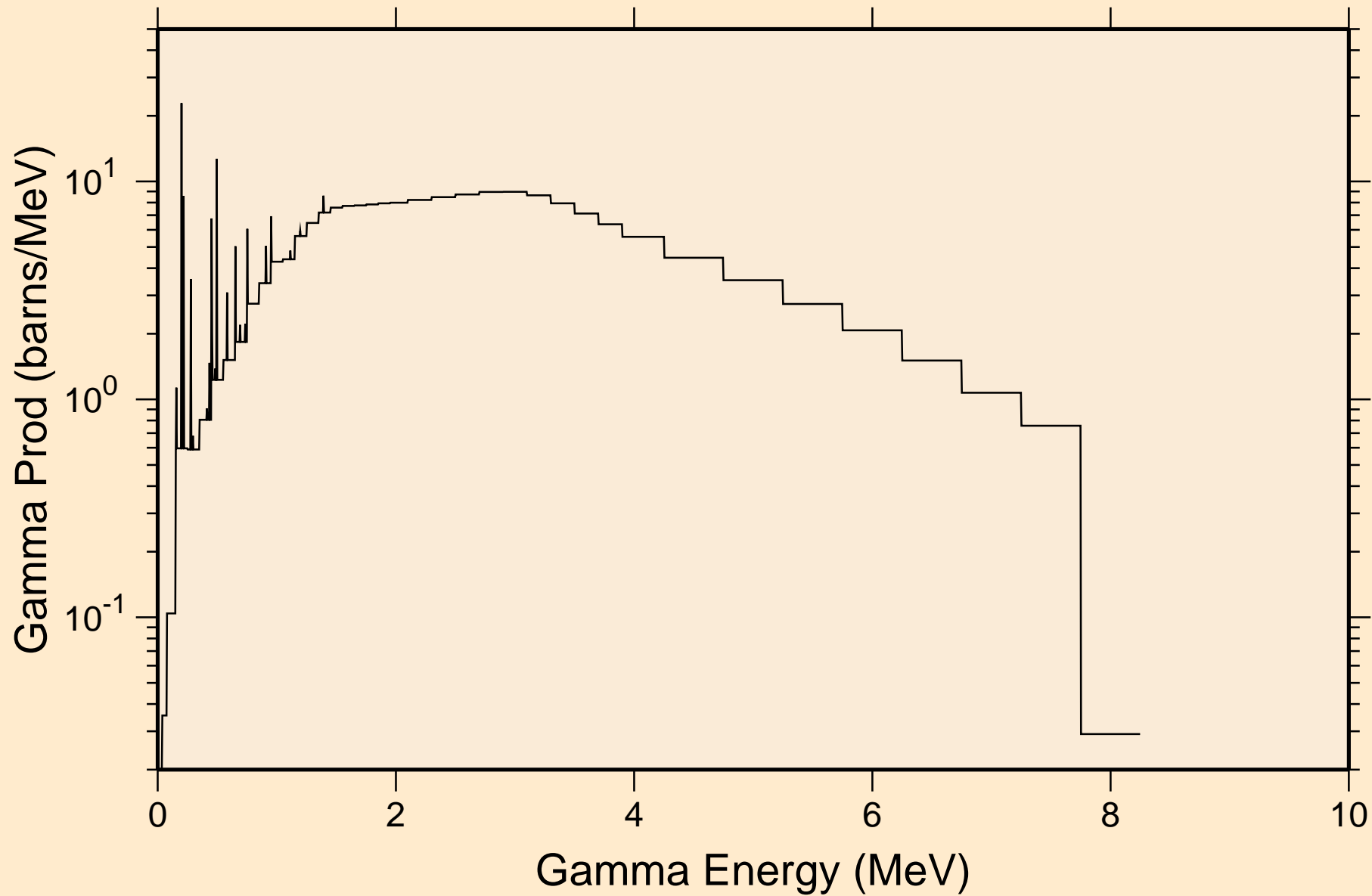

GA072 NEUTRON ACER TENDL-2023 LIBRARY; T=0.K
14 MeV photon spectrum

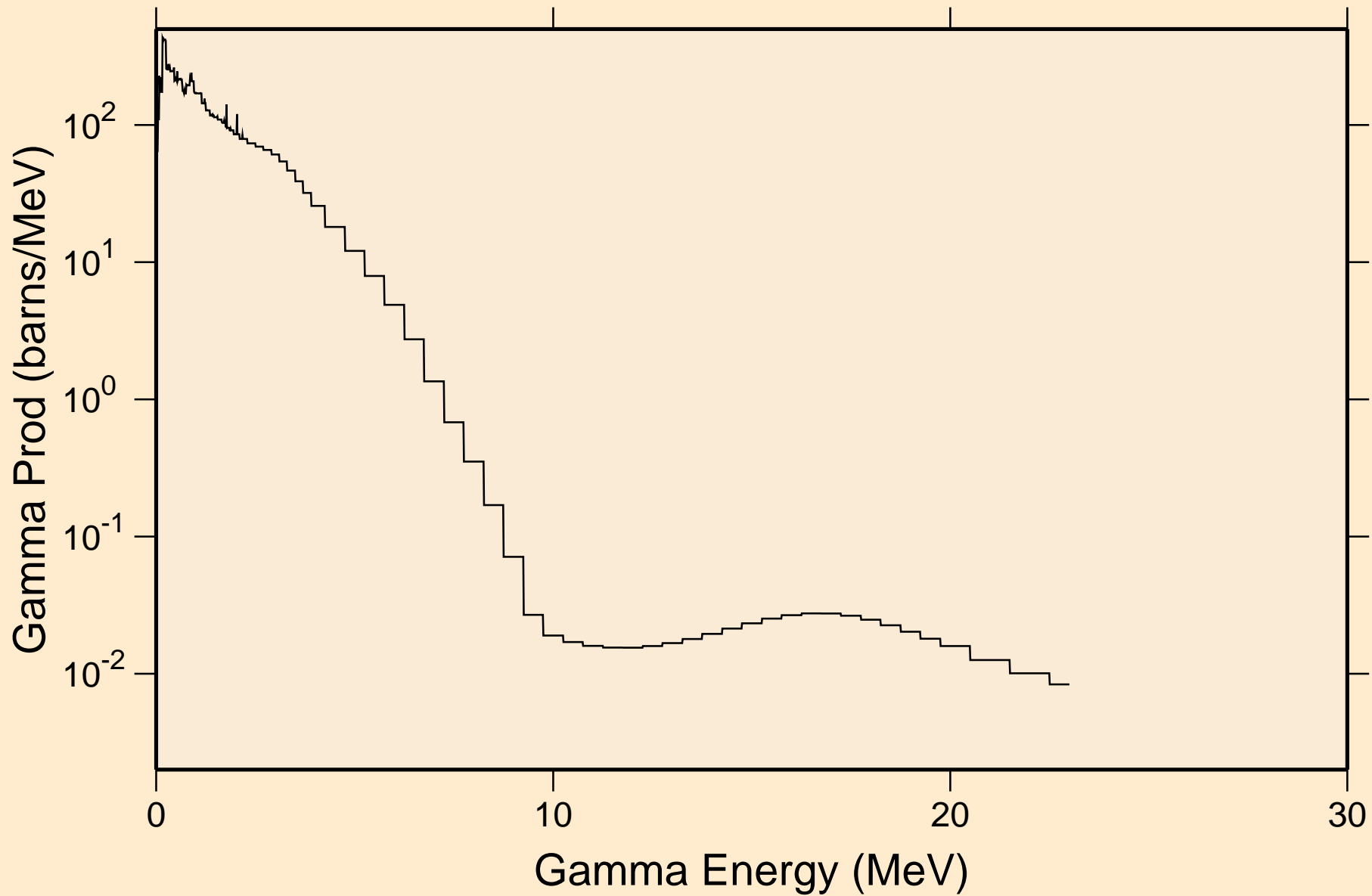

GA072 NEUTRON ACER TENDL-2023 LIBRARY; T=0.K

Particle heating contributions

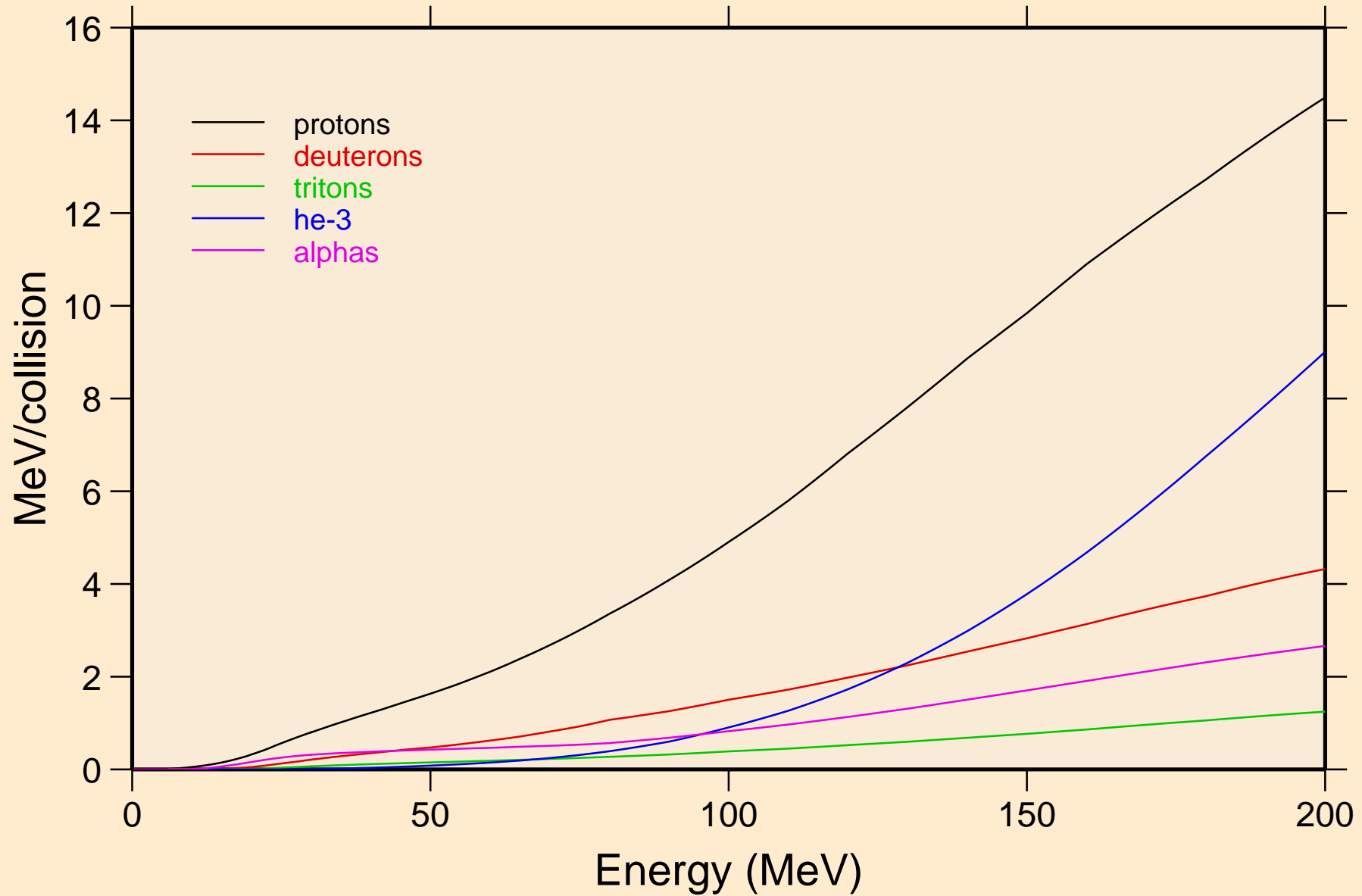

GA072 NEUTRON ACER TENDL-2023 LIBRARY; T=0.K
Recoil Heating

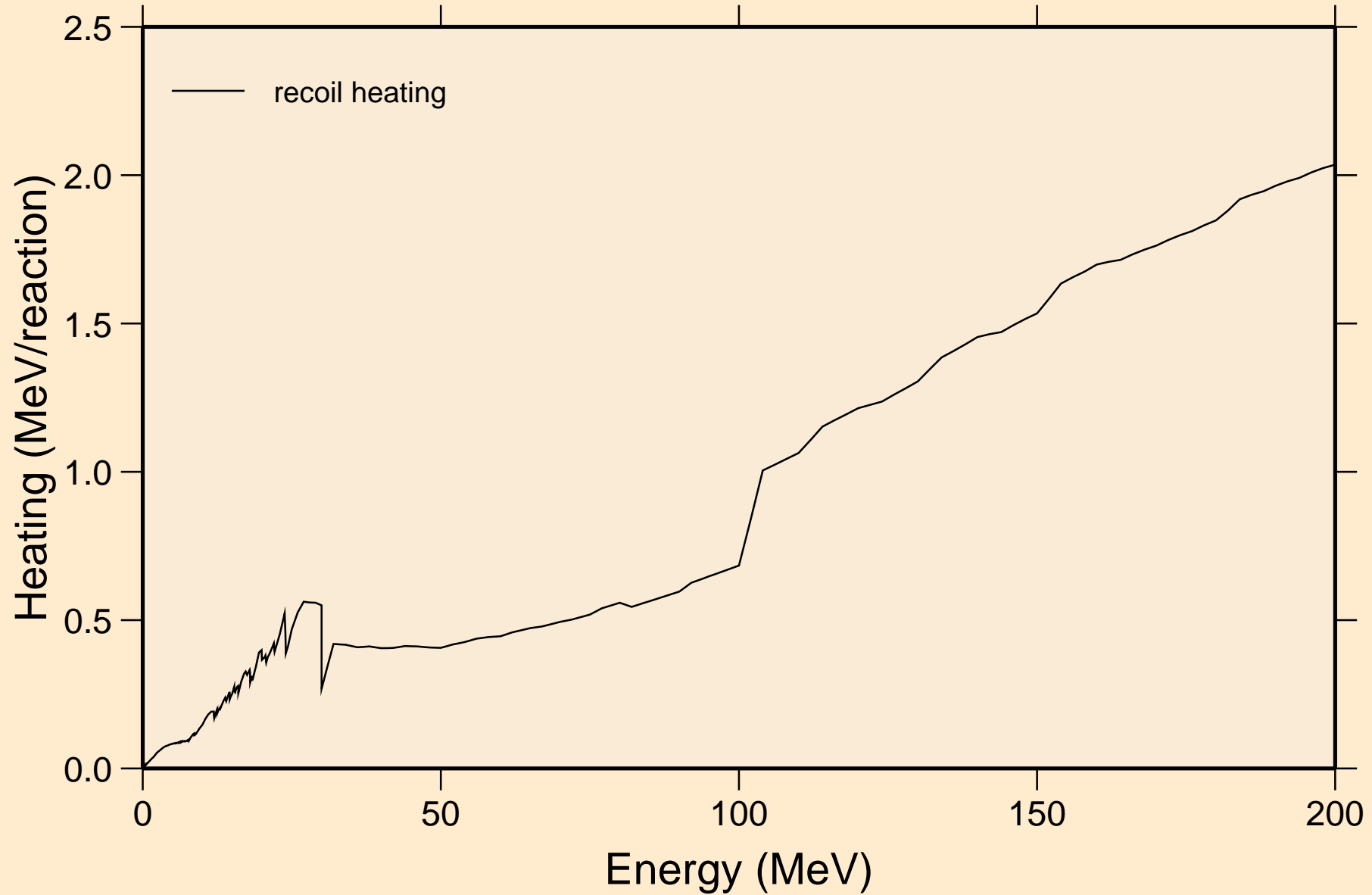

GA072 NEUTRON ACER TENDL-2023 LIBRARY; T=0.K

Particle production cross sections

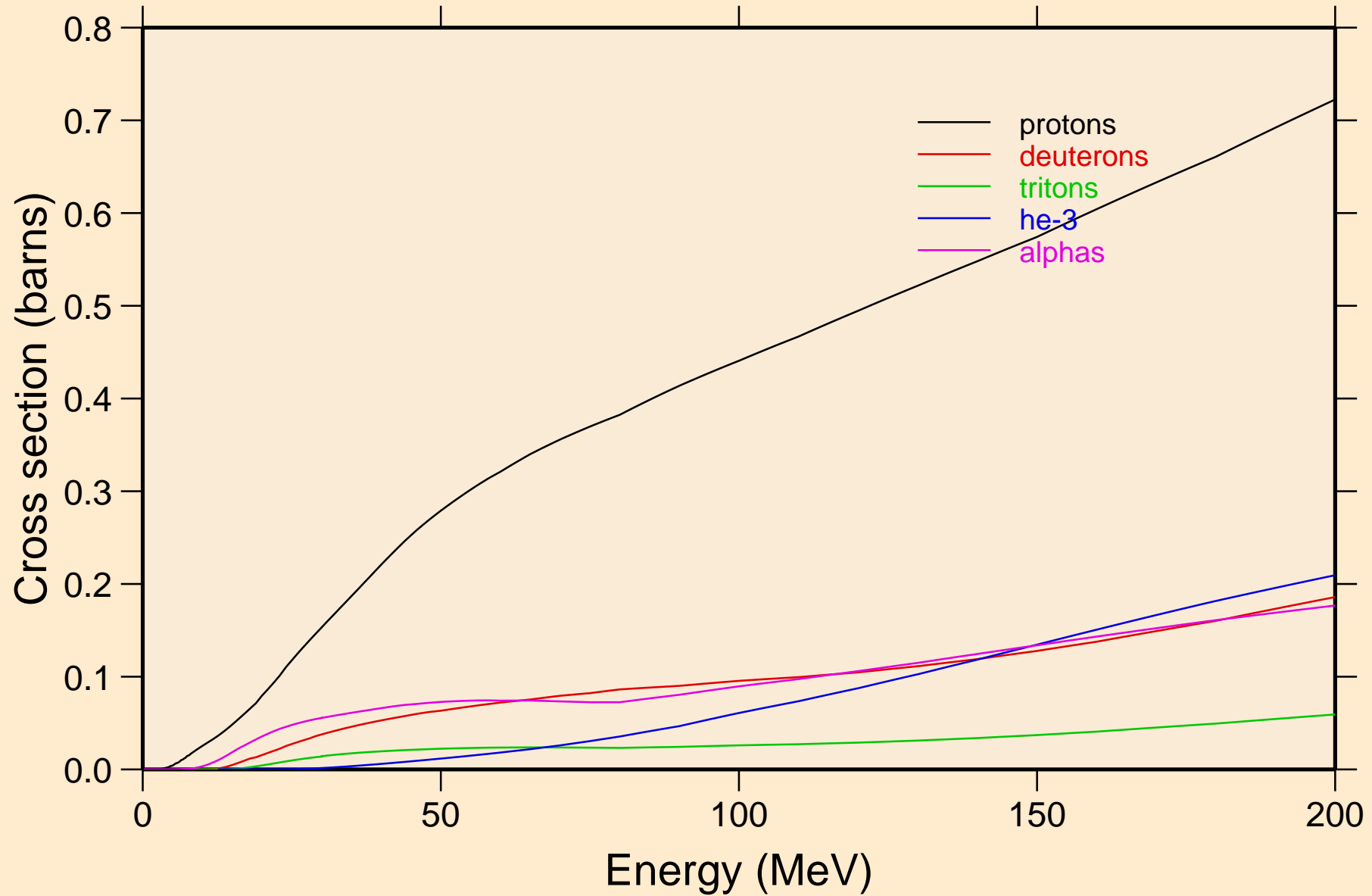

GA072 NEUTRON ACER TENDL-2023 LIBRARY; T=0.K
protons from (n,x)

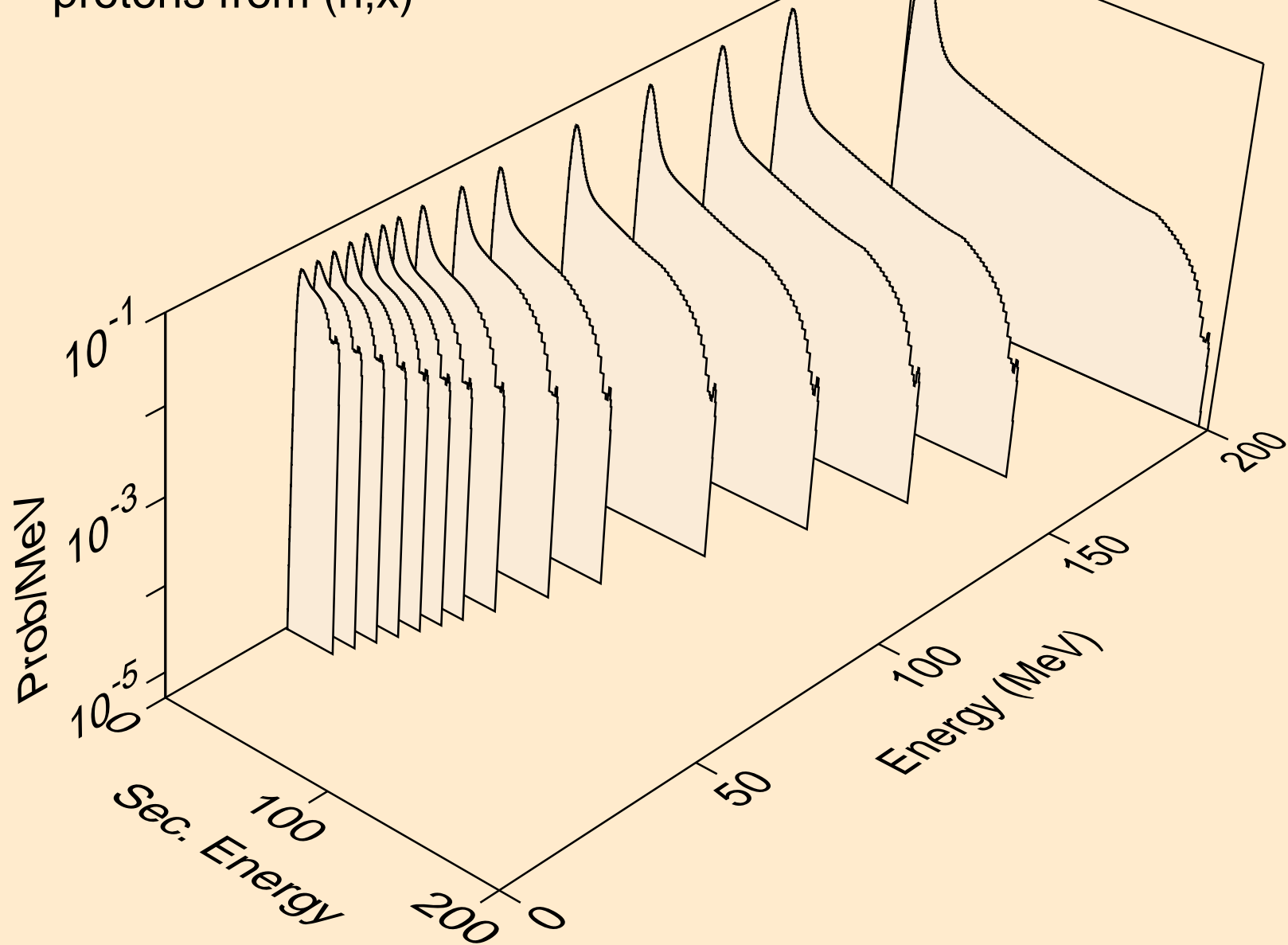

GA072 NEUTRON ACER TENDL-2023 LIBRARY; T=0.K
protons from (n,n*)p

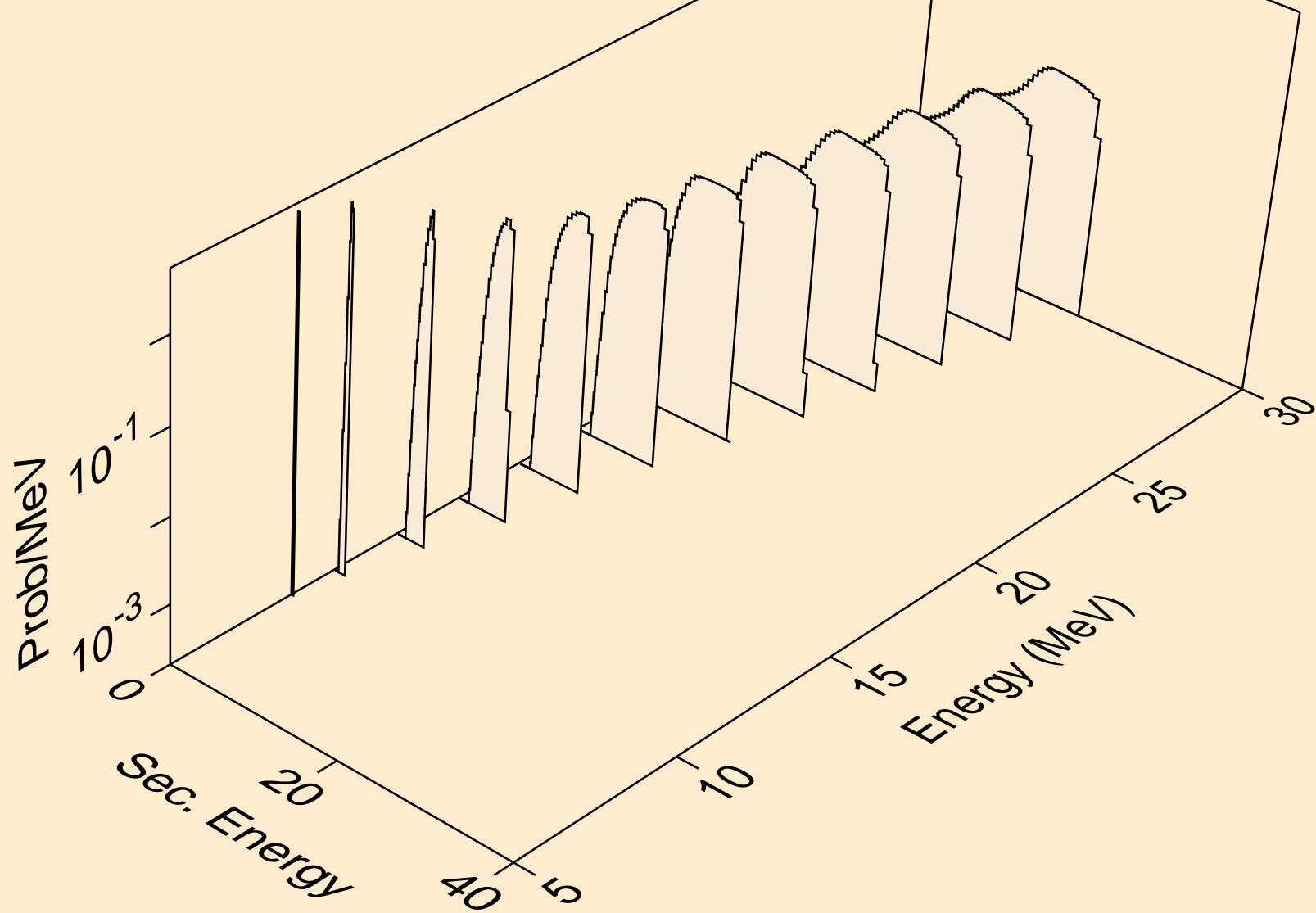

GA072 NEUTRON ACER TENDL-2023 LIBRARY; T=0.K
protons from (n,2np)

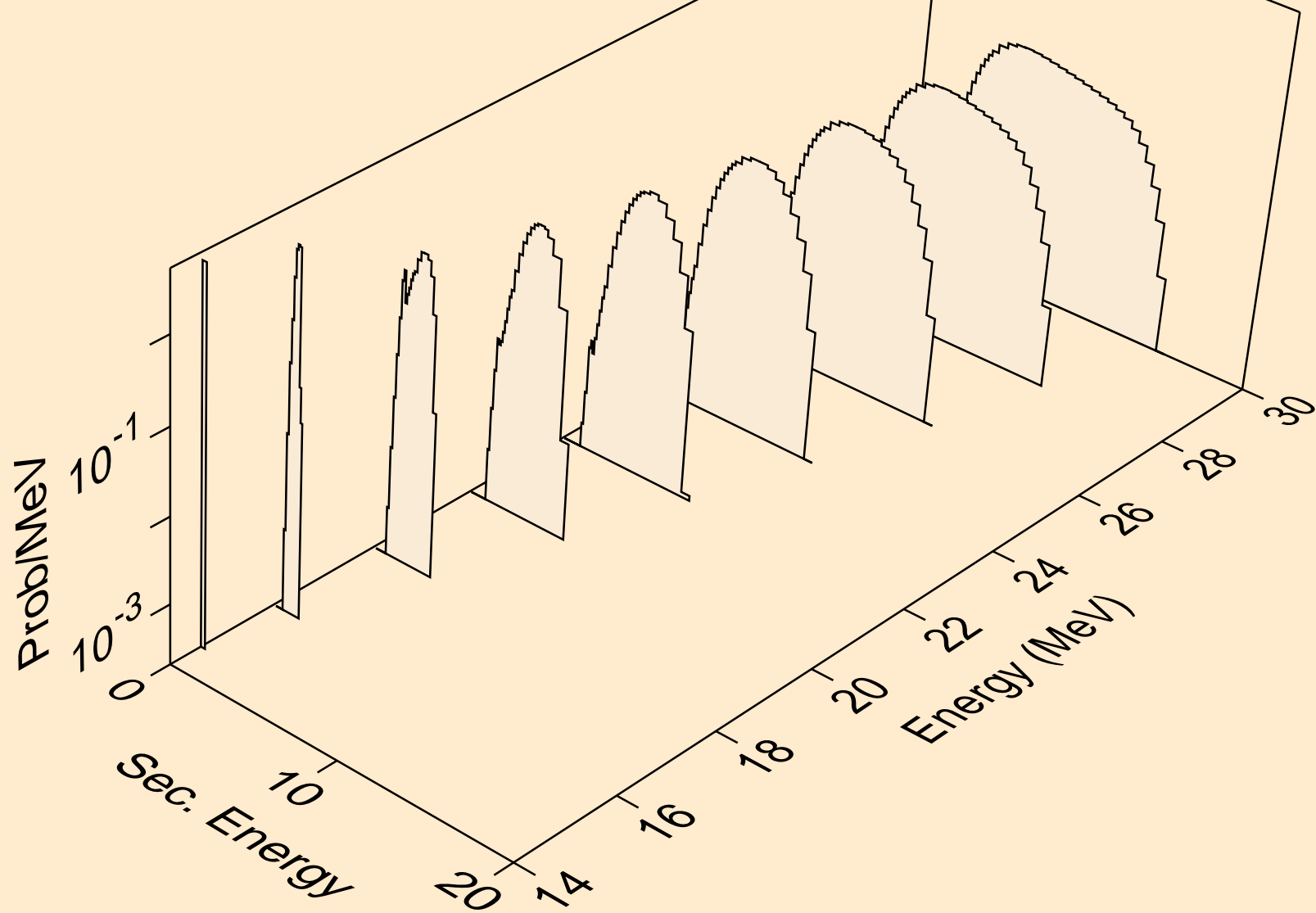

GA072 NEUTRON ACER TENDL-2023 LIBRARY; T=0.K
protons from (n,3np)

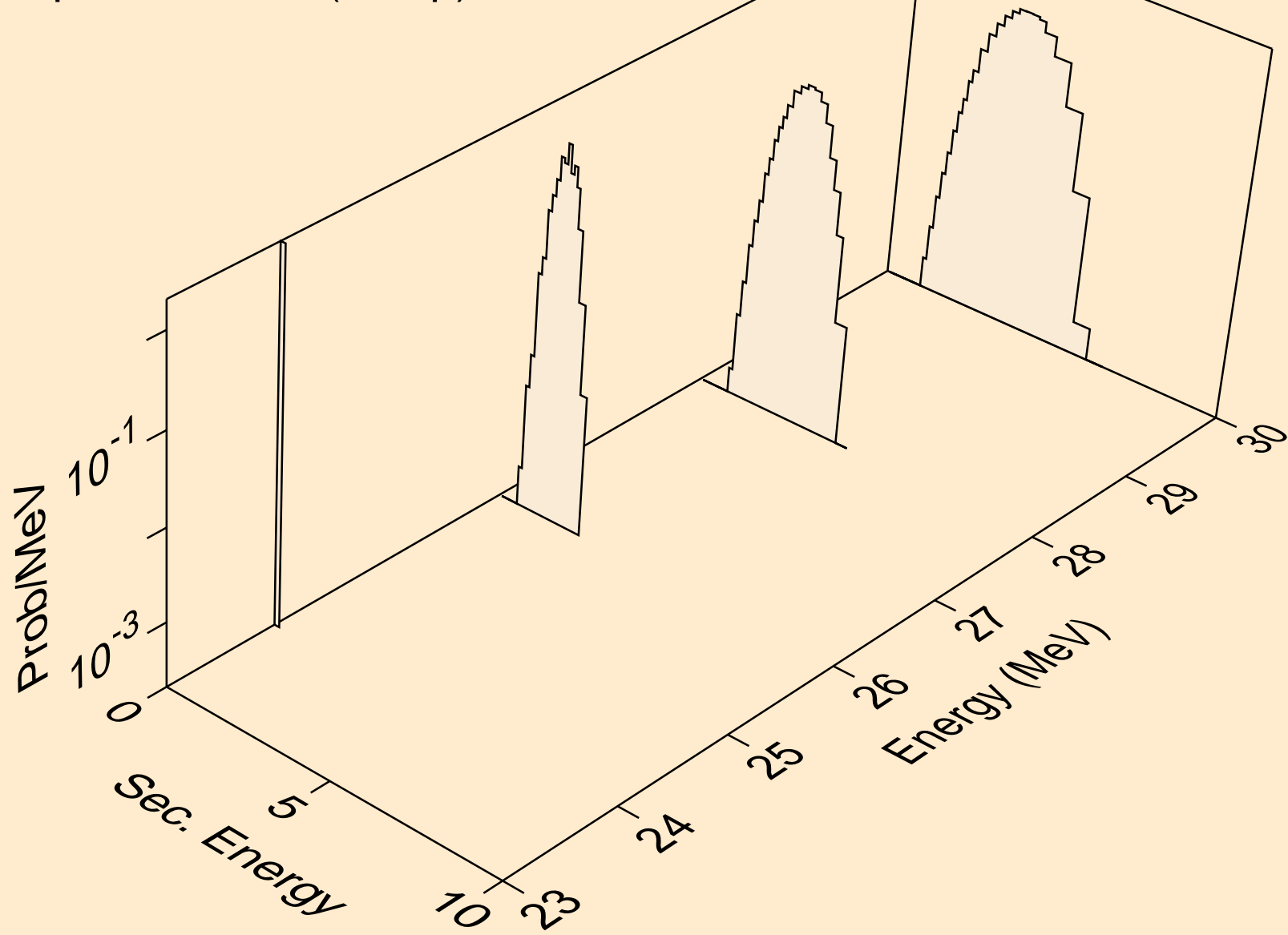

GA072 NEUTRON ACER TENDL-2023 LIBRARY; T=0.K
protons from (n,n2p)

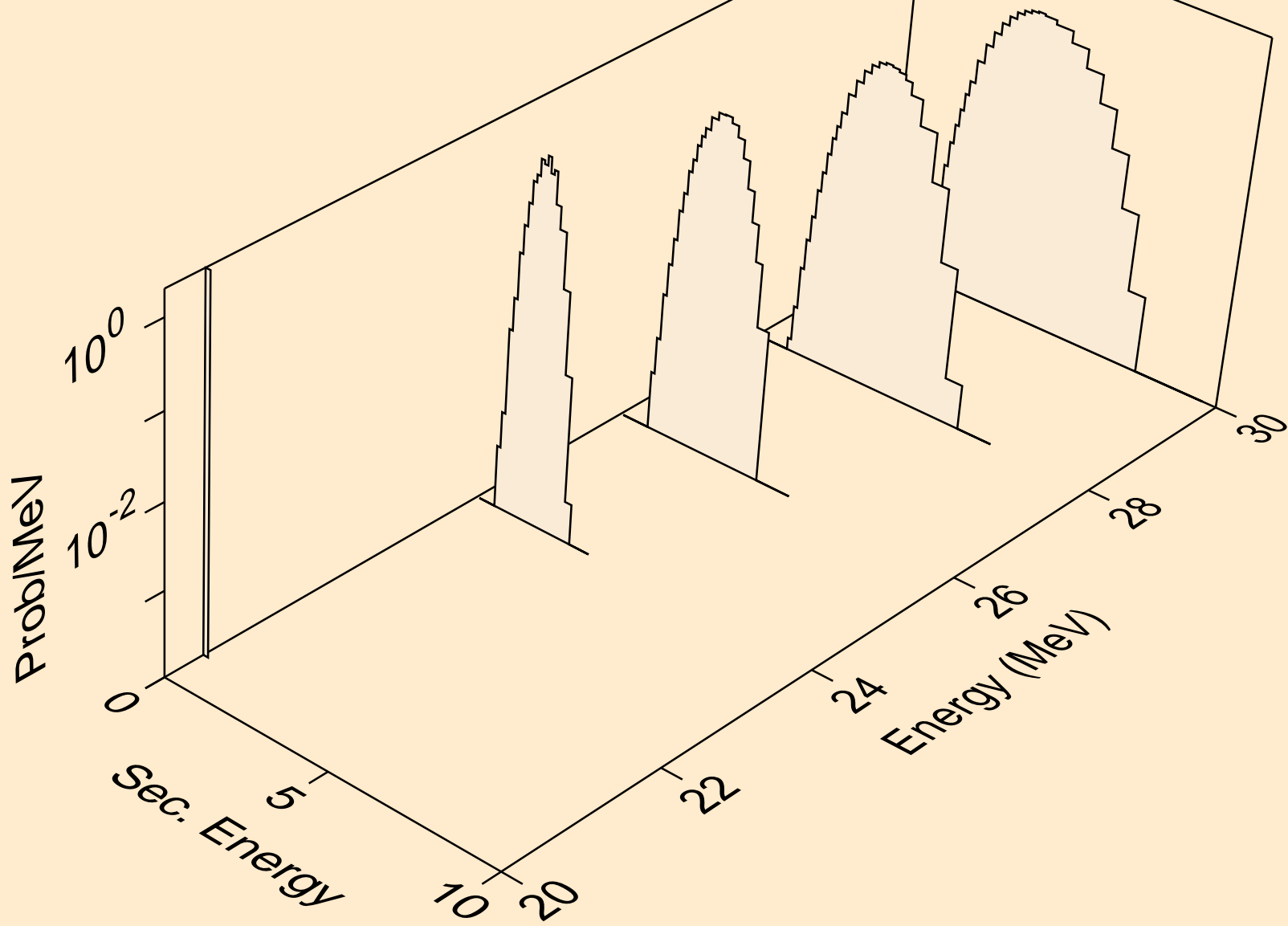

GA072 NEUTRON ACER TENDL-2023 LIBRARY; T=0.K
protons from (n,npa)

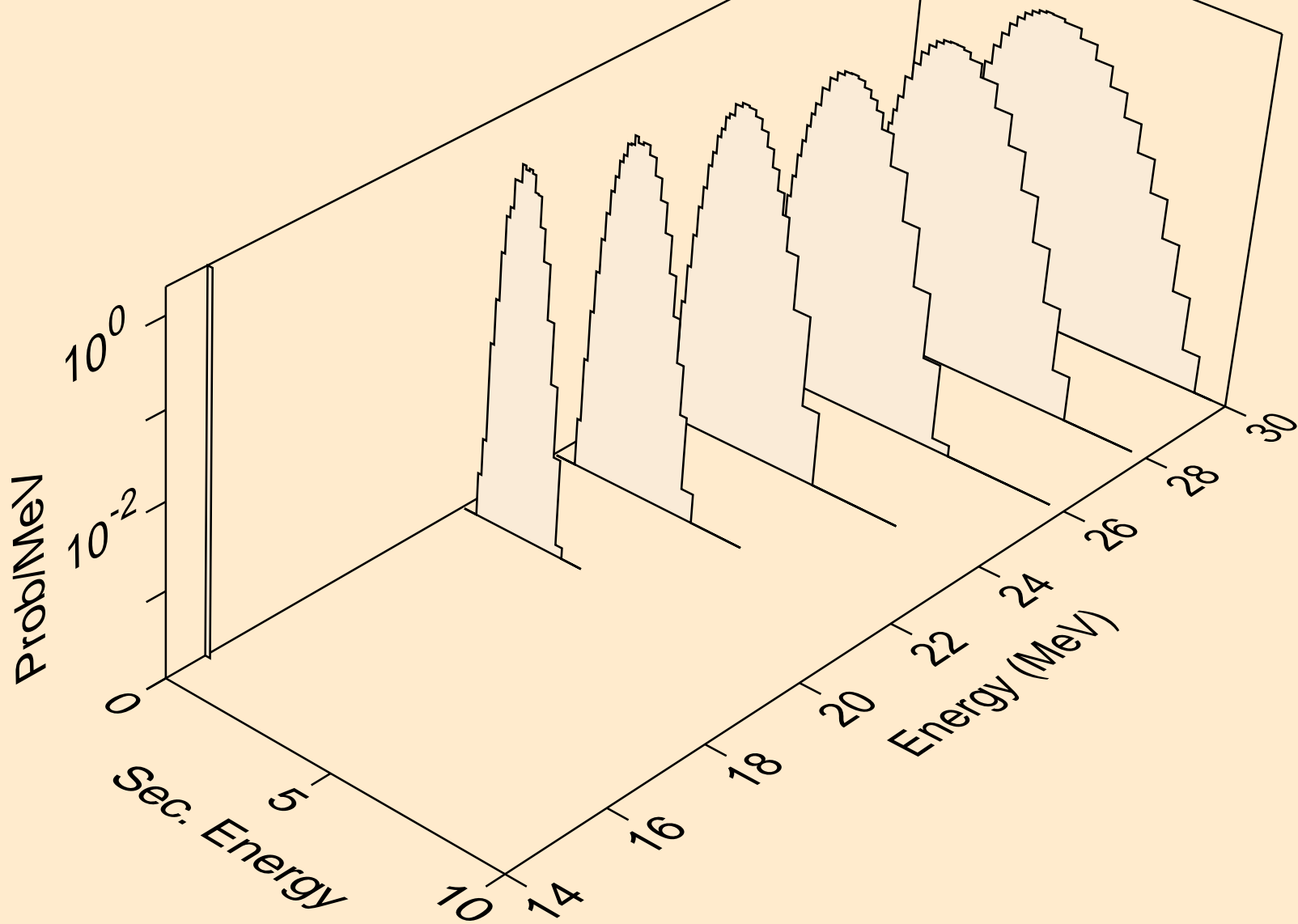

GA072 NEUTRON ACER TENDL-2023 LIBRARY; T=0.K
protons from (n,p)

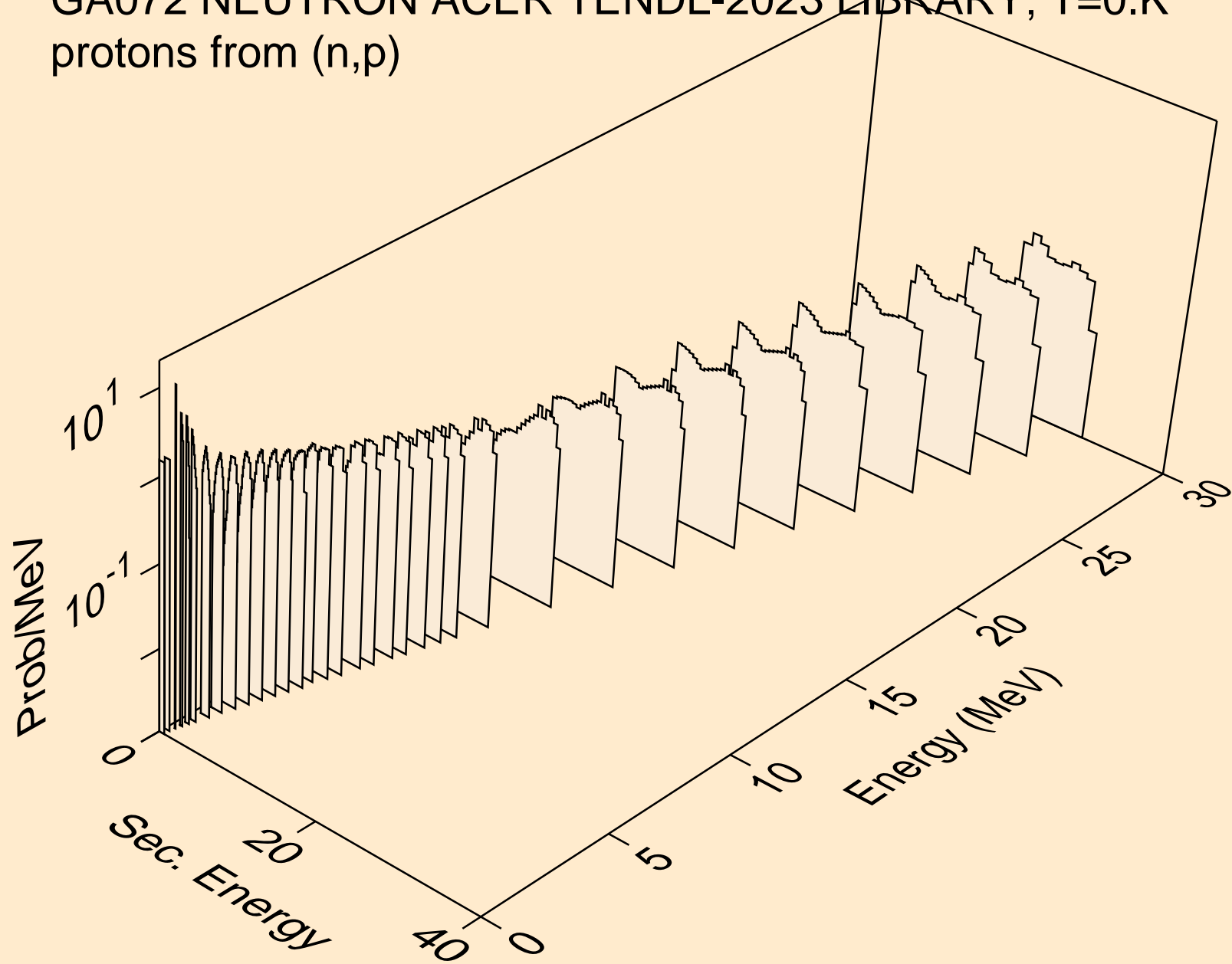

GA072 NEUTRON ACER TENDL-2023 LIBRARY; T=0.K
protons from (n,2p)

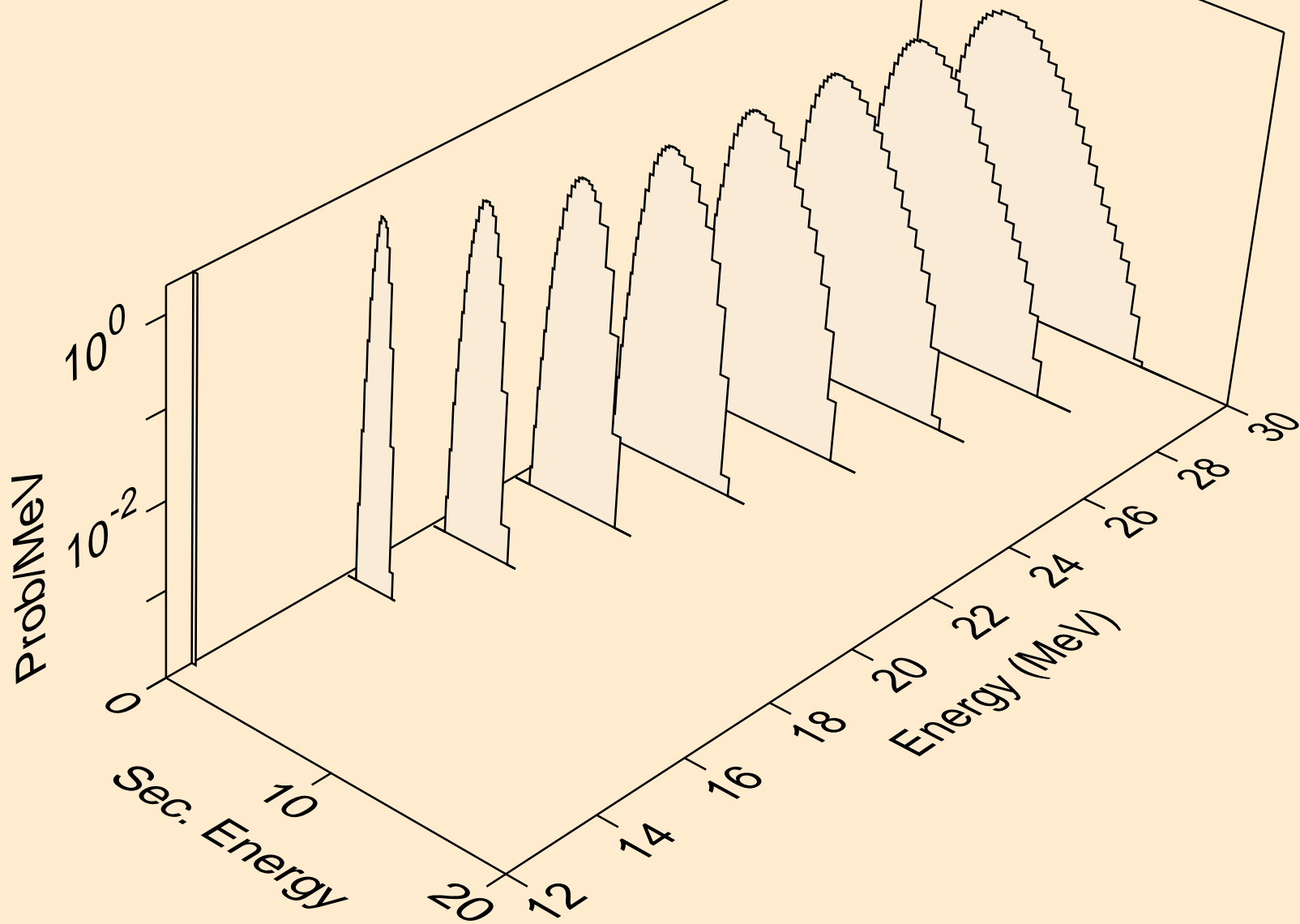

GA072 NEUTRON ACER TENDL-2023 LIBRARY; T=0.K
protons from (n,p)

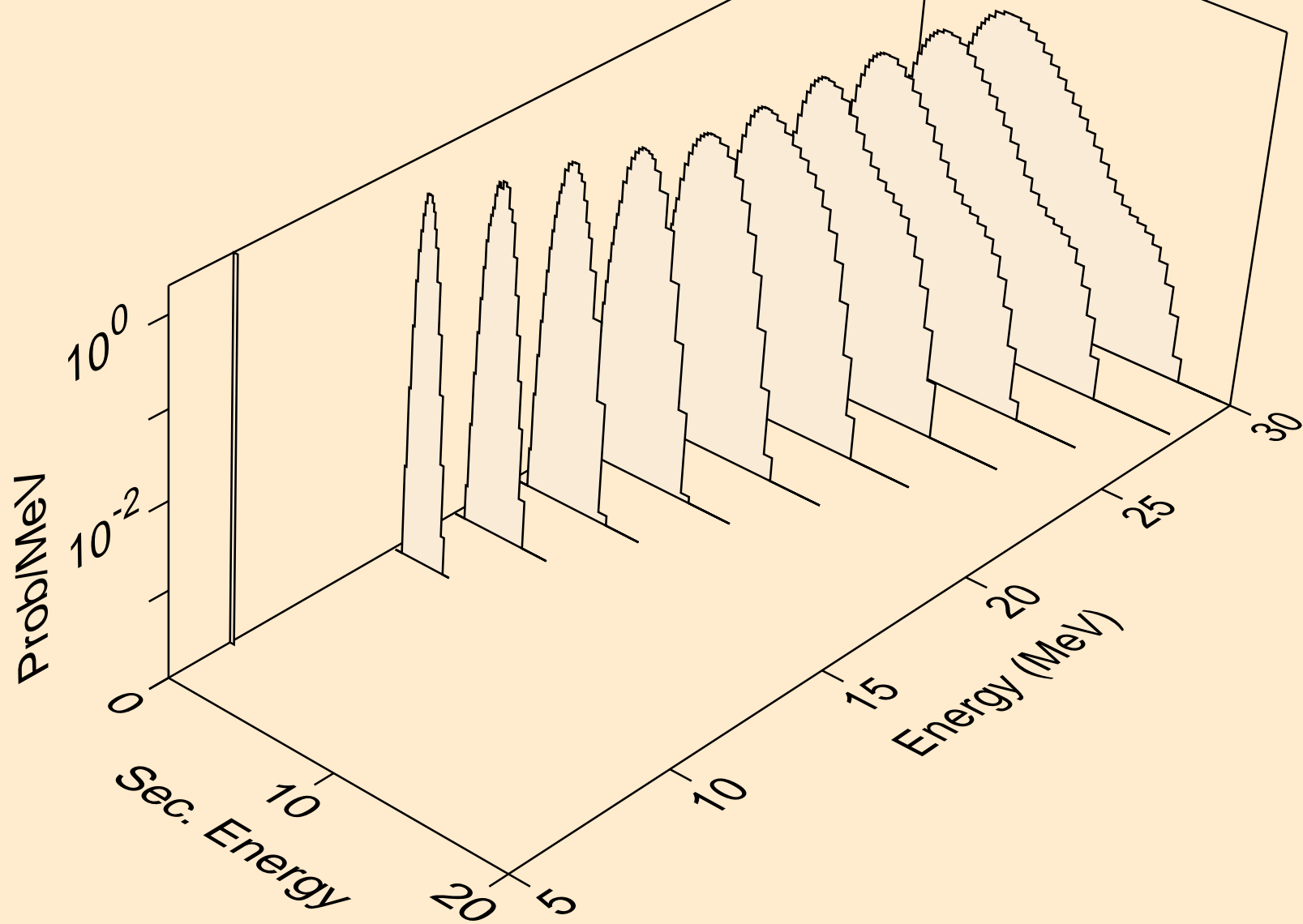

GA072 NEUTRON ACER TENDL-2023 LIBRARY; T=0.K
protons from (n,pd)

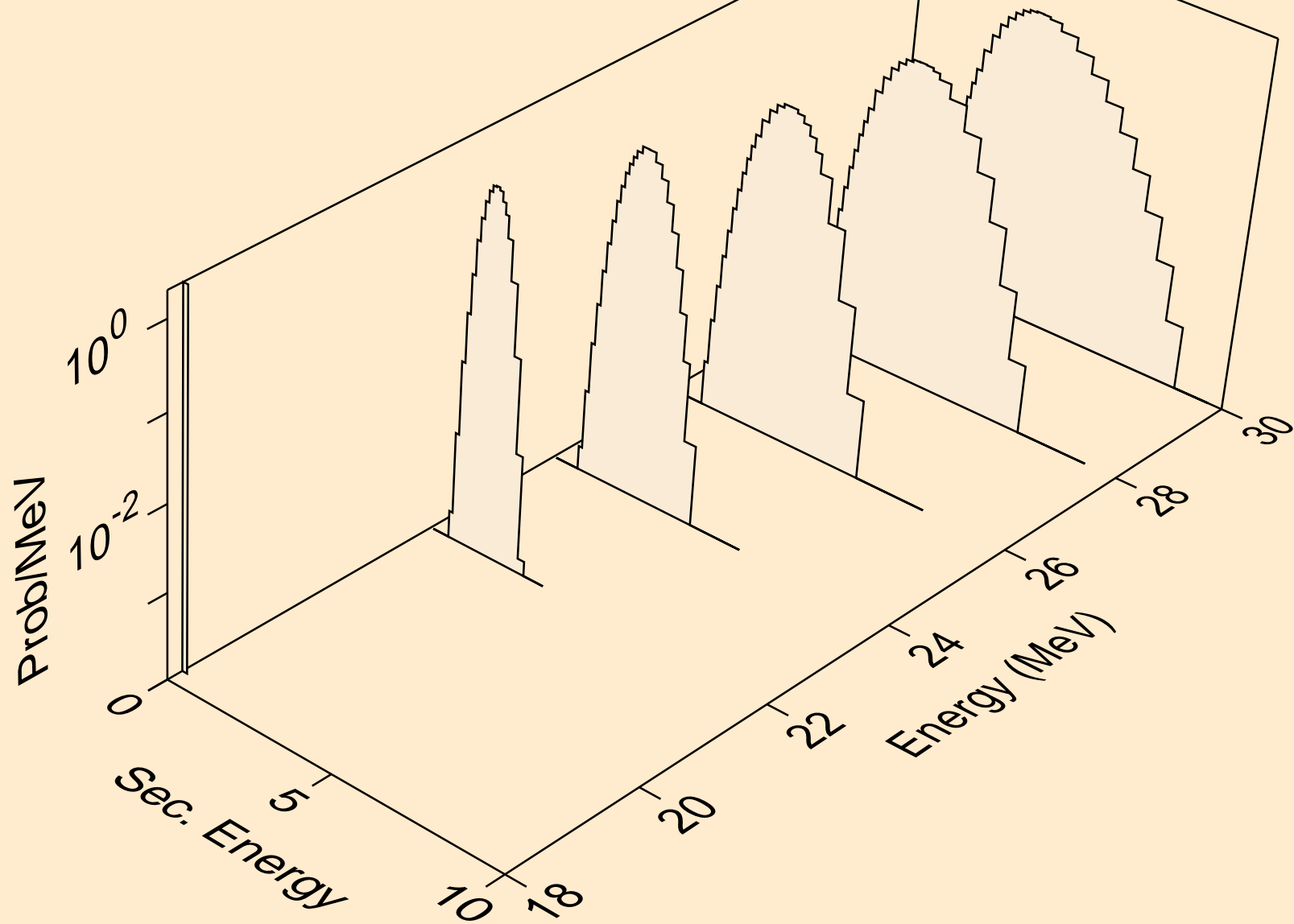

GA072 NEUTRON ACER TENDL-2023 LIBRARY; T=0.K
protons from (n,pt)

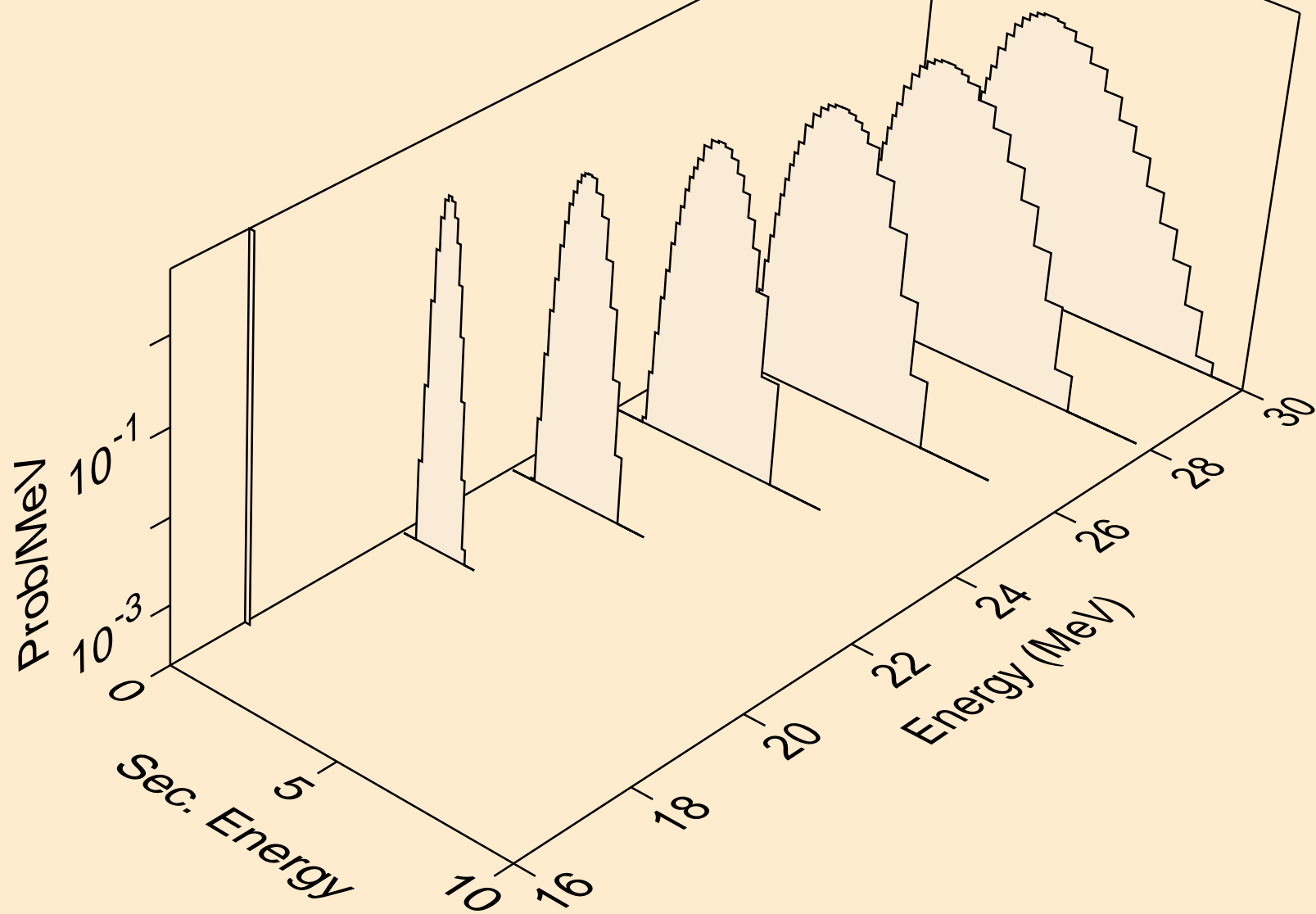

GA072 NEUTRON ACER TENDL-2023 LIBRARY; T=0.K
deuterons from (n,x)

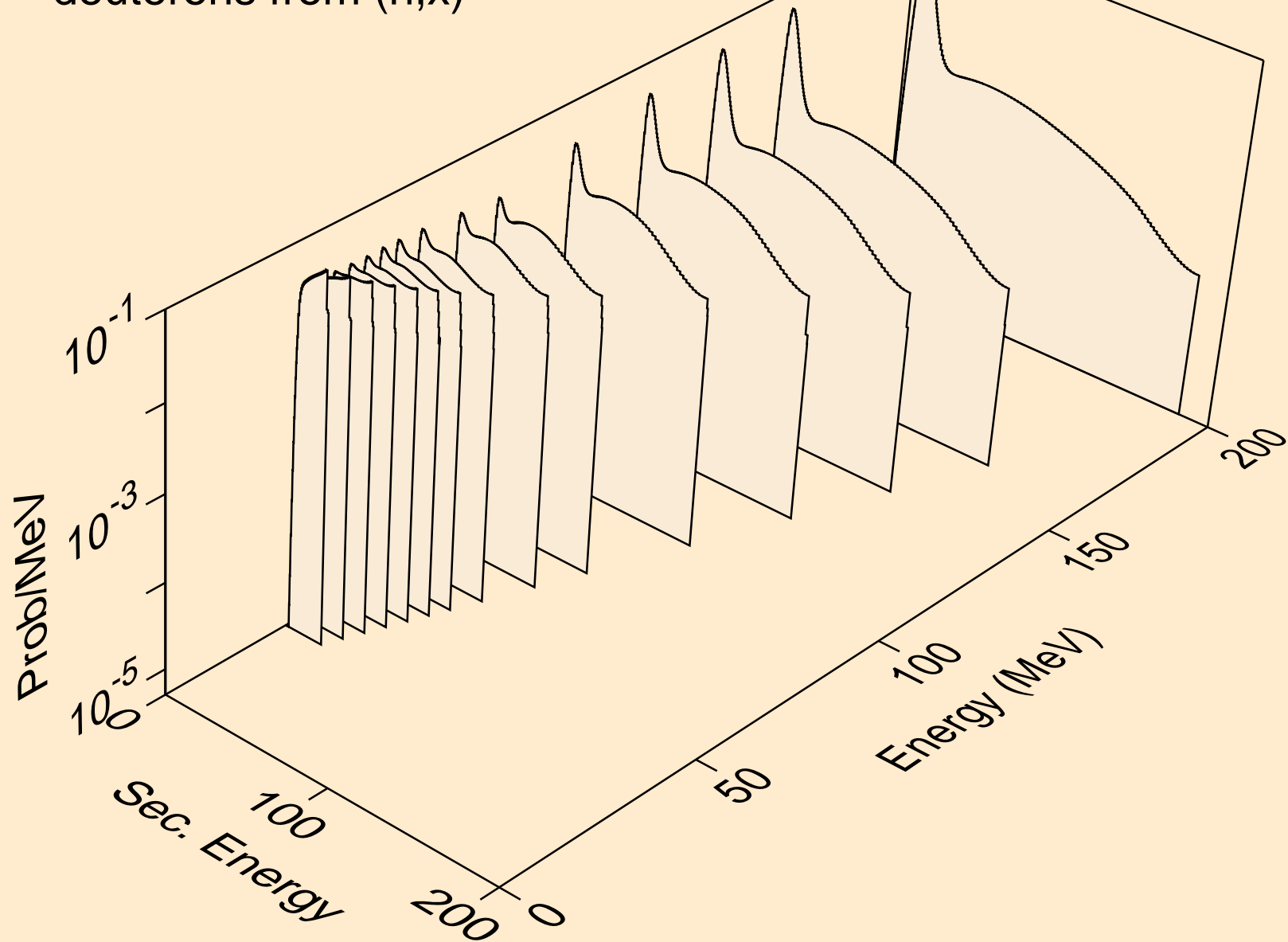

GA072 NEUTRON ACER TENDL-2023 LIBRARY; T=0.K
deuterons from (n,2nd)

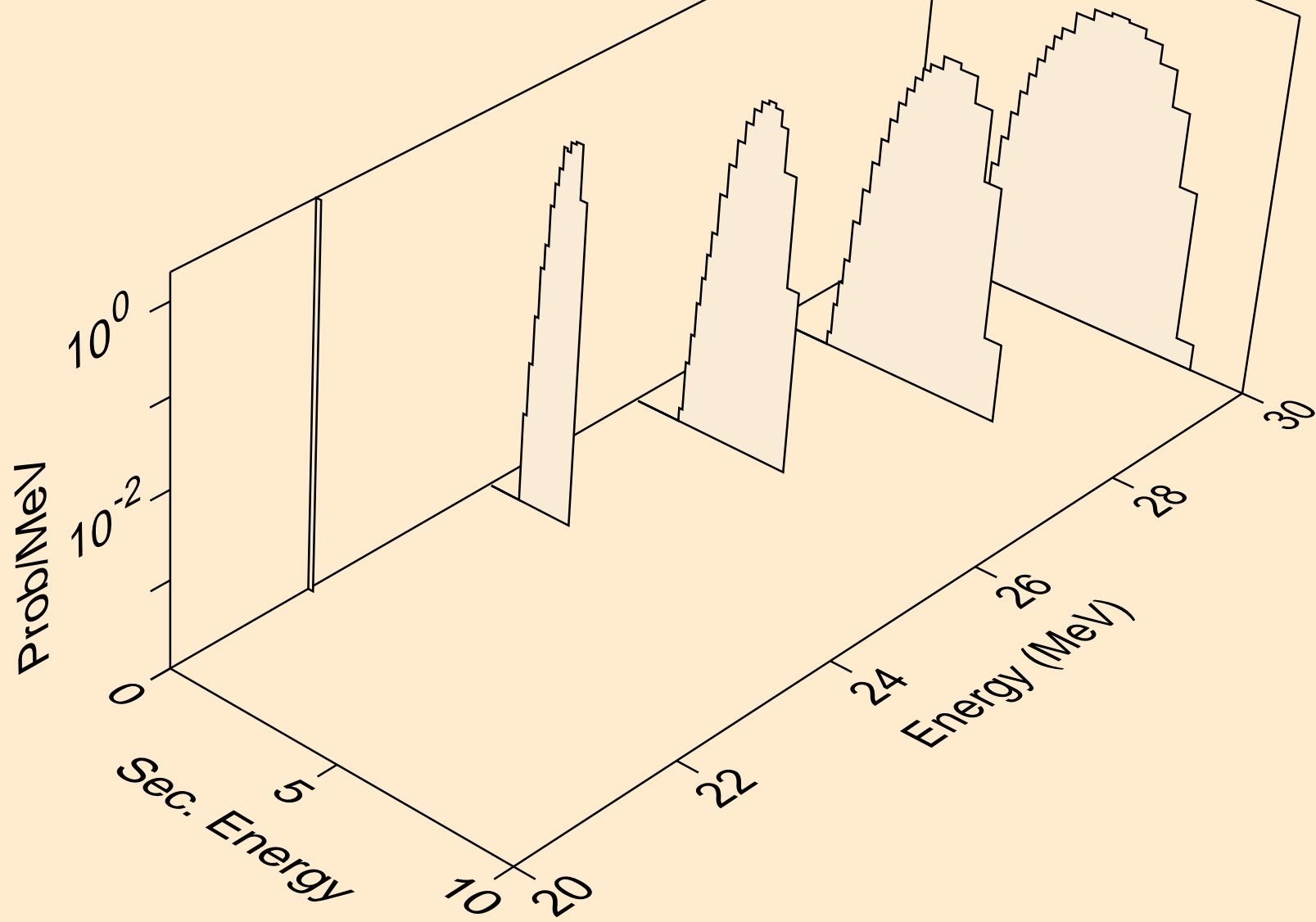

GA072 NEUTRON ACER TENDL-2023 LIBRARY; T=0.K
deuterons from (n,n*)d

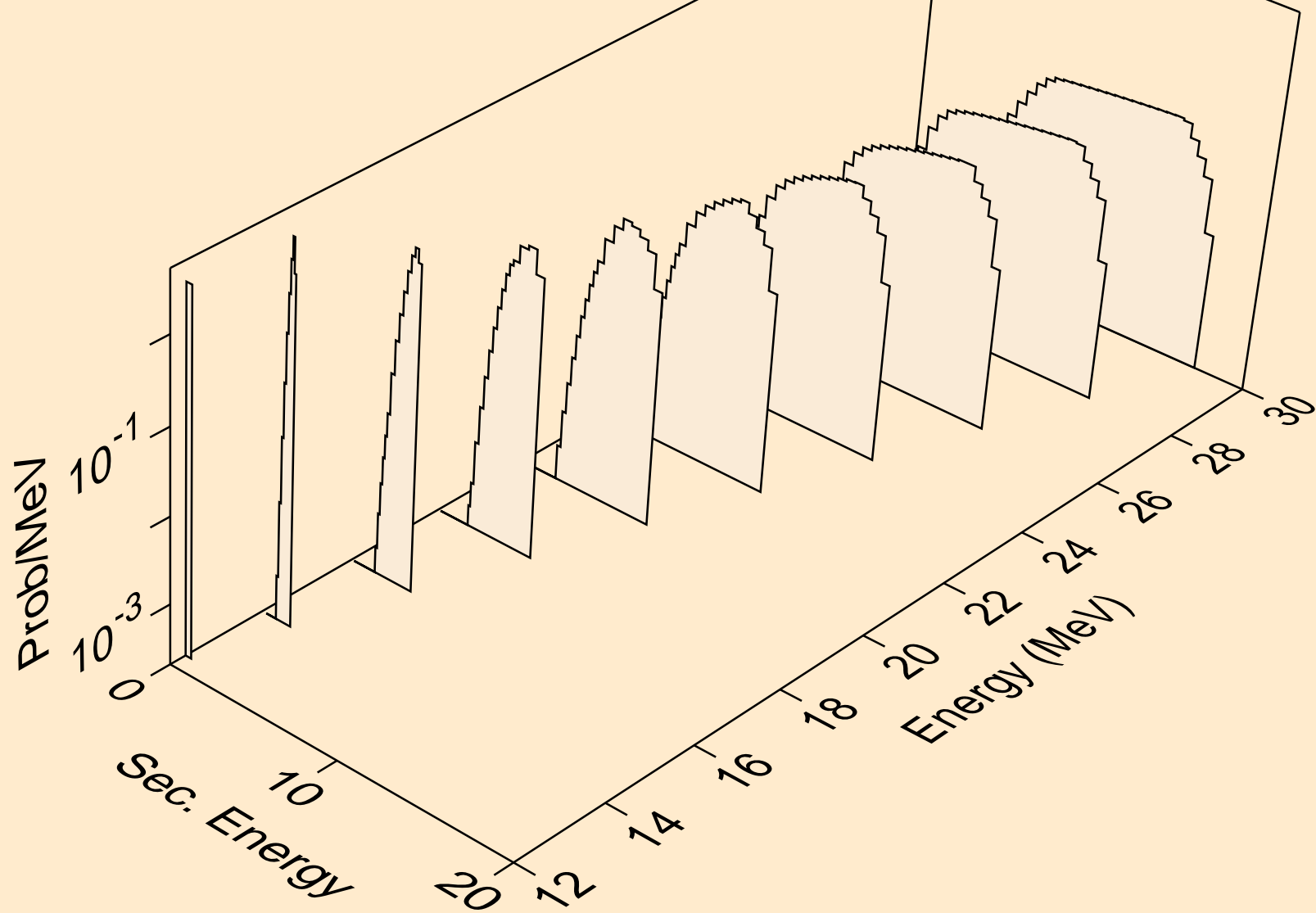

GA072 NEUTRON ACER TENDL-2023 LIBRARY; T=0.K
deuterons from (n,d)

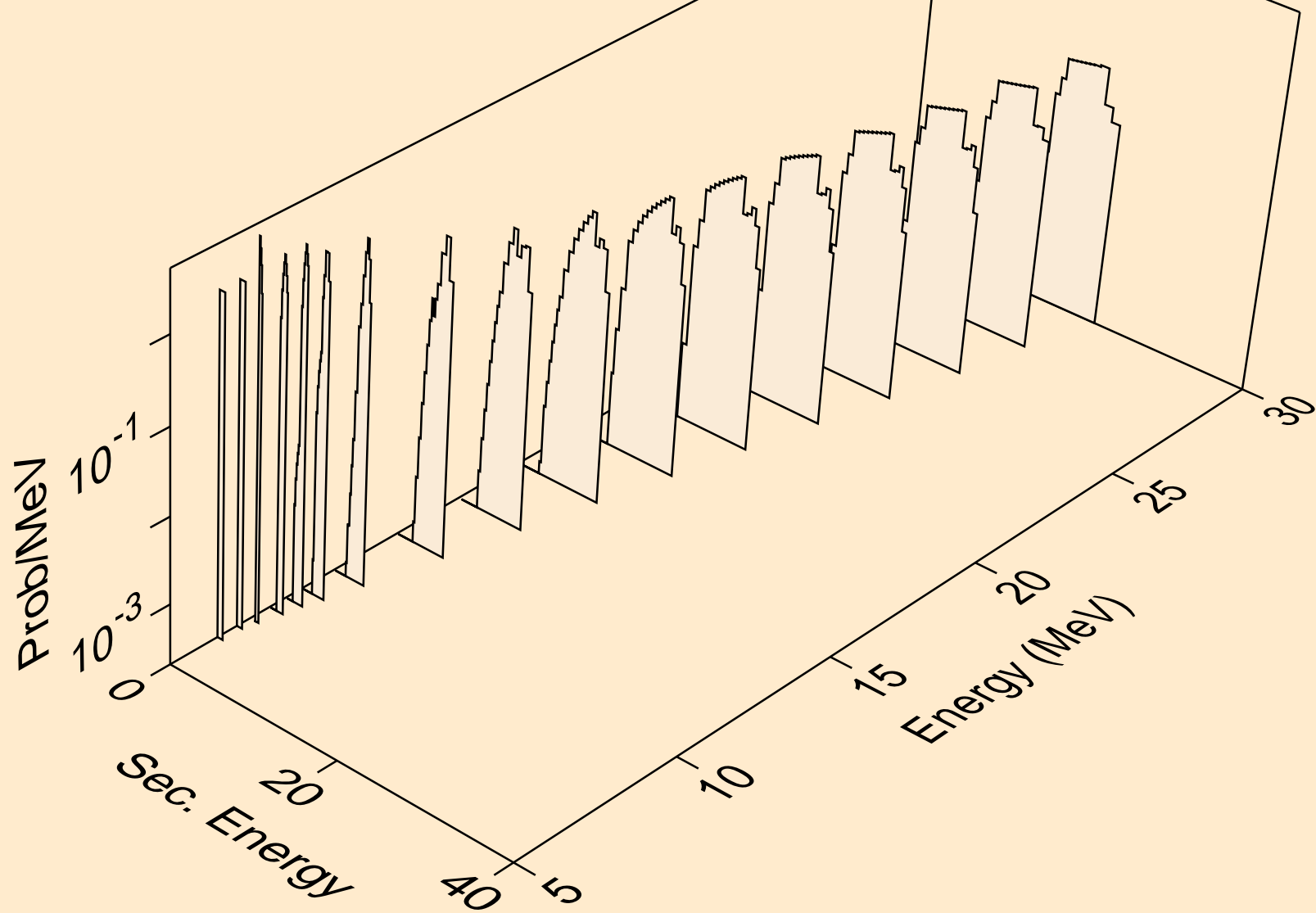

GA072 NEUTRON ACER TENDL-2023 LIBRARY; T=0.K
deuterons from (n,pd)

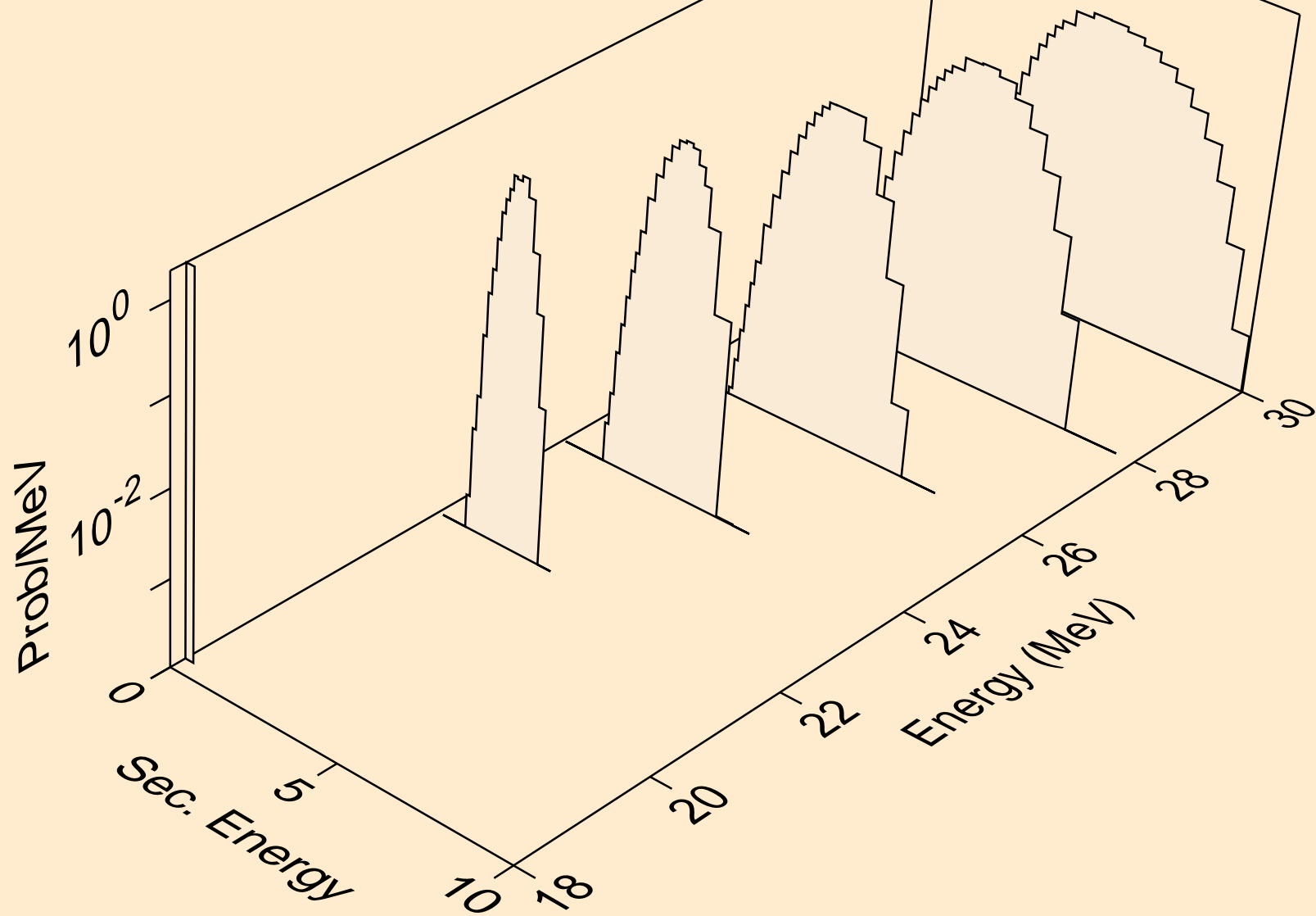

GA072 NEUTRON ACER TENDL-2023 LIBRARY; T=0.K
deuterons from (n,da)

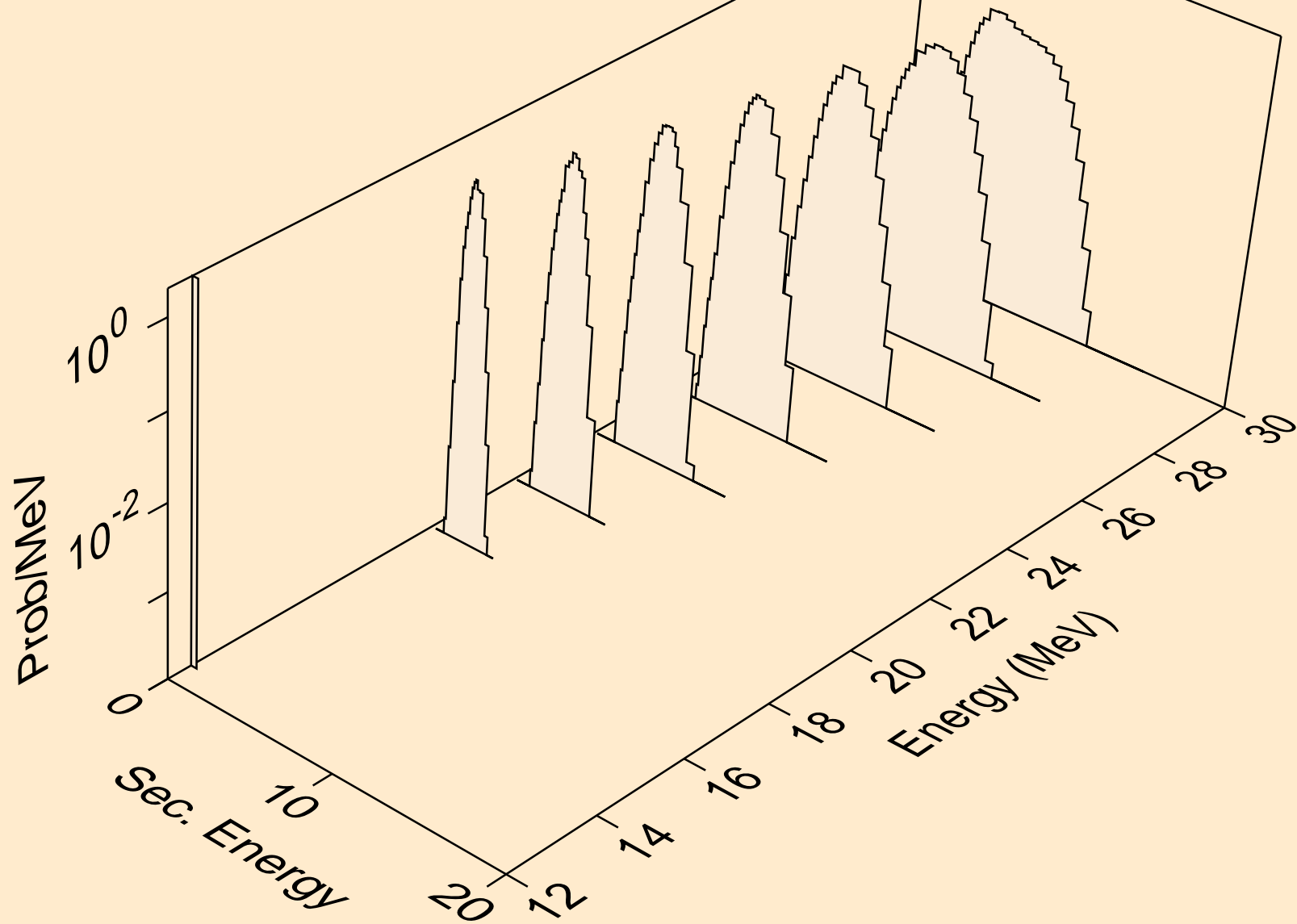

GA072 NEUTRON ACER TENDL-2023 LIBRARY; T=0.K
tritons from (n,x)

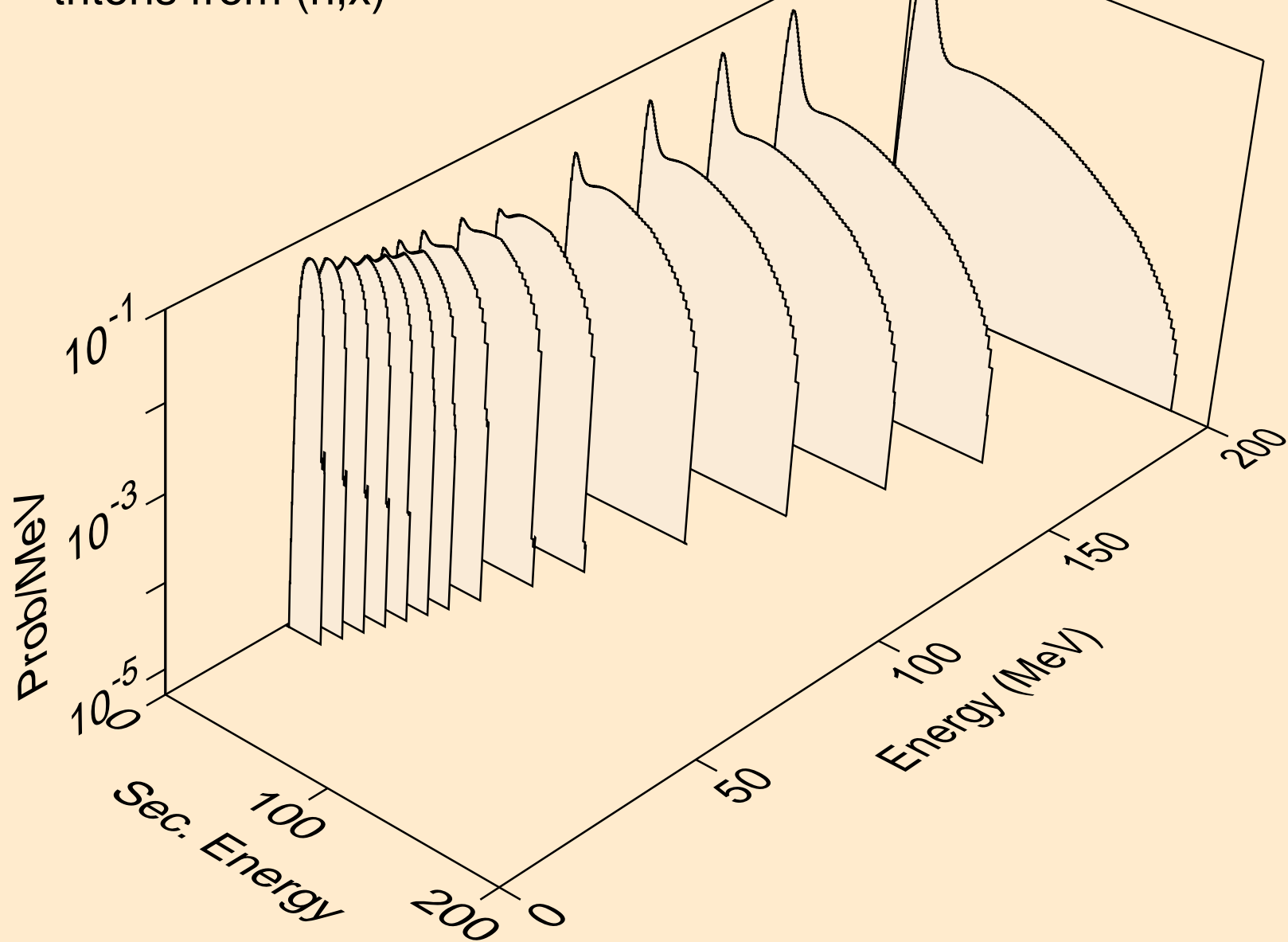

GA072 NEUTRON ACER TENDL-2023 LIBRARY; T=0.K
tritons from (n,n*)t

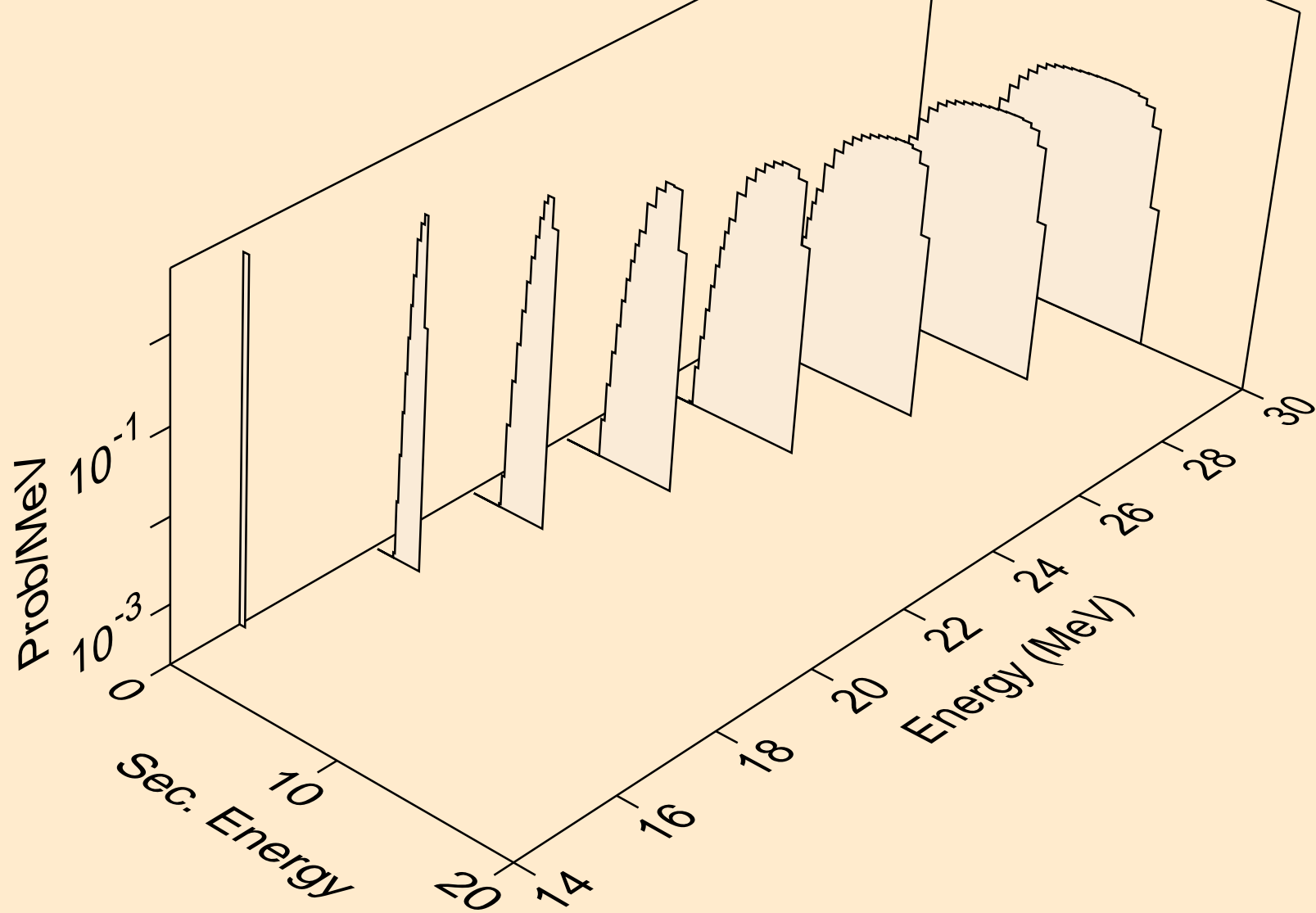

GA072 NEUTRON ACER TENDL-2023 LIBRARY; T=0.K
tritons from (n,t)

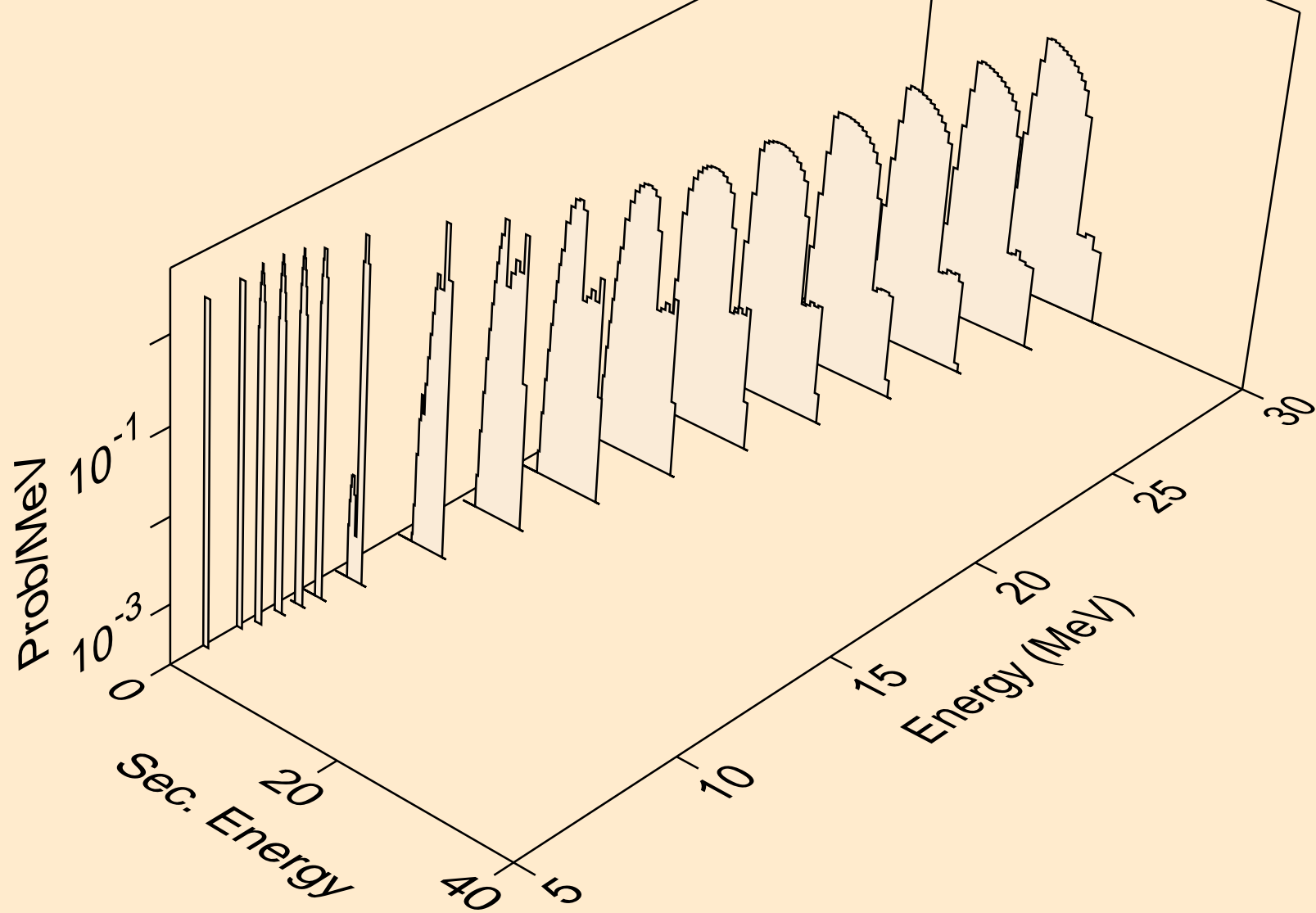

GA072 NEUTRON ACER TENDL-2023 LIBRARY; T=0.K
tritons from (n,pt)

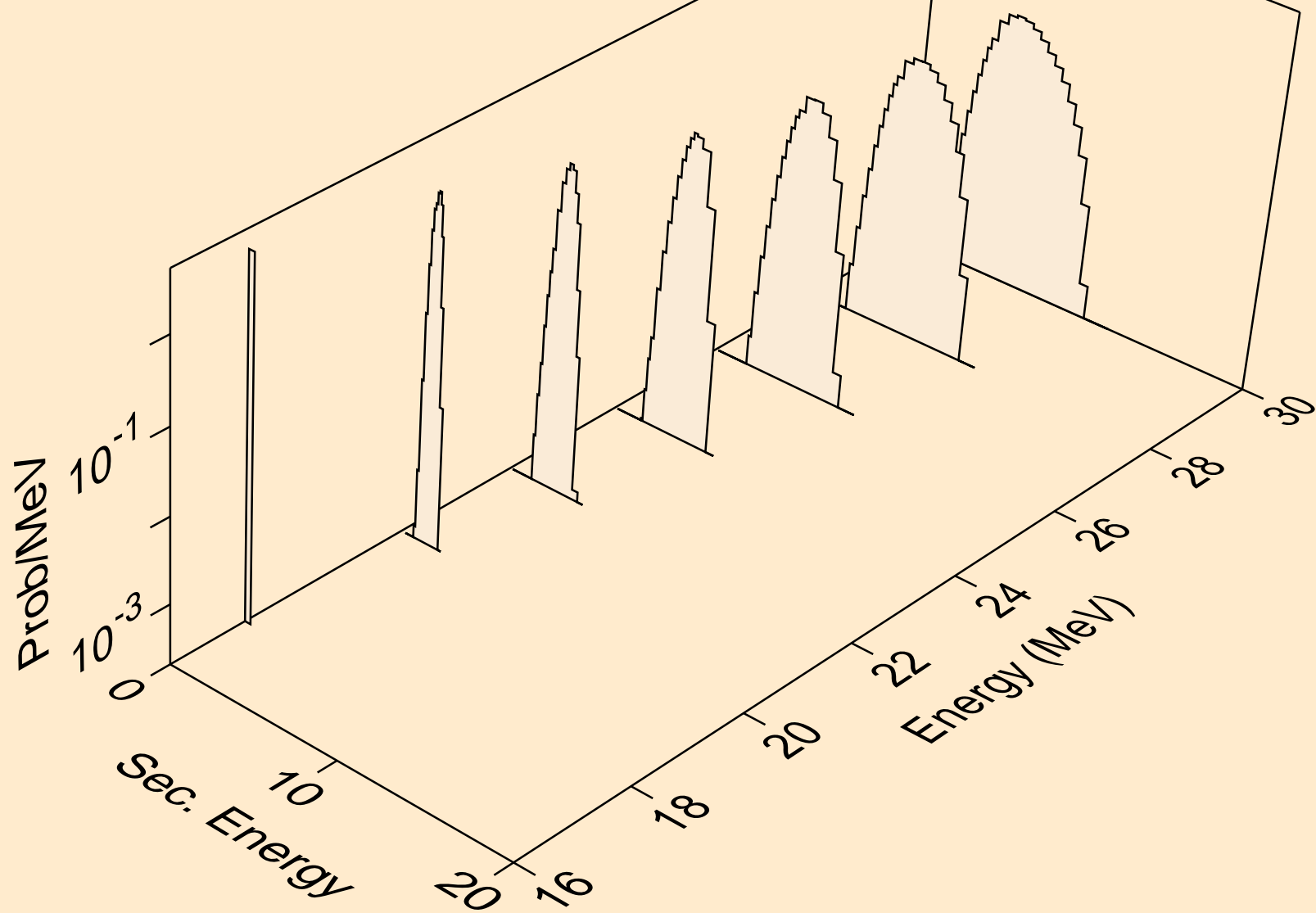

GA072 NEUTRON ACER TENDL-2023 LIBRARY; T=0.K
he3s from (n,x)

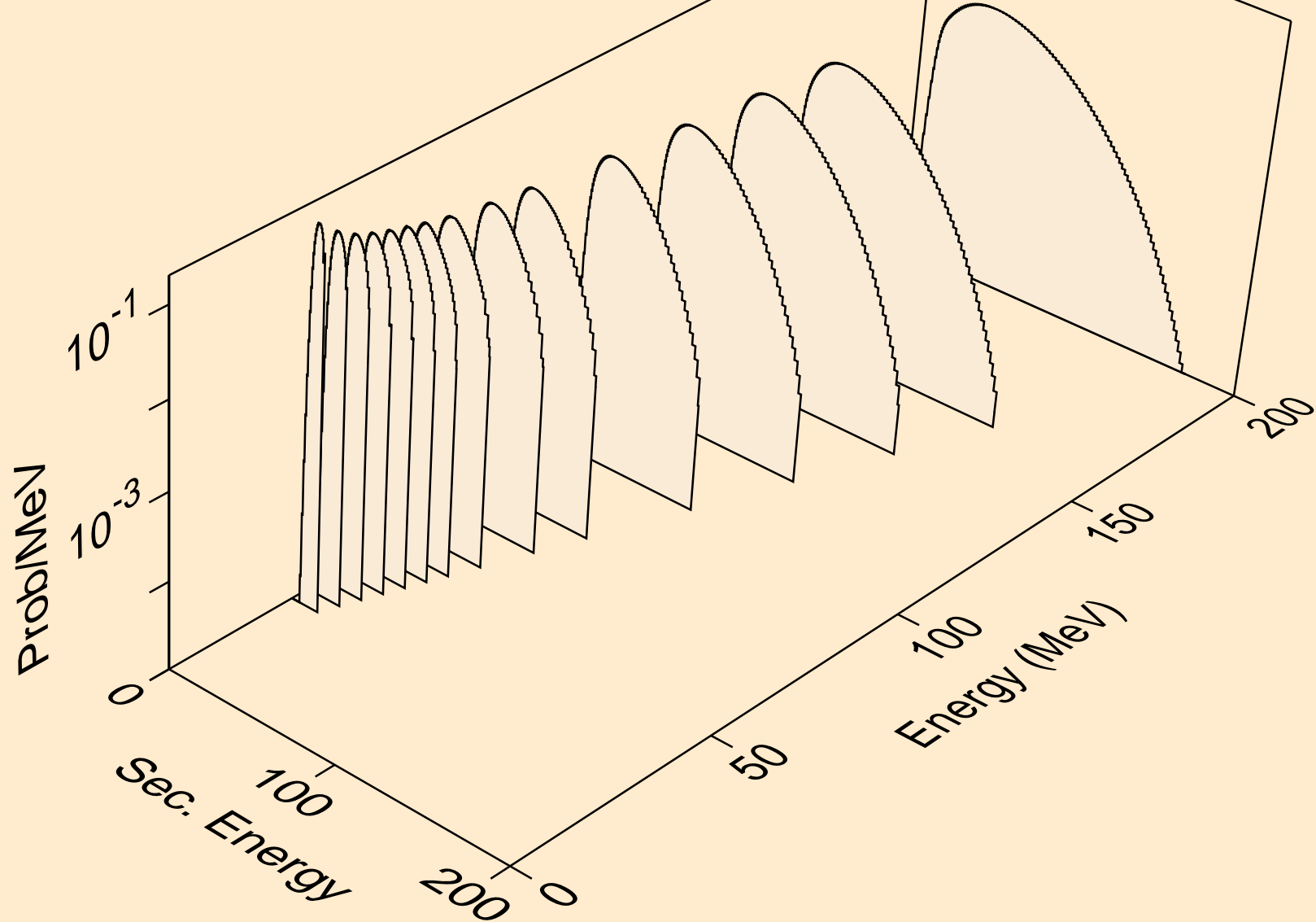

GA072 NEUTRON ACER TENDL-2023 LIBRARY; T=0.K
he3s from (n,n*)he3

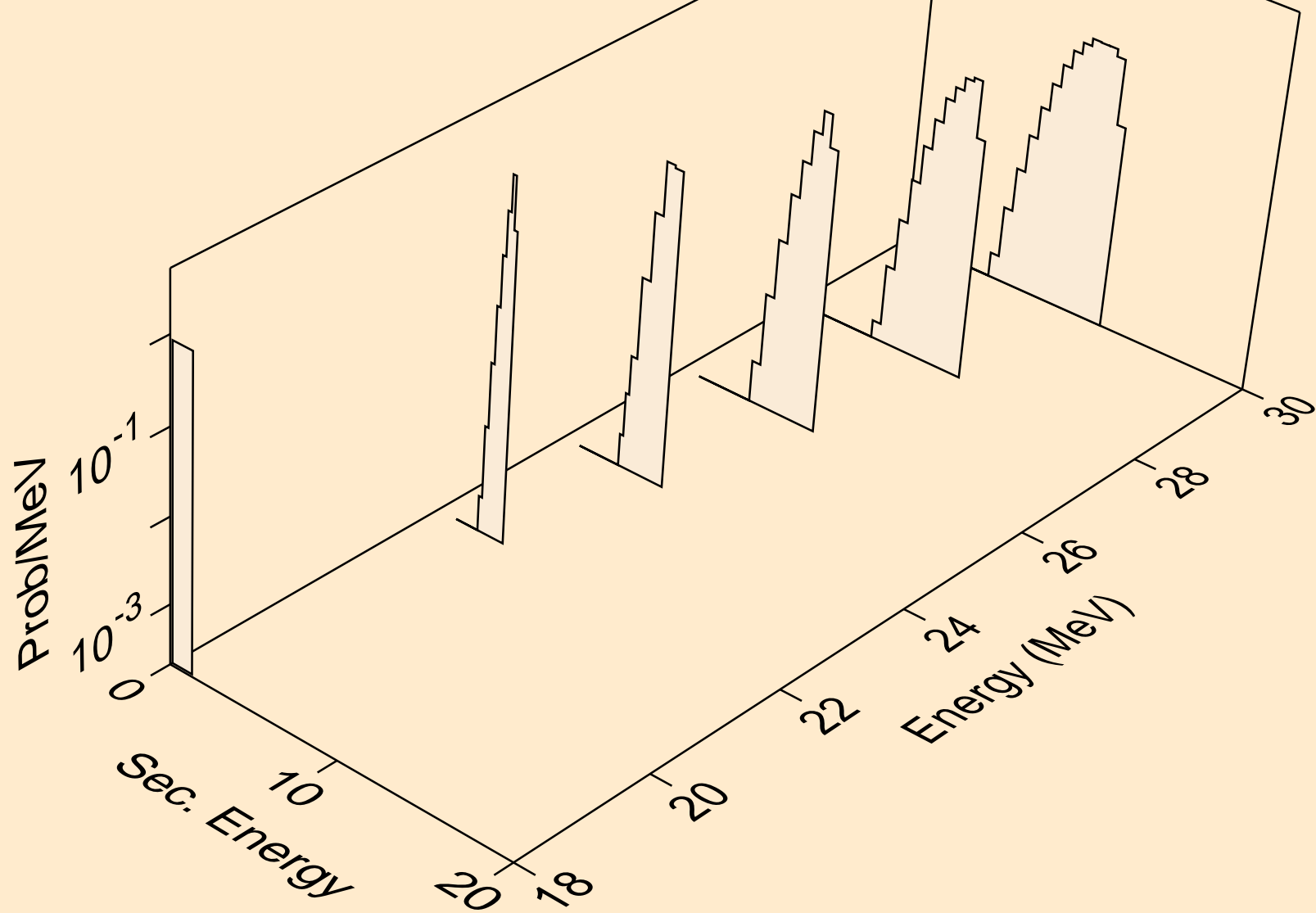

GA072 NEUTRON ACER TENDL-2023 LIBRARY; T=0.K
he3s from (n,he3)

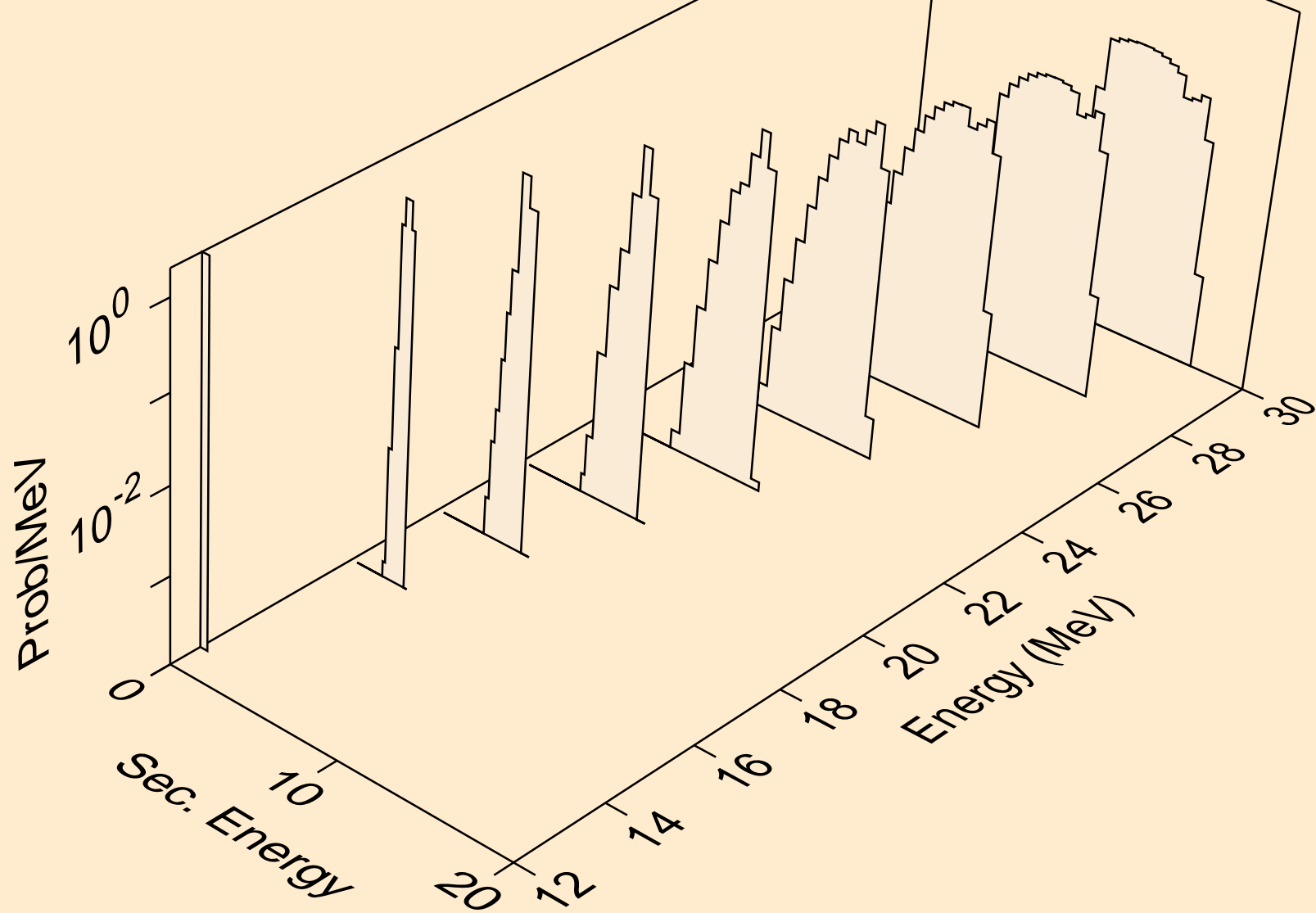

GA072 NEUTRON ACER TENDL-2023 LIBRARY; T=0.K
alphas from (n,x)

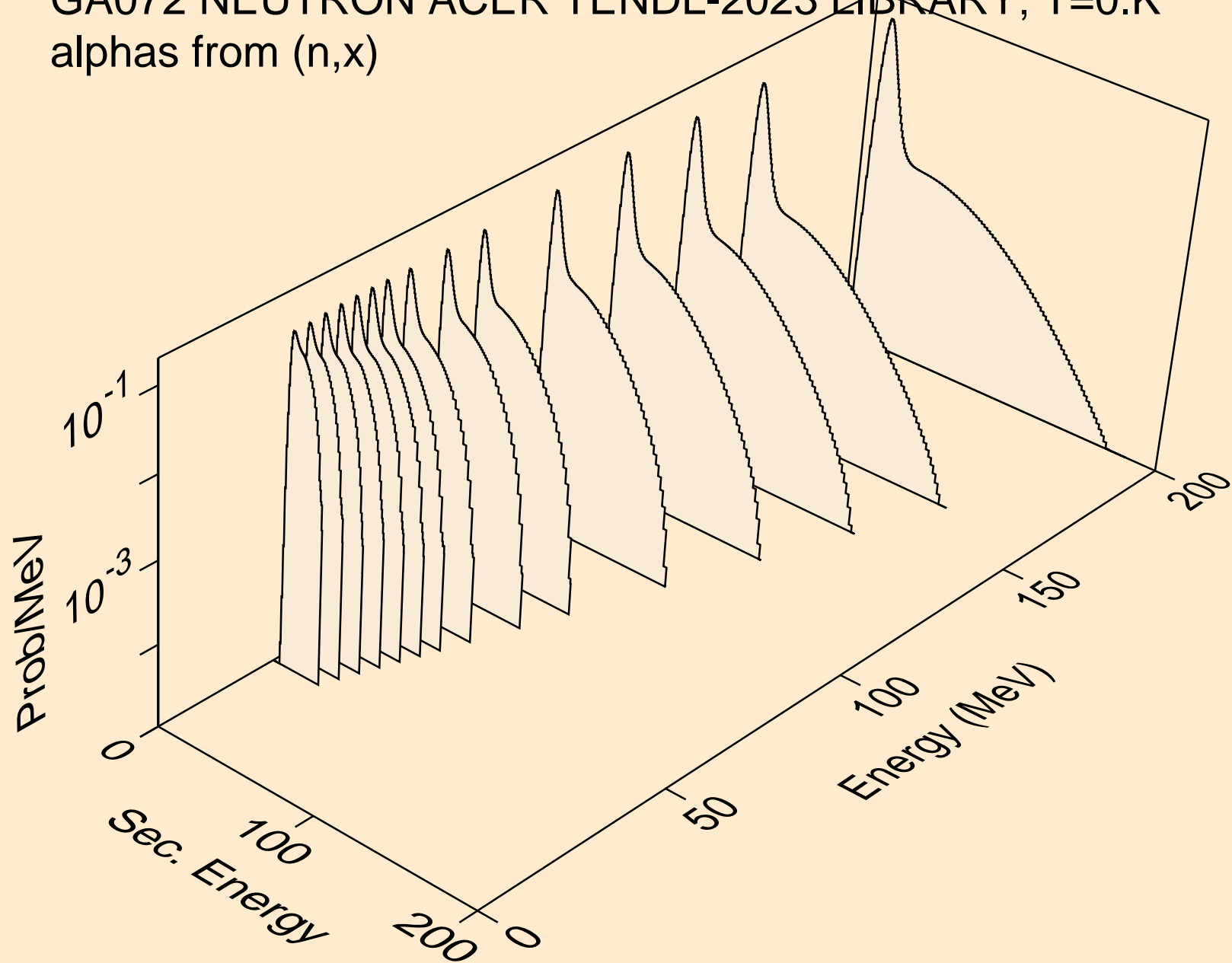

GA072 NEUTRON ACER TENDL-2023 LIBRARY; T=0.K
alphas from (n,n*)a

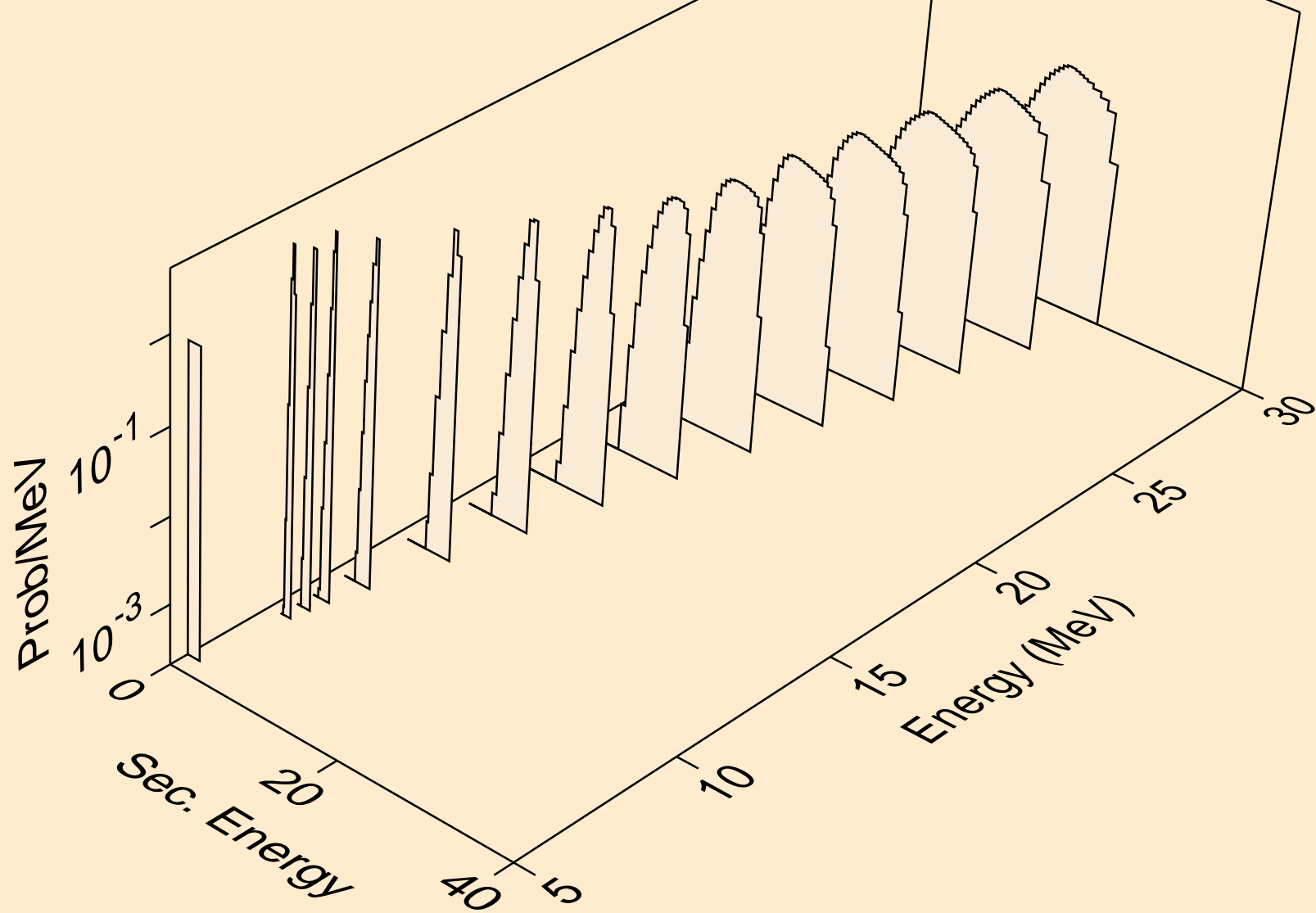

GA072 NEUTRON ACER TENDL-2023 LIBRARY; T=0.K
alphas from (n,2n)a

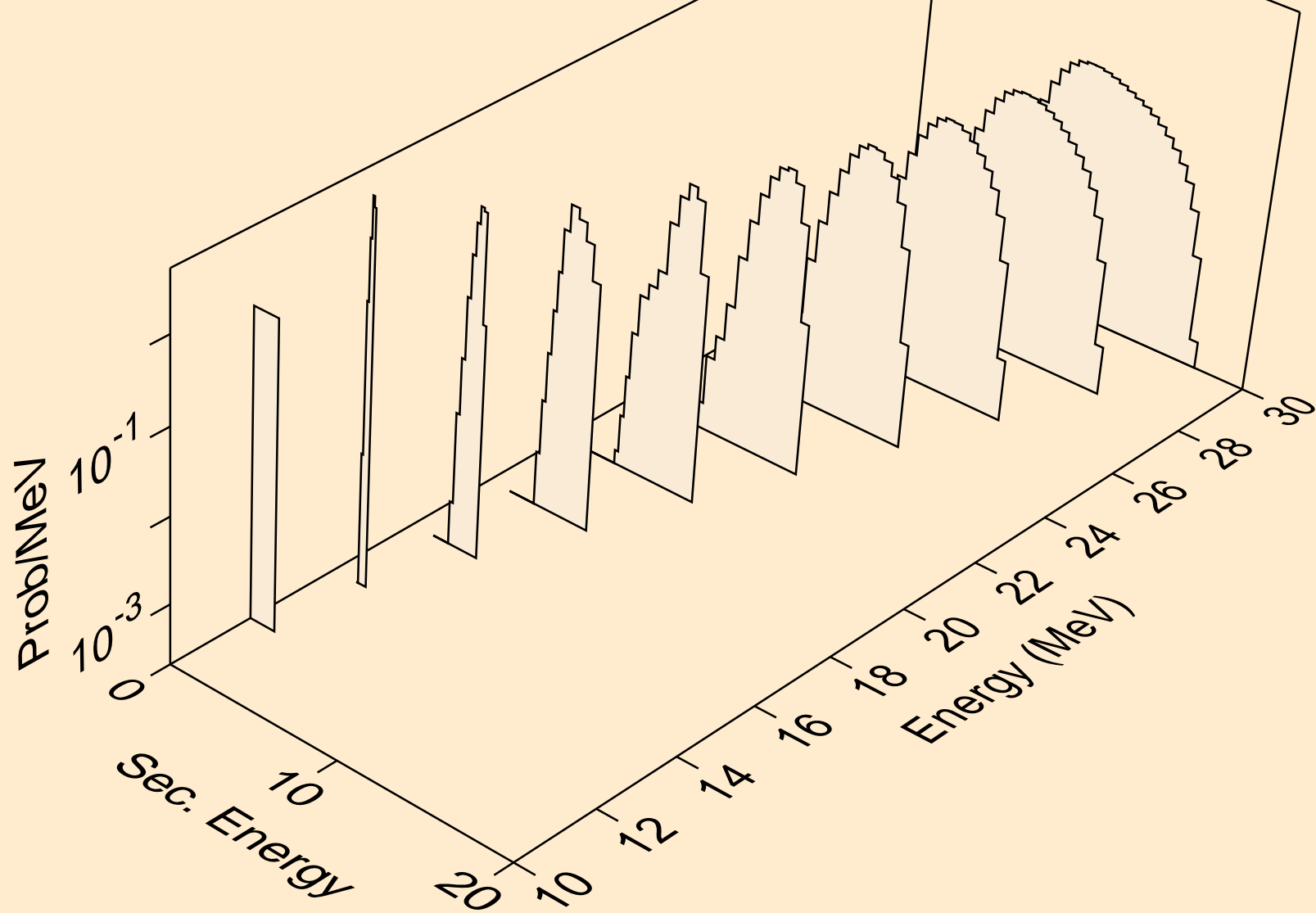

GA072 NEUTRON ACER TENDL-2023 LIBRARY; T=0.K
alphas from (n,3n)a

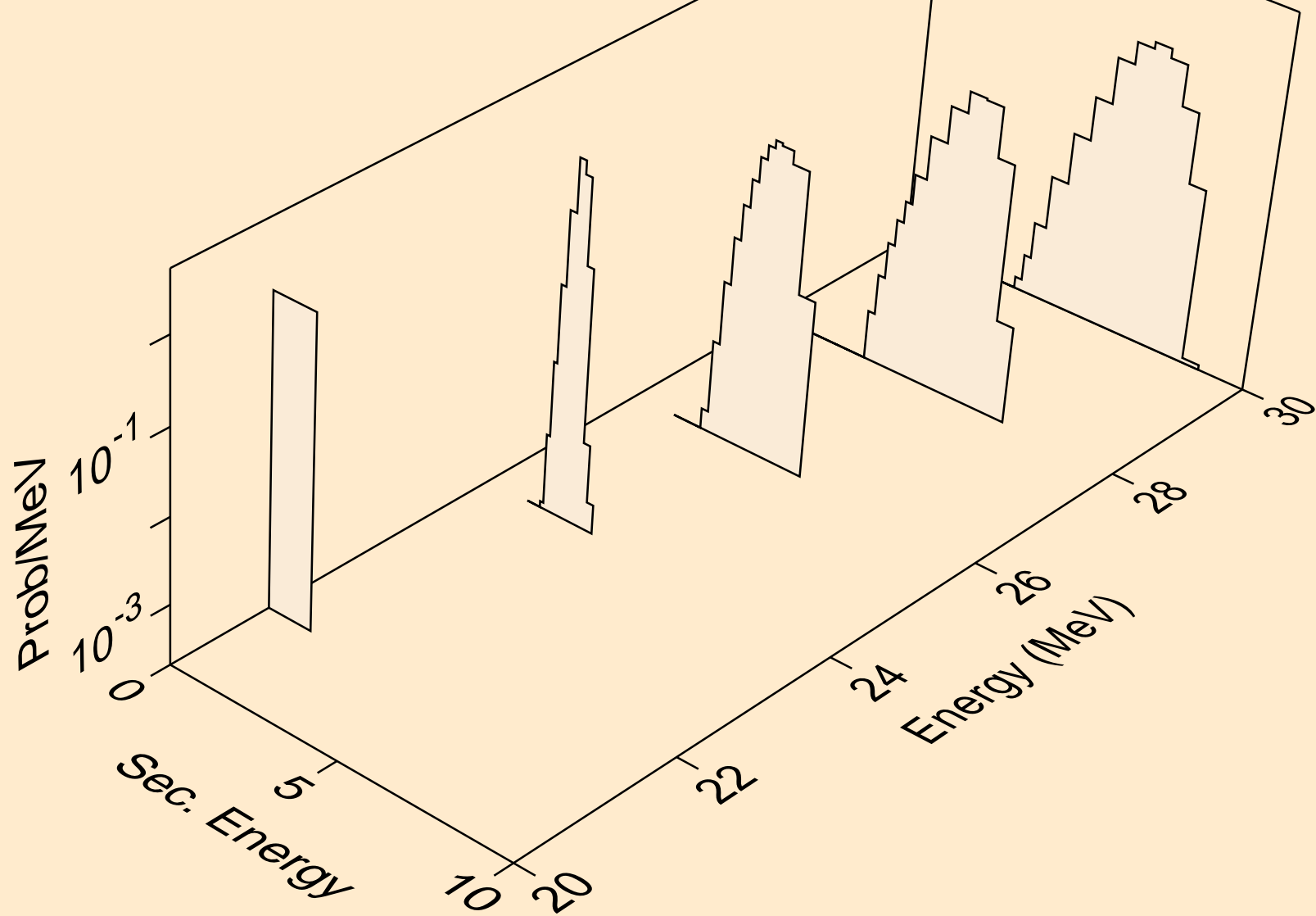

GA072 NEUTRON ACER TENDL-2023 LIBRARY; T=0.K
alphas from (n,n*)2a

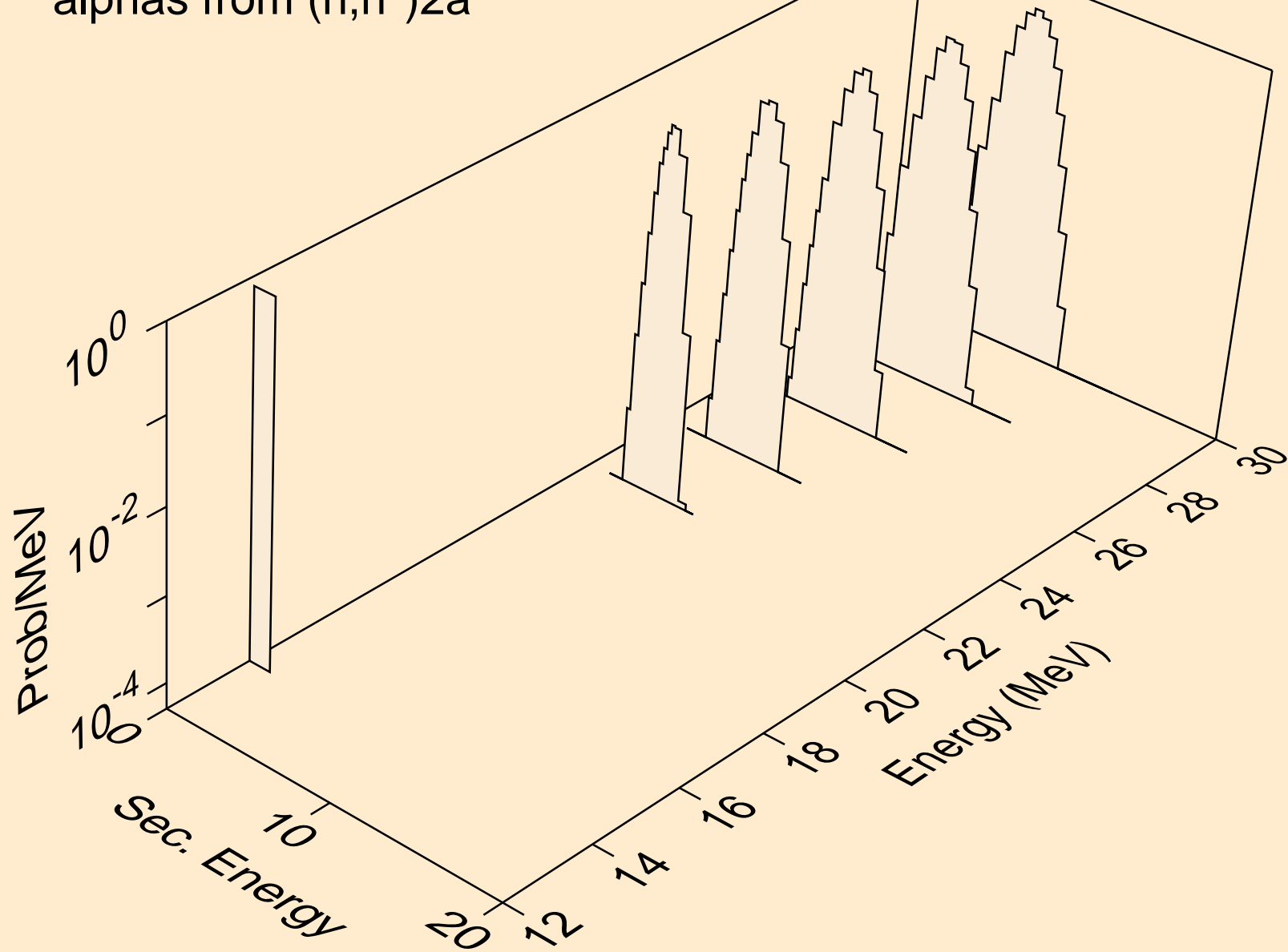

GA072 NEUTRON ACER TENDL-2023 LIBRARY; T=0.K
alphas from (n,npa)

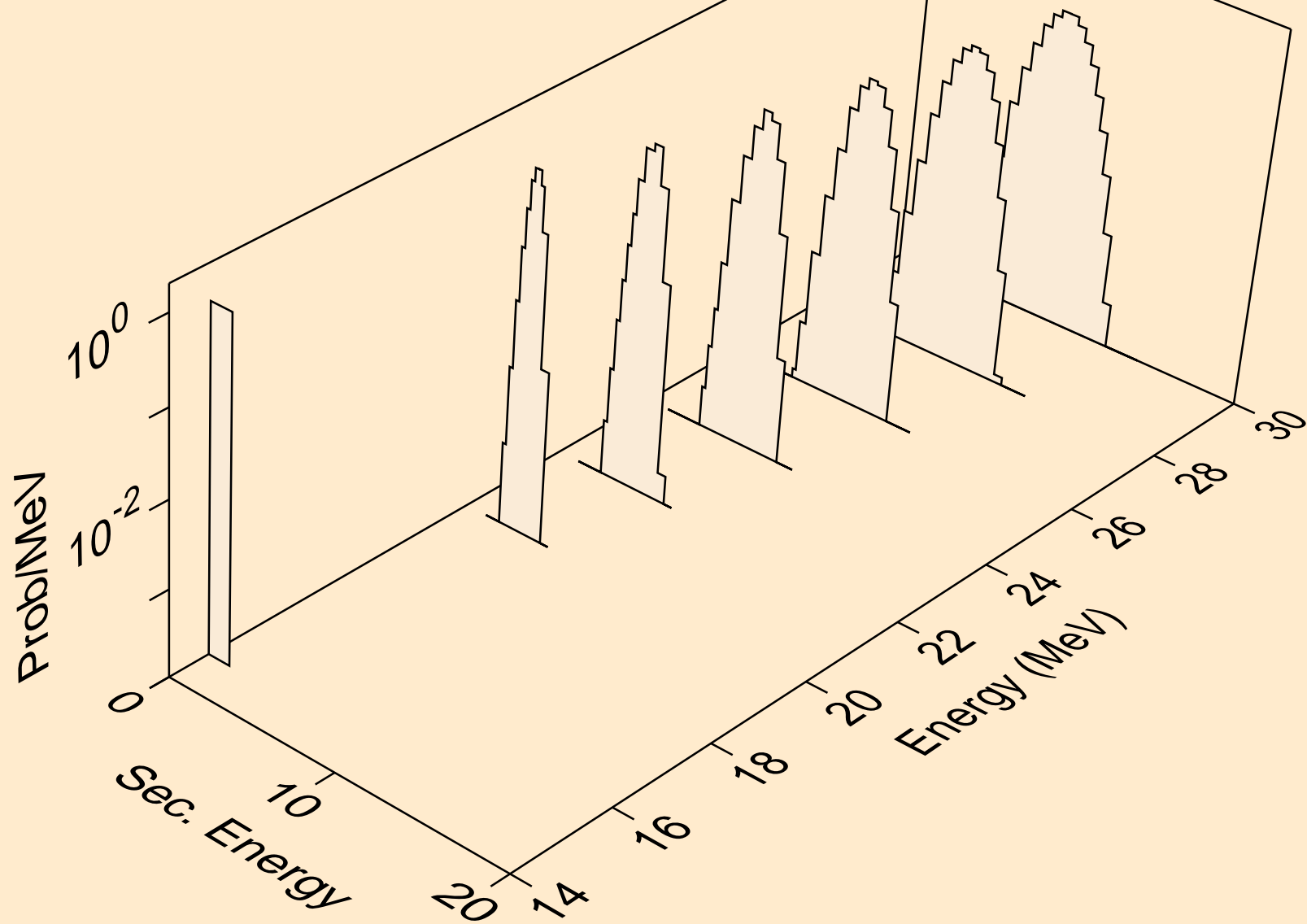

GA072 NEUTRON ACER TENDL-2023 LIBRARY; T=0.K
alphas from (n,a)

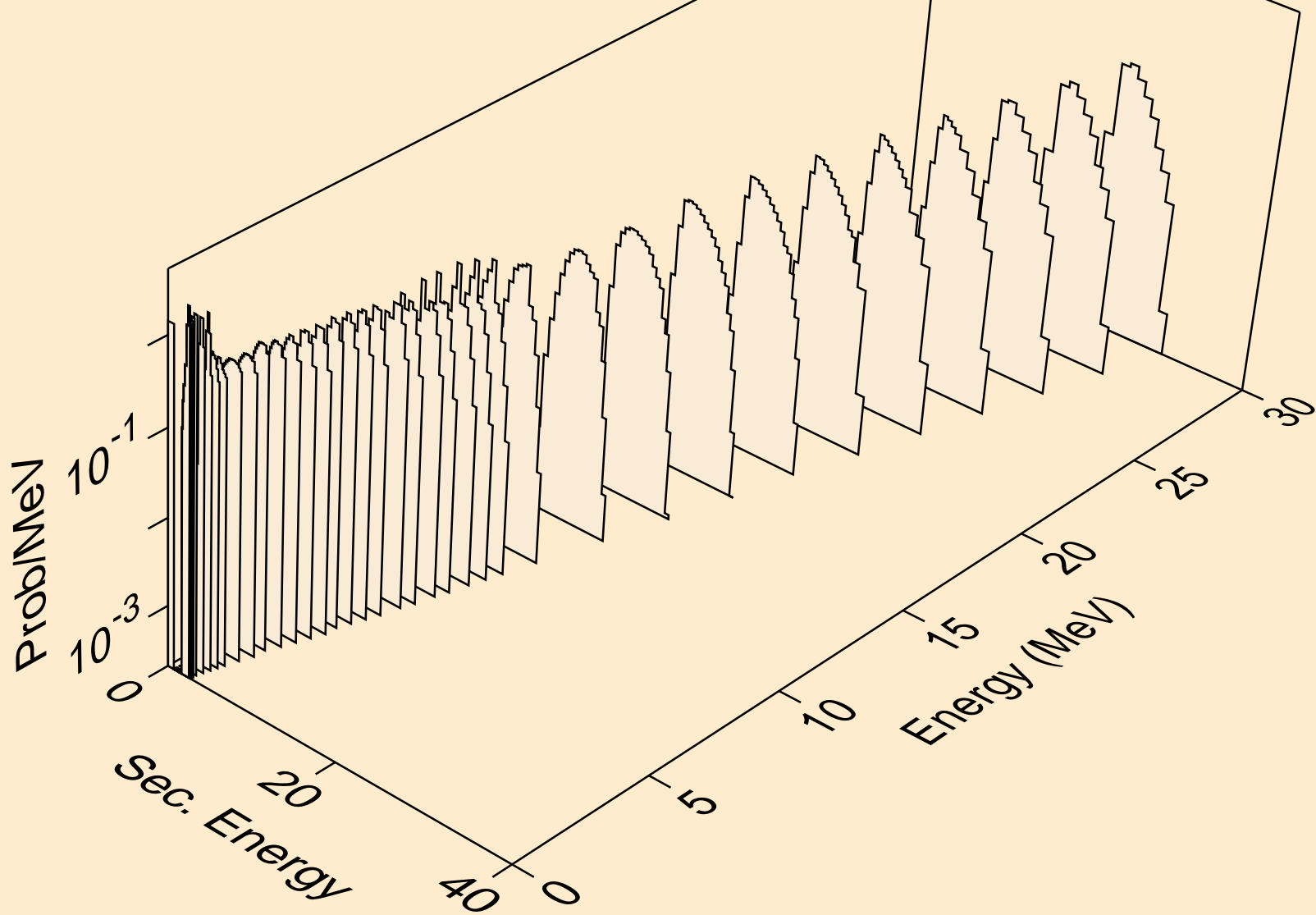

GA072 NEUTRON ACER TENDL-2023 LIBRARY; T=0.K
alphas from (n,2a)

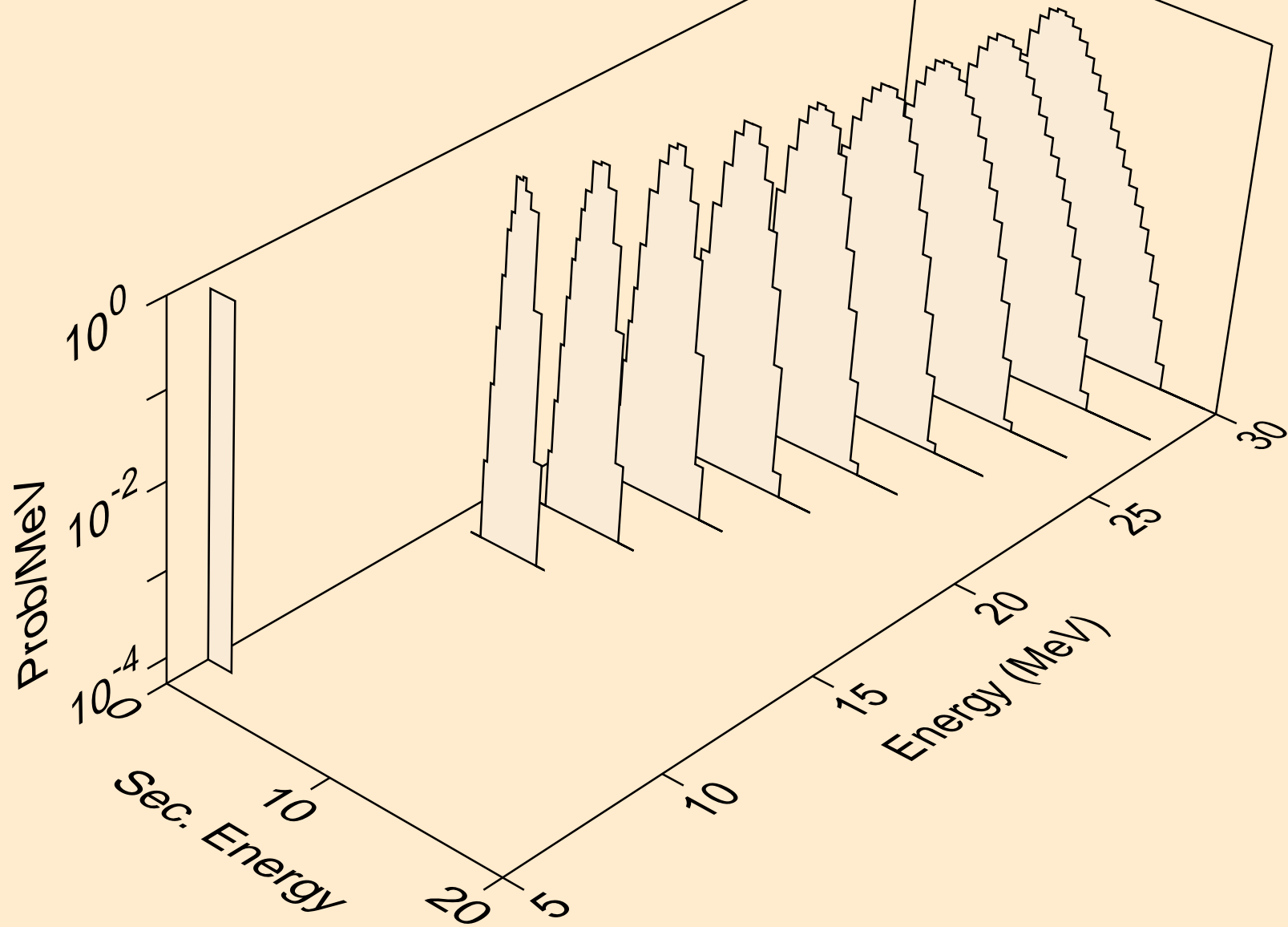

GA072 NEUTRON ACER TENDL-2023 LIBRARY; T=0.K
alphas from (n,pa)

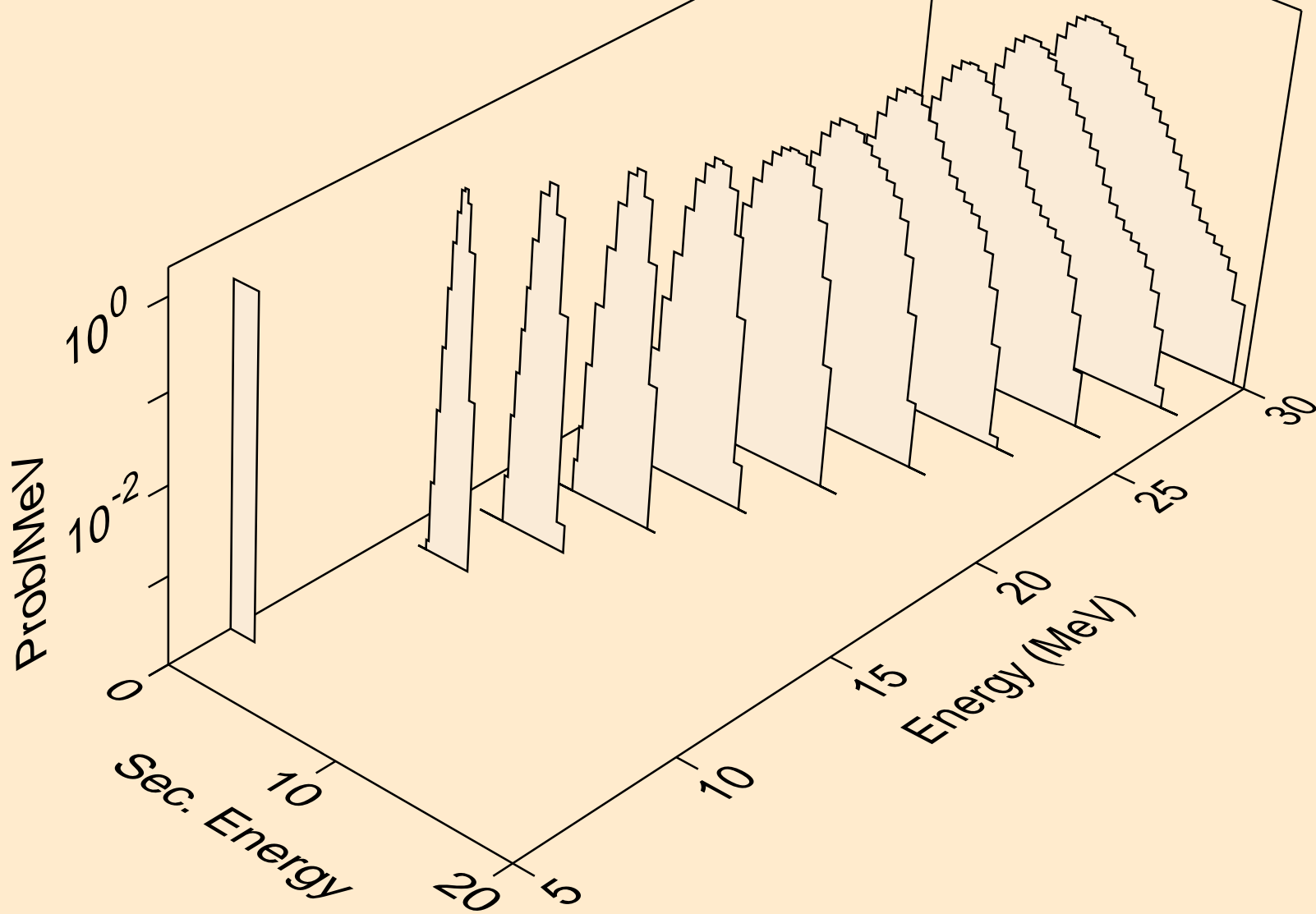

GA072 NEUTRON ACER TENDL-2023 LIBRARY; T=0.K
alphas from (n,da)

