

HS279 NEUTRON ACER TENDL-2023 LIBRARY; T=0.K

Principal cross sections

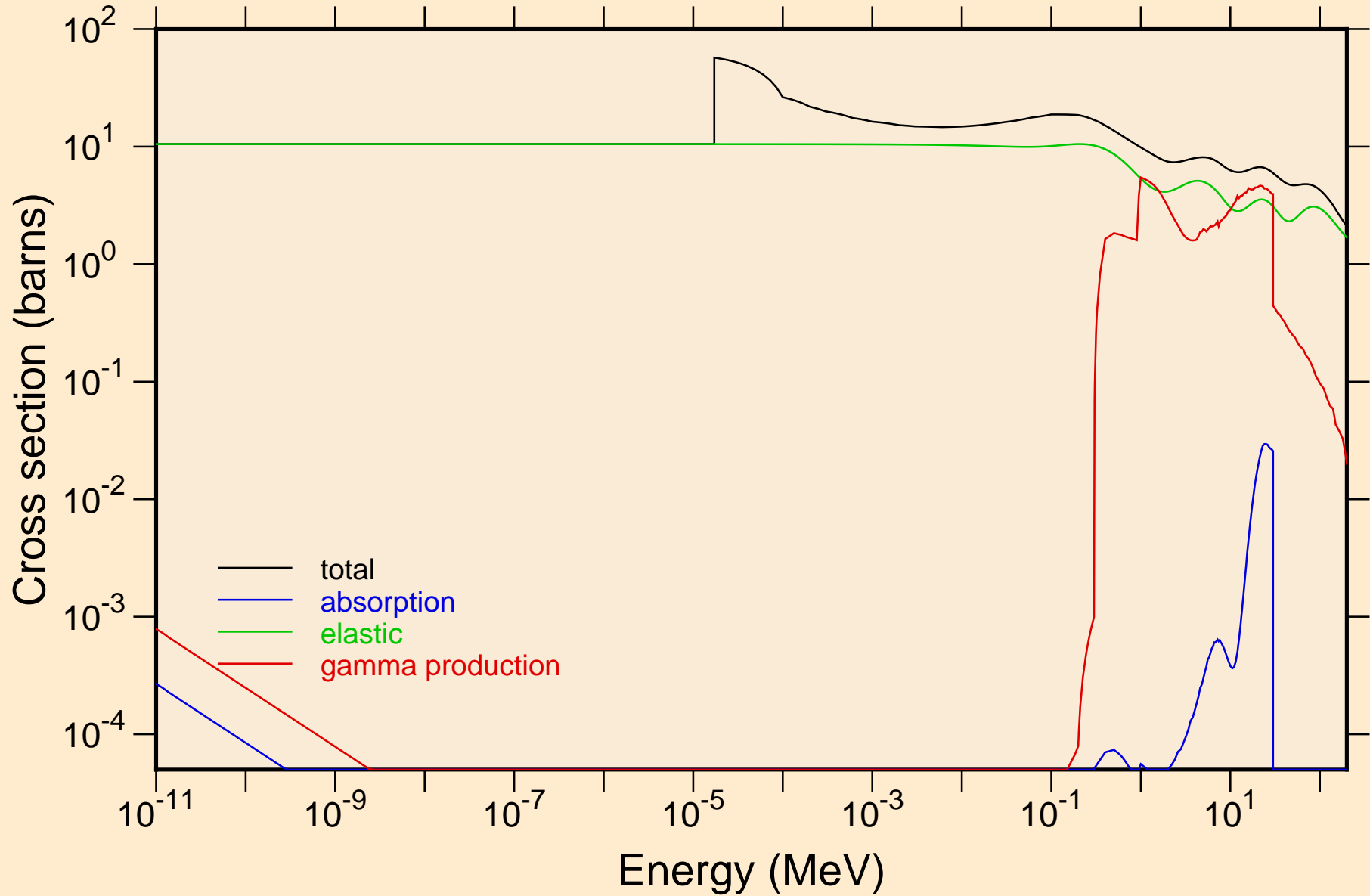

HS279 NEUTRON ACER TENDL-2023 LIBRARY; T=0.K
Heating

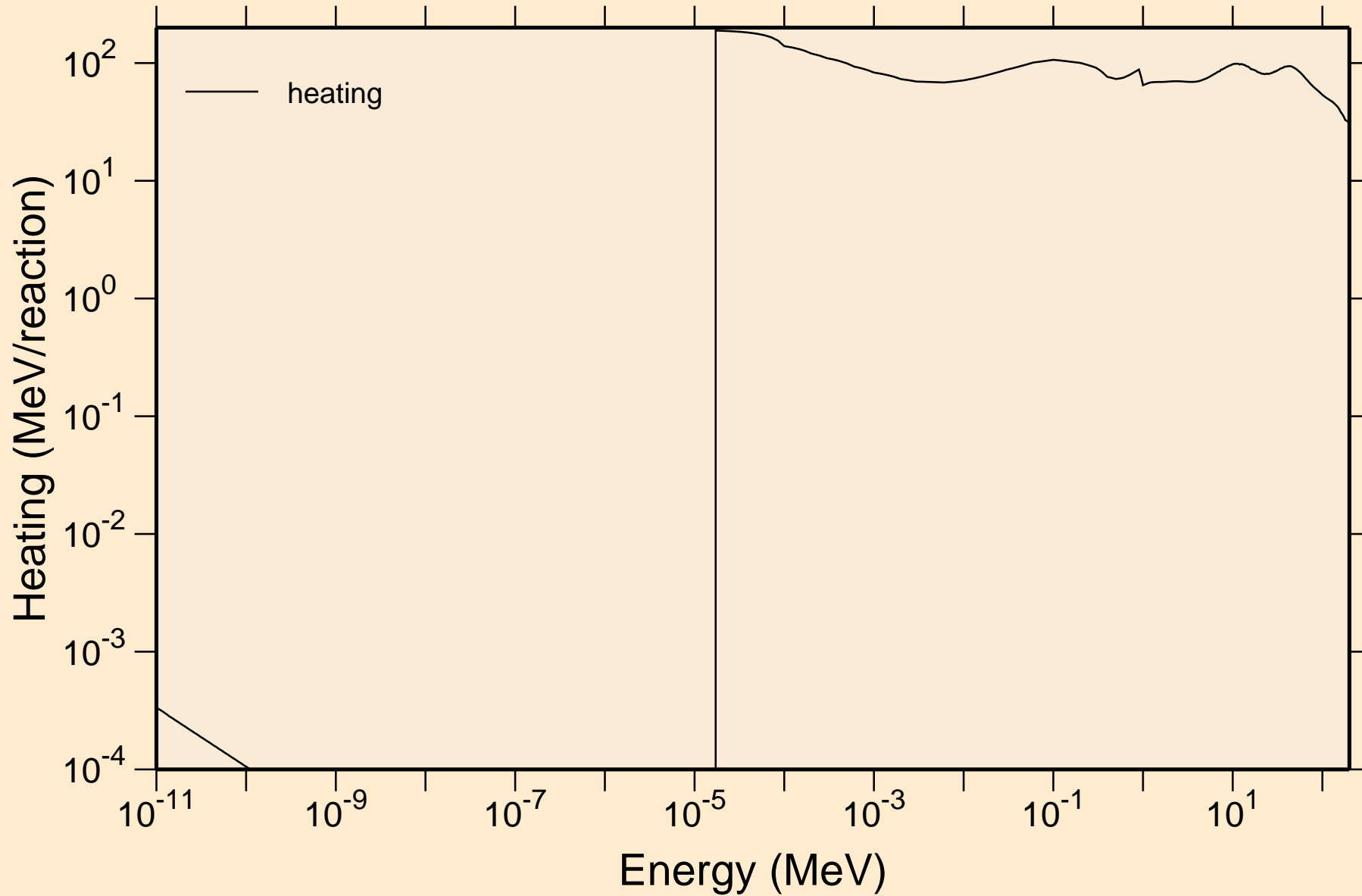

HS279 NEUTRON ACER TENDL-2023 LIBRARY; T=0.K

Damage

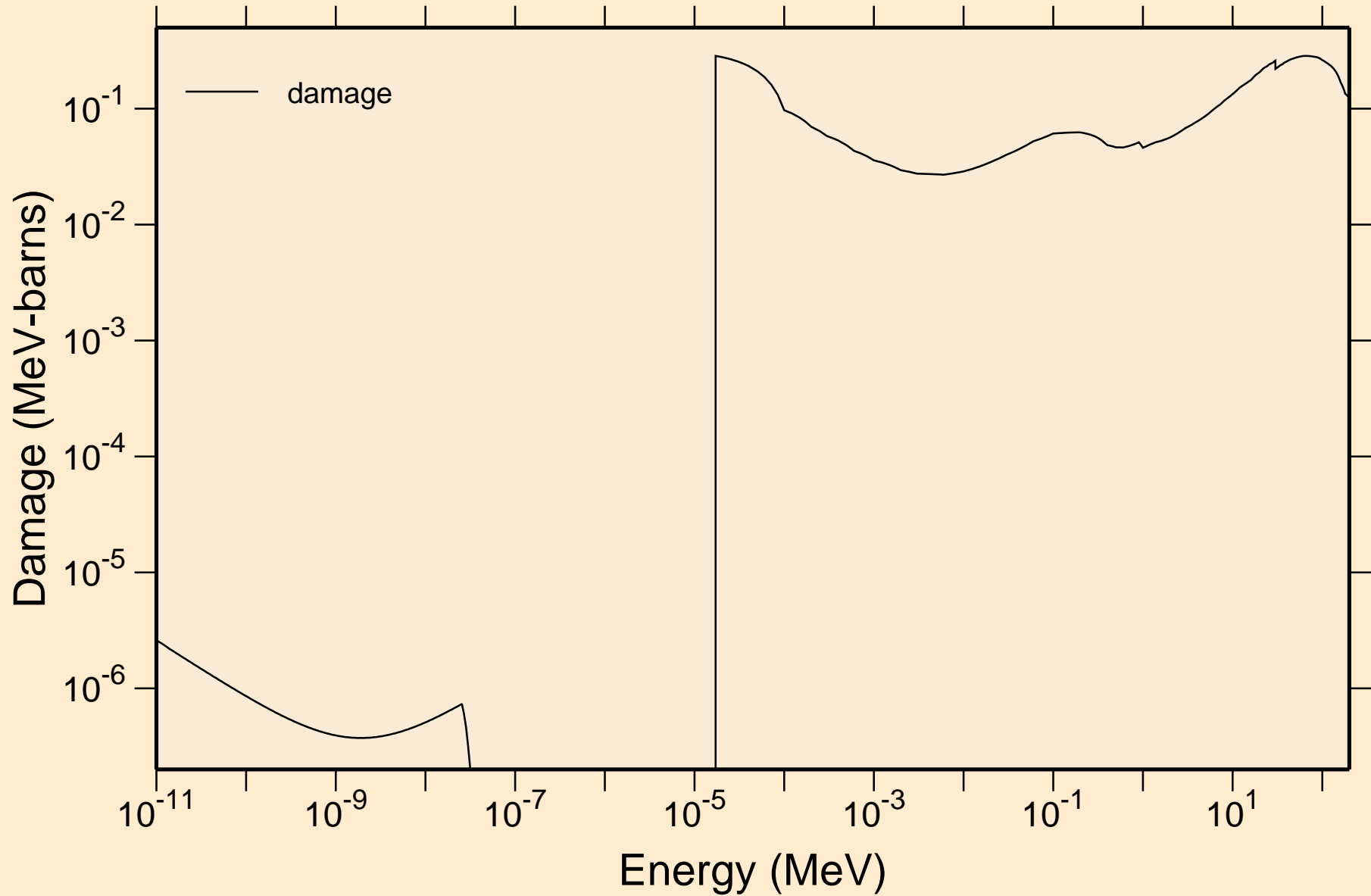

HS279 NEUTRON ACER TENDL-2023 LIBRARY; T=0.K

Non-threshold reactions

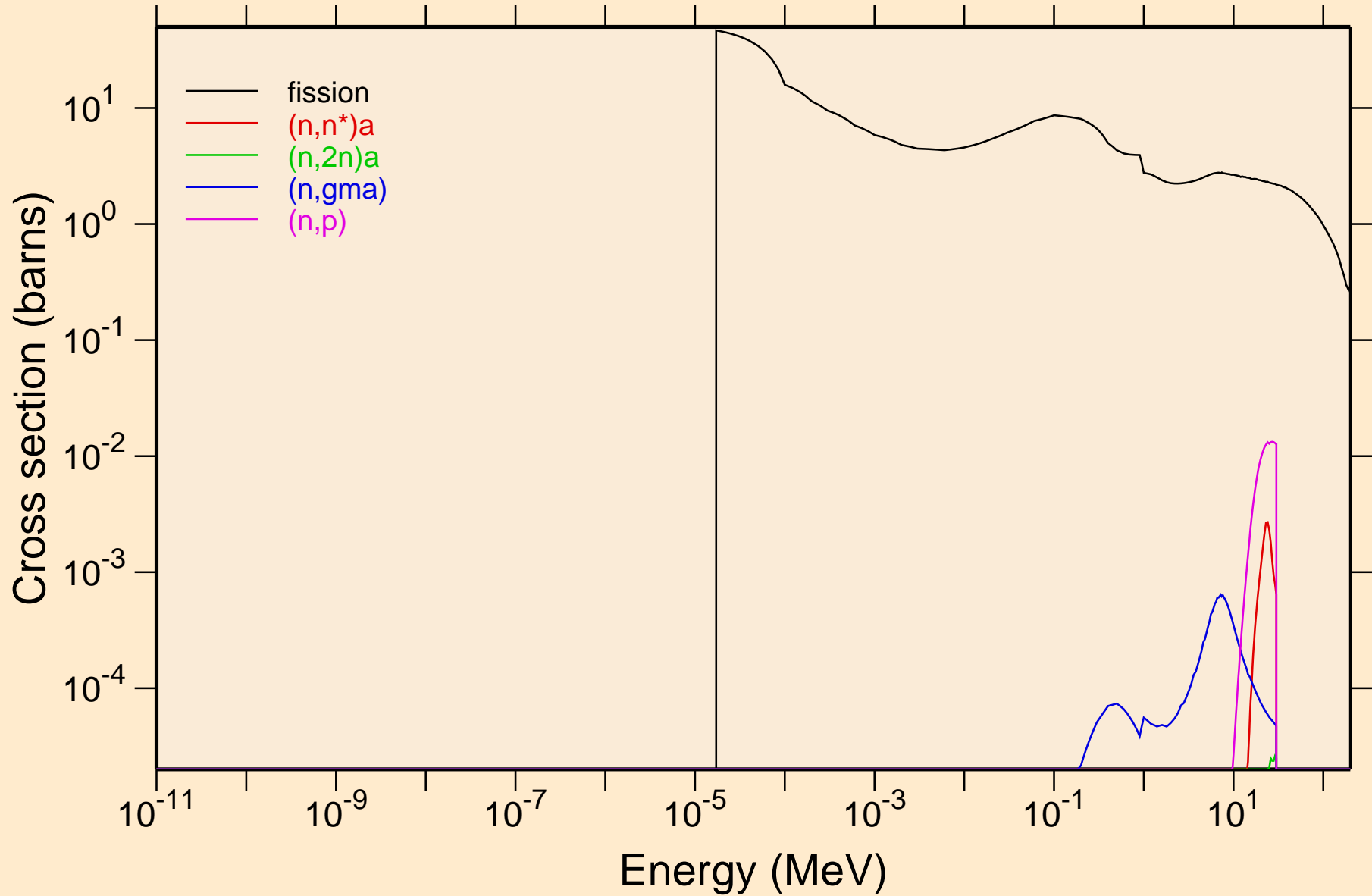

HS279 NEUTRON ACER TENDL-2023 LIBRARY; T=0.K
Non-threshold reactions

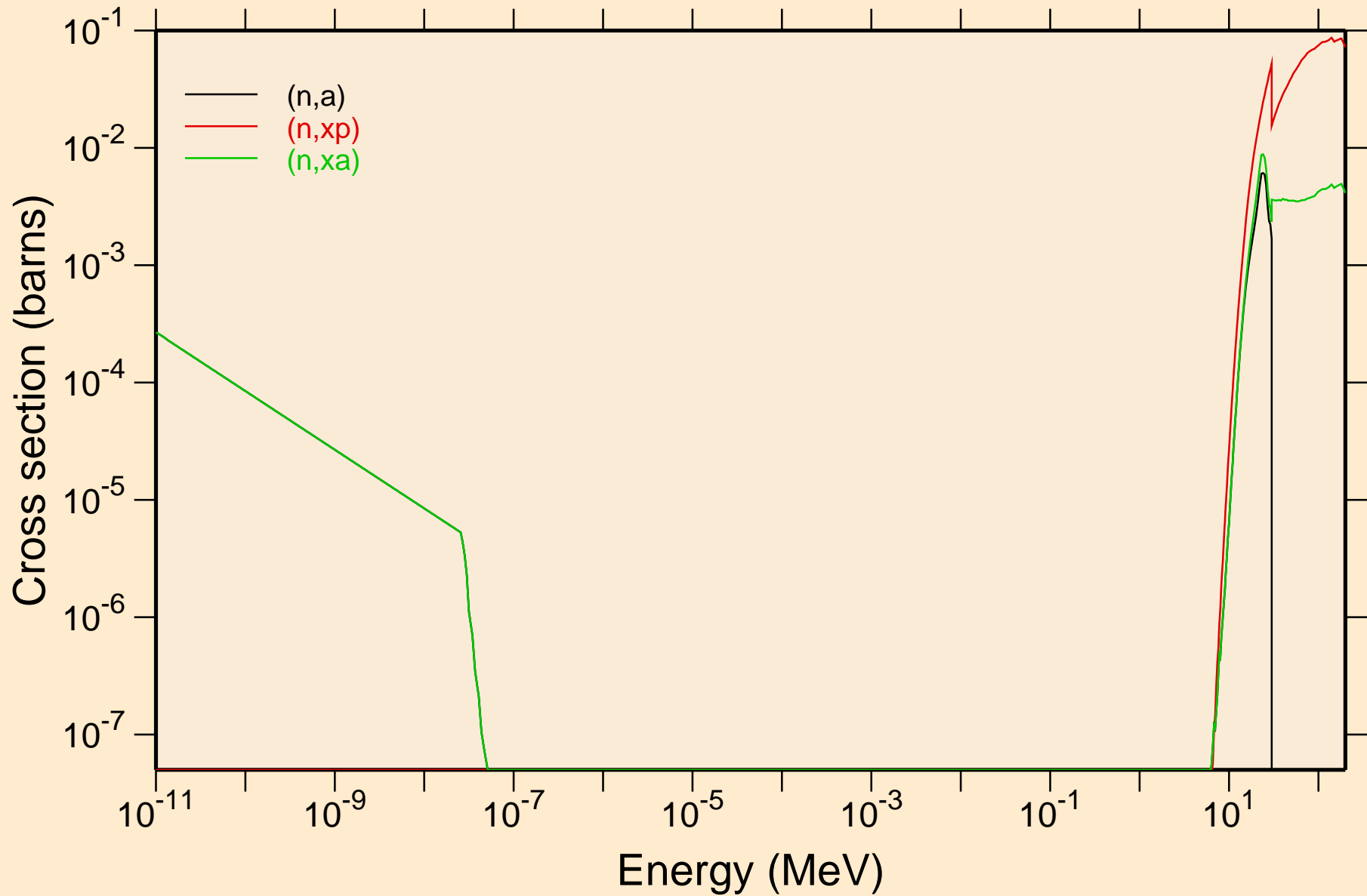

HS279 NEUTRON ACER TENDL-2023 LIBRARY; T=0.K

Principal cross sections

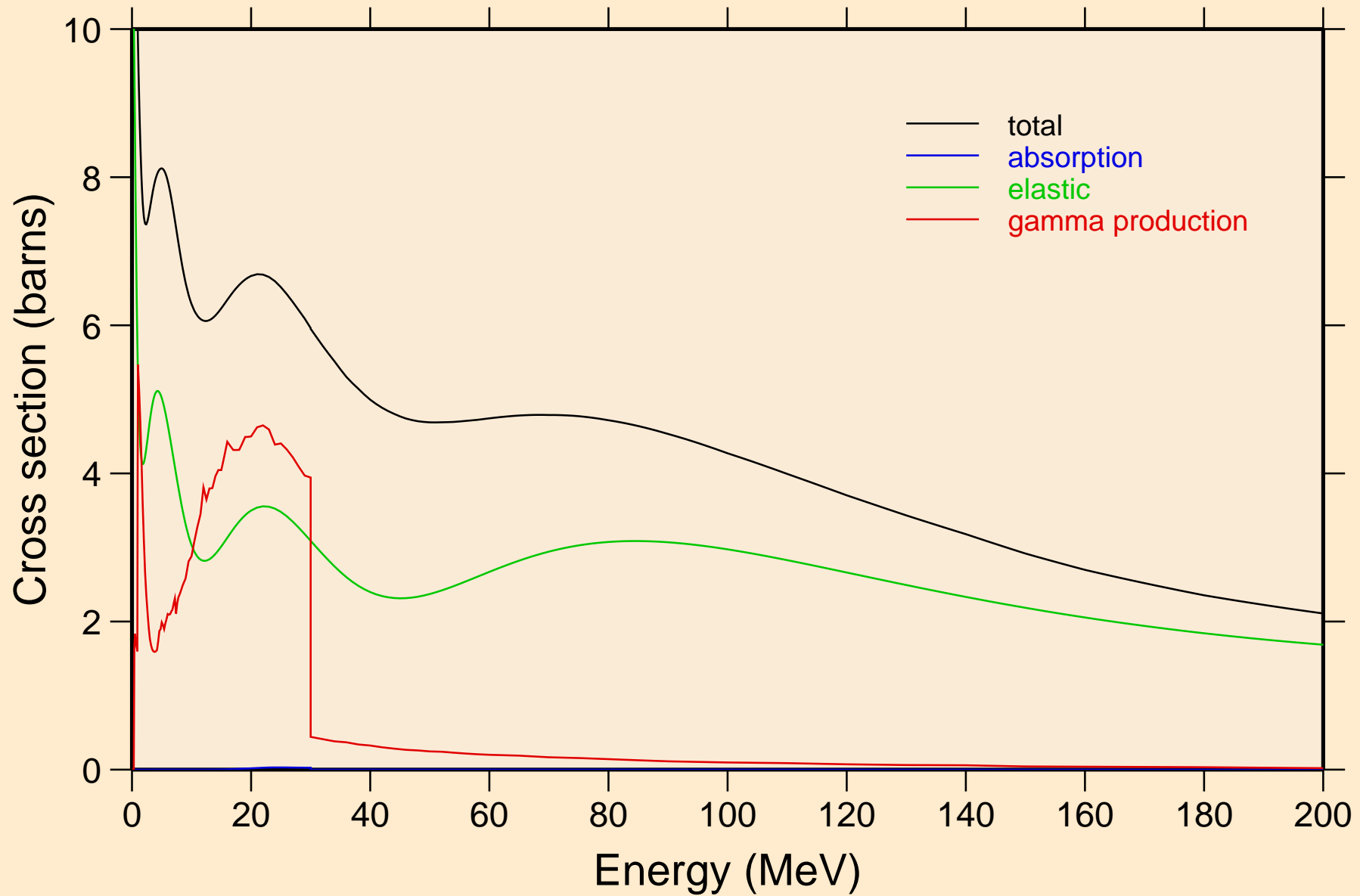

HS279 NEUTRON ACER TENDL-2023 LIBRARY; T=0.K

Heating

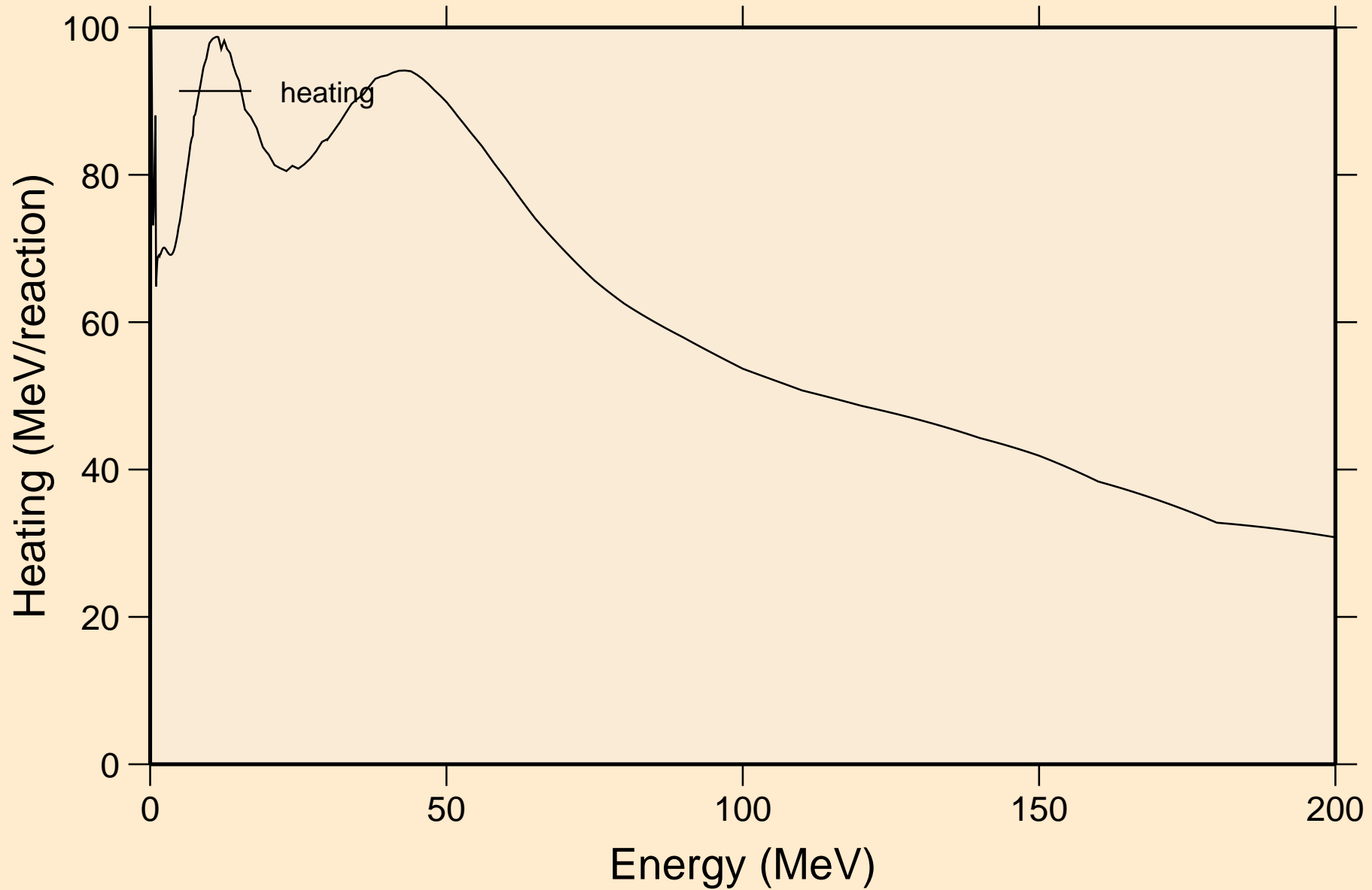

HS279 NEUTRON ACER TENDL-2023 LIBRARY; T=0.K

Damage

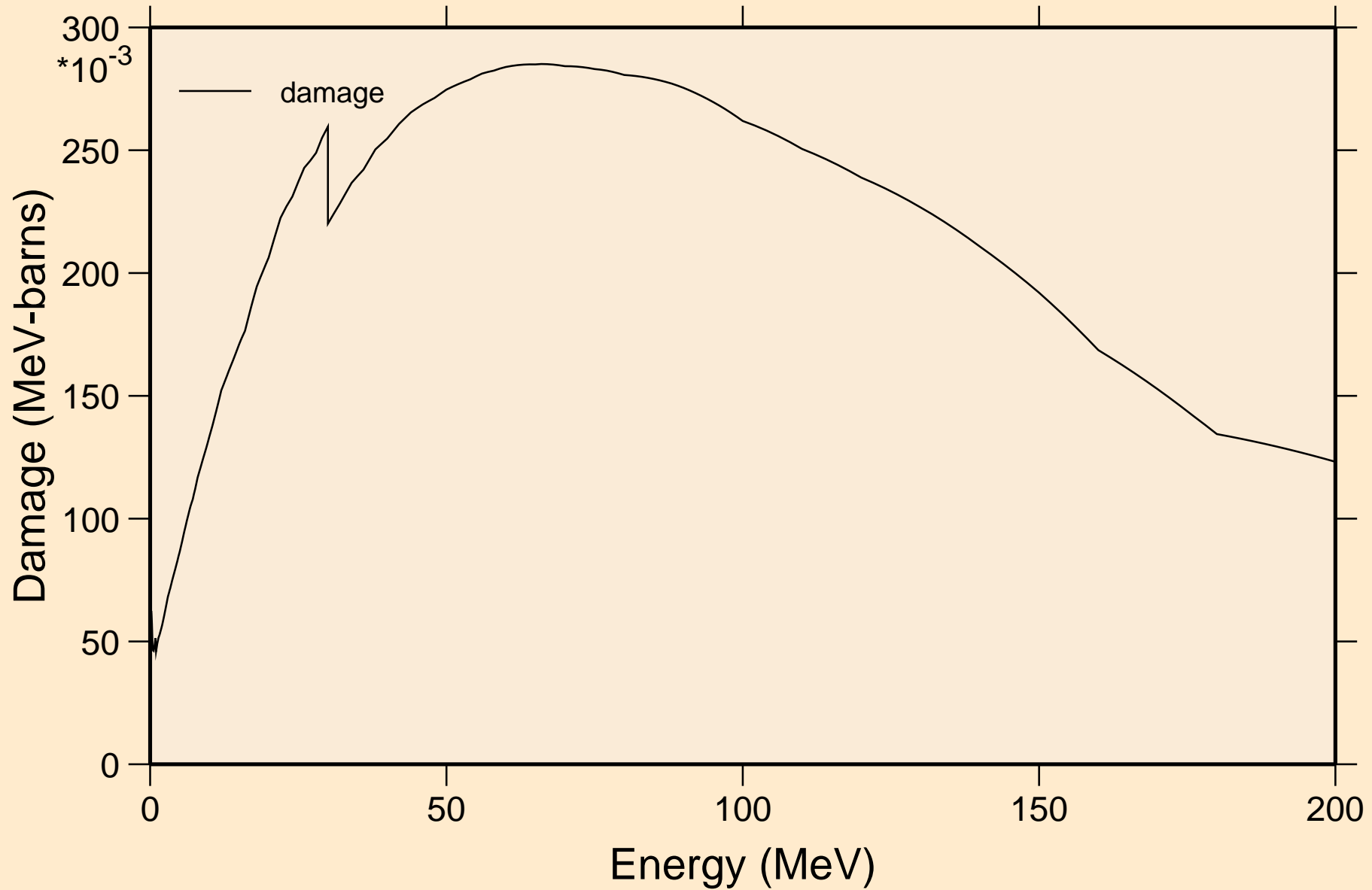

HS279 NEUTRON ACER TENDL-2023 LIBRARY; T=0.K

Non-threshold reactions

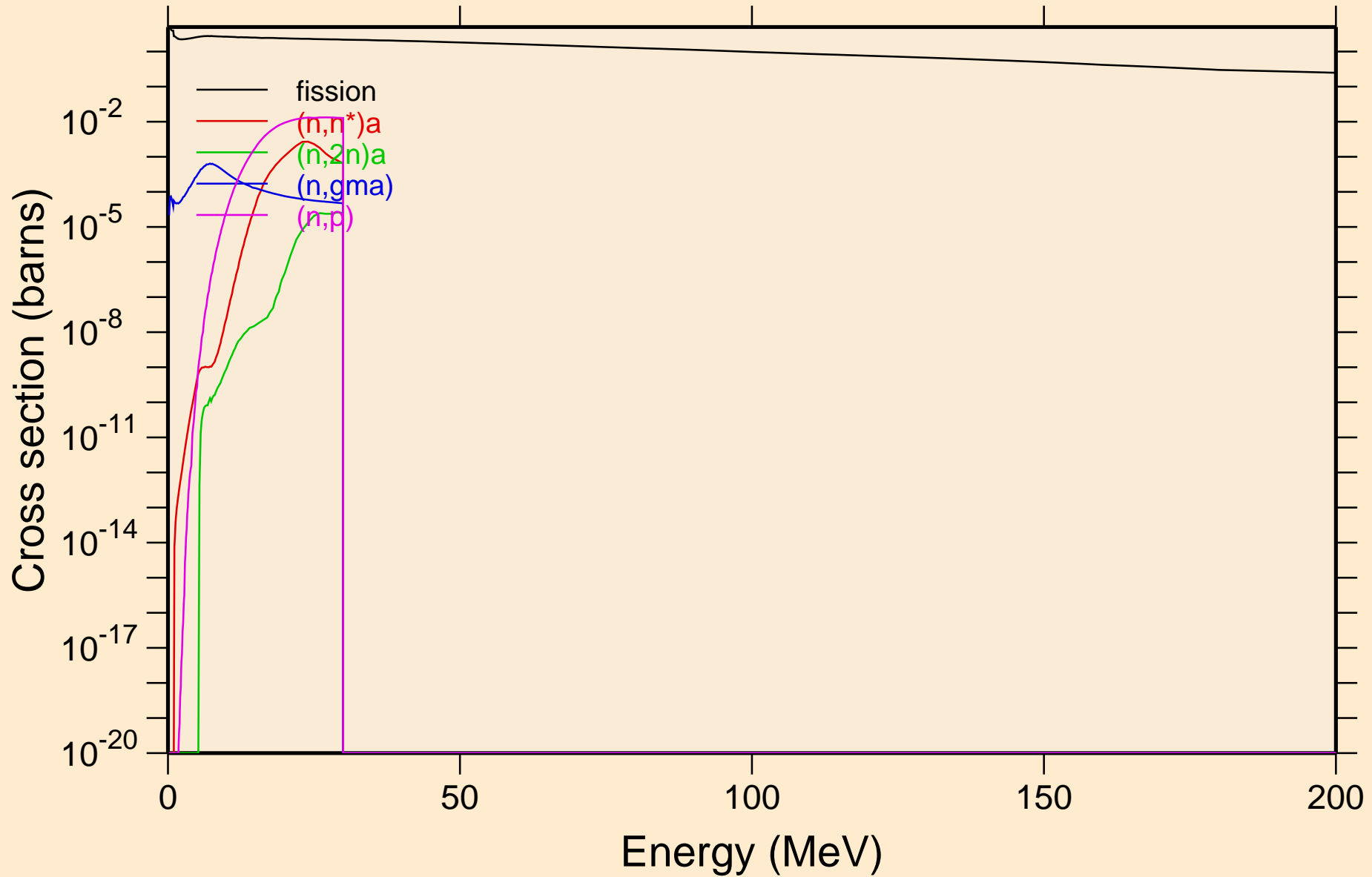

HS279 NEUTRON ACER TENDL-2023 LIBRARY; T=0.K
Non-threshold reactions

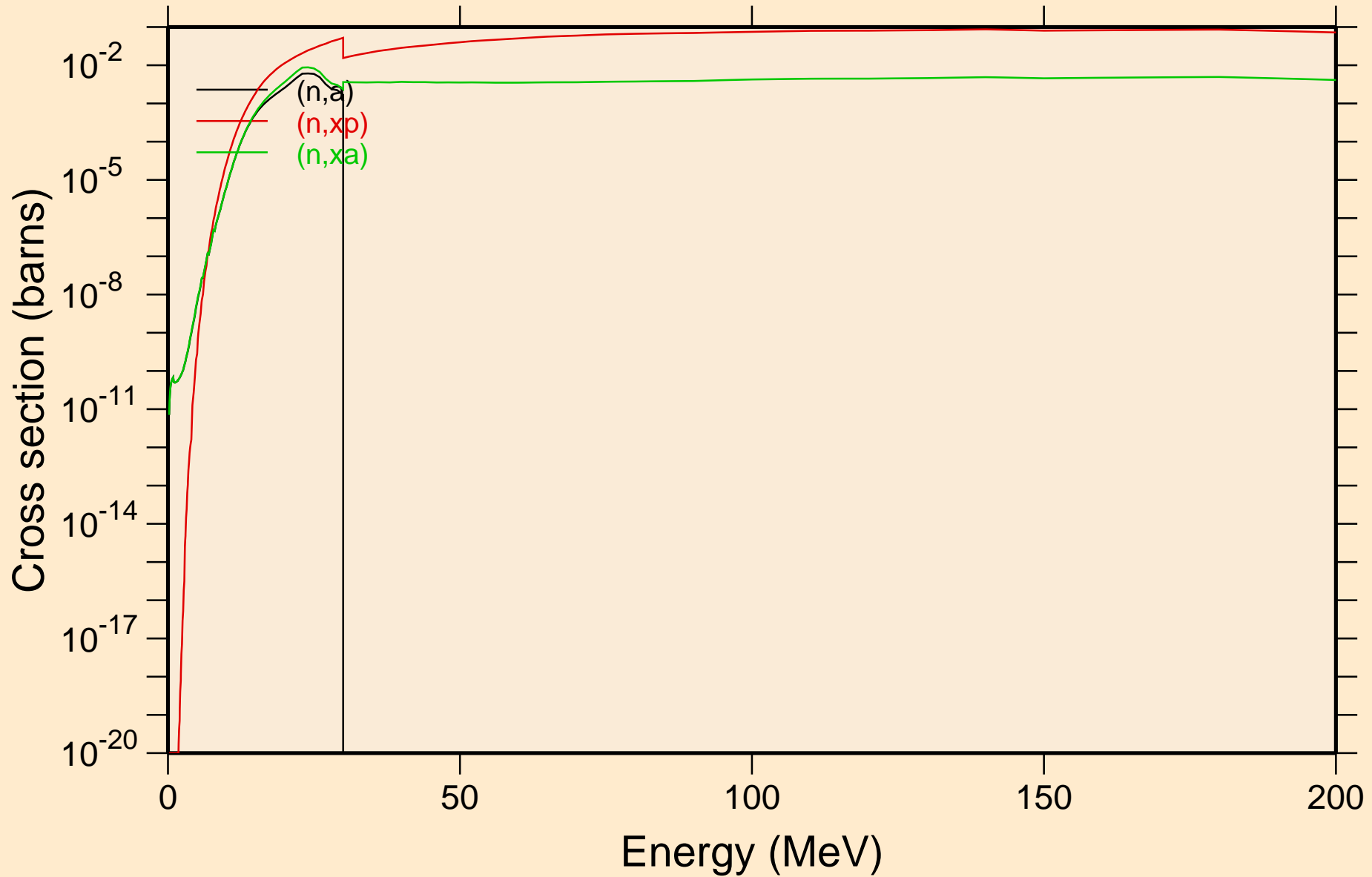

HS279 NEUTRON ACER TENDL-2023 LIBRARY; T=0.K
Inelastic levels

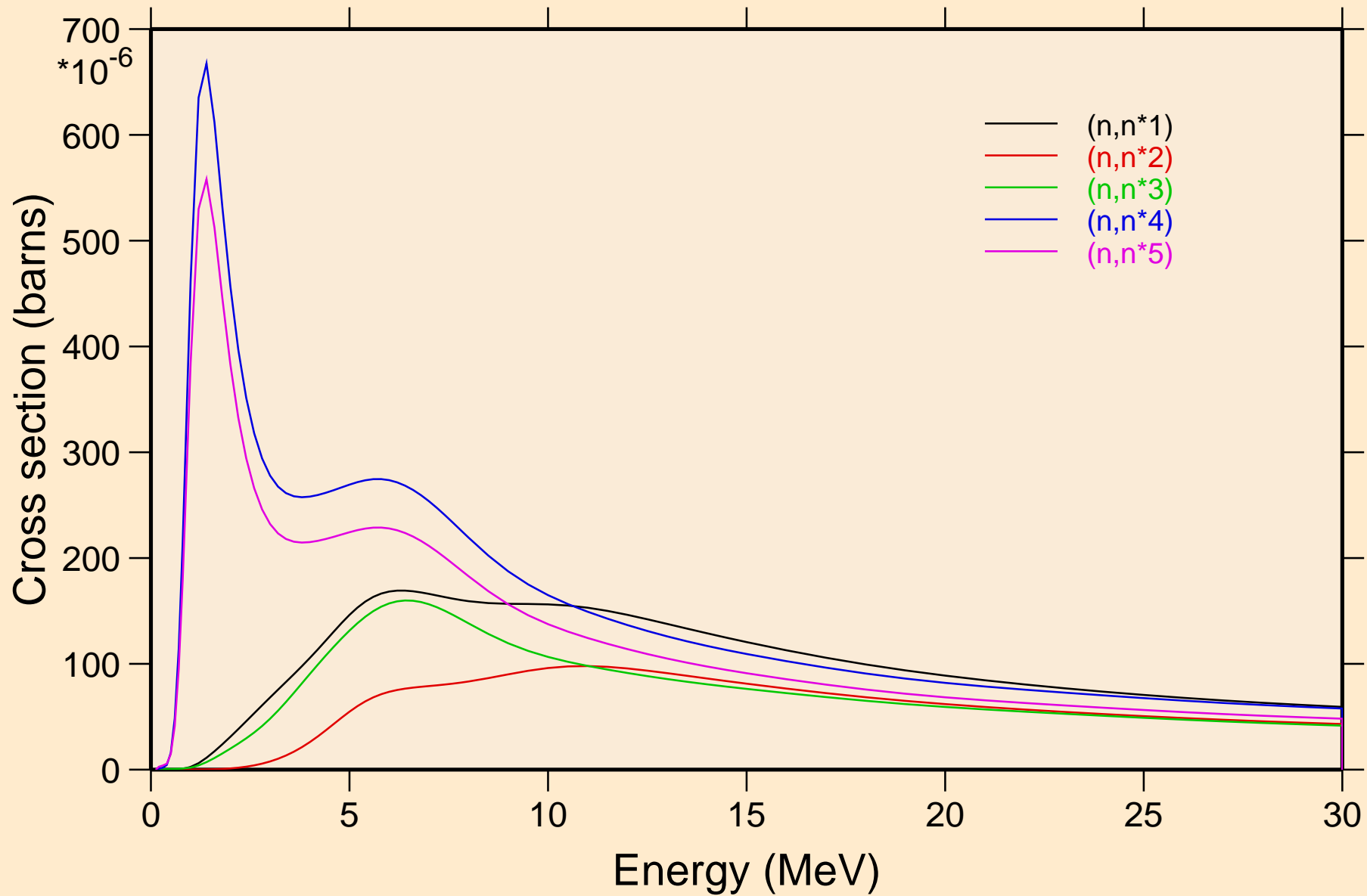

HS279 NEUTRON ACER TENDL-2023 LIBRARY; T=0.K

Inelastic levels

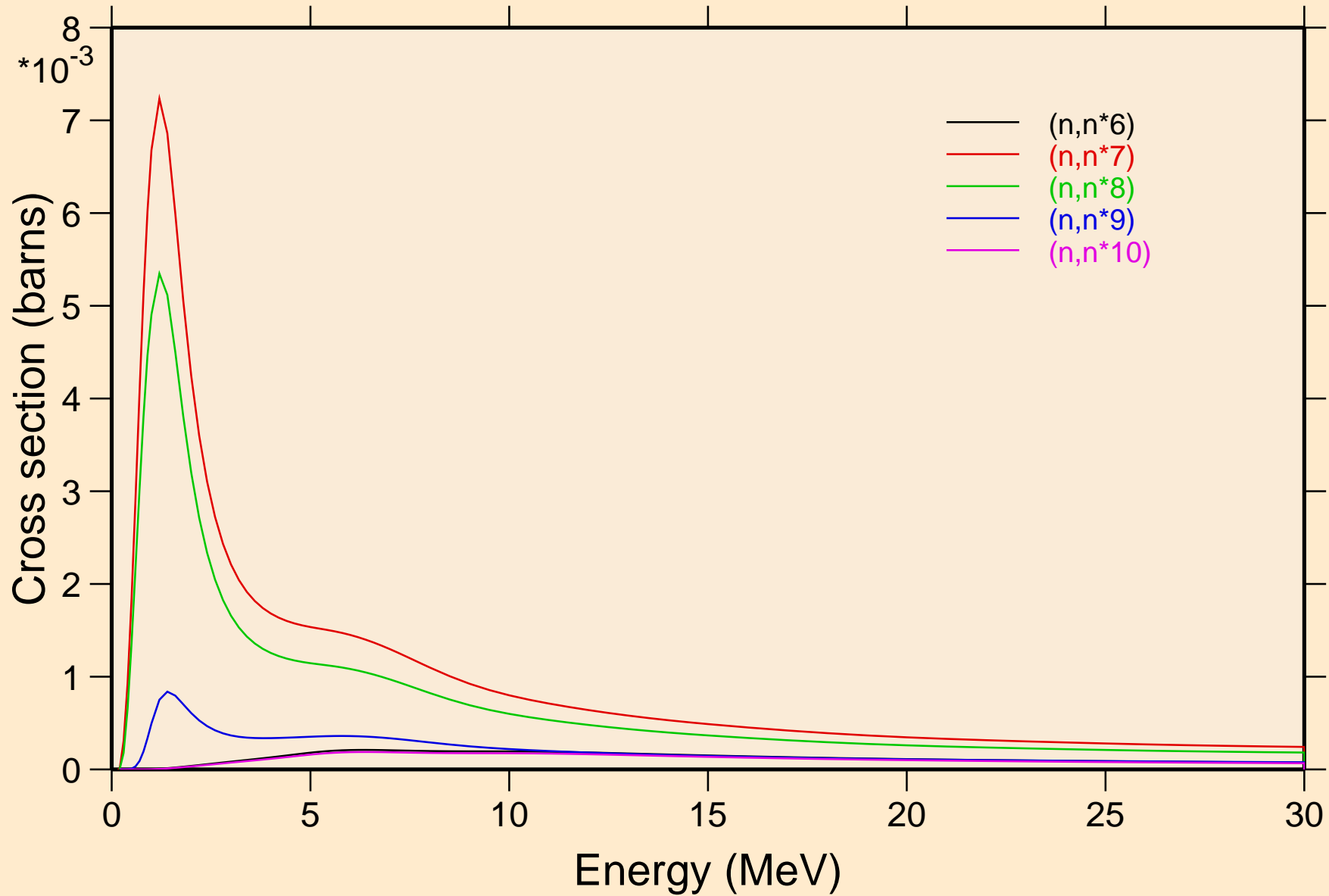

HS279 NEUTRON ACER TENDL-2023 LIBRARY; T=0.K
Inelastic levels

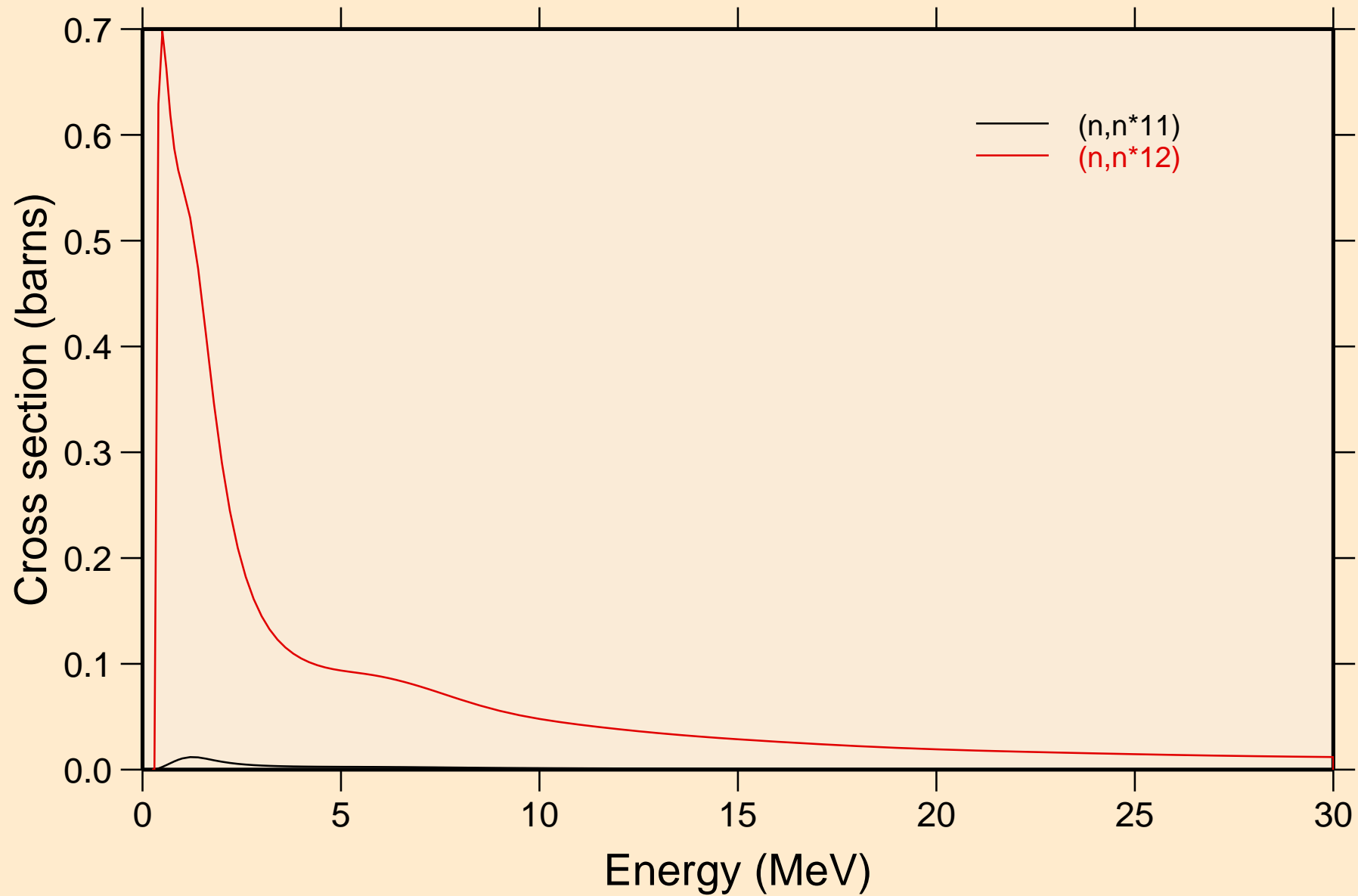

HS279 NEUTRON ACER TENDL-2023 LIBRARY; T=0.K

Threshold reactions

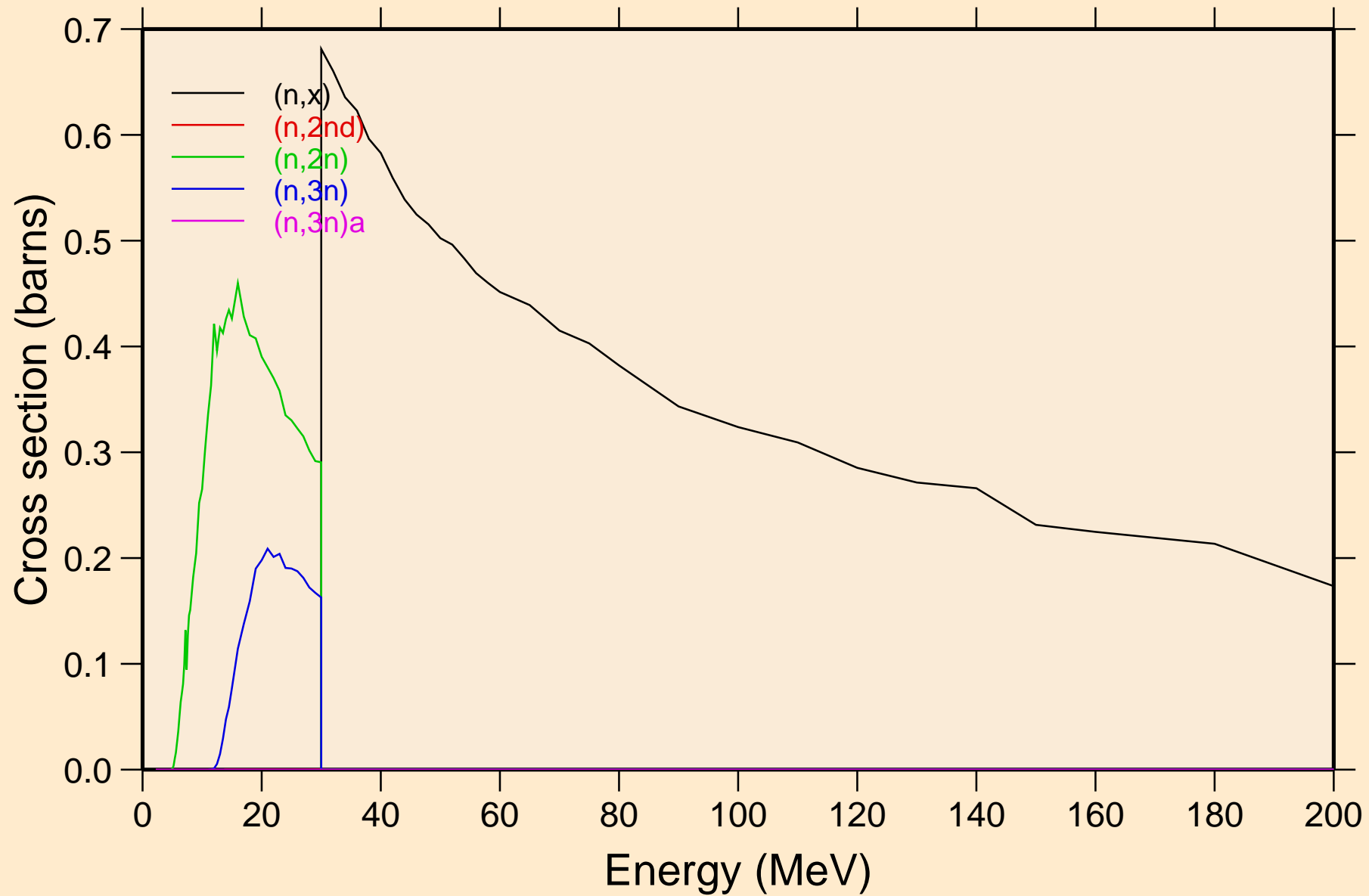

HS279 NEUTRON ACER TENDL-2023 LIBRARY; T=0.K

Threshold reactions

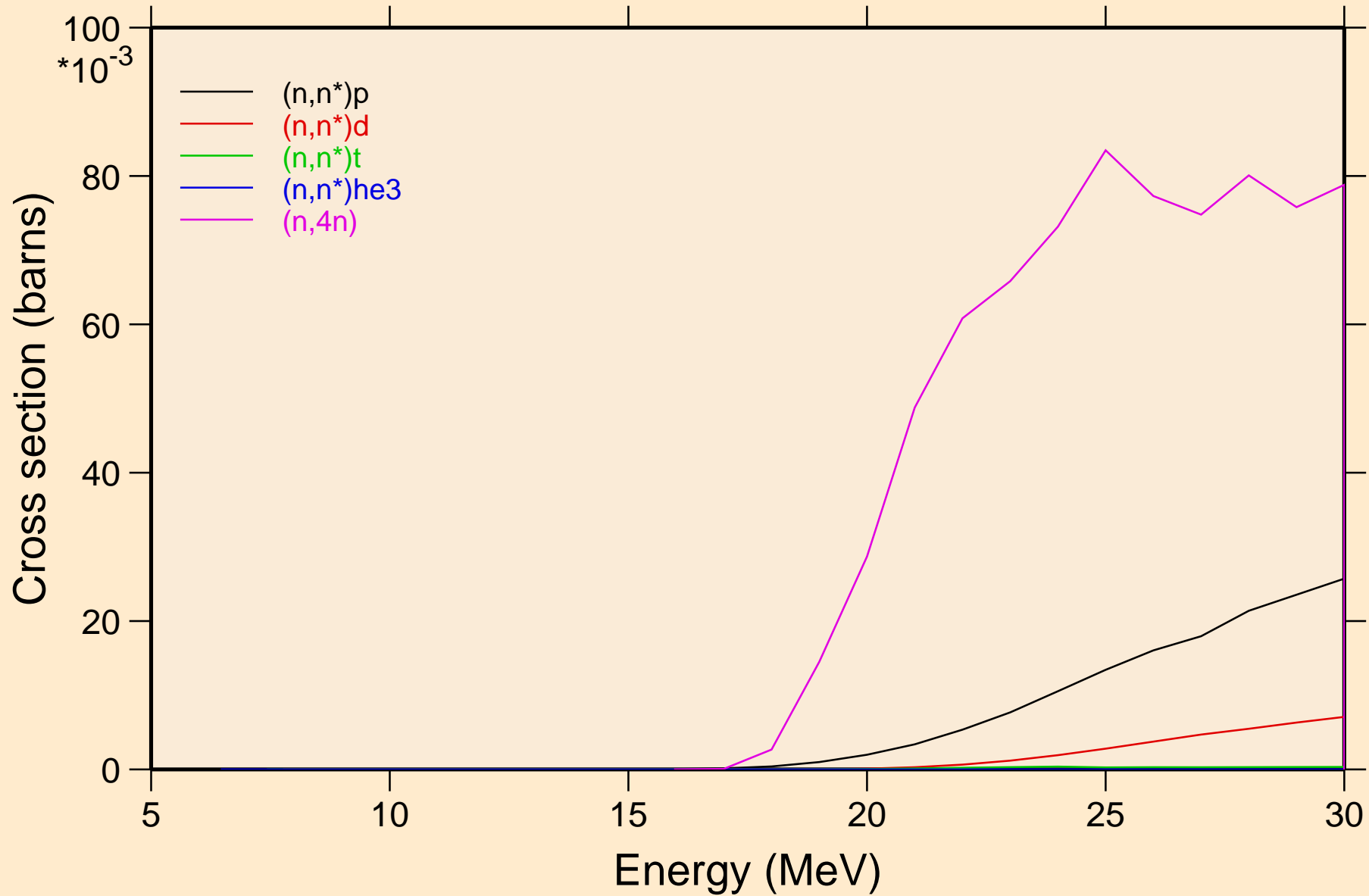

HS279 NEUTRON ACER TENDL-2023 LIBRARY; T=0.K

Threshold reactions

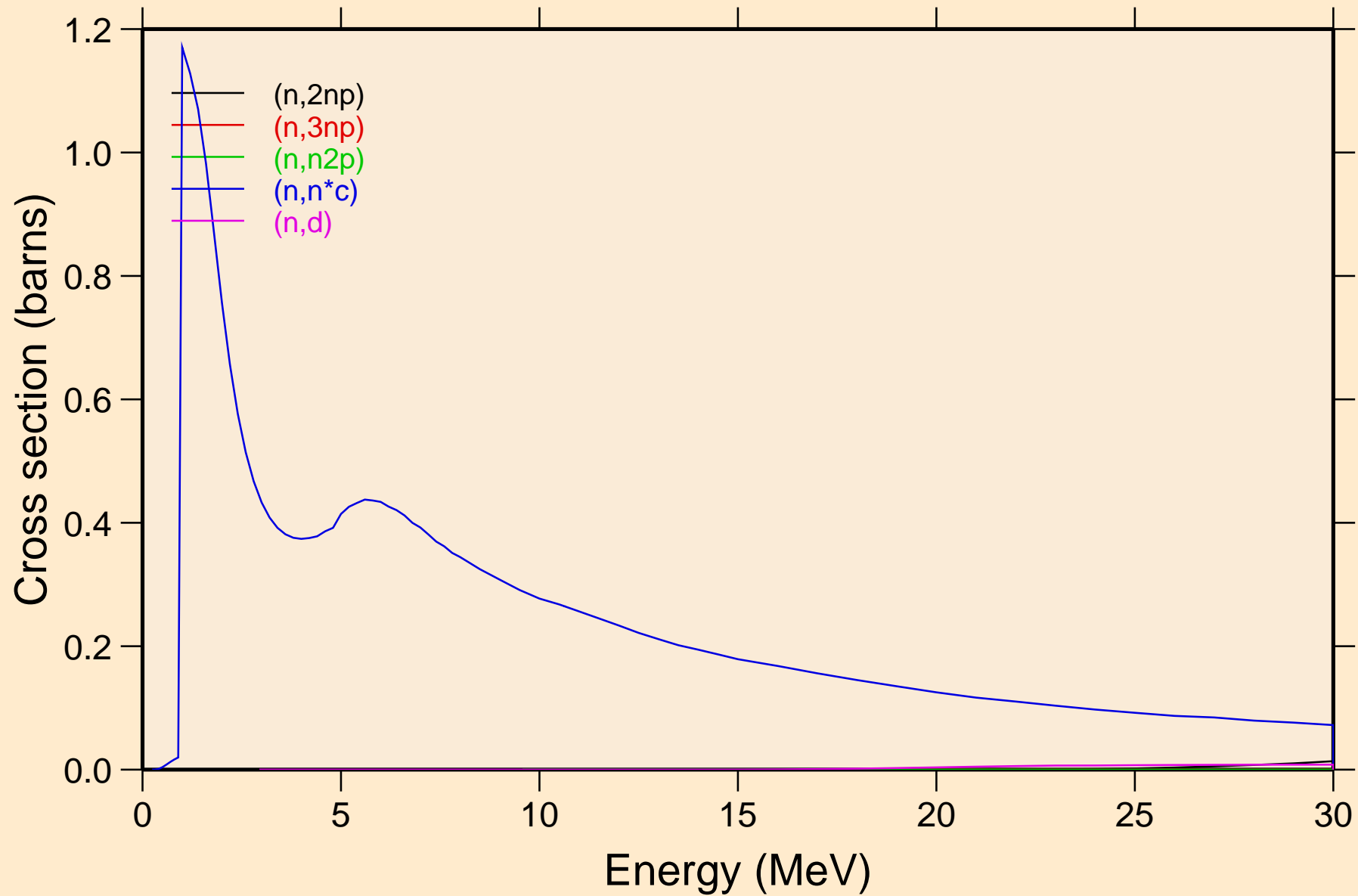

HS279 NEUTRON ACER TENDL-2023 LIBRARY; T=0.K

Threshold reactions

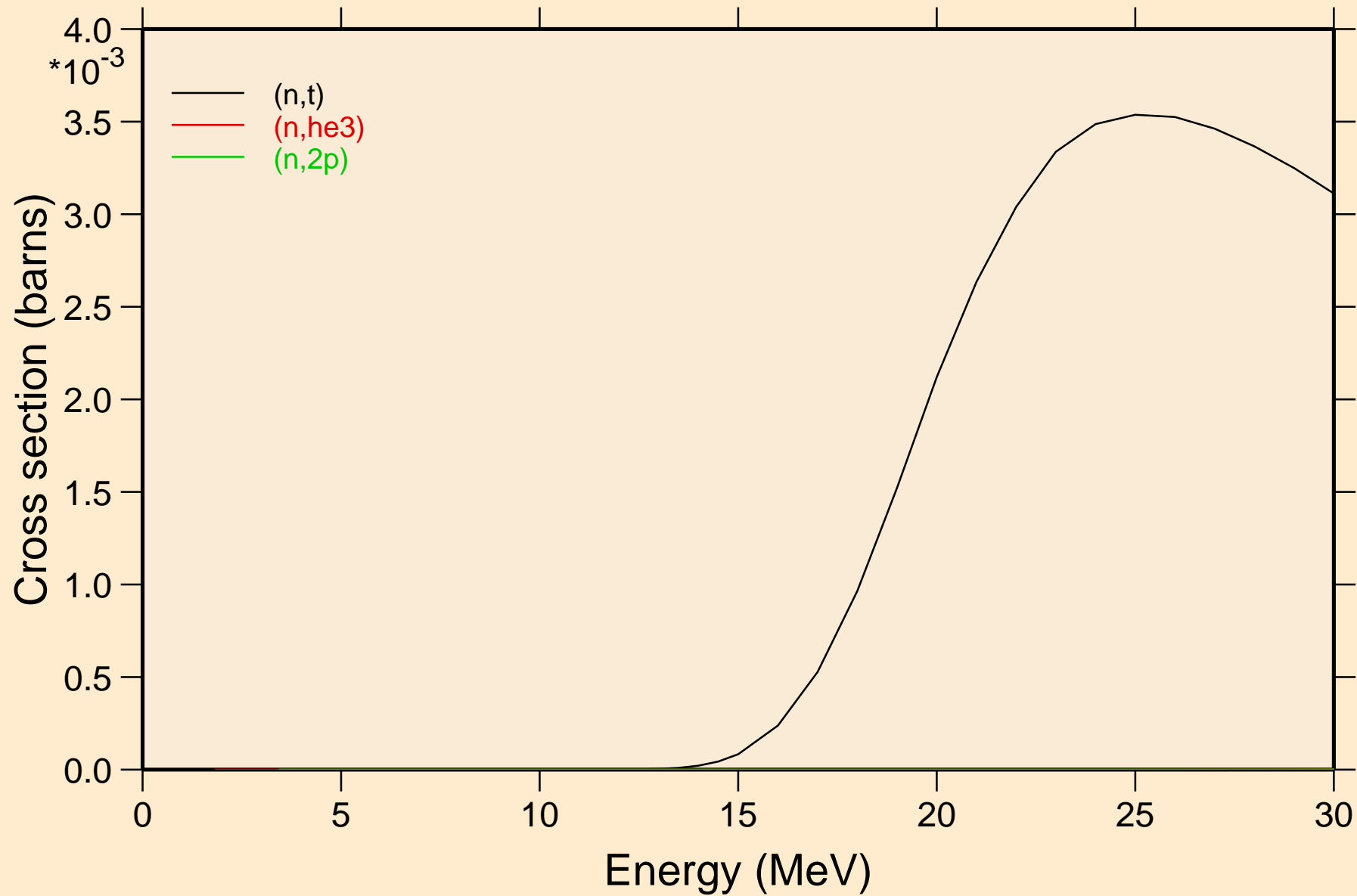

HS279 NEUTRON ACER TENDL-2023 LIBRARY; T=0.K

Threshold reactions

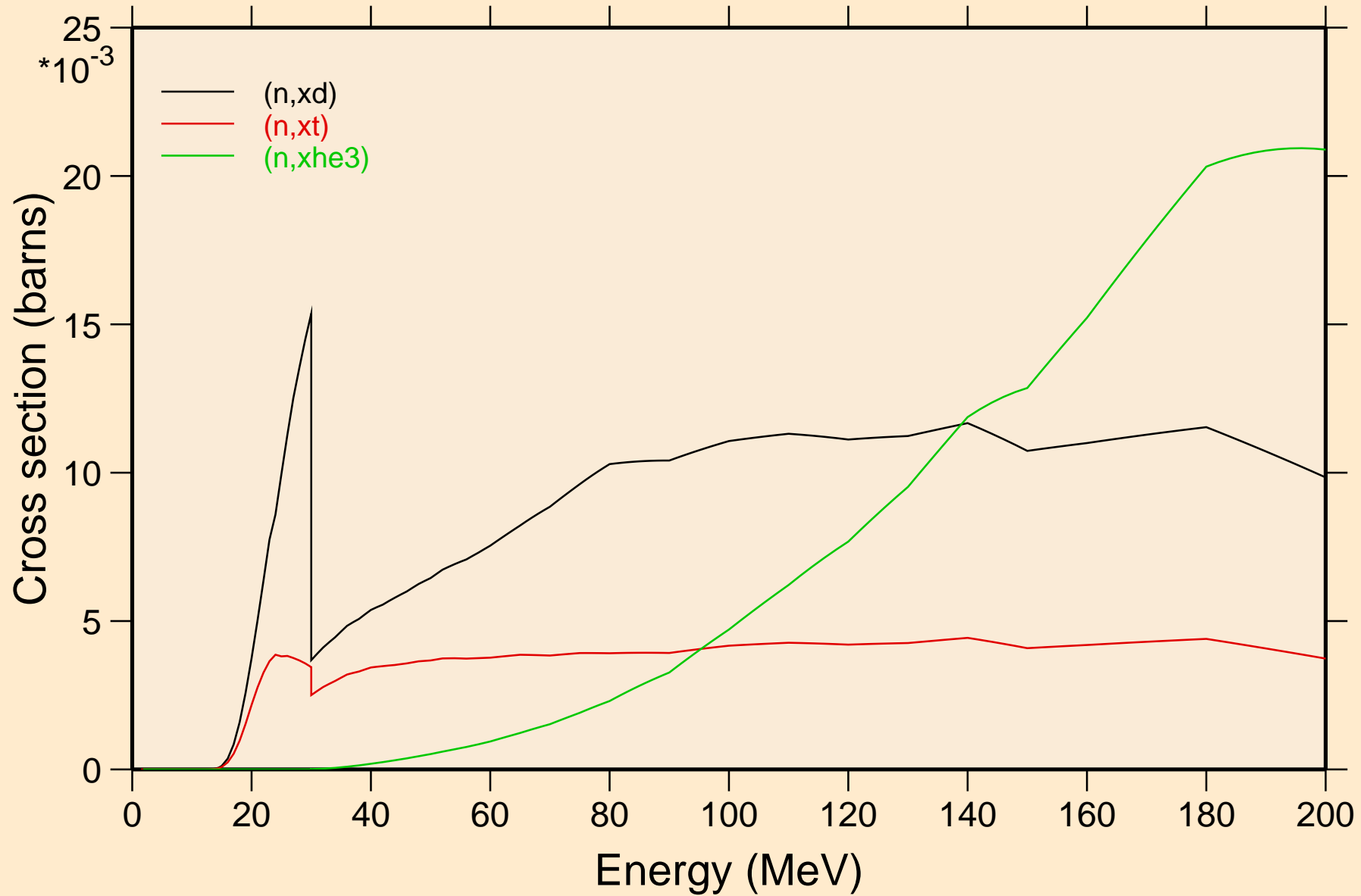

HS279 NEUTRON ACER TENDL-2023 LIBRARY; T=0.K
angular distribution for elastic

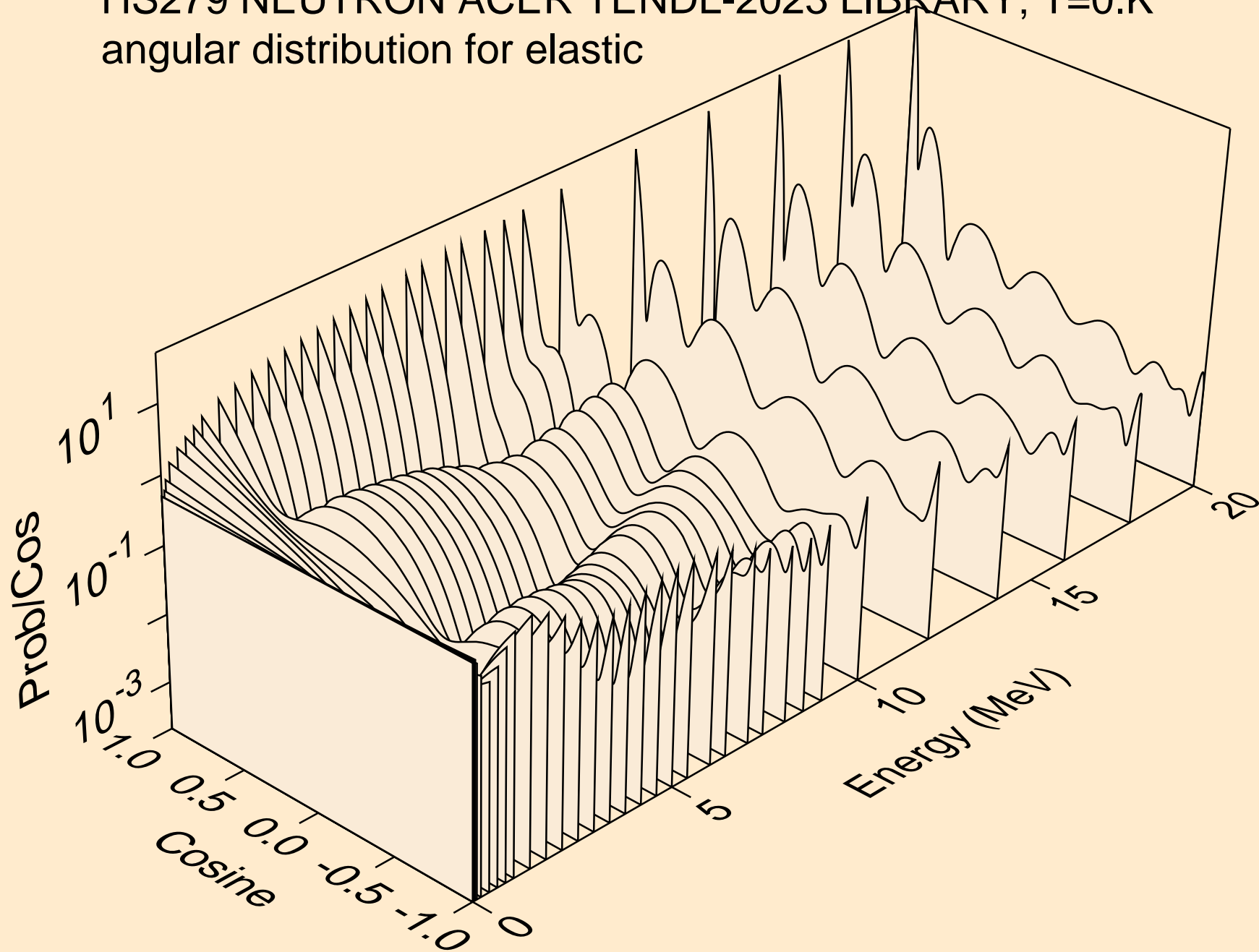

HS279 NEUTRON ACER TENDL-2023 LIBRARY; T=0.K
angular distribution for elastic

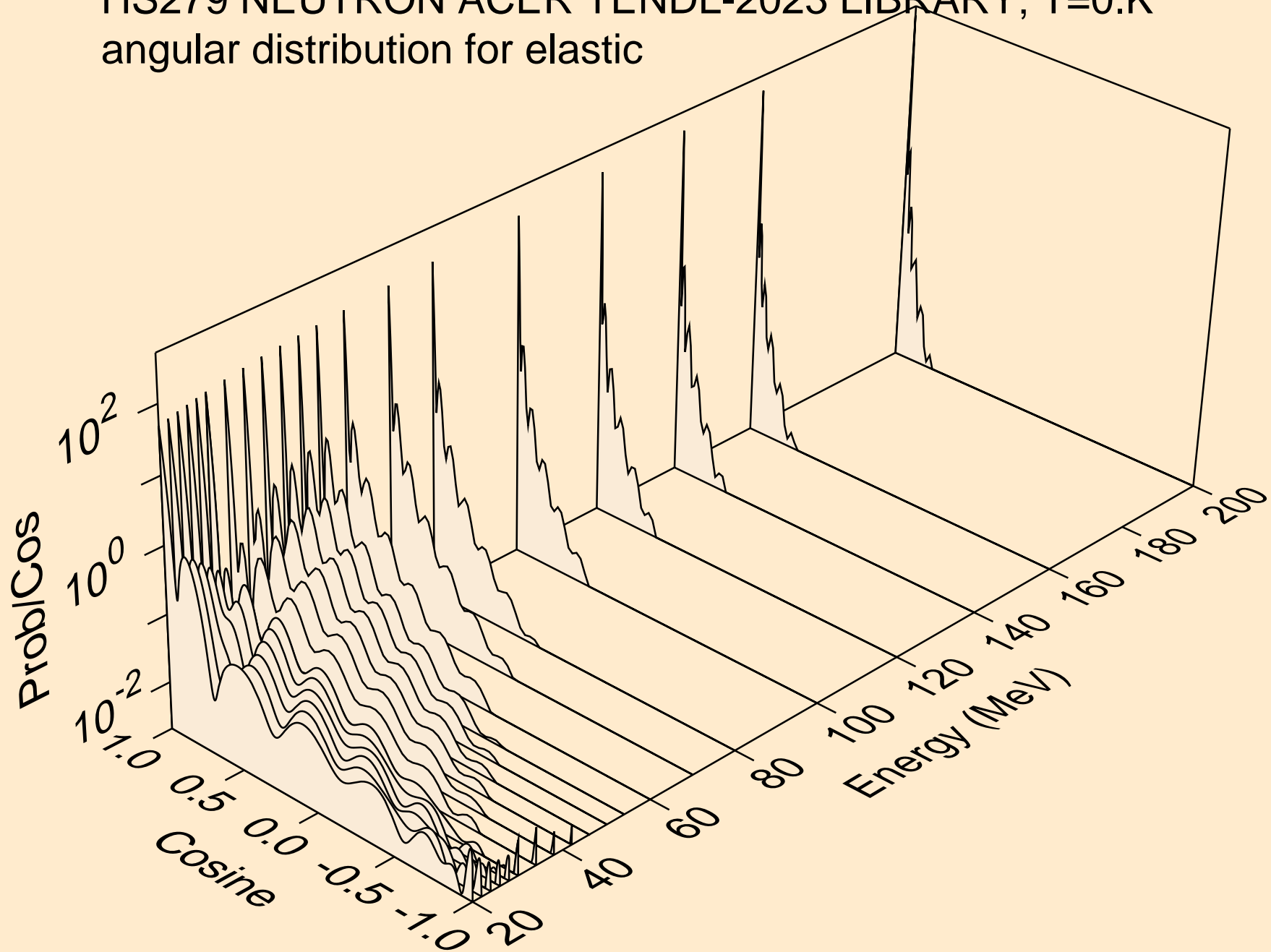

HS279 NEUTRON ACER TENDL-2023 LIBRARY; T=0.K
angular distribution for (n,n*1)

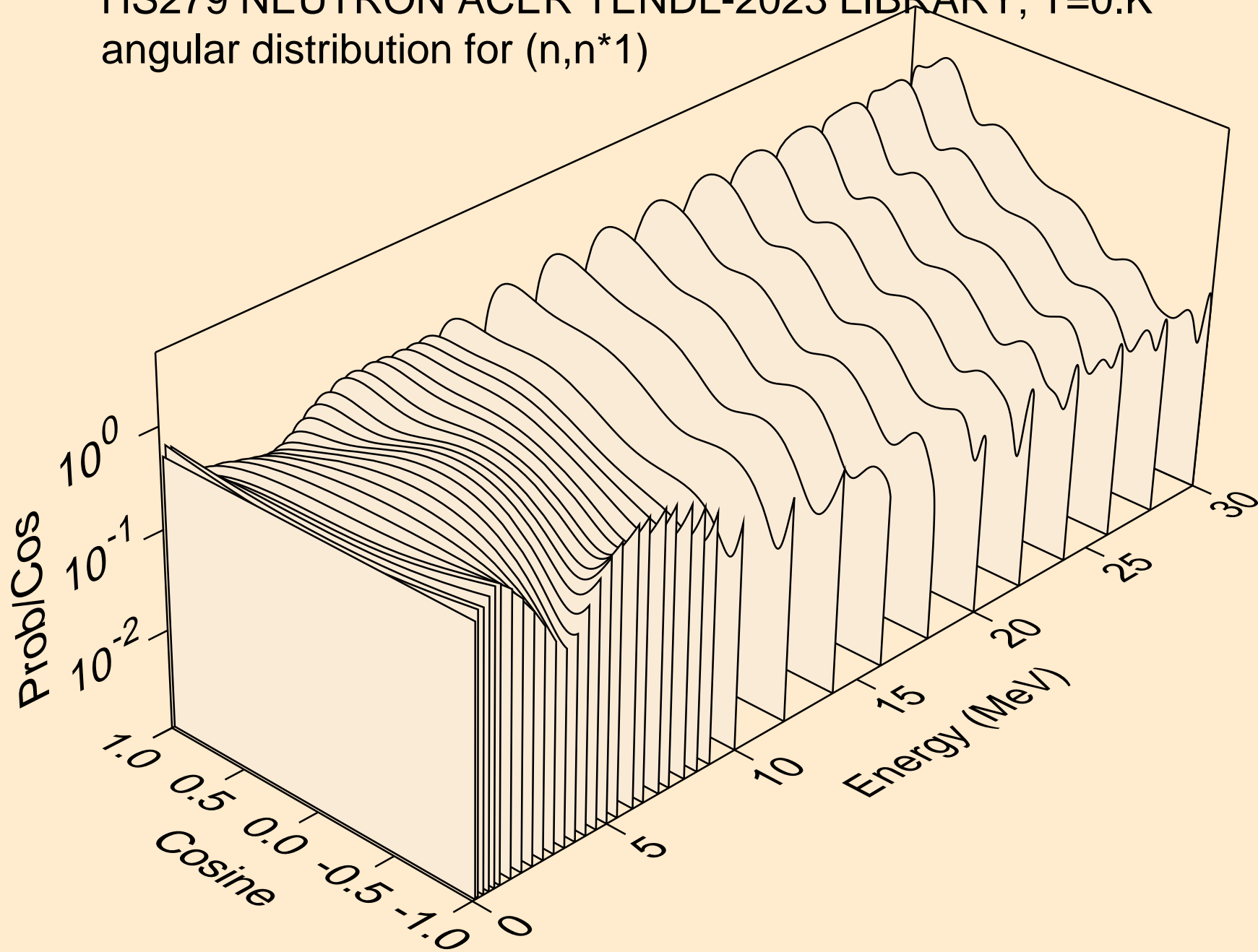

HS279 NEUTRON ACER TENDL-2023 LIBRARY; T=0.K
angular distribution for (n,n*2)

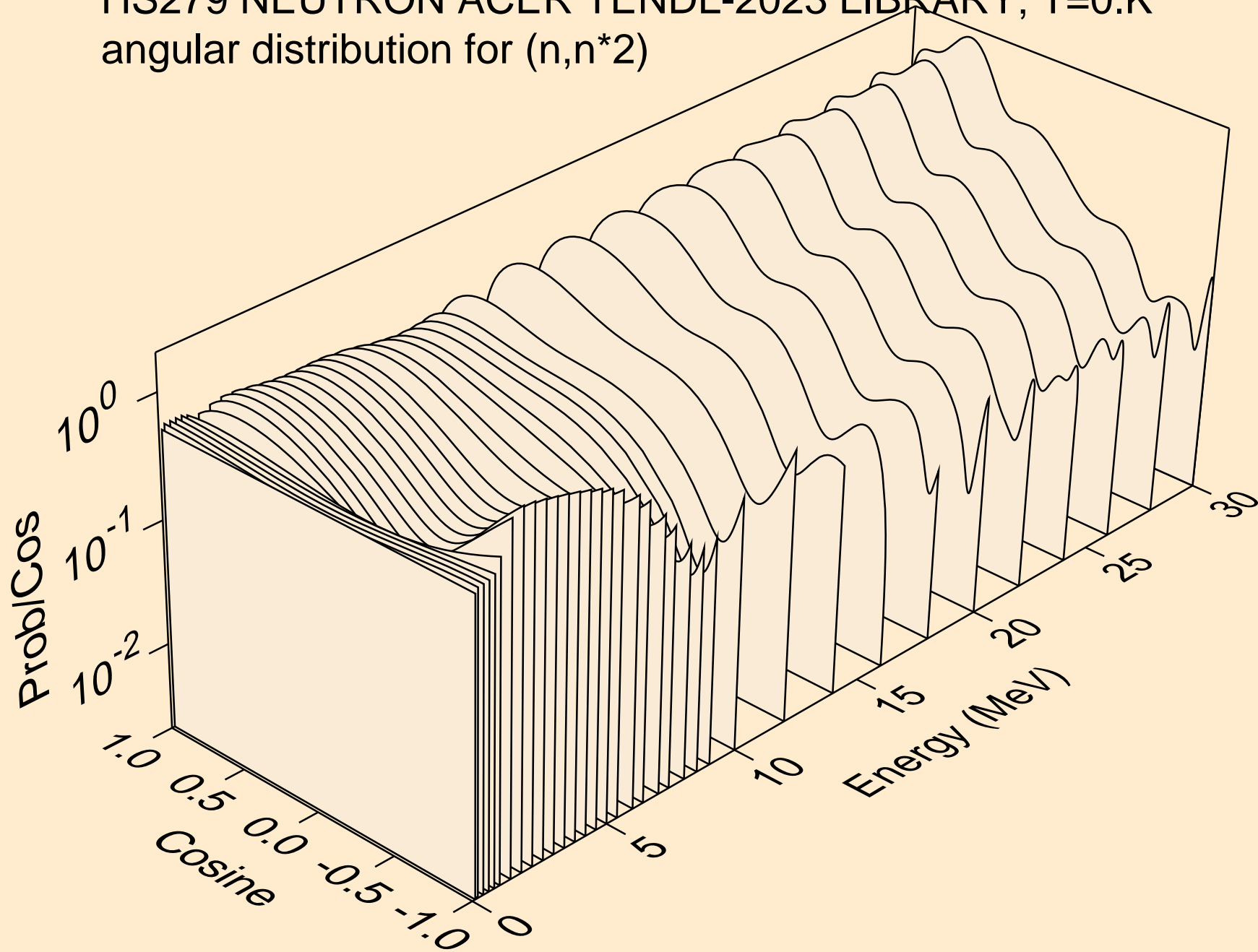

HS279 NEUTRON ACER TENDL-2023 LIBRARY; T=0.K
angular distribution for (n,n*3)

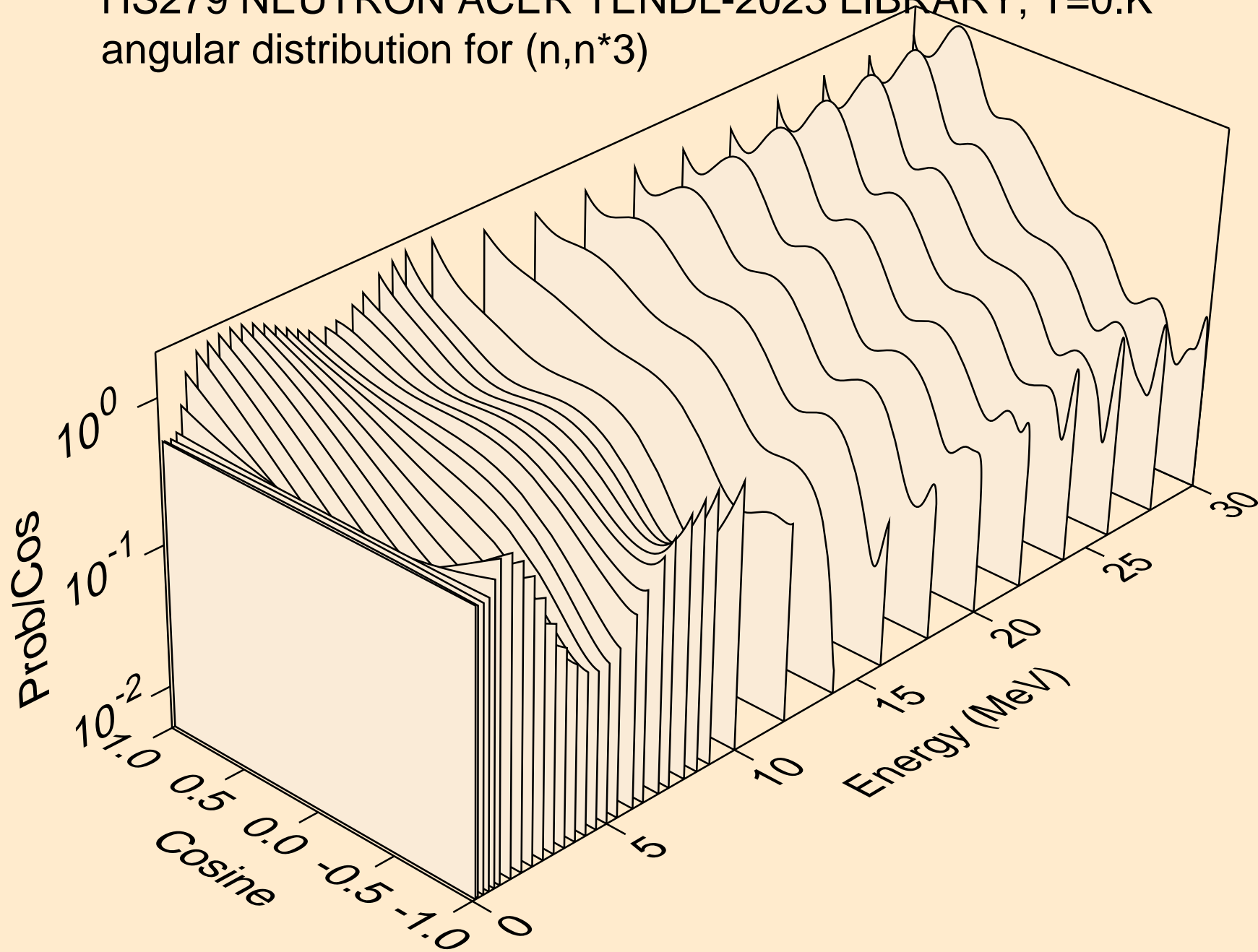

HS279 NEUTRON ACER TENDL-2023 LIBRARY; T=0.K
angular distribution for (n,n*4)

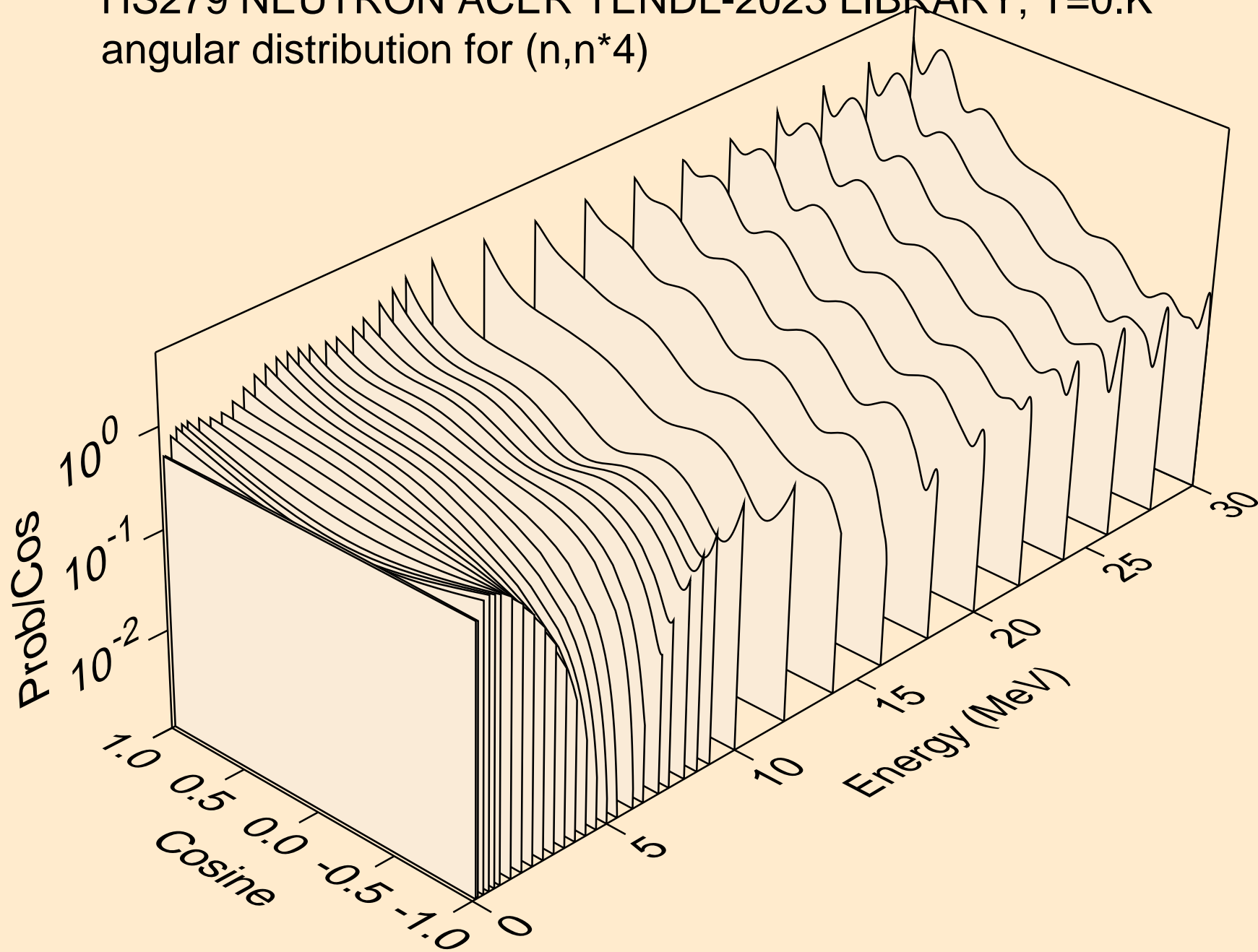

HS279 NEUTRON ACER TENDL-2023 LIBRARY; T=0.K
angular distribution for (n,n*5)

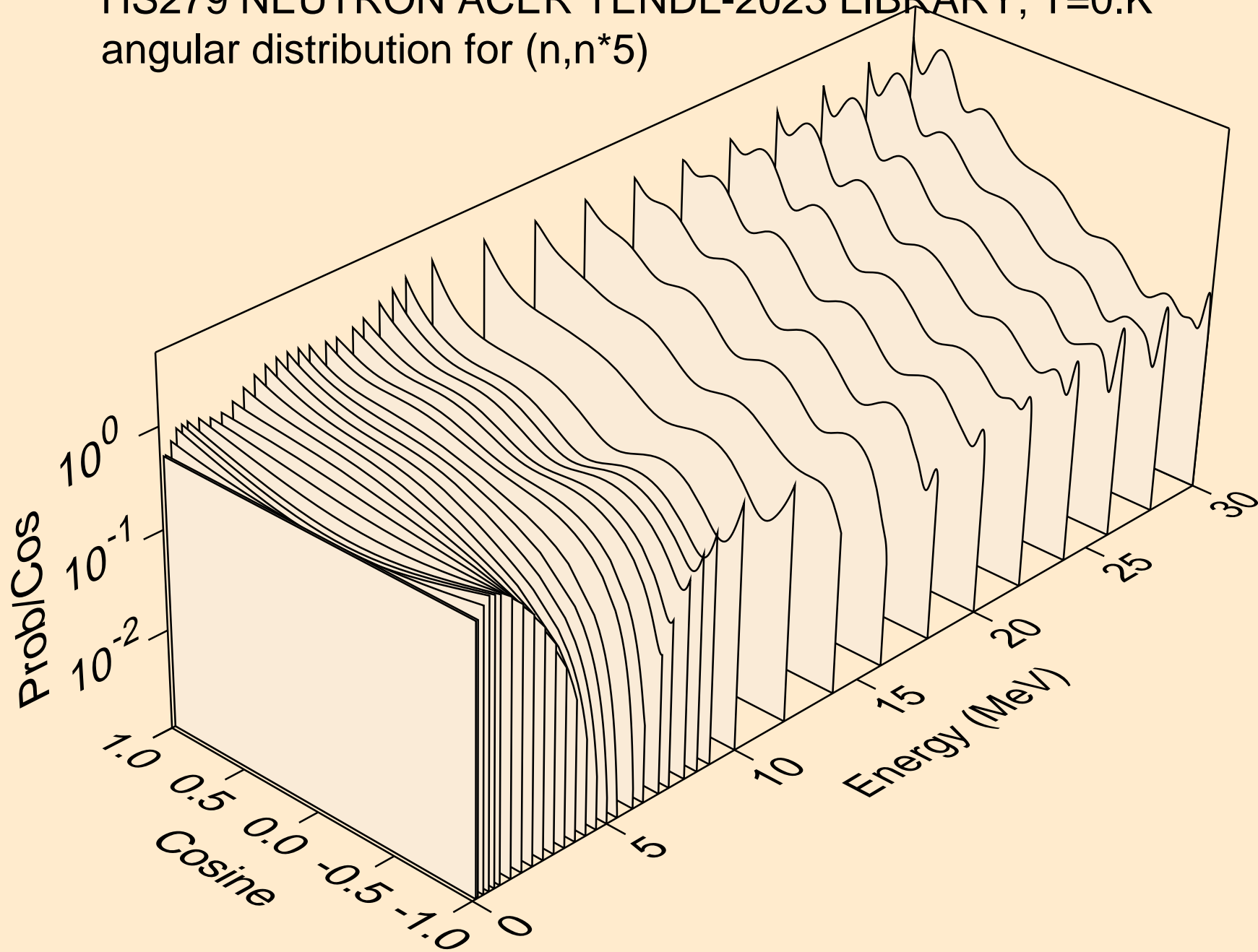

HS279 NEUTRON ACER TENDL-2023 LIBRARY; T=0.K
angular distribution for (n,n*6)

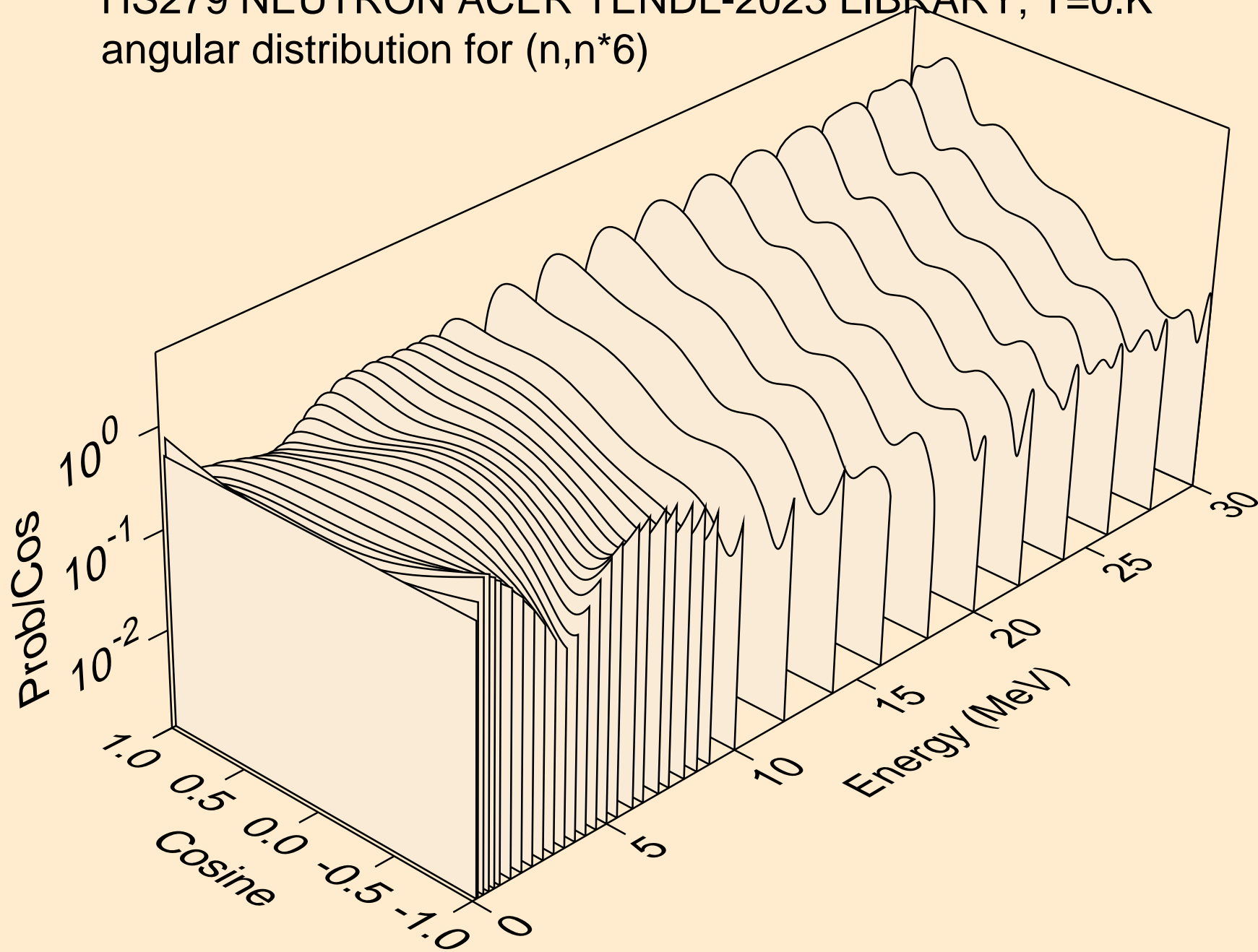

HS279 NEUTRON ACER TENDL-2023 LIBRARY; T=0.K
angular distribution for (n,n*7)

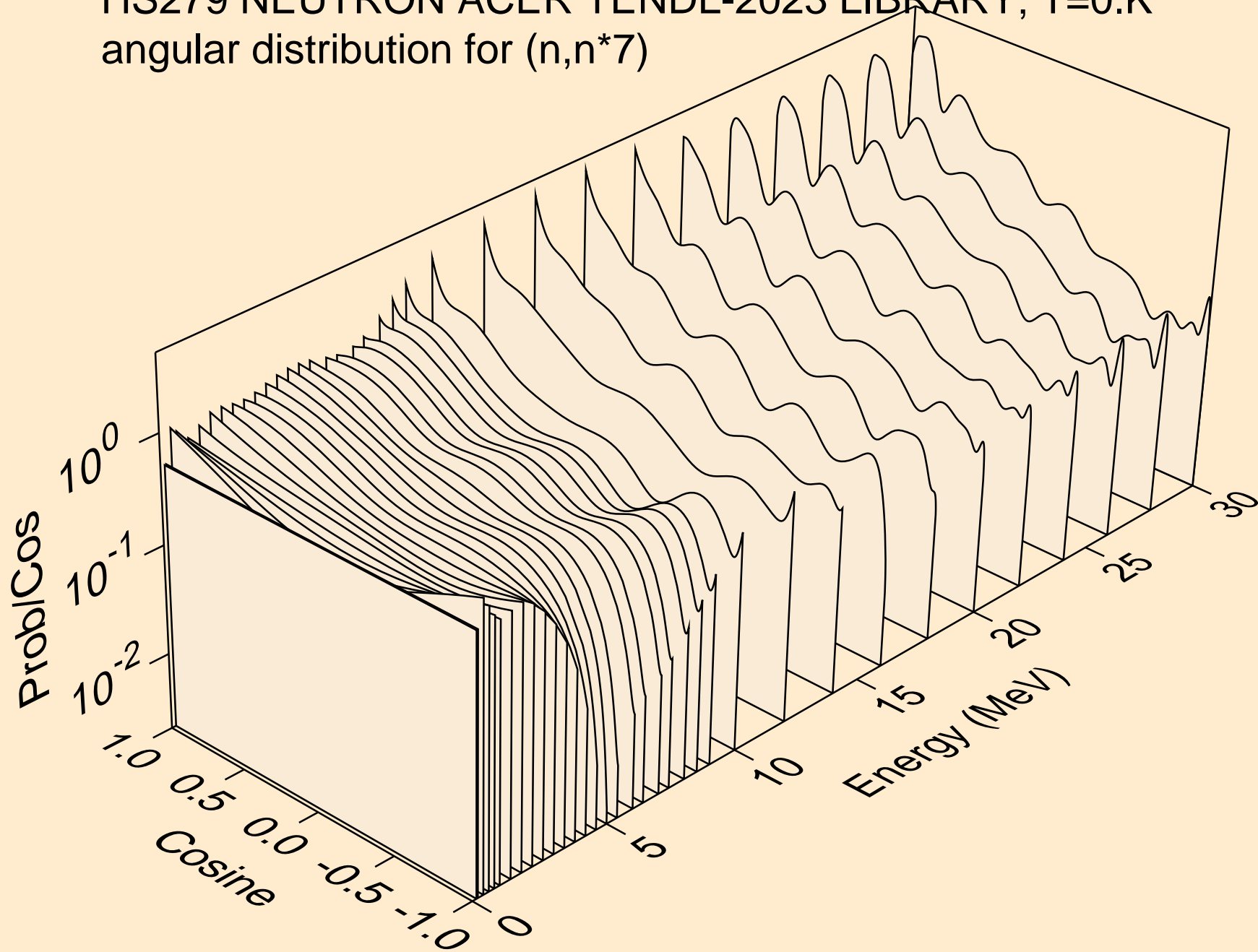

HS279 NEUTRON ACER TENDL-2023 LIBRARY; T=0.K
angular distribution for (n,n*8)

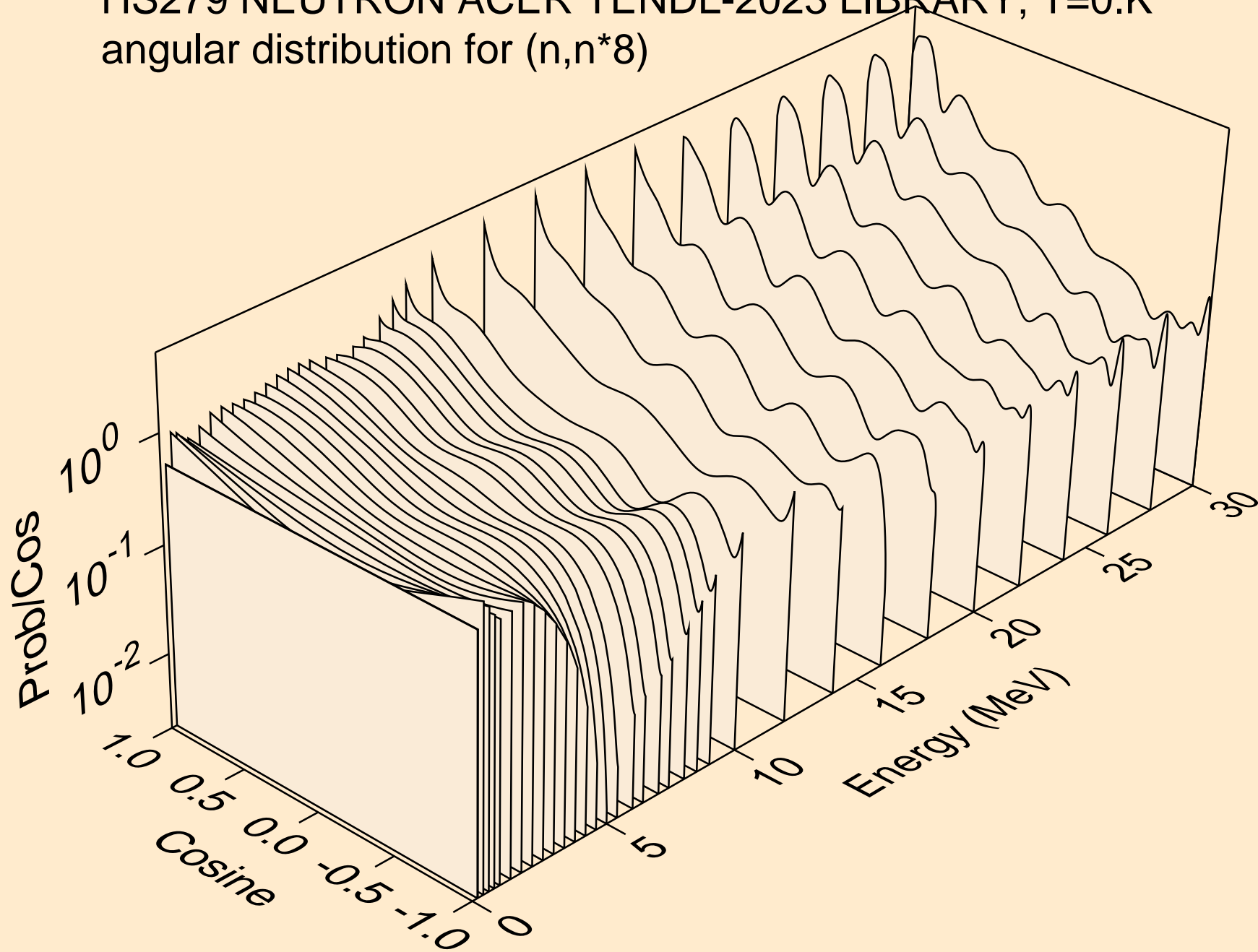

HS279 NEUTRON ACER TENDL-2023 LIBRARY; T=0.K
angular distribution for (n,n*9)

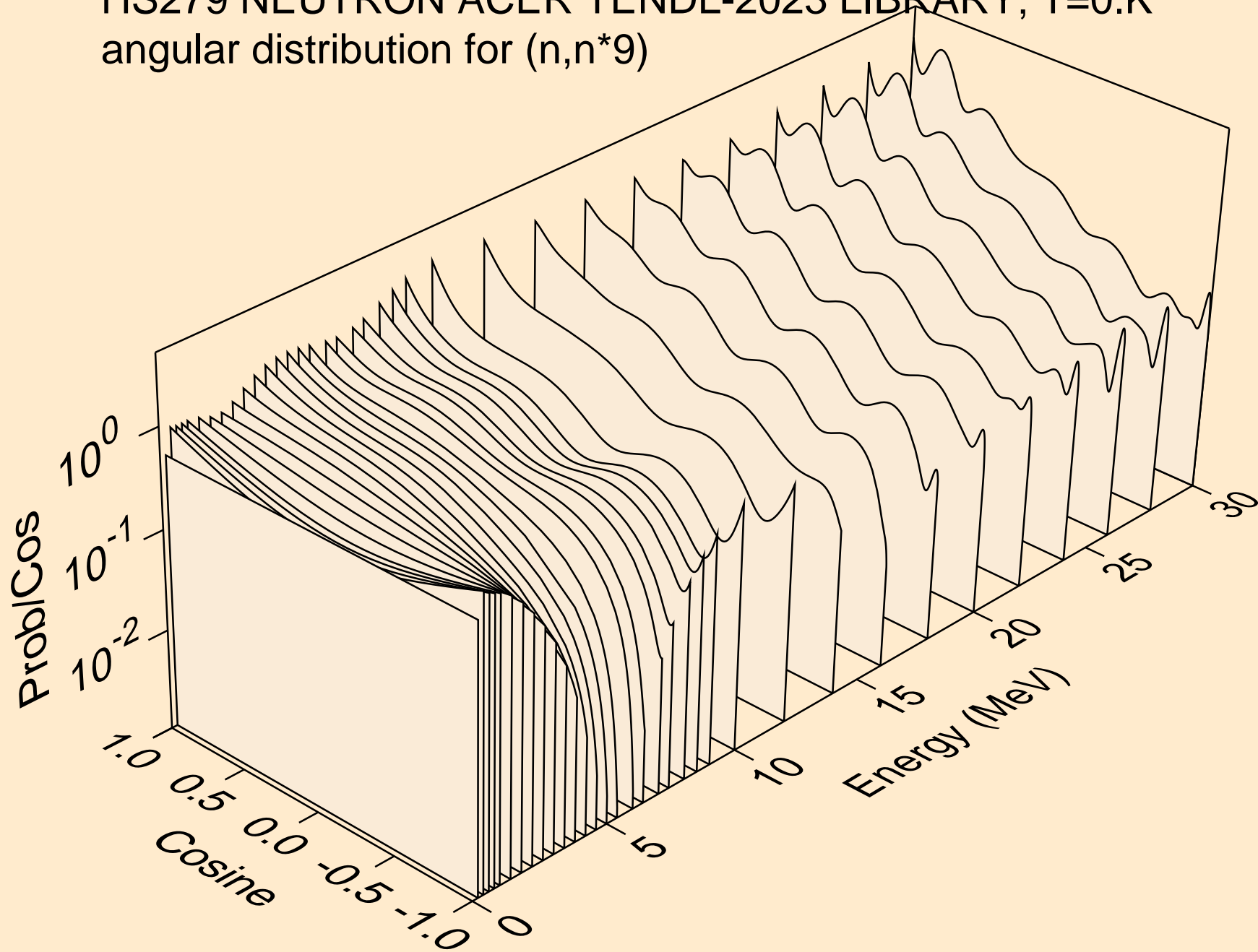

HS279 NEUTRON ACER TENDL-2023 LIBRARY; T=0.K
angular distribution for (n,n*10)

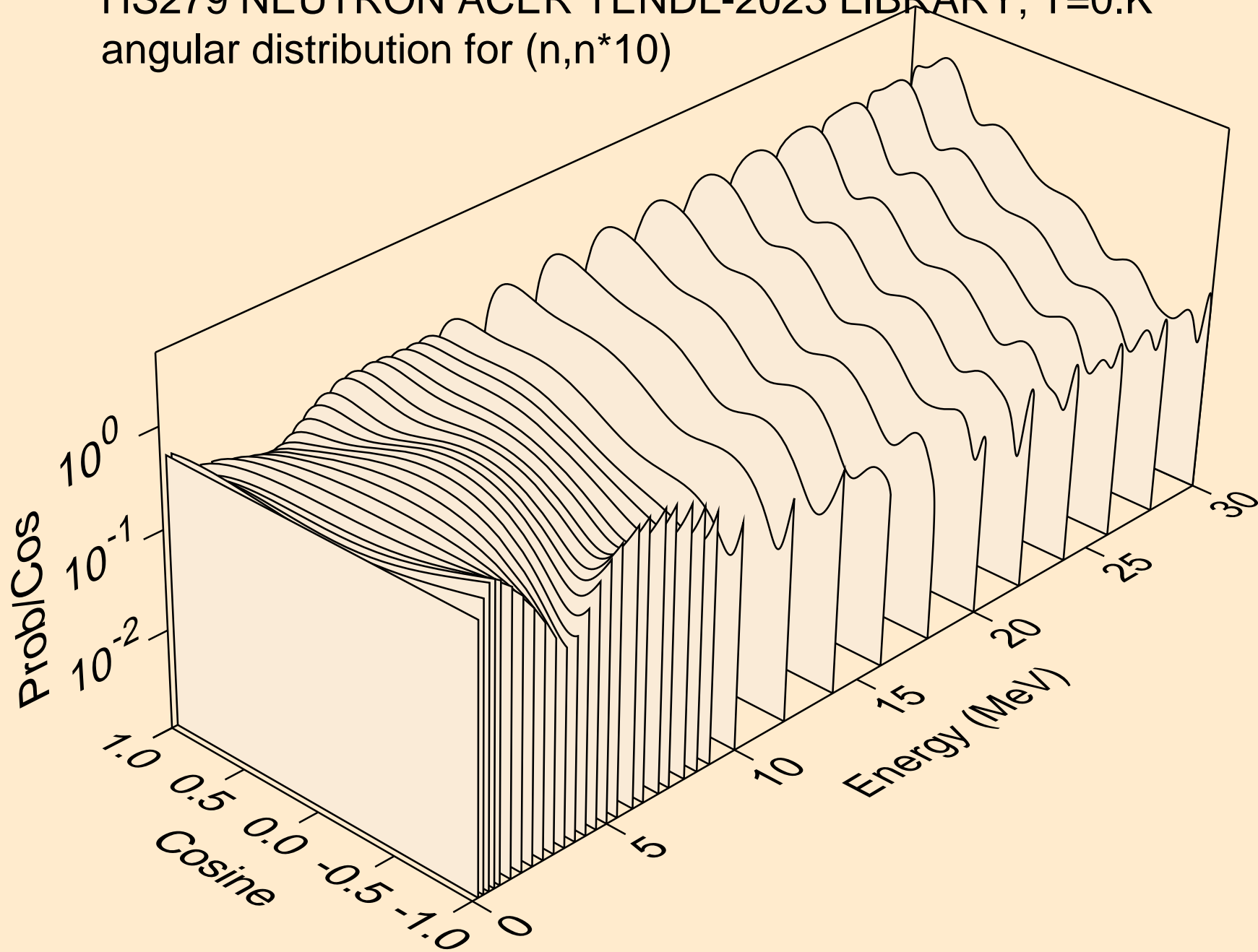

HS279 NEUTRON ACER TENDL-2023 LIBRARY; T=0.K
angular distribution for (n,n*11)

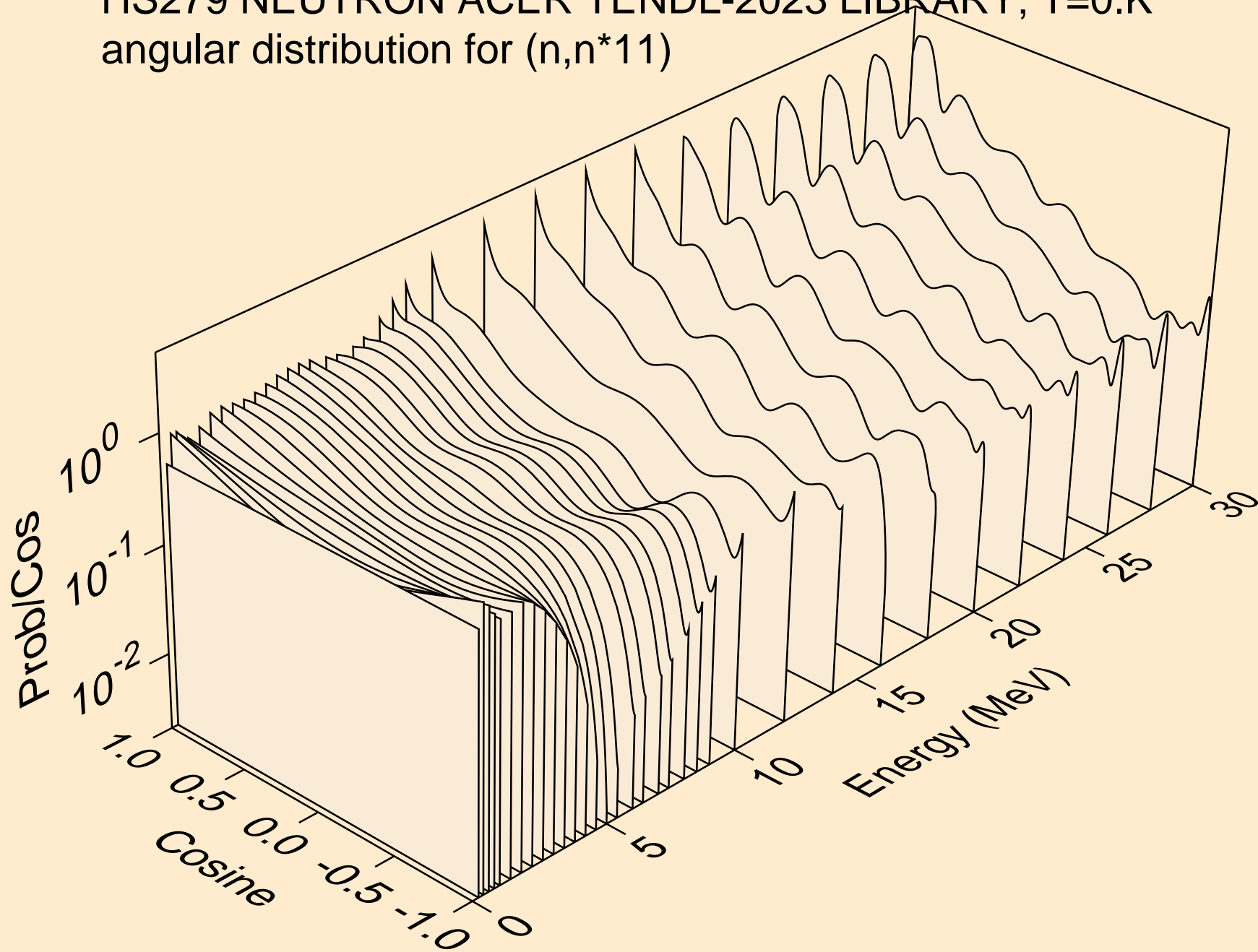

HS279 NEUTRON ACER TENDL-2023 LIBRARY; T=0.K
angular distribution for (n,n*12)

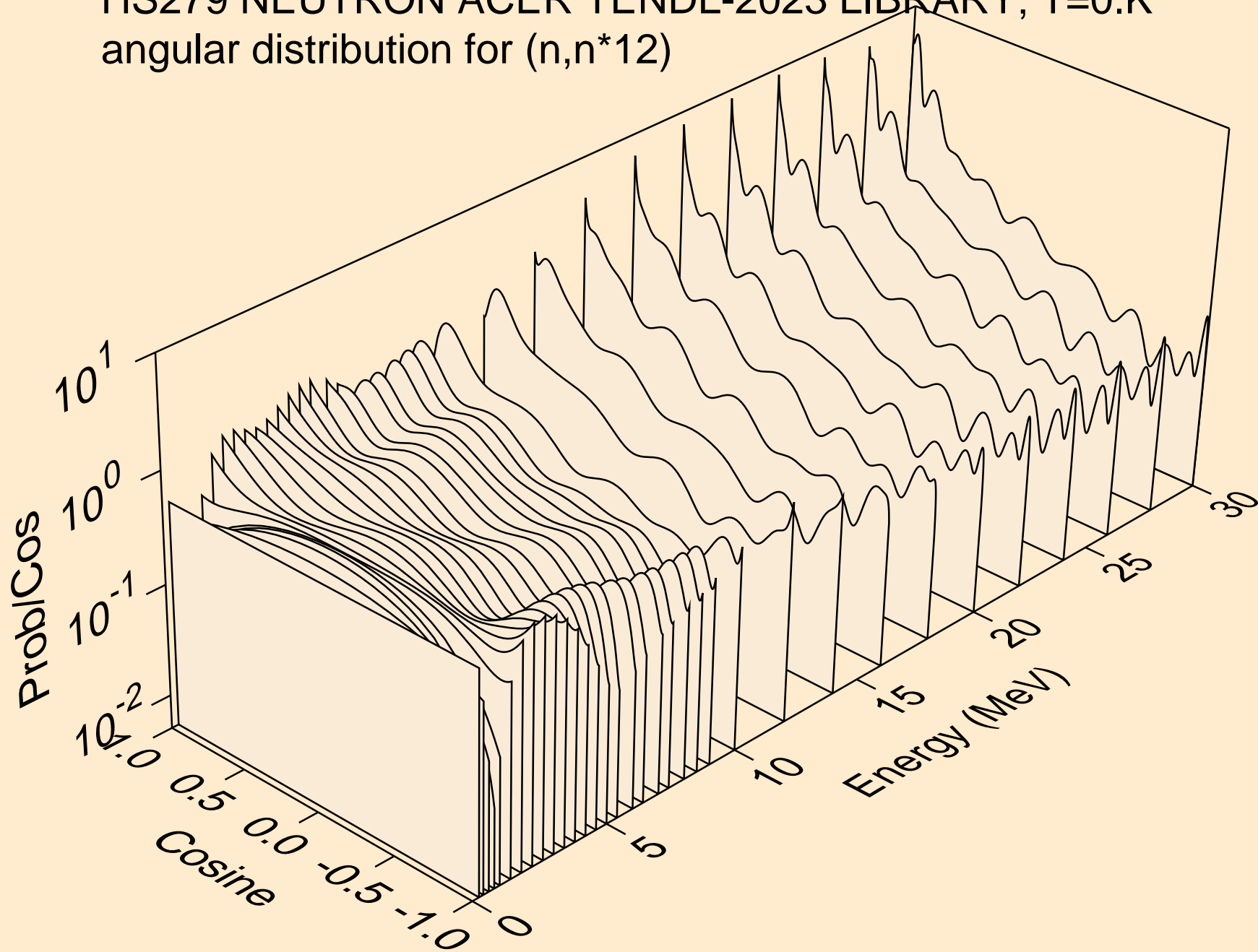

HS279 NEUTRON ACER TENDL-2023 LIBRARY; T=0.K

Total fission nubar

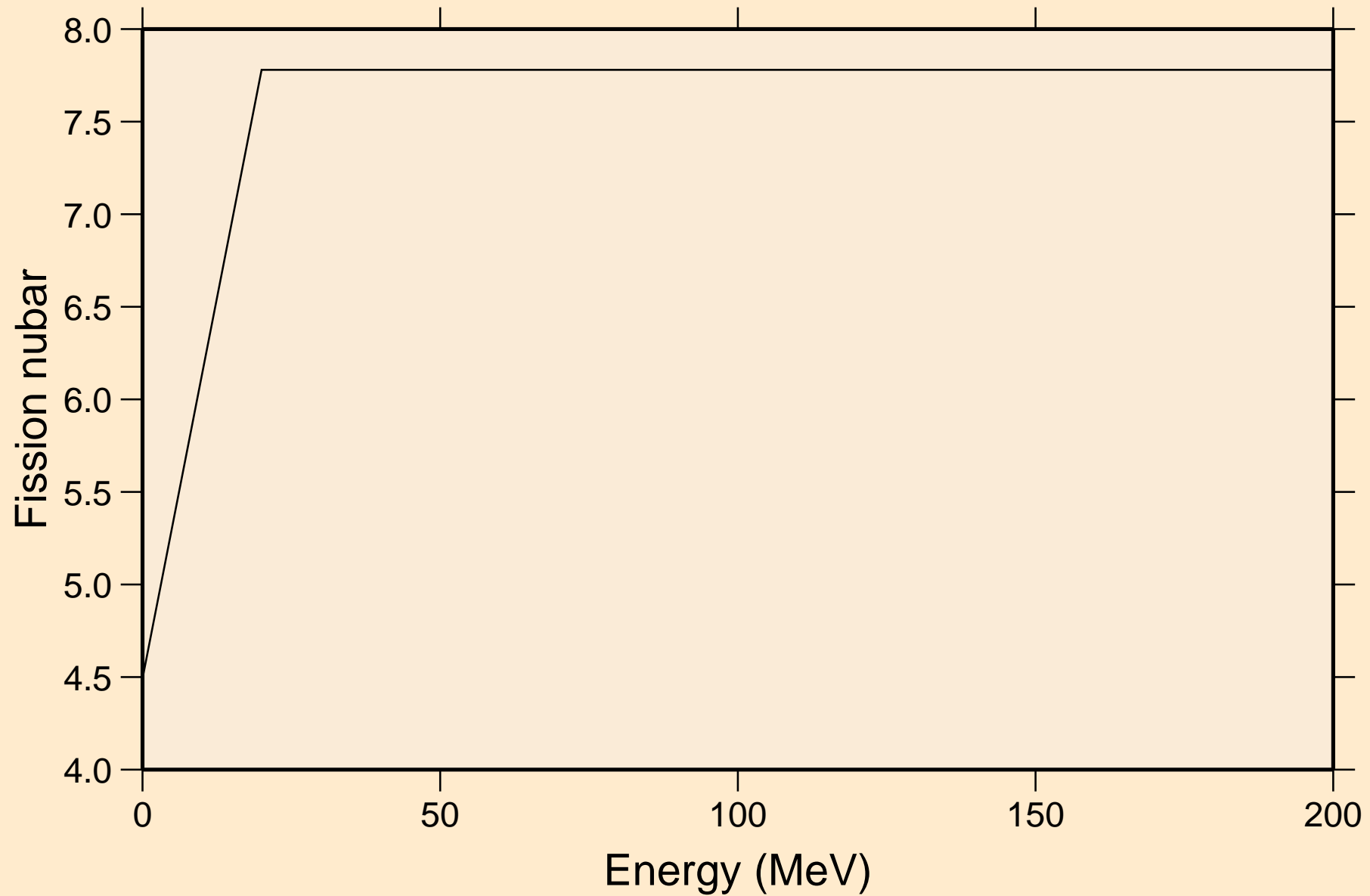

HS279 NEUTRON ACER TENDL-2023 LIBRARY; T=0.K
Neutron emission for (n,x)

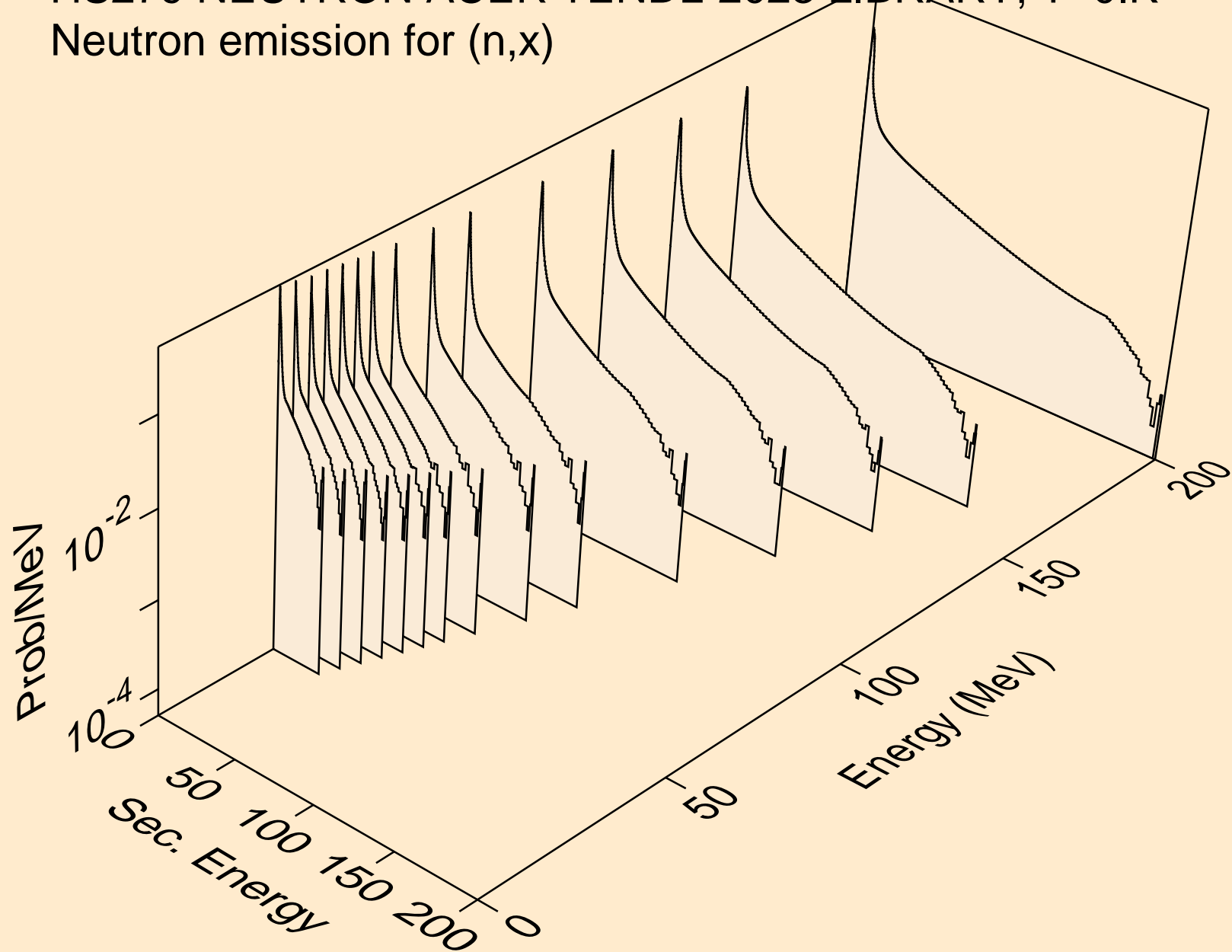

HS279 NEUTRON ACER TENDL-2023 LIBRARY; T=0.K
Neutron emission for (n,2nd)

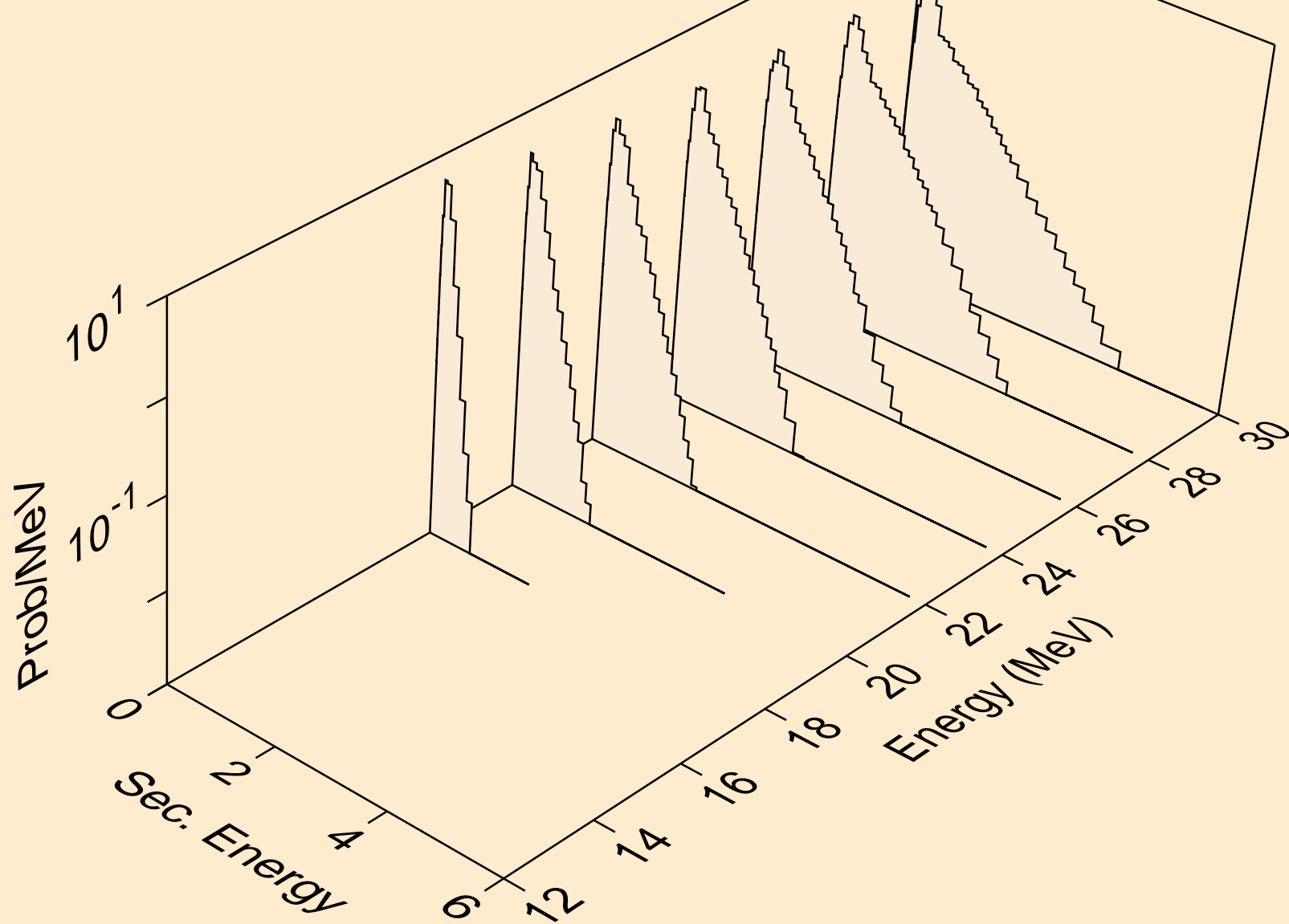

HS279 NEUTRON ACER TENDL-2023 LIBRARY; T=0.K
Neutron emission for (n,2n)

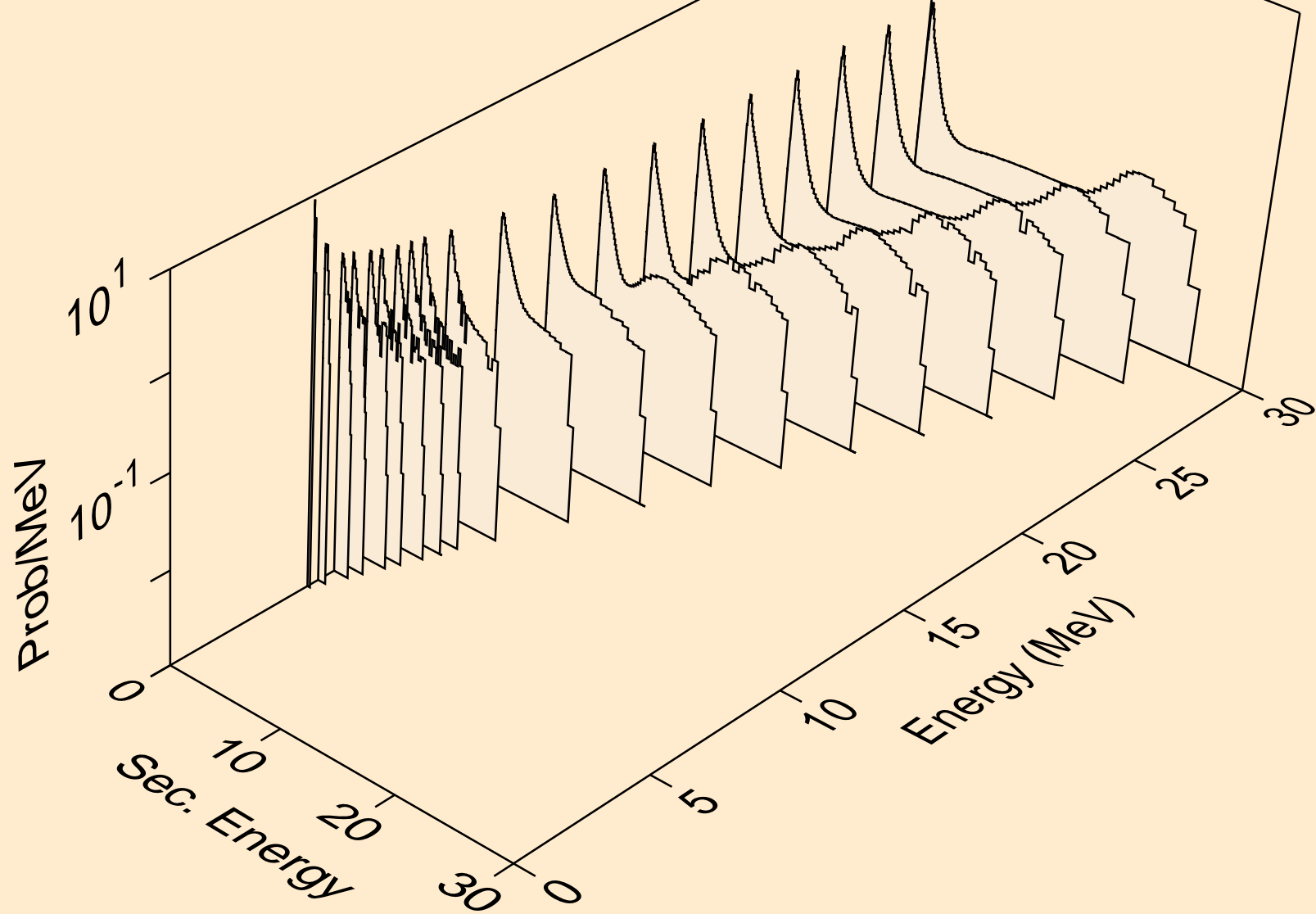

HS279 NEUTRON ACER TENDL-2023 LIBRARY; T=0.K
Neutron emission for (n,3n)

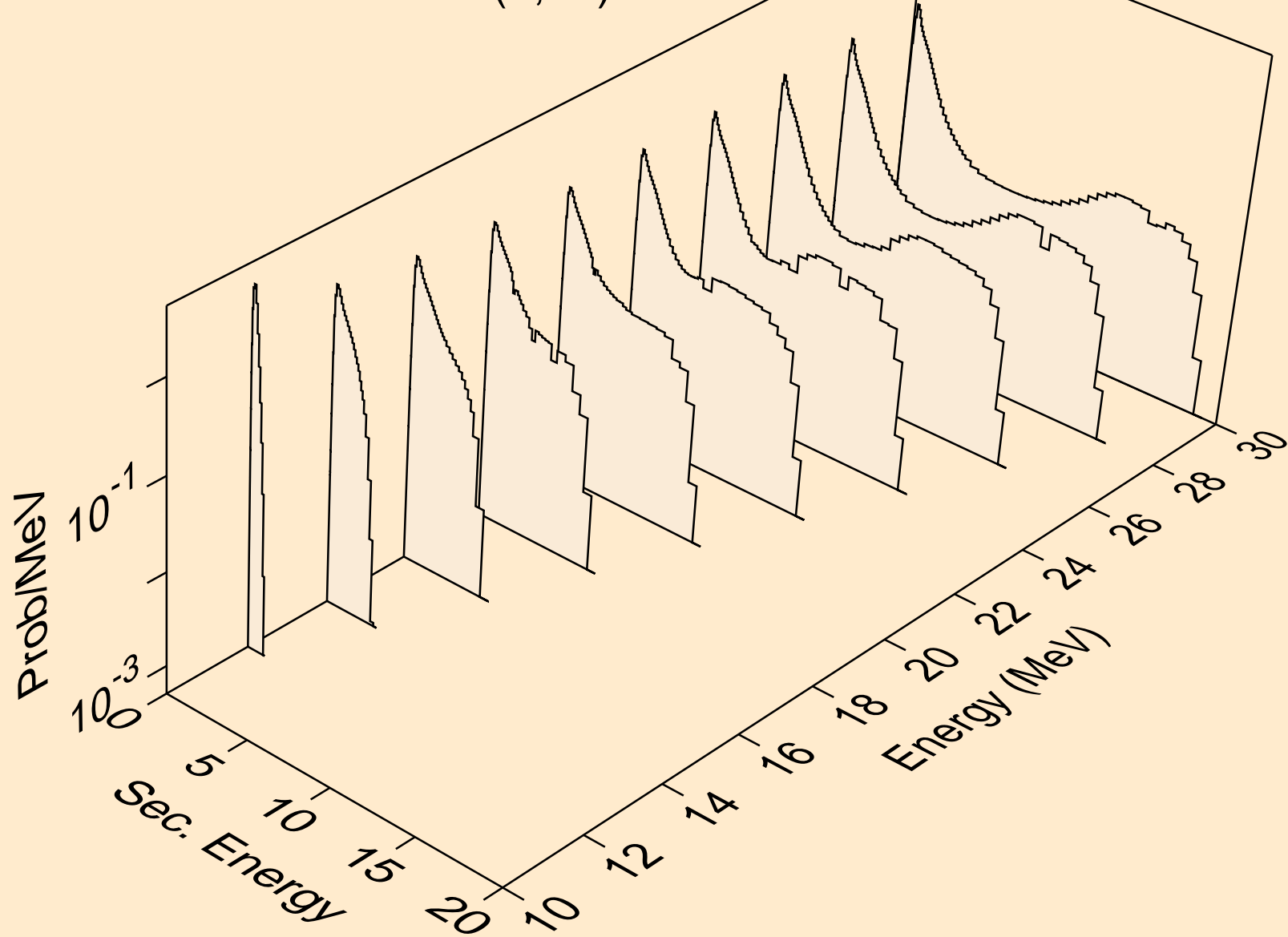

HS279 NEUTRON ACER TENDL-2023 LIBRARY; T=0.K
Neutron emission for fission

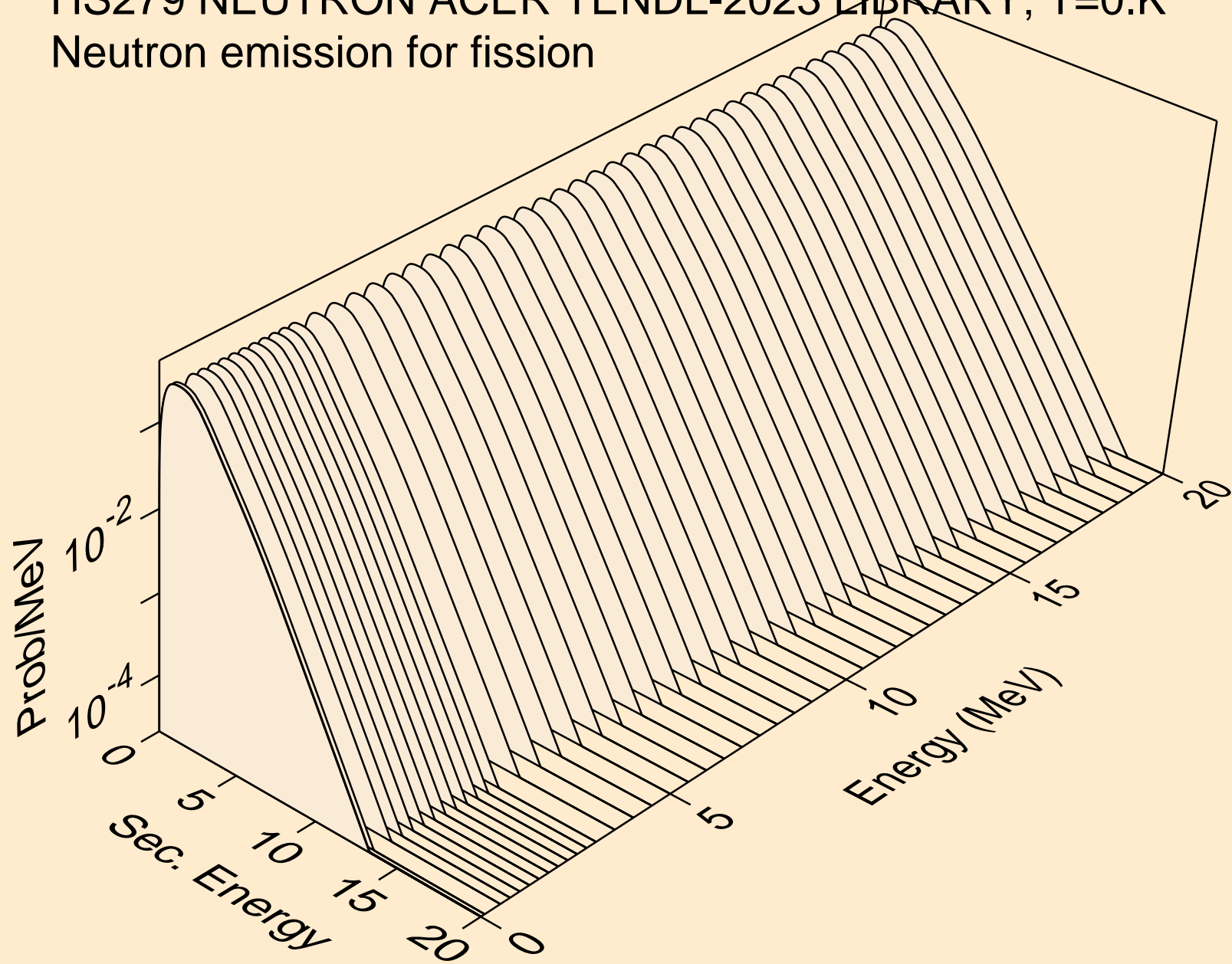

HS279 NEUTRON ACER TENDL-2023 LIBRARY; T=0.K
Neutron emission for (n,n*)a

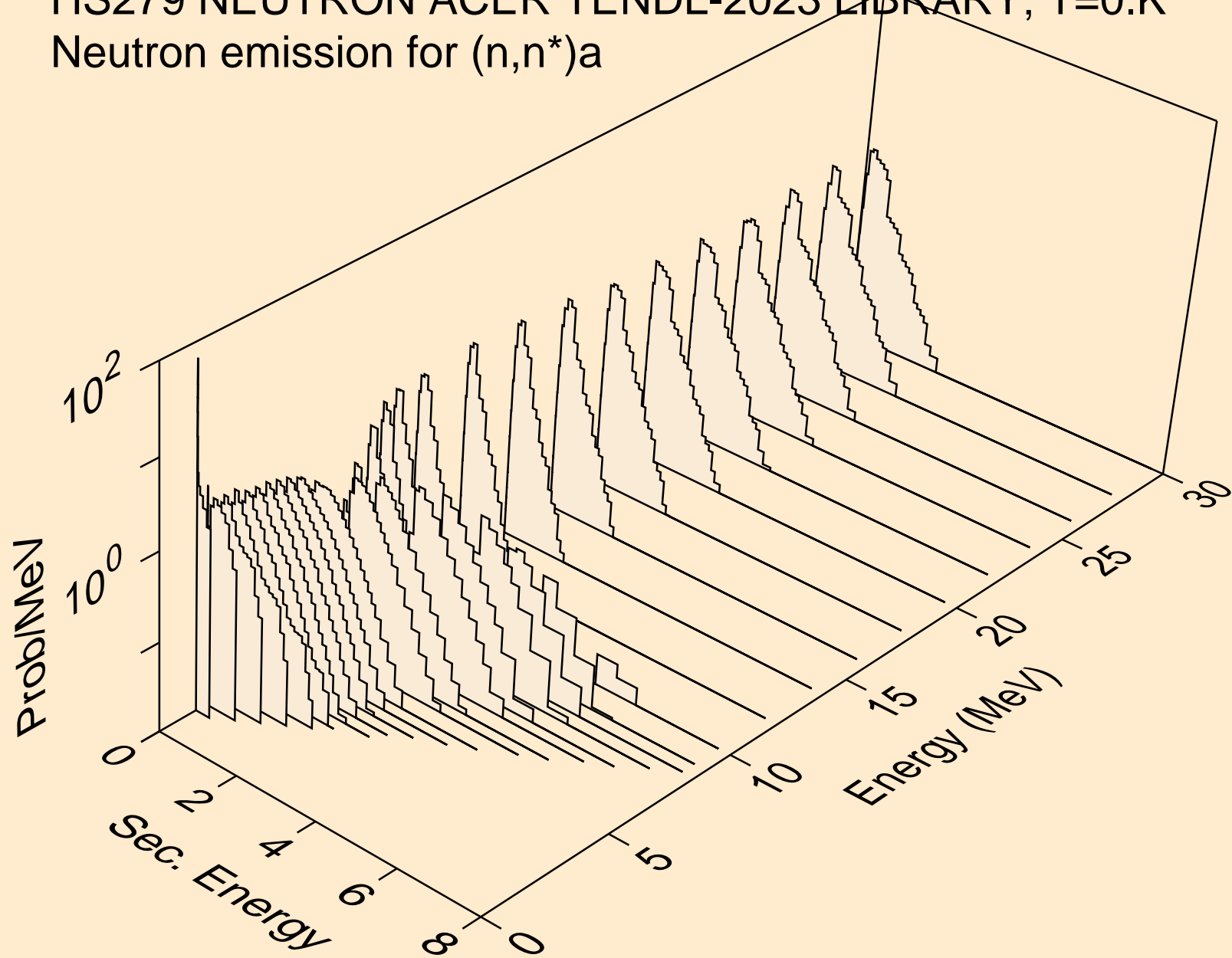

HS279 NEUTRON ACER TENDL-2023 LIBRARY; T=0.K
Neutron emission for (n,2n)a

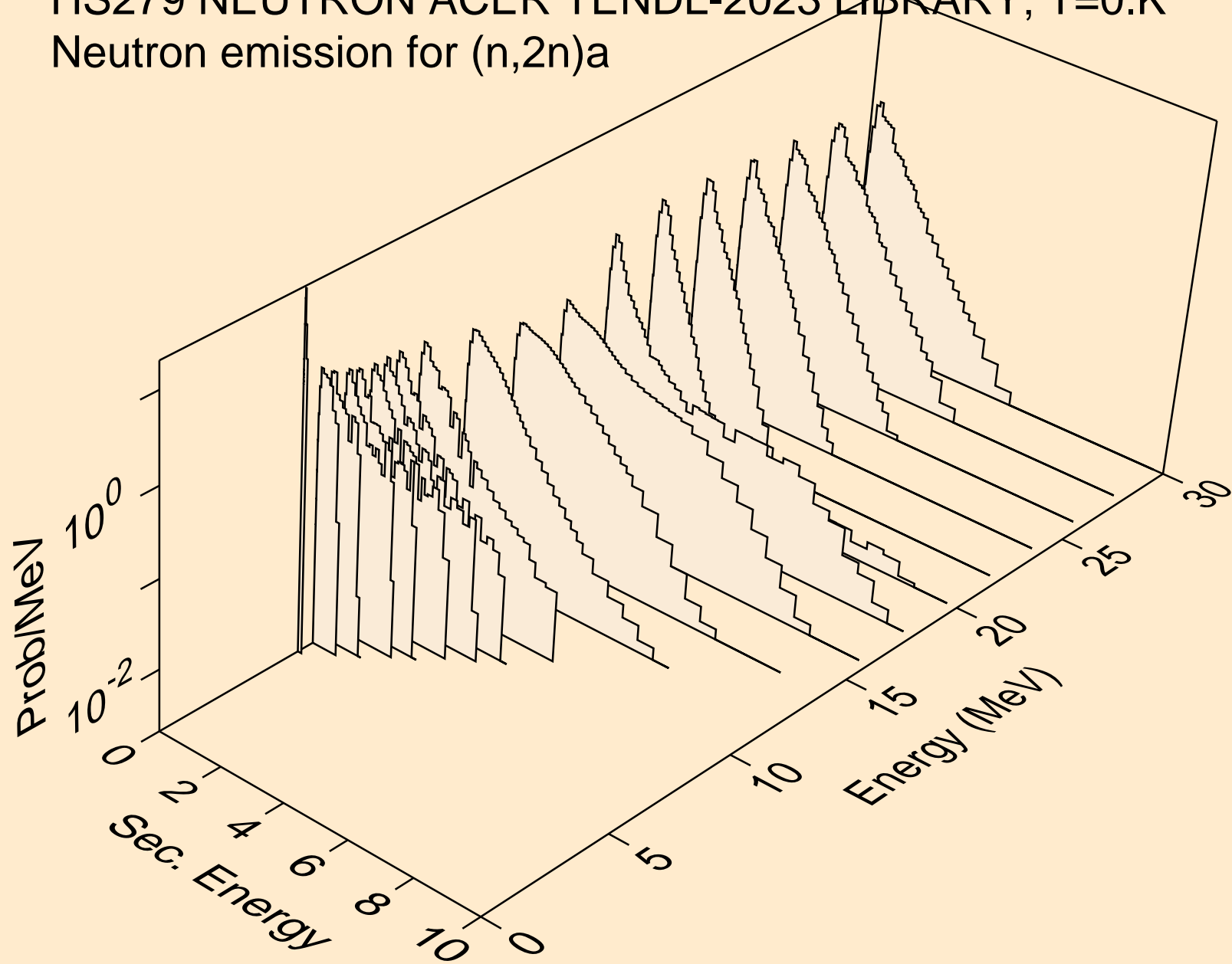

HS279 NEUTRON ACER TENDL-2023 LIBRARY; T=0.K
Neutron emission for (n,3n)a

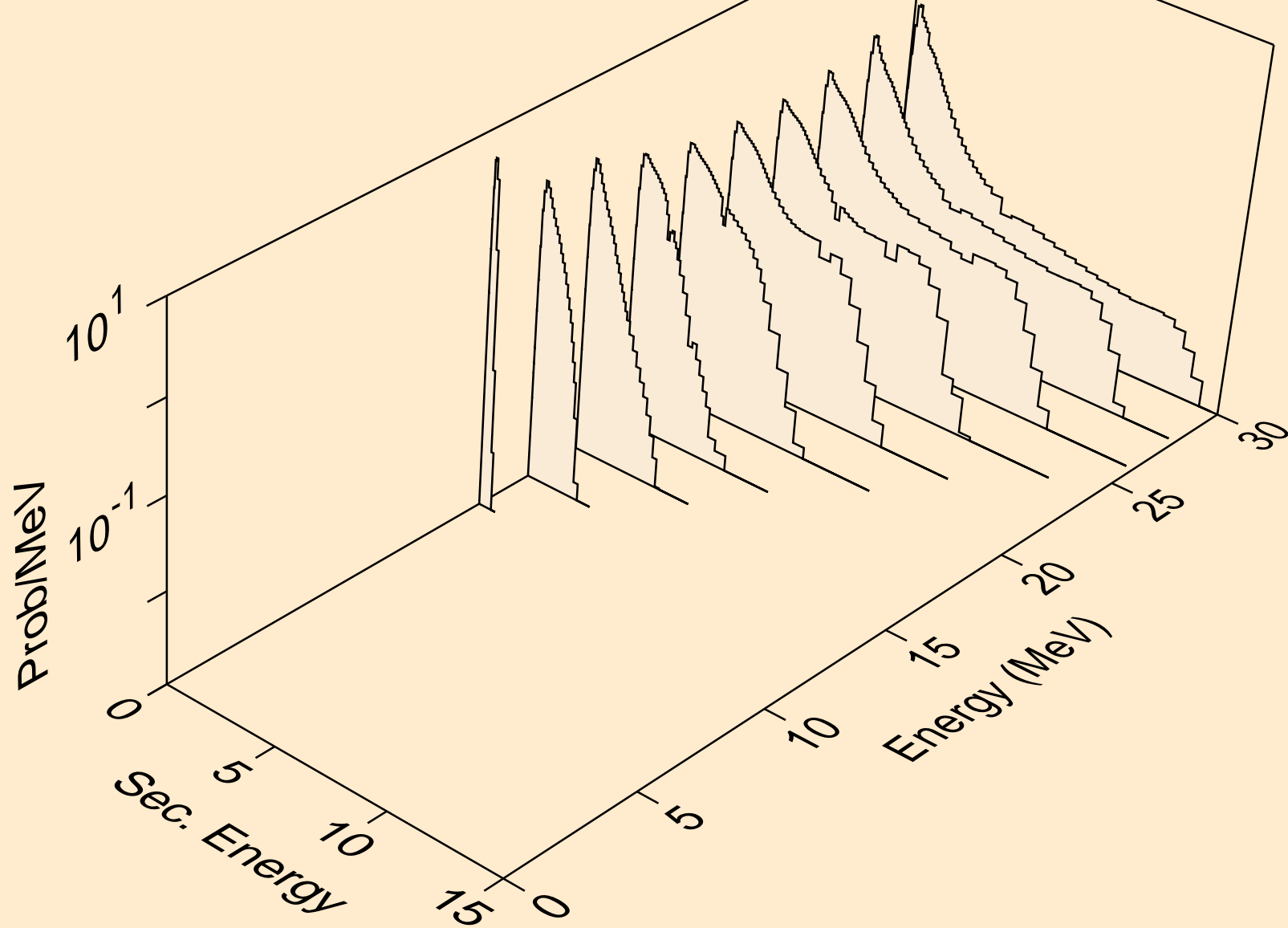

HS279 NEUTRON ACER TENDL-2023 LIBRARY; T=0.K
Neutron emission for (n,n*)p

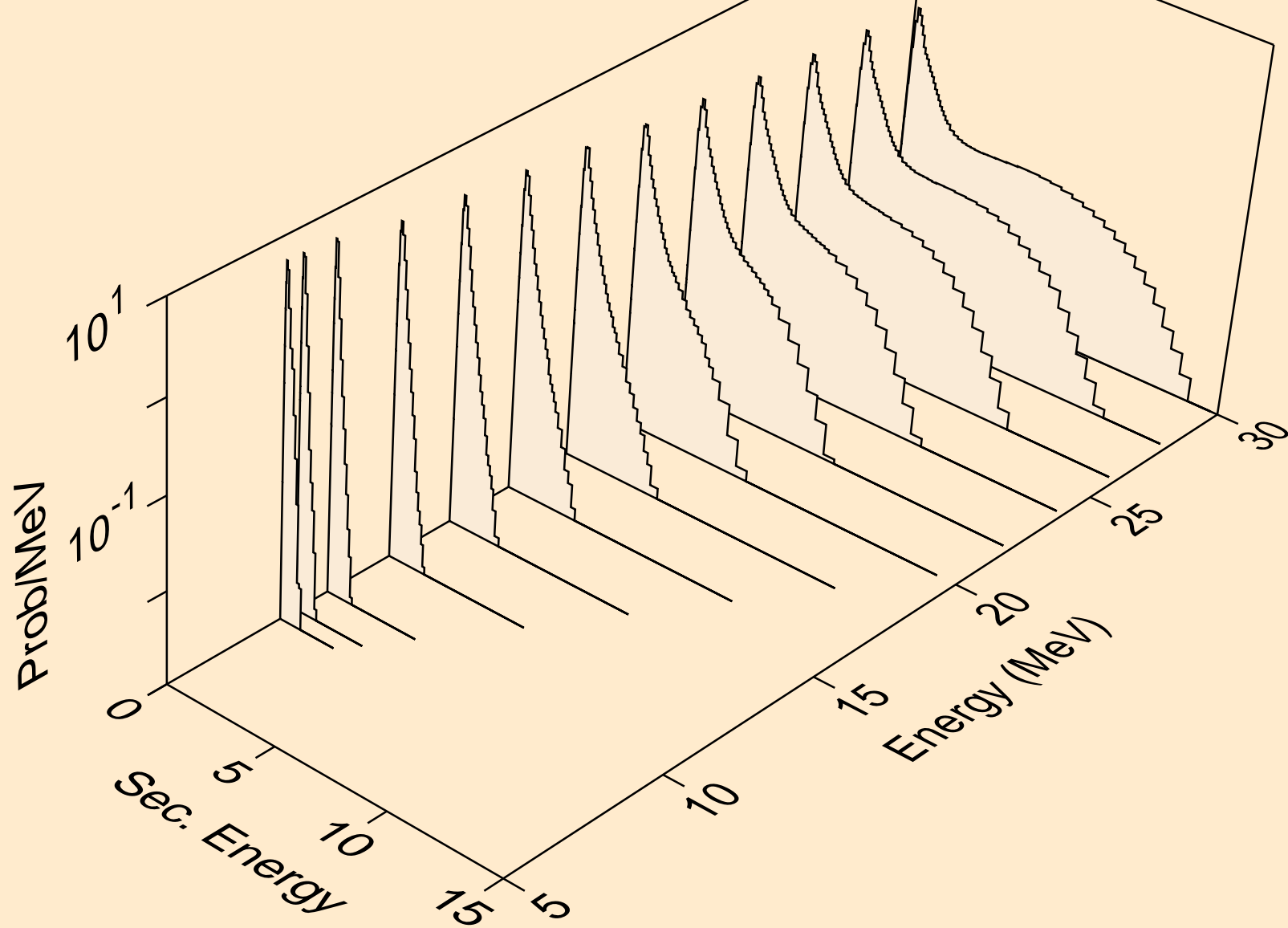

HS279 NEUTRON ACER TENDL-2023 LIBRARY; T=0.K
Neutron emission for (n,n*)d

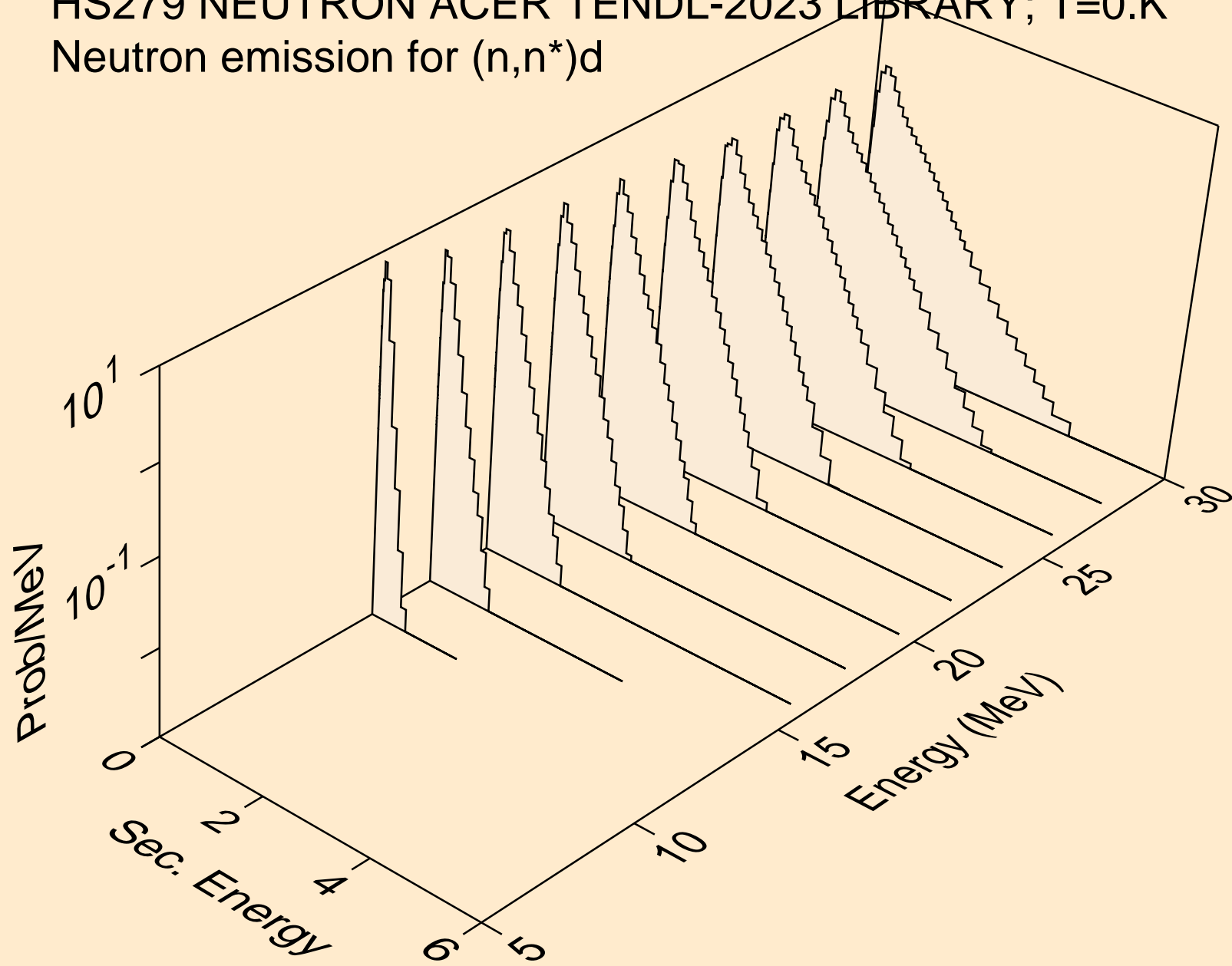

HS279 NEUTRON ACER TENDL-2023 LIBRARY; T=0.K
Neutron emission for (n,n*)t

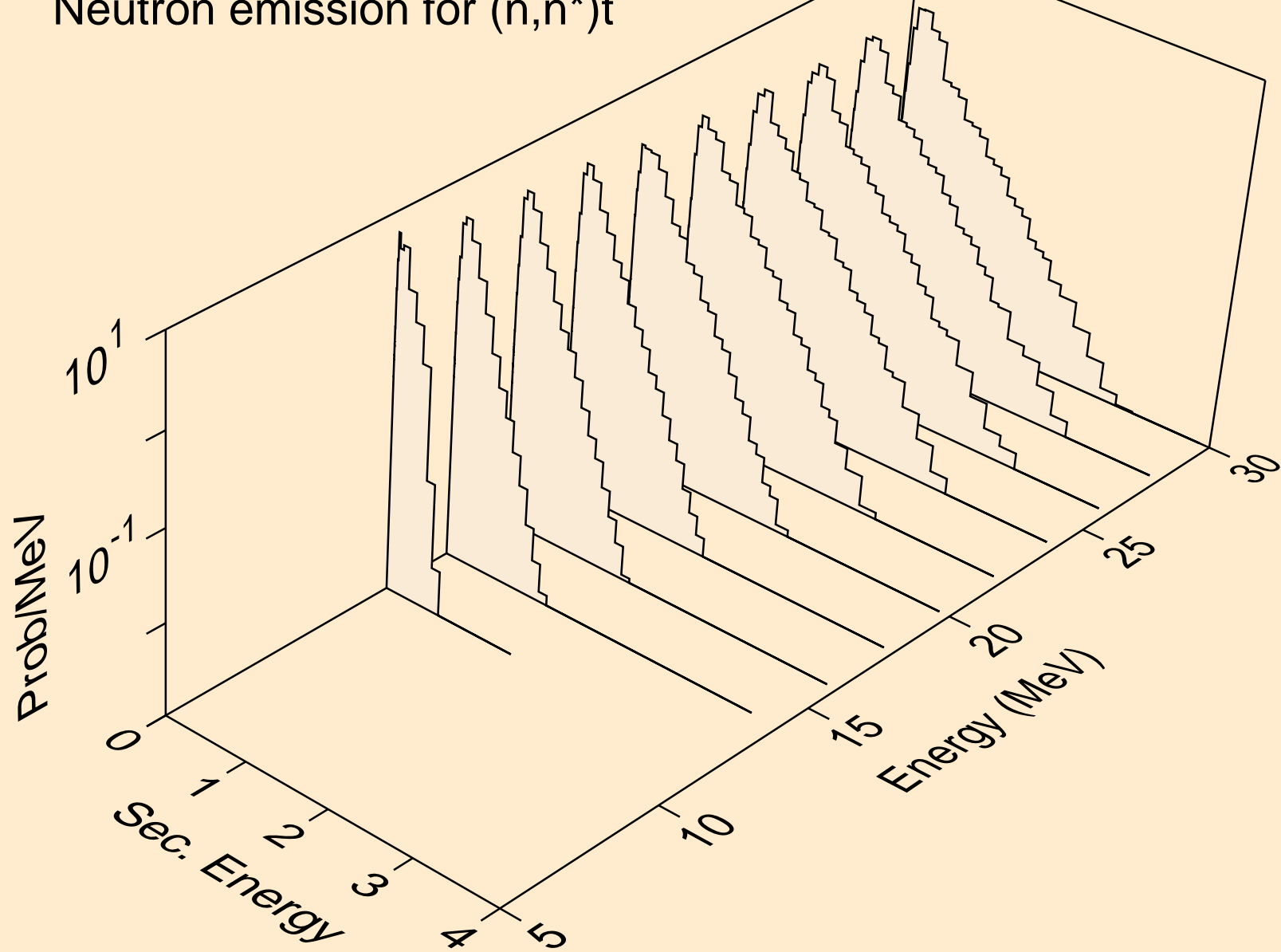

HS279 NEUTRON ACER TENDL-2023 LIBRARY; T=0.K
Neutron emission for (n,n*)he3

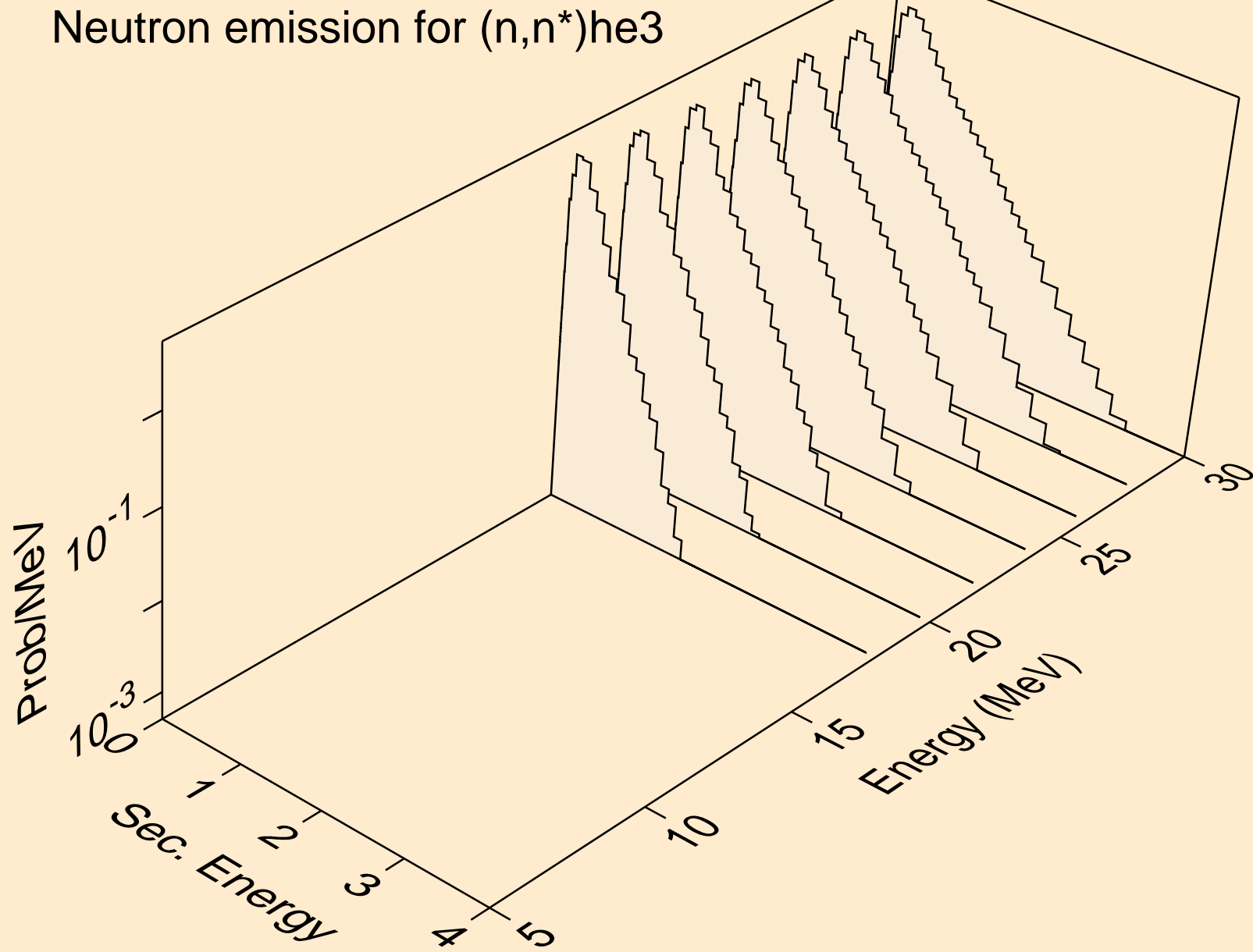

HS279 NEUTRON ACER TENDL-2023 LIBRARY; T=0.K
Neutron emission for (n,4n)

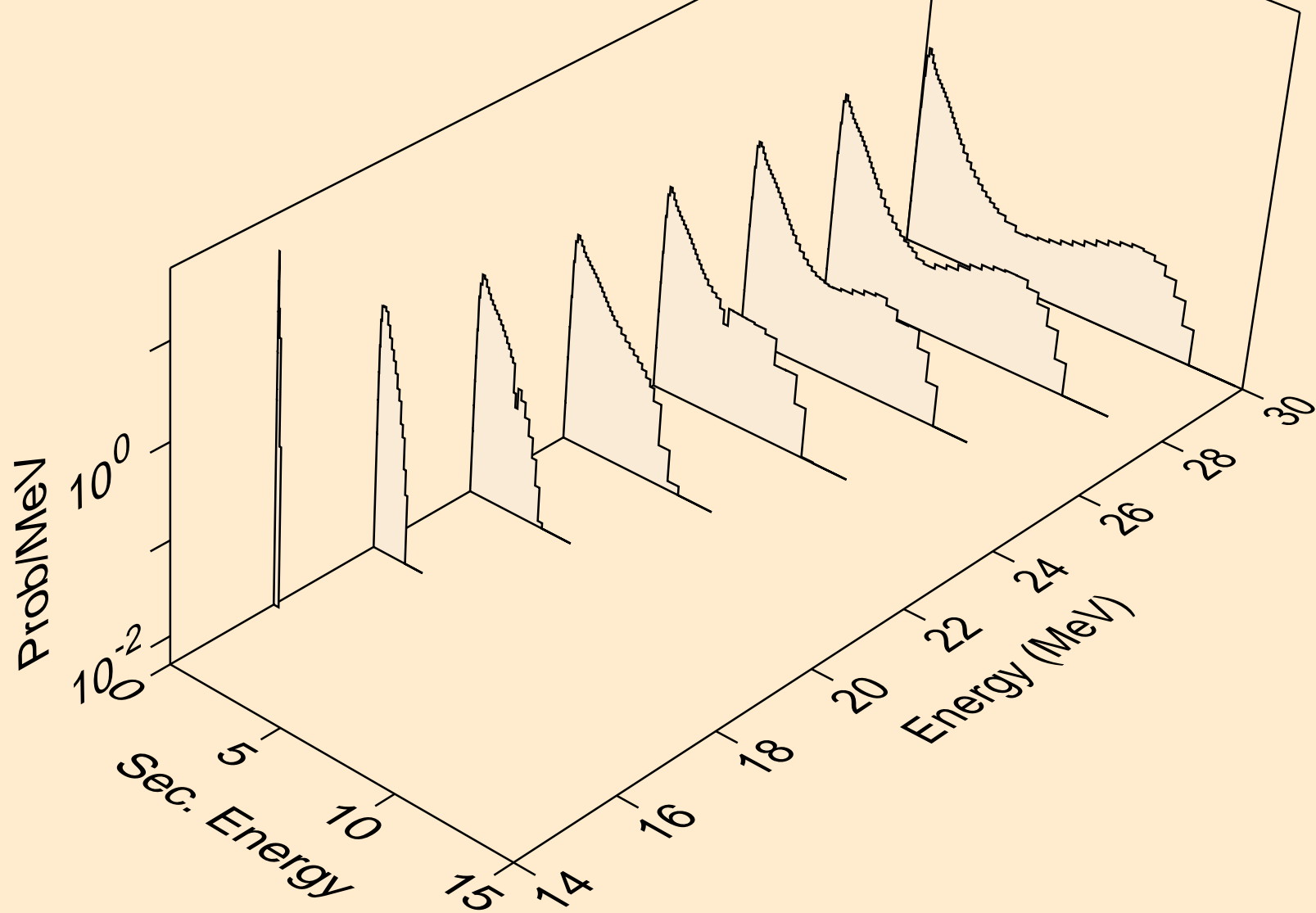

HS279 NEUTRON ACER TENDL-2023 LIBRARY; T=0.K
Neutron emission for (n,2np)

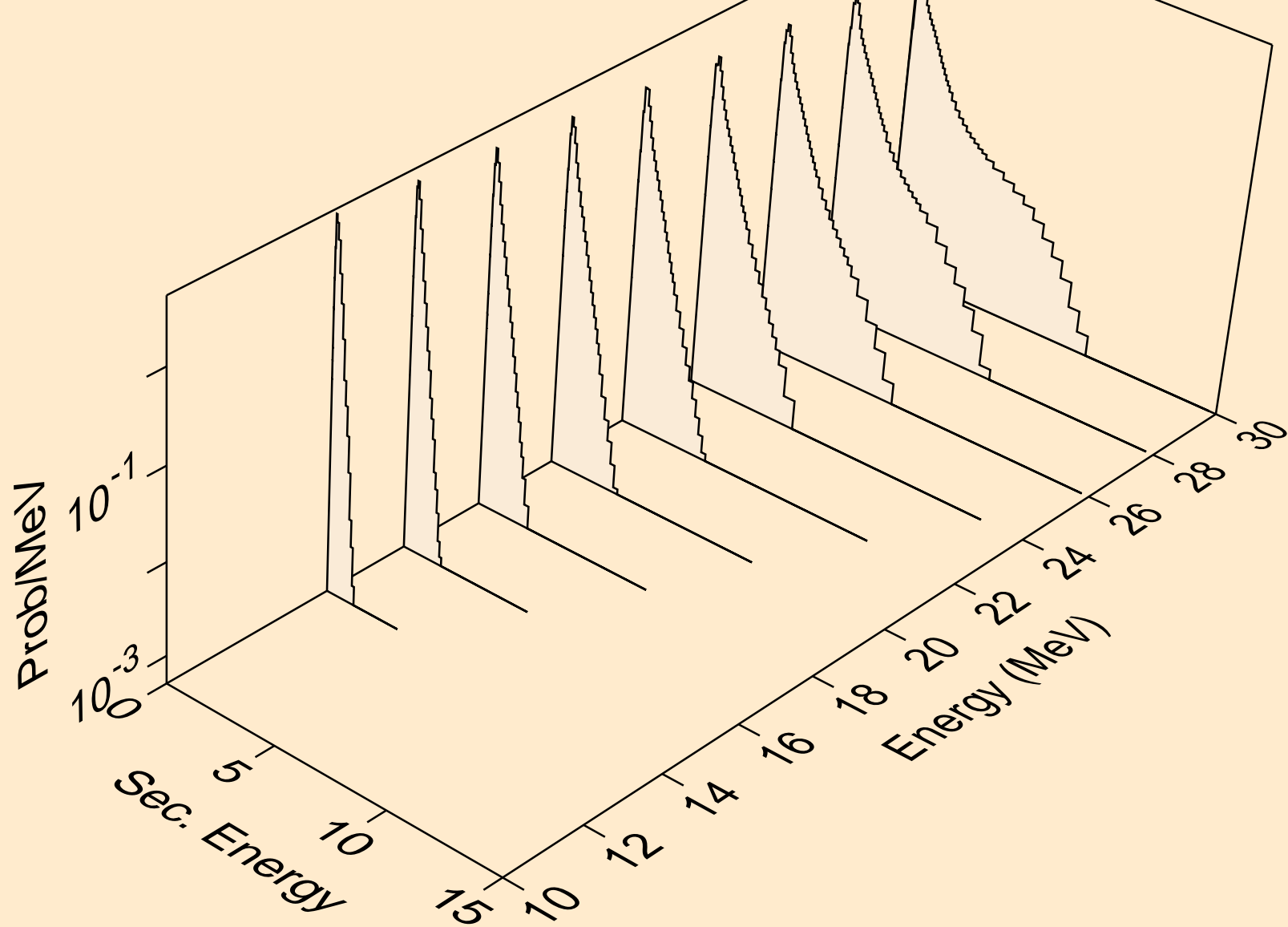

HS279 NEUTRON ACER TENDL-2023 LIBRARY; T=0.K
Neutron emission for (n,3np)

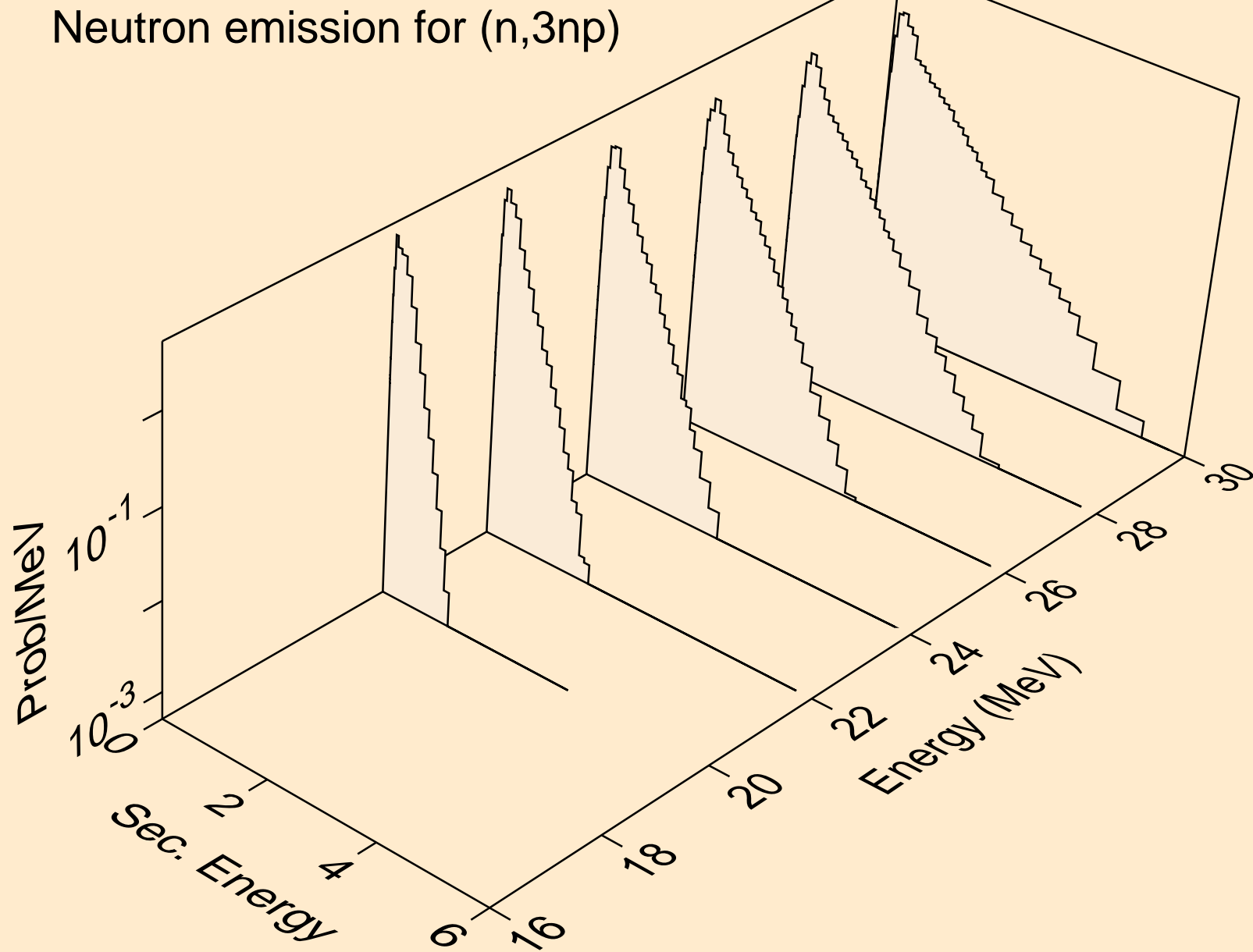

HS279 NEUTRON ACER TENDL-2023 LIBRARY; T=0.K
Neutron emission for (n,n2p)

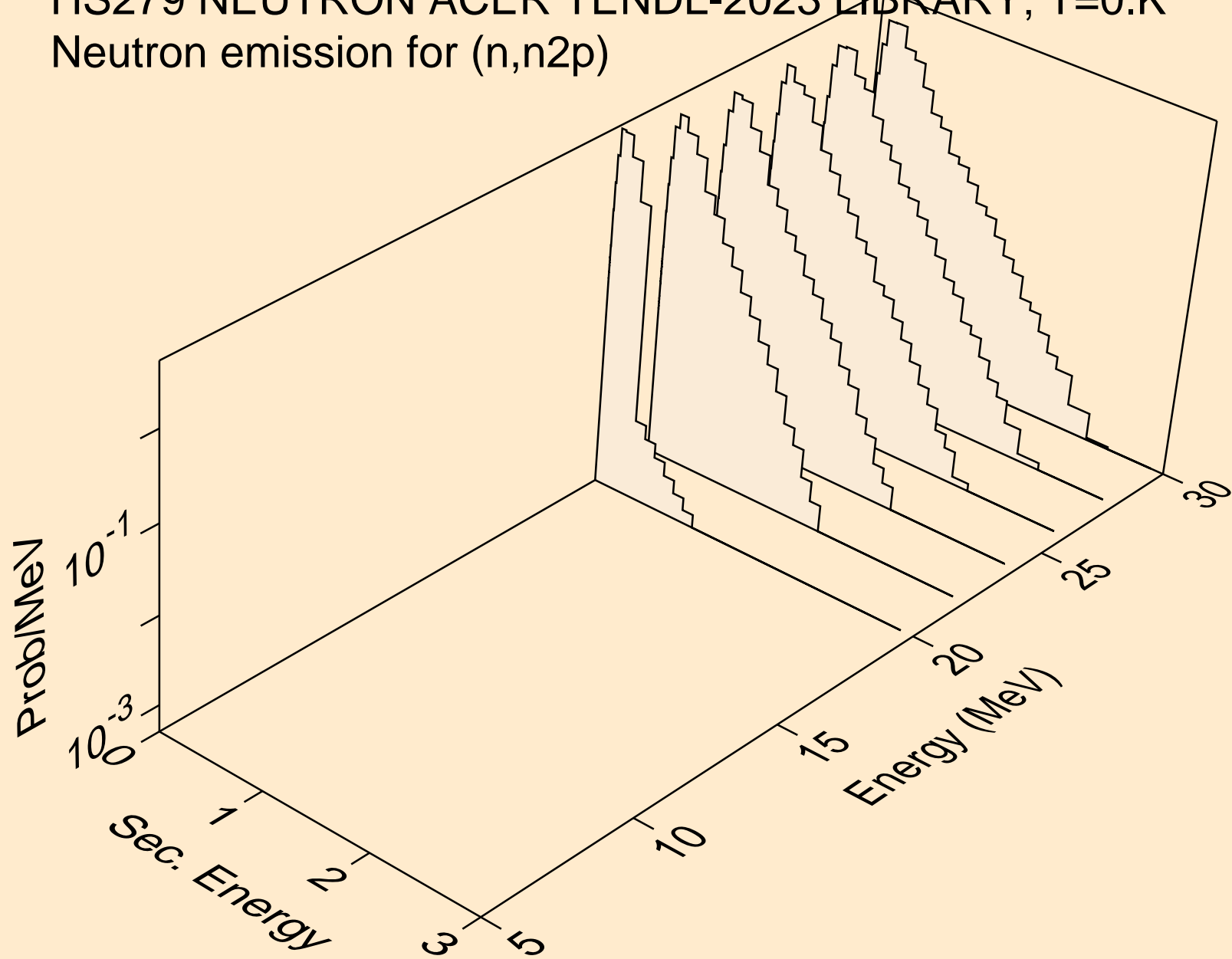

HS279 NEUTRON ACER TENDL-2023 LIBRARY; T=0.K
Neutron emission for (n,n*c)

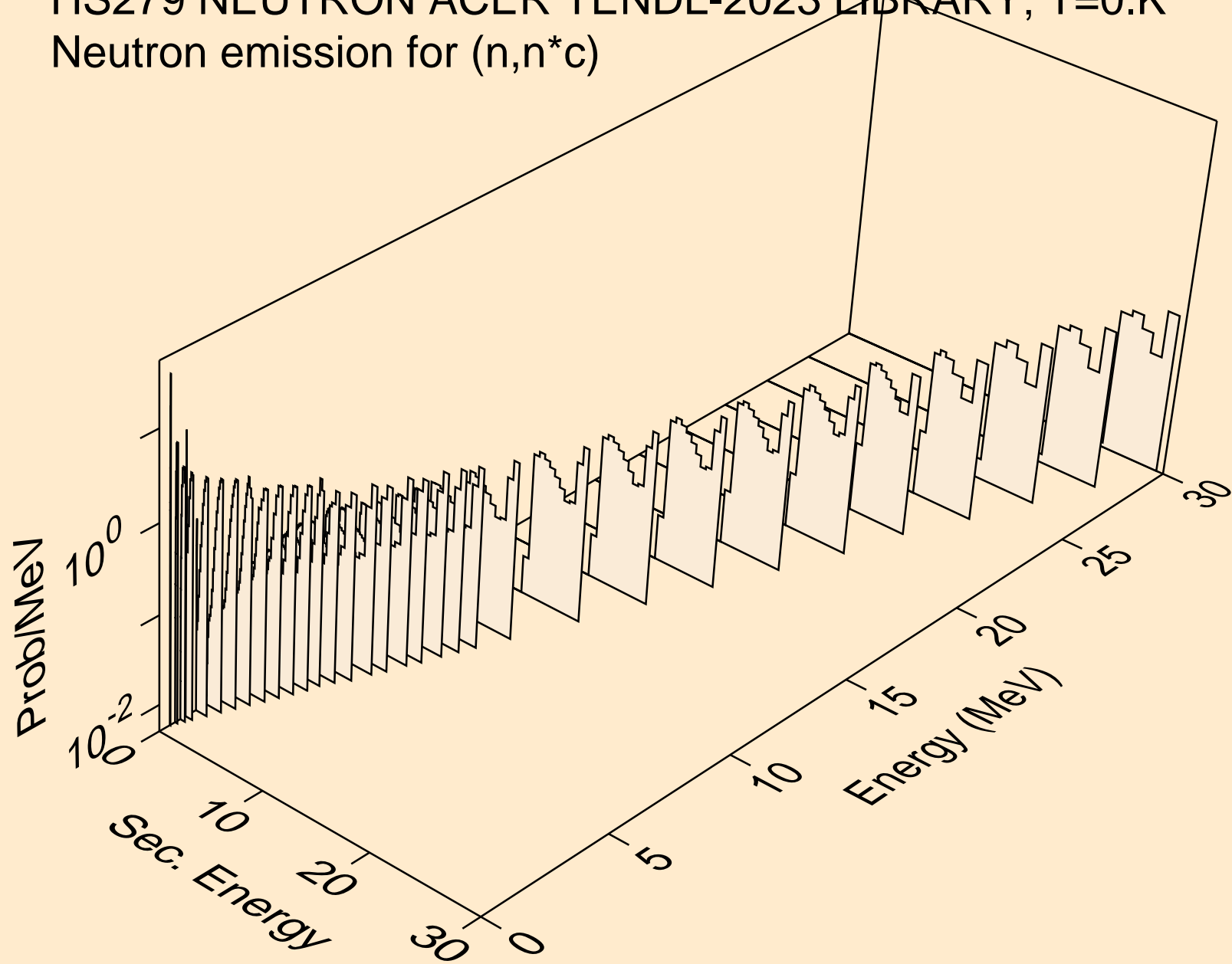

HS279 NEUTRON ACER TENDL-2023 LIBRARY; T=0.K

Delayed nubar

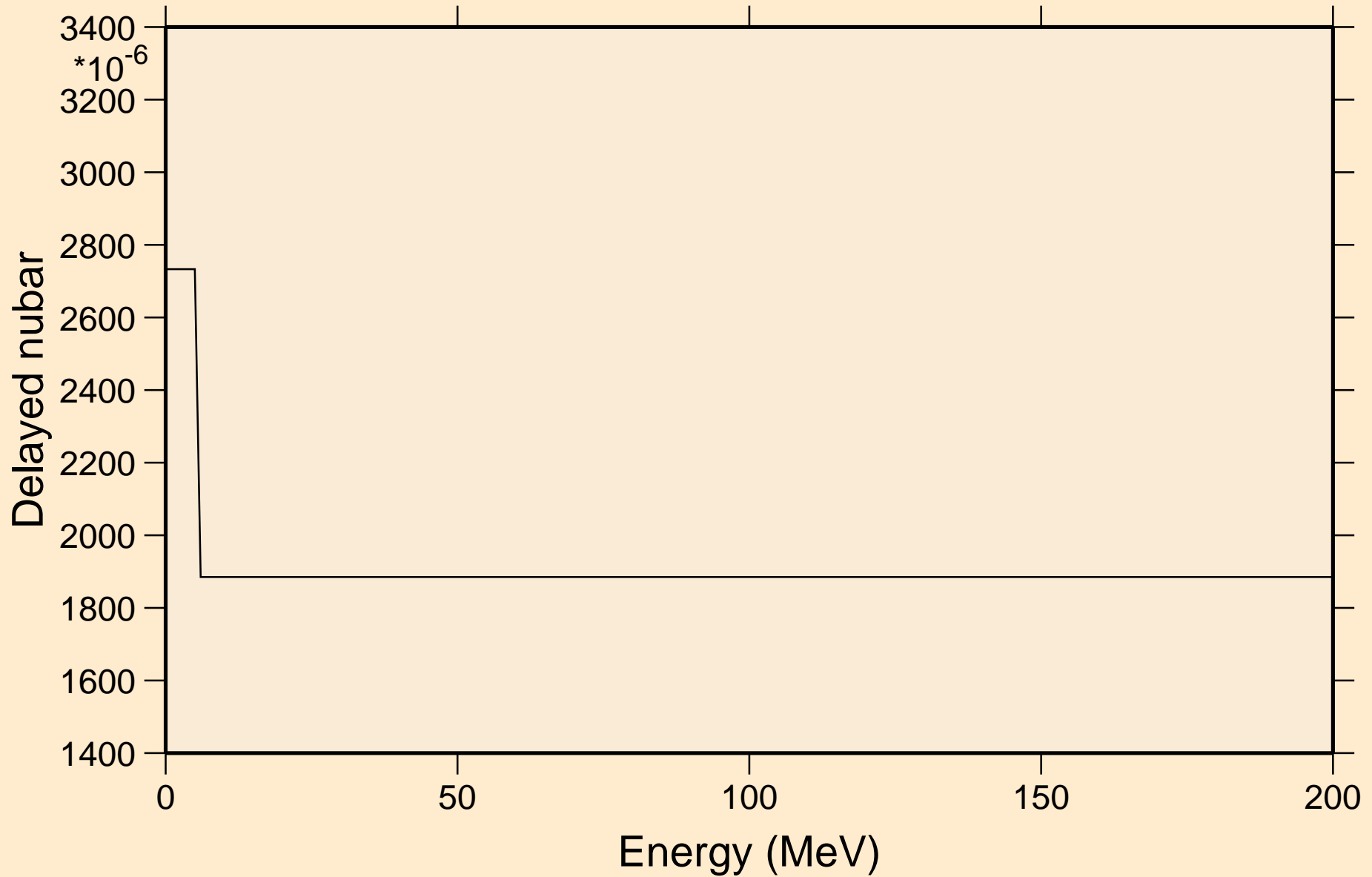

HS279 NEUTRON ACER TENDL-2023 LIBRARY; T=0.K

Delayed neutron spectra

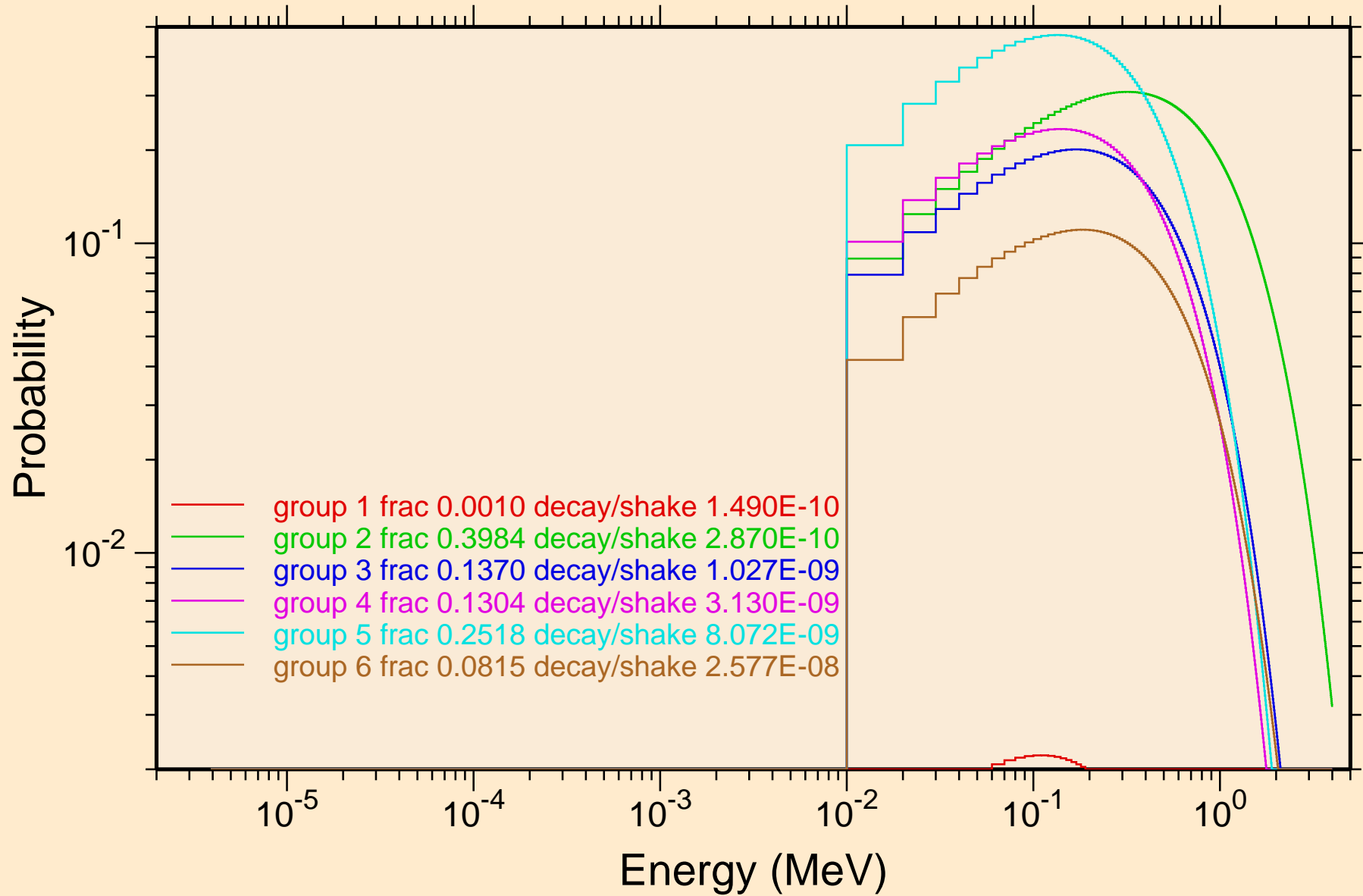

HS279 NEUTRON ACER TENDL-2023 LIBRARY; T=0.K
Photon emission for (n,x)

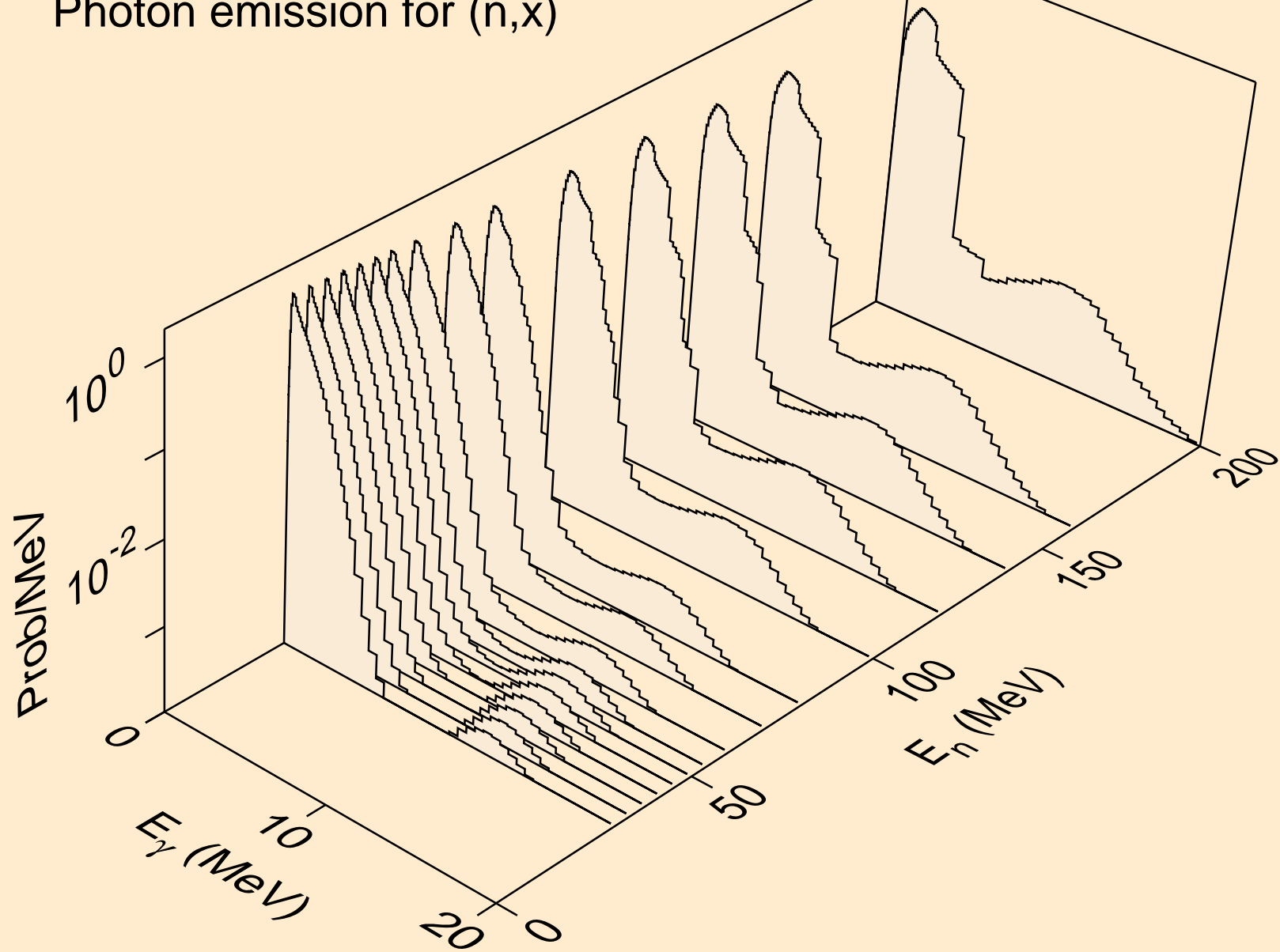

HS279 NEUTRON ACER TENDL-2023 LIBRARY; T=0.K
Photon emission for (n,2nd)

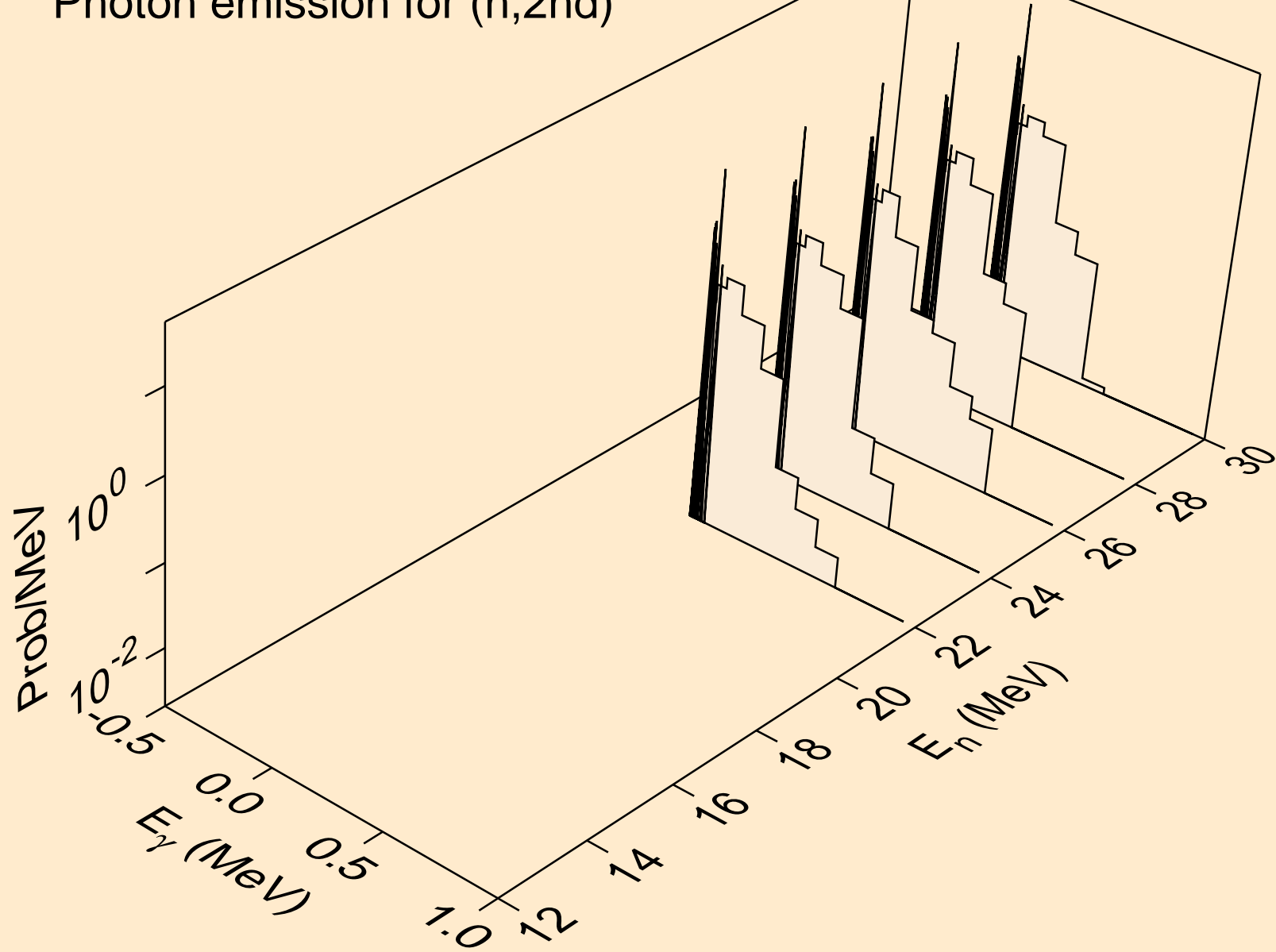

HS279 NEUTRON ACER TENDL-2023 LIBRARY; T=0.K
Photon emission for (n,2n)

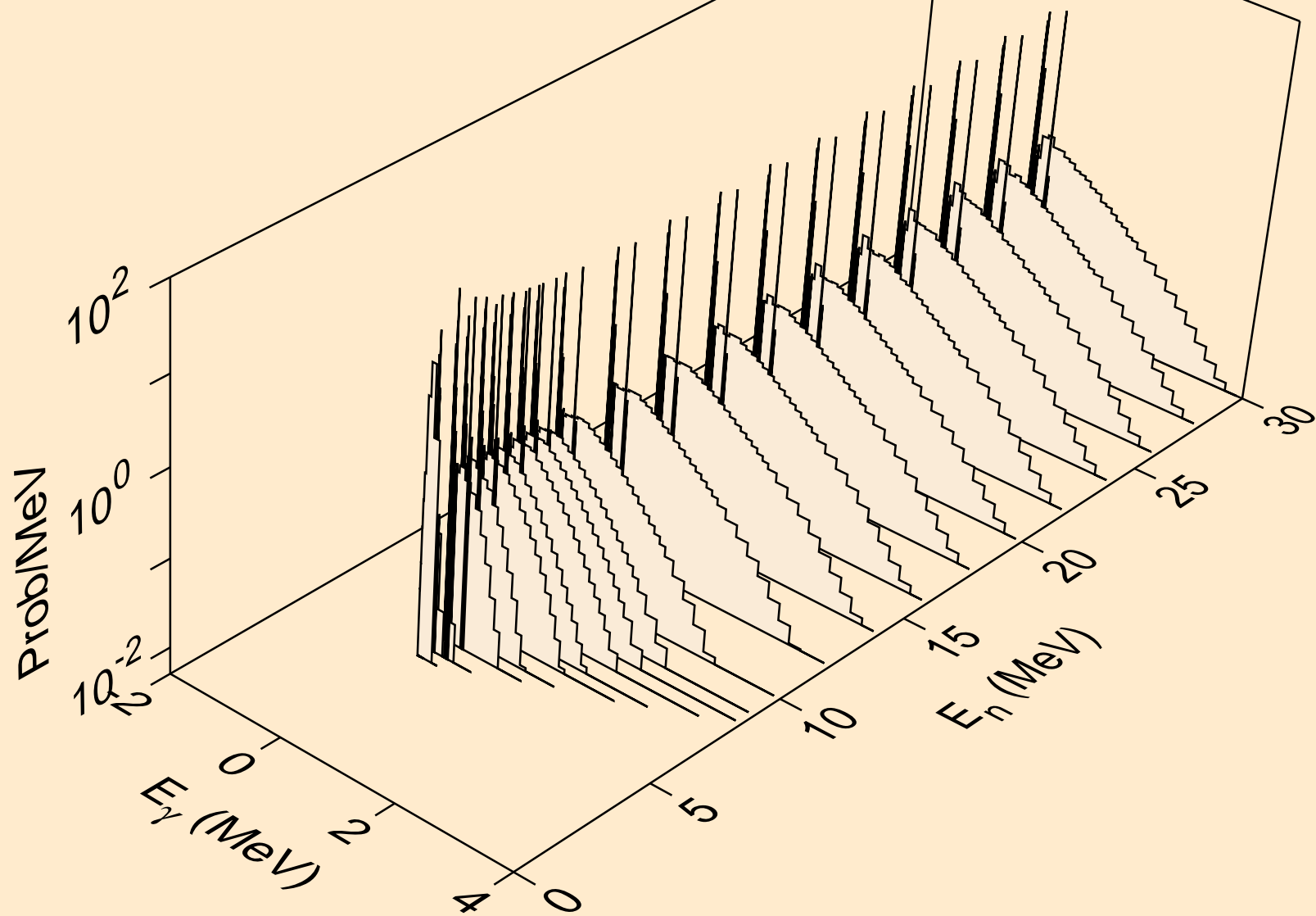

HS279 NEUTRON ACER TENDL-2023 LIBRARY; T=0.K
Photon emission for (n,3n)

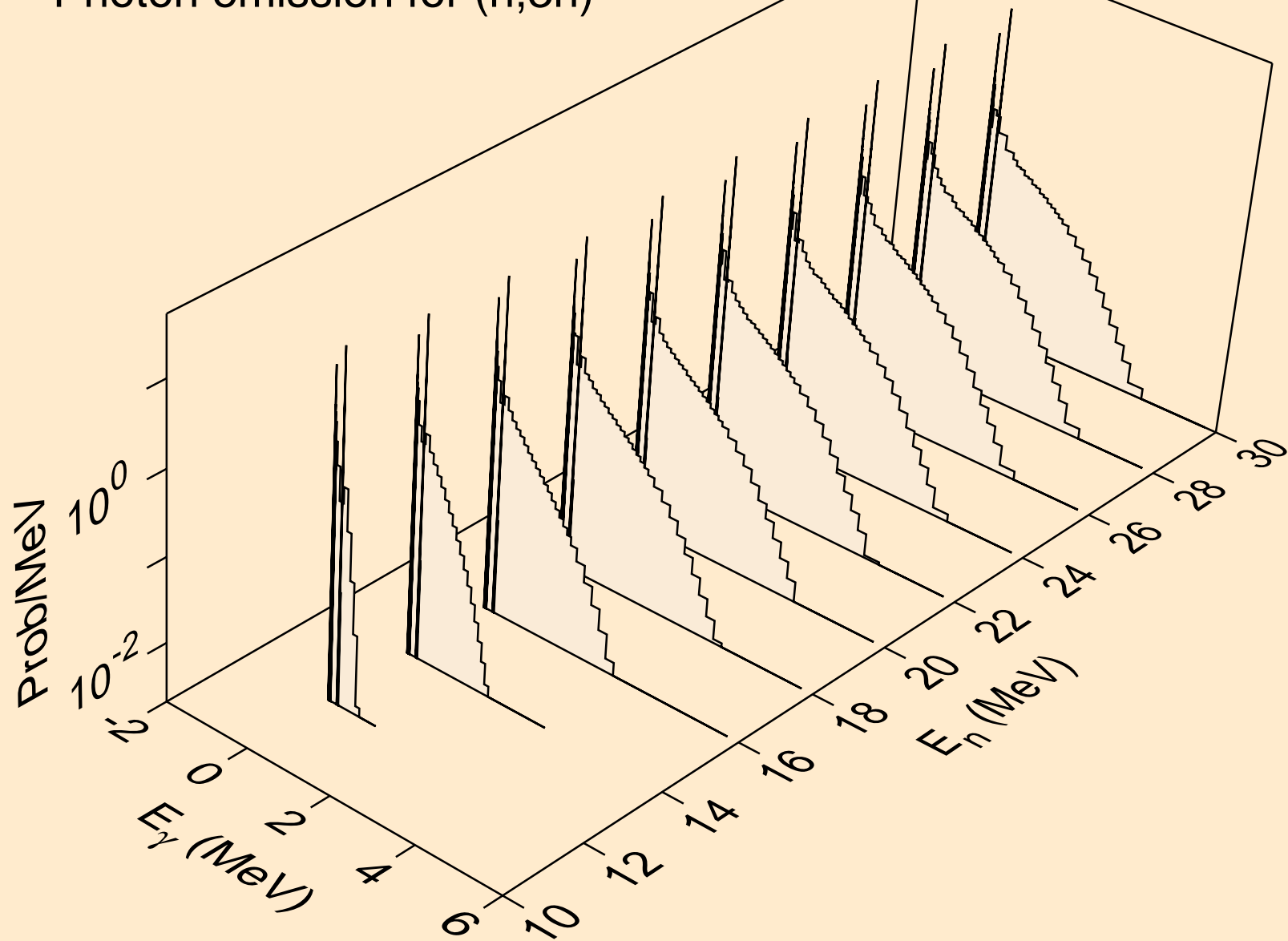

HS279 NEUTRON ACER TENDL-2023 LIBRARY; T=0.K
Photon emission for (n,n*)a

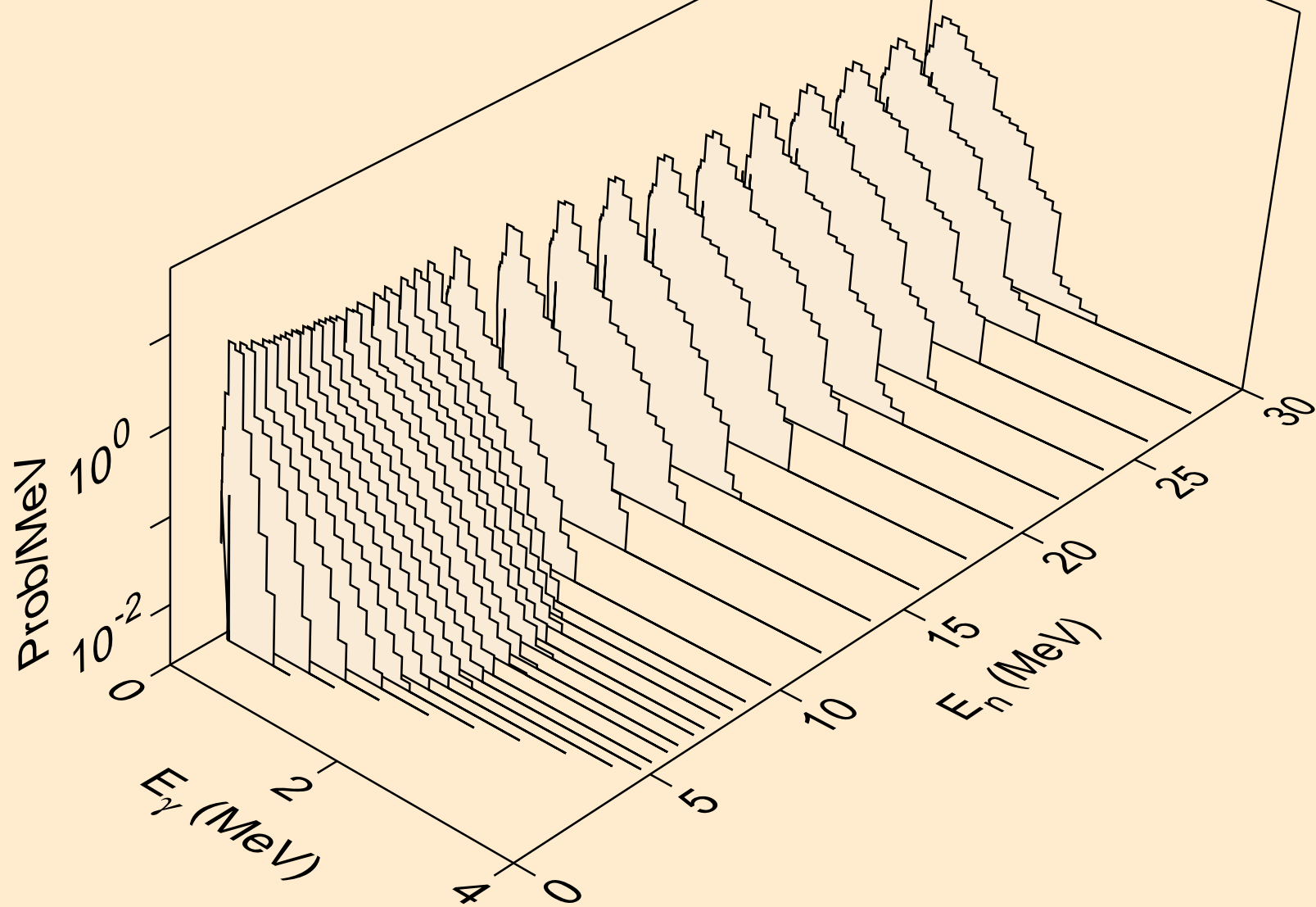

HS279 NEUTRON ACER TENDL-2023 LIBRARY; T=0.K
Photon emission for (n,2n)a

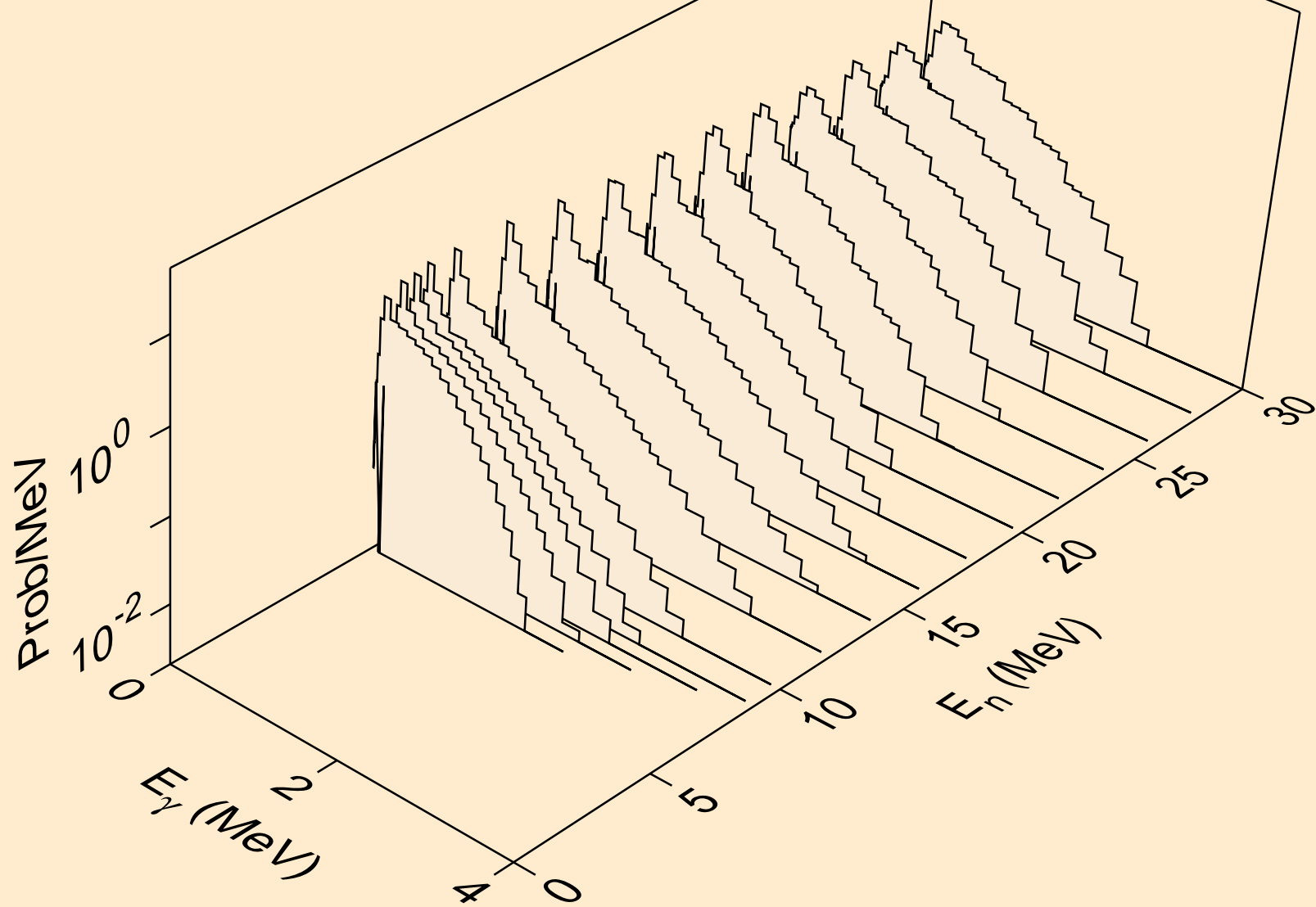

HS279 NEUTRON ACER TENDL-2023 LIBRARY; T=0.K
Photon emission for (n,3n)a

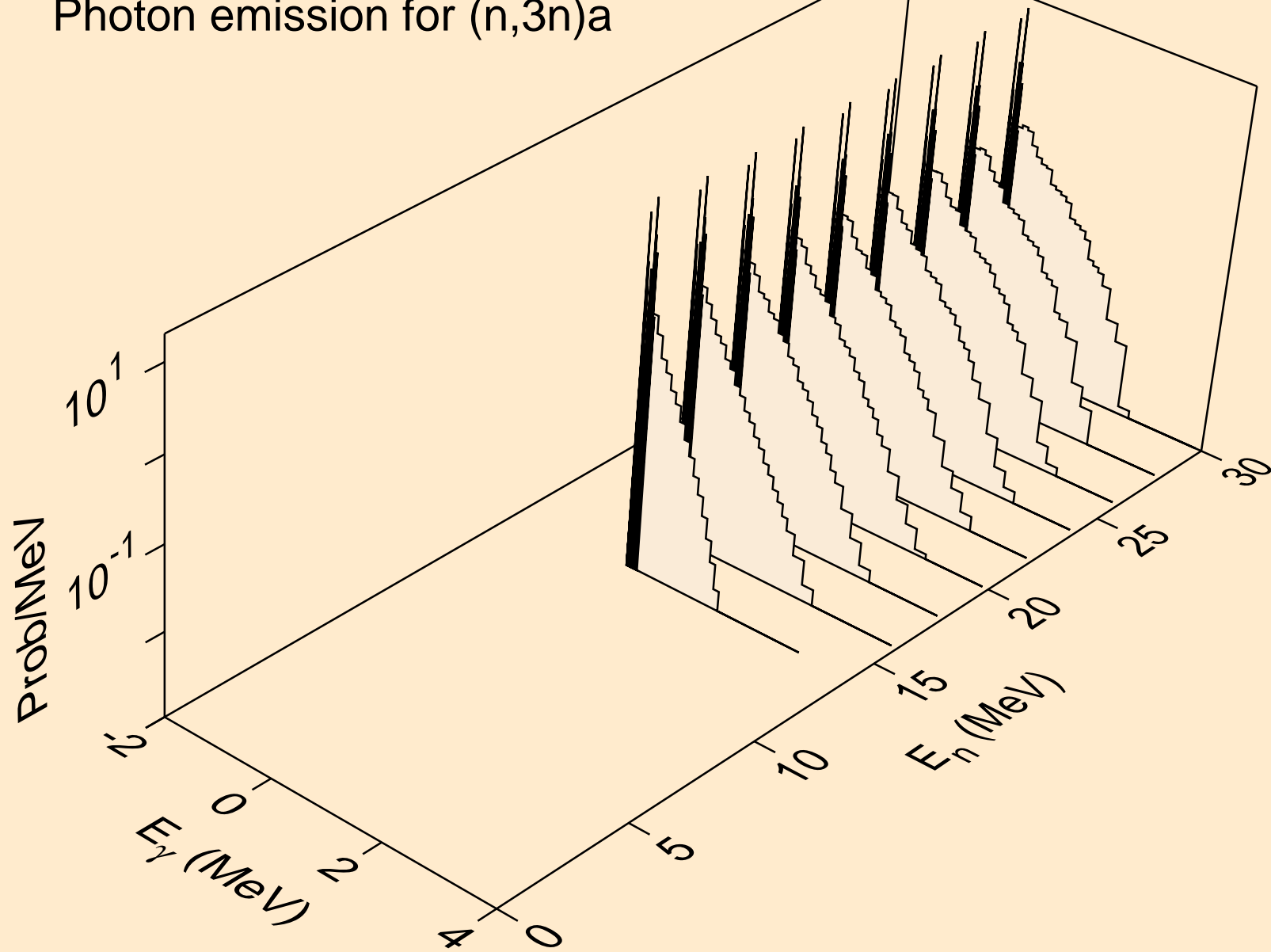

HS279 NEUTRON ACER TENDL-2023 LIBRARY; T=0.K
Photon emission for (n,n*)p

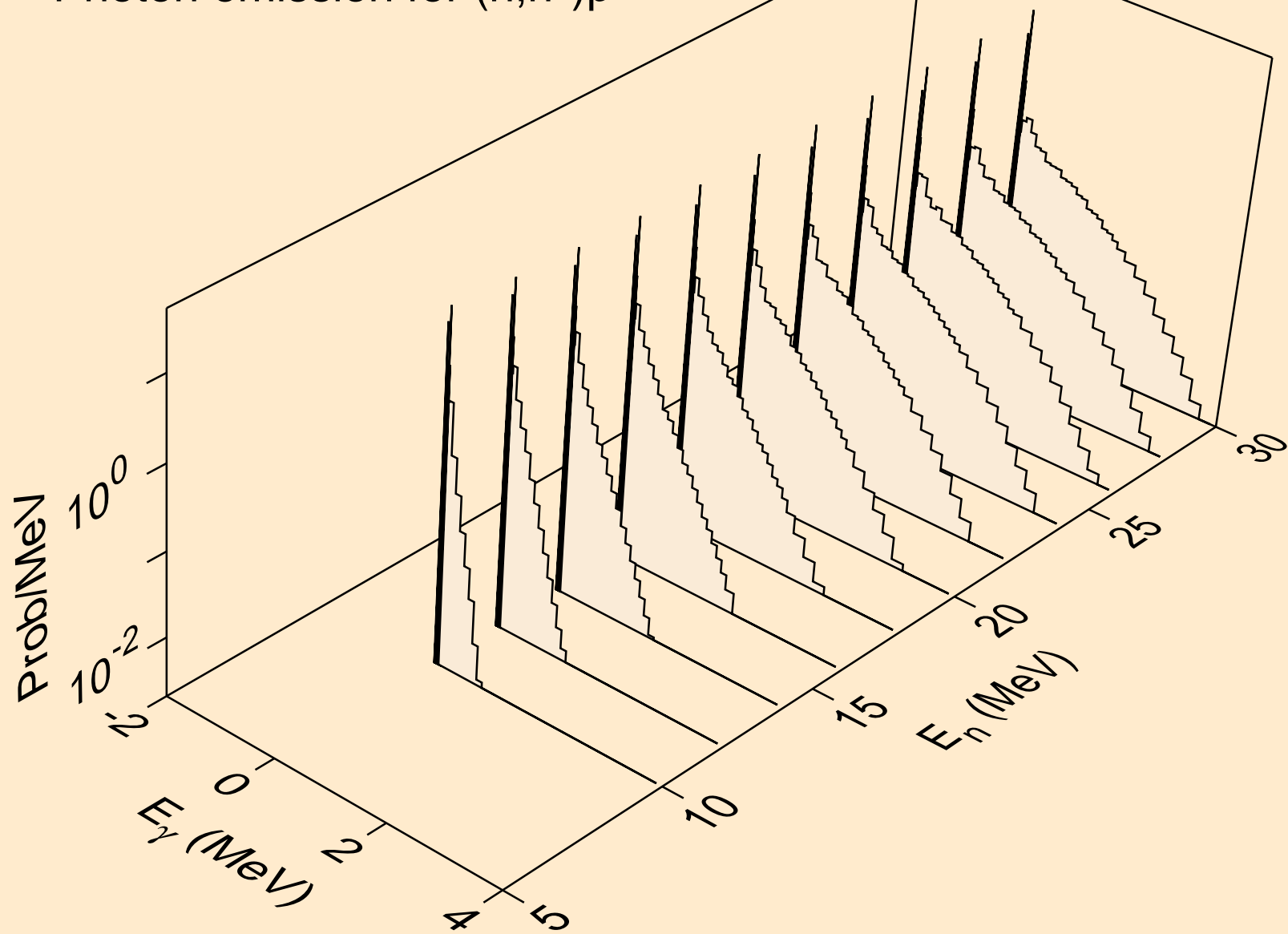

HS279 NEUTRON ACER TENDL-2023 LIBRARY; T=0.K
Photon emission for (n,n*)d

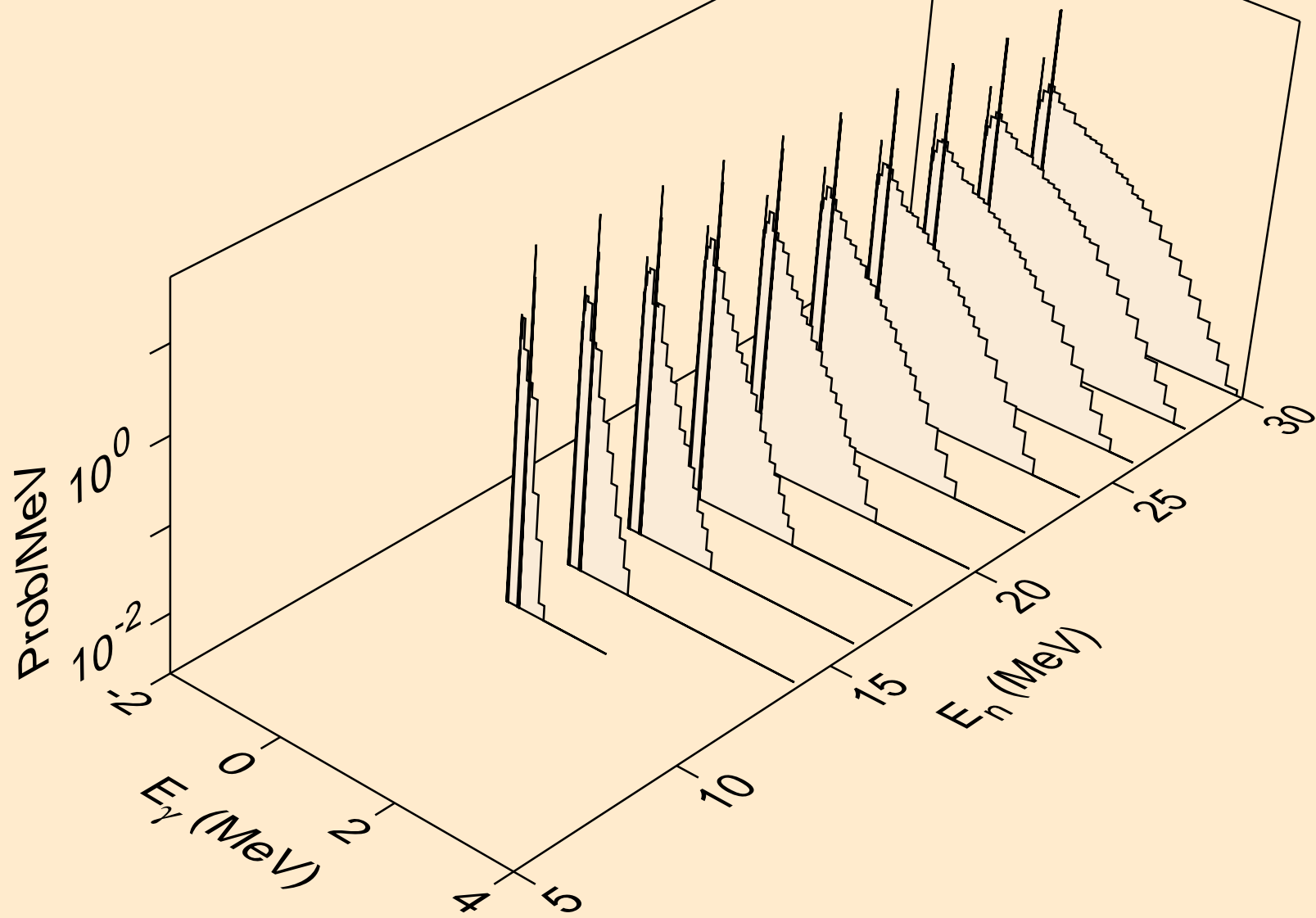

HS279 NEUTRON ACER TENDL-2023 LIBRARY; T=0.K
Photon emission for (n,n*)t

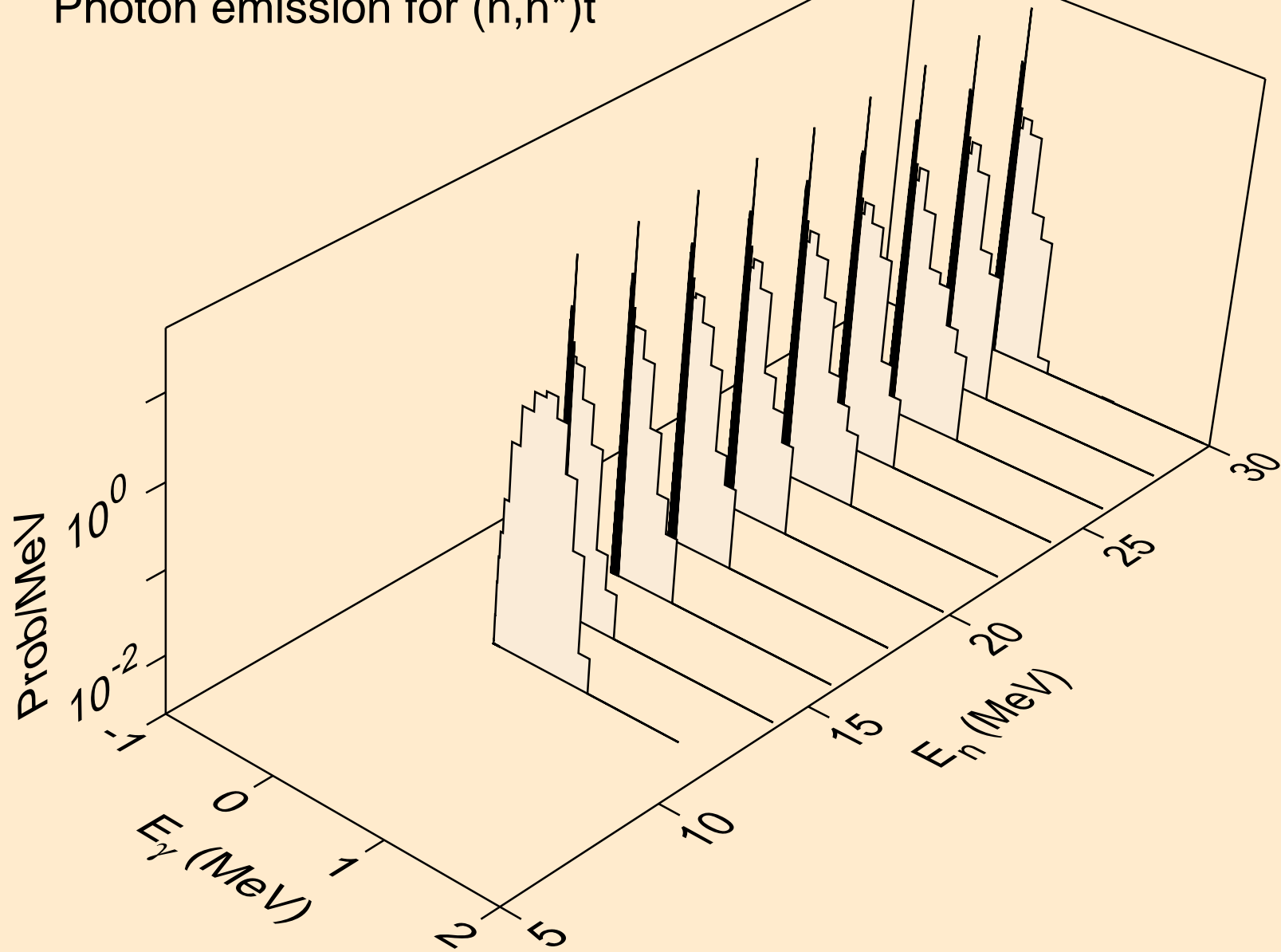

HS279 NEUTRON ACER TENDL-2023 LIBRARY; T=0.K
Photon emission for (n,n*)he3

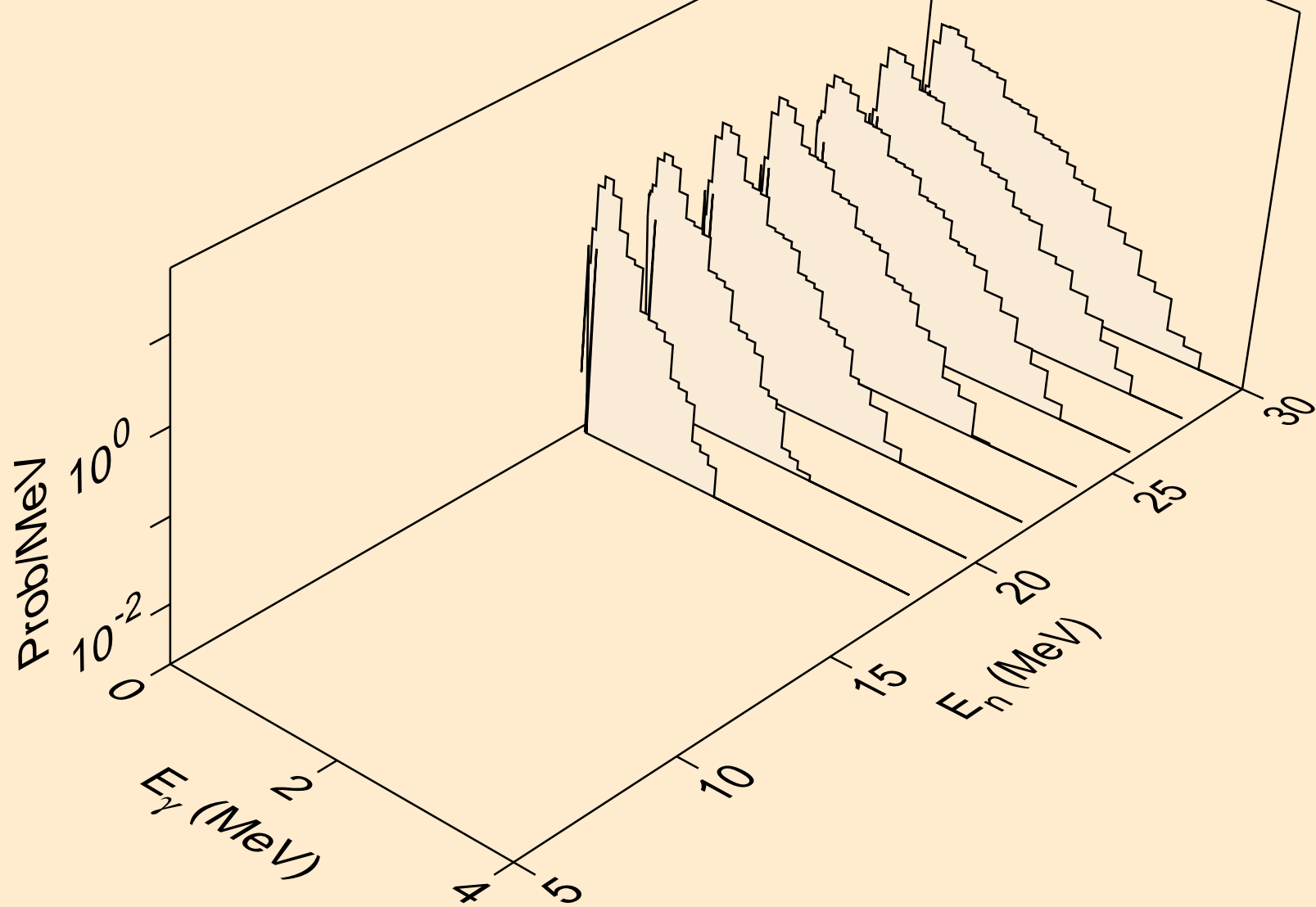

HS279 NEUTRON ACER TENDL-2023 LIBRARY; T=0.K
Photon emission for (n,4n)

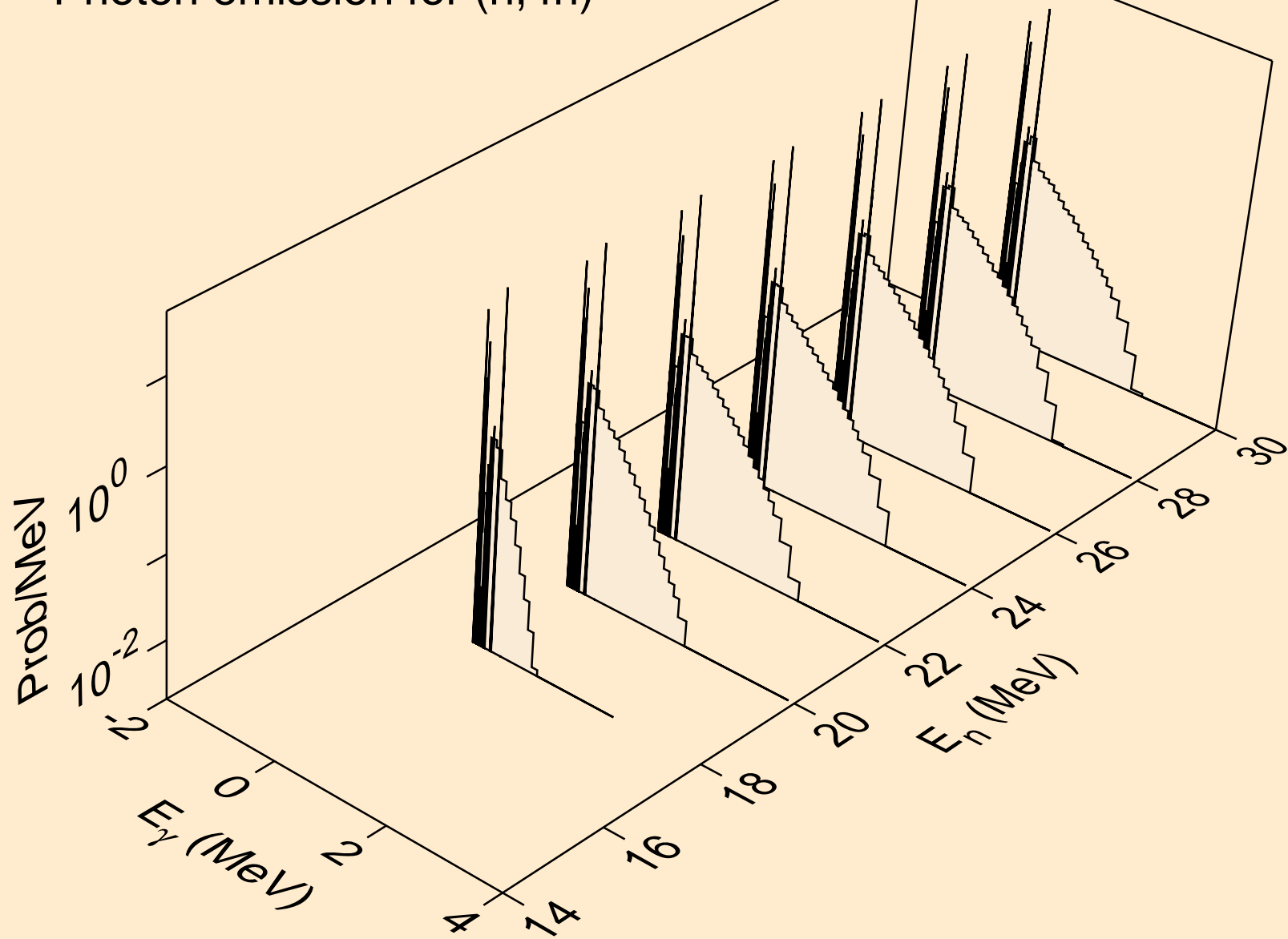

HS279 NEUTRON ACER TENDL-2023 LIBRARY; T=0.K
Photon emission for (n,2np)

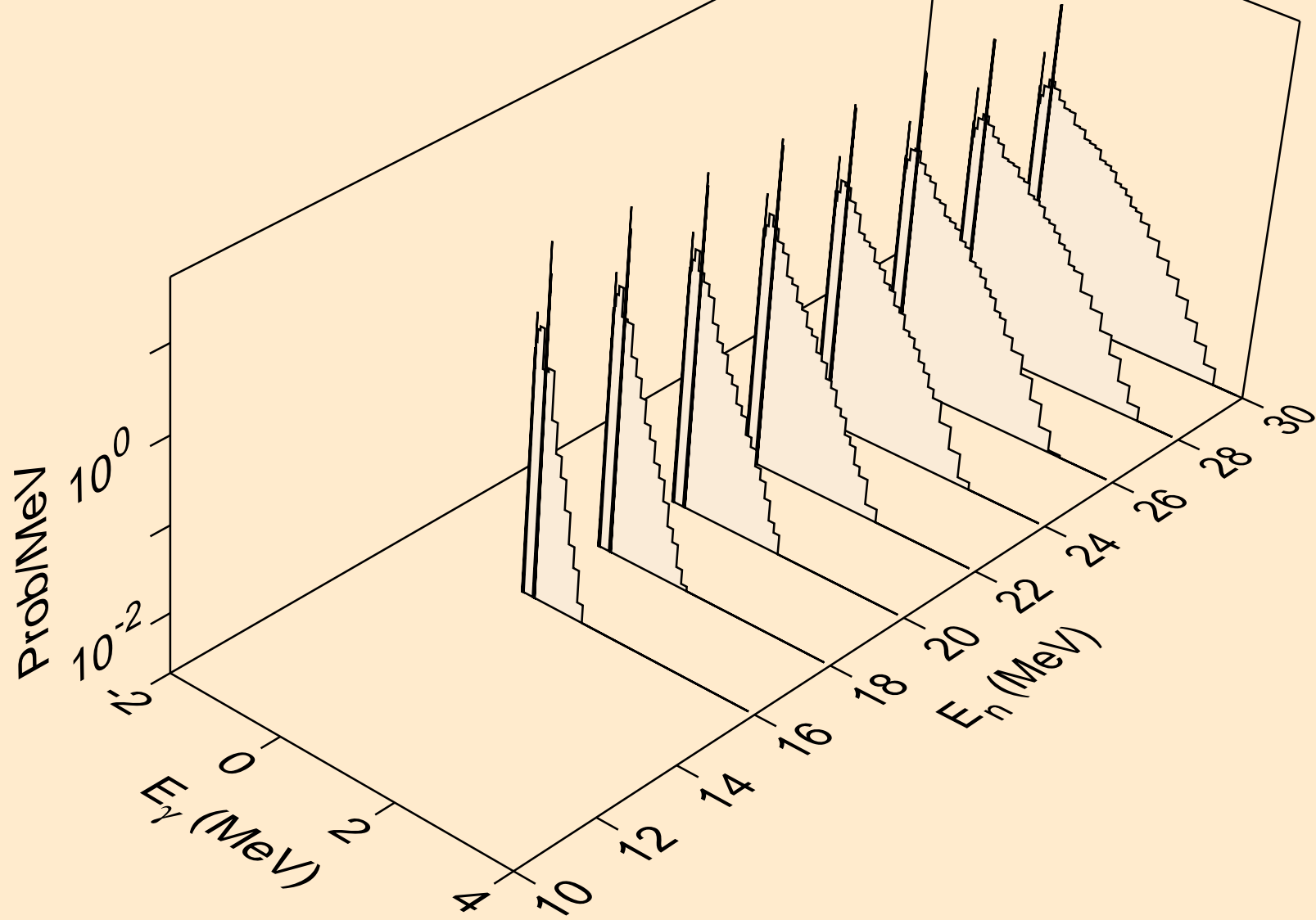

HS279 NEUTRON ACER TENDL-2023 LIBRARY; T=0.K
Photon emission for (n,3np)

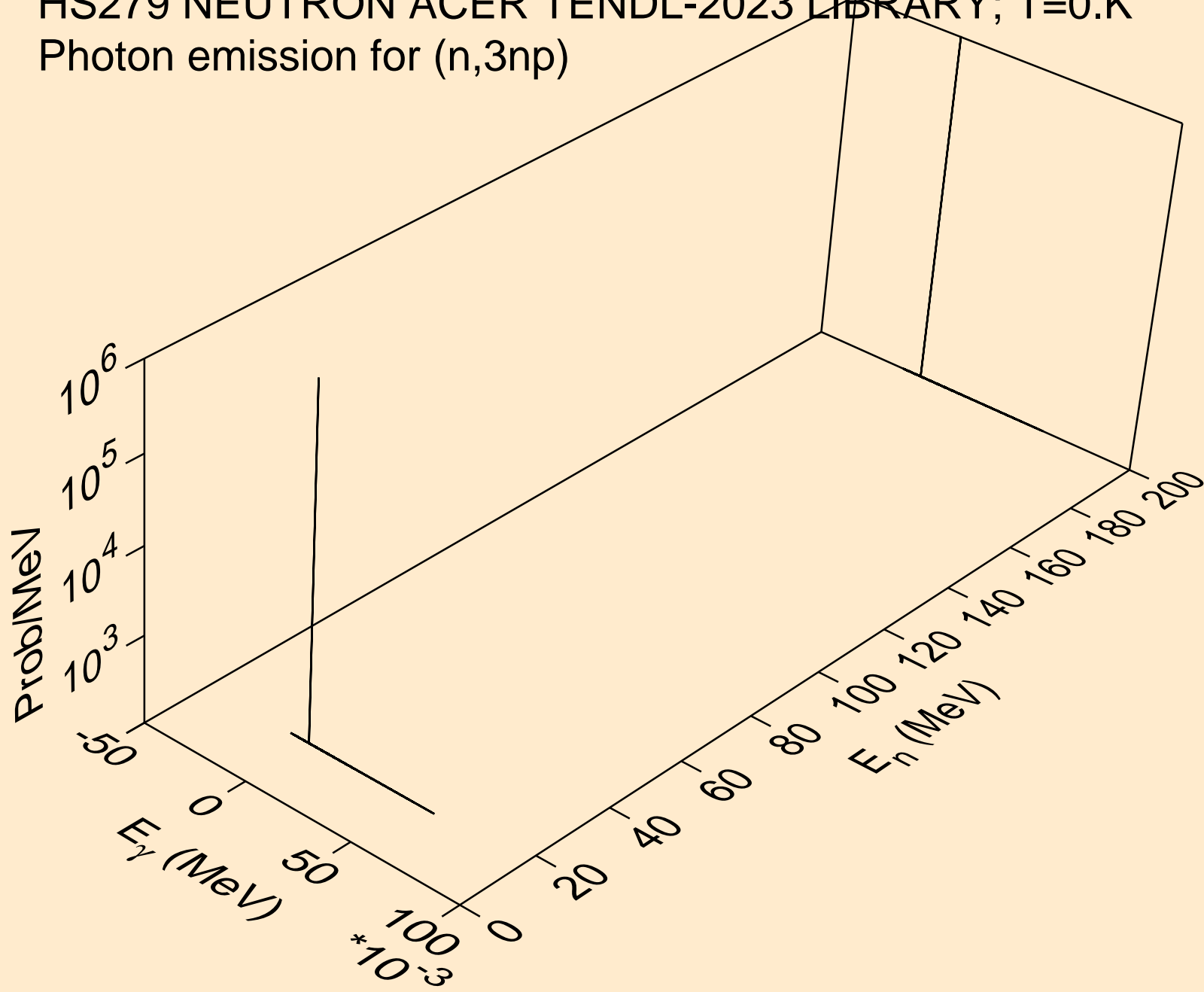

HS279 NEUTRON ACER TENDL-2023 LIBRARY; T=0.K
Photon emission for (n,n2p)

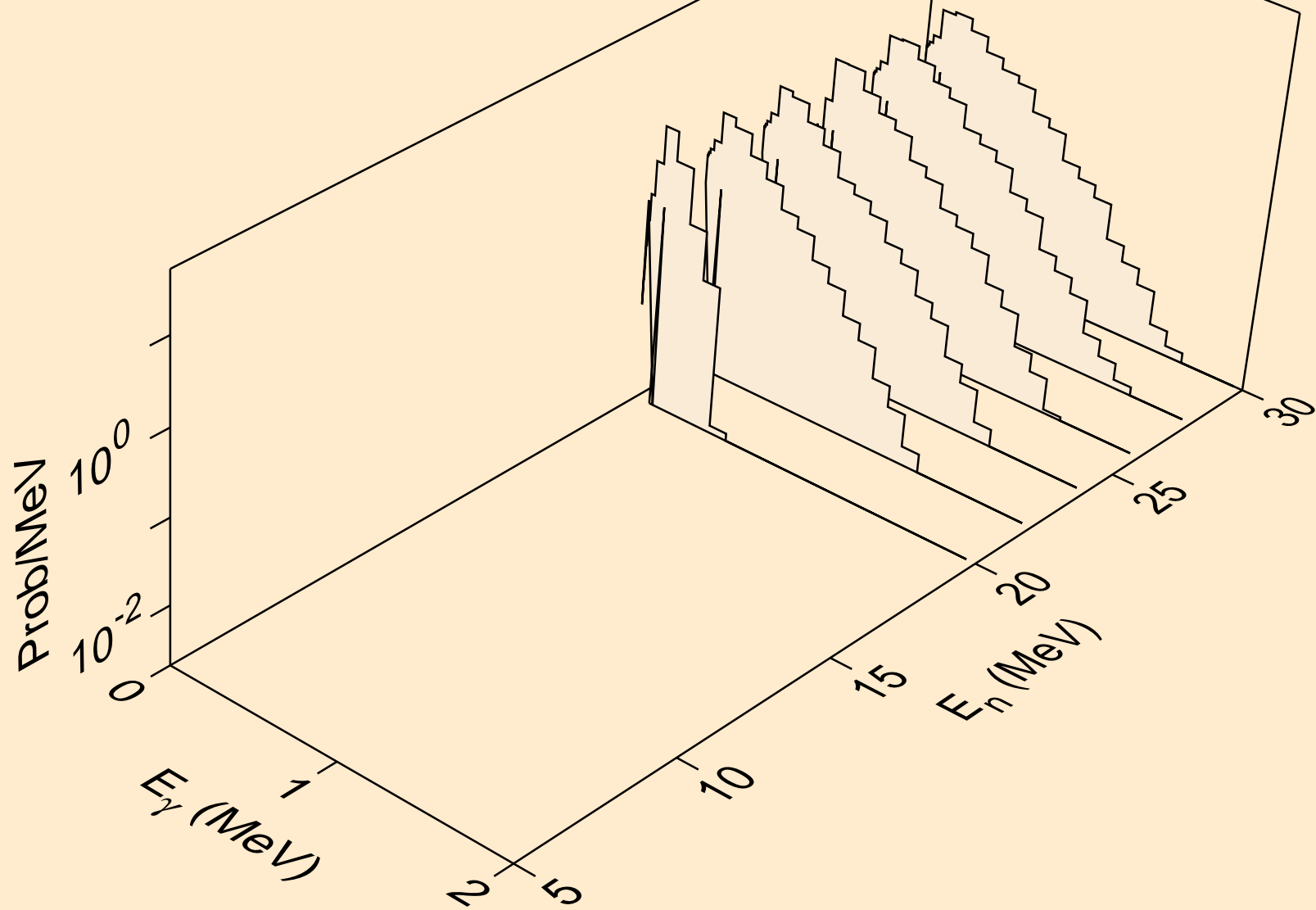

HS279 NEUTRON ACER TENDL-2023 LIBRARY; T=0.K
Photon emission for (n,n*c)

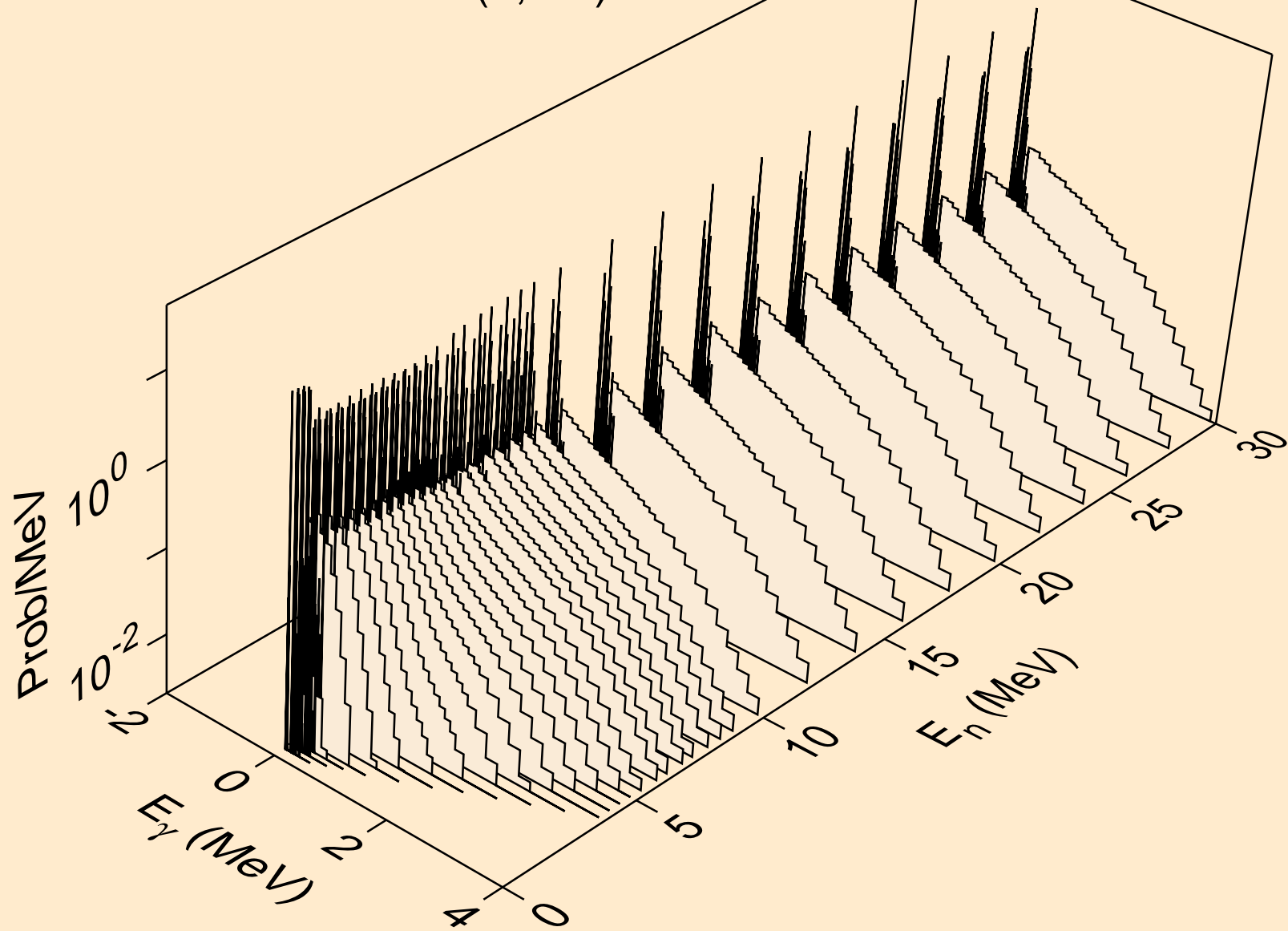

HS279 NEUTRON ACER TENDL-2023 LIBRARY; T=0.K
Photon emission for (n,gma)

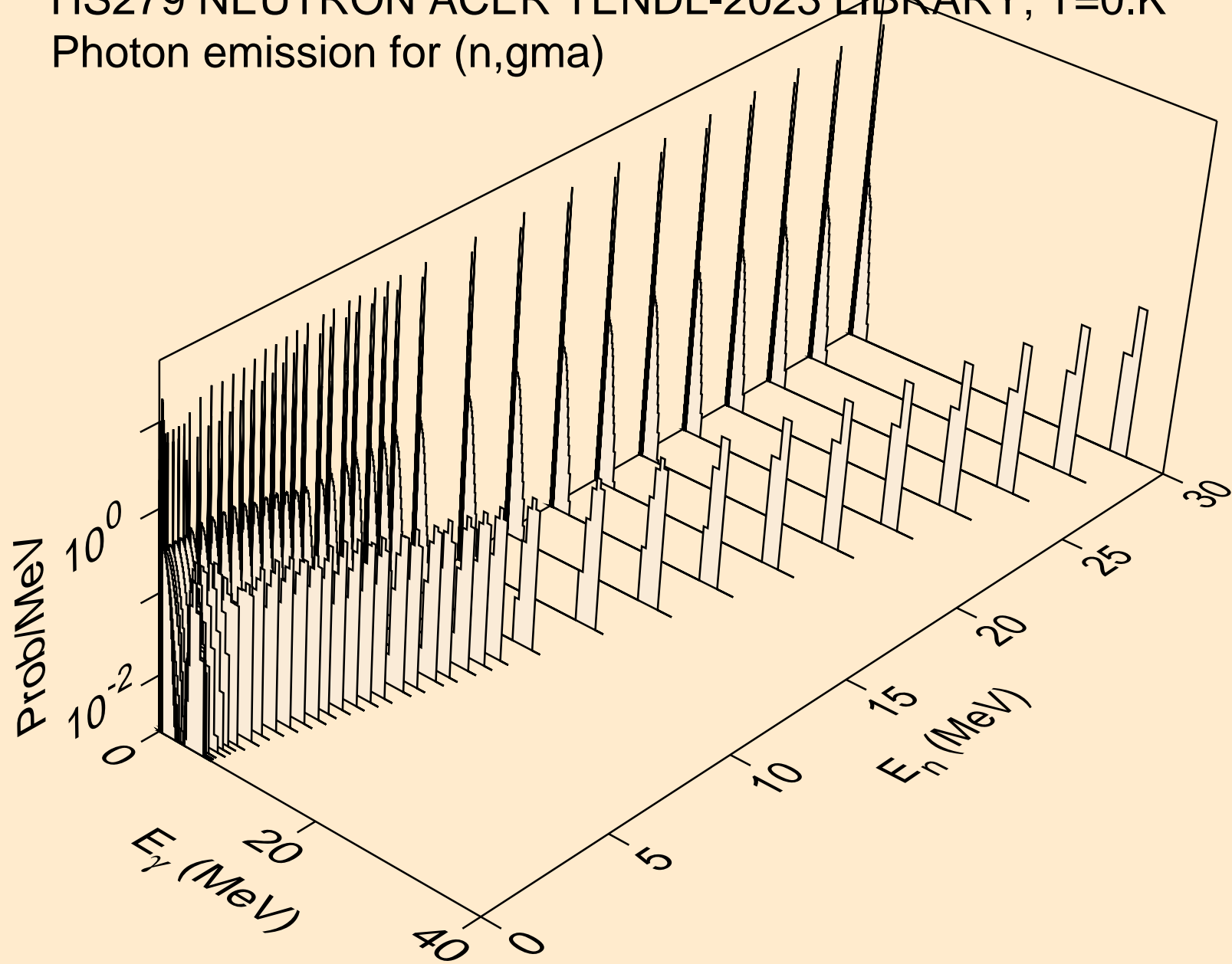

HS279 NEUTRON ACER TENDL-2023 LIBRARY; T=0.K
Photon emission for (n,p)

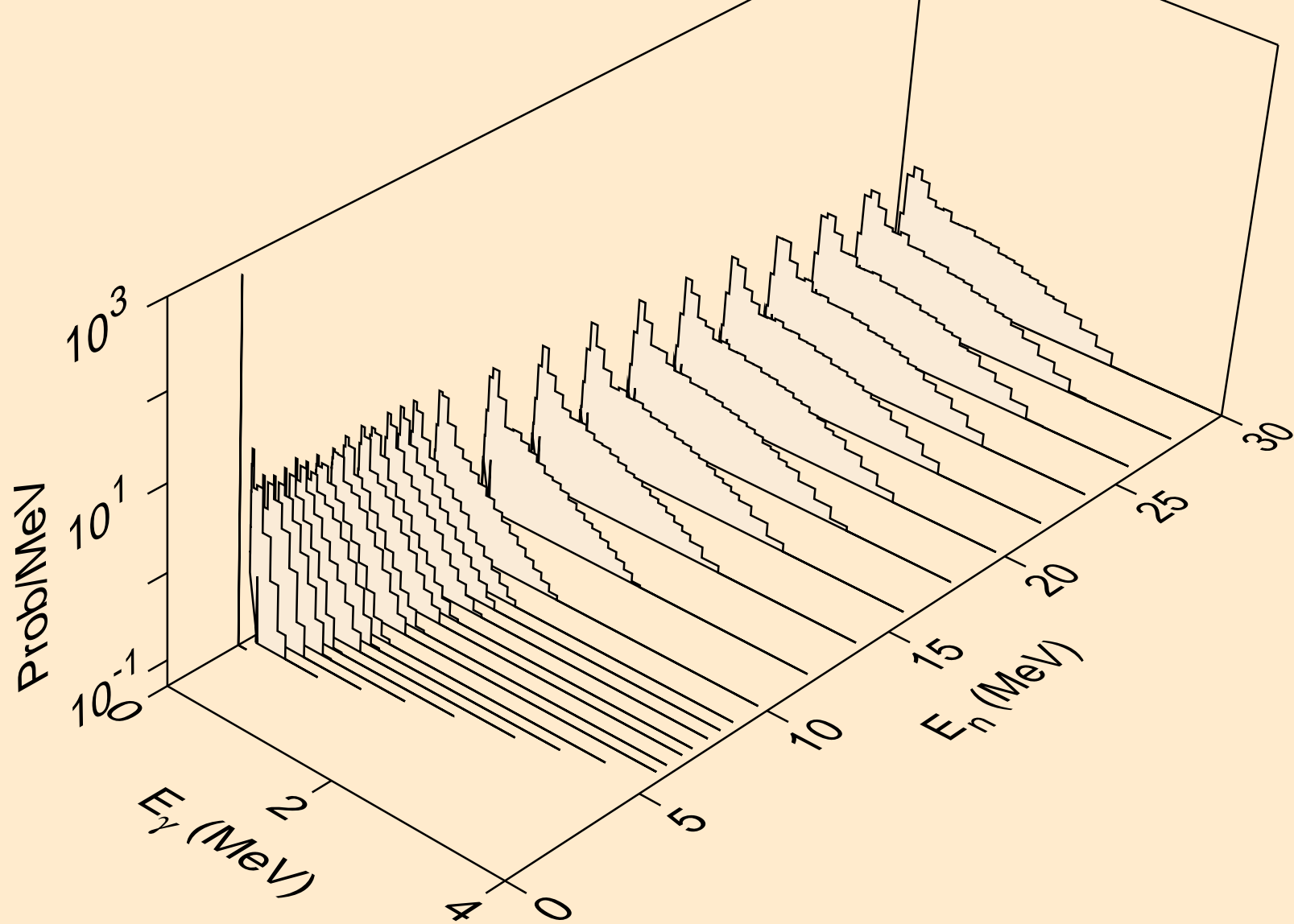

HS279 NEUTRON ACER TENDL-2023 LIBRARY; T=0.K
Photon emission for (n,d)

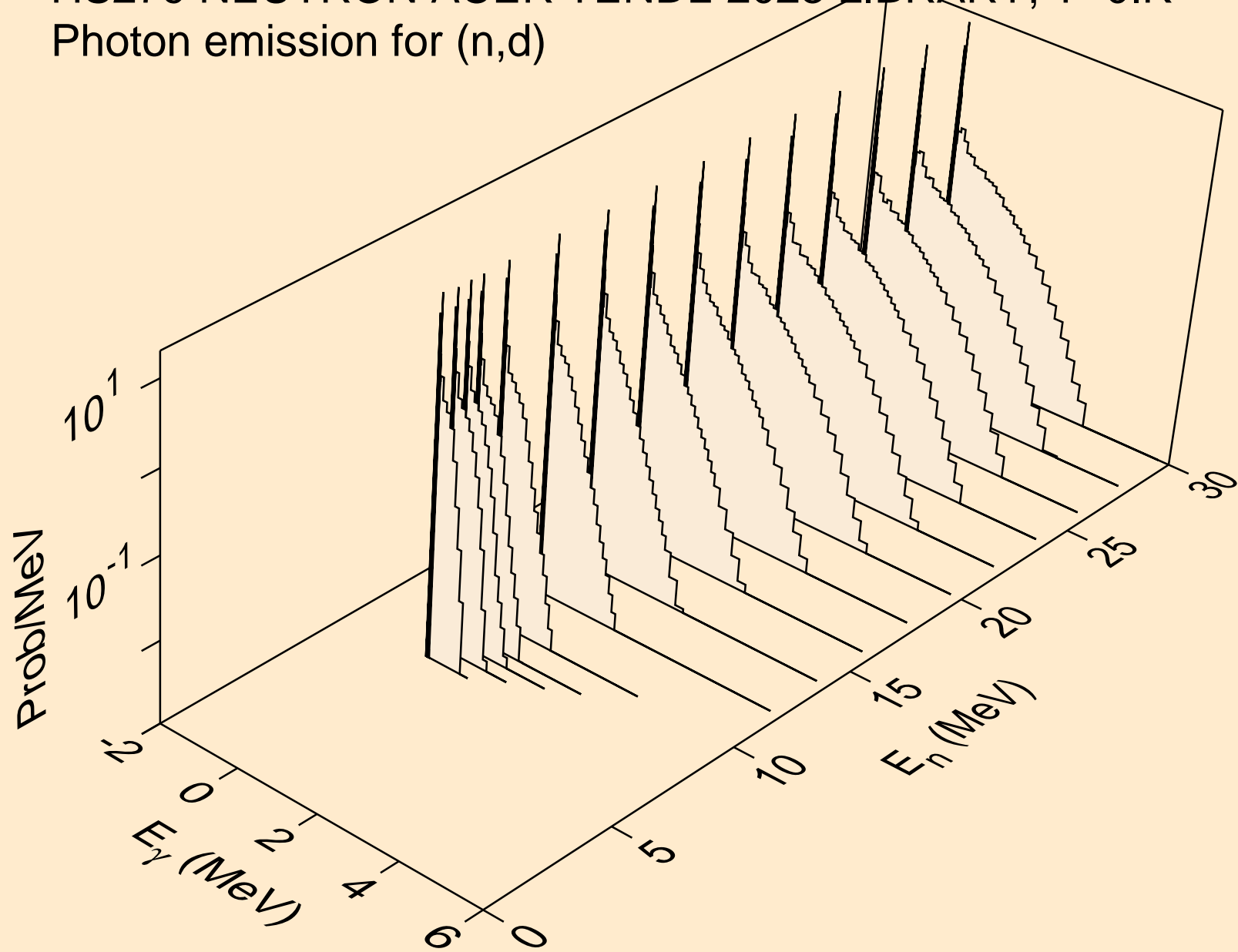

HS279 NEUTRON ACER TENDL-2023 LIBRARY; T=0.K
Photon emission for (n,t)

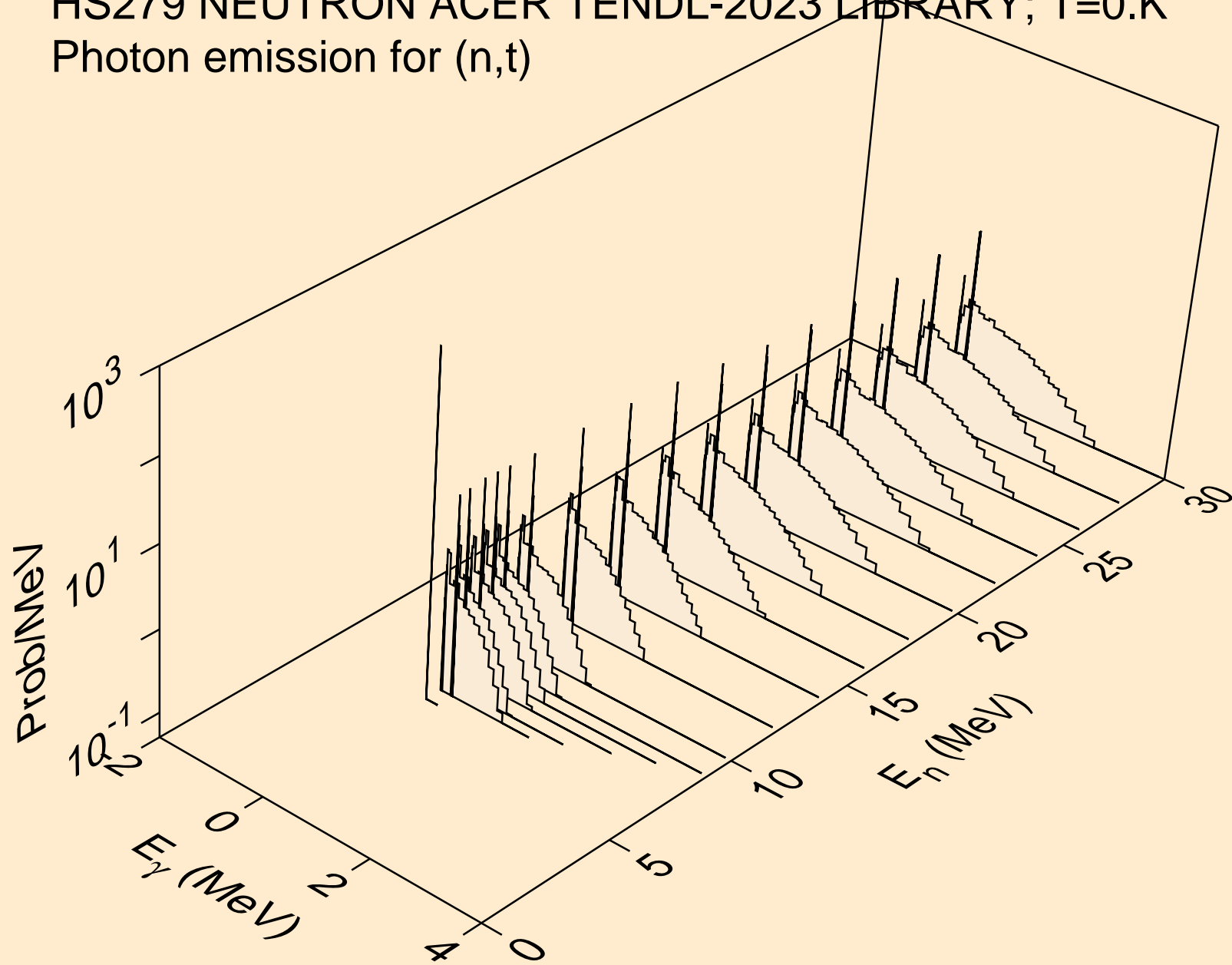

HS279 NEUTRON ACER TENDL-2023 LIBRARY; T=0.K
Photon emission for (n,he3)

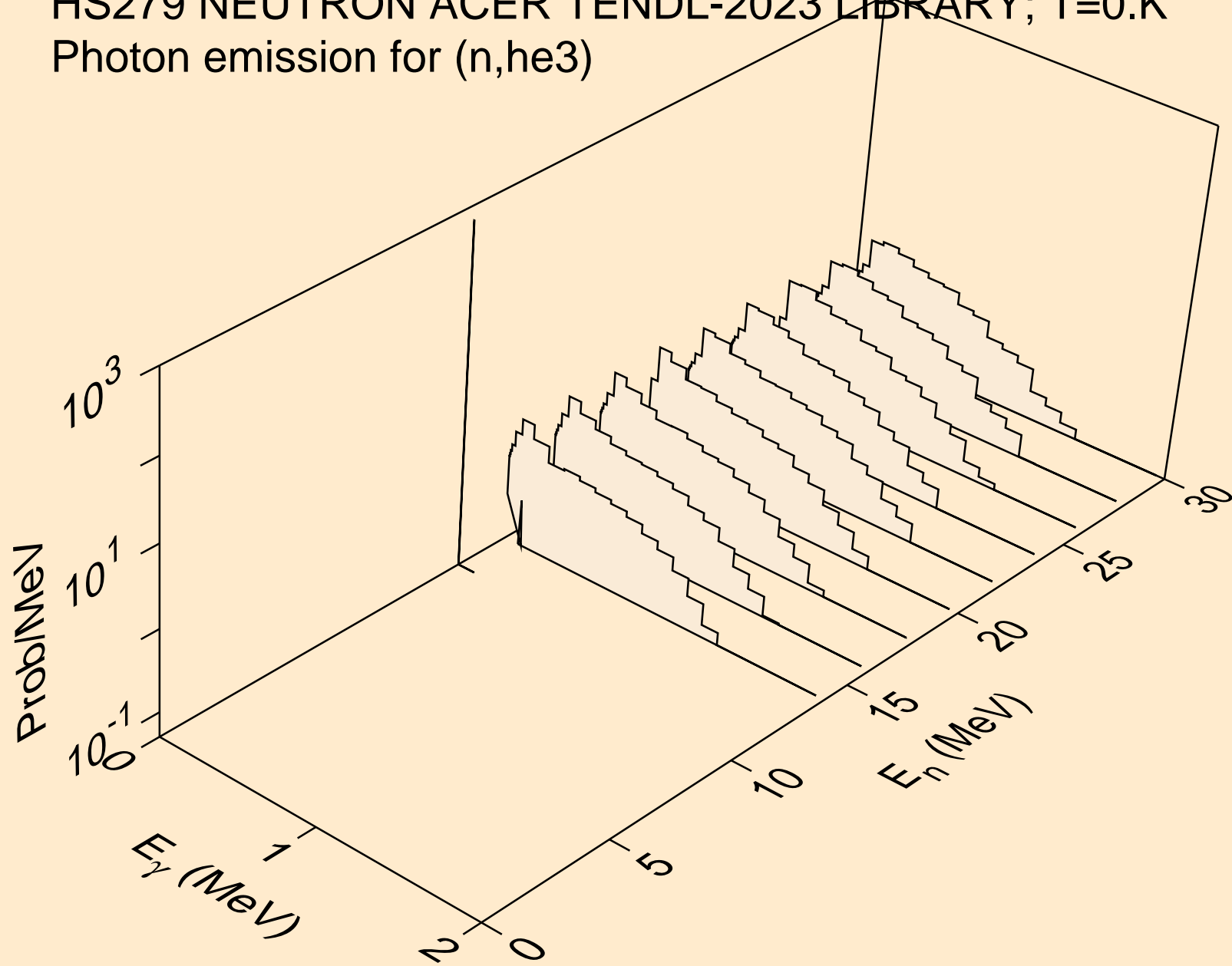

HS279 NEUTRON ACER TENDL-2023 LIBRARY; T=0.K
Photon emission for (n,a)

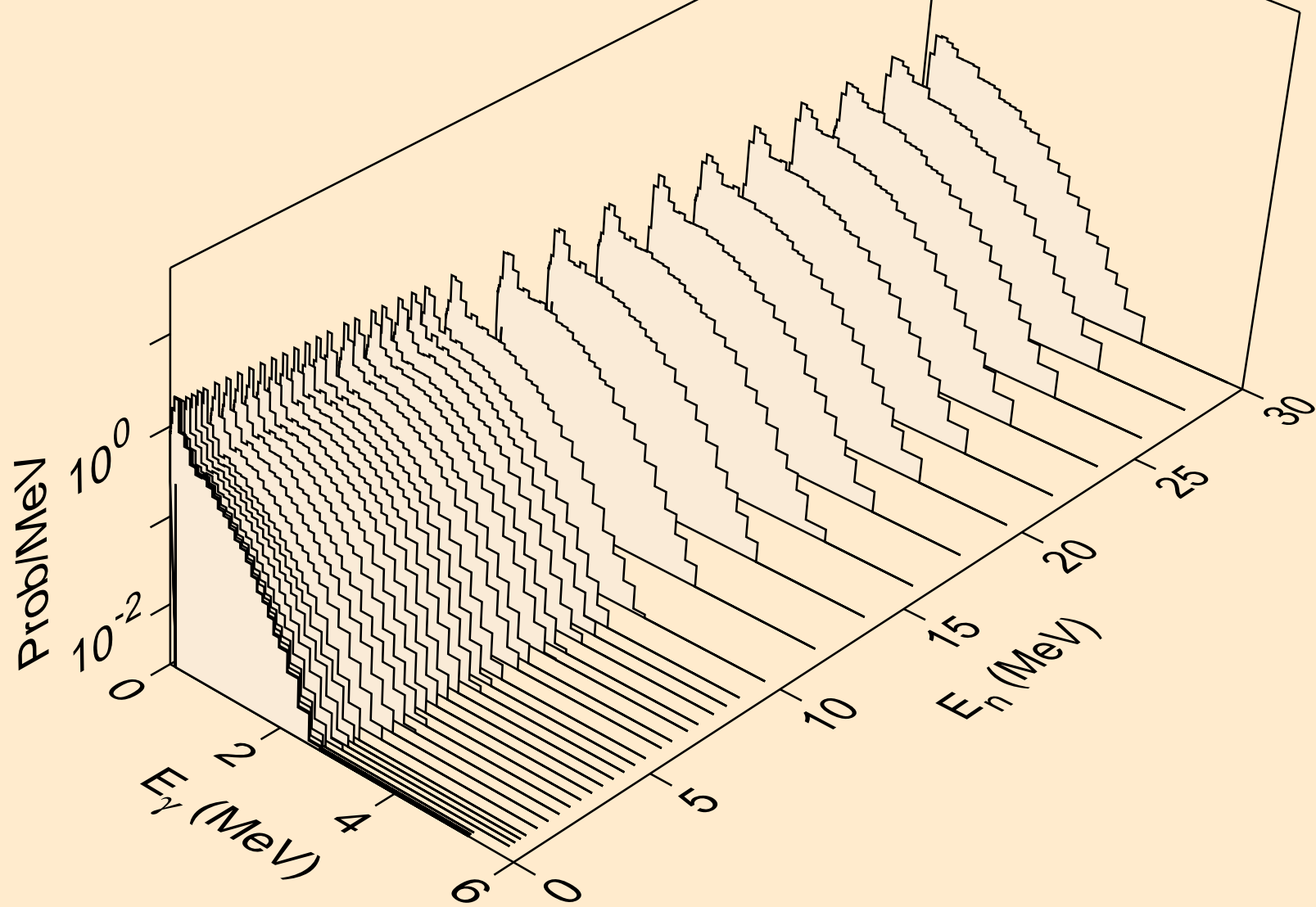

HS279 NEUTRON ACER TENDL-2023 LIBRARY; T=0.K
Photon emission for (n,2p)

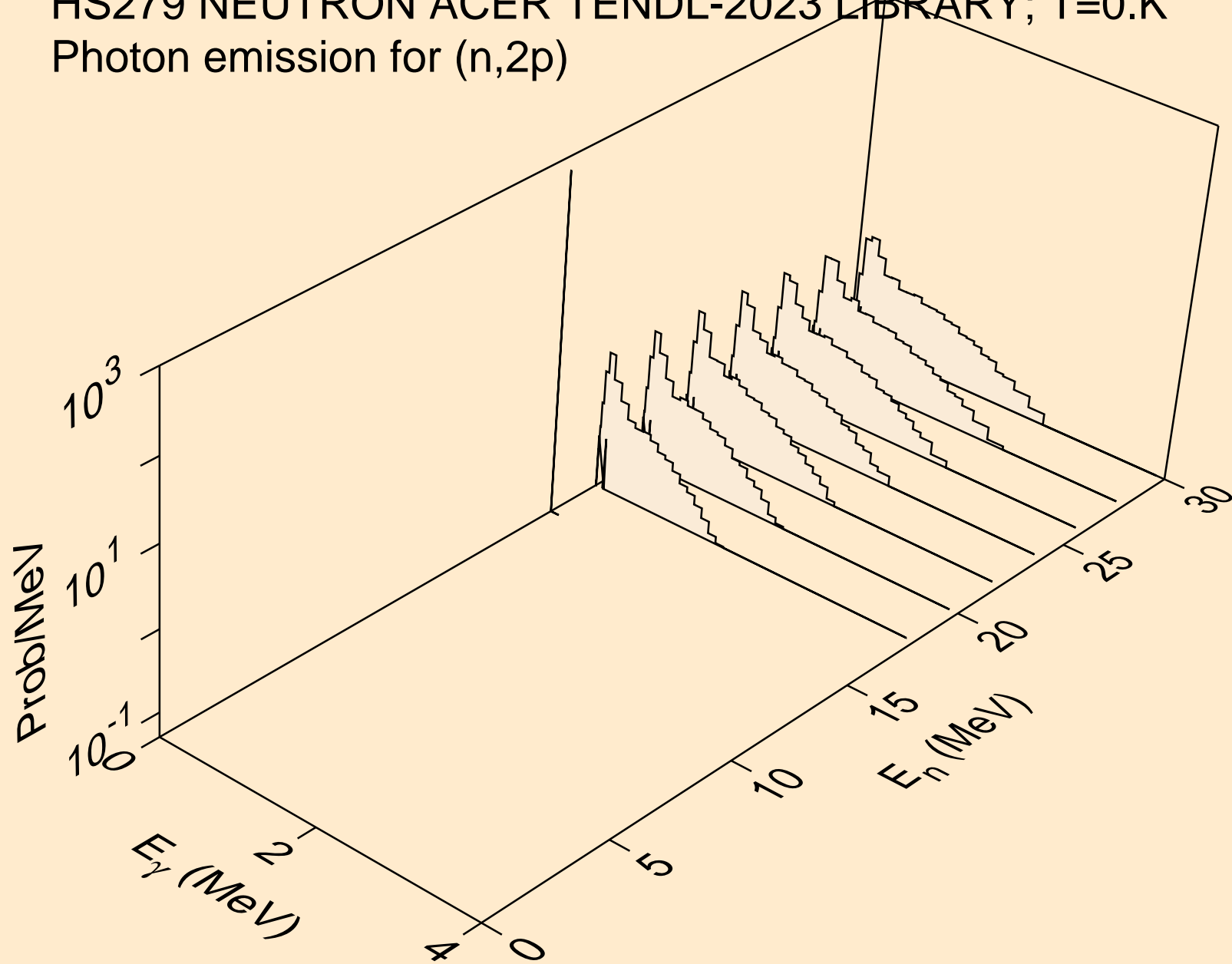

HS279 NEUTRON ACER TENDL-2023 LIBRARY; T=0.K
thermal capture photon spectrum

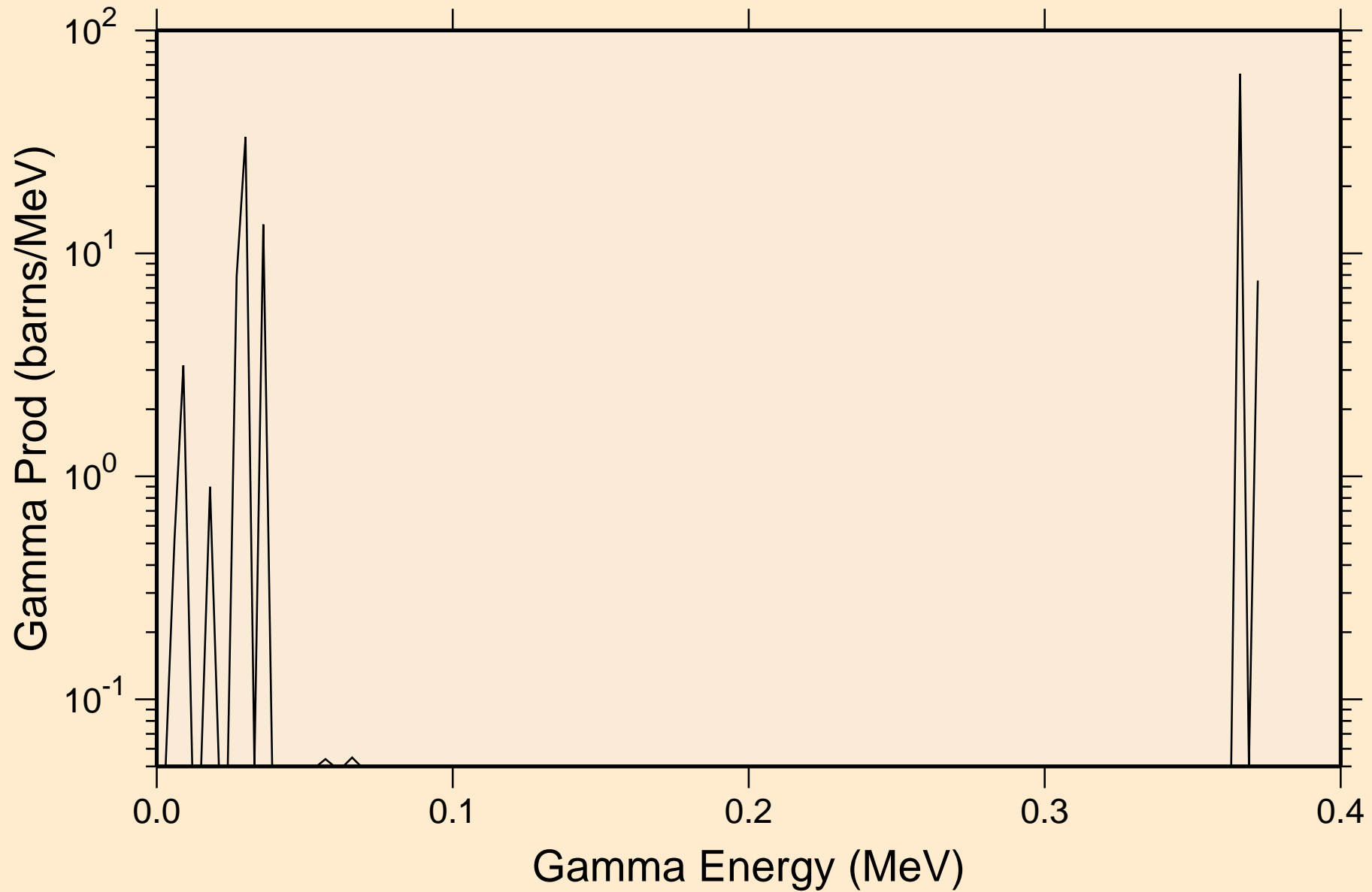

HS279 NEUTRON ACER TENDL-2023 LIBRARY; T=0.K
14 MeV photon spectrum

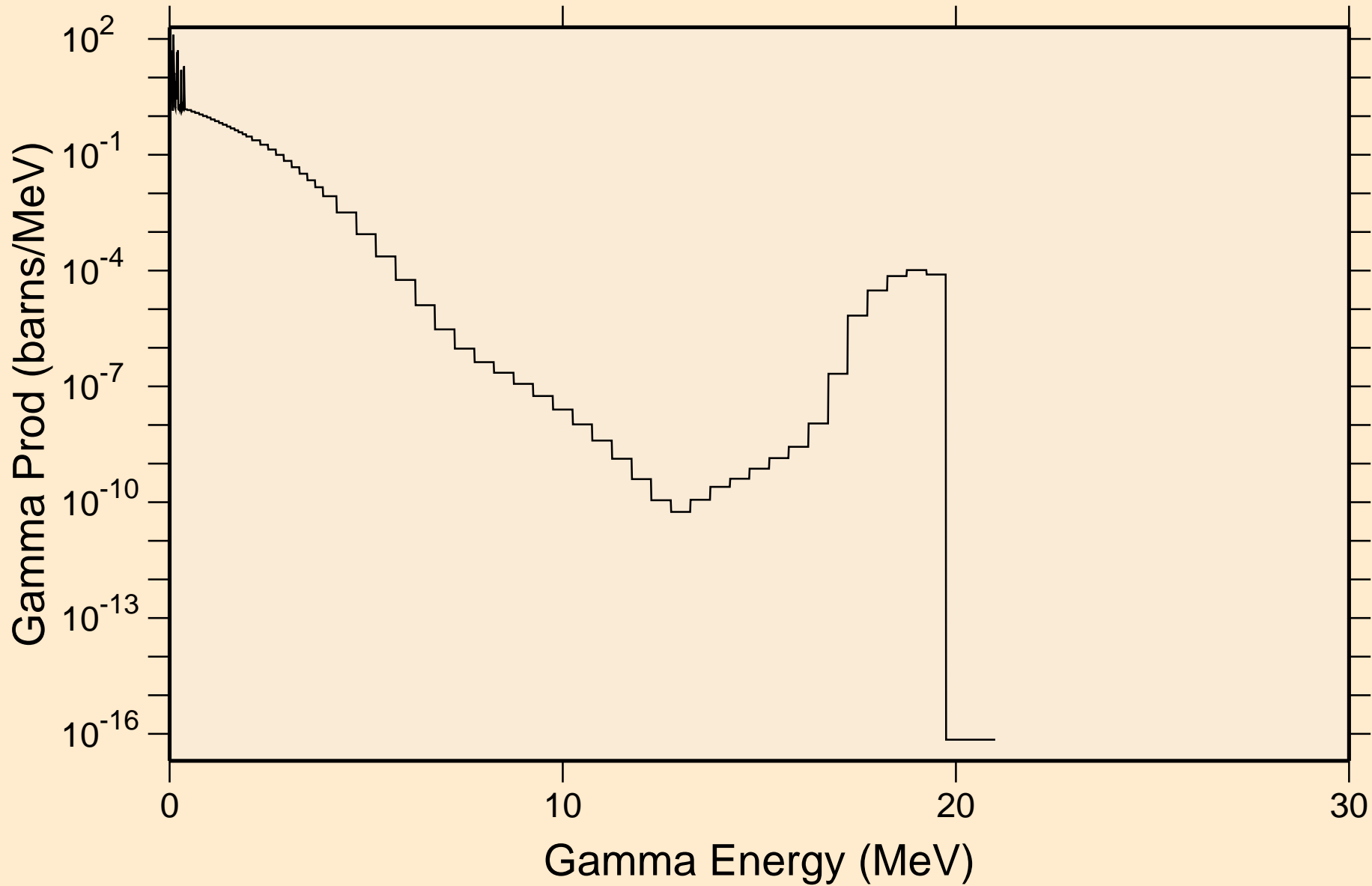

HS279 NEUTRON ACER TENDL-2023 LIBRARY; T=0.K

Particle heating contributions

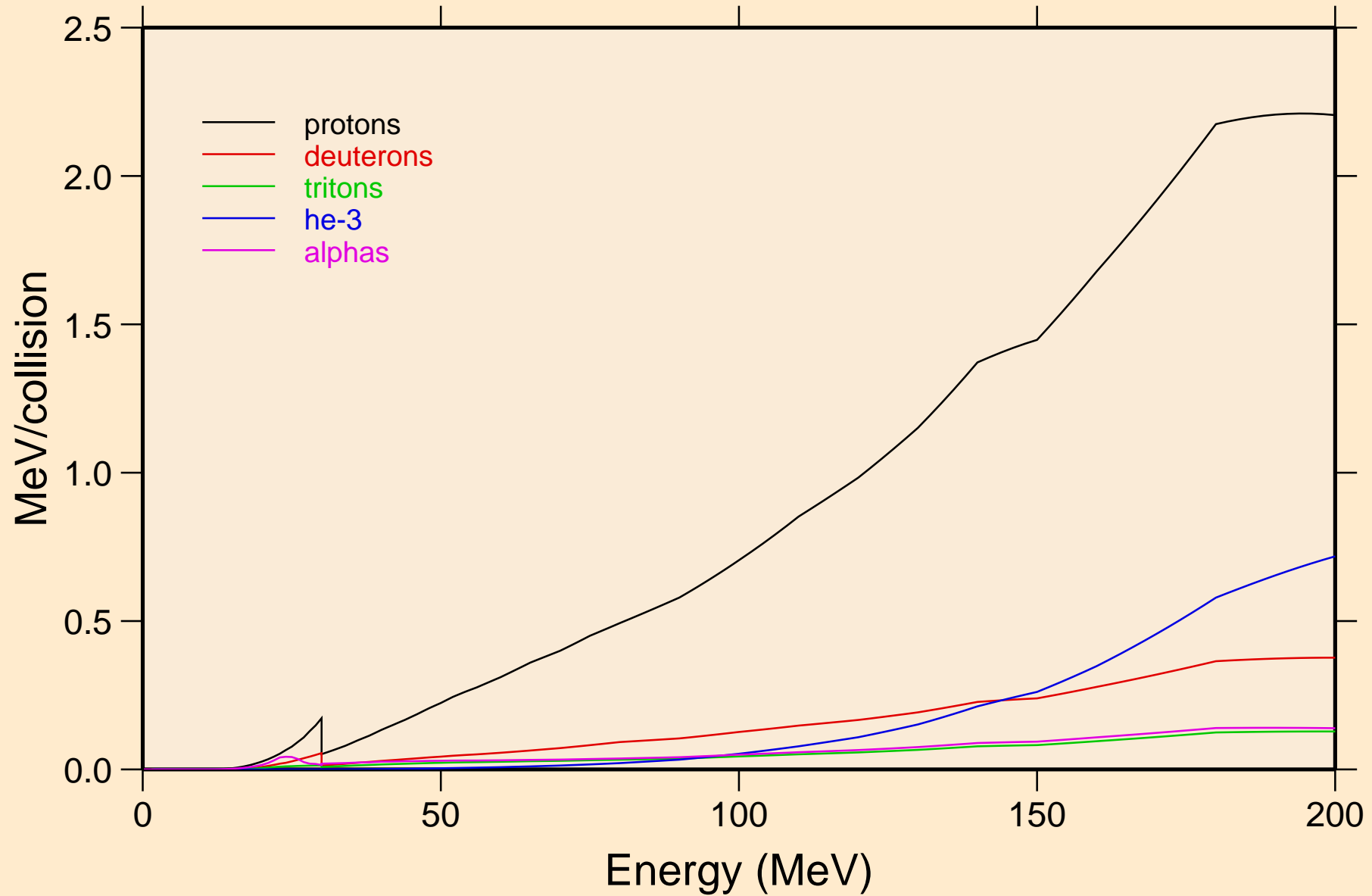

HS279 NEUTRON ACER TENDL-2023 LIBRARY; T=0.K

Recoil Heating

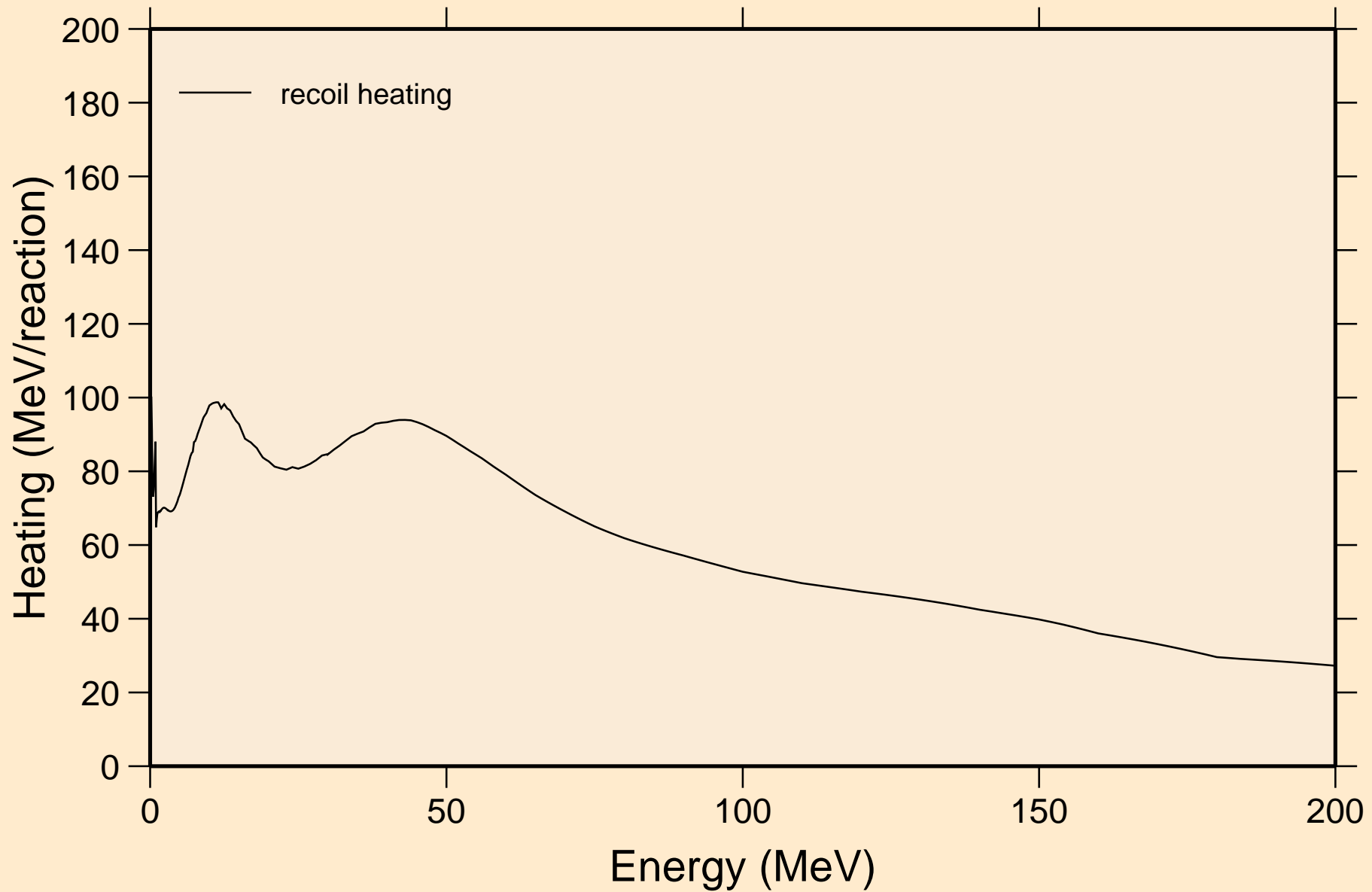

HS279 NEUTRON ACER TENDL-2023 LIBRARY; T=0.K

Particle production cross sections

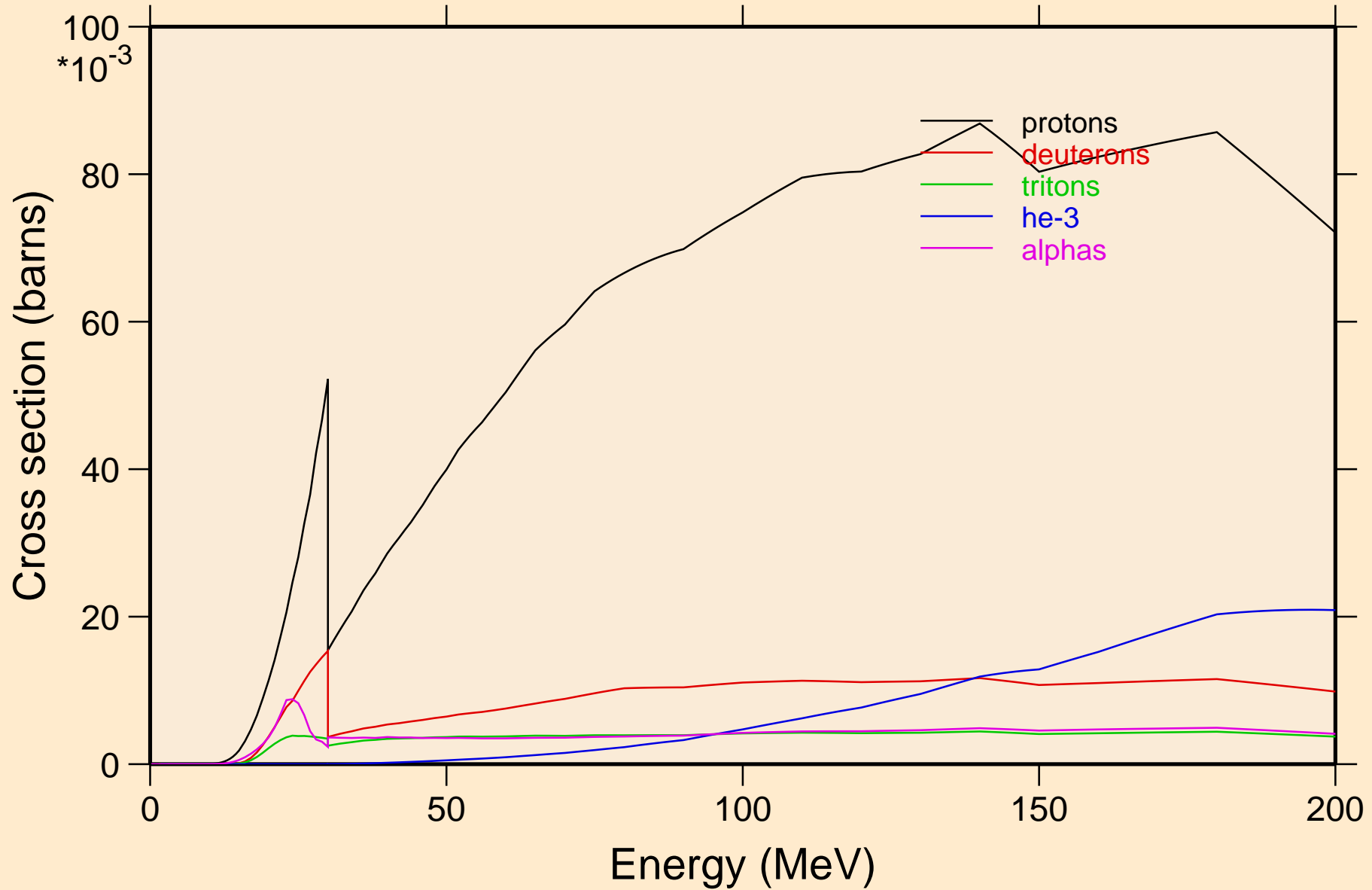

HS279 NEUTRON ACER TENDL-2023 LIBRARY; T=0.K
protons from (n,x)

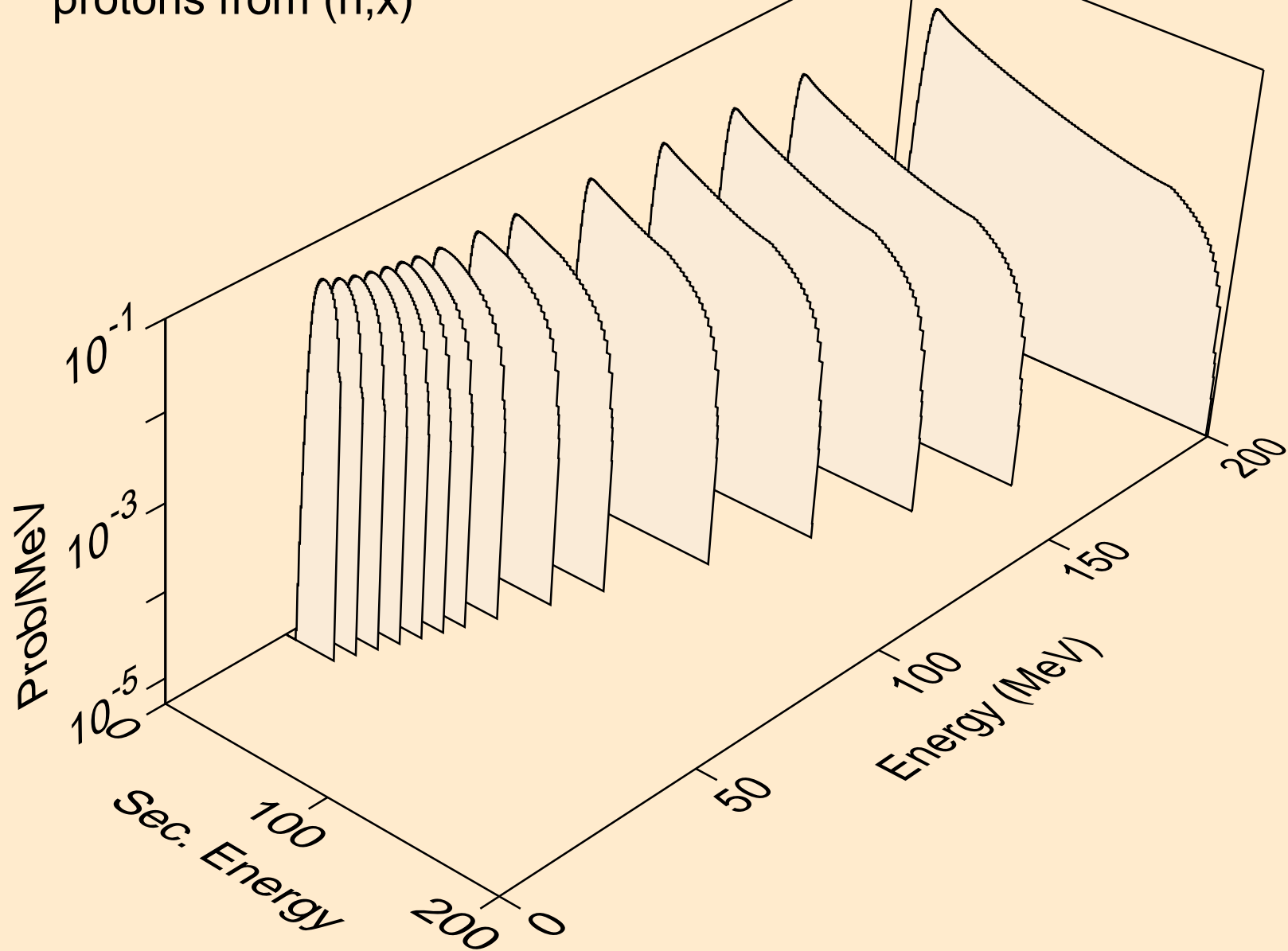

HS279 NEUTRON ACER TENDL-2023 LIBRARY; T=0.K
protons from (n,n*)p

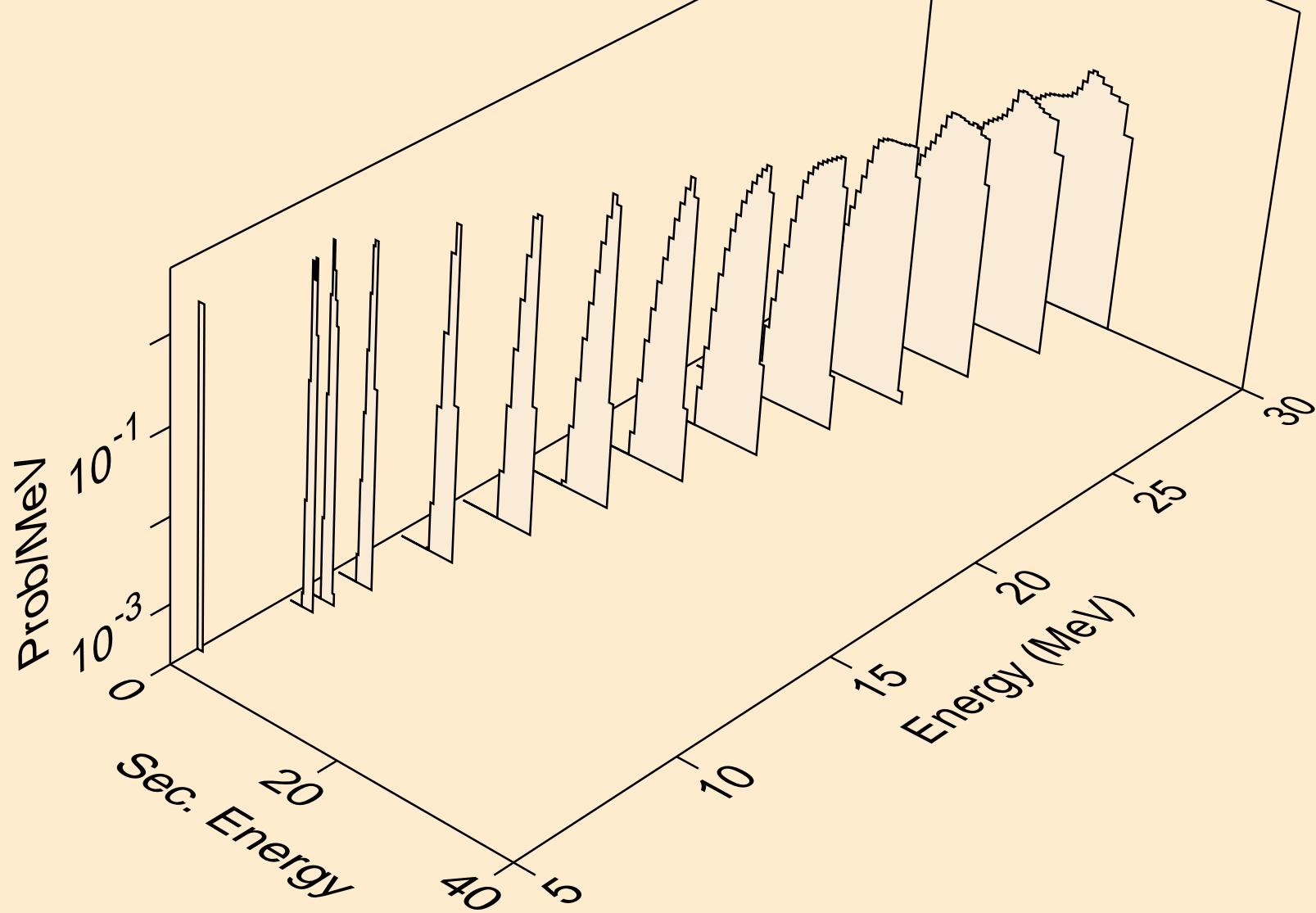

HS279 NEUTRON ACER TENDL-2023 LIBRARY; T=0.K
protons from (n,2np)

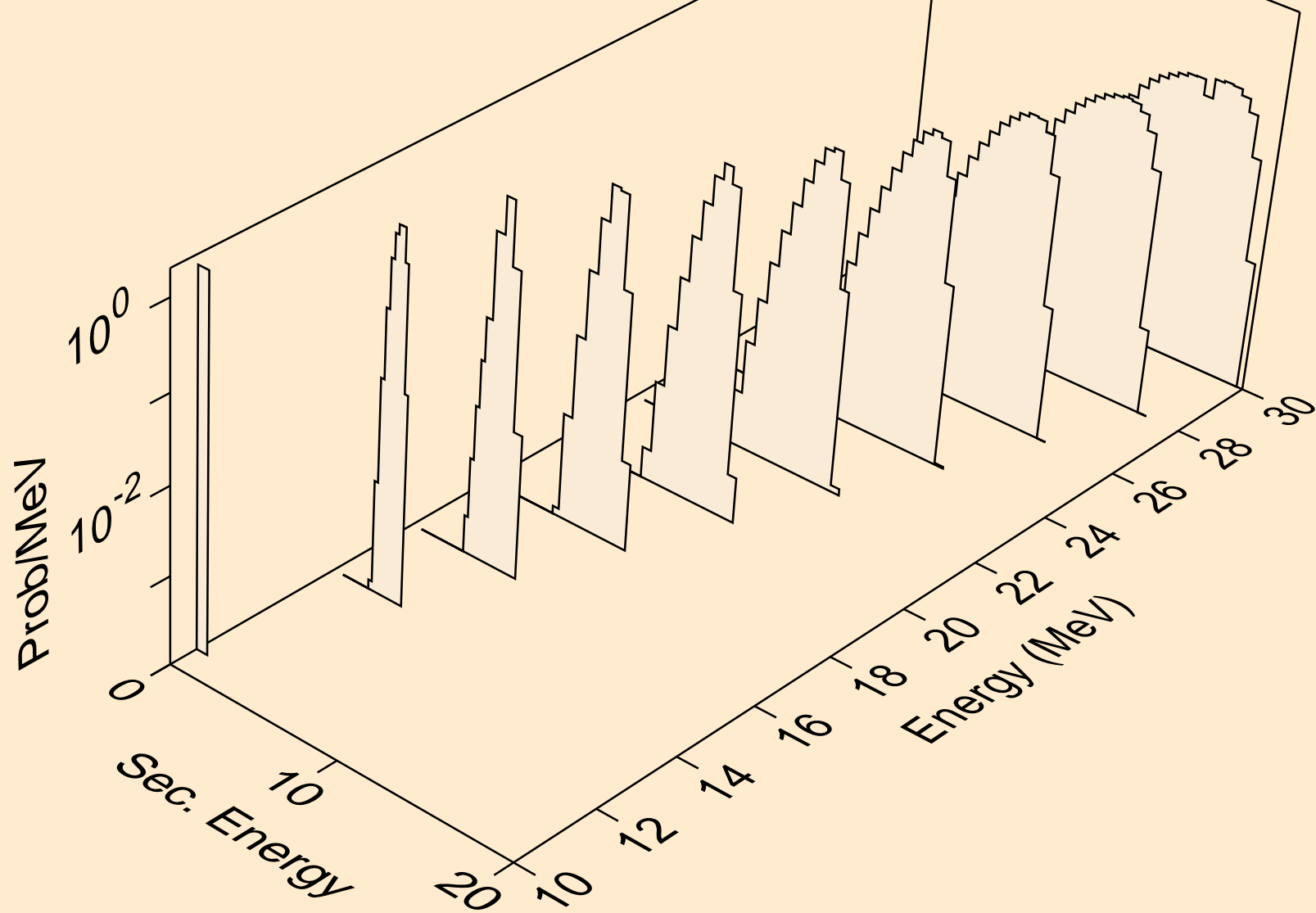

HS279 NEUTRON ACER TENDL-2023 LIBRARY; T=0.K
protons from (n,3np)

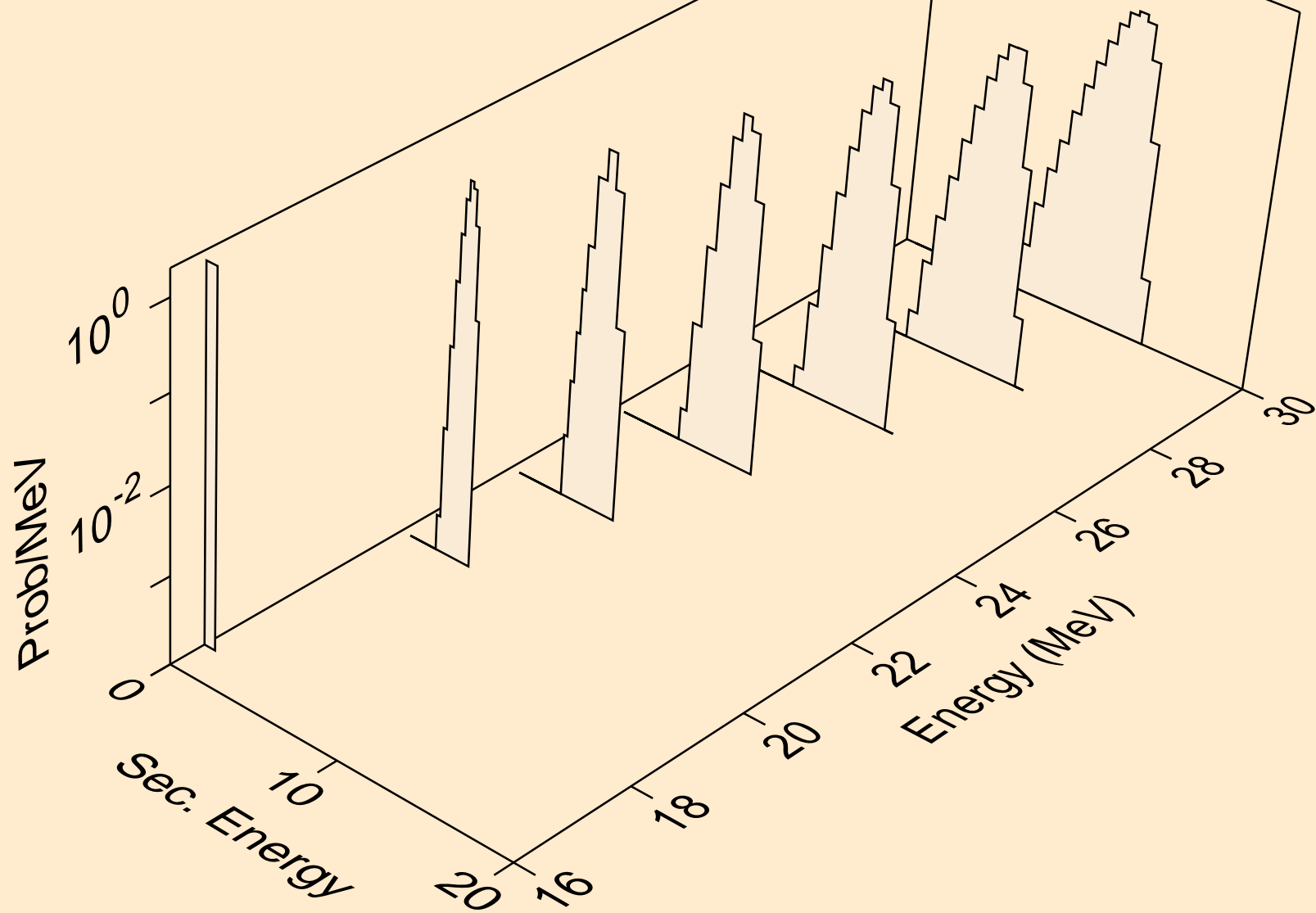

HS279 NEUTRON ACER TENDL-2023 LIBRARY; T=0.K
protons from (n,n2p)

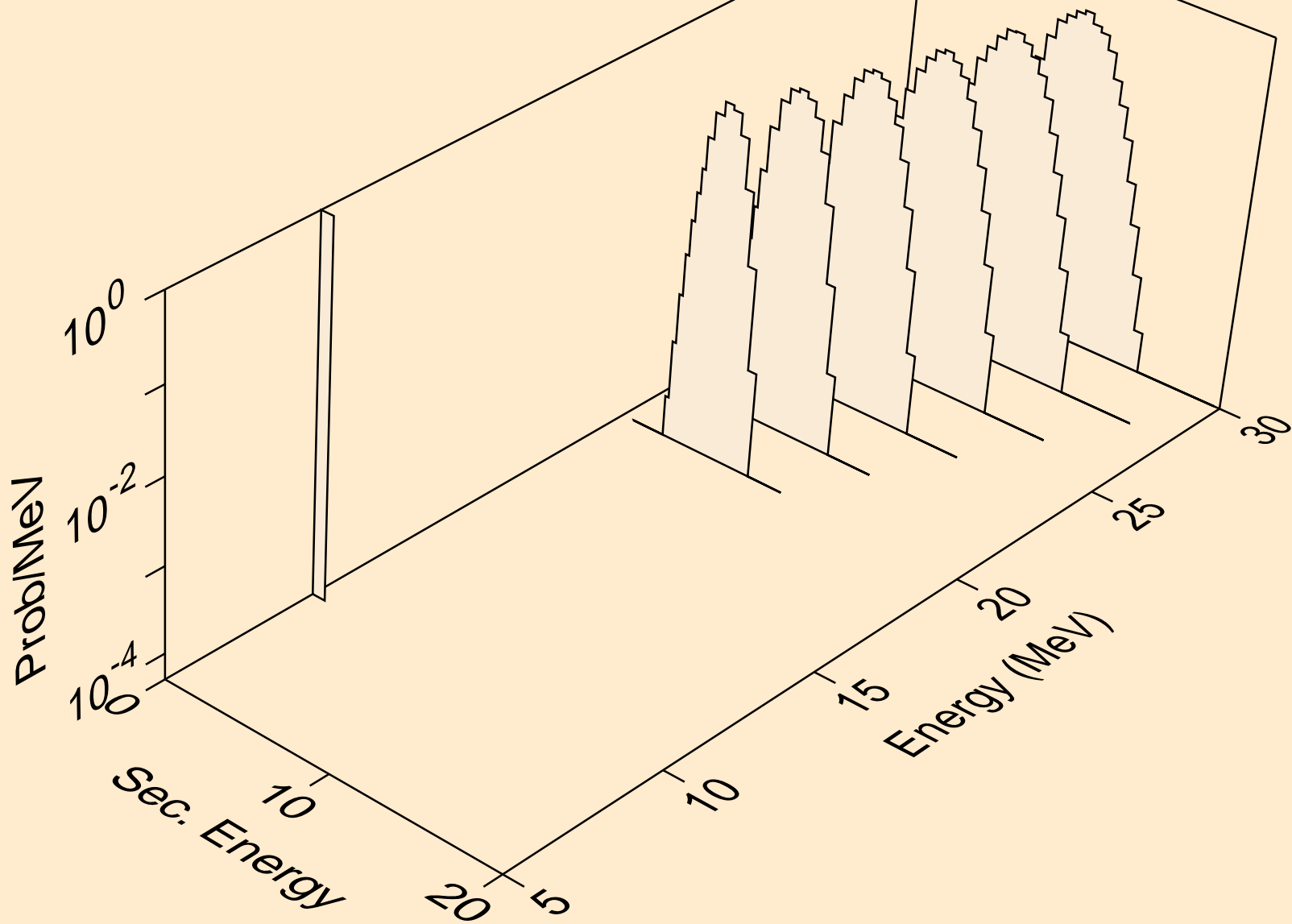

HS279 NEUTRON ACER TENDL-2023 LIBRARY; T=0.K
protons from (n,p)

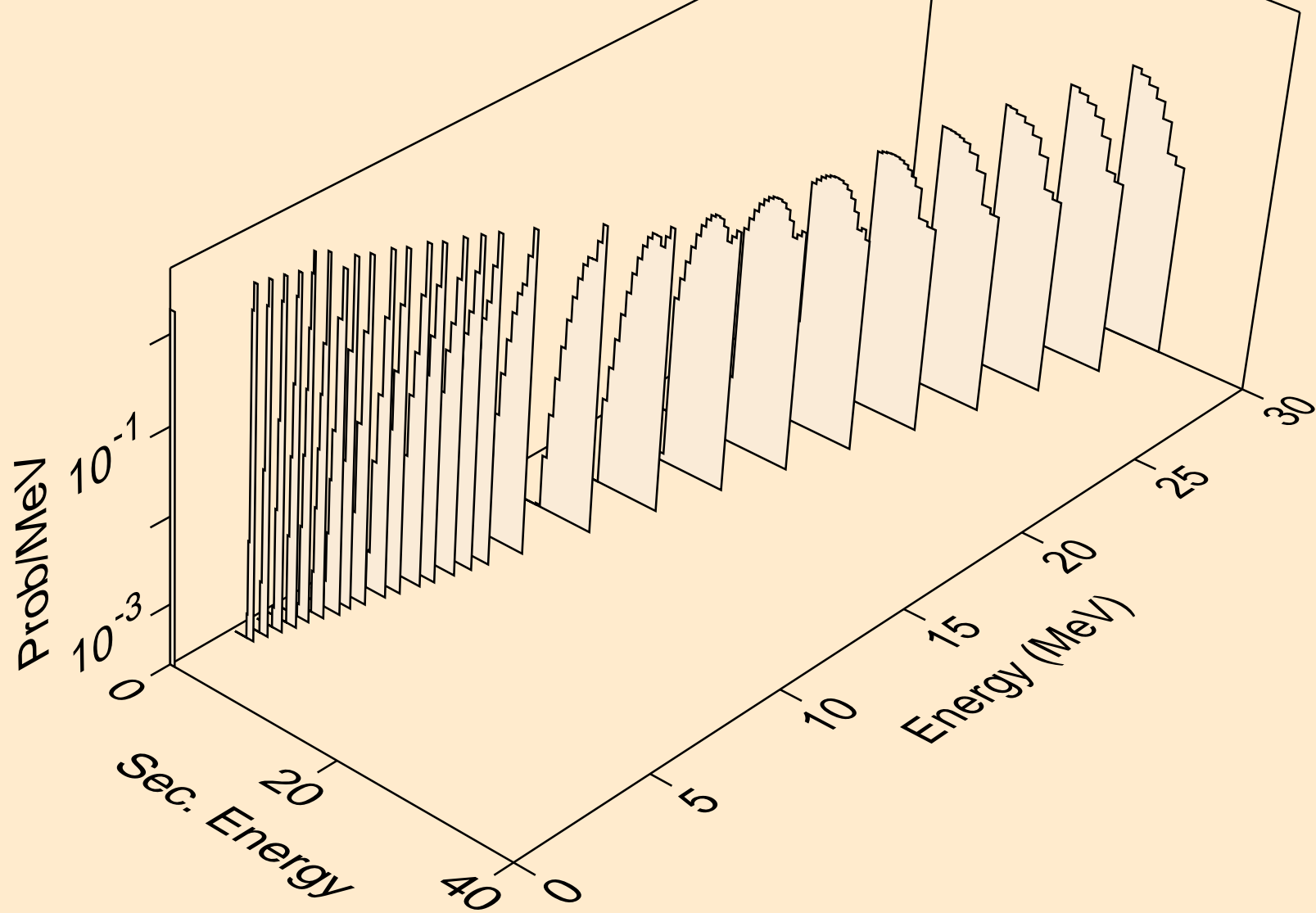

HS279 NEUTRON ACER TENDL-2023 LIBRARY; T=0.K
protons from (n,2p)

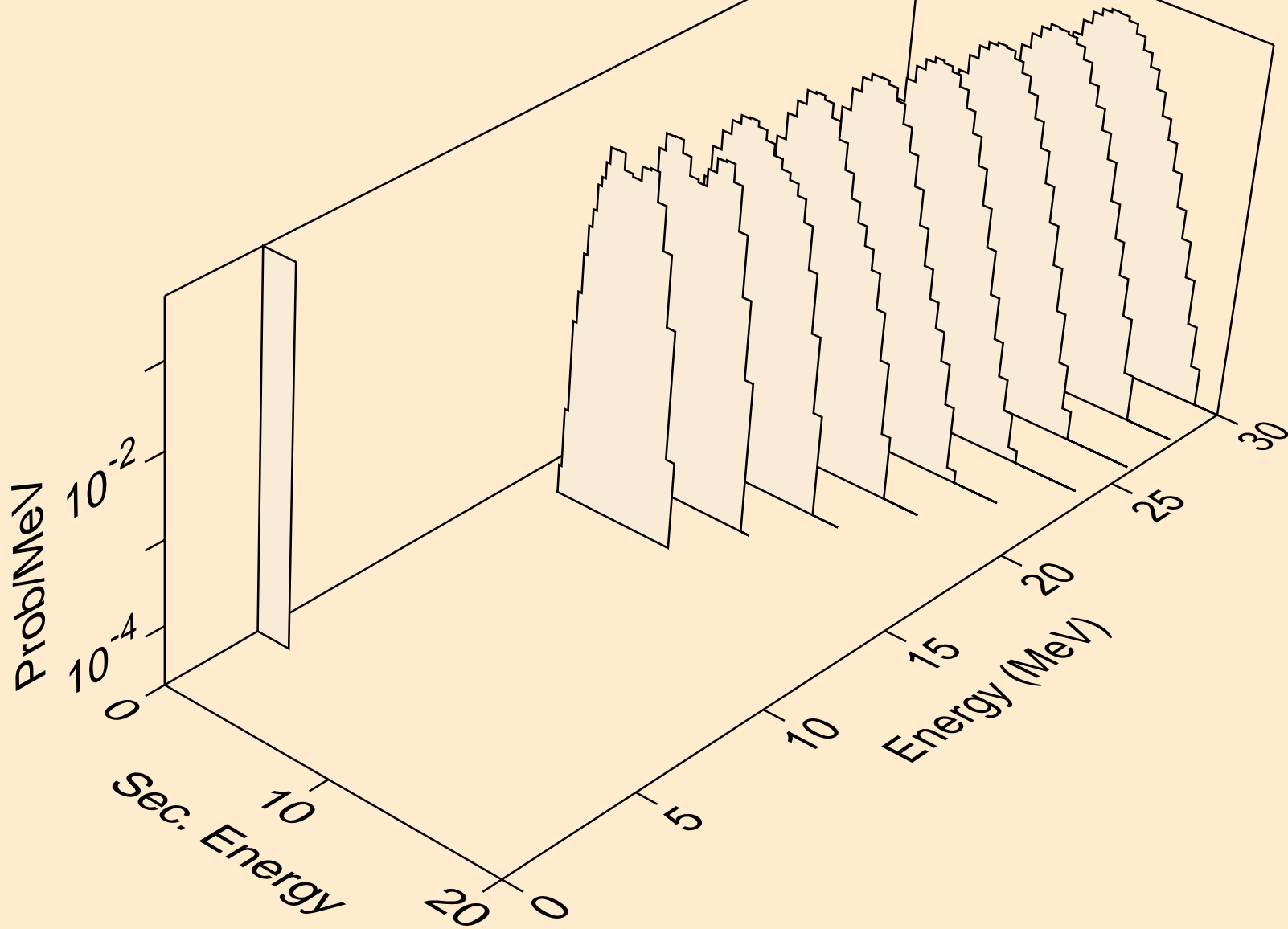

HS279 NEUTRON ACER TENDL-2023 LIBRARY; T=0.K
deuterons from (n,x)

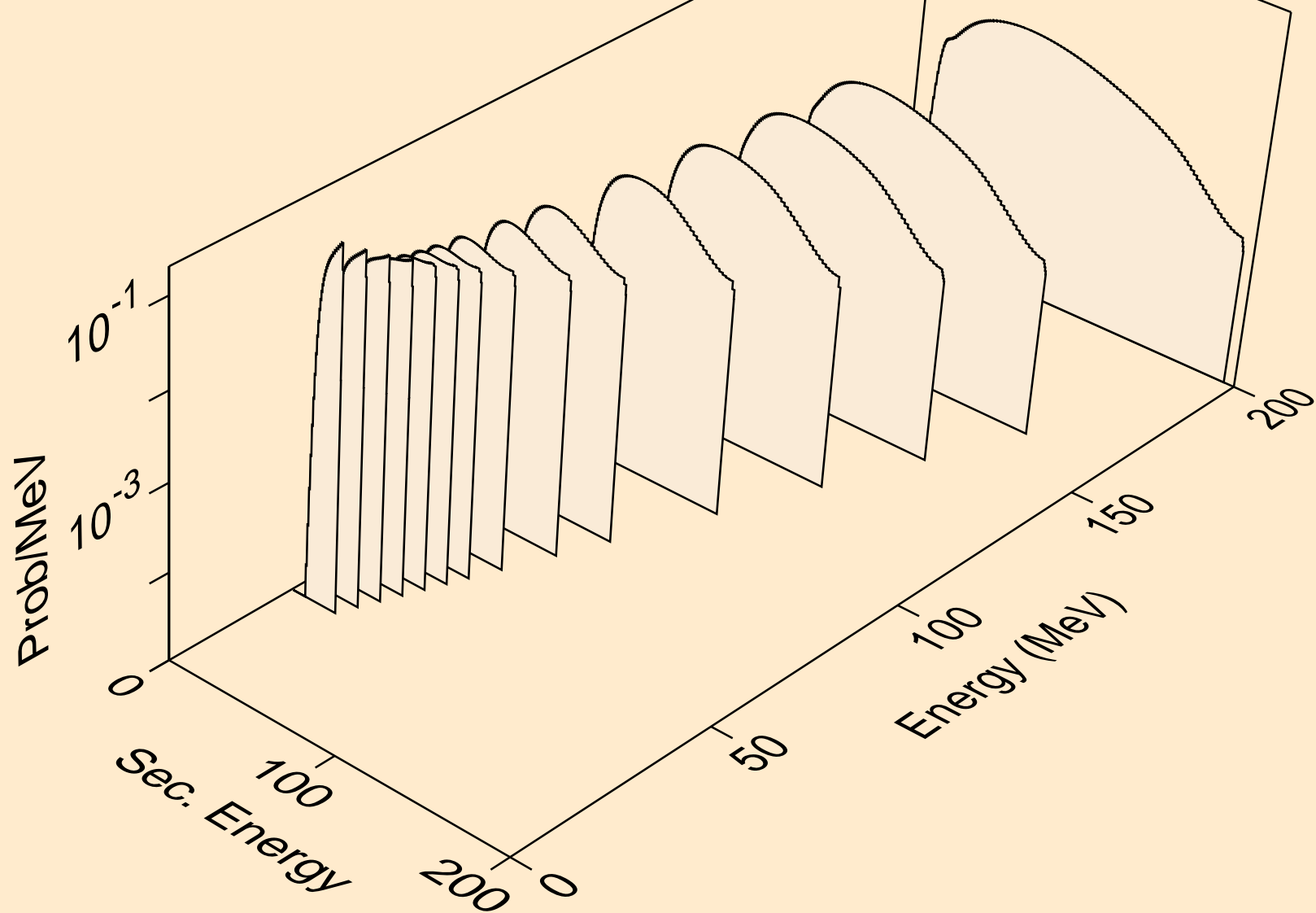

HS279 NEUTRON ACER TENDL-2023 LIBRARY; T=0.K
deuterons from (n,2nd)

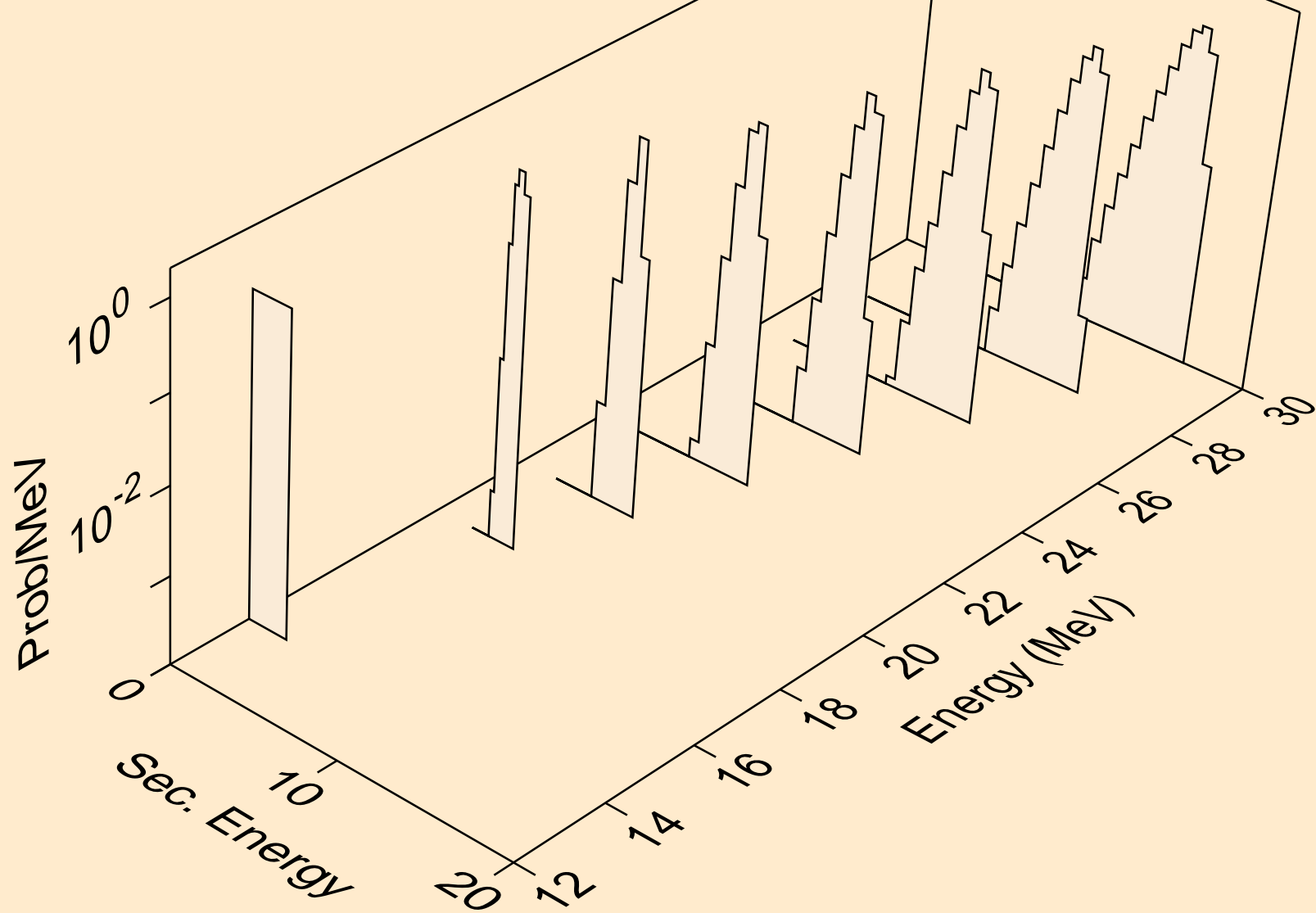

HS279 NEUTRON ACER TENDL-2023 LIBRARY; T=0.K
deuterons from (n,n*)d

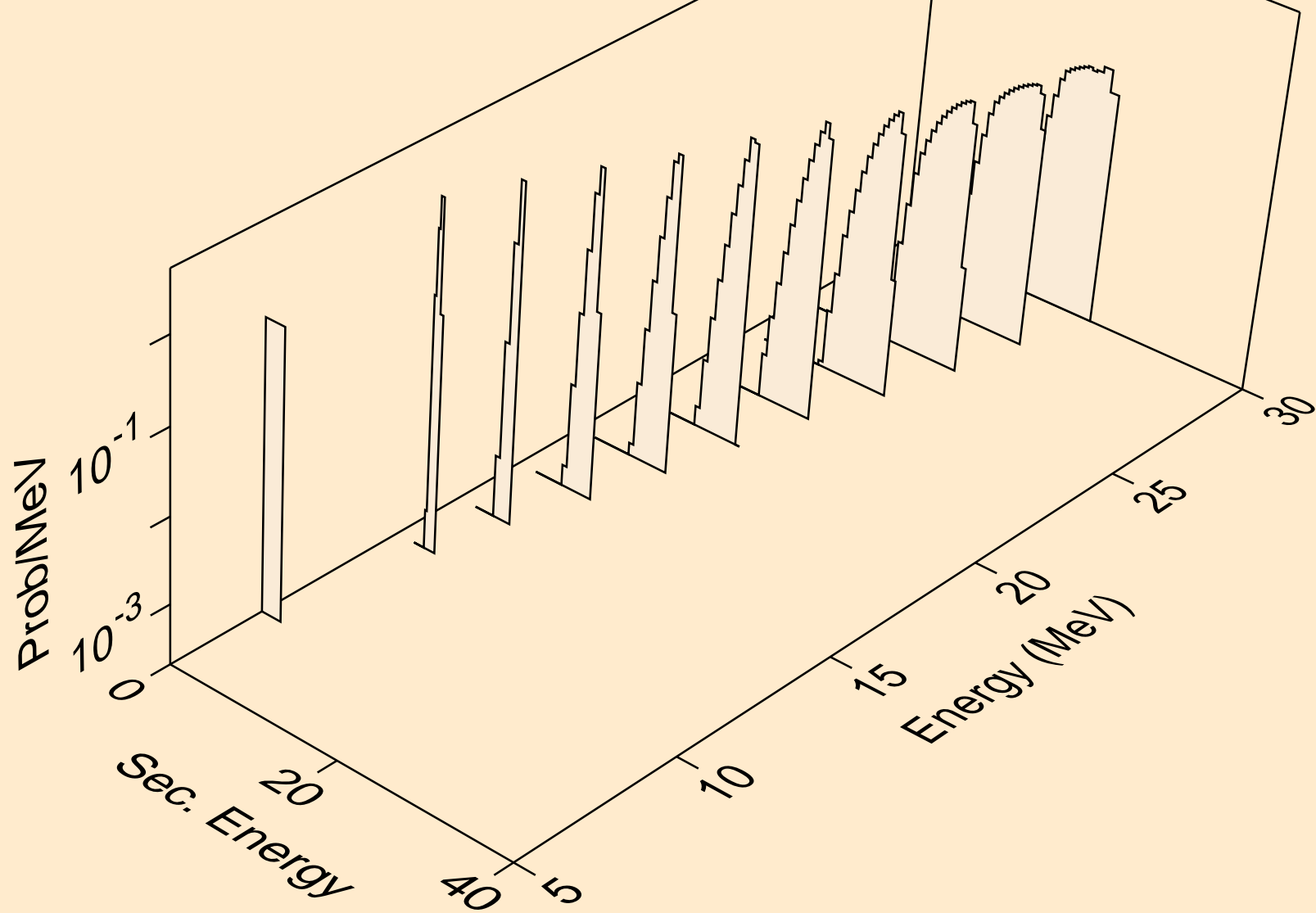

HS279 NEUTRON ACER TENDL-2023 LIBRARY; T=0.K
deuterons from (n,d)

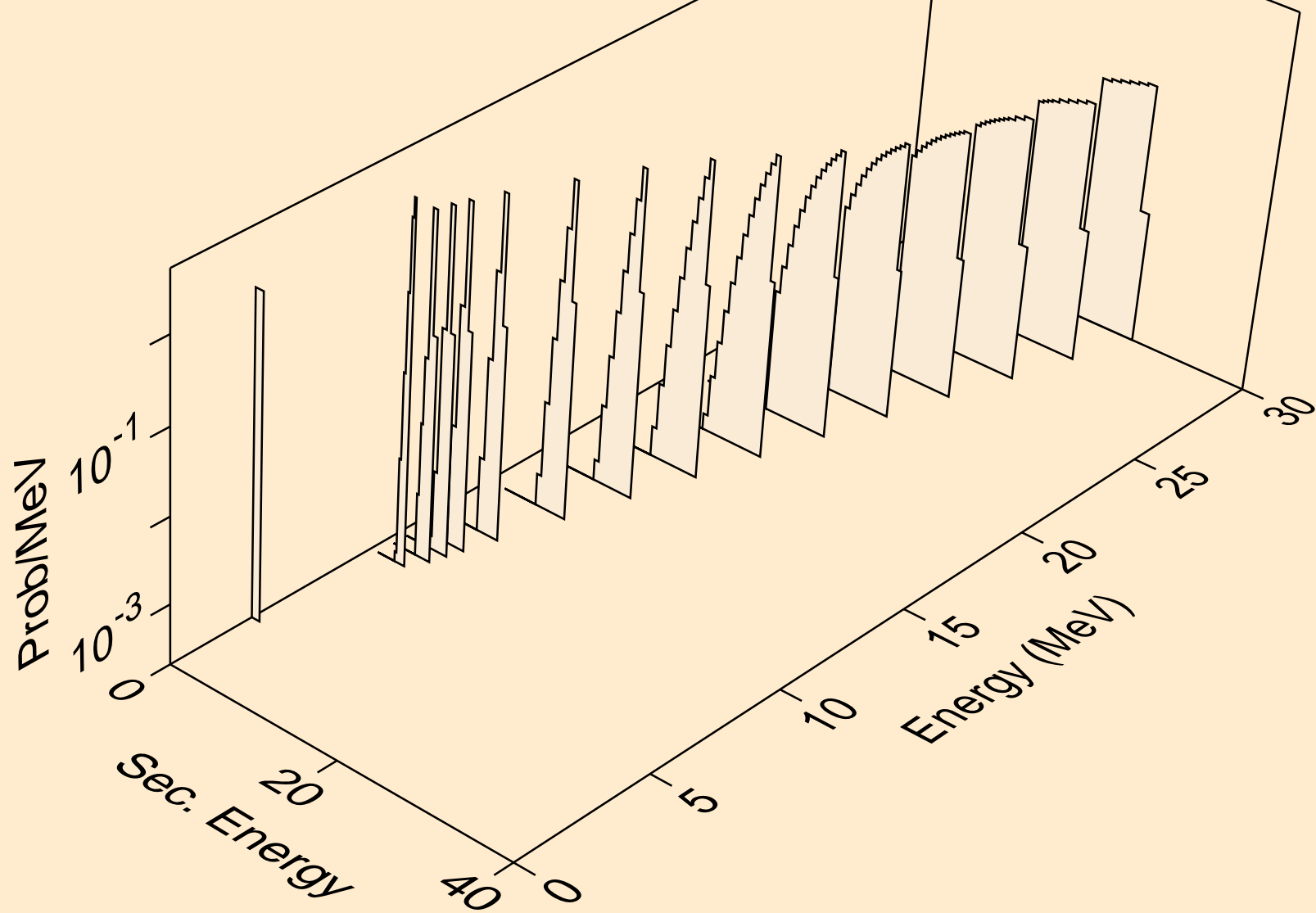

HS279 NEUTRON ACER TENDL-2023 LIBRARY; T=0.K
tritons from (n,x)

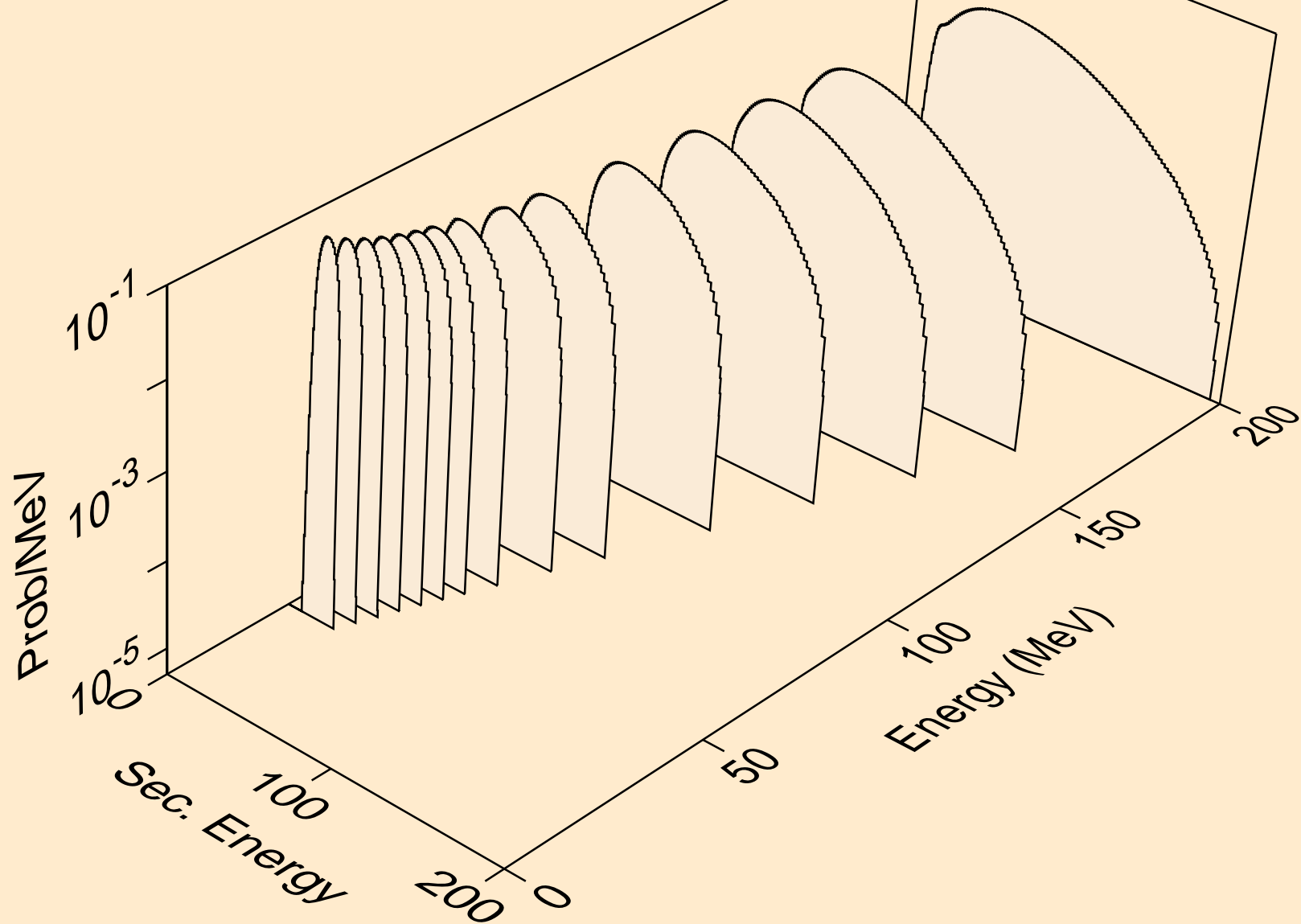

HS279 NEUTRON ACER TENDL-2023 LIBRARY; T=0.K
tritons from (n,n*)t

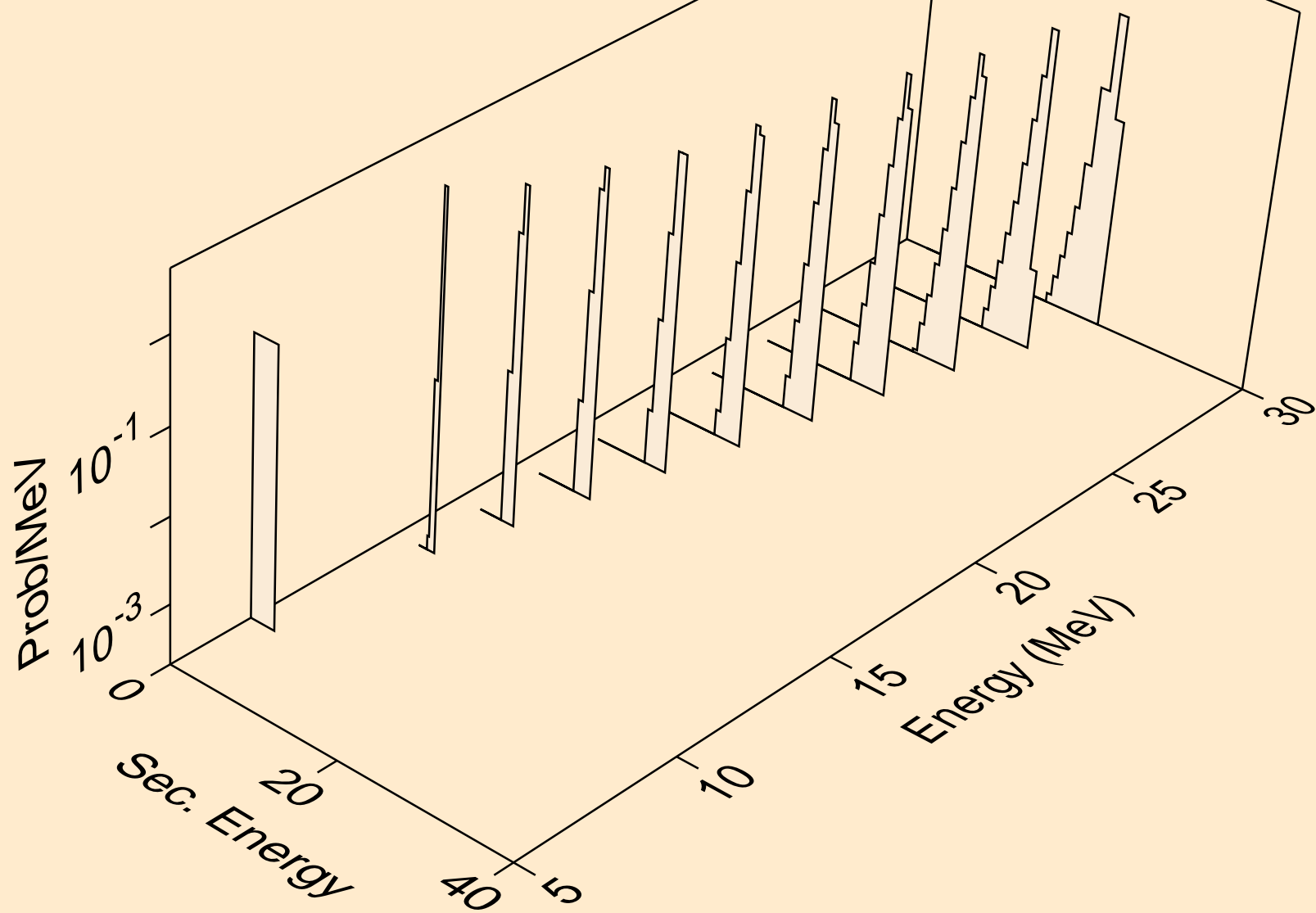

HS279 NEUTRON ACER TENDL-2023 LIBRARY; T=0.K
tritons from (n,t)

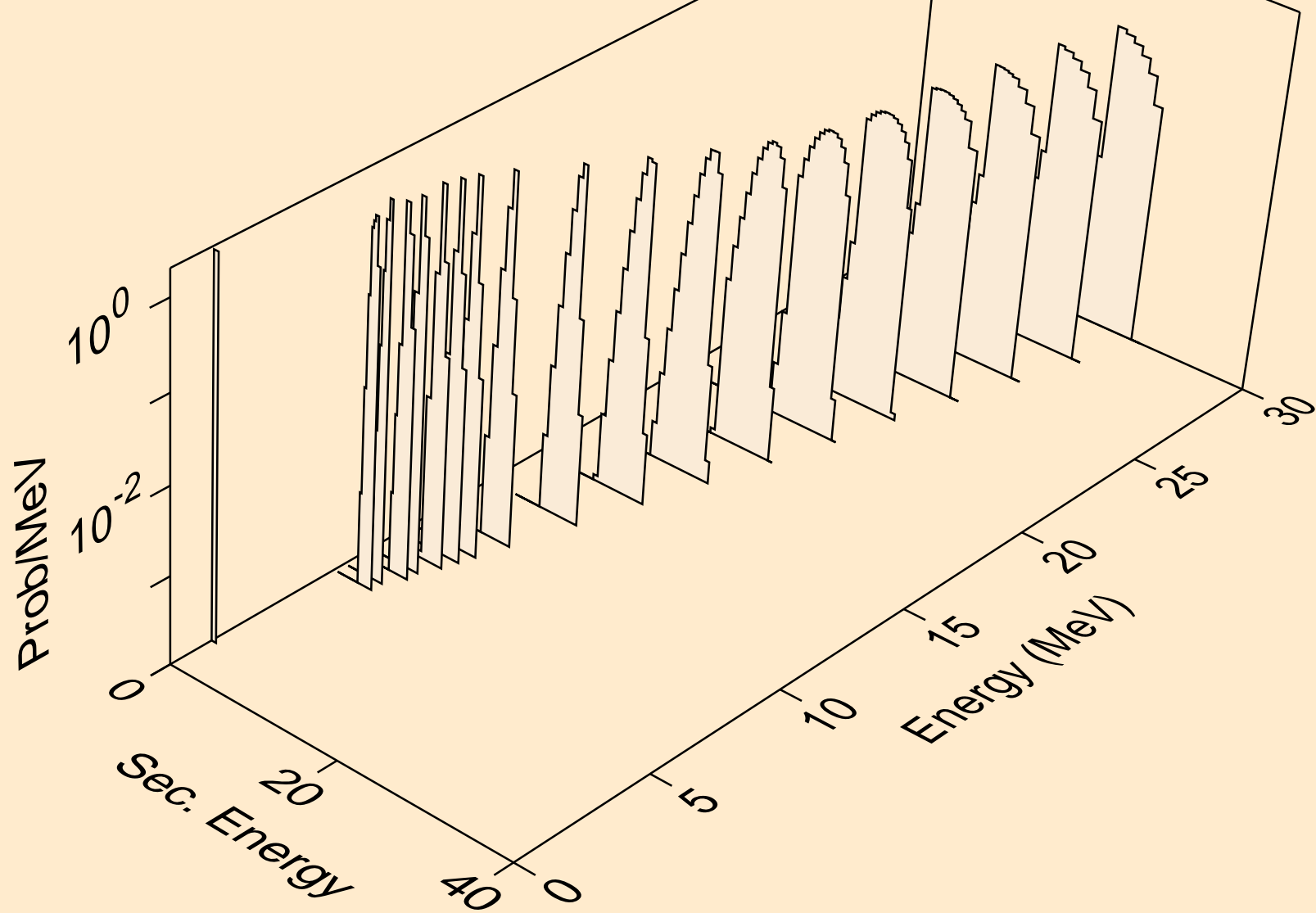

HS279 NEUTRON ACER TENDL-2023 LIBRARY; T=0.K
he3s from (n,x)

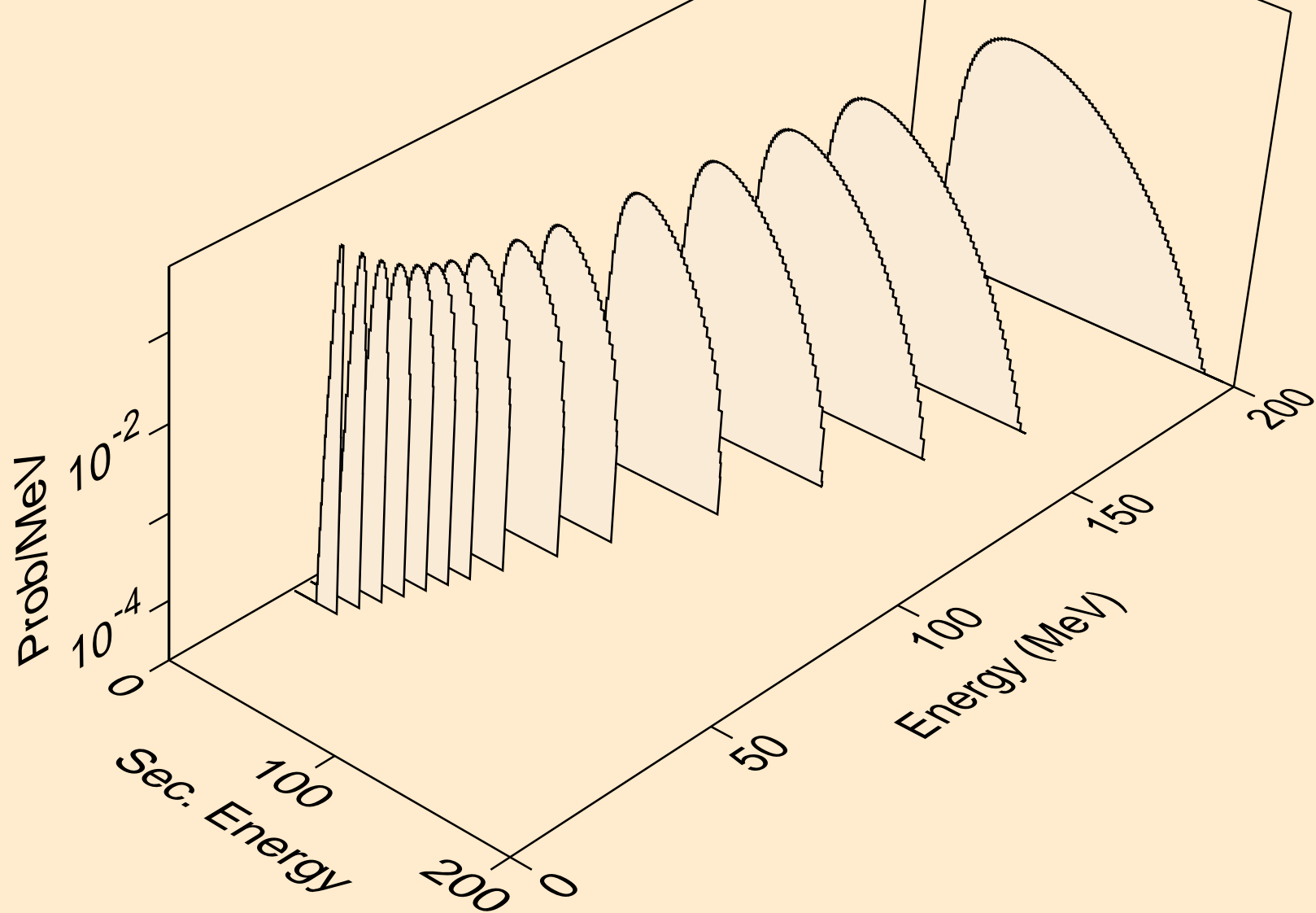

HS279 NEUTRON ACER TENDL-2023 LIBRARY; T=0.K
he3s from (n,n*)he3

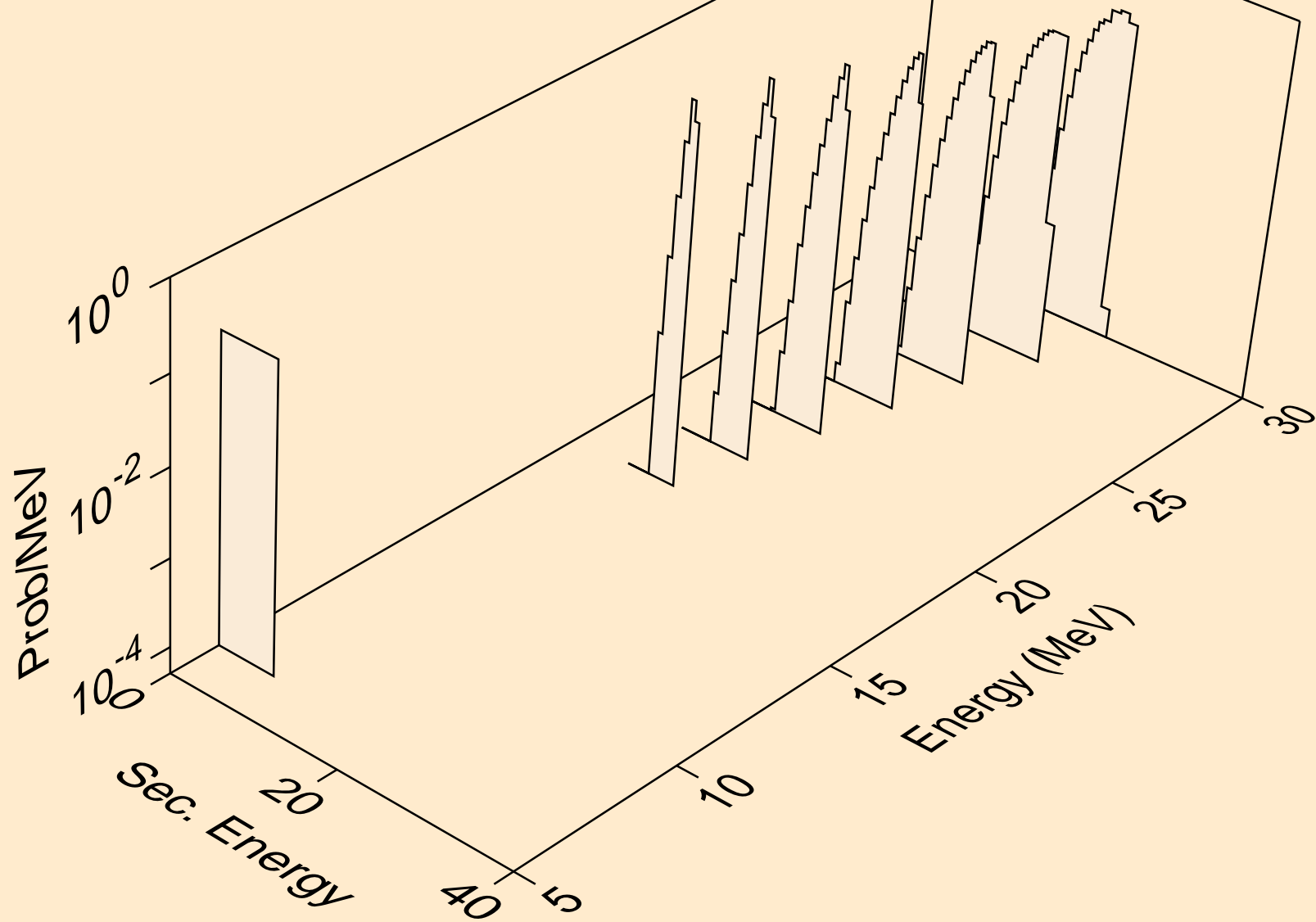

HS279 NEUTRON ACER TENDL-2023 LIBRARY; T=0.K
he3s from (n,he3)

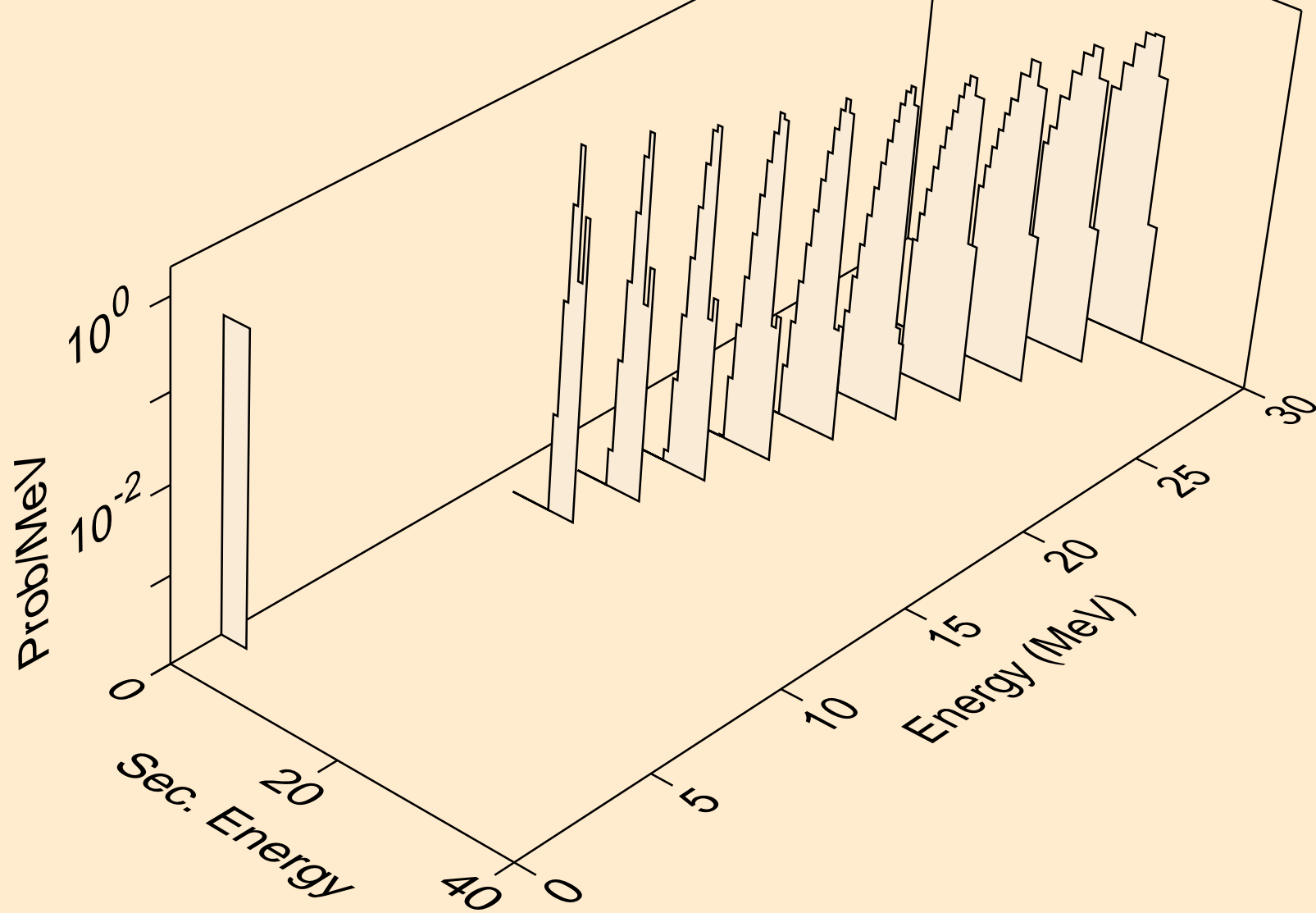

HS279 NEUTRON ACER TENDL-2023 LIBRARY; T=0.K
alphas from (n,x)

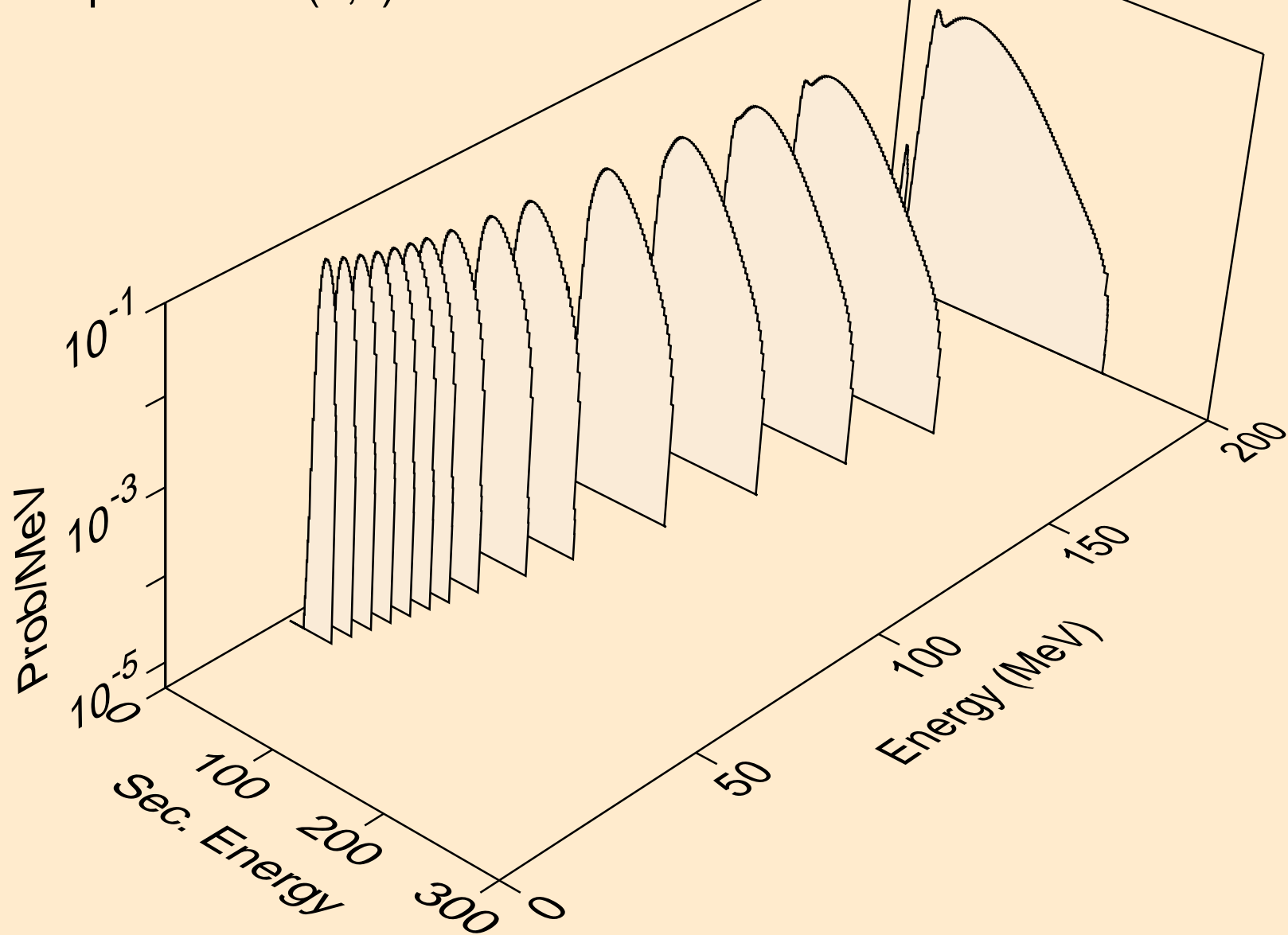

HS279 NEUTRON ACER TENDL-2023 LIBRARY; T=0.K
alphas from (n,n*)a

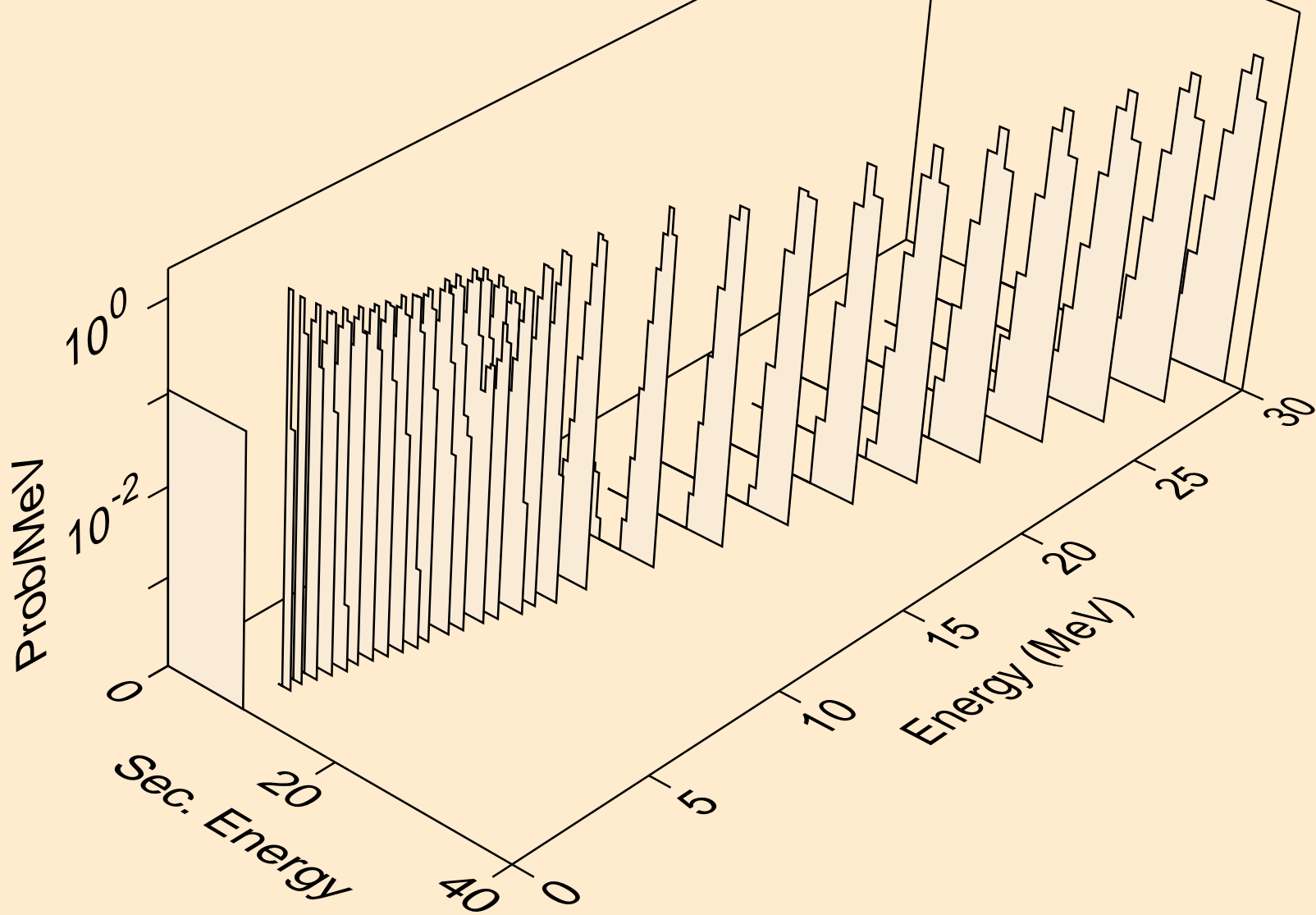

HS279 NEUTRON ACER TENDL-2023 LIBRARY; T=0.K
alphas from (n,2n)a

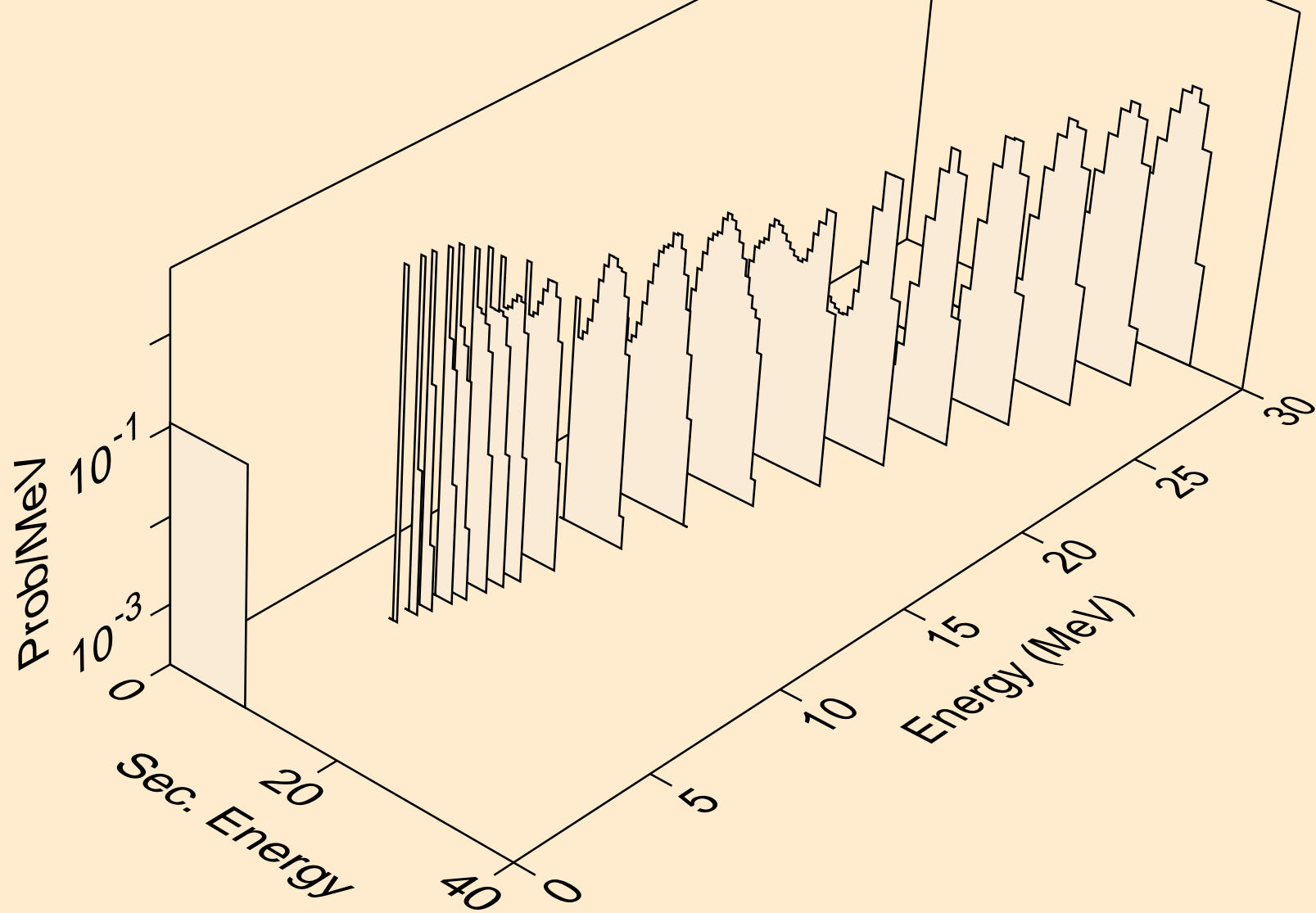

HS279 NEUTRON ACER TENDL-2023 LIBRARY; T=0.K
alphas from (n,3n)a

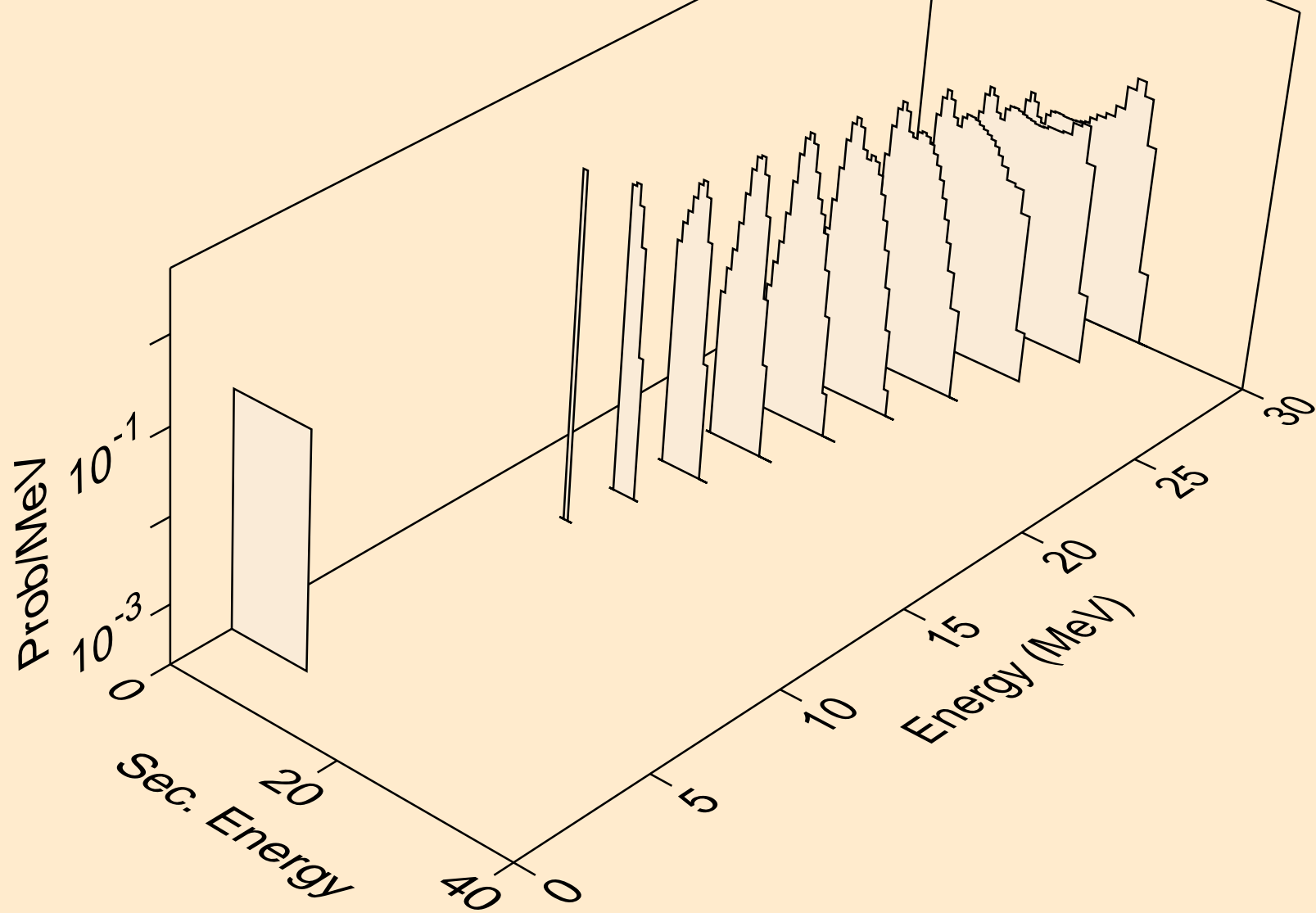

HS279 NEUTRON ACER TENDL-2023 LIBRARY; T=0.K
alphas from (n,a)

