

NP228 NEUTRON ACER TENDL-2023 LIBRARY; T=0.K

Principal cross sections

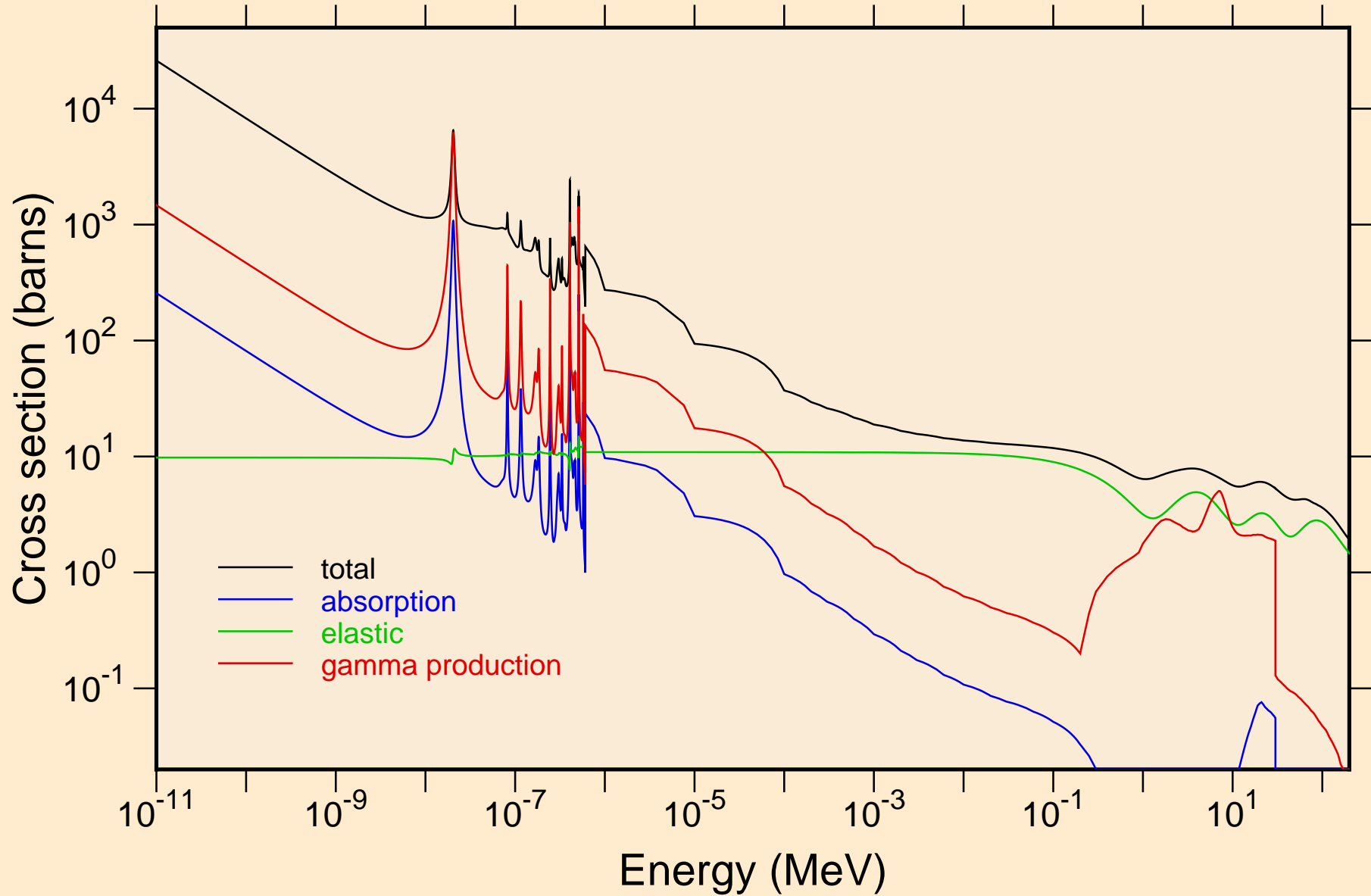

NP228 NEUTRON ACER TENDL-2023 LIBRARY; T=0.K
resonance total cross section

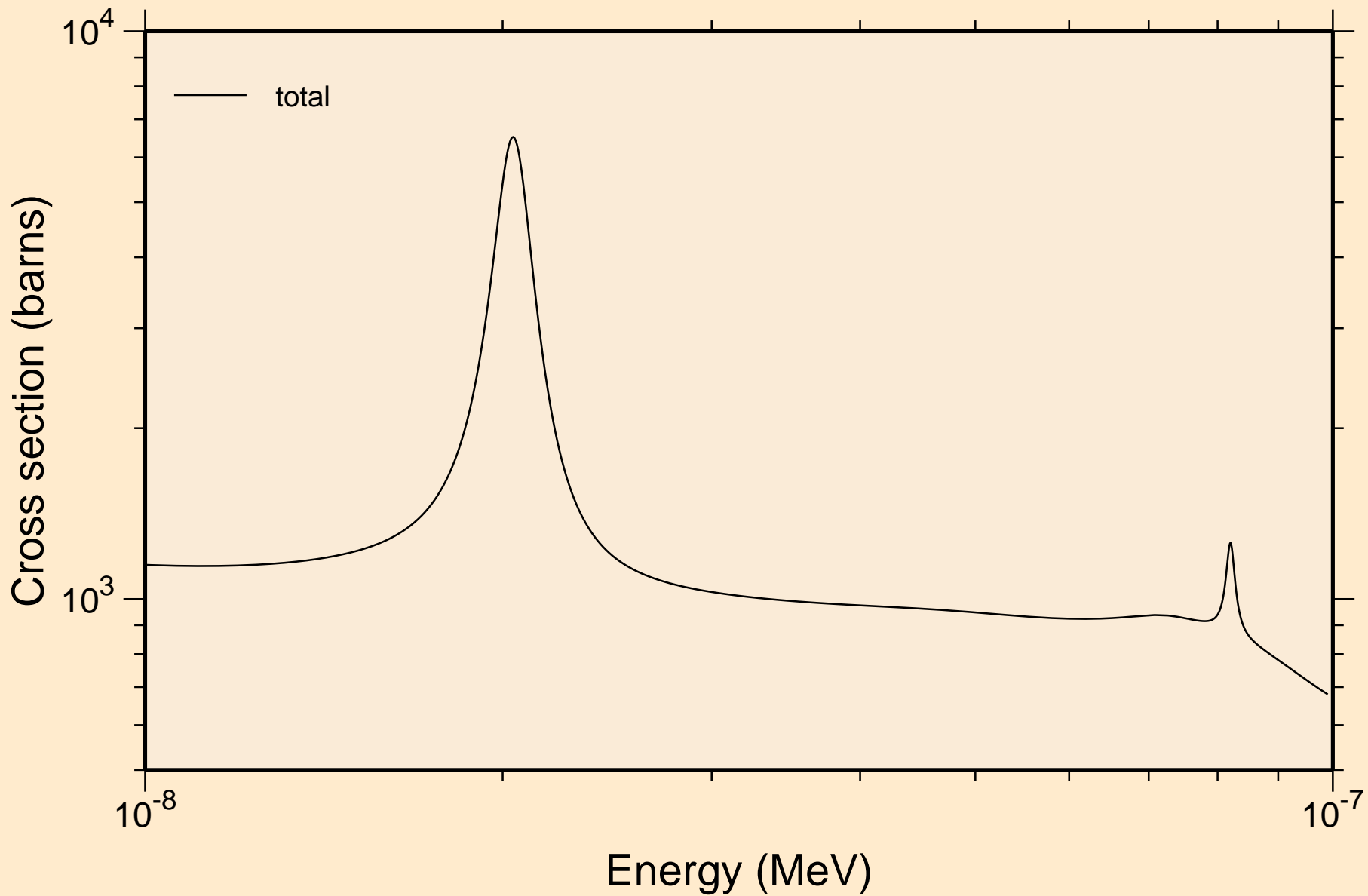

NP228 NEUTRON ACER TENDL-2023 LIBRARY; T=0.K
resonance total cross section

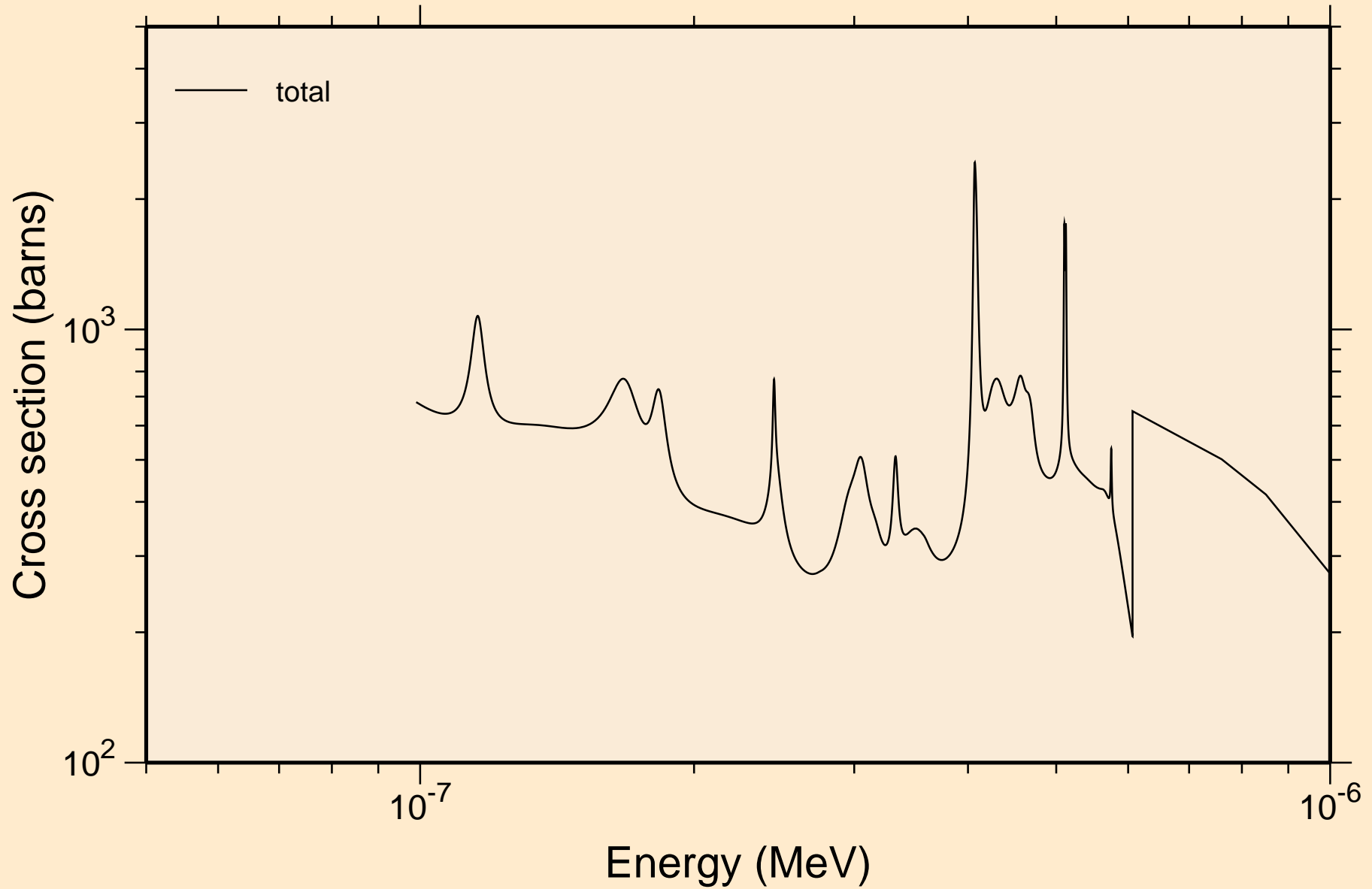

NP228 NEUTRON ACER TENDL-2023 LIBRARY; T=0.K
resonance total cross section

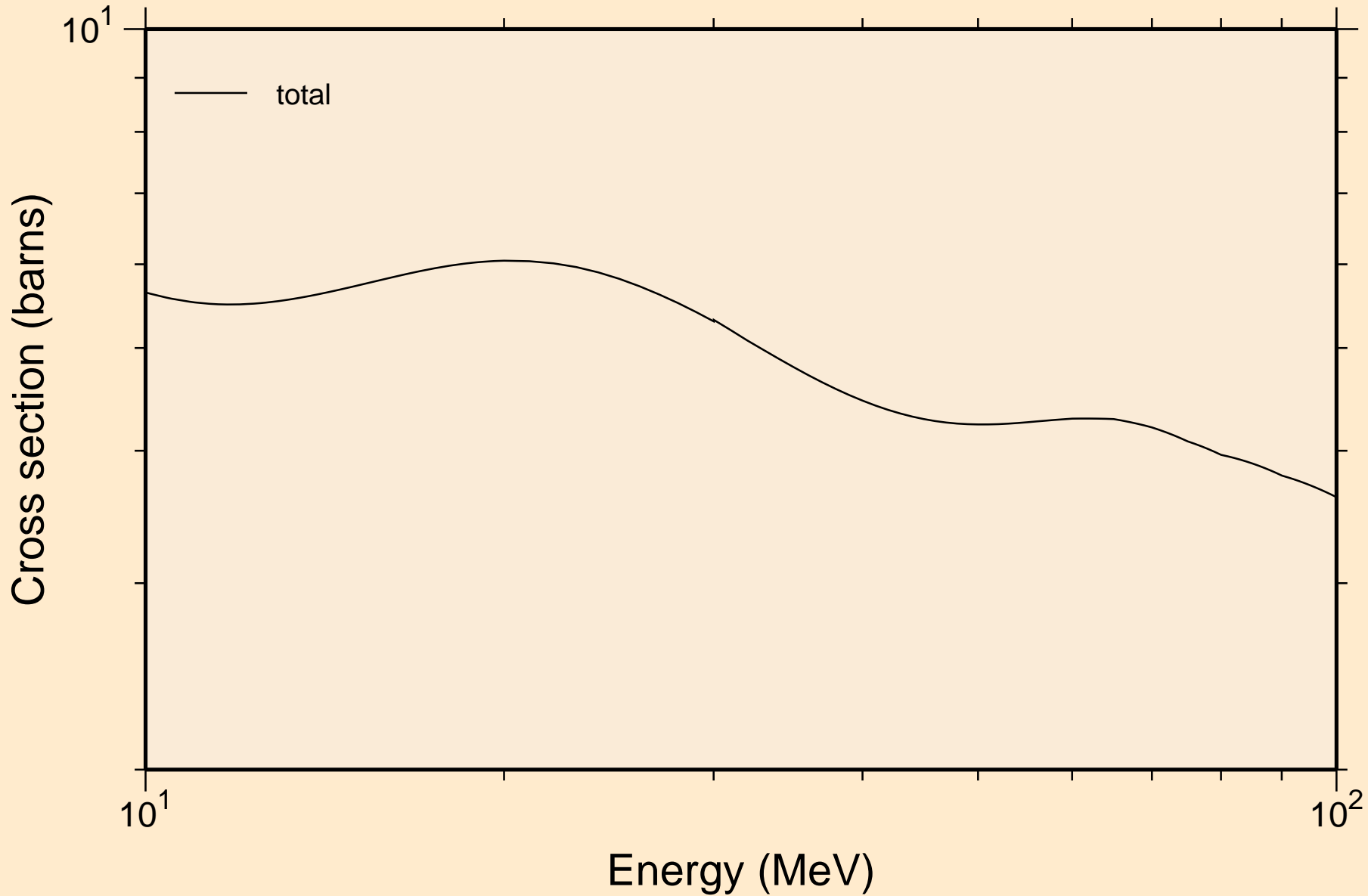

NP228 NEUTRON ACER TENDL-2023 LIBRARY; T=0.K
resonance absorption cross sections

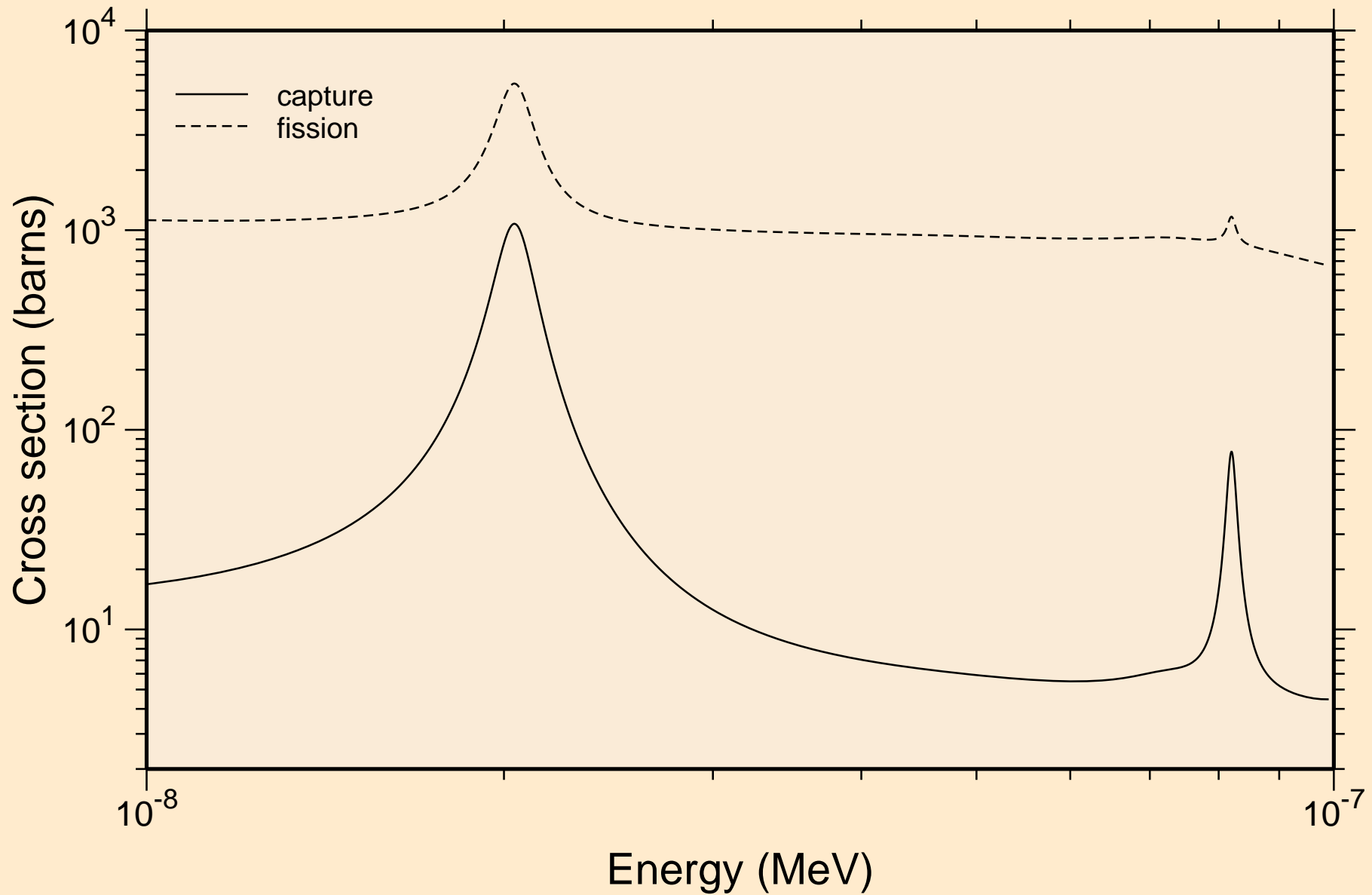

NP228 NEUTRON ACER TENDL-2023 LIBRARY; T=0.K
resonance absorption cross sections

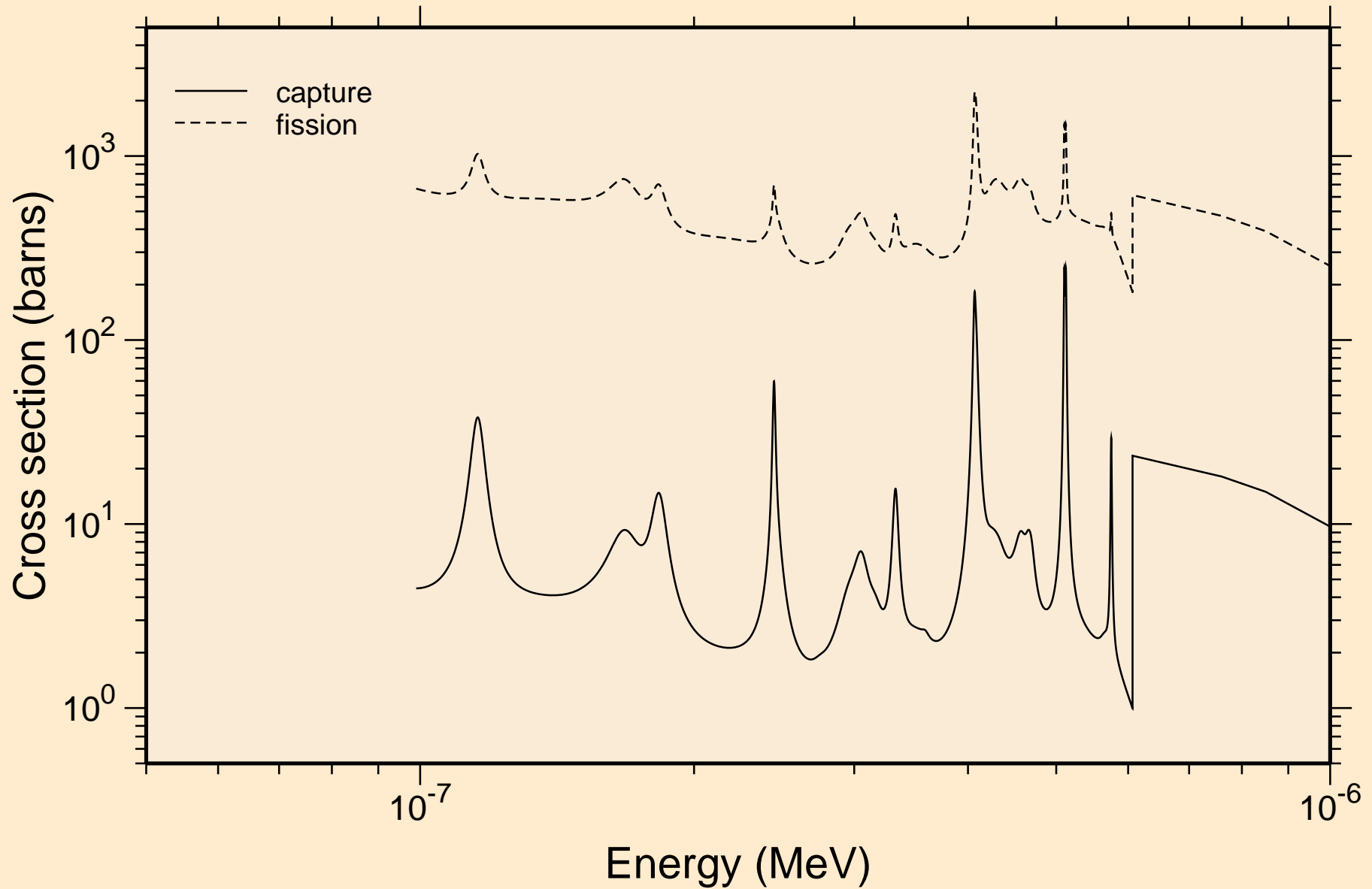

NP228 NEUTRON ACER TENDL-2023 LIBRARY; T=0.K
resonance absorption cross sections

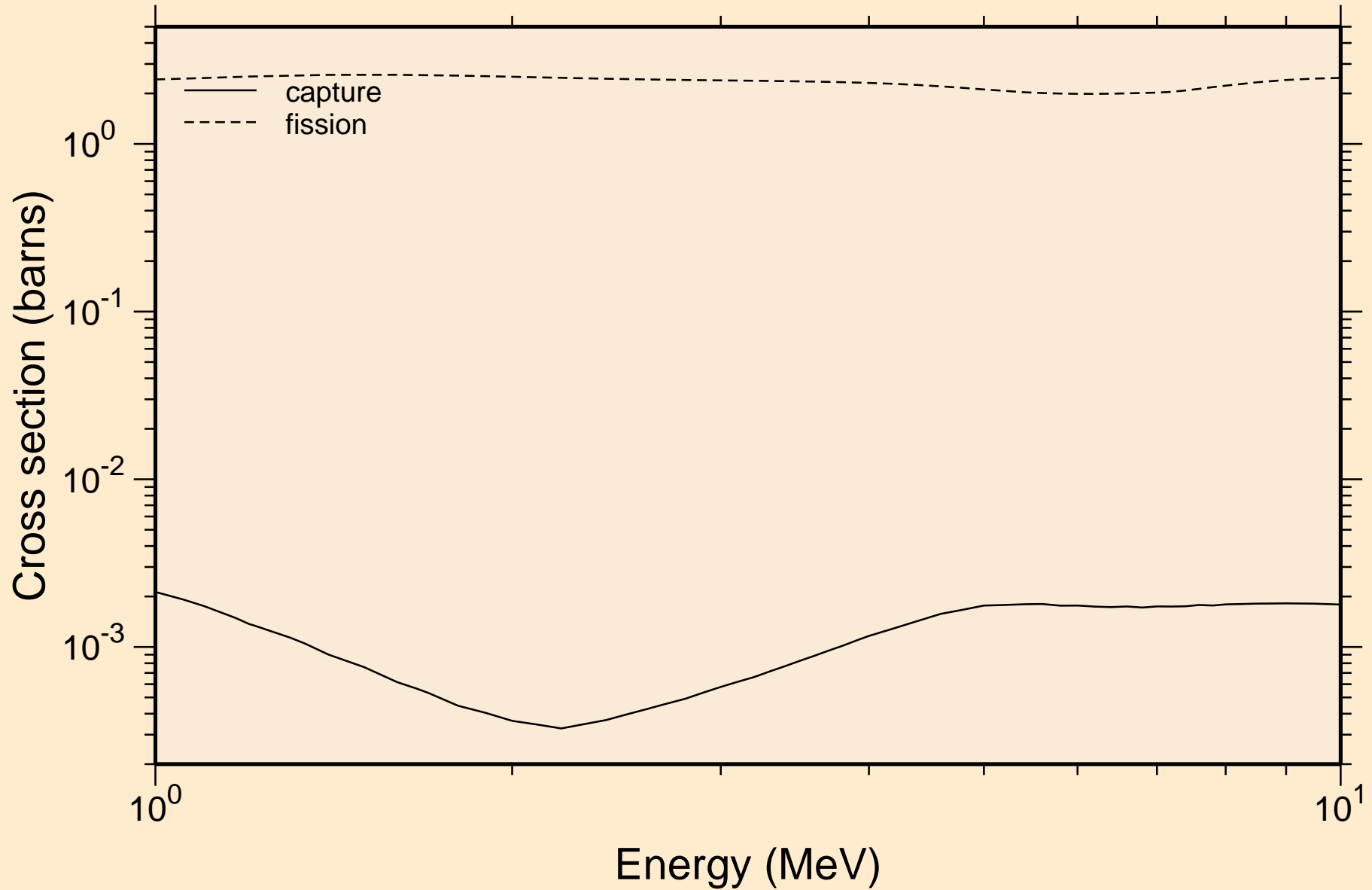

NP228 NEUTRON ACER TENDL-2023 LIBRARY; T=0.K

Heating

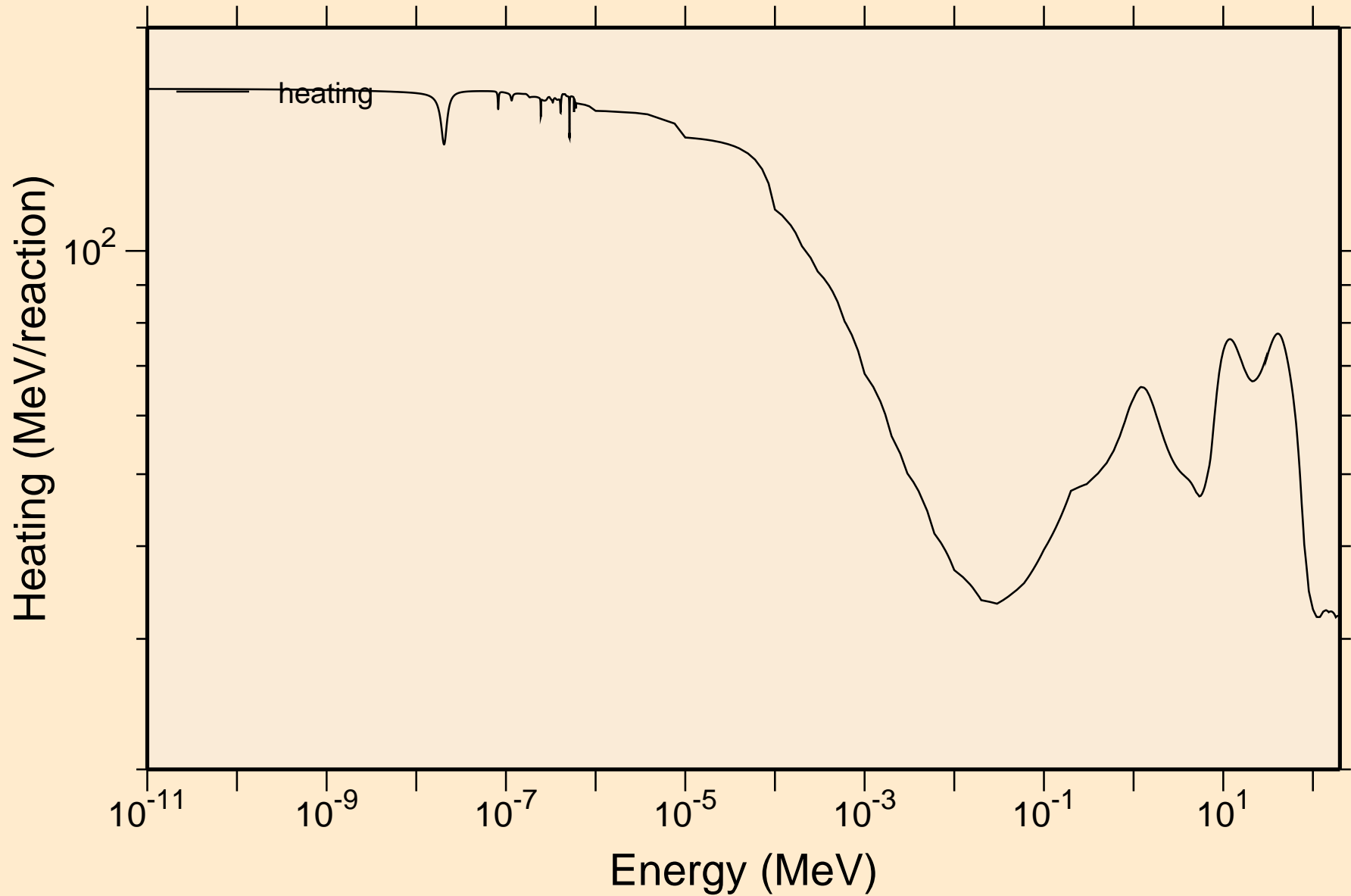

NP228 NEUTRON ACER TENDL-2023 LIBRARY; T=0.K

Damage

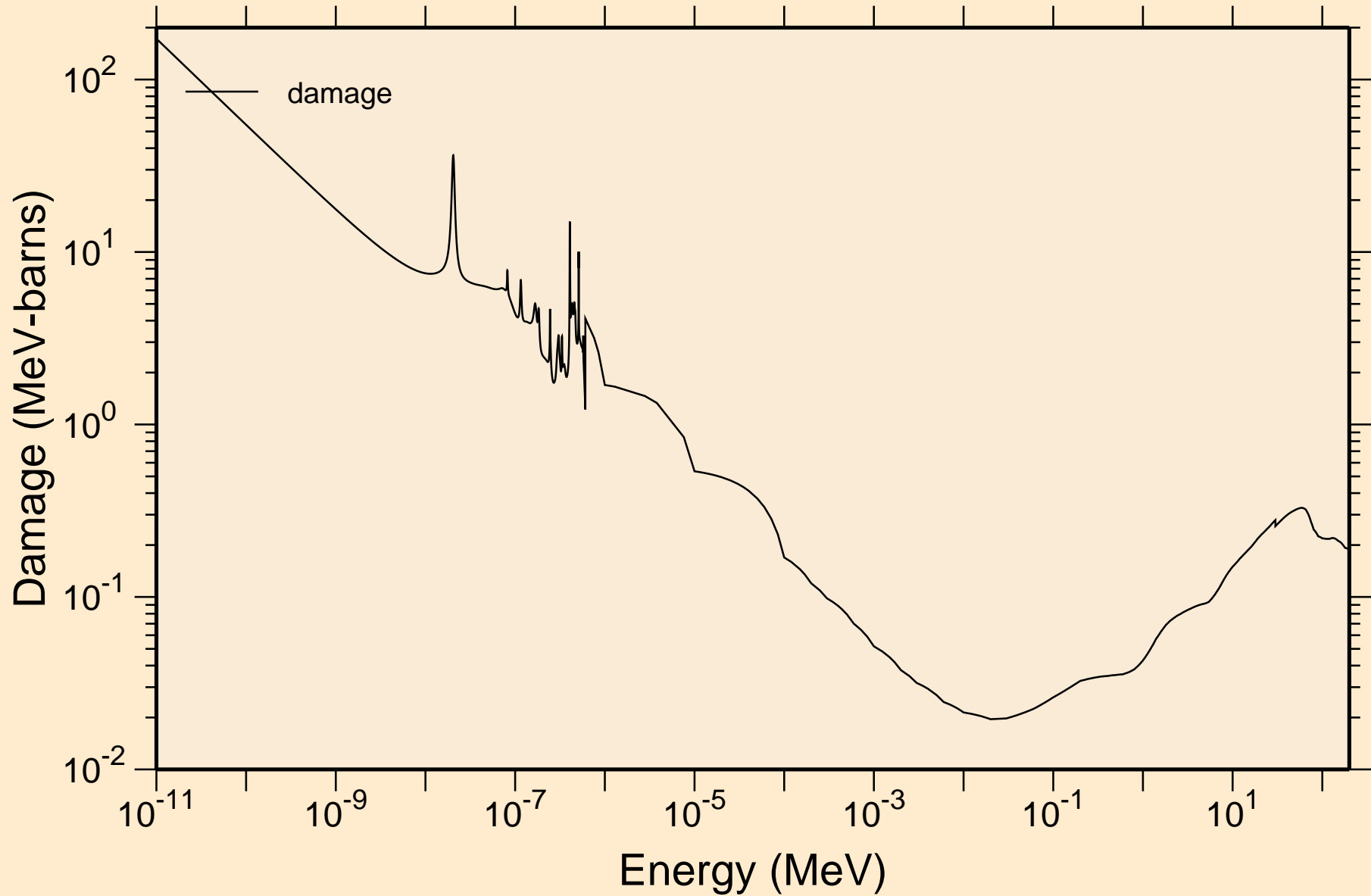

NP228 NEUTRON ACER TENDL-2023 LIBRARY; T=0.K

Non-threshold reactions

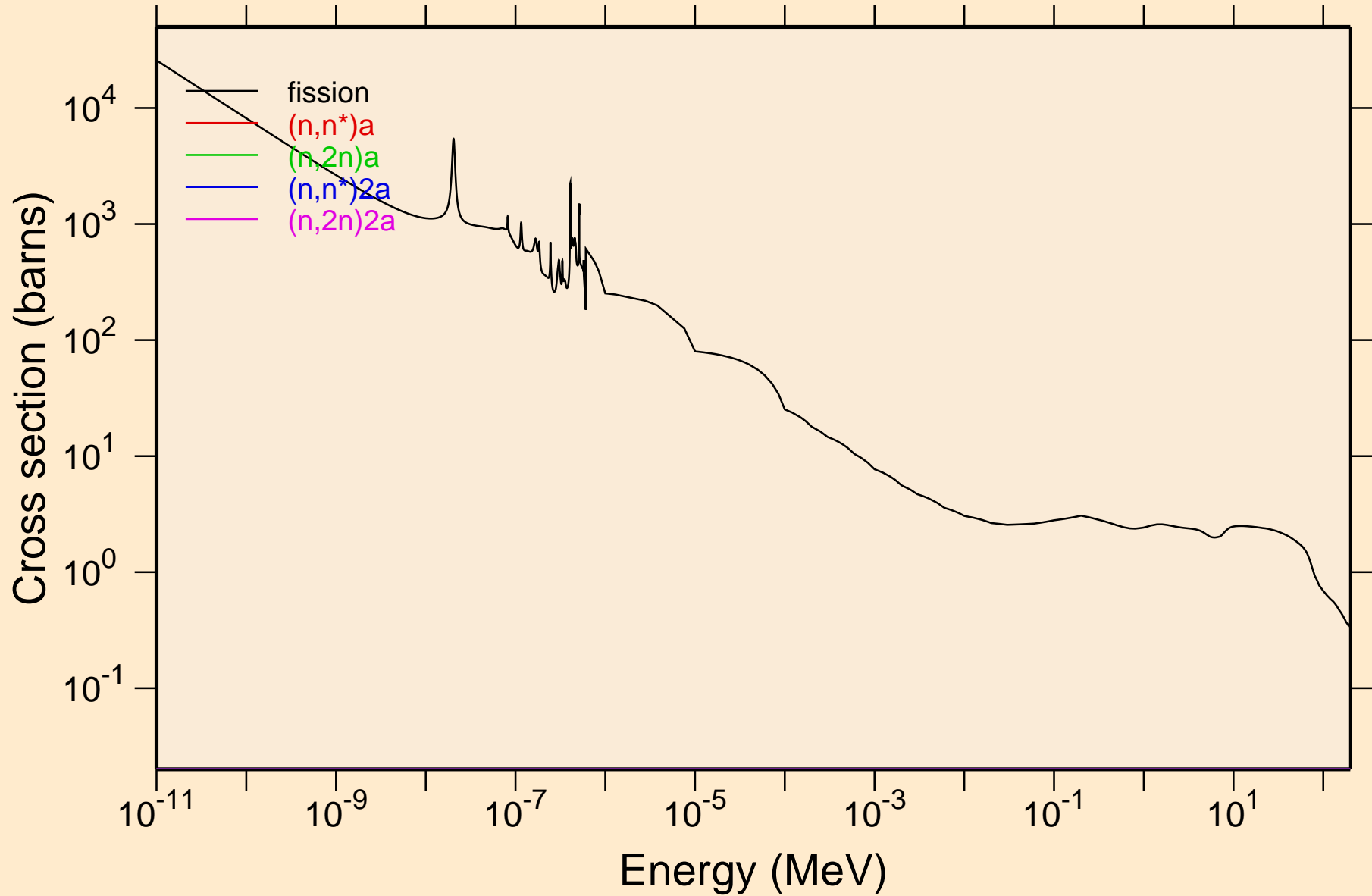

NP228 NEUTRON ACER TENDL-2023 LIBRARY; T=0.K

Non-threshold reactions

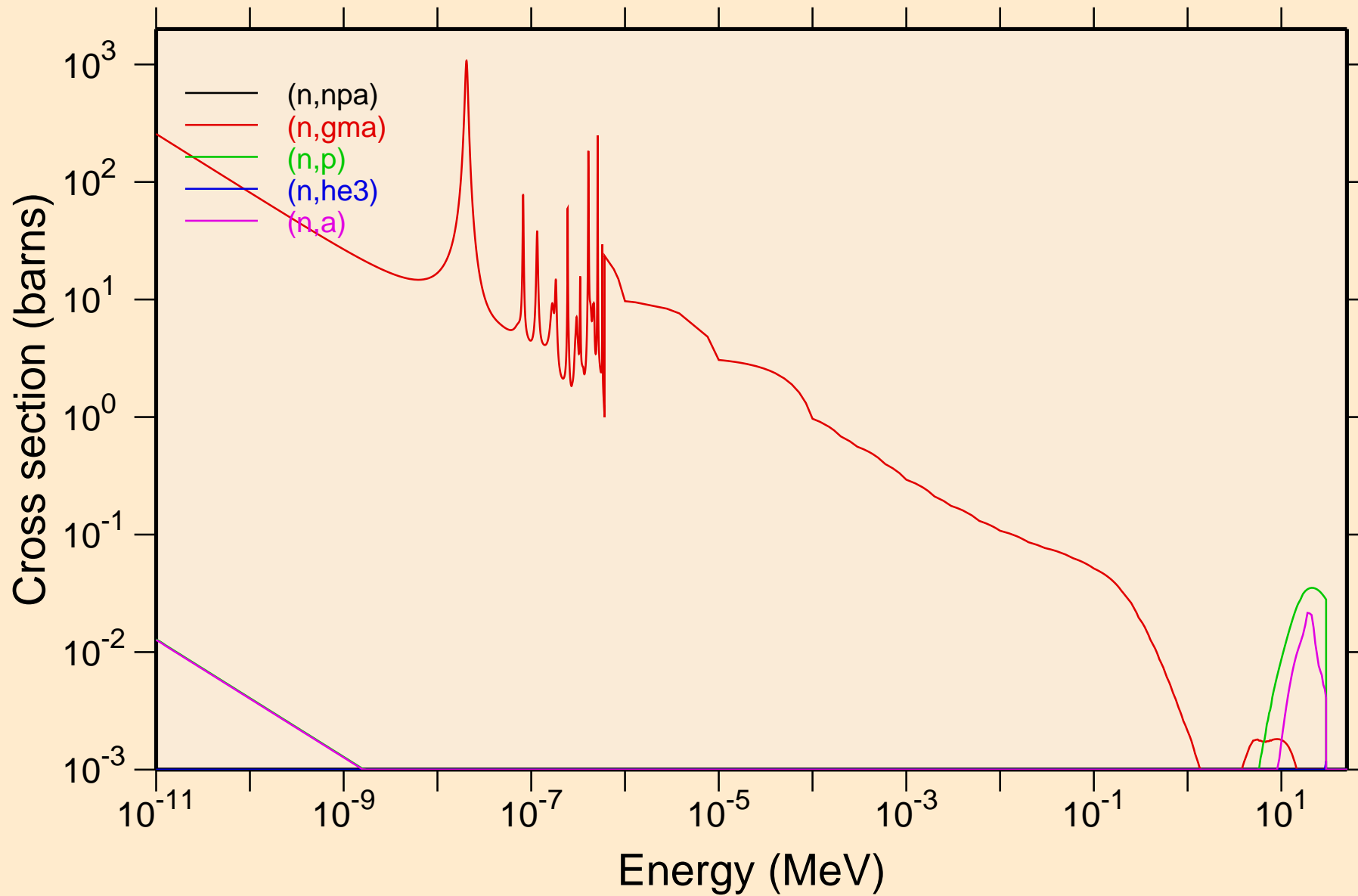

NP228 NEUTRON ACER TENDL-2023 LIBRARY; T=0.K
Non-threshold reactions

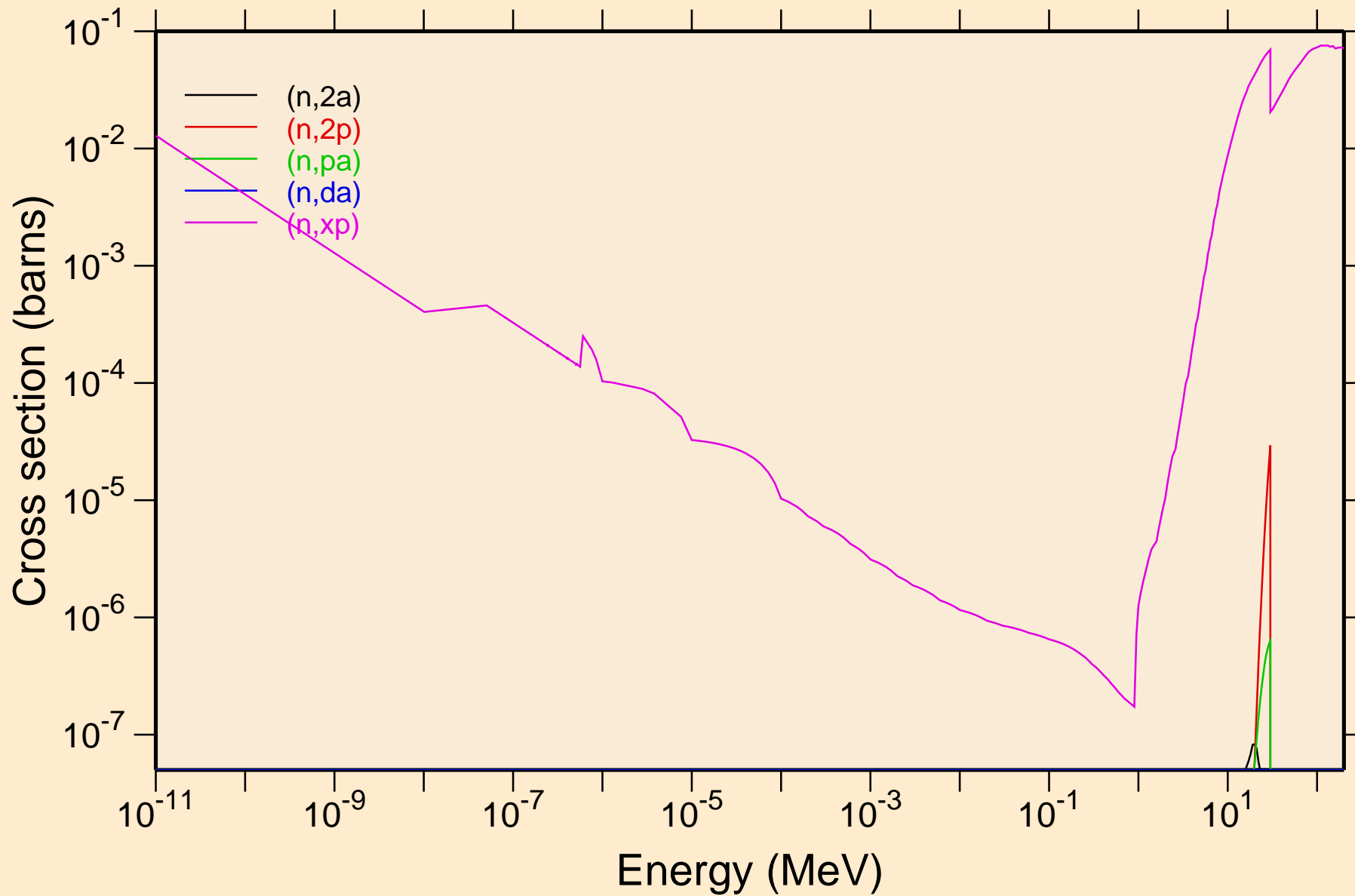

NP228 NEUTRON ACER TENDL-2023 LIBRARY; T=0.K
Non-threshold reactions

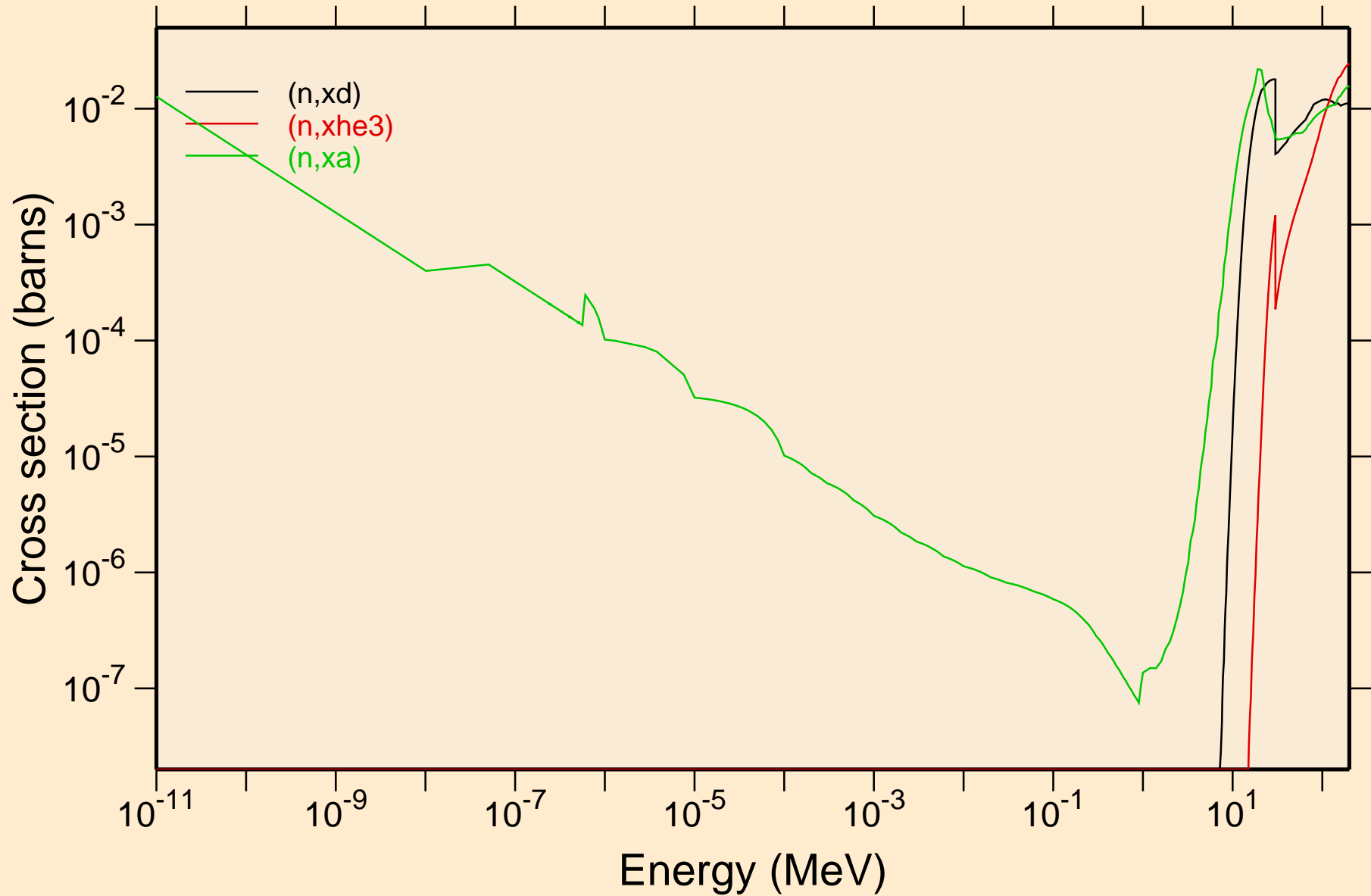

NP228 NEUTRON ACER TENDL-2023 LIBRARY; T=0.K

Principal cross sections

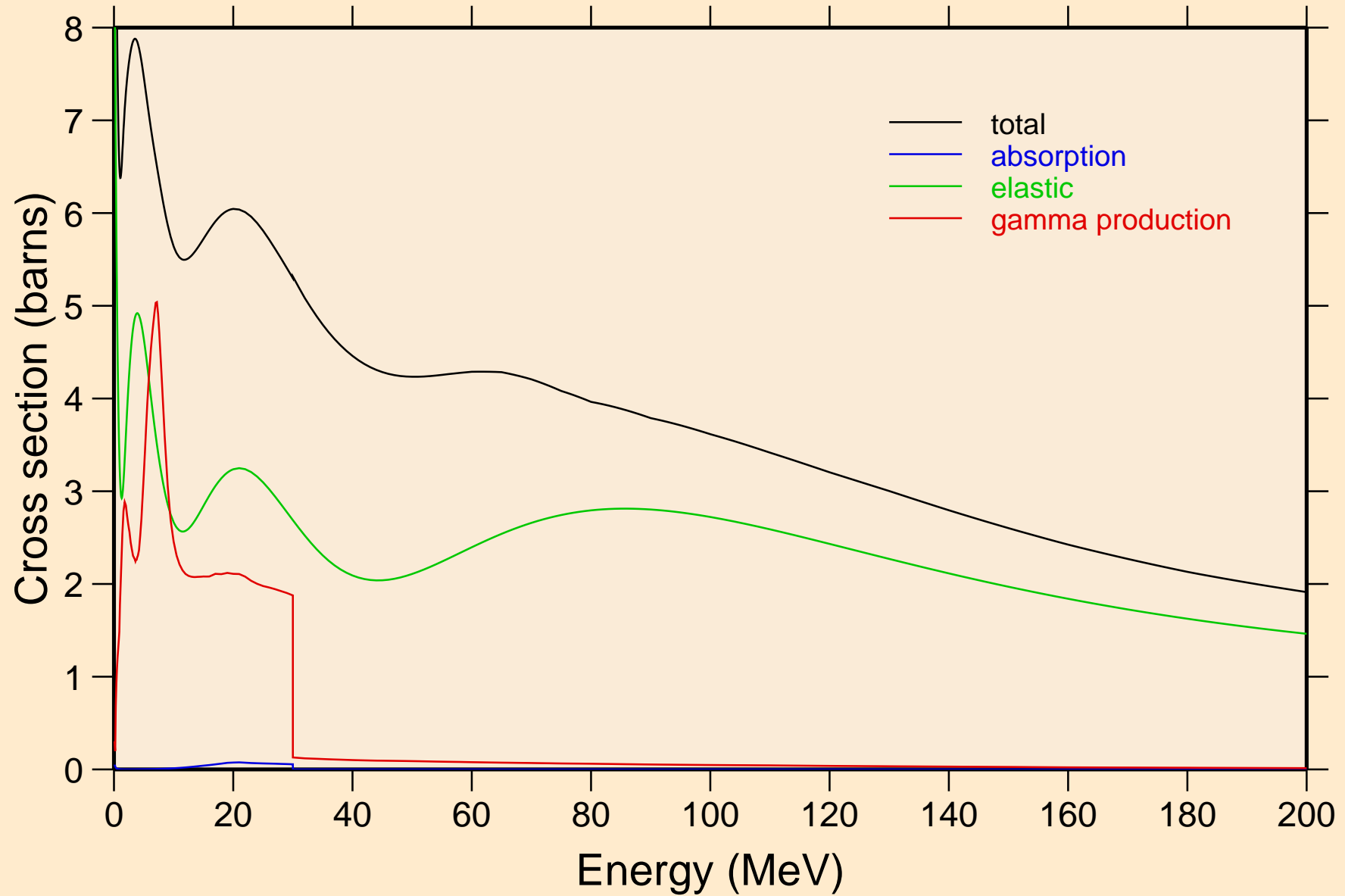

NP228 NEUTRON ACER TENDL-2023 LIBRARY; T=0.K

Heating

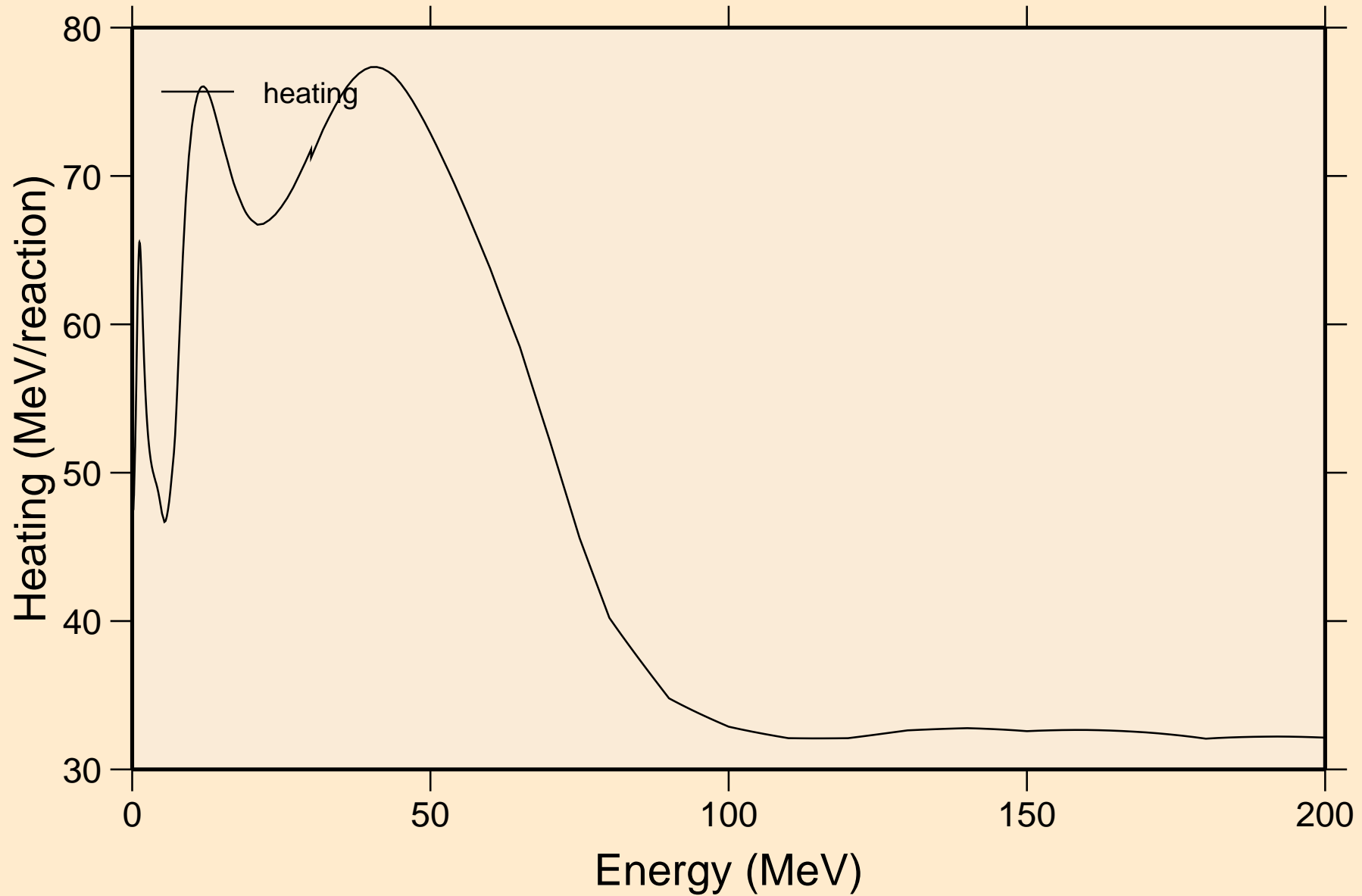

NP228 NEUTRON ACER TENDL-2023 LIBRARY; T=0.K
Damage

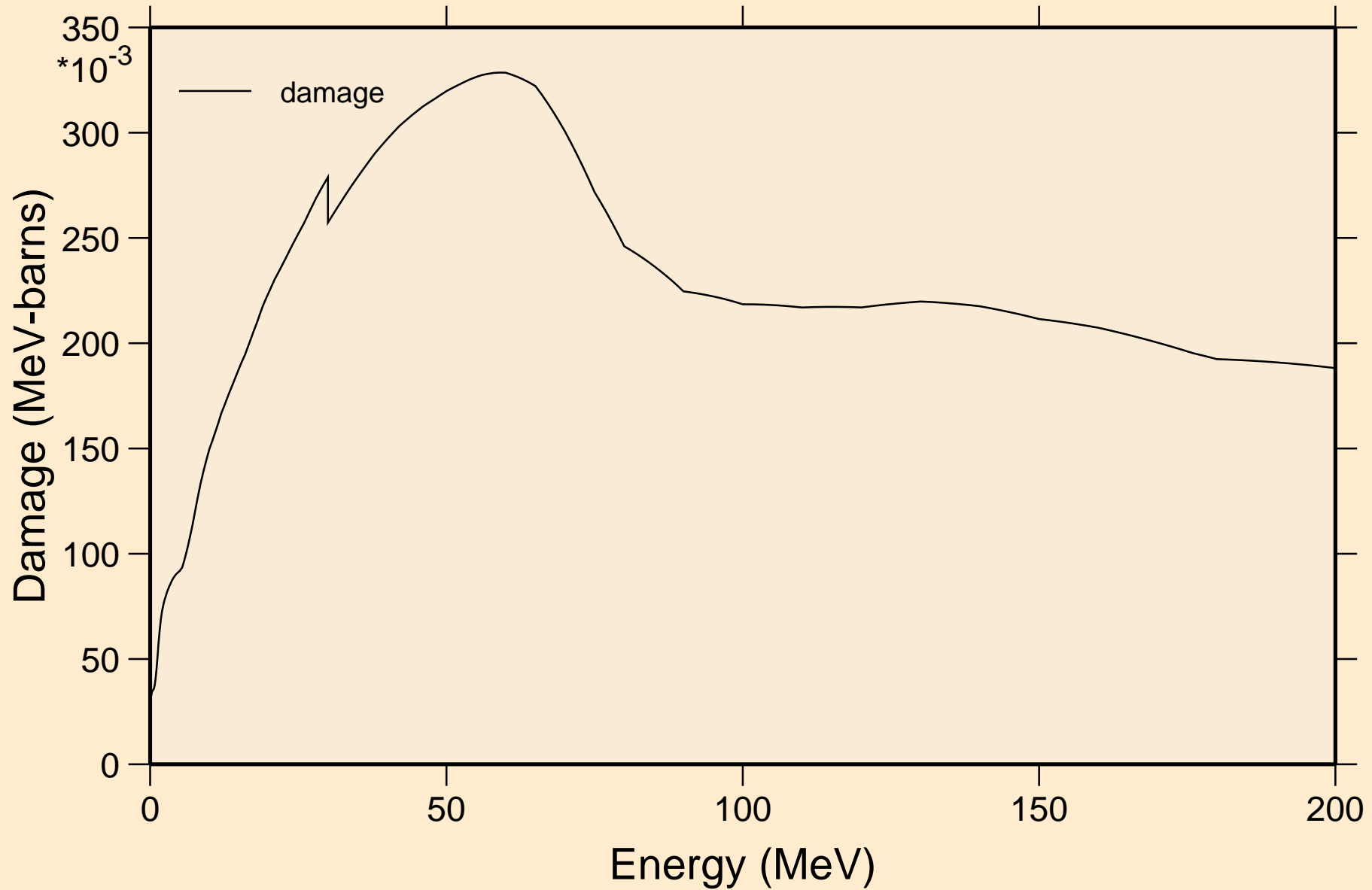

NP228 NEUTRON ACER TENDL-2023 LIBRARY; T=0.K

Non-threshold reactions

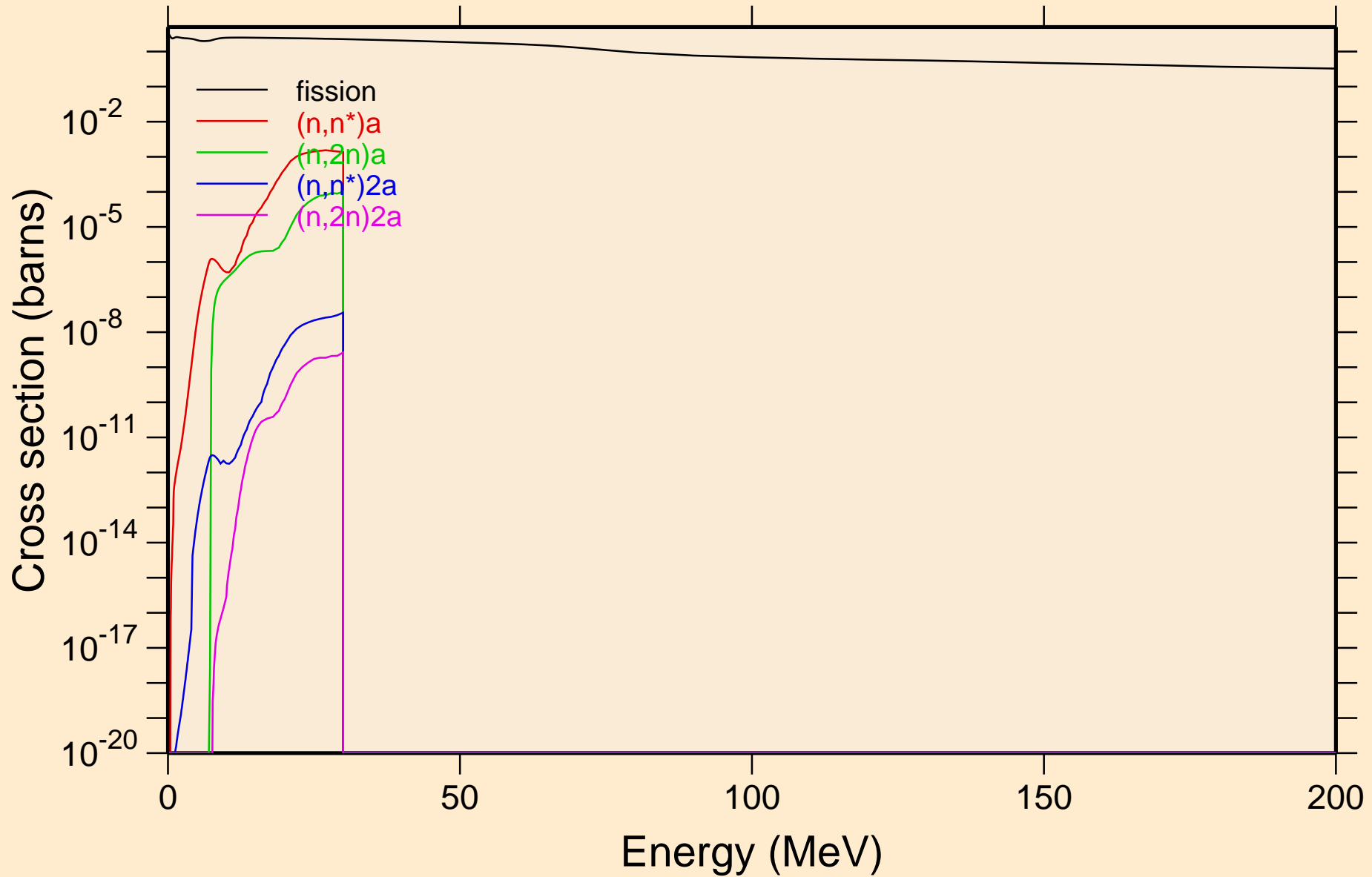

NP228 NEUTRON ACER TENDL-2023 LIBRARY; T=0.K

Non-threshold reactions

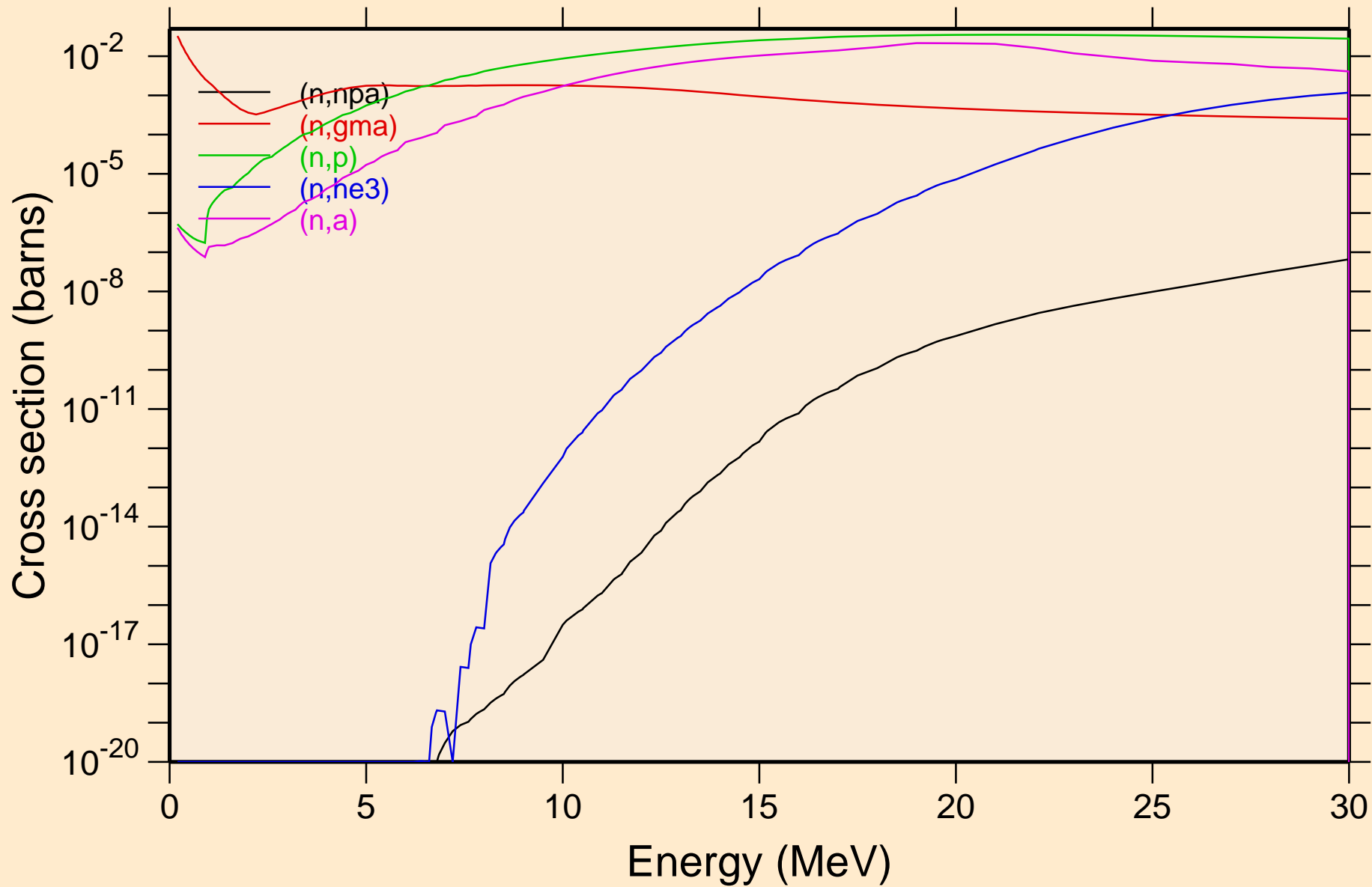

NP228 NEUTRON ACER TENDL-2023 LIBRARY; T=0.K

Non-threshold reactions

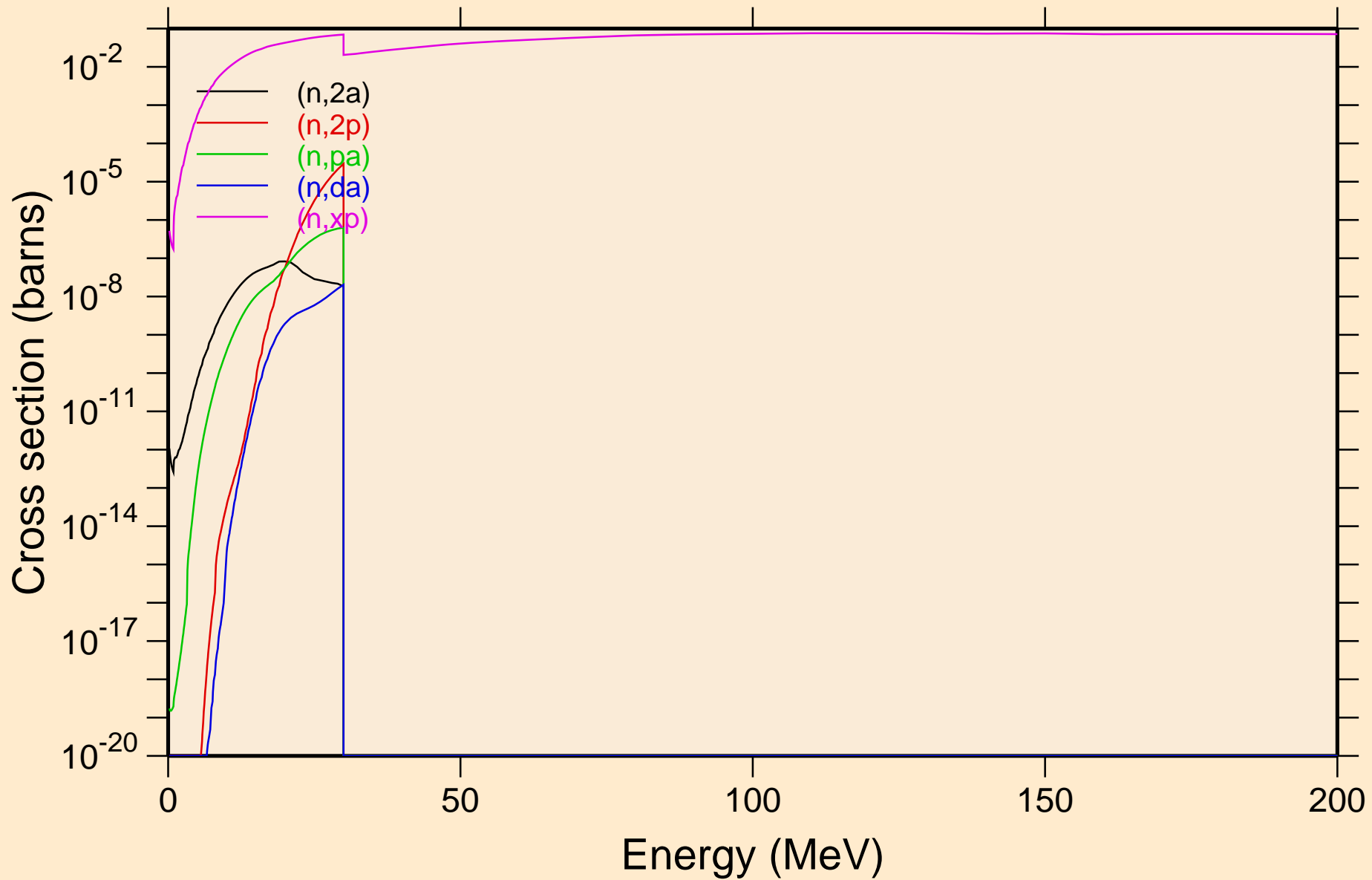

NP228 NEUTRON ACER TENDL-2023 LIBRARY; T=0.K
Non-threshold reactions

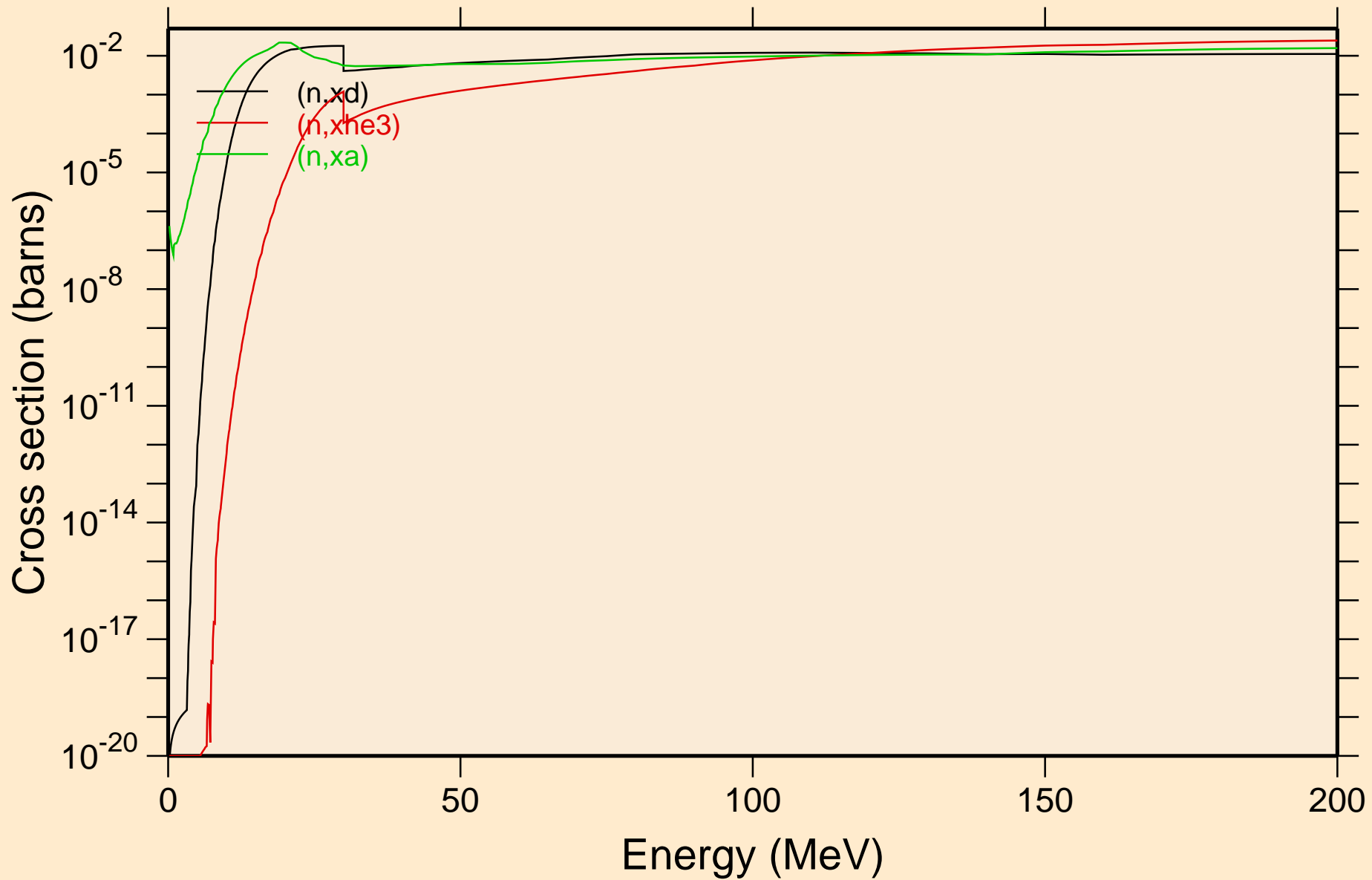

NP228 NEUTRON ACER TENDL-2023 LIBRARY; T=0.K
Inelastic levels

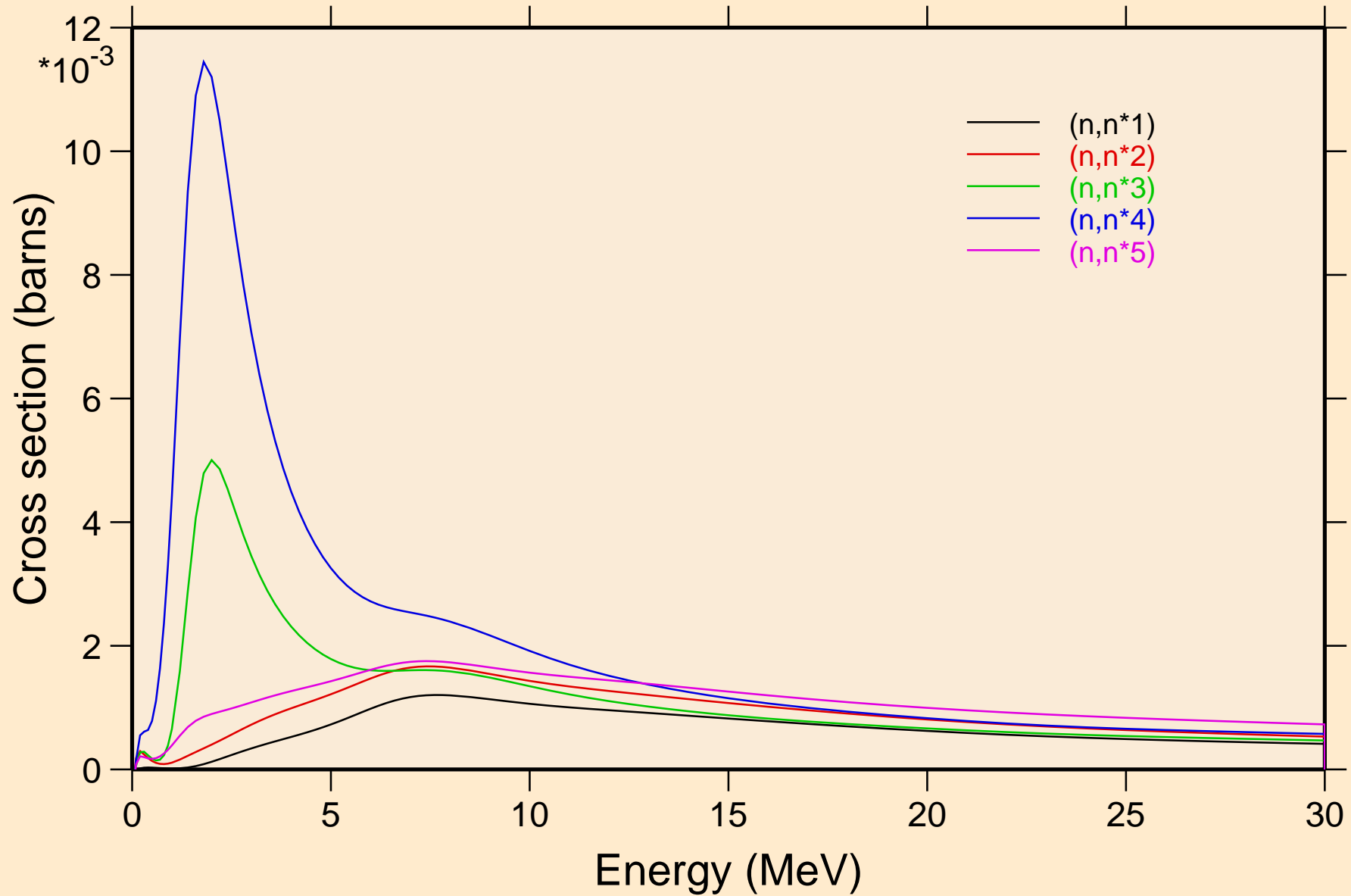

NP228 NEUTRON ACER TENDL-2023 LIBRARY; T=0.K
Inelastic levels

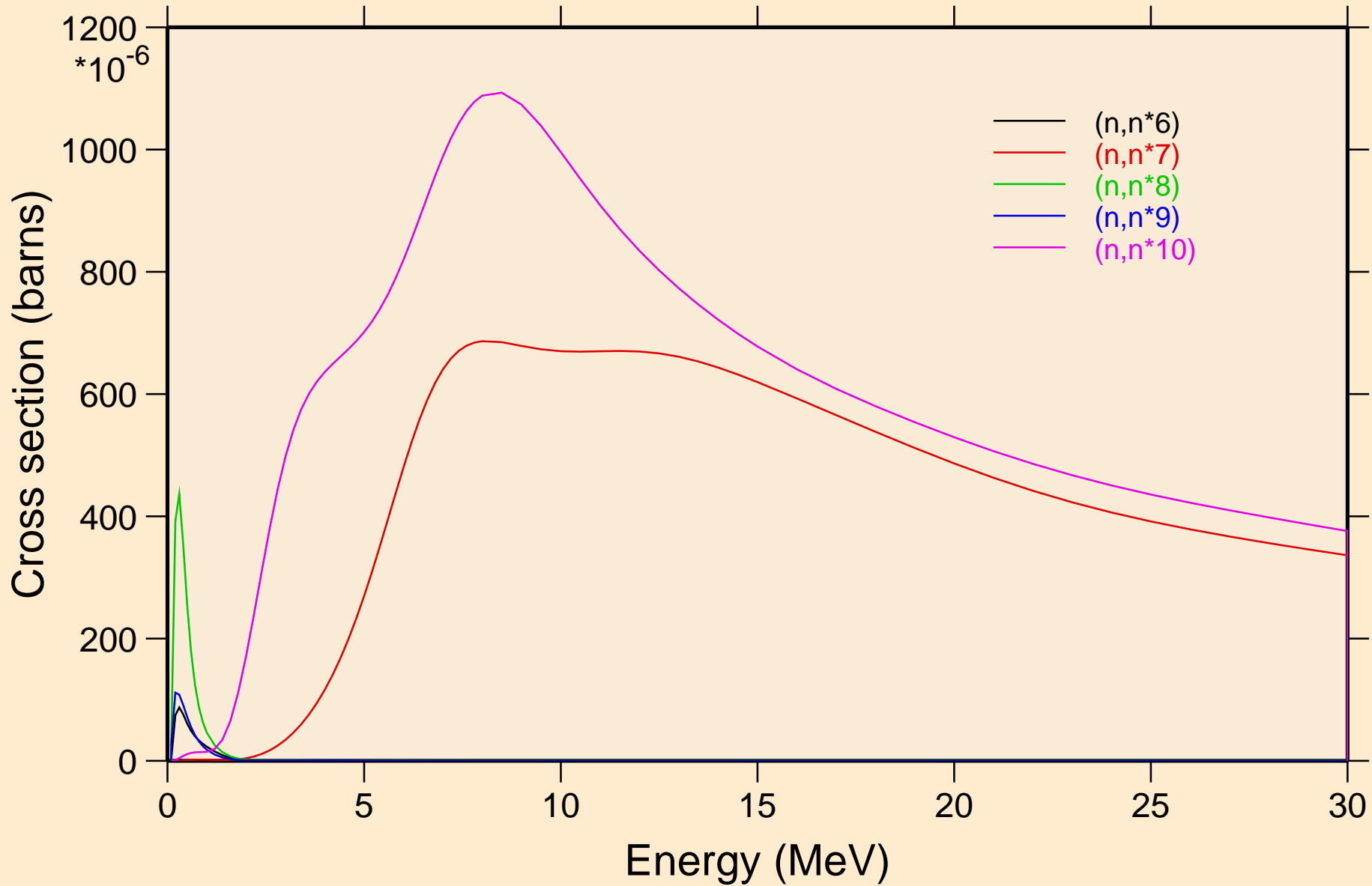

NP228 NEUTRON ACER TENDL-2023 LIBRARY; T=0.K
Inelastic levels

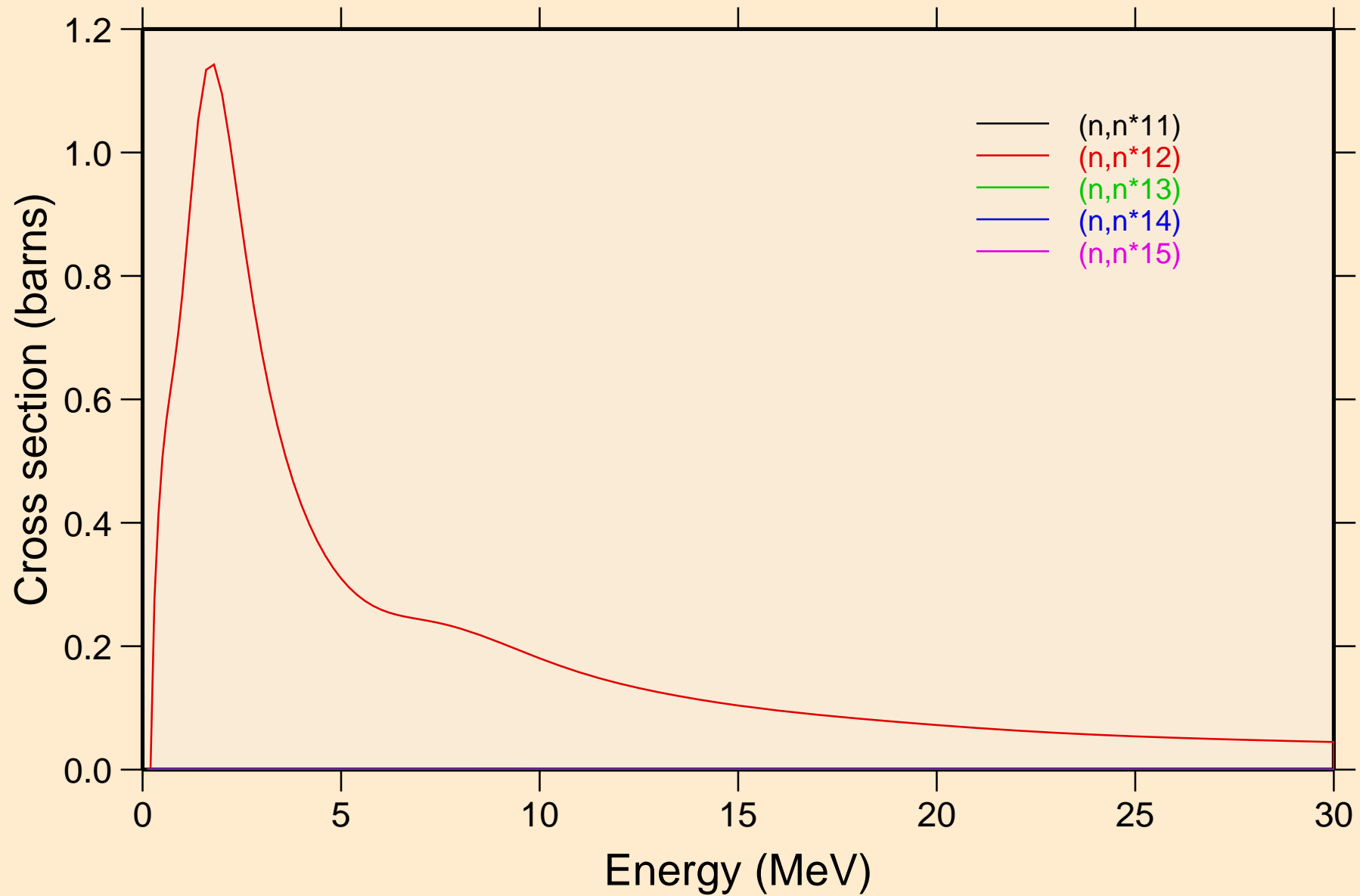

NP228 NEUTRON ACER TENDL-2023 LIBRARY; T=0.K
Inelastic levels

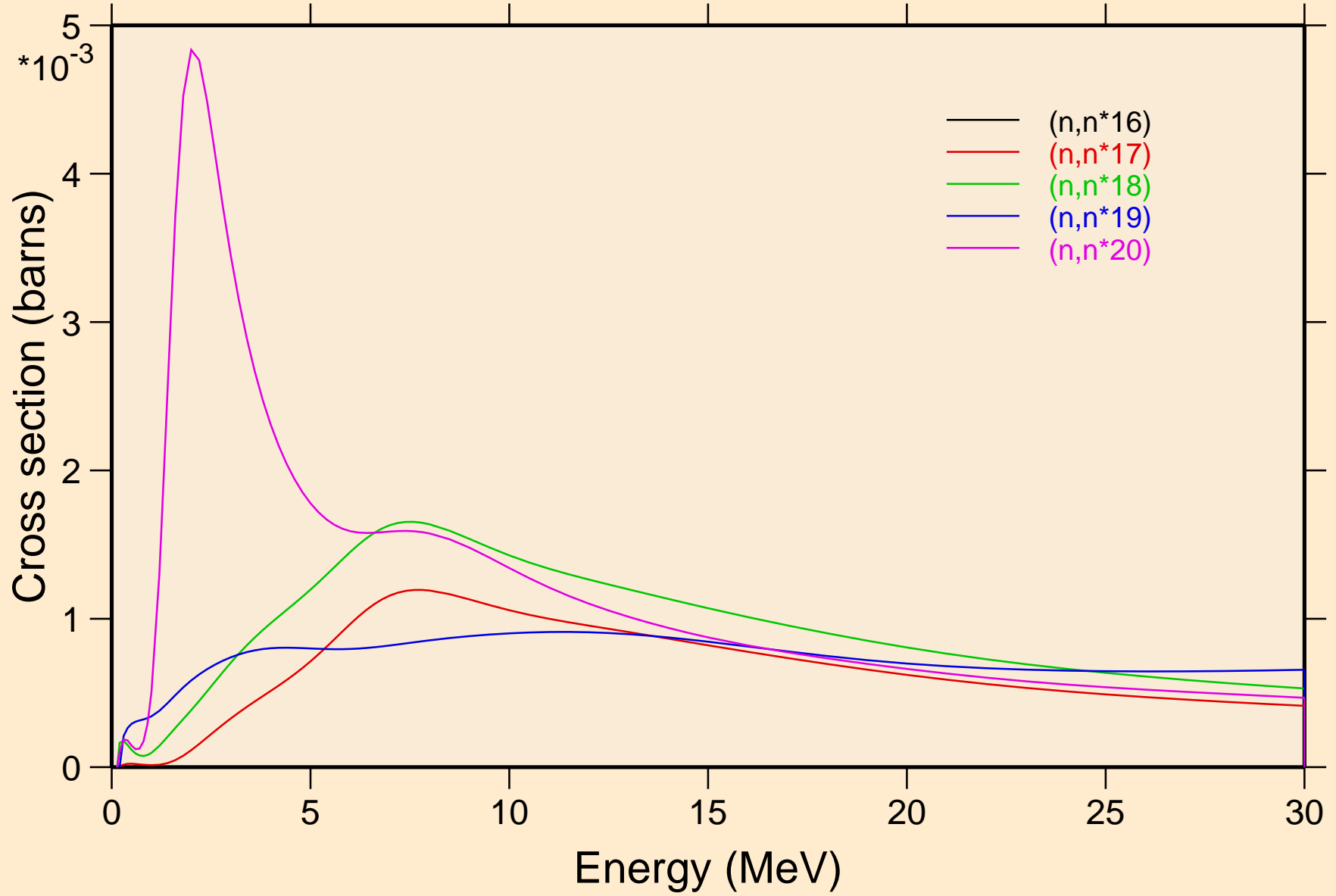

NP228 NEUTRON ACER TENDL-2023 LIBRARY; T=0.K
Inelastic levels

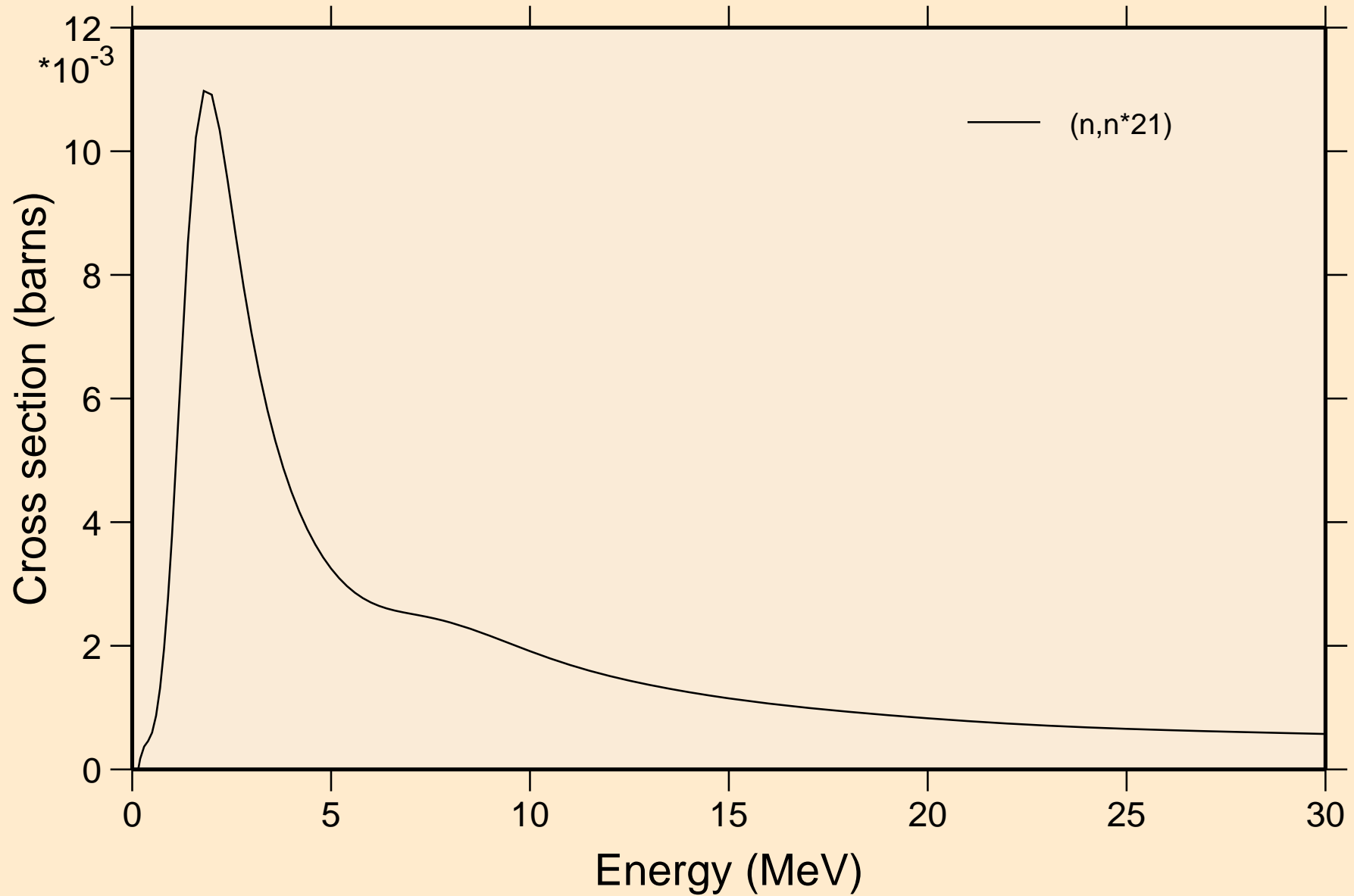

NP228 NEUTRON ACER TENDL-2023 LIBRARY; T=0.K

Threshold reactions

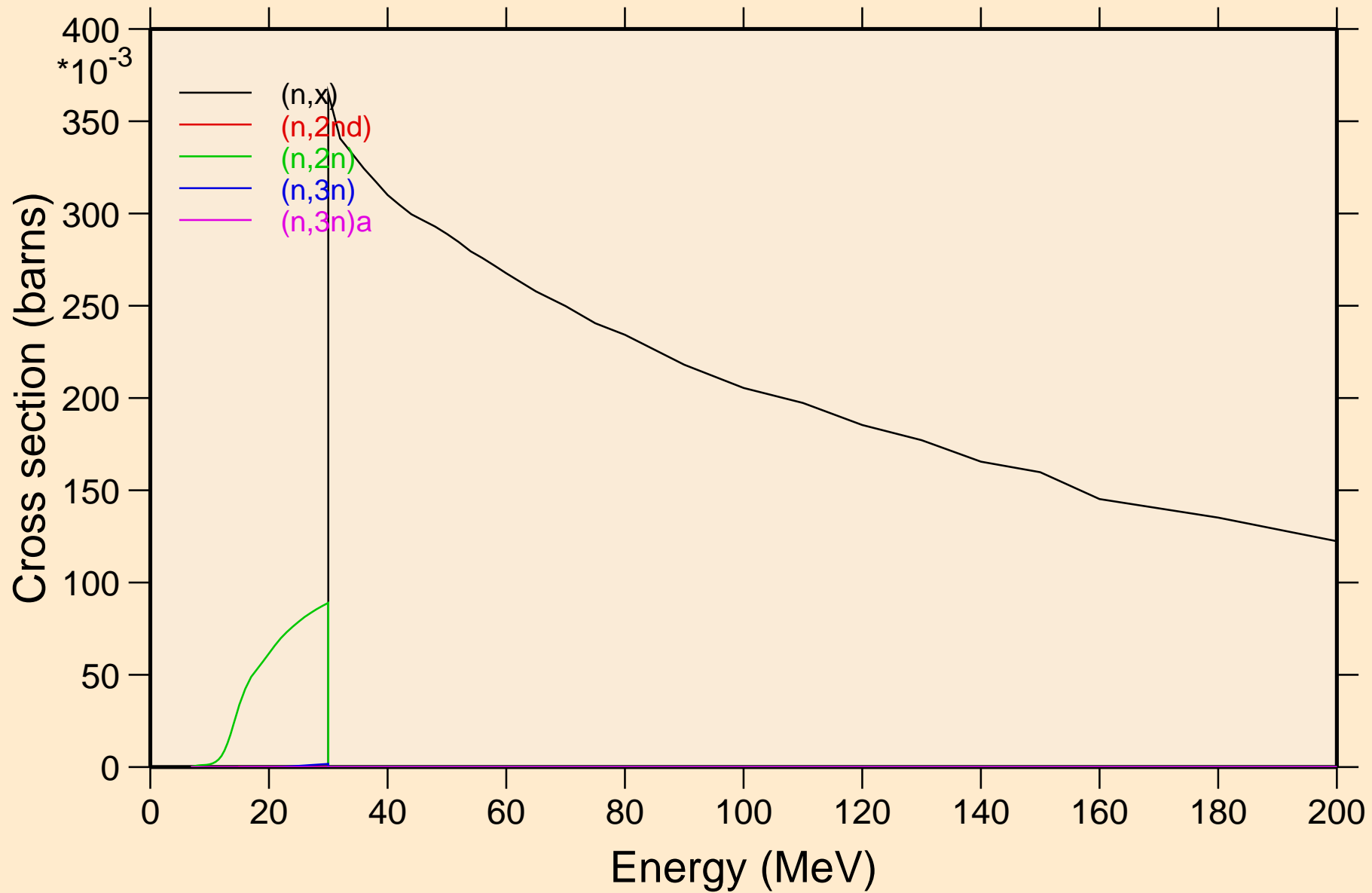

NP228 NEUTRON ACER TENDL-2023 LIBRARY; T=0.K

Threshold reactions

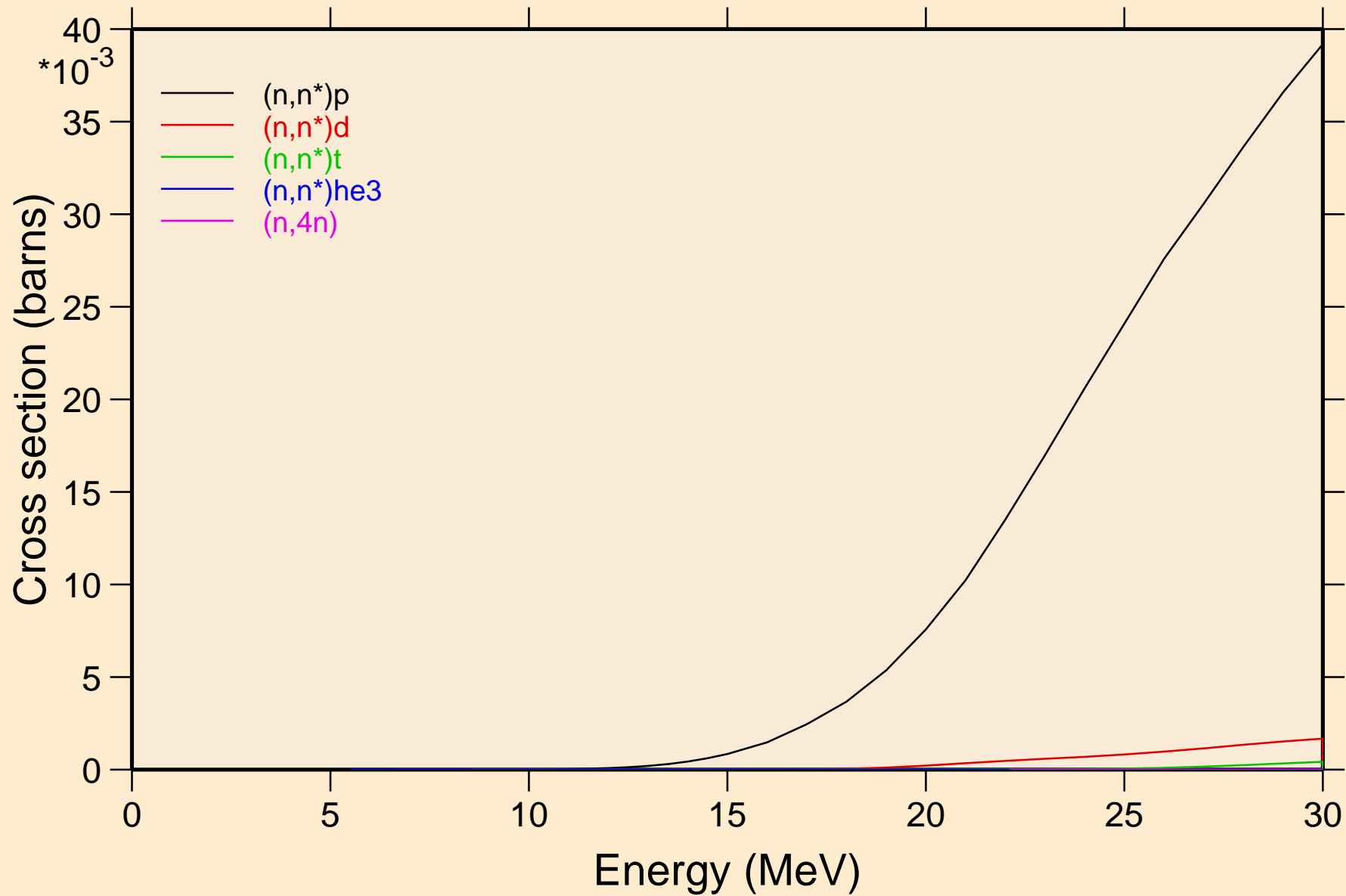

NP228 NEUTRON ACER TENDL-2023 LIBRARY; T=0.K
Threshold reactions

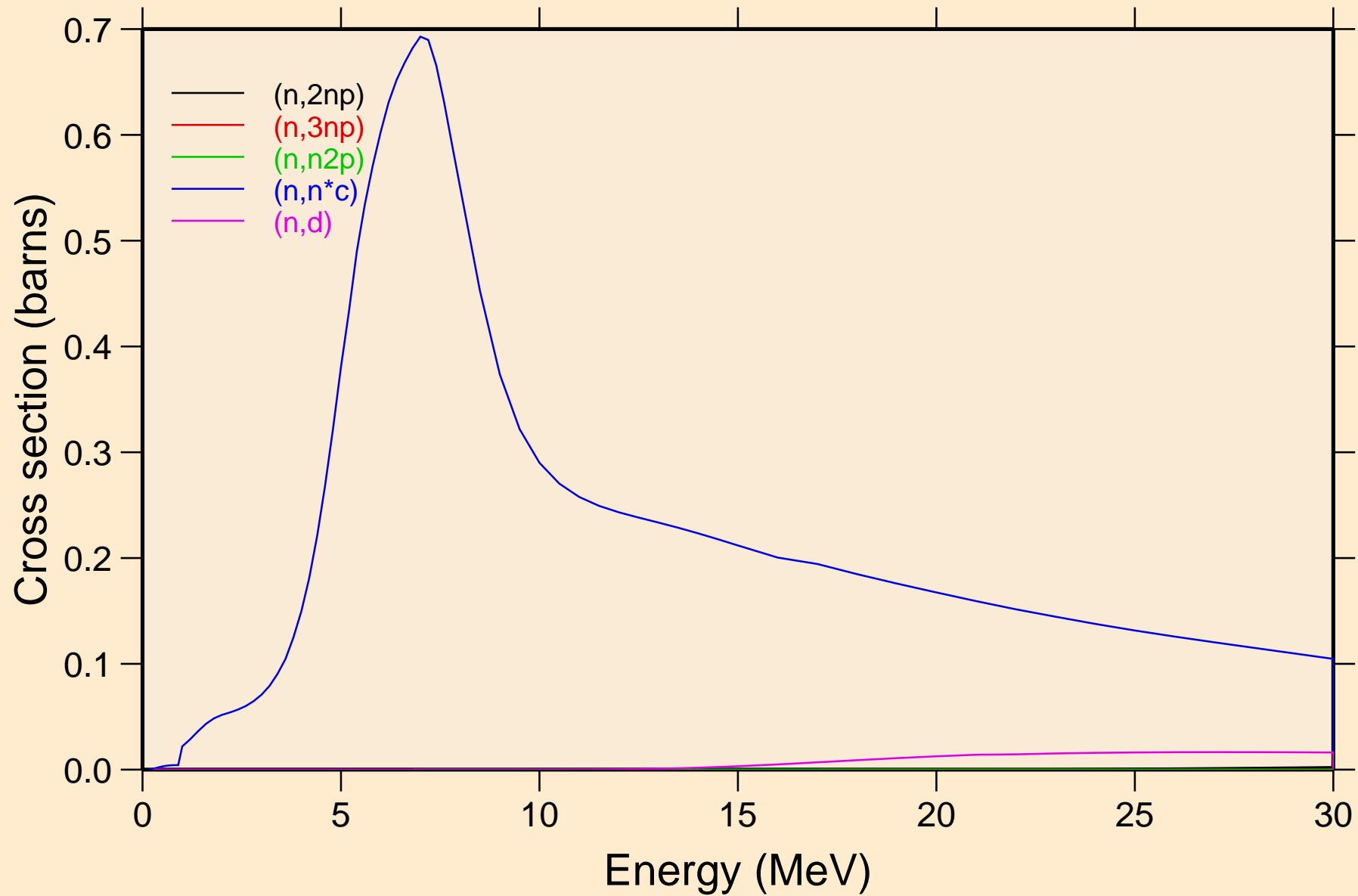

NP228 NEUTRON ACER TENDL-2023 LIBRARY; T=0.K

Threshold reactions

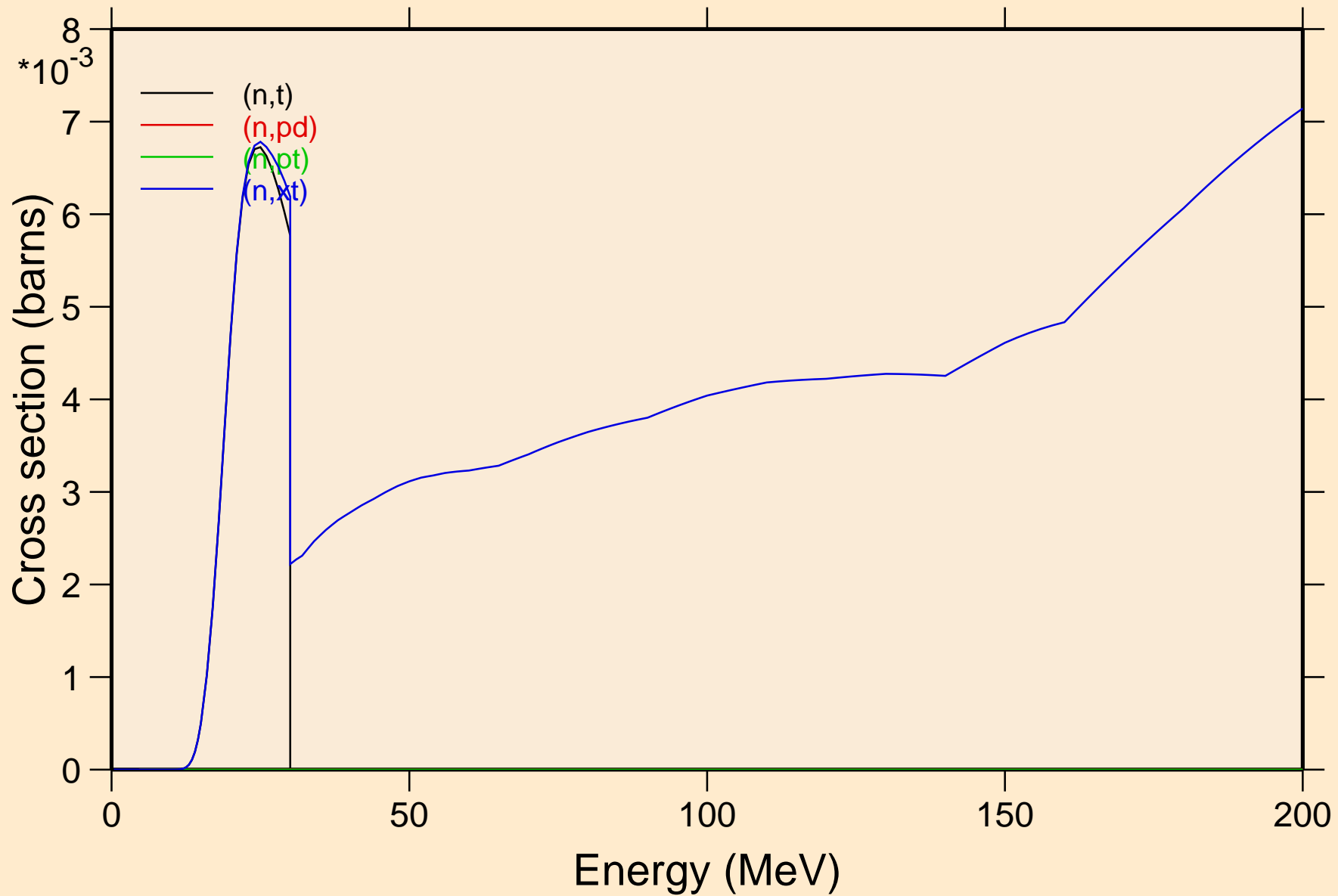

NP228 NEUTRON ACER TENDL-2023 LIBRARY; T=0.K
angular distribution for elastic

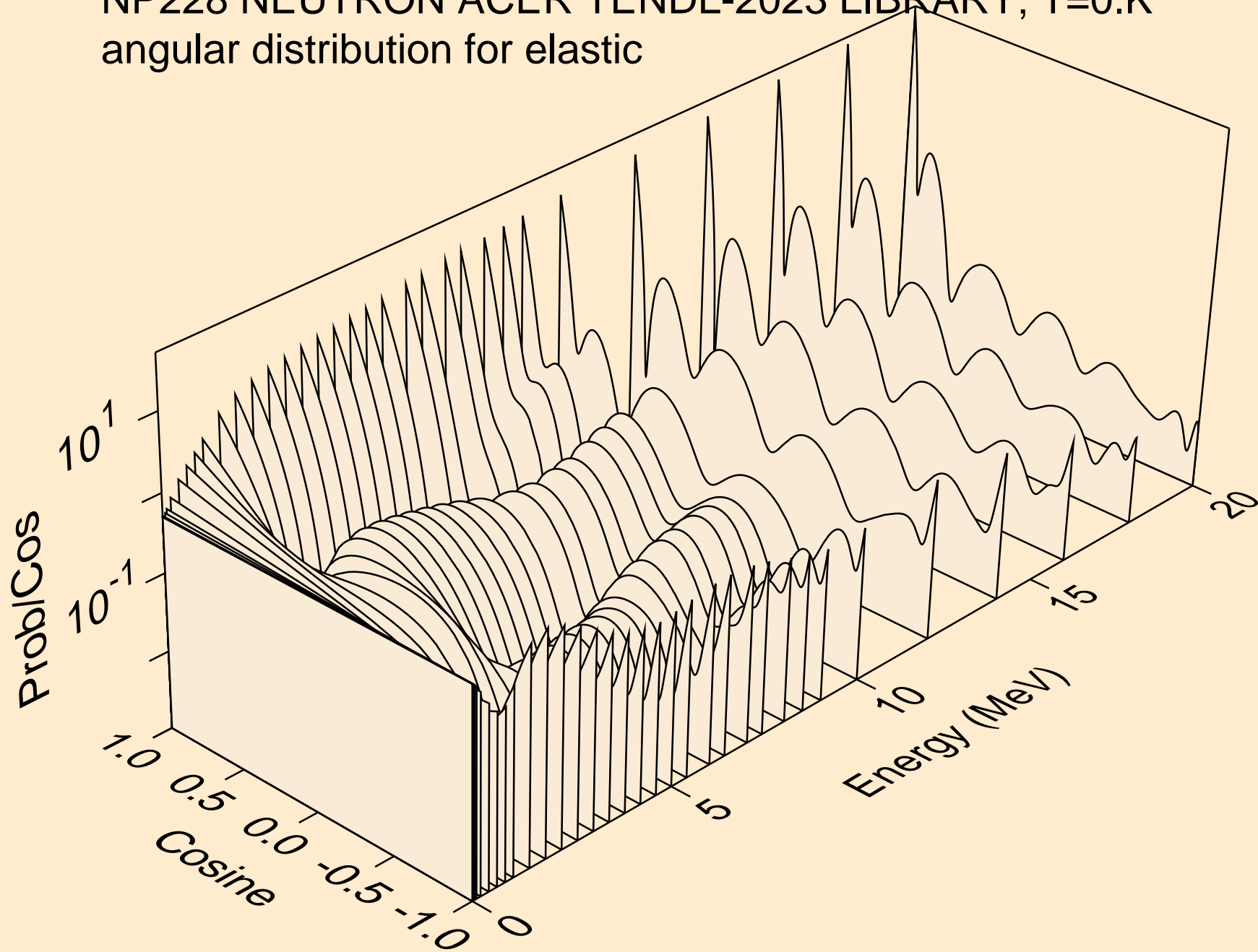

NP228 NEUTRON ACER TENDL-2023 LIBRARY; T=0.K
angular distribution for elastic

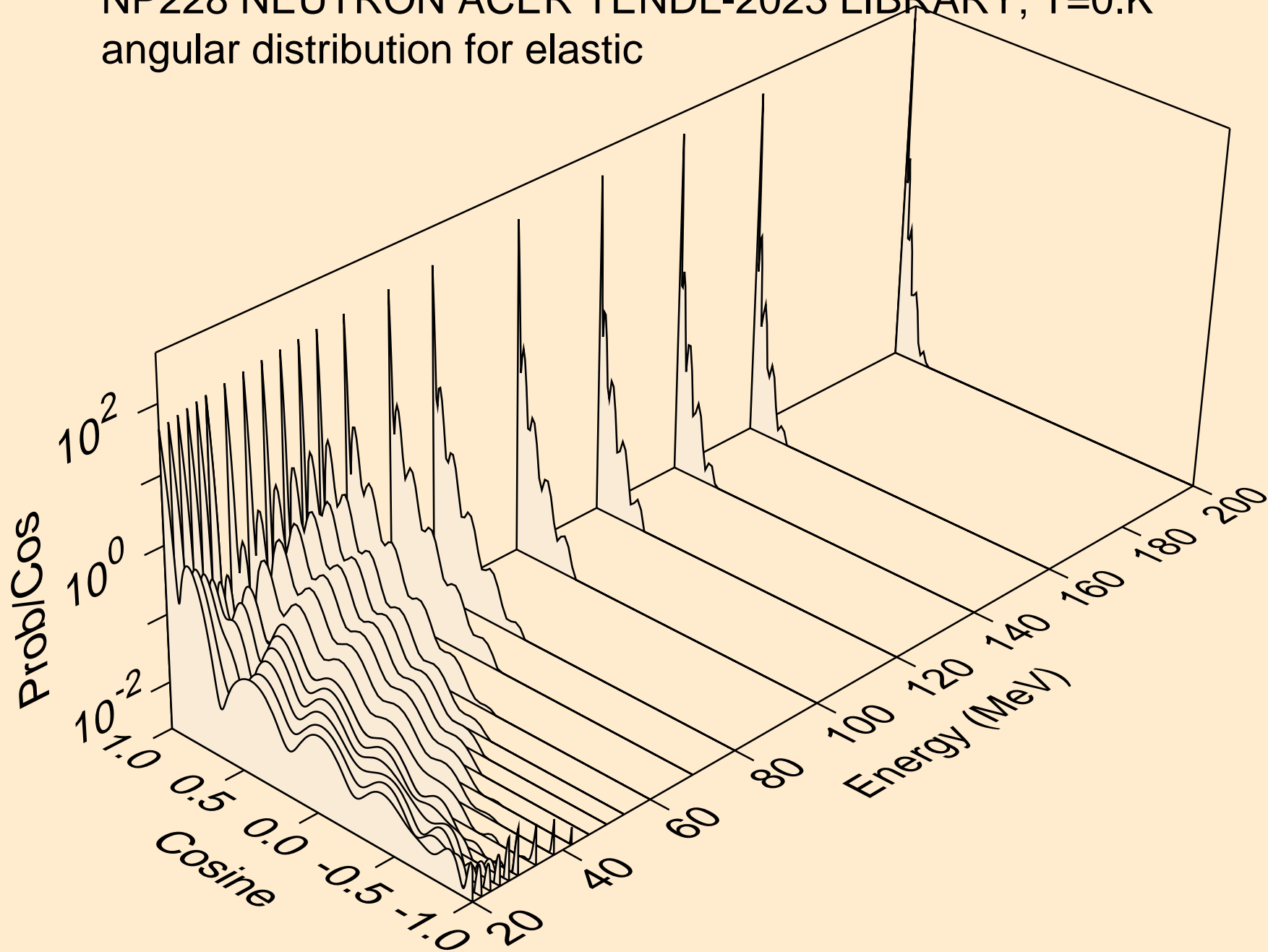

NP228 NEUTRON ACER TENDL-2023 LIBRARY; T=0.K
angular distribution for (n,n*1)

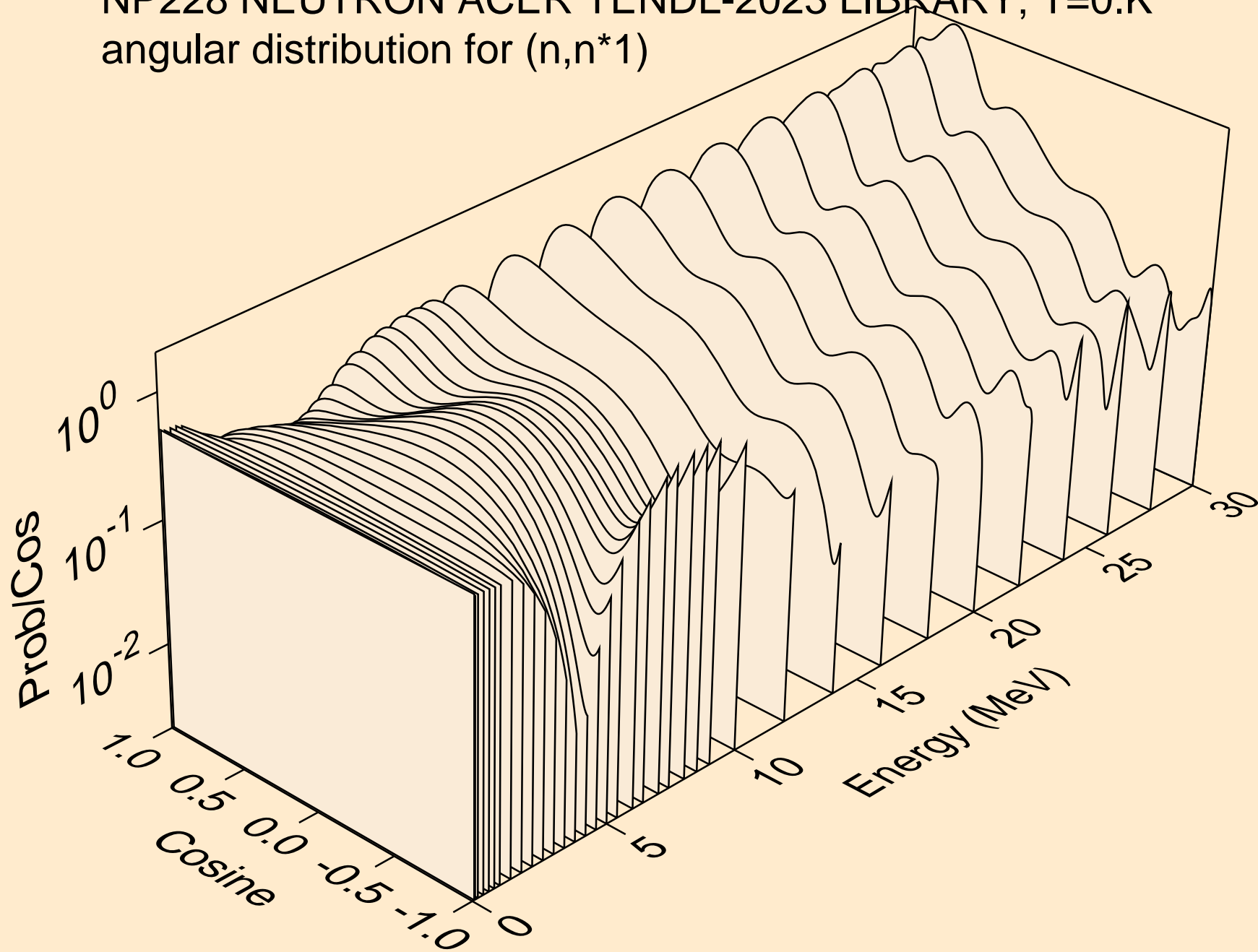

NP228 NEUTRON ACER TENDL-2023 LIBRARY; T=0.K
angular distribution for (n,n*2)

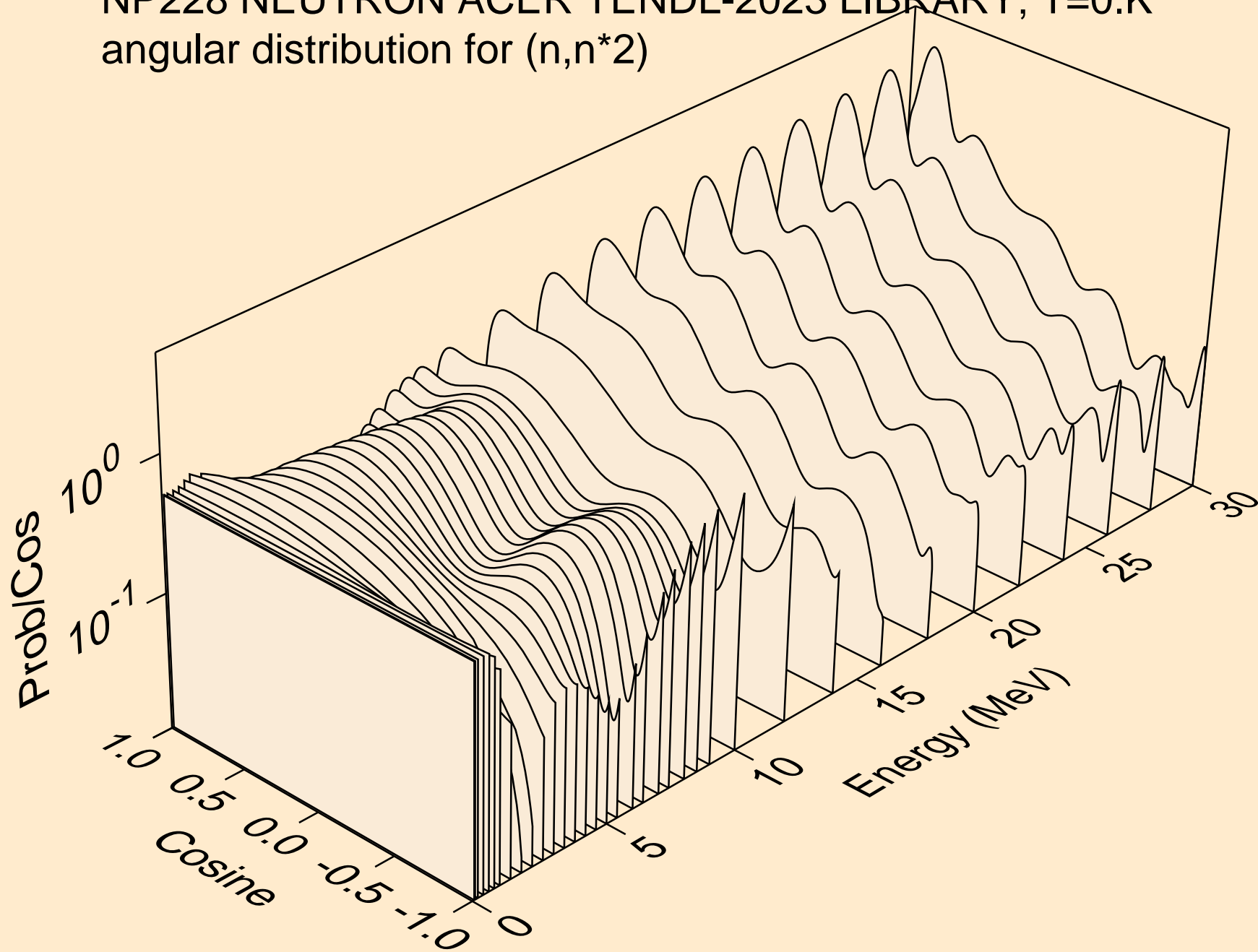

NP228 NEUTRON ACER TENDL-2023 LIBRARY; T=0.K
angular distribution for (n,n*3)

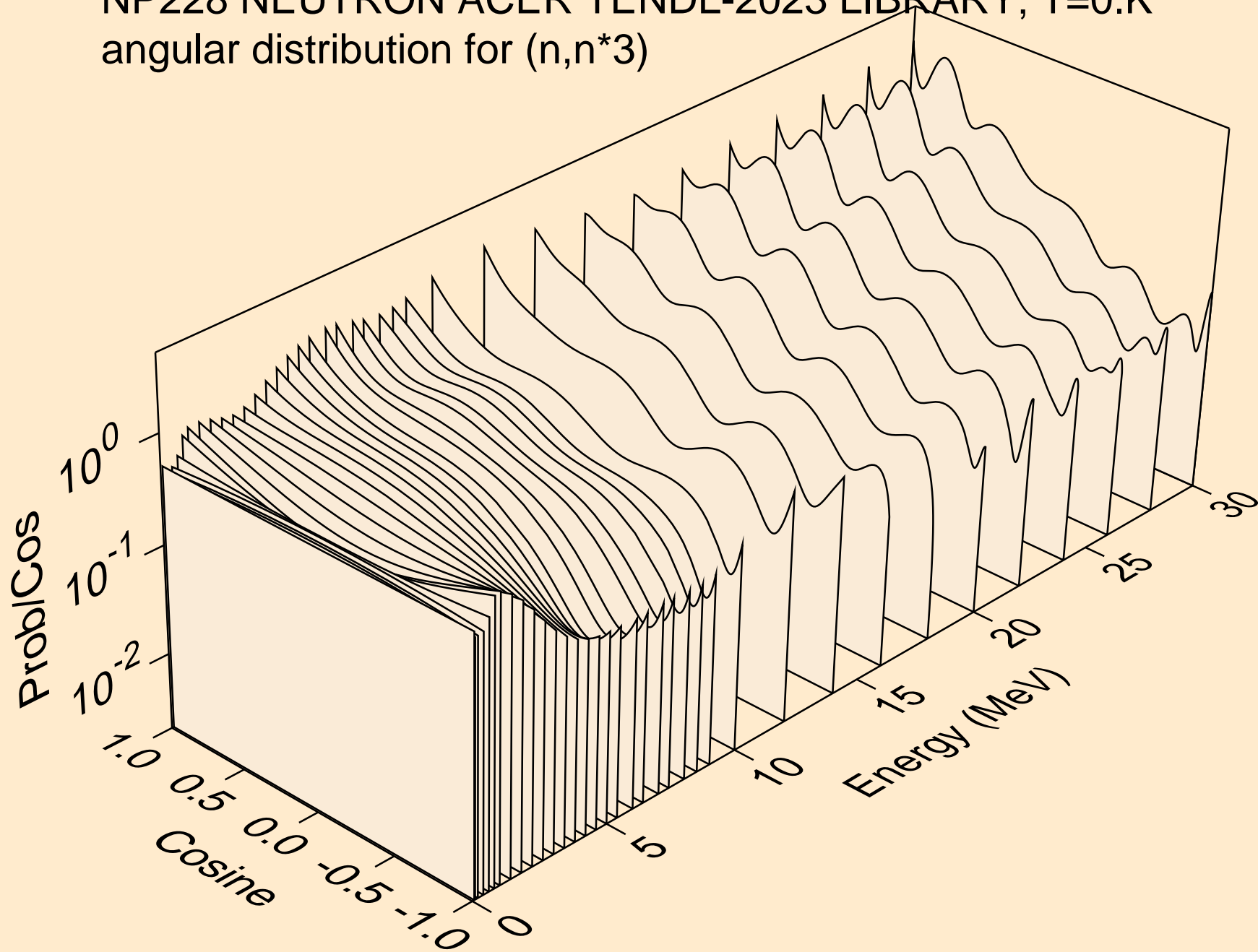

NP228 NEUTRON ACER TENDL-2023 LIBRARY; T=0.K
angular distribution for (n,n*4)

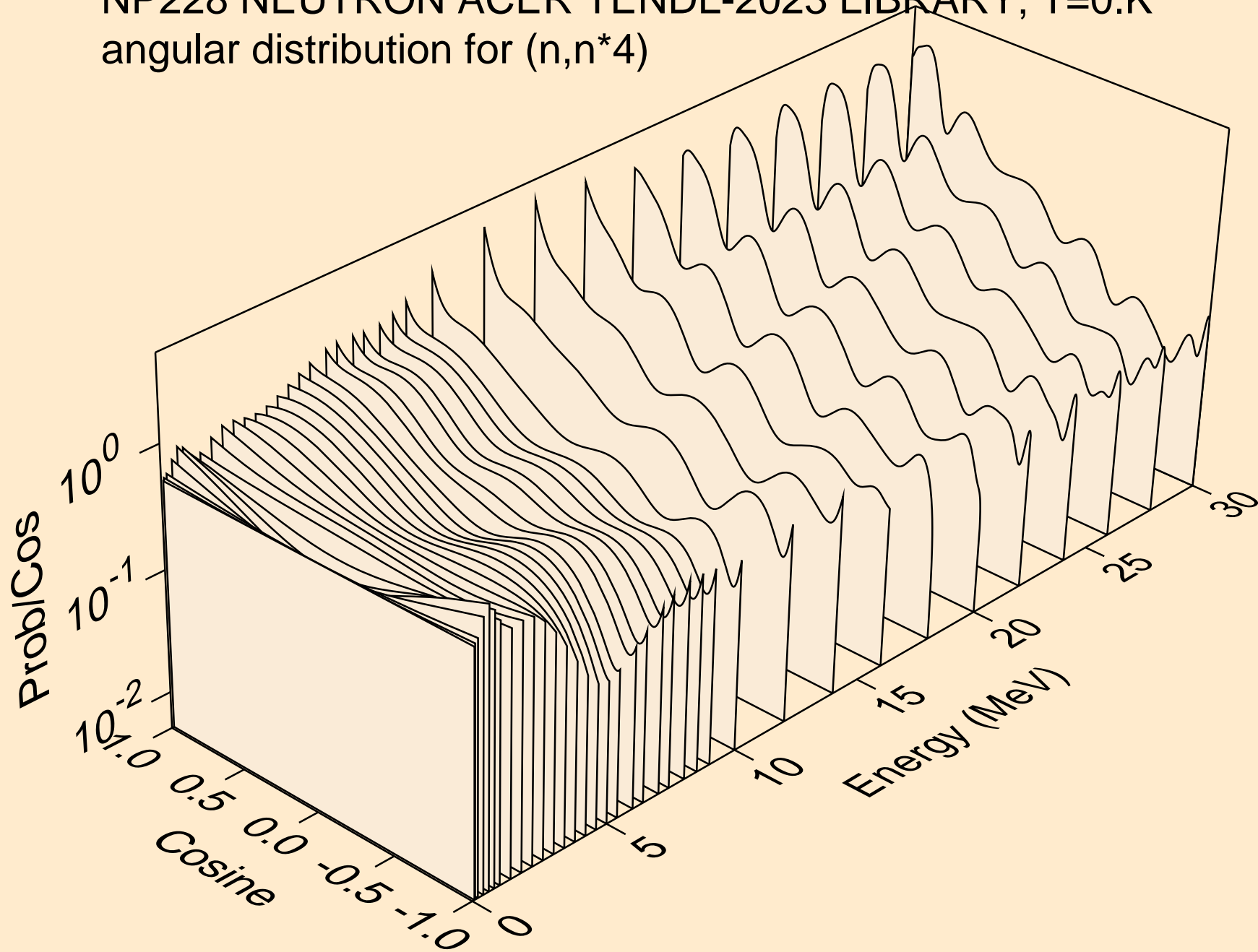

NP228 NEUTRON ACER TENDL-2023 LIBRARY; T=0.K
angular distribution for (n,n*5)

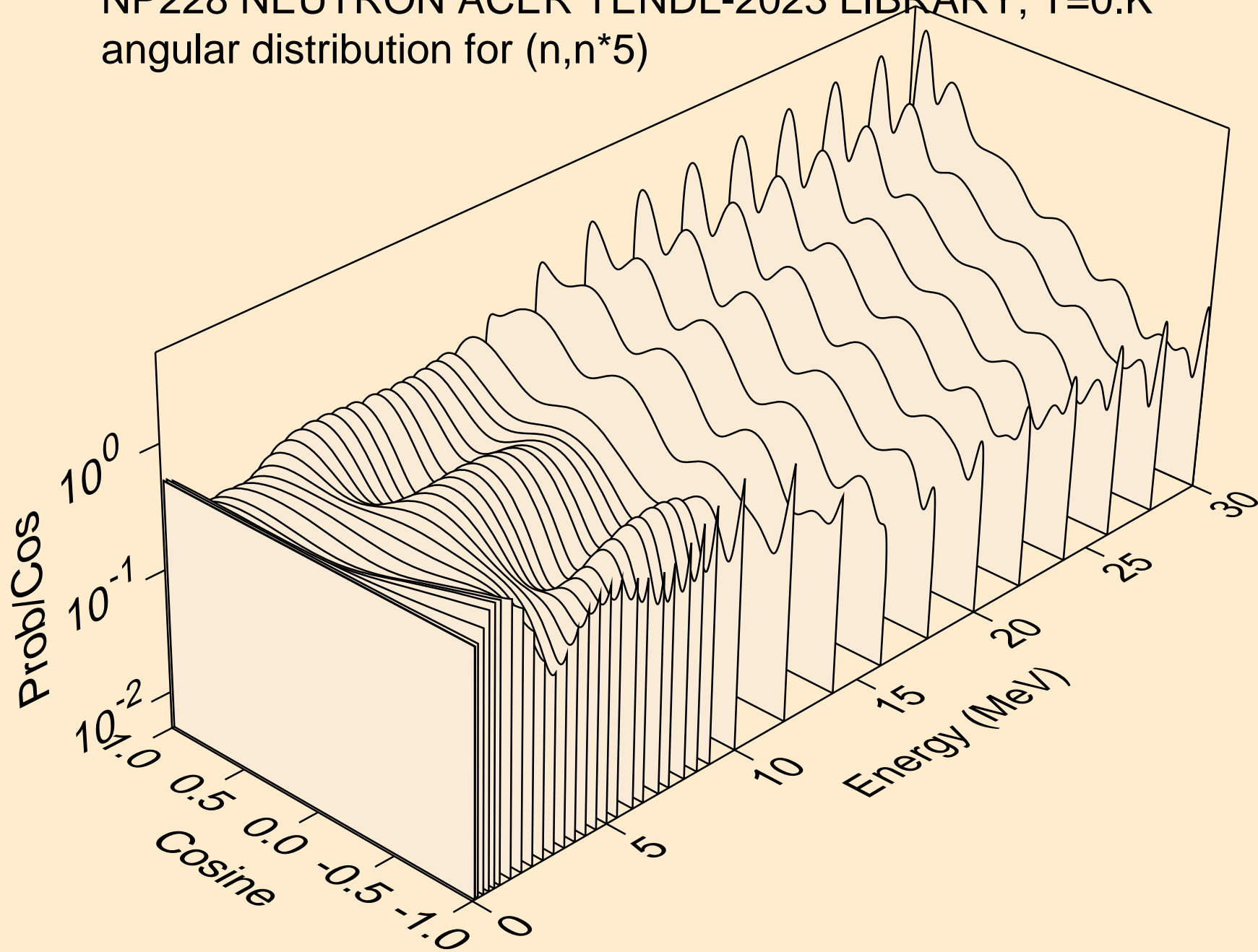

NP228 NEUTRON ACER TENDL-2023 LIBRARY; T=0.K
angular distribution for (n,n*6)

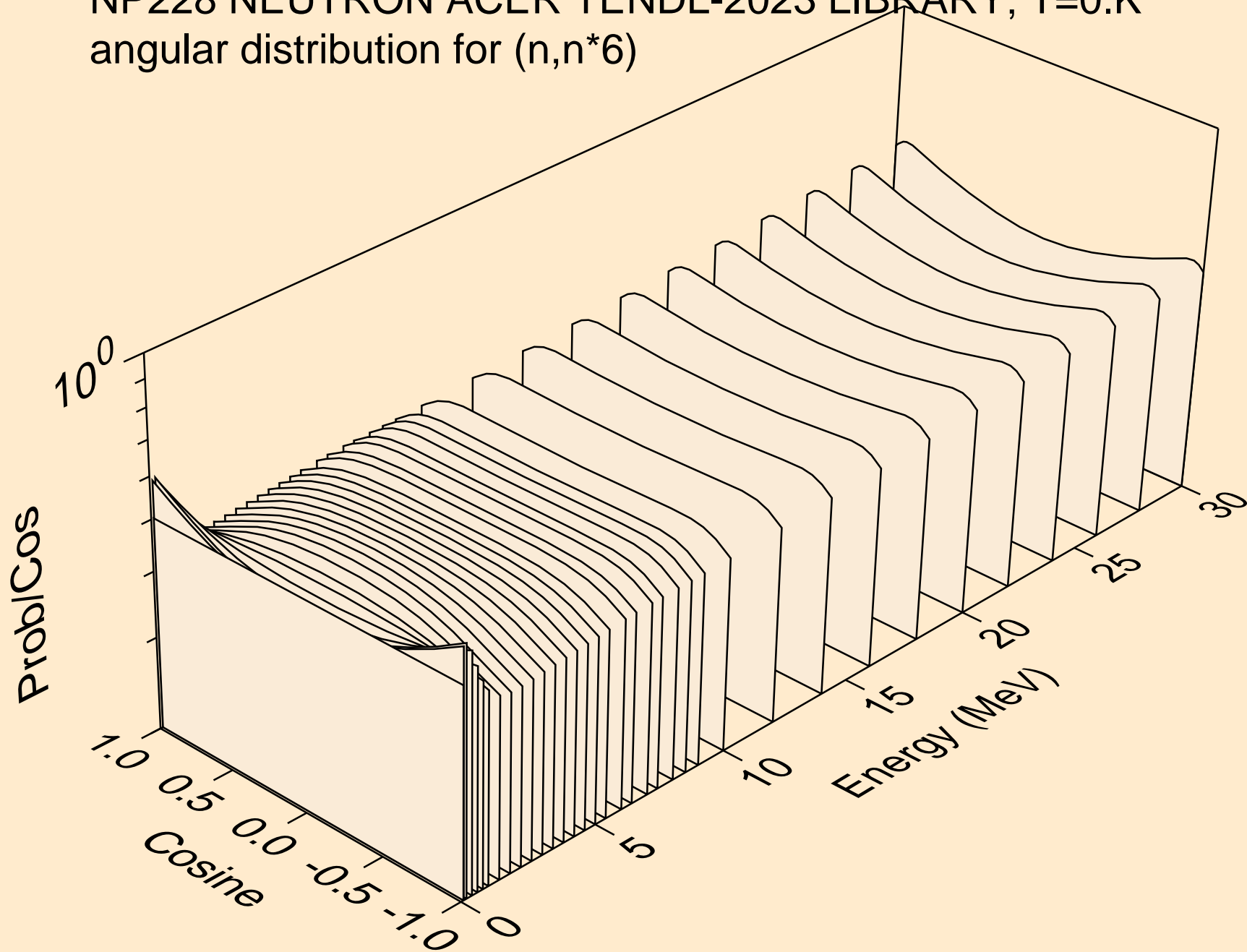

NP228 NEUTRON ACER TENDL-2023 LIBRARY; T=0.K
angular distribution for (n,n*7)

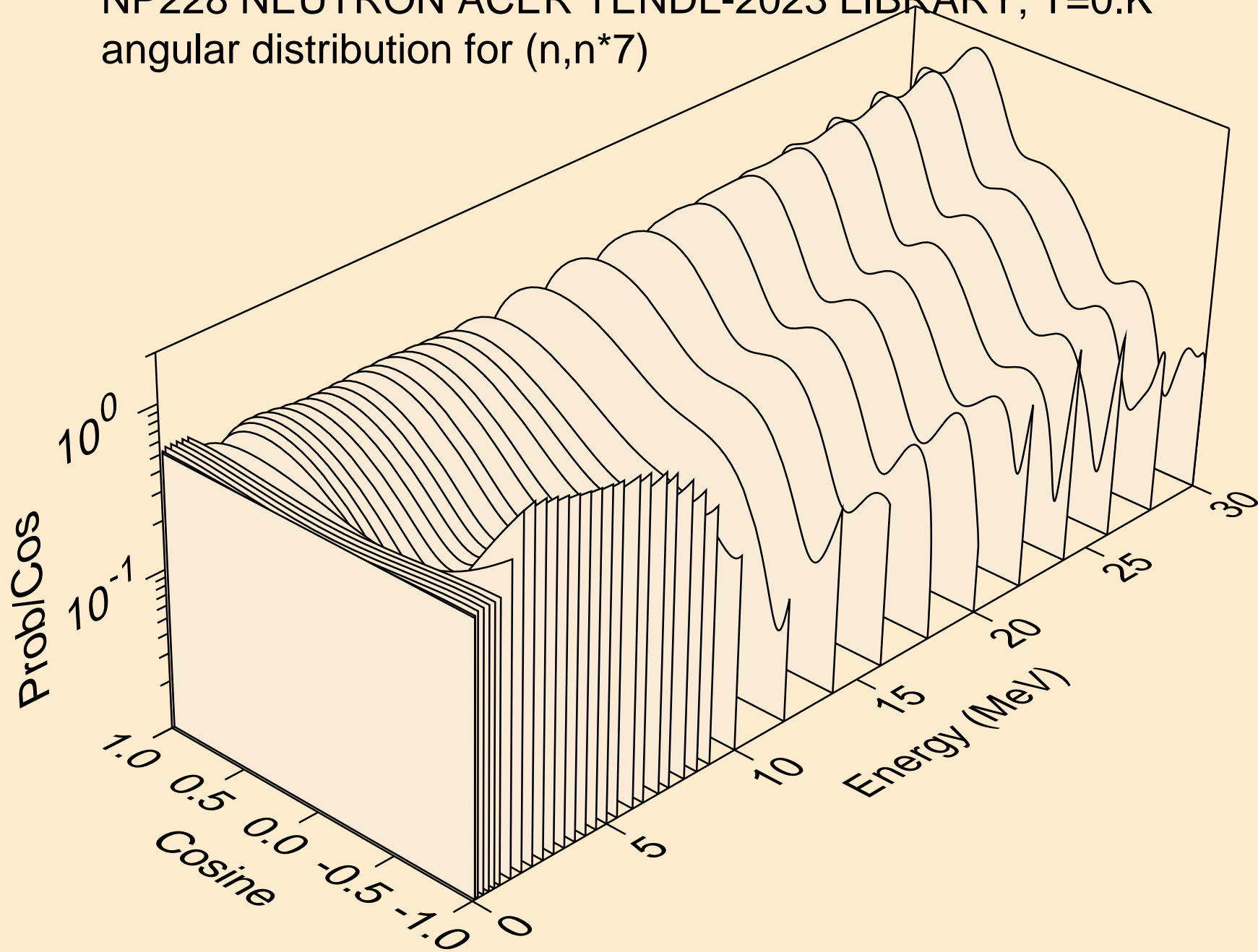

NP228 NEUTRON ACER TENDL-2023 LIBRARY; T=0.K
angular distribution for (n,n*8)

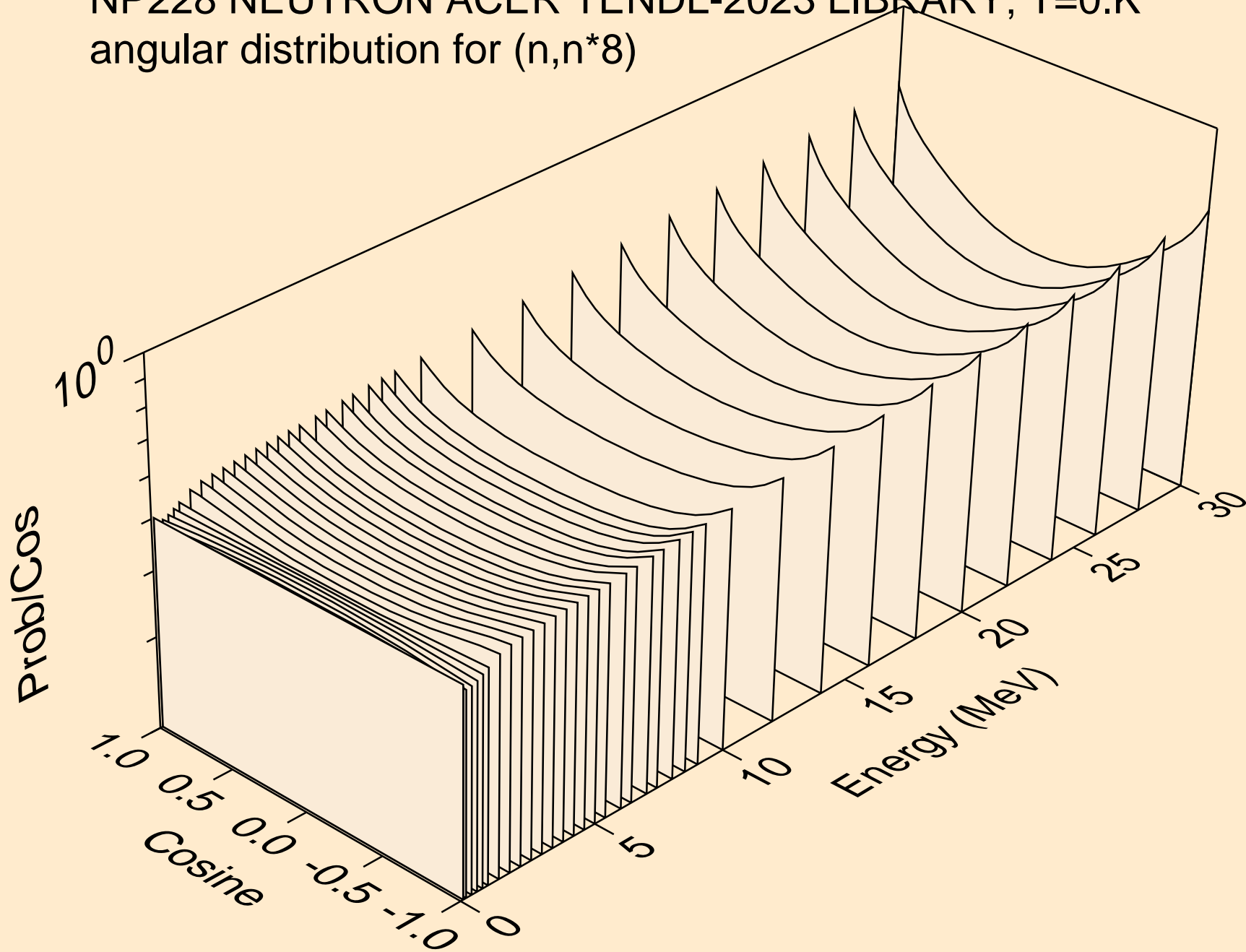

NP228 NEUTRON ACER TENDL-2023 LIBRARY; T=0.K
angular distribution for (n,n*9)

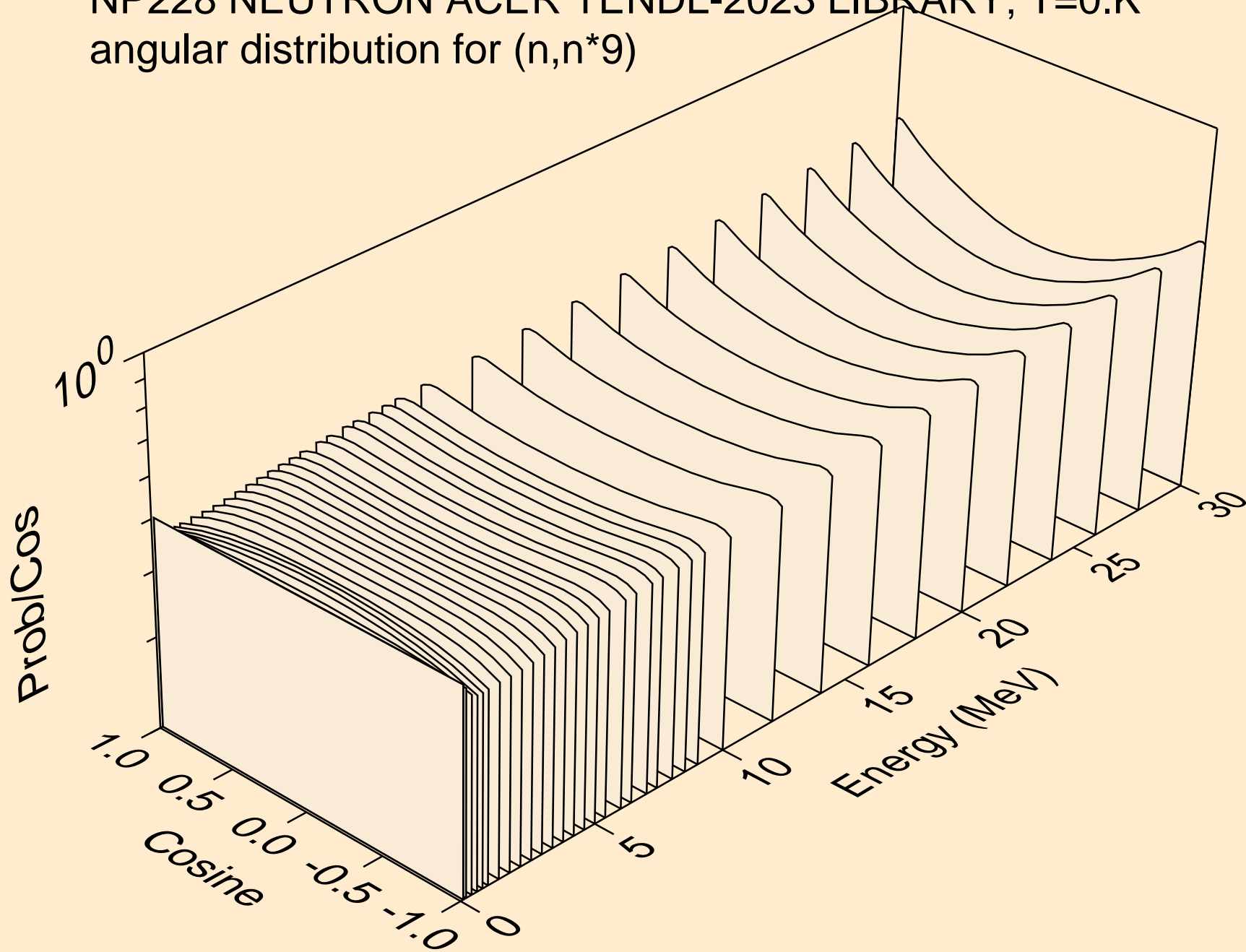

NP228 NEUTRON ACER TENDL-2023 LIBRARY; T=0.K
angular distribution for (n,n*10)

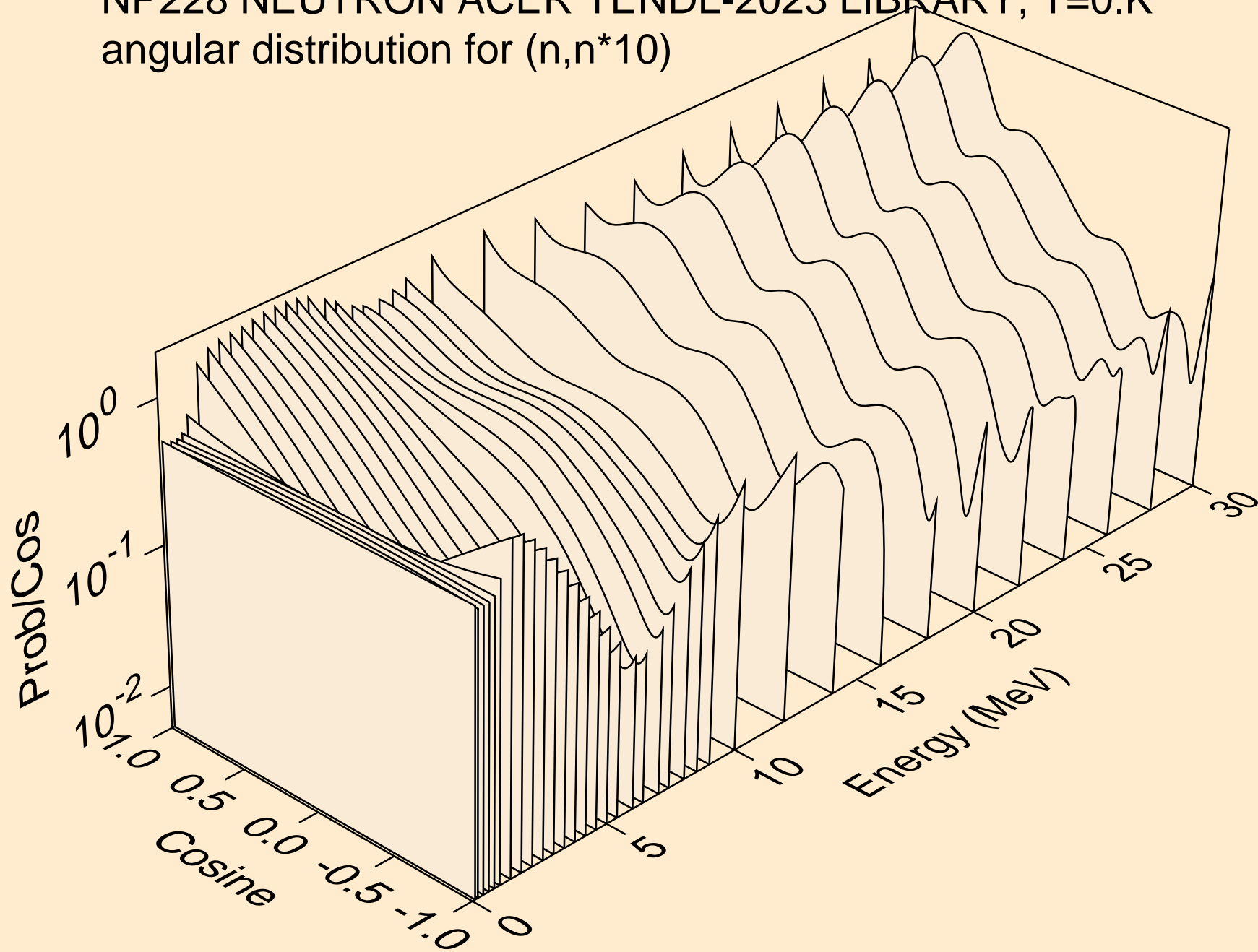

NP228 NEUTRON ACER TENDL-2023 LIBRARY; T=0.K
angular distribution for (n,n*11)

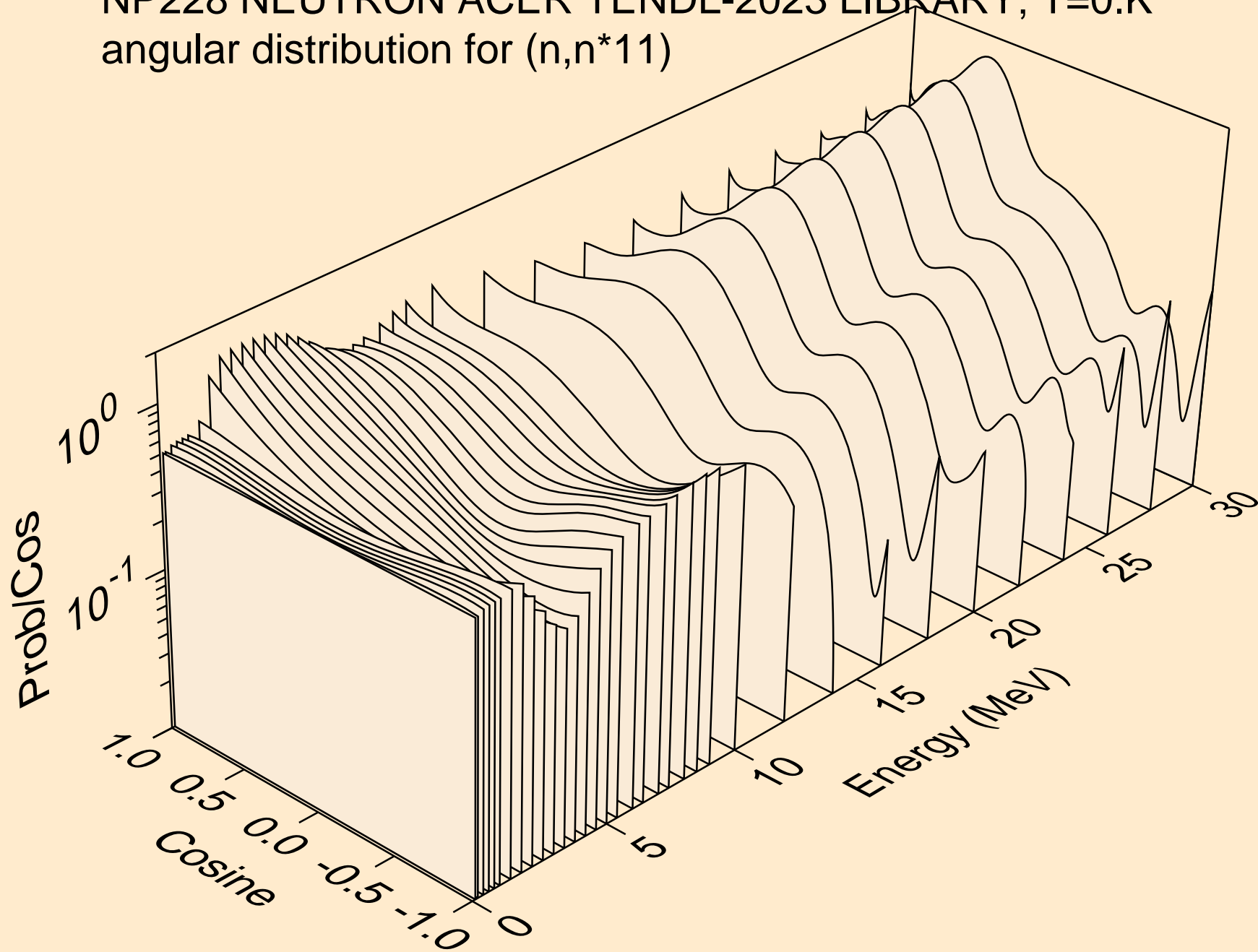

NP228 NEUTRON ACER TENDL-2023 LIBRARY; T=0.K
angular distribution for (n,n*12)

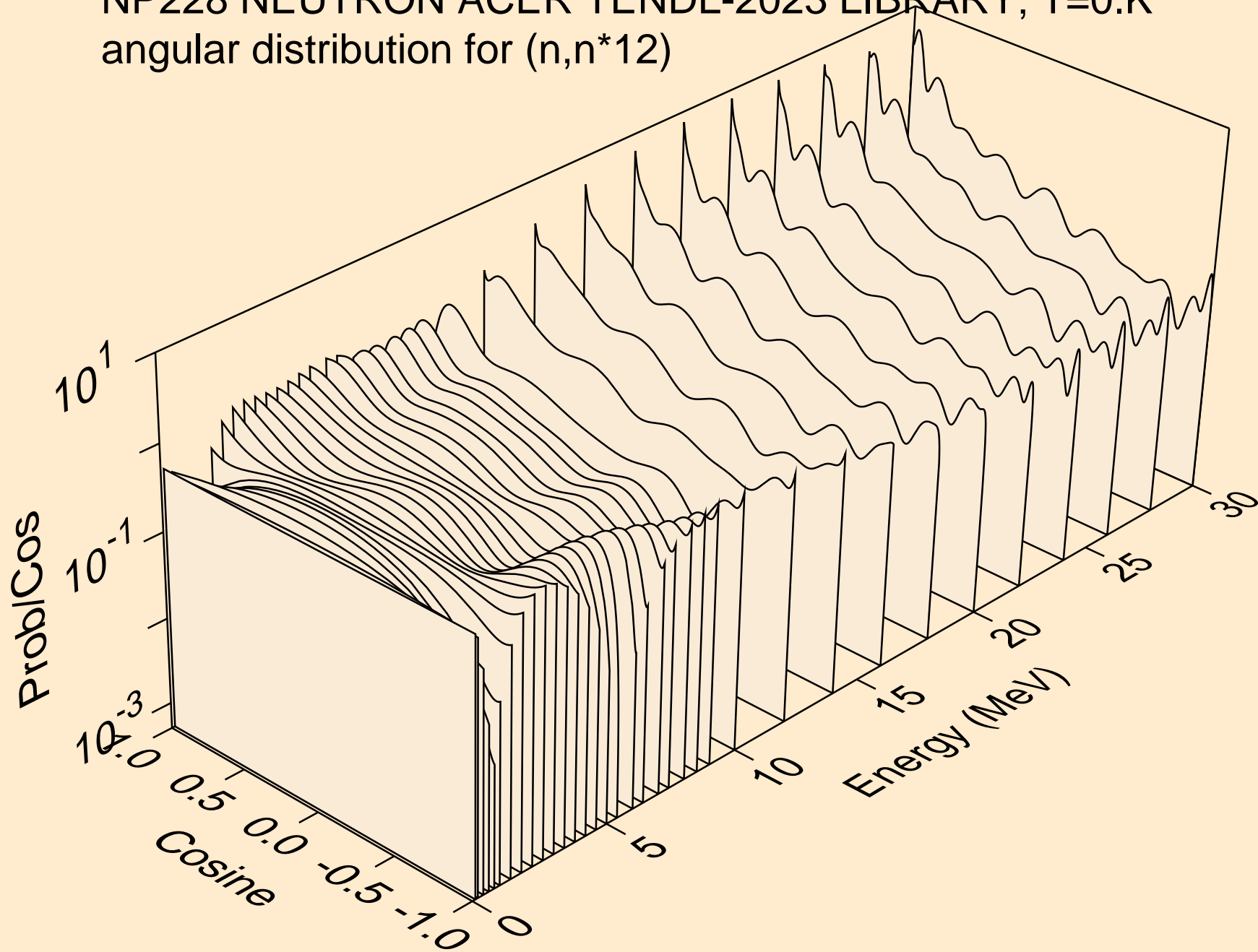

NP228 NEUTRON ACER TENDL-2023 LIBRARY; T=0.K
angular distribution for (n,n*13)

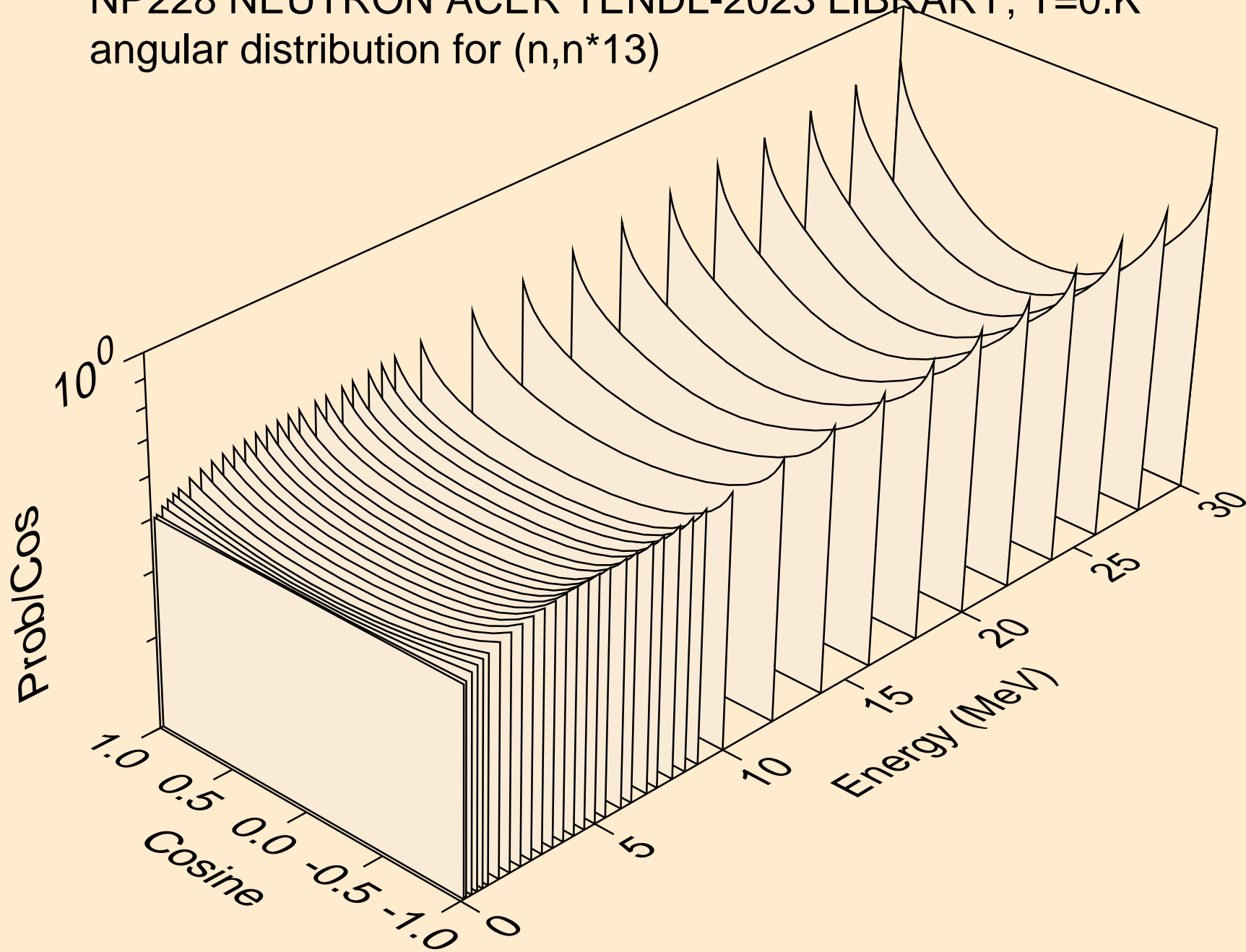

NP228 NEUTRON ACER TENDL-2023 LIBRARY; T=0.K
angular distribution for (n,n*14)

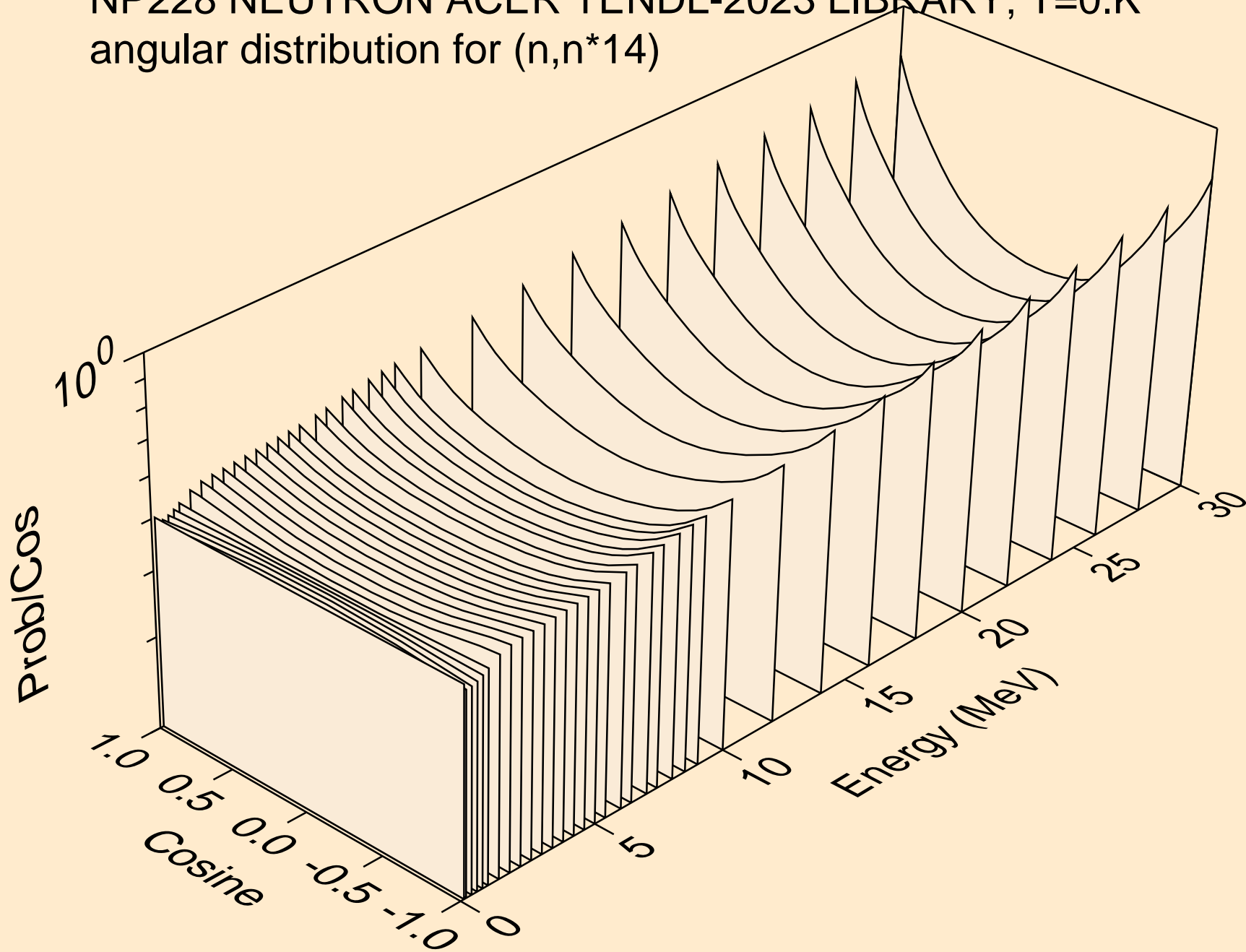

NP228 NEUTRON ACER TENDL-2023 LIBRARY; T=0.K
angular distribution for (n,n*15)

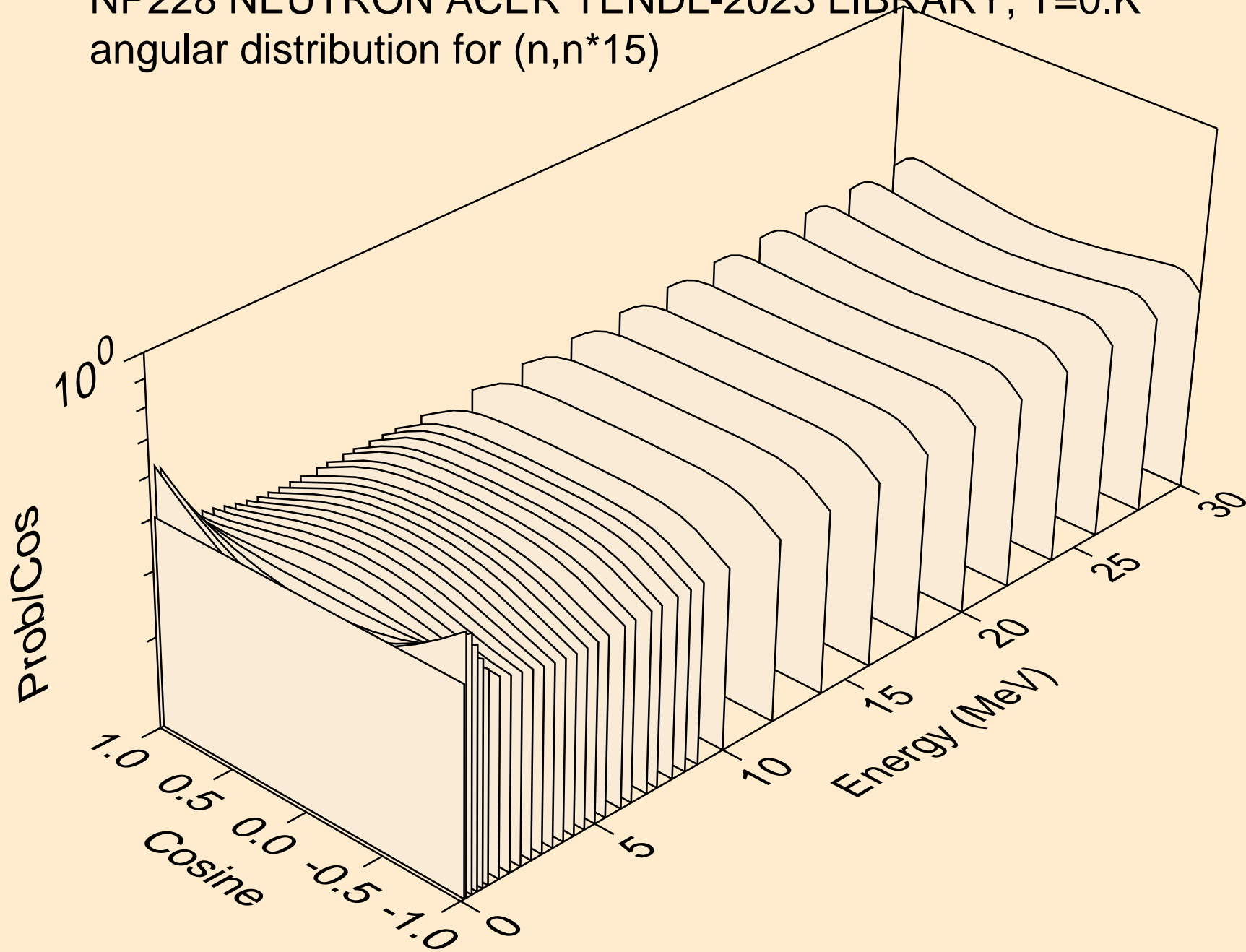

NP228 NEUTRON ACER TENDL-2023 LIBRARY; T=0.K
angular distribution for (n,n*16)

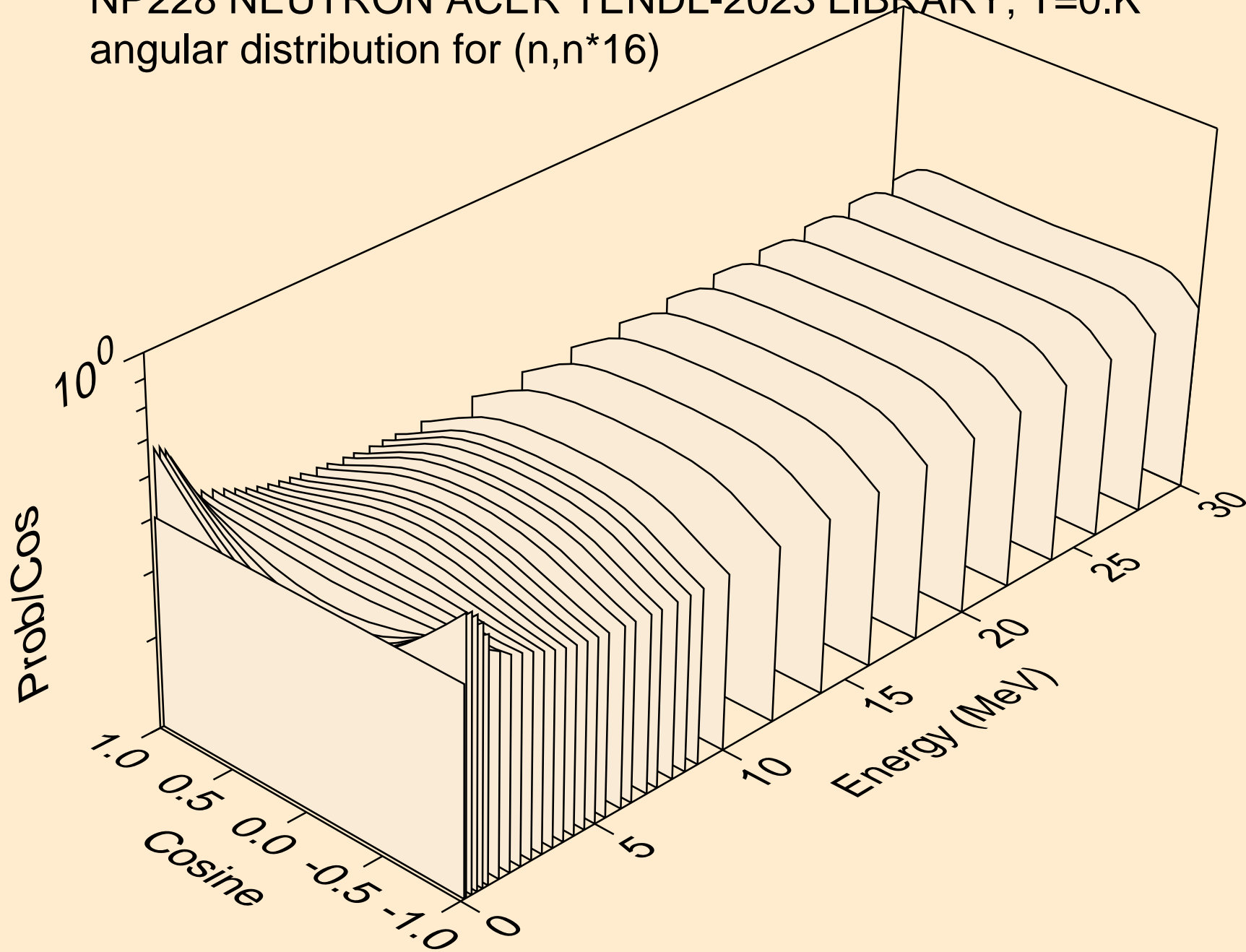

NP228 NEUTRON ACER TENDL-2023 LIBRARY; T=0.K
angular distribution for (n,n*17)

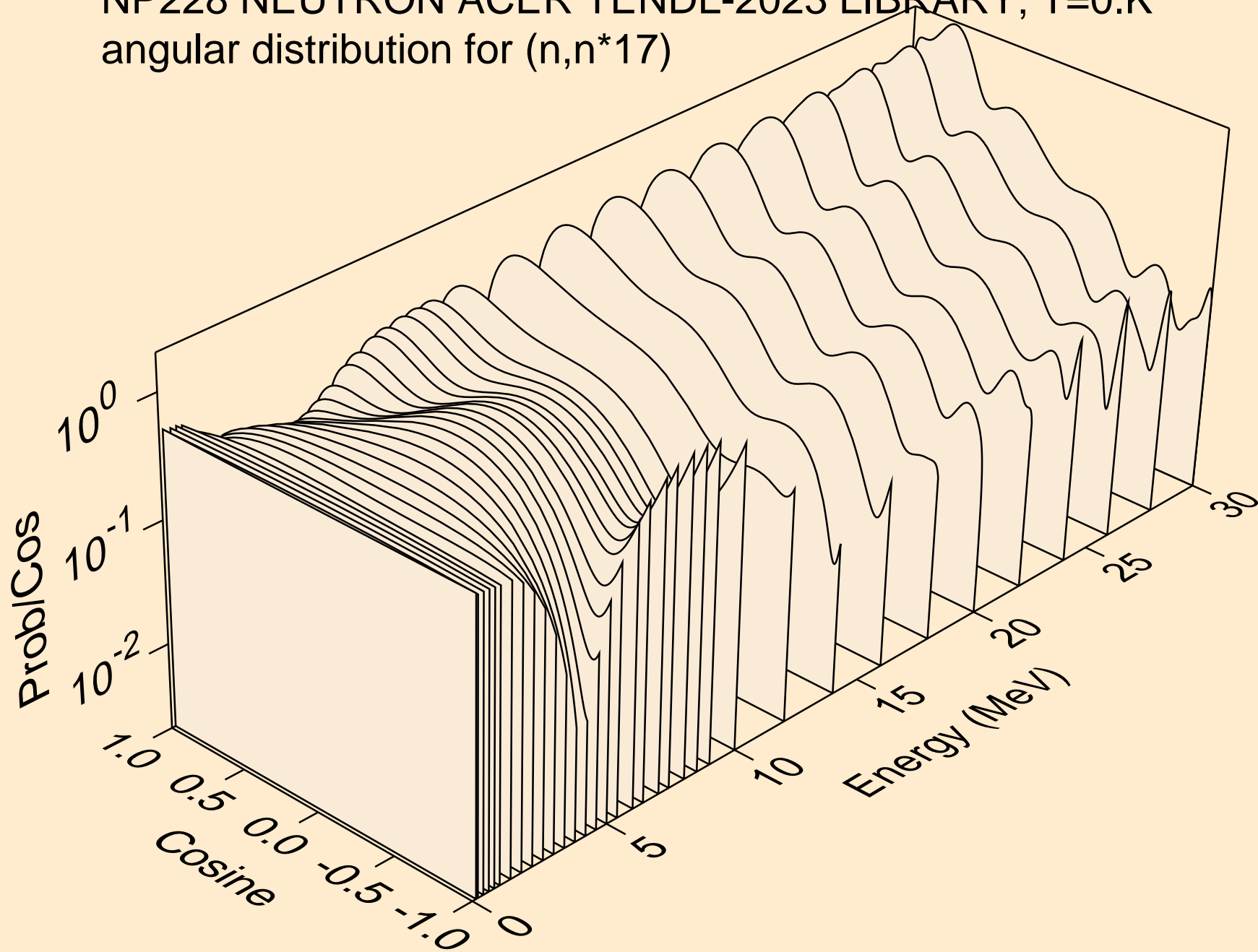

NP228 NEUTRON ACER TENDL-2023 LIBRARY; T=0.K
angular distribution for (n,n*18)

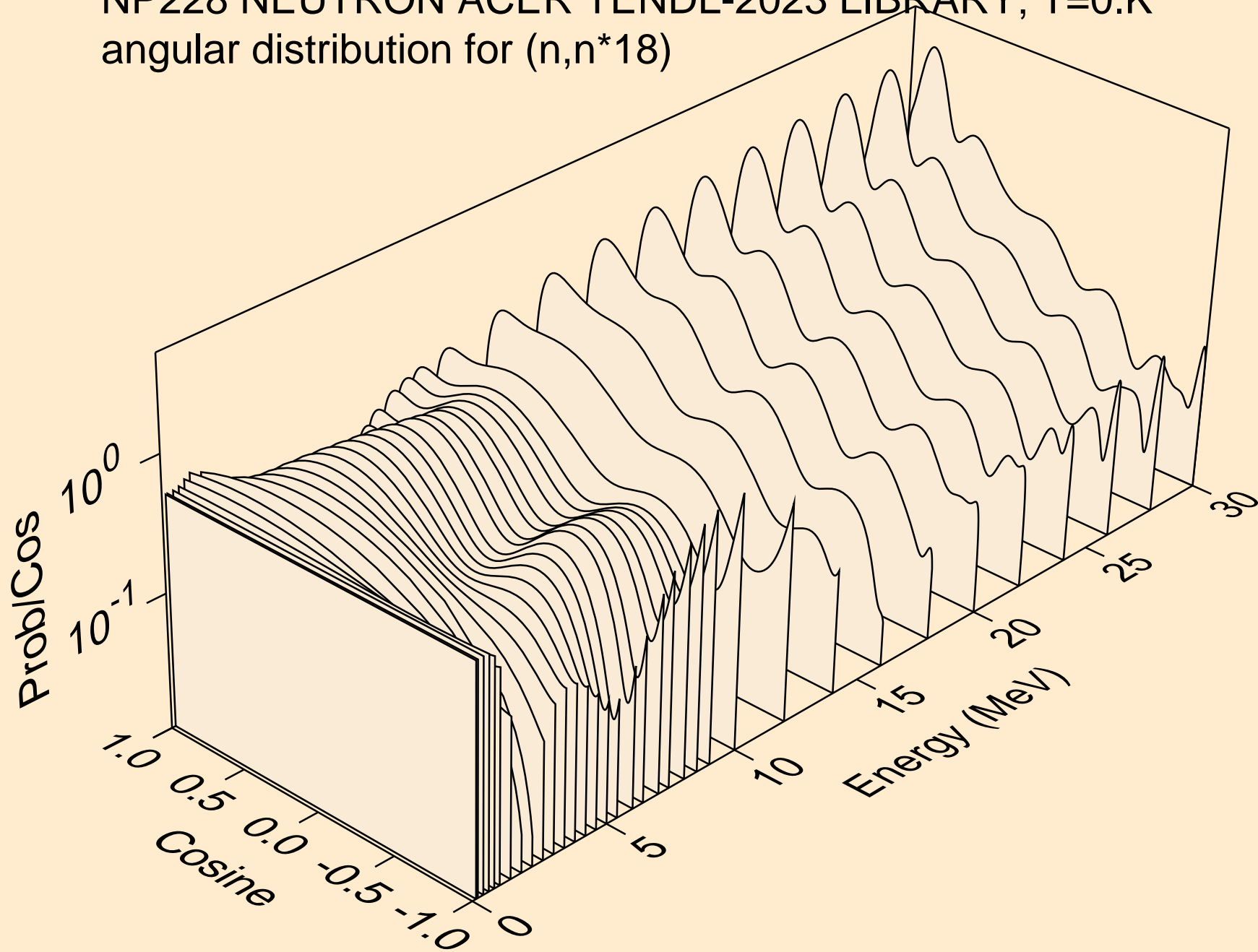

NP228 NEUTRON ACER TENDL-2023 LIBRARY; T=0.K
angular distribution for (n,n*19)

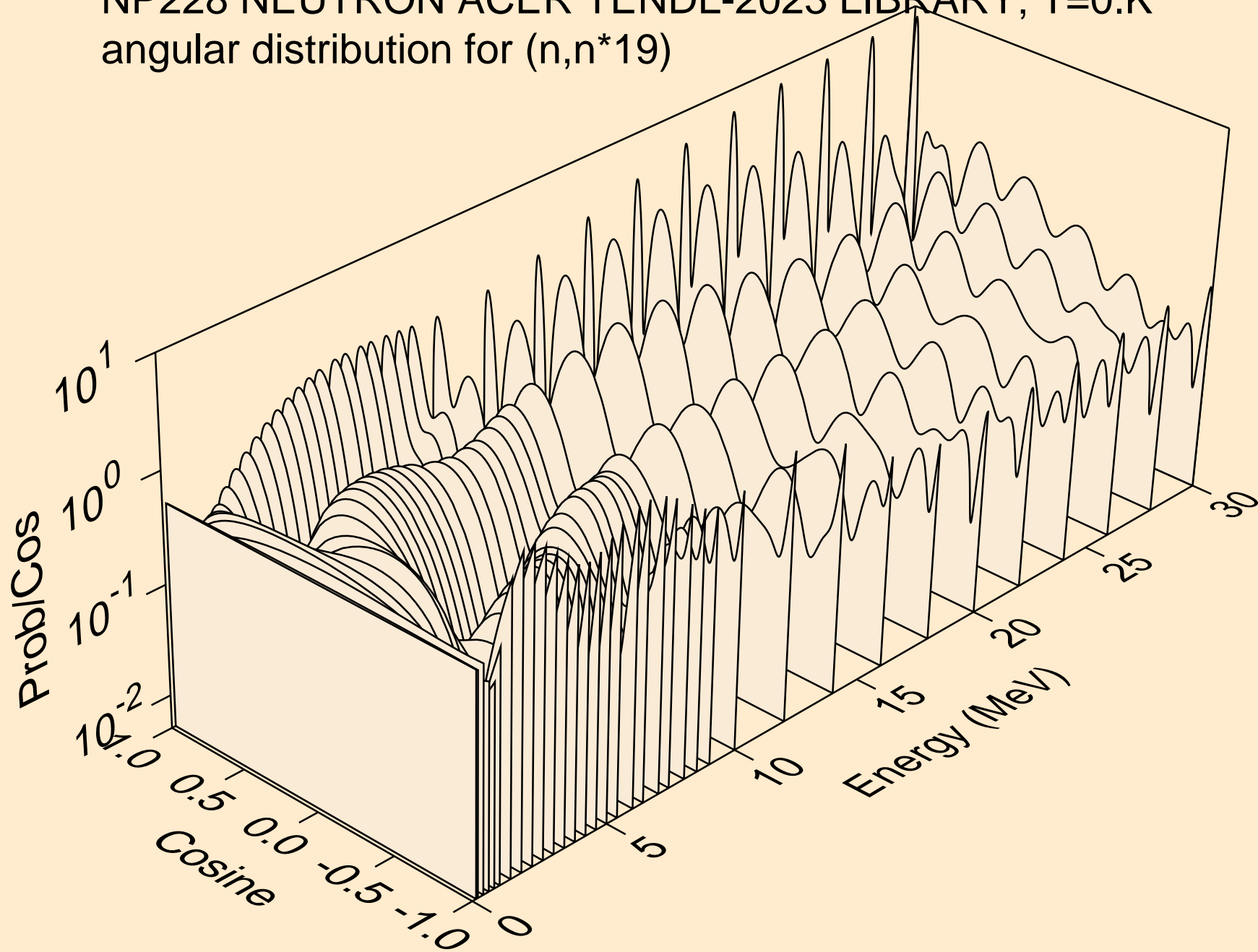

NP228 NEUTRON ACER TENDL-2023 LIBRARY; T=0.K
angular distribution for (n,n*20)

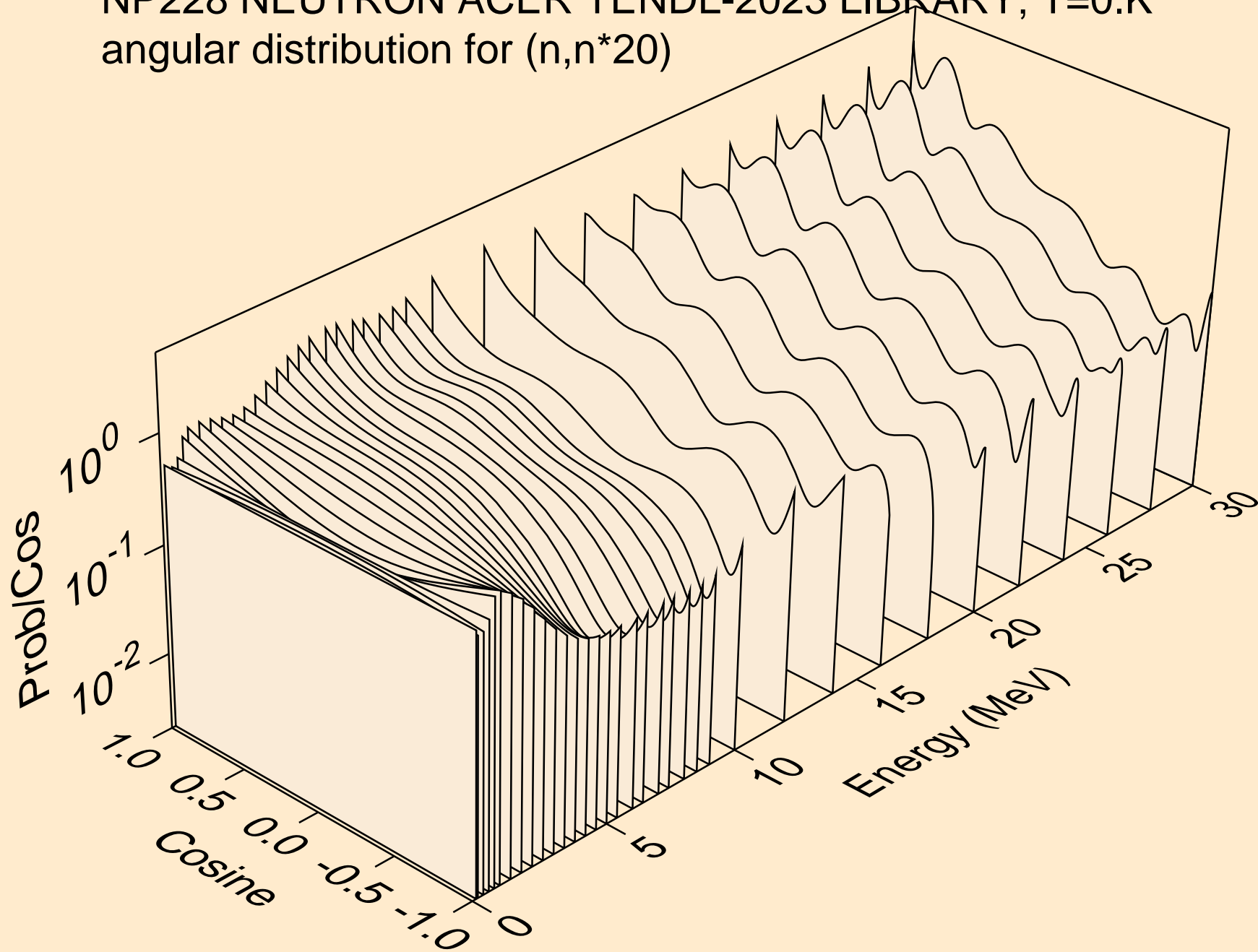

NP228 NEUTRON ACER TENDL-2023 LIBRARY; T=0.K
angular distribution for (n,n*21)

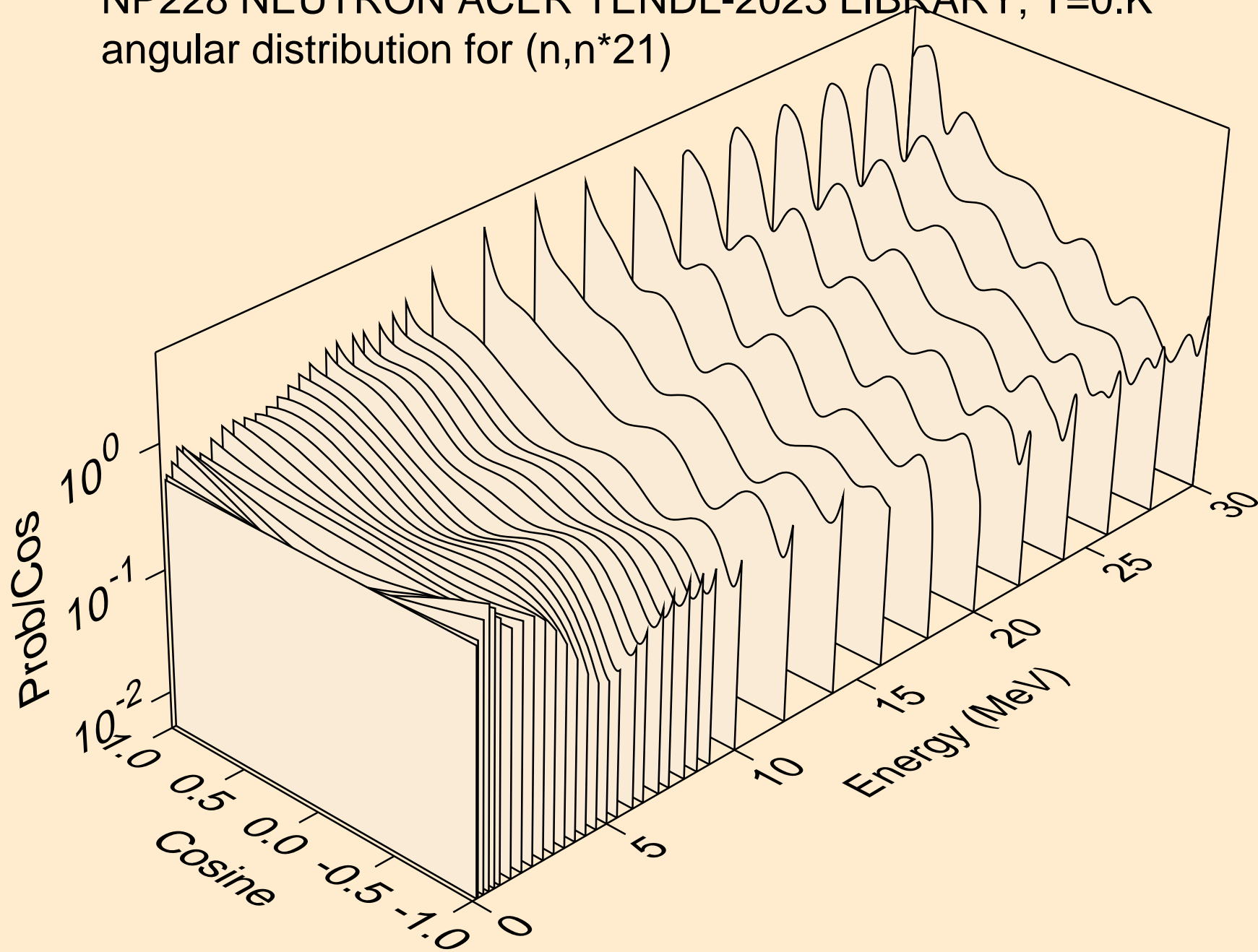

NP228 NEUTRON ACER TENDL-2023 LIBRARY; T=0.K

Total fission nubar

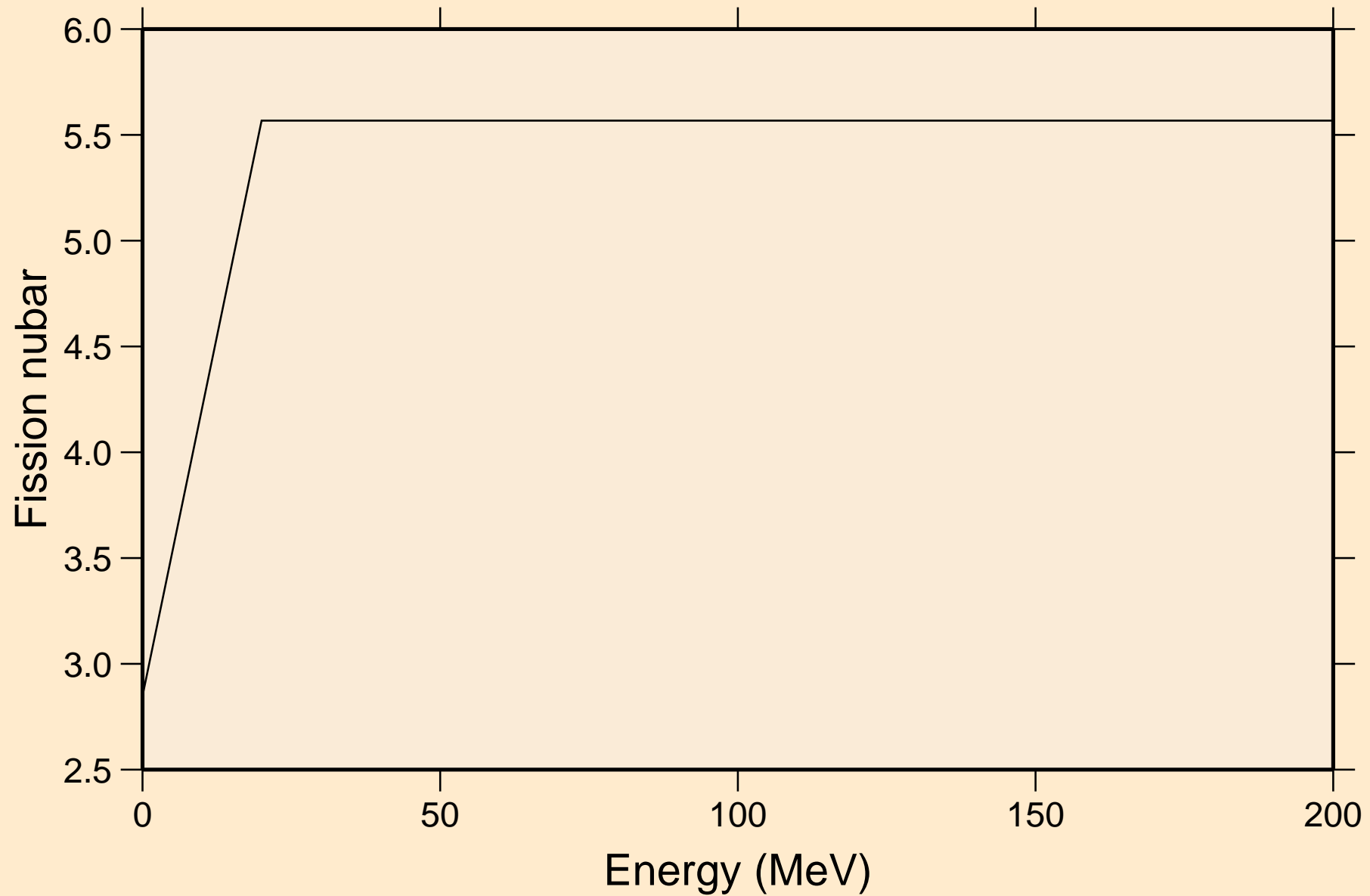

NP228 NEUTRON ACER TENDL-2023 LIBRARY; T=0.K
Neutron emission for (n,x)

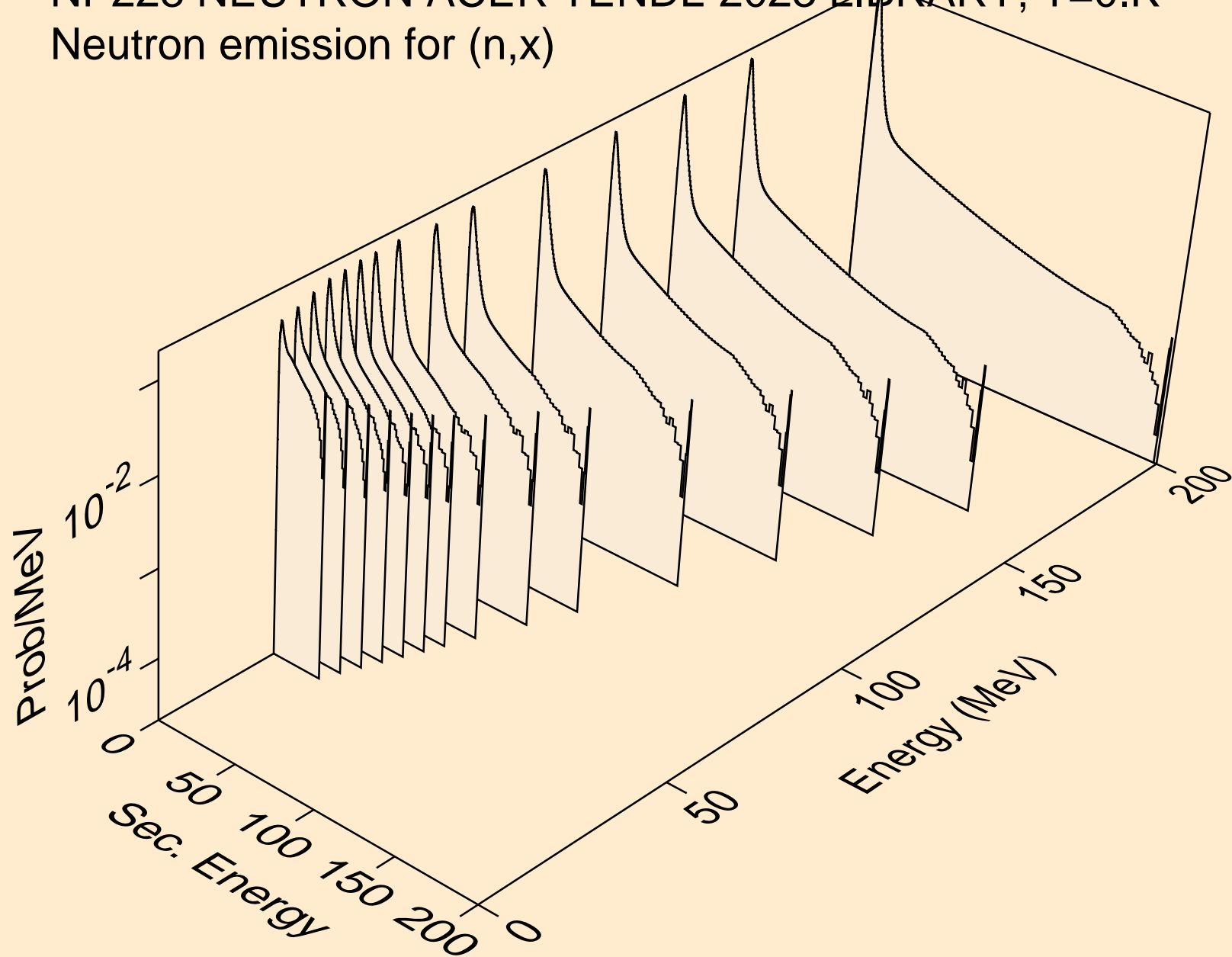

NP228 NEUTRON ACER TENDL-2023 LIBRARY; T=0.K
Neutron emission for (n,2nd)

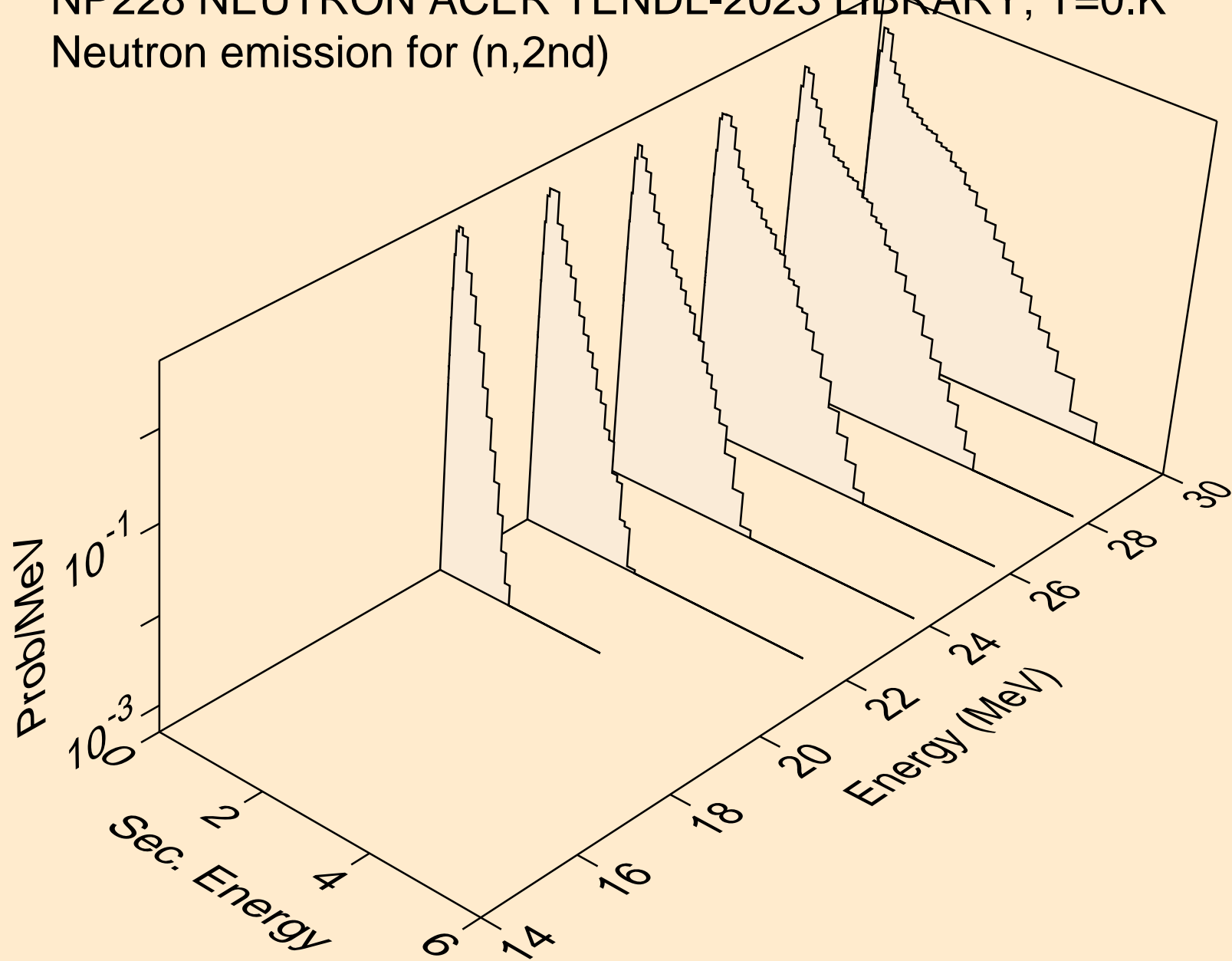

NP228 NEUTRON ACER TENDL-2023 LIBRARY; T=0.K
Neutron emission for (n,2n)

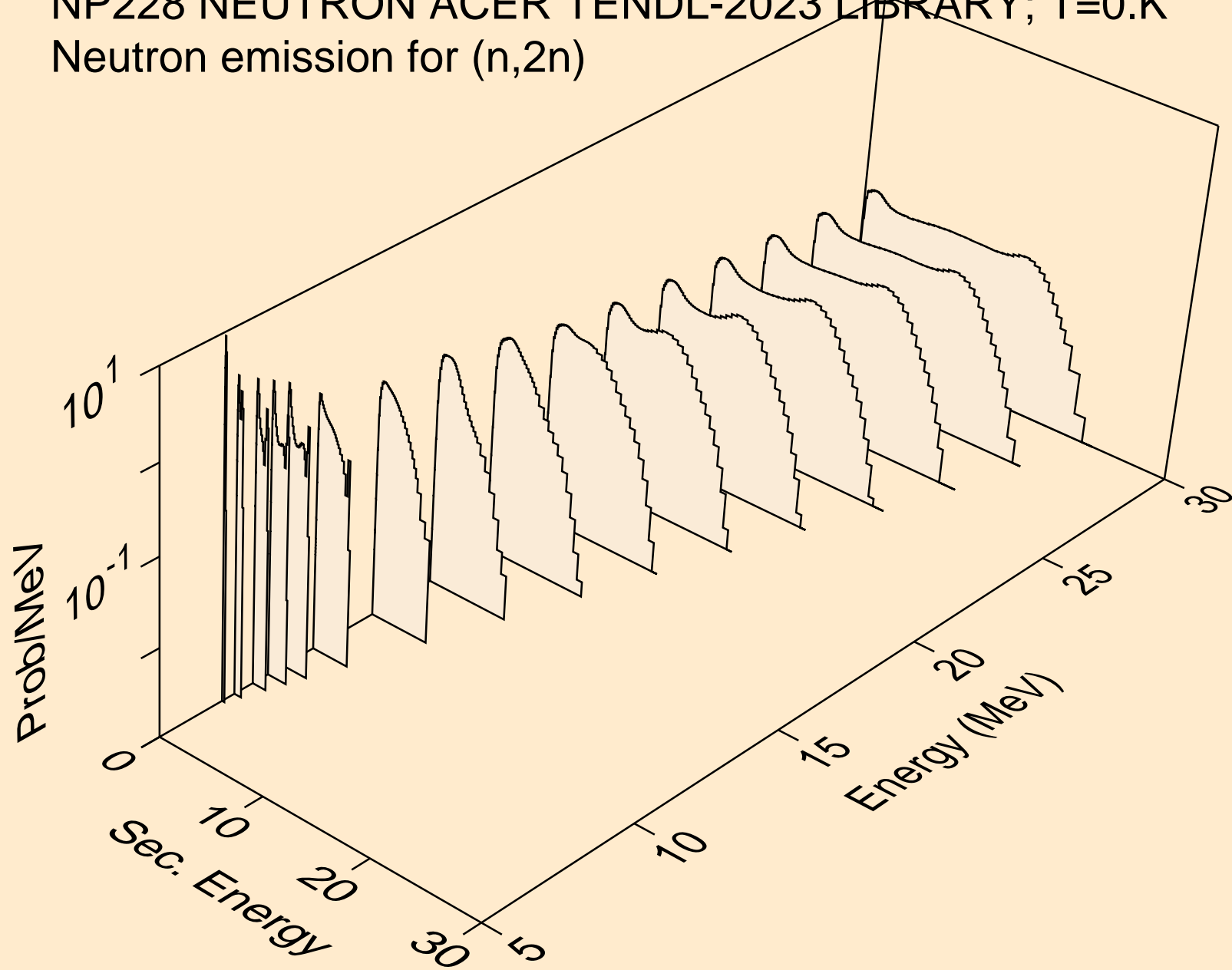

NP228 NEUTRON ACER TENDL-2023 LIBRARY; T=0.K
Neutron emission for (n,3n)

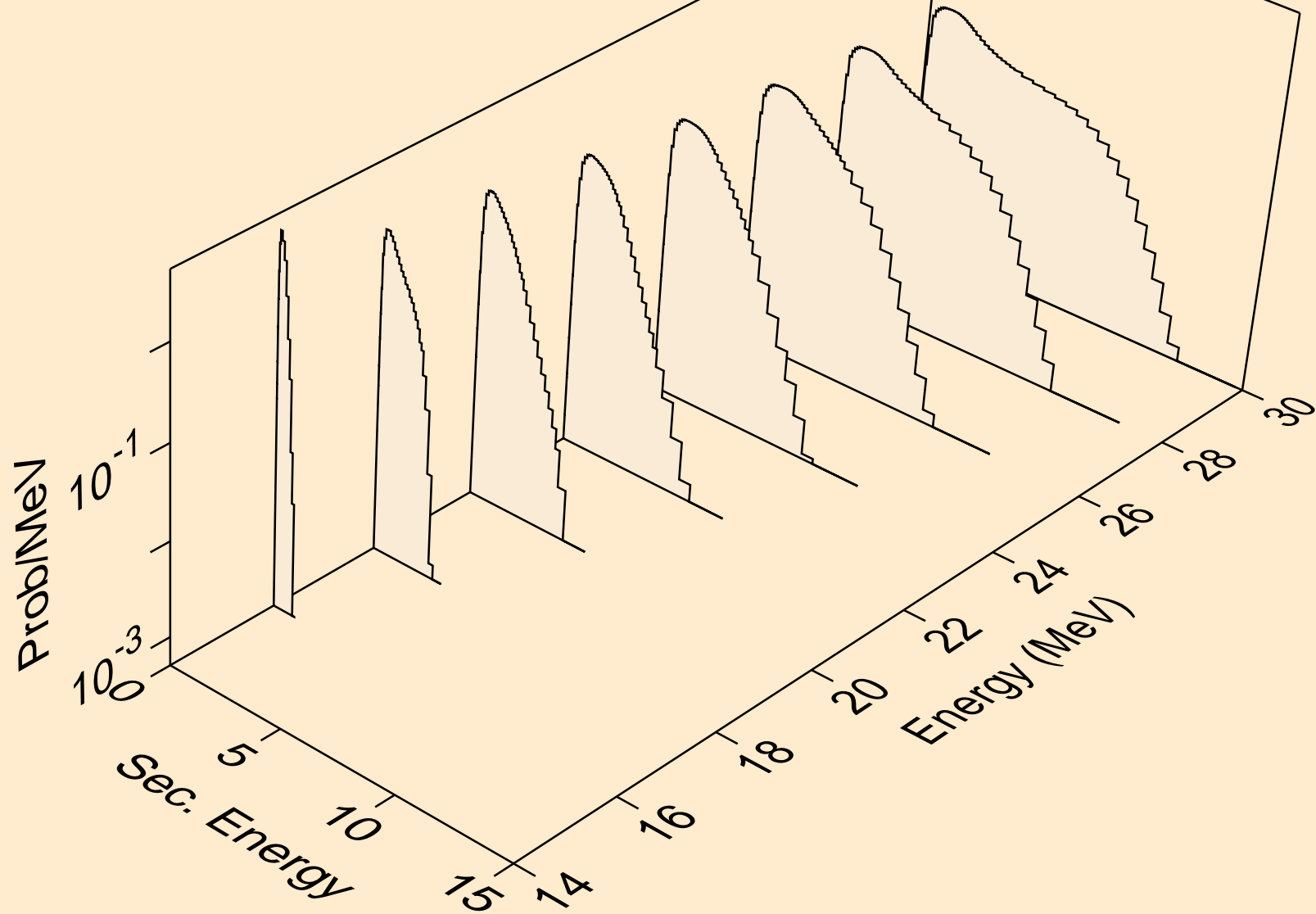

NP228 NEUTRON ACER TENDL-2023 LIBRARY; T=0.K
Neutron emission for fission

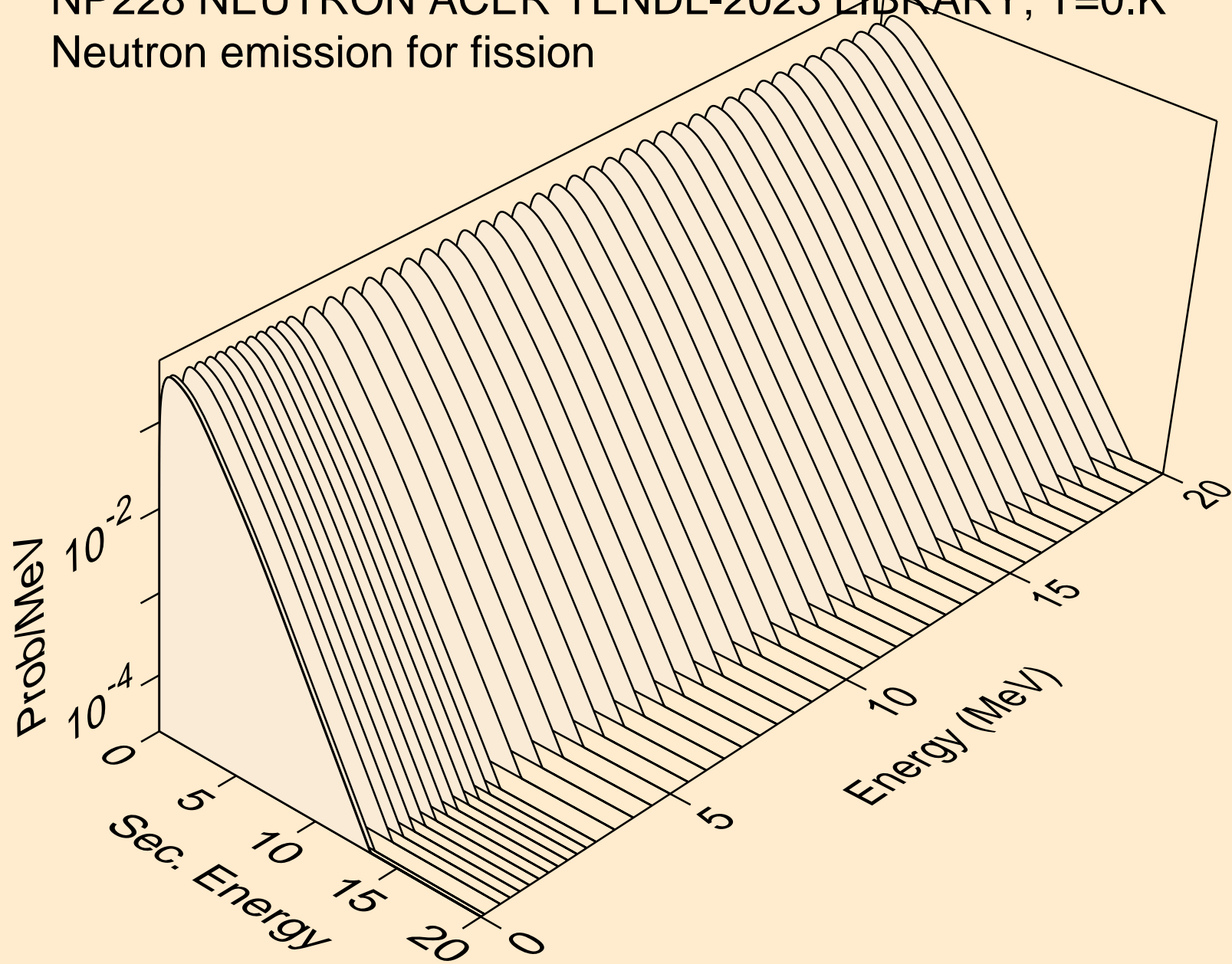

NP228 NEUTRON ACER TENDL-2023 LIBRARY; T=0.K
Neutron emission for (n,n*)a

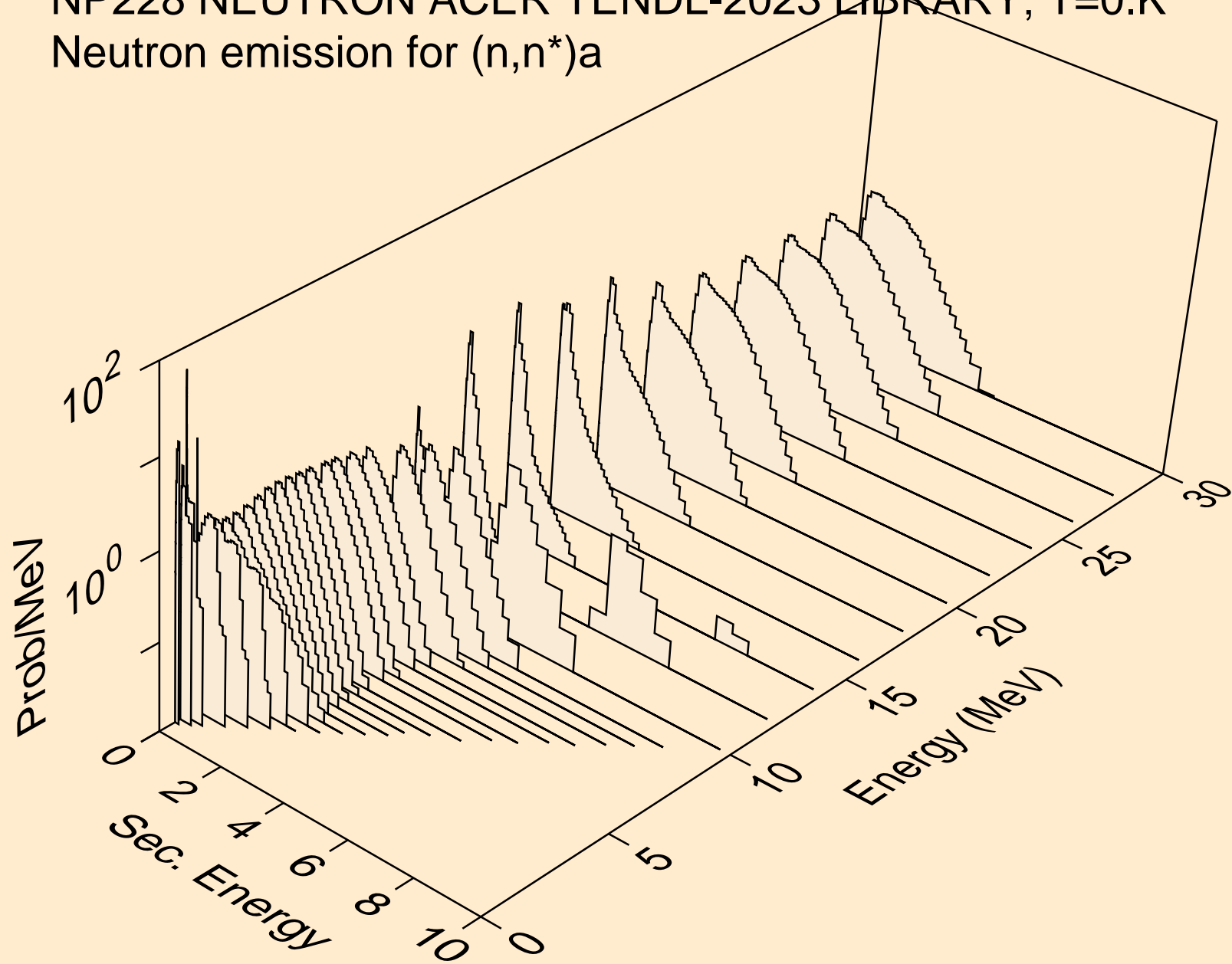

NP228 NEUTRON ACER TENDL-2023 LIBRARY; T=0.K
Neutron emission for (n,2n)a

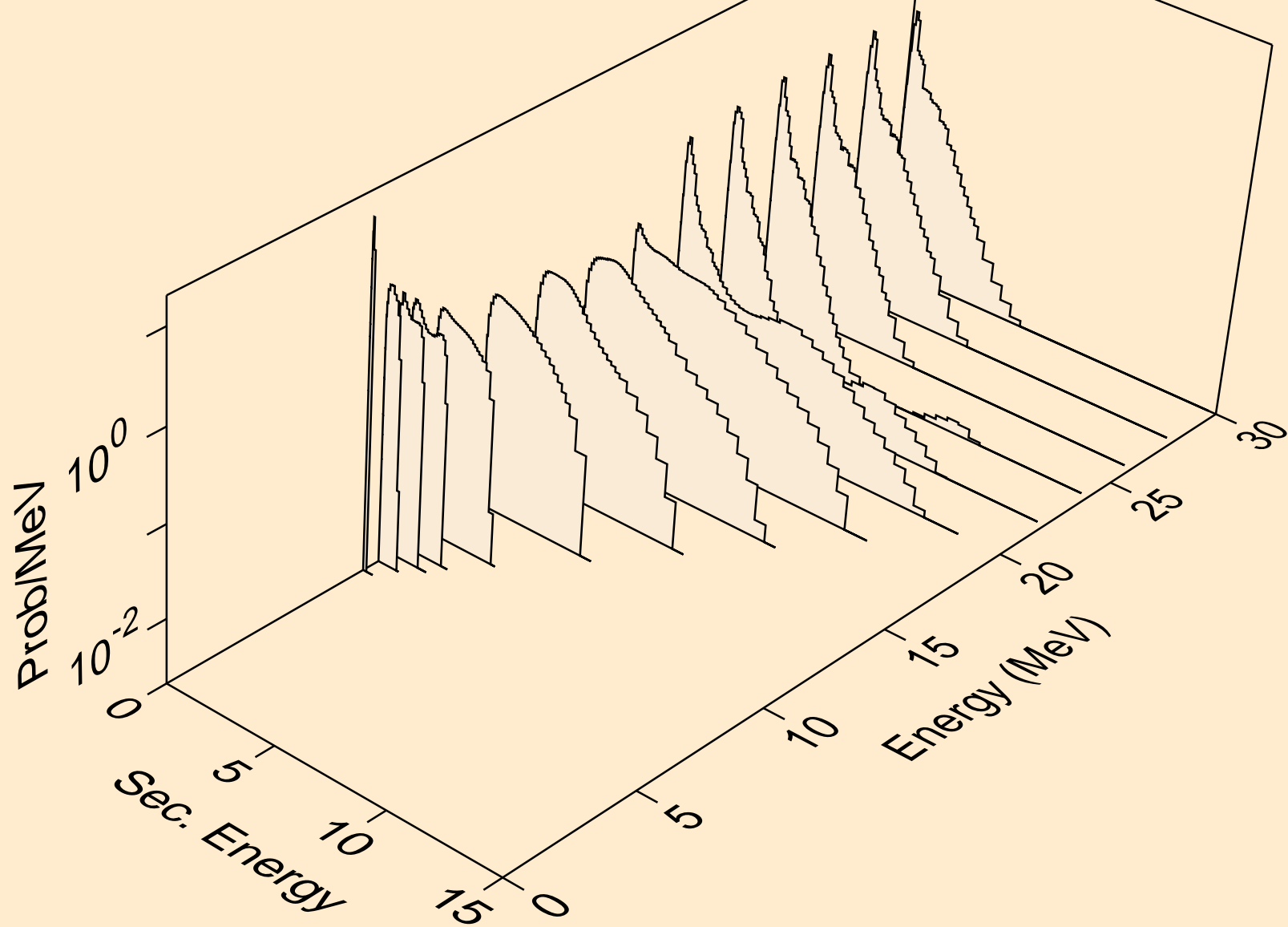

NP228 NEUTRON ACER TENDL-2023 LIBRARY; T=0.K
Neutron emission for (n,3n)a

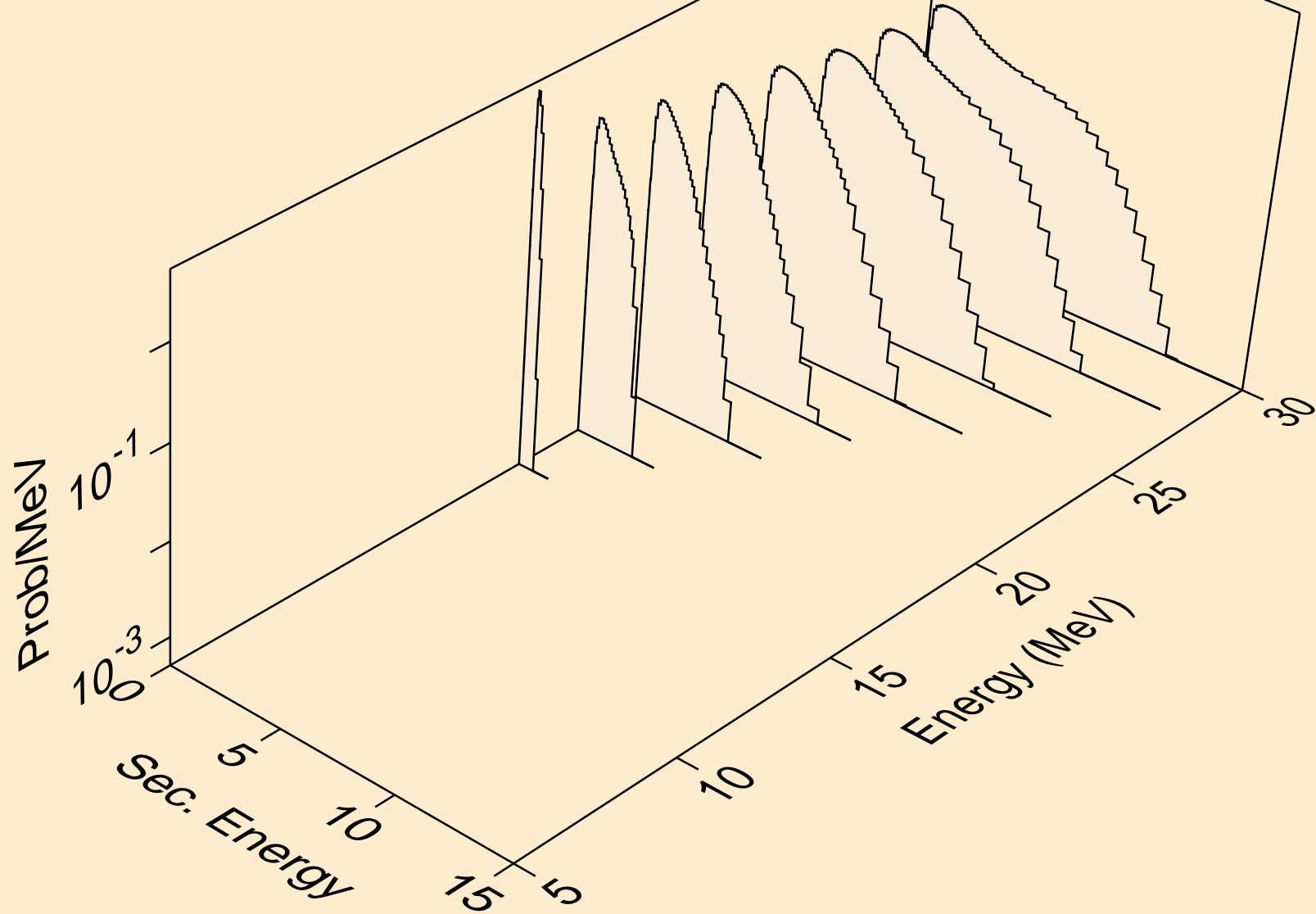

NP228 NEUTRON ACER TENDL-2023 LIBRARY; T=0.K
Neutron emission for (n,n*)p

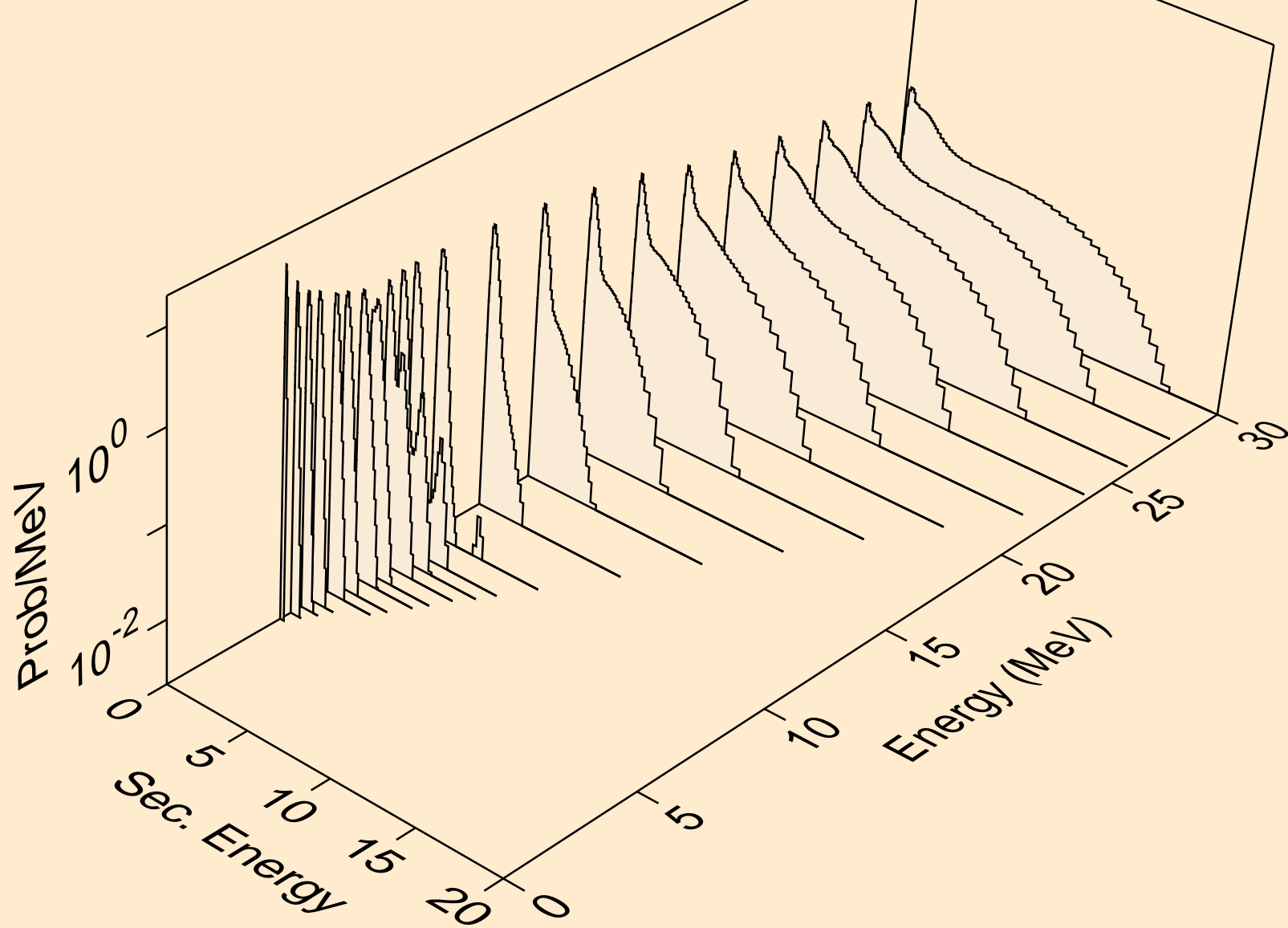

NP228 NEUTRON ACER TENDL-2023 LIBRARY; T=0.K
Neutron emission for (n,n*)2a

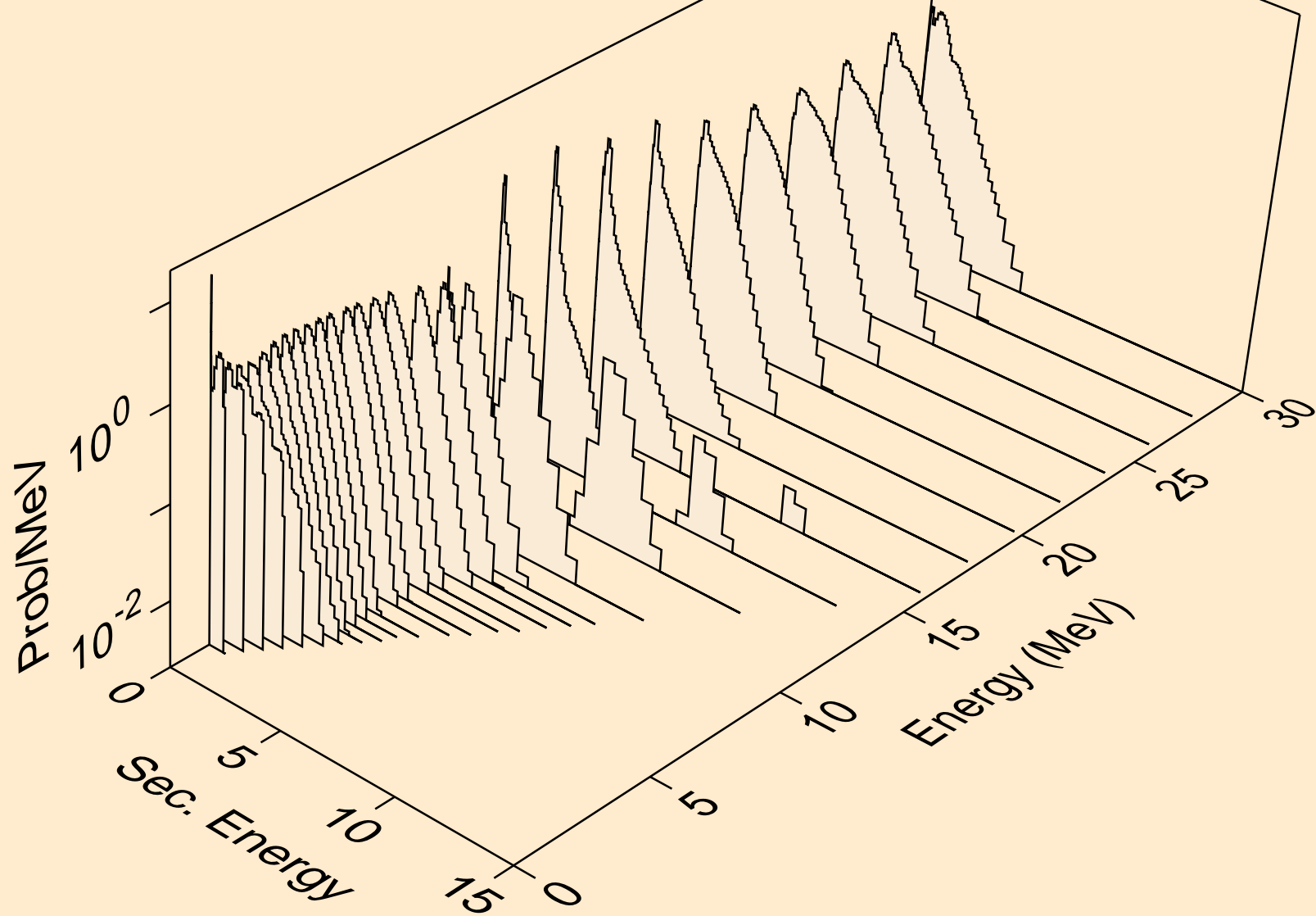

NP228 NEUTRON ACER TENDL-2023 LIBRARY; T=0.K
Neutron emission for (n,2n)2a

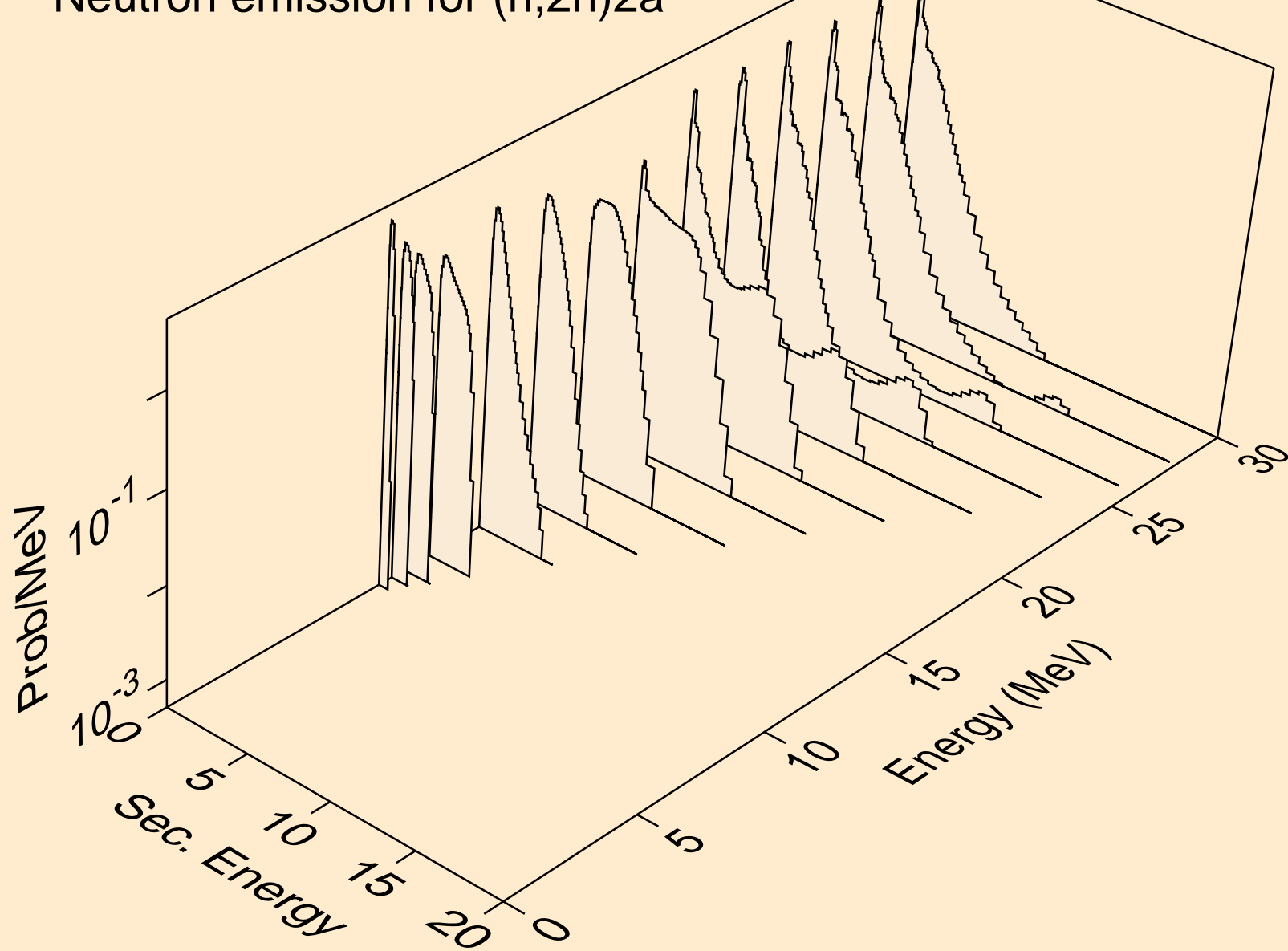

NP228 NEUTRON ACER TENDL-2023 LIBRARY; T=0.K
Neutron emission for (n,n*)d

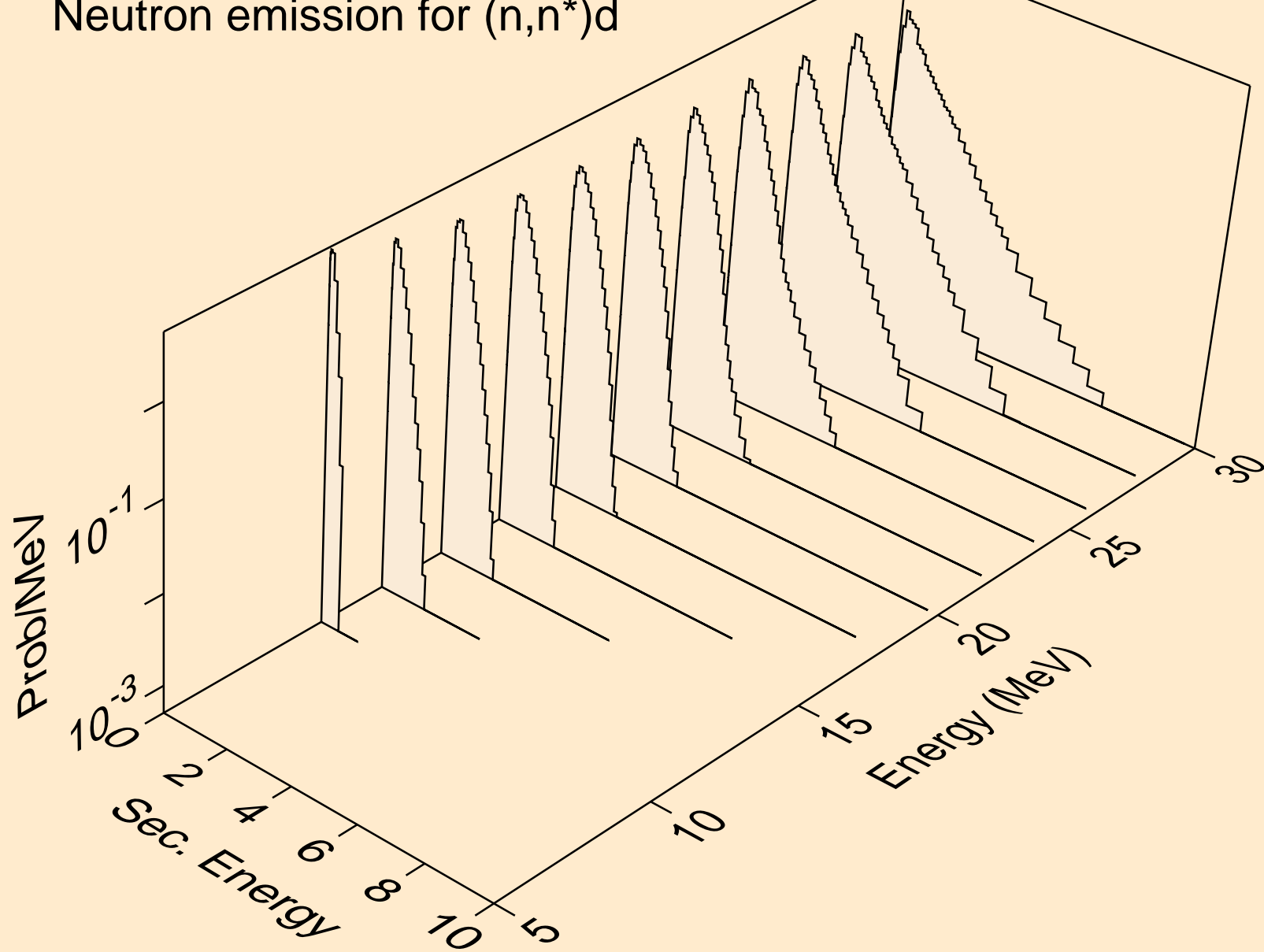

NP228 NEUTRON ACER TENDL-2023 LIBRARY; T=0.K
Neutron emission for (n,n*)t

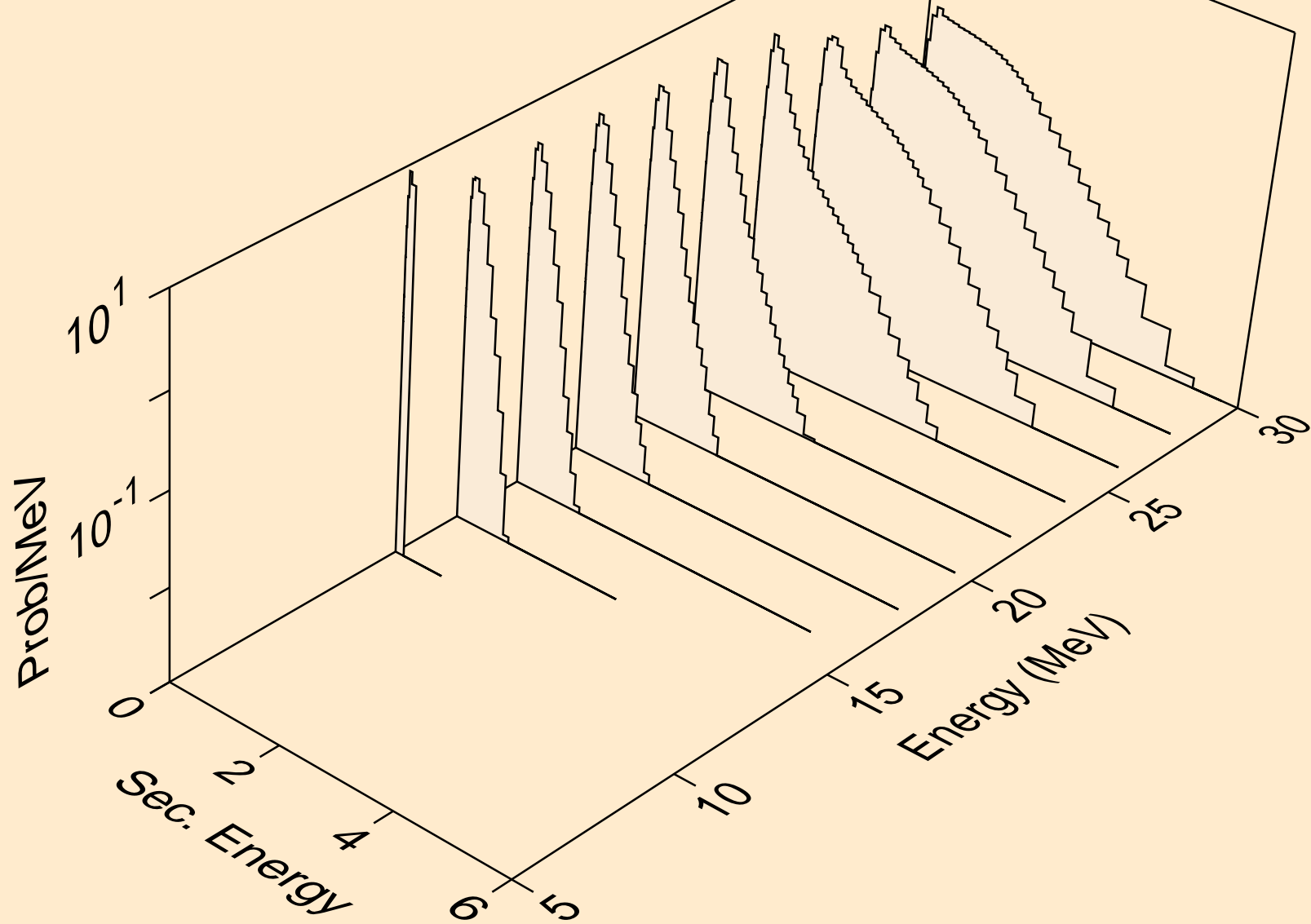

NP228 NEUTRON ACER TENDL-2023 LIBRARY; T=0.K
Neutron emission for (n,n*)he3

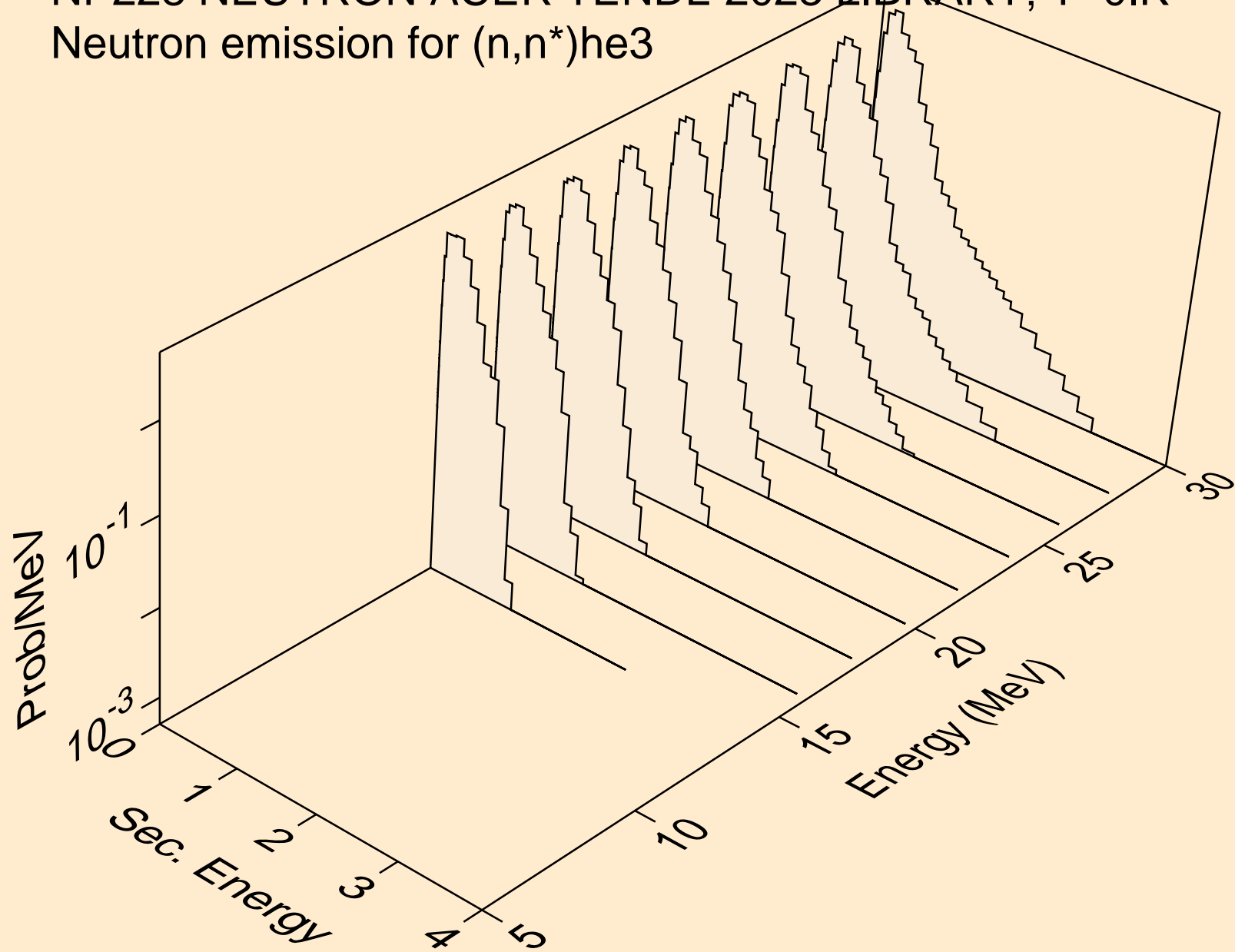

NP228 NEUTRON ACER TENDL-2023 LIBRARY; T=0.K
Neutron emission for (n,4n)

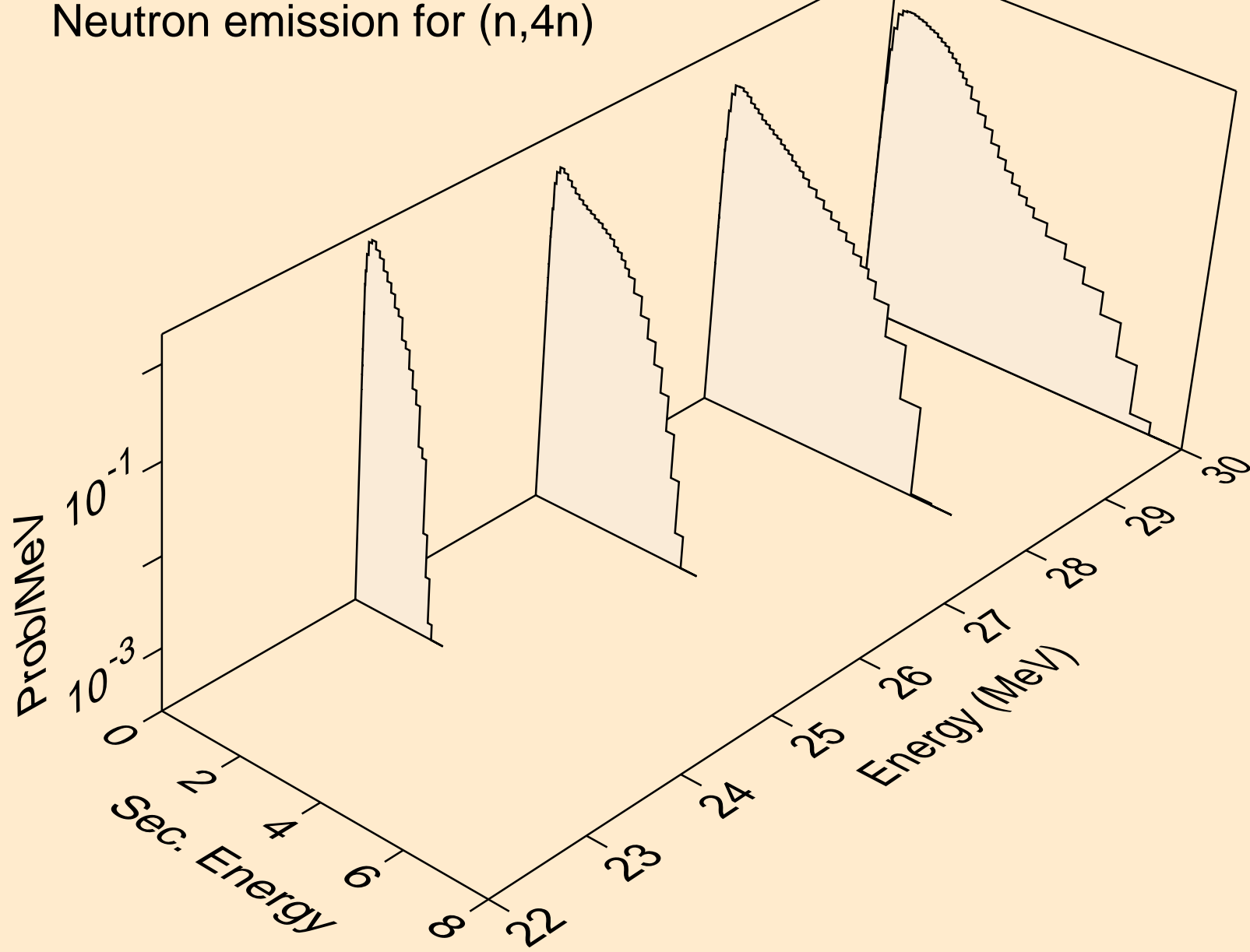

NP228 NEUTRON ACER TENDL-2023 LIBRARY; T=0.K
Neutron emission for (n,2np)

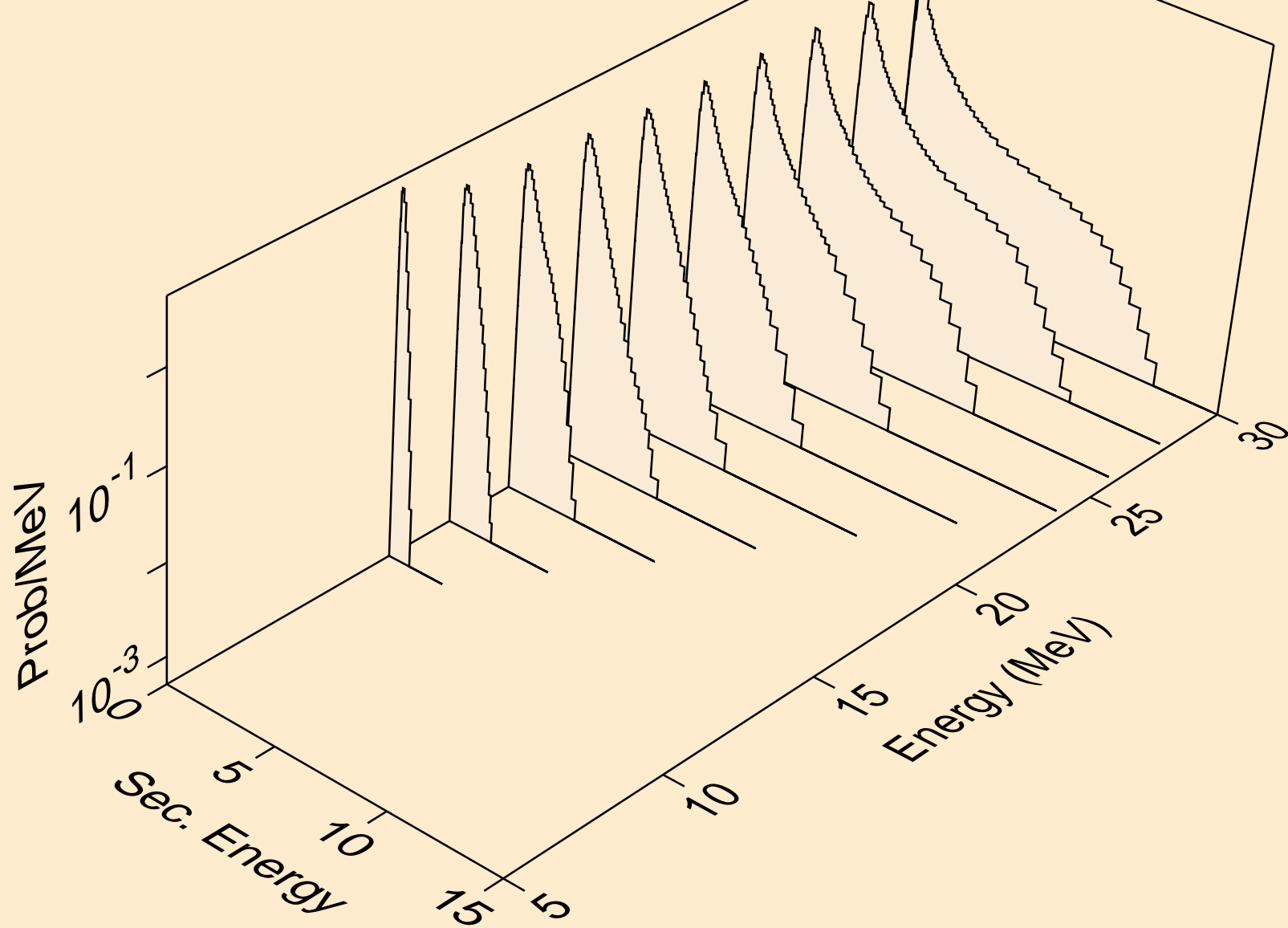

NP228 NEUTRON ACER TENDL-2023 LIBRARY; T=0.K
Neutron emission for (n,3np)

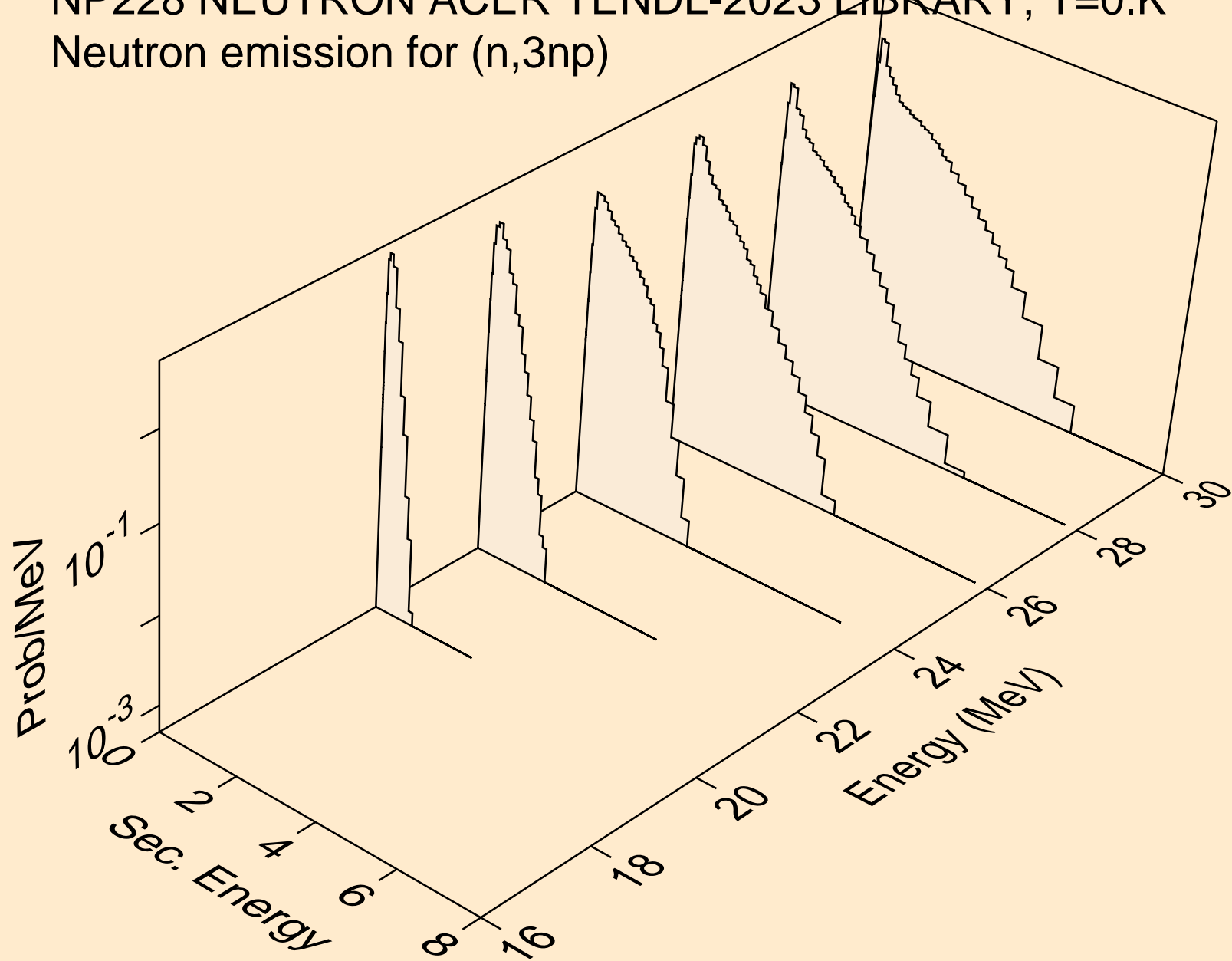

NP228 NEUTRON ACER TENDL-2023 LIBRARY; T=0.K
Neutron emission for (n,n2p)

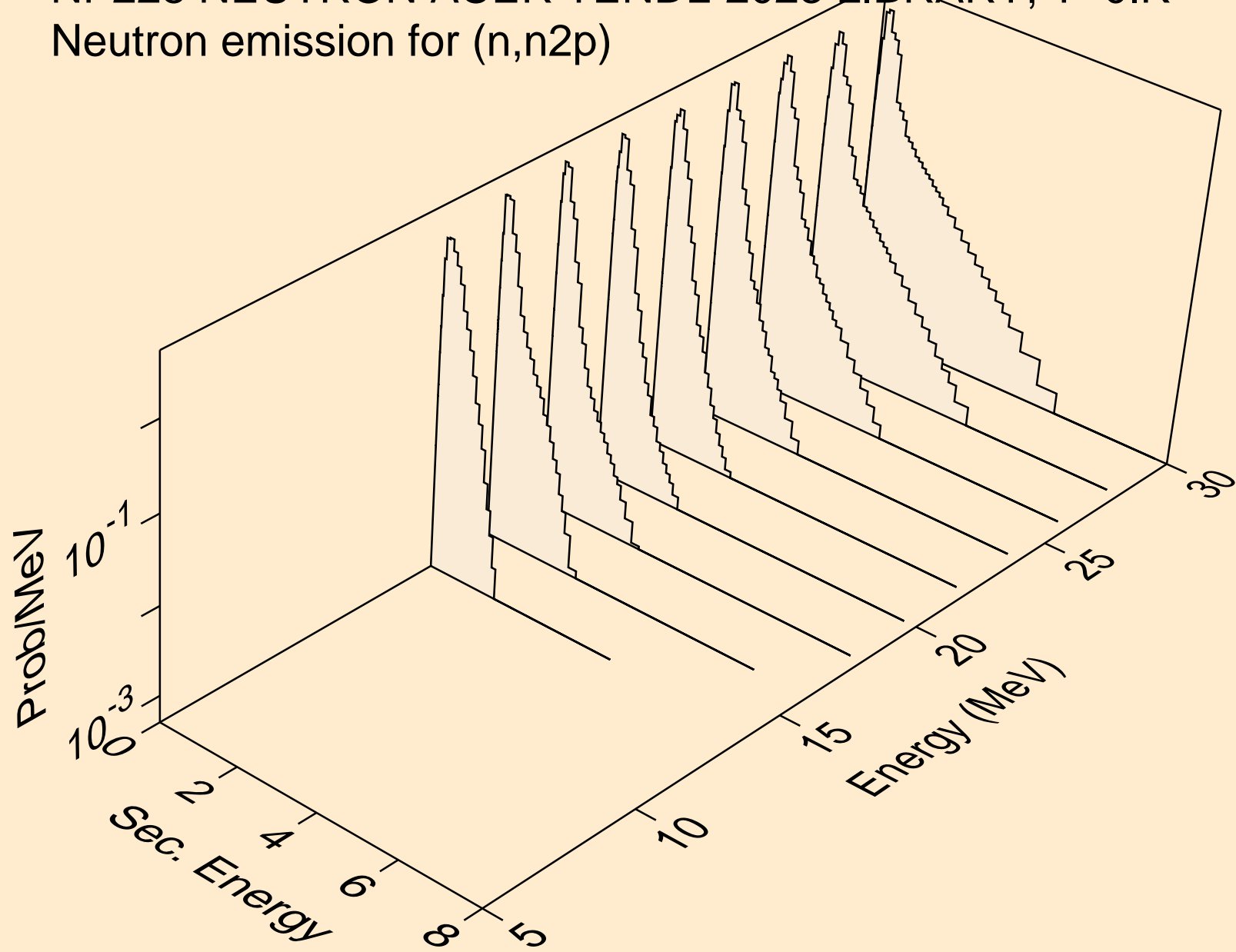

NP228 NEUTRON ACER TENDL-2023 LIBRARY; T=0.K
Neutron emission for (n,npa)

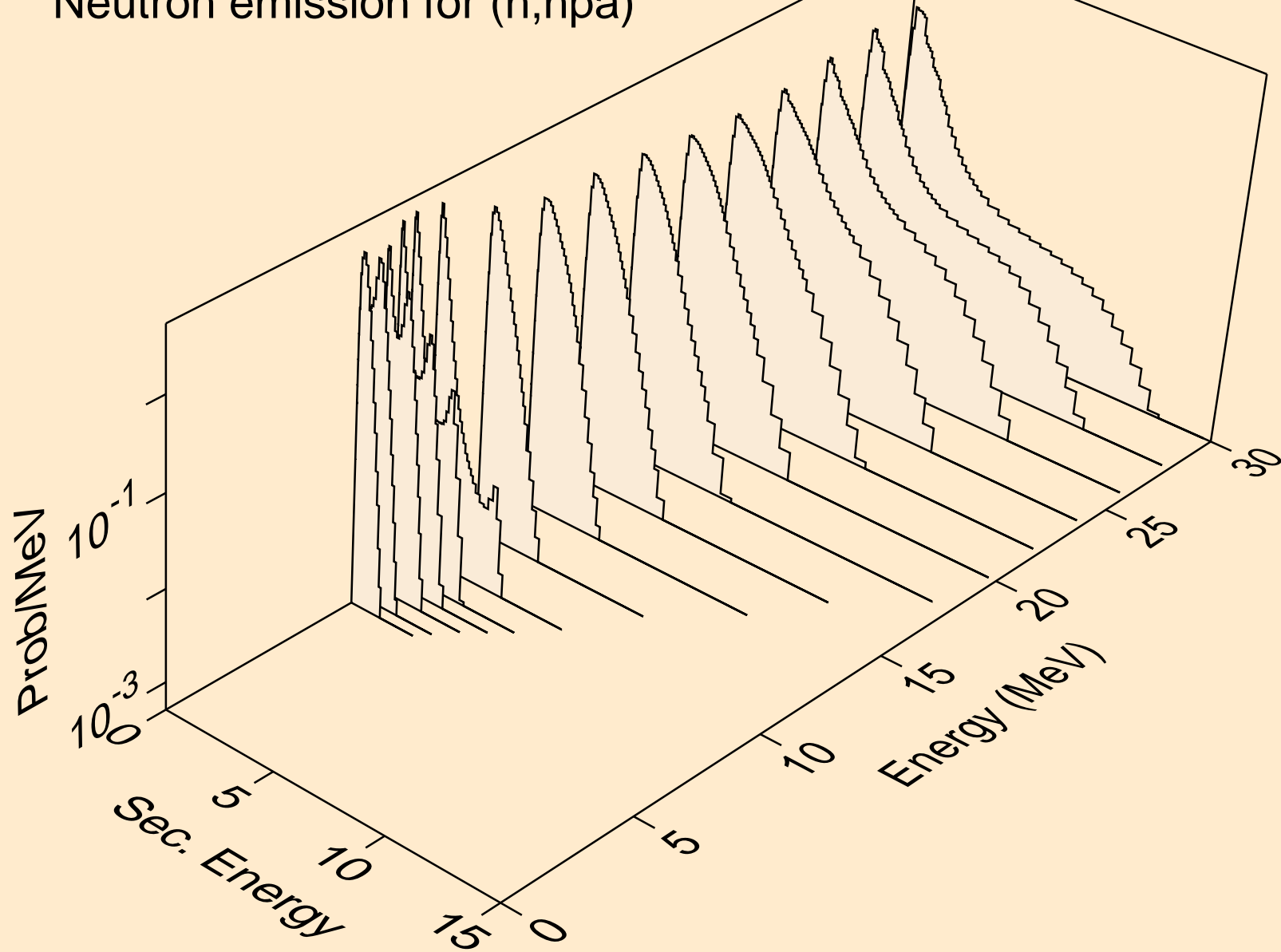

NP228 NEUTRON ACER TENDL-2023 LIBRARY; T=0.K
Neutron emission for (n,n*c)

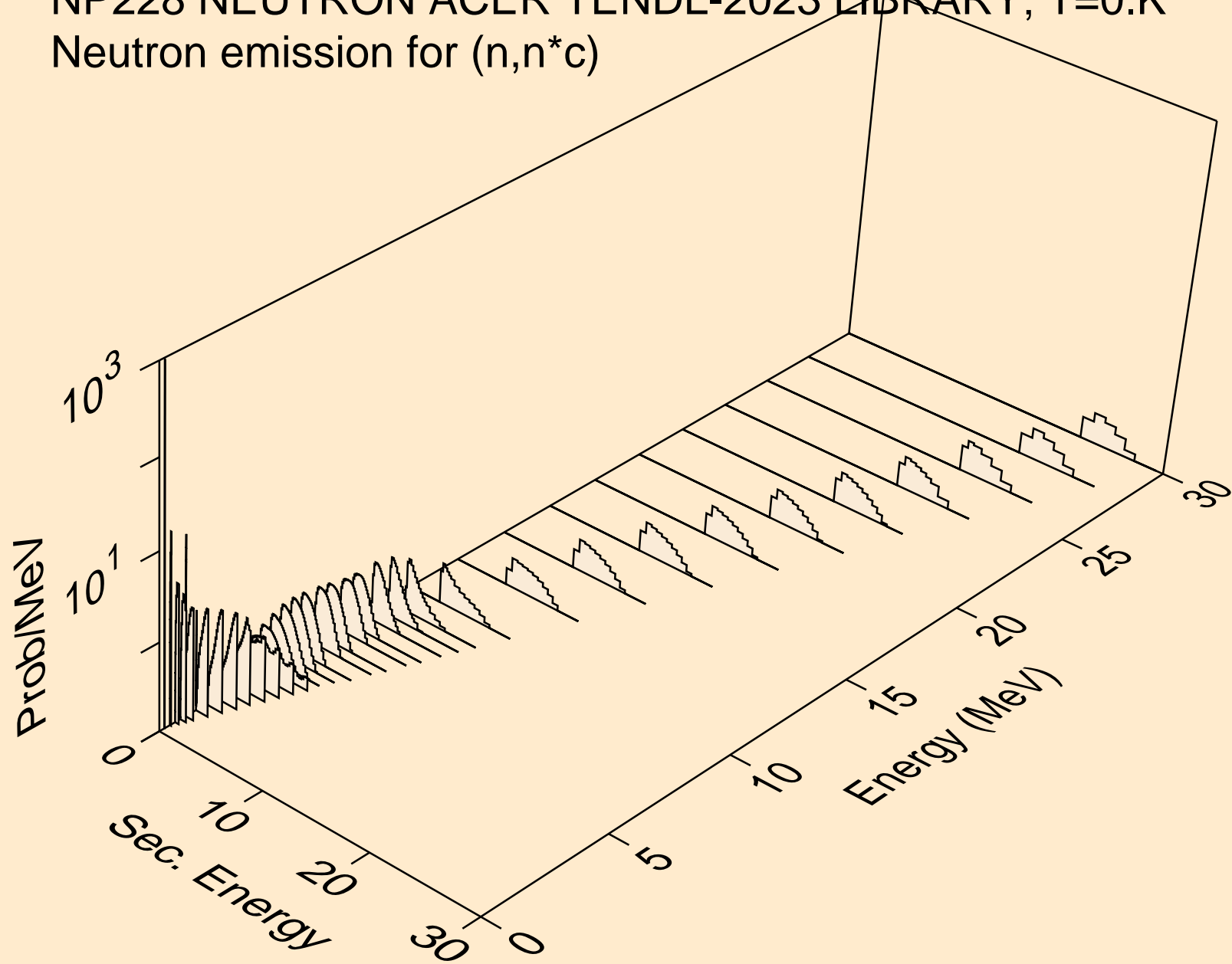

NP228 NEUTRON ACER TENDL-2023 LIBRARY; T=0.K

Delayed nubar

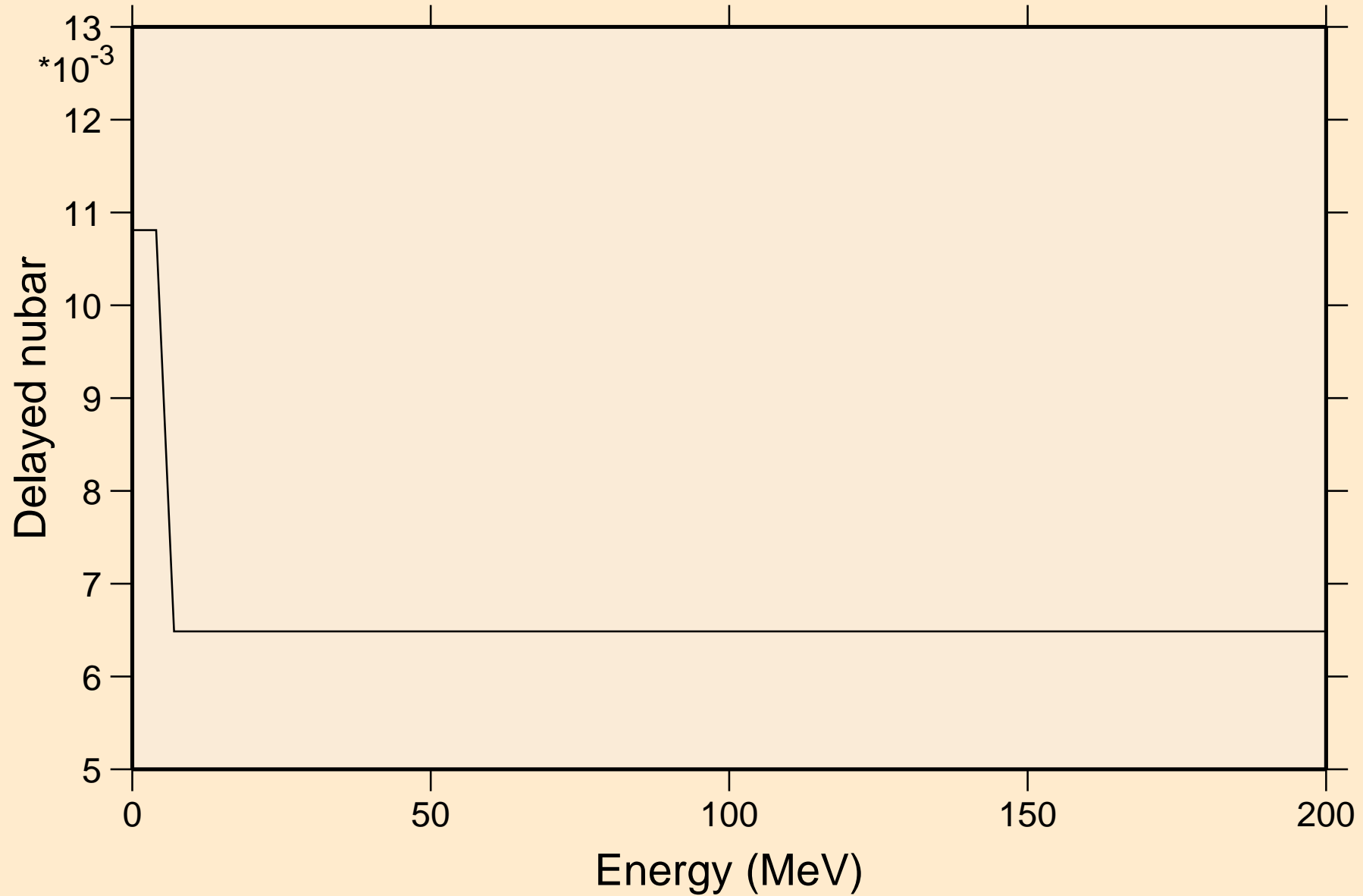

NP228 NEUTRON ACER TENDL-2023 LIBRARY; T=0.K

Delayed neutron spectra

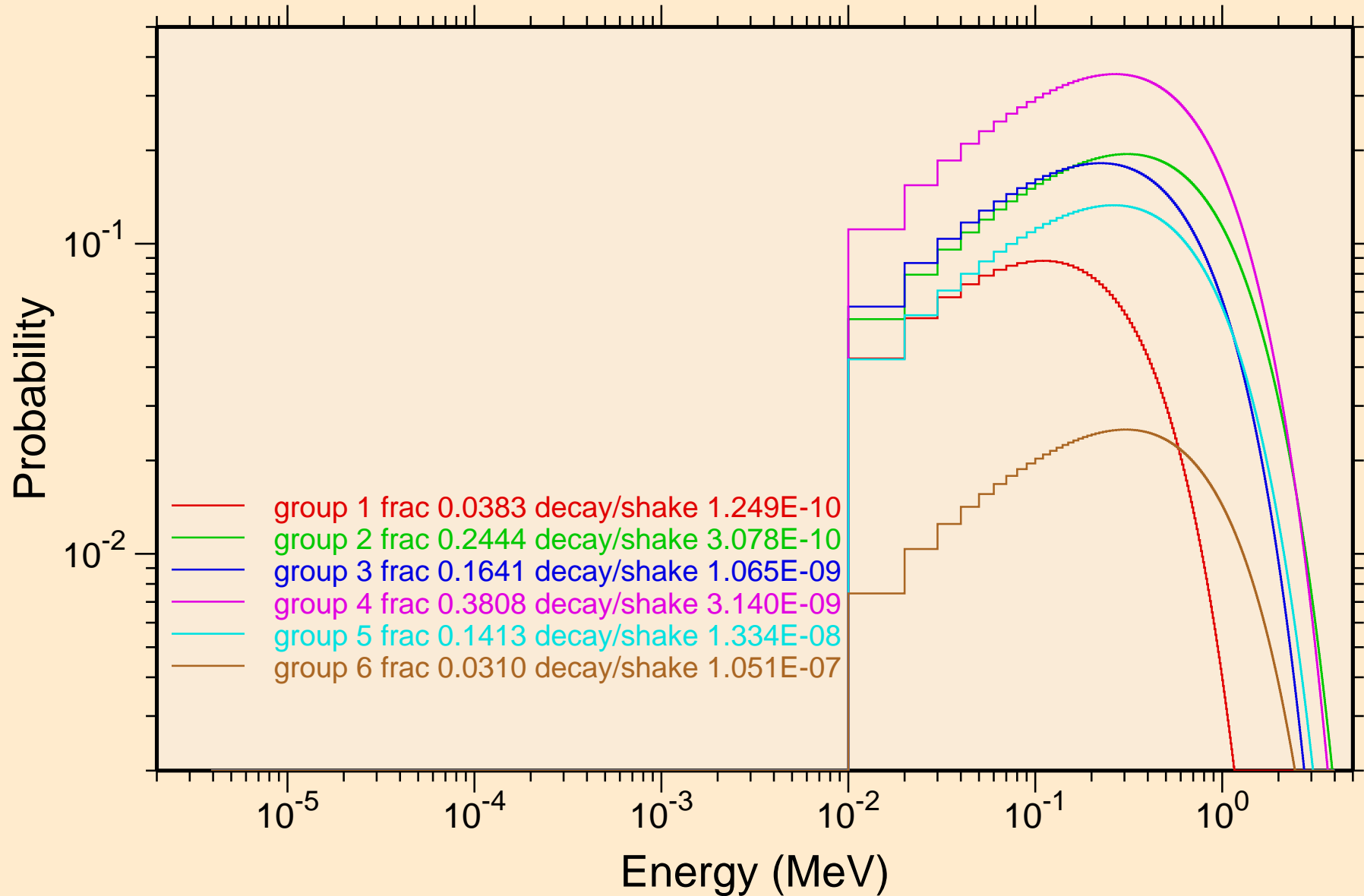

NP228 NEUTRON ACER TENDL-2023 LIBRARY; T=0.K
Photon emission for (n,x)

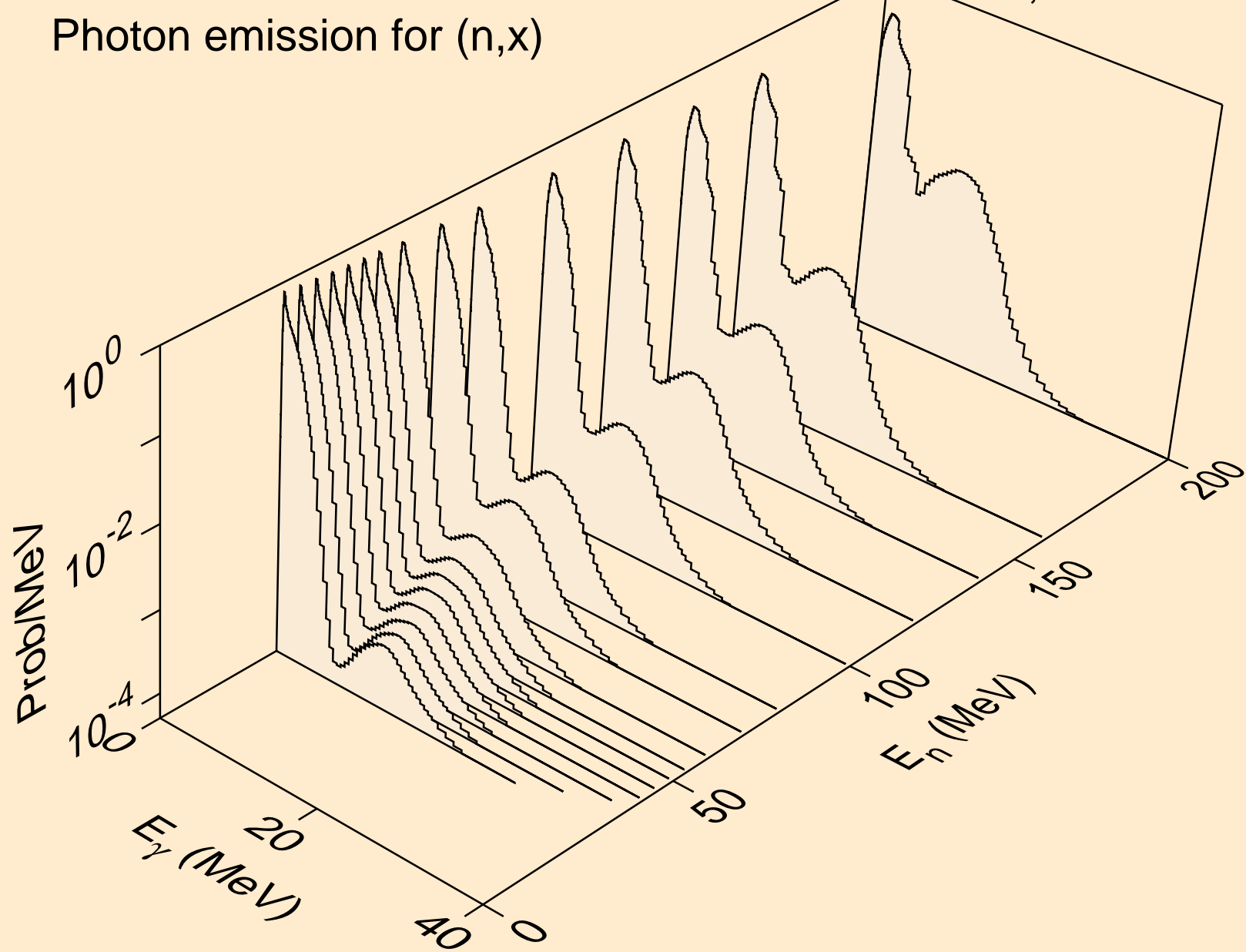

NP228 NEUTRON ACER TENDL-2023 LIBRARY; T=0.K
Photon emission for (n,2nd)

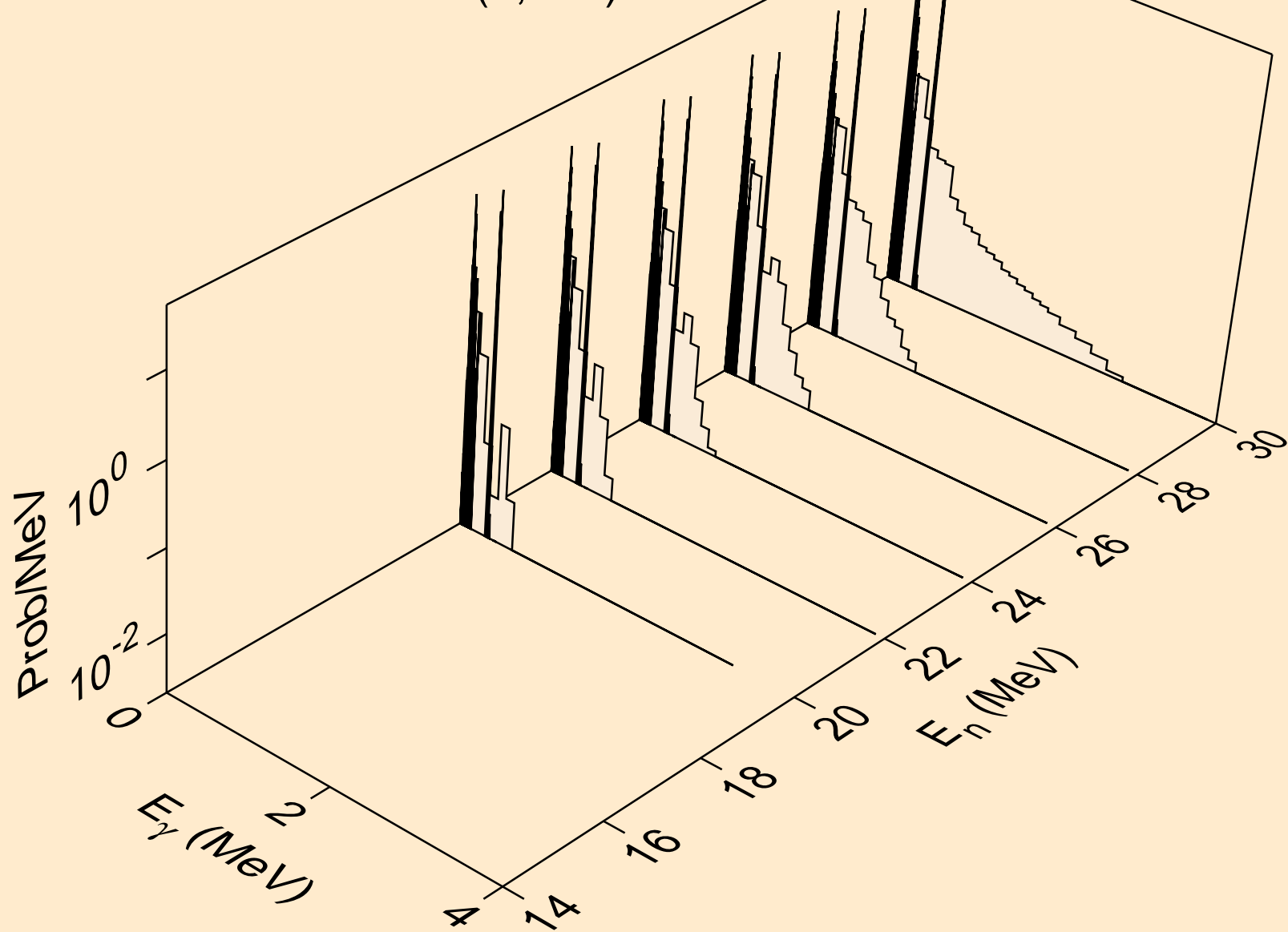

NP228 NEUTRON ACER TENDL-2023 LIBRARY; T=0.K
Photon emission for (n,2n)

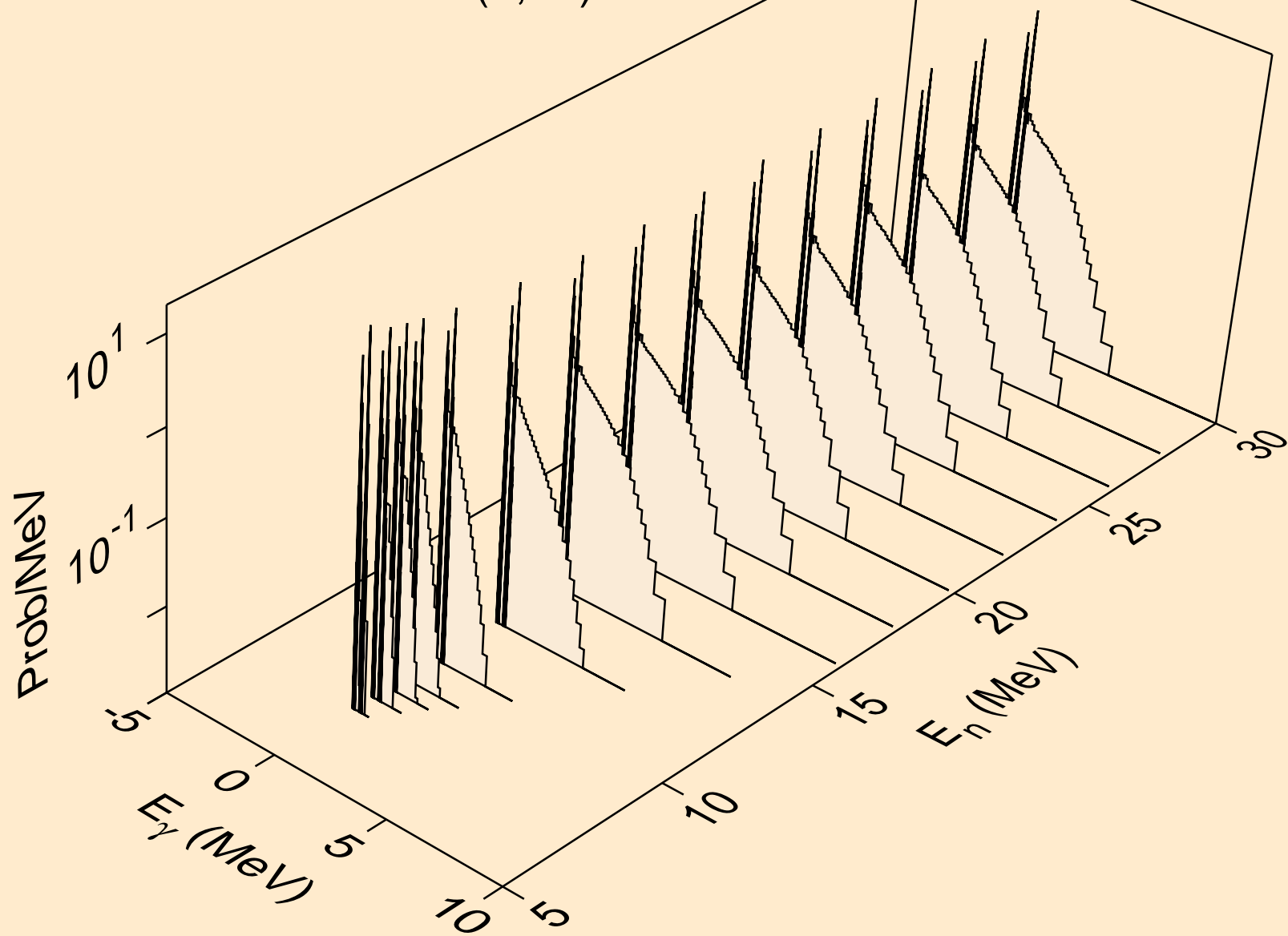

NP228 NEUTRON ACER TENDL-2023 LIBRARY; T=0.K
Photon emission for (n,3n)

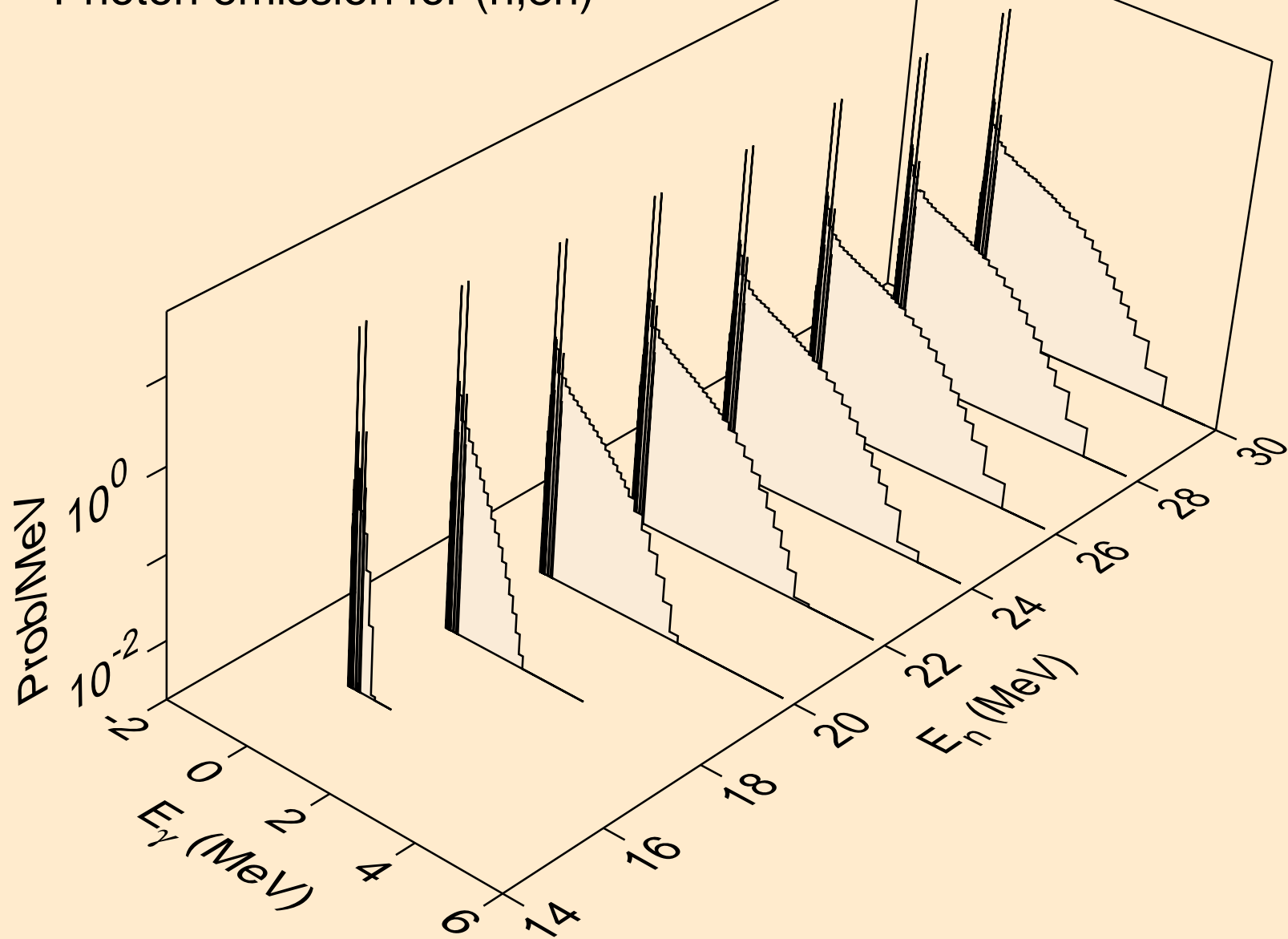

NP228 NEUTRON ACER TENDL-2023 LIBRARY; T=0.K
Photon emission for (n,n*)a

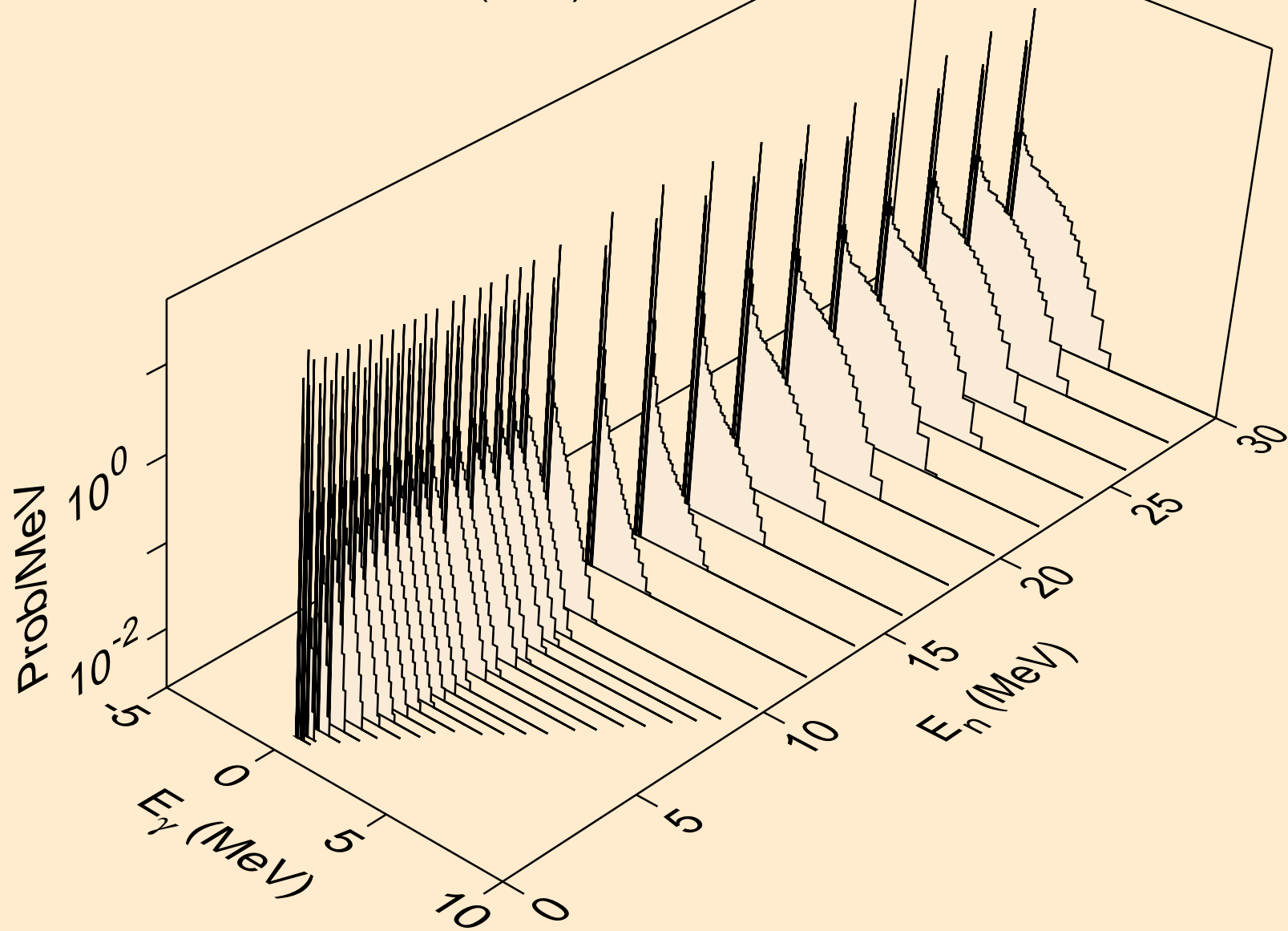

NP228 NEUTRON ACER TENDL-2023 LIBRARY; T=0.K
Photon emission for (n,2n)a

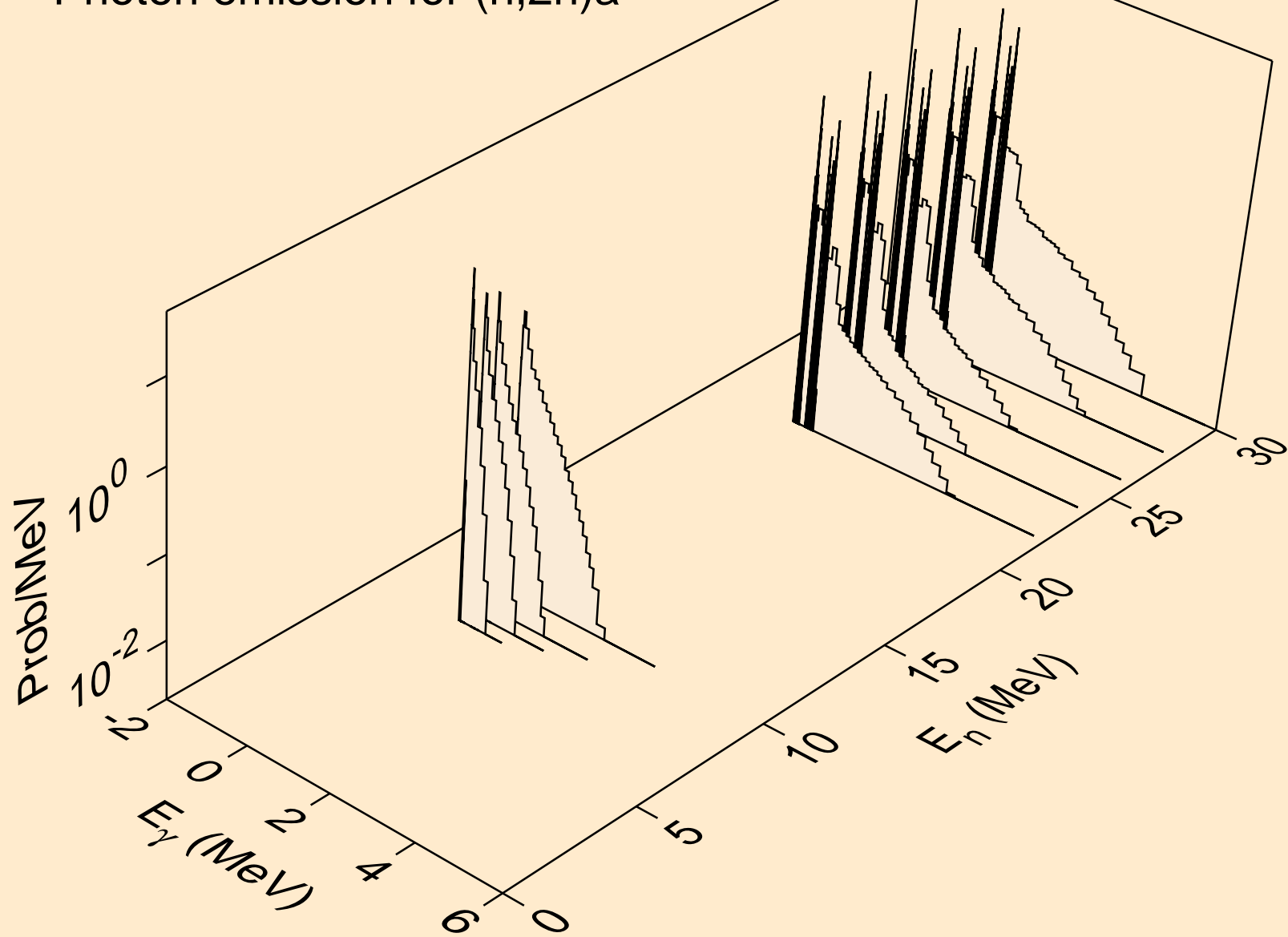

NP228 NEUTRON ACER TENDL-2023 LIBRARY; T=0.K
Photon emission for (n,3n)a

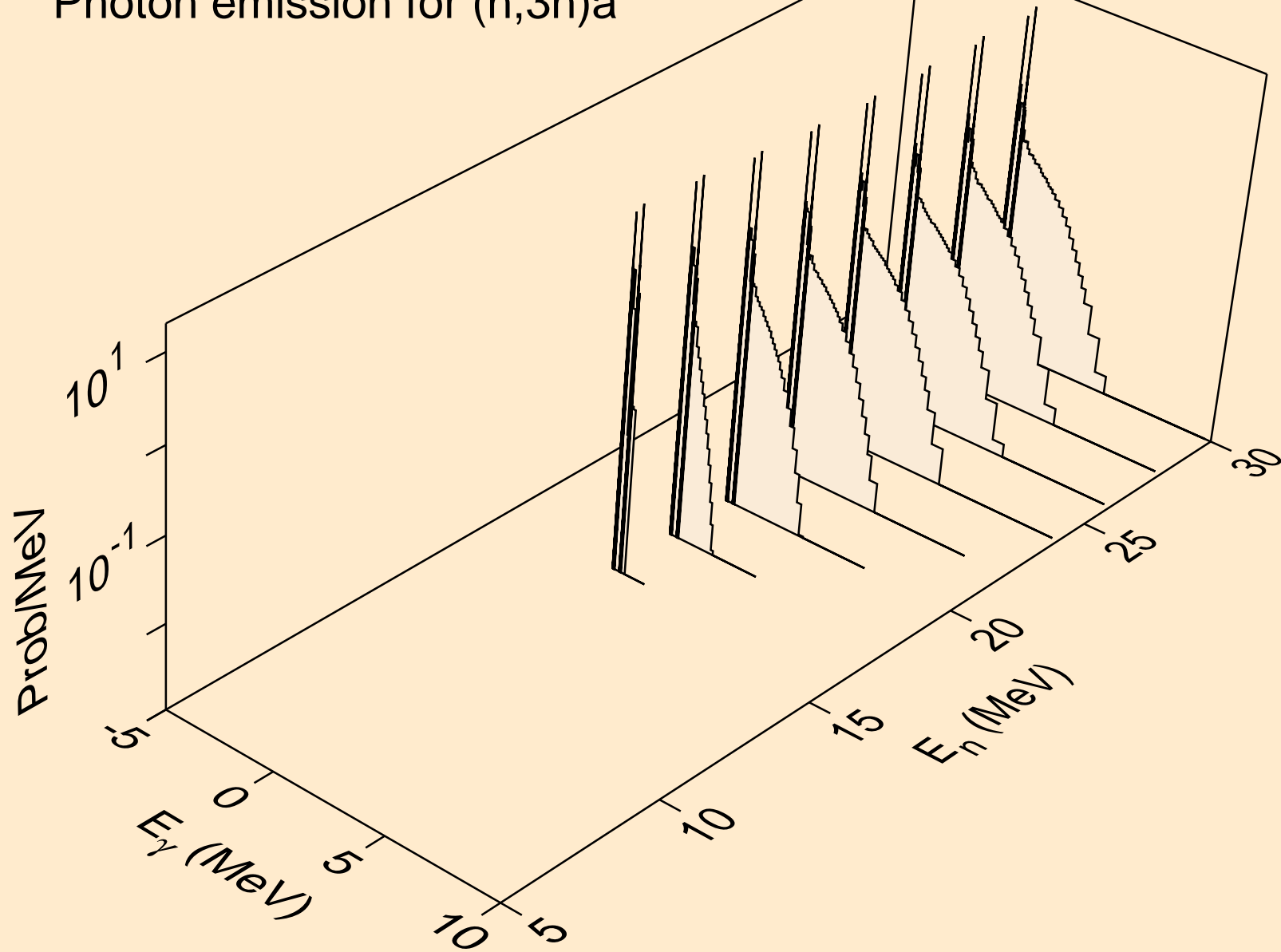

NP228 NEUTRON ACER TENDL-2023 LIBRARY; T=0.K
Photon emission for (n,n*)p

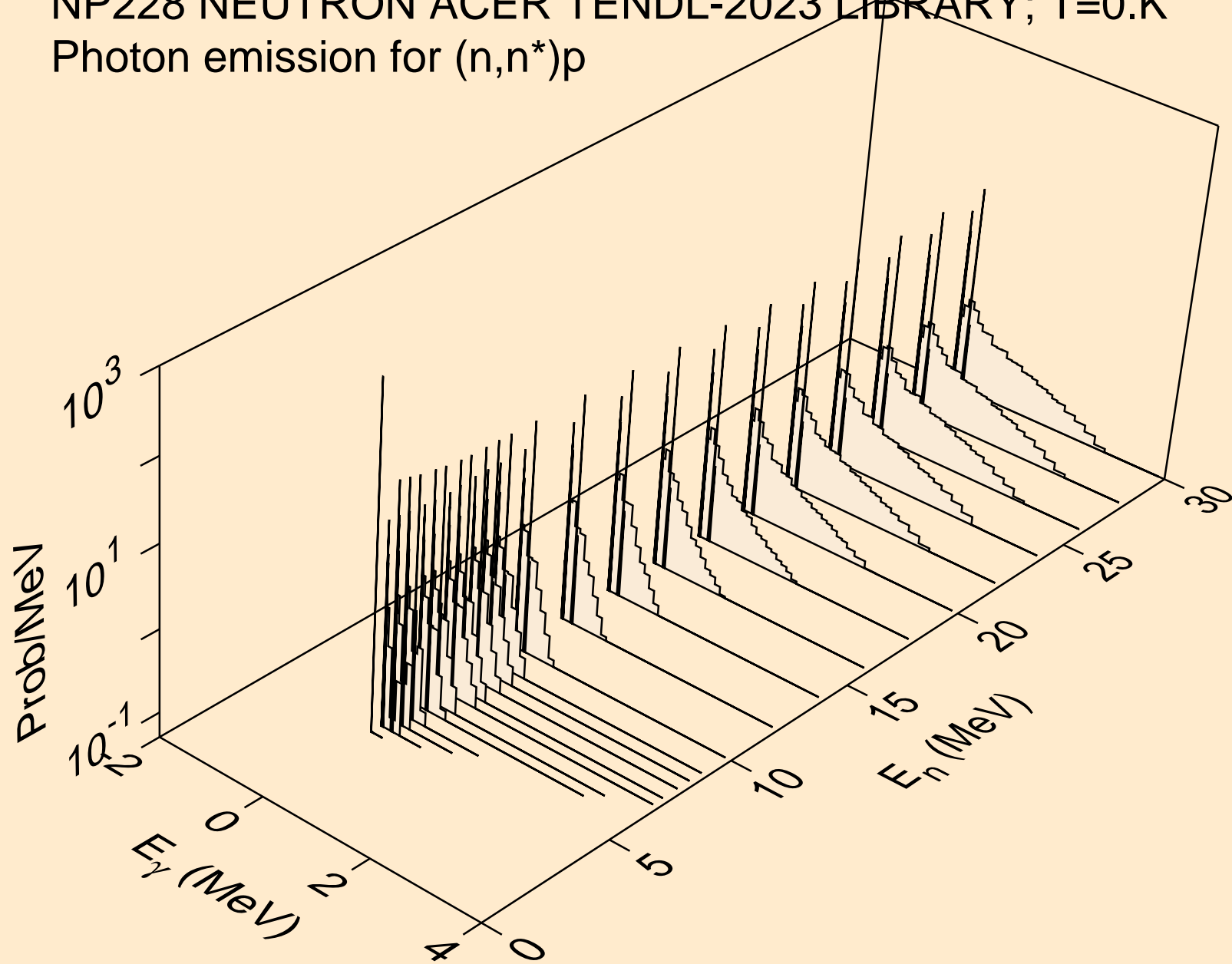

NP228 NEUTRON ACER TENDL-2023 LIBRARY; T=0.K
Photon emission for (n,n*)2a

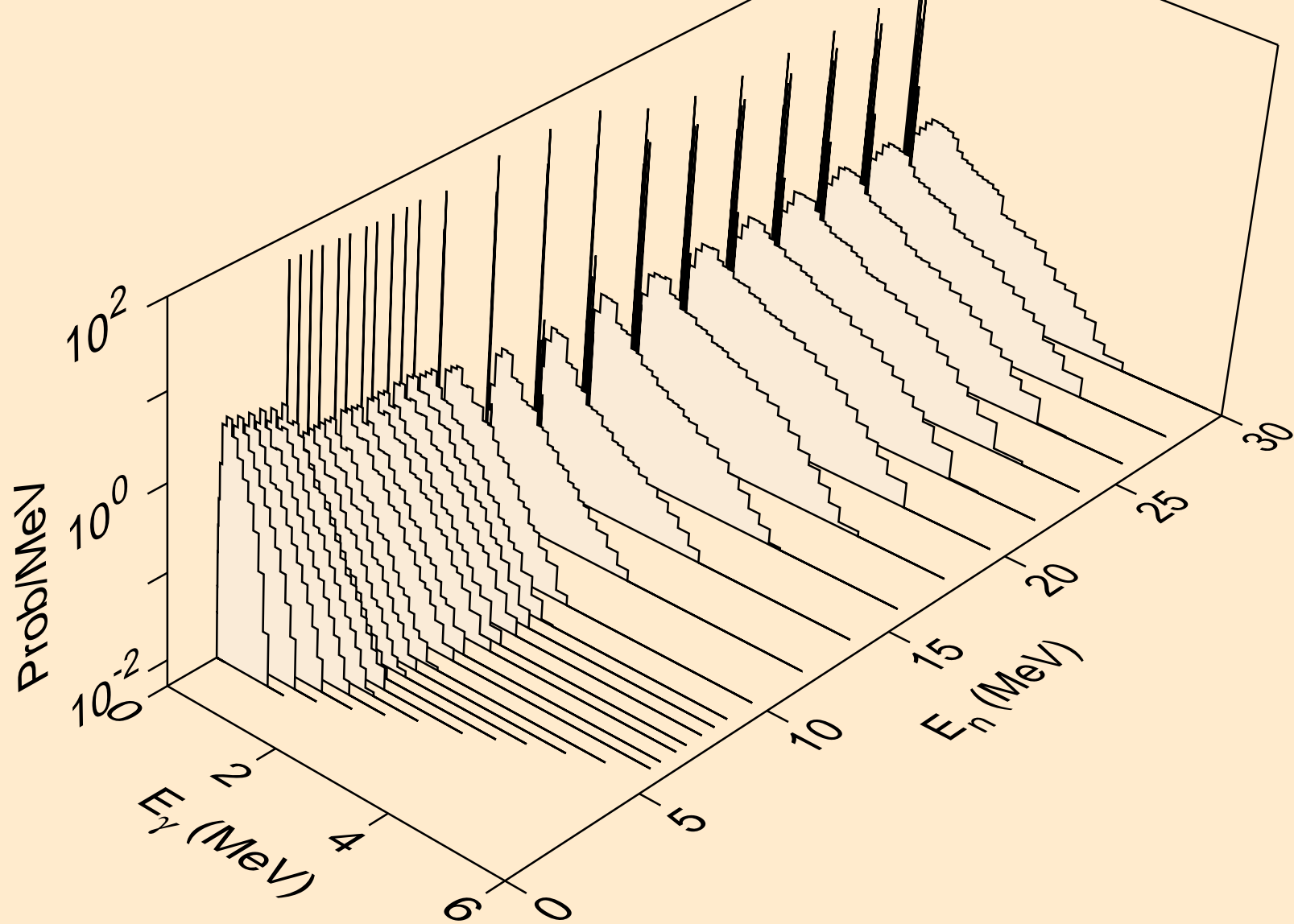

NP228 NEUTRON ACER TENDL-2023 LIBRARY; T=0.K
Photon emission for (n,2n)2a

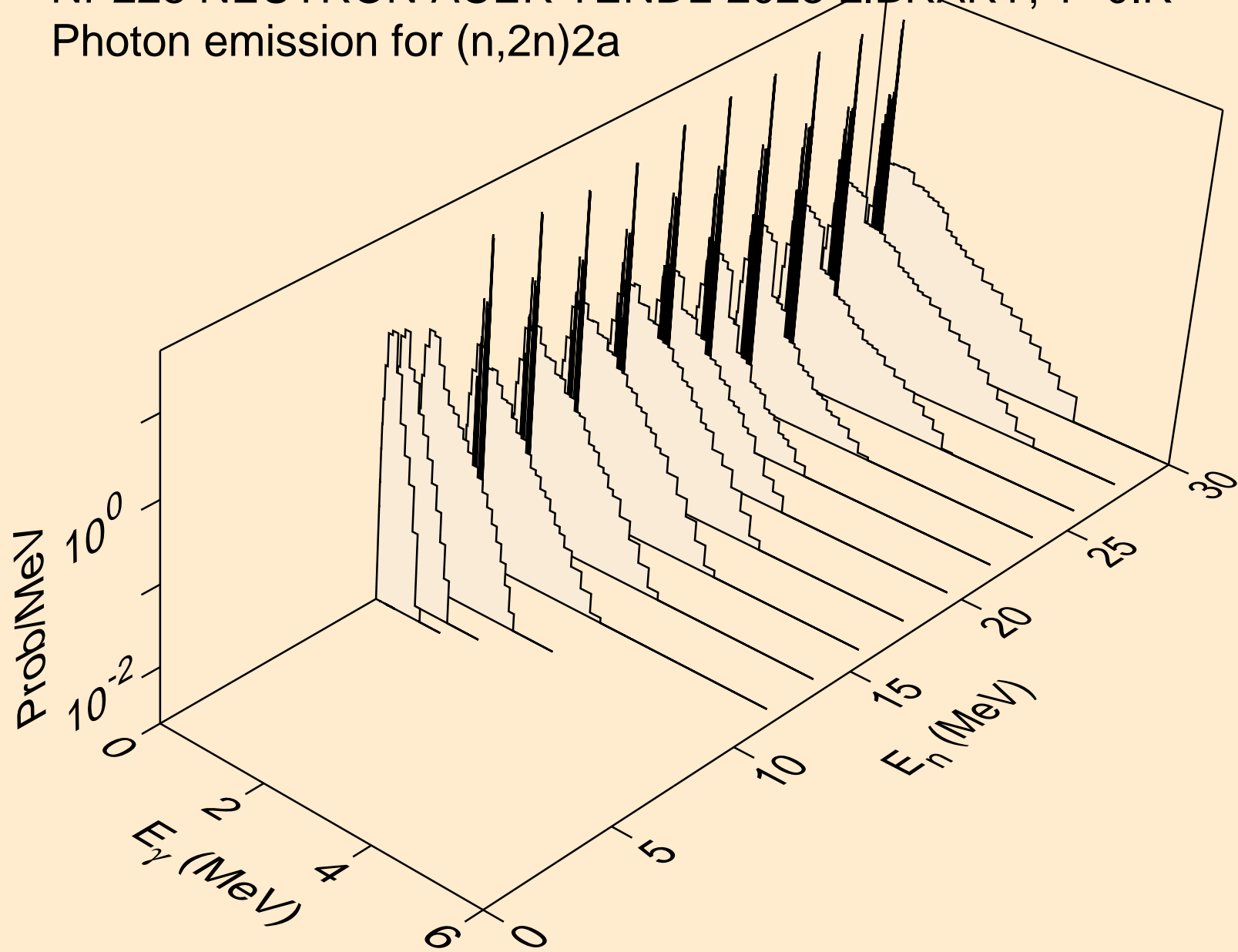

NP228 NEUTRON ACER TENDL-2023 LIBRARY; T=0.K
Photon emission for (n,n*)d

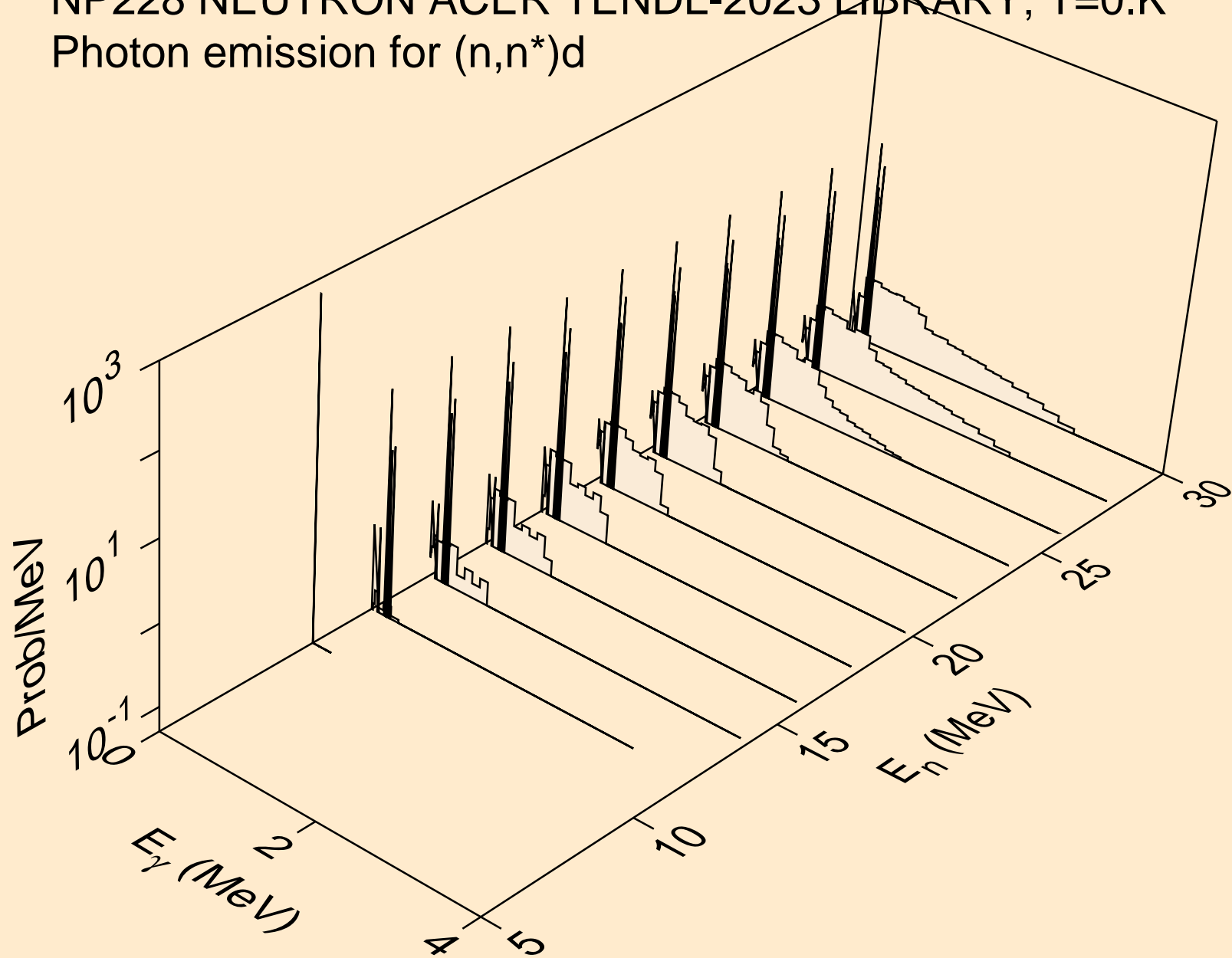

NP228 NEUTRON ACER TENDL-2023 LIBRARY; T=0.K
Photon emission for (n,n*)t

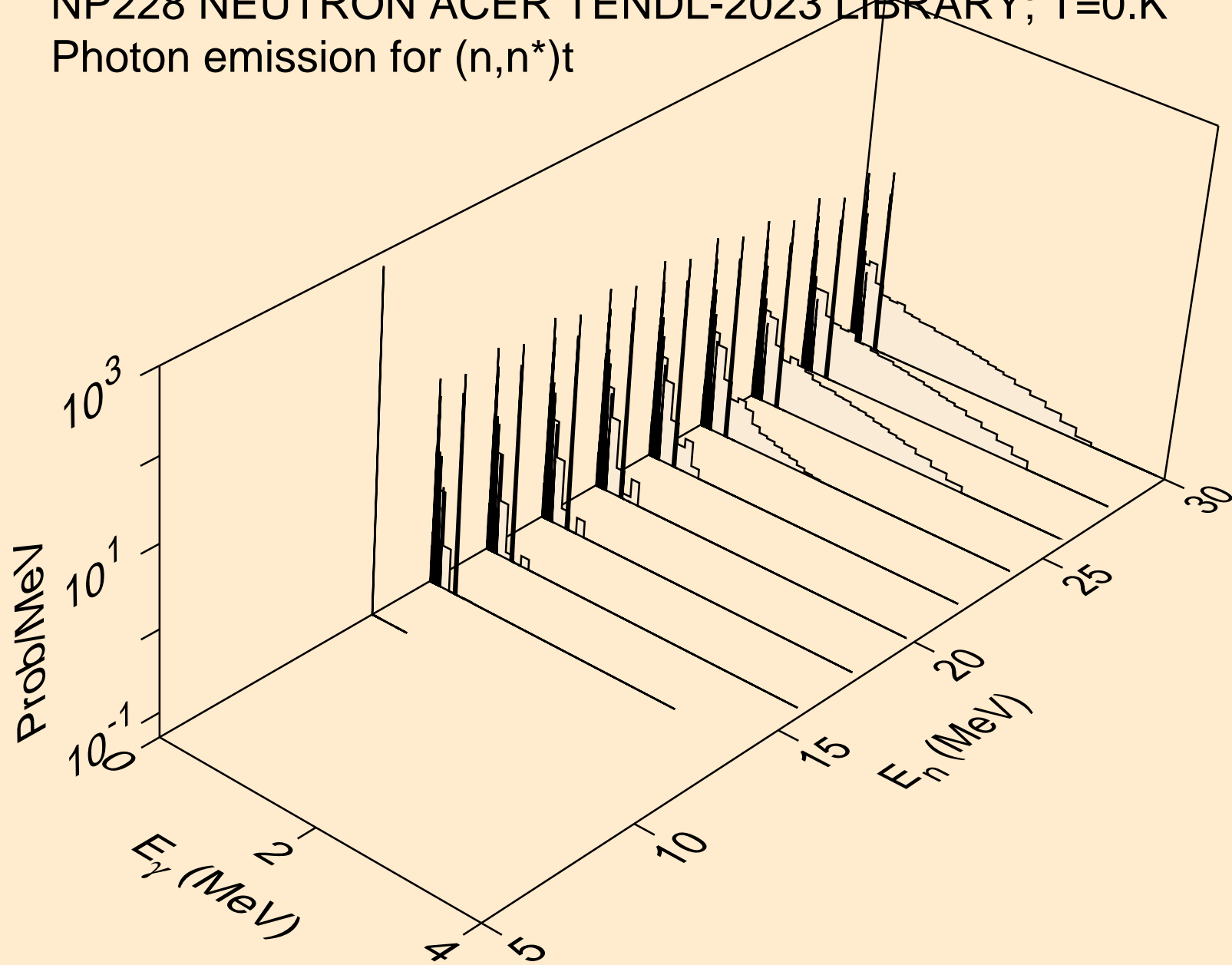

NP228 NEUTRON ACER TENDL-2023 LIBRARY; T=0.K
Photon emission for (n,n*)he3

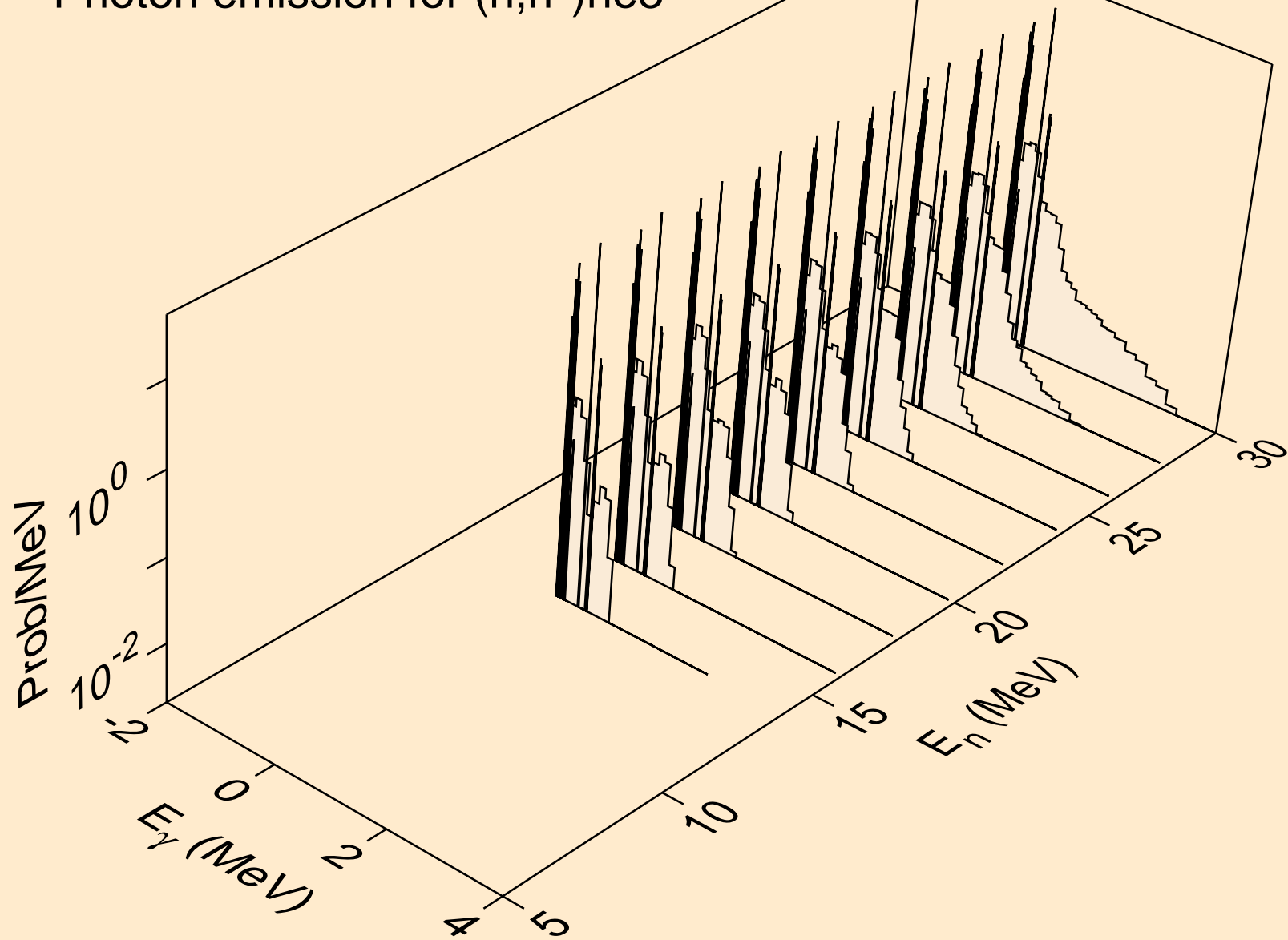

NP228 NEUTRON ACER TENDL-2023 LIBRARY; T=0.K
Photon emission for (n,4n)

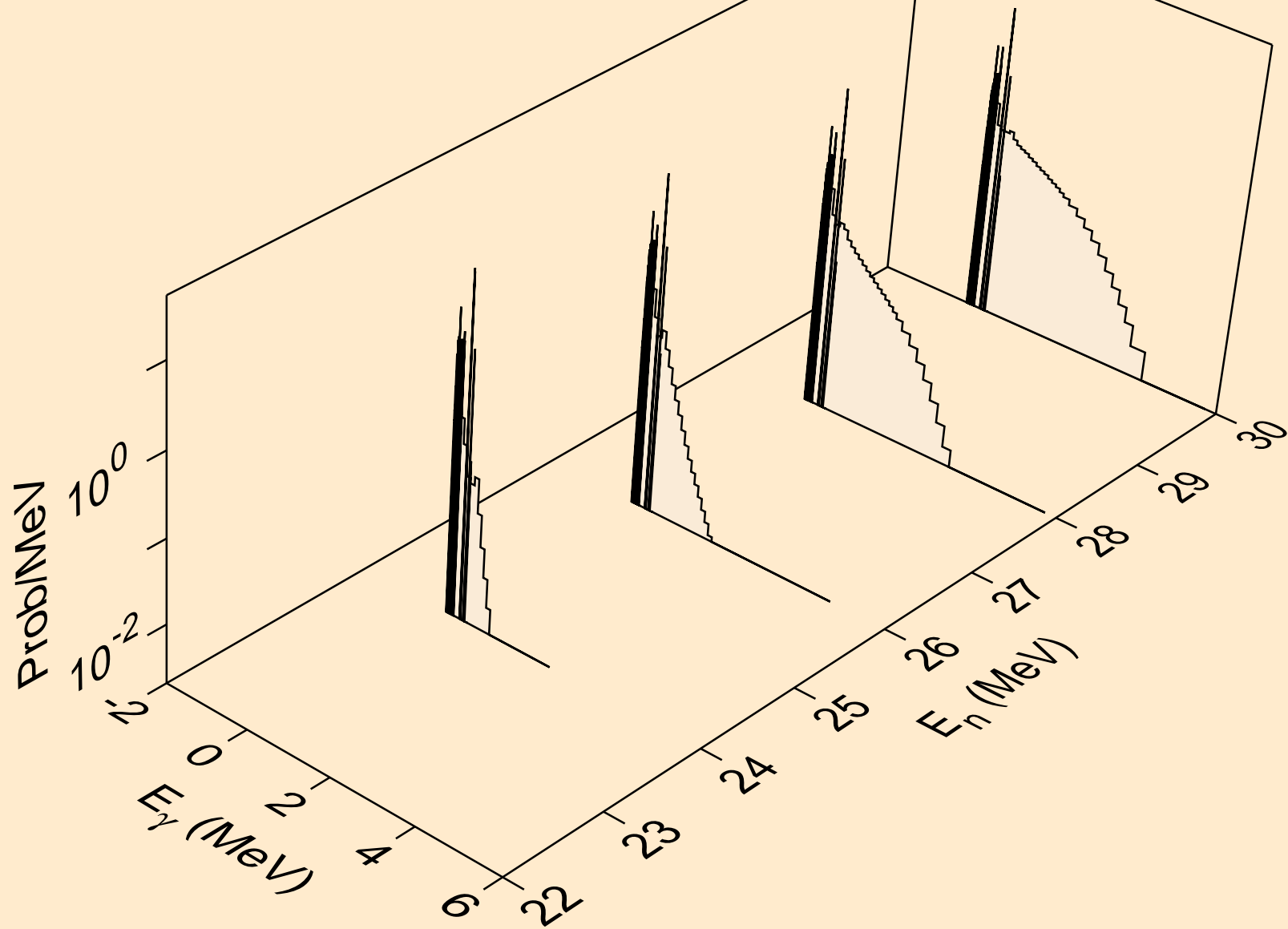

NP228 NEUTRON ACER TENDL-2023 LIBRARY; T=0.K
Photon emission for (n,2np)

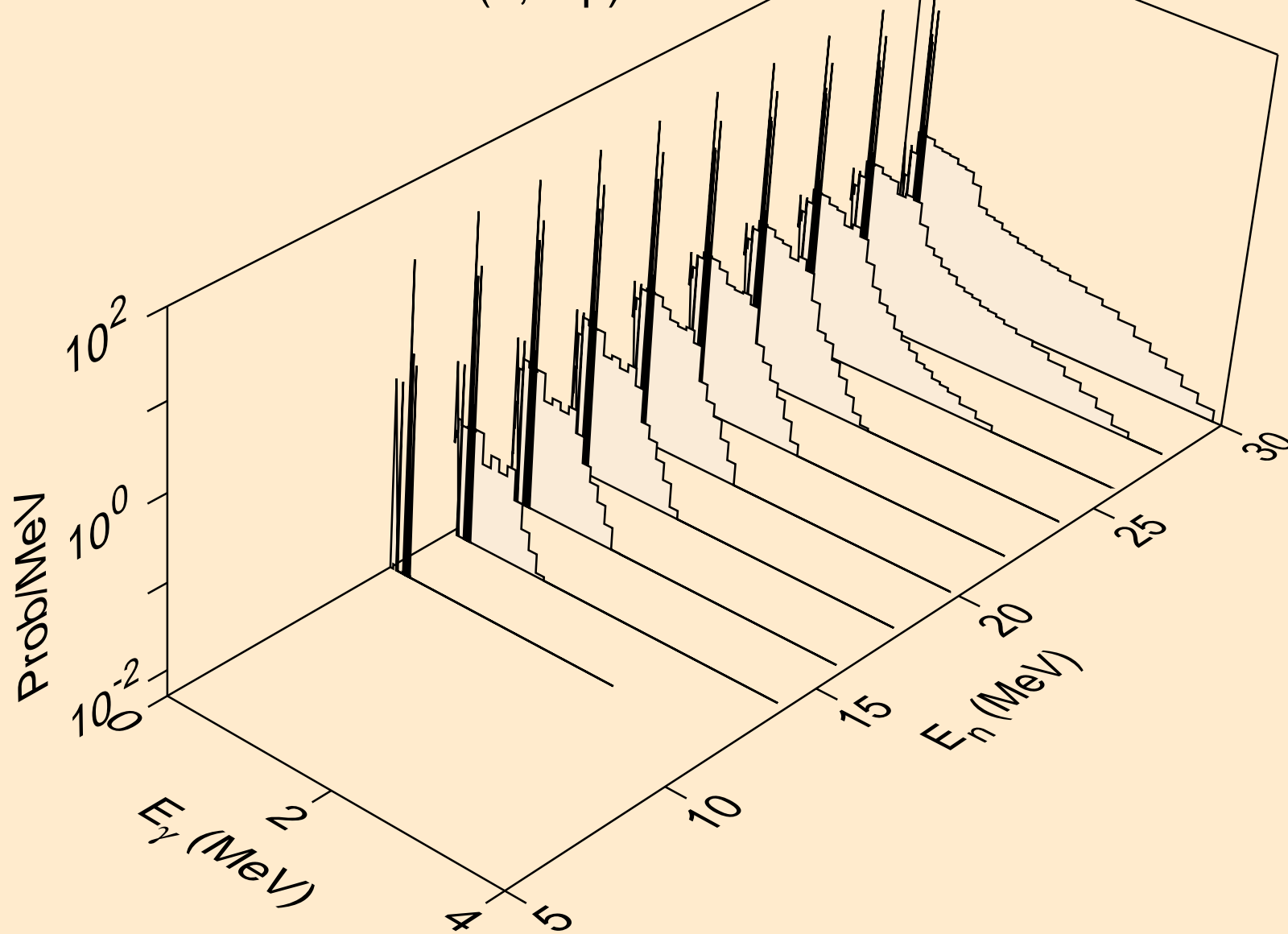

NP228 NEUTRON ACER TENDL-2023 LIBRARY; T=0.K
Photon emission for (n,3np)

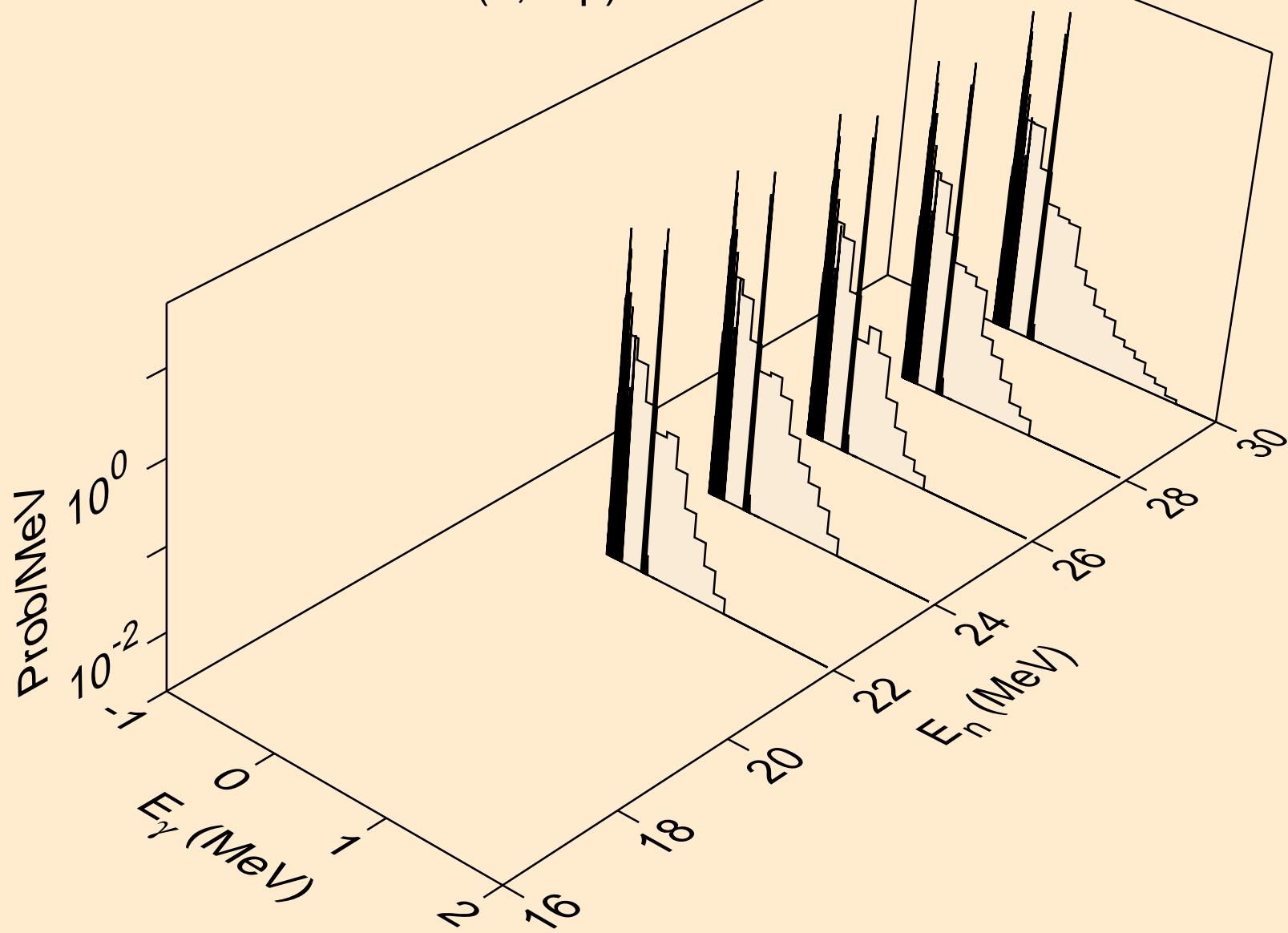

NP228 NEUTRON ACER TENDL-2023 LIBRARY; T=0.K
Photon emission for (n,n2p)

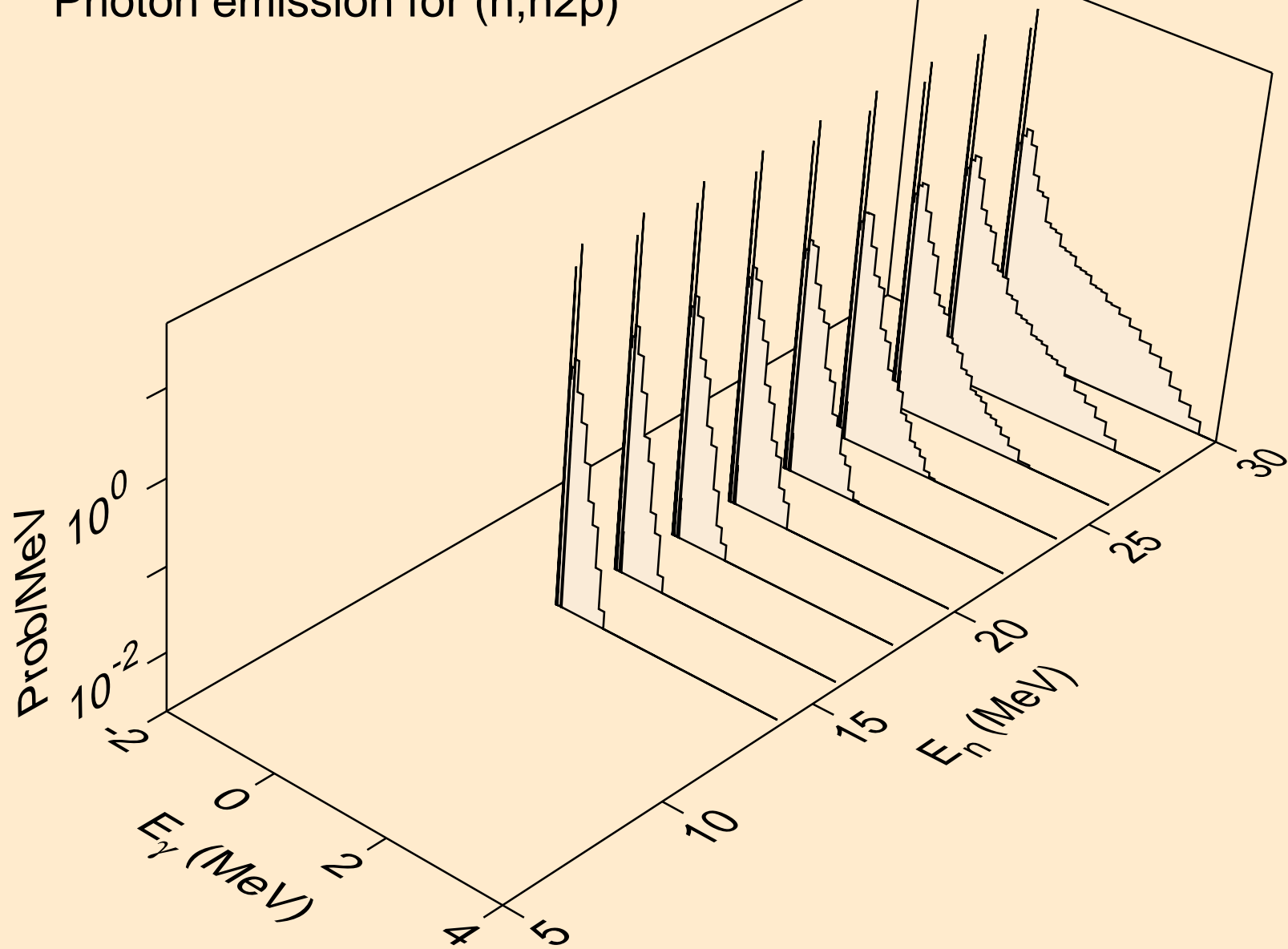

NP228 NEUTRON ACER TENDL-2023 LIBRARY; T=0.K
Photon emission for (n,npa)

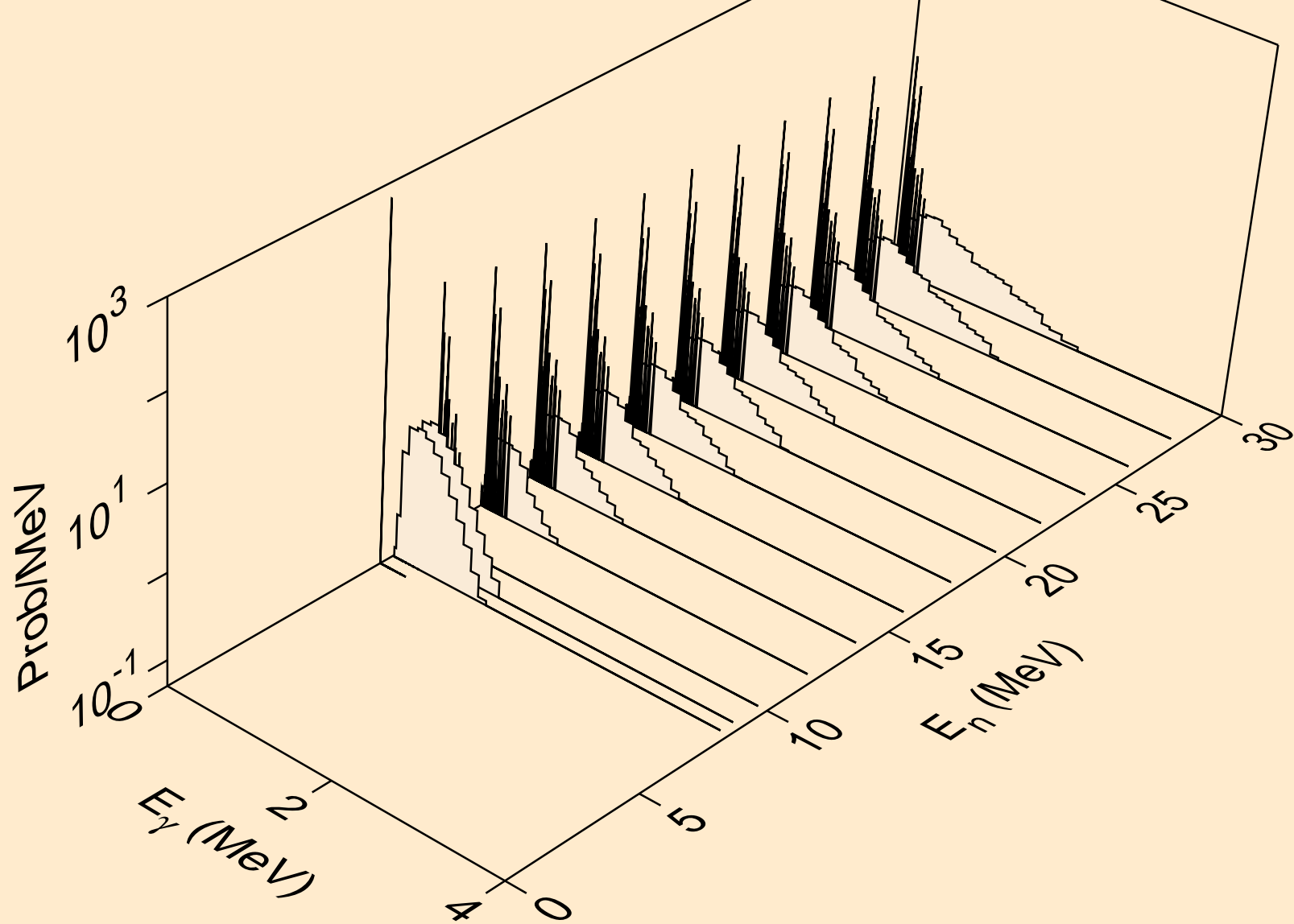

NP228 NEUTRON ACER TENDL-2023 LIBRARY; T=0.K
Photon emission for (n,n*c)

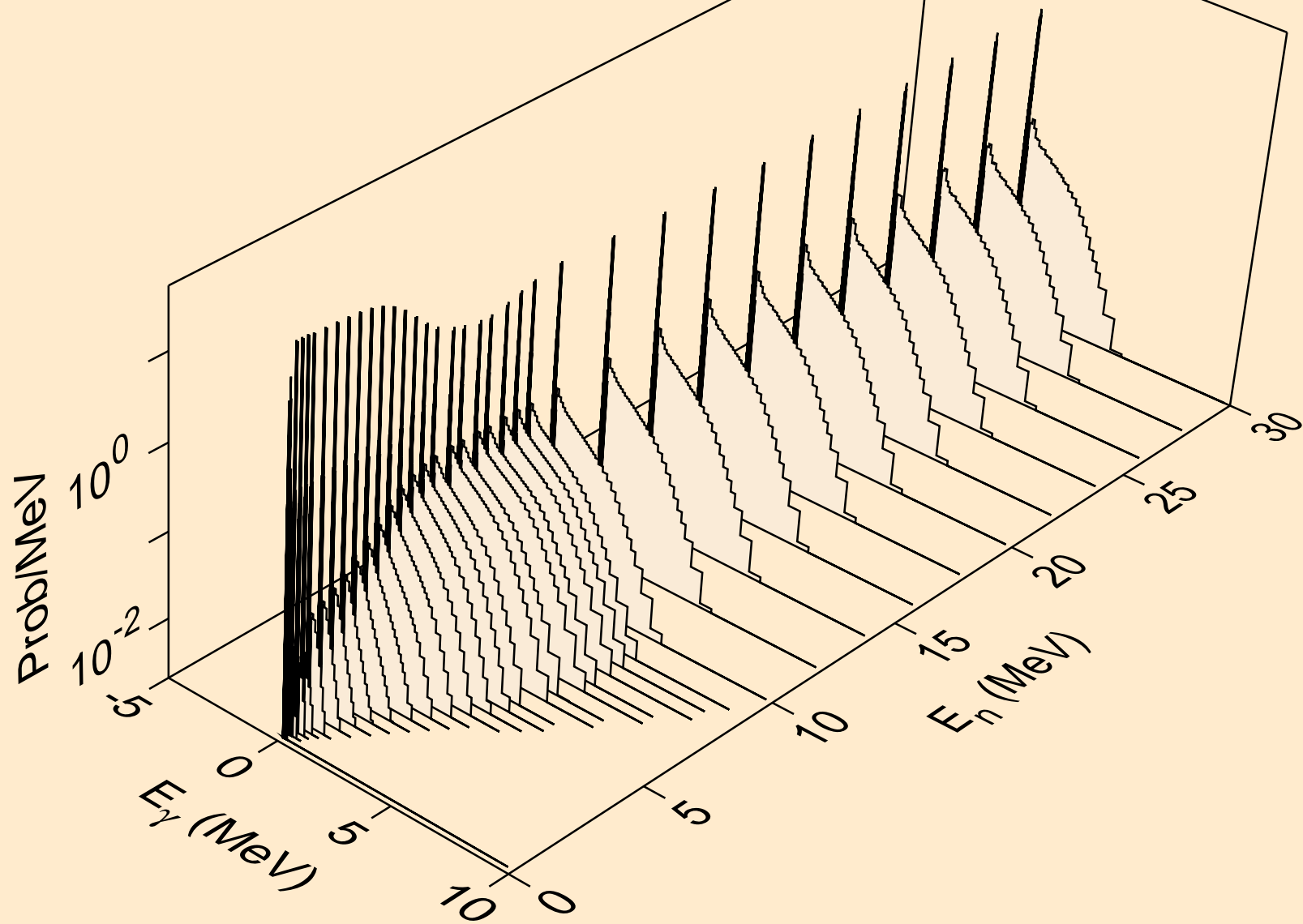

NP228 NEUTRON ACER TENDL-2023 LIBRARY; T=0.K
Photon emission for (n,gma)

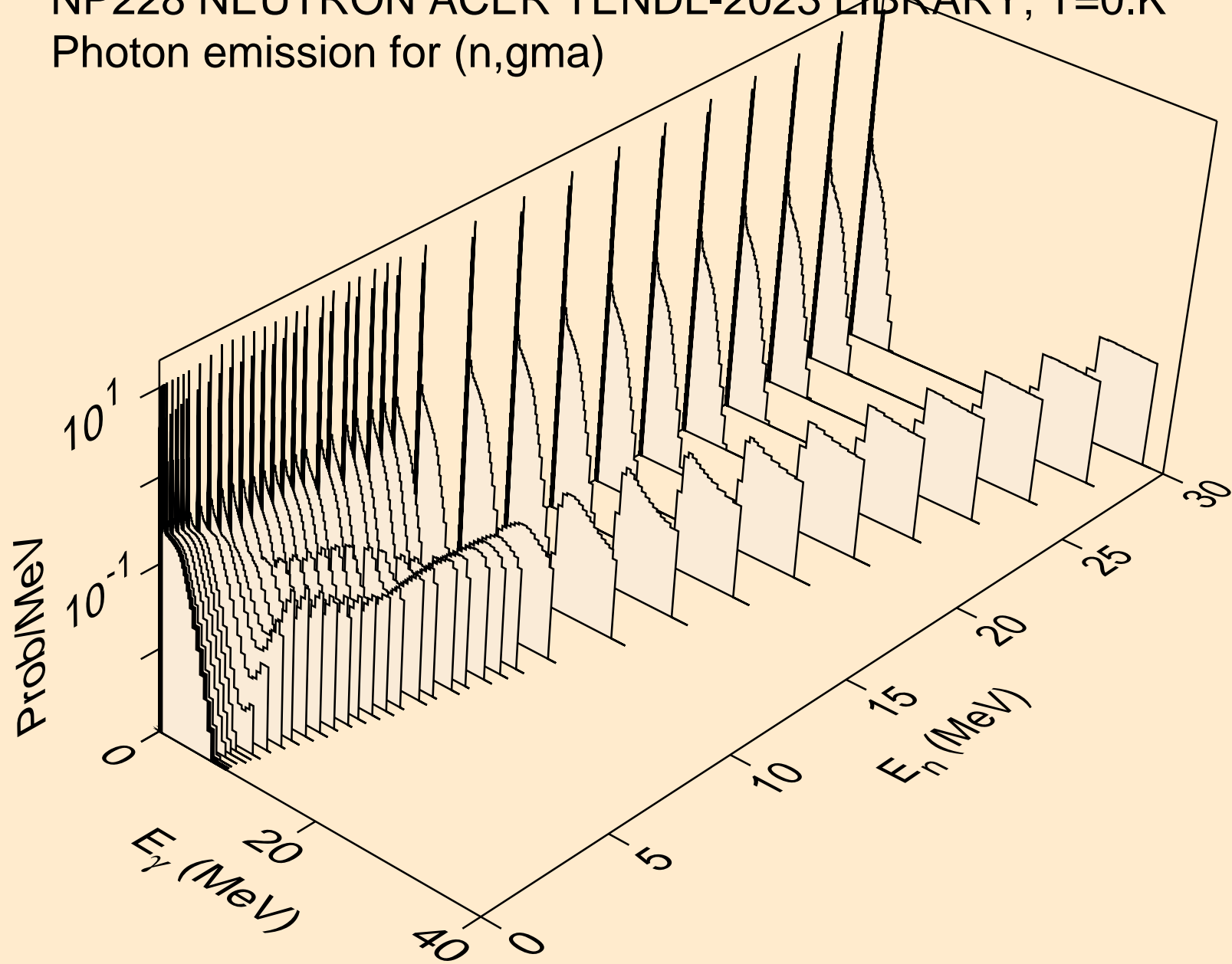

NP228 NEUTRON ACER TENDL-2023 LIBRARY; T=0.K
Photon emission for (n,p)

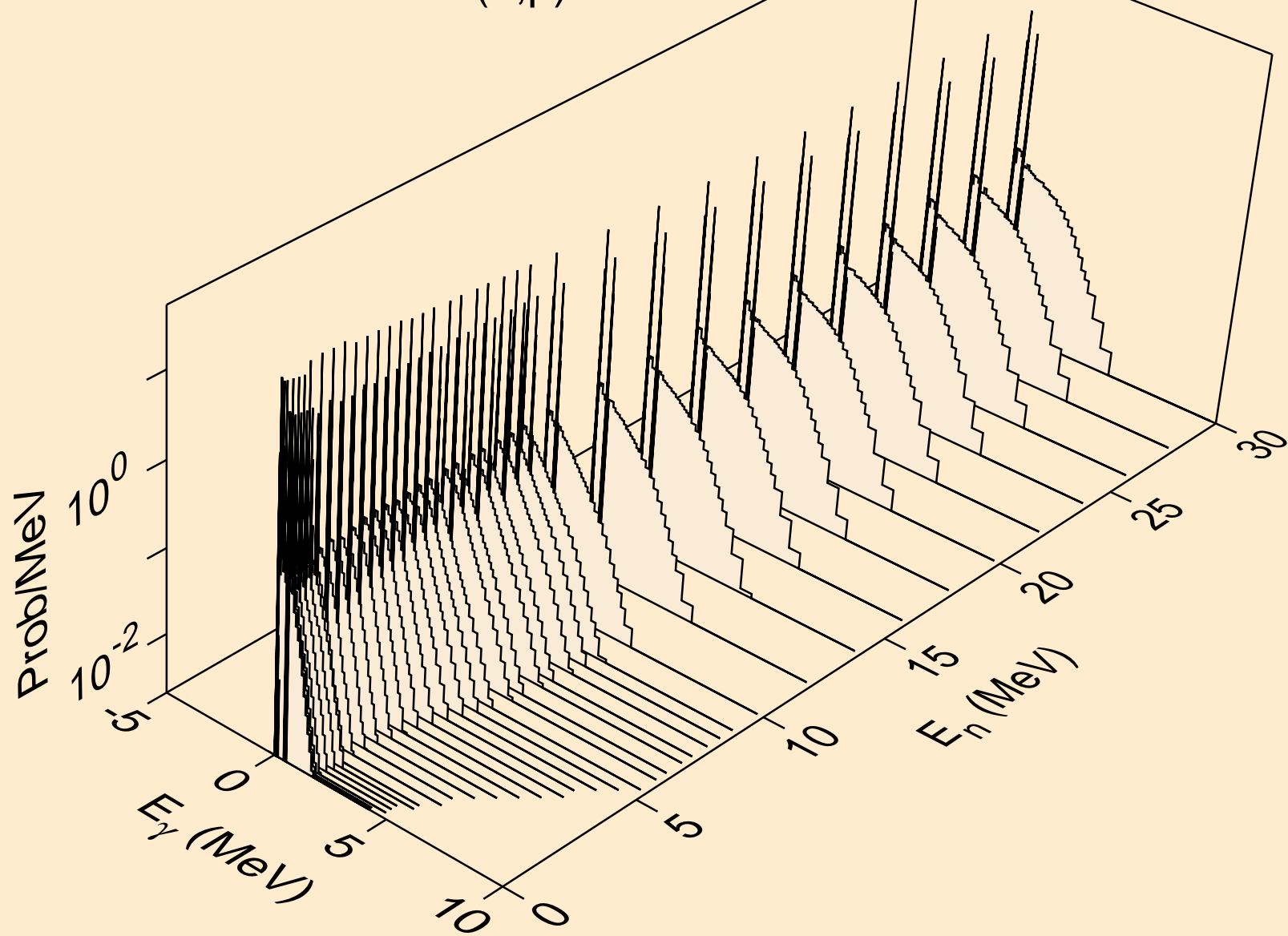

NP228 NEUTRON ACER TENDL-2023 LIBRARY; T=0.K
Photon emission for (n,d)

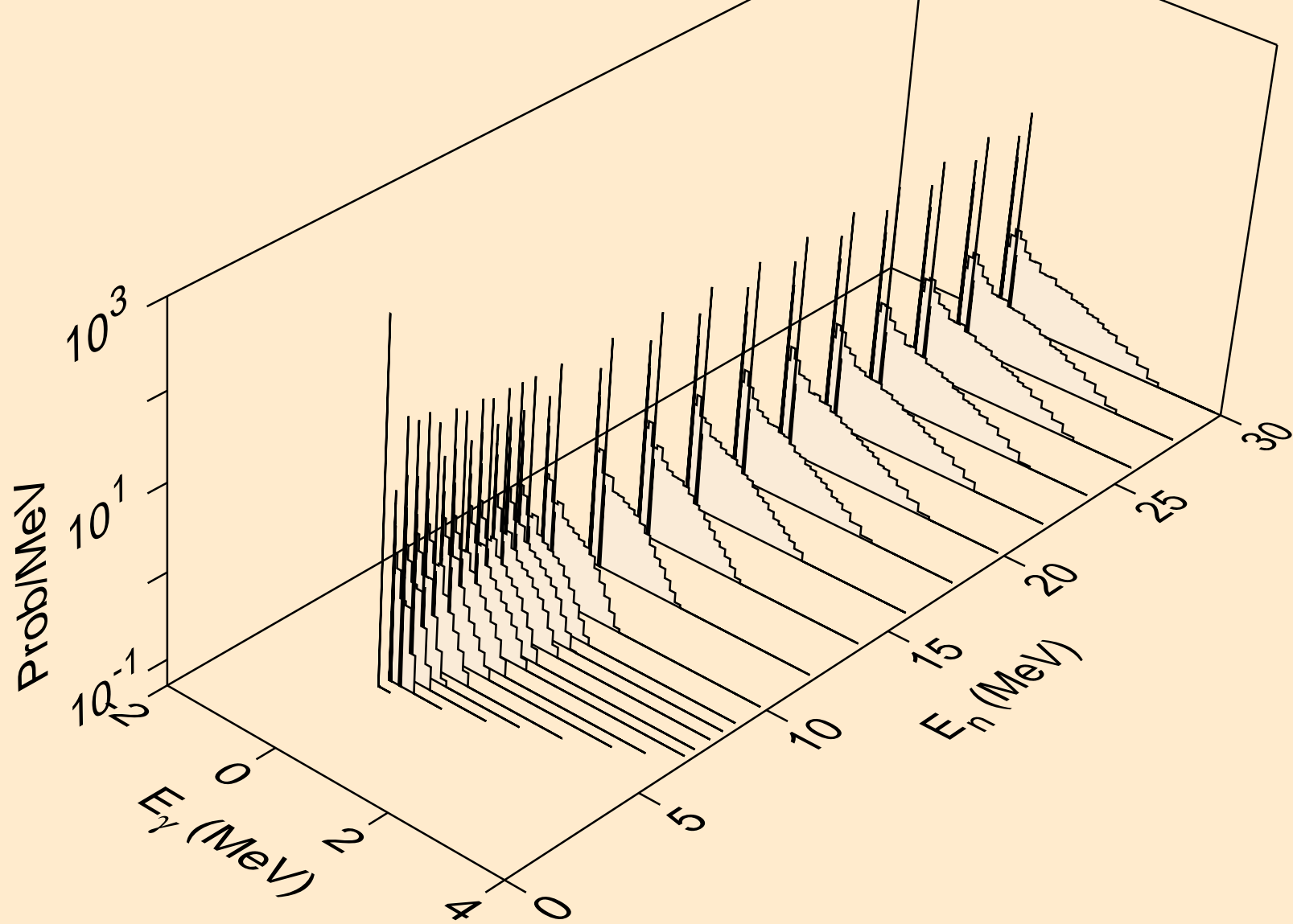

NP228 NEUTRON ACER TENDL-2023 LIBRARY; T=0.K
Photon emission for (n,t)

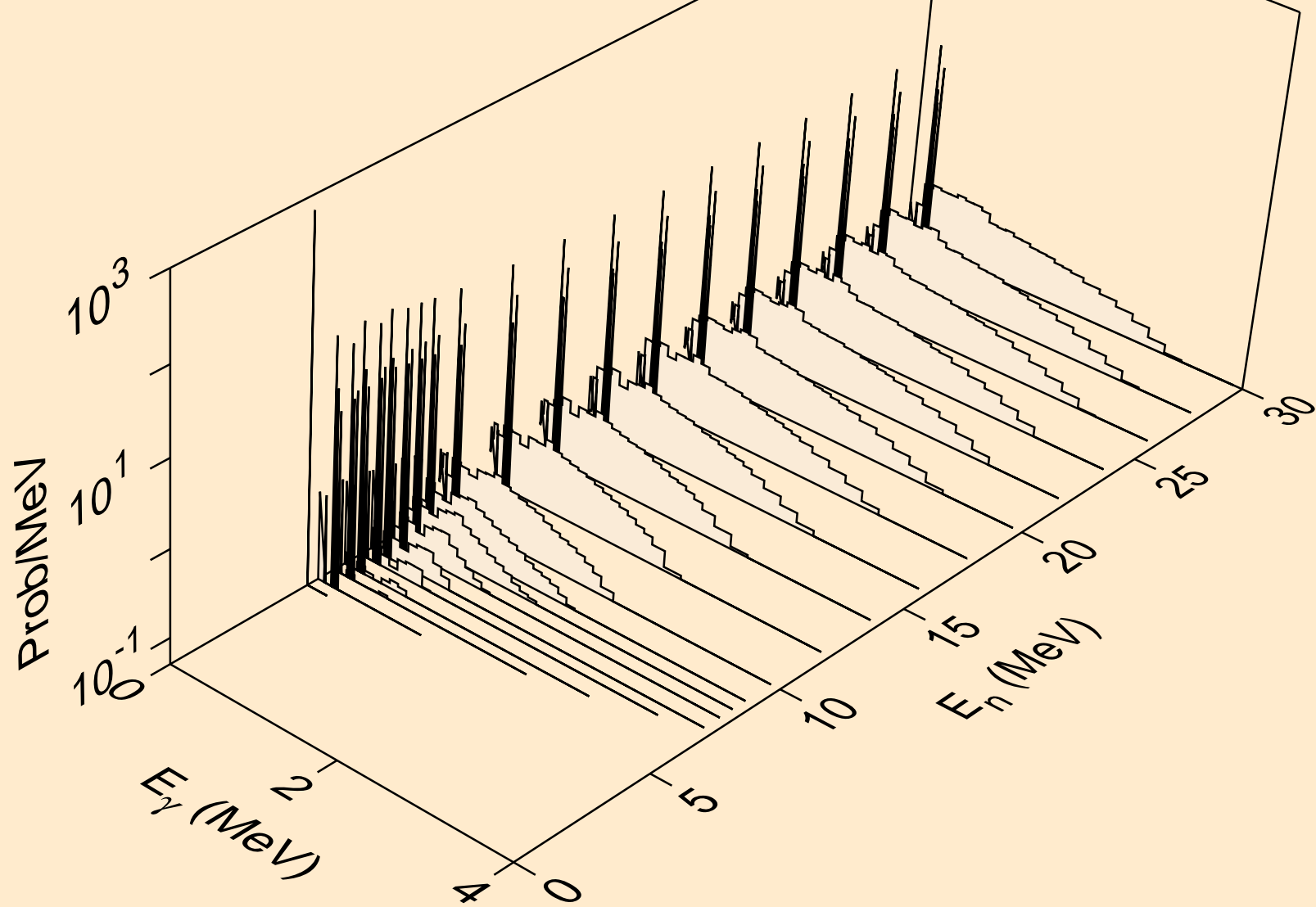

NP228 NEUTRON ACER TENDL-2023 LIBRARY; T=0.K
Photon emission for (n,he3)

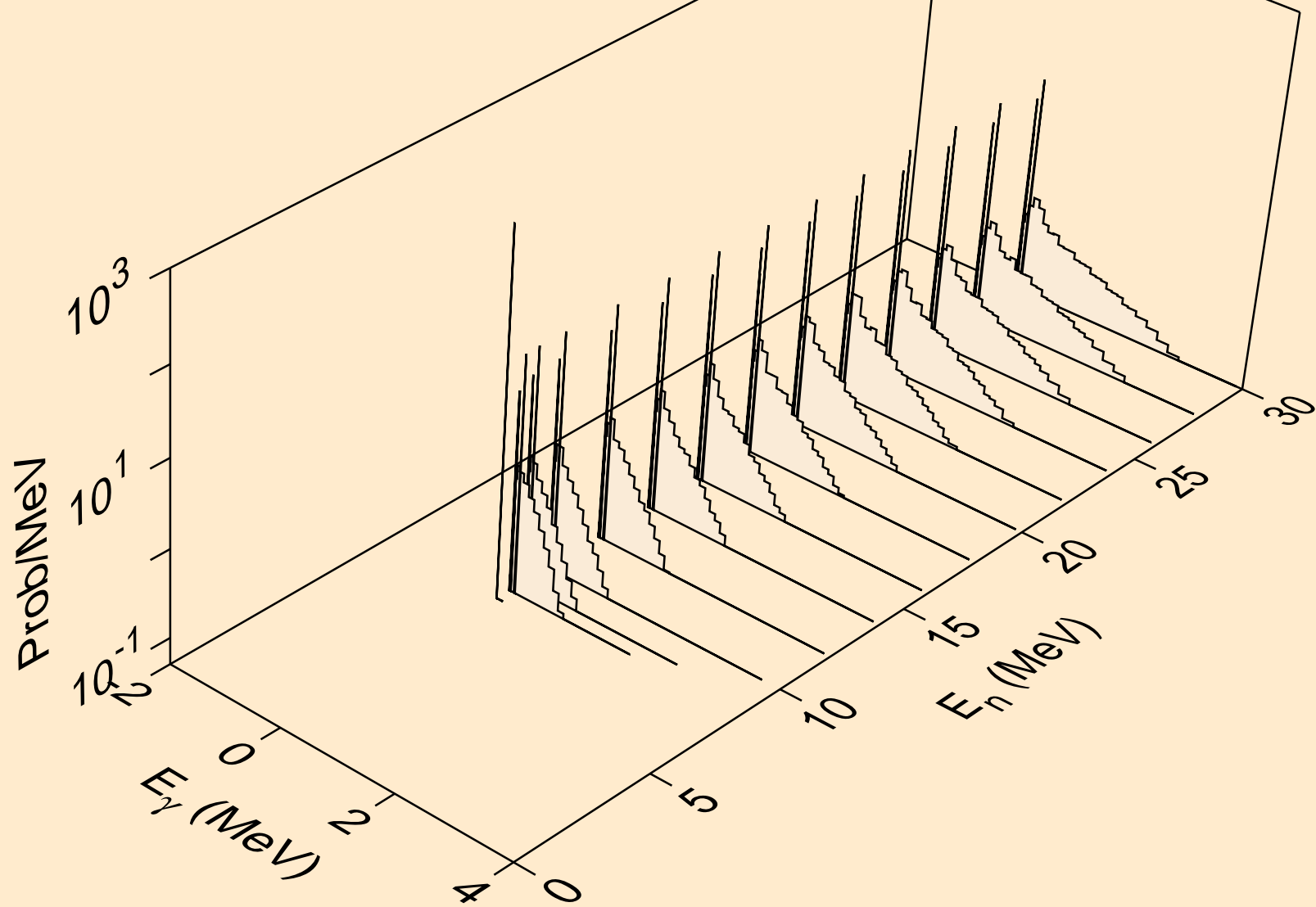

NP228 NEUTRON ACER TENDL-2023 LIBRARY; T=0.K
Photon emission for (n,a)

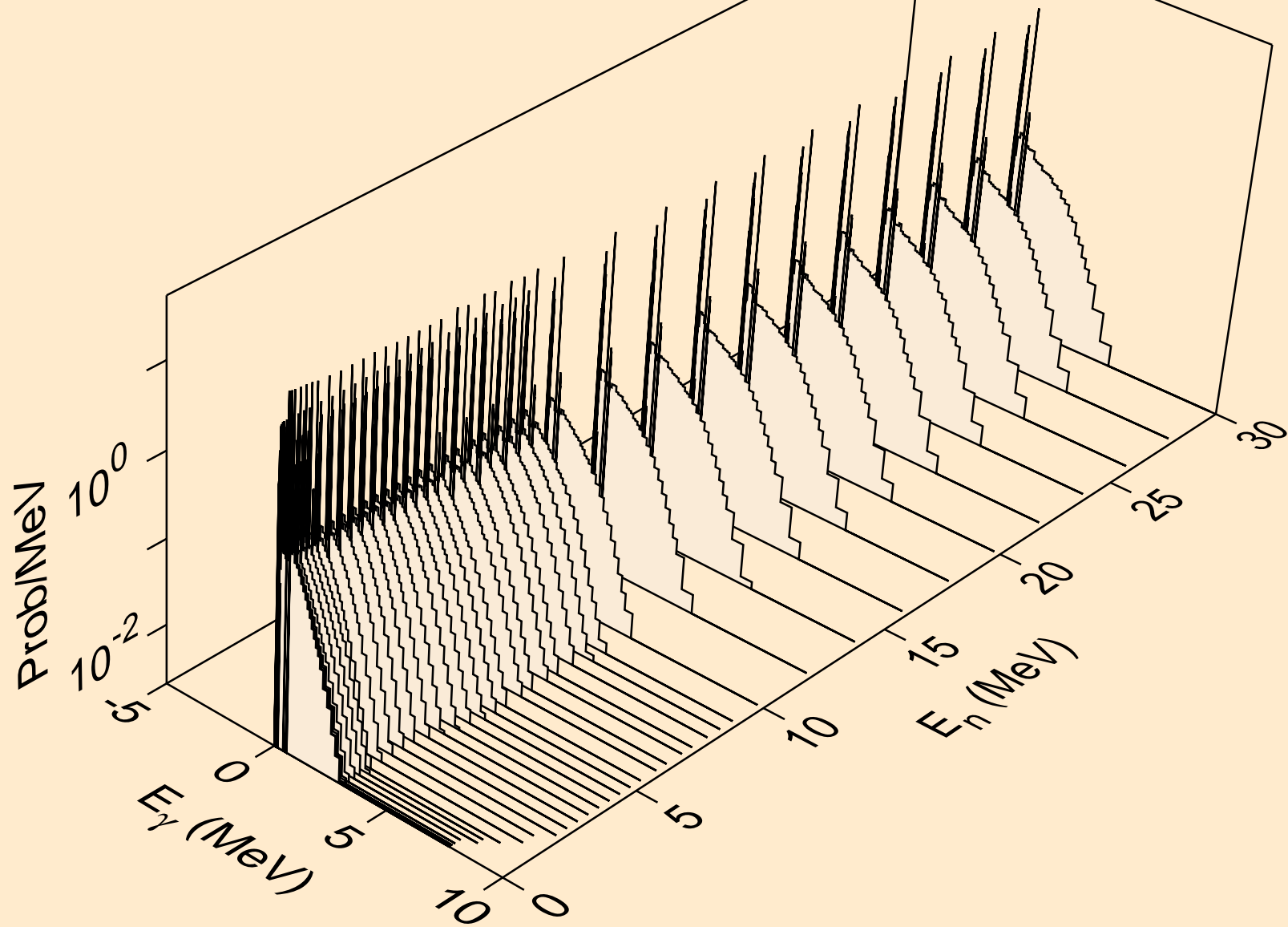

NP228 NEUTRON ACER TENDL-2023 LIBRARY; T=0.K
Photon emission for (n,2a)

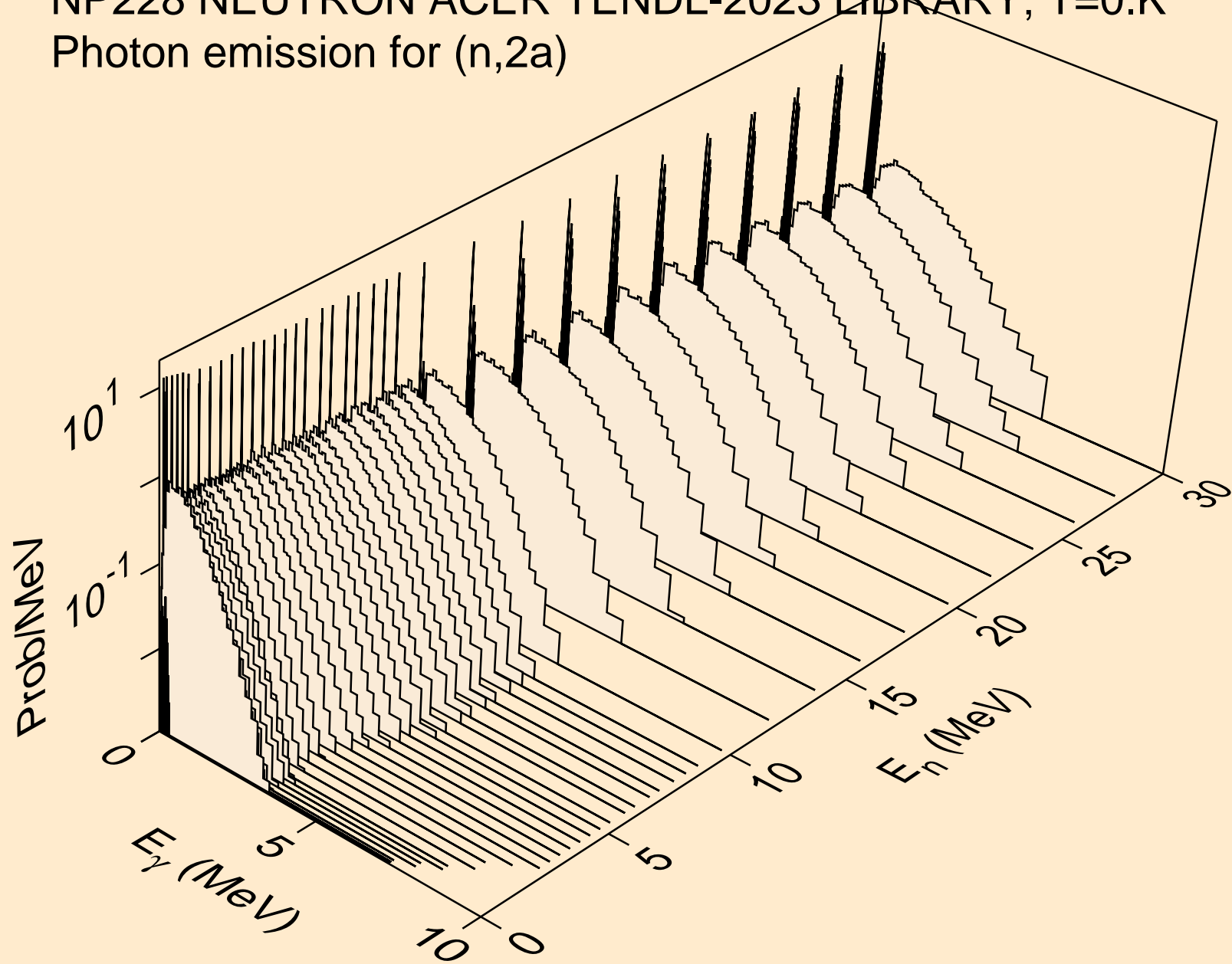

NP228 NEUTRON ACER TENDL-2023 LIBRARY; T=0.K
Photon emission for (n,2p)

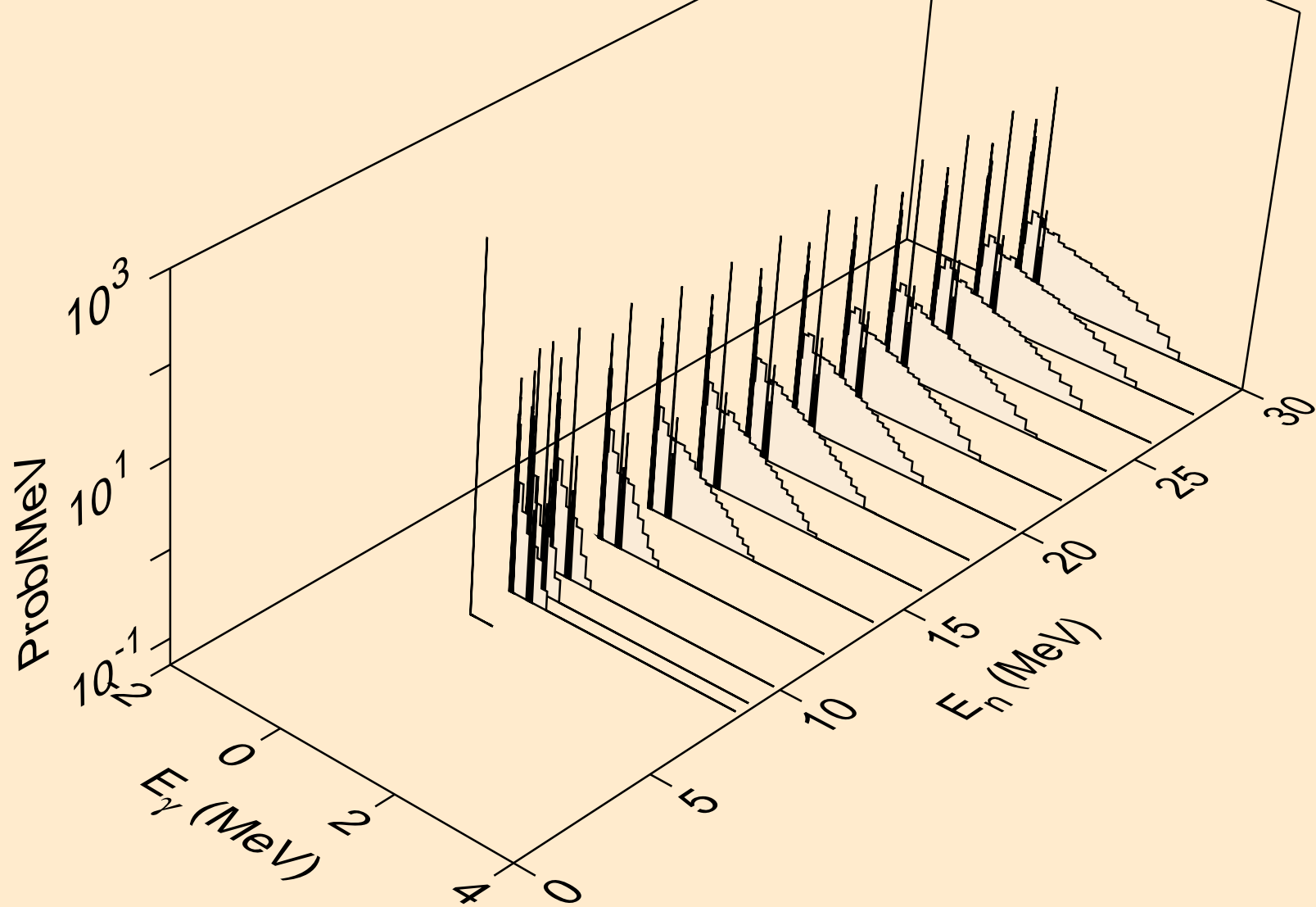

NP228 NEUTRON ACER TENDL-2023 LIBRARY; T=0.K
Photon emission for (n,p α)

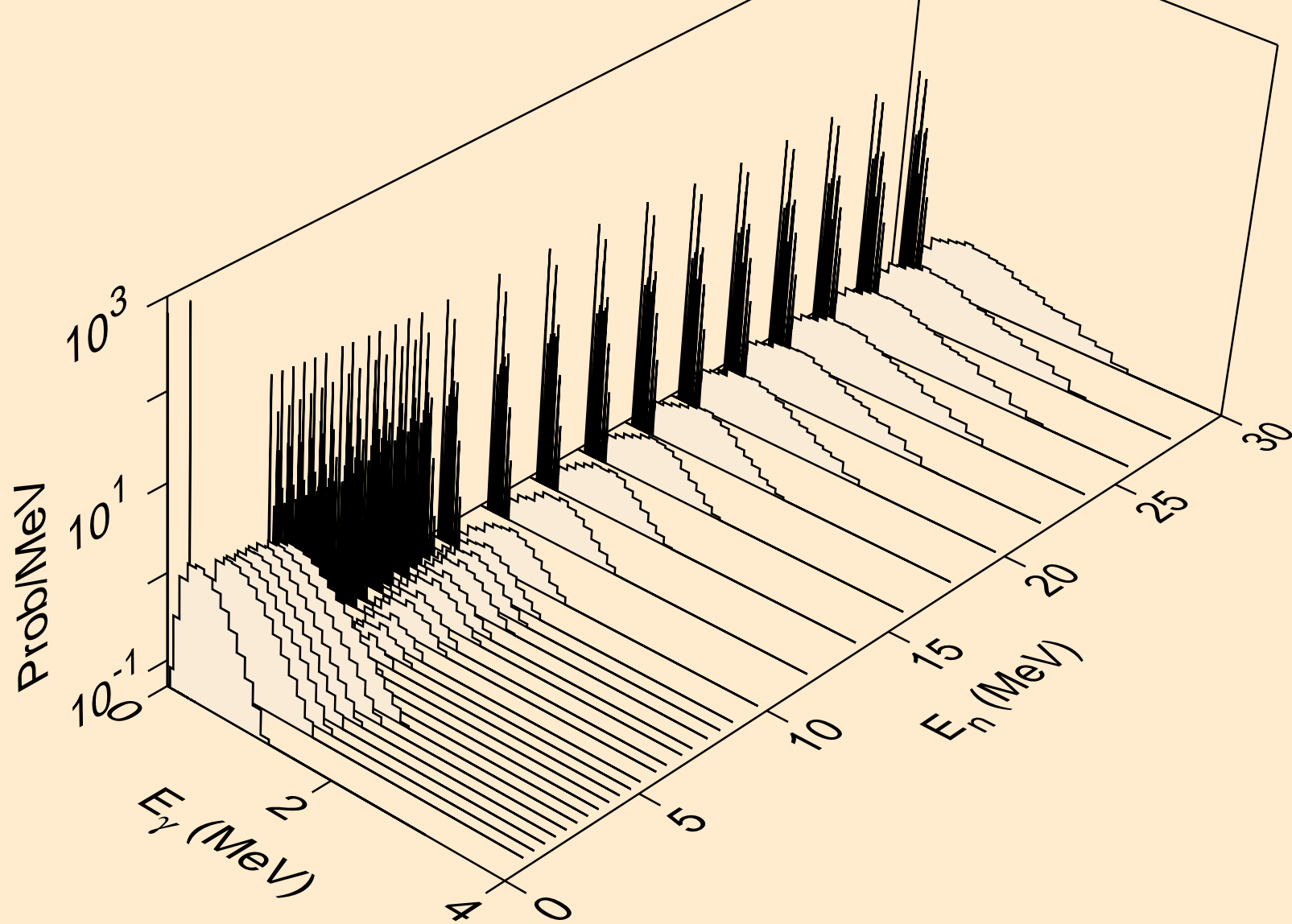

NP228 NEUTRON ACER TENDL-2023 LIBRARY; T=0.K
Photon emission for (n,pd)

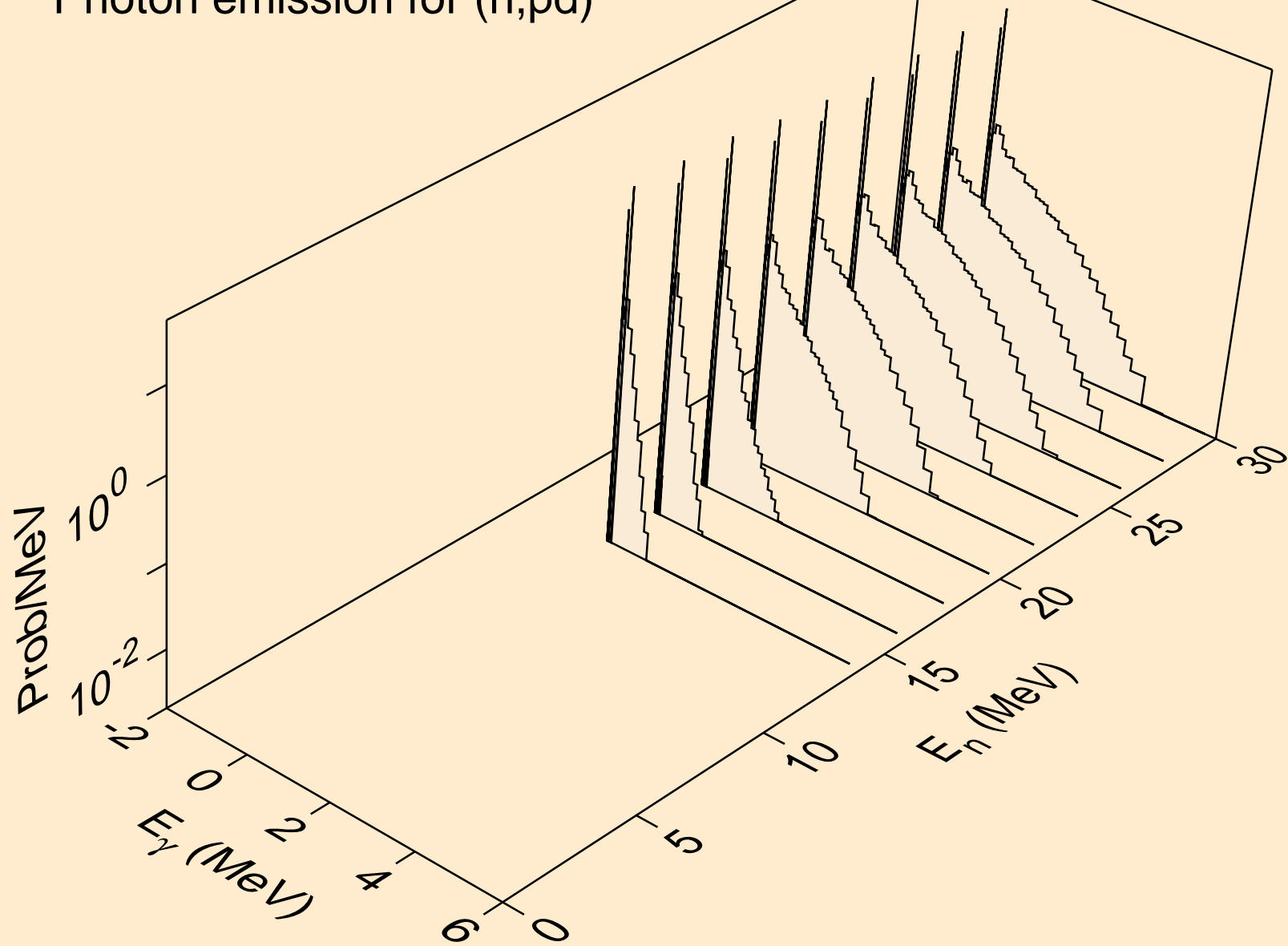

NP228 NEUTRON ACER TENDL-2023 LIBRARY; T=0.K
Photon emission for (n,p)

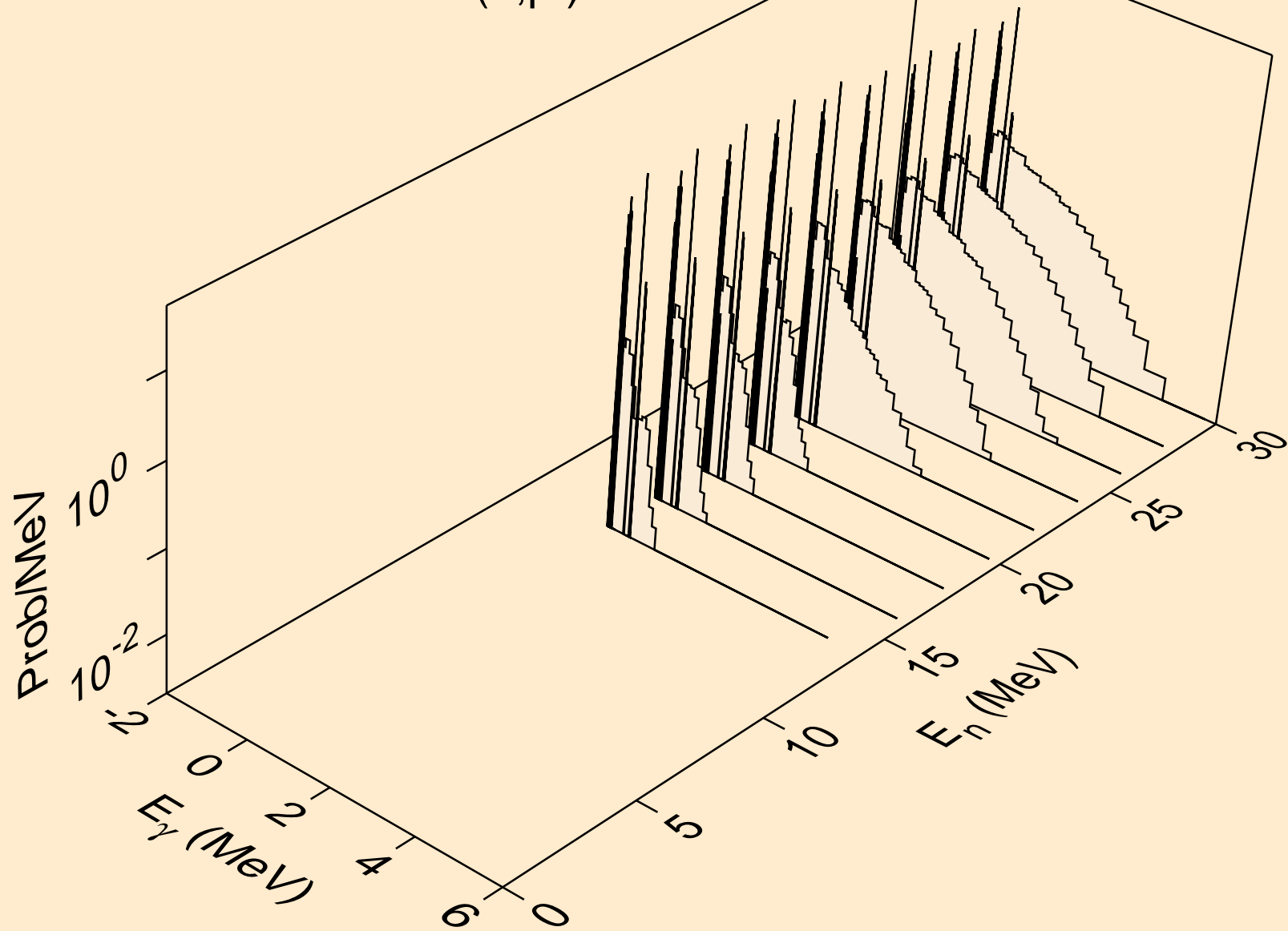

NP228 NEUTRON ACER TENDL-2023 LIBRARY; T=0.K
Photon emission for (n,da)

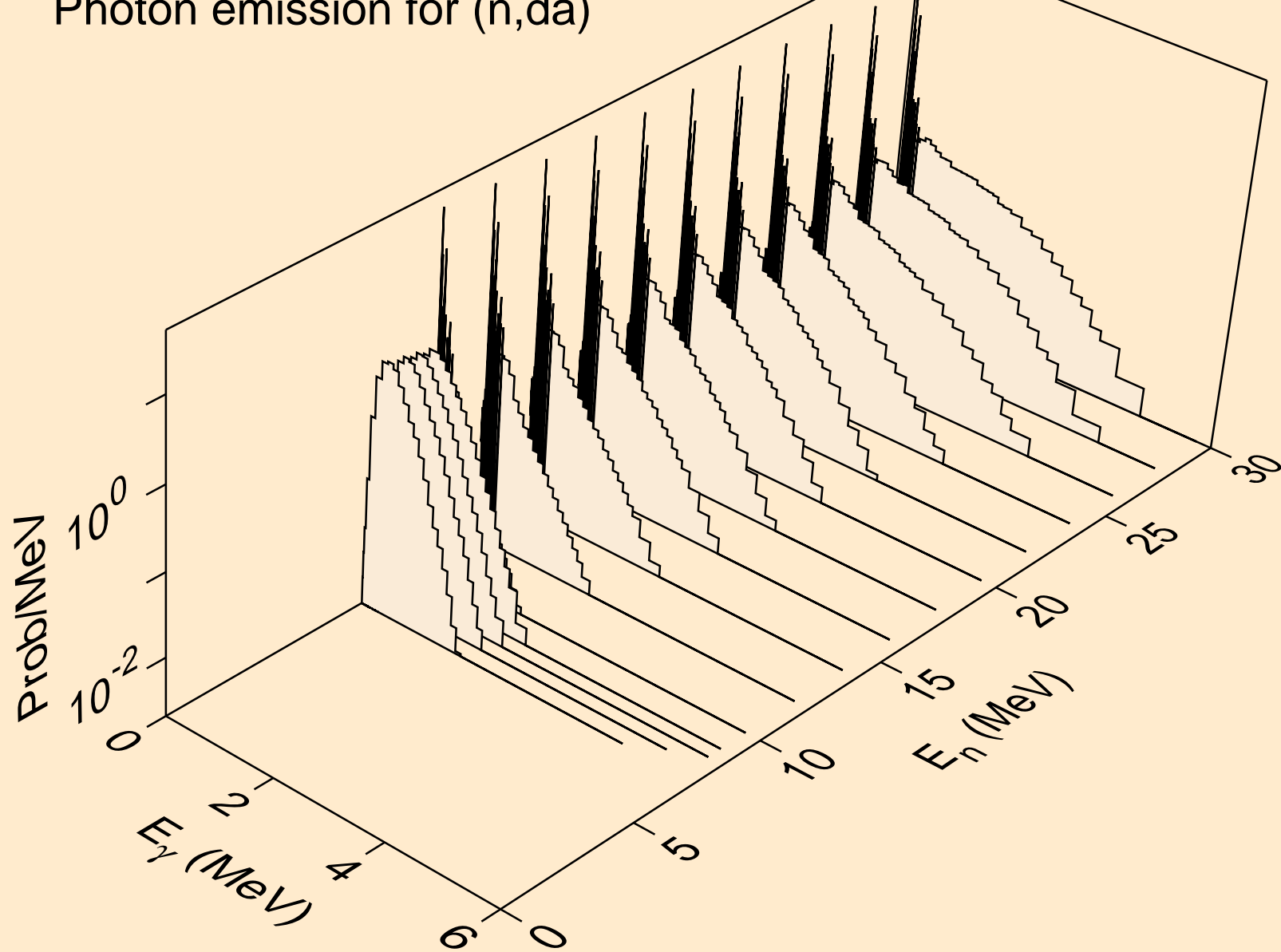

NP228 NEUTRON ACER TENDL-2023 LIBRARY; T=0.K
thermal capture photon spectrum

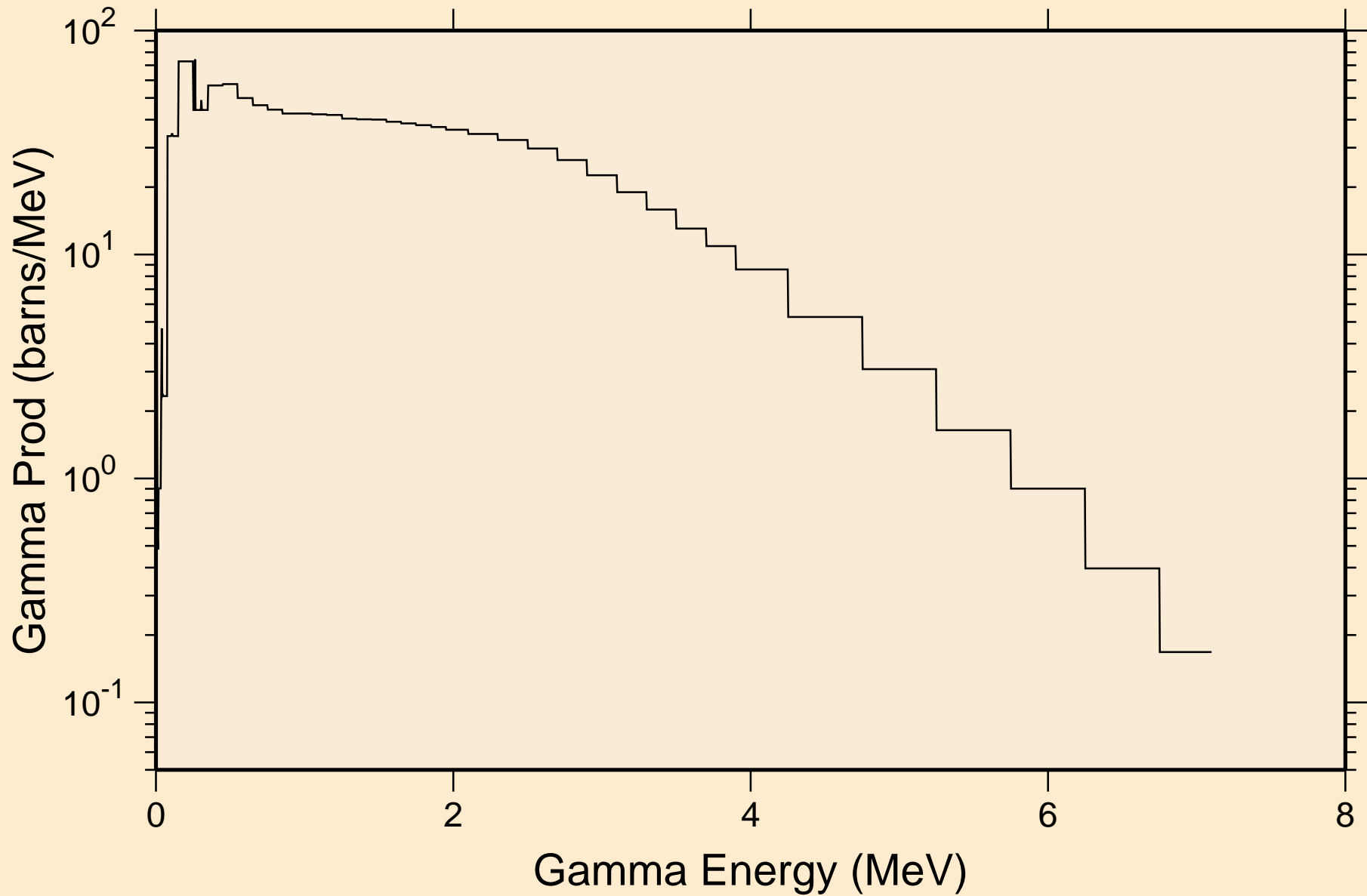

NP228 NEUTRON ACER TENDL-2023 LIBRARY; T=0.K
14 MeV photon spectrum

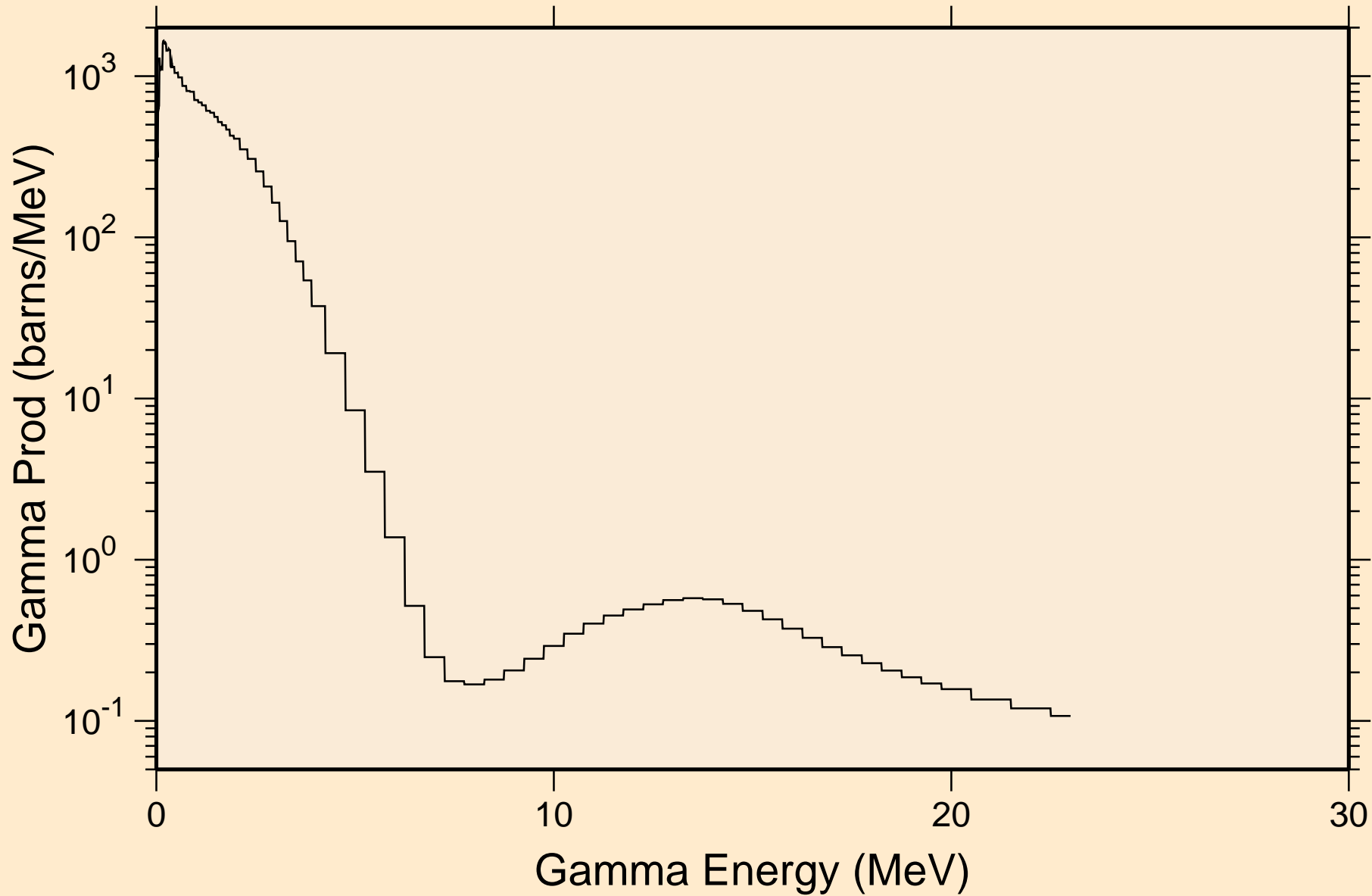

NP228 NEUTRON ACER TENDL-2023 LIBRARY; T=0.K

Particle heating contributions

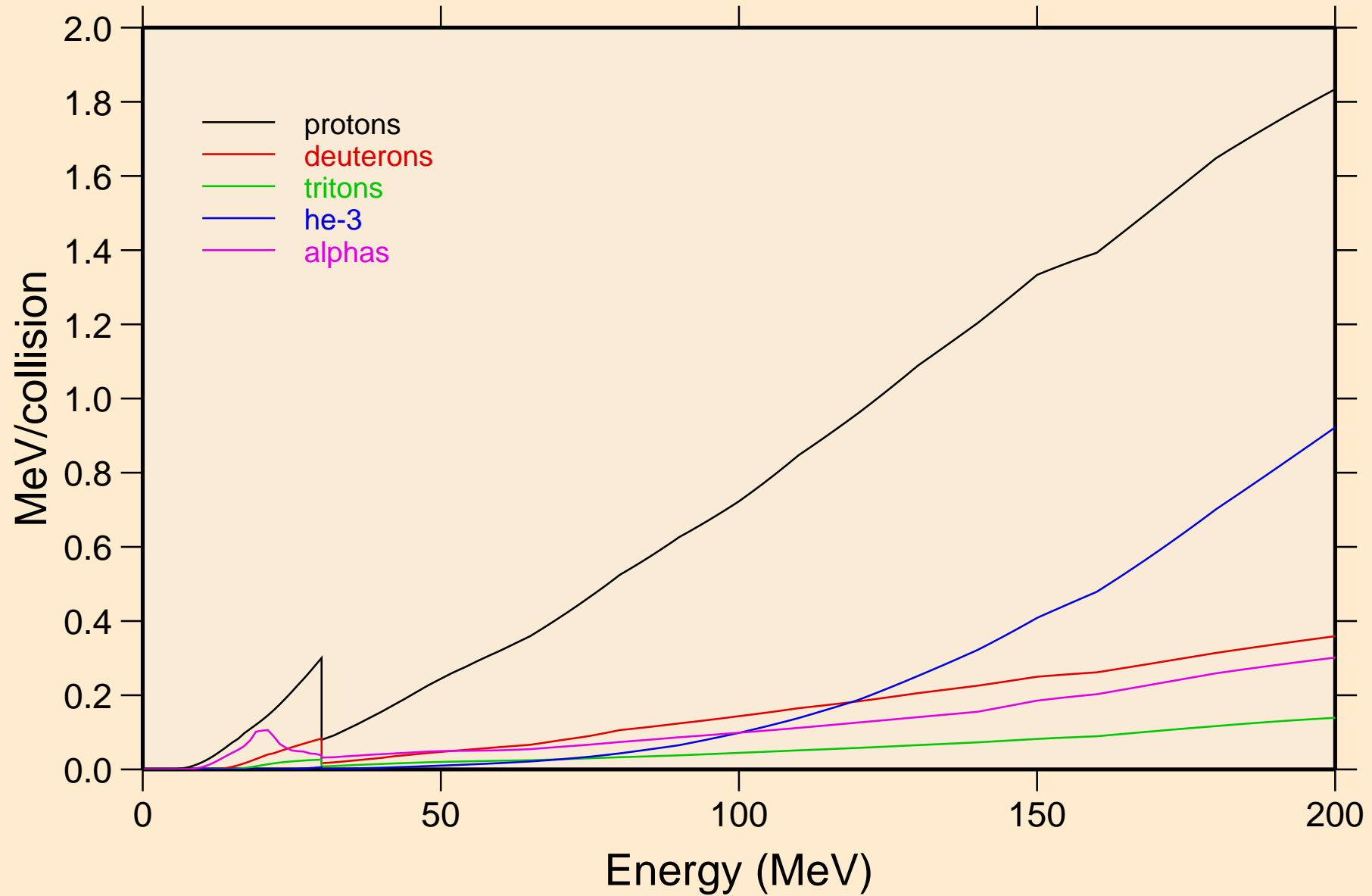

NP228 NEUTRON ACER TENDL-2023 LIBRARY; T=0.K

Recoil Heating

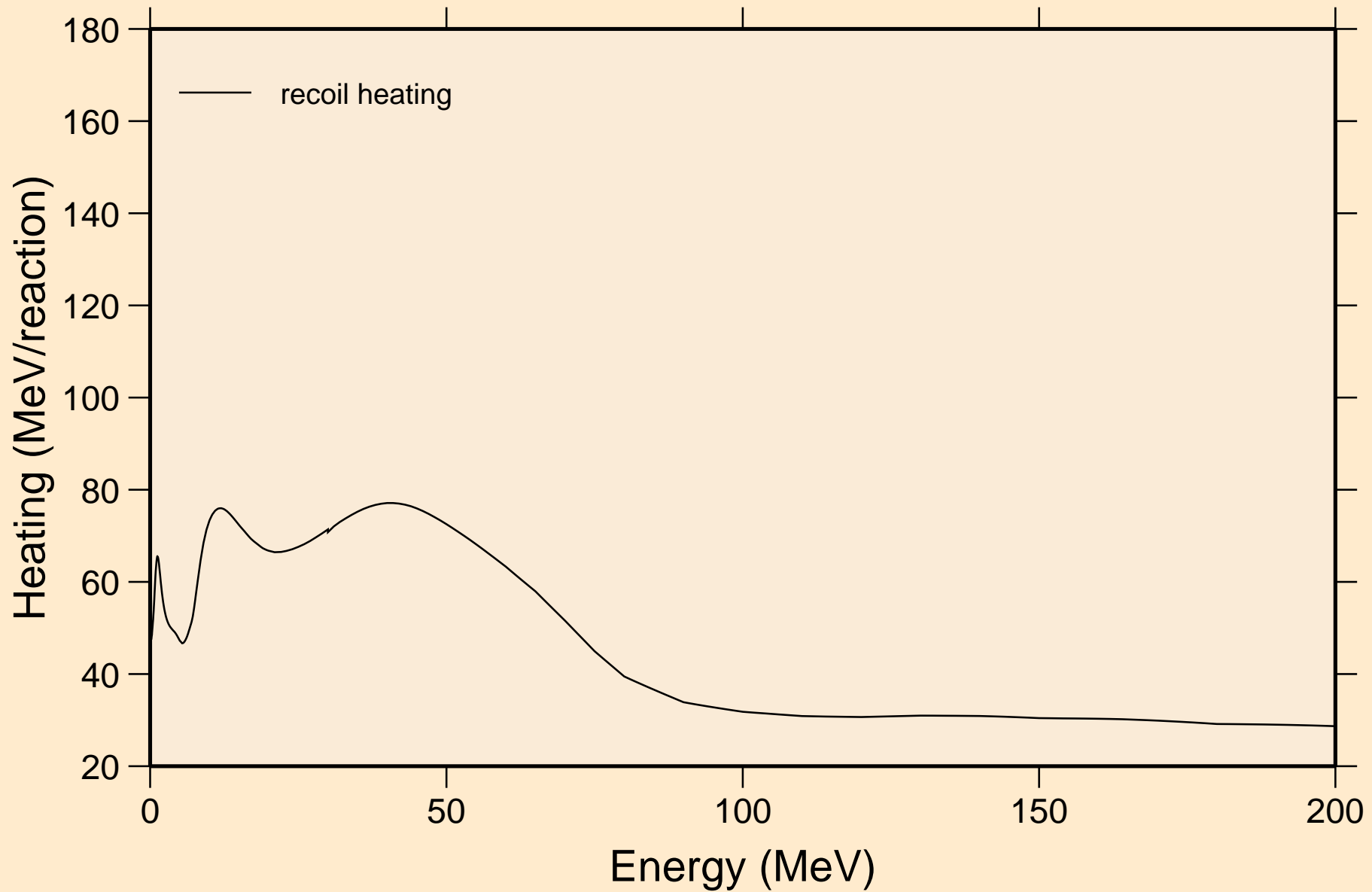

NP228 NEUTRON ACER TENDL-2023 LIBRARY; T=0.K

Particle production cross sections

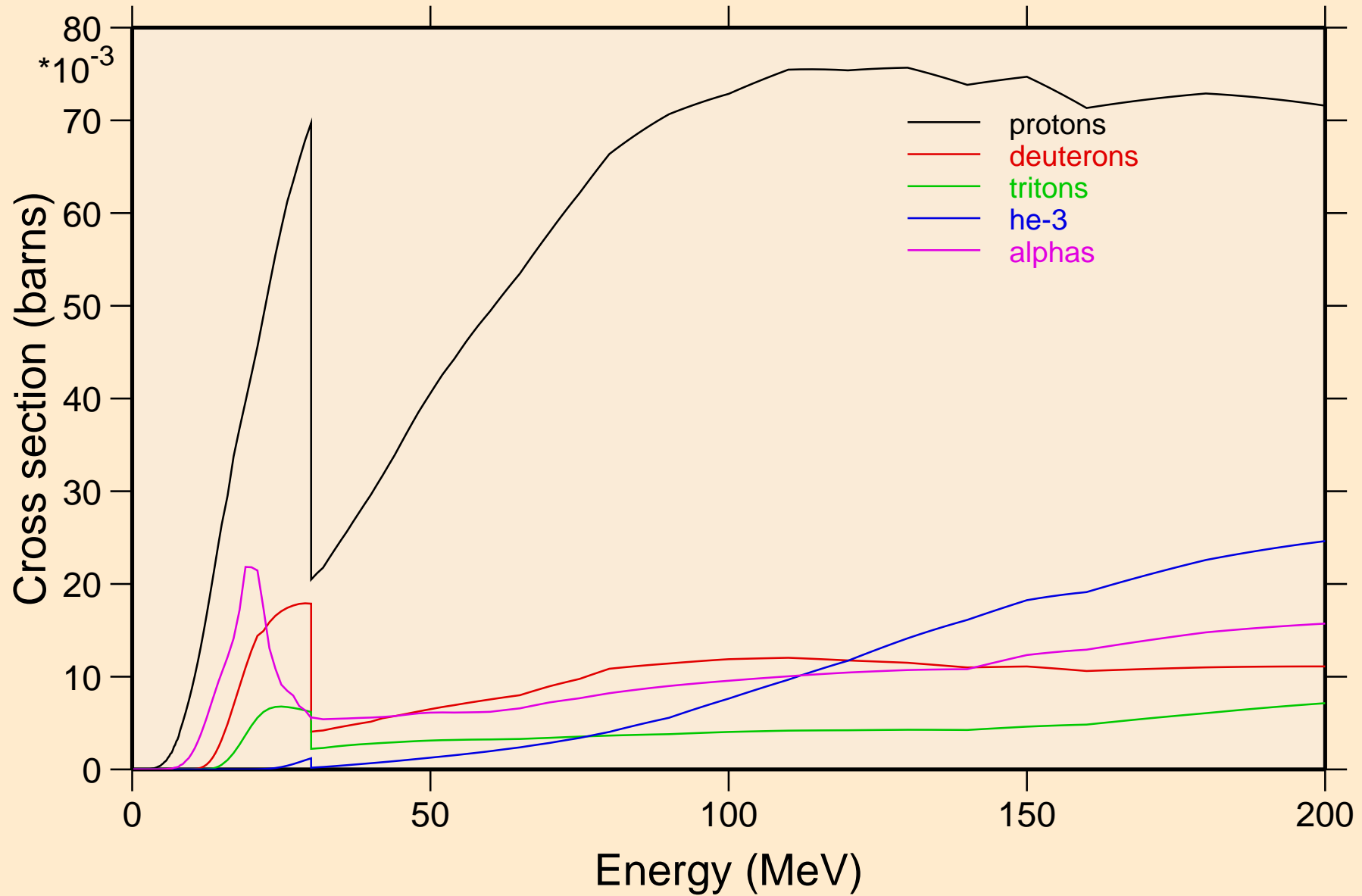

NP228 NEUTRON ACER TENDL-2023 LIBRARY; T=0.K
protons from (n,x)

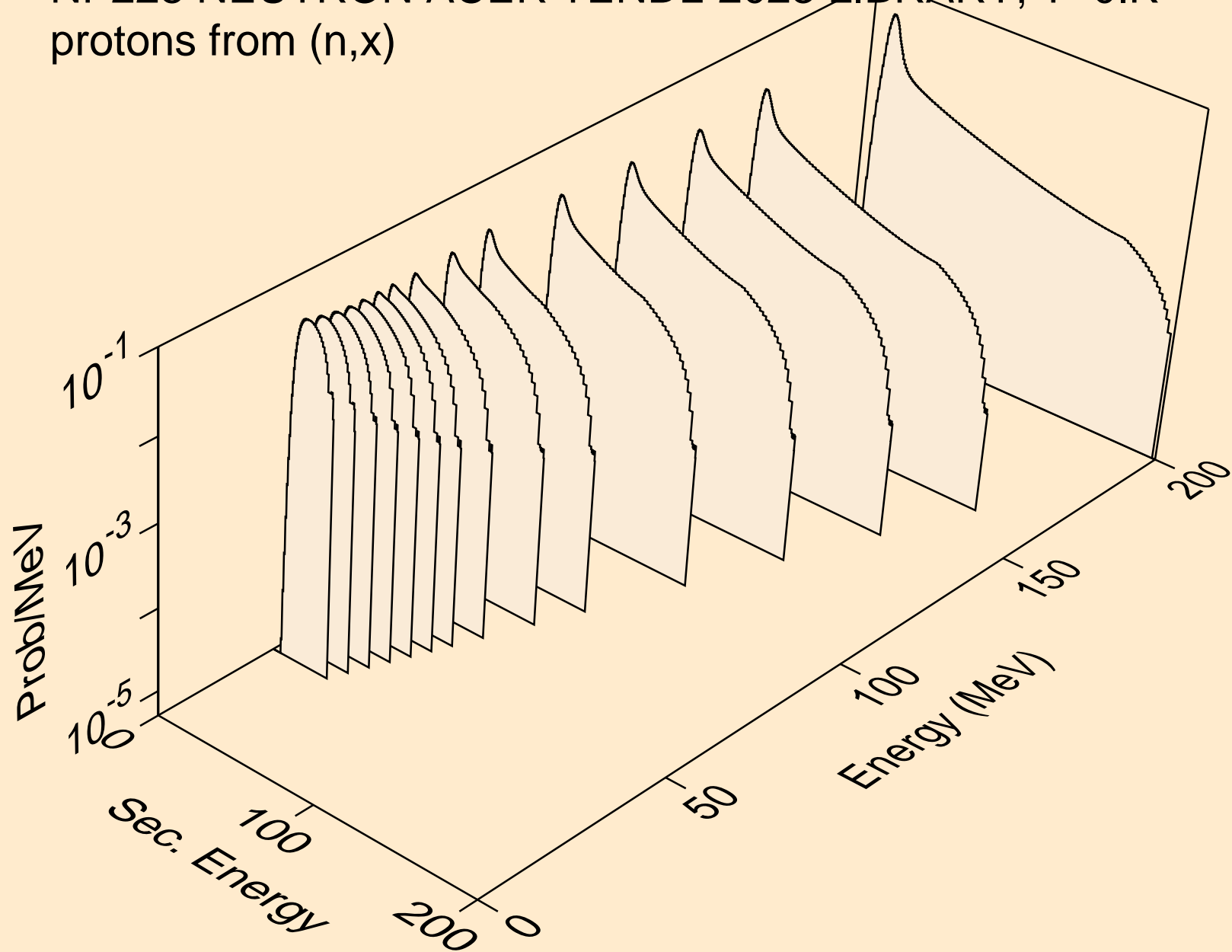

NP228 NEUTRON ACER TENDL-2023 LIBRARY; T=0.K
protons from (n,n*)p

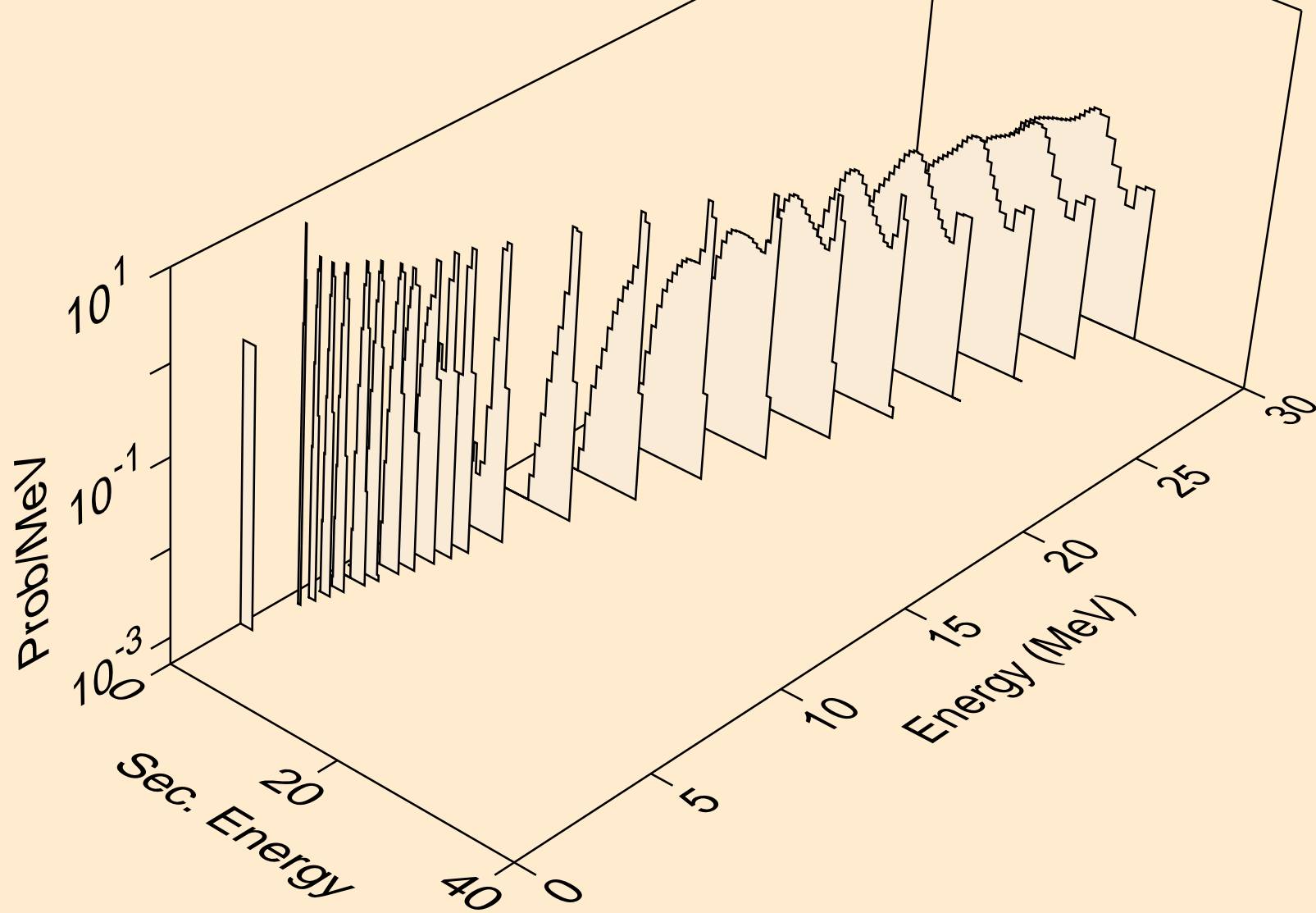

NP228 NEUTRON ACER TENDL-2023 LIBRARY; T=0.K
protons from (n,2np)

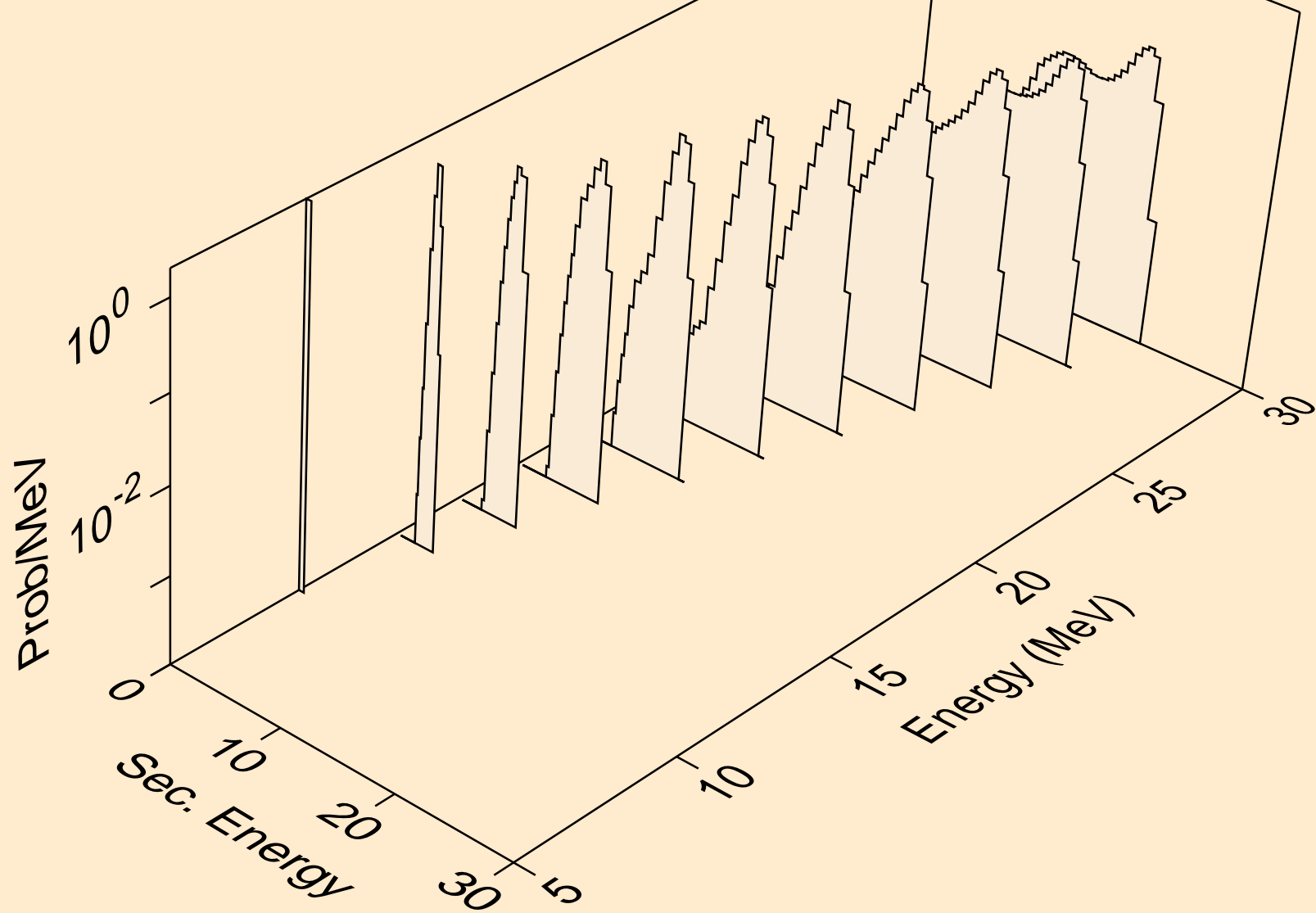

NP228 NEUTRON ACER TENDL-2023 LIBRARY; T=0.K
protons from (n,3np)

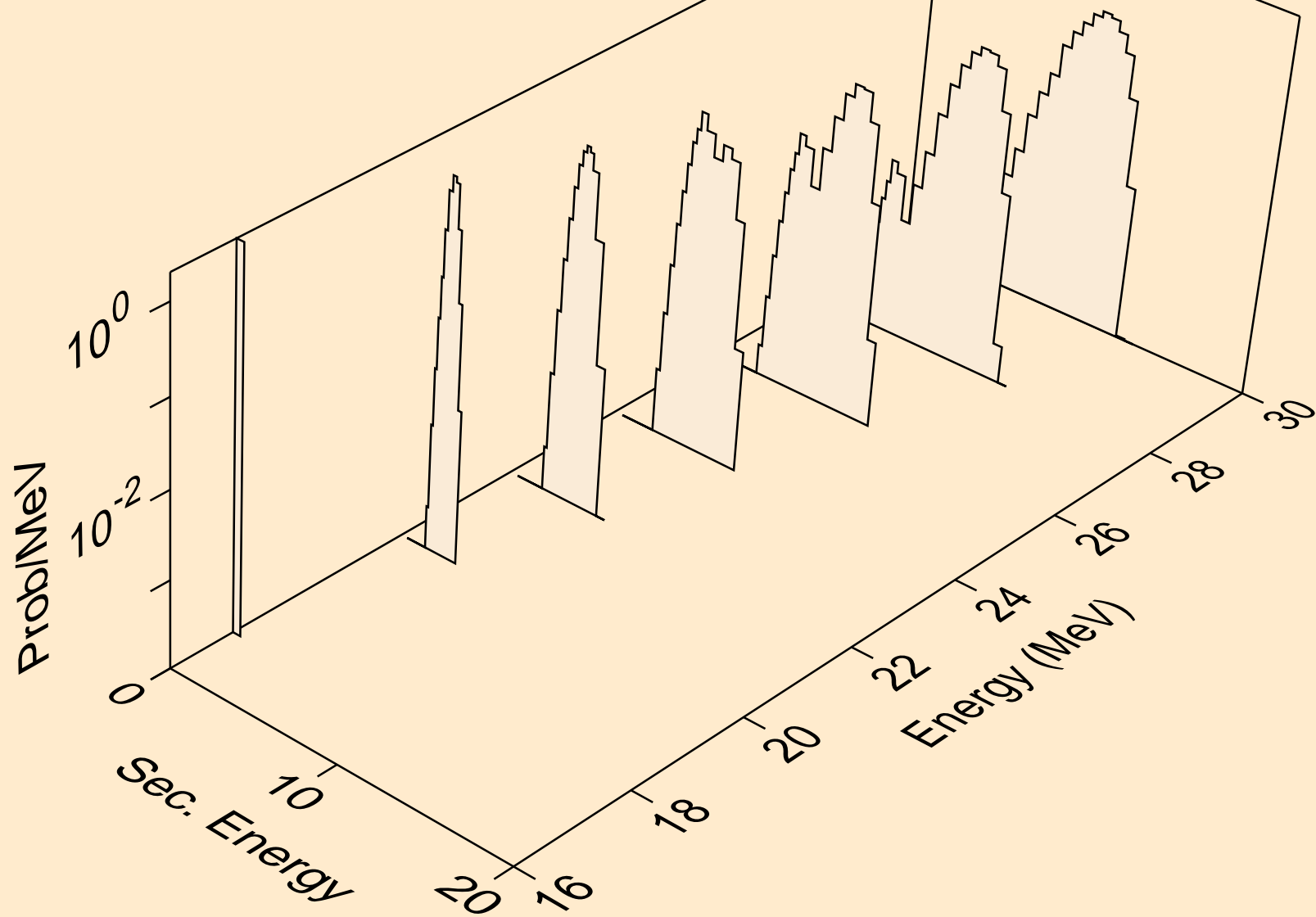

NP228 NEUTRON ACER TENDL-2023 LIBRARY; T=0.K
protons from (n,n2p)

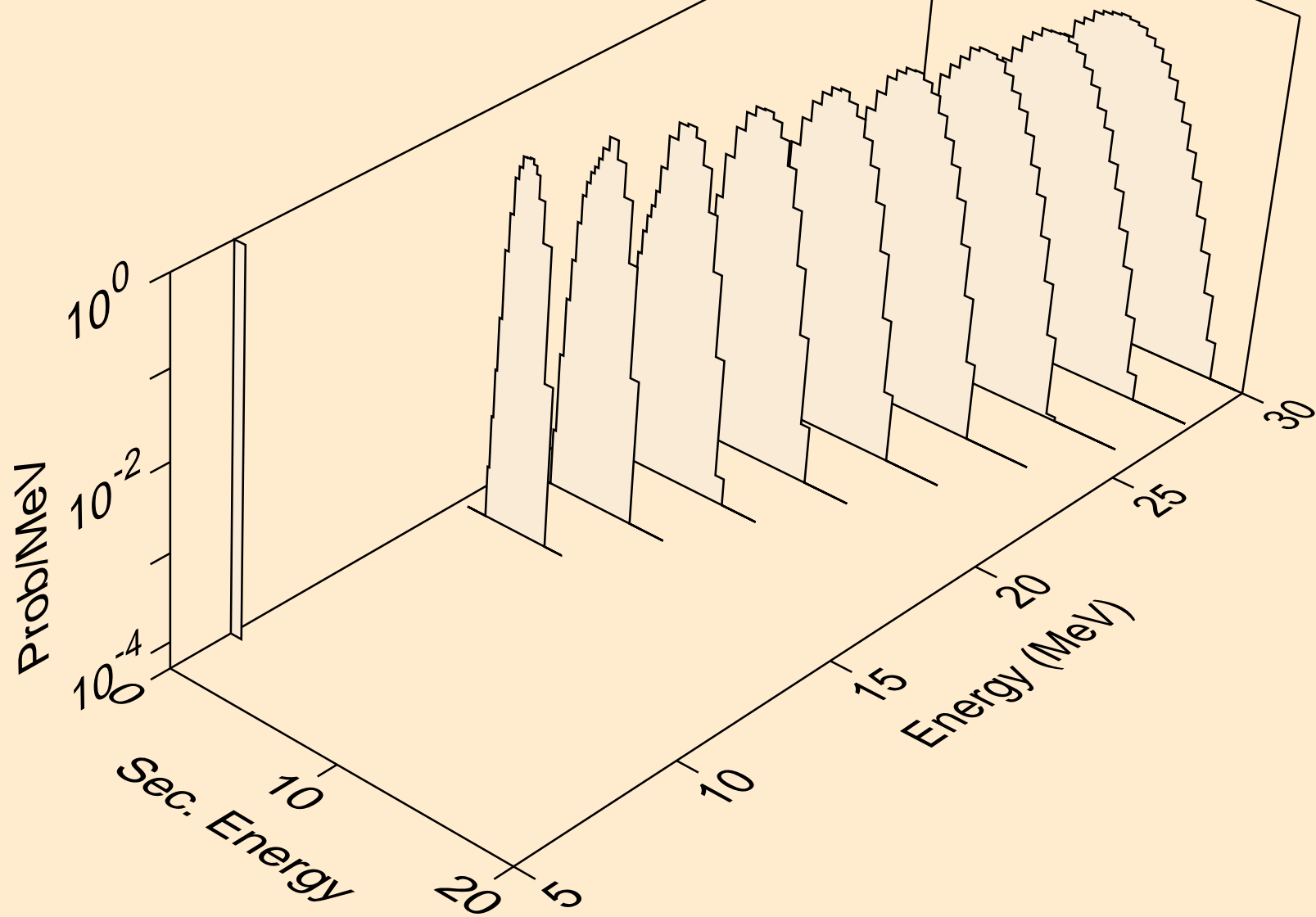

NP228 NEUTRON ACER TENDL-2023 LIBRARY; T=0.K
protons from (n,npa)

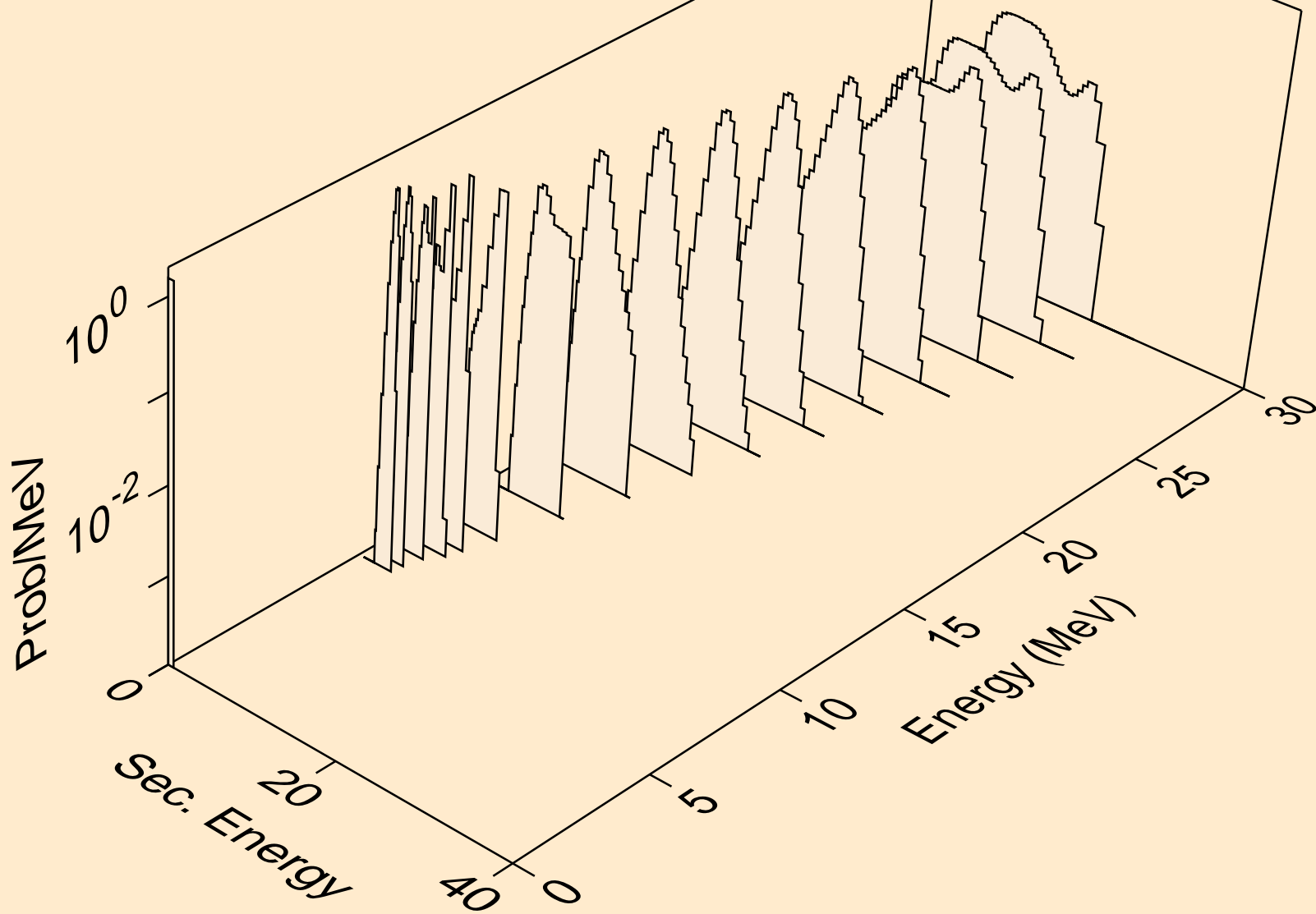

NP228 NEUTRON ACER TENDL-2023 LIBRARY; T=0.K
protons from (n,p)

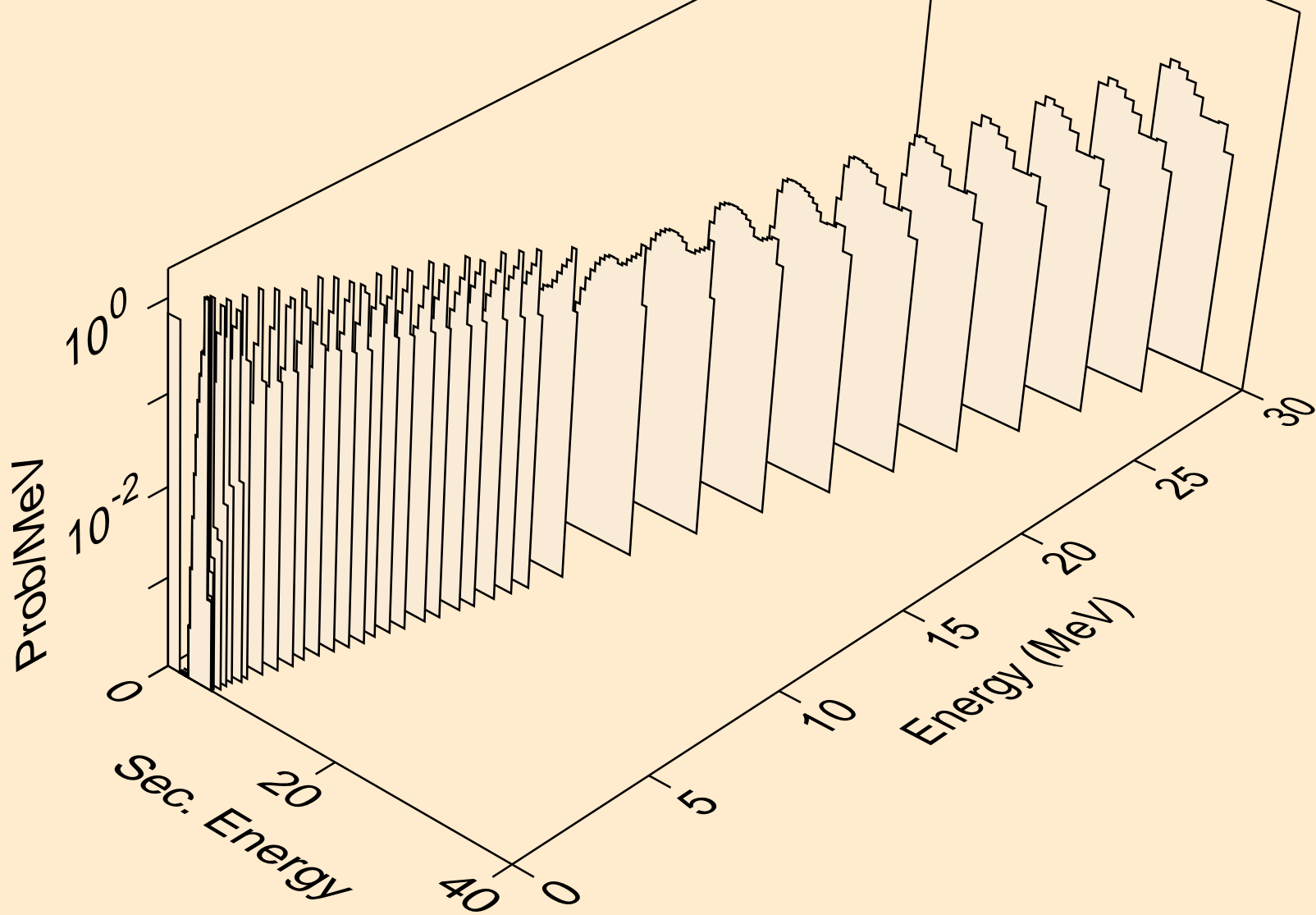

NP228 NEUTRON ACER TENDL-2023 LIBRARY; T=0.K
protons from (n,2p)

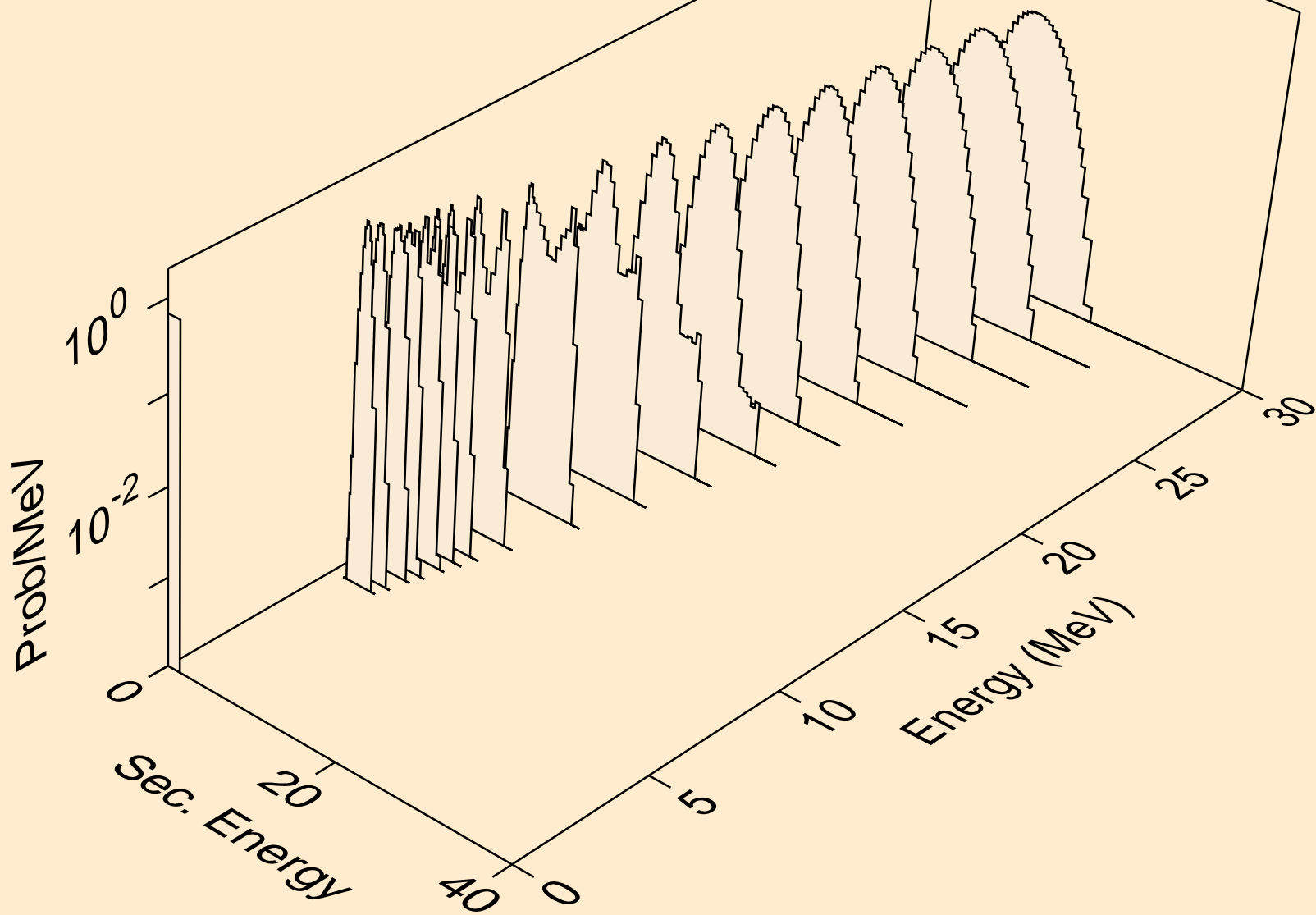

NP228 NEUTRON ACER TENDL-2023 LIBRARY; T=0.K
protons from (n,p)

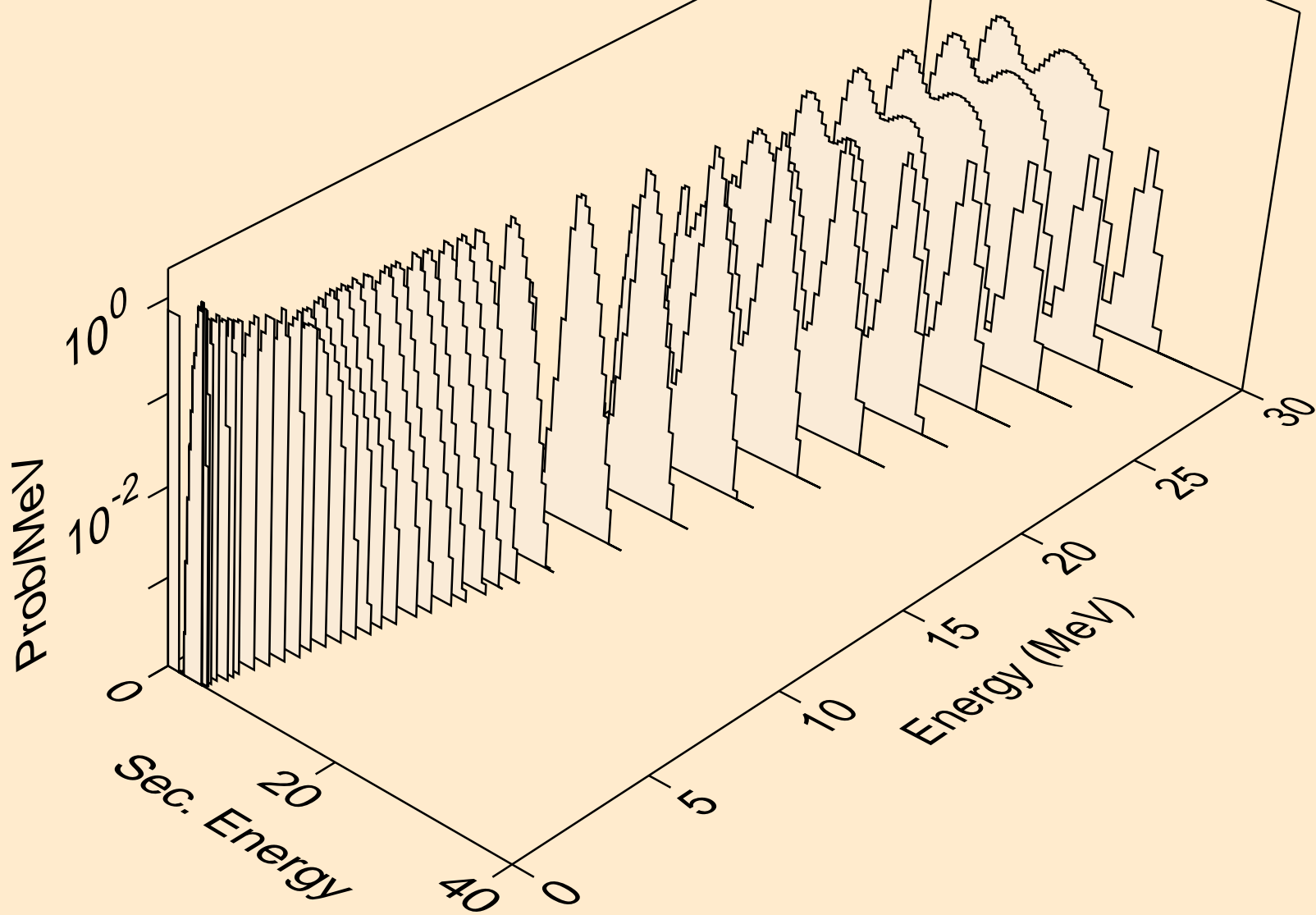

NP228 NEUTRON ACER TENDL-2023 LIBRARY; T=0.K
protons from (n,pd)

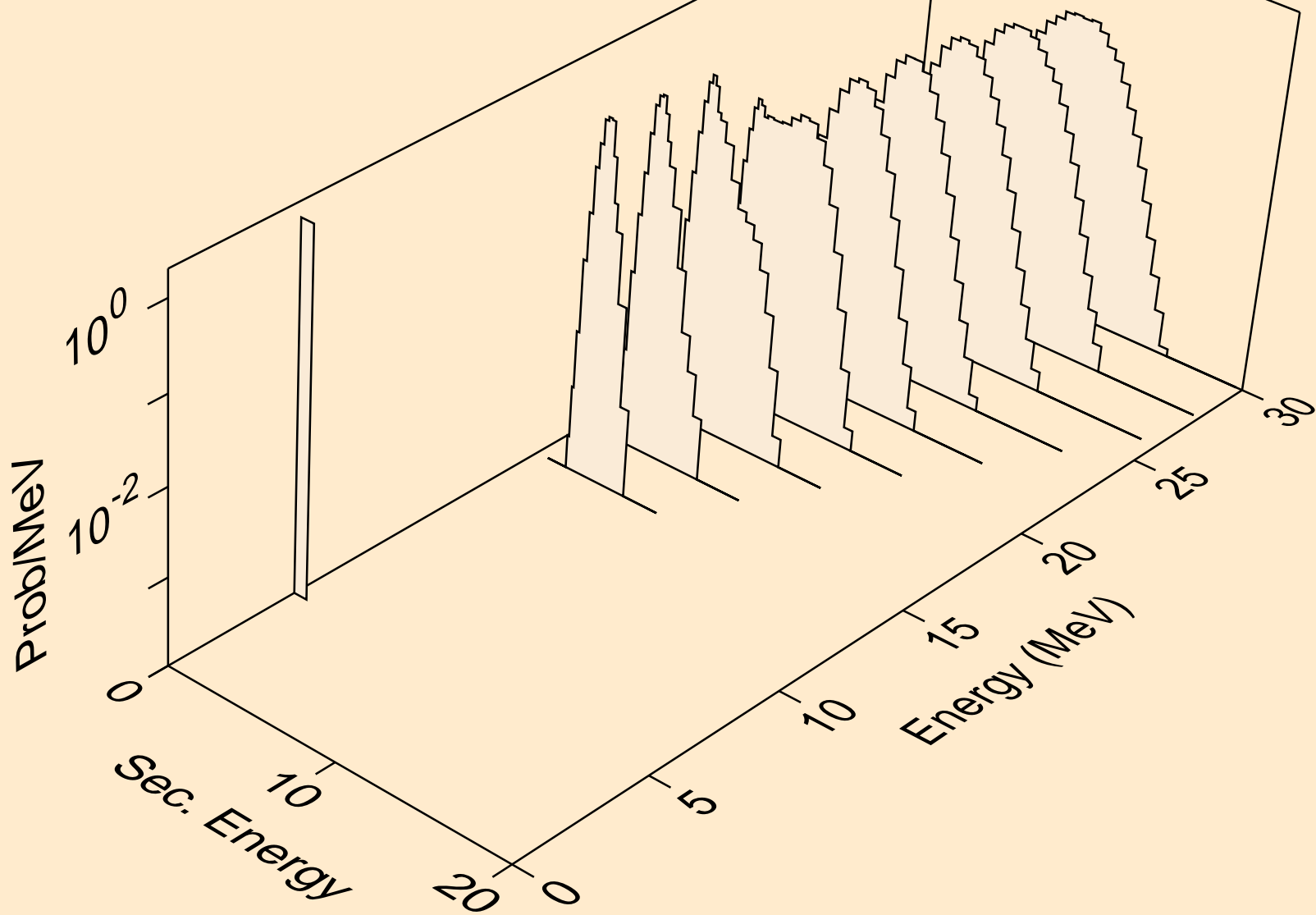

NP228 NEUTRON ACER TENDL-2023 LIBRARY; T=0.K
protons from (n,pt)

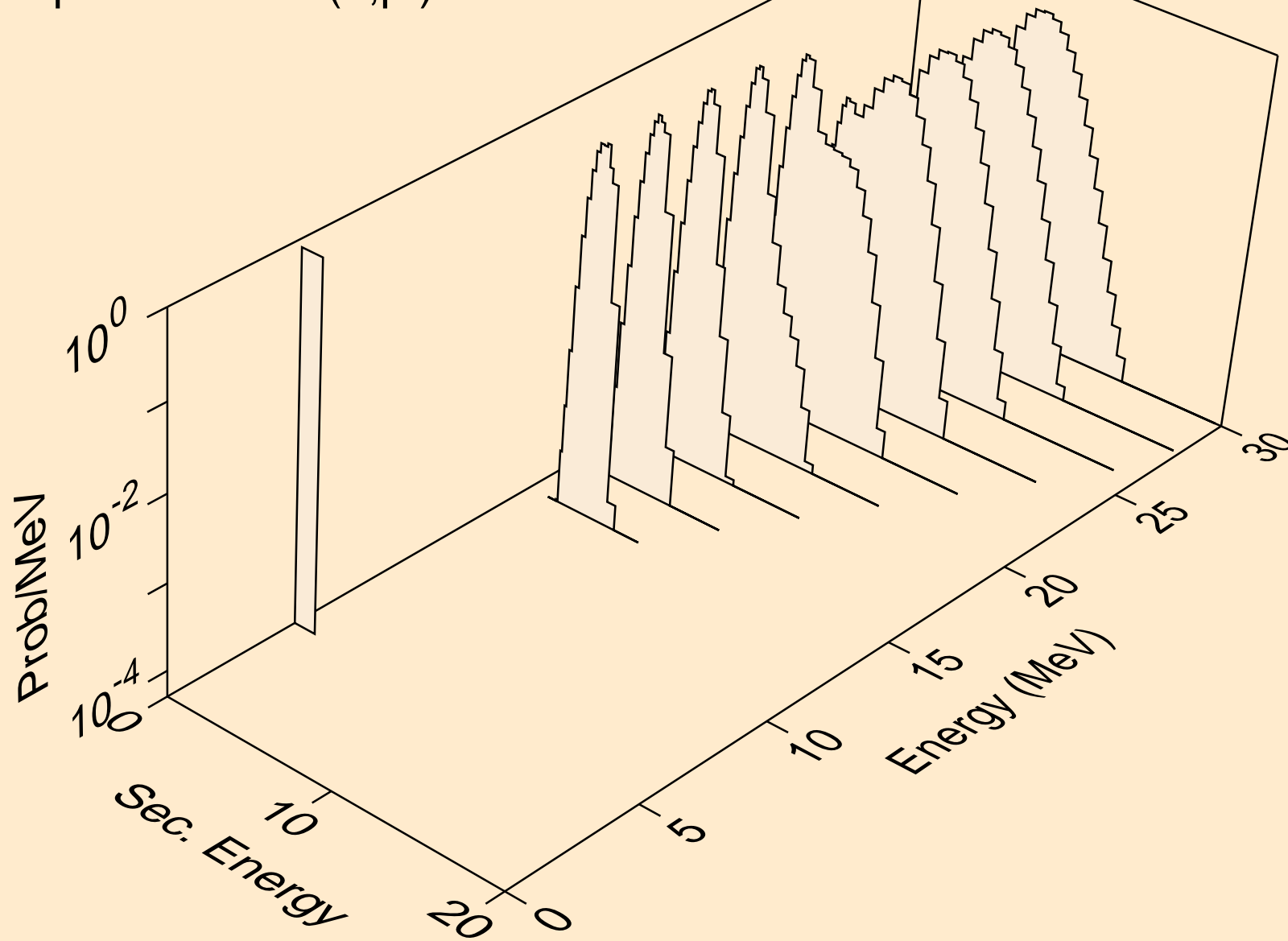

NP228 NEUTRON ACER TENDL-2023 LIBRARY; T=0.K
deuterons from (n,x)

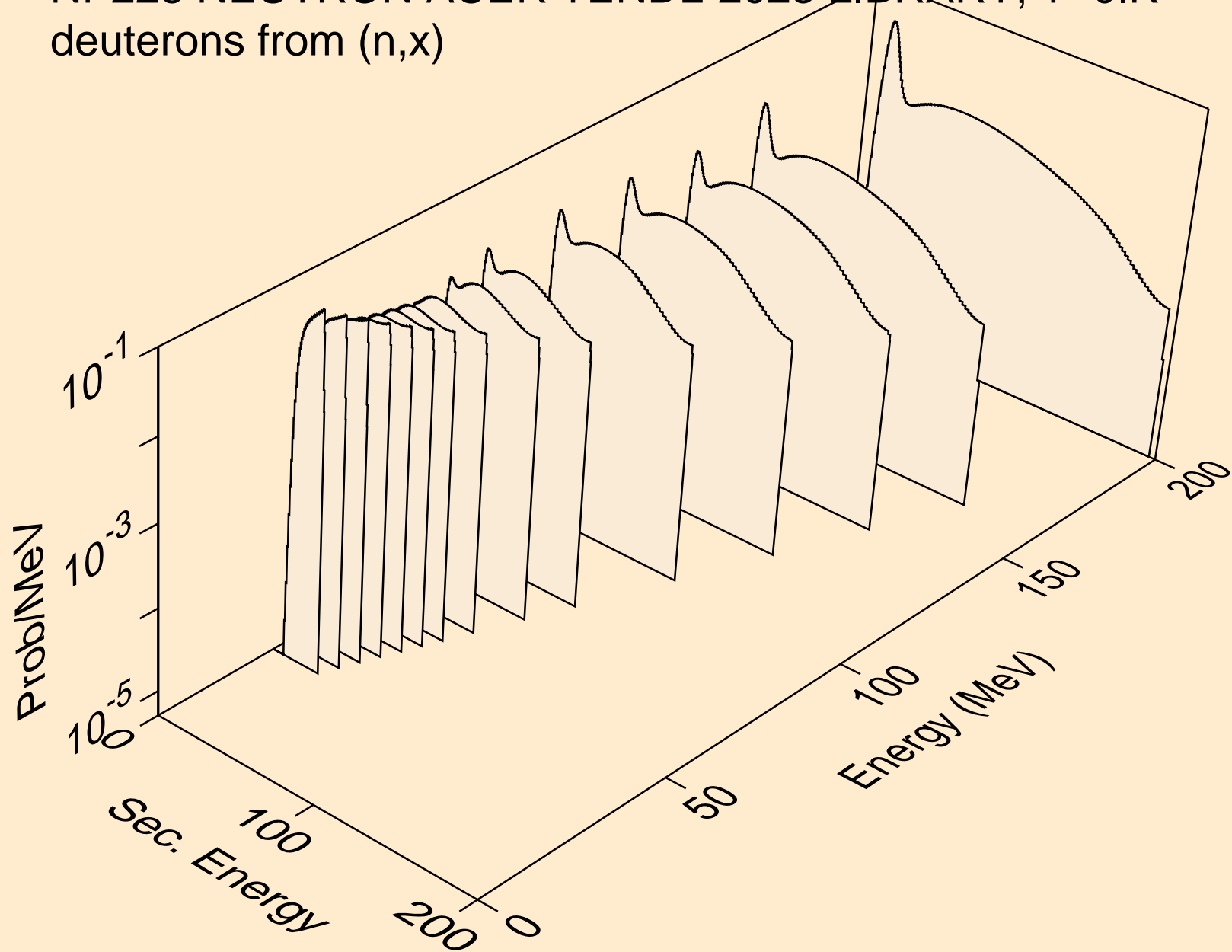

NP228 NEUTRON ACER TENDL-2023 LIBRARY; T=0.K
deuterons from (n,2nd)

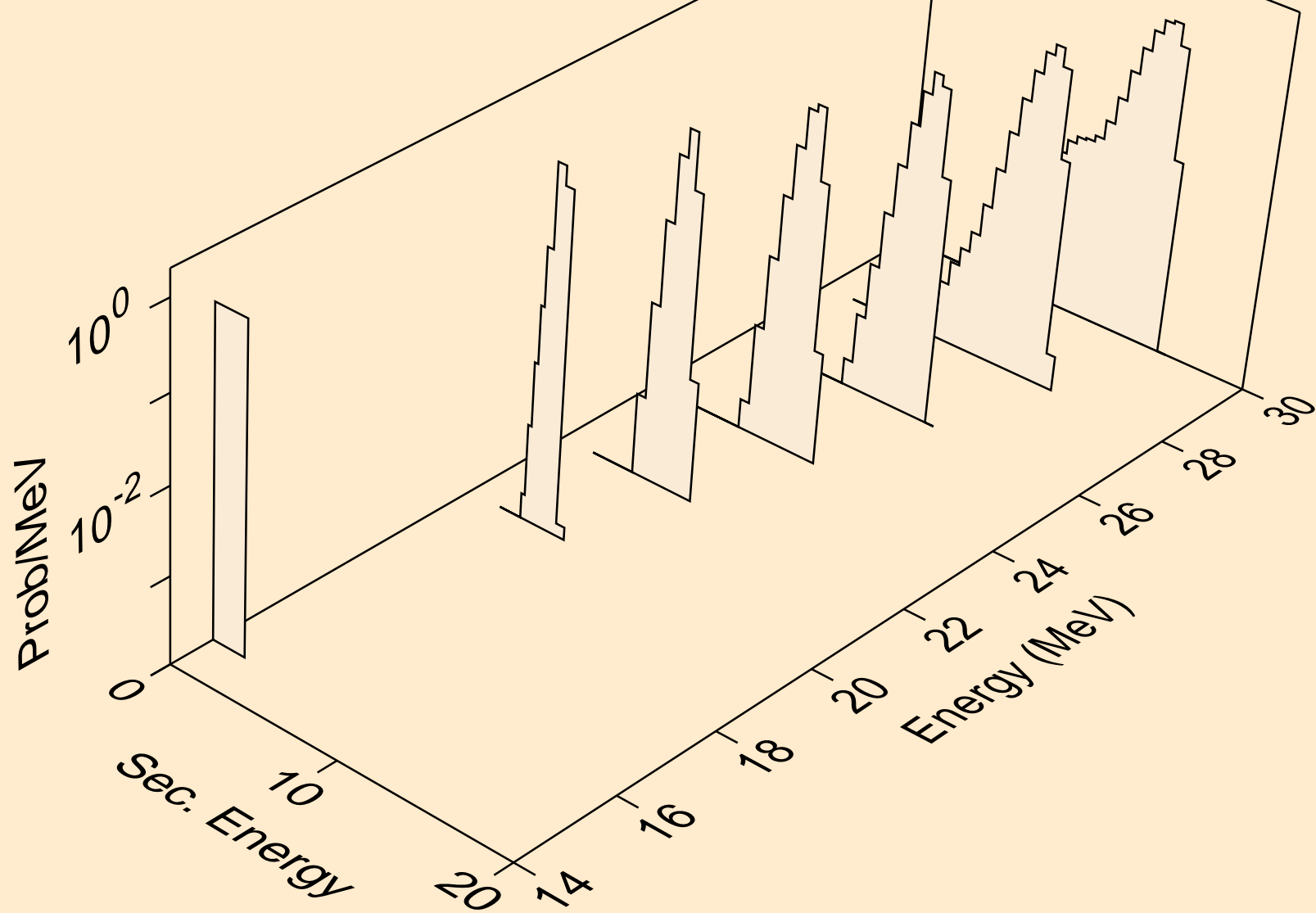

NP228 NEUTRON ACER TENDL-2023 LIBRARY; T=0.K
deuterons from (n,n*)d

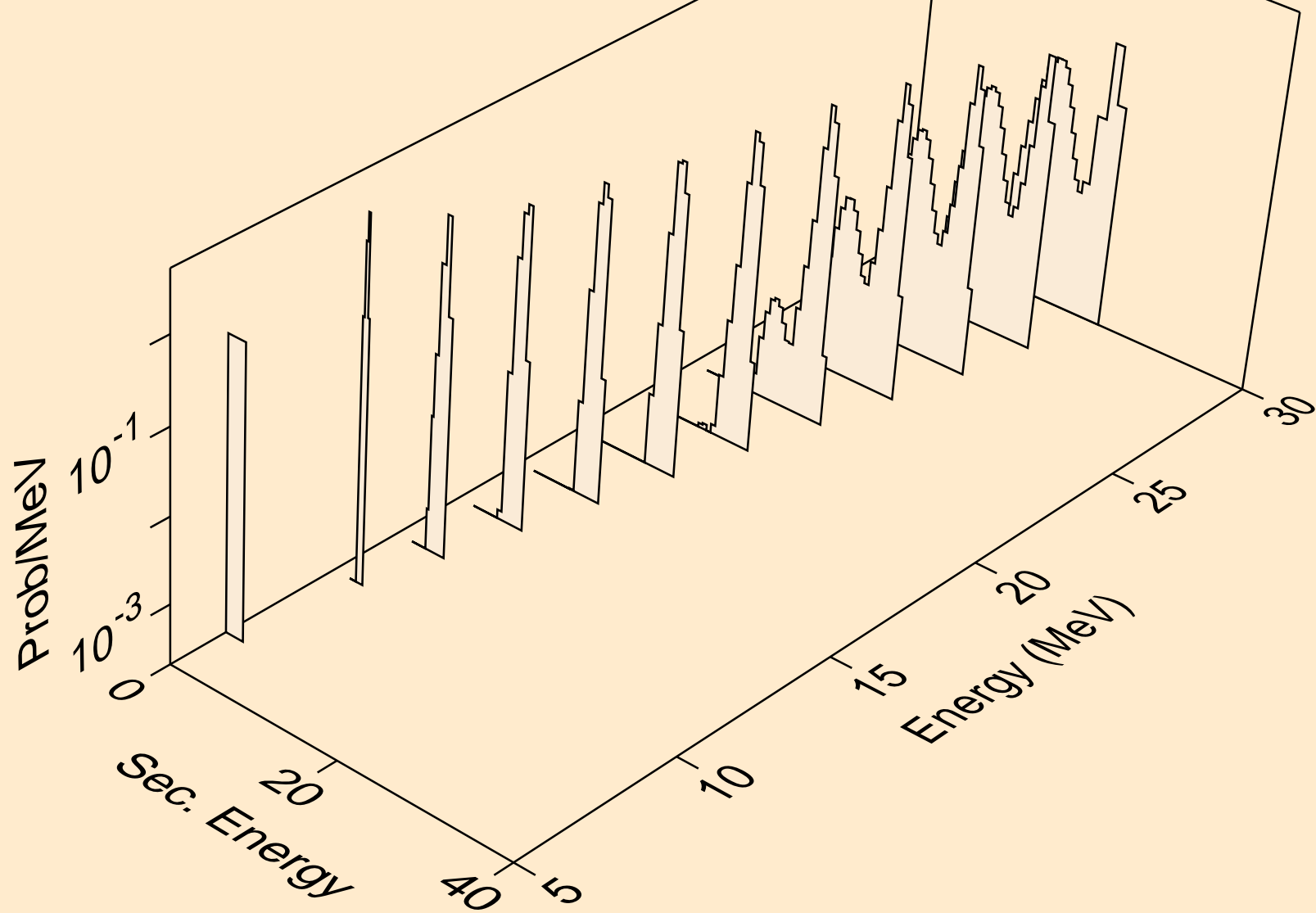

NP228 NEUTRON ACER TENDL-2023 LIBRARY; T=0.K
deuterons from (n,d)

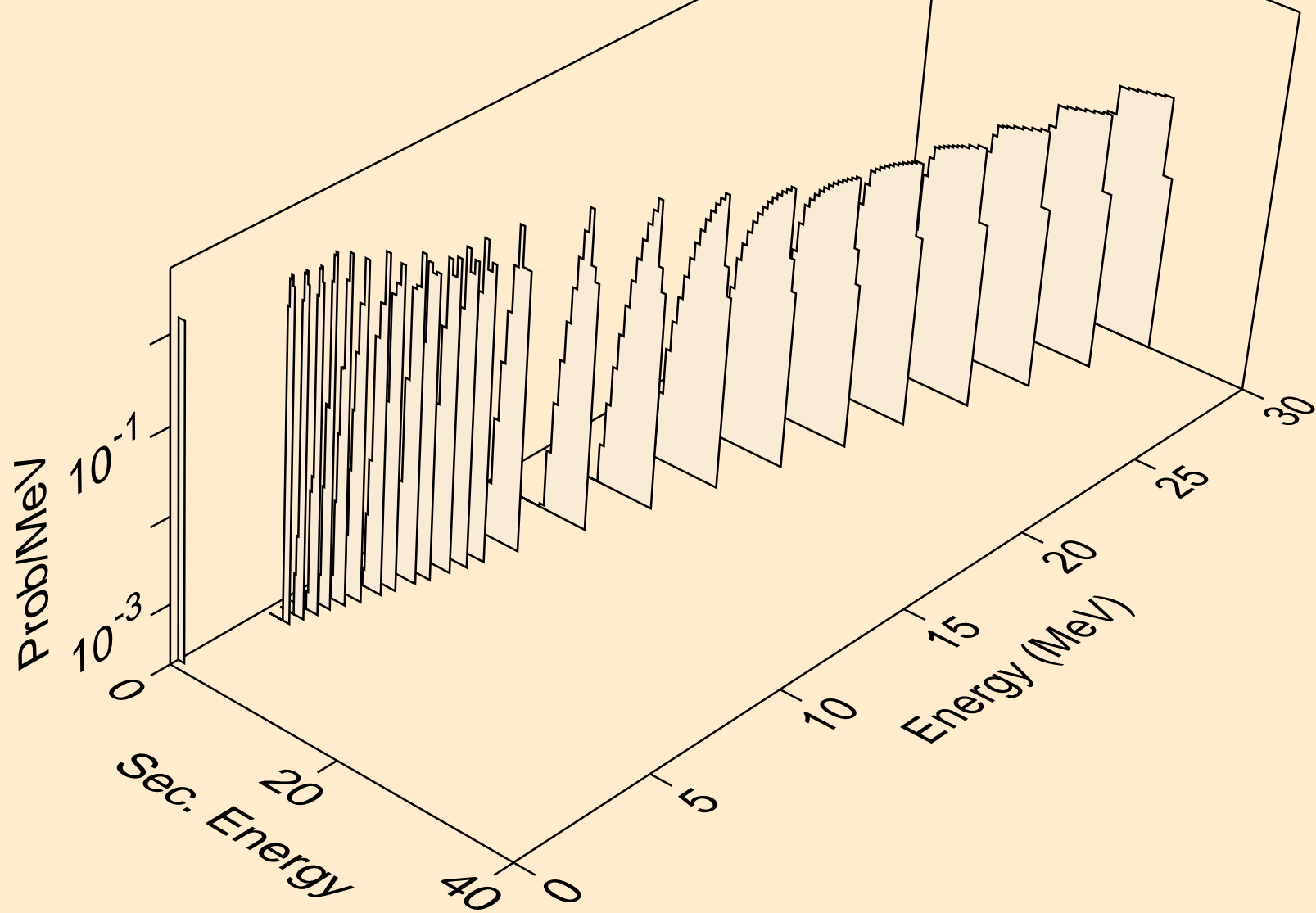

NP228 NEUTRON ACER TENDL-2023 LIBRARY; T=0.K
deuterons from (n,pd)

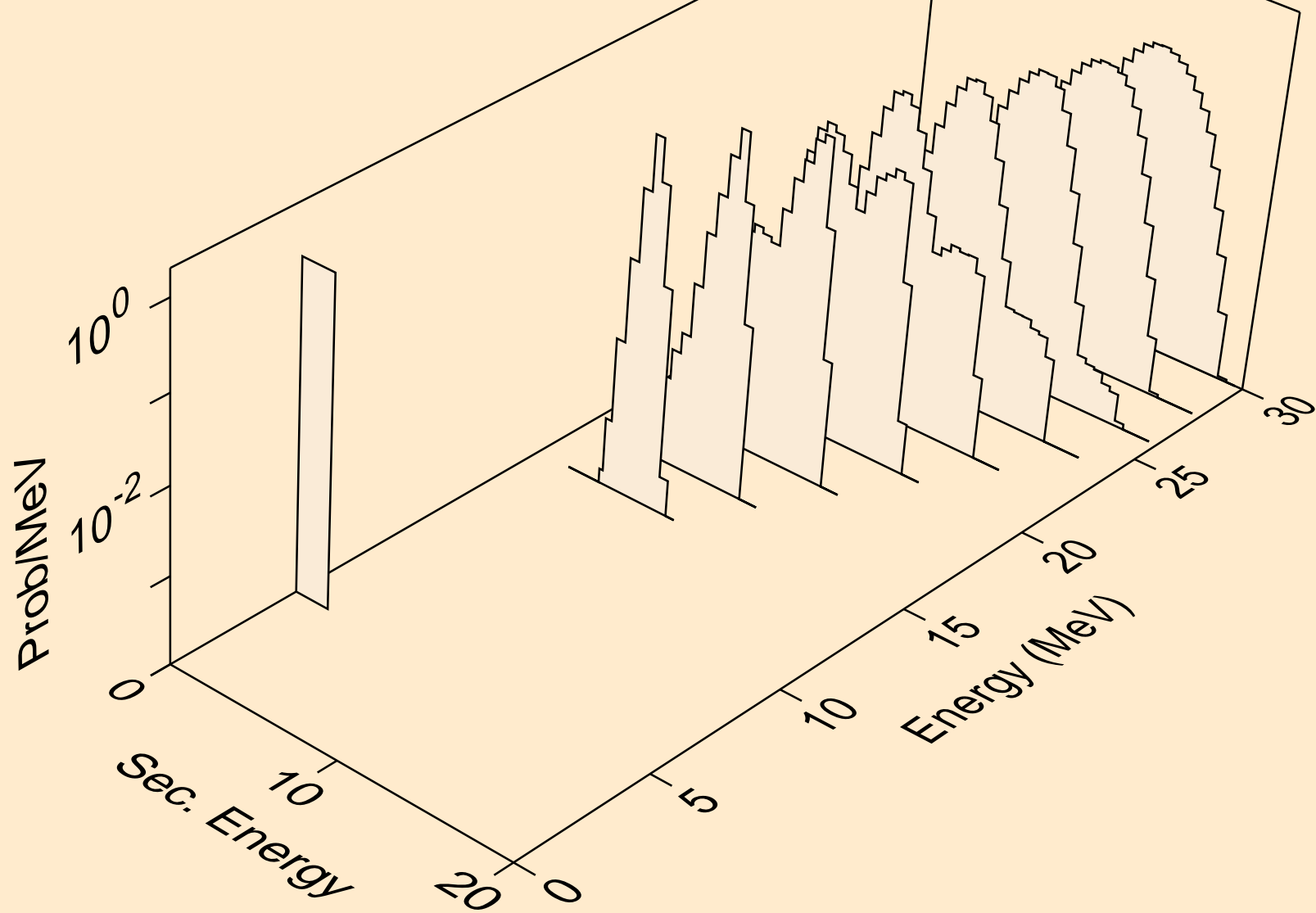

NP228 NEUTRON ACER TENDL-2023 LIBRARY; T=0.K
deuterons from (n,da)

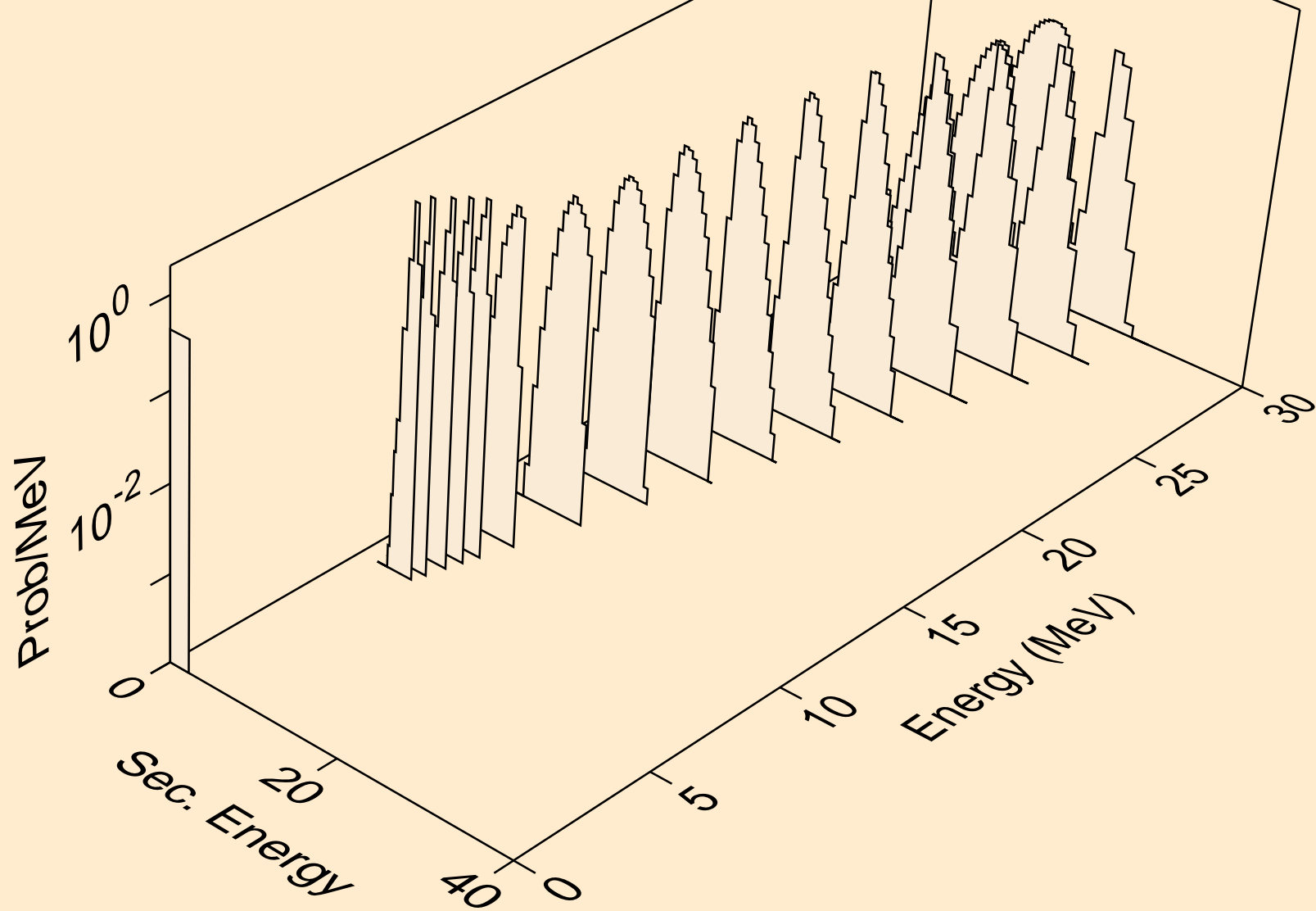

NP228 NEUTRON ACER TENDL-2023 LIBRARY; T=0.K
tritons from (n,x)

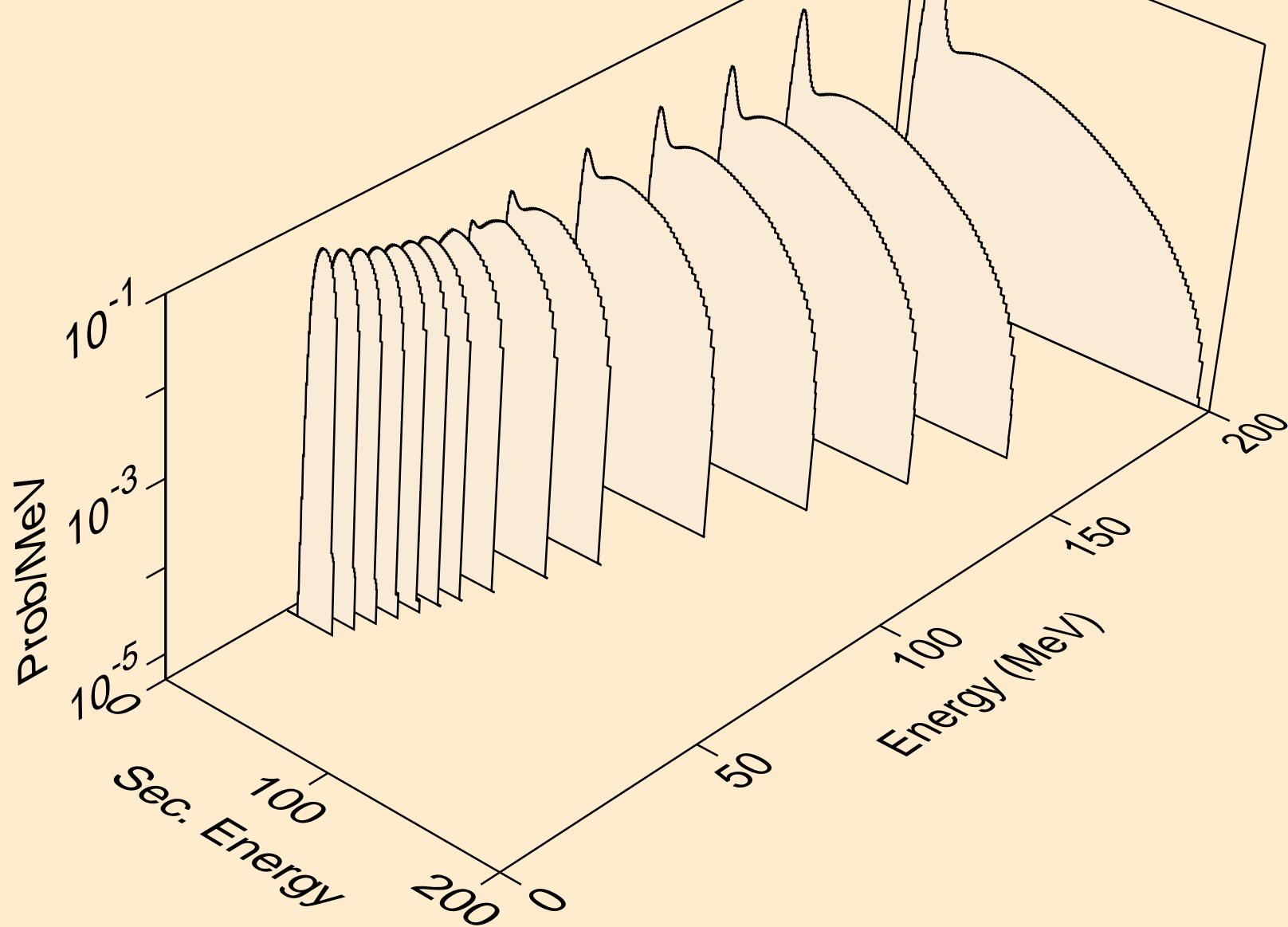

NP228 NEUTRON ACER TENDL-2023 LIBRARY; T=0.K
tritons from (n,n*)t

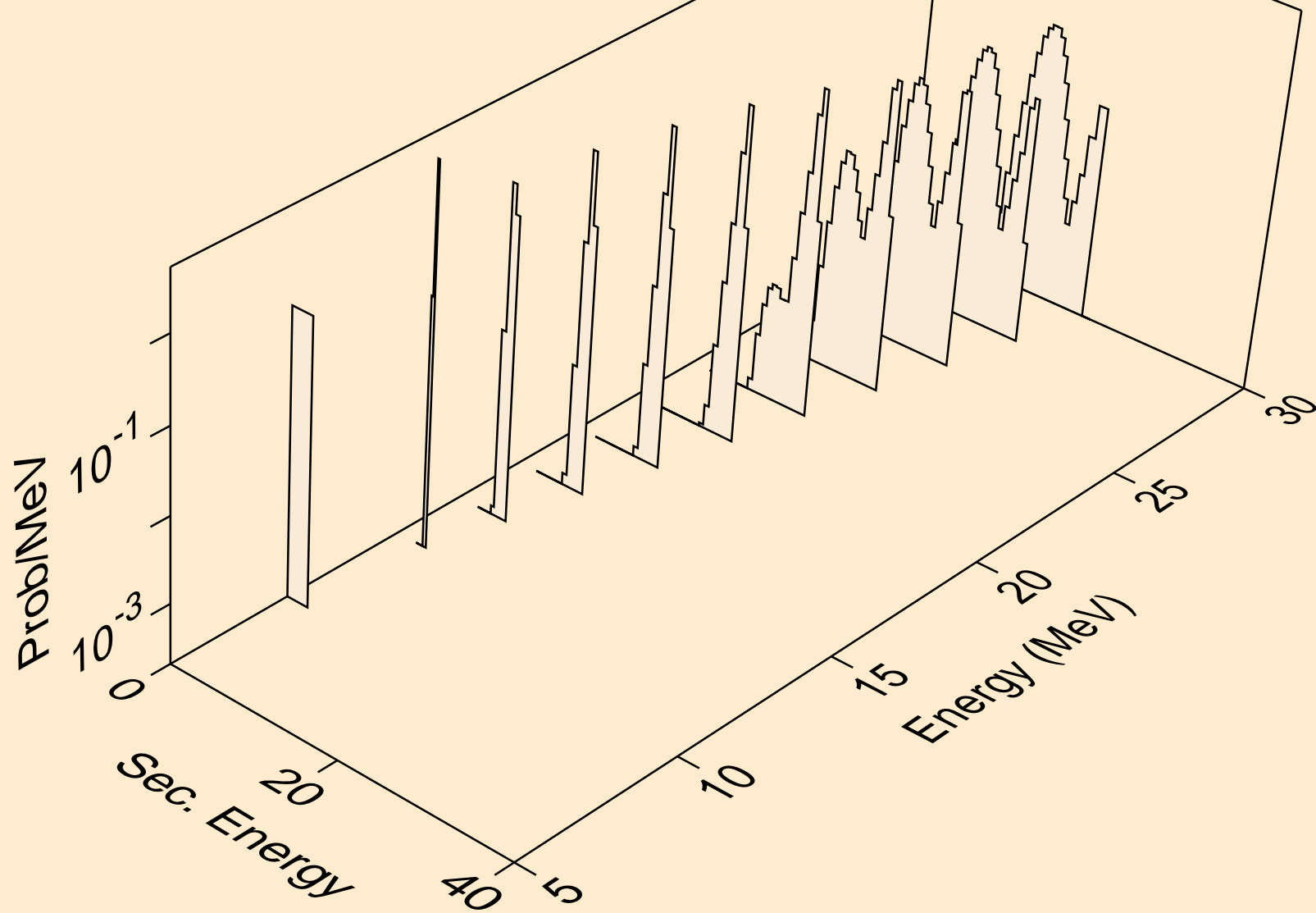

NP228 NEUTRON ACER TENDL-2023 LIBRARY; T=0.K
tritons from (n,t)

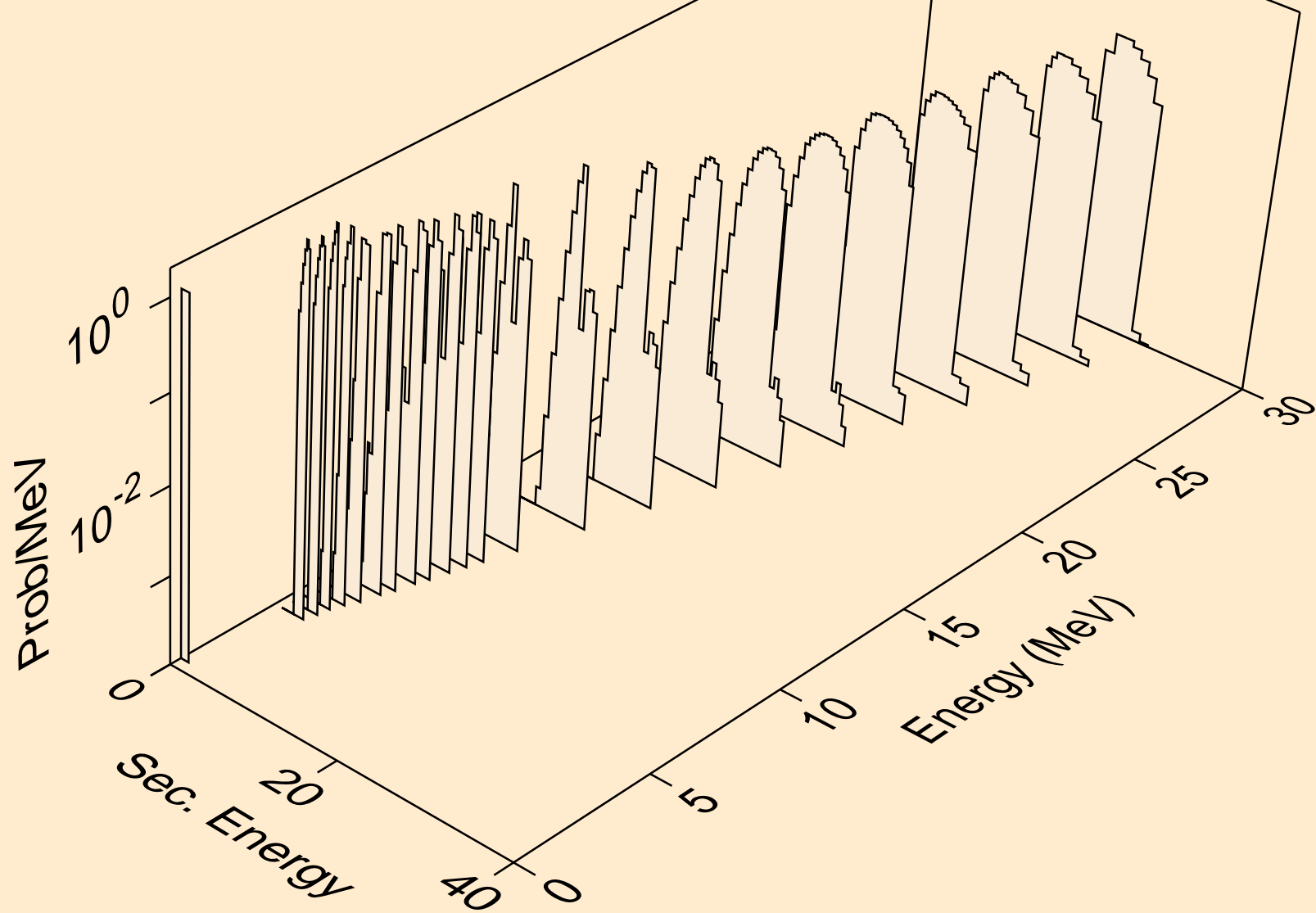

NP228 NEUTRON ACER TENDL-2023 LIBRARY; T=0.K
tritons from (n,pt)

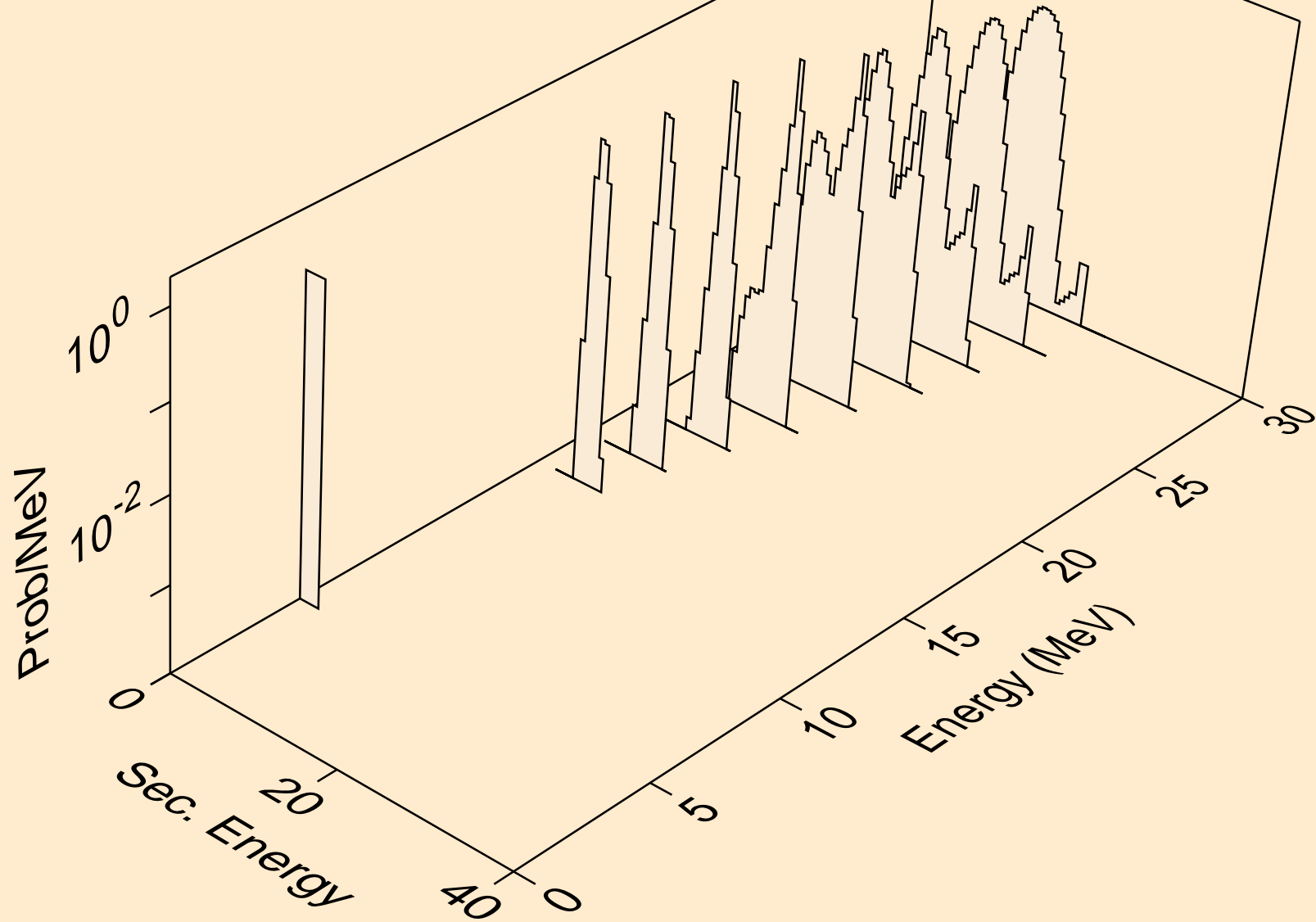

NP228 NEUTRON ACER TENDL-2023 LIBRARY; T=0.K
he3s from (n,x)

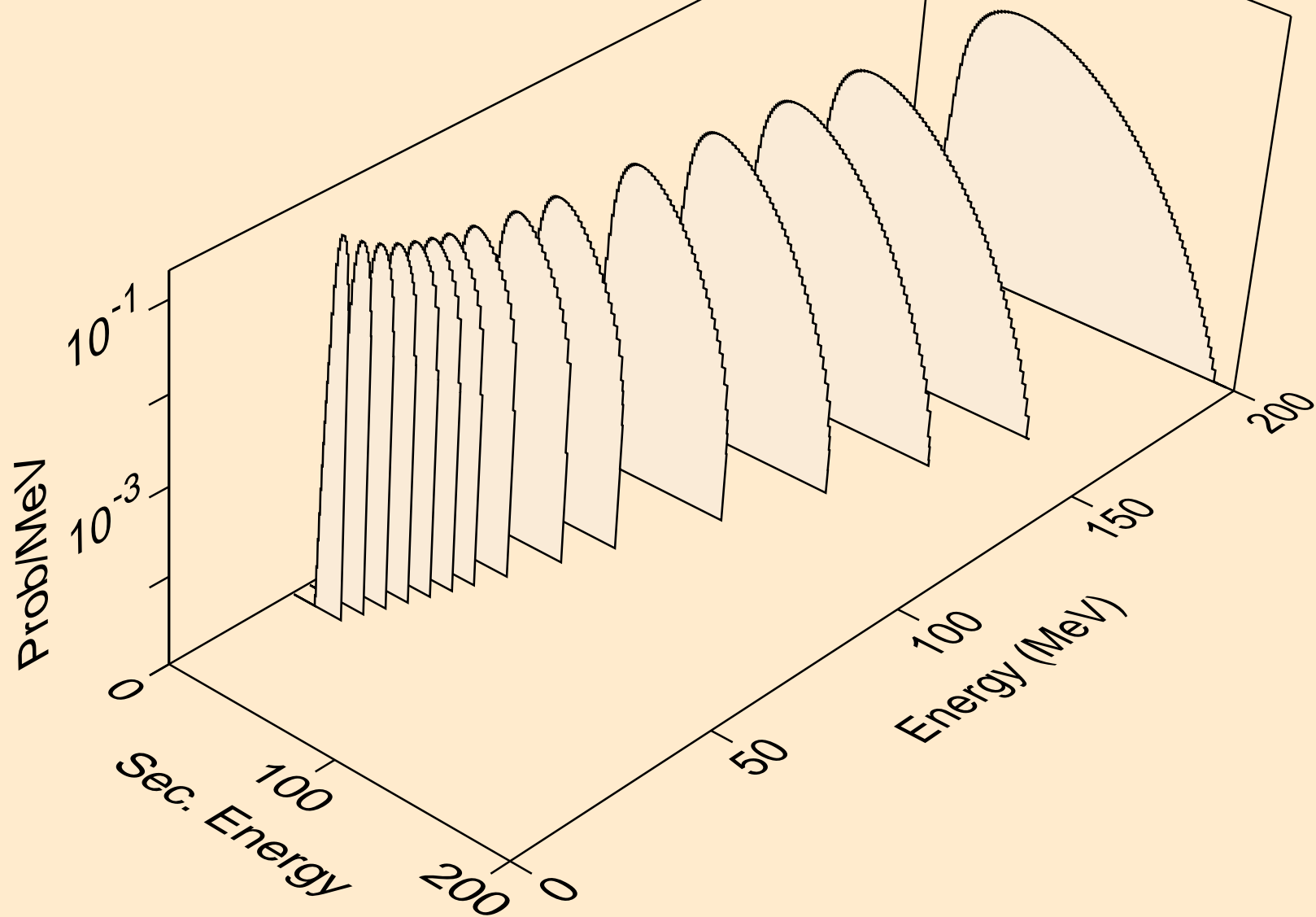

NP228 NEUTRON ACER TENDL-2023 LIBRARY; T=0.K
he3s from (n,n*)he3

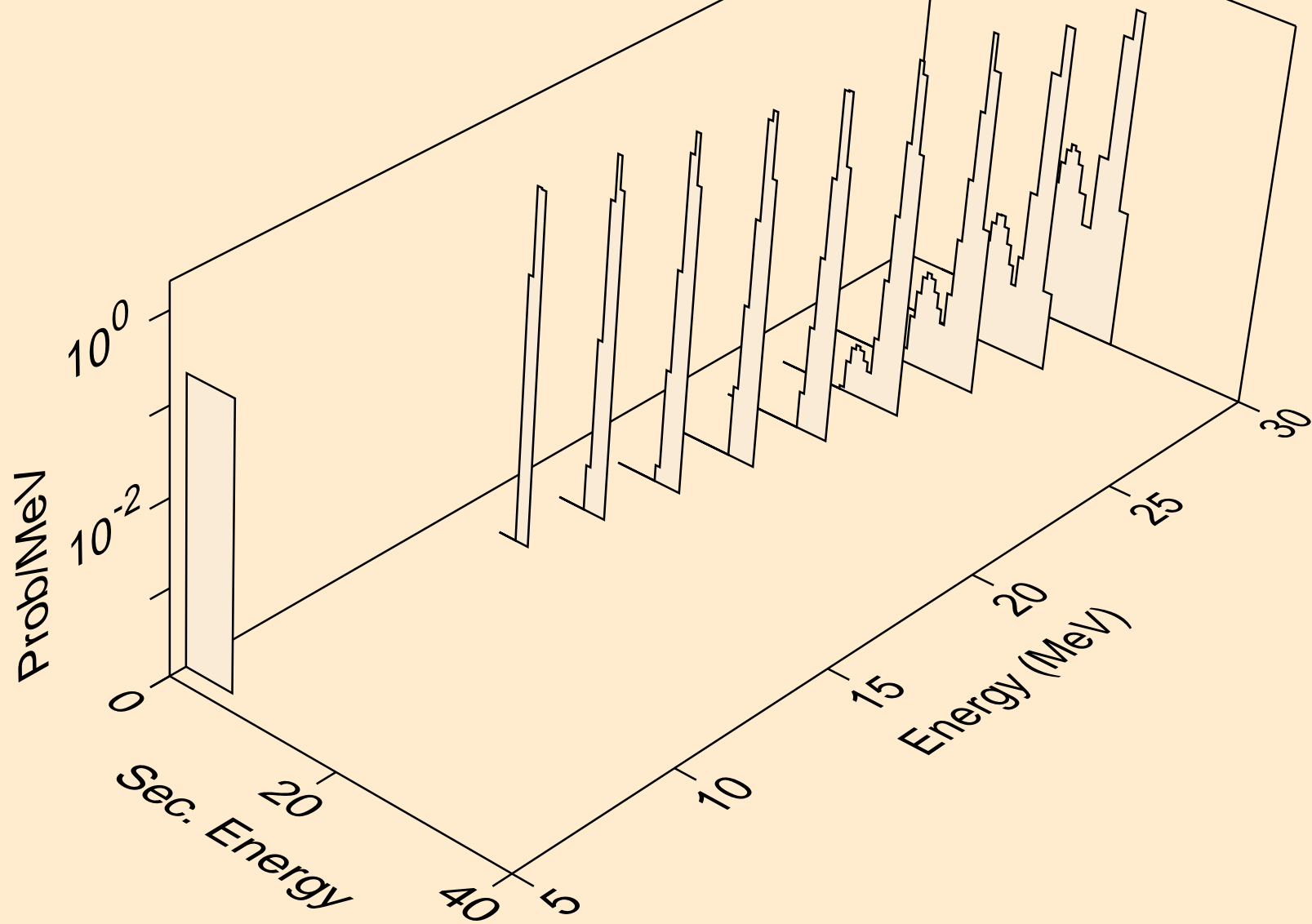

NP228 NEUTRON ACER TENDL-2023 LIBRARY; T=0.K
he3s from (n,he3)

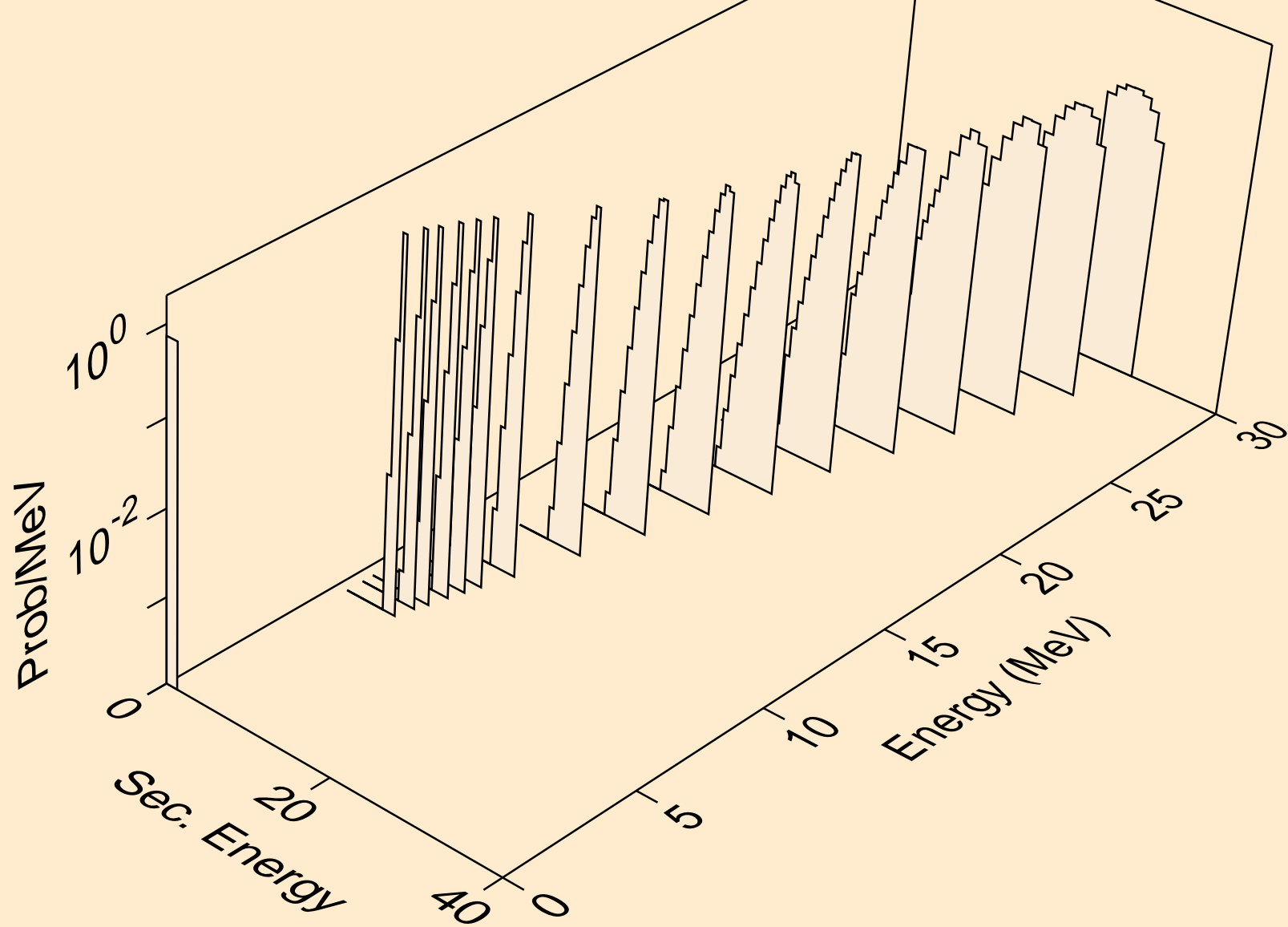

NP228 NEUTRON ACER TENDL-2023 LIBRARY; T=0.K
alphas from (n,x)

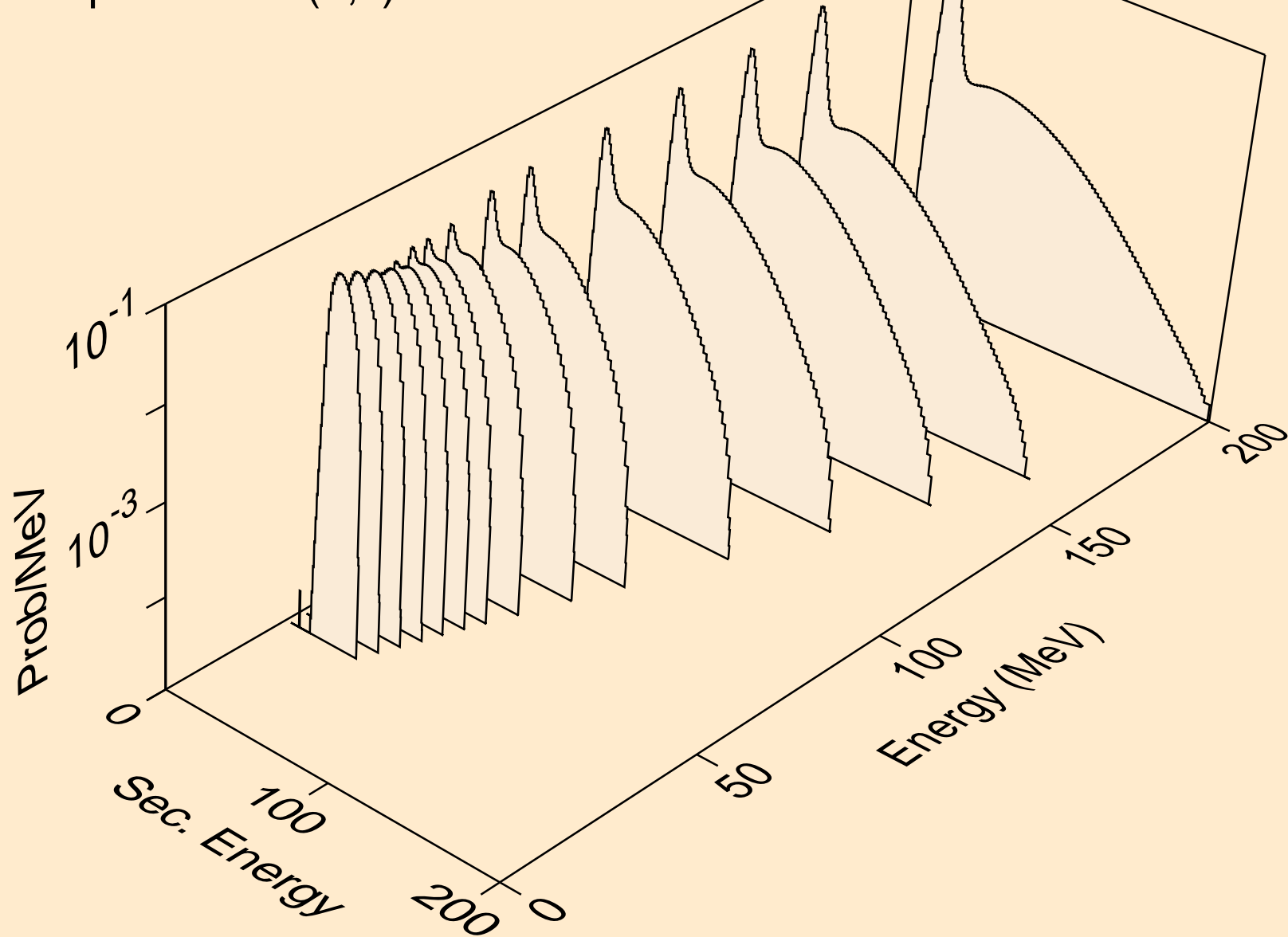

NP228 NEUTRON ACER TENDL-2023 LIBRARY; T=0.K
alphas from (n,n*)a

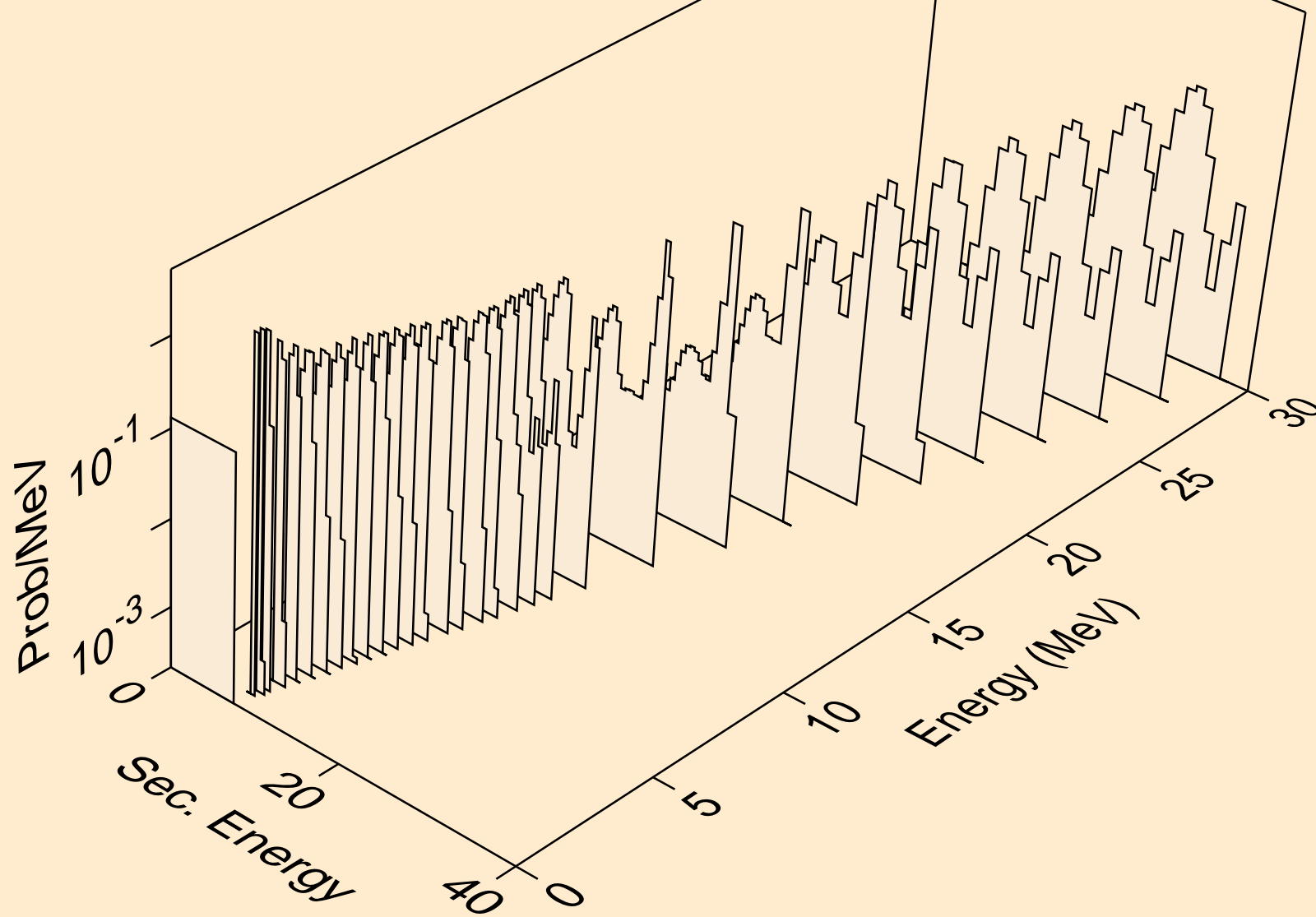

NP228 NEUTRON ACER TENDL-2023 LIBRARY; T=0.K
alphas from (n,2n)a

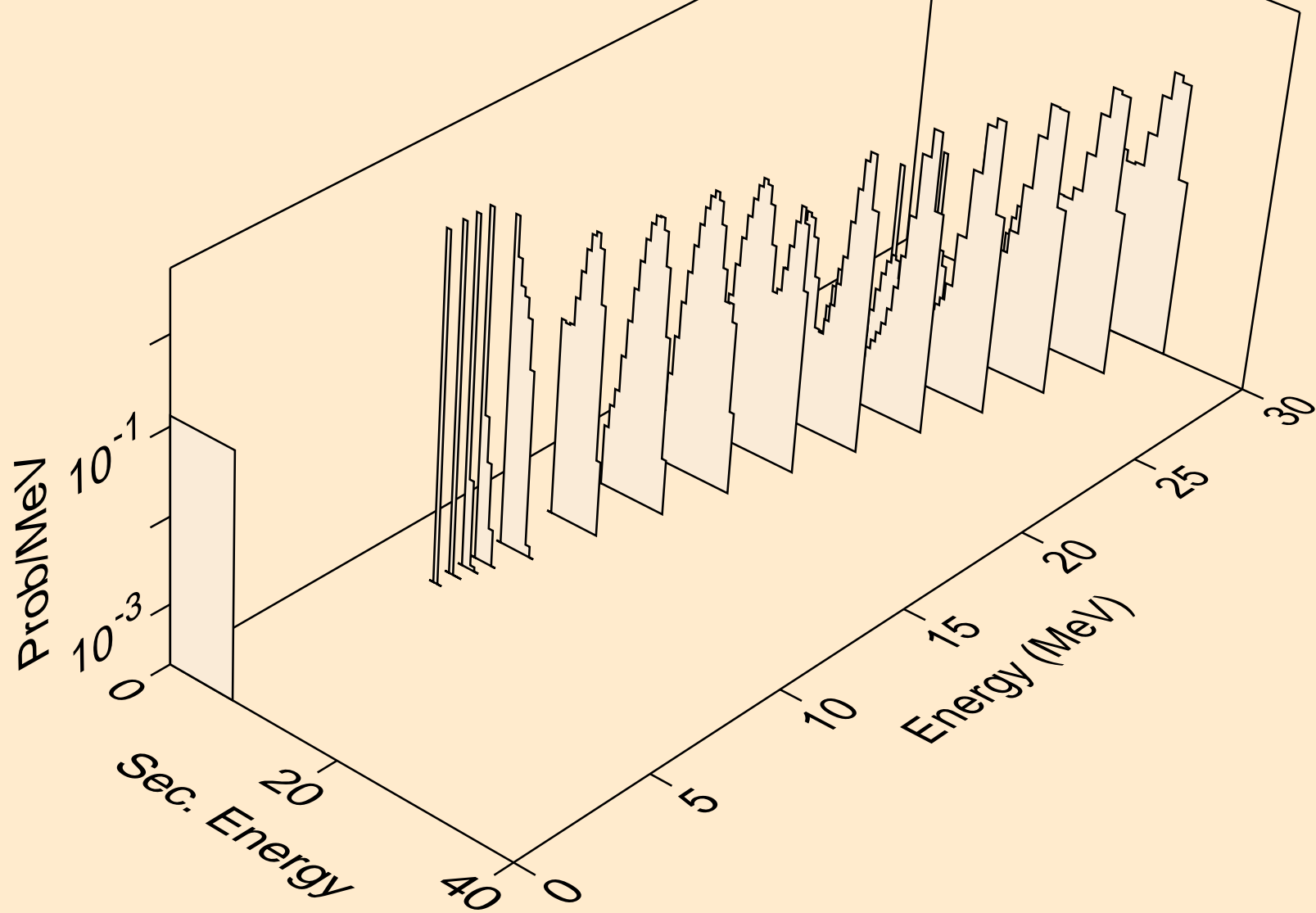

NP228 NEUTRON ACER TENDL-2023 LIBRARY; T=0.K
alphas from (n,3n)a

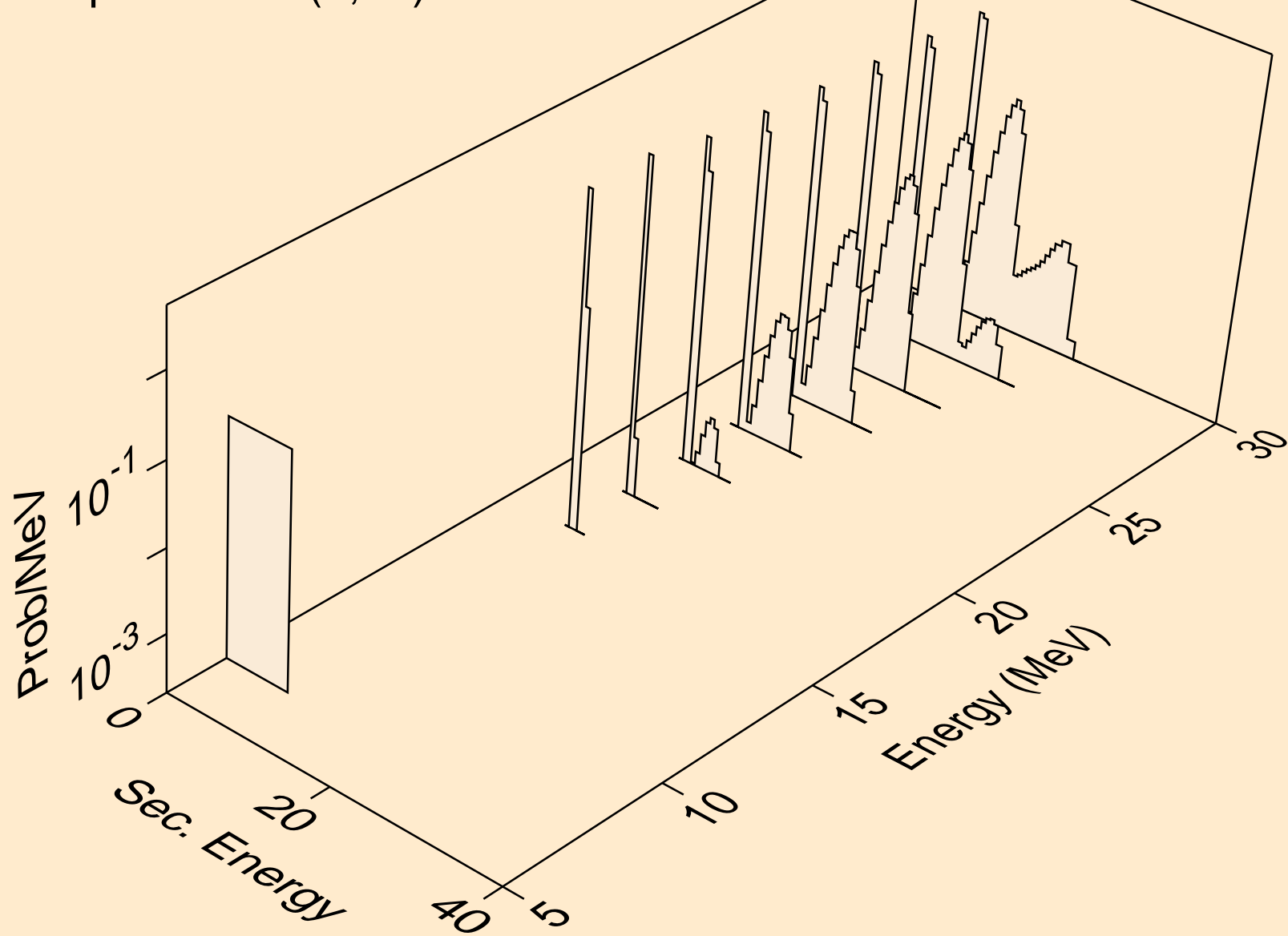

NP228 NEUTRON ACER TENDL-2023 LIBRARY; T=0.K
alphas from (n,n*)2a

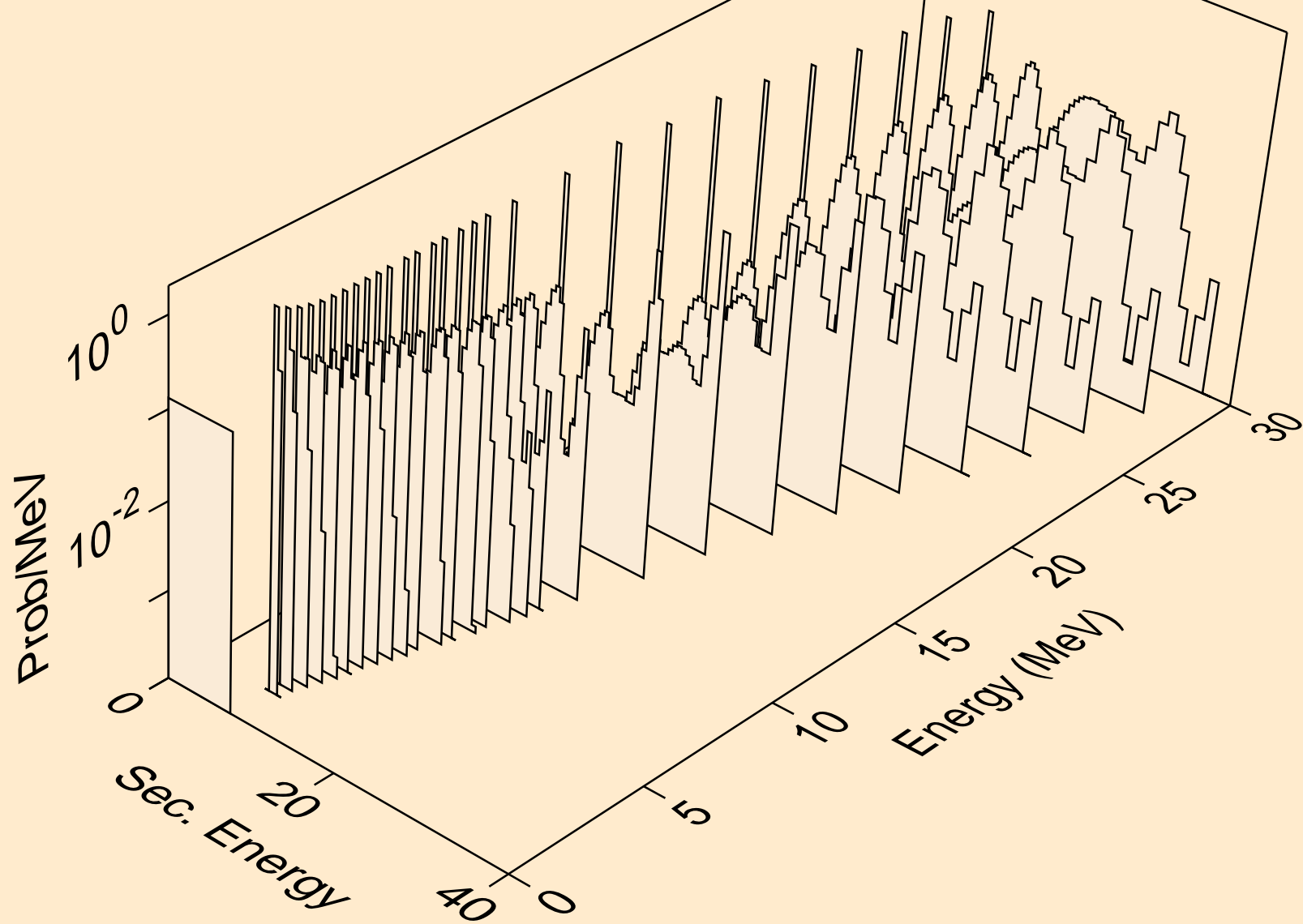

NP228 NEUTRON ACER TENDL-2023 LIBRARY; T=0.K
alphas from (n,2n)2a

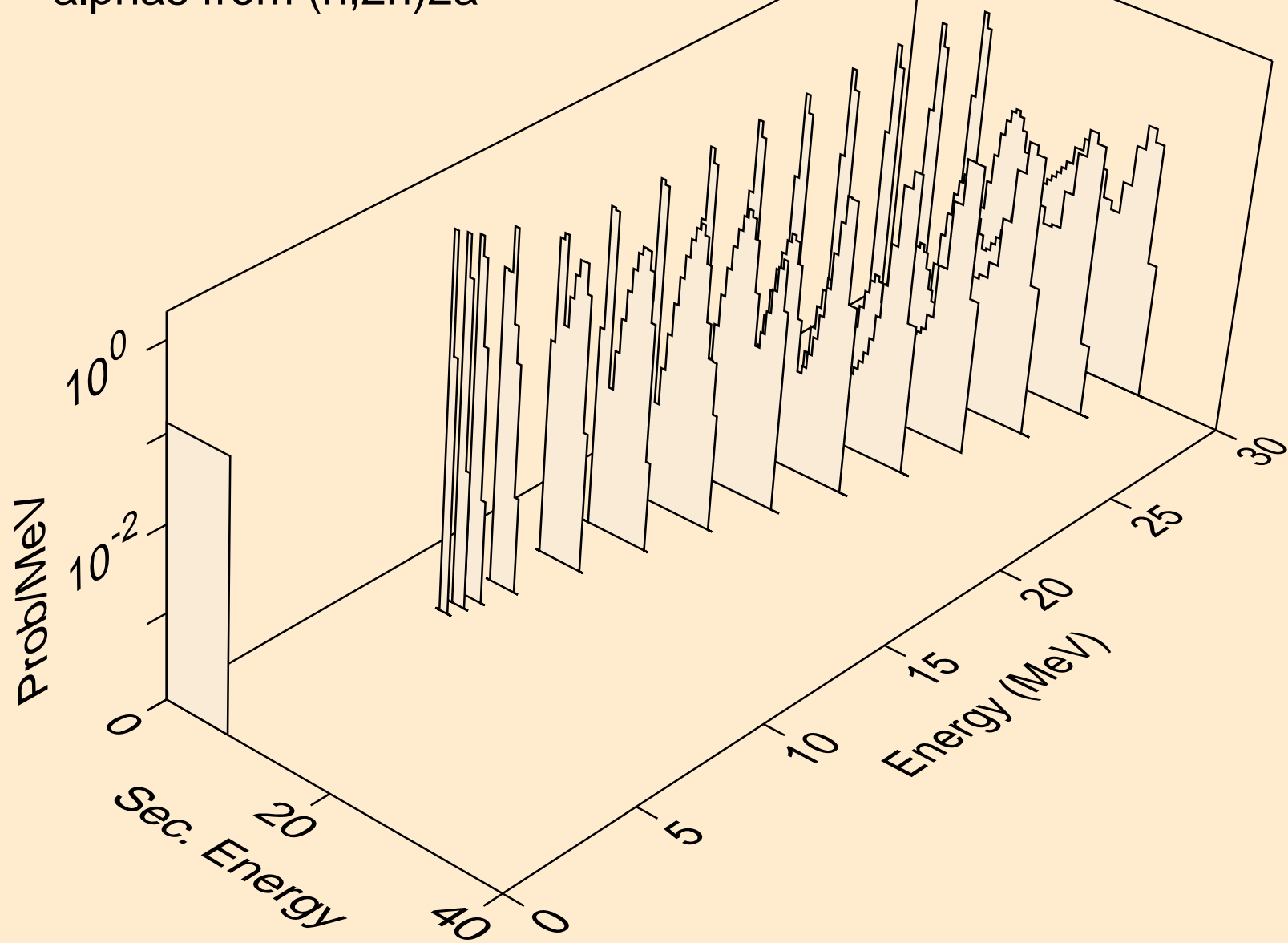

NP228 NEUTRON ACER TENDL-2023 LIBRARY; T=0.K
alphas from (n,npa)

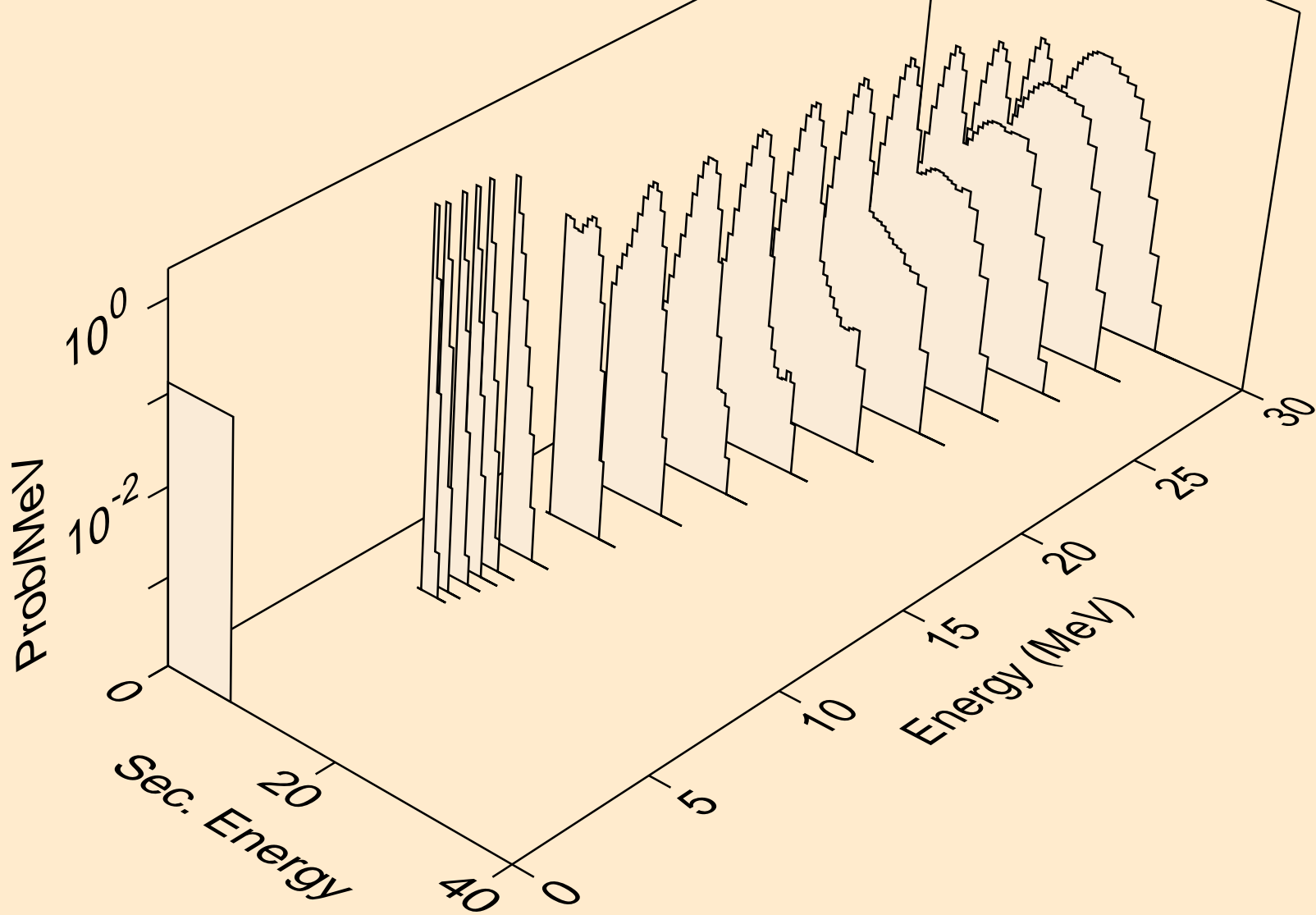

NP228 NEUTRON ACER TENDL-2023 LIBRARY; T=0.K
alphas from (n,a)

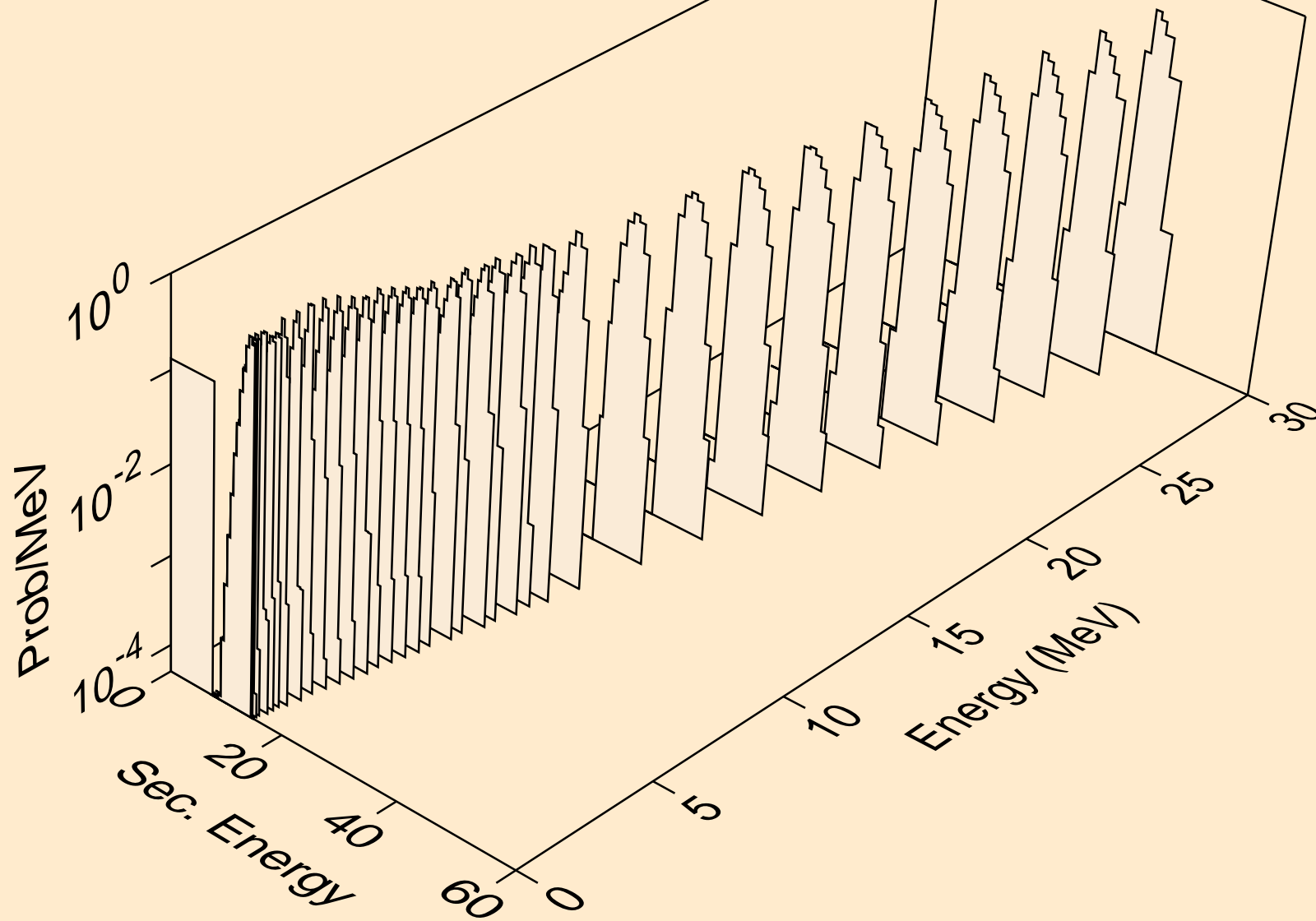

NP228 NEUTRON ACER TENDL-2023 LIBRARY; T=0.K
alphas from (n,2a)

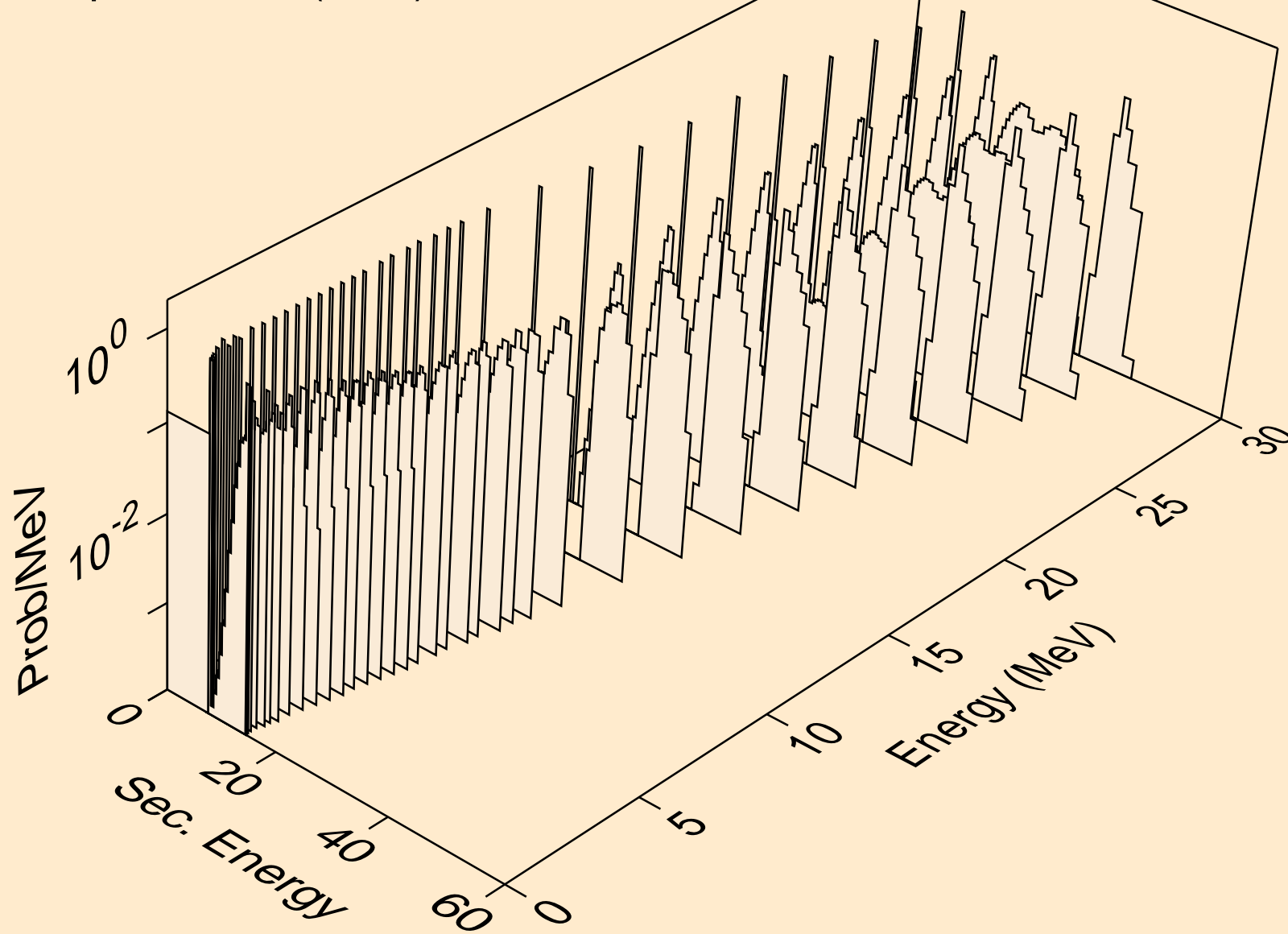

NP228 NEUTRON ACER TENDL-2023 LIBRARY; T=0.K
alphas from (n,pa)

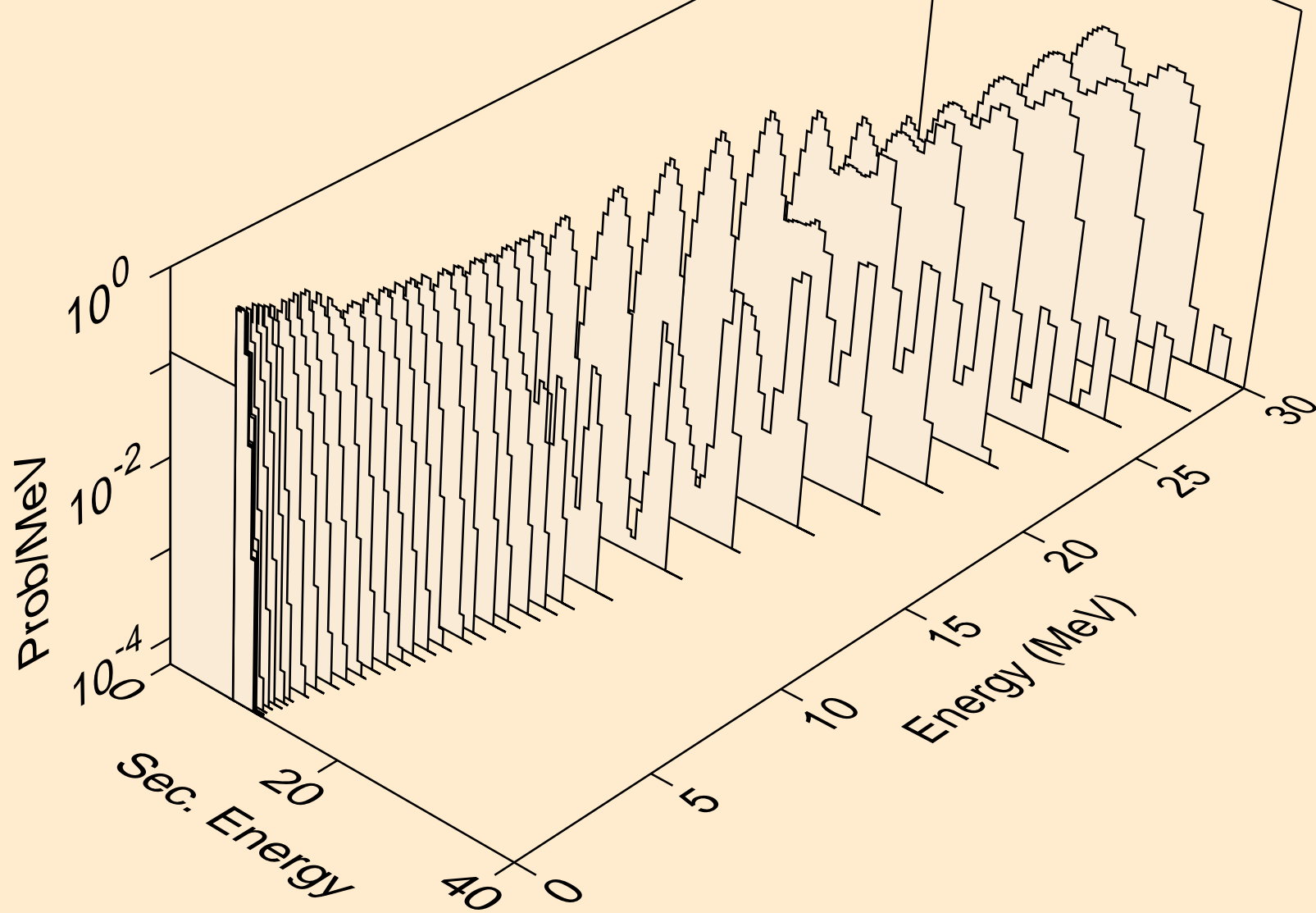

NP228 NEUTRON ACER TENDL-2023 LIBRARY; T=0.K
alphas from (n,da)

