

OS184 NEUTRON ACER TENDL-2023 LIBRARY; T=0.K

Principal cross sections

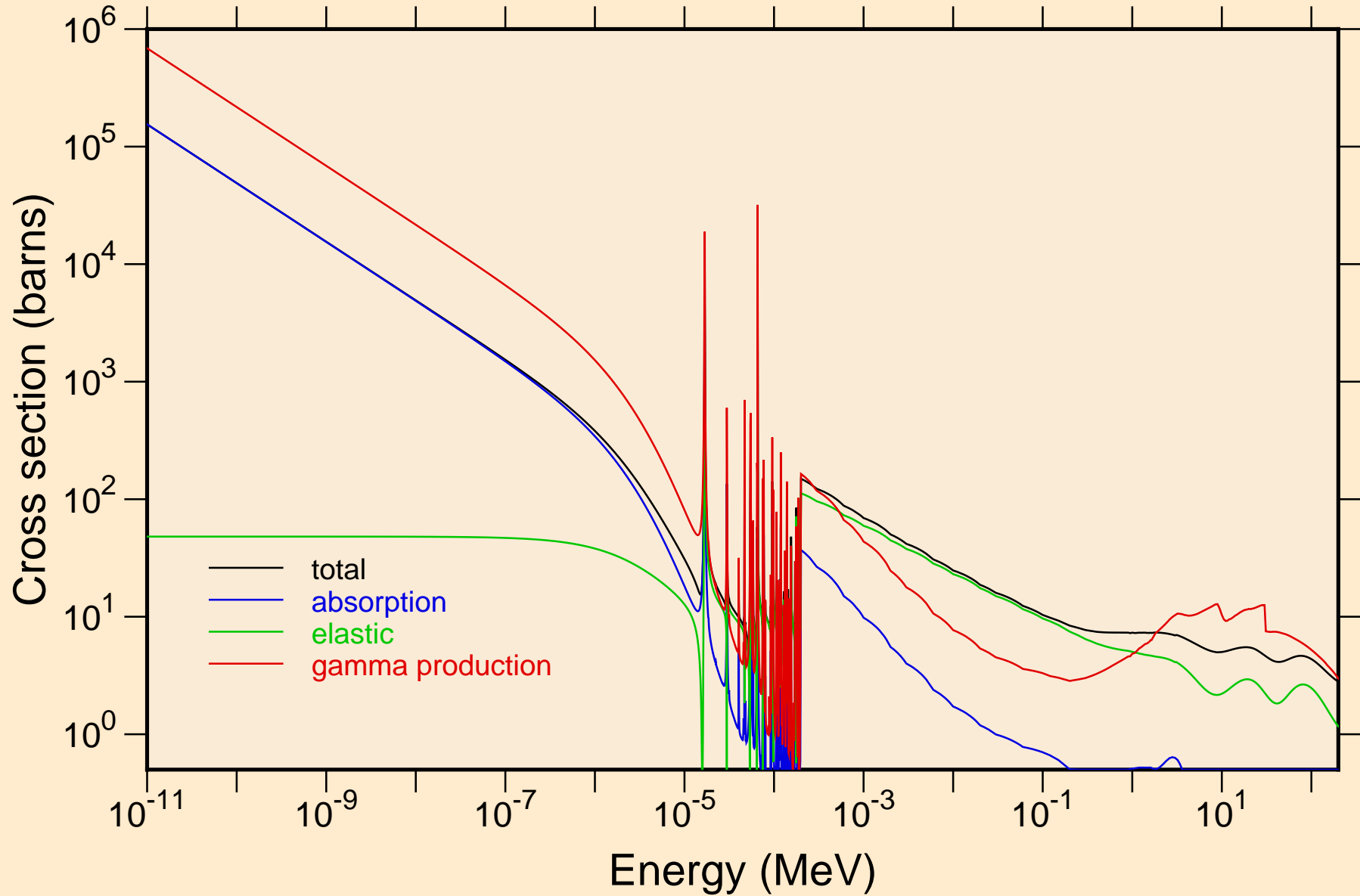

OS184 NEUTRON ACER TENDL-2023 LIBRARY; T=0.K
resonance total cross section

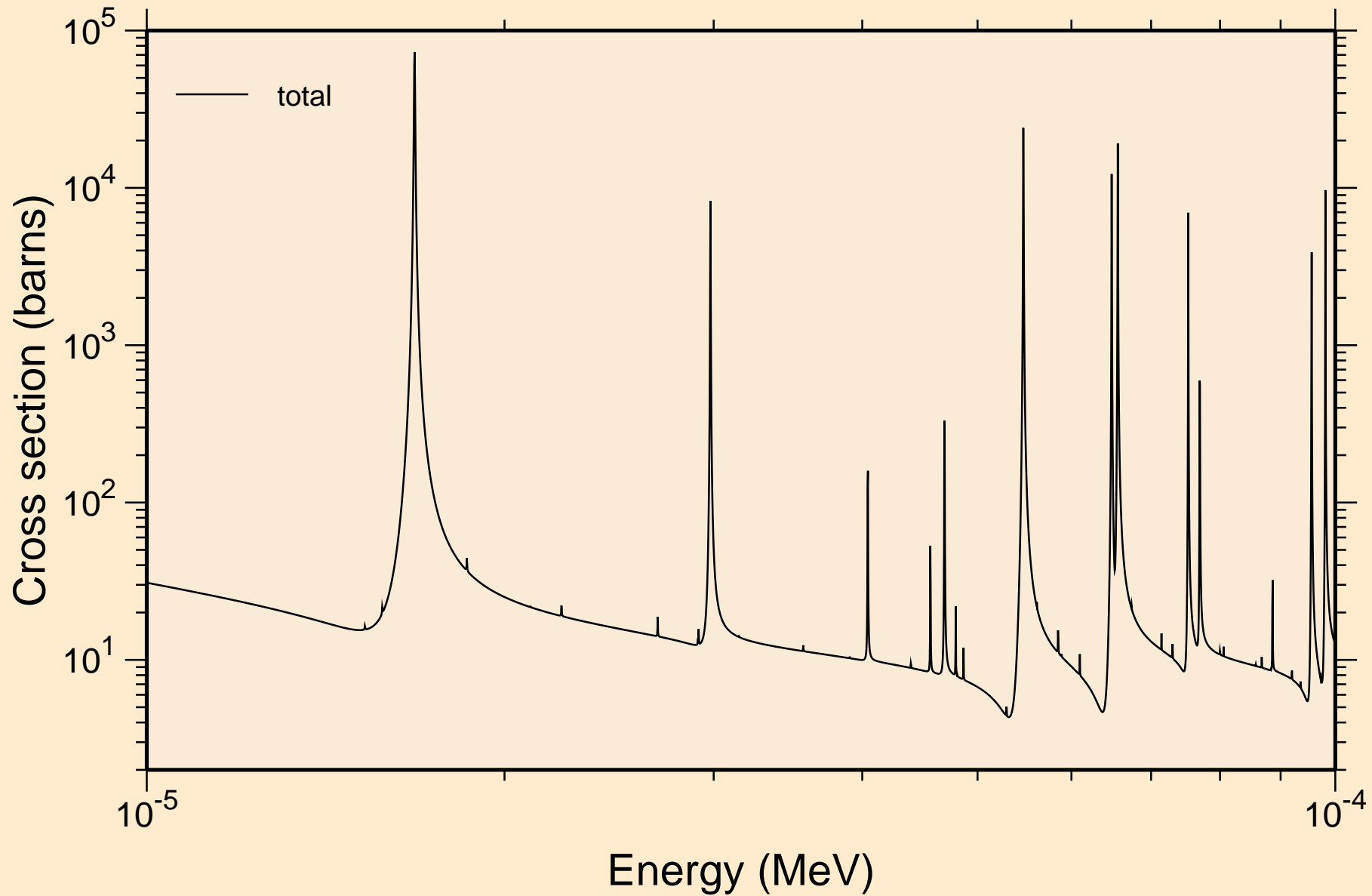

OS184 NEUTRON ACER TENDL-2023 LIBRARY; T=0.K
resonance total cross section

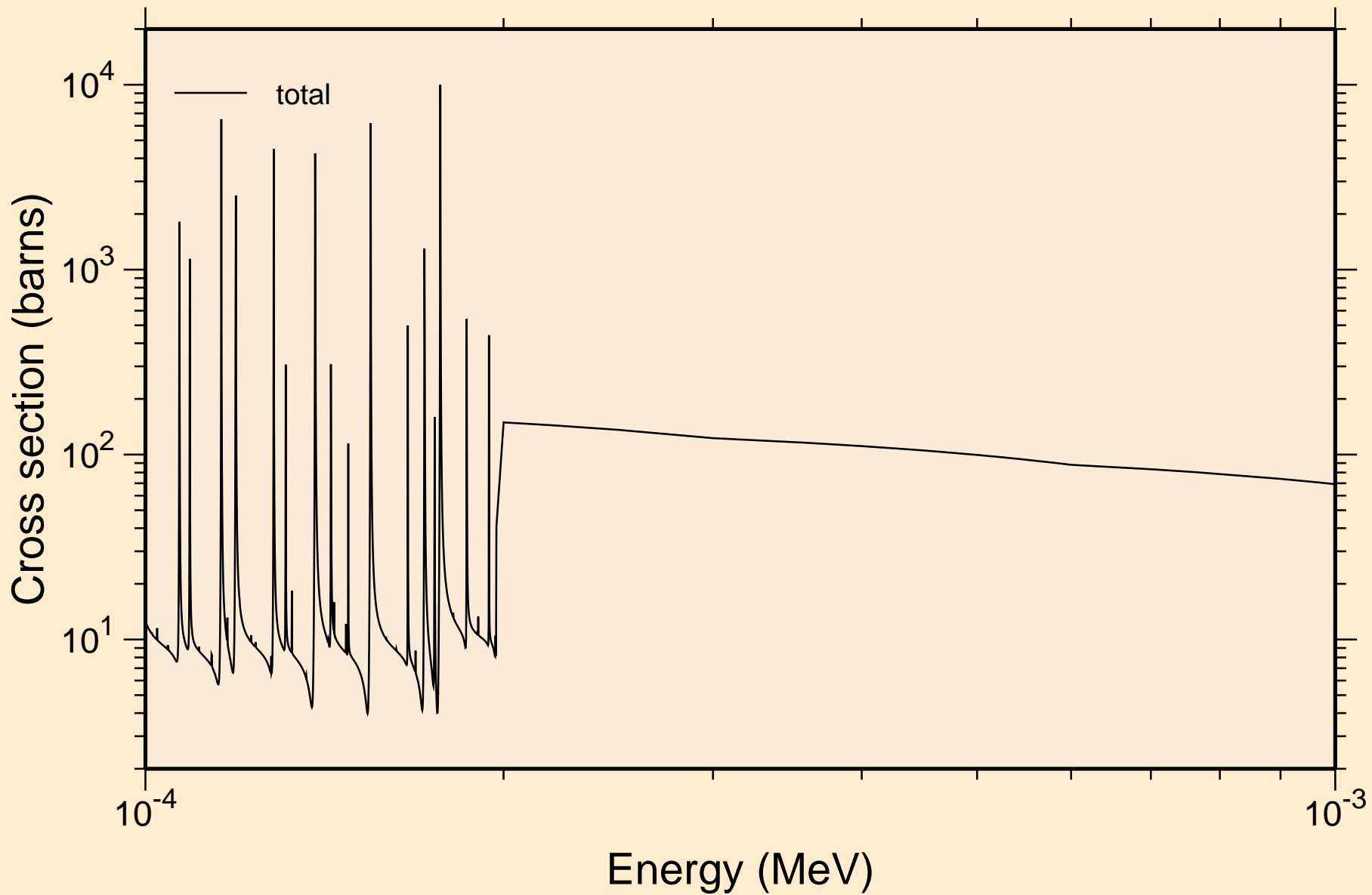

OS184 NEUTRON ACER TENDL-2023 LIBRARY; T=0.K
resonance total cross section

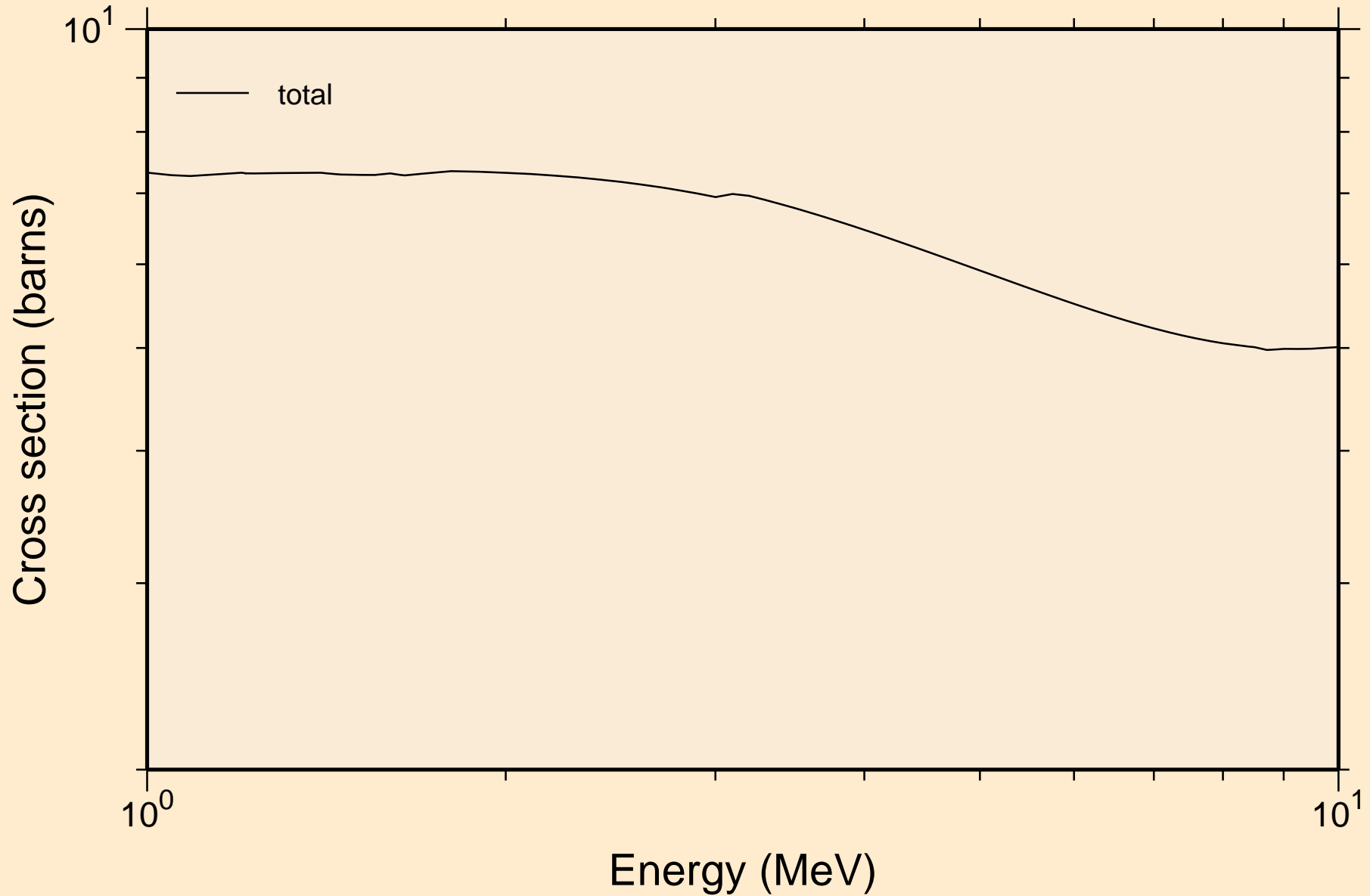

OS184 NEUTRON ACER TENDL-2023 LIBRARY; T=0.K
resonance absorption cross sections

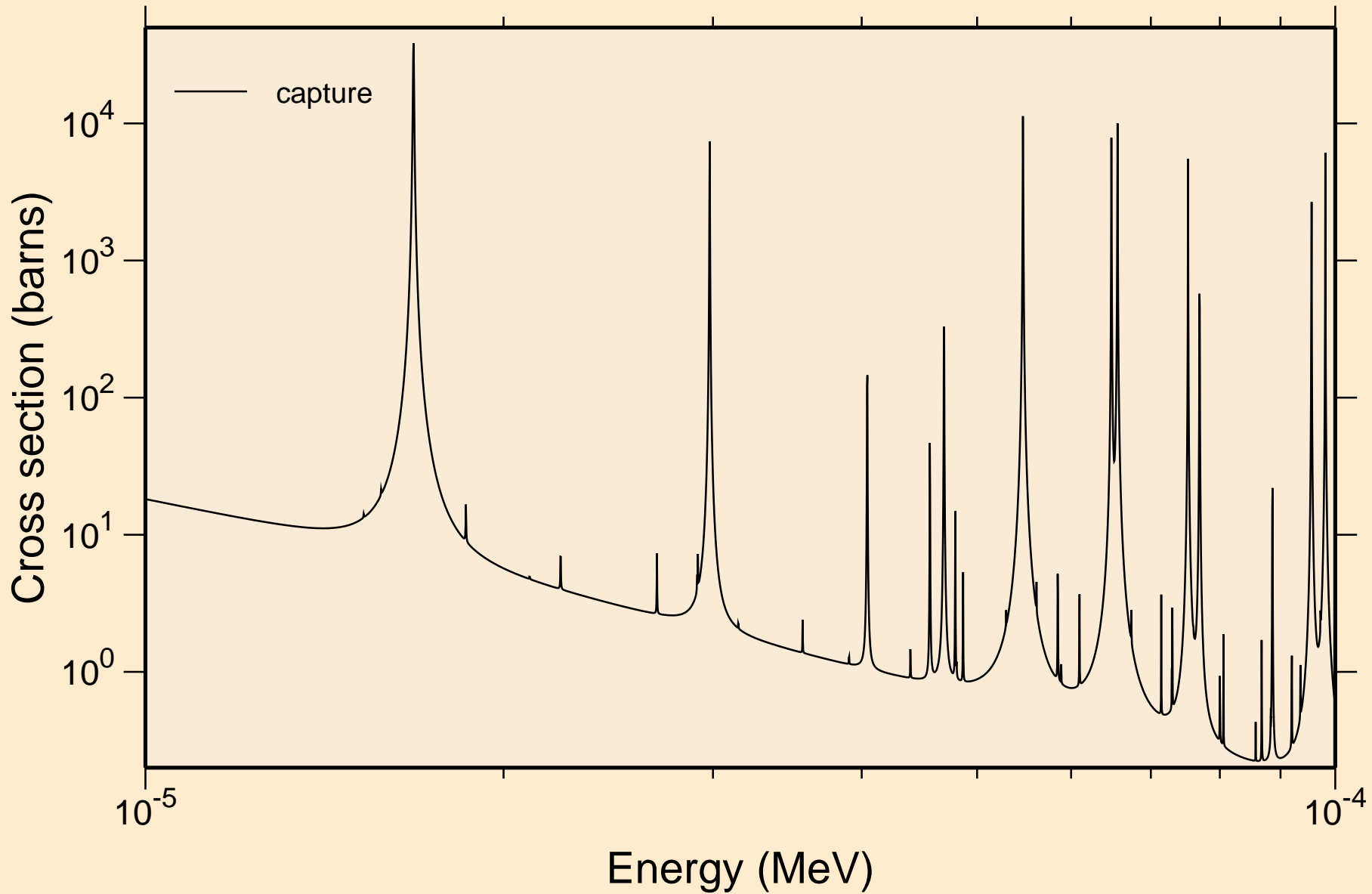

OS184 NEUTRON ACER TENDL-2023 LIBRARY; T=0.K
resonance absorption cross sections

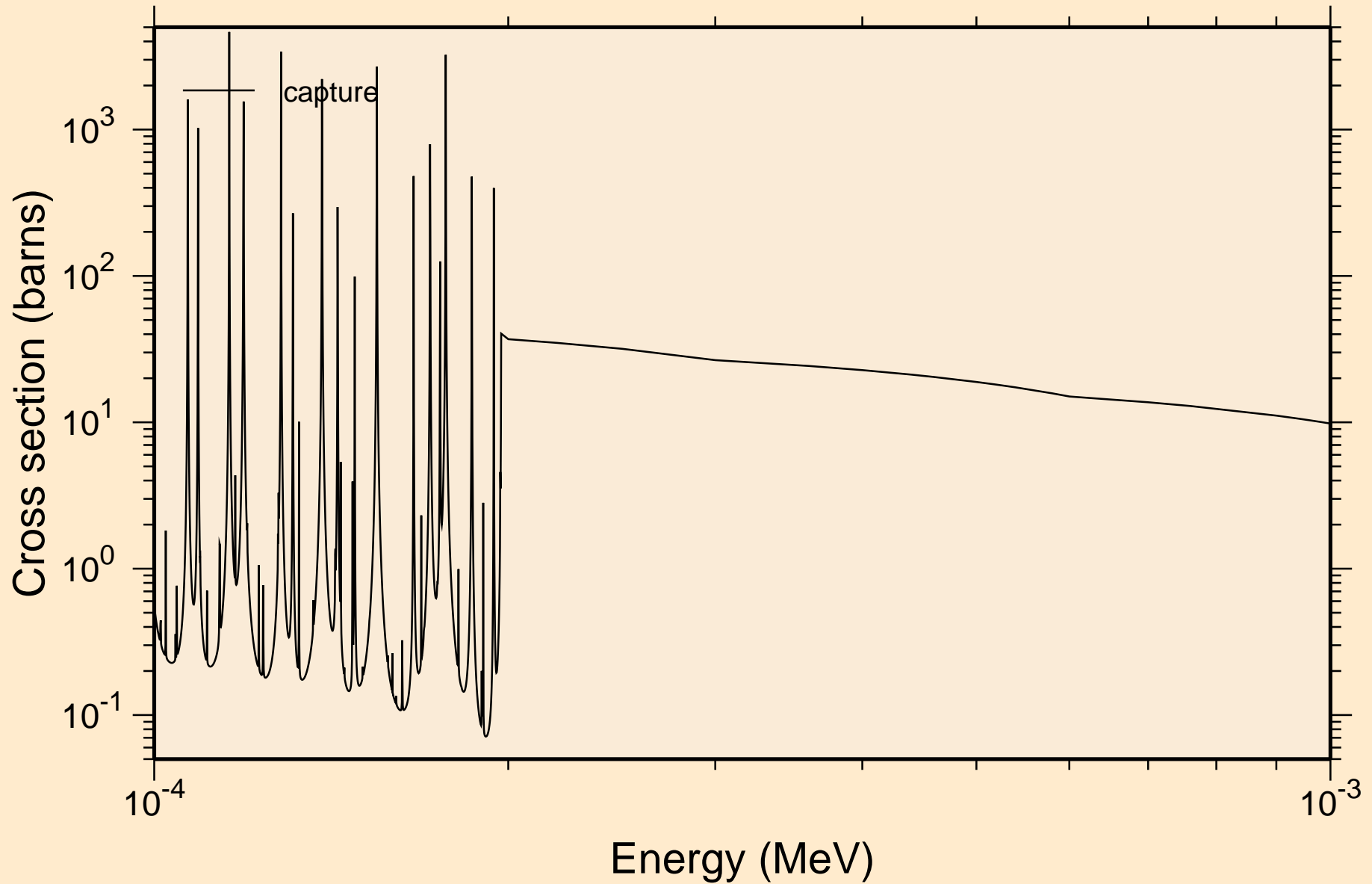

OS184 NEUTRON ACER TENDL-2023 LIBRARY; T=0.K
resonance absorption cross sections

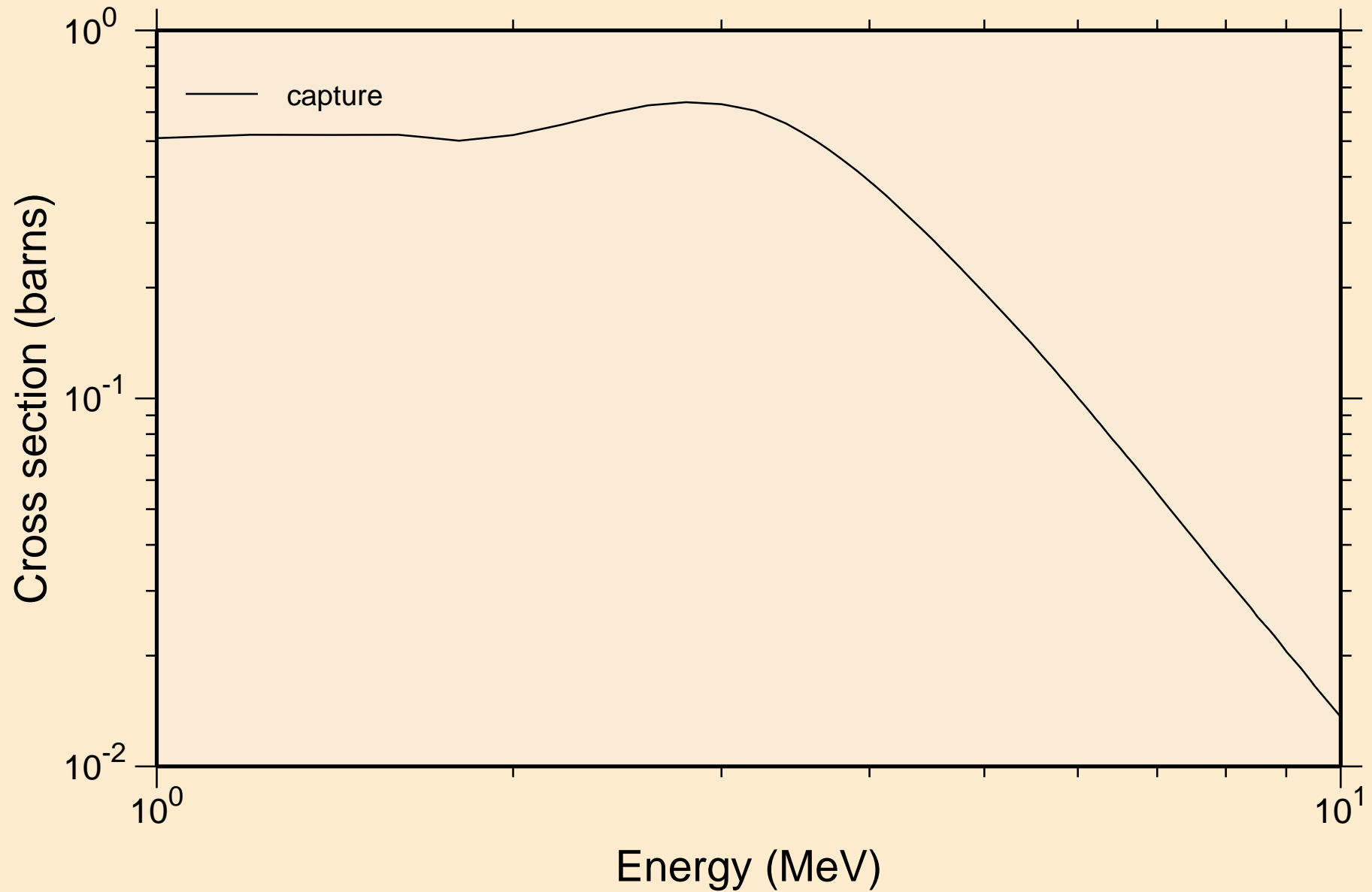

OS184 NEUTRON ACER TENDL-2023 LIBRARY; T=0.K
Heating

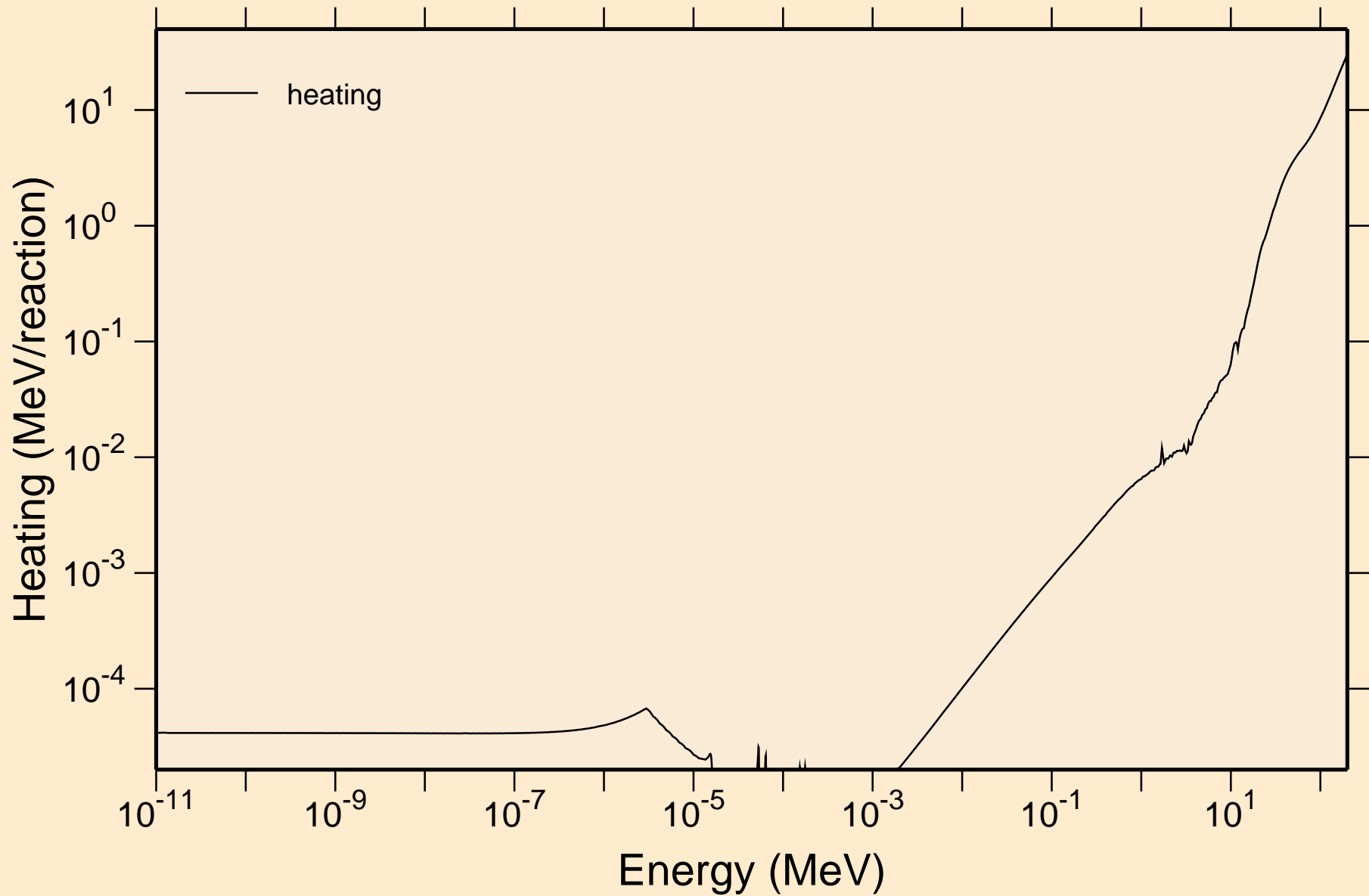

OS184 NEUTRON ACER TENDL-2023 LIBRARY; T=0.K
Damage

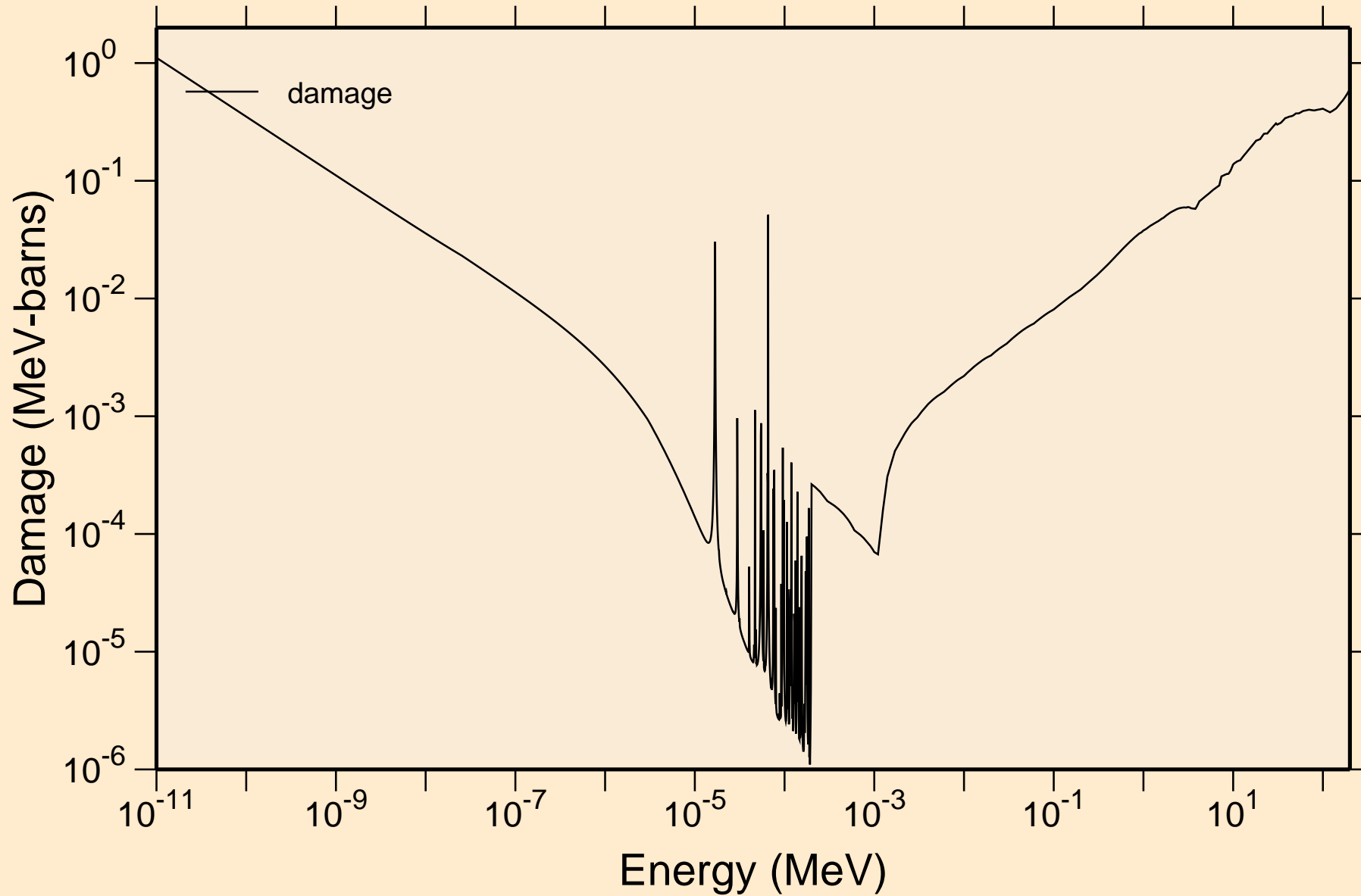

OS184 NEUTRON ACER TENDL-2023 LIBRARY; T=0.K

Non-threshold reactions

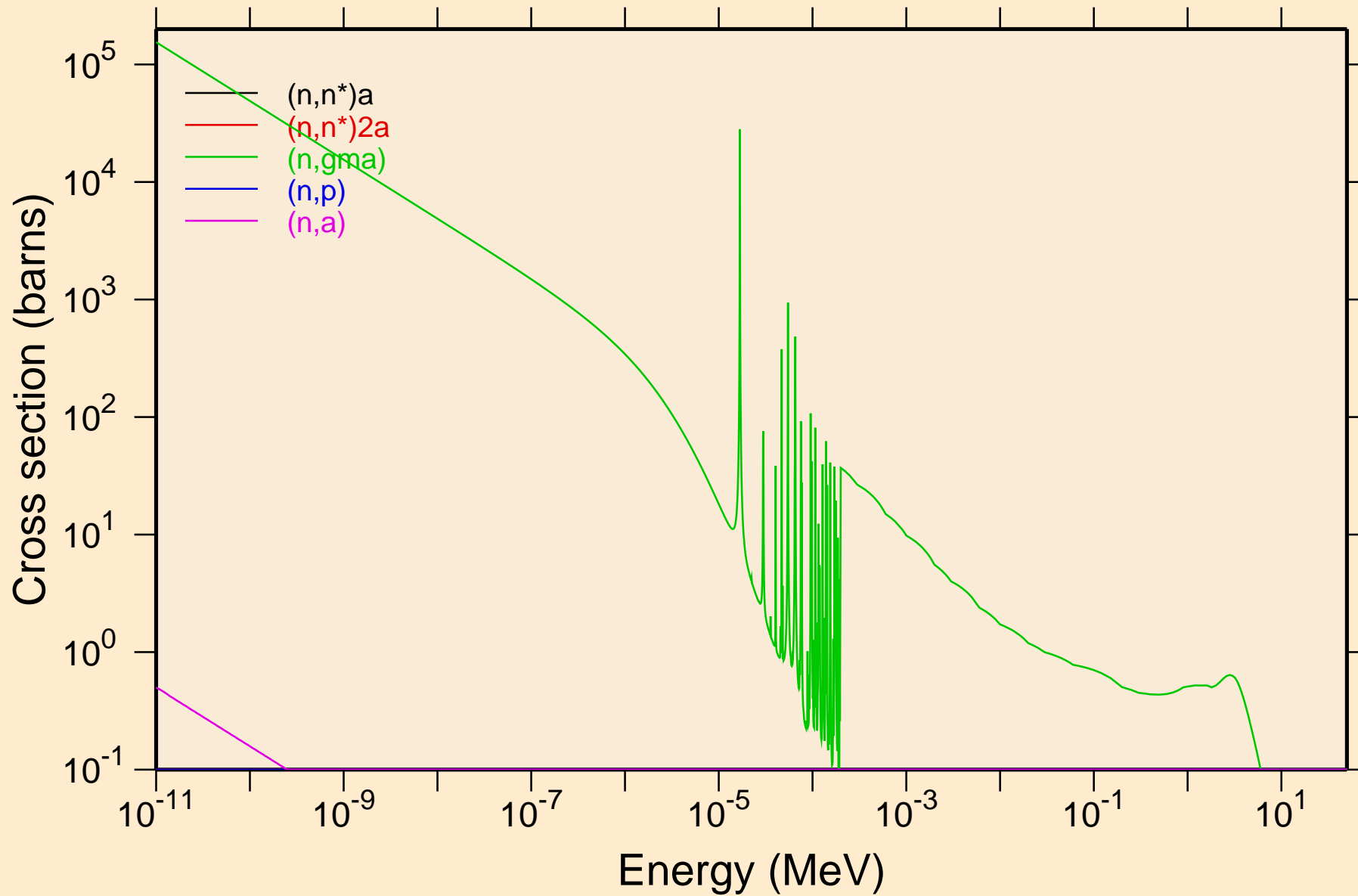

OS184 NEUTRON ACER TENDL-2023 LIBRARY; T=0.K
Non-threshold reactions

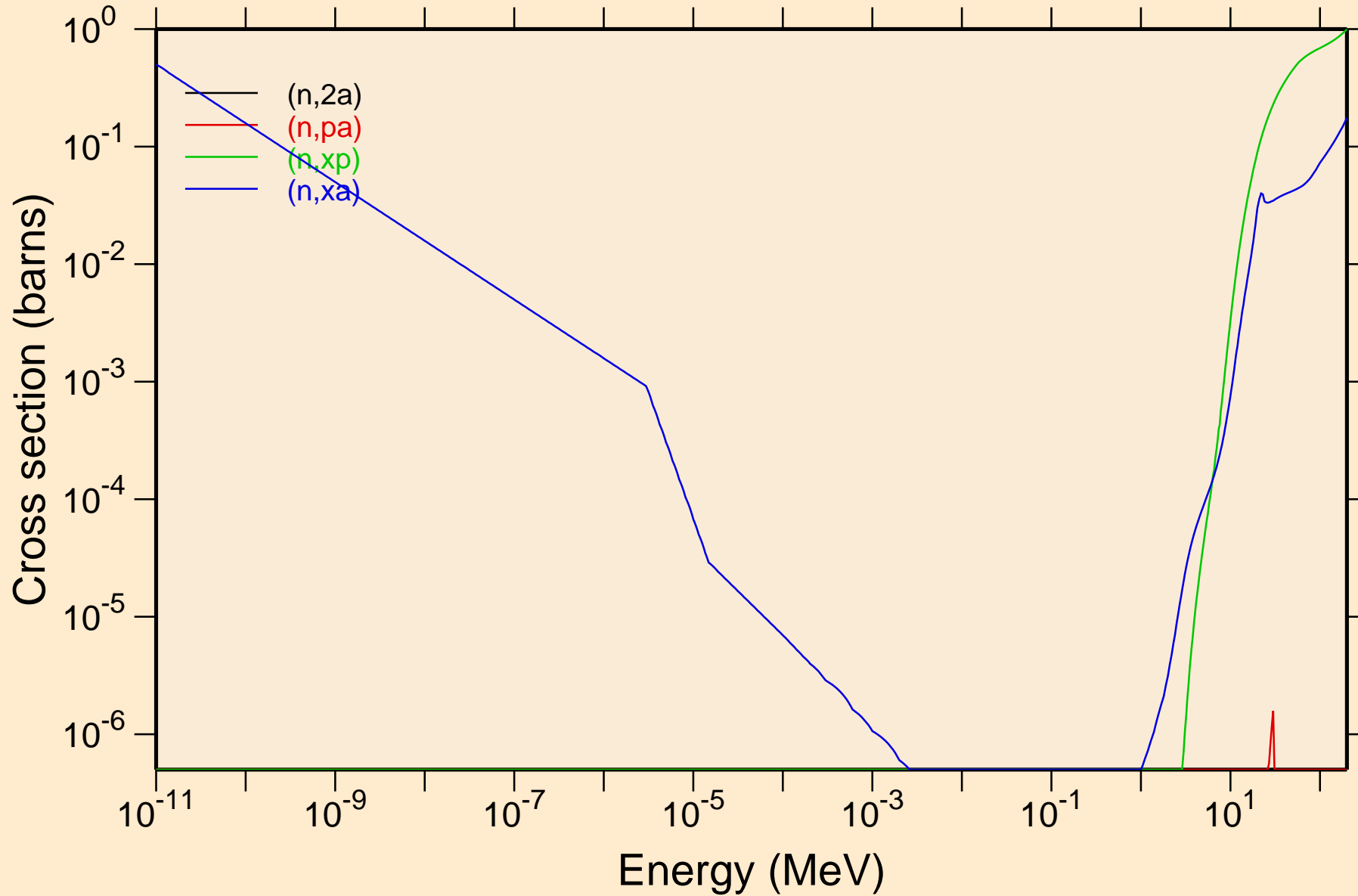

OS184 NEUTRON ACER TENDL-2023 LIBRARY; T=0.K

Principal cross sections

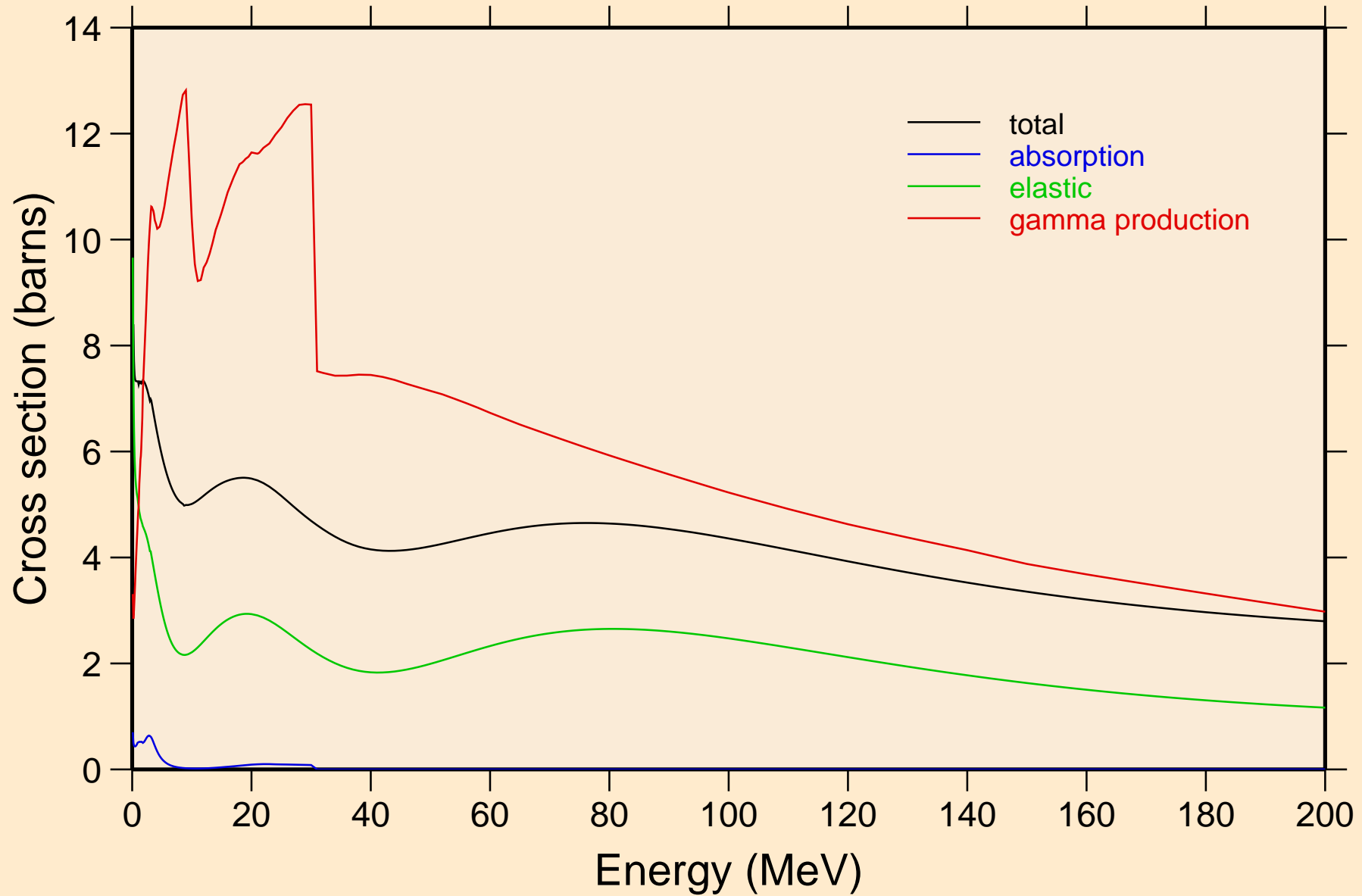

OS184 NEUTRON ACER TENDL-2023 LIBRARY; T=0.K

Heating

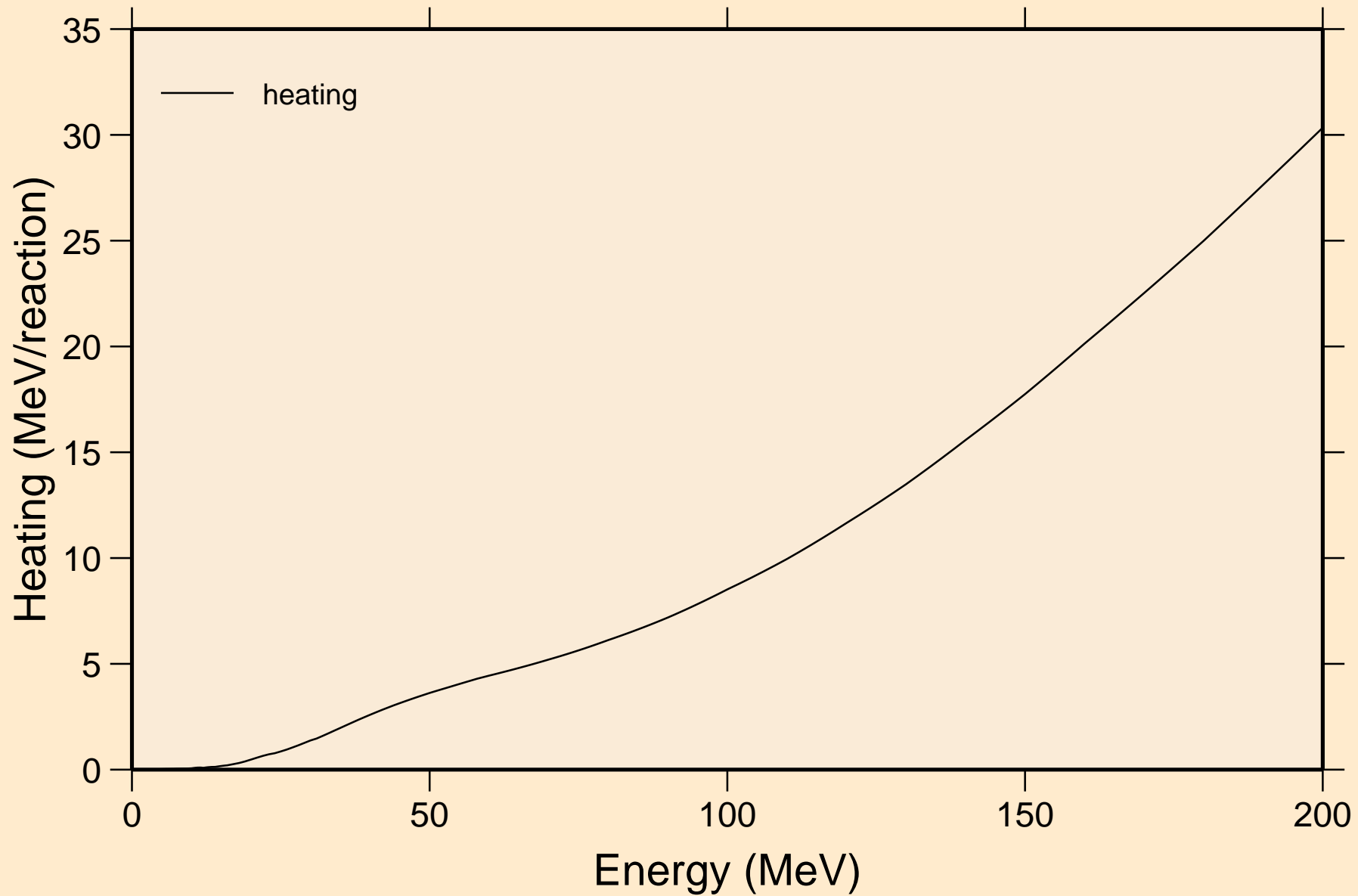

OS184 NEUTRON ACER TENDL-2023 LIBRARY; T=0.K

Damage

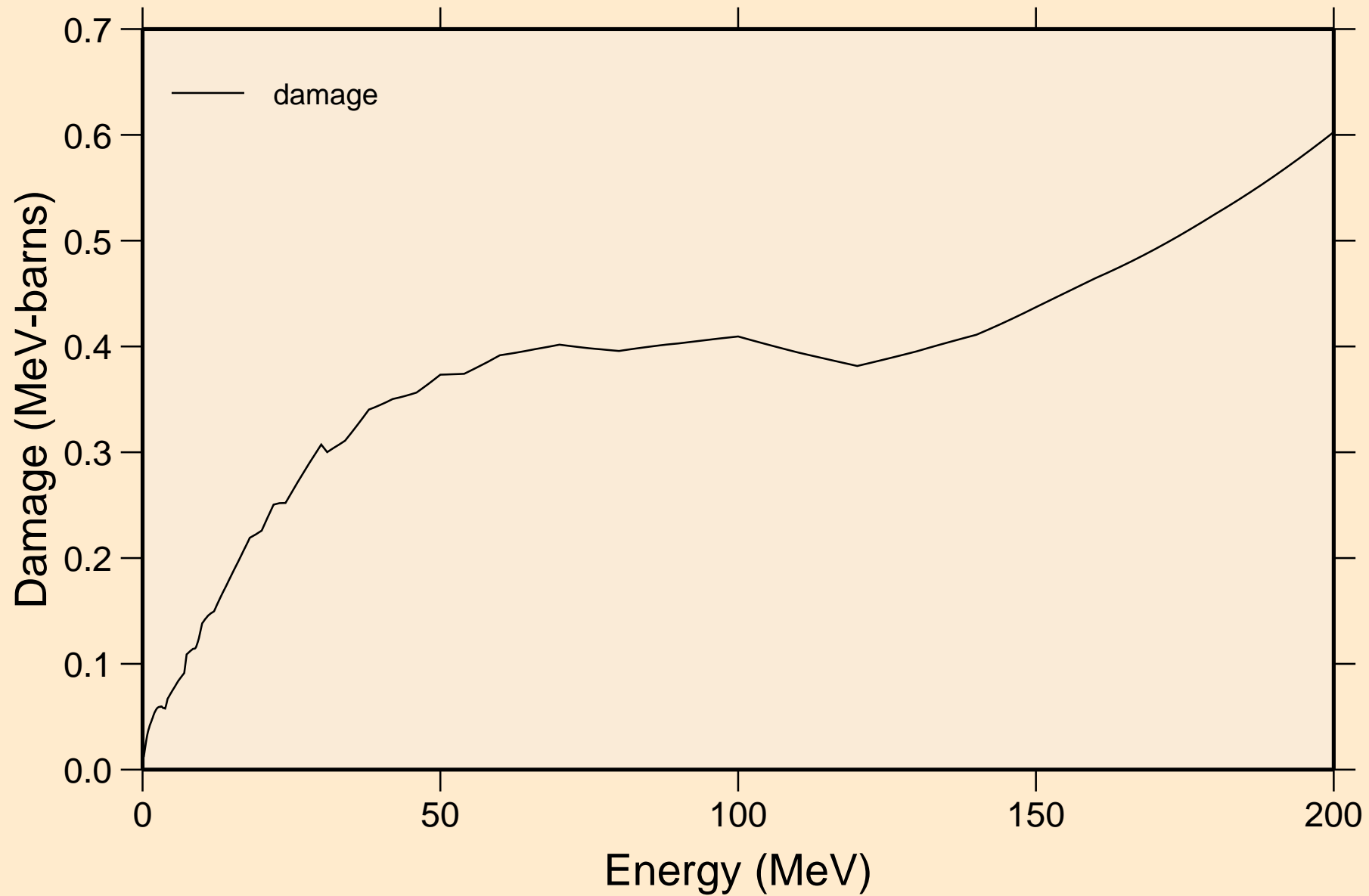

OS184 NEUTRON ACER TENDL-2023 LIBRARY; T=0.K

Non-threshold reactions

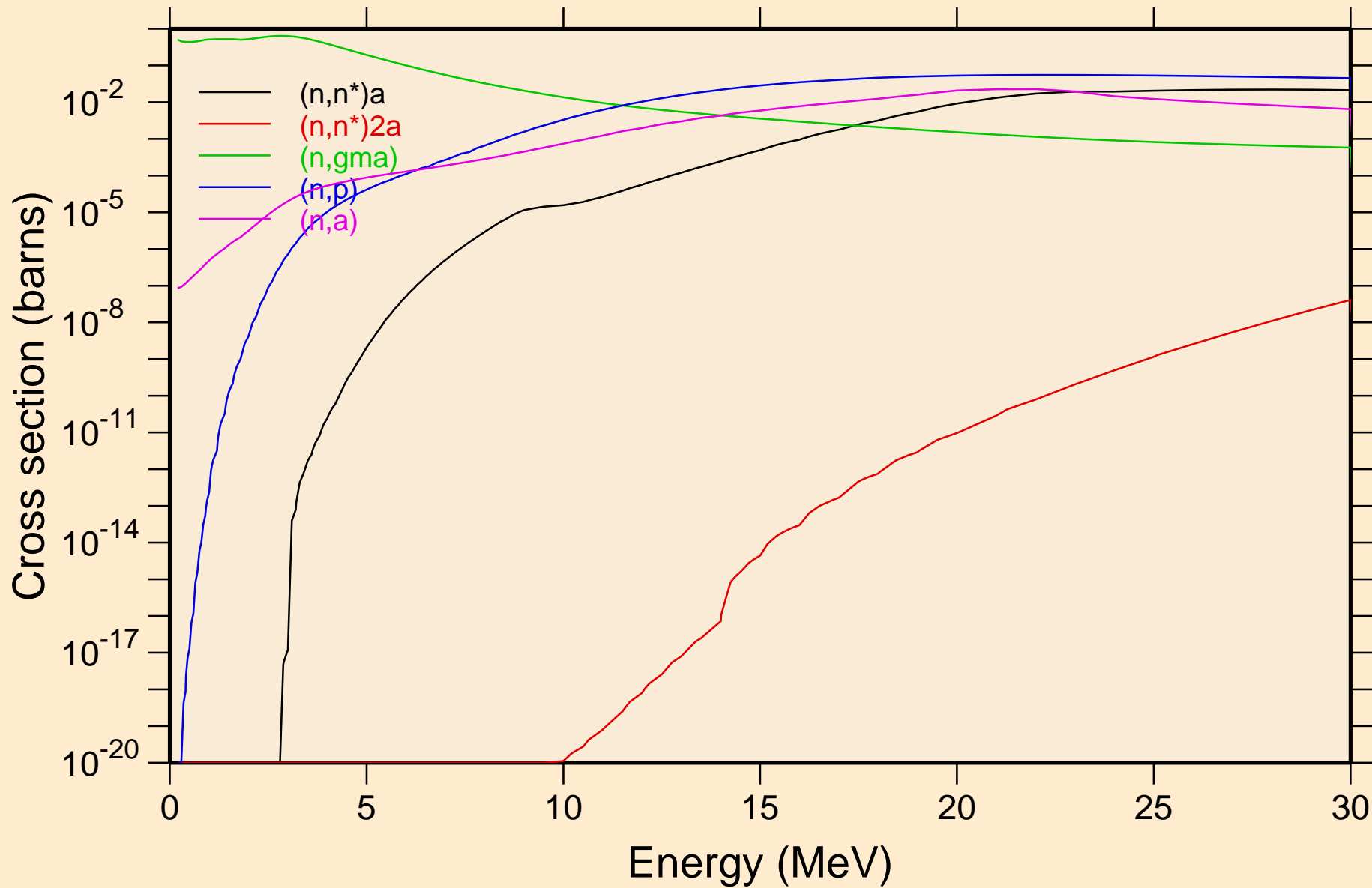

OS184 NEUTRON ACER TENDL-2023 LIBRARY; T=0.K
Non-threshold reactions

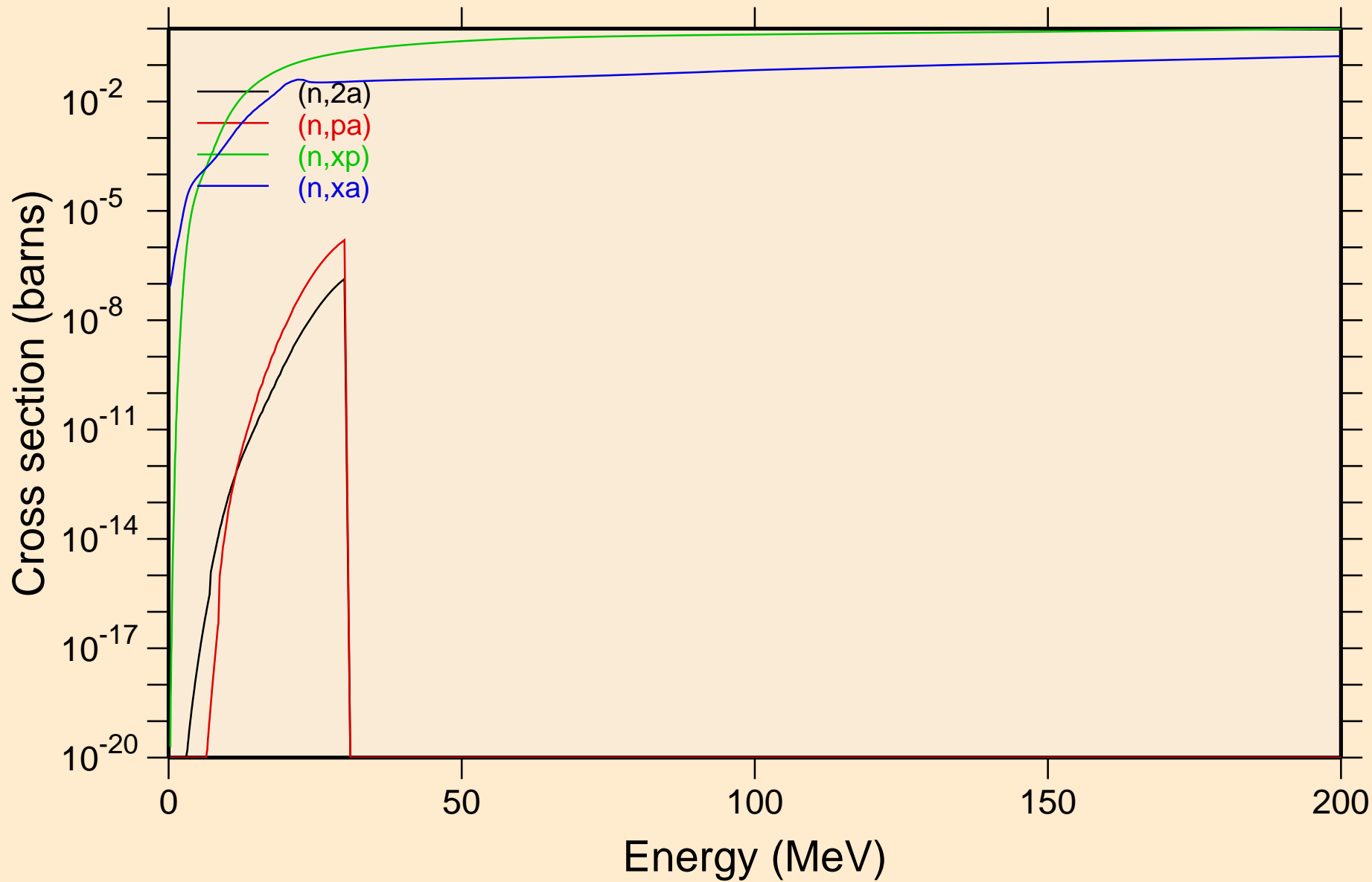

OS184 NEUTRON ACER TENDL-2023 LIBRARY; T=0.K
Inelastic levels

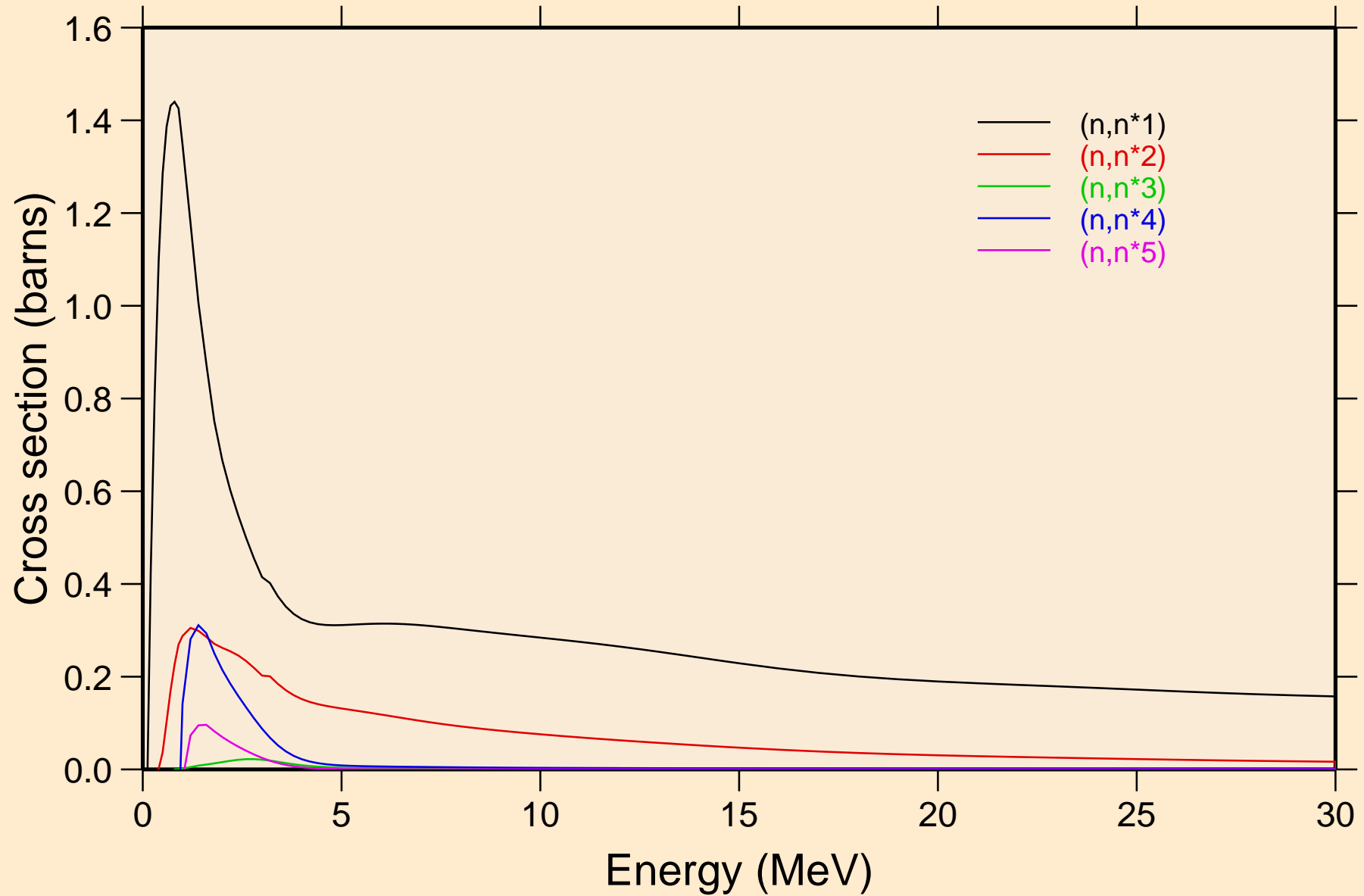

OS184 NEUTRON ACER TENDL-2023 LIBRARY; T=0.K
Inelastic levels

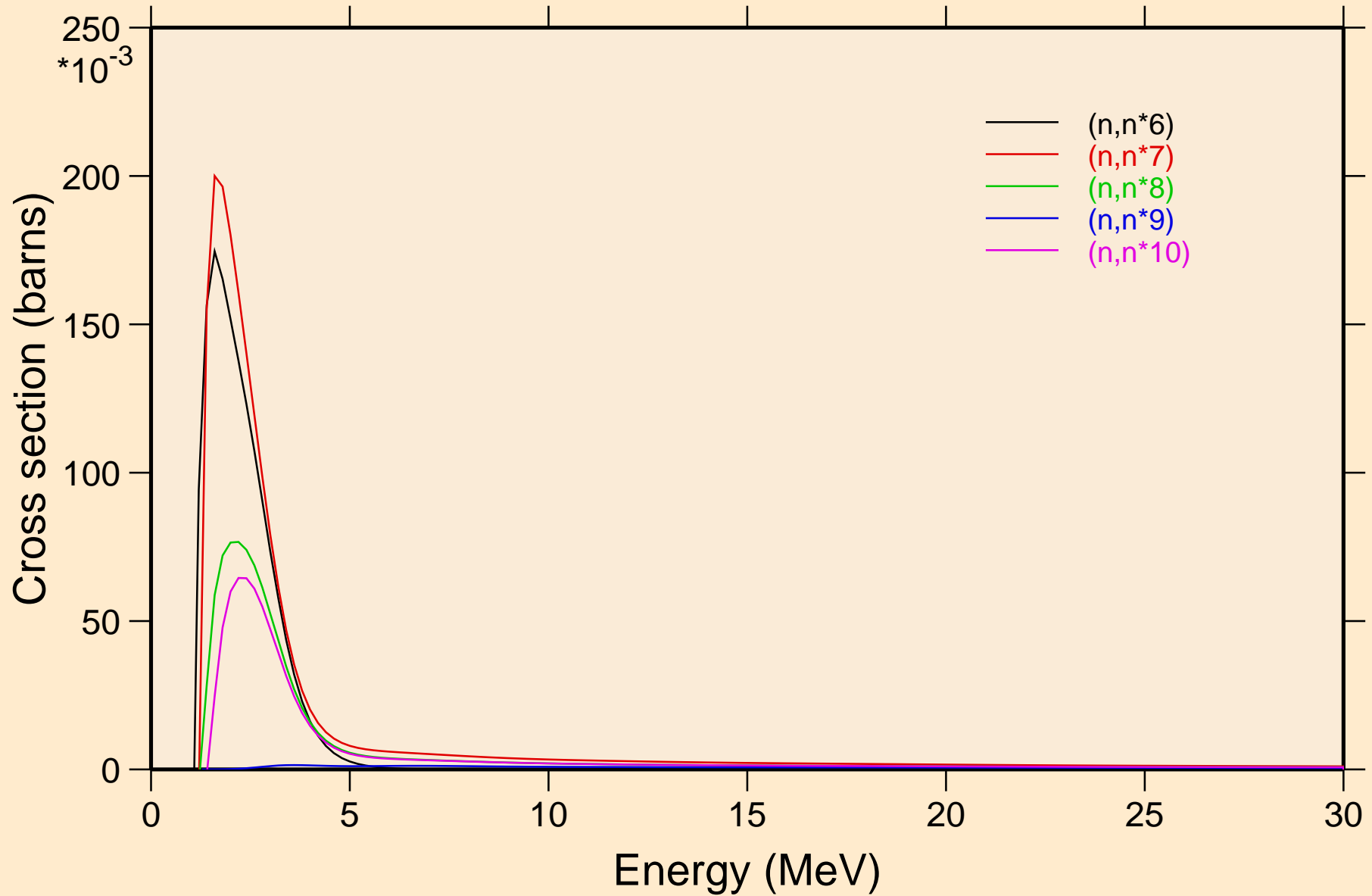

OS184 NEUTRON ACER TENDL-2023 LIBRARY; T=0.K
Inelastic levels

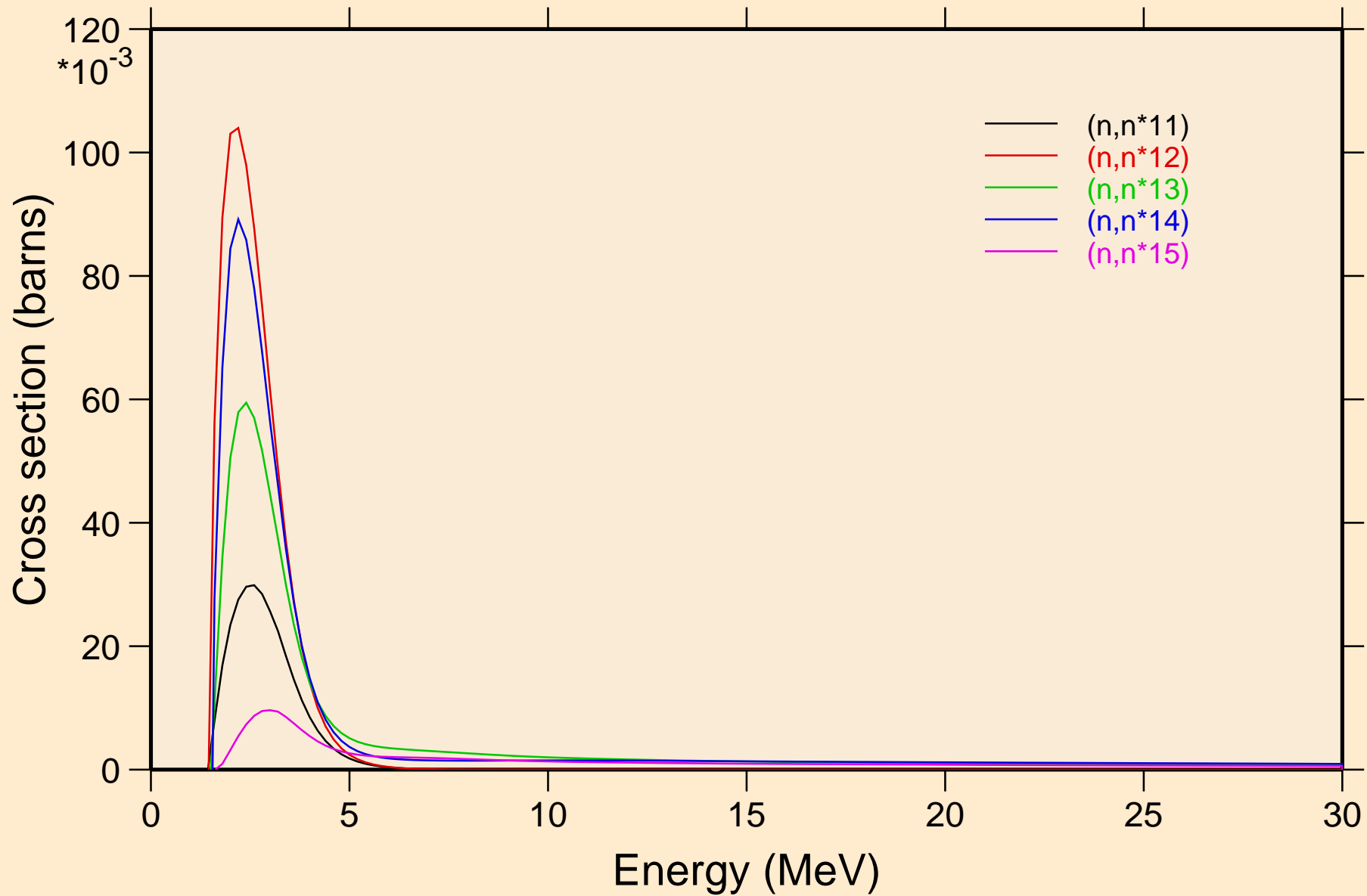

OS184 NEUTRON ACER TENDL-2023 LIBRARY; T=0.K
Inelastic levels

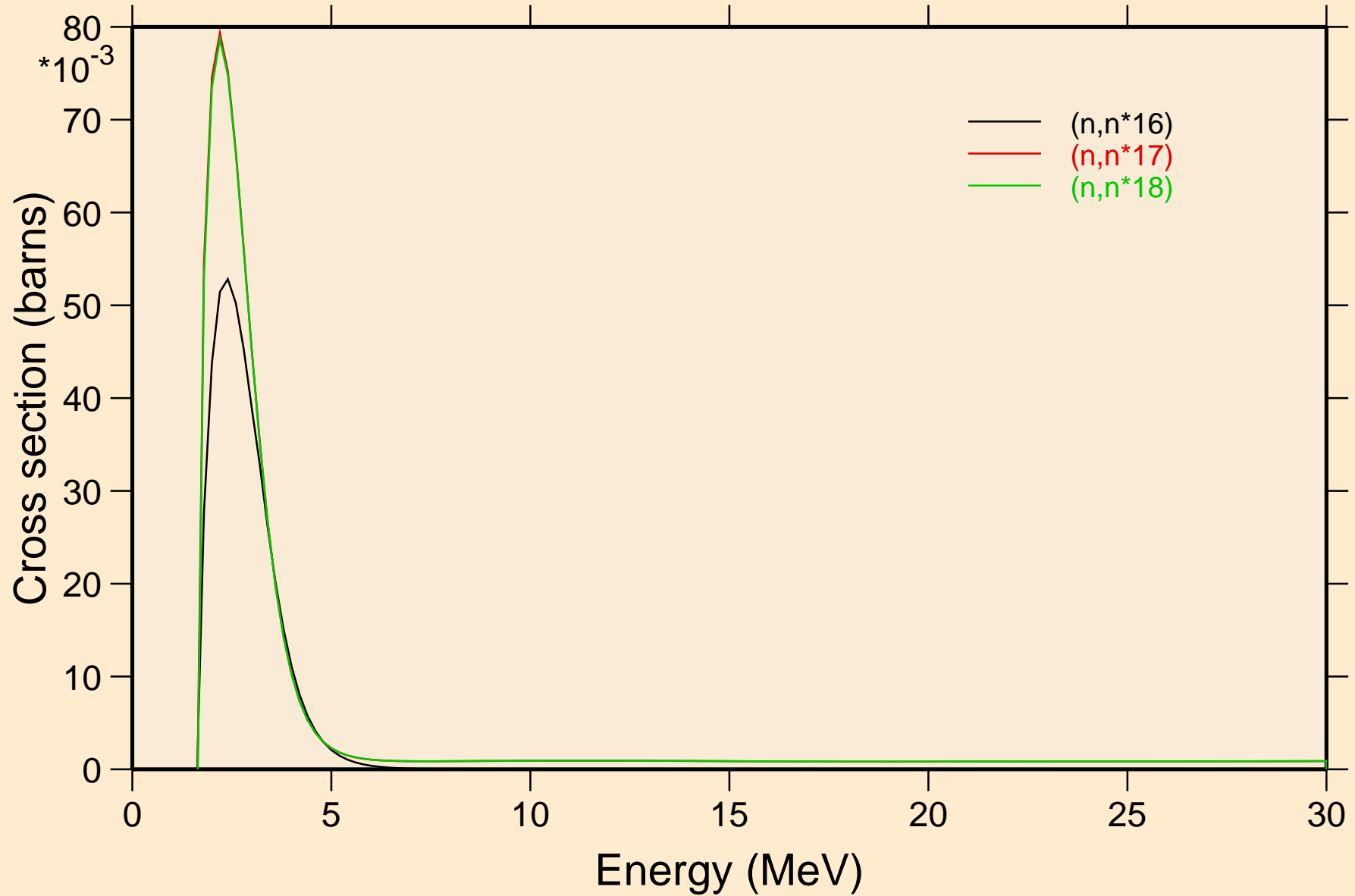

OS184 NEUTRON ACER TENDL-2023 LIBRARY; T=0.K
Threshold reactions

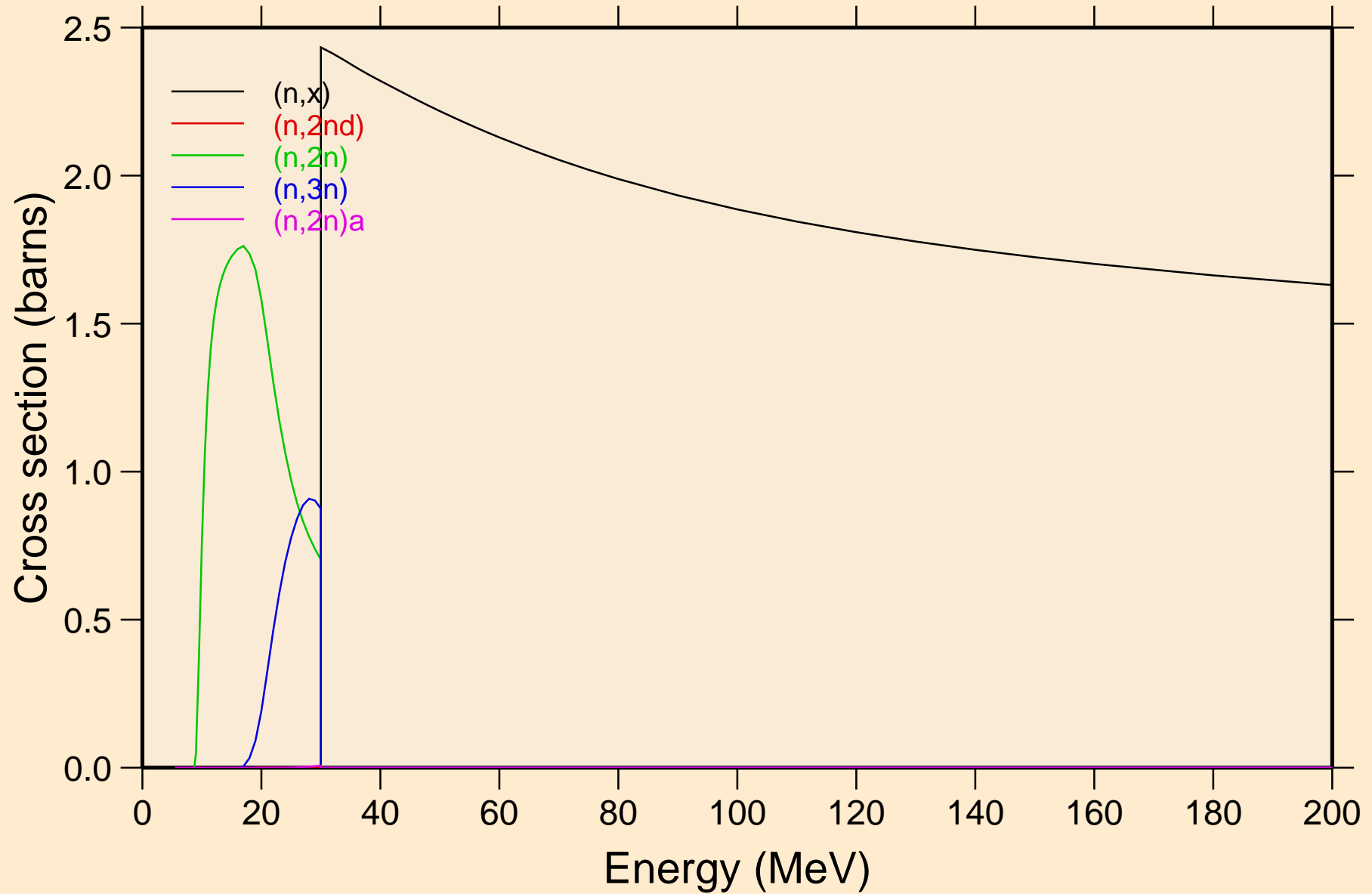

OS184 NEUTRON ACER TENDL-2023 LIBRARY; T=0.K

Threshold reactions

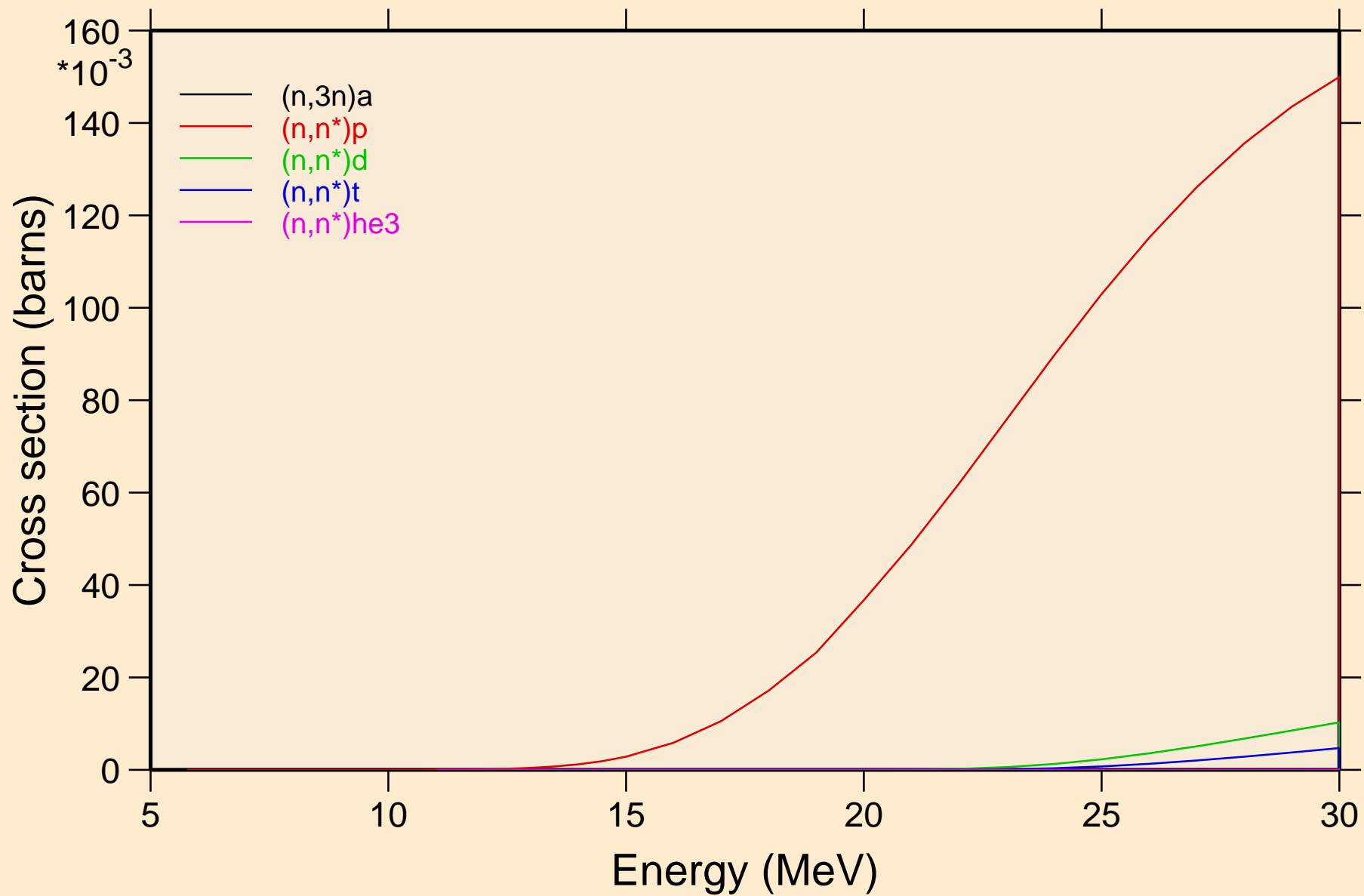

OS184 NEUTRON ACER TENDL-2023 LIBRARY; T=0.K

Threshold reactions

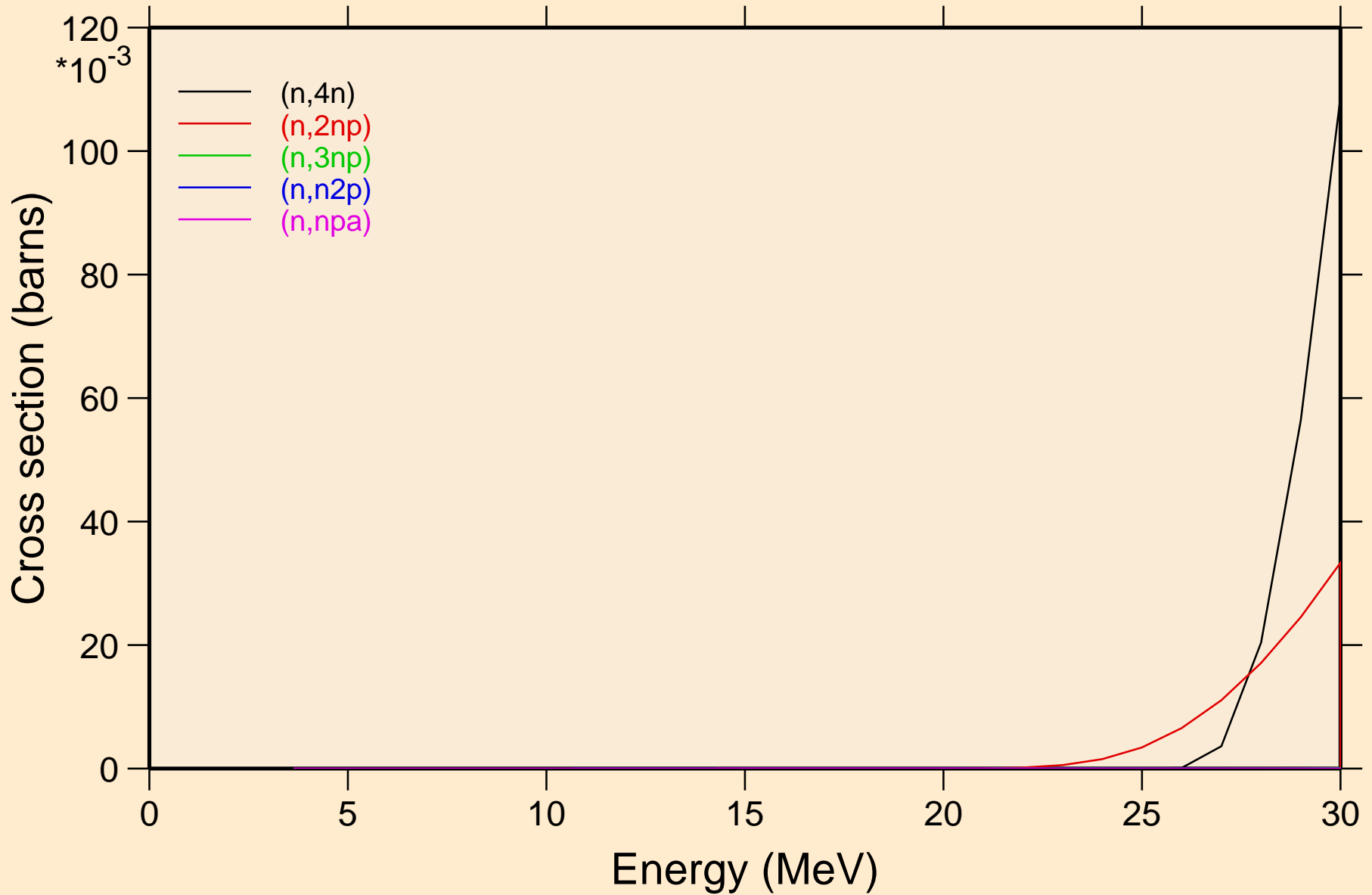

OS184 NEUTRON ACER TENDL-2023 LIBRARY; T=0.K

Threshold reactions

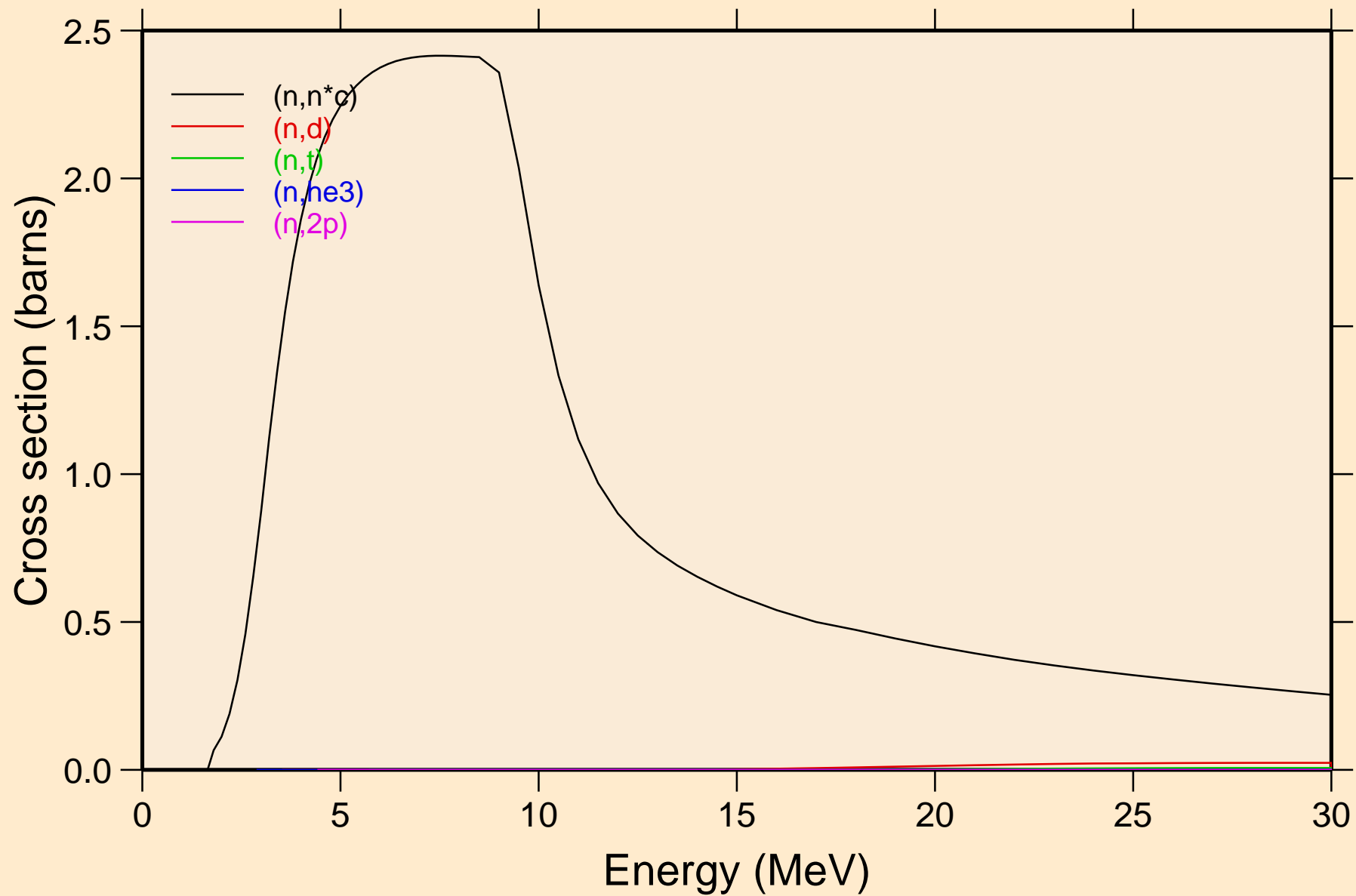

OS184 NEUTRON ACER TENDL-2023 LIBRARY; T=0.K

Threshold reactions

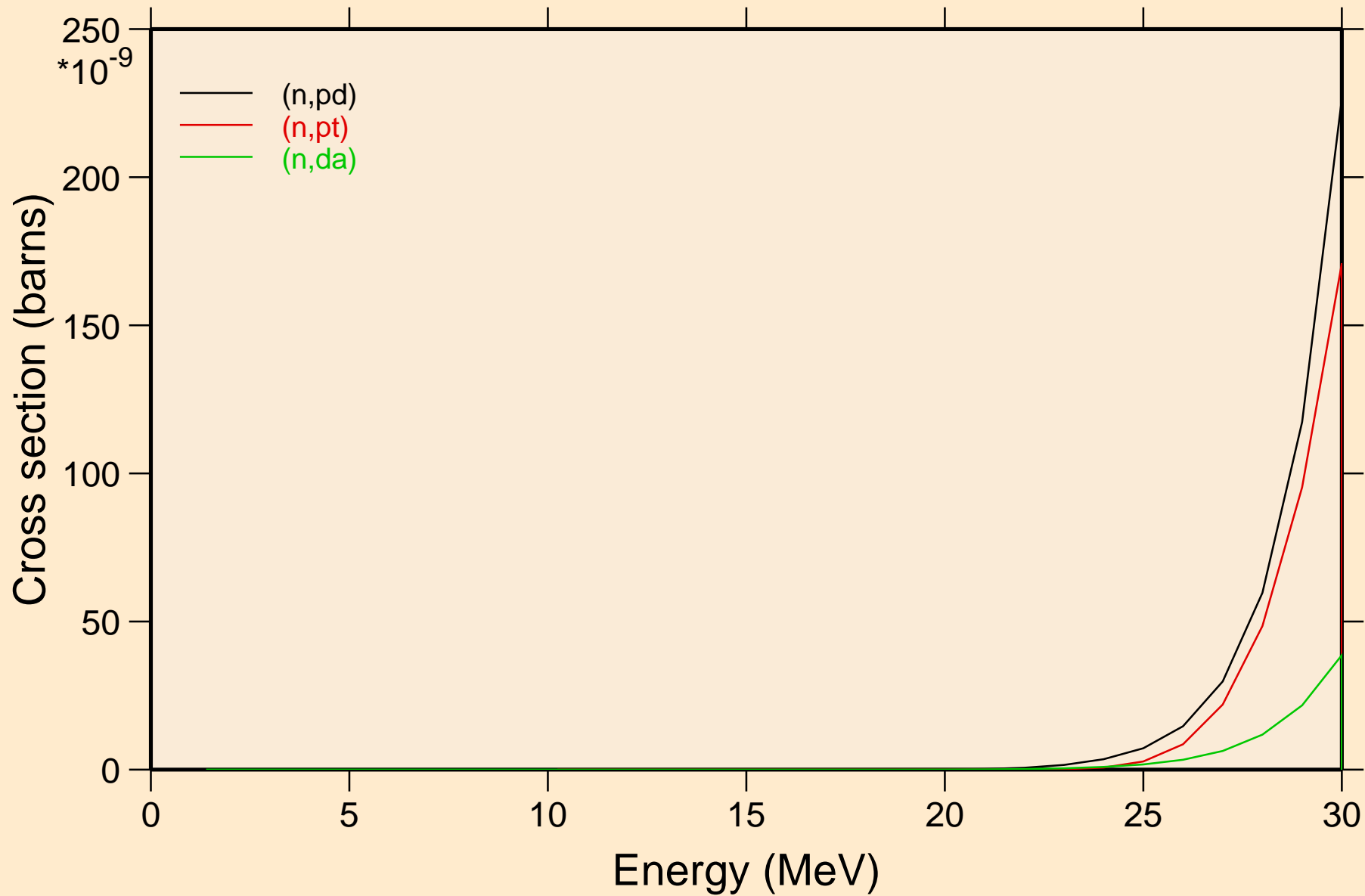

OS184 NEUTRON ACER TENDL-2023 LIBRARY; T=0.K

Threshold reactions

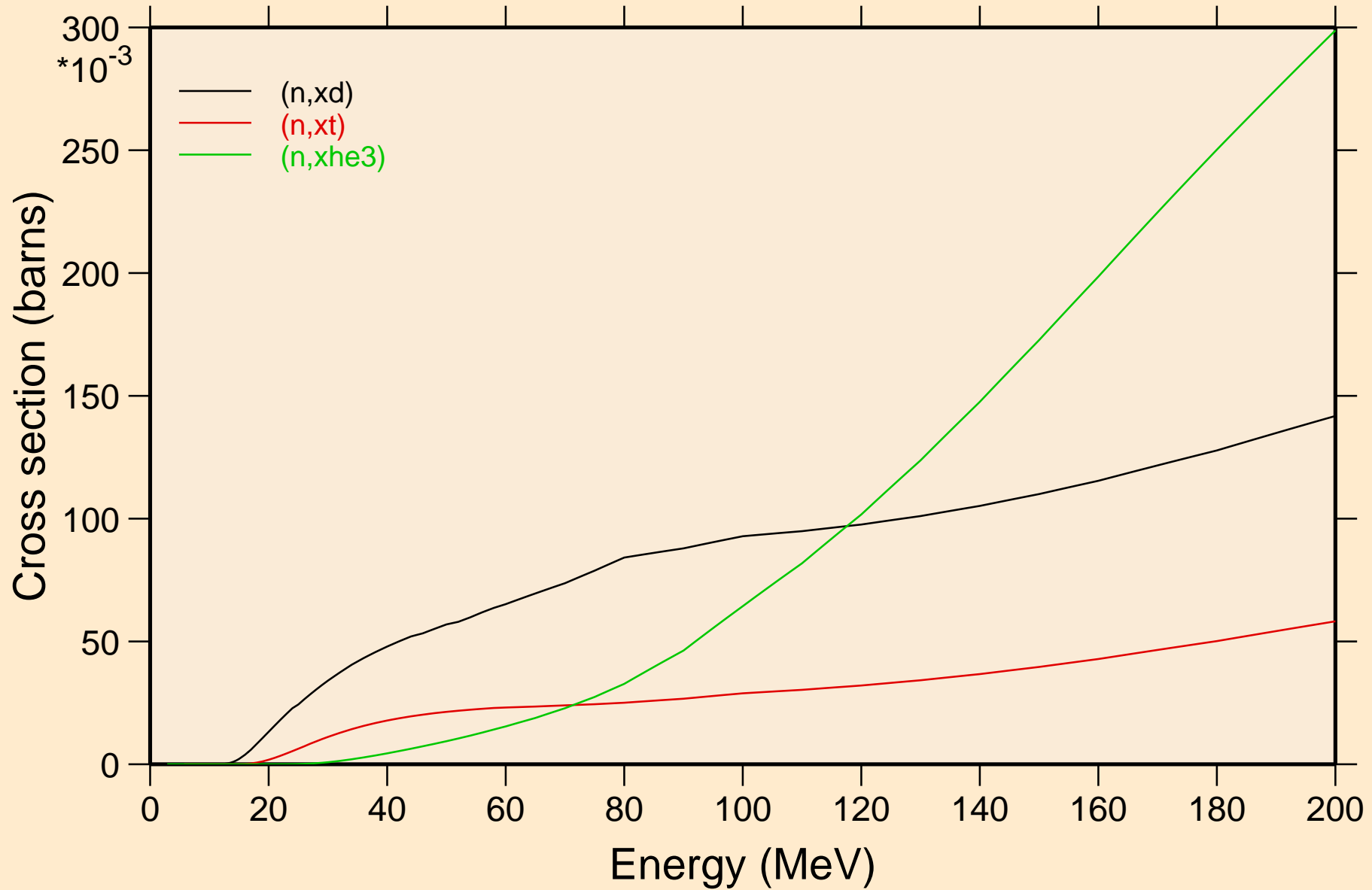

OS184 NEUTRON ACER TENDL-2023 LIBRARY; T=0.K
angular distribution for elastic

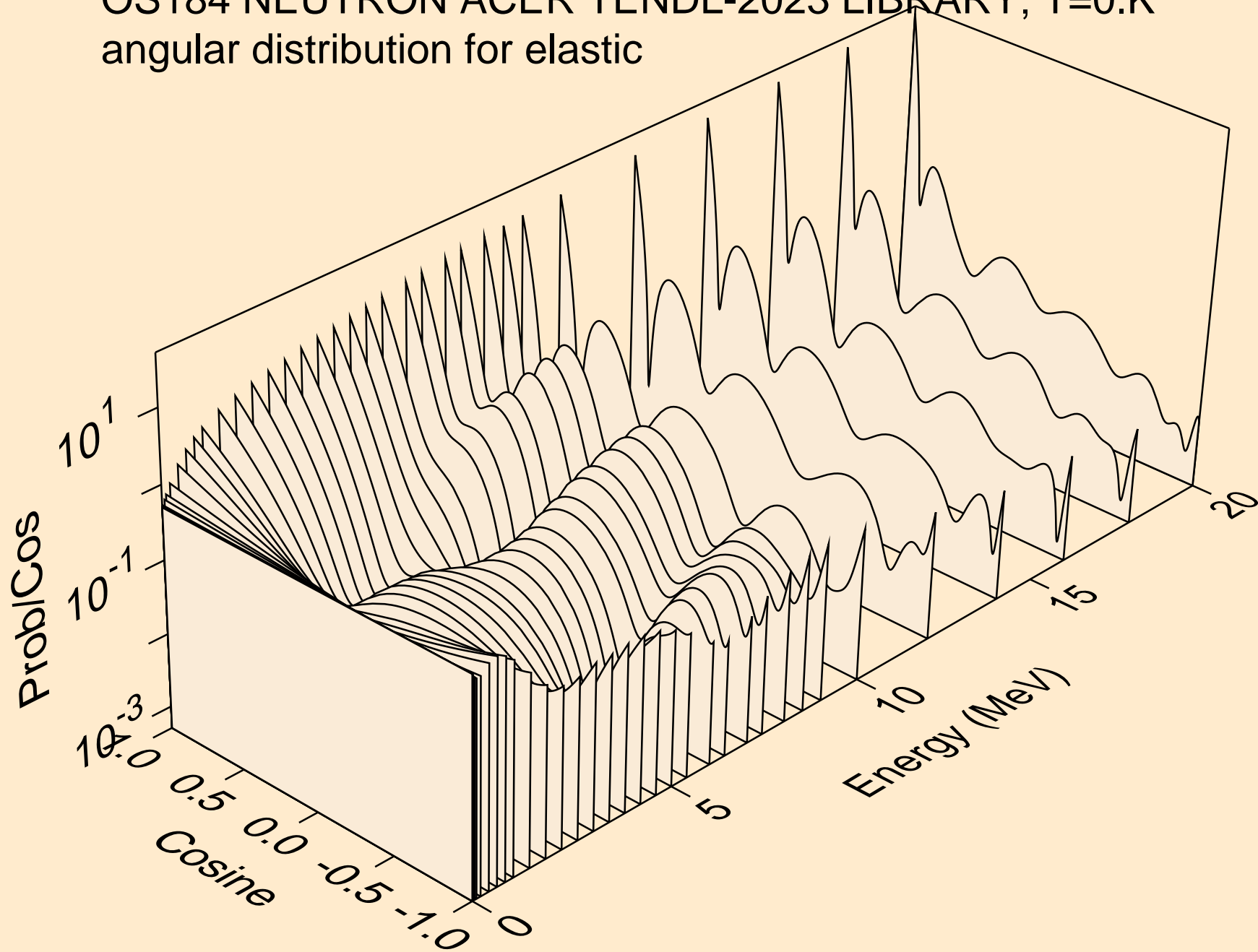

OS184 NEUTRON ACER TENDL-2023 LIBRARY; T=0.K
angular distribution for elastic

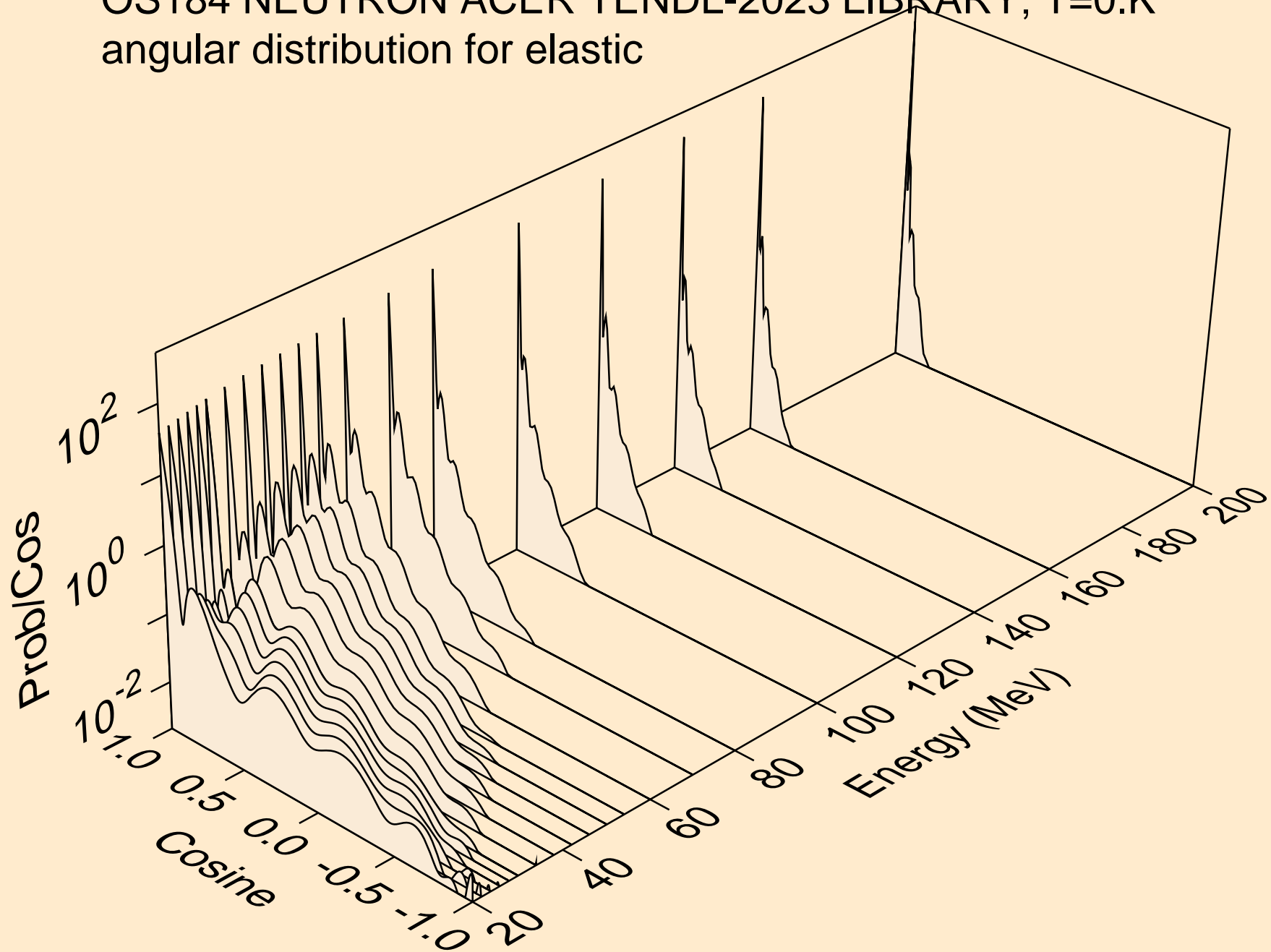

OS184 NEUTRON ACER TENDL-2023 LIBRARY; T=0.K
angular distribution for (n,n*1)

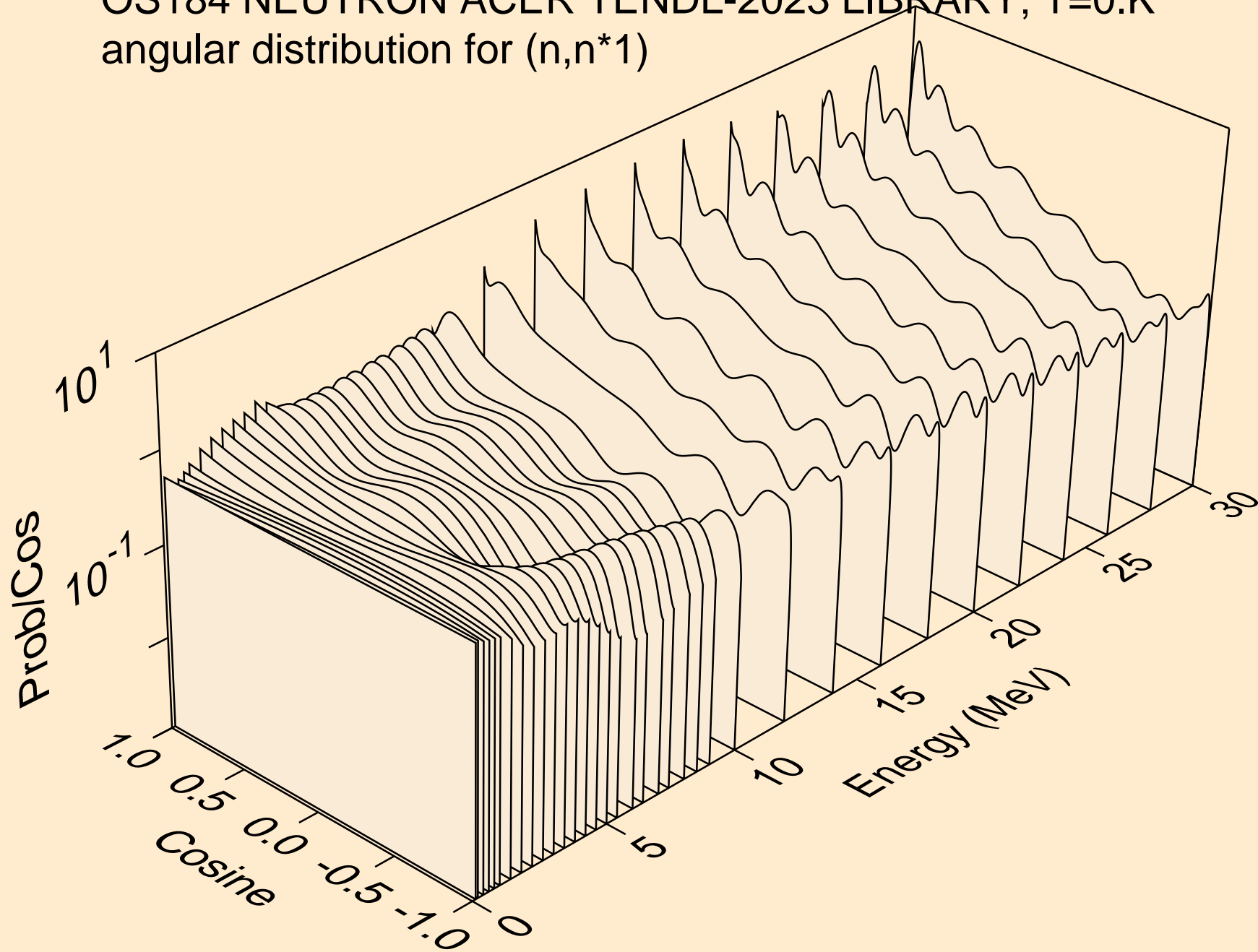

OS184 NEUTRON ACER TENDL-2023 LIBRARY; T=0.K
angular distribution for (n,n*2)

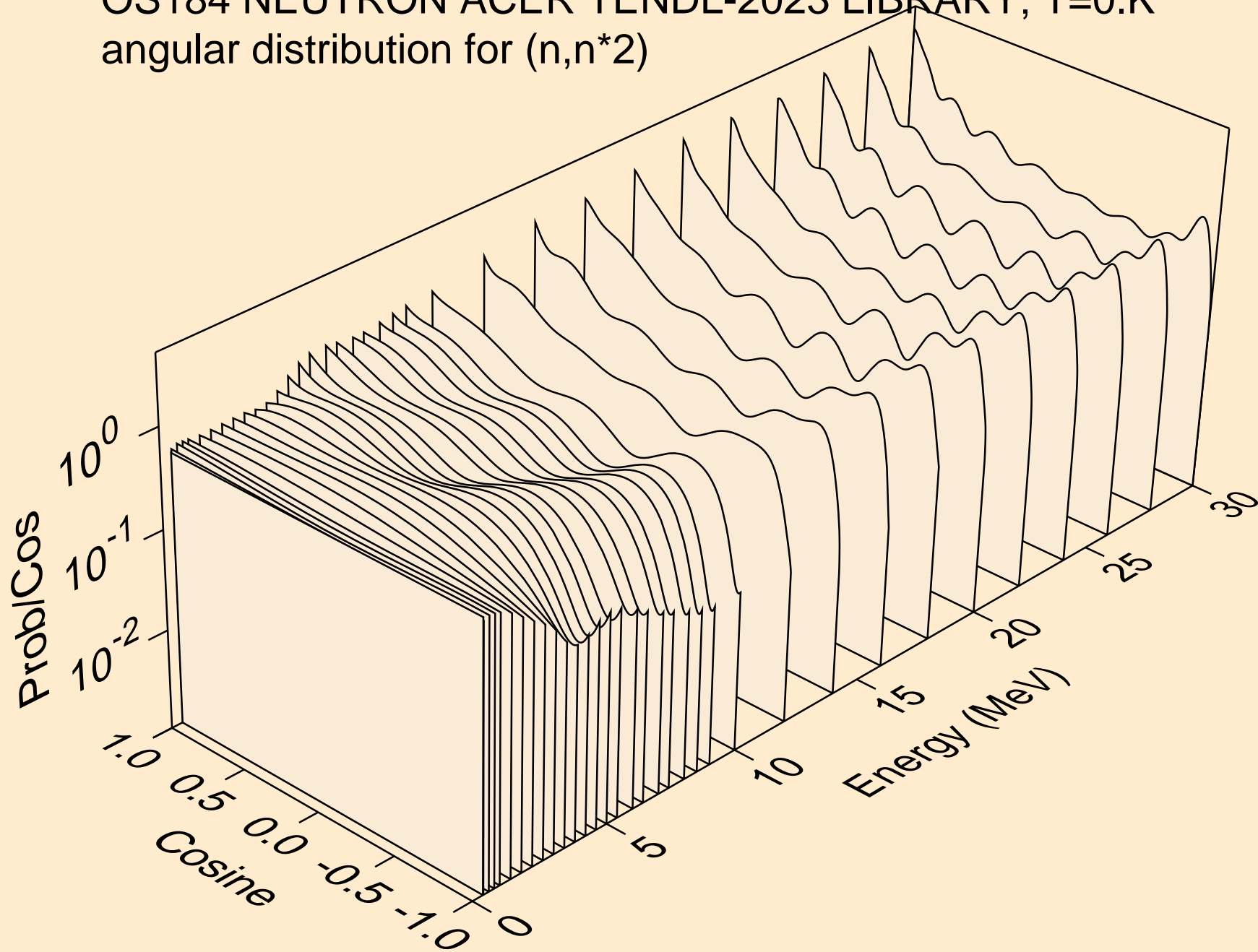

OS184 NEUTRON ACER TENDL-2023 LIBRARY; T=0.K
angular distribution for (n,n*3)

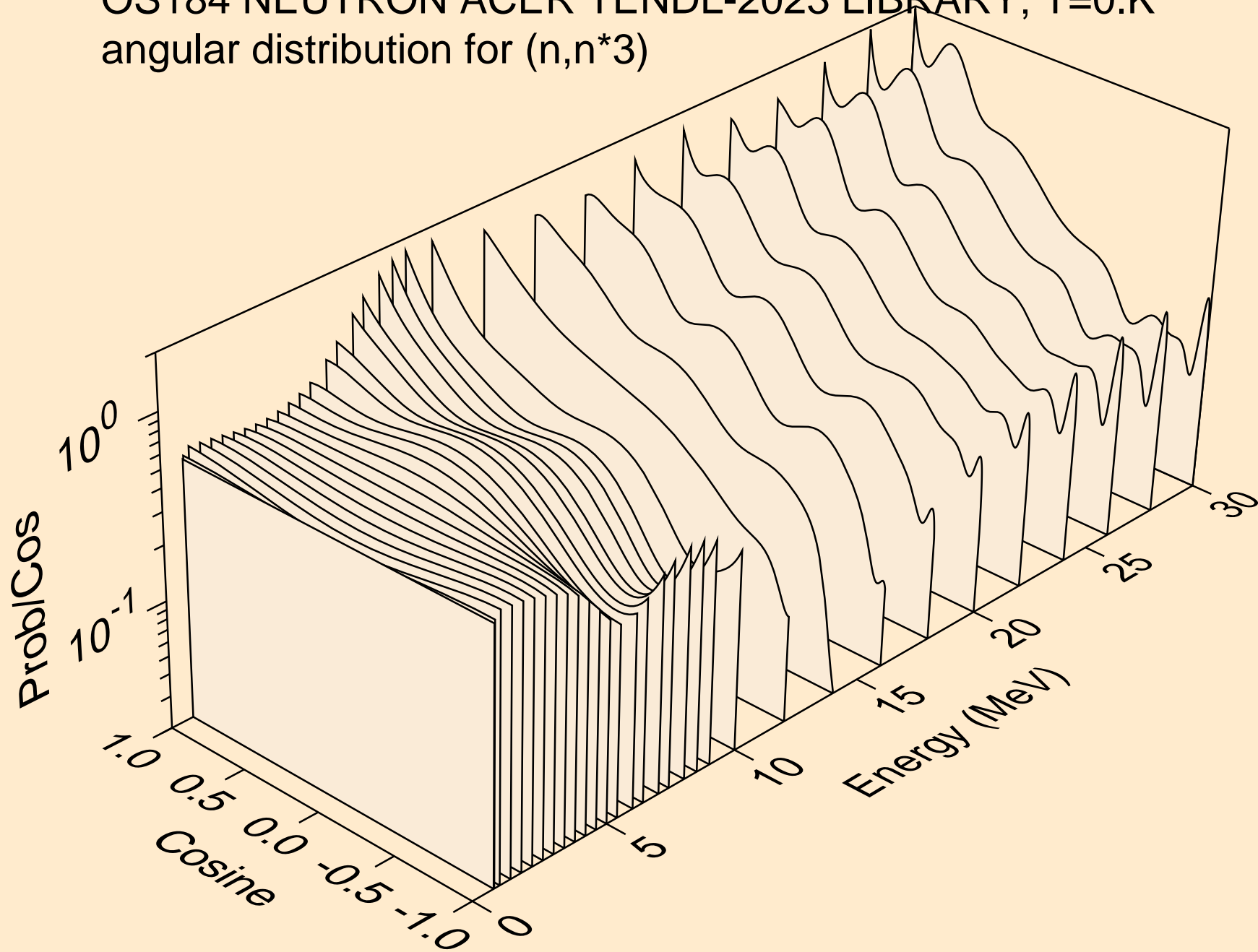

OS184 NEUTRON ACER TENDL-2023 LIBRARY; T=0.K
angular distribution for (n,n*4)

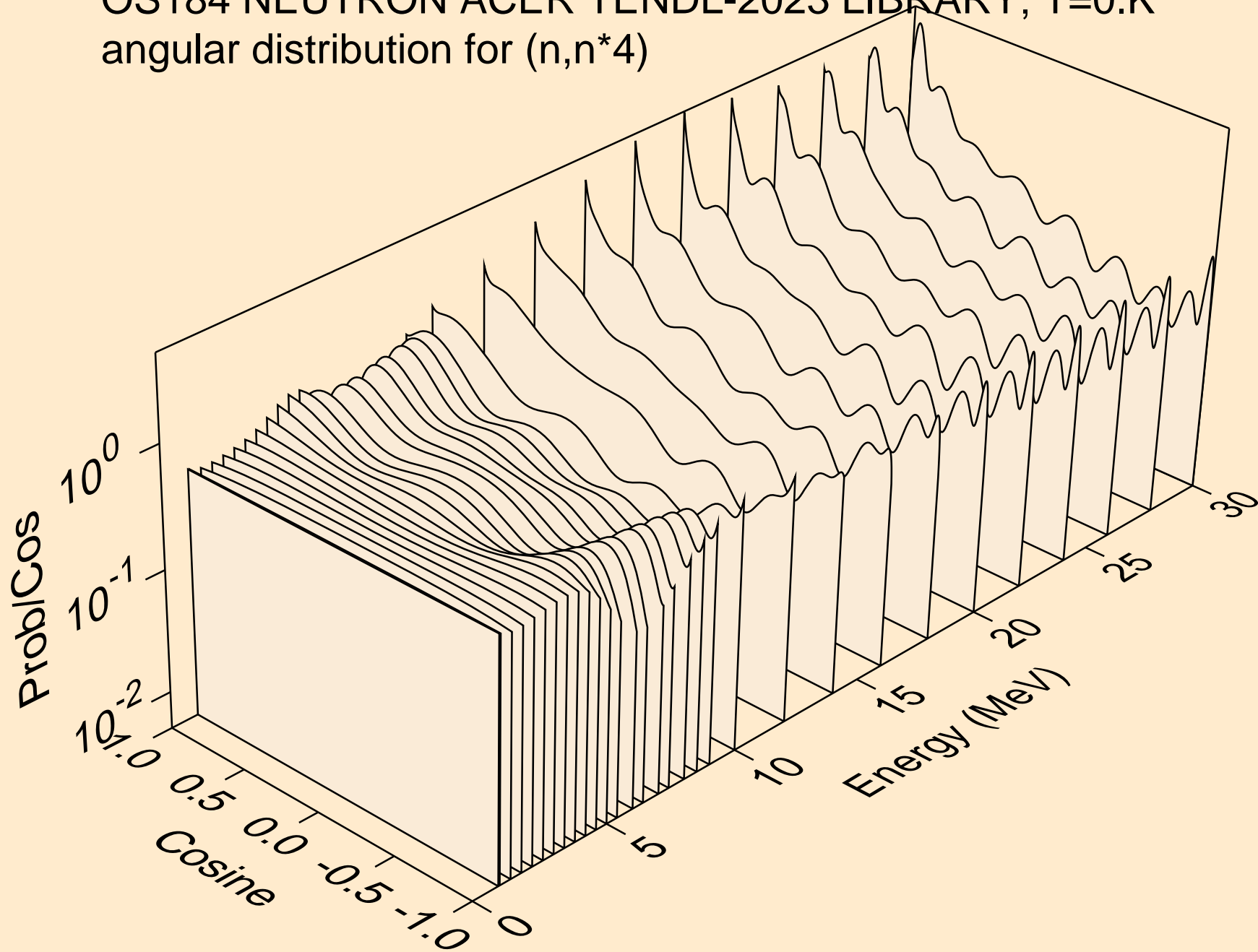

OS184 NEUTRON ACER TENDL-2023 LIBRARY; T=0.K
angular distribution for (n,n*5)

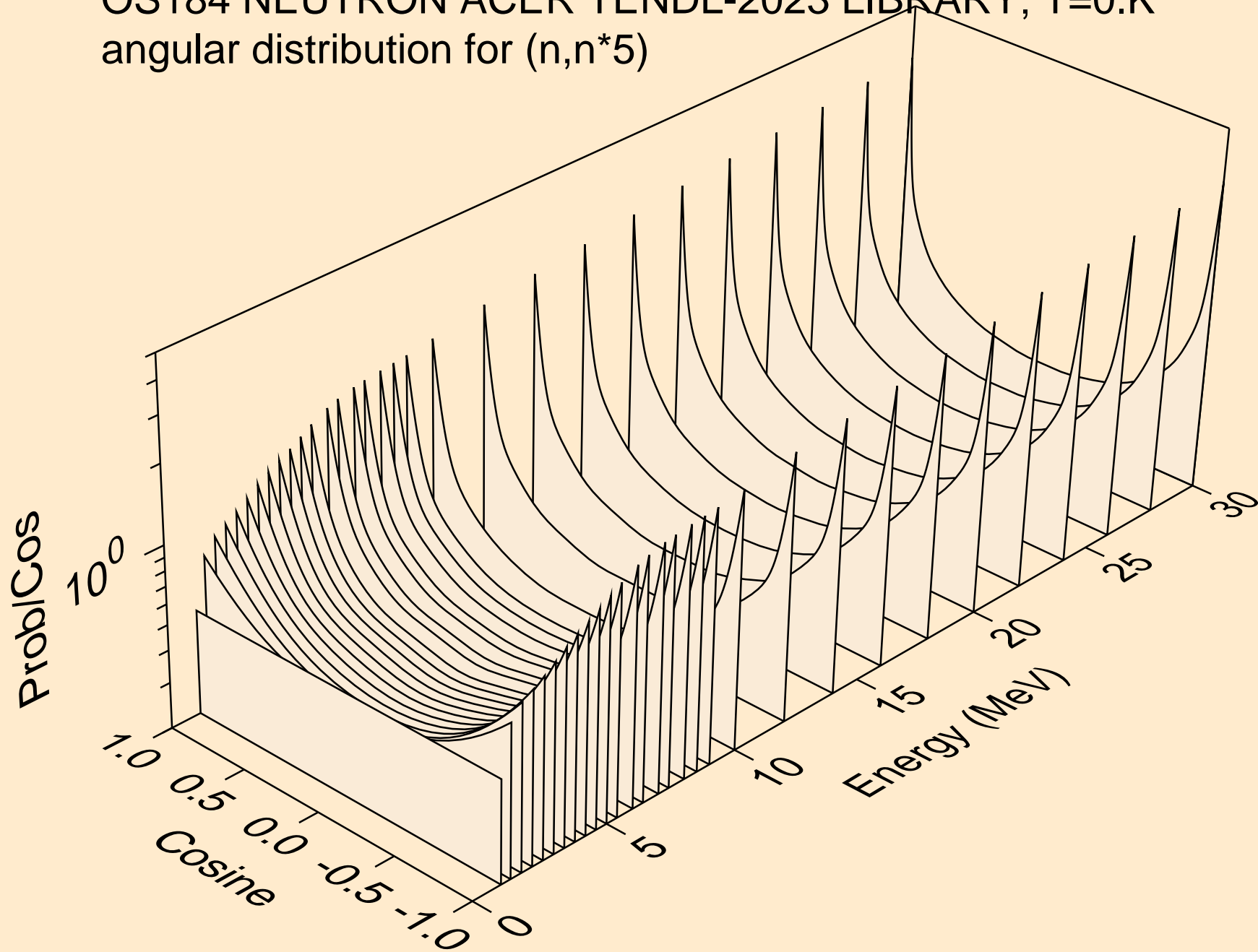

OS184 NEUTRON ACER TENDL-2023 LIBRARY; T=0.K
angular distribution for (n,n*6)

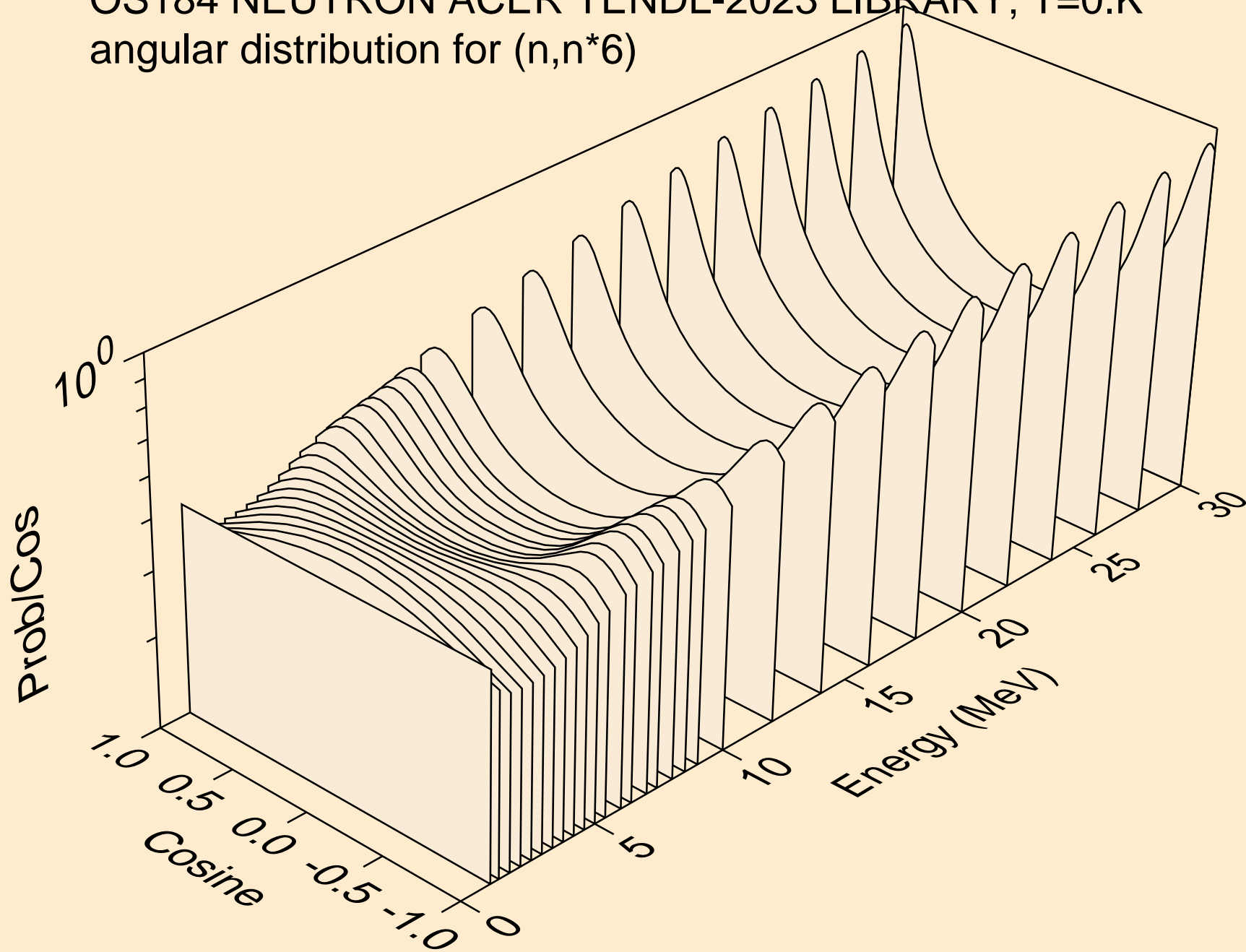

OS184 NEUTRON ACER TENDL-2023 LIBRARY; T=0.K
angular distribution for (n,n*7)

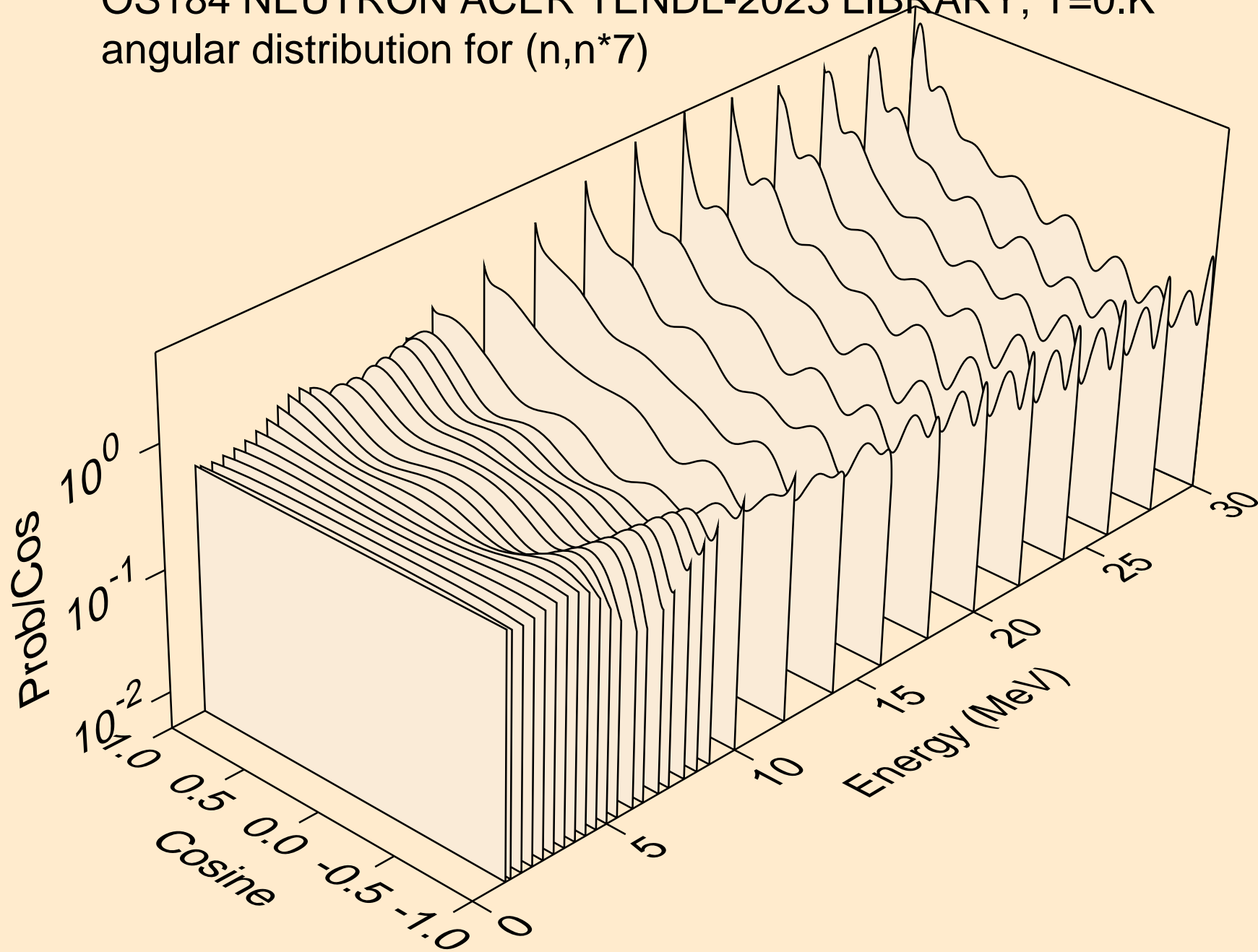

OS184 NEUTRON ACER TENDL-2023 LIBRARY; T=0.K
angular distribution for (n,n*8)

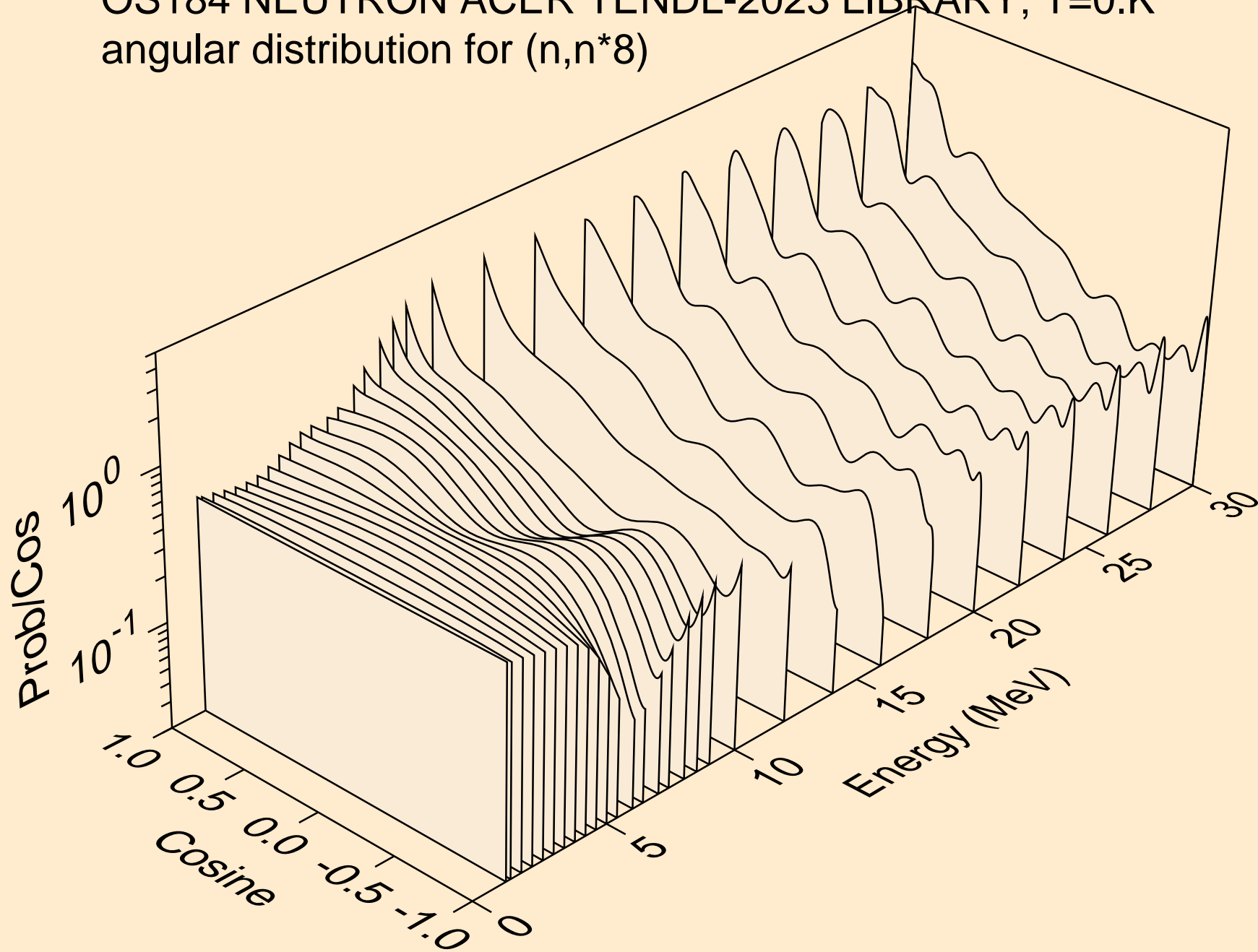

OS184 NEUTRON ACER TENDL-2023 LIBRARY; T=0.K
angular distribution for (n,n*9)

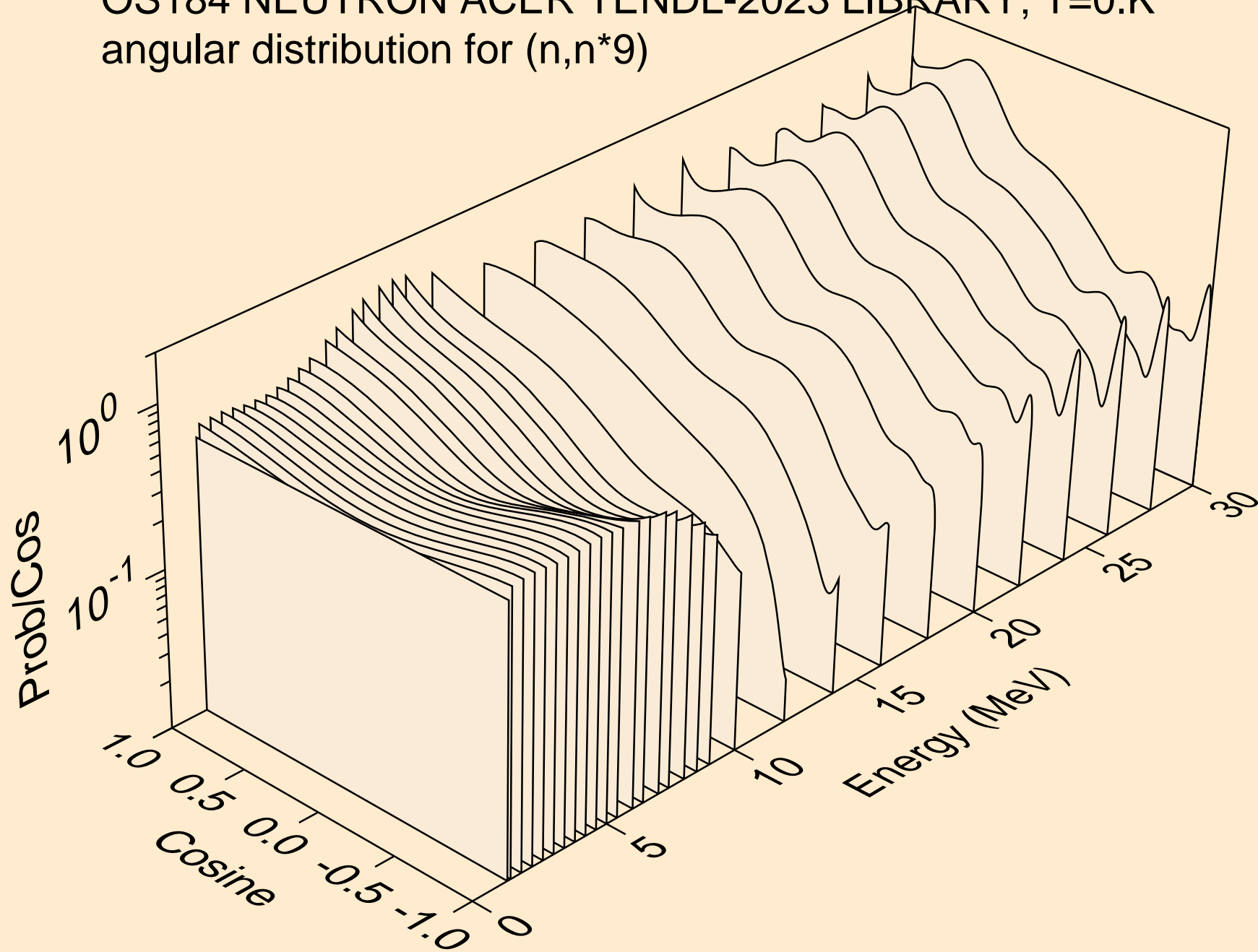

OS184 NEUTRON ACER TENDL-2023 LIBRARY; T=0.K
angular distribution for (n,n*10)

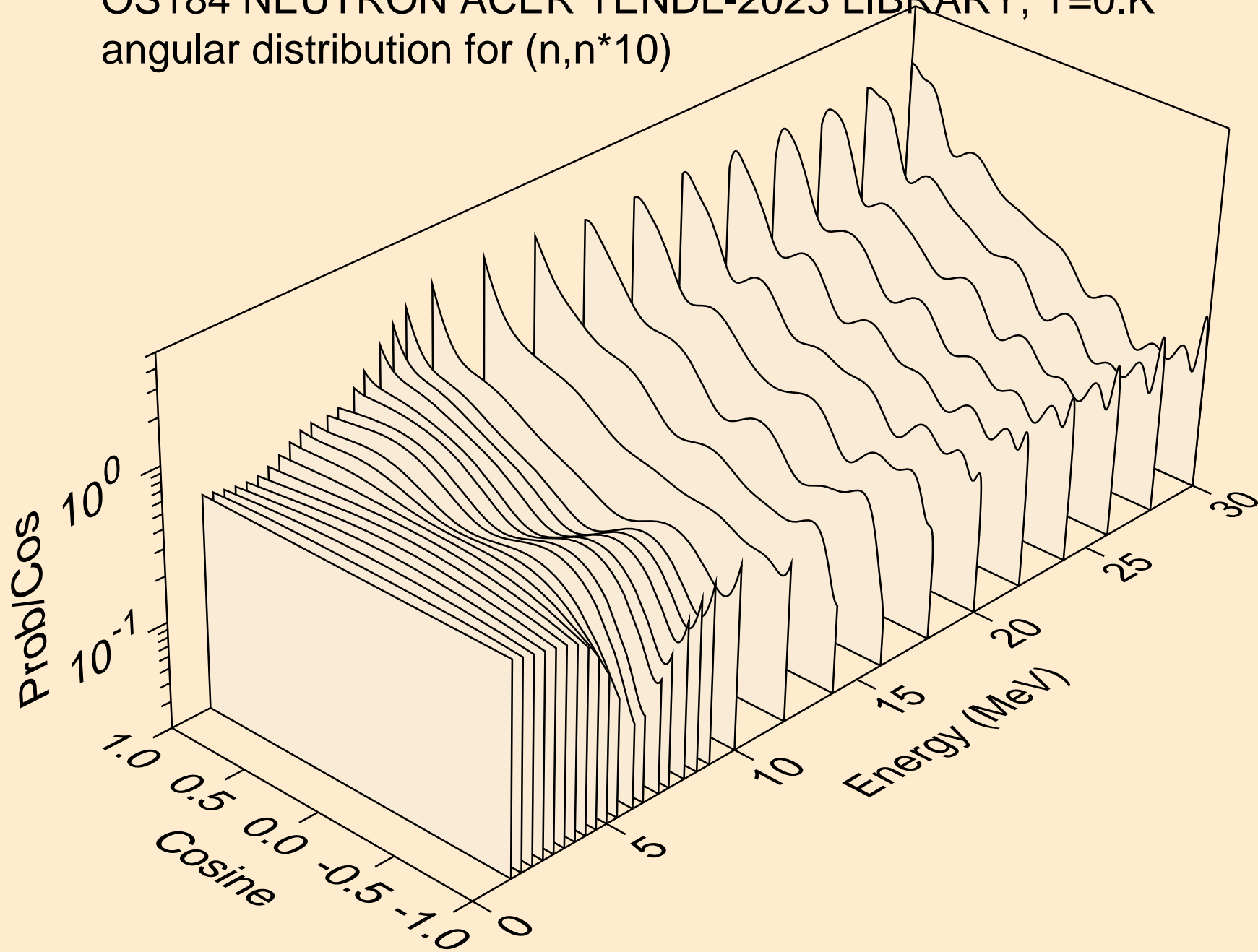

OS184 NEUTRON ACER TENDL-2023 LIBRARY; T=0.K
angular distribution for (n,n*11)

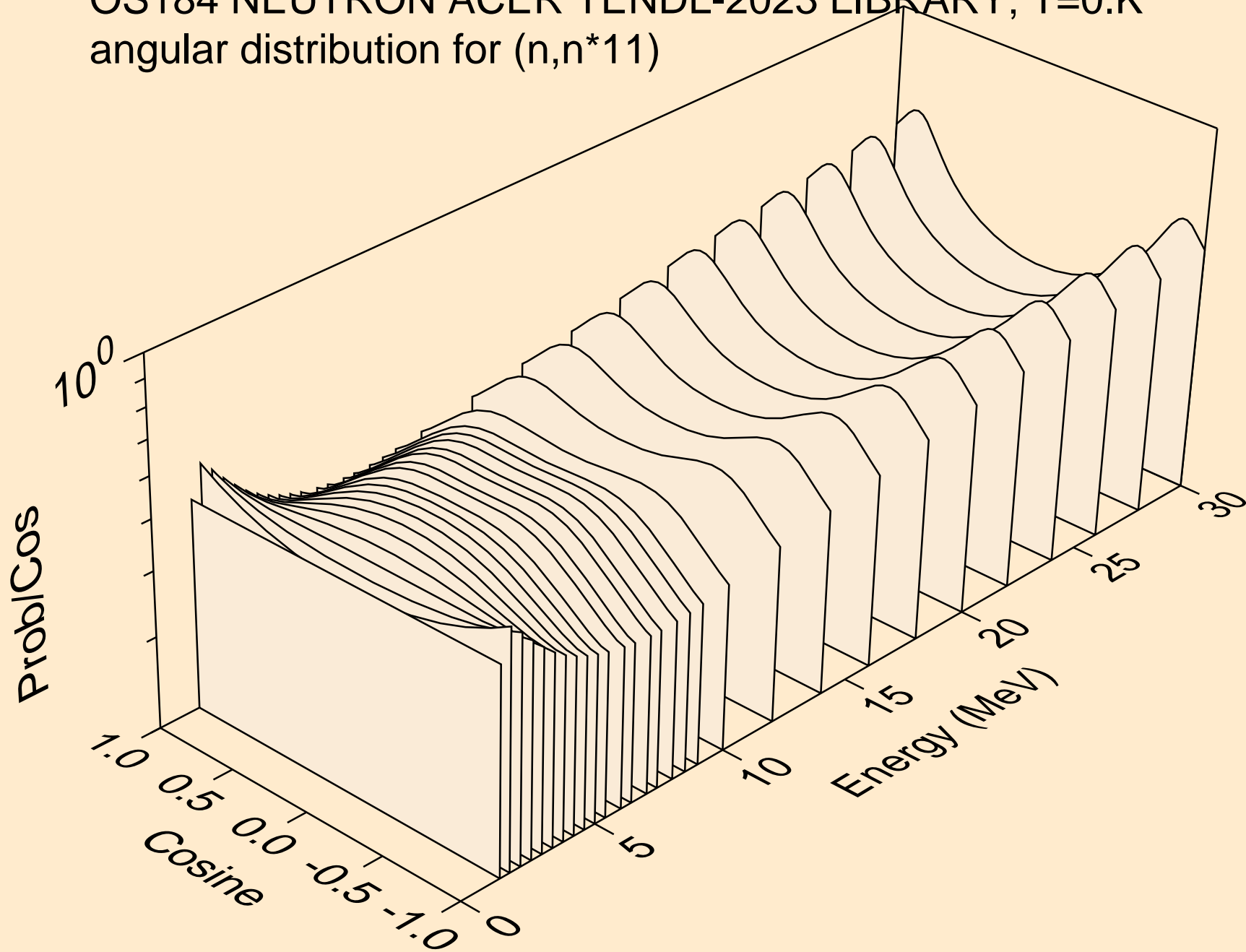

OS184 NEUTRON ACER TENDL-2023 LIBRARY; T=0.K
angular distribution for (n,n*12)

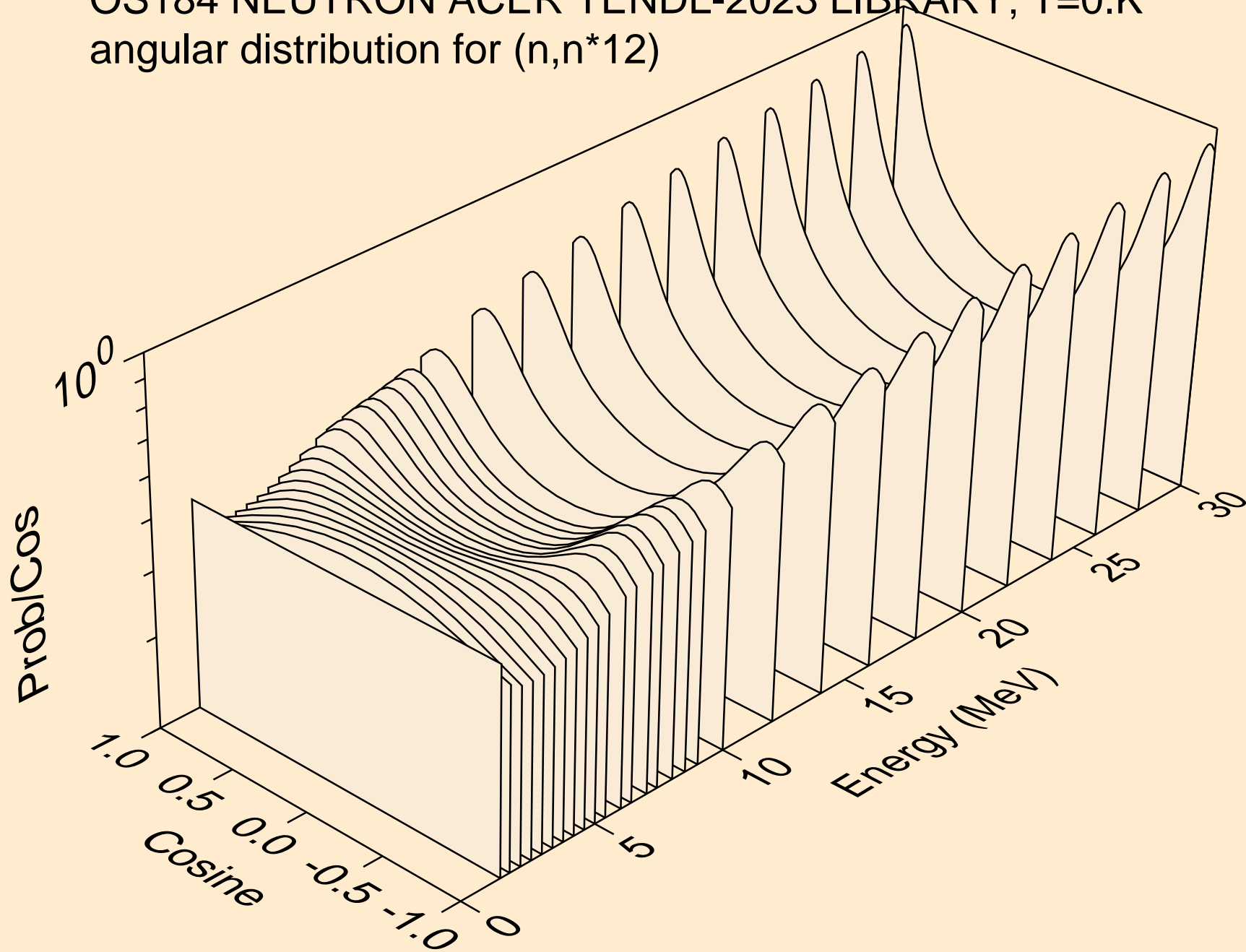

OS184 NEUTRON ACER TENDL-2023 LIBRARY; T=0.K
angular distribution for (n,n*13)

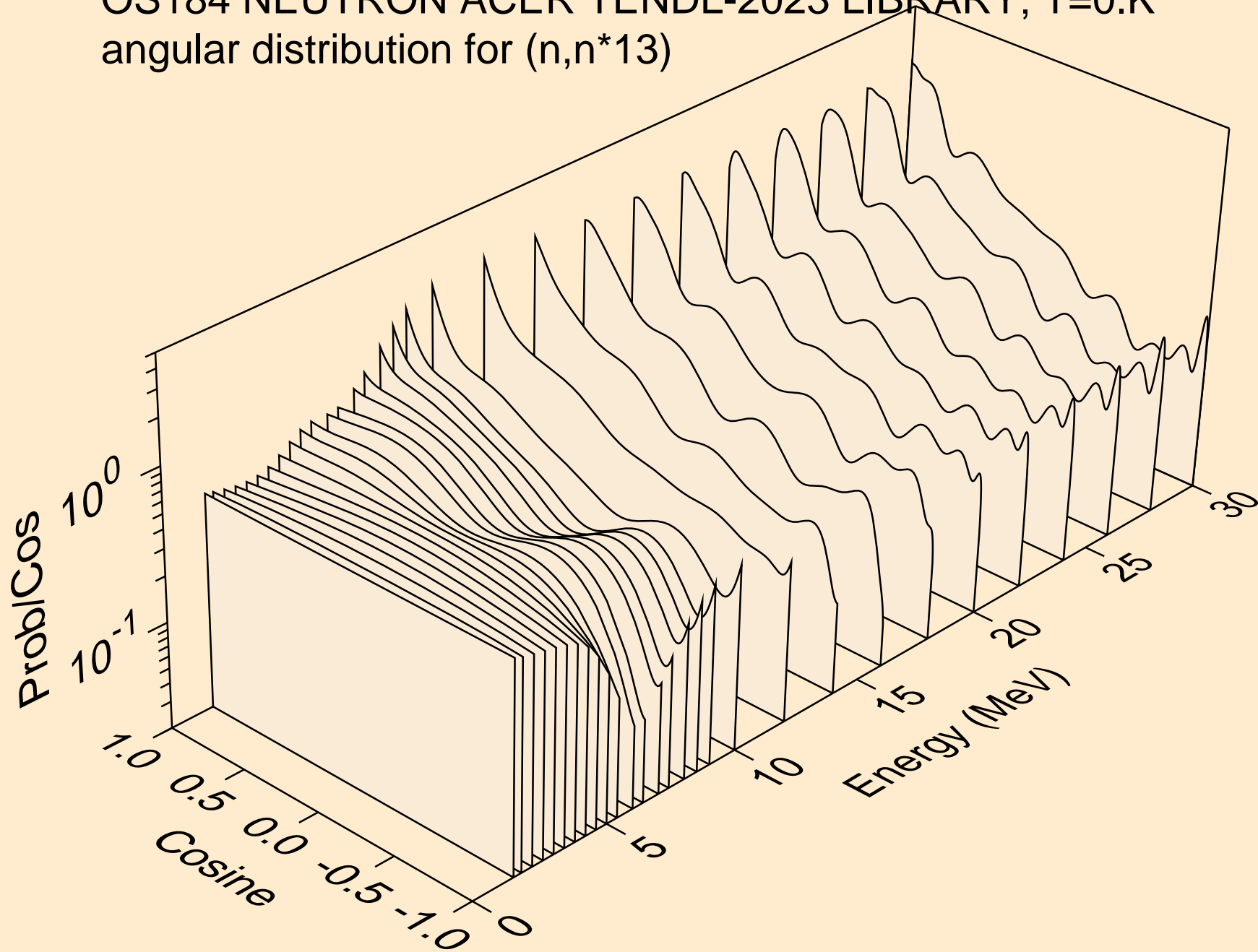

OS184 NEUTRON ACER TENDL-2023 LIBRARY; T=0.K
angular distribution for (n,n*14)

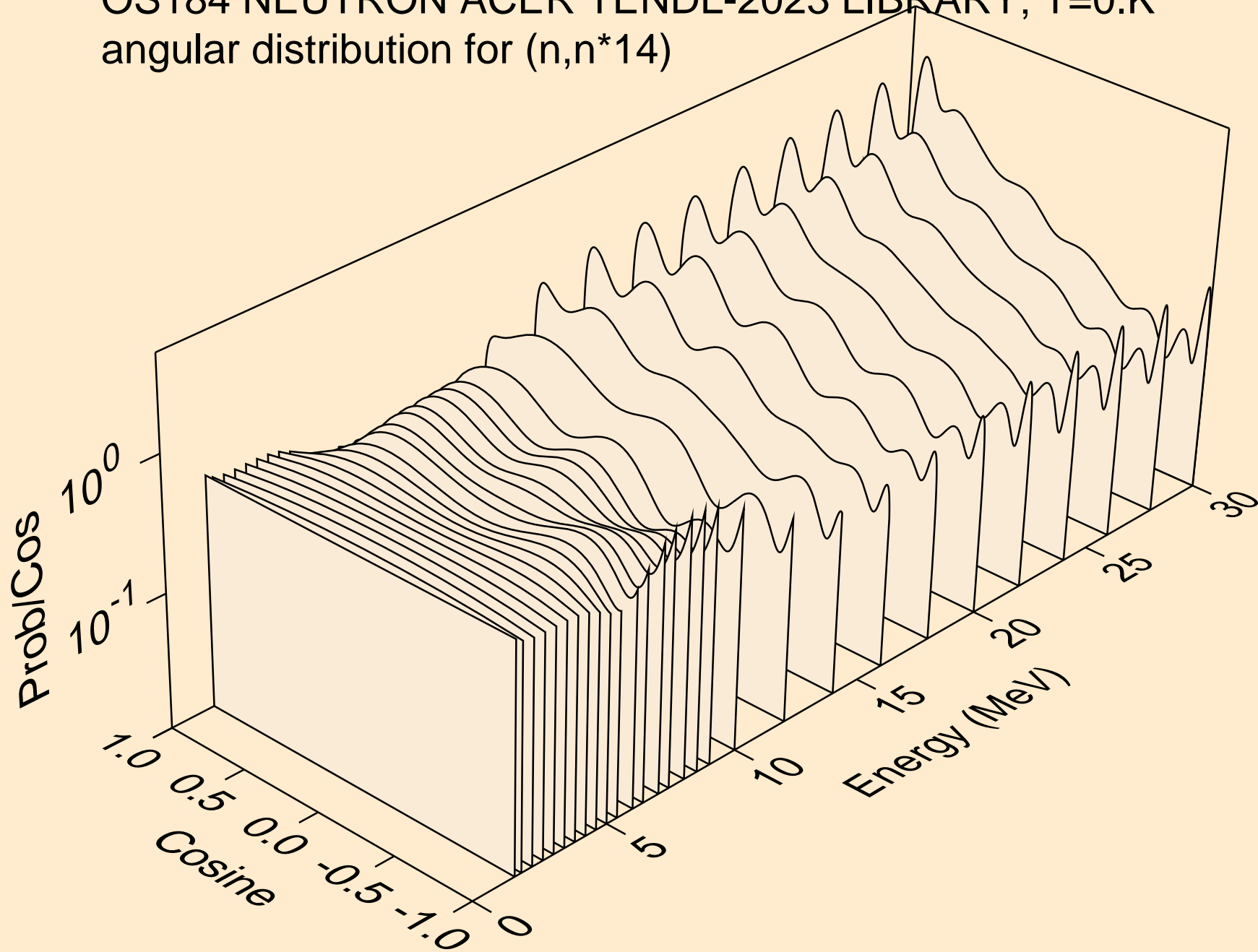

OS184 NEUTRON ACER TENDL-2023 LIBRARY; T=0.K
angular distribution for (n,n*15)

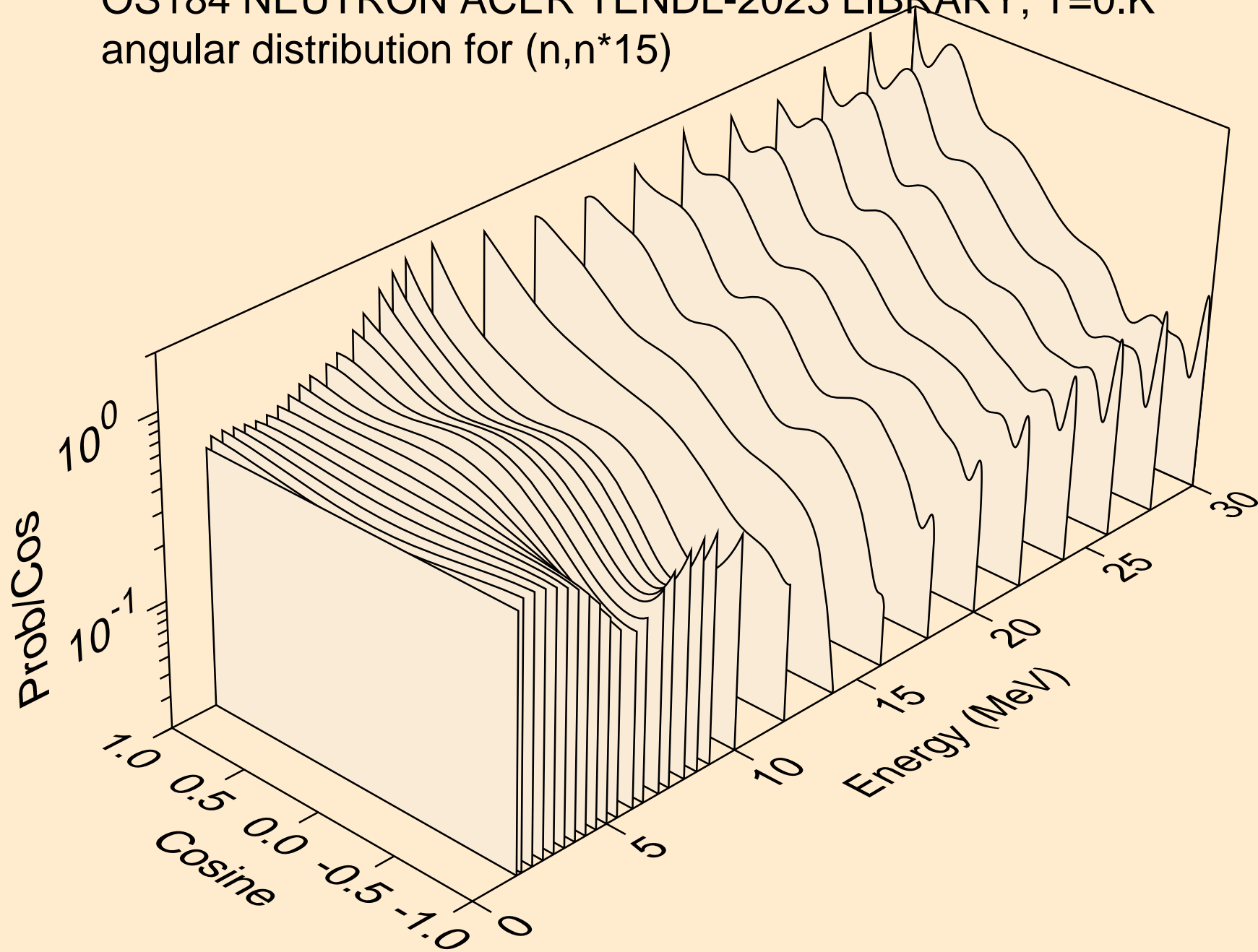

OS184 NEUTRON ACER TENDL-2023 LIBRARY; T=0.K
angular distribution for (n,n*16)

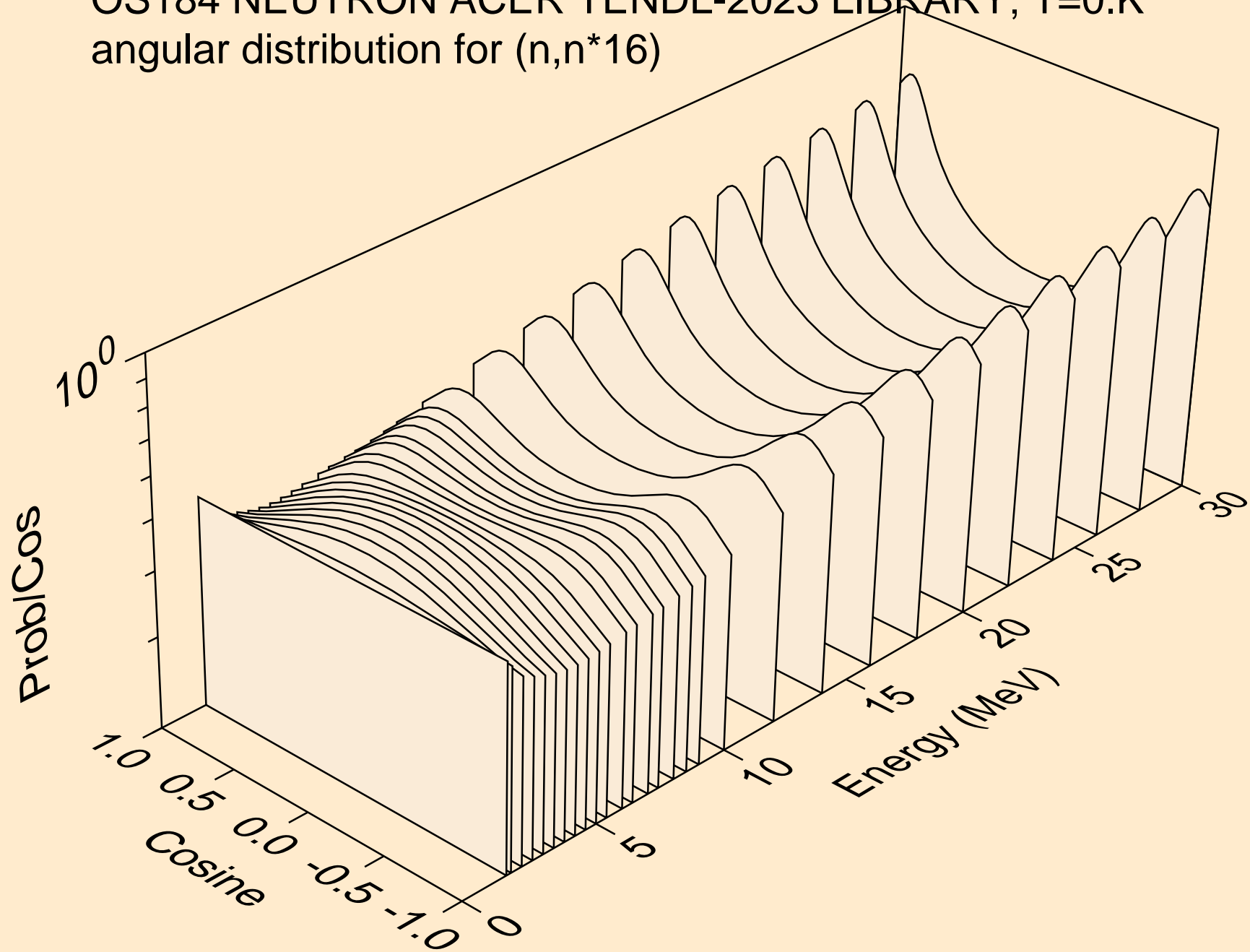

OS184 NEUTRON ACER TENDL-2023 LIBRARY; T=0.K
angular distribution for (n,n*17)

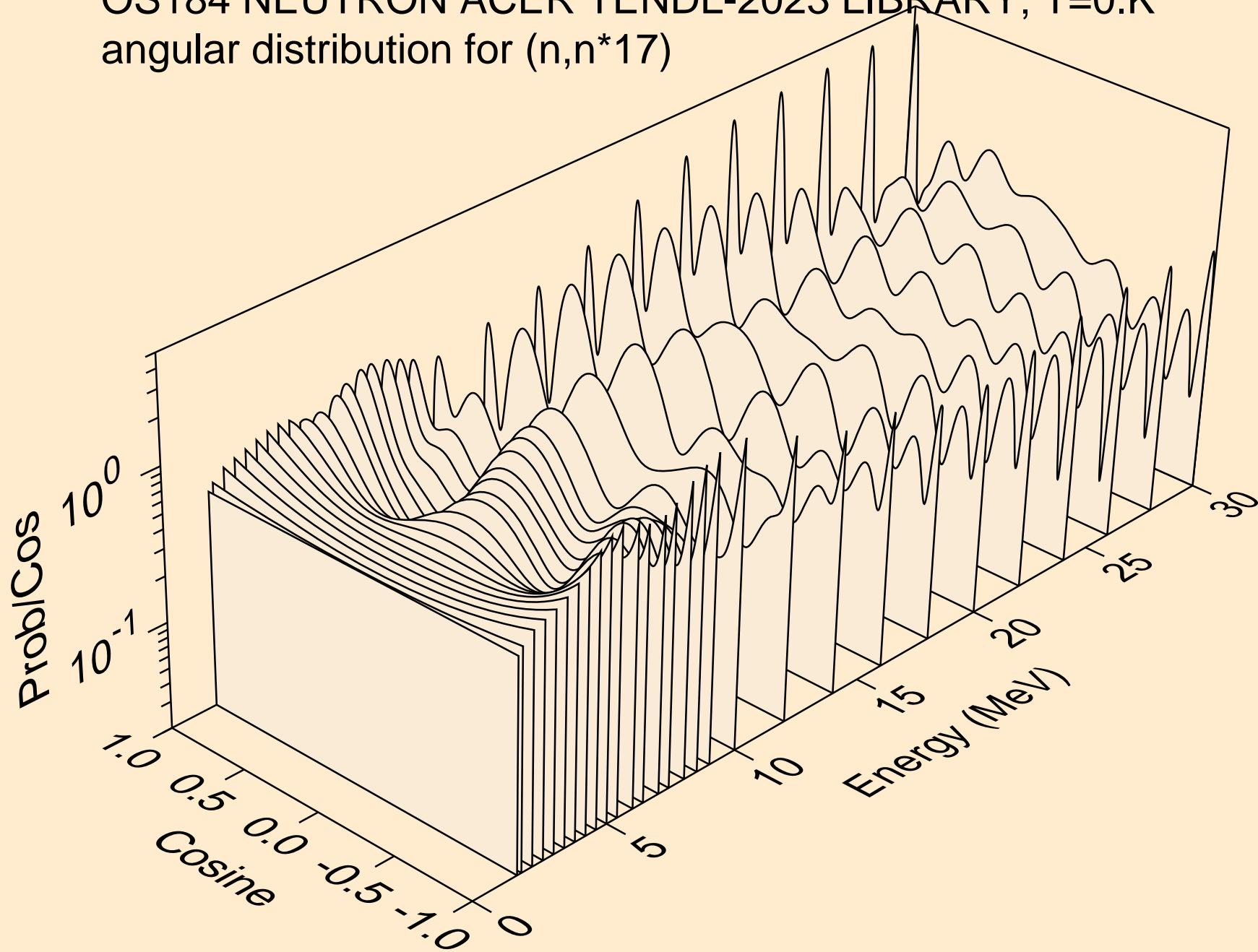

OS184 NEUTRON ACER TENDL-2023 LIBRARY; T=0.K
angular distribution for (n,n*18)

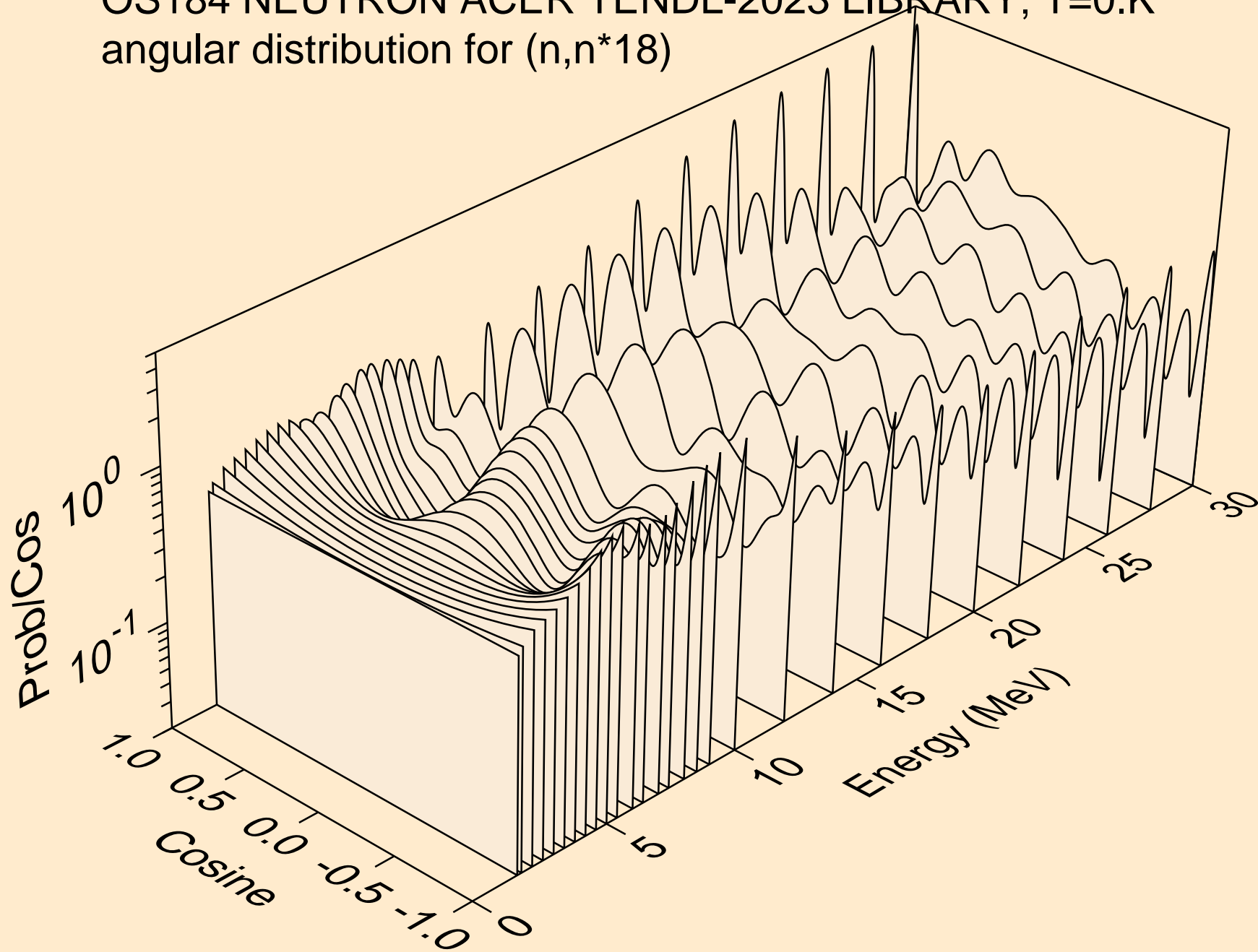

OS184 NEUTRON ACER TENDL-2023 LIBRARY; T=0.K
Neutron emission for (n,x)

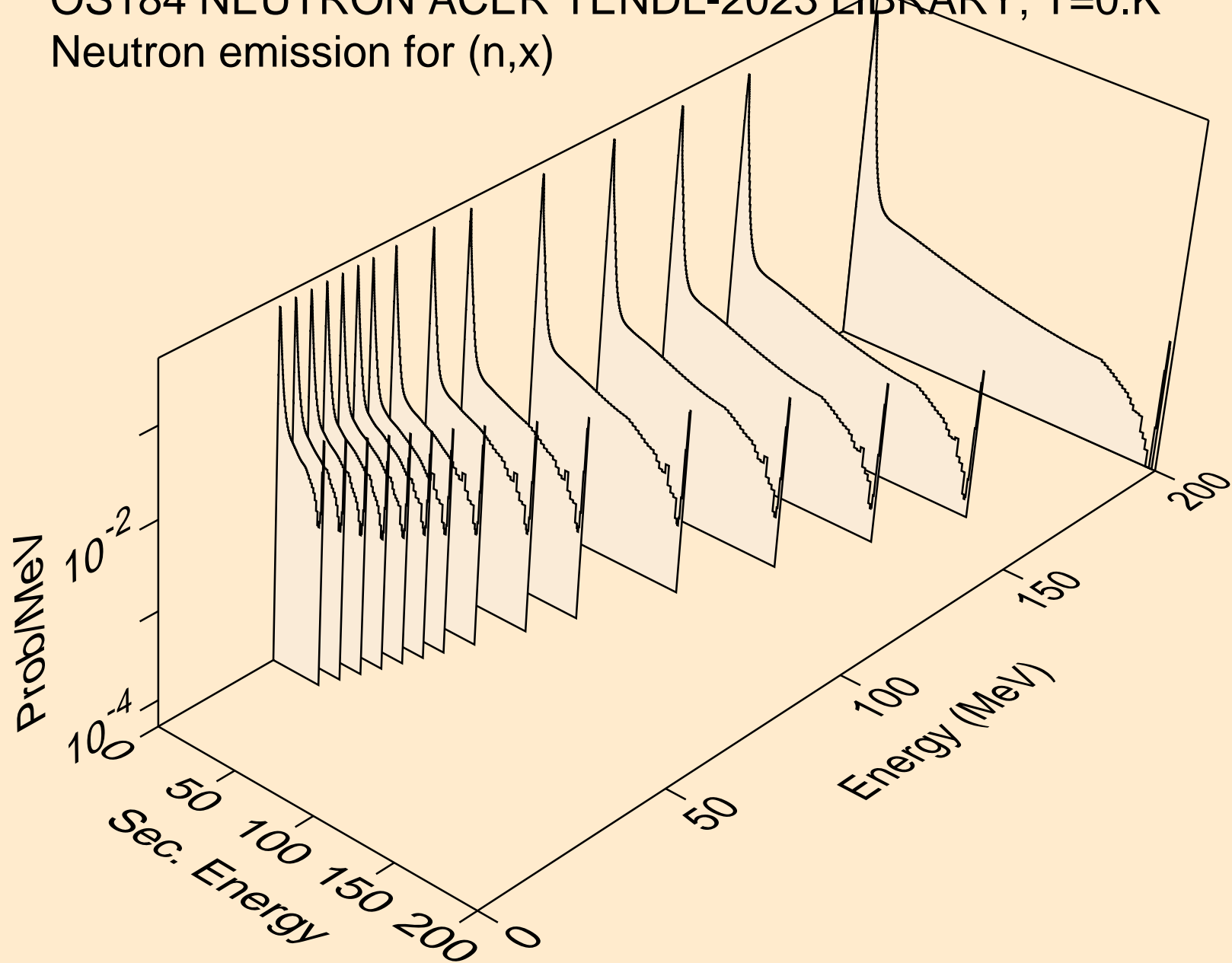

OS184 NEUTRON ACER TENDL-2023 LIBRARY; T=0.K
Neutron emission for (n,2nd)

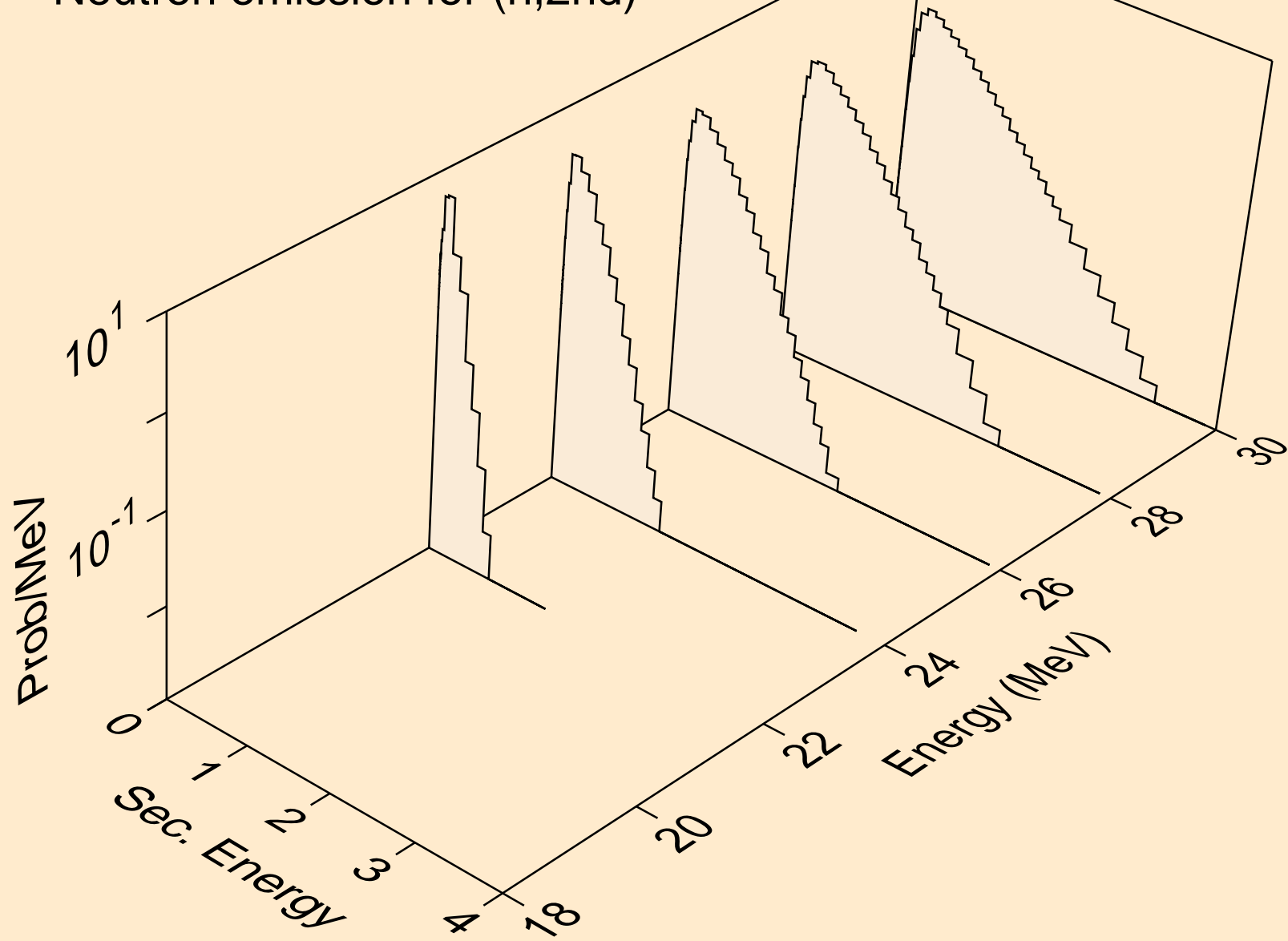

OS184 NEUTRON ACER TENDL-2023 LIBRARY; T=0.K
Neutron emission for (n,2n)

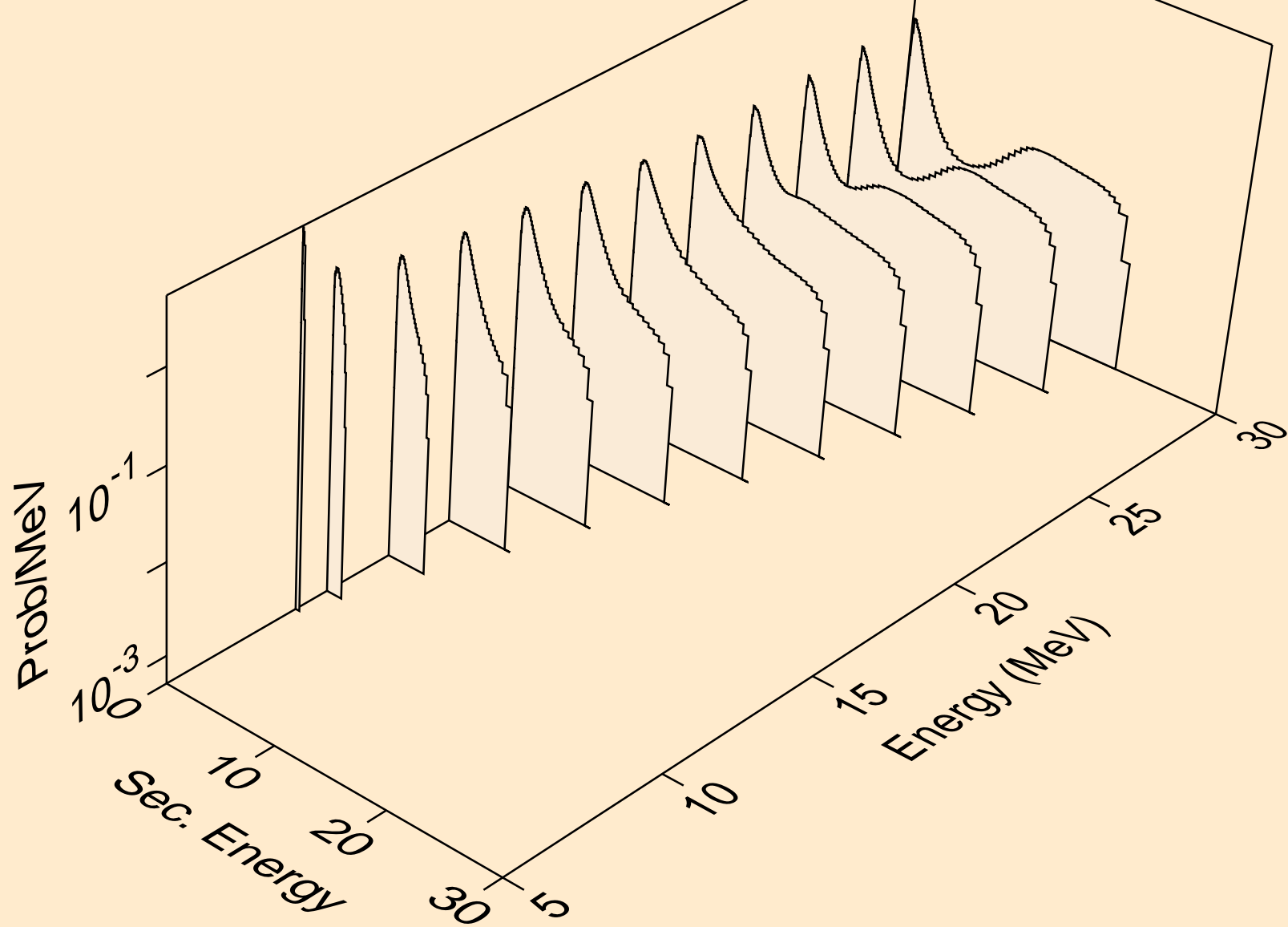

OS184 NEUTRON ACER TENDL-2023 LIBRARY; T=0.K
Neutron emission for (n,3n)

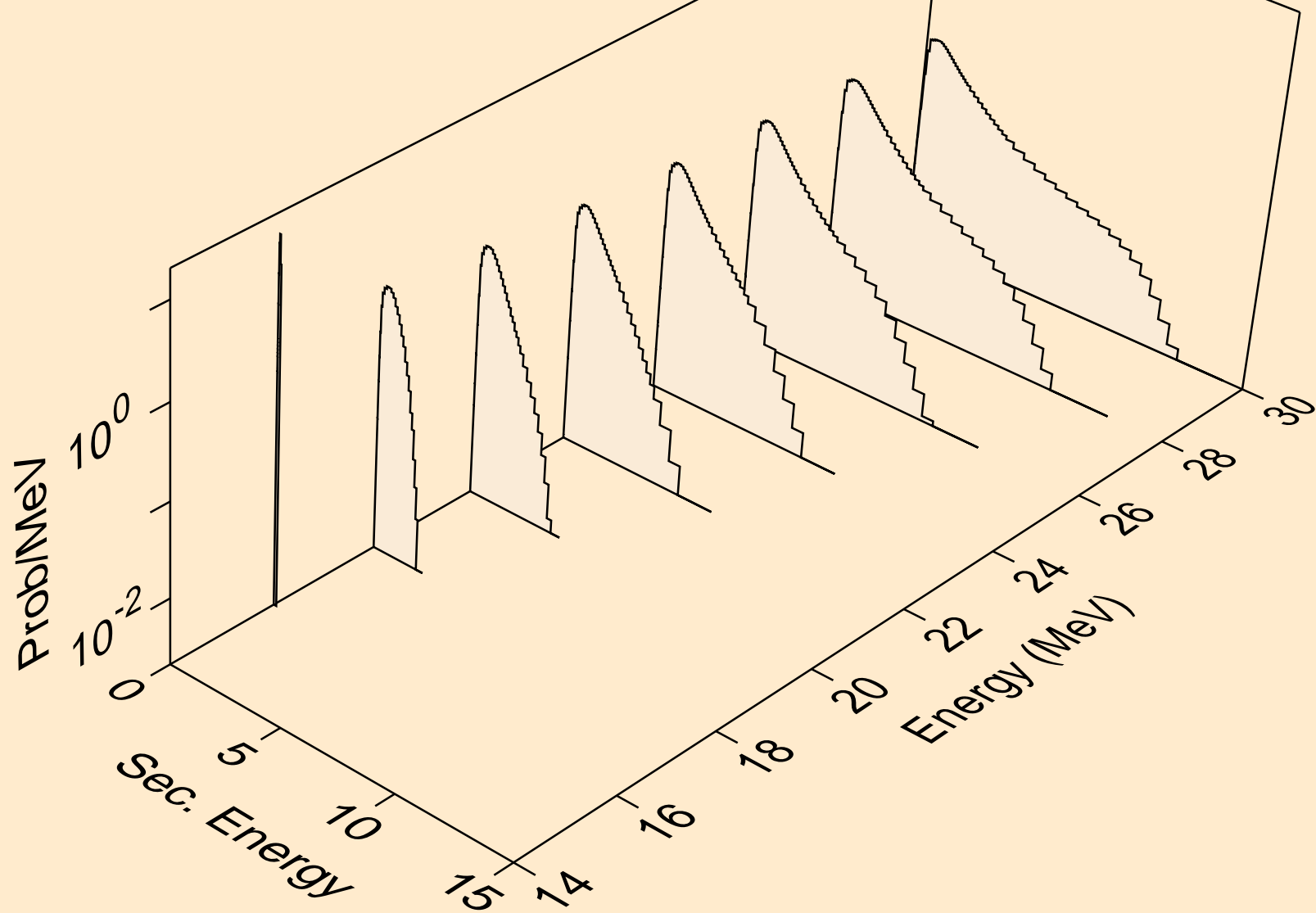

OS184 NEUTRON ACER TENDL-2023 LIBRARY; T=0.K
Neutron emission for (n,n*)a

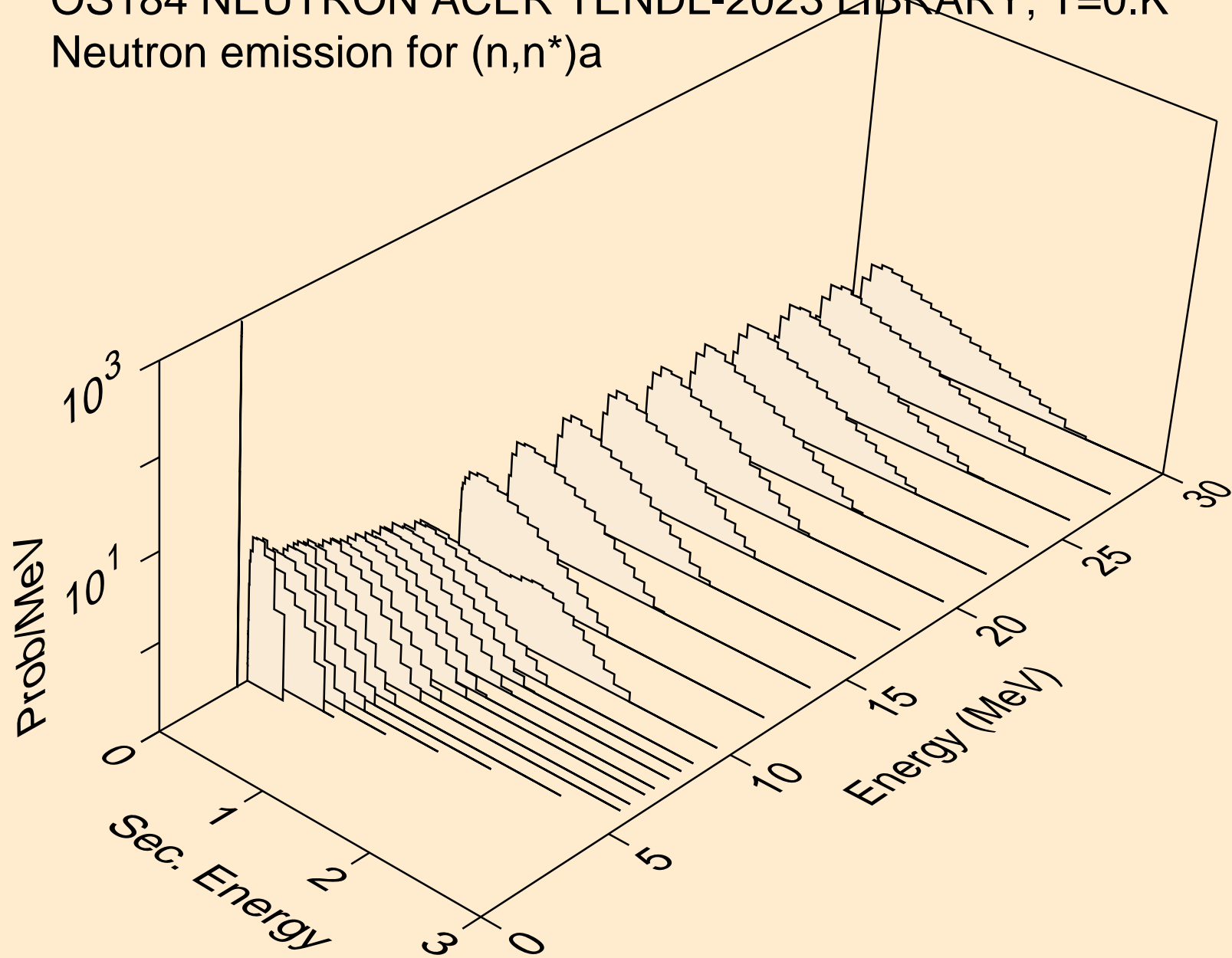

OS184 NEUTRON ACER TENDL-2023 LIBRARY; T=0.K
Neutron emission for (n,2n)a

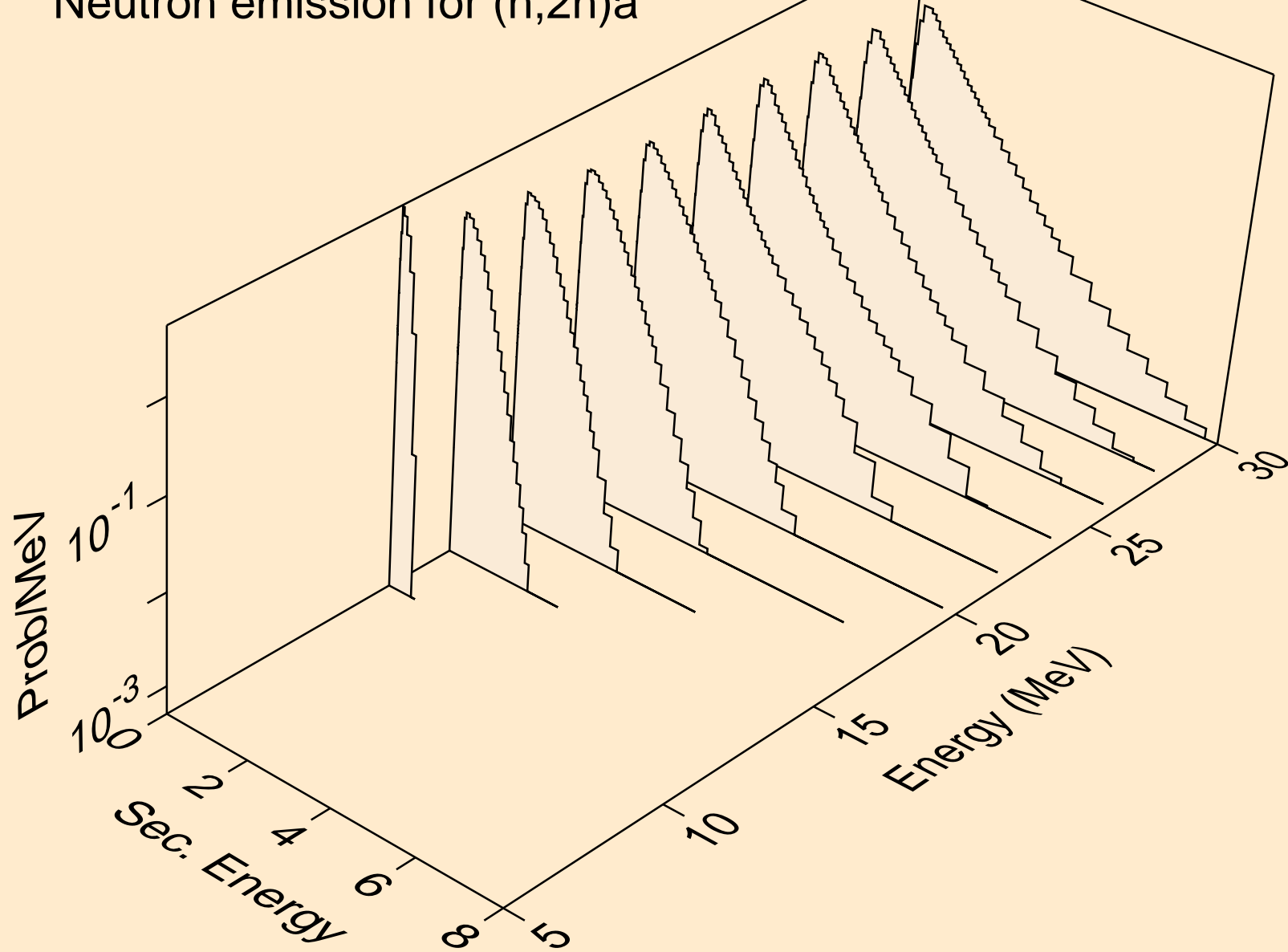

OS184 NEUTRON ACER TENDL-2023 LIBRARY; T=0.K
Neutron emission for (n,3n)a

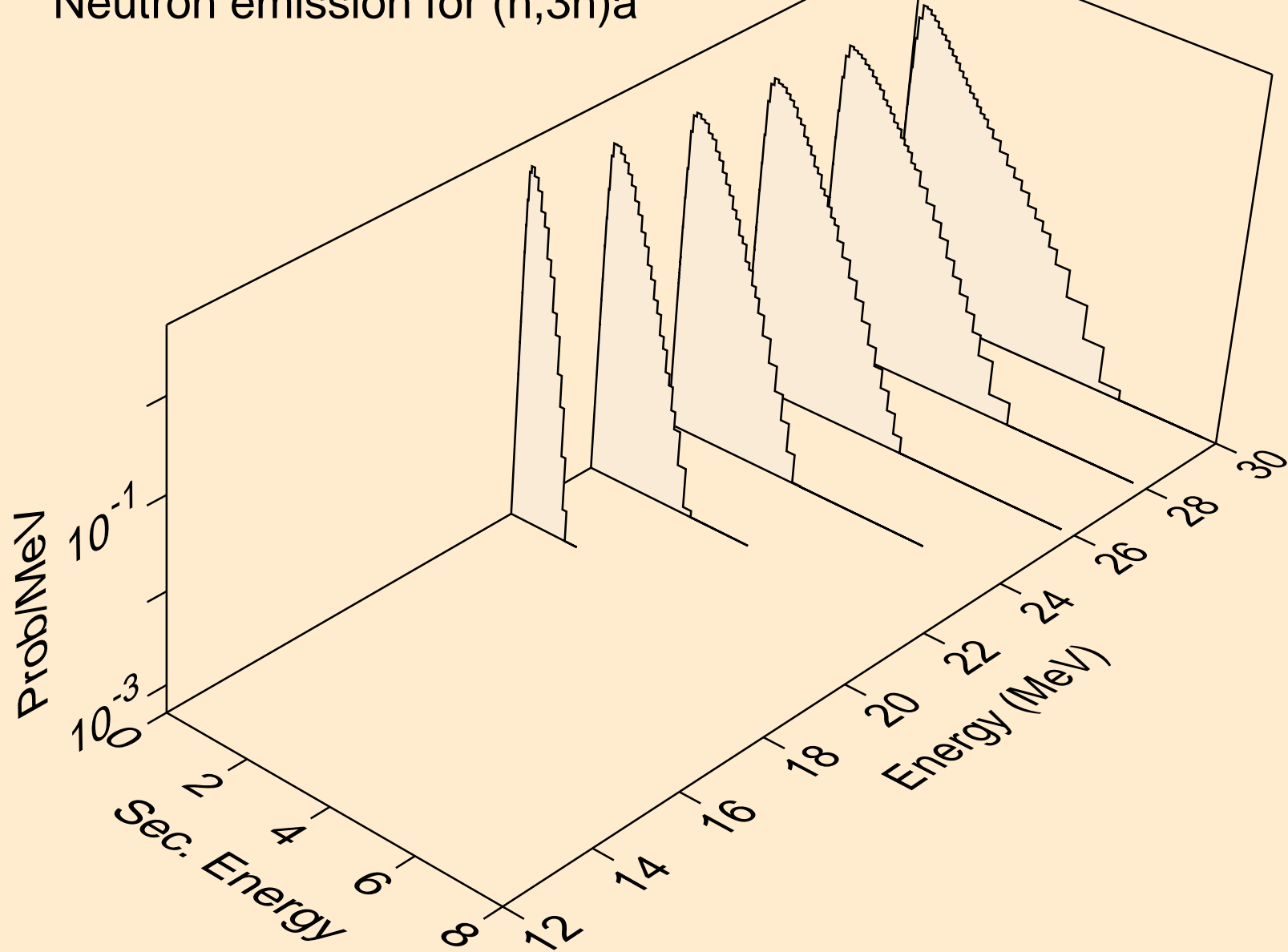

OS184 NEUTRON ACER TENDL-2023 LIBRARY; T=0.K
Neutron emission for (n,n*)p

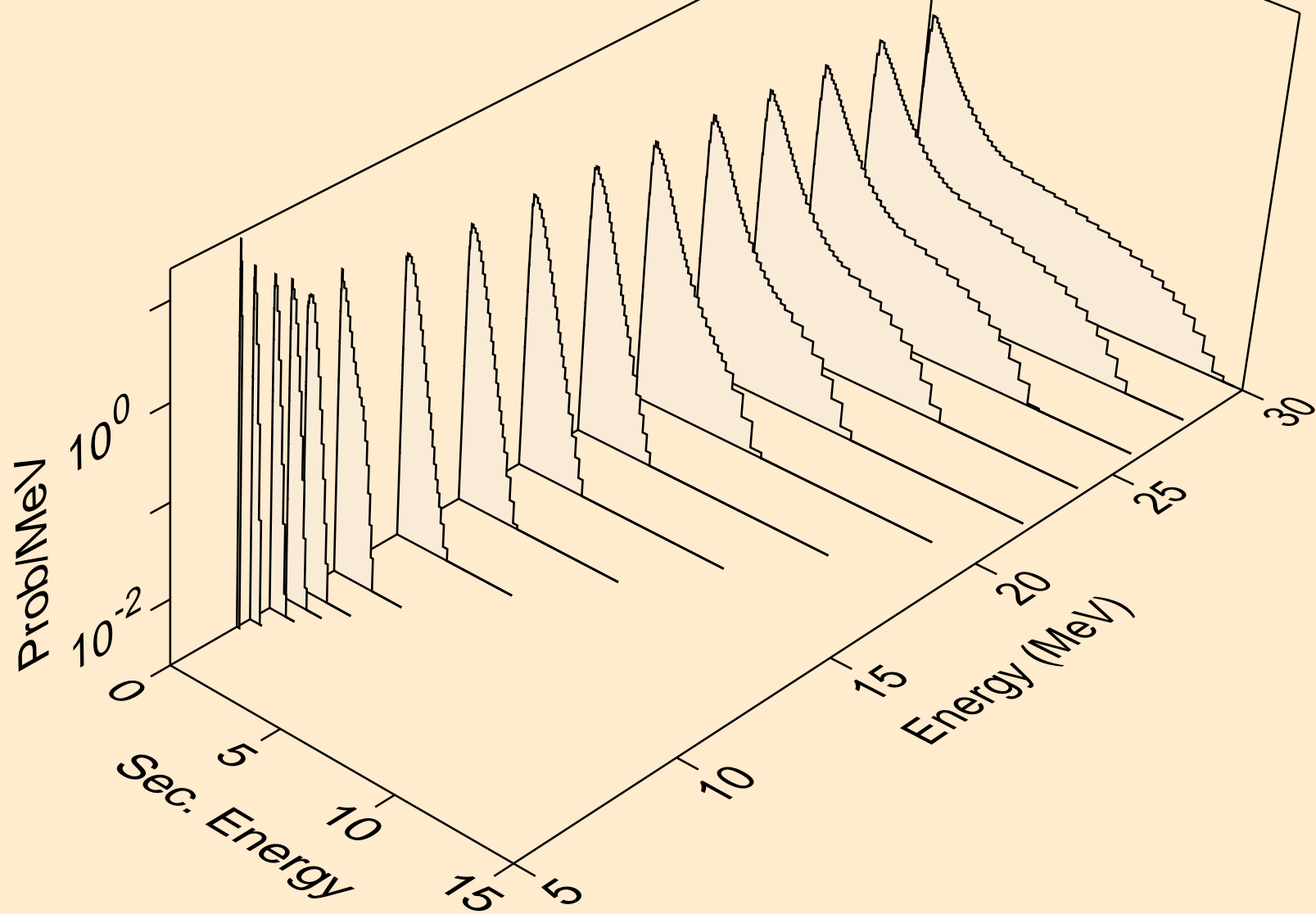

OS184 NEUTRON ACER TENDL-2023 LIBRARY; T=0.K
Neutron emission for (n,n*)2a

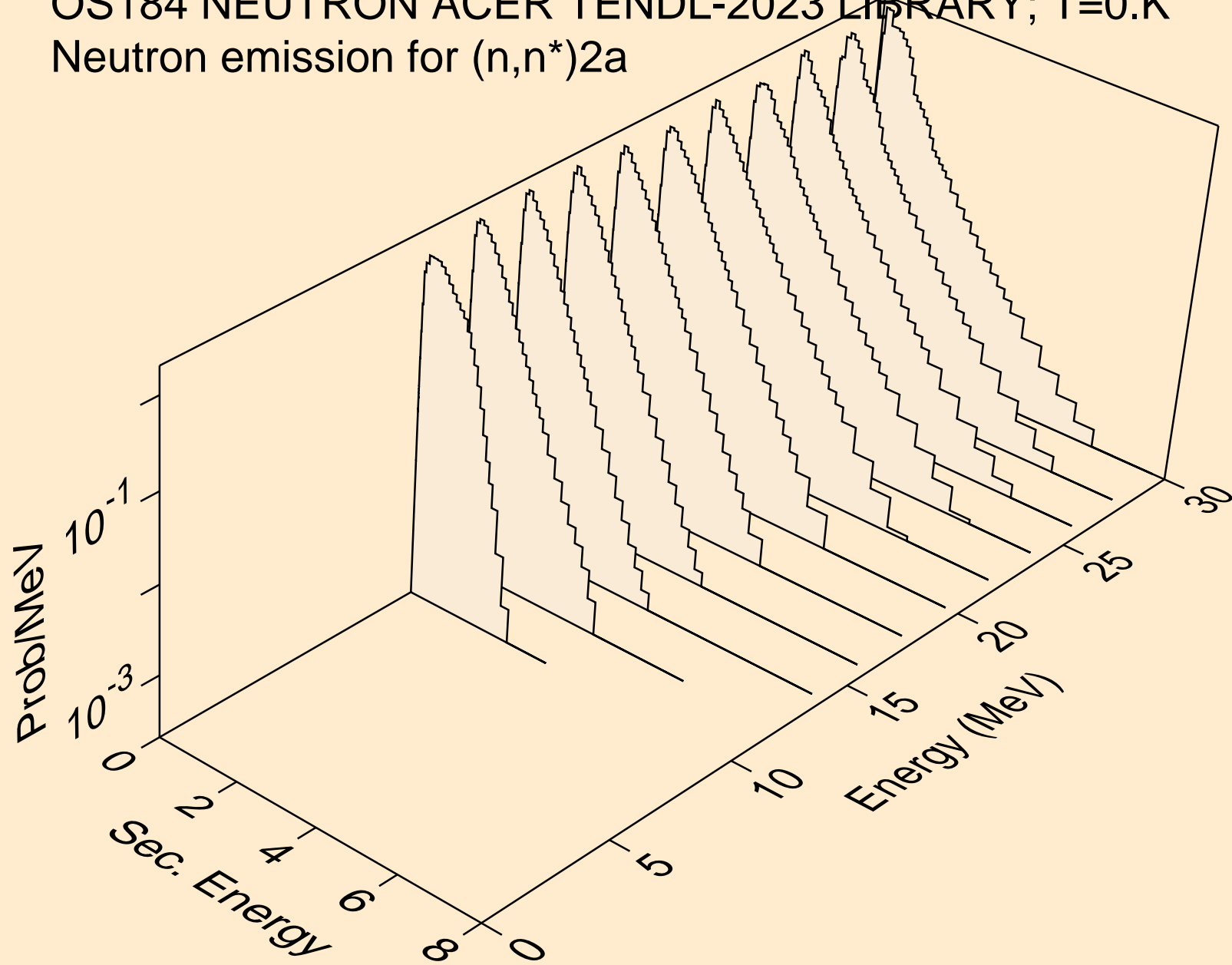

OS184 NEUTRON ACER TENDL-2023 LIBRARY; T=0.K
Neutron emission for (n,n*)d

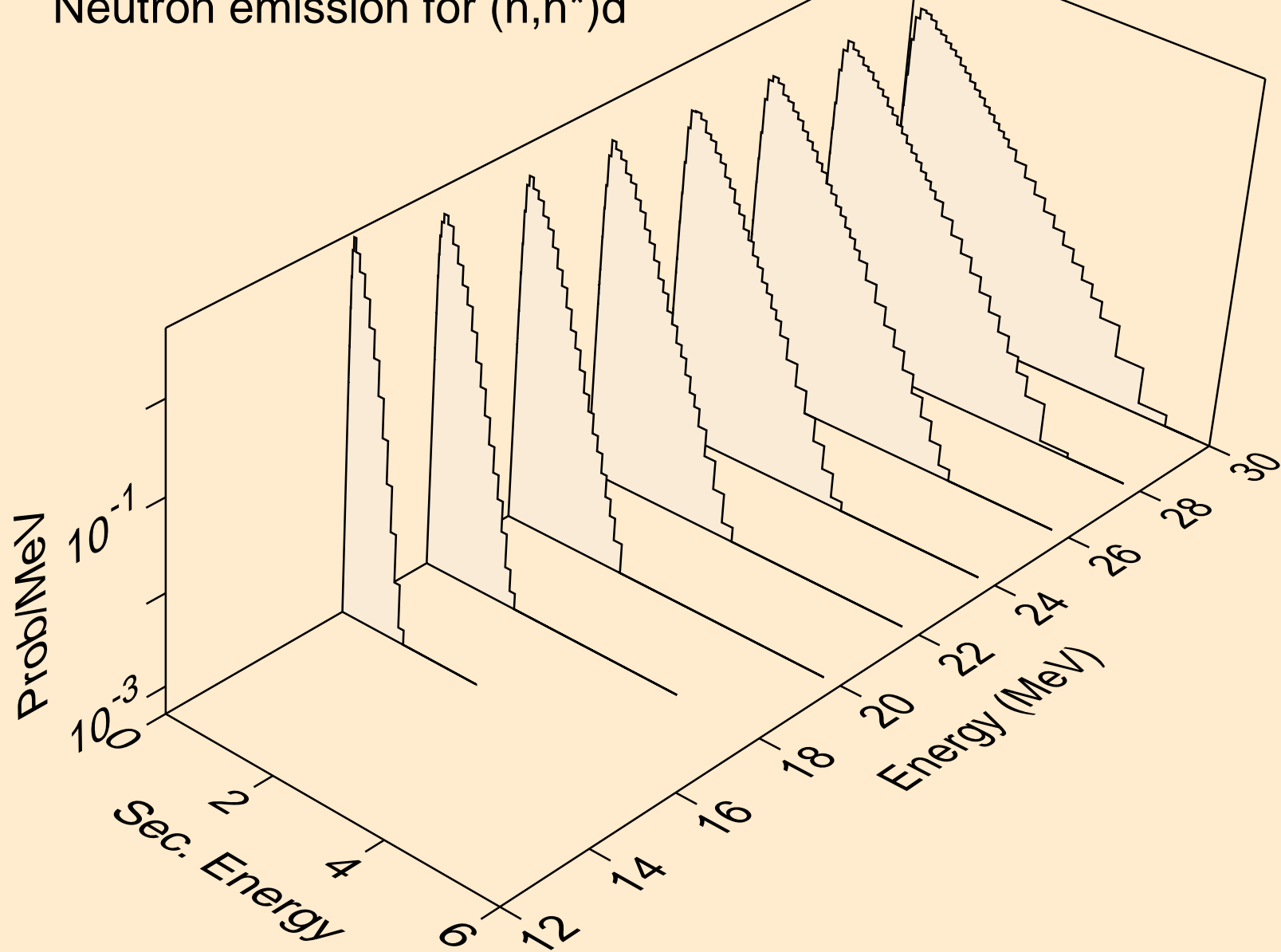

OS184 NEUTRON ACER TENDL-2023 LIBRARY; T=0.K
Neutron emission for (n,n*)t

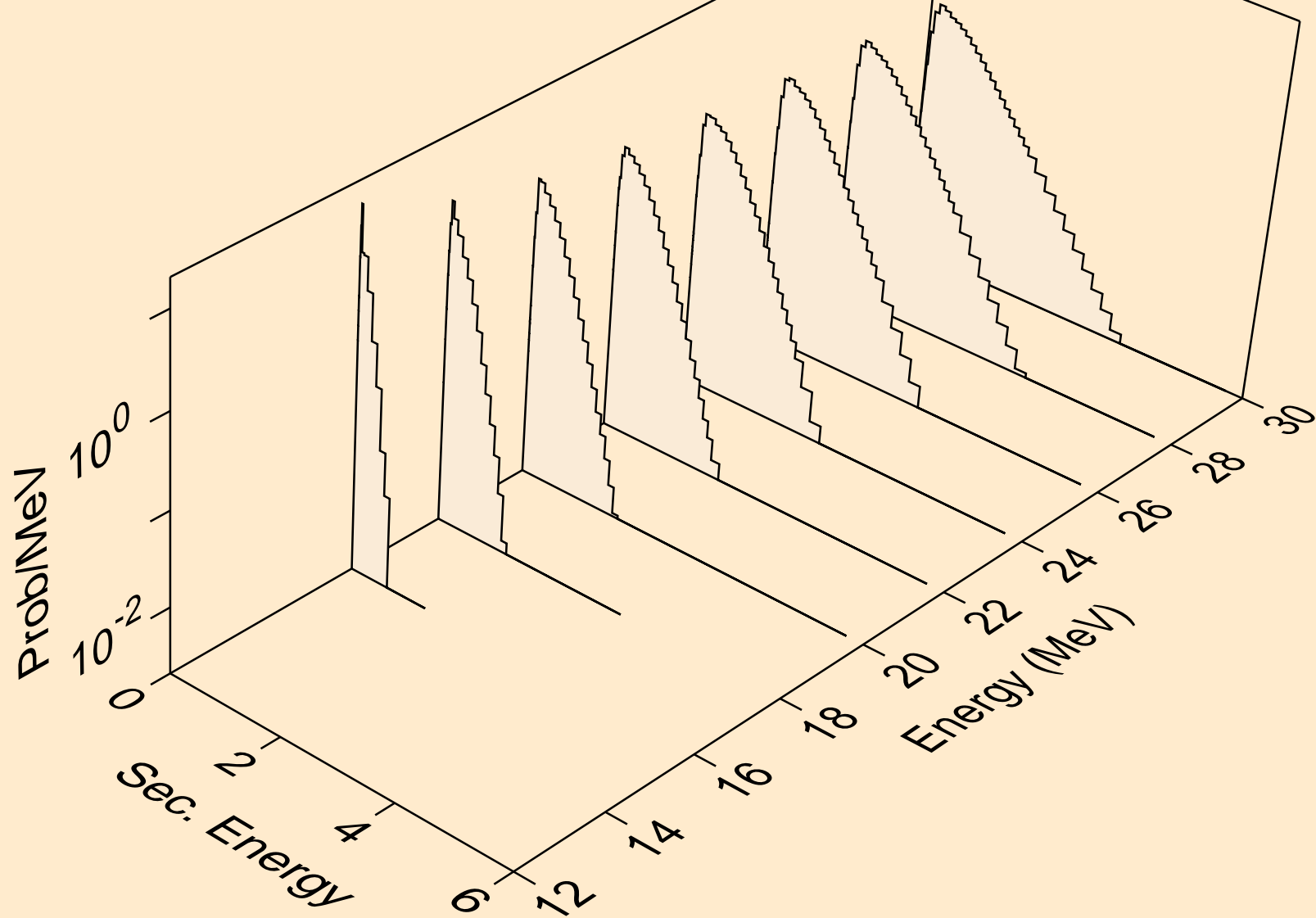

OS184 NEUTRON ACER TENDL-2023 LIBRARY; T=0.K
Neutron emission for (n,n*)he3

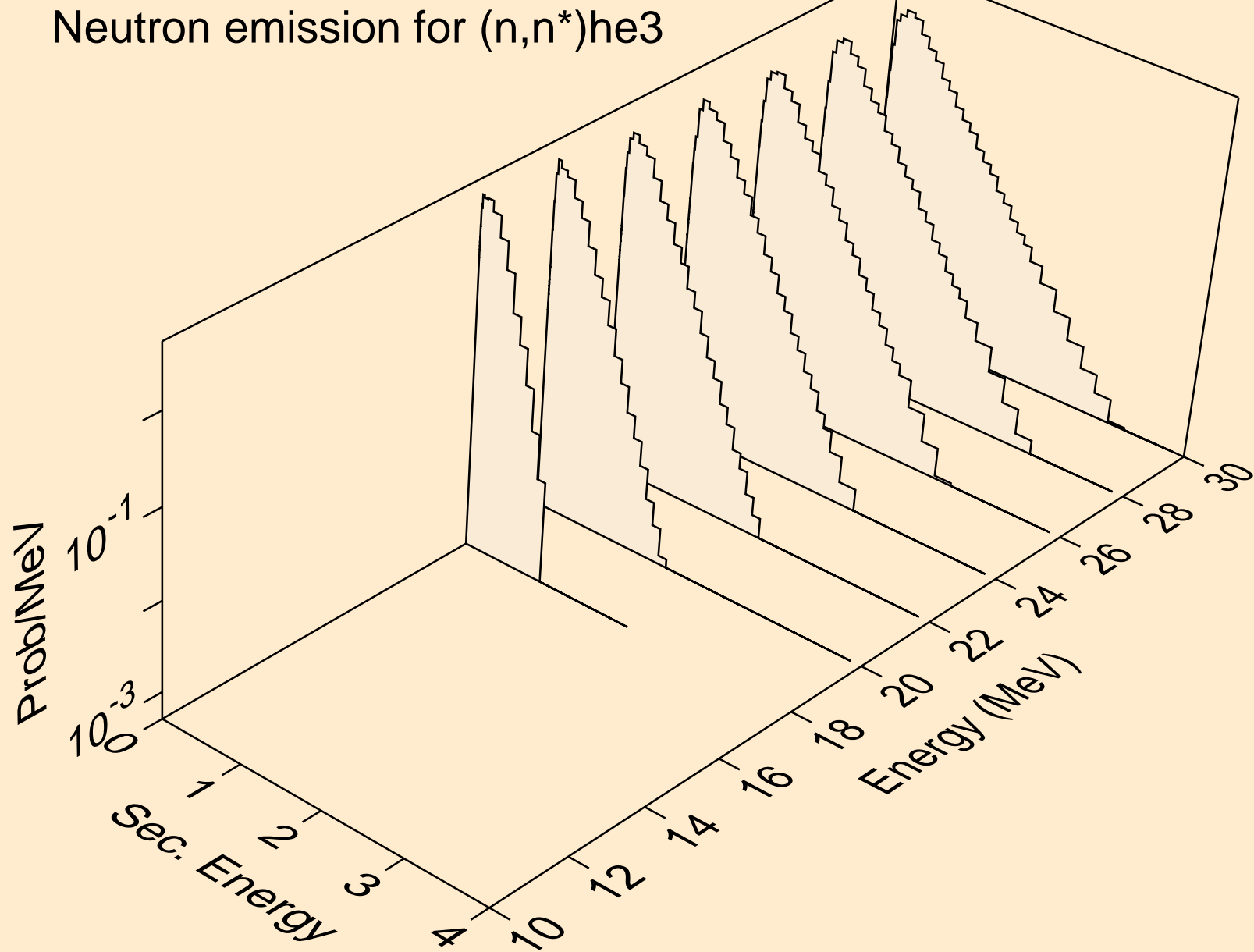

OS184 NEUTRON ACER TENDL-2023 LIBRARY; T=0.K
Neutron emission for (n,4n)

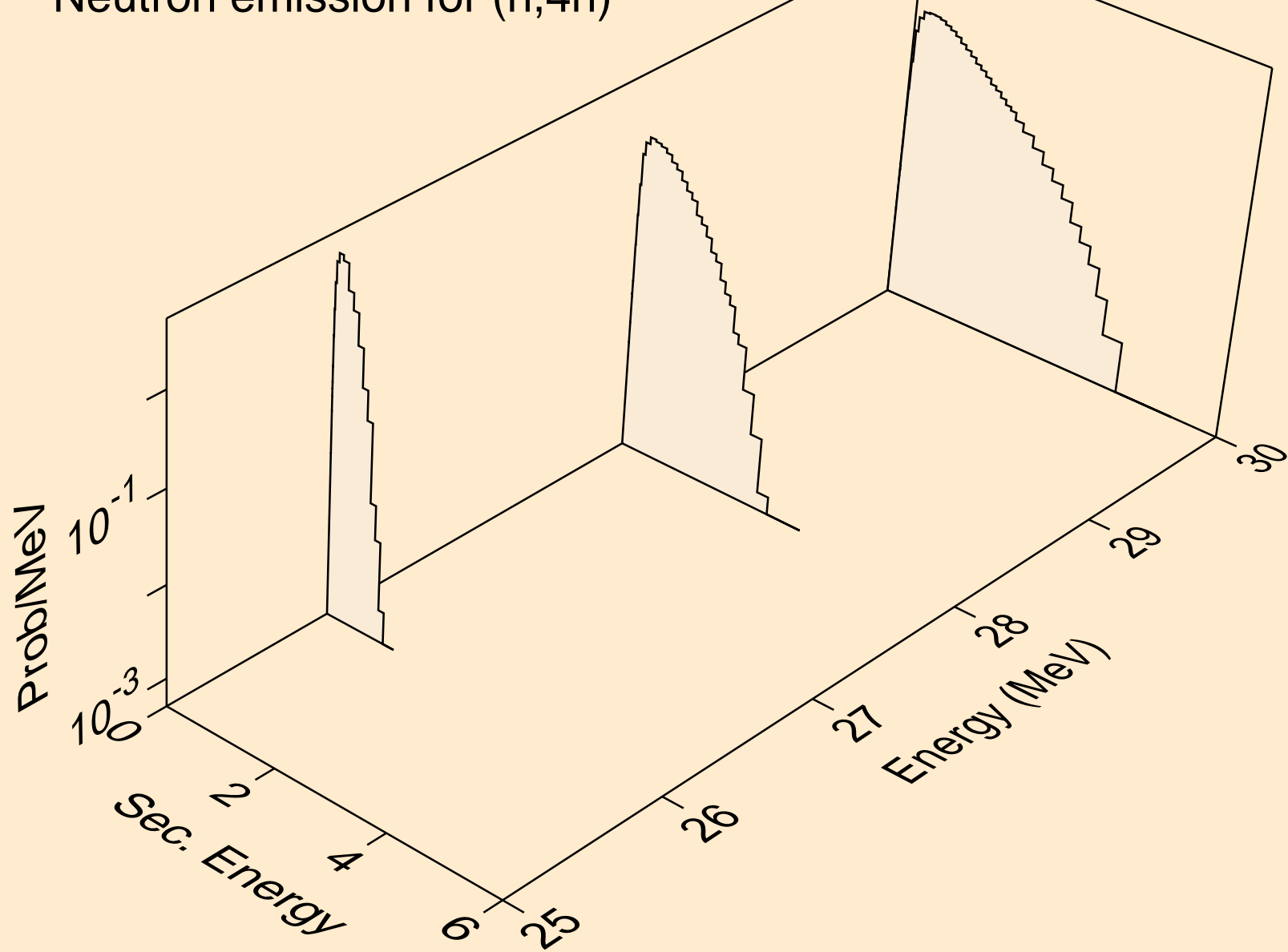

OS184 NEUTRON ACER TENDL-2023 LIBRARY; T=0.K
Neutron emission for (n,2np)

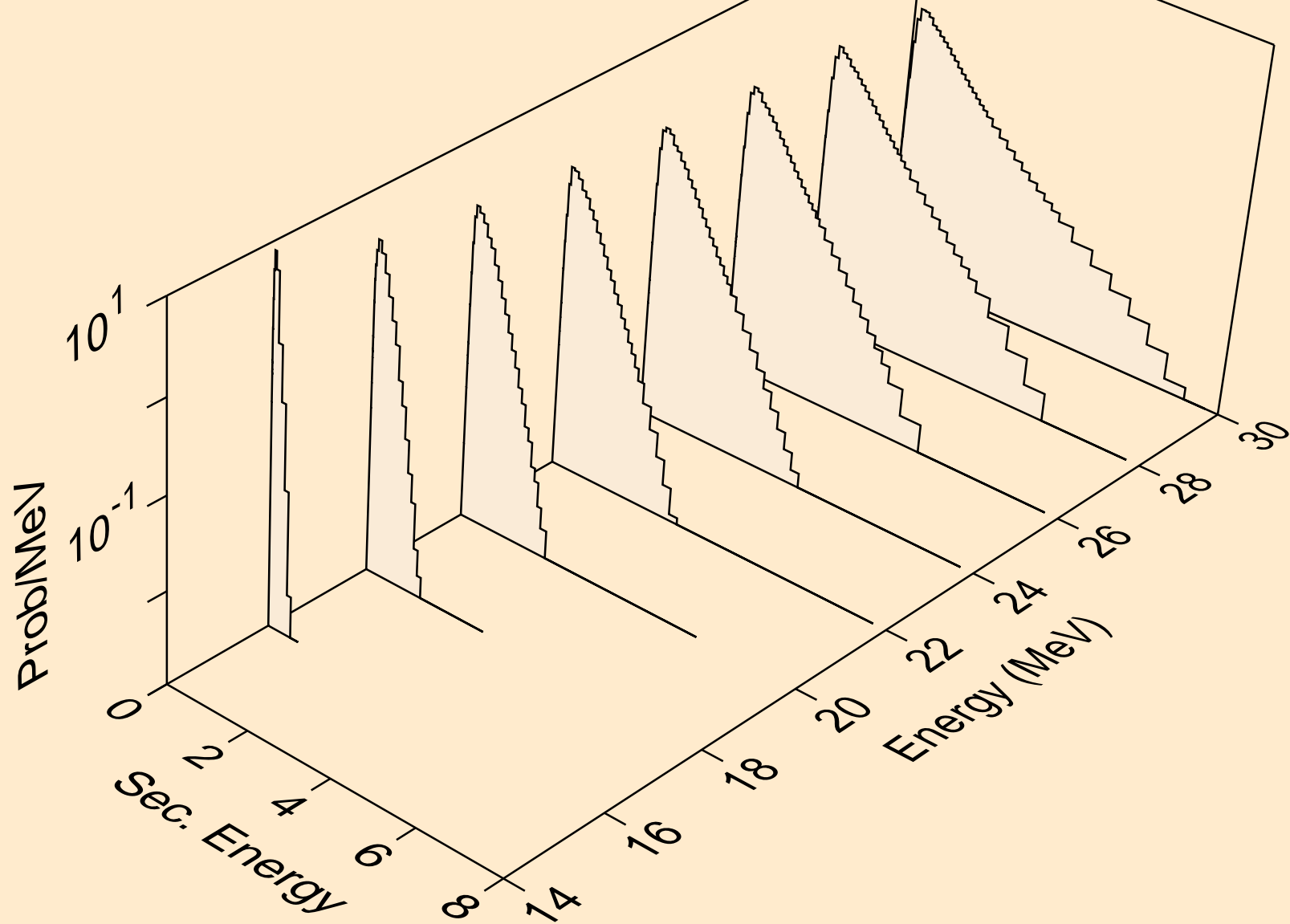

OS184 NEUTRON ACER TENDL-2023 LIBRARY; T=0.K
Neutron emission for (n,3np)

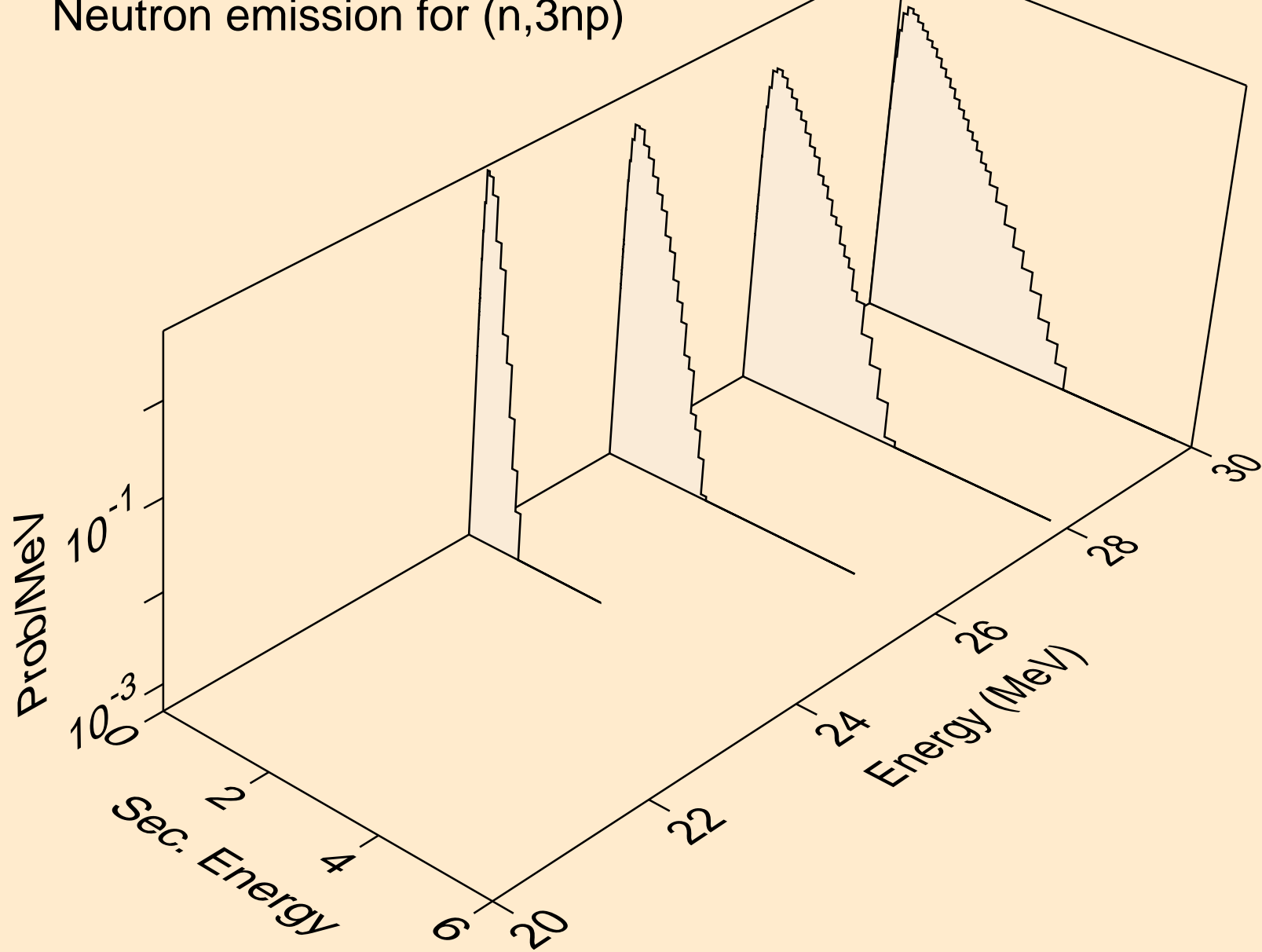

OS184 NEUTRON ACER TENDL-2023 LIBRARY; T=0.K
Neutron emission for (n,n2p)

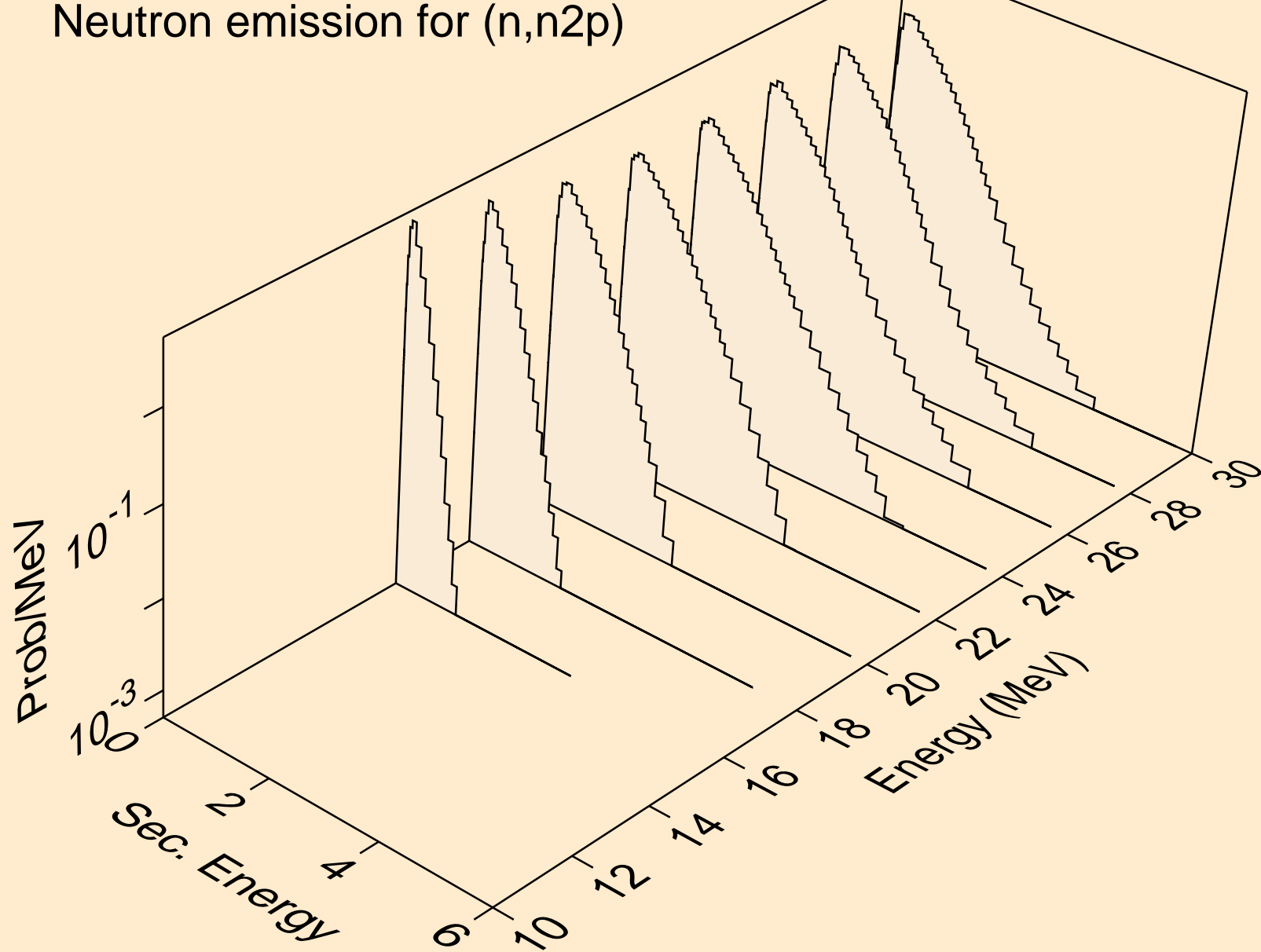

OS184 NEUTRON ACER TENDL-2023 LIBRARY; T=0.K
Neutron emission for (n,npa)

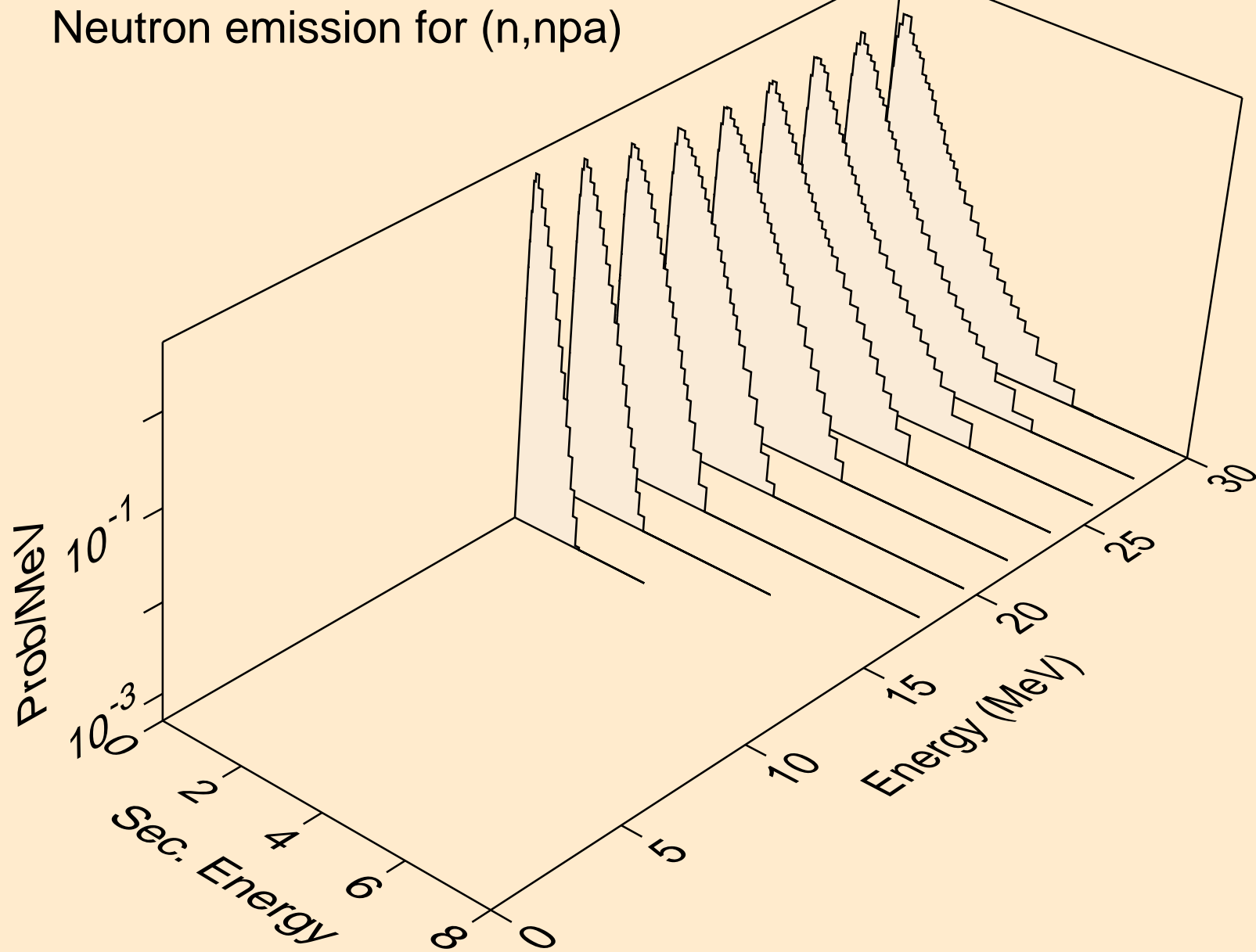

OS184 NEUTRON ACER TENDL-2023 LIBRARY; T=0.K
Neutron emission for (n,n*c)

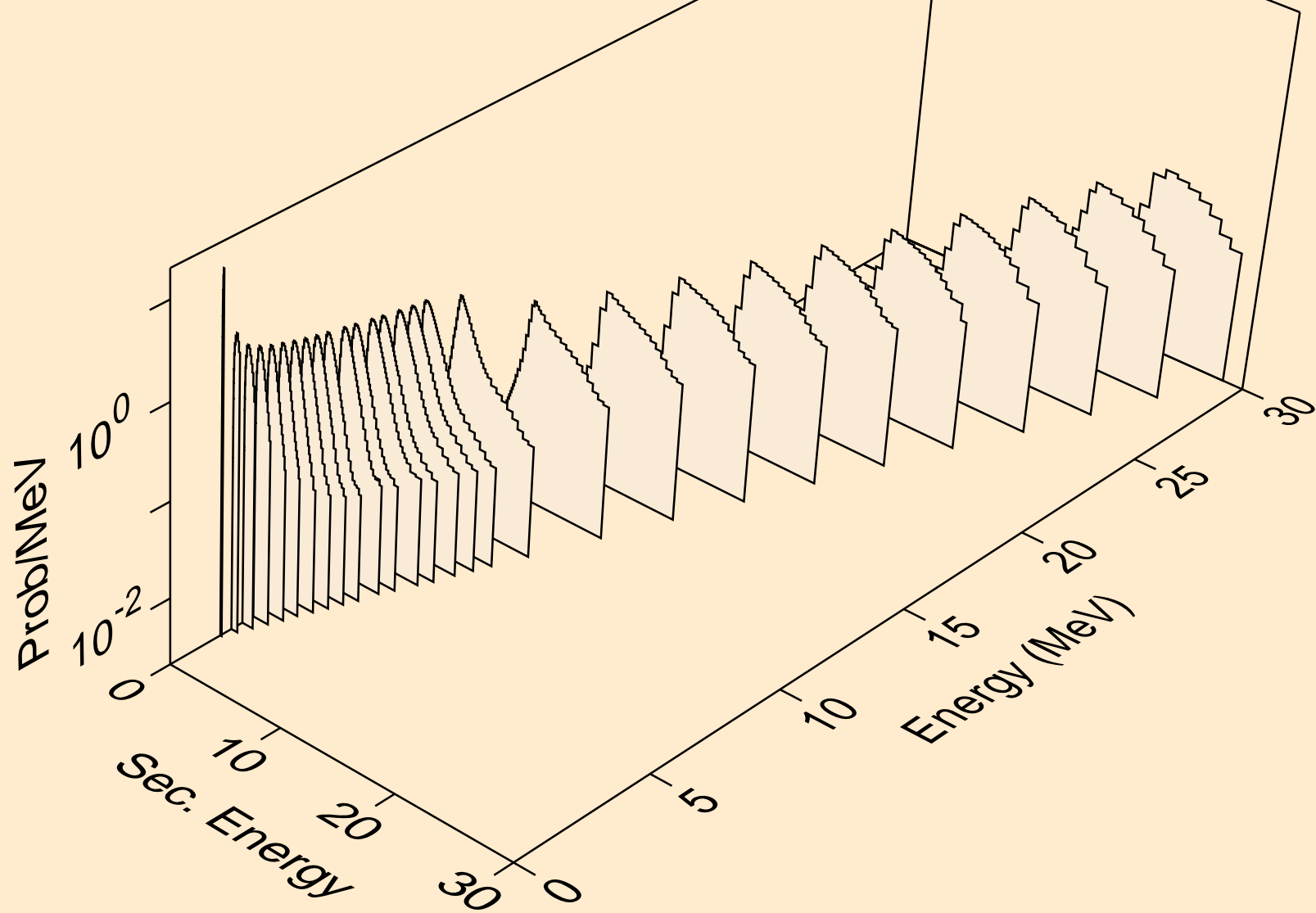

OS184 NEUTRON ACER TENDL-2023 LIBRARY; T=0.K
Photon emission for (n,x)

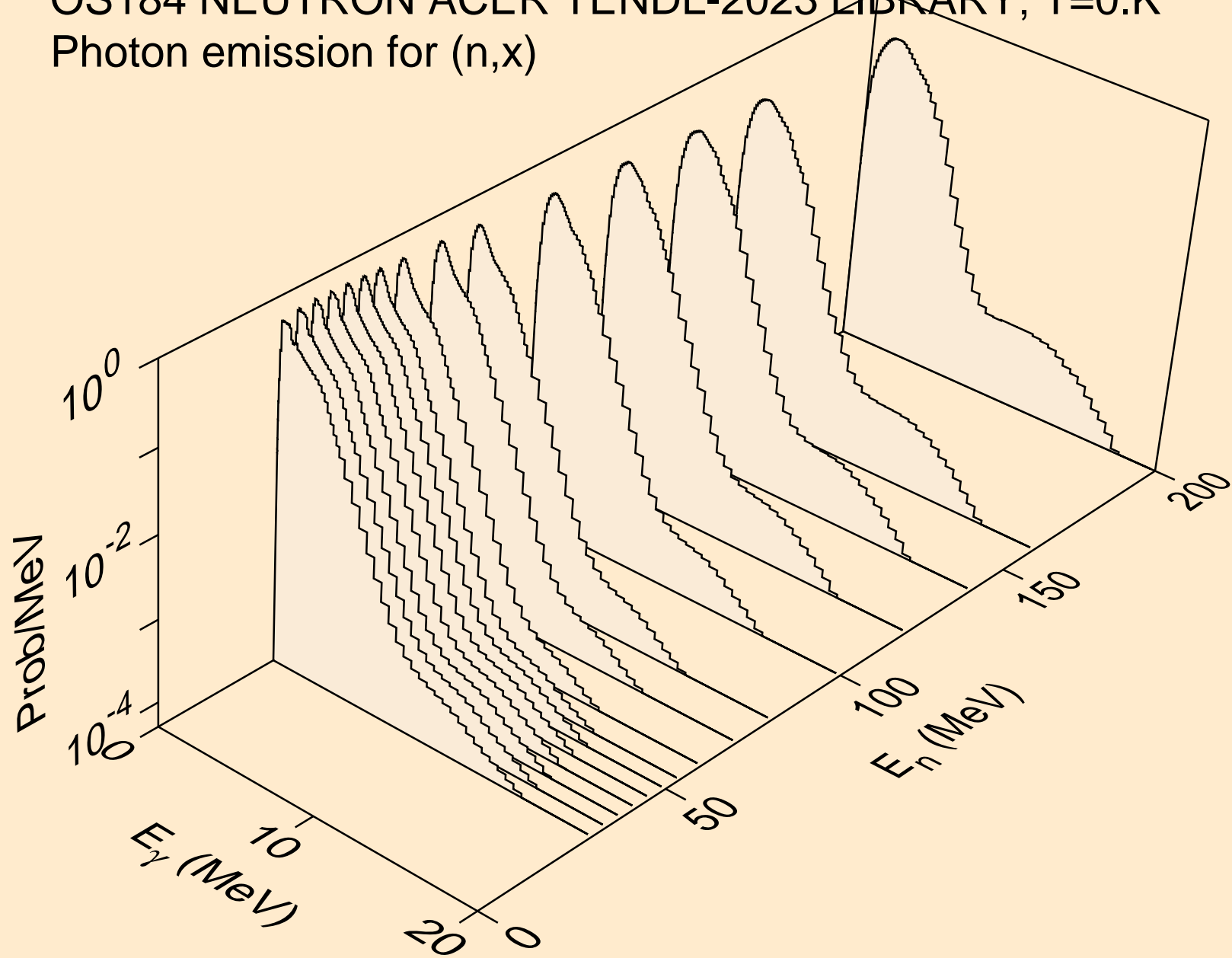

OS184 NEUTRON ACER TENDL-2023 LIBRARY; T=0.K
Photon emission for (n,2nd)

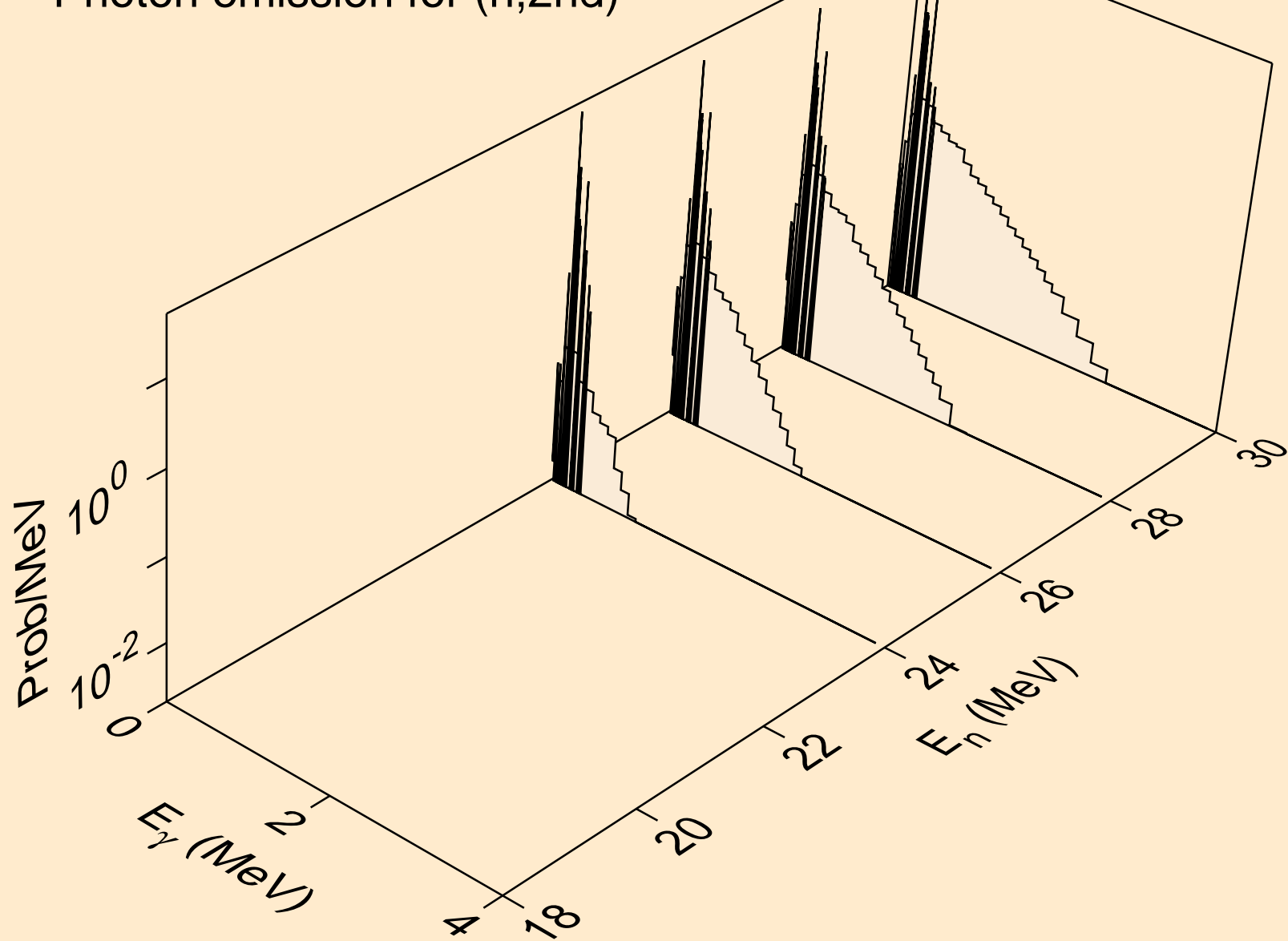

OS184 NEUTRON ACER TENDL-2023 LIBRARY; T=0.K
Photon emission for (n,2n)

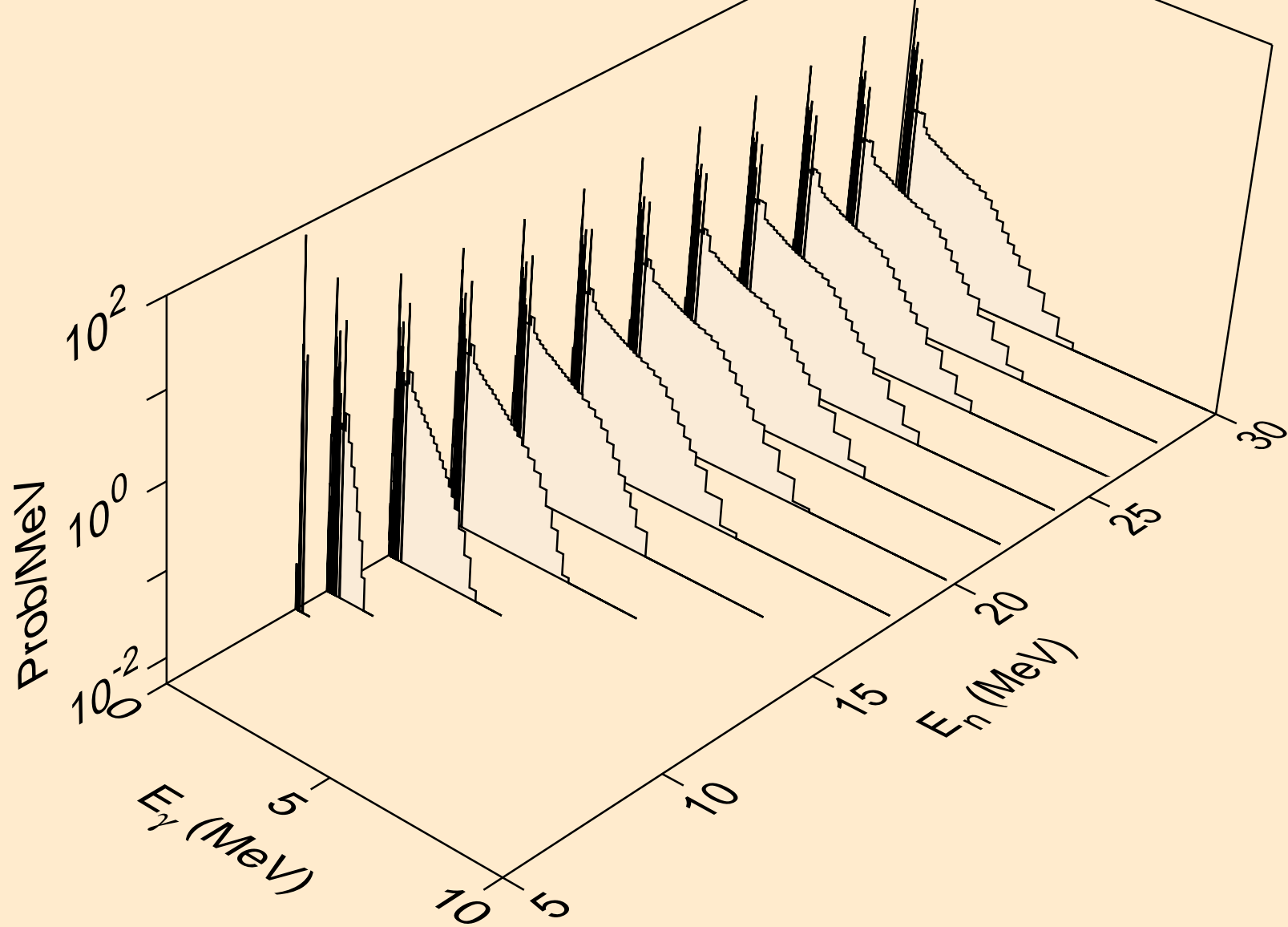

OS184 NEUTRON ACER TENDL-2023 LIBRARY; T=0.K
Photon emission for (n,3n)

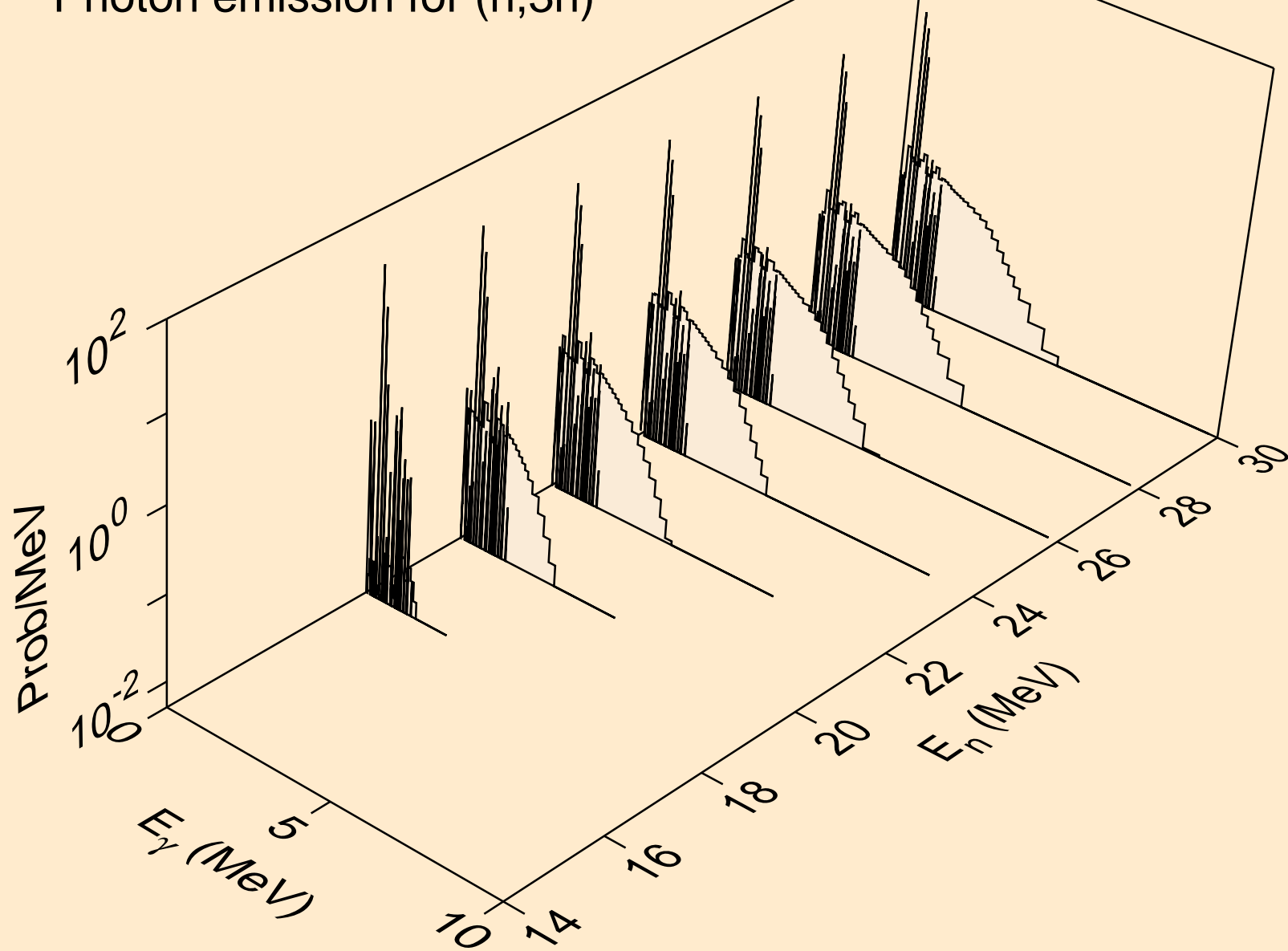

OS184 NEUTRON ACER TENDL-2023 LIBRARY; T=0.K
Photon emission for (n,n*)a

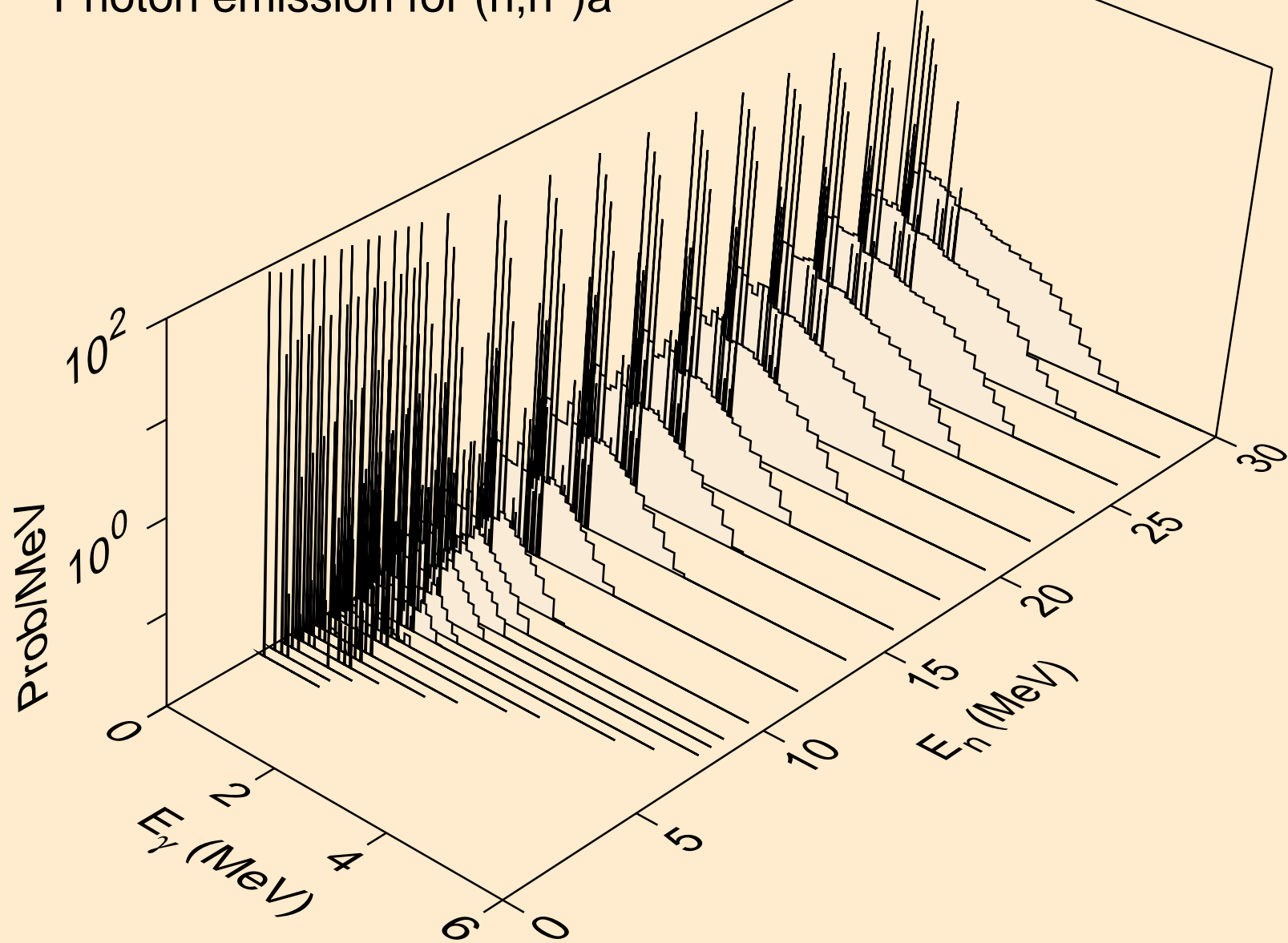

OS184 NEUTRON ACER TENDL-2023 LIBRARY; T=0.K
Photon emission for (n,2n)a

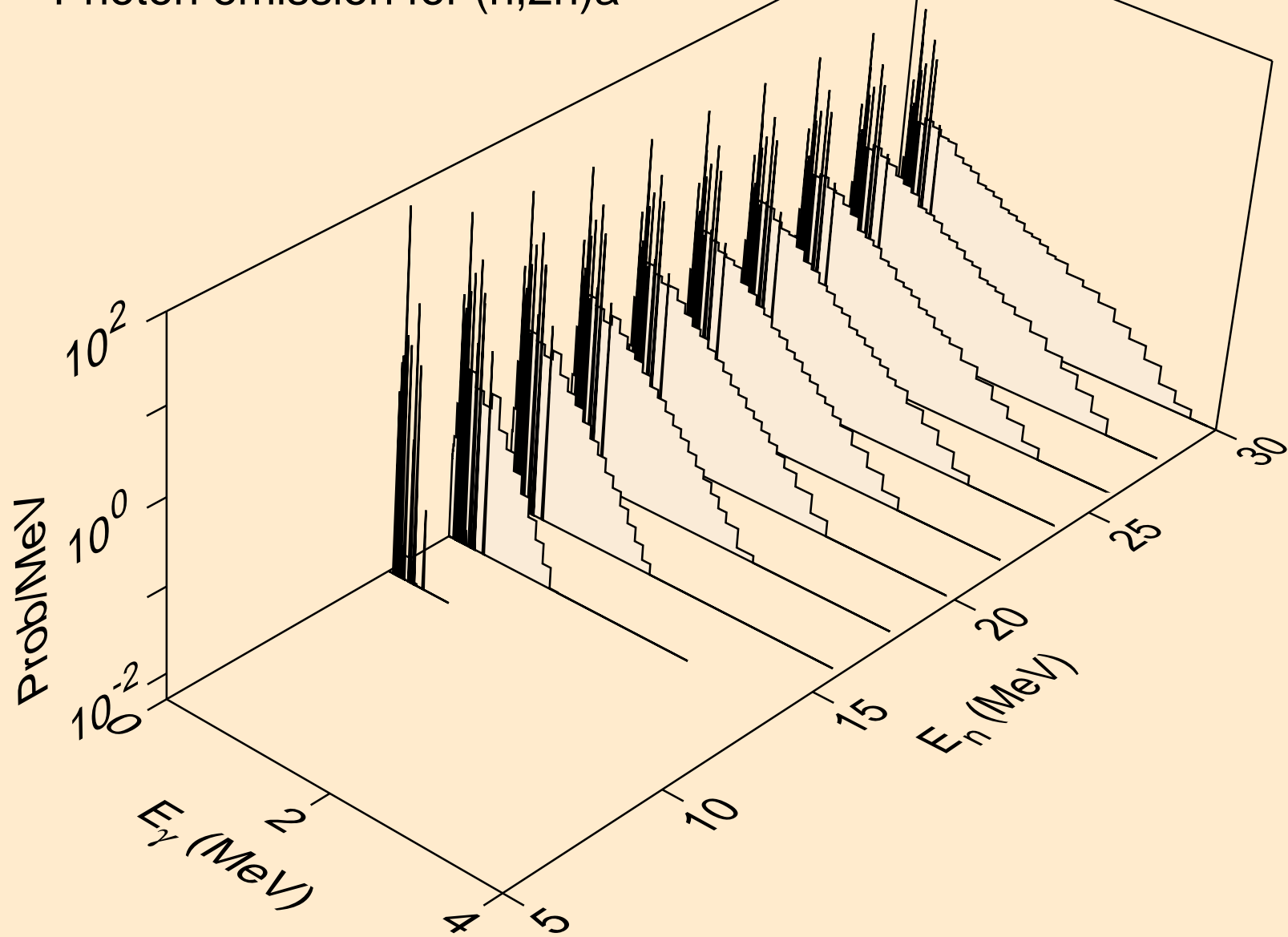

OS184 NEUTRON ACER TENDL-2023 LIBRARY; T=0.K
Photon emission for (n,3n)a

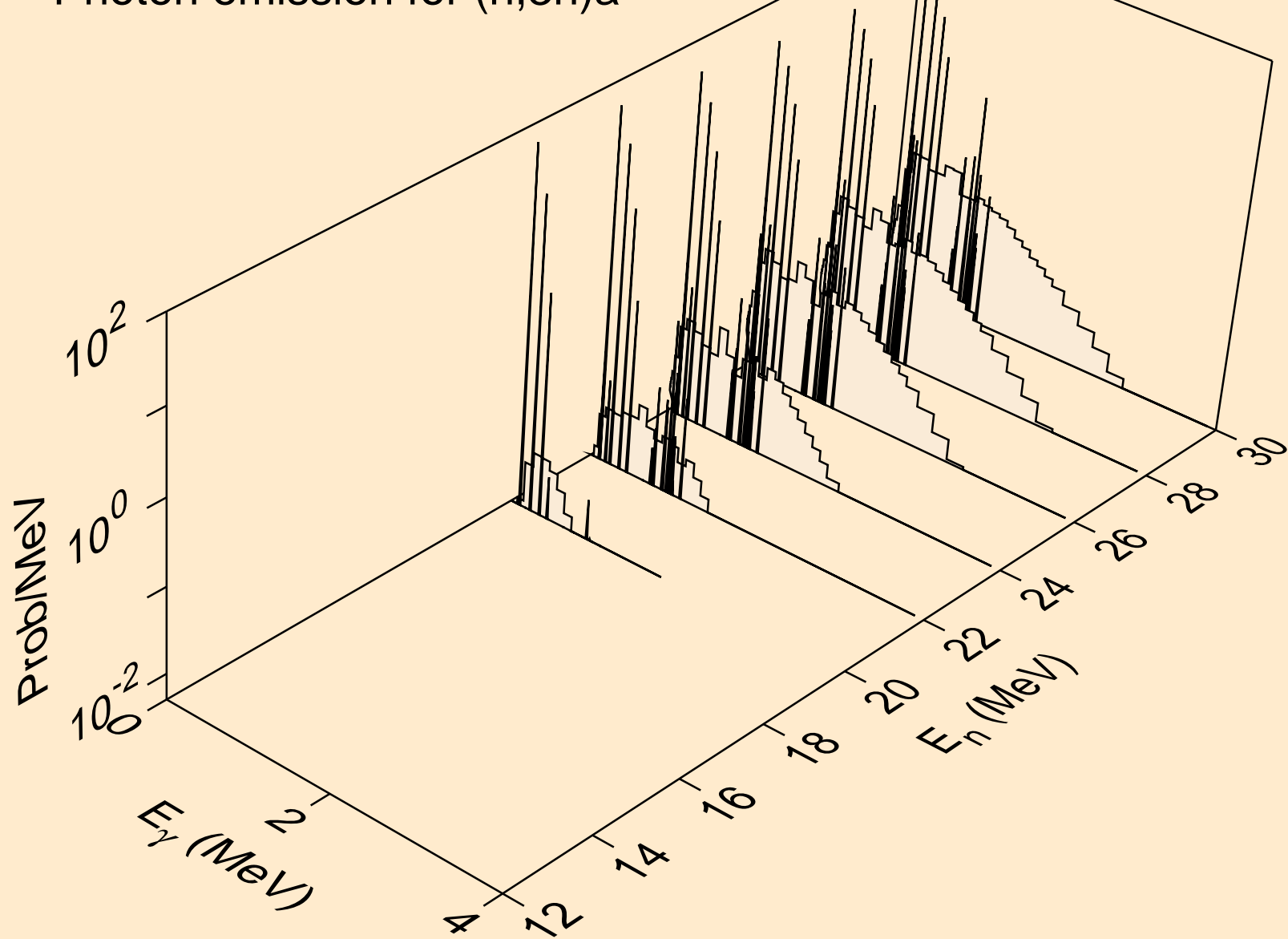

OS184 NEUTRON ACER TENDL-2023 LIBRARY; T=0.K
Photon emission for (n,n*)p

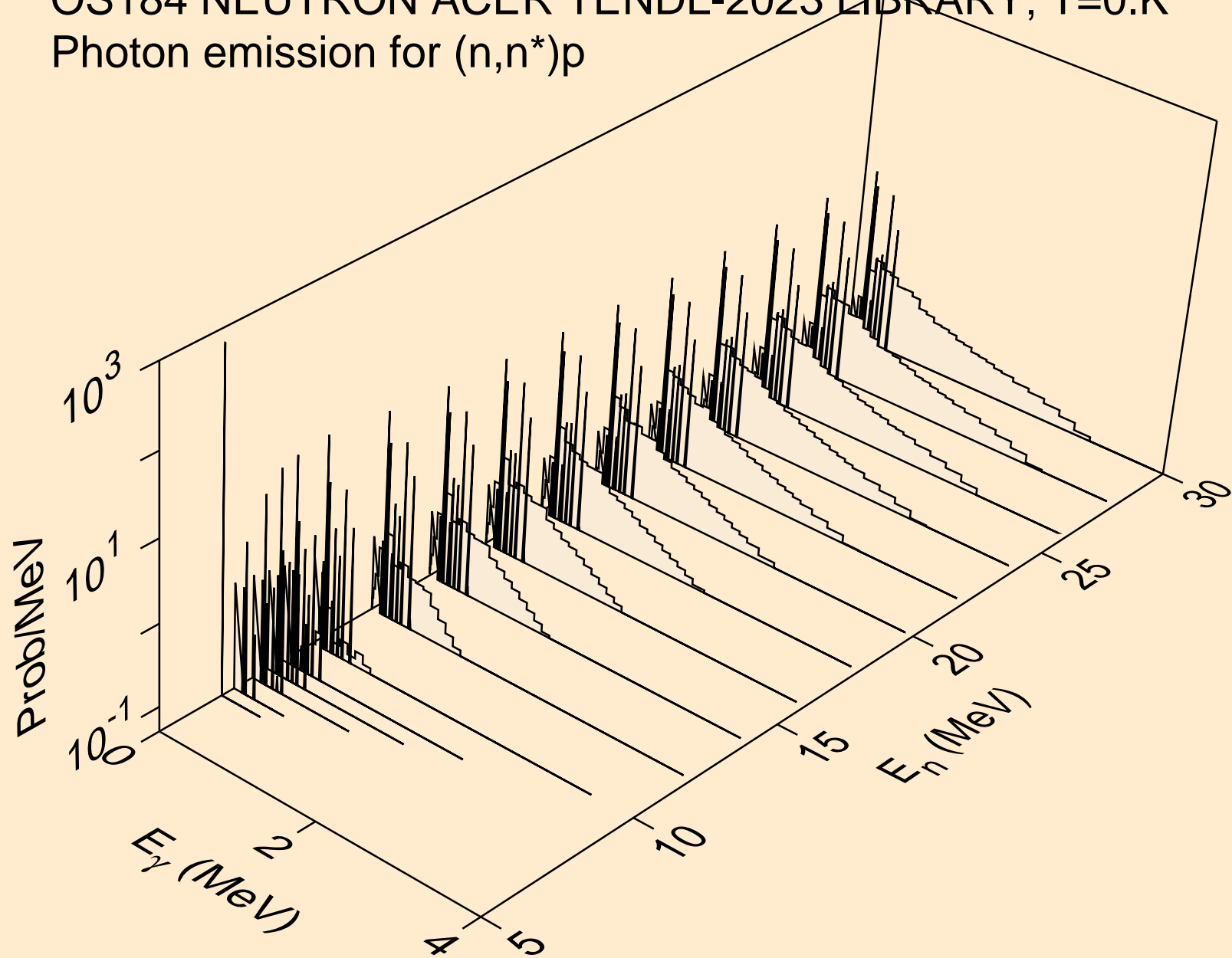

OS184 NEUTRON ACER TENDL-2023 LIBRARY; T=0.K
Photon emission for (n,n*)2a

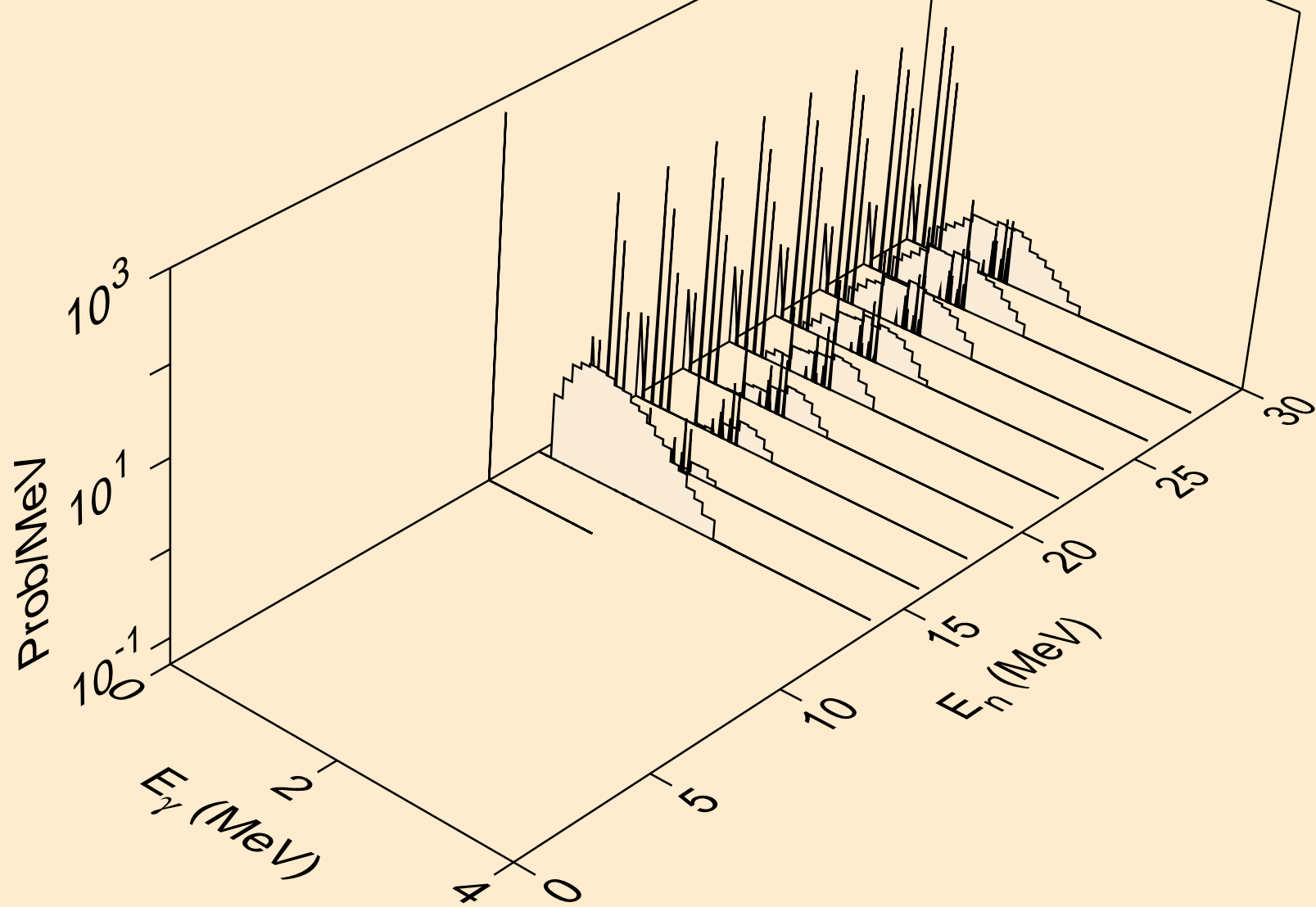

OS184 NEUTRON ACER TENDL-2023 LIBRARY; T=0.K
Photon emission for (n,n*)d

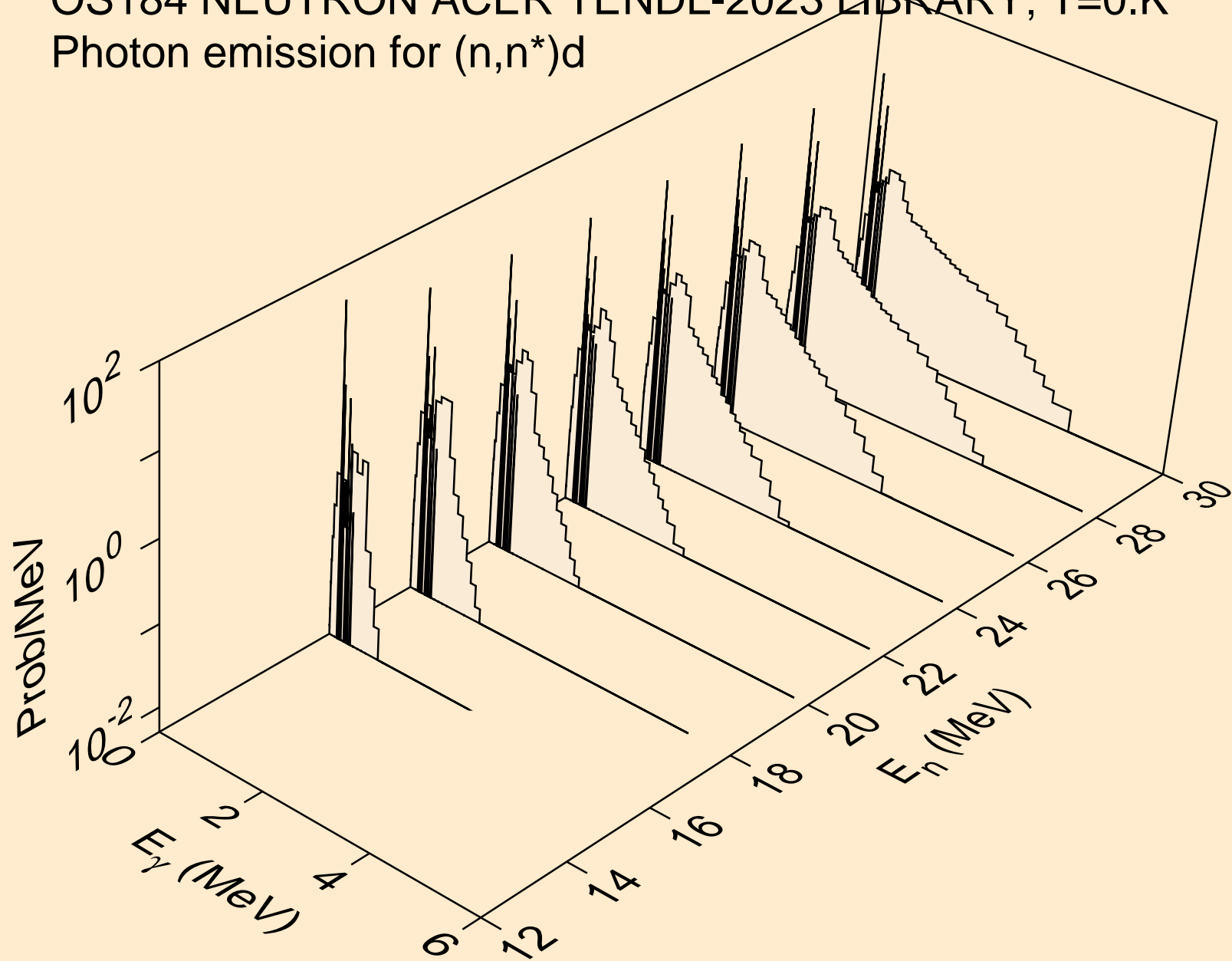

OS184 NEUTRON ACER TENDL-2023 LIBRARY; T=0.K
Photon emission for (n,n*)t

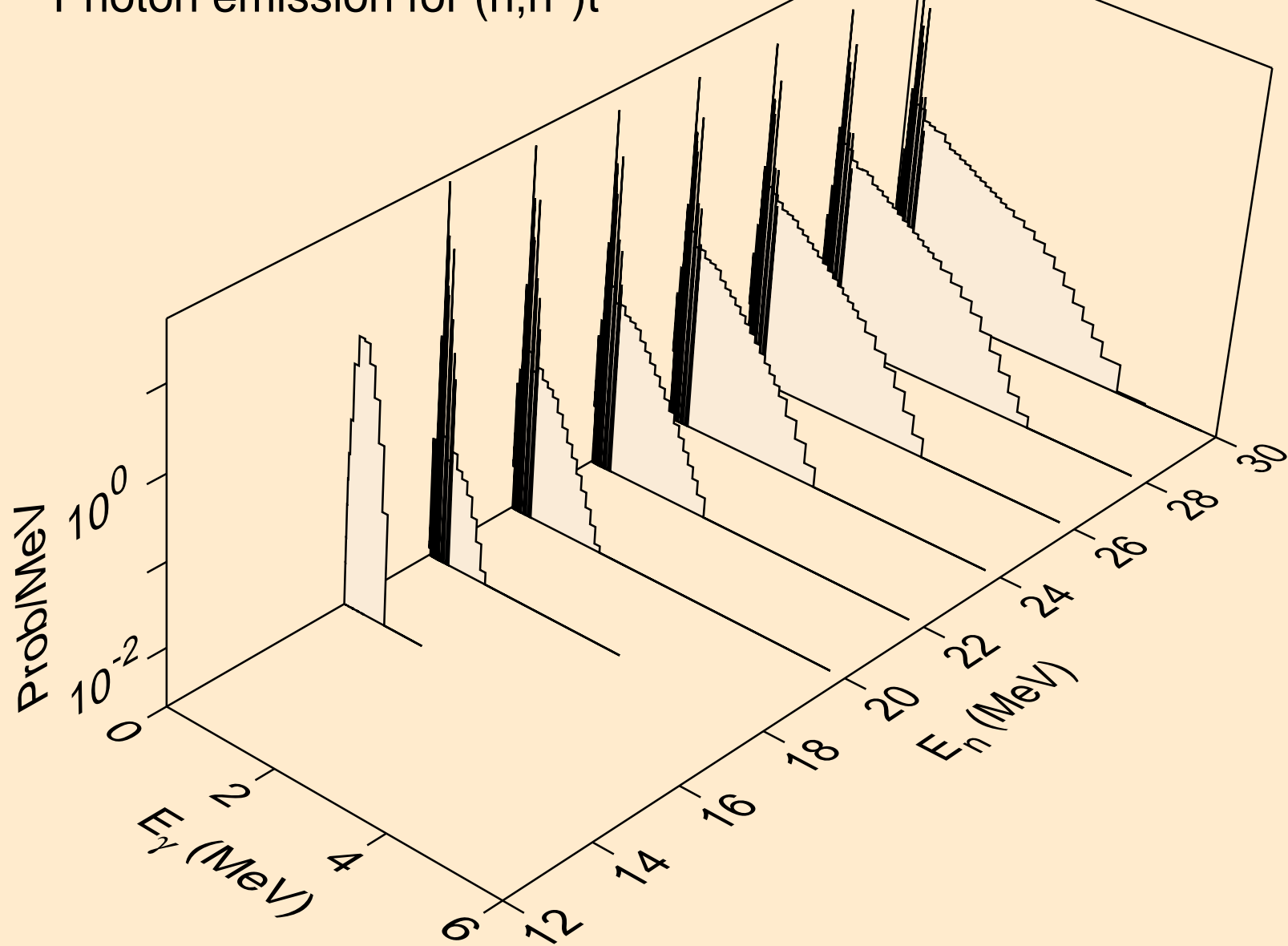

OS184 NEUTRON ACER TENDL-2023 LIBRARY; T=0.K
Photon emission for (n,n*)he3

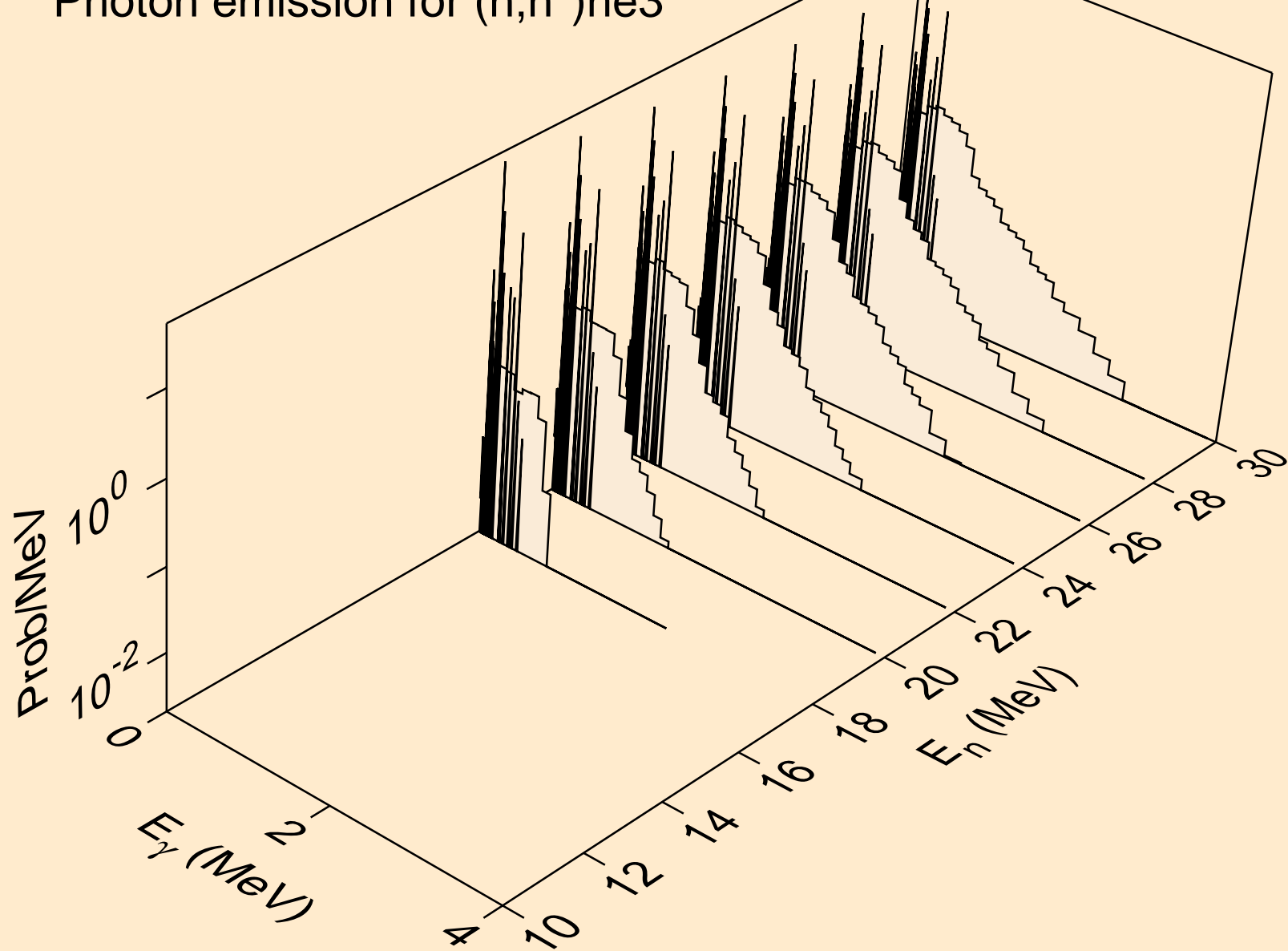

OS184 NEUTRON ACER TENDL-2023 LIBRARY; T=0.K
Photon emission for (n,4n)

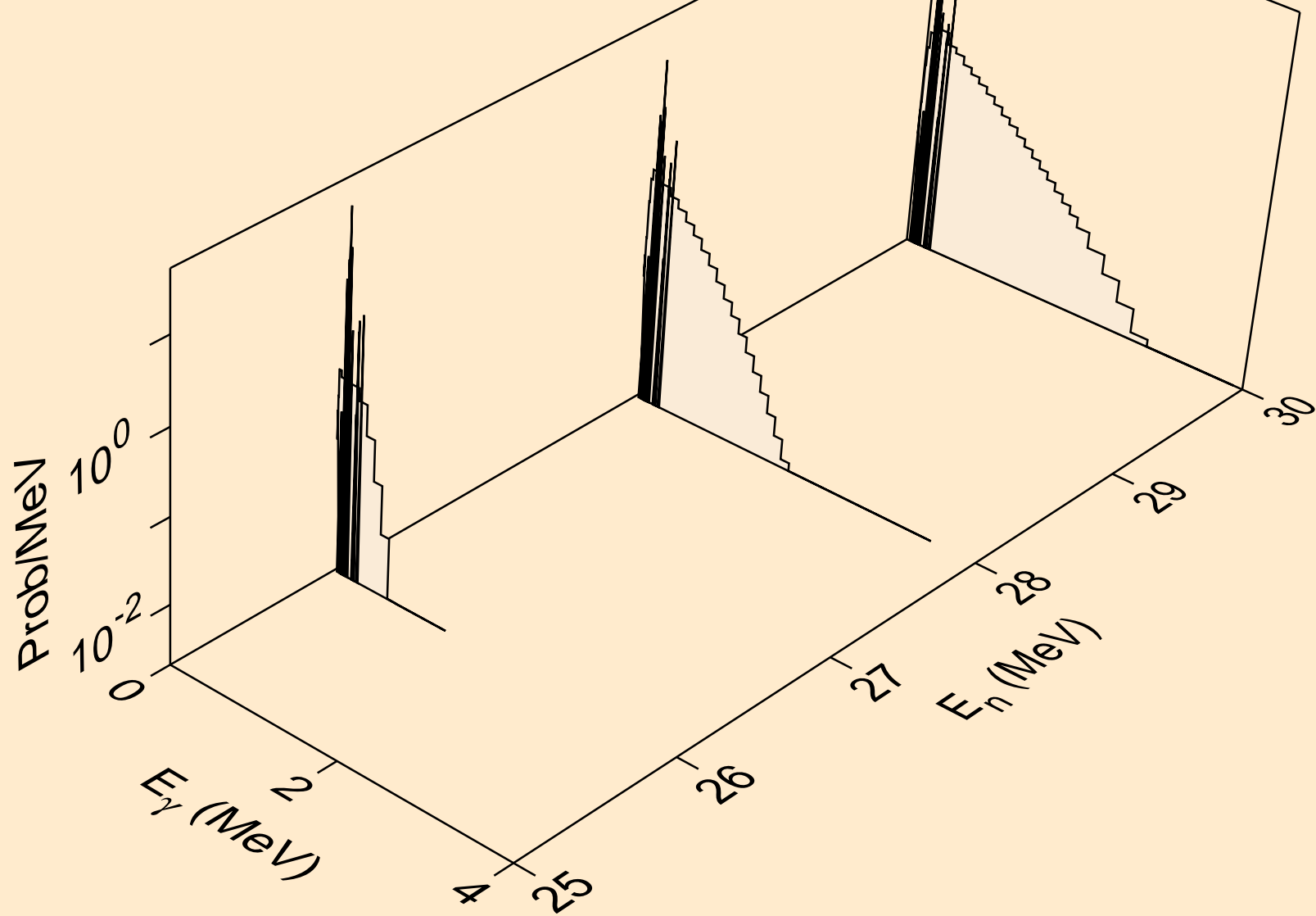

OS184 NEUTRON ACER TENDL-2023 LIBRARY; T=0.K
Photon emission for (n,2np)

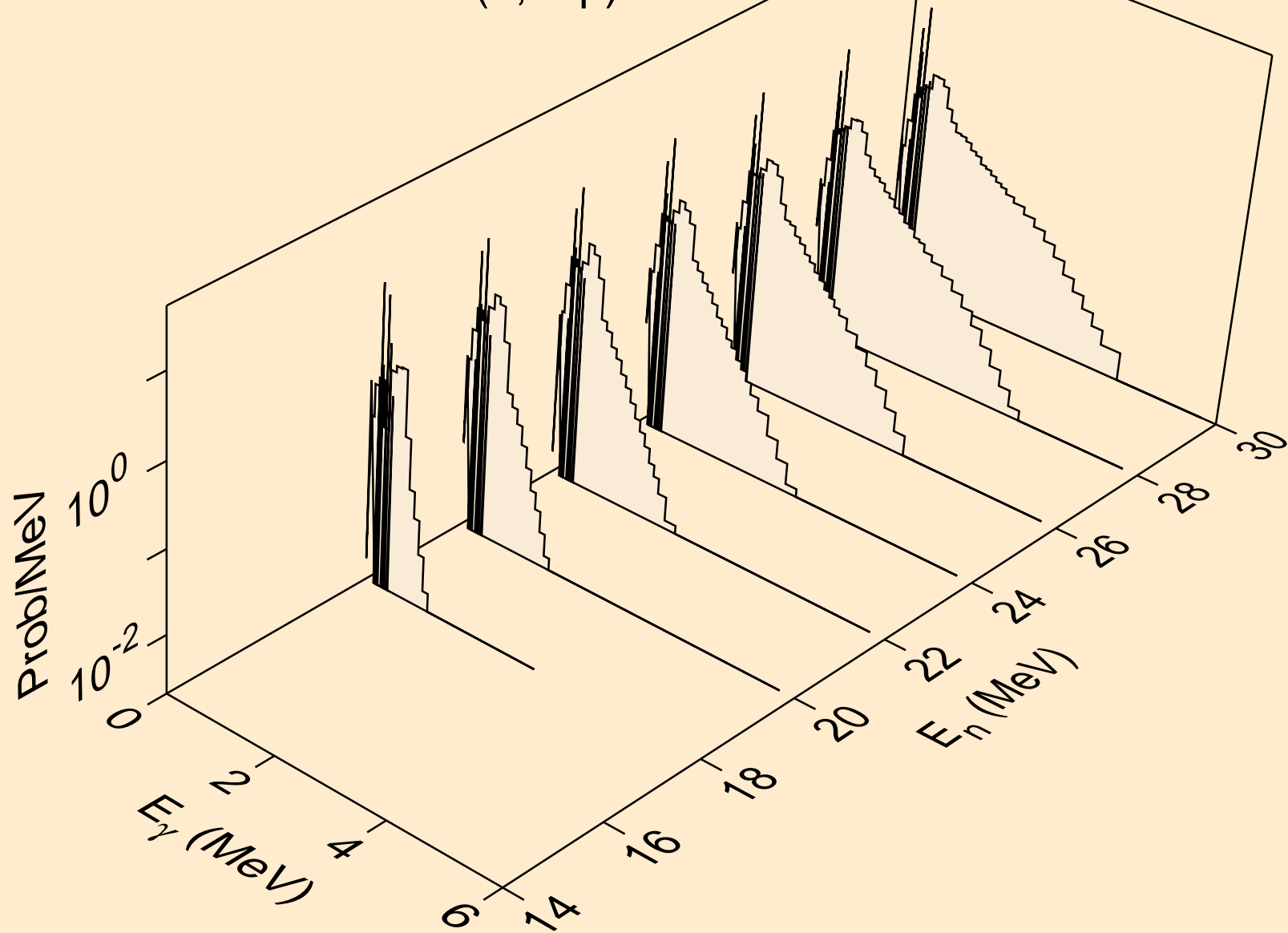

OS184 NEUTRON ACER TENDL-2023 LIBRARY; T=0.K
Photon emission for (n,3np)

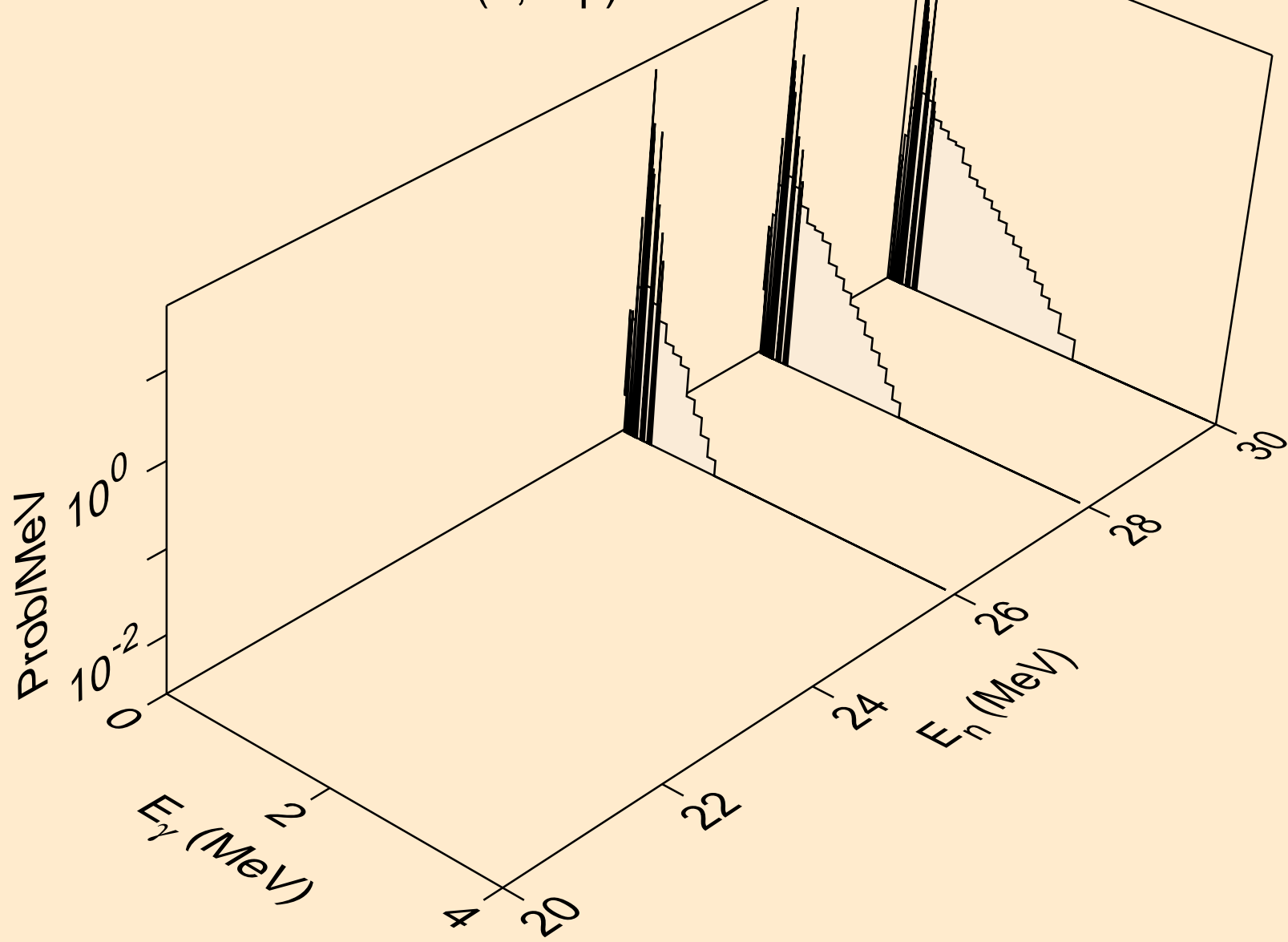

OS184 NEUTRON ACER TENDL-2023 LIBRARY; T=0.K
Photon emission for (n,n2p)

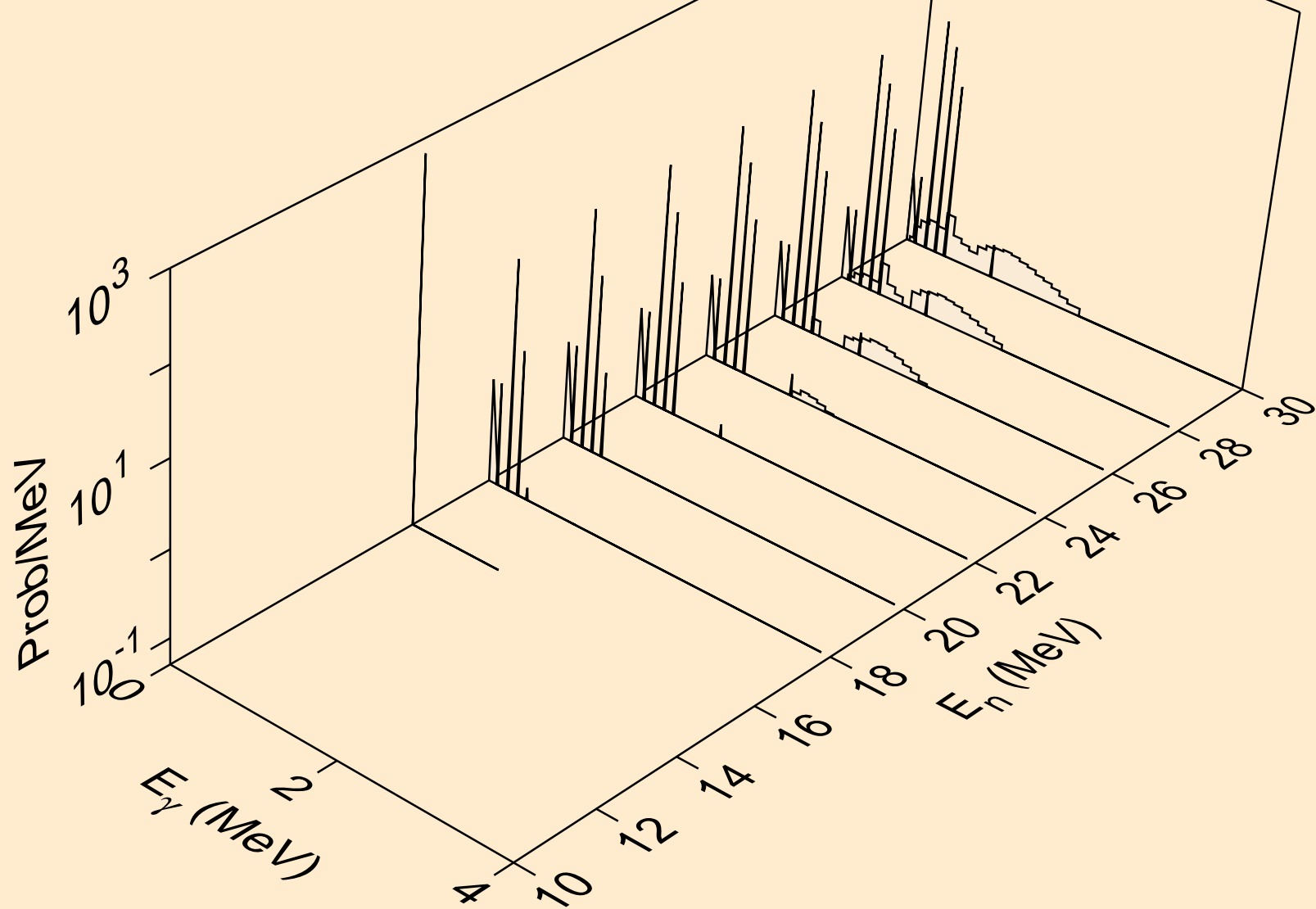

OS184 NEUTRON ACER TENDL-2023 LIBRARY; T=0.K
Photon emission for (n,npa)

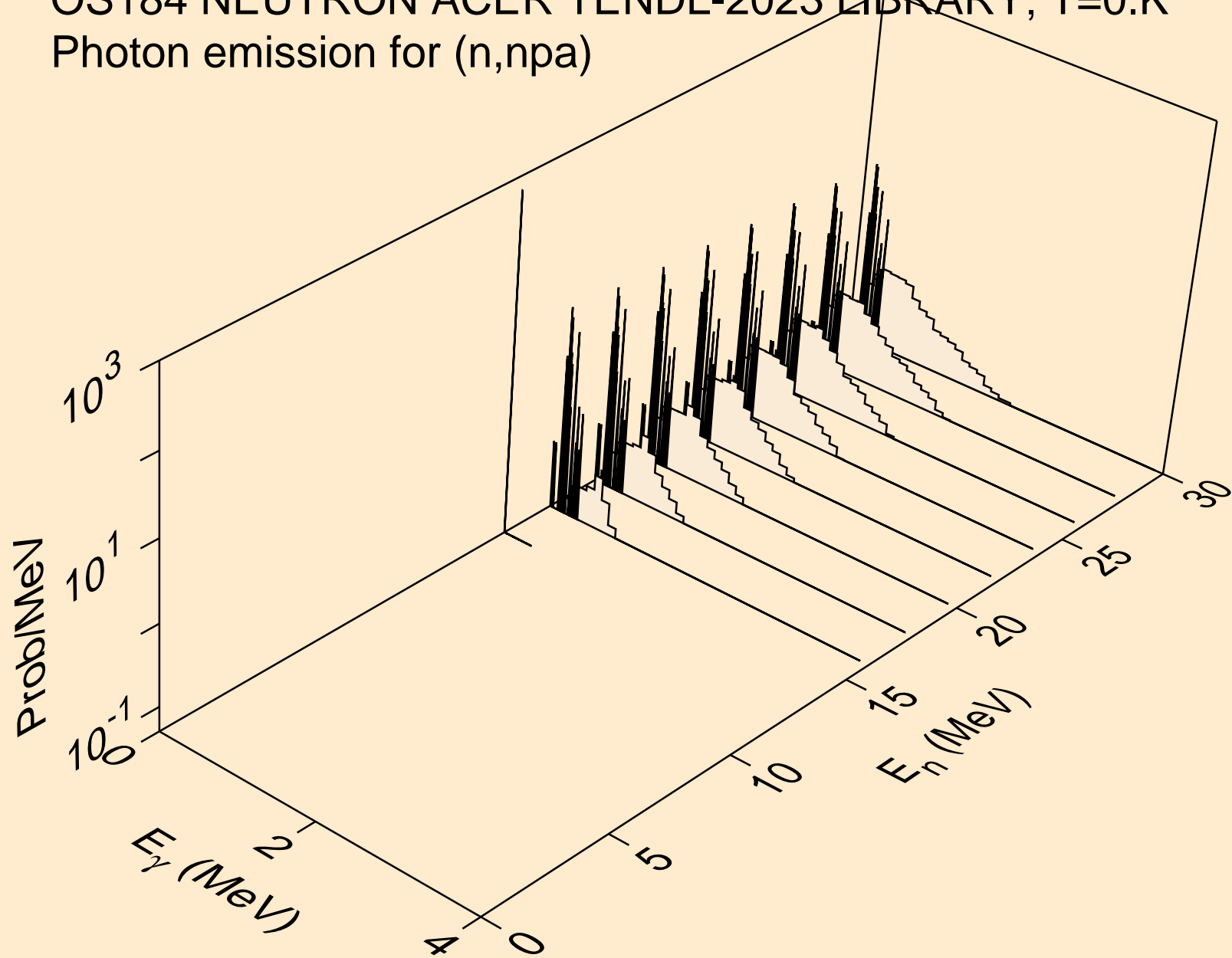

OS184 NEUTRON ACER TENDL-2023 LIBRARY; T=0.K
Photon emission for (n,n*c)

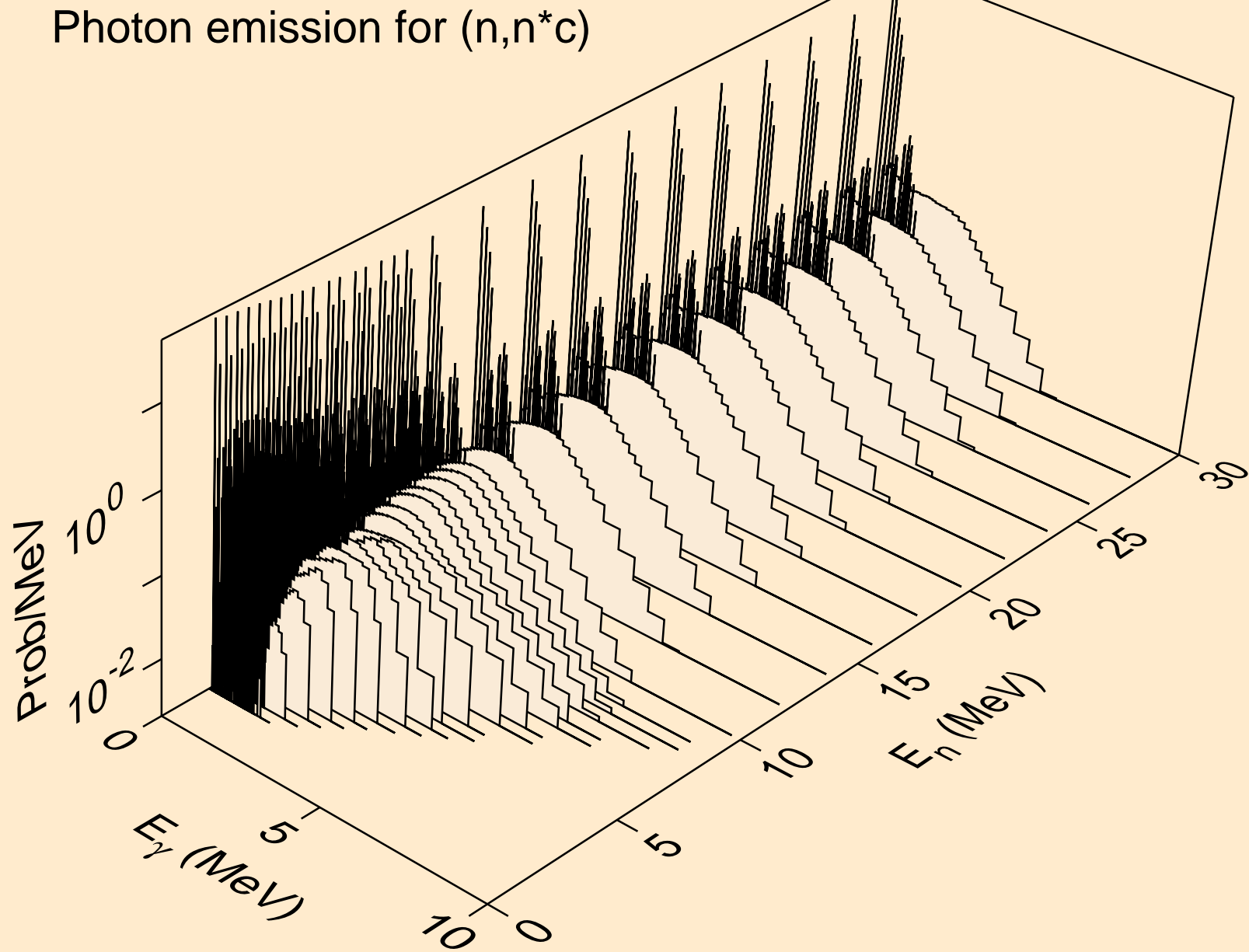

OS184 NEUTRON ACER TENDL-2023 LIBRARY; T=0.K
Photon emission for (n,gma)

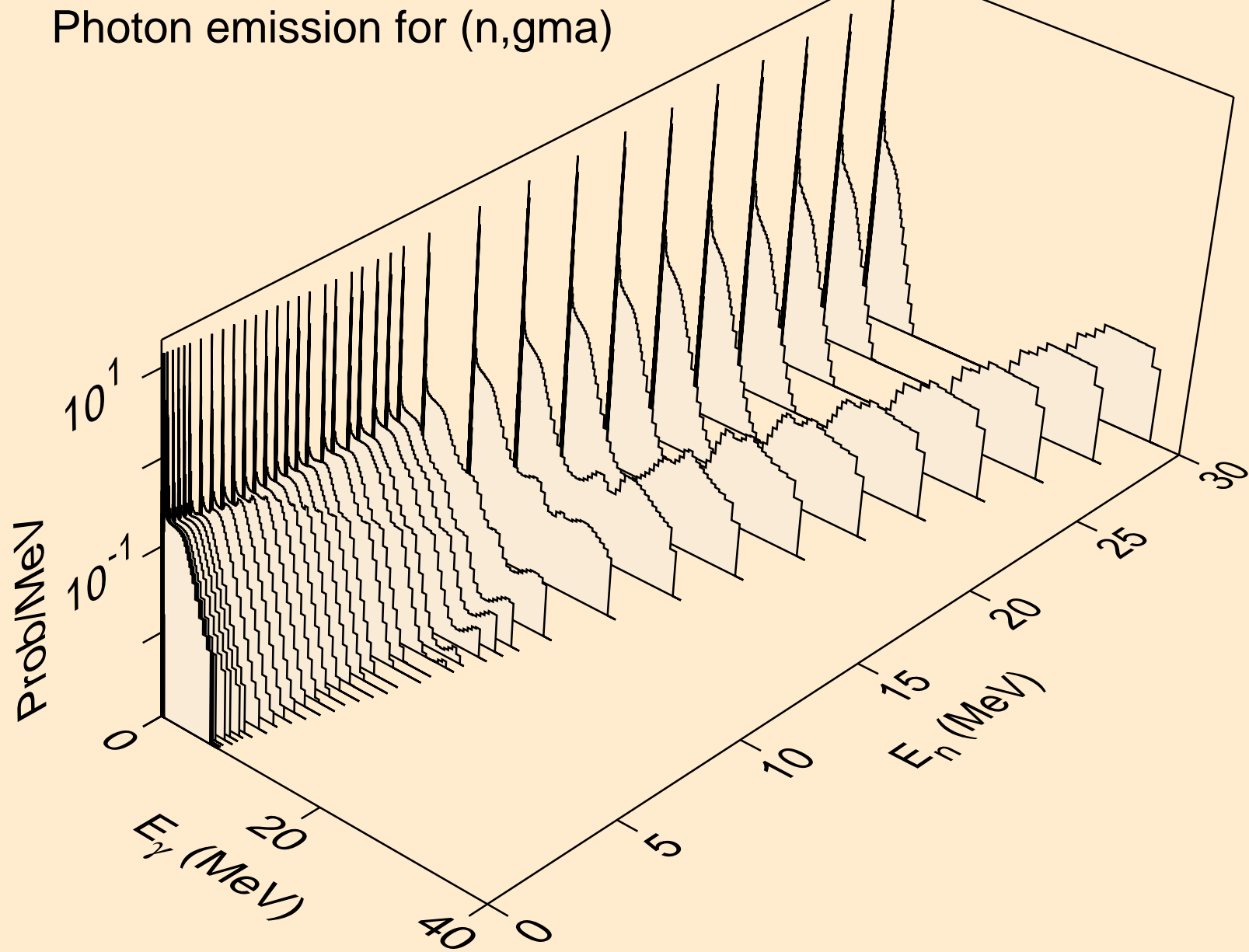

OS184 NEUTRON ACER TENDL-2023 LIBRARY; T=0.K
Photon emission for (n,p)

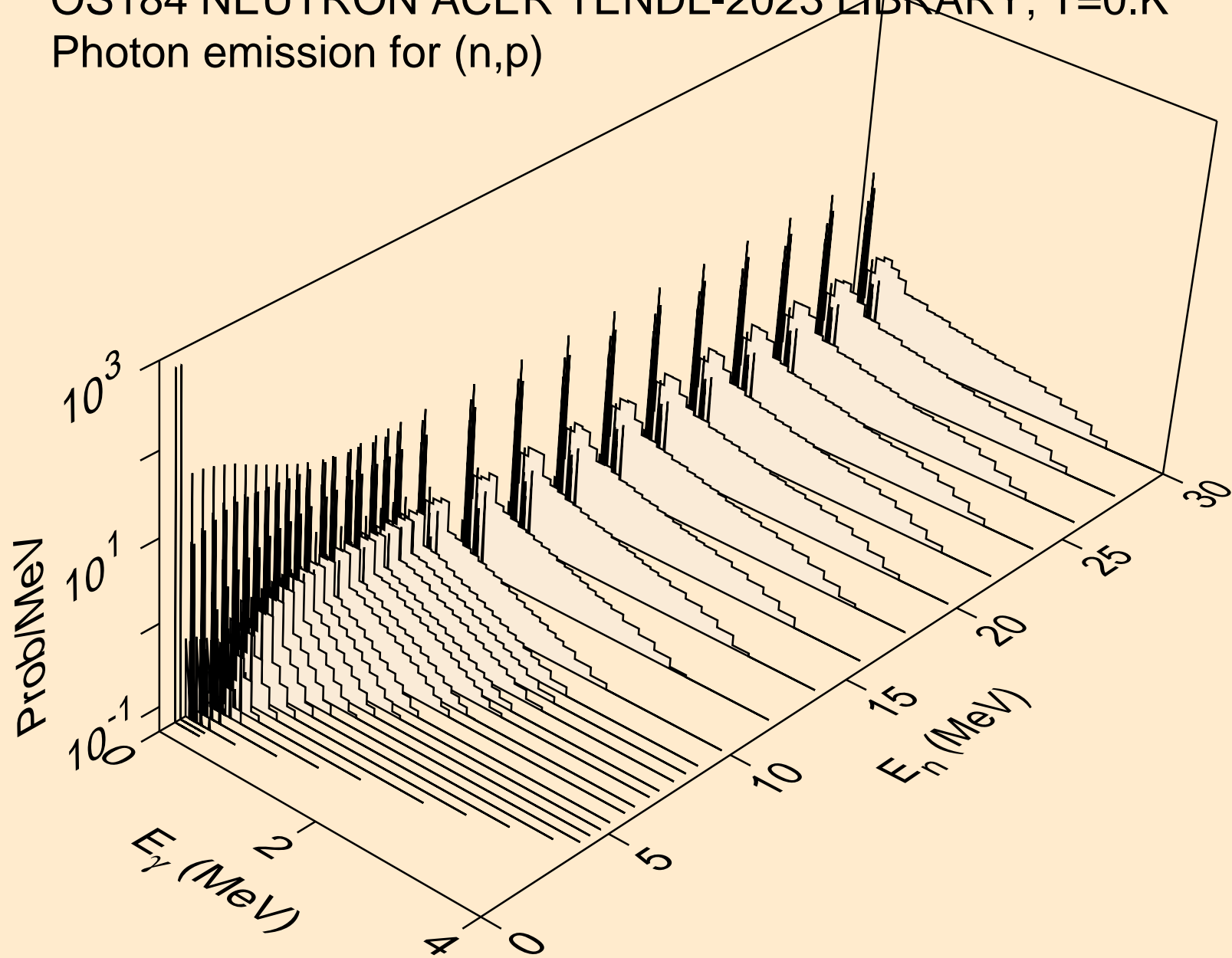

OS184 NEUTRON ACER TENDL-2023 LIBRARY; T=0.K
Photon emission for (n,d)

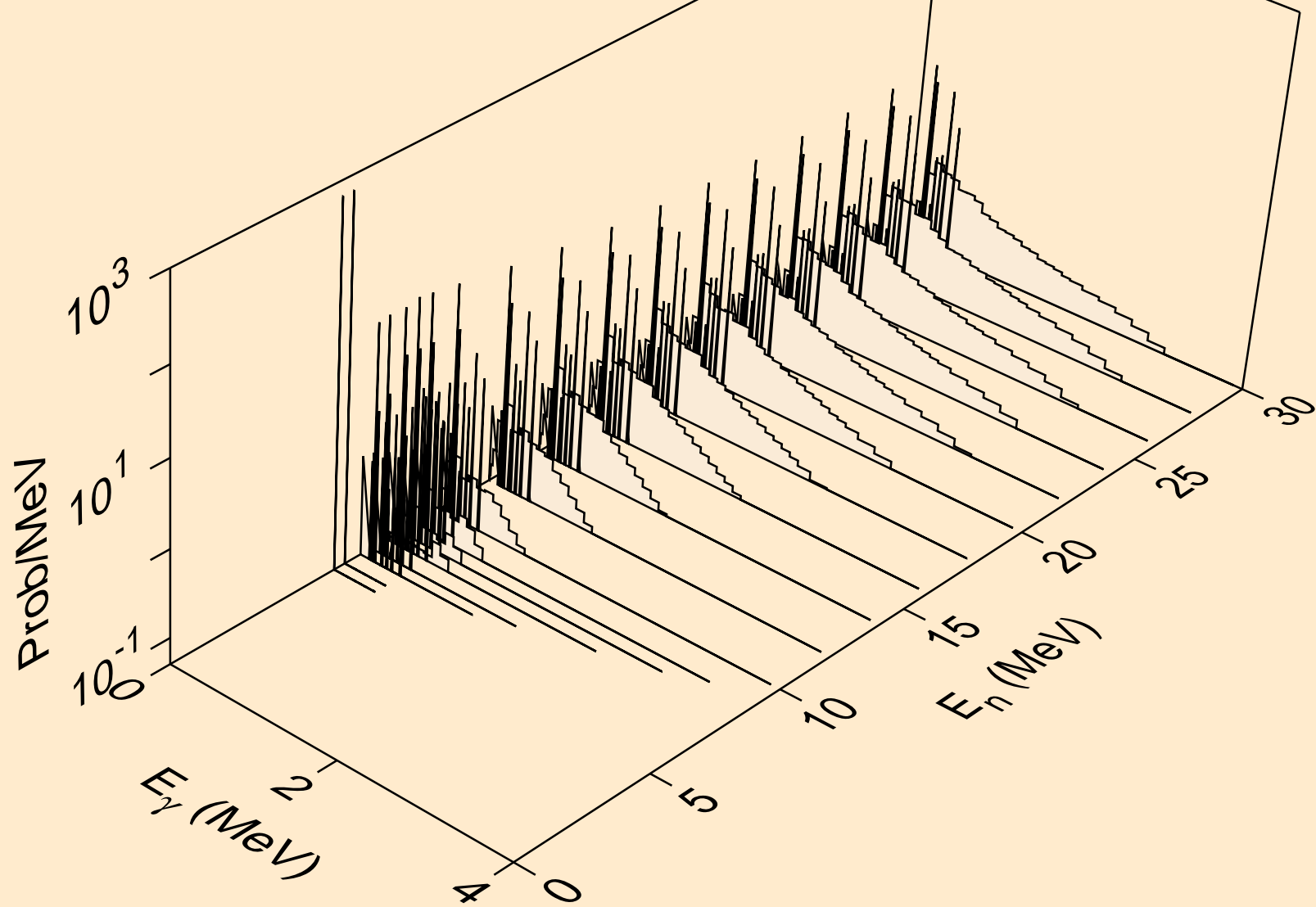

OS184 NEUTRON ACER TENDL-2023 LIBRARY; T=0.K
Photon emission for (n,t)

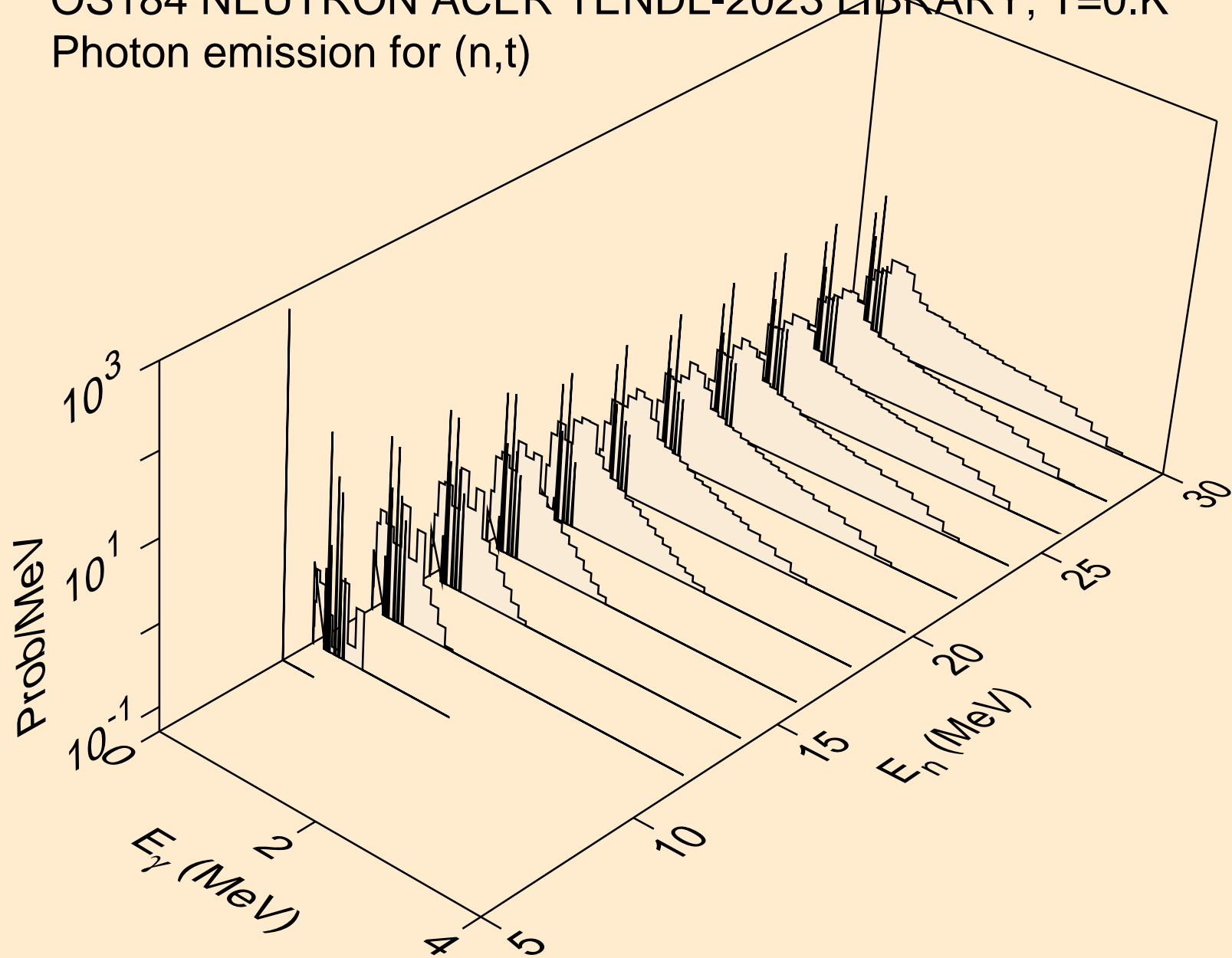

OS184 NEUTRON ACER TENDL-2023 LIBRARY; T=0.K
Photon emission for (n,he3)

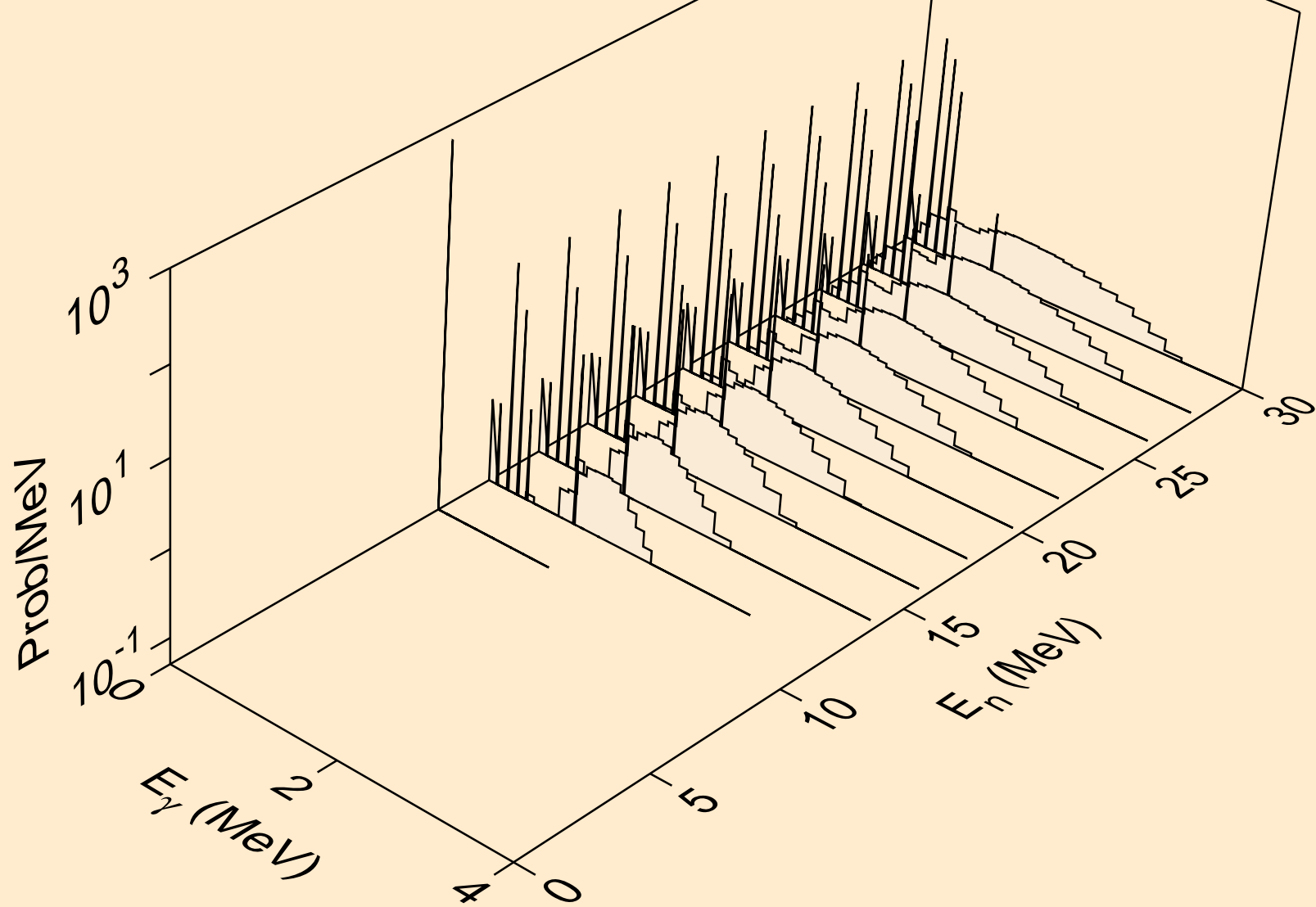

OS184 NEUTRON ACER TENDL-2023 LIBRARY; T=0.K
Photon emission for (n,a)

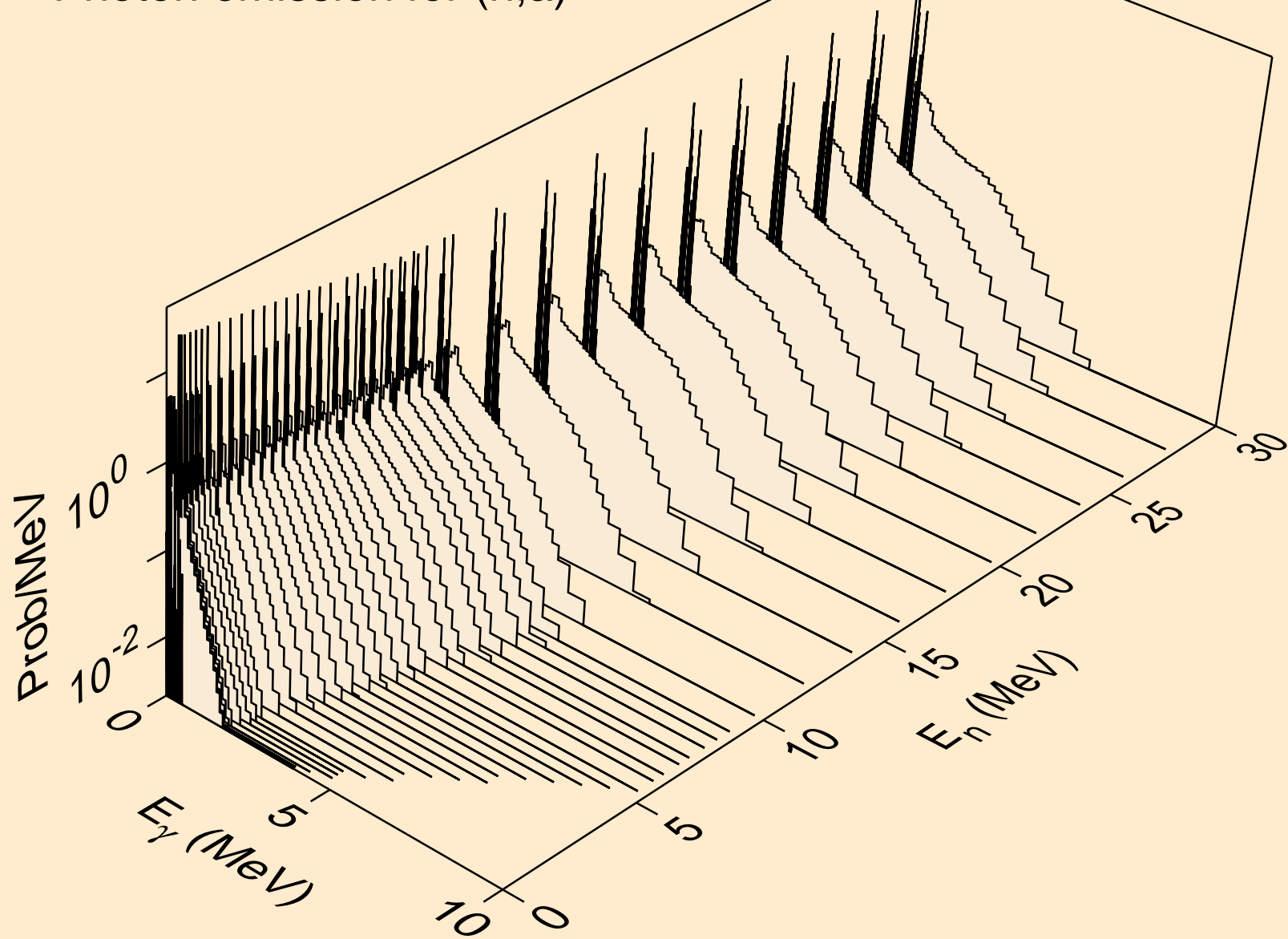

OS184 NEUTRON ACER TENDL-2023 LIBRARY; T=0.K
Photon emission for (n,2a)

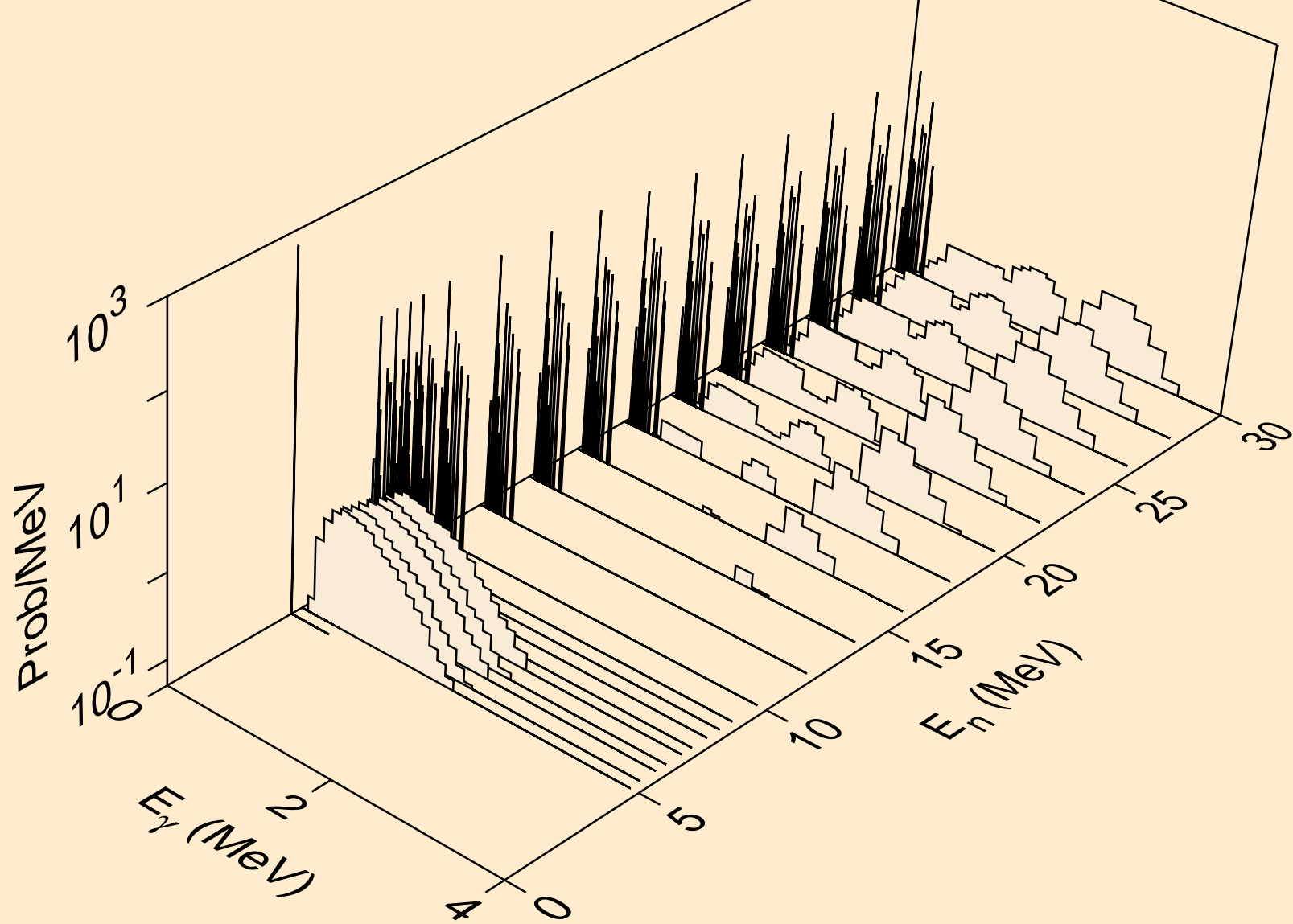

OS184 NEUTRON ACER TENDL-2023 LIBRARY; T=0.K
Photon emission for (n,2p)

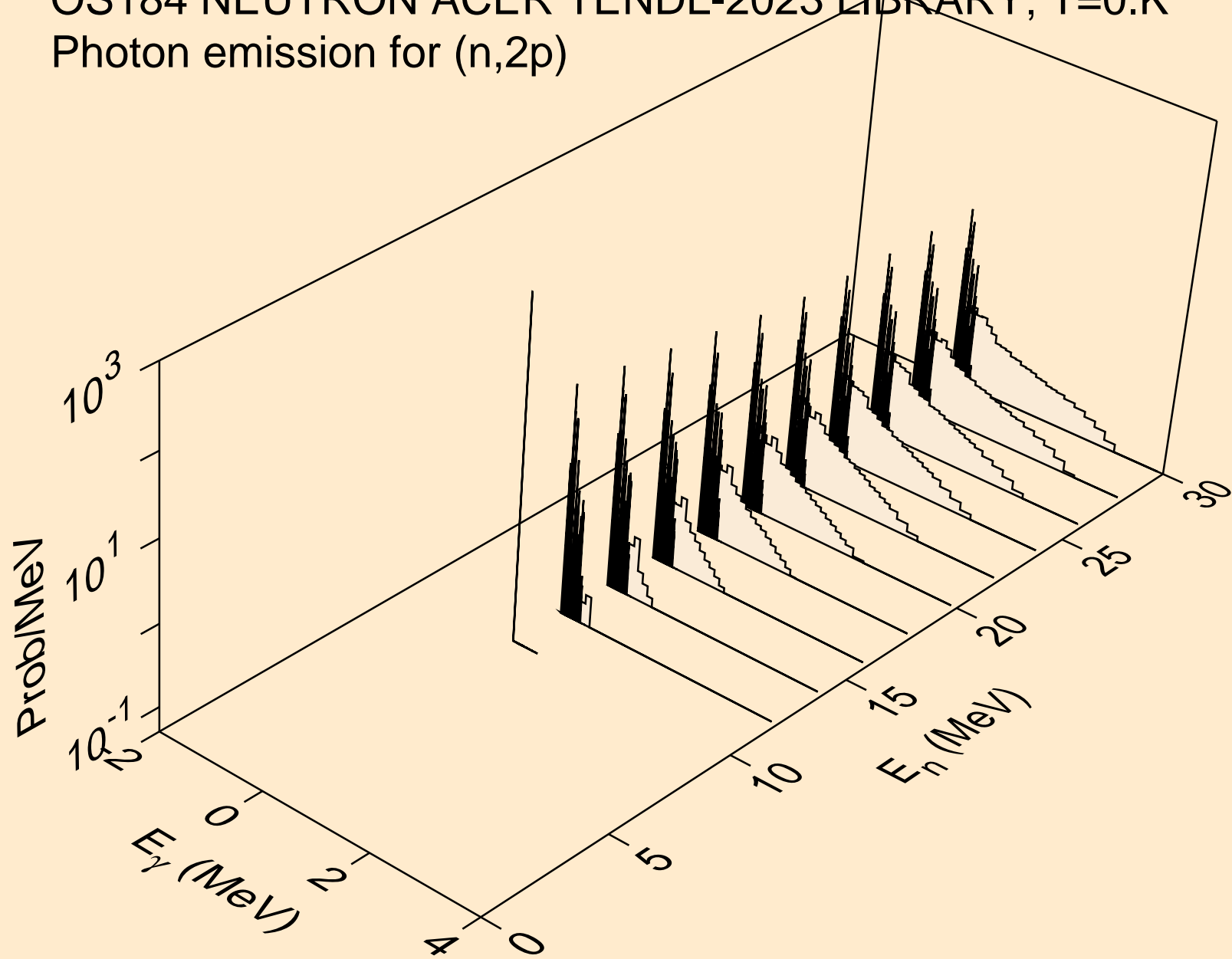

OS184 NEUTRON ACER TENDL-2023 LIBRARY; T=0.K
Photon emission for (n,p α)

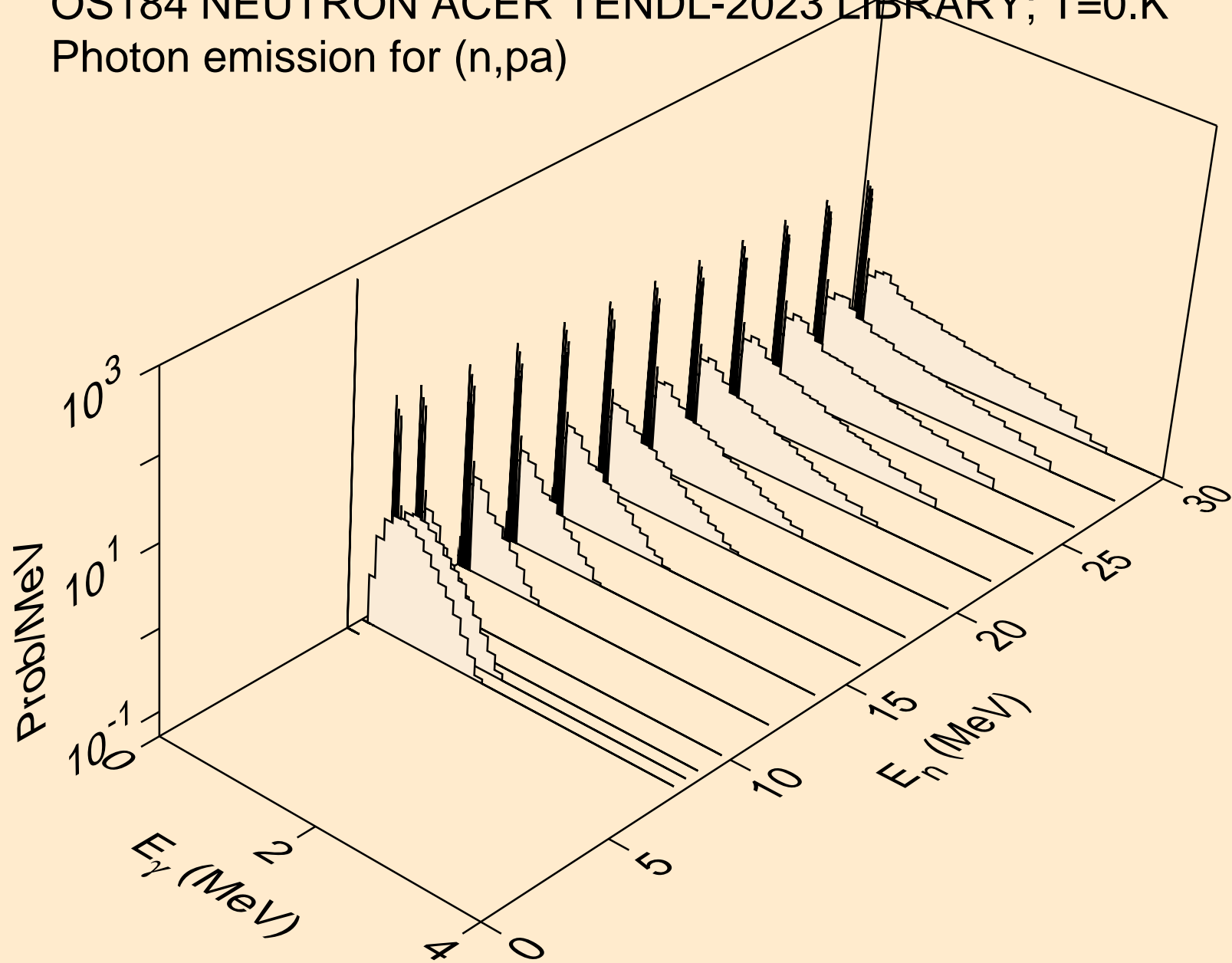

OS184 NEUTRON ACER TENDL-2023 LIBRARY; T=0.K
Photon emission for (n,pd)

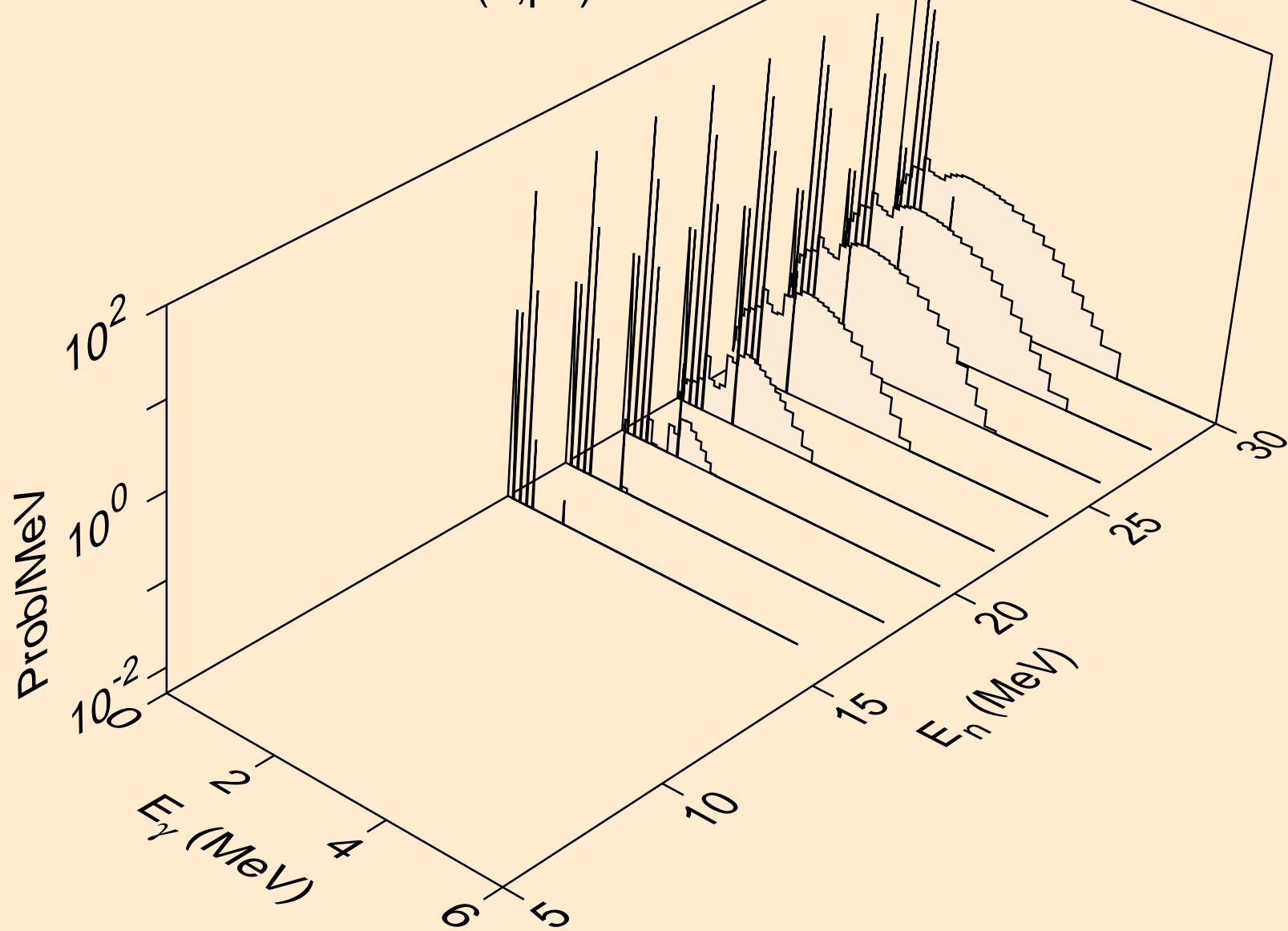

OS184 NEUTRON ACER TENDL-2023 LIBRARY; T=0.K
Photon emission for (n,pt)

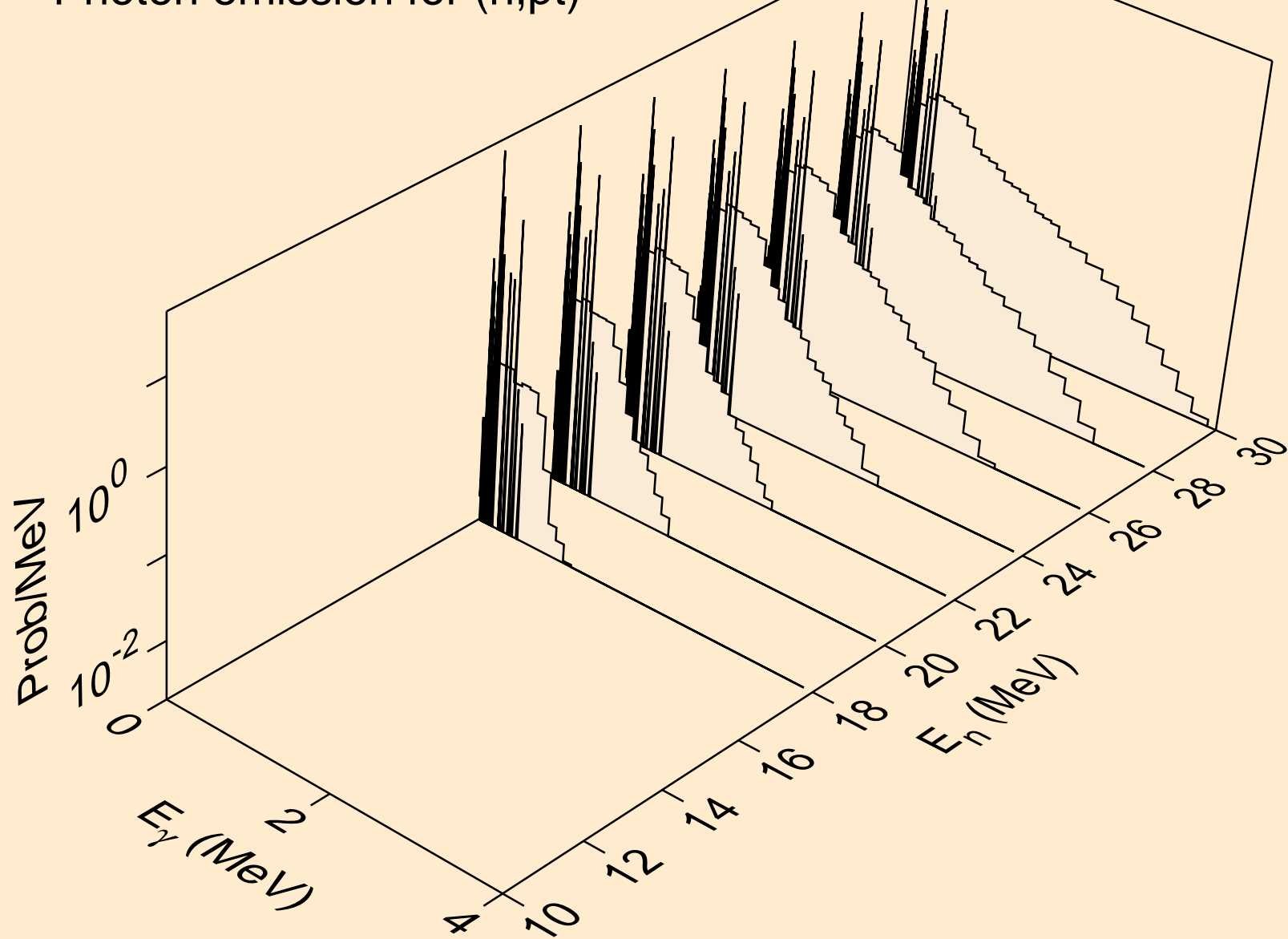

OS184 NEUTRON ACER TENDL-2023 LIBRARY; T=0.K
Photon emission for (n,da)

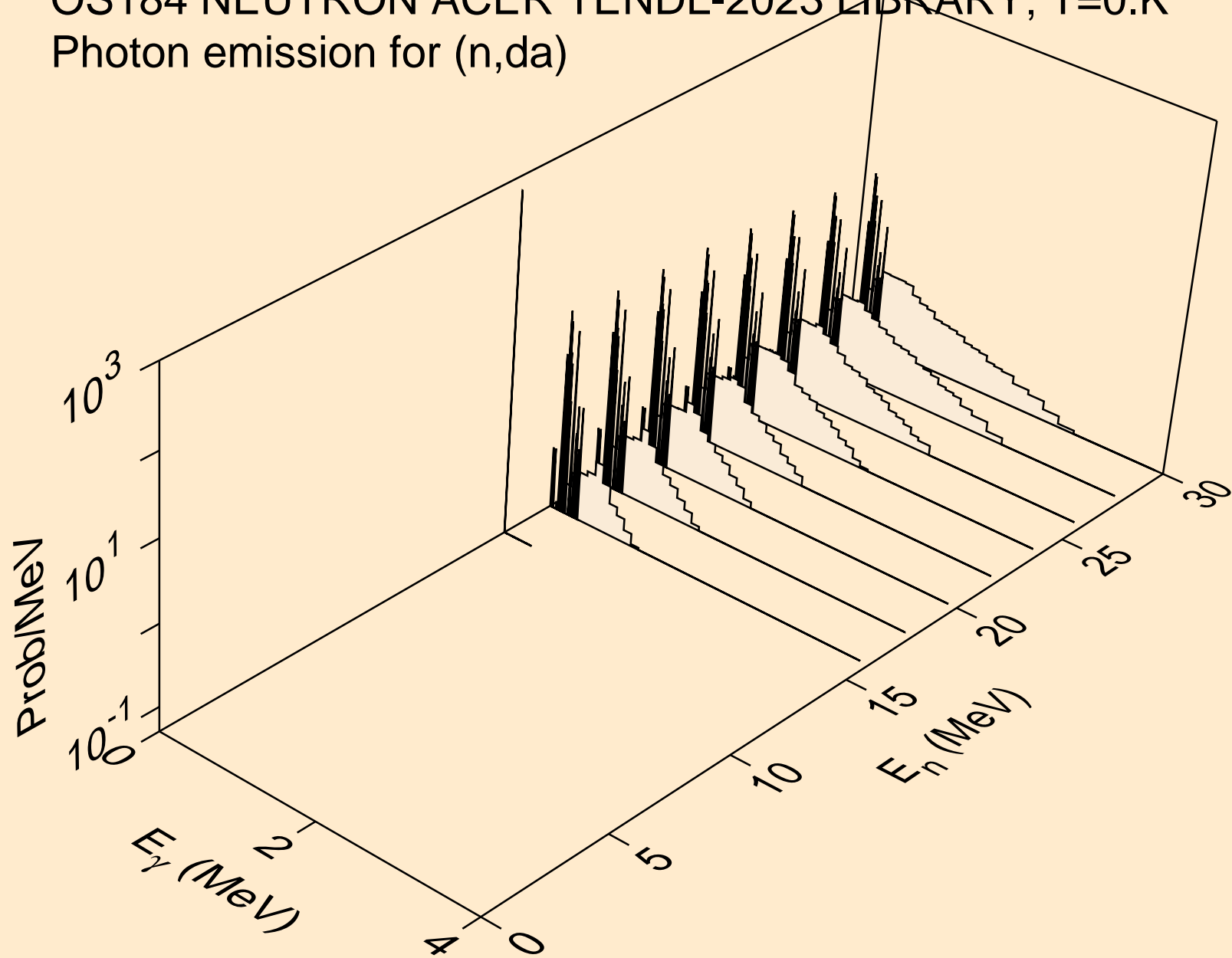

OS184 NEUTRON ACER TENDL-2023 LIBRARY; T=0.K
thermal capture photon spectrum

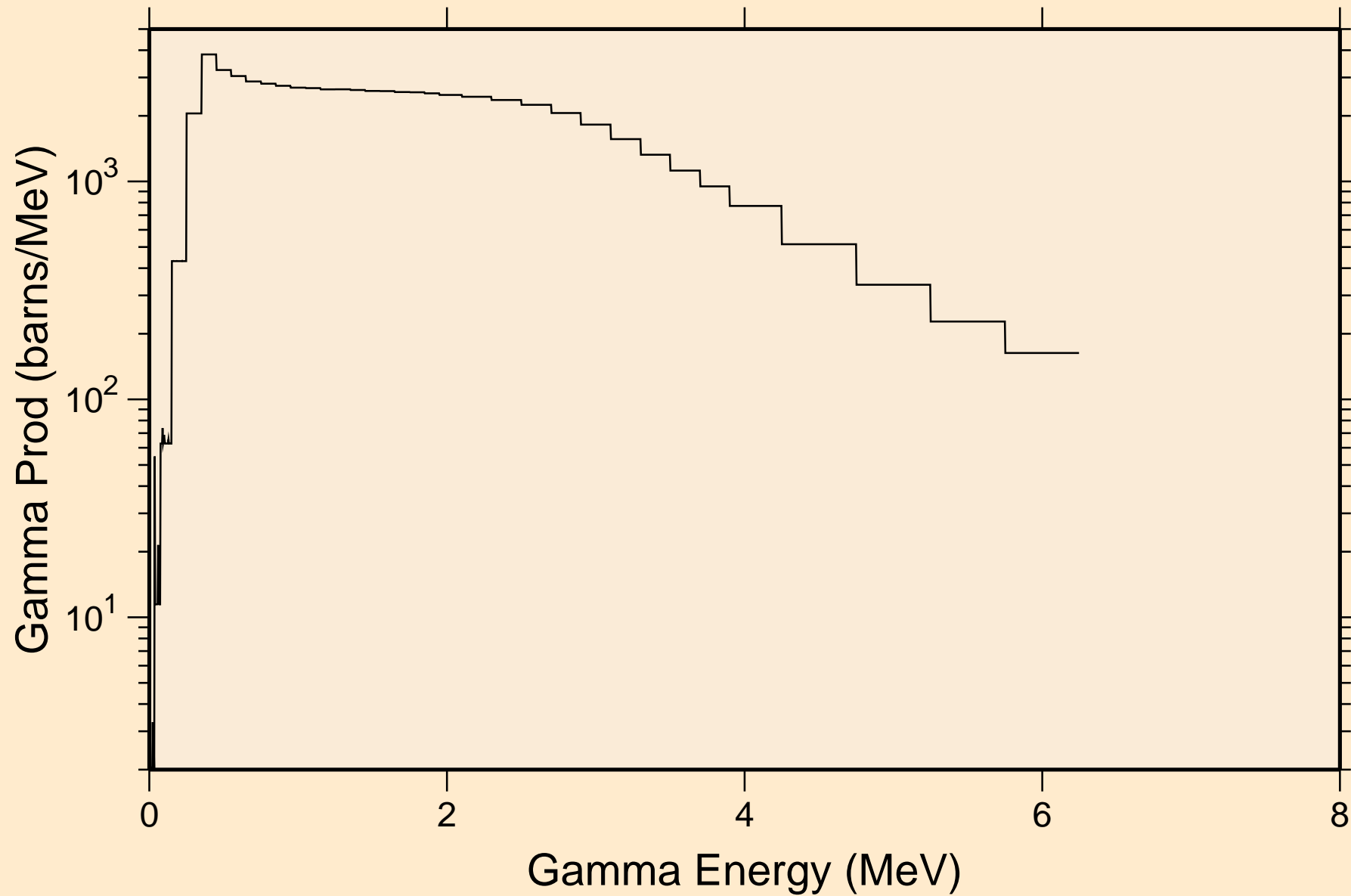

OS184 NEUTRON ACER TENDL-2023 LIBRARY; T=0.K
14 MeV photon spectrum

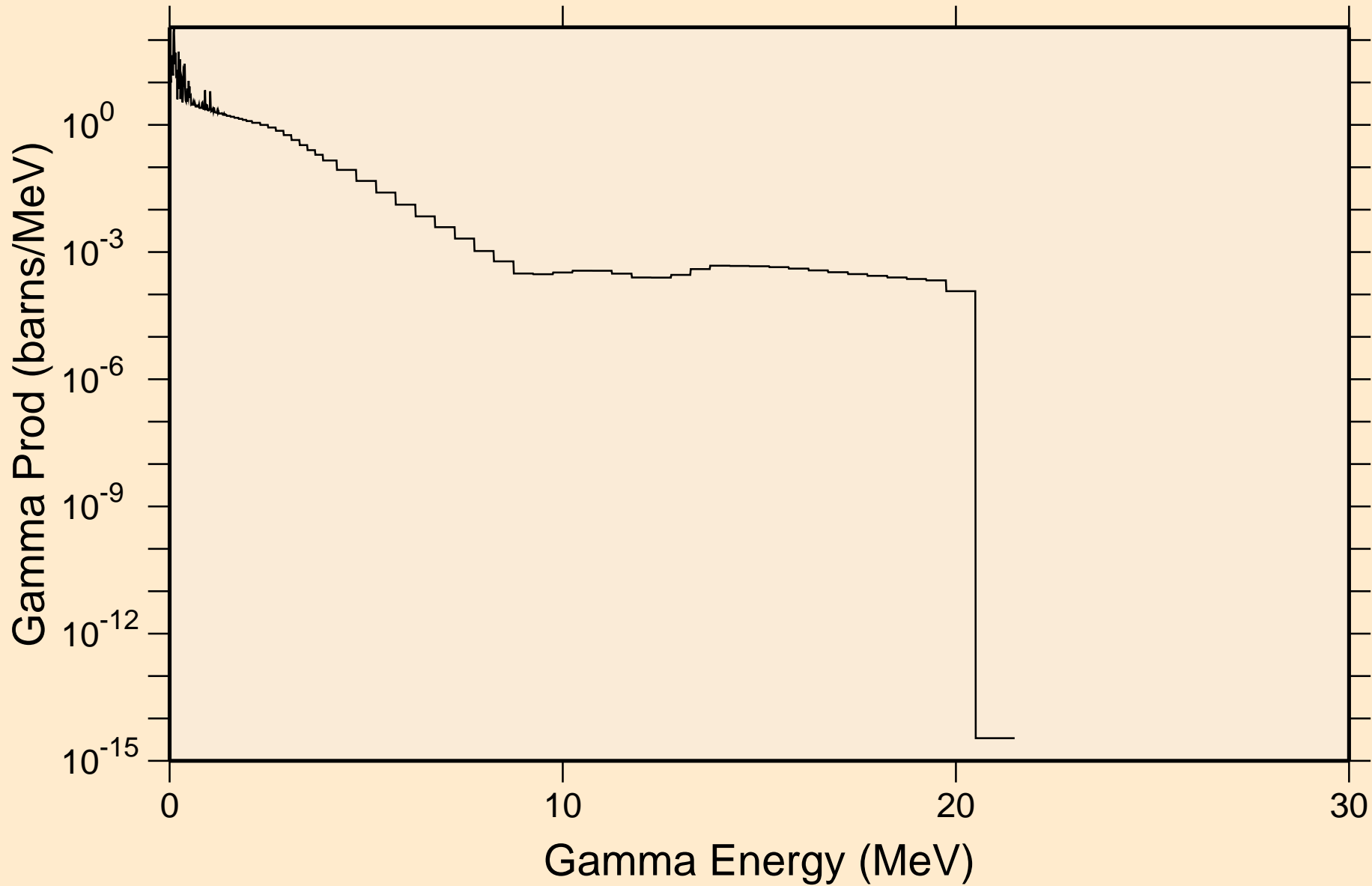

OS184 NEUTRON ACER TENDL-2023 LIBRARY; T=0.K
Particle heating contributions

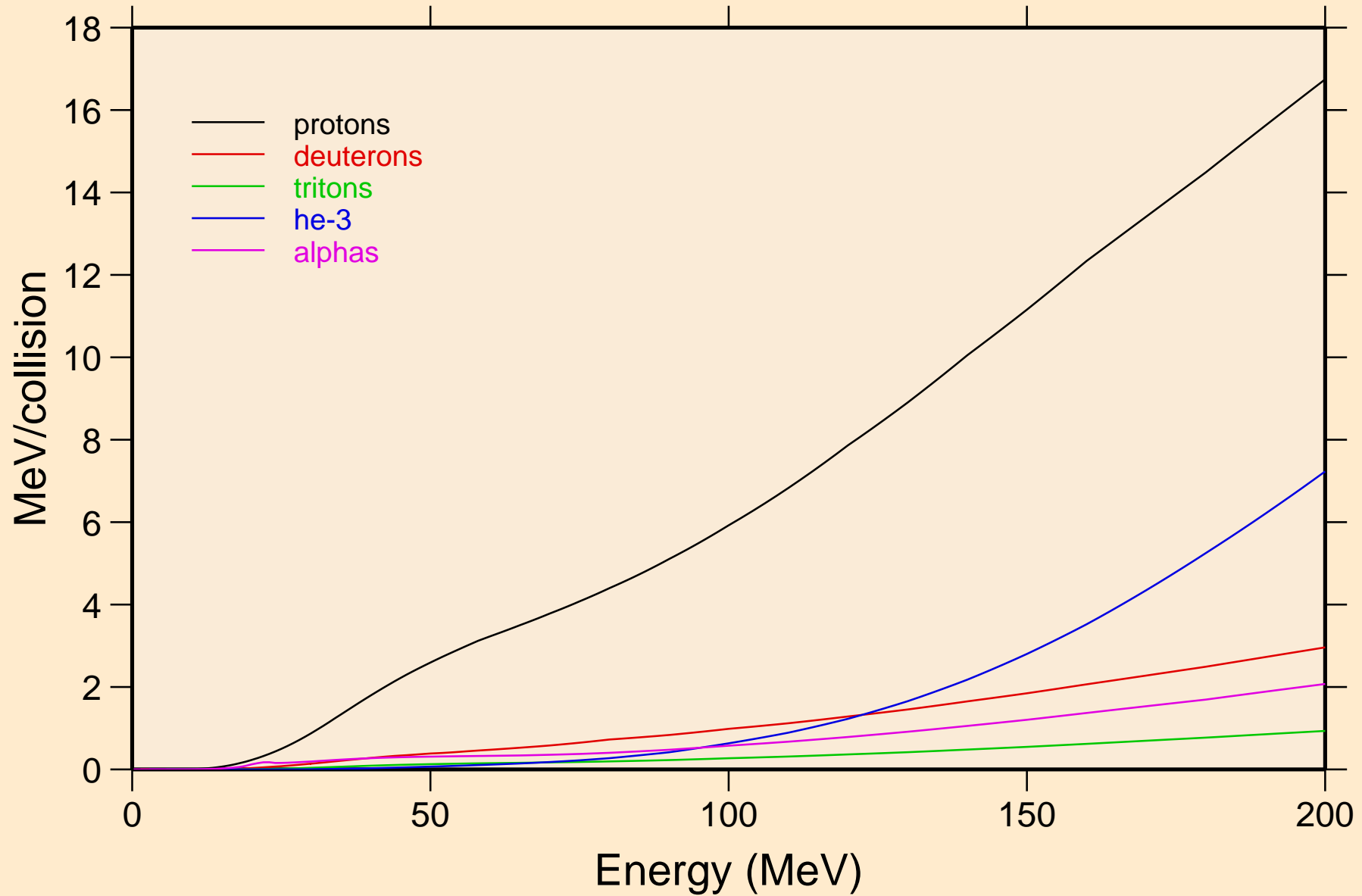

OS184 NEUTRON ACER TENDL-2023 LIBRARY; T=0.K
Recoil Heating

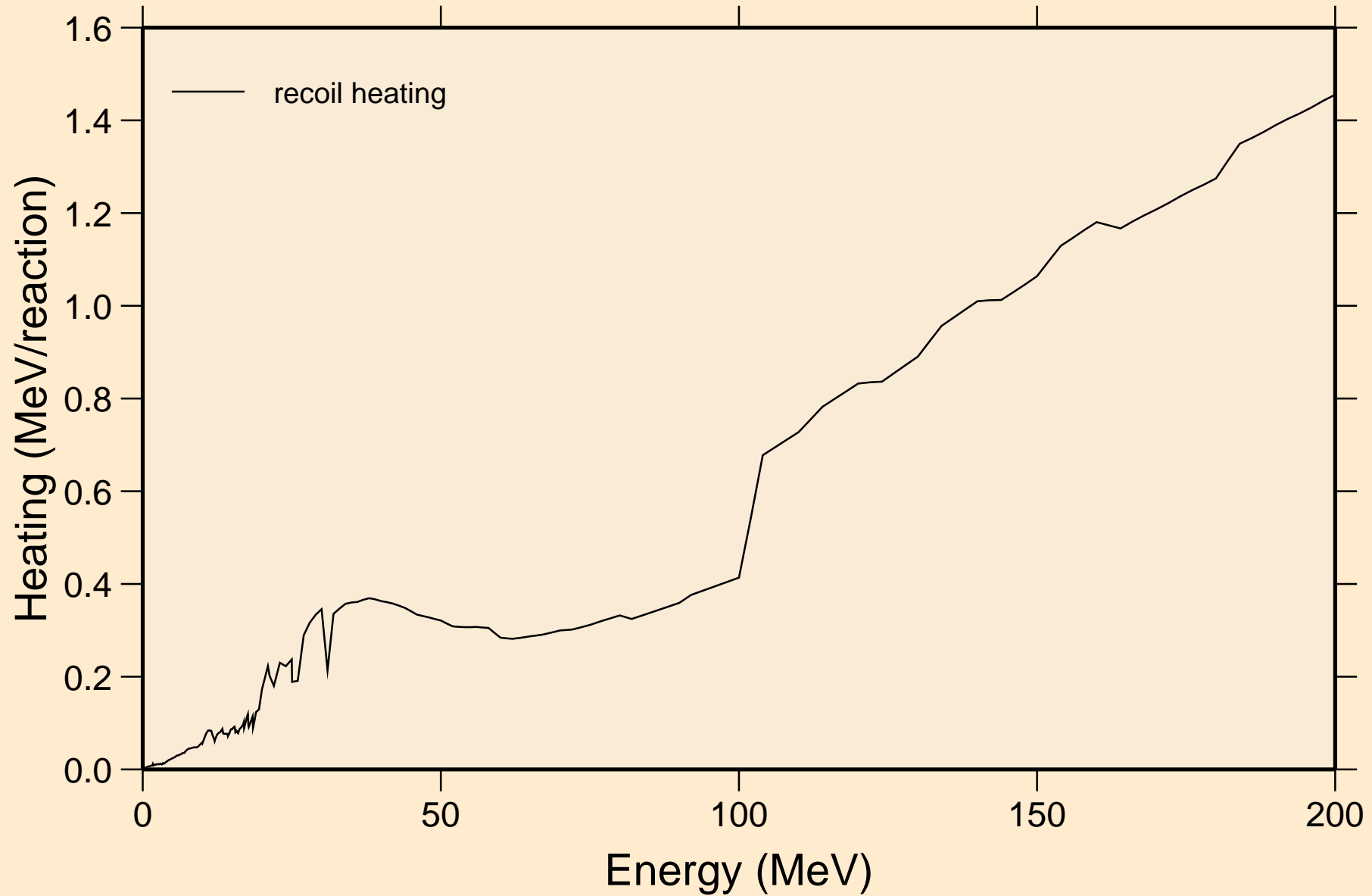

OS184 NEUTRON ACER TENDL-2023 LIBRARY; T=0.K
Particle production cross sections

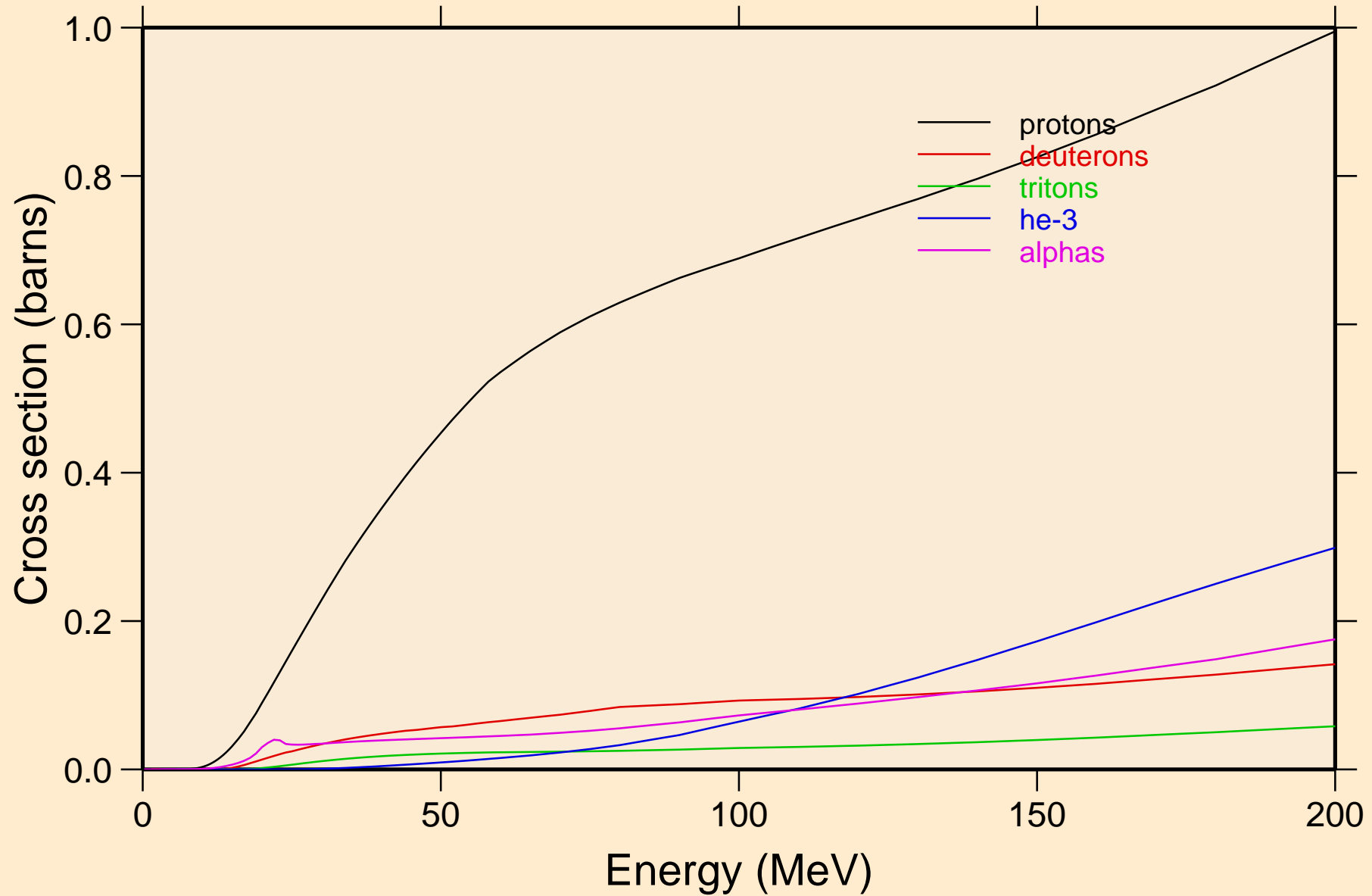

OS184 NEUTRON ACER TENDL-2023 LIBRARY; T=0.K
protons from (n,x)

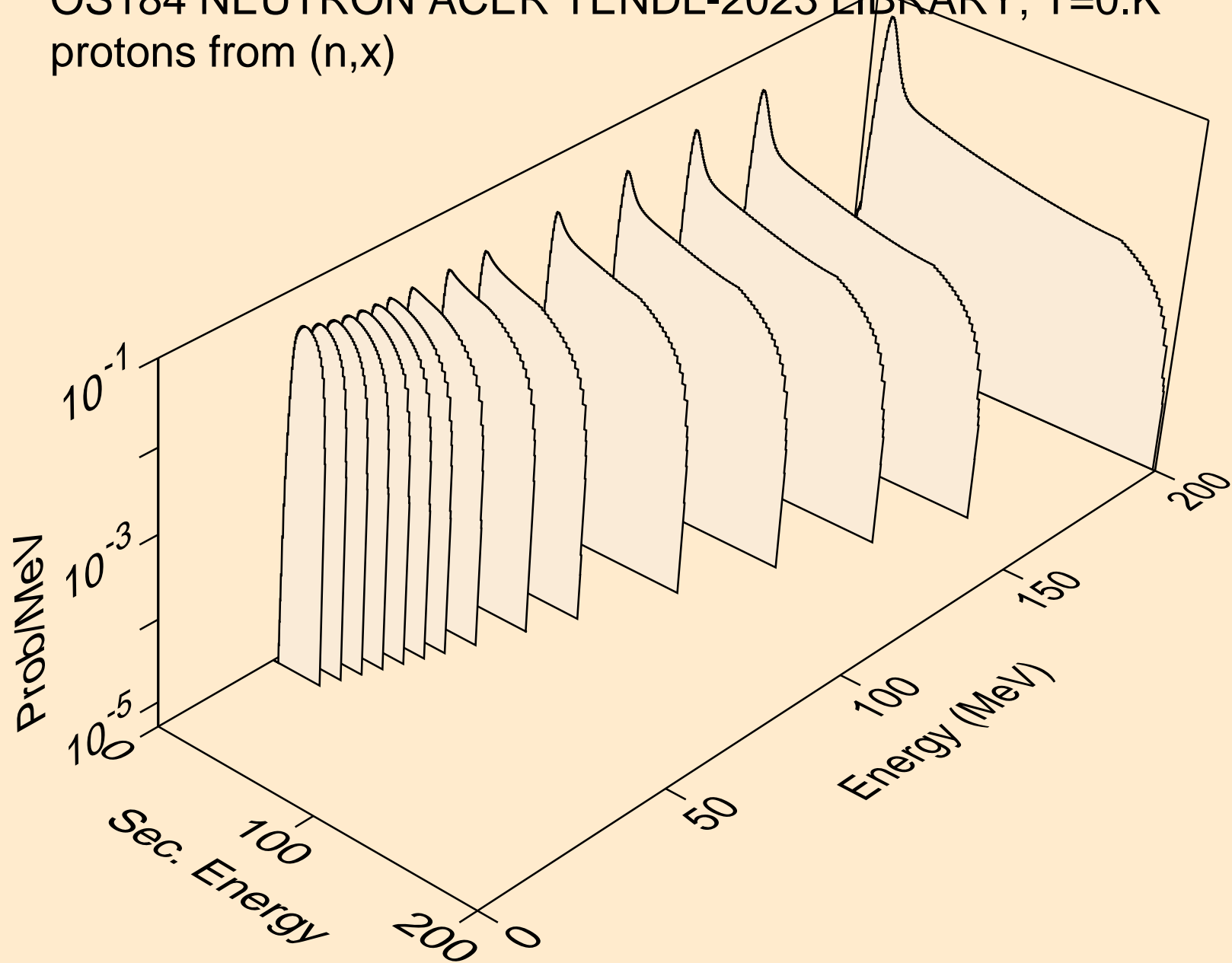

OS184 NEUTRON ACER TENDL-2023 LIBRARY; T=0.K
protons from (n,n*)p

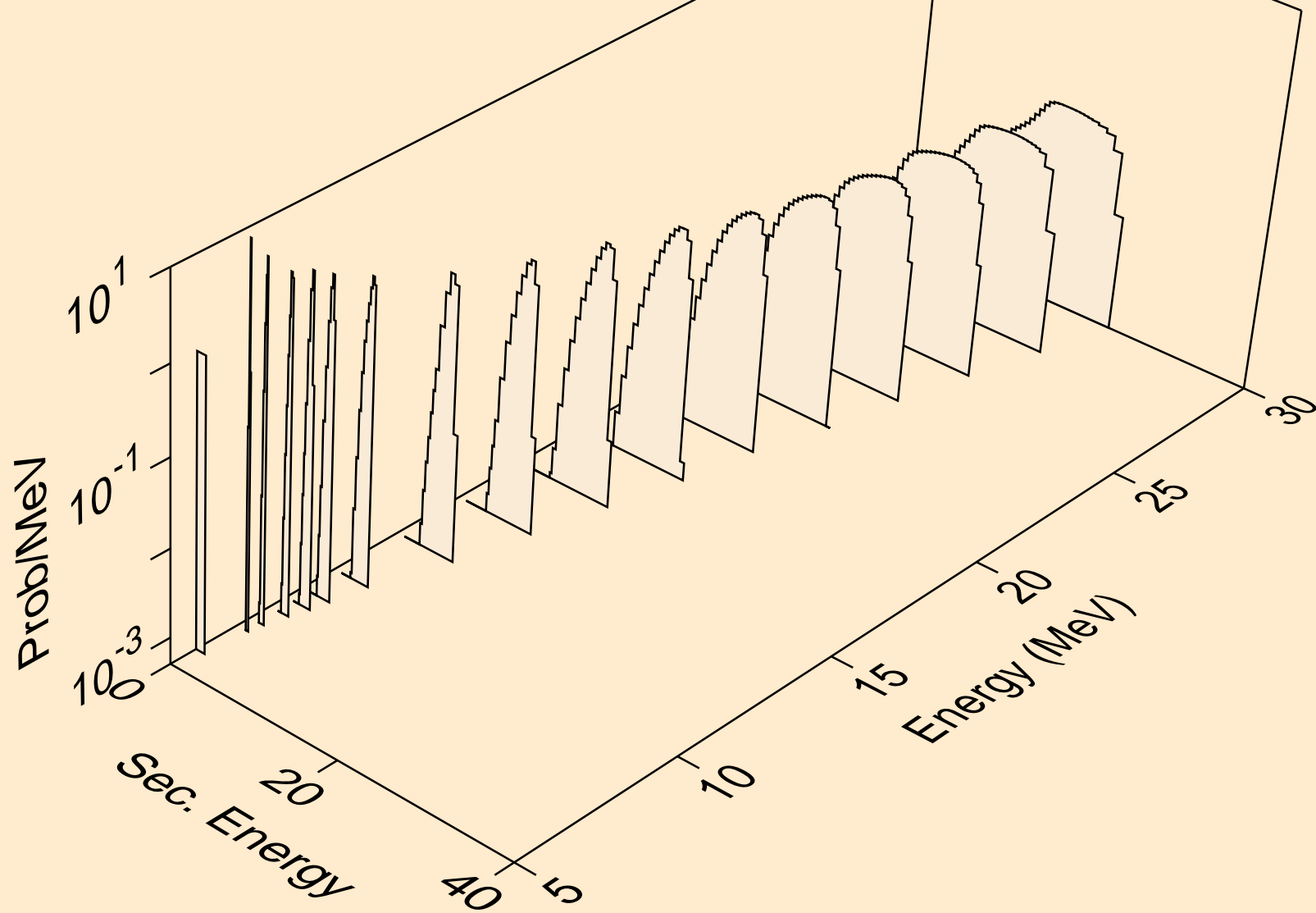

OS184 NEUTRON ACER TENDL-2023 LIBRARY; T=0.K
protons from (n,2np)

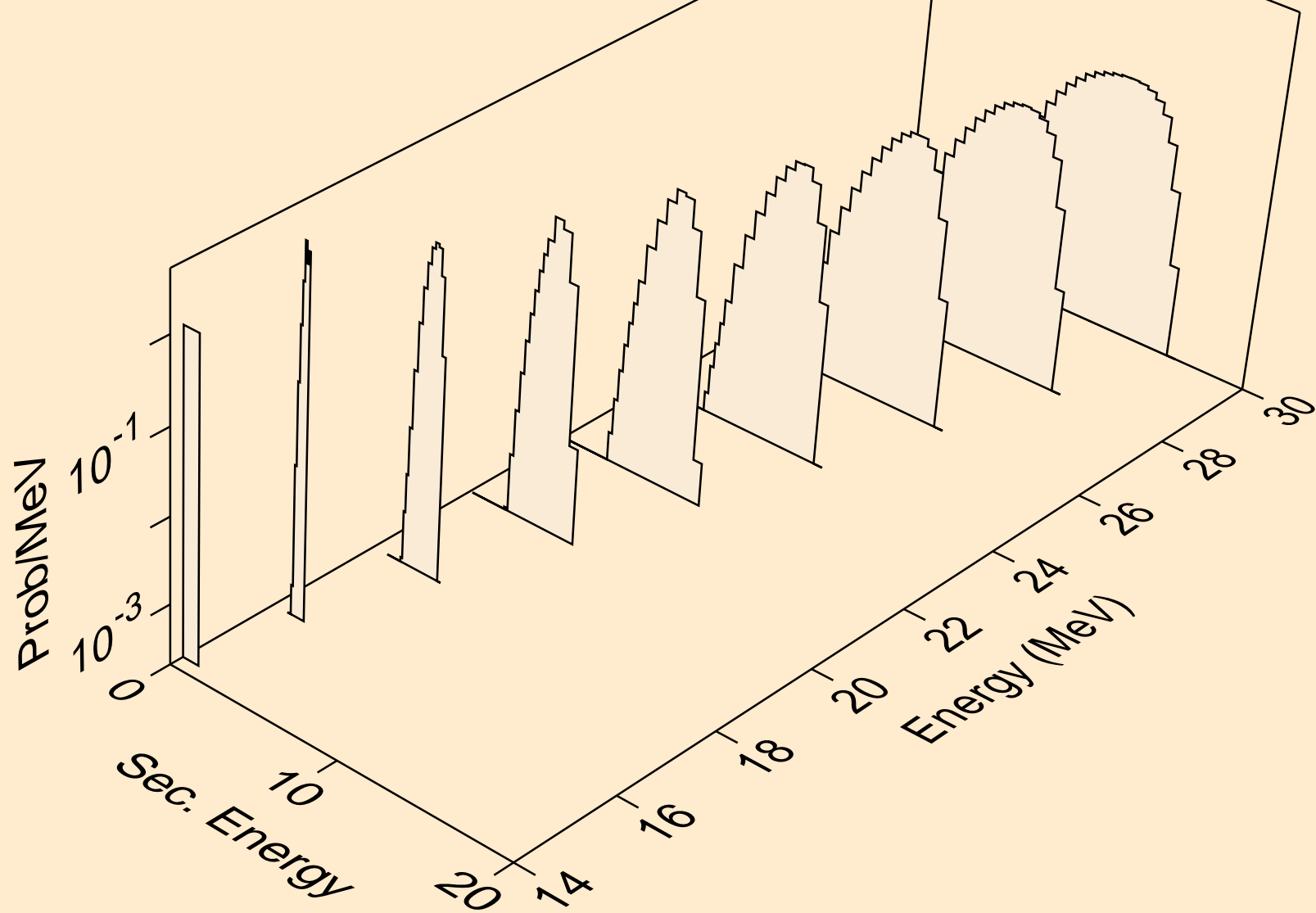

OS184 NEUTRON ACER TENDL-2023 LIBRARY; T=0.K
protons from (n,3np)

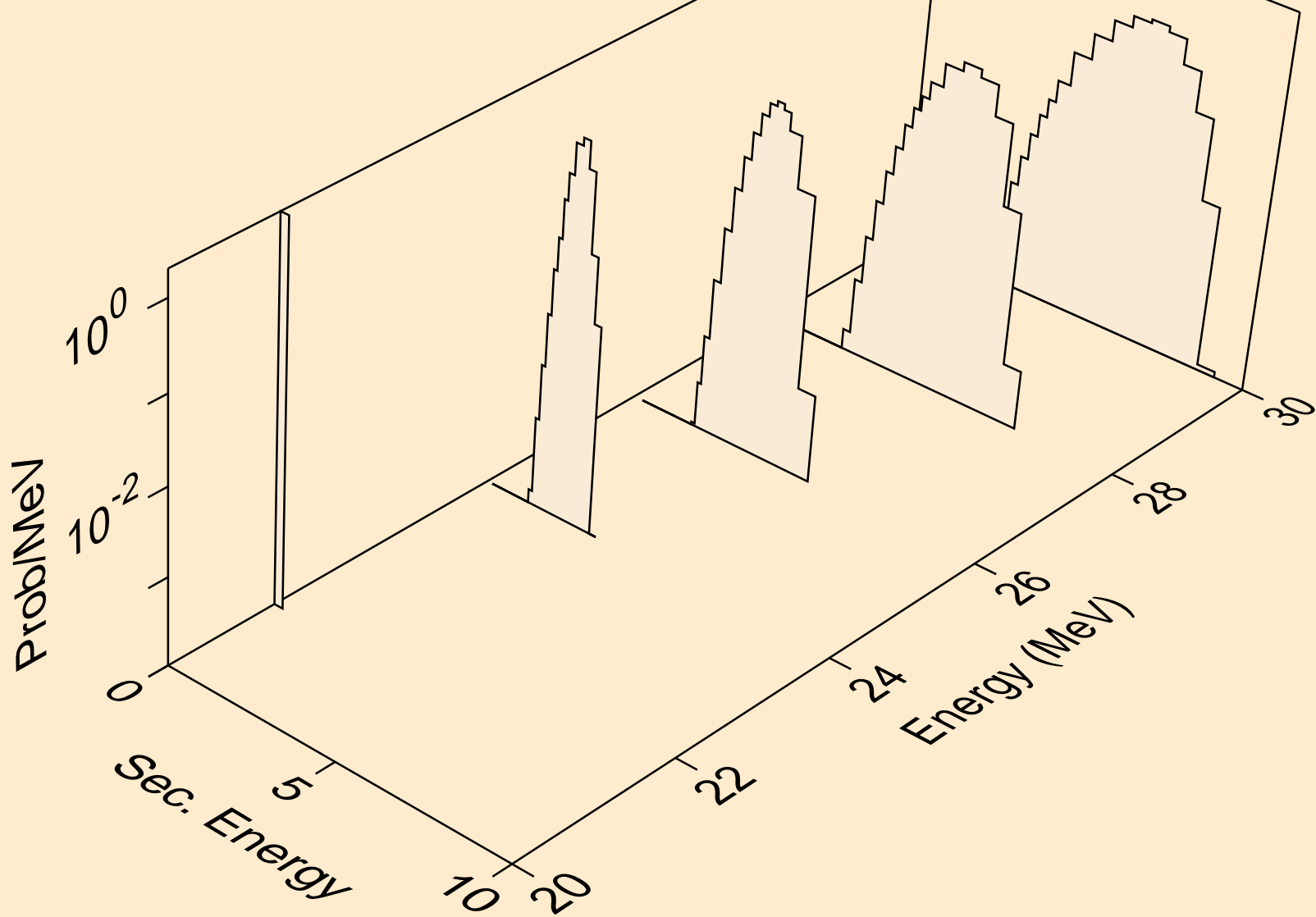

OS184 NEUTRON ACER TENDL-2023 LIBRARY; T=0.K
protons from (n,n2p)

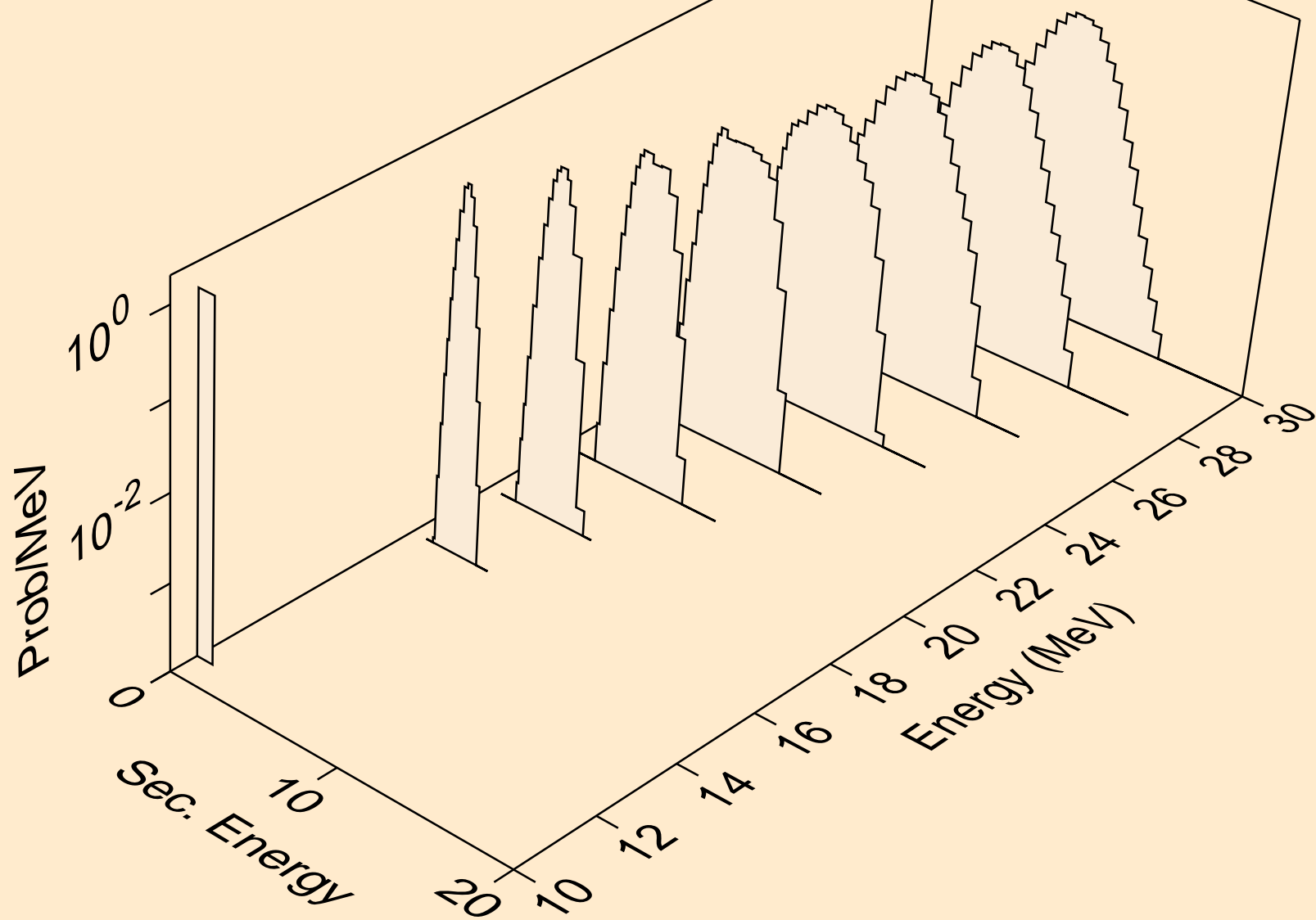

OS184 NEUTRON ACER TENDL-2023 LIBRARY; T=0.K
protons from (n,npa)

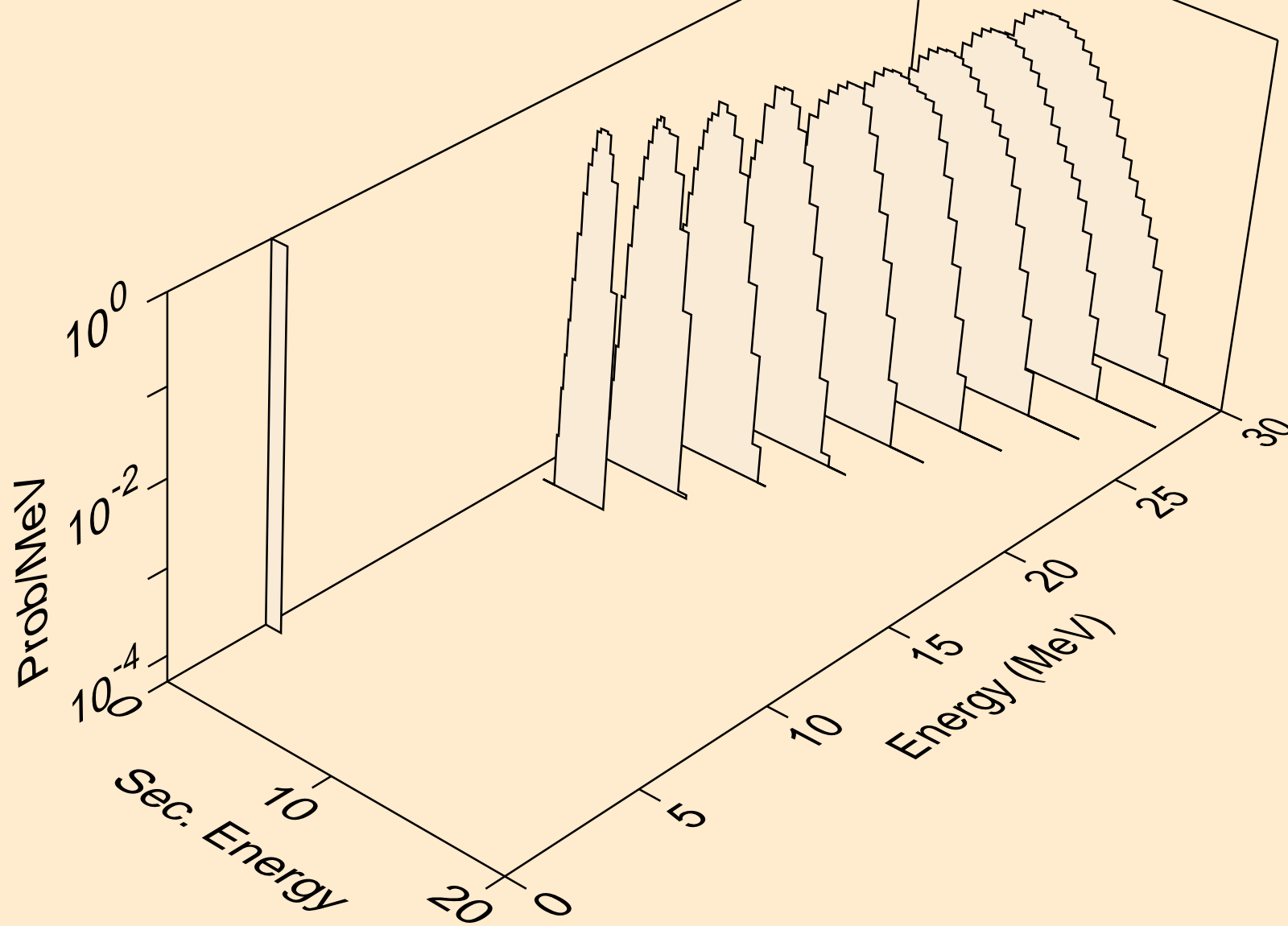

OS184 NEUTRON ACER TENDL-2023 LIBRARY; T=0.K
protons from (n,p)

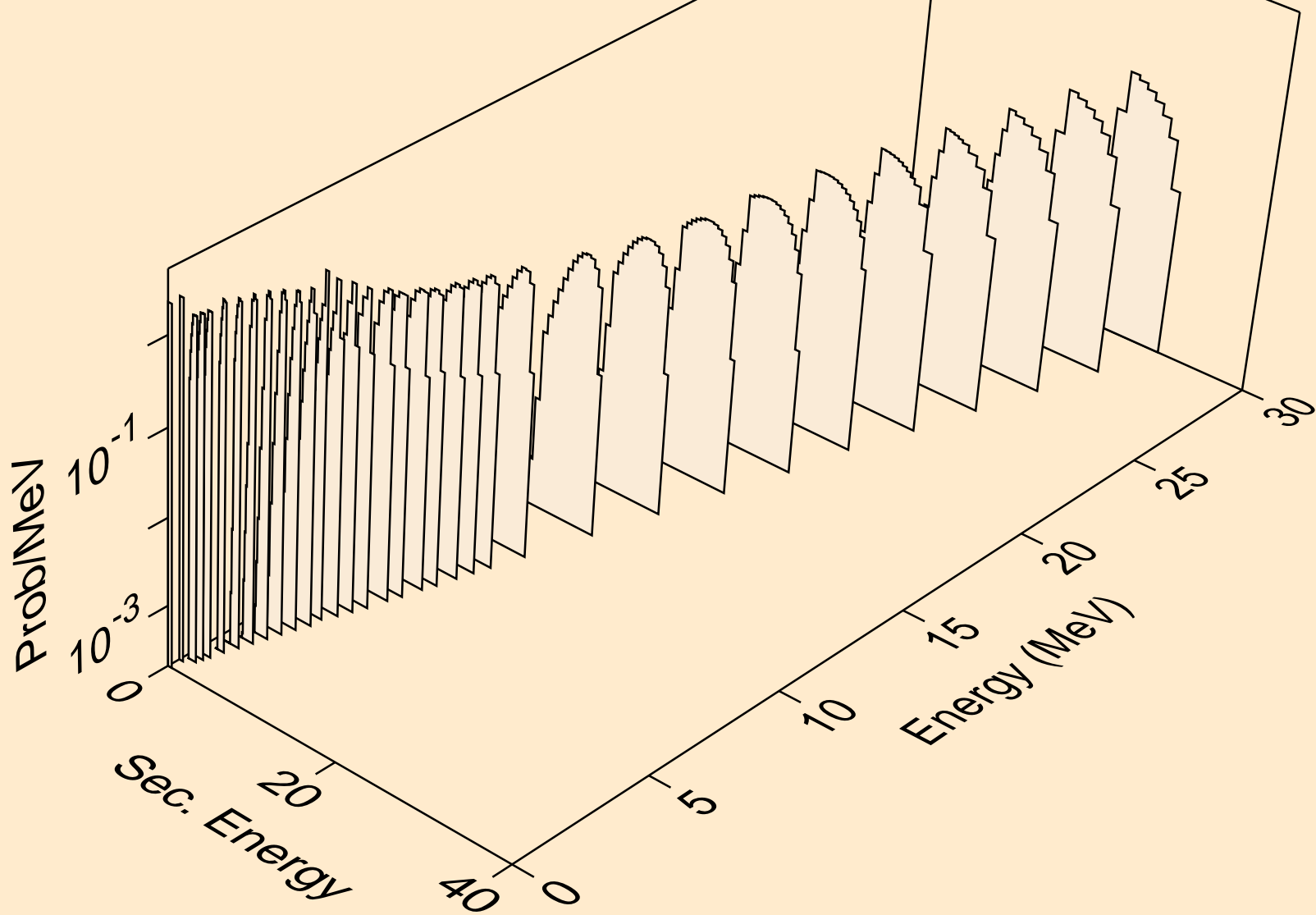

OS184 NEUTRON ACER TENDL-2023 LIBRARY; T=0.K
protons from (n,2p)

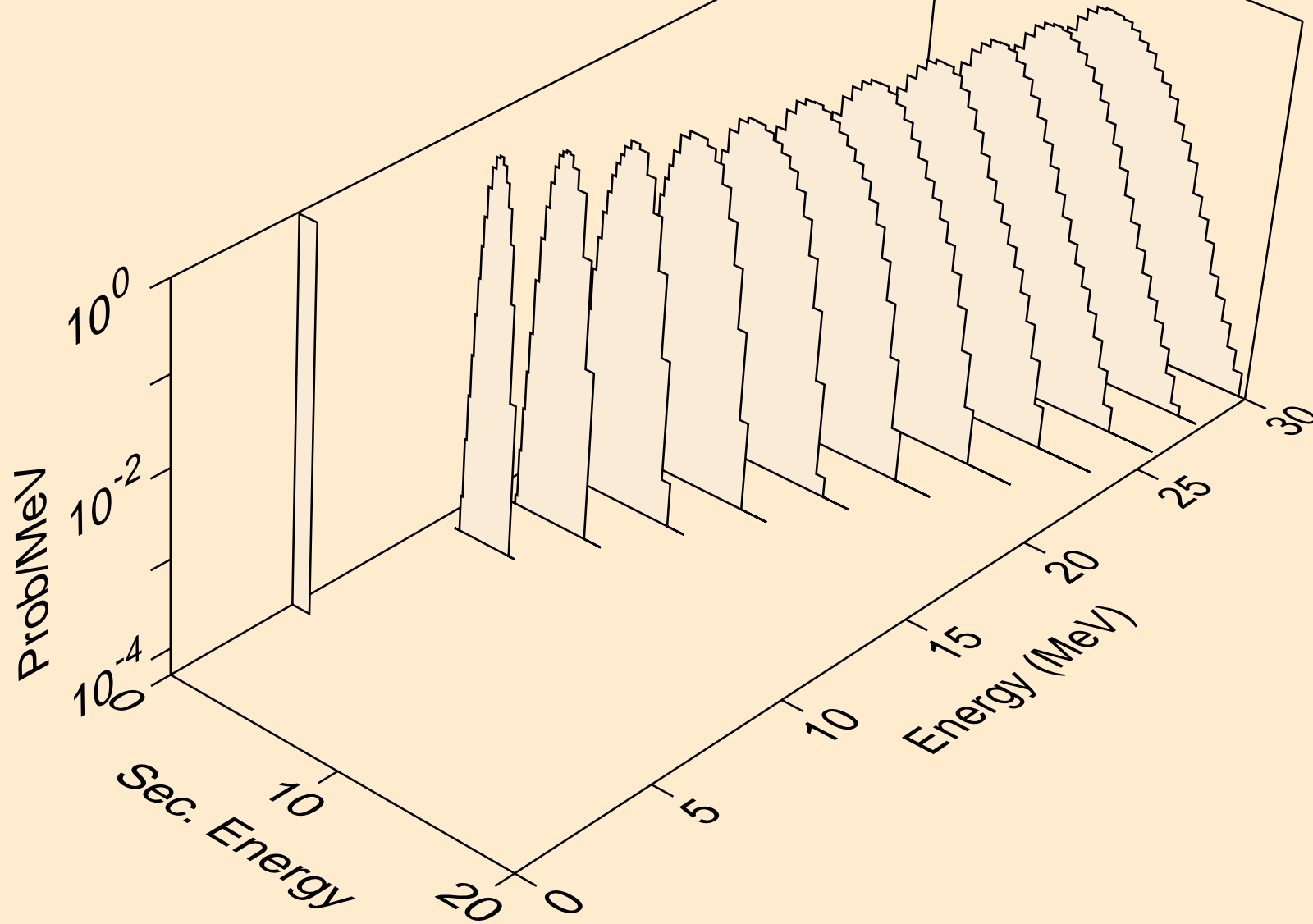

OS184 NEUTRON ACER TENDL-2023 LIBRARY; T=0.K
protons from (n,p)

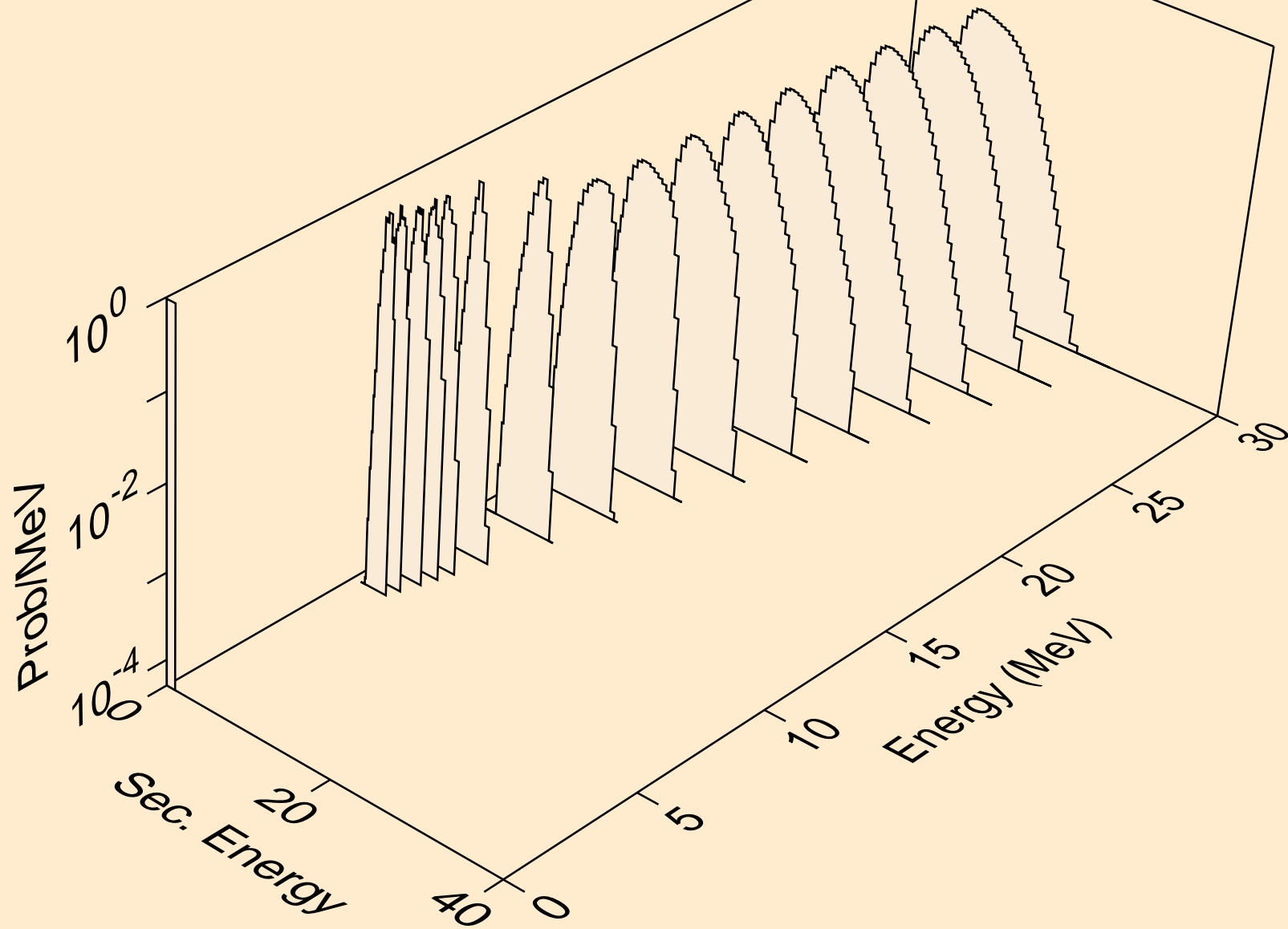

OS184 NEUTRON ACER TENDL-2023 LIBRARY; T=0.K
protons from (n,pd)

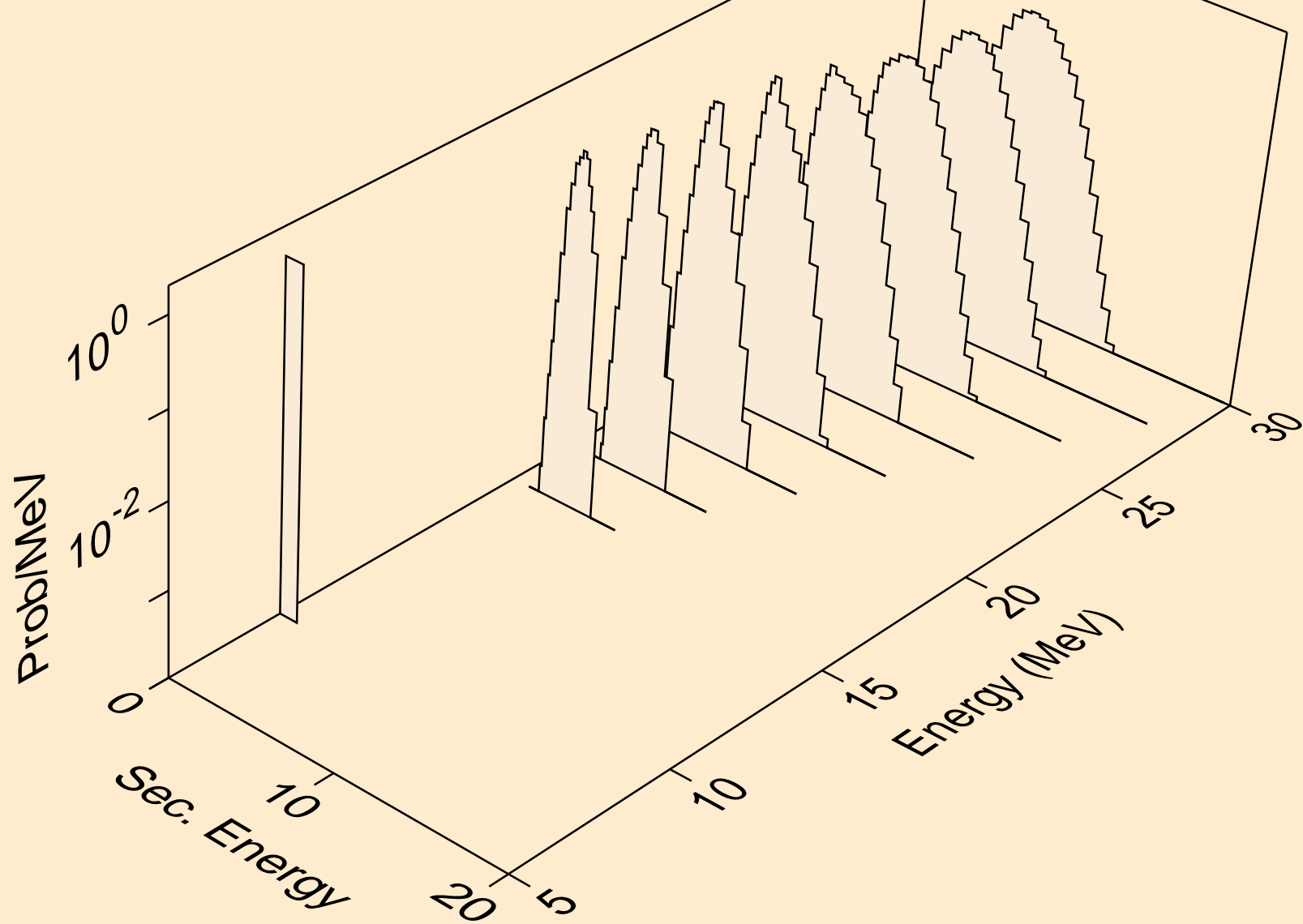

OS184 NEUTRON ACER TENDL-2023 LIBRARY; T=0.K
protons from (n,pt)

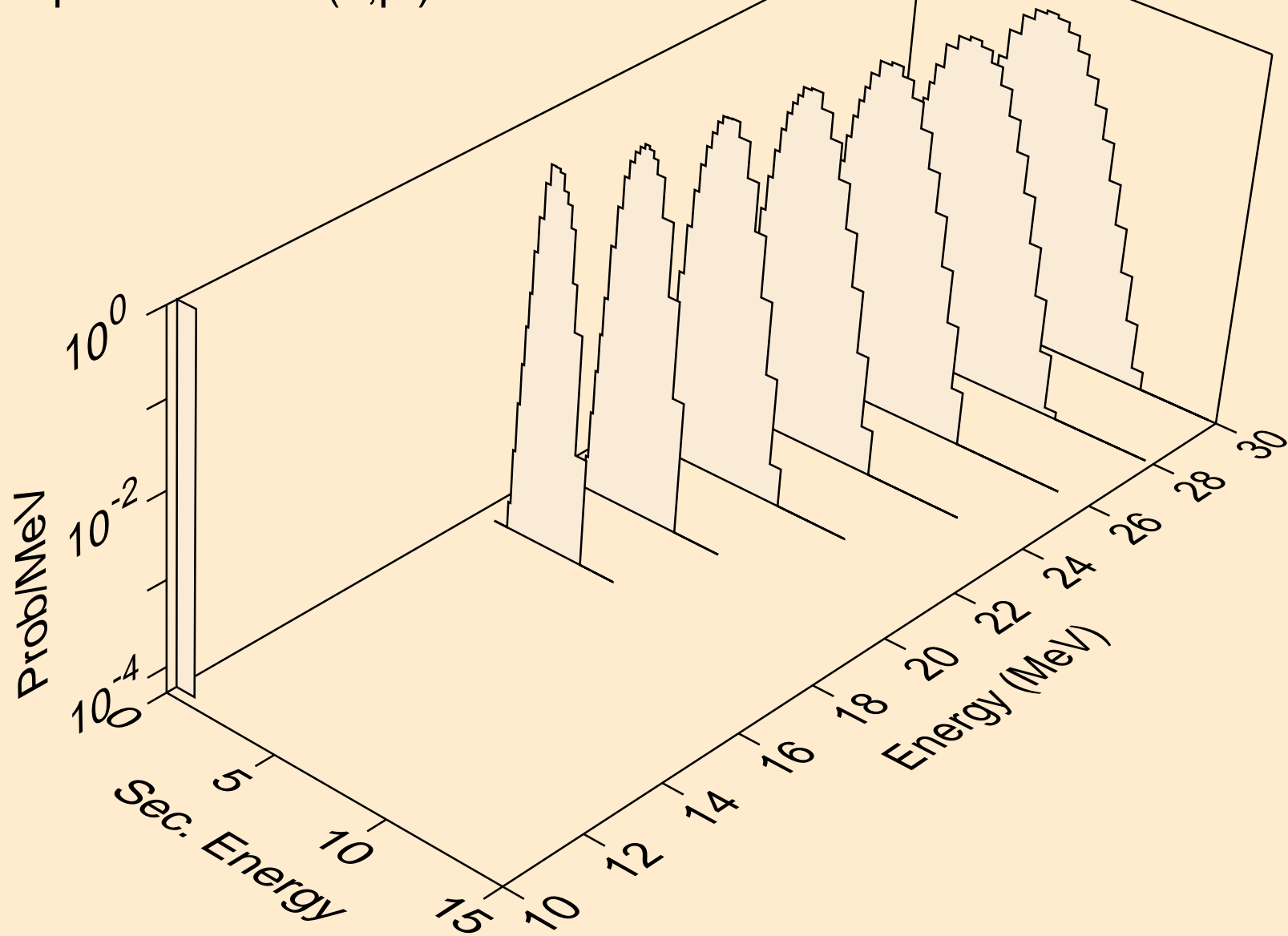

OS184 NEUTRON ACER TENDL-2023 LIBRARY; T=0.K
deuterons from (n,x)

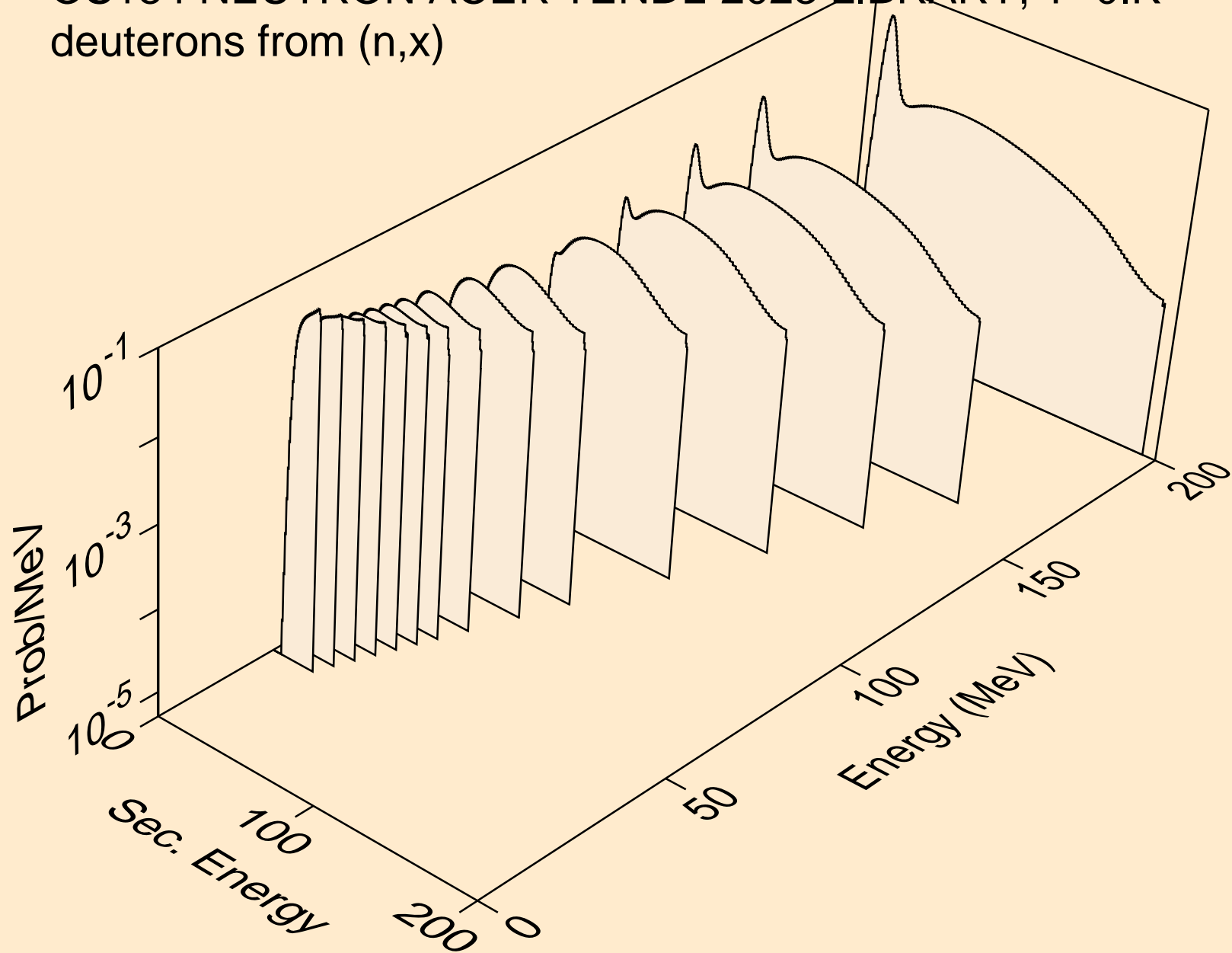

OS184 NEUTRON ACER TENDL-2023 LIBRARY; T=0.K
deuterons from (n,2nd)

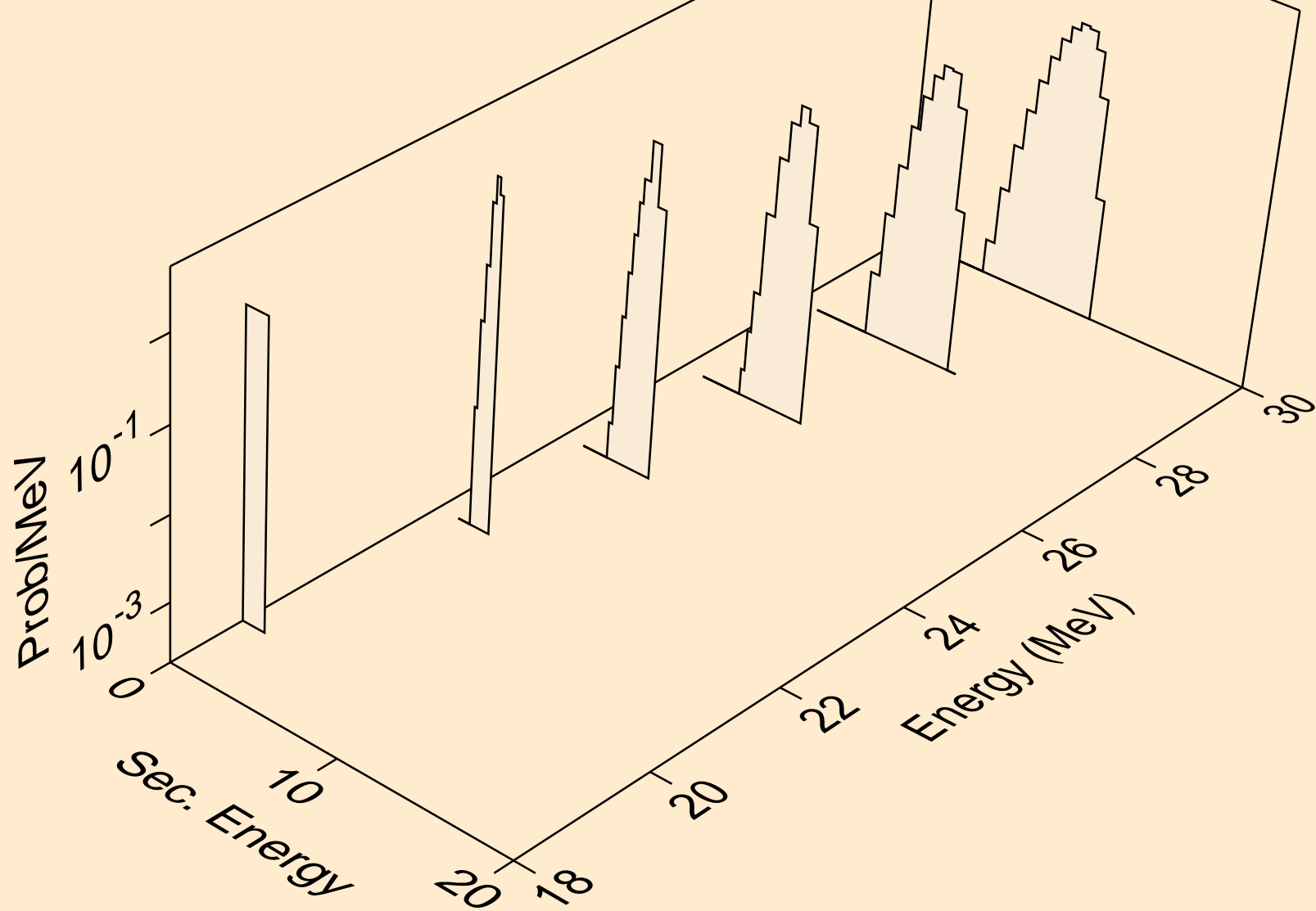

OS184 NEUTRON ACER TENDL-2023 LIBRARY; T=0.K
deuterons from (n,n*)d

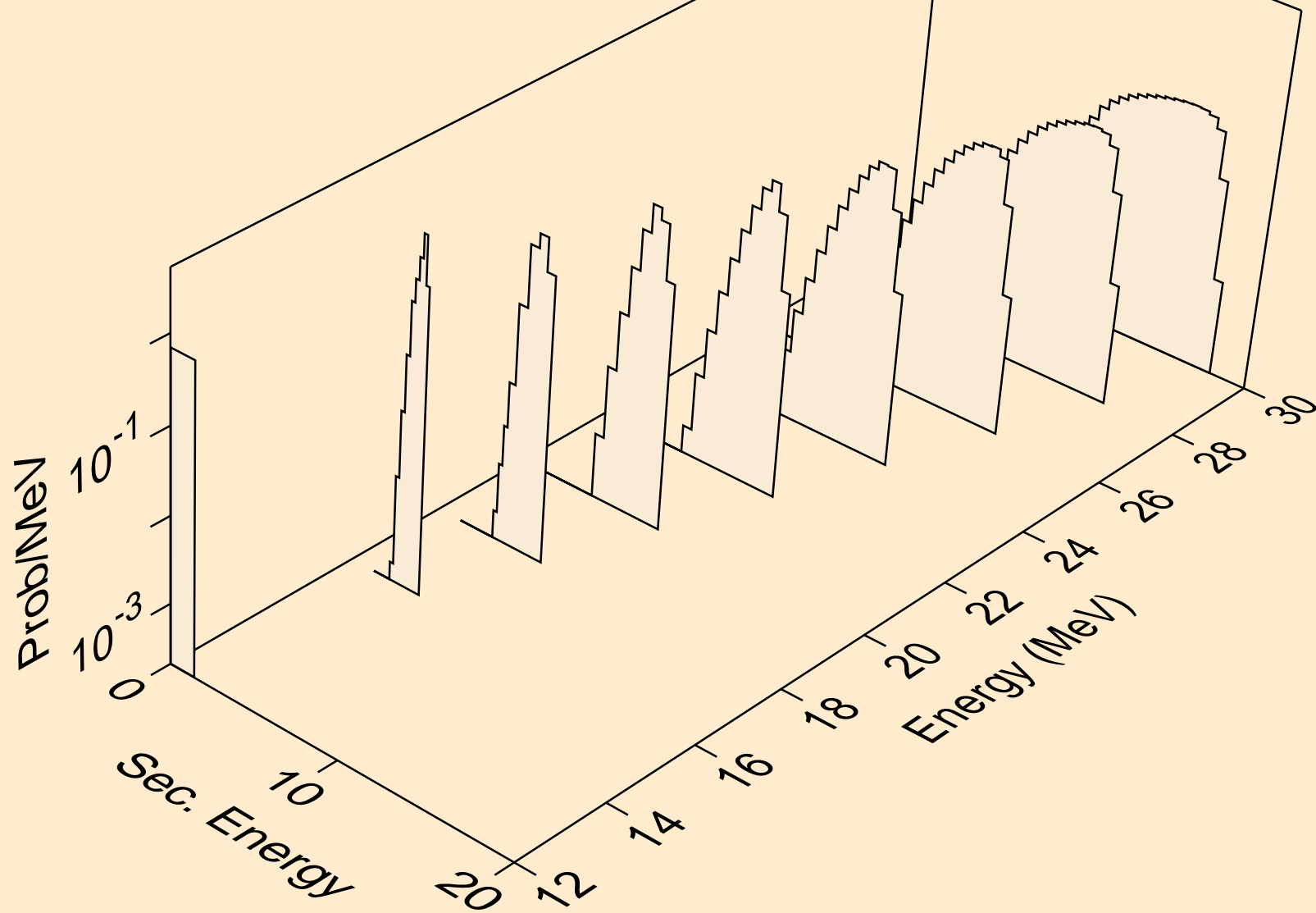

OS184 NEUTRON ACER TENDL-2023 LIBRARY; T=0.K
deuterons from (n,d)

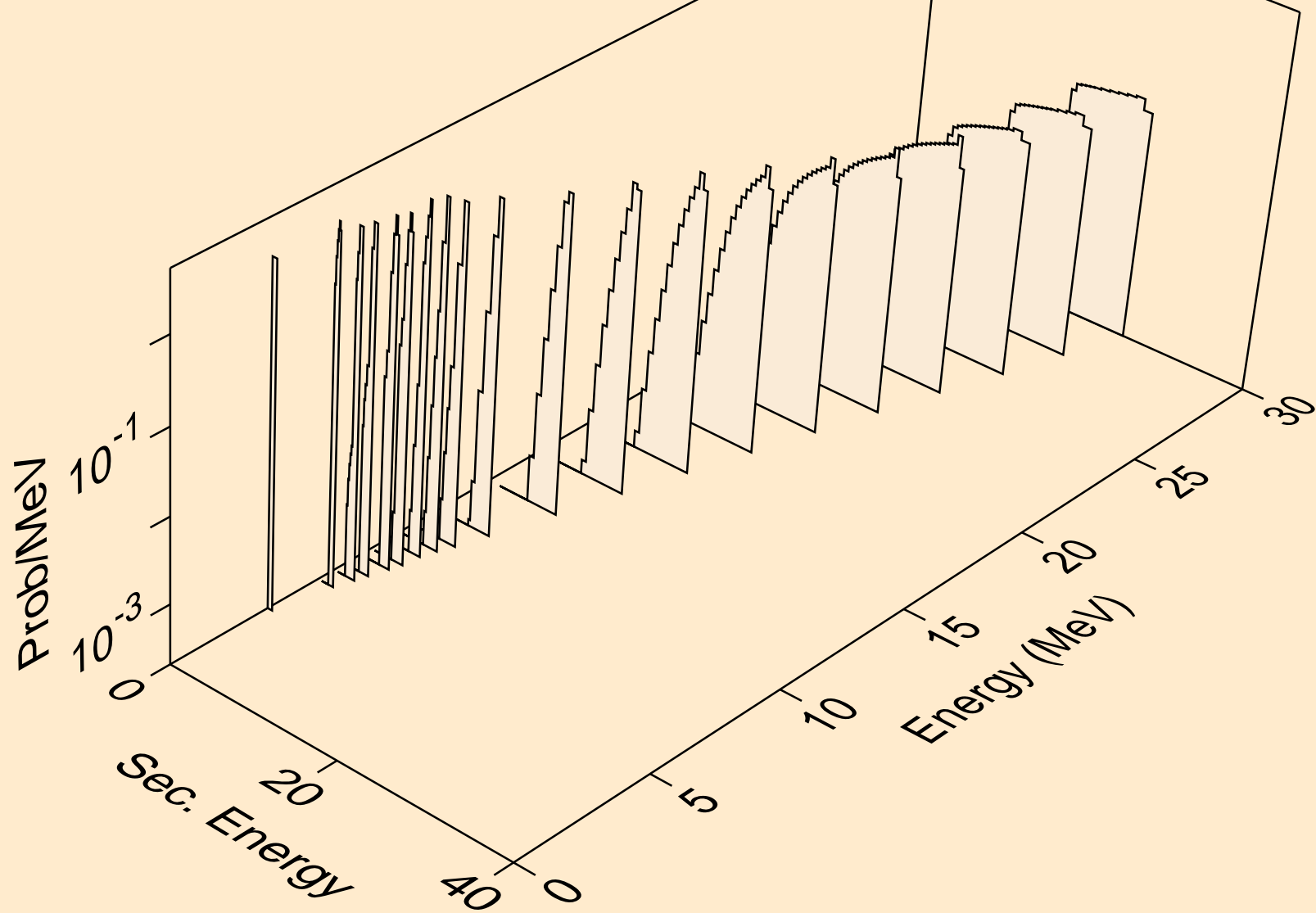

OS184 NEUTRON ACER TENDL-2023 LIBRARY; T=0.K
deuterons from (n,pd)

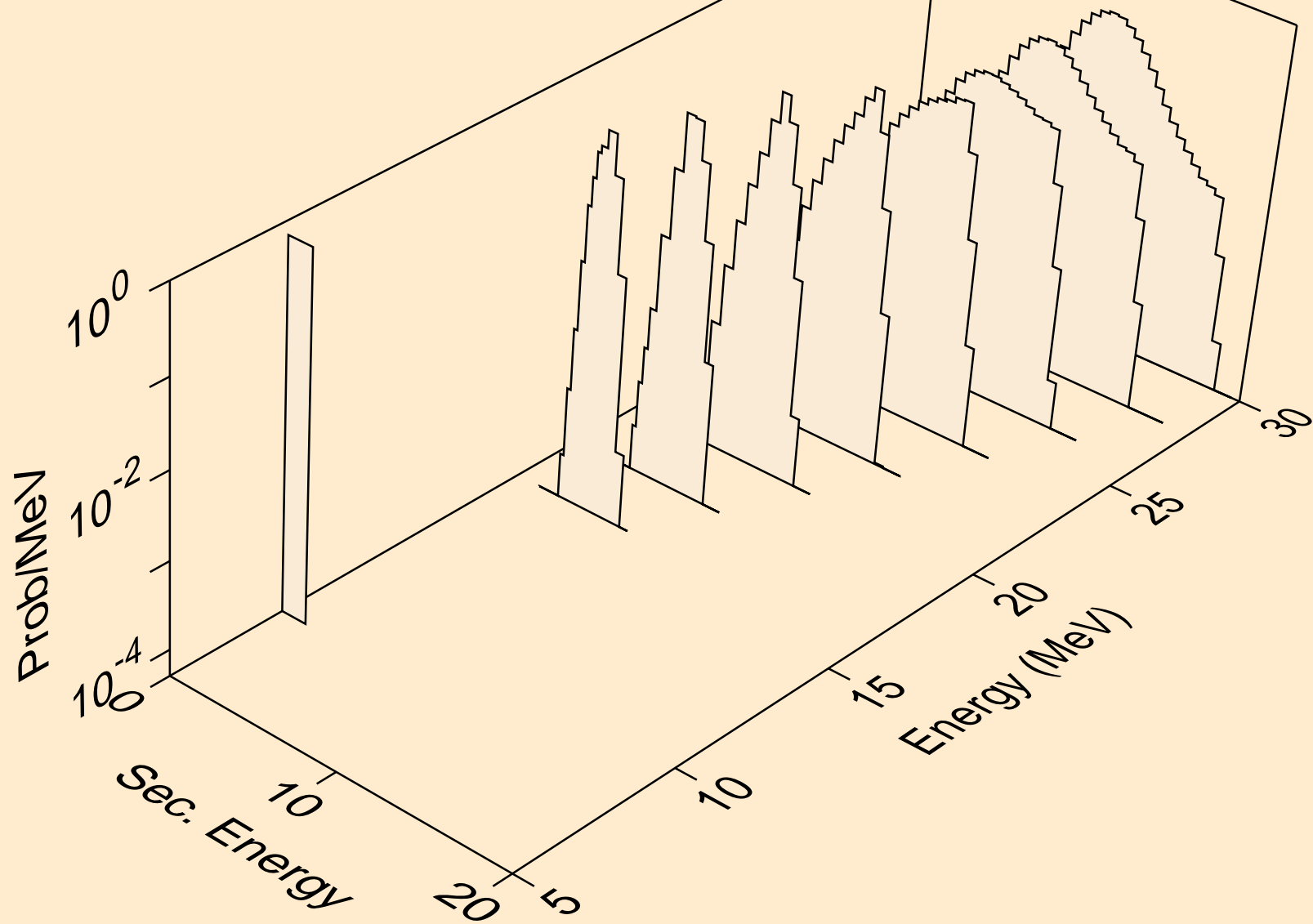

OS184 NEUTRON ACER TENDL-2023 LIBRARY; T=0.K
deuterons from (n,da)

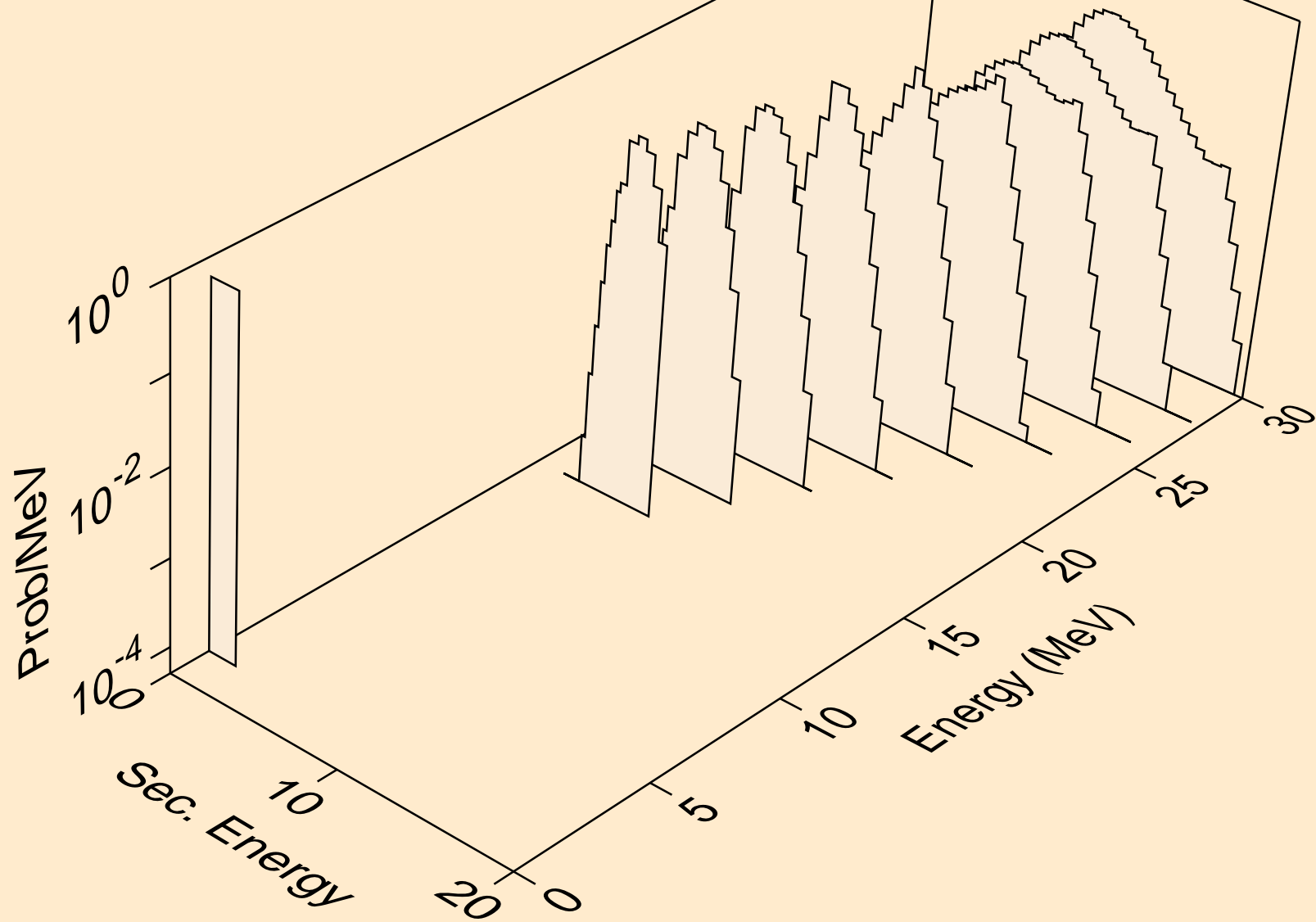

OS184 NEUTRON ACER TENDL-2023 LIBRARY; T=0.K
tritons from (n,x)

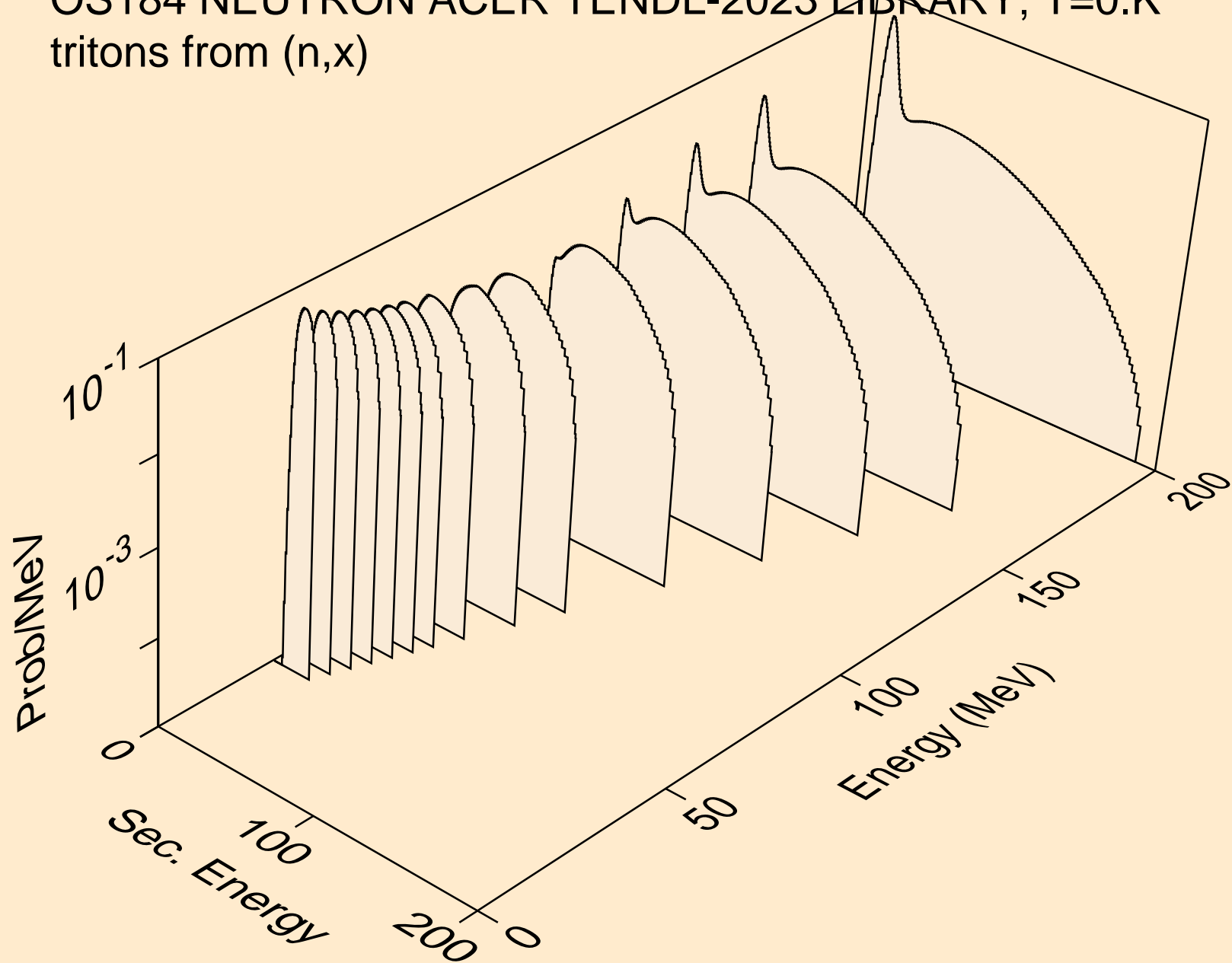

OS184 NEUTRON ACER TENDL-2023 LIBRARY; T=0.K
tritons from (n,n*)t

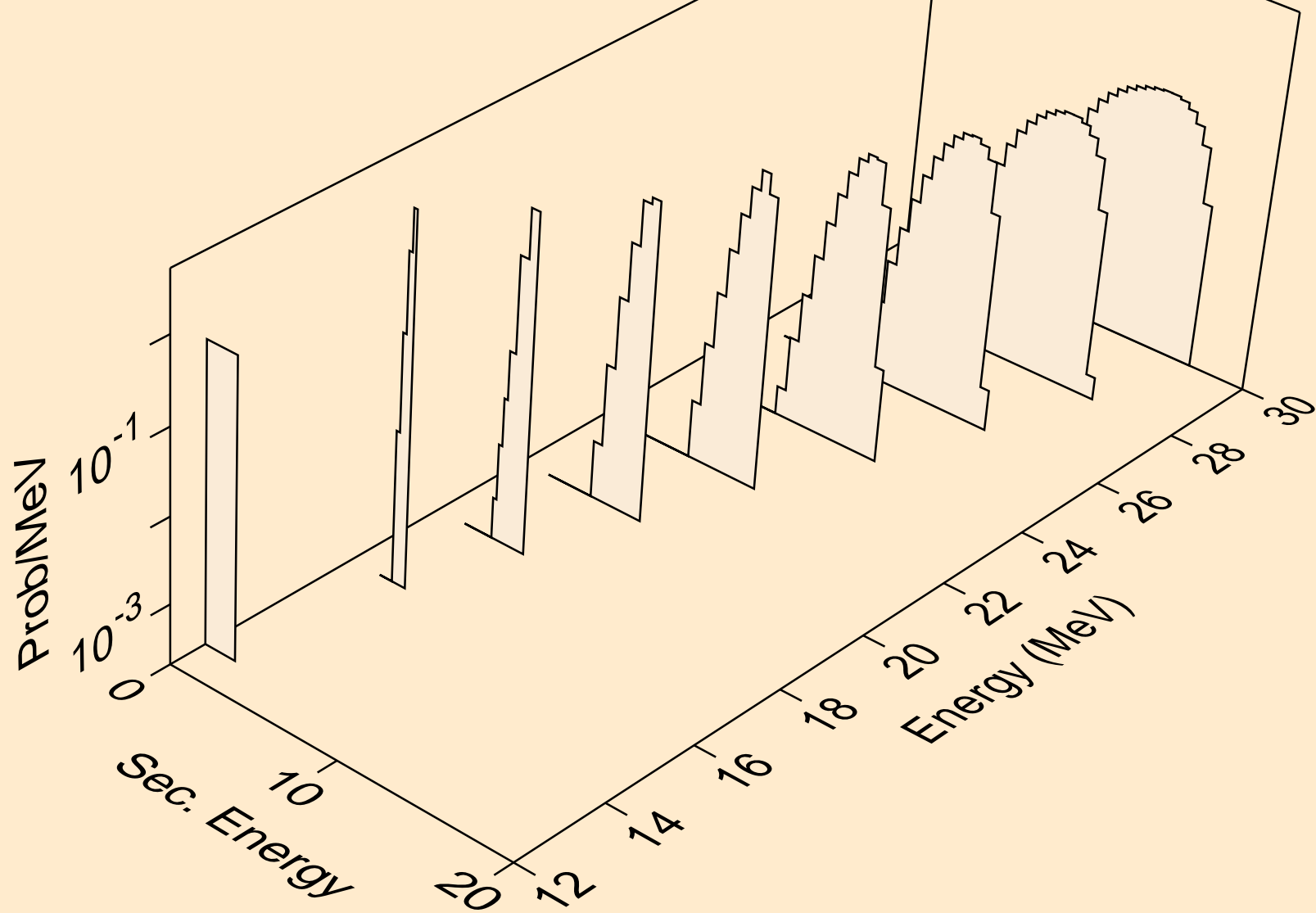

OS184 NEUTRON ACER TENDL-2023 LIBRARY; T=0.K
tritons from (n,t)

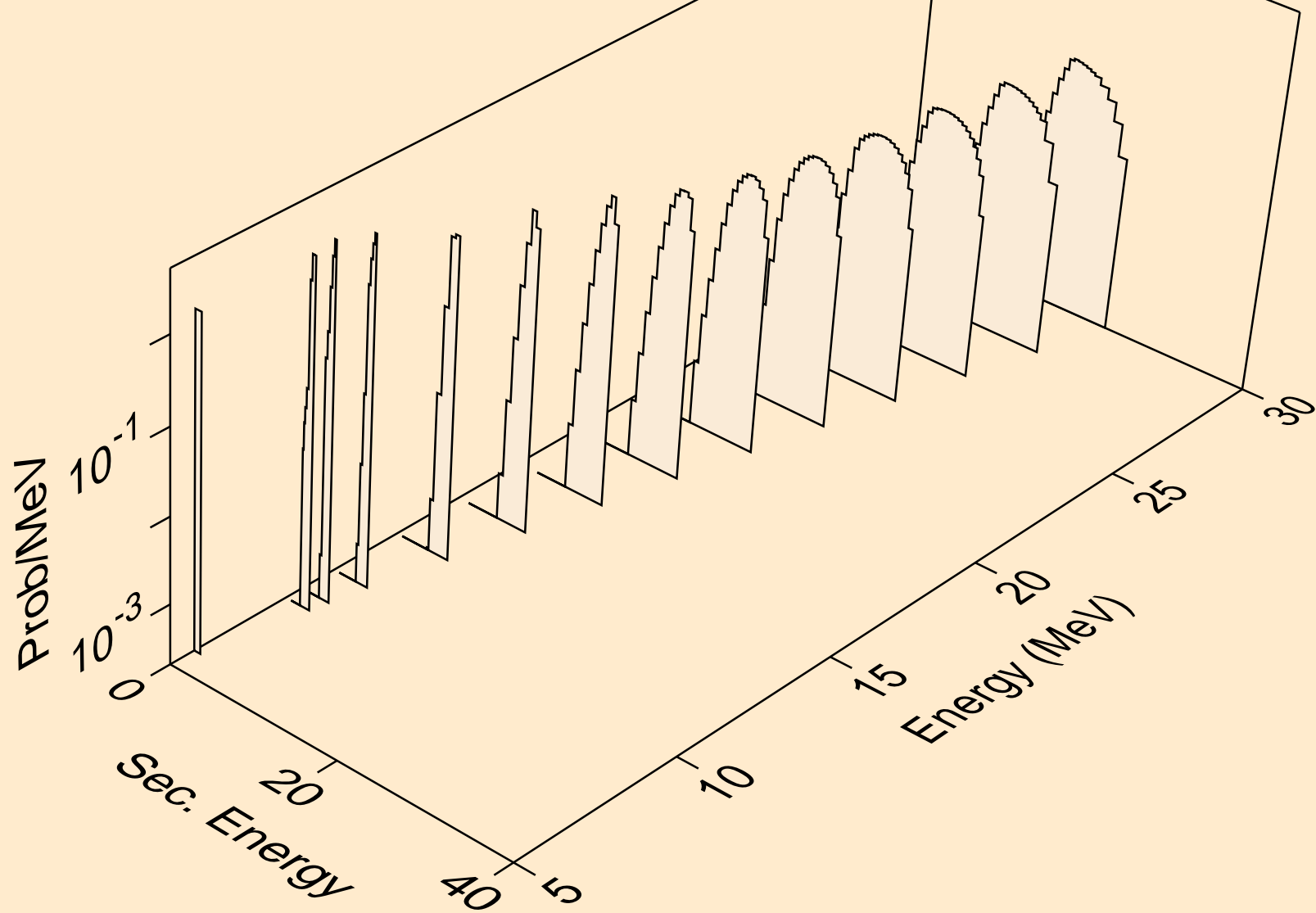

OS184 NEUTRON ACER TENDL-2023 LIBRARY; T=0.K
tritons from (n,pt)

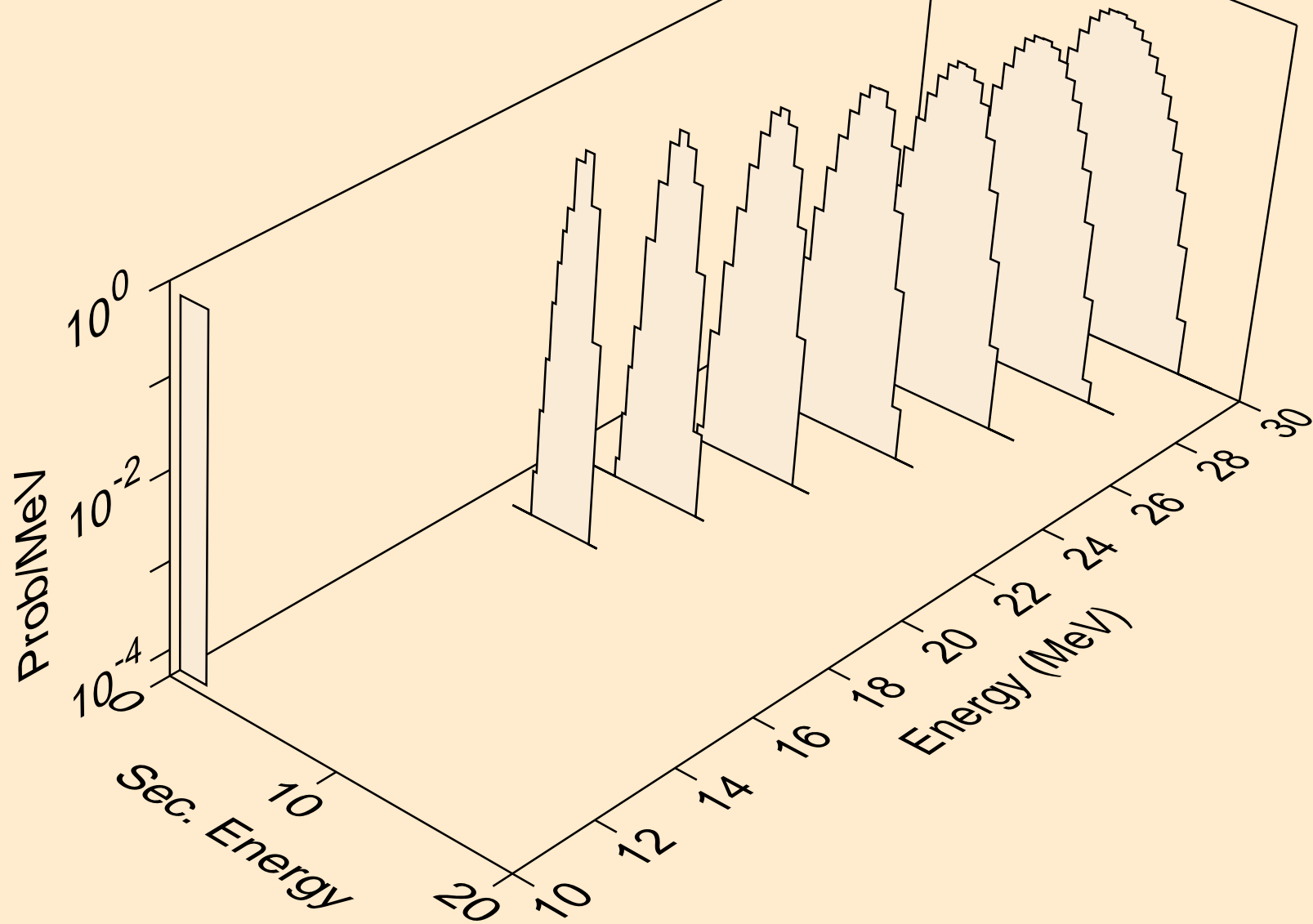

OS184 NEUTRON ACER TENDL-2023 LIBRARY; T=0.K
he3s from (n,x)

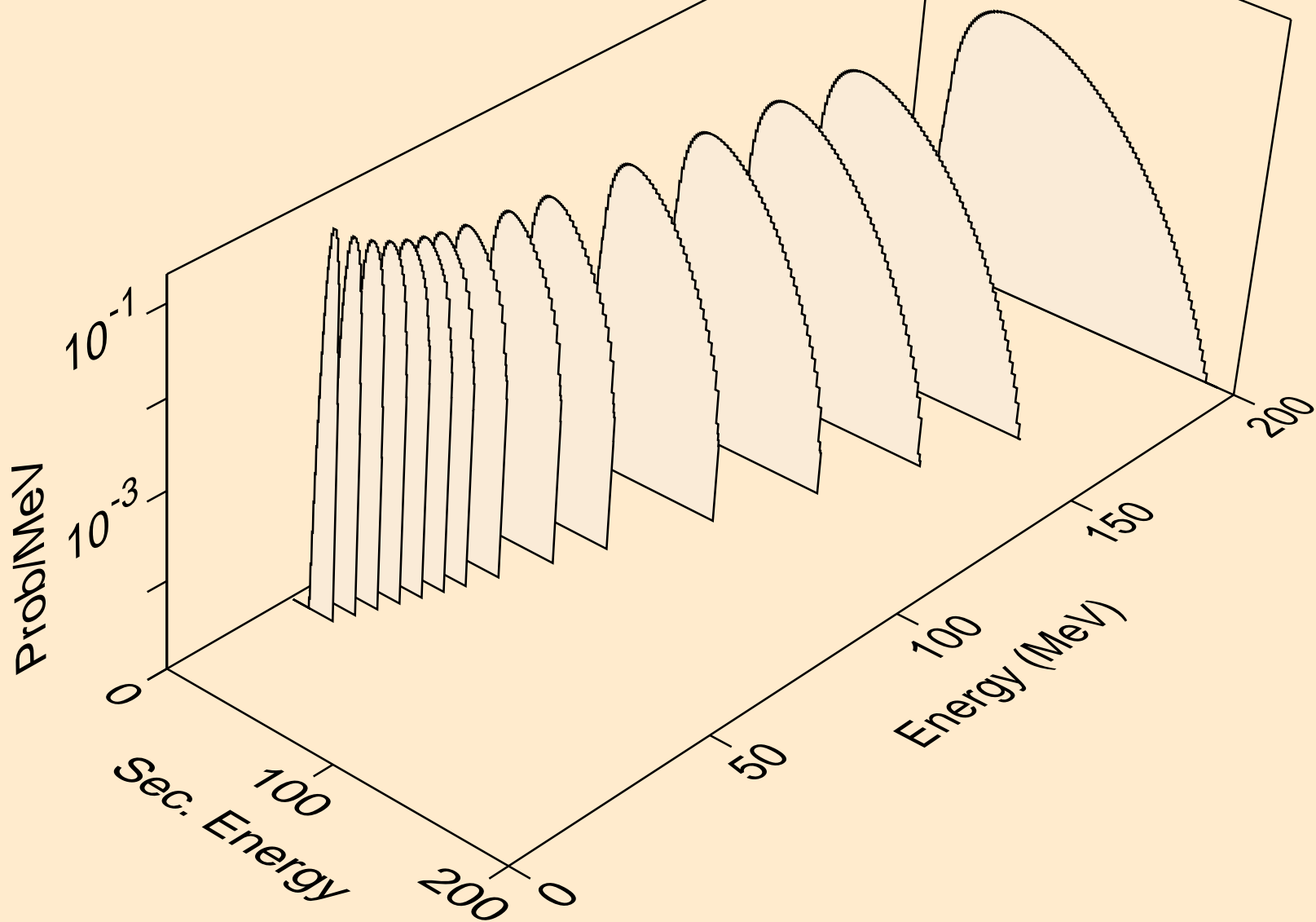

OS184 NEUTRON ACER TENDL-2023 LIBRARY; T=0.K
he3s from (n,n*)he3

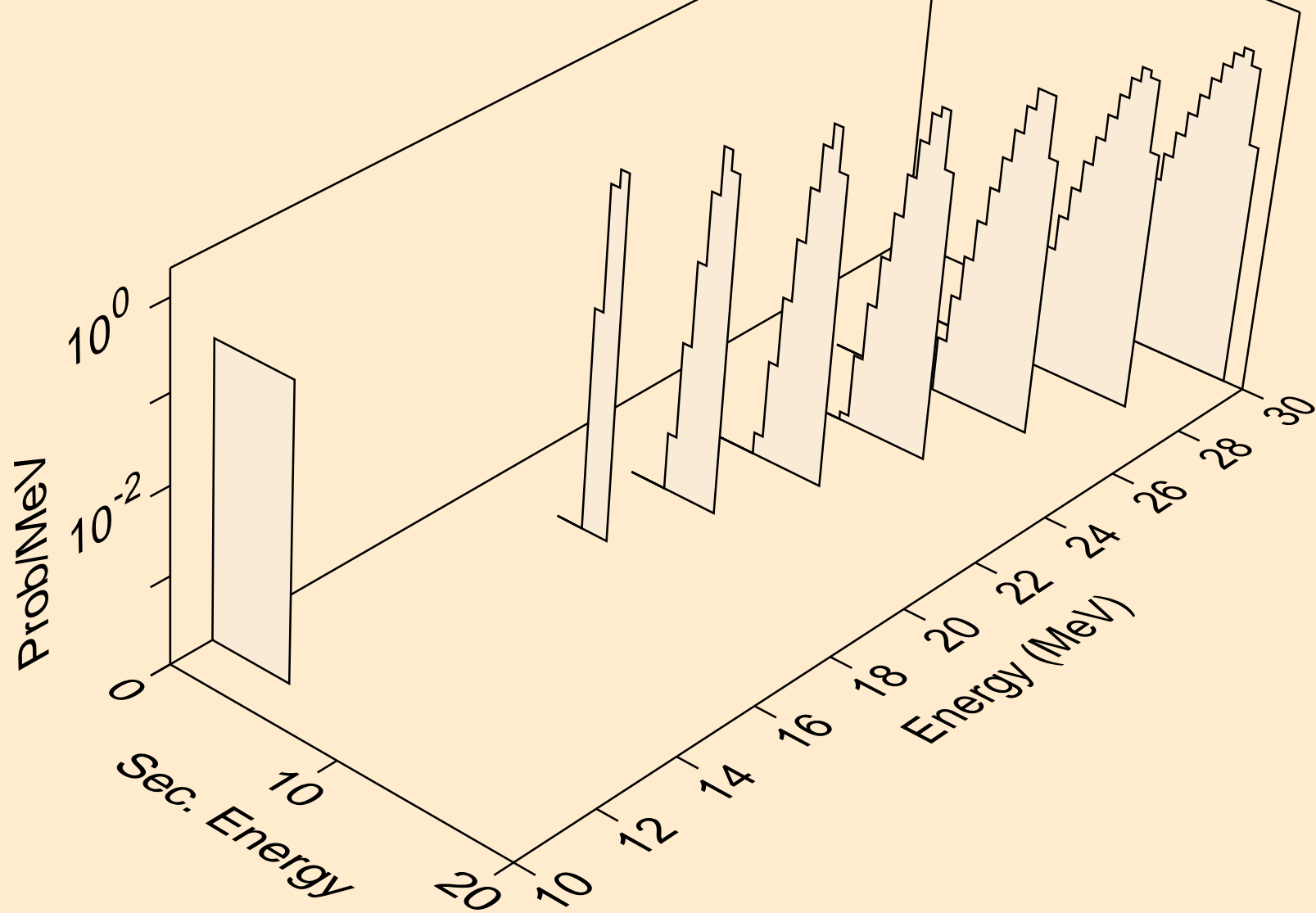

OS184 NEUTRON ACER TENDL-2023 LIBRARY; T=0.K
he3s from (n,he3)

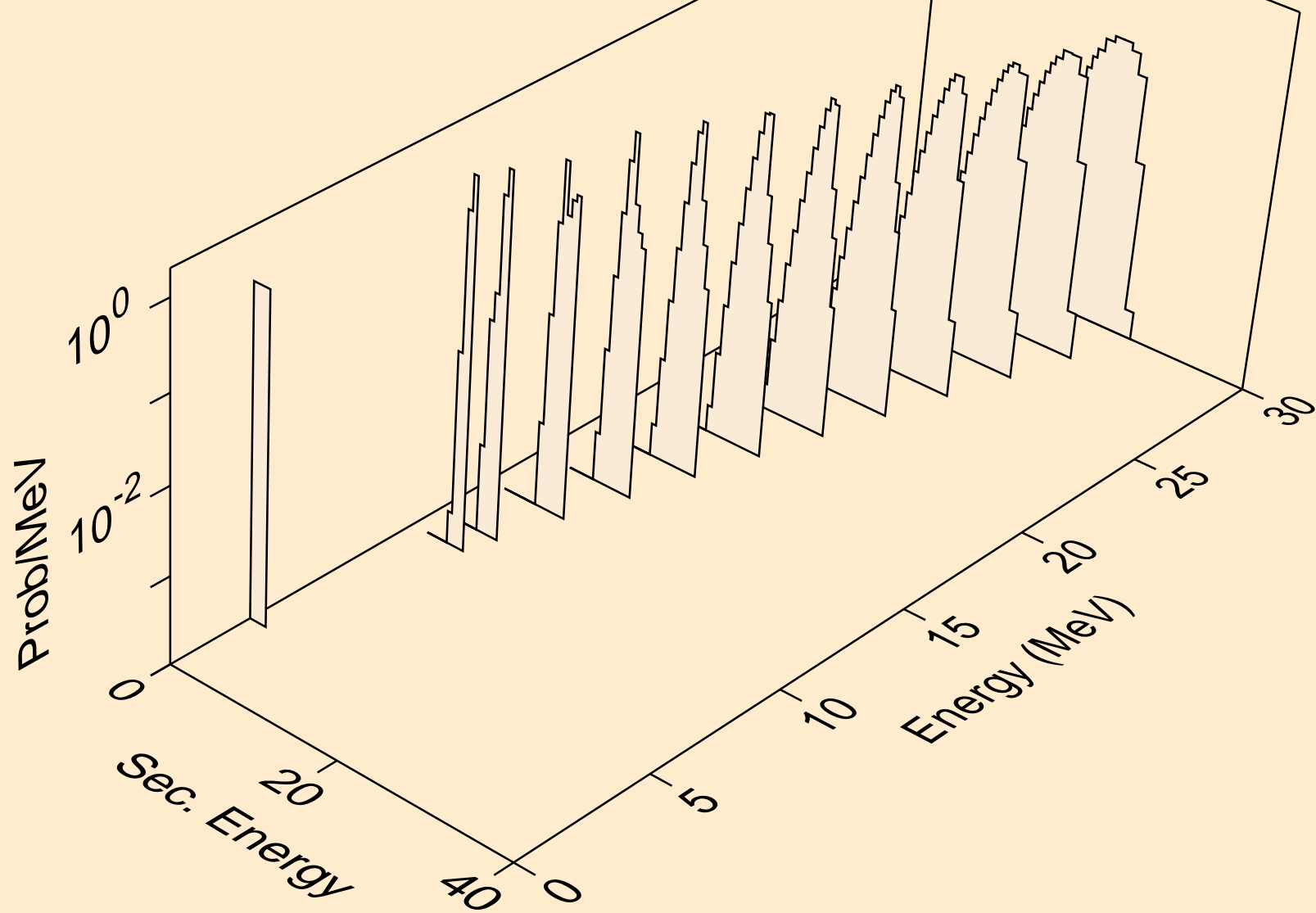

OS184 NEUTRON ACER TENDL-2023 LIBRARY; T=0.K
alphas from (n,x)

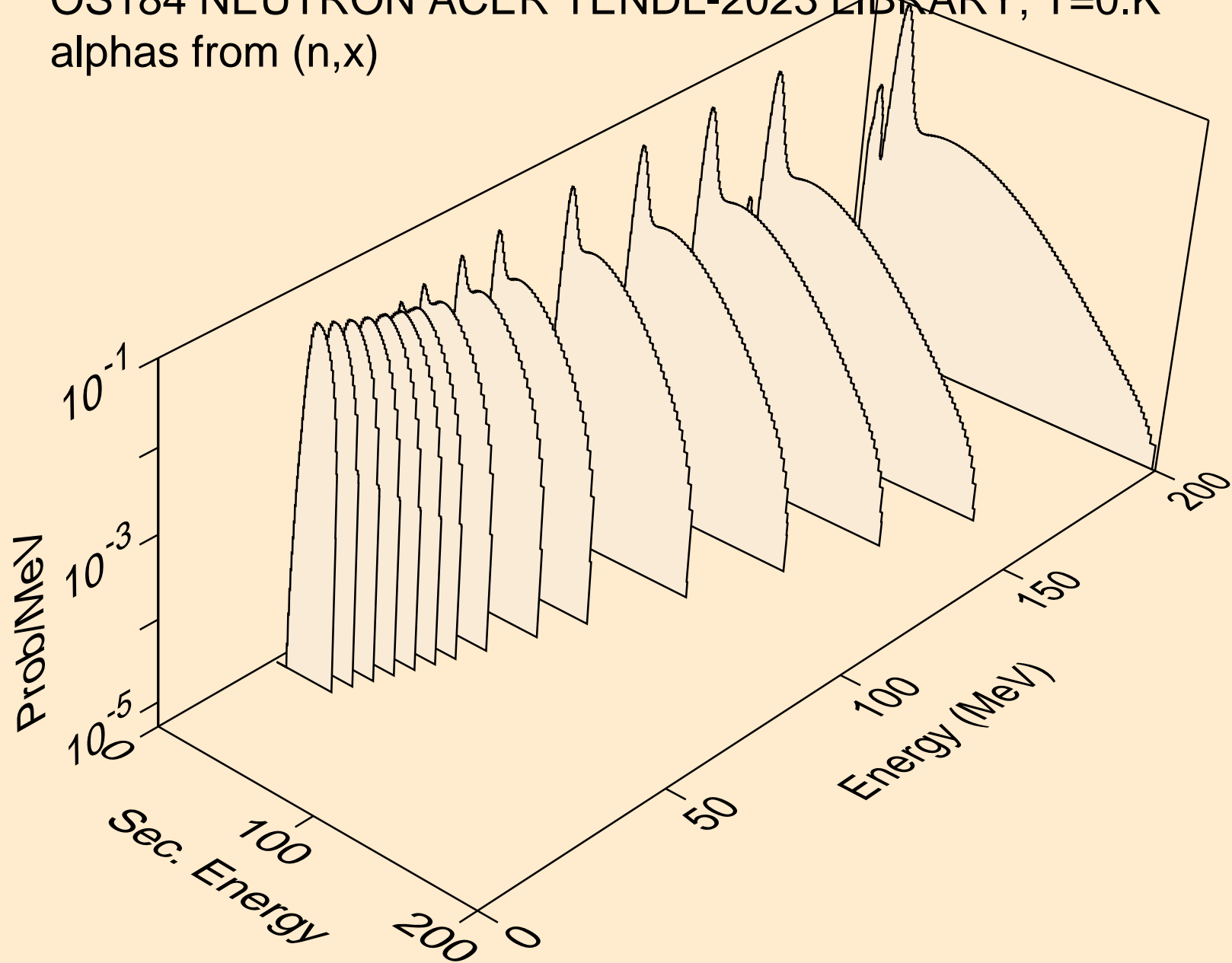

OS184 NEUTRON ACER TENDL-2023 LIBRARY; T=0.K
alphas from (n,n*)a

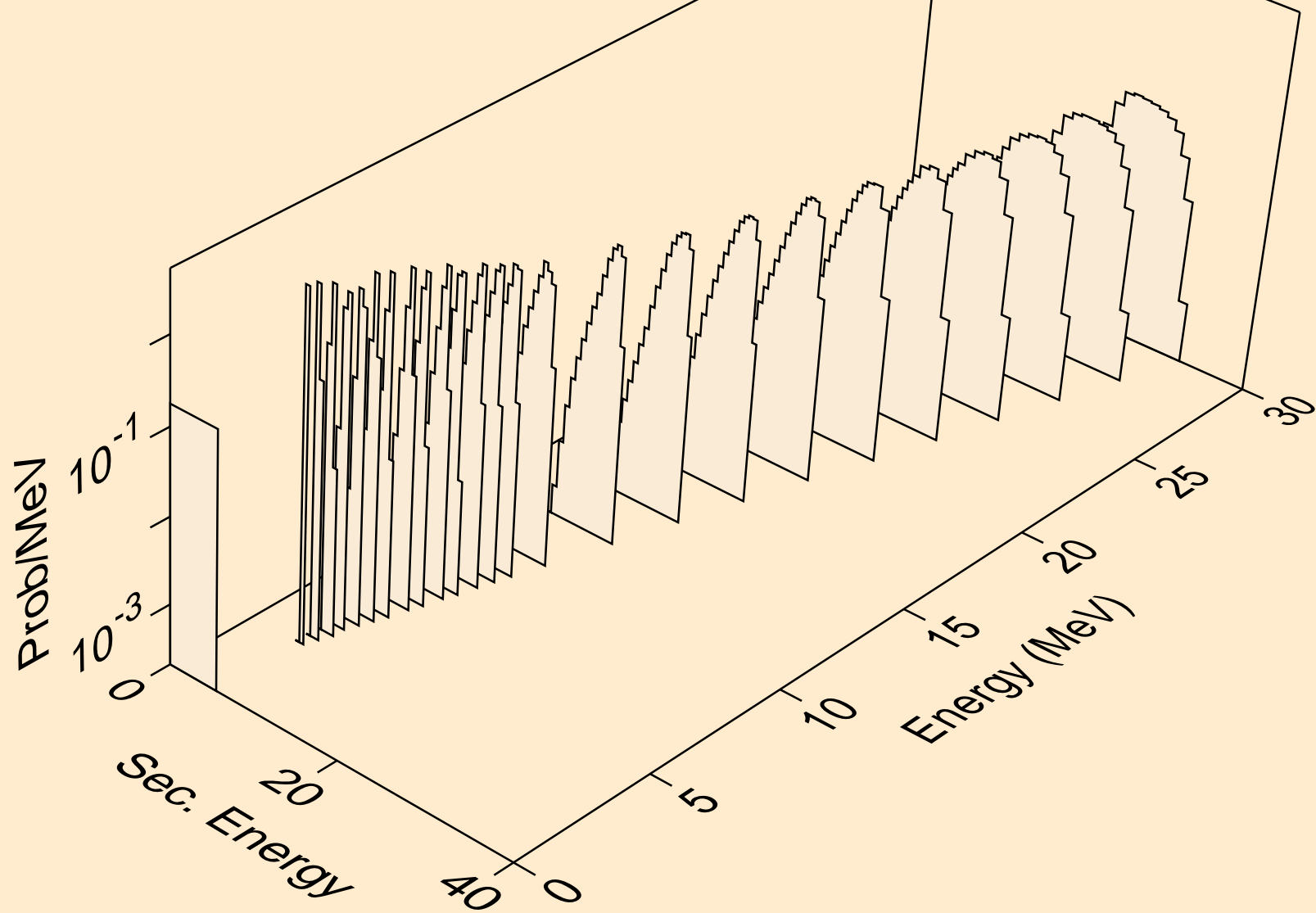

OS184 NEUTRON ACER TENDL-2023 LIBRARY; T=0.K
alphas from (n,2n)a

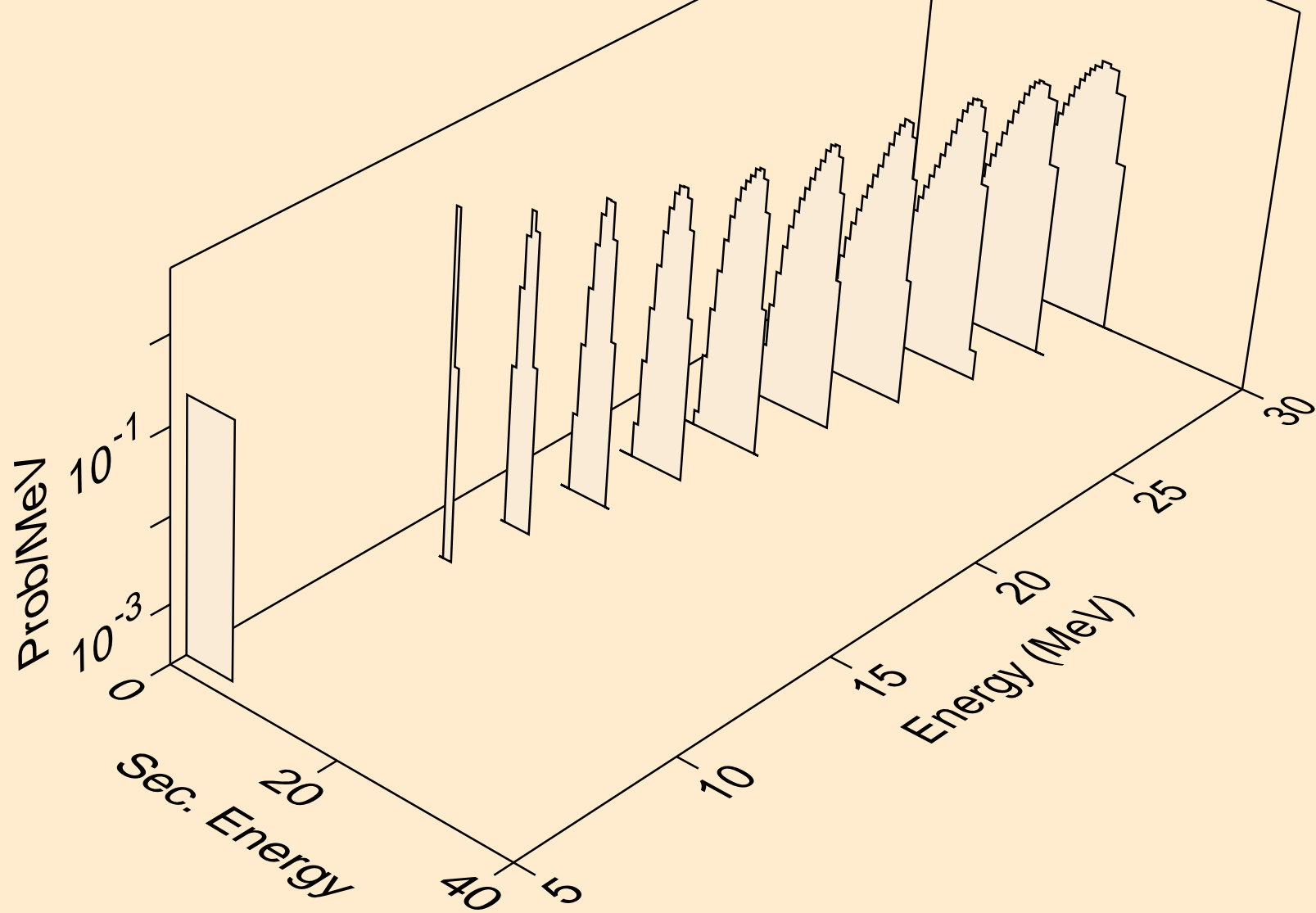

OS184 NEUTRON ACER TENDL-2023 LIBRARY; T=0.K
alphas from (n,3n)a

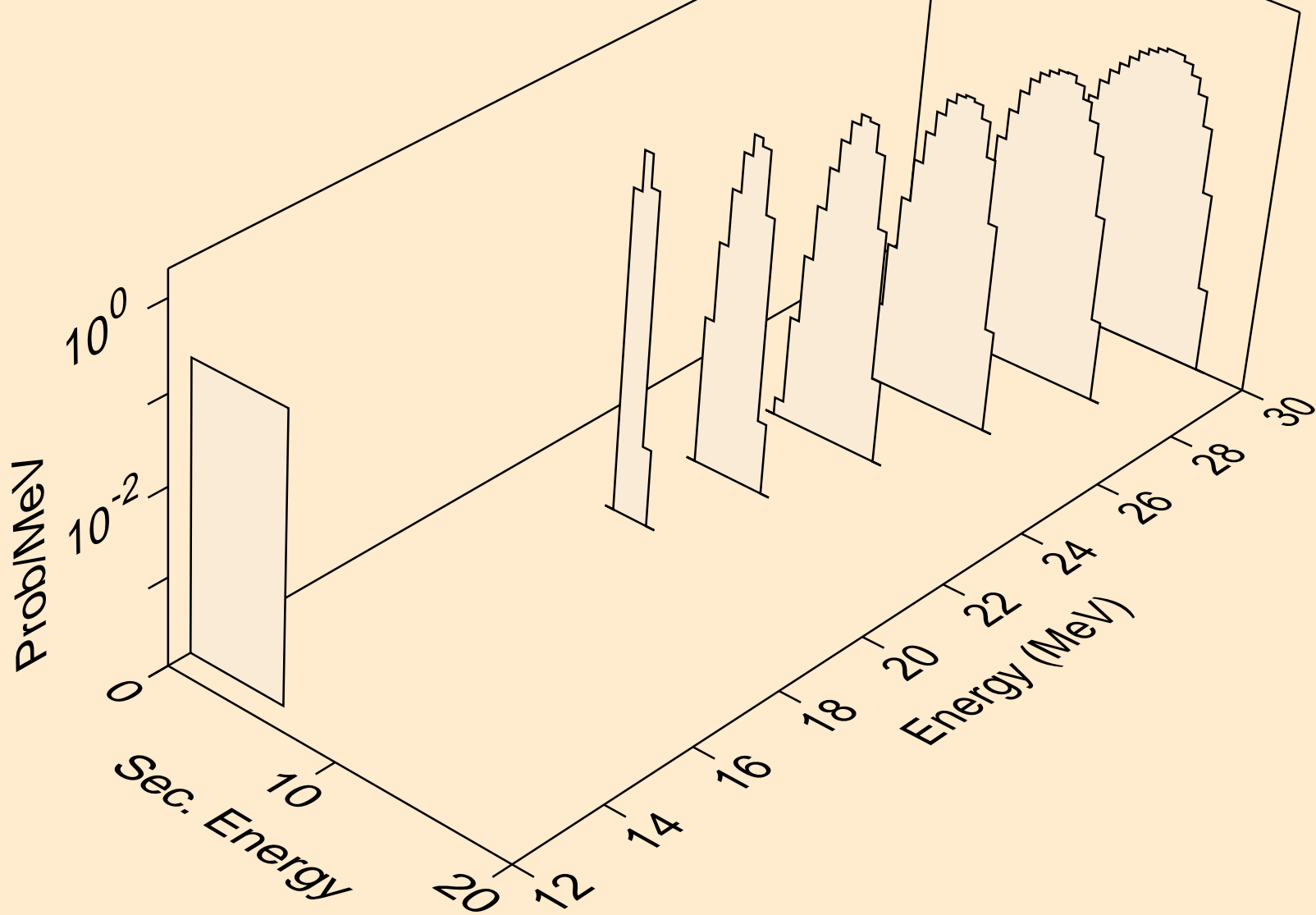

OS184 NEUTRON ACER TENDL-2023 LIBRARY; T=0.K
alphas from (n,n*)2a

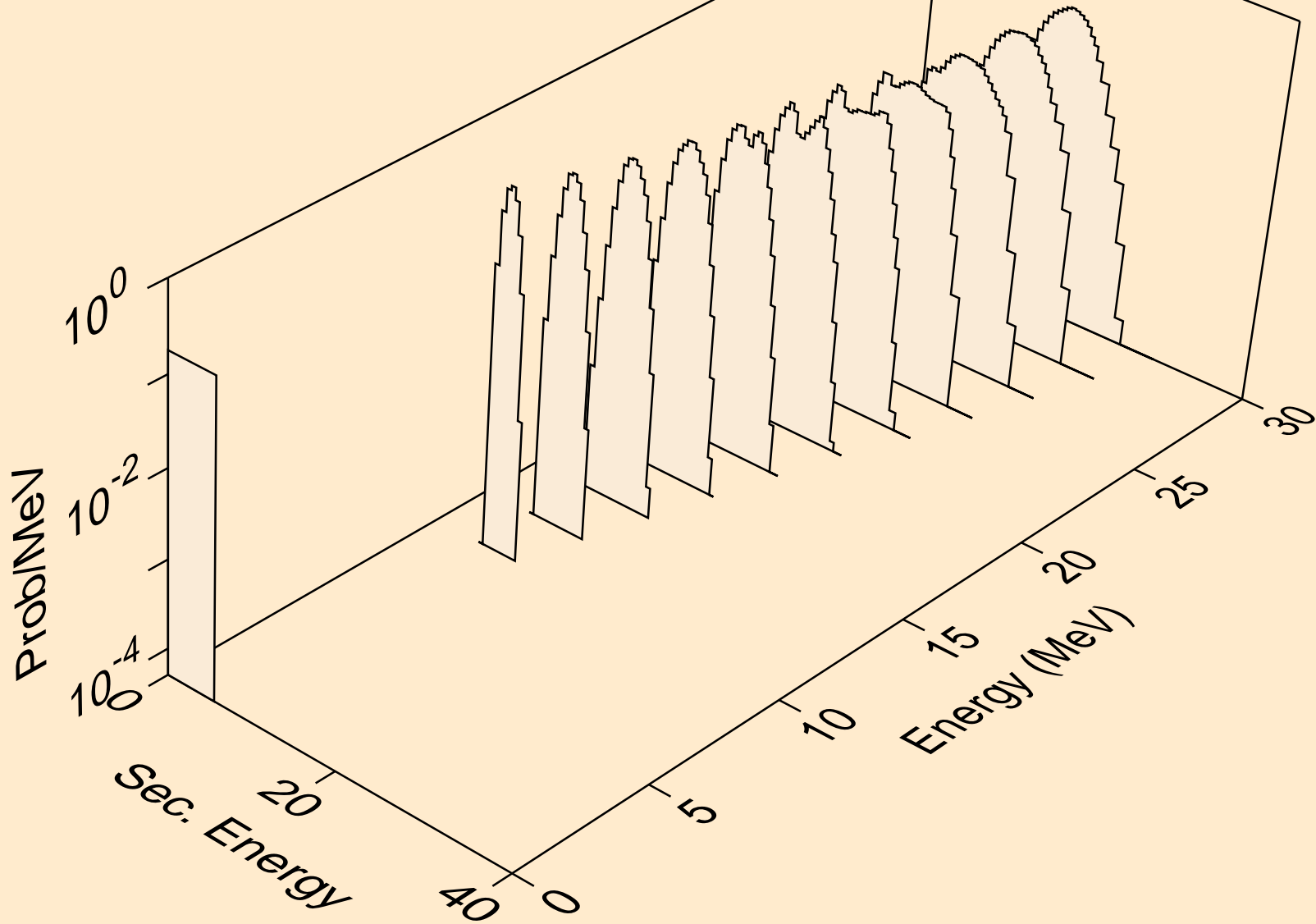

OS184 NEUTRON ACER TENDL-2023 LIBRARY; T=0.K
alphas from (n,npa)

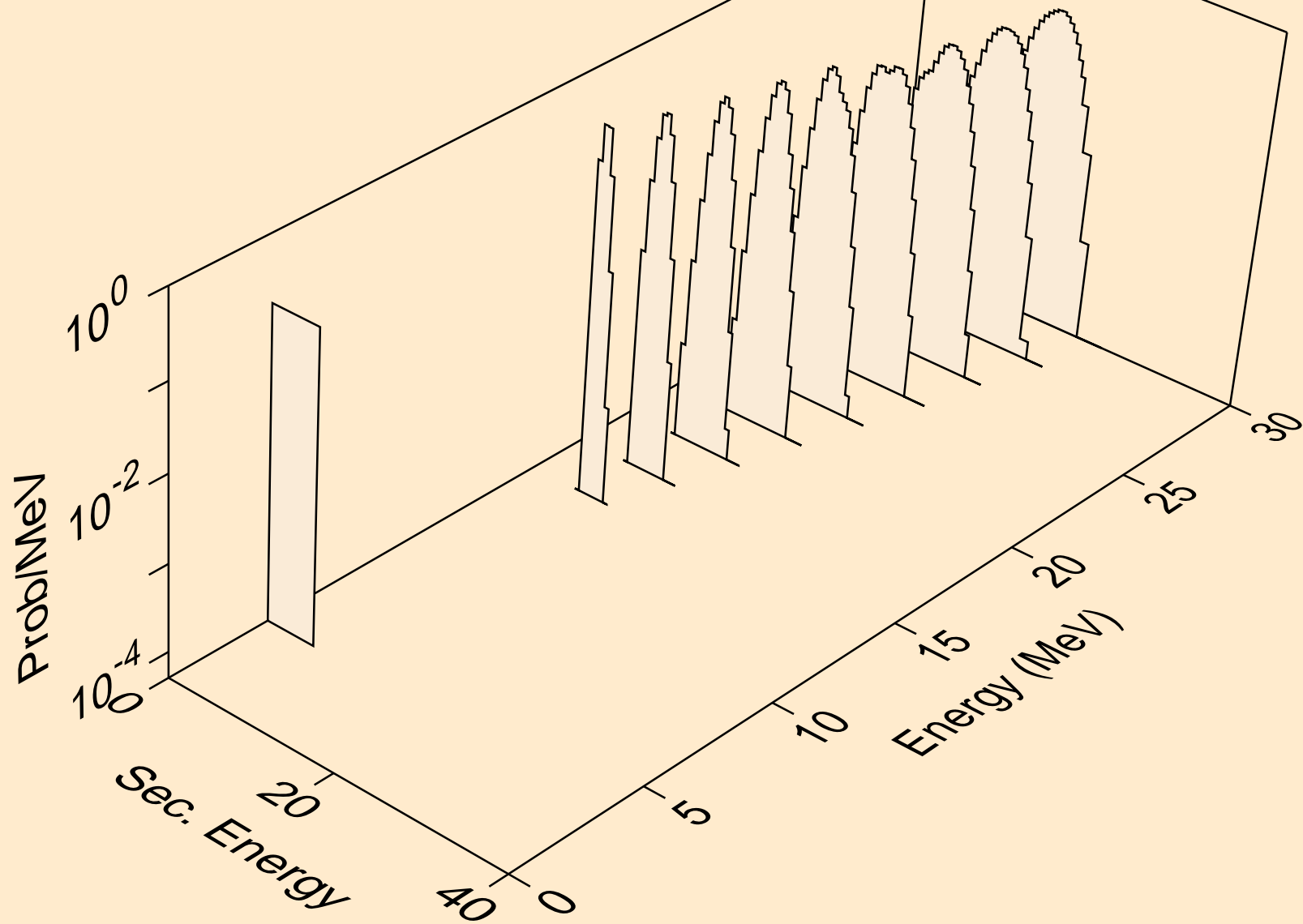

OS184 NEUTRON ACER TENDL-2023 LIBRARY; T=0.K
alphas from (n,a)

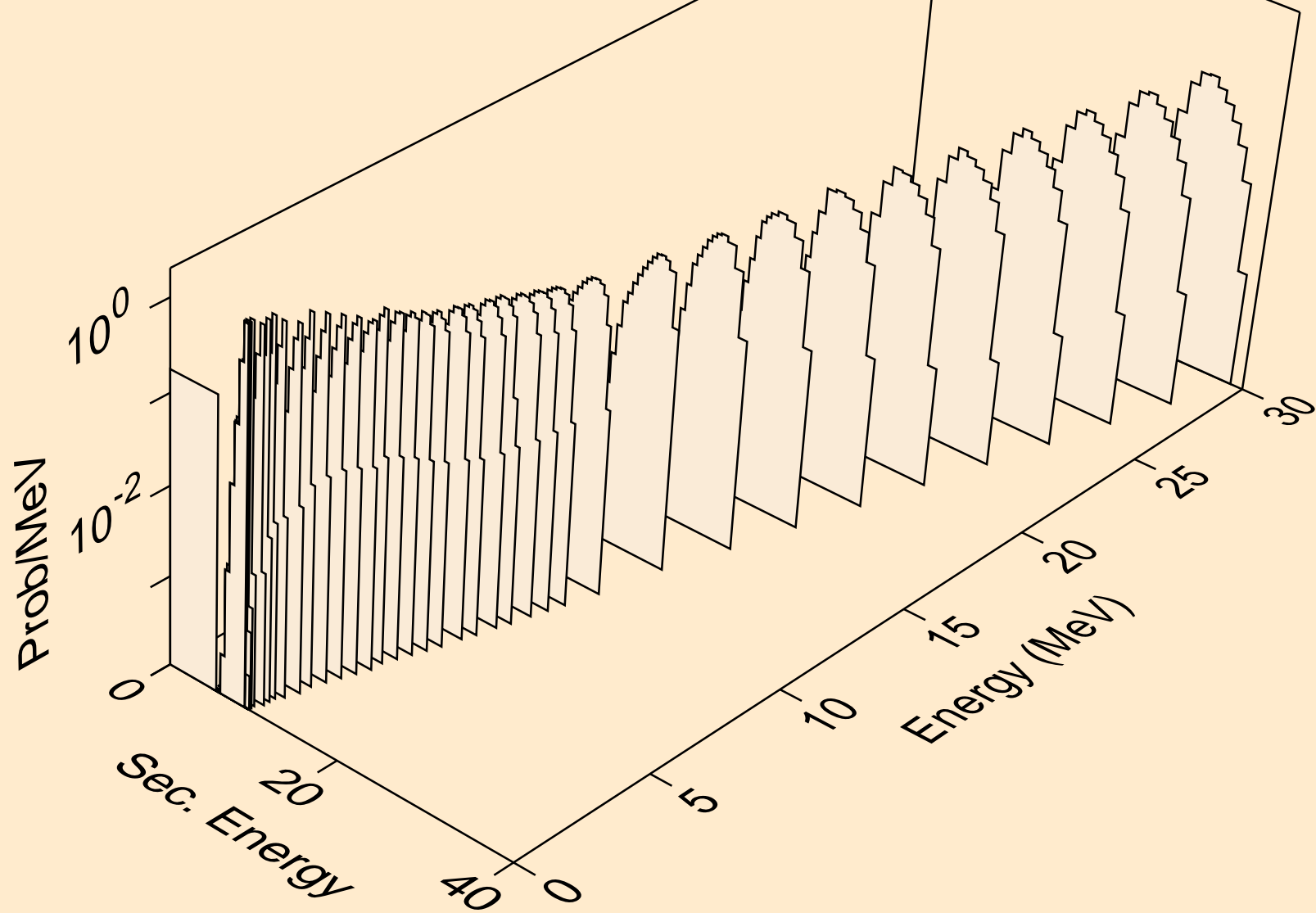

OS184 NEUTRON ACER TENDL-2023 LIBRARY; T=0.K
alphas from (n,2a)

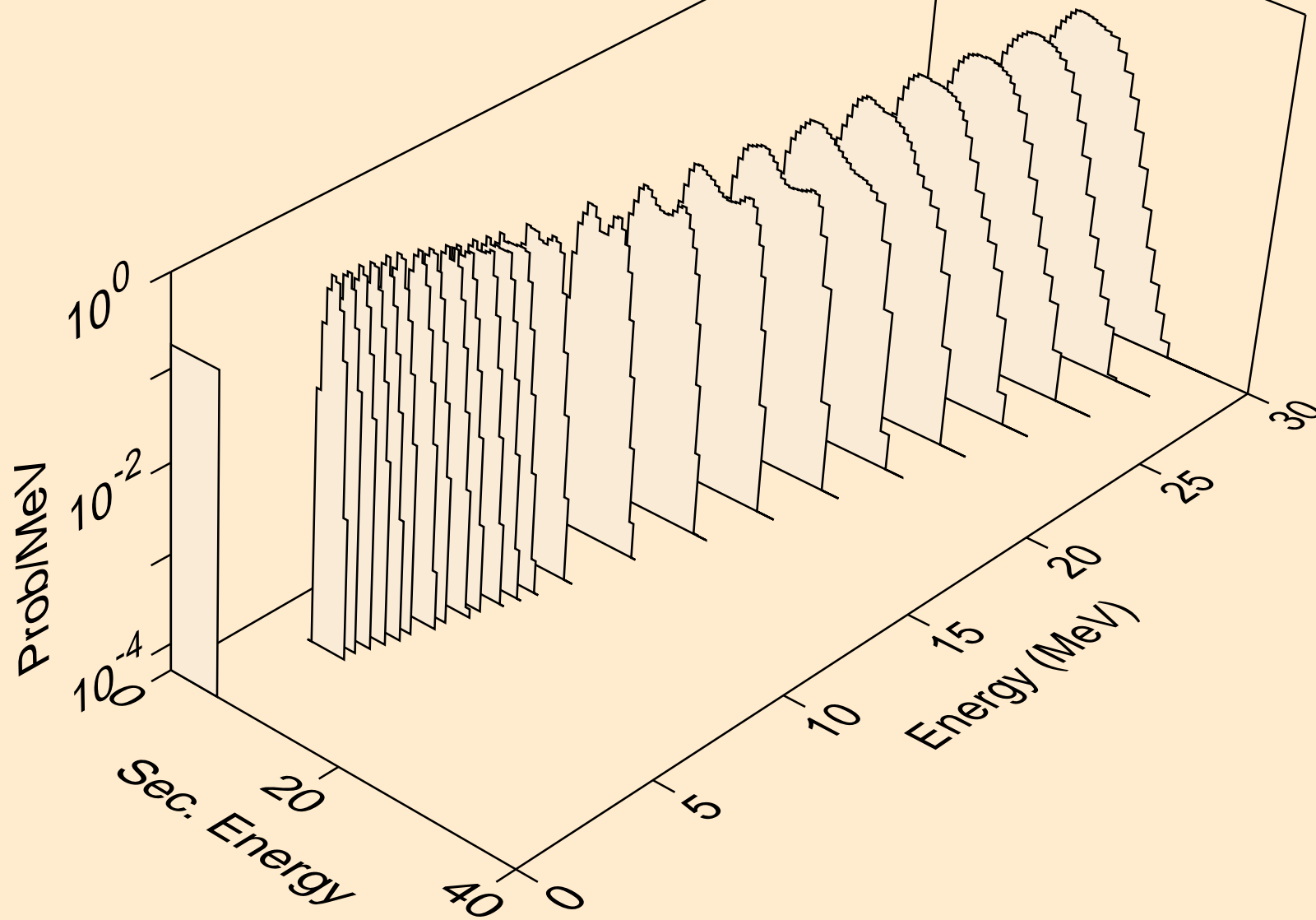

OS184 NEUTRON ACER TENDL-2023 LIBRARY; T=0.K
alphas from (n,pa)

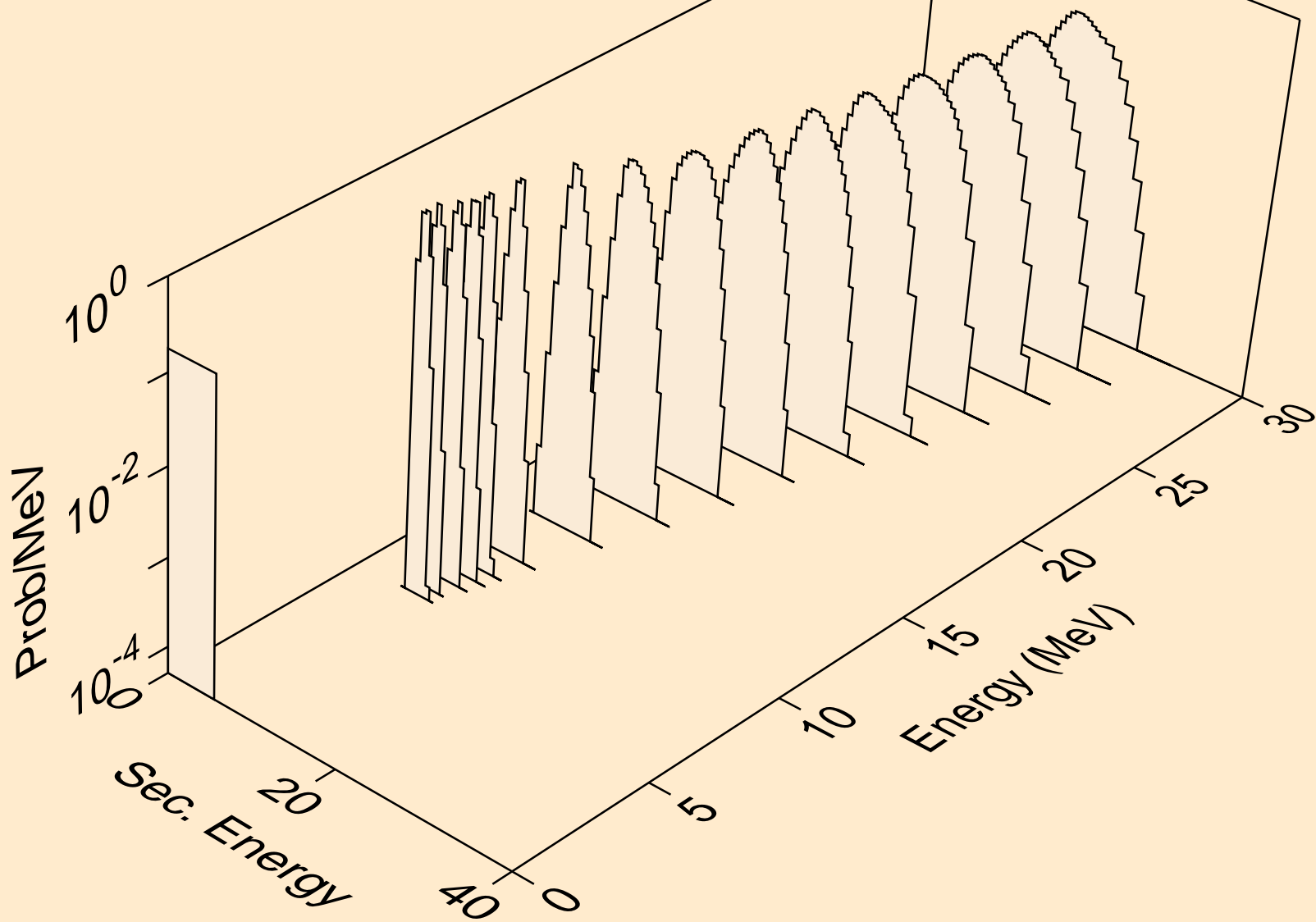

OS184 NEUTRON ACER TENDL-2023 LIBRARY; T=0.K
alphas from (n,da)

