

# OS201 NEUTRON ACER TENDL-2023 LIBRARY; T=0.K

## Principal cross sections

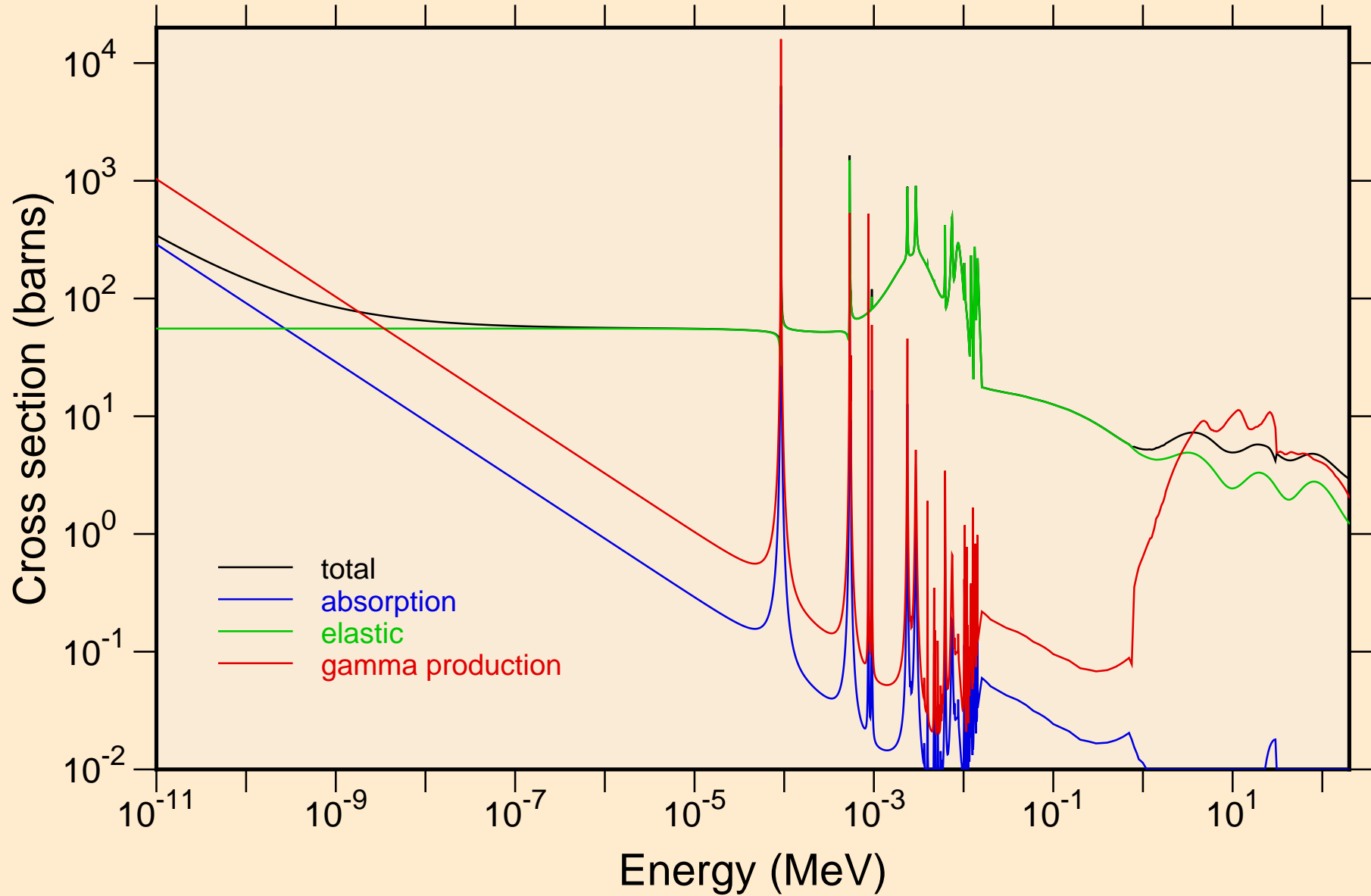

OS201 NEUTRON ACER TENDL-2023 LIBRARY; T=0.K  
resonance total cross section

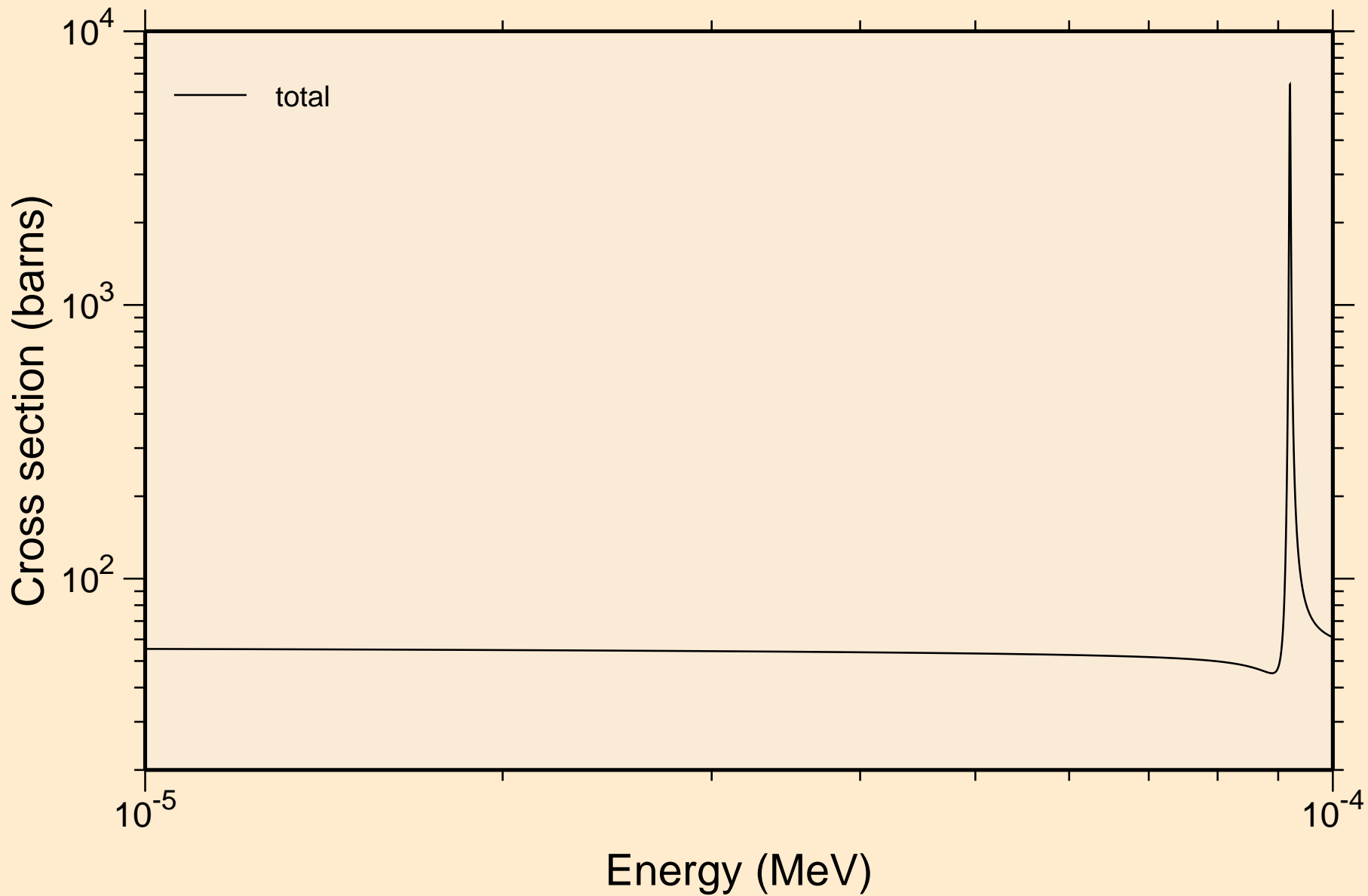

OS201 NEUTRON ACER TENDL-2023 LIBRARY; T=0.K  
resonance total cross section

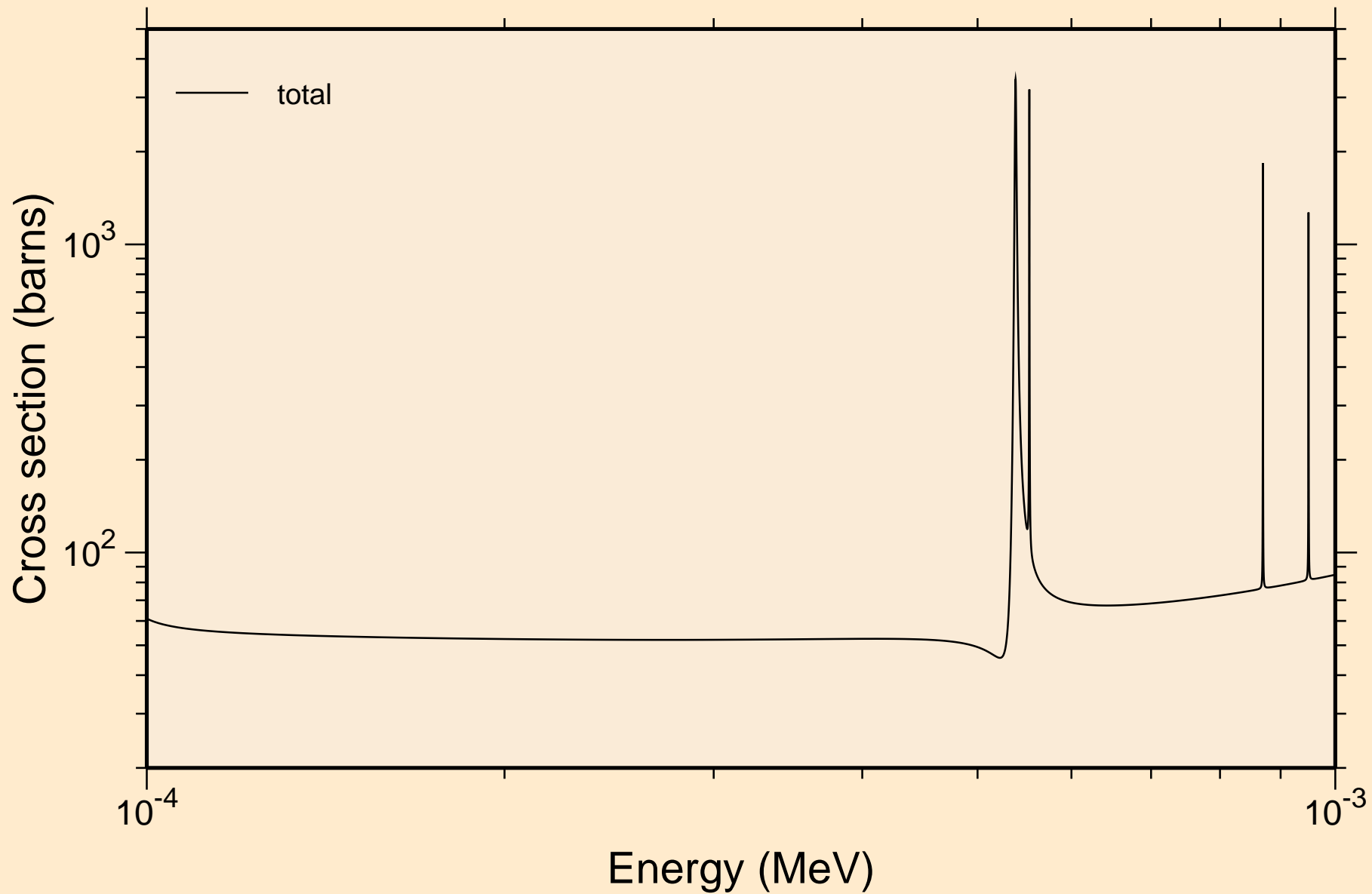

OS201 NEUTRON ACER TENDL-2023 LIBRARY; T=0.K  
resonance total cross section

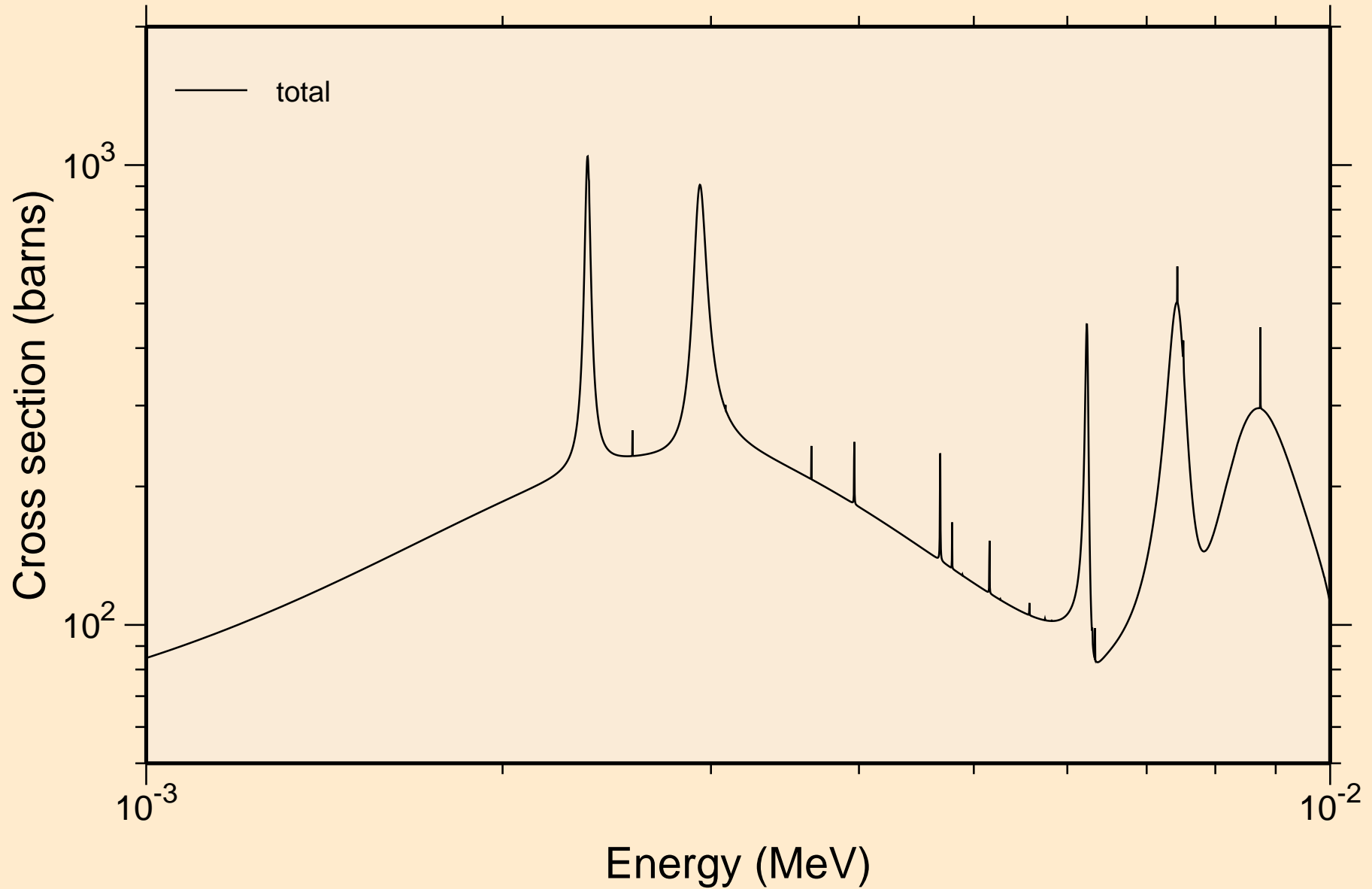

OS201 NEUTRON ACER TENDL-2023 LIBRARY; T=0.K  
resonance total cross section

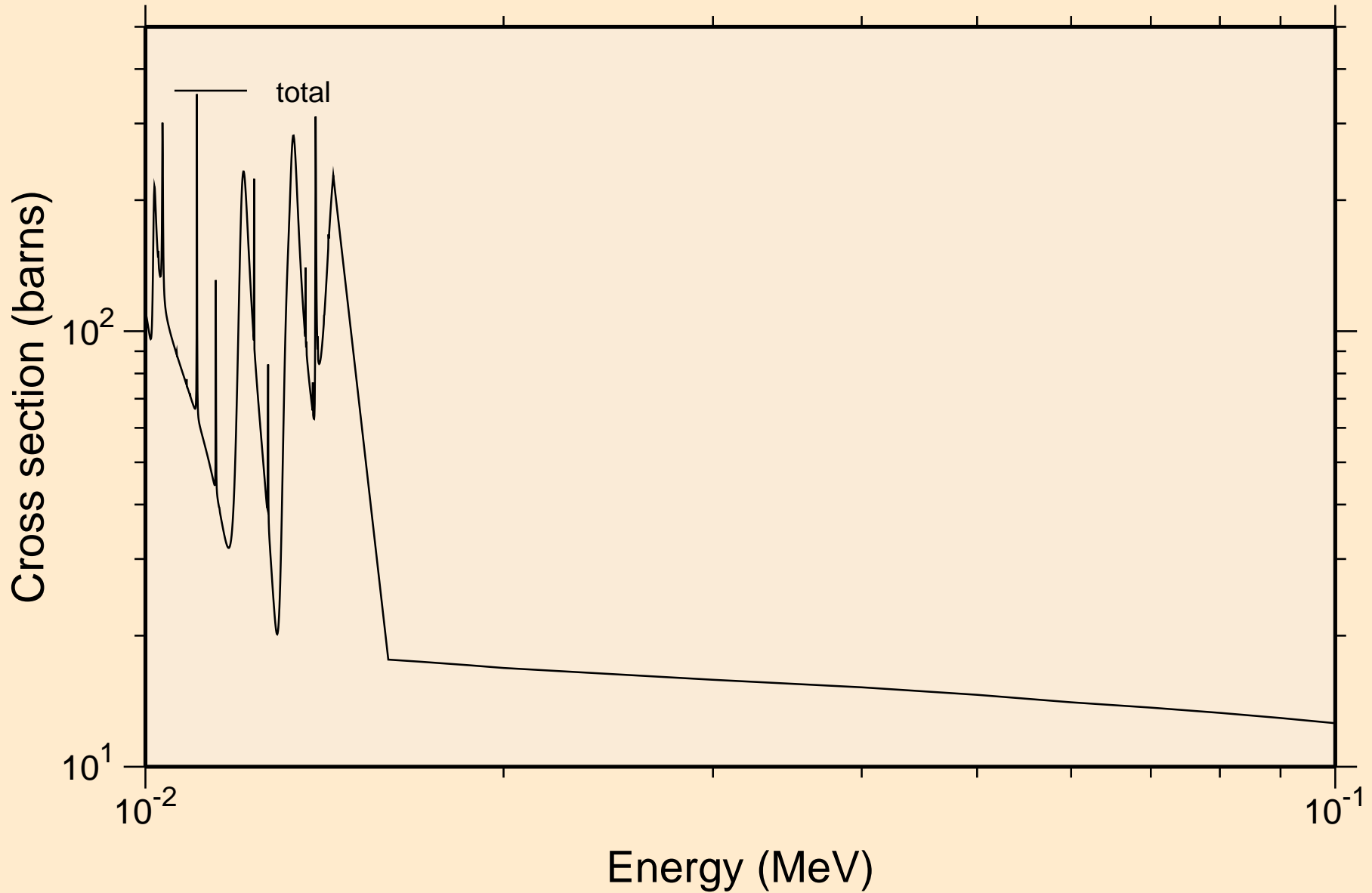

OS201 NEUTRON ACER TENDL-2023 LIBRARY; T=0.K  
resonance total cross section

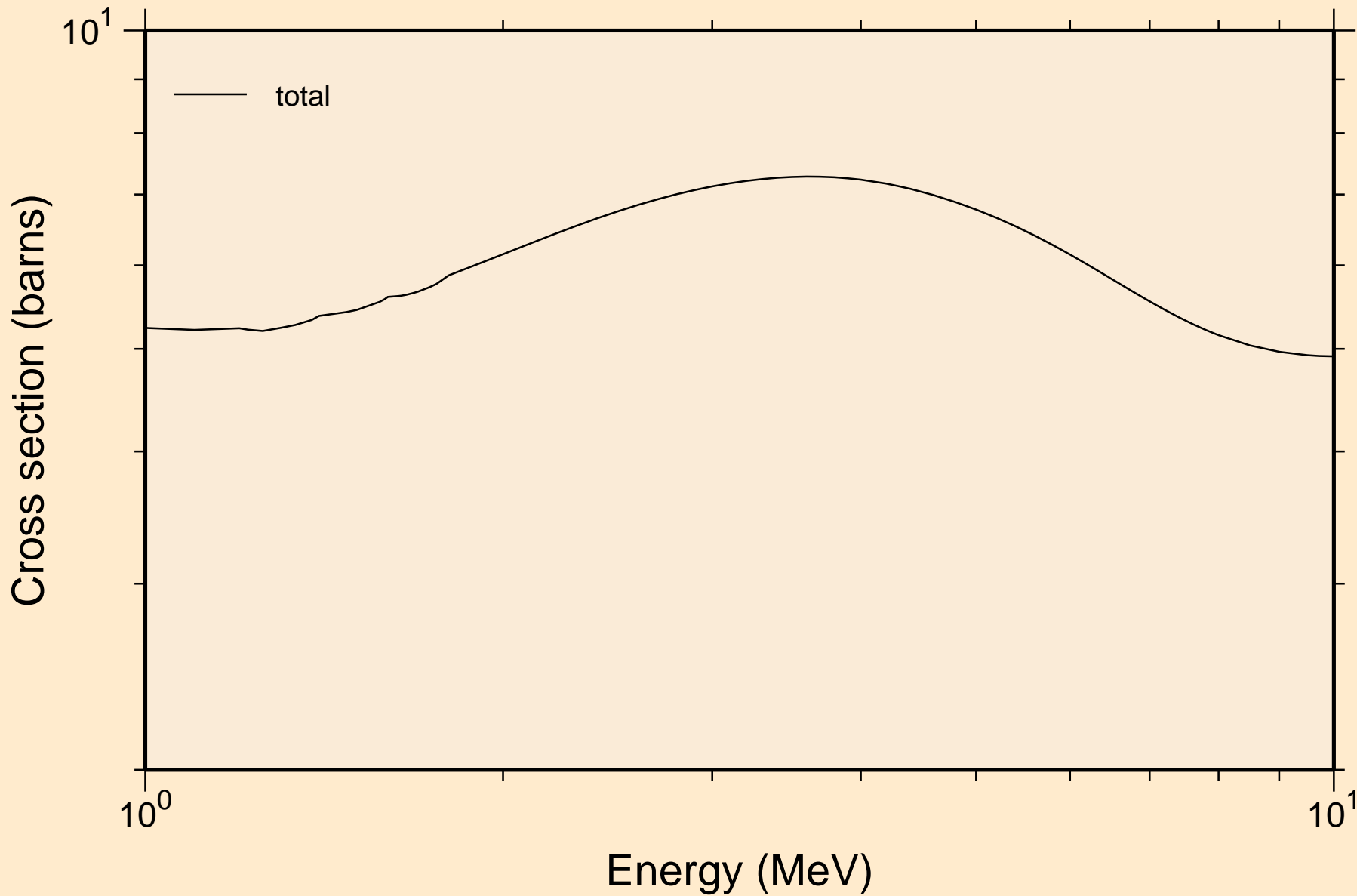

OS201 NEUTRON ACER TENDL-2023 LIBRARY; T=0.K  
resonance absorption cross sections

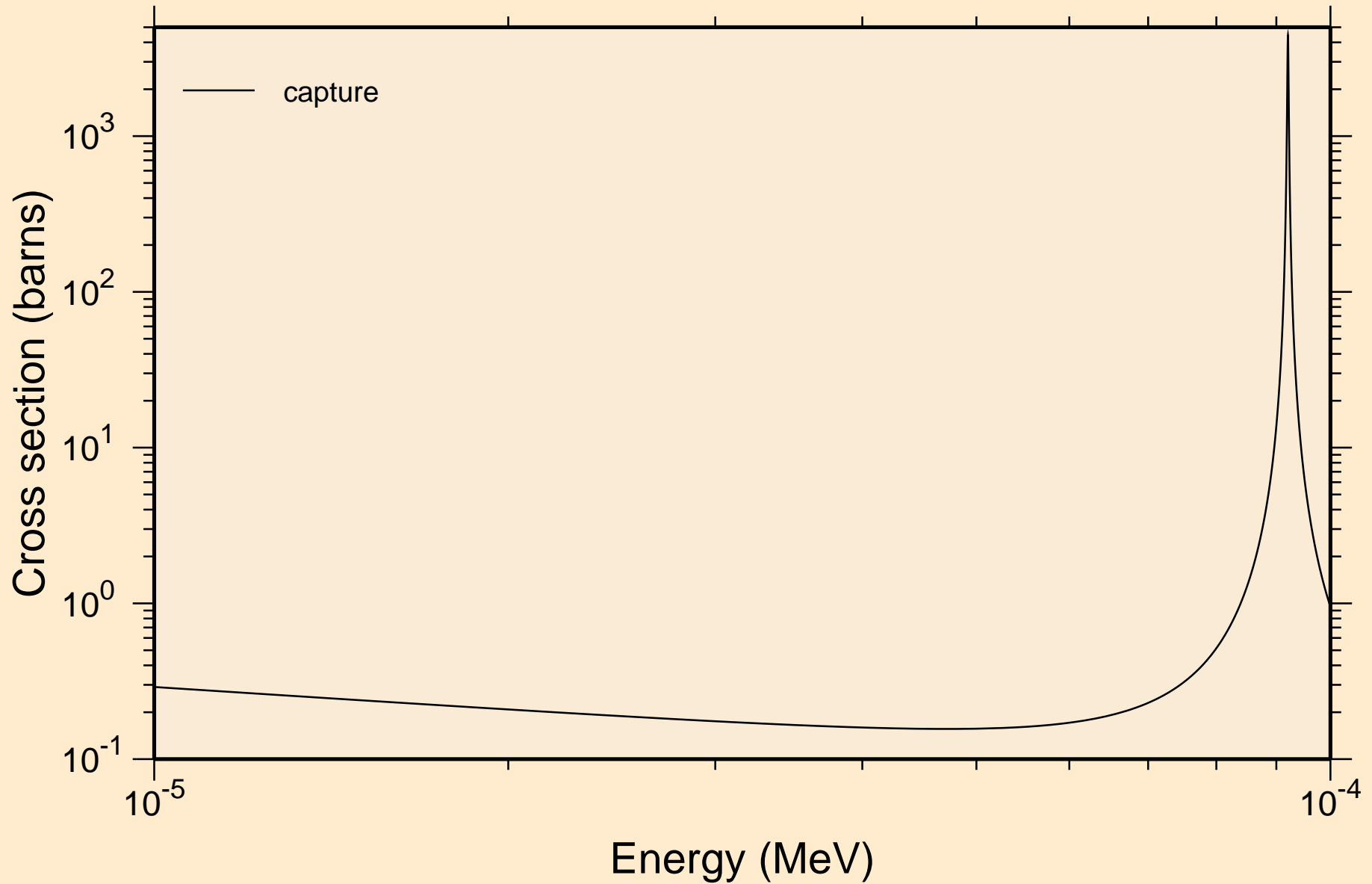

OS201 NEUTRON ACER TENDL-2023 LIBRARY; T=0.K  
resonance absorption cross sections

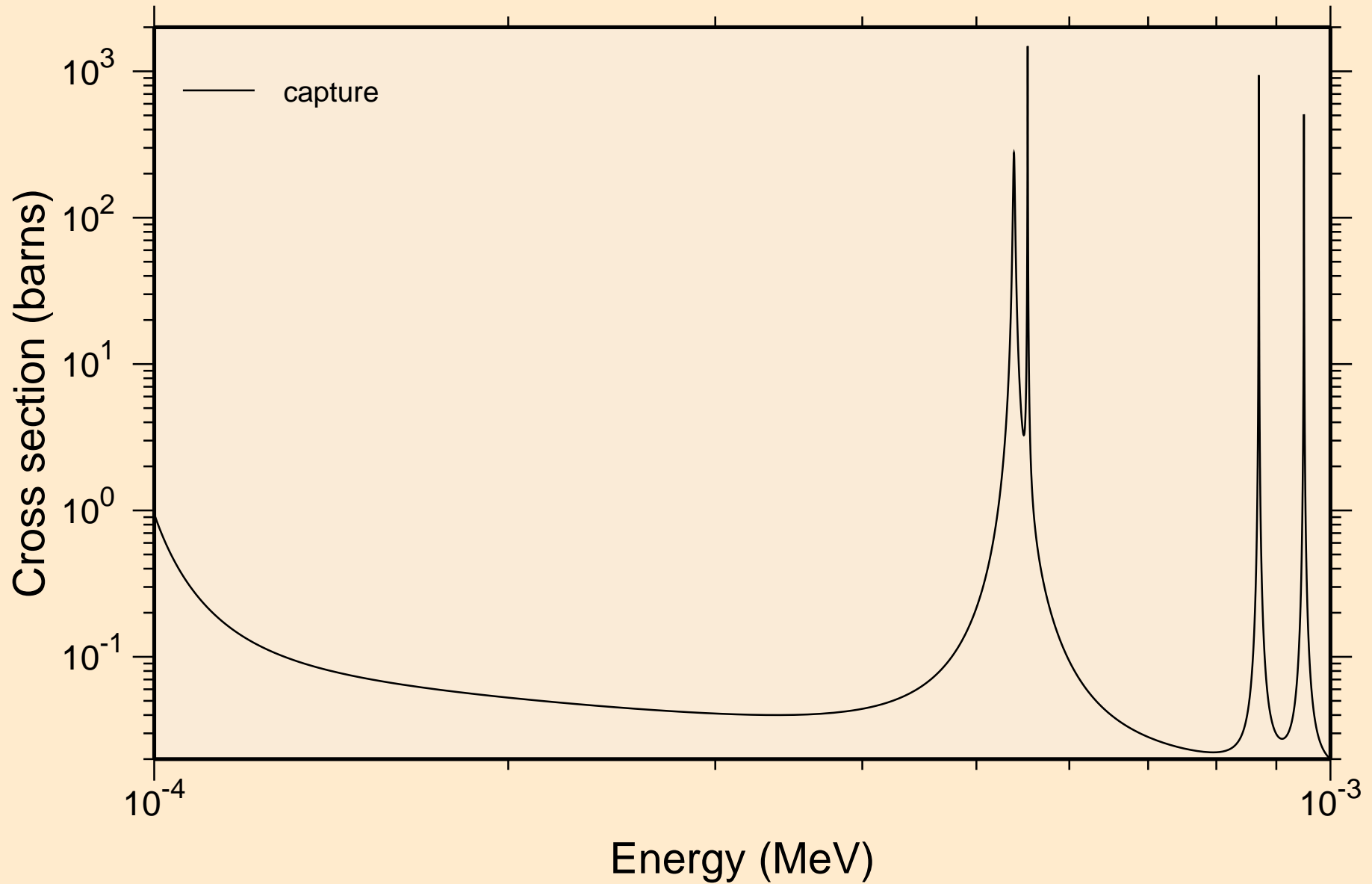

OS201 NEUTRON ACER TENDL-2023 LIBRARY; T=0.K  
resonance absorption cross sections

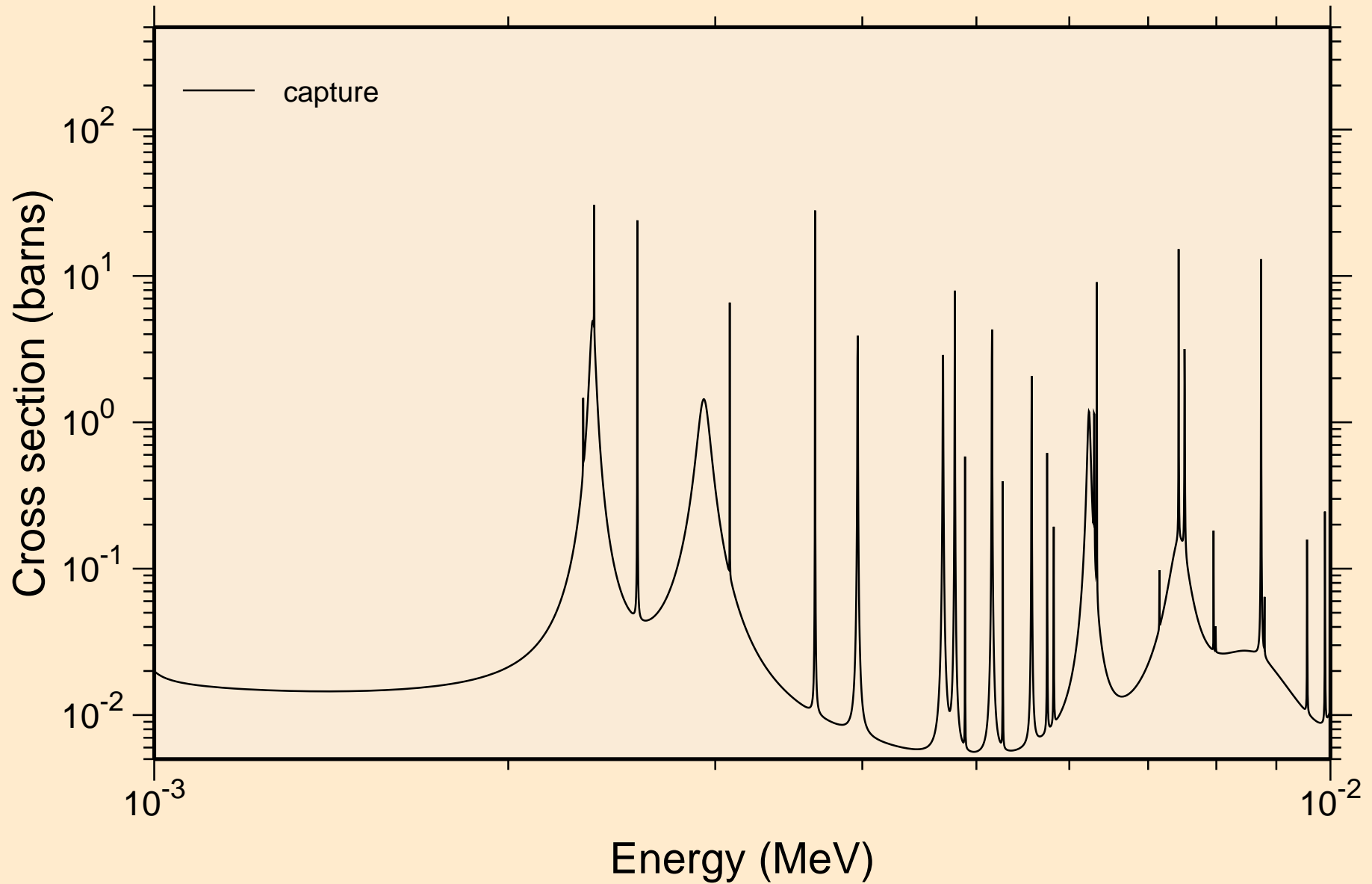

OS201 NEUTRON ACER TENDL-2023 LIBRARY; T=0.K  
resonance absorption cross sections

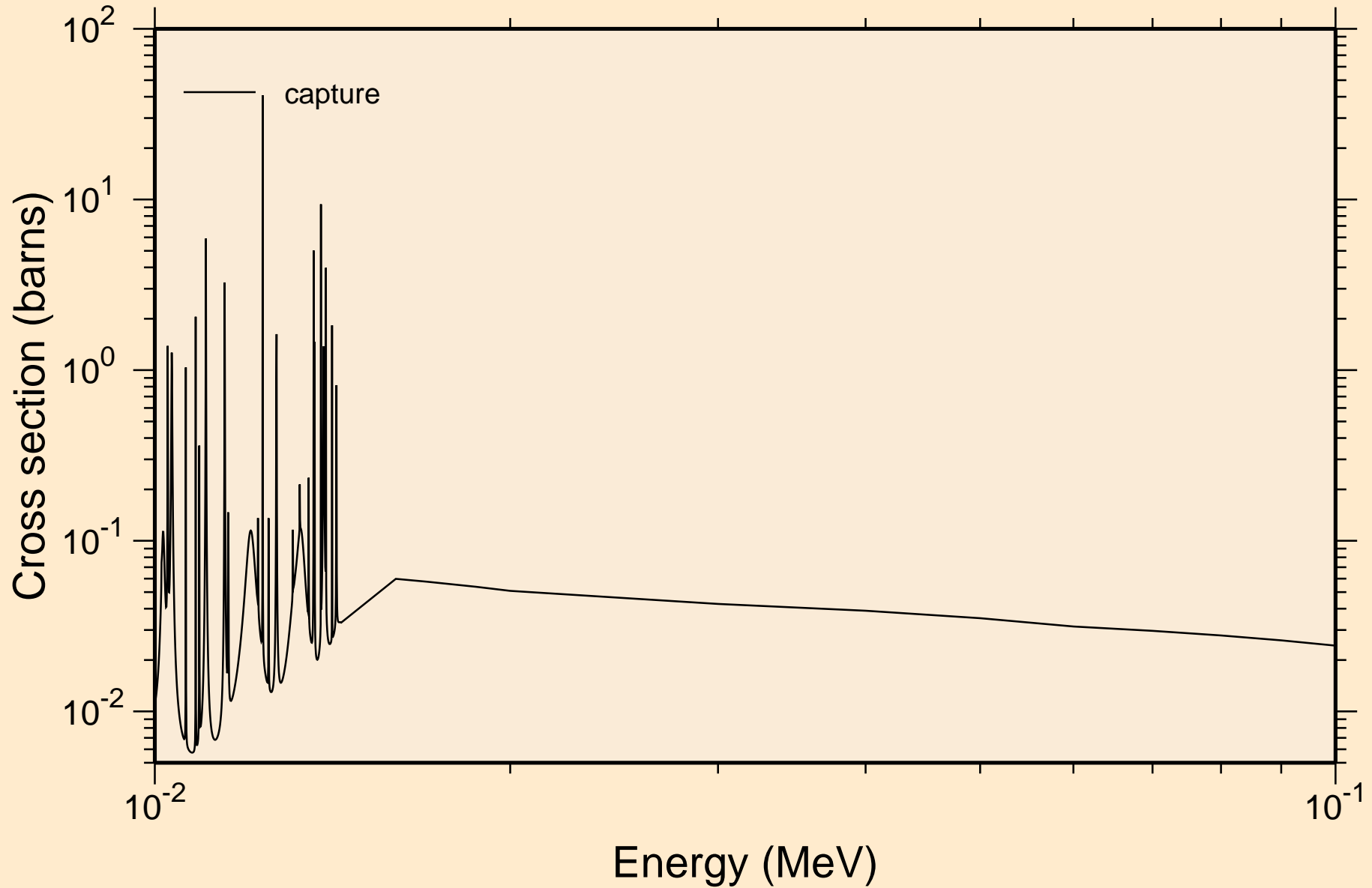

OS201 NEUTRON ACER TENDL-2023 LIBRARY; T=0.K  
resonance absorption cross sections

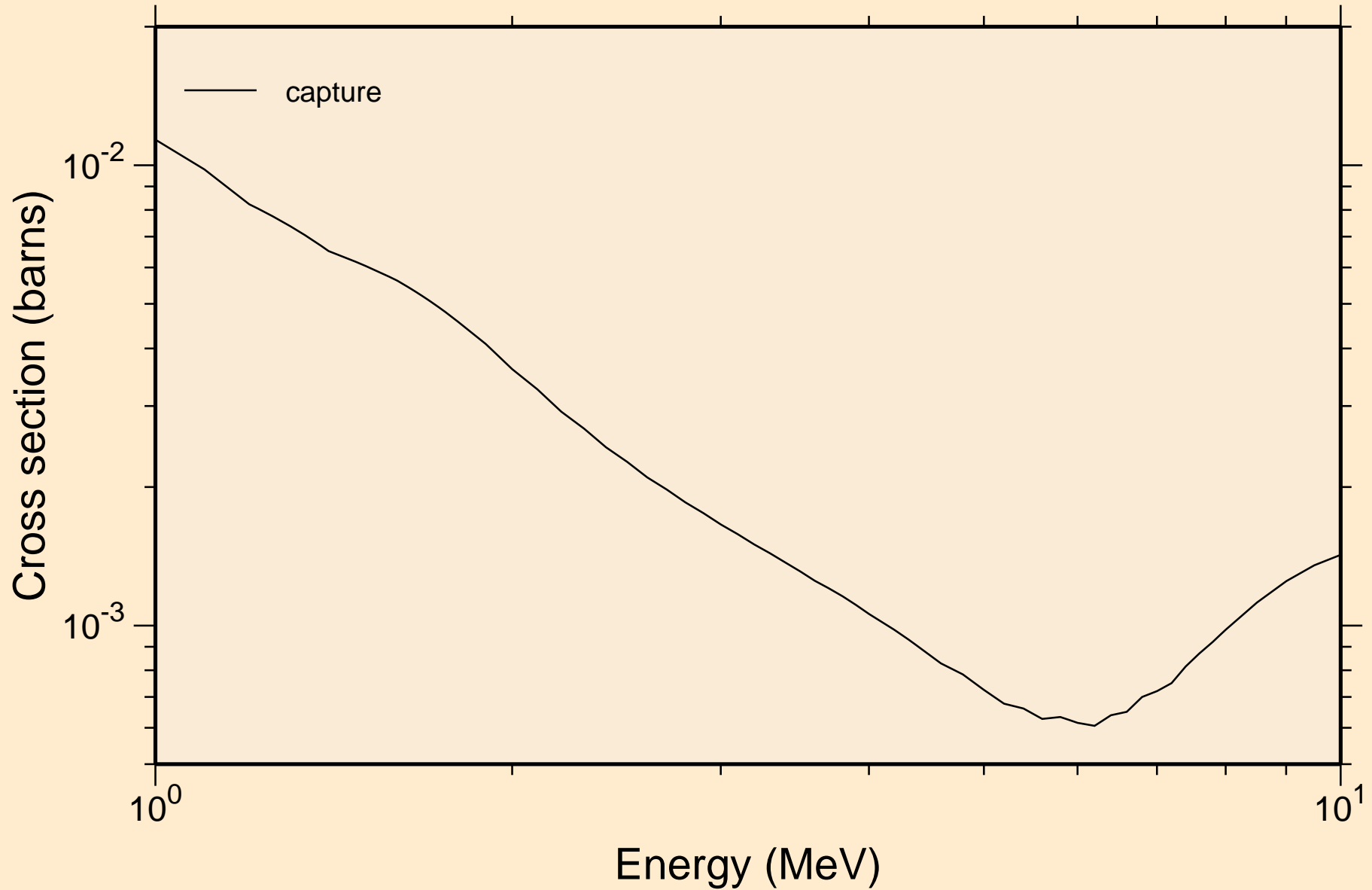

# OS201 NEUTRON ACER TENDL-2023 LIBRARY; T=0.K

## Heating

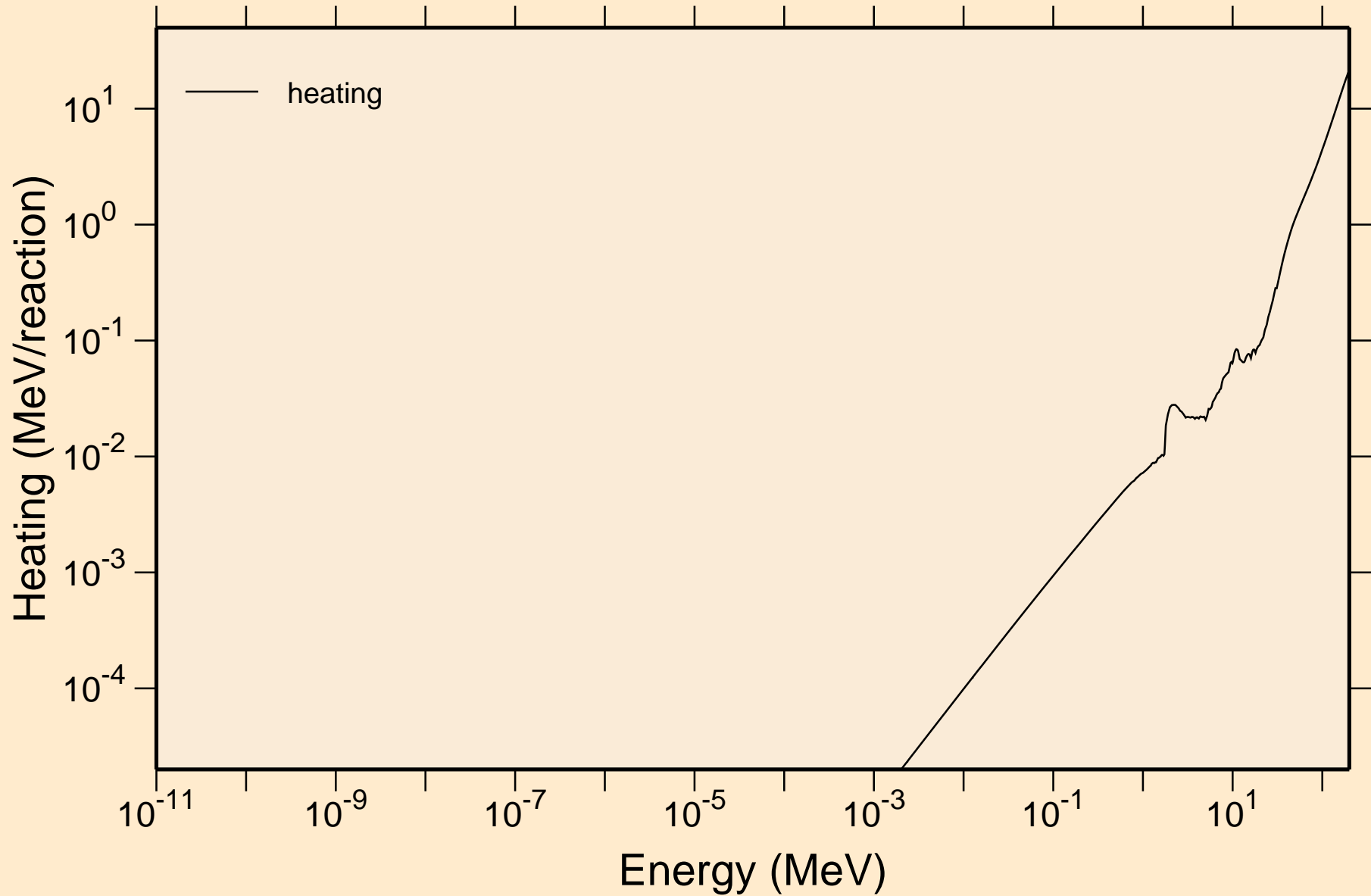

# OS201 NEUTRON ACER TENDL-2023 LIBRARY; T=0.K

## Damage

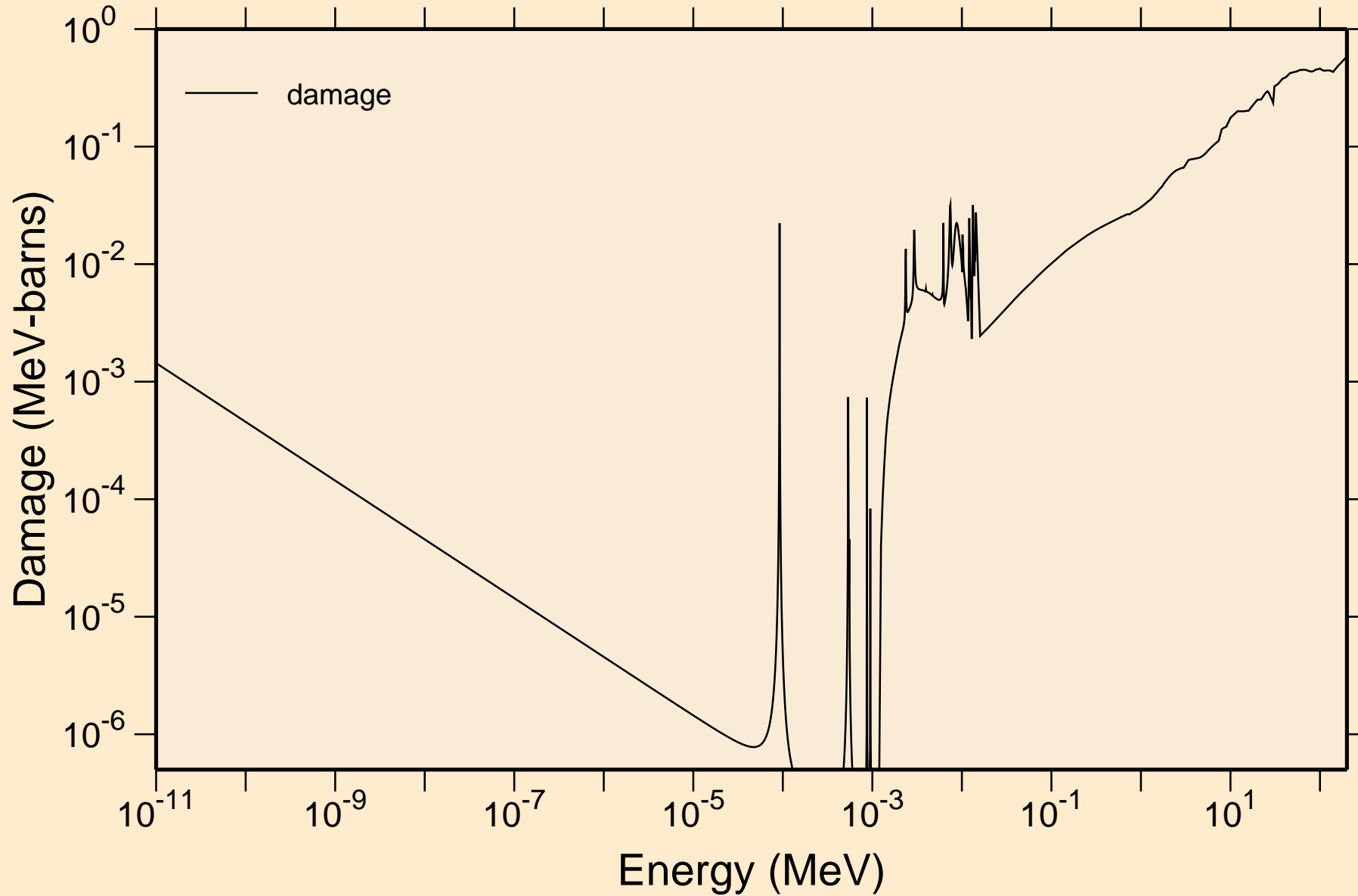

OS201 NEUTRON ACER TENDL-2023 LIBRARY; T=0.K  
Non-threshold reactions

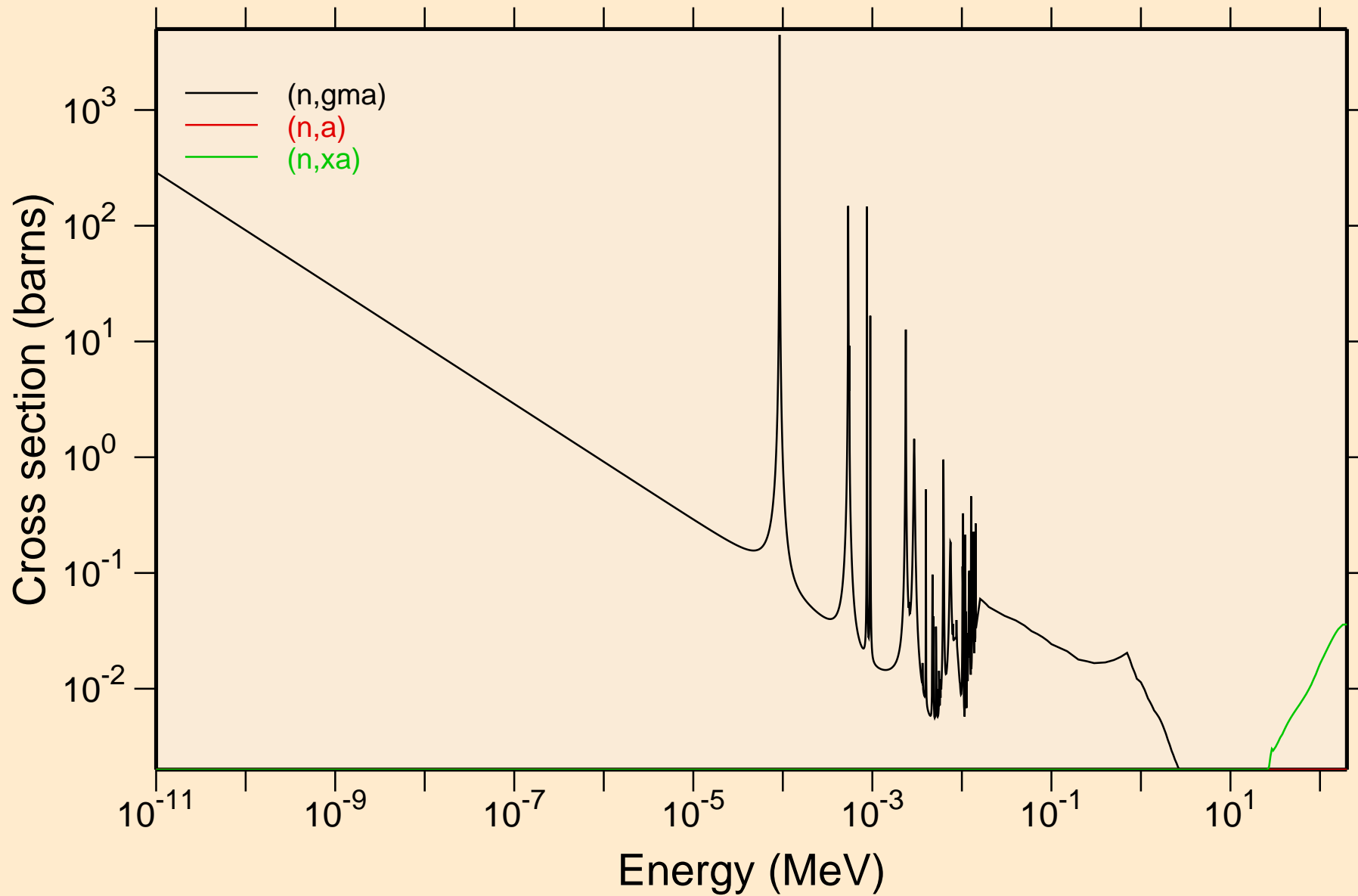

# OS201 NEUTRON ACER TENDL-2023 LIBRARY; T=0.K

## Principal cross sections

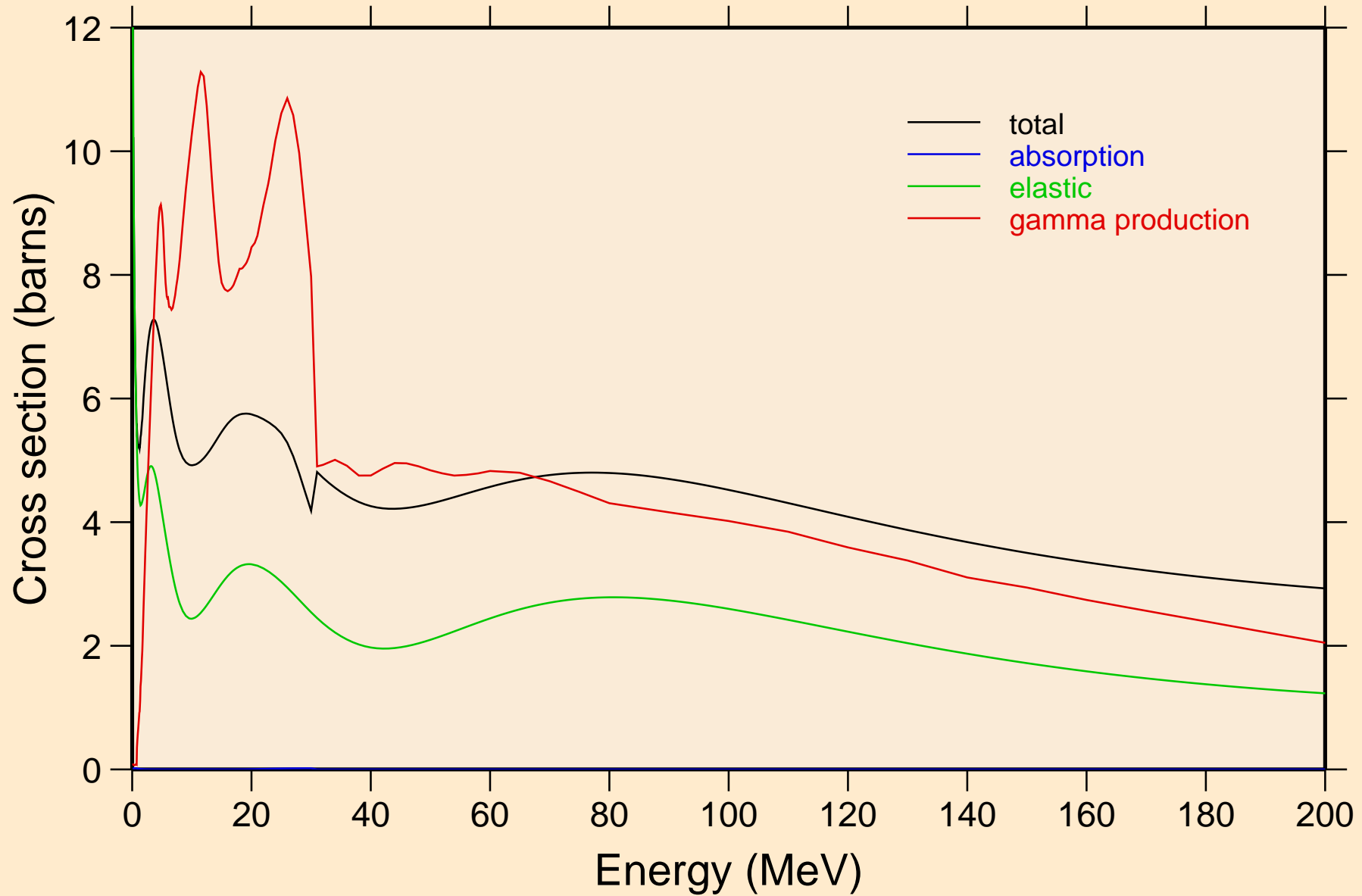

# OS201 NEUTRON ACER TENDL-2023 LIBRARY; T=0.K

## Heating

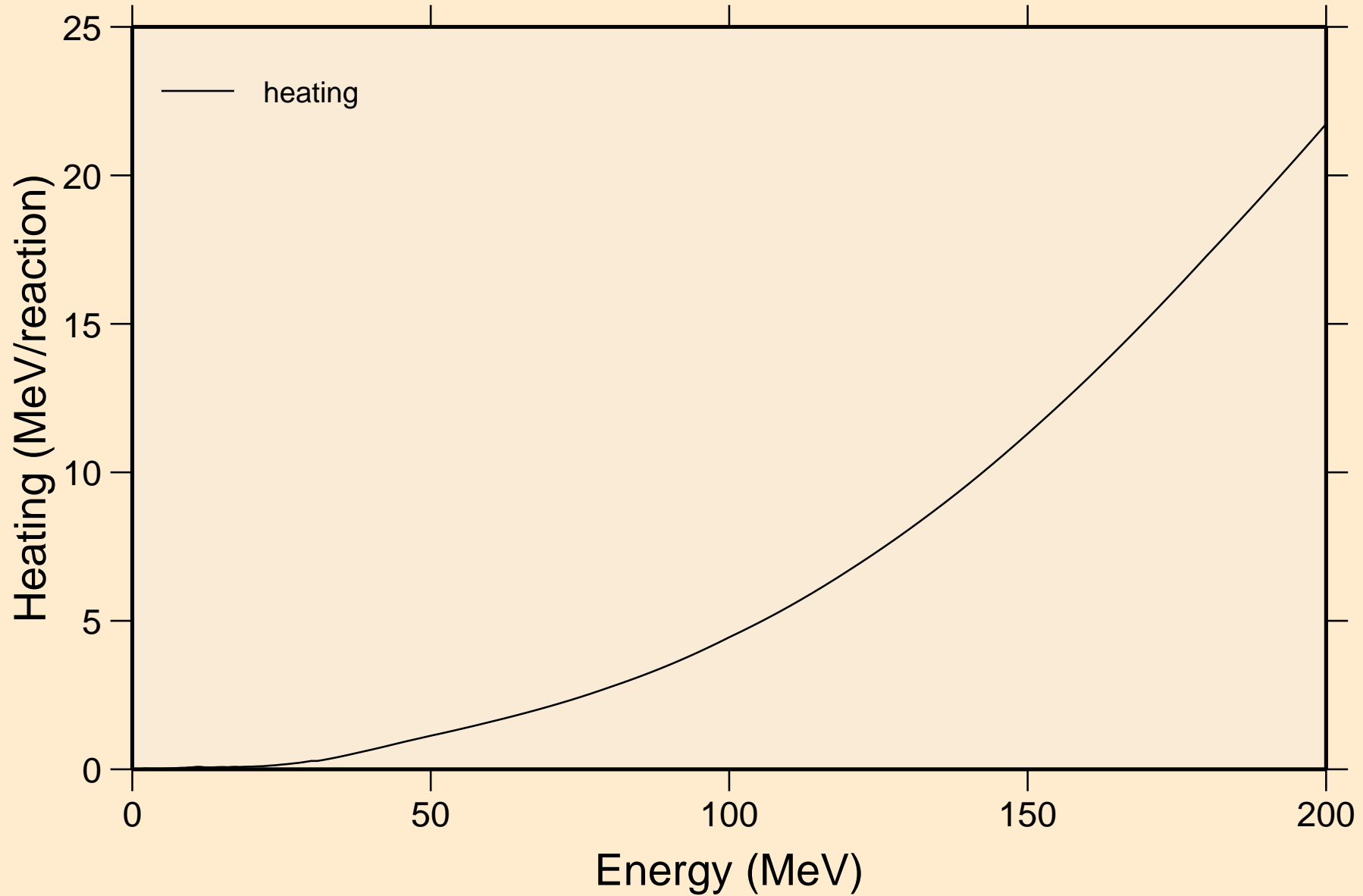

OS201 NEUTRON ACER TENDL-2023 LIBRARY; T=0.K  
Damage

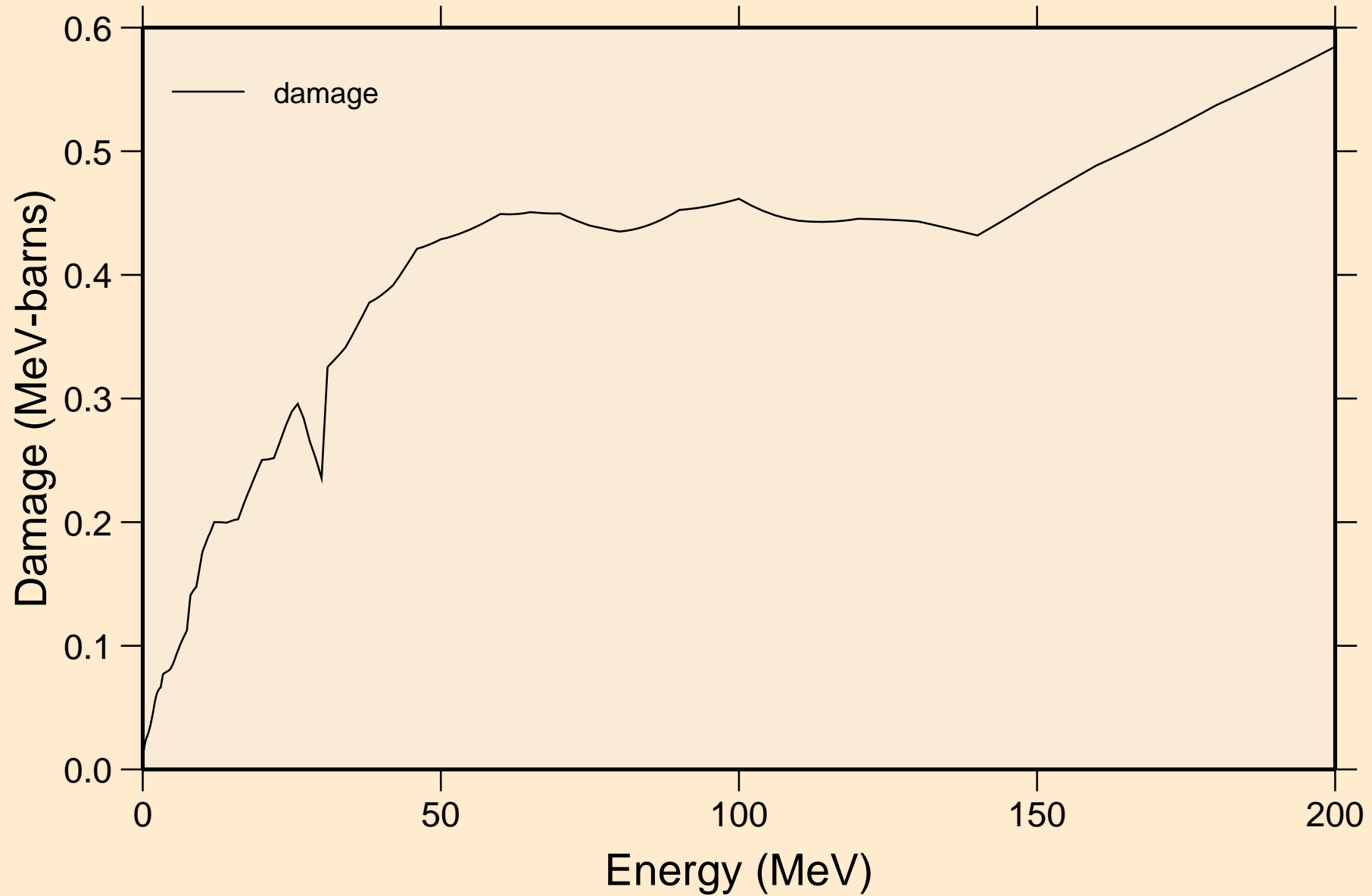

OS201 NEUTRON ACER TENDL-2023 LIBRARY; T=0.K  
Non-threshold reactions

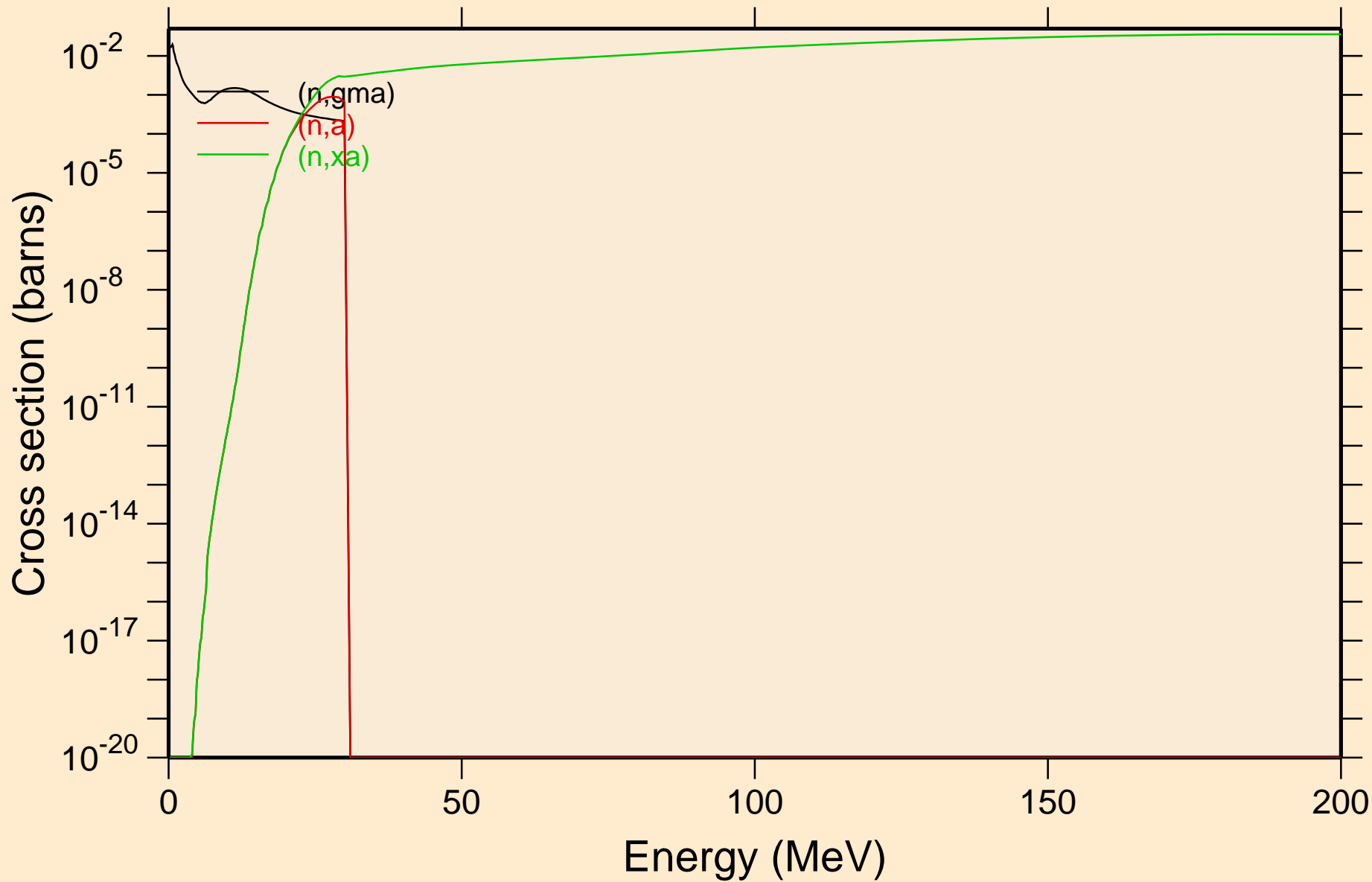

OS201 NEUTRON ACER TENDL-2023 LIBRARY; T=0.K  
Inelastic levels

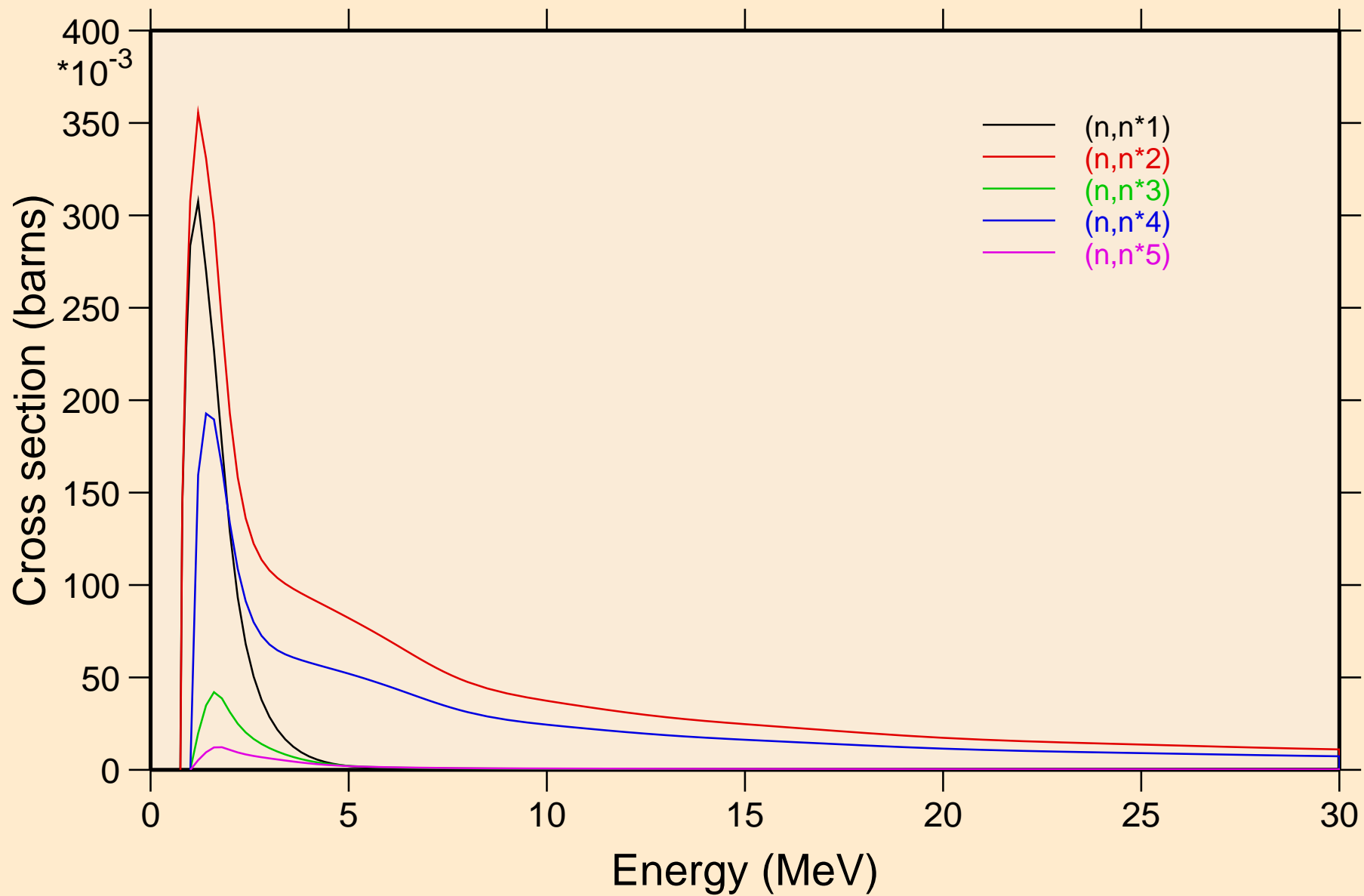

OS201 NEUTRON ACER TENDL-2023 LIBRARY; T=0.K  
Inelastic levels

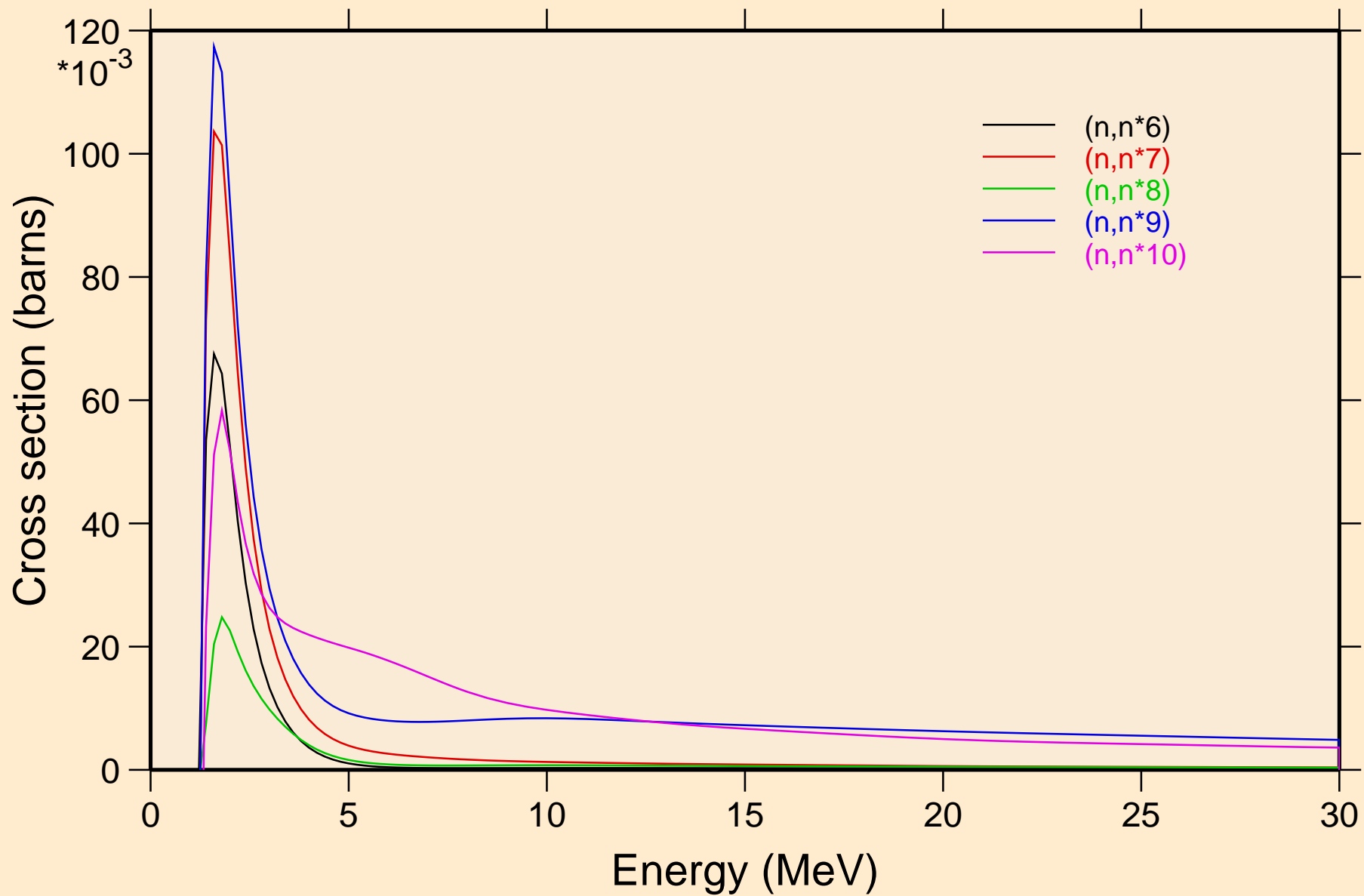

OS201 NEUTRON ACER TENDL-2023 LIBRARY; T=0.K  
Inelastic levels

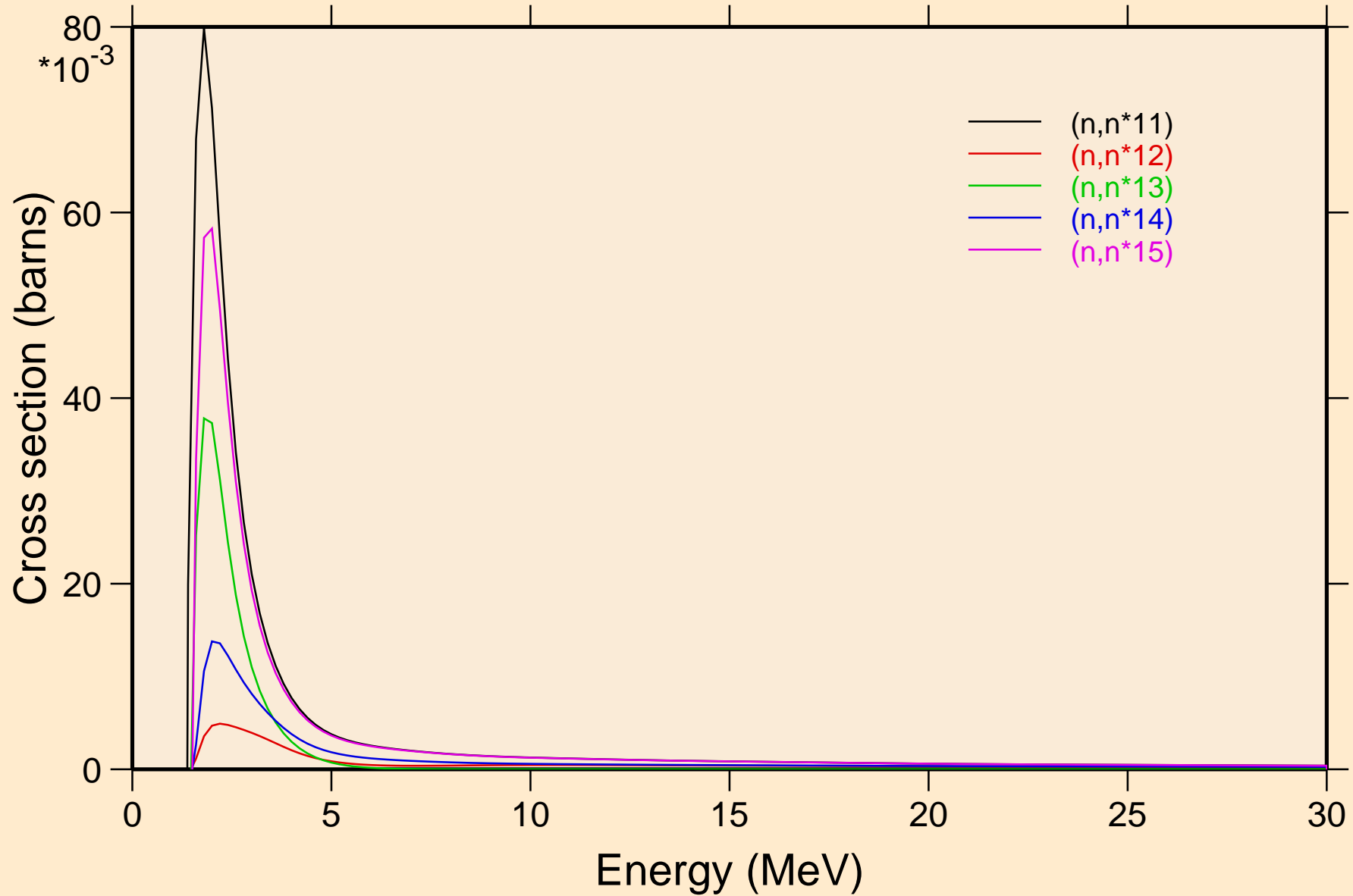

OS201 NEUTRON ACER TENDL-2023 LIBRARY; T=0.K  
Inelastic levels

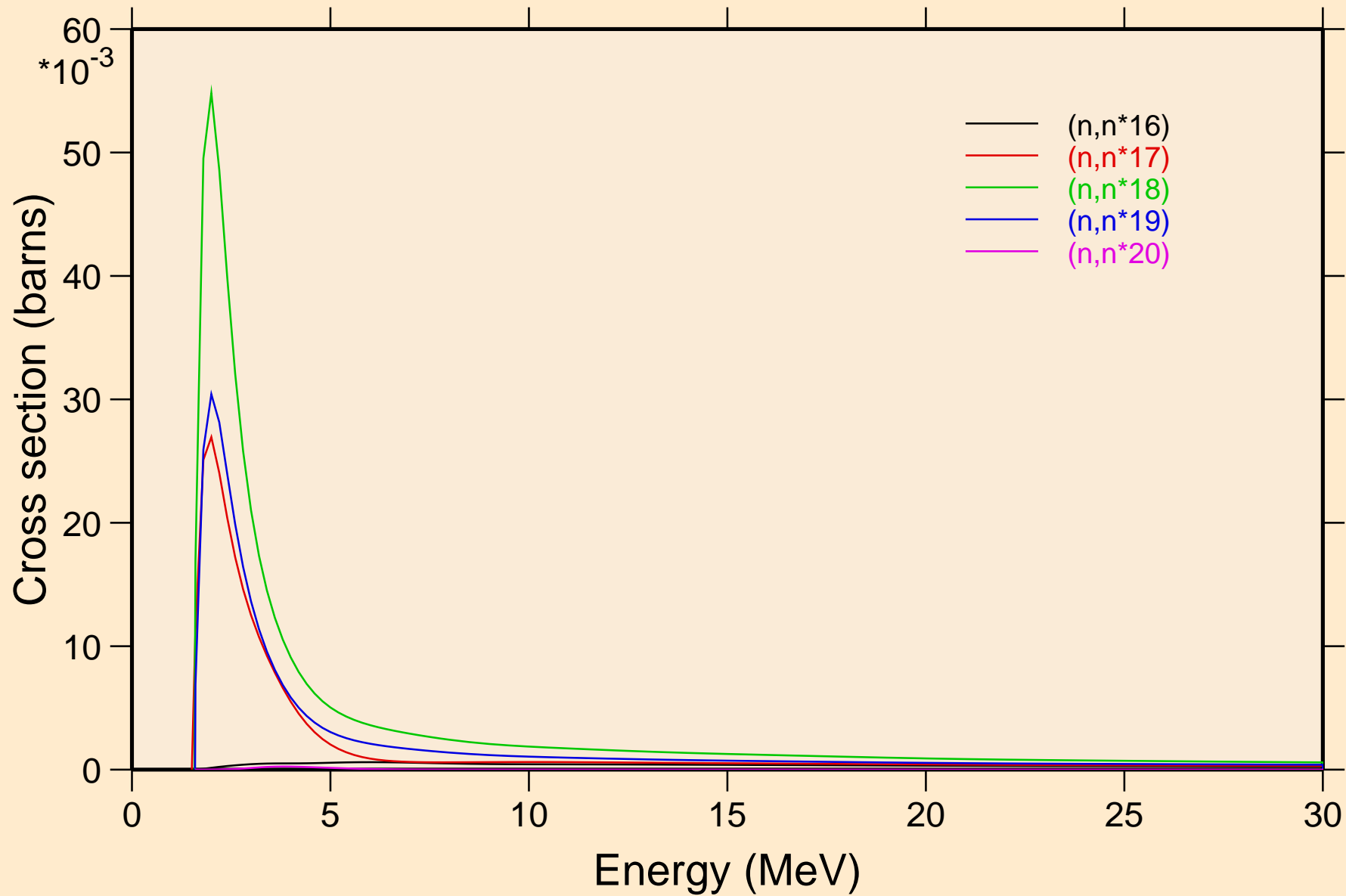

OS201 NEUTRON ACER TENDL-2023 LIBRARY; T=0.K  
Inelastic levels

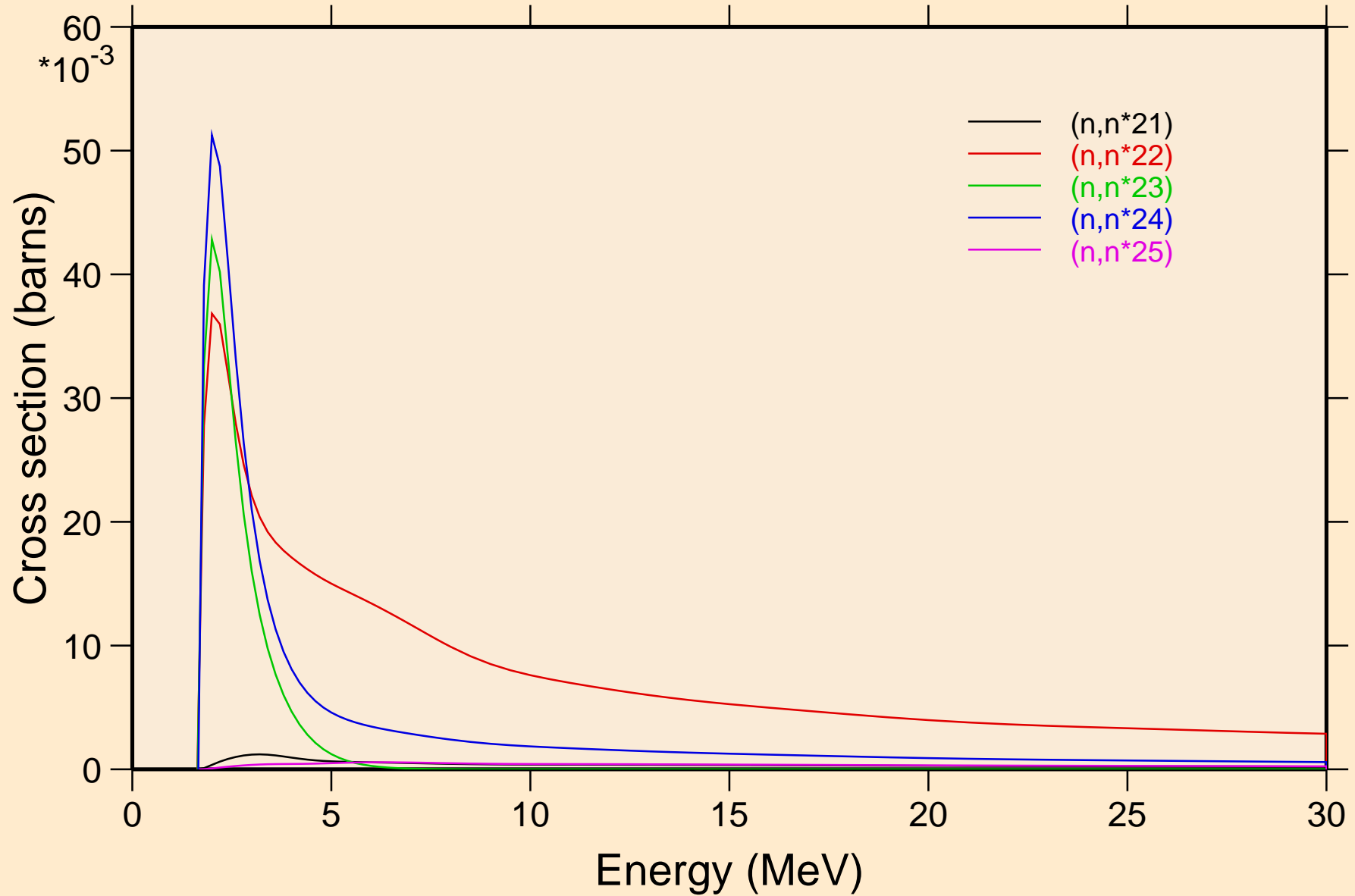

OS201 NEUTRON ACER TENDL-2023 LIBRARY; T=0.K  
Inelastic levels

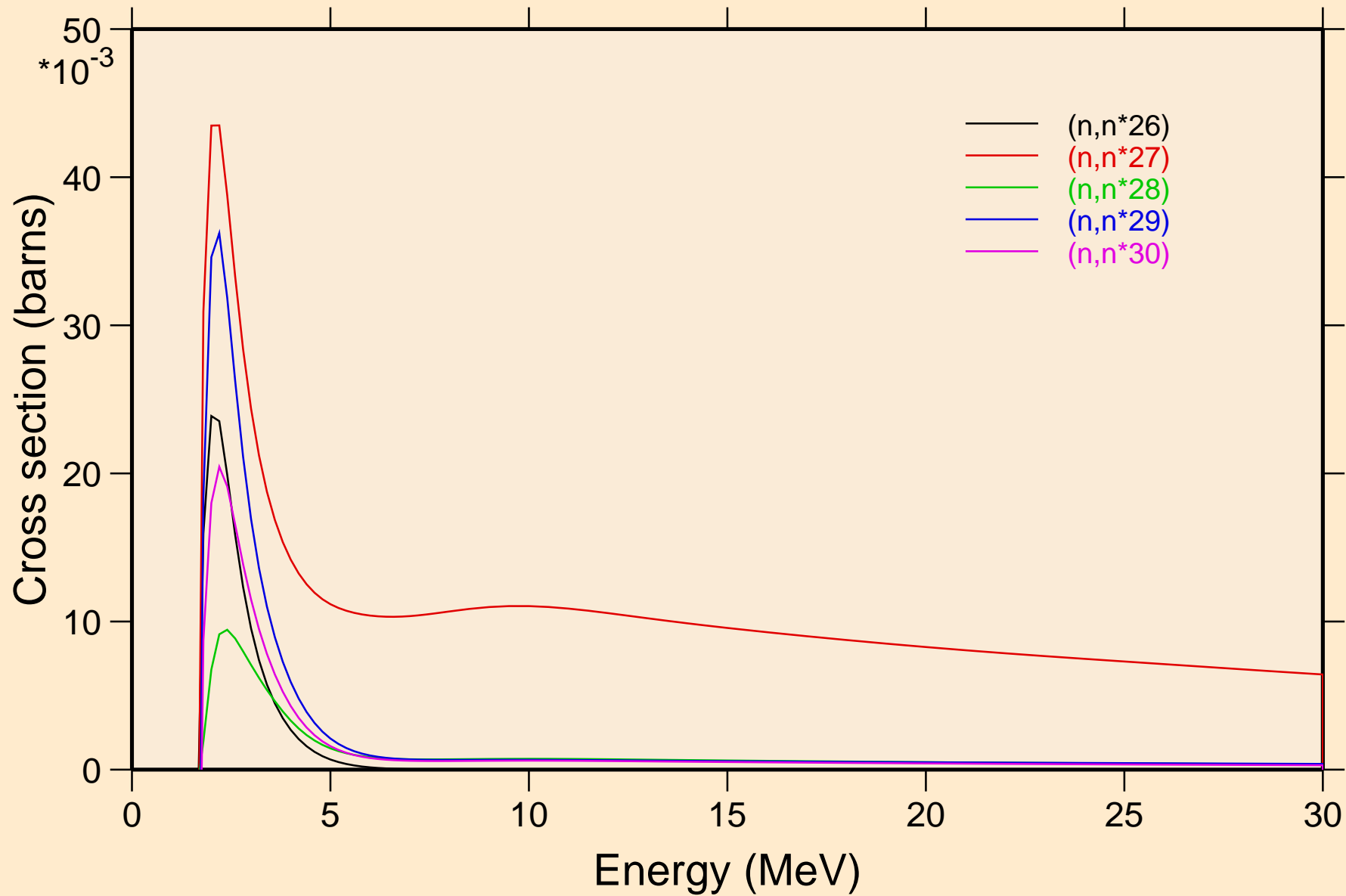

OS201 NEUTRON ACER TENDL-2023 LIBRARY; T=0.K  
Threshold reactions

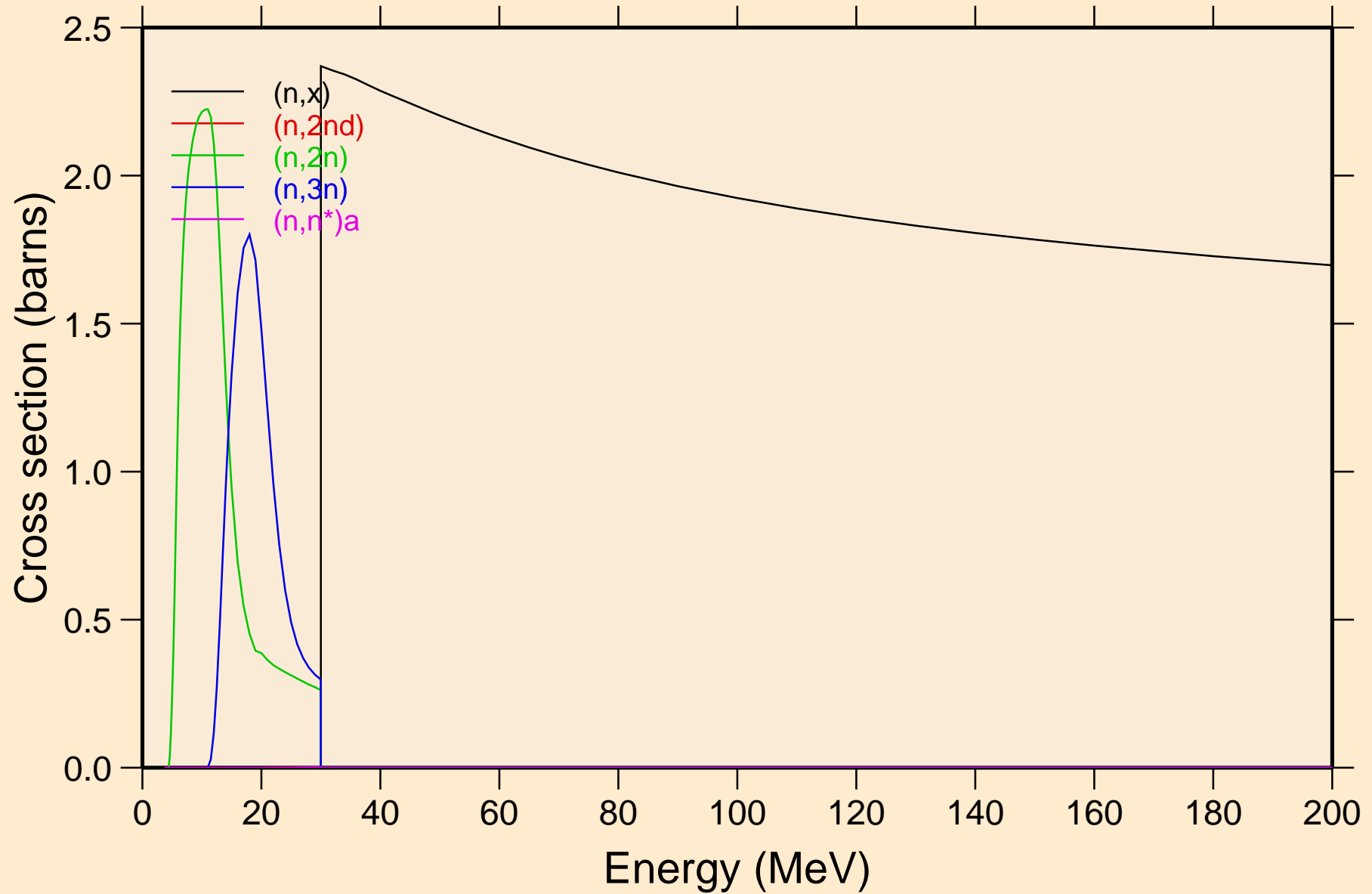

OS201 NEUTRON ACER TENDL-2023 LIBRARY; T=0.K  
Threshold reactions

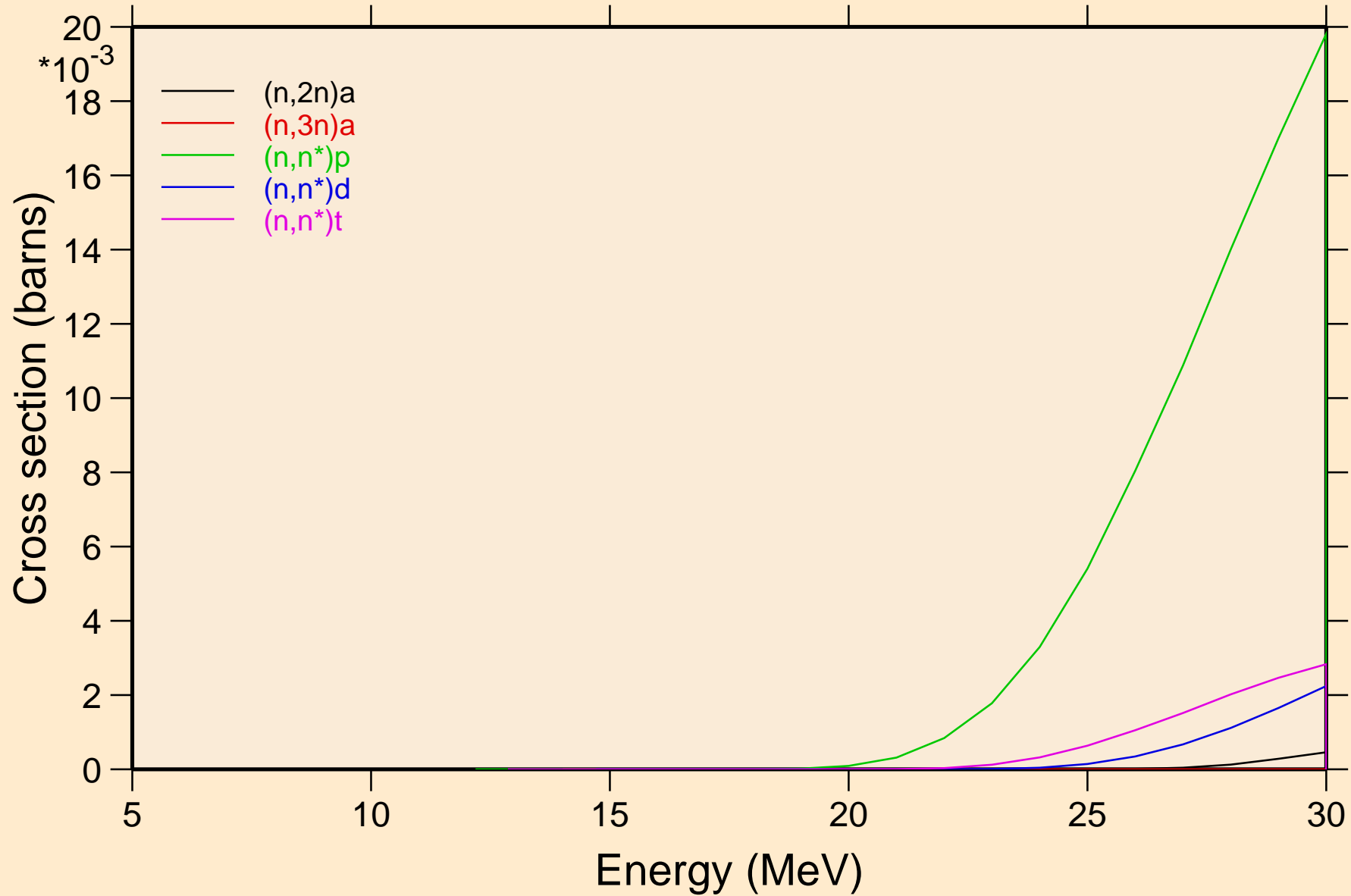

OS201 NEUTRON ACER TENDL-2023 LIBRARY; T=0.K  
Threshold reactions

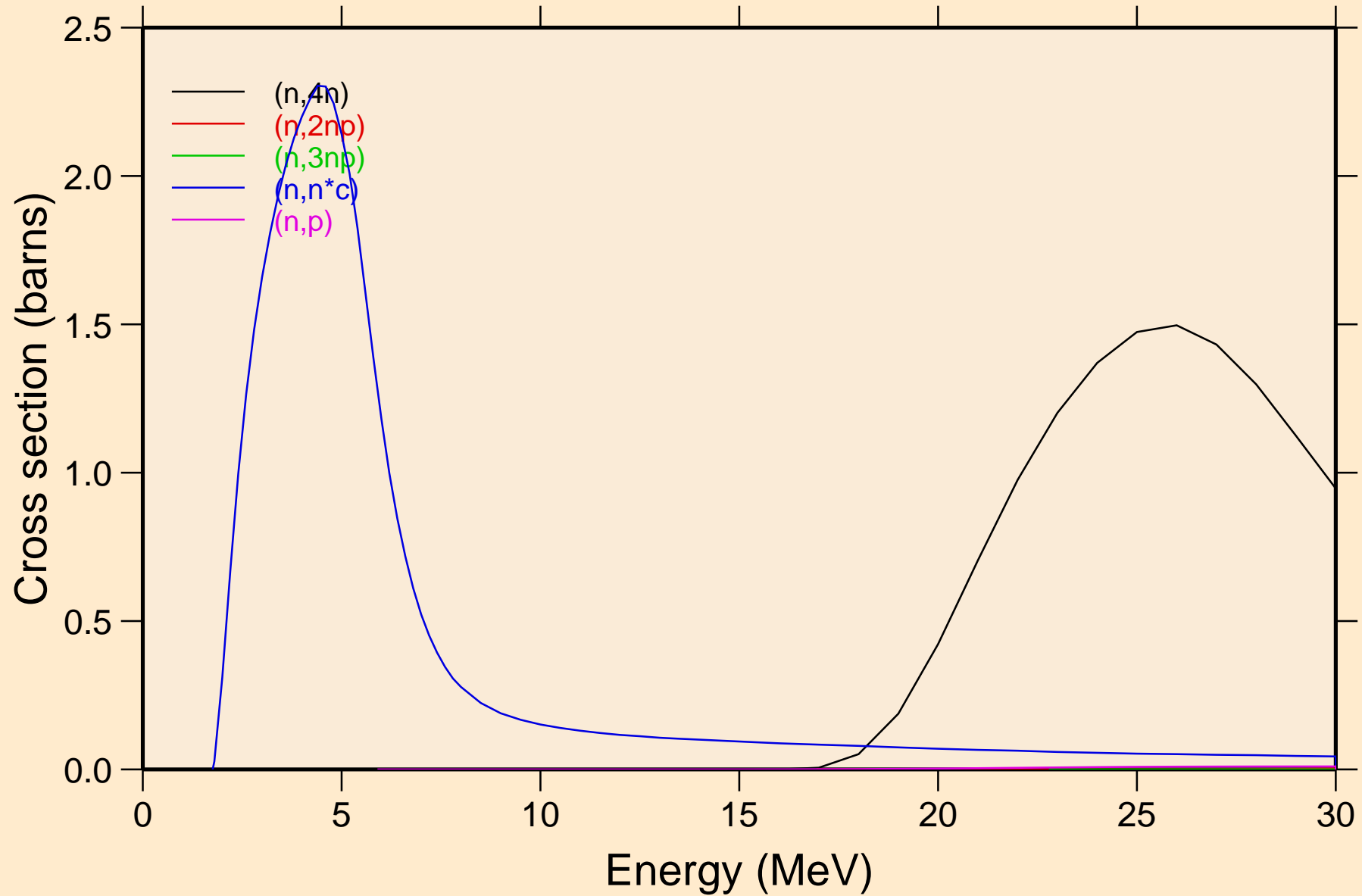

OS201 NEUTRON ACER TENDL-2023 LIBRARY; T=0.K  
Threshold reactions

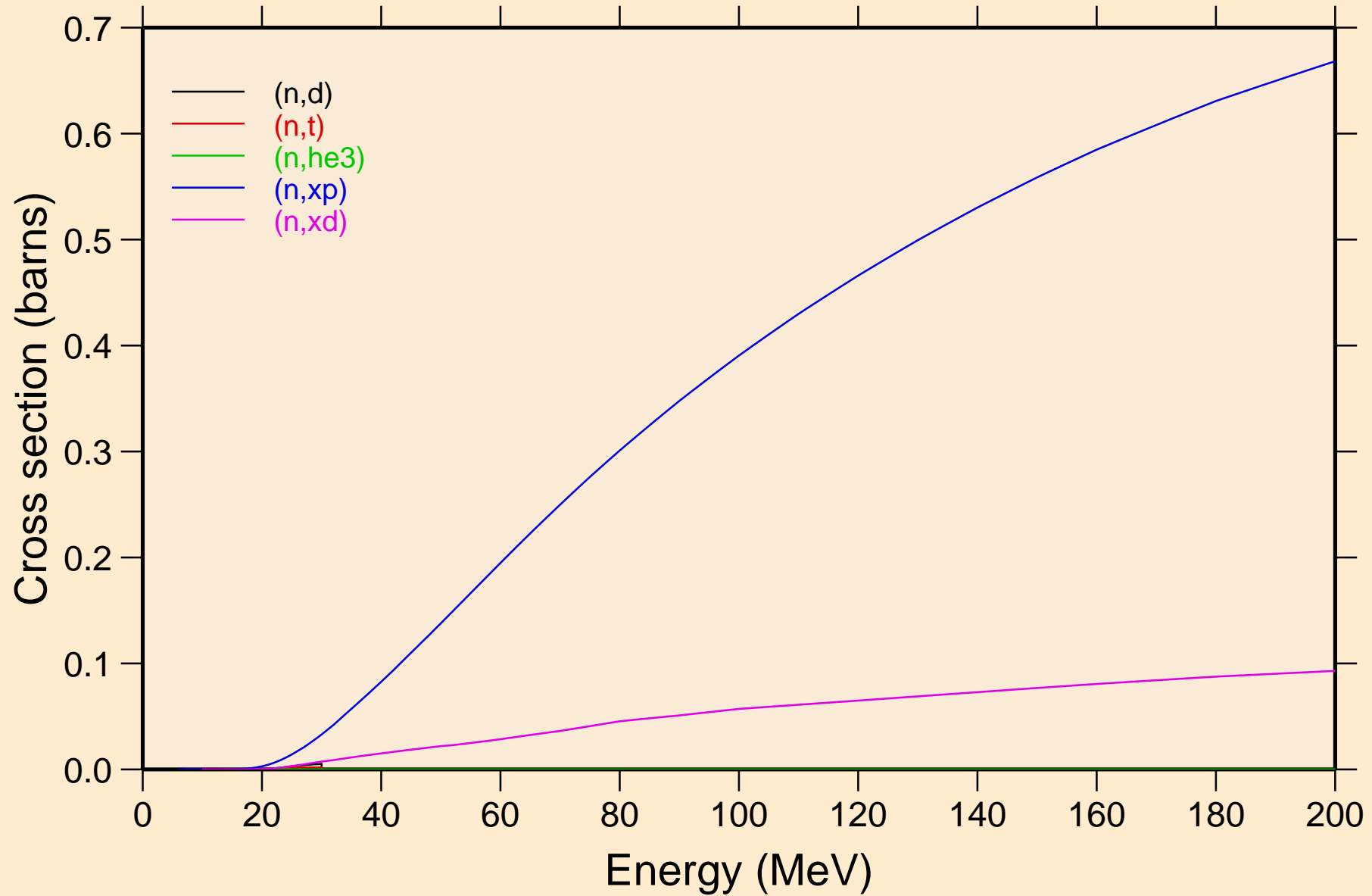

OS201 NEUTRON ACER TENDL-2023 LIBRARY; T=0.K  
Threshold reactions

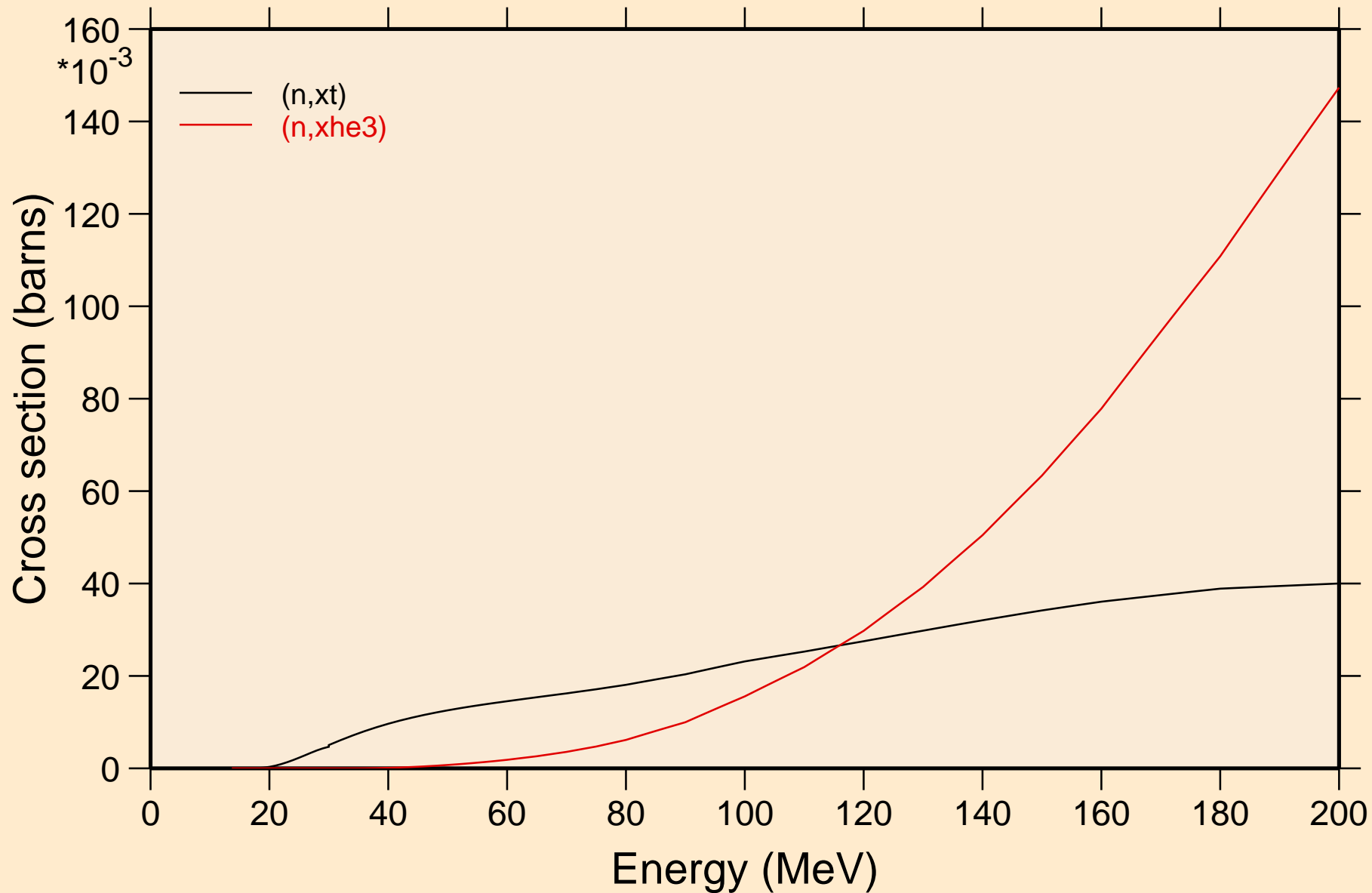

OS201 NEUTRON ACER TENDL-2023 LIBRARY; T=0.K  
angular distribution for elastic

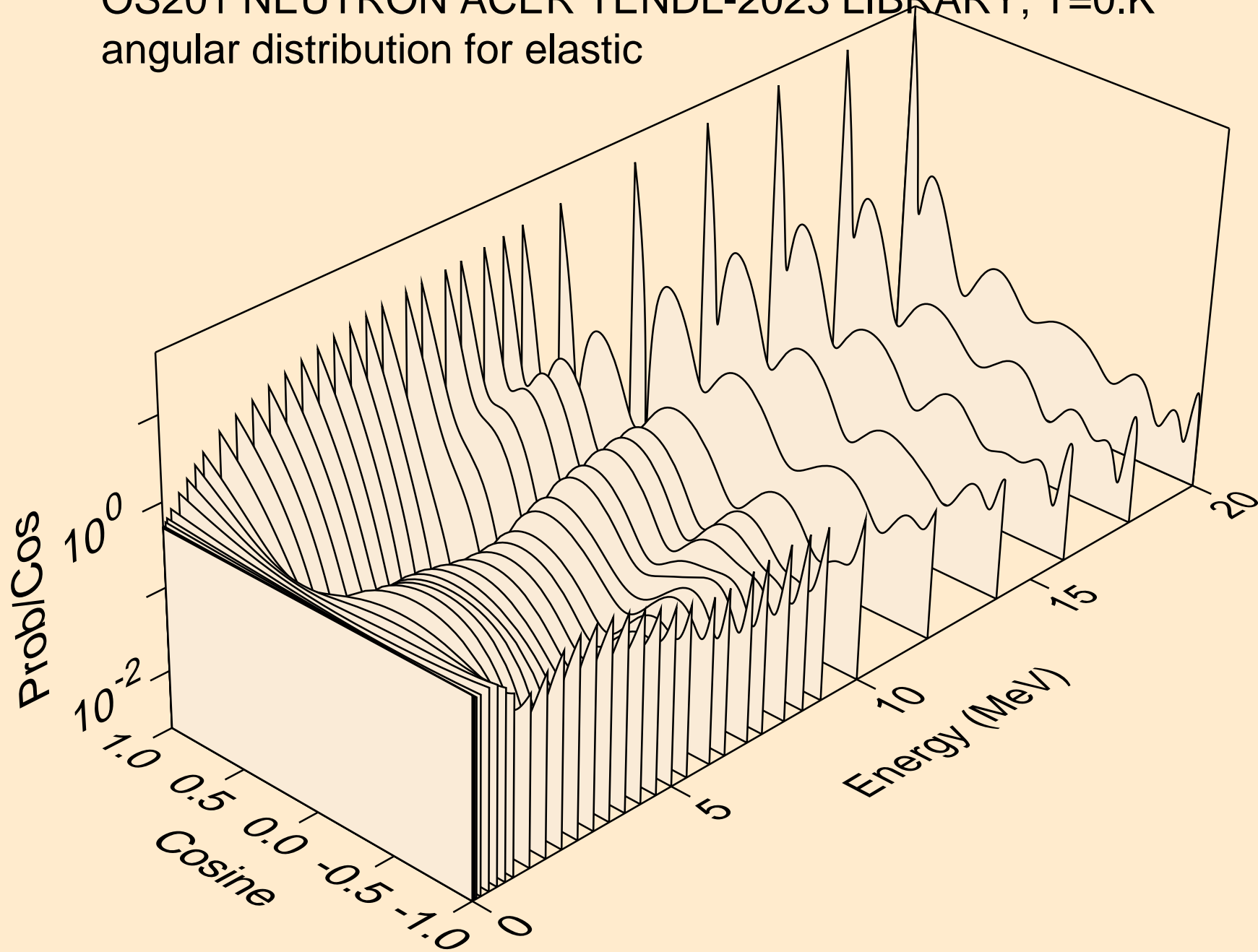

OS201 NEUTRON ACER TENDL-2023 LIBRARY; T=0.K  
angular distribution for elastic

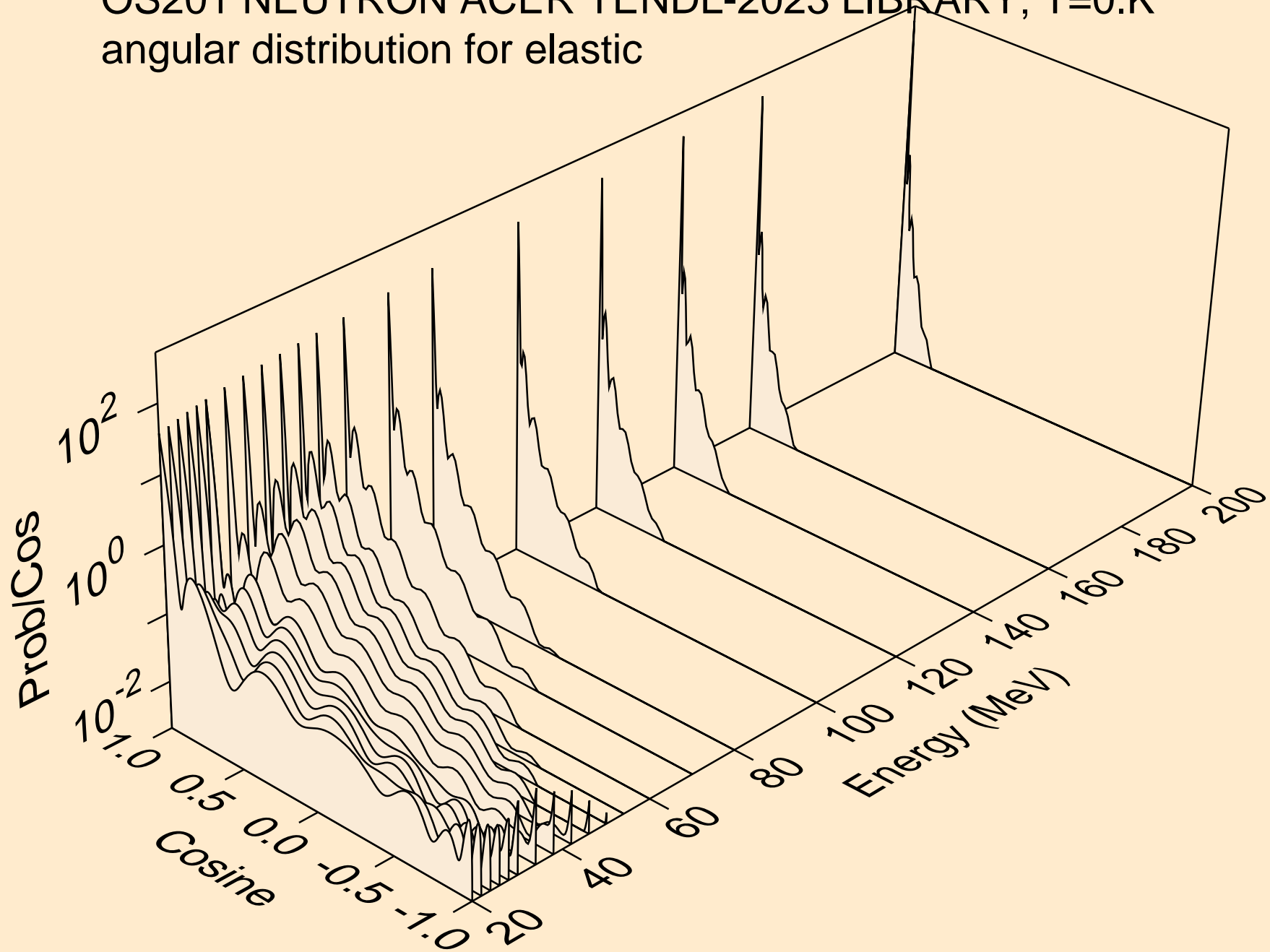

OS201 NEUTRON ACER TENDL-2023 LIBRARY; T=0.K  
angular distribution for (n,n\*1)

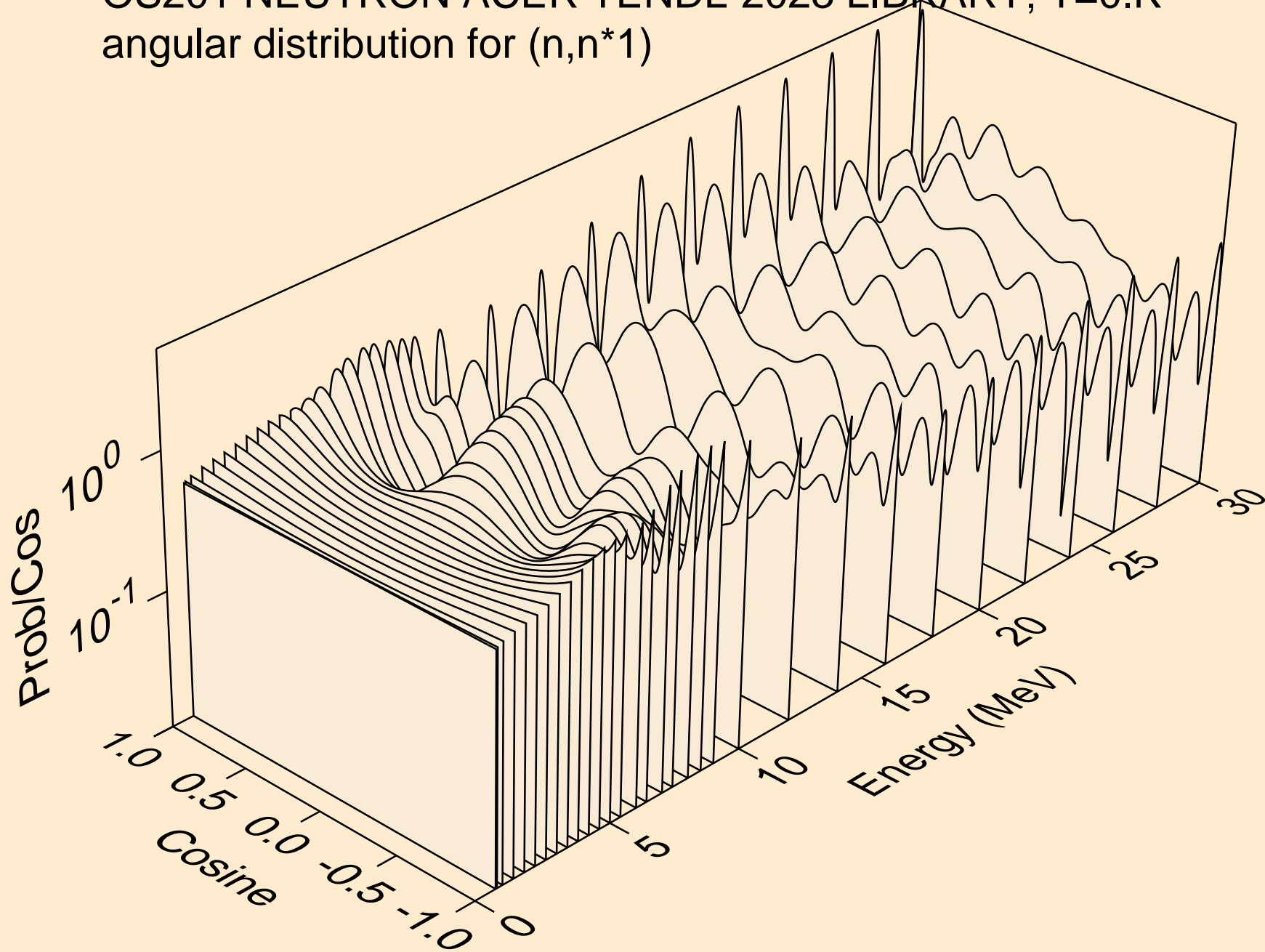

OS201 NEUTRON ACER TENDL-2023 LIBRARY; T=0.K  
angular distribution for (n,n\*2)

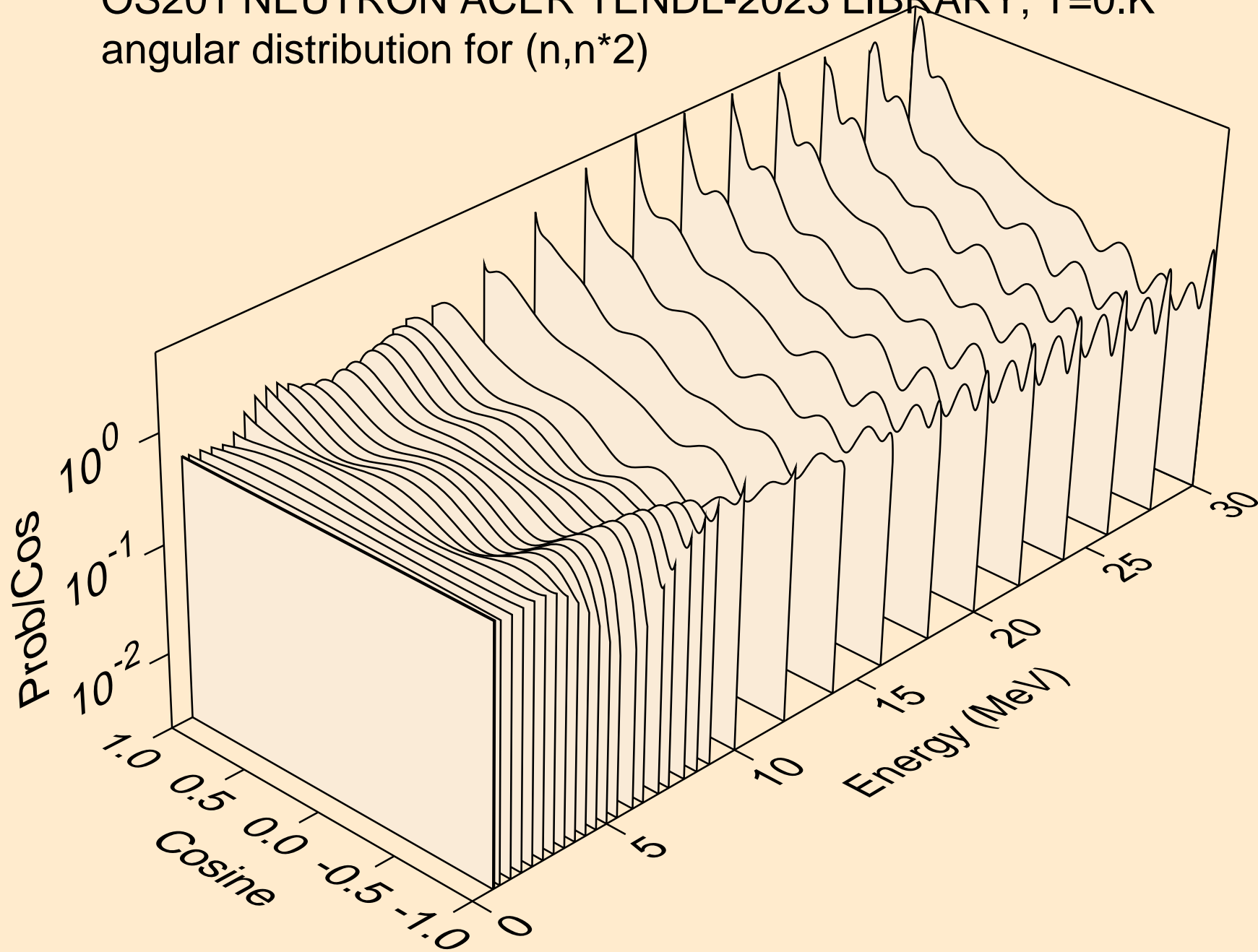

OS201 NEUTRON ACER TENDL-2023 LIBRARY; T=0.K  
angular distribution for (n,n\*3)

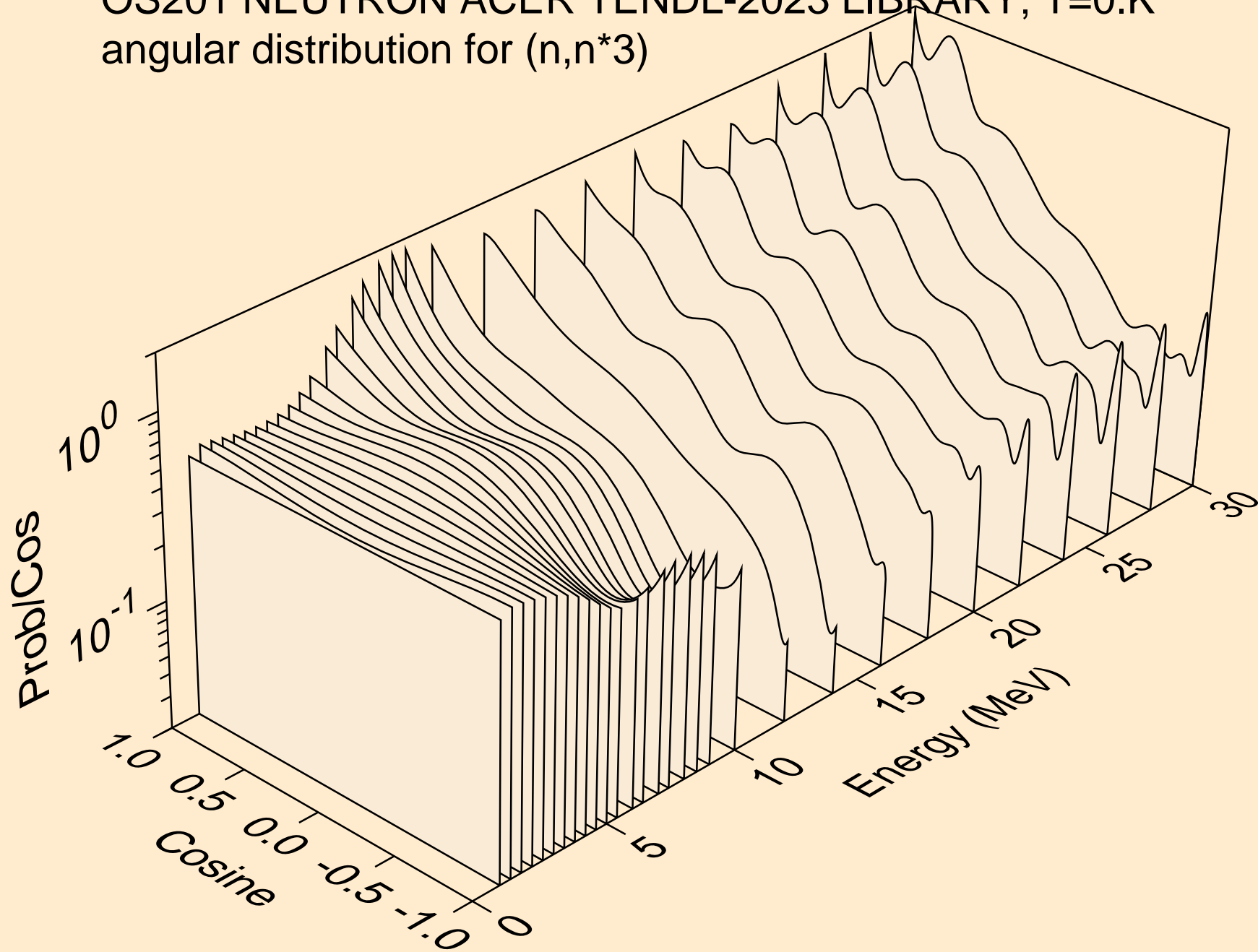

OS201 NEUTRON ACER TENDL-2023 LIBRARY; T=0.K  
angular distribution for (n,n\*4)

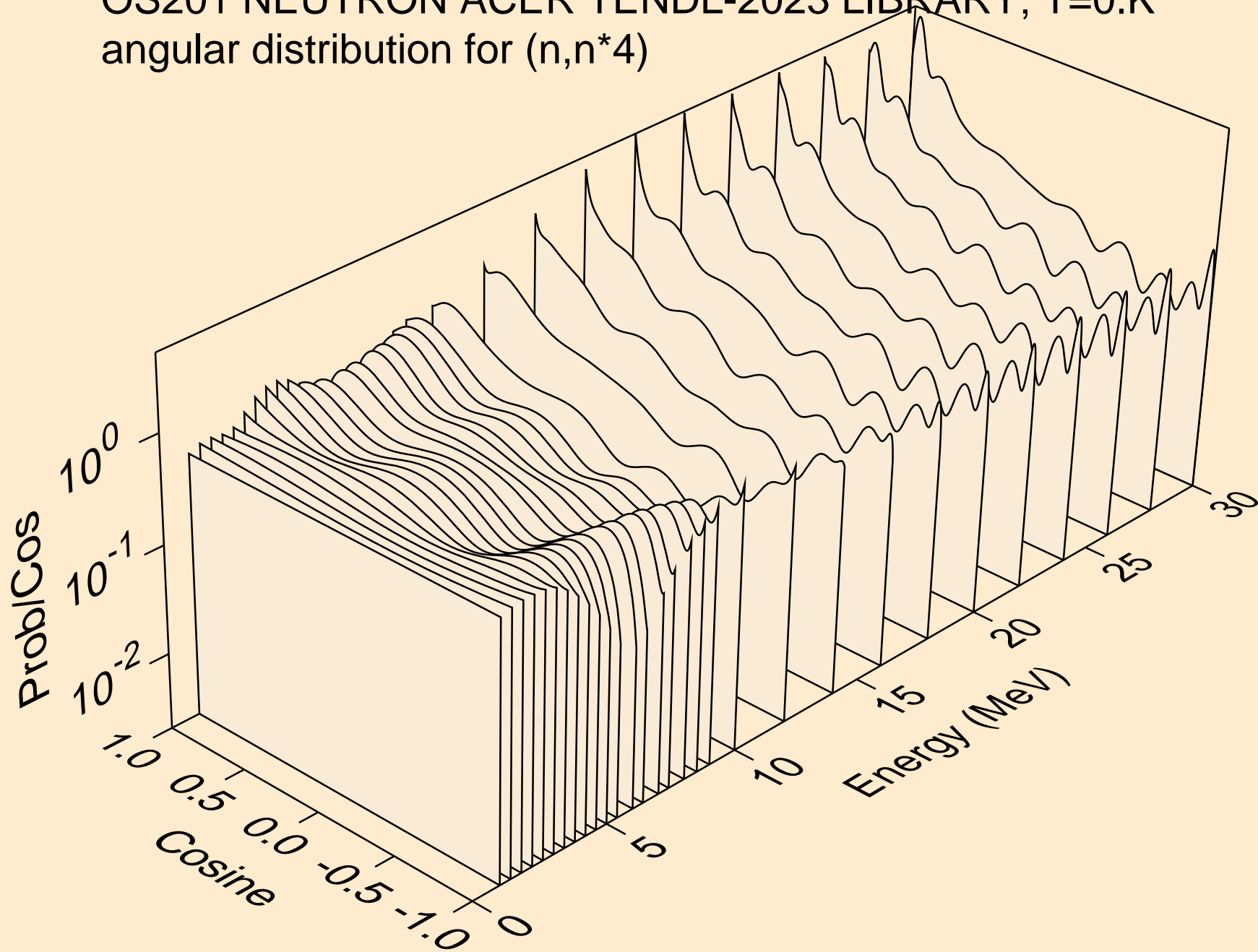

OS201 NEUTRON ACER TENDL-2023 LIBRARY; T=0.K  
angular distribution for (n,n\*5)

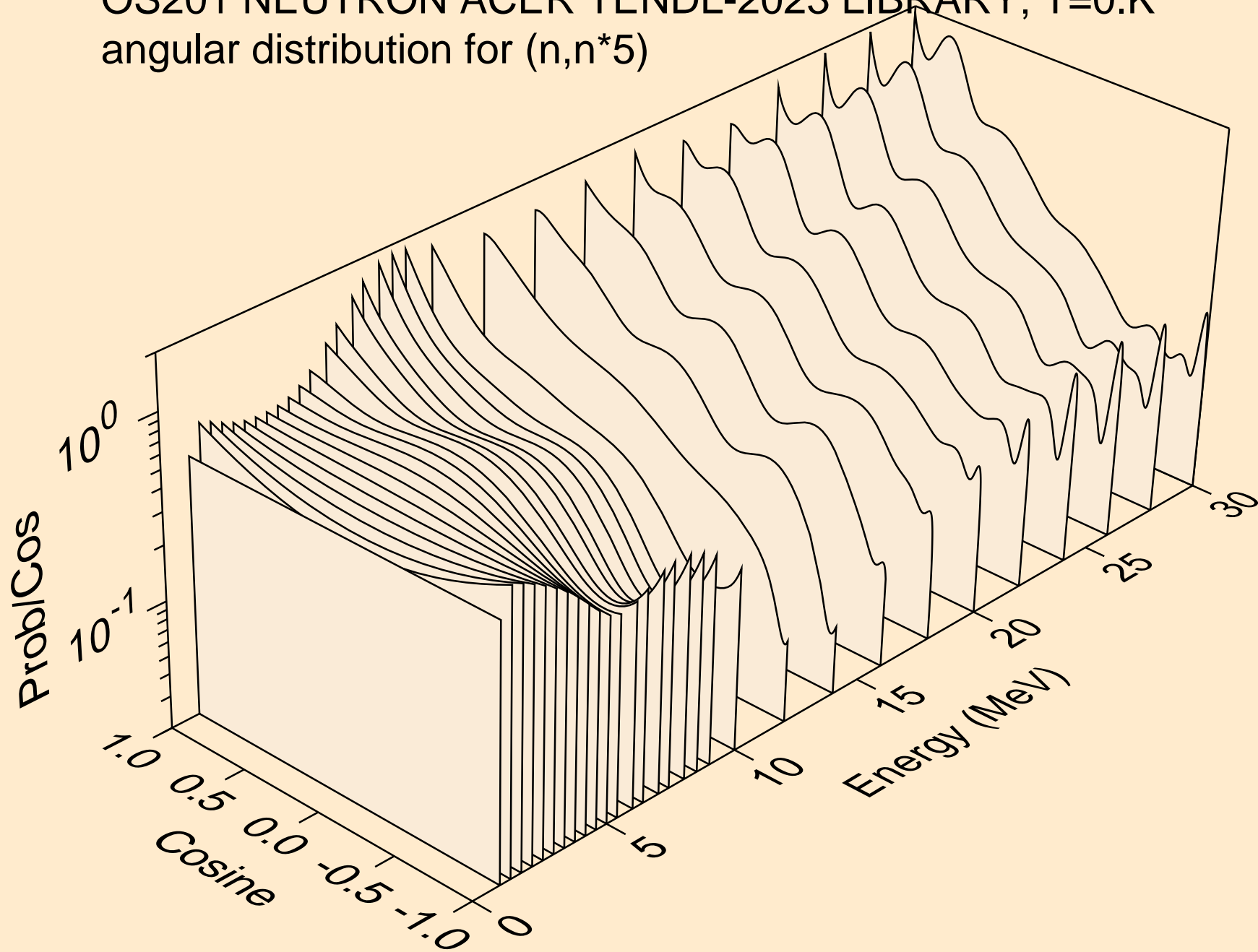

OS201 NEUTRON ACER TENDL-2023 LIBRARY; T=0.K  
angular distribution for (n,n\*6)

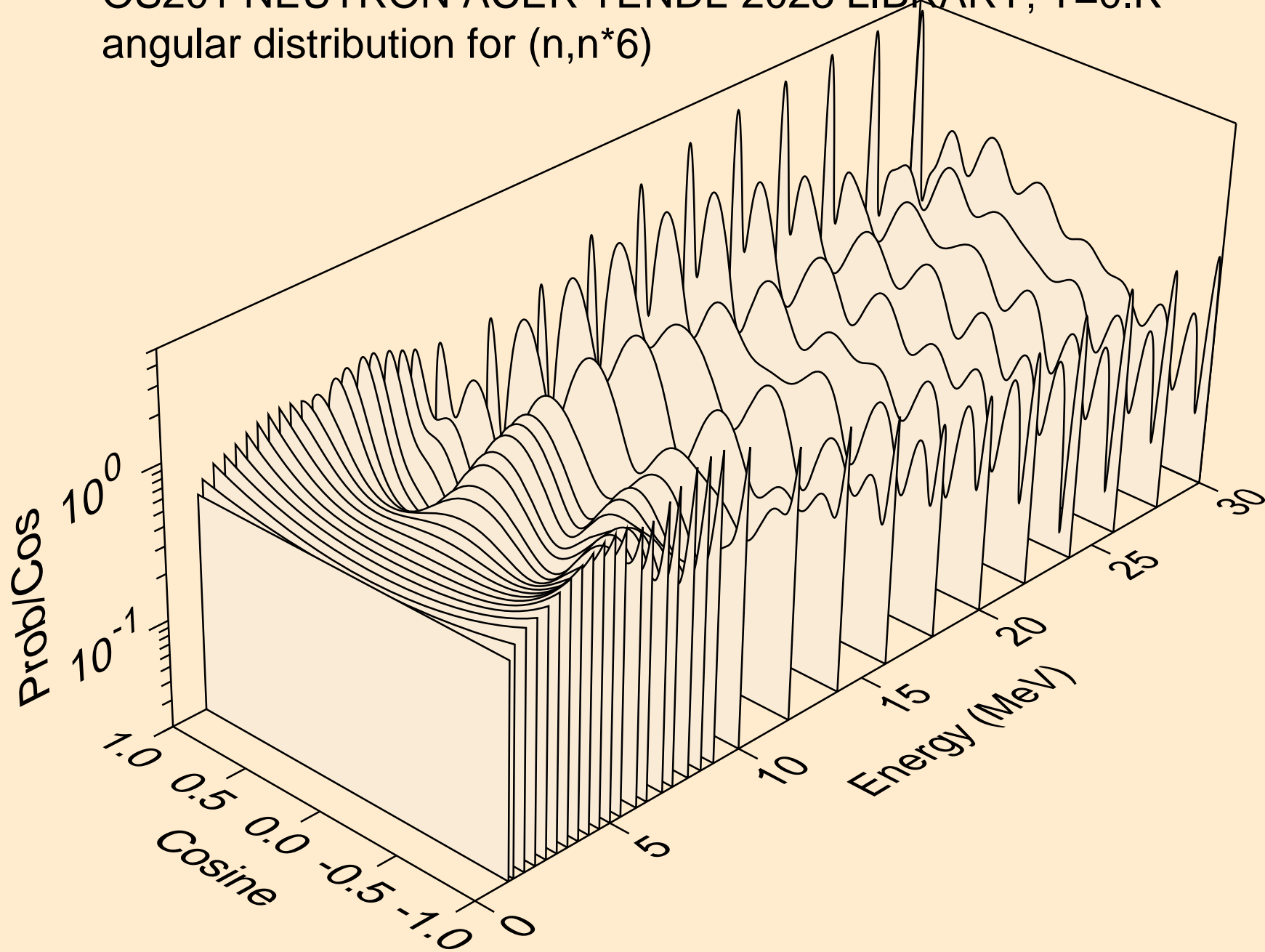

OS201 NEUTRON ACER TENDL-2023 LIBRARY; T=0.K  
angular distribution for (n,n\*7)

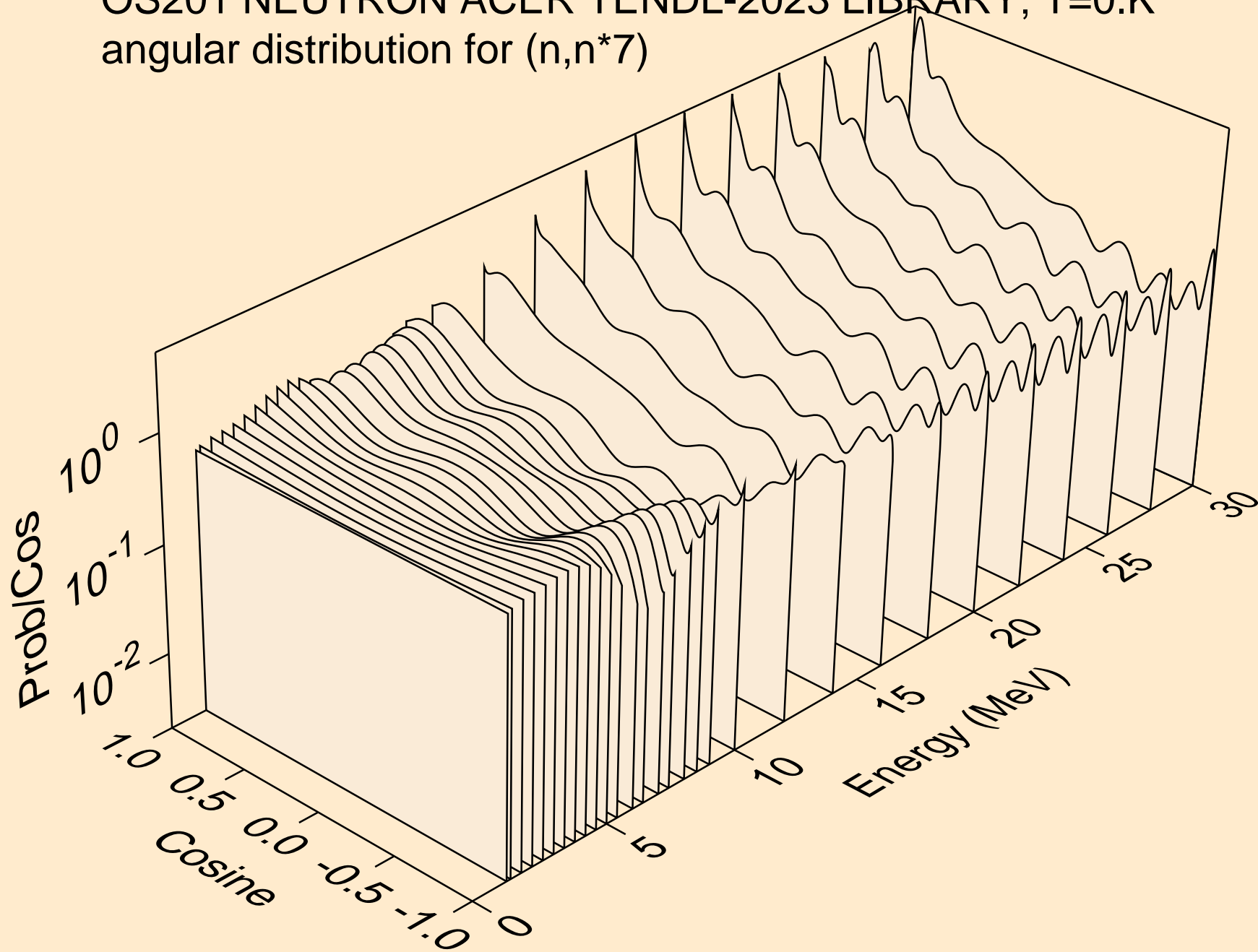

OS201 NEUTRON ACER TENDL-2023 LIBRARY; T=0.K  
angular distribution for (n,n\*8)

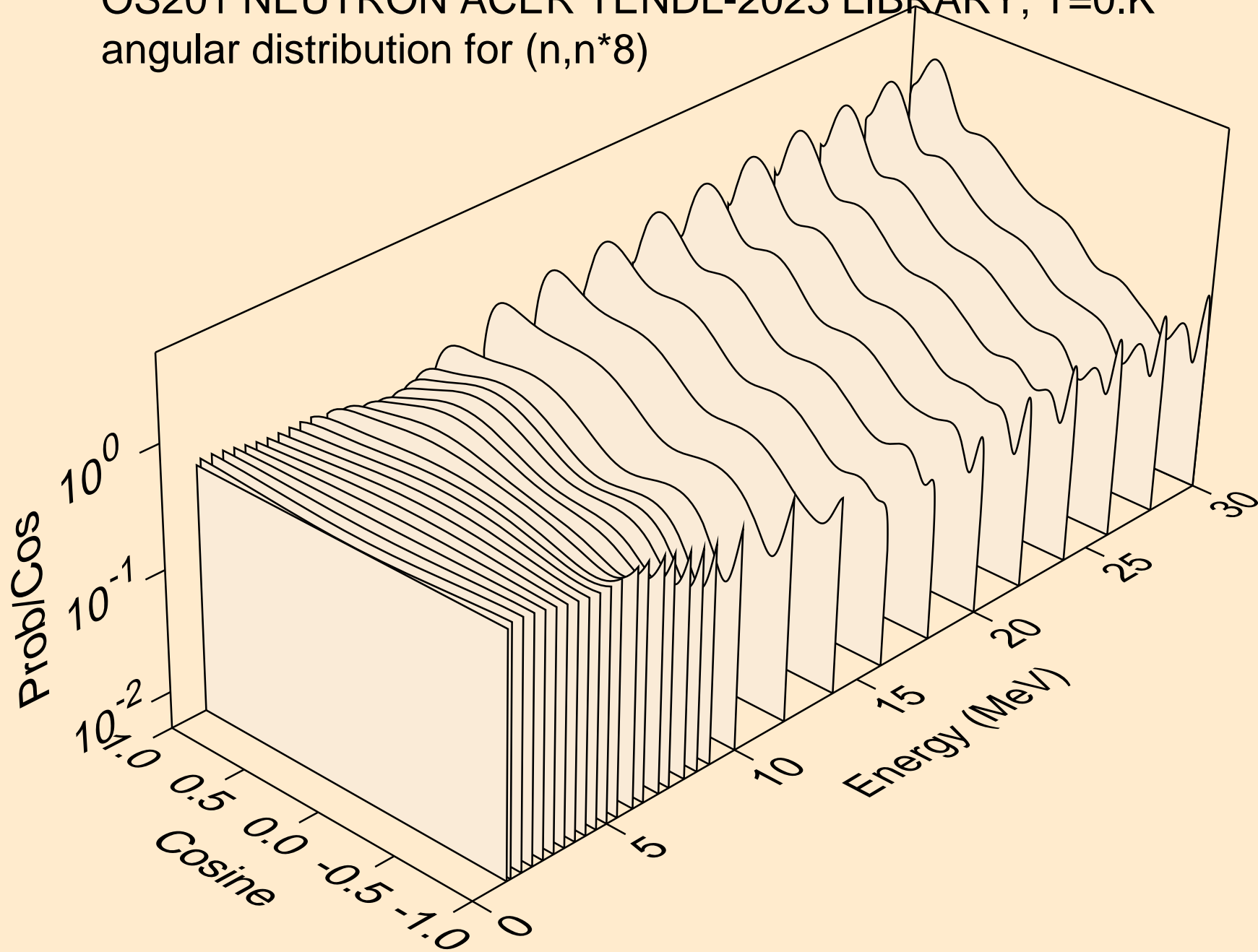

OS201 NEUTRON ACER TENDL-2023 LIBRARY; T=0.K  
angular distribution for (n,n\*9)

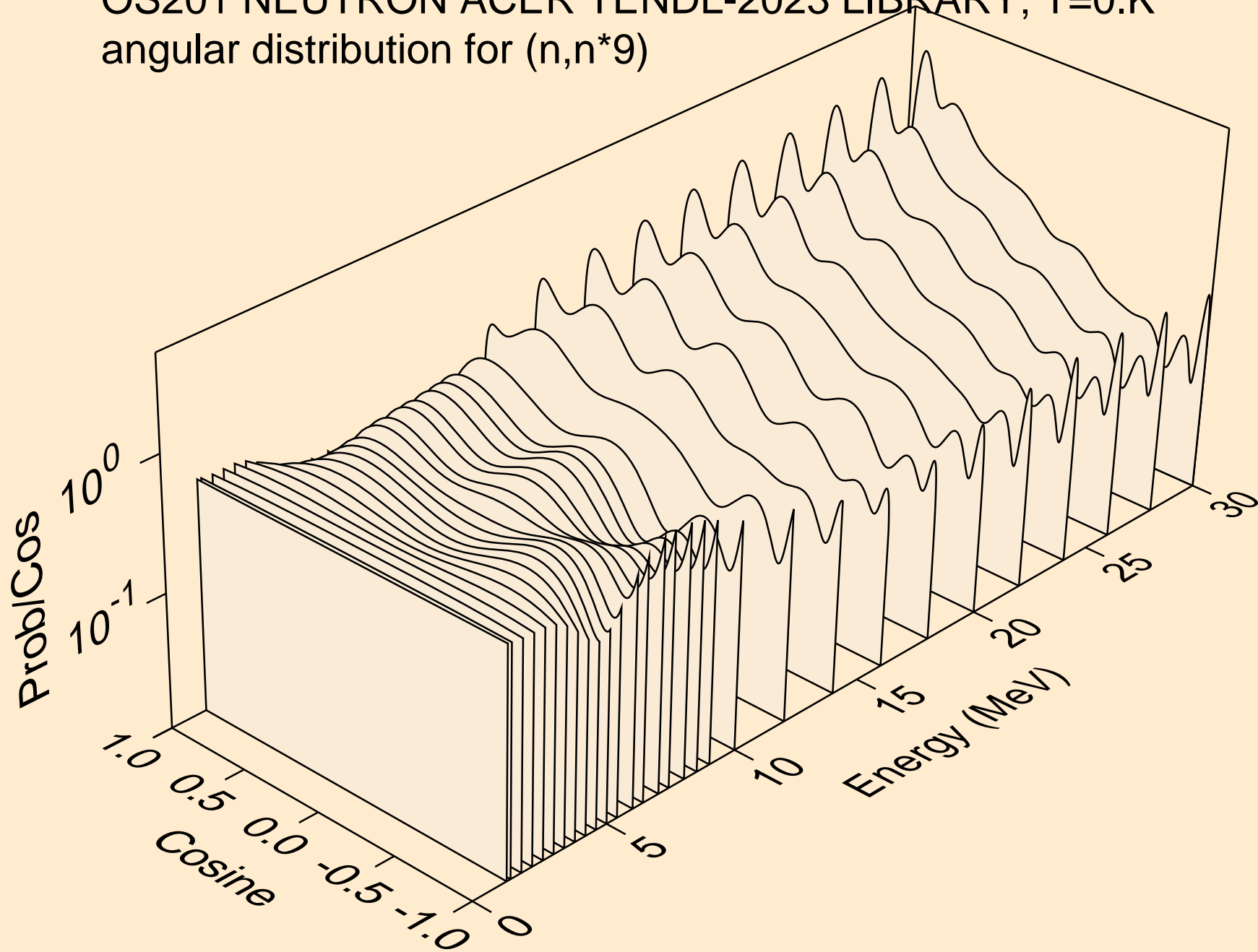

OS201 NEUTRON ACER TENDL-2023 LIBRARY; T=0.K  
angular distribution for (n,n\*10)

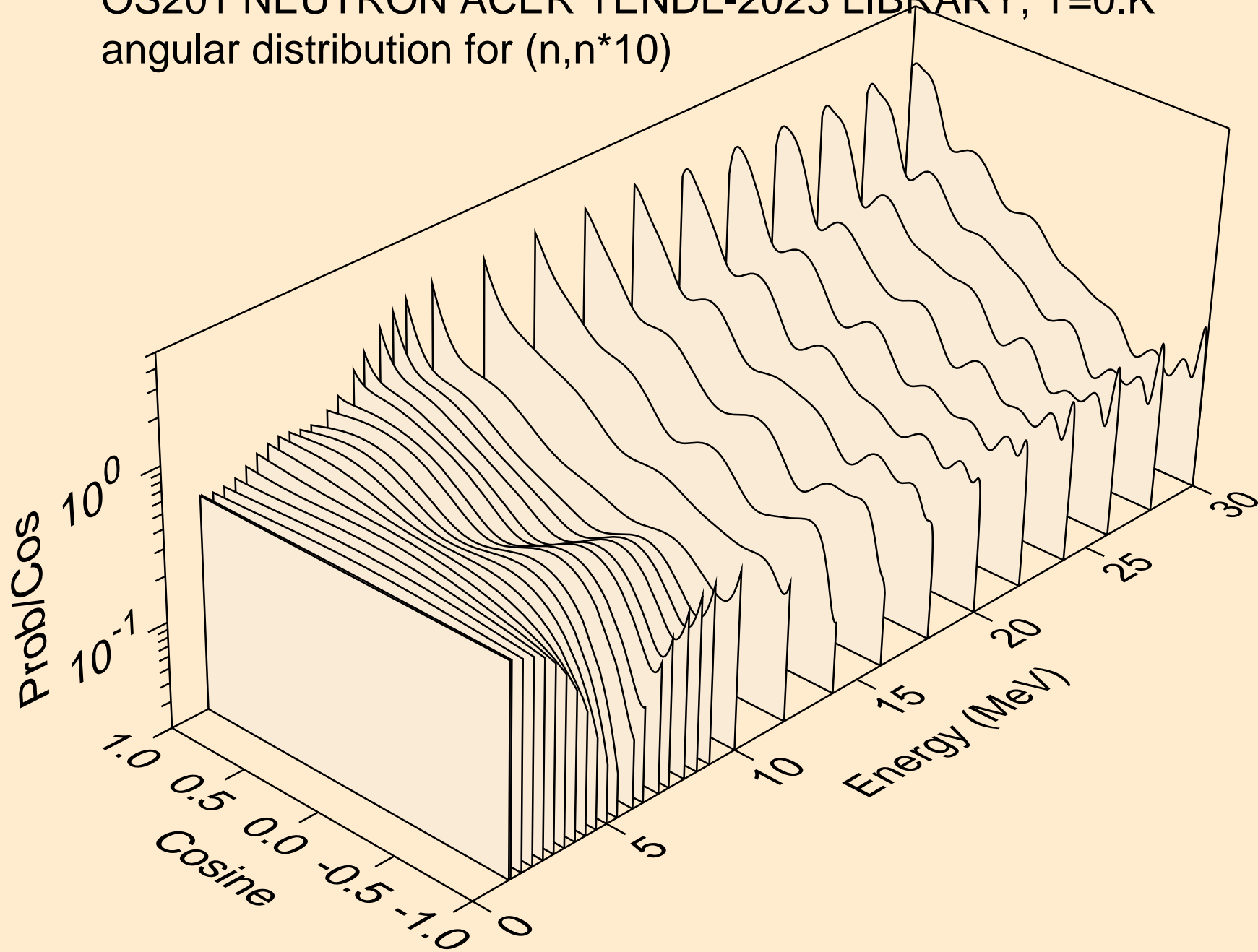

OS201 NEUTRON ACER TENDL-2023 LIBRARY; T=0.K  
angular distribution for (n,n\*11)

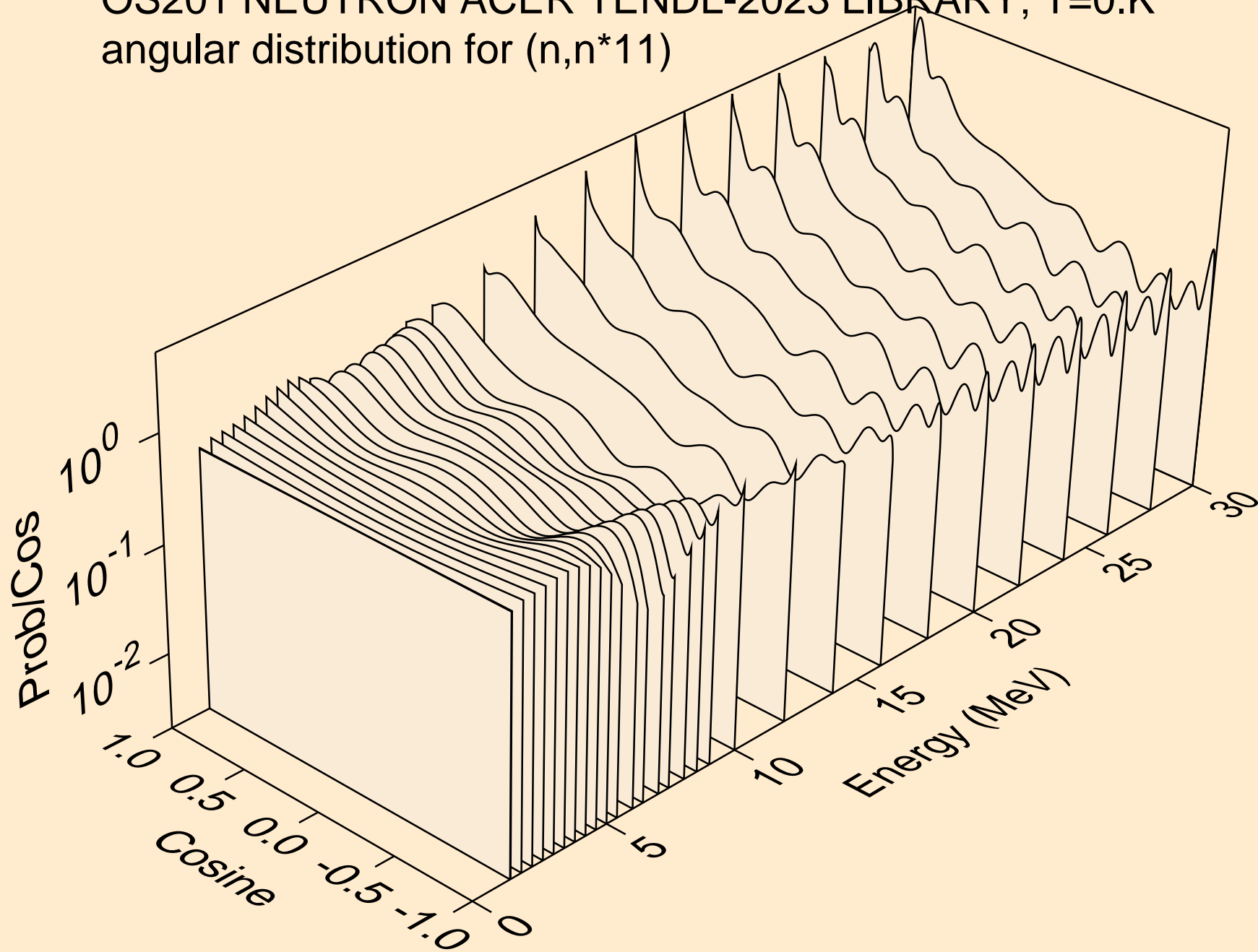

OS201 NEUTRON ACER TENDL-2023 LIBRARY; T=0.K  
angular distribution for (n,n\*12)

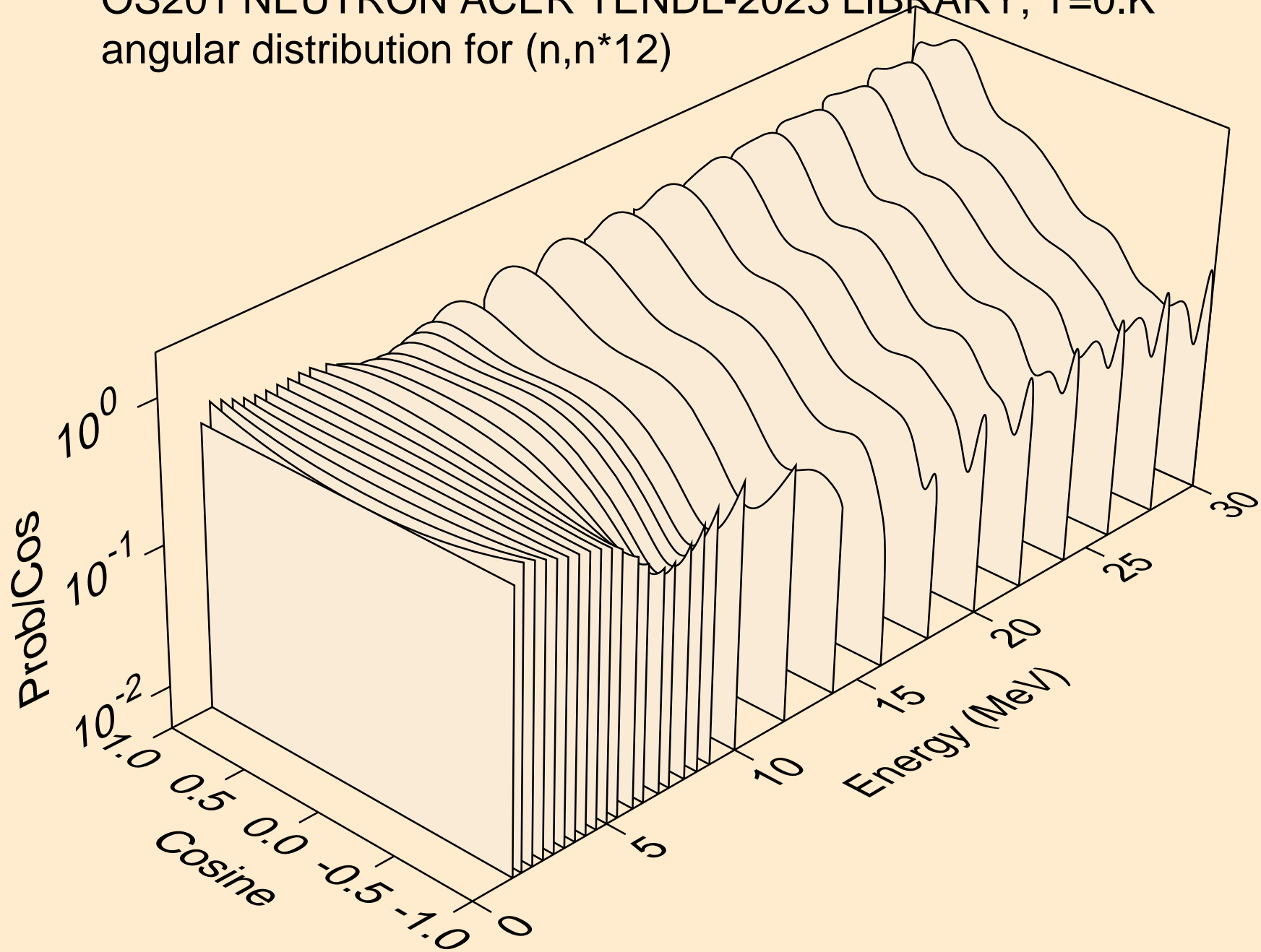

OS201 NEUTRON ACER TENDL-2023 LIBRARY; T=0.K  
angular distribution for (n,n\*13)

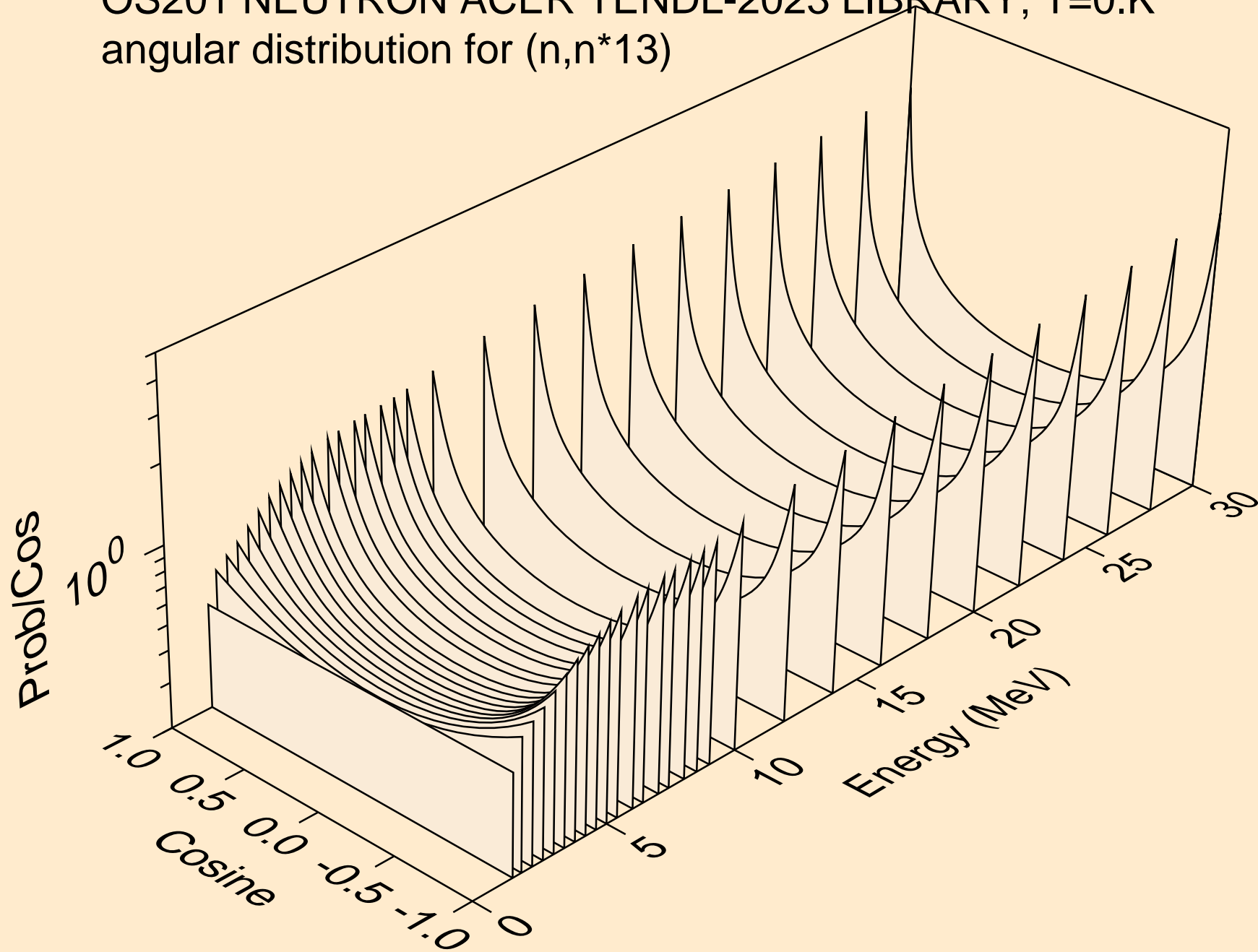

OS201 NEUTRON ACER TENDL-2023 LIBRARY; T=0.K  
angular distribution for (n,n\*14)

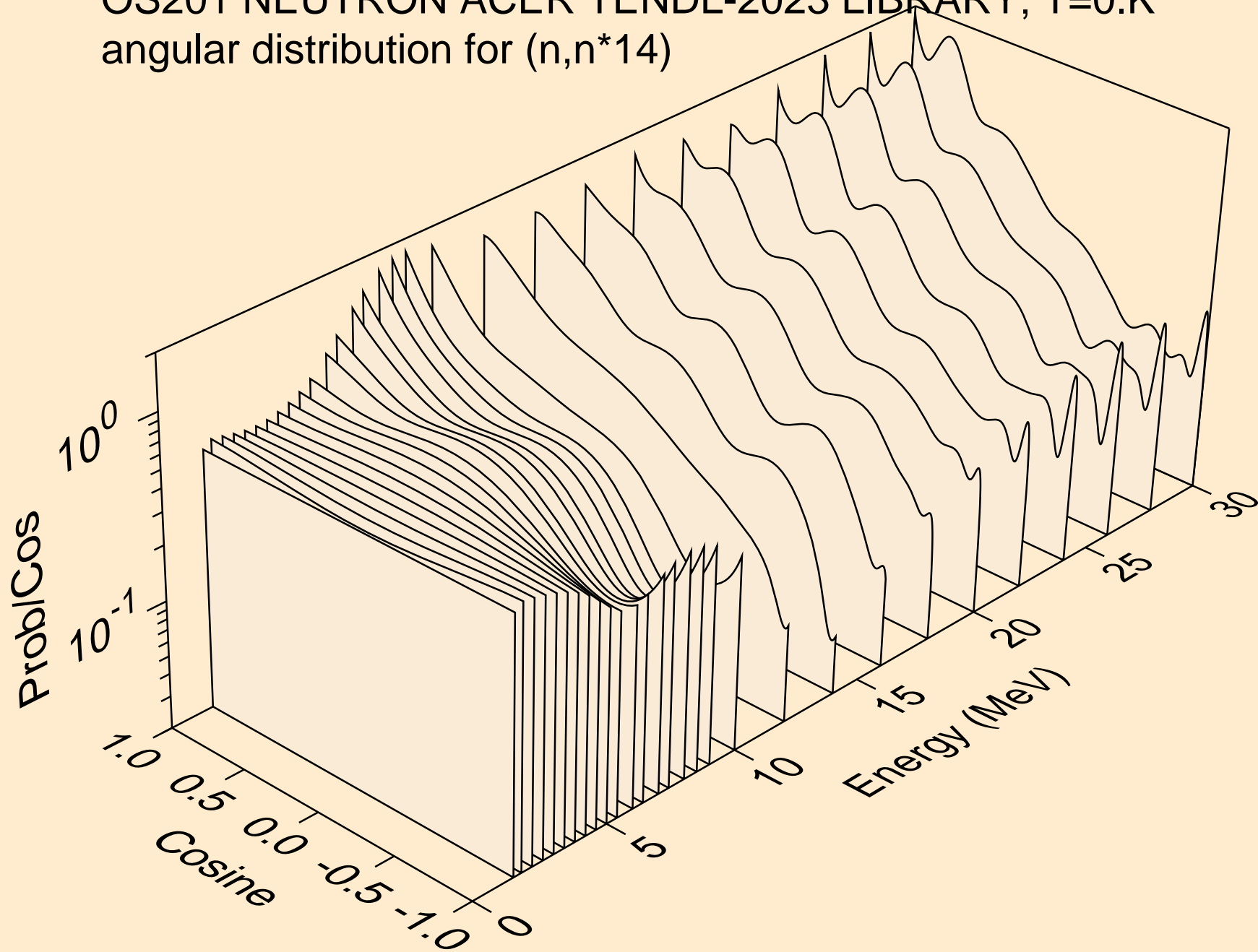

OS201 NEUTRON ACER TENDL-2023 LIBRARY; T=0.K  
angular distribution for (n,n\*15)

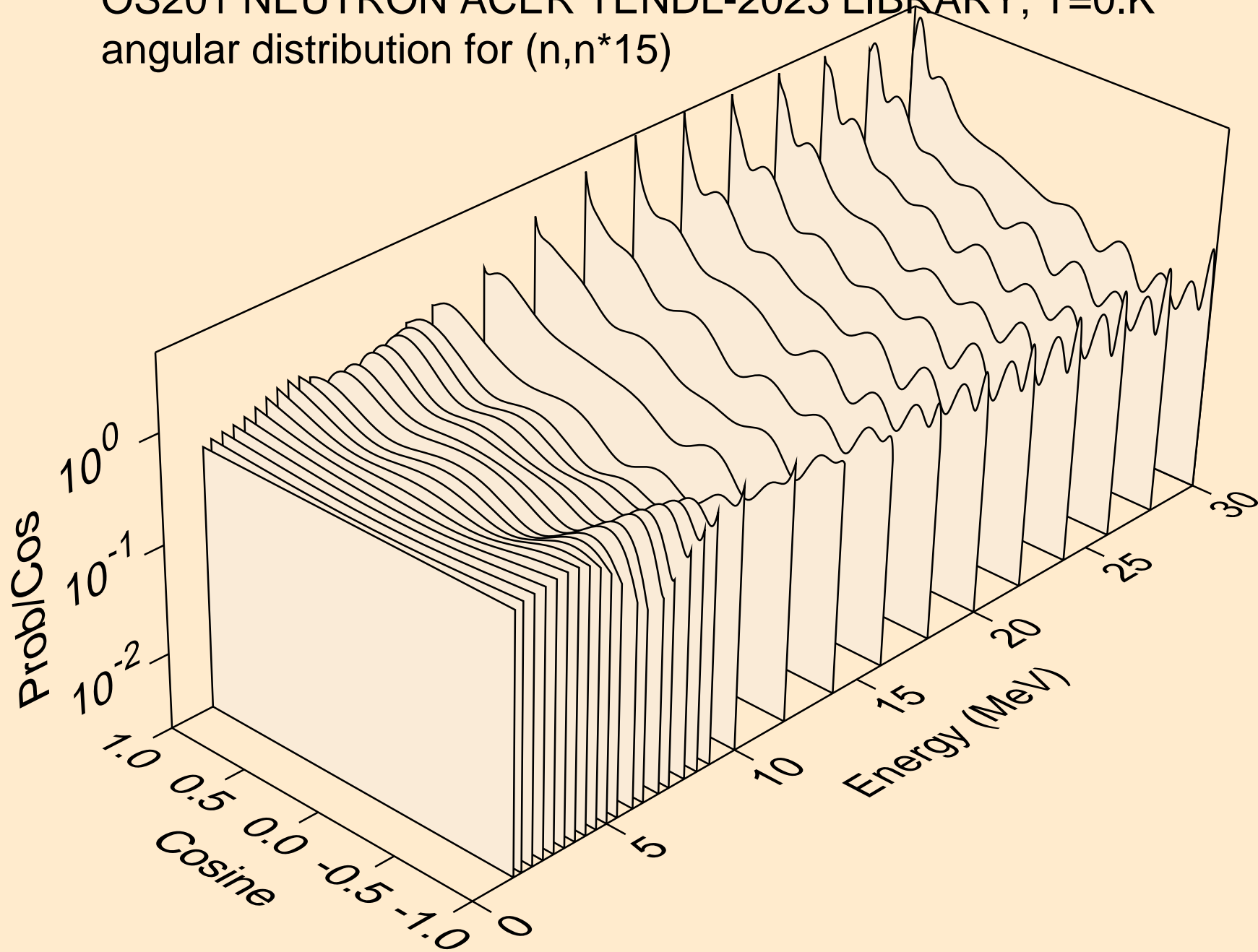

OS201 NEUTRON ACER TENDL-2023 LIBRARY; T=0.K  
angular distribution for (n,n\*16)

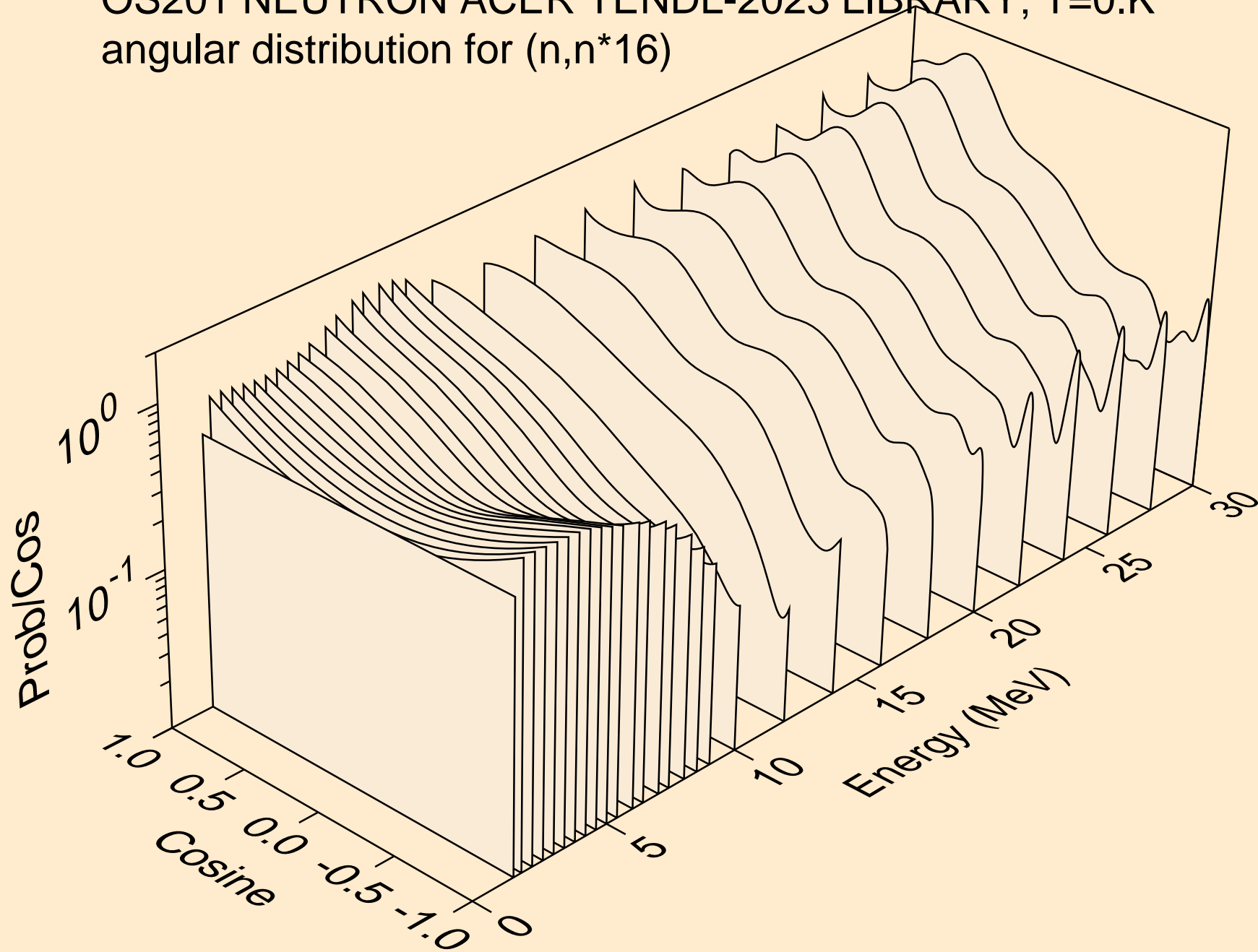

OS201 NEUTRON ACER TENDL-2023 LIBRARY; T=0.K  
angular distribution for (n,n\*17)

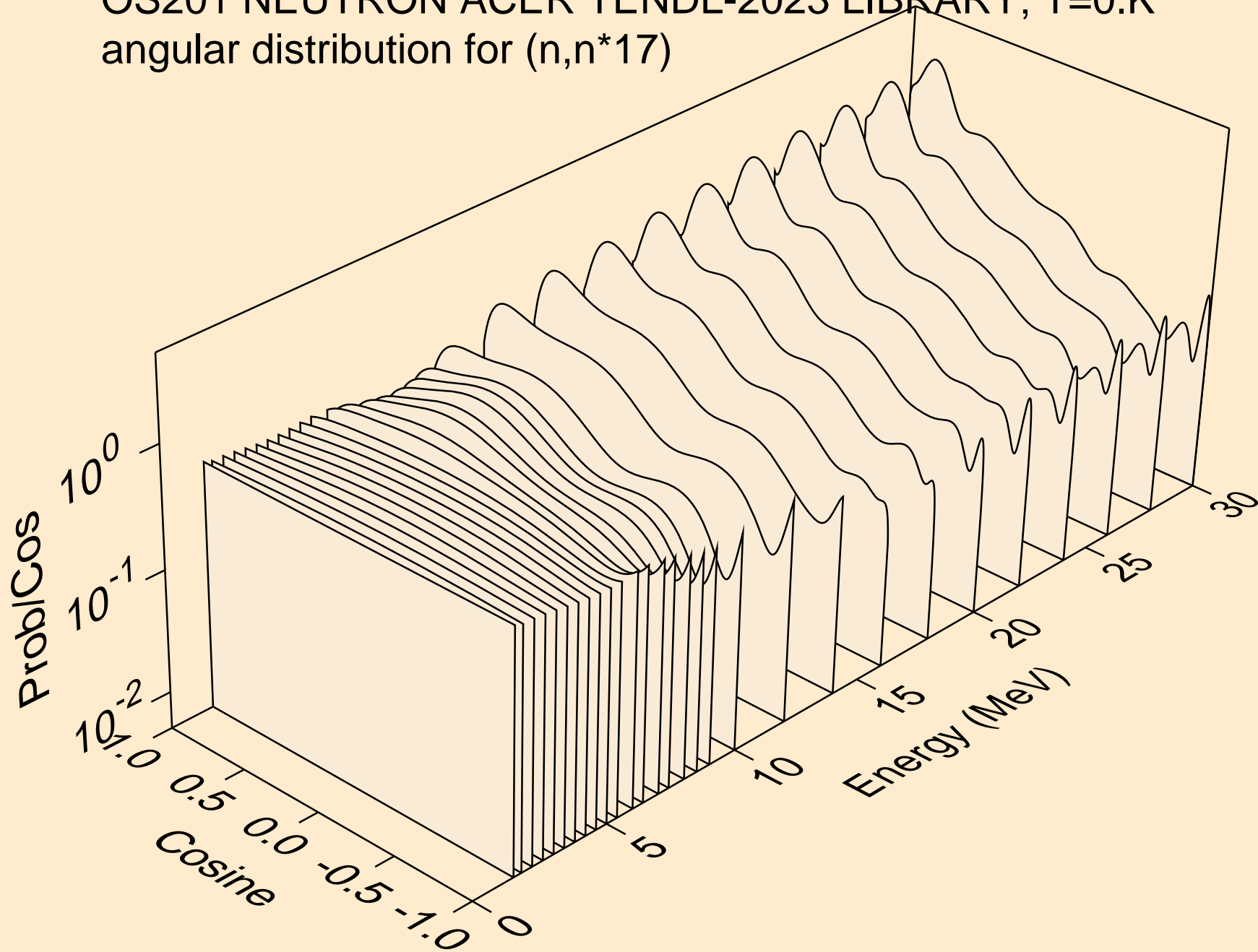

OS201 NEUTRON ACER TENDL-2023 LIBRARY; T=0.K  
angular distribution for (n,n\*18)

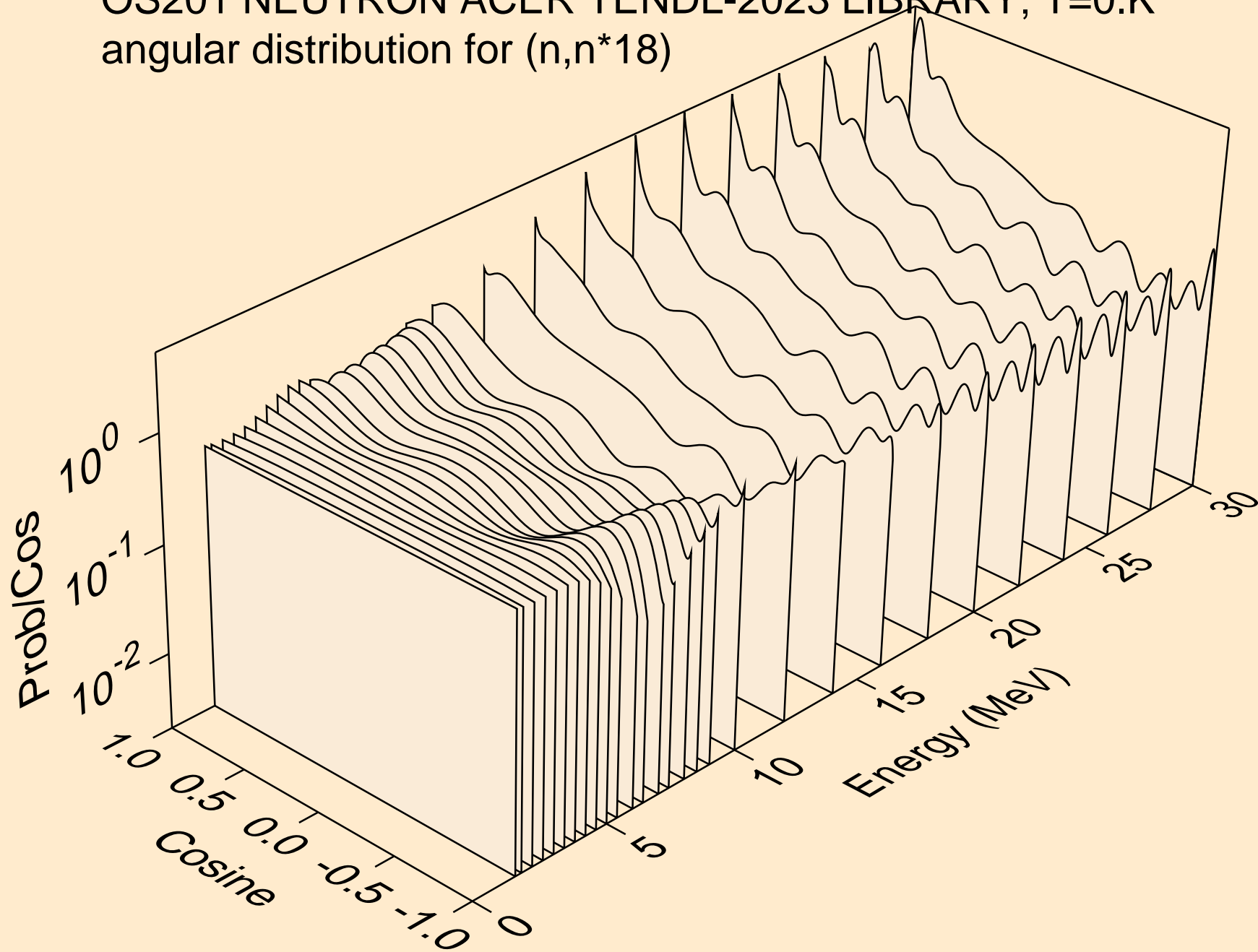

OS201 NEUTRON ACER TENDL-2023 LIBRARY; T=0.K  
angular distribution for (n,n\*19)

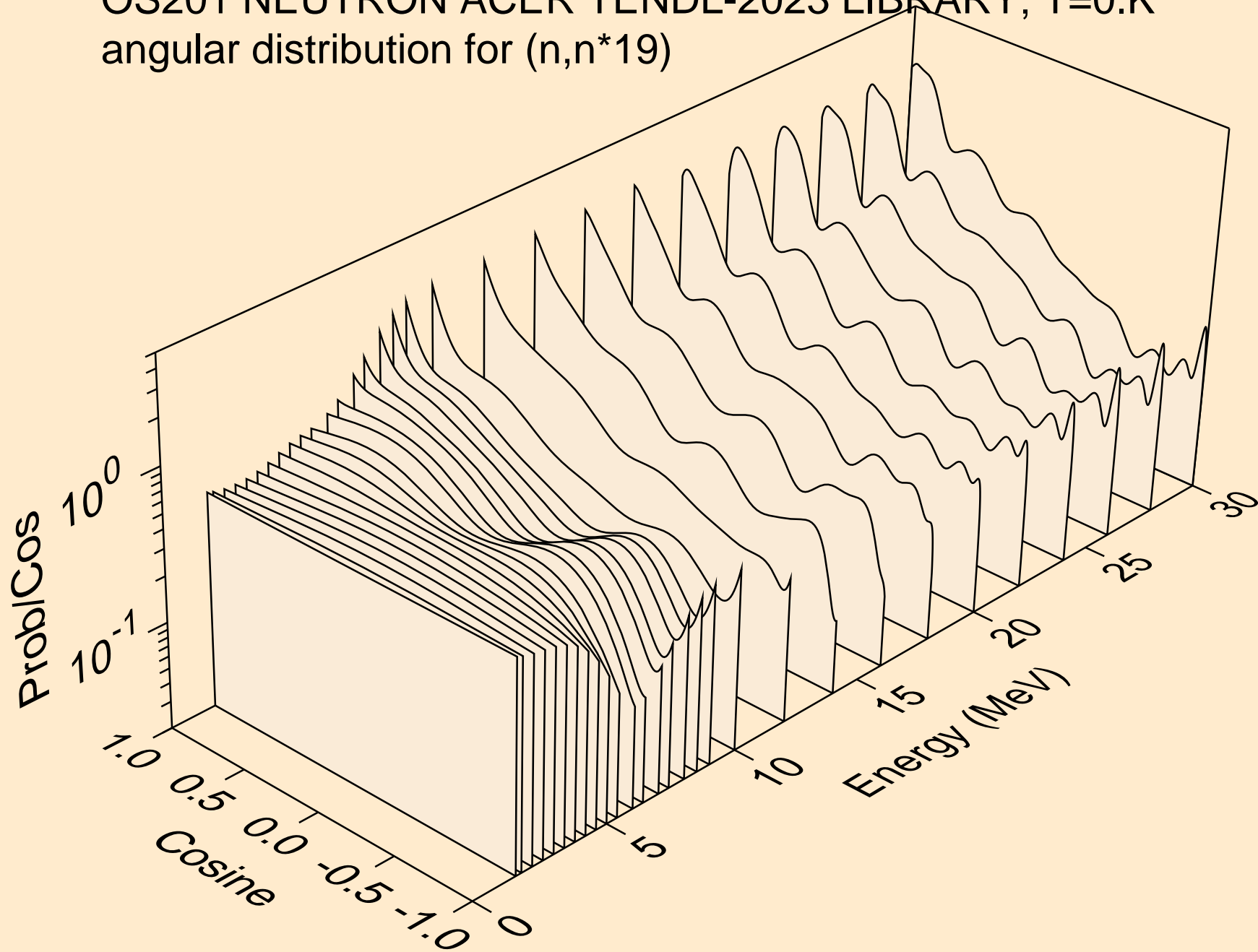

OS201 NEUTRON ACER TENDL-2023 LIBRARY; T=0.K  
angular distribution for (n,n\*20)

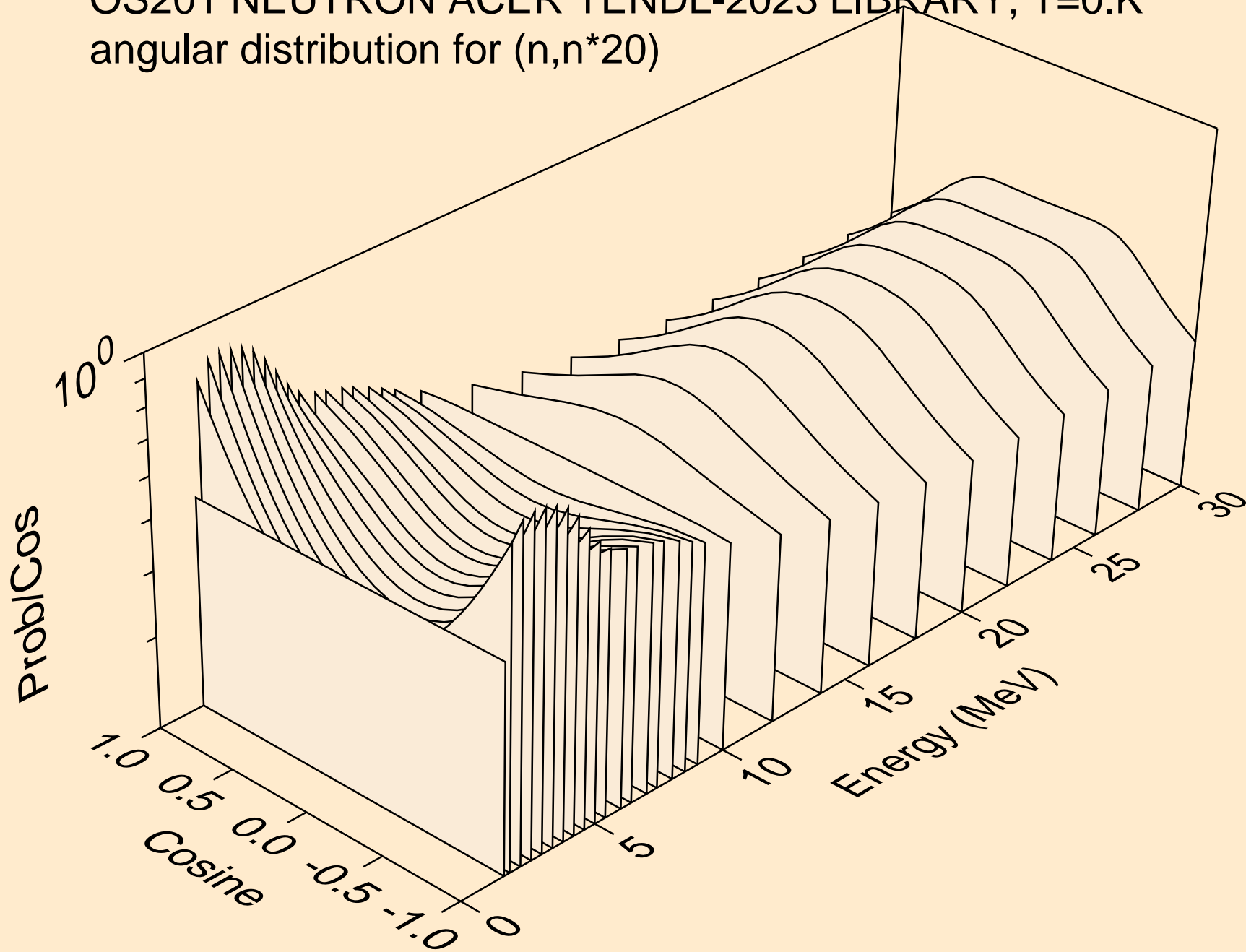

OS201 NEUTRON ACER TENDL-2023 LIBRARY; T=0.K  
angular distribution for (n,n\*21)

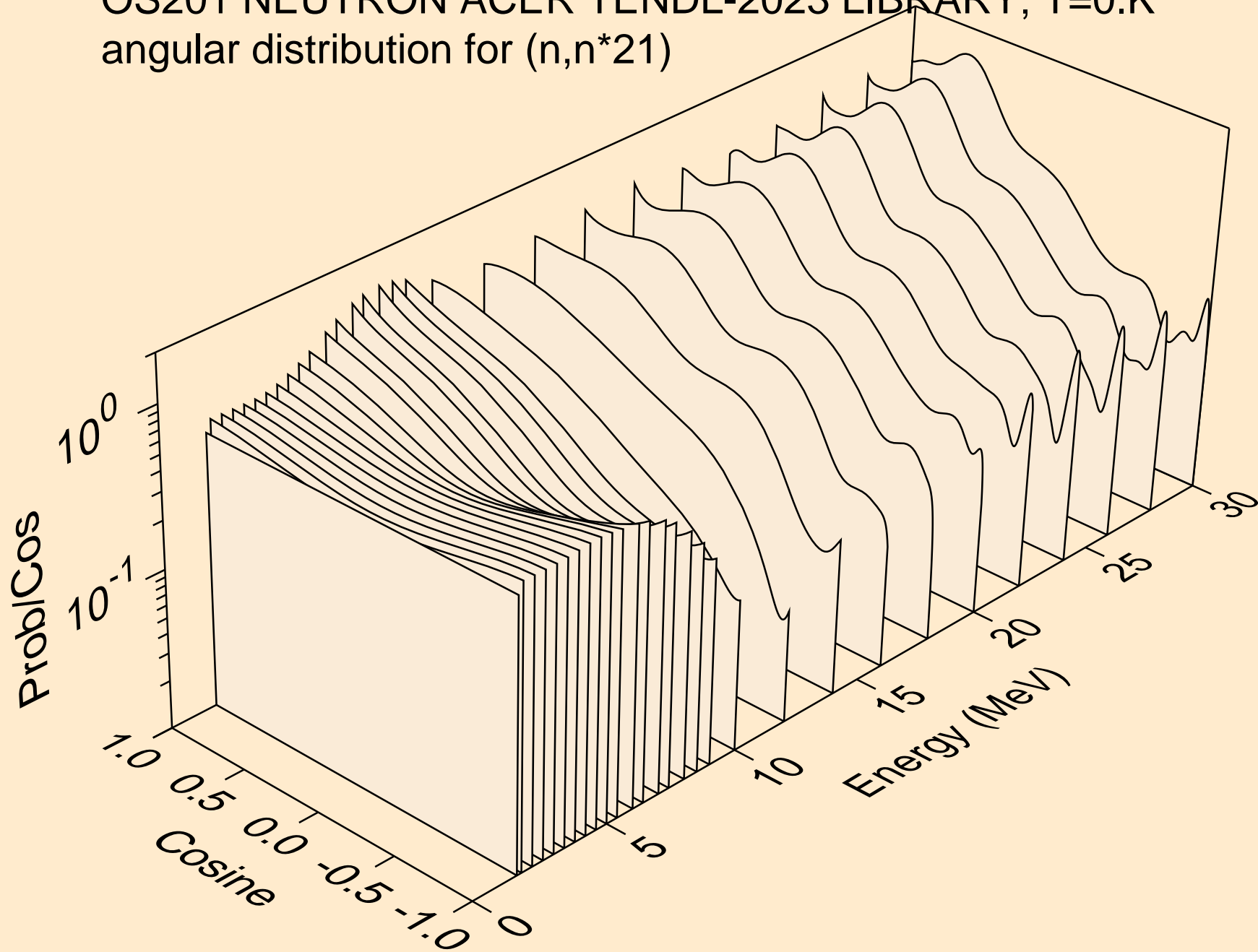

OS201 NEUTRON ACER TENDL-2023 LIBRARY; T=0.K  
angular distribution for (n,n\*22)

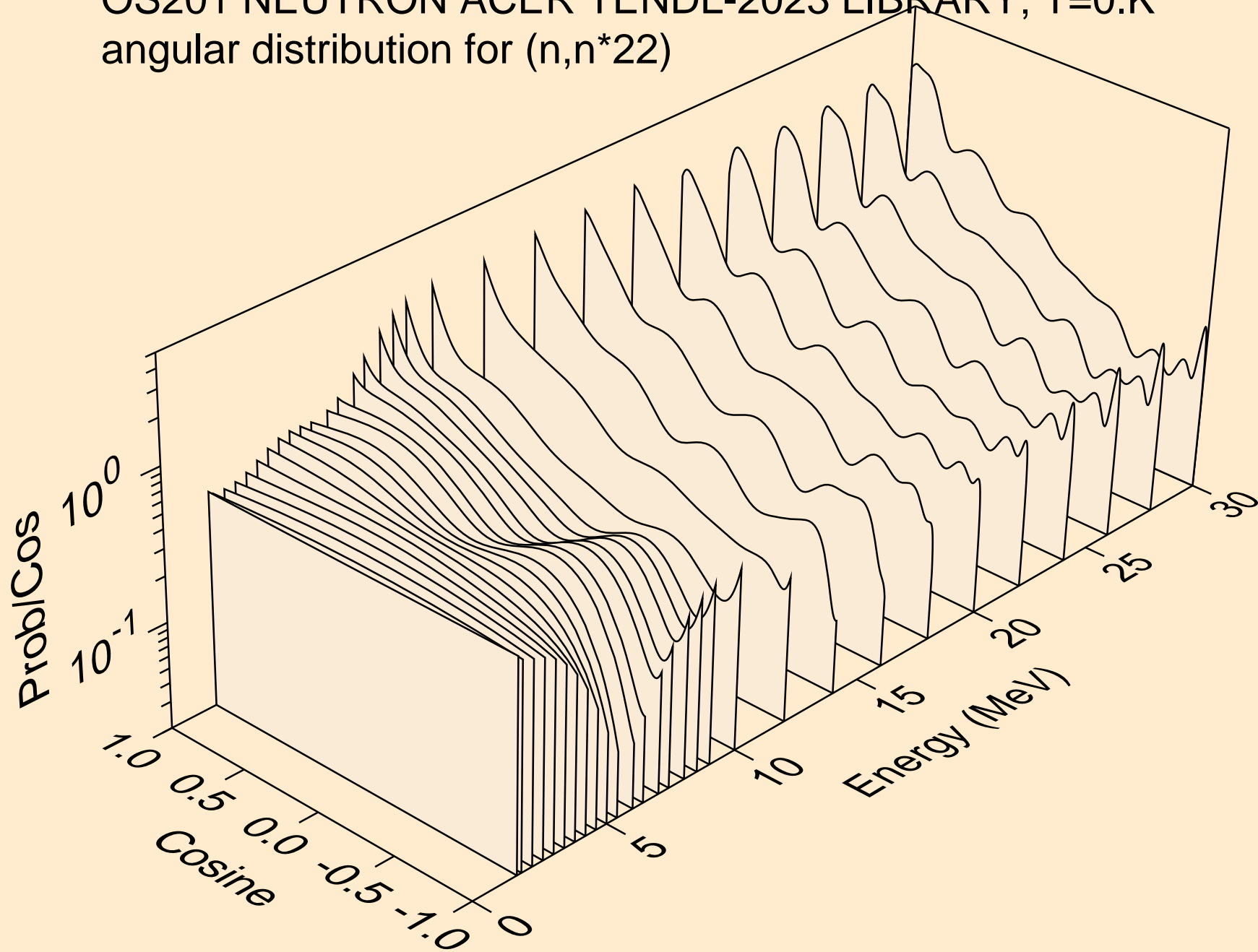

OS201 NEUTRON ACER TENDL-2023 LIBRARY; T=0.K  
angular distribution for (n,n\*23)

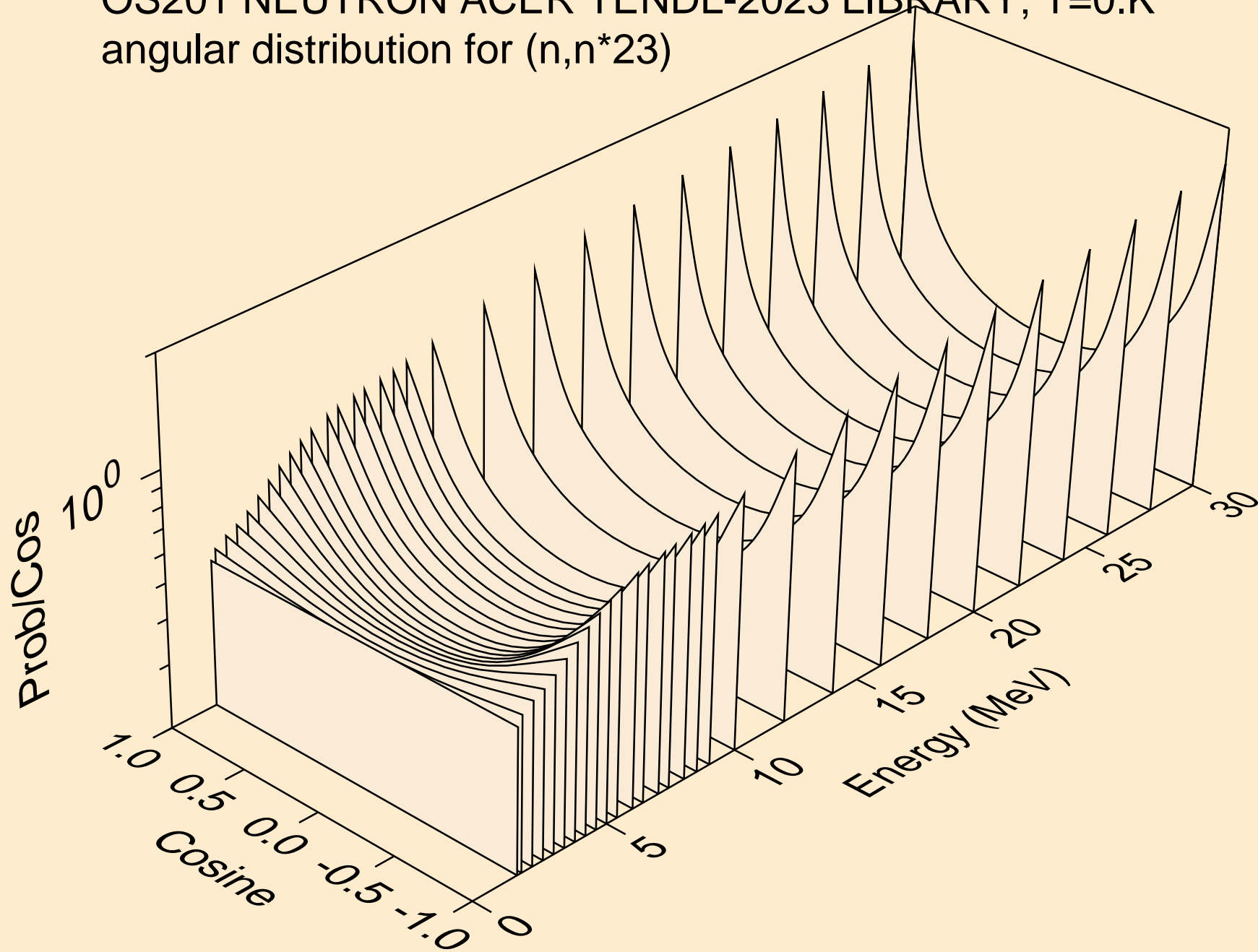

OS201 NEUTRON ACER TENDL-2023 LIBRARY; T=0.K  
angular distribution for (n,n\*24)

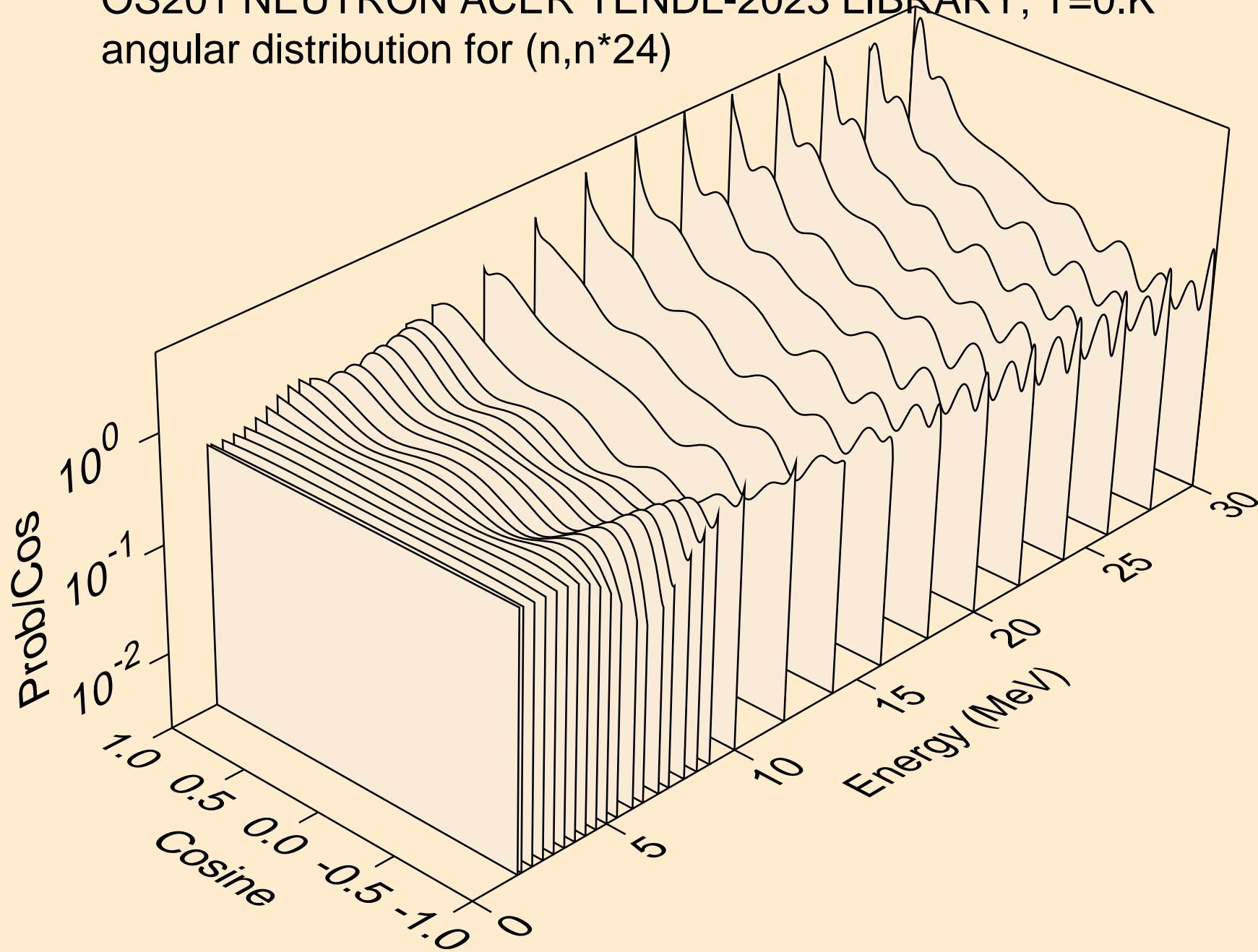

OS201 NEUTRON ACER TENDL-2023 LIBRARY; T=0.K  
angular distribution for (n,n\*25)

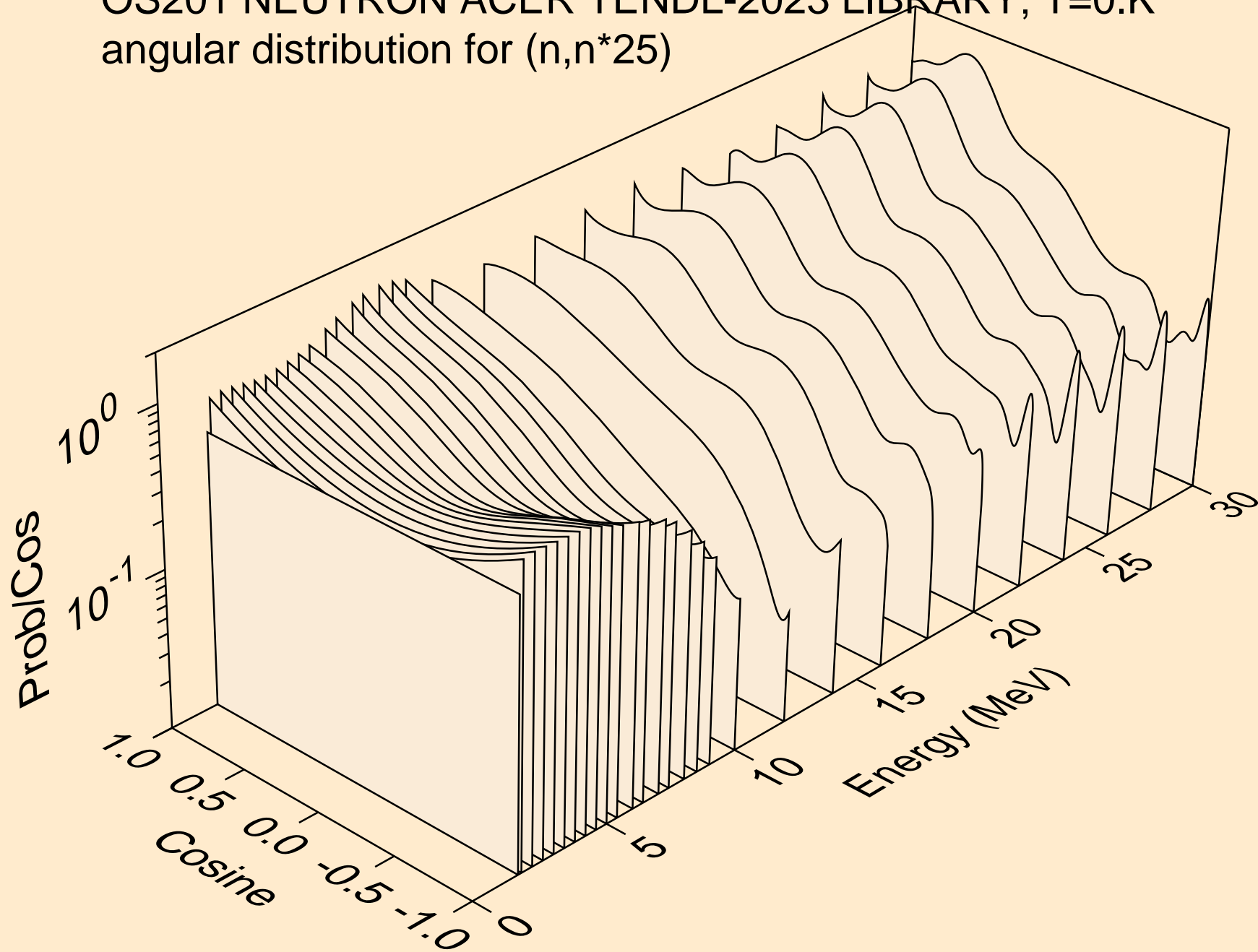

OS201 NEUTRON ACER TENDL-2023 LIBRARY; T=0.K  
angular distribution for (n,n\*26)

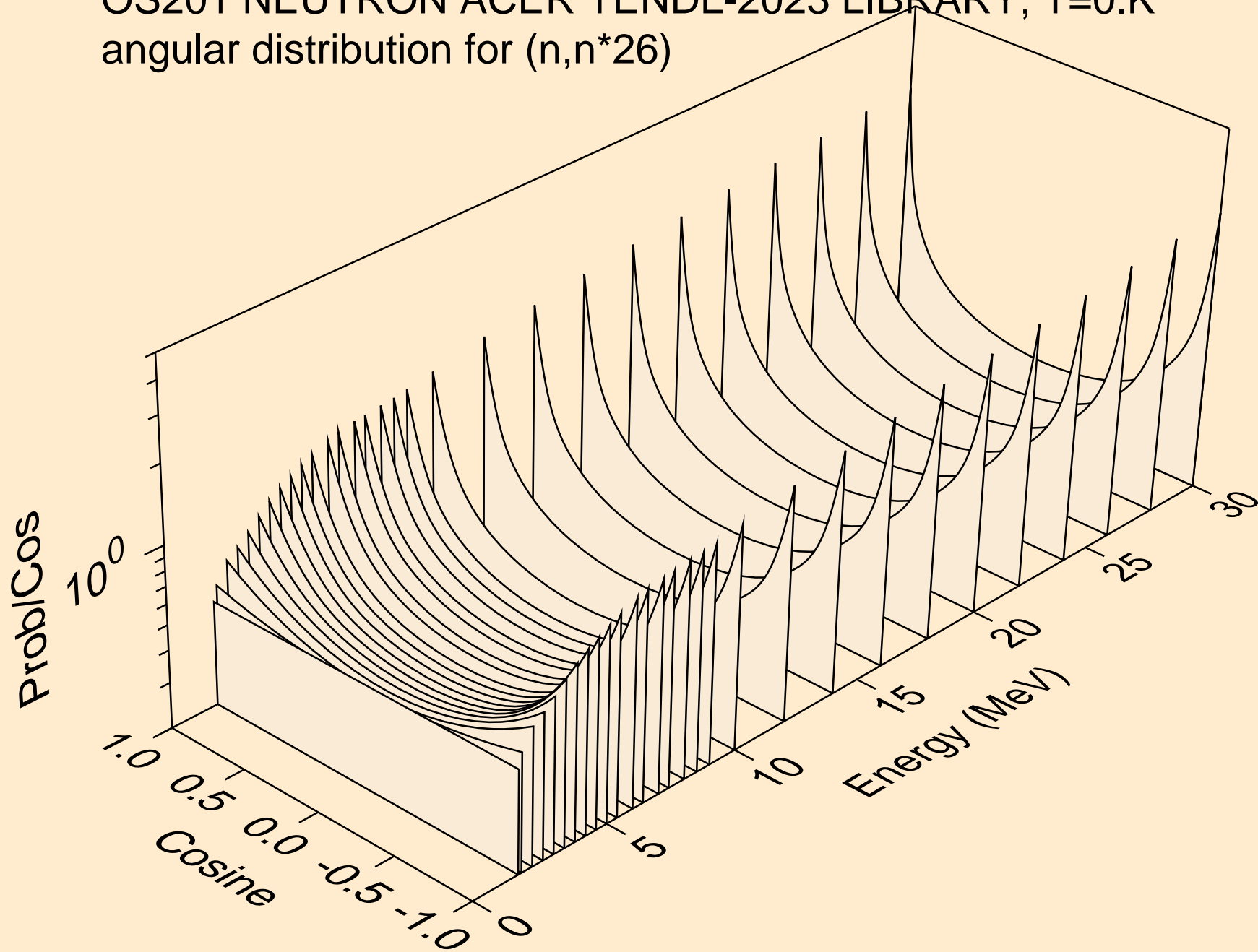

OS201 NEUTRON ACER TENDL-2023 LIBRARY; T=0.K  
angular distribution for (n,n\*27)

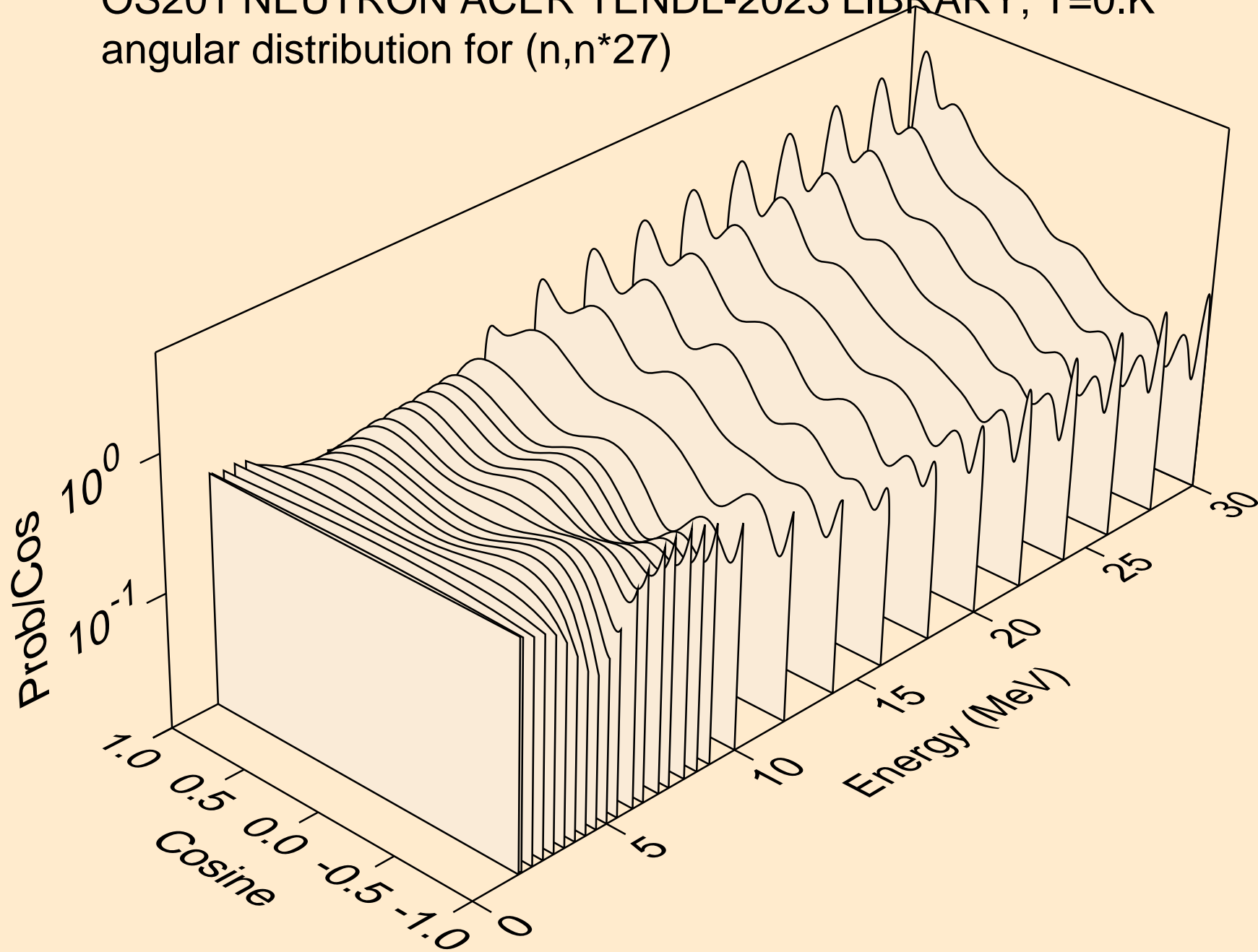

OS201 NEUTRON ACER TENDL-2023 LIBRARY; T=0.K  
angular distribution for (n,n\*28)

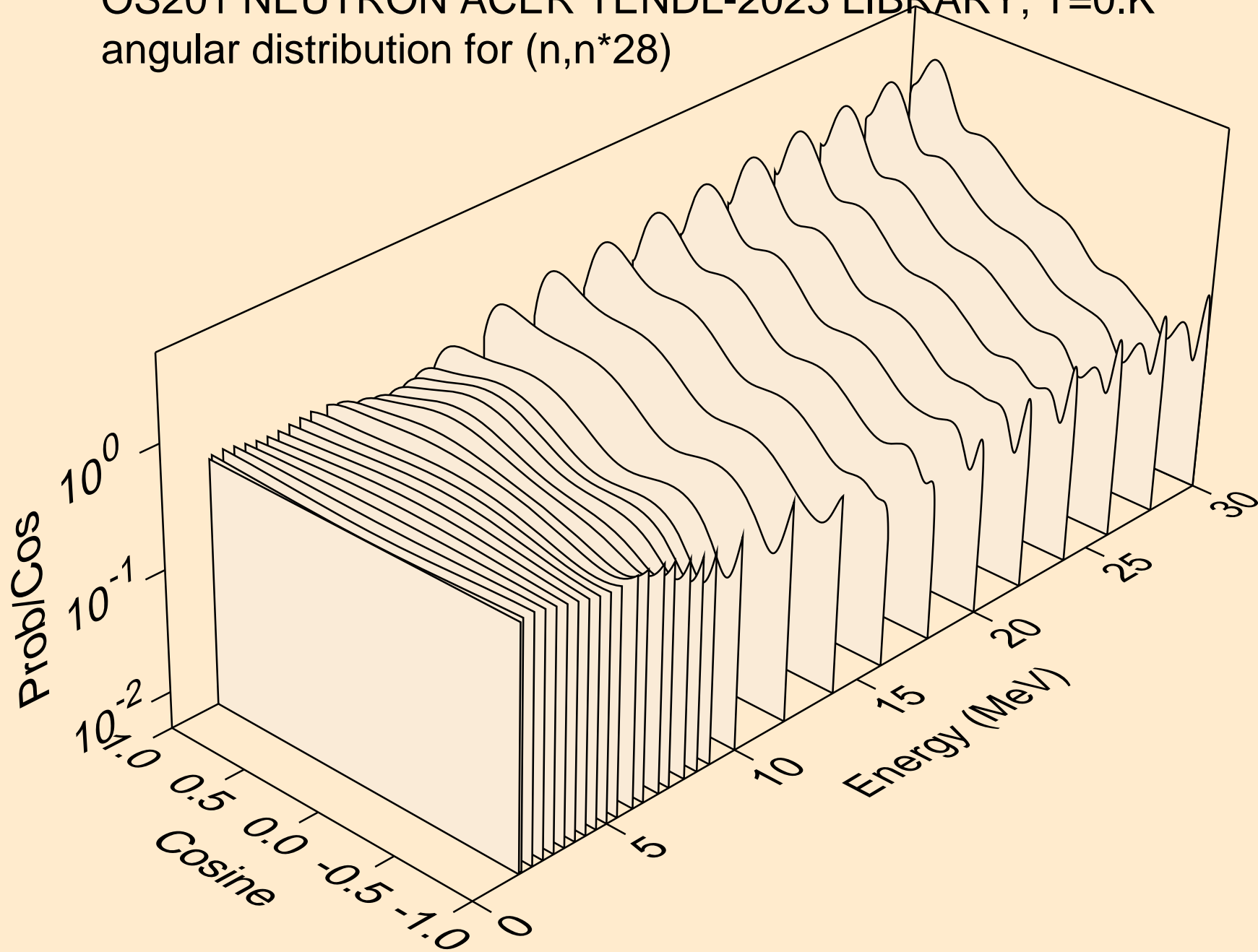

OS201 NEUTRON ACER TENDL-2023 LIBRARY; T=0.K  
angular distribution for (n,n\*29)

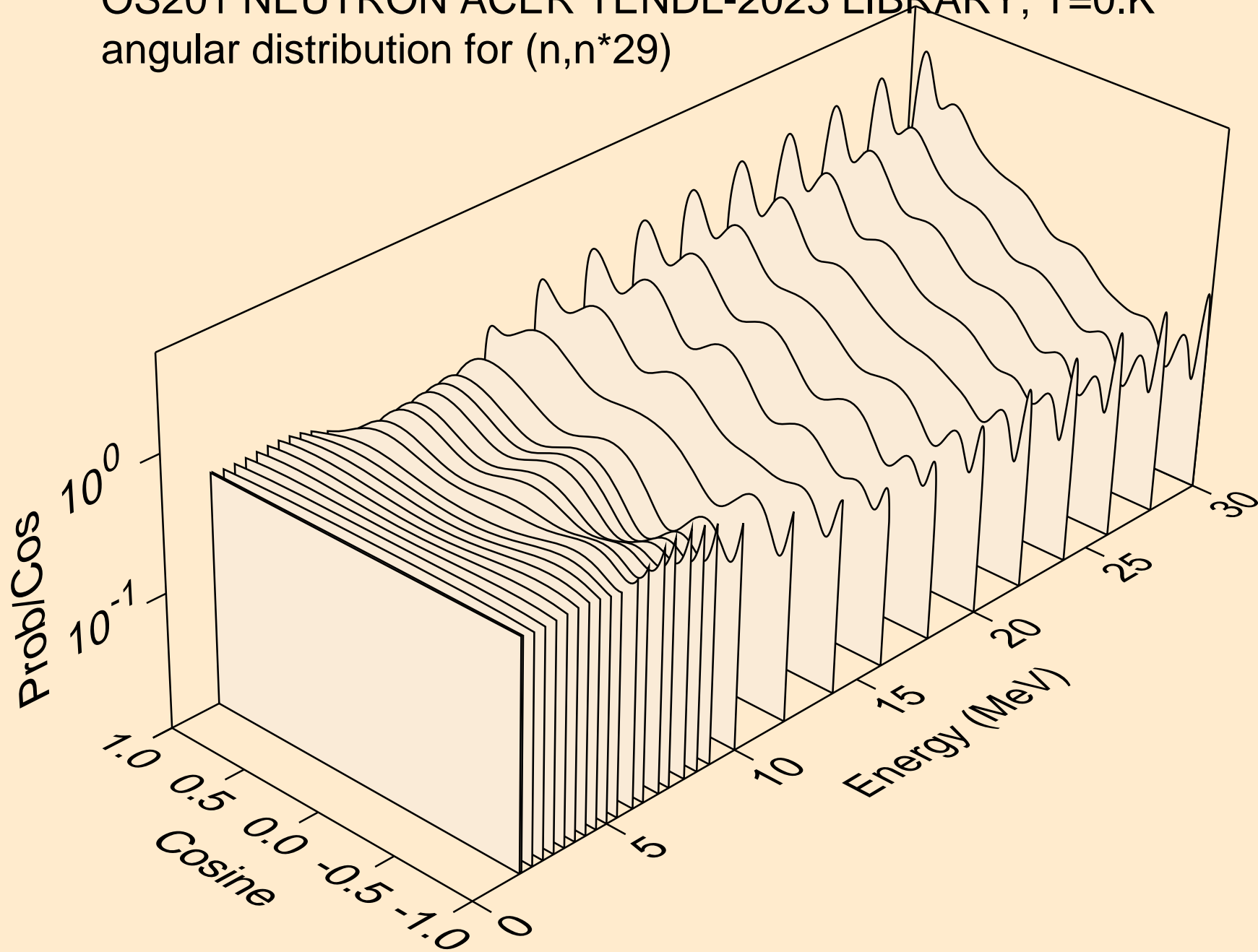

OS201 NEUTRON ACER TENDL-2023 LIBRARY; T=0.K  
angular distribution for (n,n\*30)

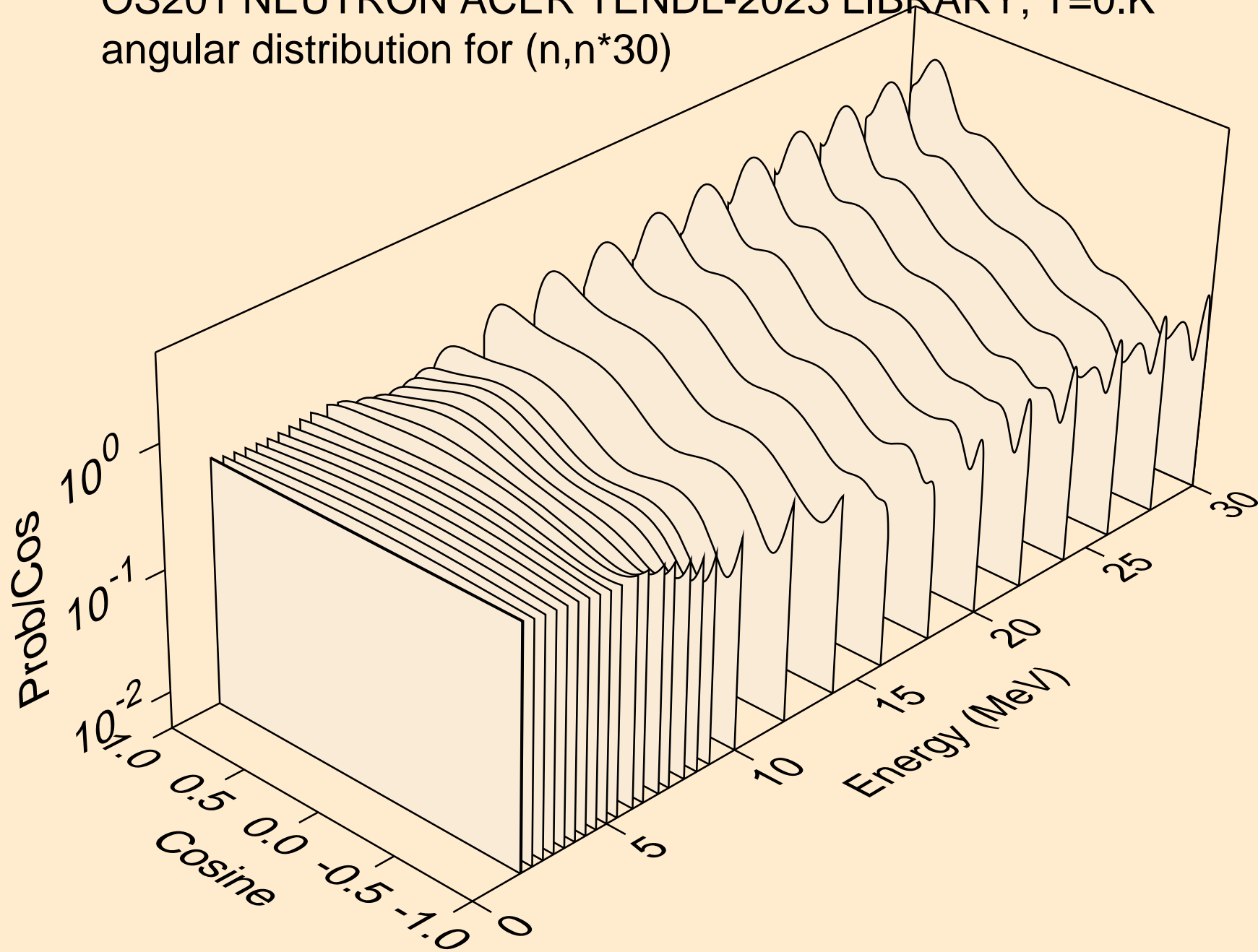

OS201 NEUTRON ACER TENDL-2023 LIBRARY; T=0.K  
Neutron emission for (n,x)

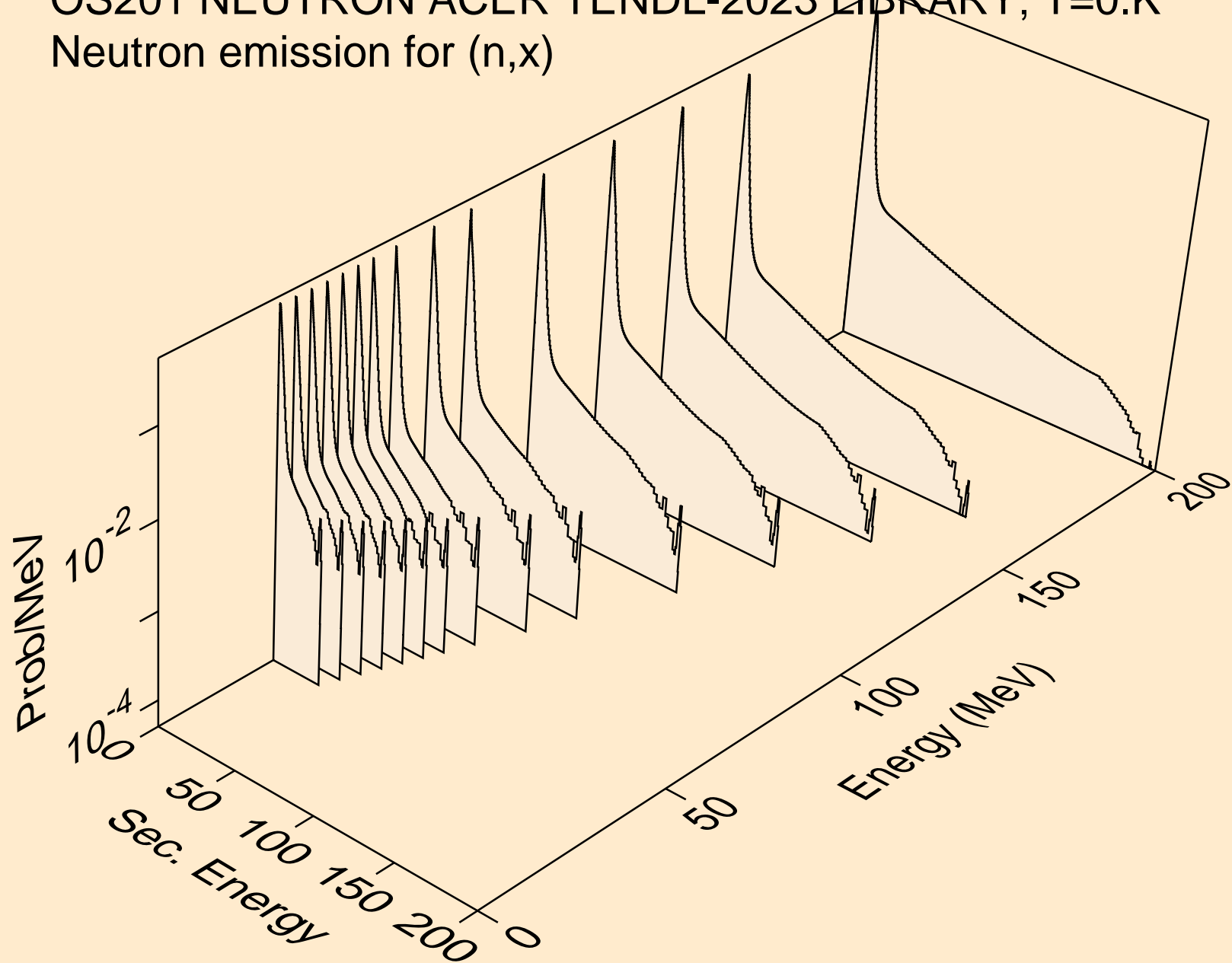

OS201 NEUTRON ACER TENDL-2023 LIBRARY; T=0.K  
Neutron emission for (n,2nd)

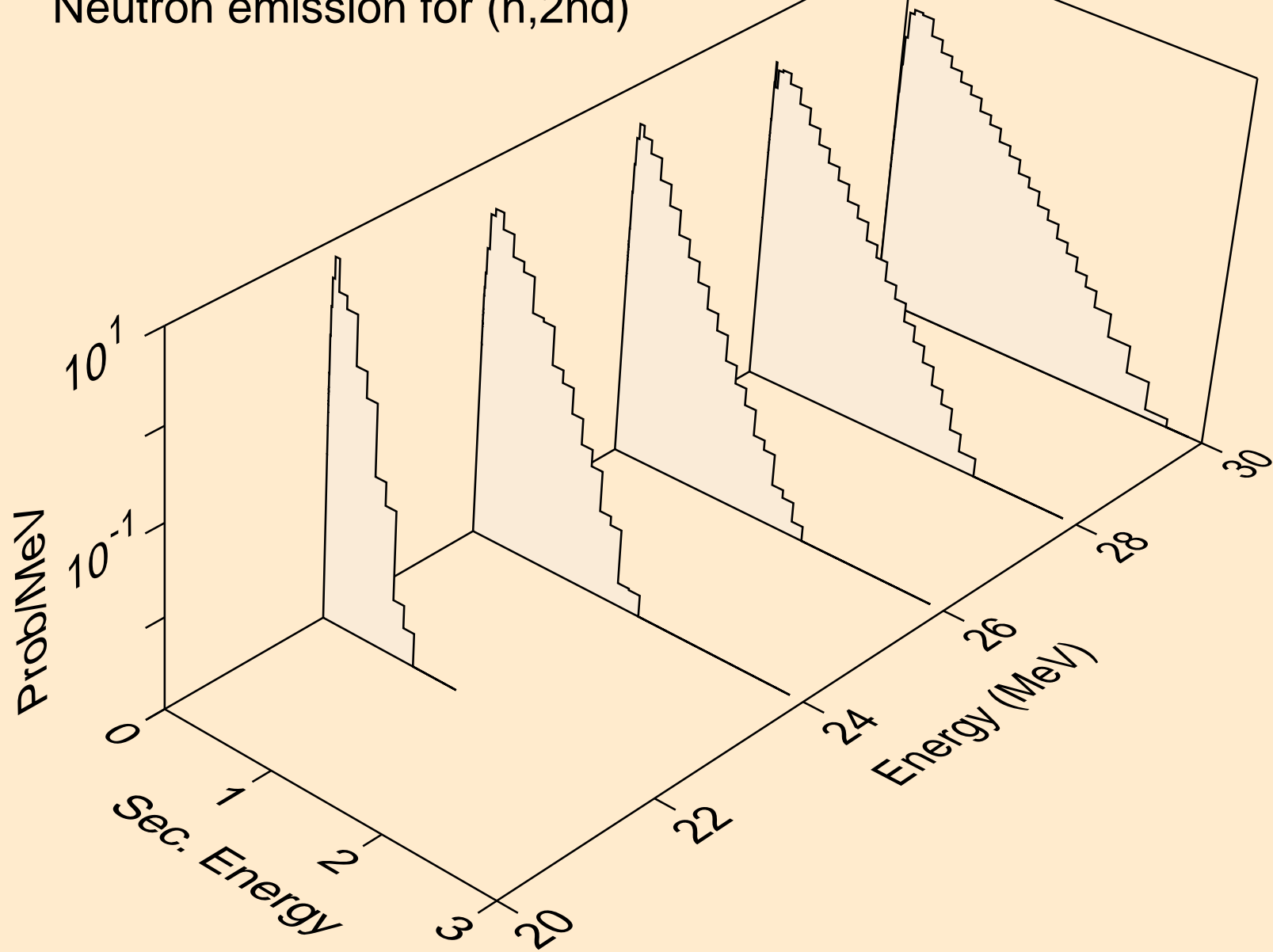

OS201 NEUTRON ACER TENDL-2023 LIBRARY; T=0.K  
Neutron emission for (n,2n)

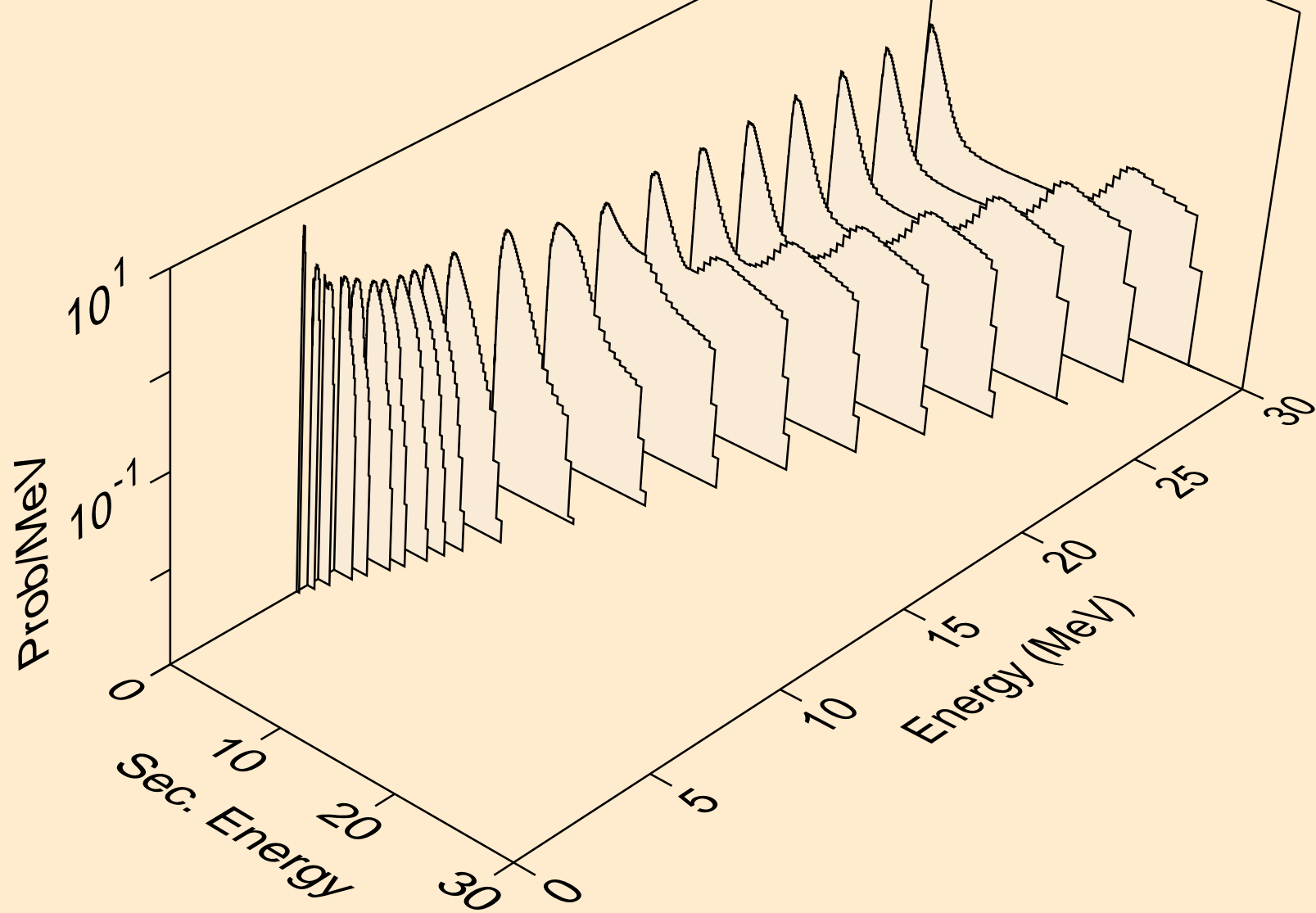

OS201 NEUTRON ACER TENDL-2023 LIBRARY; T=0.K  
Neutron emission for (n,3n)

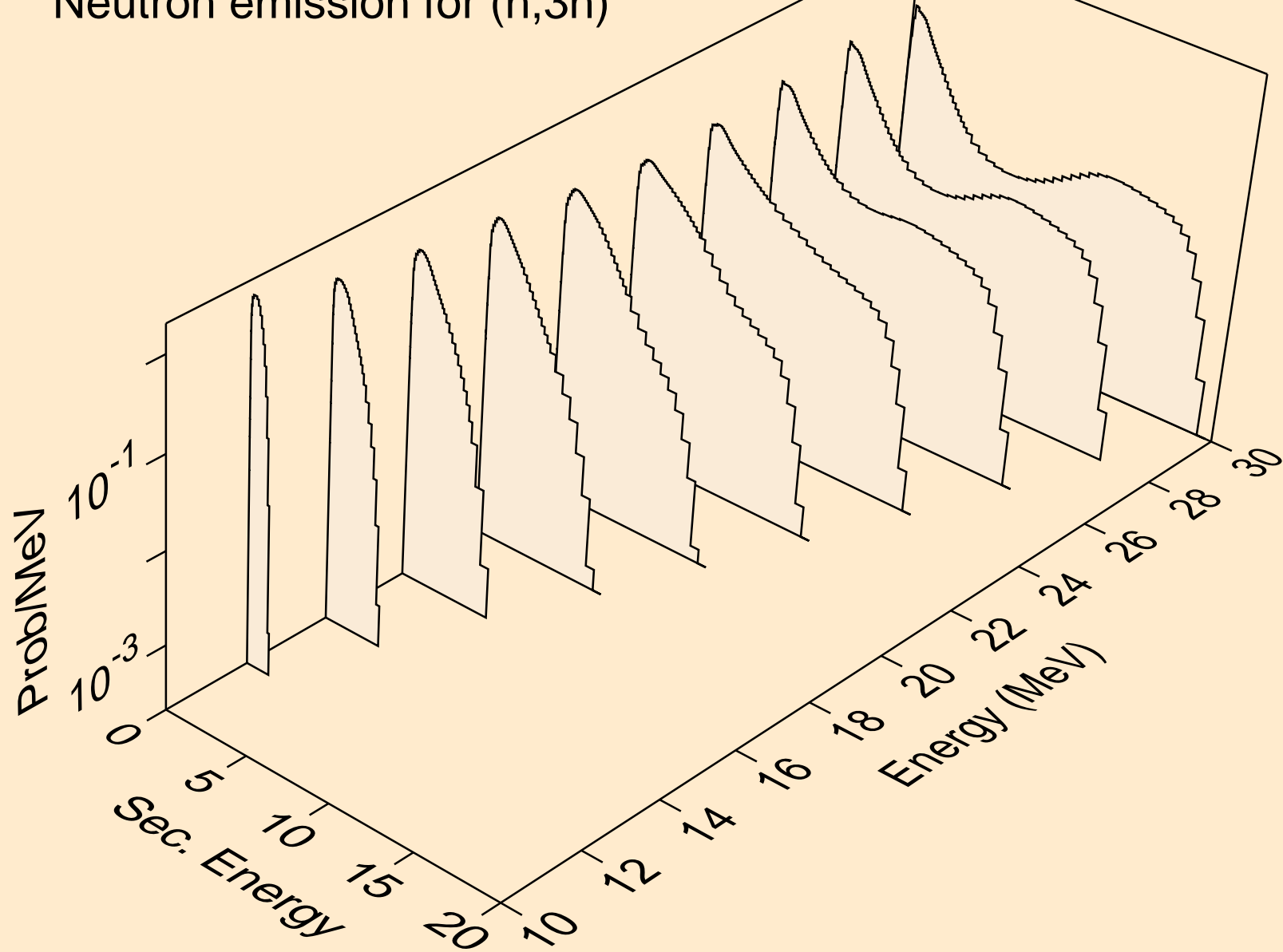

OS201 NEUTRON ACER TENDL-2023 LIBRARY; T=0.K  
Neutron emission for (n,n\*)a

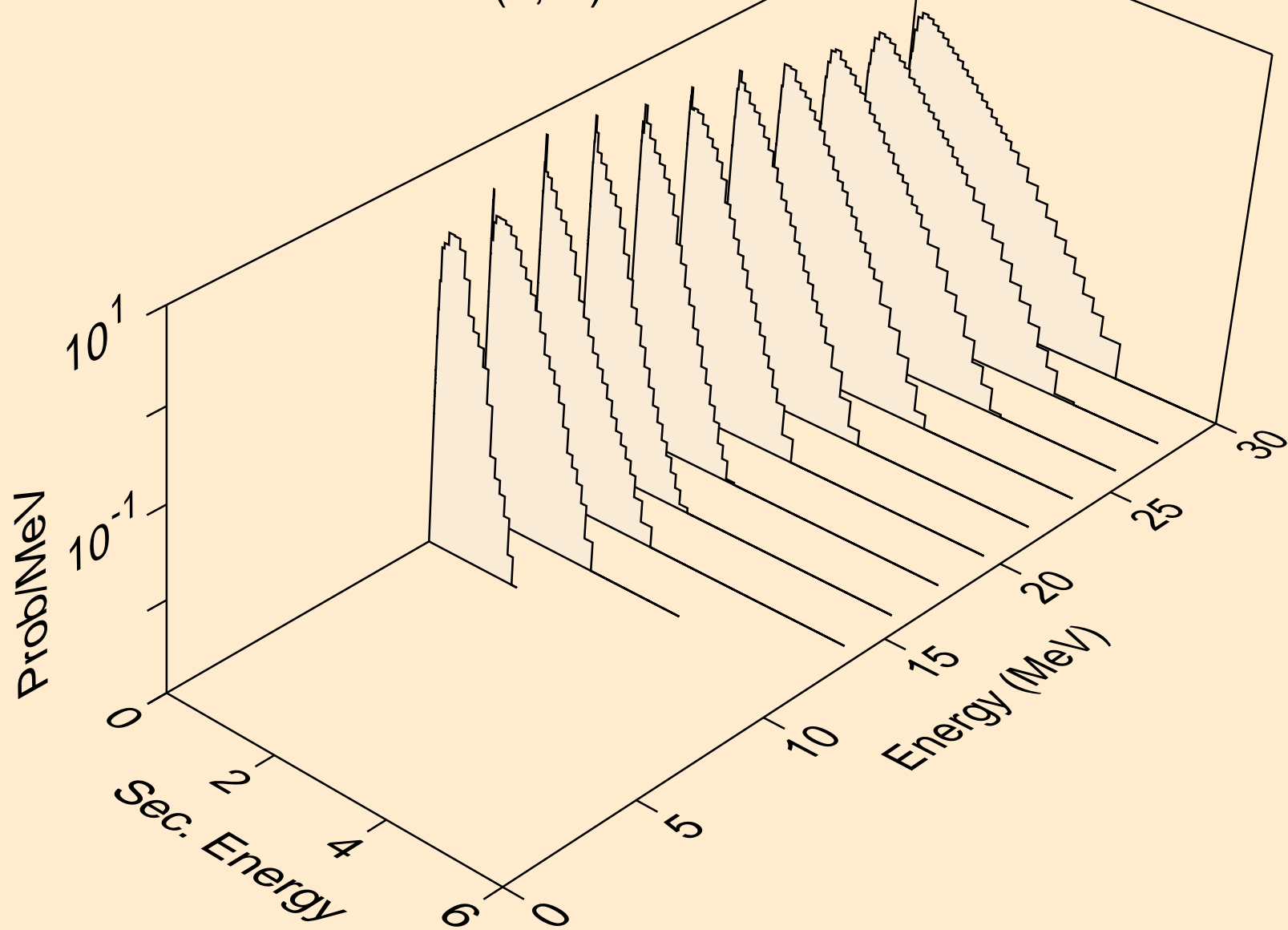

OS201 NEUTRON ACER TENDL-2023 LIBRARY; T=0.K  
Neutron emission for (n,2n)a

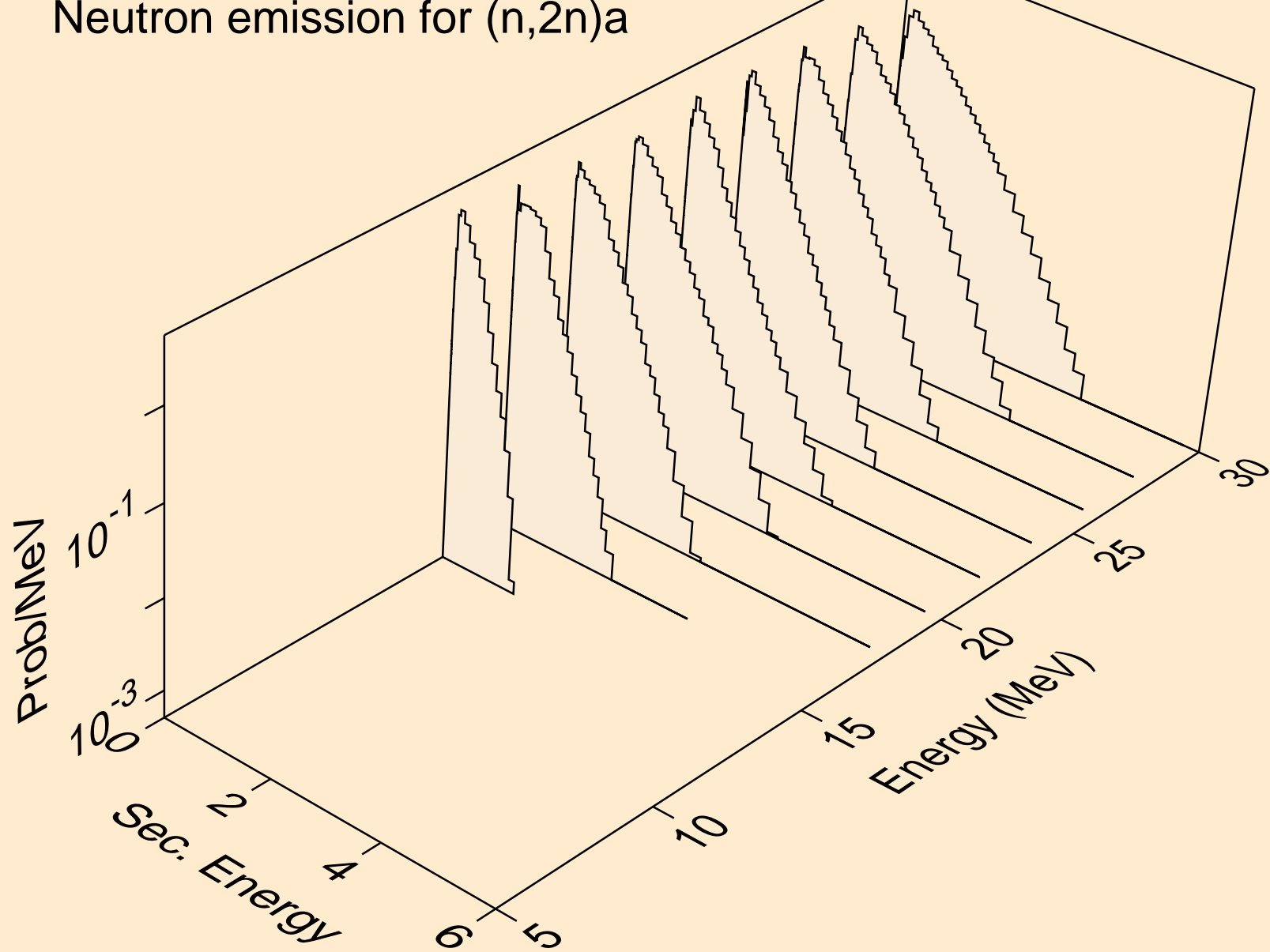

OS201 NEUTRON ACER TENDL-2023 LIBRARY; T=0.K  
Neutron emission for (n,3n)a

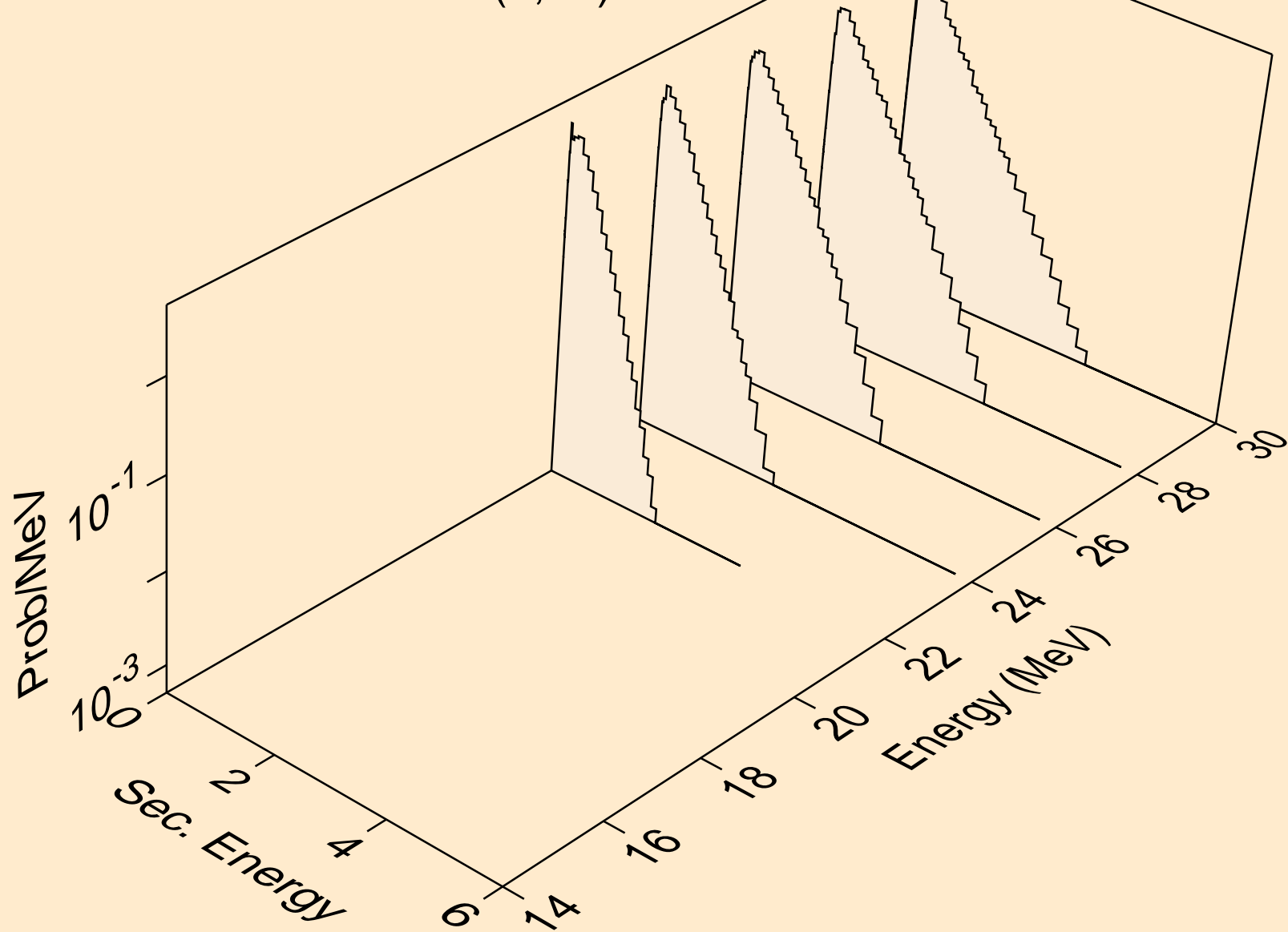

OS201 NEUTRON ACER TENDL-2023 LIBRARY; T=0.K  
Neutron emission for (n,n\*)p

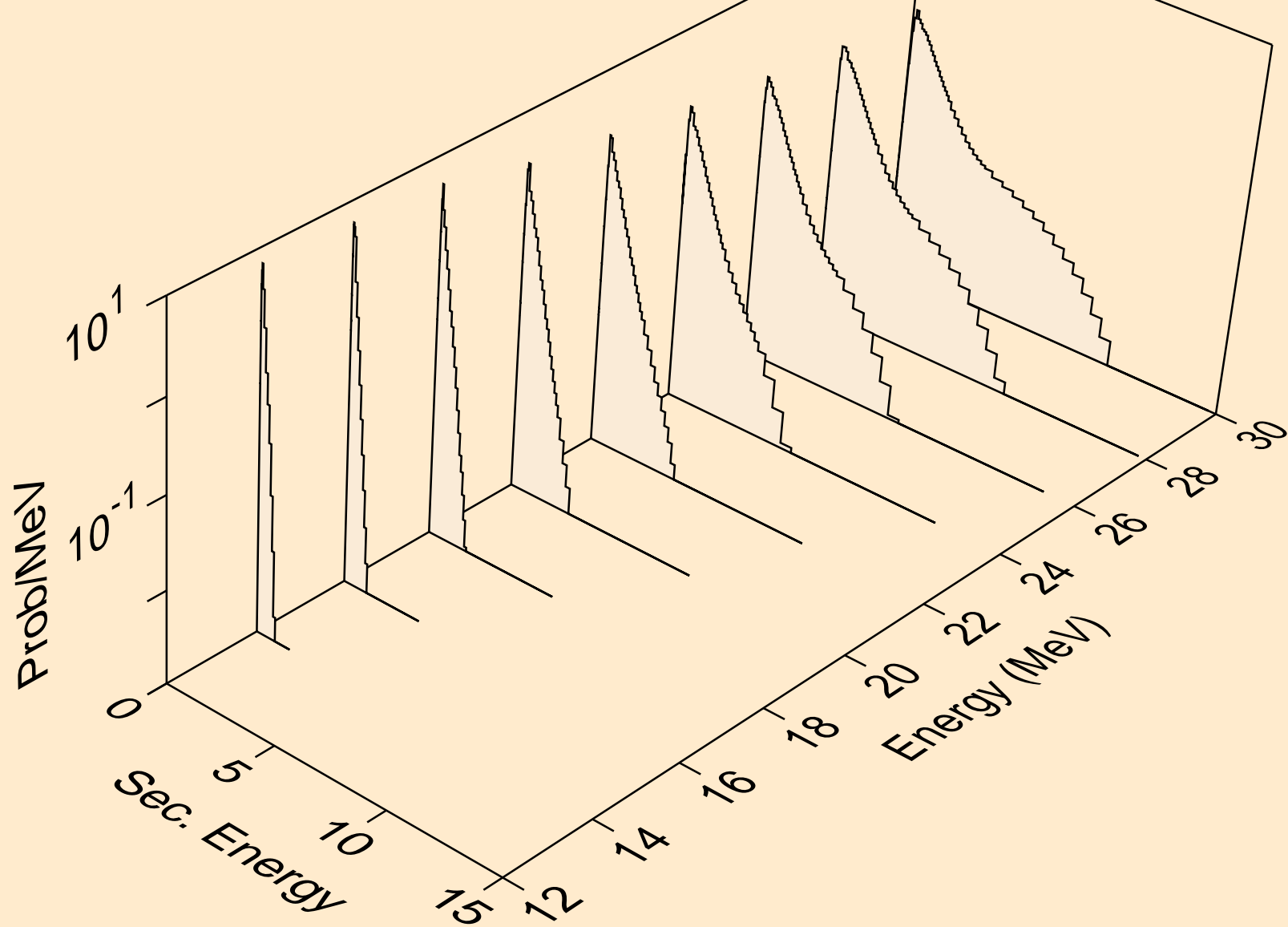

OS201 NEUTRON ACER TENDL-2023 LIBRARY; T=0.K  
Neutron emission for (n,n\*)d

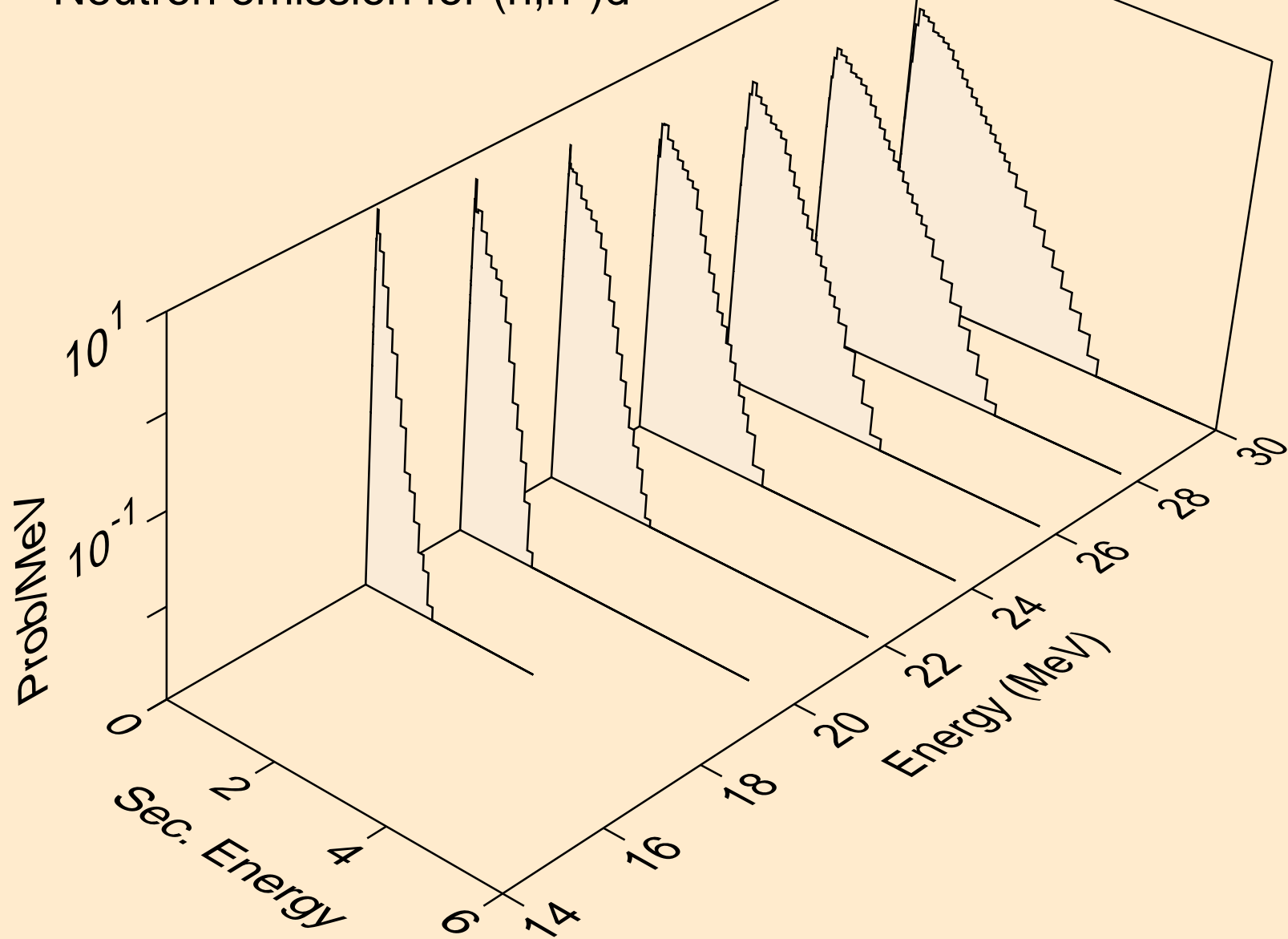

OS201 NEUTRON ACER TENDL-2023 LIBRARY; T=0.K  
Neutron emission for (n,n\*)t

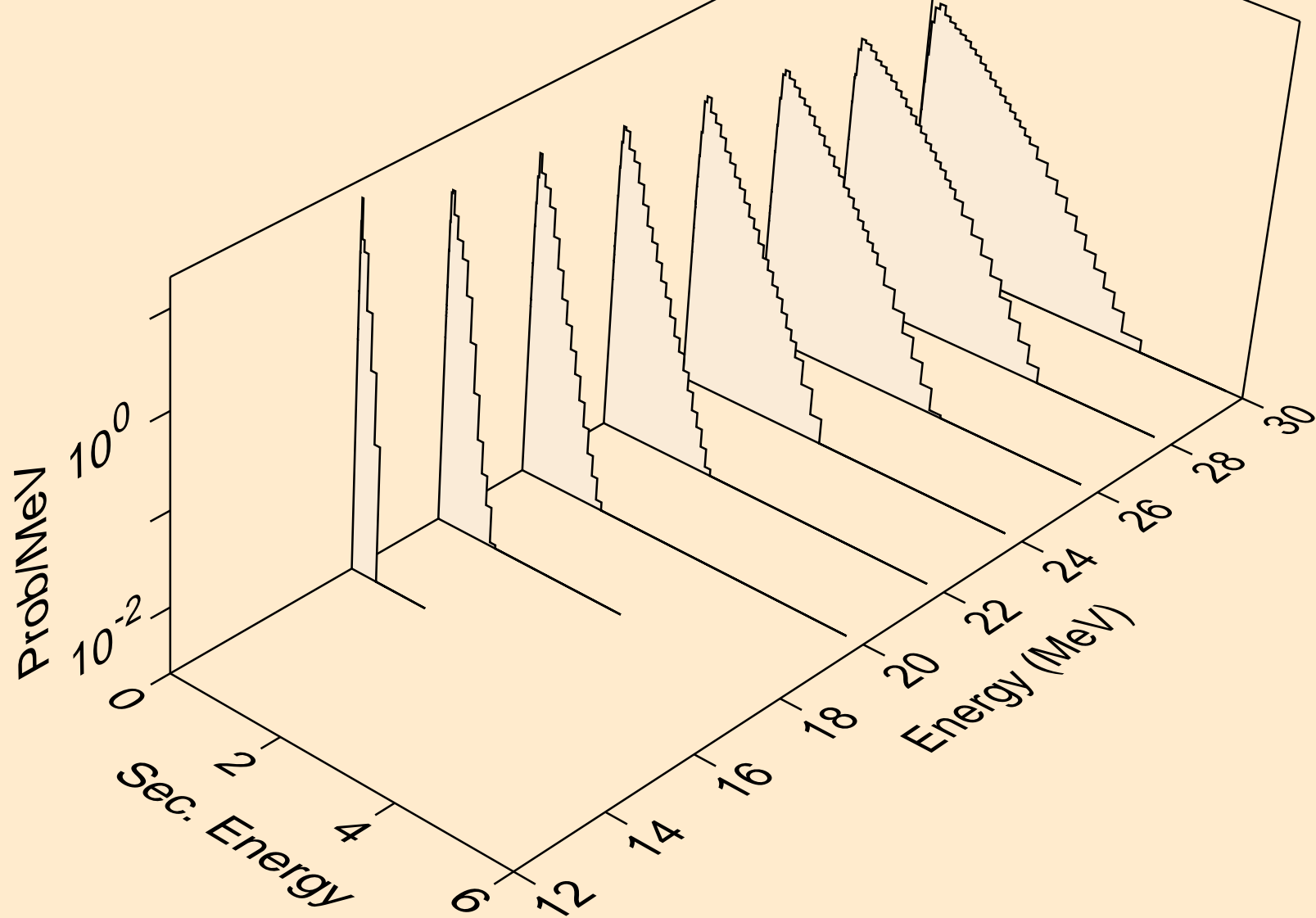

OS201 NEUTRON ACER TENDL-2023 LIBRARY; T=0.K  
Neutron emission for (n,4n)

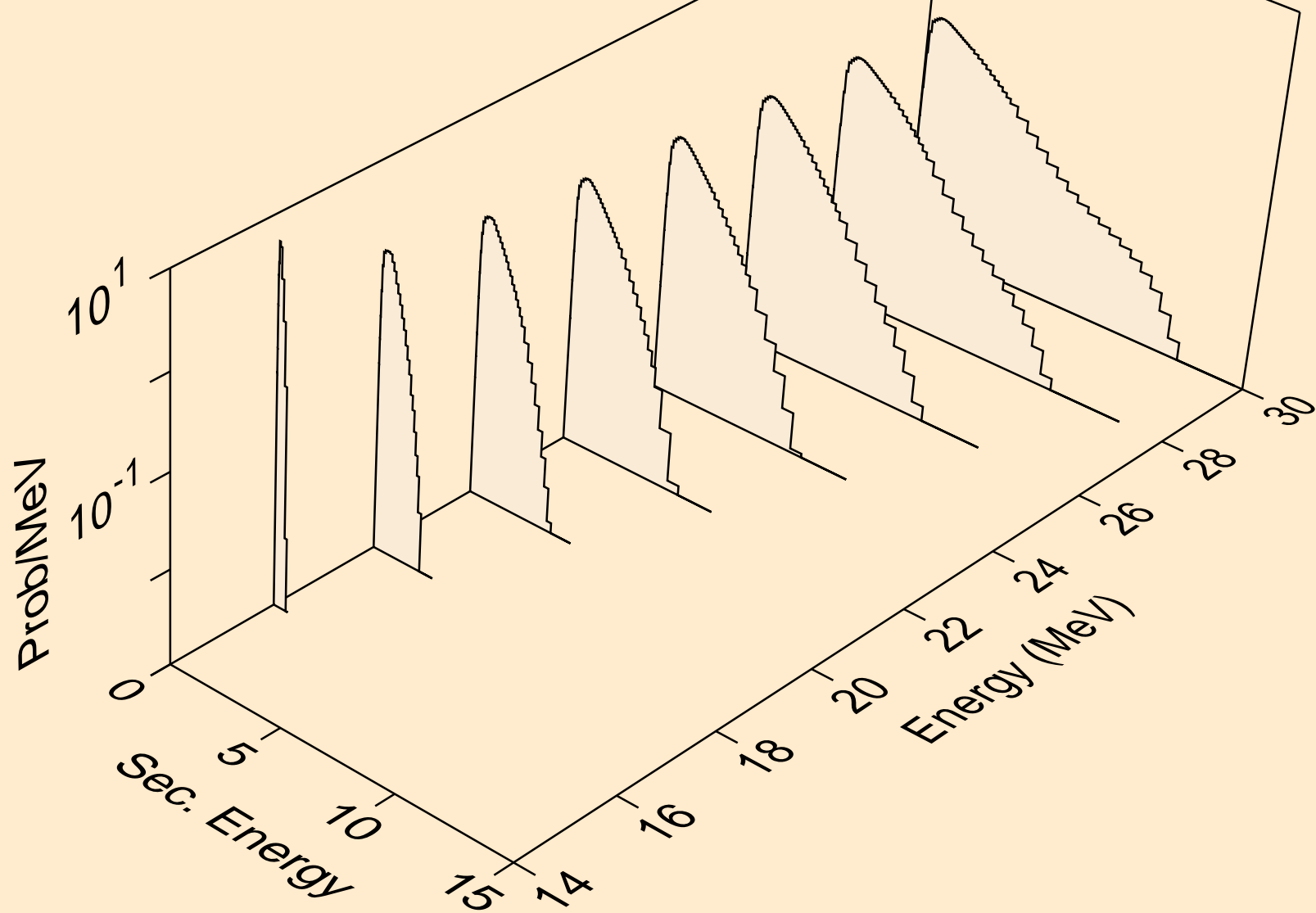

OS201 NEUTRON ACER TENDL-2023 LIBRARY; T=0.K  
Neutron emission for (n,2np)

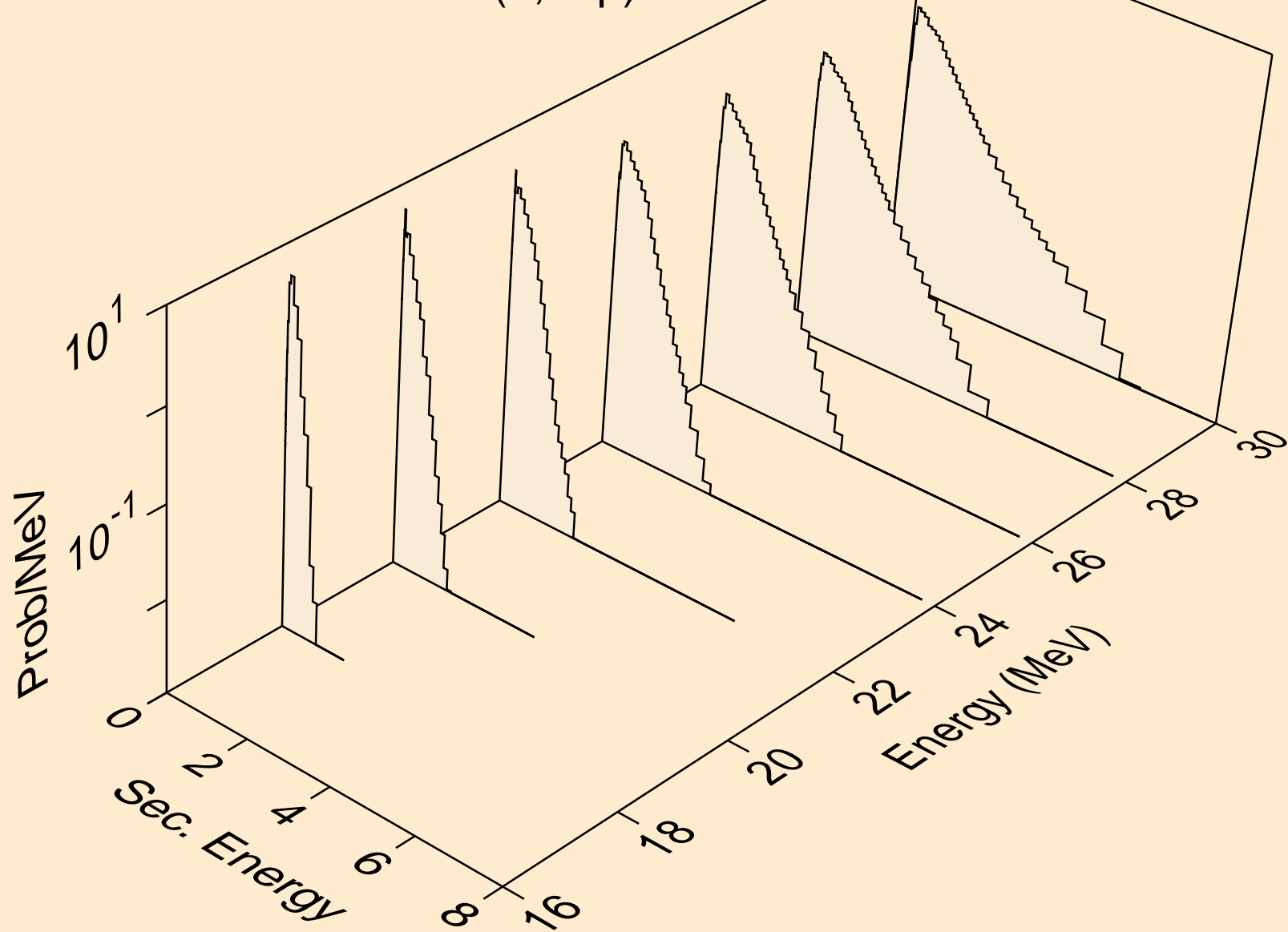

OS201 NEUTRON ACER TENDL-2023 LIBRARY; T=0.K  
Neutron emission for (n,3np)

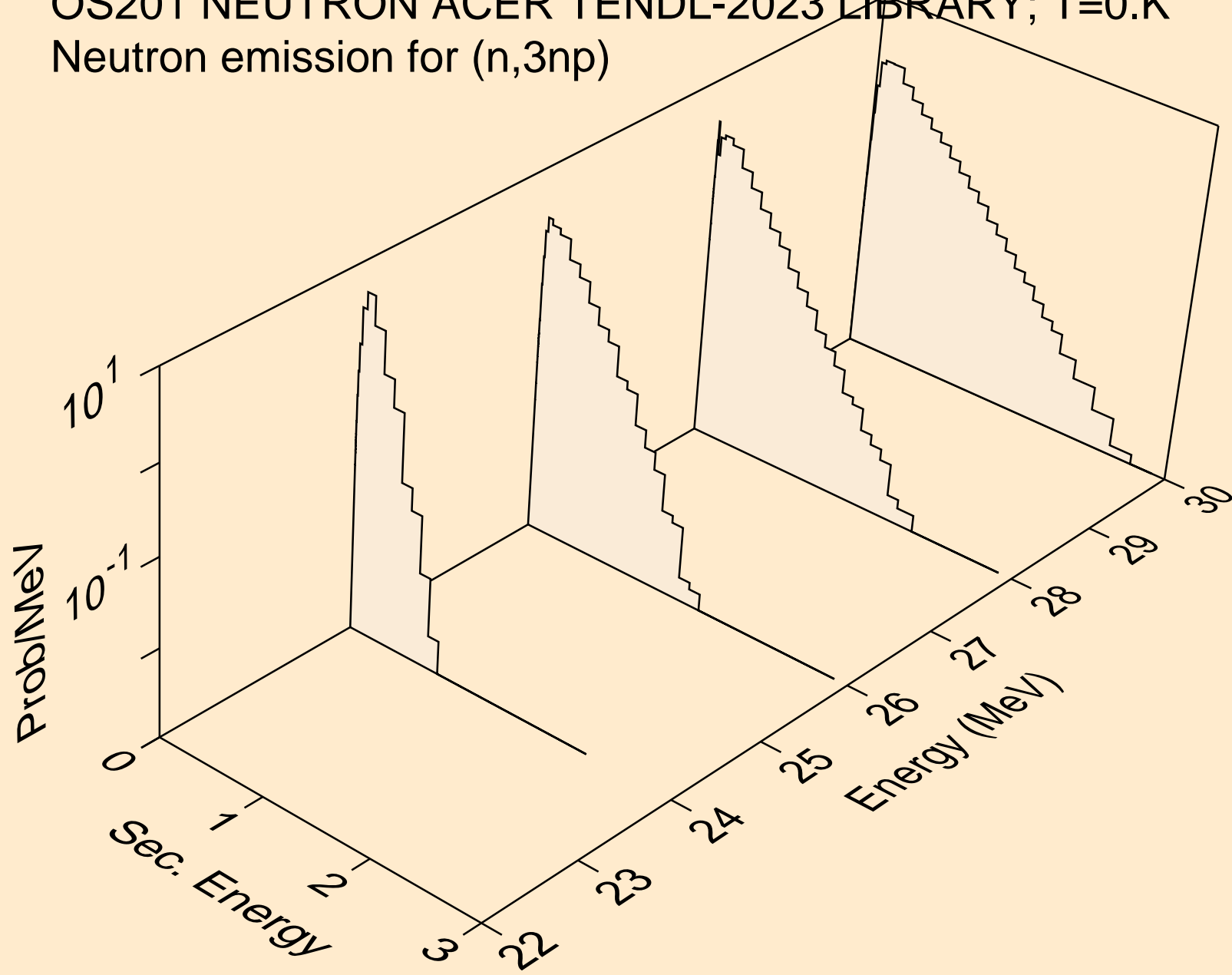

OS201 NEUTRON ACER TENDL-2023 LIBRARY; T=0.K  
Neutron emission for (n,n\*c)

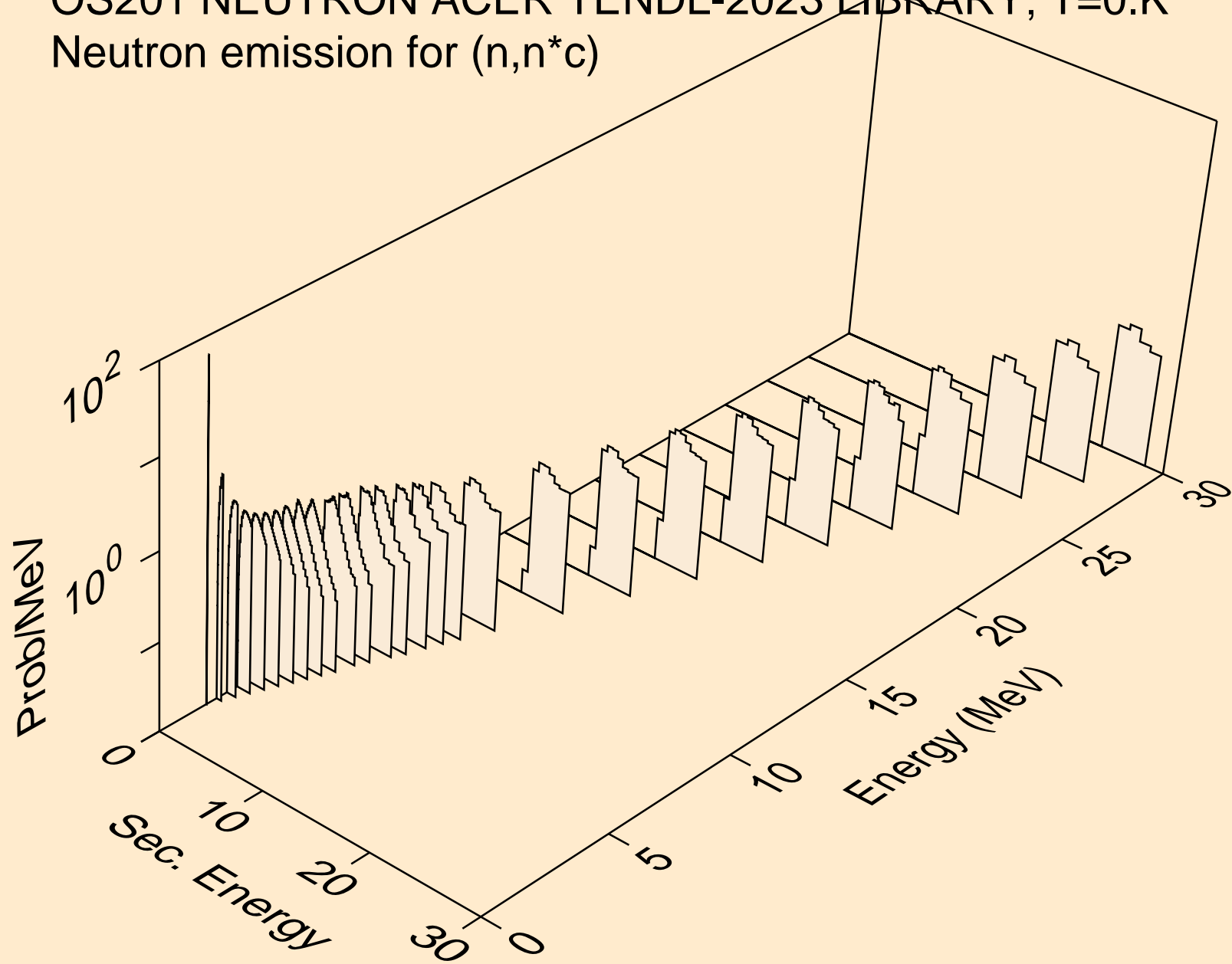

OS201 NEUTRON ACER TENDL-2023 LIBRARY; T=0.K  
Photon emission for (n,x)

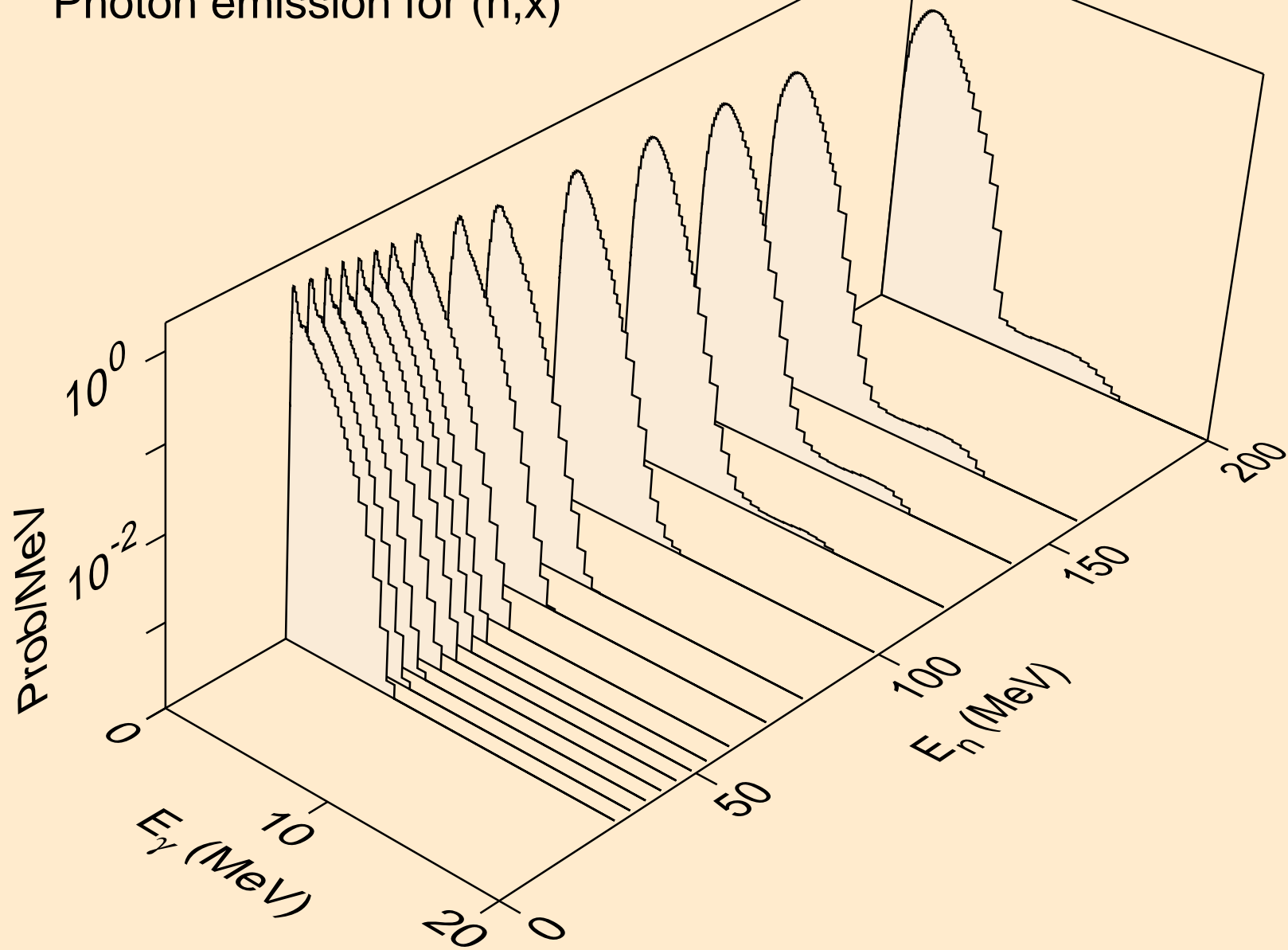

OS201 NEUTRON ACER TENDL-2023 LIBRARY; T=0.K  
Photon emission for (n,2nd)

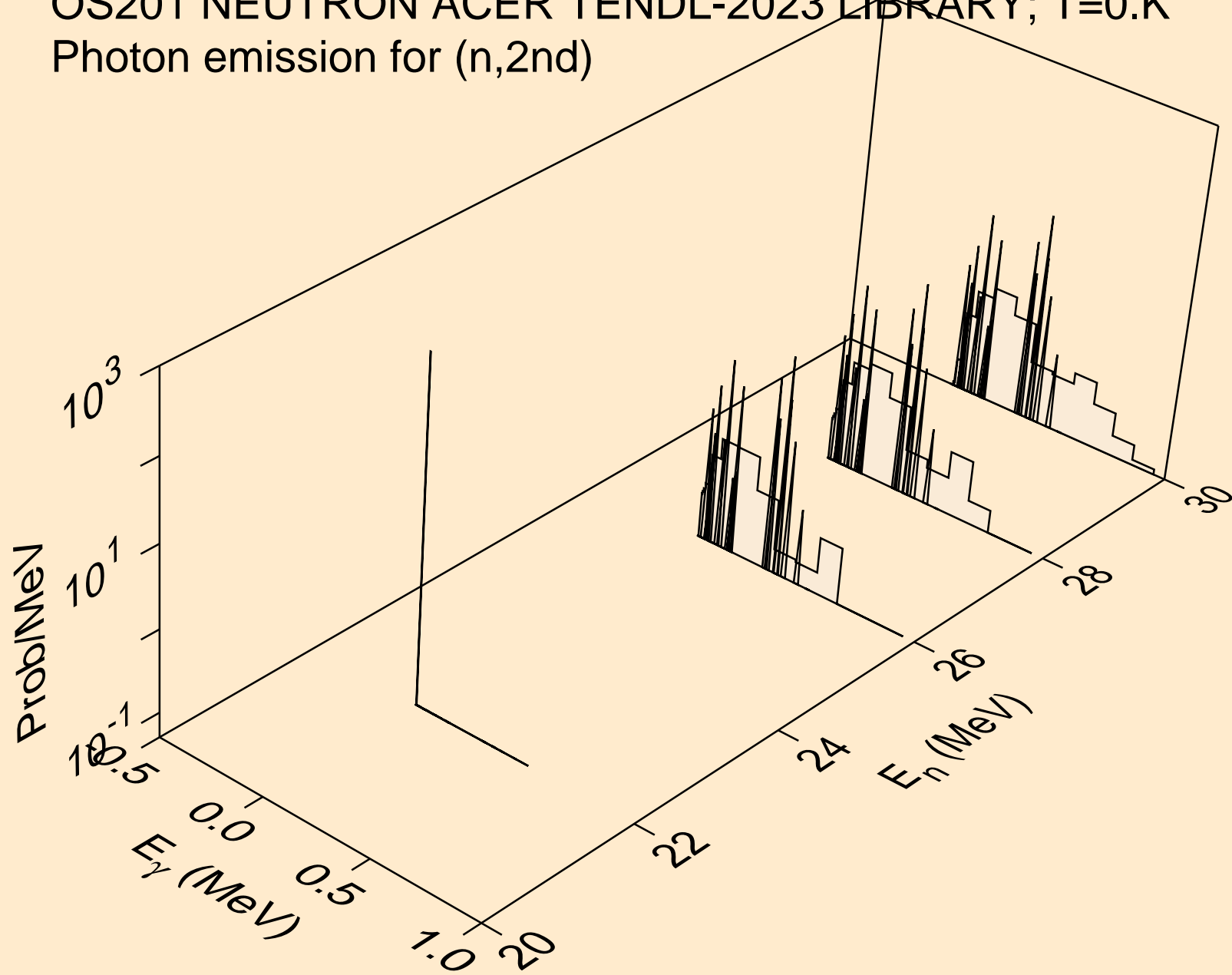

OS201 NEUTRON ACER TENDL-2023 LIBRARY; T=0.K  
Photon emission for (n,2n)

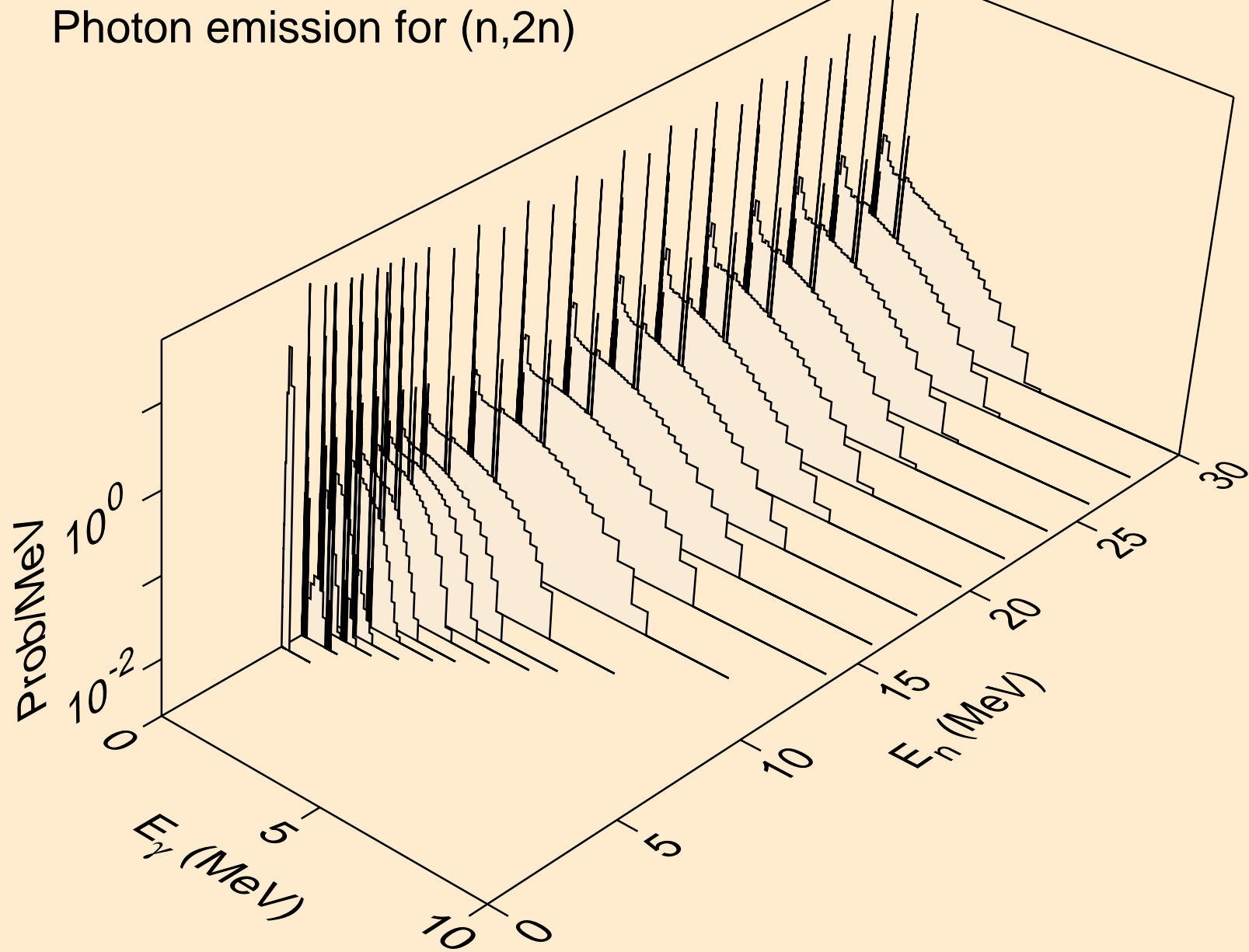

OS201 NEUTRON ACER TENDL-2023 LIBRARY; T=0.K  
Photon emission for (n,3n)

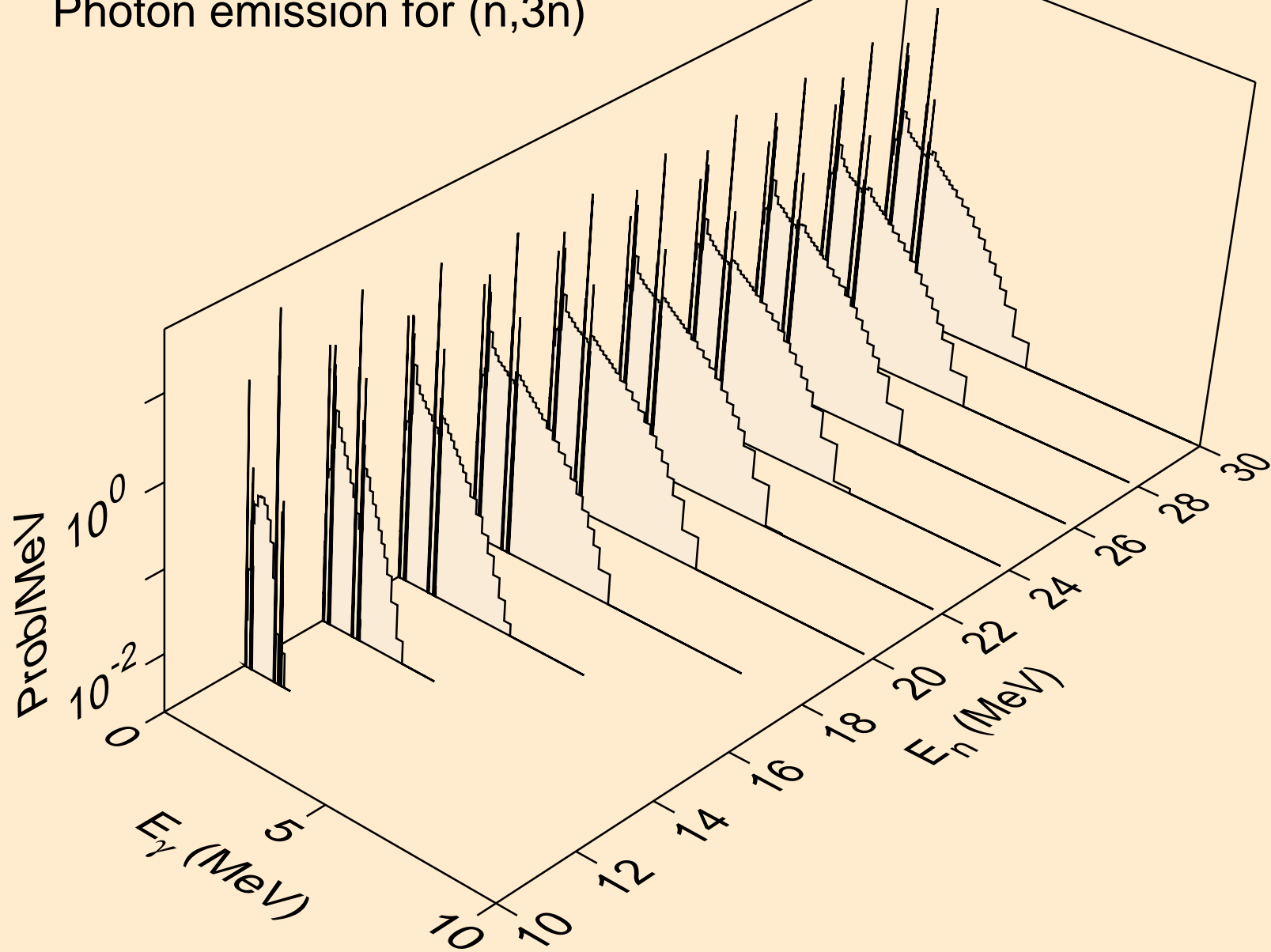

OS201 NEUTRON ACER TENDL-2023 LIBRARY; T=0.K  
Photon emission for (n,n\*)a

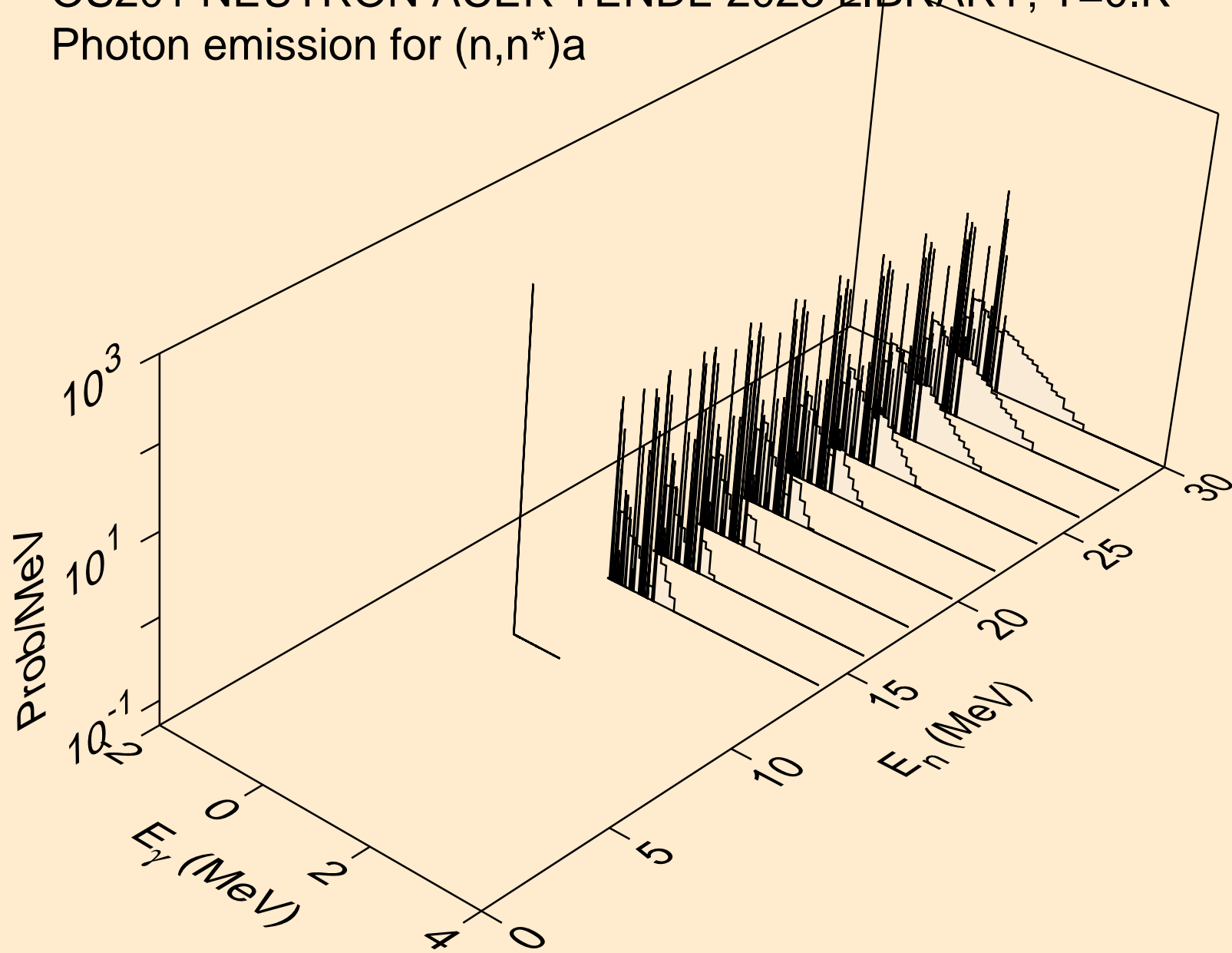

OS201 NEUTRON ACER TENDL-2023 LIBRARY; T=0.K  
Photon emission for (n,2n)a

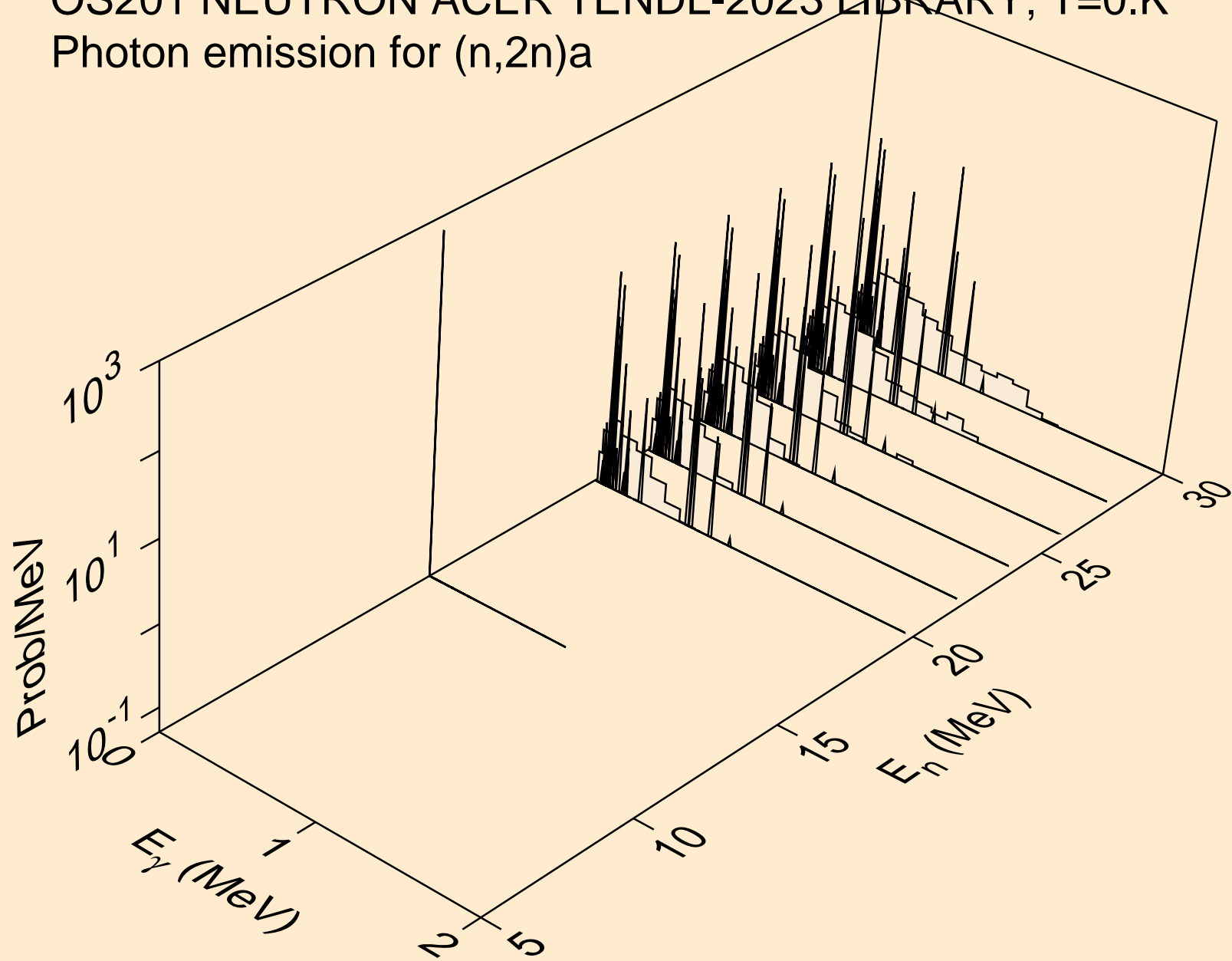

OS201 NEUTRON ACER TENDL-2023 LIBRARY; T=0.K  
Photon emission for (n,3n)a

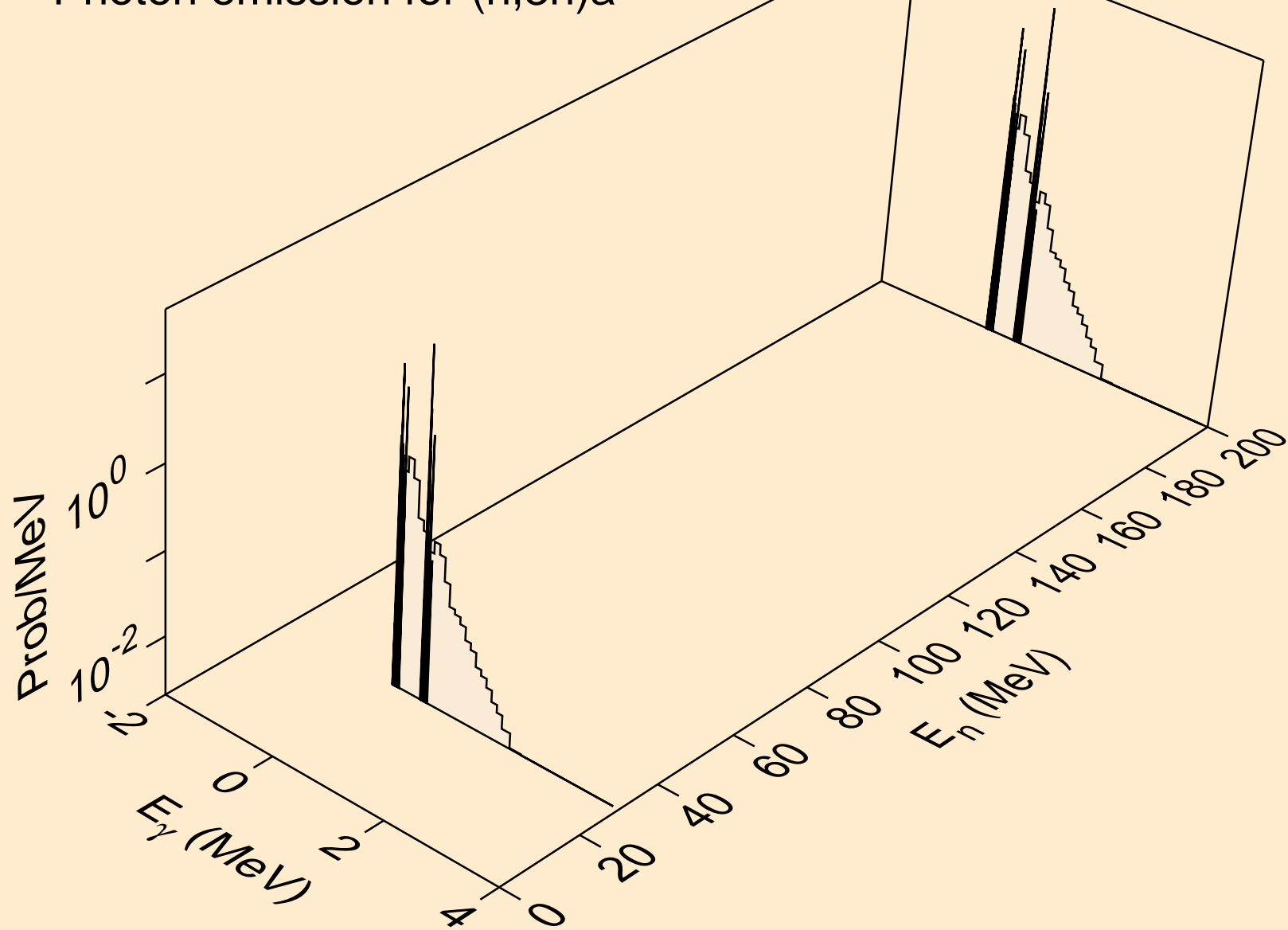

OS201 NEUTRON ACER TENDL-2023 LIBRARY; T=0.K  
Photon emission for (n,n\*)p

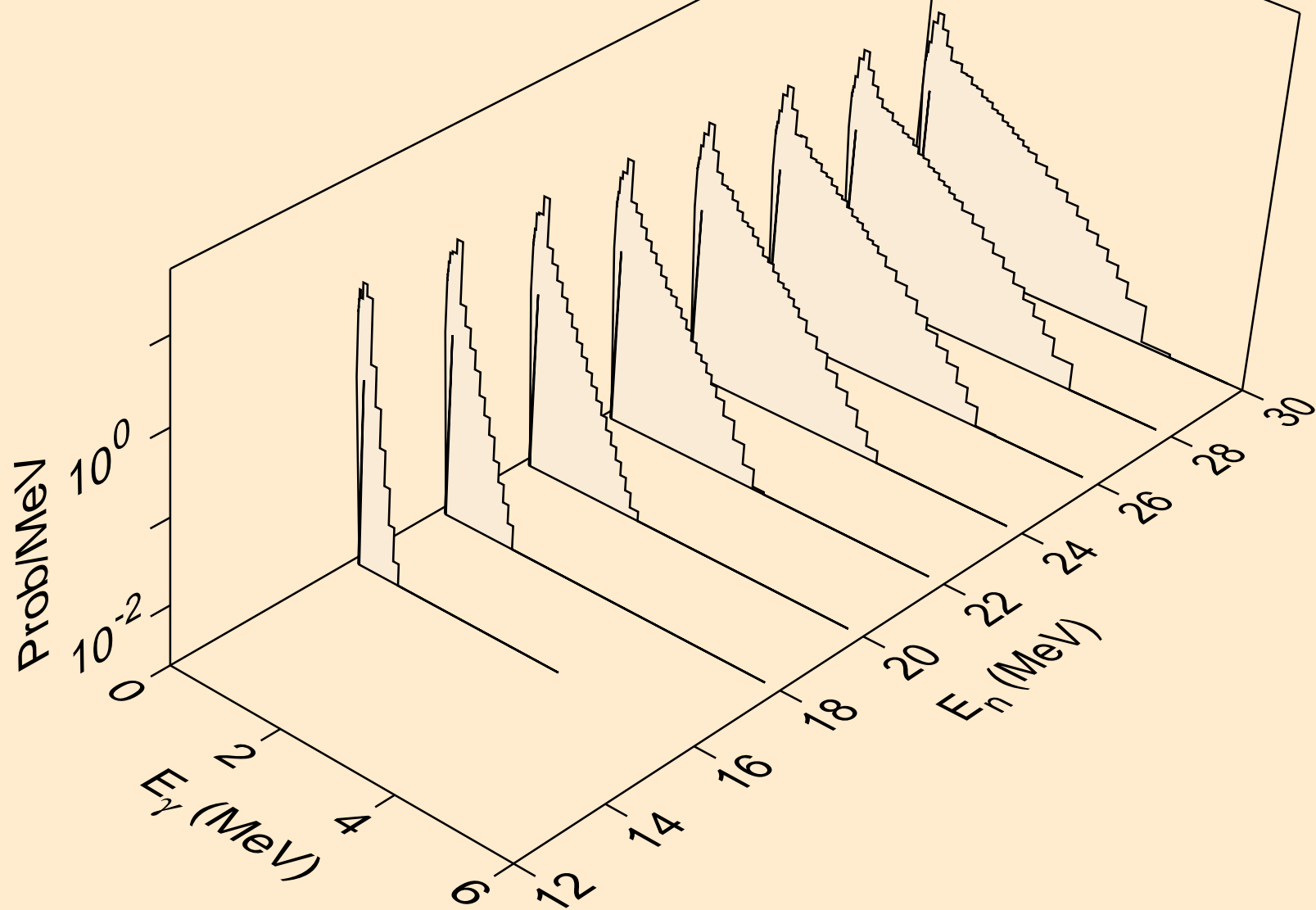

OS201 NEUTRON ACER TENDL-2023 LIBRARY; T=0.K  
Photon emission for (n,n\*)d

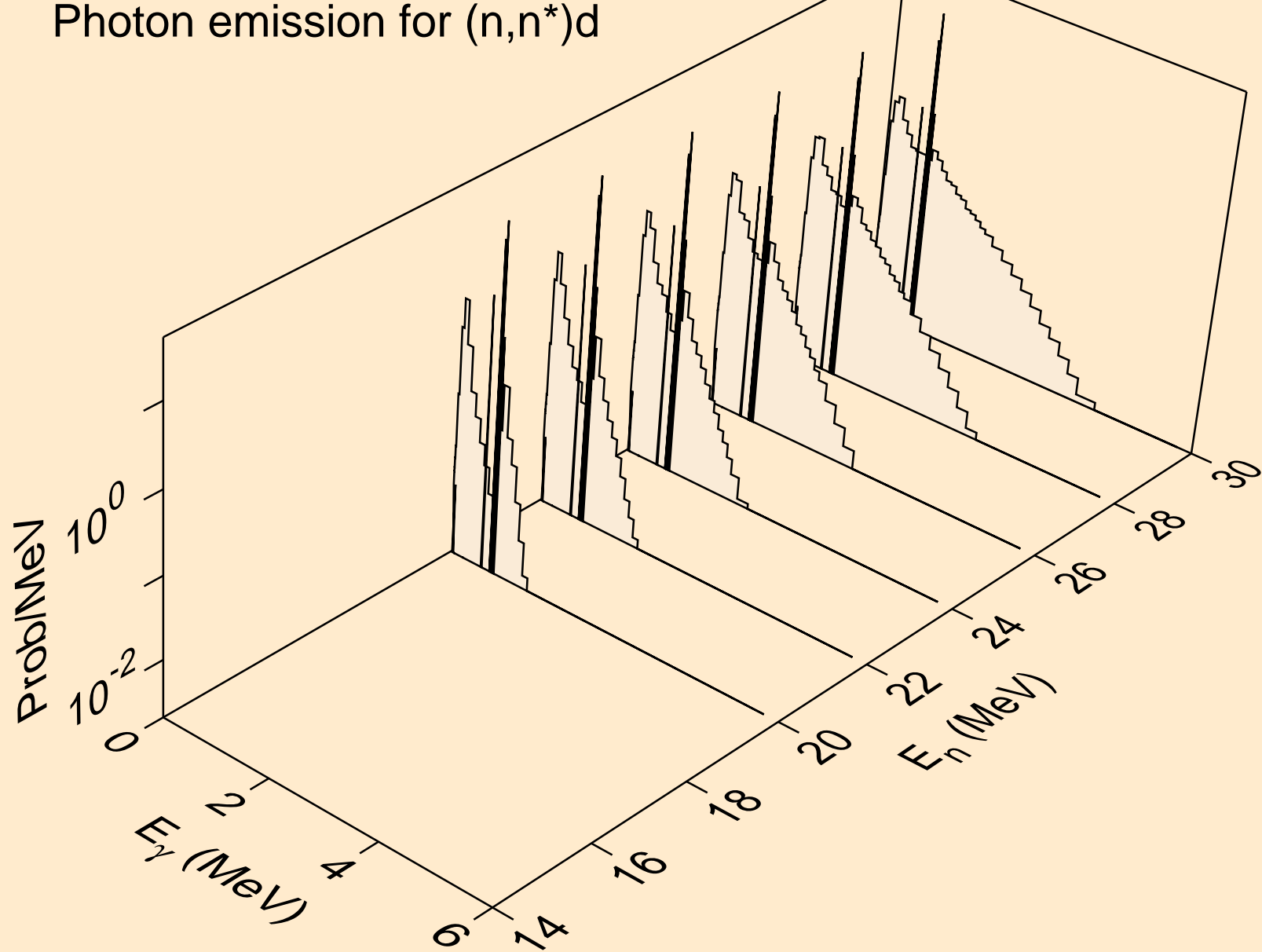

OS201 NEUTRON ACER TENDL-2023 LIBRARY; T=0.K  
Photon emission for (n,n\*)t

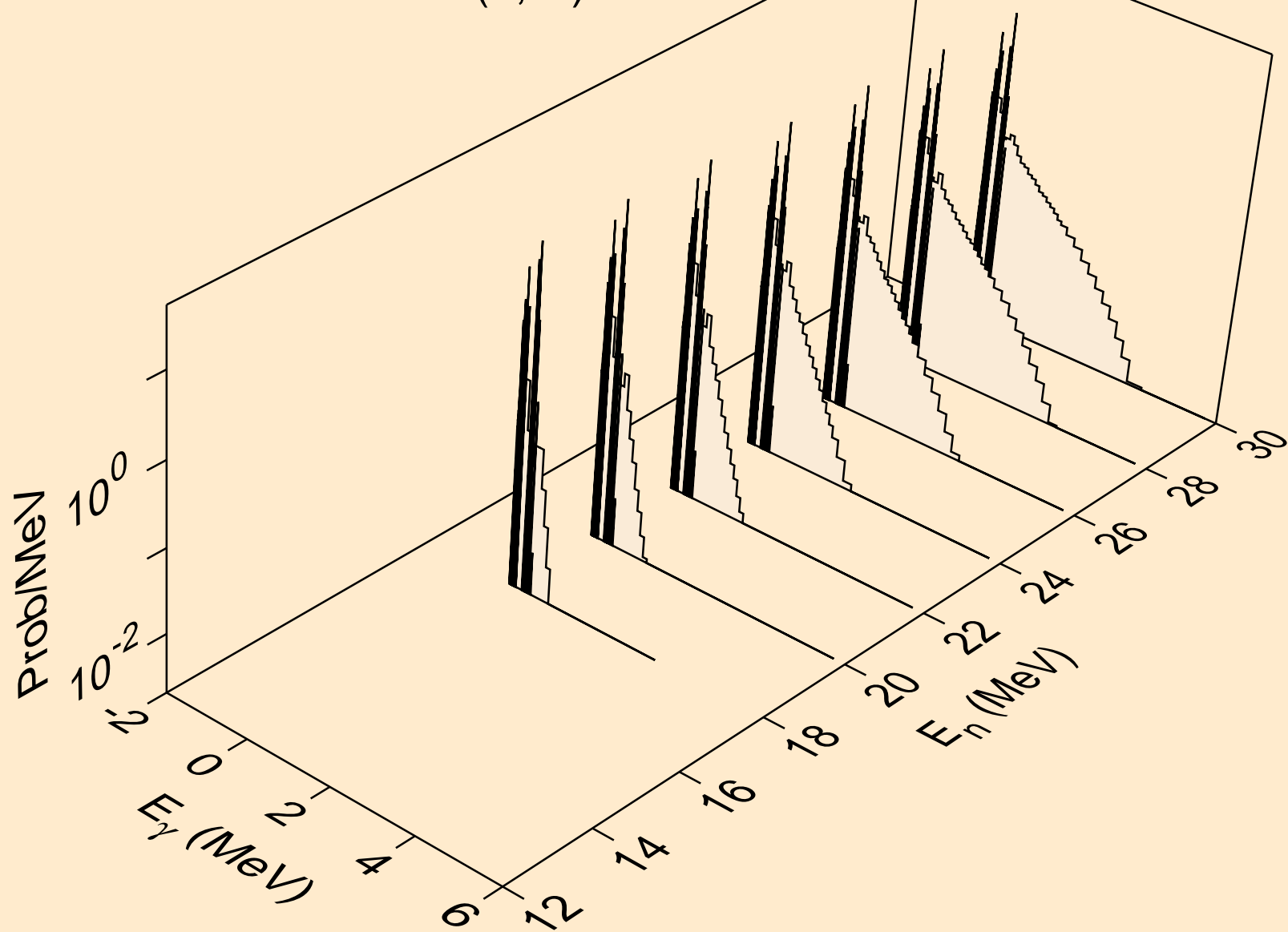

OS201 NEUTRON ACER TENDL-2023 LIBRARY; T=0.K  
Photon emission for (n,4n)

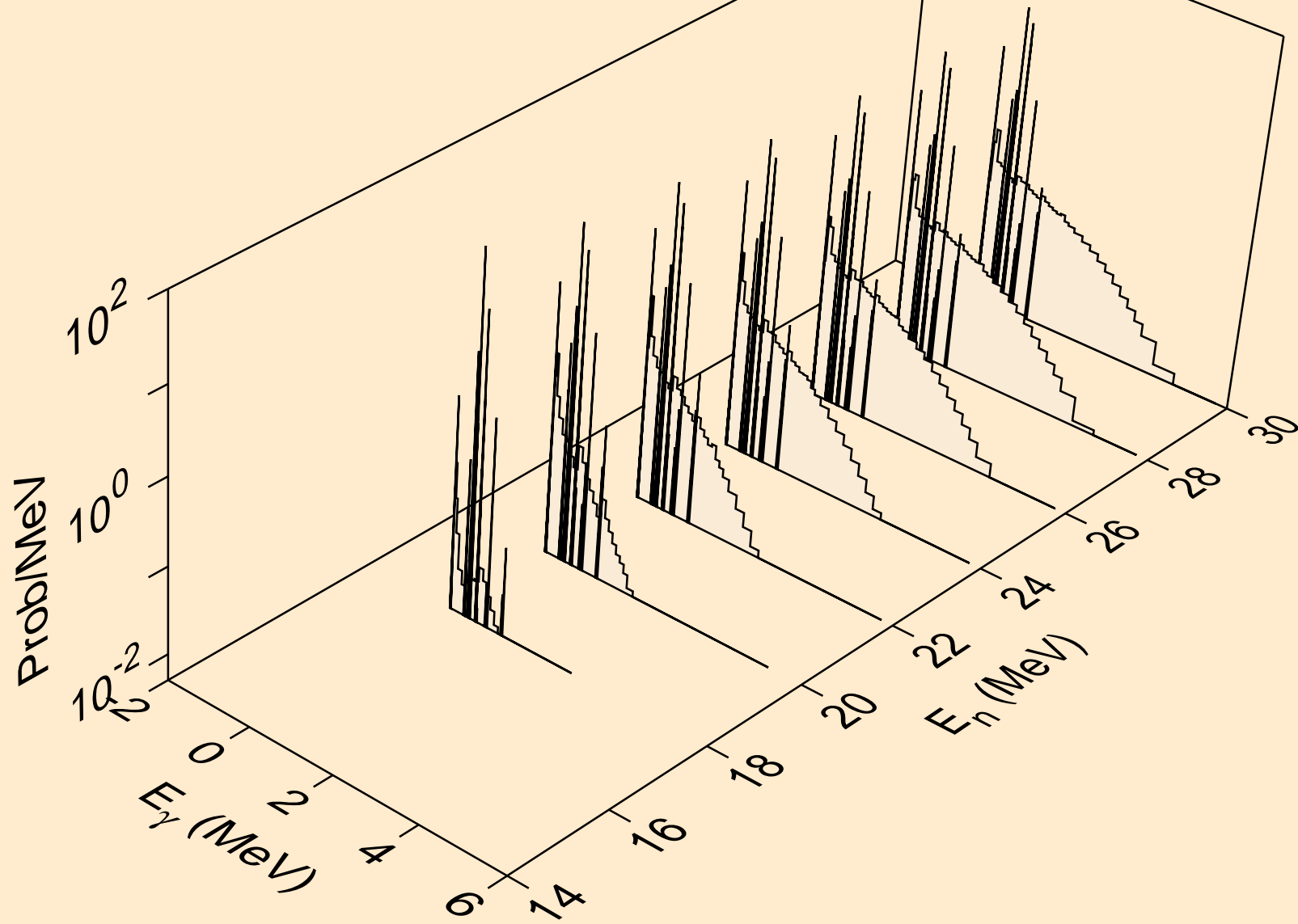

OS201 NEUTRON ACER TENDL-2023 LIBRARY; T=0.K  
Photon emission for (n,2np)

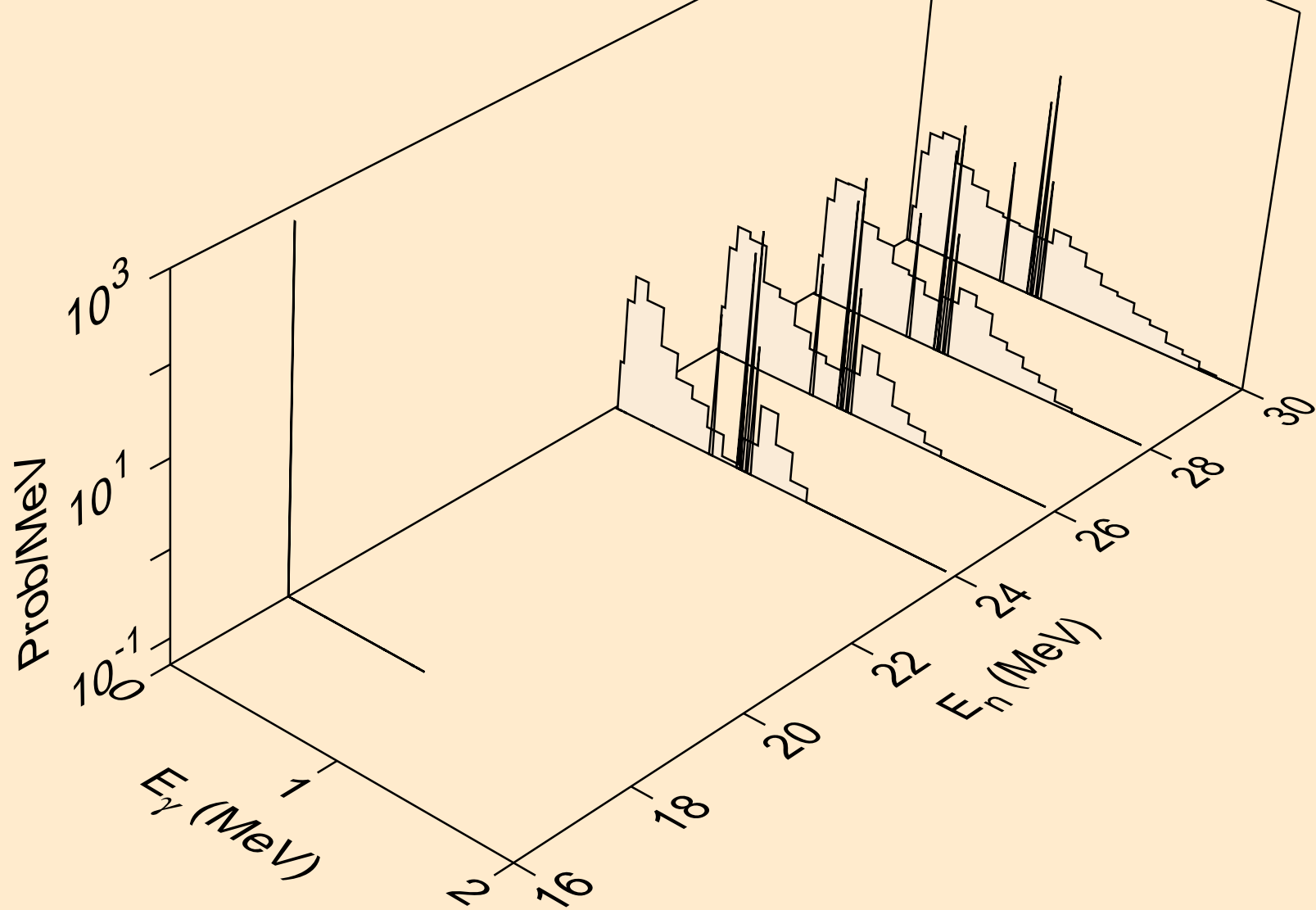

OS201 NEUTRON ACER TENDL-2023 LIBRARY; T=0.K  
Photon emission for (n,3np)

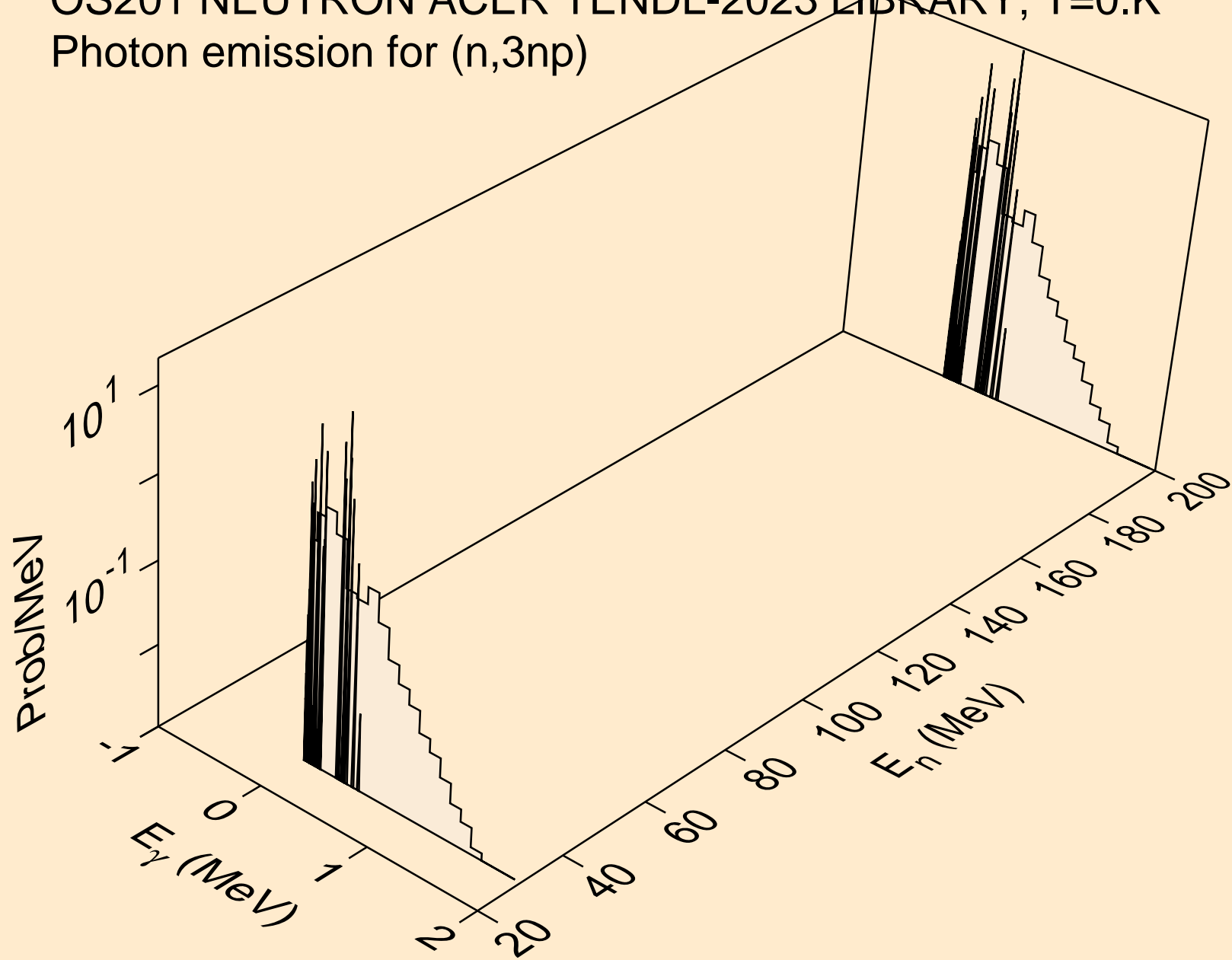

OS201 NEUTRON ACER TENDL-2023 LIBRARY; T=0.K  
Photon emission for (n,n\*c)

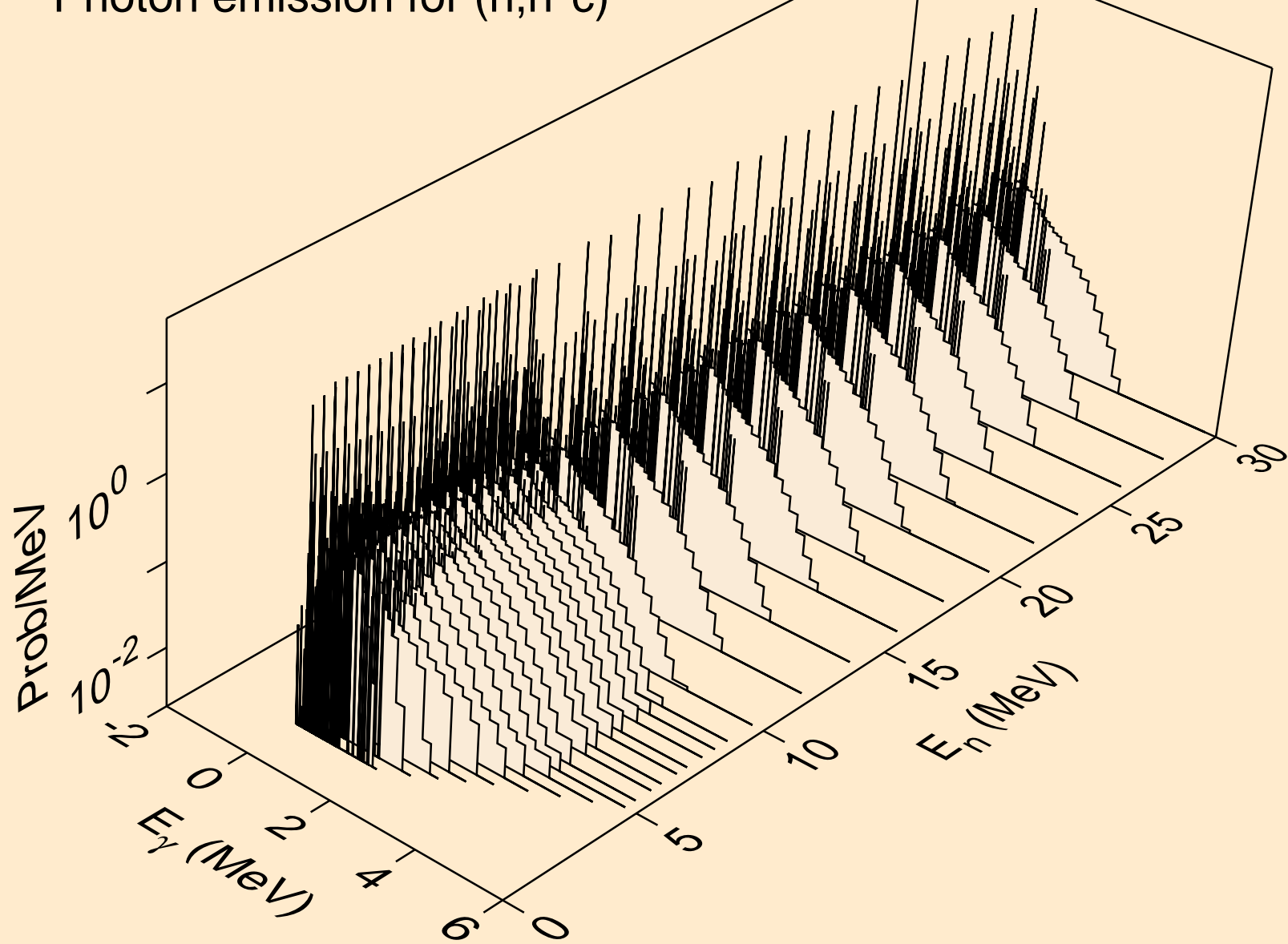

OS201 NEUTRON ACER TENDL-2023 LIBRARY; T=0.K  
Photon emission for (n,gma)

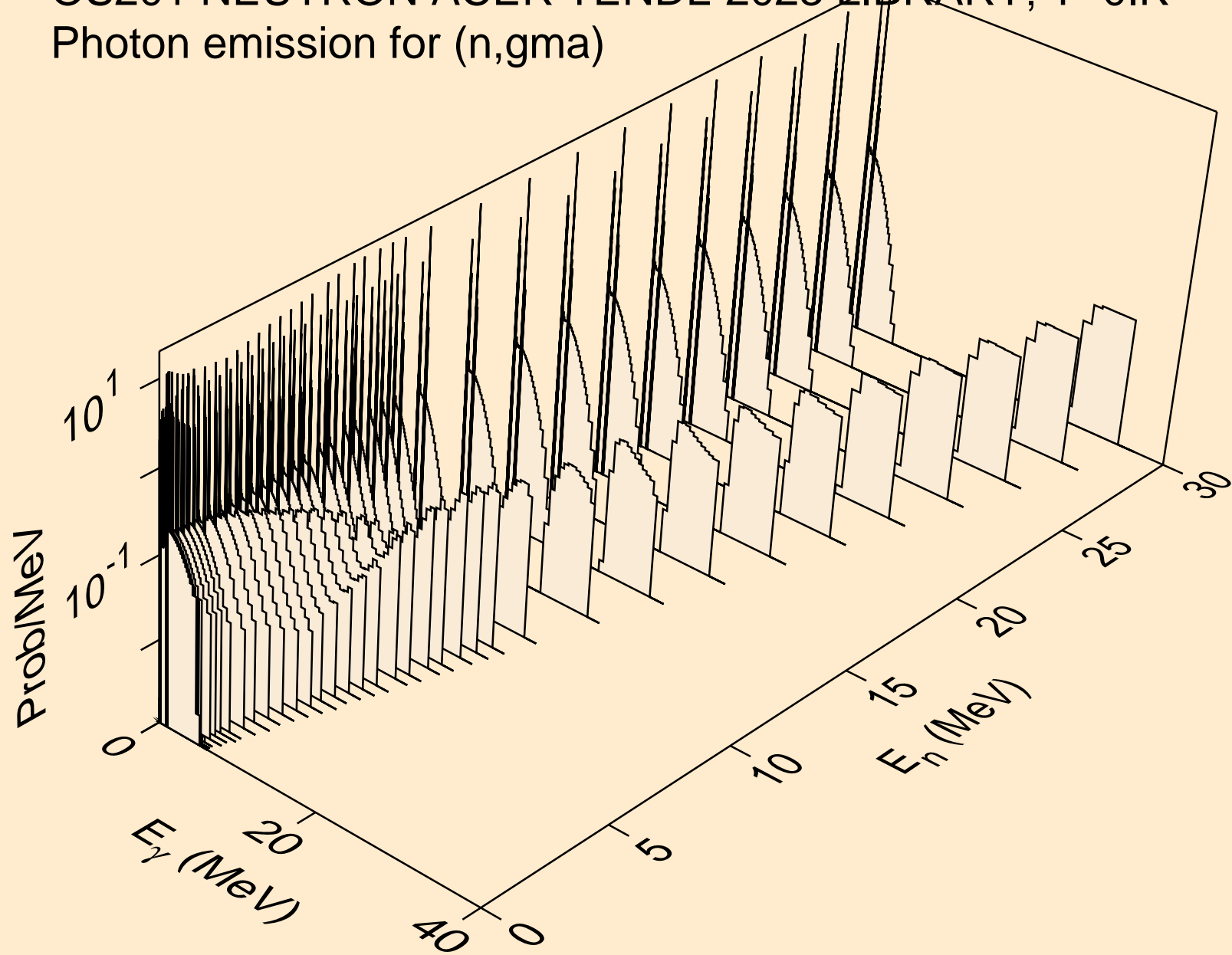

OS201 NEUTRON ACER TENDL-2023 LIBRARY; T=0.K  
Photon emission for (n,p)

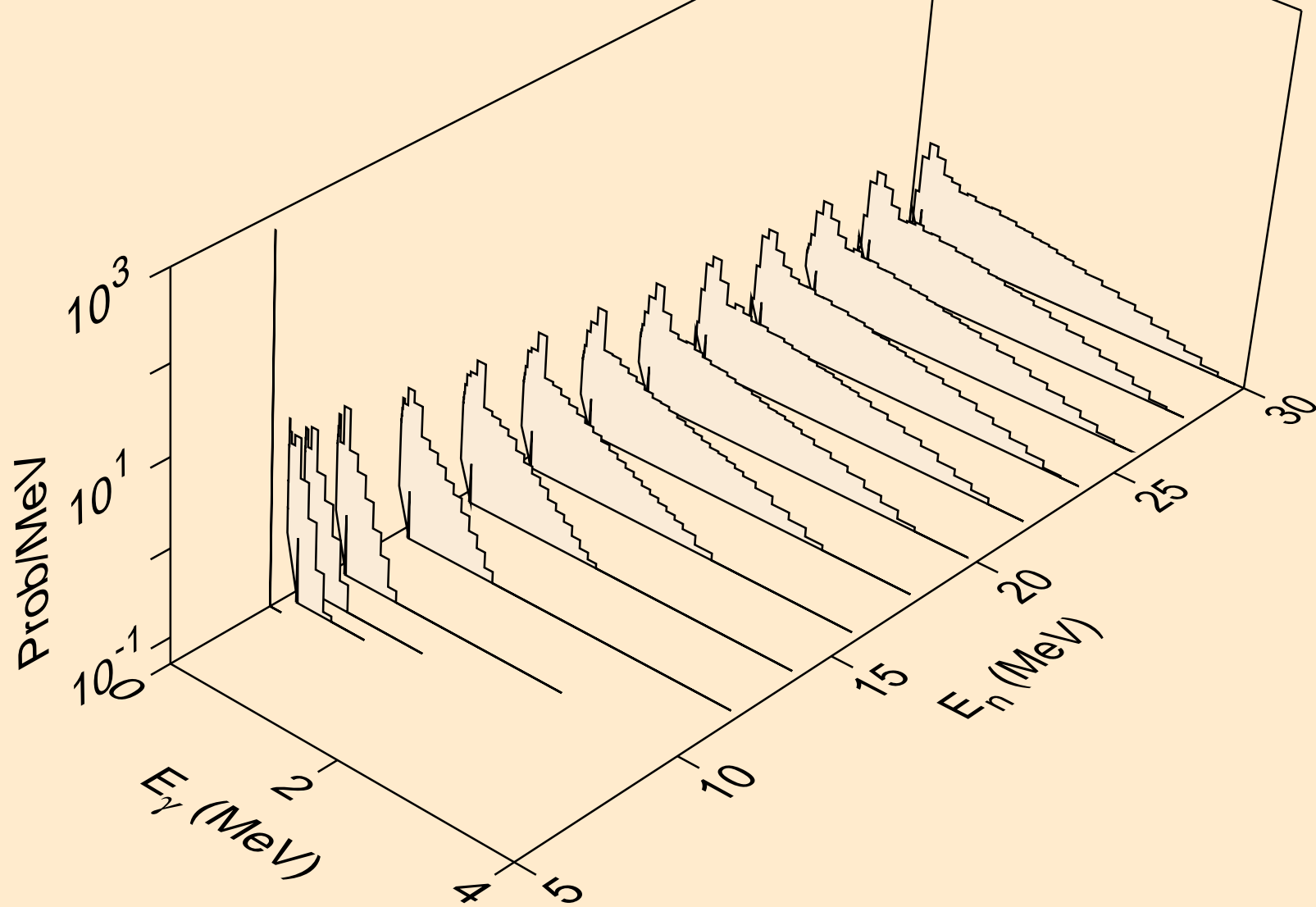

OS201 NEUTRON ACER TENDL-2023 LIBRARY; T=0.K  
Photon emission for (n,d)

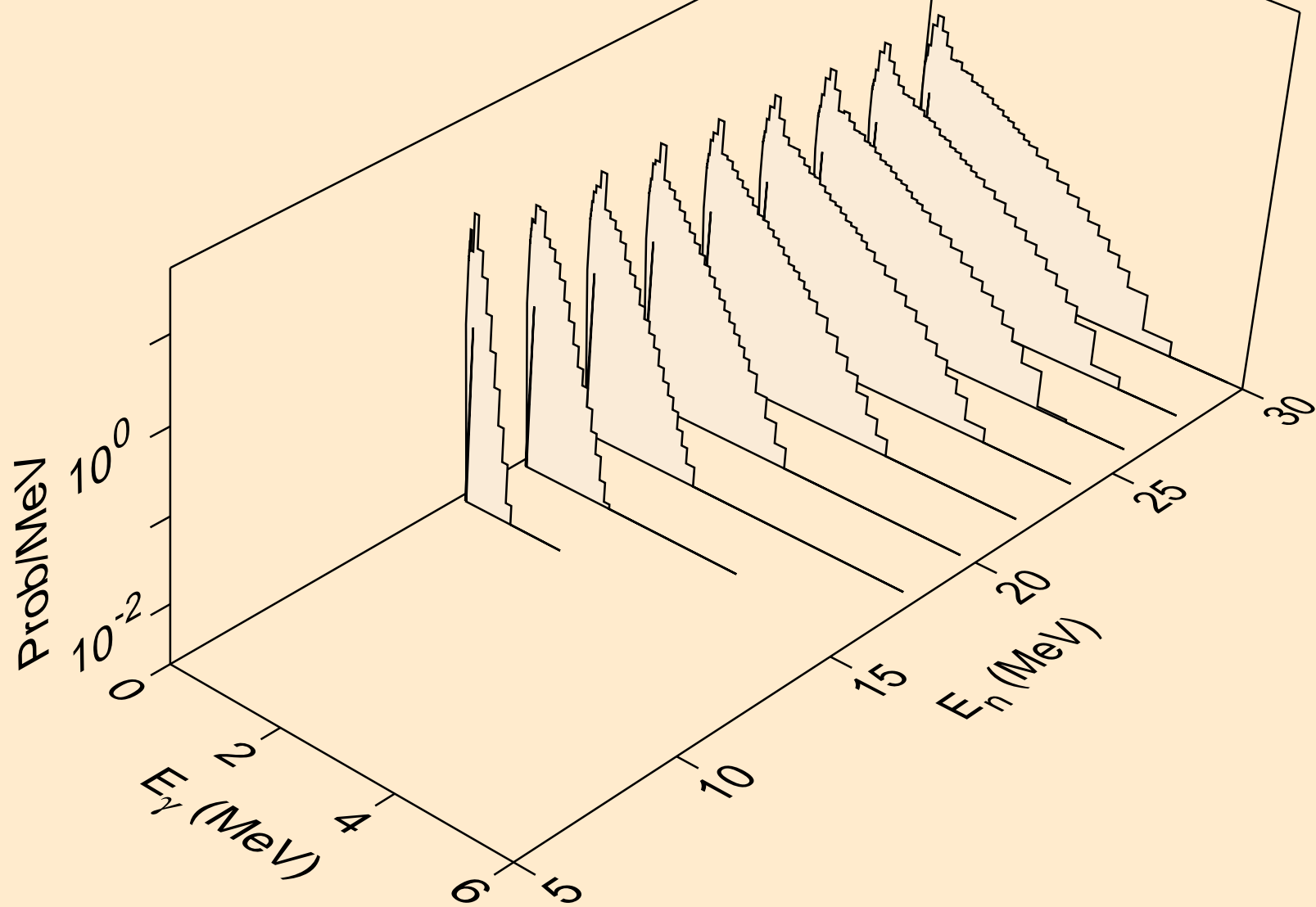

OS201 NEUTRON ACER TENDL-2023 LIBRARY; T=0.K  
Photon emission for (n,t)

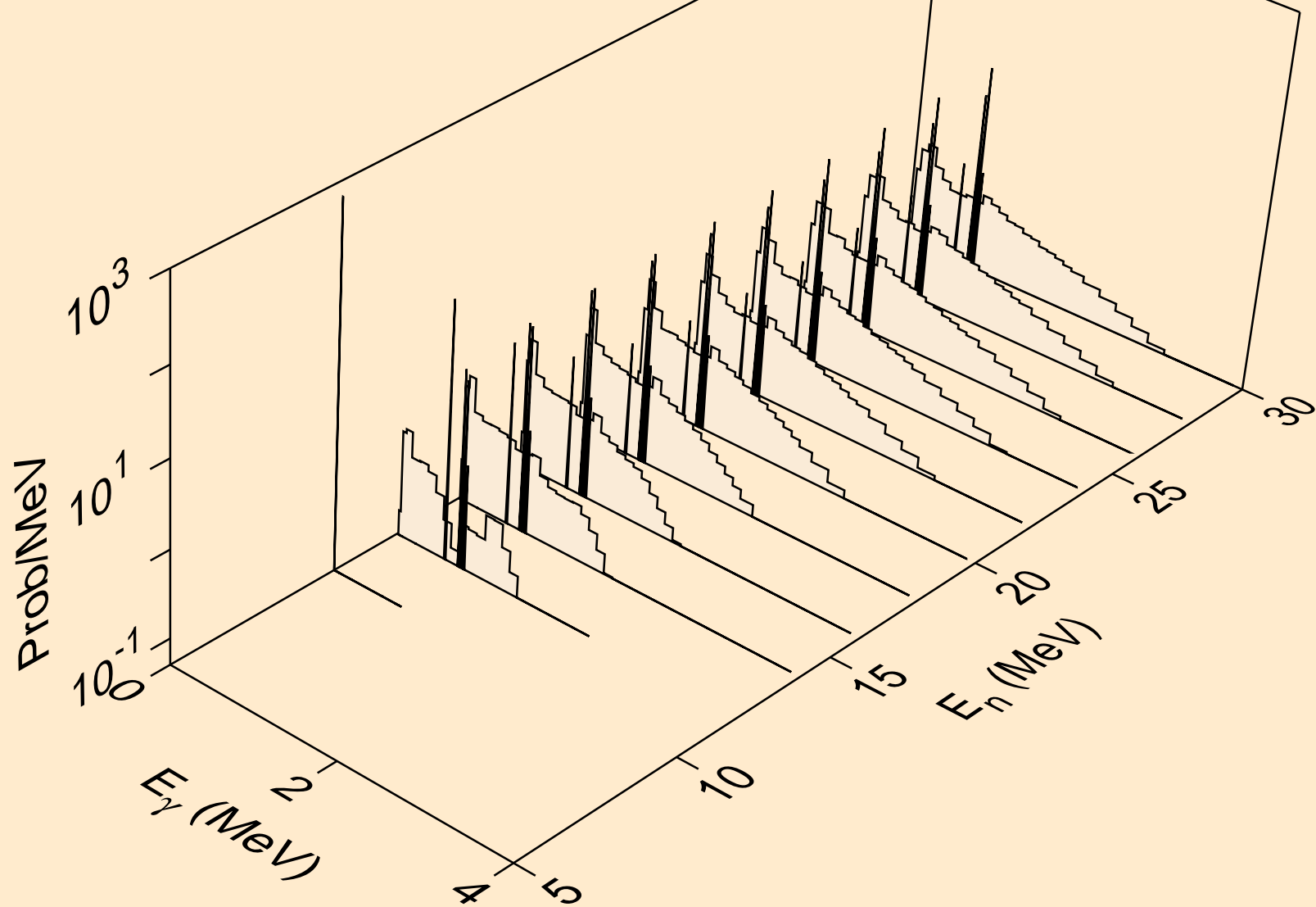

OS201 NEUTRON ACER TENDL-2023 LIBRARY; T=0.K  
Photon emission for (n,he3)

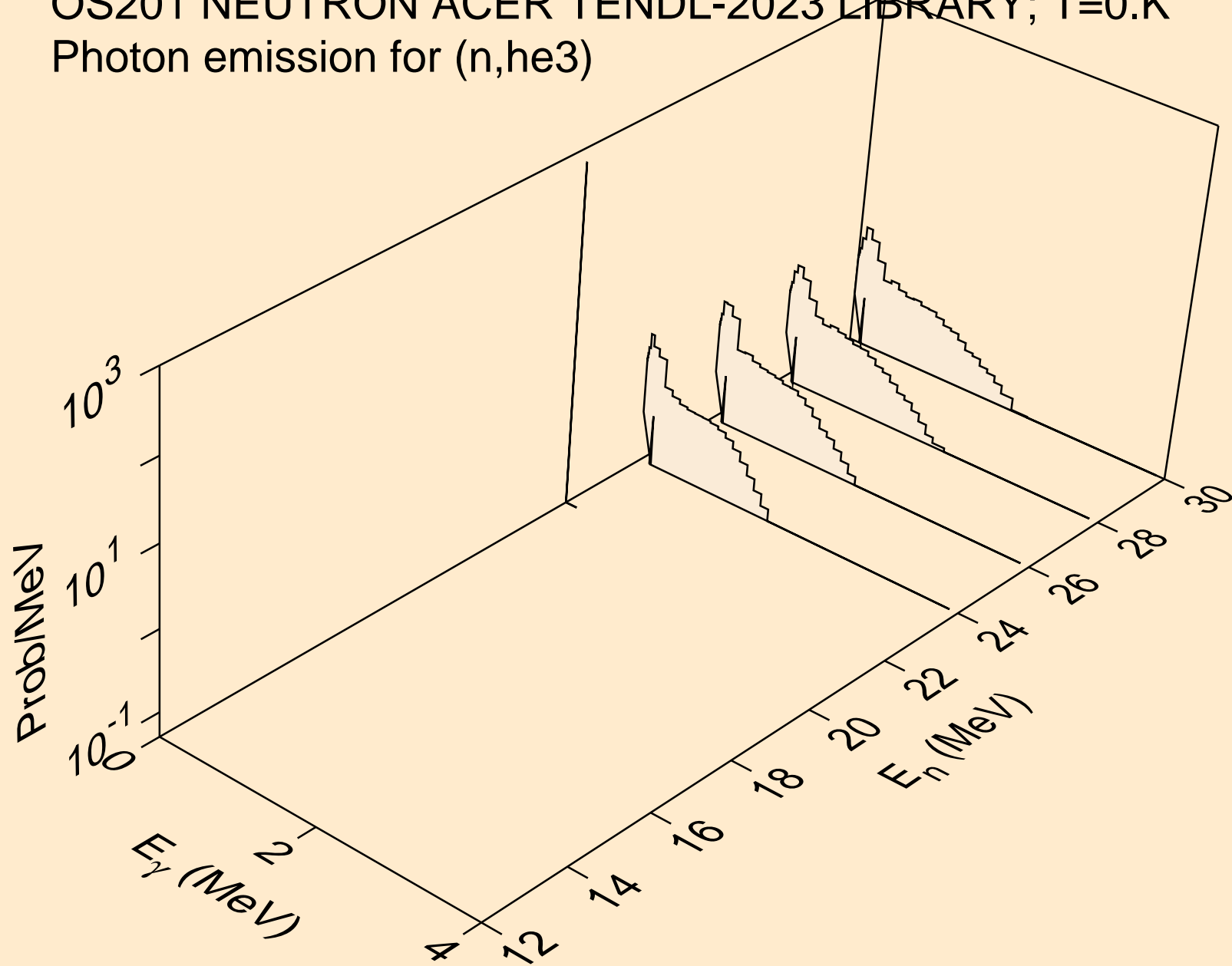

OS201 NEUTRON ACER TENDL-2023 LIBRARY; T=0.K  
Photon emission for (n,a)

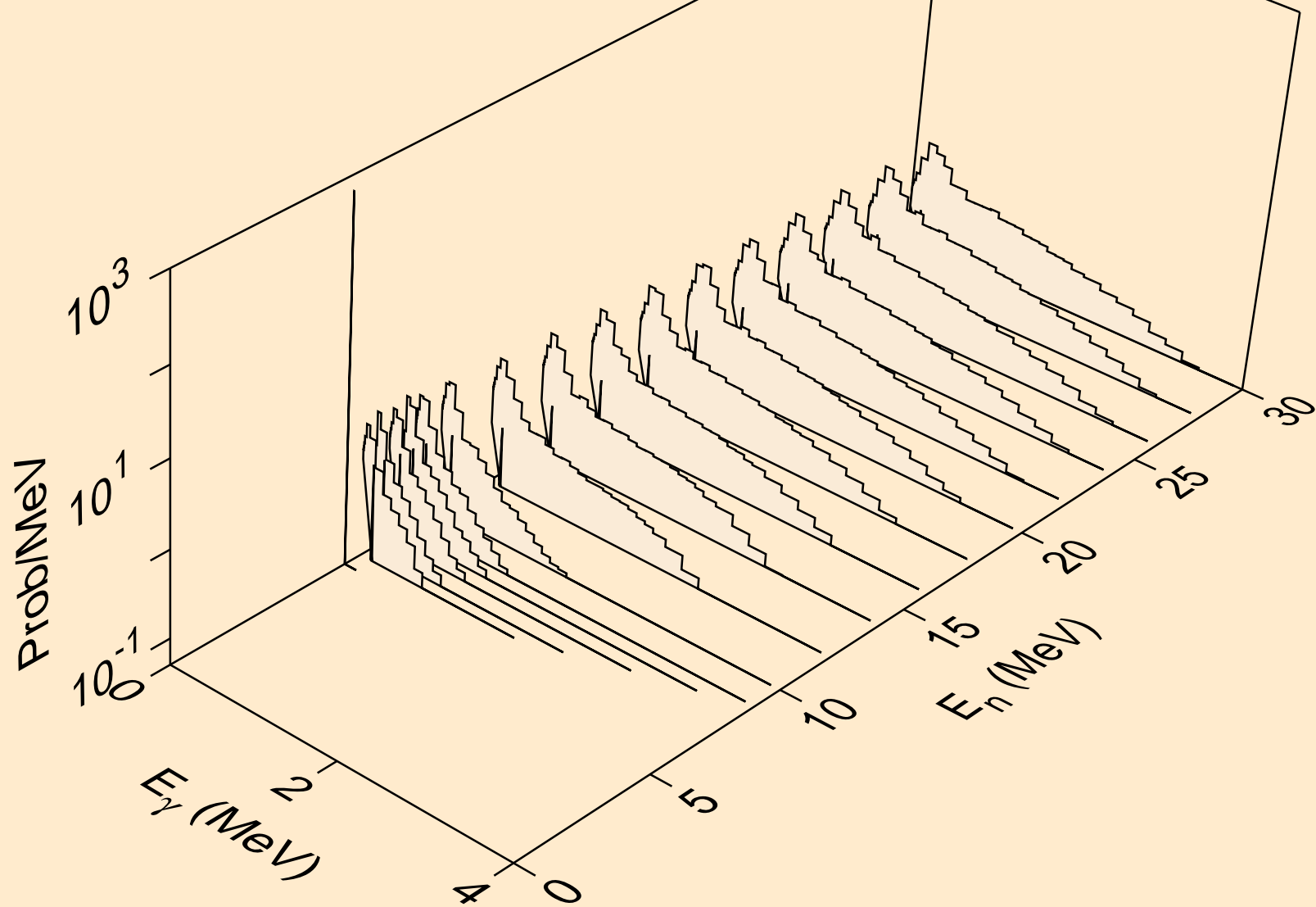

OS201 NEUTRON ACER TENDL-2023 LIBRARY; T=0.K  
thermal capture photon spectrum

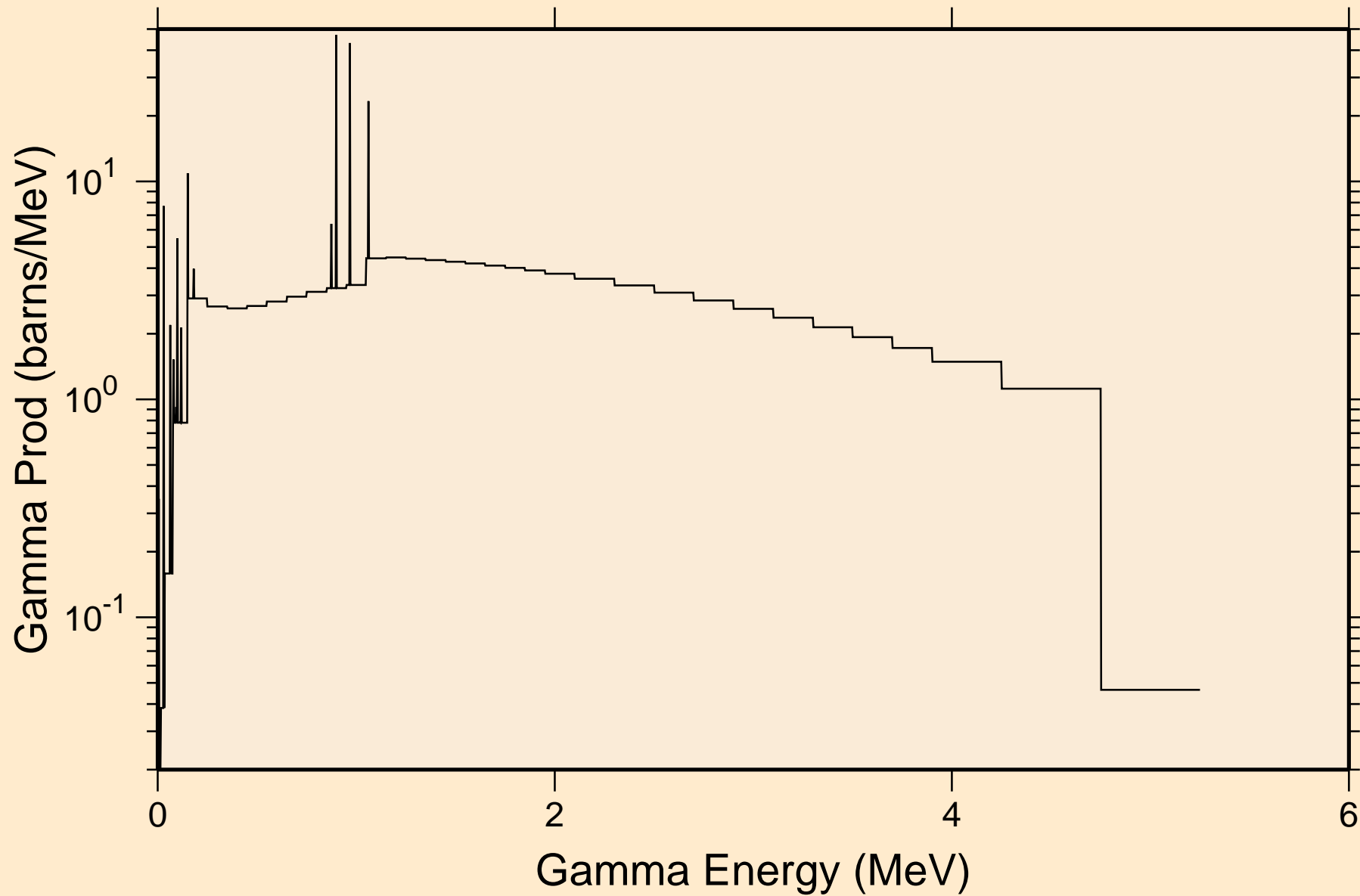

OS201 NEUTRON ACER TENDL-2023 LIBRARY; T=0.K  
14 MeV photon spectrum

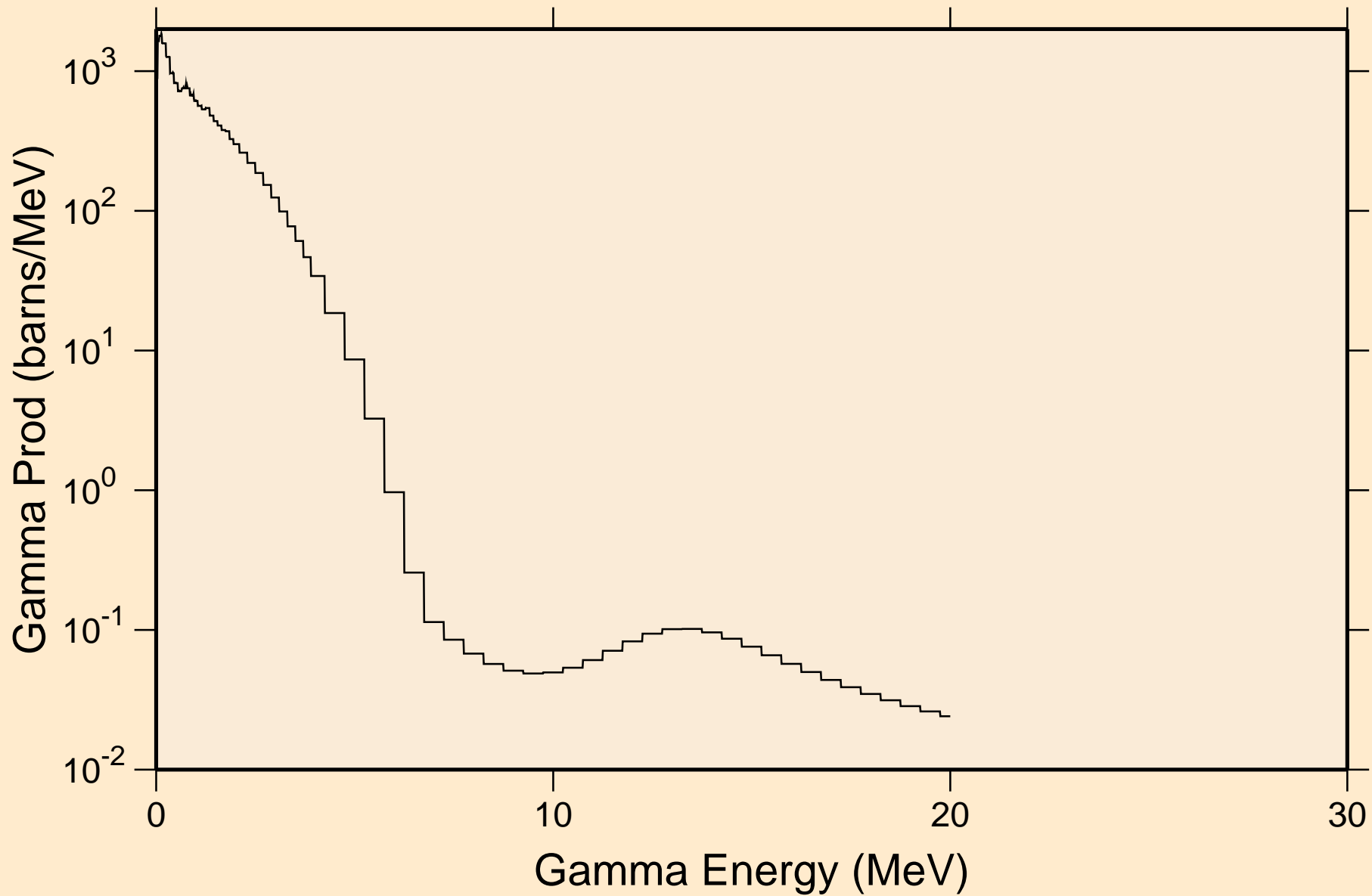

# OS201 NEUTRON ACER TENDL-2023 LIBRARY; T=0.K

## Particle heating contributions

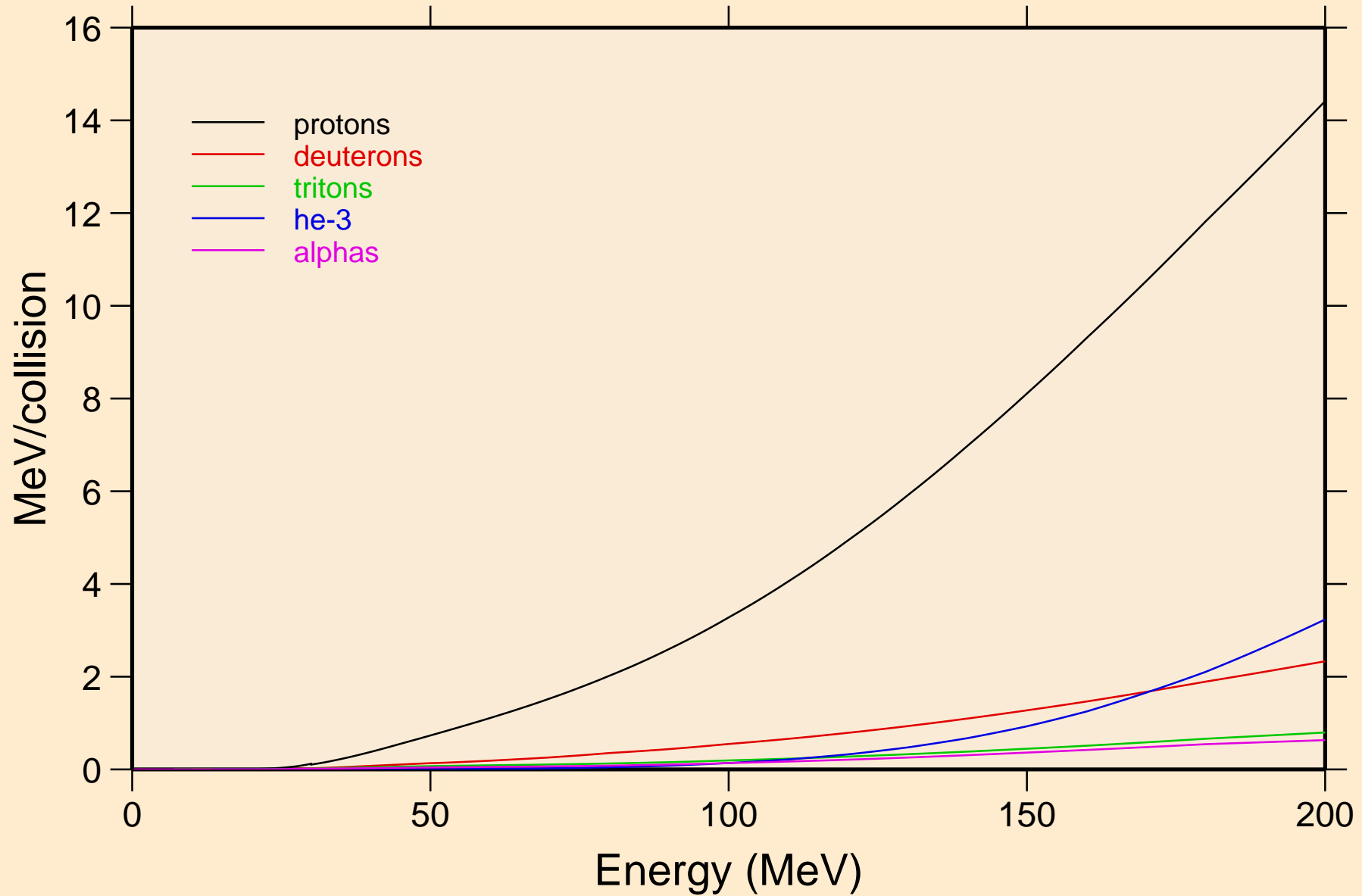

OS201 NEUTRON ACER TENDL-2023 LIBRARY; T=0.K  
Recoil Heating

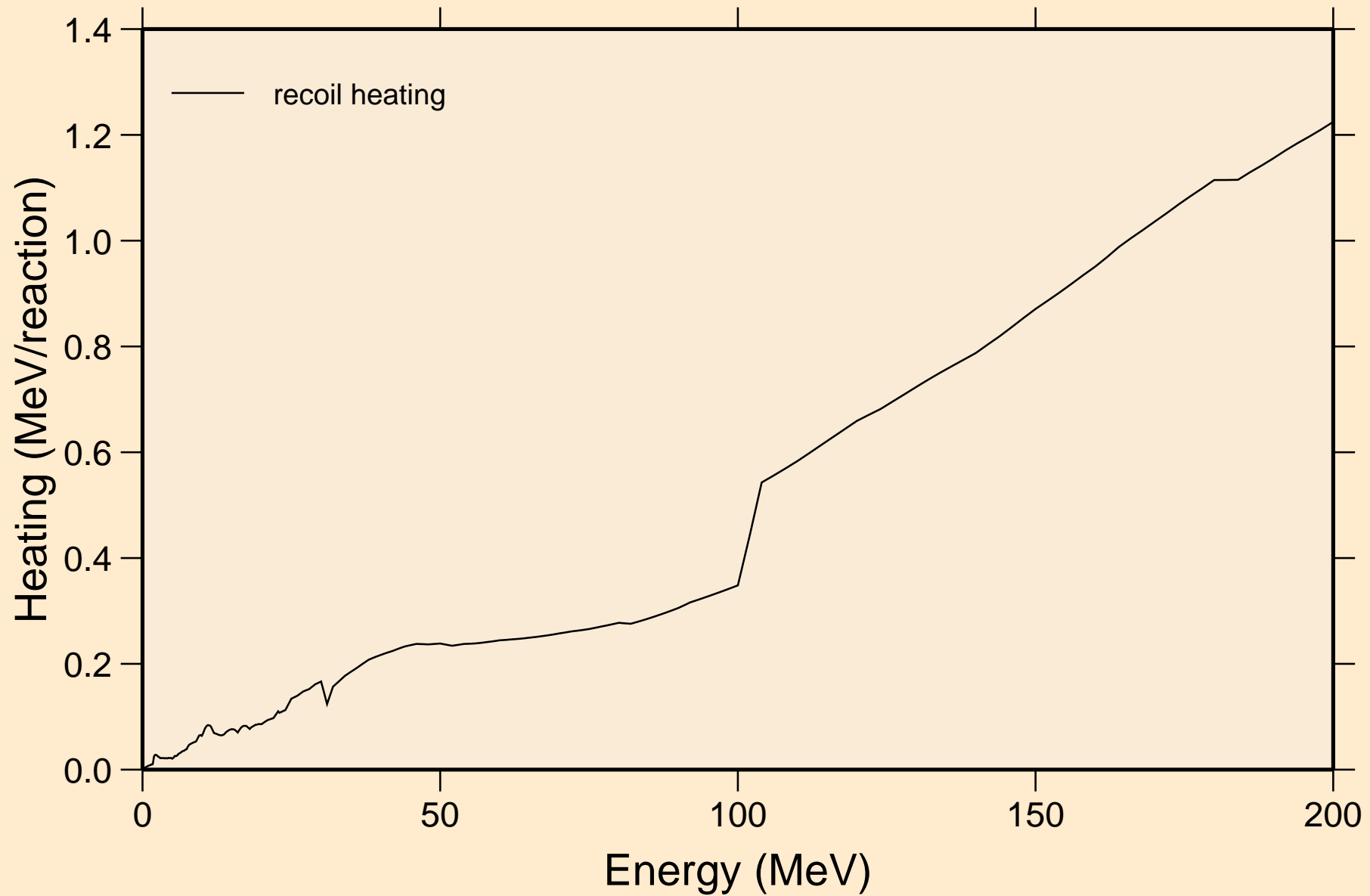

OS201 NEUTRON ACER TENDL-2023 LIBRARY; T=0.K  
Particle production cross sections

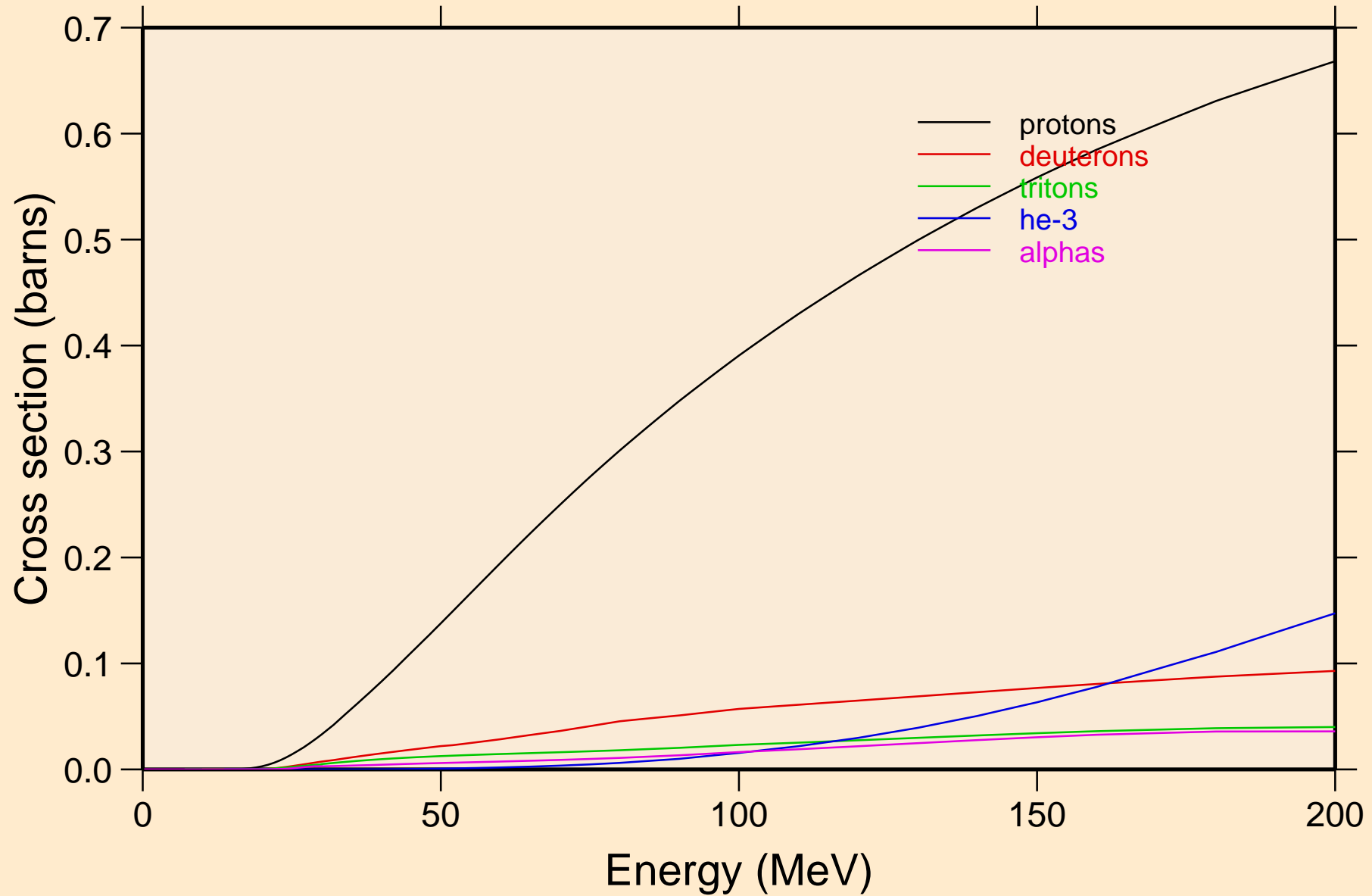

OS201 NEUTRON ACER TENDL-2023 LIBRARY; T=0.K  
protons from (n,x)

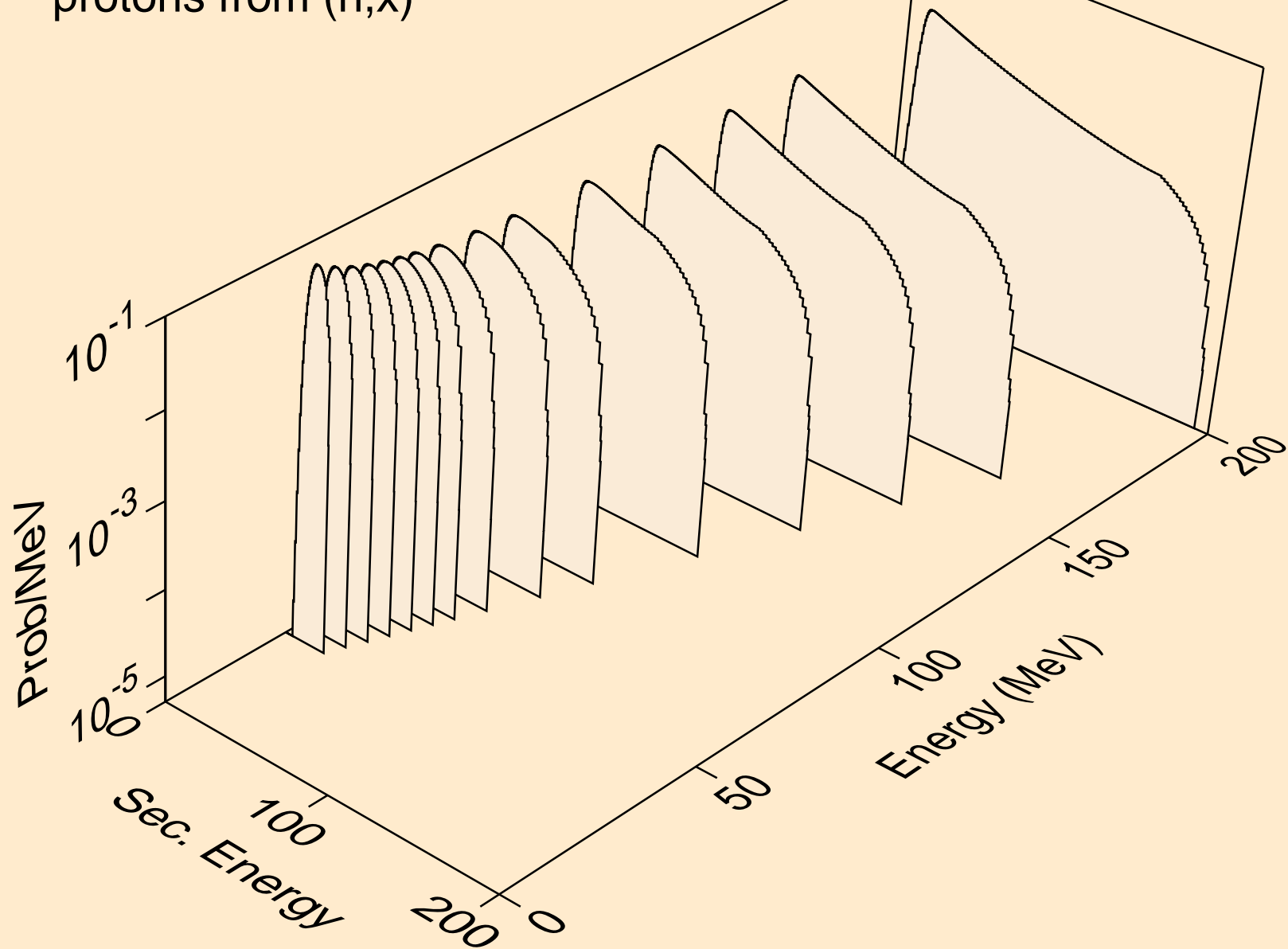

OS201 NEUTRON ACER TENDL-2023 LIBRARY; T=0.K  
protons from (n,n\*)p

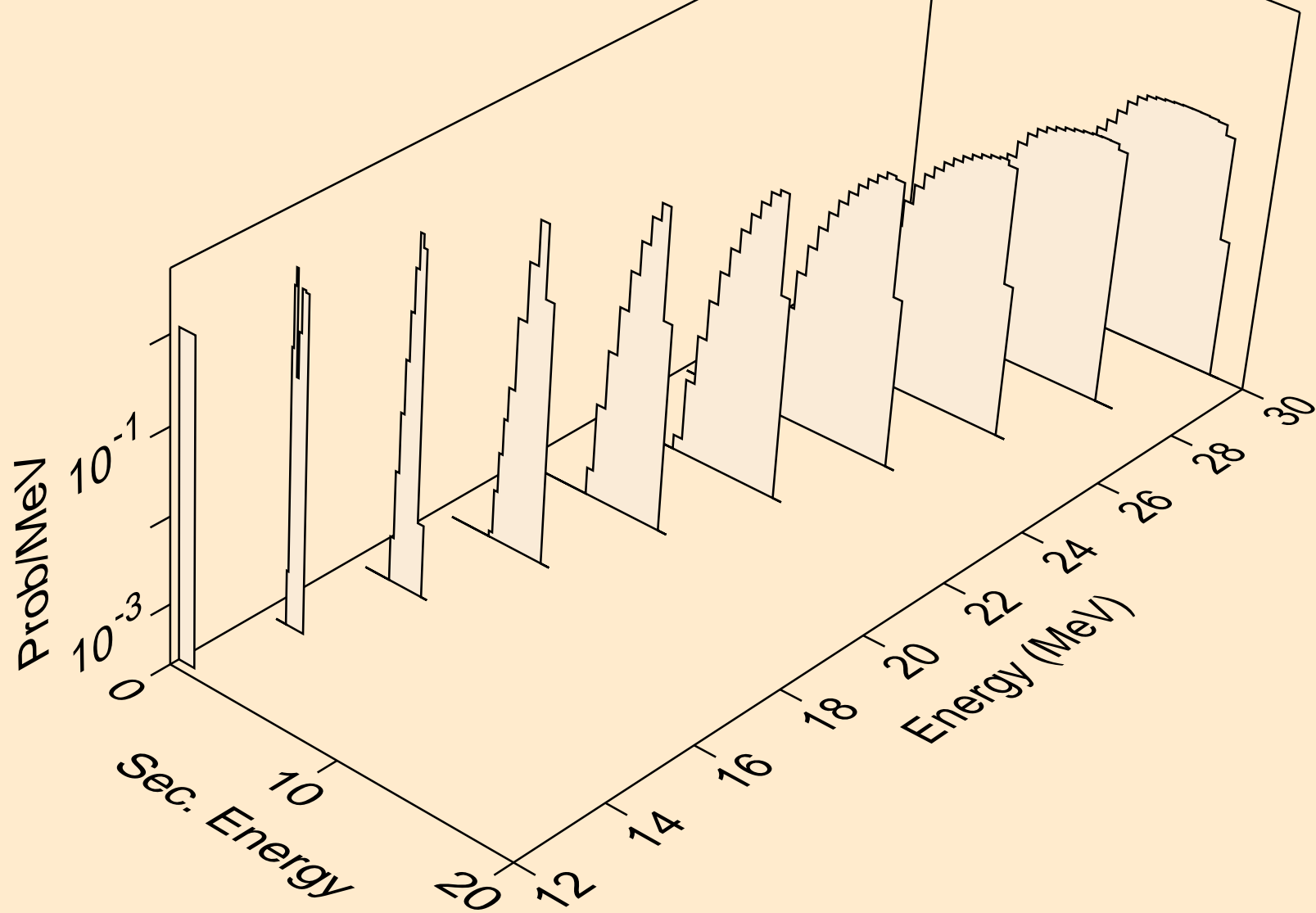

OS201 NEUTRON ACER TENDL-2023 LIBRARY; T=0.K  
protons from (n,2np)

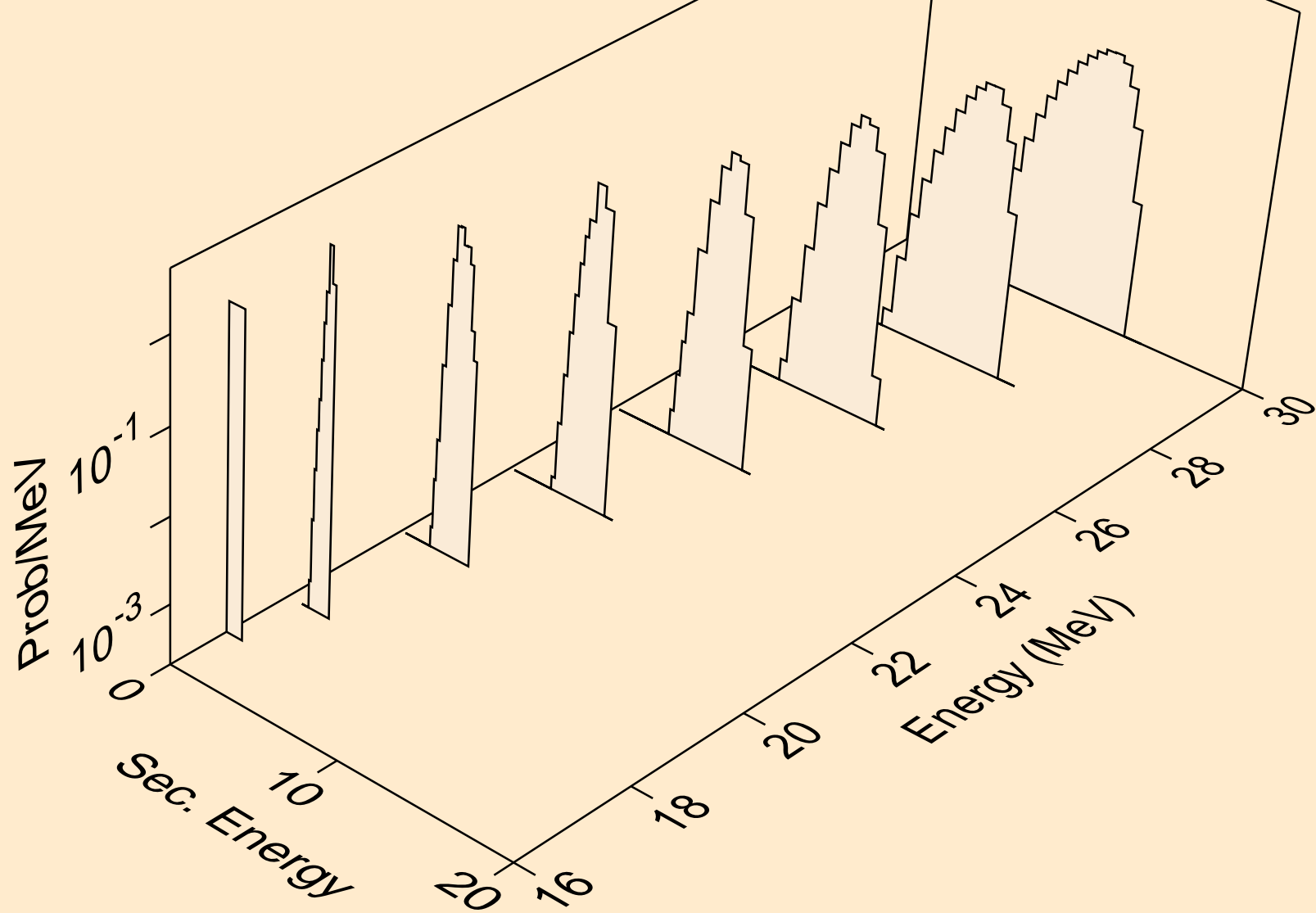

OS201 NEUTRON ACER TENDL-2023 LIBRARY; T=0.K  
protons from (n,3np)

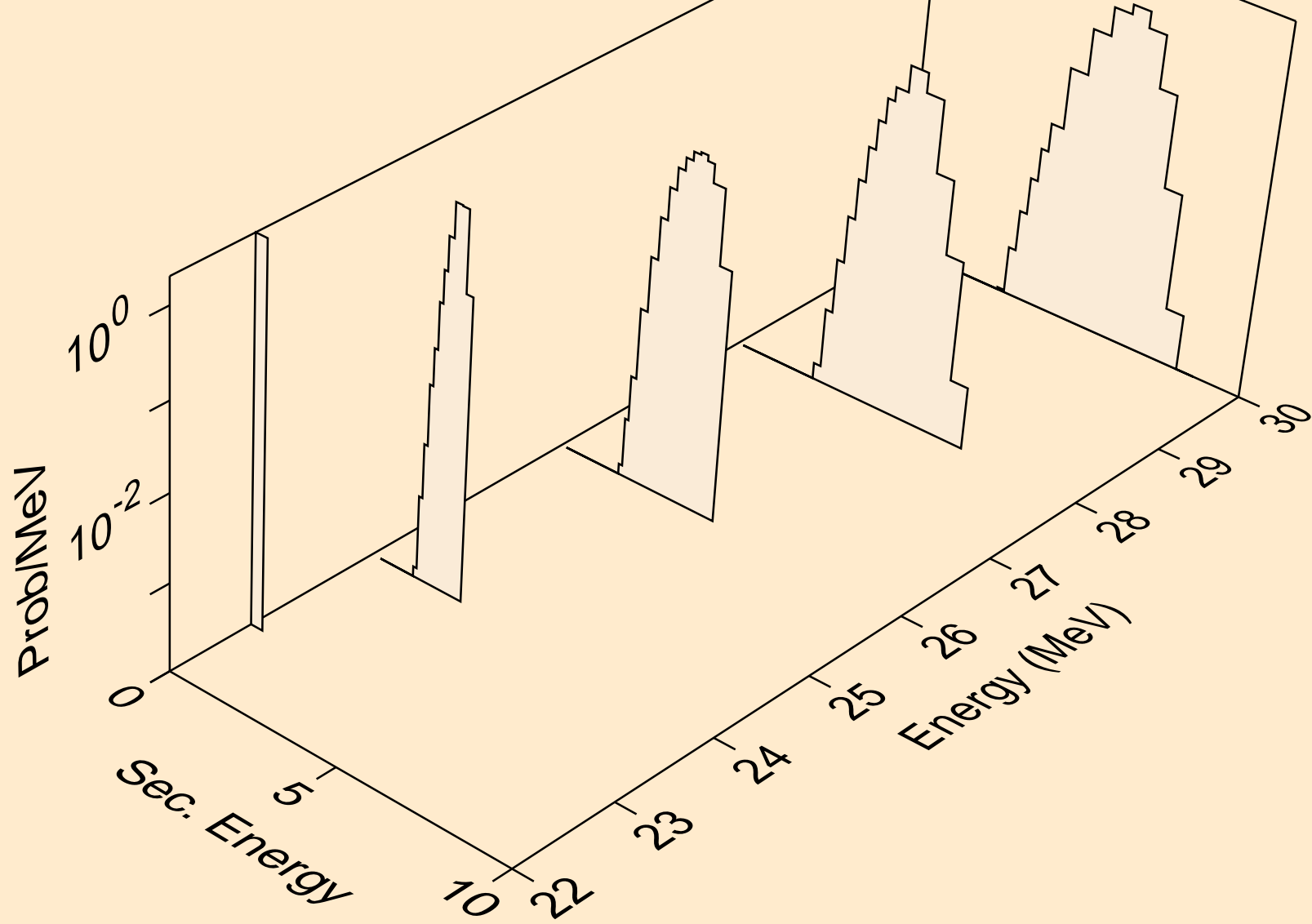

OS201 NEUTRON ACER TENDL-2023 LIBRARY; T=0.K  
protons from (n,p)

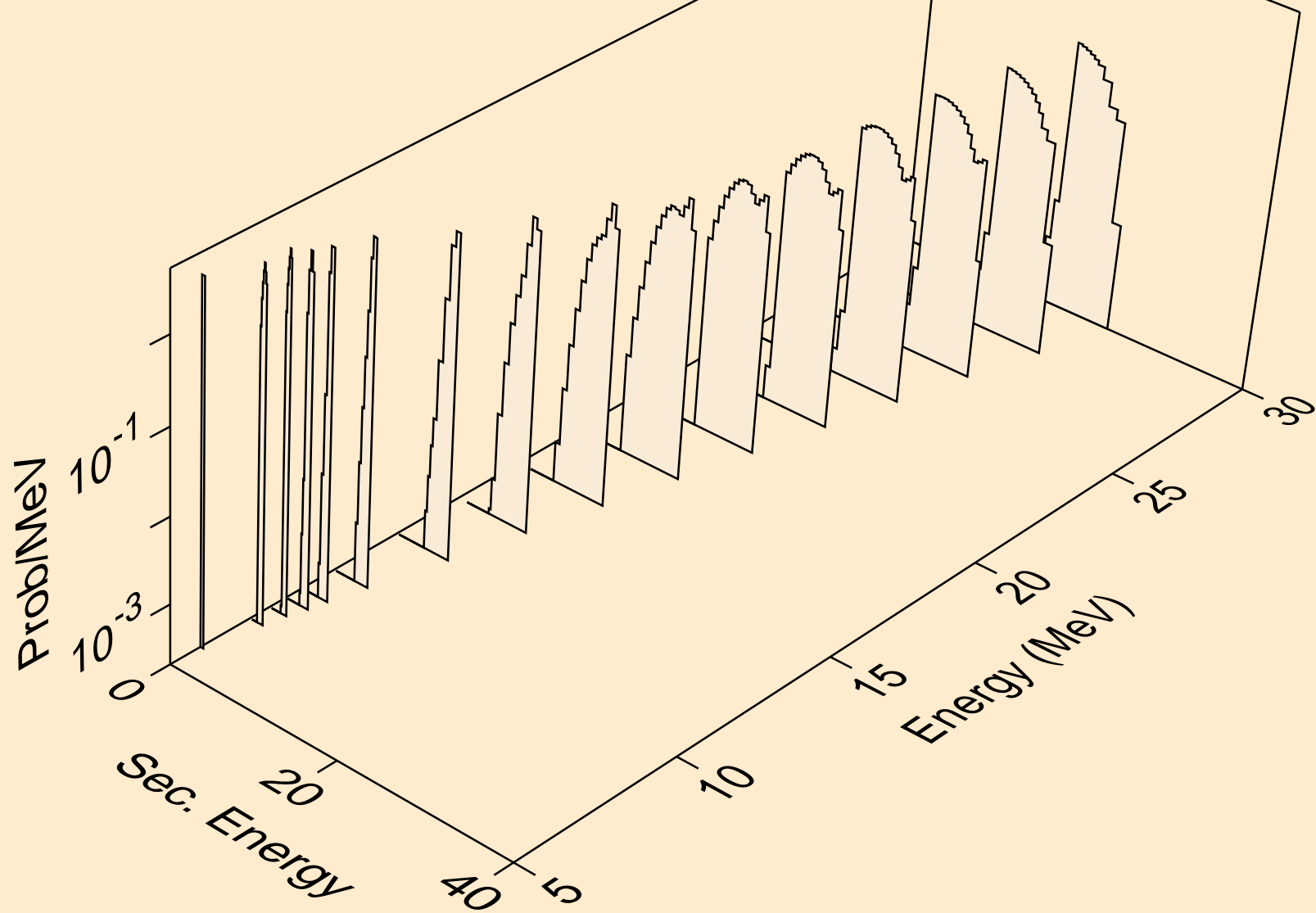

OS201 NEUTRON ACER TENDL-2023 LIBRARY; T=0.K  
deuterons from (n,x)

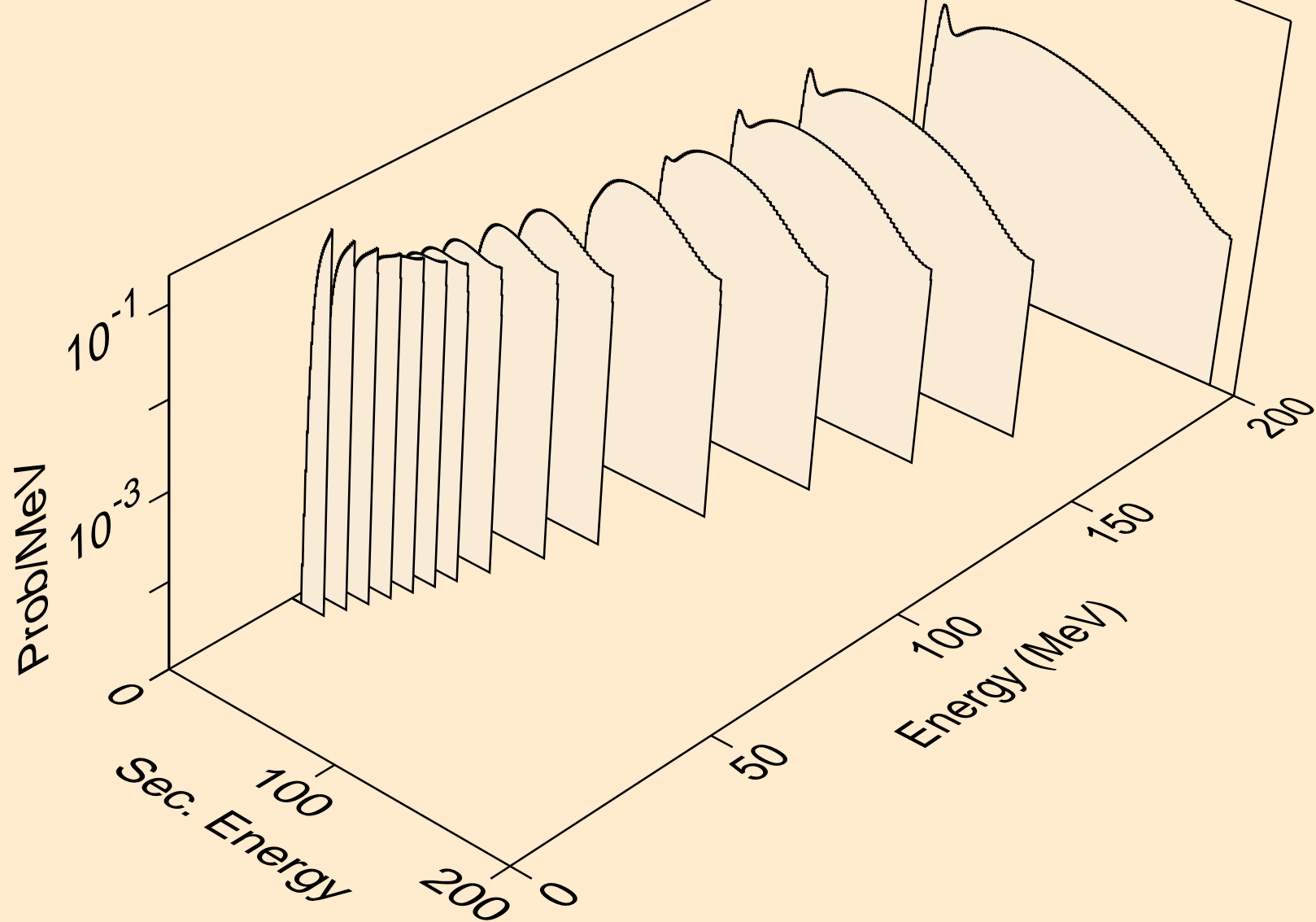

OS201 NEUTRON ACER TENDL-2023 LIBRARY; T=0.K  
deuterons from (n,2nd)

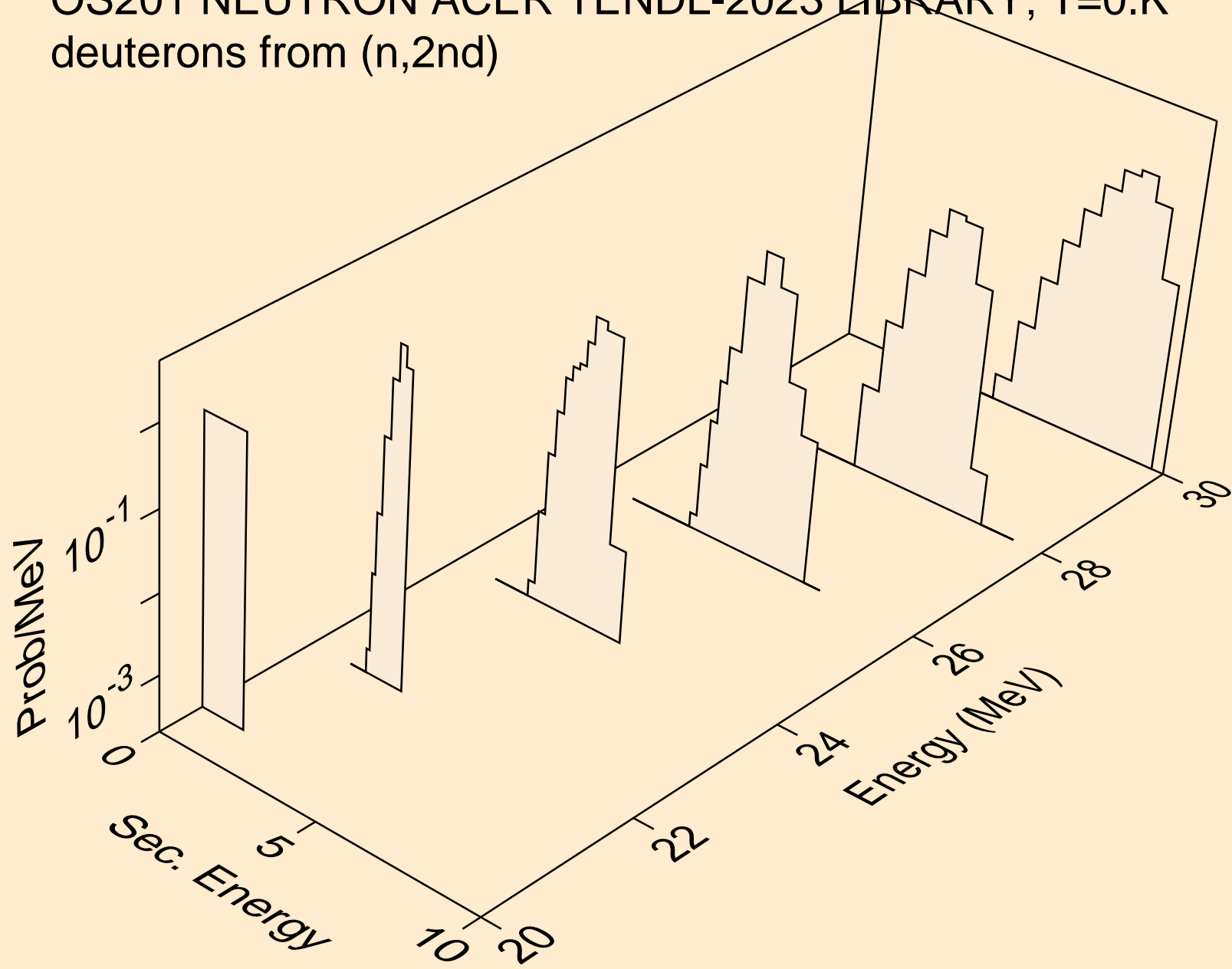

OS201 NEUTRON ACER TENDL-2023 LIBRARY; T=0.K  
deuterons from (n,n\*)d

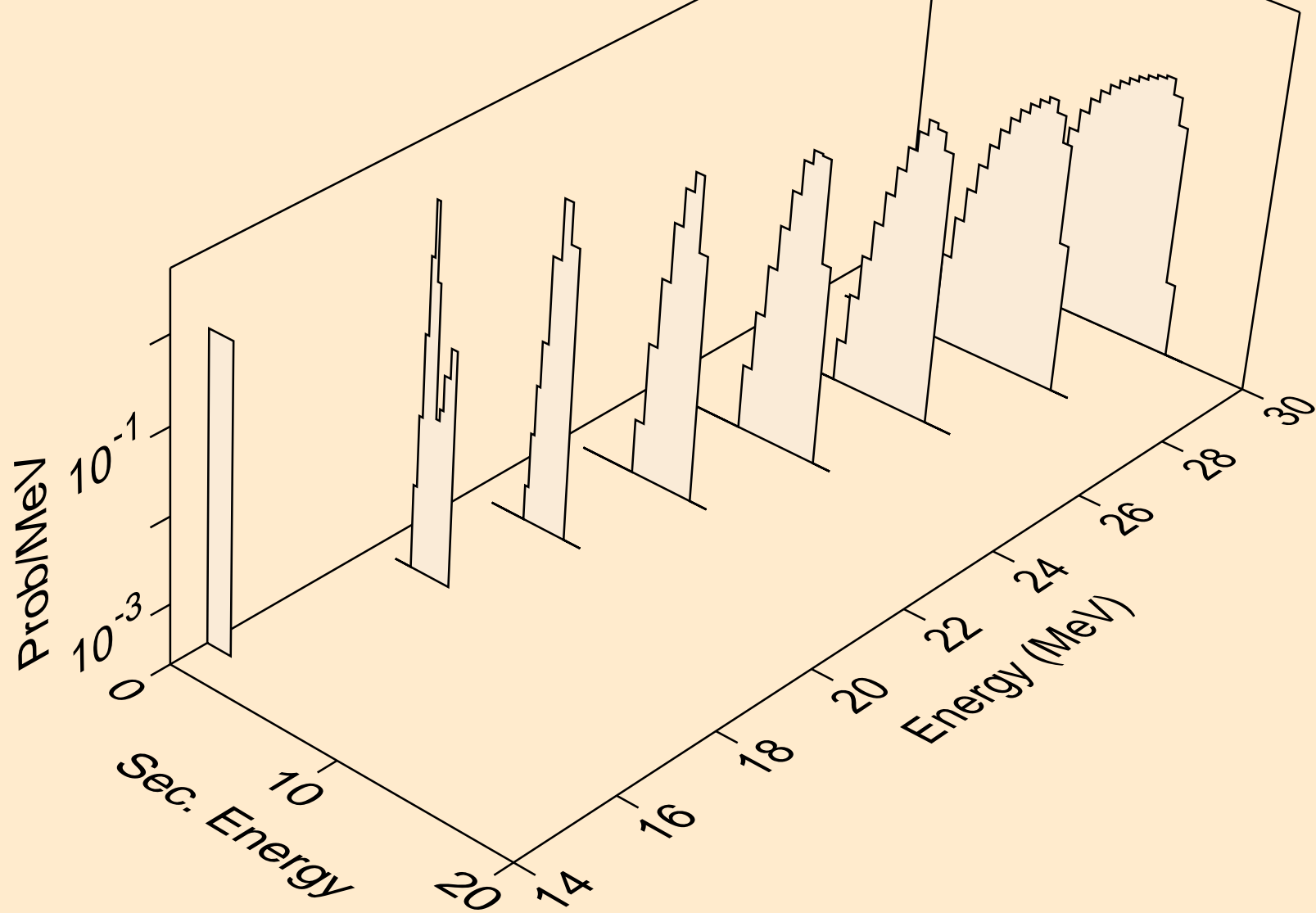

OS201 NEUTRON ACER TENDL-2023 LIBRARY; T=0.K  
deuterons from (n,d)

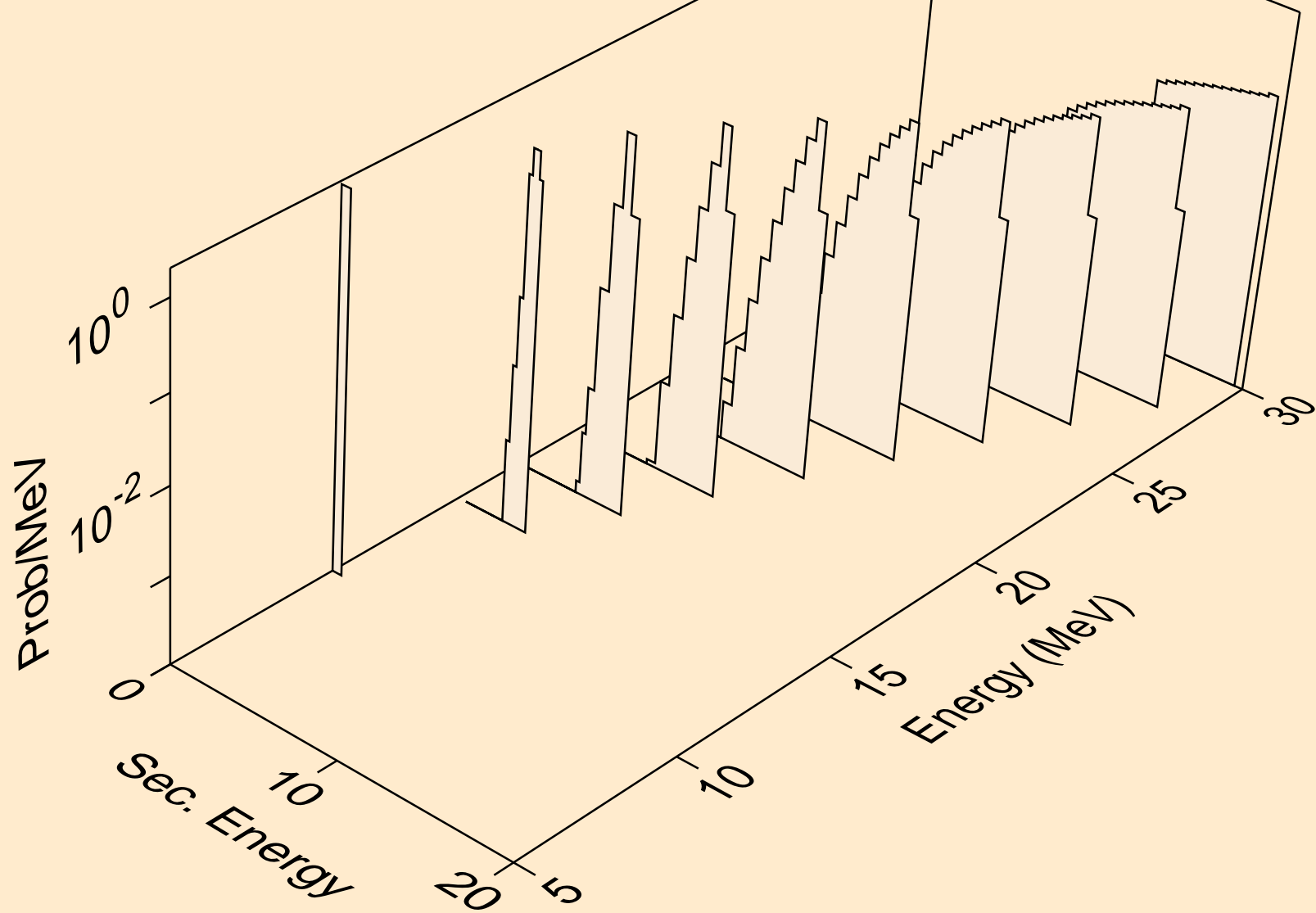

OS201 NEUTRON ACER TENDL-2023 LIBRARY; T=0.K  
tritons from (n,x)

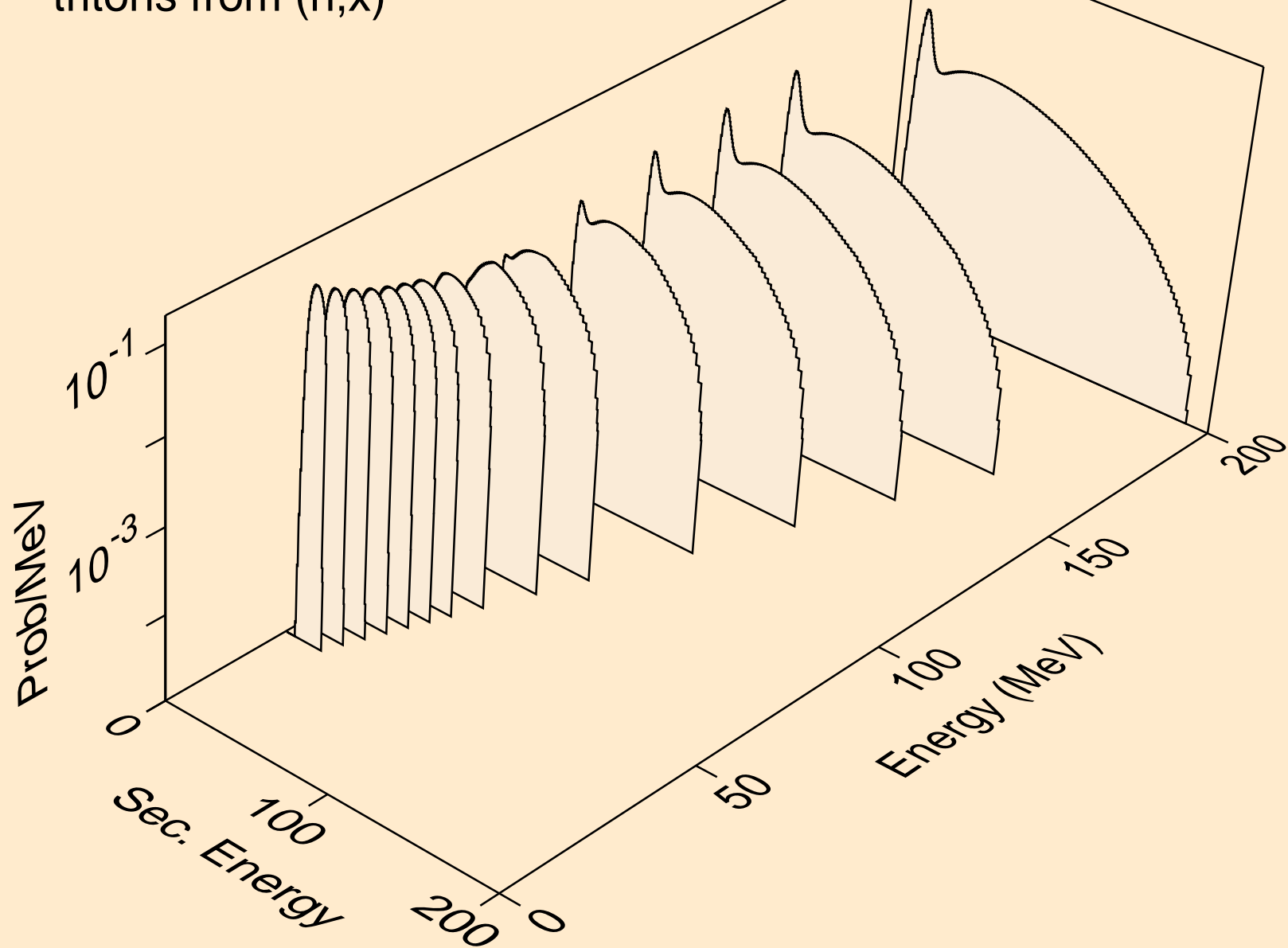

OS201 NEUTRON ACER TENDL-2023 LIBRARY; T=0.K  
tritons from (n,n\*)t

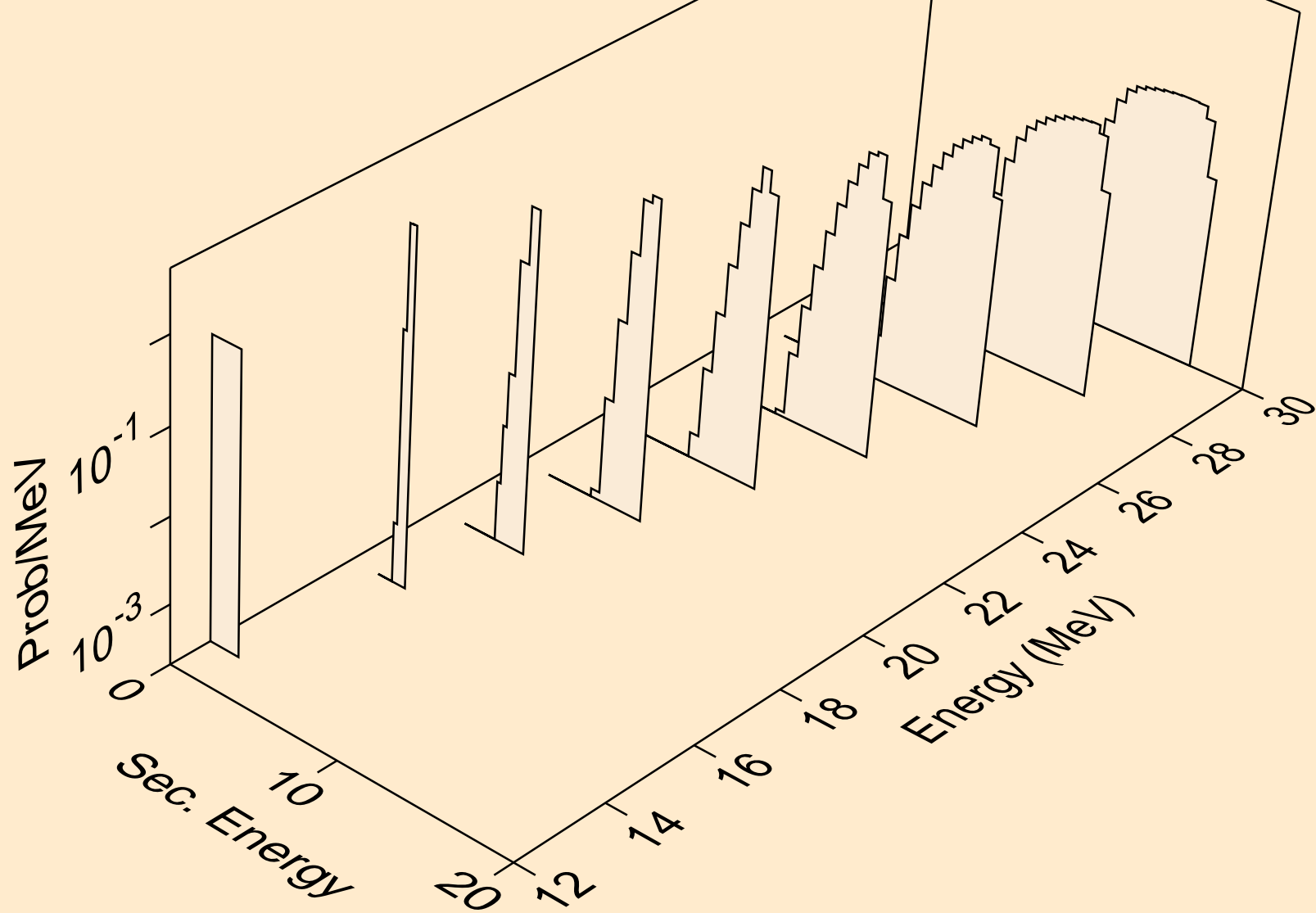

OS201 NEUTRON ACER TENDL-2023 LIBRARY; T=0.K  
tritons from (n,t)

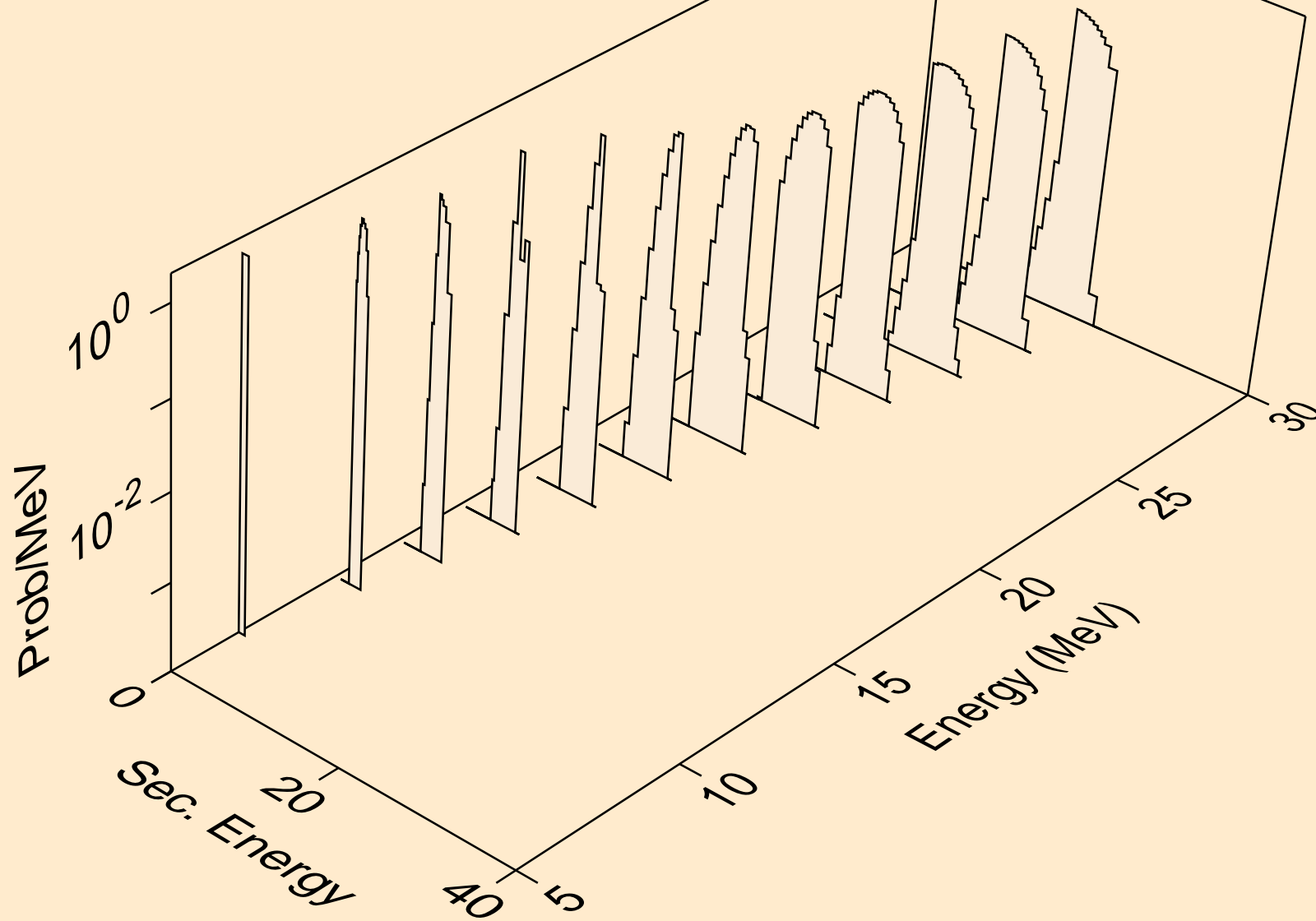

OS201 NEUTRON ACER TENDL-2023 LIBRARY; T=0.K  
he3s from (n,x)

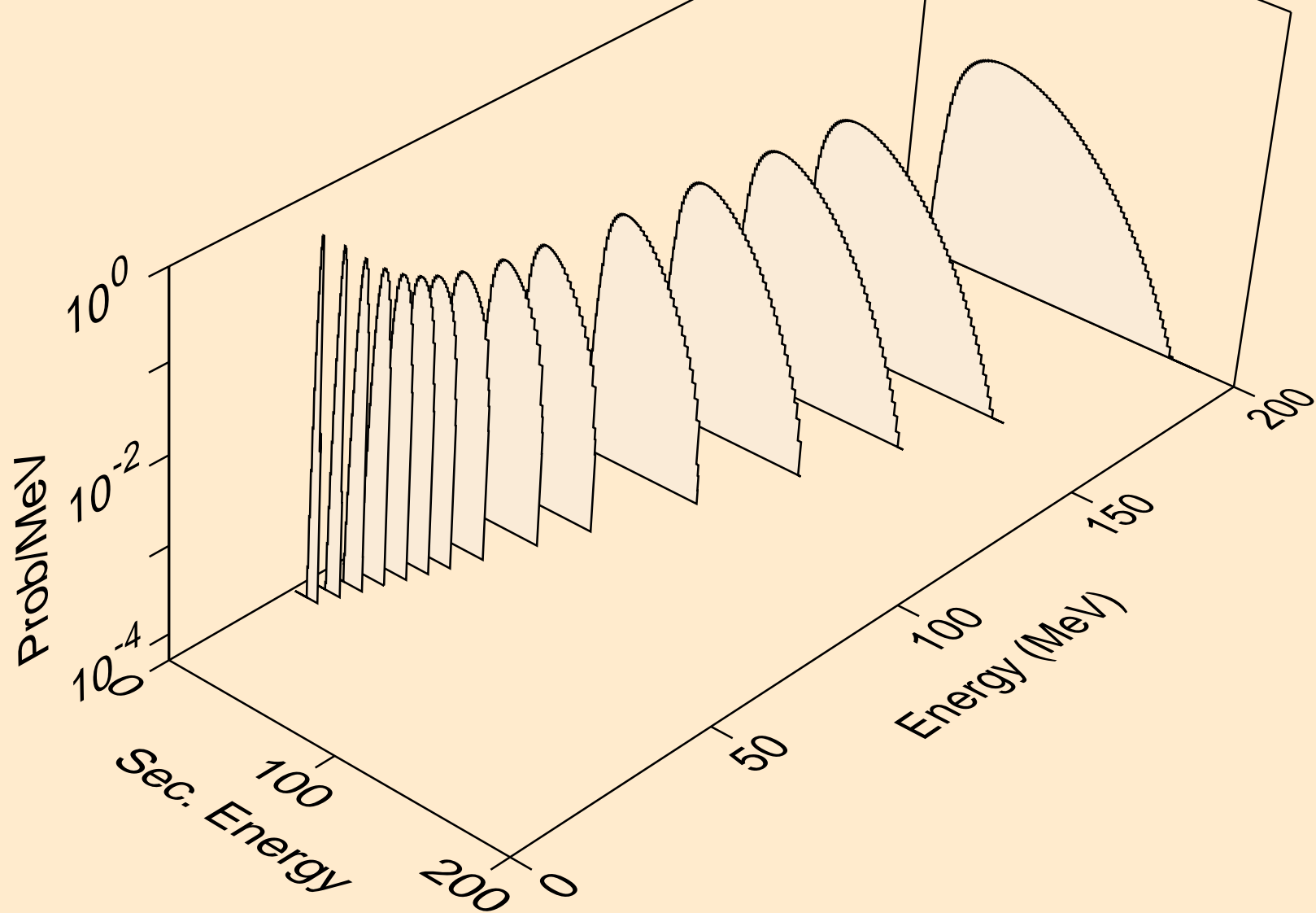

OS201 NEUTRON ACER TENDL-2023 LIBRARY; T=0.K  
he3s from (n,he3)

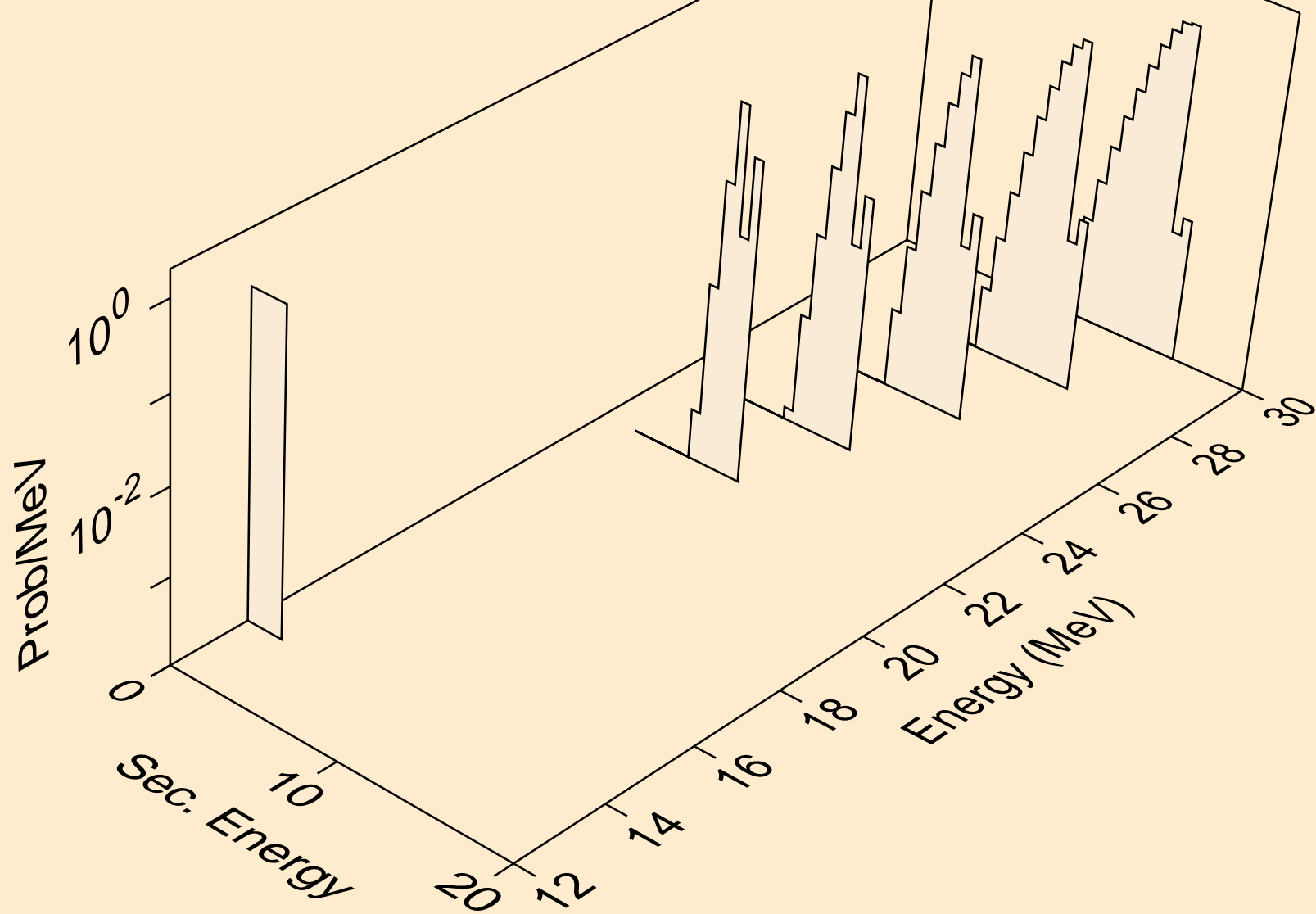

OS201 NEUTRON ACER TENDL-2023 LIBRARY; T=0.K  
alphas from (n,x)

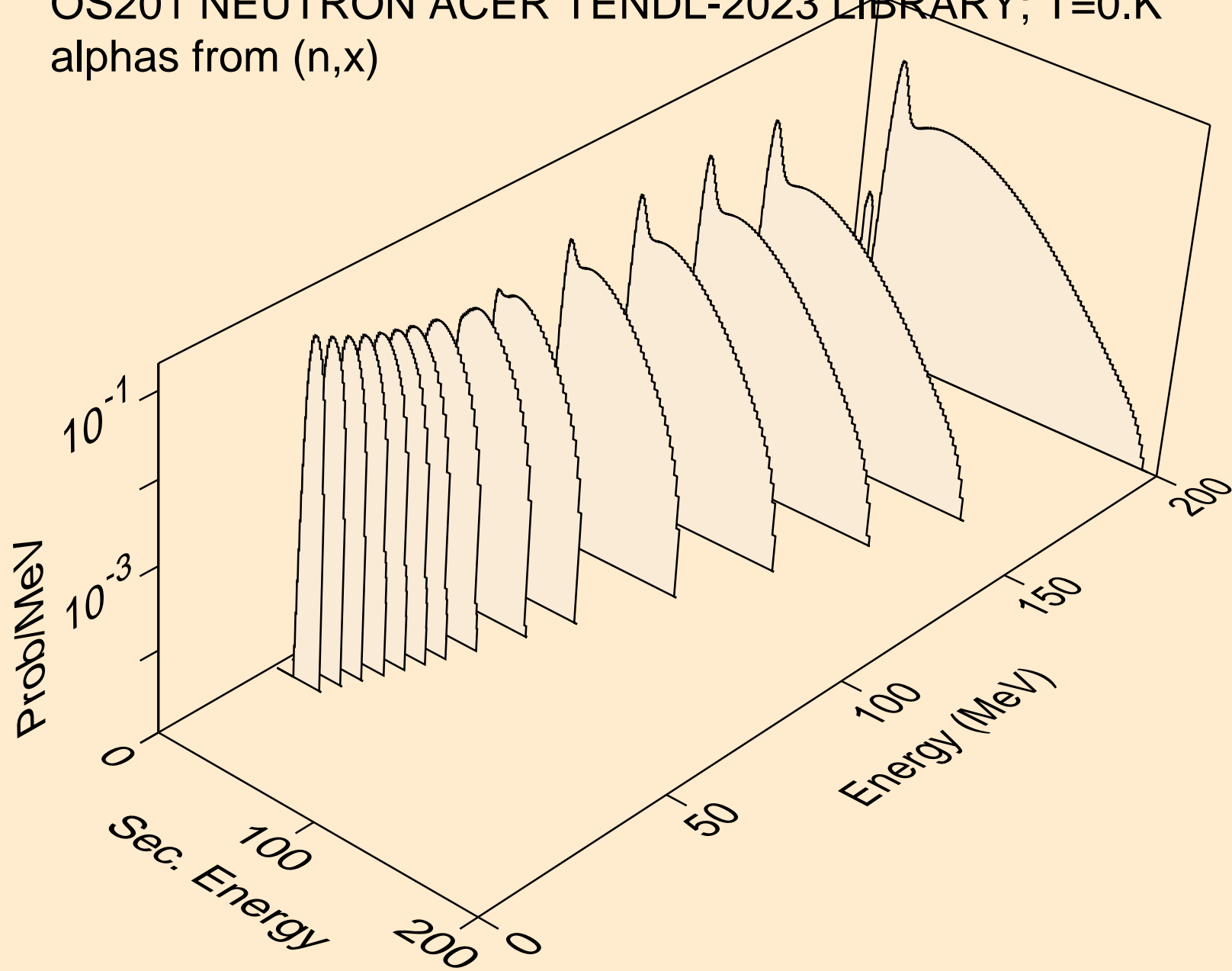

OS201 NEUTRON ACER TENDL-2023 LIBRARY; T=0.K  
alphas from (n,n\*)a

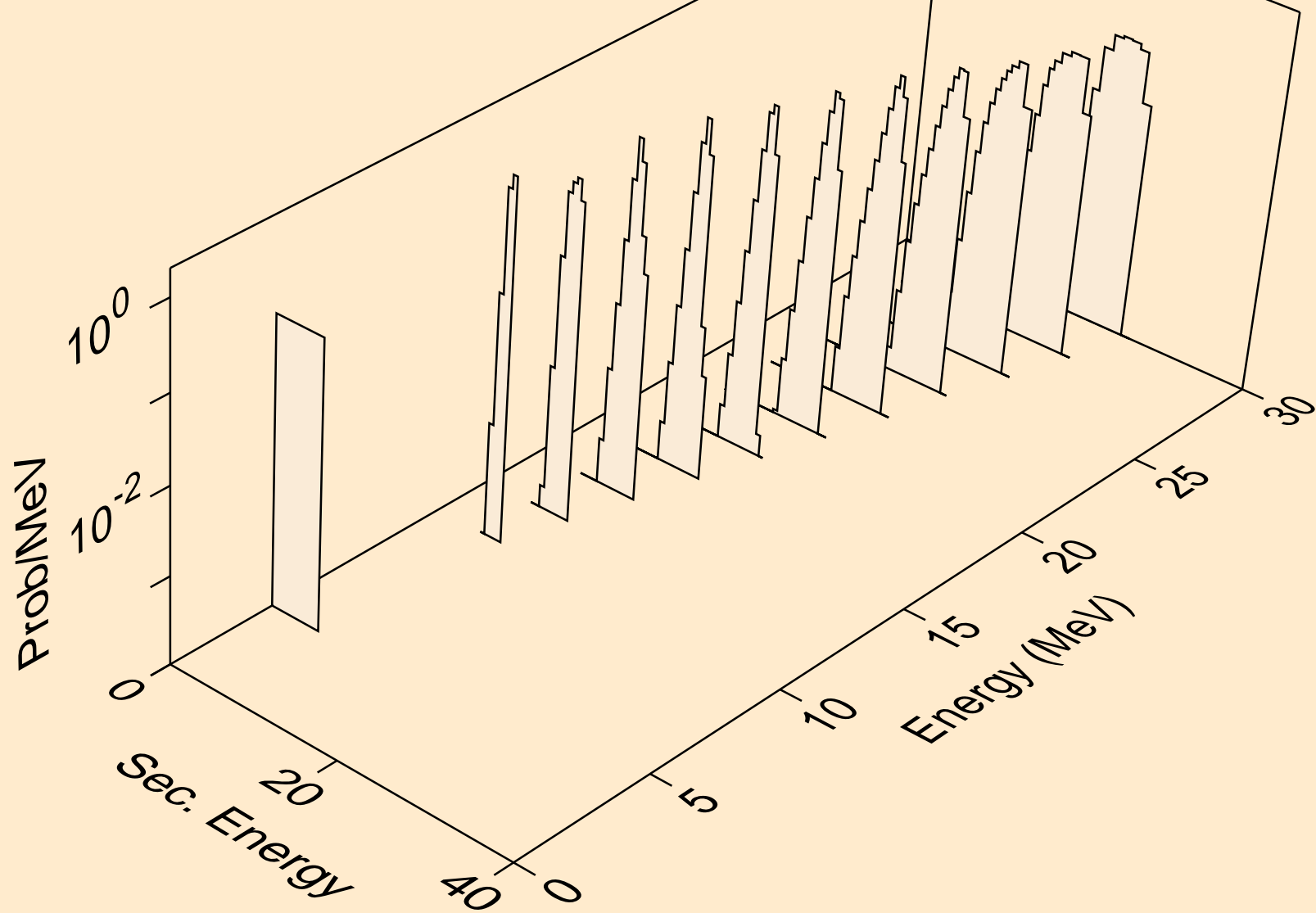

OS201 NEUTRON ACER TENDL-2023 LIBRARY; T=0.K  
alphas from (n,2n)a

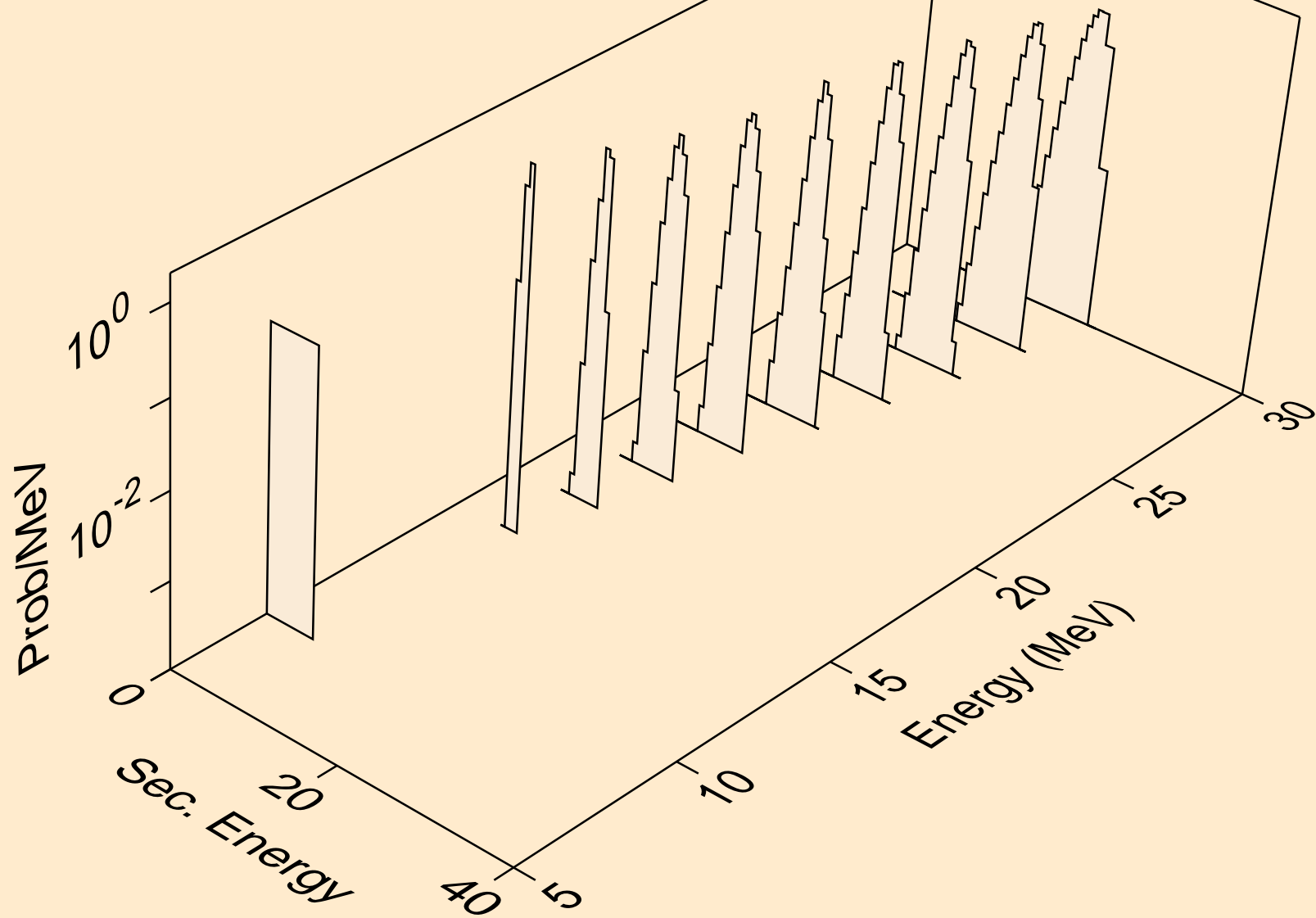

OS201 NEUTRON ACER TENDL-2023 LIBRARY; T=0.K  
alphas from (n,3n)a

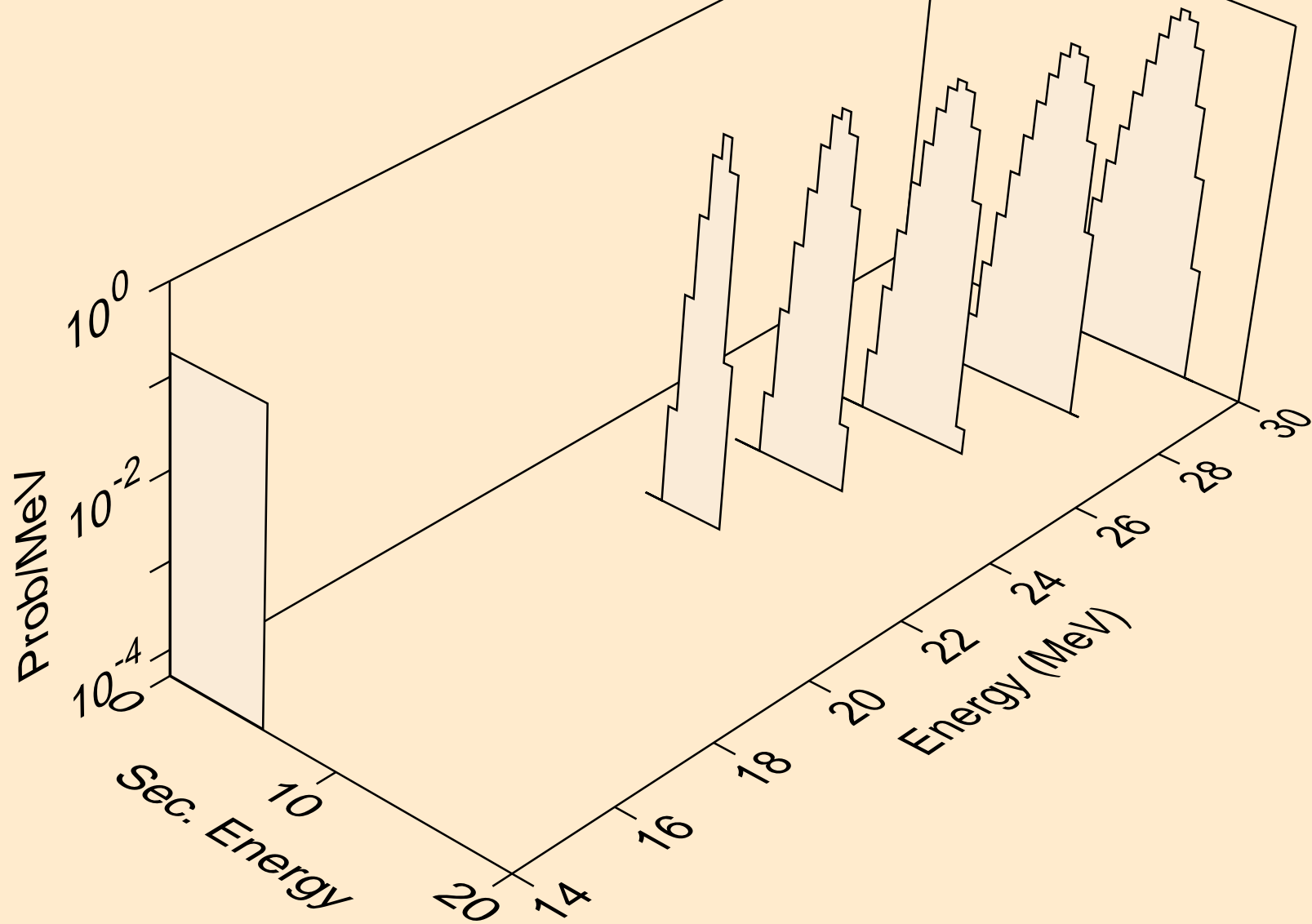

OS201 NEUTRON ACER TENDL-2023 LIBRARY; T=0.K  
alphas from (n,a)

