

P031 NEUTRON ACER TENDL-2023 LIBRARY; T=0.K  
Principal cross sections

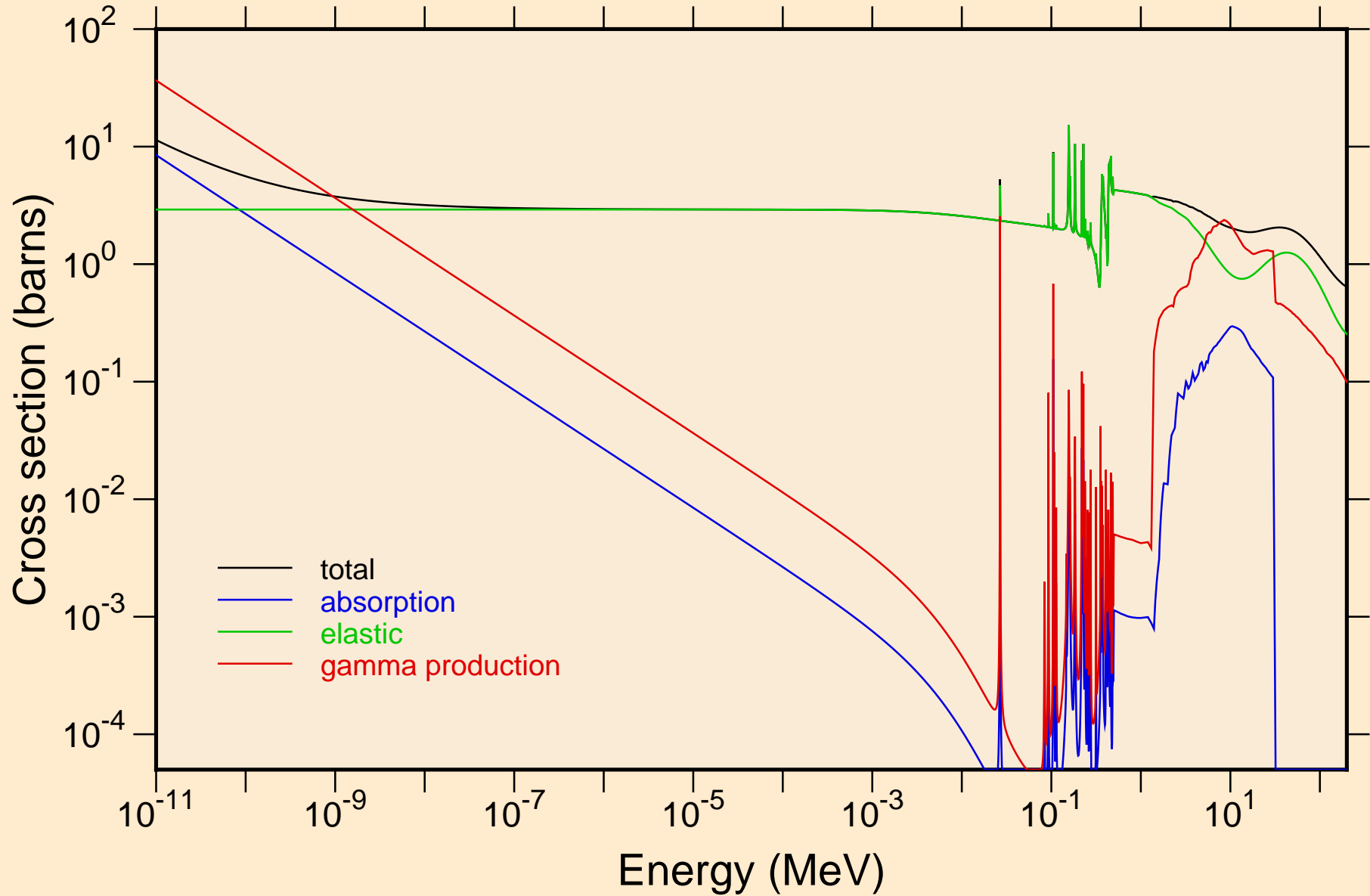

P031 NEUTRON ACER TENDL-2023 LIBRARY; T=0.K  
resonance total cross section

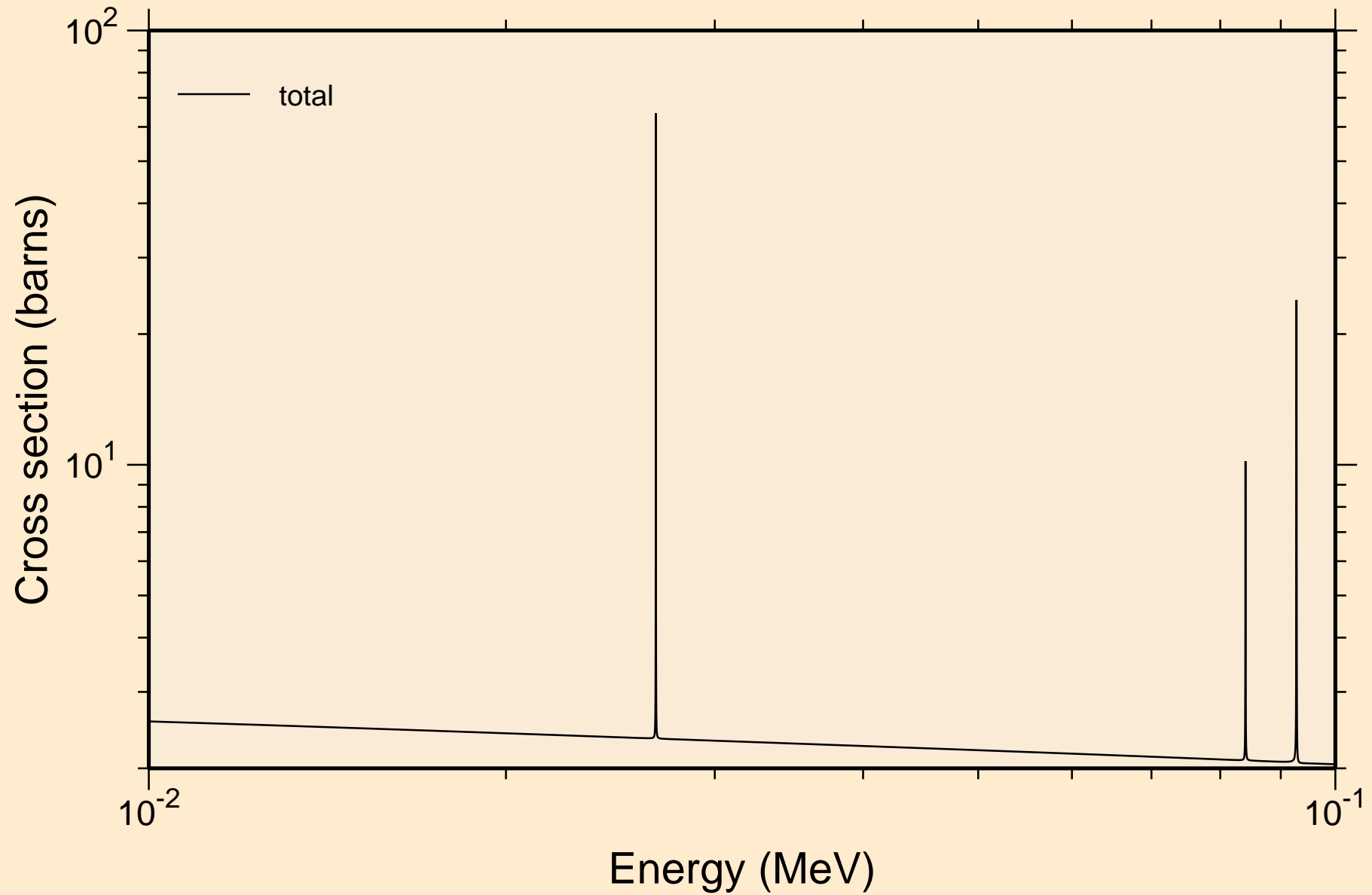

P031 NEUTRON ACER TENDL-2023 LIBRARY; T=0.K  
resonance total cross section

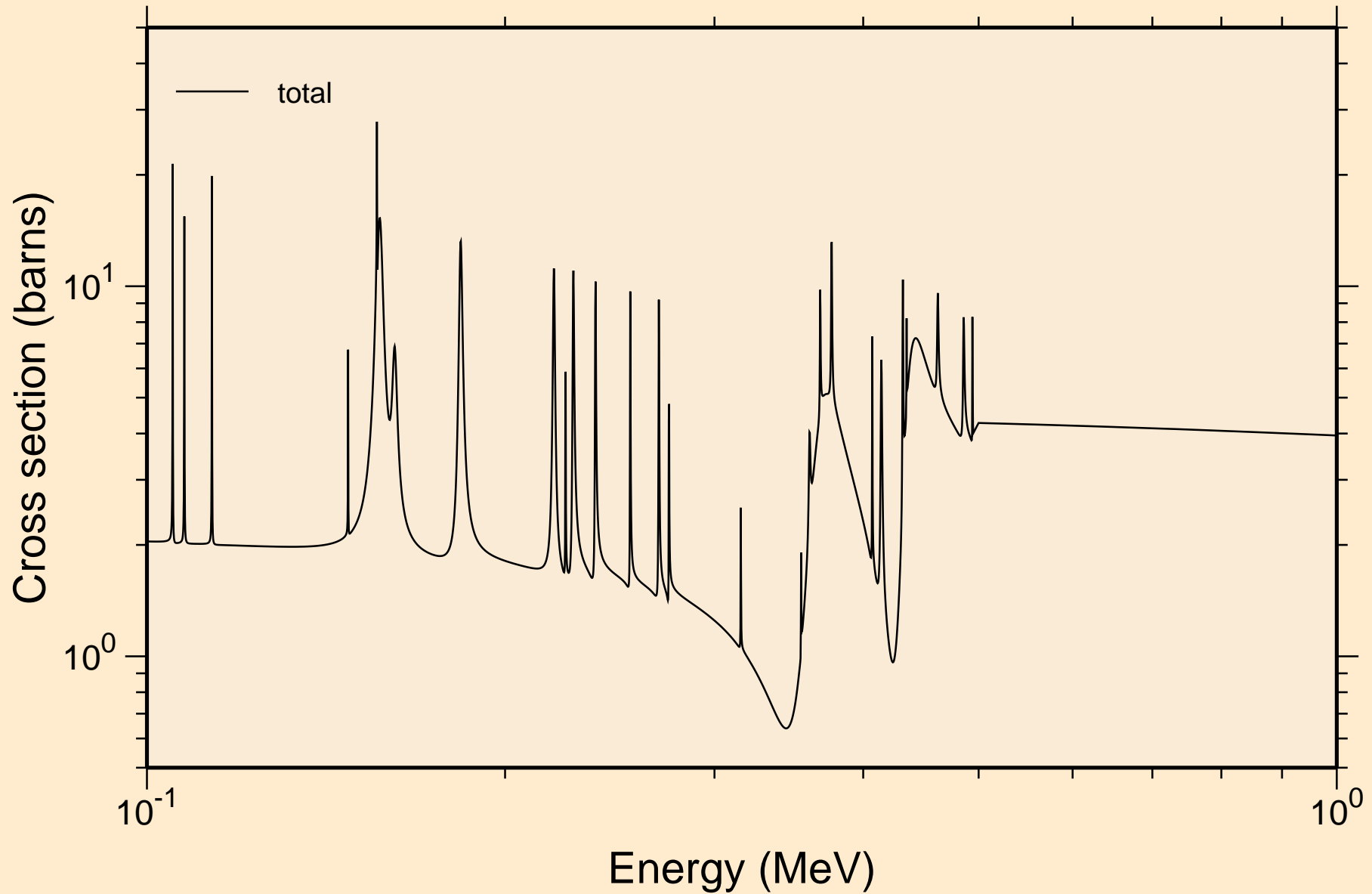

P031 NEUTRON ACER TENDL-2023 LIBRARY; T=0.K  
resonance total cross section

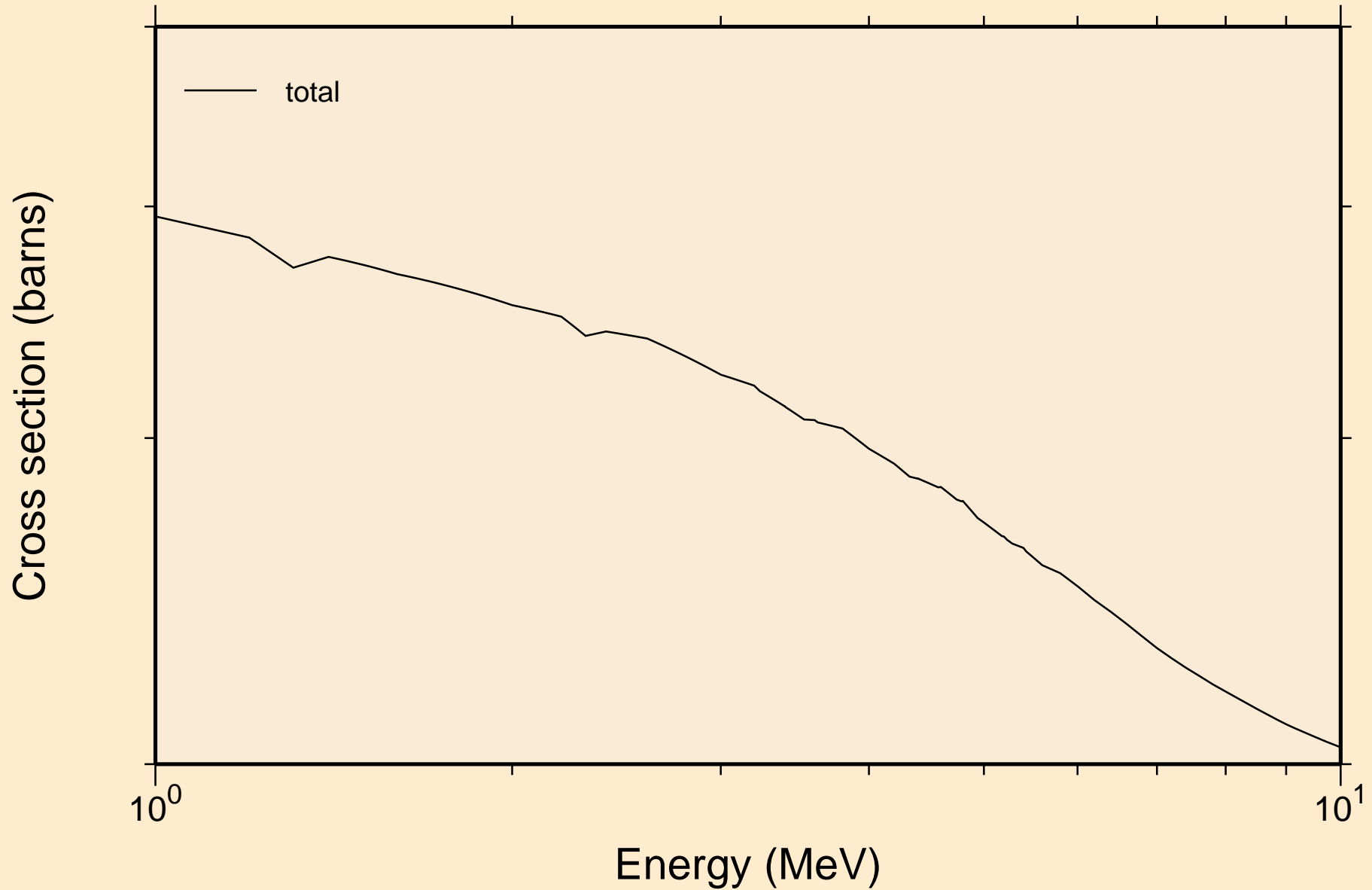

P031 NEUTRON ACER TENDL-2023 LIBRARY; T=0.K  
resonance absorption cross sections

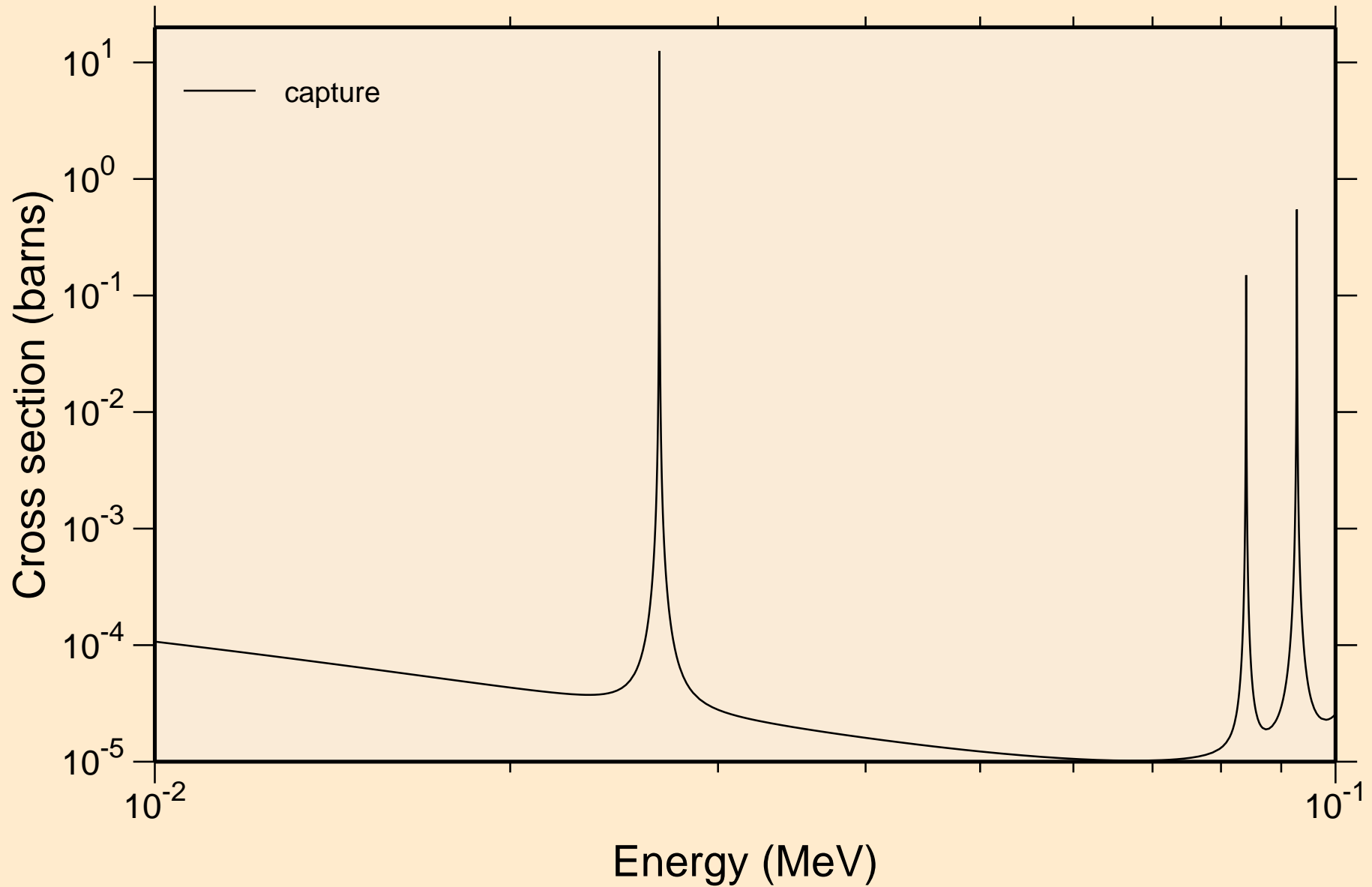

P031 NEUTRON ACER TENDL-2023 LIBRARY; T=0.K  
resonance absorption cross sections

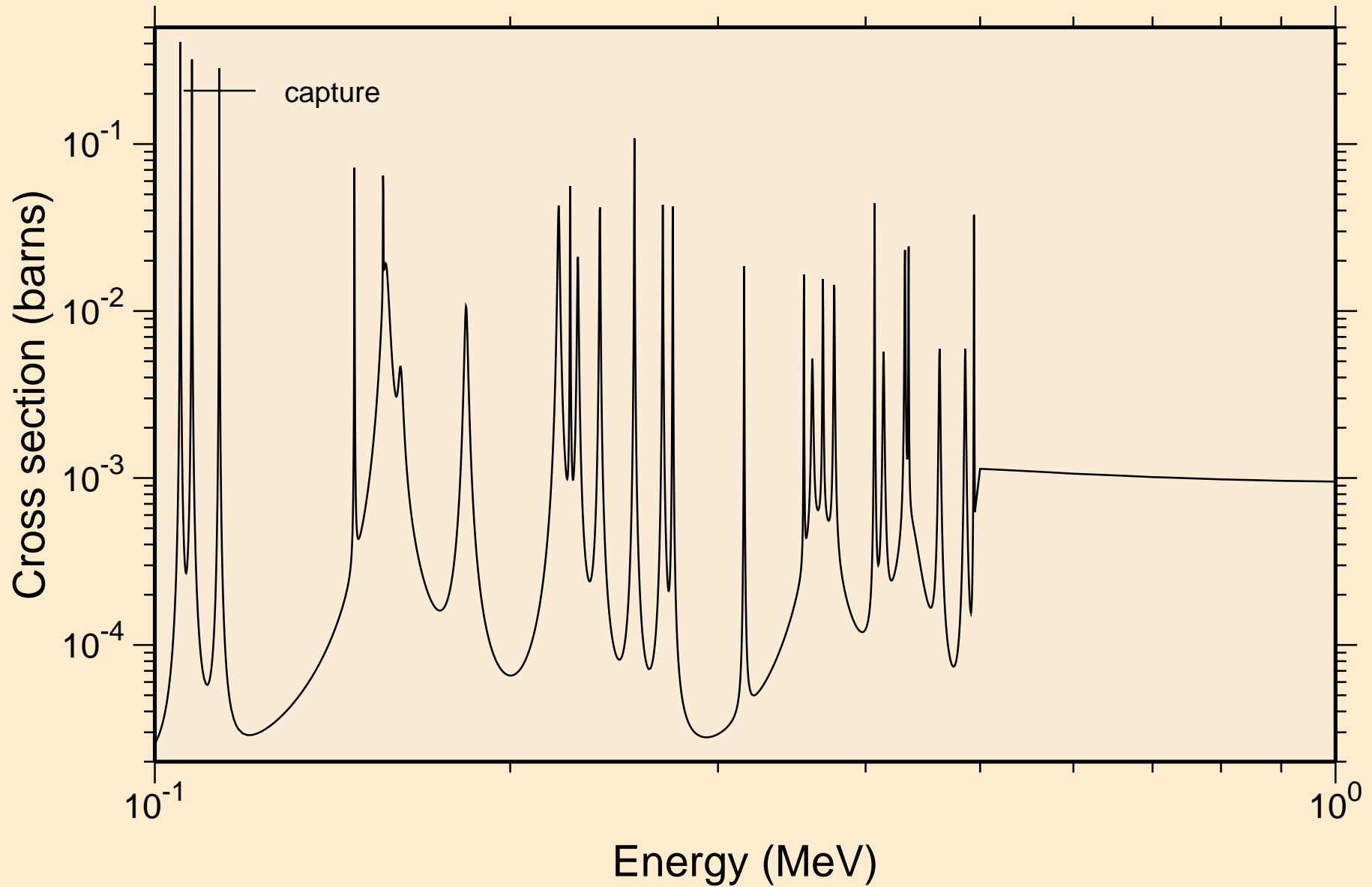

P031 NEUTRON ACER TENDL-2023 LIBRARY; T=0.K  
resonance absorption cross sections

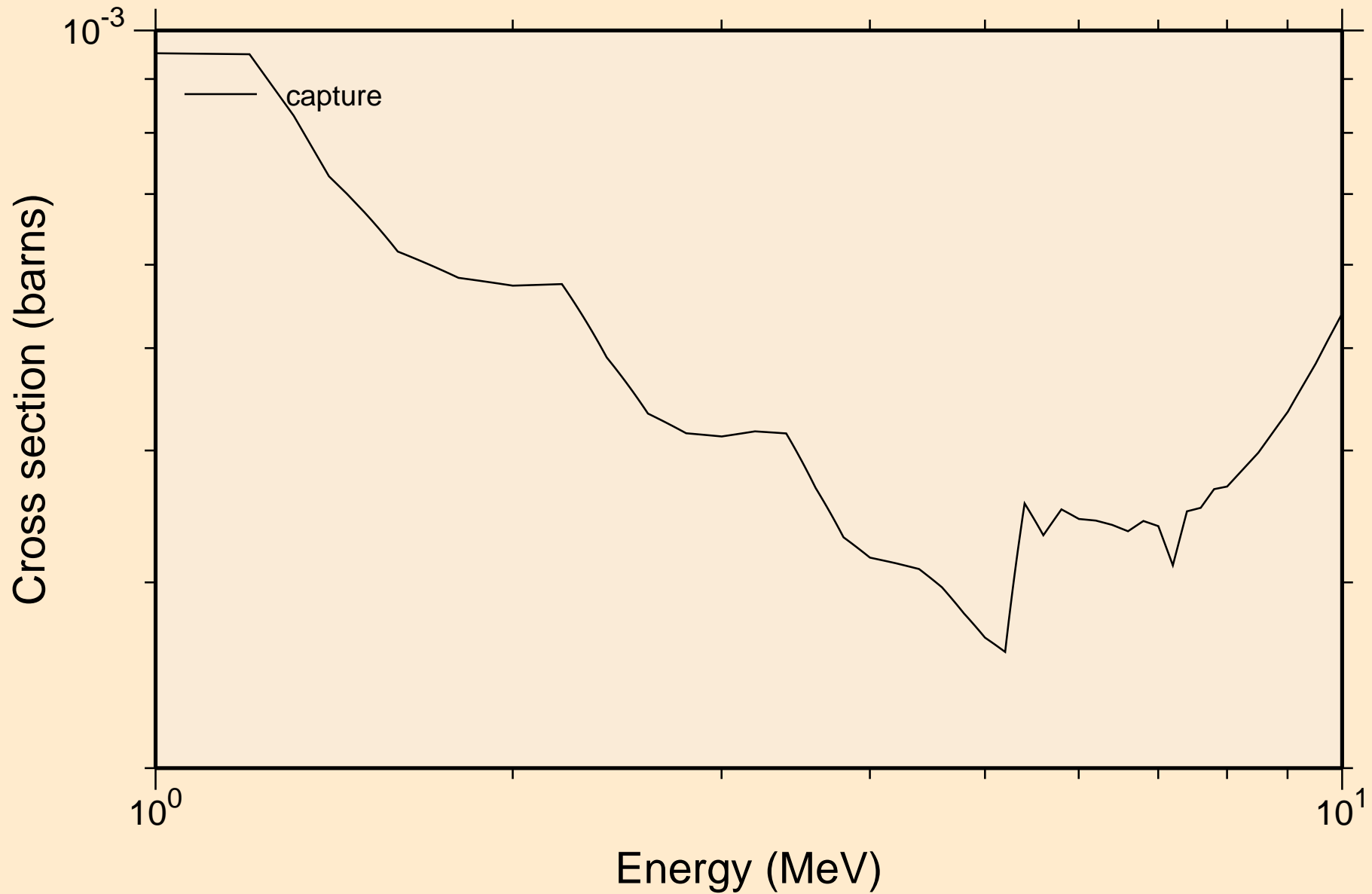

# P031 NEUTRON ACER TENDL-2023 LIBRARY; T=0.K

## Heating

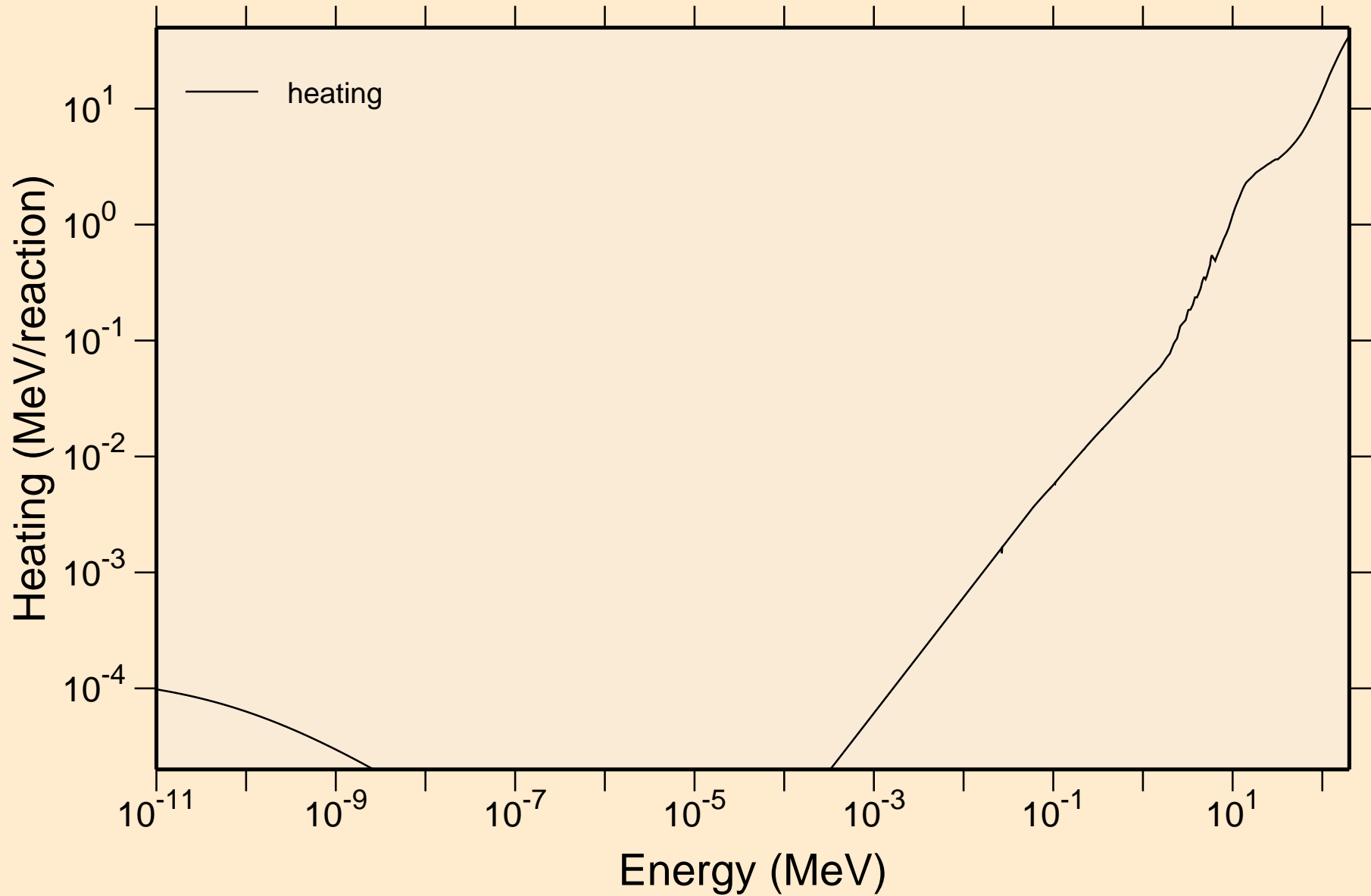

P031 NEUTRON ACER TENDL-2023 LIBRARY; T=0.K  
Damage

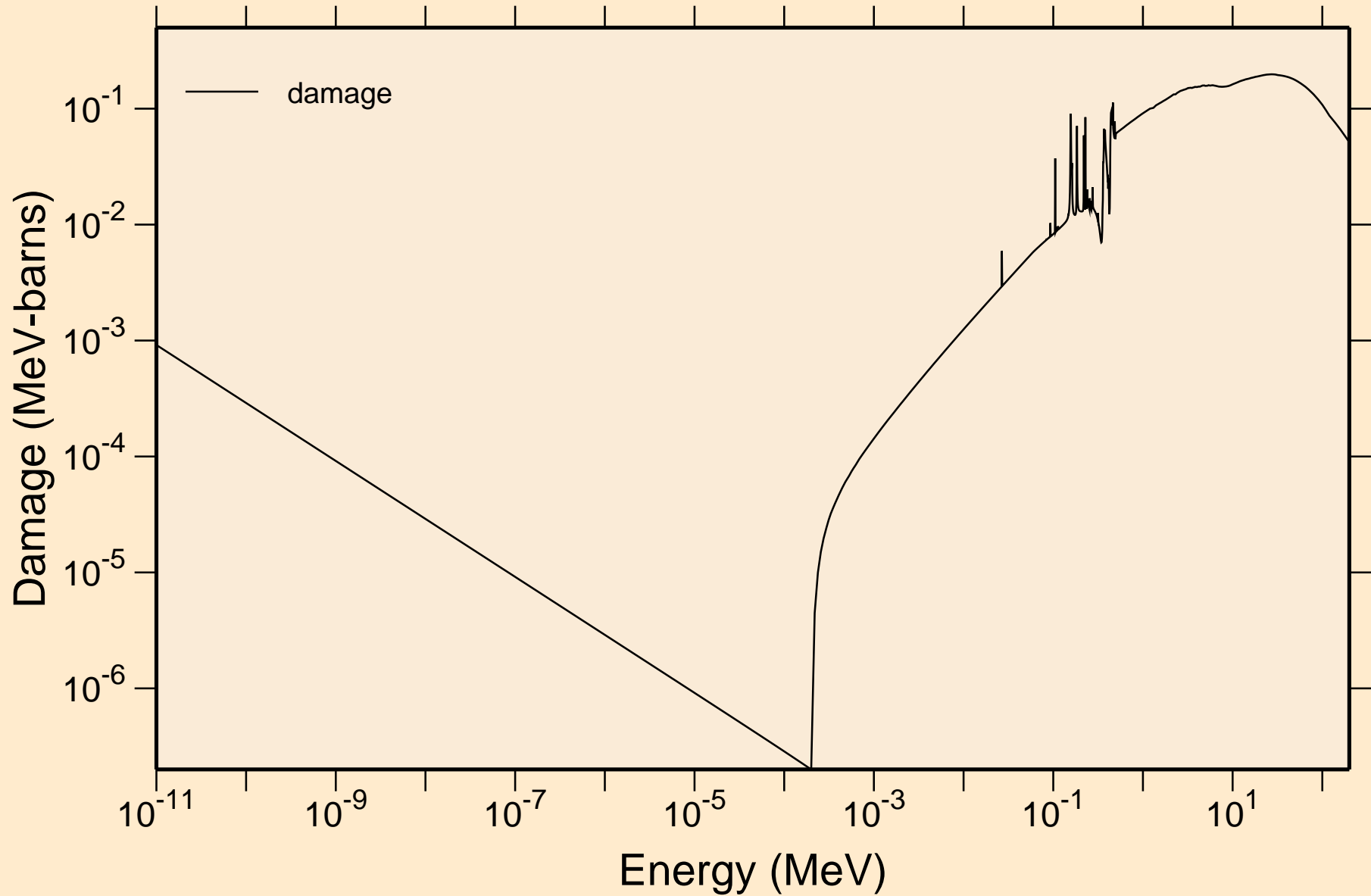

P031 NEUTRON ACER TENDL-2023 LIBRARY; T=0.K  
Non-threshold reactions

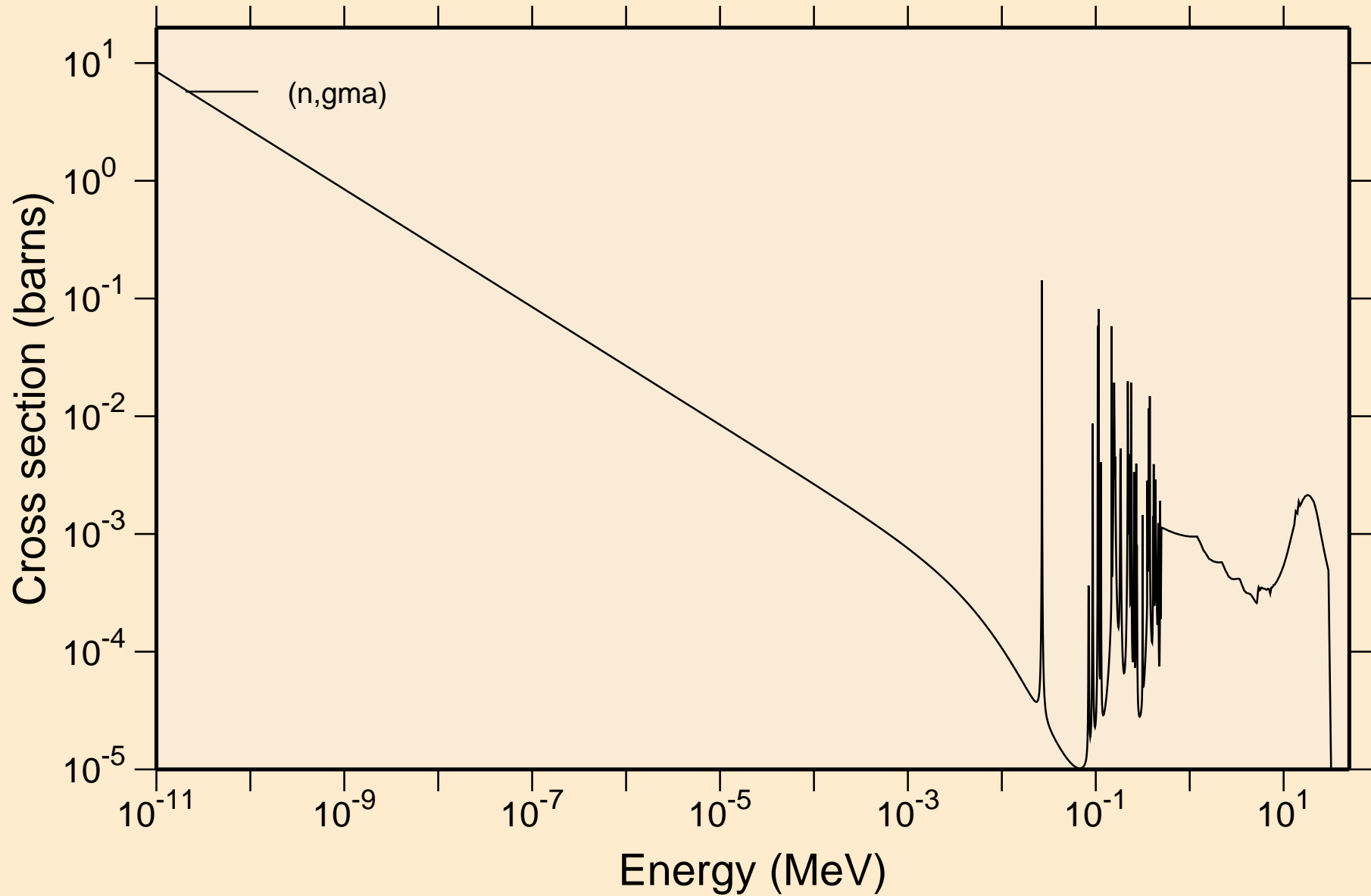

# P031 NEUTRON ACER TENDL-2023 LIBRARY; T=0.K

## Principal cross sections

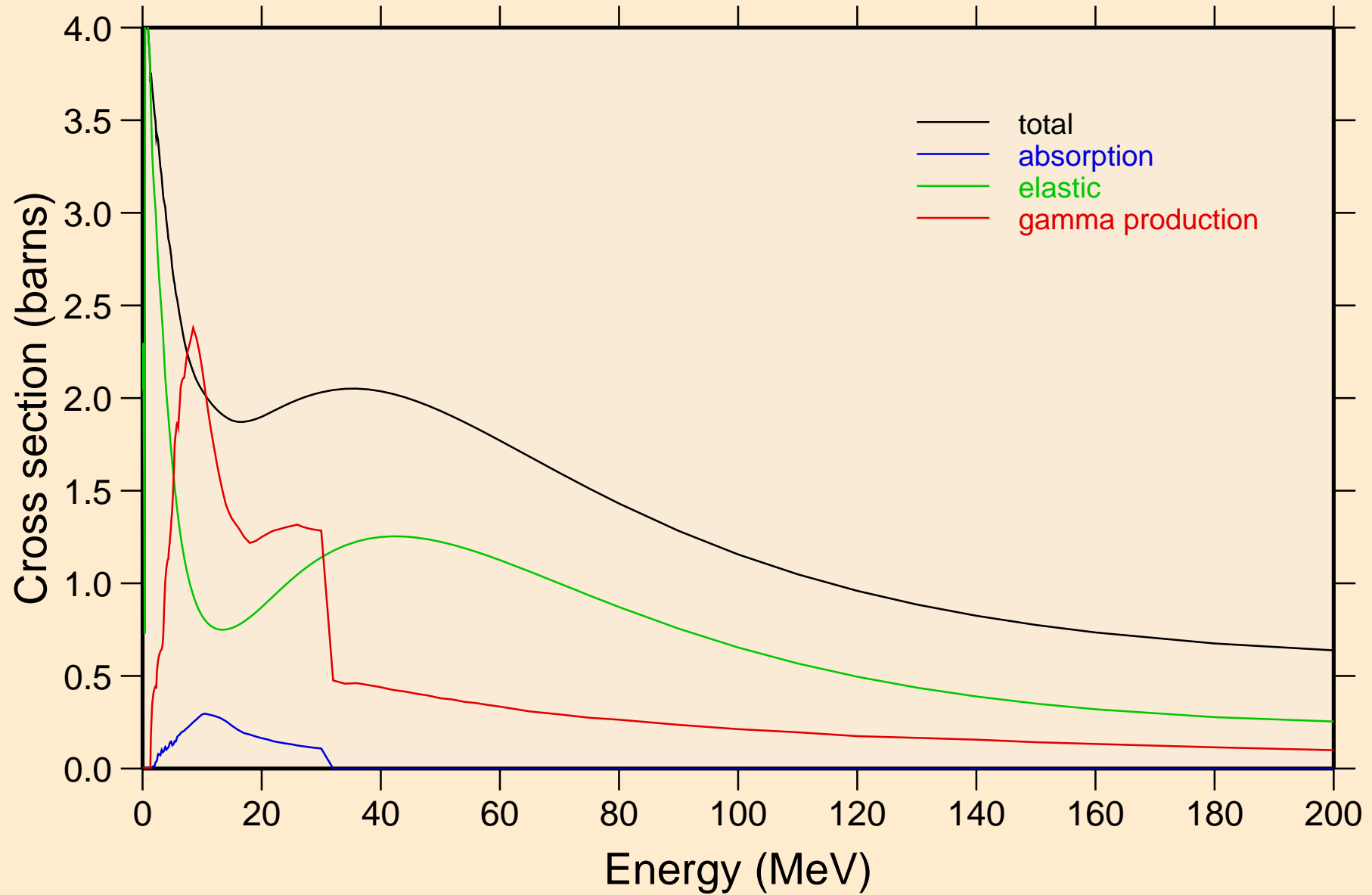

# P031 NEUTRON ACER TENDL-2023 LIBRARY; T=0.K

## Heating

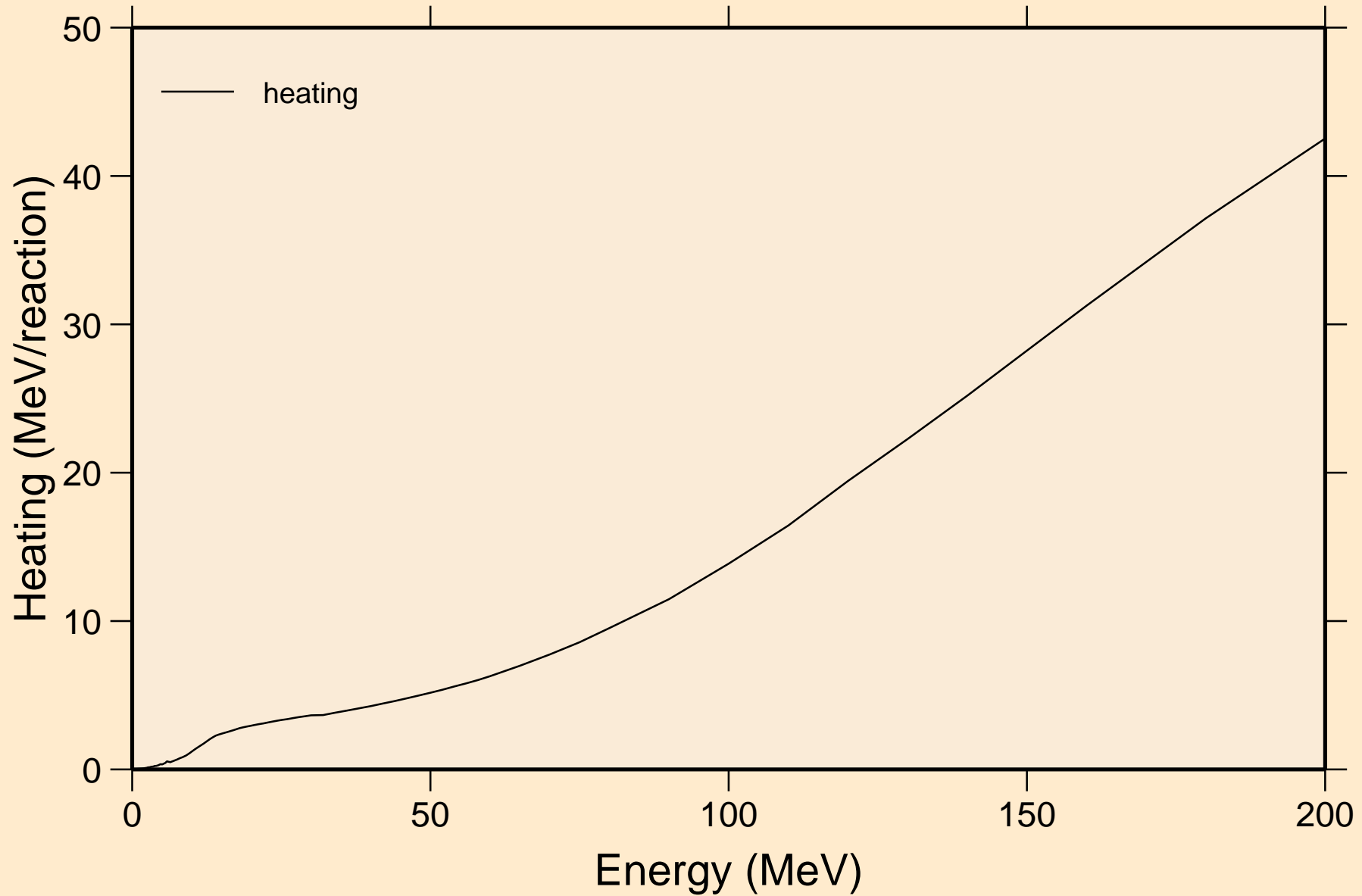

# P031 NEUTRON ACER TENDL-2023 LIBRARY; T=0.K

## Damage

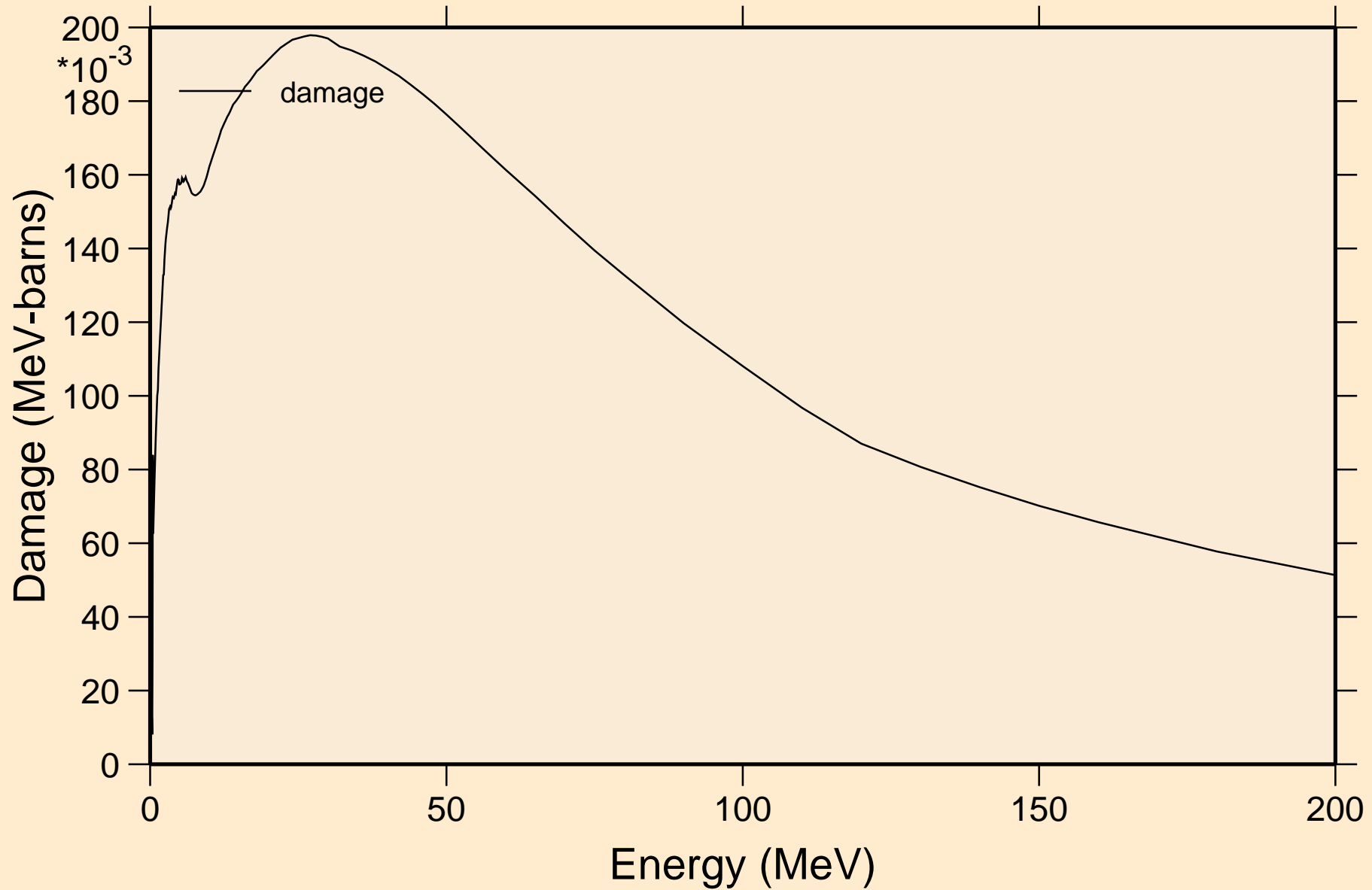

P031 NEUTRON ACER TENDL-2023 LIBRARY; T=0.K  
Non-threshold reactions

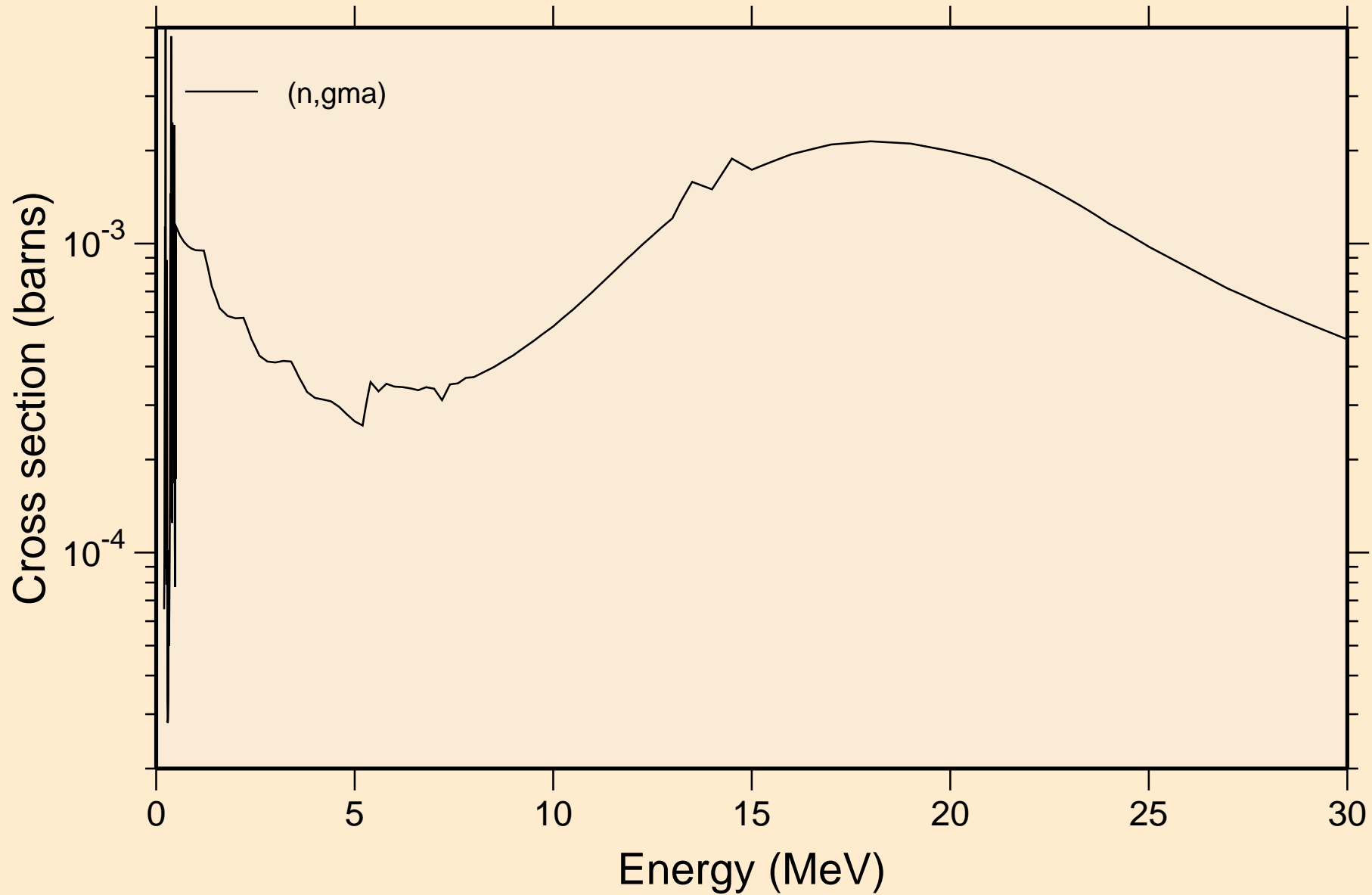

P031 NEUTRON ACER TENDL-2023 LIBRARY; T=0.K  
Inelastic levels

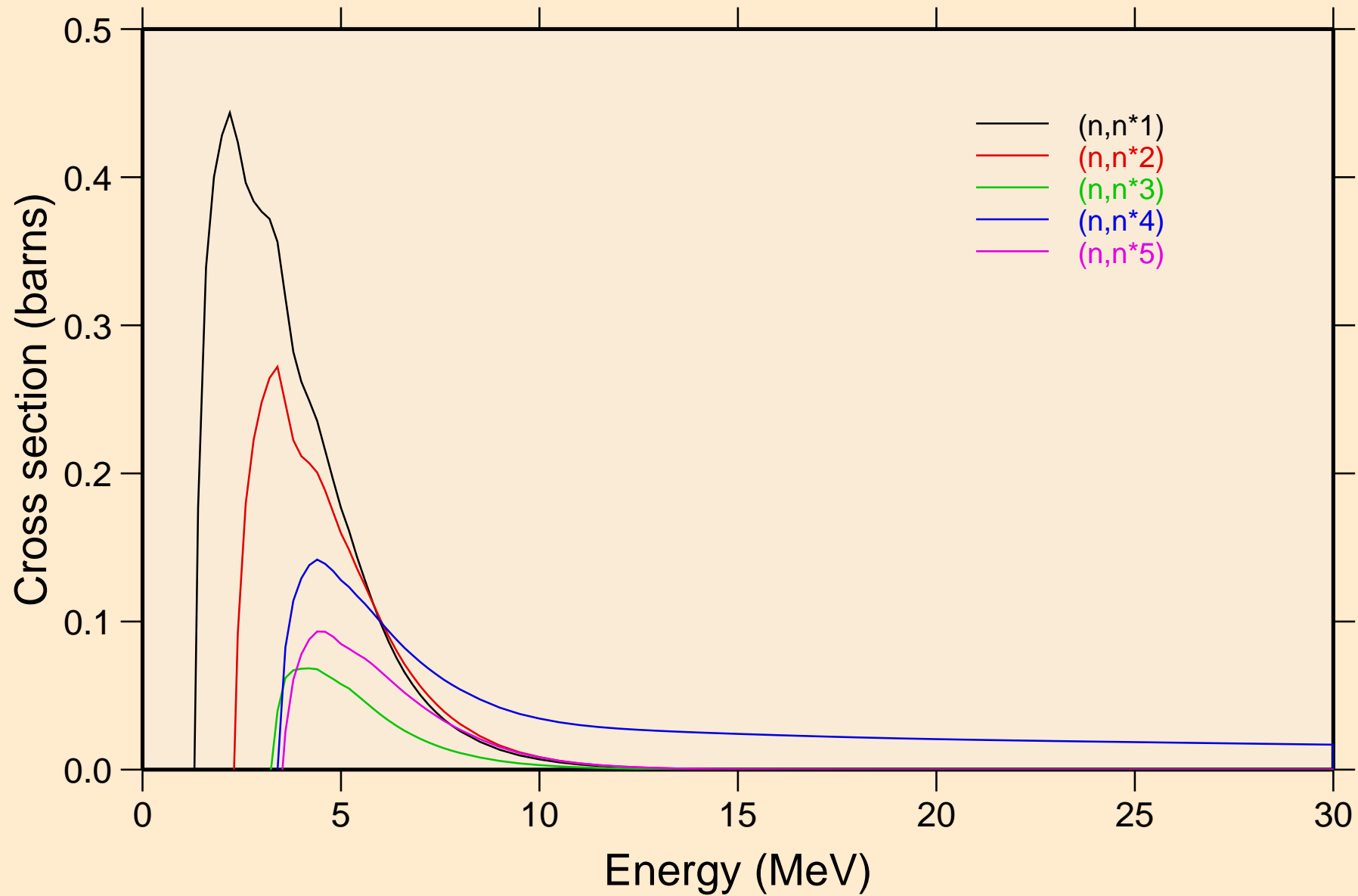

P031 NEUTRON ACER TENDL-2023 LIBRARY; T=0.K  
Inelastic levels

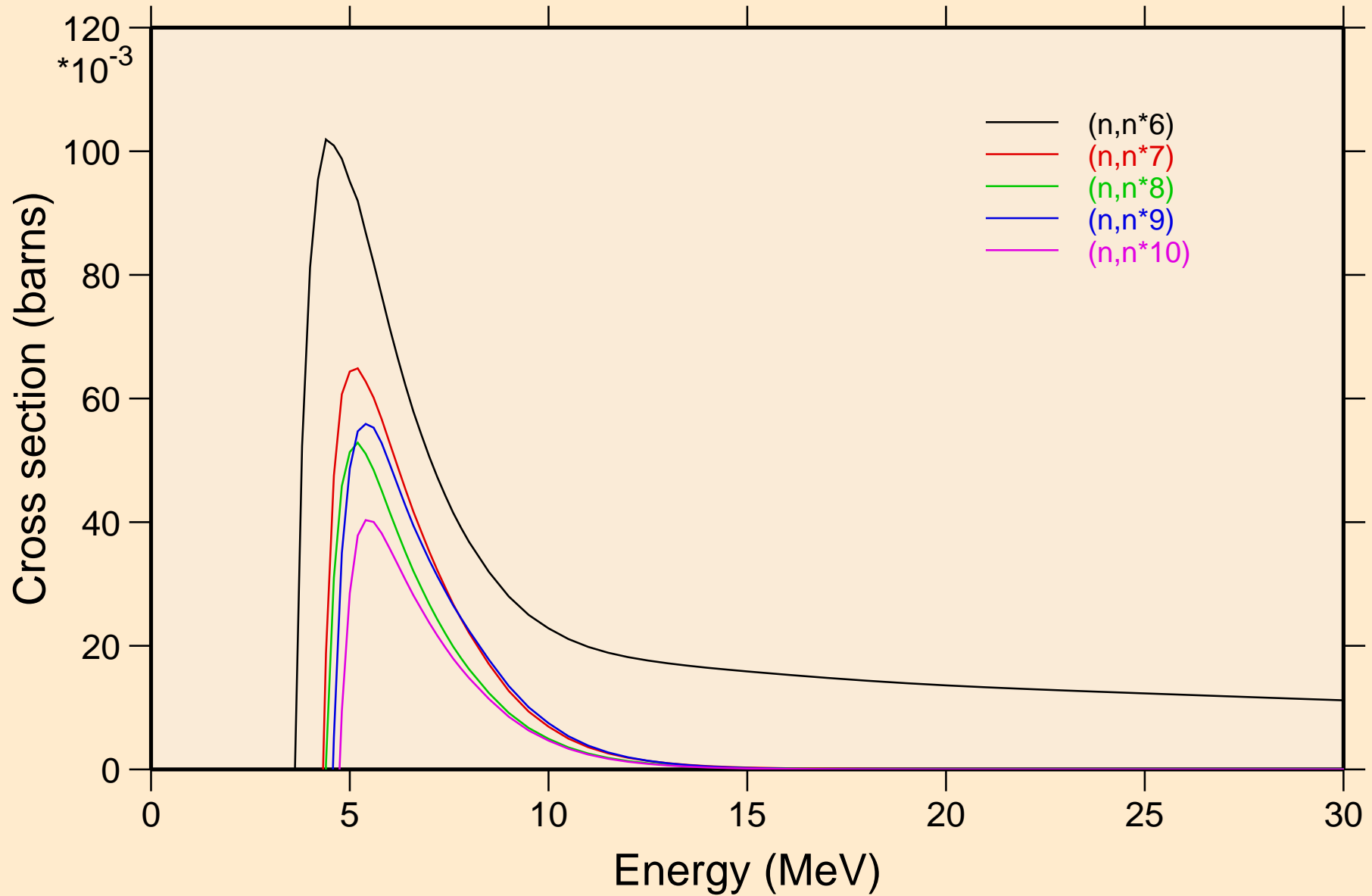

P031 NEUTRON ACER TENDL-2023 LIBRARY; T=0.K  
Inelastic levels

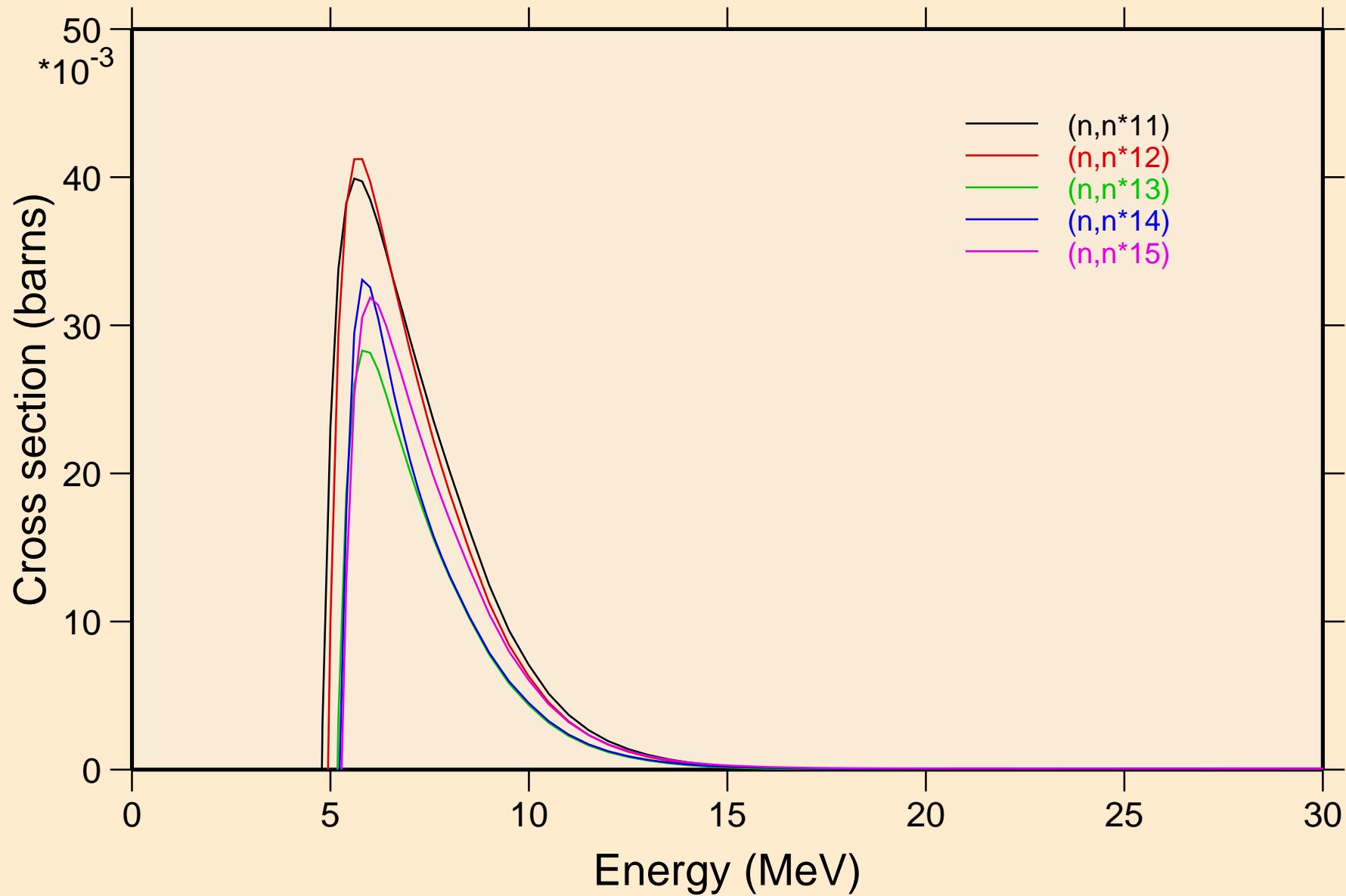

P031 NEUTRON ACER TENDL-2023 LIBRARY; T=0.K  
Inelastic levels

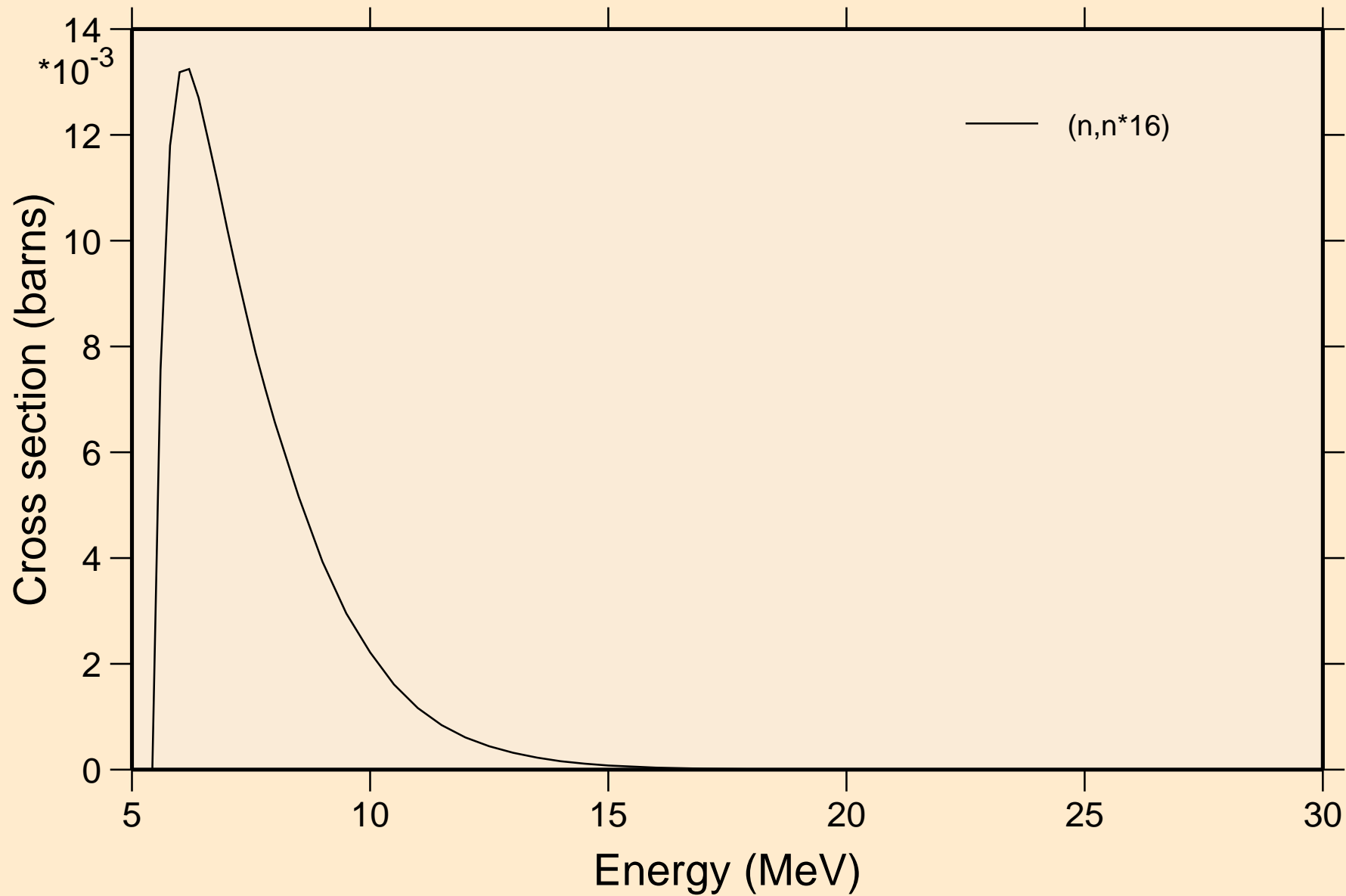

P031 NEUTRON ACER TENDL-2023 LIBRARY; T=0.K  
Threshold reactions

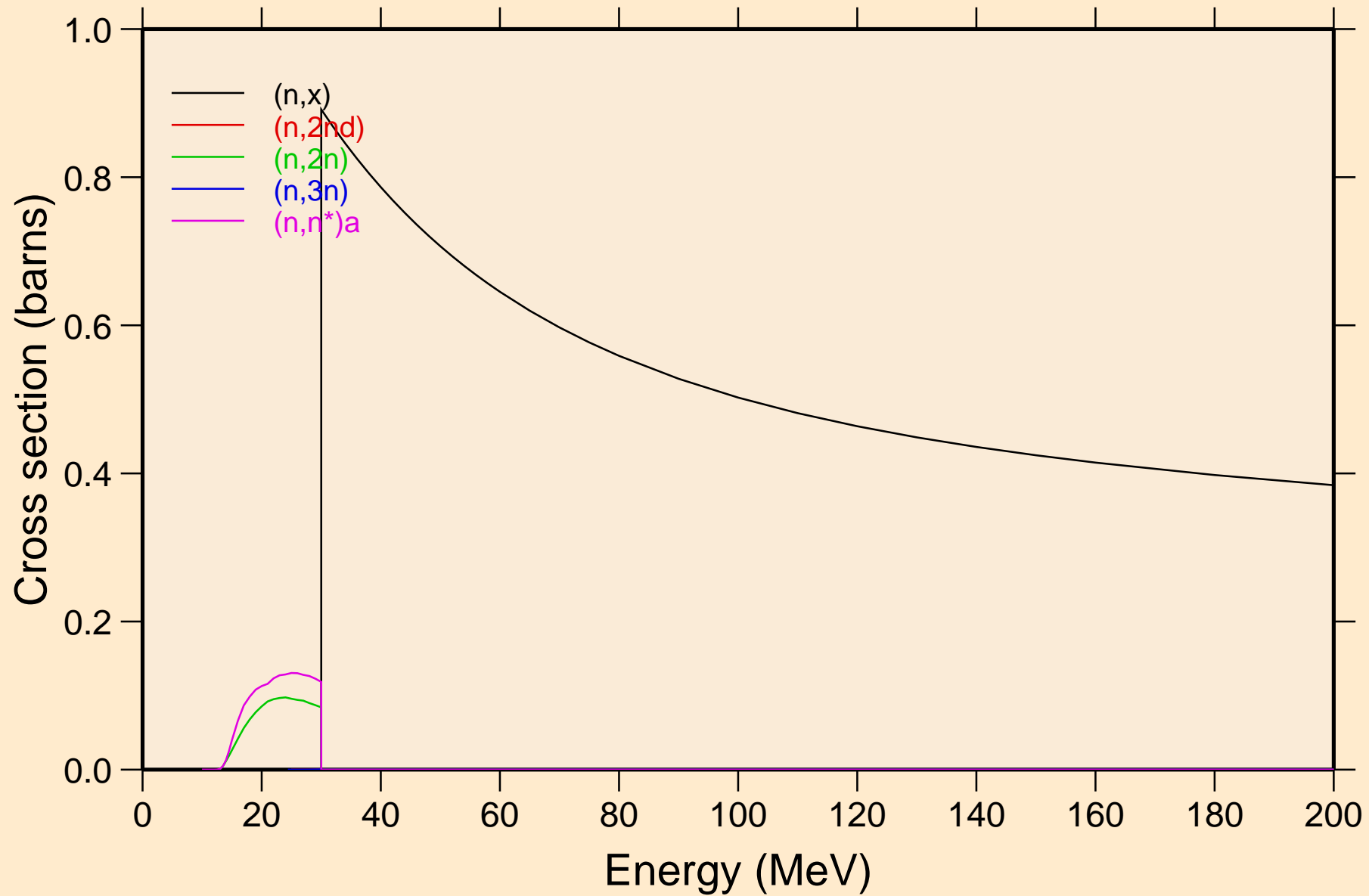

P031 NEUTRON ACER TENDL-2023 LIBRARY; T=0.K  
Threshold reactions

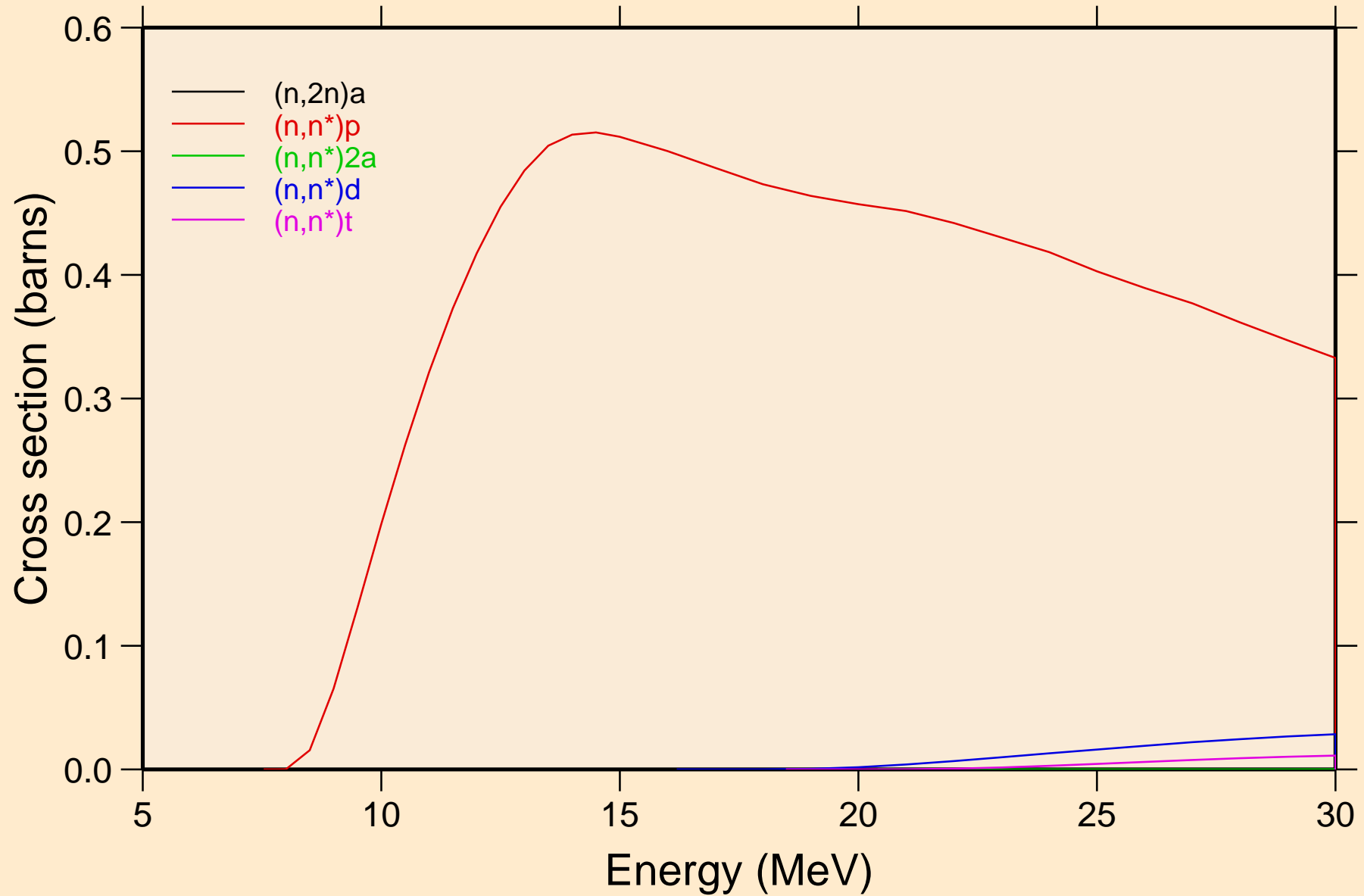

P031 NEUTRON ACER TENDL-2023 LIBRARY; T=0.K  
Threshold reactions

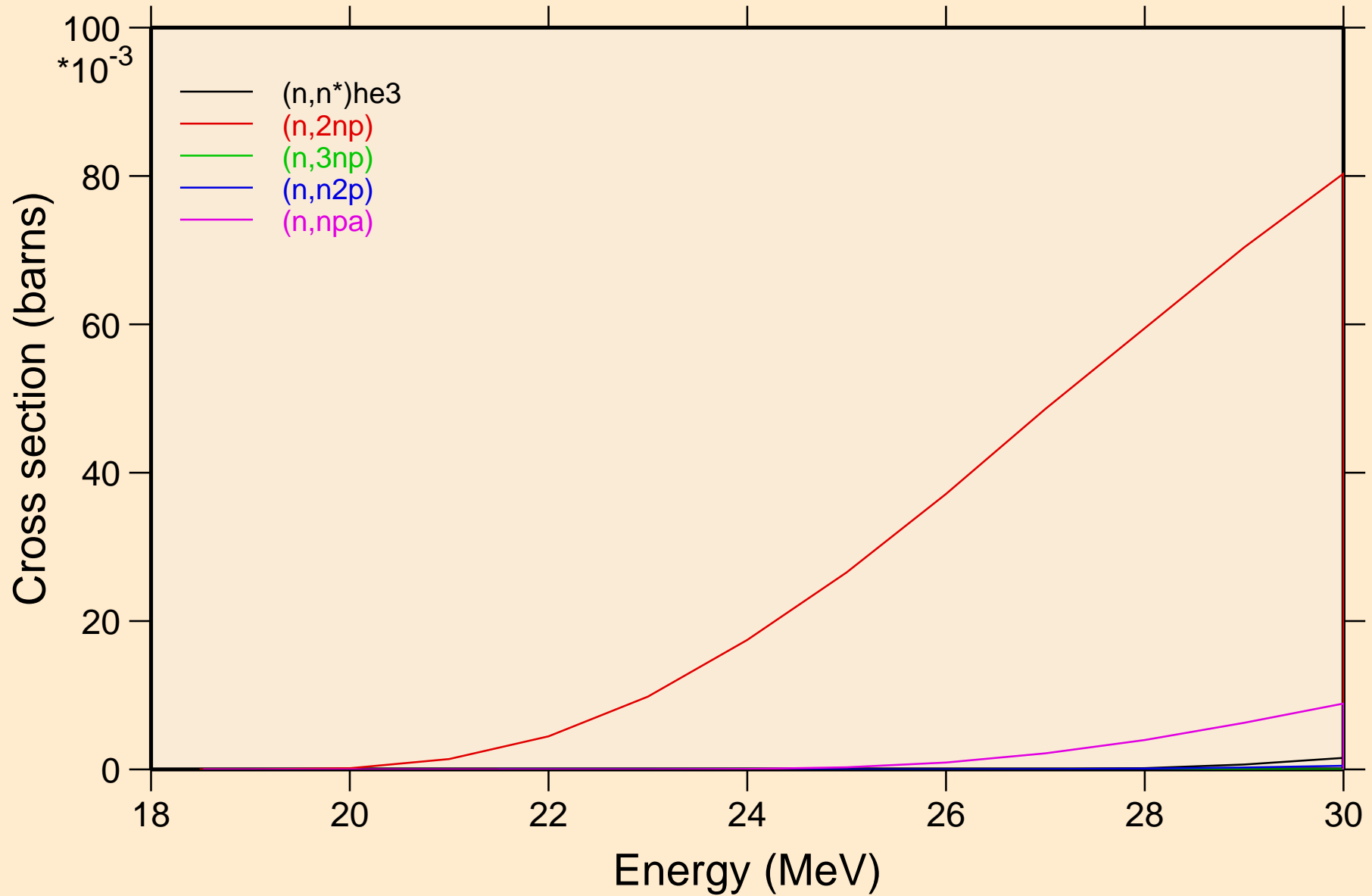

P031 NEUTRON ACER TENDL-2023 LIBRARY; T=0.K  
Threshold reactions

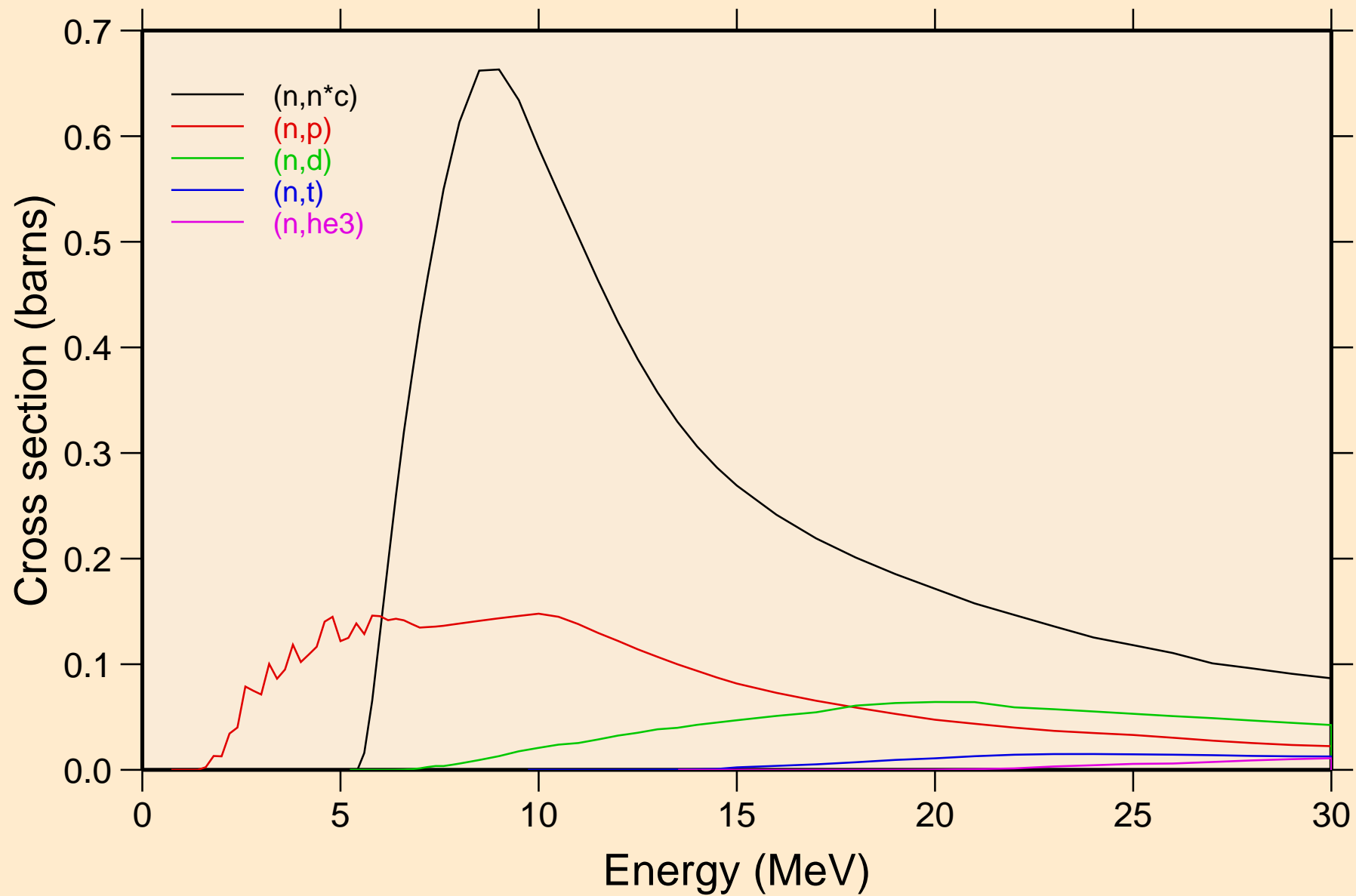

P031 NEUTRON ACER TENDL-2023 LIBRARY; T=0.K  
Threshold reactions

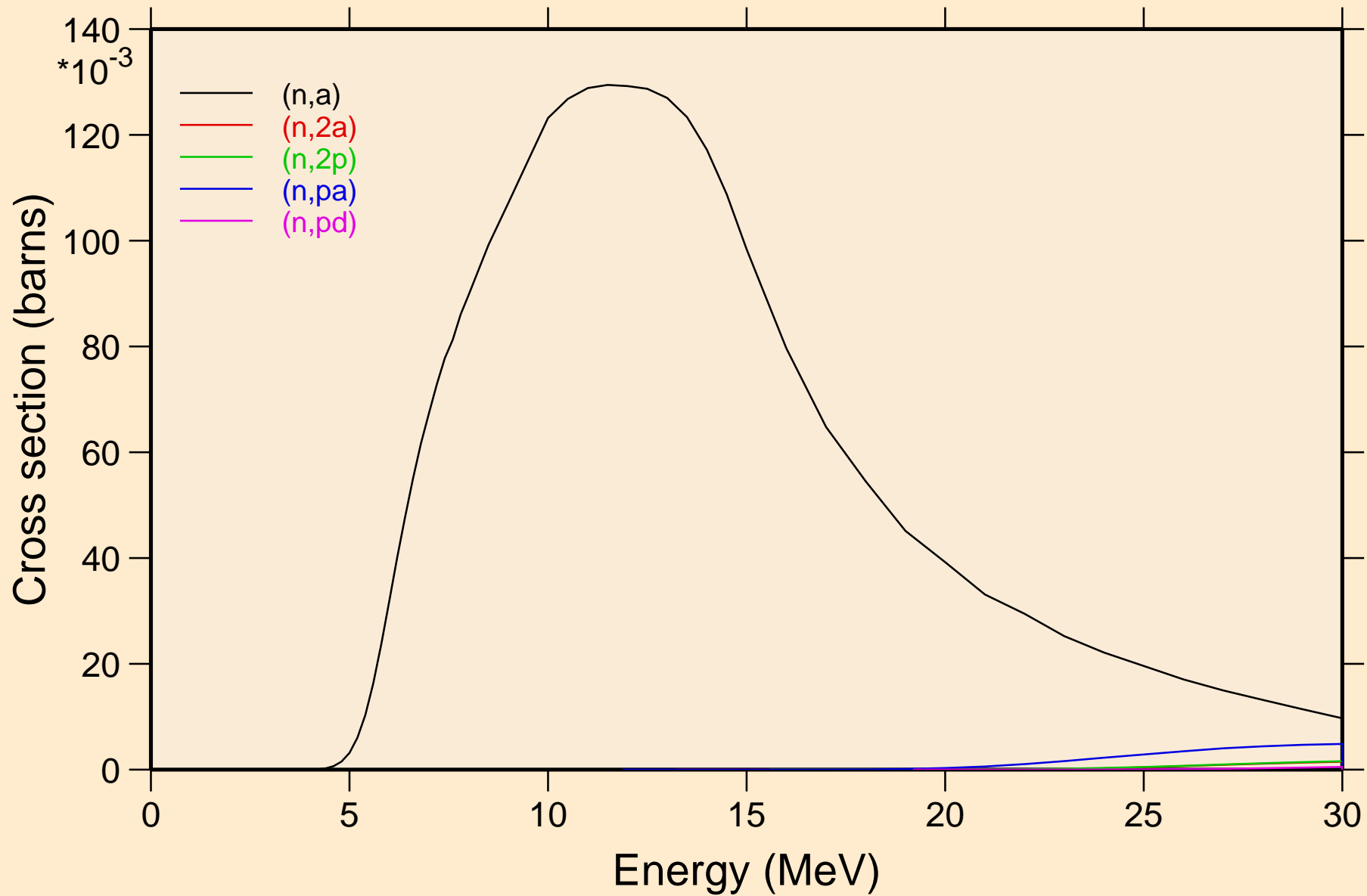

P031 NEUTRON ACER TENDL-2023 LIBRARY; T=0.K  
Threshold reactions

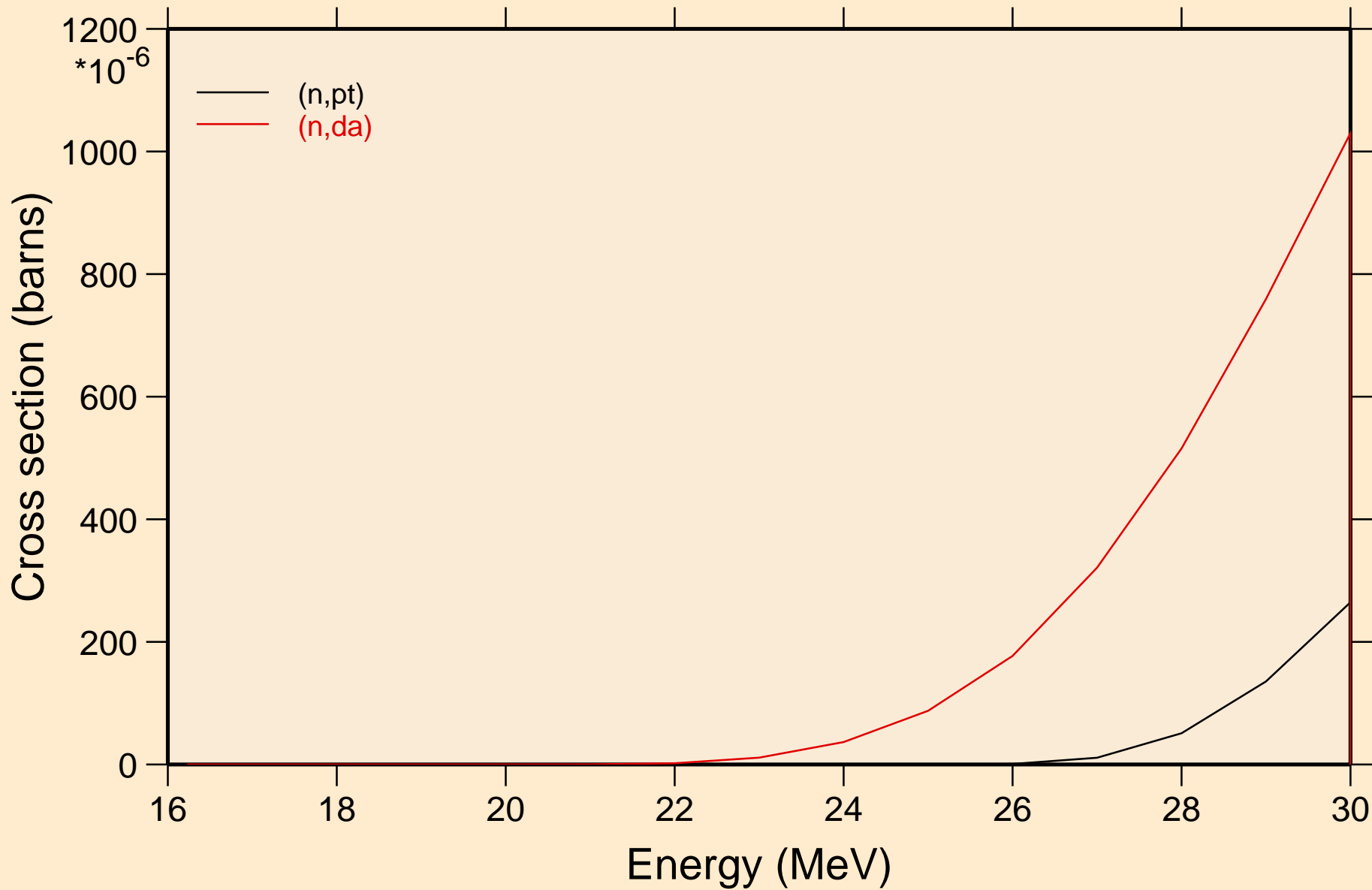

P031 NEUTRON ACER TENDL-2023 LIBRARY; T=0.K  
Threshold reactions

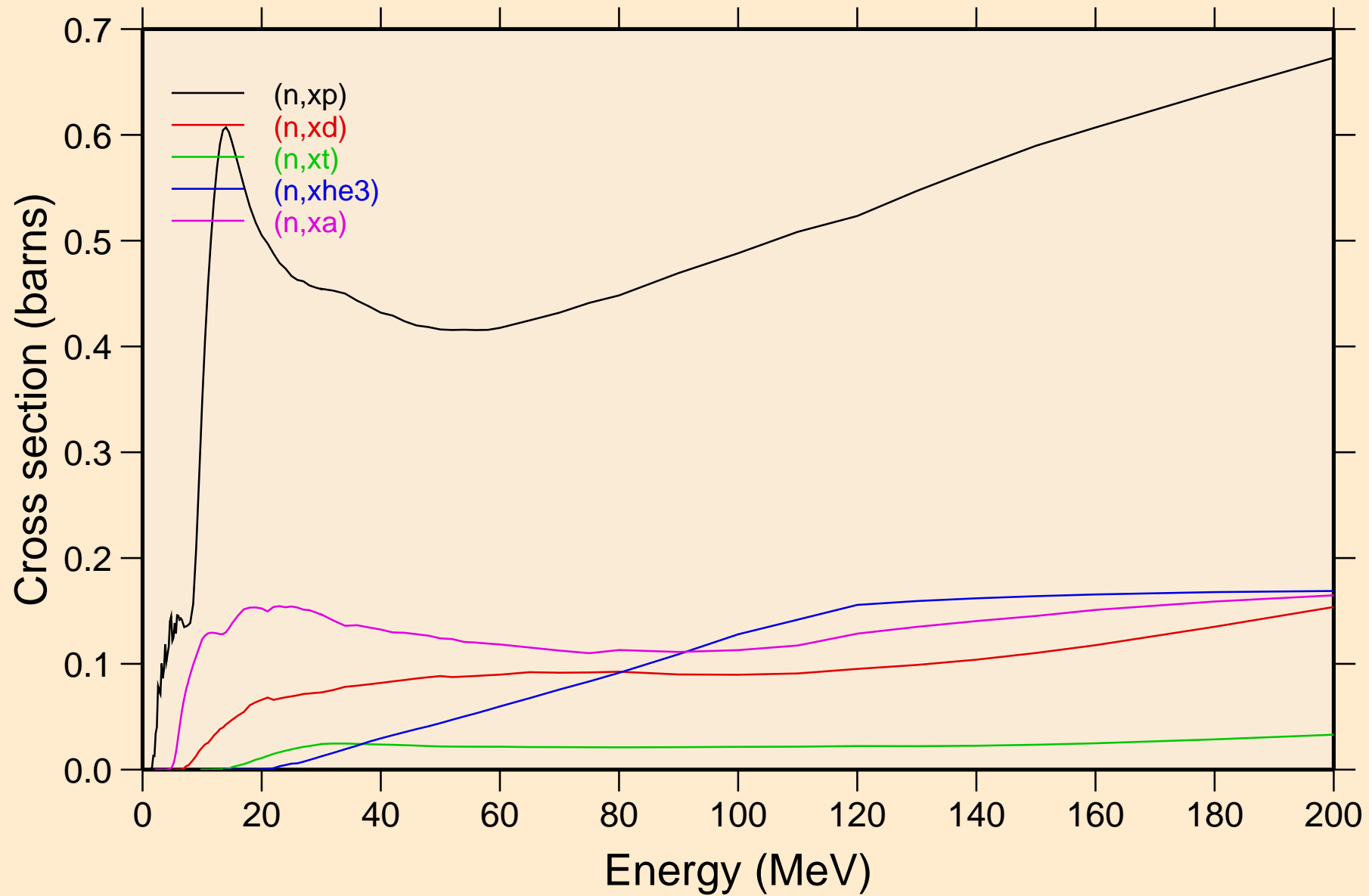

P031 NEUTRON ACER TENDL-2023 LIBRARY; T=0.K  
angular distribution for elastic

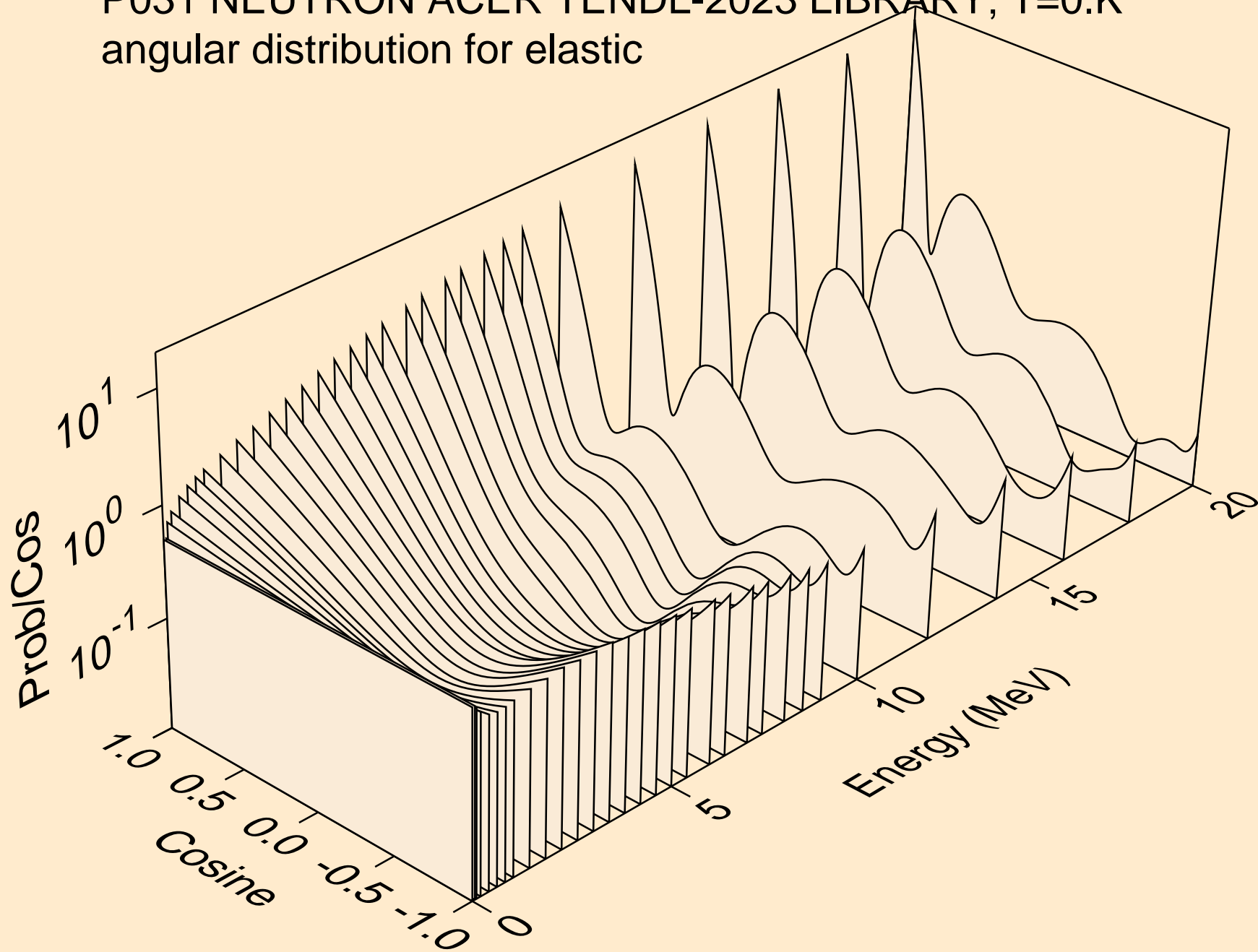

P031 NEUTRON ACER TENDL-2023 LIBRARY; T=0.K  
angular distribution for elastic

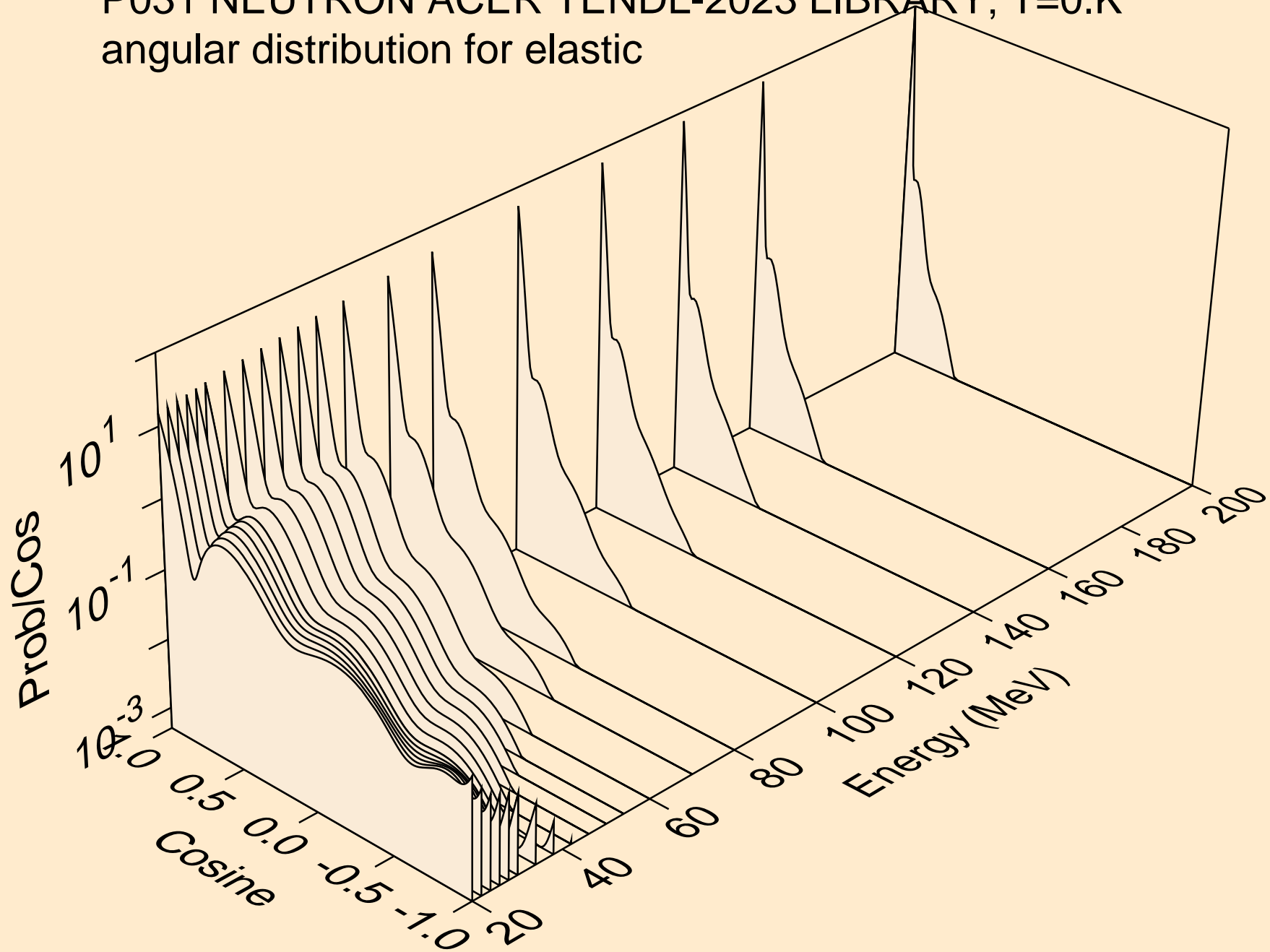

P031 NEUTRON ACER TENDL-2023 LIBRARY; T=0.K  
angular distribution for (n,n\*1)

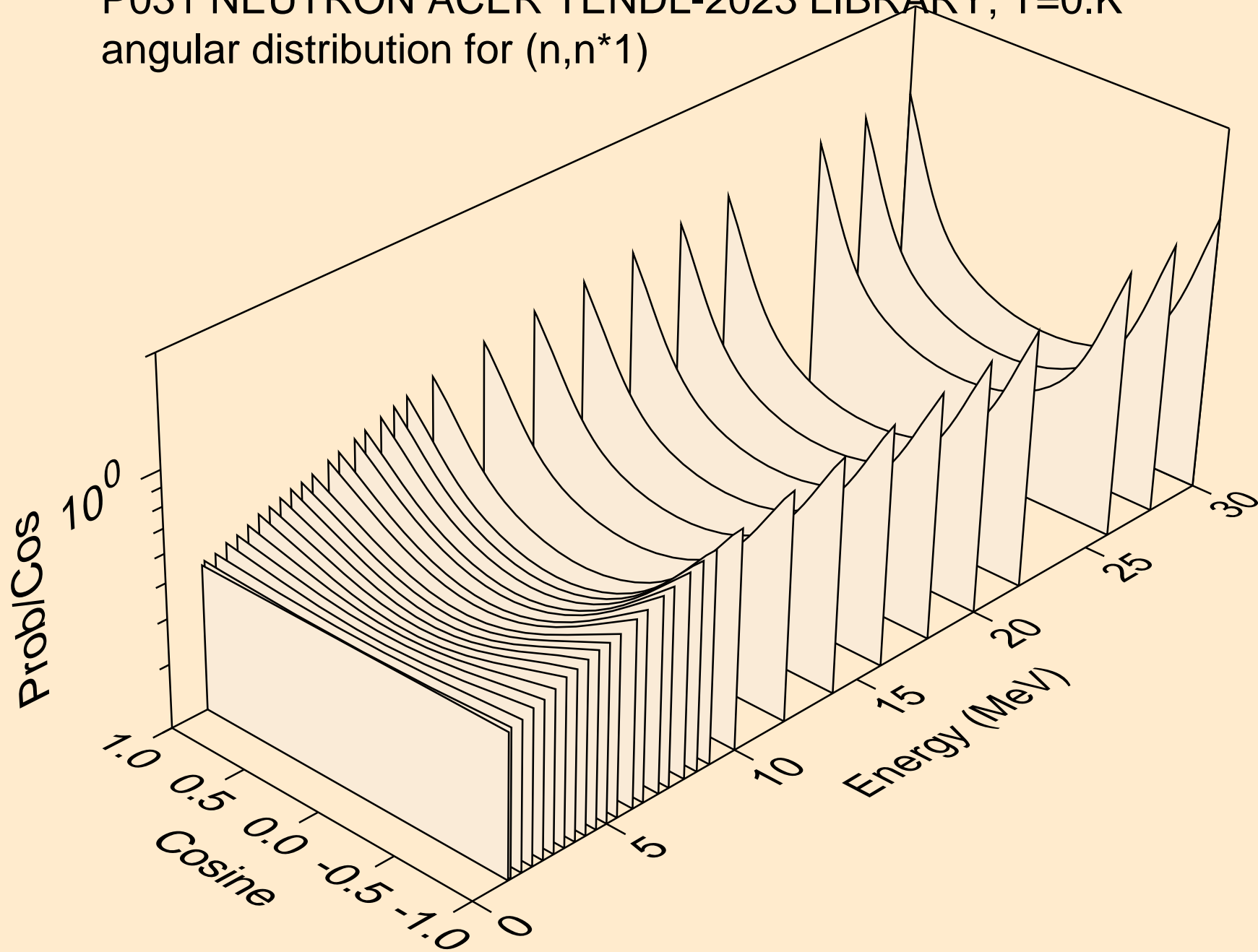

P031 NEUTRON ACER TENDL-2023 LIBRARY; T=0.K  
angular distribution for (n,n\*2)

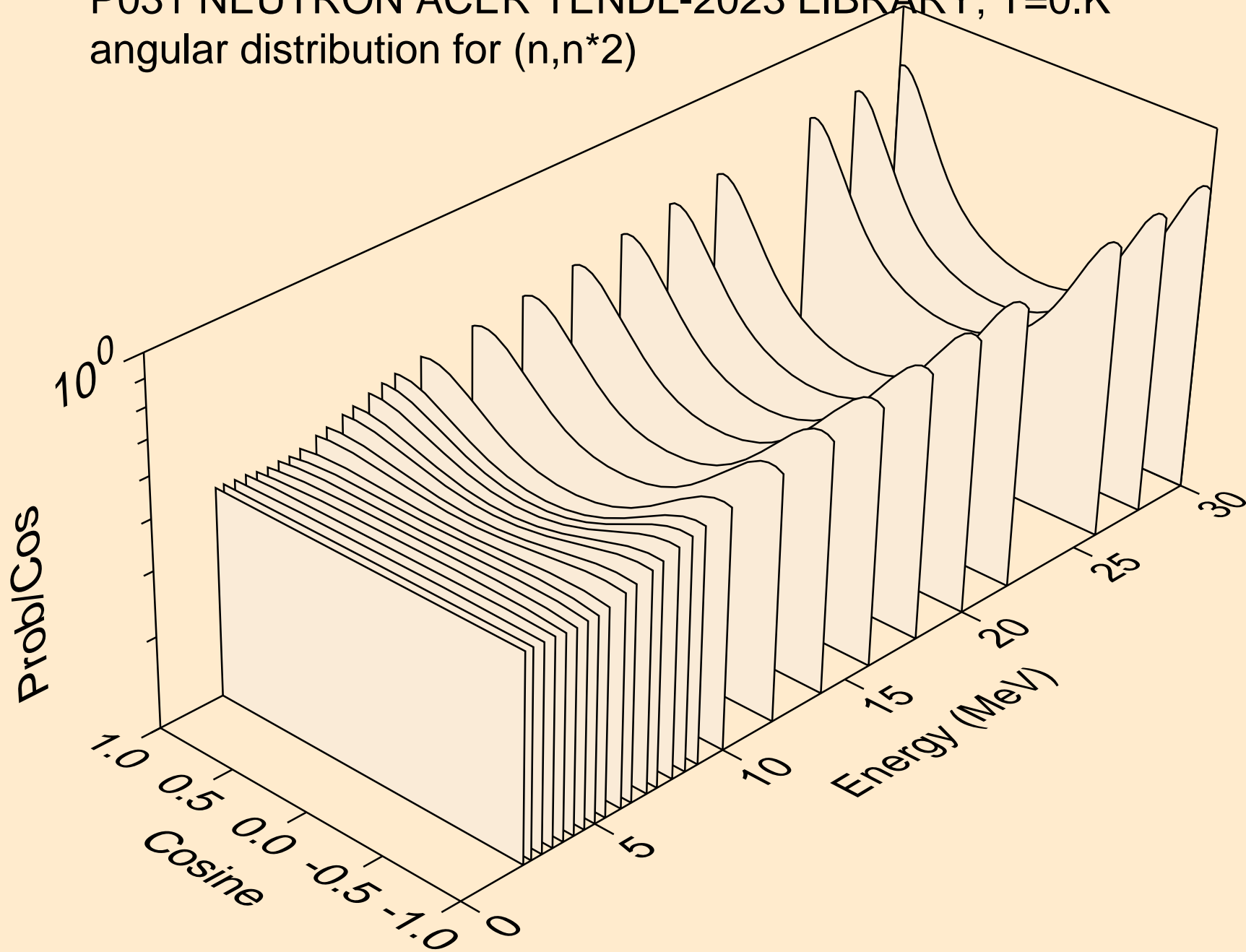

P031 NEUTRON ACER TENDL-2023 LIBRARY; T=0.K  
angular distribution for (n,n\*3)

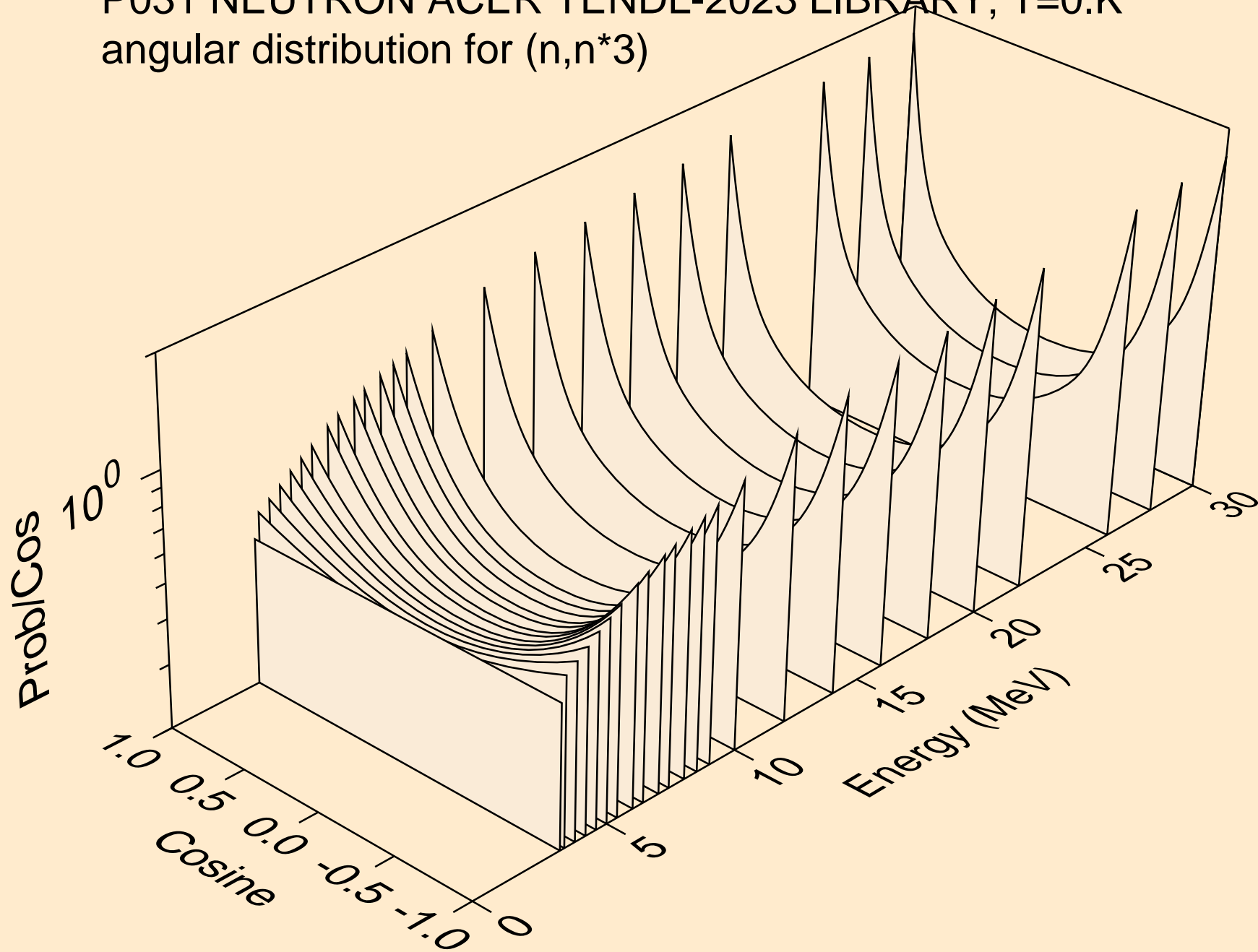

P031 NEUTRON ACER TENDL-2023 LIBRARY; T=0.K  
angular distribution for (n,n\*4)

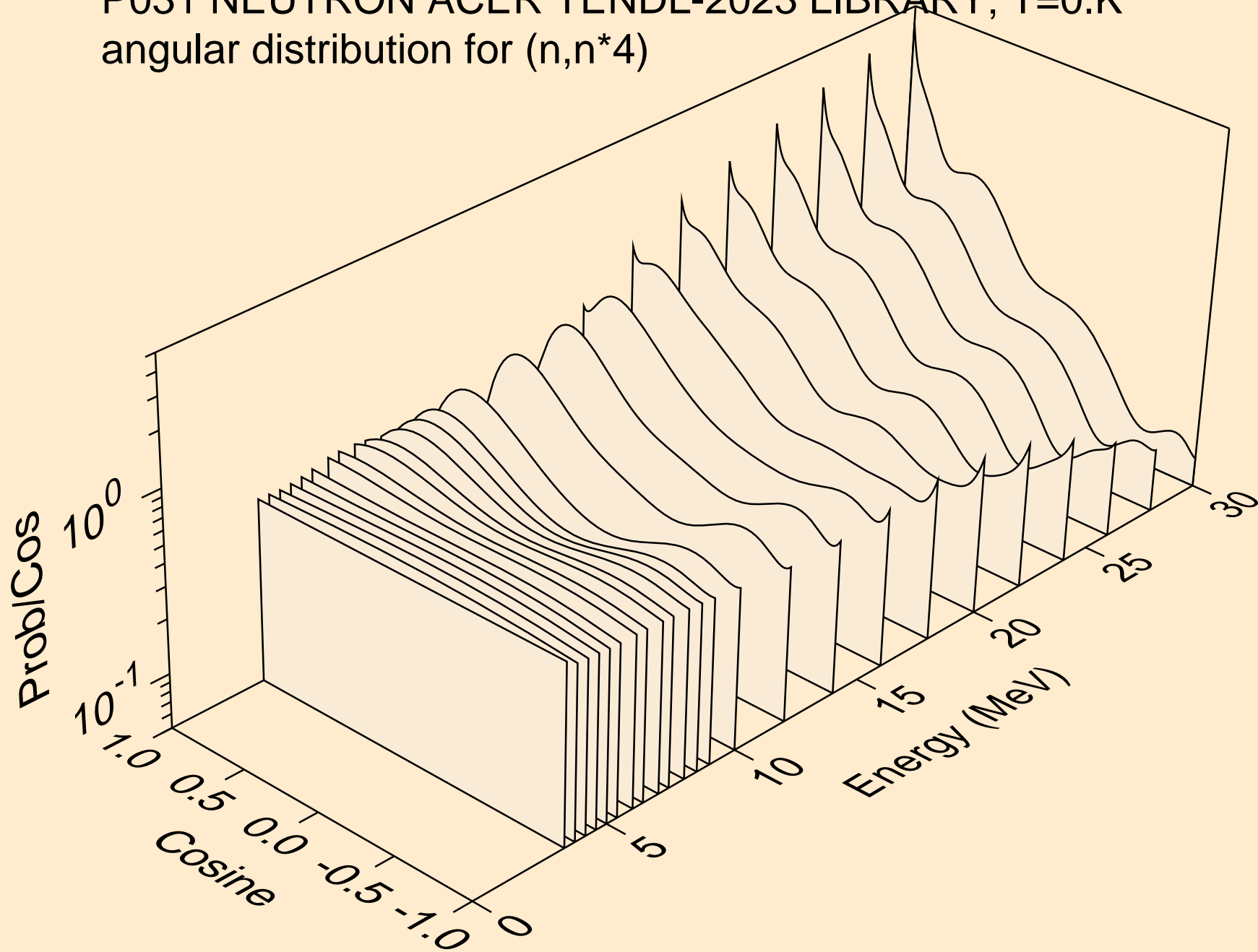

P031 NEUTRON ACER TENDL-2023 LIBRARY; T=0.K  
angular distribution for (n,n\*5)

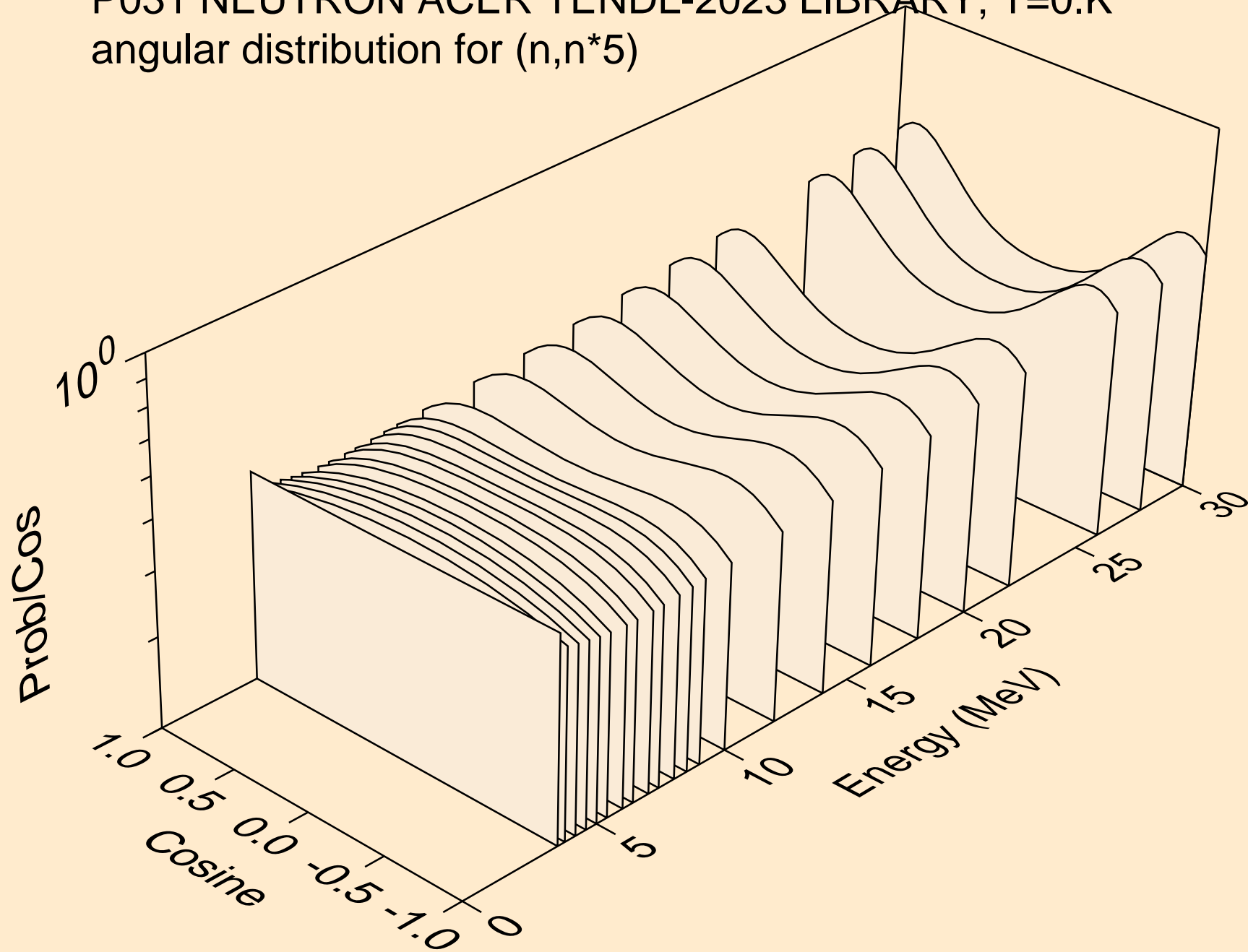

P031 NEUTRON ACER TENDL-2023 LIBRARY; T=0.K  
angular distribution for (n,n\*6)

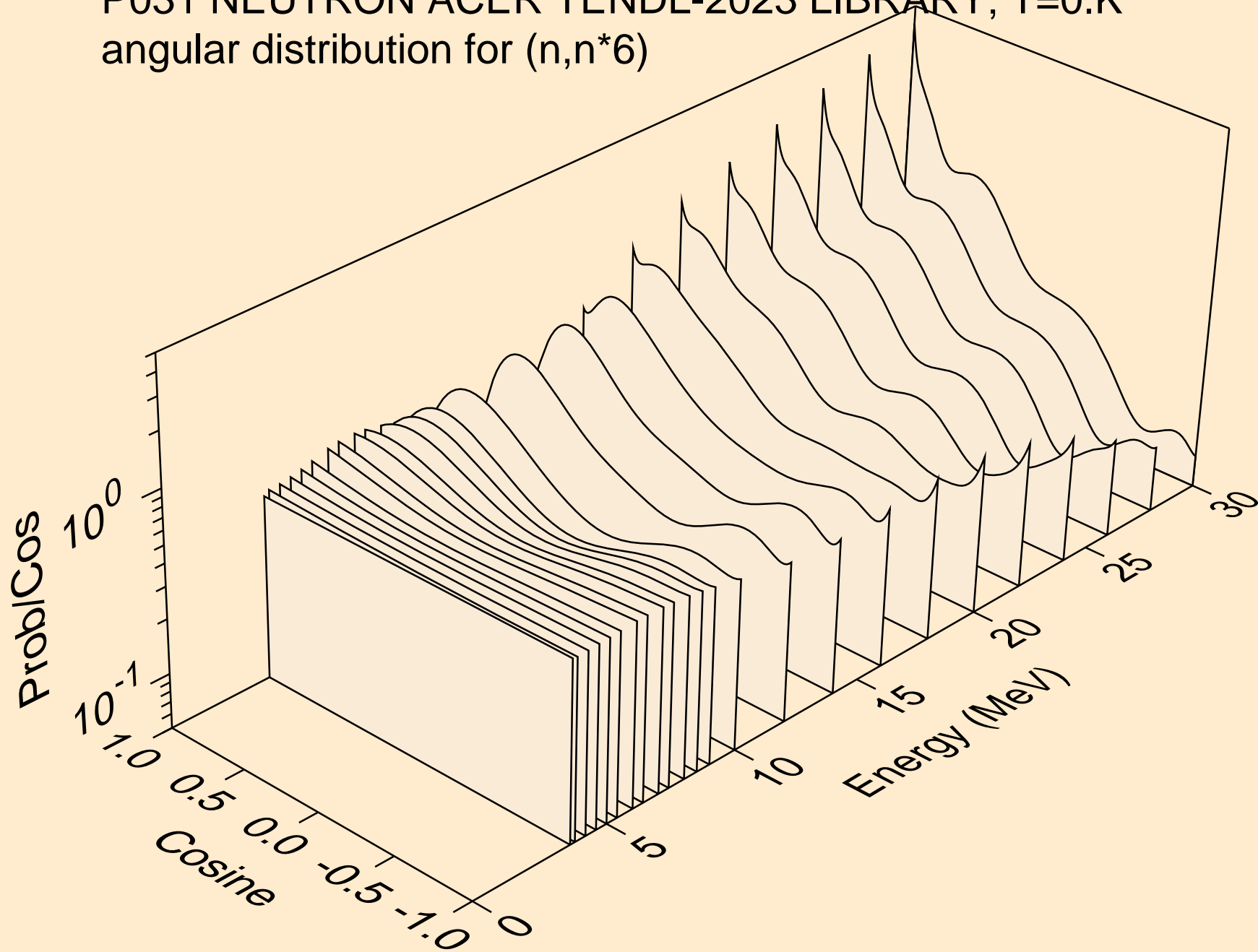

P031 NEUTRON ACER TENDL-2023 LIBRARY; T=0.K  
angular distribution for (n,n\*7)

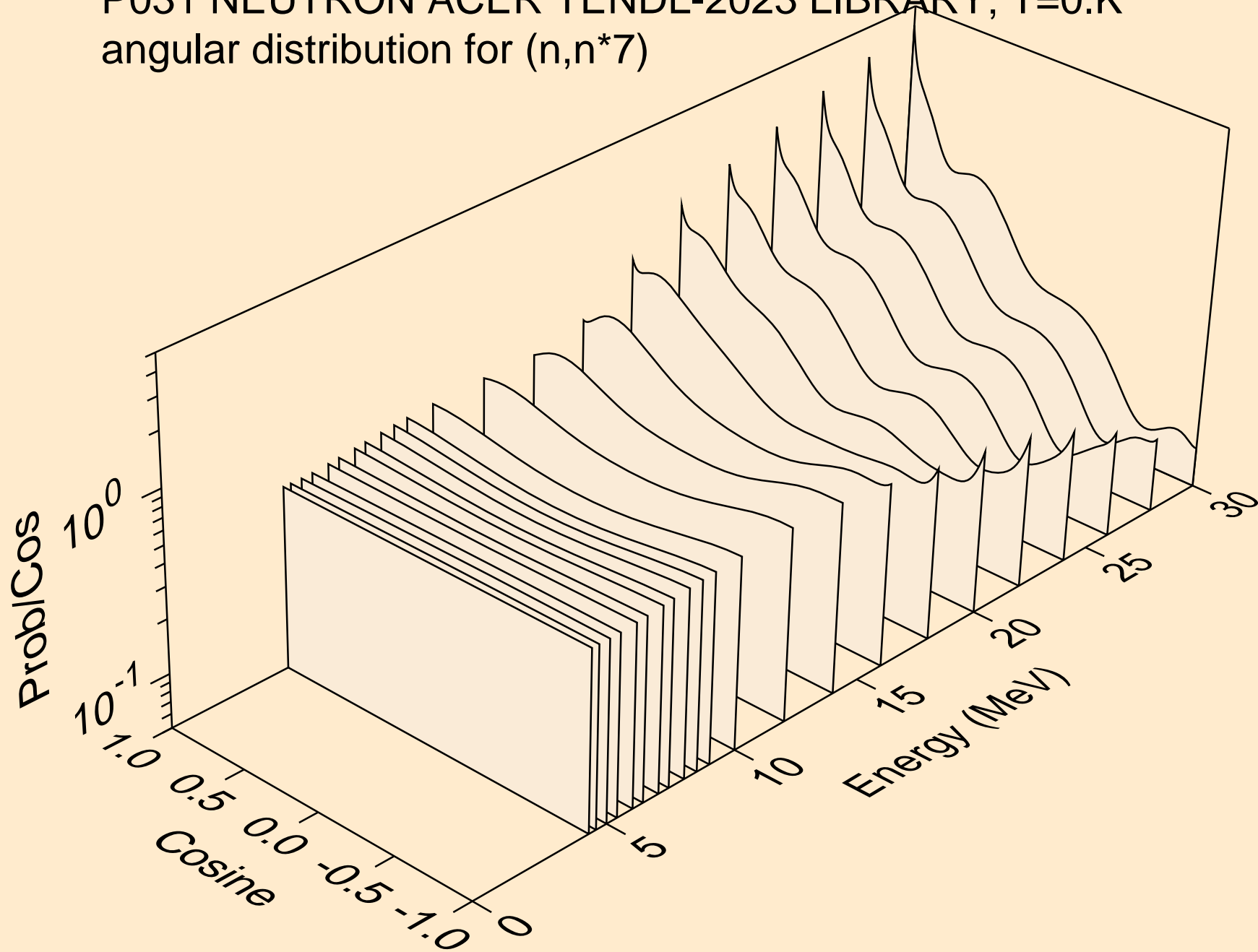

P031 NEUTRON ACER TENDL-2023 LIBRARY; T=0.K  
angular distribution for (n,n\*8)

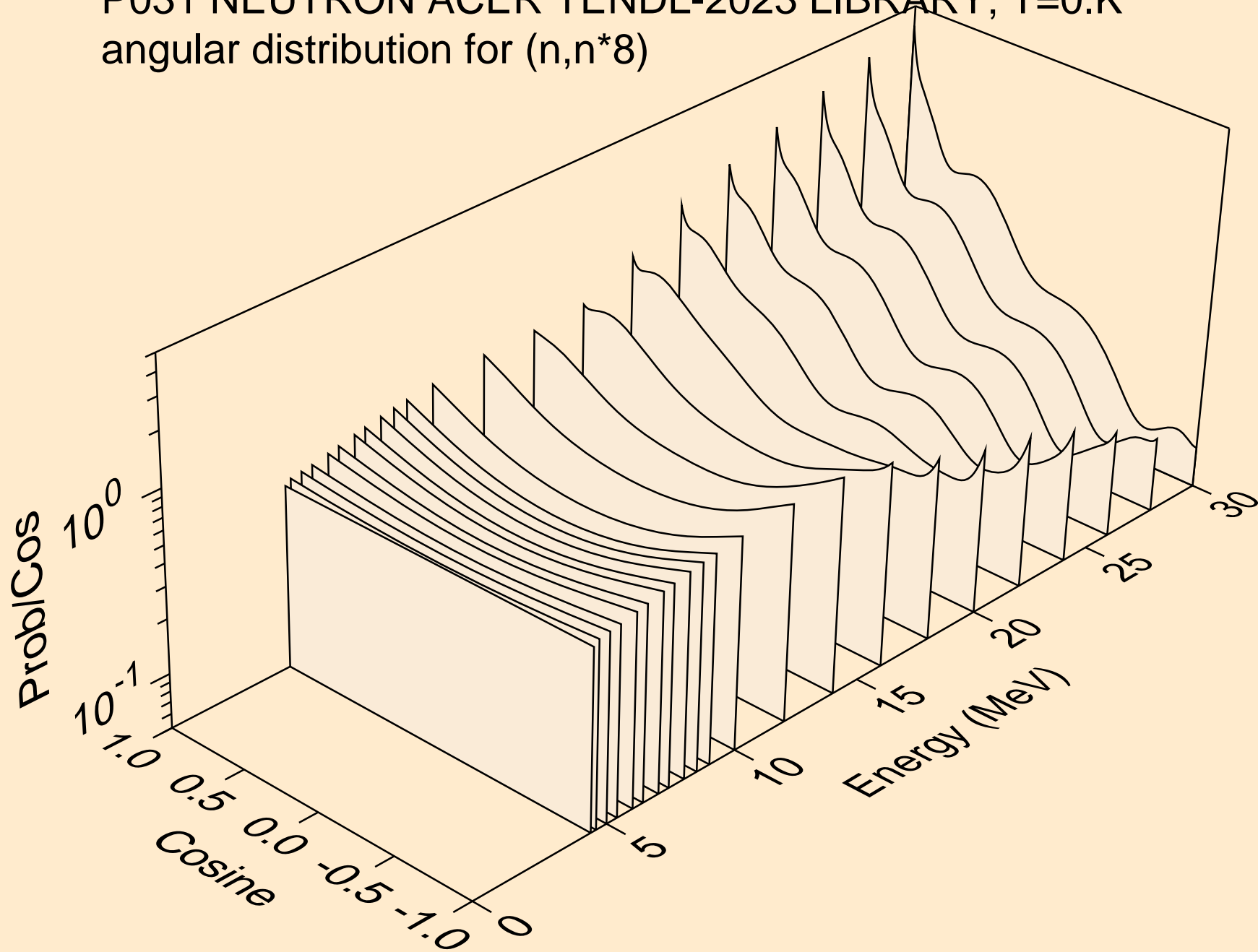

P031 NEUTRON ACER TENDL-2023 LIBRARY; T=0.K  
angular distribution for (n,n\*9)

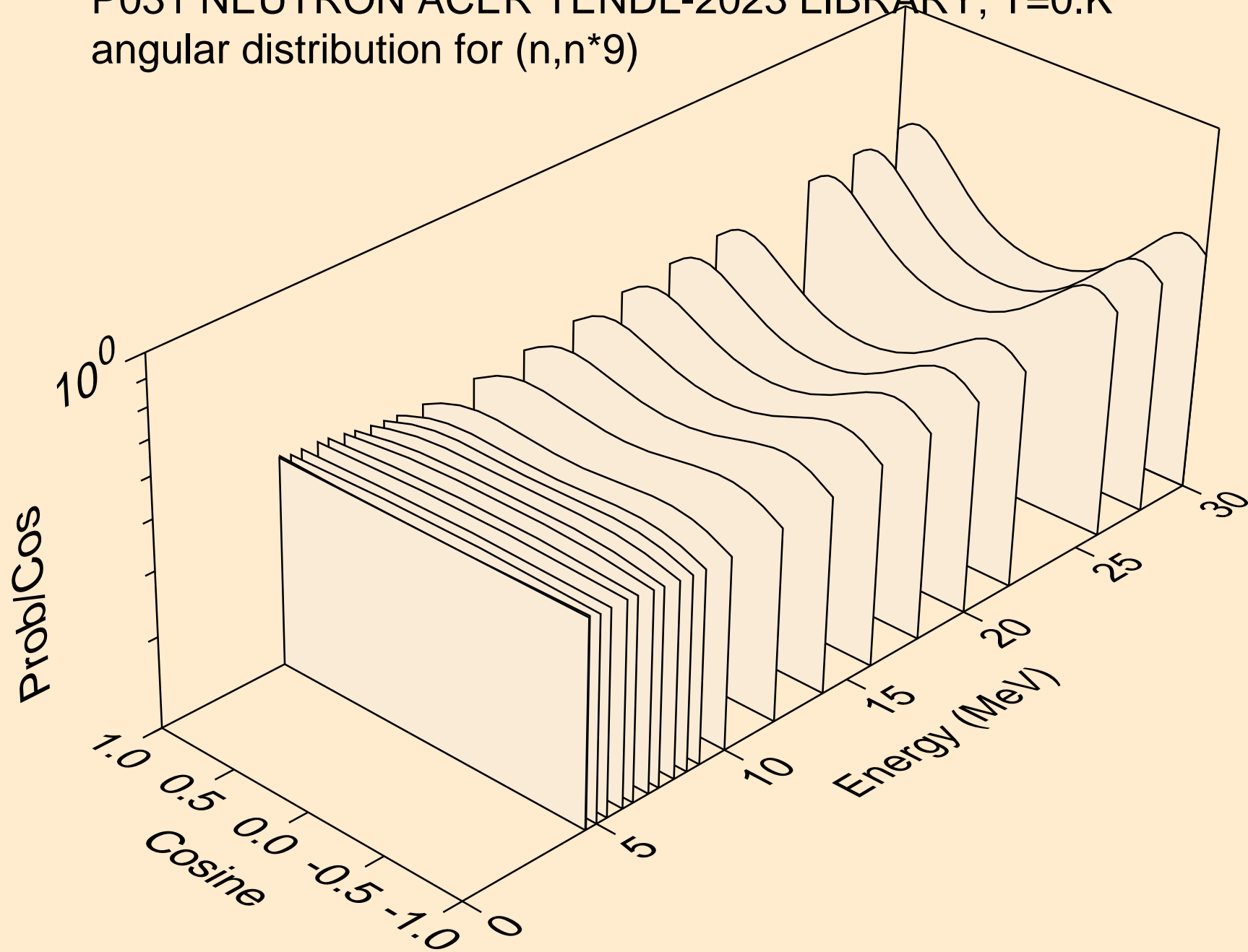

P031 NEUTRON ACER TENDL-2023 LIBRARY; T=0.K  
angular distribution for (n,n\*10)

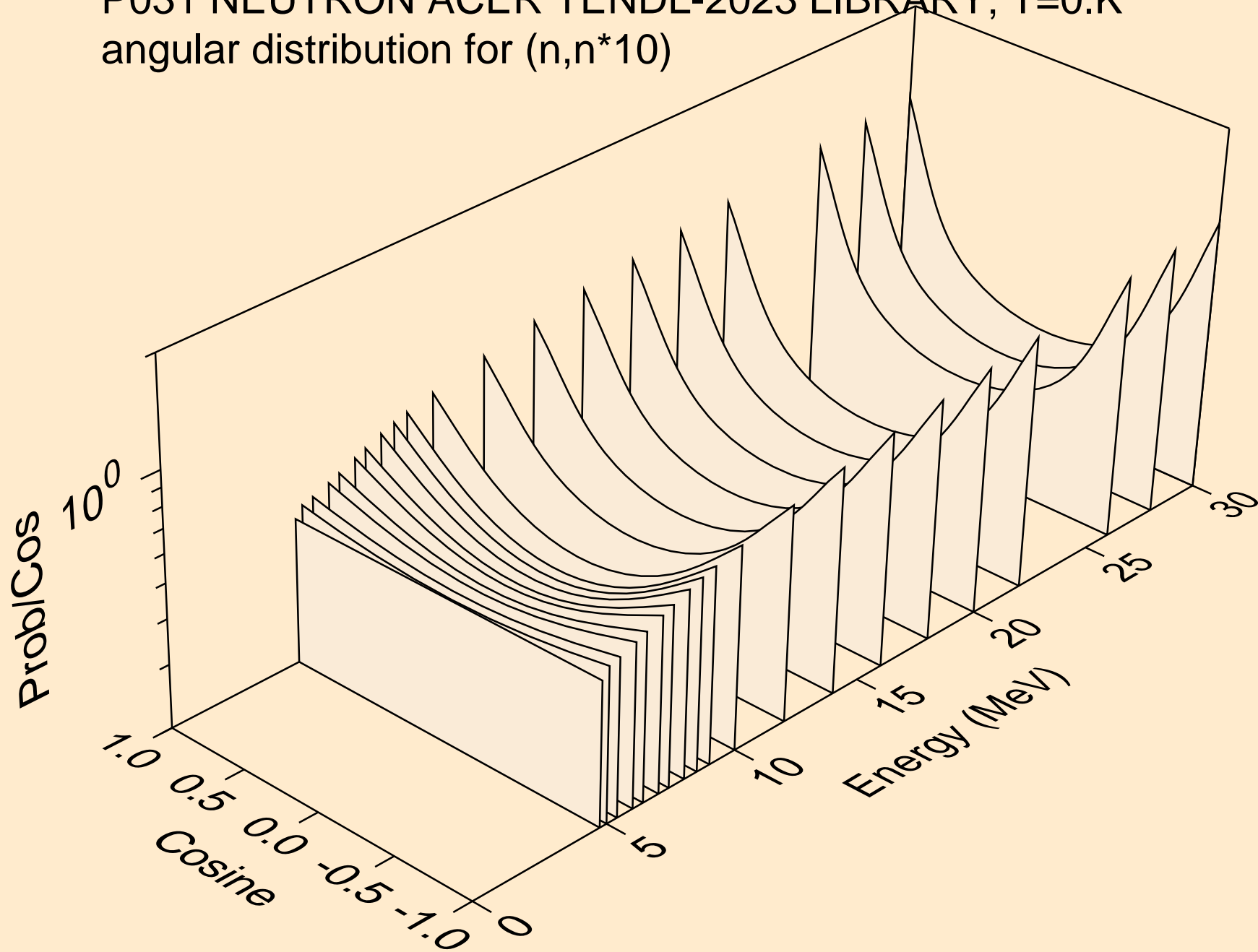

P031 NEUTRON ACER TENDL-2023 LIBRARY; T=0.K  
angular distribution for (n,n\*11)

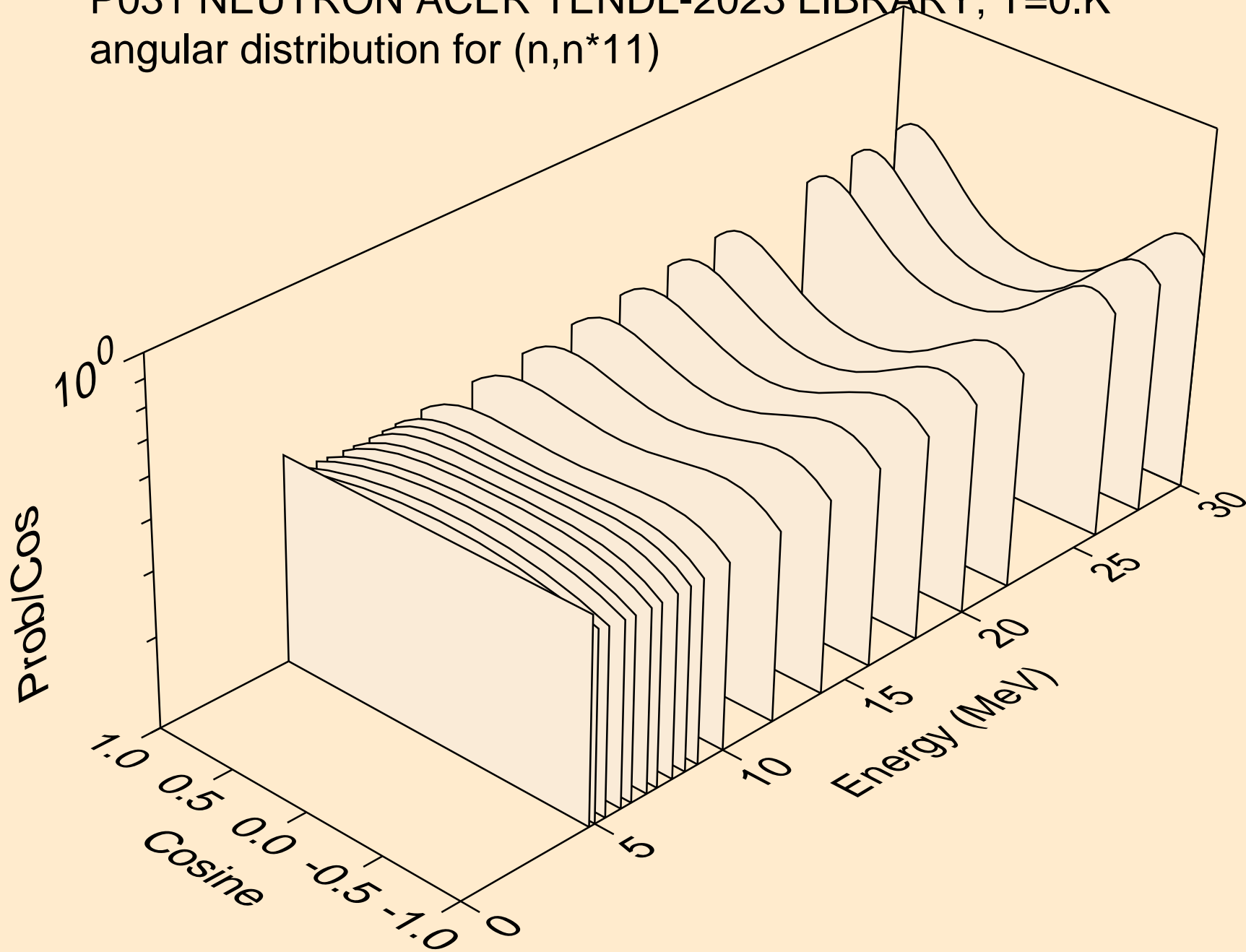

P031 NEUTRON ACER TENDL-2023 LIBRARY; T=0.K  
angular distribution for (n,n\*12)

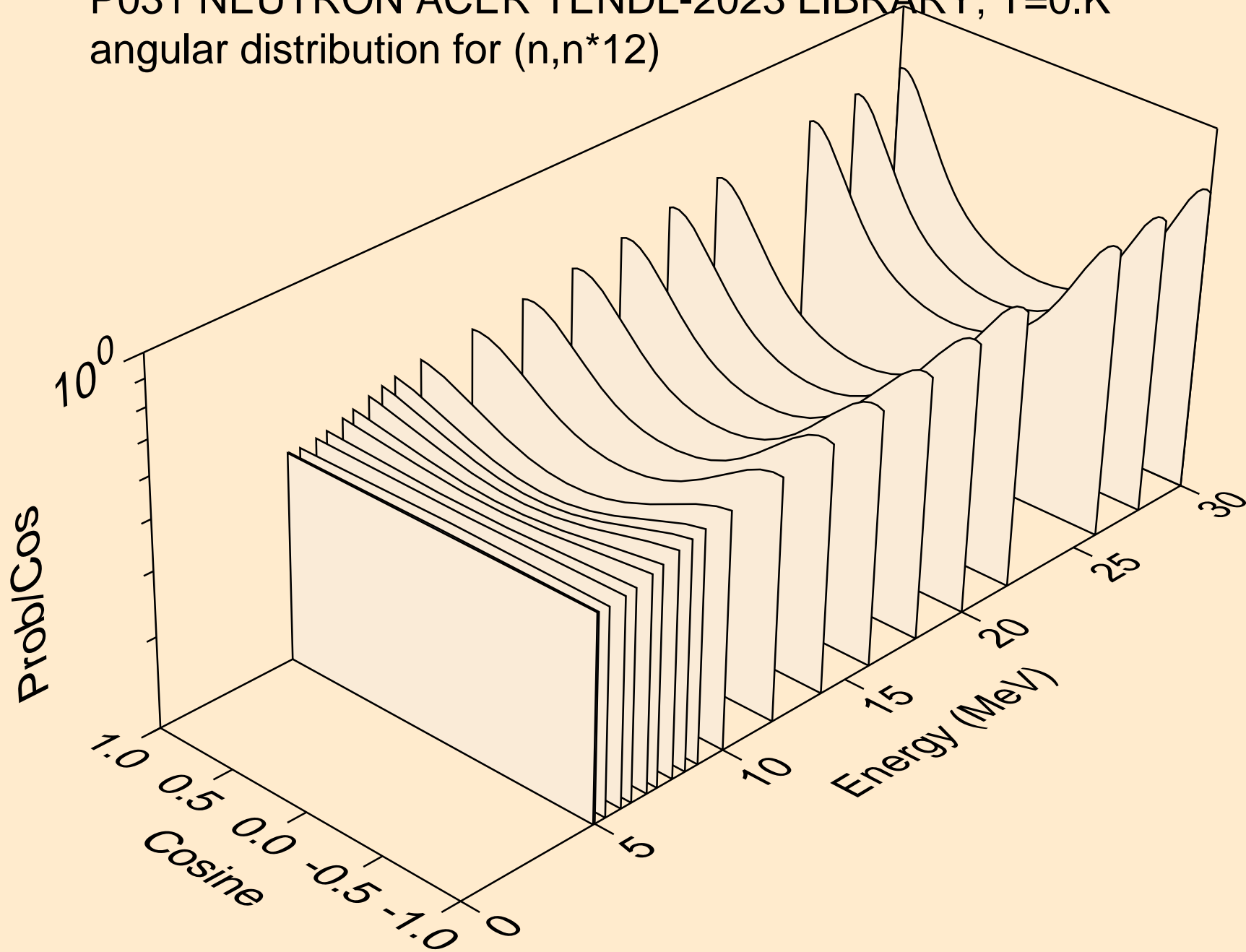

P031 NEUTRON ACER TENDL-2023 LIBRARY; T=0.K  
angular distribution for (n,n\*13)

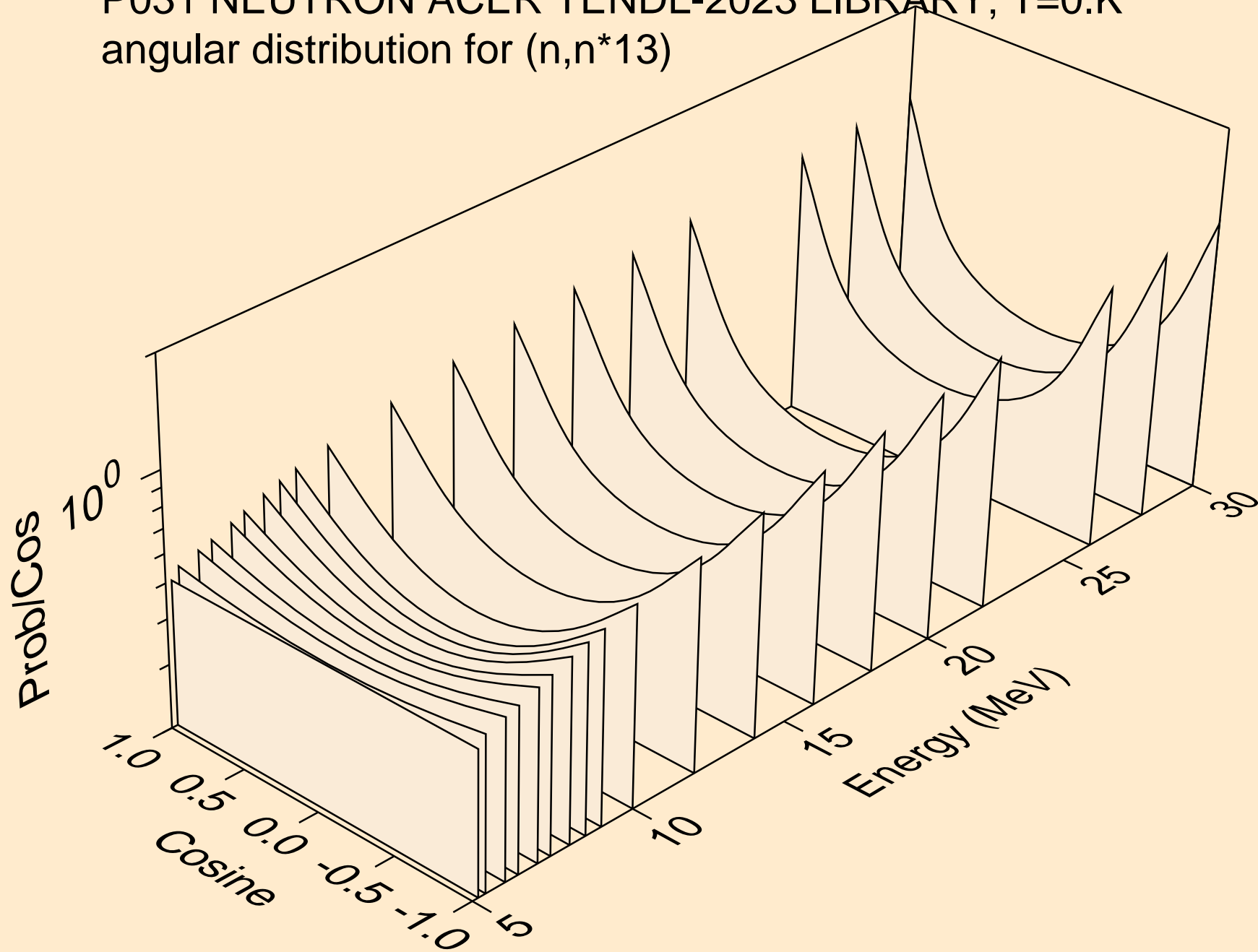

P031 NEUTRON ACER TENDL-2023 LIBRARY; T=0.K  
angular distribution for (n,n\*14)

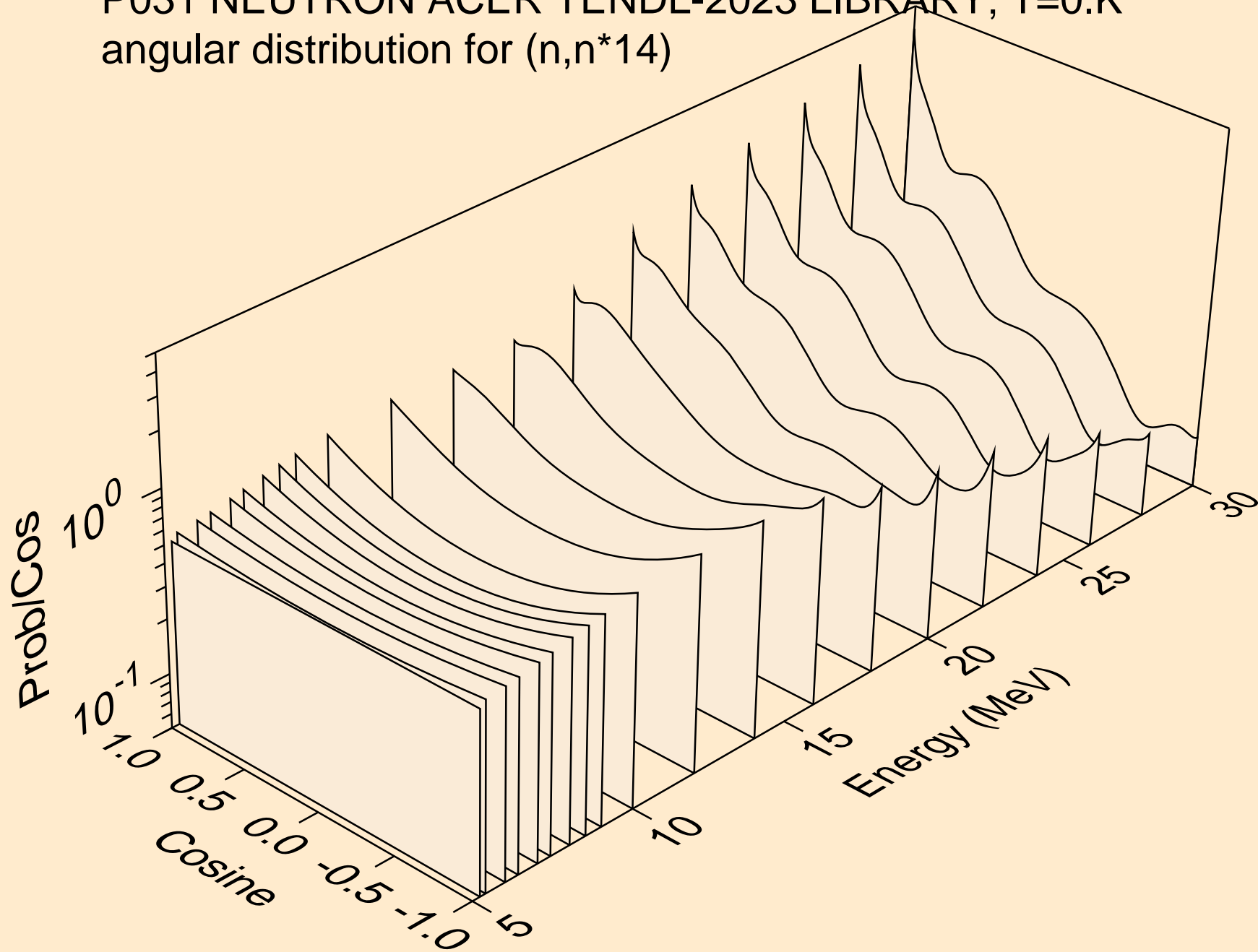

P031 NEUTRON ACER TENDL-2023 LIBRARY; T=0.K  
angular distribution for (n,n\*15)

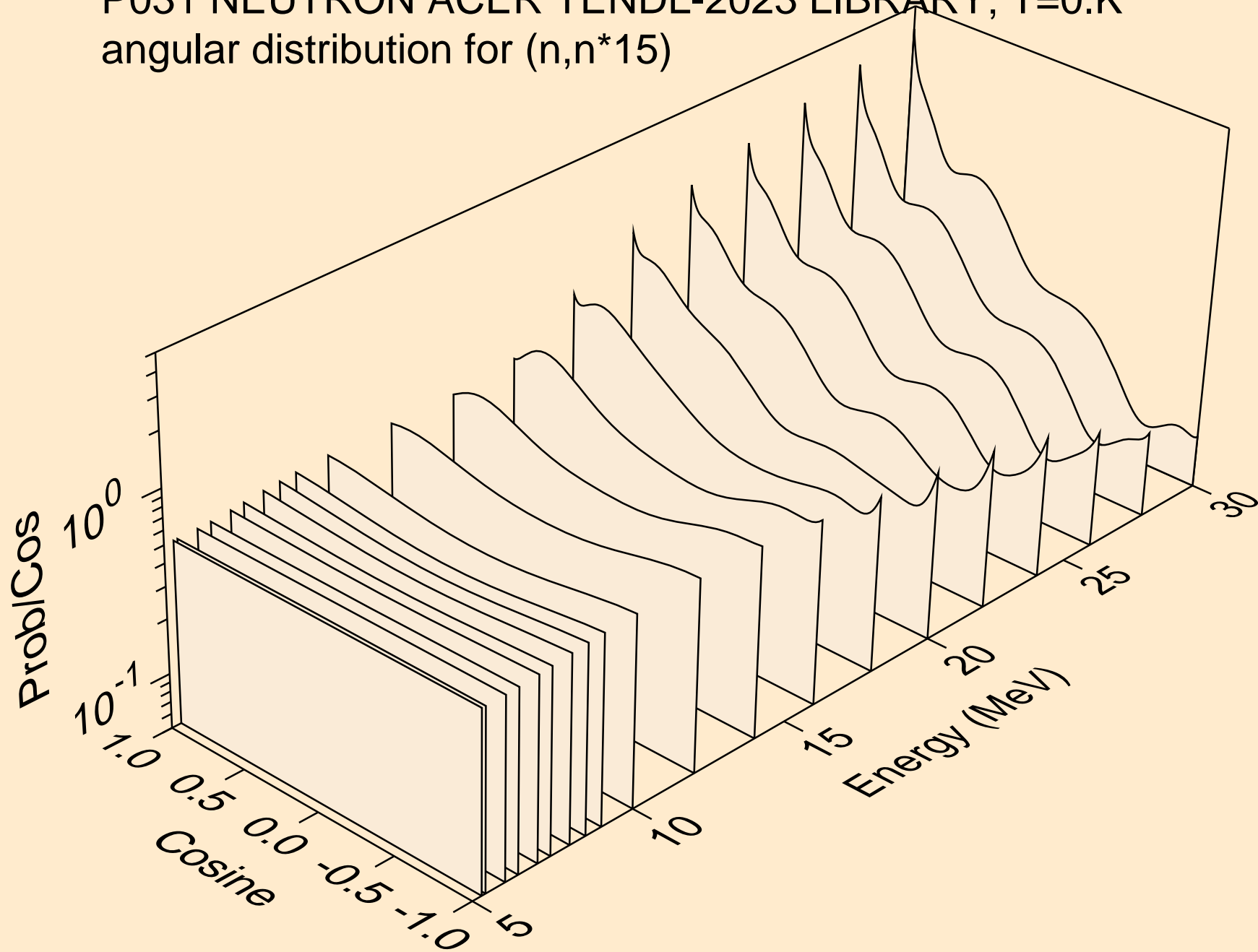

P031 NEUTRON ACER TENDL-2023 LIBRARY; T=0.K  
angular distribution for (n,n\*16)

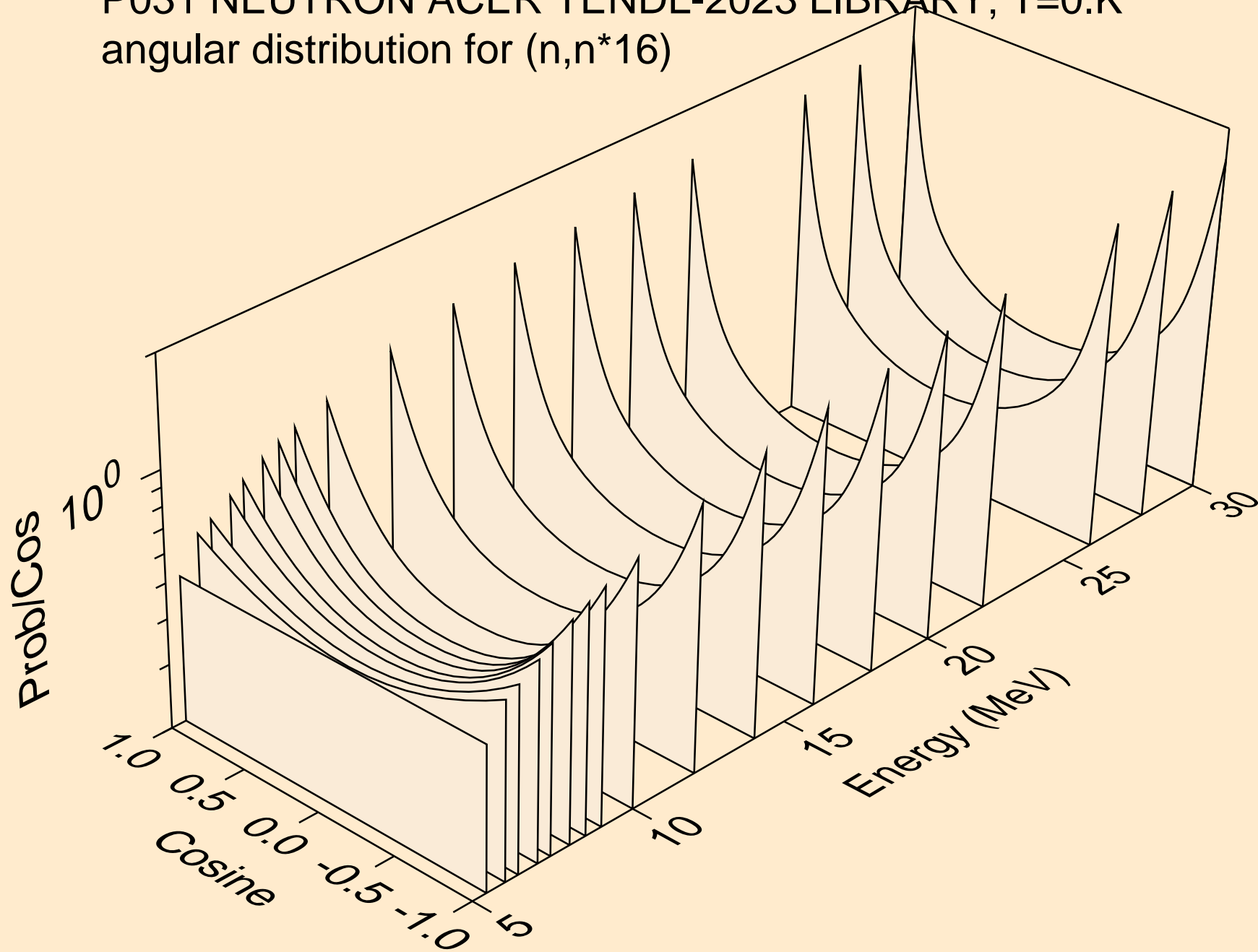

P031 NEUTRON ACER TENDL-2023 LIBRARY; T=0.K  
Neutron emission for (n,x)

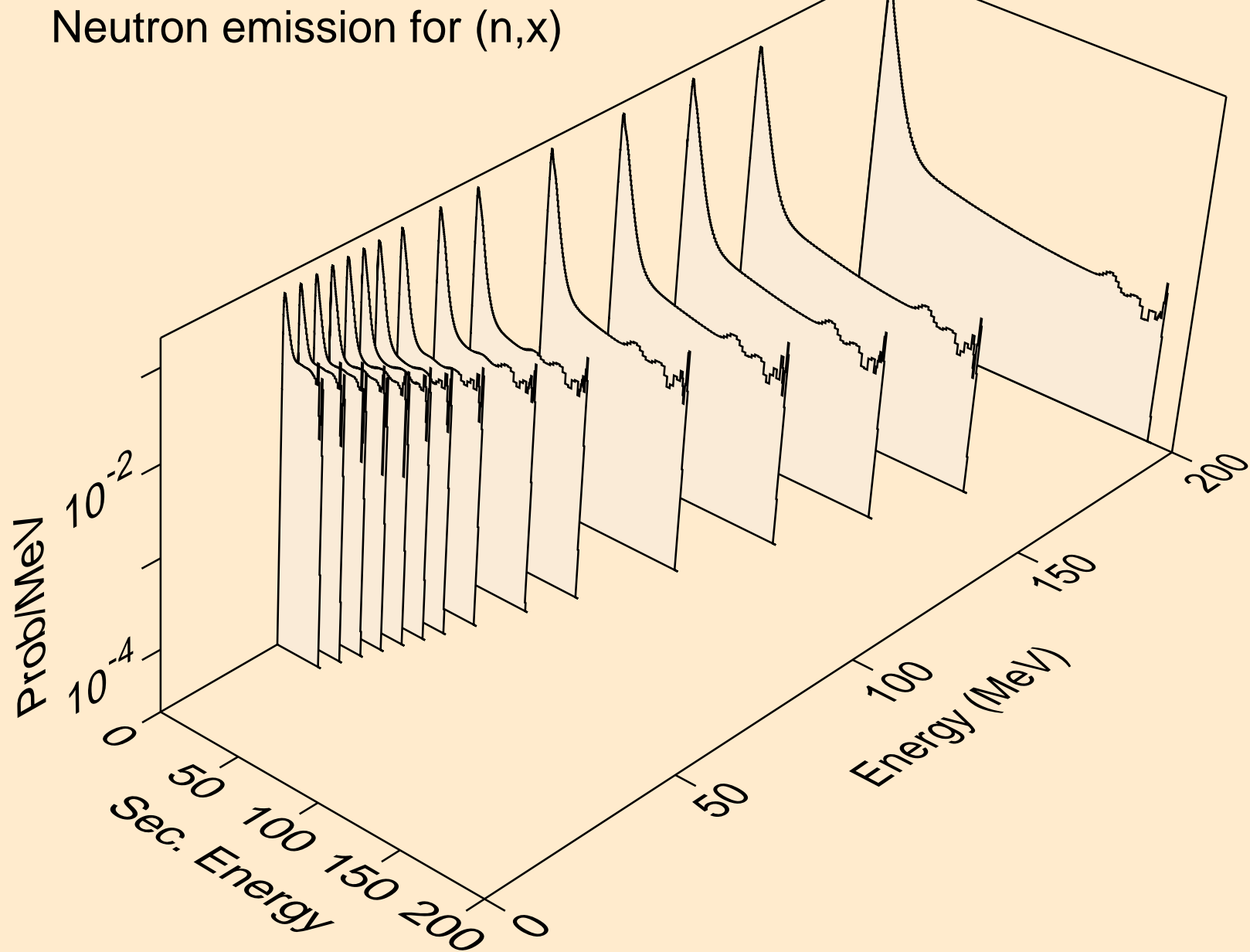

P031 NEUTRON ACER TENDL-2023 LIBRARY; T=0.K  
Neutron emission for (n,2nd)

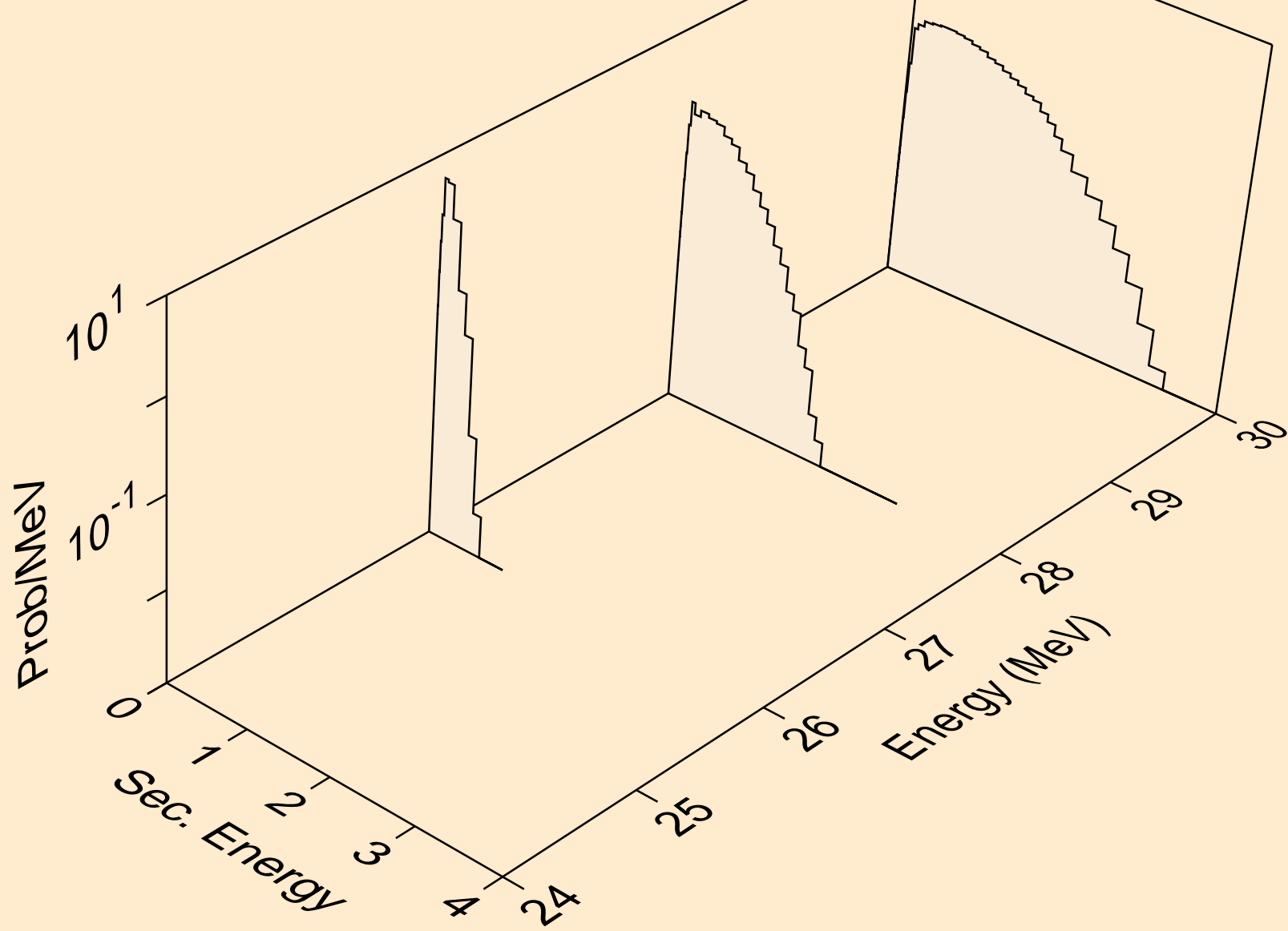

P031 NEUTRON ACER TENDL-2023 LIBRARY; T=0.K  
Neutron emission for (n,2n)

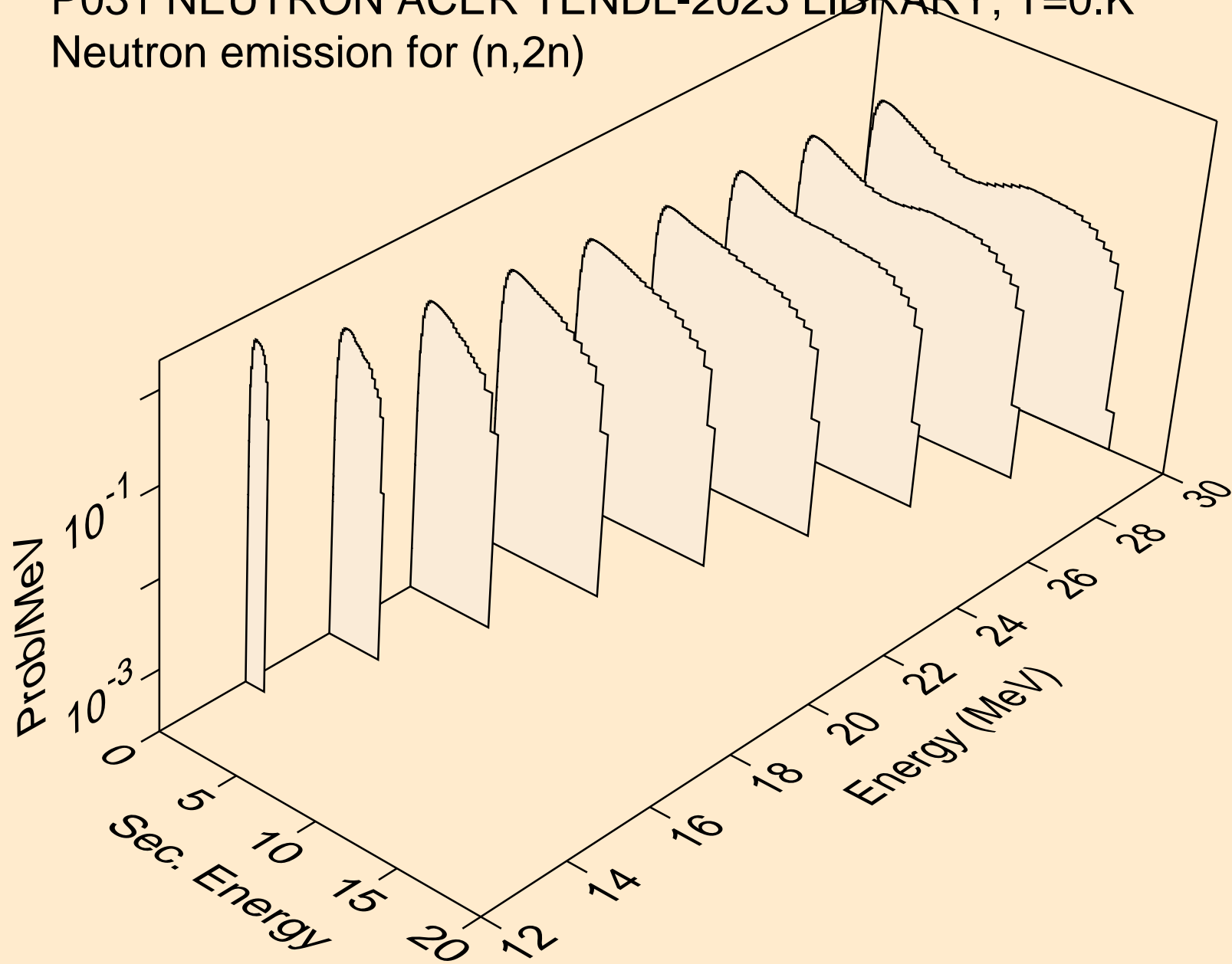

P031 NEUTRON ACER TENDL-2023 LIBRARY; T=0.K  
Neutron emission for (n,3n)

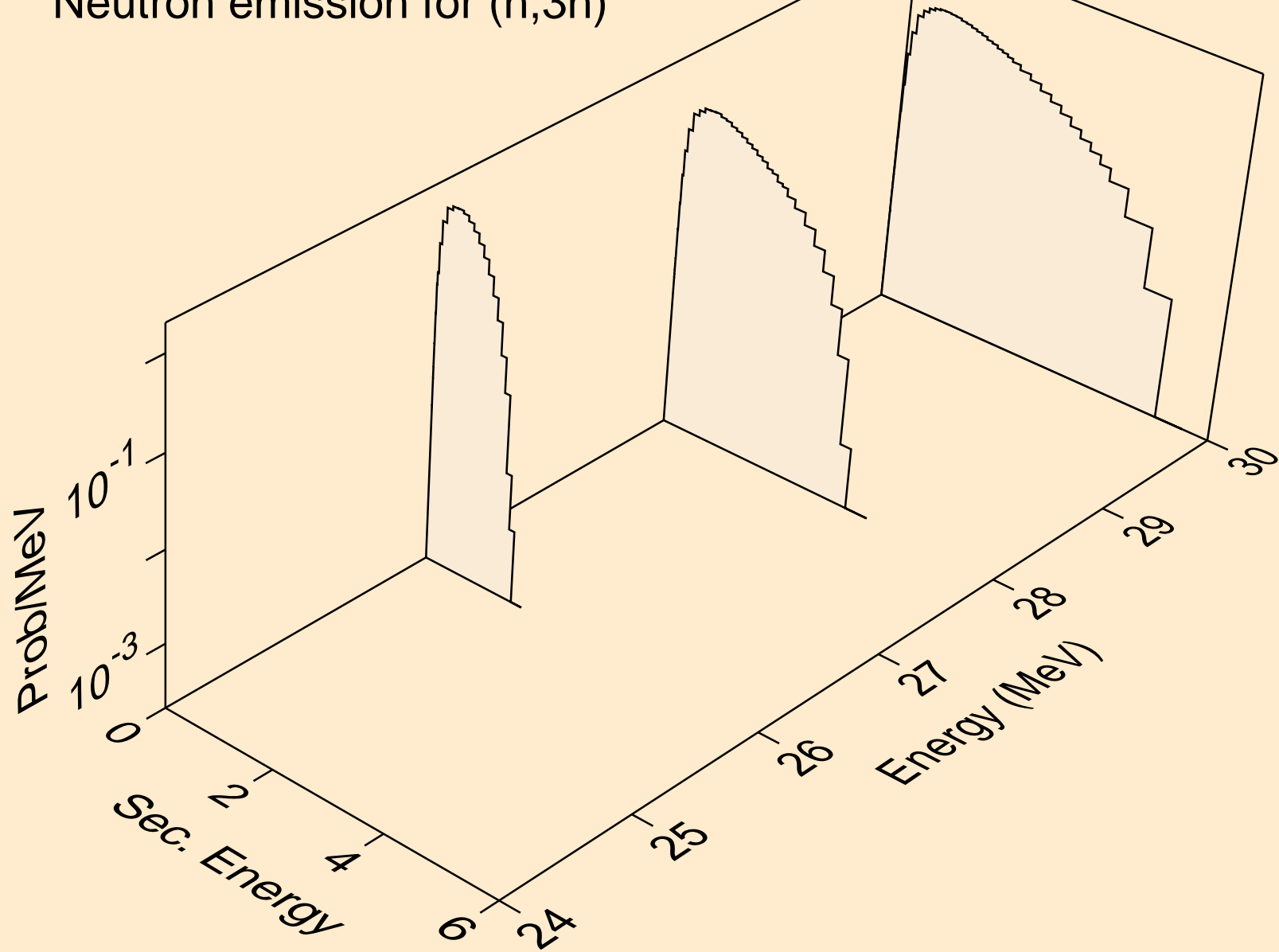

P031 NEUTRON ACER TENDL-2023 LIBRARY; T=0.K  
Neutron emission for (n,n\*)a

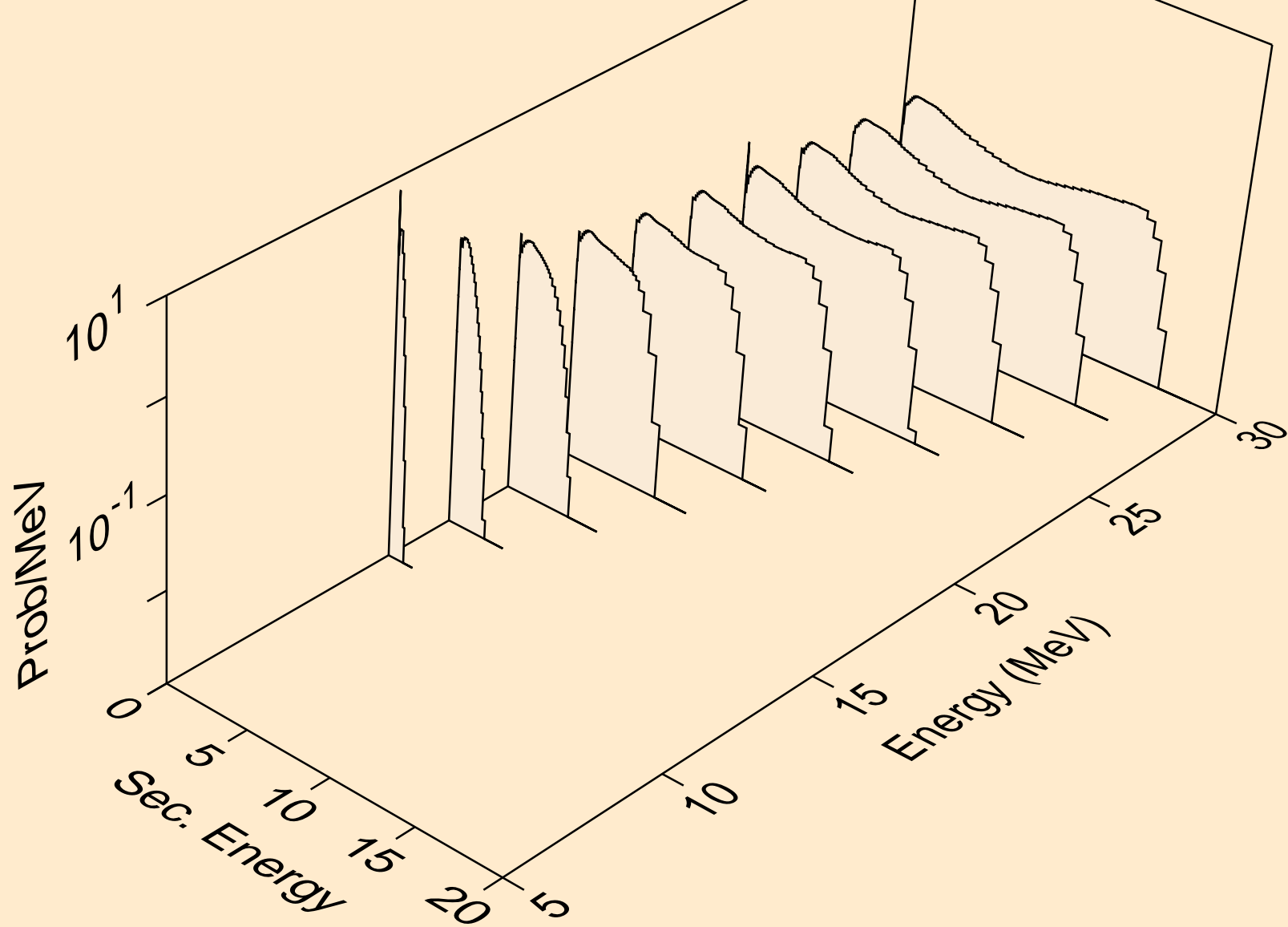

P031 NEUTRON ACER TENDL-2023 LIBRARY; T=0.K  
Neutron emission for (n,2n)a

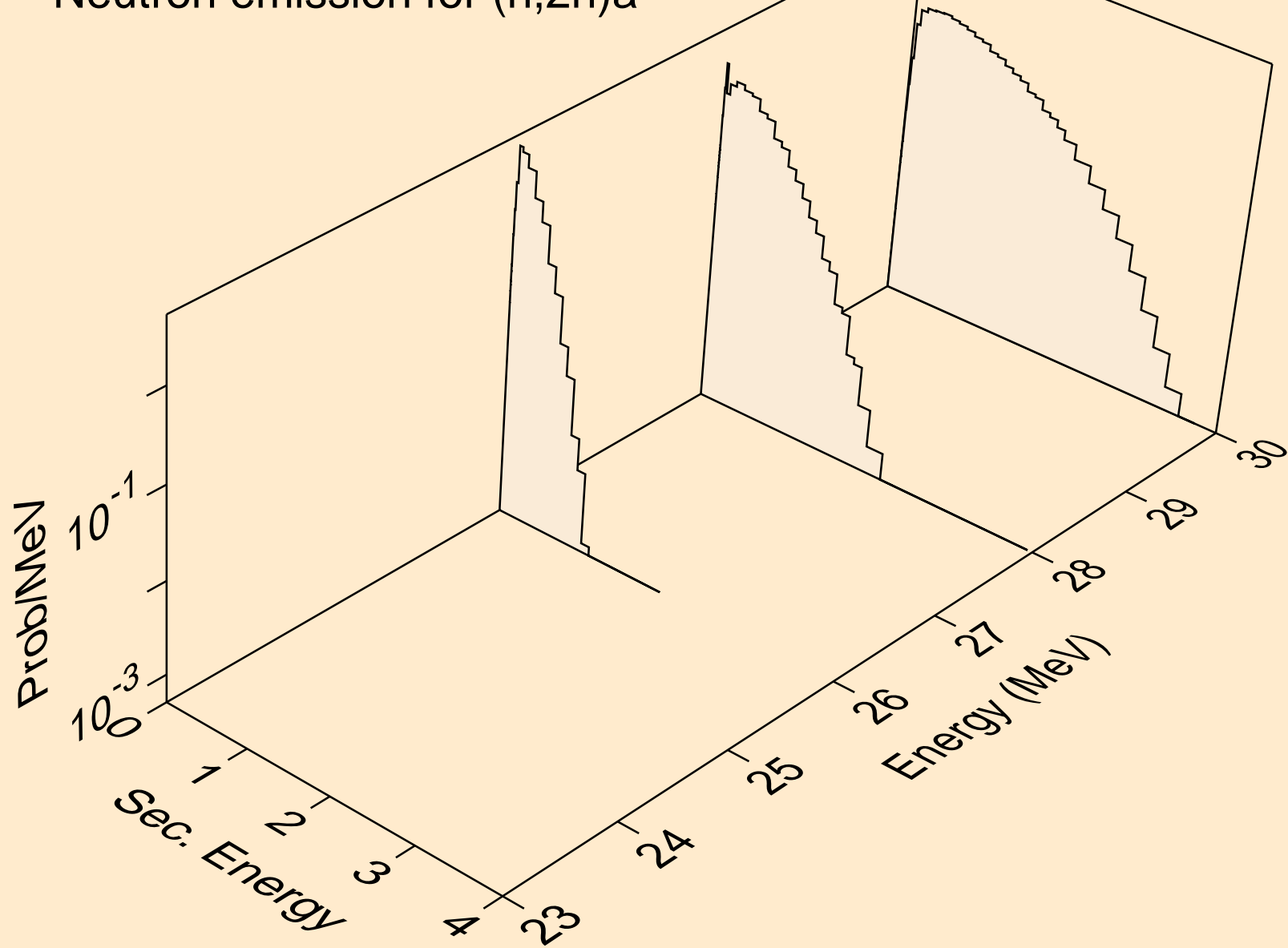

P031 NEUTRON ACER TENDL-2023 LIBRARY; T=0.K  
Neutron emission for (n,n\*)p

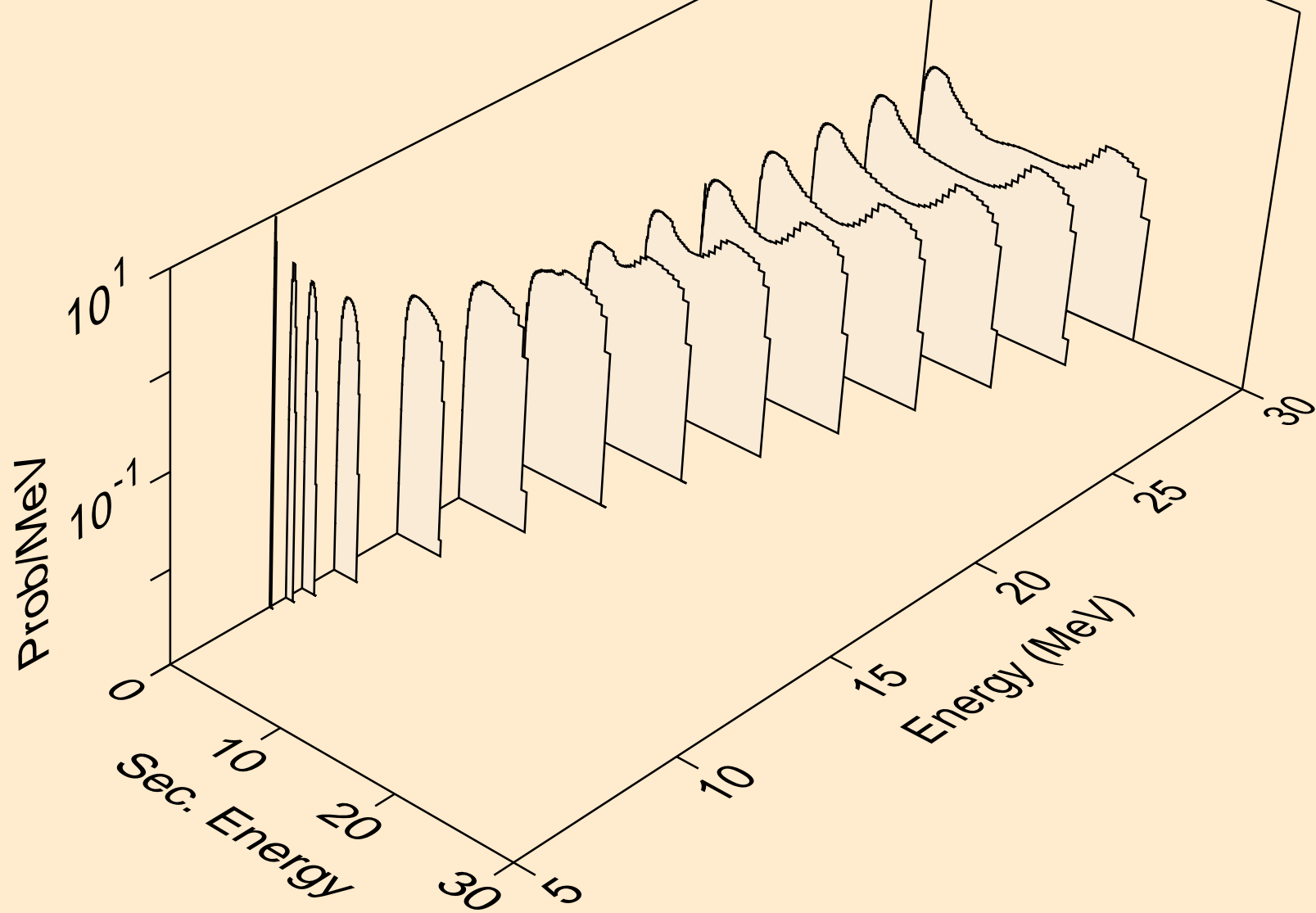

P031 NEUTRON ACER TENDL-2023 LIBRARY; T=0.K  
Neutron emission for (n,n\*)2a

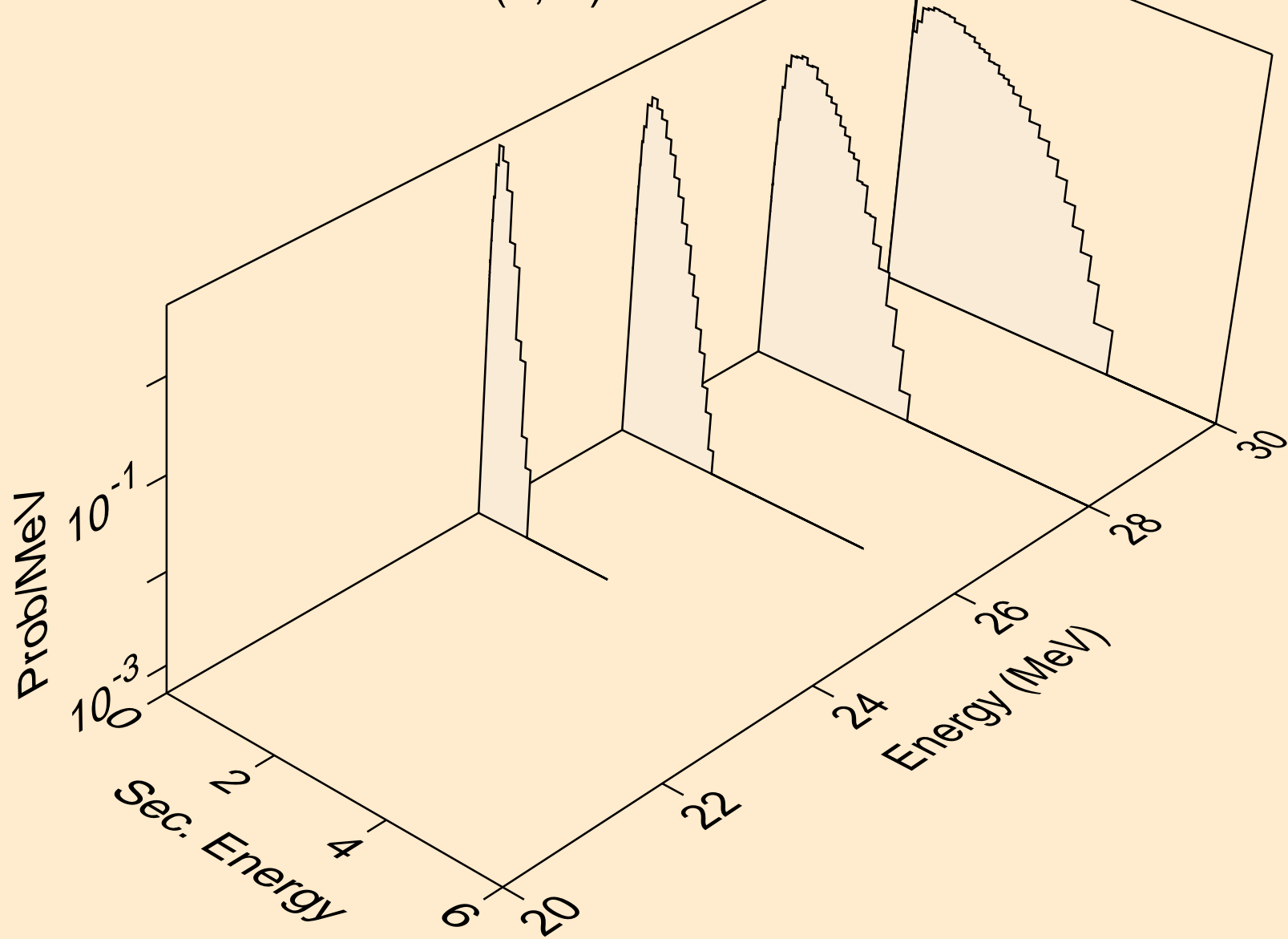

P031 NEUTRON ACER TENDL-2023 LIBRARY; T=0.K  
Neutron emission for (n,n\*)d

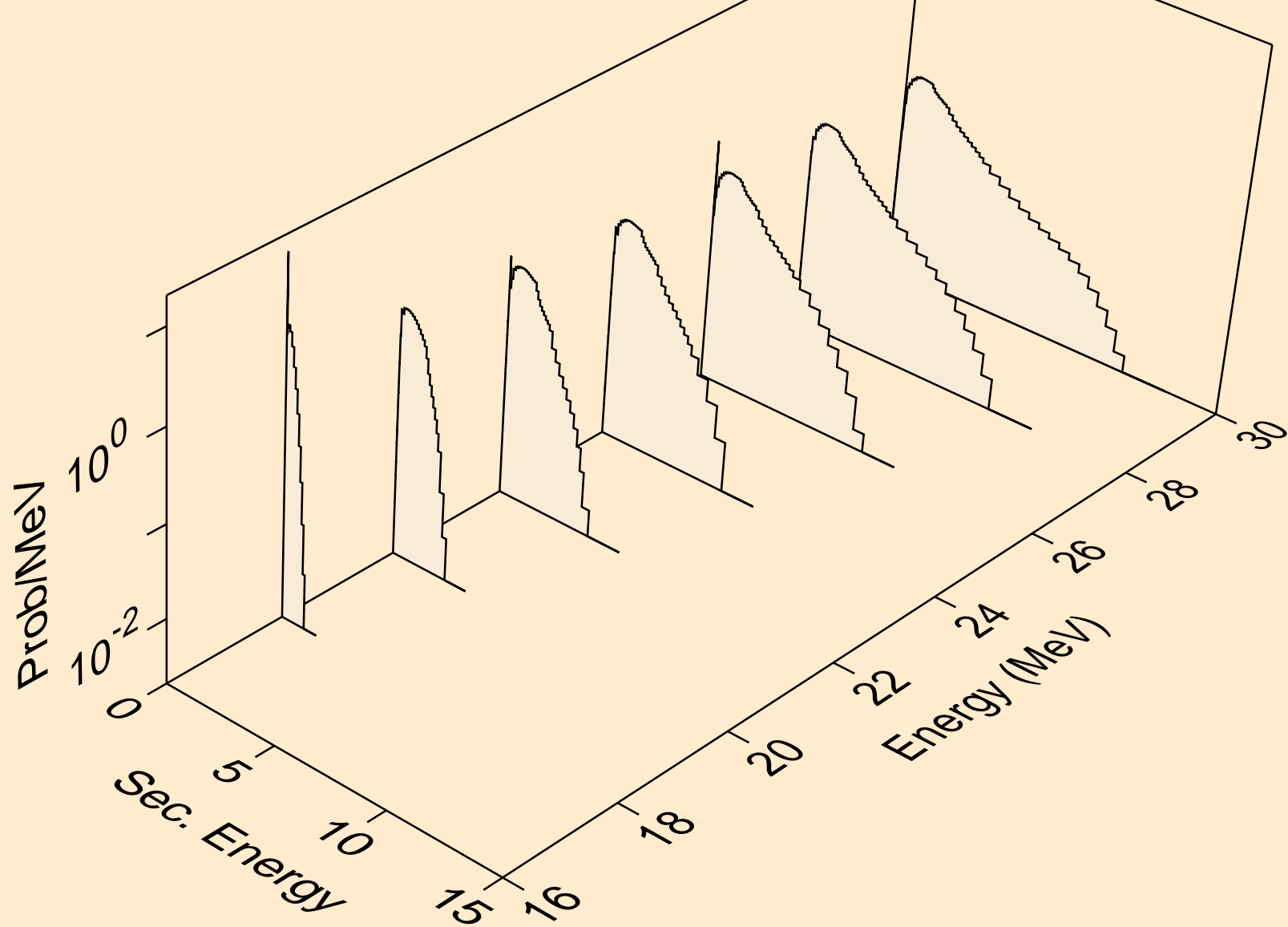

P031 NEUTRON ACER TENDL-2023 LIBRARY; T=0.K  
Neutron emission for (n,n\*)t

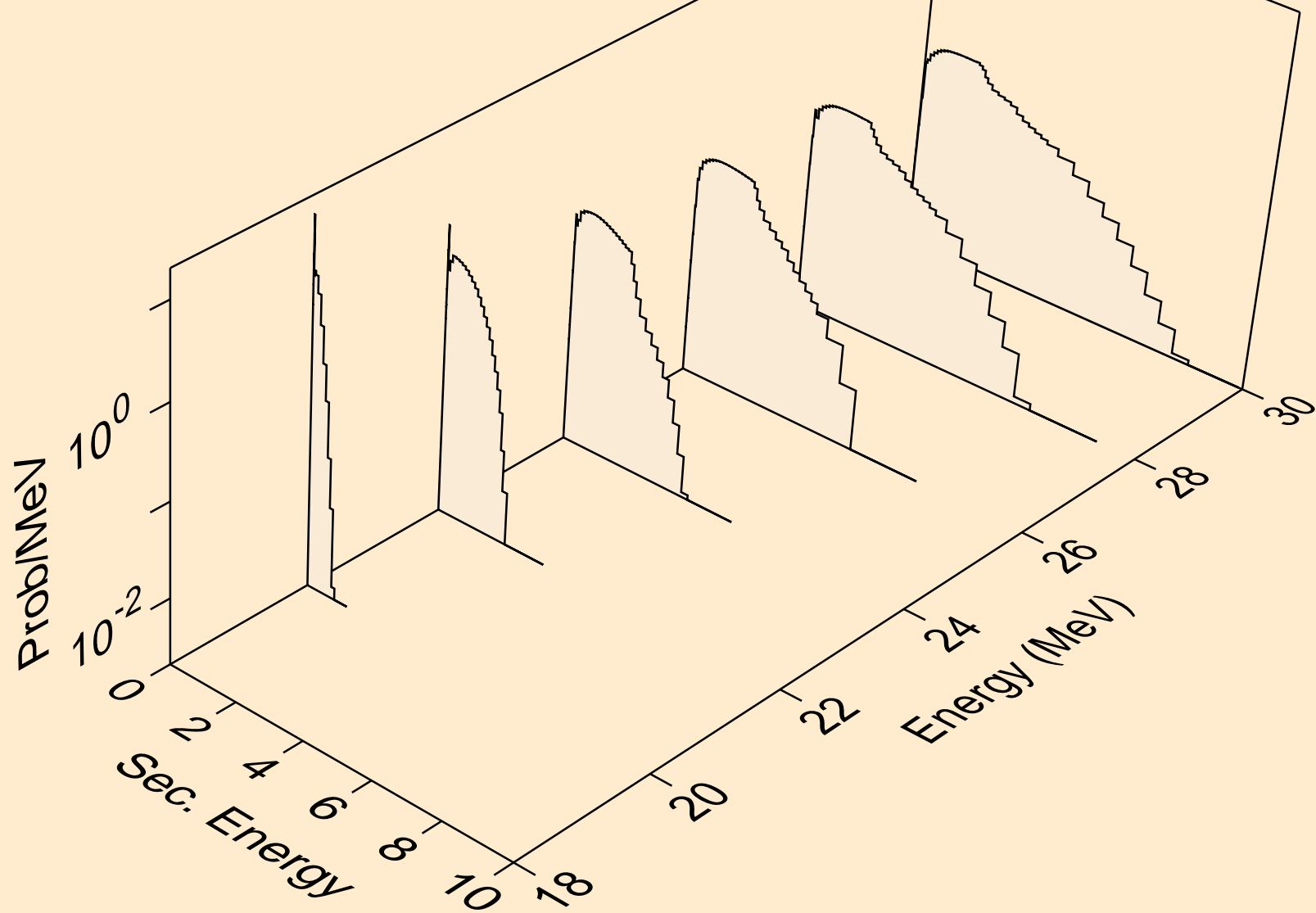

P031 NEUTRON ACER TENDL-2023 LIBRARY; T=0.K  
Neutron emission for (n,n\*)he3

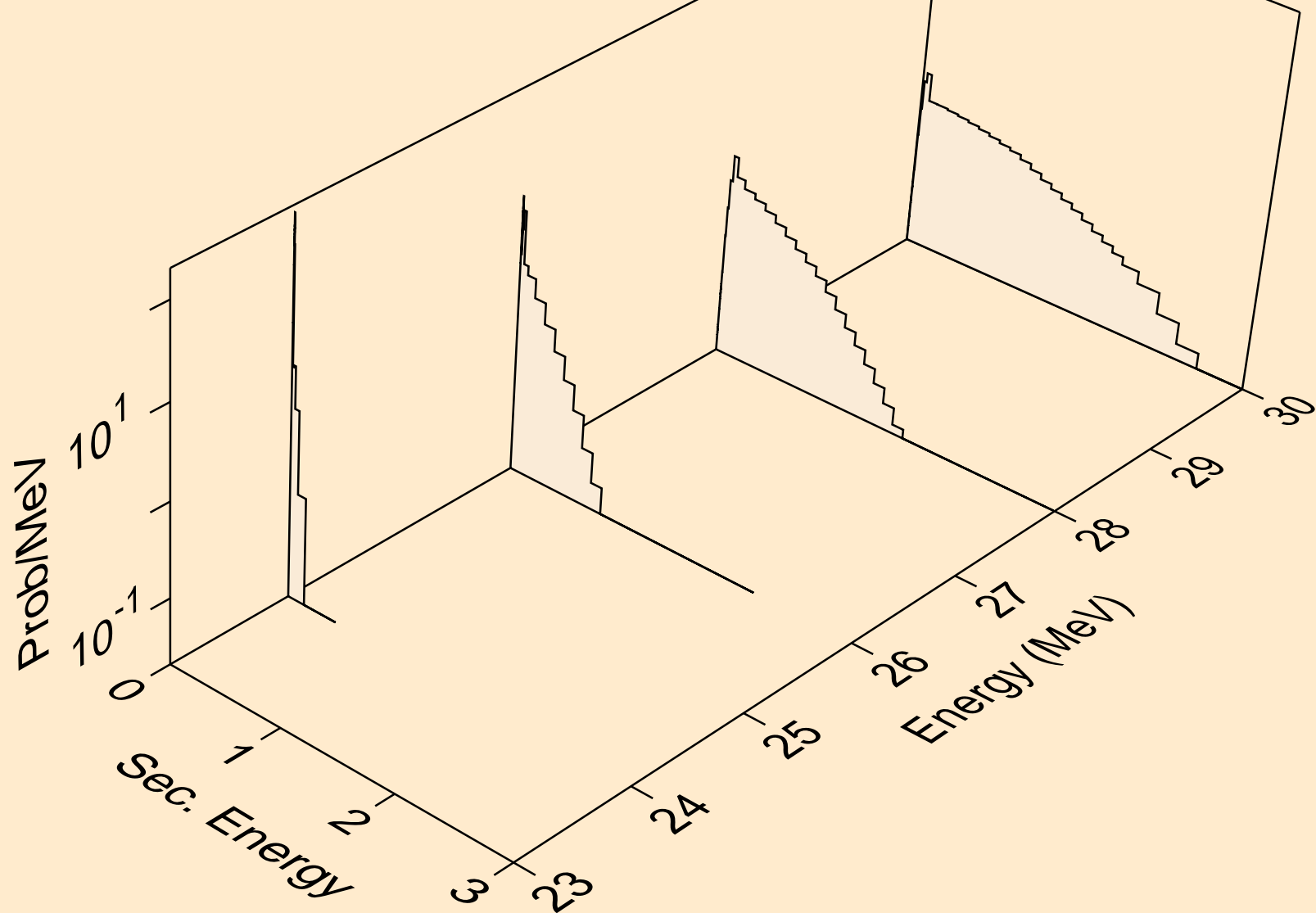

P031 NEUTRON ACER TENDL-2023 LIBRARY; T=0.K  
Neutron emission for (n,2np)

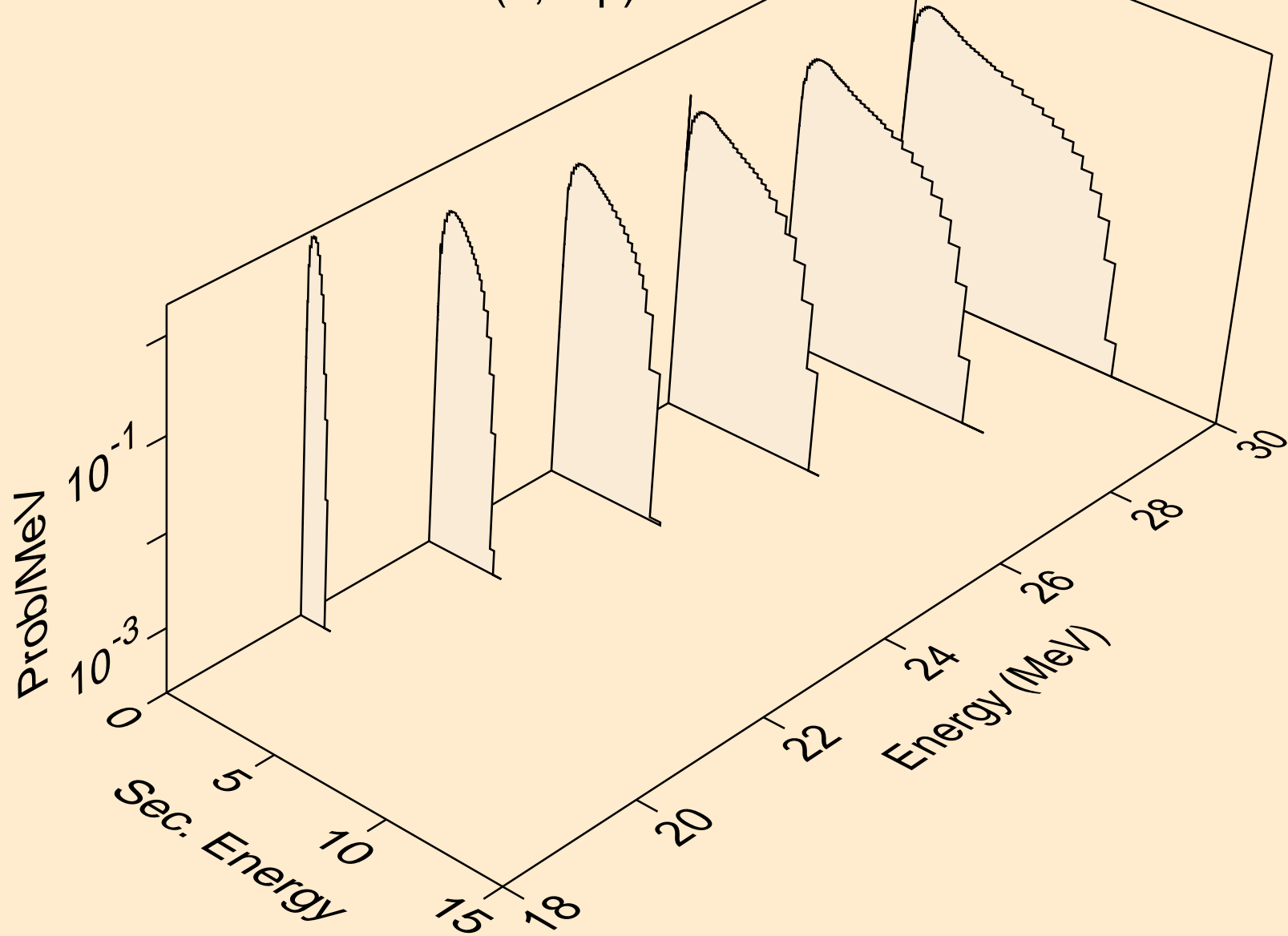

P031 NEUTRON ACER TENDL-2023 LIBRARY; T=0.K  
Neutron emission for (n,3np)

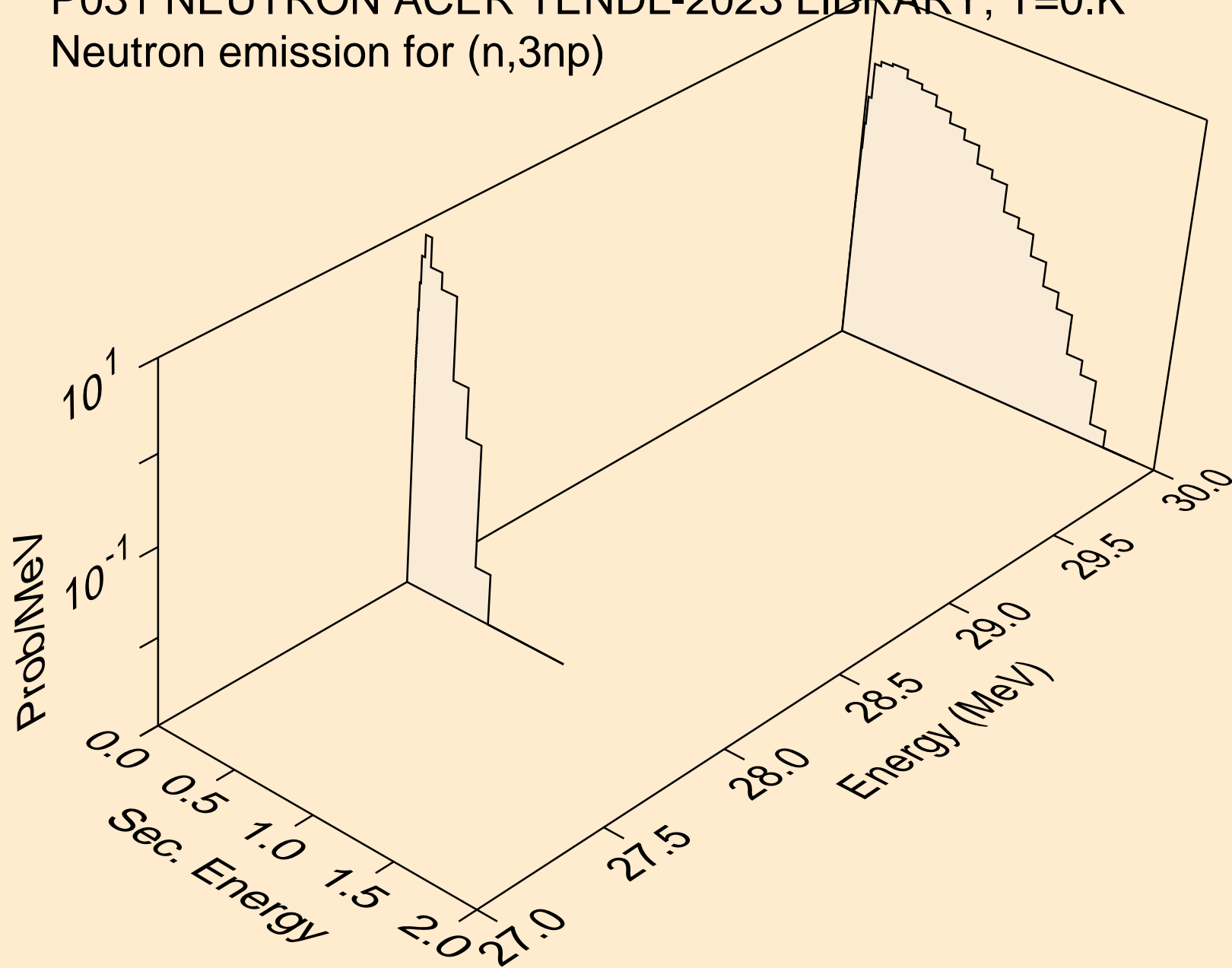

P031 NEUTRON ACER TENDL-2023 LIBRARY; T=0.K  
Neutron emission for (n,n2p)

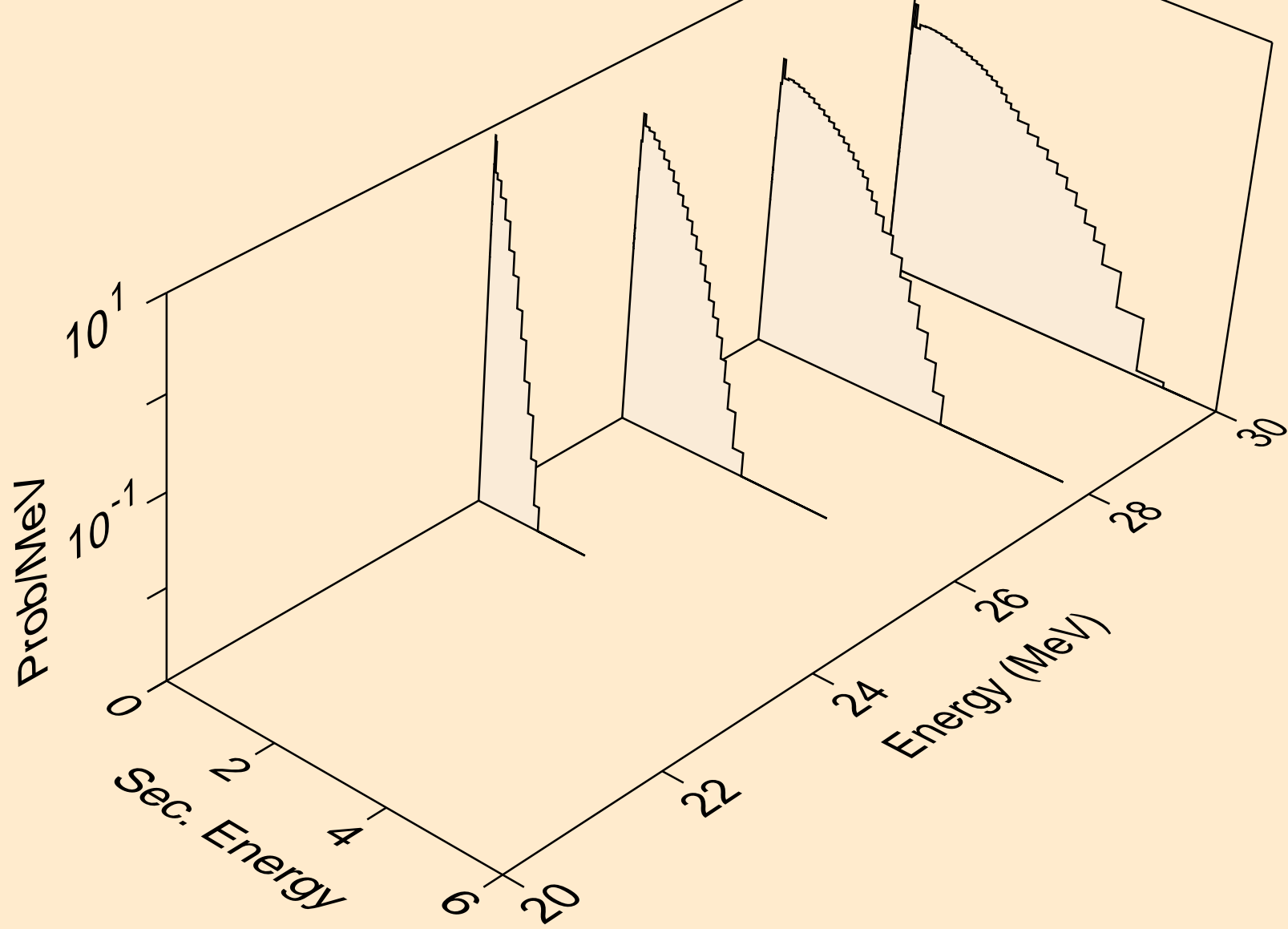

P031 NEUTRON ACER TENDL-2023 LIBRARY; T=0.K  
Neutron emission for (n,npa)

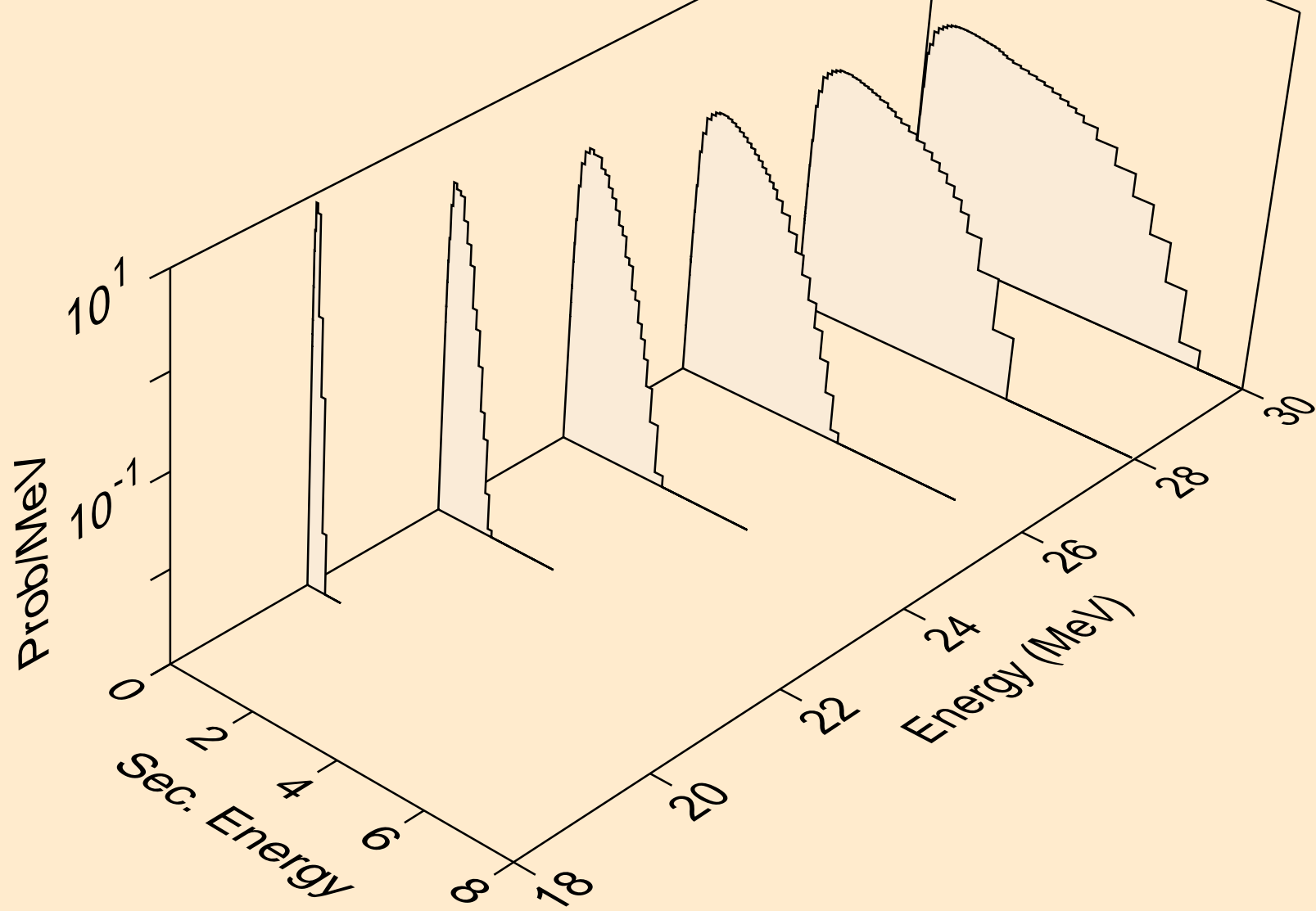

P031 NEUTRON ACER TENDL-2023 LIBRARY; T=0.K  
Neutron emission for (n,n\*c)

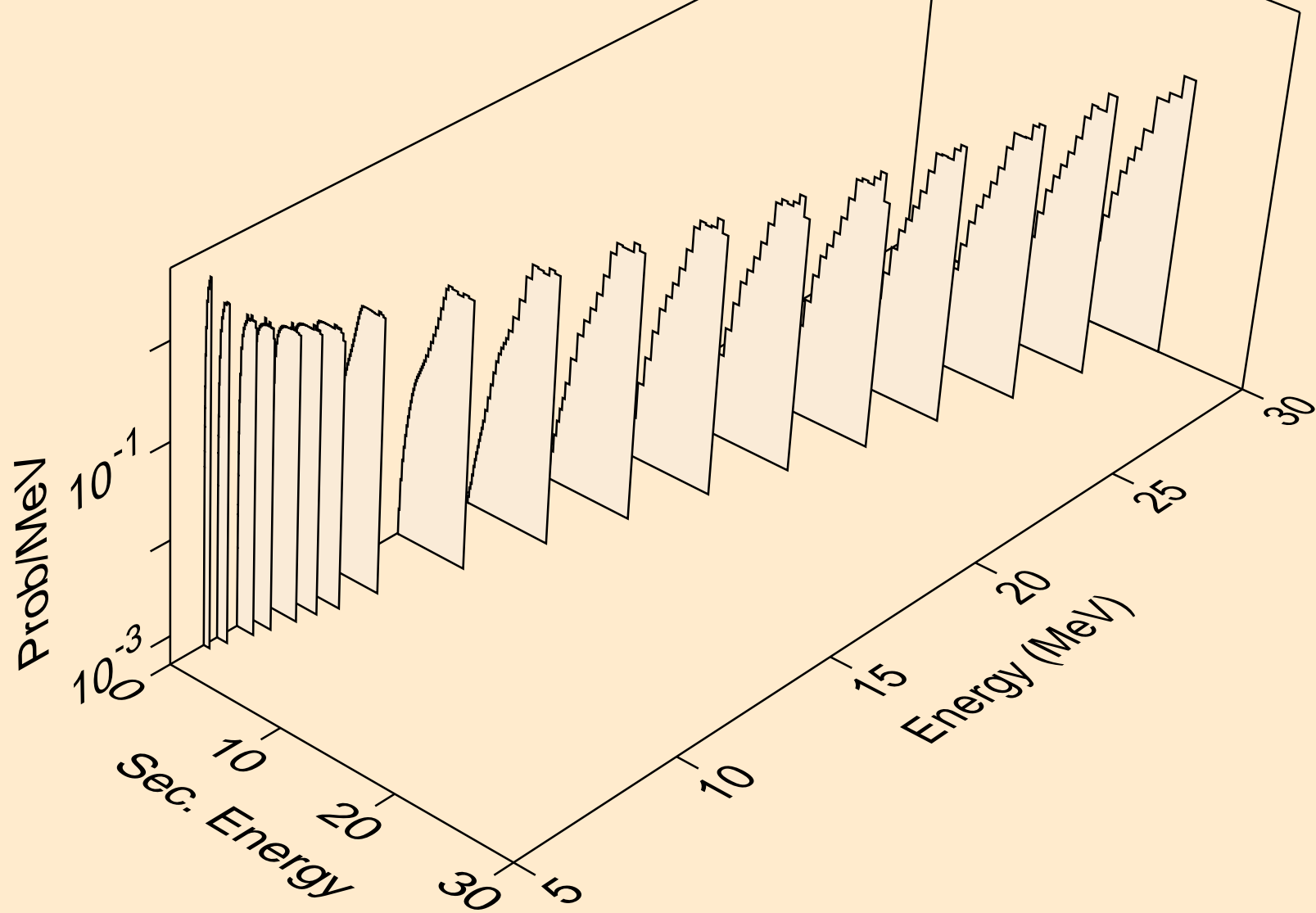

P031 NEUTRON ACER TENDL-2023 LIBRARY; T=0.K  
Photon emission for (n,x)

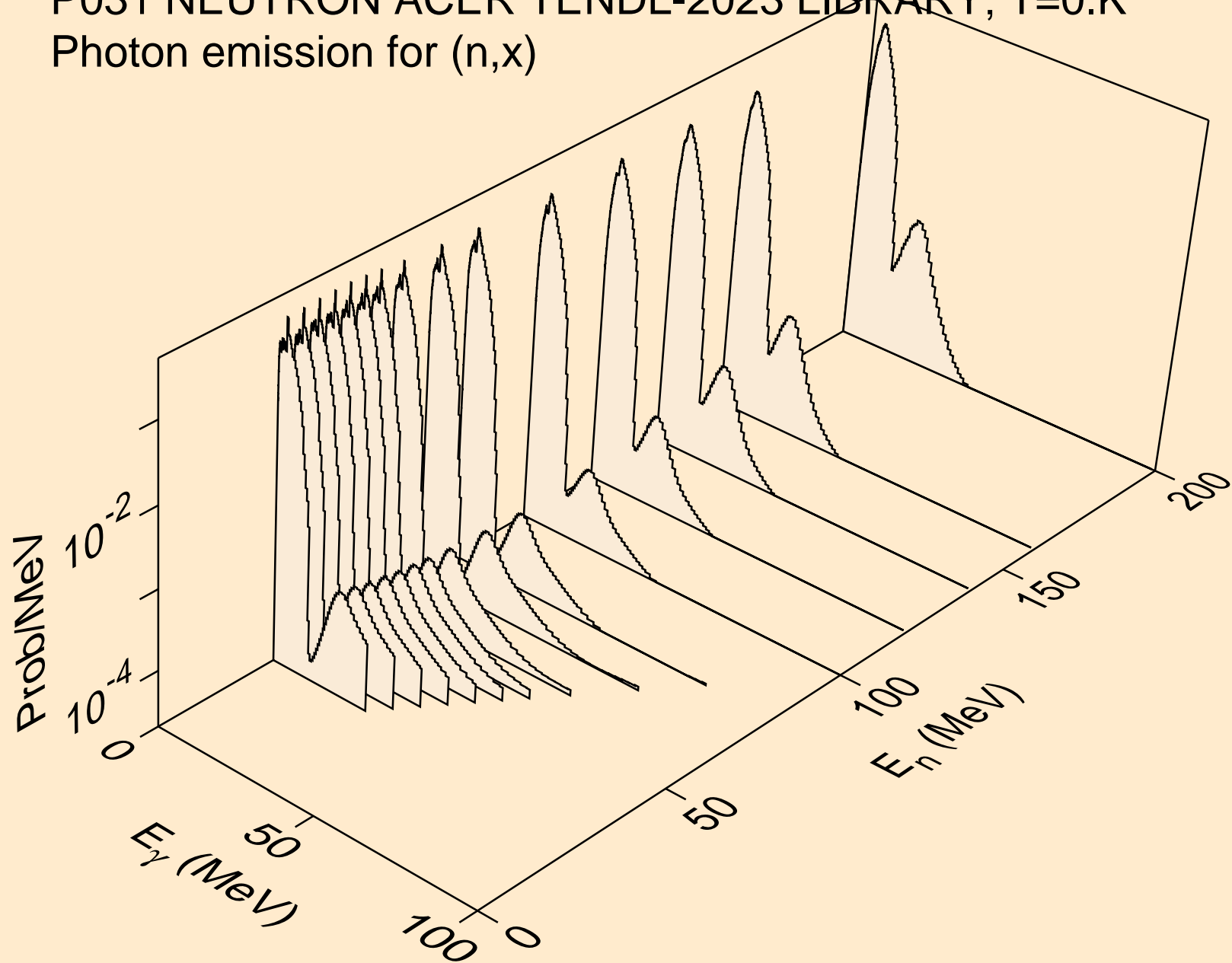

P031 NEUTRON ACER TENDL-2023 LIBRARY; T=0.K  
Photon emission for (n,2nd)

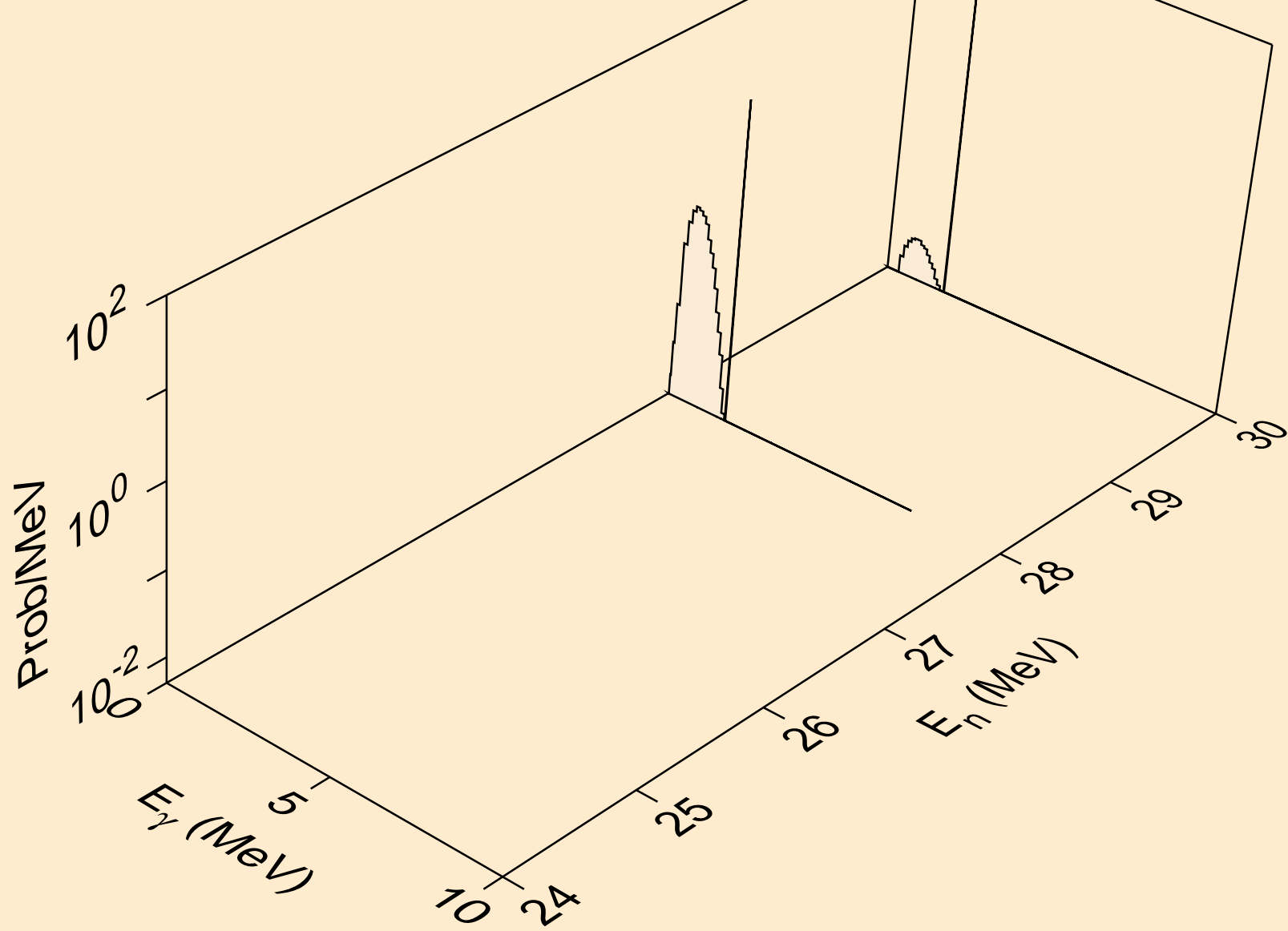

P031 NEUTRON ACER TENDL-2023 LIBRARY; T=0.K  
Photon emission for (n,2n)

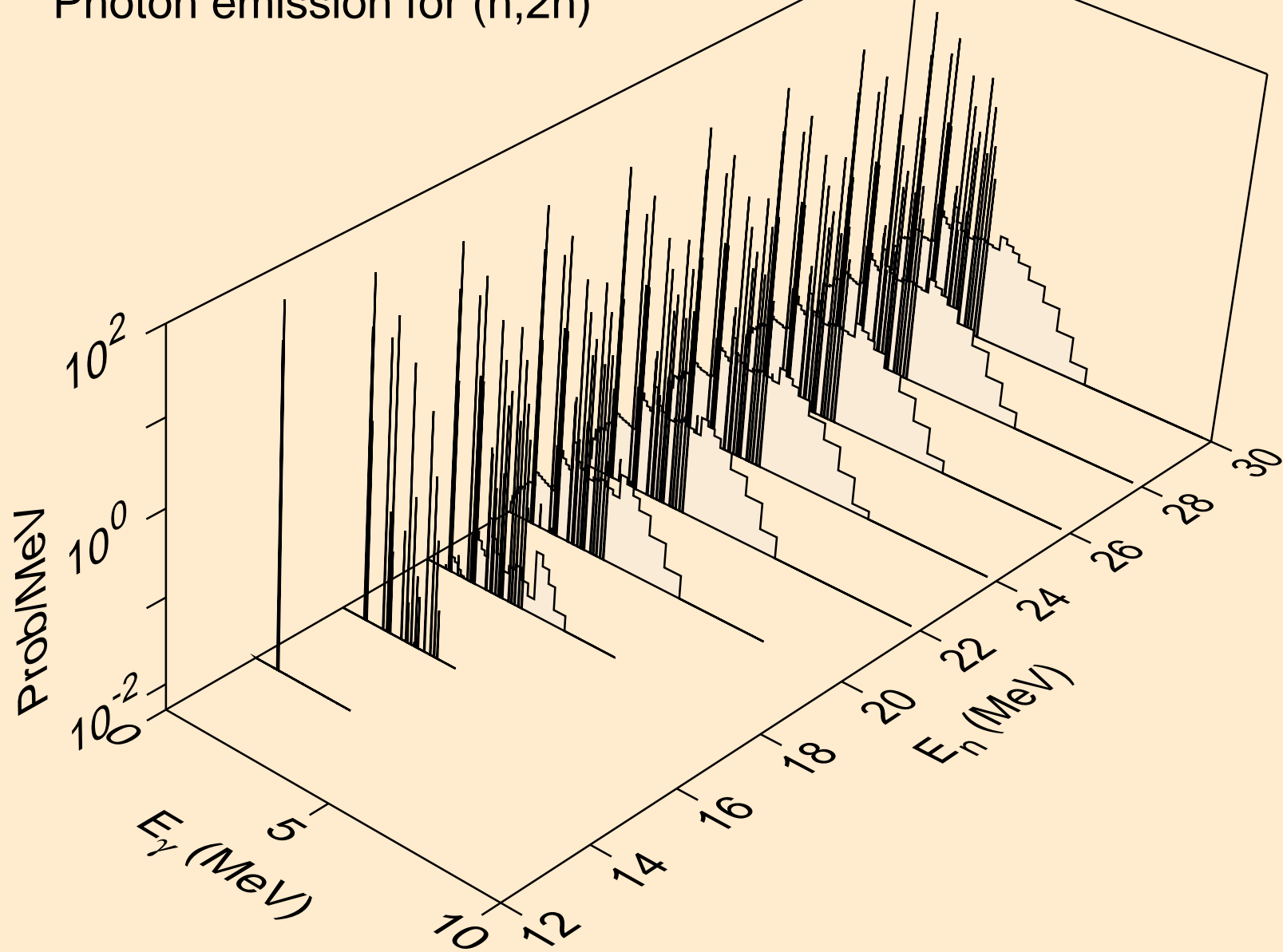

P031 NEUTRON ACER TENDL-2023 LIBRARY; T=0.K  
Photon emission for (n,3n)

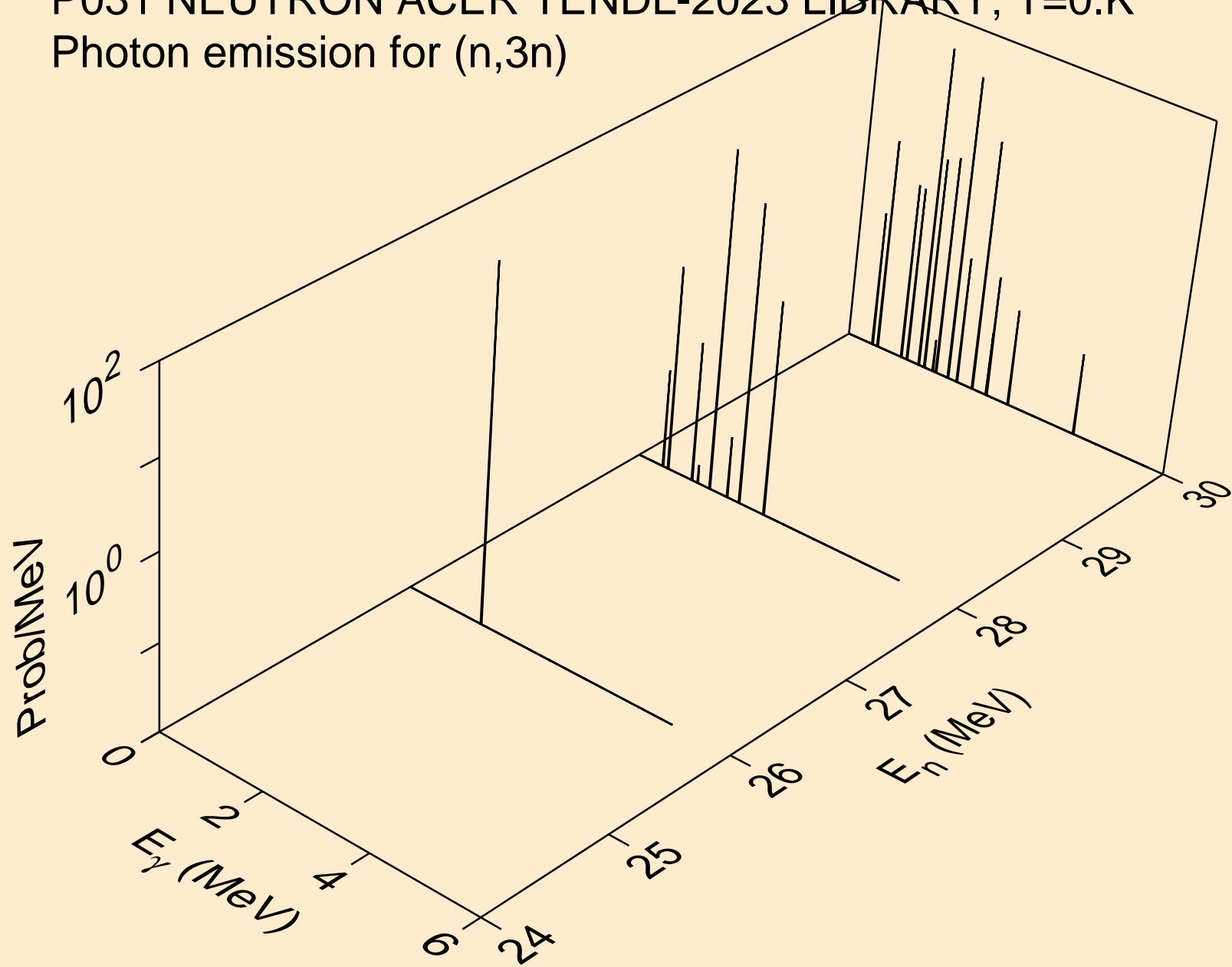

P031 NEUTRON ACER TENDL-2023 LIBRARY; T=0.K  
Photon emission for (n,n\*)a

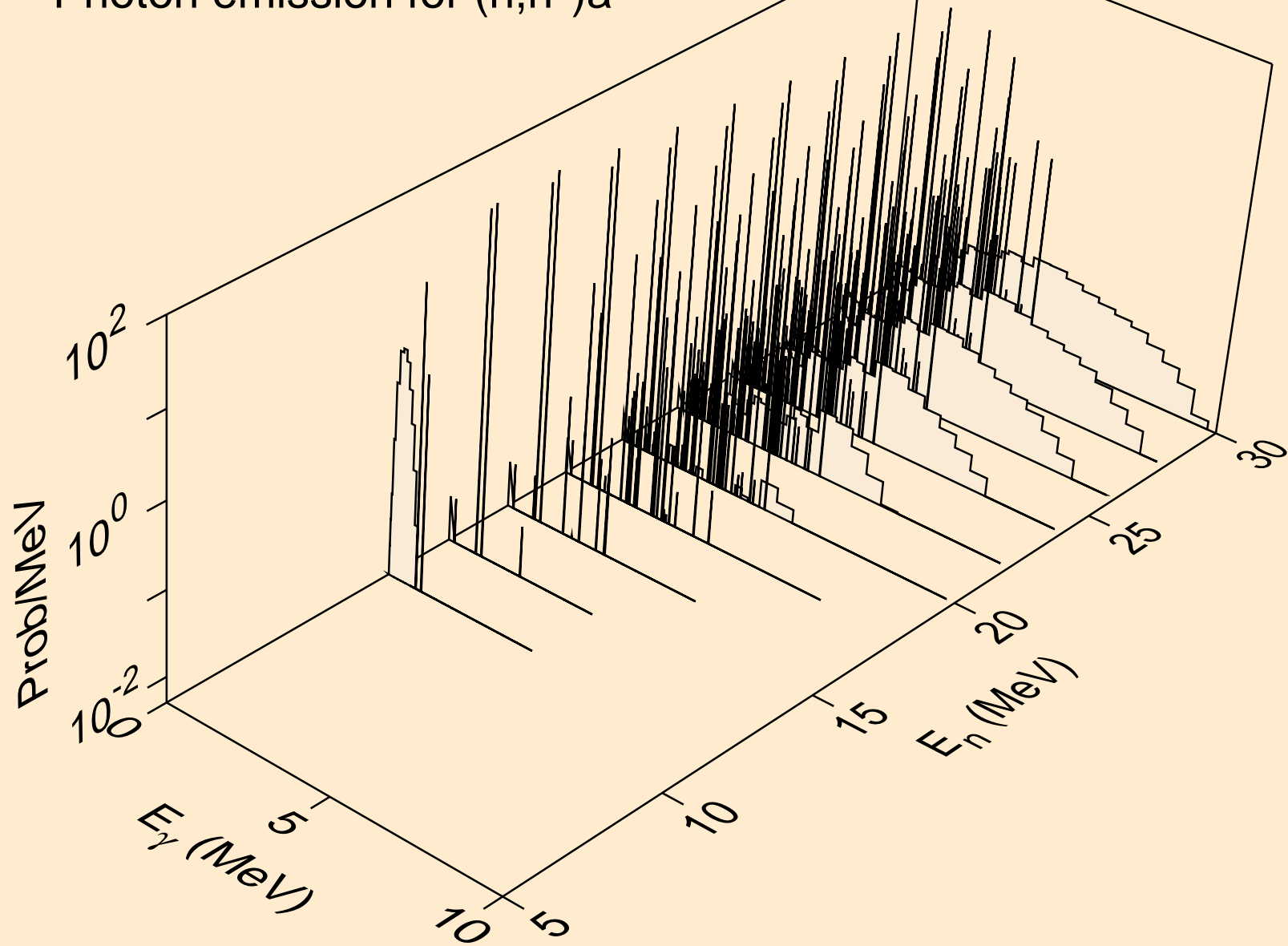

P031 NEUTRON ACER TENDL-2023 LIBRARY; T=0.K  
Photon emission for (n,2n)a

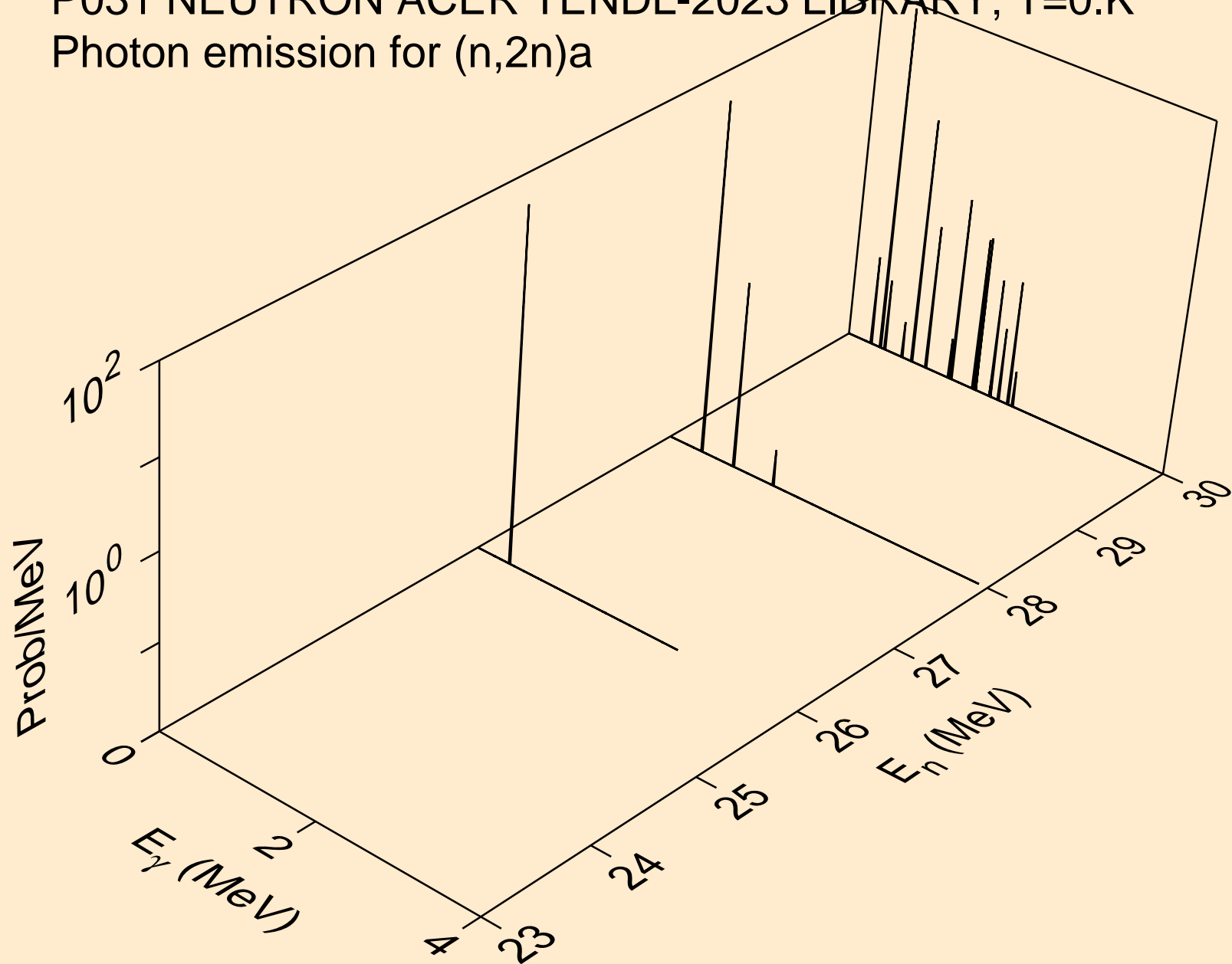

P031 NEUTRON ACER TENDL-2023 LIBRARY; T=0.K  
Photon emission for (n,n\*)p

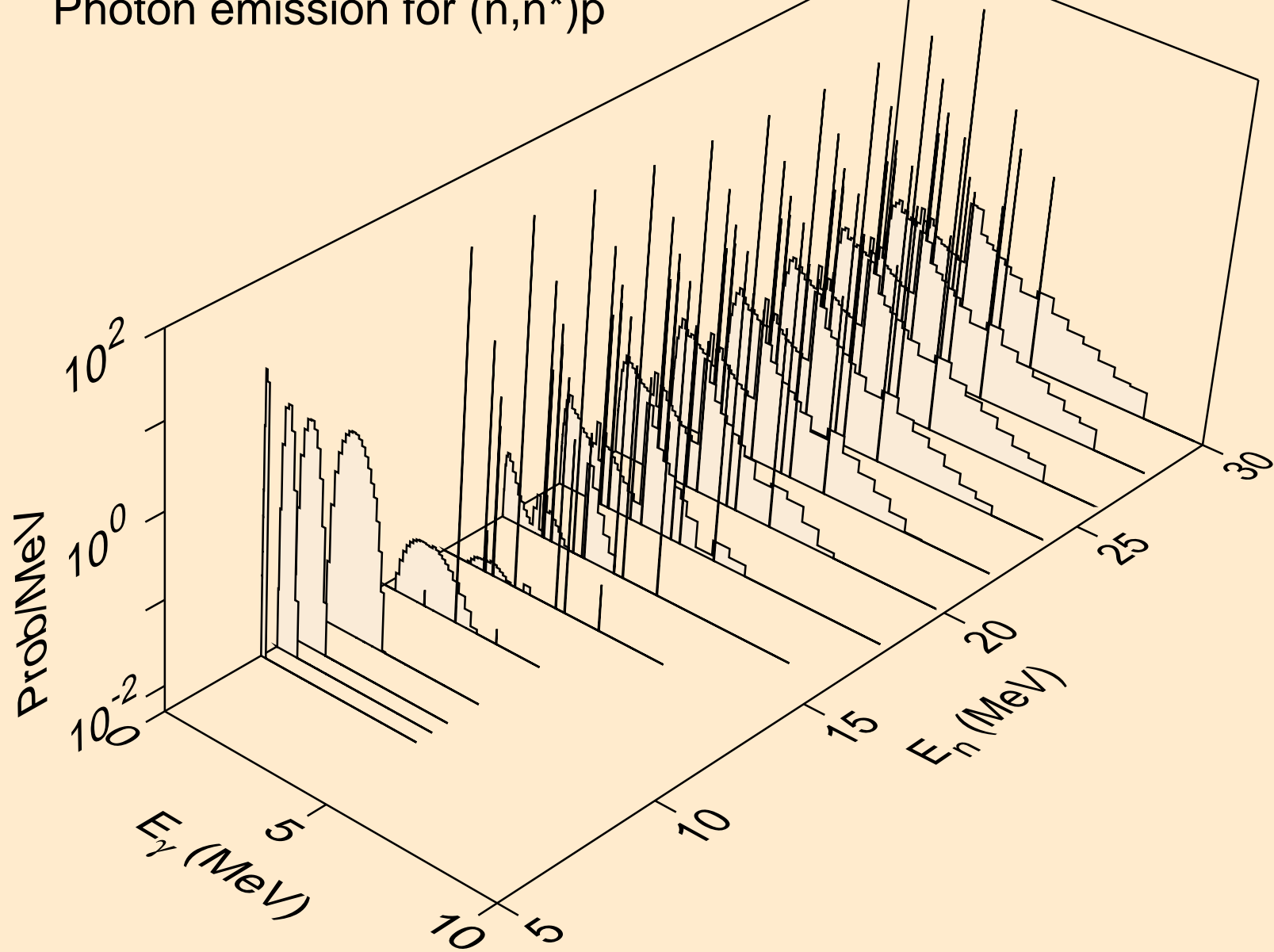

P031 NEUTRON ACER TENDL-2023 LIBRARY; T=0.K  
Photon emission for (n,n\*)2a

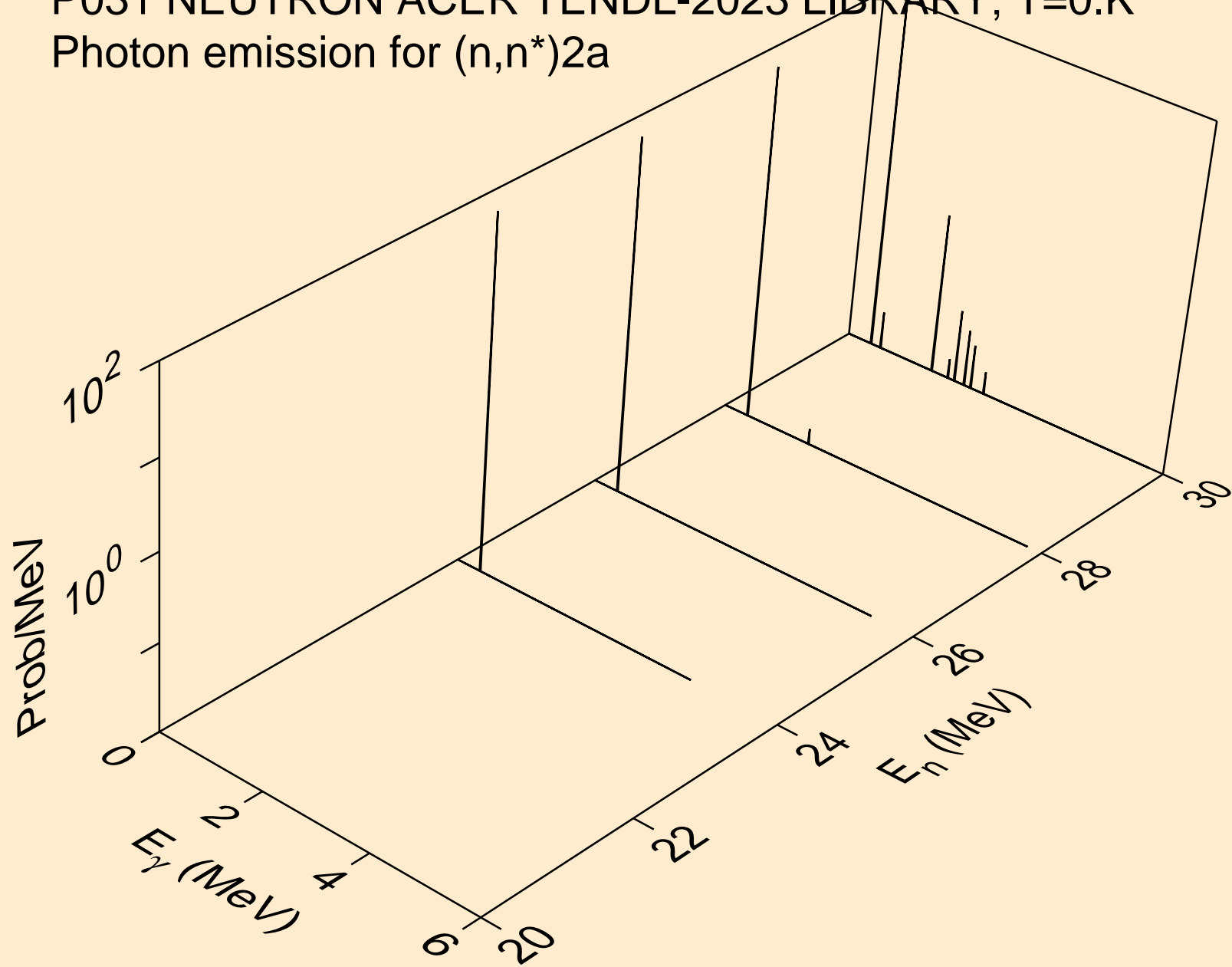

P031 NEUTRON ACER TENDL-2023 LIBRARY; T=0.K  
Photon emission for (n,n\*)d

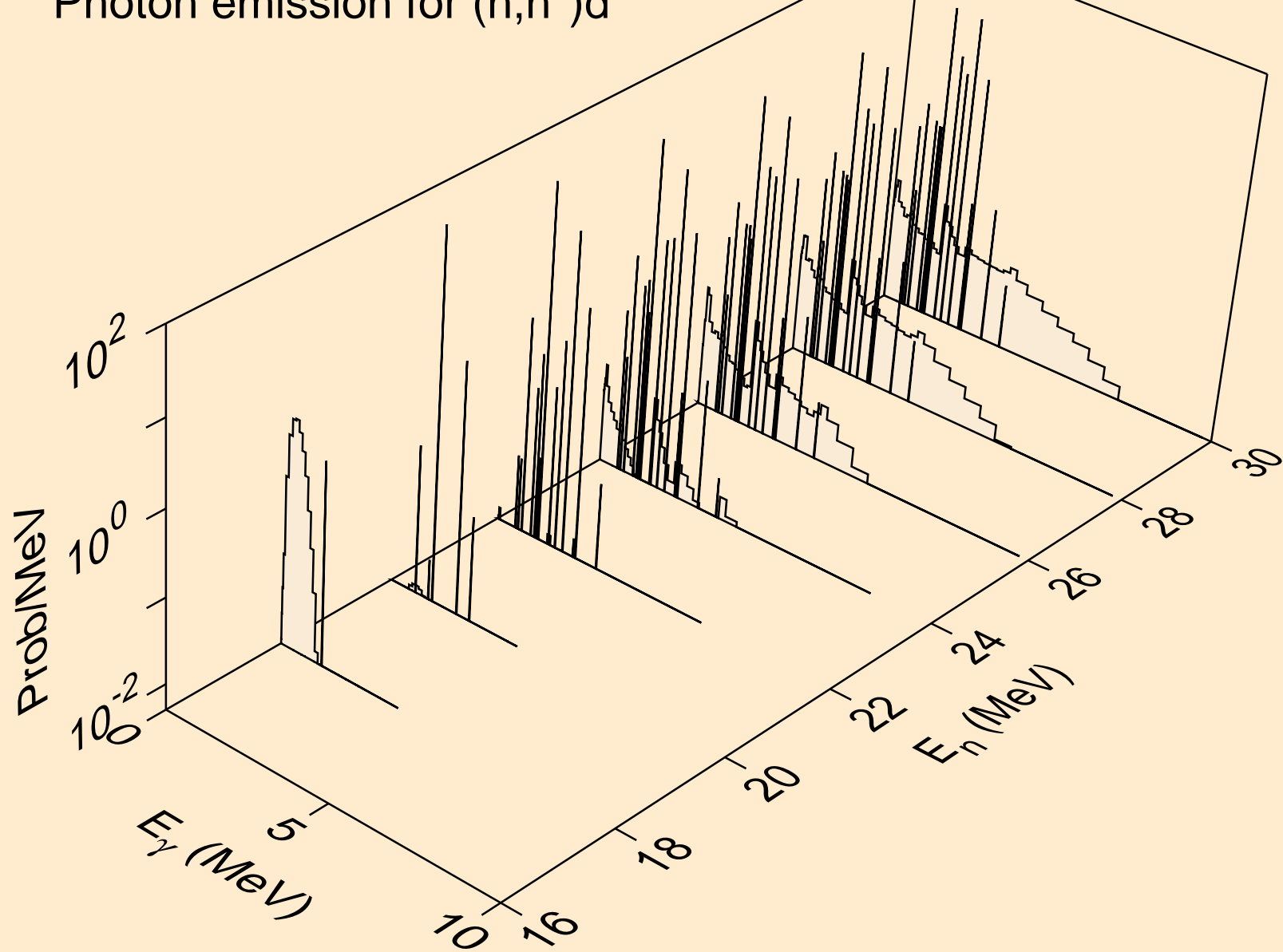

P031 NEUTRON ACER TENDL-2023 LIBRARY; T=0.K  
Photon emission for (n,n\*)t

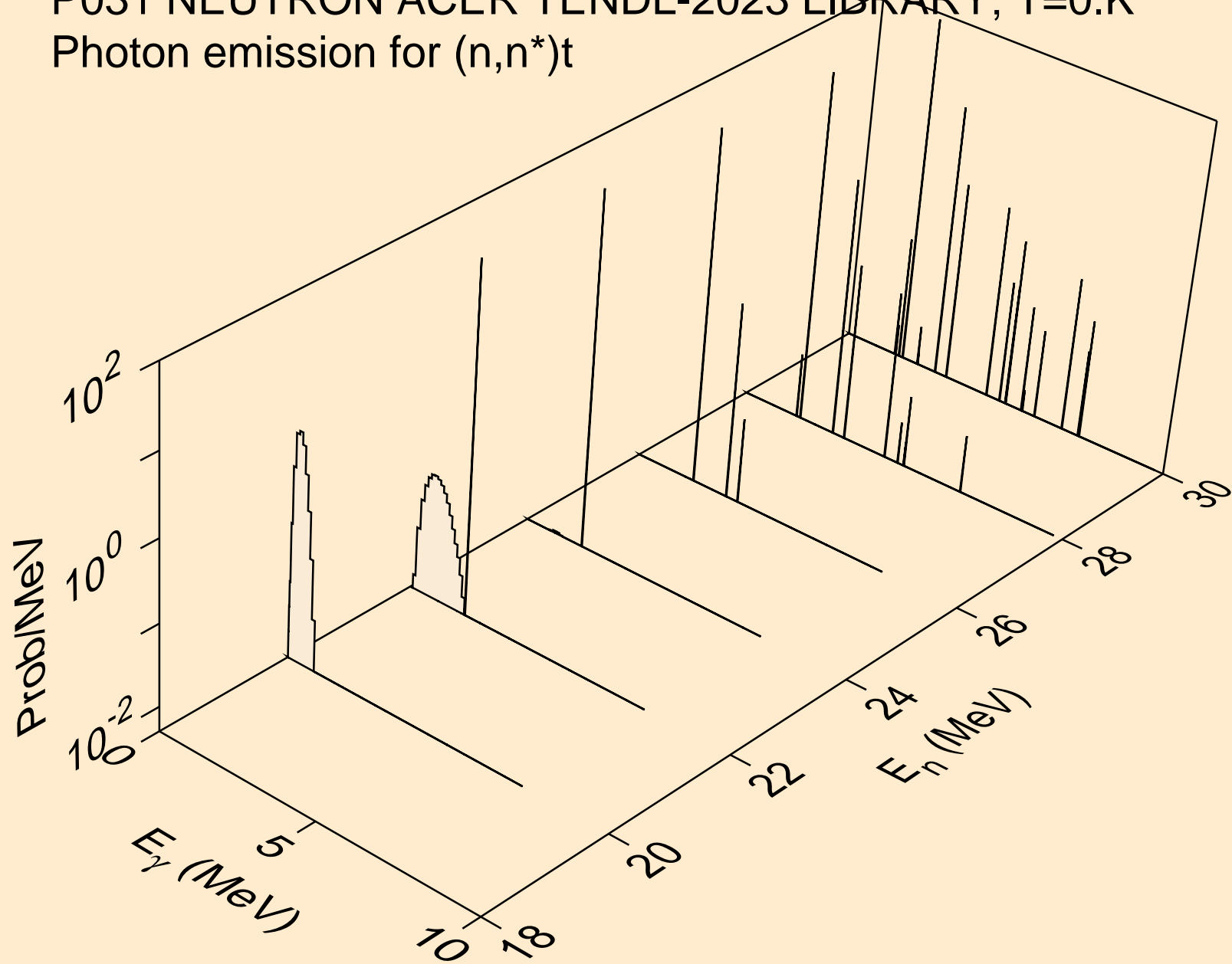

P031 NEUTRON ACER TENDL-2023 LIBRARY; T=0.K  
Photon emission for (n,n\*)he3

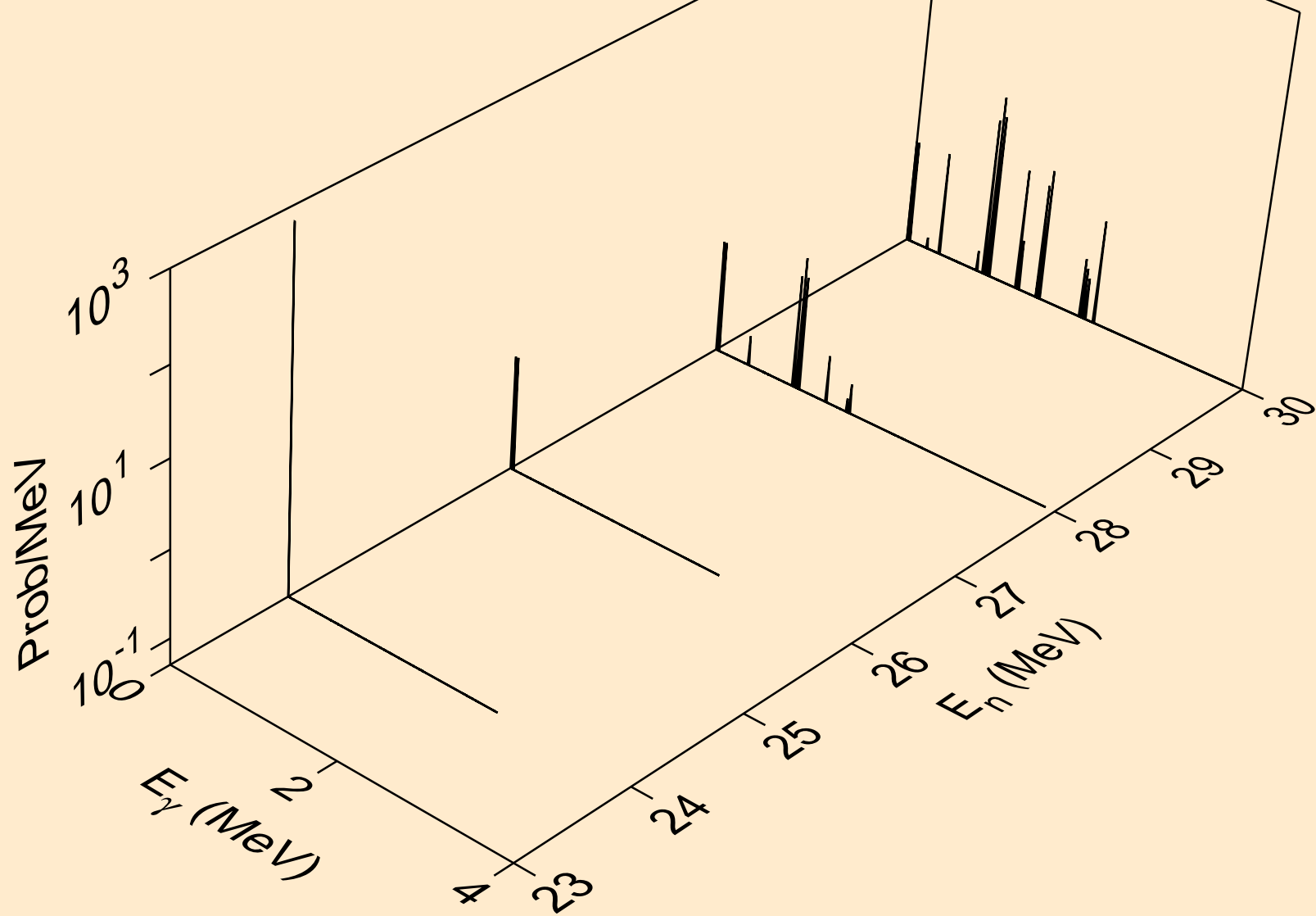

P031 NEUTRON ACER TENDL-2023 LIBRARY; T=0.K  
Photon emission for (n,2np)

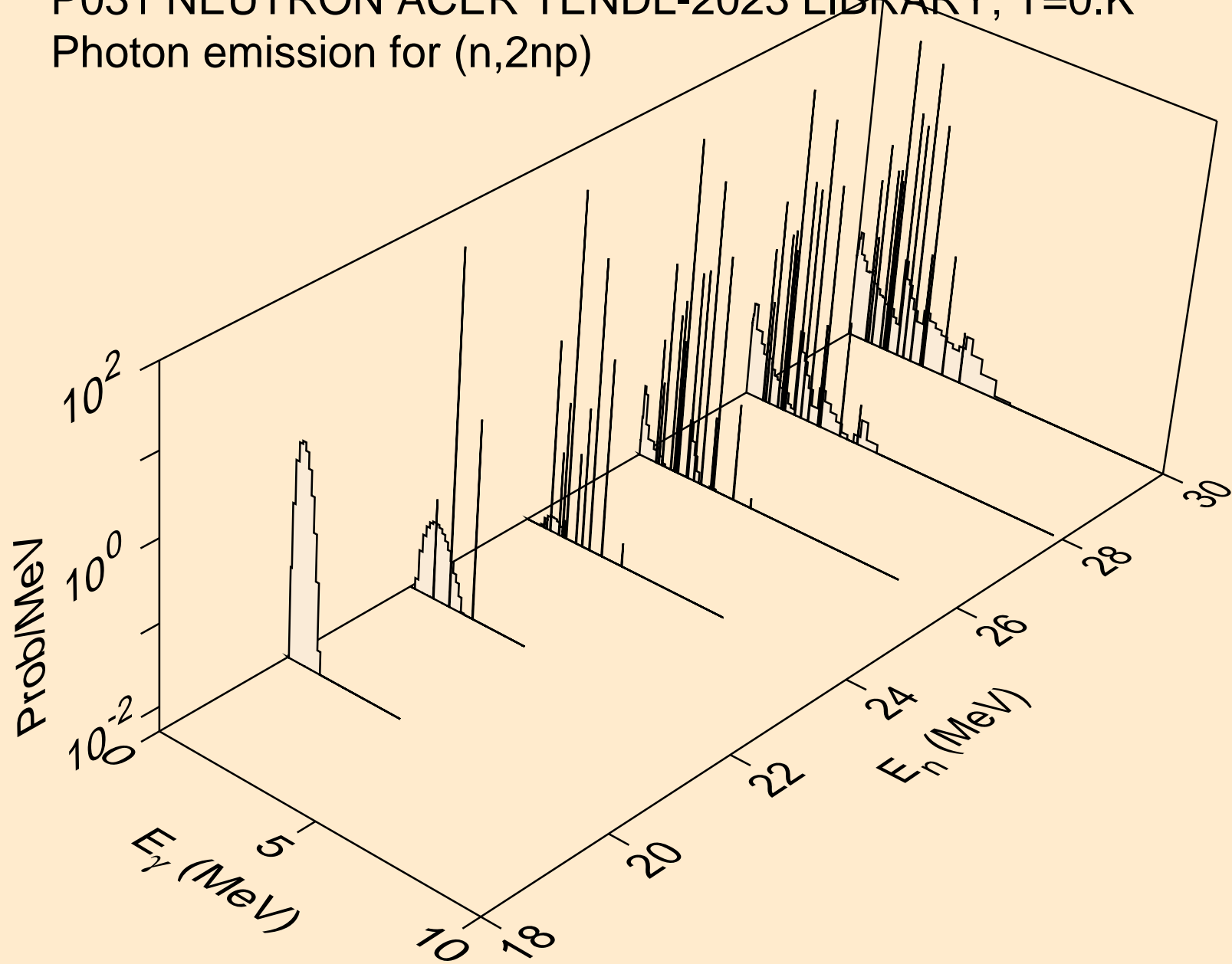

P031 NEUTRON ACER TENDL-2023 LIBRARY; T=0.K  
Photon emission for (n,3np)

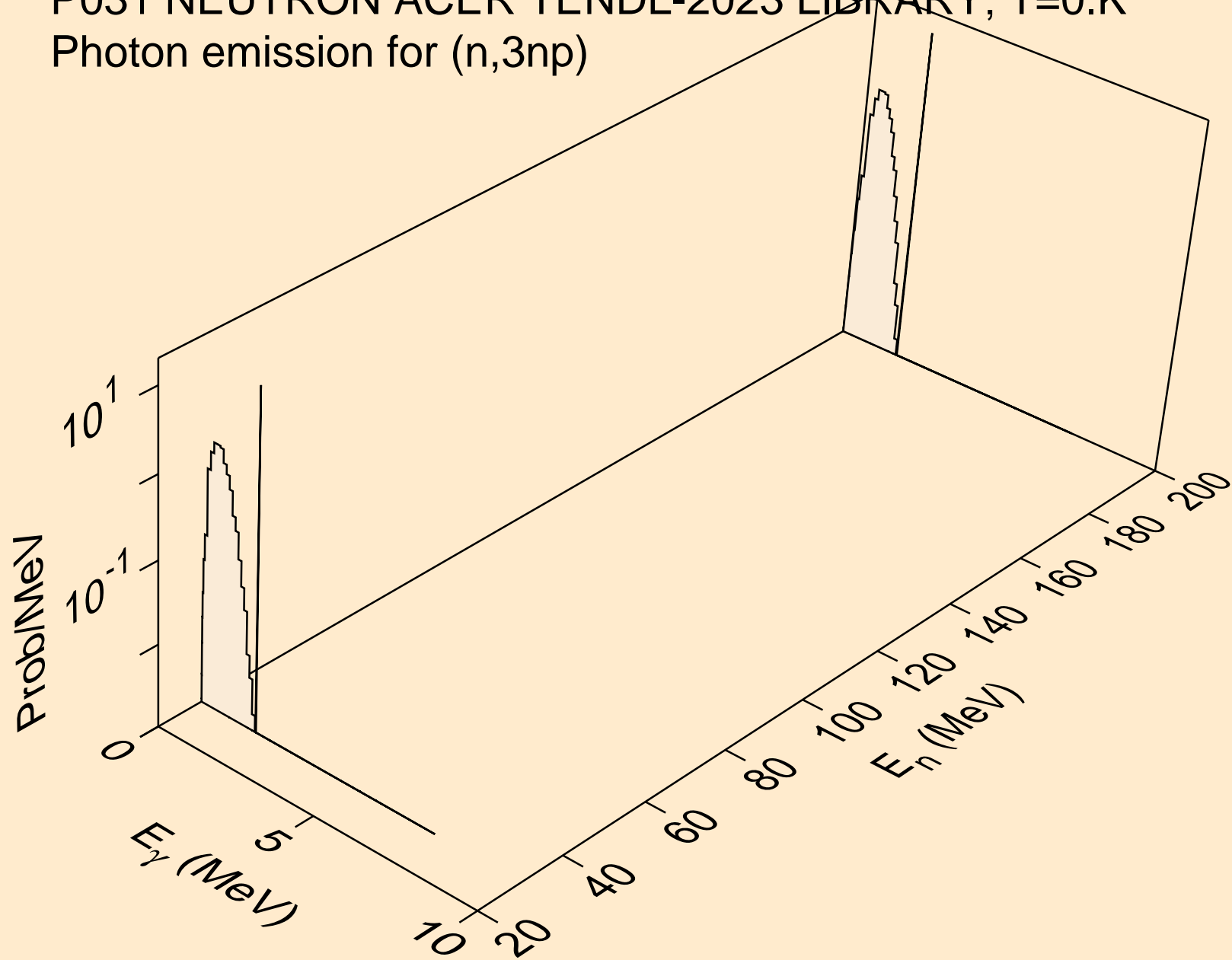

P031 NEUTRON ACER TENDL-2023 LIBRARY; T=0.K  
Photon emission for (n,n2p)

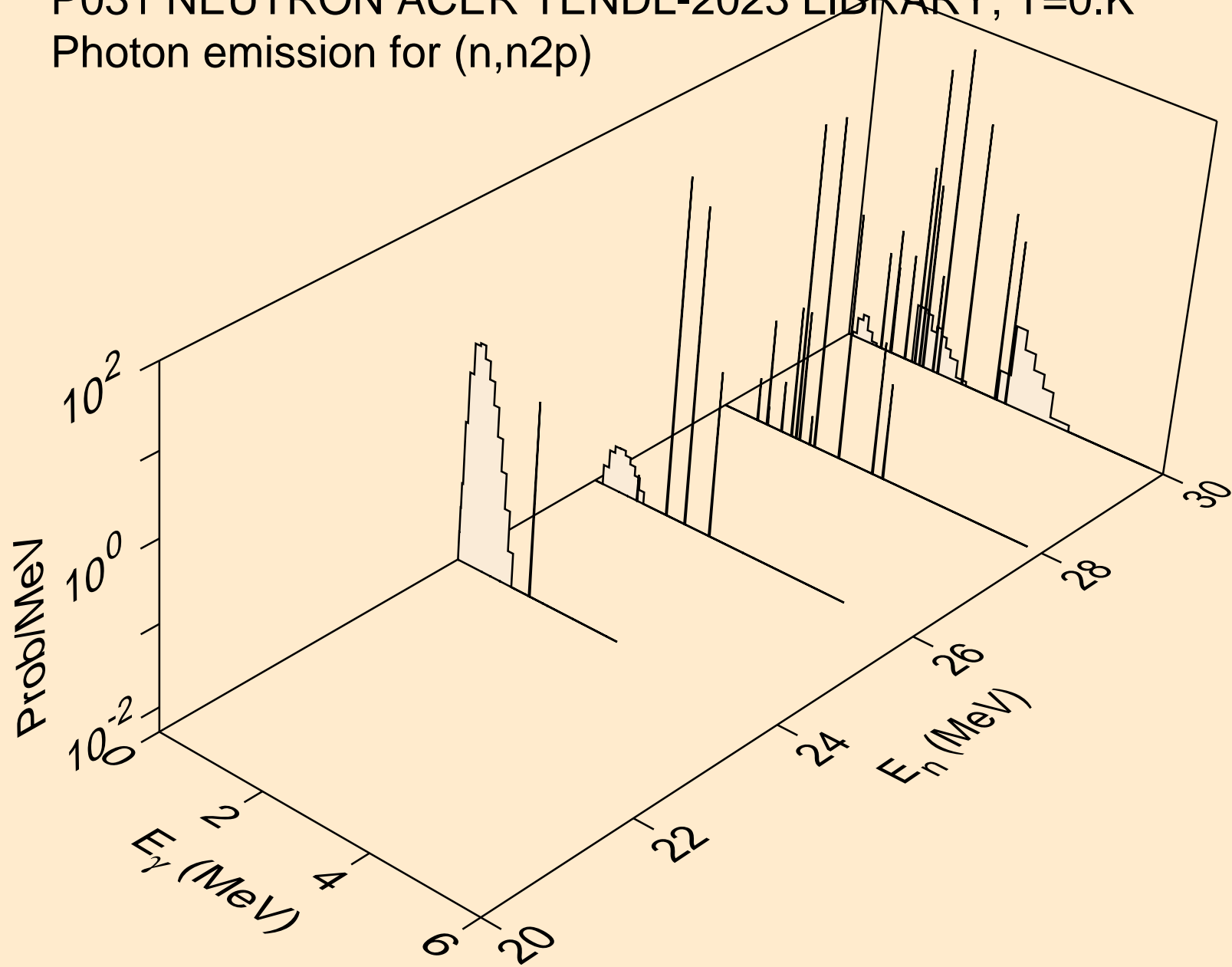

P031 NEUTRON ACER TENDL-2023 LIBRARY; T=0.K  
Photon emission for (n,npa)

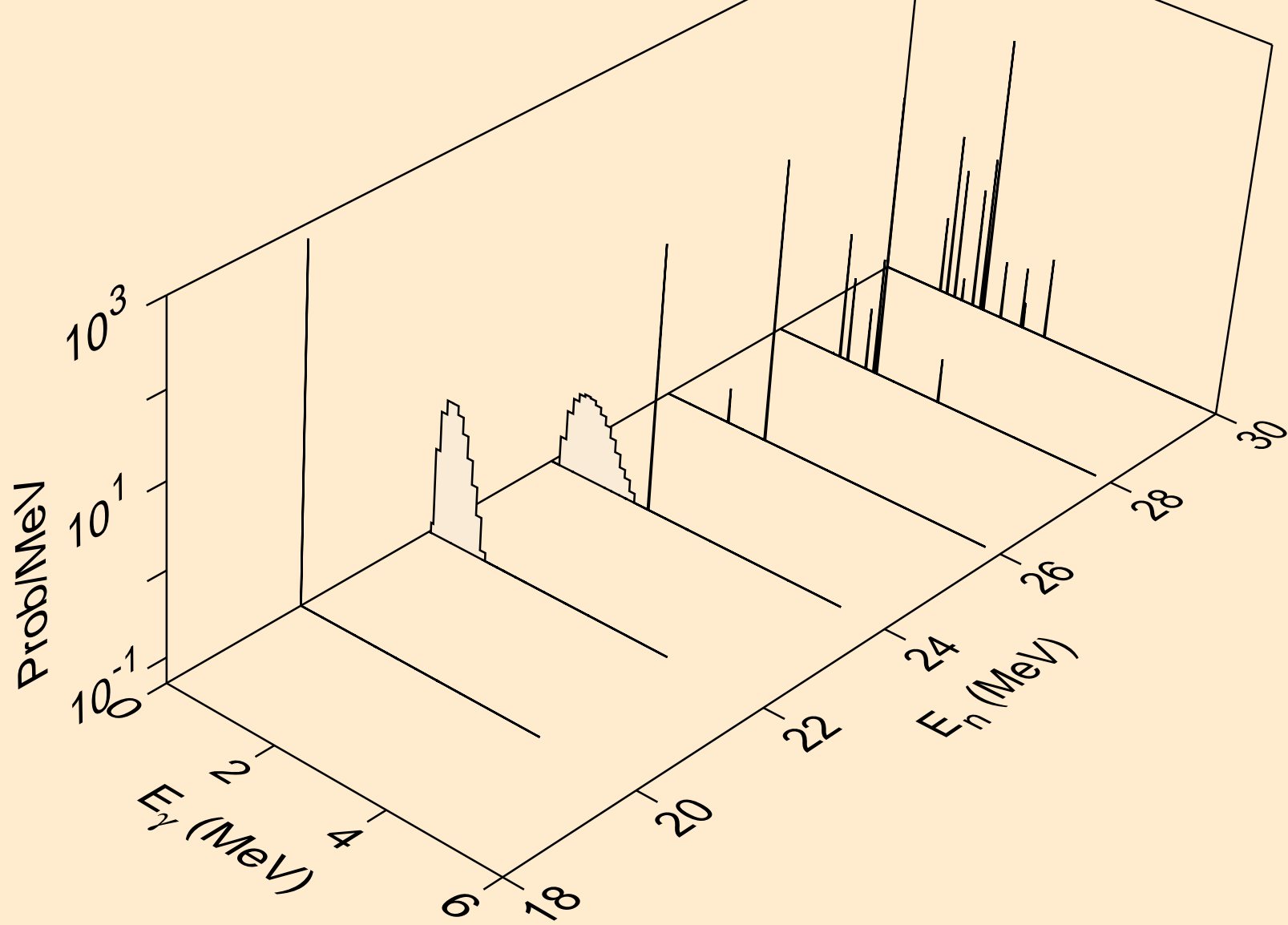

P031 NEUTRON ACER TENDL-2023 LIBRARY; T=0.K  
Photon emission for (n,n\*c)

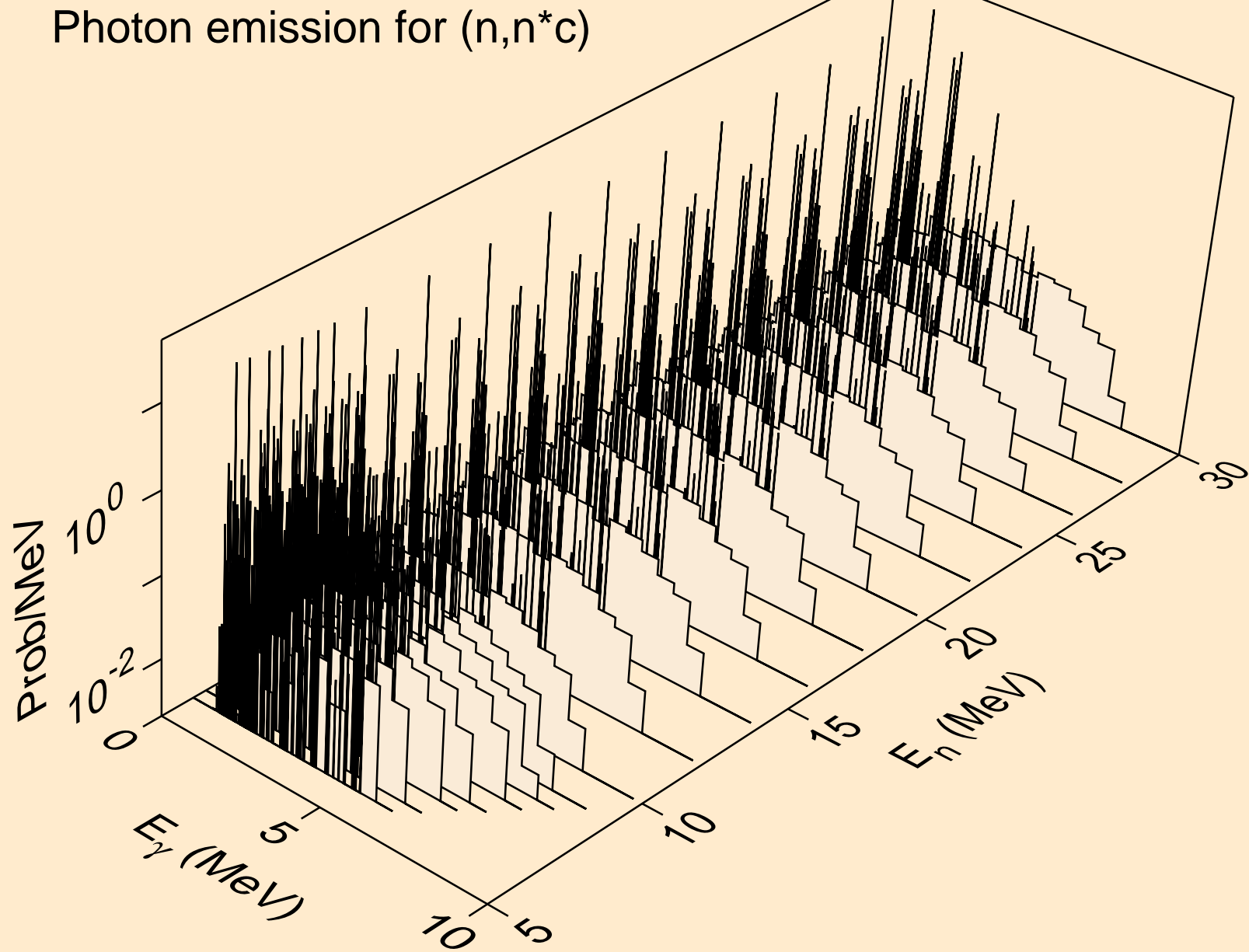

P031 NEUTRON ACER TENDL-2023 LIBRARY; T=0.K  
Photon emission for (n,gma)

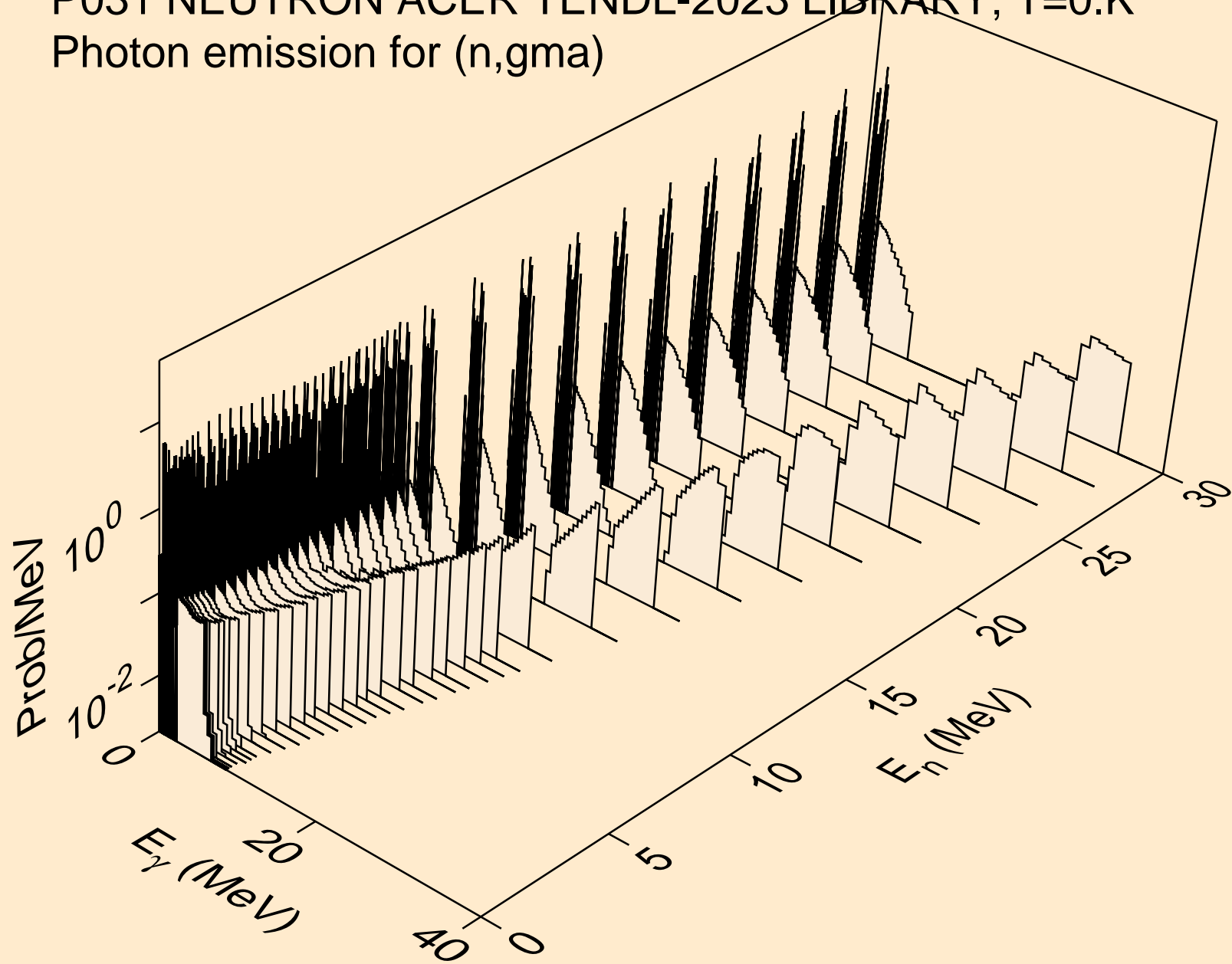

P031 NEUTRON ACER TENDL-2023 LIBRARY; T=0.K  
Photon emission for (n,p)

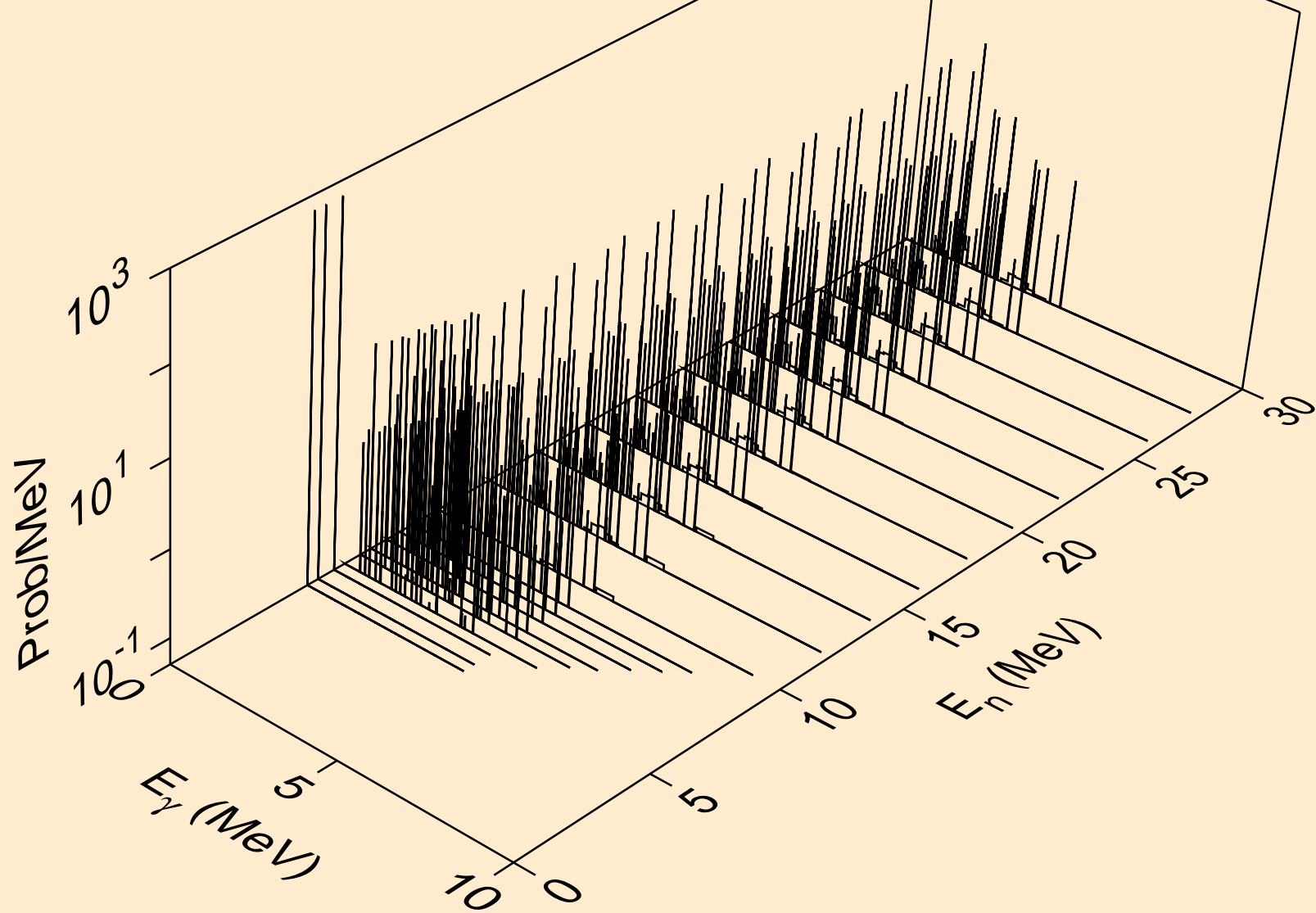

P031 NEUTRON ACER TENDL-2023 LIBRARY; T=0.K  
Photon emission for (n,d)

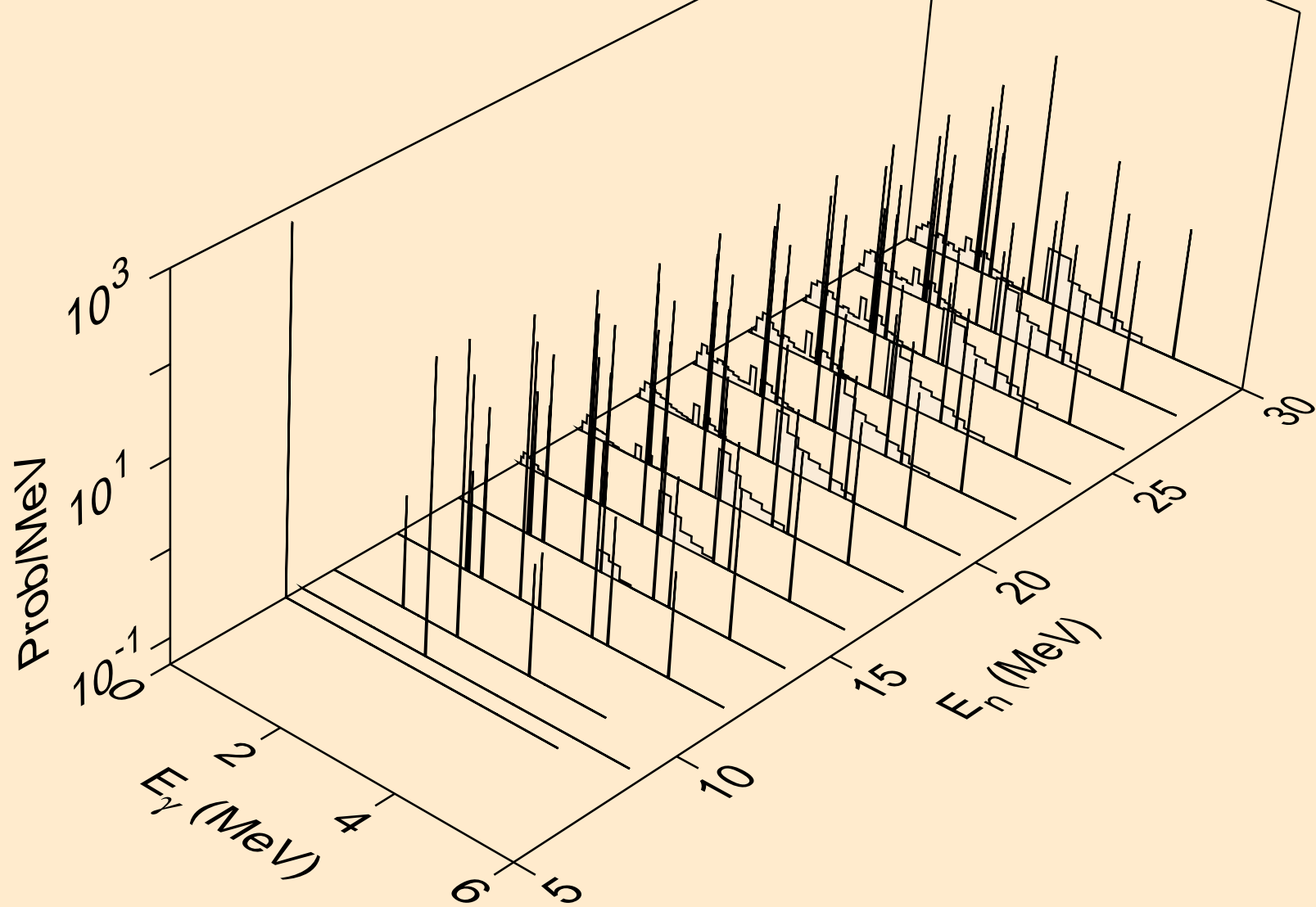

P031 NEUTRON ACER TENDL-2023 LIBRARY; T=0.K  
Photon emission for (n,t)

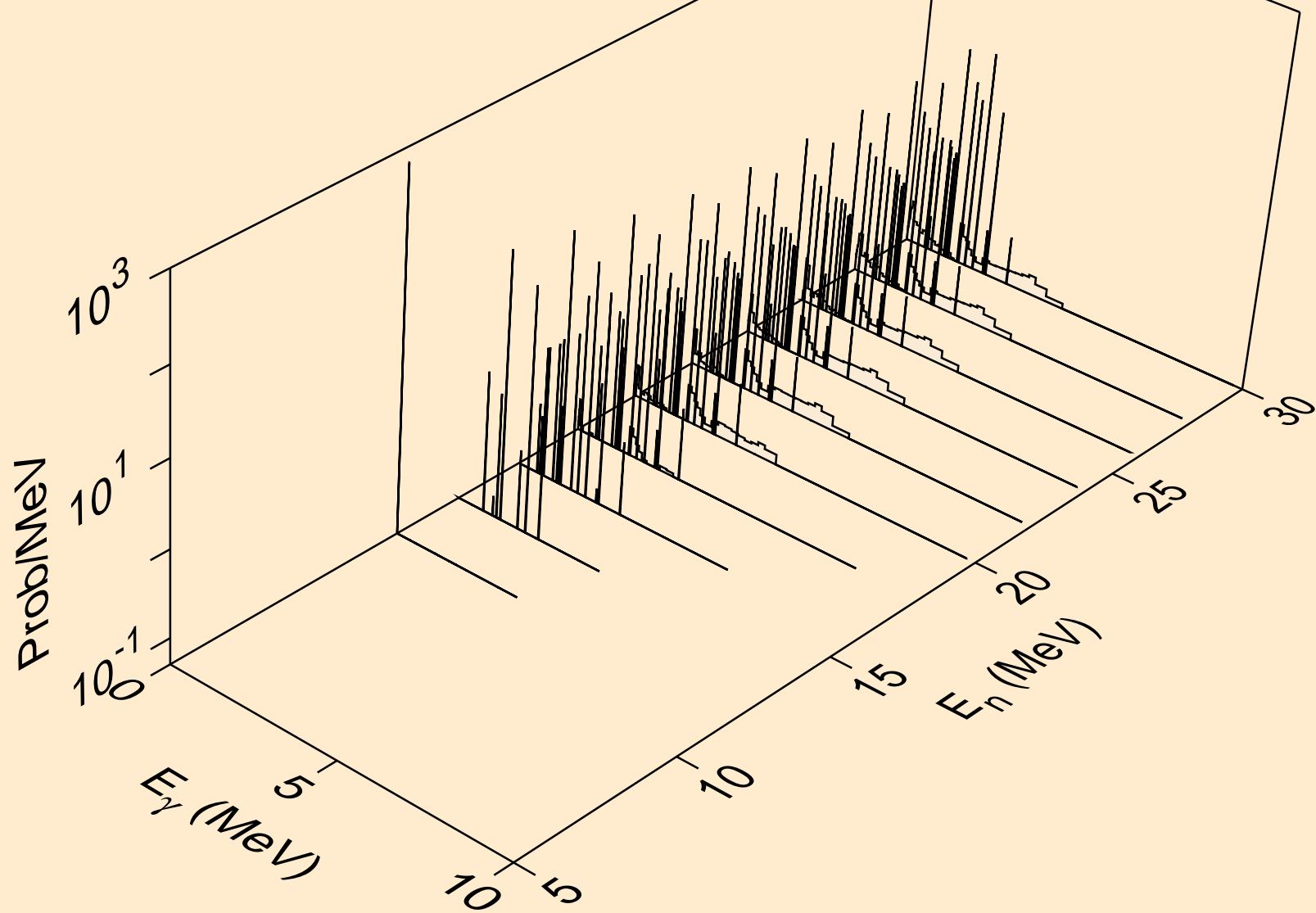

P031 NEUTRON ACER TENDL-2023 LIBRARY; T=0.K  
Photon emission for (n,he3)

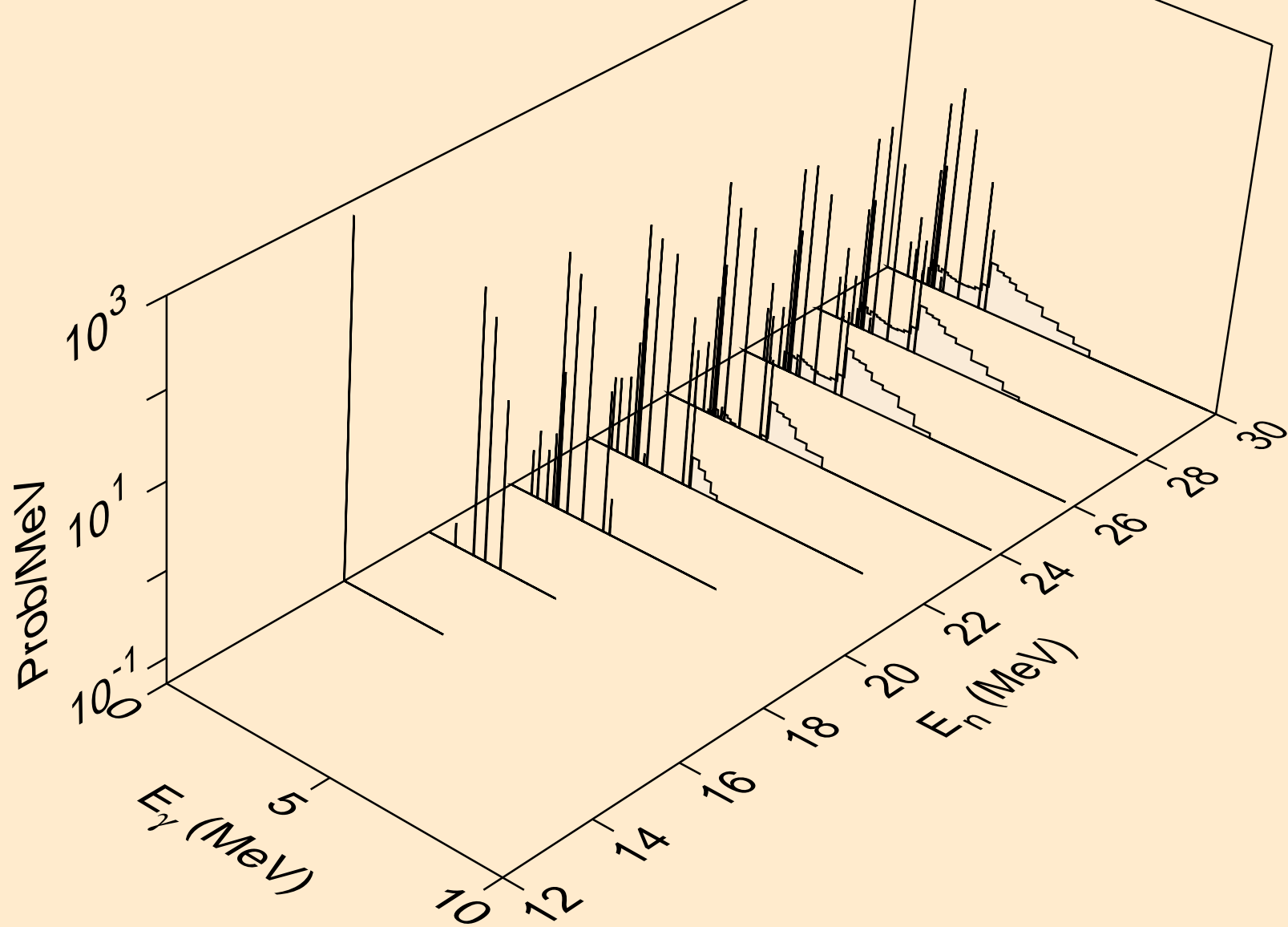

P031 NEUTRON ACER TENDL-2023 LIBRARY; T=0.K  
Photon emission for (n,a)

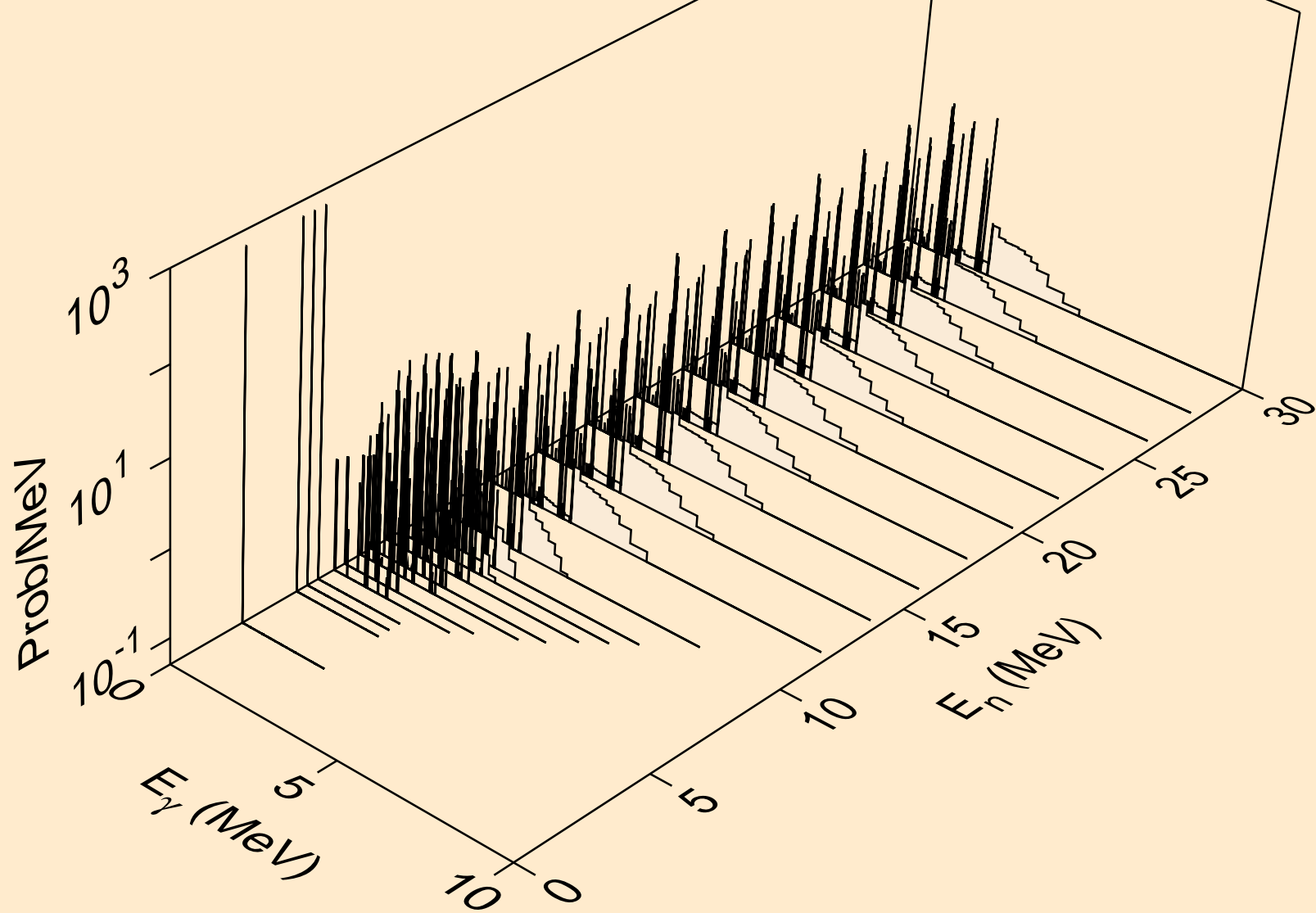

P031 NEUTRON ACER TENDL-2023 LIBRARY; T=0.K  
Photon emission for (n,2a)

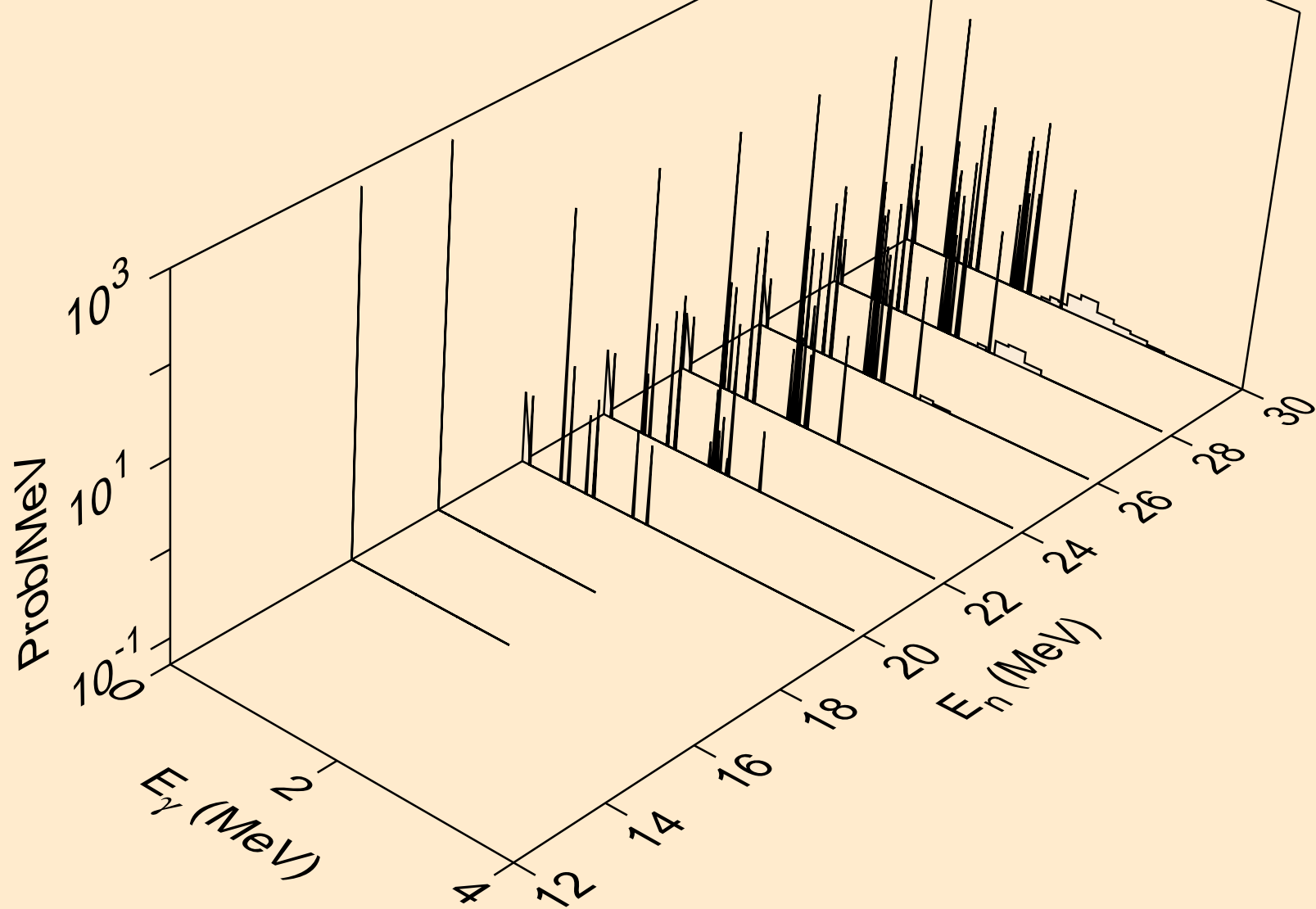

P031 NEUTRON ACER TENDL-2023 LIBRARY; T=0.K  
Photon emission for (n,2p)

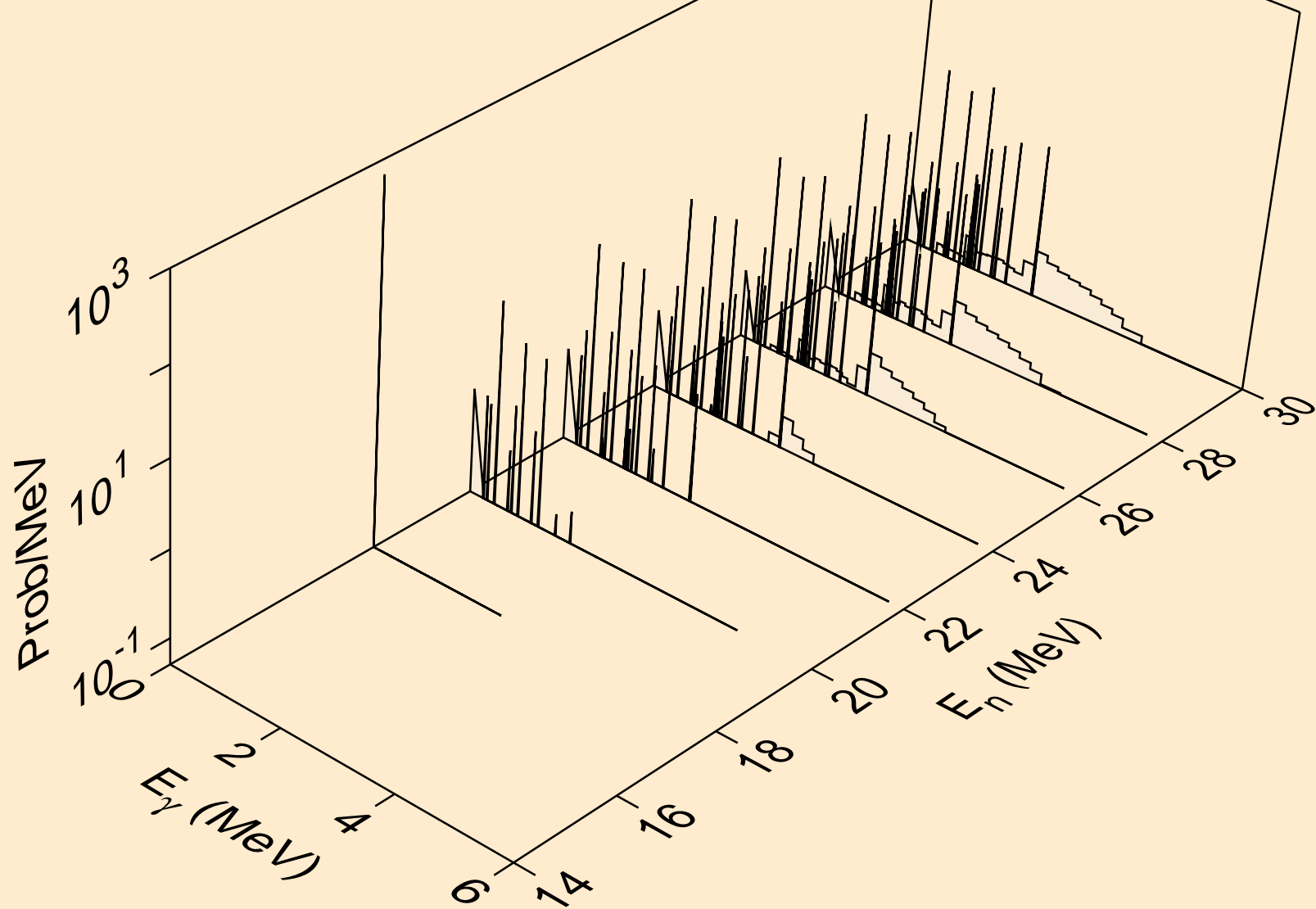

P031 NEUTRON ACER TENDL-2023 LIBRARY; T=0.K  
Photon emission for (n,p $\alpha$ )

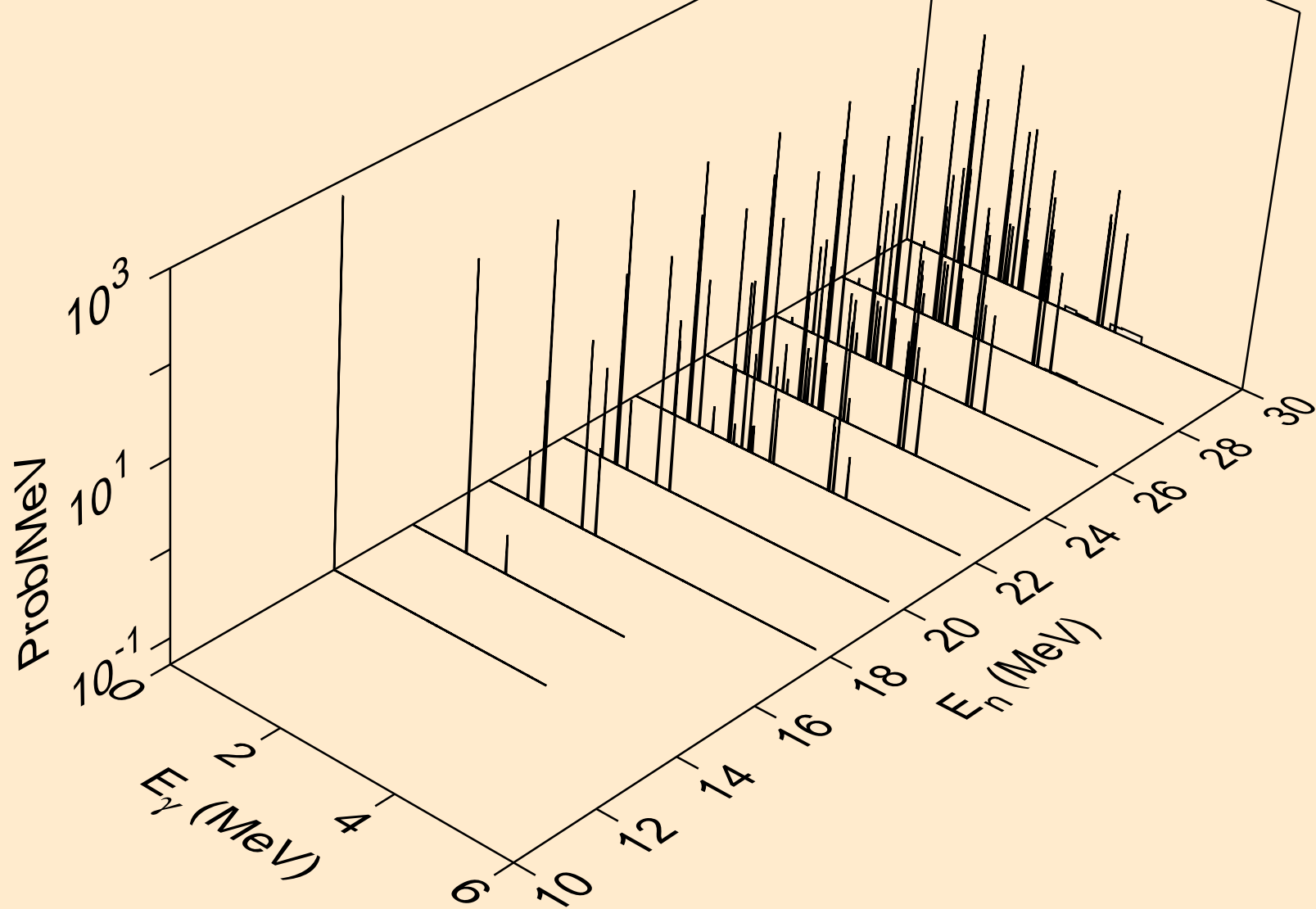

P031 NEUTRON ACER TENDL-2023 LIBRARY; T=0.K  
Photon emission for (n,pd)

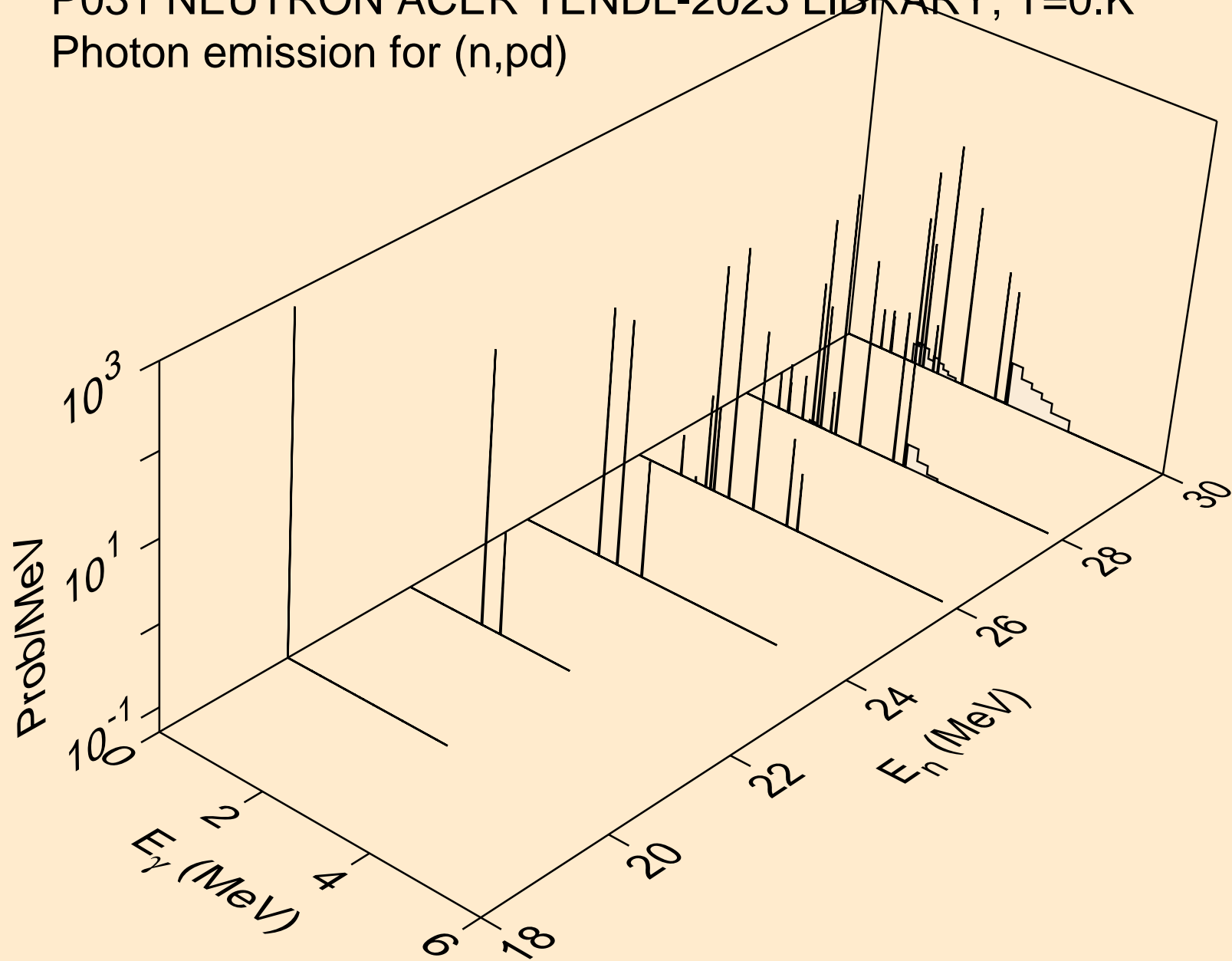

P031 NEUTRON ACER TENDL-2023 LIBRARY; T=0.K  
Photon emission for (n,pt)

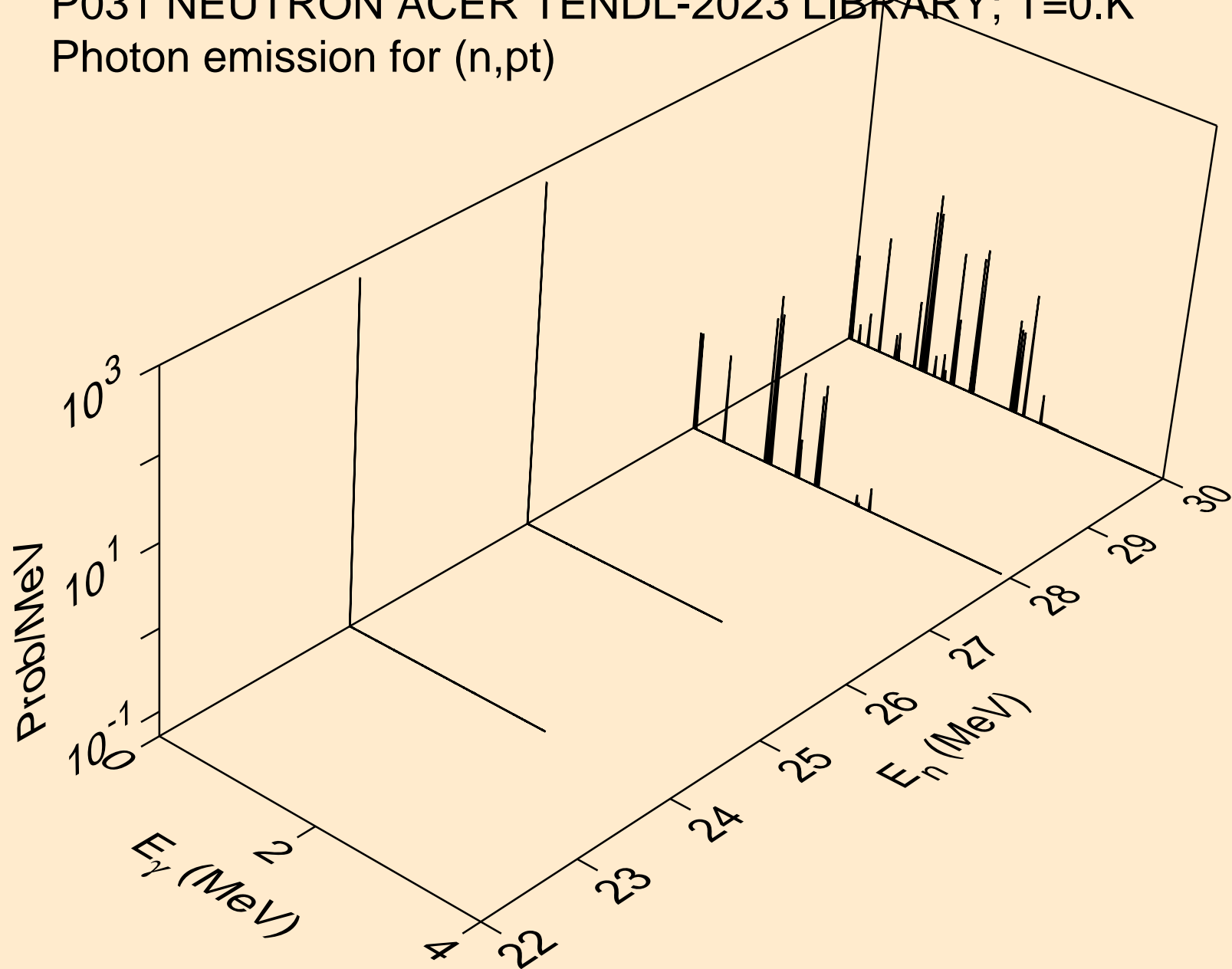

P031 NEUTRON ACER TENDL-2023 LIBRARY; T=0.K  
Photon emission for (n,da)

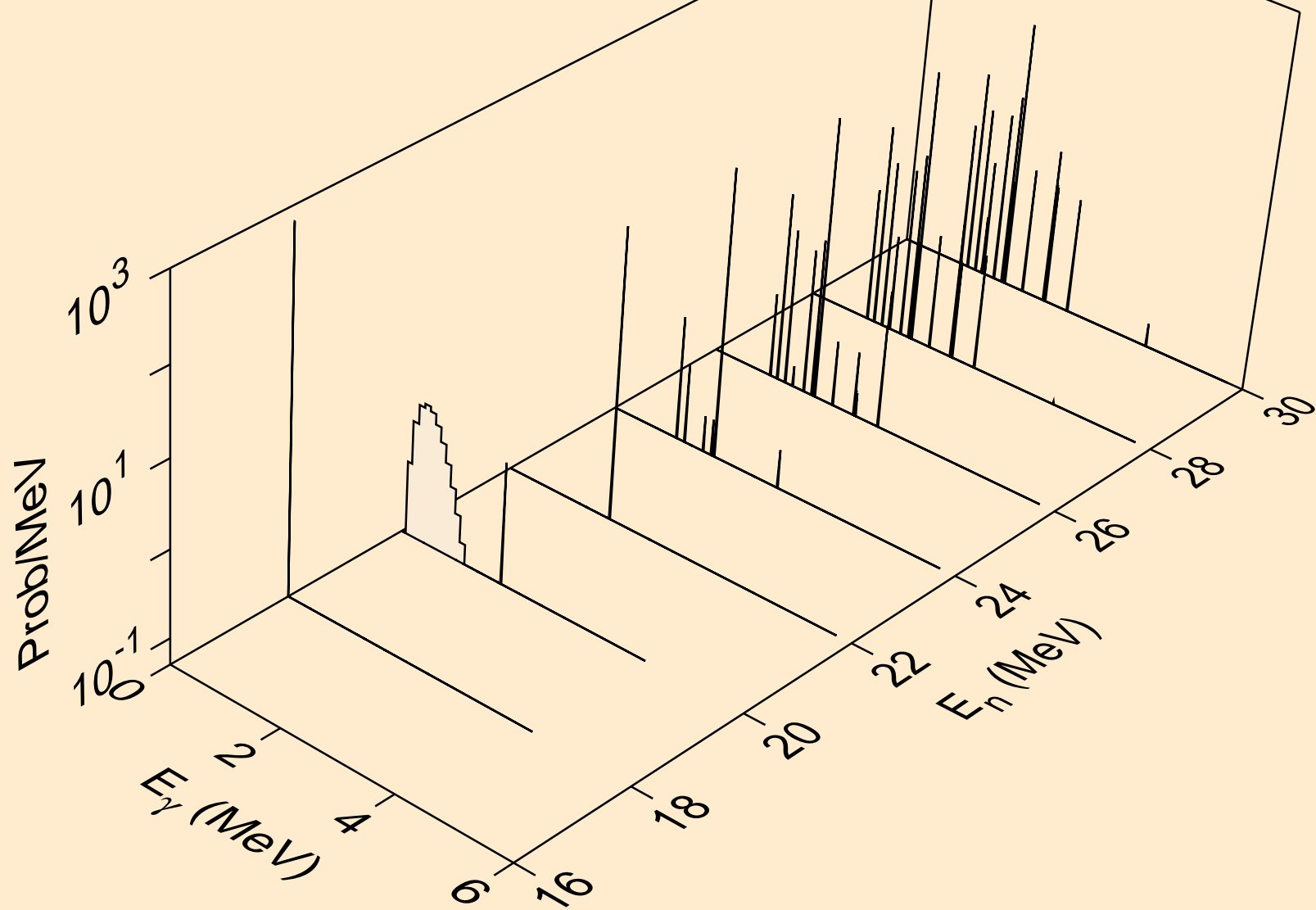

P031 NEUTRON ACER TENDL-2023 LIBRARY; T=0.K  
thermal capture photon spectrum

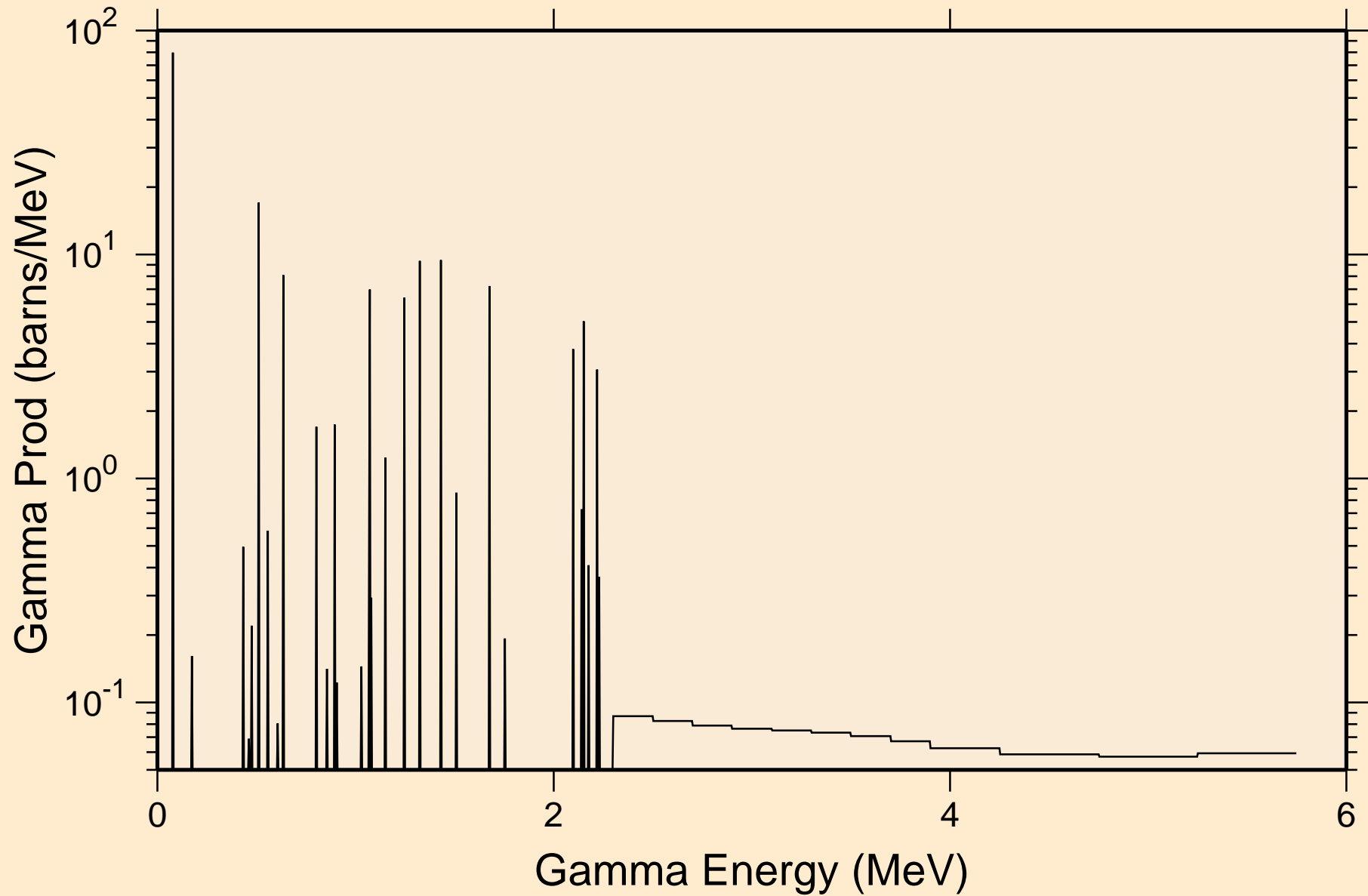

P031 NEUTRON ACER TENDL-2023 LIBRARY; T=0.K  
14 MeV photon spectrum

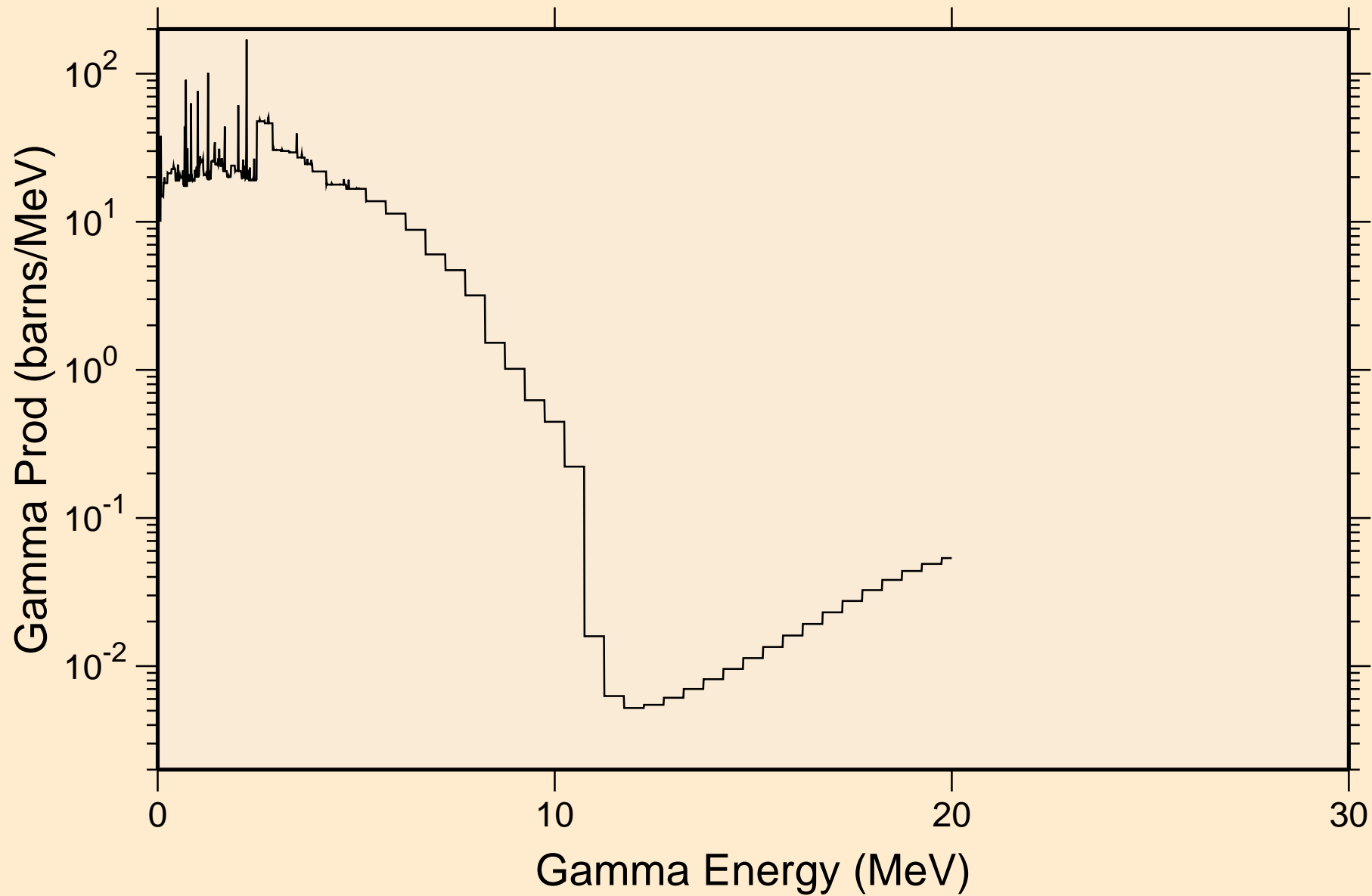

P031 NEUTRON ACER TENDL-2023 LIBRARY; T=0.K  
Particle heating contributions

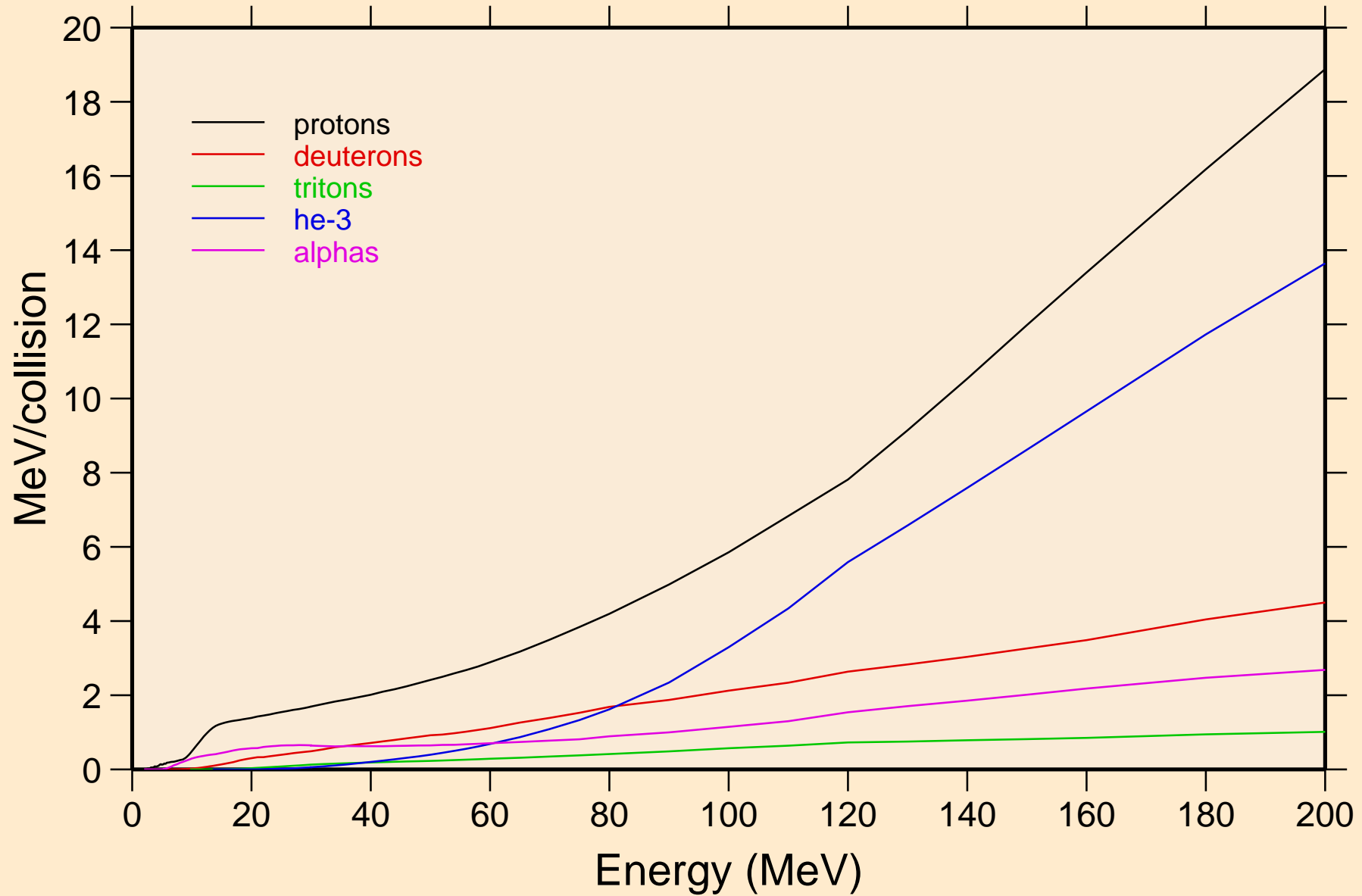

P031 NEUTRON ACER TENDL-2023 LIBRARY; T=0.K  
Recoil Heating

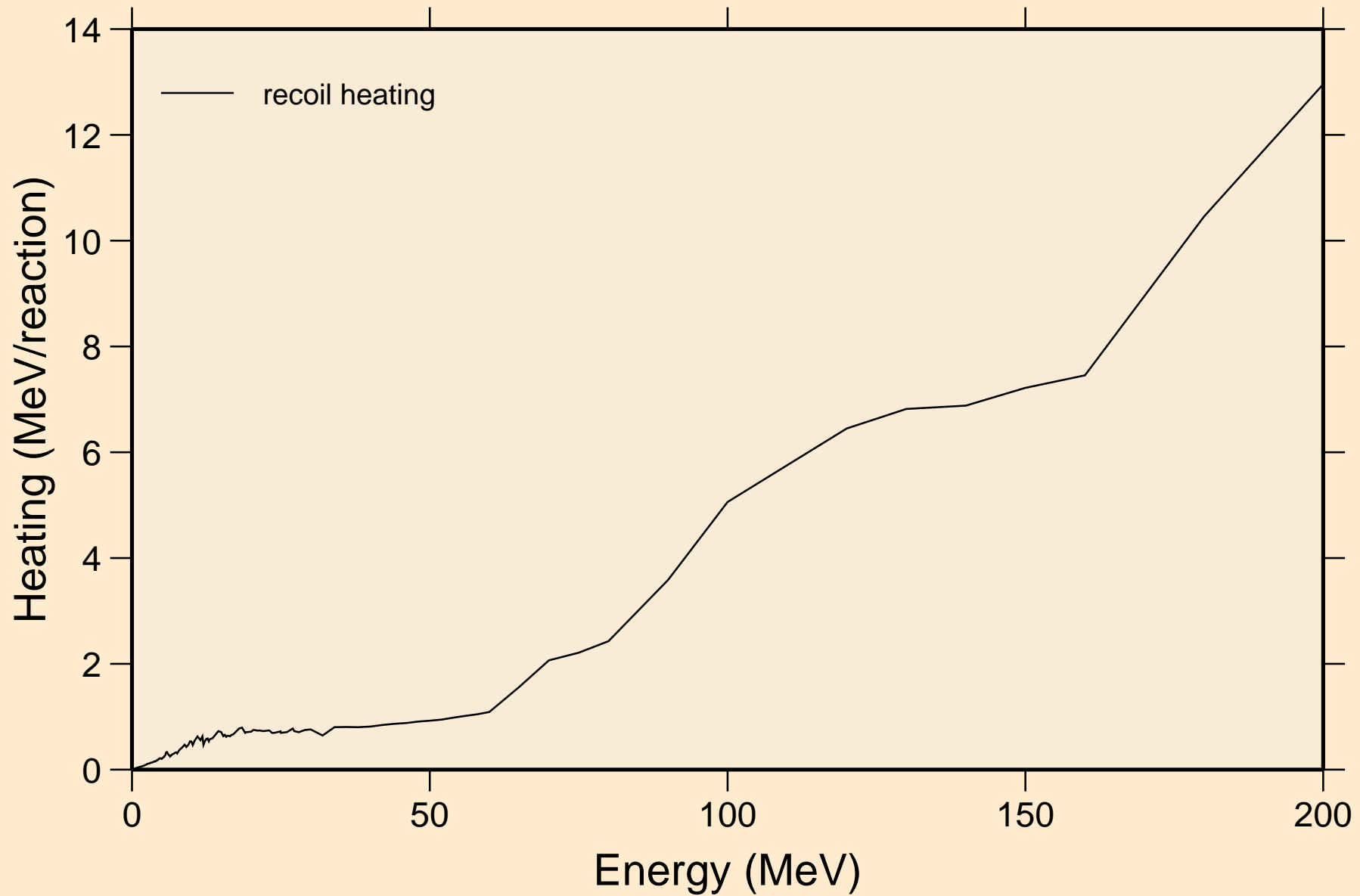

P031 NEUTRON ACER TENDL-2023 LIBRARY; T=0.K  
Particle production cross sections

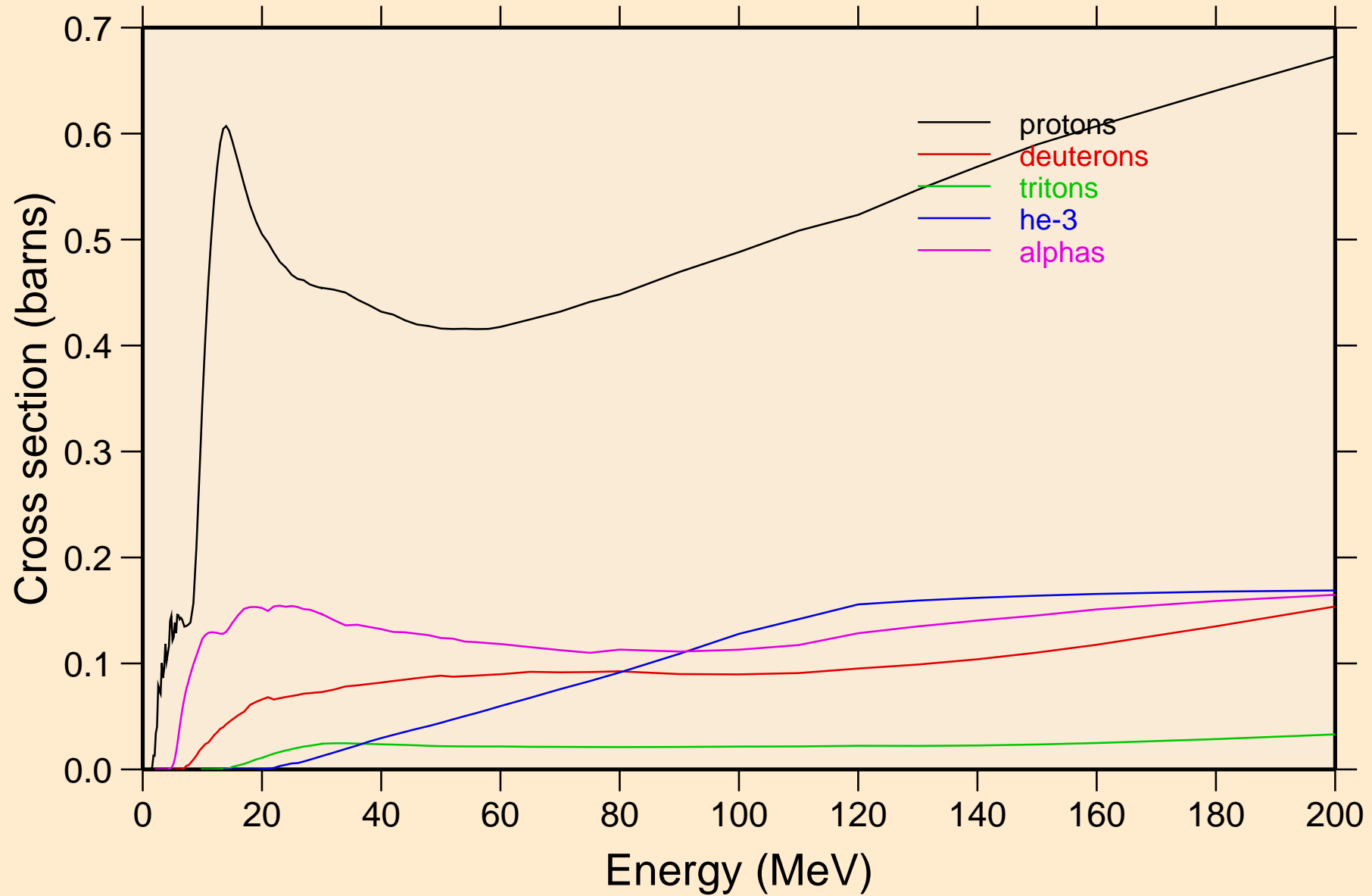

P031 NEUTRON ACER TENDL-2023 LIBRARY; T=0.K  
protons from (n,x)

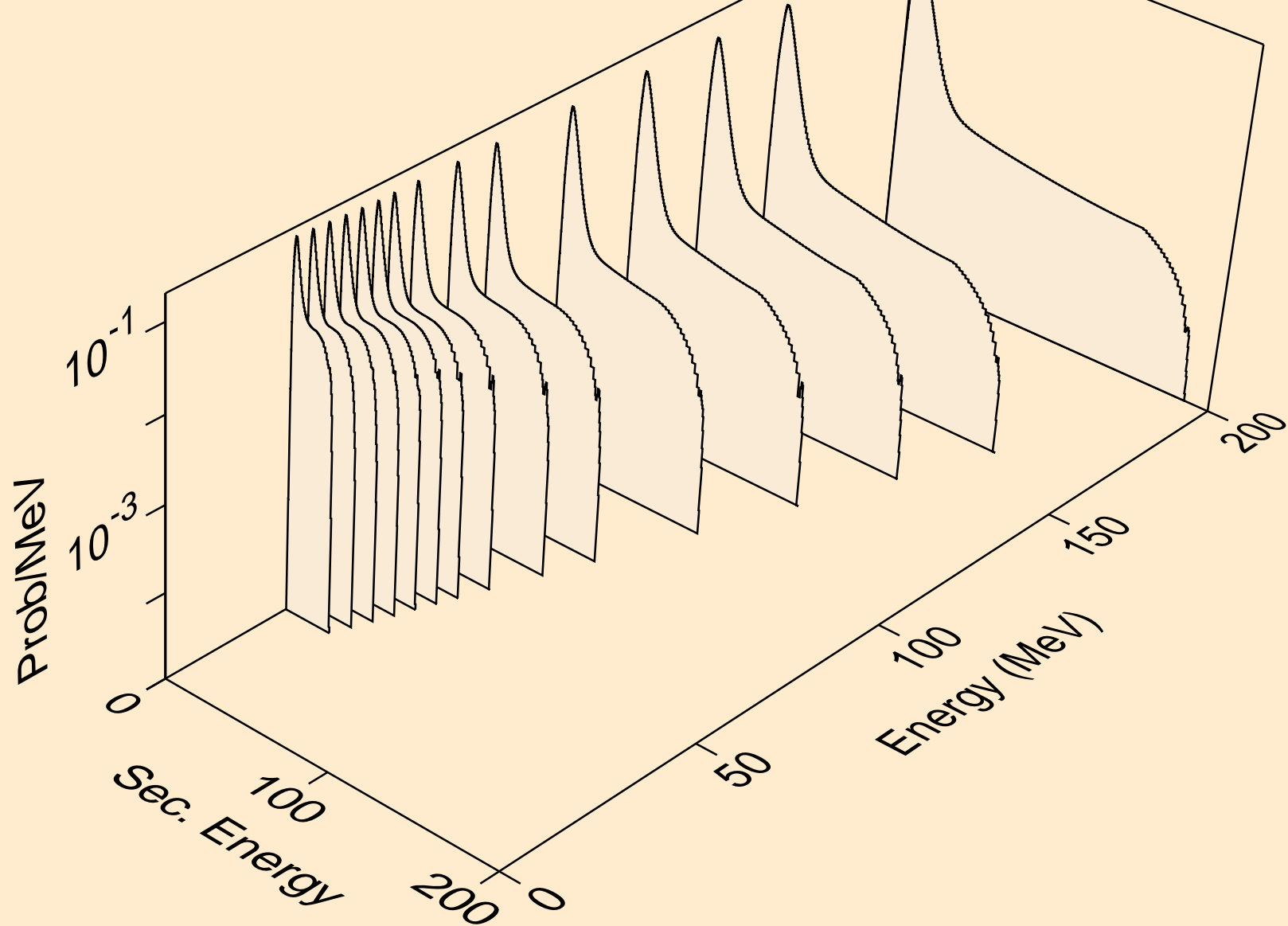

P031 NEUTRON ACER TENDL-2023 LIBRARY; T=0.K  
protons from (n,n\*)p

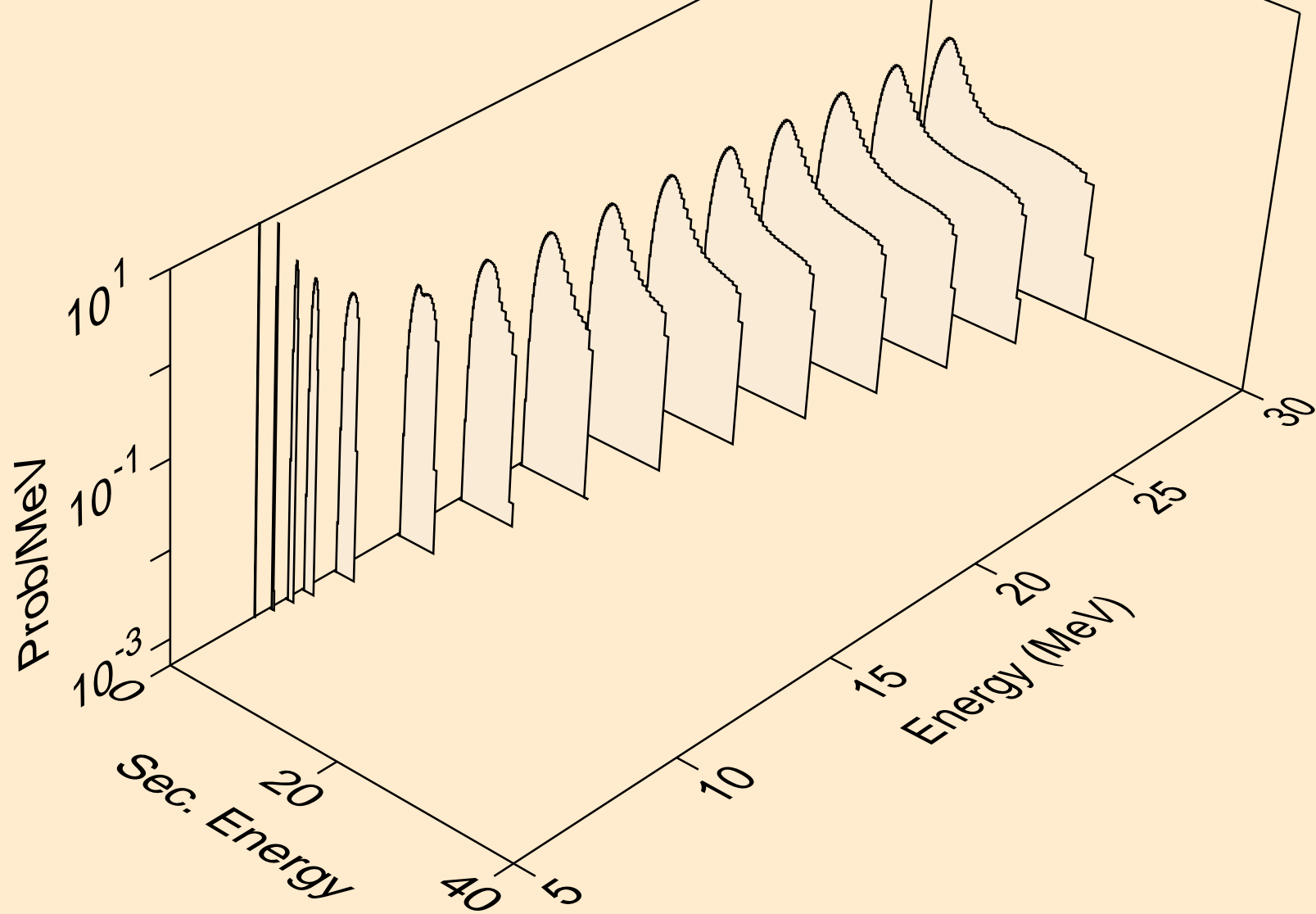

P031 NEUTRON ACER TENDL-2023 LIBRARY; T=0.K  
protons from (n,2np)

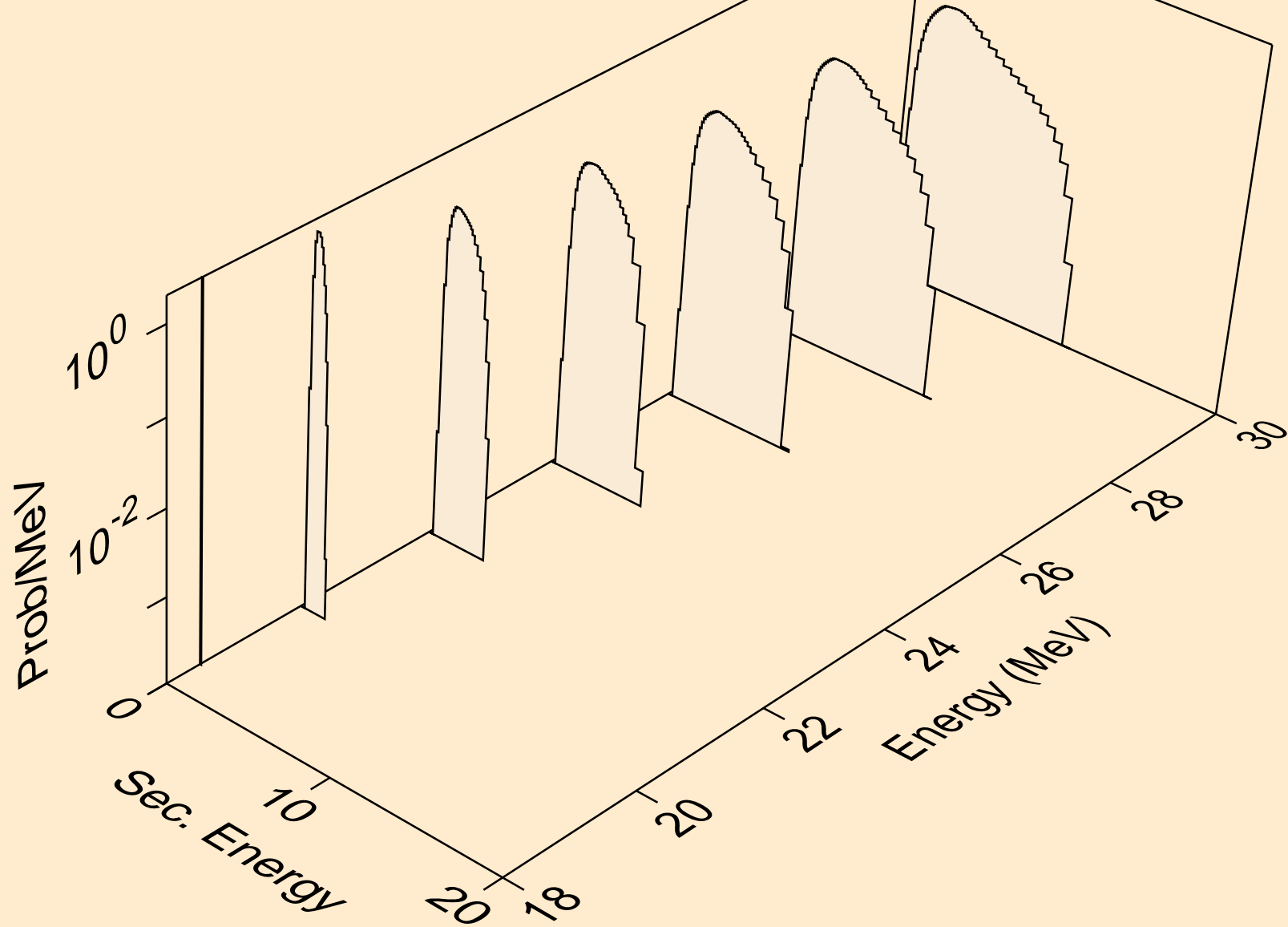

P031 NEUTRON ACER TENDL-2023 LIBRARY; T=0.K  
protons from (n,3np)

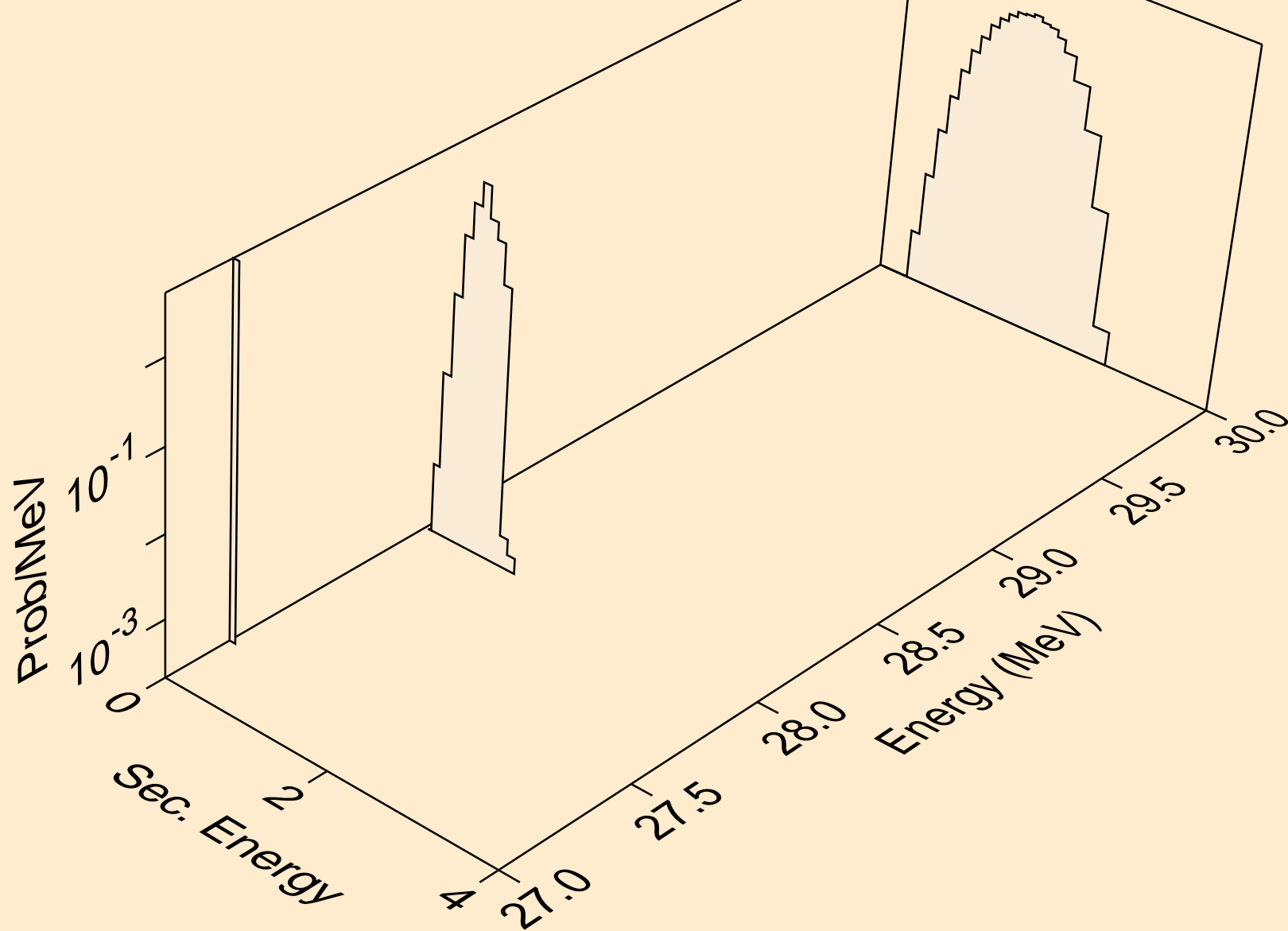

P031 NEUTRON ACER TENDL-2023 LIBRARY; T=0.K  
protons from (n,n2p)

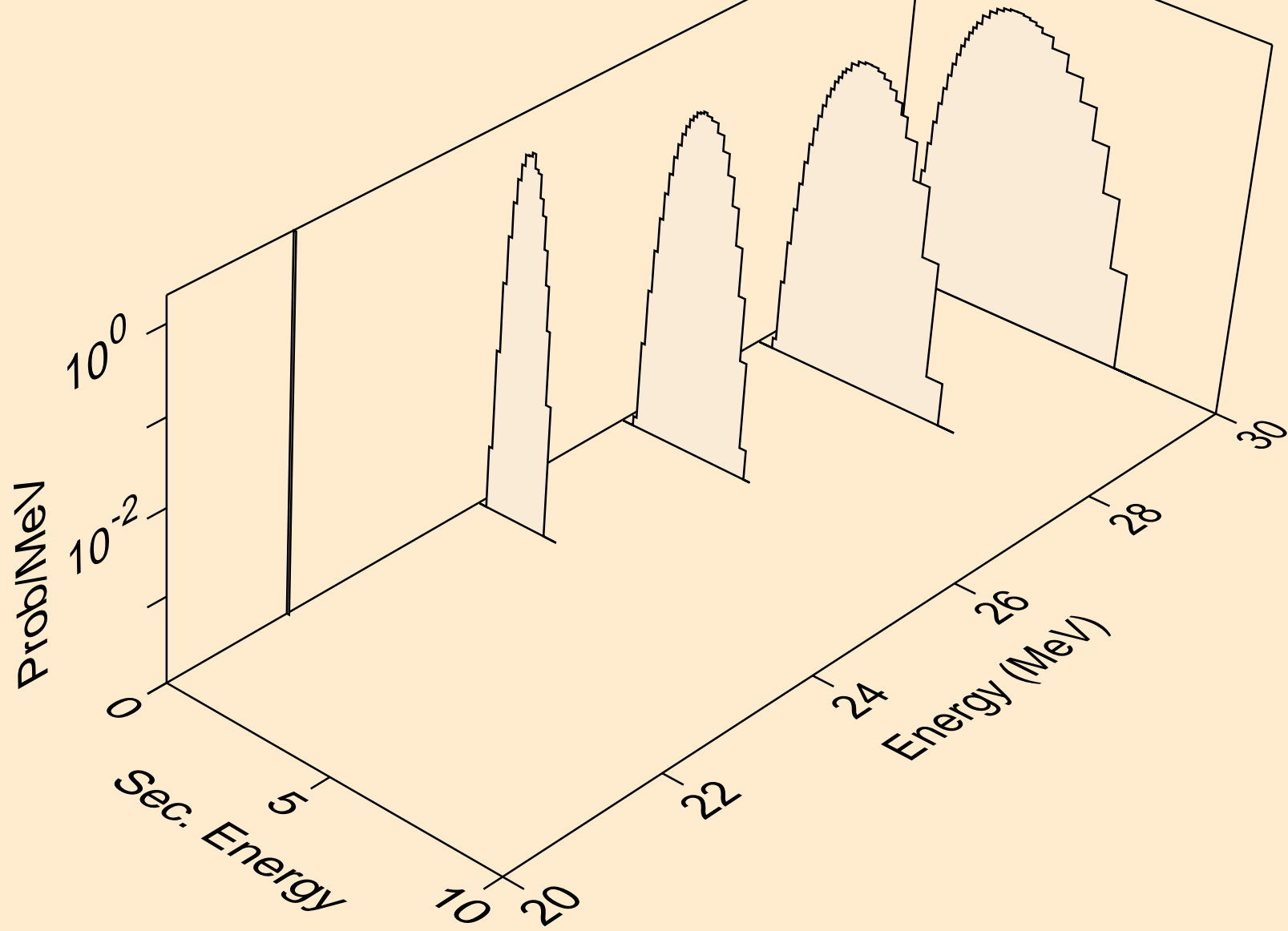

P031 NEUTRON ACER TENDL-2023 LIBRARY; T=0.K  
protons from (n,npa)

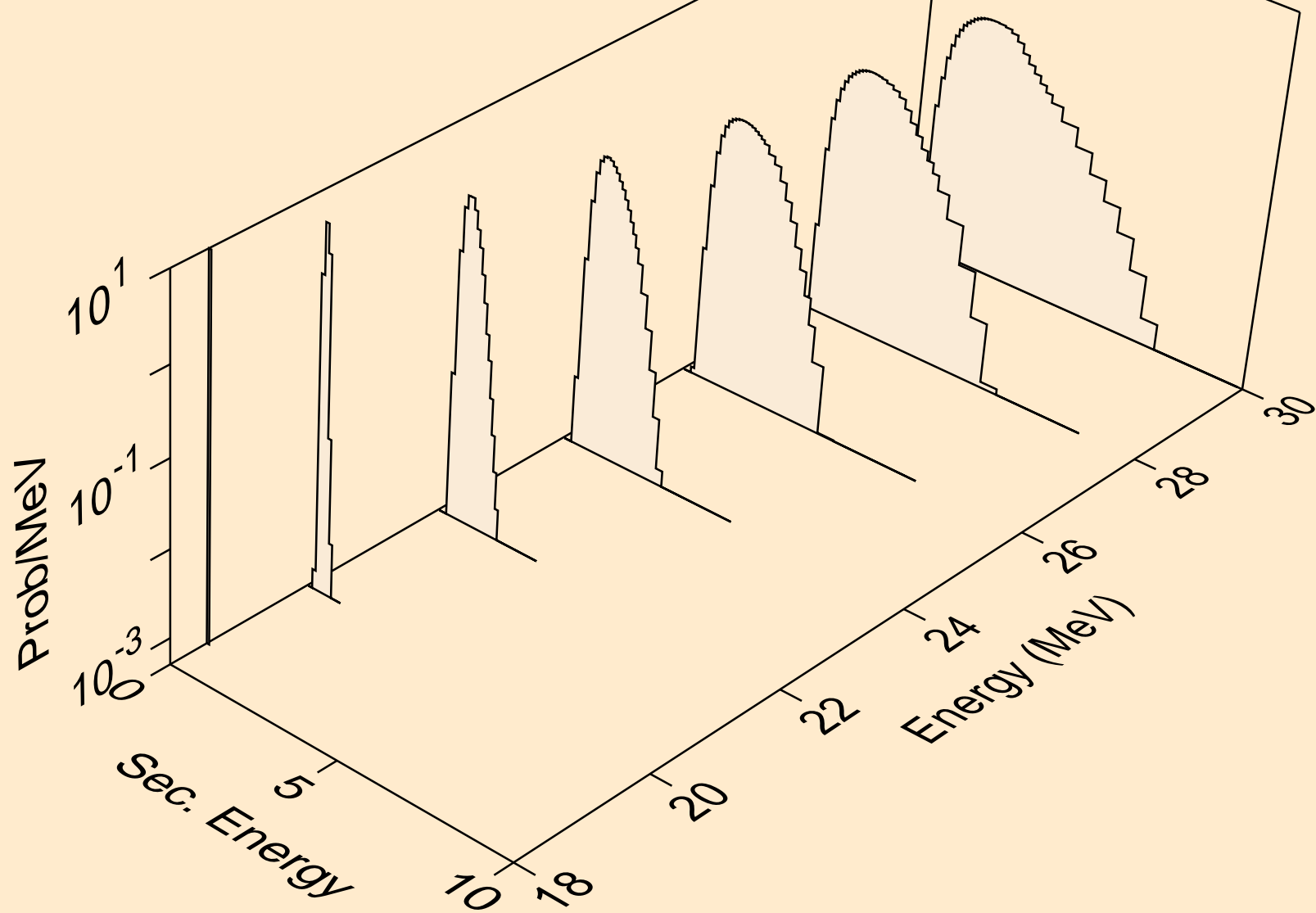

P031 NEUTRON ACER TENDL-2023 LIBRARY; T=0.K  
protons from (n,p)

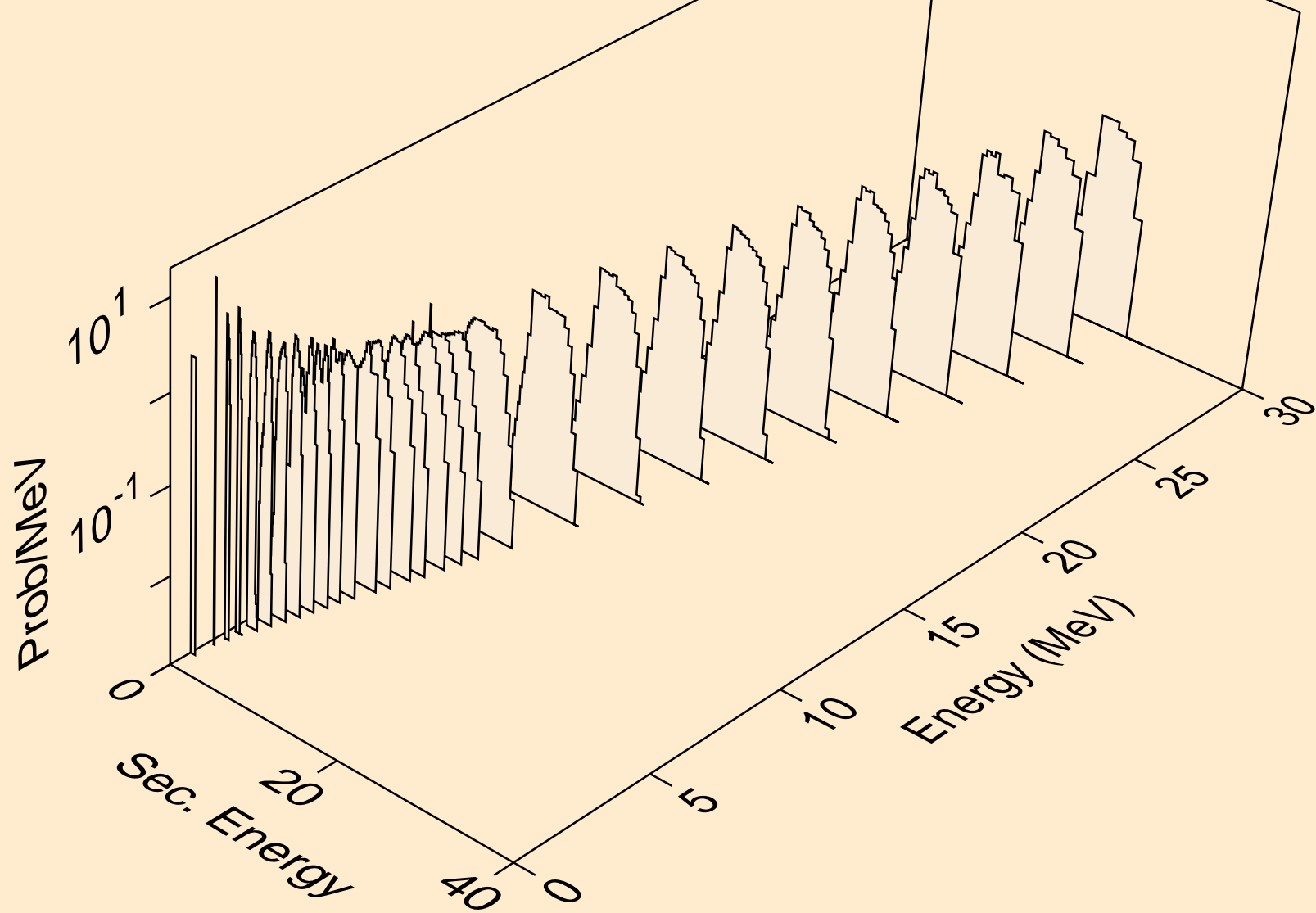

P031 NEUTRON ACER TENDL-2023 LIBRARY; T=0.K  
protons from (n,2p)

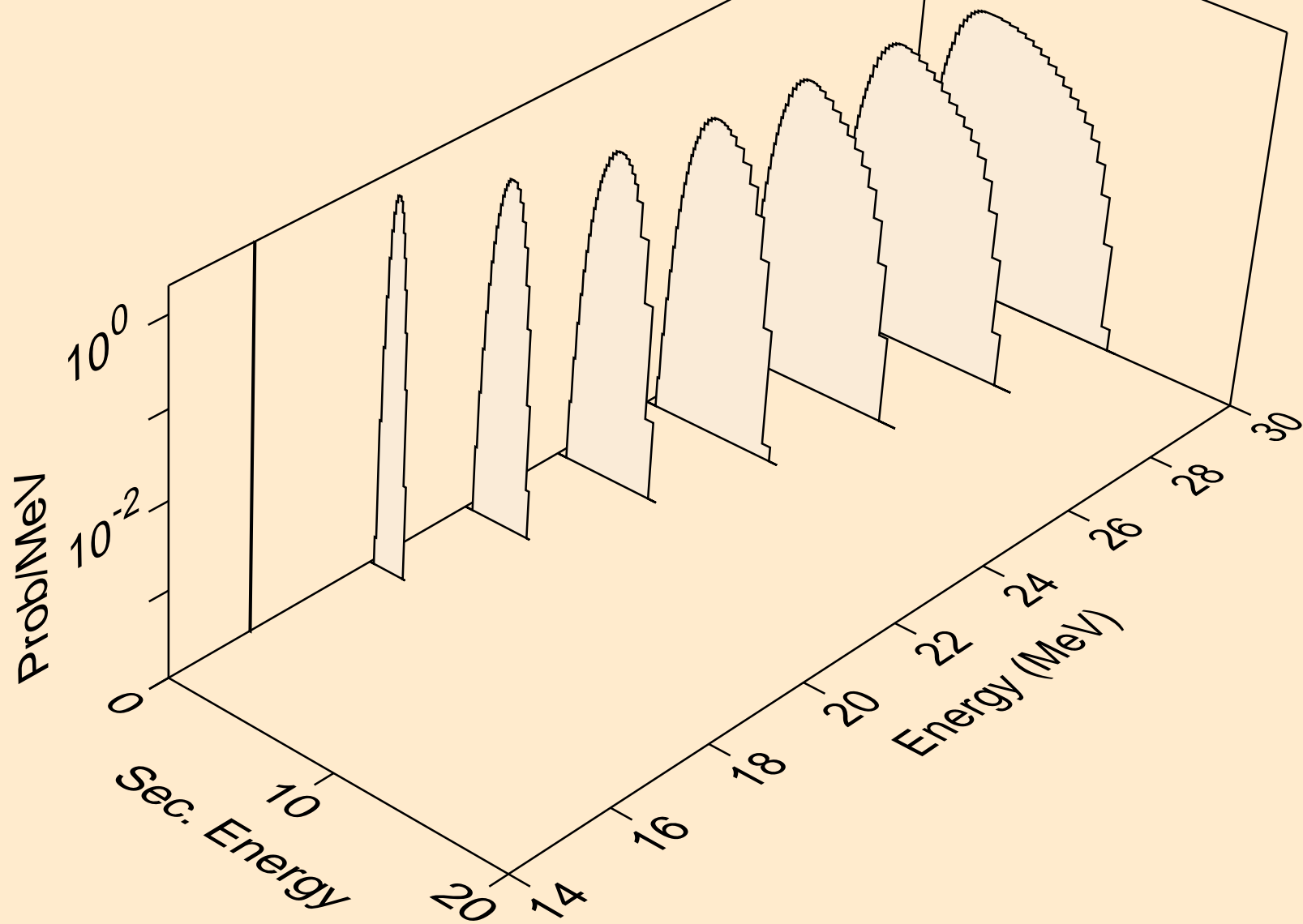

P031 NEUTRON ACER TENDL-2023 LIBRARY; T=0.K  
protons from (n,p)

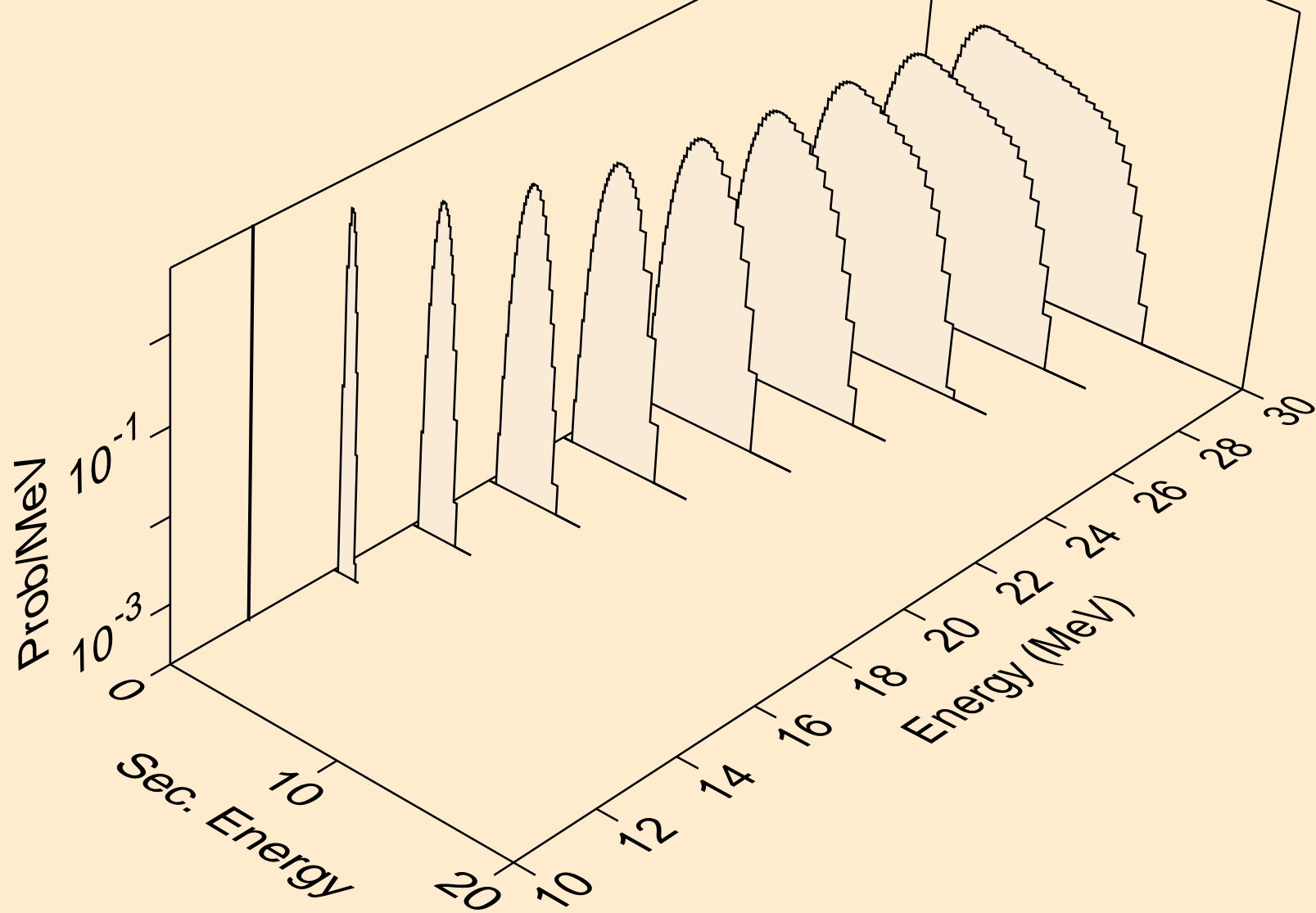

P031 NEUTRON ACER TENDL-2023 LIBRARY; T=0.K  
protons from (n,pd)

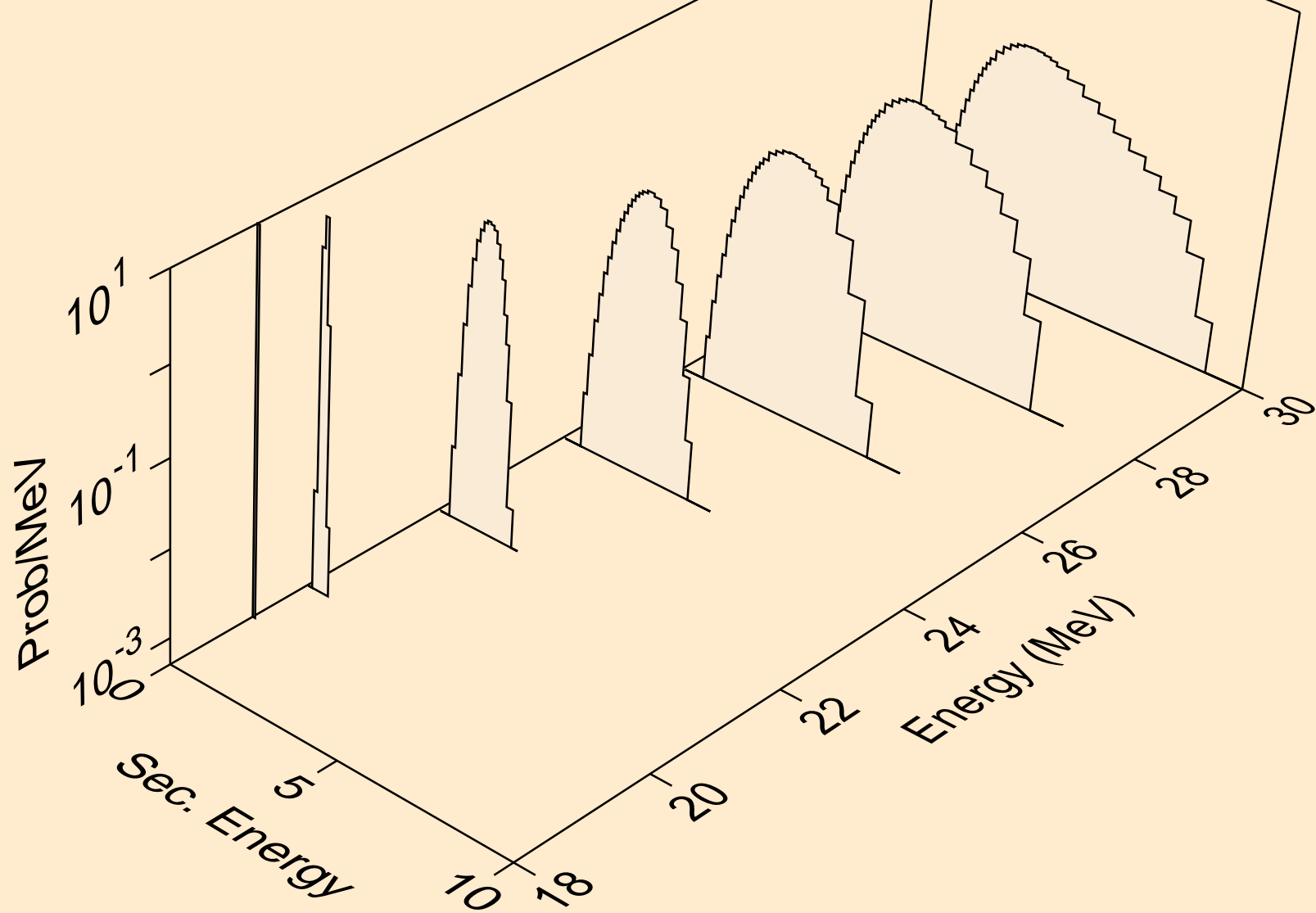

P031 NEUTRON ACER TENDL-2023 LIBRARY; T=0.K  
protons from (n,pt)

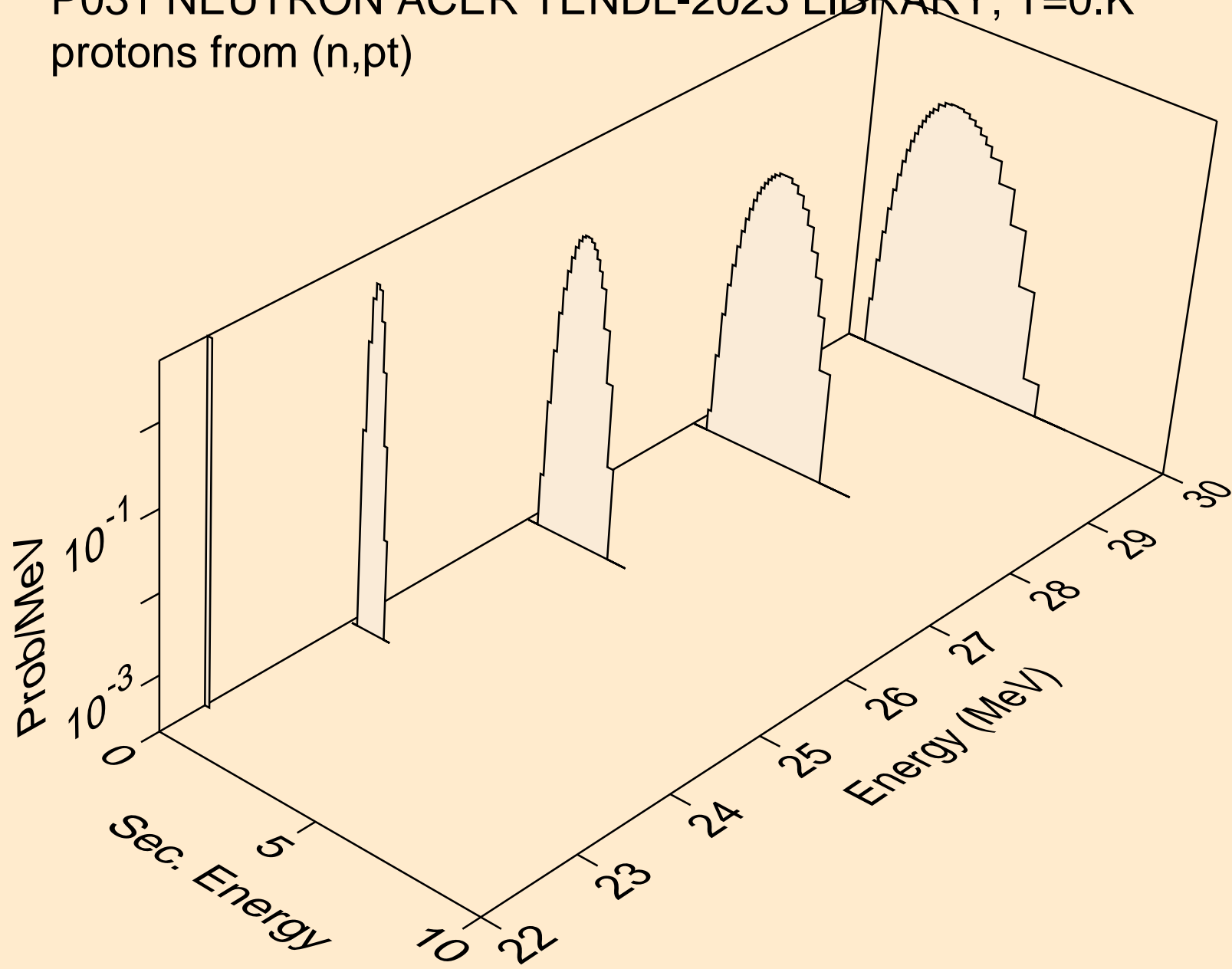

P031 NEUTRON ACER TENDL-2023 LIBRARY; T=0.K  
deuterons from (n,x)

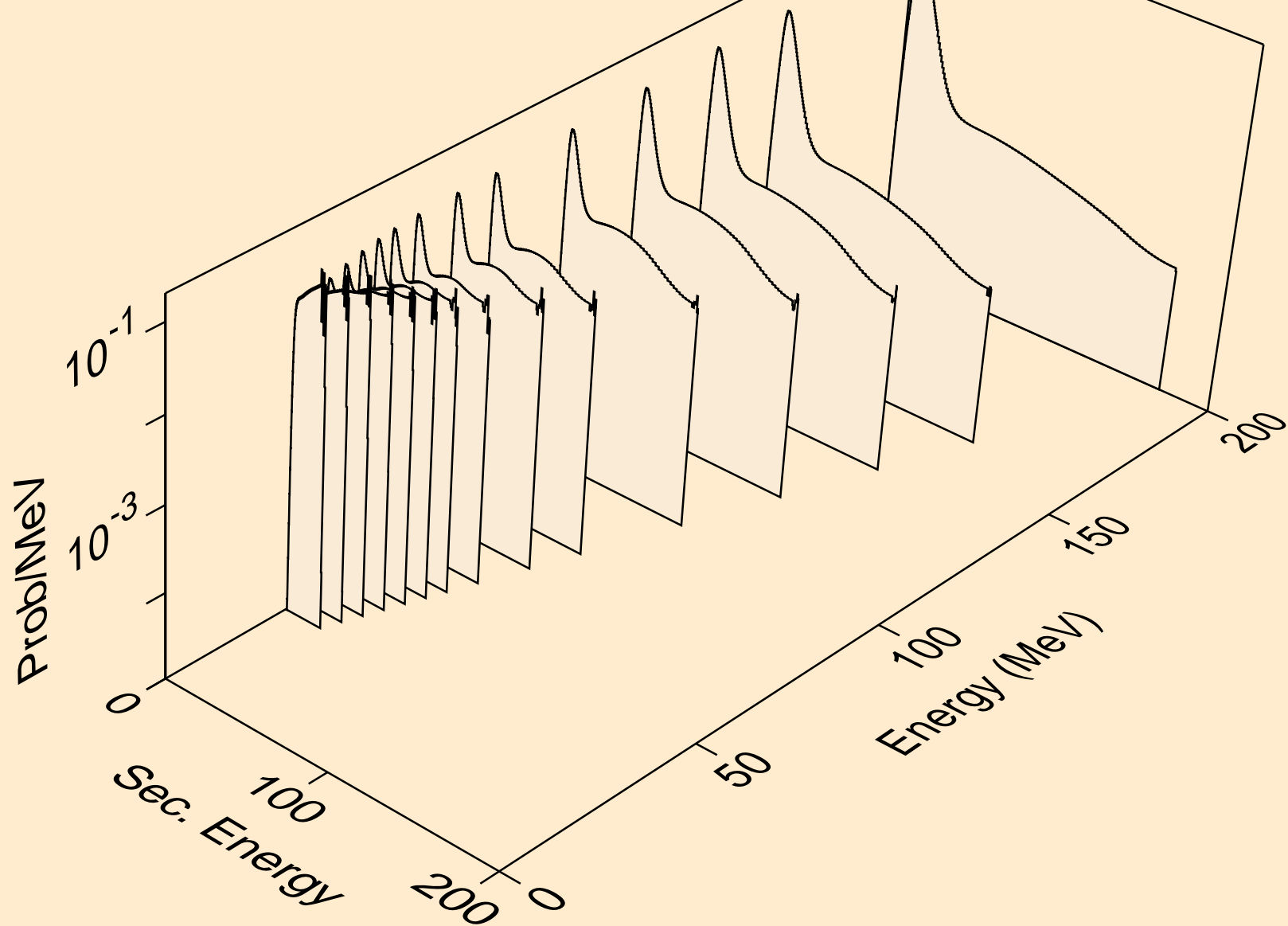

P031 NEUTRON ACER TENDL-2023 LIBRARY; T=0.K  
deuterons from (n,2nd)

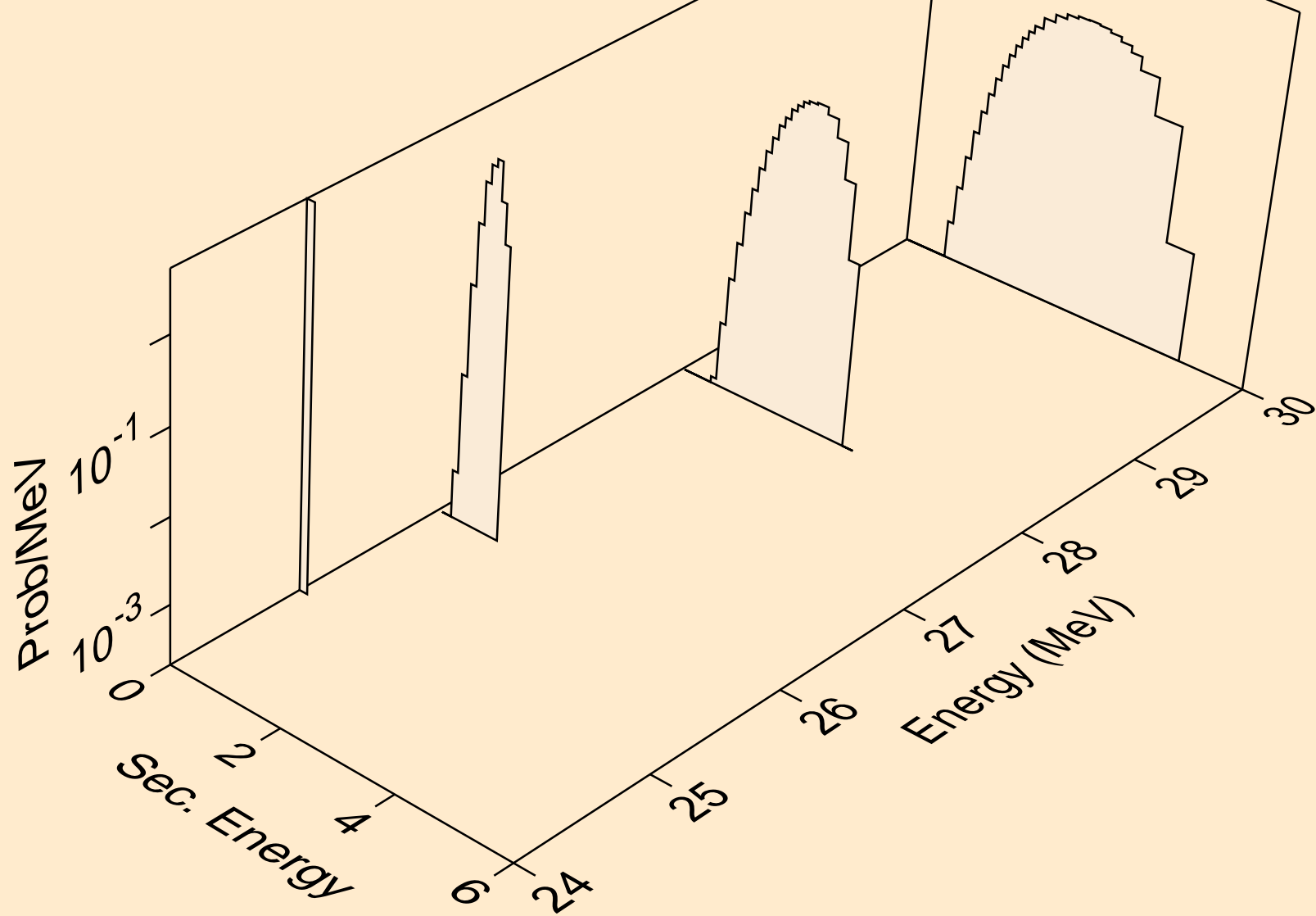

P031 NEUTRON ACER TENDL-2023 LIBRARY; T=0.K  
deuterons from (n,n\*)d

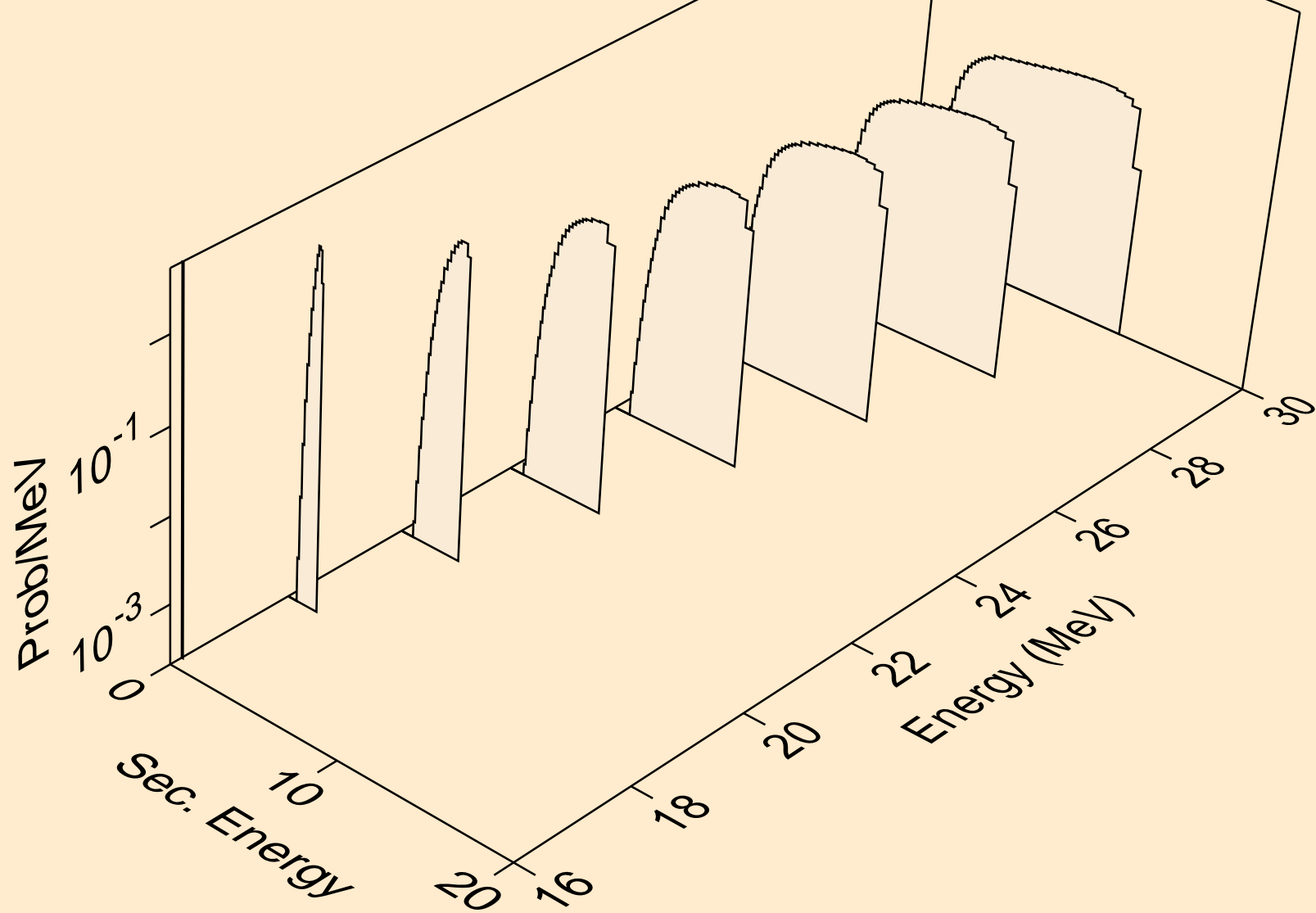

P031 NEUTRON ACER TENDL-2023 LIBRARY; T=0.K  
deuterons from (n,d)

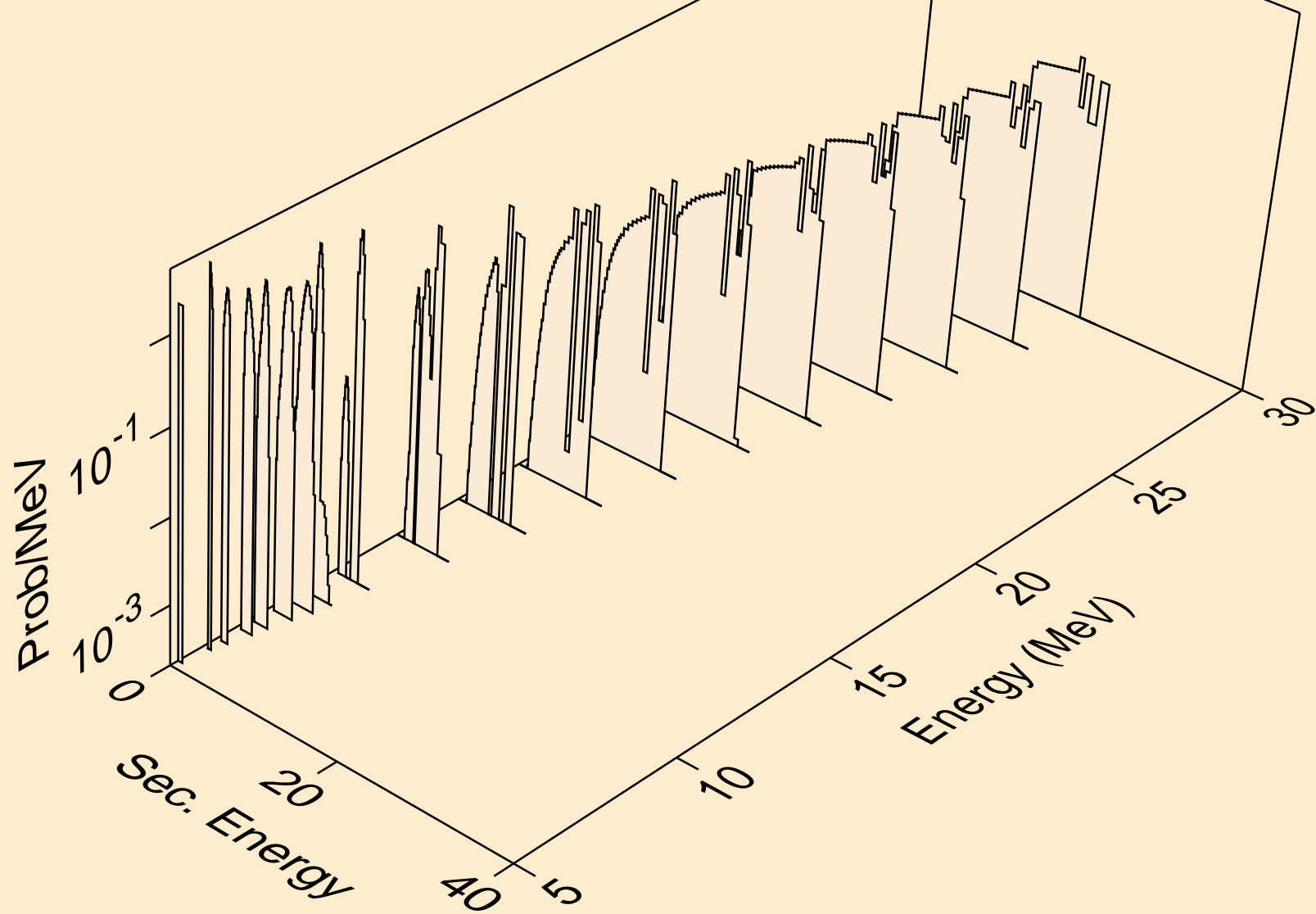

P031 NEUTRON ACER TENDL-2023 LIBRARY; T=0.K  
deuterons from (n,pd)

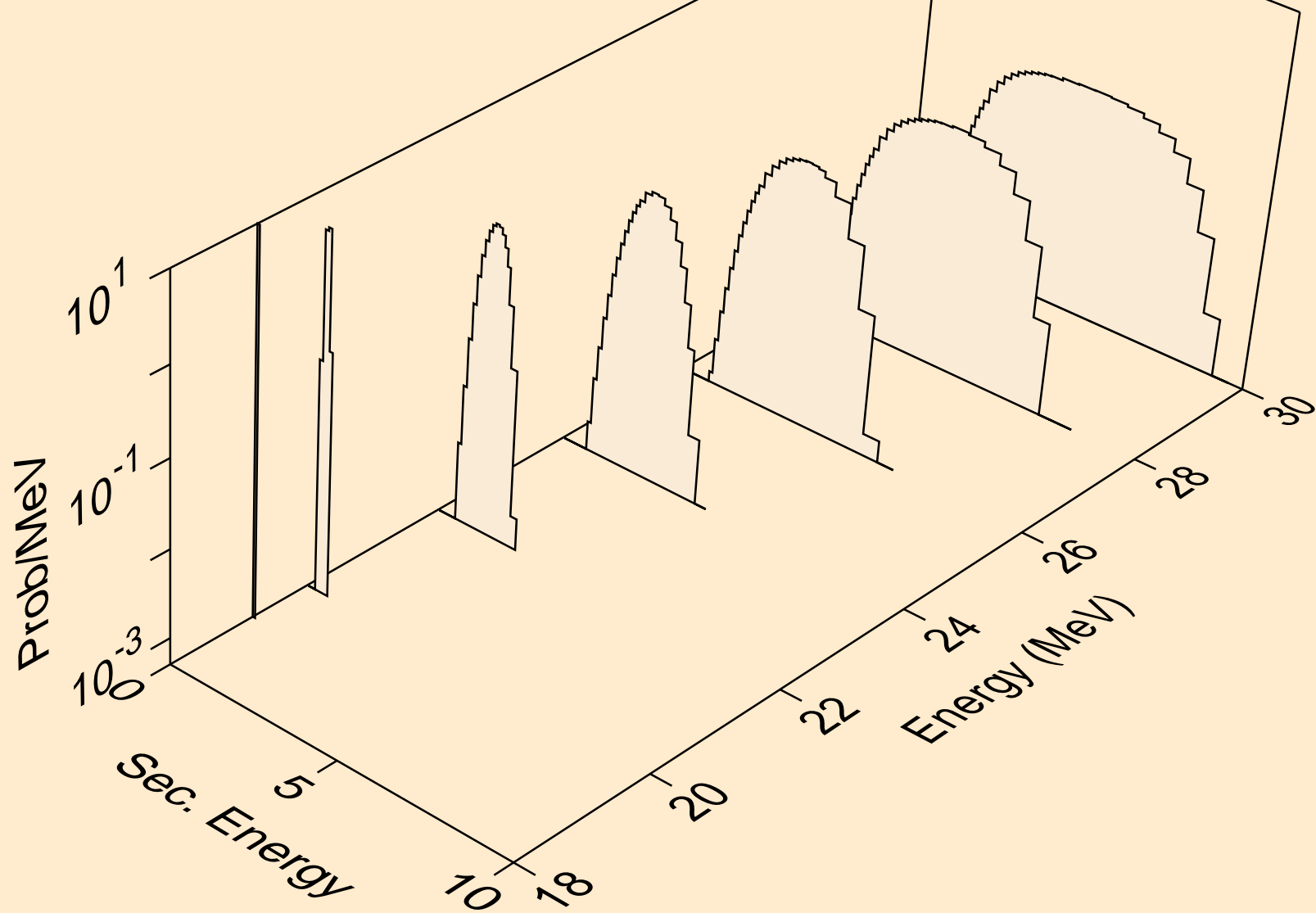

P031 NEUTRON ACER TENDL-2023 LIBRARY; T=0.K  
deuterons from (n,da)

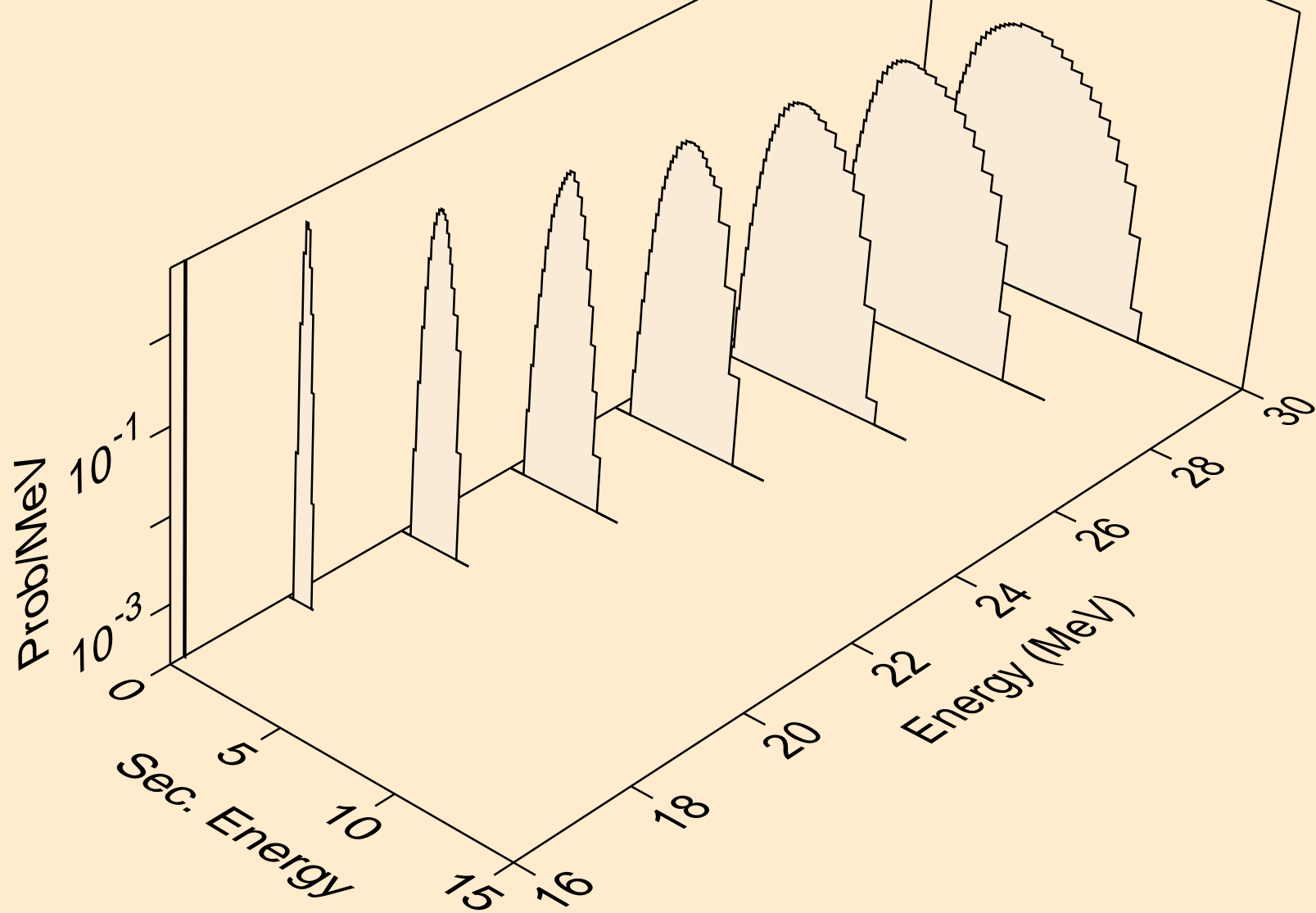

P031 NEUTRON ACER TENDL-2023 LIBRARY; T=0.K  
tritons from (n,x)

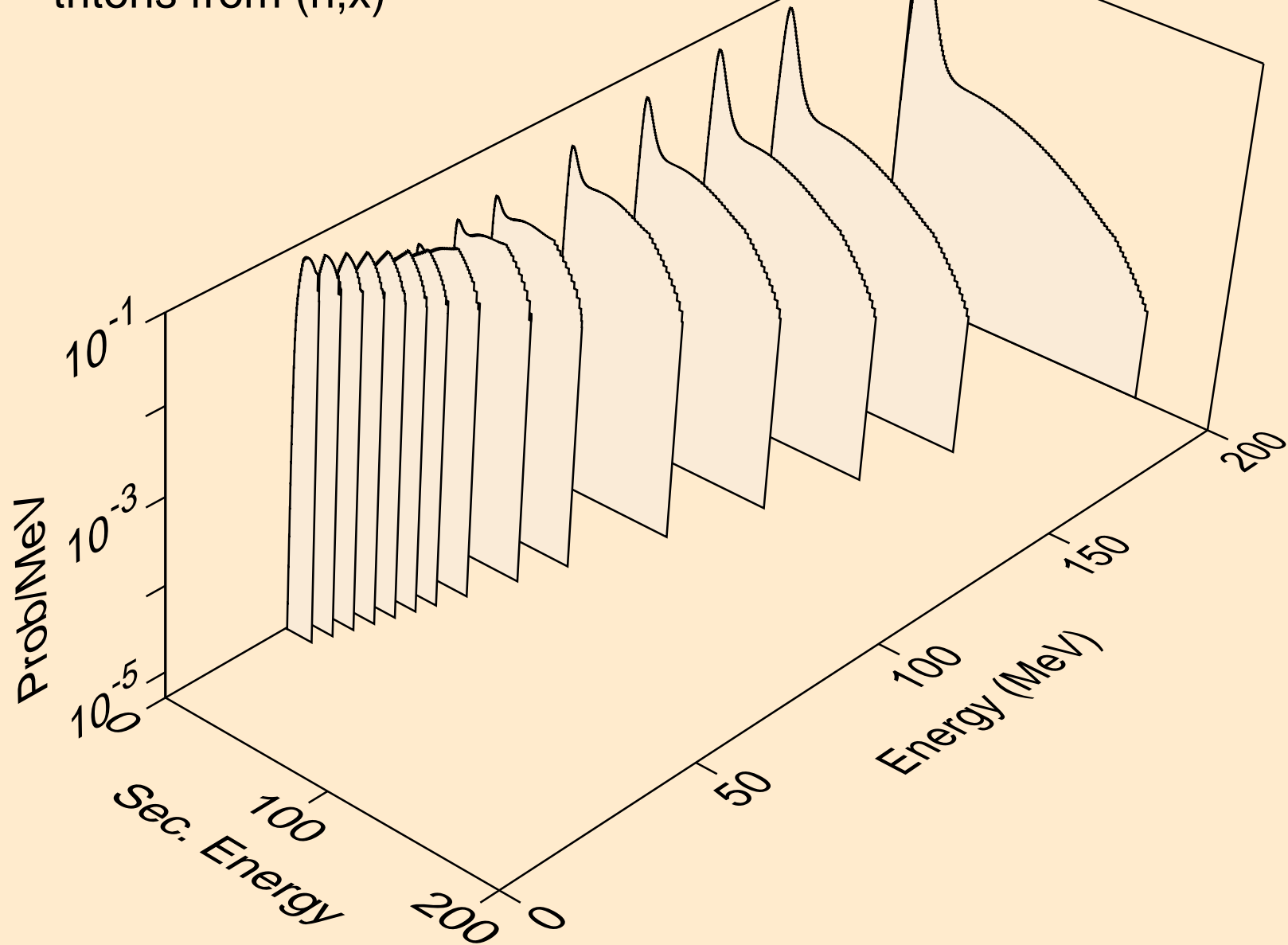

P031 NEUTRON ACER TENDL-2023 LIBRARY; T=0.K  
tritons from (n,n\*)t

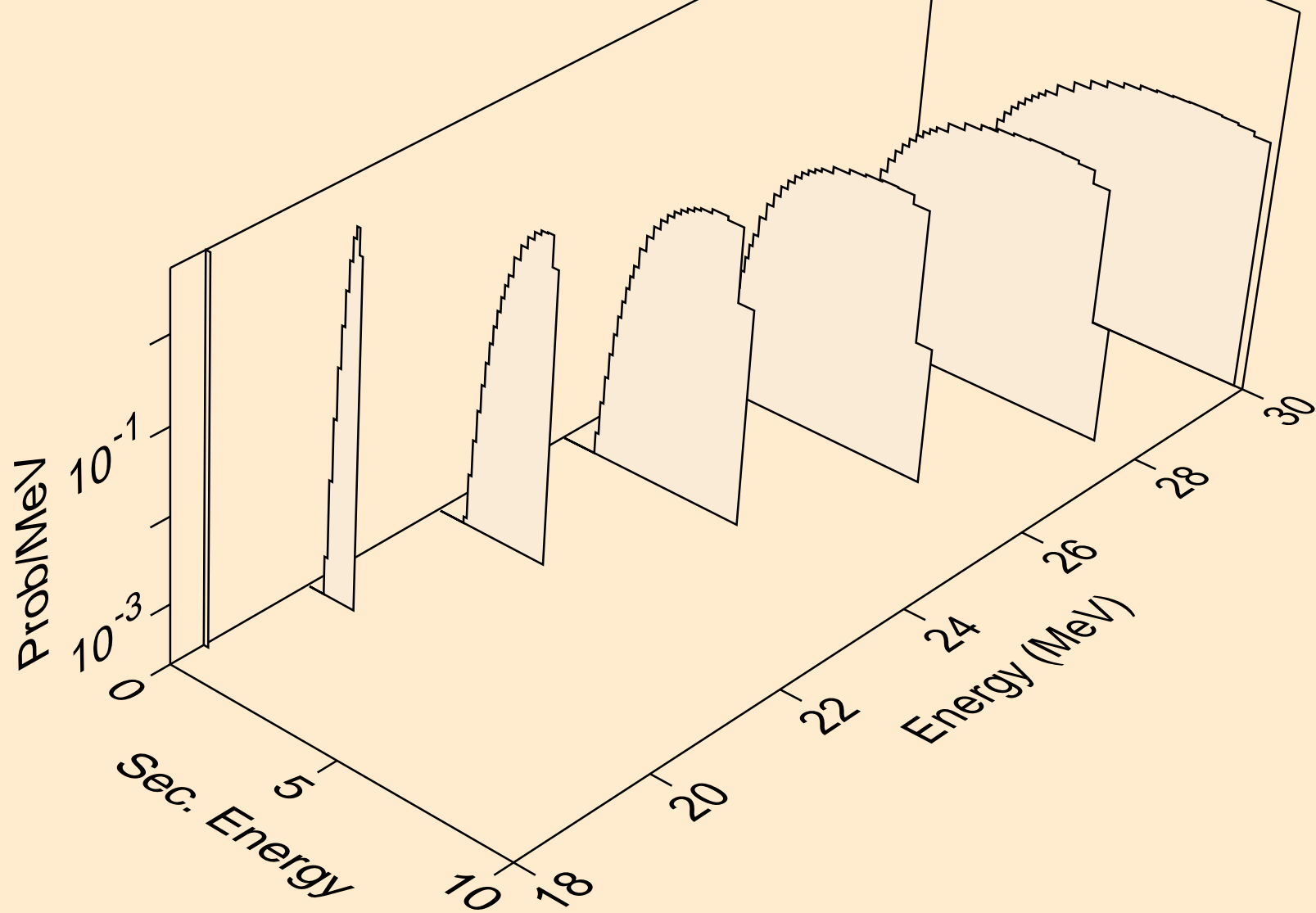

P031 NEUTRON ACER TENDL-2023 LIBRARY; T=0.K  
tritons from (n,t)

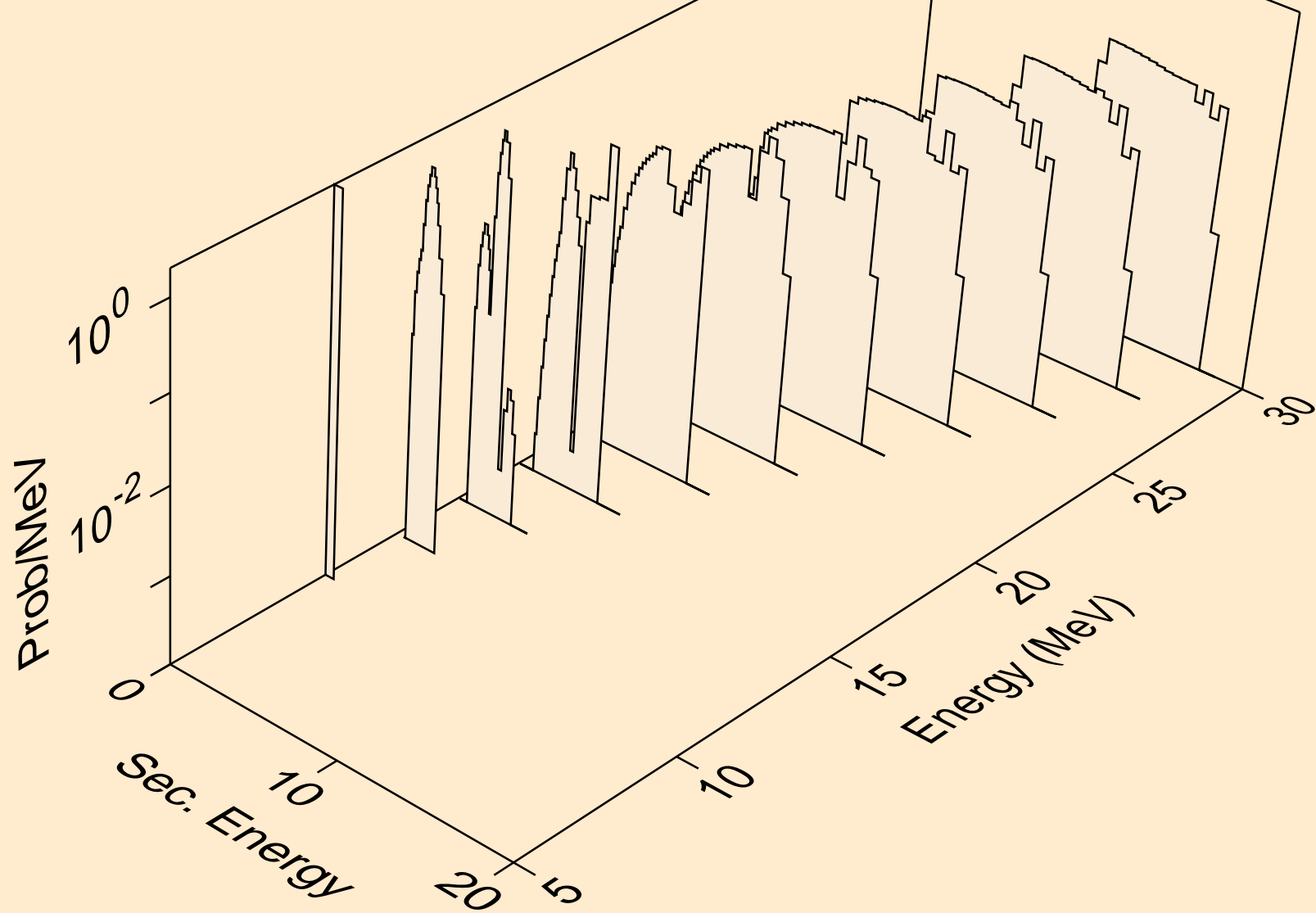

P031 NEUTRON ACER TENDL-2023 LIBRARY; T=0.K  
tritons from (n,pt)

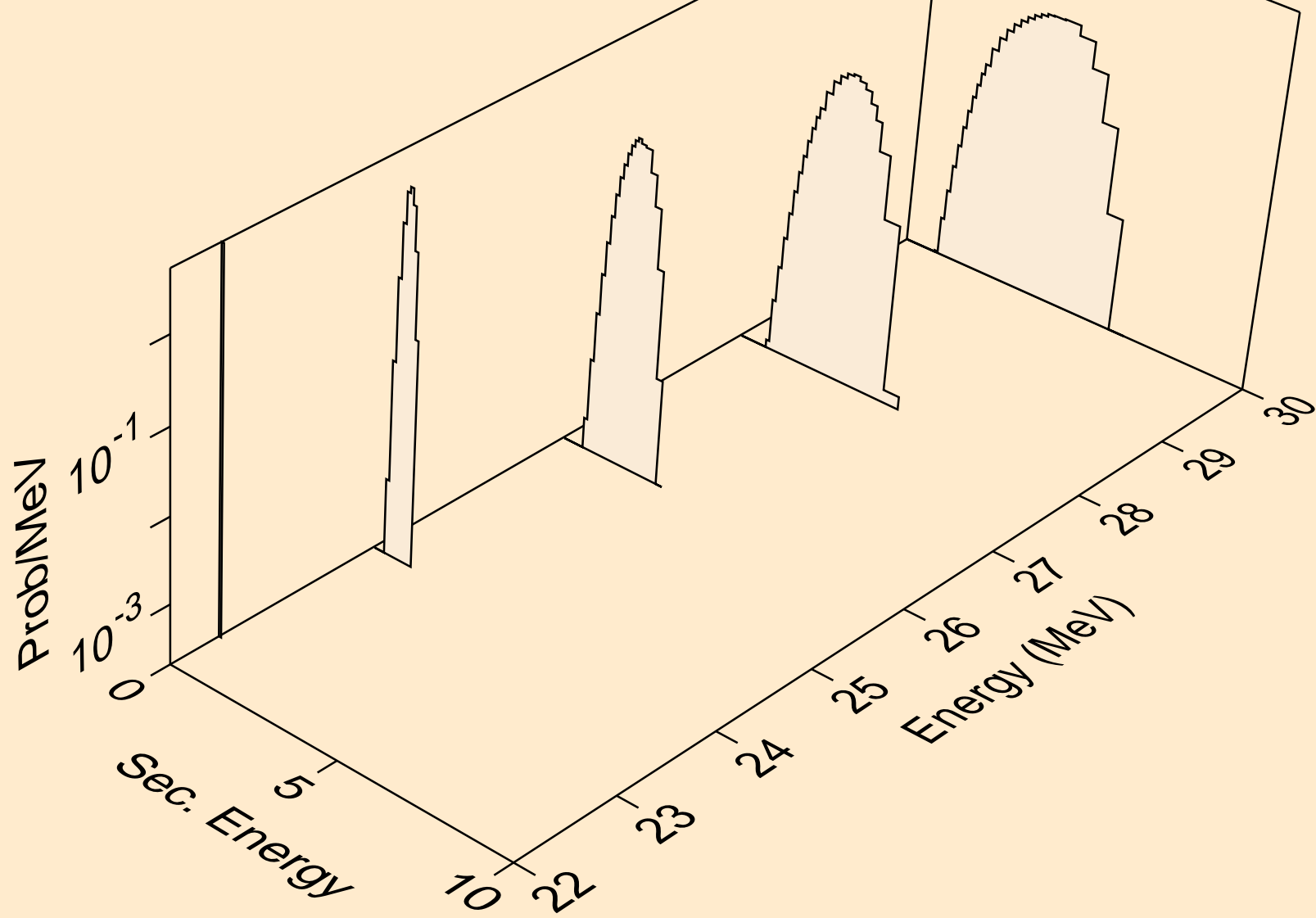

P031 NEUTRON ACER TENDL-2023 LIBRARY; T=0.K  
he3s from (n,x)

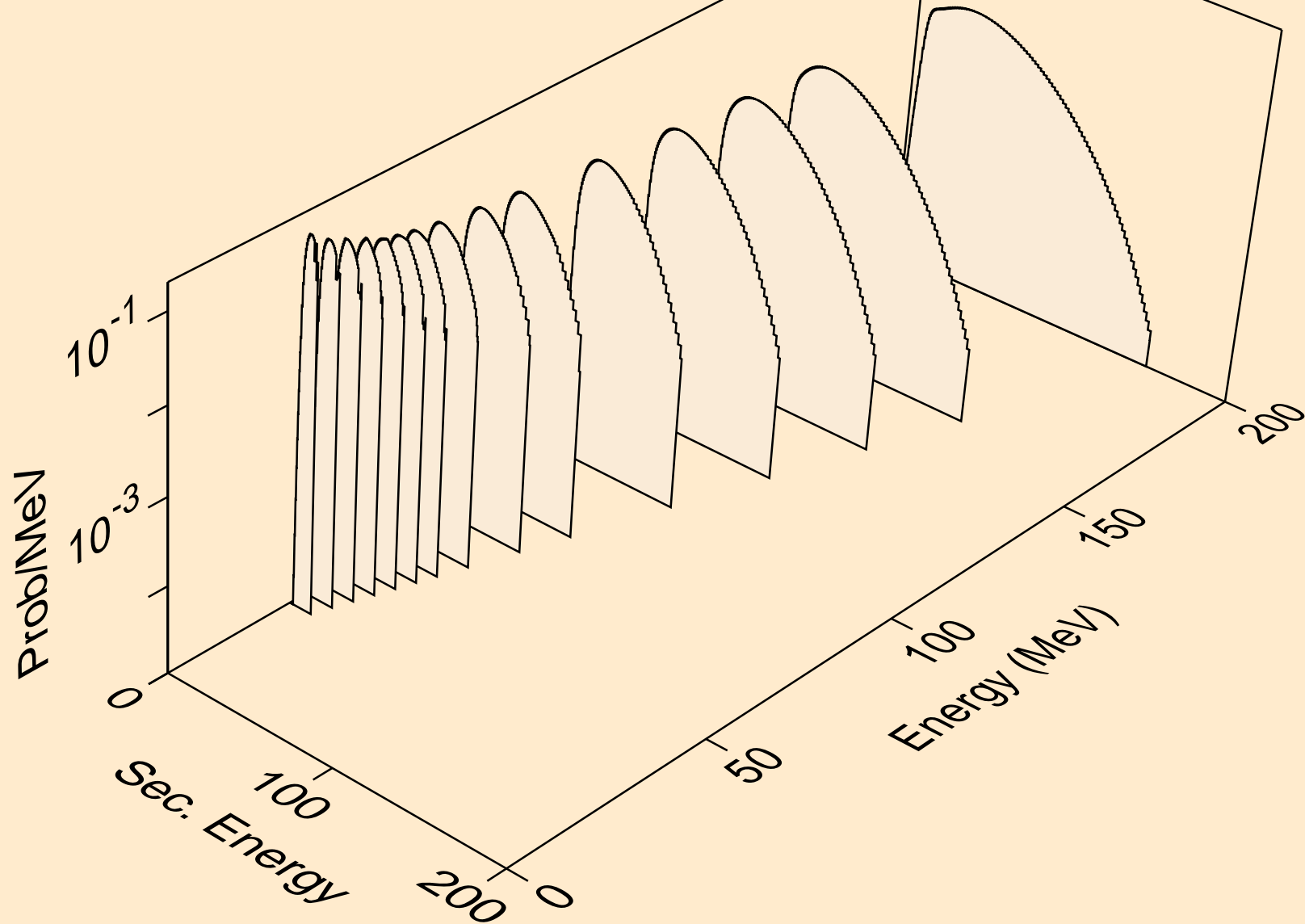

P031 NEUTRON ACER TENDL-2023 LIBRARY; T=0.K  
he3s from (n,n\*)he3

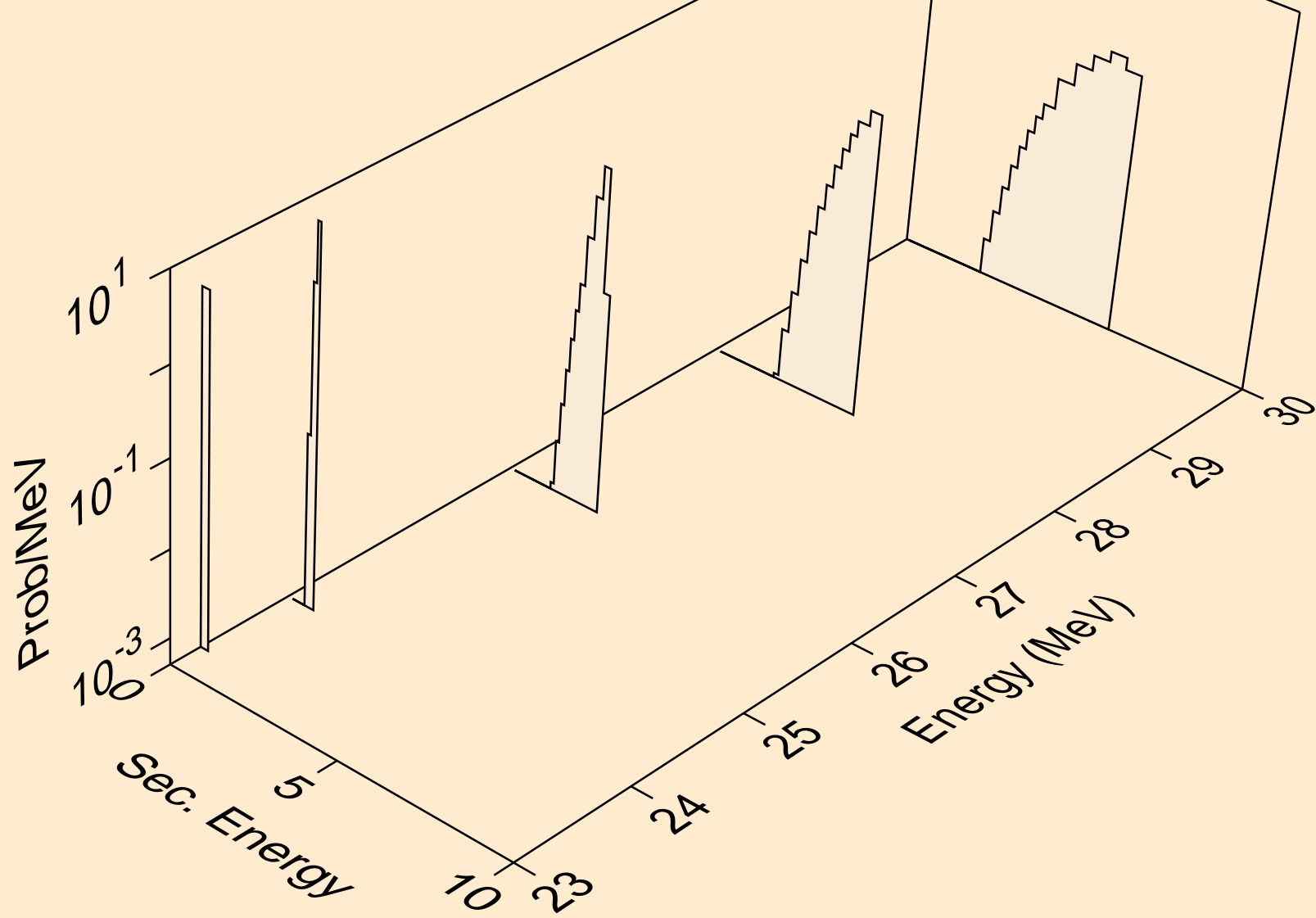

P031 NEUTRON ACER TENDL-2023 LIBRARY; T=0.K  
he3s from (n,he3)

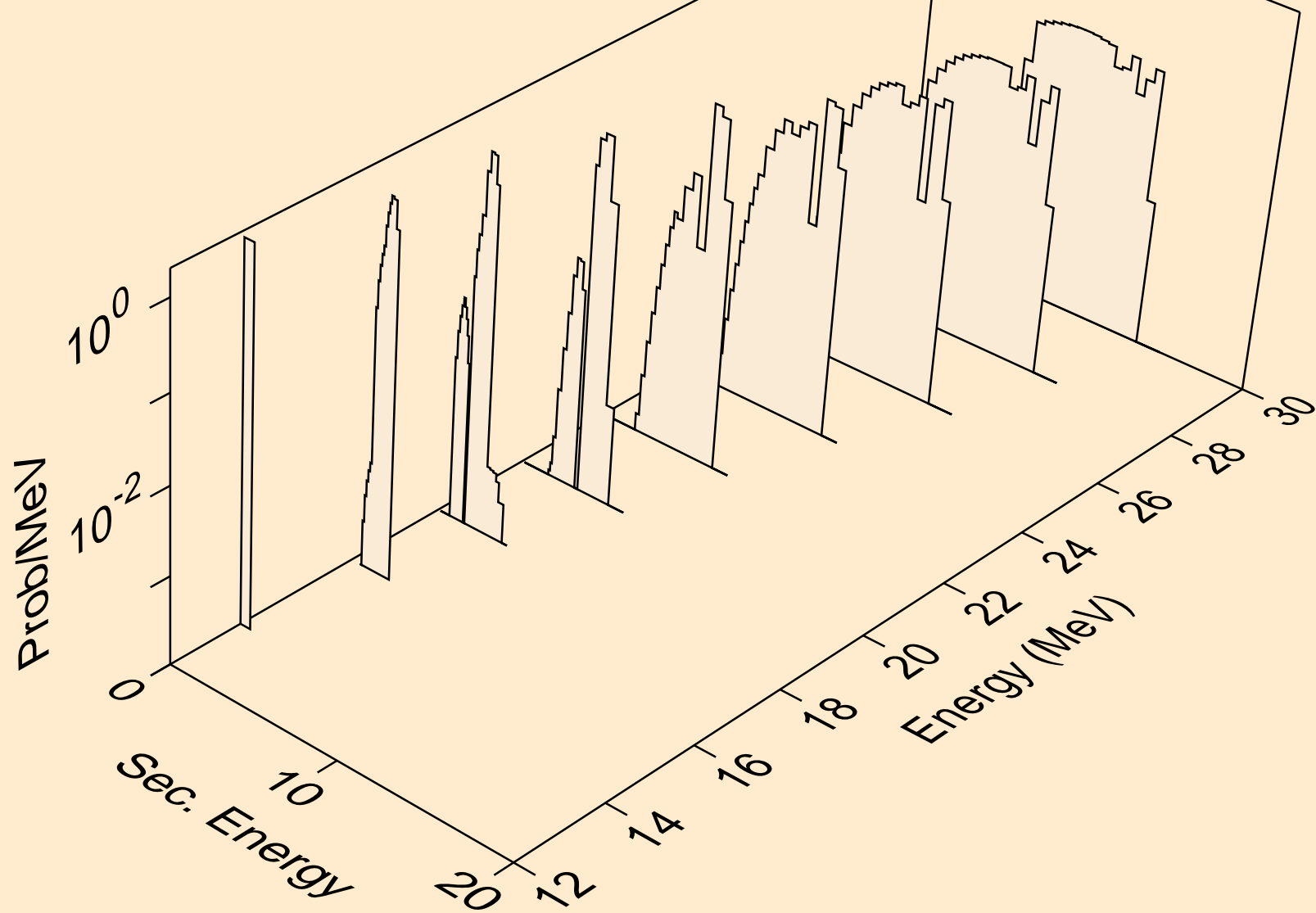

P031 NEUTRON ACER TENDL-2023 LIBRARY; T=0.K  
alphas from (n,x)

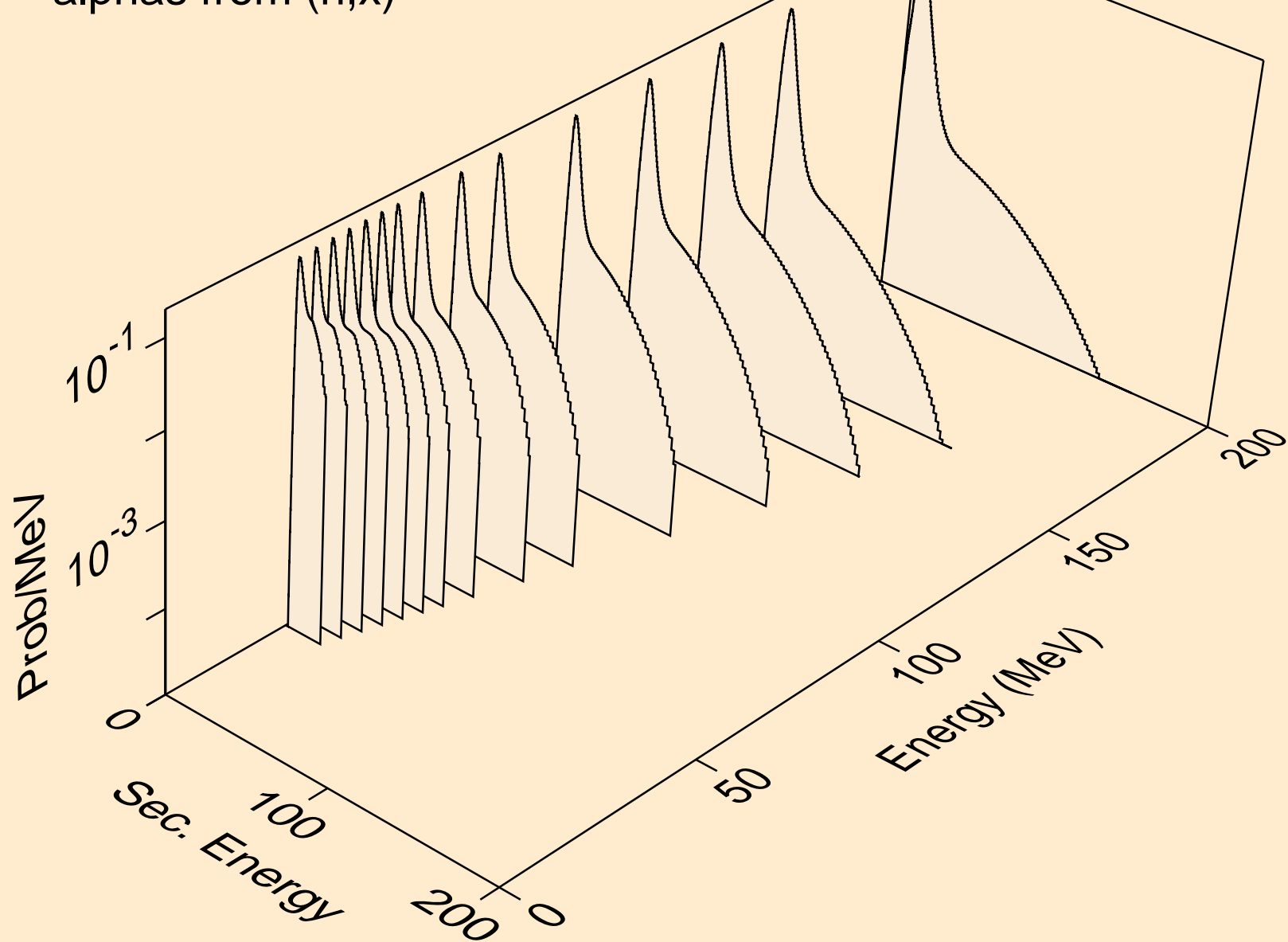

P031 NEUTRON ACER TENDL-2023 LIBRARY; T=0.K  
alphas from (n,n\*)a

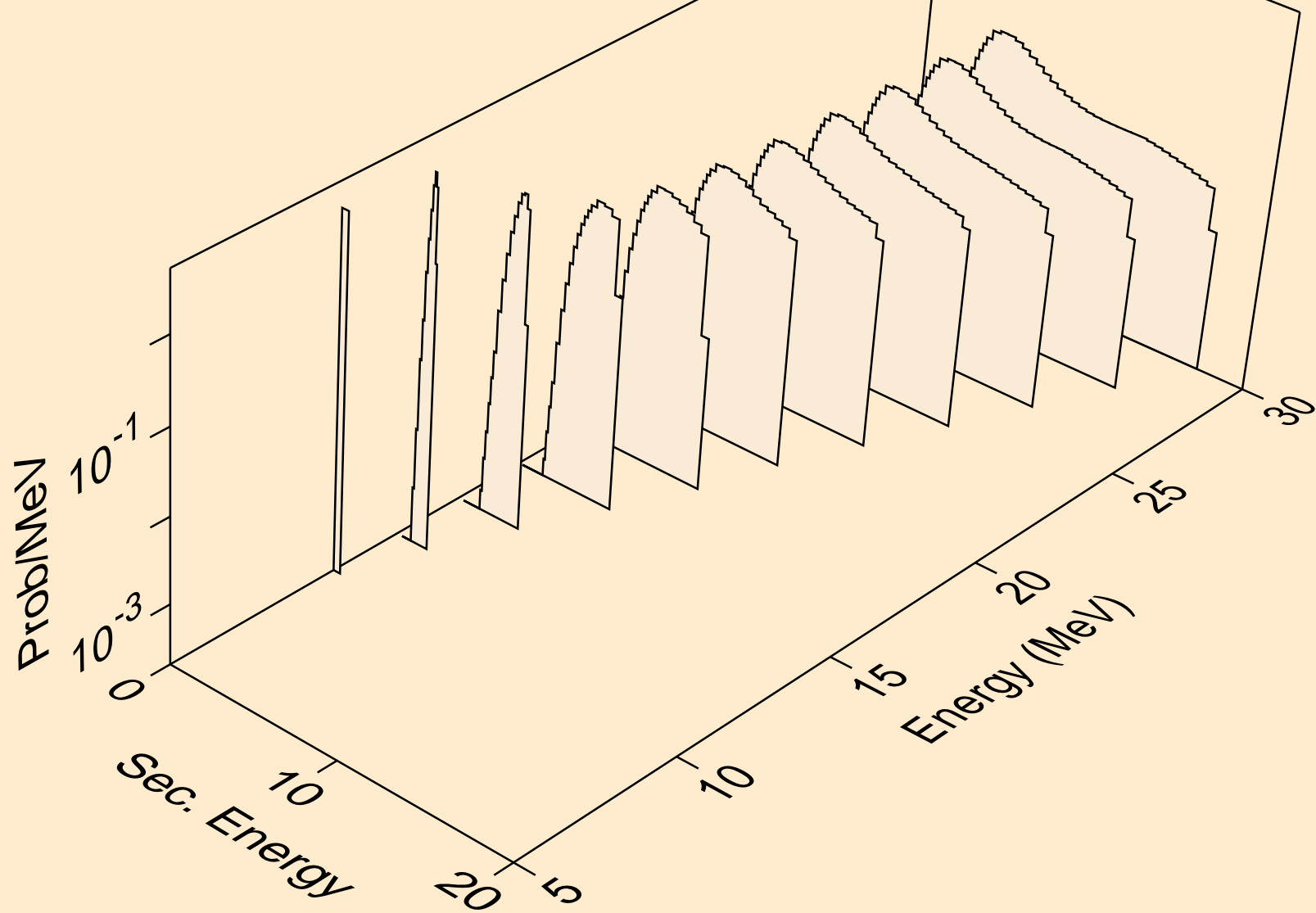

P031 NEUTRON ACER TENDL-2023 LIBRARY; T=0.K  
alphas from (n,2n)a

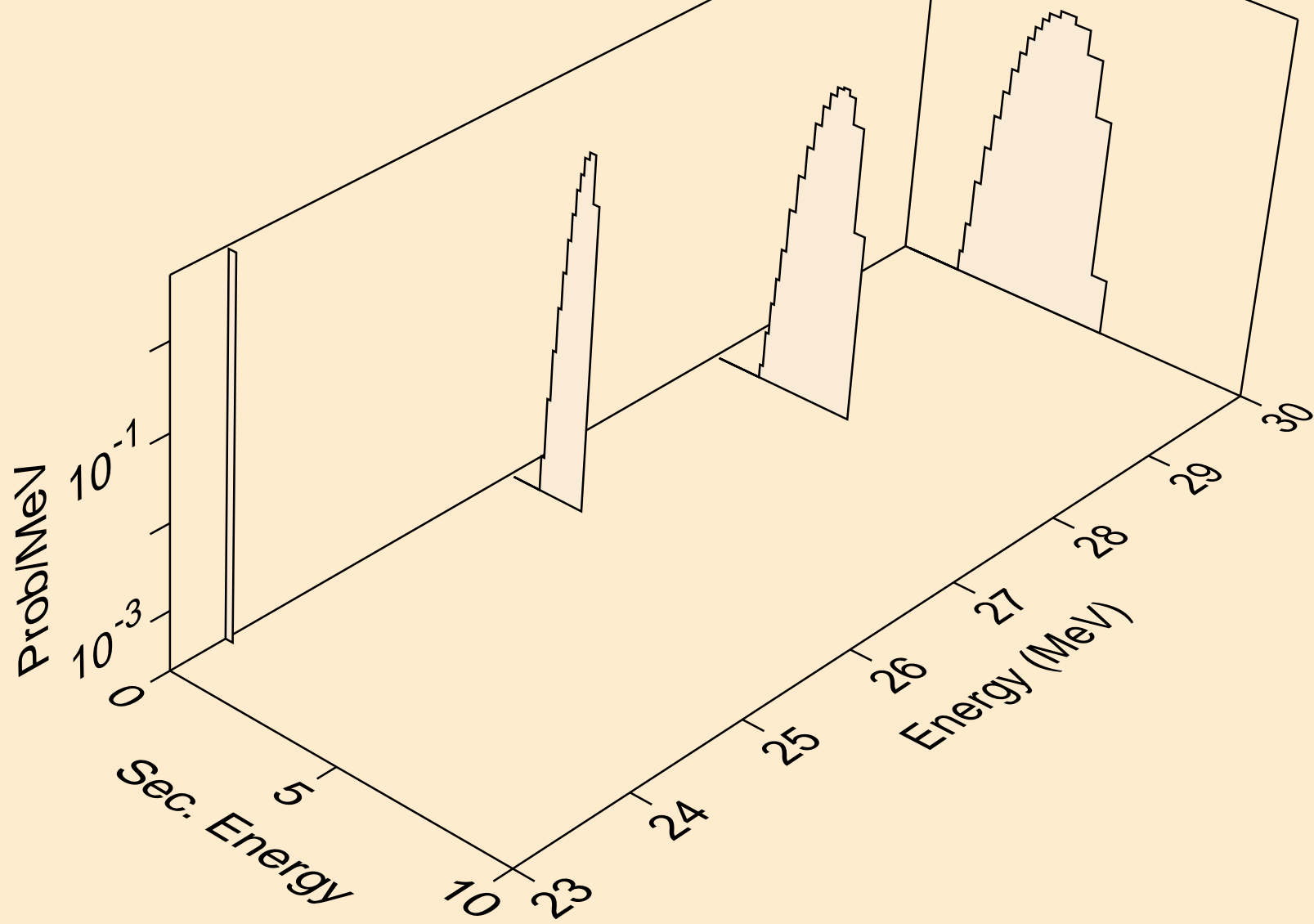

P031 NEUTRON ACER TENDL-2023 LIBRARY; T=0.K  
alphas from (n,n\*)2a

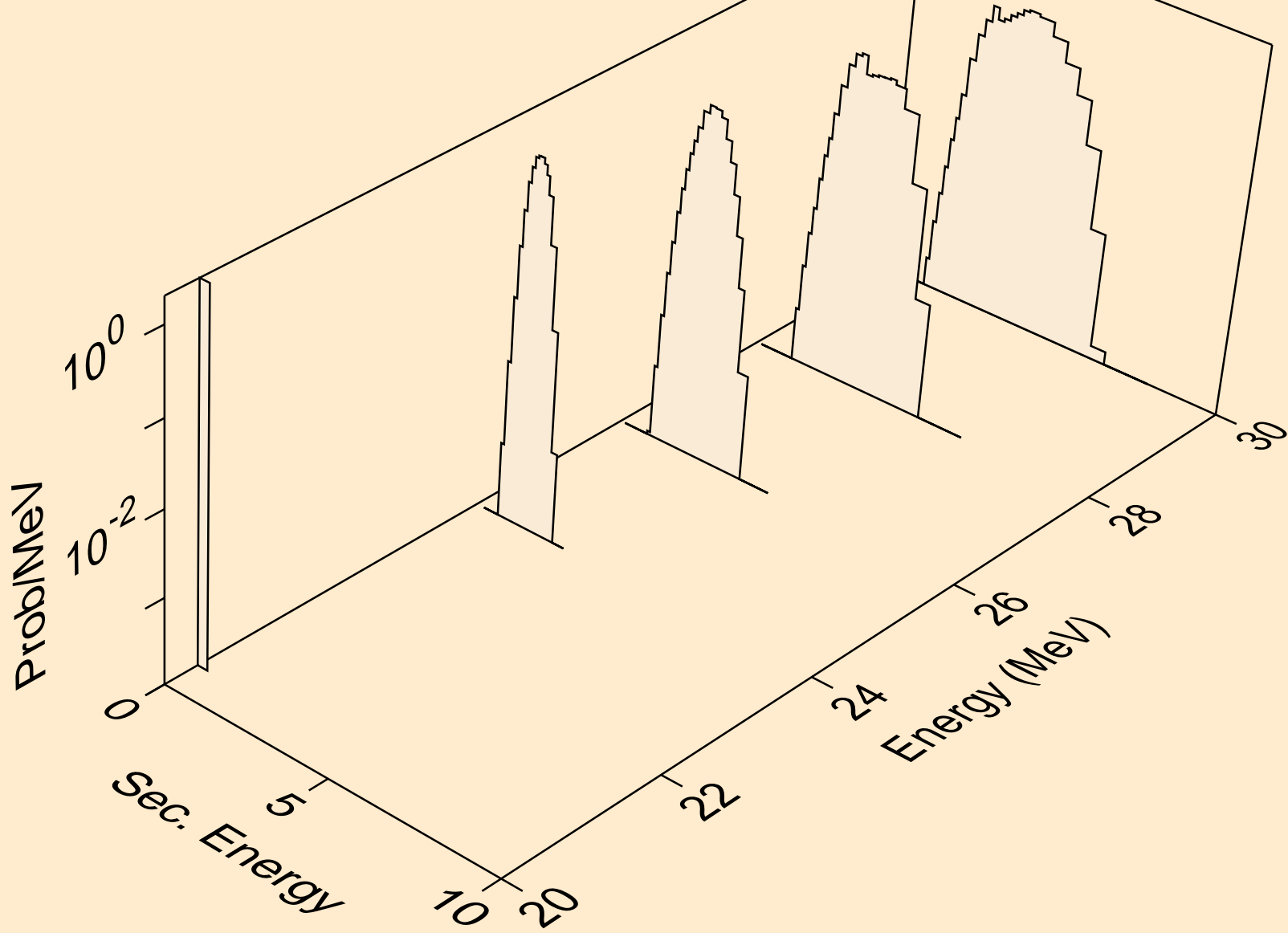

P031 NEUTRON ACER TENDL-2023 LIBRARY; T=0.K  
alphas from (n,npa)

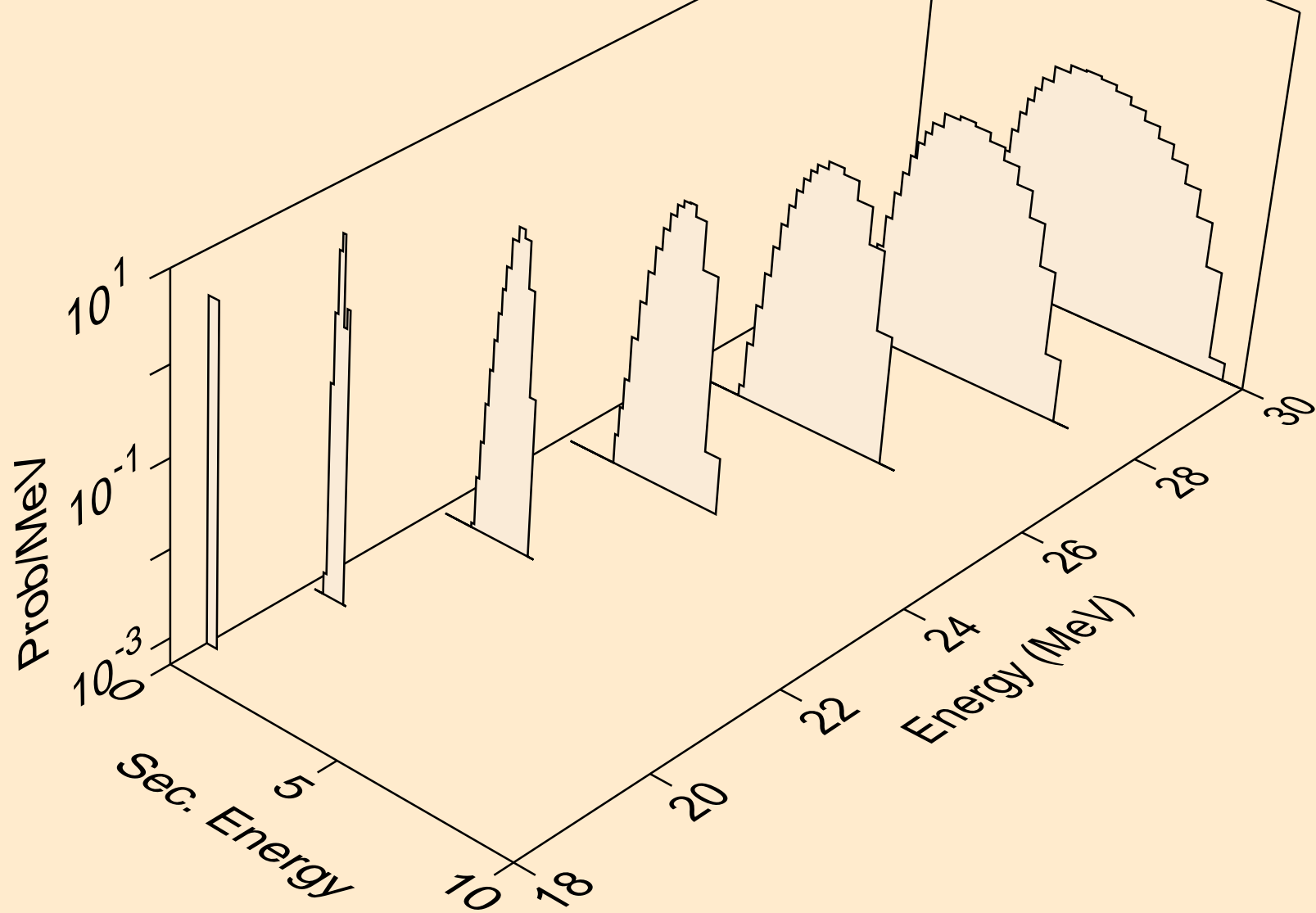

P031 NEUTRON ACER TENDL-2023 LIBRARY; T=0.K  
alphas from (n,a)

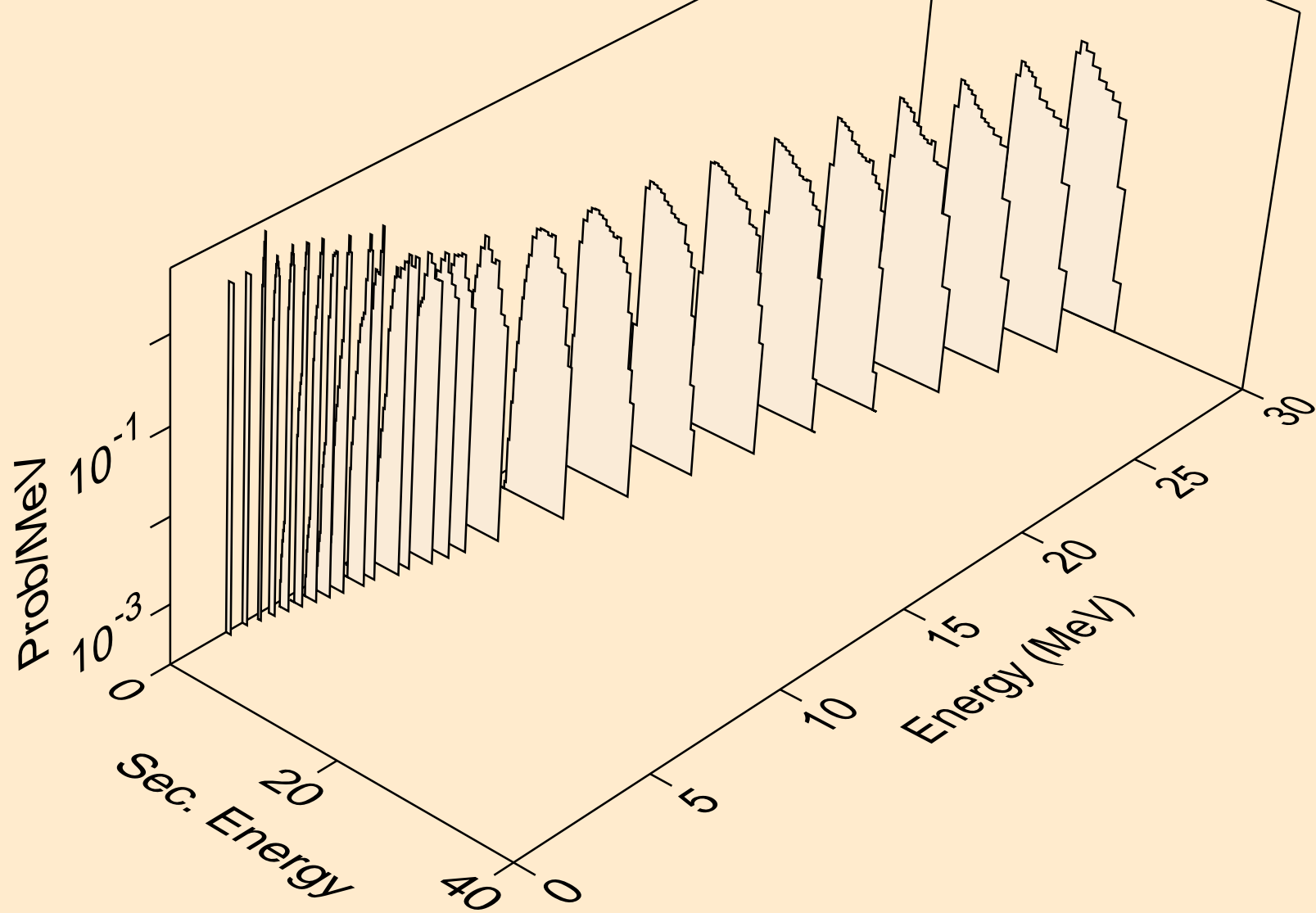

P031 NEUTRON ACER TENDL-2023 LIBRARY; T=0.K  
alphas from (n,2a)

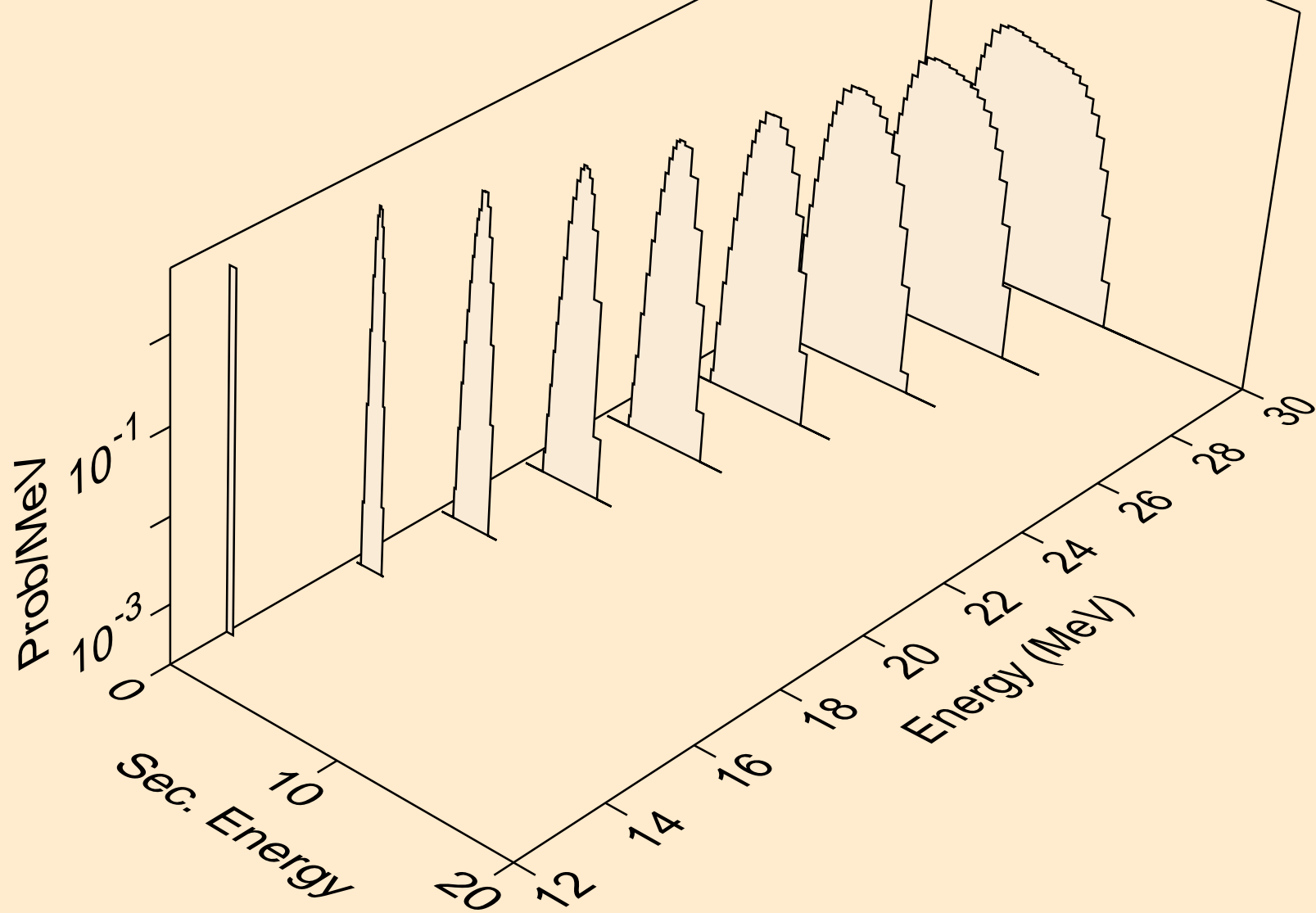

P031 NEUTRON ACER TENDL-2023 LIBRARY; T=0.K  
alphas from (n,pa)

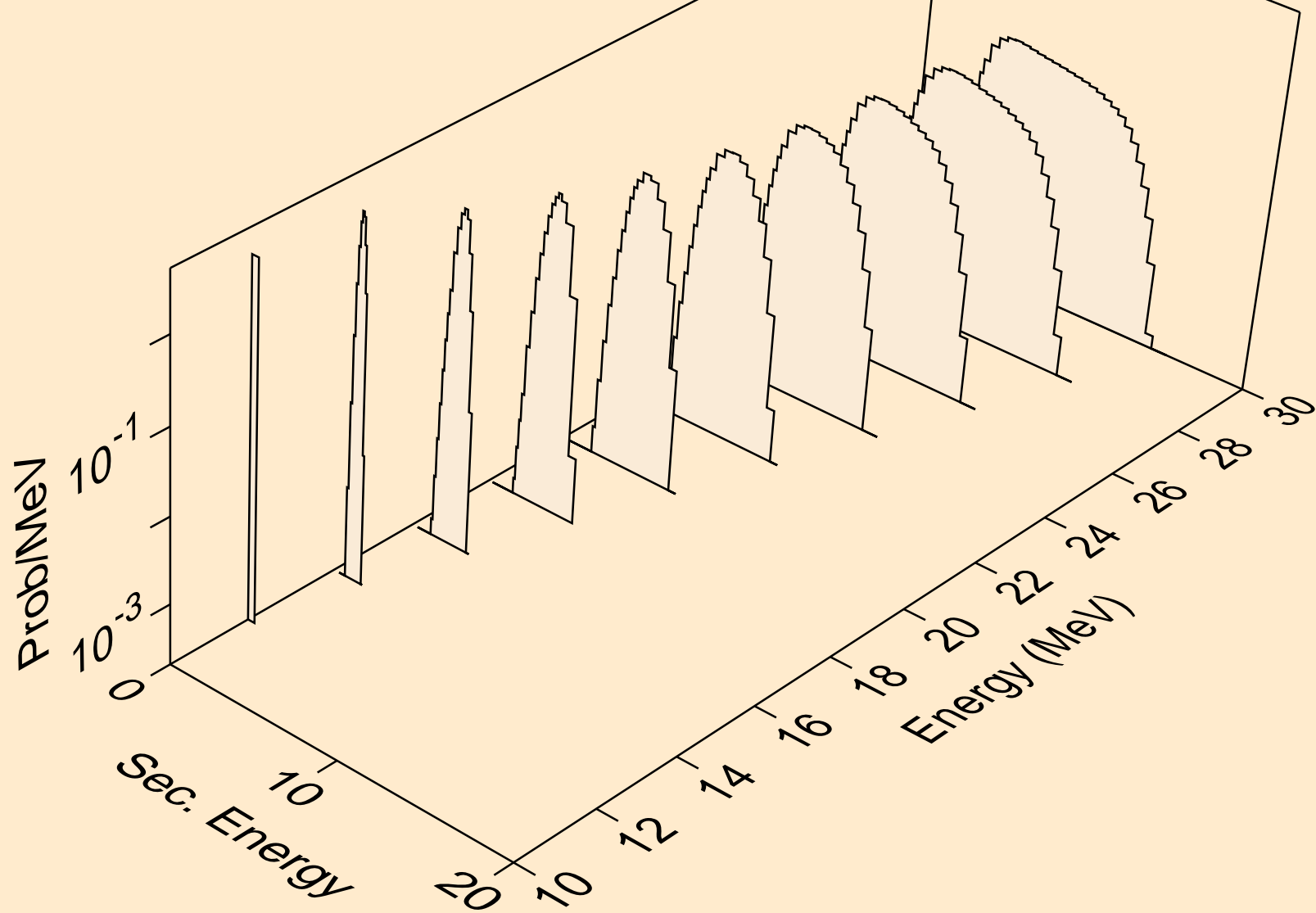

P031 NEUTRON ACER TENDL-2023 LIBRARY; T=0.K  
alphas from (n,da)

