

SE073M NEUTRON ACER TENDL-2023 LIBRARY; T=0.K

Principal cross sections

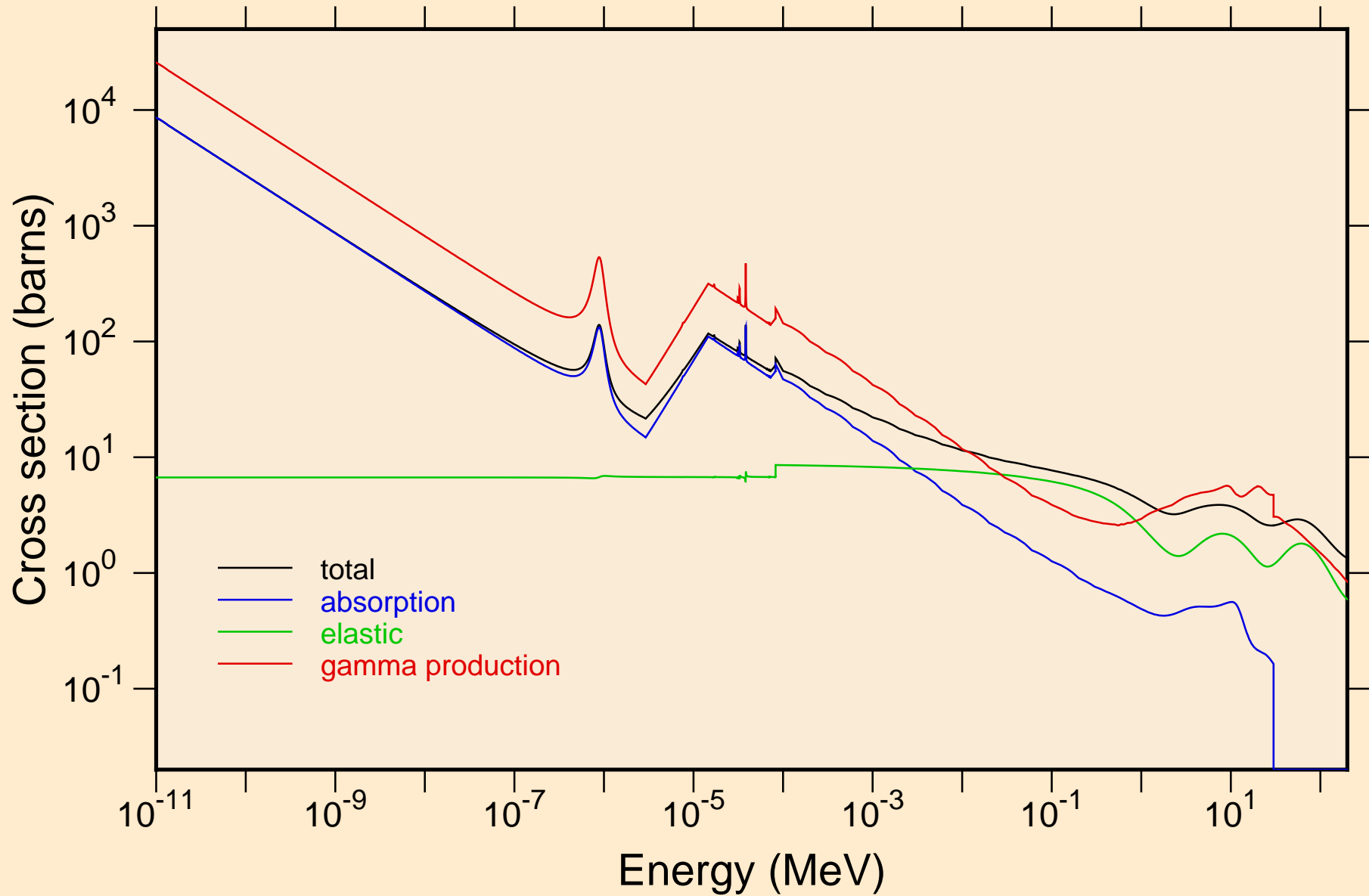

SE073M NEUTRON ACER TENDL-2023 LIBRARY; T=0.K
resonance total cross section

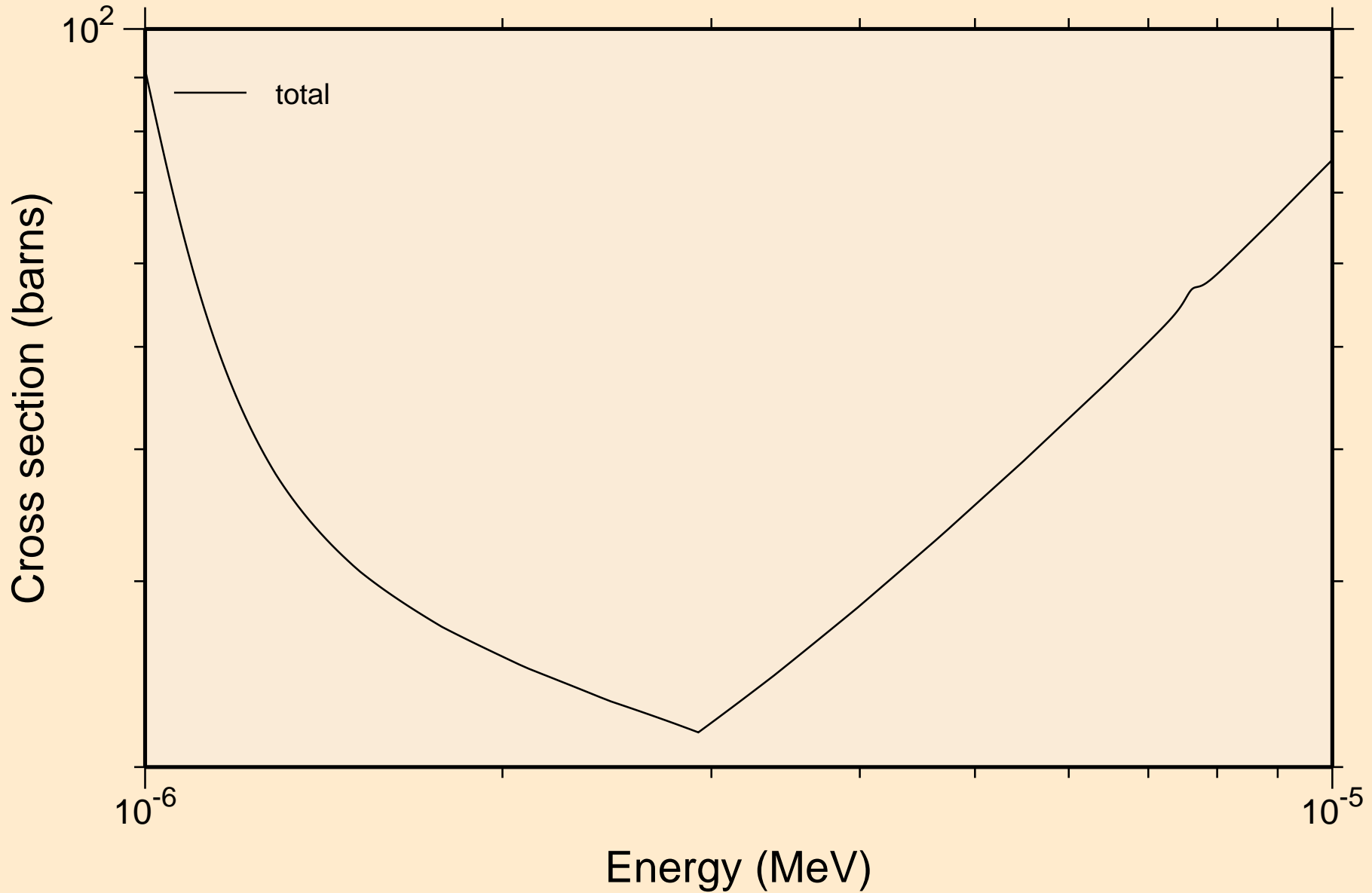

SE073M NEUTRON ACER TENDL-2023 LIBRARY; T=0.K
resonance total cross section

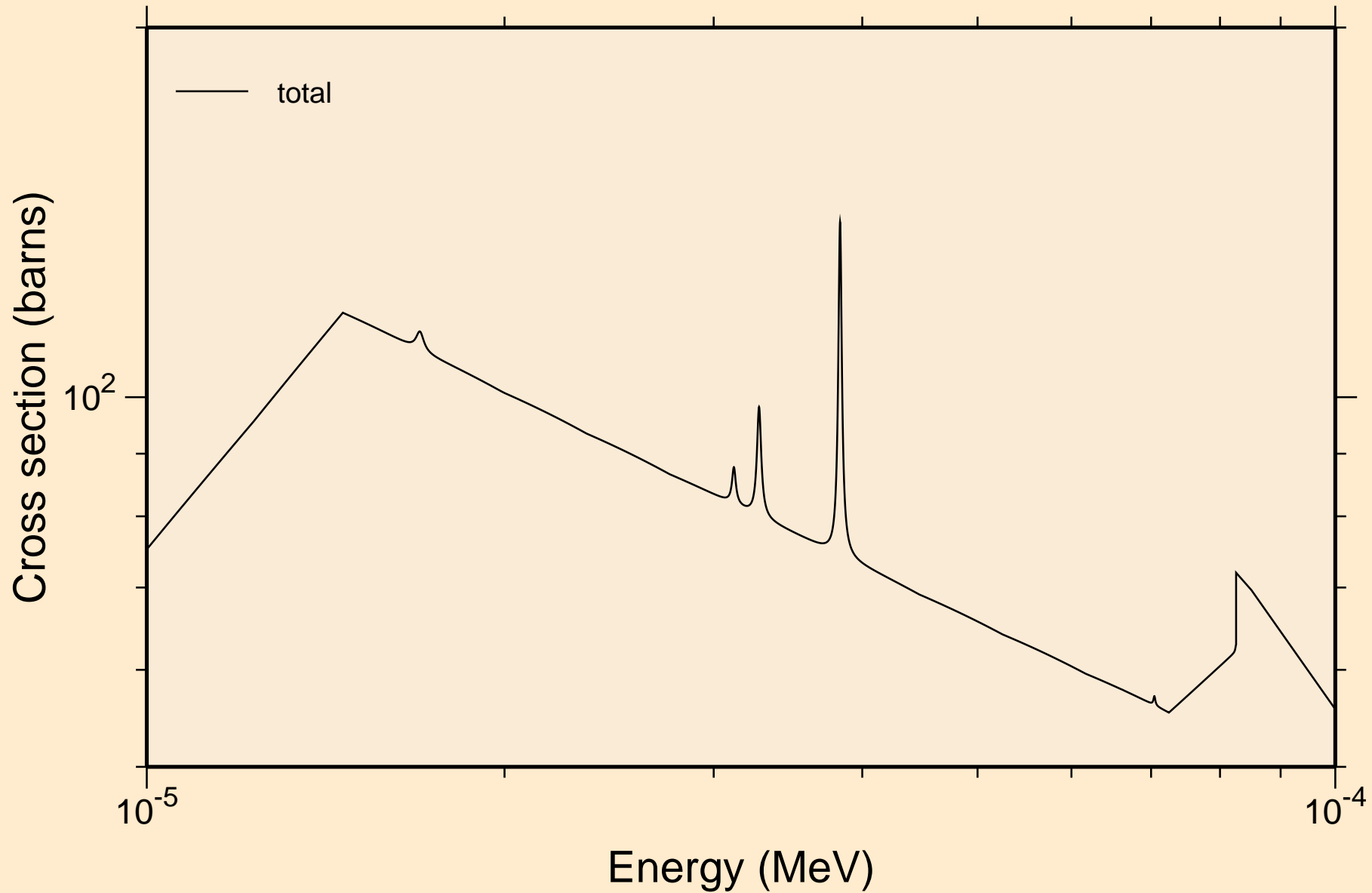

S \bar{E} 073M NEUTRON ACER TENDL-2023 LIBRARY; T=0.K
resonance total cross section

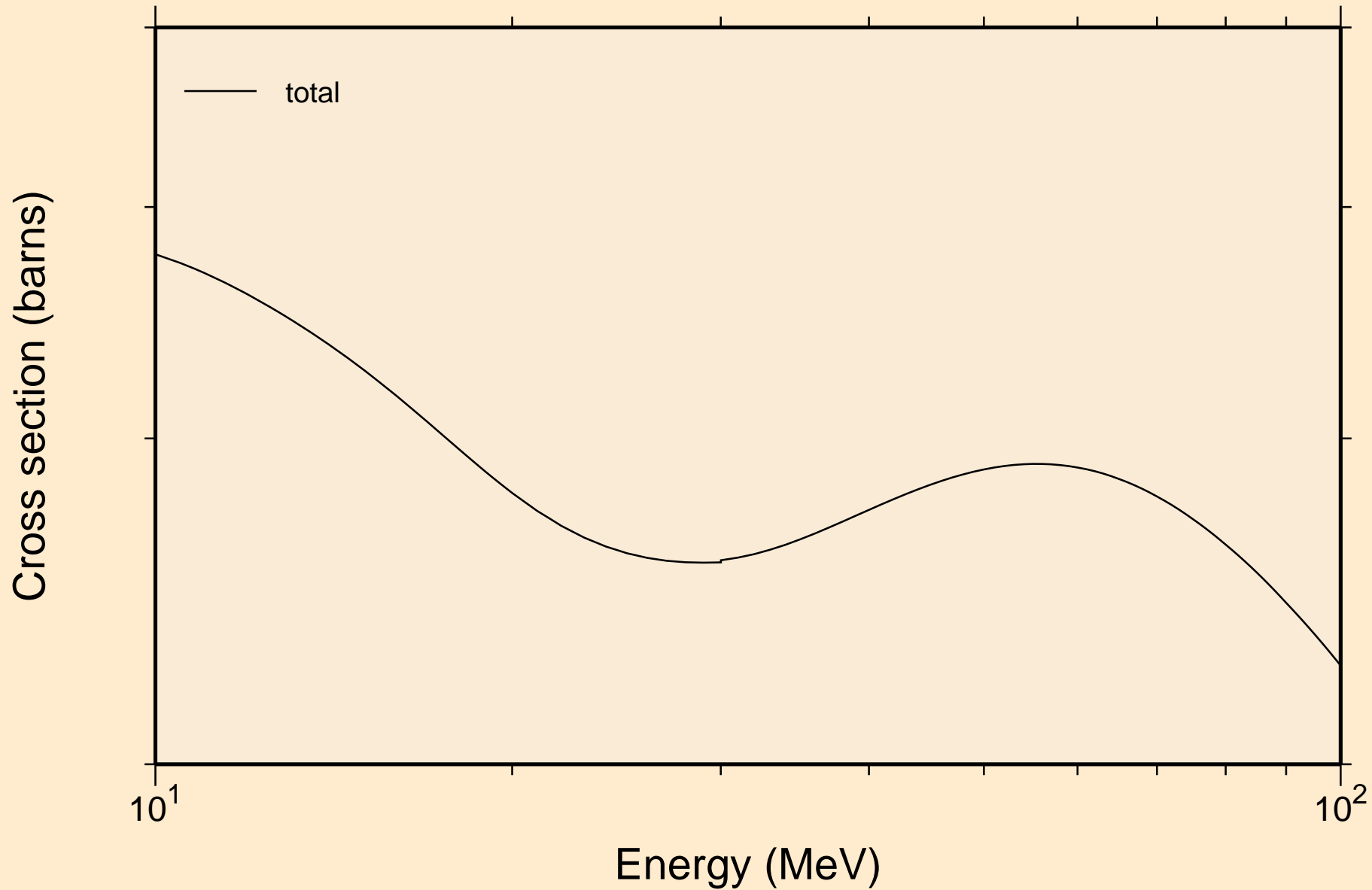

SE073M NEUTRON ACER TENDL-2023 LIBRARY; T=0.K
resonance absorption cross sections

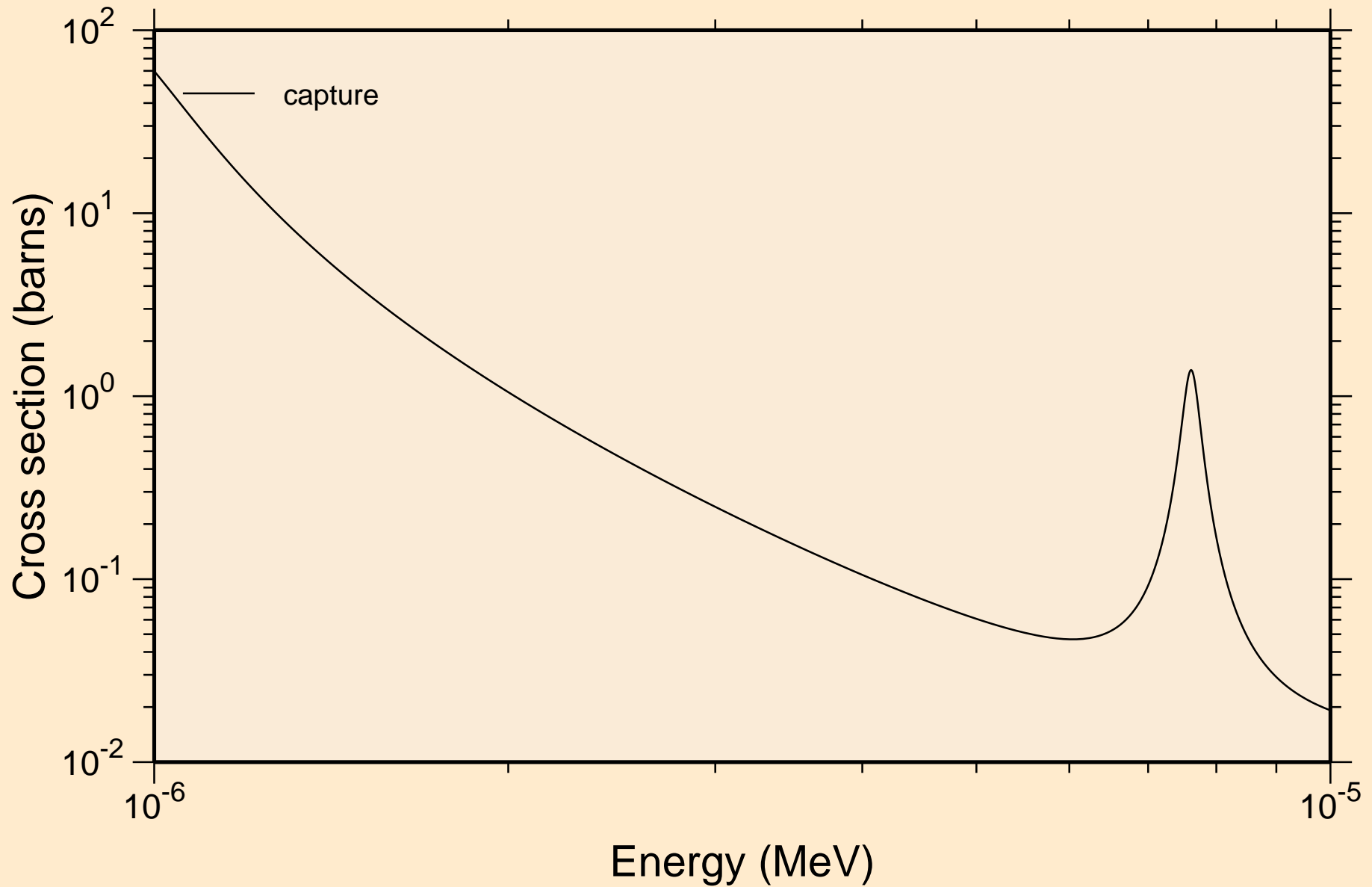

SE073M NEUTRON ACER TENDL-2023 LIBRARY; T=0.K
resonance absorption cross sections

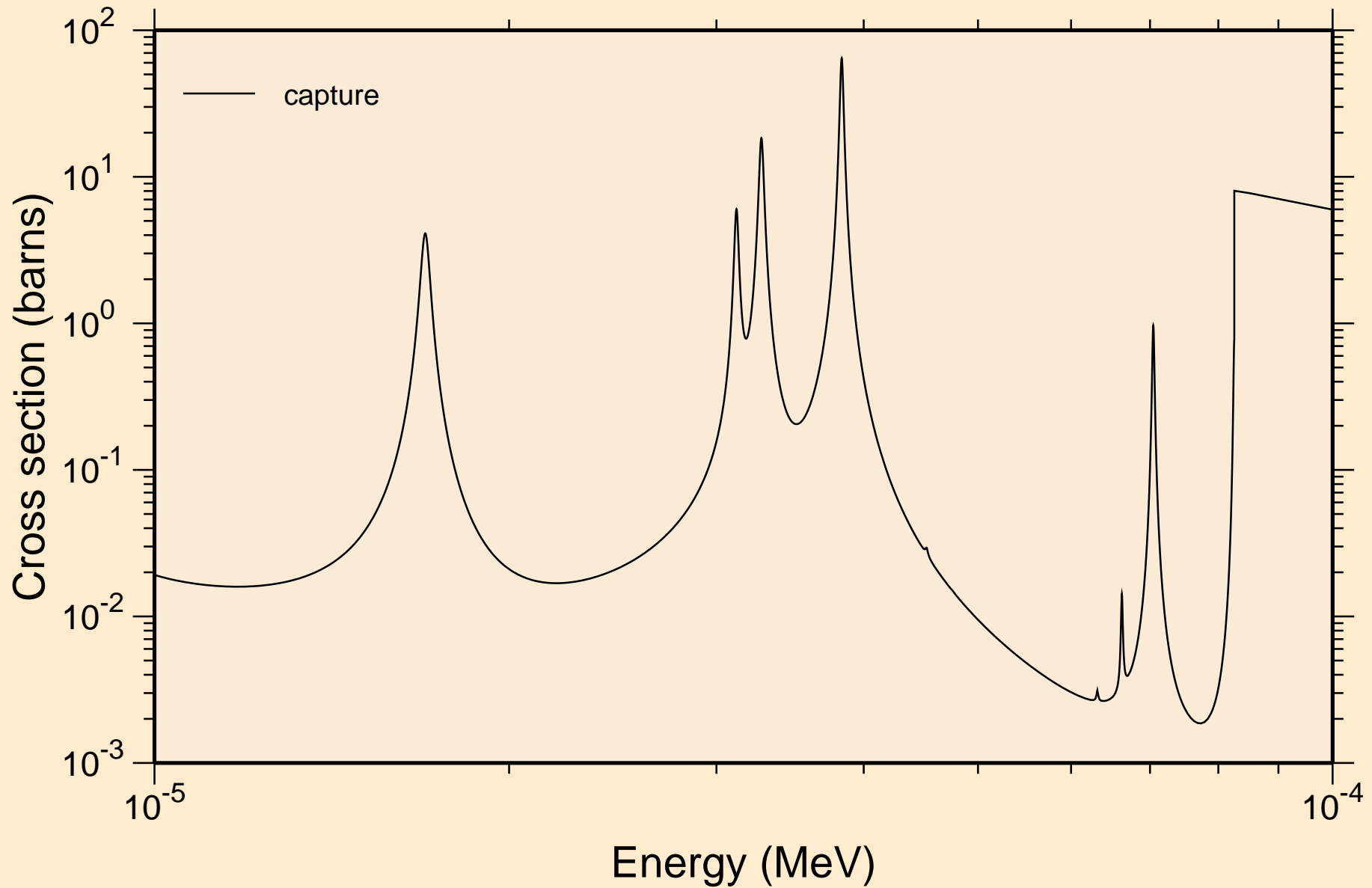

SE073M NEUTRON ACER TENDL-2023 LIBRARY; T=0.K
resonance absorption cross sections

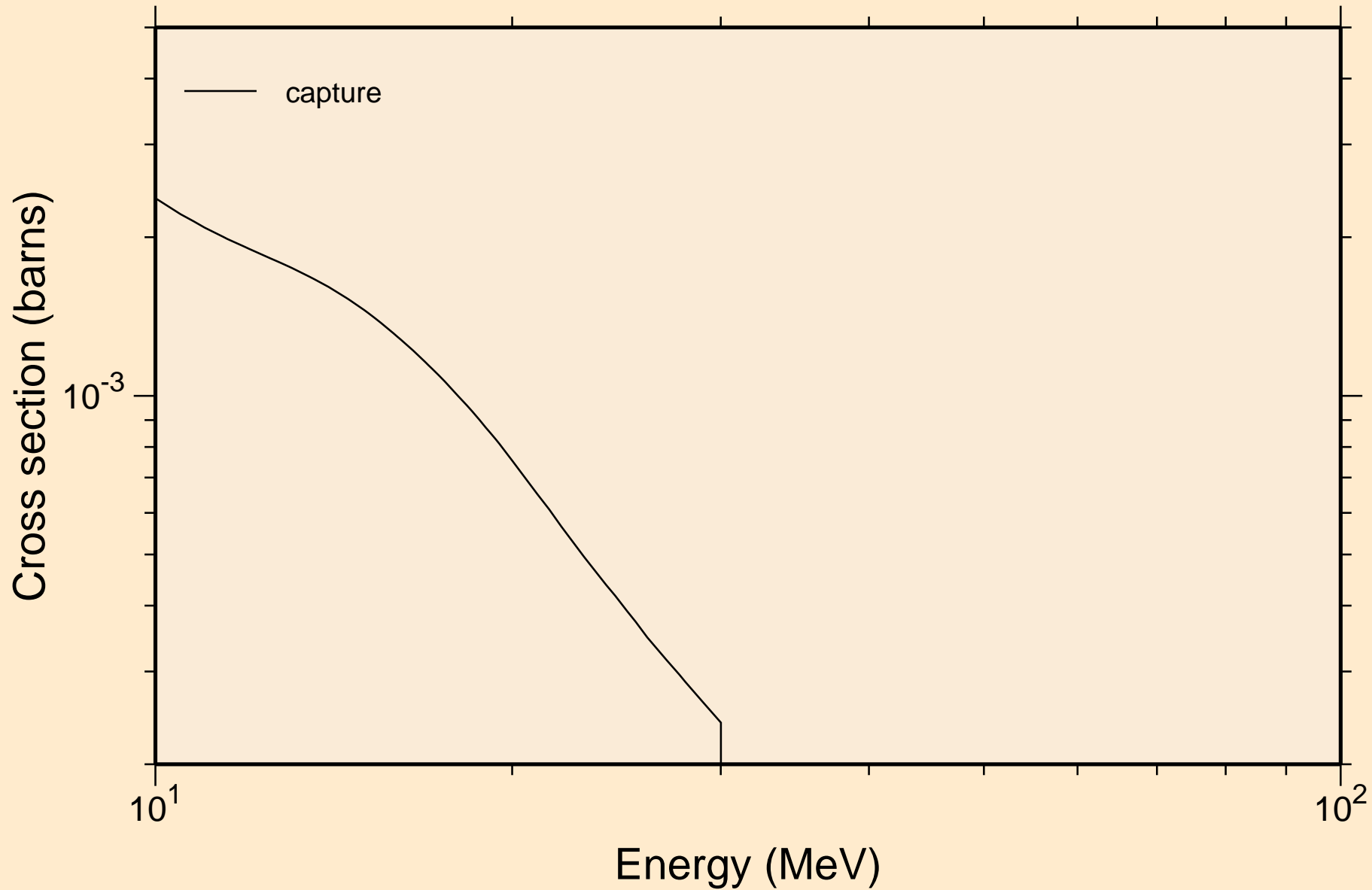

SE073M NEUTRON ACER TENDL-2023 LIBRARY; T=0.K

Heating

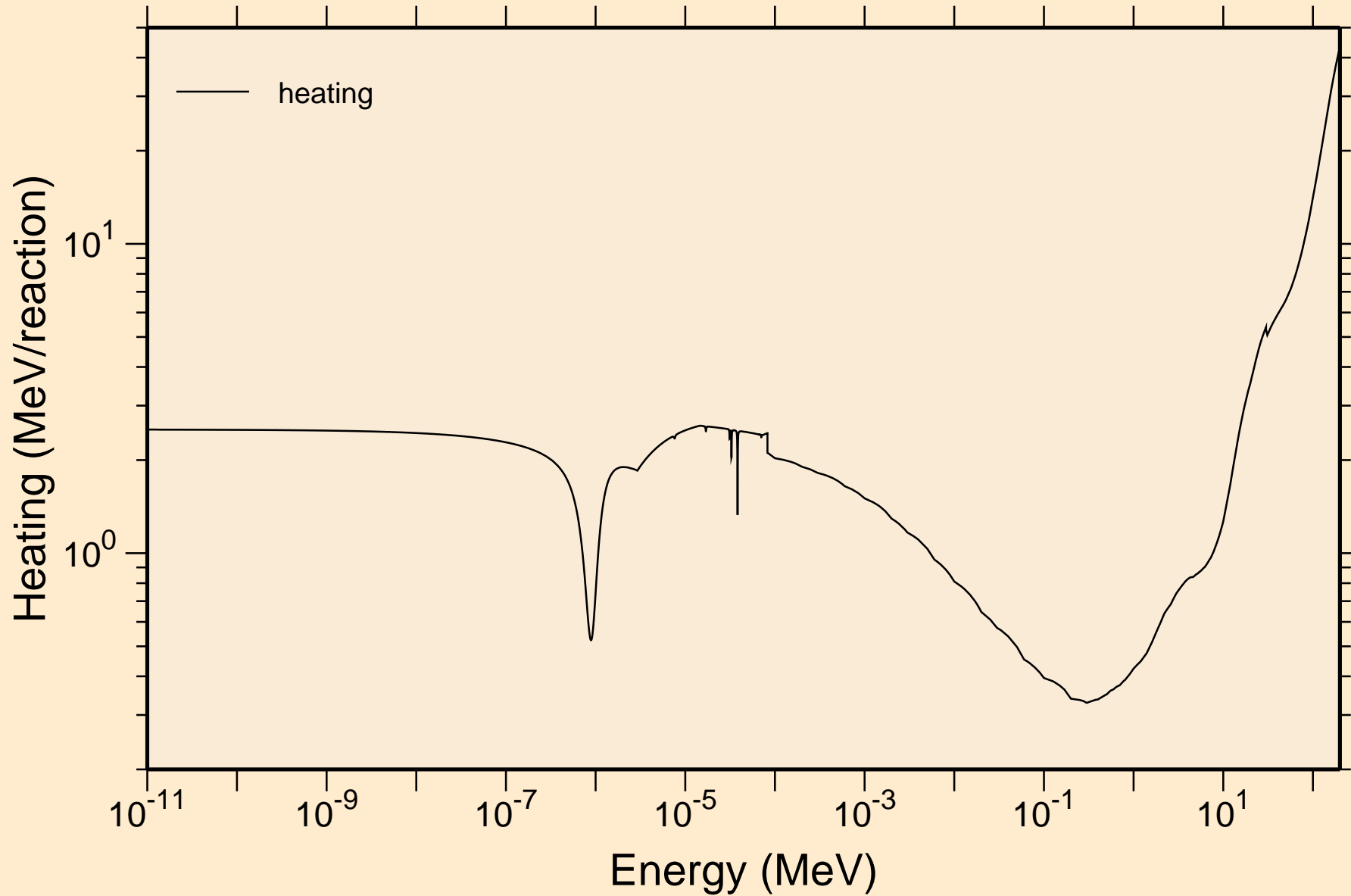

SE073M NEUTRON ACER TENDL-2023 LIBRARY; T=0.K
Damage

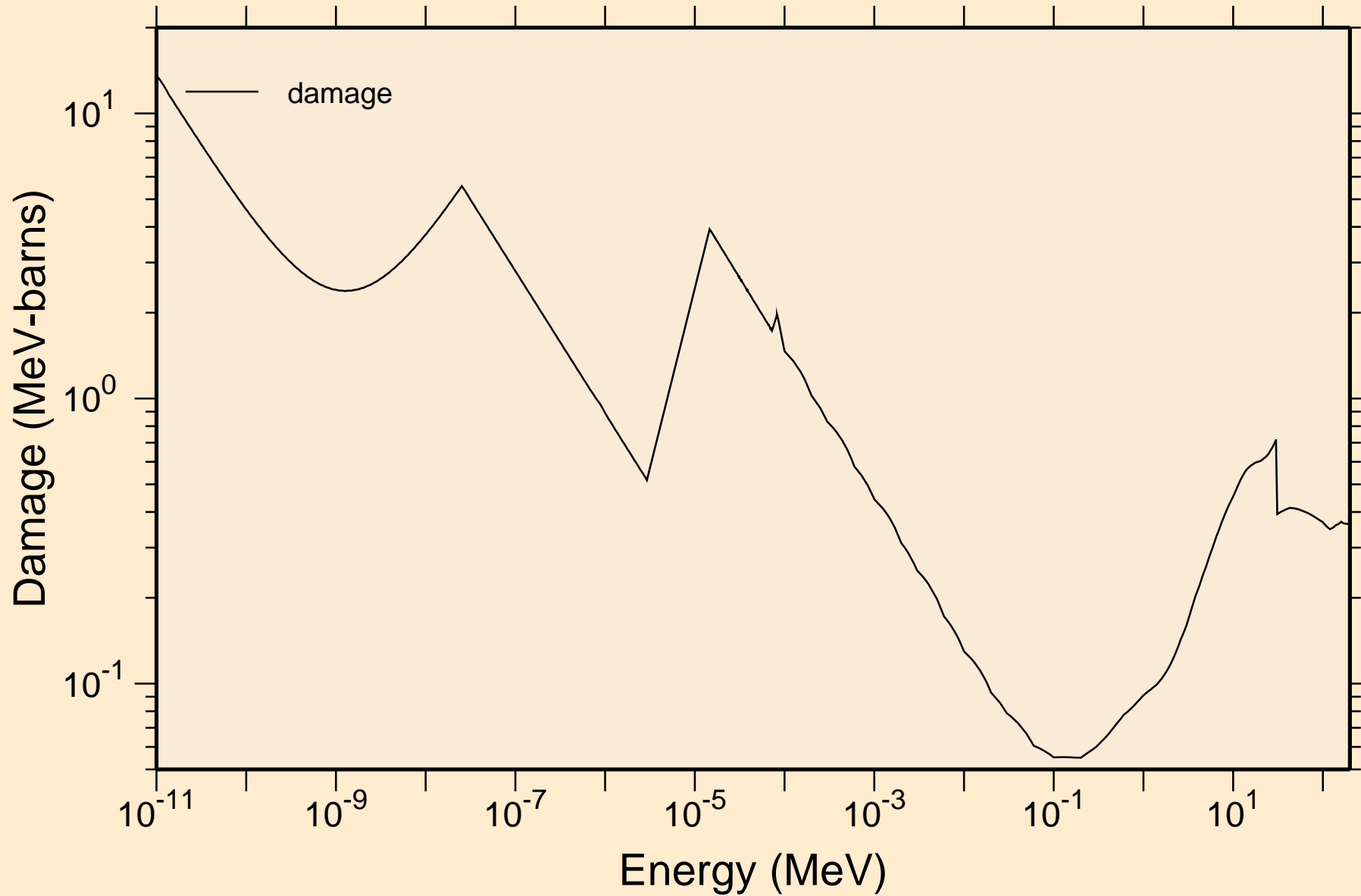

SE073M NEUTRON ACER TENDL-2023 LIBRARY; T=0.K

Non-threshold reactions

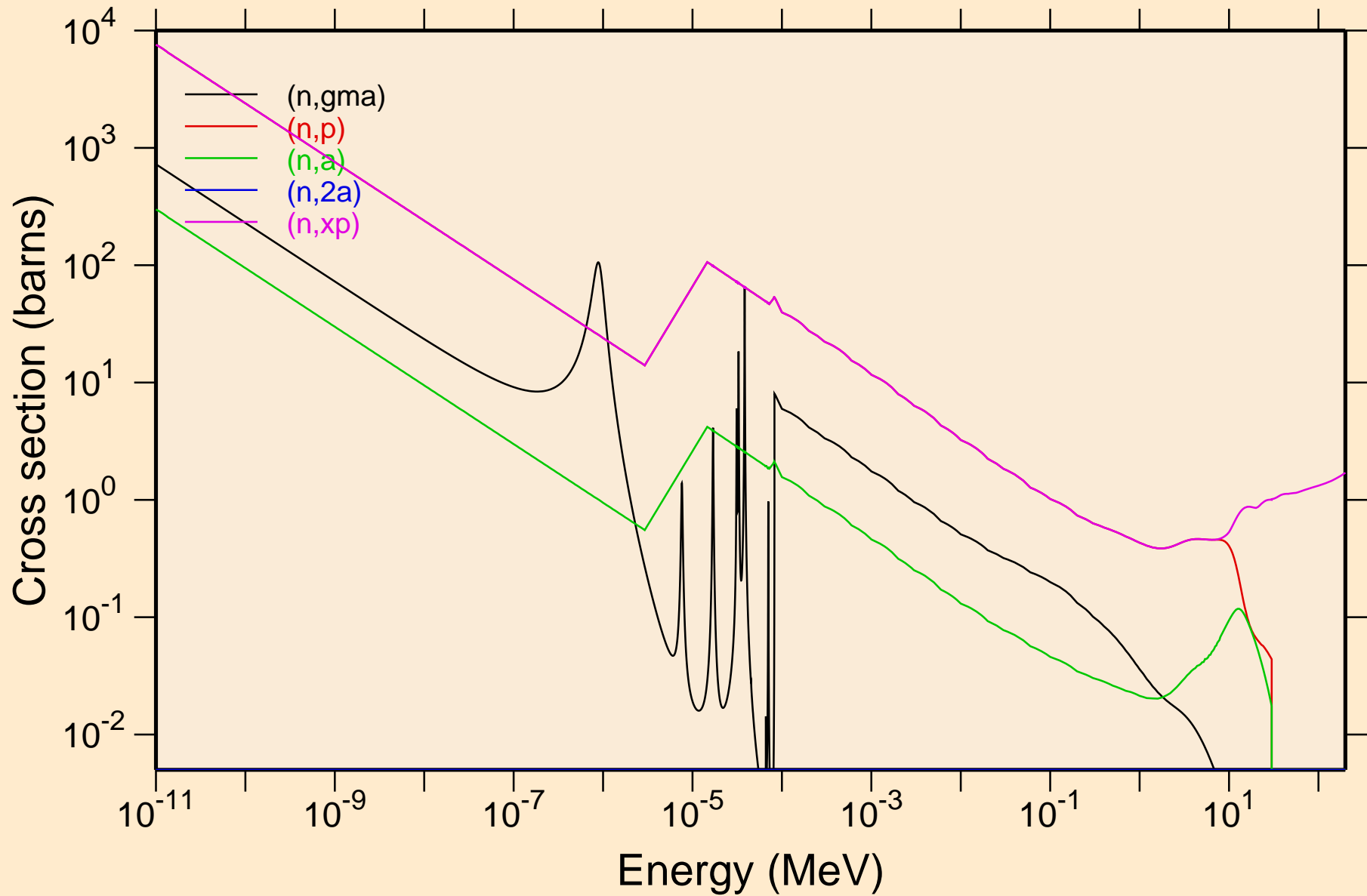

SE073M NEUTRON ACER TENDL-2023 LIBRARY; T=0.K
Non-threshold reactions

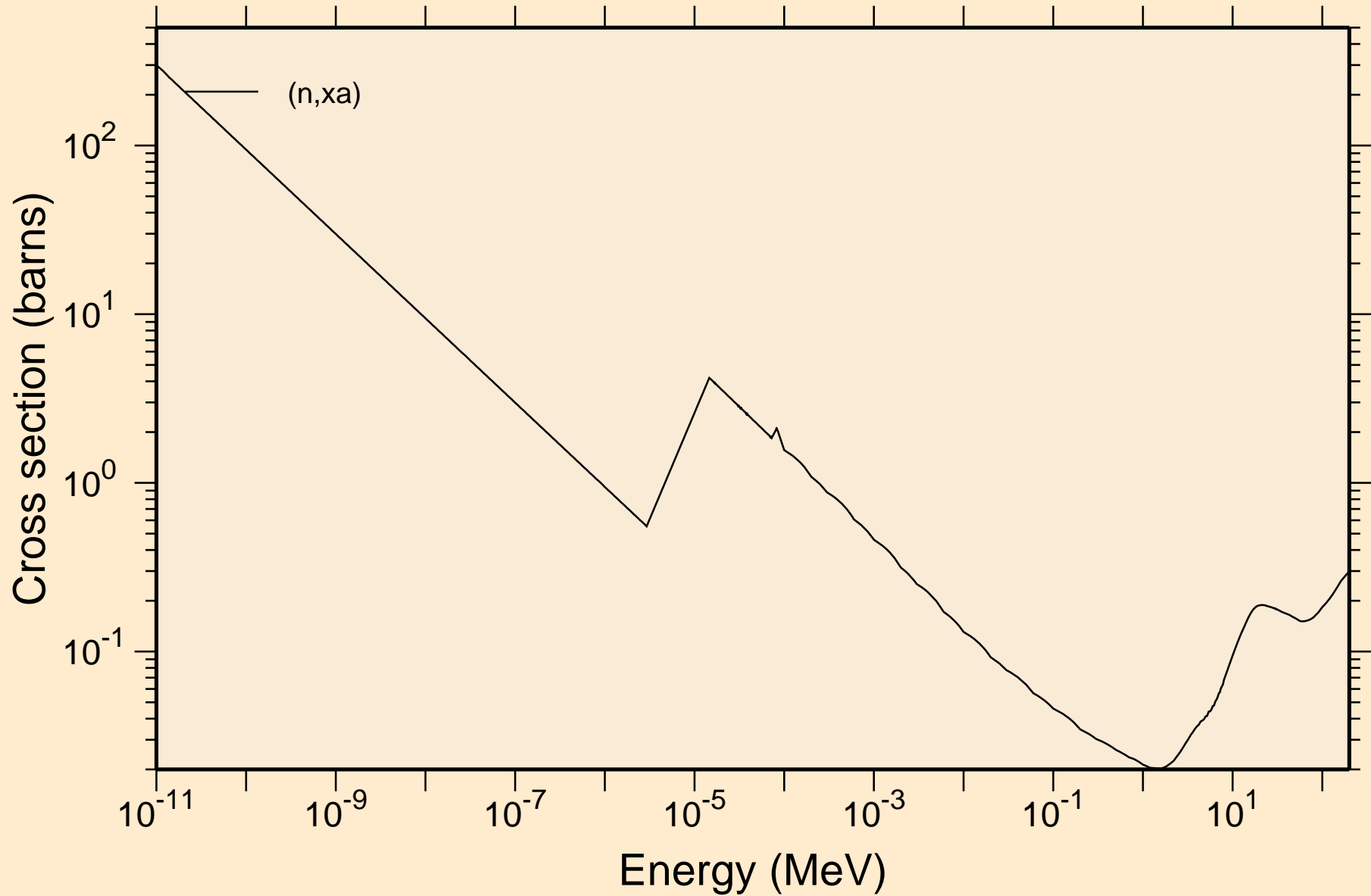

SE073M NEUTRON ACER TENDL-2023 LIBRARY; T=0.K

Principal cross sections

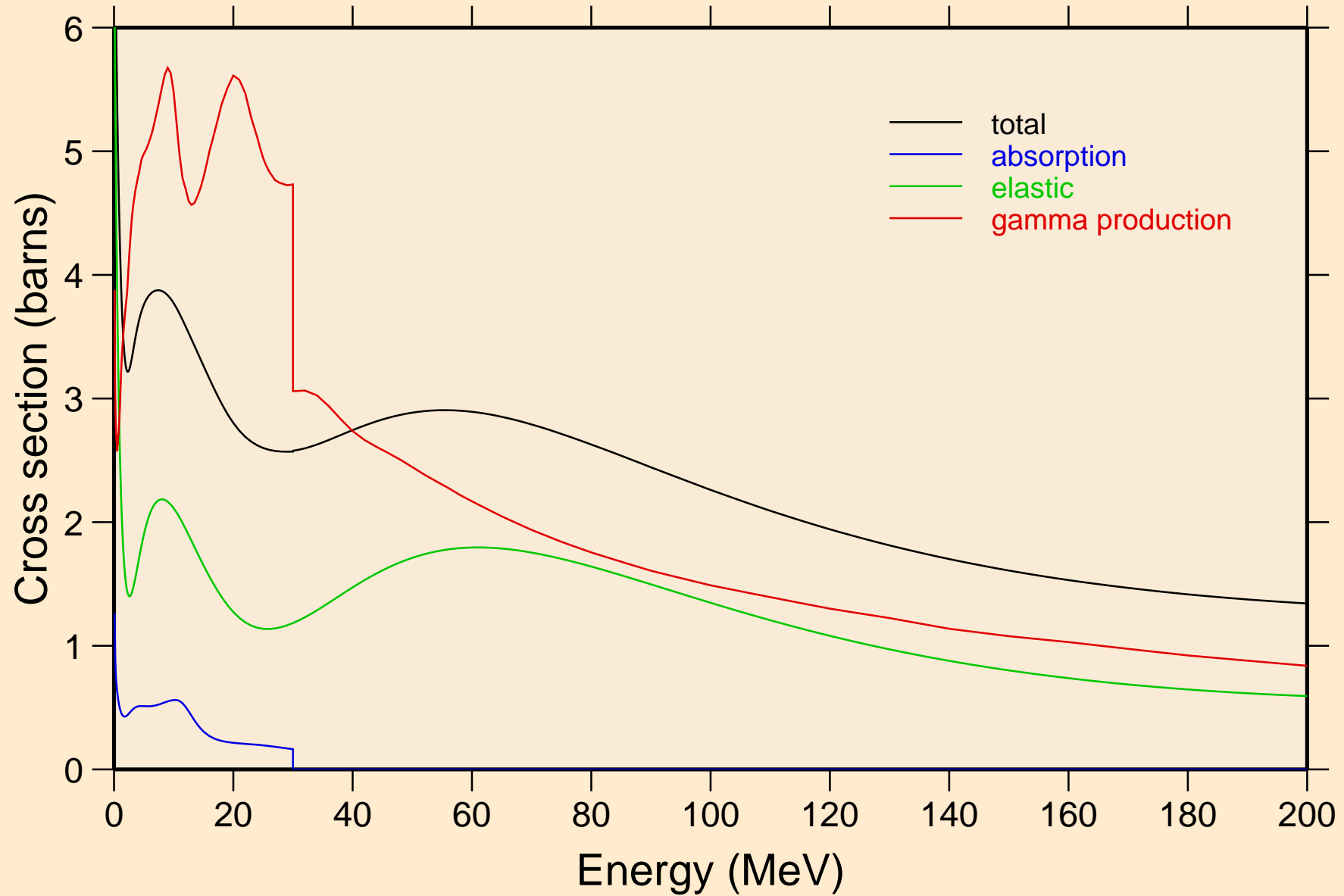

SE073M NEUTRON ACER TENDL-2023 LIBRARY; T=0.K

Heating

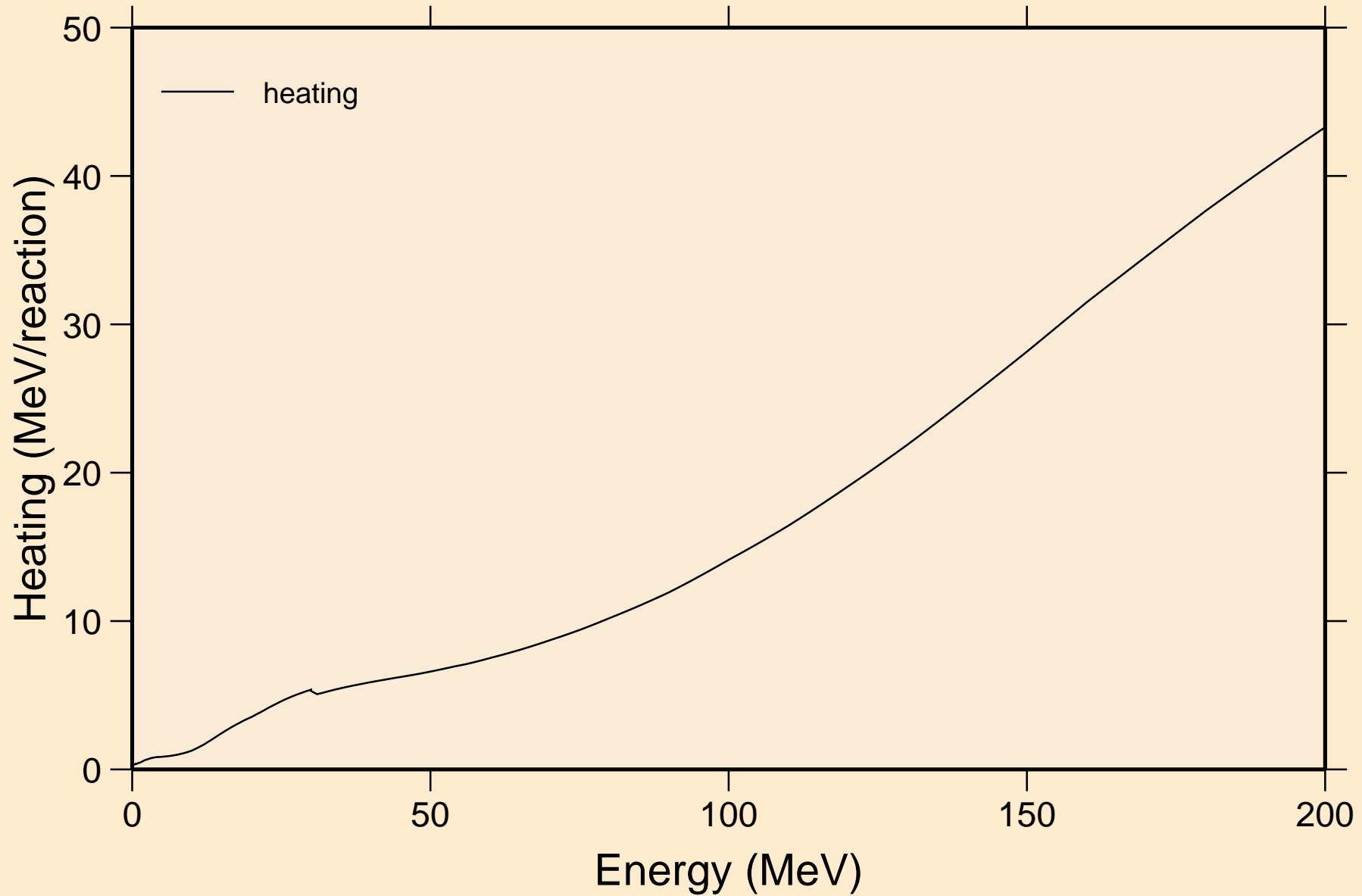

SE073M NEUTRON ACER TENDL-2023 LIBRARY; T=0.K
Damage

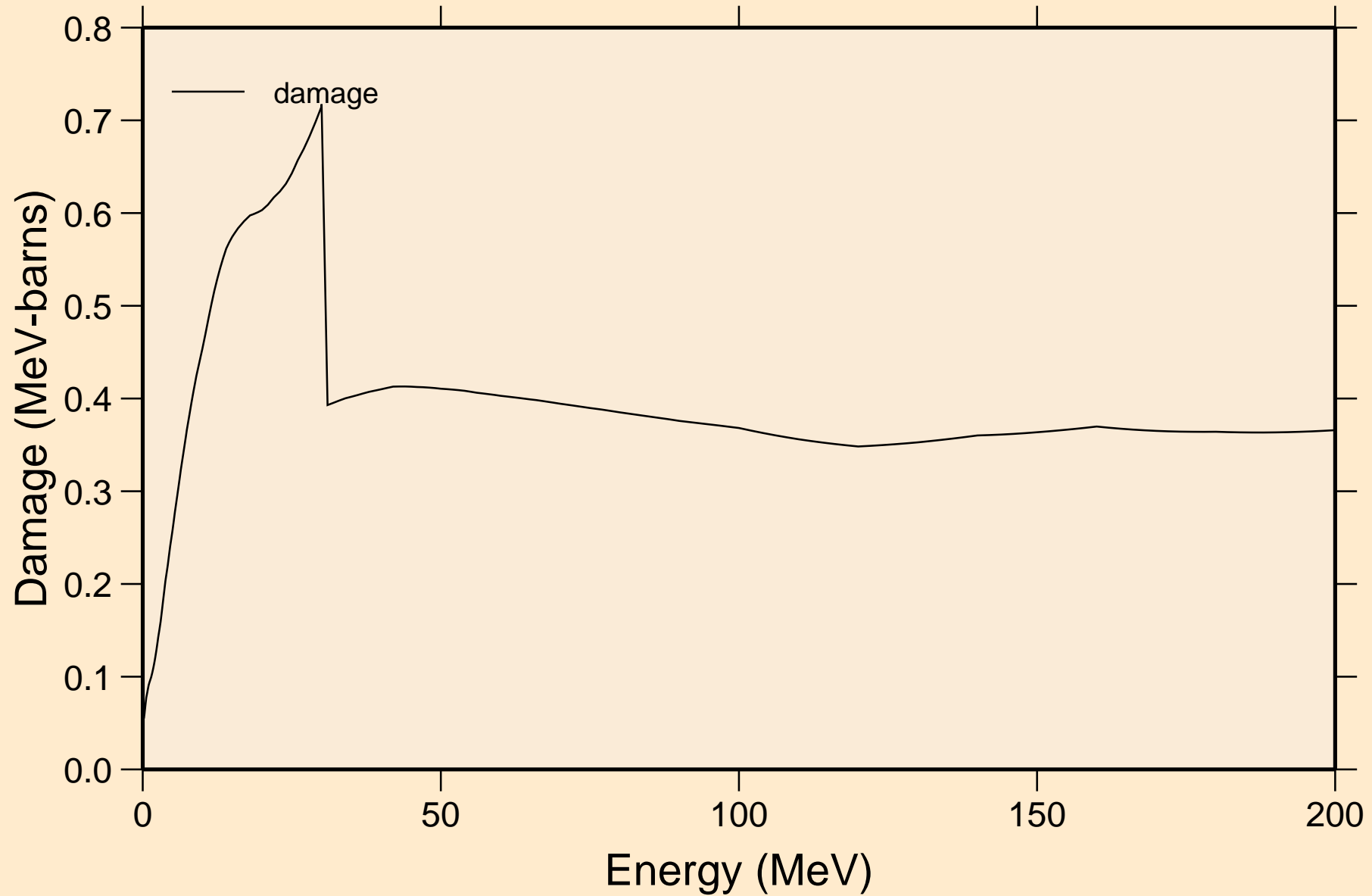

SE073M NEUTRON ACER TENDL-2023 LIBRARY; T=0.K

Non-threshold reactions

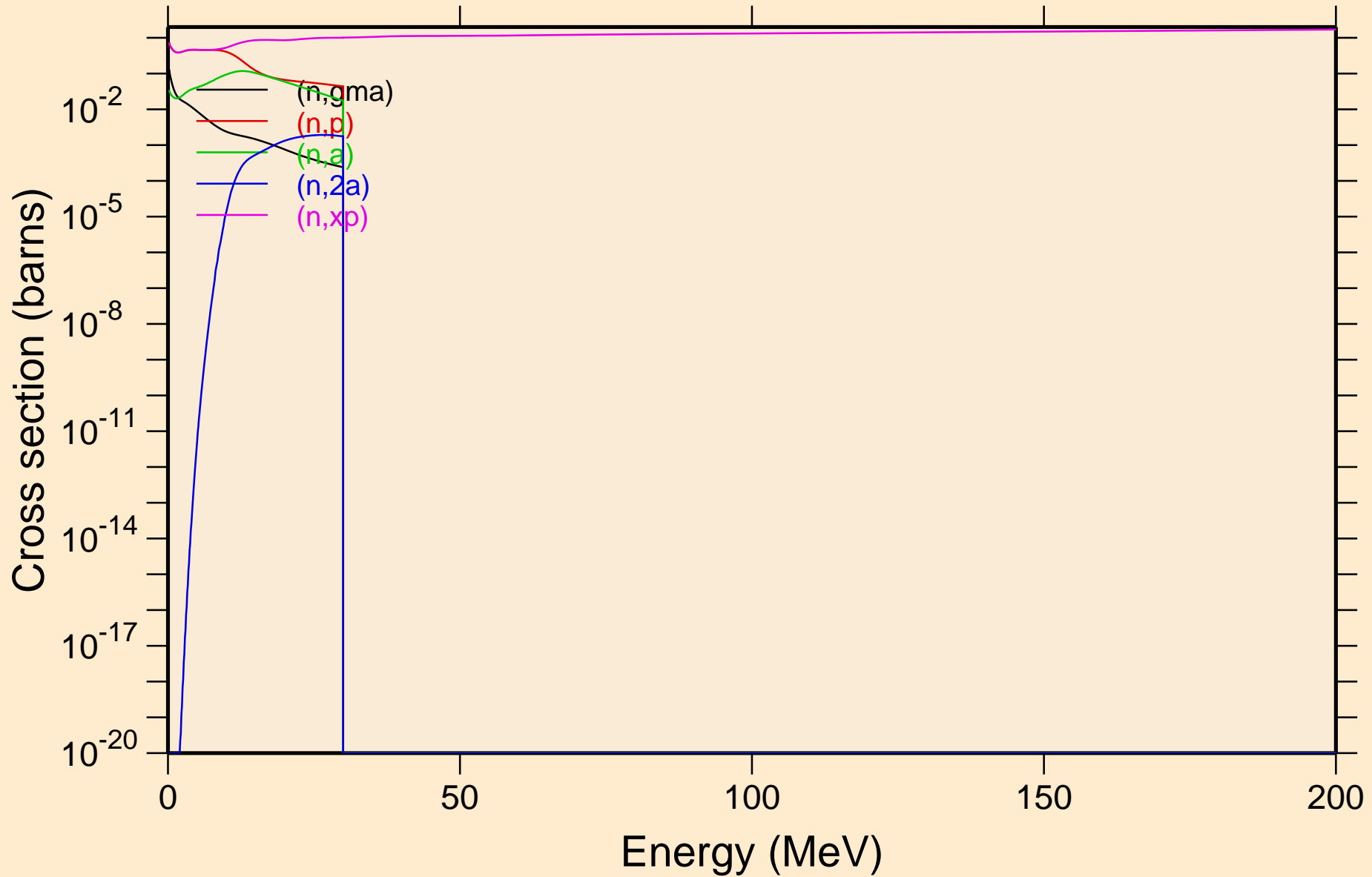

SE073M NEUTRON ACER TENDL-2023 LIBRARY; T=0.K
Non-threshold reactions

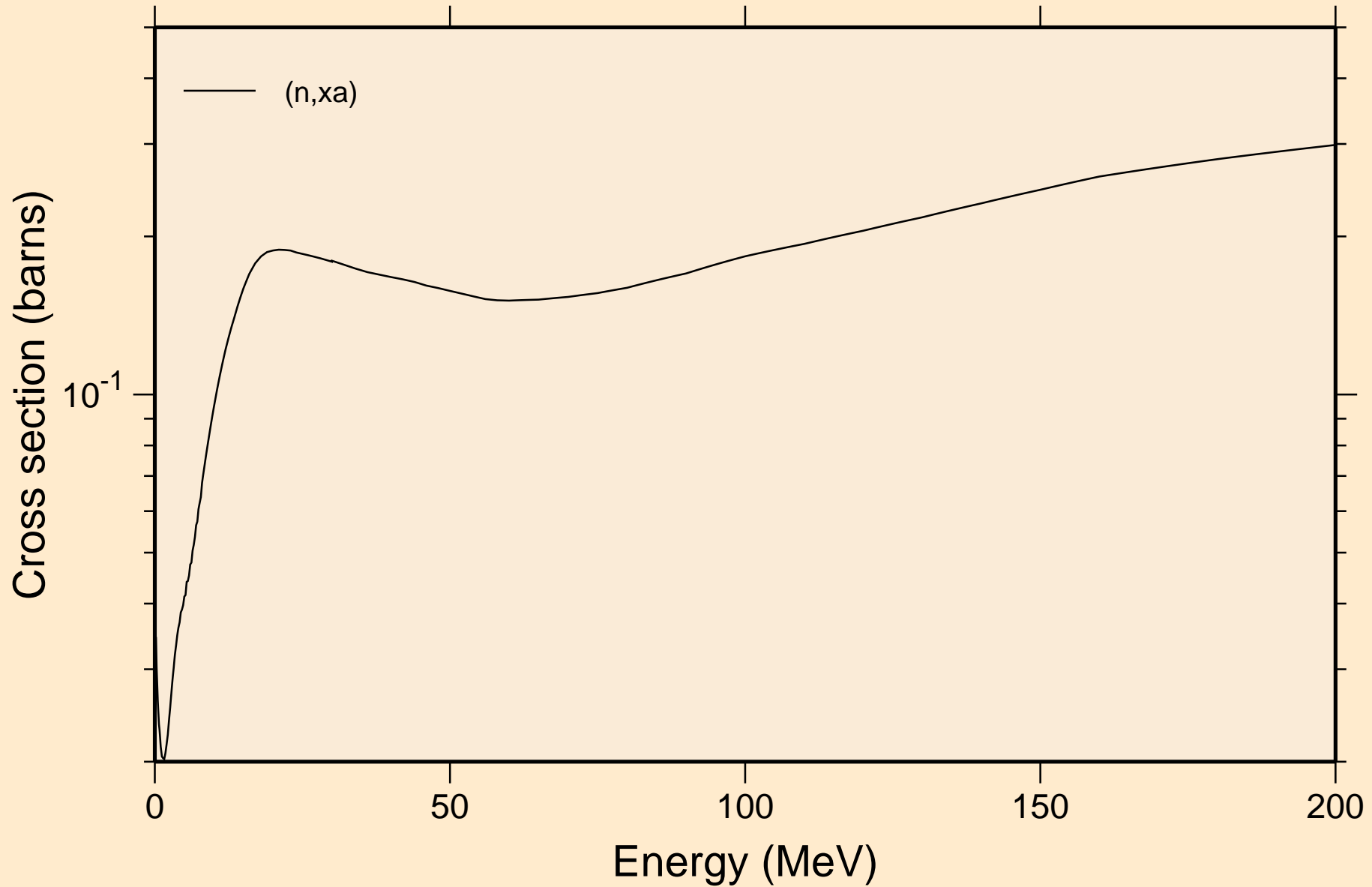

SE073M NEUTRON ACER TENDL-2023 LIBRARY; T=0.K
Inelastic levels

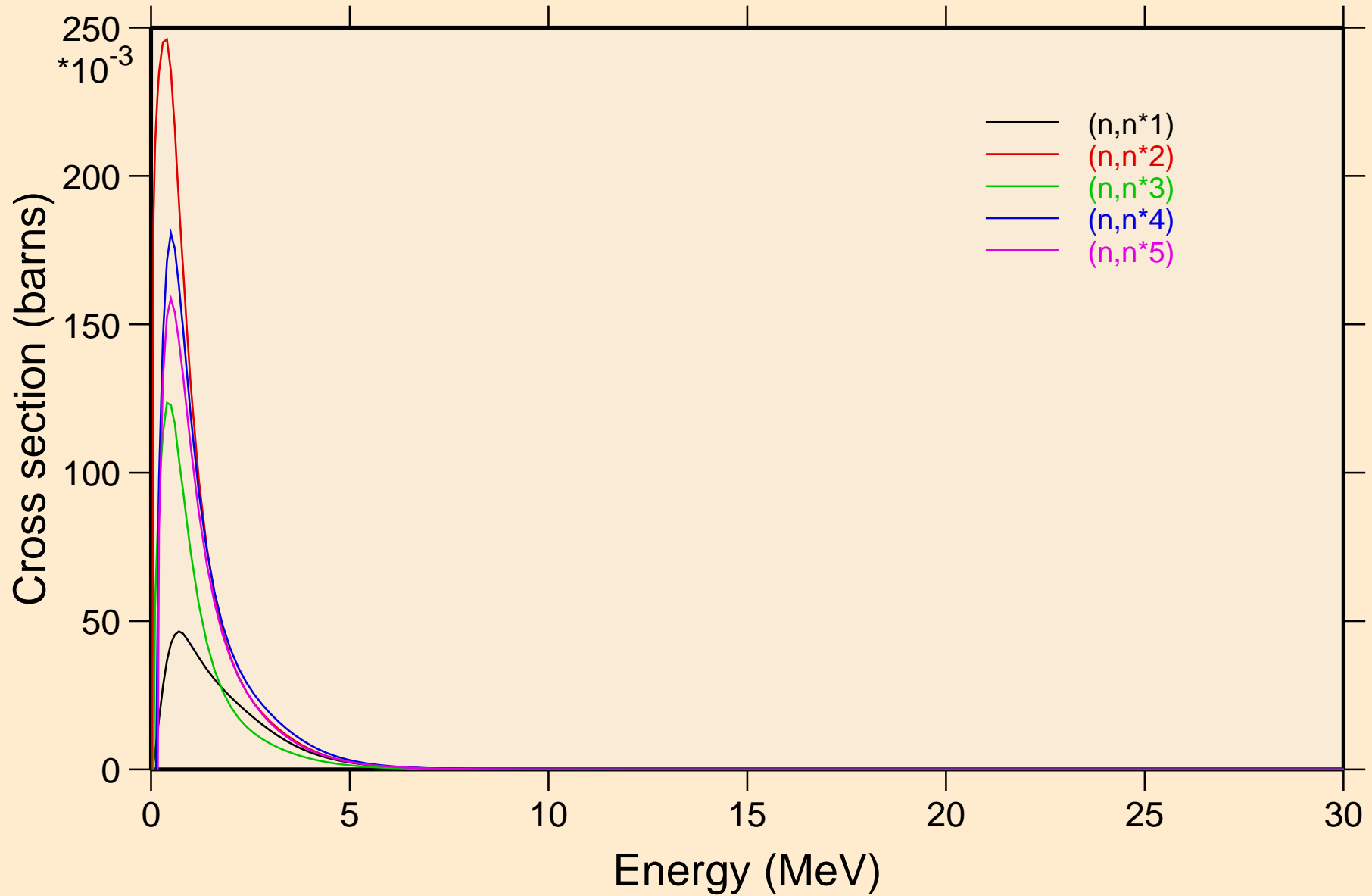

SE073M NEUTRON ACER TENDL-2023 LIBRARY; T=0.K
Inelastic levels

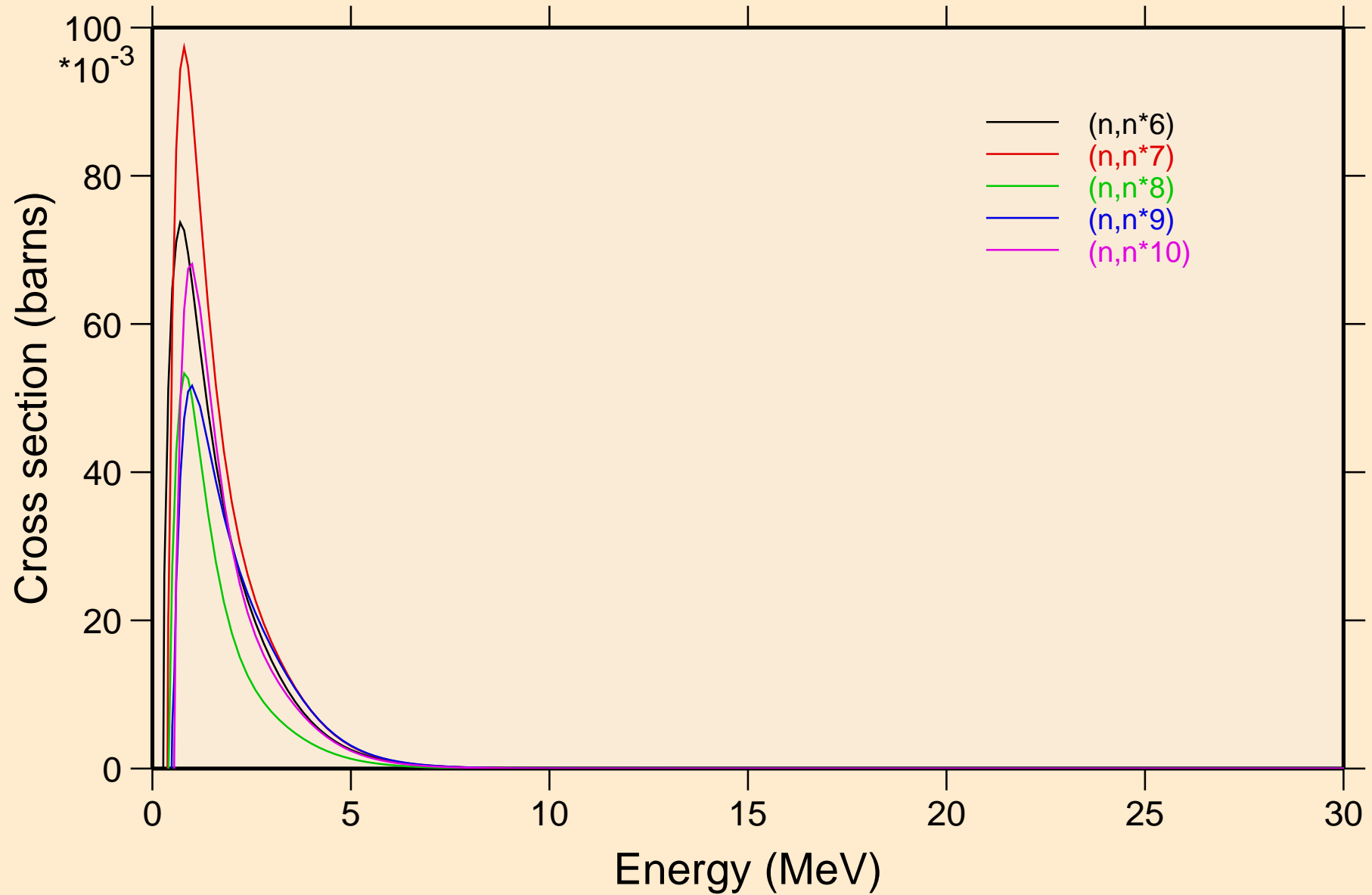

SE073M NEUTRON ACER TENDL-2023 LIBRARY; T=0.K
Inelastic levels

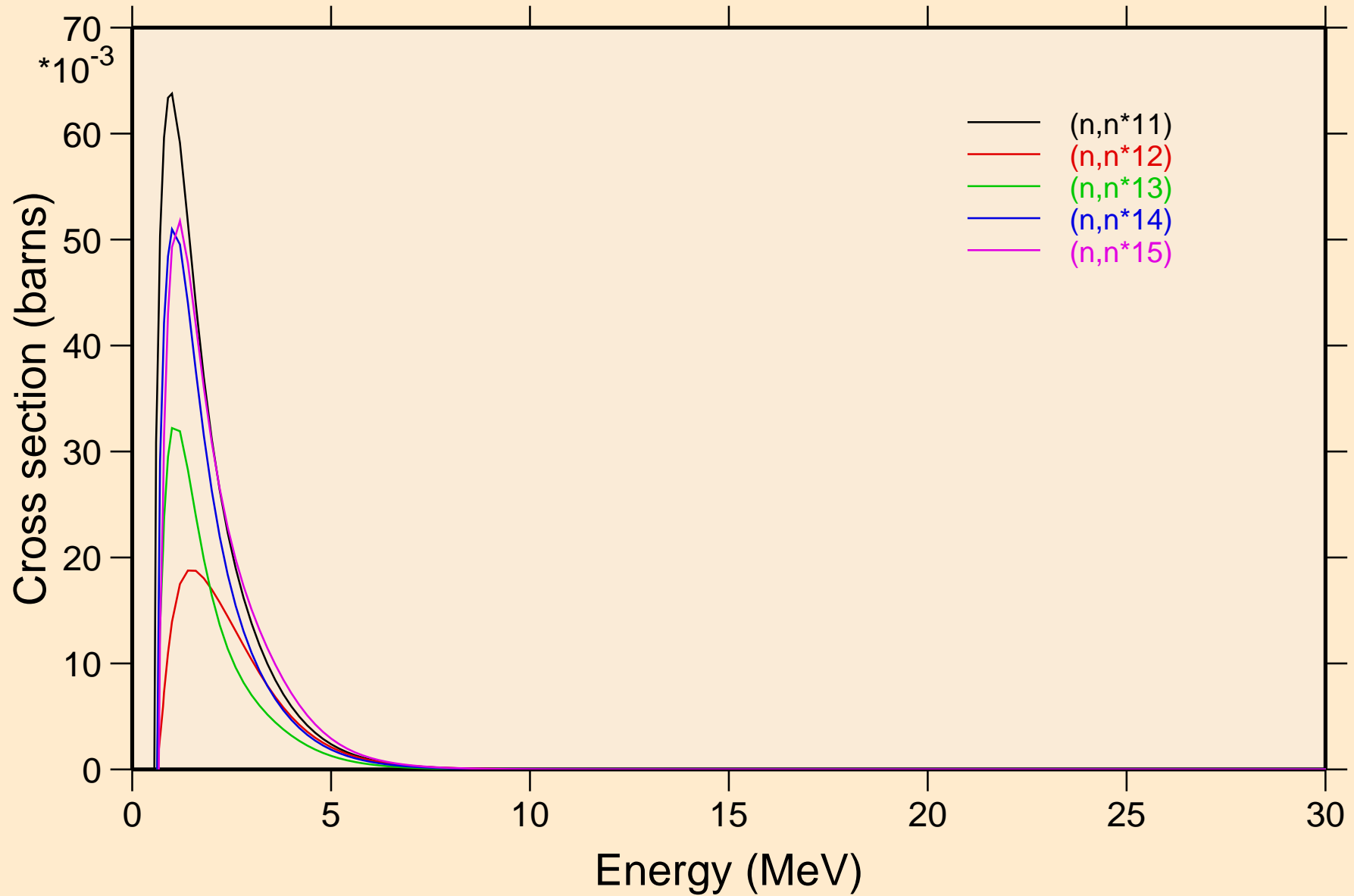

SE073M NEUTRON ACER TENDL-2023 LIBRARY; T=0.K
Inelastic levels

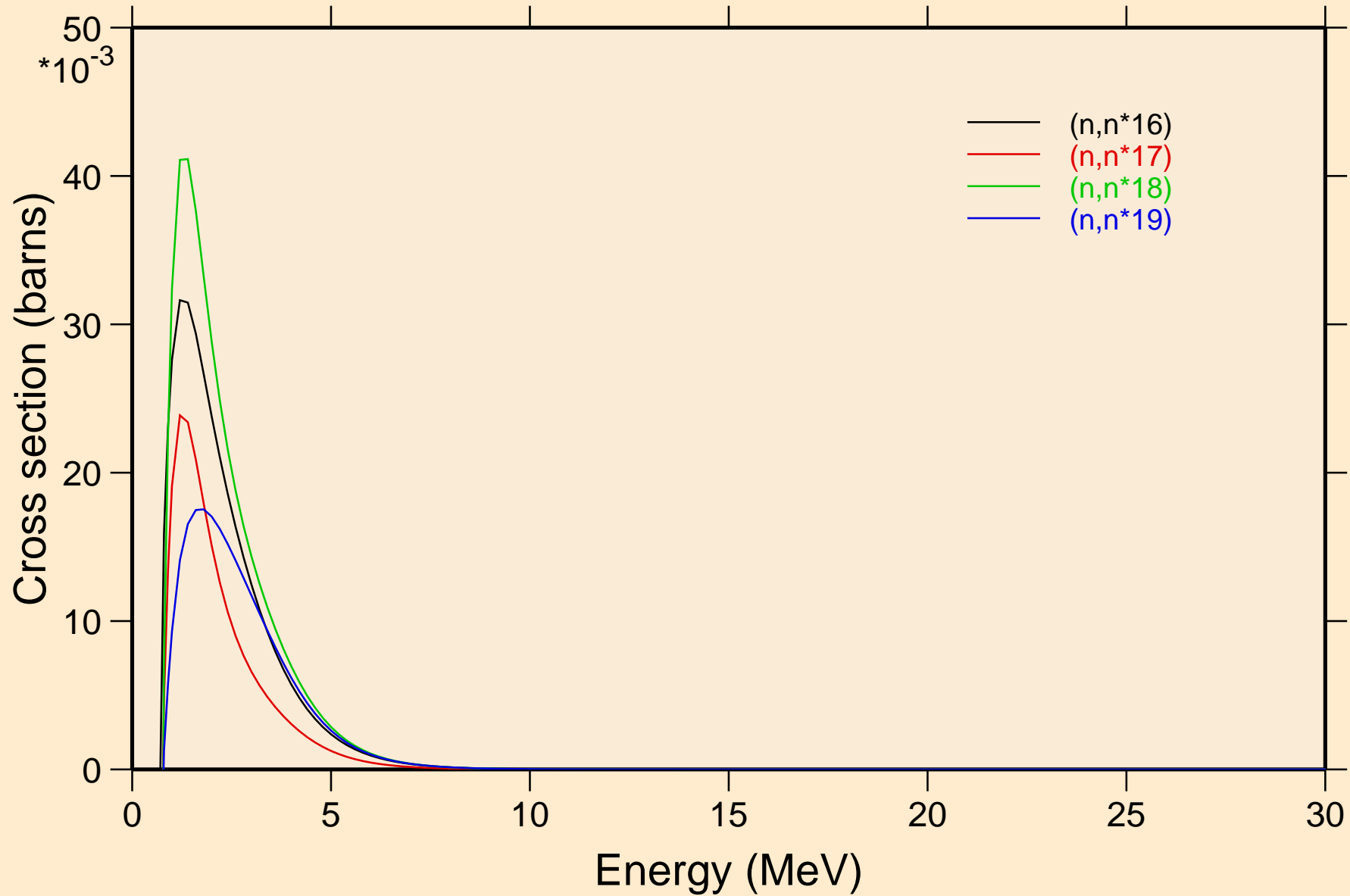

SE073M NEUTRON ACER TENDL-2023 LIBRARY; T=0.K

Threshold reactions

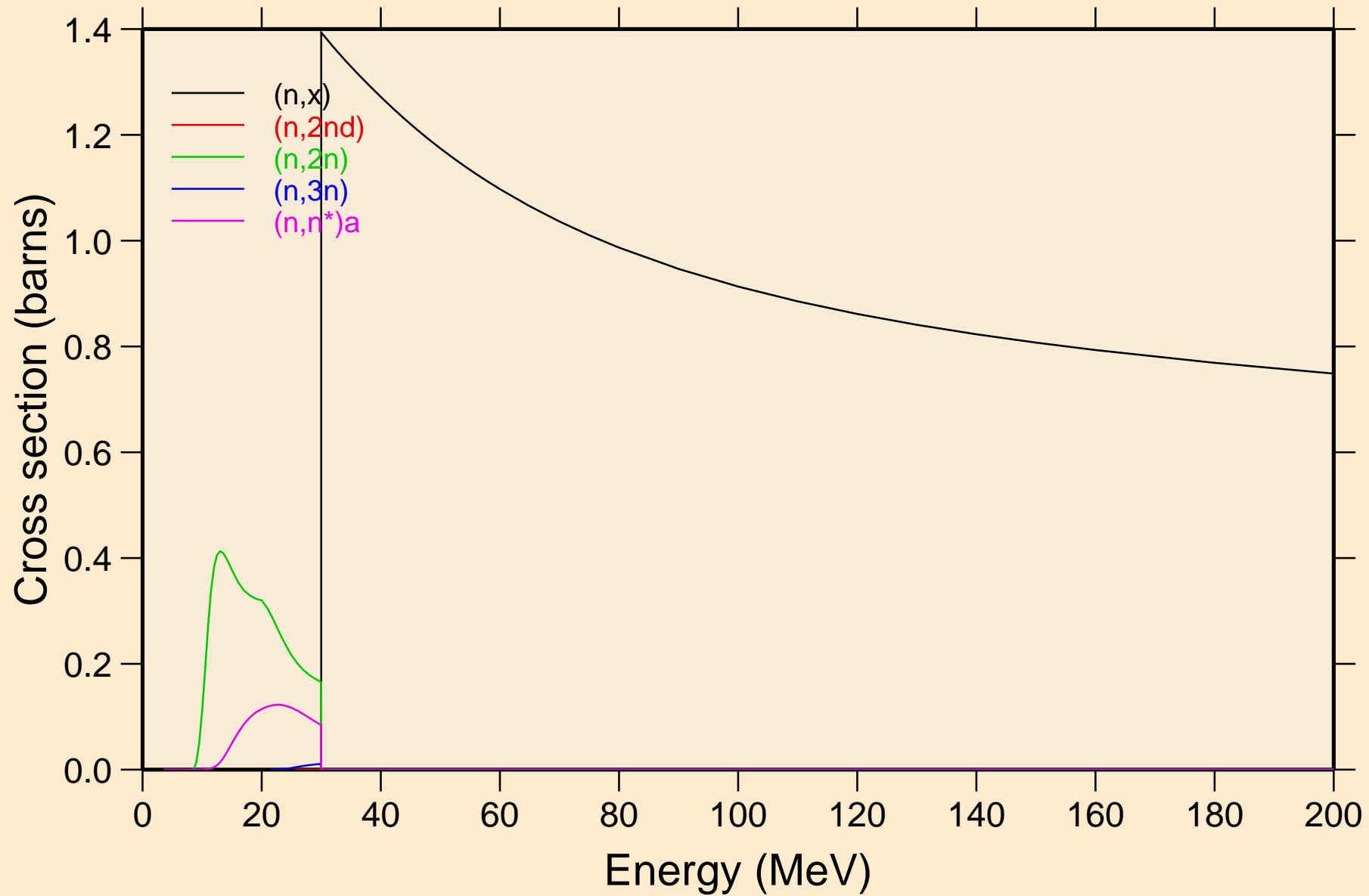

SE073M NEUTRON ACER TENDL-2023 LIBRARY; T=0.K

Threshold reactions

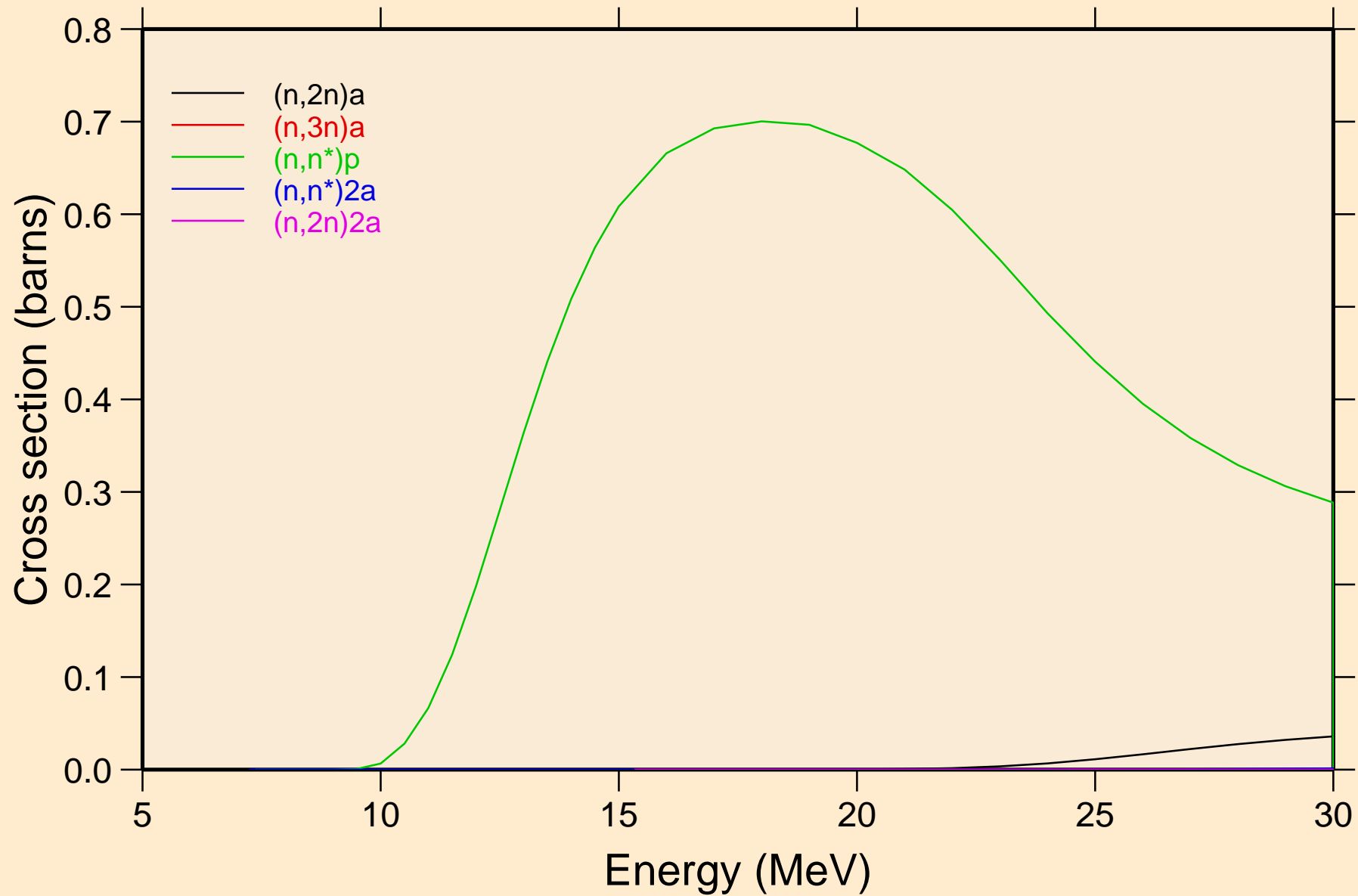

SE073M NEUTRON ACER TENDL-2023 LIBRARY; T=0.K

Threshold reactions

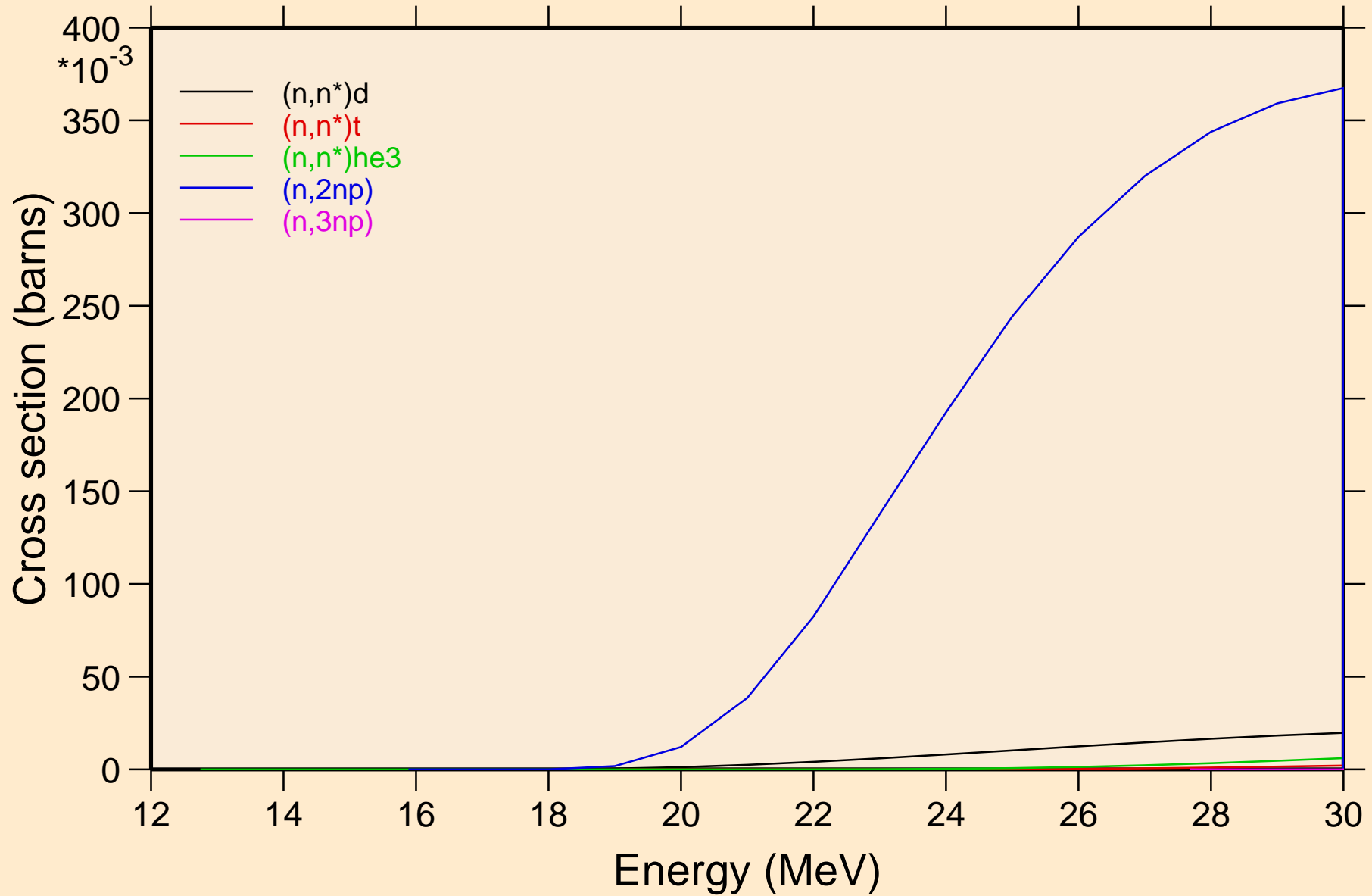

SE073M NEUTRON ACER TENDL-2023 LIBRARY; T=0.K
Threshold reactions

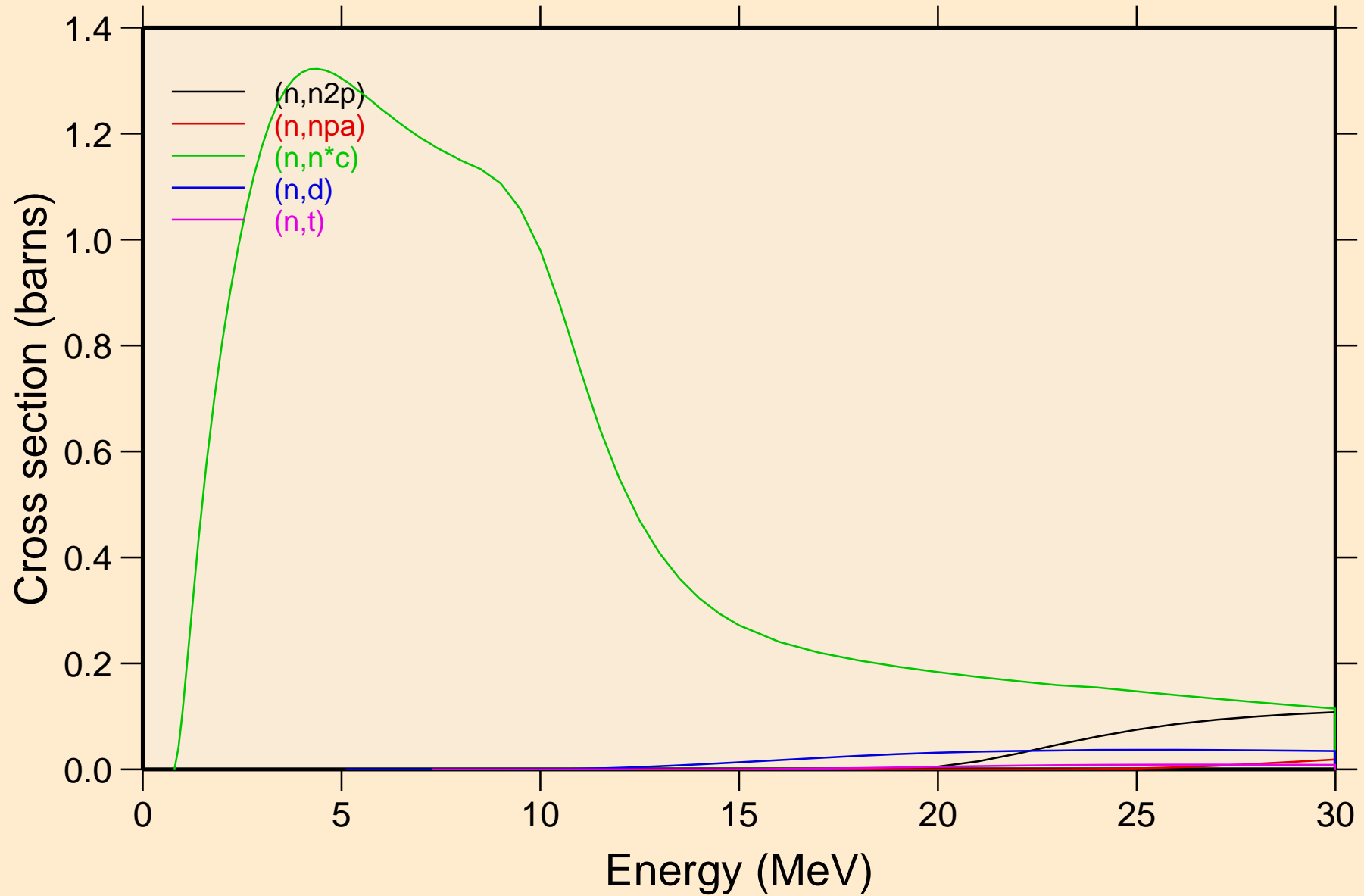

SE073M NEUTRON ACER TENDL-2023 LIBRARY; T=0.K

Threshold reactions

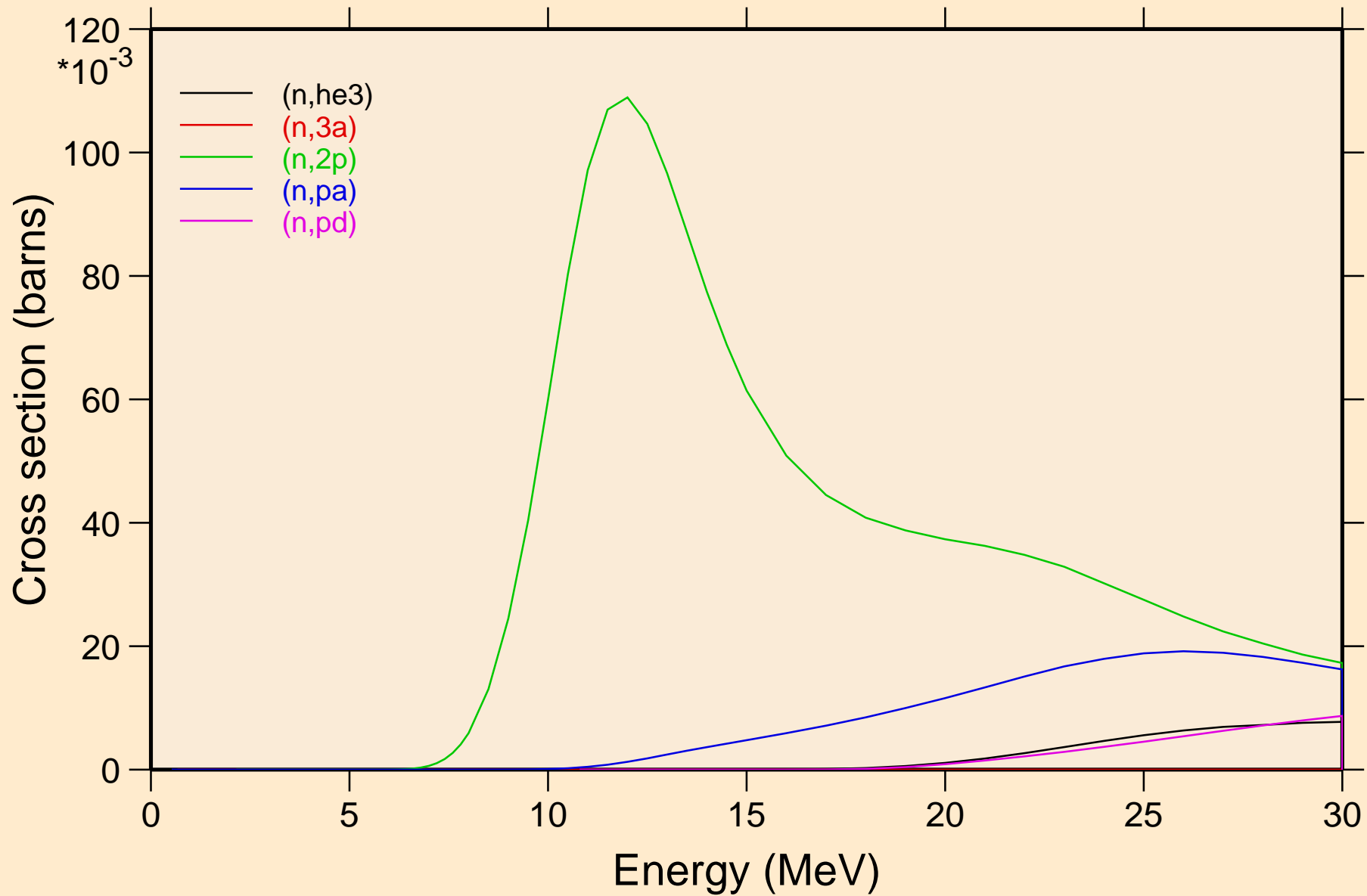

SE073M NEUTRON ACER TENDL-2023 LIBRARY; T=0.K
Threshold reactions

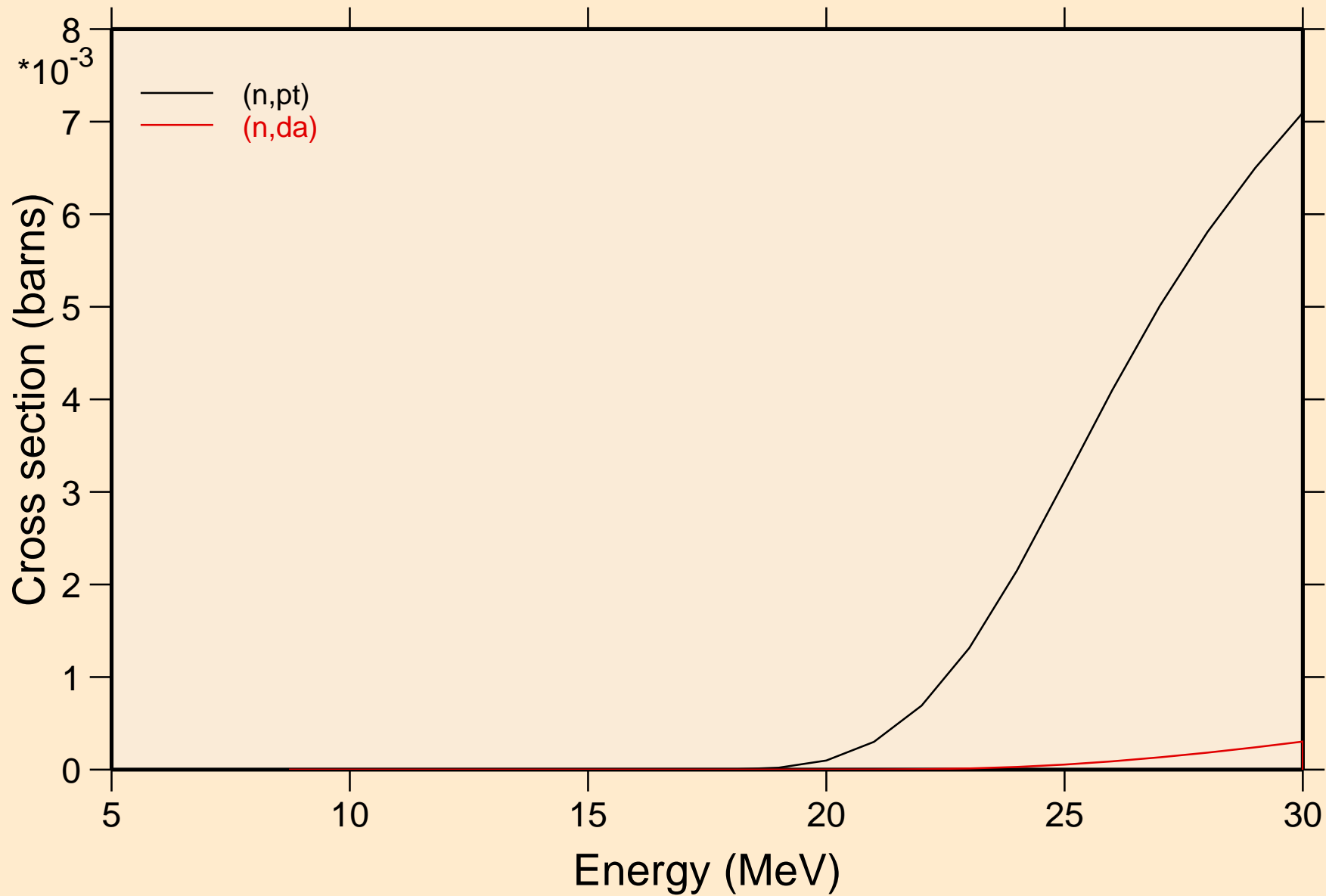

SE073M NEUTRON ACER TENDL-2023 LIBRARY; T=0.K

Threshold reactions

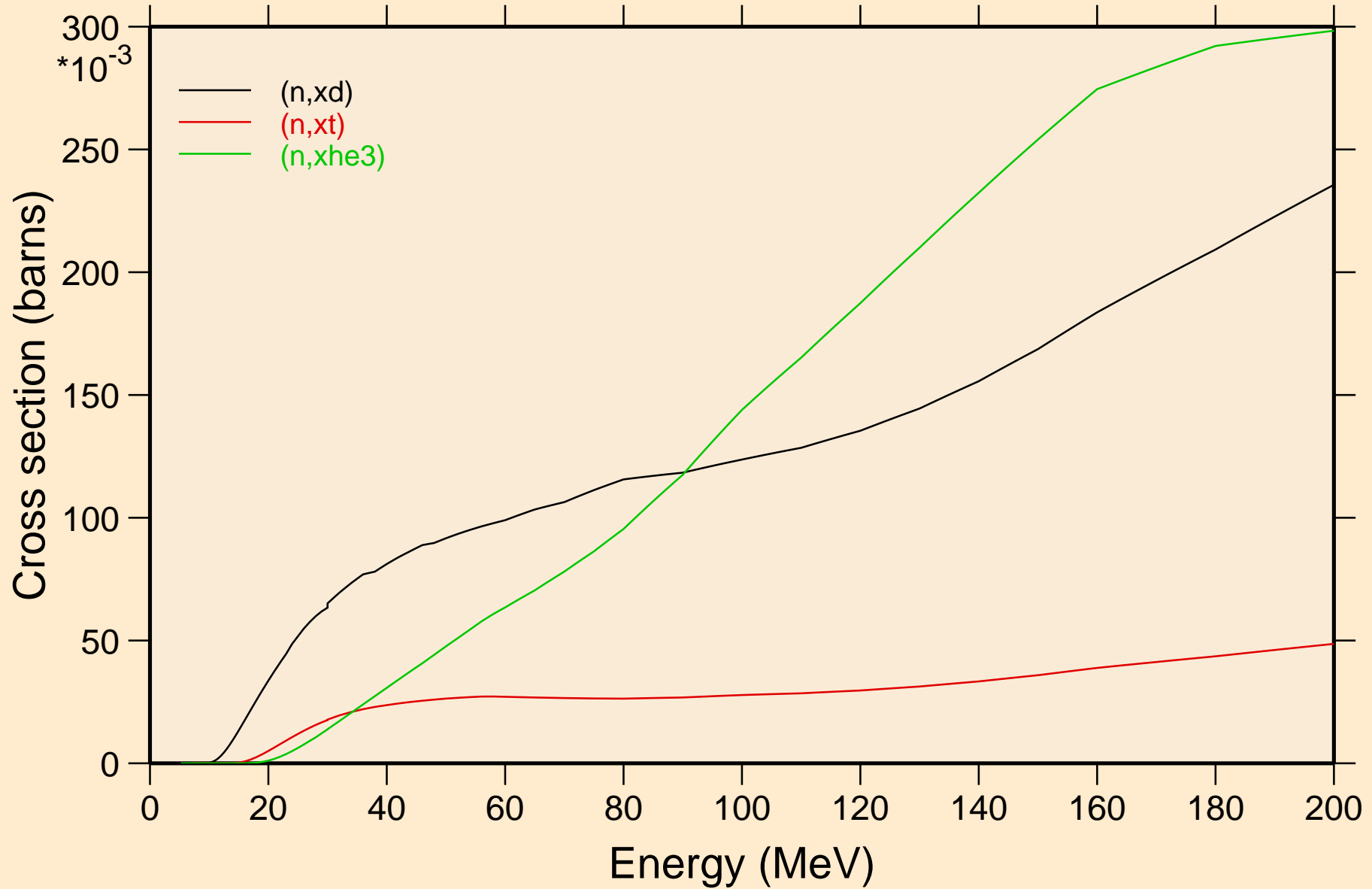

SE073M NEUTRON ACER TENDL-2023 LIBRARY; T=0.K
angular distribution for elastic

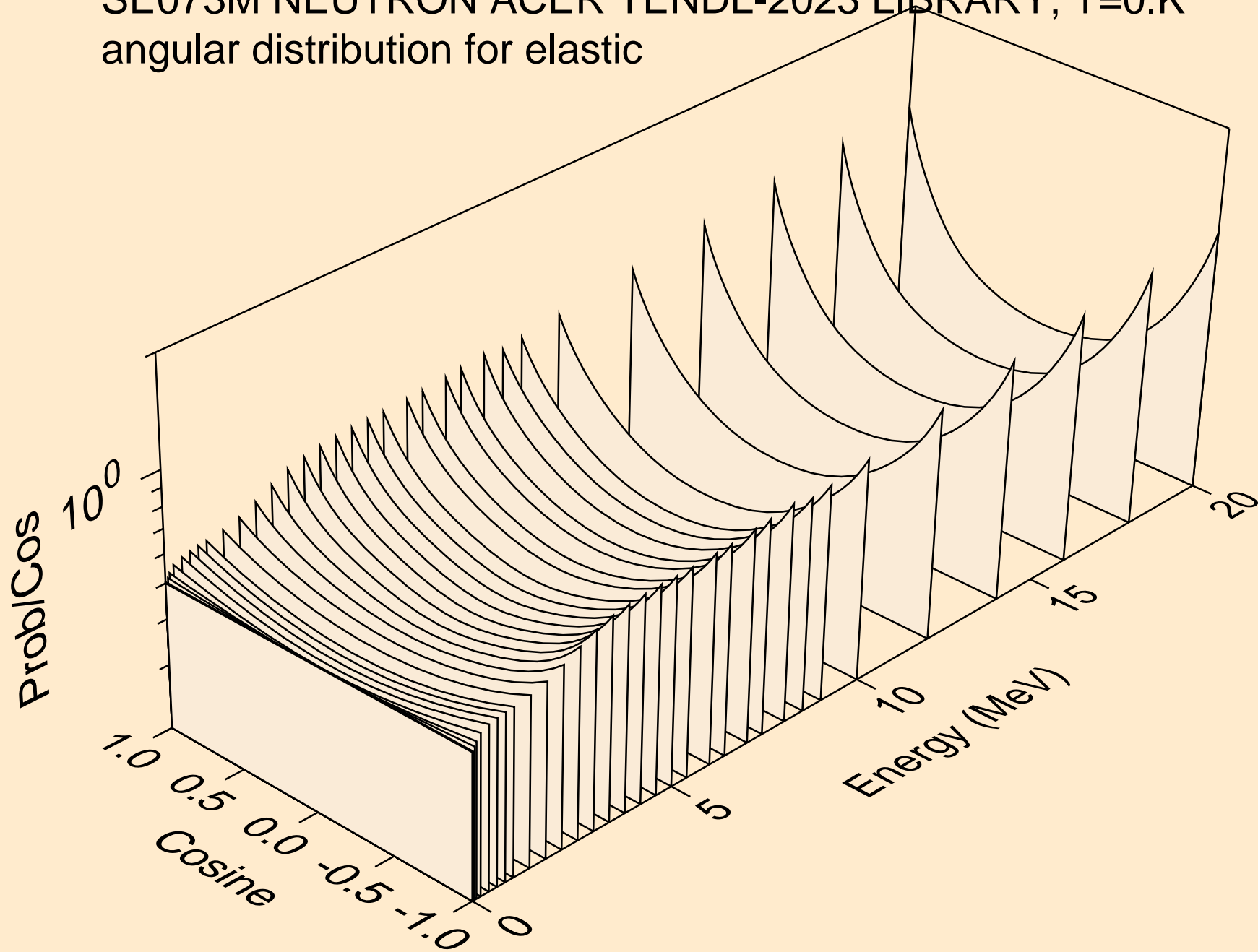

SE073M NEUTRON ACER TENDL-2023 LIBRARY; T=0.K
angular distribution for elastic

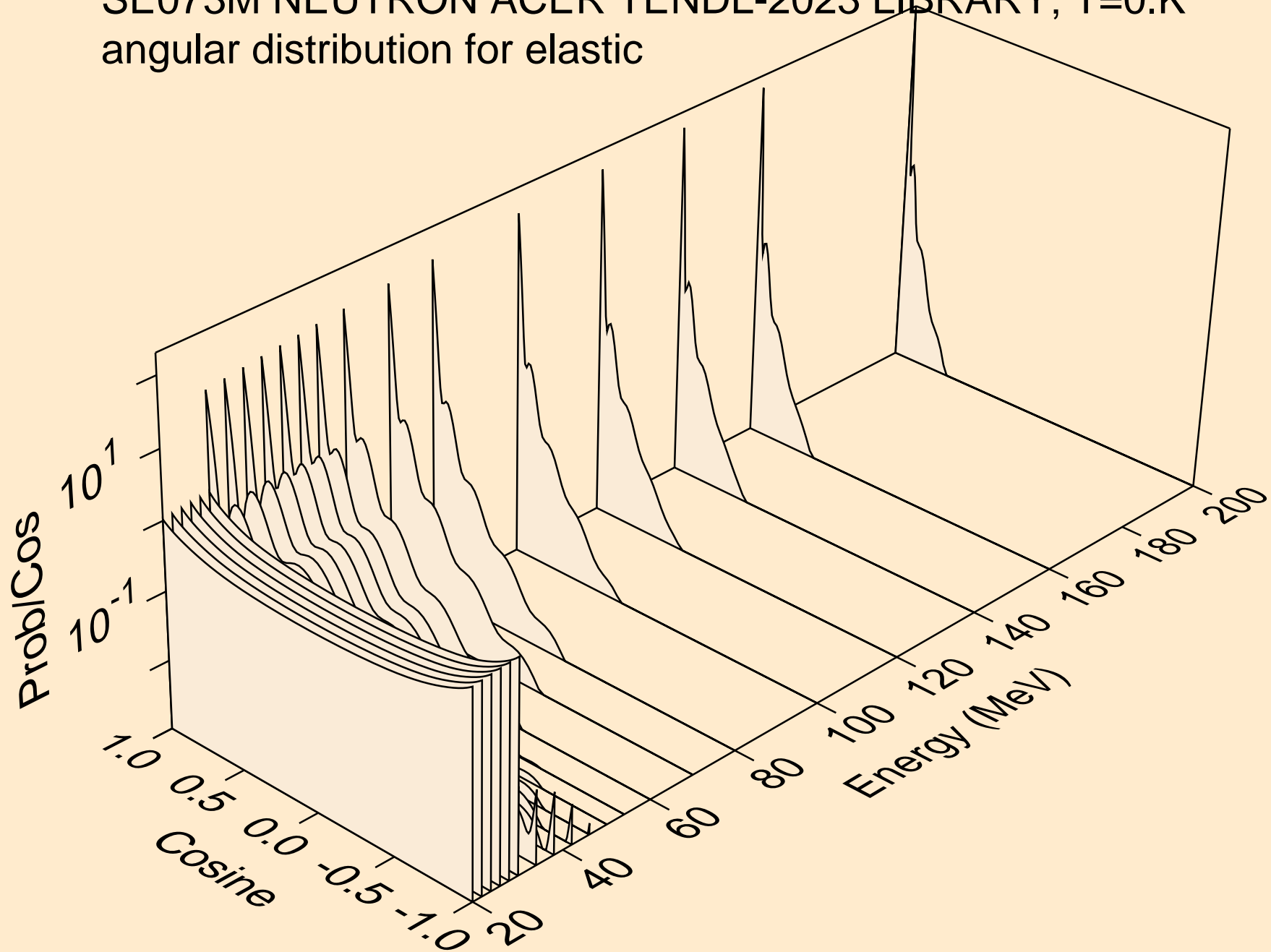

SE073M NEUTRON ACER TENDL-2023 LIBRARY; T=0.K
angular distribution for (n,n*1)

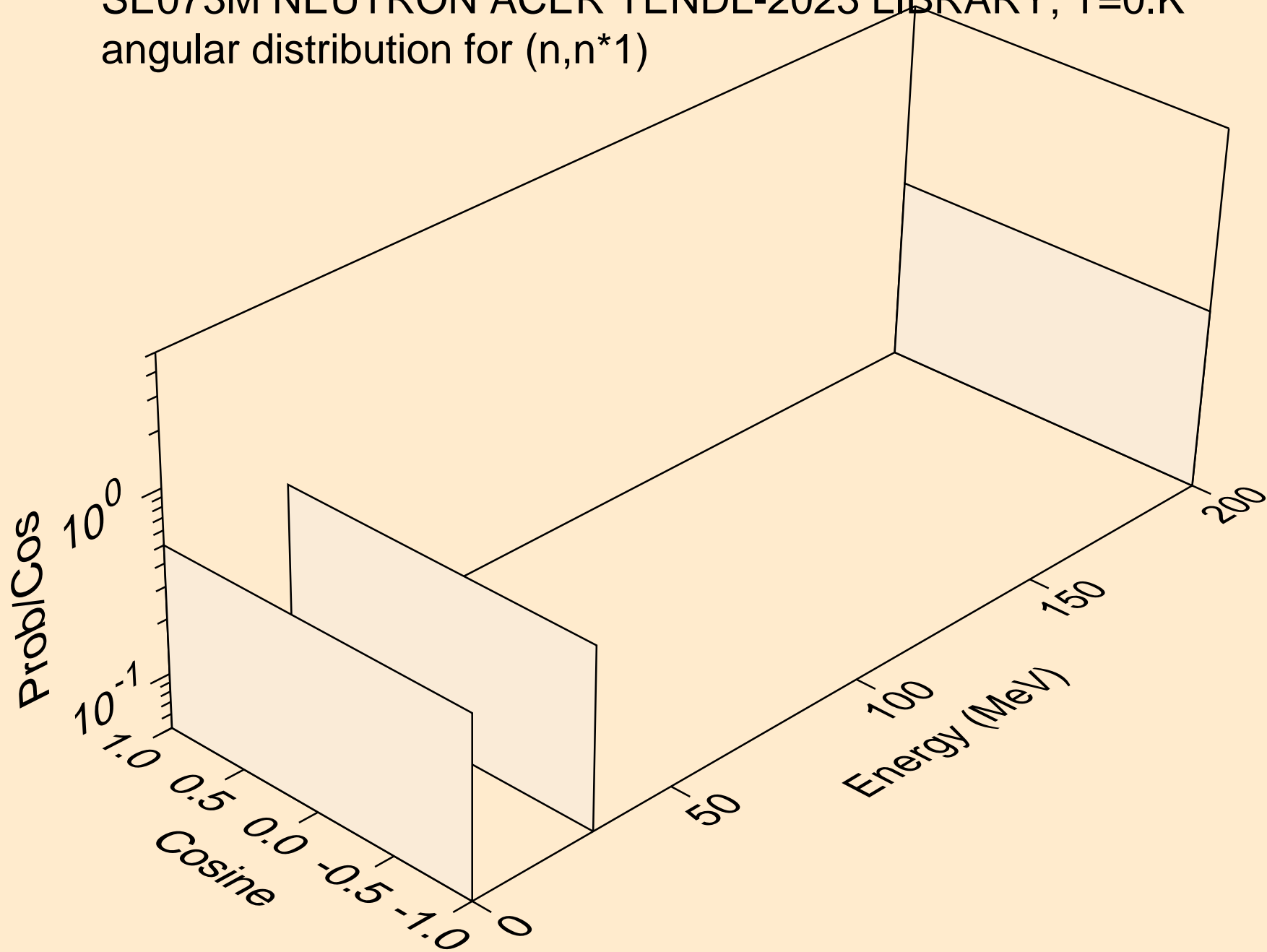

SE073M NEUTRON ACER TENDL-2023 LIBRARY; T=0.K
angular distribution for (n,n*2)

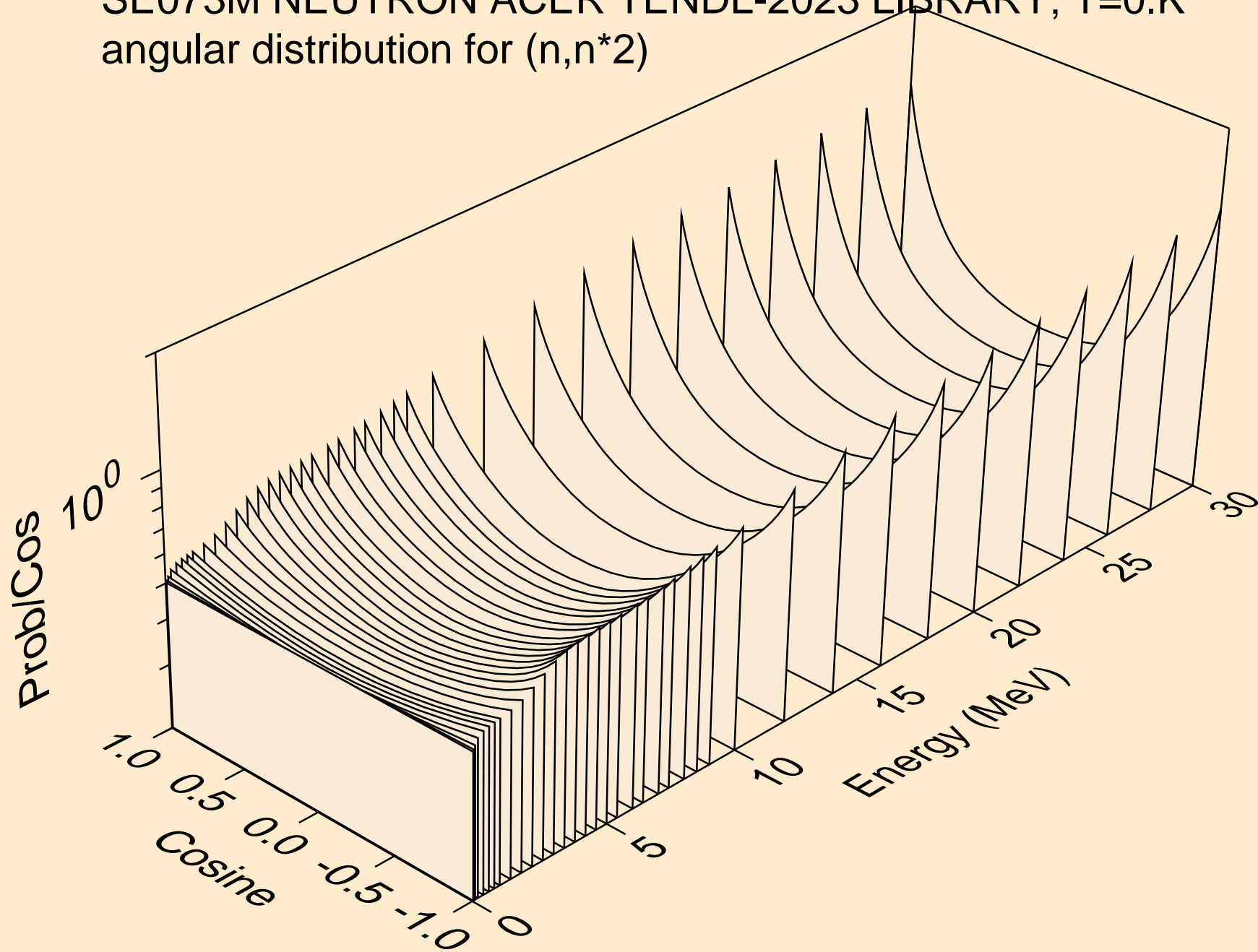

SE073M NEUTRON ACER TENDL-2023 LIBRARY; T=0.K
angular distribution for (n,n*3)

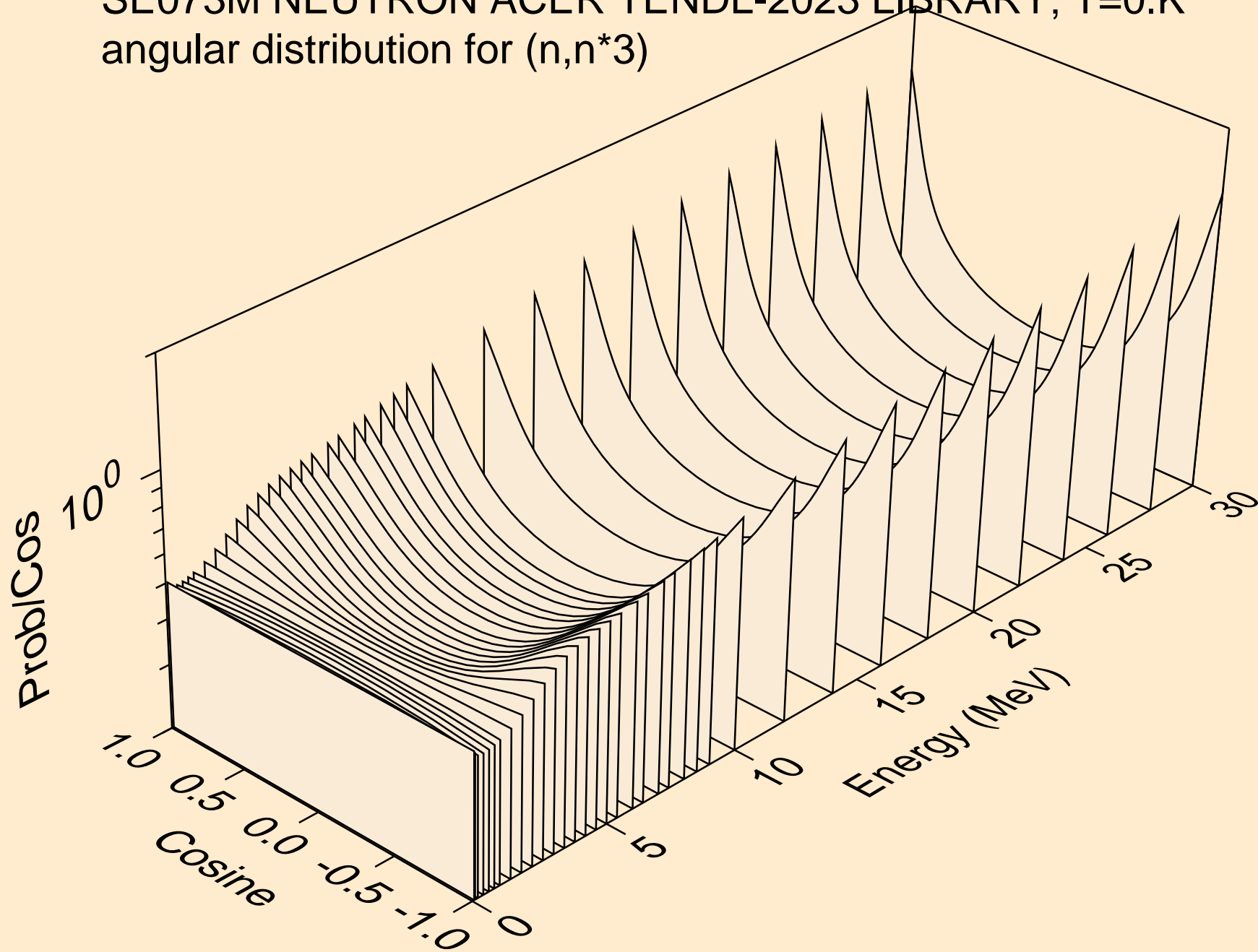

SE073M NEUTRON ACER TENDL-2023 LIBRARY; T=0.K
angular distribution for (n,n*4)

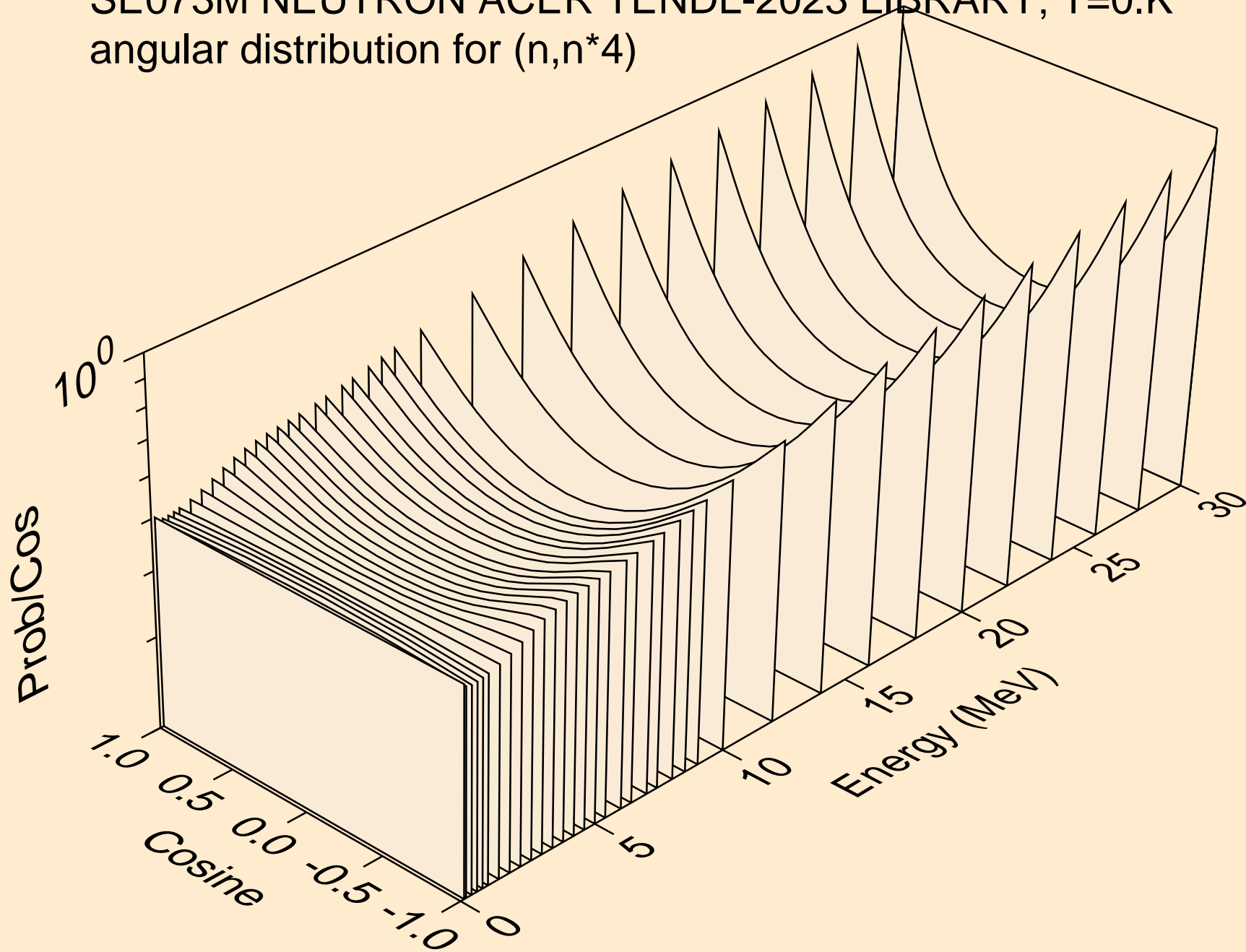

SE073M NEUTRON ACER TENDL-2023 LIBRARY; T=0.K
angular distribution for (n,n*5)

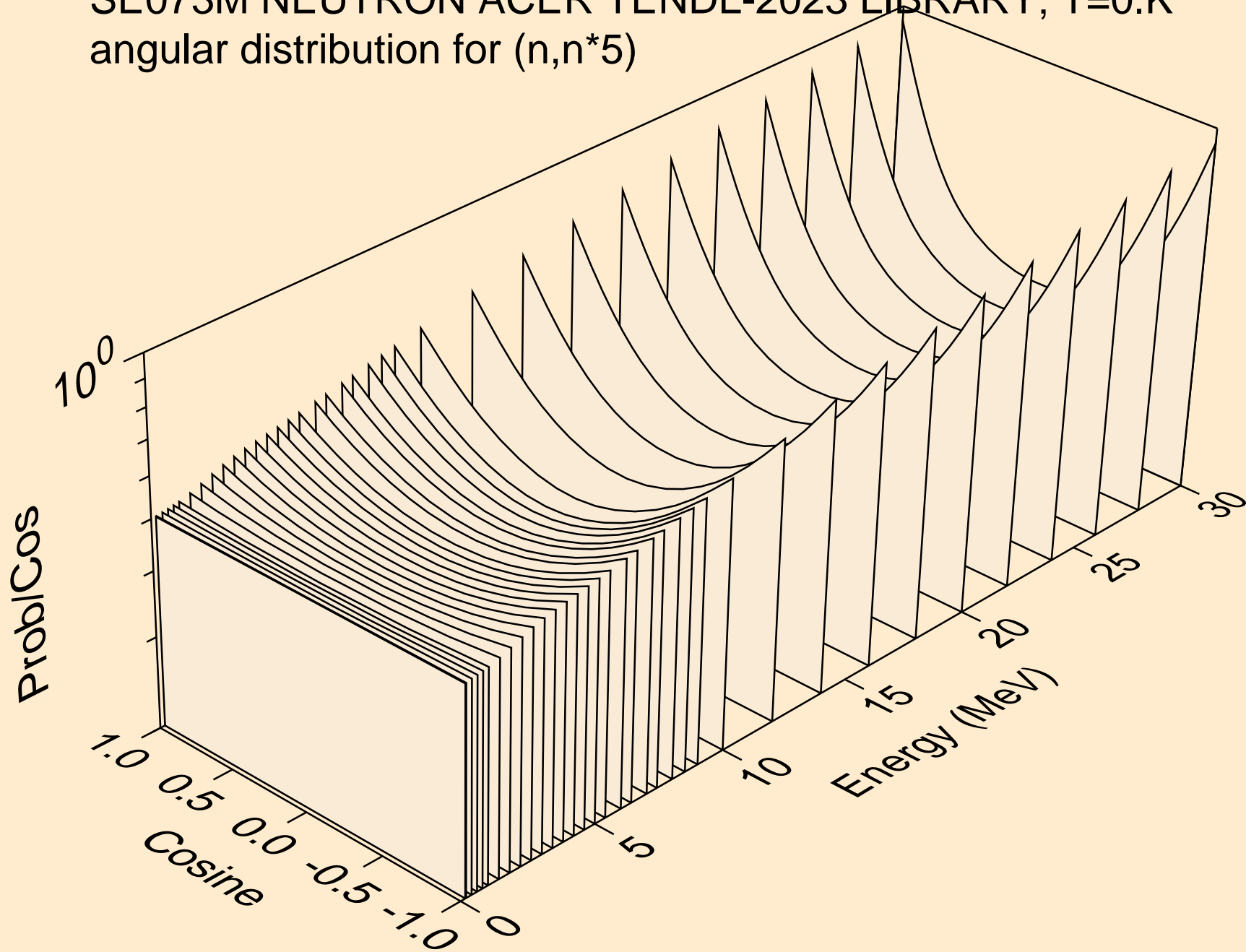

SE073M NEUTRON ACER TENDL-2023 LIBRARY; T=0.K
angular distribution for (n,n*6)

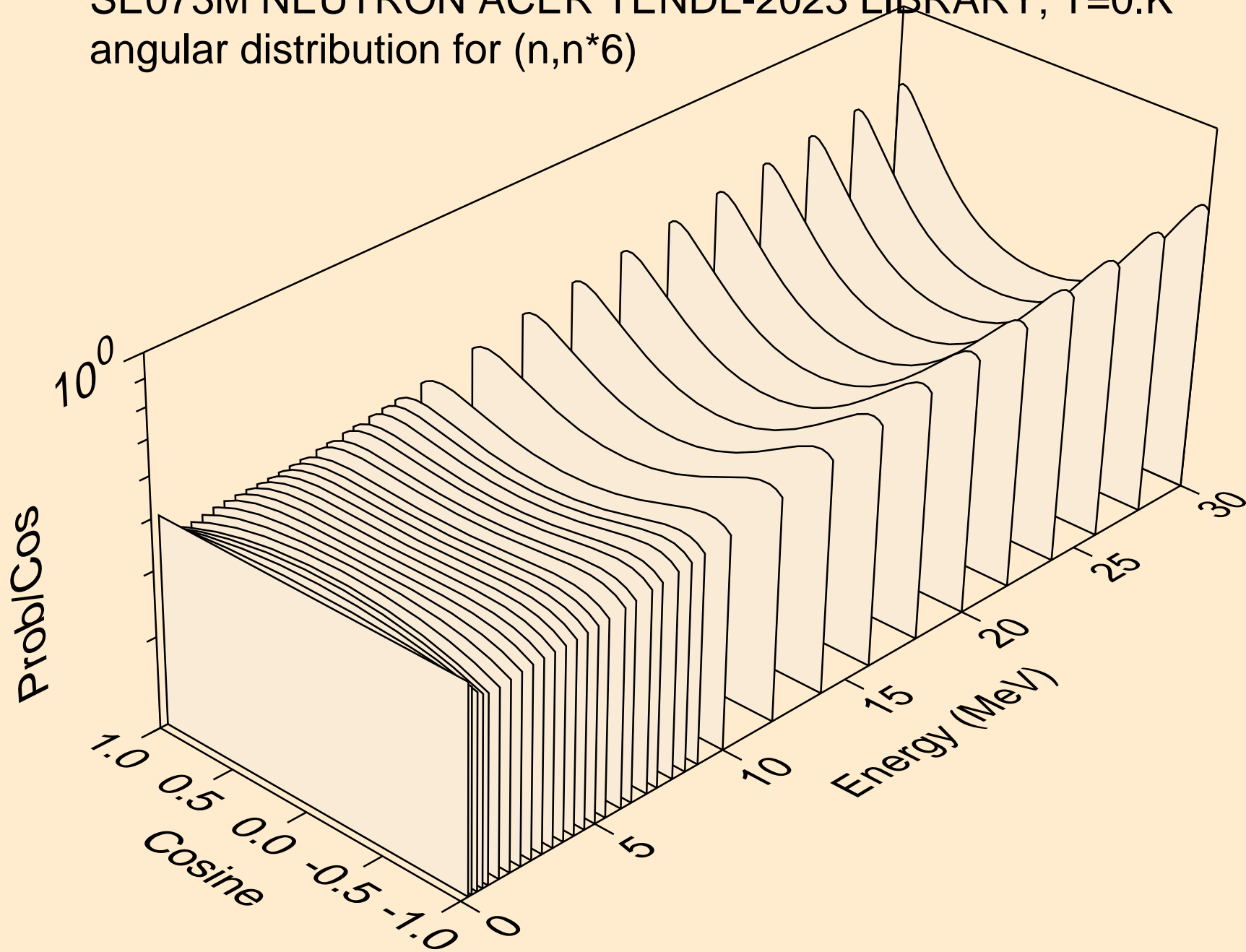

SE073M NEUTRON ACER TENDL-2023 LIBRARY; T=0.K
angular distribution for (n,n*7)

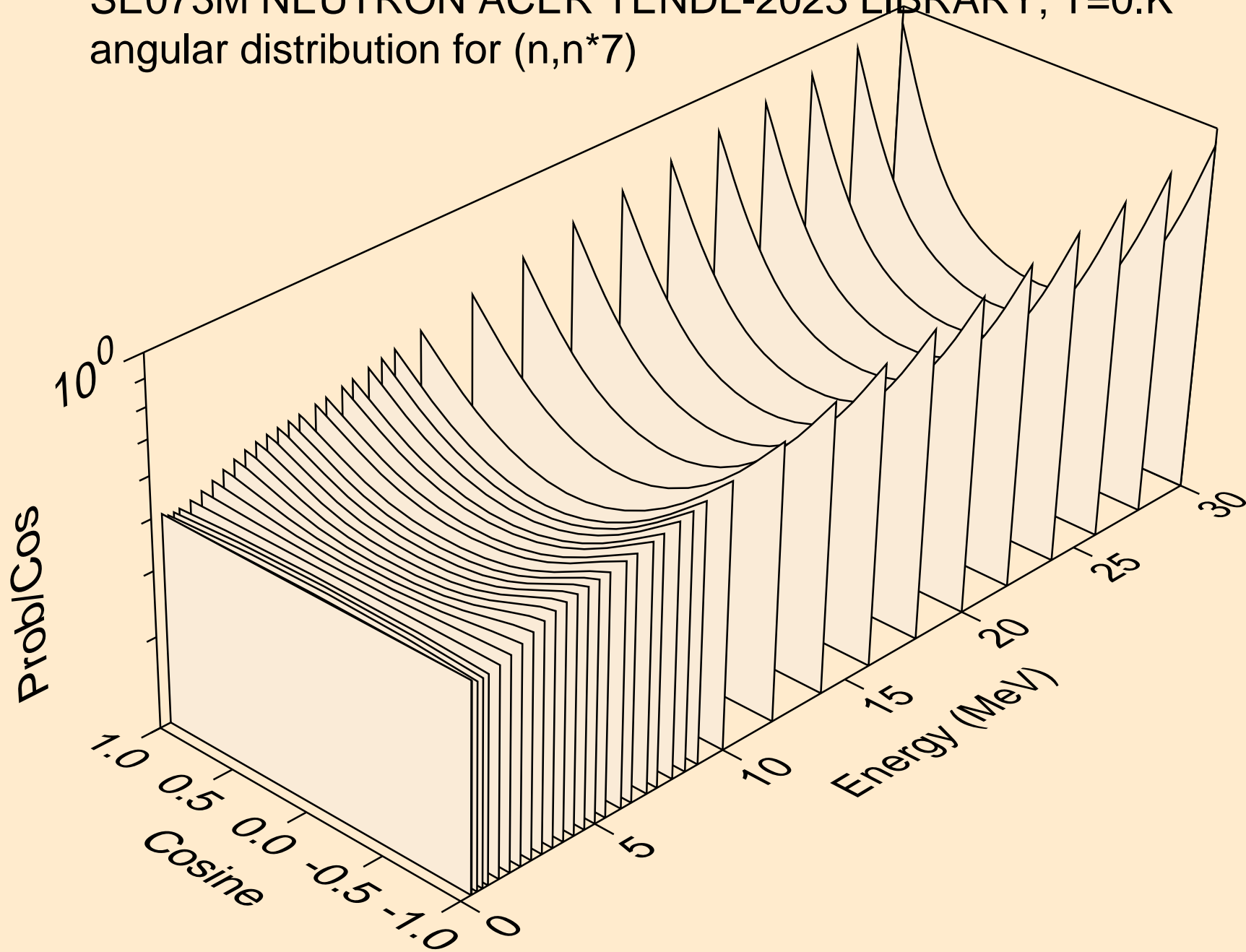

SE073M NEUTRON ACER TENDL-2023 LIBRARY; T=0.K
angular distribution for (n,n*8)

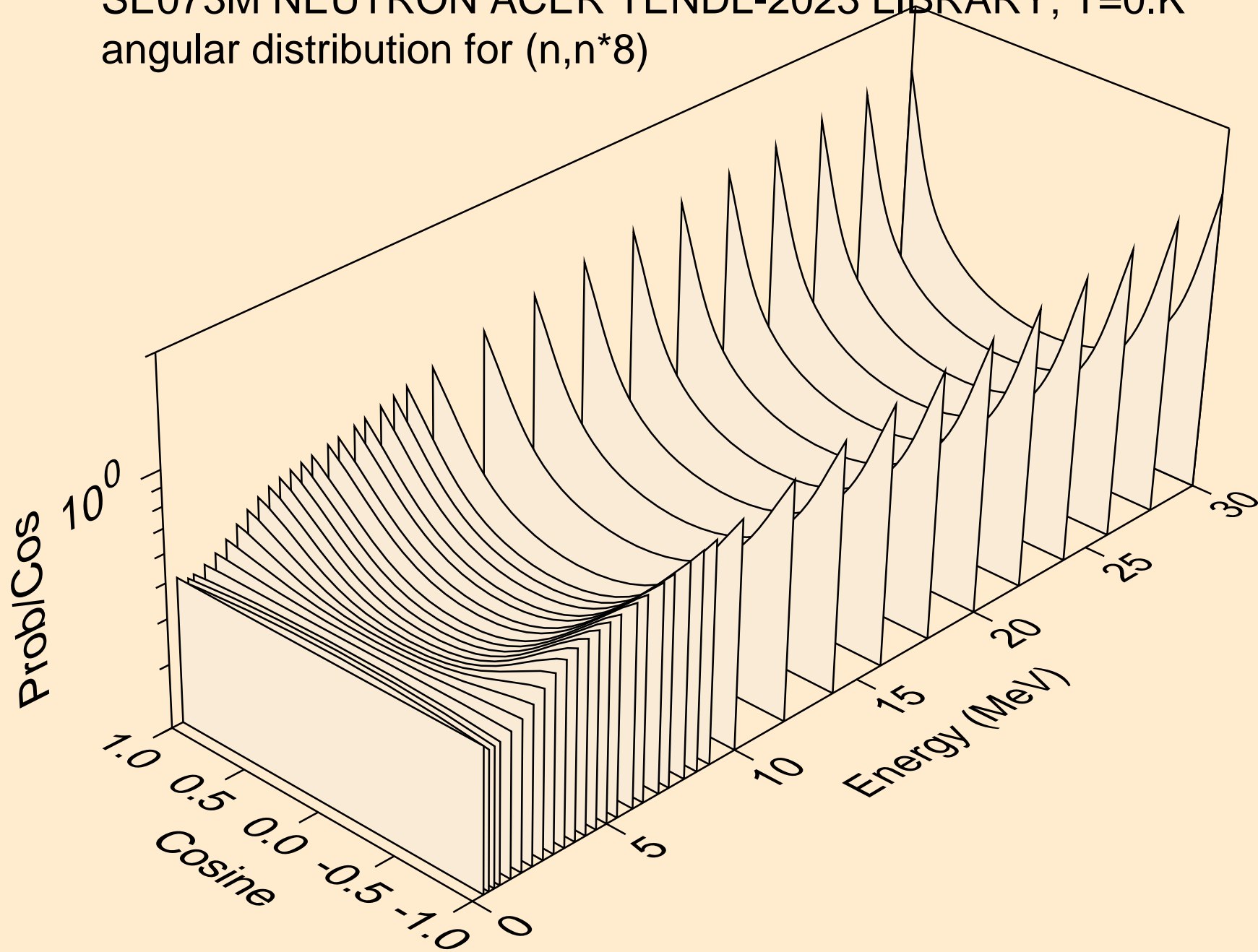

SE073M NEUTRON ACER TENDL-2023 LIBRARY; T=0.K
angular distribution for (n,n*9)

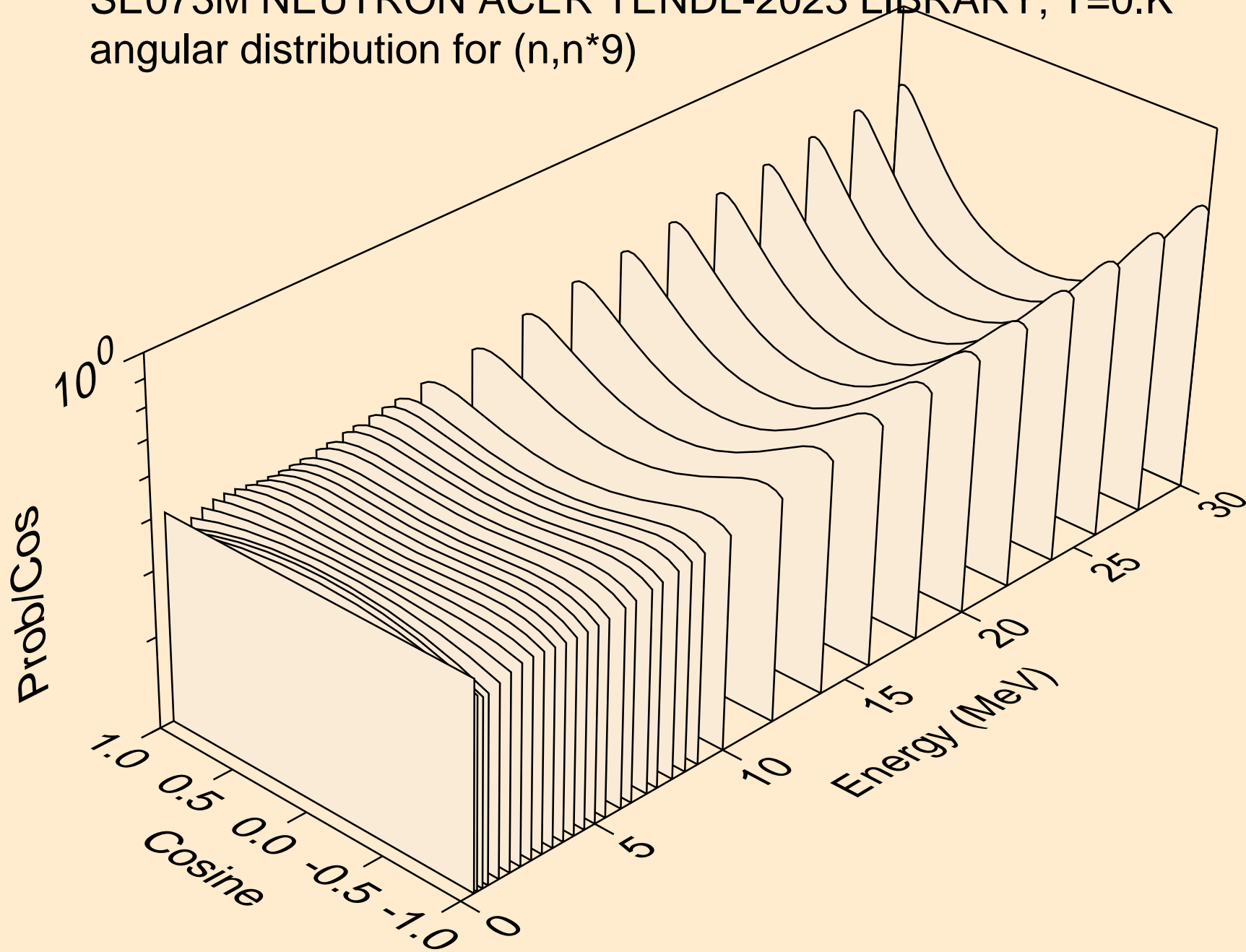

SE073M NEUTRON ACER TENDL-2023 LIBRARY; T=0.K
angular distribution for (n,n*10)

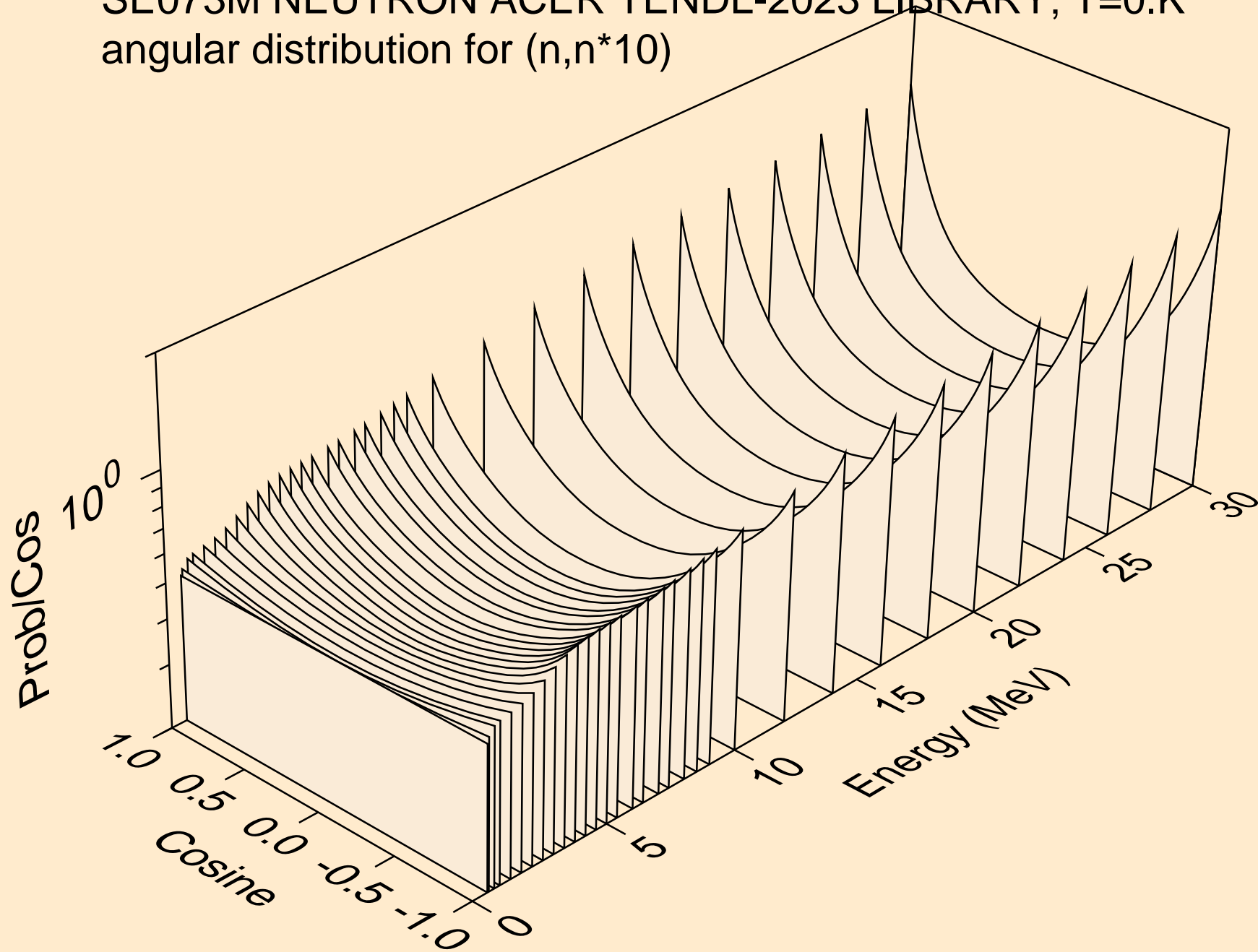

SE073M NEUTRON ACER TENDL-2023 LIBRARY; T=0.K
angular distribution for (n,n*11)

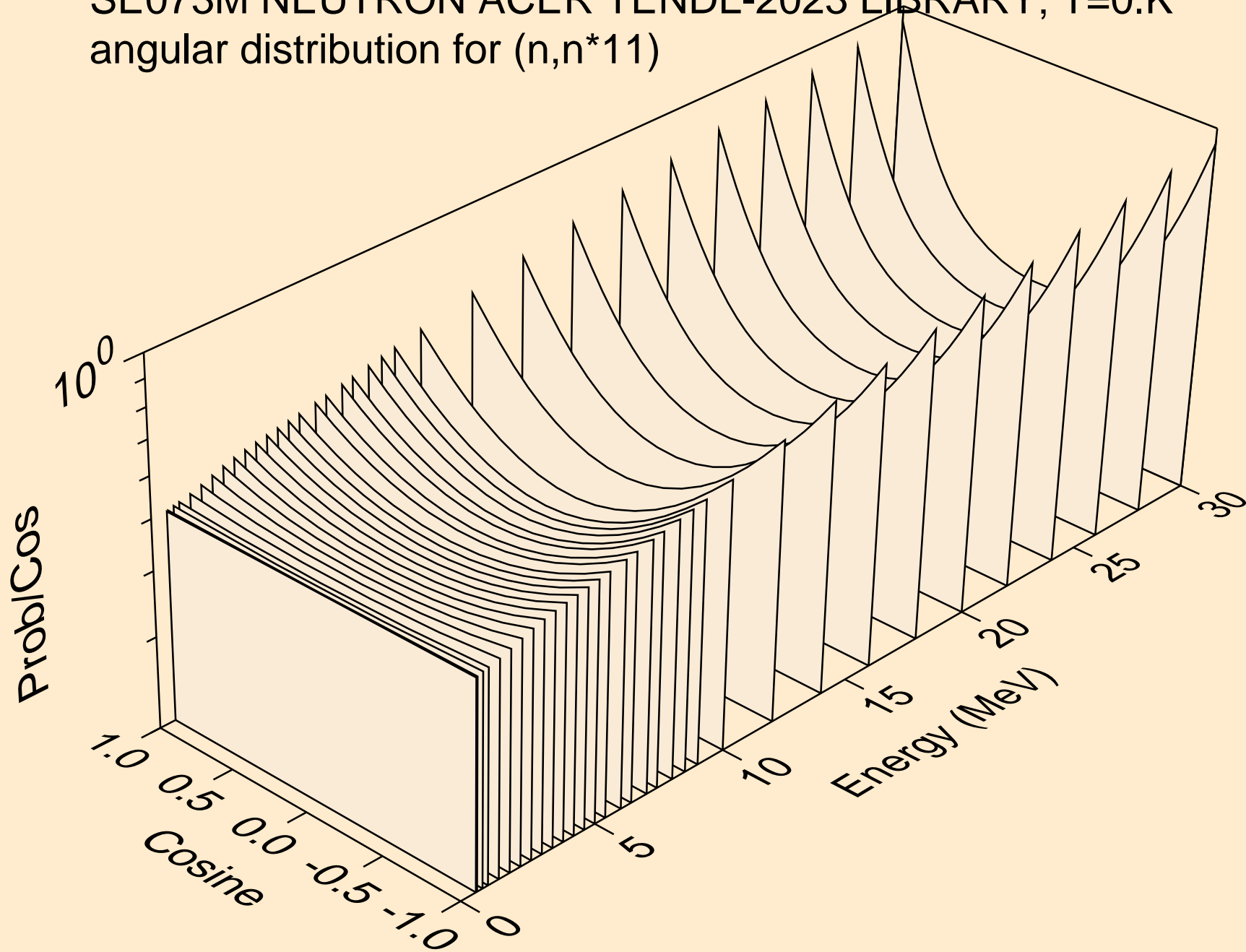

SE073M NEUTRON ACER TENDL-2023 LIBRARY; T=0.K
angular distribution for (n,n*12)

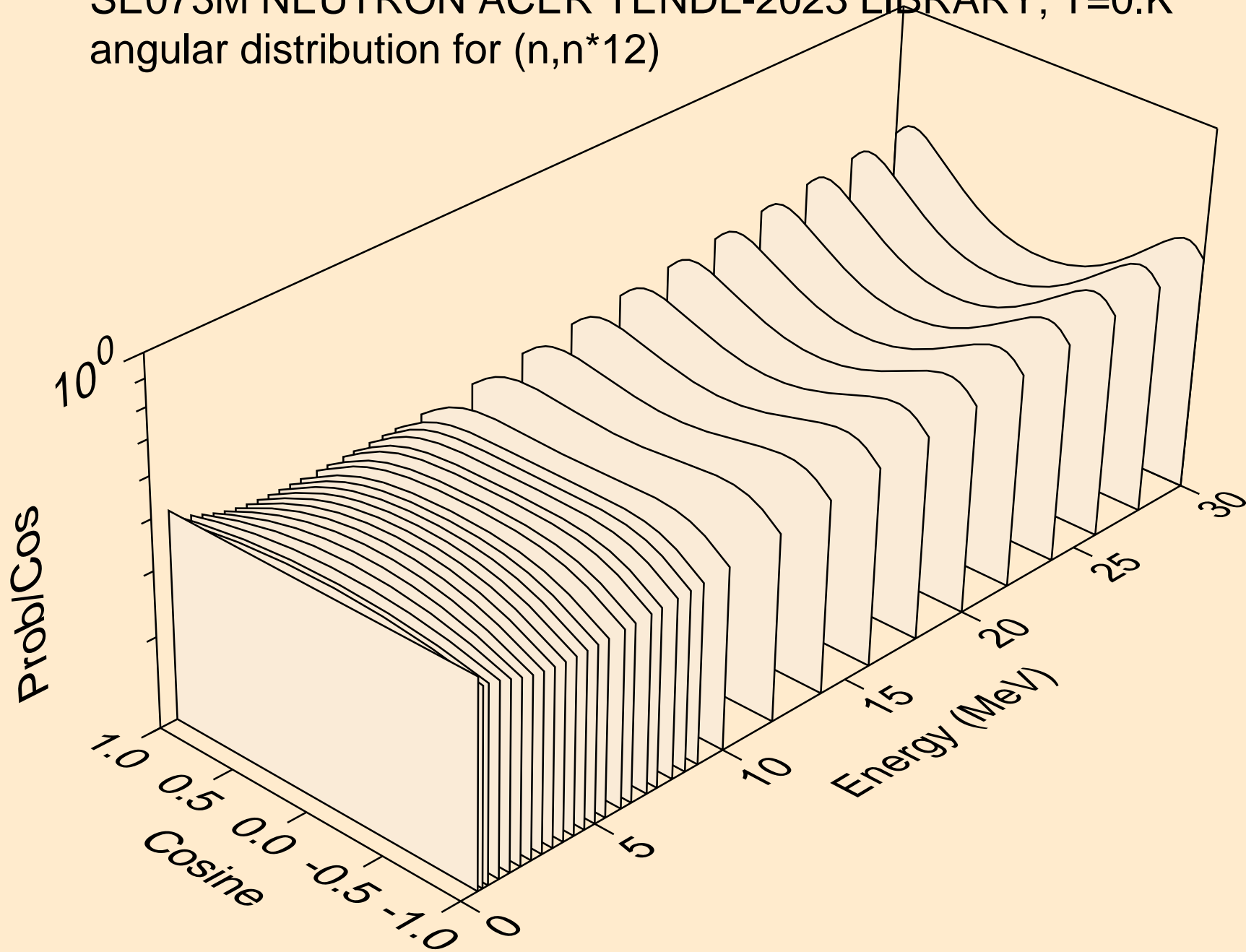

SE073M NEUTRON ACER TENDL-2023 LIBRARY; T=0.K
angular distribution for (n,n*13)

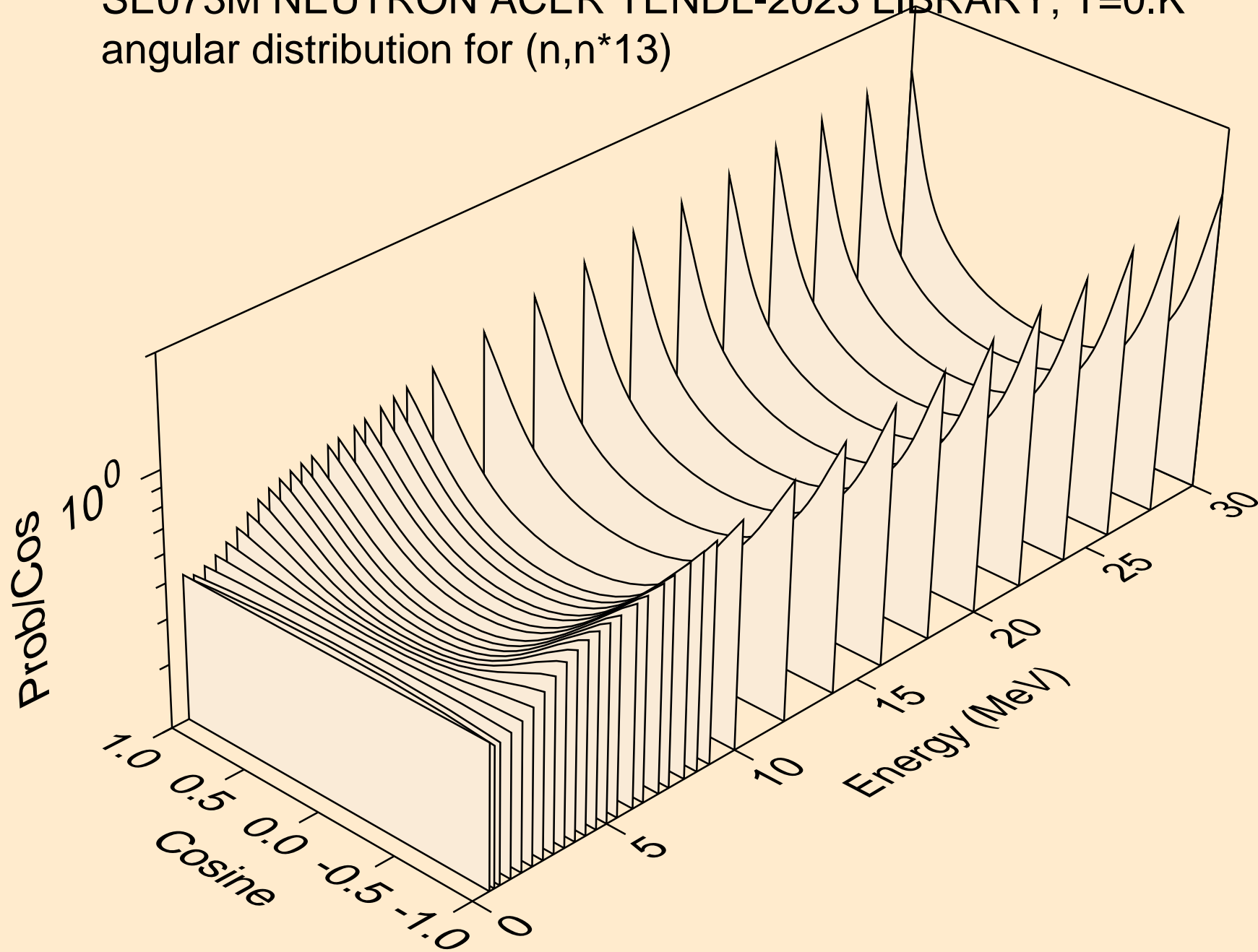

SE073M NEUTRON ACER TENDL-2023 LIBRARY; T=0.K
angular distribution for (n,n*14)

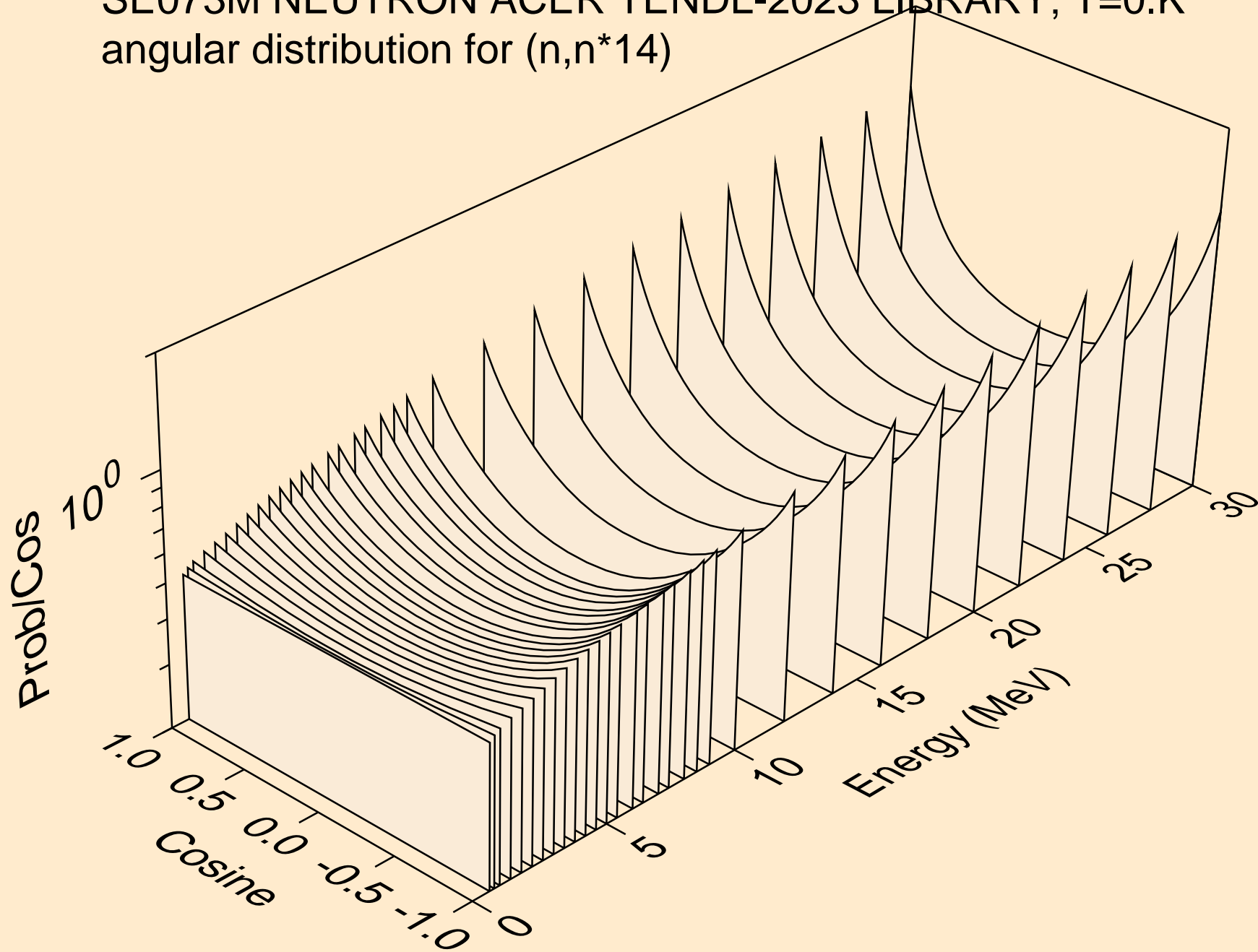

SE073M NEUTRON ACER TENDL-2023 LIBRARY; T=0.K
angular distribution for (n,n*15)

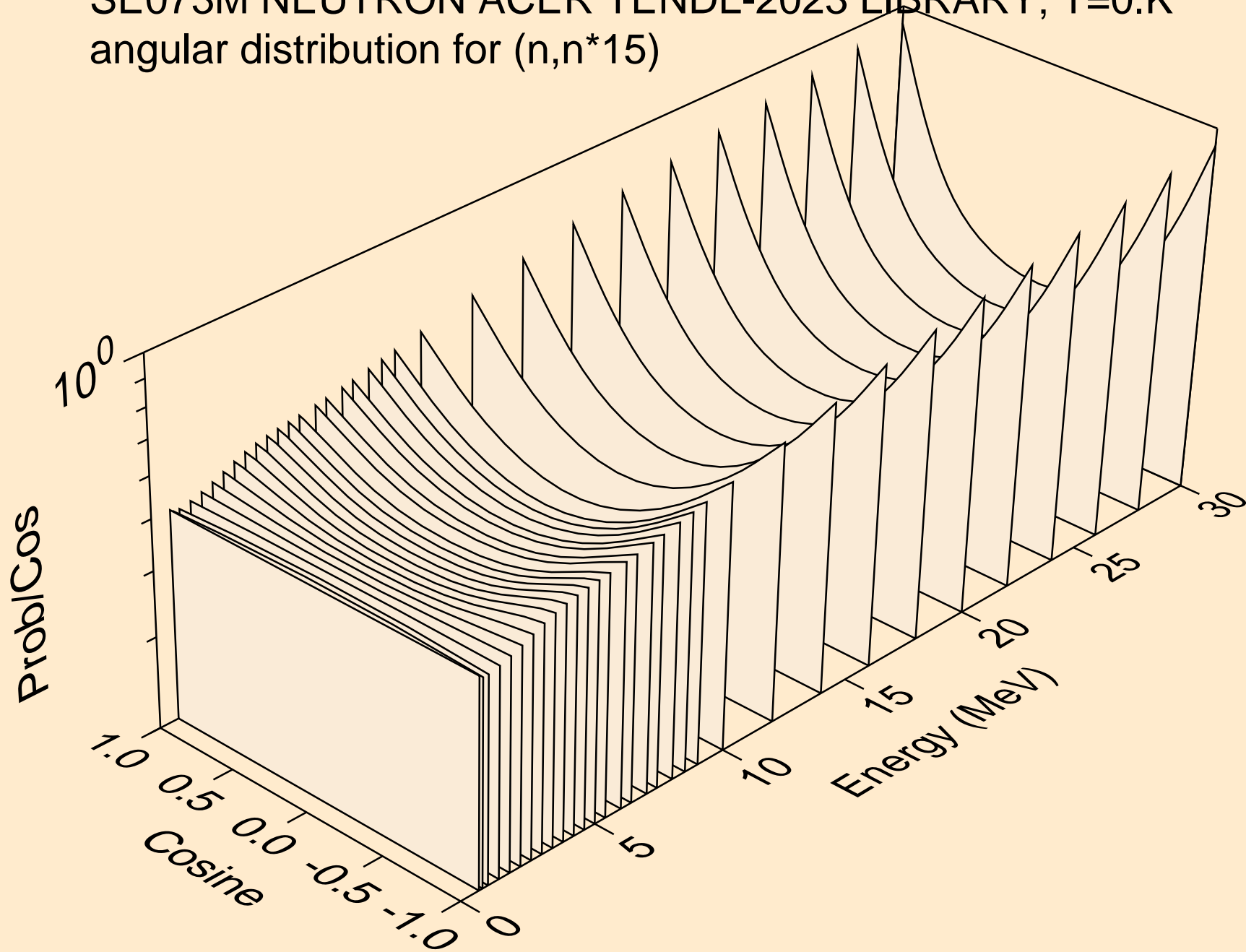

SE073M NEUTRON ACER TENDL-2023 LIBRARY; T=0.K
angular distribution for (n,n*16)

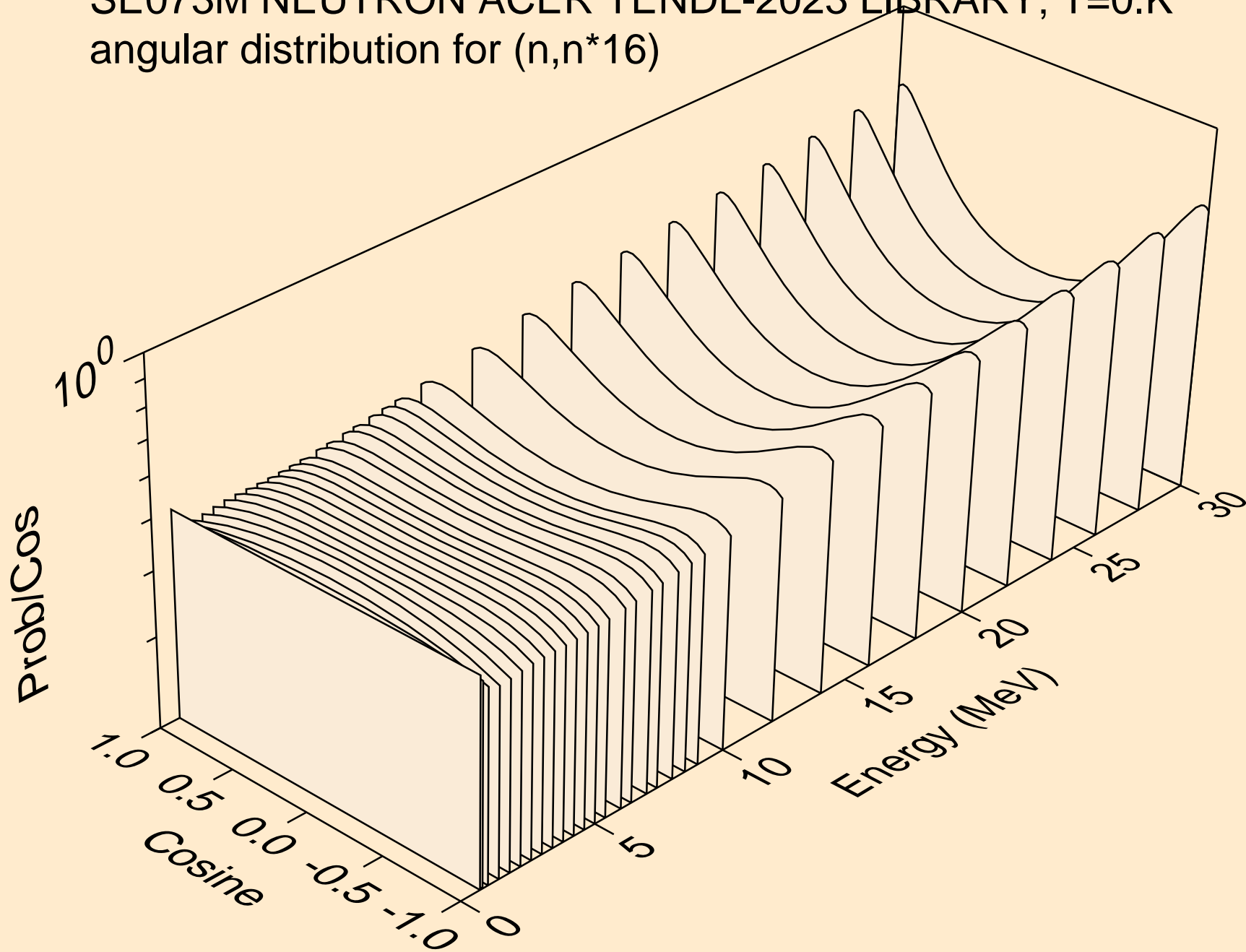

SE073M NEUTRON ACER TENDL-2023 LIBRARY; T=0.K
angular distribution for (n,n*17)

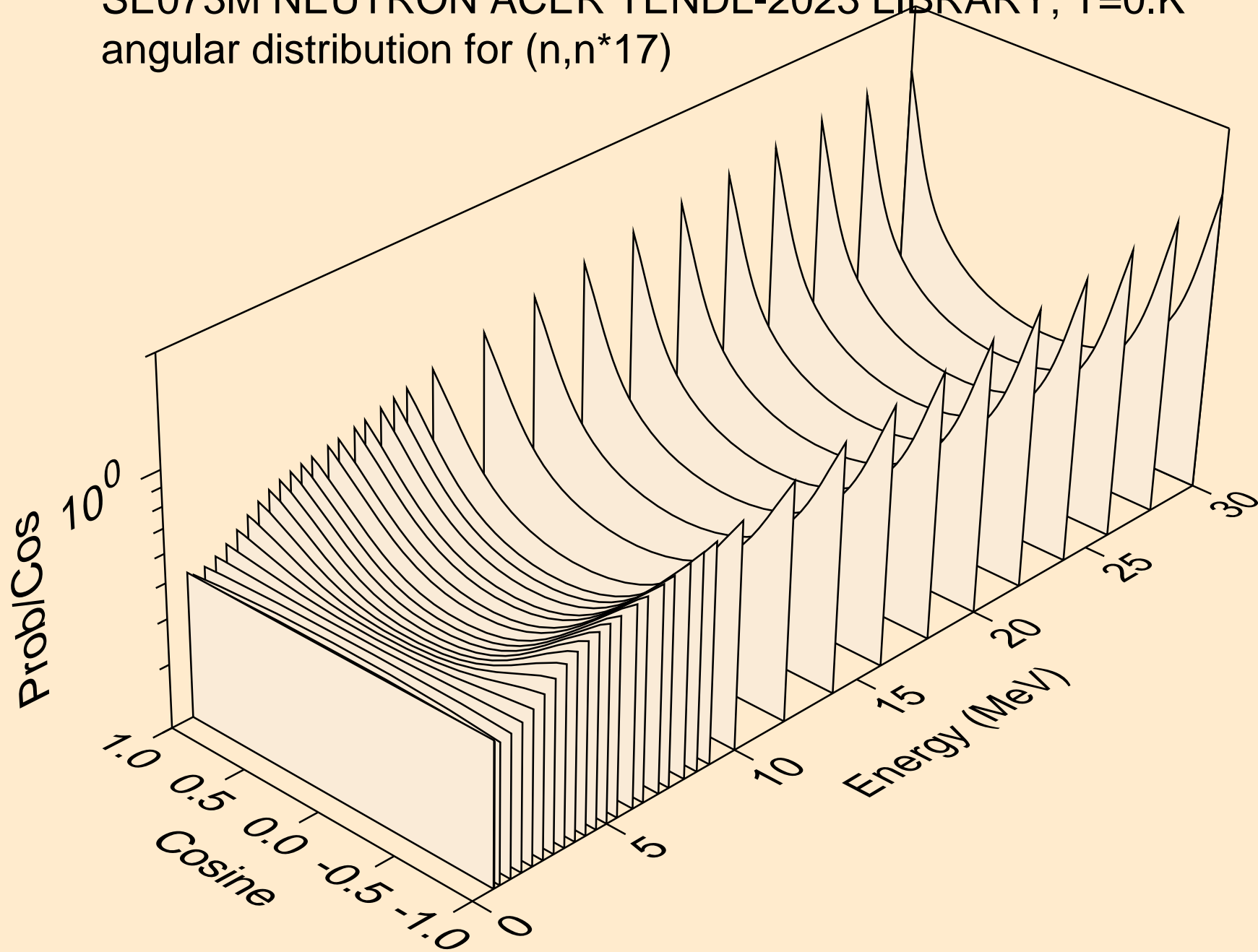

SE073M NEUTRON ACER TENDL-2023 LIBRARY; T=0.K
angular distribution for (n,n*18)

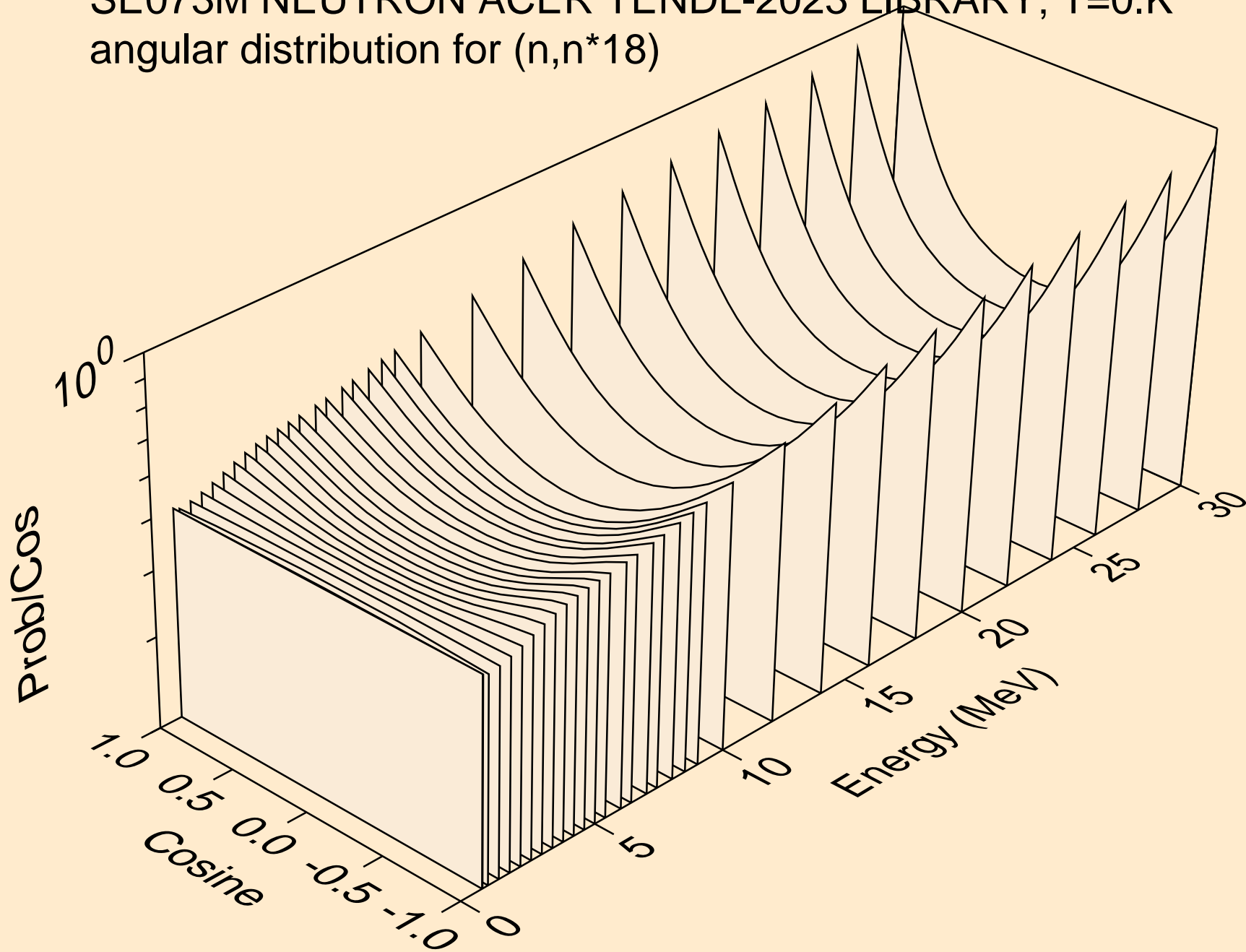

SE073M NEUTRON ACER TENDL-2023 LIBRARY; T=0.K
angular distribution for (n,n*19)

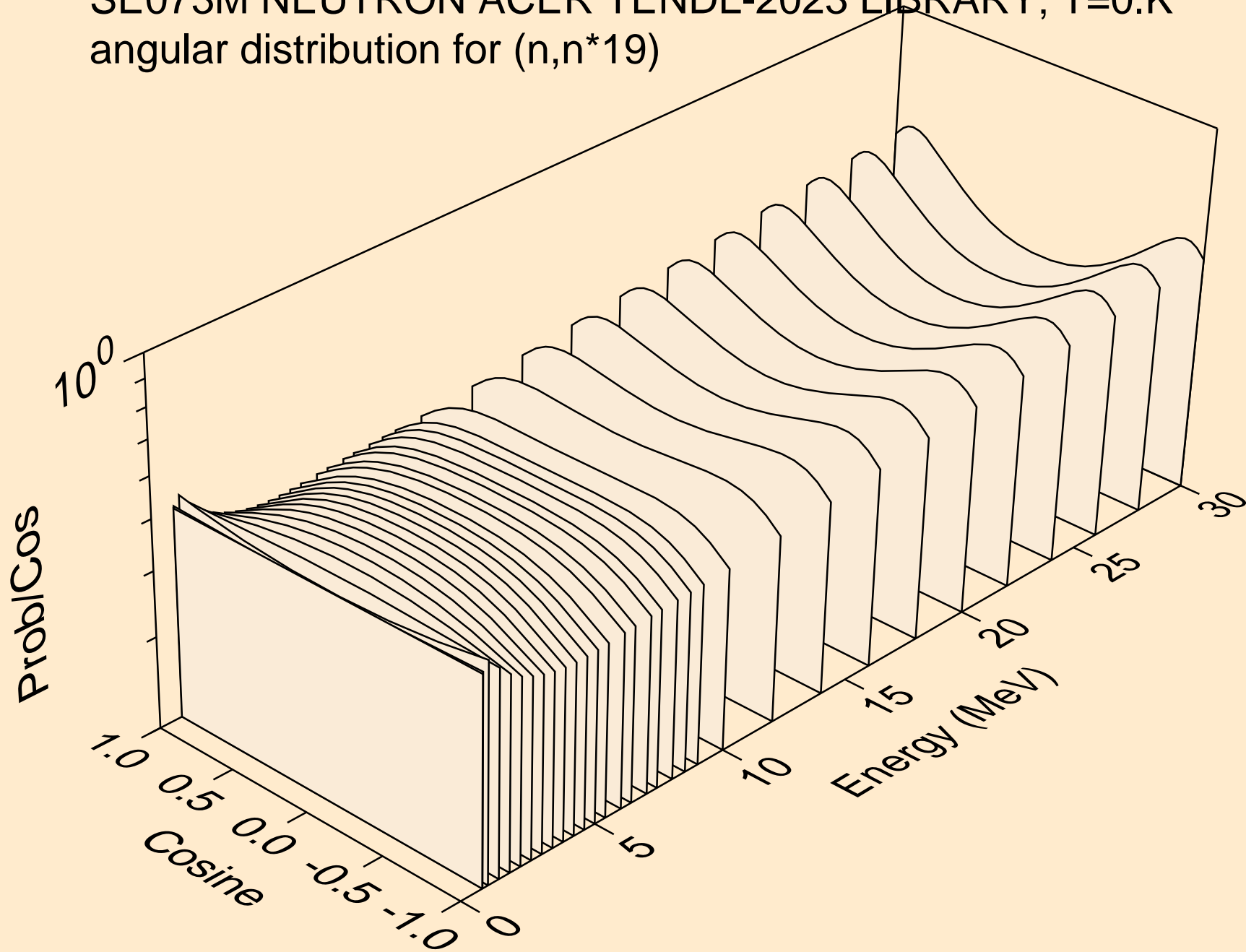

SE073M NEUTRON ACER TENDL-2023 LIBRARY; T=0.K
Neutron emission for (n,x)

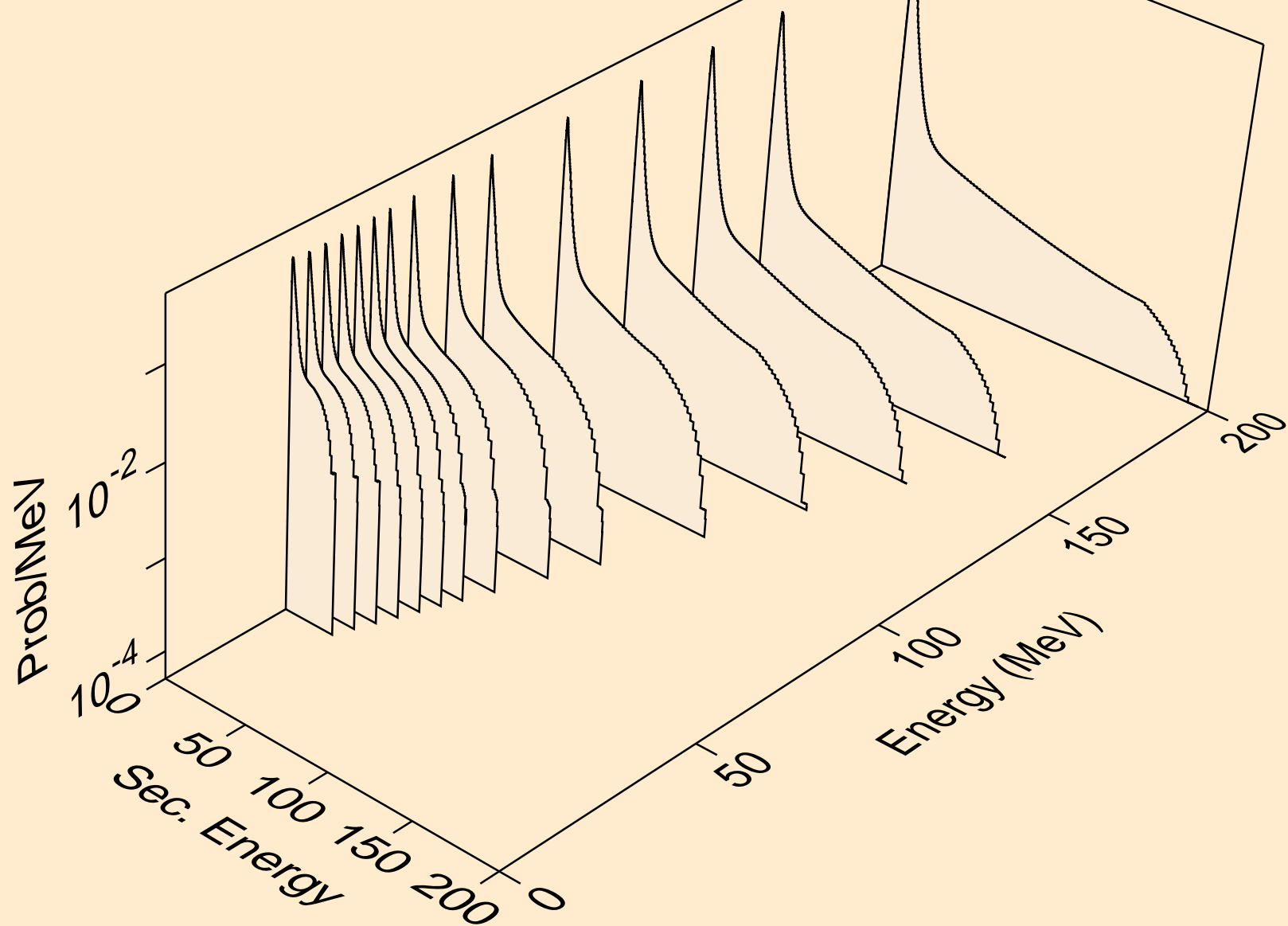

SE073M NEUTRON ACER TENDL-2023 LIBRARY; T=0.K
Neutron emission for (n,2nd)

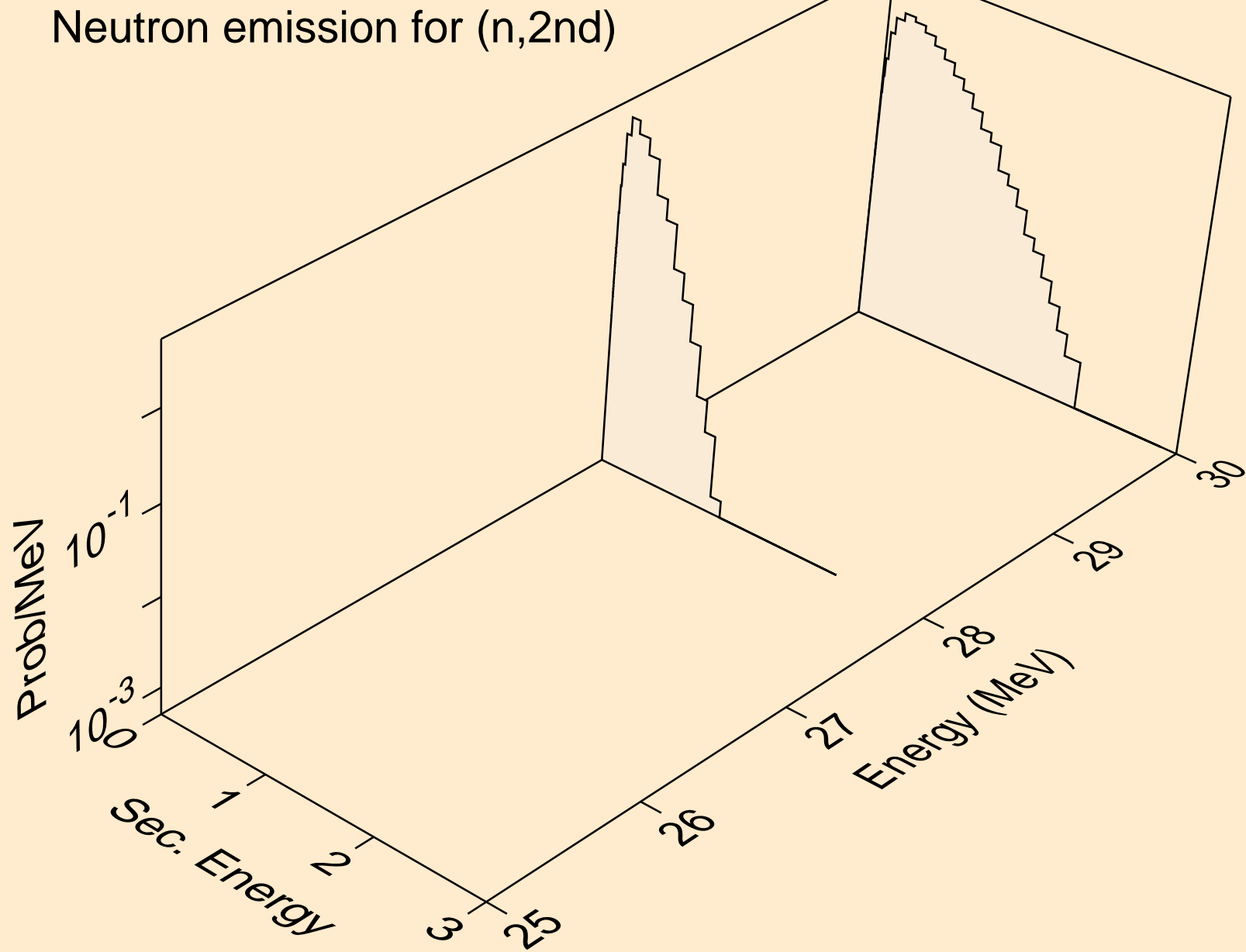

SE073M NEUTRON ACER TENDL-2023 LIBRARY; T=0.K
Neutron emission for (n,2n)

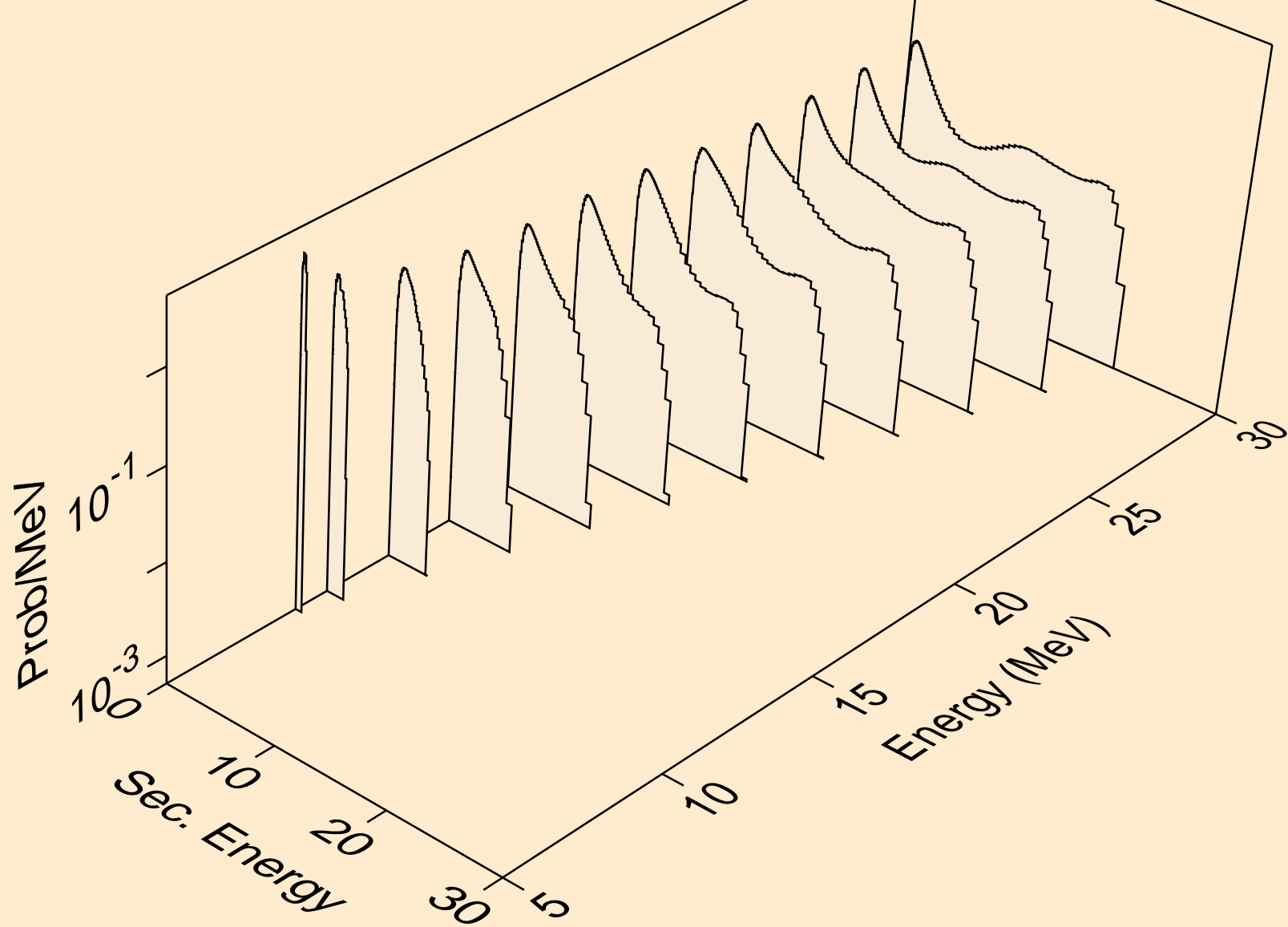

SE073M NEUTRON ACER TENDL-2023 LIBRARY; T=0.K
Neutron emission for (n,3n)

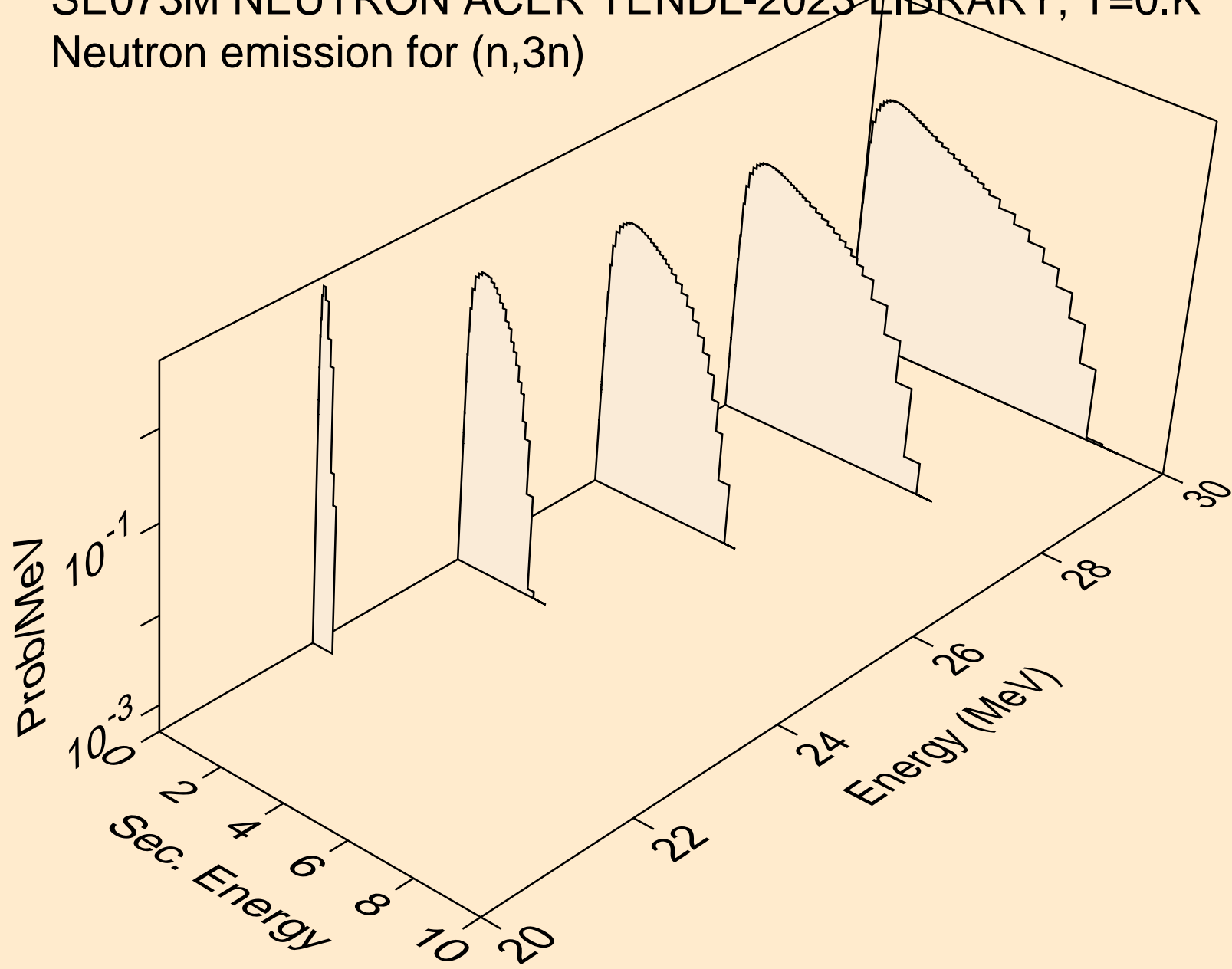

SE073M NEUTRON ACER TENDL-2023 LIBRARY; T=0.K
Neutron emission for (n,n*)a

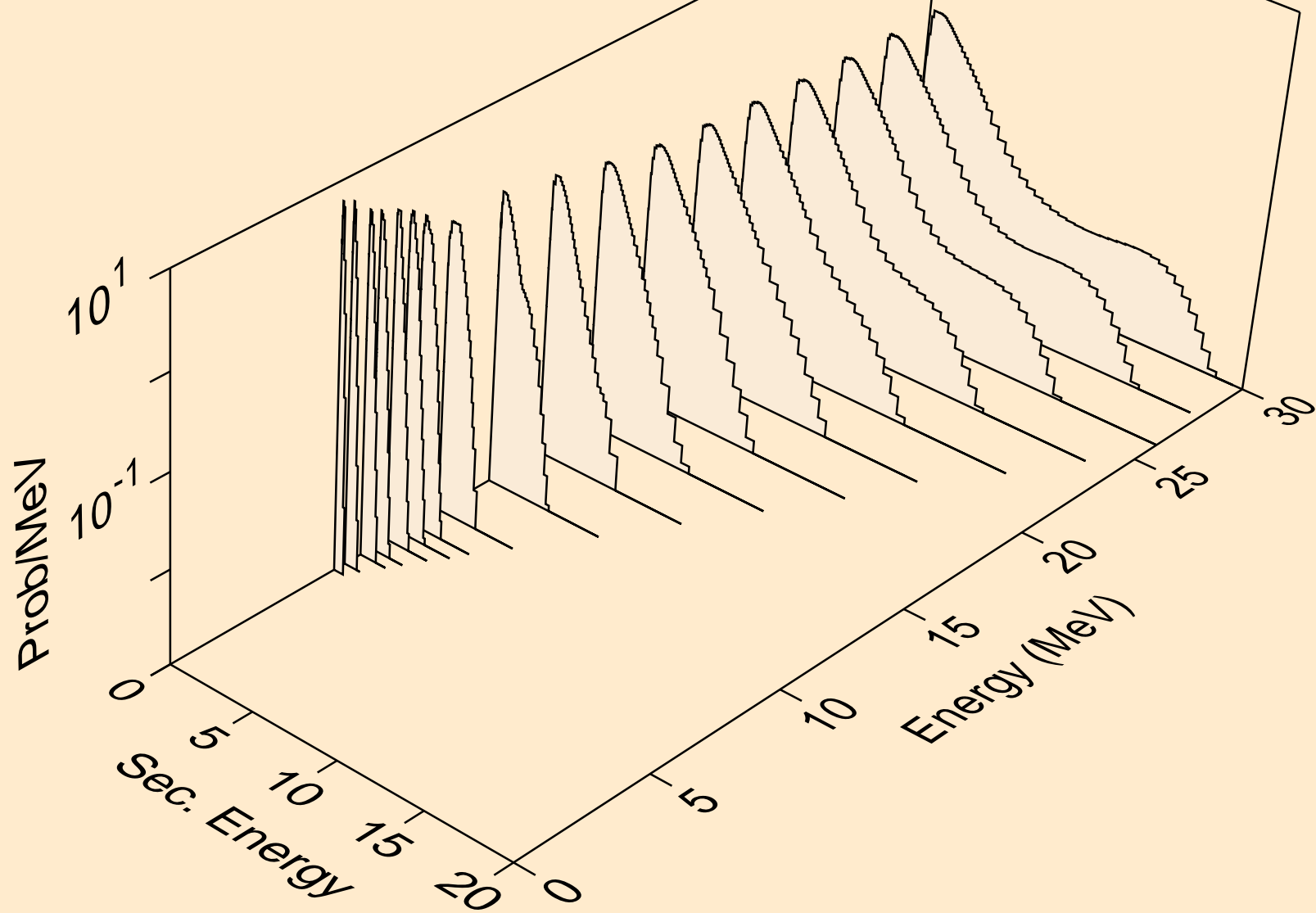

SE073M NEUTRON ACER TENDL-2023 LIBRARY; T=0.K
Neutron emission for (n,2n)a

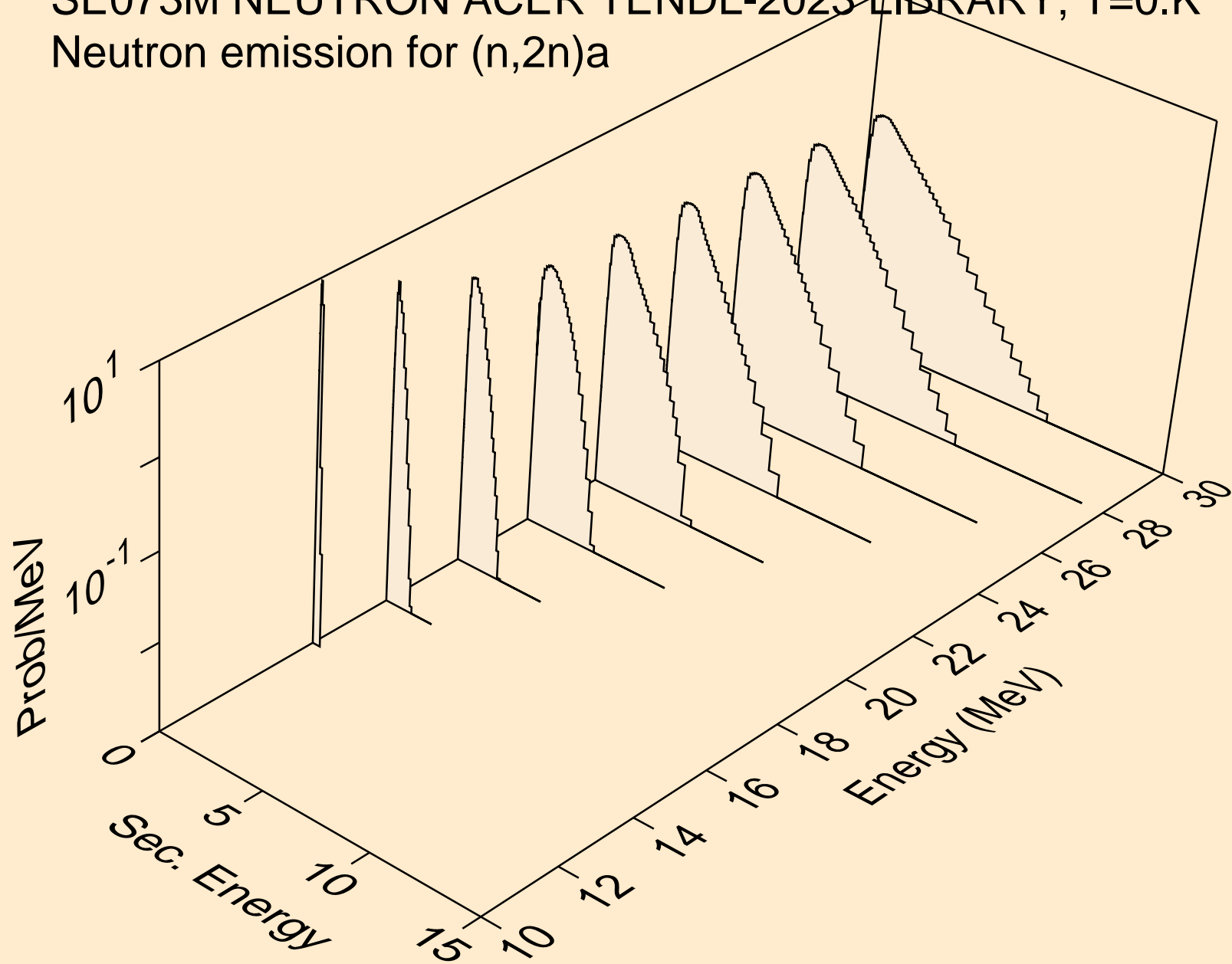

SE073M NEUTRON ACER TENDL-2023 LIBRARY; T=0.K
Neutron emission for (n,3n)a

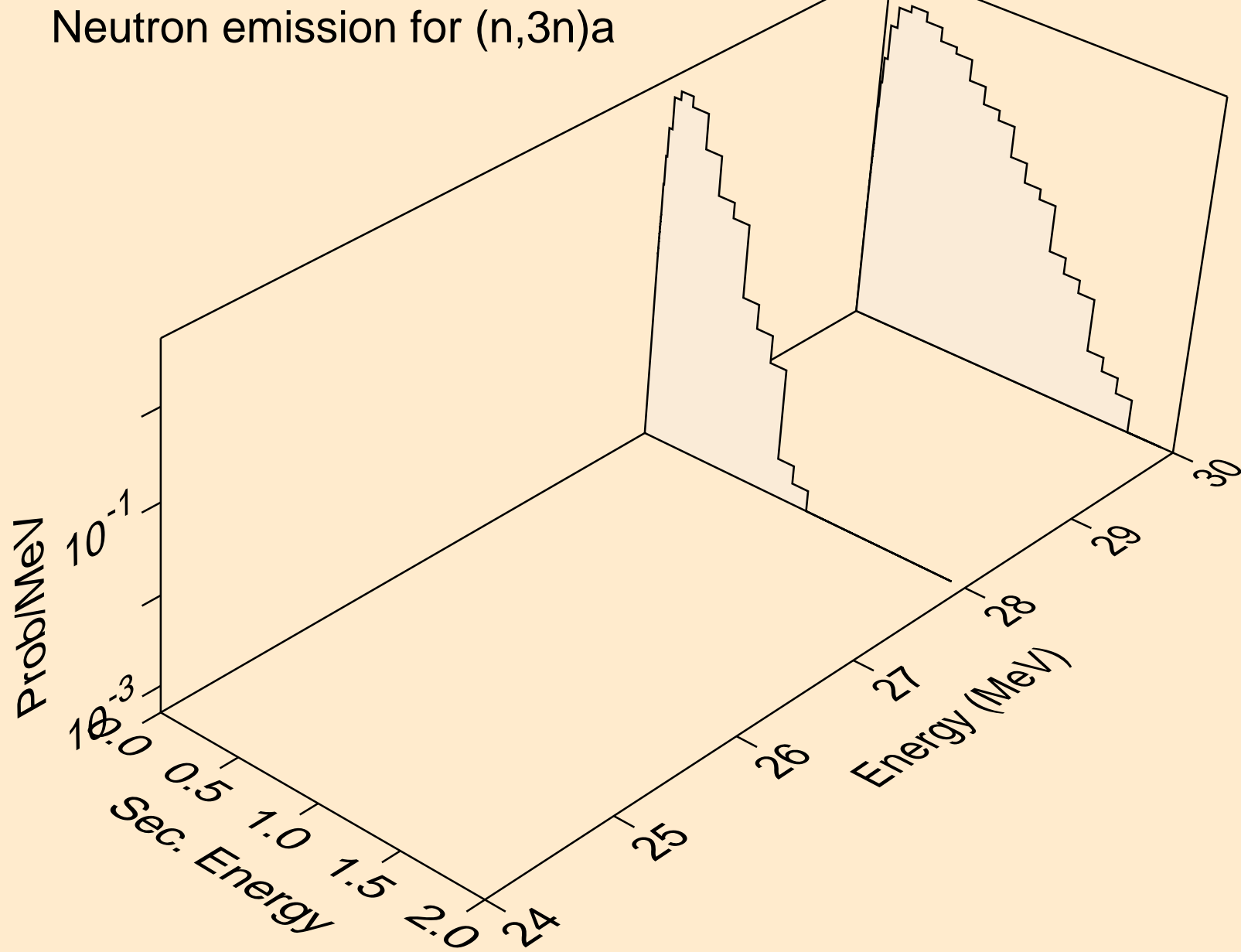

SE073M NEUTRON ACER TENDL-2023 LIBRARY; T=0.K
Neutron emission for (n,n*)p

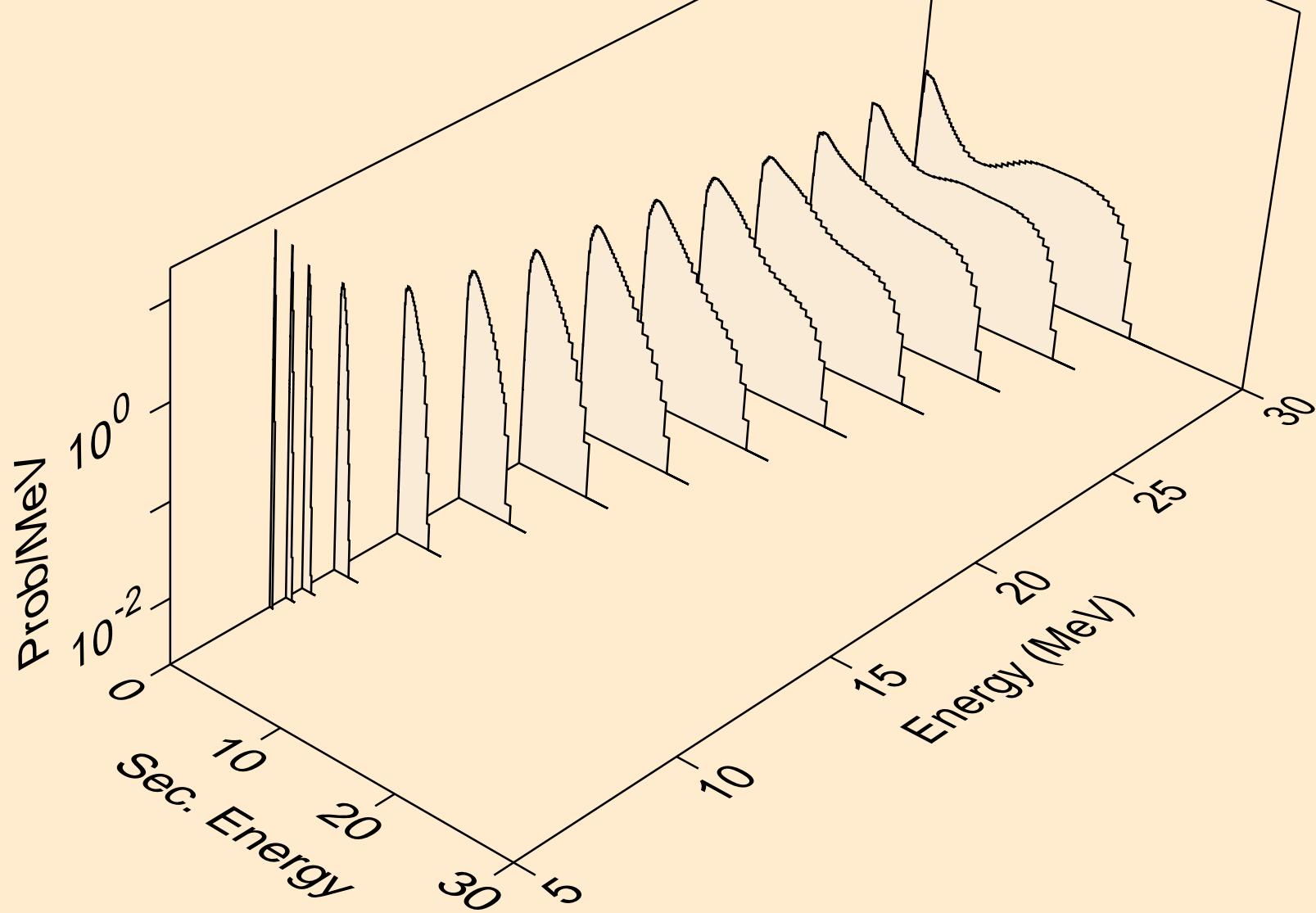

SE073M NEUTRON ACER TENDL-2023 LIBRARY; T=0.K
Neutron emission for (n,n*)2a

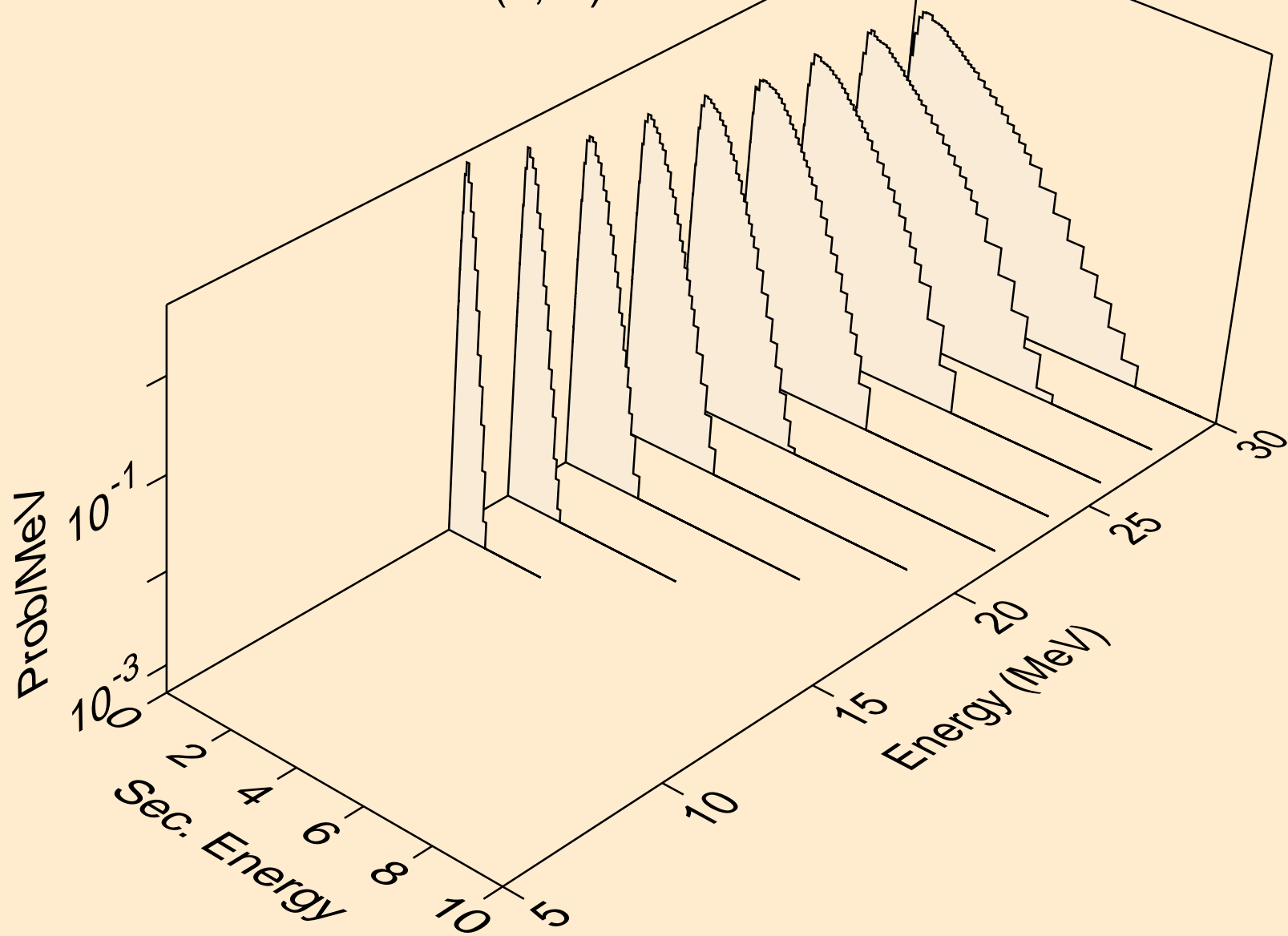

SE073M NEUTRON ACER TENDL-2023 LIBRARY; T=0.K
Neutron emission for (n,2n)2a

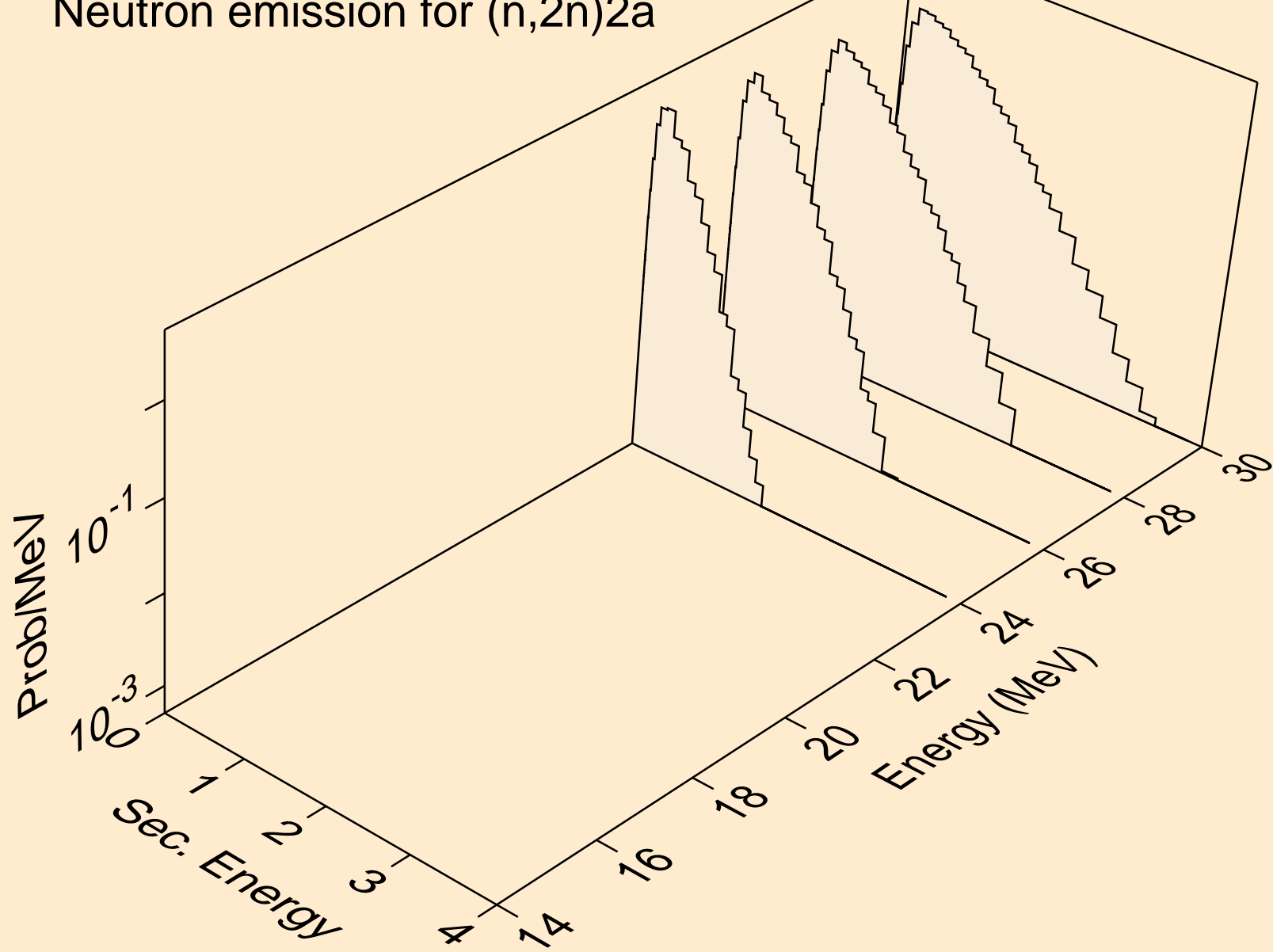

SE073M NEUTRON ACER TENDL-2023 LIBRARY; T=0.K
Neutron emission for (n,n*)d

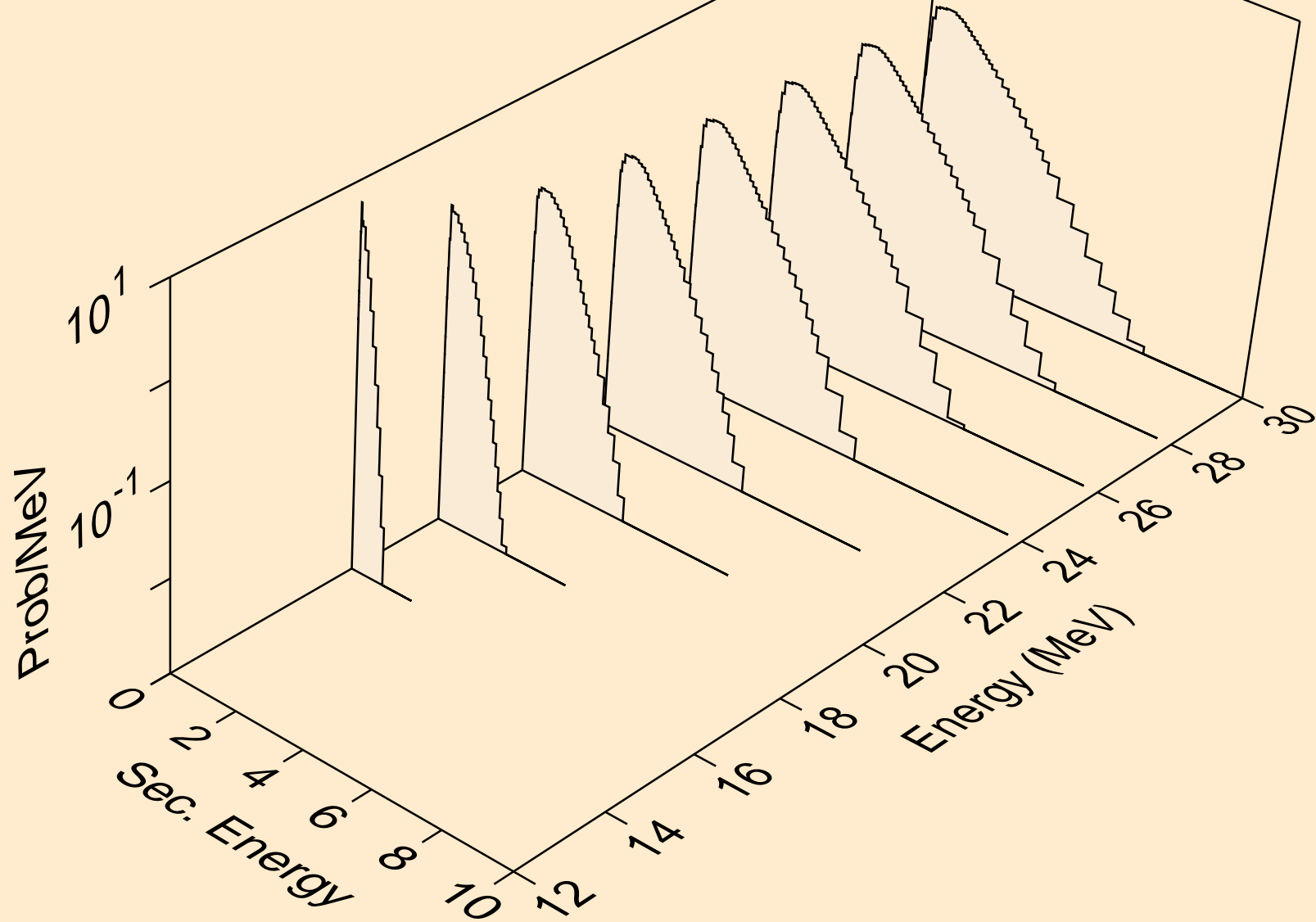

SE073M NEUTRON ACER TENDL-2023 LIBRARY; T=0.K
Neutron emission for (n,n*)t

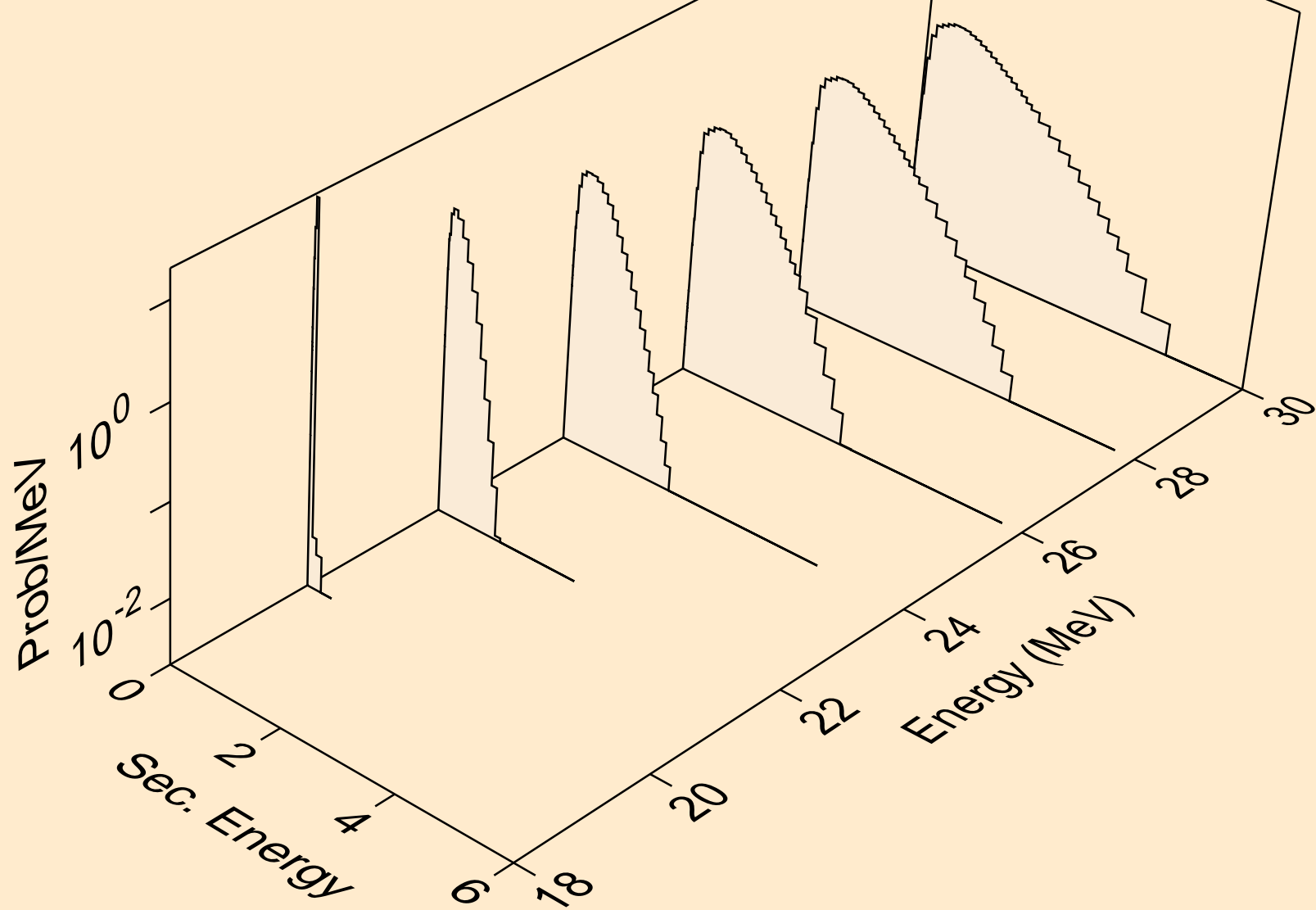

SE073M NEUTRON ACER TENDL-2023 LIBRARY; T=0.K
Neutron emission for (n,n*)he3

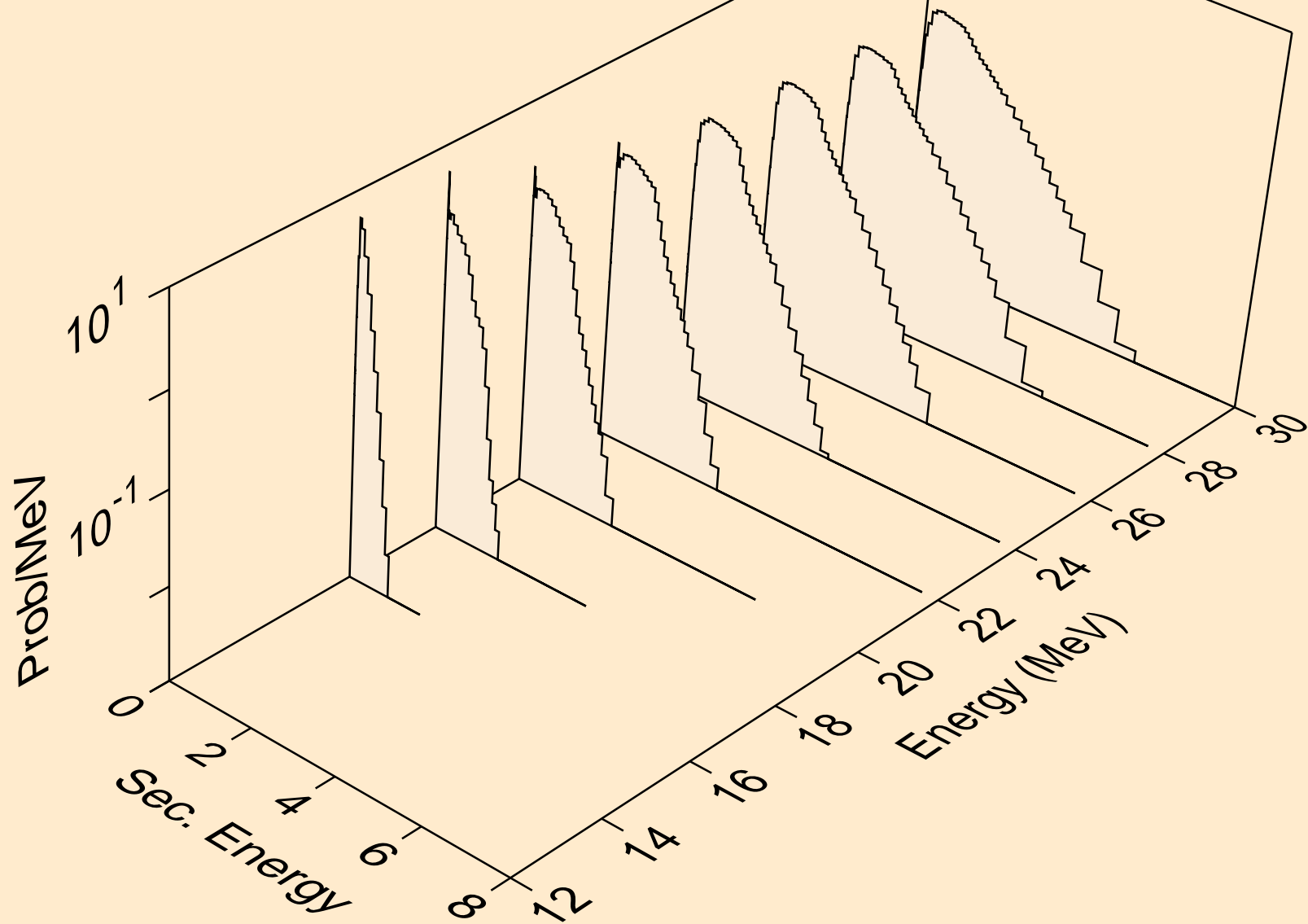

SE073M NEUTRON ACER TENDL-2023 LIBRARY; T=0.K
Neutron emission for (n,2np)

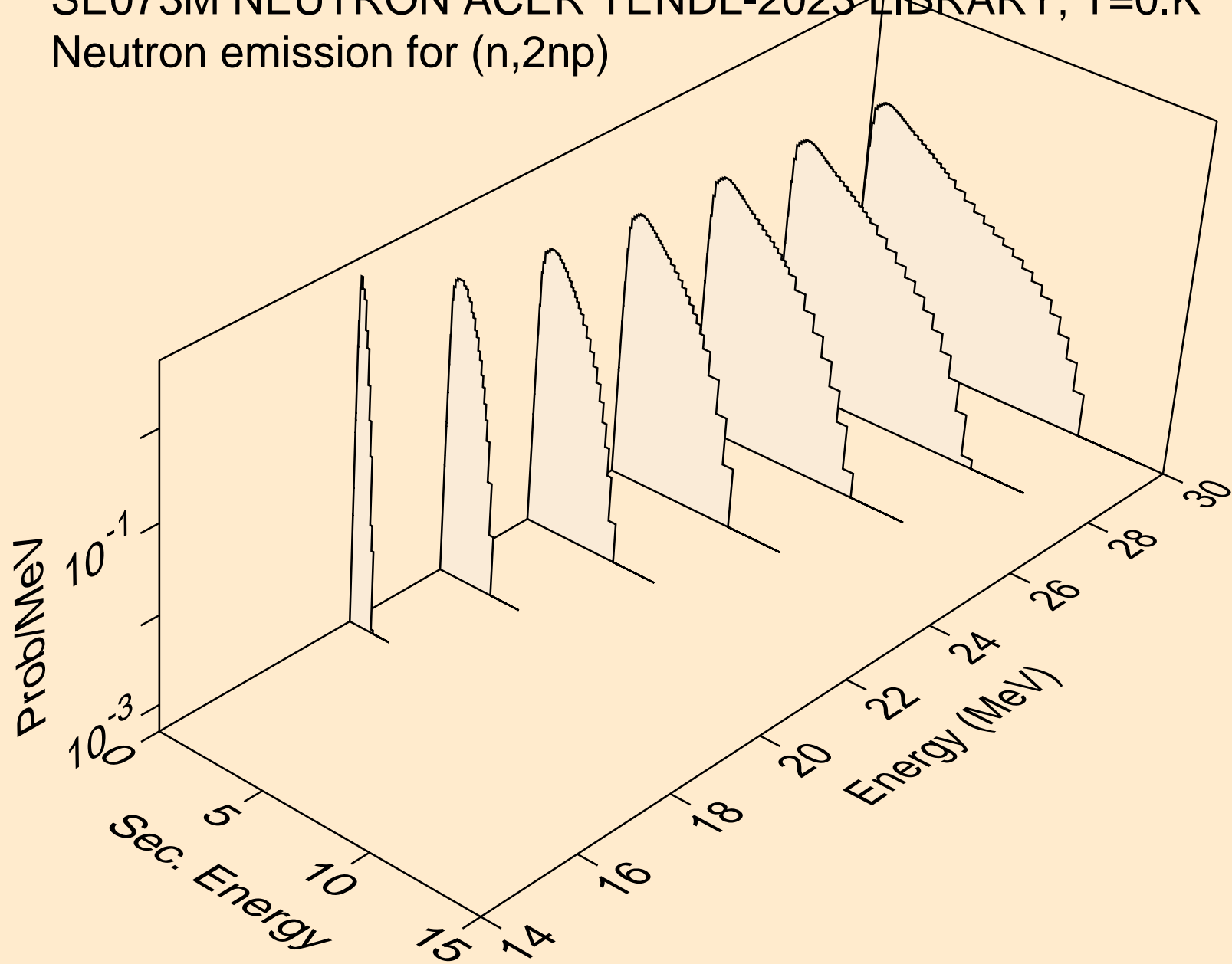

SE073M NEUTRON ACER TENDL-2023 LIBRARY; T=0.K
Neutron emission for (n,3np)

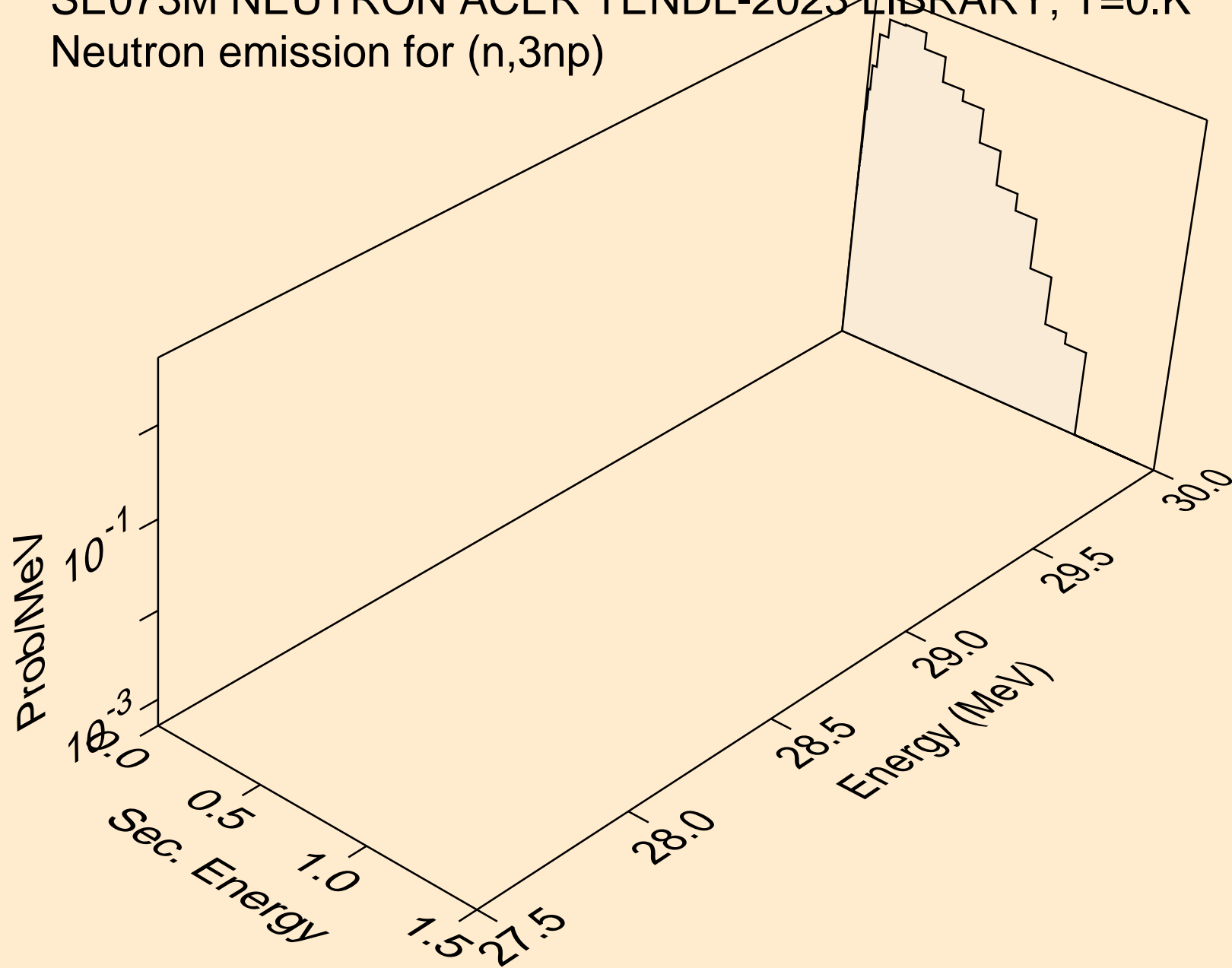

SE073M NEUTRON ACER TENDL-2023 LIBRARY; T=0.K
Neutron emission for (n,n2p)

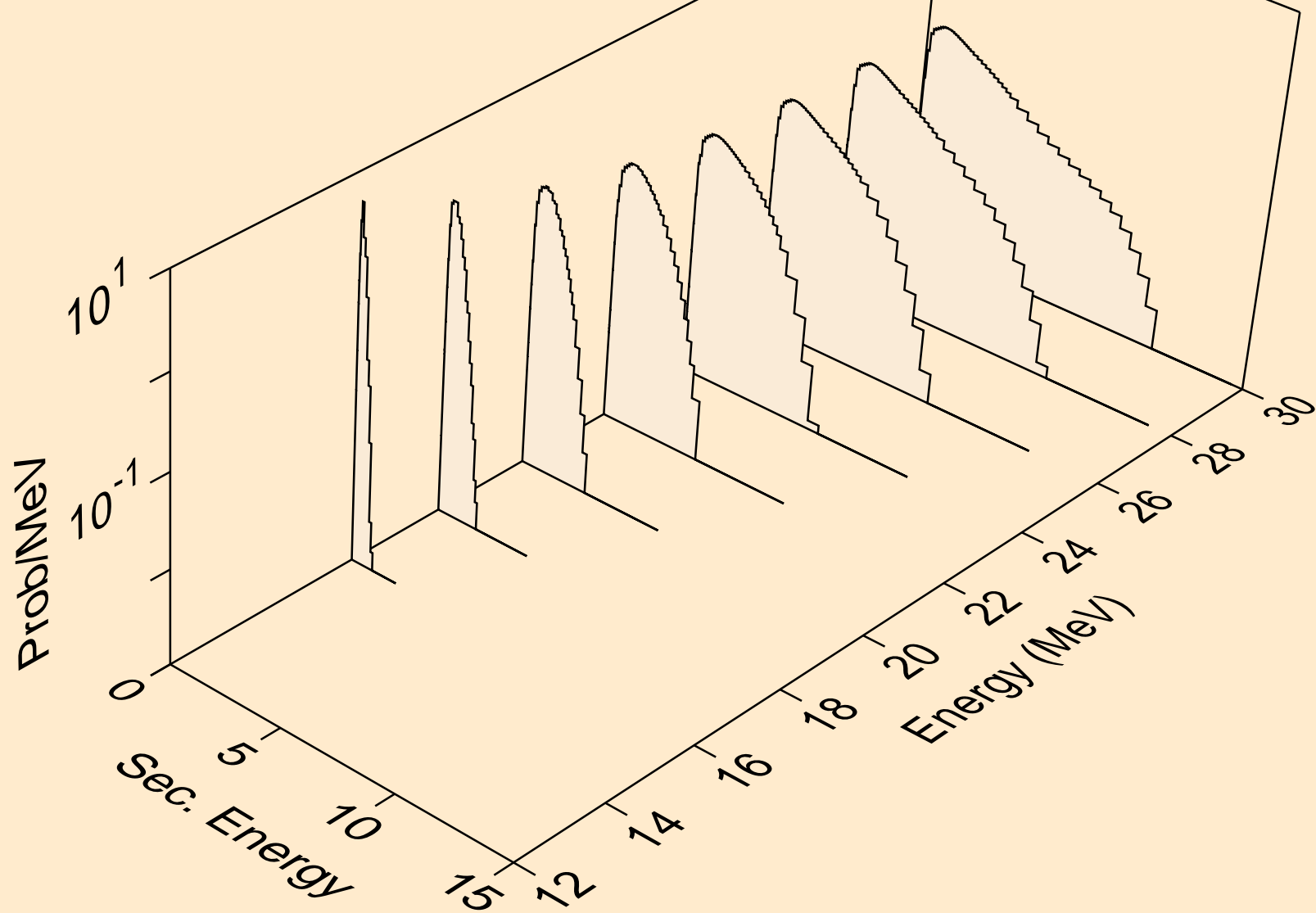

SE073M NEUTRON ACER TENDL-2023 LIBRARY; T=0.K
Neutron emission for (n,npa)

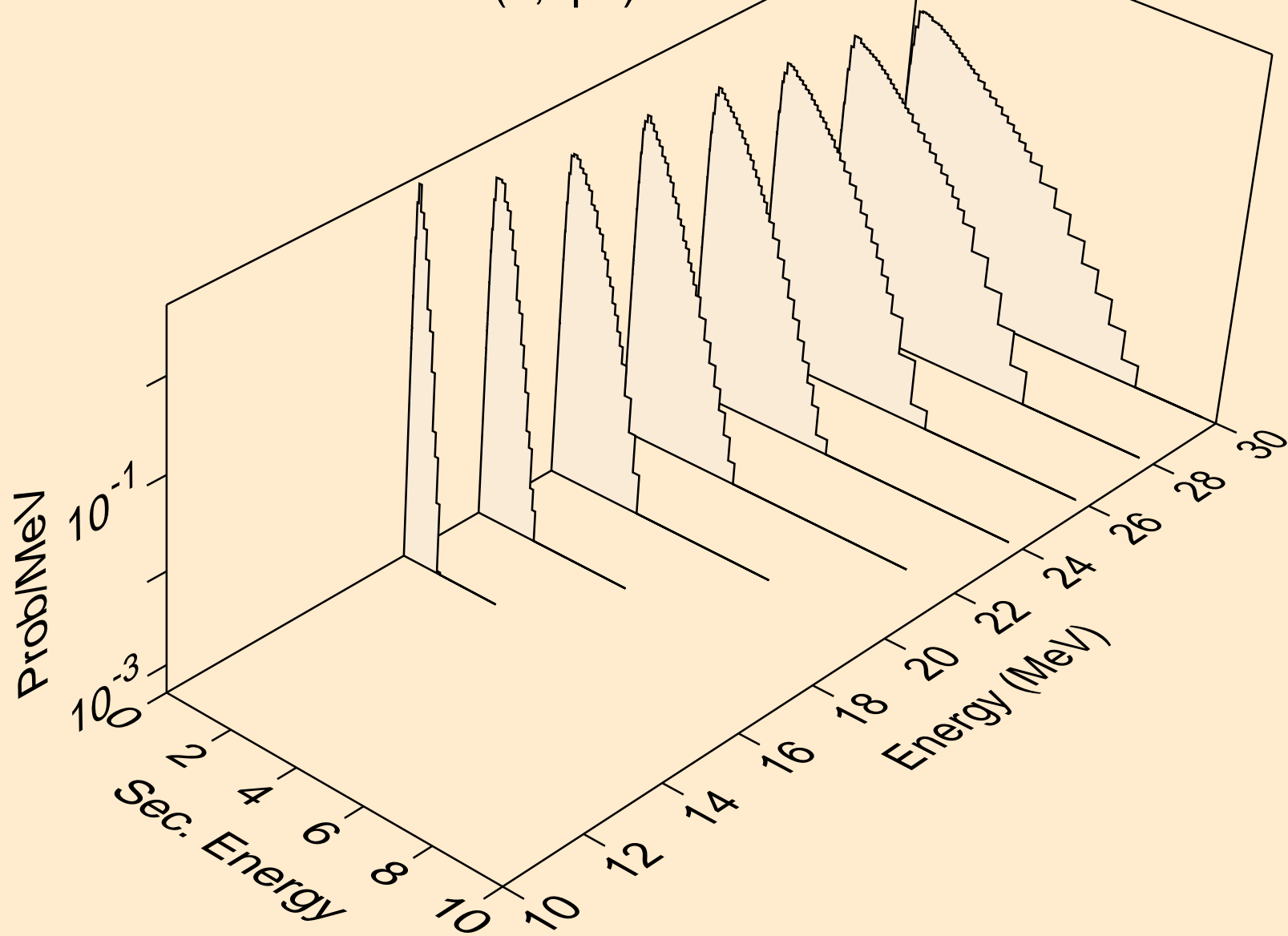

SE073M NEUTRON ACER TENDL-2023 LIBRARY; T=0.K
Neutron emission for (n,n*c)

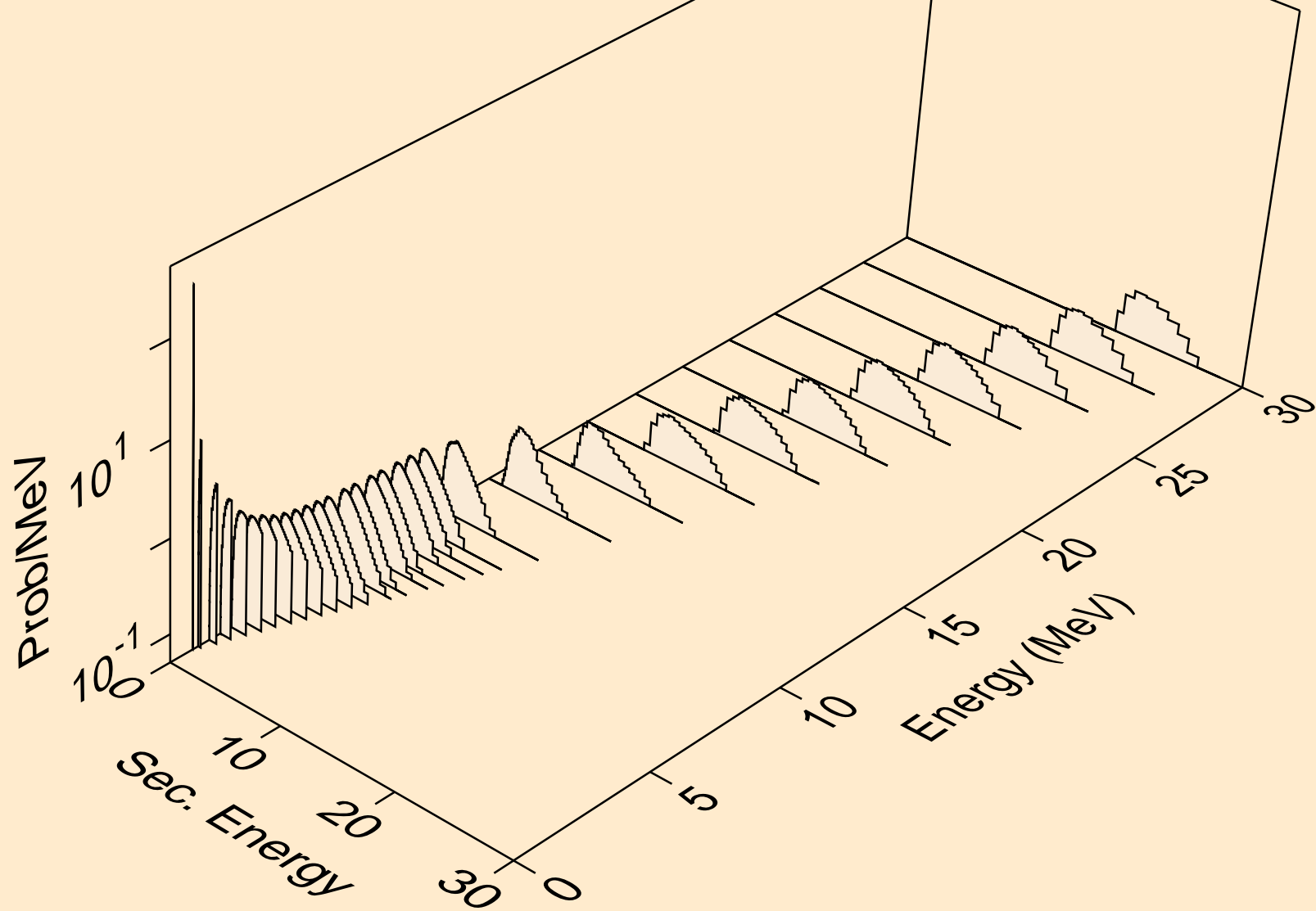

SE073M NEUTRON ACER TENDL-2023 LIBRARY; T=0.K
Photon emission for (n,x)

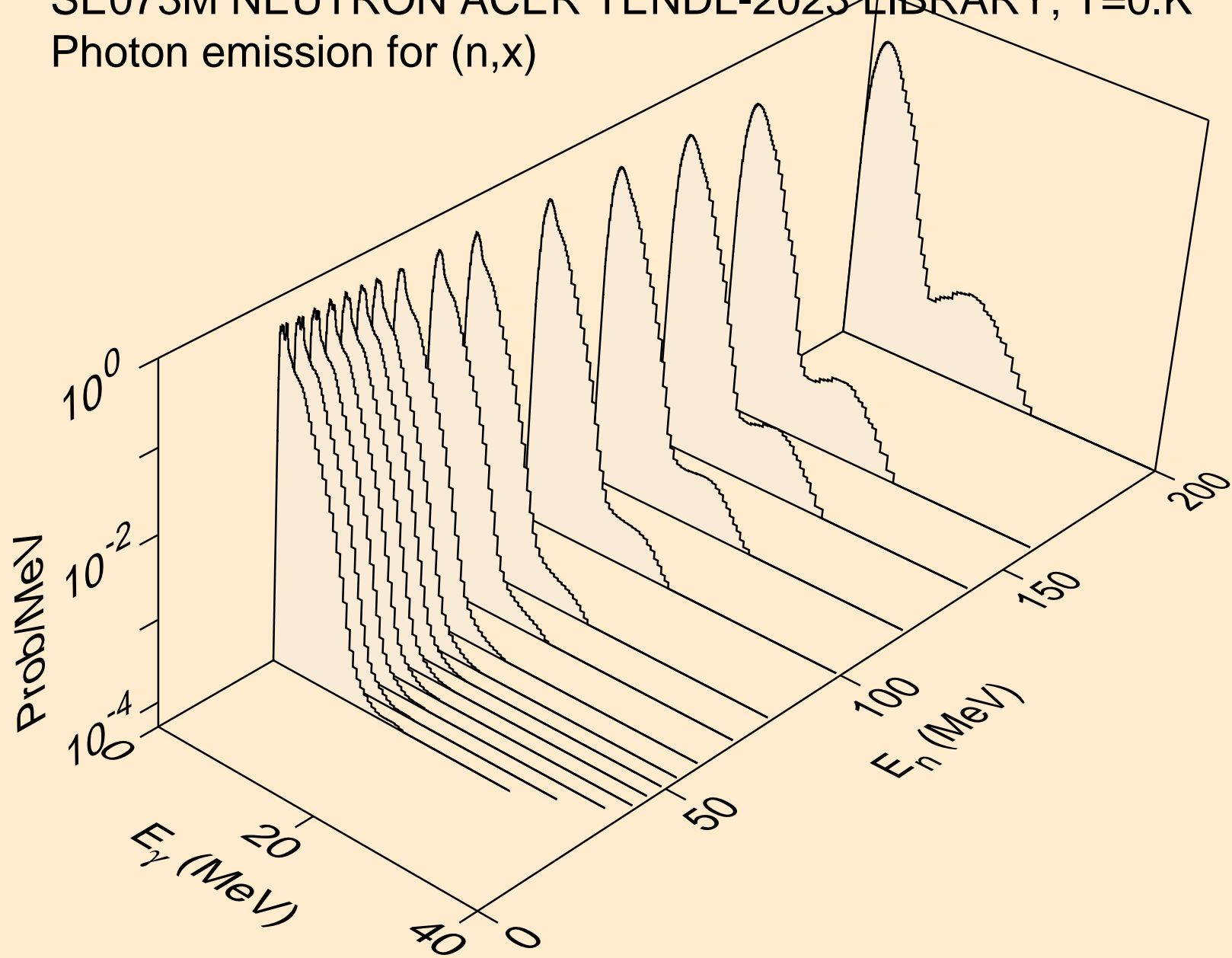

SE073M NEUTRON ACER TENDL-2023 LIBRARY; T=0.K
Photon emission for (n,2nd)

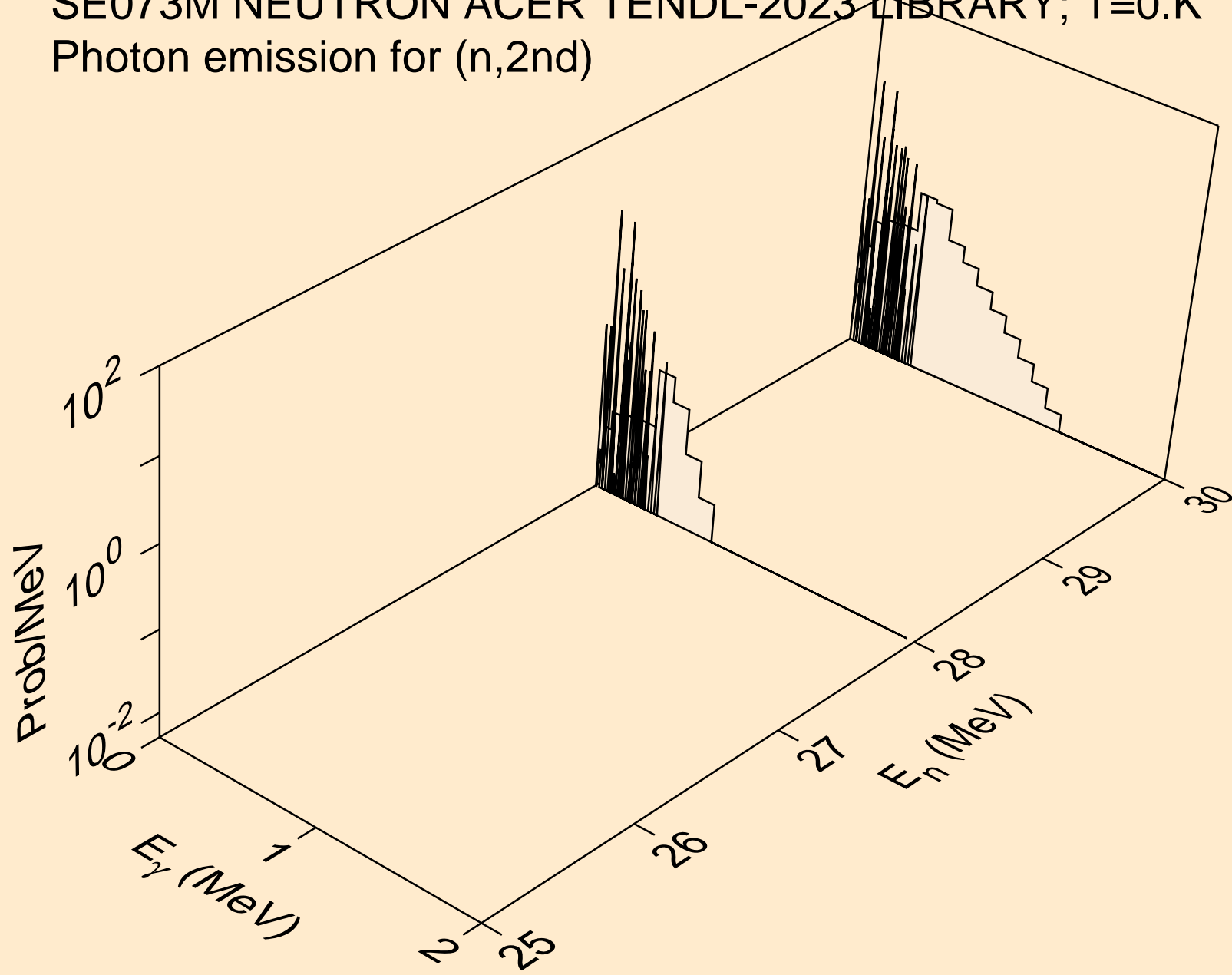

SE073M NEUTRON ACER TENDL-2023 LIBRARY; T=0.K
Photon emission for (n,2n)

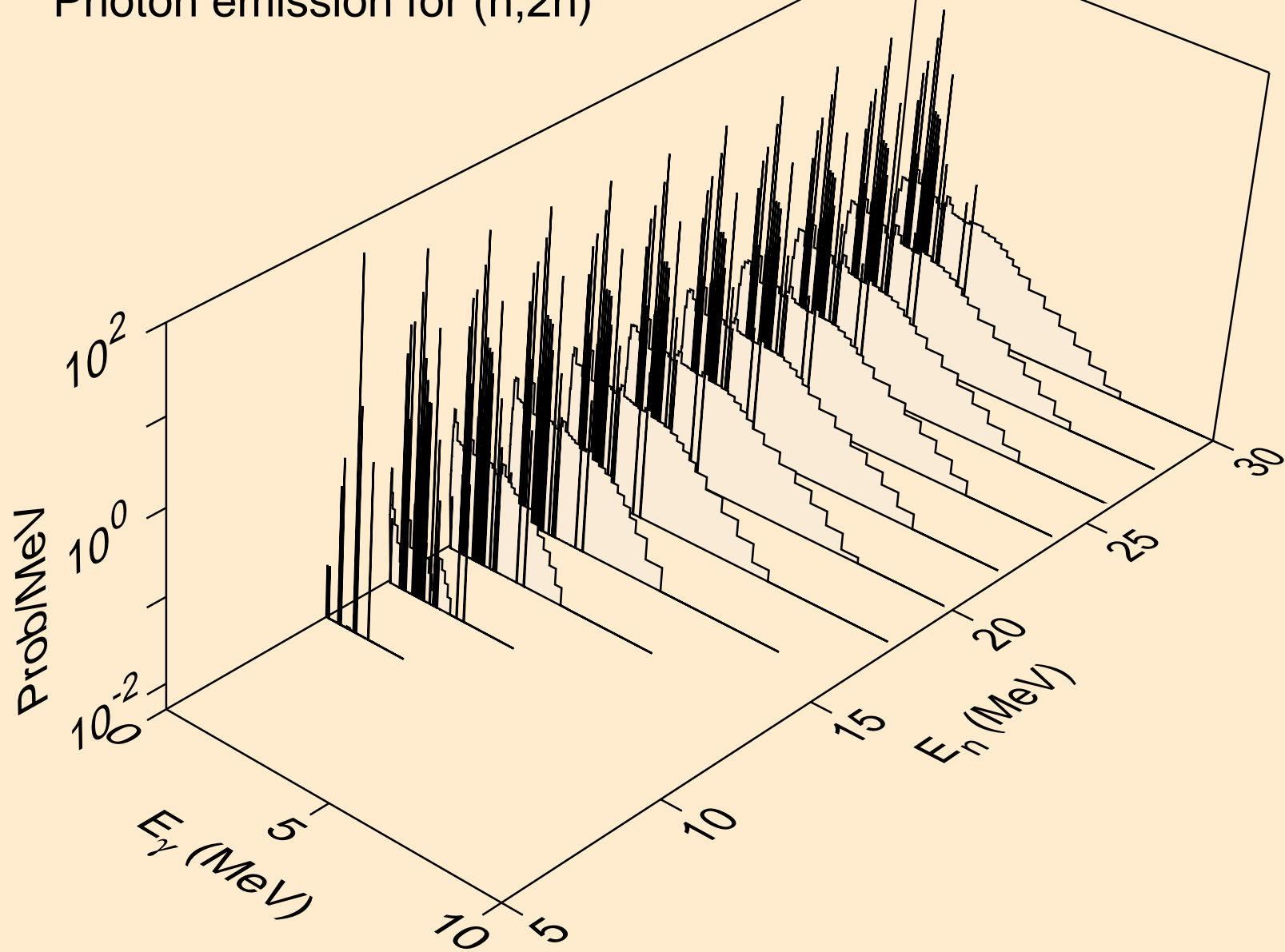

SE073M NEUTRON ACER TENDL-2023 LIBRARY; T=0.K
Photon emission for (n,3n)

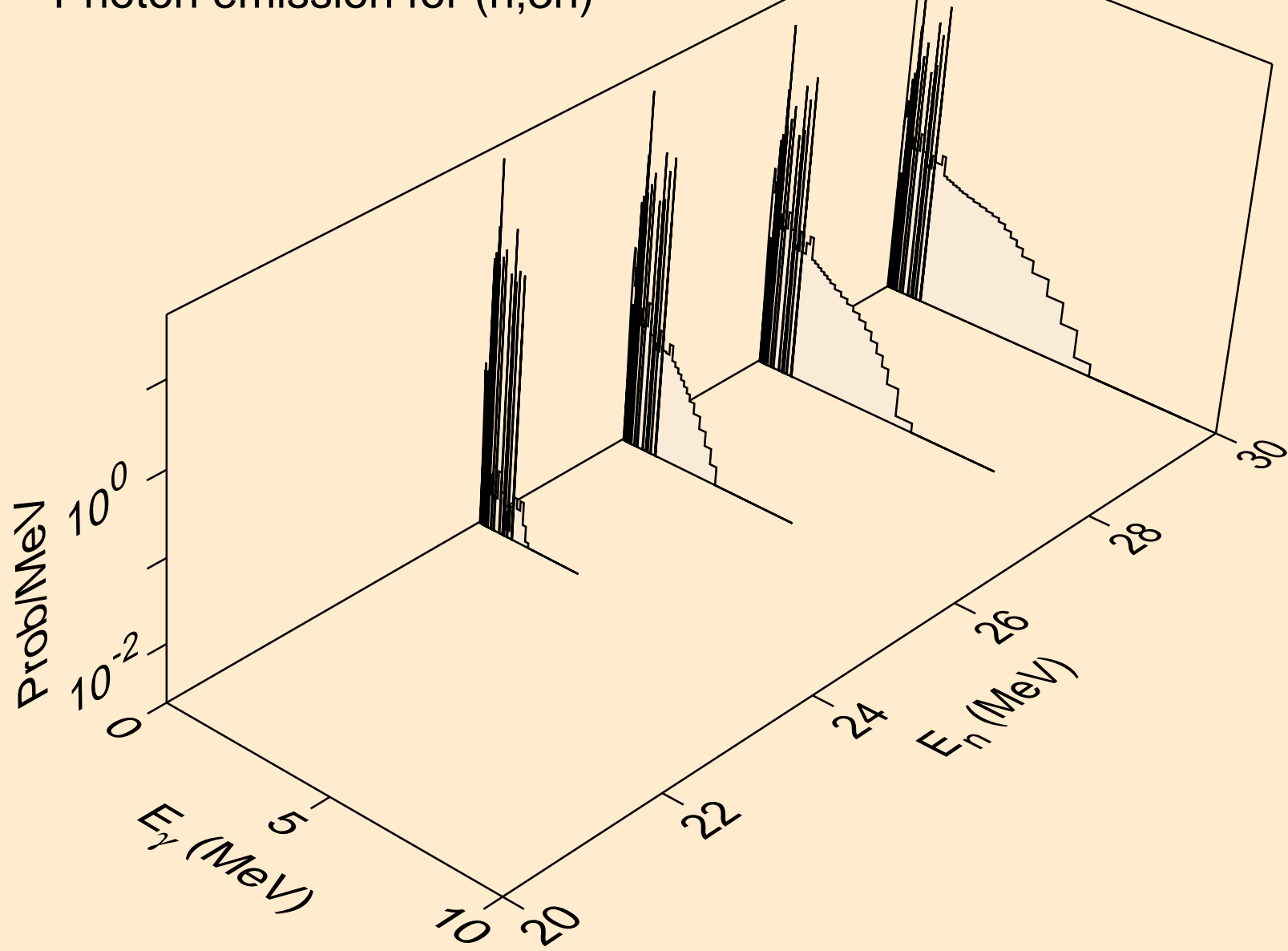

SE073M NEUTRON ACER TENDL-2023 LIBRARY; T=0.K
Photon emission for (n,n*)a

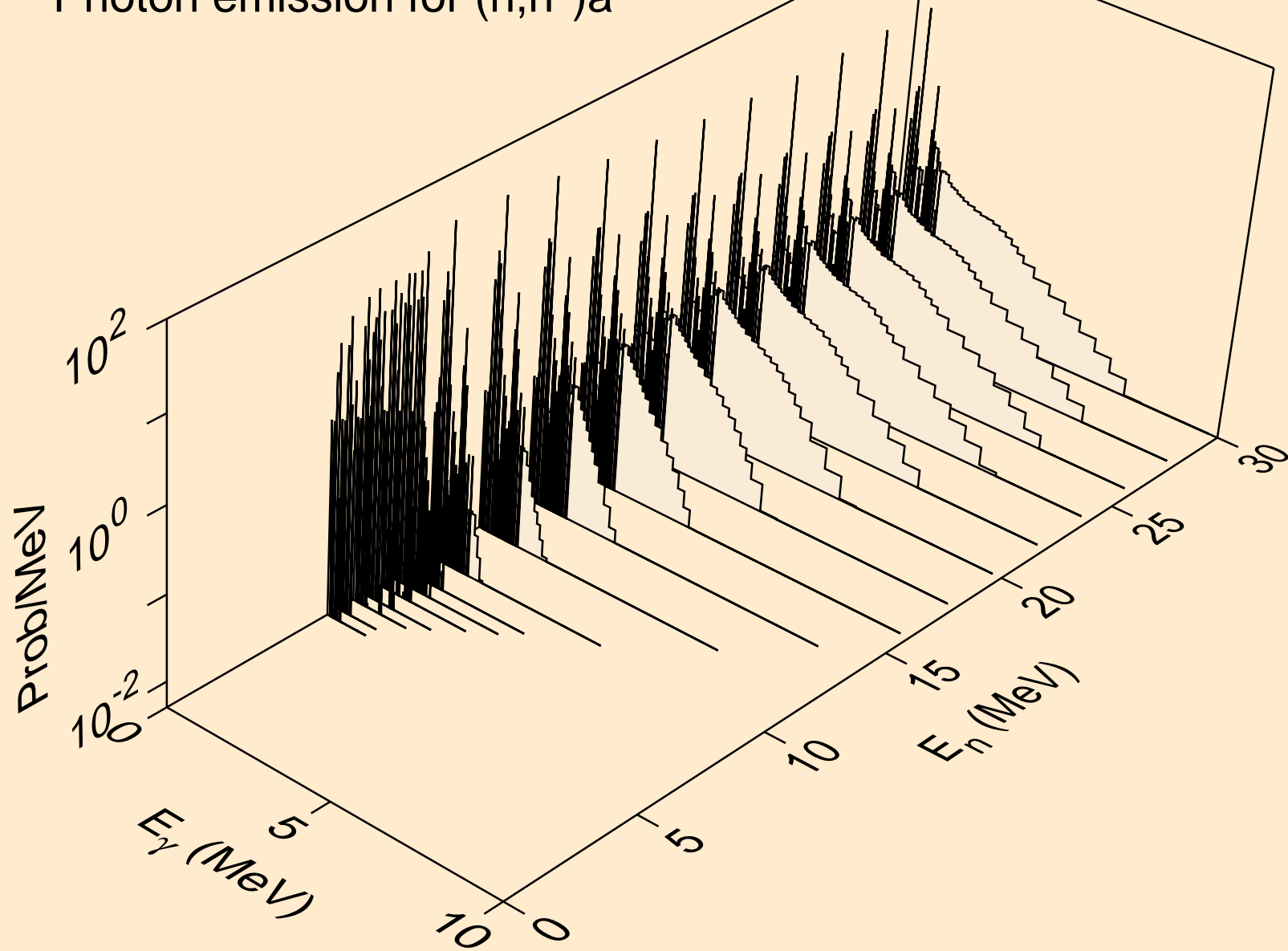

SE073M NEUTRON ACER TENDL-2023 LIBRARY; T=0.K
Photon emission for (n,2n)a

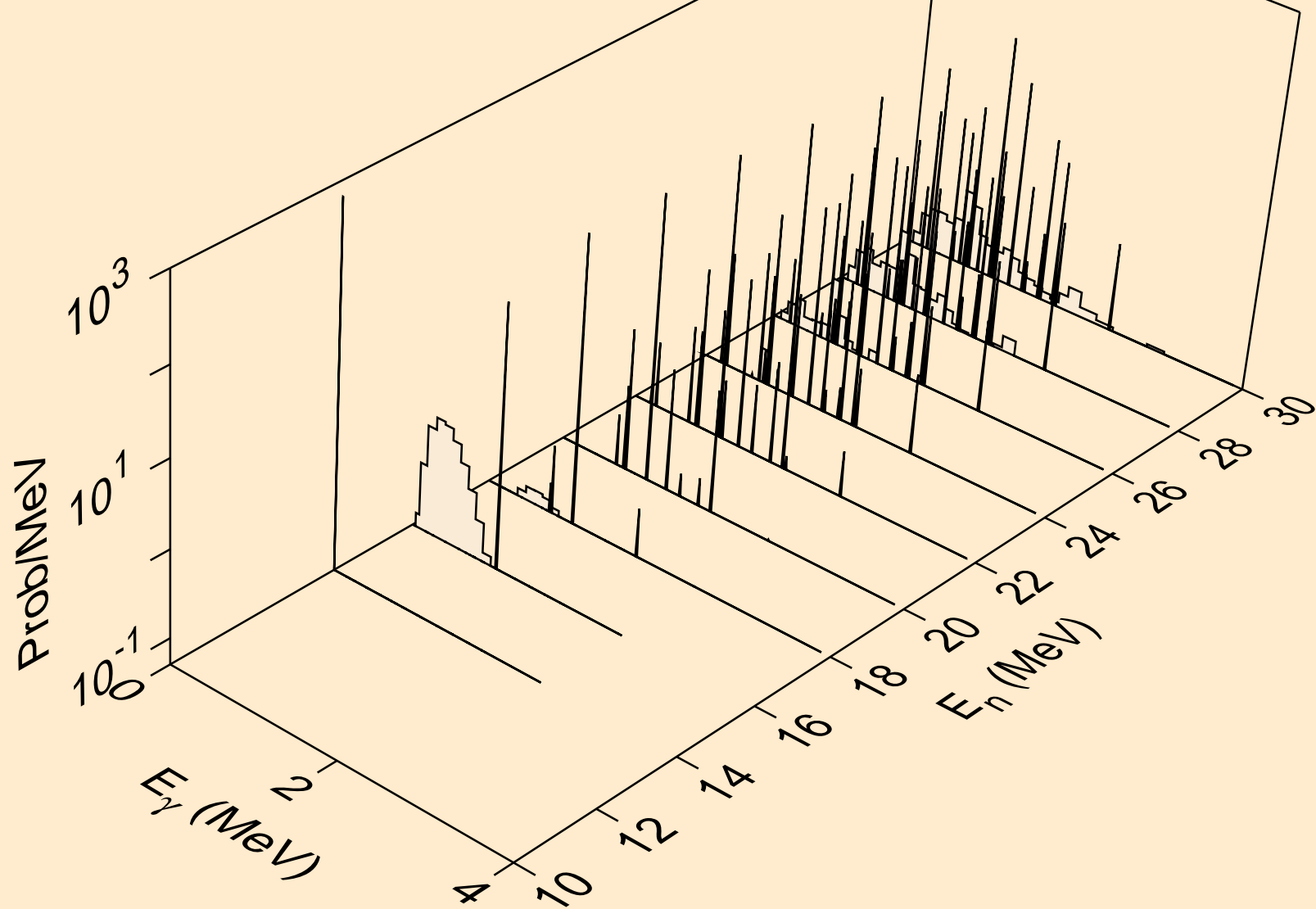

SE073M NEUTRON ACER TENDL-2023 LIBRARY; T=0.K
Photon emission for (n,3n)a

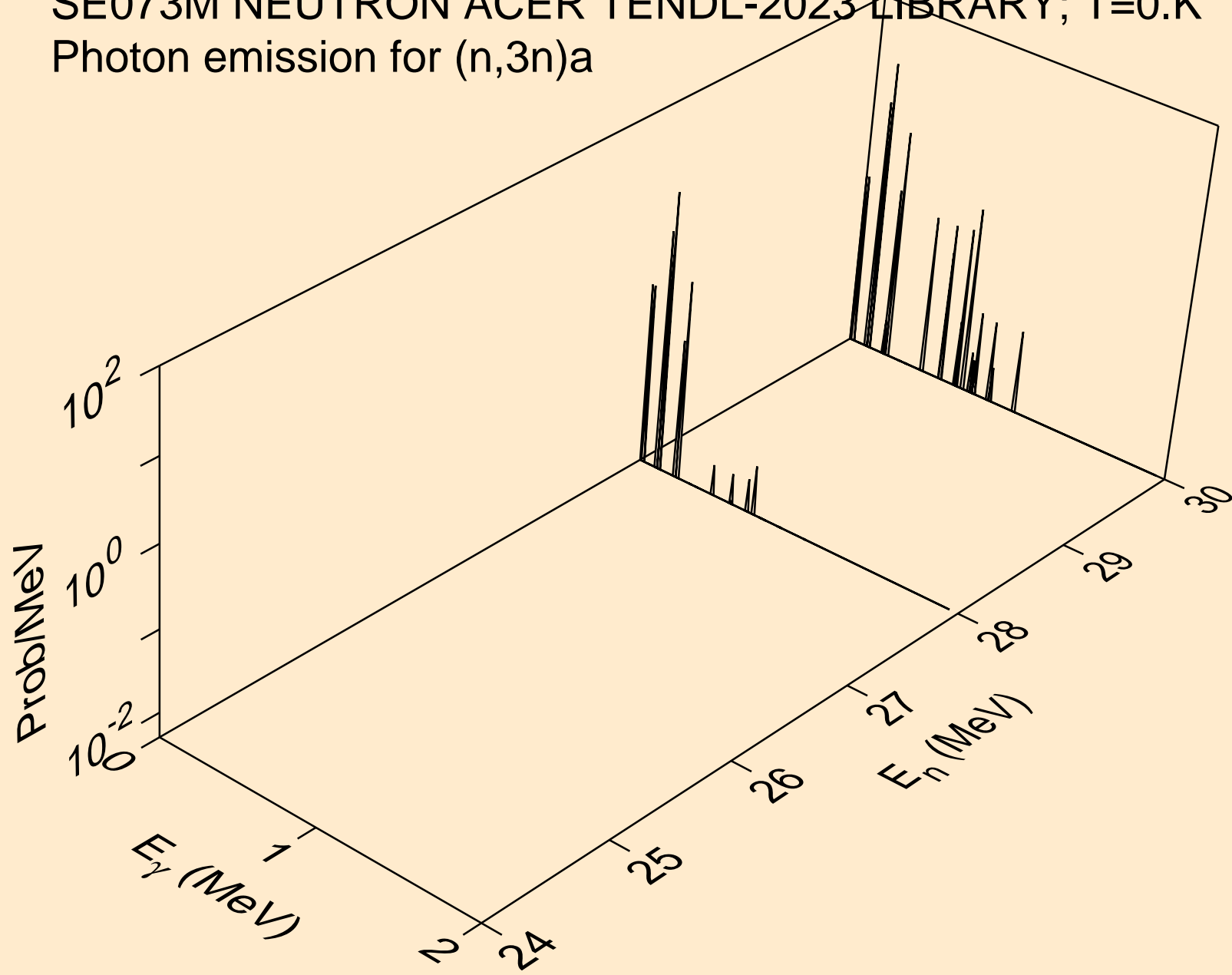

SE073M NEUTRON ACER TENDL-2023 LIBRARY; T=0.K
Photon emission for (n,n*)p

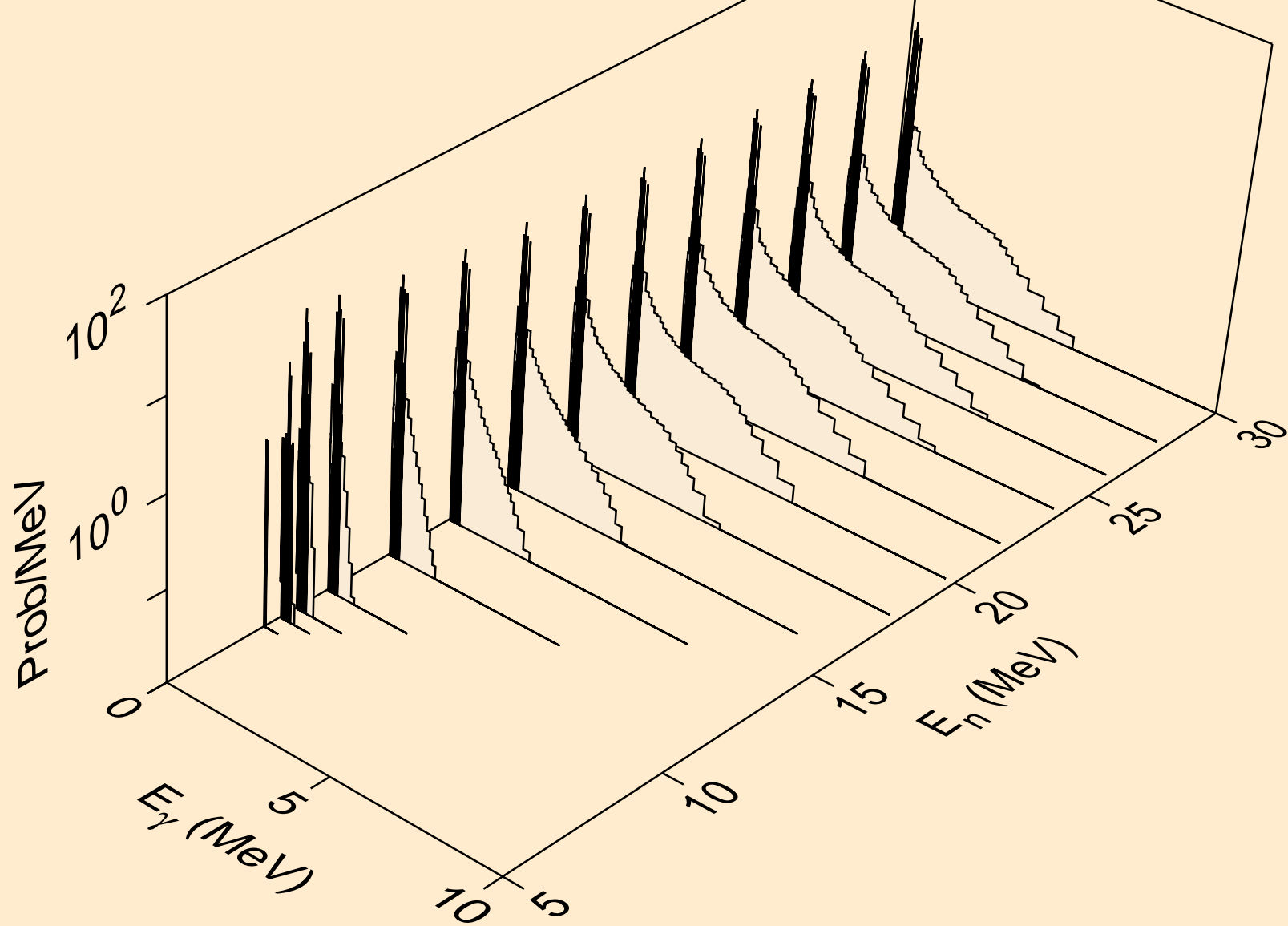

SE073M NEUTRON ACER TENDL-2023 LIBRARY; T=0.K
Photon emission for (n,n*)2a

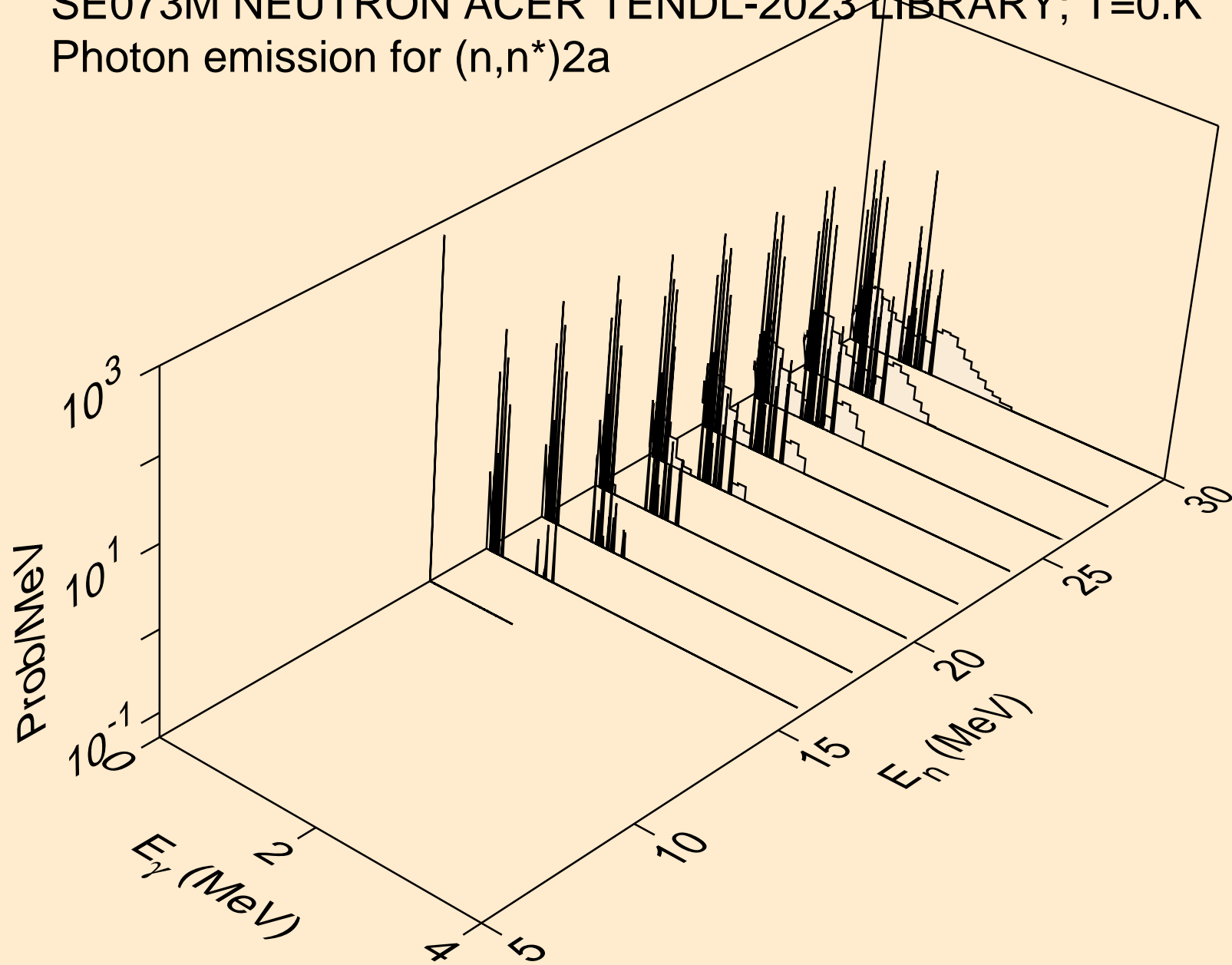

SE073M NEUTRON ACER TENDL-2023 LIBRARY; T=0.K
Photon emission for (n,2n)2a

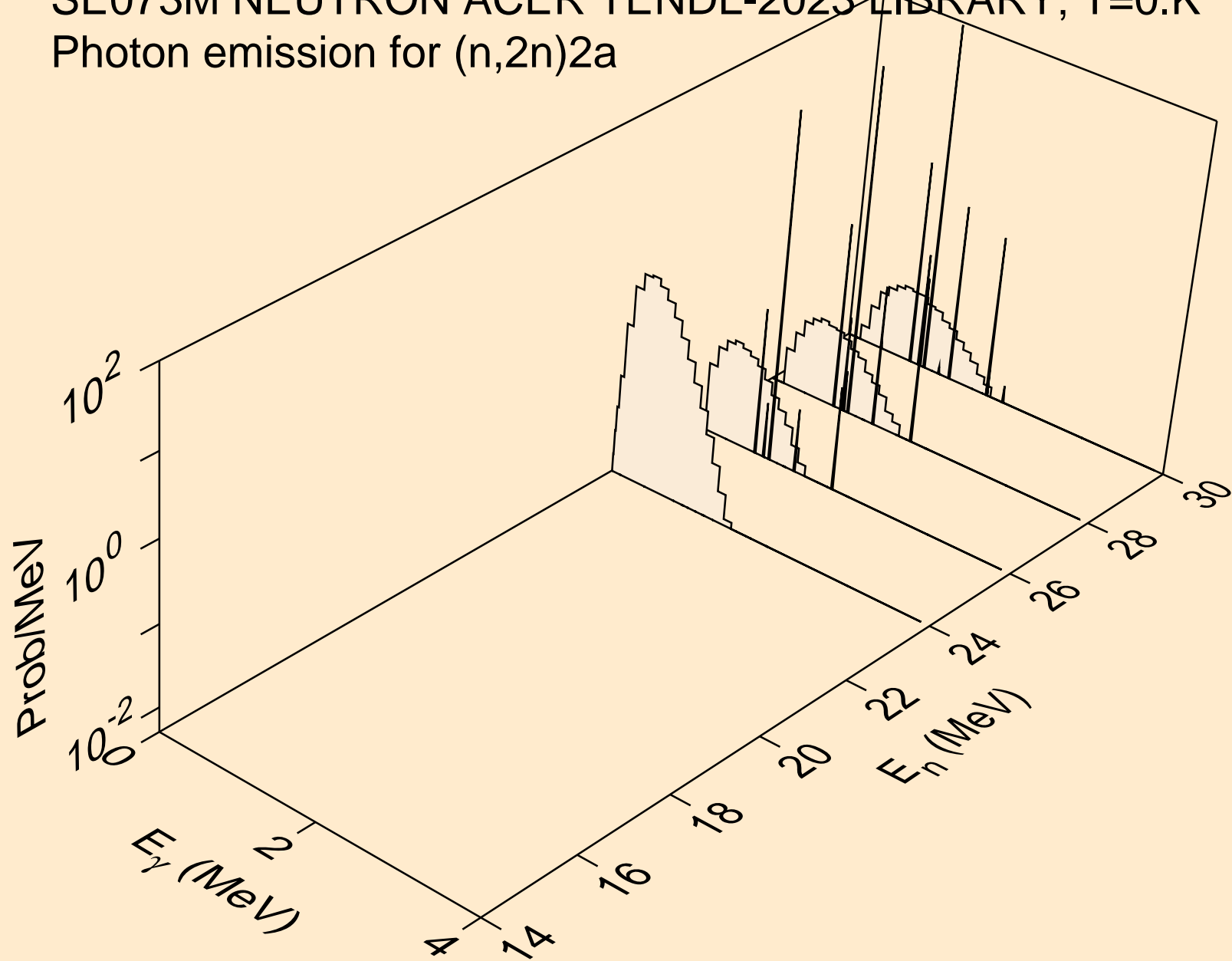

SE073M NEUTRON ACER TENDL-2023 LIBRARY; T=0.K
Photon emission for (n,n*)d

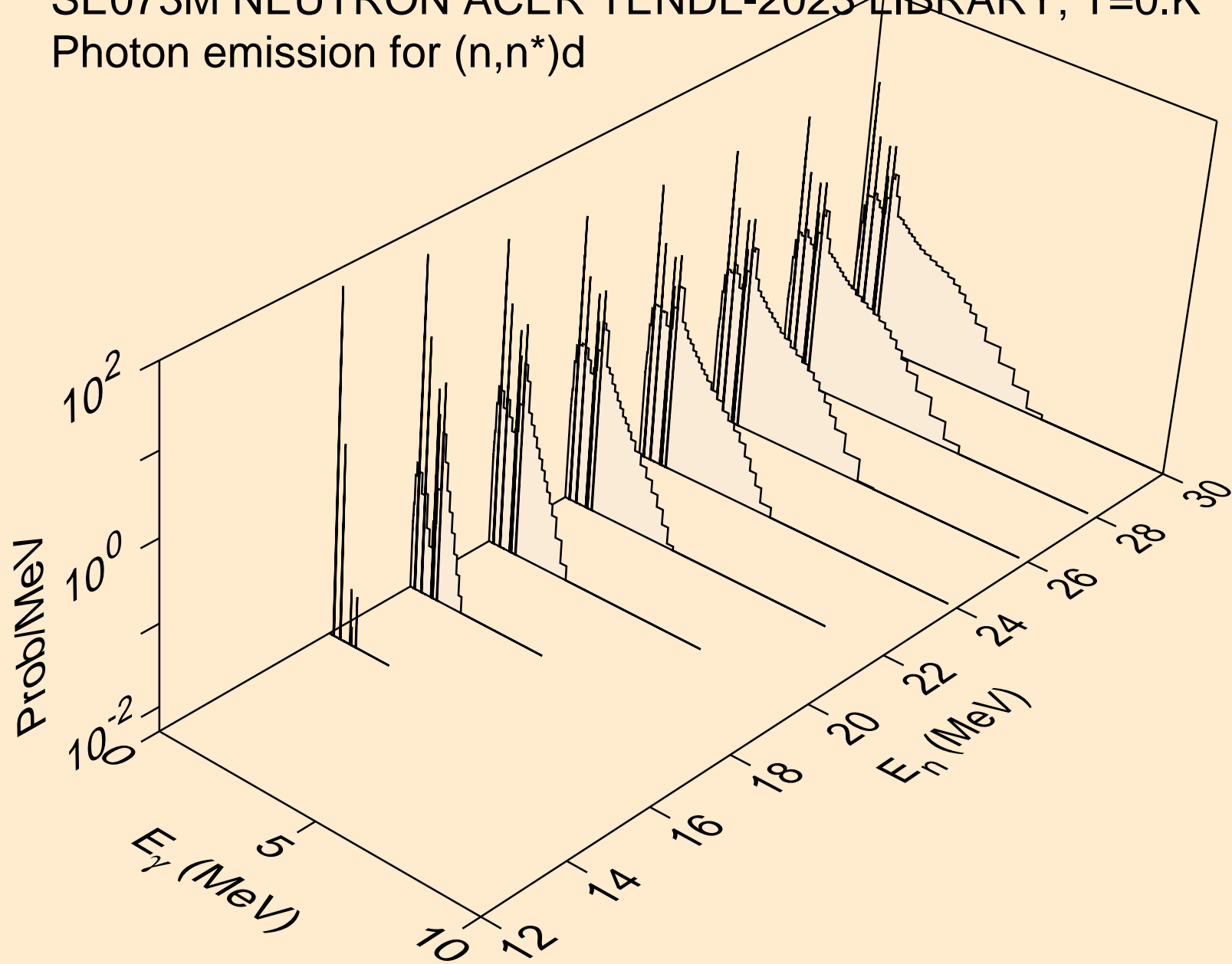

SE073M NEUTRON ACER TENDL-2023 LIBRARY; T=0.K
Photon emission for (n,n*)t

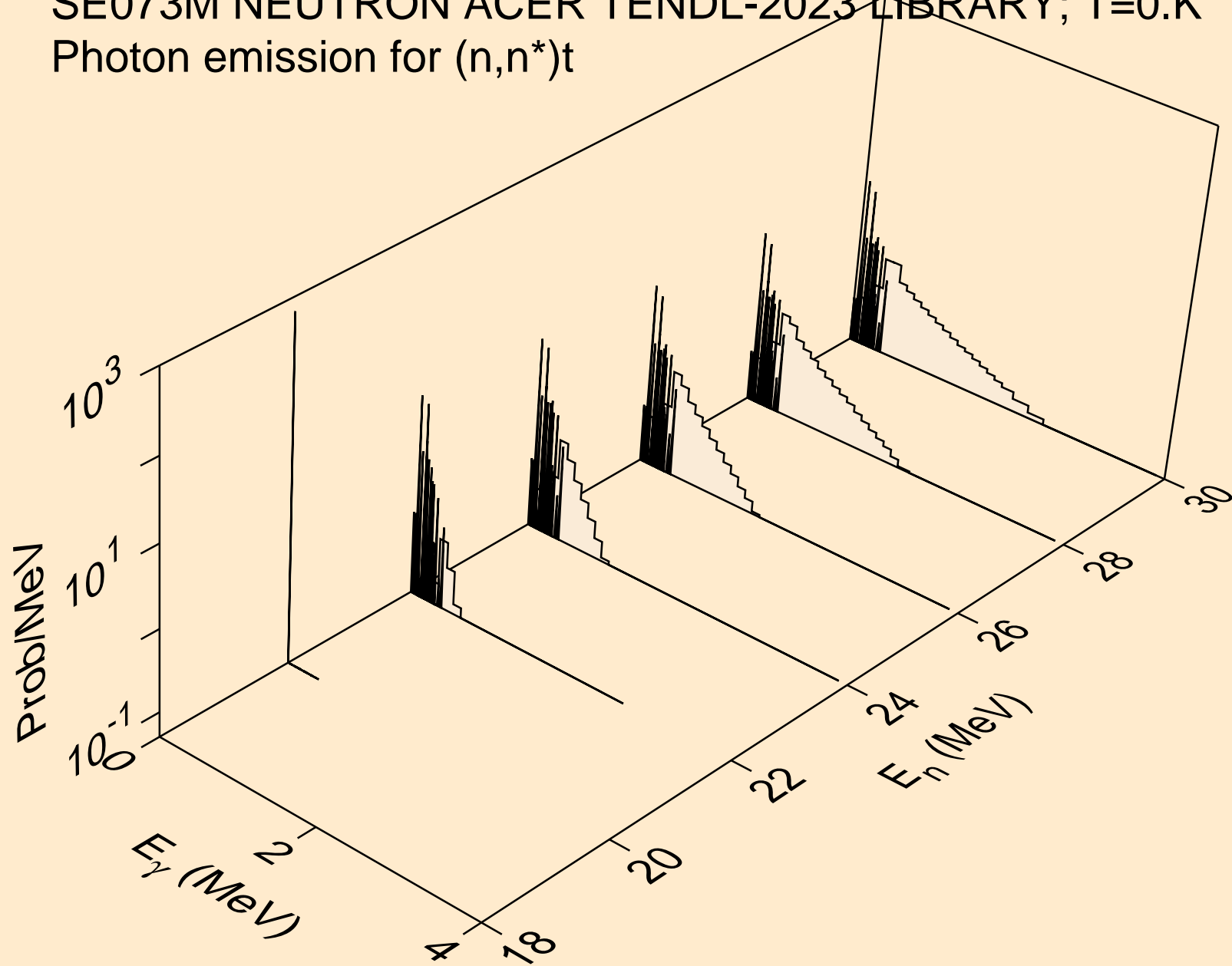

SE073M NEUTRON ACER TENDL-2023 LIBRARY; T=0.K
Photon emission for (n,n*)he3

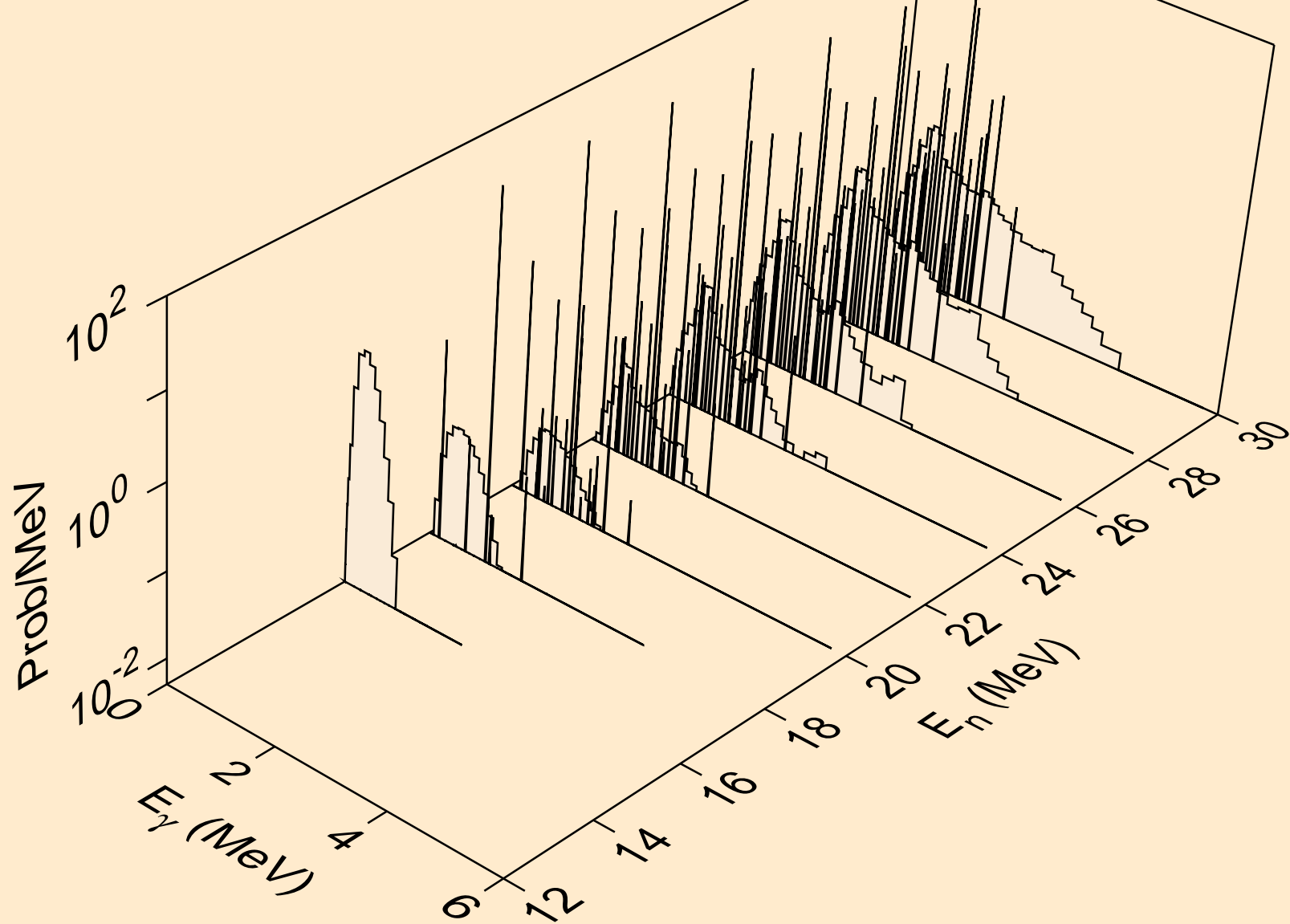

SE073M NEUTRON ACER TENDL-2023 LIBRARY; T=0.K
Photon emission for (n,2np)

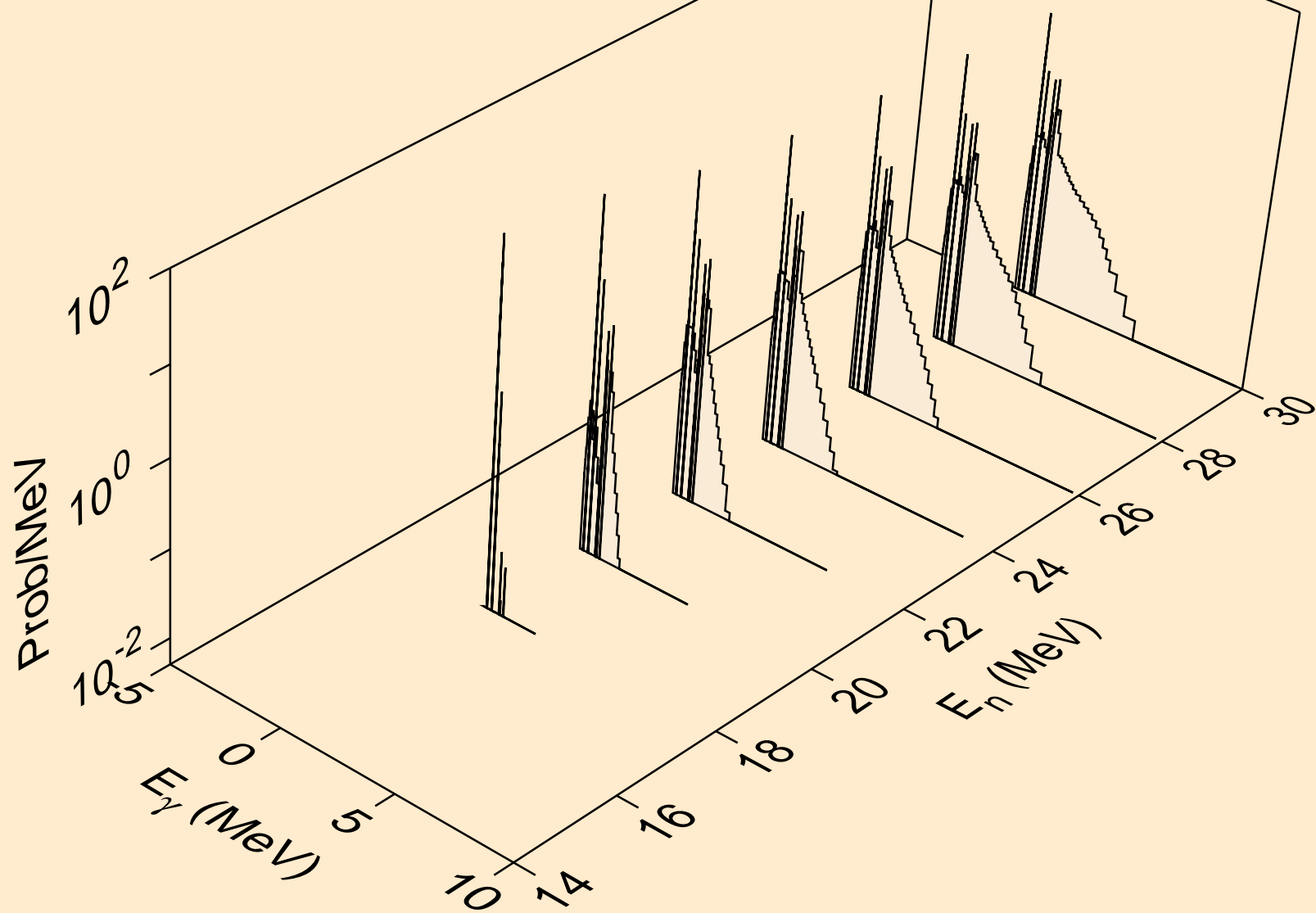

SE073M NEUTRON ACER TENDL-2023 LIBRARY; T=0.K
Photon emission for (n,3np)

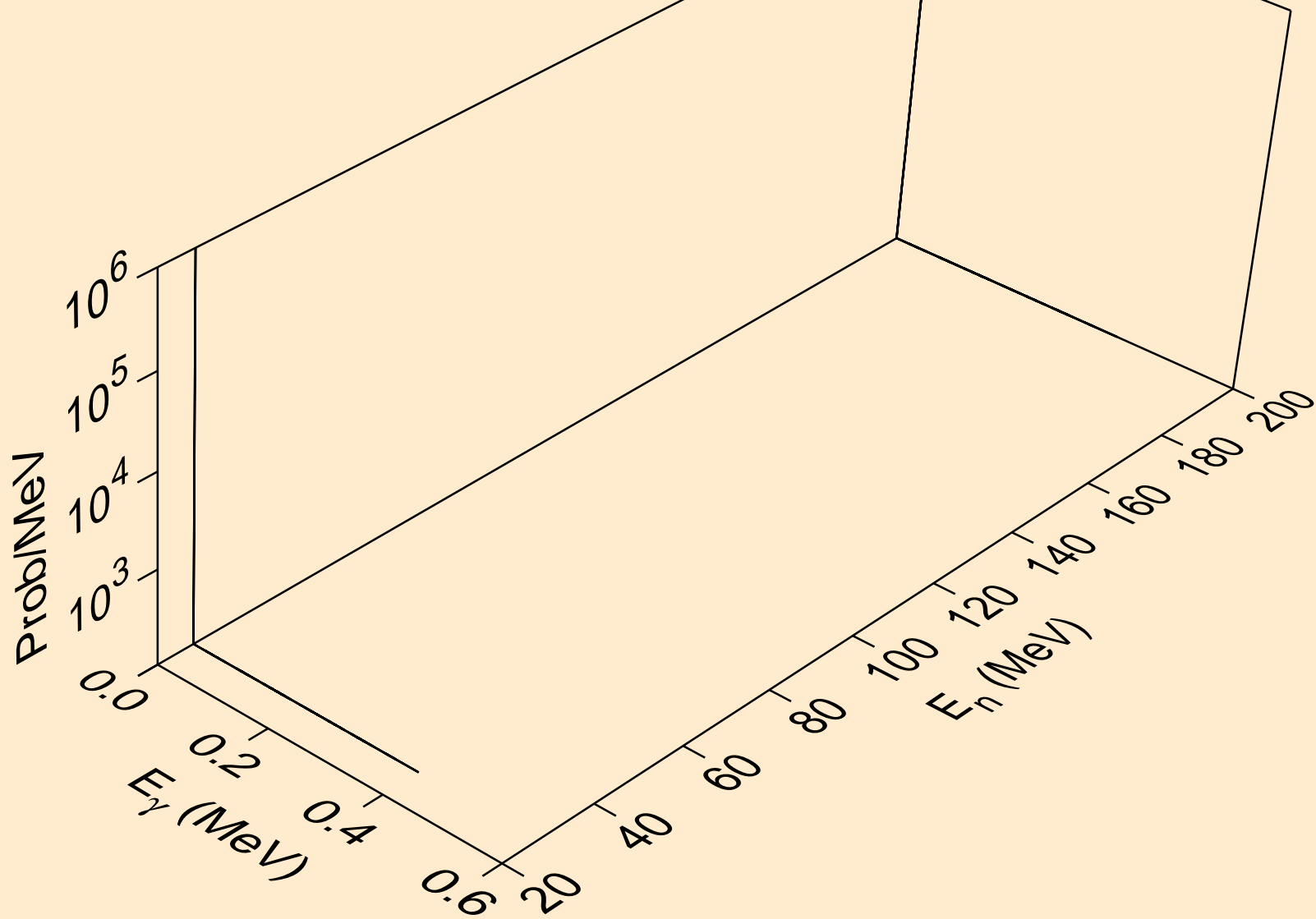

SE073M NEUTRON ACER TENDL-2023 LIBRARY; T=0.K
Photon emission for (n,n2p)

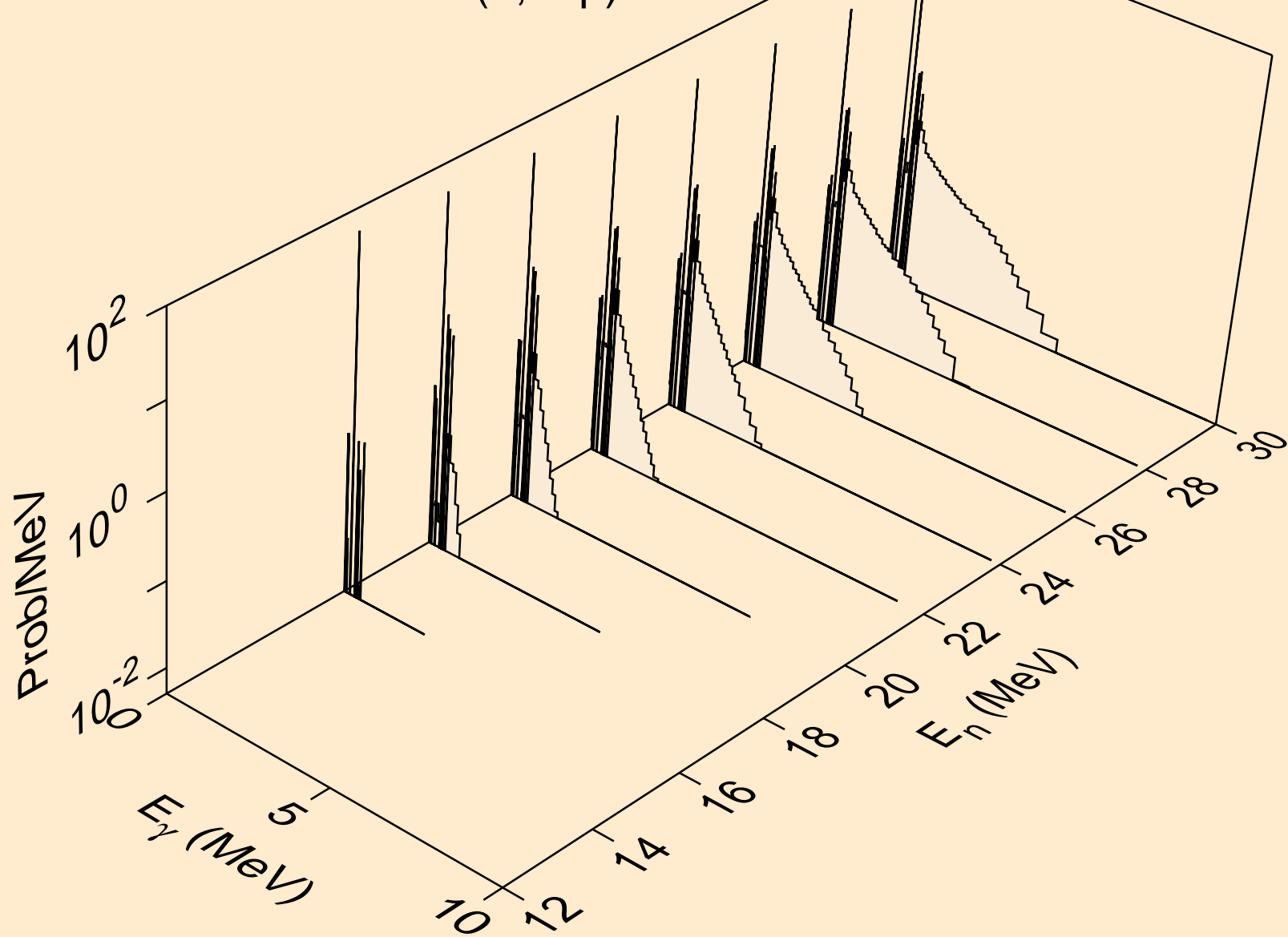

SE073M NEUTRON ACER TENDL-2023 LIBRARY; T=0.K
Photon emission for (n,npa)

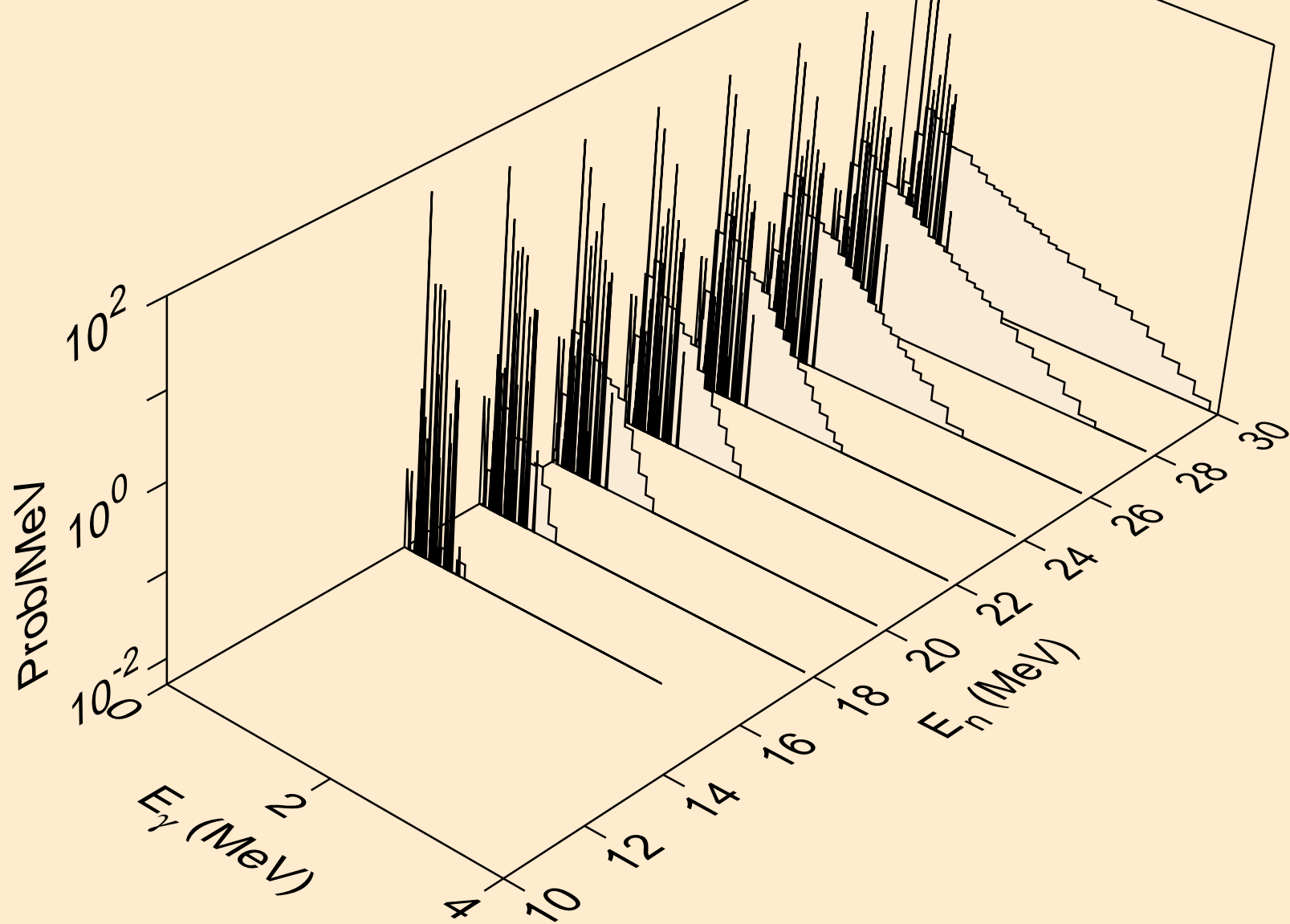

SE073M NEUTRON ACER TENDL-2023 LIBRARY; T=0.K
Photon emission for (n,n*2)

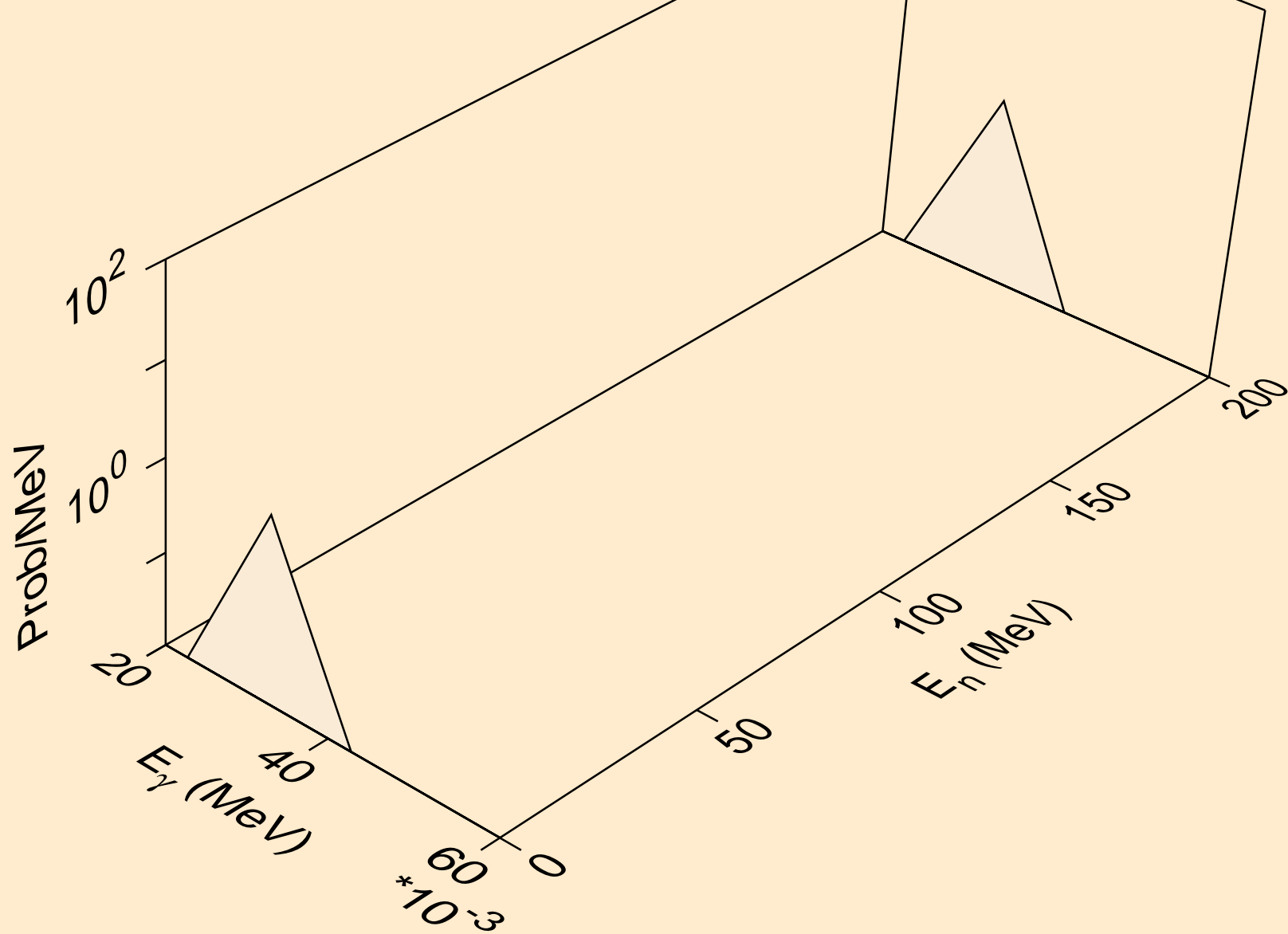

SE073M NEUTRON ACER TENDL-2023 LIBRARY; T=0.K
Photon emission for (n,n*3)

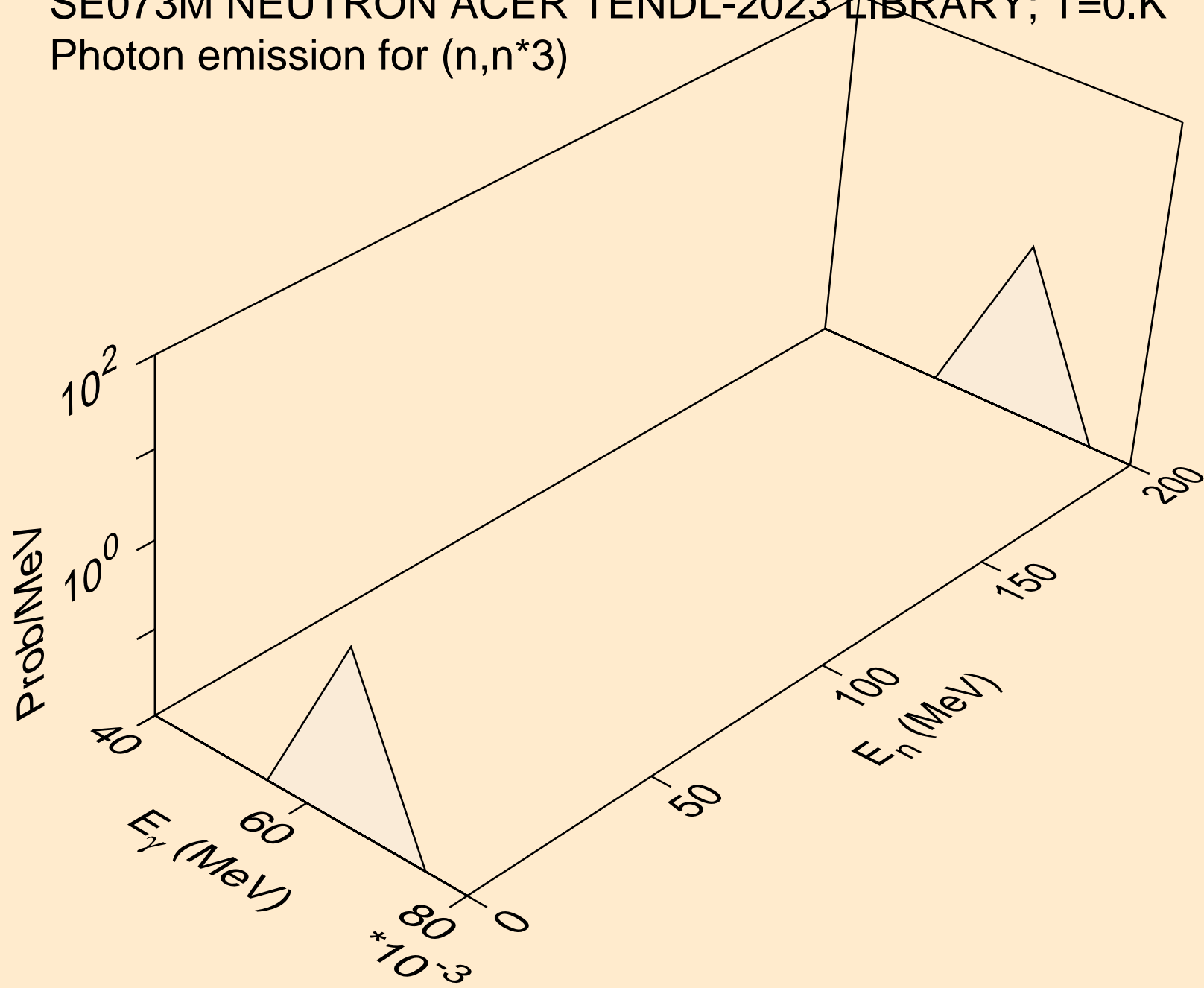

SE073M NEUTRON ACER TENDL-2023 LIBRARY; T=0.K
Photon emission for (n,n*4)

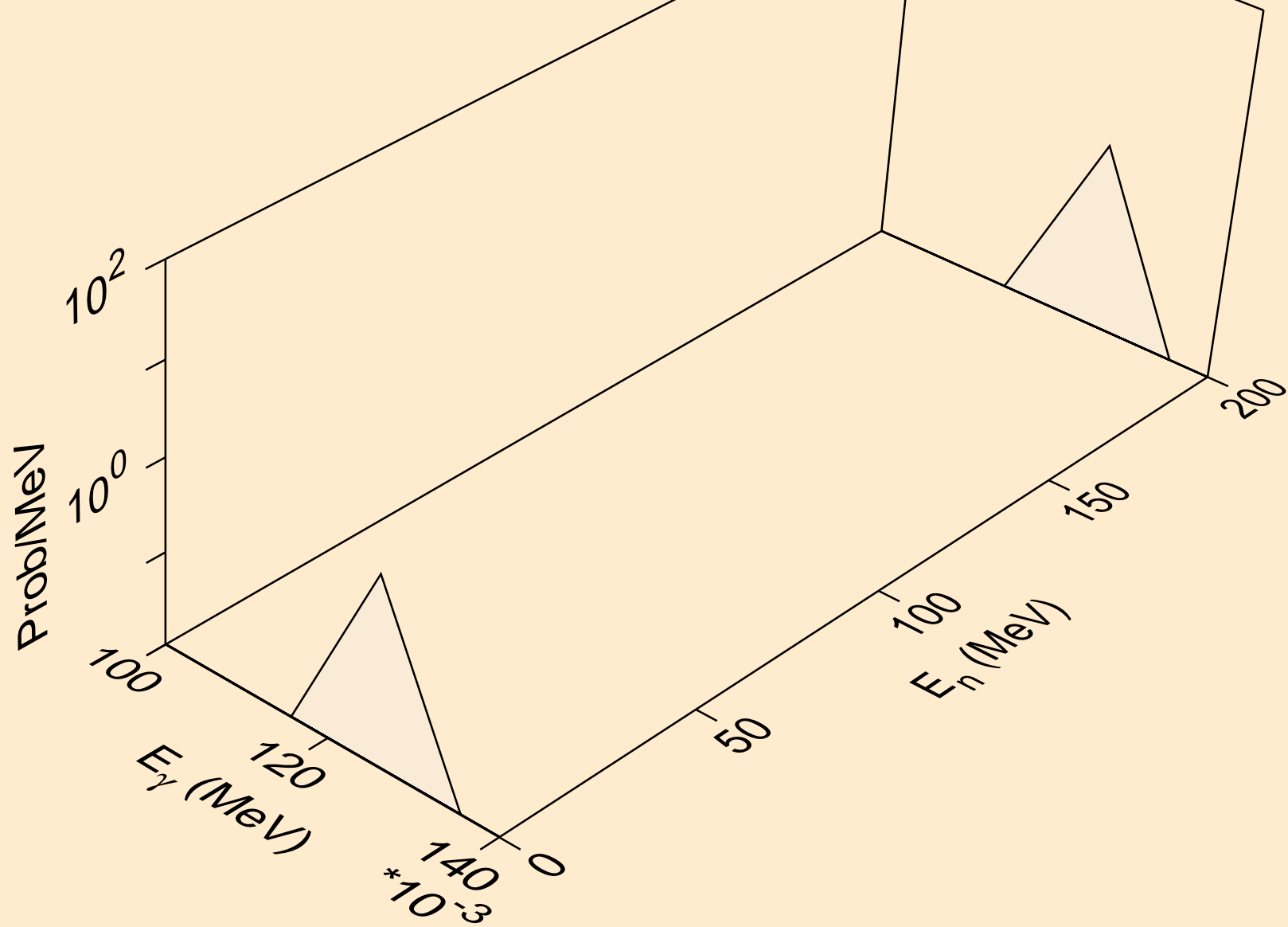

SE073M NEUTRON ACER TENDL-2023 LIBRARY; T=0.K
Photon emission for (n,n*5)

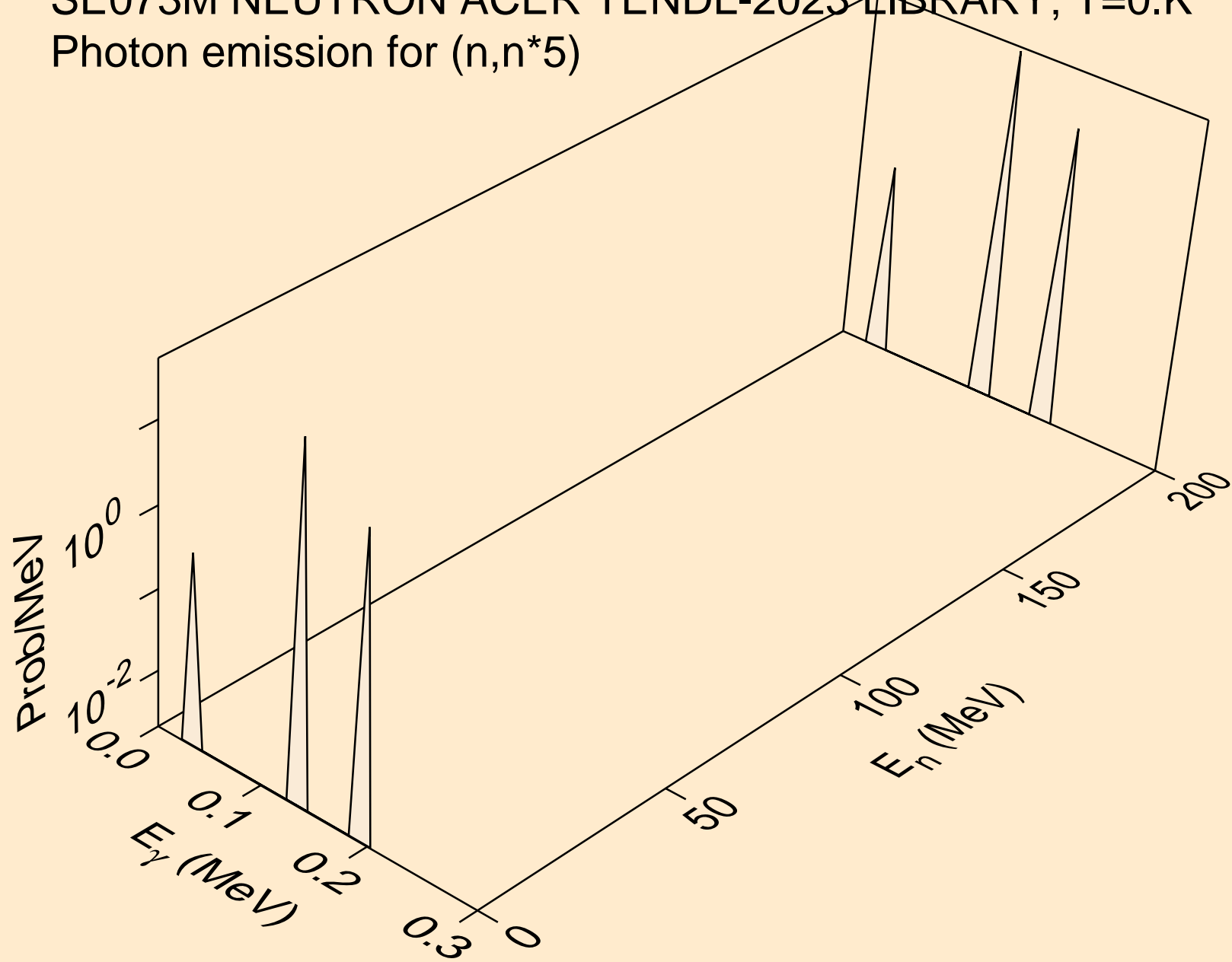

SE073M NEUTRON ACER TENDL-2023 LIBRARY; T=0.K
Photon emission for (n,n*6)

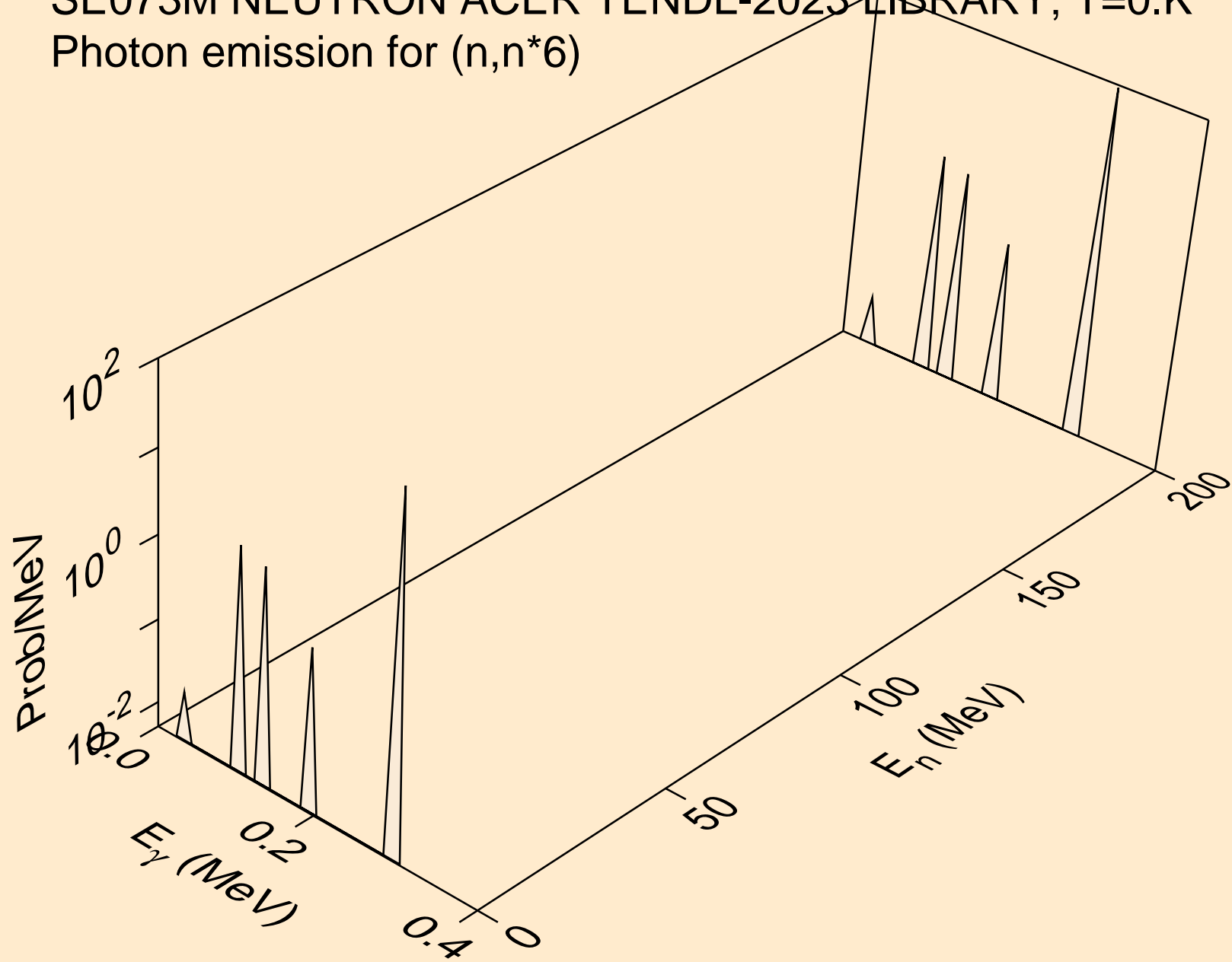

SE073M NEUTRON ACER TENDL-2023 LIBRARY; T=0.K
Photon emission for (n,n*7)

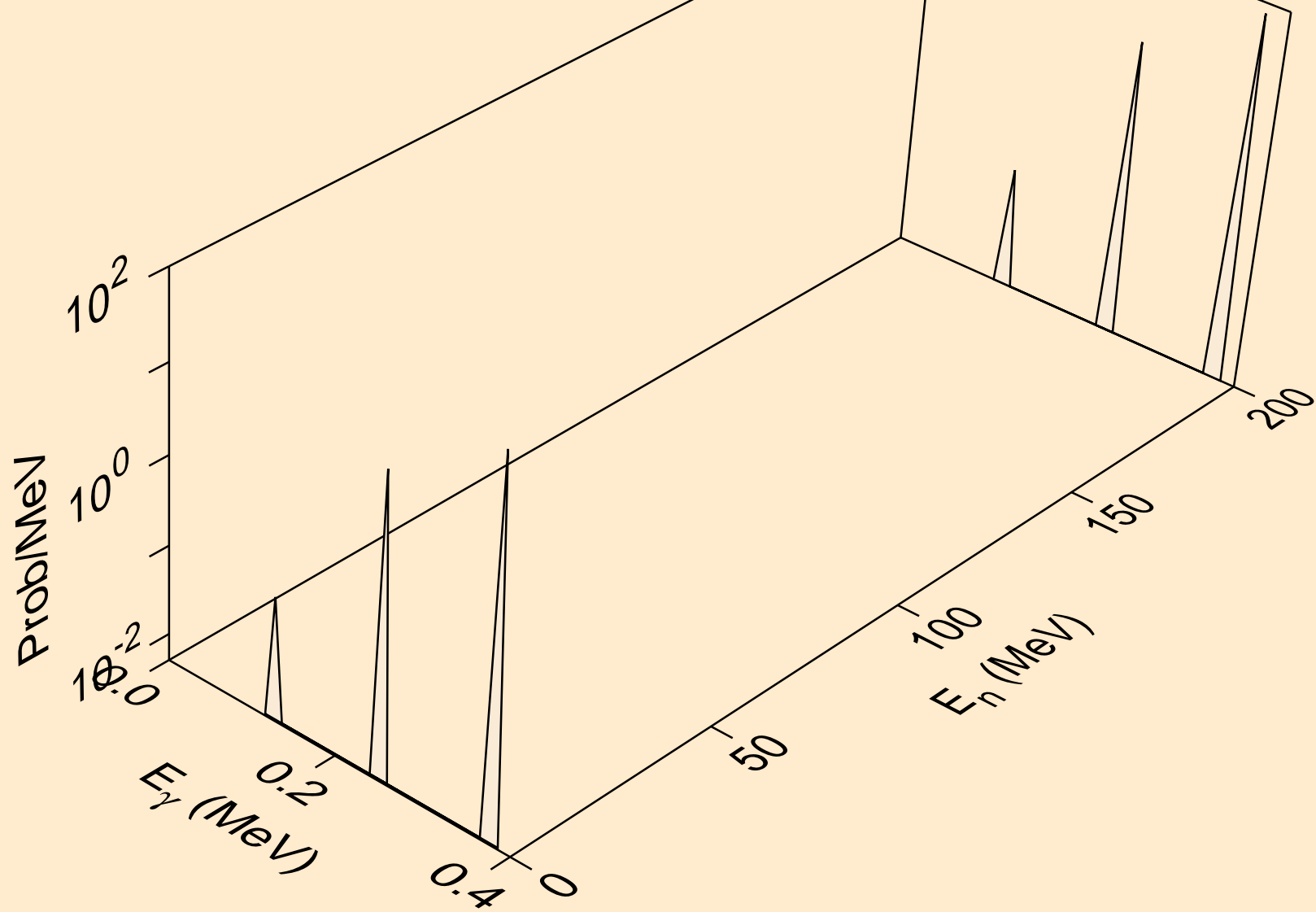

SE073M NEUTRON ACER TENDL-2023 LIBRARY; T=0.K
Photon emission for (n,n*8)

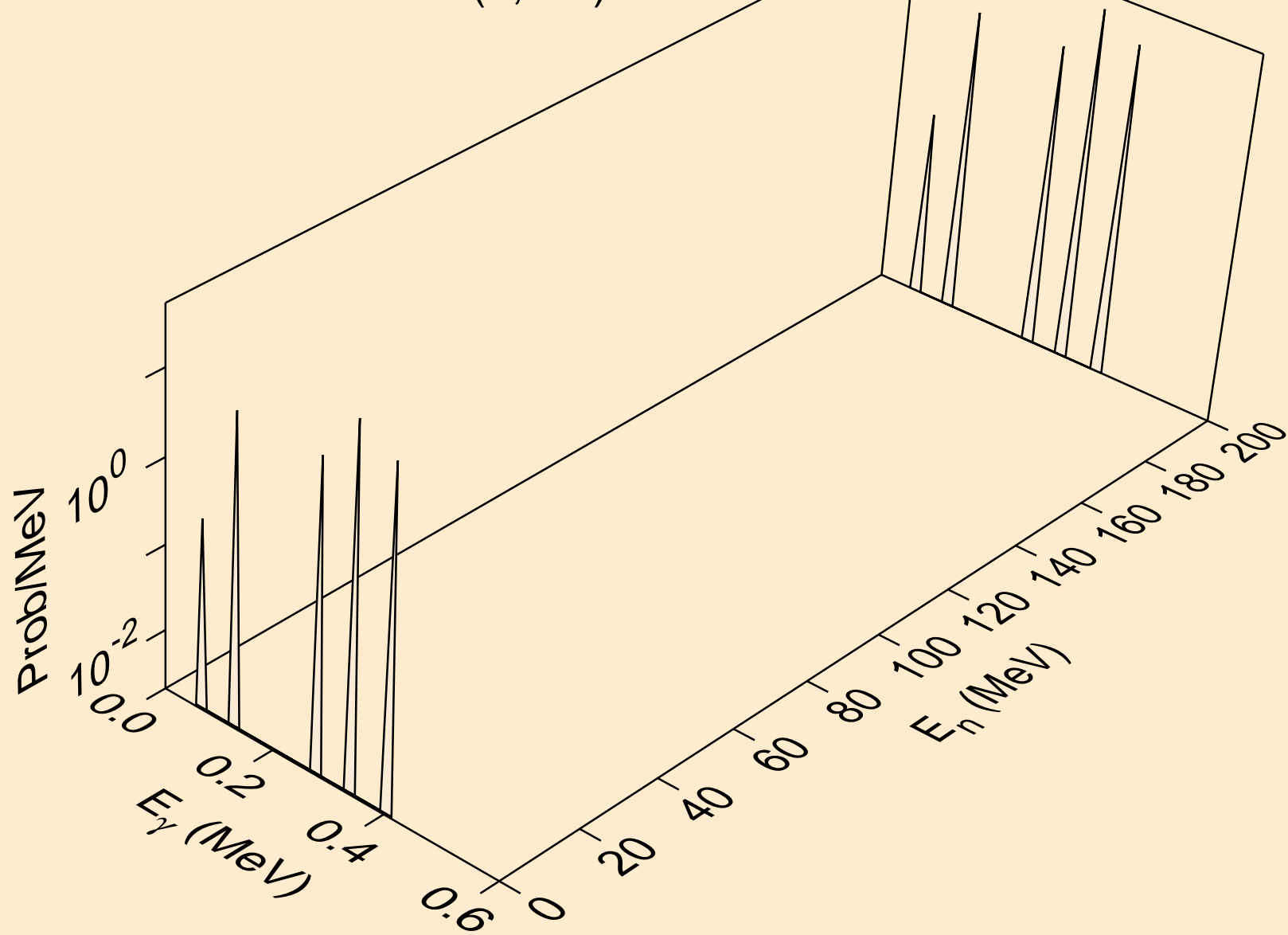

SE073M NEUTRON ACER TENDL-2023 LIBRARY; T=0.K
Photon emission for (n,n*9)

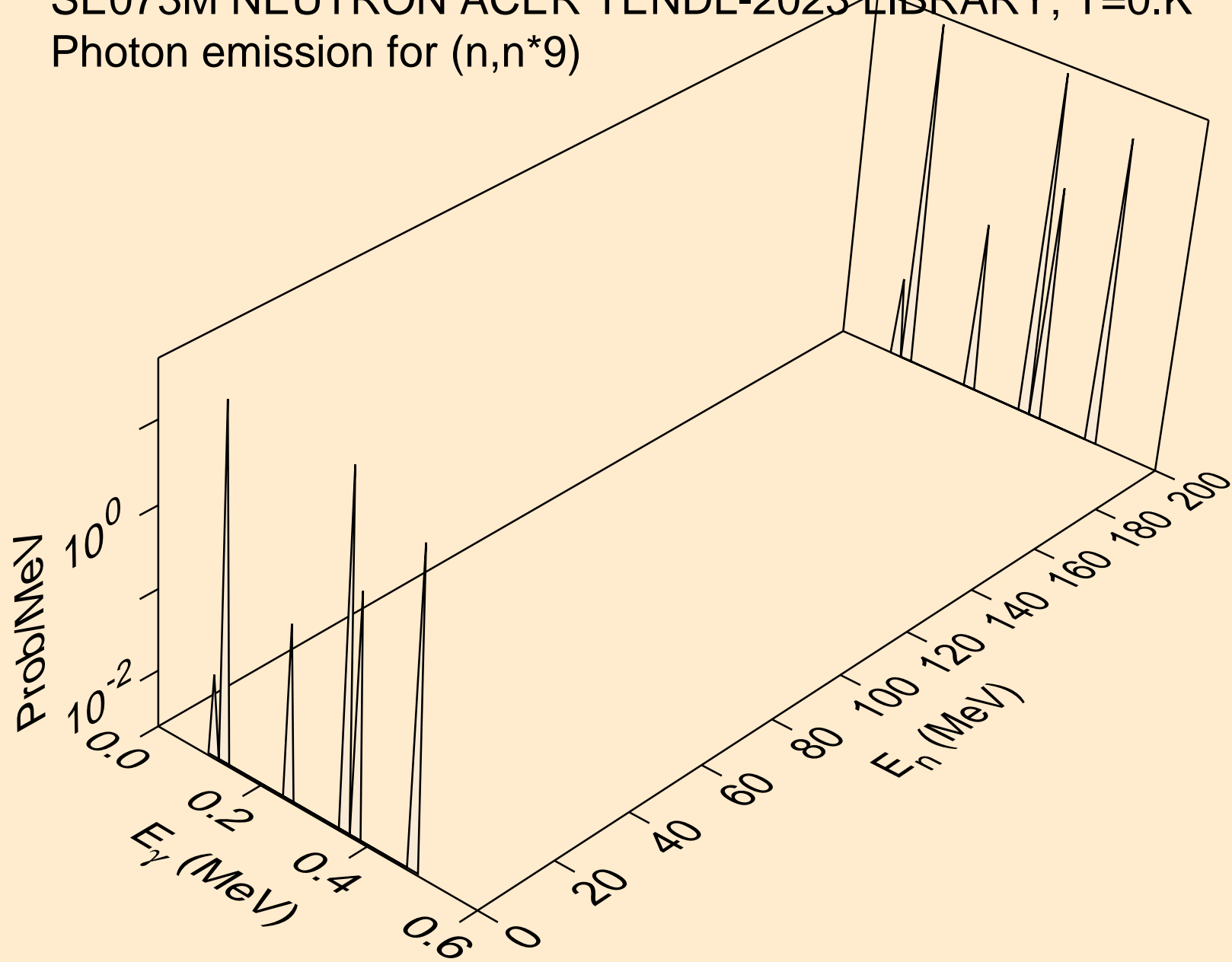

SE073M NEUTRON ACER TENDL-2023 LIBRARY; T=0.K
Photon emission for (n,n*10)

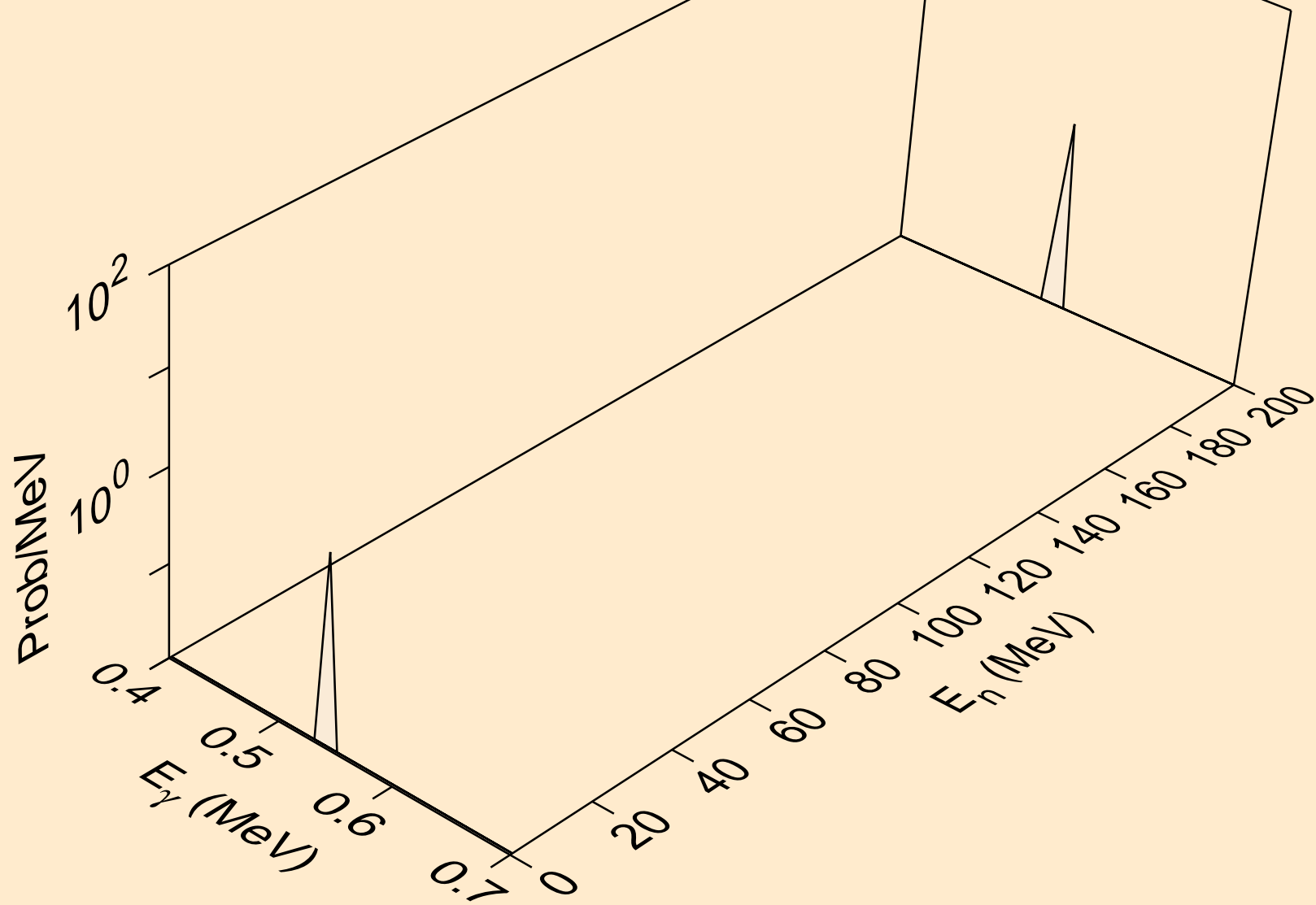

SE073M NEUTRON ACER TENDL-2023 LIBRARY; T=0.K
Photon emission for (n,n*11)

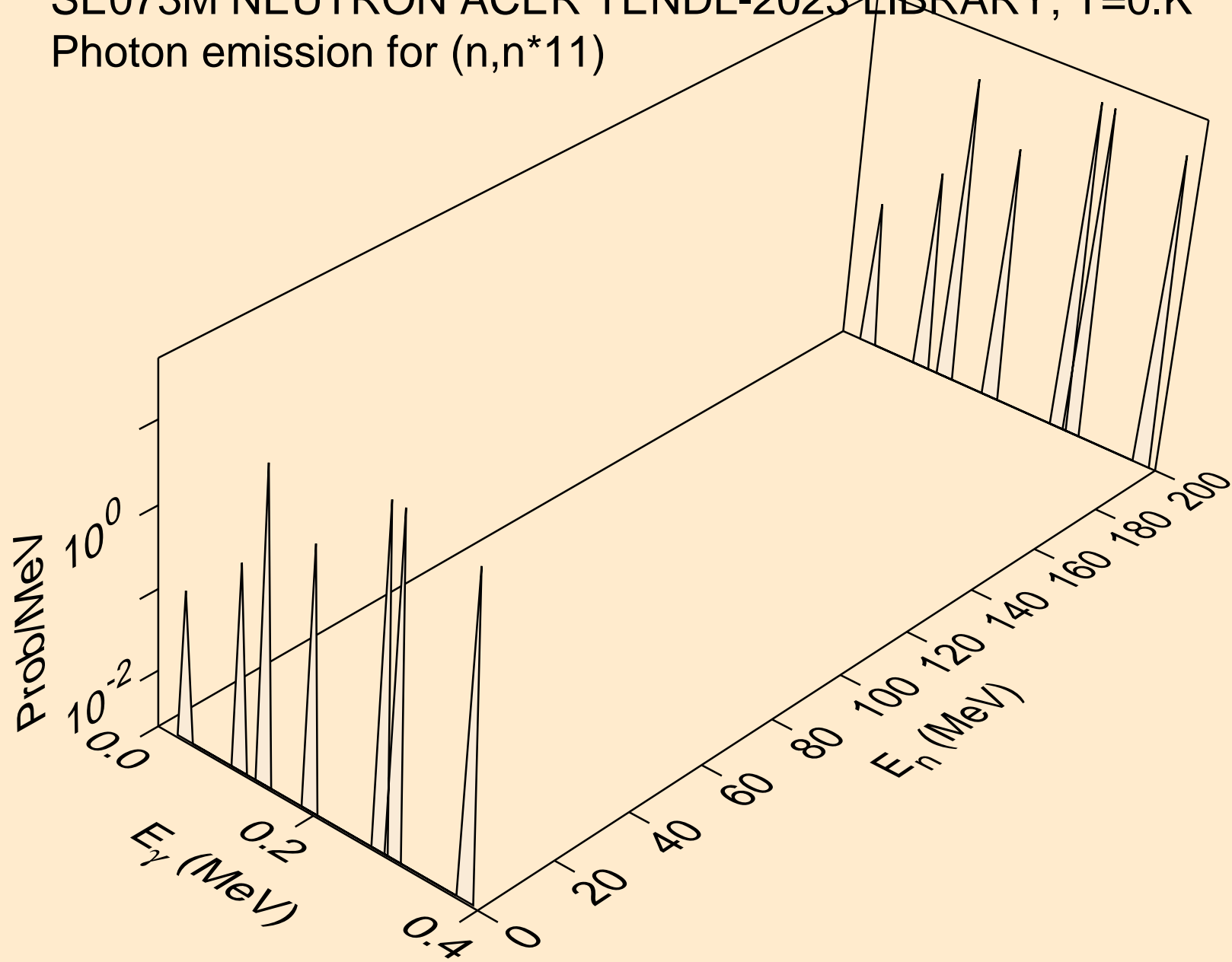

SE073M NEUTRON ACER TENDL-2023 LIBRARY; T=0.K
Photon emission for (n,n*12)

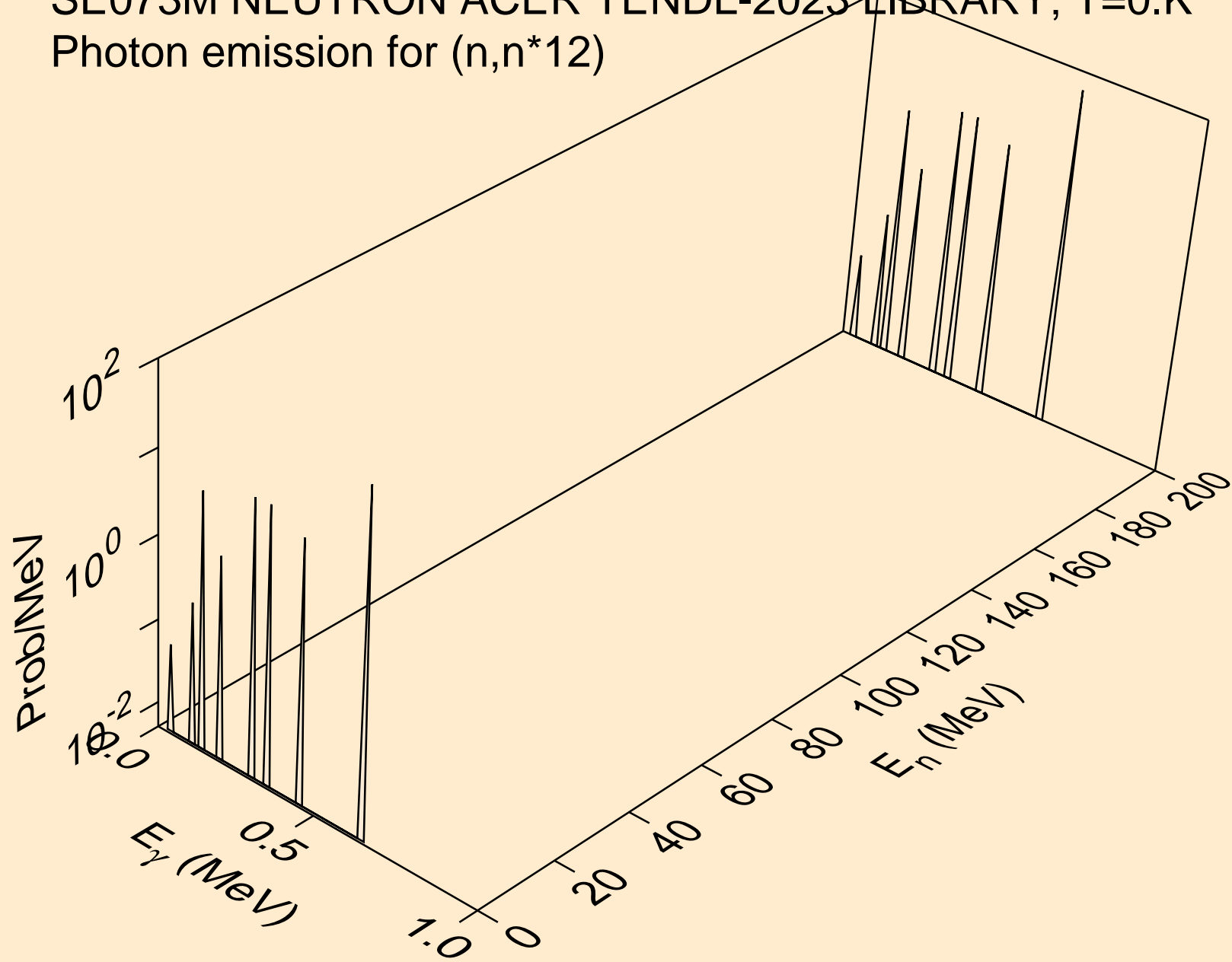

SE073M NEUTRON ACER TENDL-2023 LIBRARY; T=0.K
Photon emission for (n,n*13)

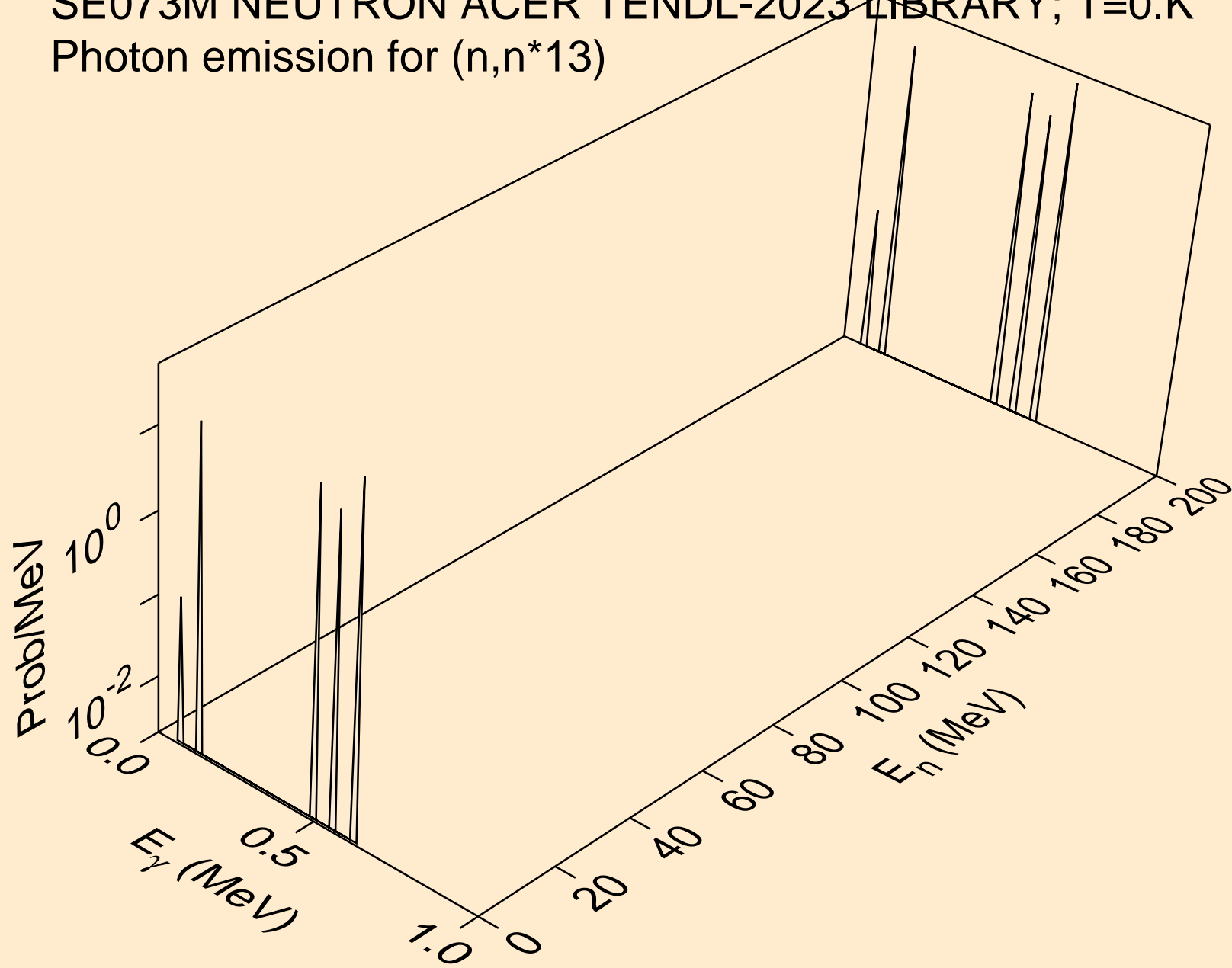

SE073M NEUTRON ACER TENDL-2023 LIBRARY; T=0.K
Photon emission for (n,n*14)

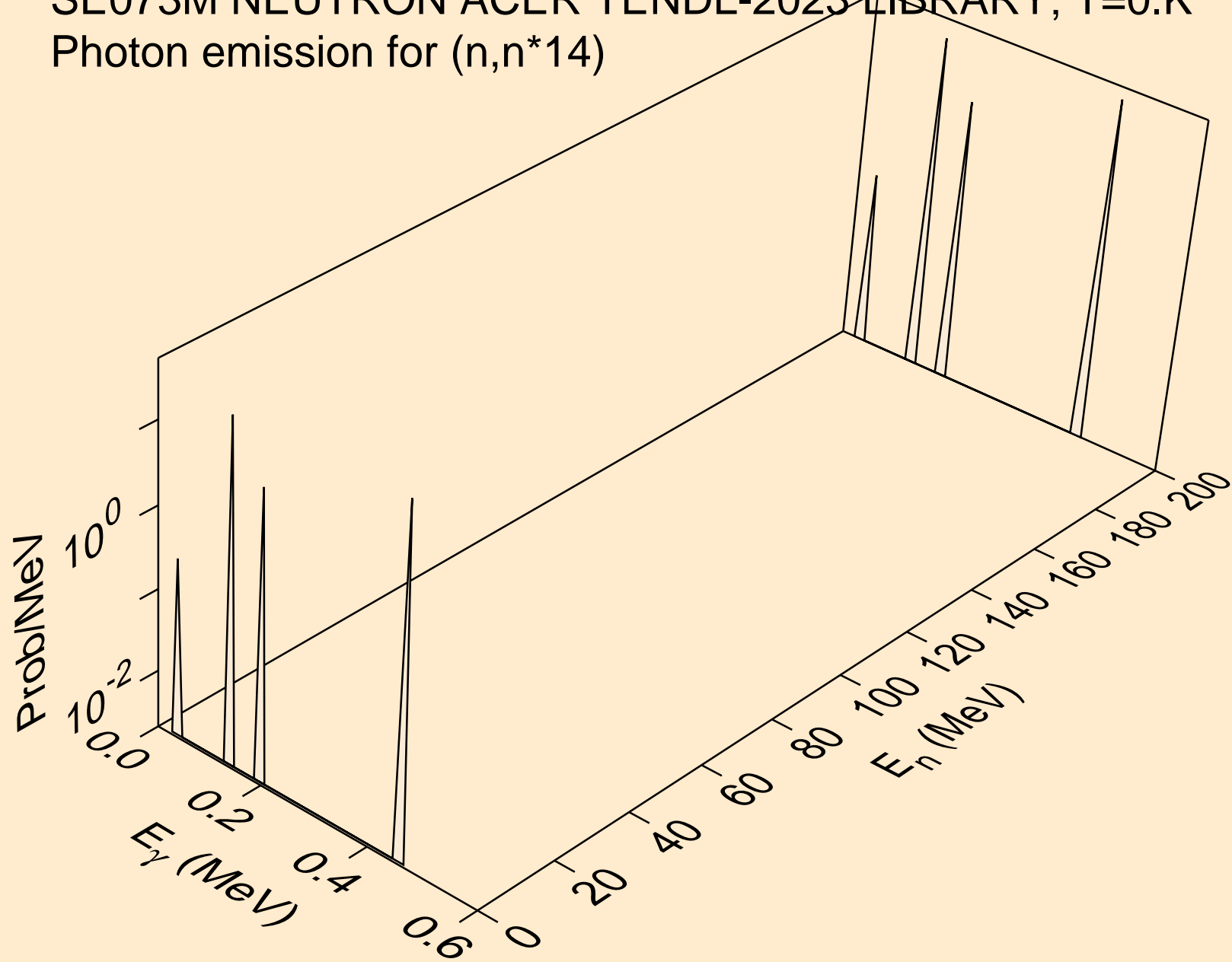

SE073M NEUTRON ACER TENDL-2023 LIBRARY; T=0.K
Photon emission for (n,n*15)

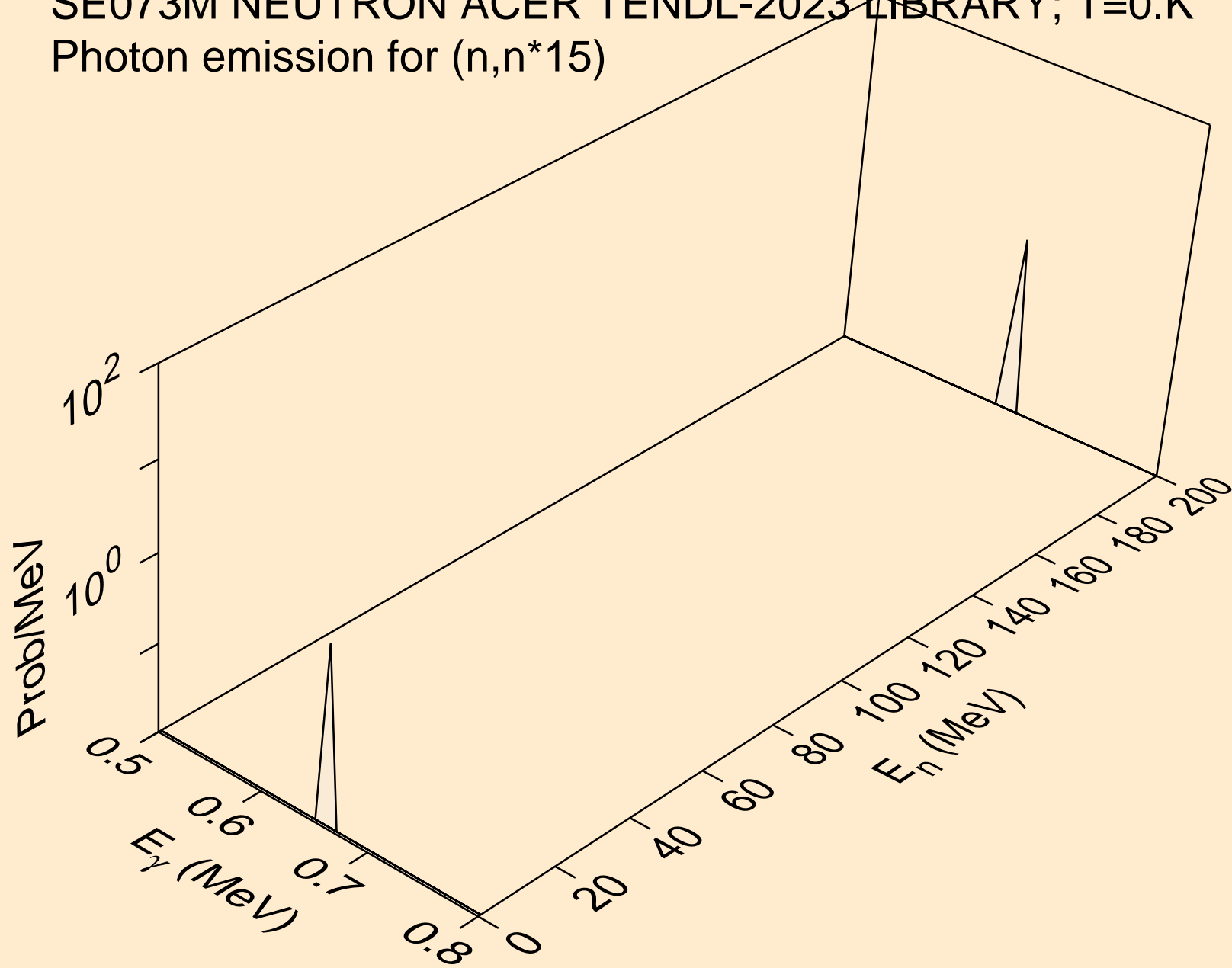

SE073M NEUTRON ACER TENDL-2023 LIBRARY; T=0.K
Photon emission for (n,n*16)

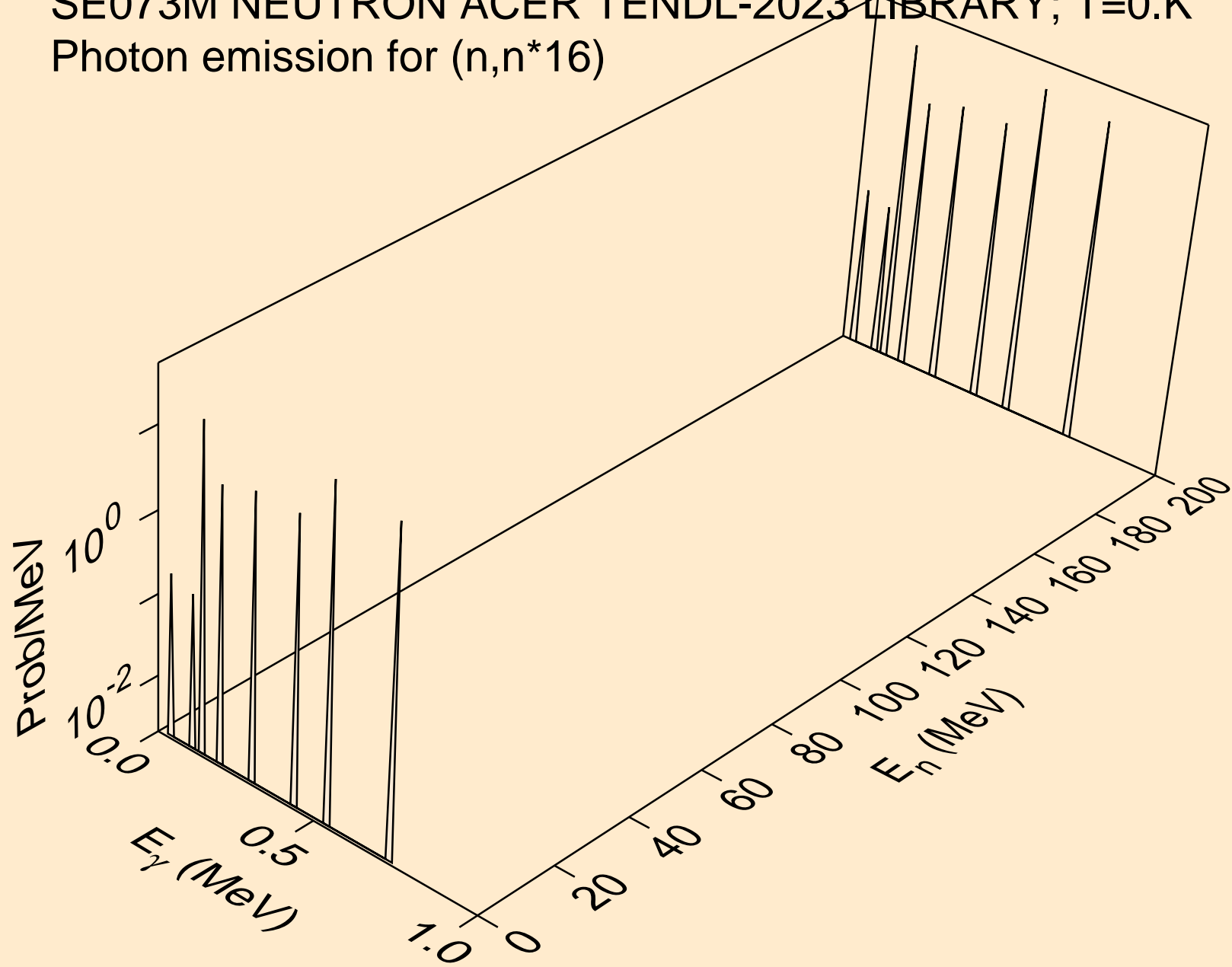

SE073M NEUTRON ACER TENDL-2023 LIBRARY; T=0.K
Photon emission for (n,n*17)

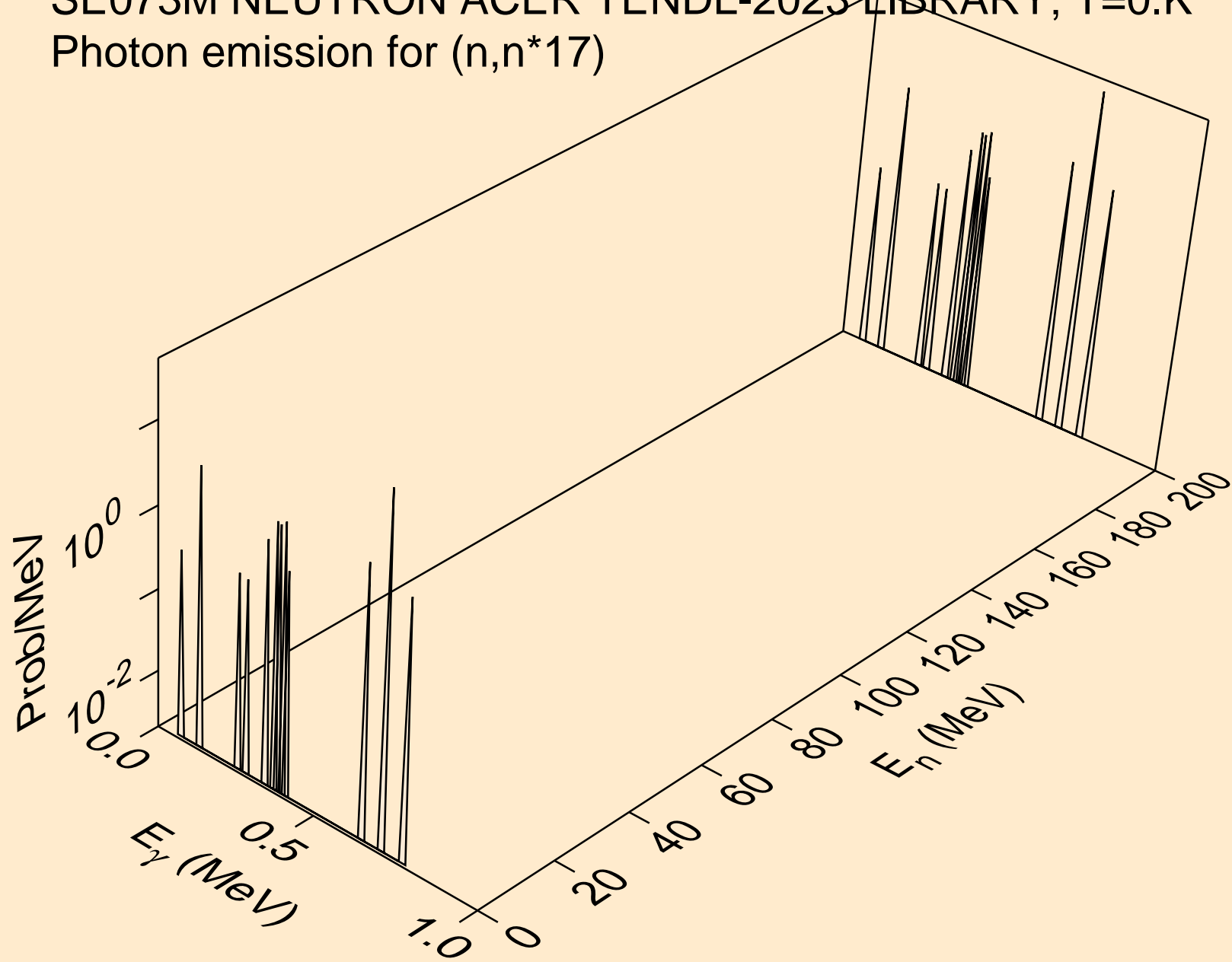

SE073M NEUTRON ACER TENDL-2023 LIBRARY; T=0.K
Photon emission for (n,n*18)

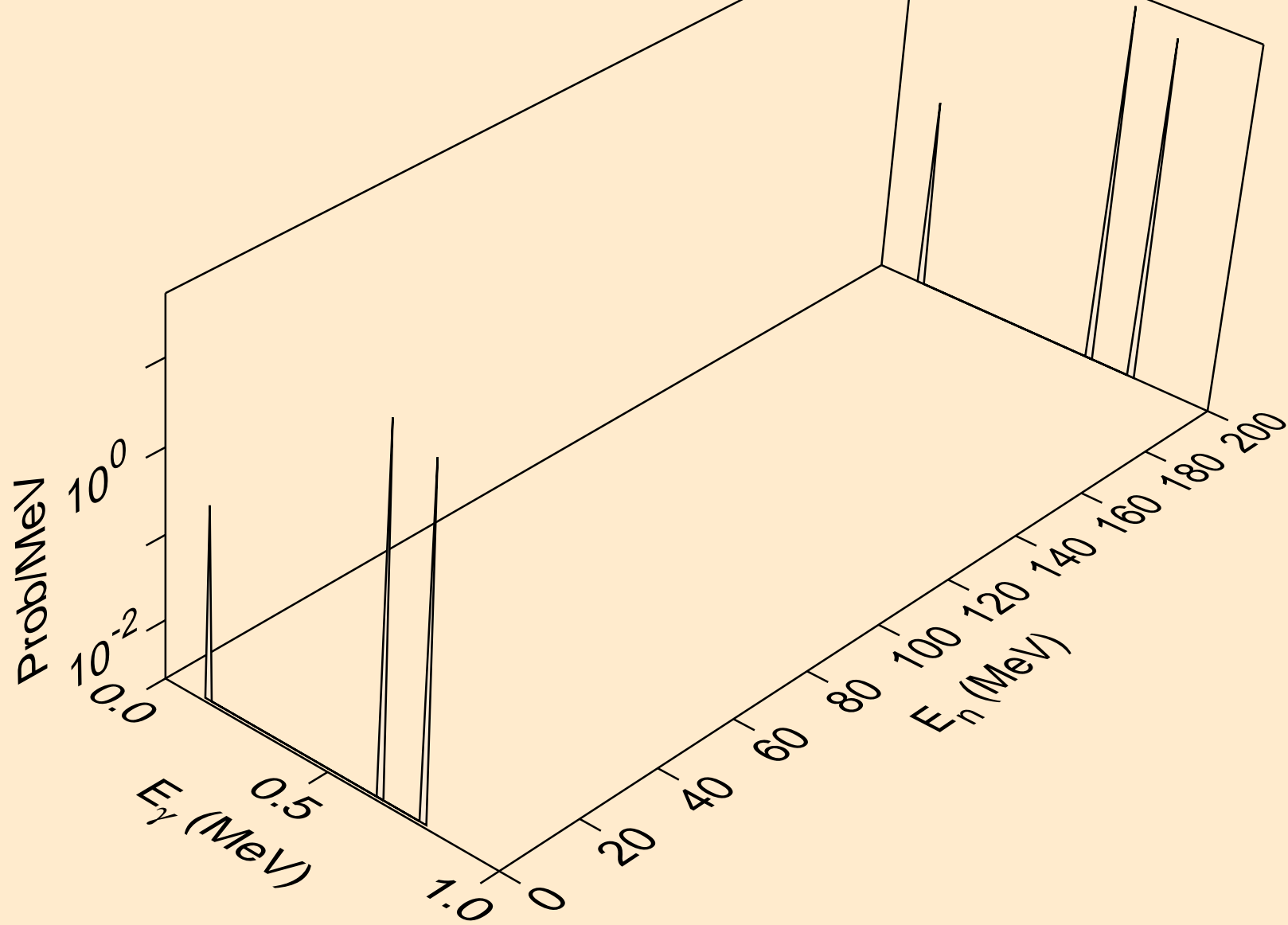

SE073M NEUTRON ACER TENDL-2023 LIBRARY; T=0.K
Photon emission for (n,n*19)

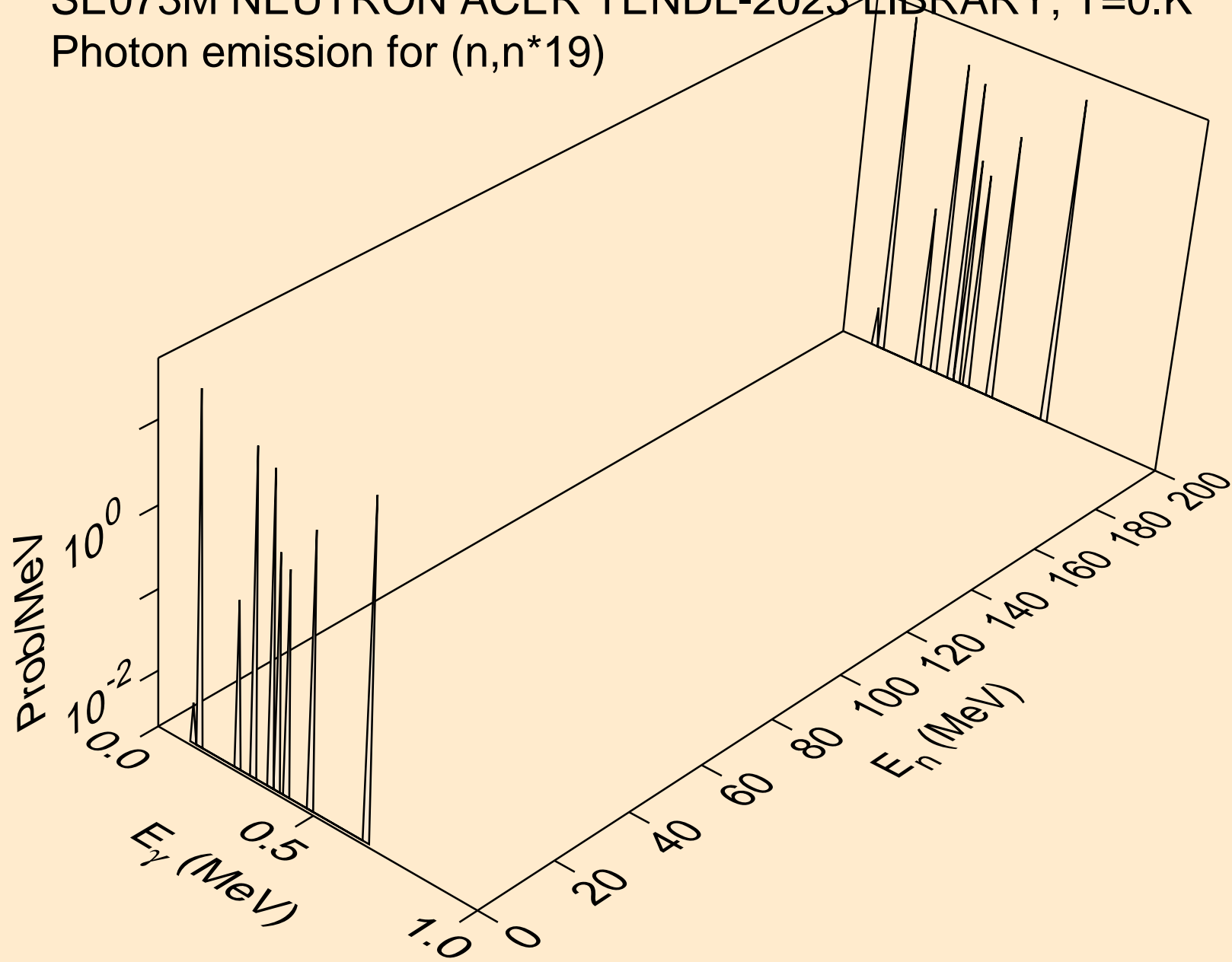

SE073M NEUTRON ACER TENDL-2023 LIBRARY; T=0.K
Photon emission for (n,n*c)

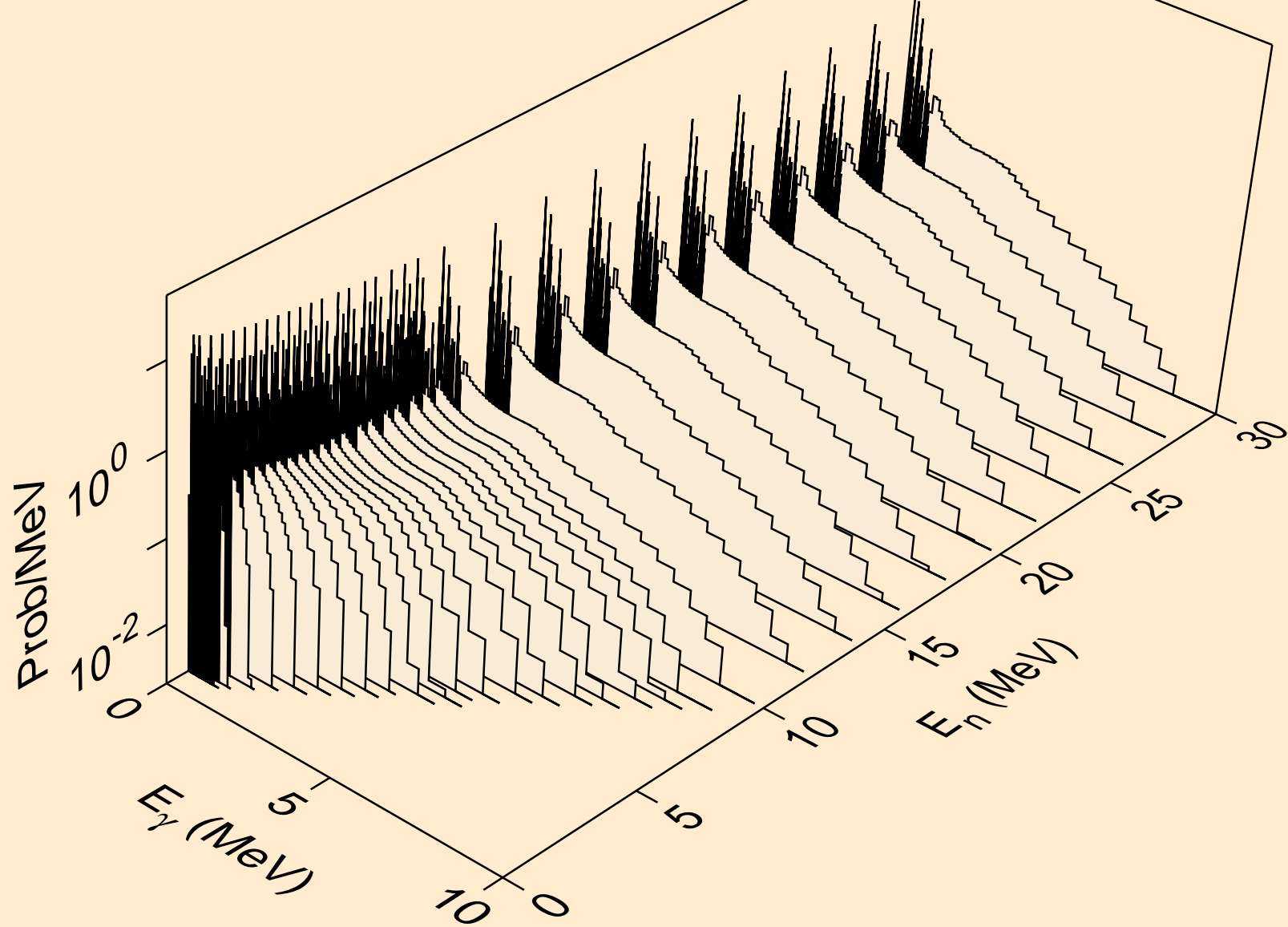

SE073M NEUTRON ACER TENDL-2023 LIBRARY; T=0.K
Photon emission for (n,gma)

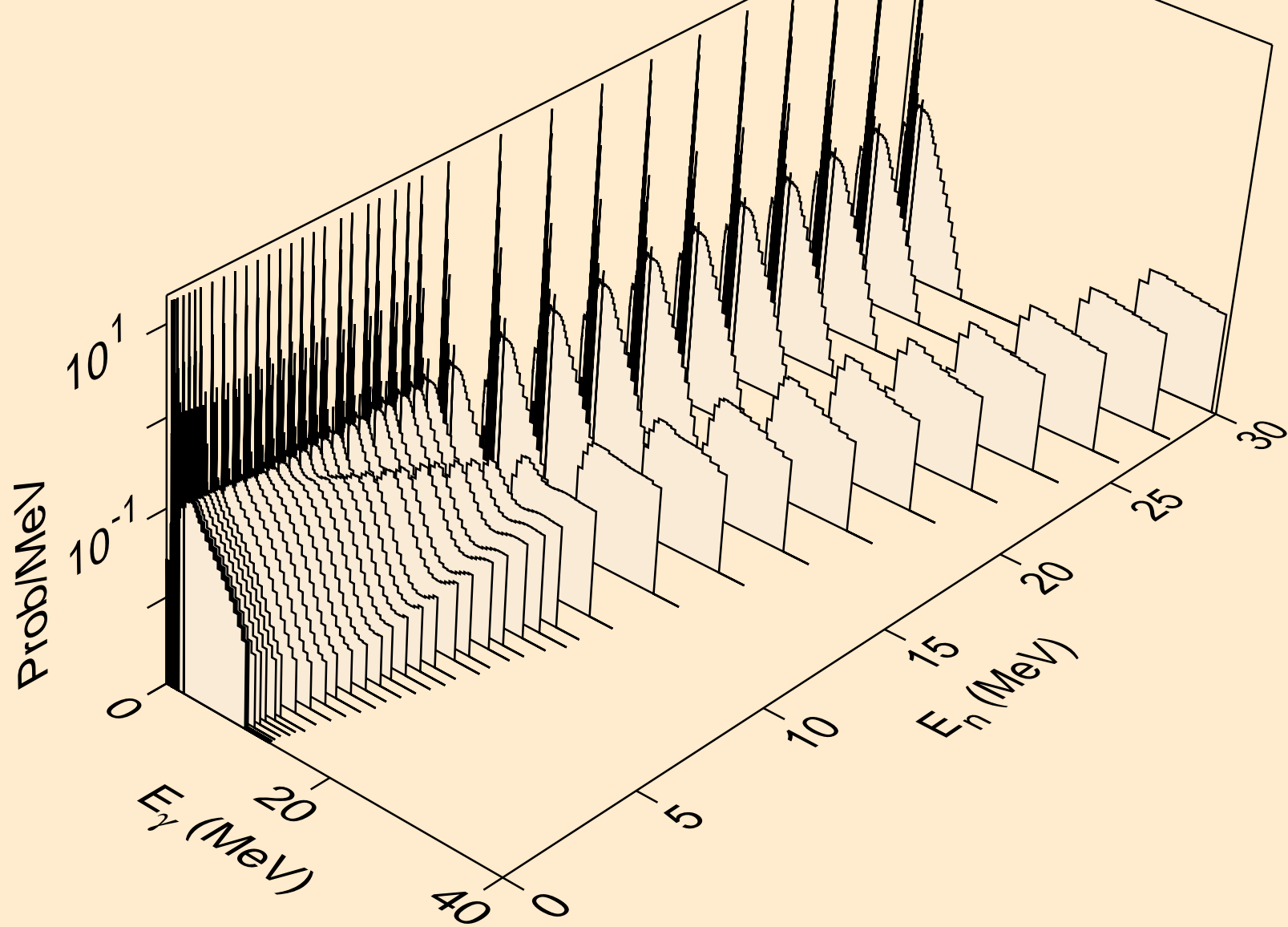

SE073M NEUTRON ACER TENDL-2023 LIBRARY; T=0.K
Photon emission for (n,p)

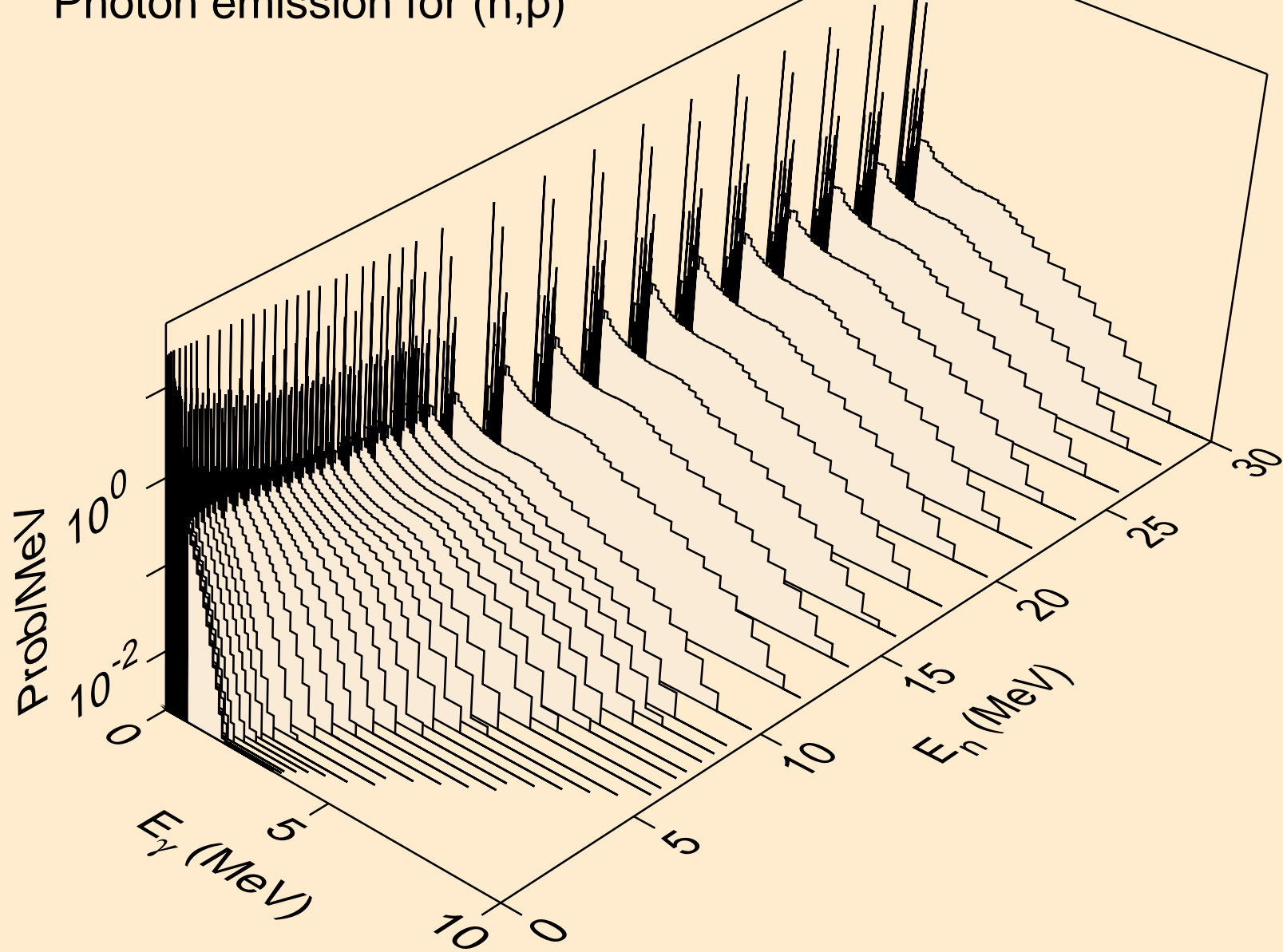

SE073M NEUTRON ACER TENDL-2023 LIBRARY; T=0.K
Photon emission for (n,d)

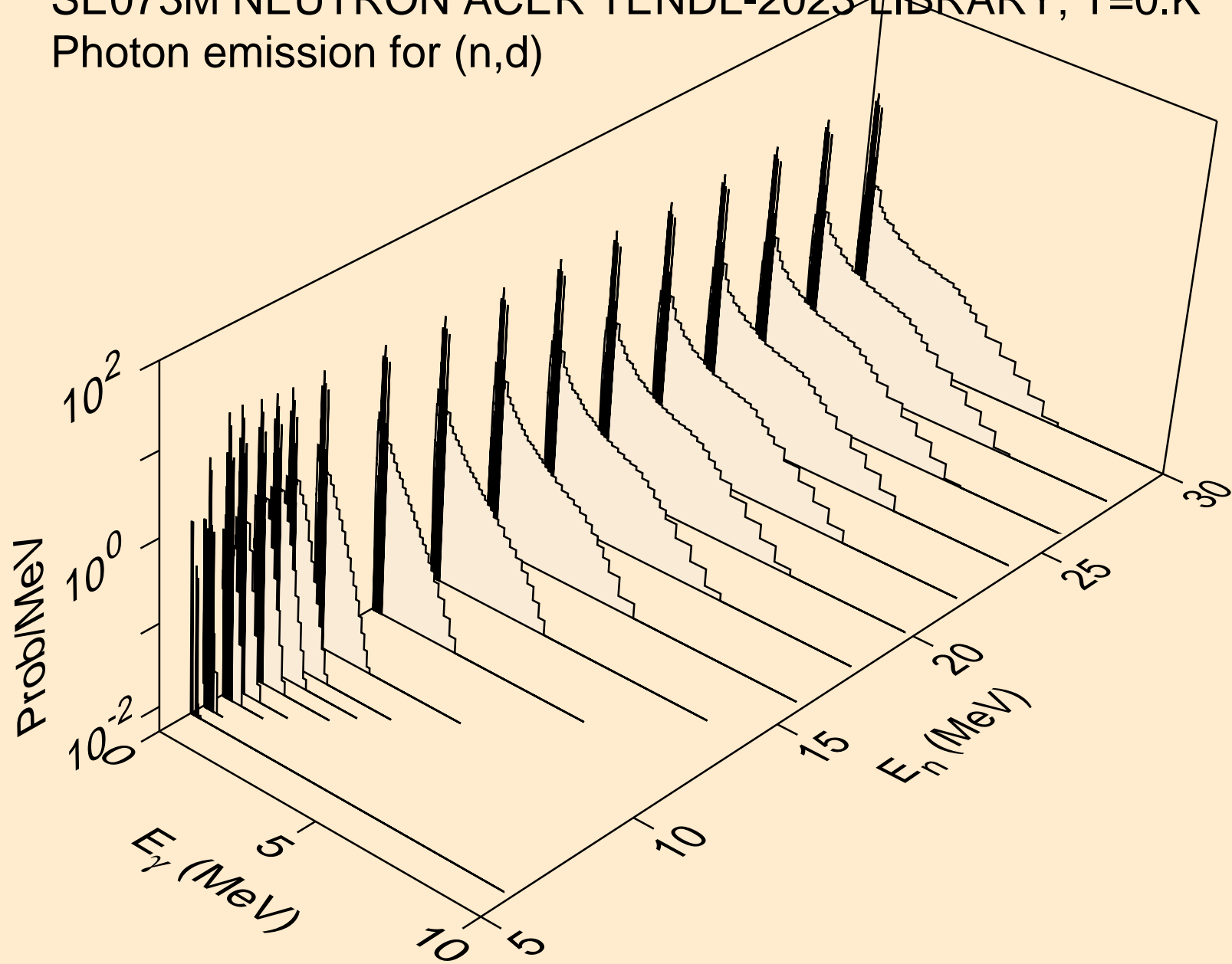

SE073M NEUTRON ACER TENDL-2023 LIBRARY; T=0.K
Photon emission for (n,t)

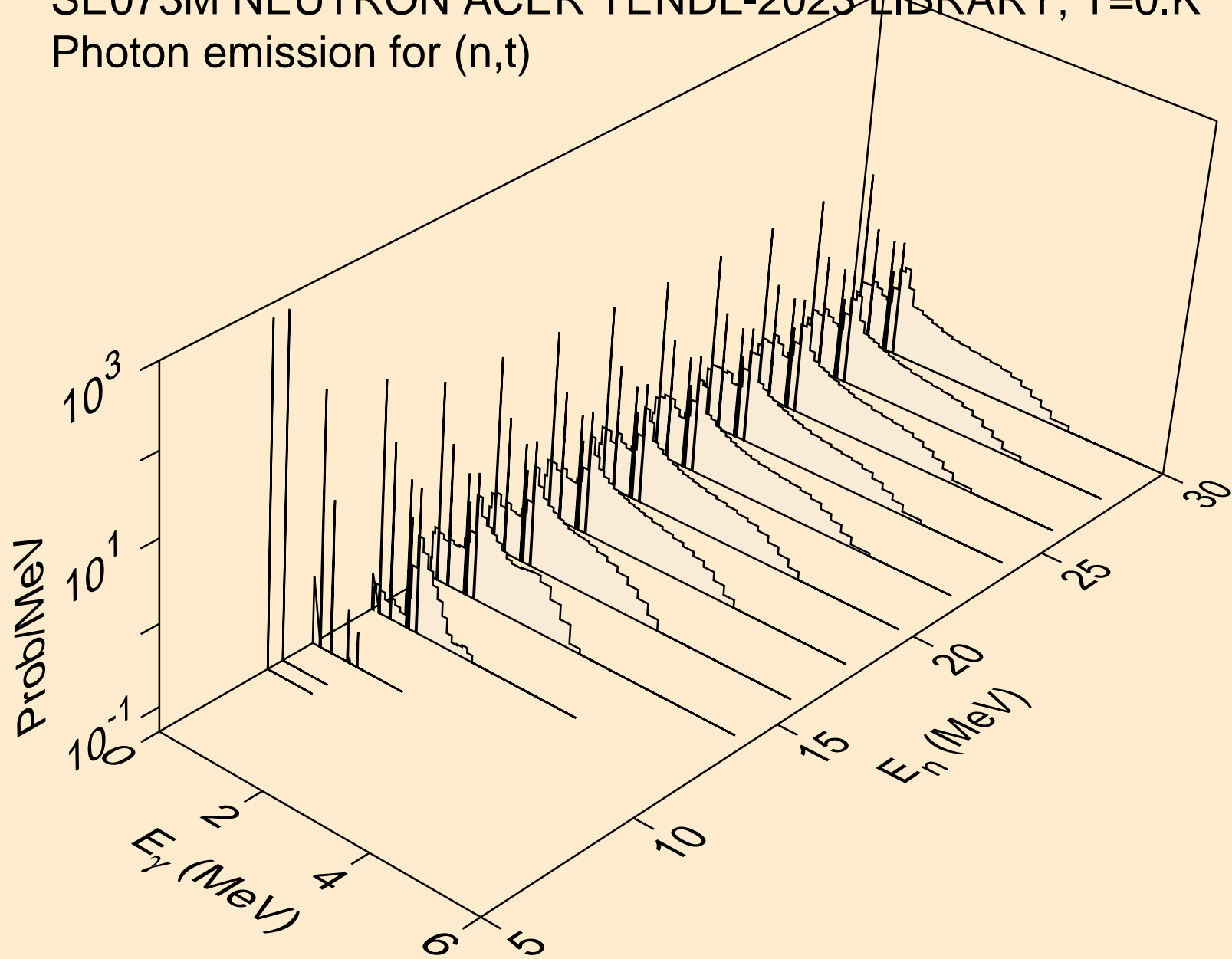

SE073M NEUTRON ACER TENDL-2023 LIBRARY; T=0.K
Photon emission for (n,he3)

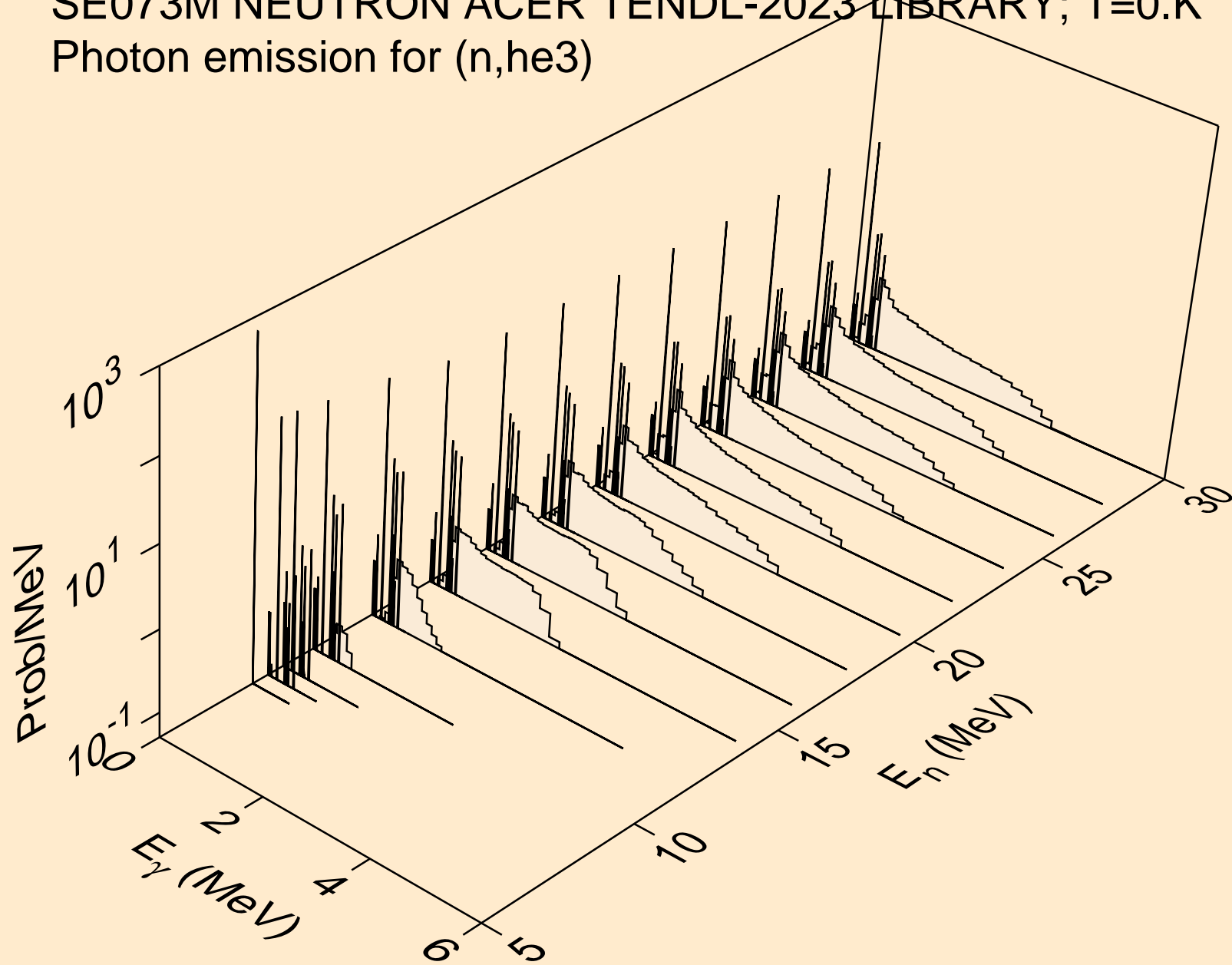

SE073M NEUTRON ACER TENDL-2023 LIBRARY; T=0.K
Photon emission for (n,a)

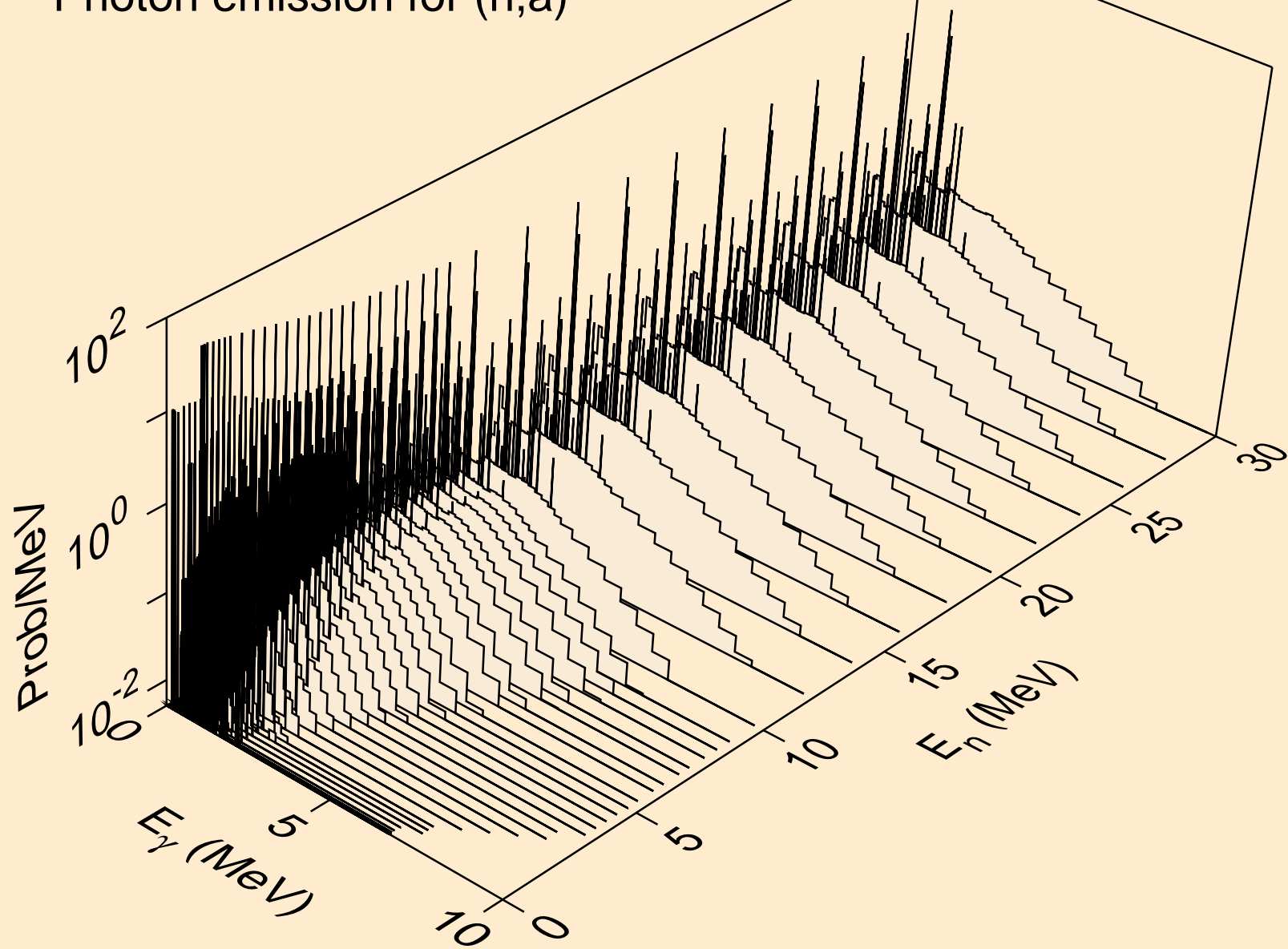

SE073M NEUTRON ACER TENDL-2023 LIBRARY; T=0.K
Photon emission for (n,2a)

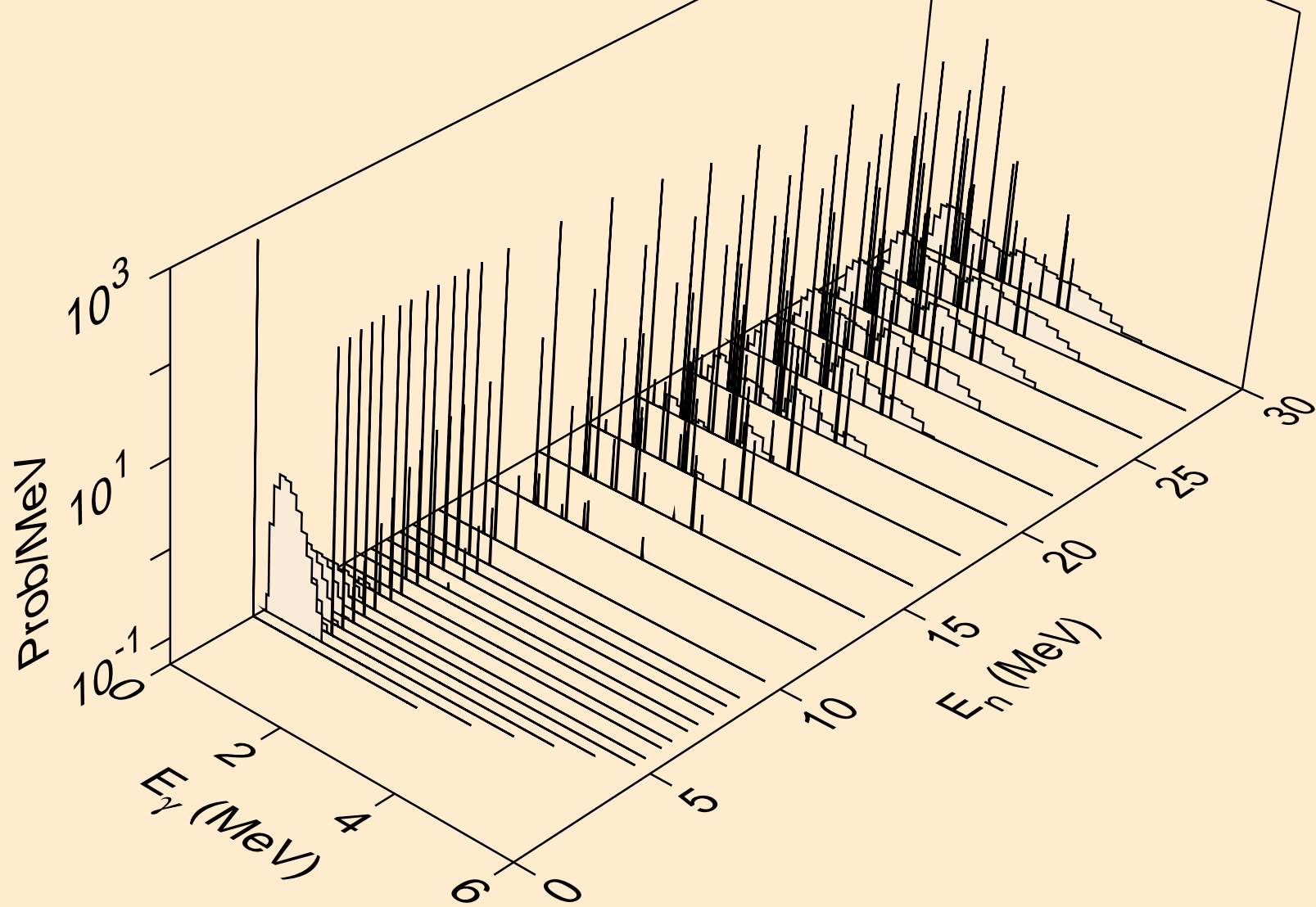

SE073M NEUTRON ACER TENDL-2023 LIBRARY; T=0.K
Photon emission for (n,3a)

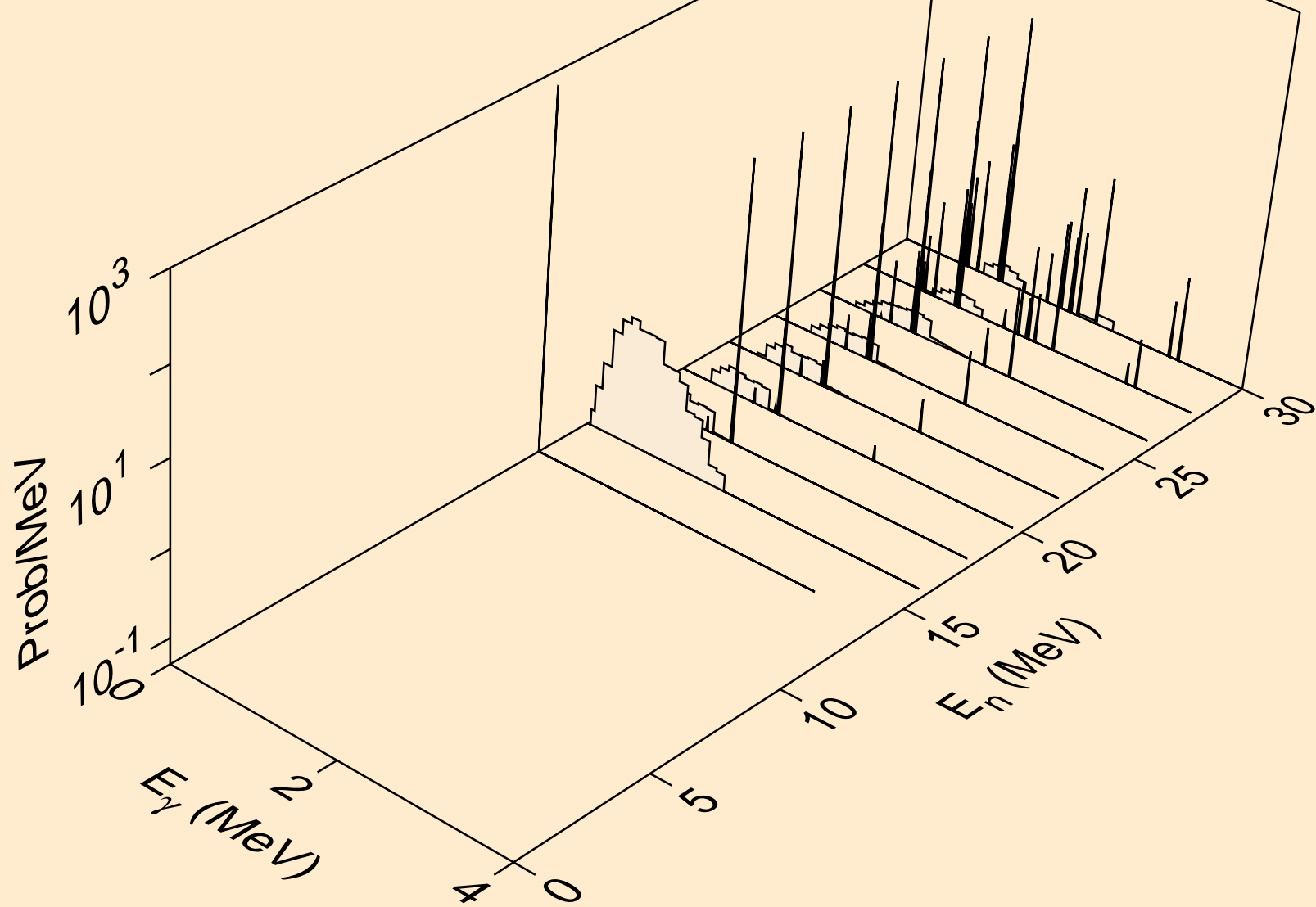

SE073M NEUTRON ACER TENDL-2023 LIBRARY; T=0.K
Photon emission for (n,2p)

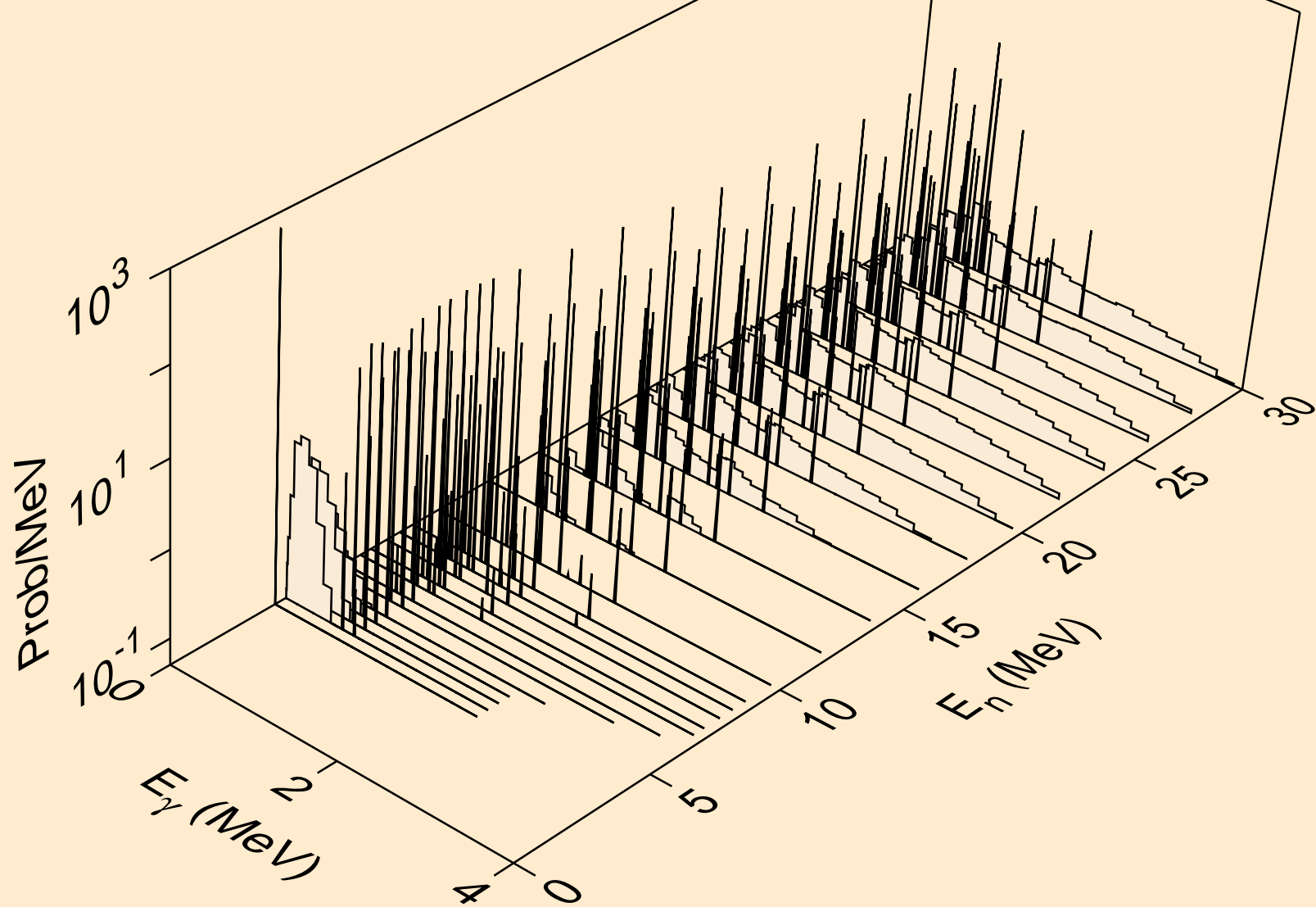

SE073M NEUTRON ACER TENDL-2023 LIBRARY; T=0.K
Photon emission for (n,p)

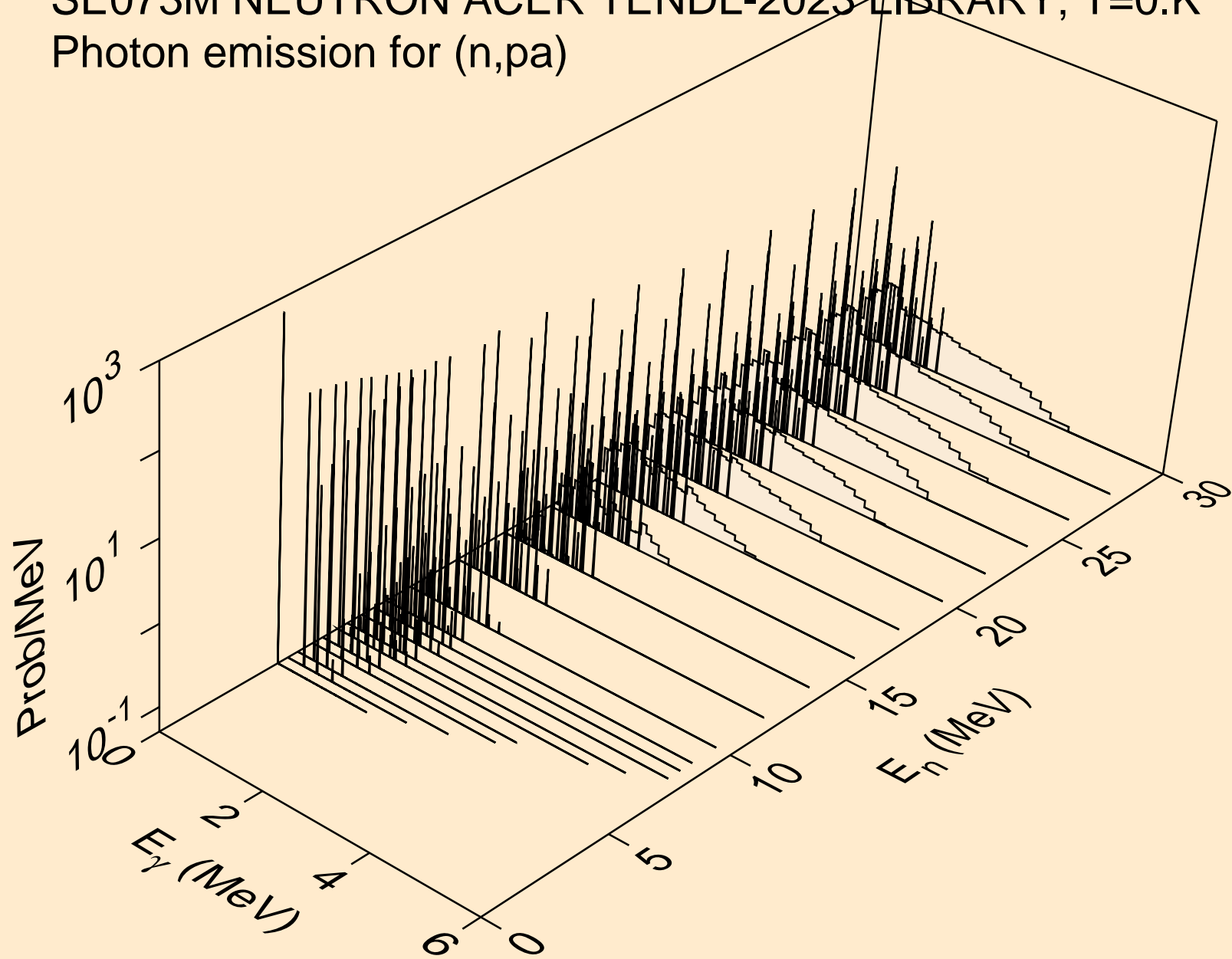

SE073M NEUTRON ACER TENDL-2023 LIBRARY; T=0.K
Photon emission for (n,pd)

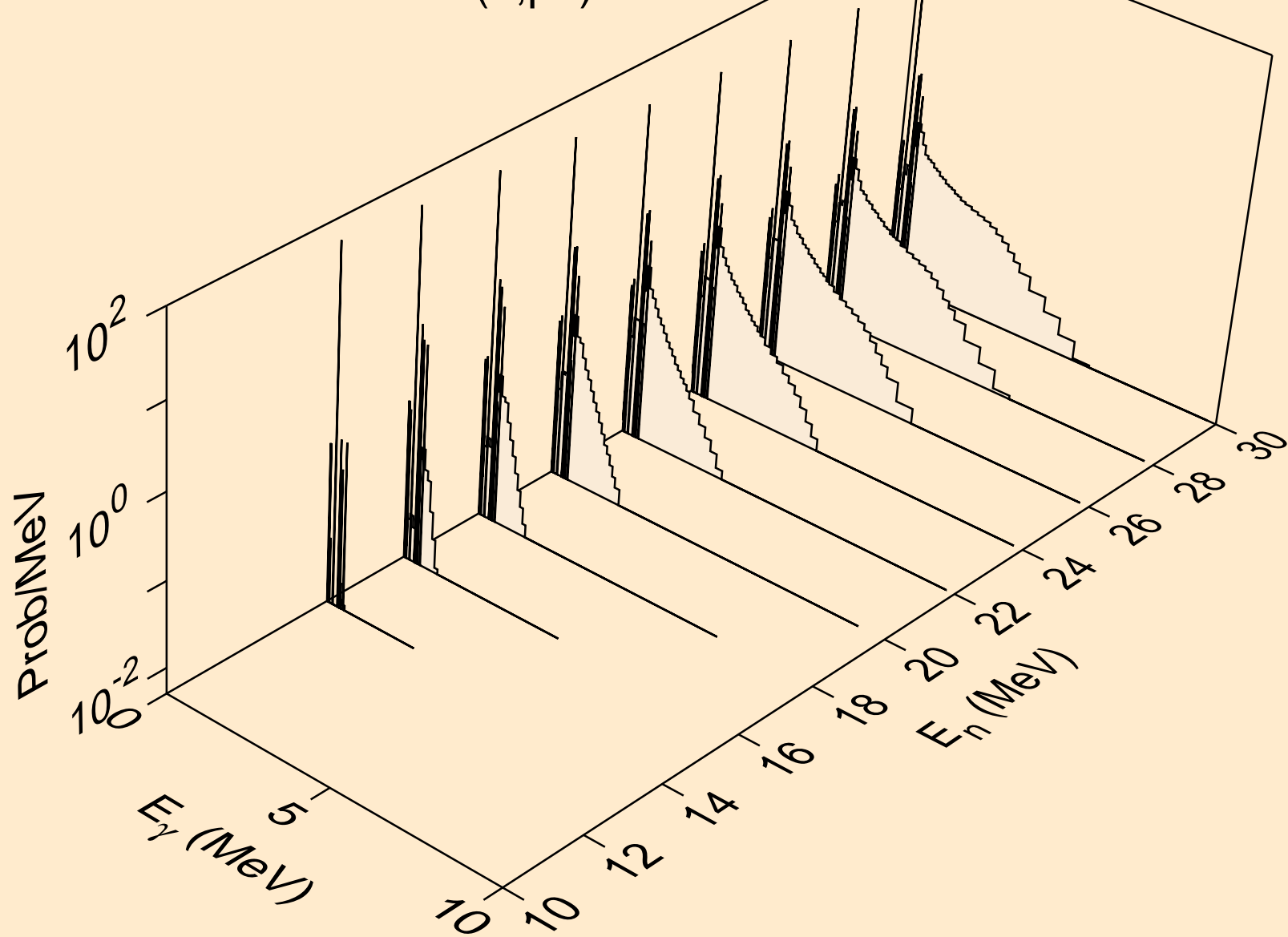

SE073M NEUTRON ACER TENDL-2023 LIBRARY; T=0.K
Photon emission for (n,pt)

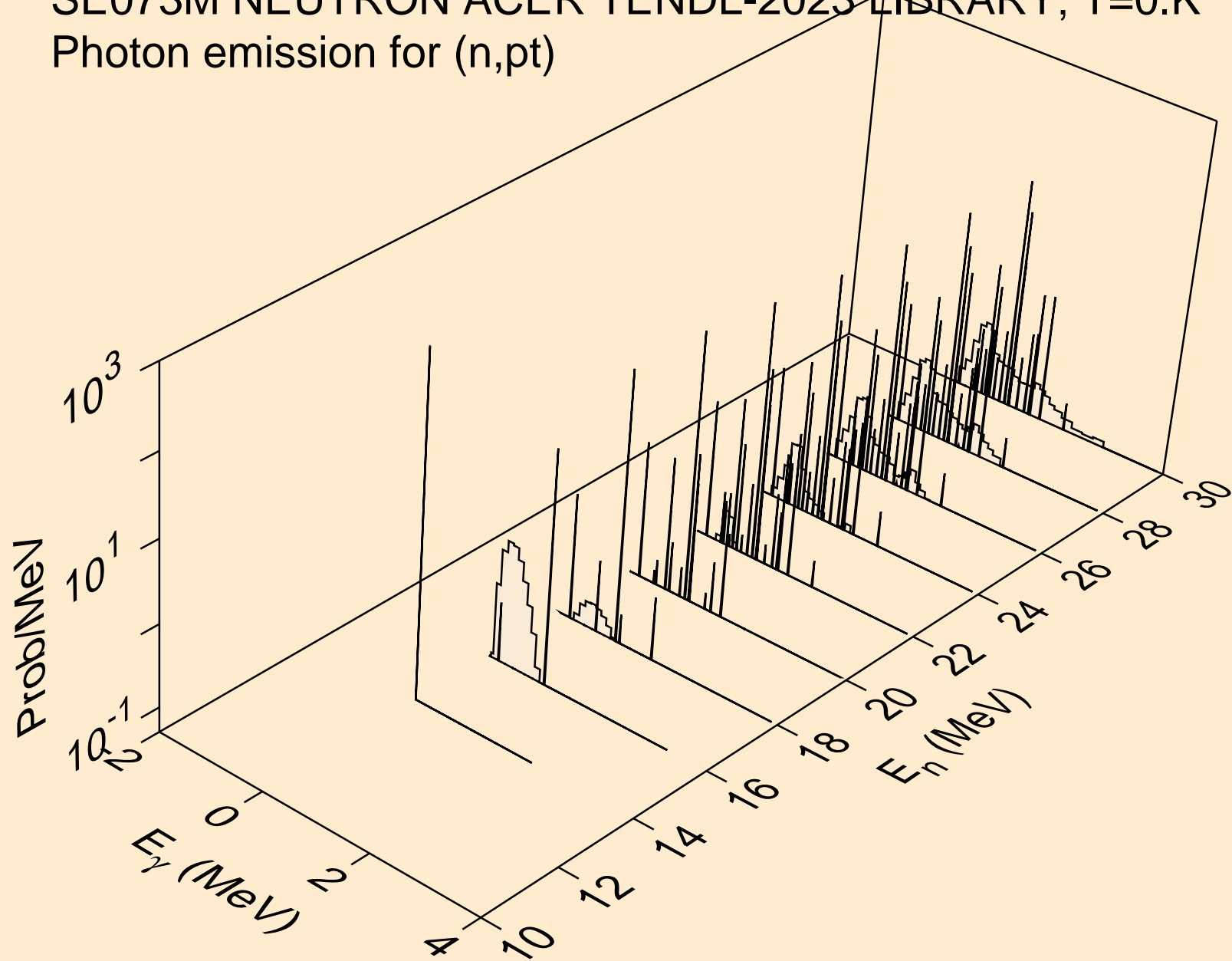

SE073M NEUTRON ACER TENDL-2023 LIBRARY; T=0.K
Photon emission for (n,da)

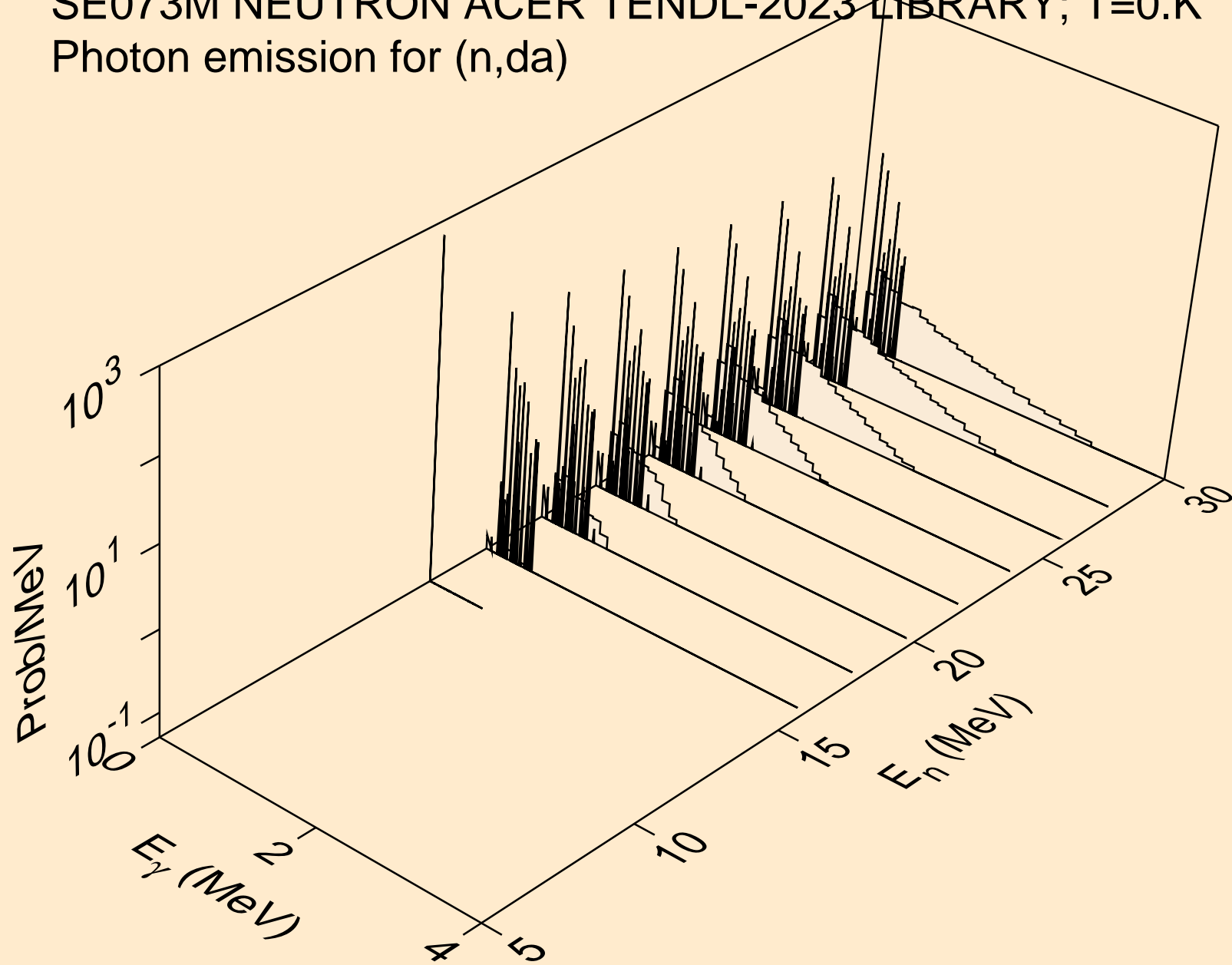

SE073M NEUTRON ACER TENDL-2023 LIBRARY; T=0.K
thermal capture photon spectrum

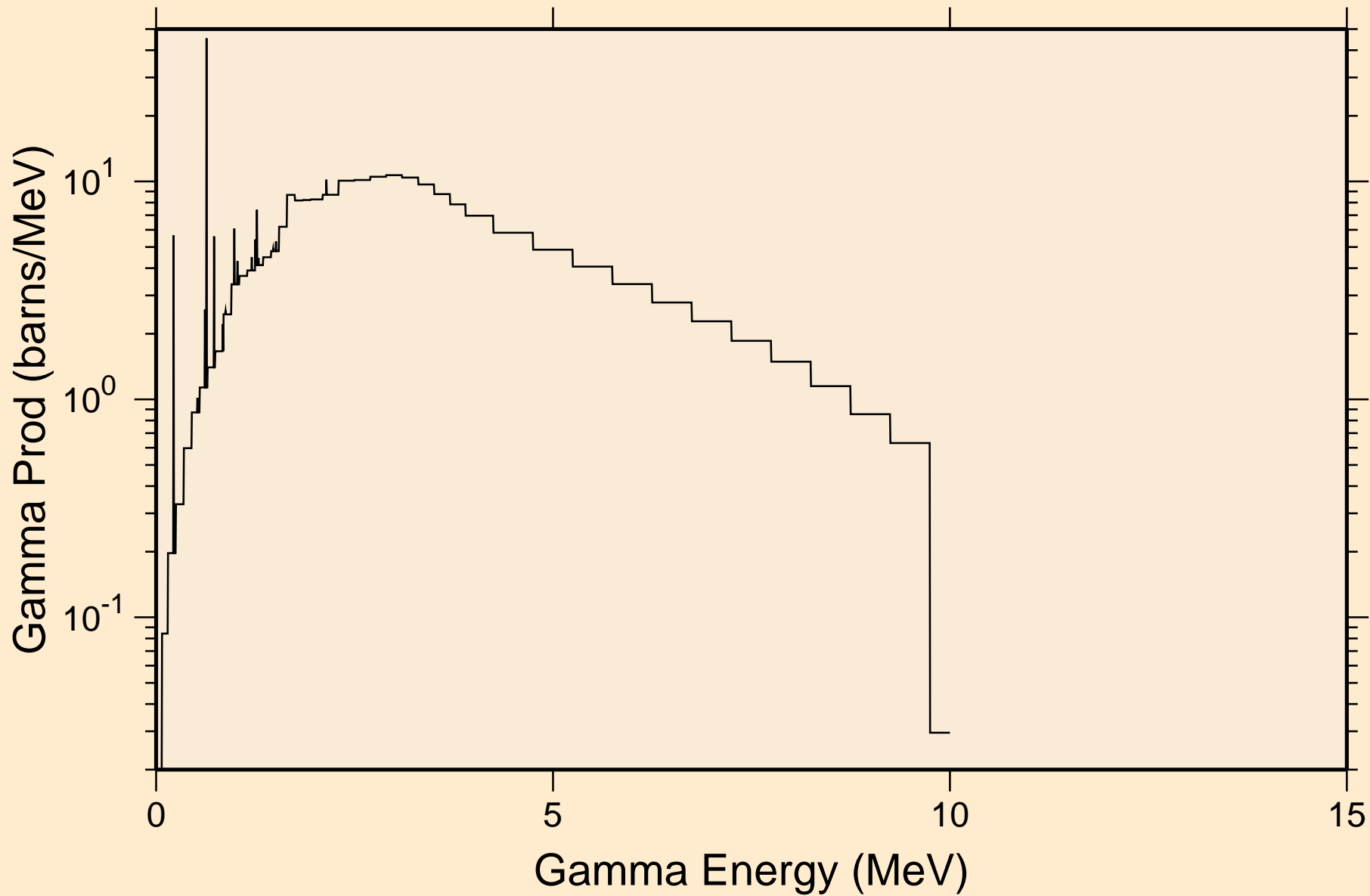

SE073M NEUTRON ACER TENDL-2023 LIBRARY; T=0.K
14 MeV photon spectrum

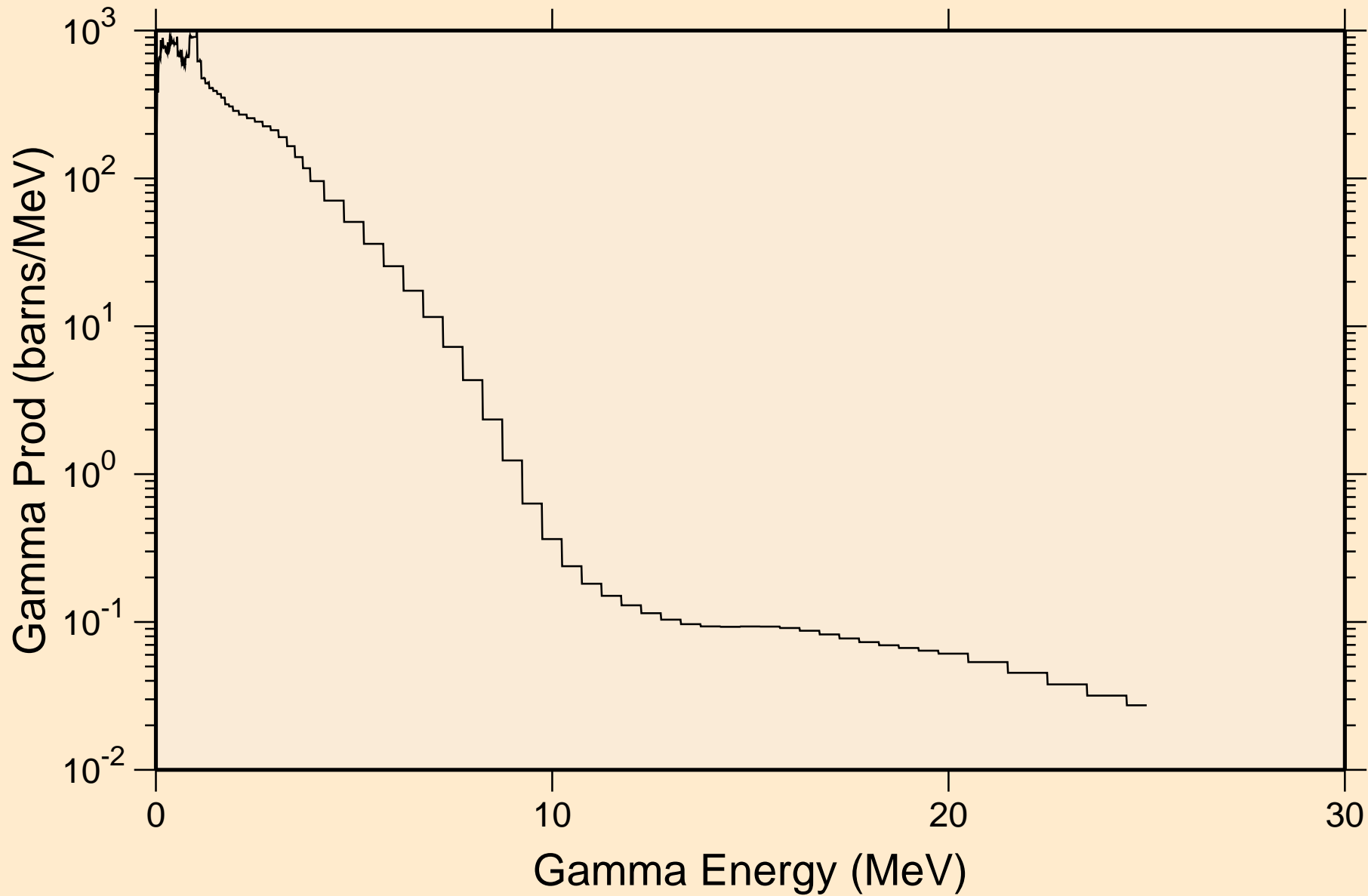

SE073M NEUTRON ACER TENDL-2023 LIBRARY; T=0.K

Particle heating contributions

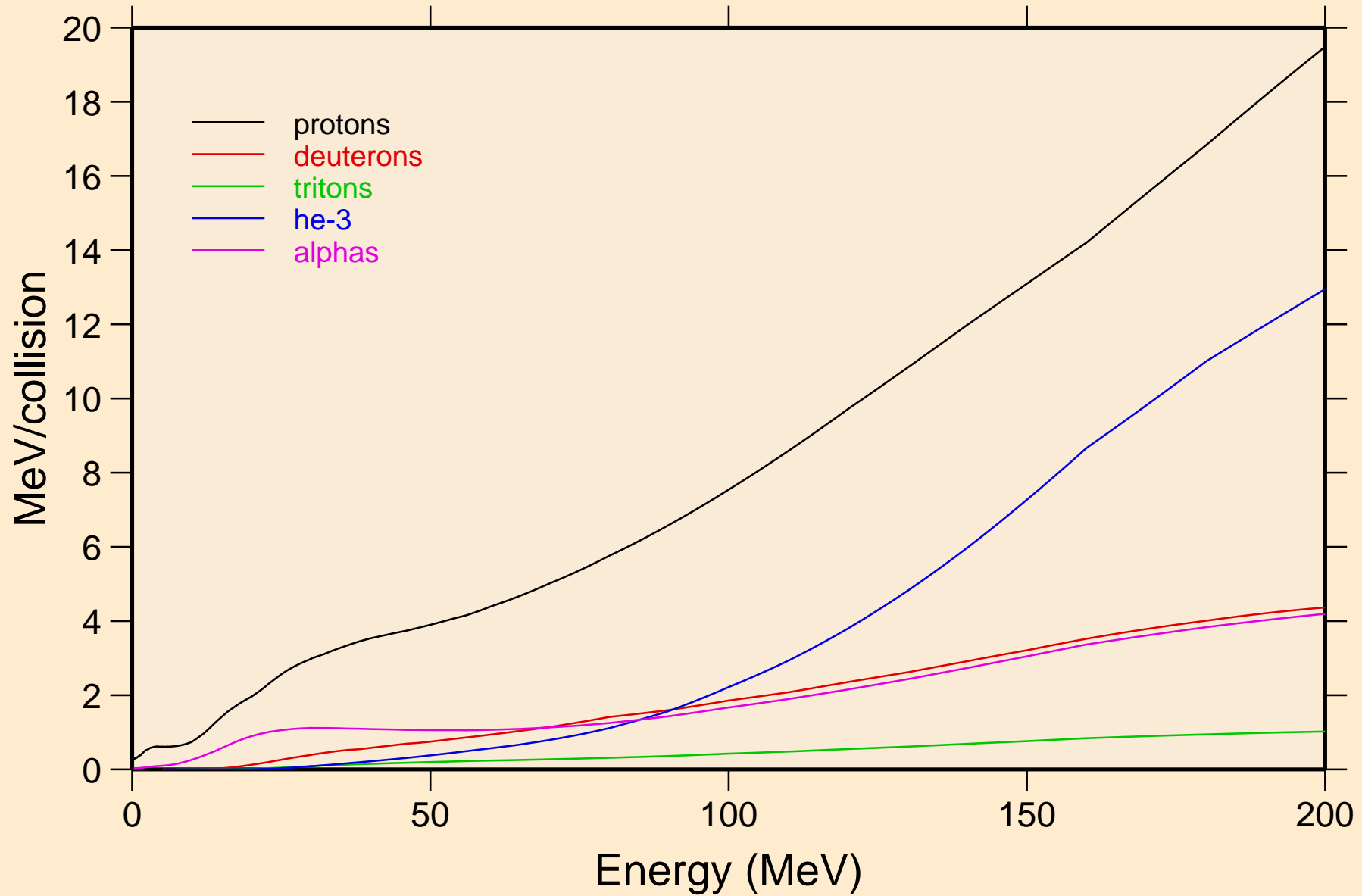

SE073M NEUTRON ACER TENDL-2023 LIBRARY; T=0.K
Recoil Heating

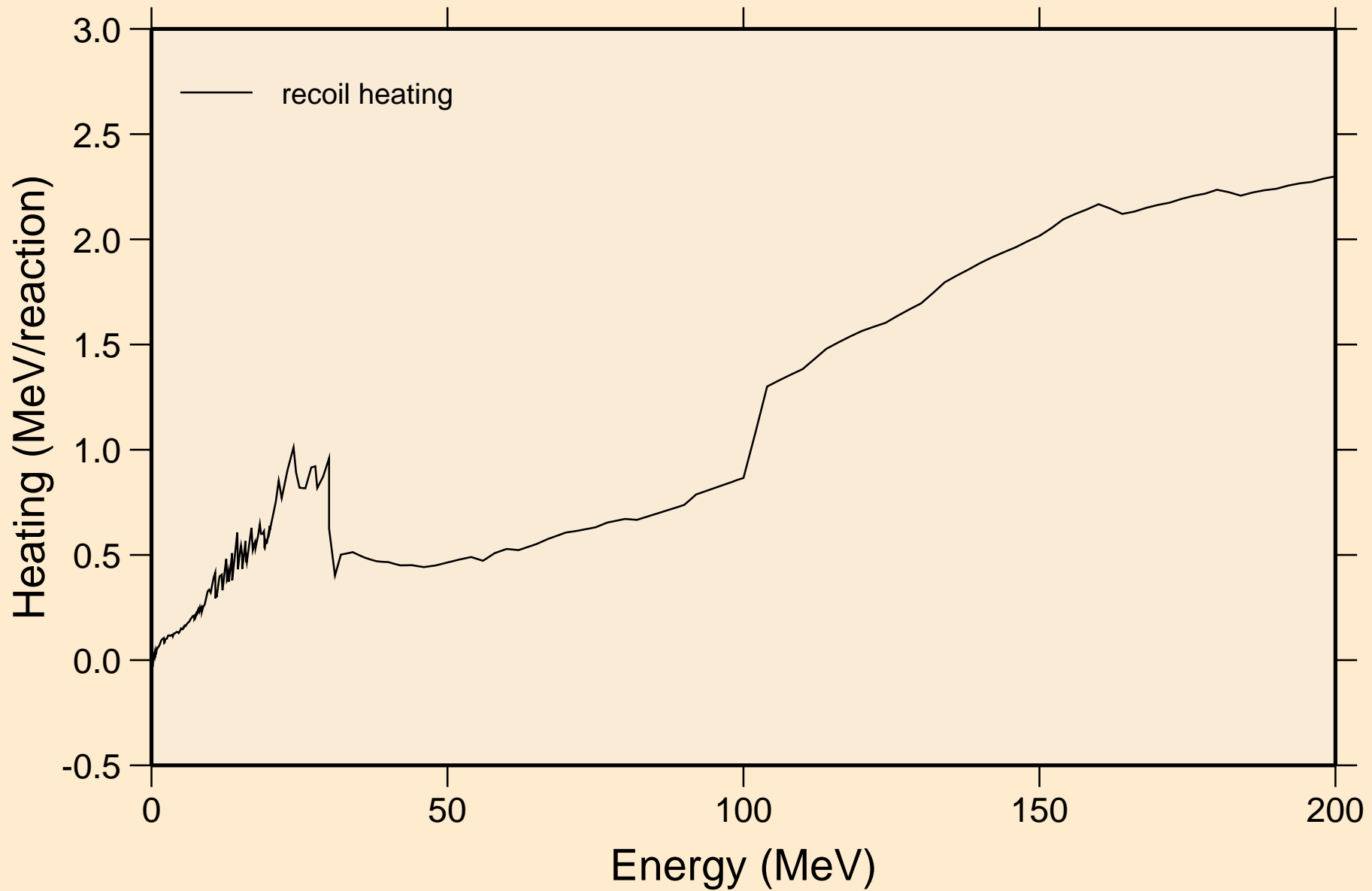

SE073M NEUTRON ACER TENDL-2023 LIBRARY; T=0.K

Particle production cross sections

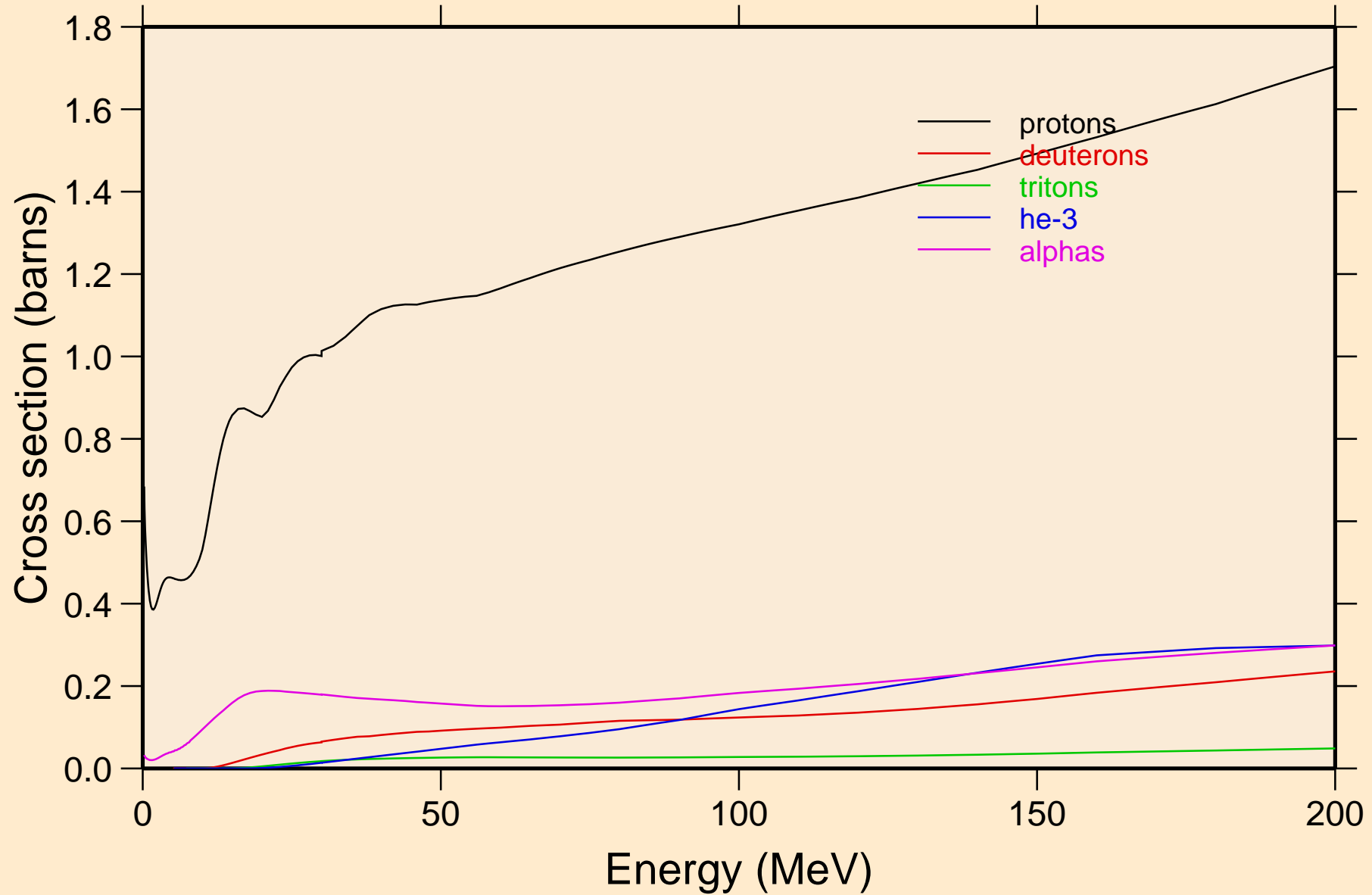

SE073M NEUTRON ACER TENDL-2023 LIBRARY; T=0.K
protons from (n,x)

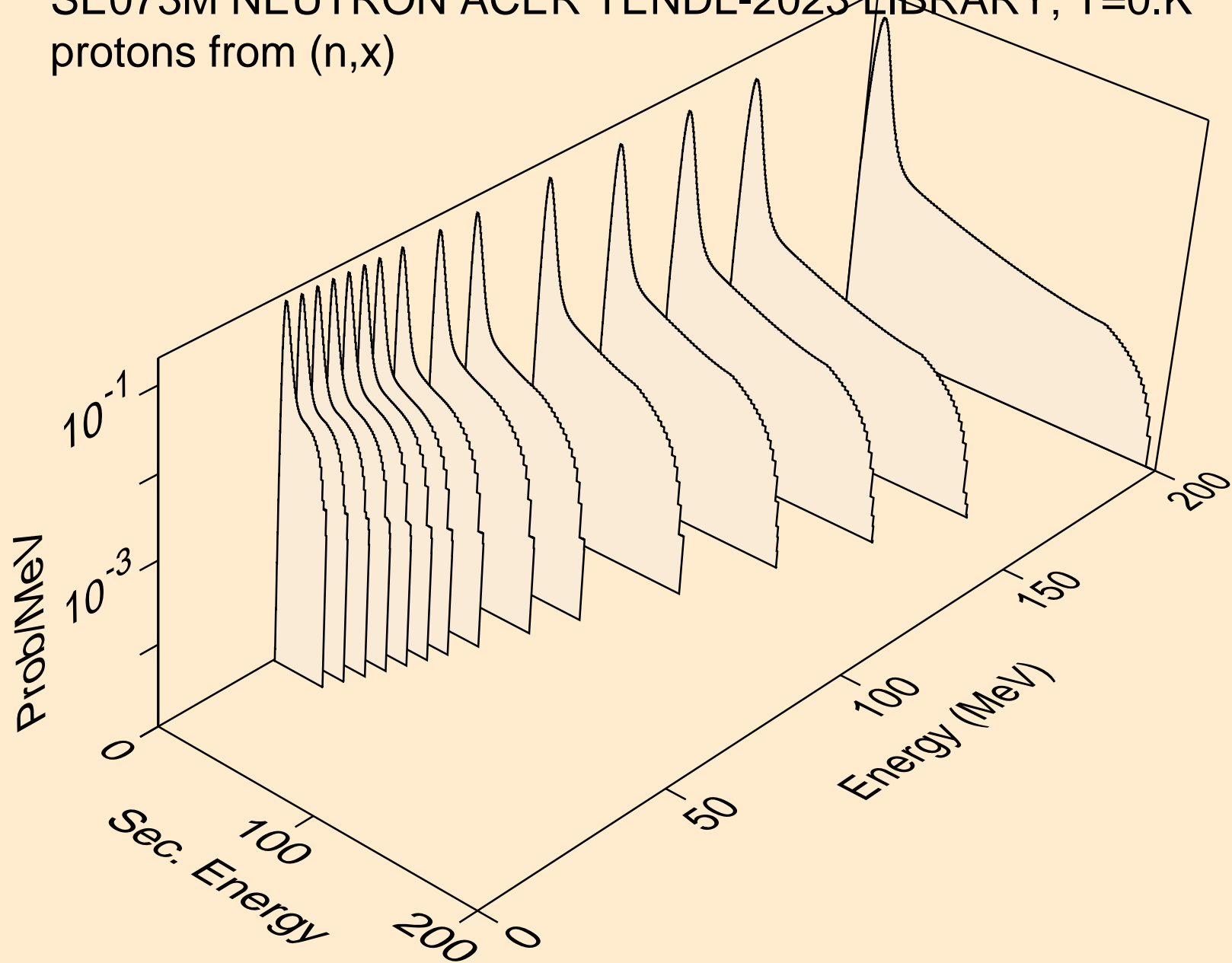

SE073M NEUTRON ACER TENDL-2023 LIBRARY; T=0.K
protons from (n,n*)p

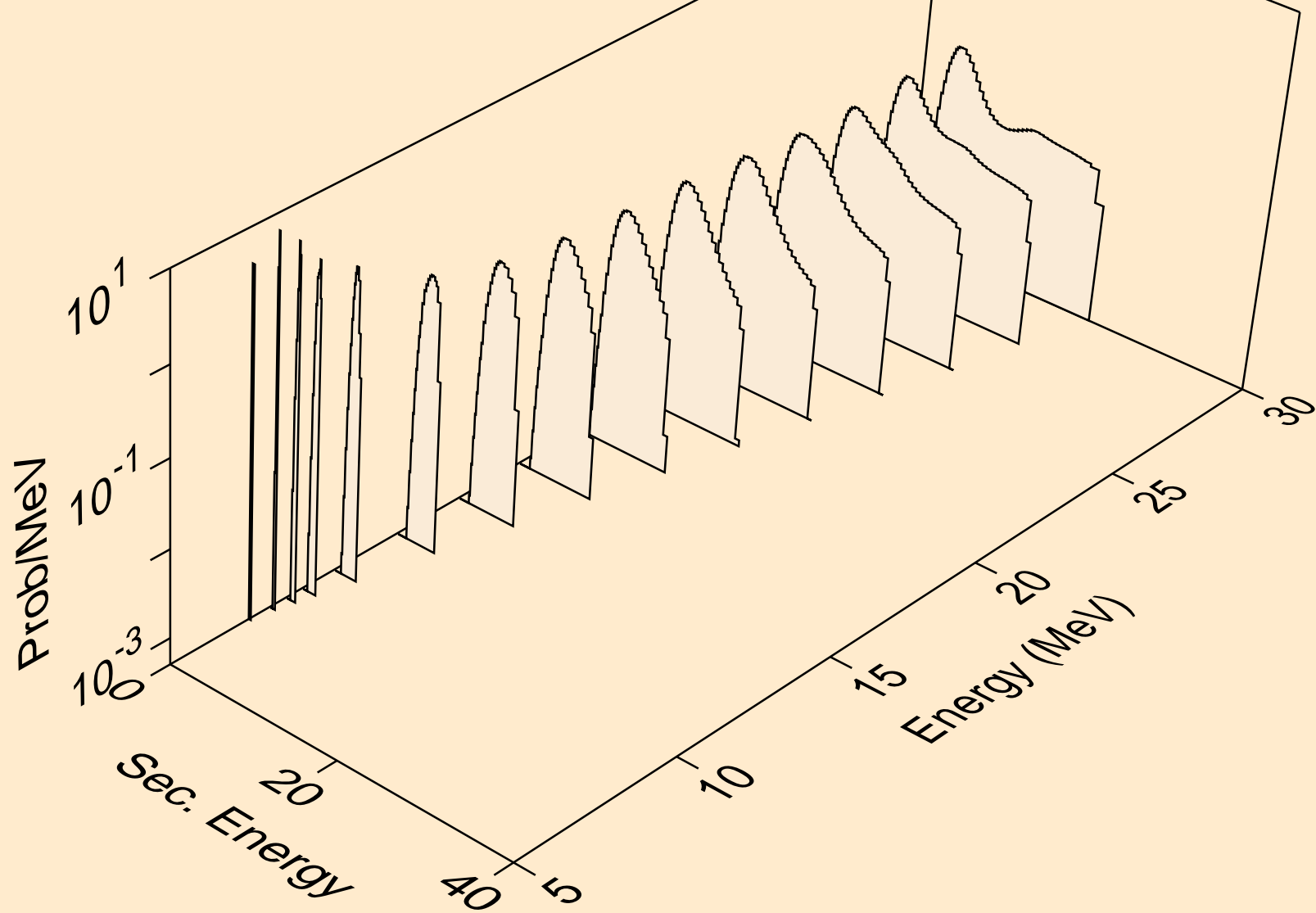

SE073M NEUTRON ACER TENDL-2023 LIBRARY; T=0.K
protons from (n,2np)

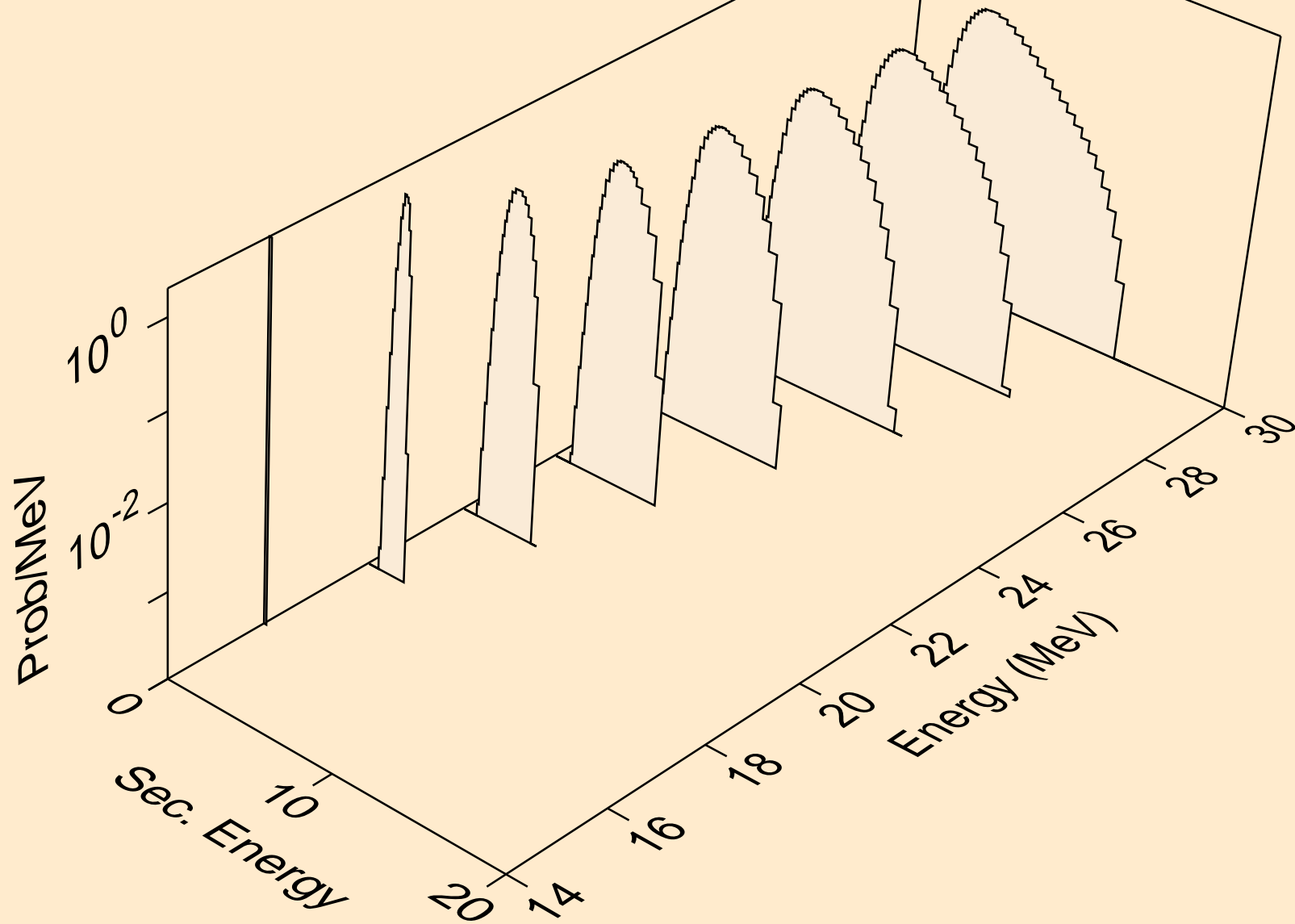

SE073M NEUTRON ACER TENDL-2023 LIBRARY; T=0.K
protons from (n,3np)

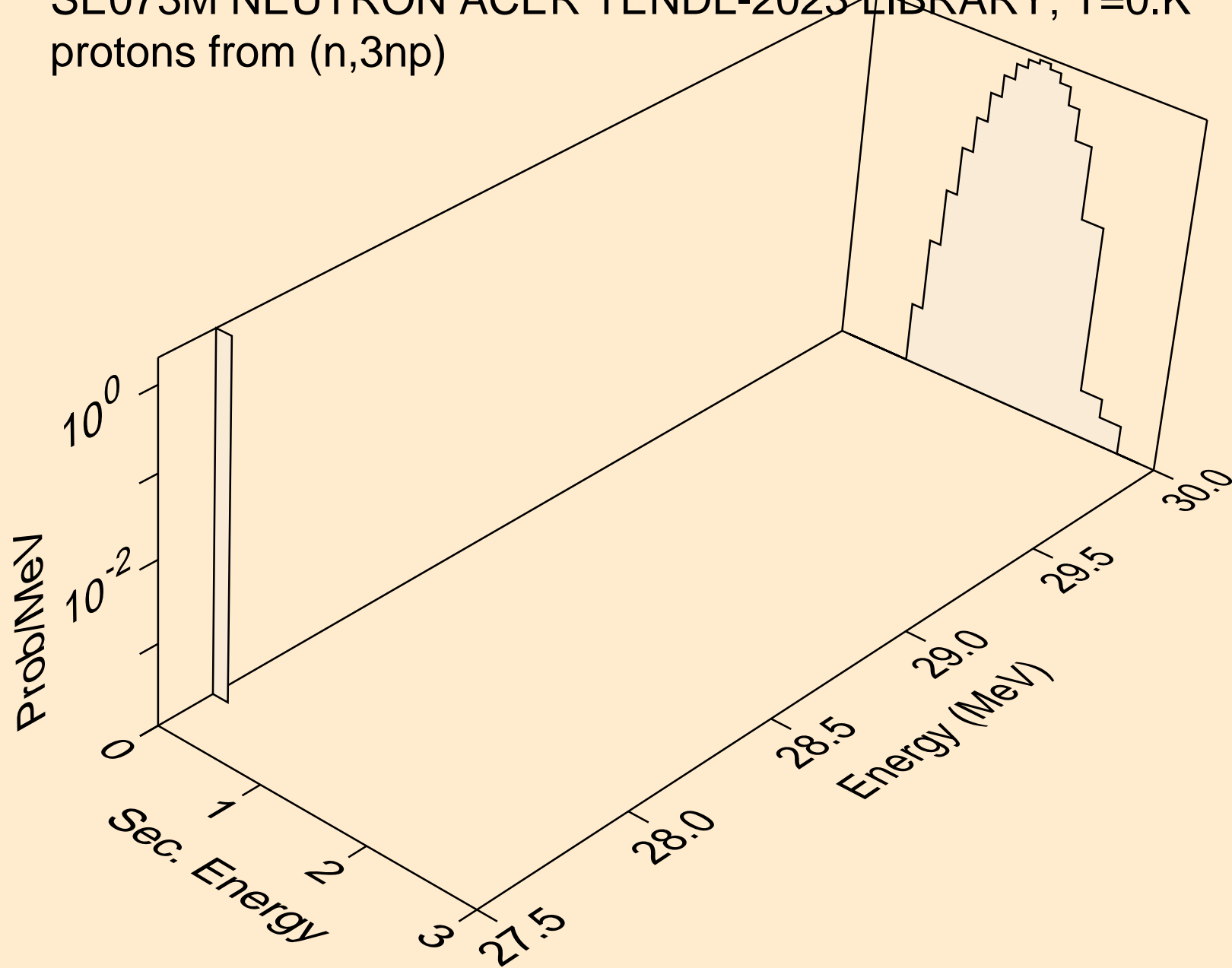

SE073M NEUTRON ACER TENDL-2023 LIBRARY; T=0.K
protons from (n,n2p)

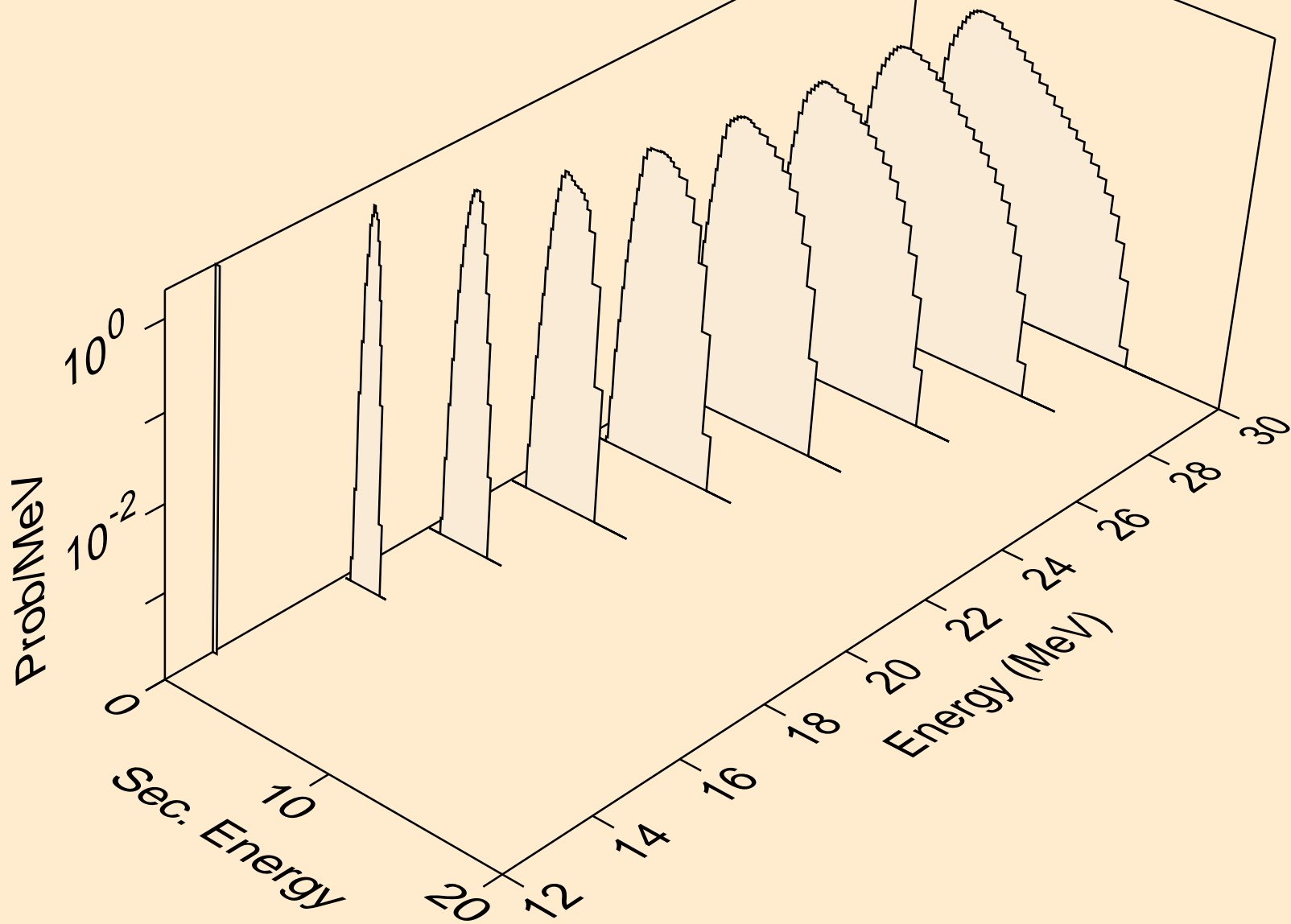

SE073M NEUTRON ACER TENDL-2023 LIBRARY; T=0.K
protons from (n,npa)

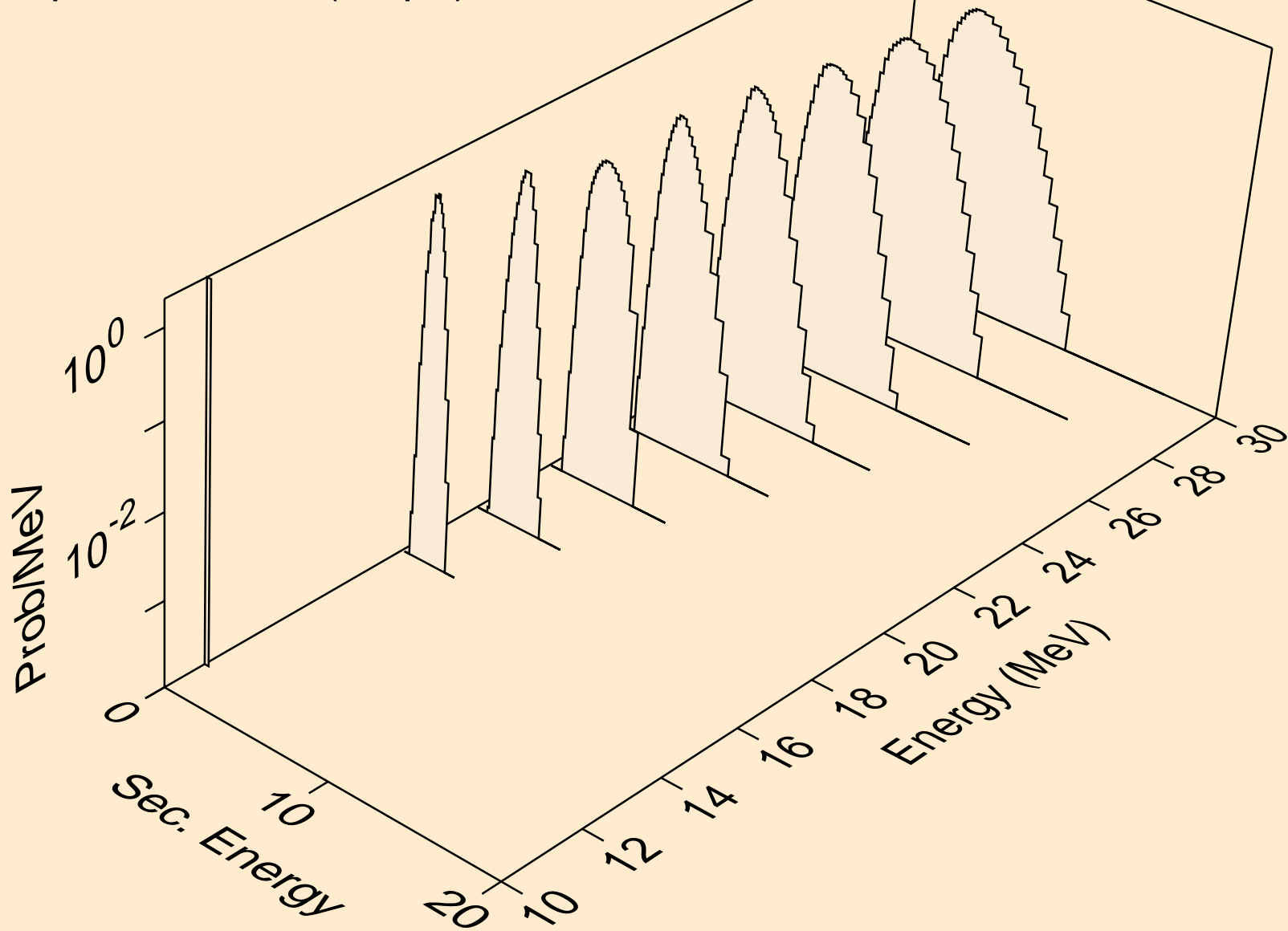

SE073M NEUTRON ACER TENDL-2023 LIBRARY; T=0.K
protons from (n,p)

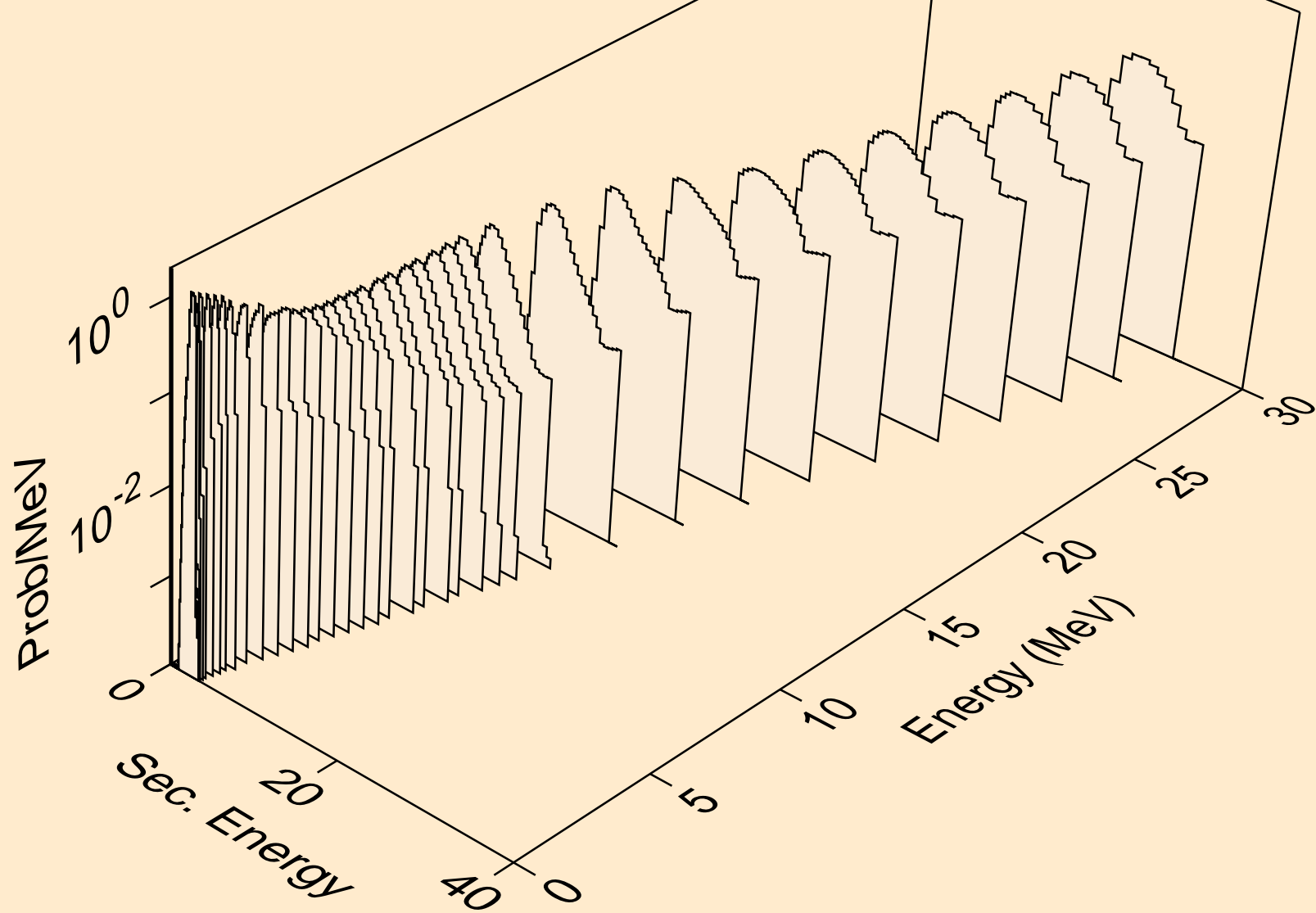

SE073M NEUTRON ACER TENDL-2023 LIBRARY; T=0.K
protons from (n,2p)

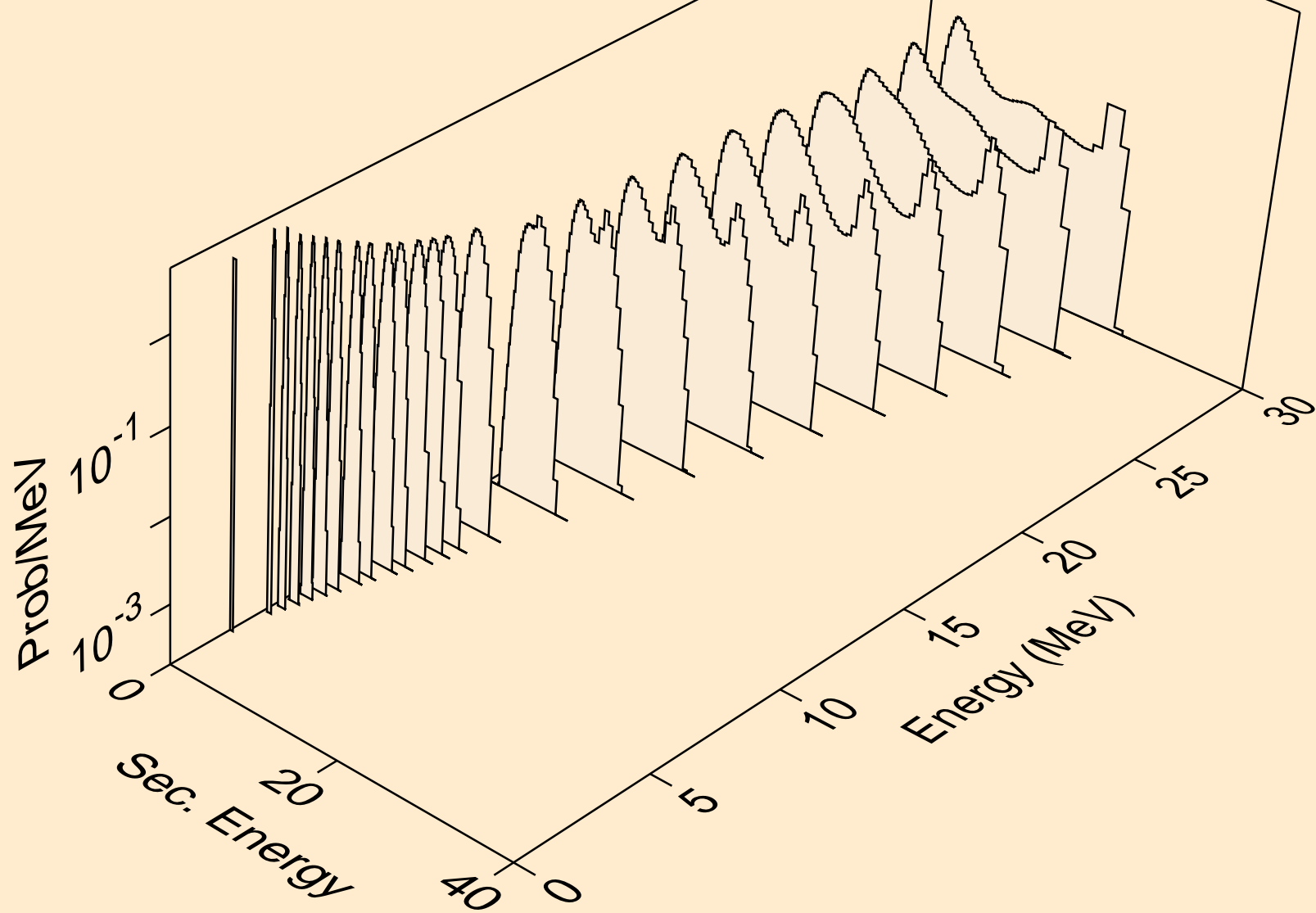

SE073M NEUTRON ACER TENDL-2023 LIBRARY; T=0.K
protons from (n,p)

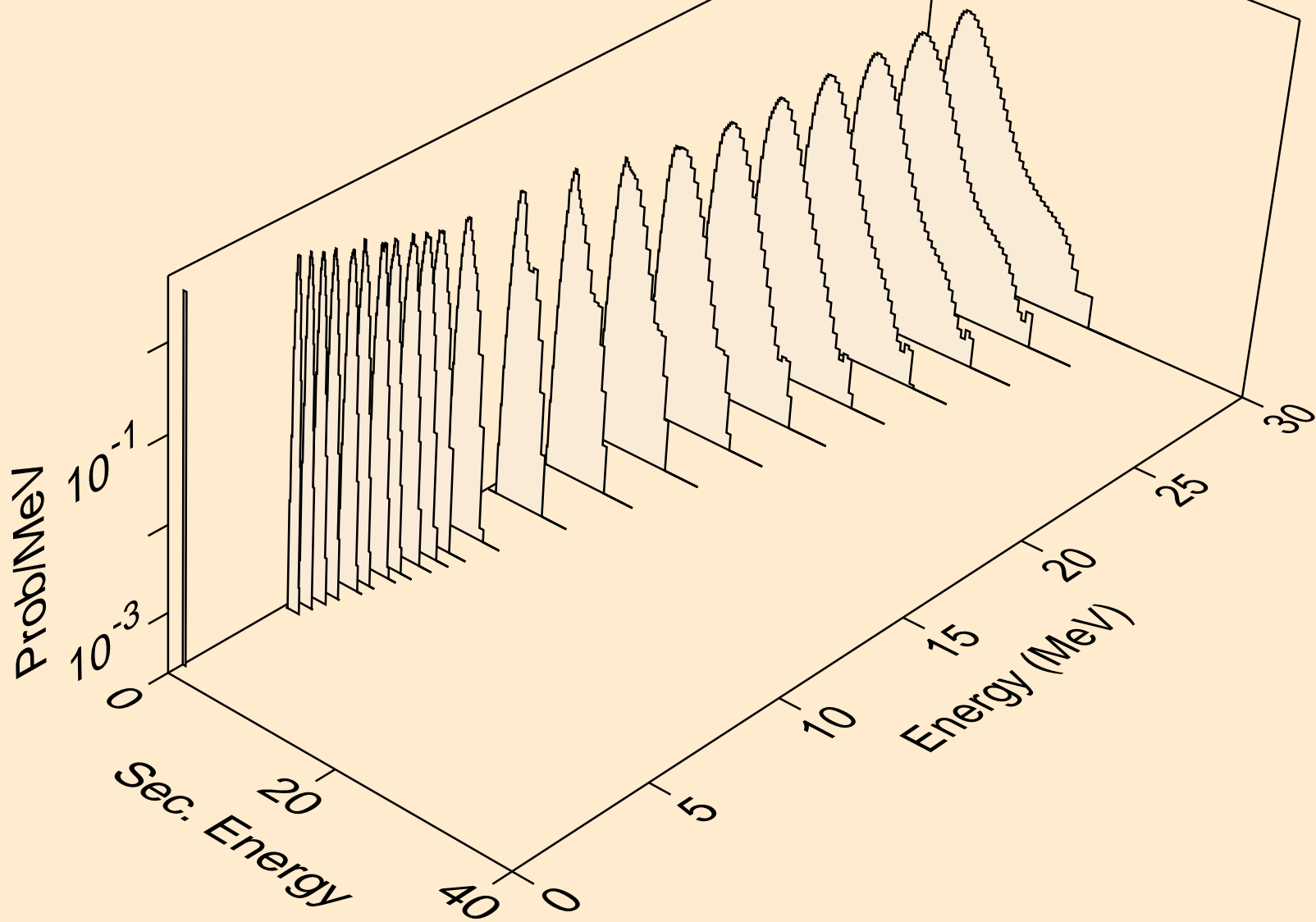

SE073M NEUTRON ACER TENDL-2023 LIBRARY; T=0.K
protons from (n,pd)

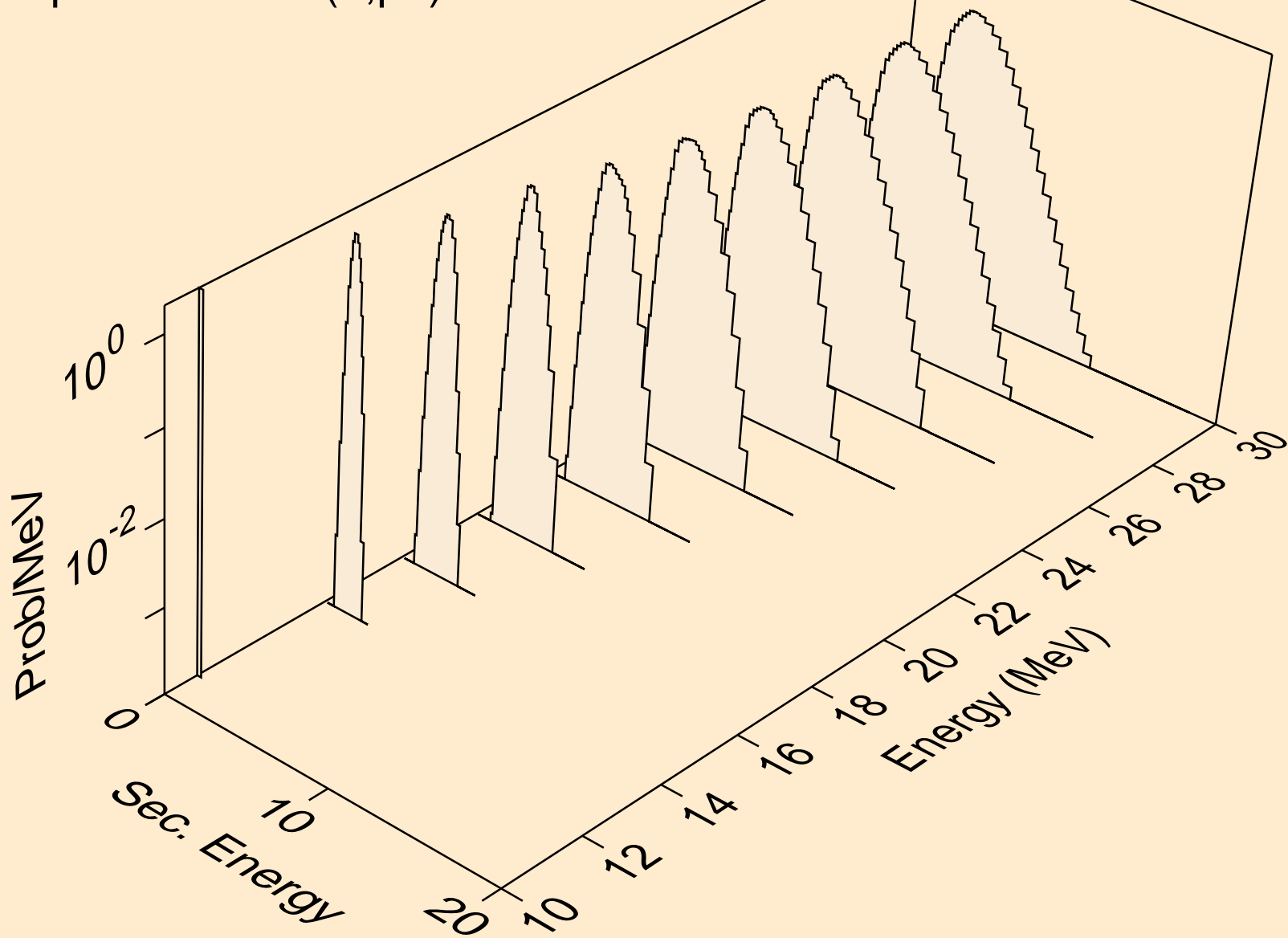

SE073M NEUTRON ACER TENDL-2023 LIBRARY; T=0.K
protons from (n,pt)

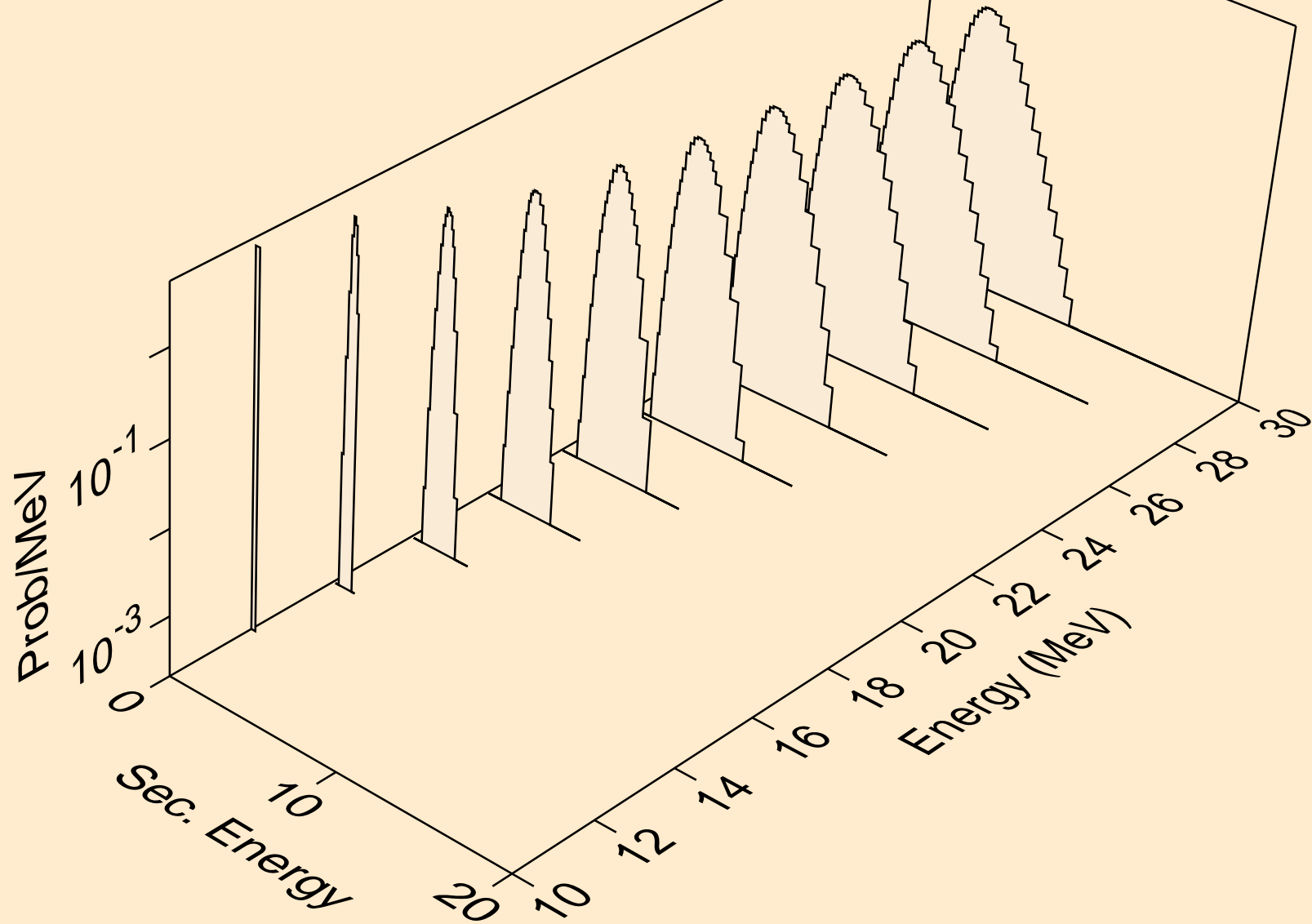

SE073M NEUTRON ACER TENDL-2023 LIBRARY; T=0.K
deuterons from (n,x)

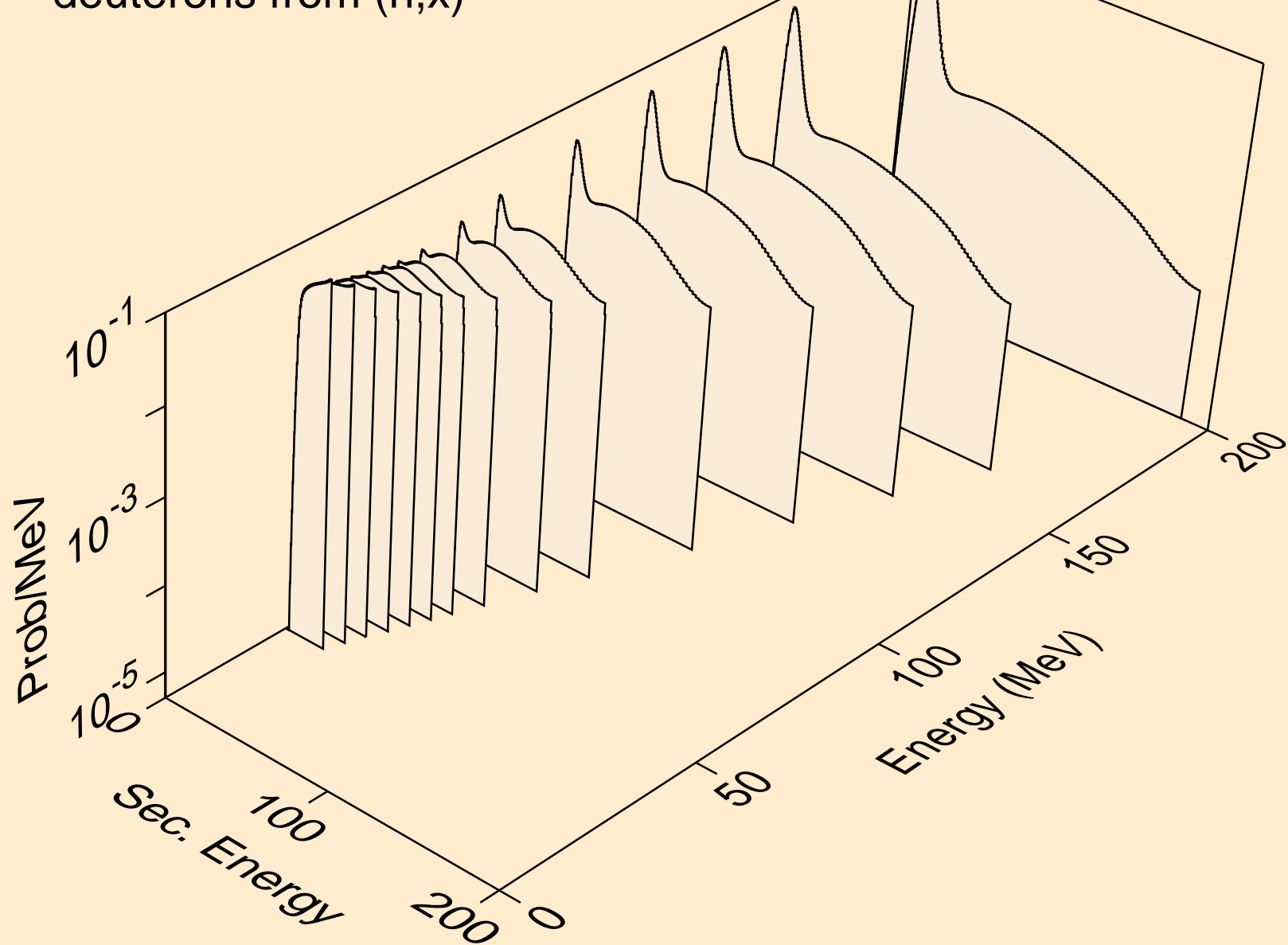

SE073M NEUTRON ACER TENDL-2023 LIBRARY; T=0.K
deuterons from (n,2nd)

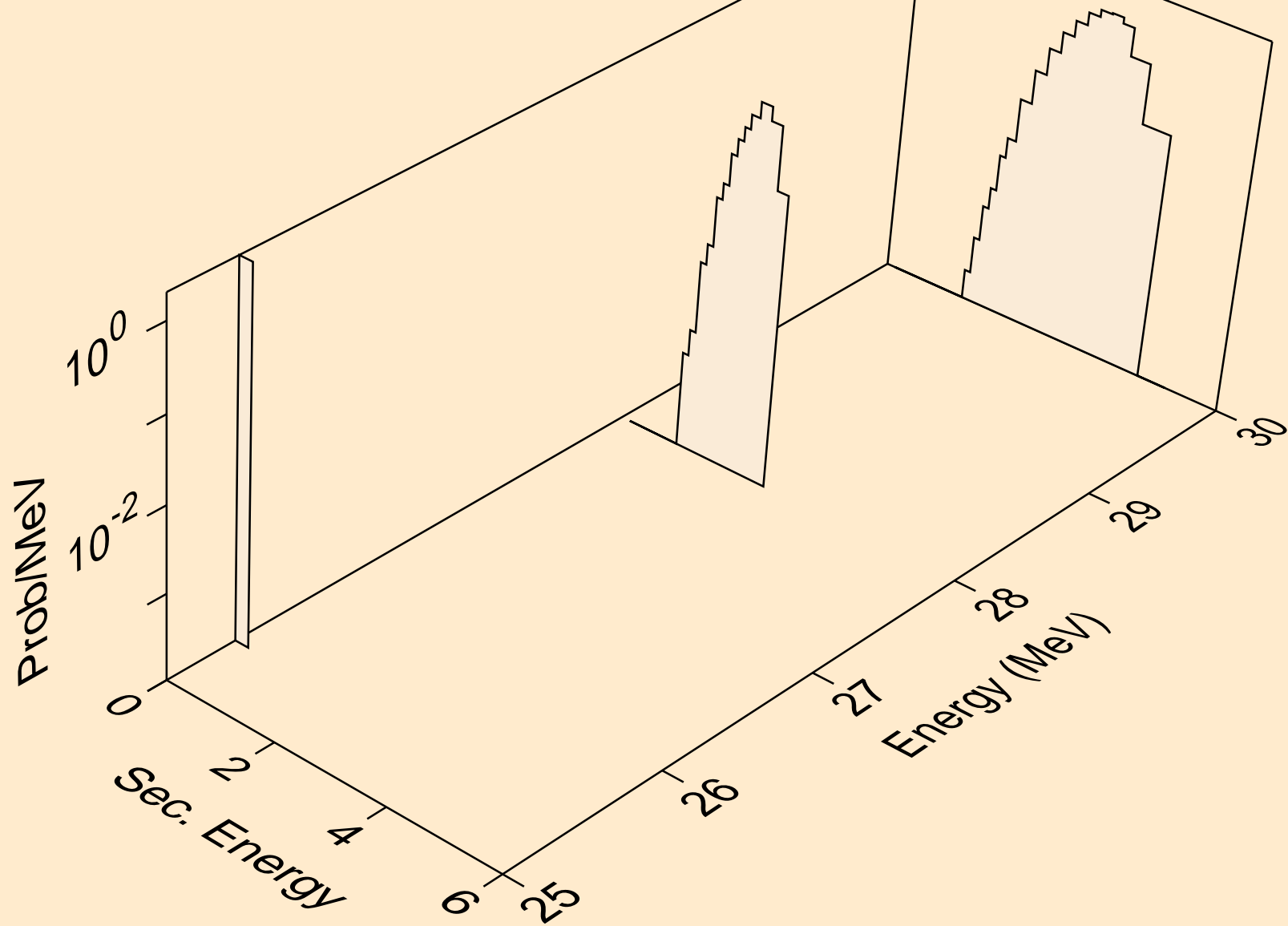

SE073M NEUTRON ACER TENDL-2023 LIBRARY; T=0.K
deuterons from (n,n*)d

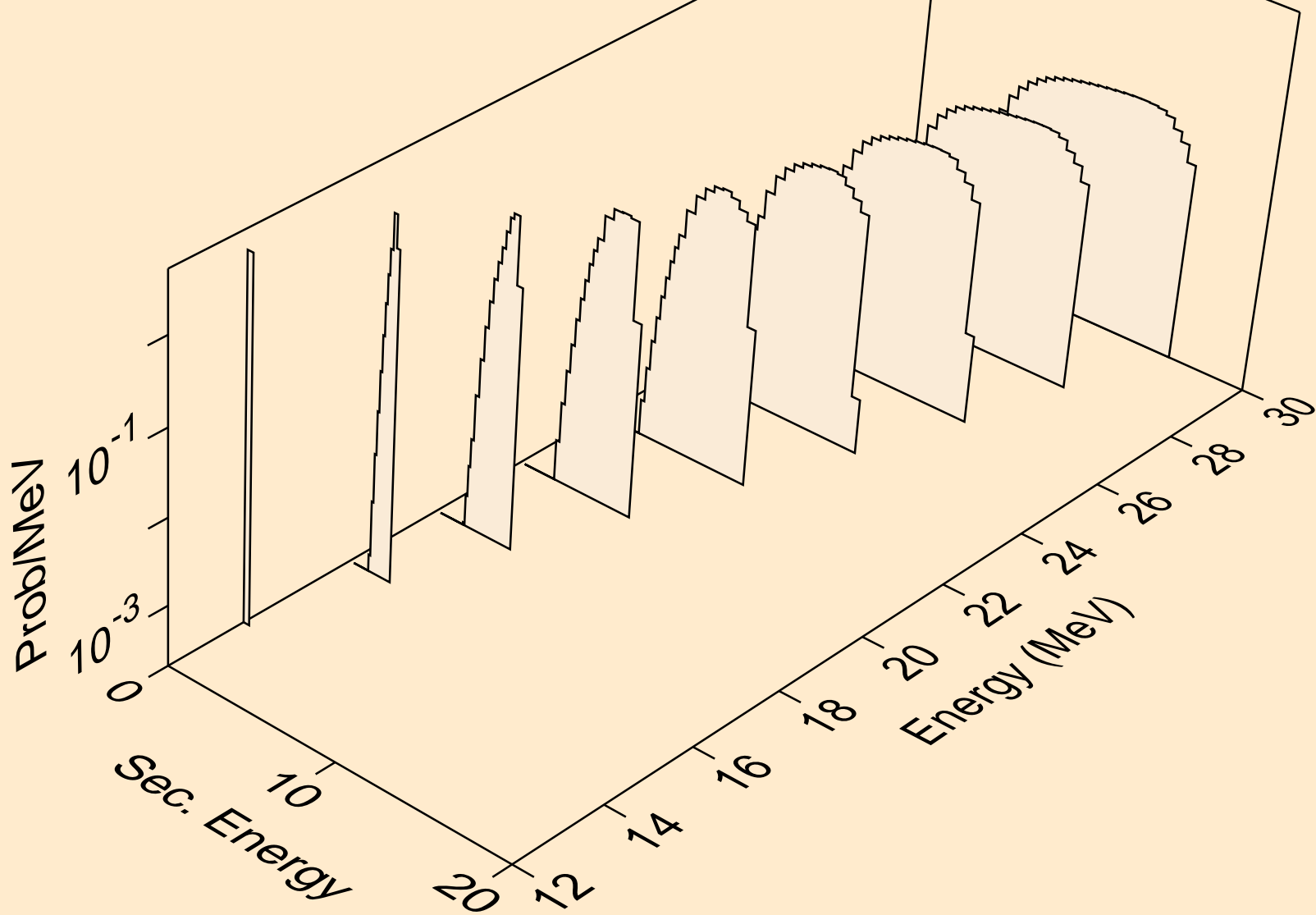

SE073M NEUTRON ACER TENDL-2023 LIBRARY; T=0.K
deuterons from (n,d)

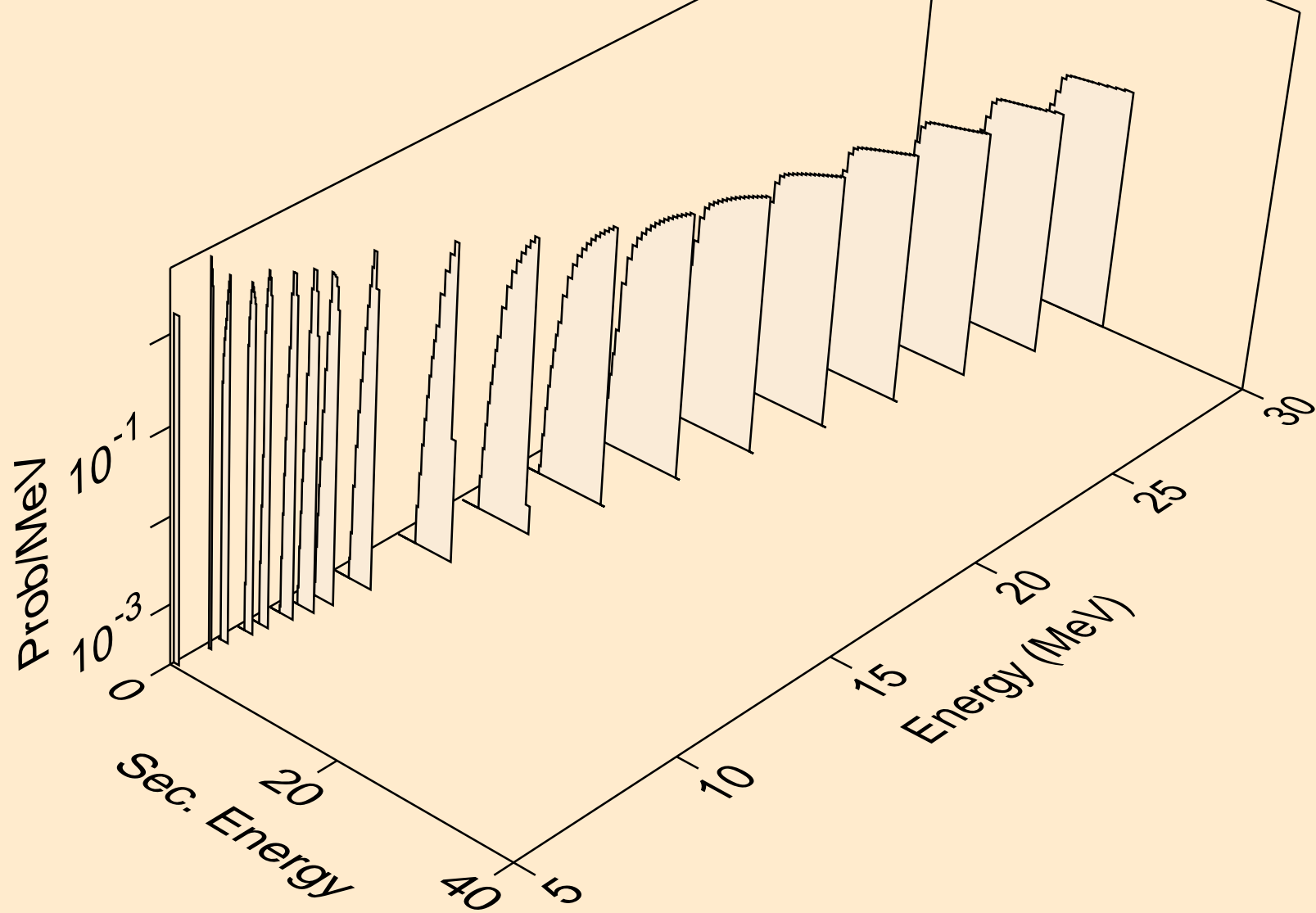

SE073M NEUTRON ACER TENDL-2023 LIBRARY; T=0.K
deuterons from (n,pd)

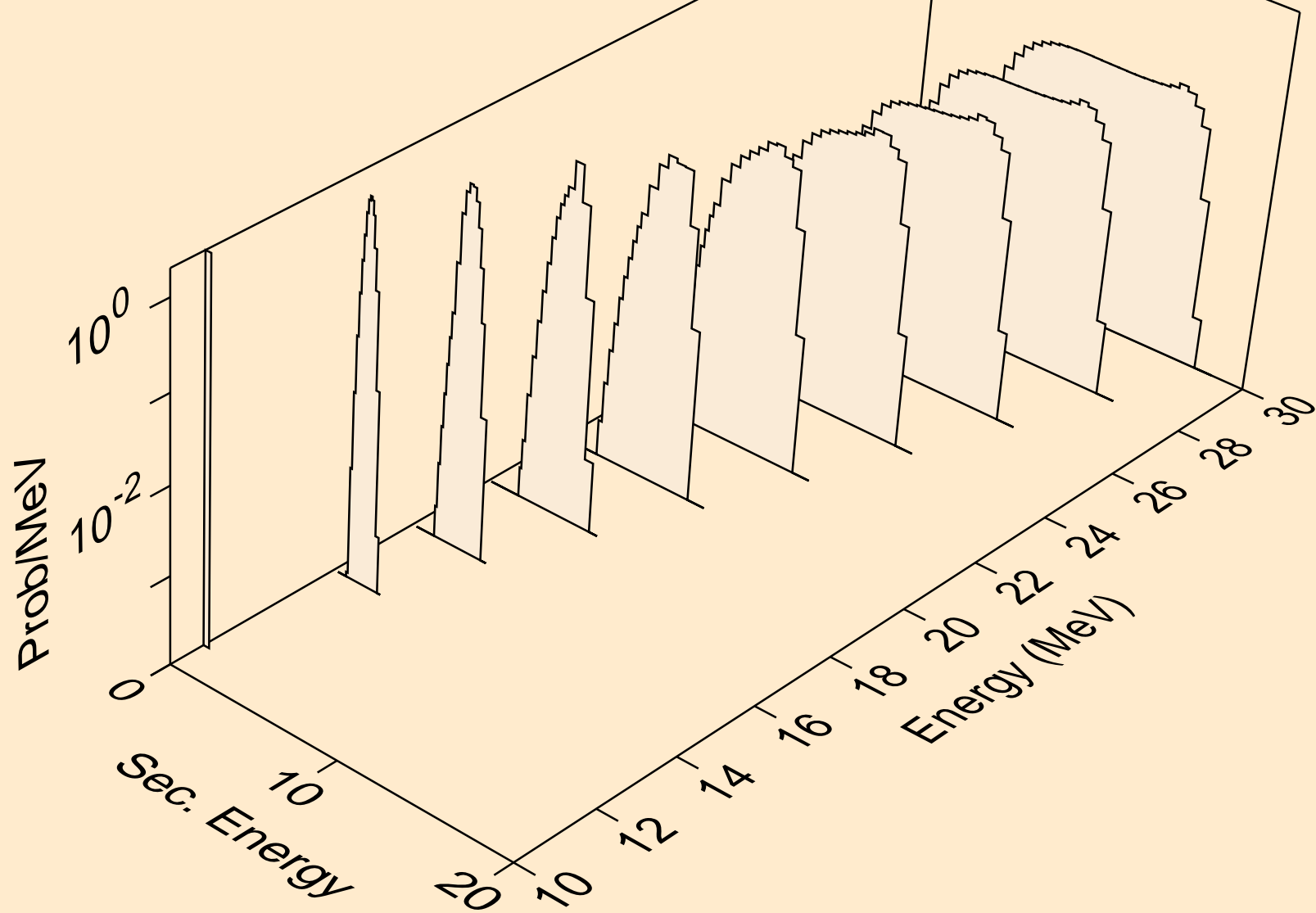

SE073M NEUTRON ACER TENDL-2023 LIBRARY; T=0.K
deuterons from (n,da)

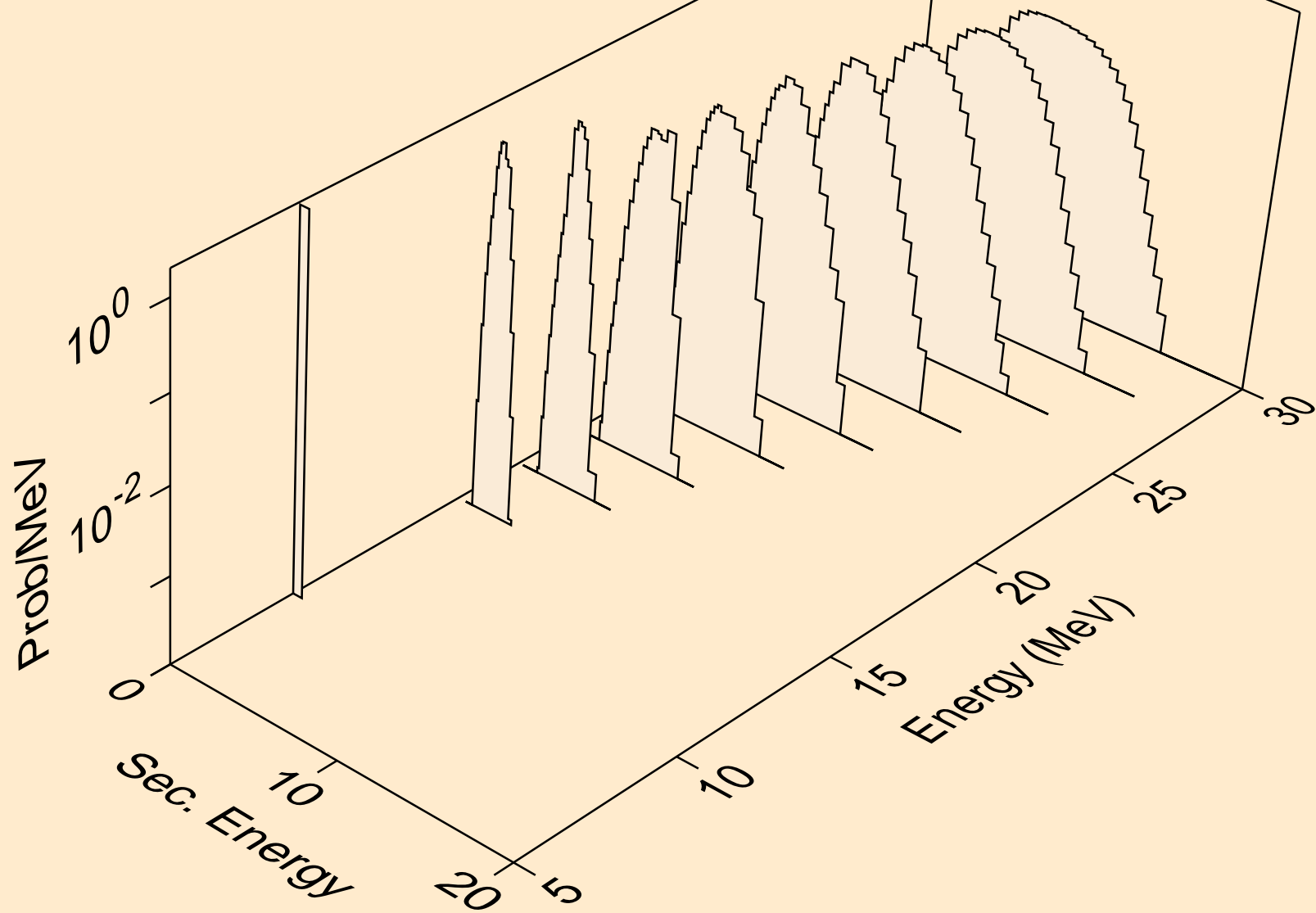

SE073M NEUTRON ACER TENDL-2023 LIBRARY; T=0.K
tritons from (n,x)

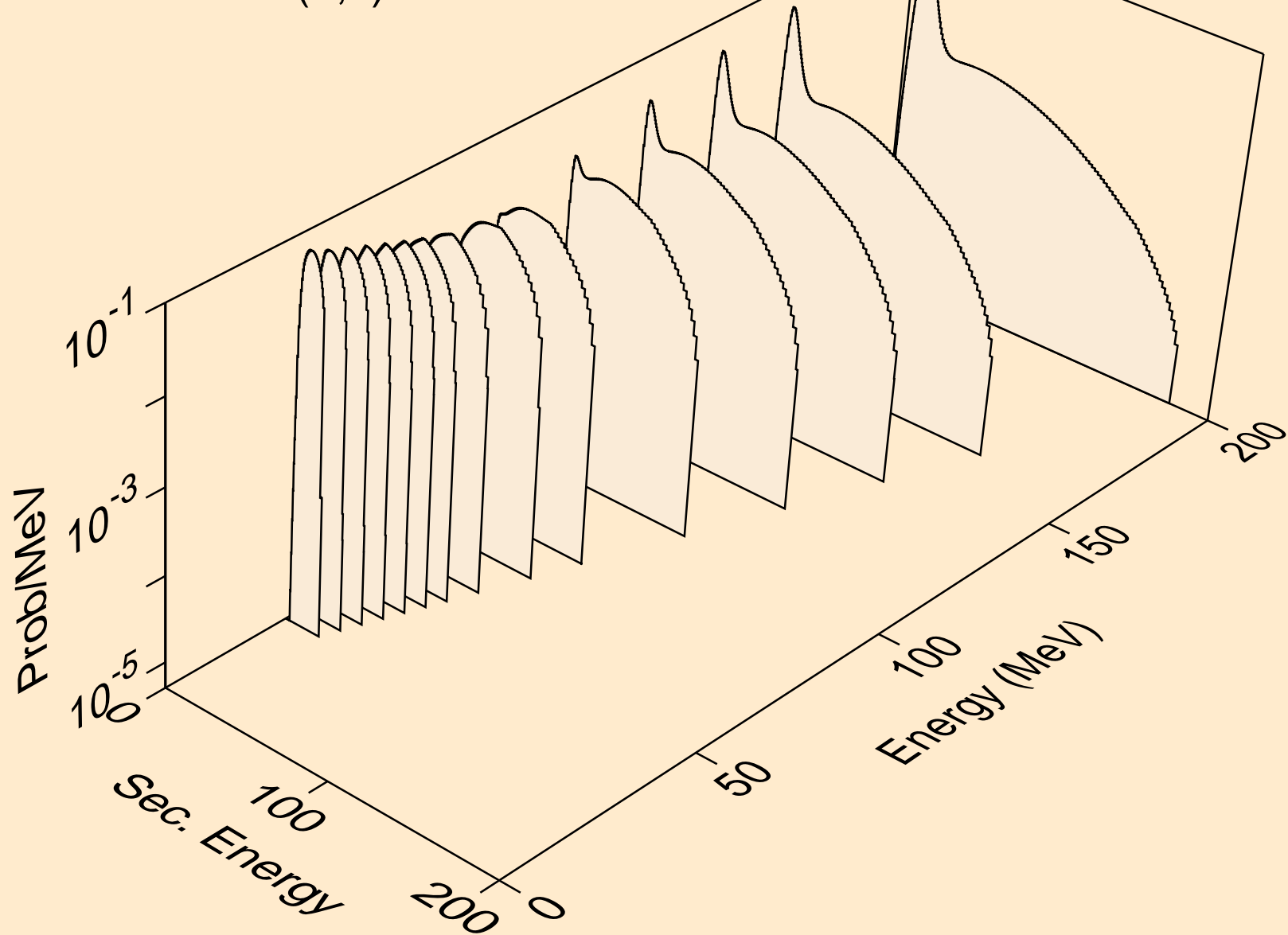

SE073M NEUTRON ACER TENDL-2023 LIBRARY; T=0.K
tritons from (n,n*)t

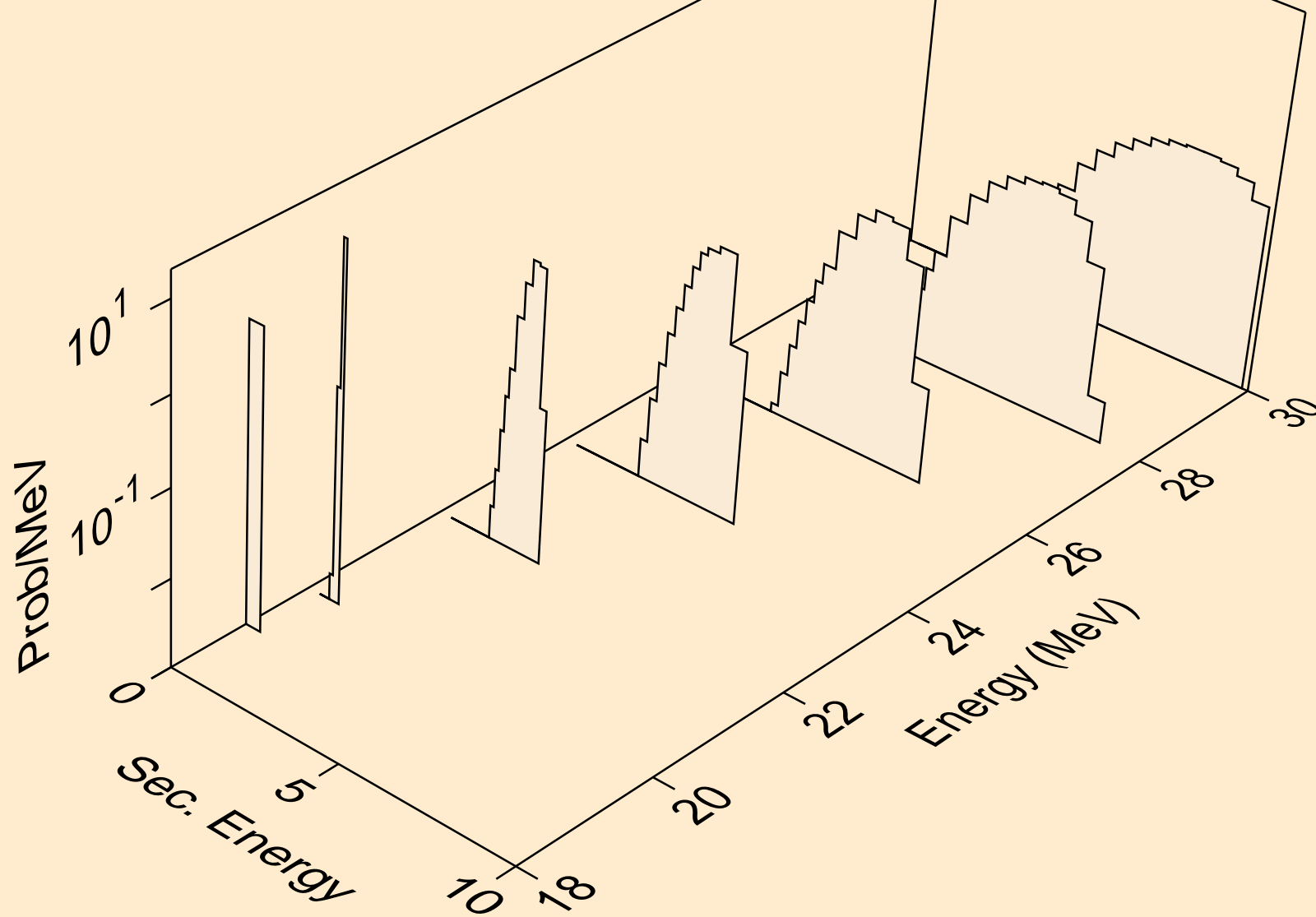

SE073M NEUTRON ACER TENDL-2023 LIBRARY; T=0.K
tritons from (n,t)

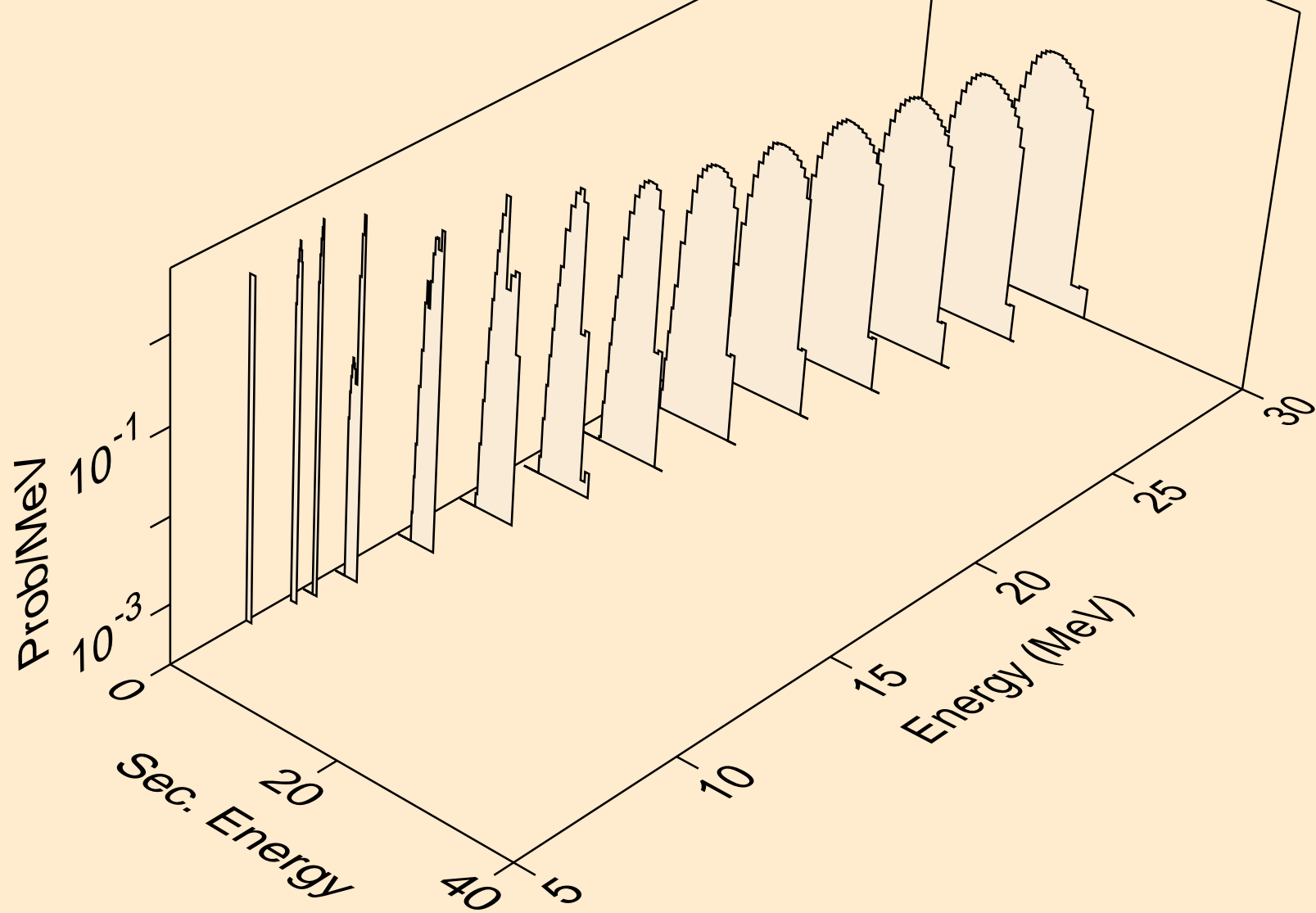

SE073M NEUTRON ACER TENDL-2023 LIBRARY; T=0.K
tritons from (n,pt)

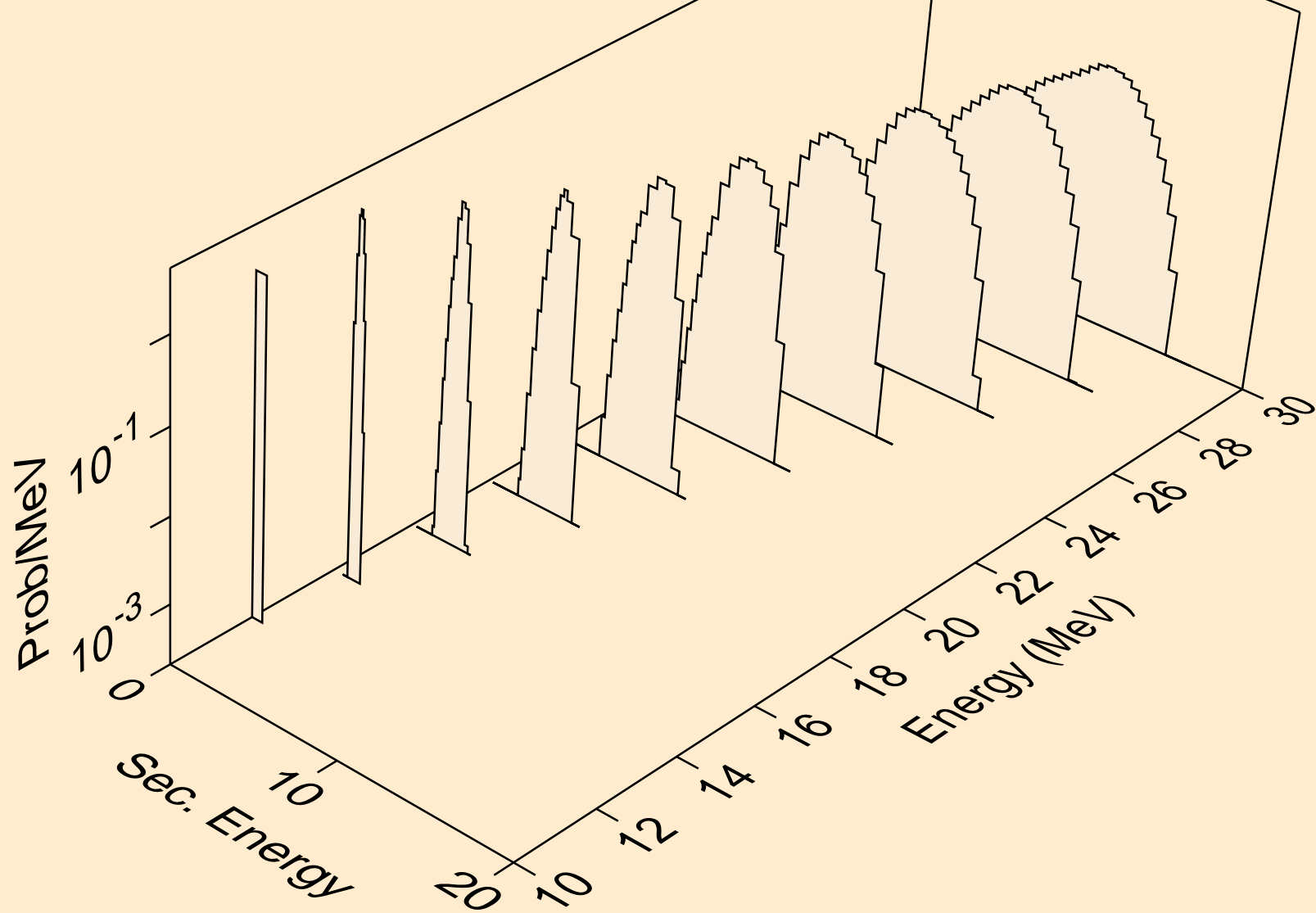

SE073M NEUTRON ACER TENDL-2023 LIBRARY; T=0.K
he3s from (n,x)

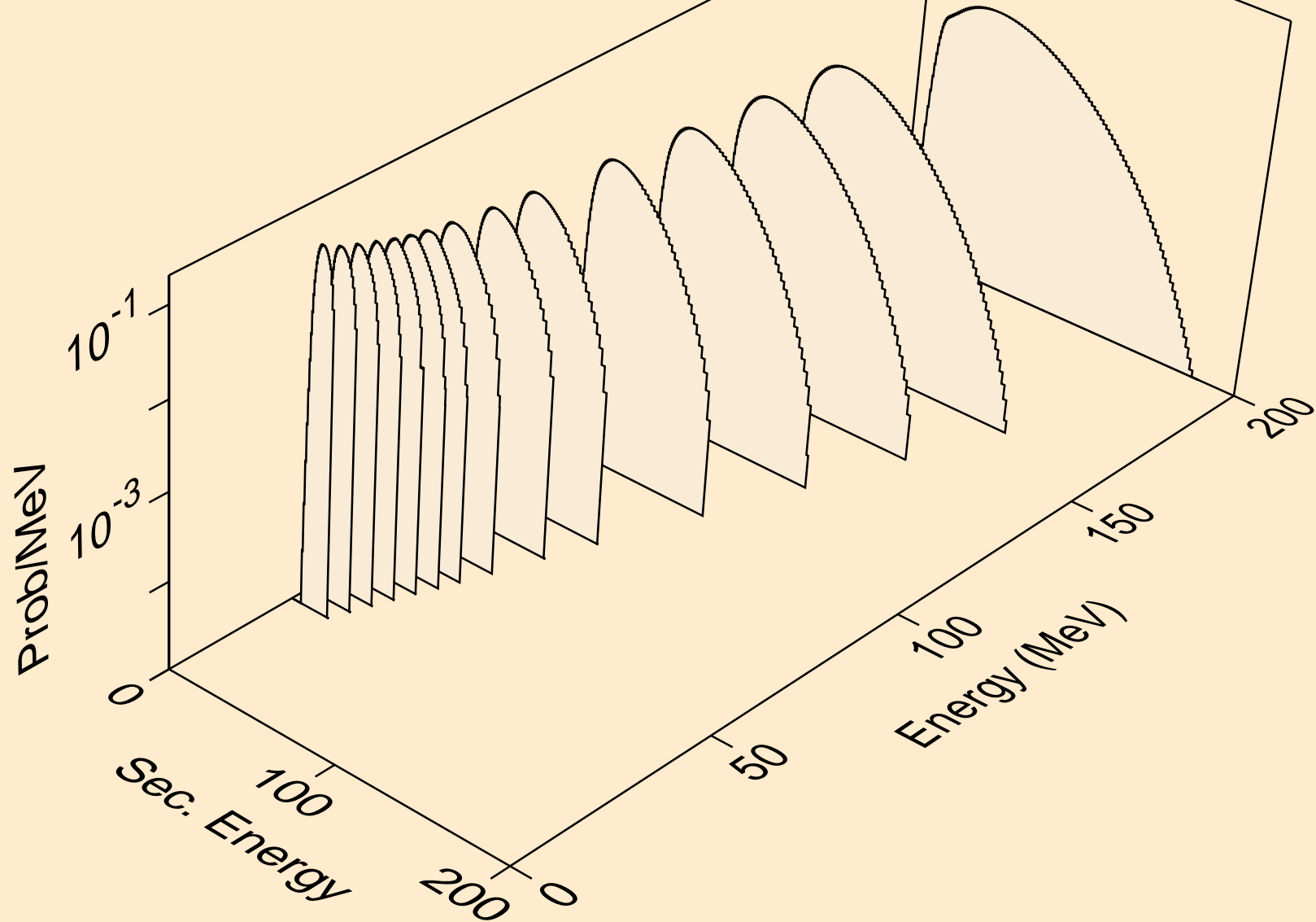

SE073M NEUTRON ACER TENDL-2023 LIBRARY; T=0.K
he3s from (n,n*)he3

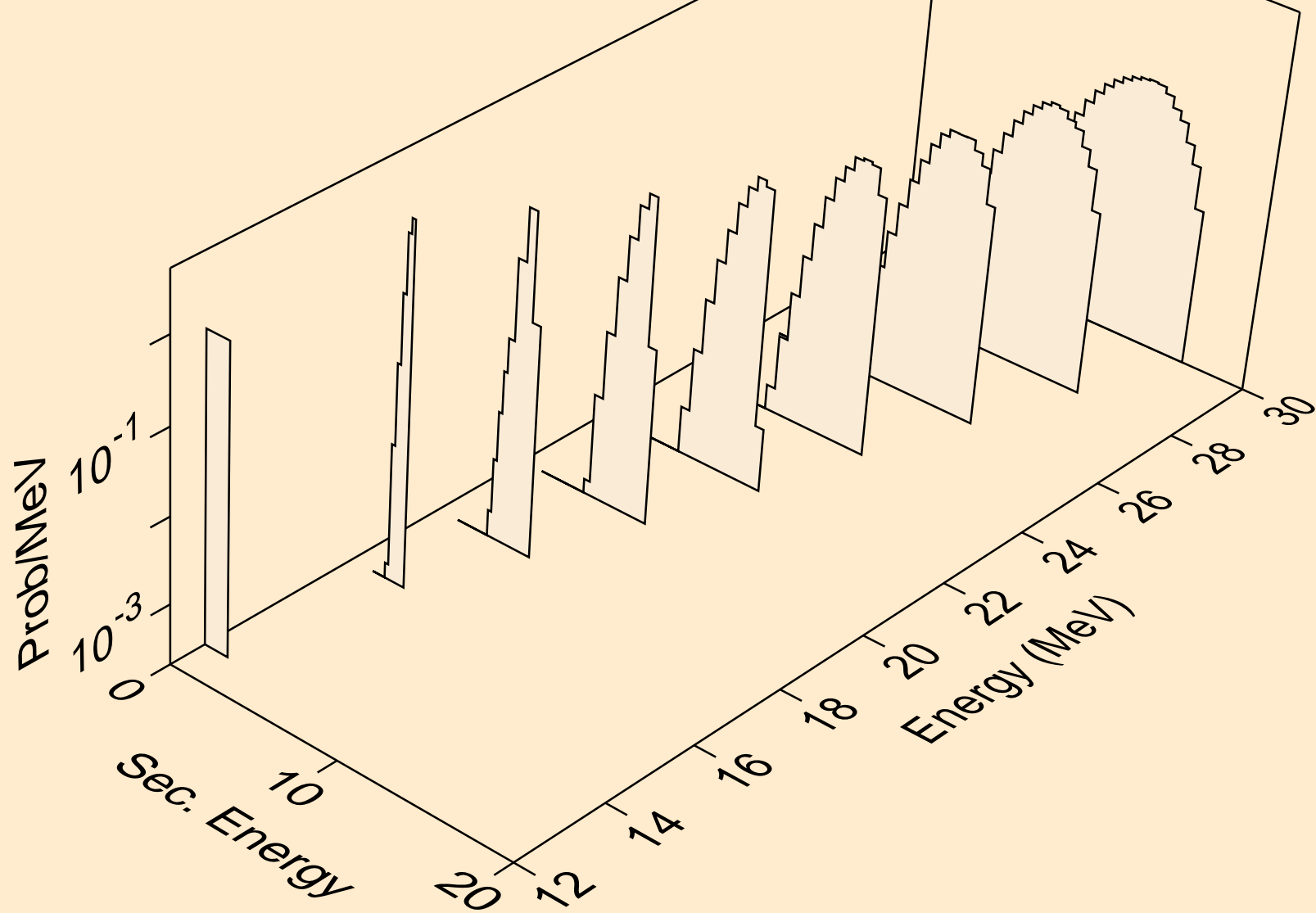

SE073M NEUTRON ACER TENDL-2023 LIBRARY; T=0.K
he3s from (n,he3)

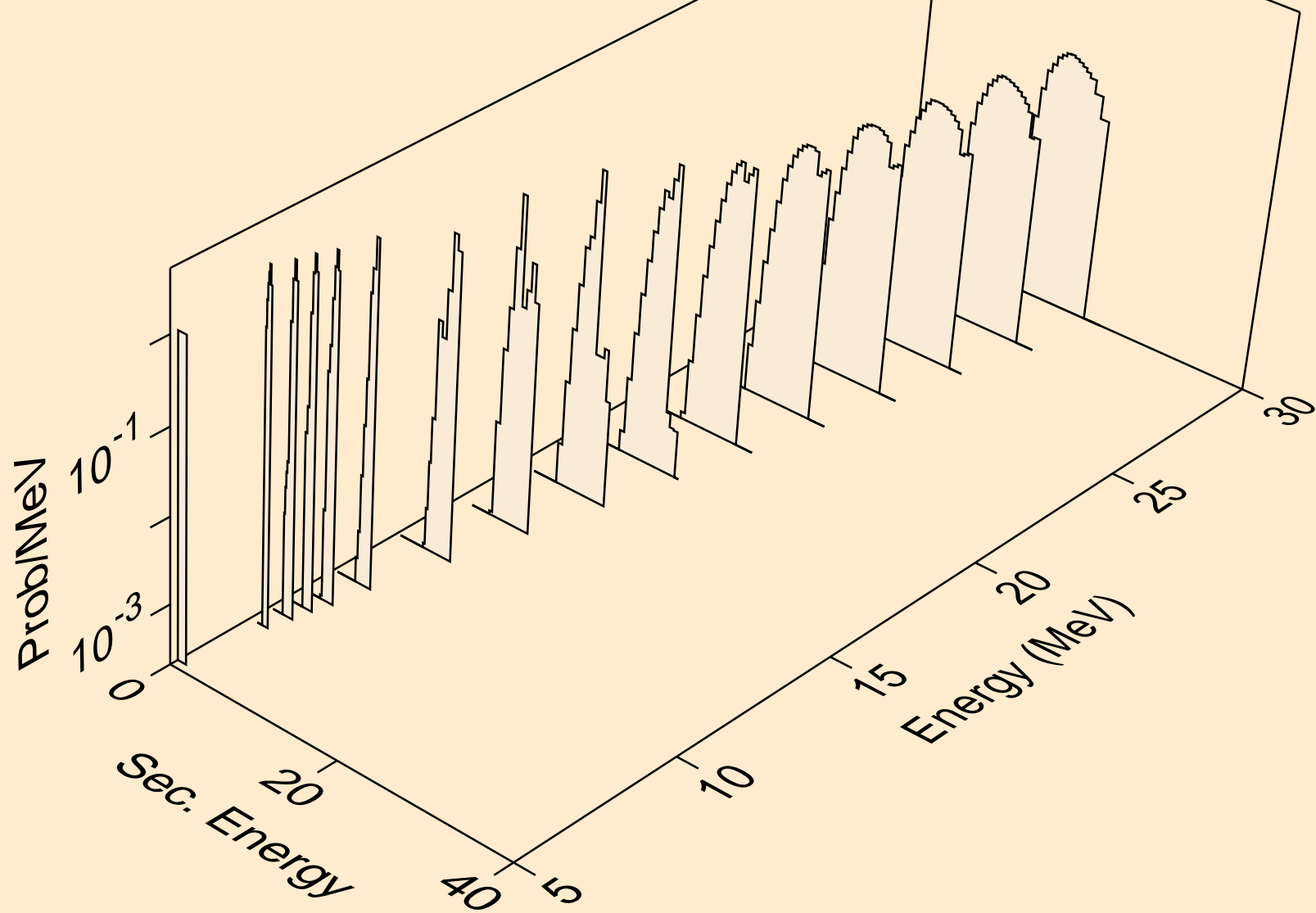

SE073M NEUTRON ACER TENDL-2023 LIBRARY; T=0.K
alphas from (n,x)

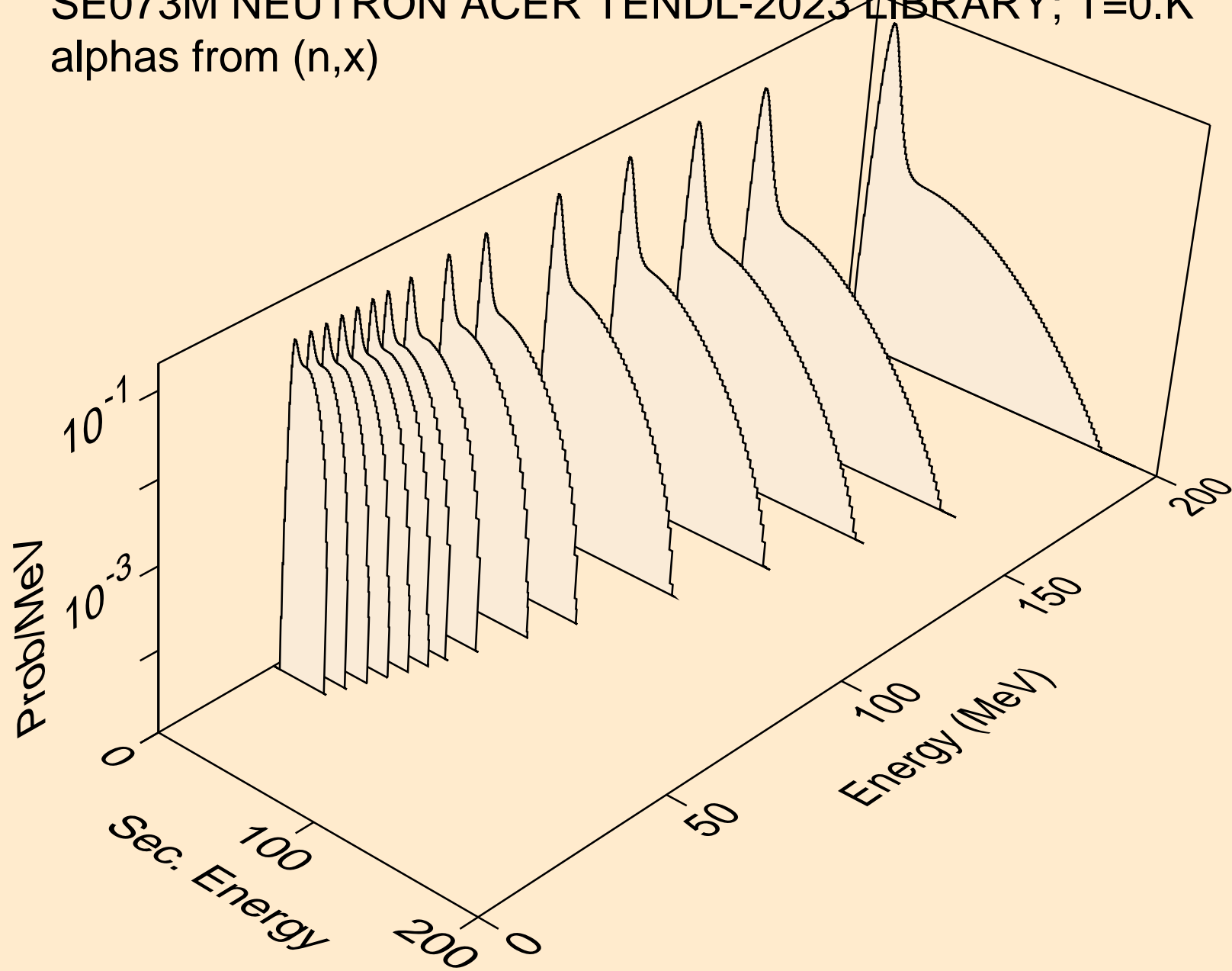

SE073M NEUTRON ACER TENDL-2023 LIBRARY; T=0.K
alphas from (n,n*)a

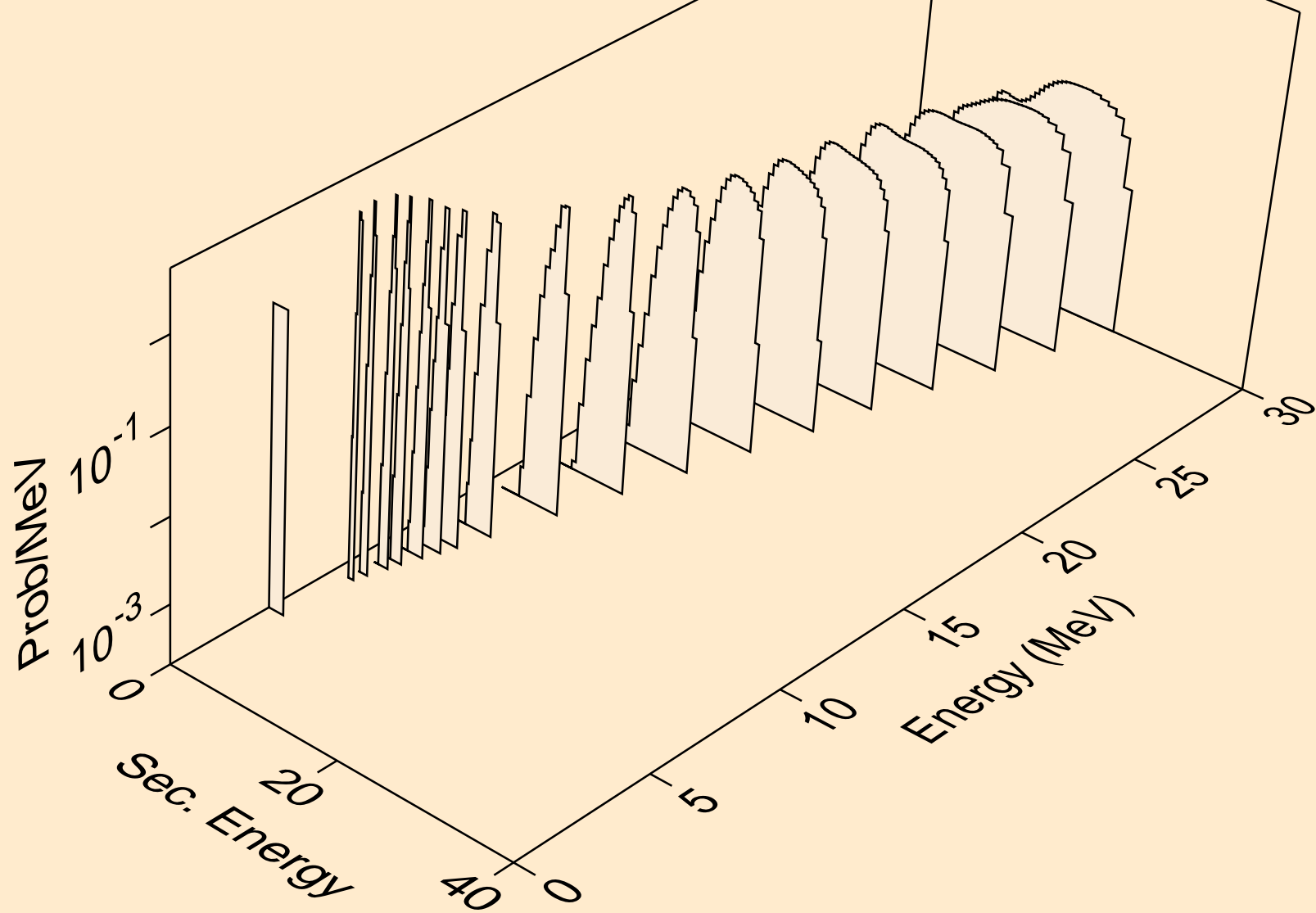

SE073M NEUTRON ACER TENDL-2023 LIBRARY; T=0.K
alphas from (n,2n)a

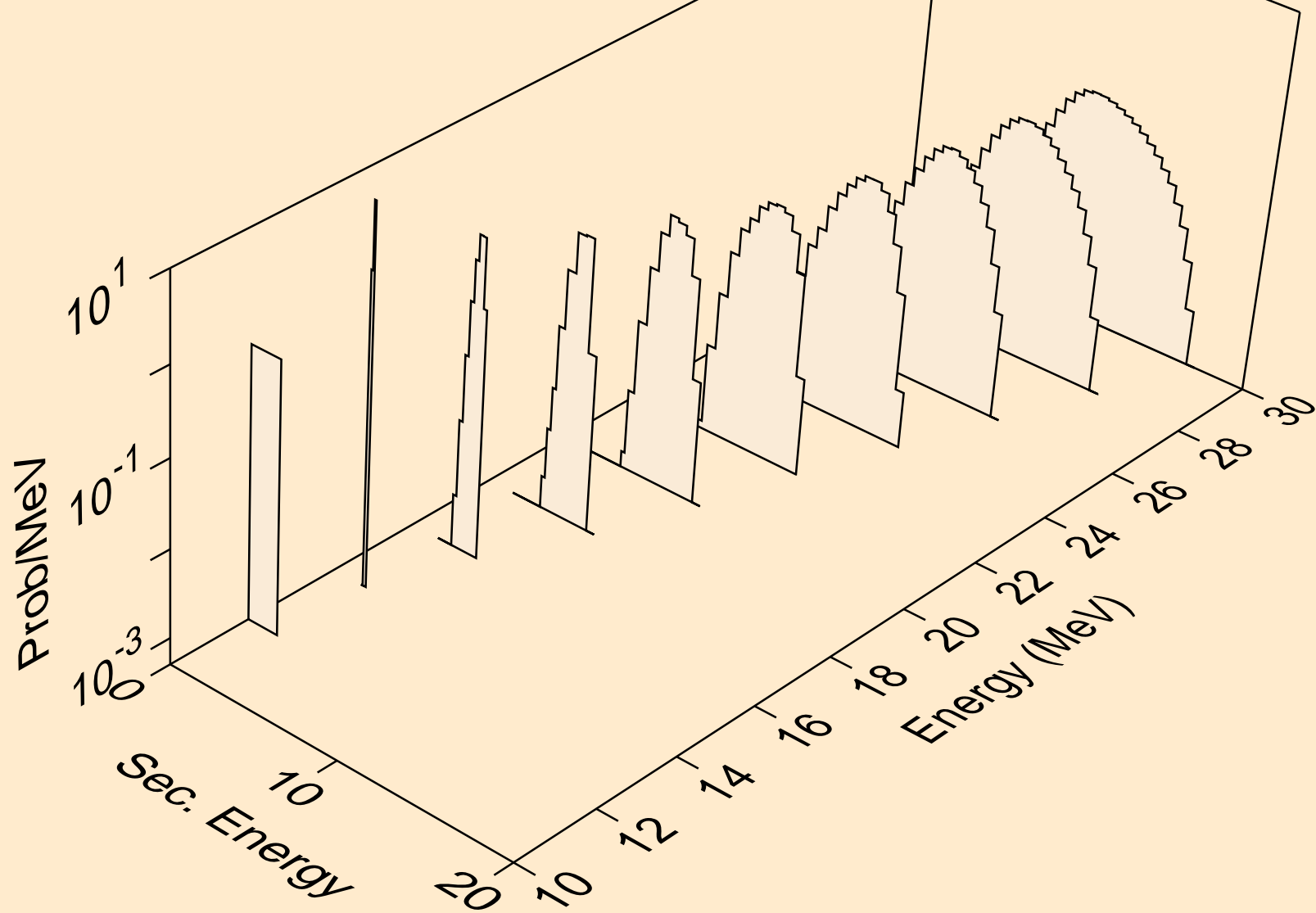

SE073M NEUTRON ACER TENDL-2023 LIBRARY; T=0.K
alphas from (n,3n)a

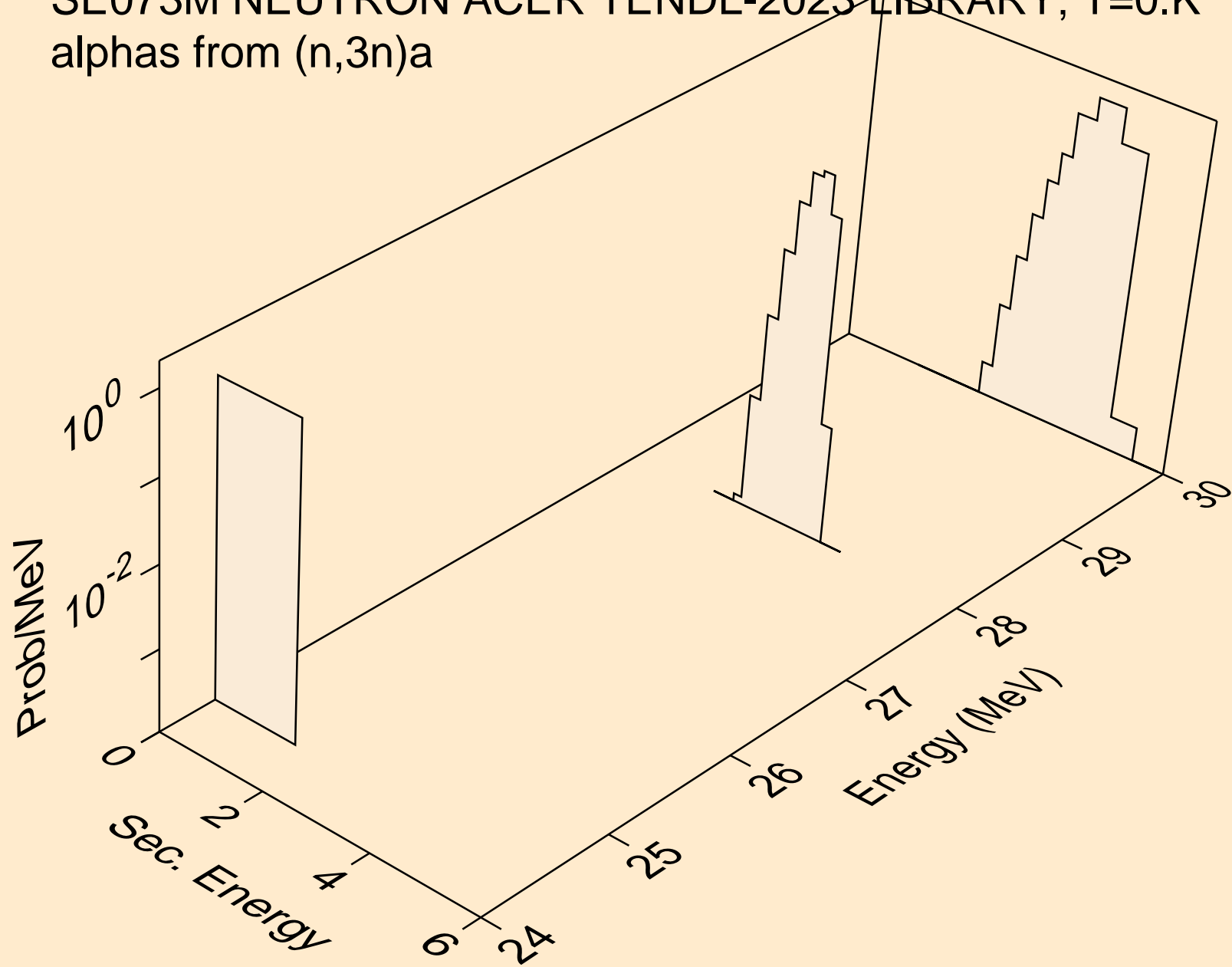

SE073M NEUTRON ACER TENDL-2023 LIBRARY; T=0.K
alphas from (n,n*)2a

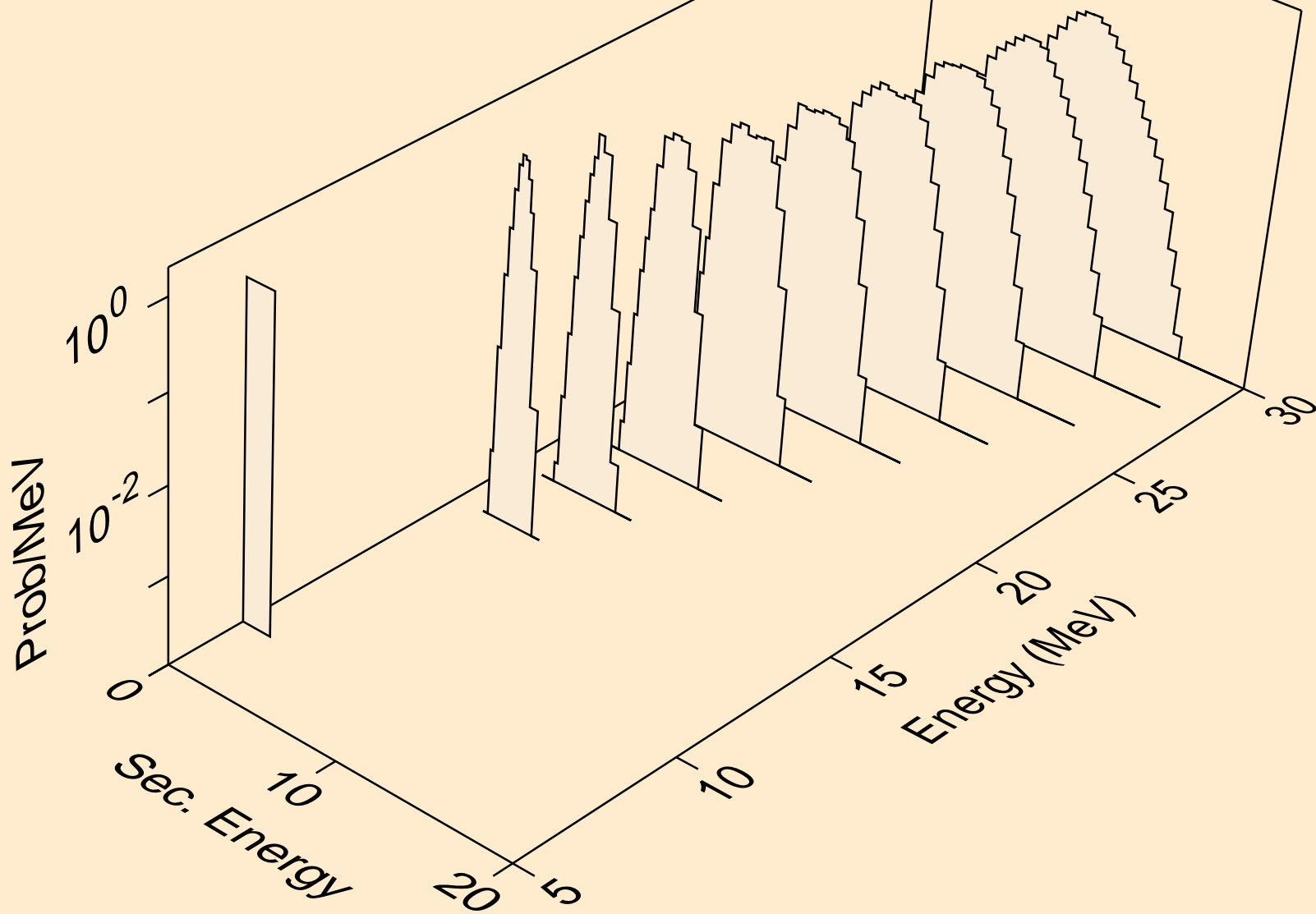

SE073M NEUTRON ACER TENDL-2023 LIBRARY; T=0.K
alphas from (n,2n)2a

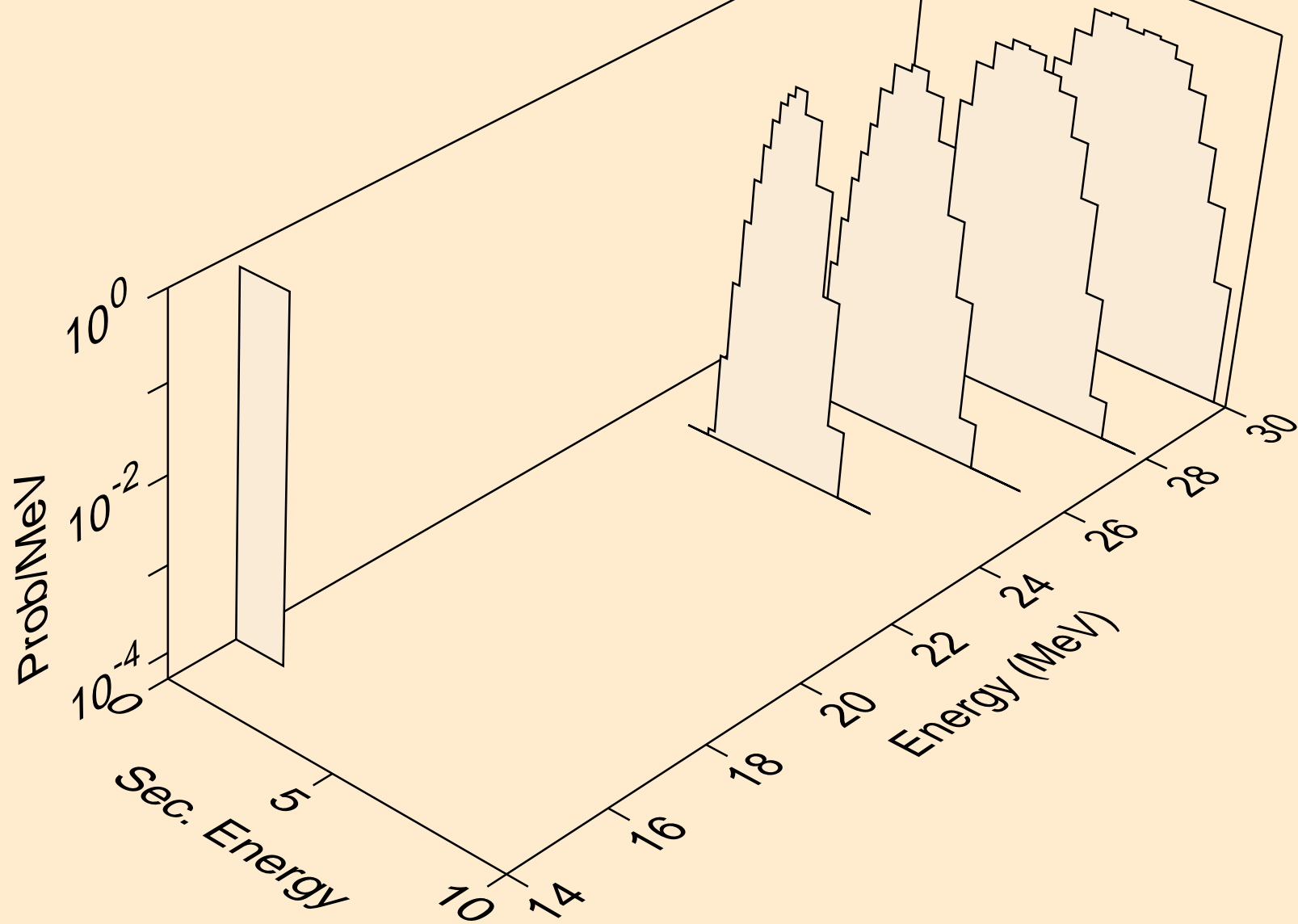

SE073M NEUTRON ACER TENDL-2023 LIBRARY; T=0.K
alphas from (n,npa)

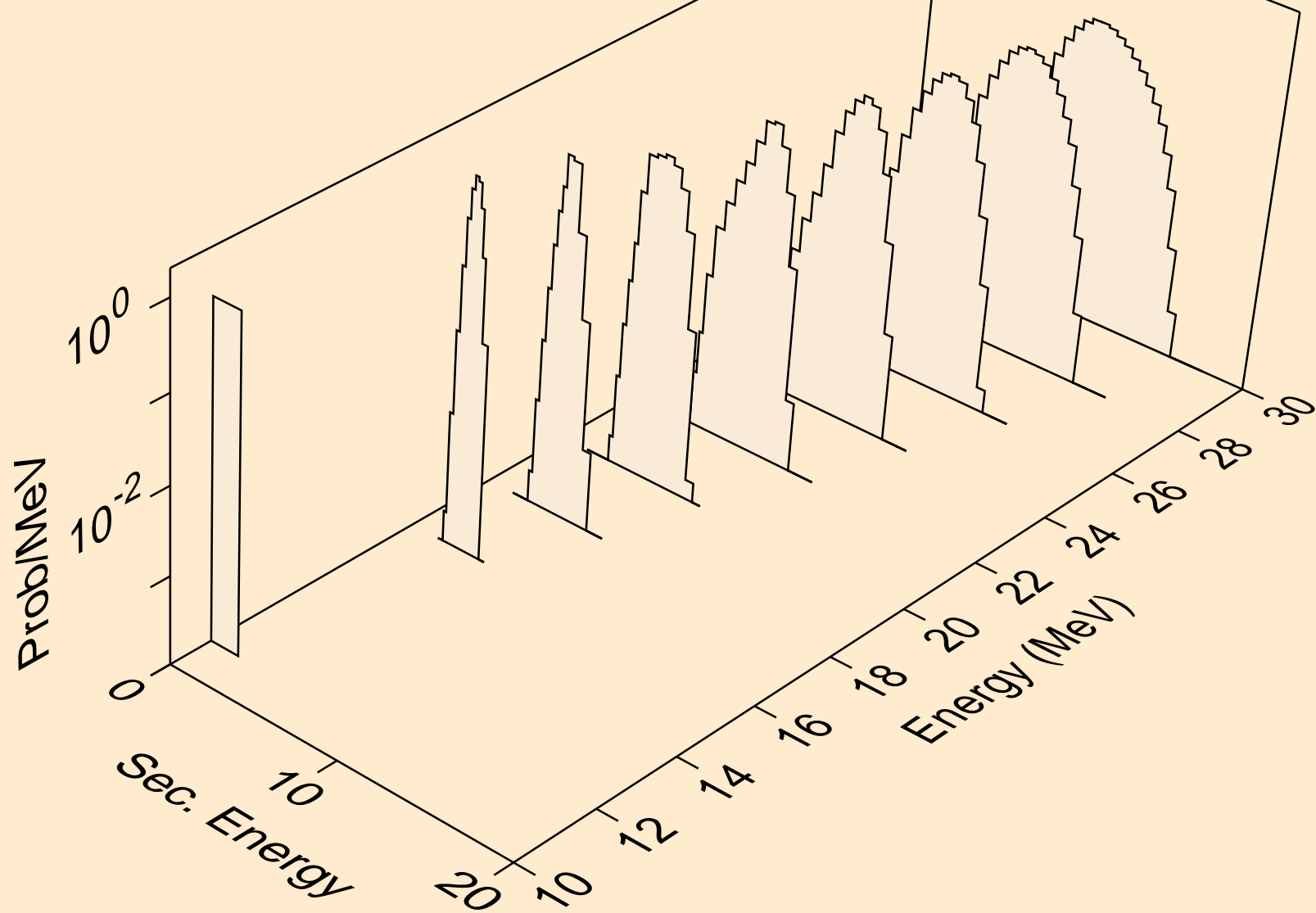

SE073M NEUTRON ACER TENDL-2023 LIBRARY; T=0.K
alphas from (n,a)

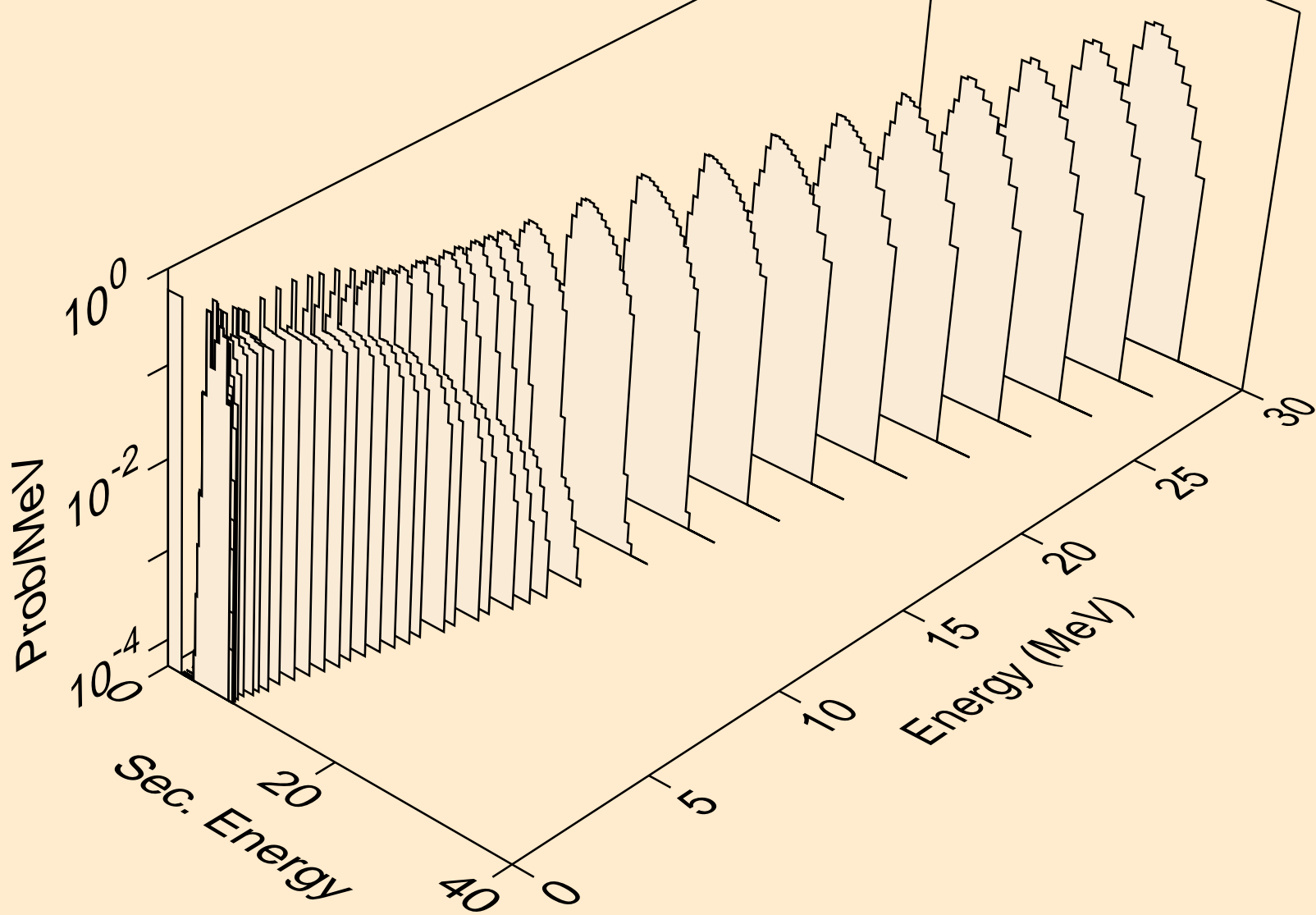

SE073M NEUTRON ACER TENDL-2023 LIBRARY; T=0.K
alphas from (n,2a)

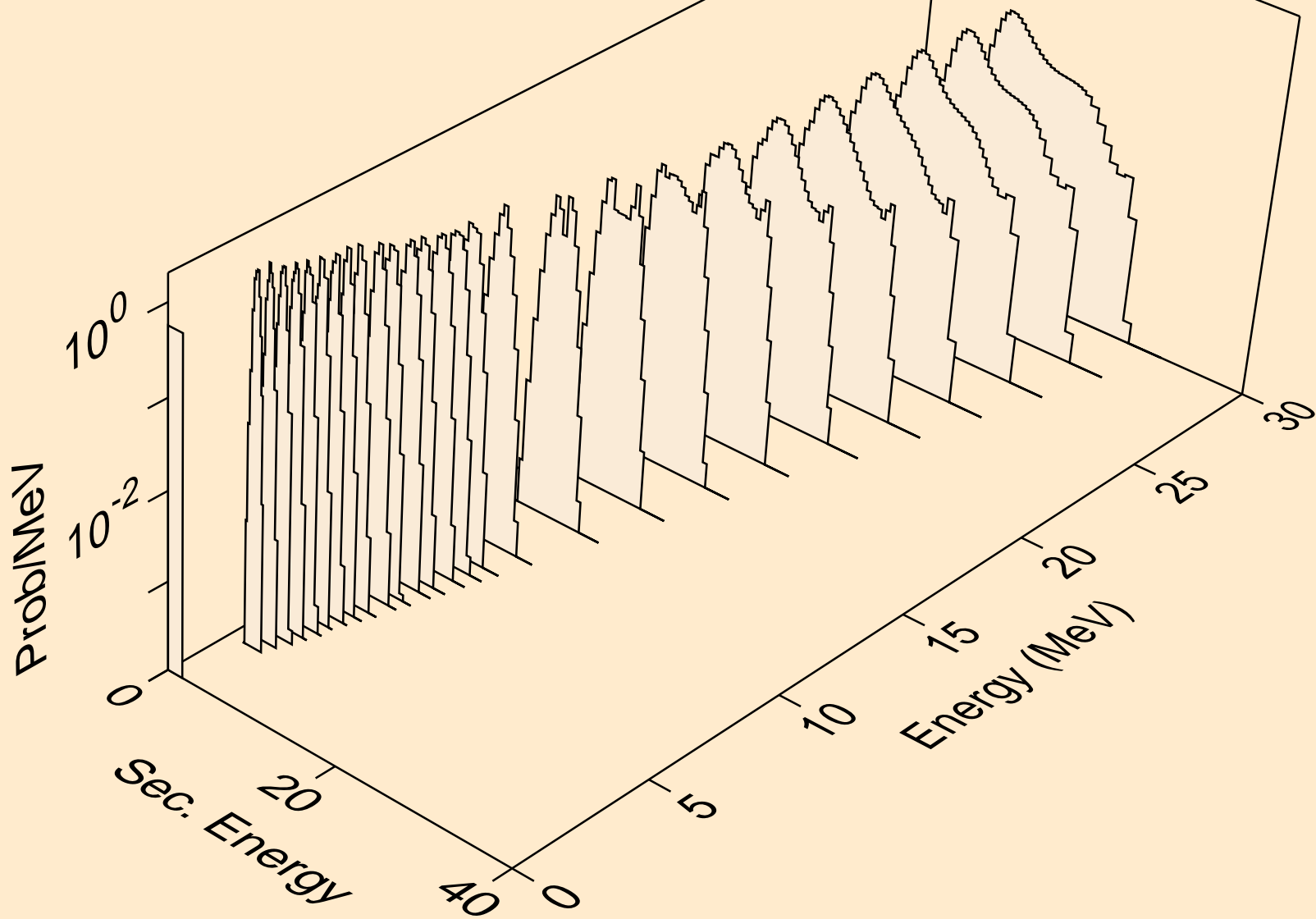

SE073M NEUTRON ACER TENDL-2023 LIBRARY; T=0.K
alphas from (n,3a)

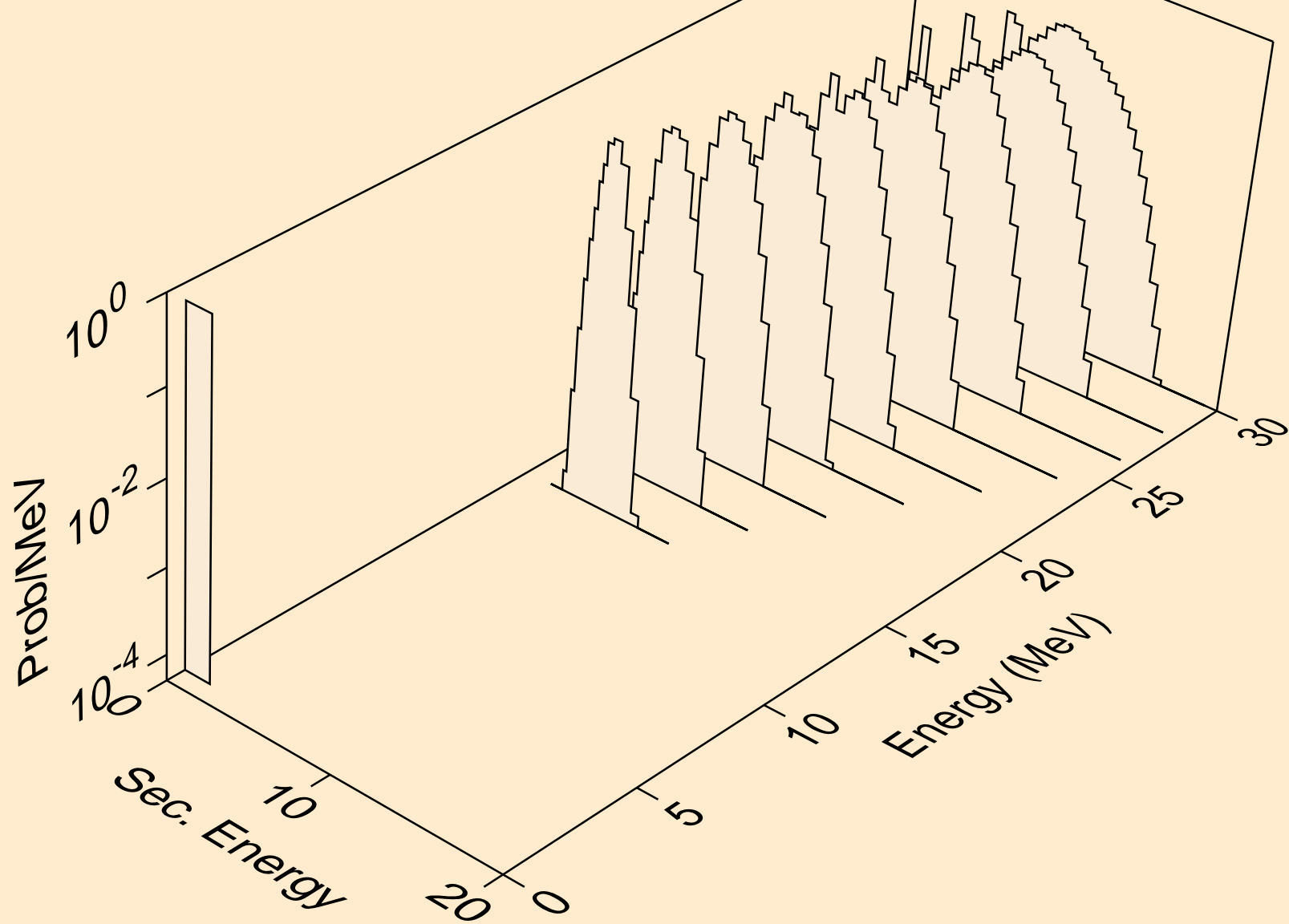

SE073M NEUTRON ACER TENDL-2023 LIBRARY; T=0.K
alphas from (n,pa)

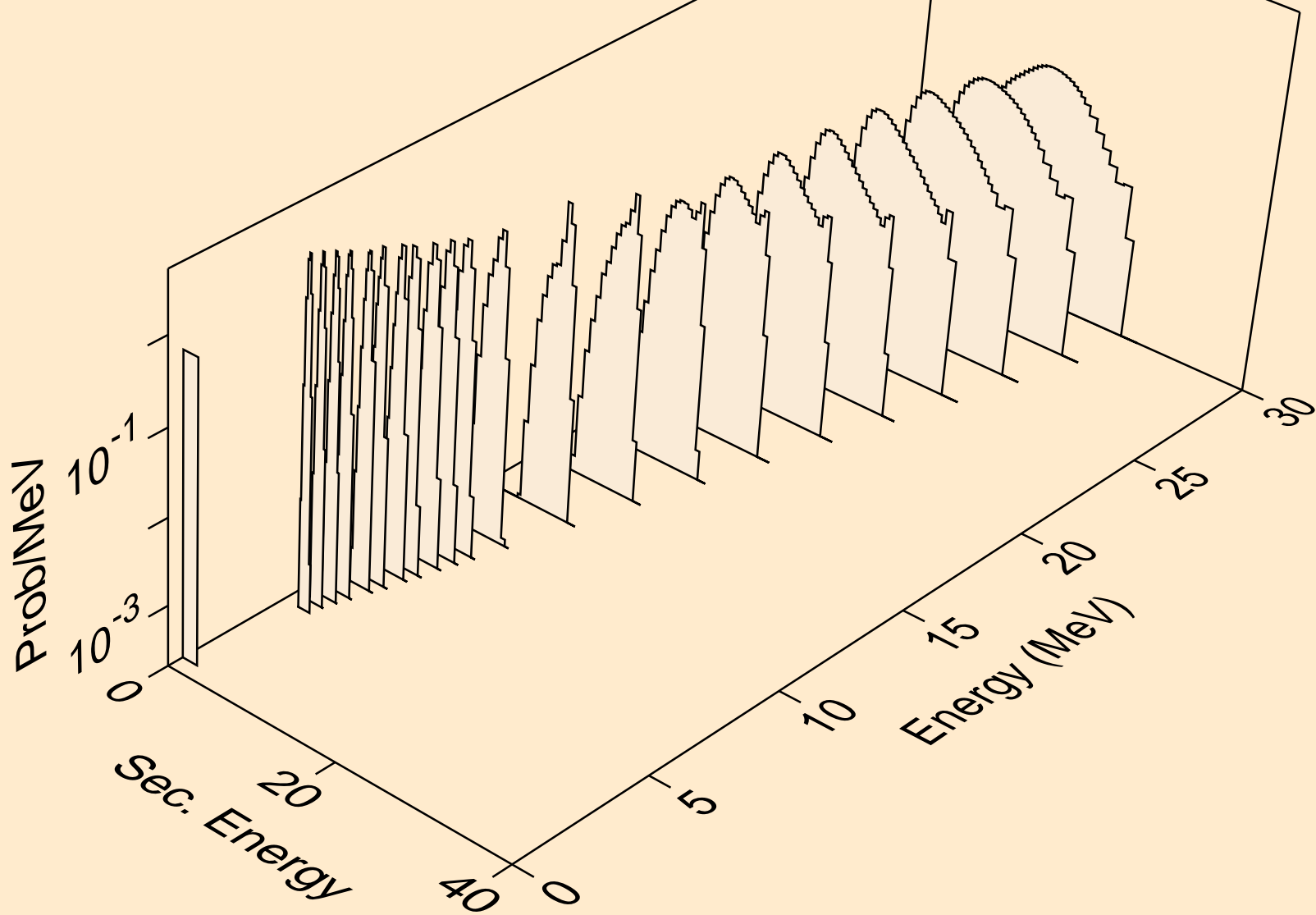

SE073M NEUTRON ACER TENDL-2023 LIBRARY; T=0.K
alphas from (n,da)

