

TL184 NEUTRON ACER TENDL-2023 LIBRARY; T=0.K
Principal cross sections

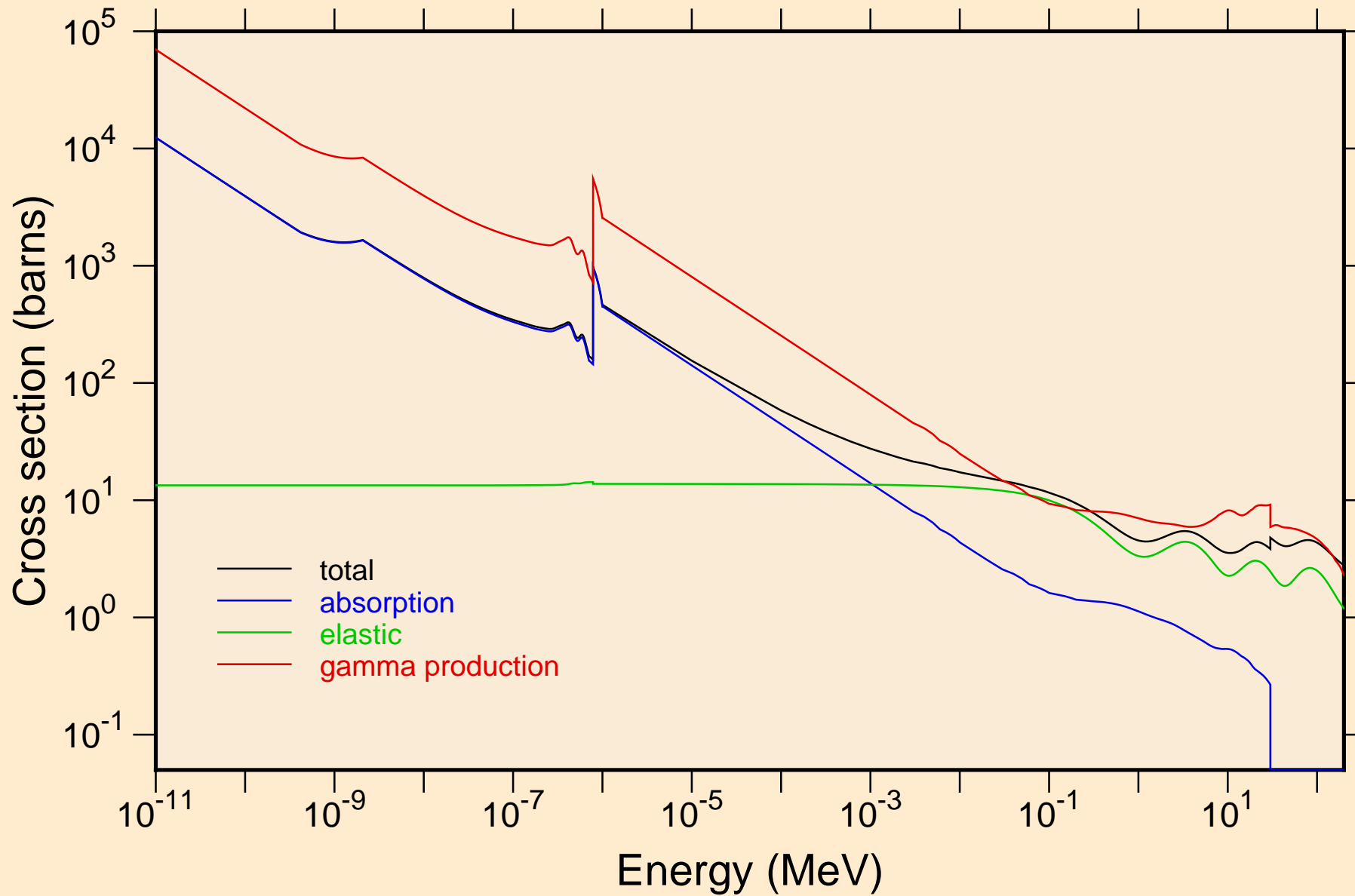

TL184 NEUTRON ACER TENDL-2023 LIBRARY; T=0.K

Heating

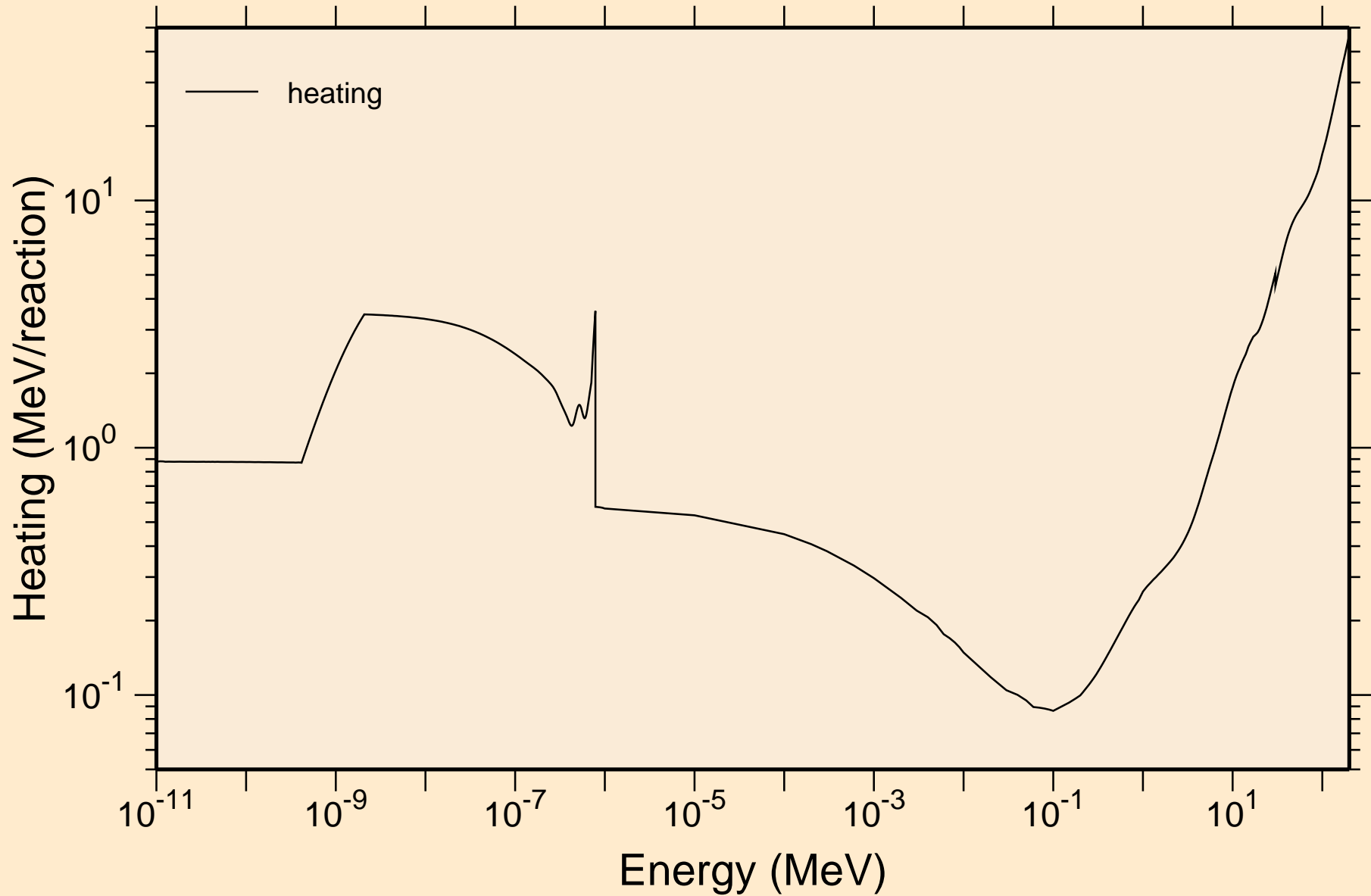

TL184 NEUTRON ACER TENDL-2023 LIBRARY; T=0.K
Damage

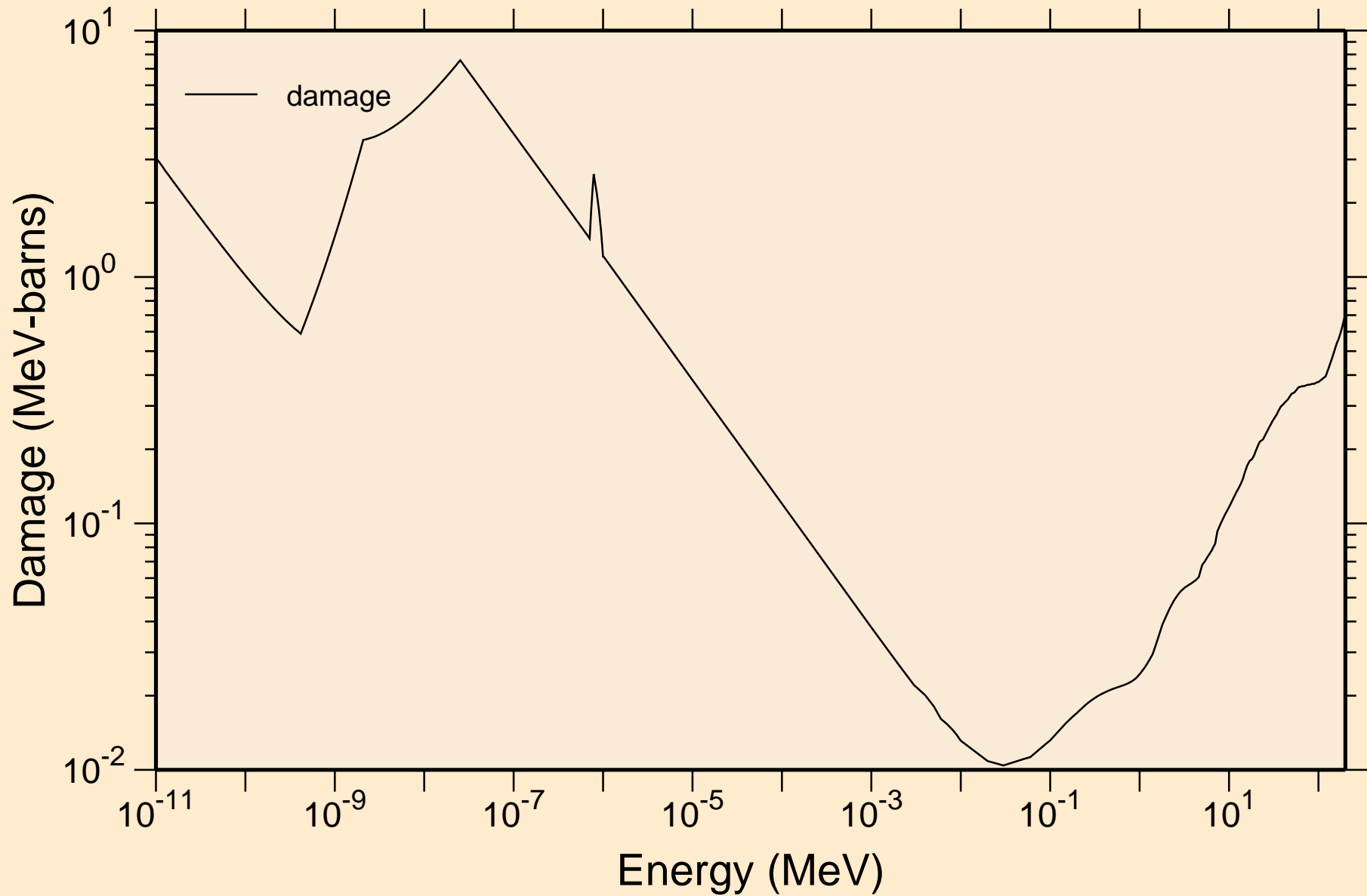

TL184 NEUTRON ACER TENDL-2023 LIBRARY; T=0.K
Non-threshold reactions

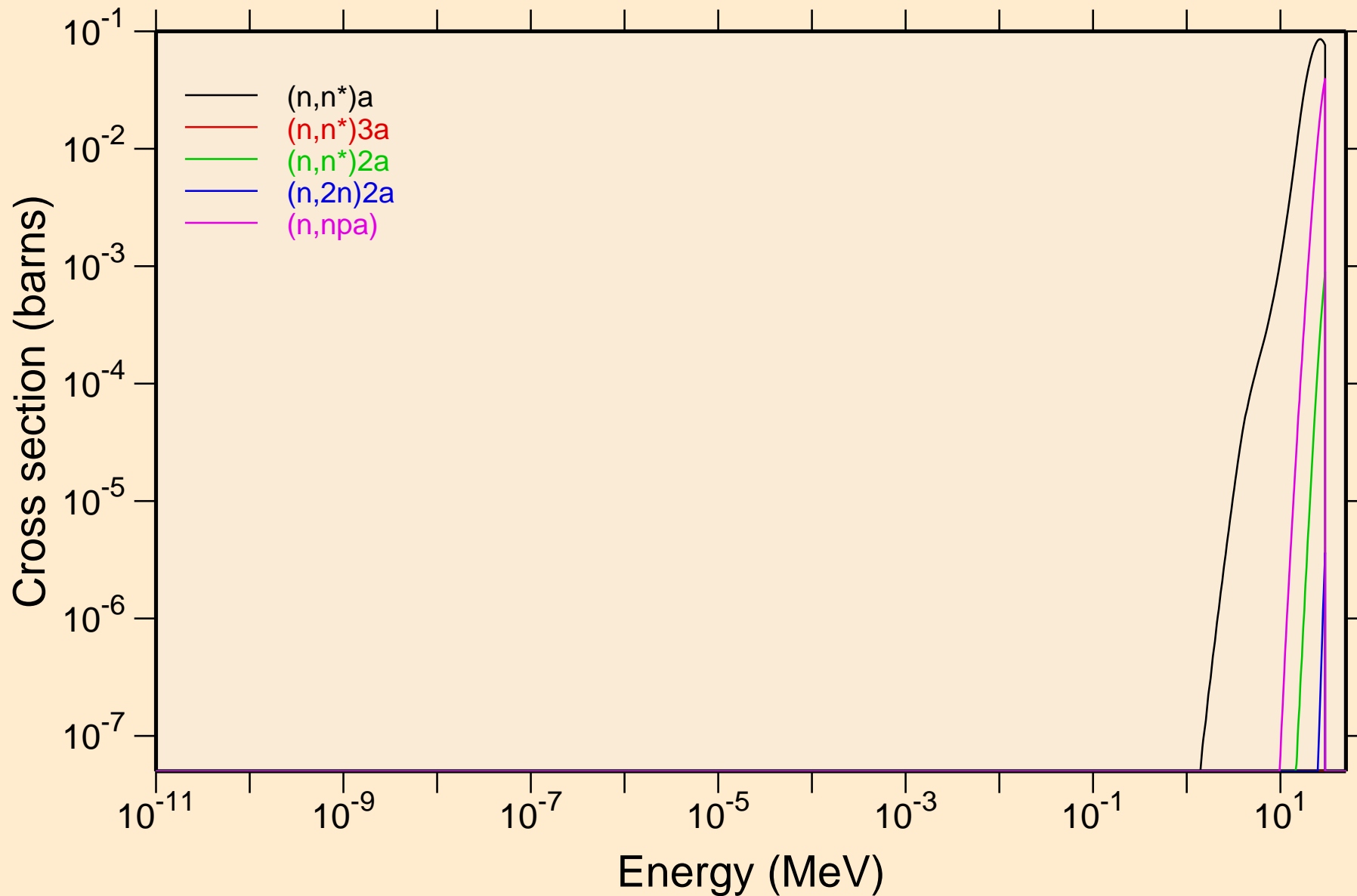

TL184 NEUTRON ACER TENDL-2023 LIBRARY; T=0.K
Non-threshold reactions

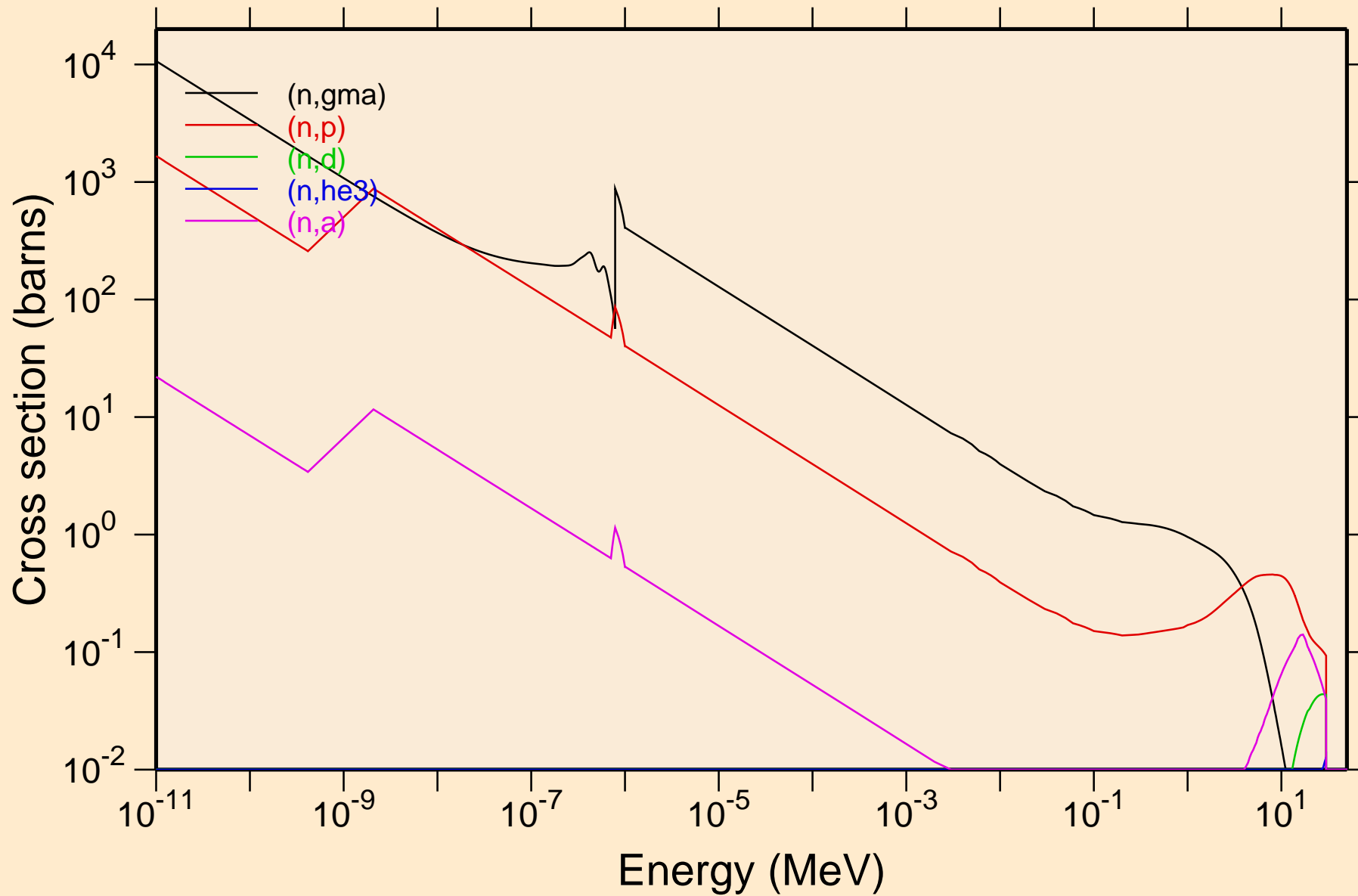

TL184 NEUTRON ACER TENDL-2023 LIBRARY; T=0.K
Non-threshold reactions

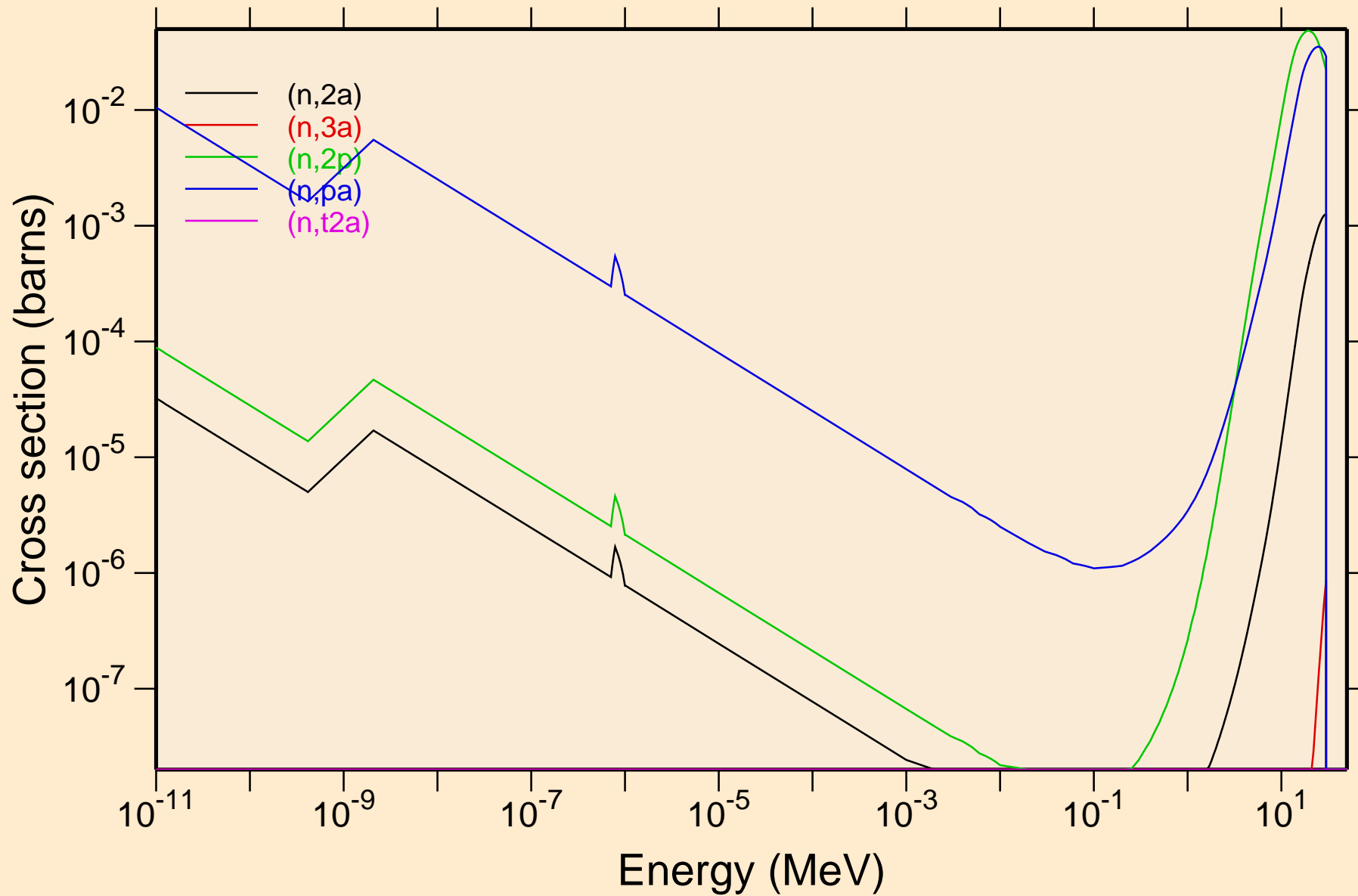

TL184 NEUTRON ACER TENDL-2023 LIBRARY; T=0.K
Non-threshold reactions

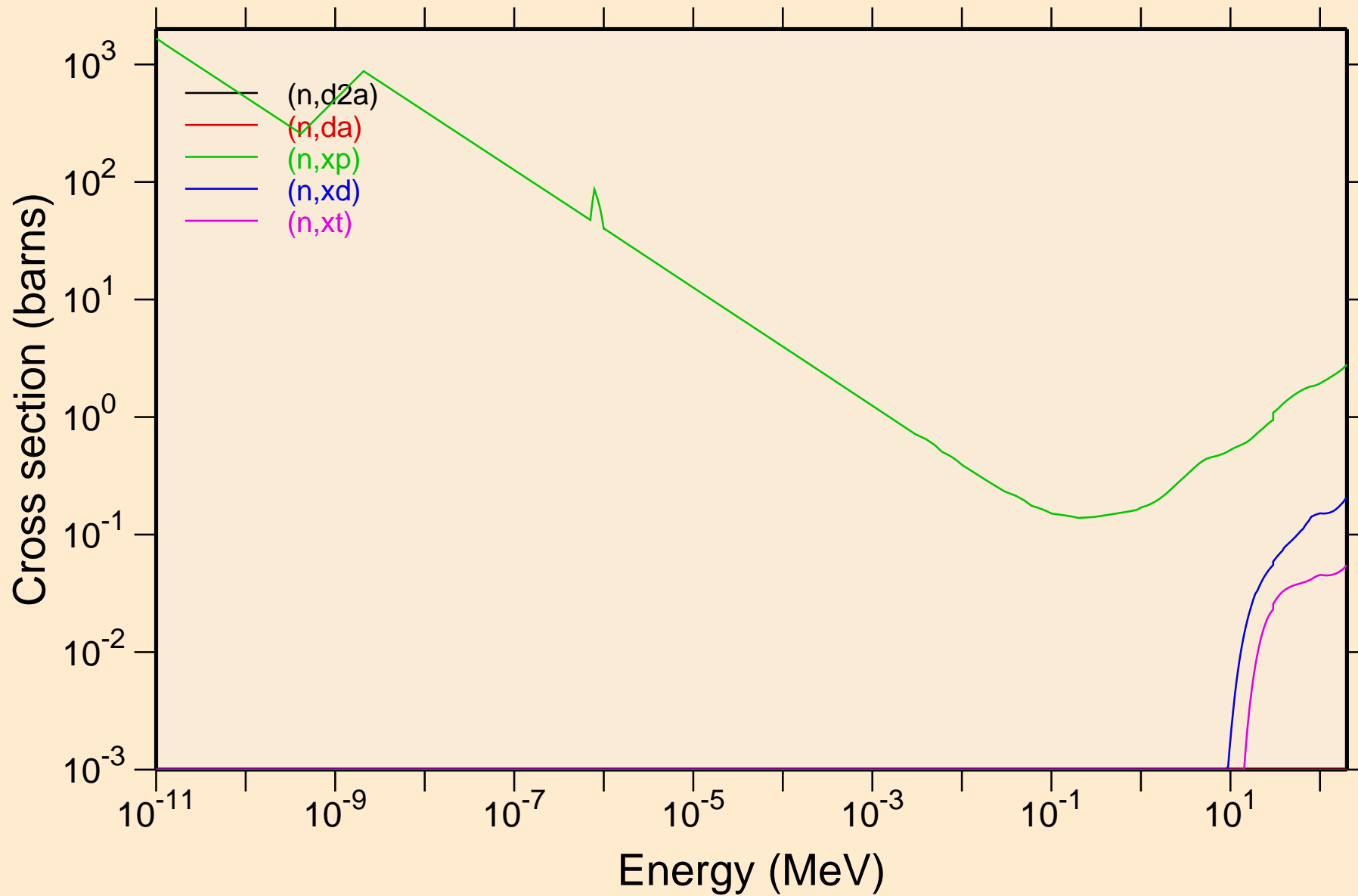

TL184 NEUTRON ACER TENDL-2023 LIBRARY; T=0.K
Non-threshold reactions

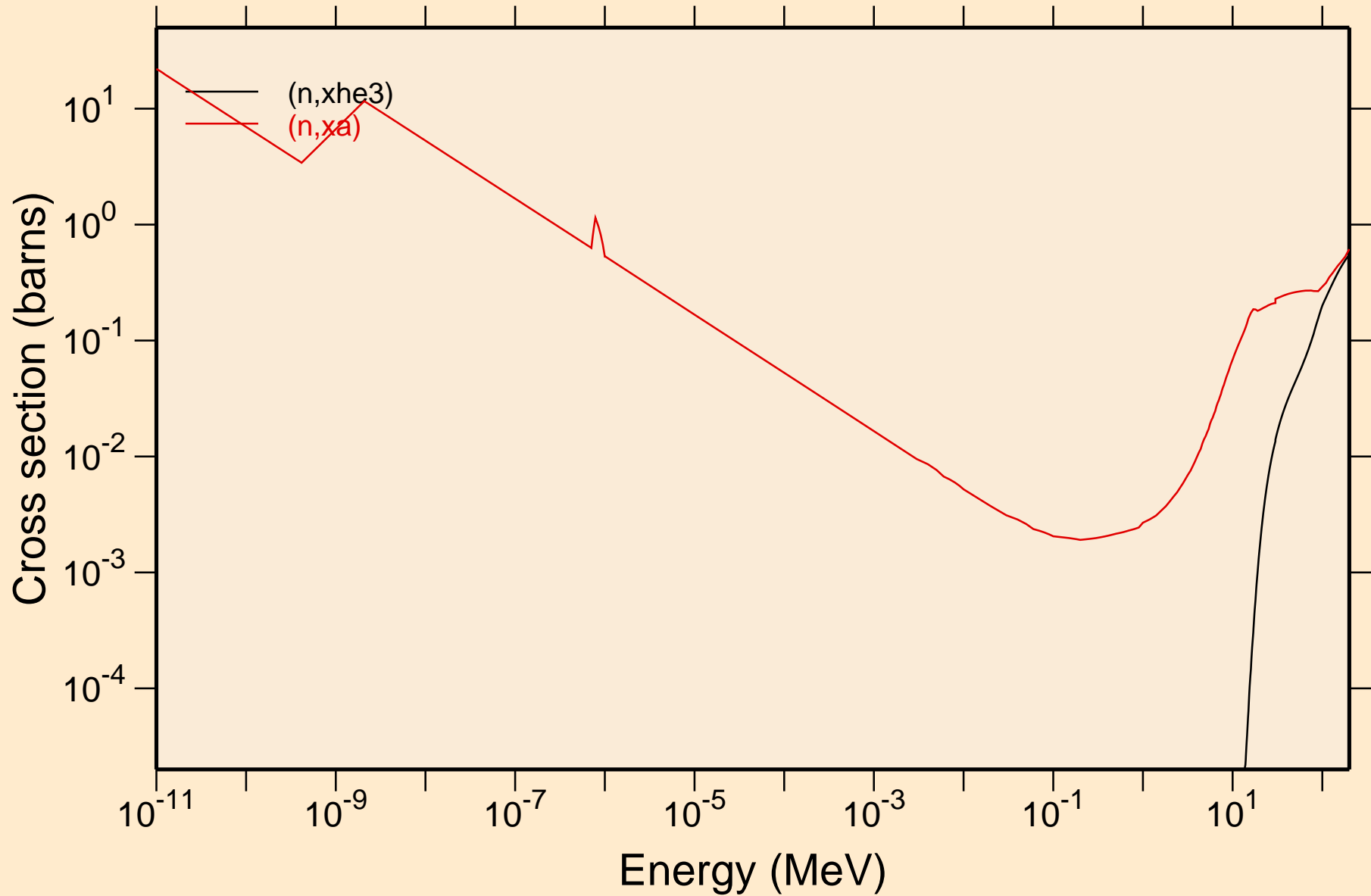

TL184 NEUTRON ACER TENDL-2023 LIBRARY; T=0.K

Principal cross sections

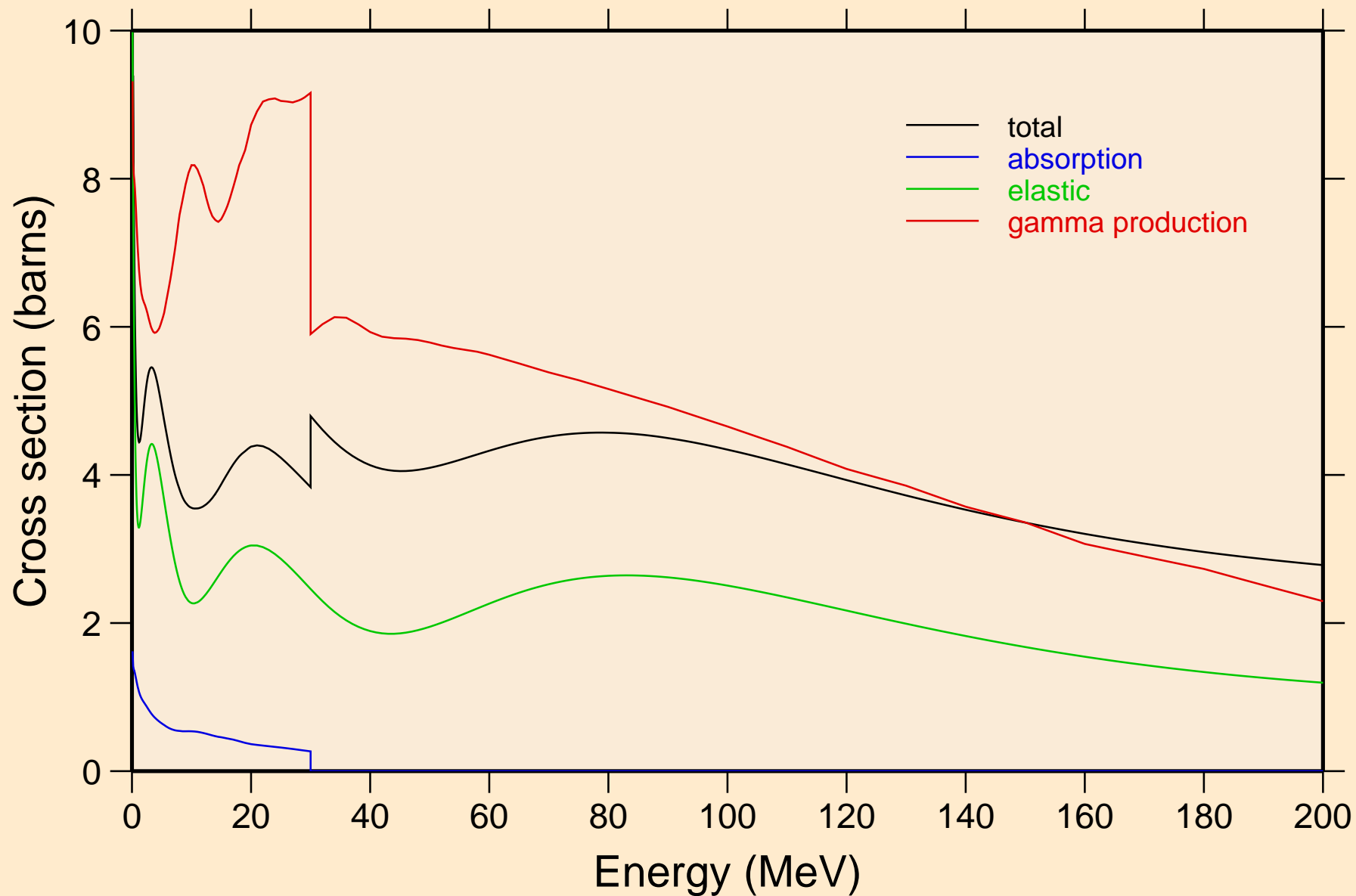

TL184 NEUTRON ACER TENDL-2023 LIBRARY; T=0.K

Heating

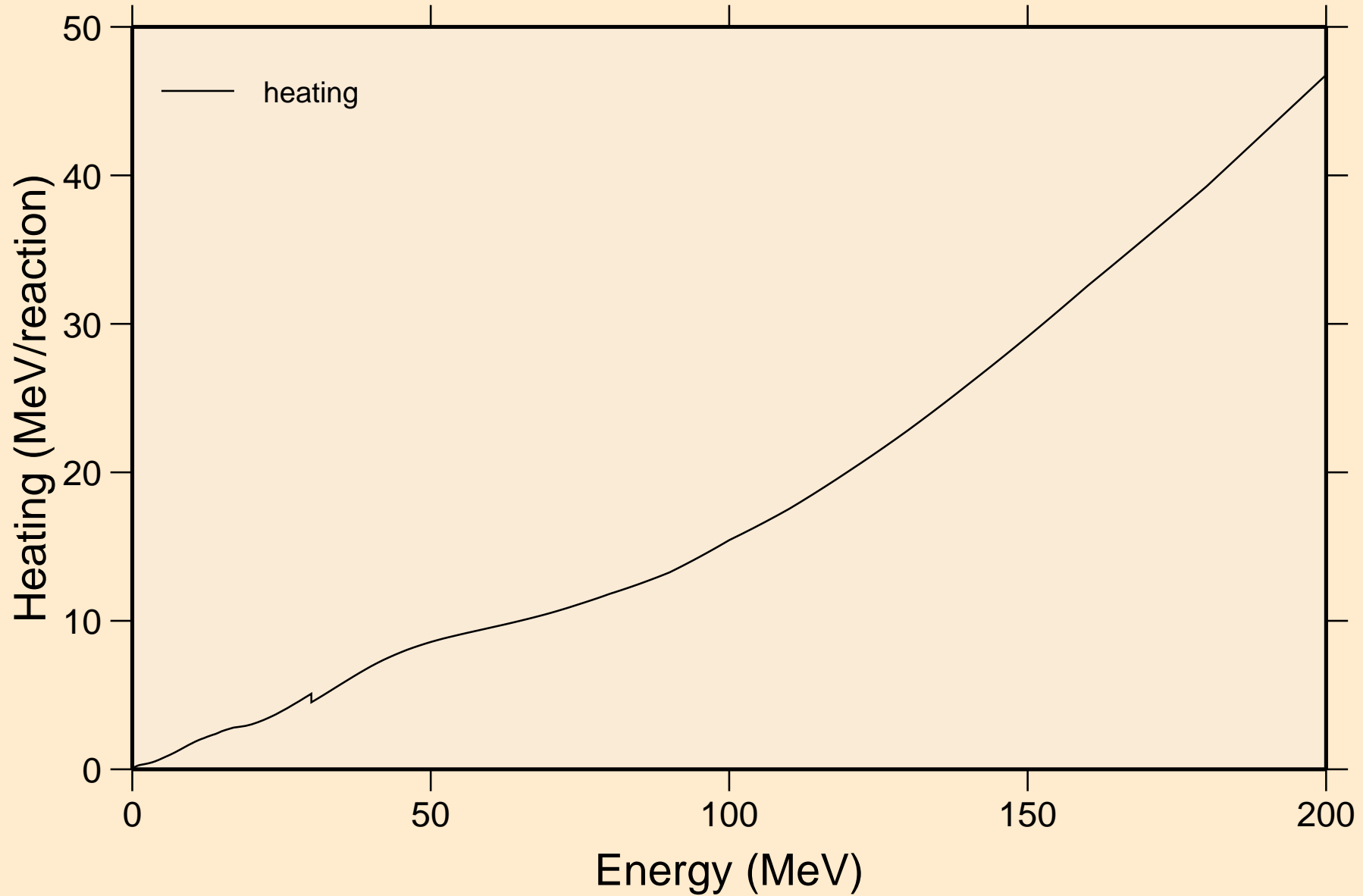

TL184 NEUTRON ACER TENDL-2023 LIBRARY; T=0.K
Damage

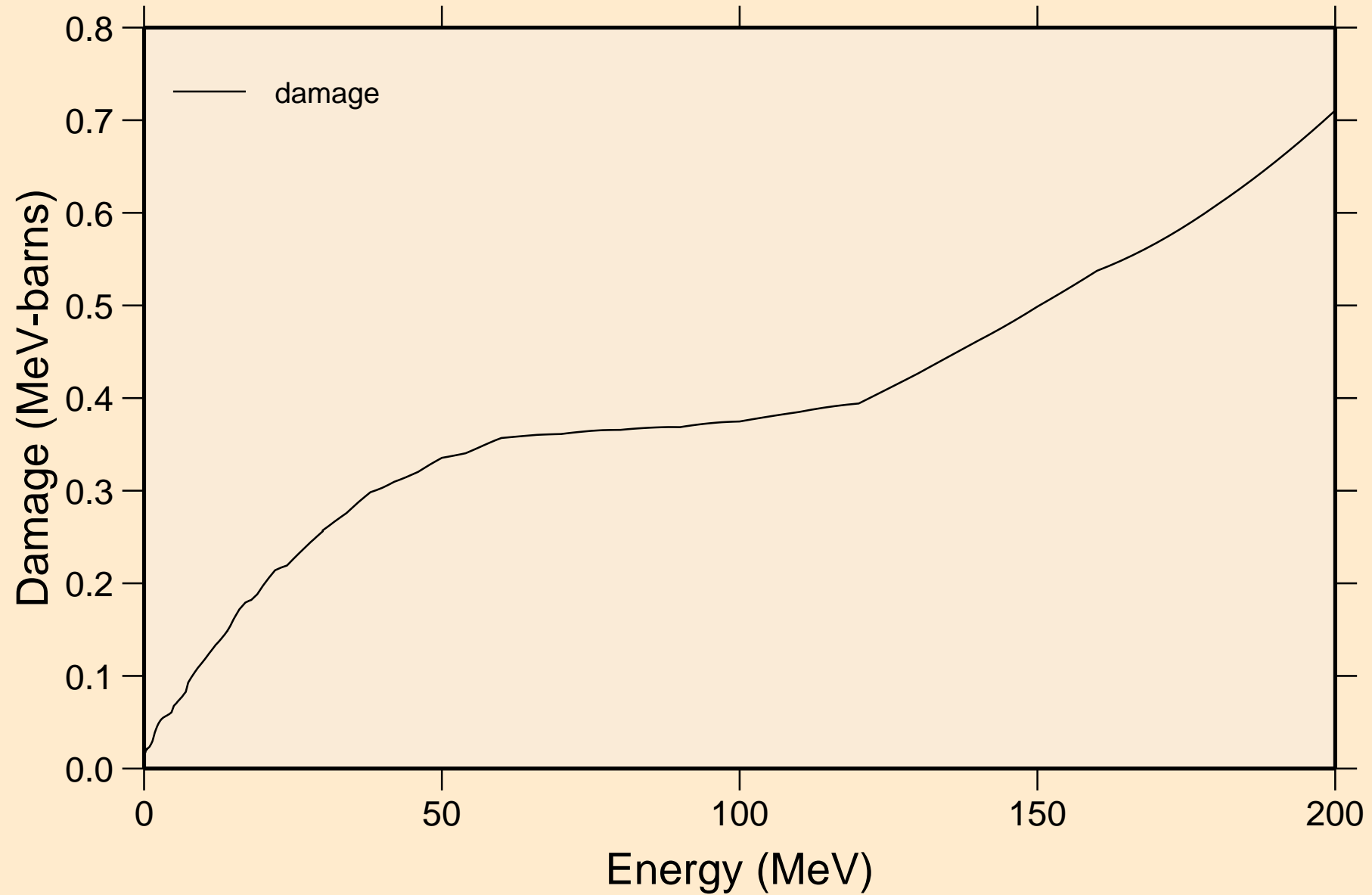

TL184 NEUTRON ACER TENDL-2023 LIBRARY; T=0.K
Non-threshold reactions

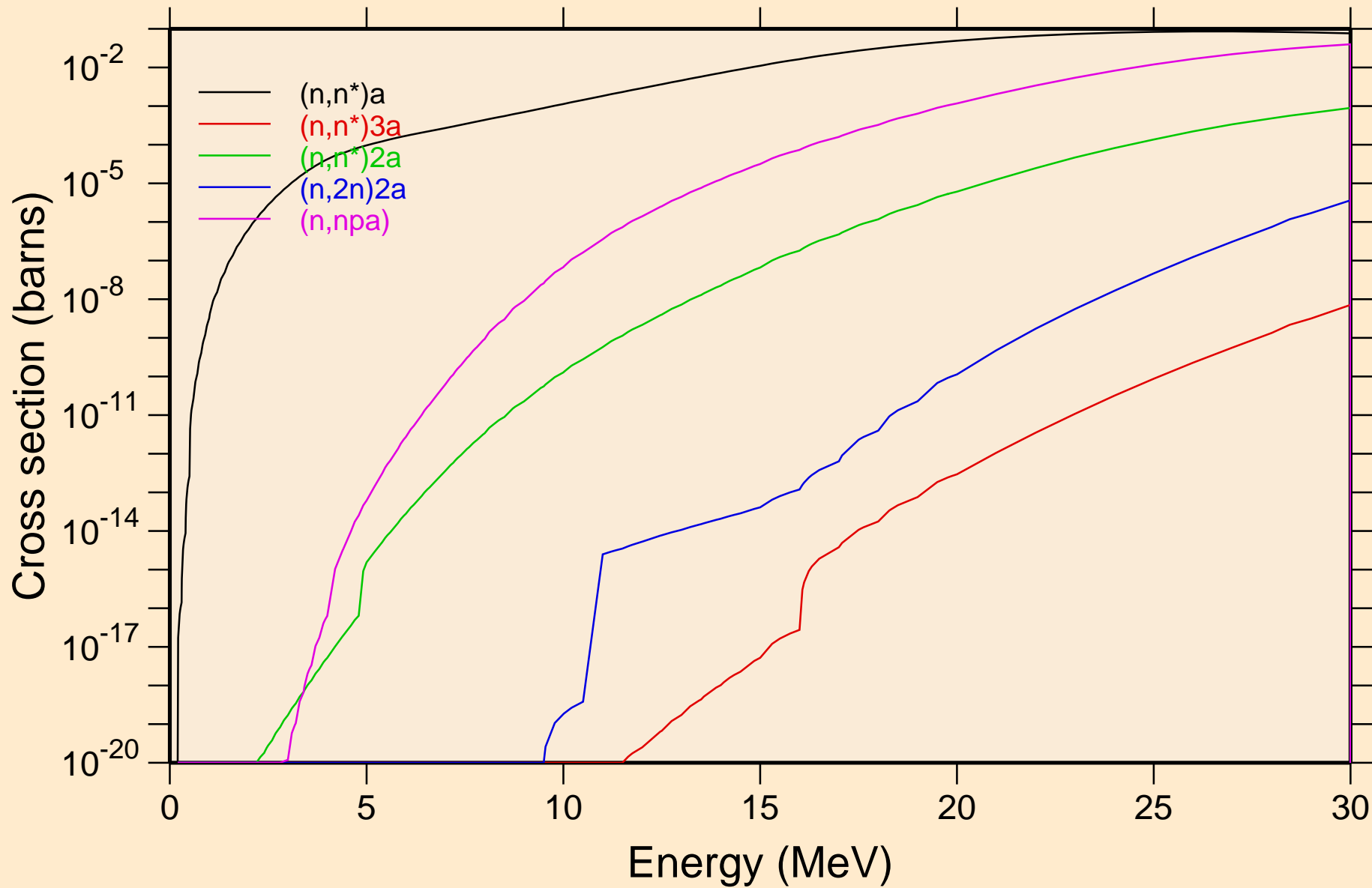

TL184 NEUTRON ACER TENDL-2023 LIBRARY; T=0.K
Non-threshold reactions

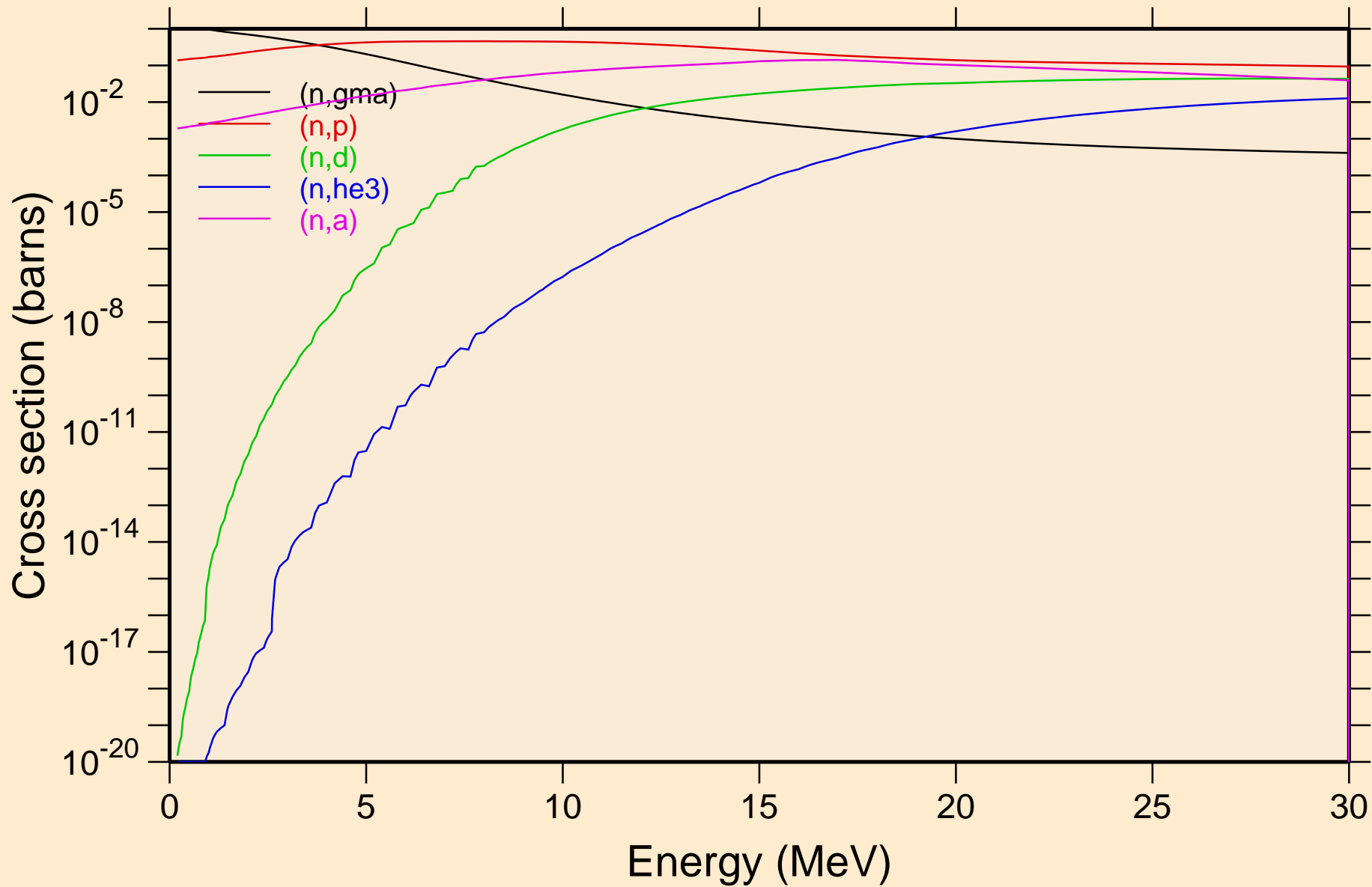

TL184 NEUTRON ACER TENDL-2023 LIBRARY; T=0.K
Non-threshold reactions

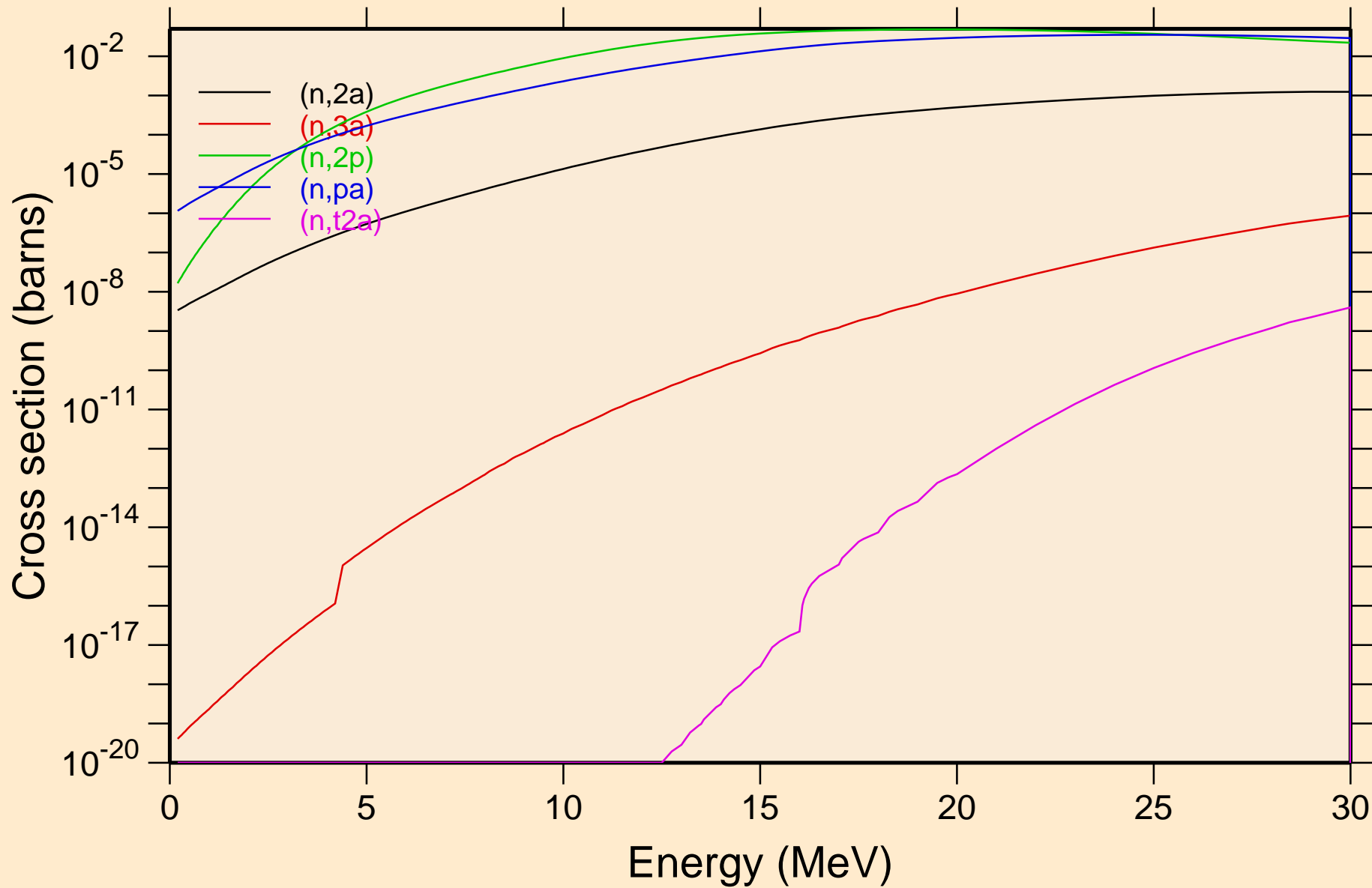

TL184 NEUTRON ACER TENDL-2023 LIBRARY; T=0.K
Non-threshold reactions

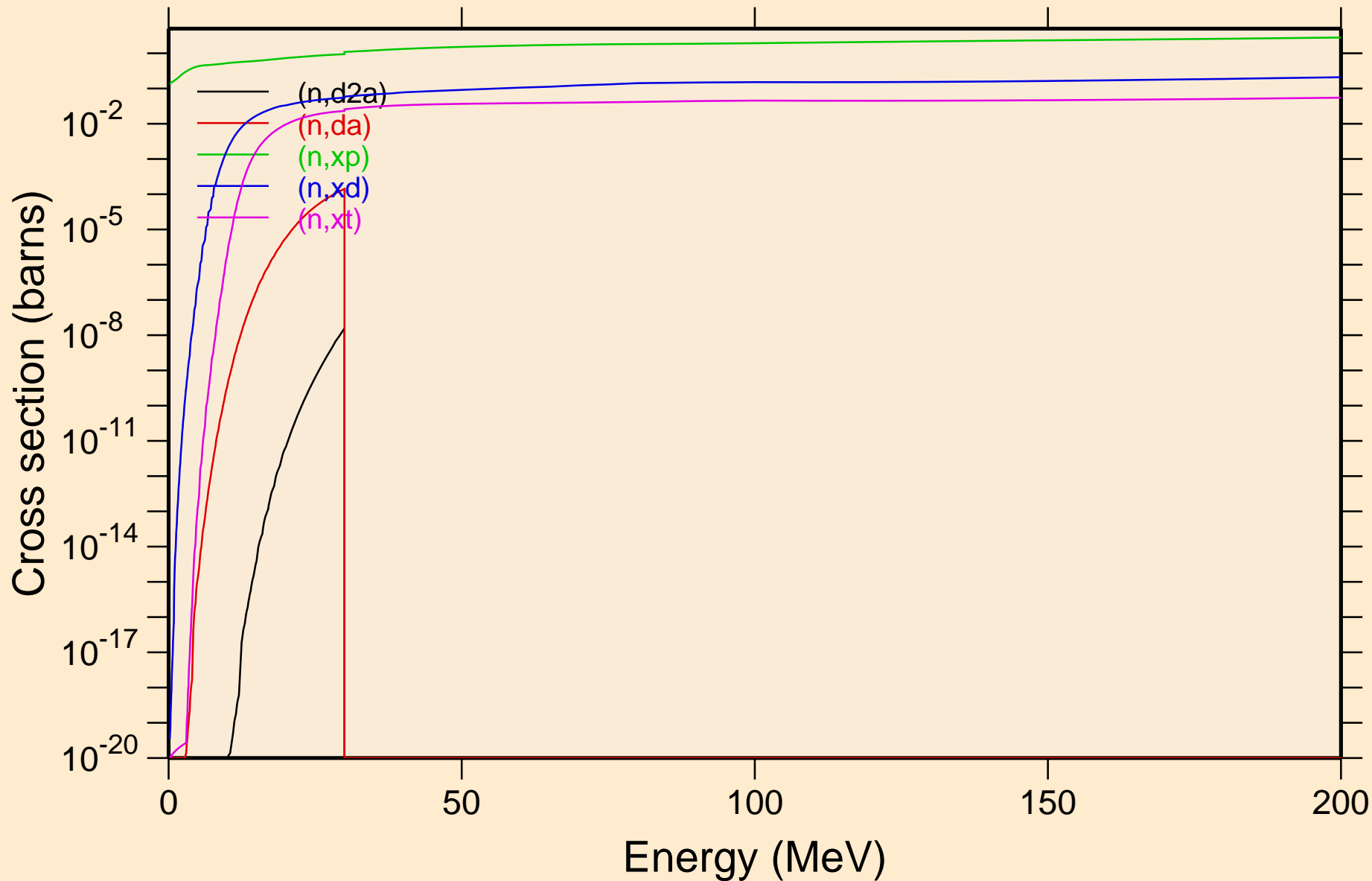

TL184 NEUTRON ACER TENDL-2023 LIBRARY; T=0.K
Non-threshold reactions

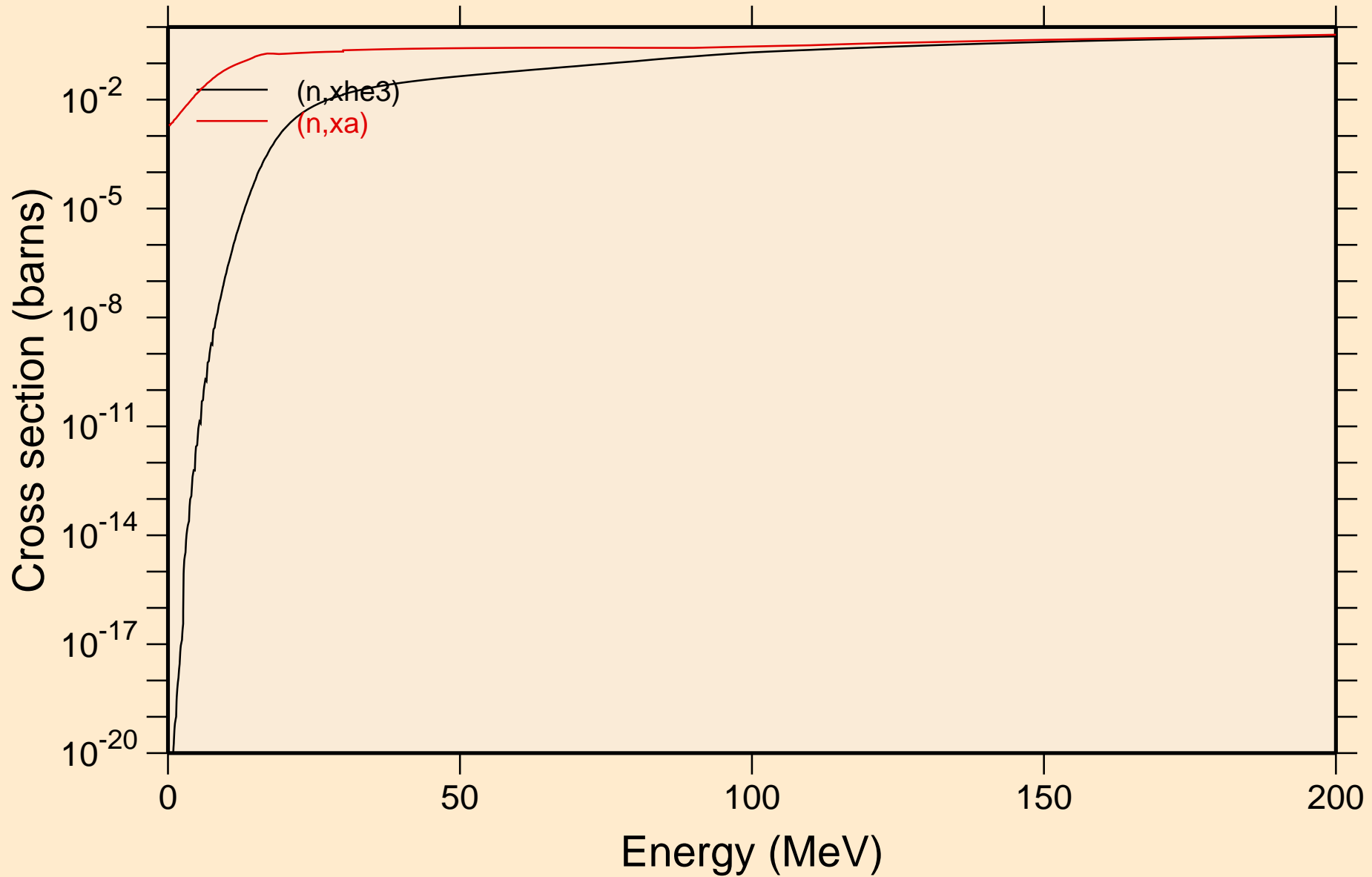

TL184 NEUTRON ACER TENDL-2023 LIBRARY; T=0.K
Inelastic levels

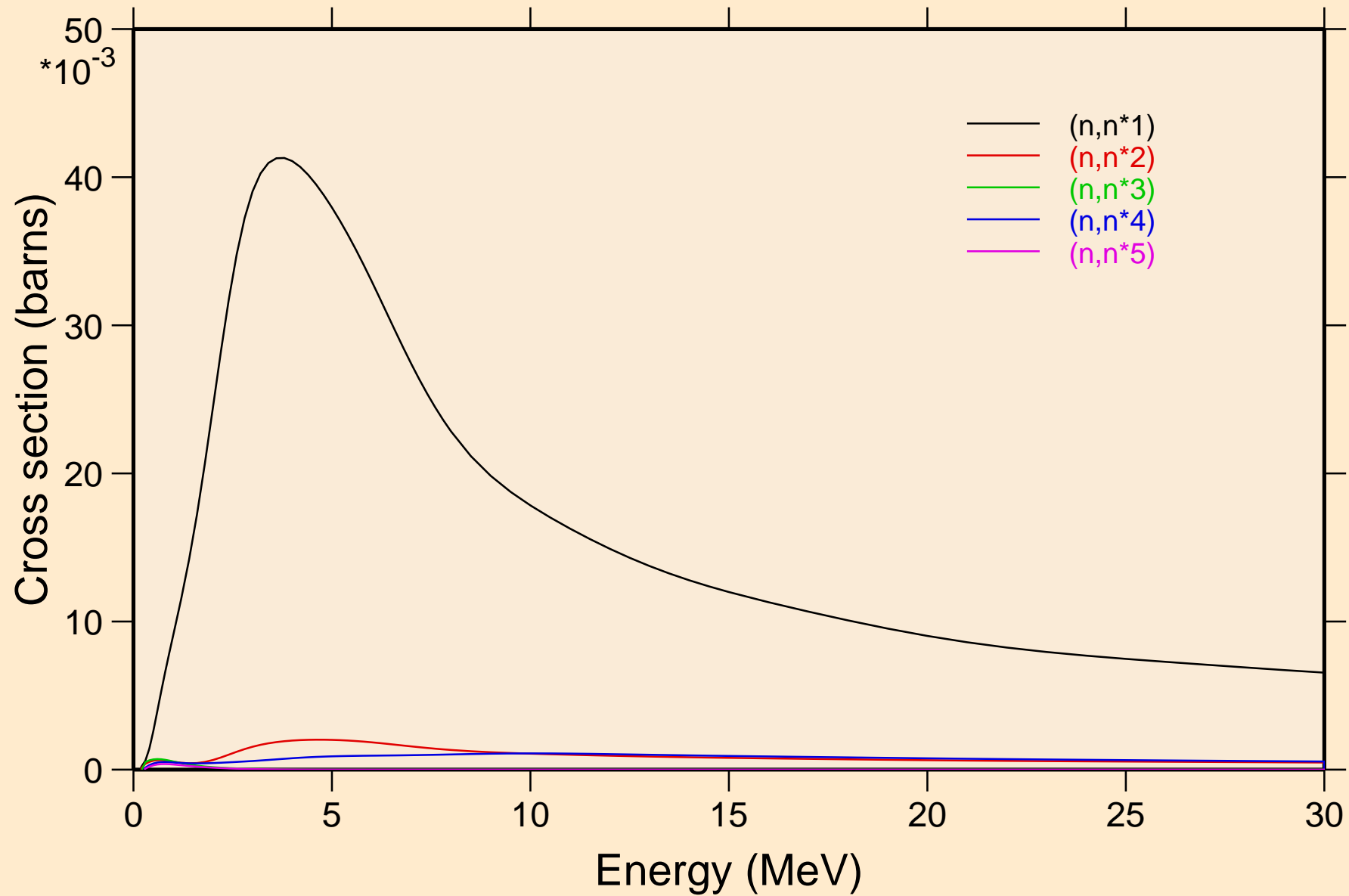

TL184 NEUTRON ACER TENDL-2023 LIBRARY; T=0.K
Inelastic levels

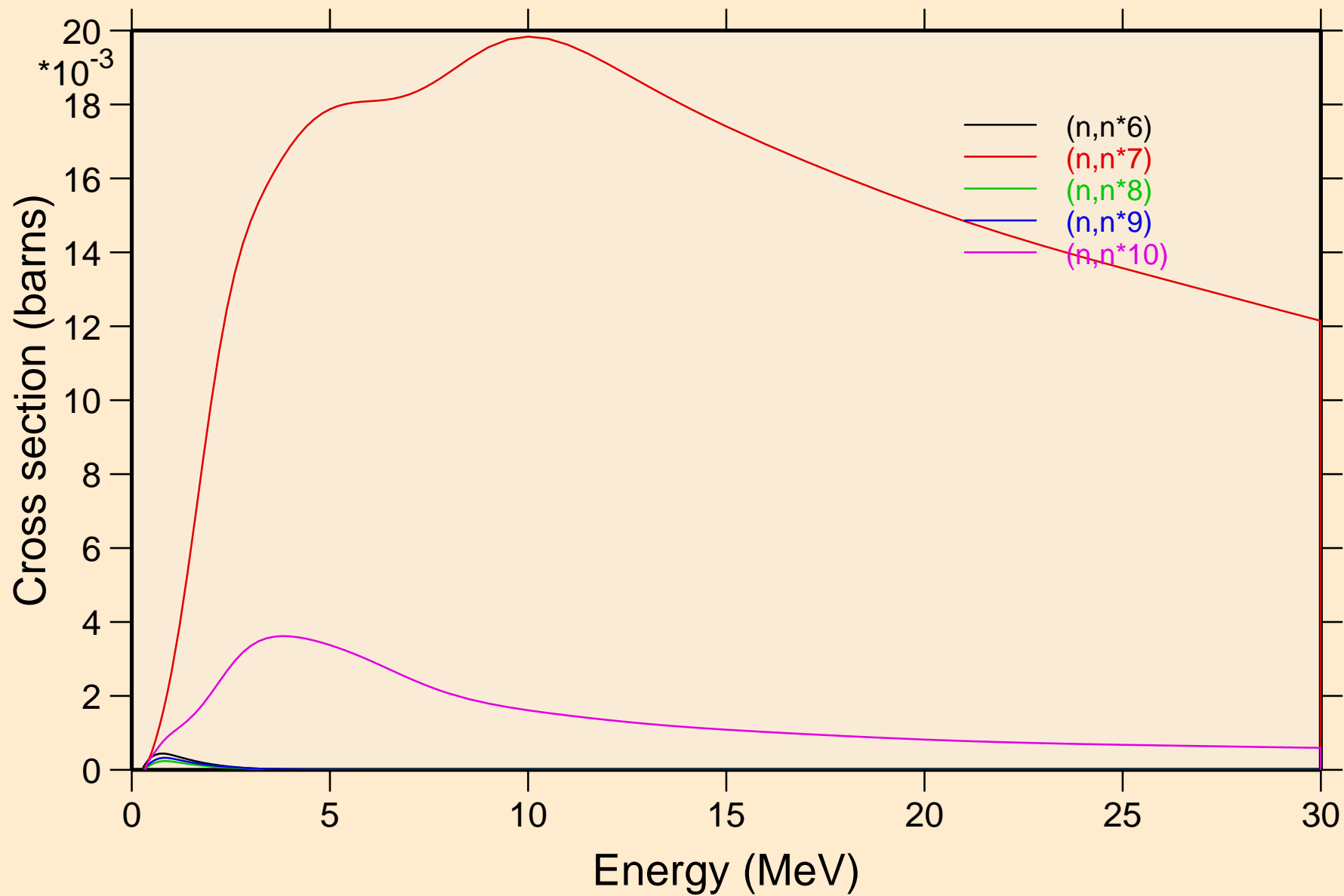

TL184 NEUTRON ACER TENDL-2023 LIBRARY; T=0.K
Inelastic levels

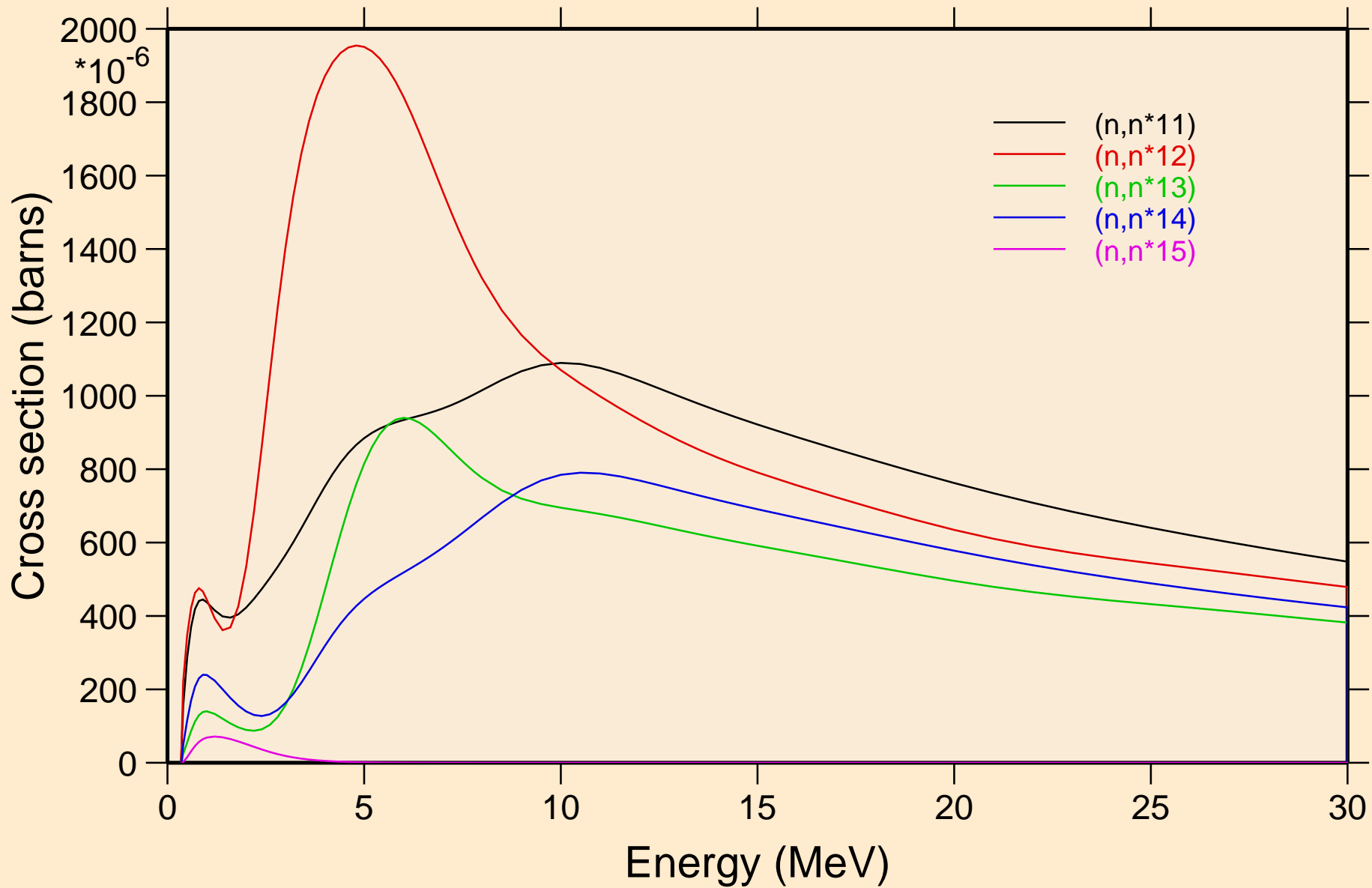

TL184 NEUTRON ACER TENDL-2023 LIBRARY; T=0.K
Inelastic levels

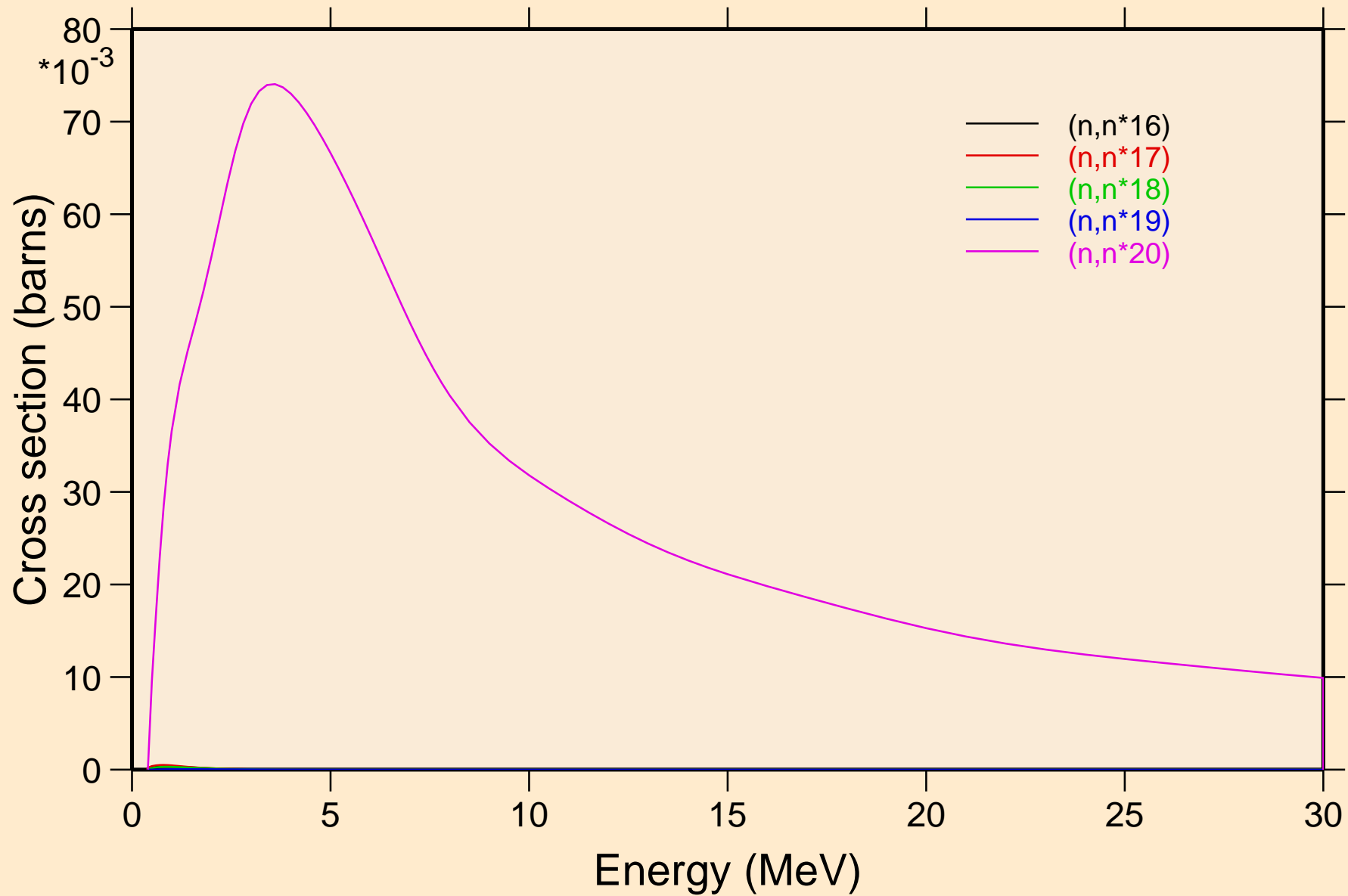

TL184 NEUTRON ACER TENDL-2023 LIBRARY; T=0.K

Threshold reactions

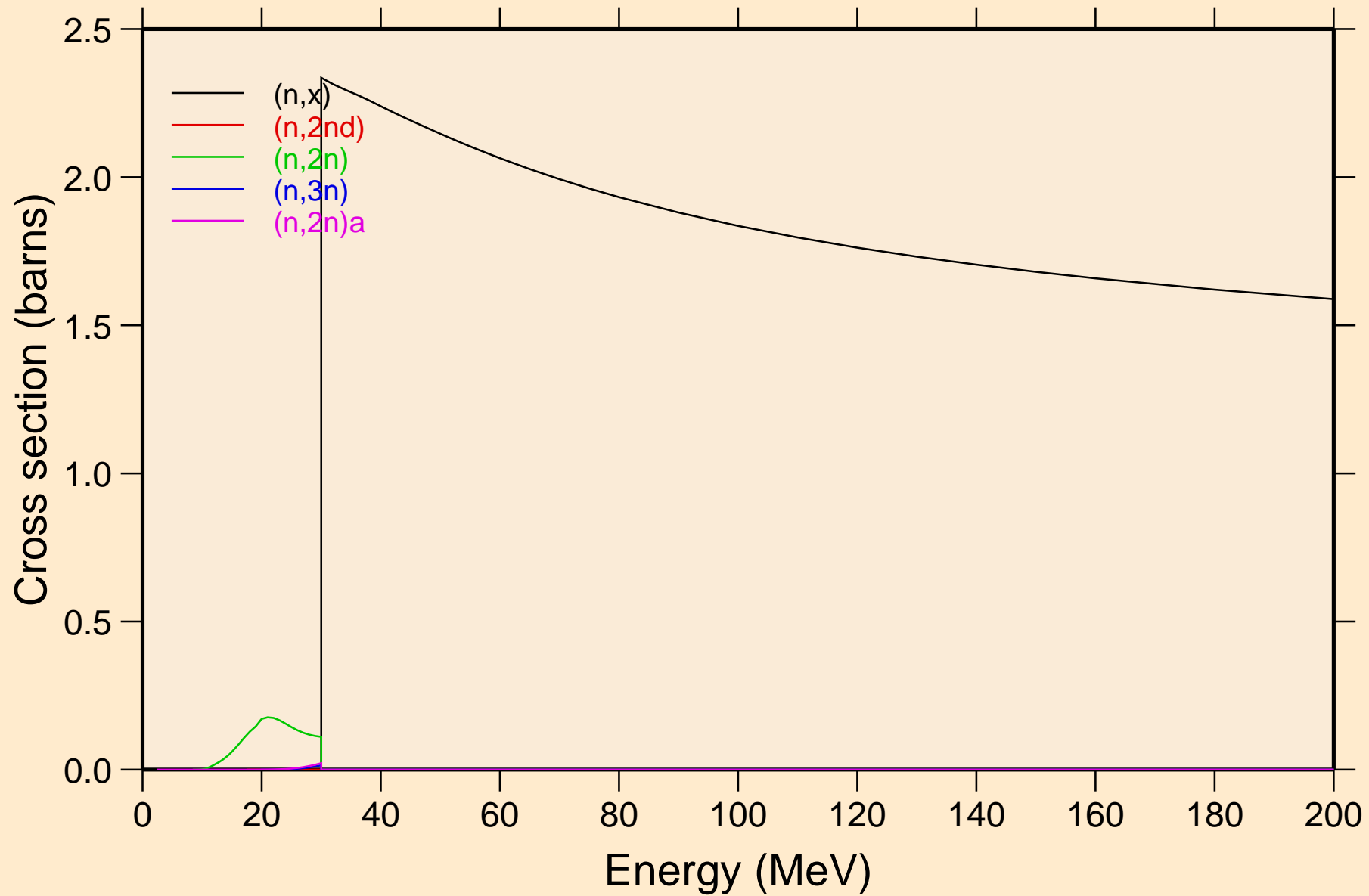

TL184 NEUTRON ACER TENDL-2023 LIBRARY; T=0.K
Threshold reactions

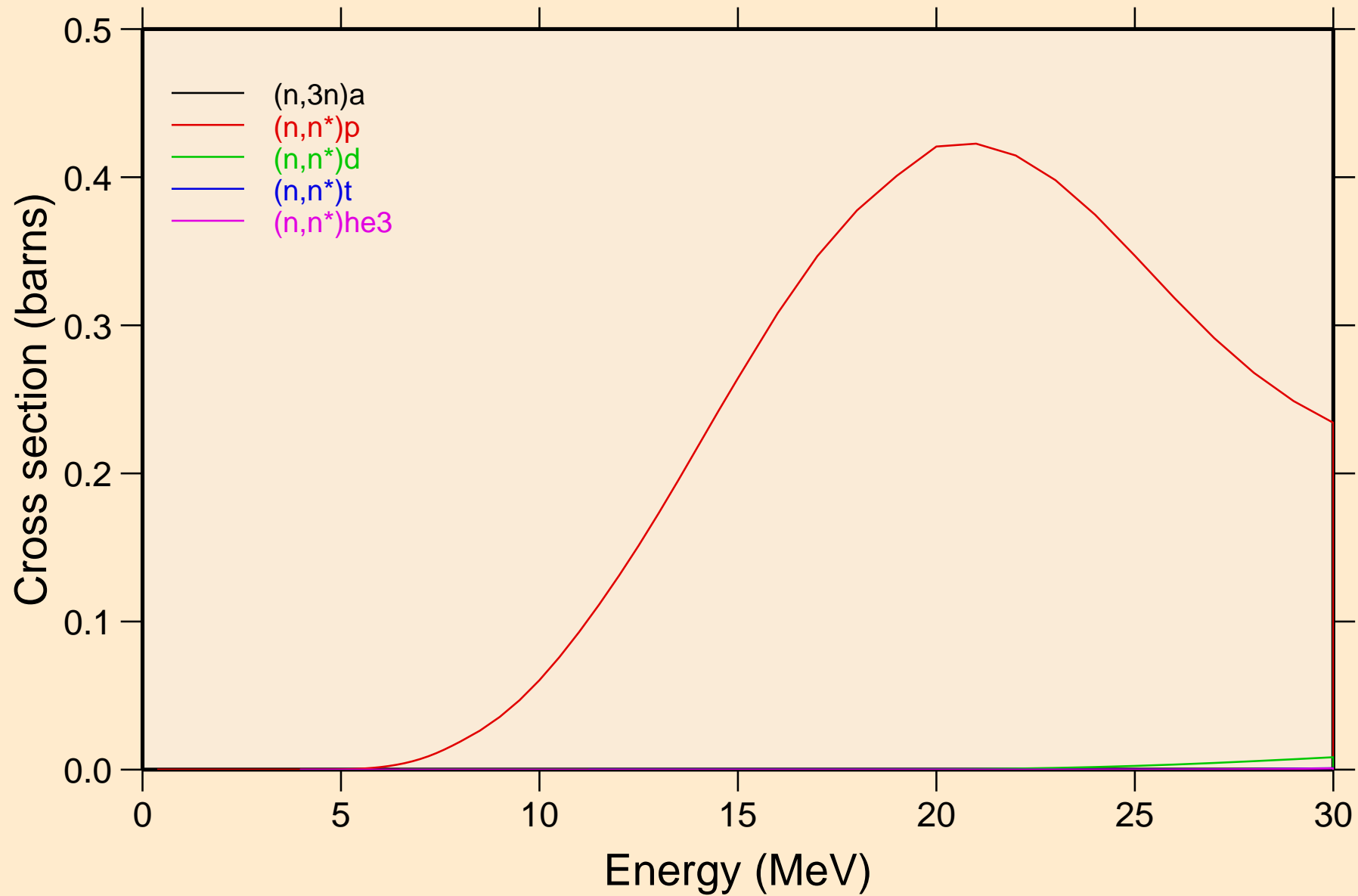

TL184 NEUTRON ACER TENDL-2023 LIBRARY; T=0.K
Threshold reactions

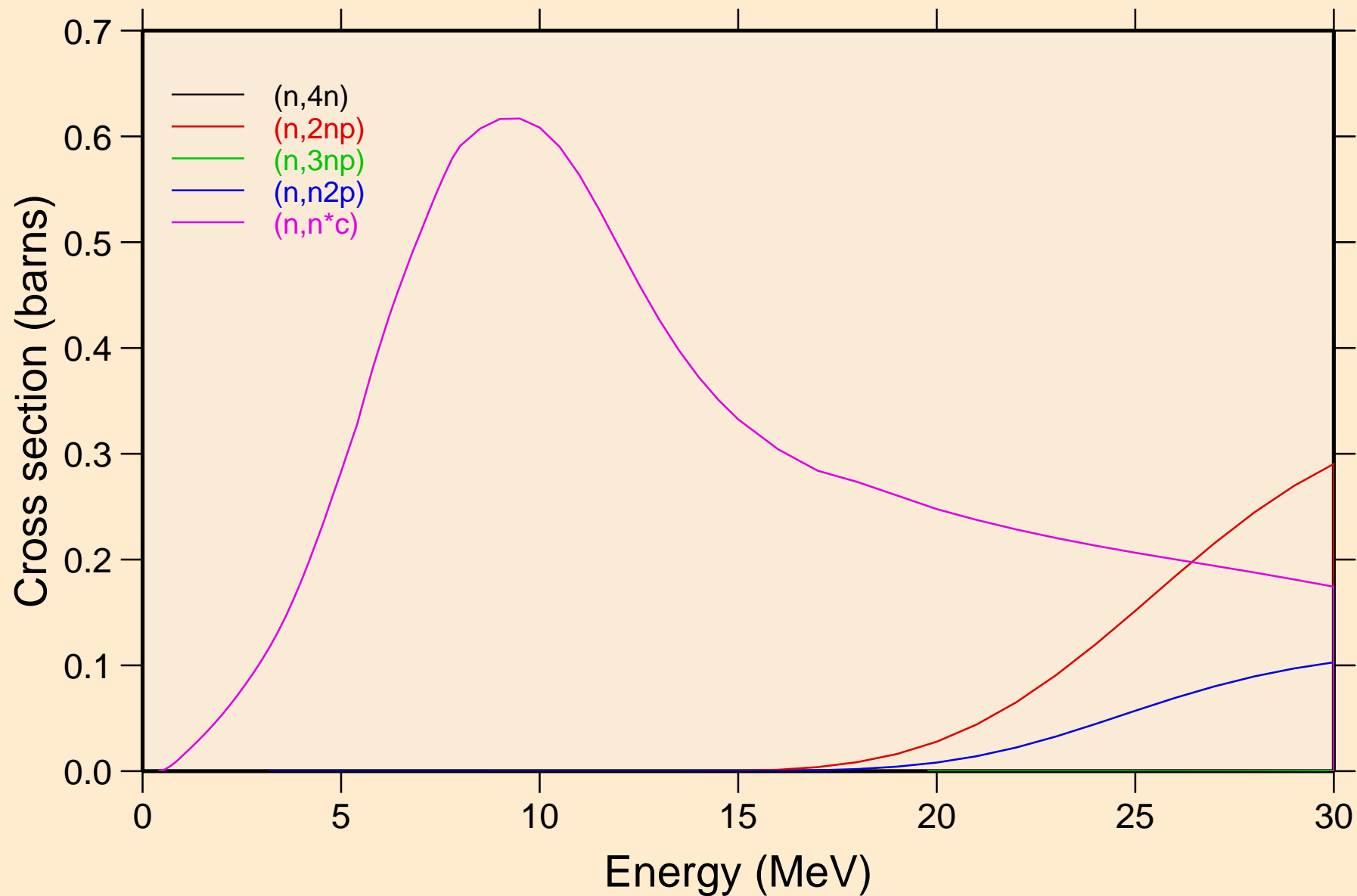

TL184 NEUTRON ACER TENDL-2023 LIBRARY; T=0.K
Threshold reactions

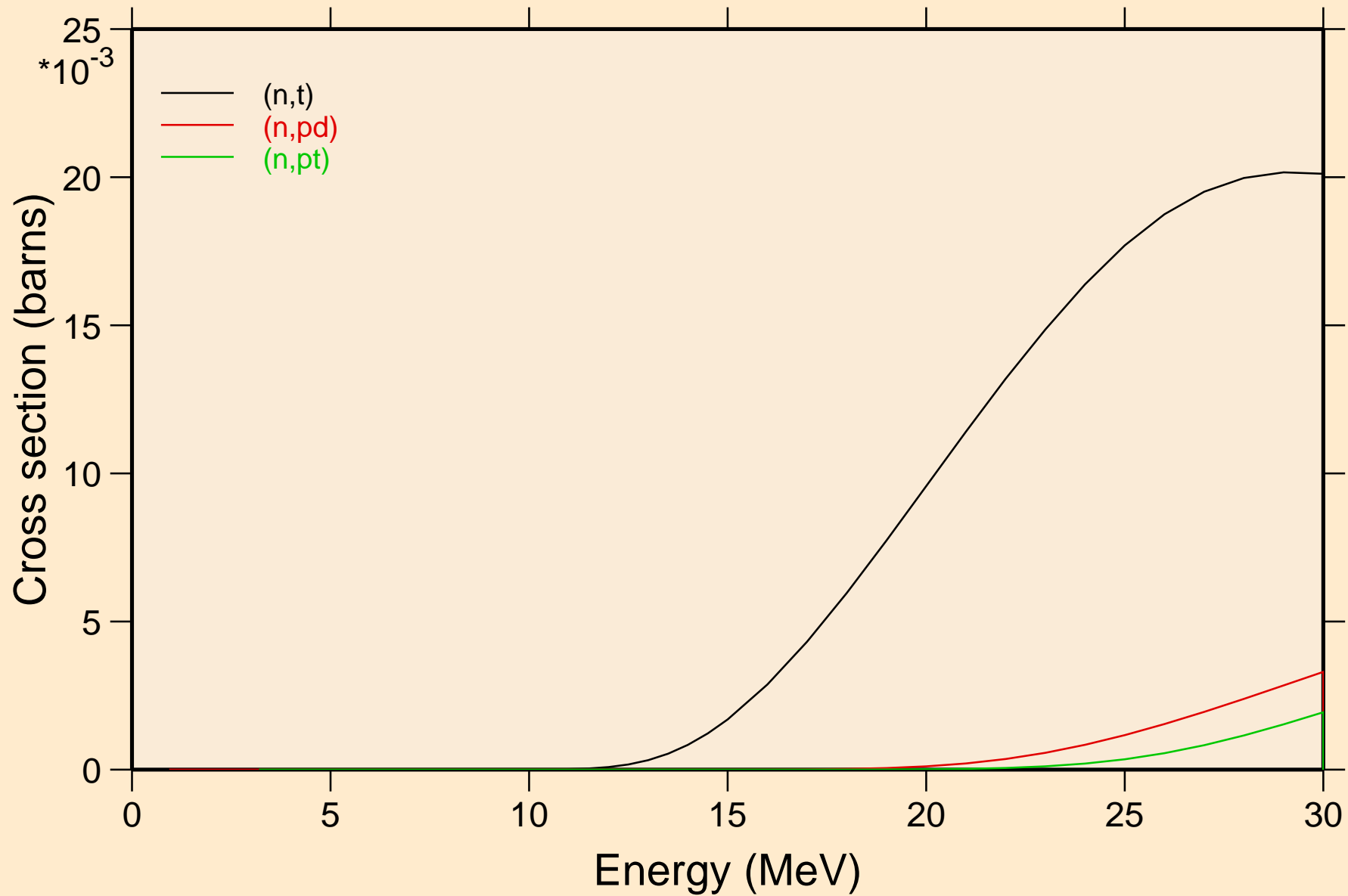

TL184 NEUTRON ACER TENDL-2023 LIBRARY; T=0.K
angular distribution for elastic

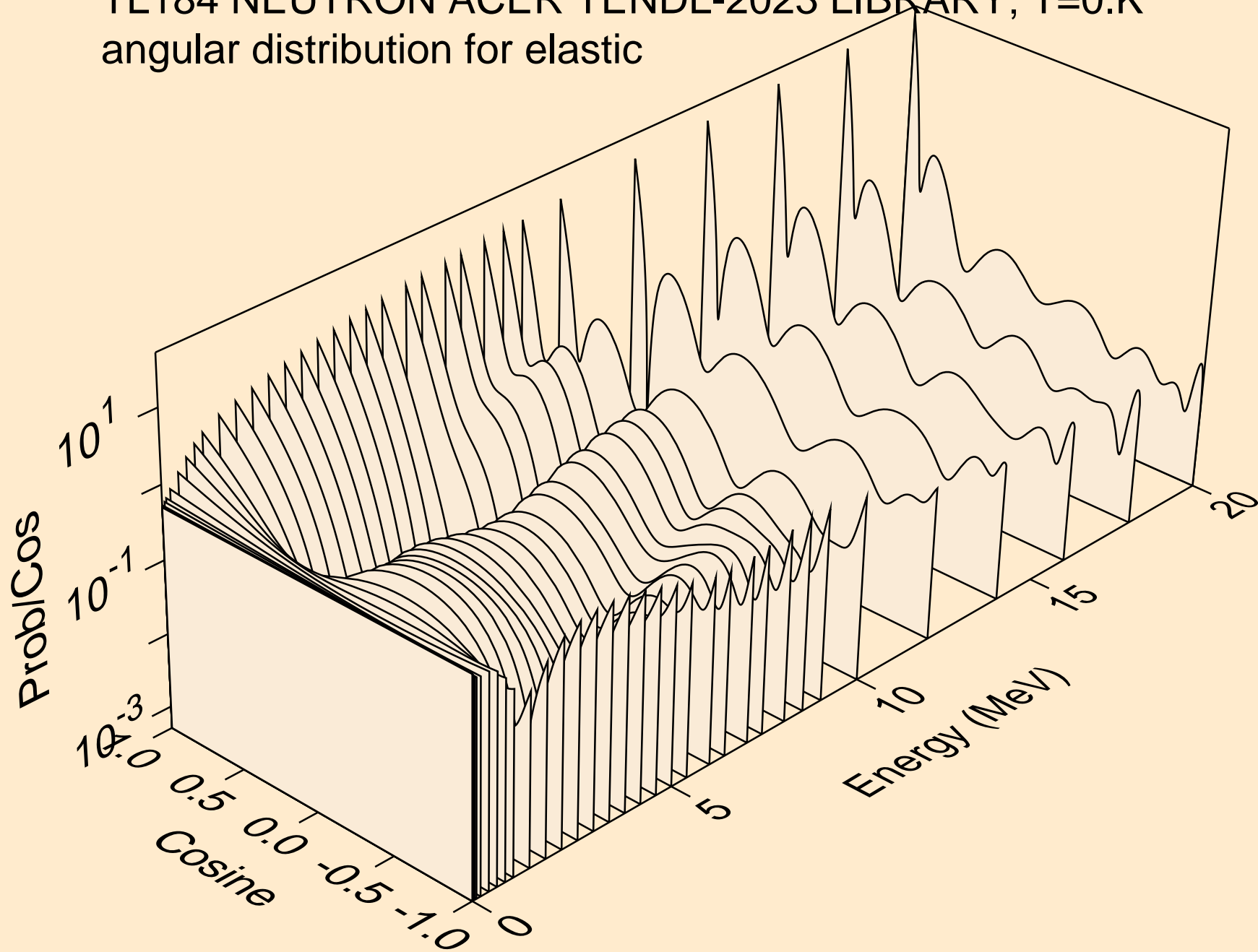

TL184 NEUTRON ACER TENDL-2023 LIBRARY; T=0.K
angular distribution for elastic

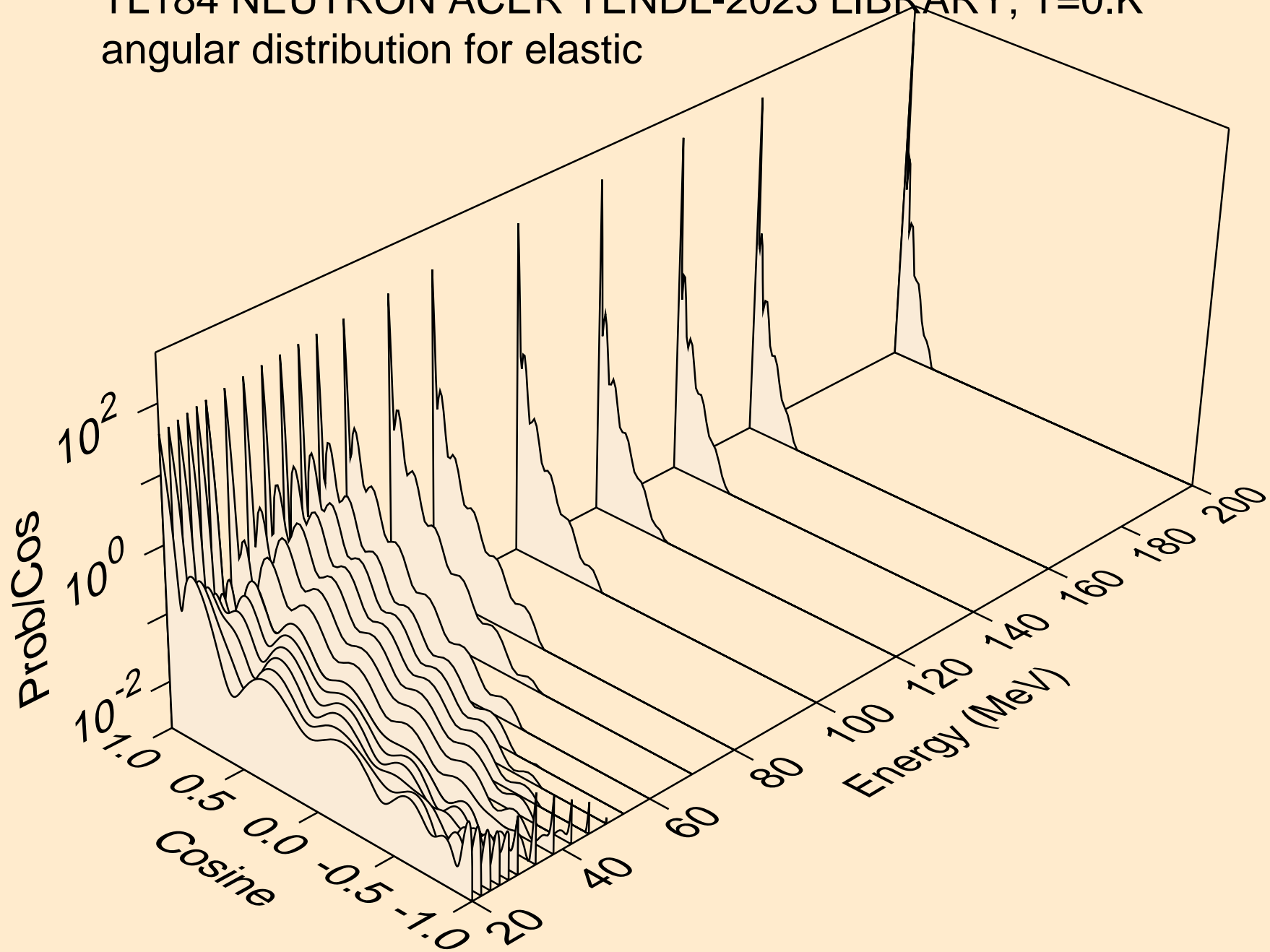

TL184 NEUTRON ACER TENDL-2023 LIBRARY; T=0.K
angular distribution for (n,n*1)

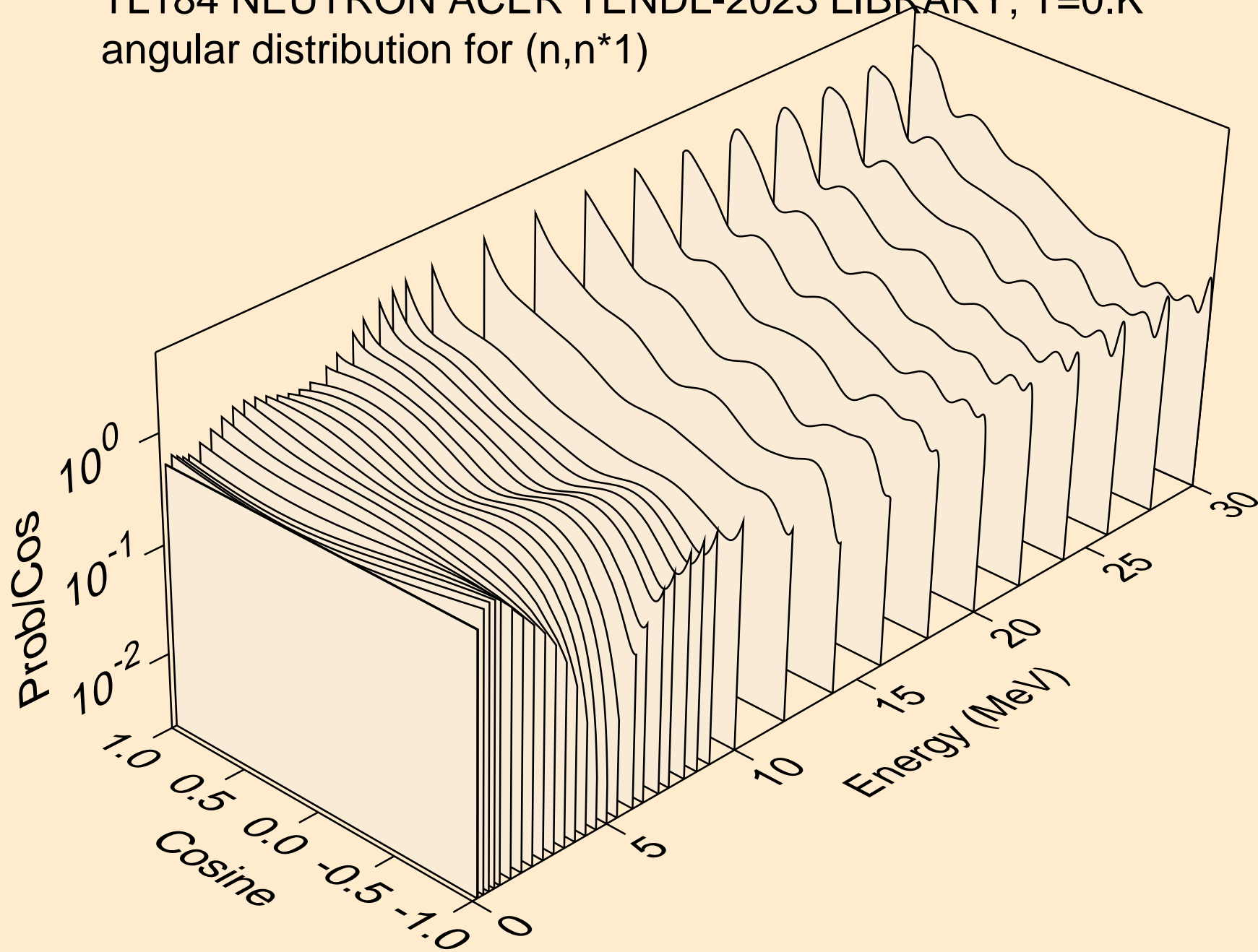

TL184 NEUTRON ACER TENDL-2023 LIBRARY; T=0.K
angular distribution for (n,n*2)

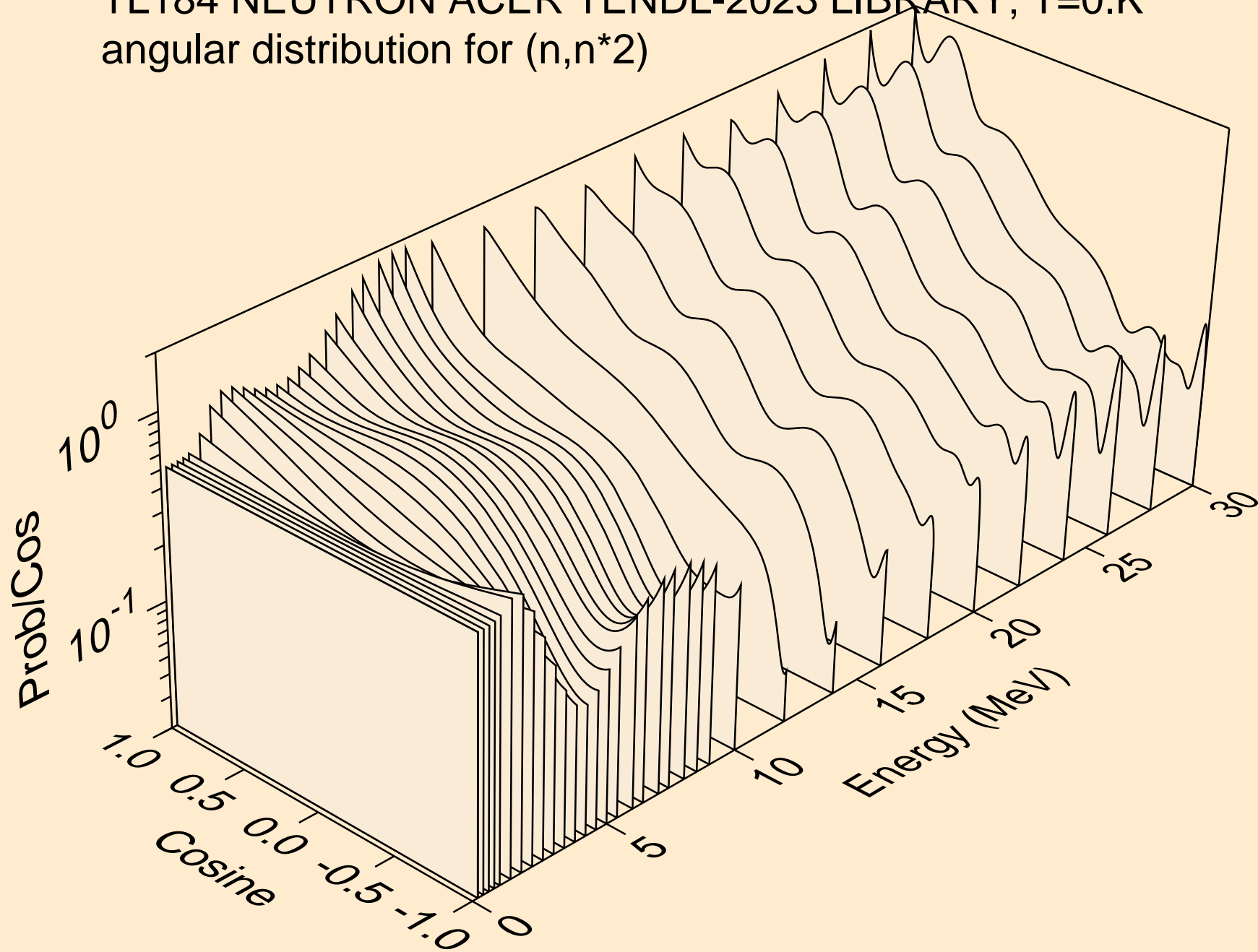

TL184 NEUTRON ACER TENDL-2023 LIBRARY; T=0.K
angular distribution for (n,n*3)

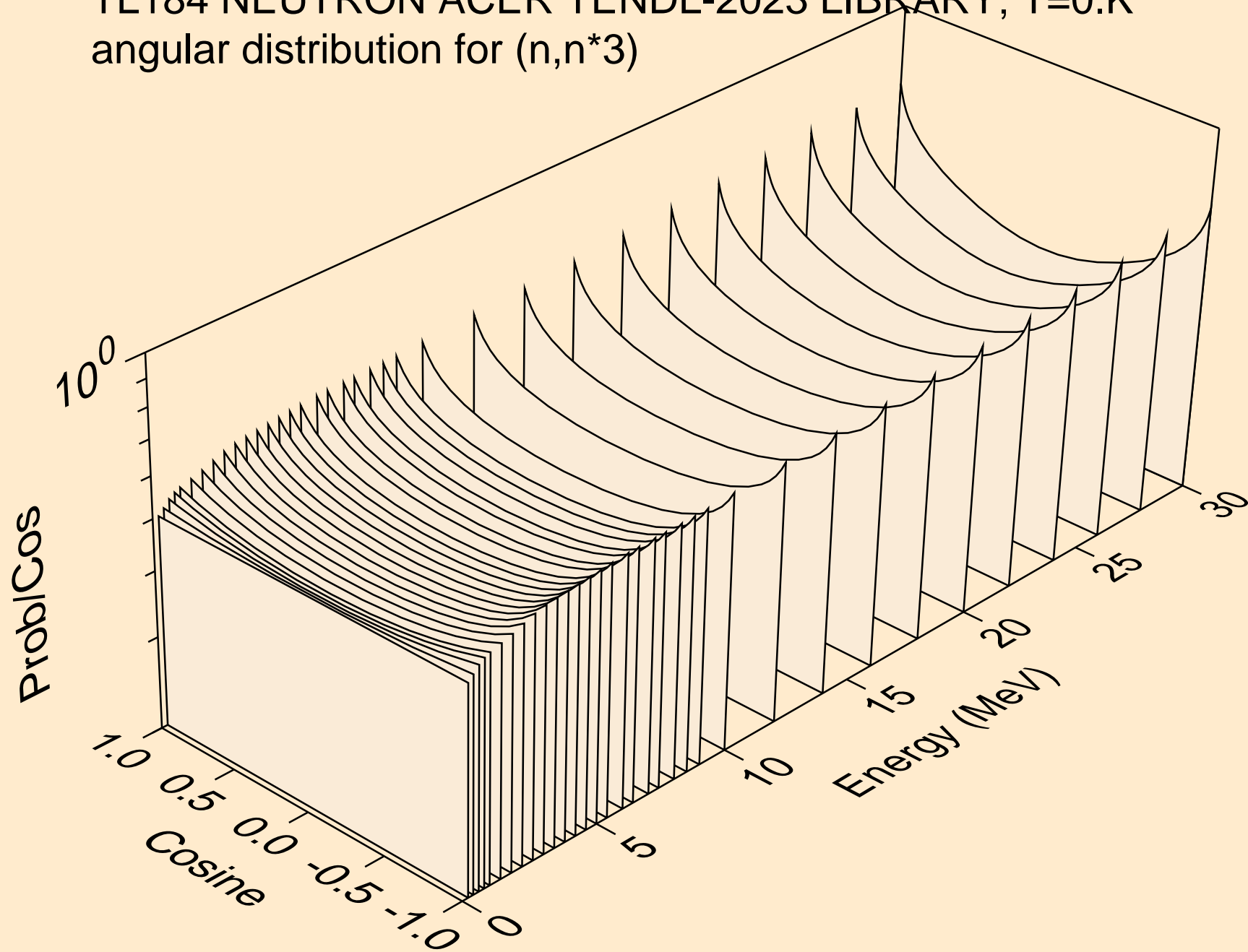

TL184 NEUTRON ACER TENDL-2023 LIBRARY; T=0.K
angular distribution for (n,n*4)

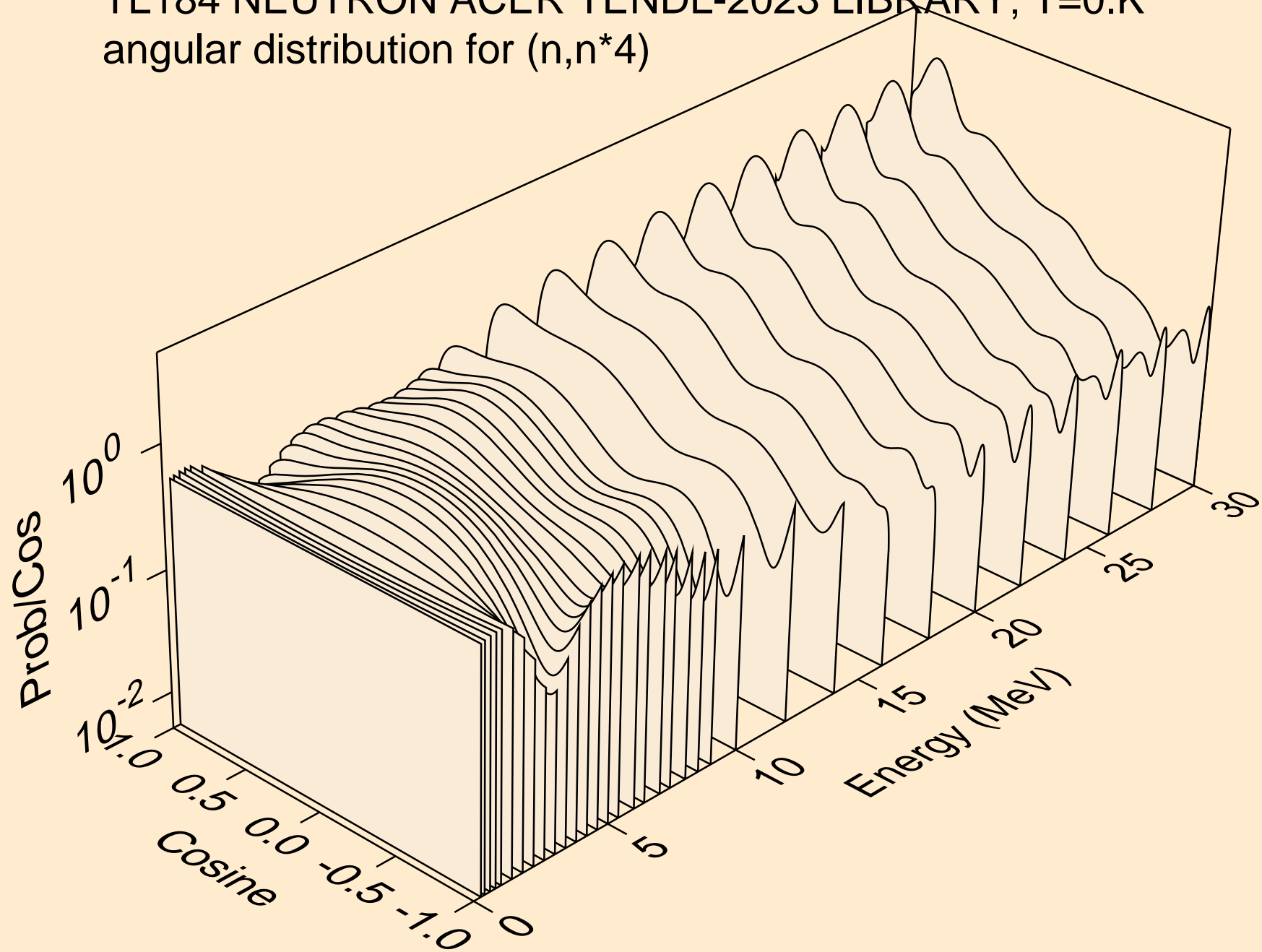

TL184 NEUTRON ACER TENDL-2023 LIBRARY; T=0.K
angular distribution for (n,n*5)

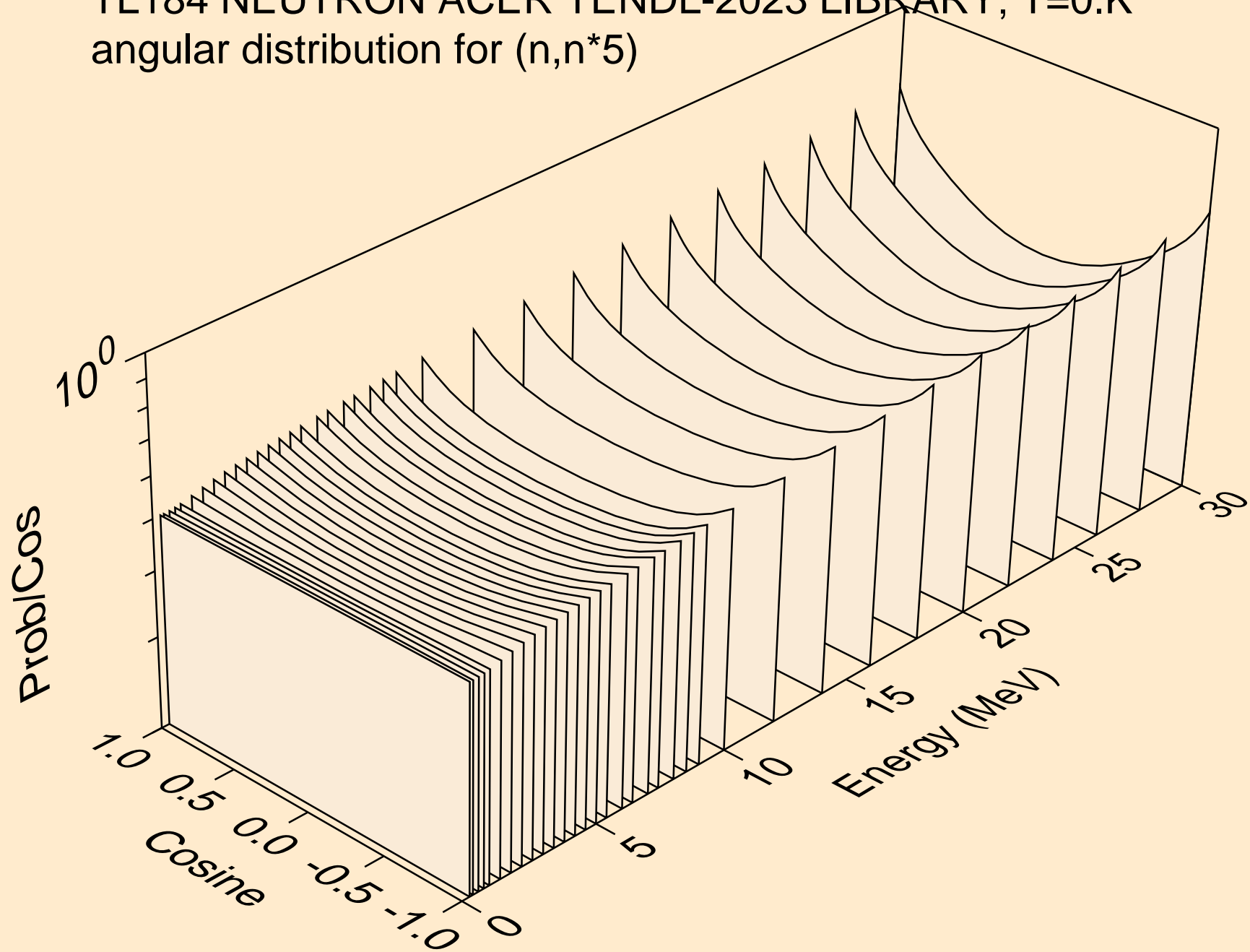

TL184 NEUTRON ACER TENDL-2023 LIBRARY; T=0.K
angular distribution for (n,n*6)

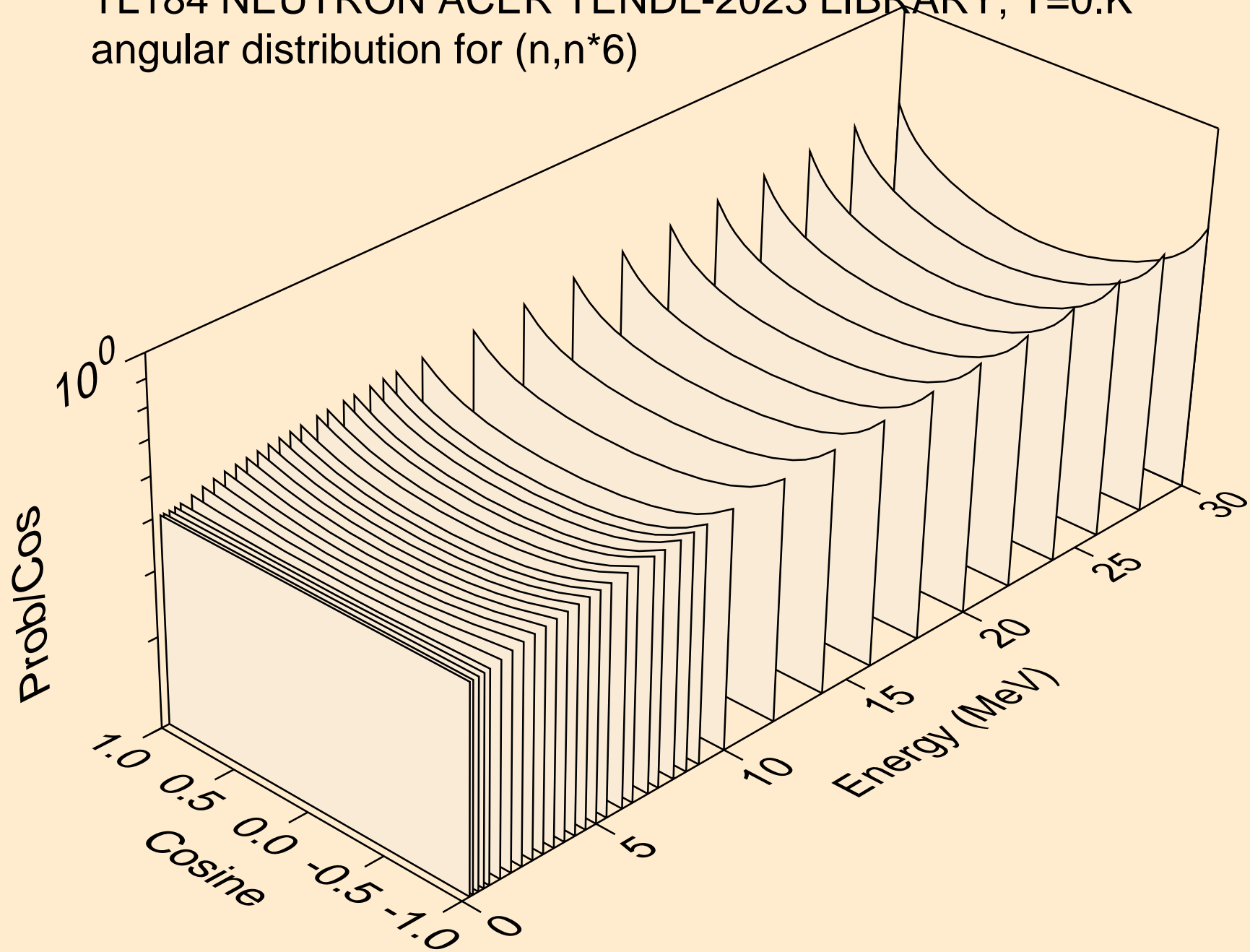

TL184 NEUTRON ACER TENDL-2023 LIBRARY; T=0.K
angular distribution for (n,n*7)

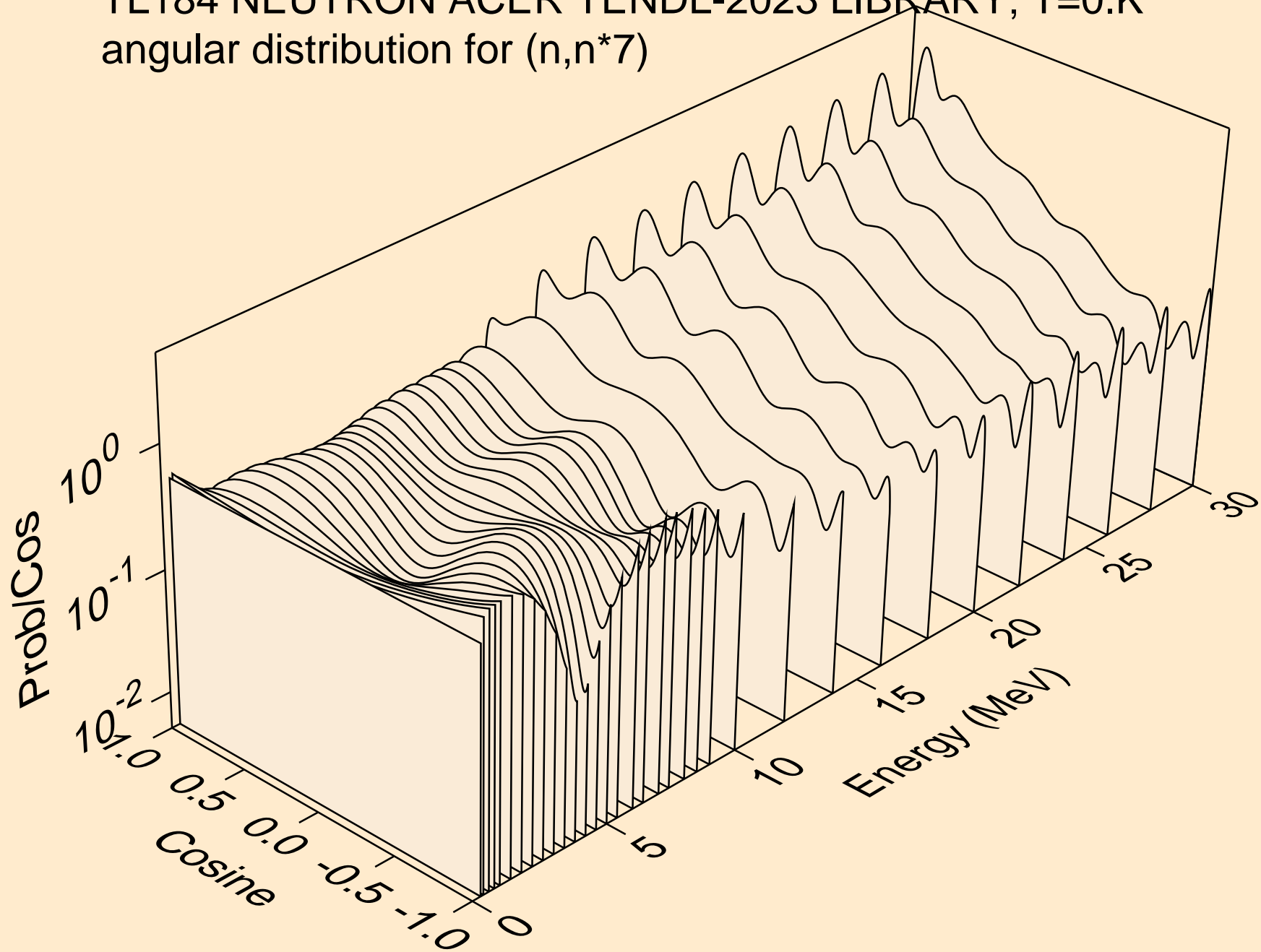

TL184 NEUTRON ACER TENDL-2023 LIBRARY; T=0.K
angular distribution for (n,n*8)

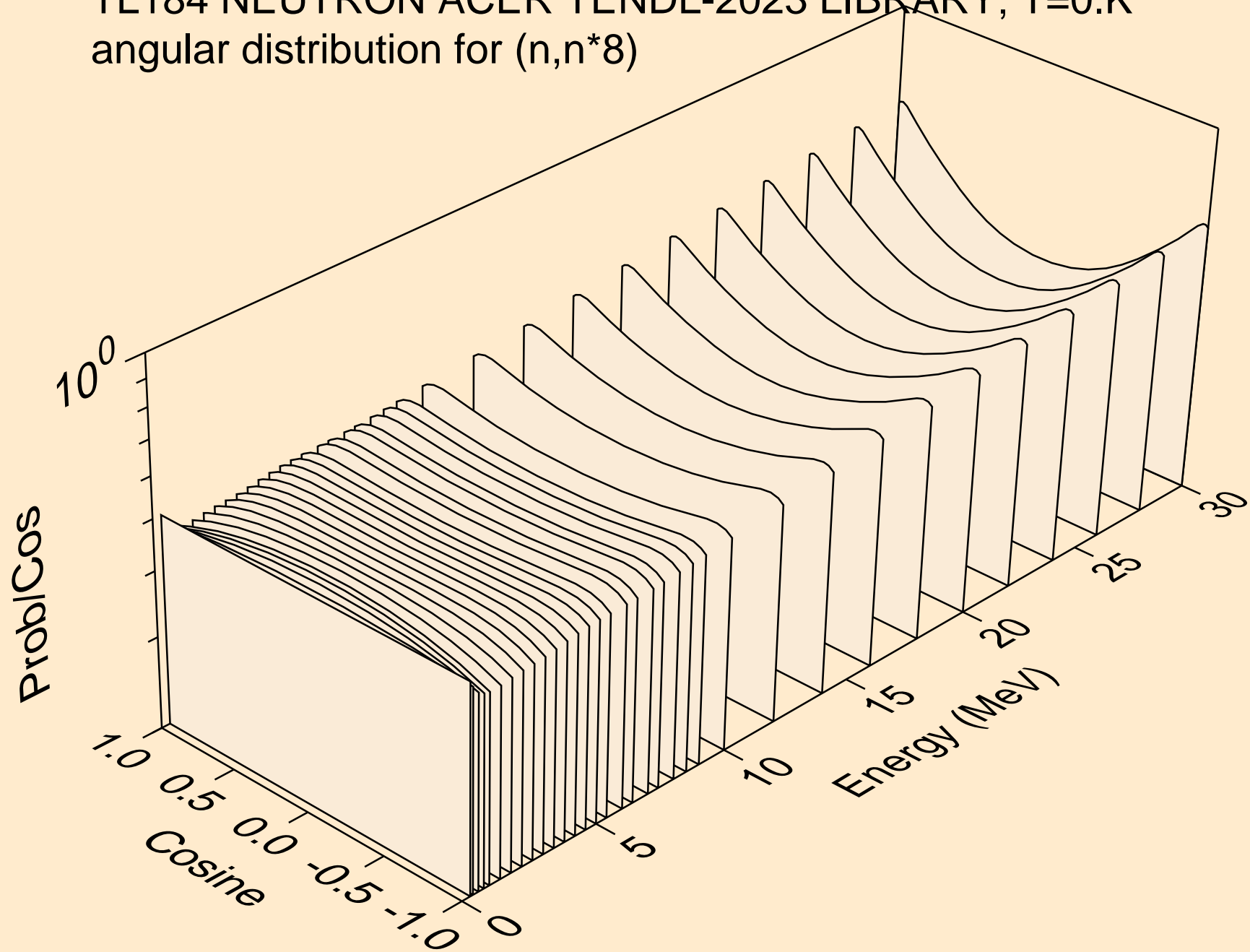

TL184 NEUTRON ACER TENDL-2023 LIBRARY; T=0.K
angular distribution for (n,n*9)

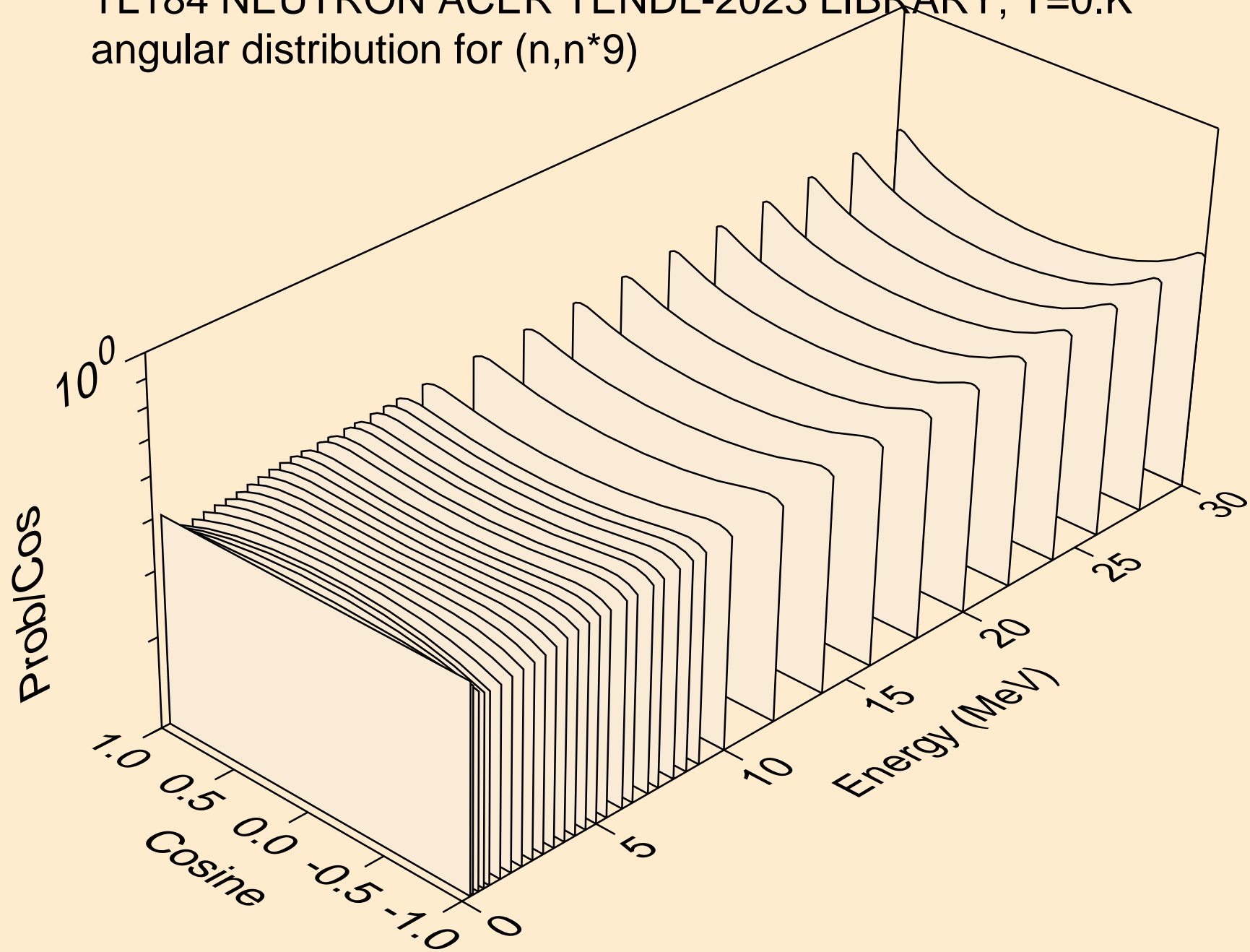

TL184 NEUTRON ACER TENDL-2023 LIBRARY; T=0.K
angular distribution for (n,n*10)

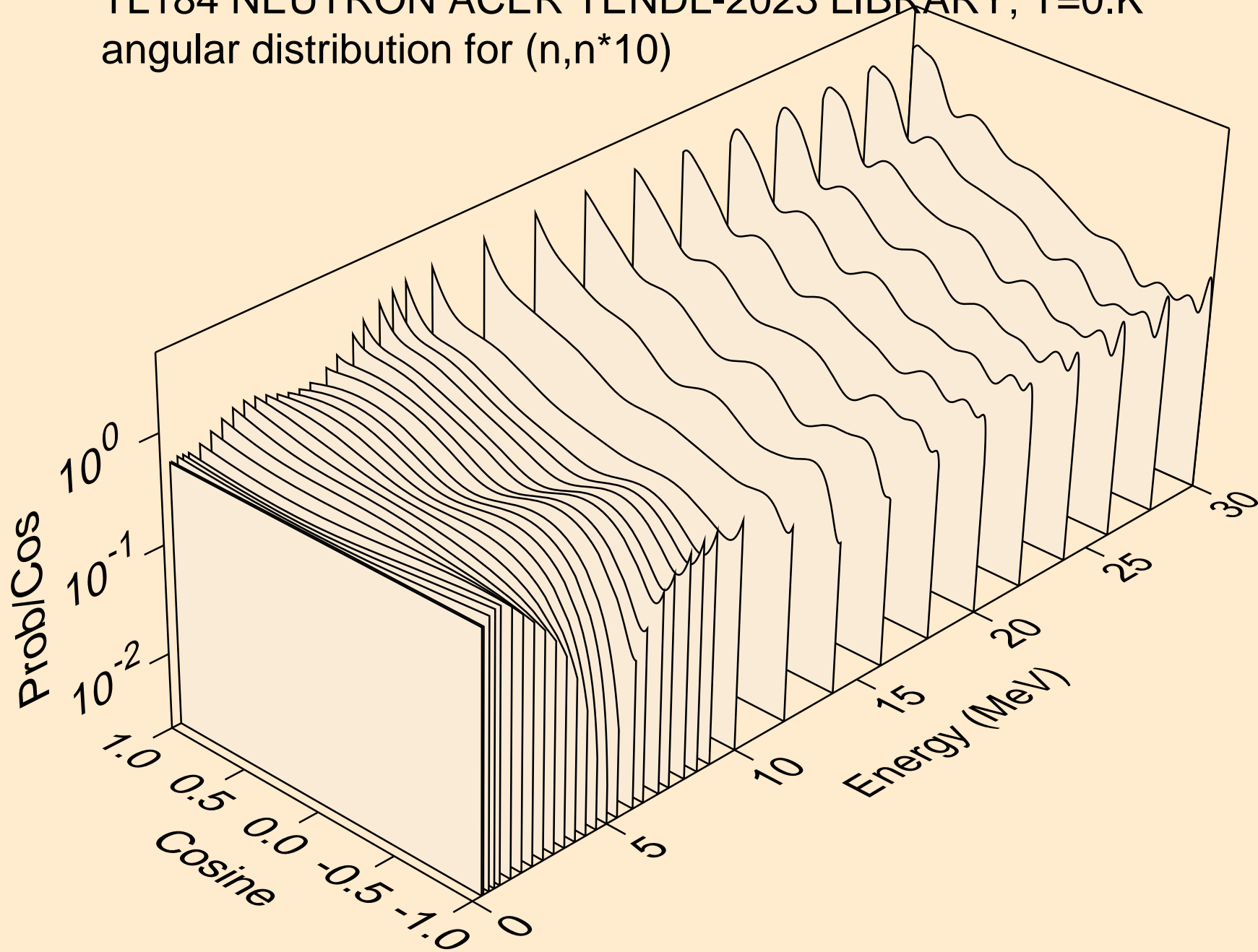

TL184 NEUTRON ACER TENDL-2023 LIBRARY; T=0.K
angular distribution for (n,n*11)

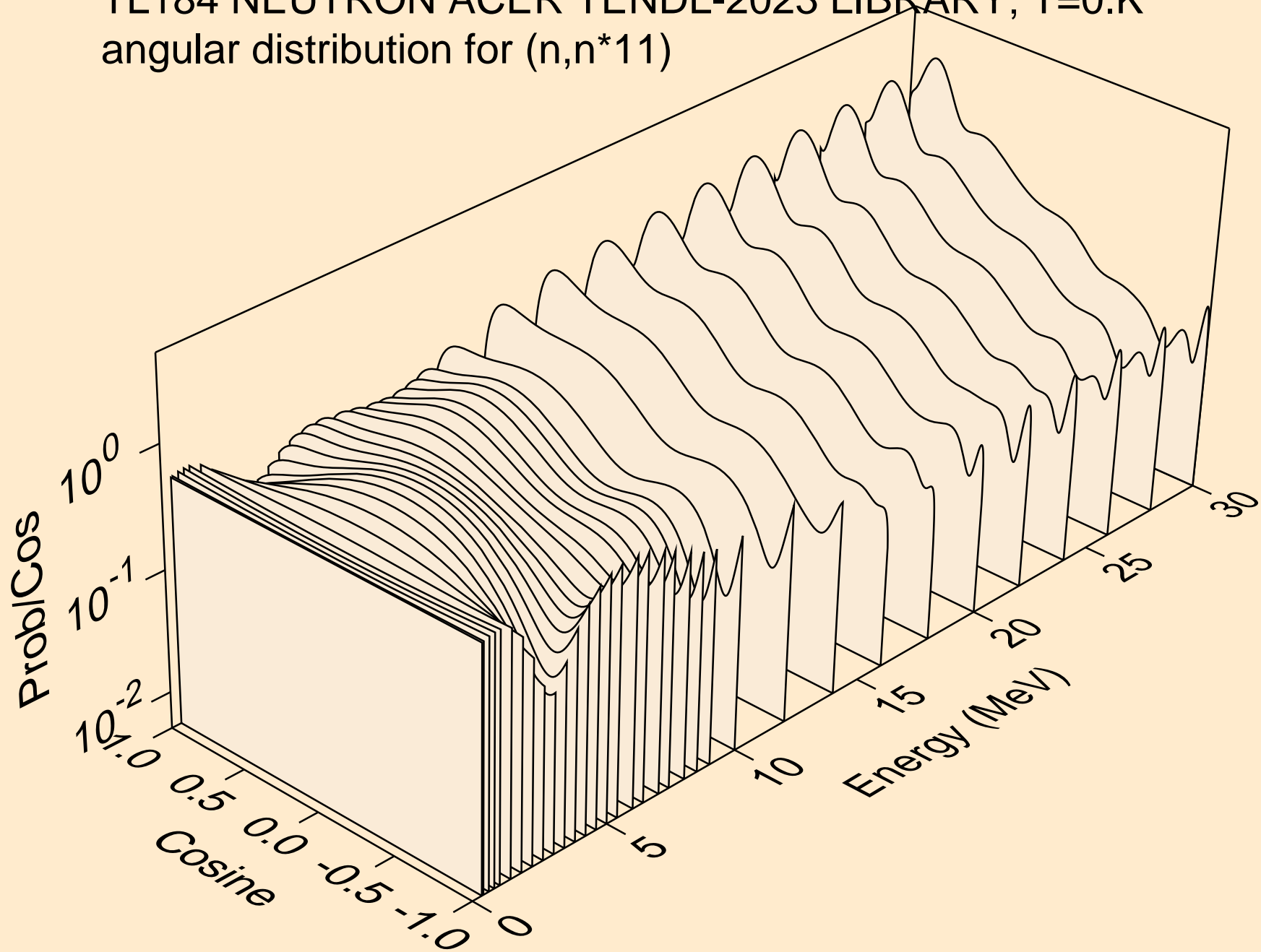

TL184 NEUTRON ACER TENDL-2023 LIBRARY; T=0.K
angular distribution for (n,n*12)

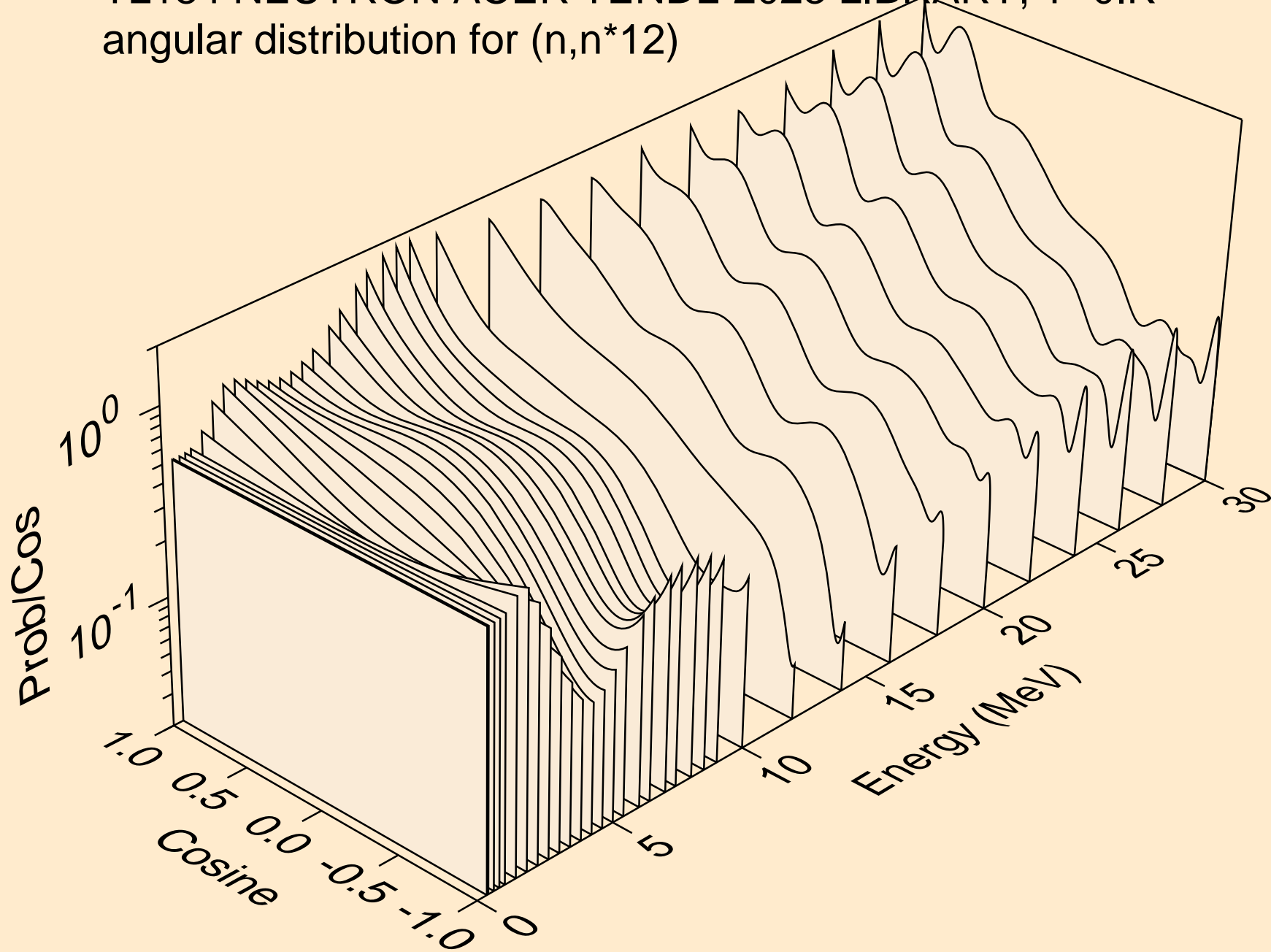

TL184 NEUTRON ACER TENDL-2023 LIBRARY; T=0.K
angular distribution for (n,n*13)

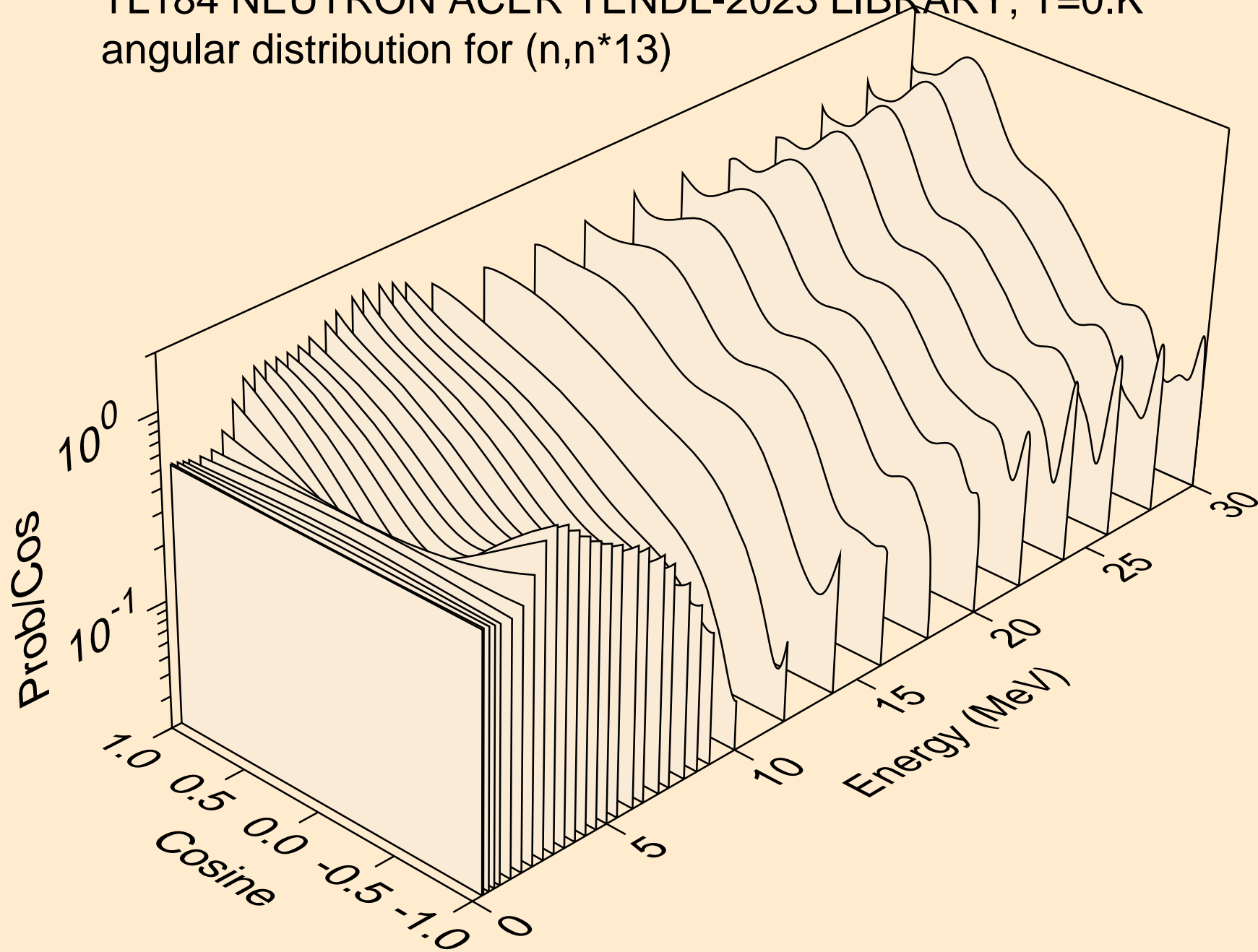

TL184 NEUTRON ACER TENDL-2023 LIBRARY; T=0.K
angular distribution for (n,n*14)

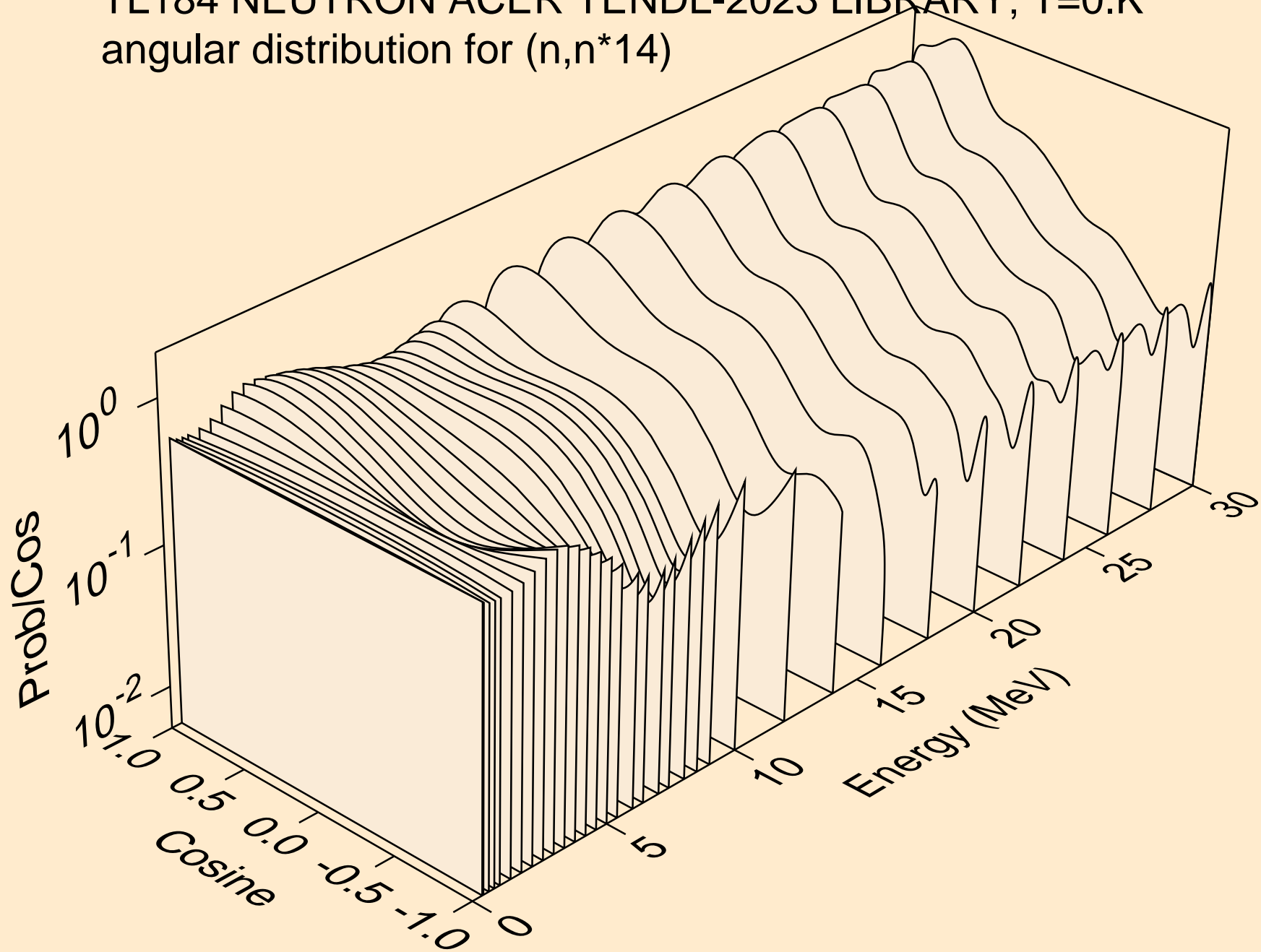

TL184 NEUTRON ACER TENDL-2023 LIBRARY; T=0.K
angular distribution for (n,n*15)

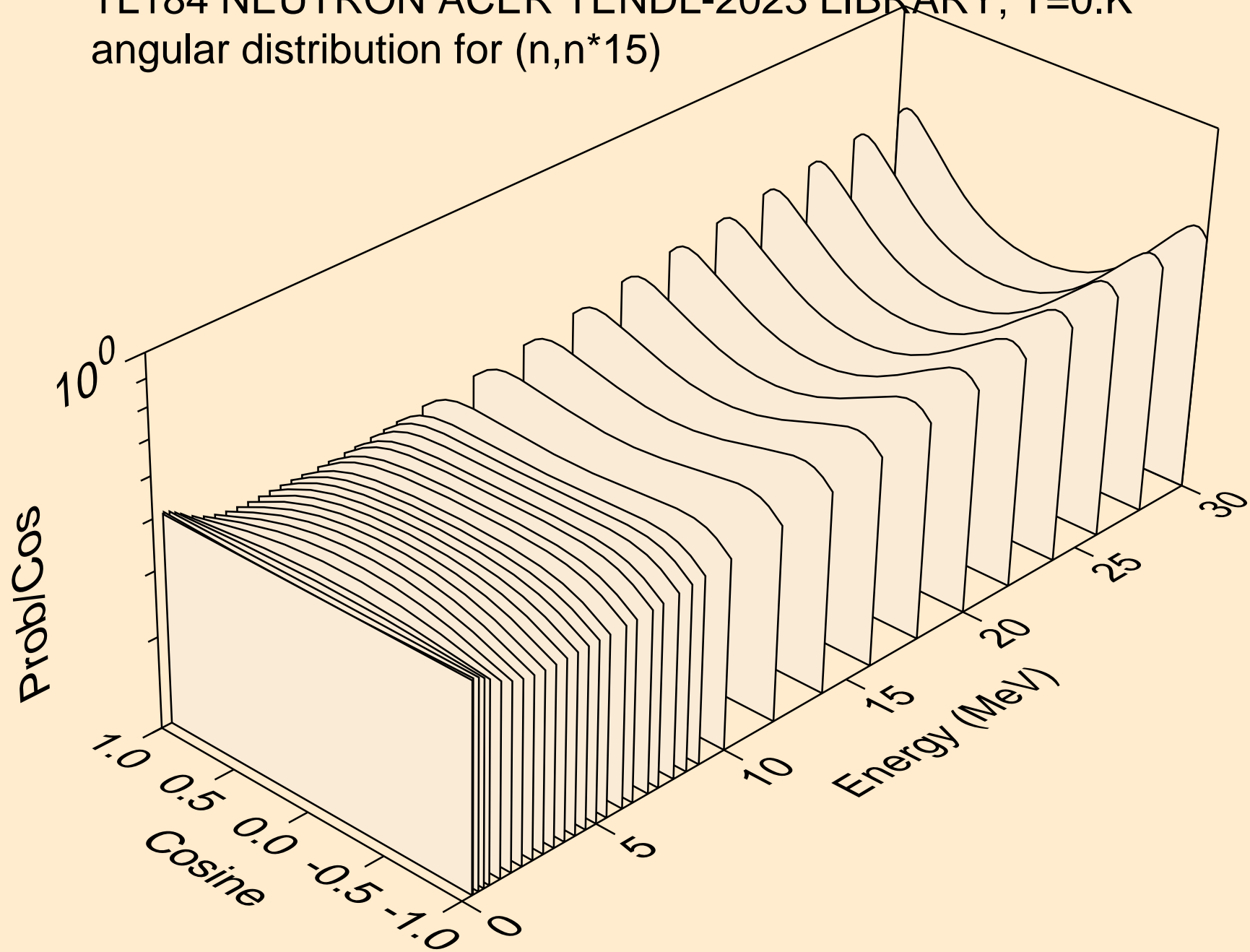

TL184 NEUTRON ACER TENDL-2023 LIBRARY; T=0.K
angular distribution for (n,n*16)

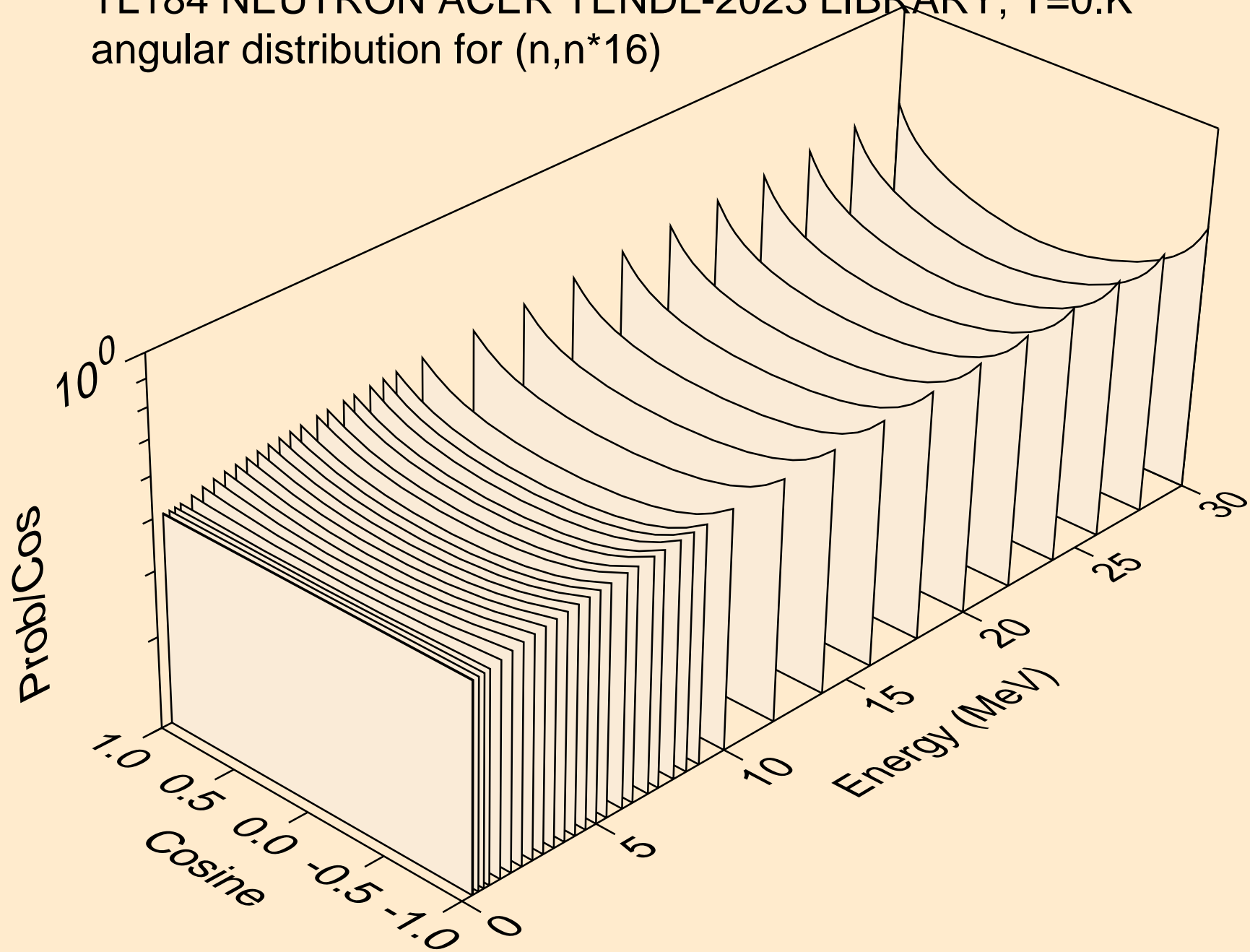

TL184 NEUTRON ACER TENDL-2023 LIBRARY; T=0.K
angular distribution for (n,n*17)

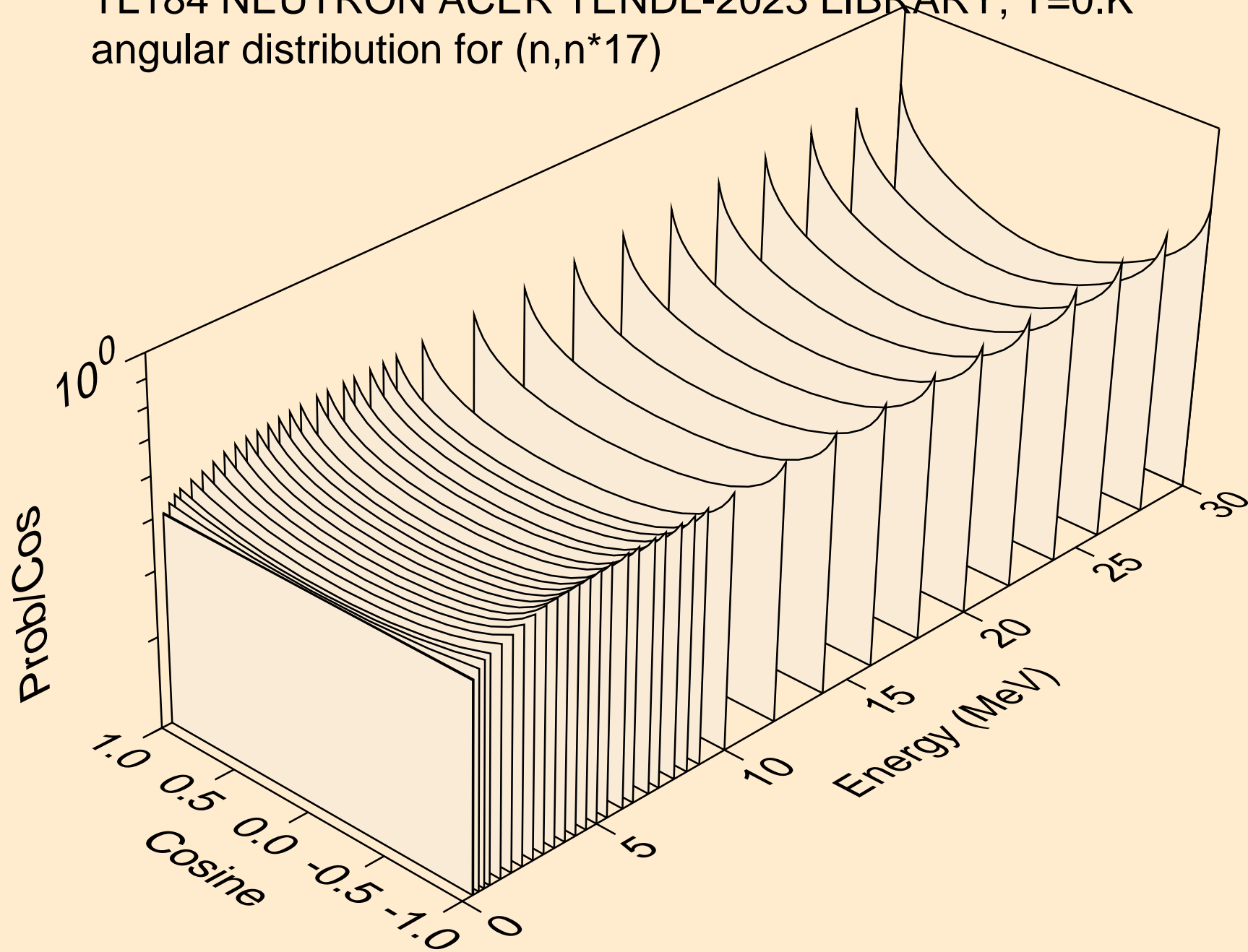

TL184 NEUTRON ACER TENDL-2023 LIBRARY; T=0.K
angular distribution for (n,n*18)

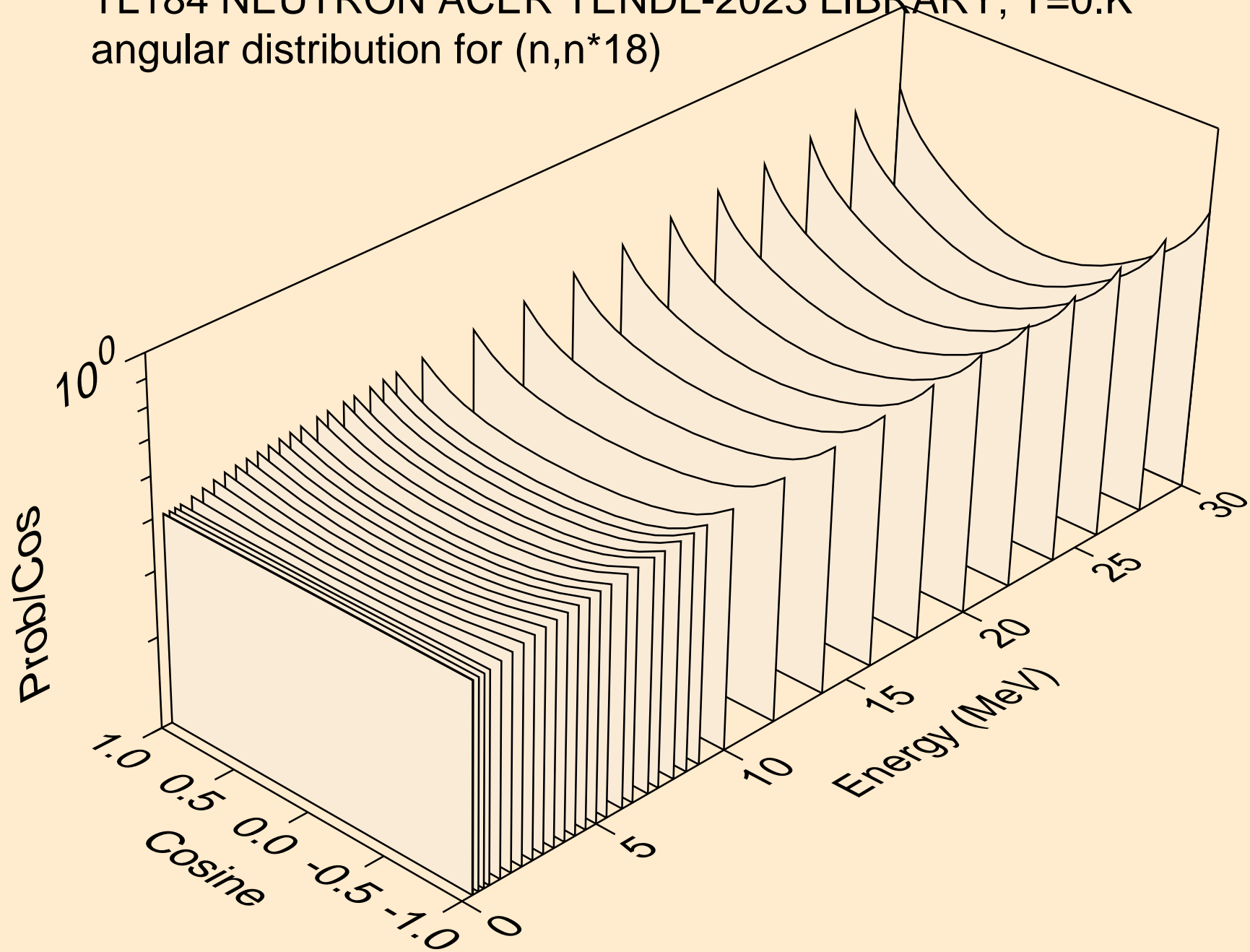

TL184 NEUTRON ACER TENDL-2023 LIBRARY; T=0.K
angular distribution for (n,n*19)

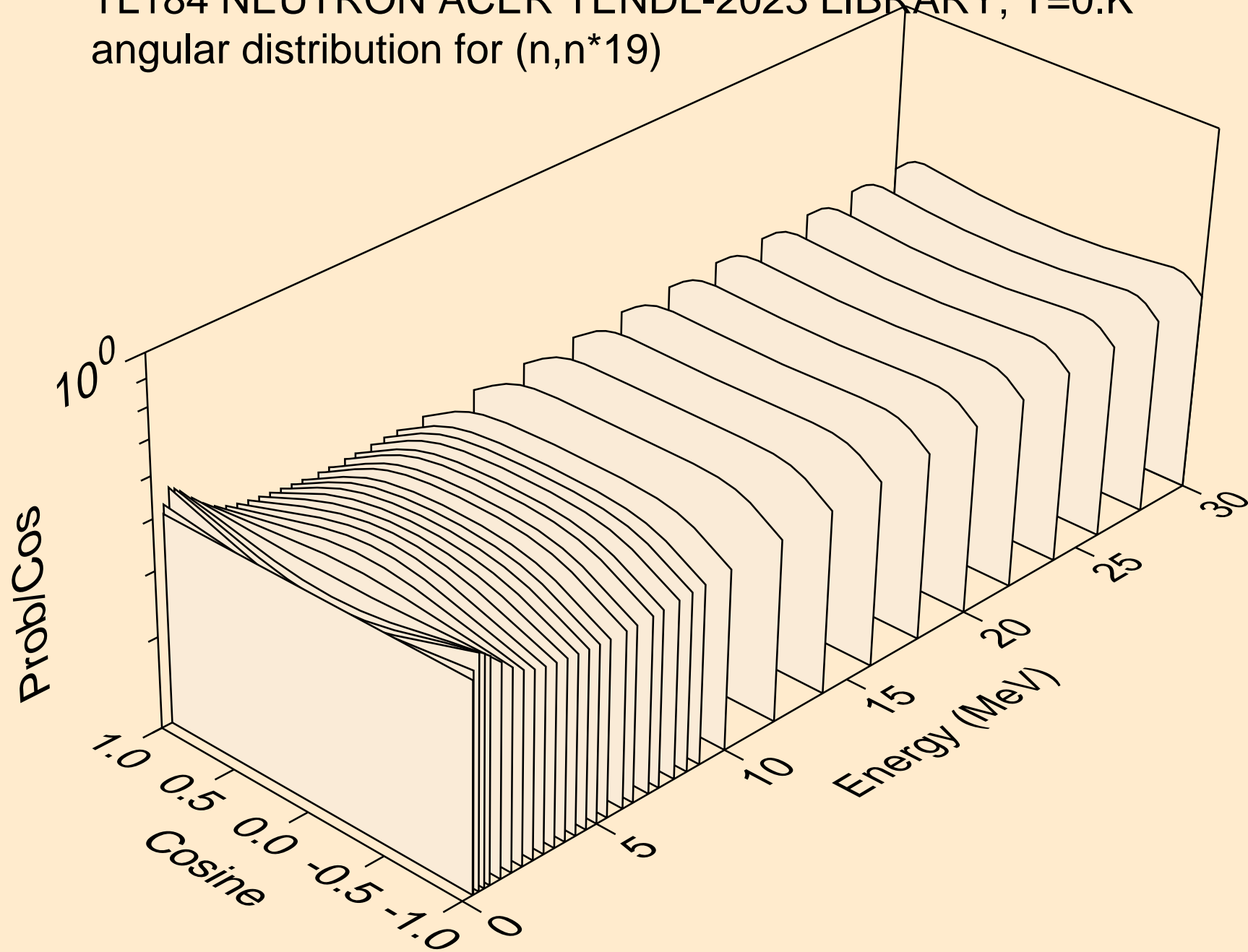

TL184 NEUTRON ACER TENDL-2023 LIBRARY; T=0.K
angular distribution for (n,n*20)

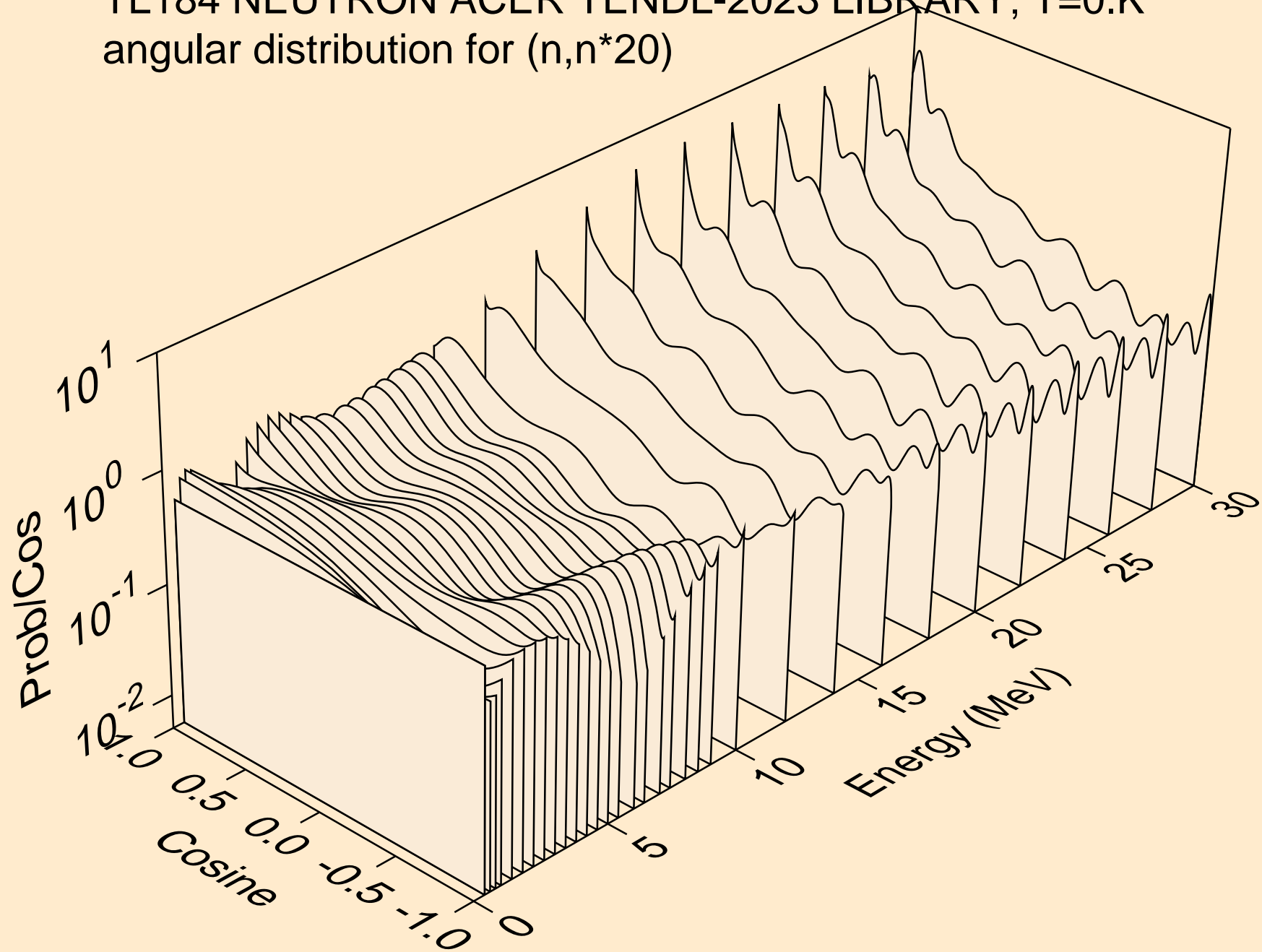

TL184 NEUTRON ACER TENDL-2023 LIBRARY; T=0.K
Neutron emission for (n,x)

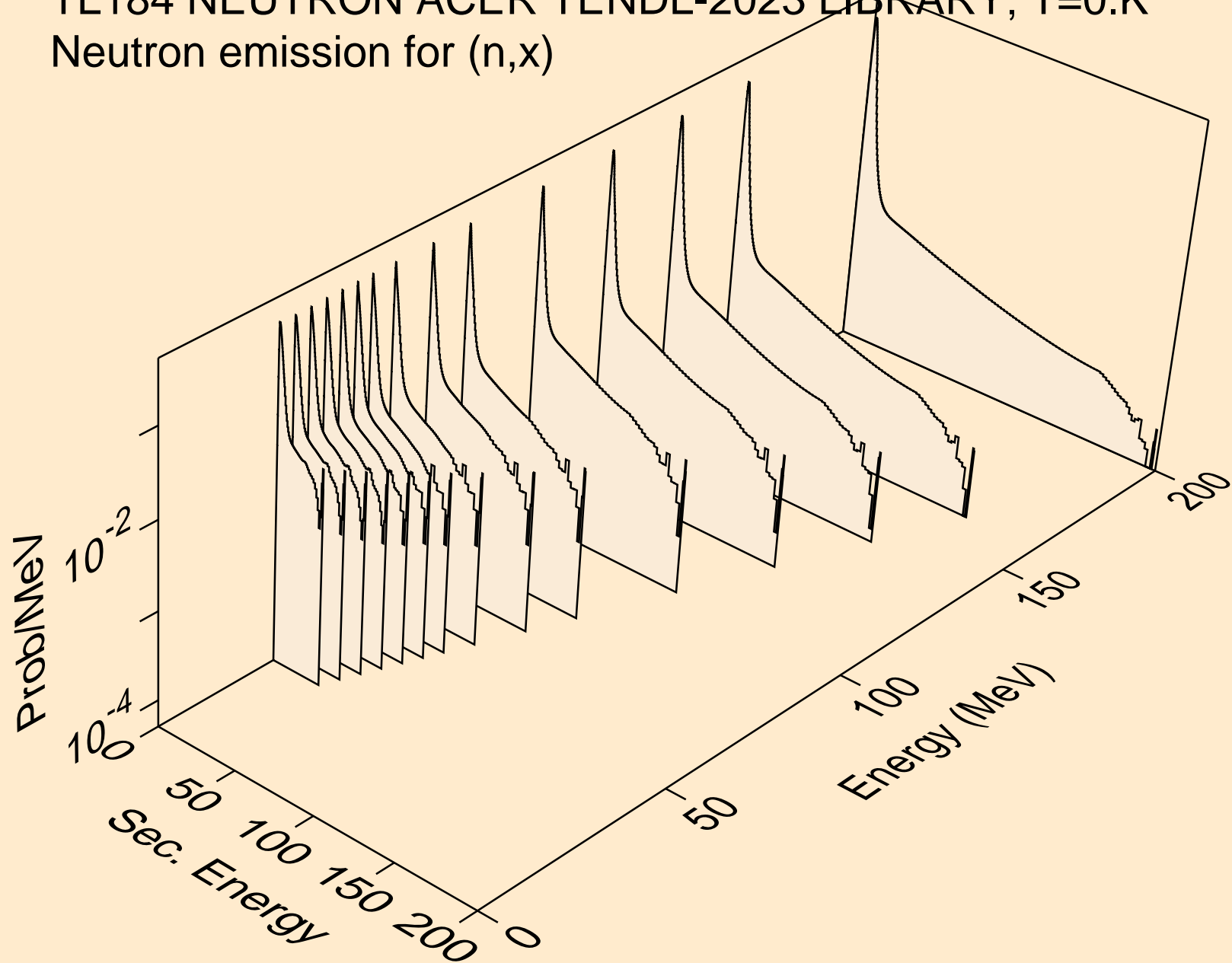

TL184 NEUTRON ACER TENDL-2023 LIBRARY; T=0.K
Neutron emission for (n,2nd)

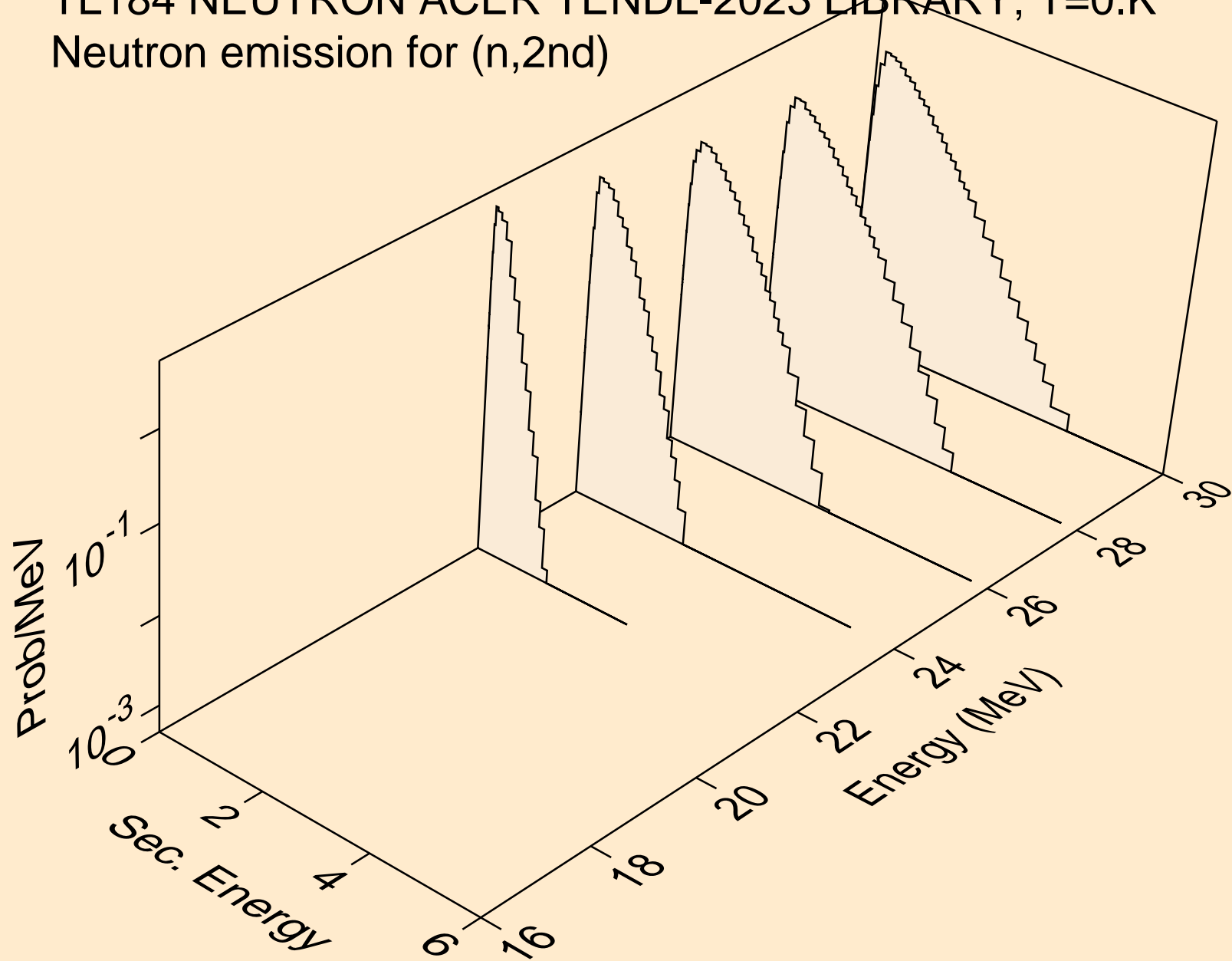

TL184 NEUTRON ACER TENDL-2023 LIBRARY; T=0.K
Neutron emission for (n,2n)

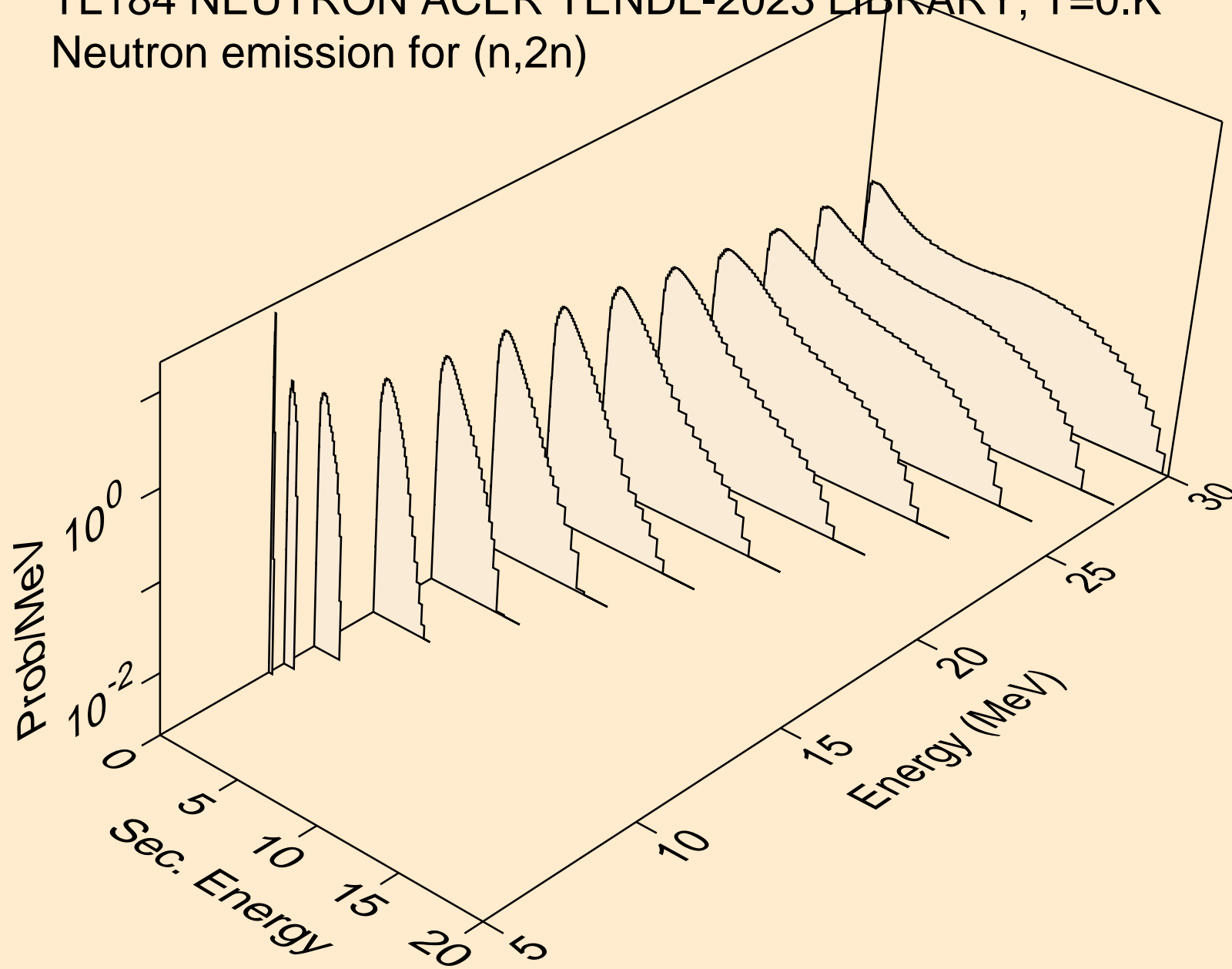

TL184 NEUTRON ACER TENDL-2023 LIBRARY; T=0.K
Neutron emission for (n,3n)

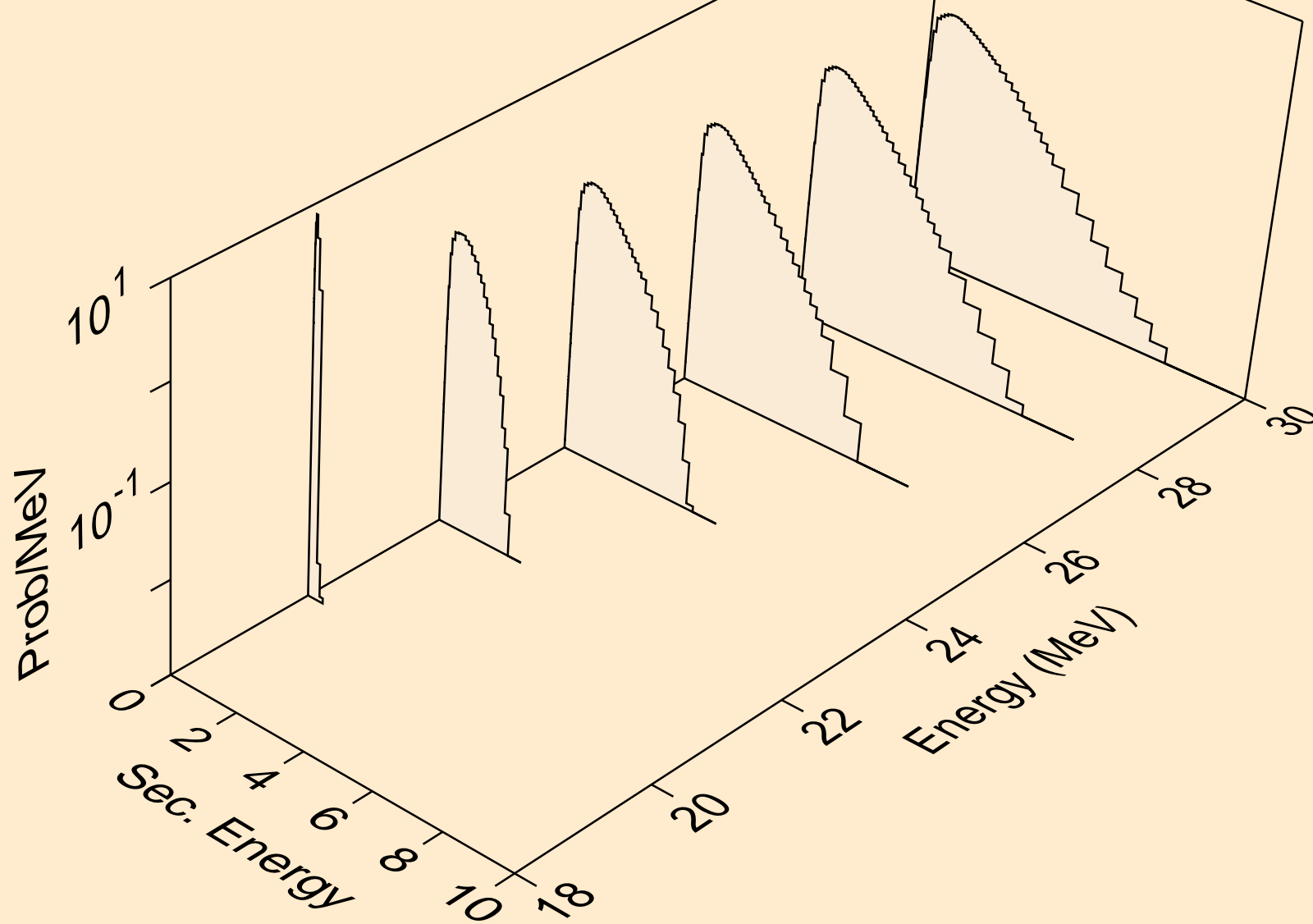

TL184 NEUTRON ACER TENDL-2023 LIBRARY; T=0.K
Neutron emission for (n,n*)a

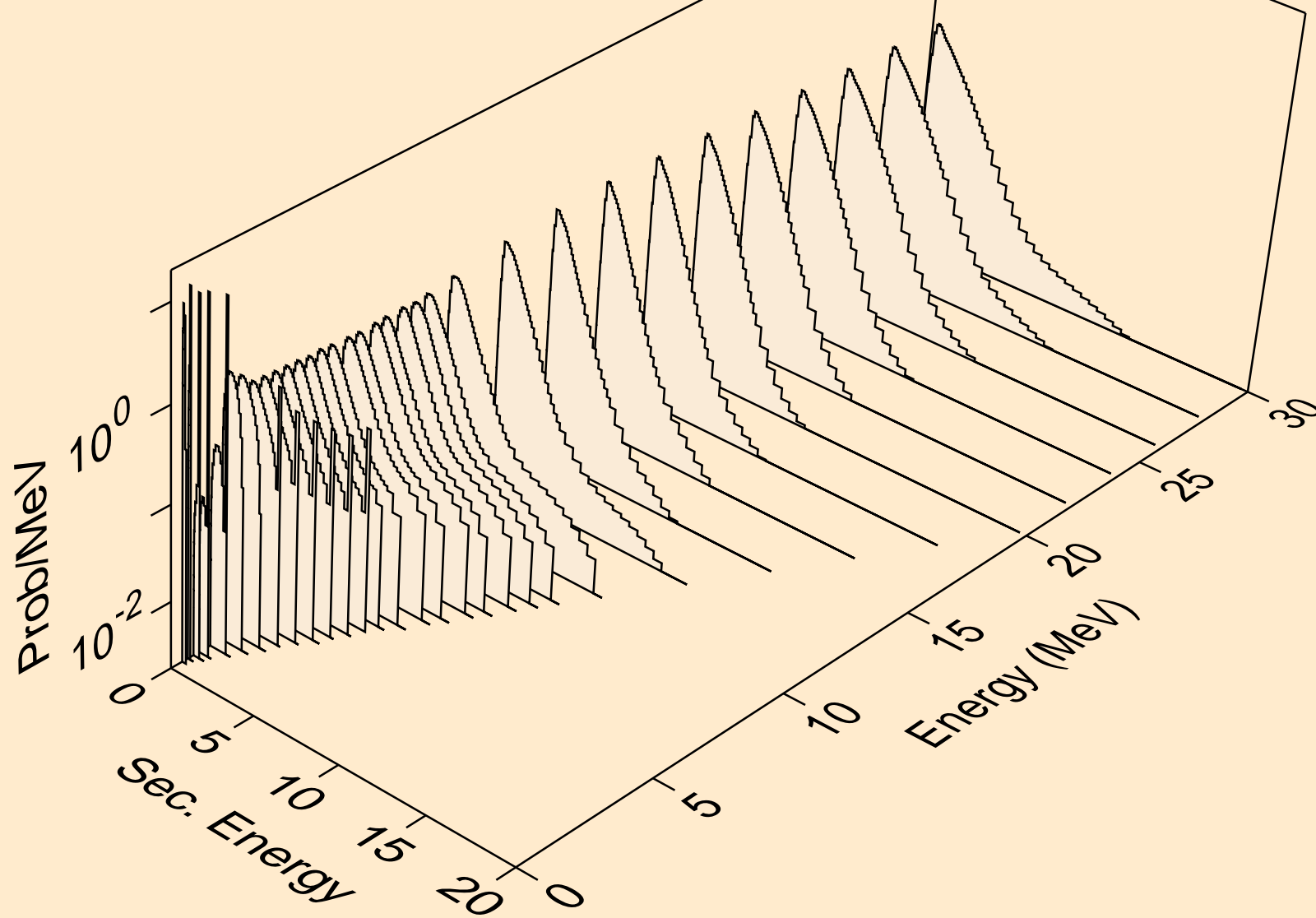

TL184 NEUTRON ACER TENDL-2023 LIBRARY; T=0.K
Neutron emission for (n,n*)3a

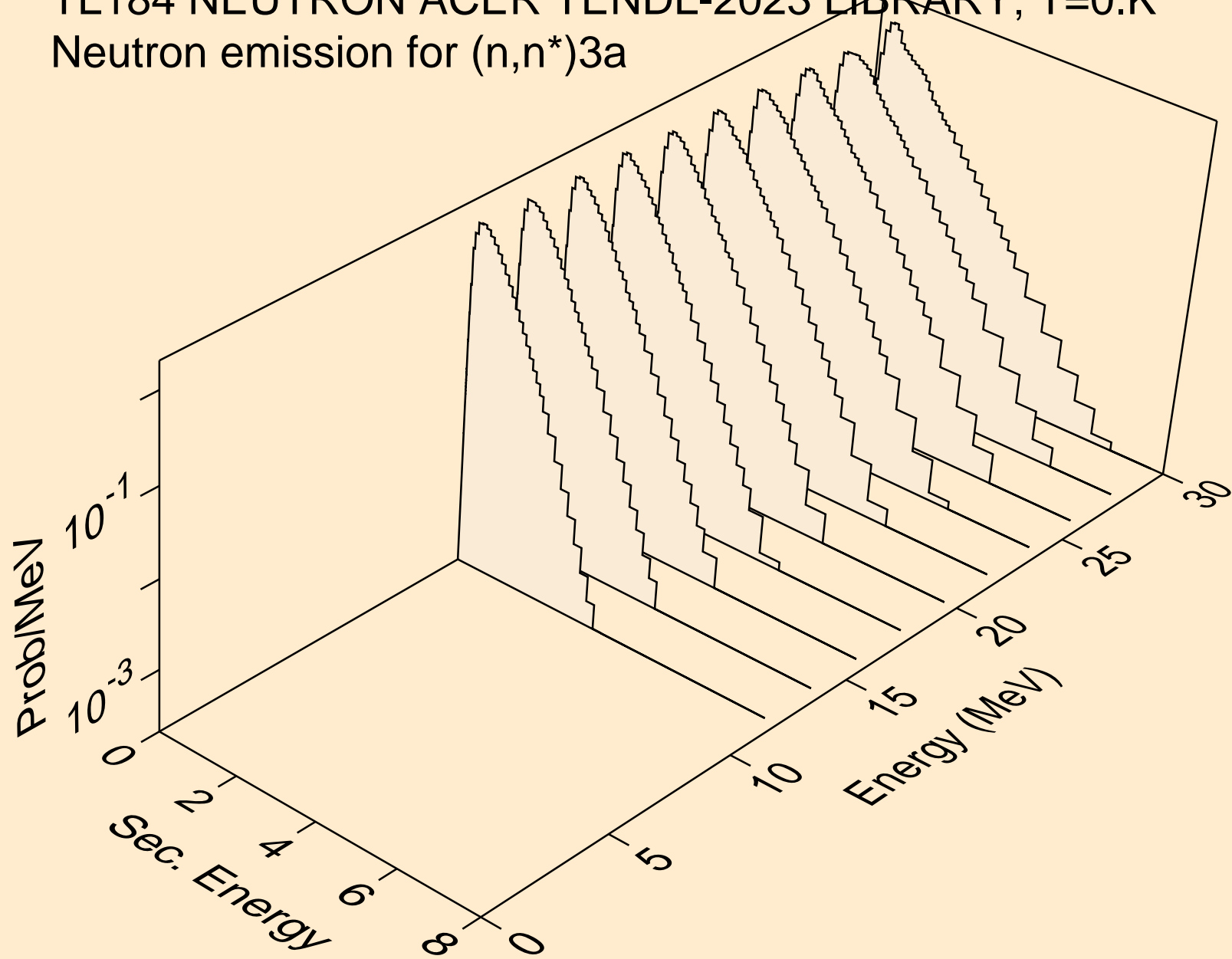

TL184 NEUTRON ACER TENDL-2023 LIBRARY; T=0.K
Neutron emission for (n,2n)a

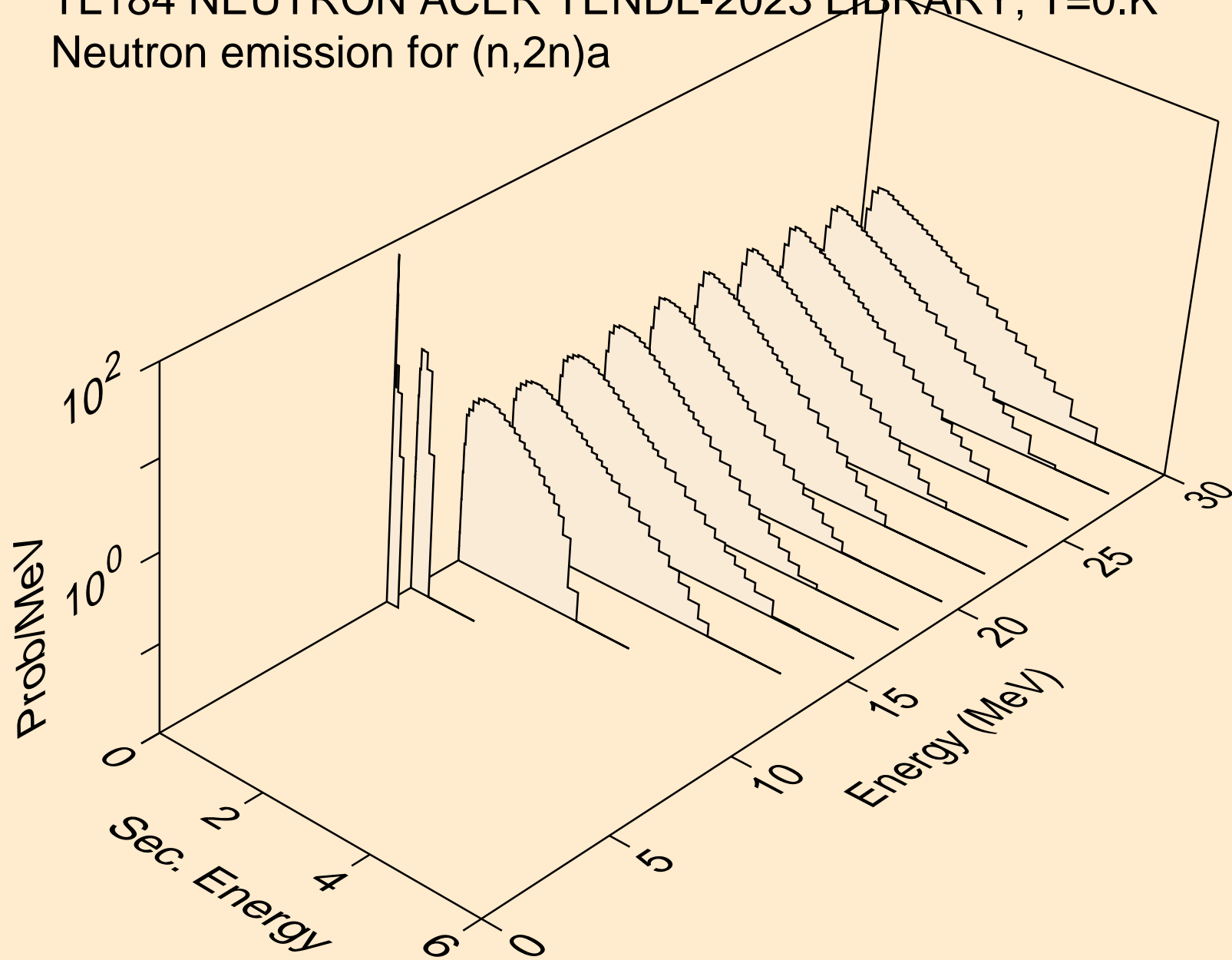

TL184 NEUTRON ACER TENDL-2023 LIBRARY; T=0.K
Neutron emission for (n,3n)a

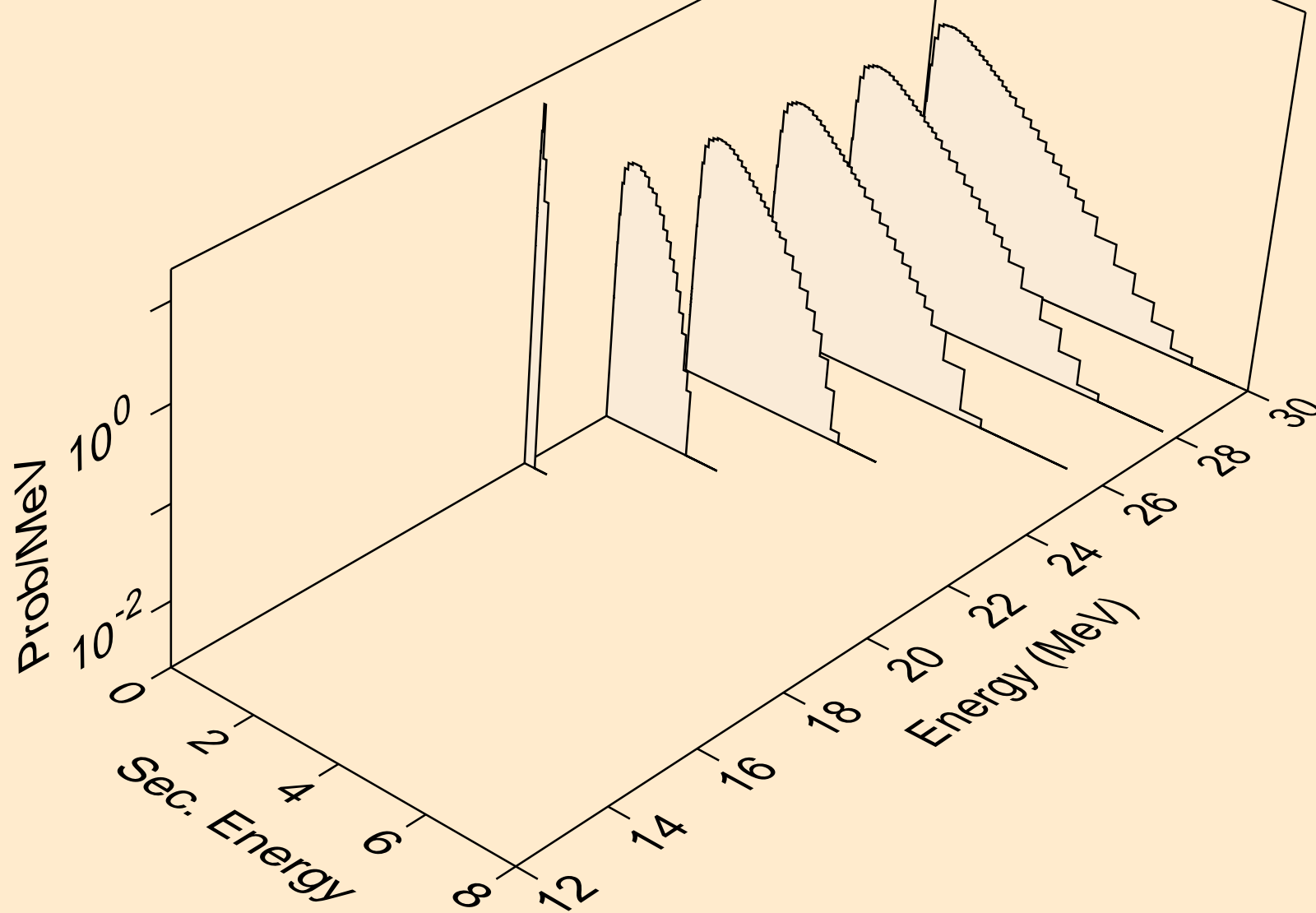

TL184 NEUTRON ACER TENDL-2023 LIBRARY; T=0.K
Neutron emission for (n,n*)p

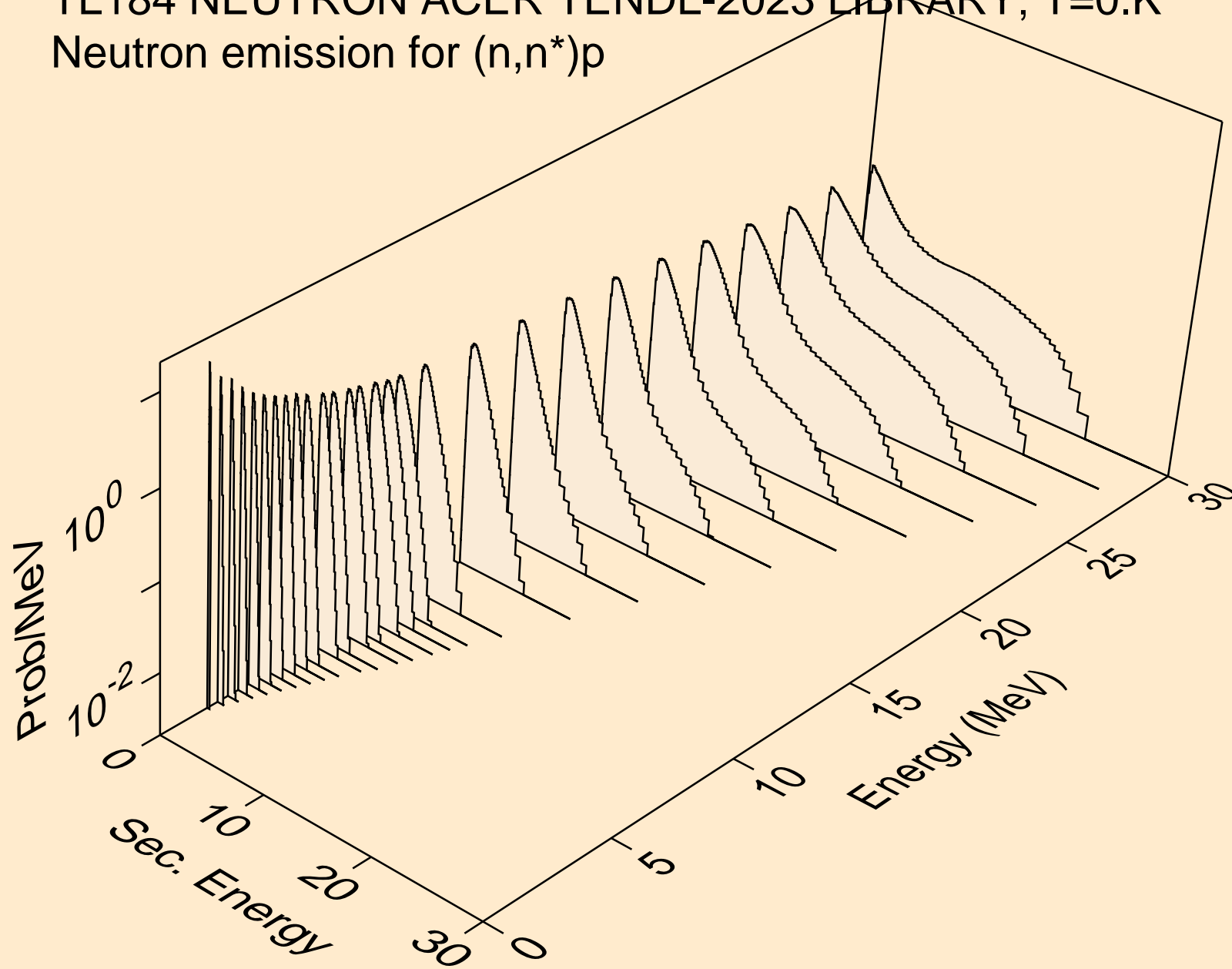

TL184 NEUTRON ACER TENDL-2023 LIBRARY; T=0.K
Neutron emission for (n,n*)2a

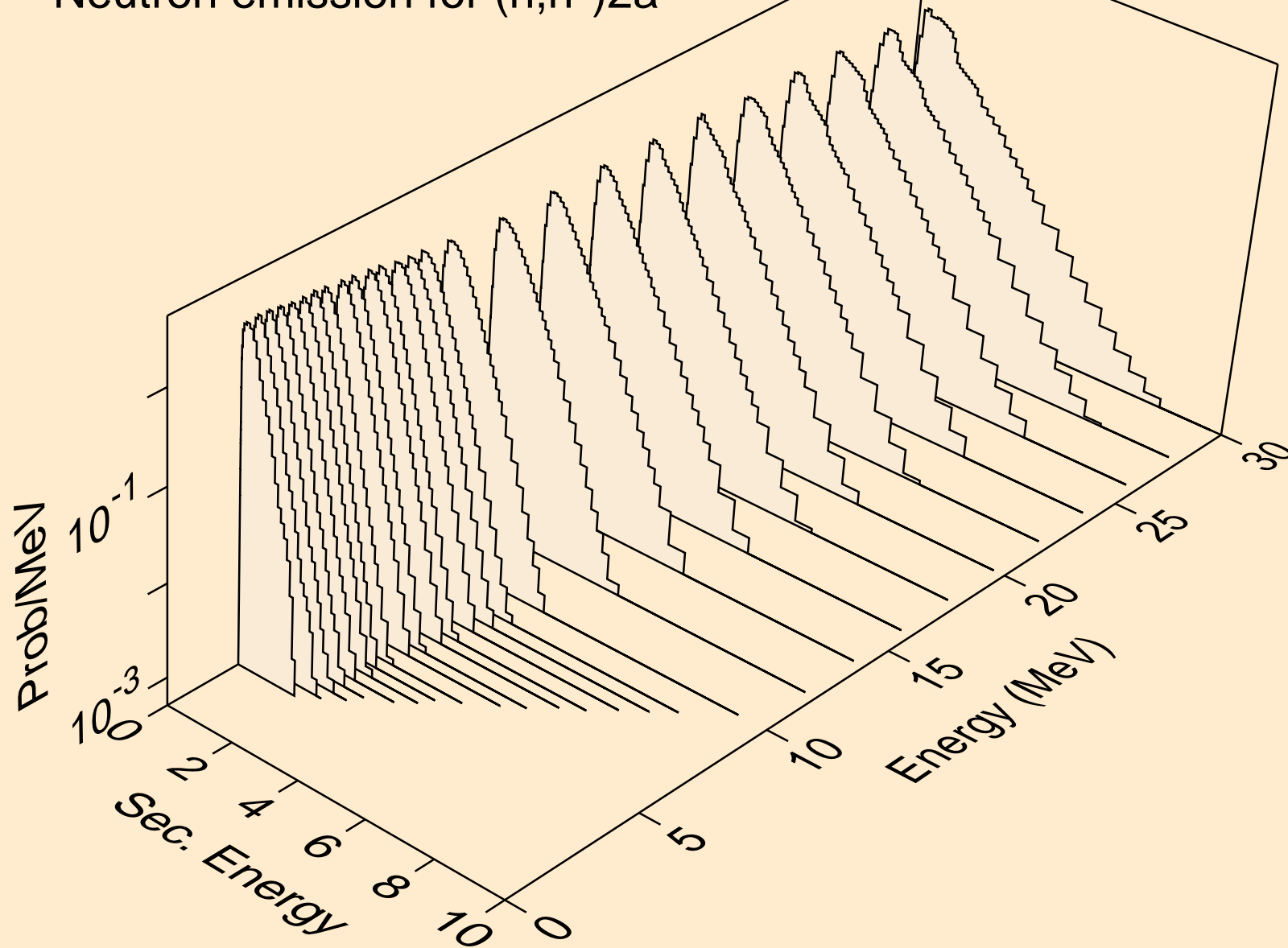

TL184 NEUTRON ACER TENDL-2023 LIBRARY; T=0.K
Neutron emission for (n,2n)2a

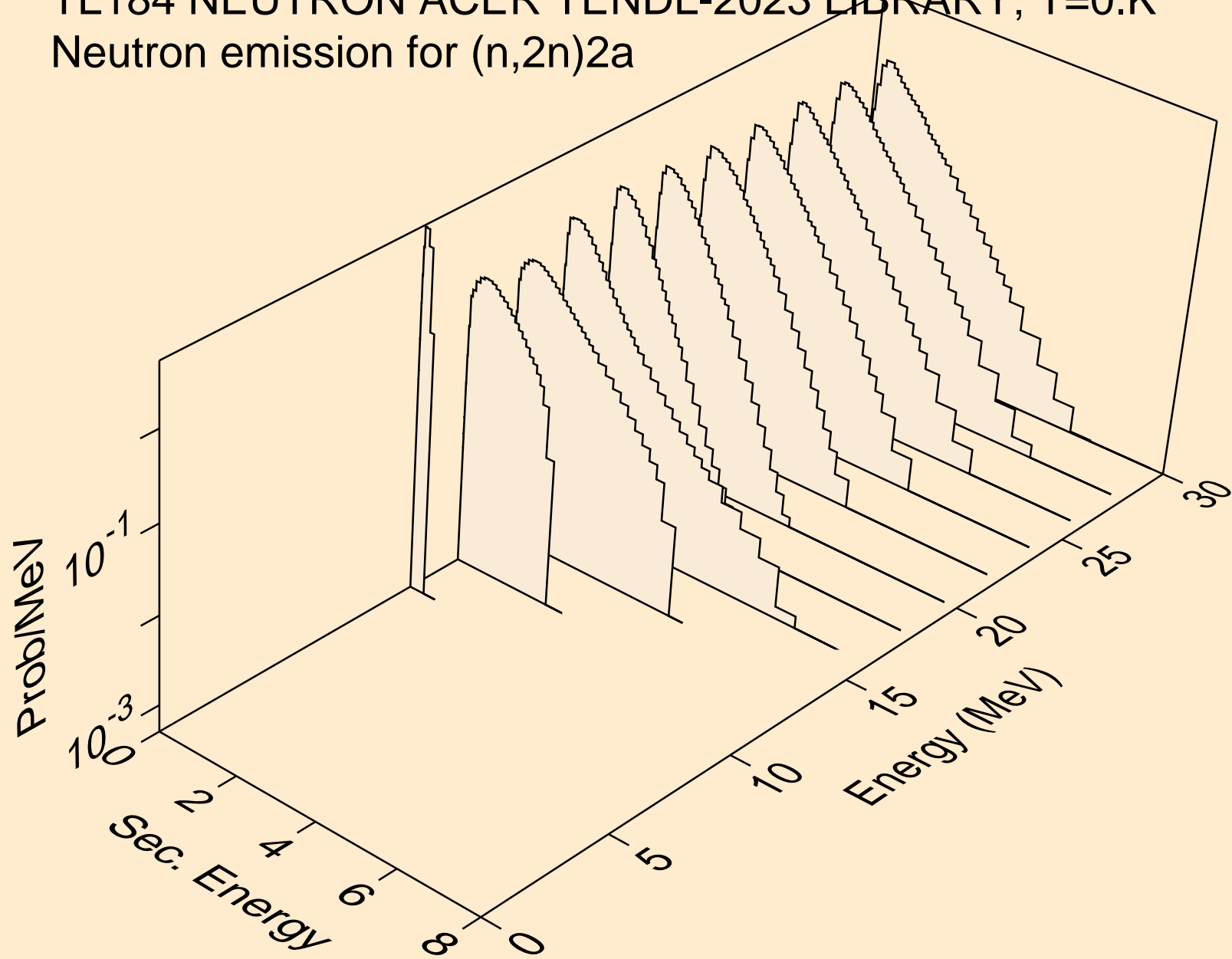

TL184 NEUTRON ACER TENDL-2023 LIBRARY; T=0.K
Neutron emission for (n,n*)d

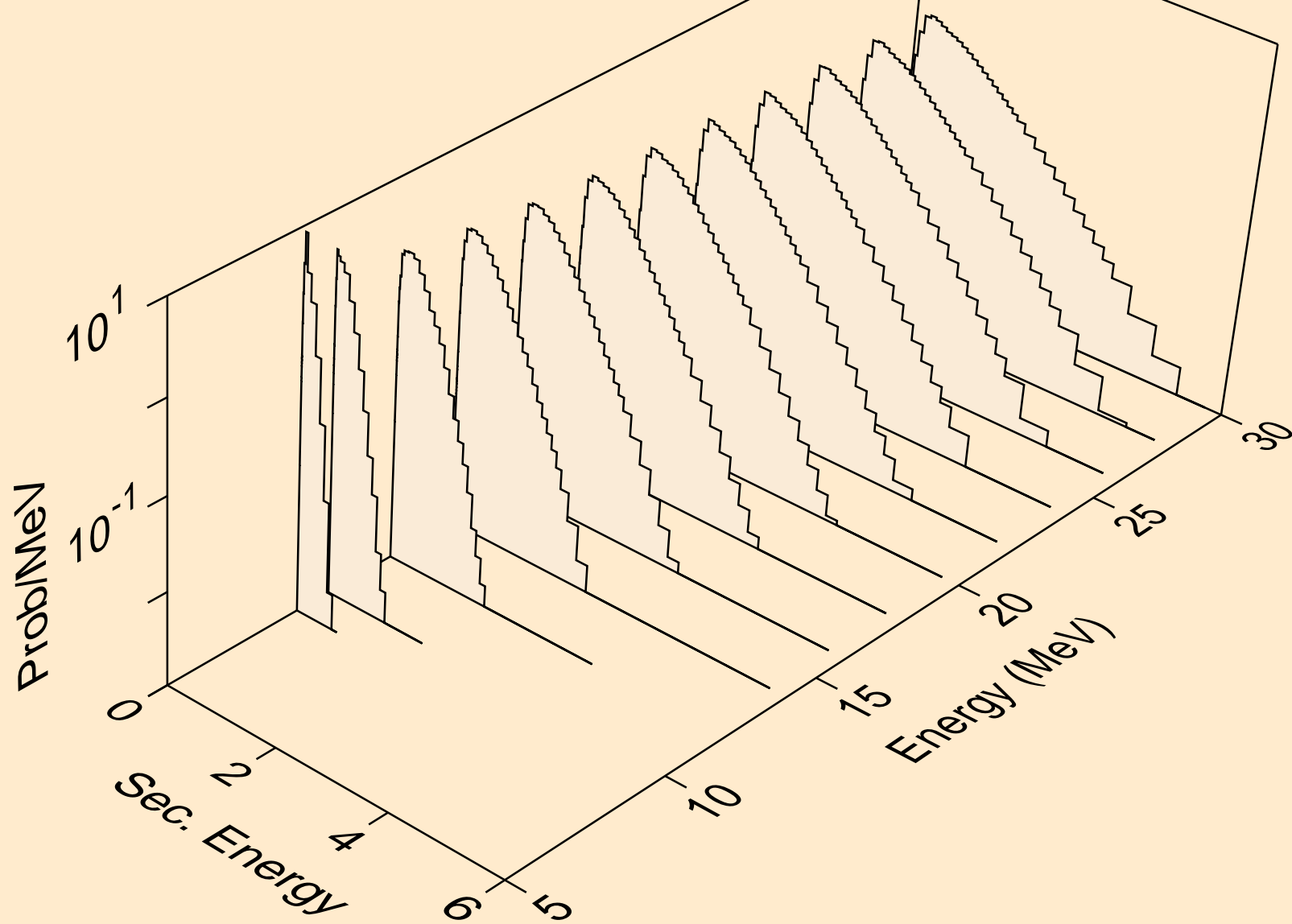

TL184 NEUTRON ACER TENDL-2023 LIBRARY; T=0.K
Neutron emission for (n,n*)t

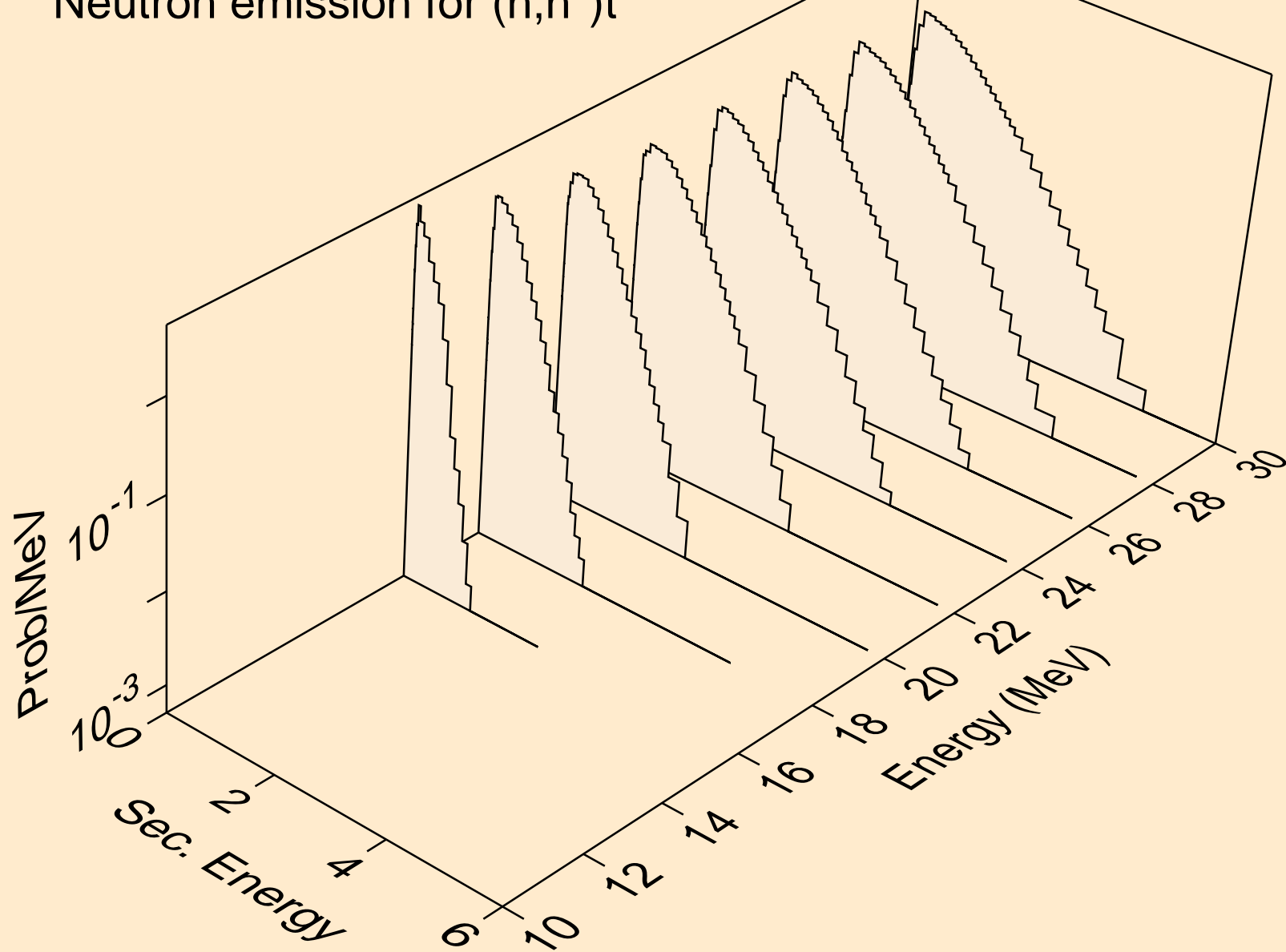

TL184 NEUTRON ACER TENDL-2023 LIBRARY; T=0.K
Neutron emission for (n,n*)he3

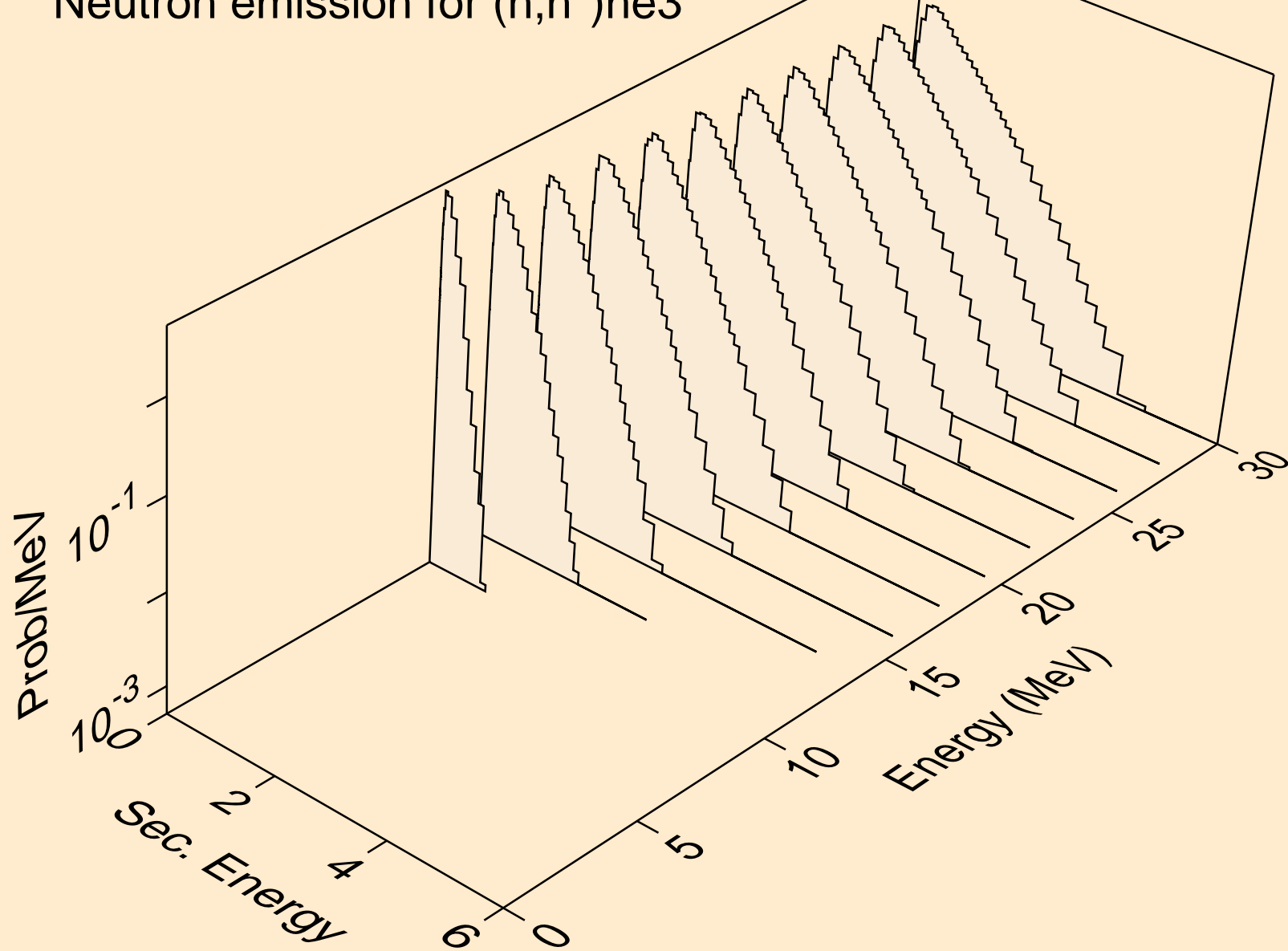

TL184 NEUTRON ACER TENDL-2023 LIBRARY; T=0.K
Neutron emission for (n,4n)

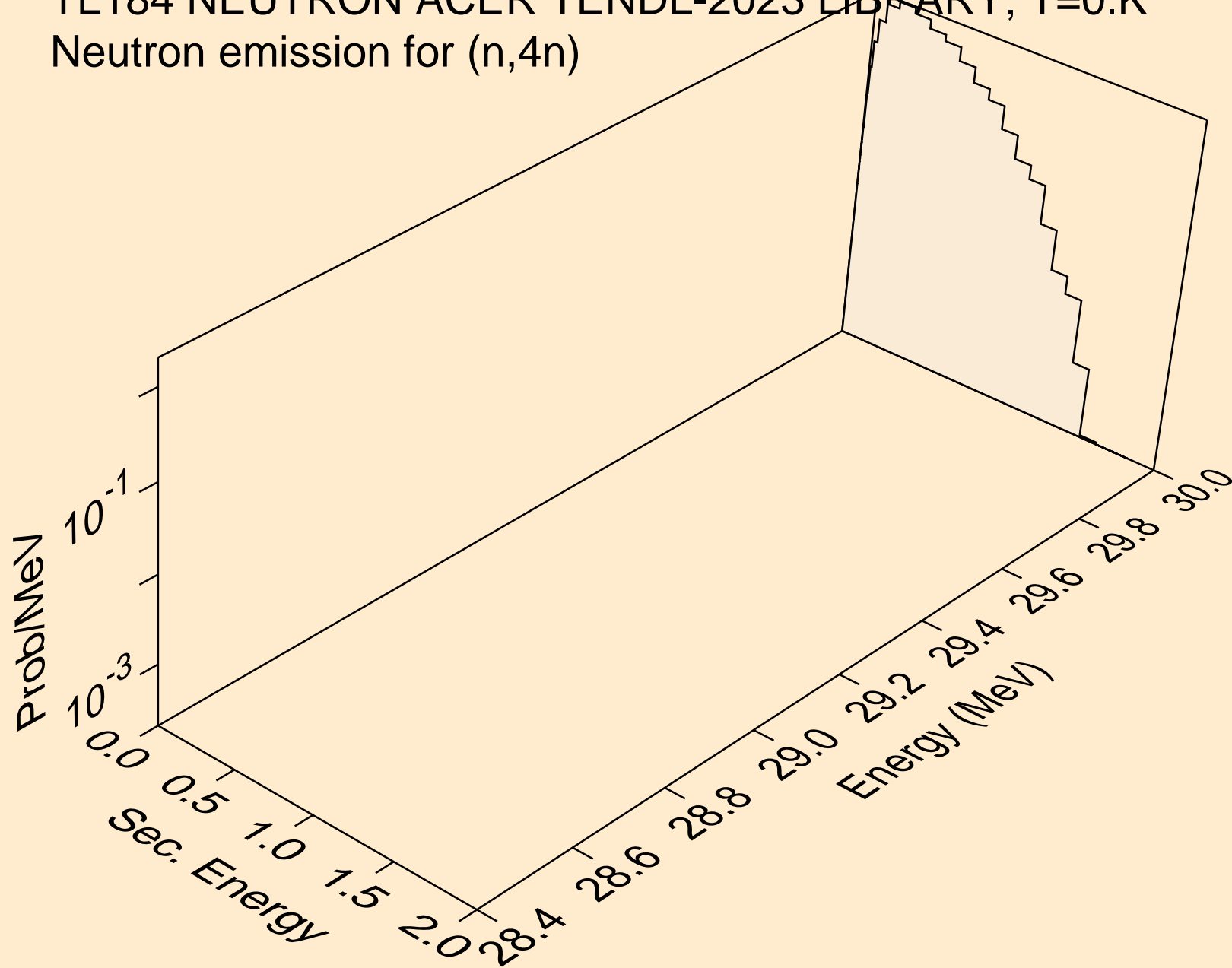

TL184 NEUTRON ACER TENDL-2023 LIBRARY; T=0.K
Neutron emission for (n,2np)

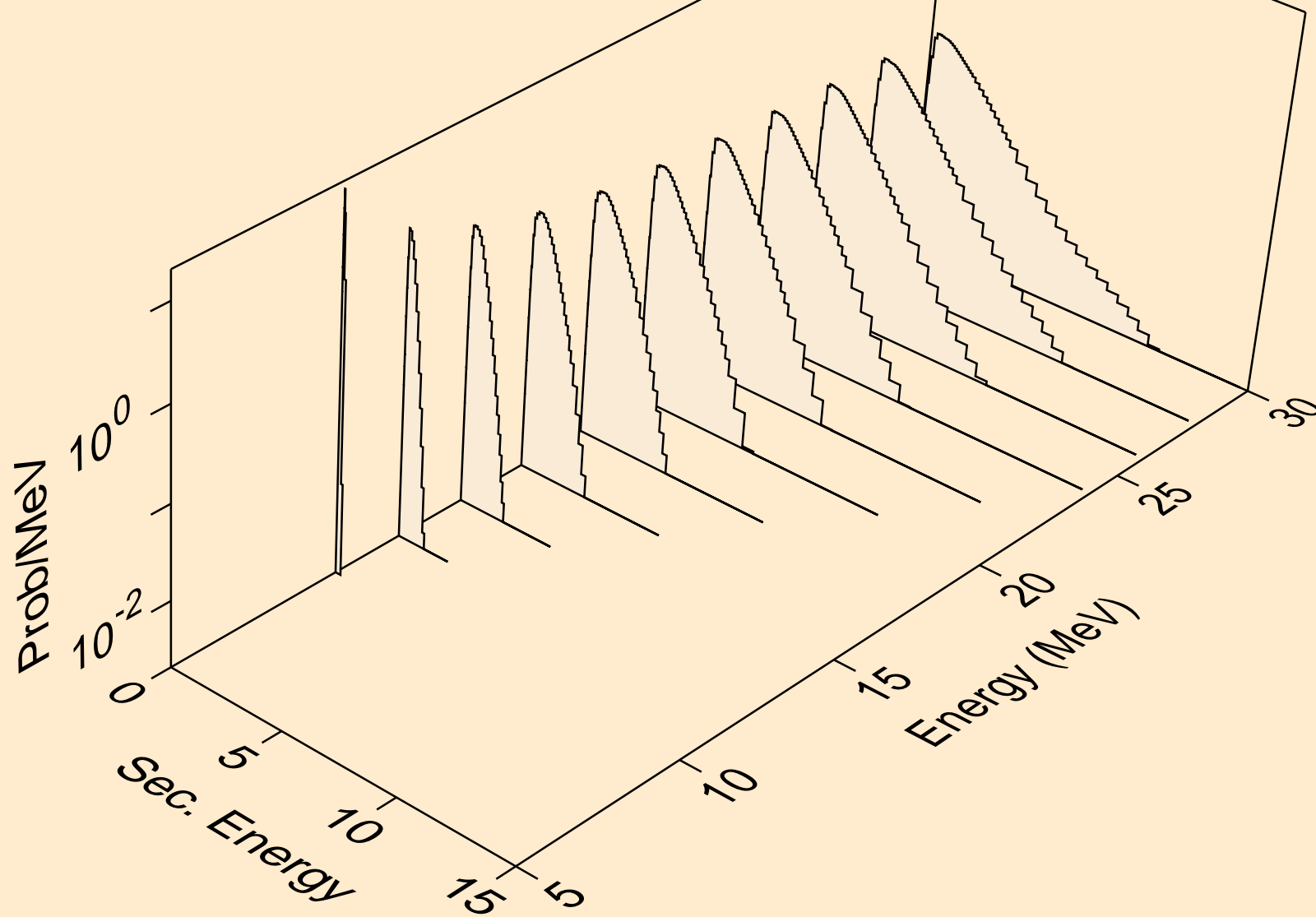

TL184 NEUTRON ACER TENDL-2023 LIBRARY; T=0.K
Neutron emission for (n,3np)

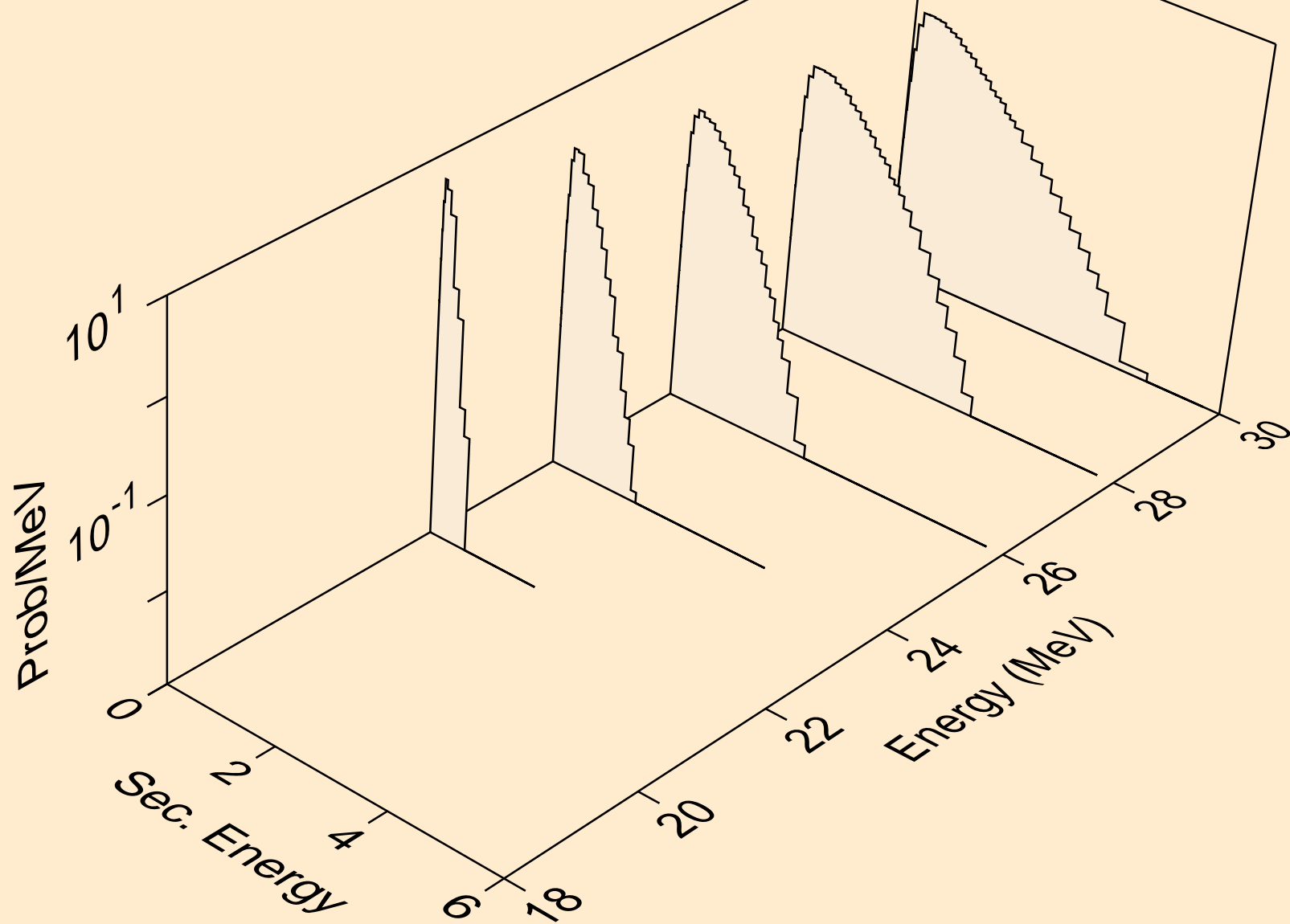

TL184 NEUTRON ACER TENDL-2023 LIBRARY; T=0.K
Neutron emission for (n,n2p)

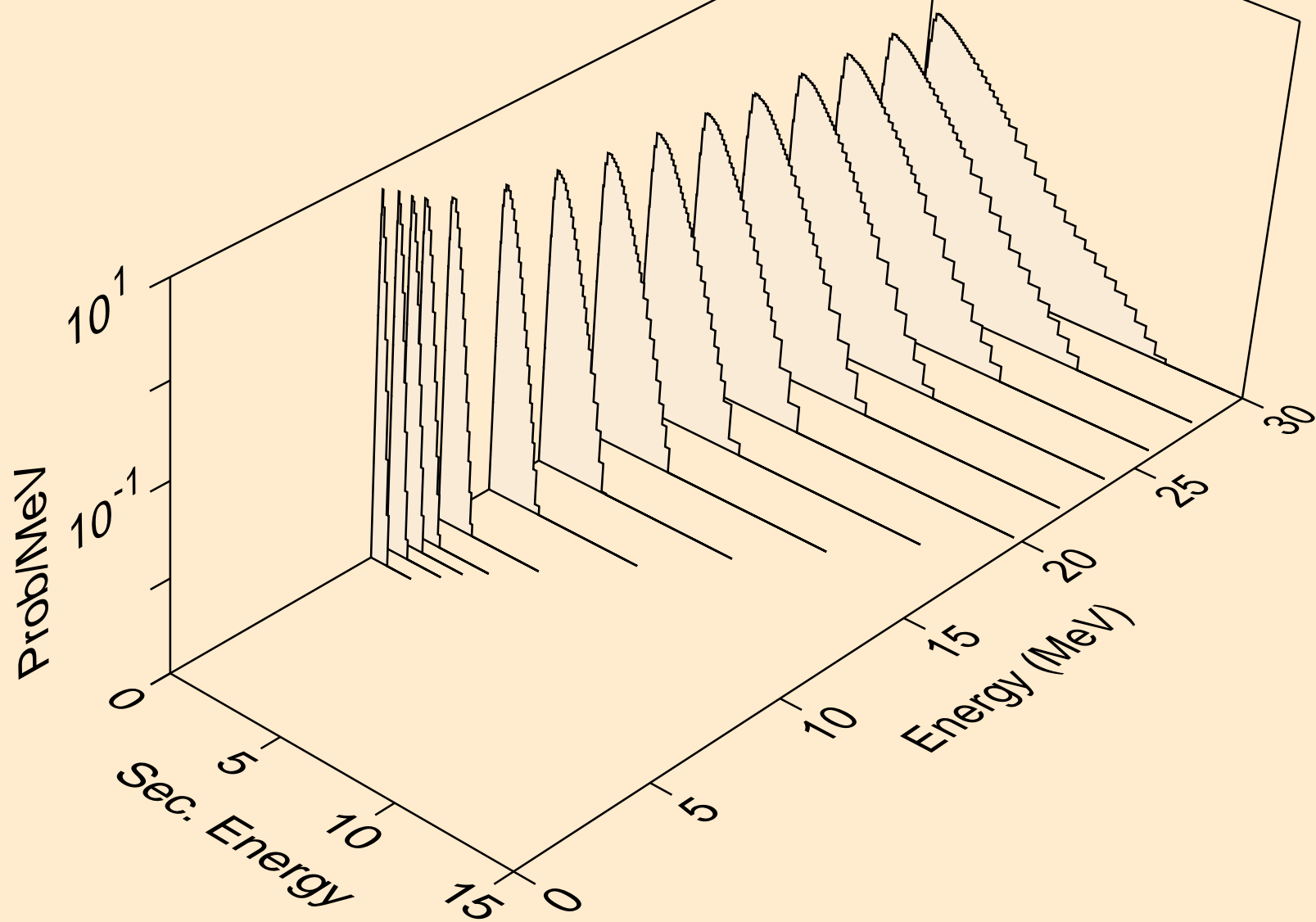

TL184 NEUTRON ACER TENDL-2023 LIBRARY; T=0.K
Neutron emission for (n,npa)

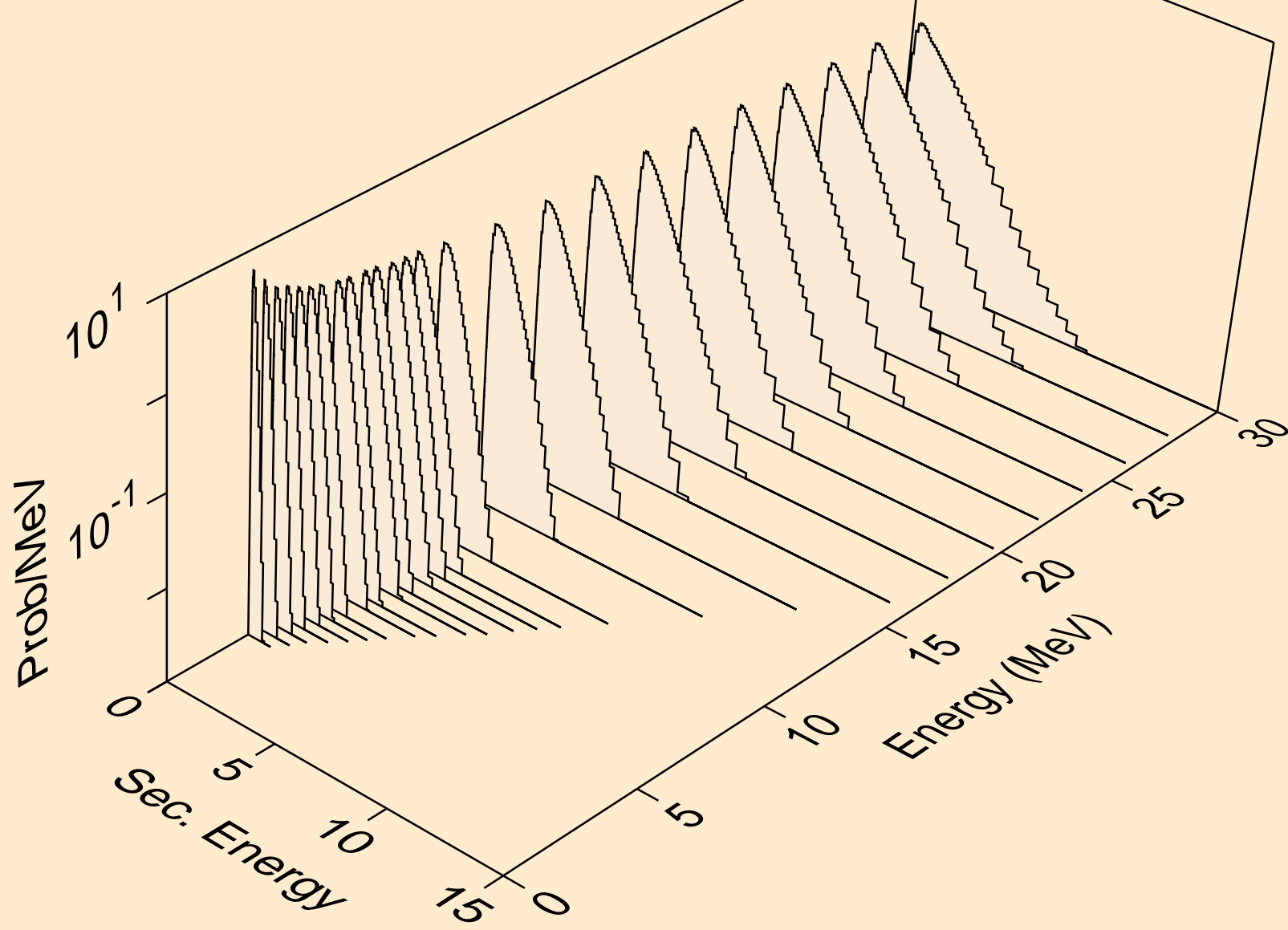

TL184 NEUTRON ACER TENDL-2023 LIBRARY; T=0.K
Neutron emission for (n,n*c)

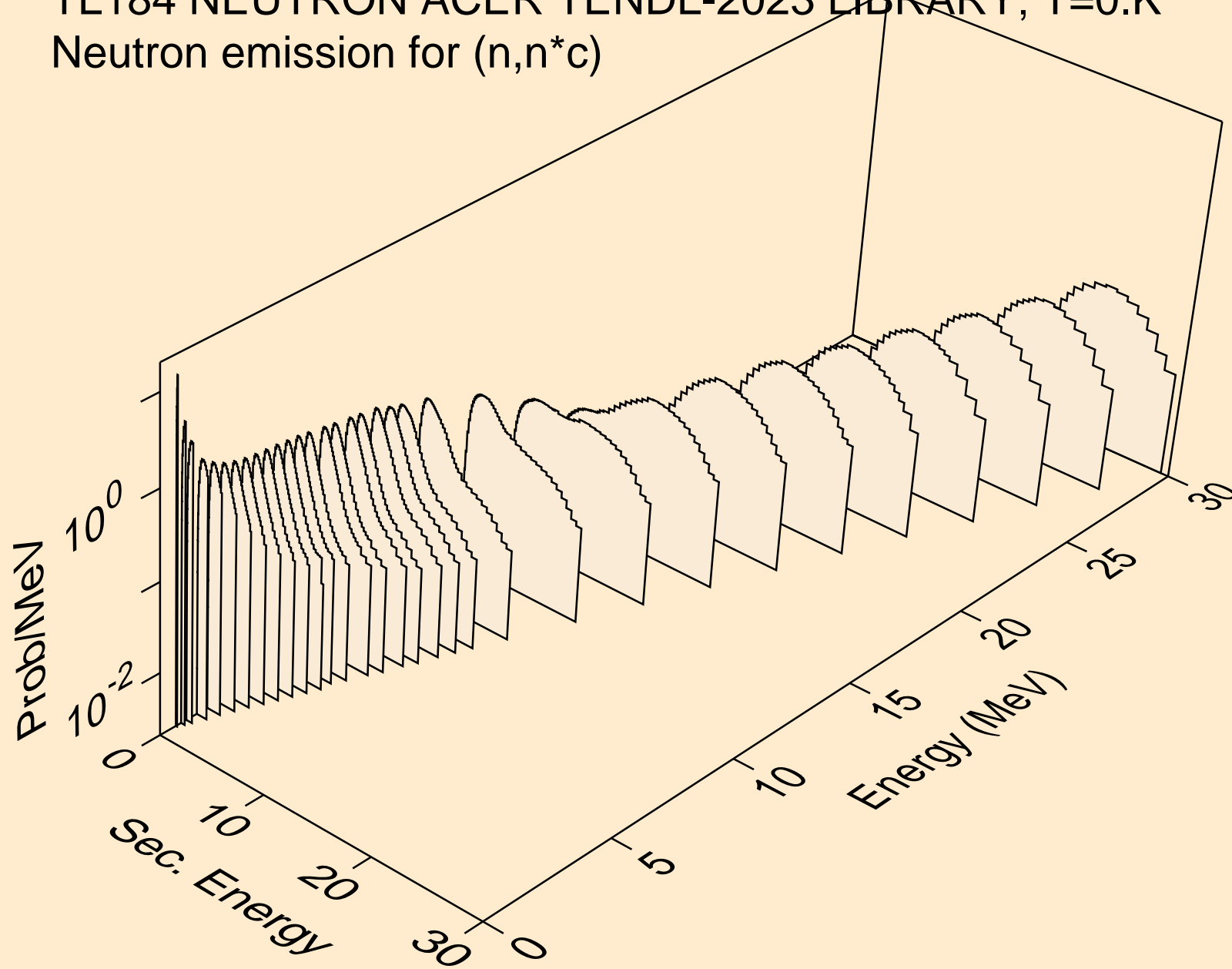

TL184 NEUTRON ACER TENDL-2023 LIBRARY; T=0.K
Photon emission for (n,x)

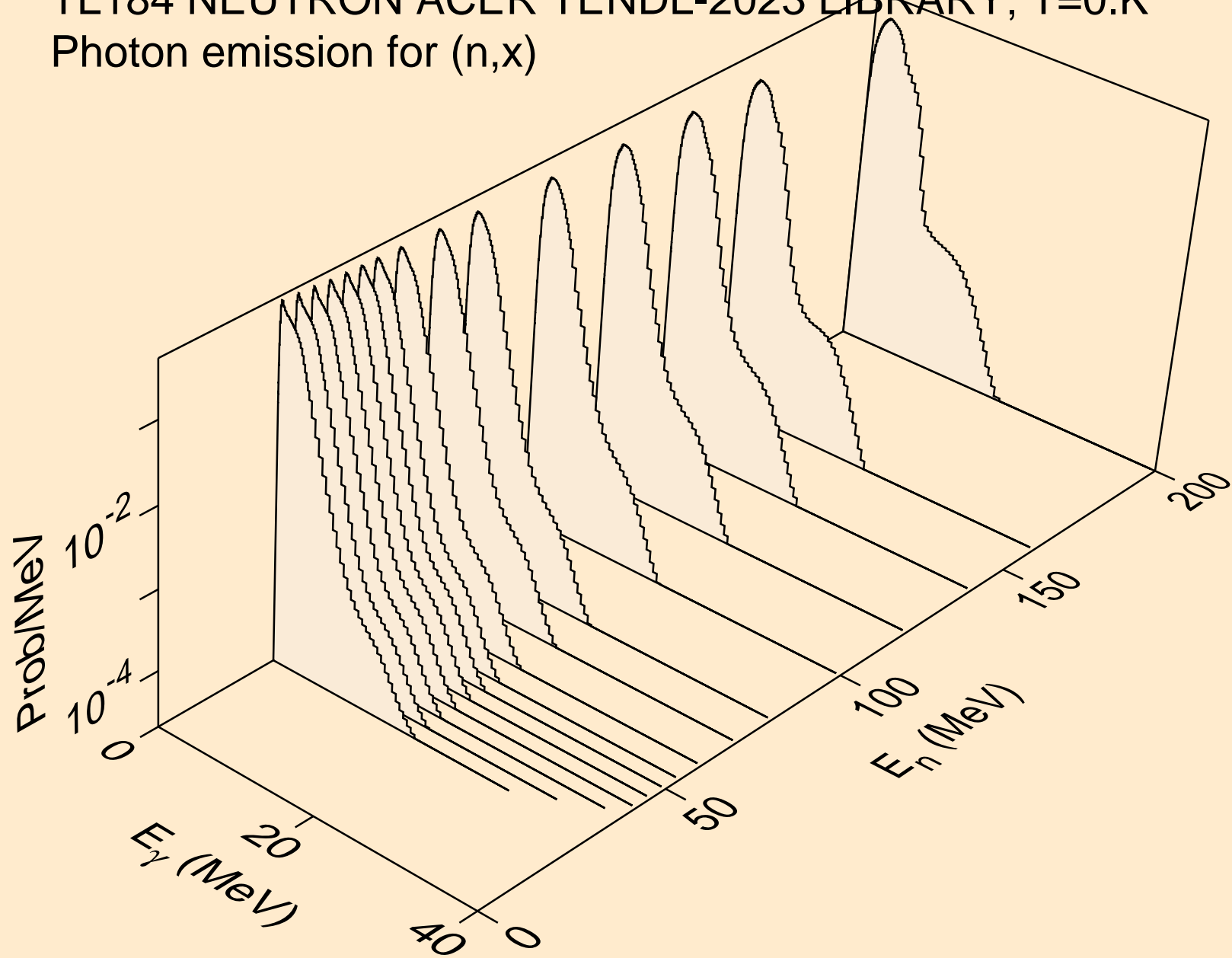

TL184 NEUTRON ACER TENDL-2023 LIBRARY; T=0.K
Photon emission for (n,2nd)

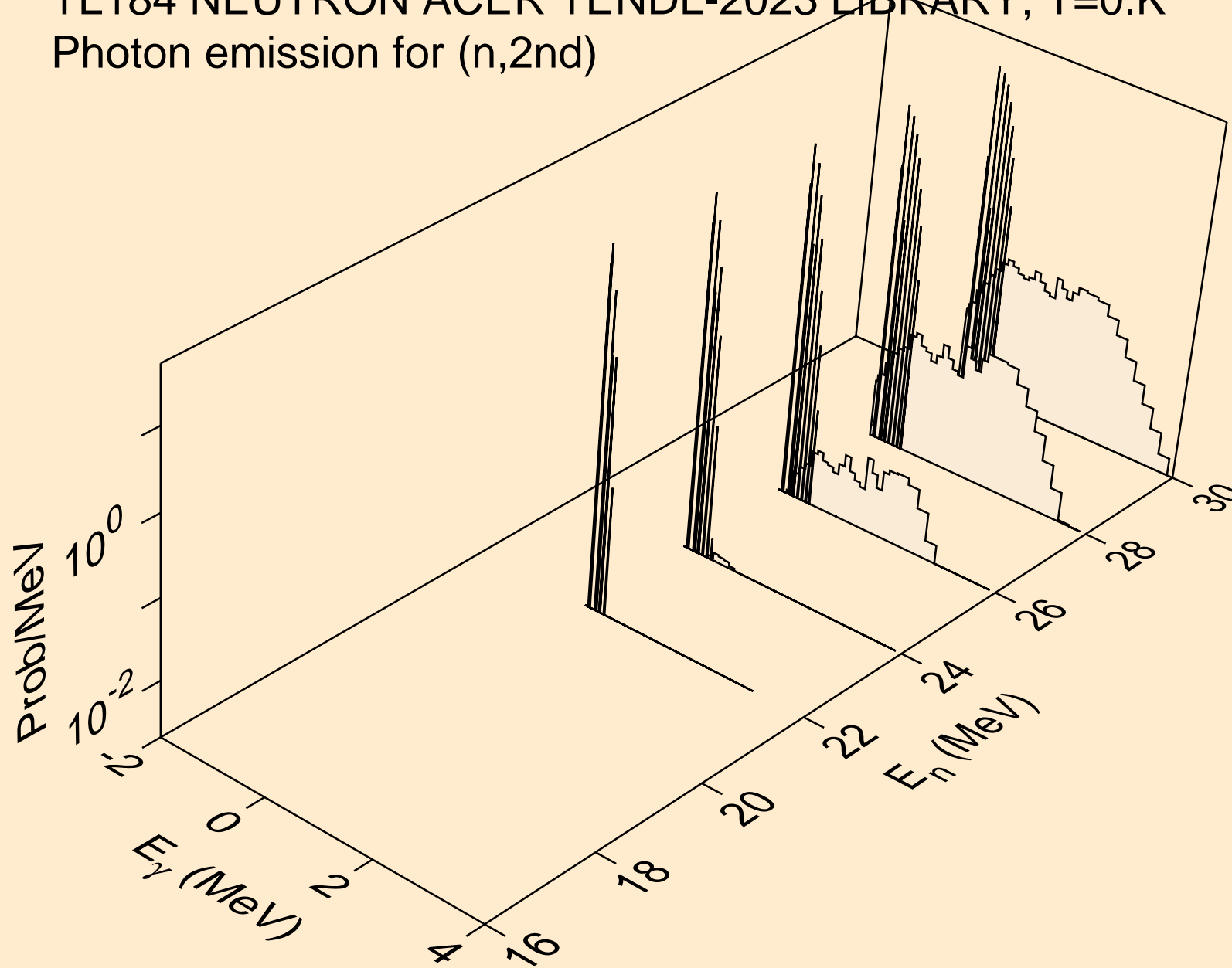

TL184 NEUTRON ACER TENDL-2023 LIBRARY; T=0.K
Photon emission for (n,2n)

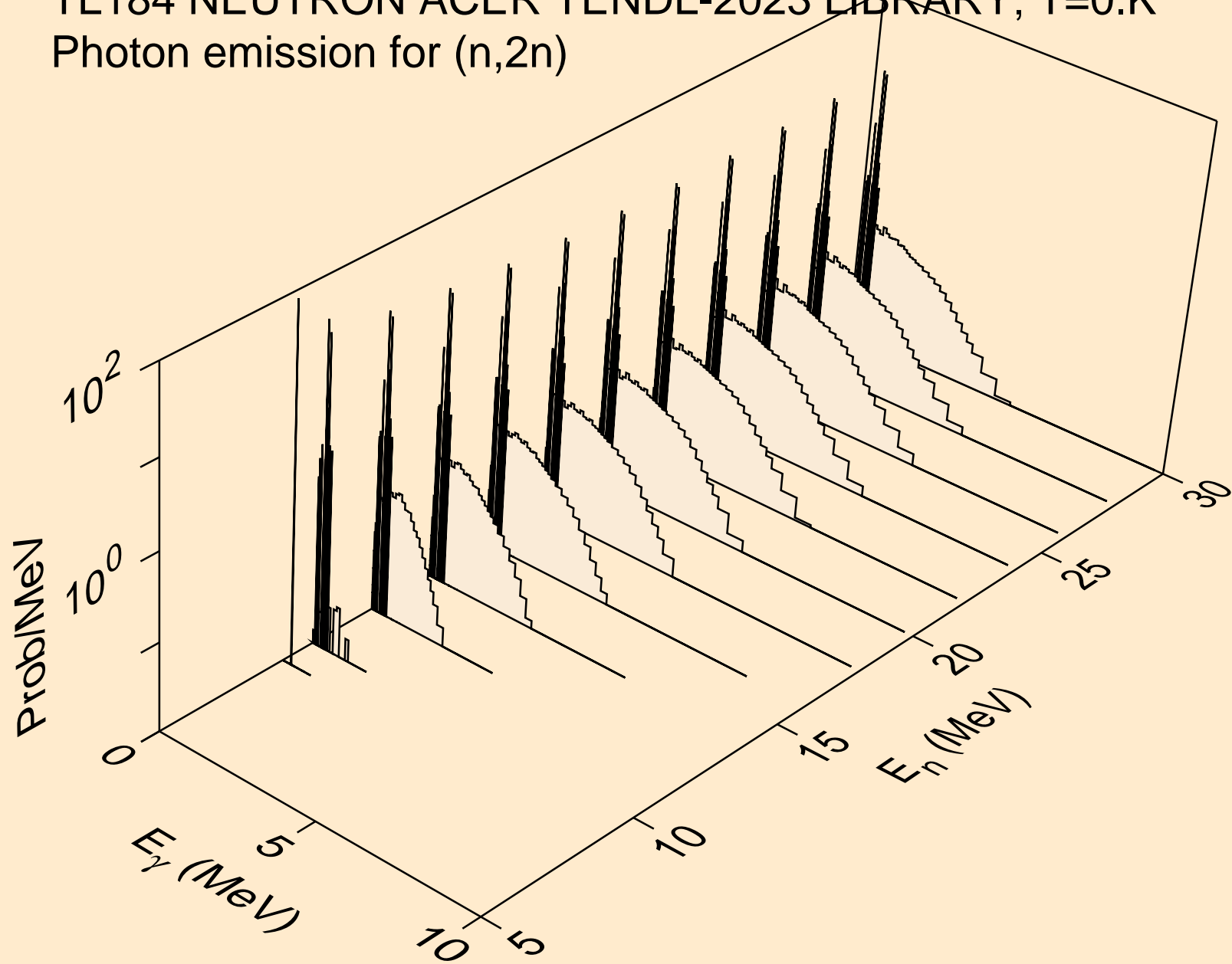

TL184 NEUTRON ACER TENDL-2023 LIBRARY; T=0.K
Photon emission for (n,3n)

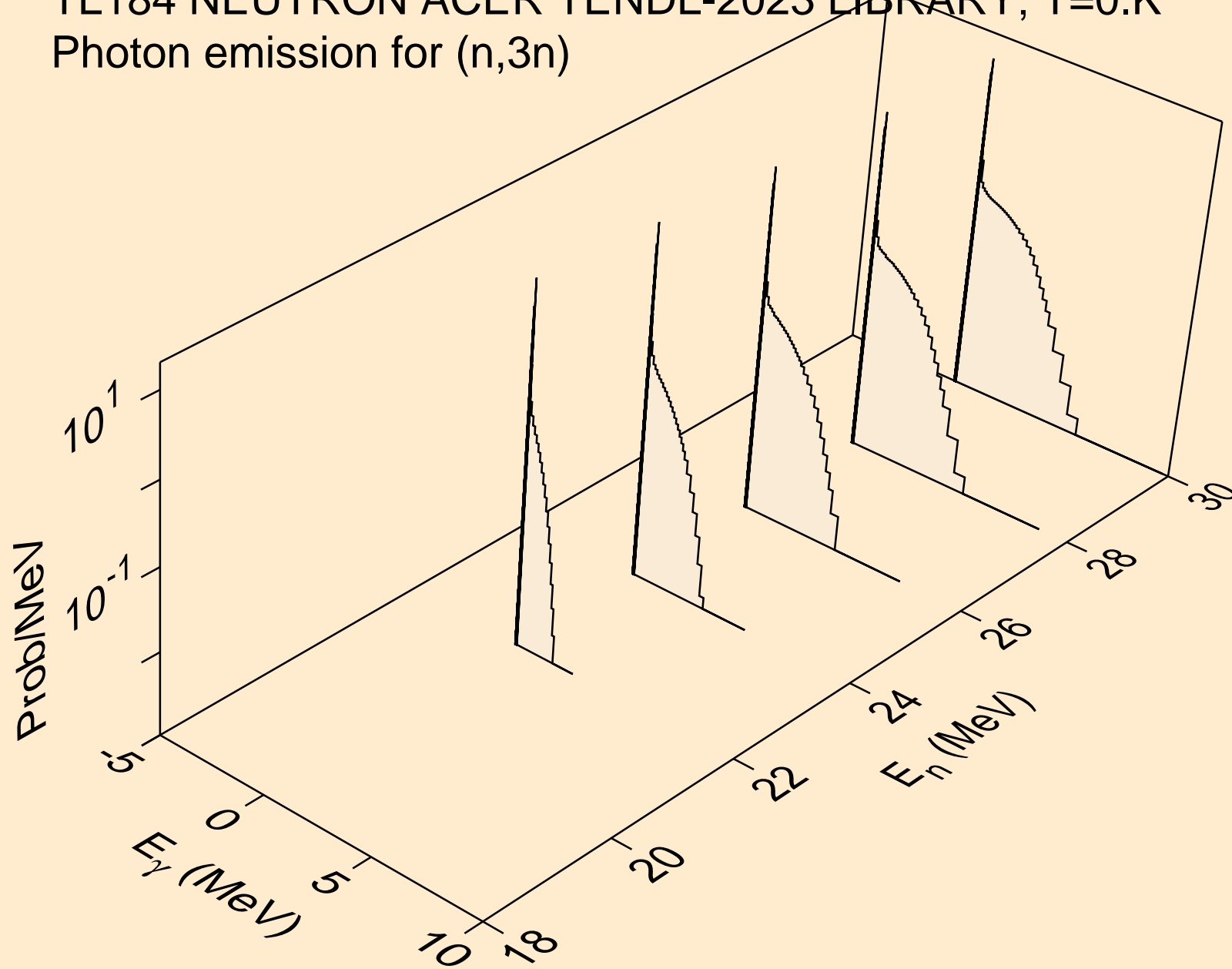

TL184 NEUTRON ACER TENDL-2023 LIBRARY; T=0.K
Photon emission for (n,n*)a

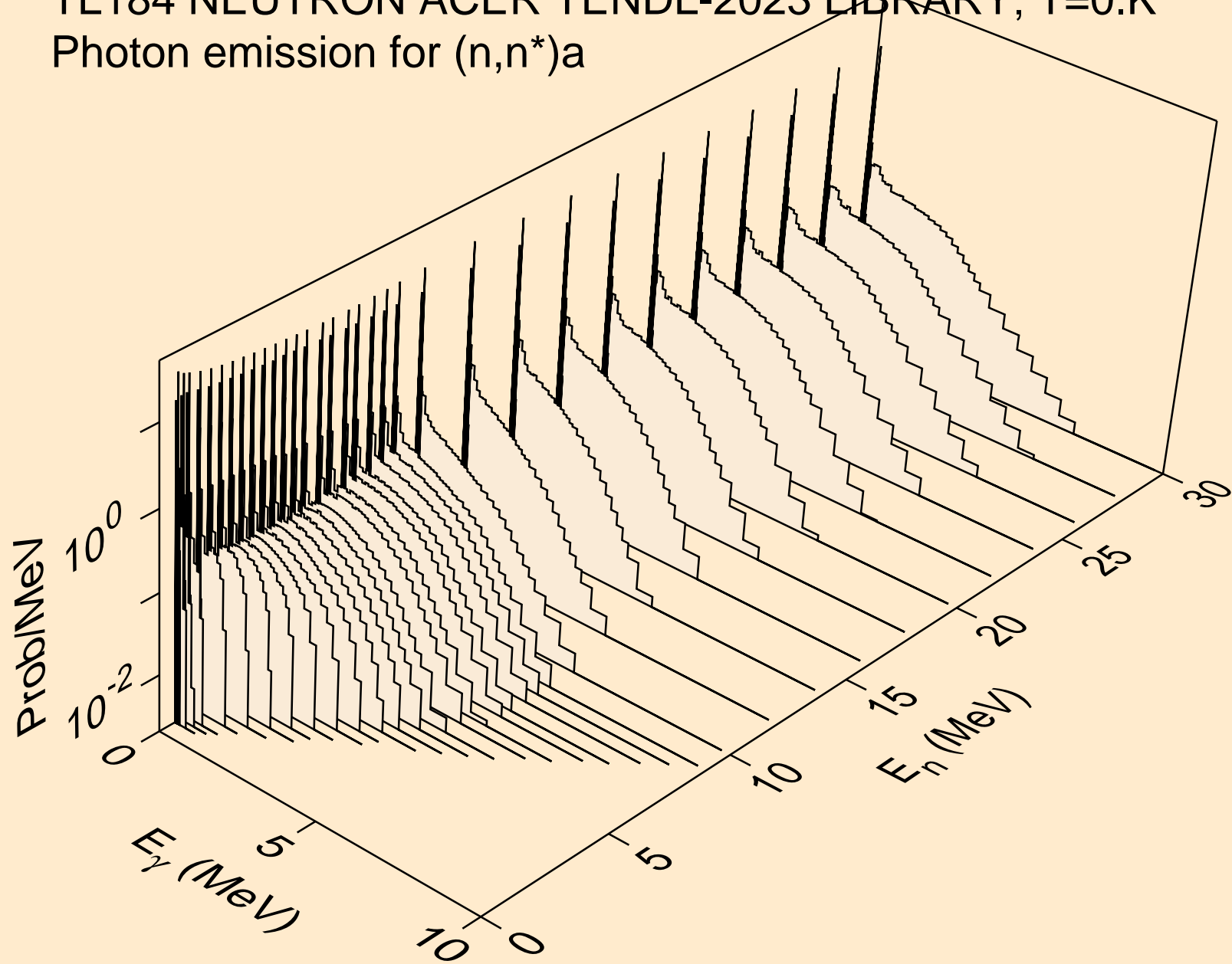

TL184 NEUTRON ACER TENDL-2023 LIBRARY; T=0.K
Photon emission for (n,n*)3a

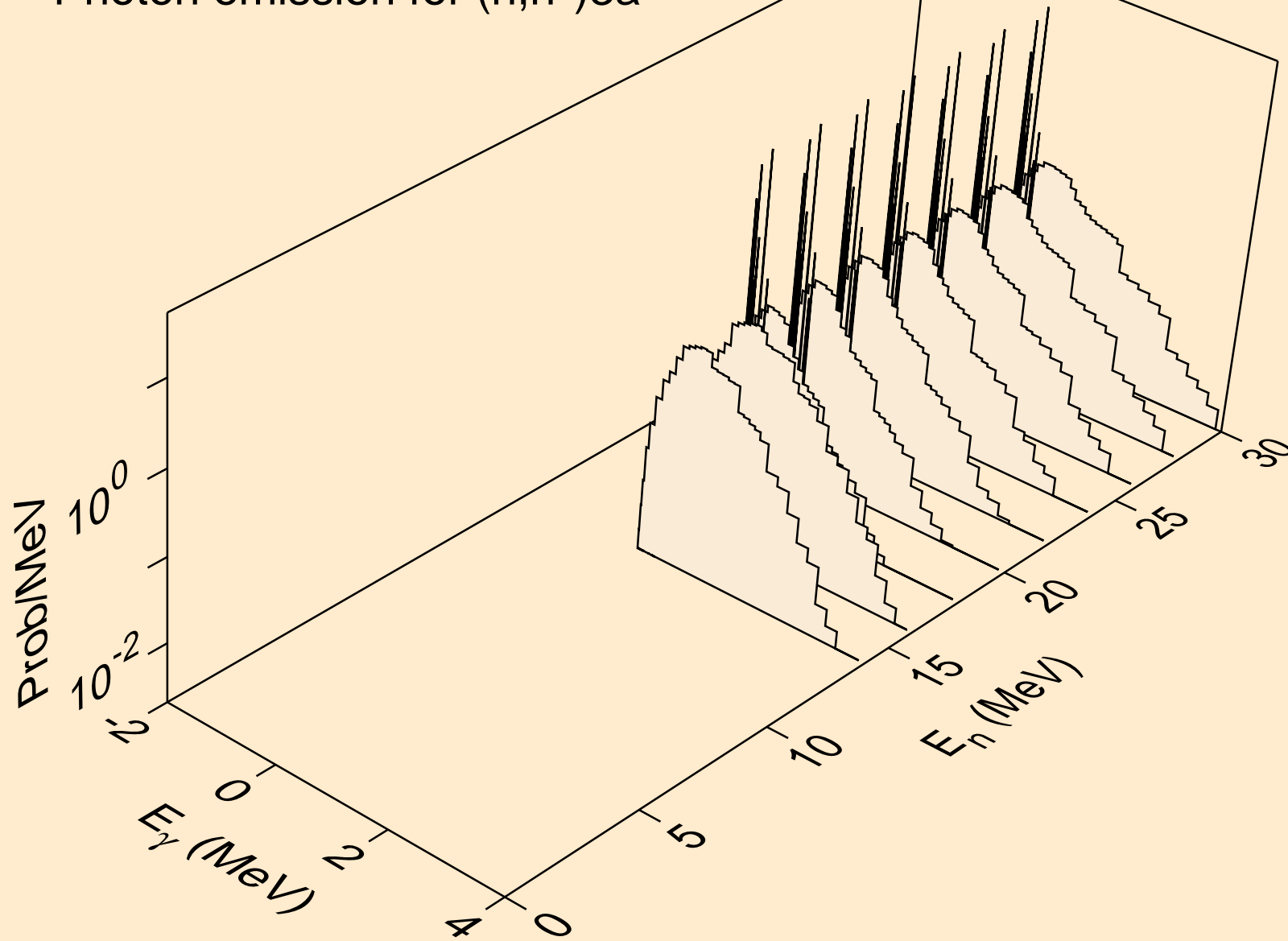

TL184 NEUTRON ACER TENDL-2023 LIBRARY; T=0.K
Photon emission for (n,2n)a

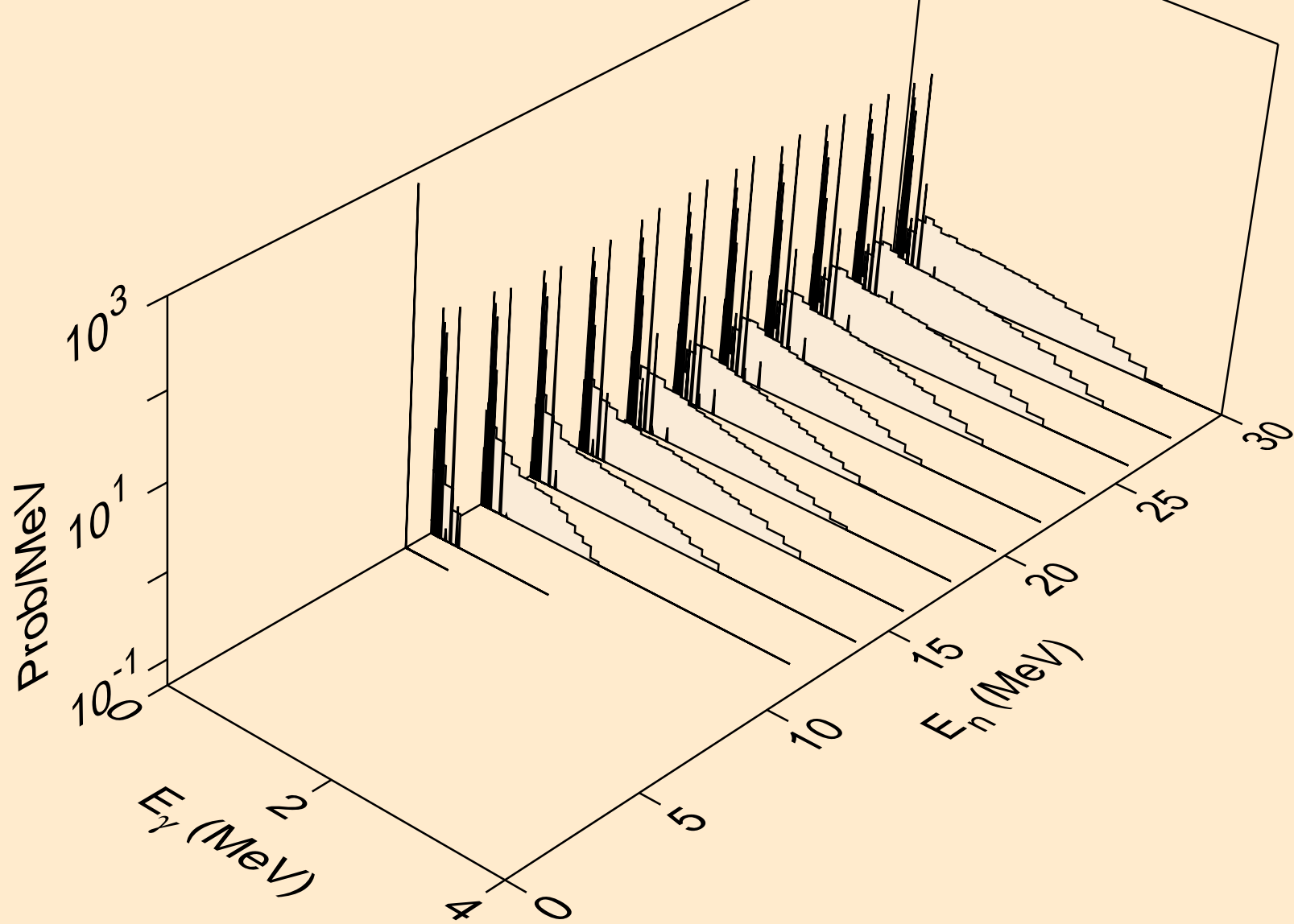

TL184 NEUTRON ACER TENDL-2023 LIBRARY; T=0.K
Photon emission for (n,3n)a

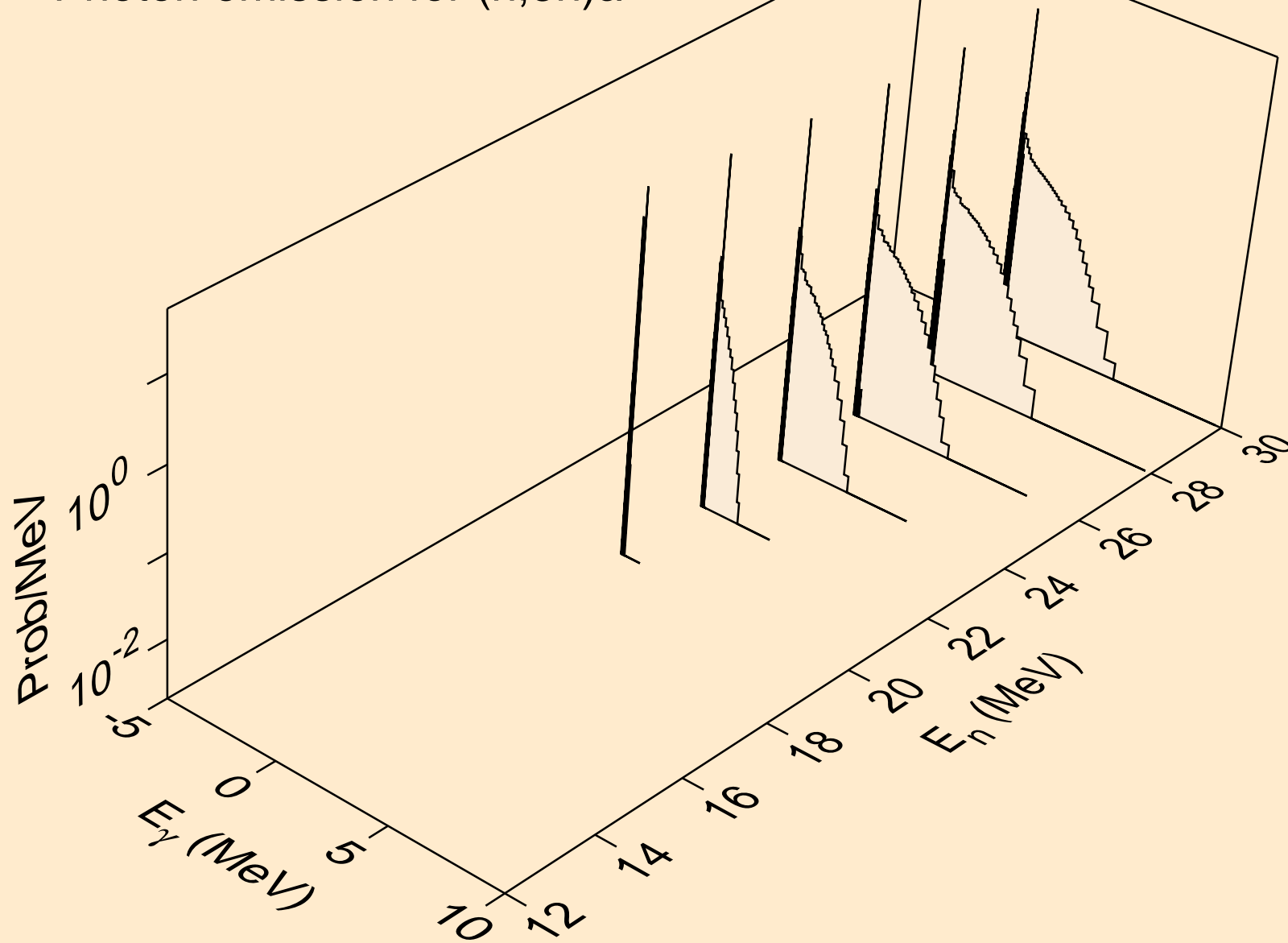

TL184 NEUTRON ACER TENDL-2023 LIBRARY; T=0.K
Photon emission for (n,n*)p

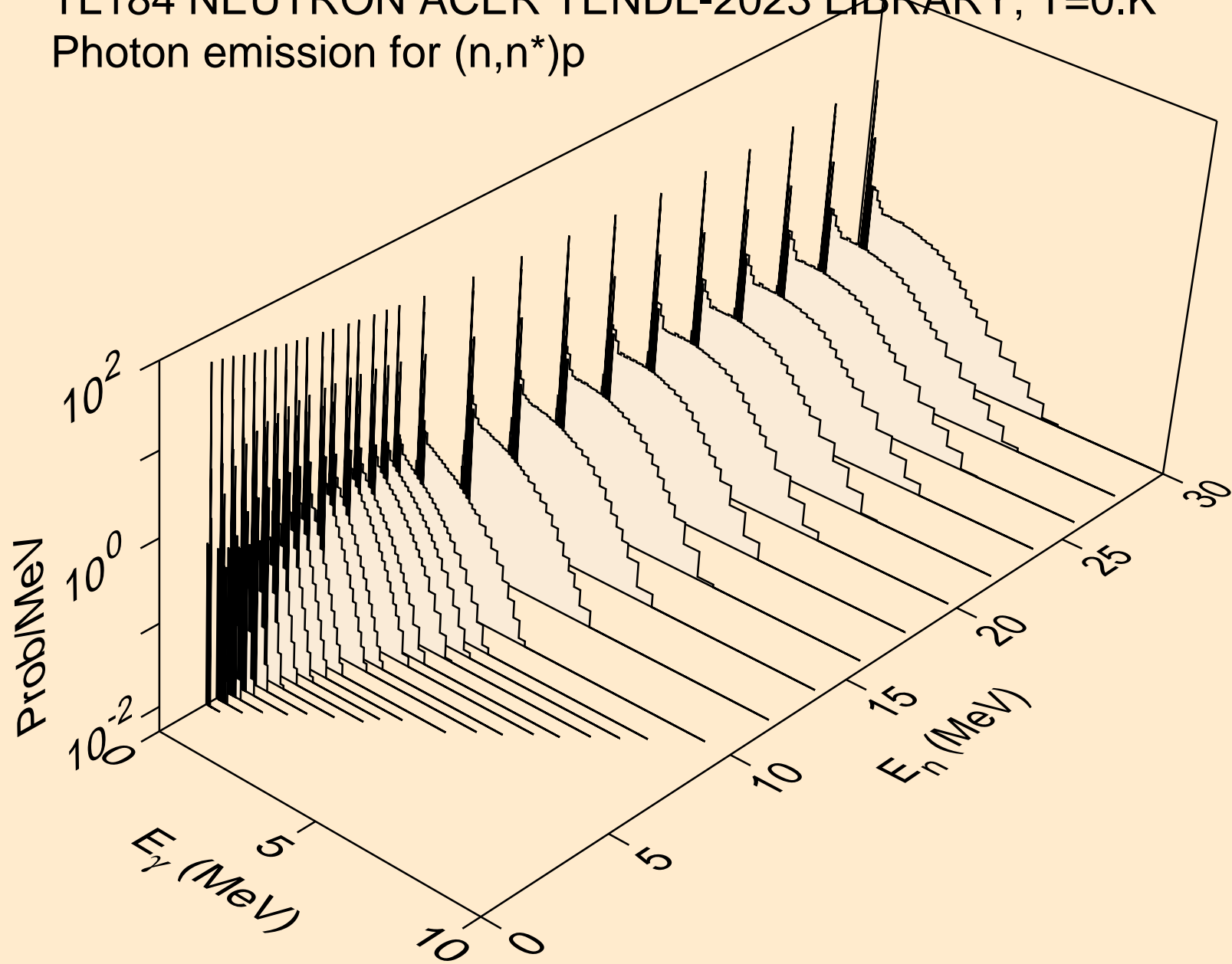

TL184 NEUTRON ACER TENDL-2023 LIBRARY; T=0.K
Photon emission for (n,n*)2a

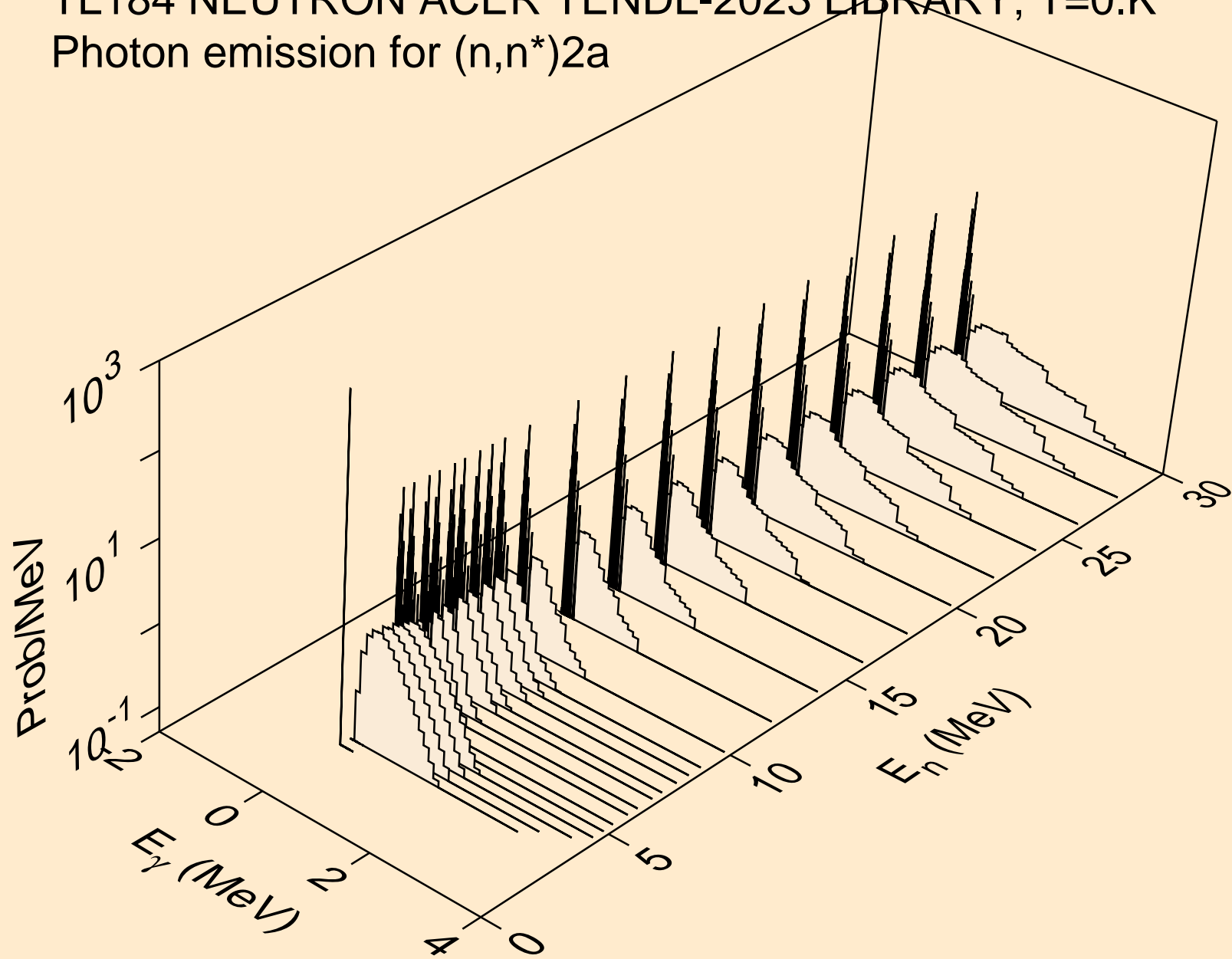

TL184 NEUTRON ACER TENDL-2023 LIBRARY; T=0.K
Photon emission for (n,2n)2a

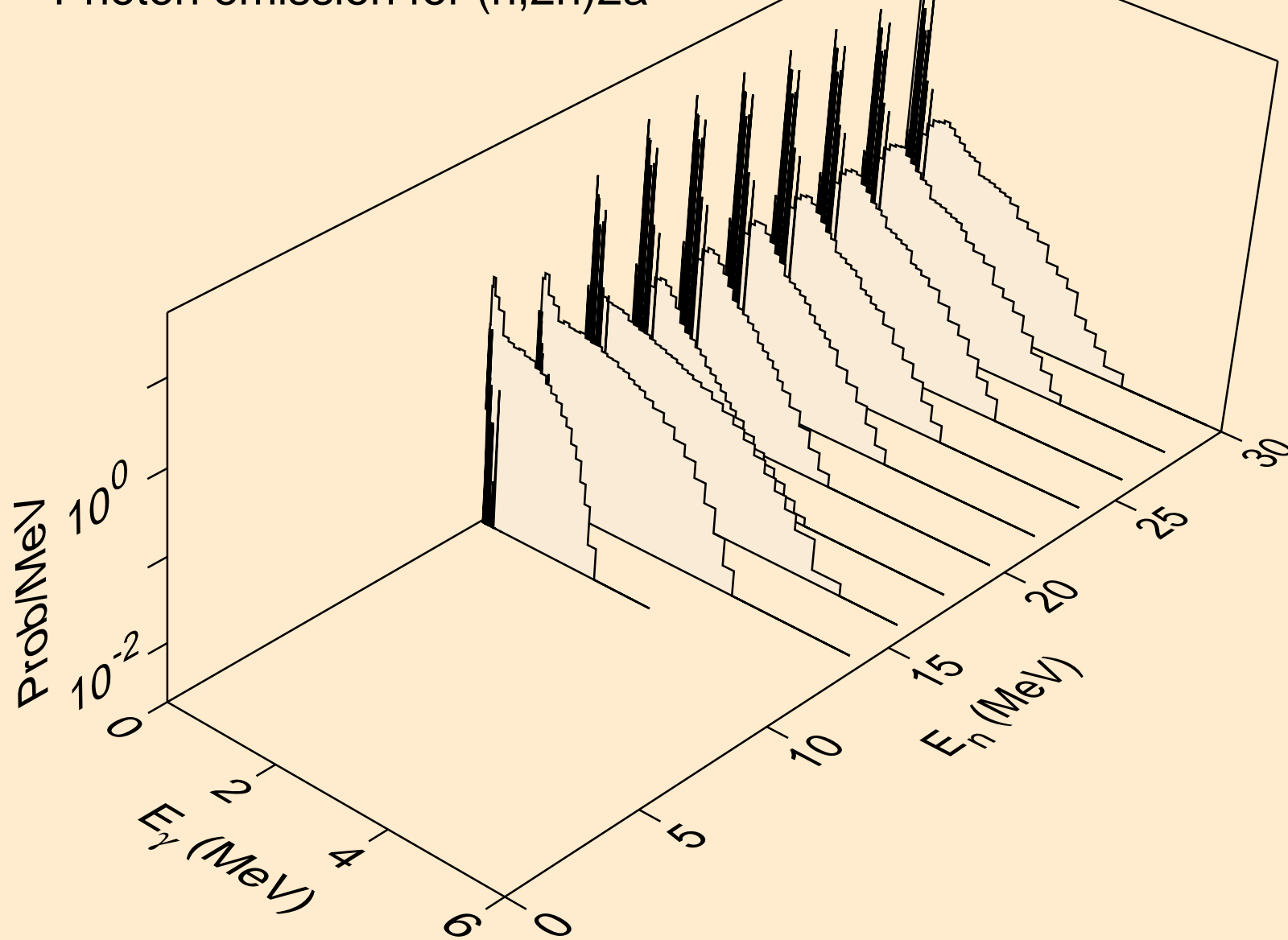

TL184 NEUTRON ACER TENDL-2023 LIBRARY; T=0.K
Photon emission for (n,n*)d

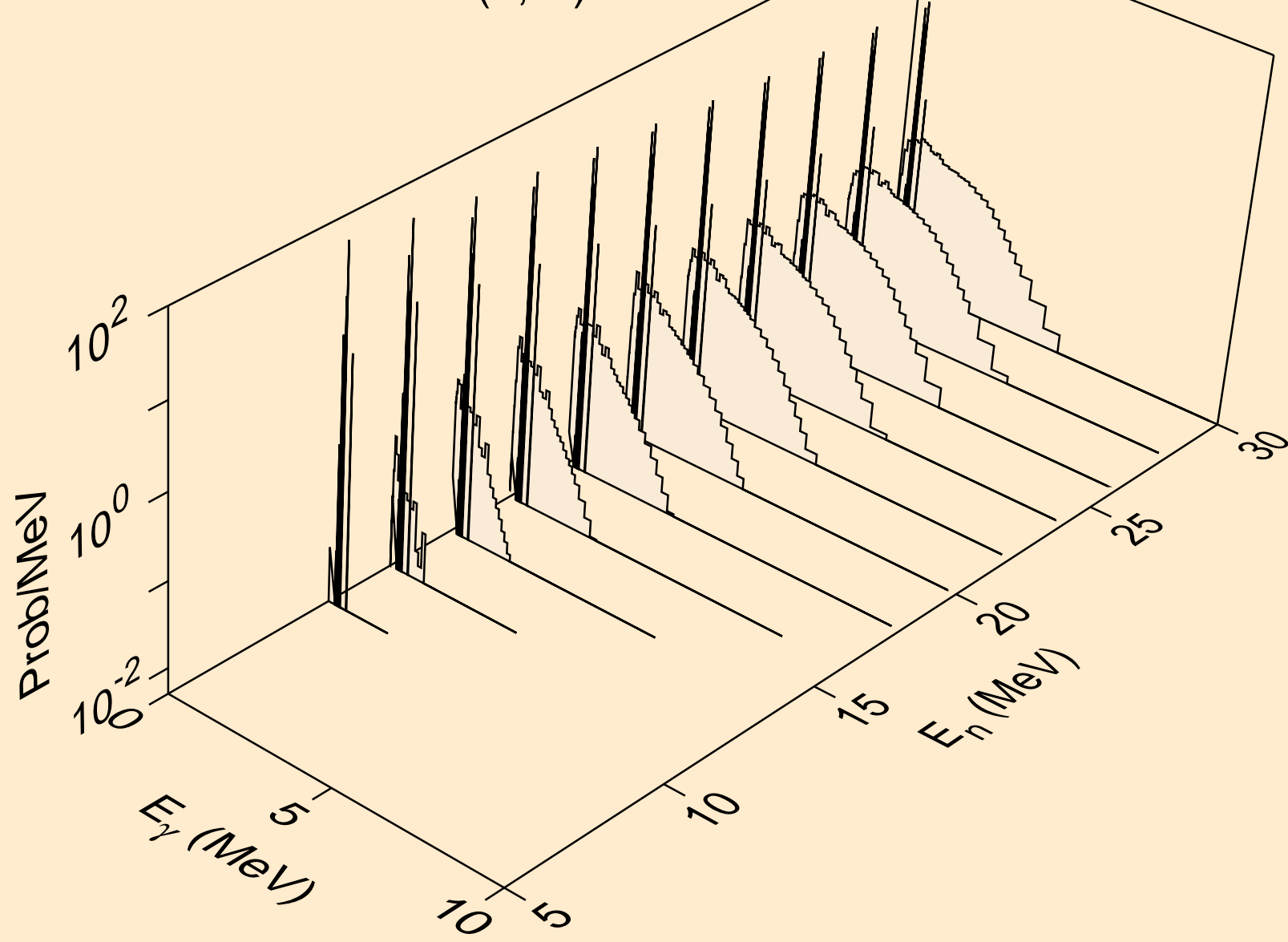

TL184 NEUTRON ACER TENDL-2023 LIBRARY; T=0.K
Photon emission for (n,n*)t

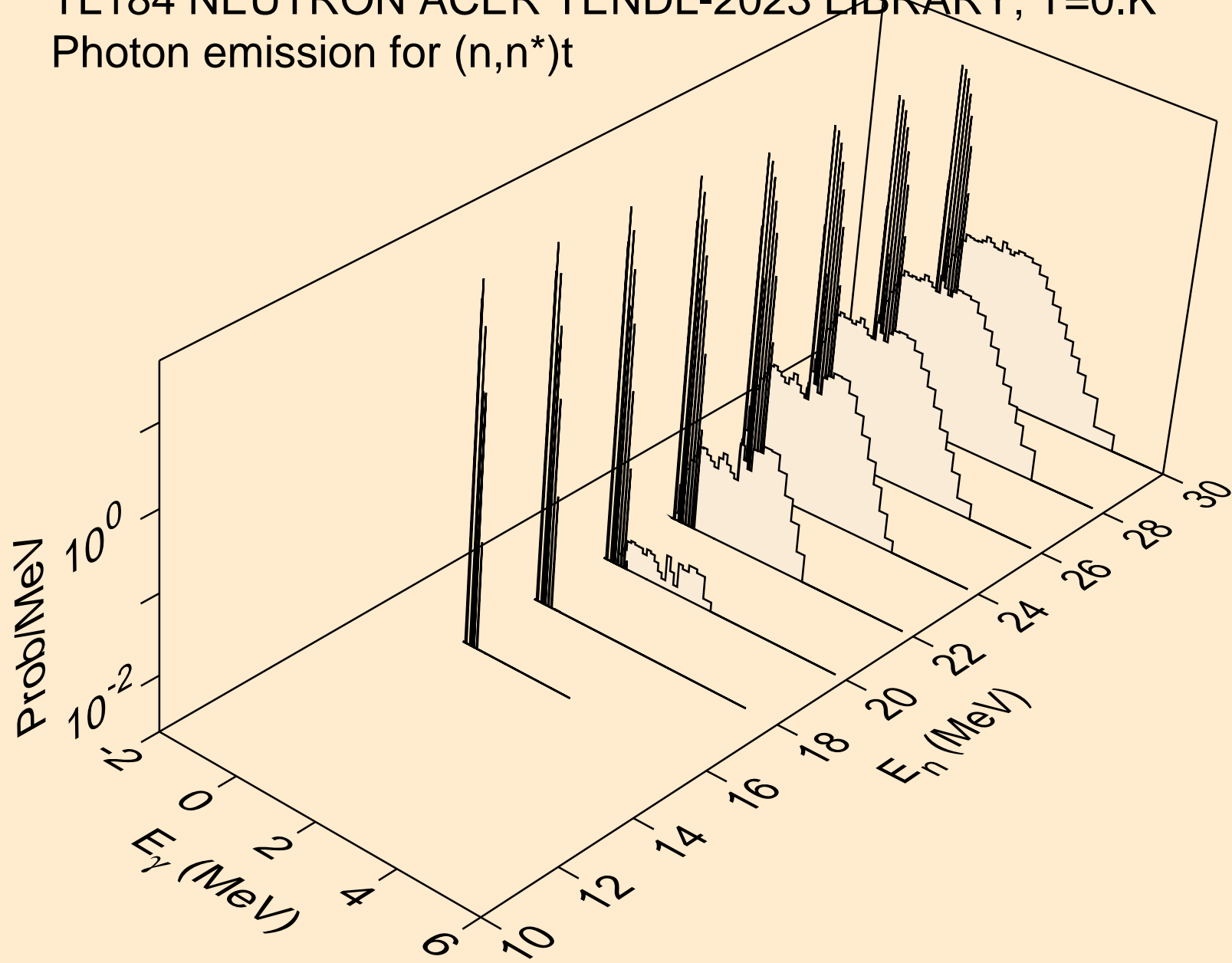

TL184 NEUTRON ACER TENDL-2023 LIBRARY; T=0.K
Photon emission for (n,n*)he3

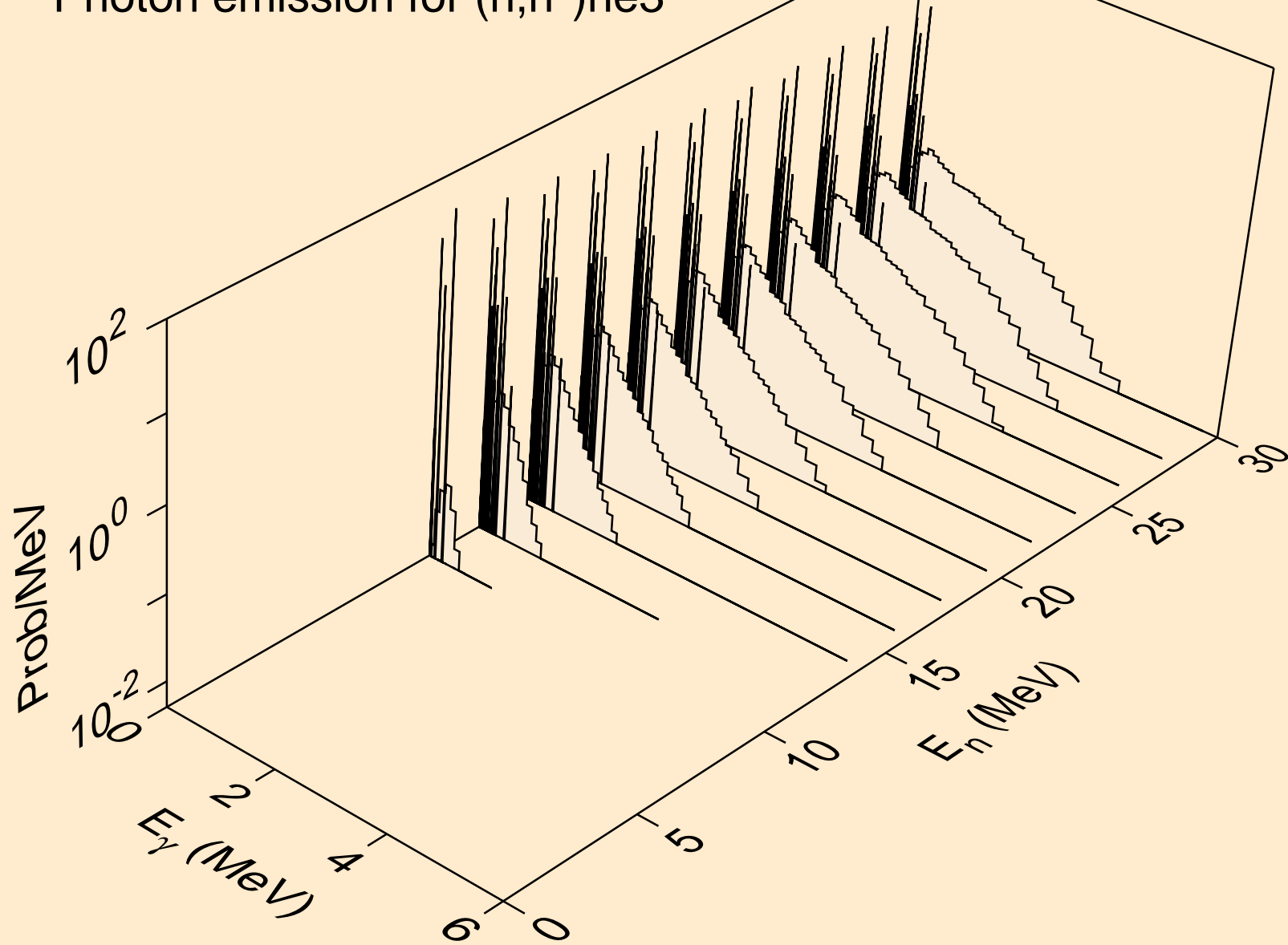

TL184 NEUTRON ACER TENDL-2023 LIBRARY; T=0.K
Photon emission for (n,4n)

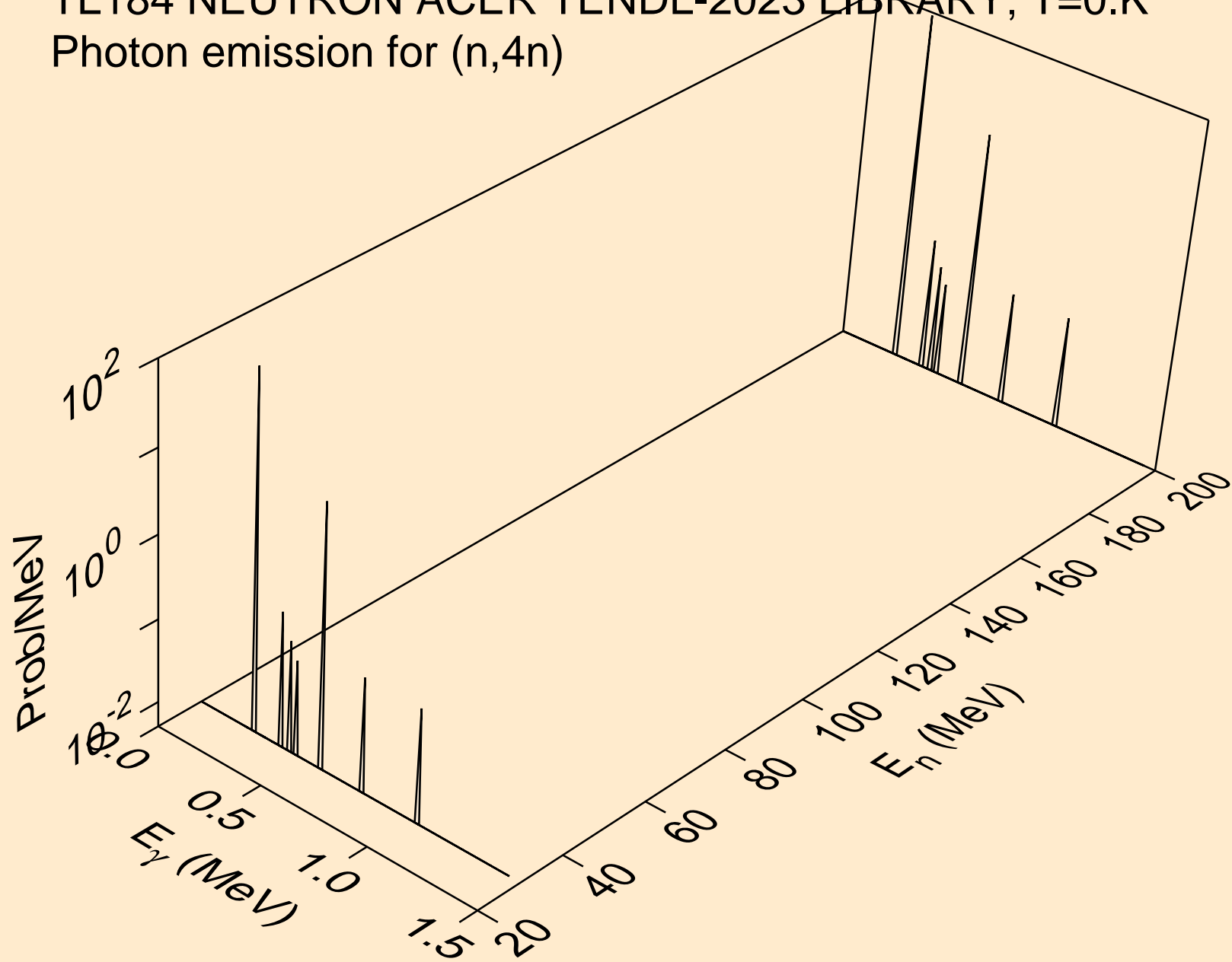

TL184 NEUTRON ACER TENDL-2023 LIBRARY; T=0.K
Photon emission for (n,2np)

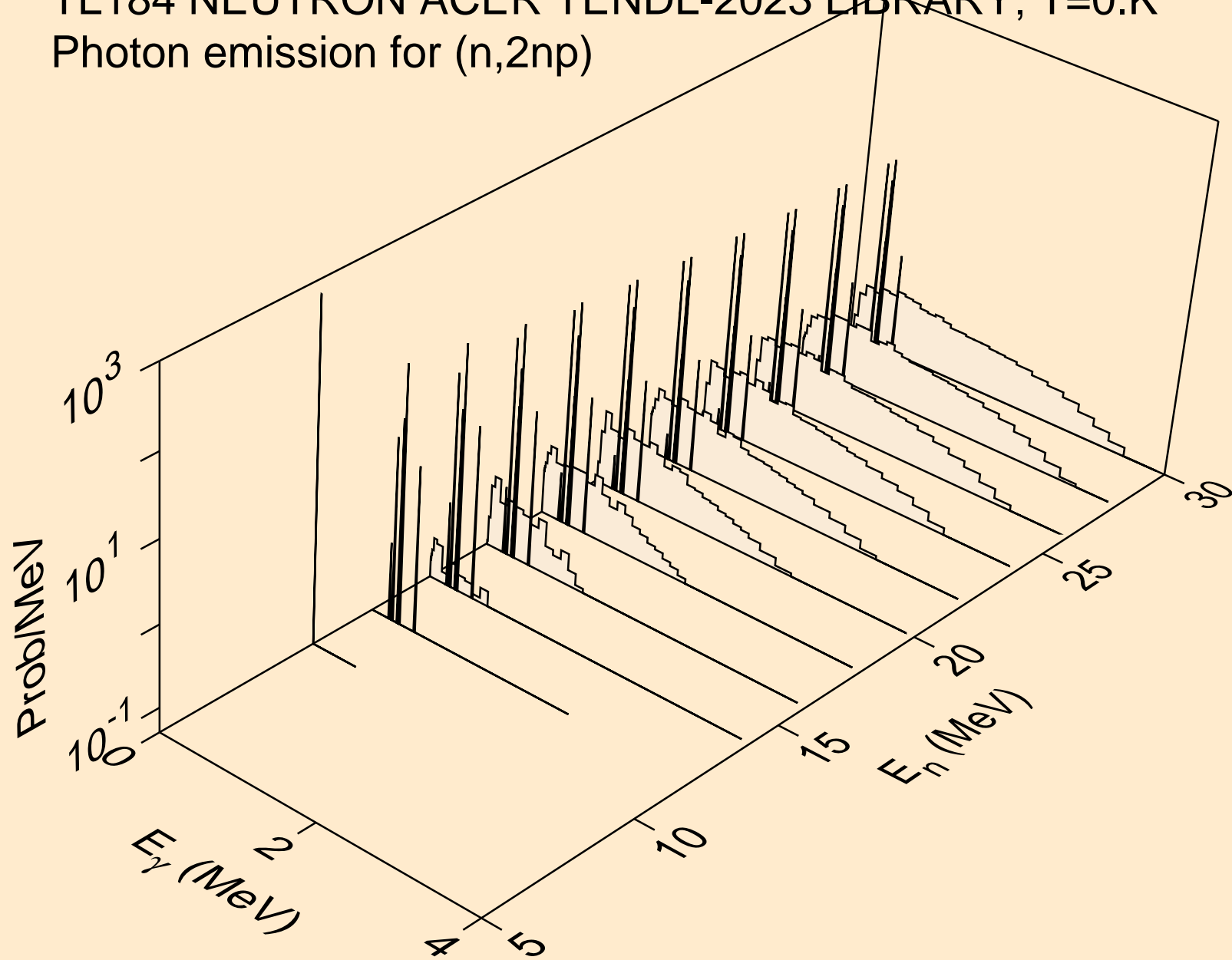

TL184 NEUTRON ACER TENDL-2023 LIBRARY; T=0.K
Photon emission for (n,3np)

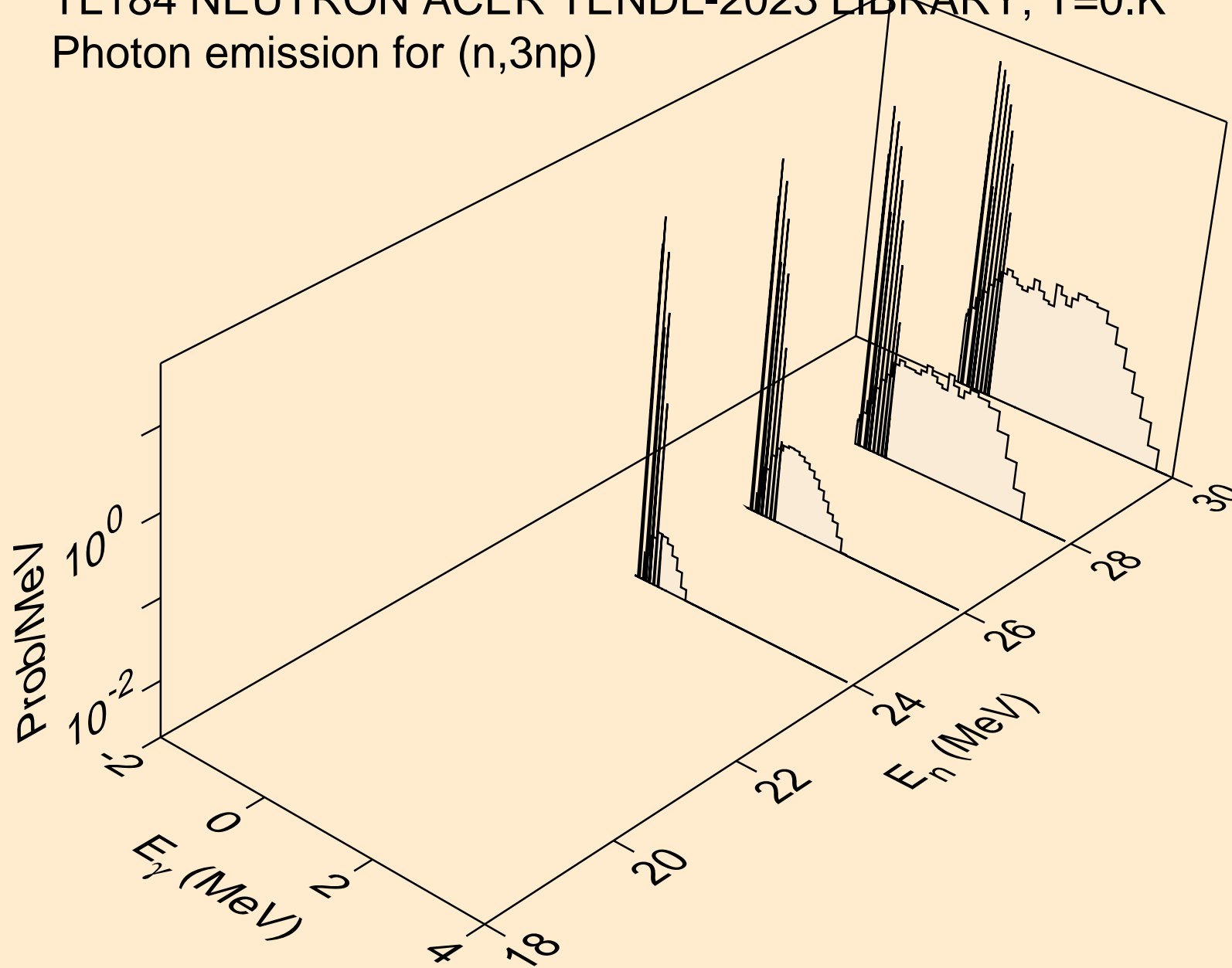

TL184 NEUTRON ACER TENDL-2023 LIBRARY; T=0.K
Photon emission for (n,n2p)

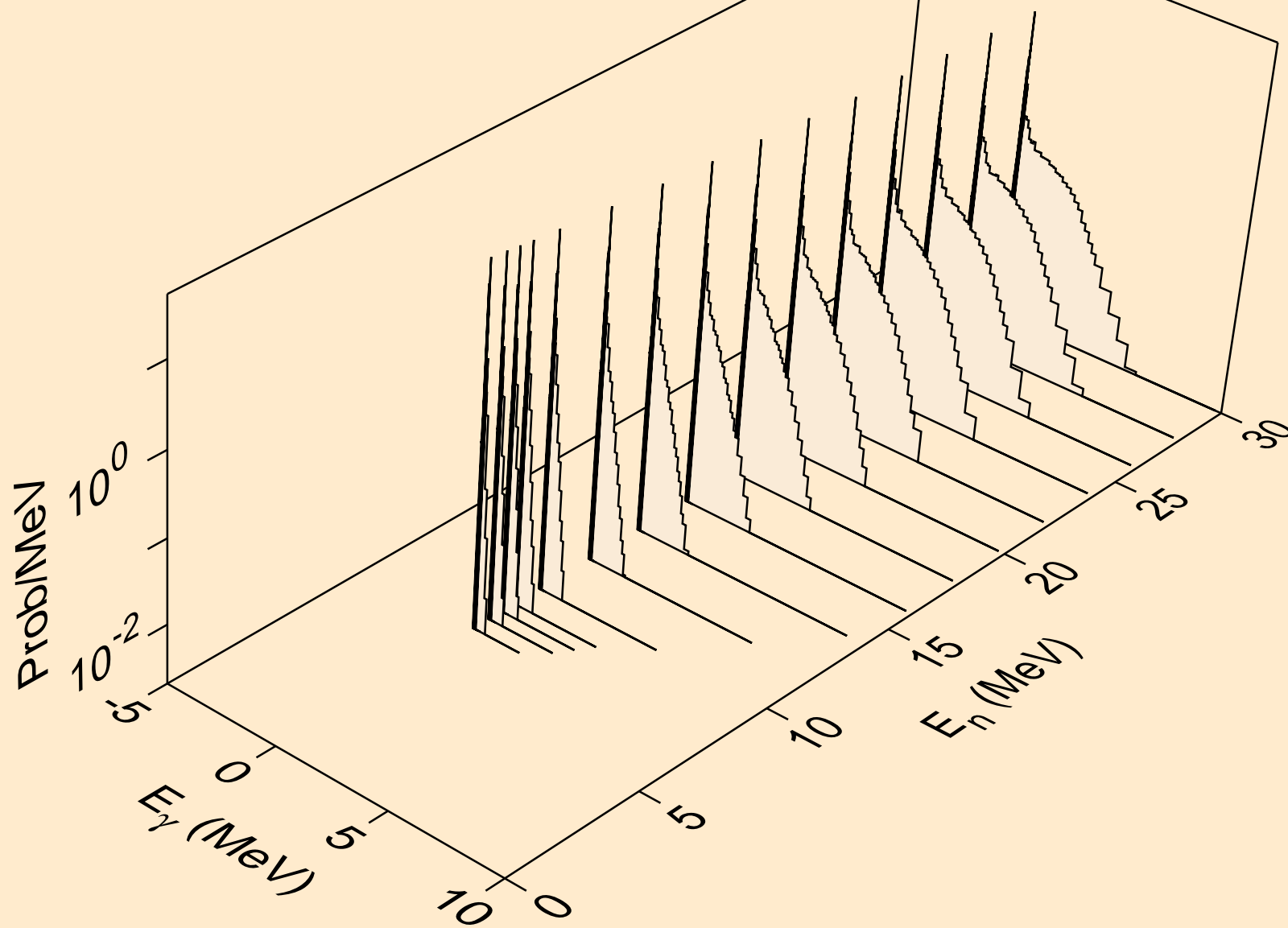

TL184 NEUTRON ACER TENDL-2023 LIBRARY; T=0.K
Photon emission for (n,npa)

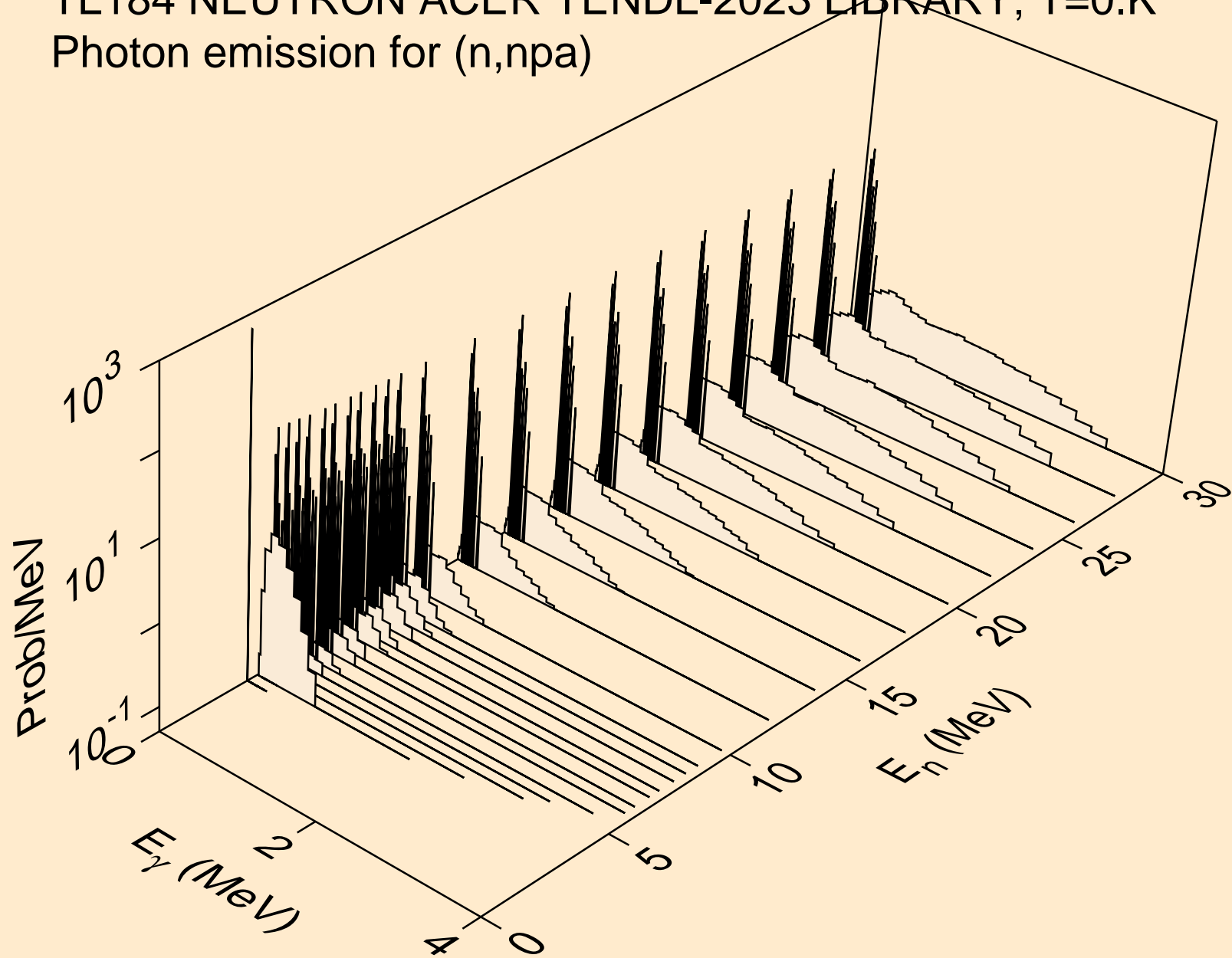

TL184 NEUTRON ACER TENDL-2023 LIBRARY; T=0.K
Photon emission for (n,n*c)

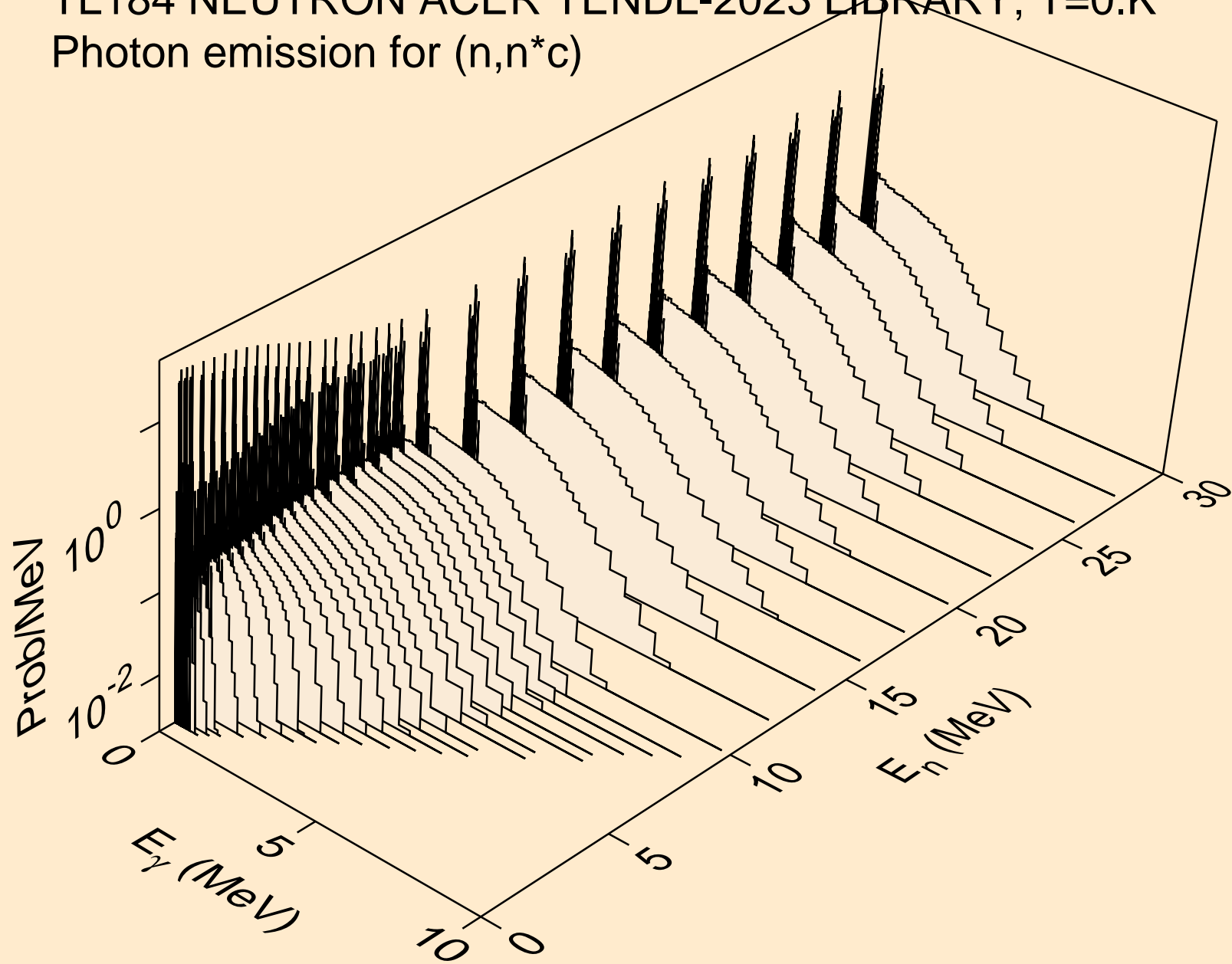

TL184 NEUTRON ACER TENDL-2023 LIBRARY; T=0.K
Photon emission for (n,gma)

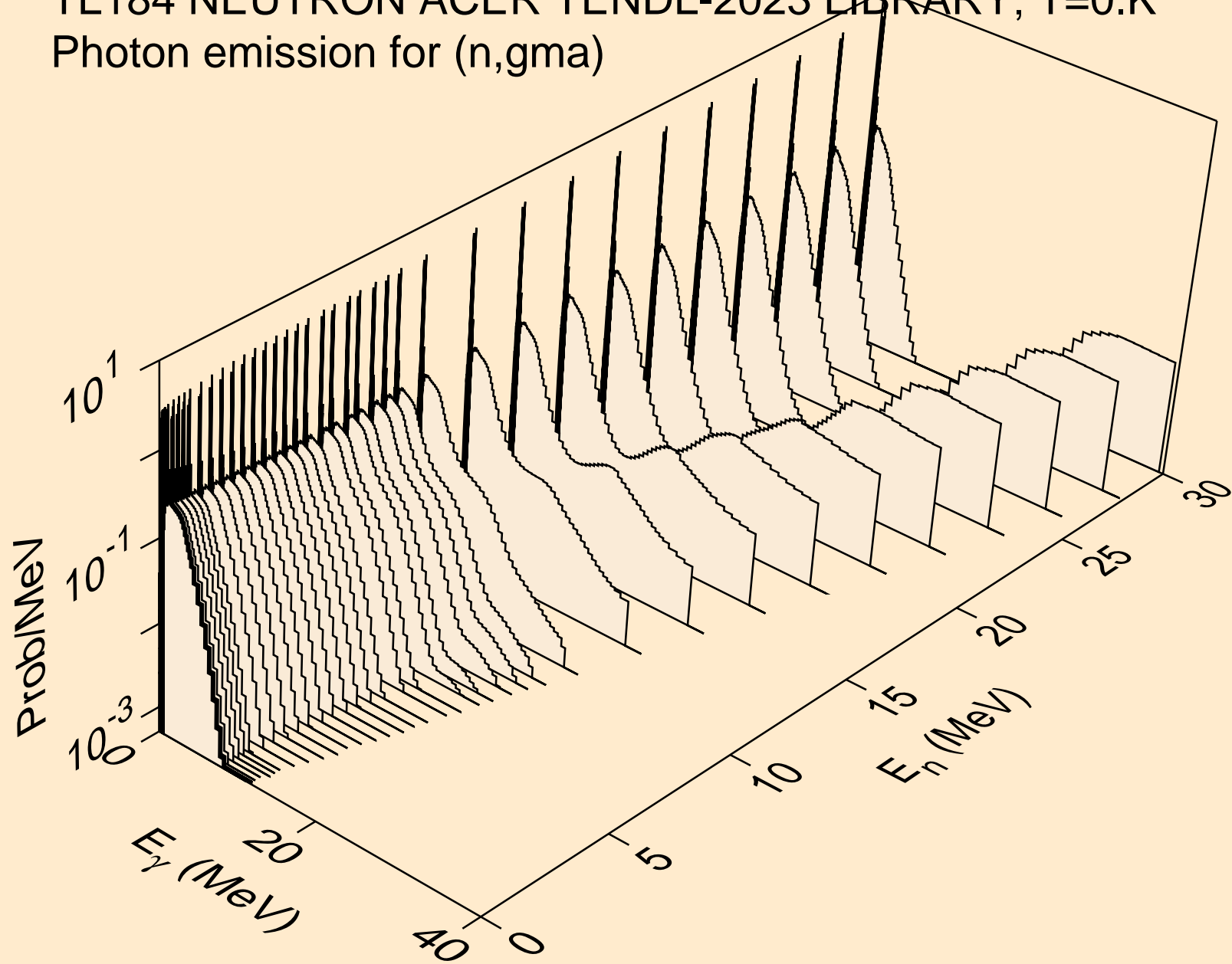

TL184 NEUTRON ACER TENDL-2023 LIBRARY; T=0.K
Photon emission for (n,p)

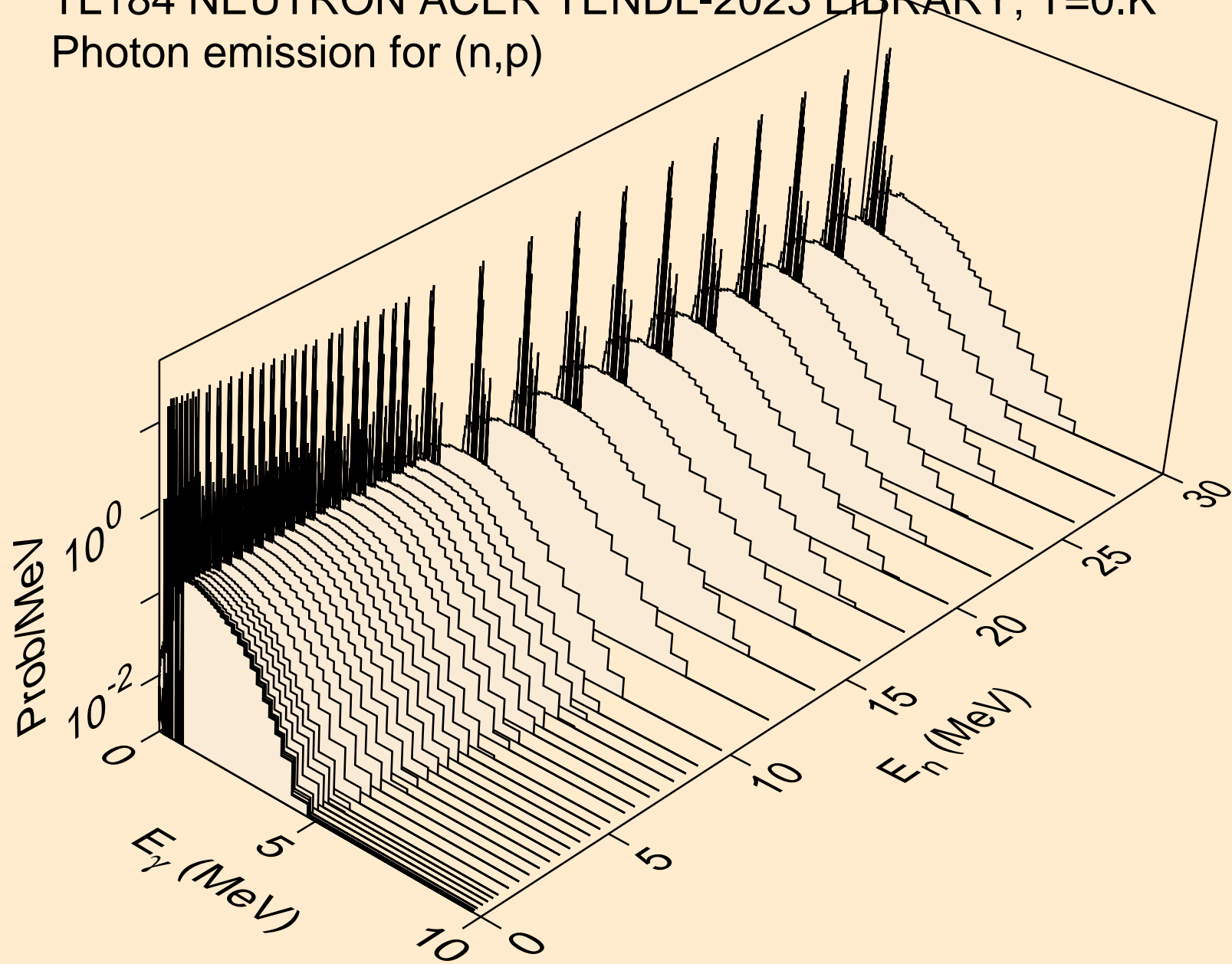

TL184 NEUTRON ACER TENDL-2023 LIBRARY; T=0.K
Photon emission for (n,d)

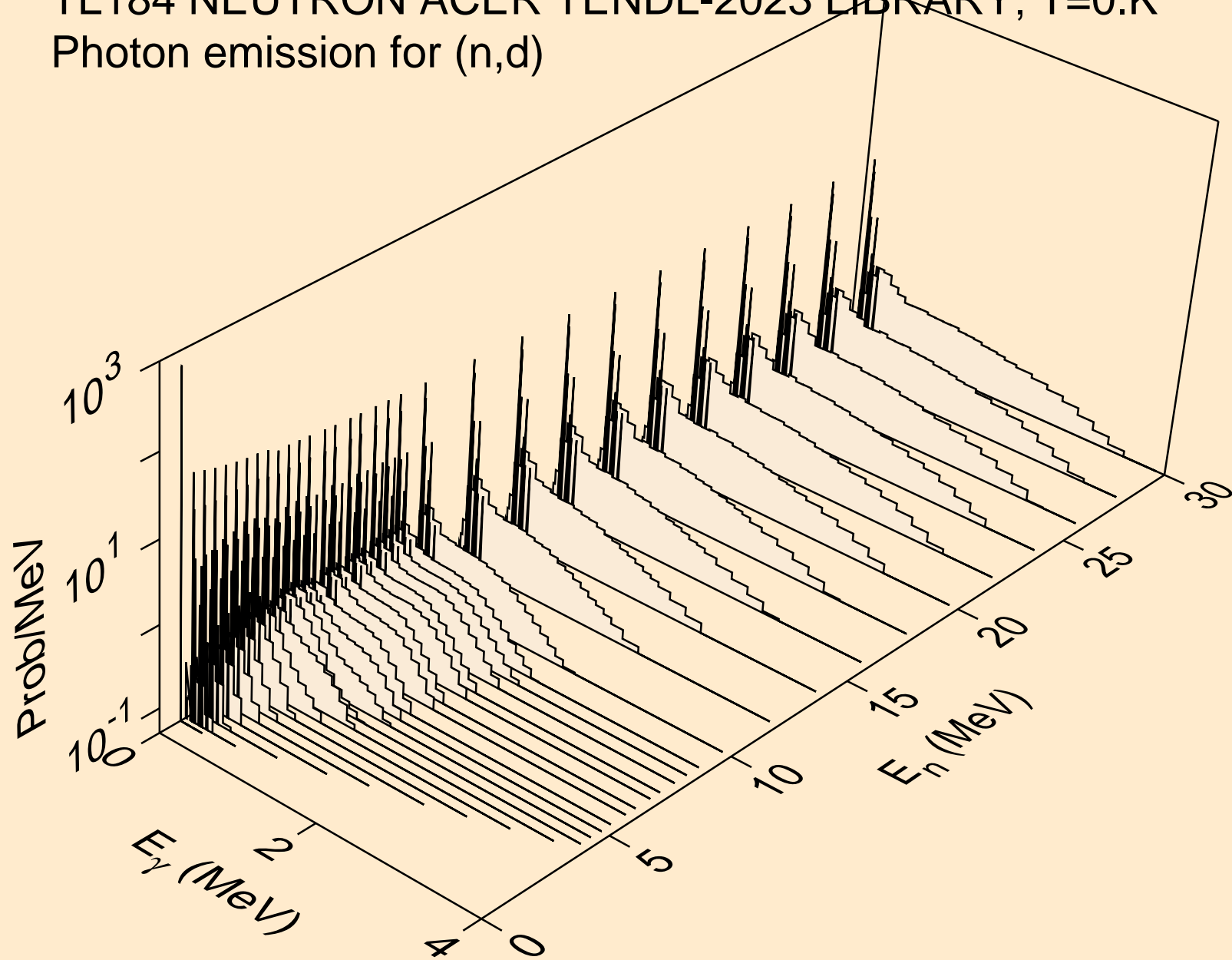

TL184 NEUTRON ACER TENDL-2023 LIBRARY; T=0.K
Photon emission for (n,t)

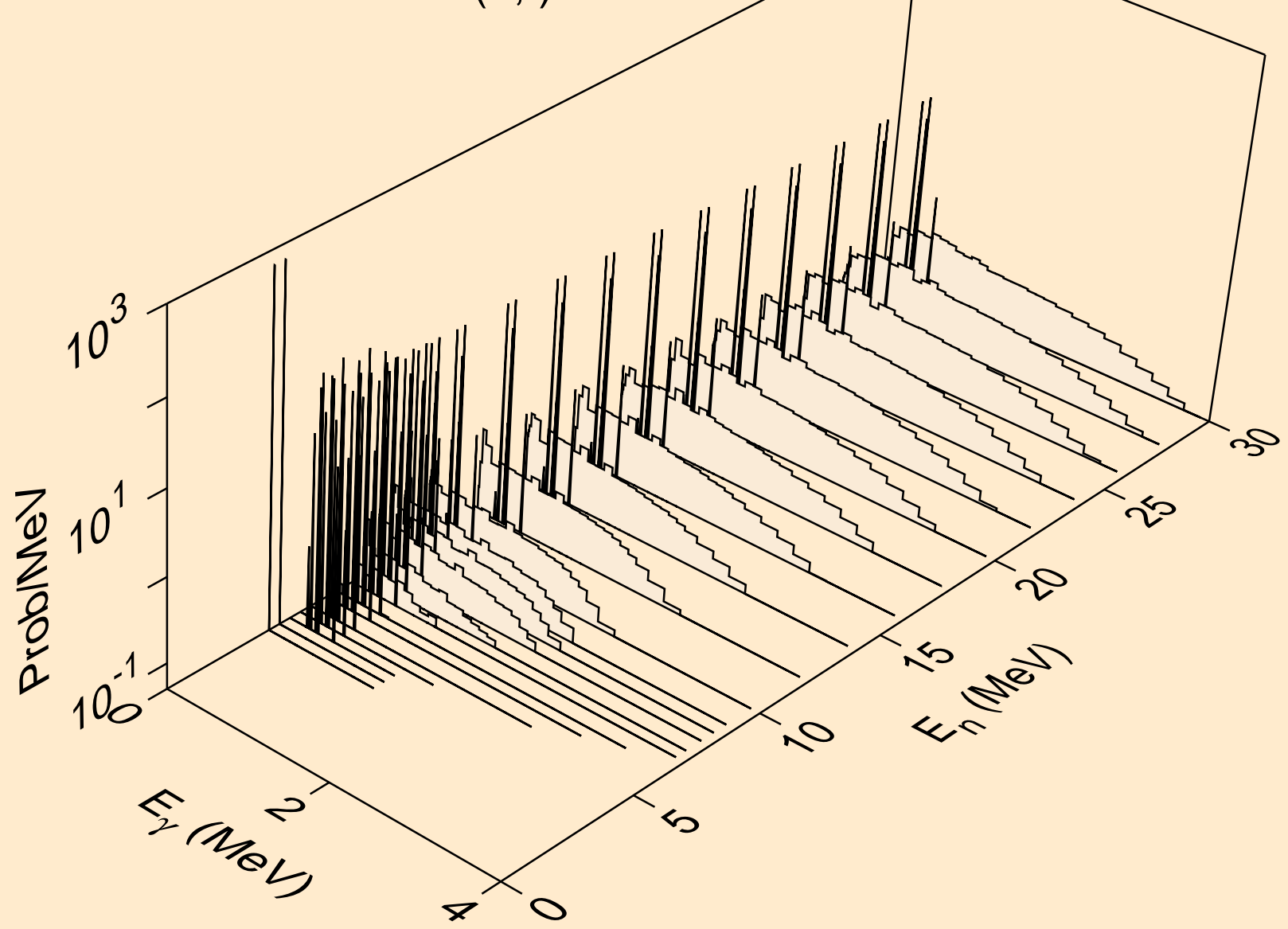

TL184 NEUTRON ACER TENDL-2023 LIBRARY; T=0.K
Photon emission for (n,he3)

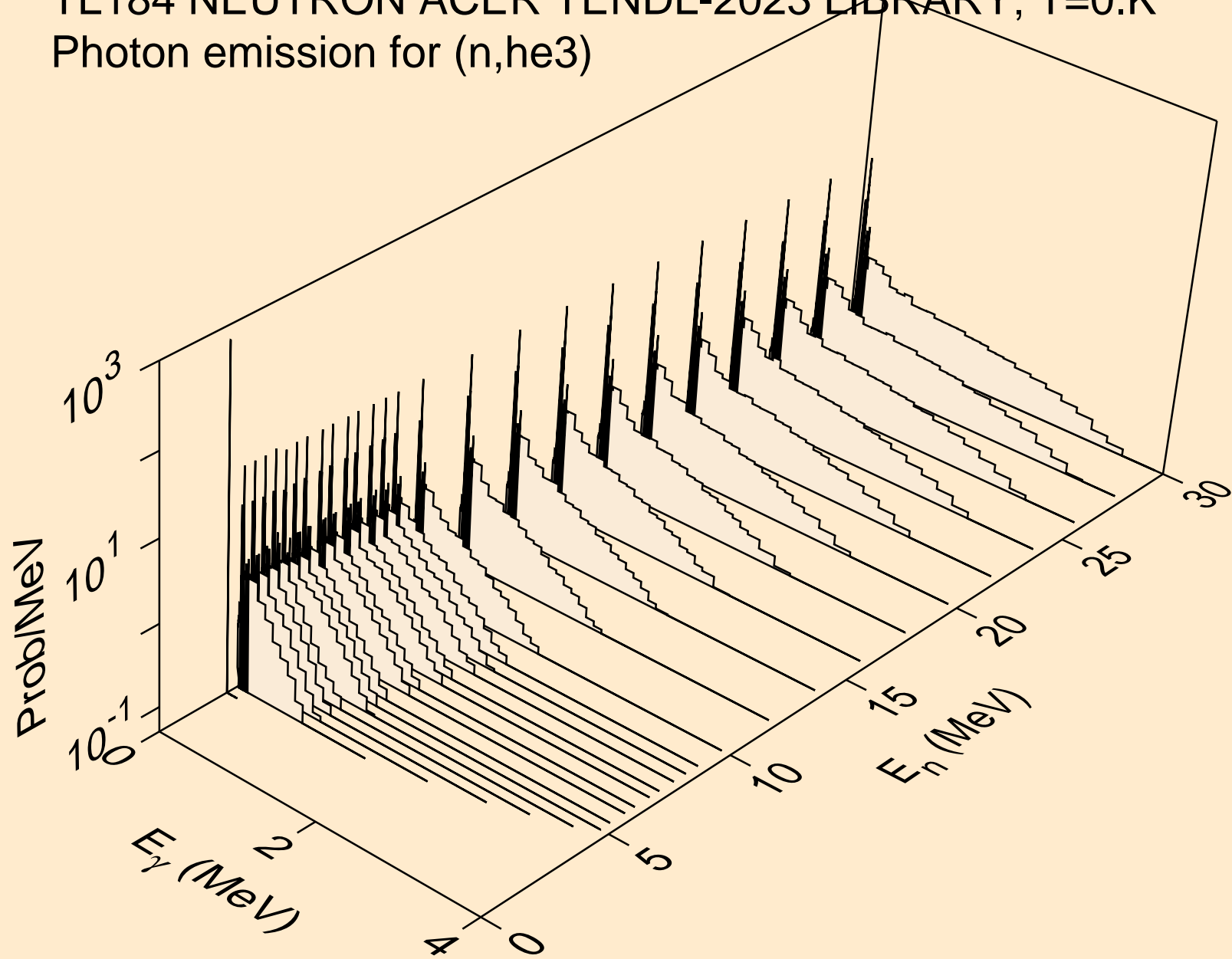

TL184 NEUTRON ACER TENDL-2023 LIBRARY; T=0.K
Photon emission for (n,a)

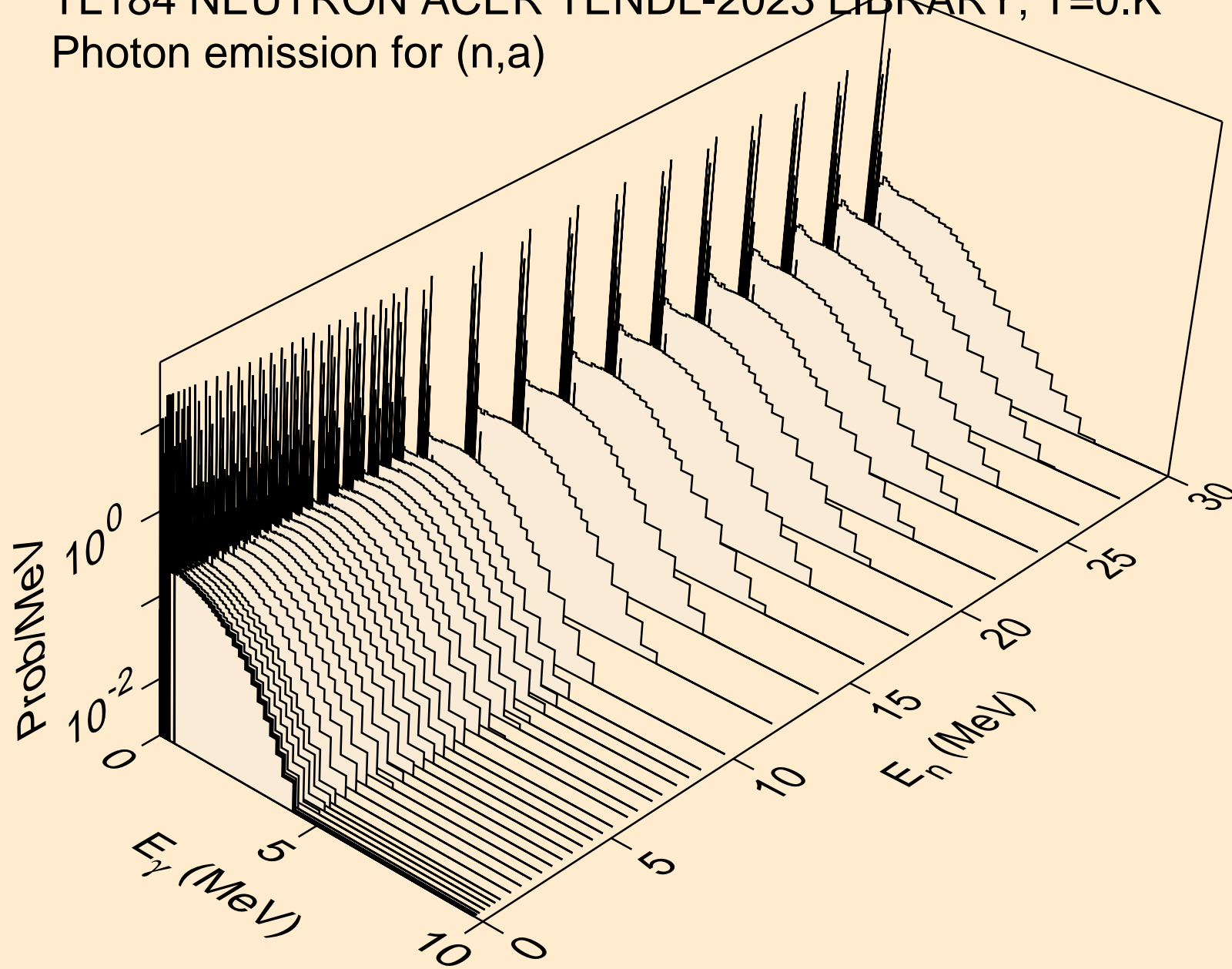

TL184 NEUTRON ACER TENDL-2023 LIBRARY; T=0.K
Photon emission for (n,2a)

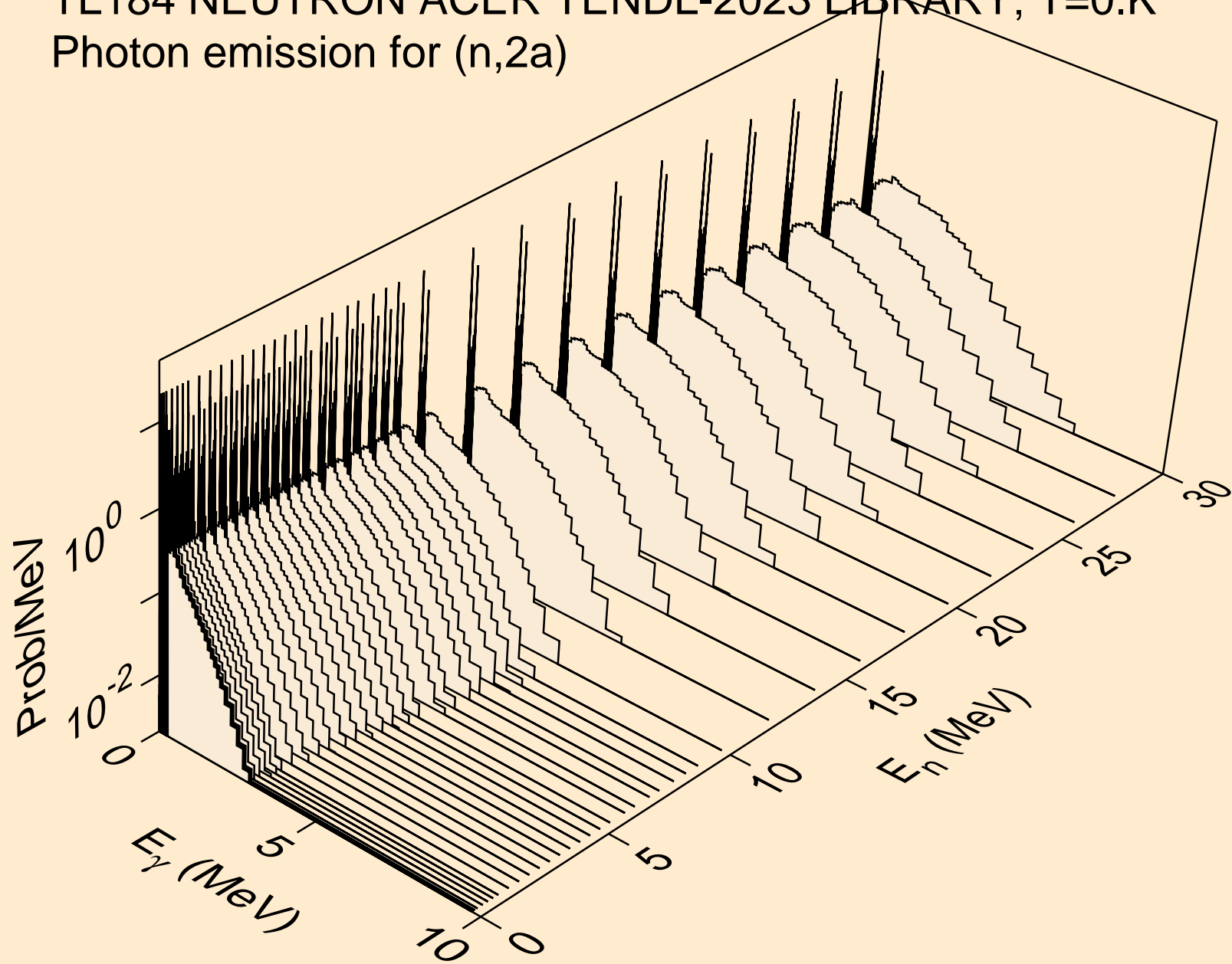

TL184 NEUTRON ACER TENDL-2023 LIBRARY; T=0.K
Photon emission for (n,3a)

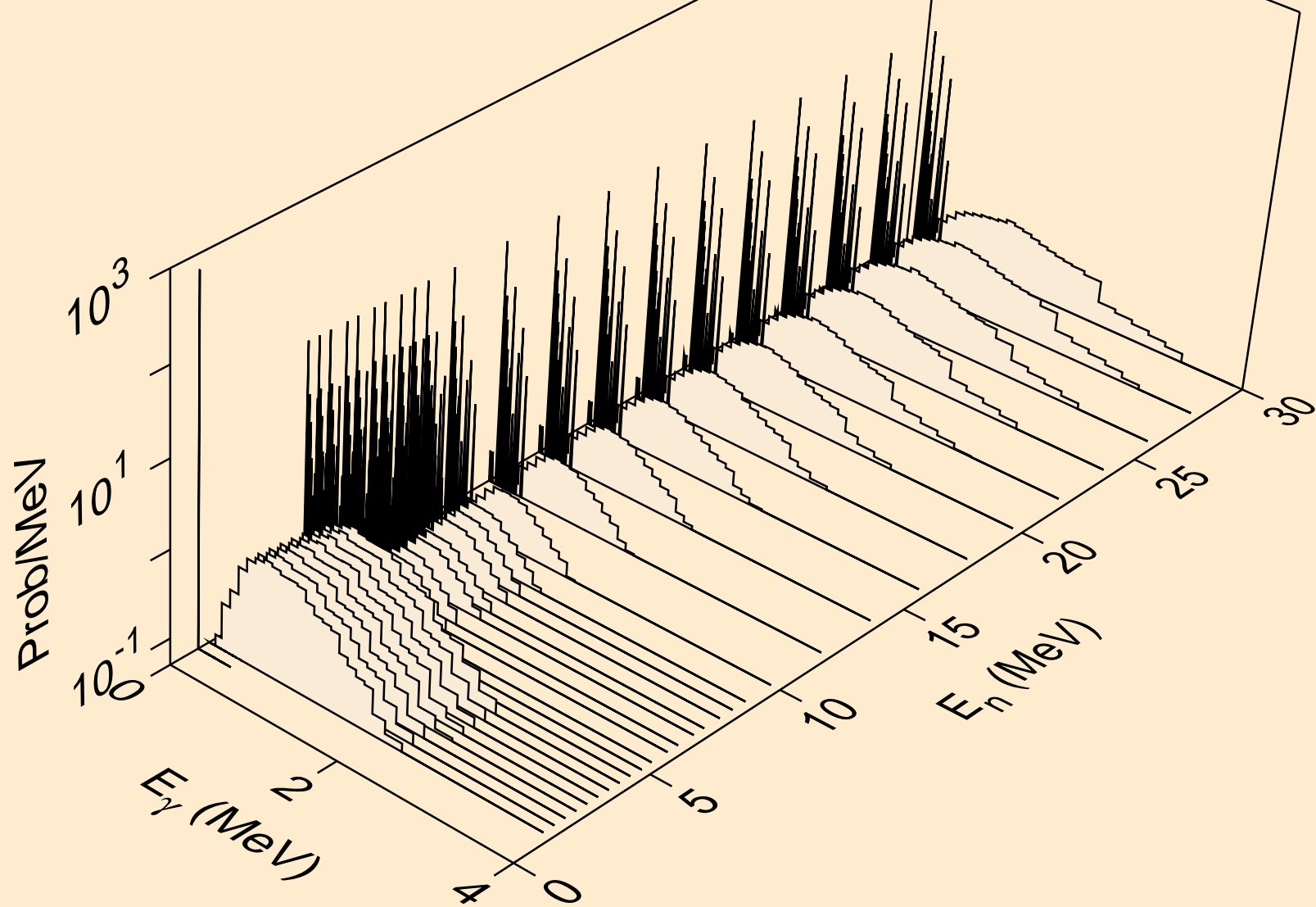

TL184 NEUTRON ACER TENDL-2023 LIBRARY; T=0.K
Photon emission for (n,2p)

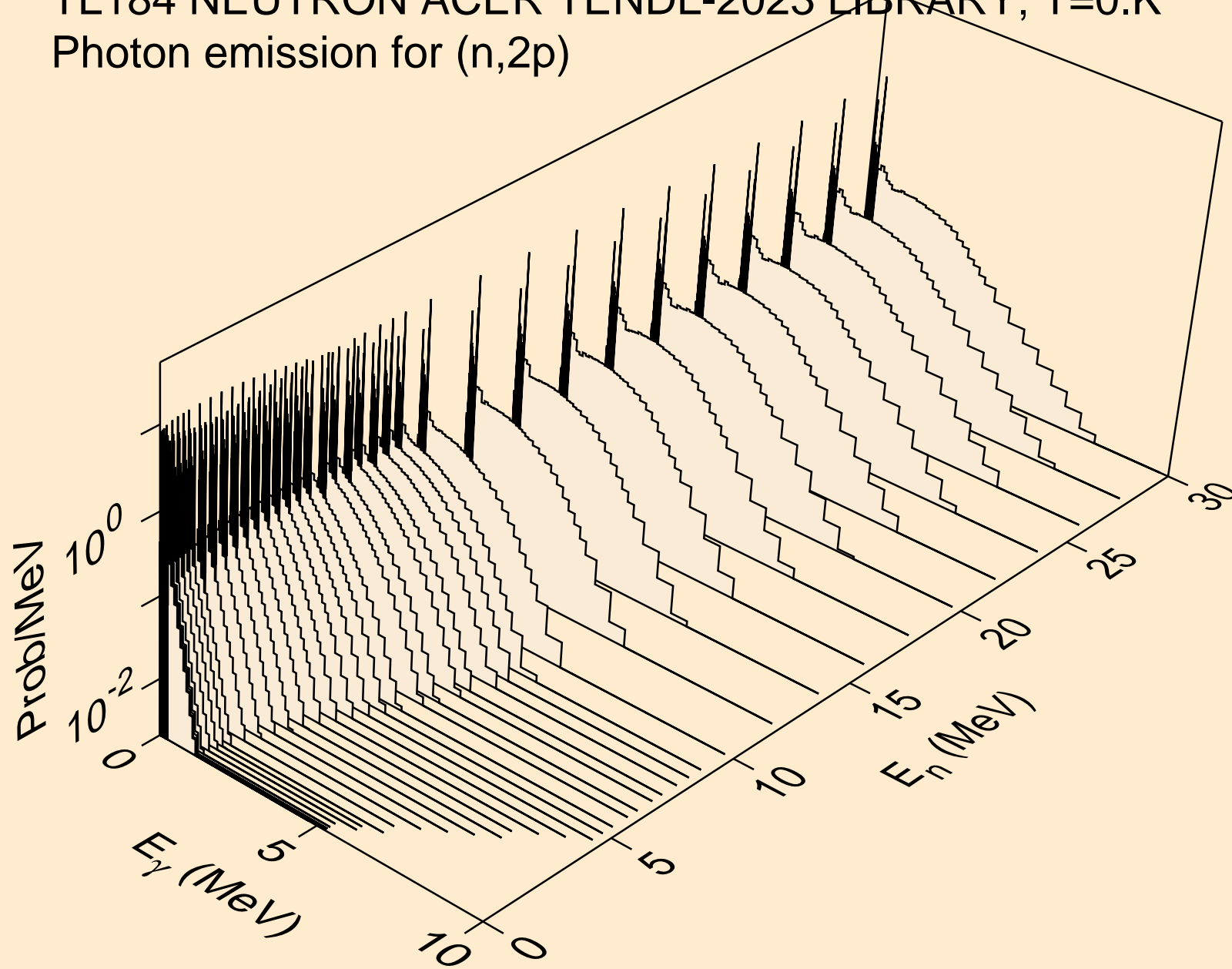

TL184 NEUTRON ACER TENDL-2023 LIBRARY; T=0.K
Photon emission for (n,p α)

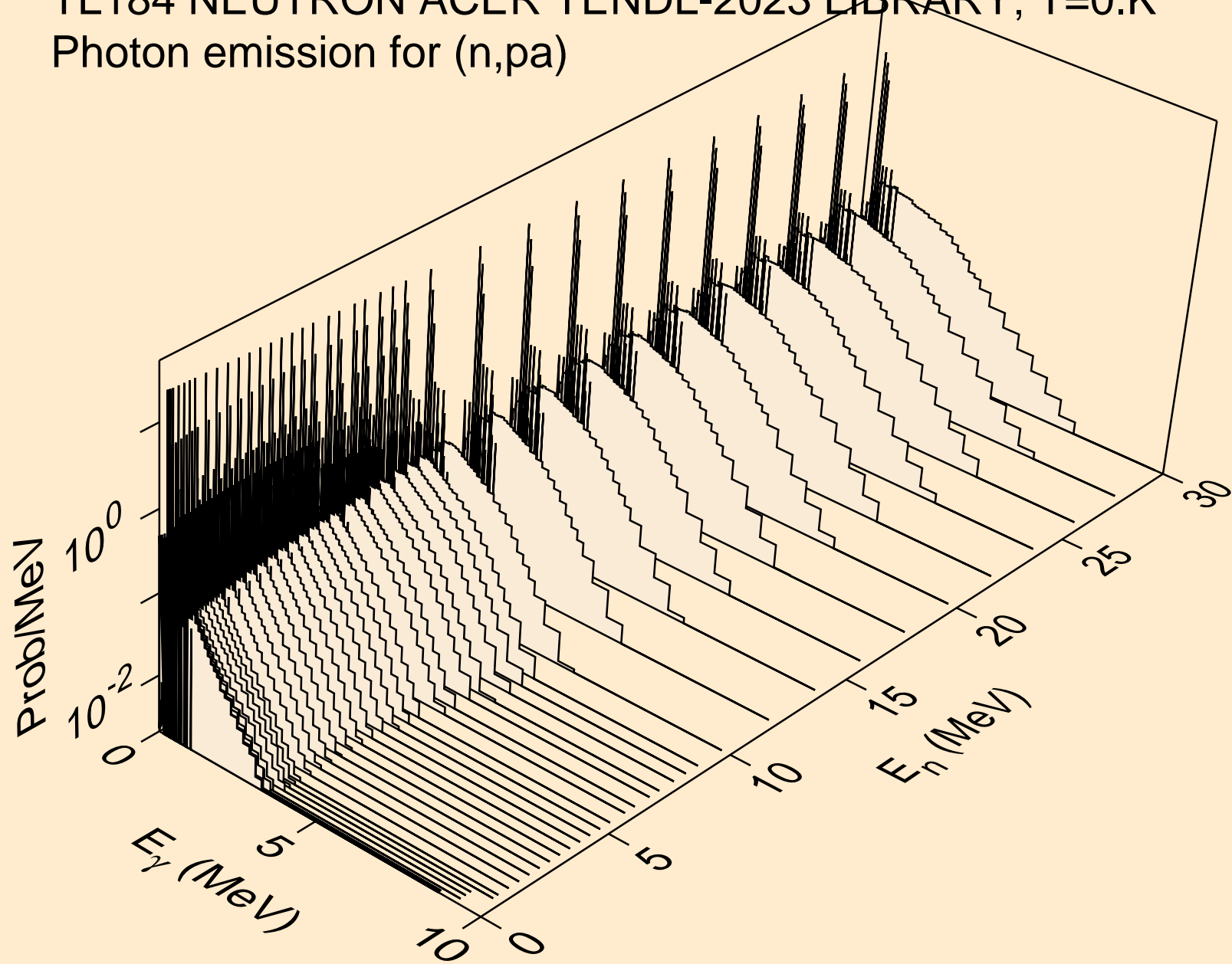

TL184 NEUTRON ACER TENDL-2023 LIBRARY; T=0.K
Photon emission for (n,t2a)

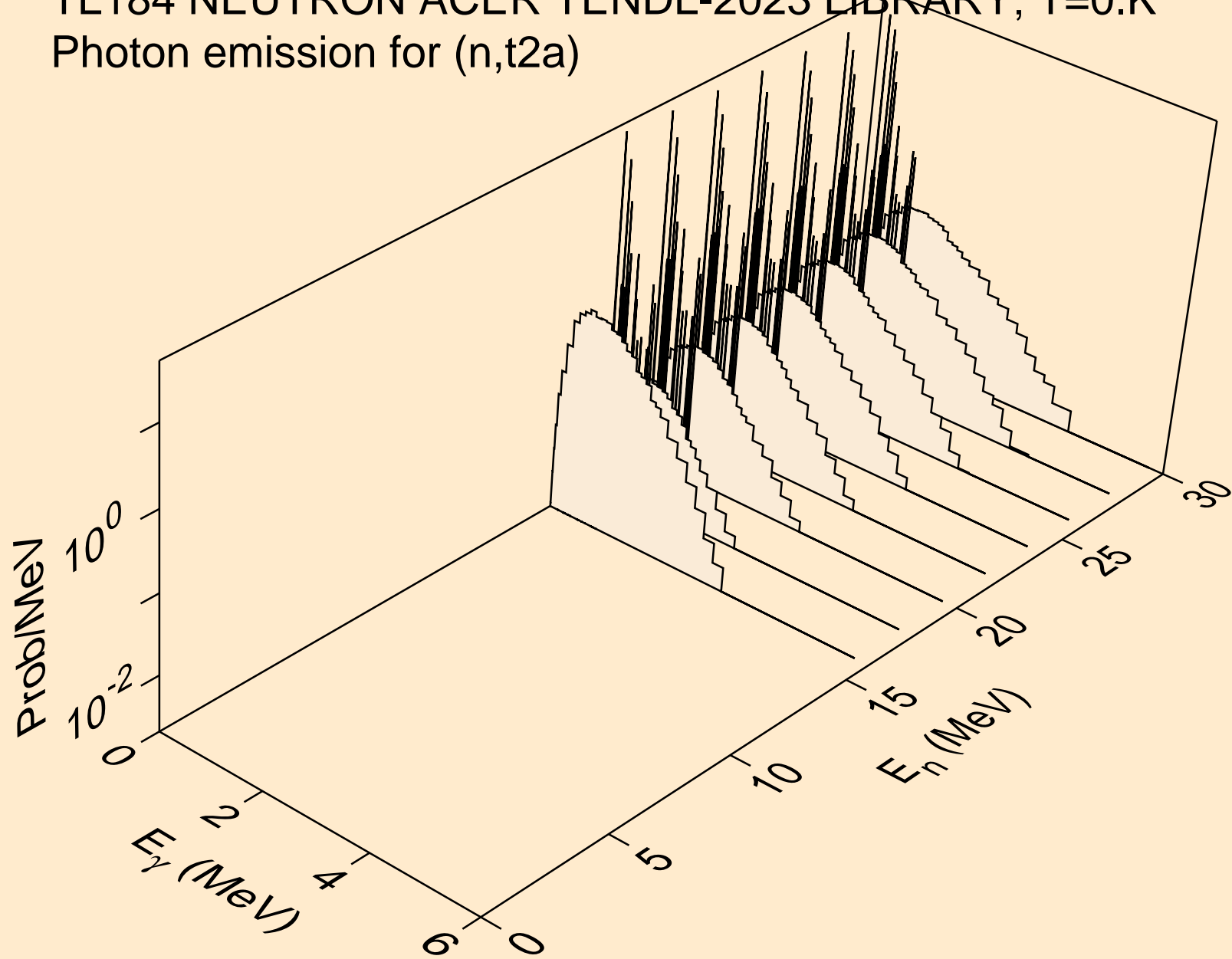

TL184 NEUTRON ACER TENDL-2023 LIBRARY; T=0.K
Photon emission for (n,d2a)

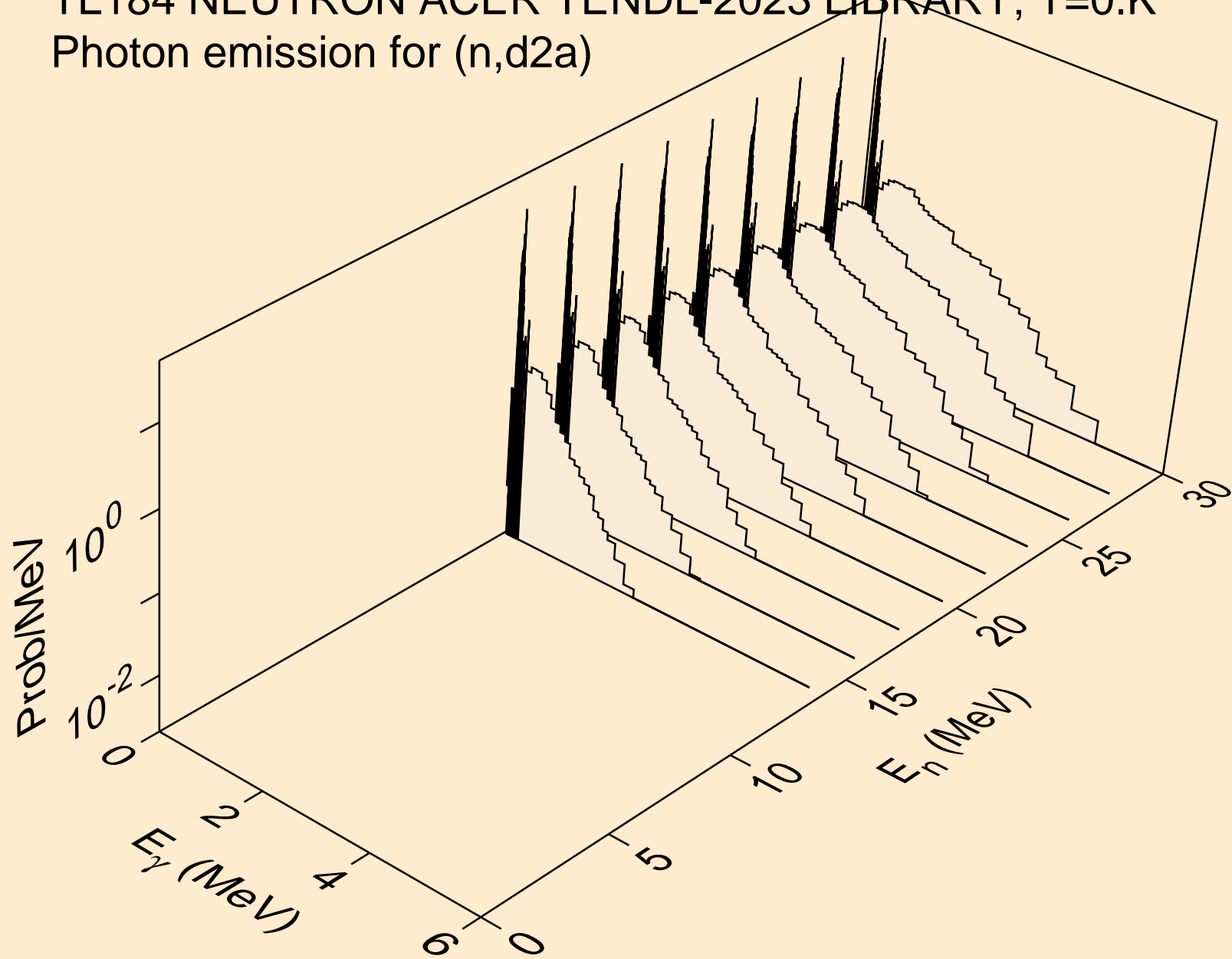

TL184 NEUTRON ACER TENDL-2023 LIBRARY; T=0.K
Photon emission for (n,pd)

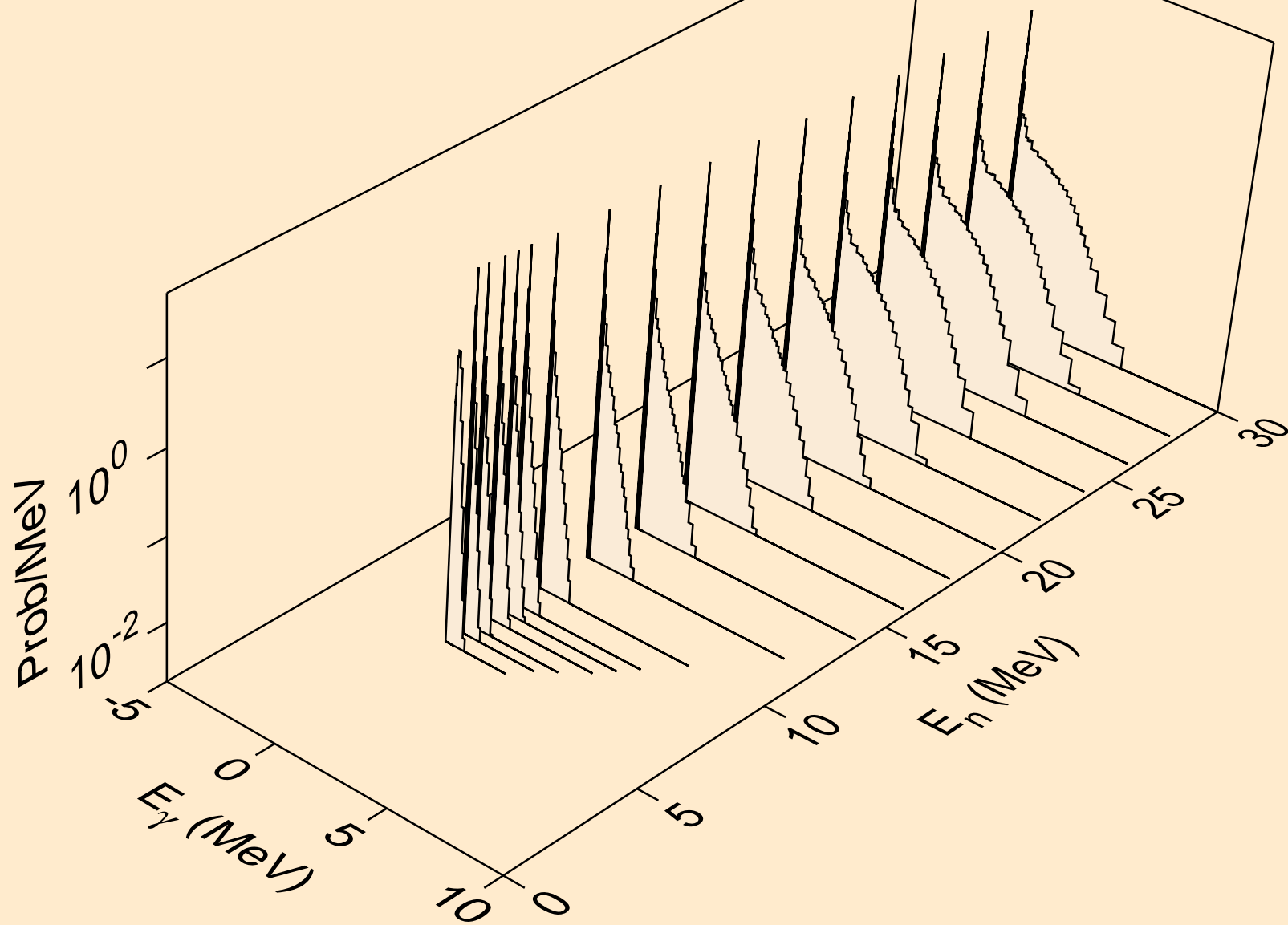

TL184 NEUTRON ACER TENDL-2023 LIBRARY; T=0.K
Photon emission for (n,pt)

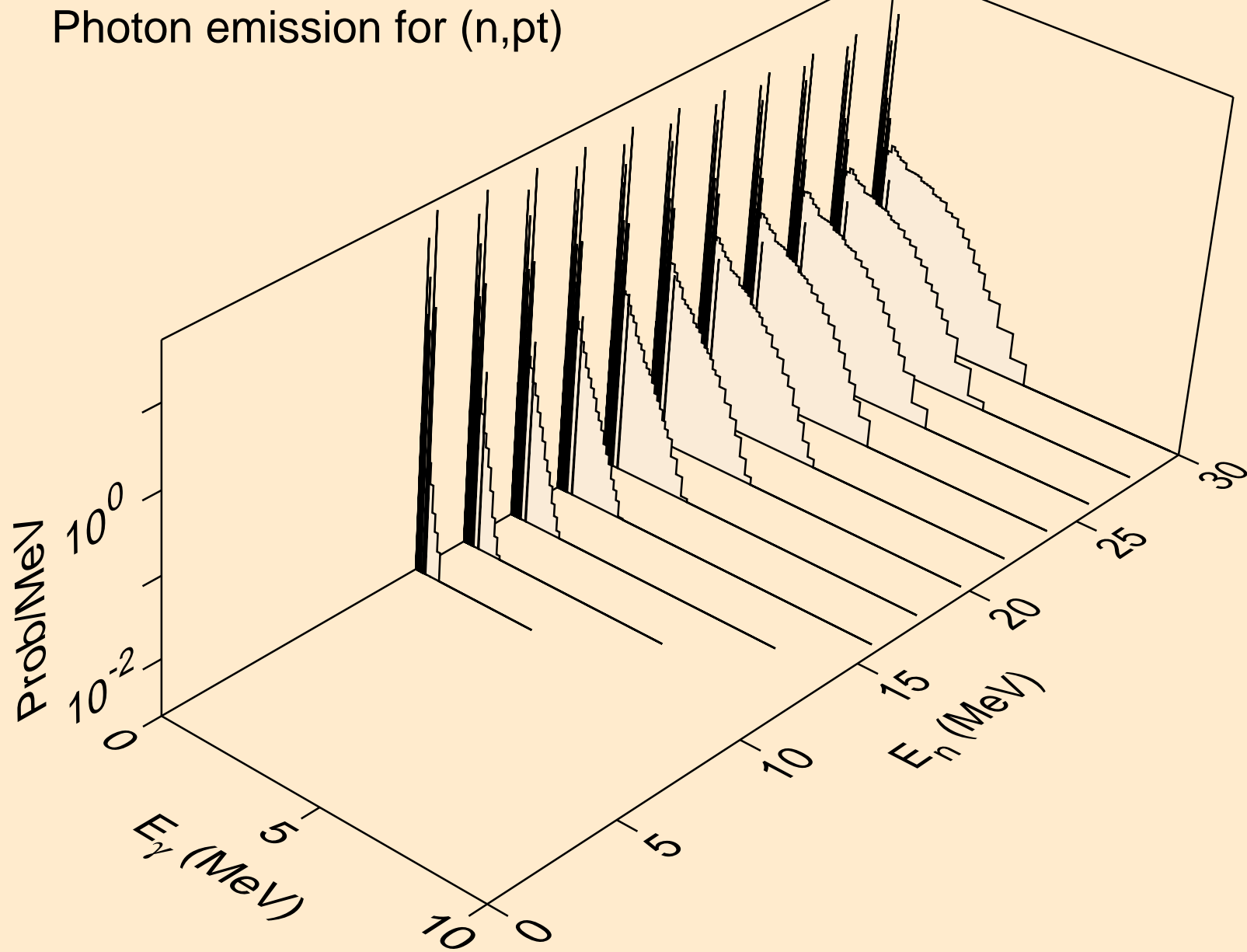

TL184 NEUTRON ACER TENDL-2023 LIBRARY; T=0.K
Photon emission for (n,da)

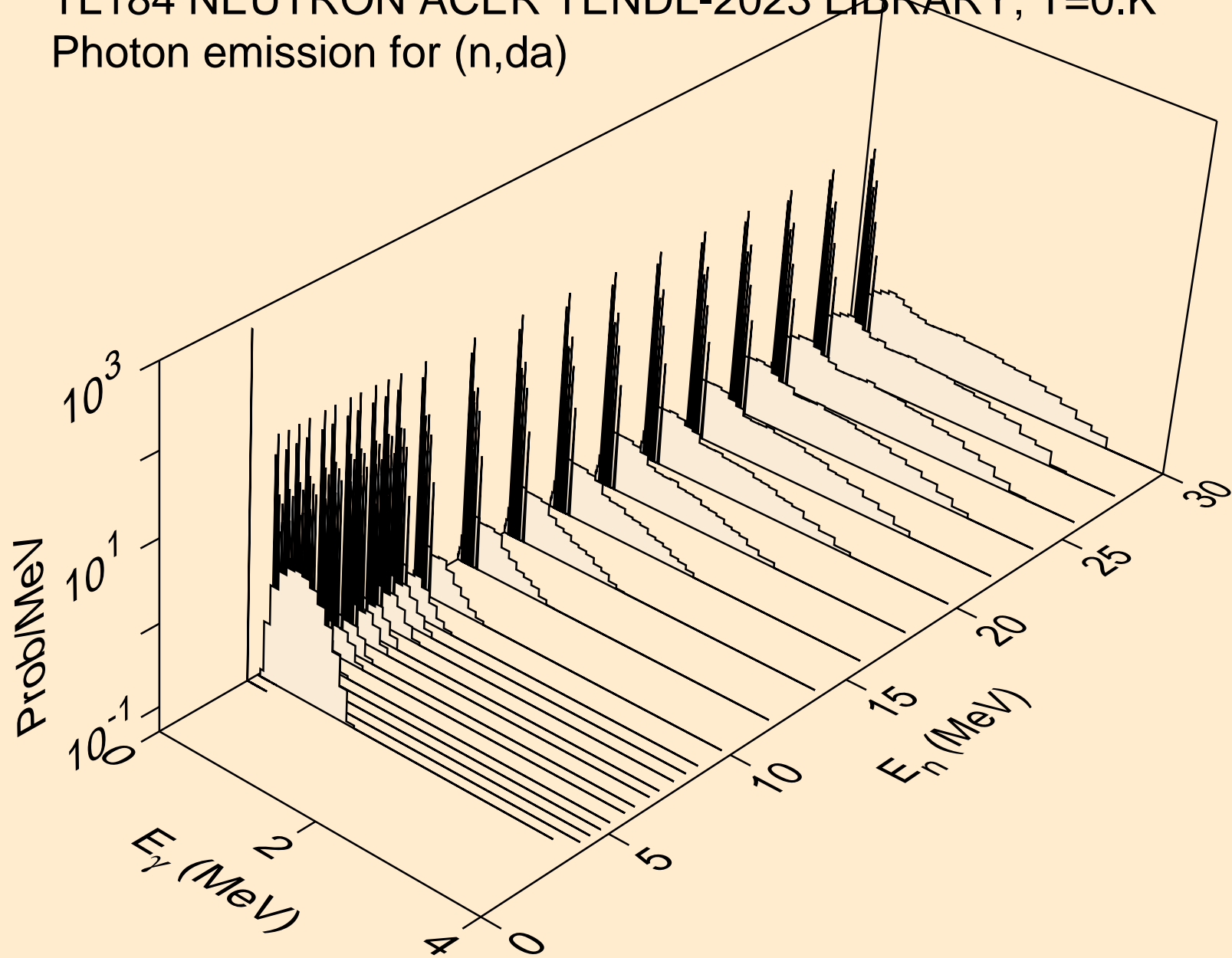

TL184 NEUTRON ACER TENDL-2023 LIBRARY; T=0.K
thermal capture photon spectrum

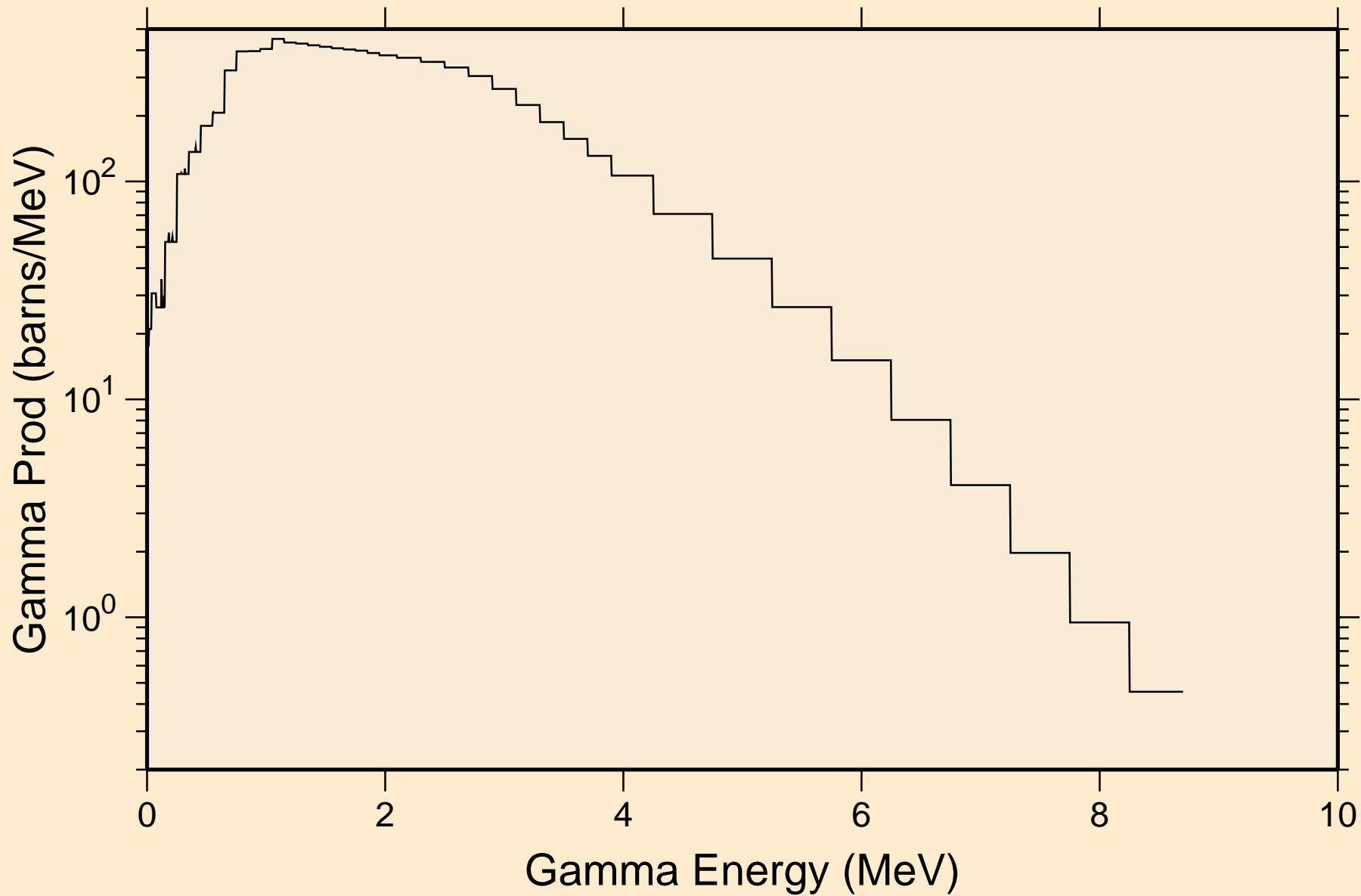

TL184 NEUTRON ACER TENDL-2023 LIBRARY; T=0.K
14 MeV photon spectrum

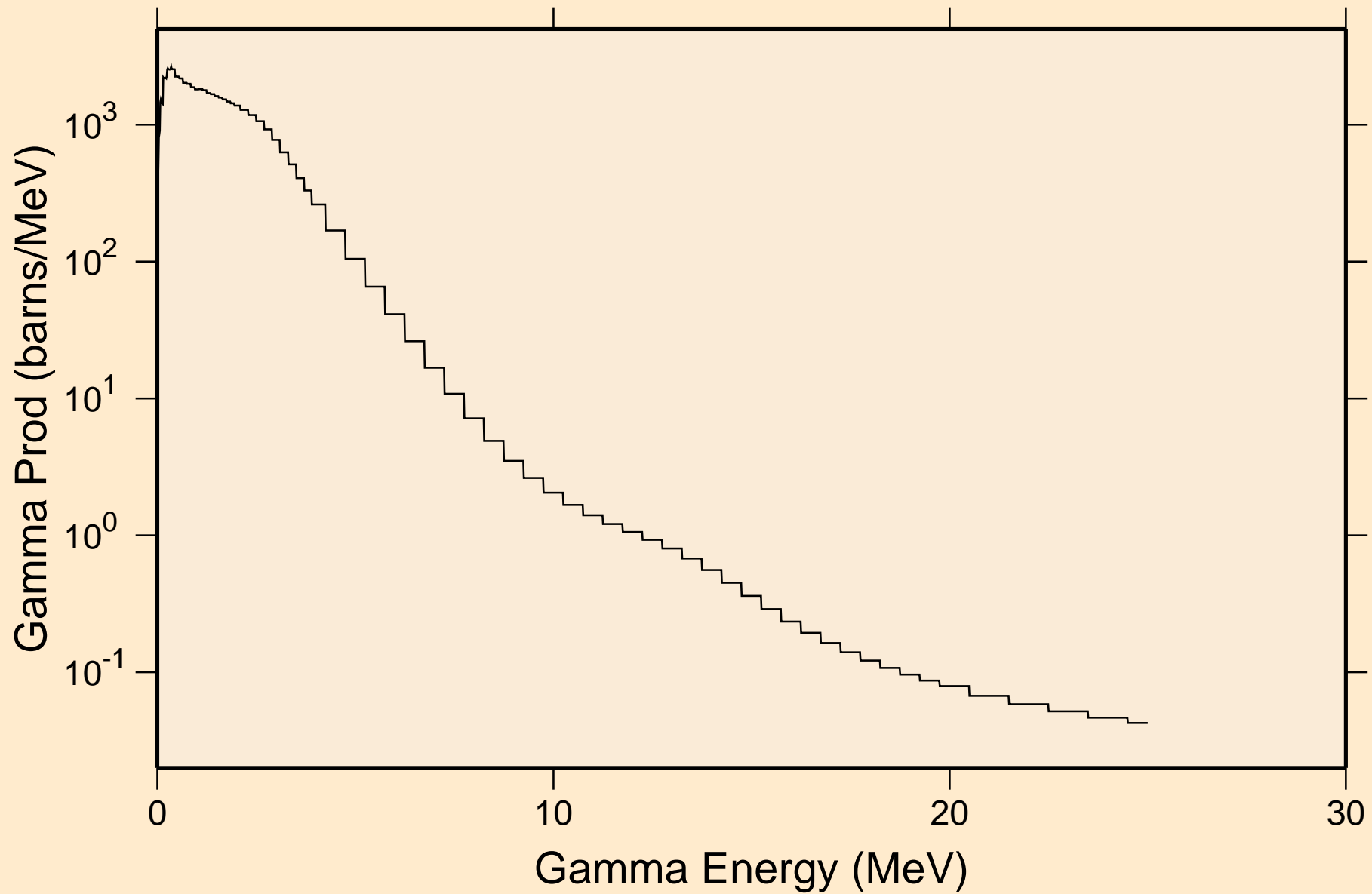

TL184 NEUTRON ACER TENDL-2023 LIBRARY; T=0.K

Particle heating contributions

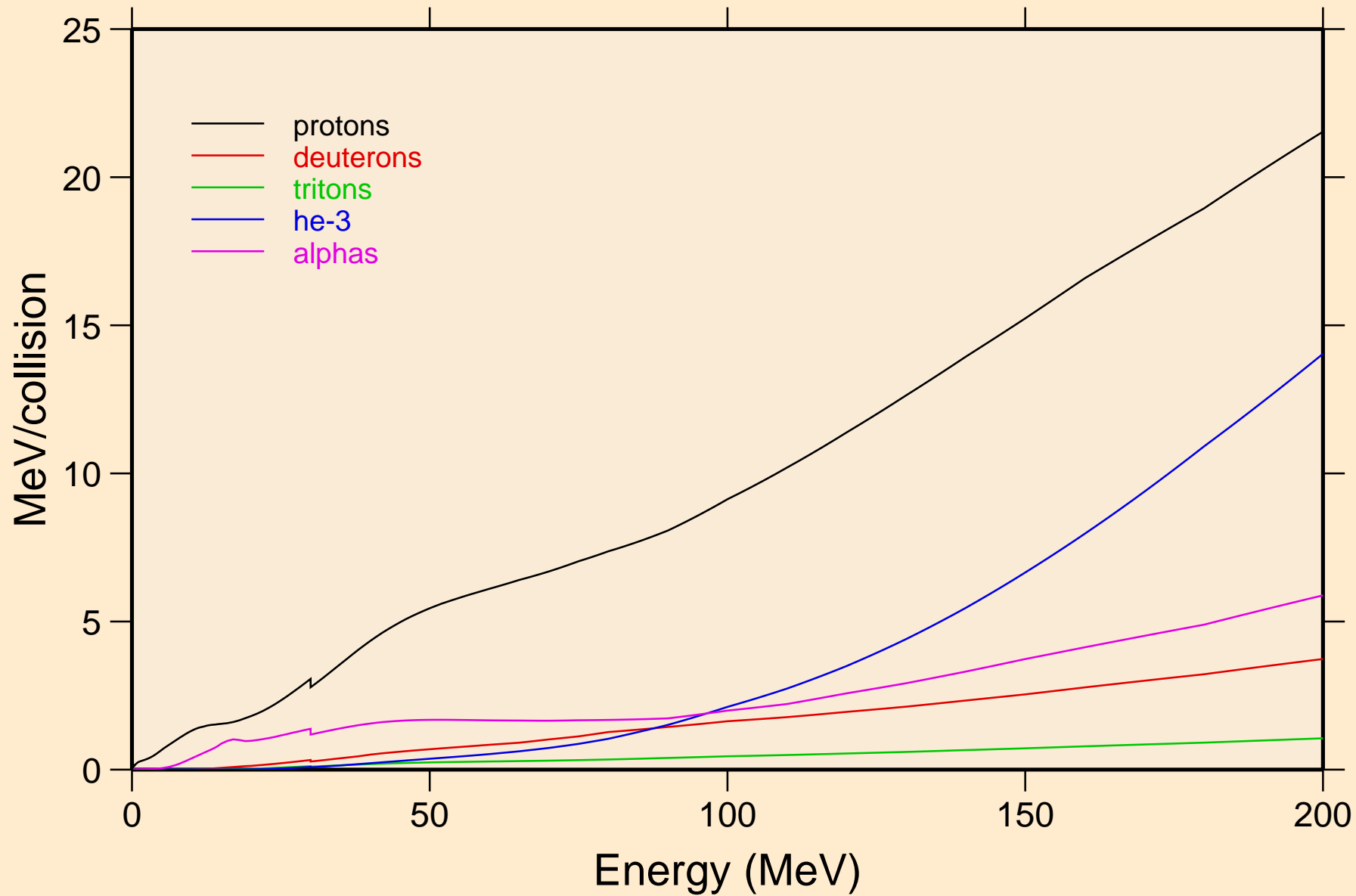

TL184 NEUTRON ACER TENDL-2023 LIBRARY; T=0.K
Recoil Heating

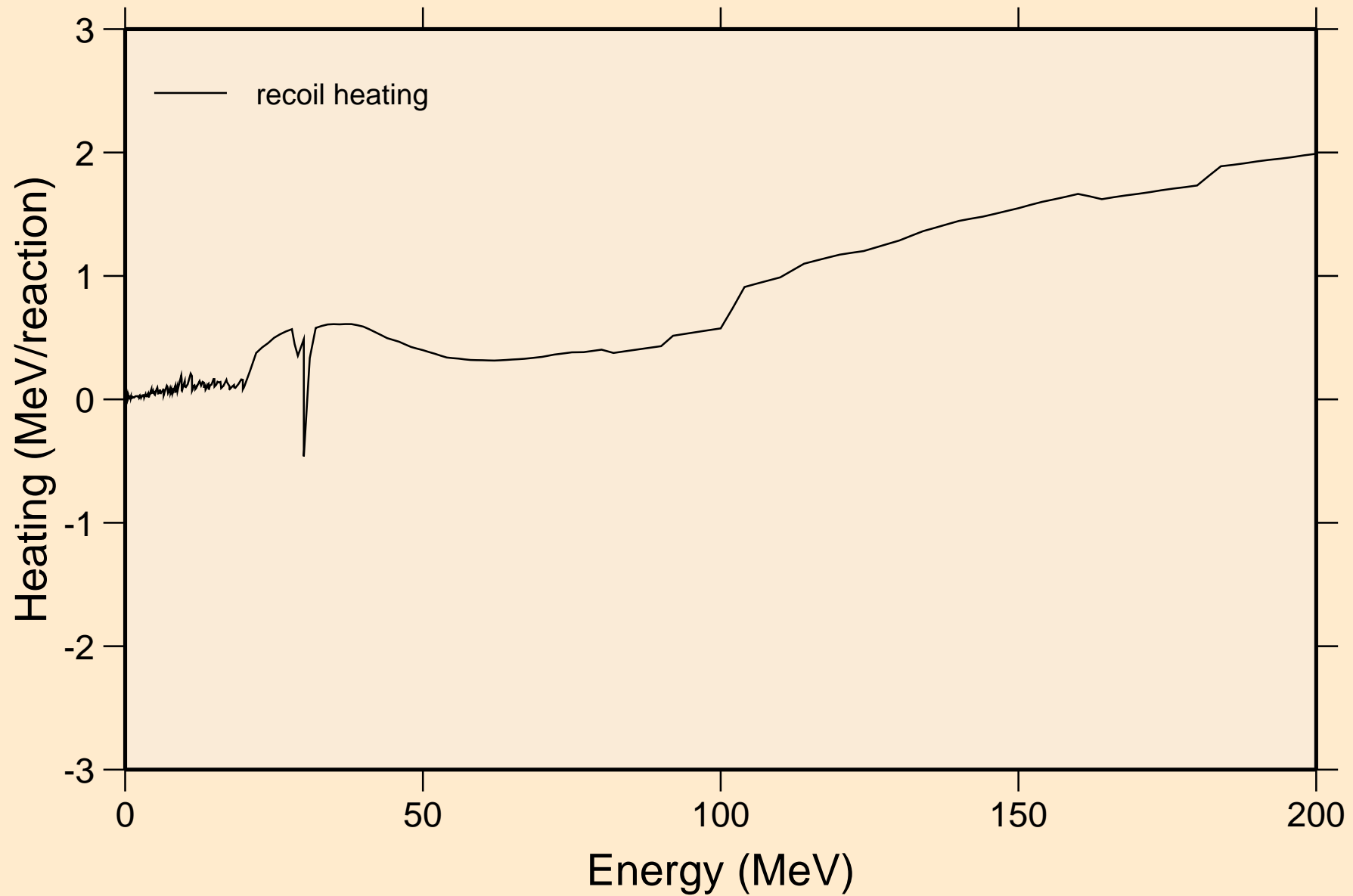

TL184 NEUTRON ACER TENDL-2023 LIBRARY; T=0.K
Particle production cross sections

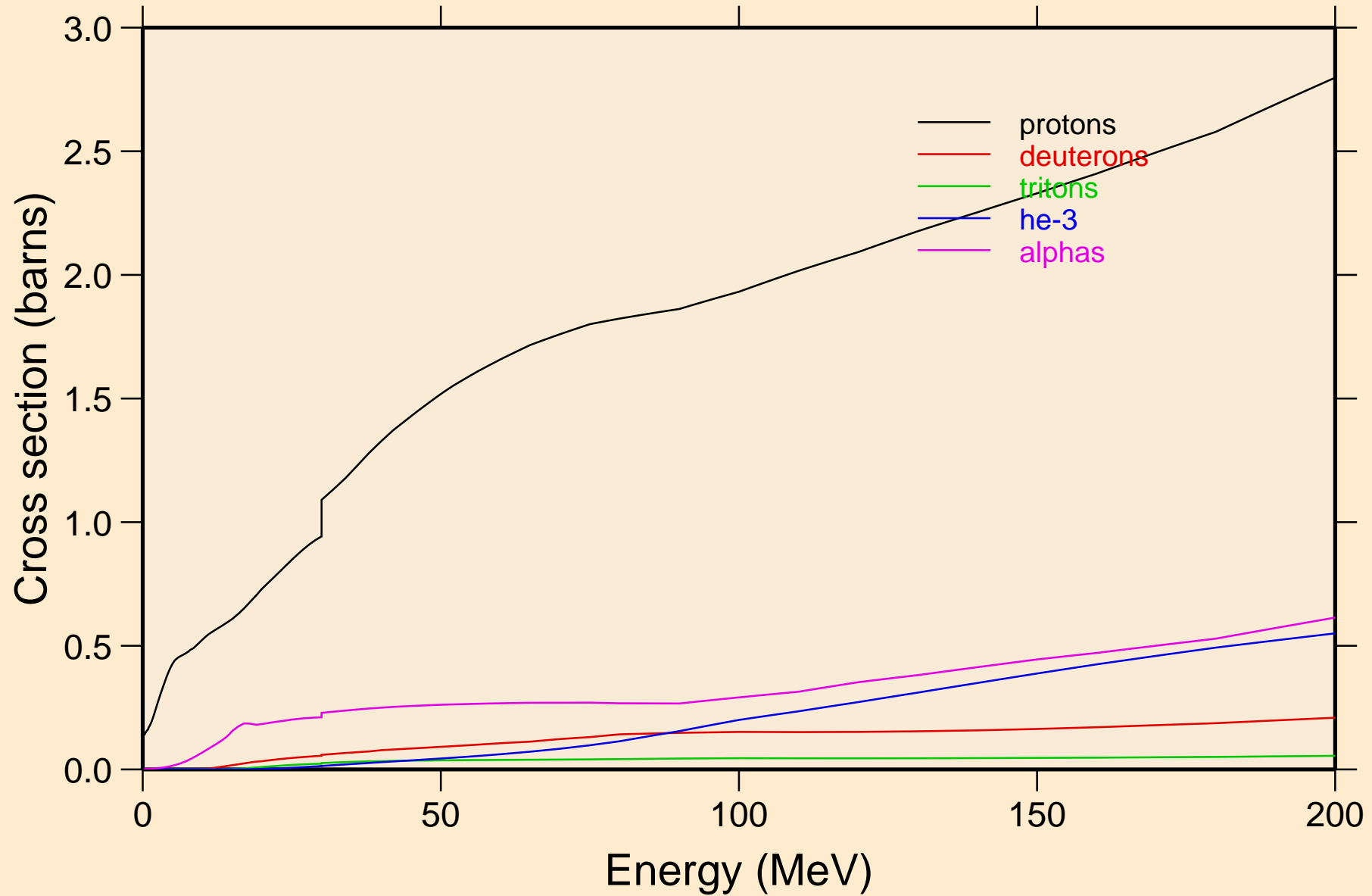

TL184 NEUTRON ACER TENDL-2023 LIBRARY; T=0.K
protons from (n,x)

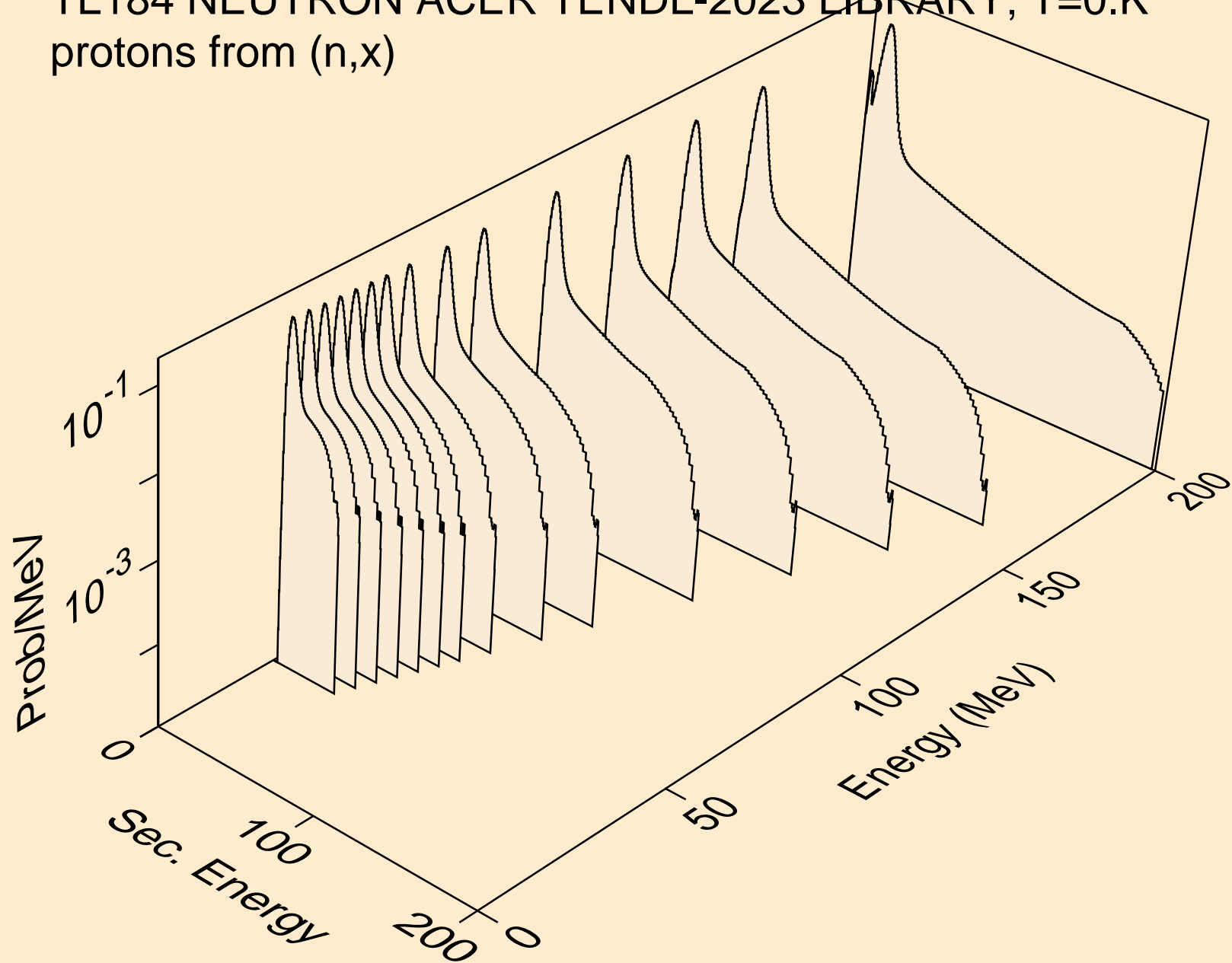

TL184 NEUTRON ACER TENDL-2023 LIBRARY; T=0.K
protons from (n,n*)p

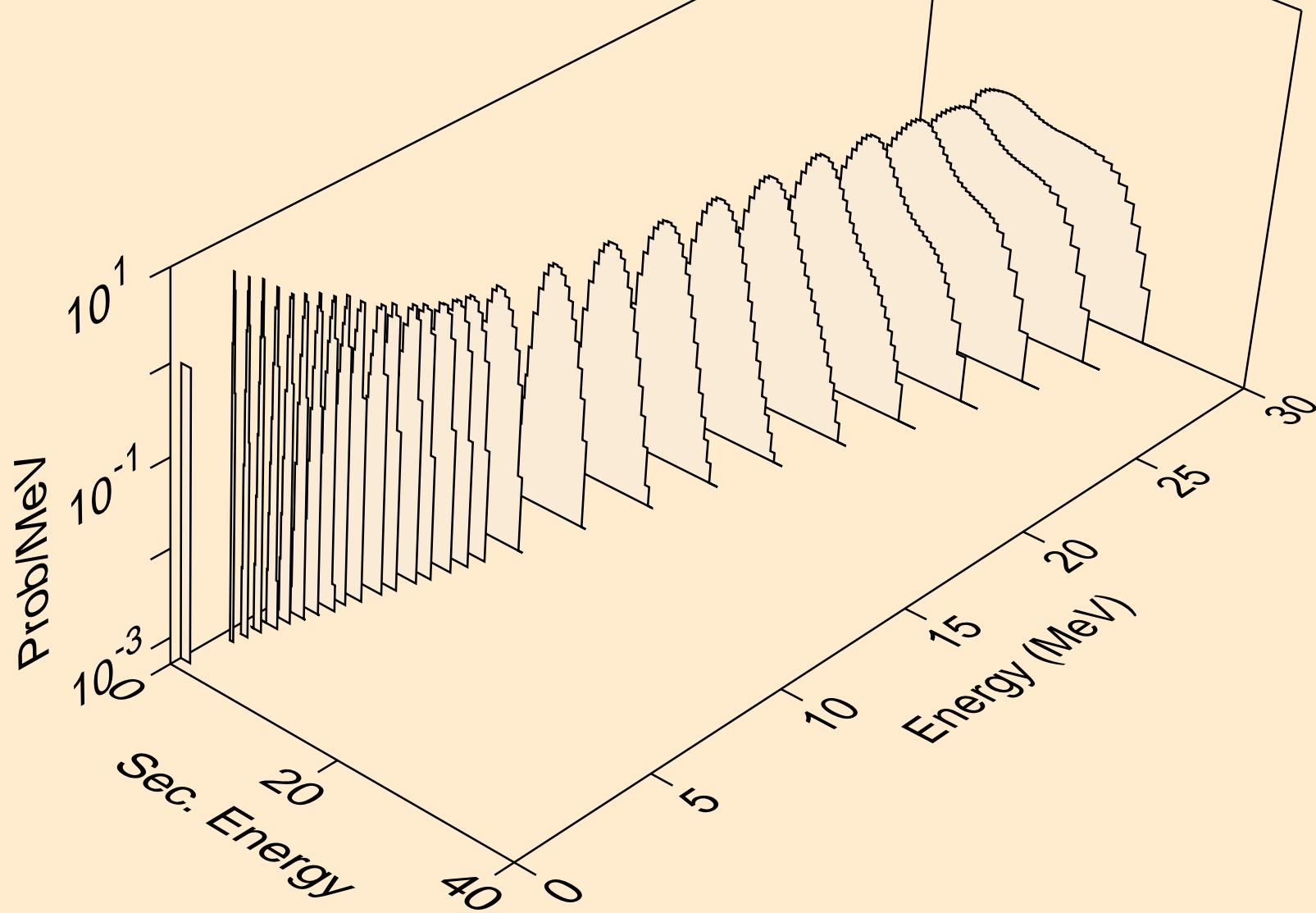

TL184 NEUTRON ACER TENDL-2023 LIBRARY; T=0.K
protons from (n,2np)

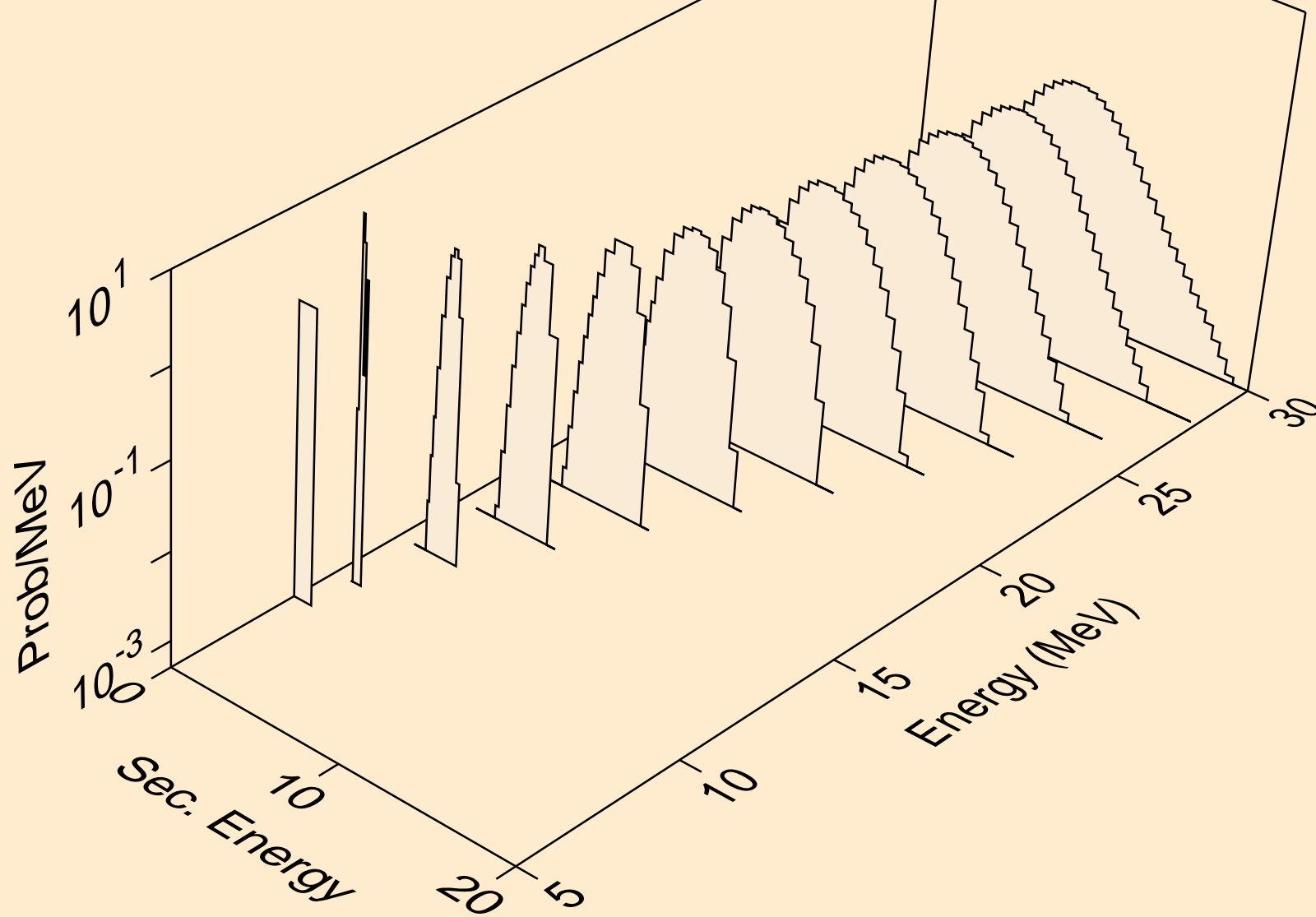

TL184 NEUTRON ACER TENDL-2023 LIBRARY; T=0.K
protons from (n,3np)

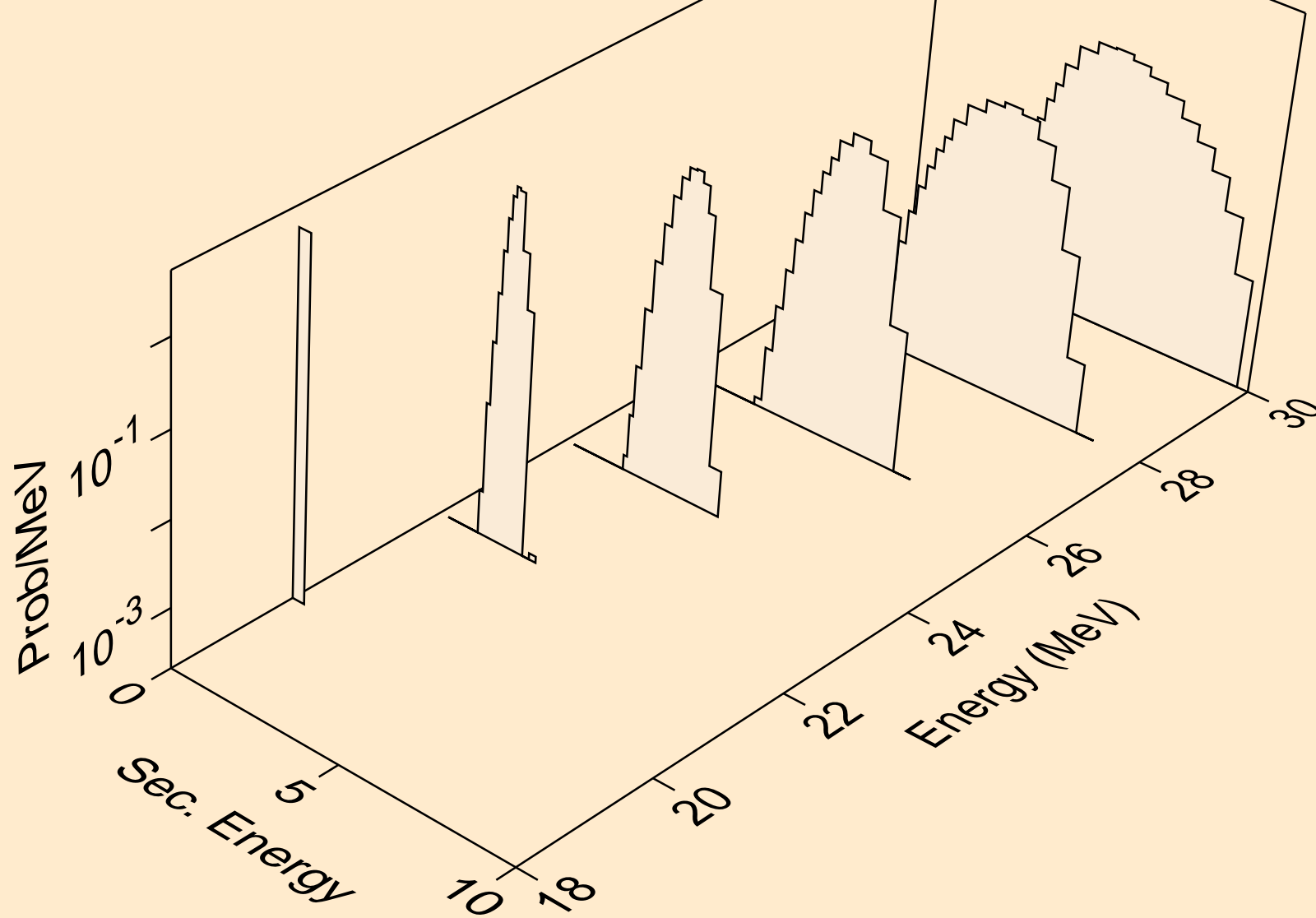

TL184 NEUTRON ACER TENDL-2023 LIBRARY; T=0.K
protons from (n,n2p)

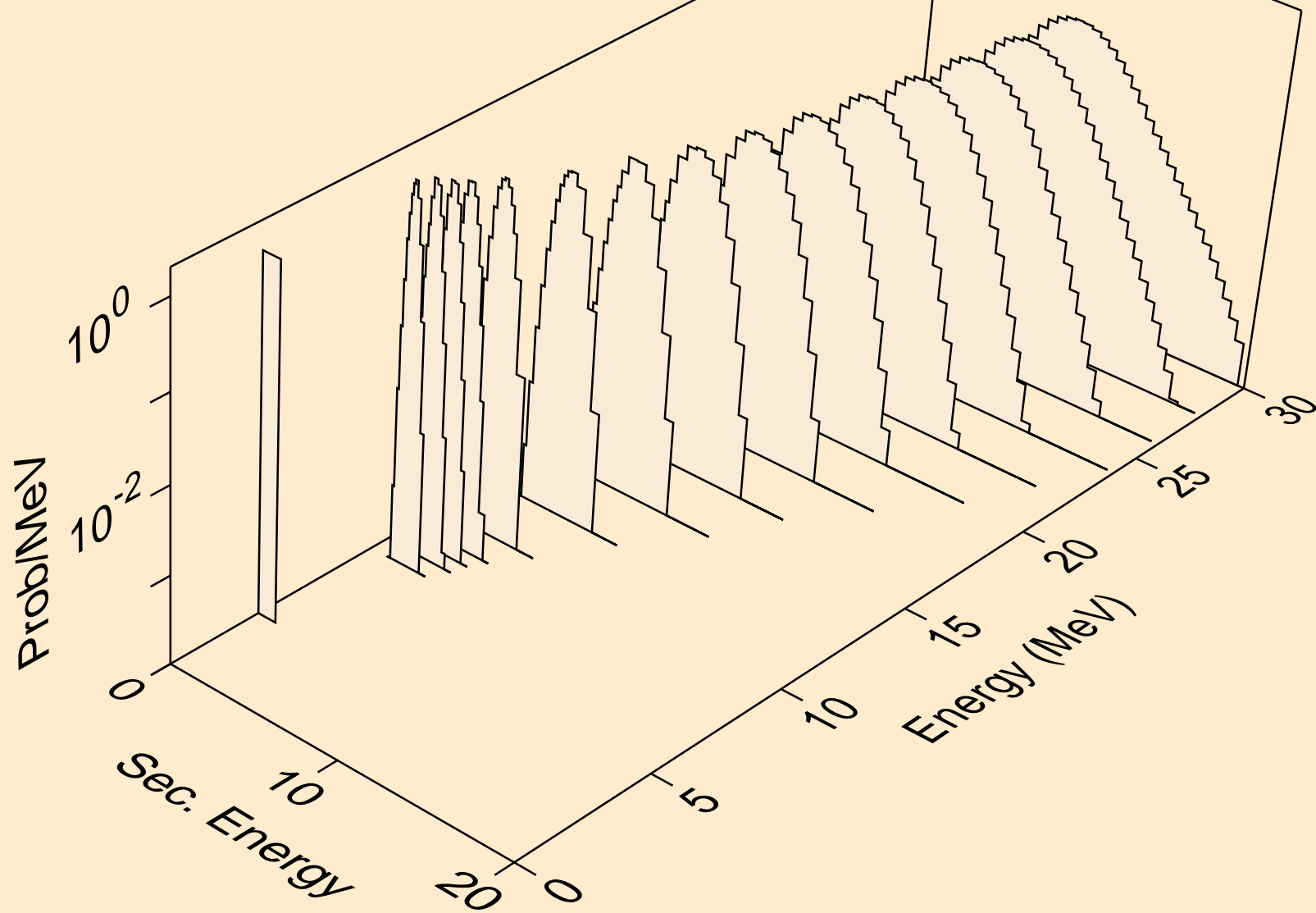

TL184 NEUTRON ACER TENDL-2023 LIBRARY; T=0.K
protons from (n,npa)

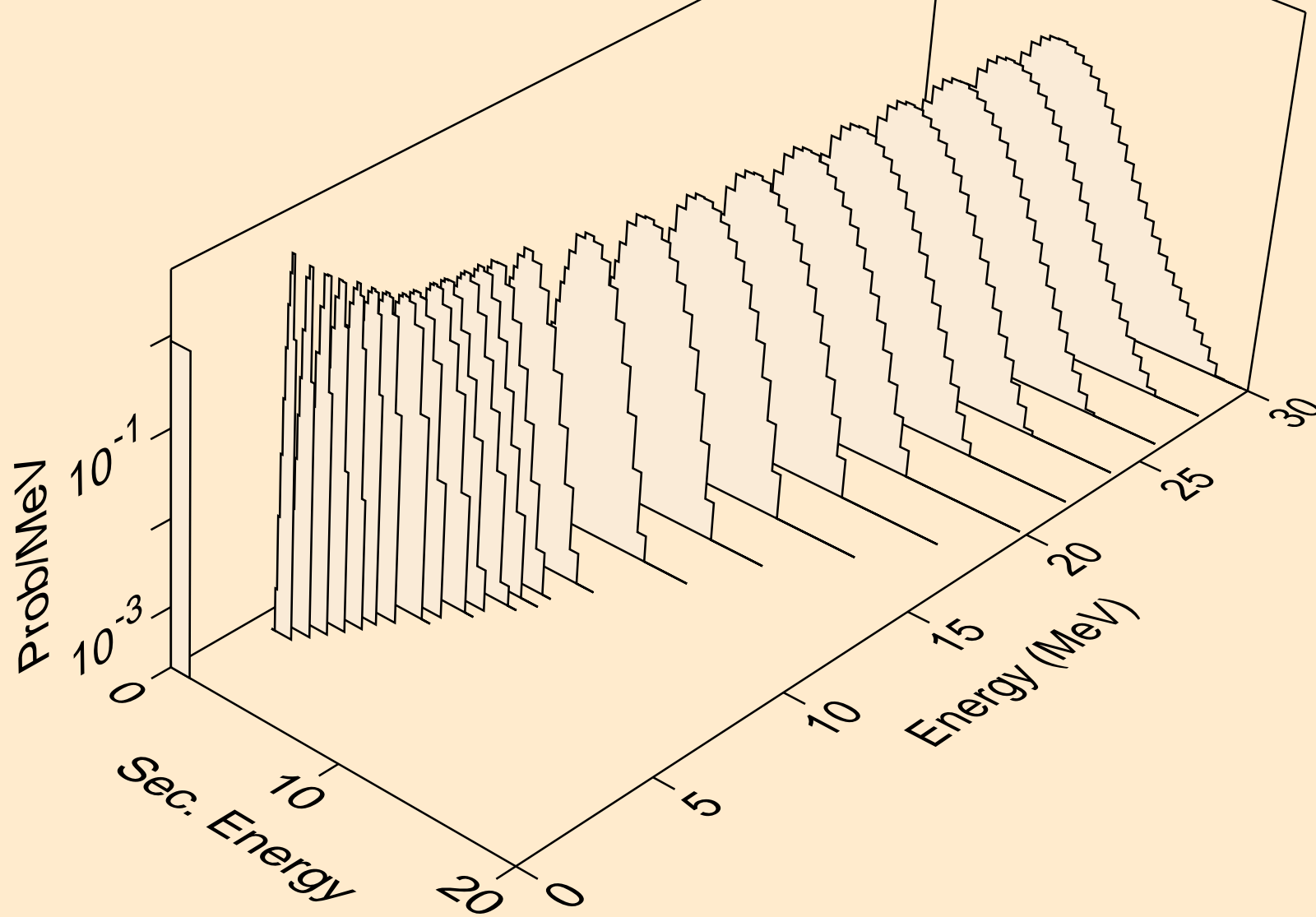

TL184 NEUTRON ACER TENDL-2023 LIBRARY; T=0.K
protons from (n,p)

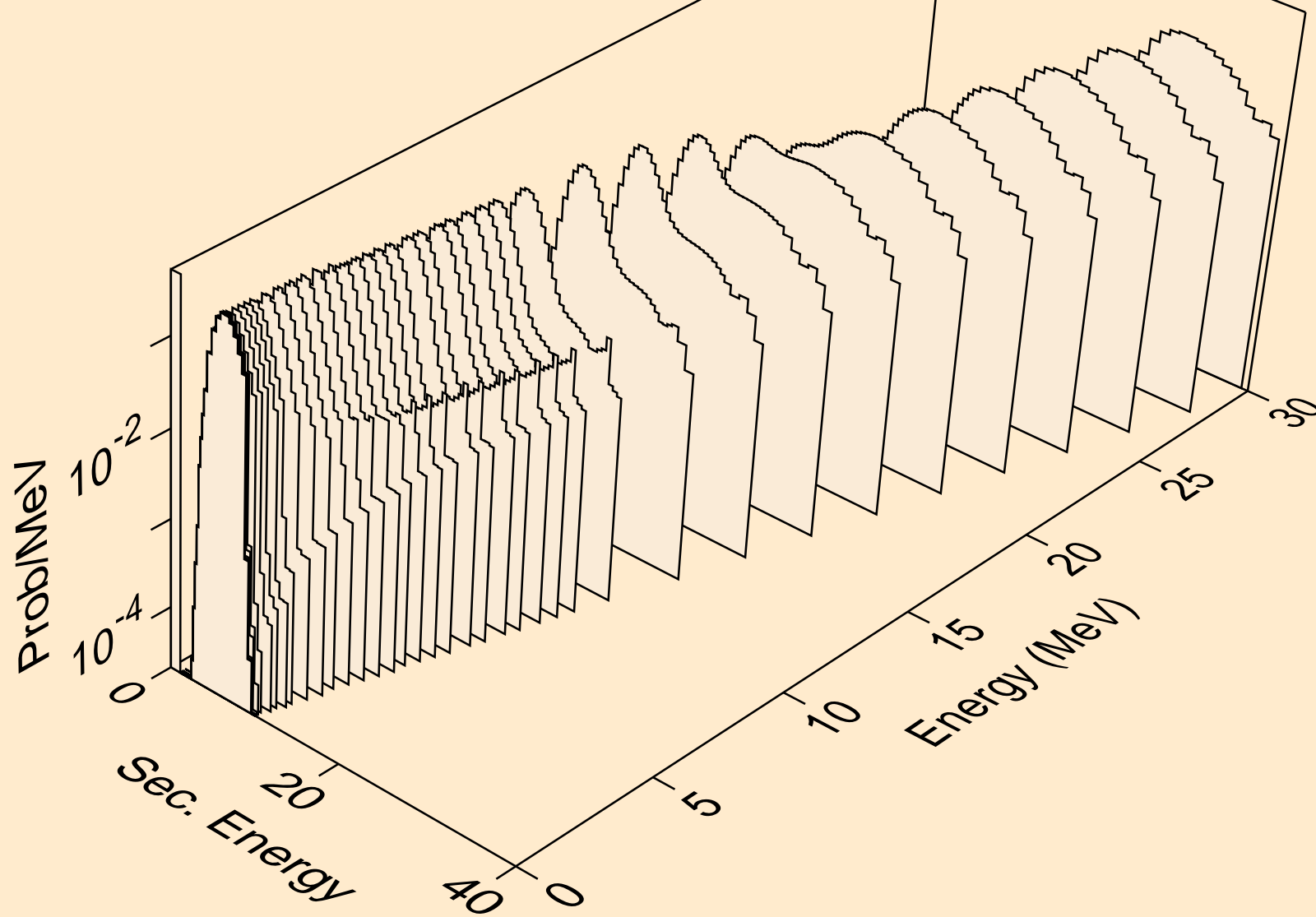

TL184 NEUTRON ACER TENDL-2023 LIBRARY; T=0.K
protons from (n,2p)

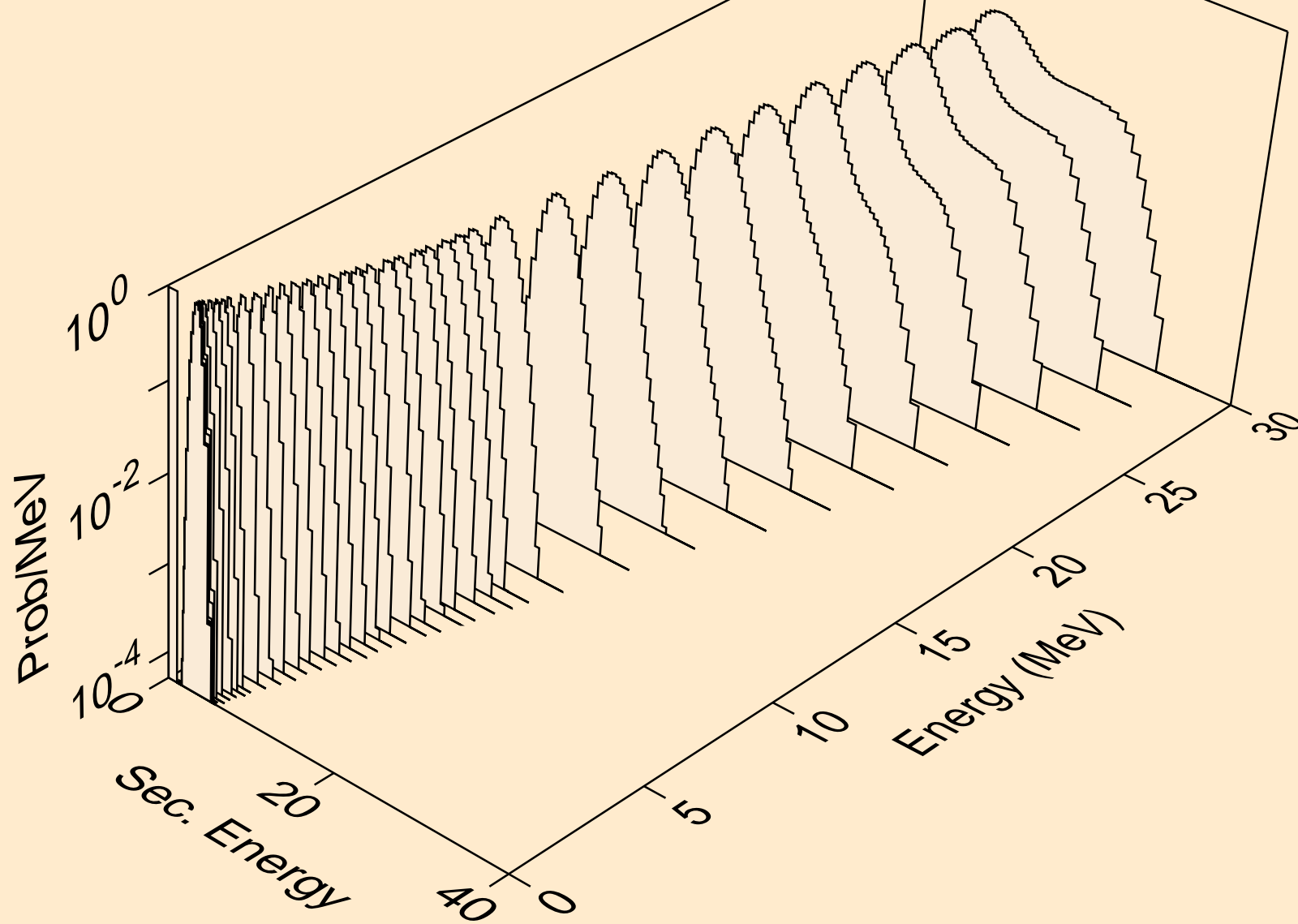

TL184 NEUTRON ACER TENDL-2023 LIBRARY; T=0.K
protons from (n,p)

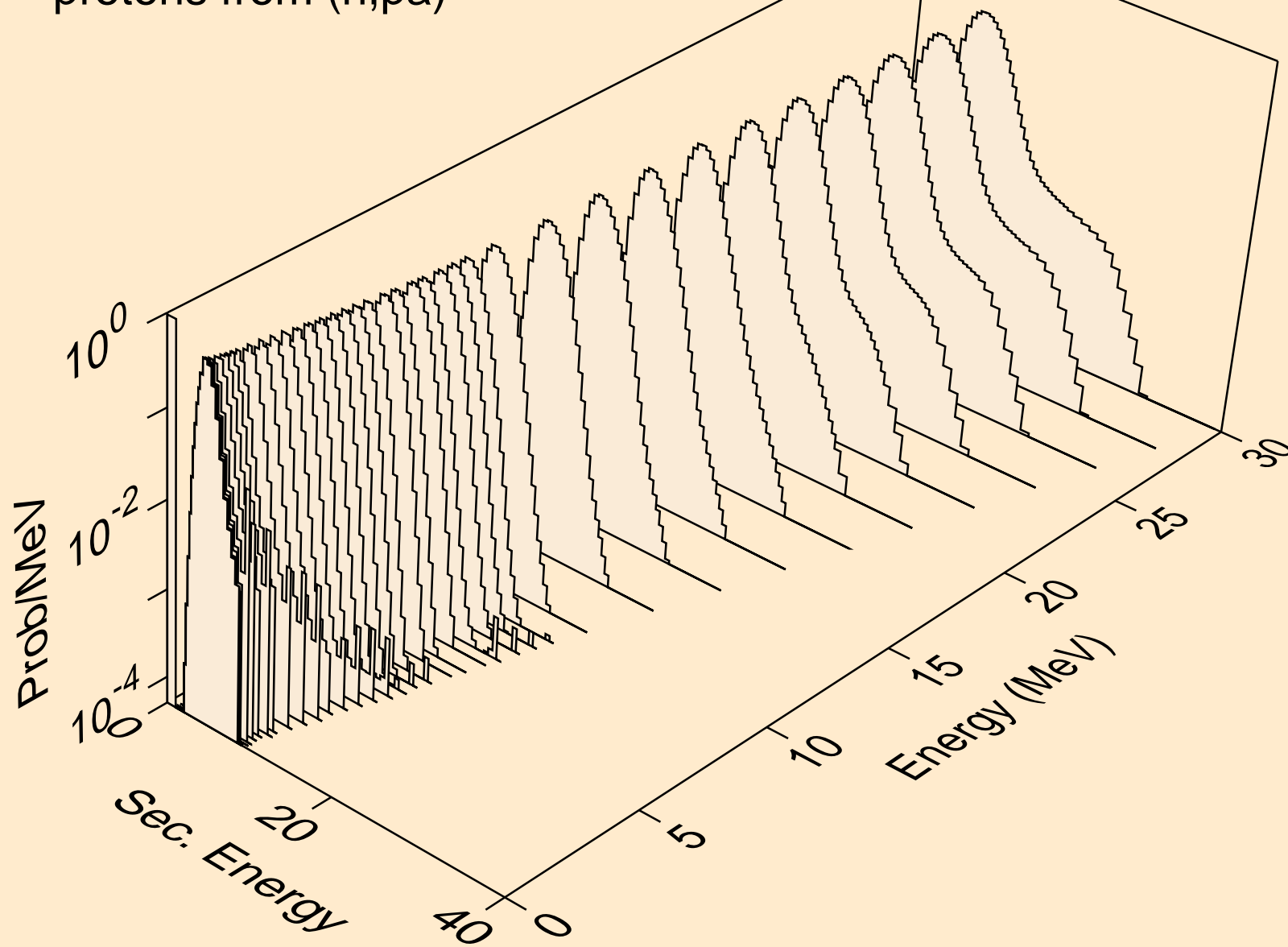

TL184 NEUTRON ACER TENDL-2023 LIBRARY; T=0.K
protons from (n,pd)

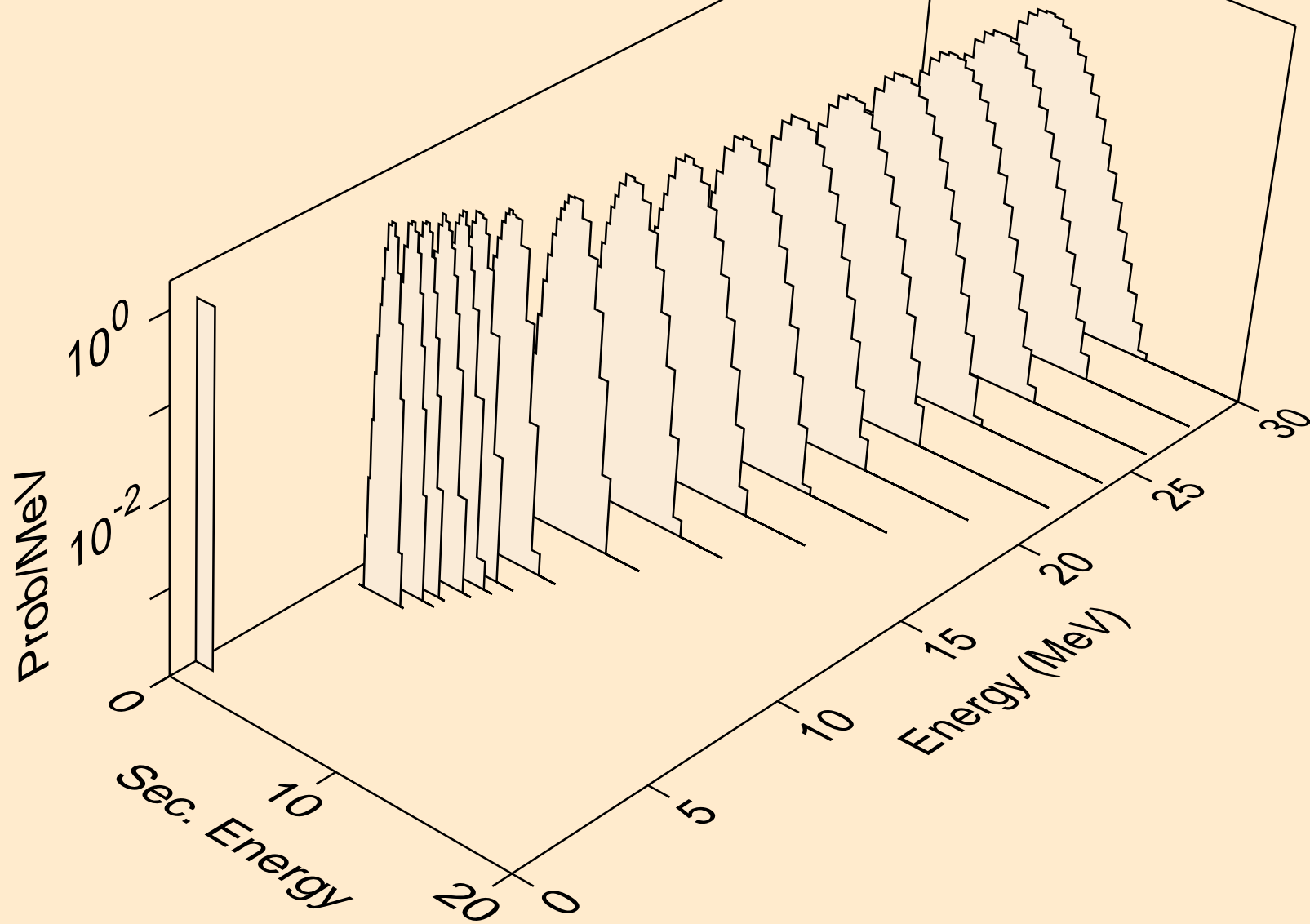

TL184 NEUTRON ACER TENDL-2023 LIBRARY; T=0.K
protons from (n,pt)

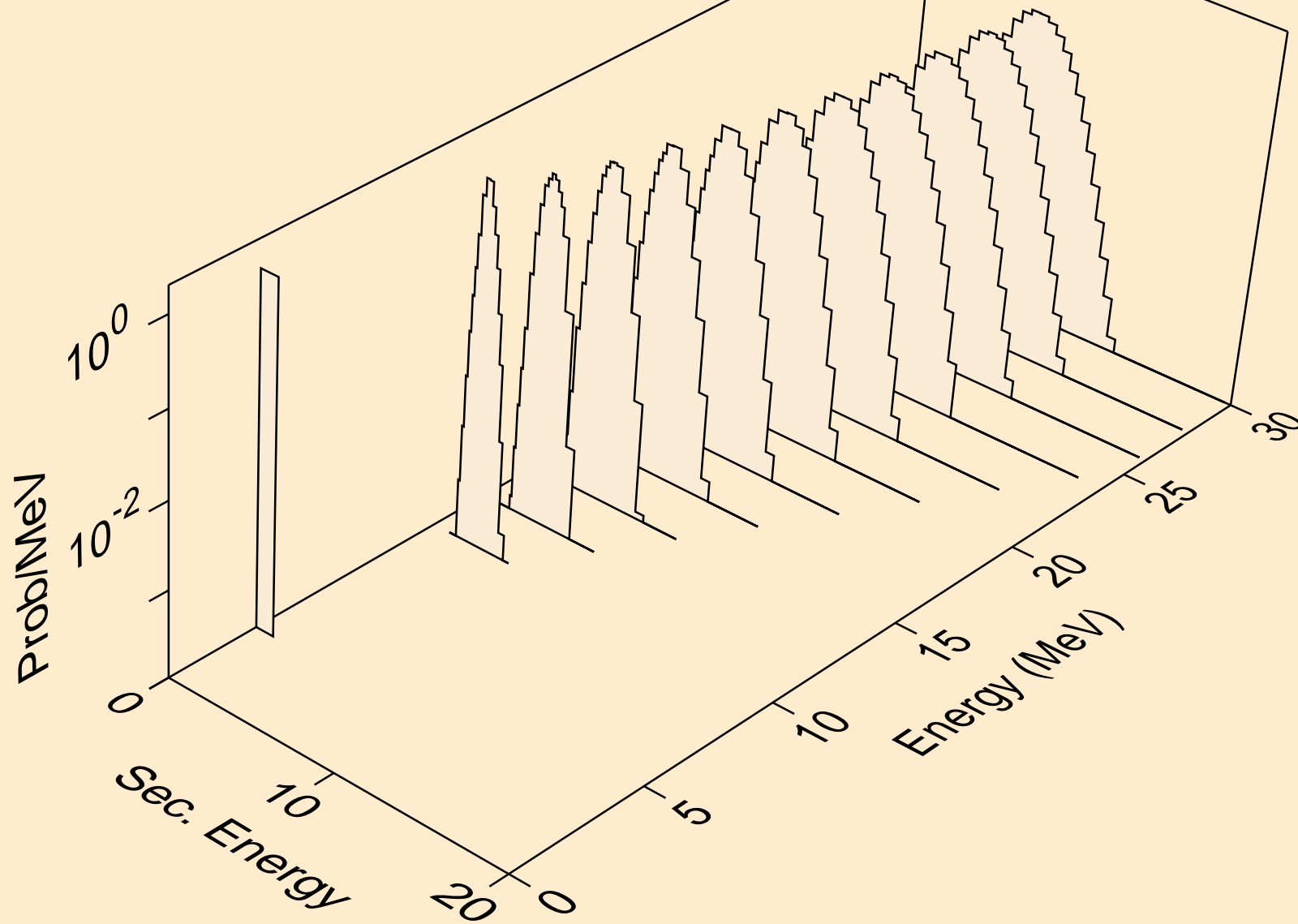

TL184 NEUTRON ACER TENDL-2023 LIBRARY; T=0.K
deuterons from (n,x)

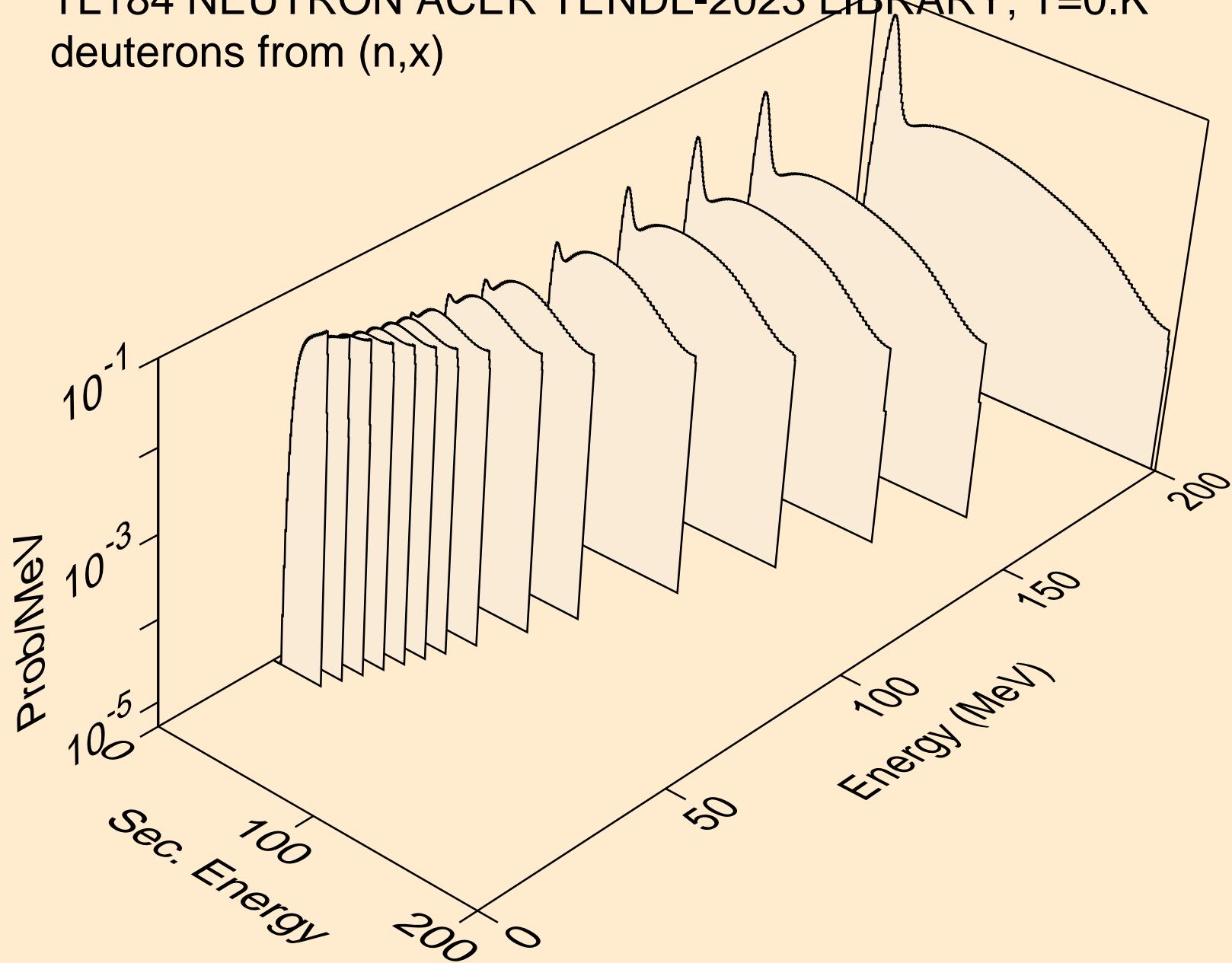

TL184 NEUTRON ACER TENDL-2023 LIBRARY; T=0.K
deuterons from (n,2nd)

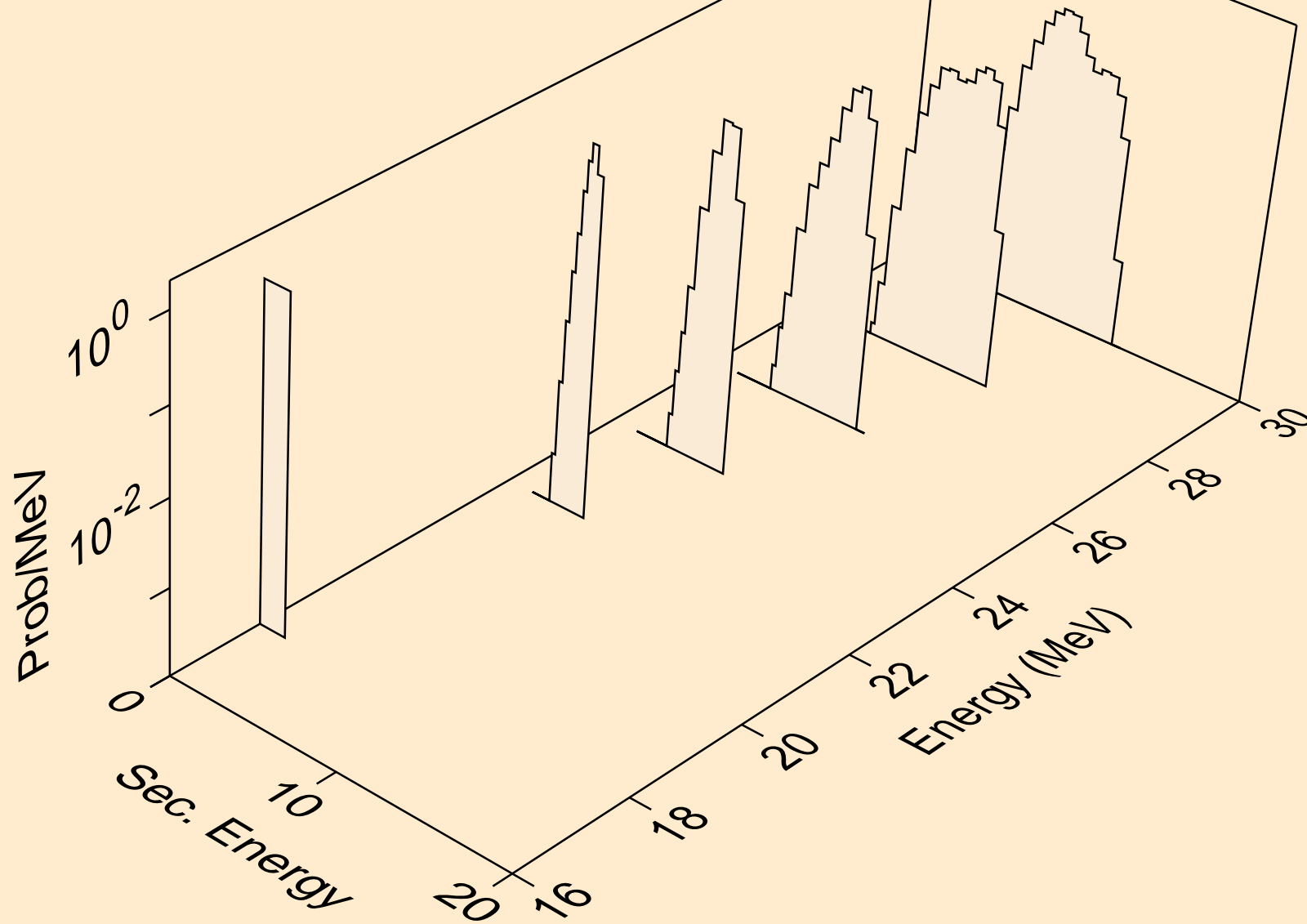

TL184 NEUTRON ACER TENDL-2023 LIBRARY; T=0.K
deuterons from (n,n*)d

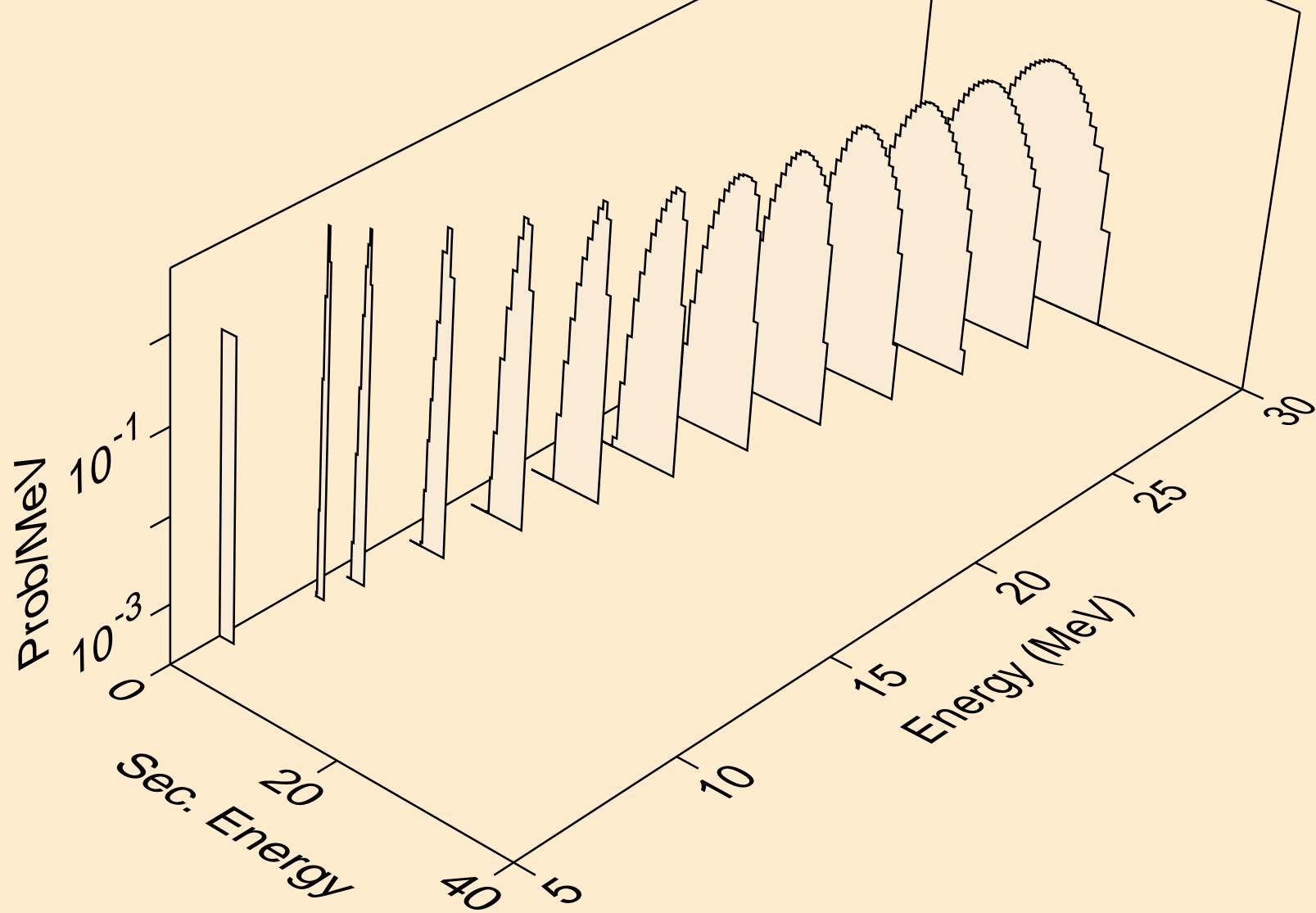

TL184 NEUTRON ACER TENDL-2023 LIBRARY; T=0.K
deuterons from (n,d)

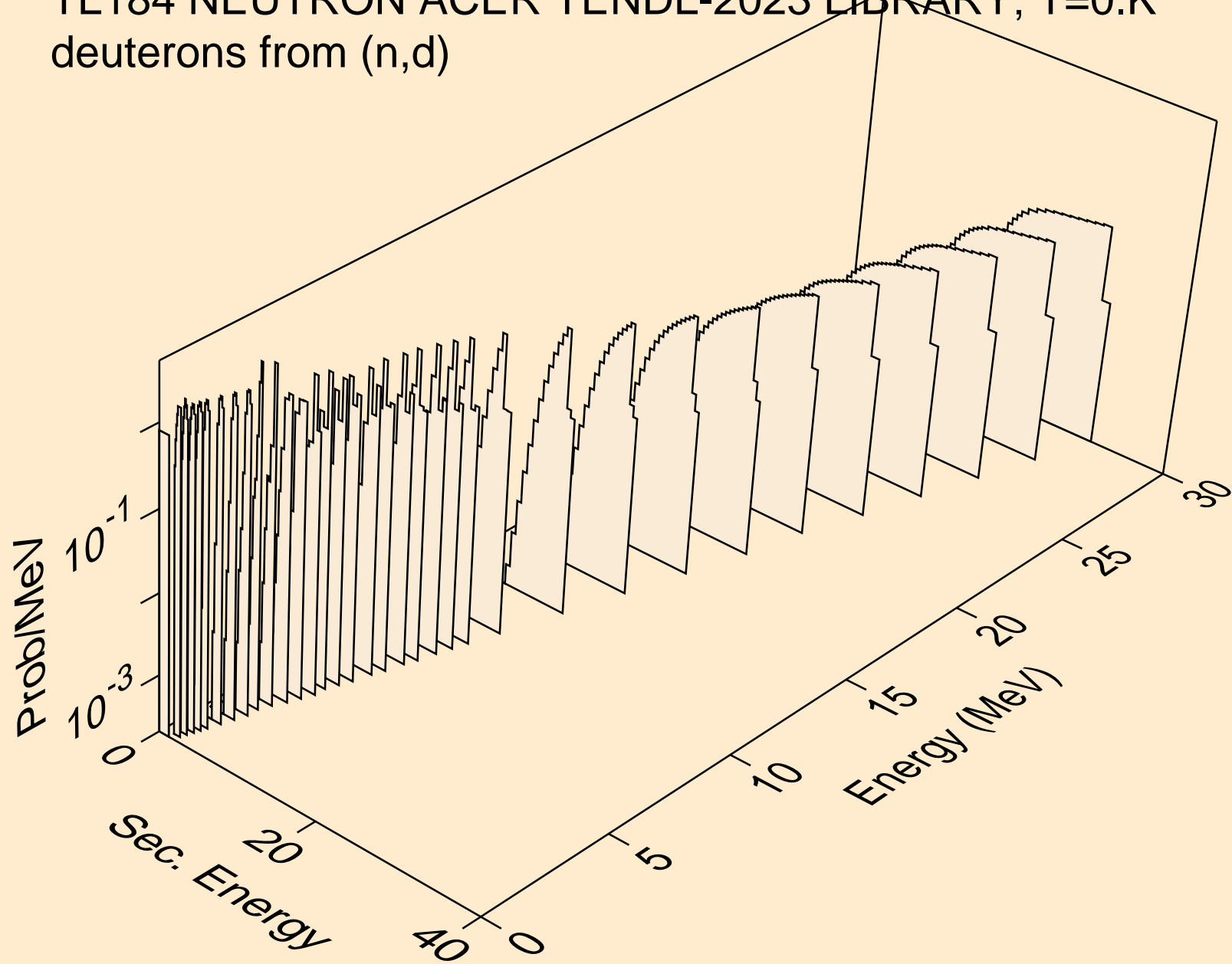

TL184 NEUTRON ACER TENDL-2023 LIBRARY; T=0.K
deuterons from (n,d2a)

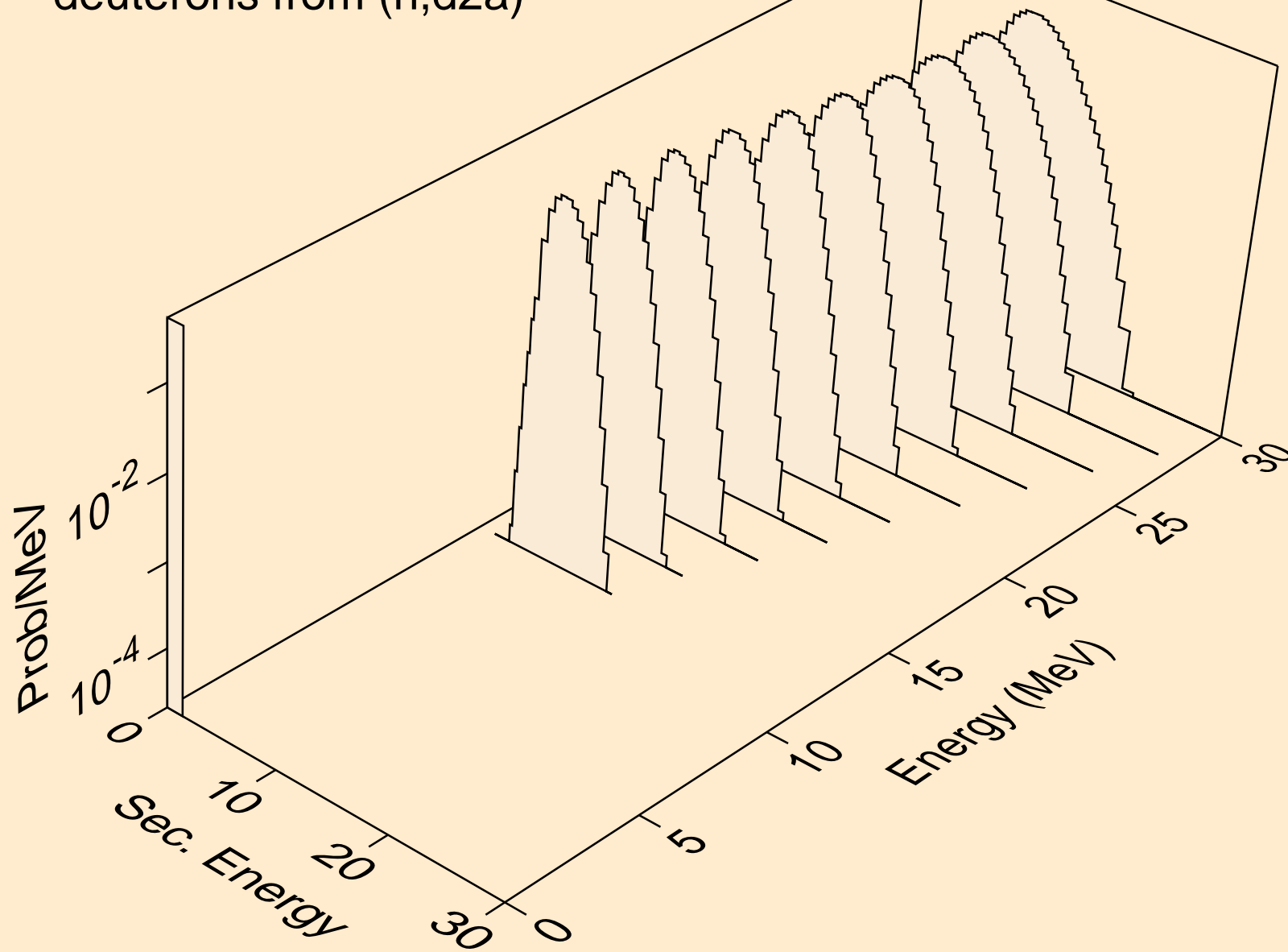

TL184 NEUTRON ACER TENDL-2023 LIBRARY; T=0.K
deuterons from (n,pd)

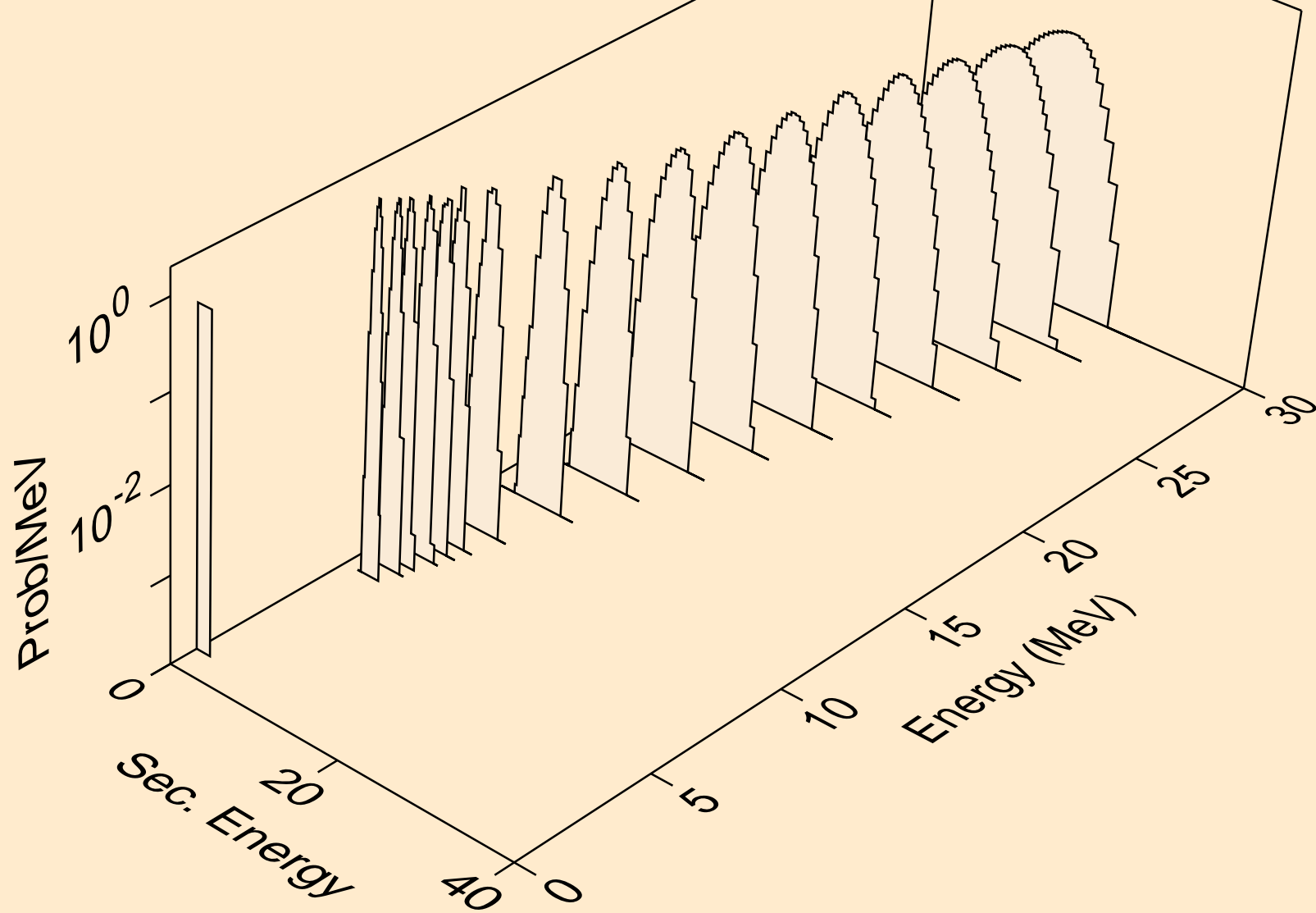

TL184 NEUTRON ACER TENDL-2023 LIBRARY; T=0.K
deuterons from (n,da)

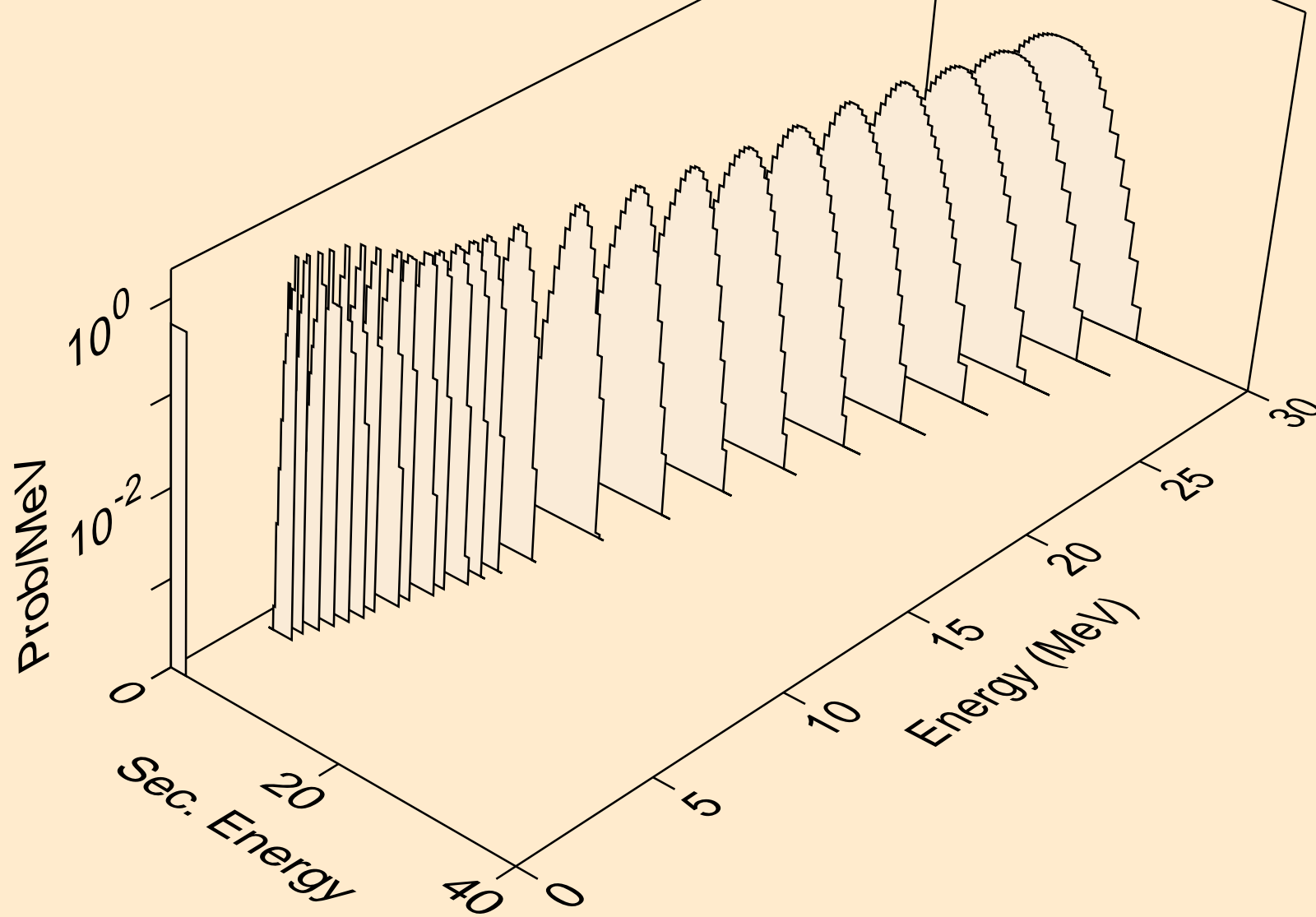

TL184 NEUTRON ACER TENDL-2023 LIBRARY; T=0.K
tritons from (n,x)

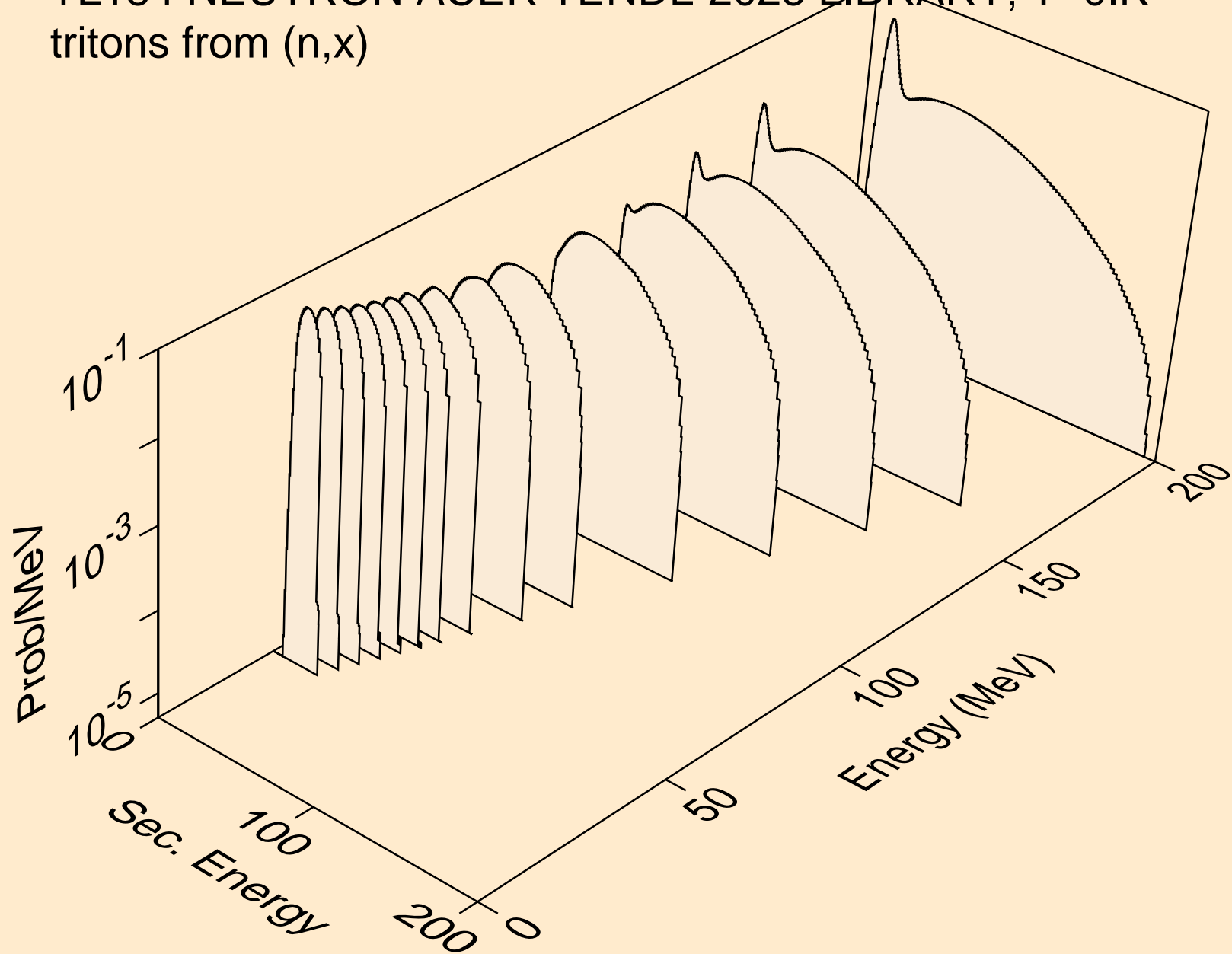

TL184 NEUTRON ACER TENDL-2023 LIBRARY; T=0.K
tritons from (n,n*)t

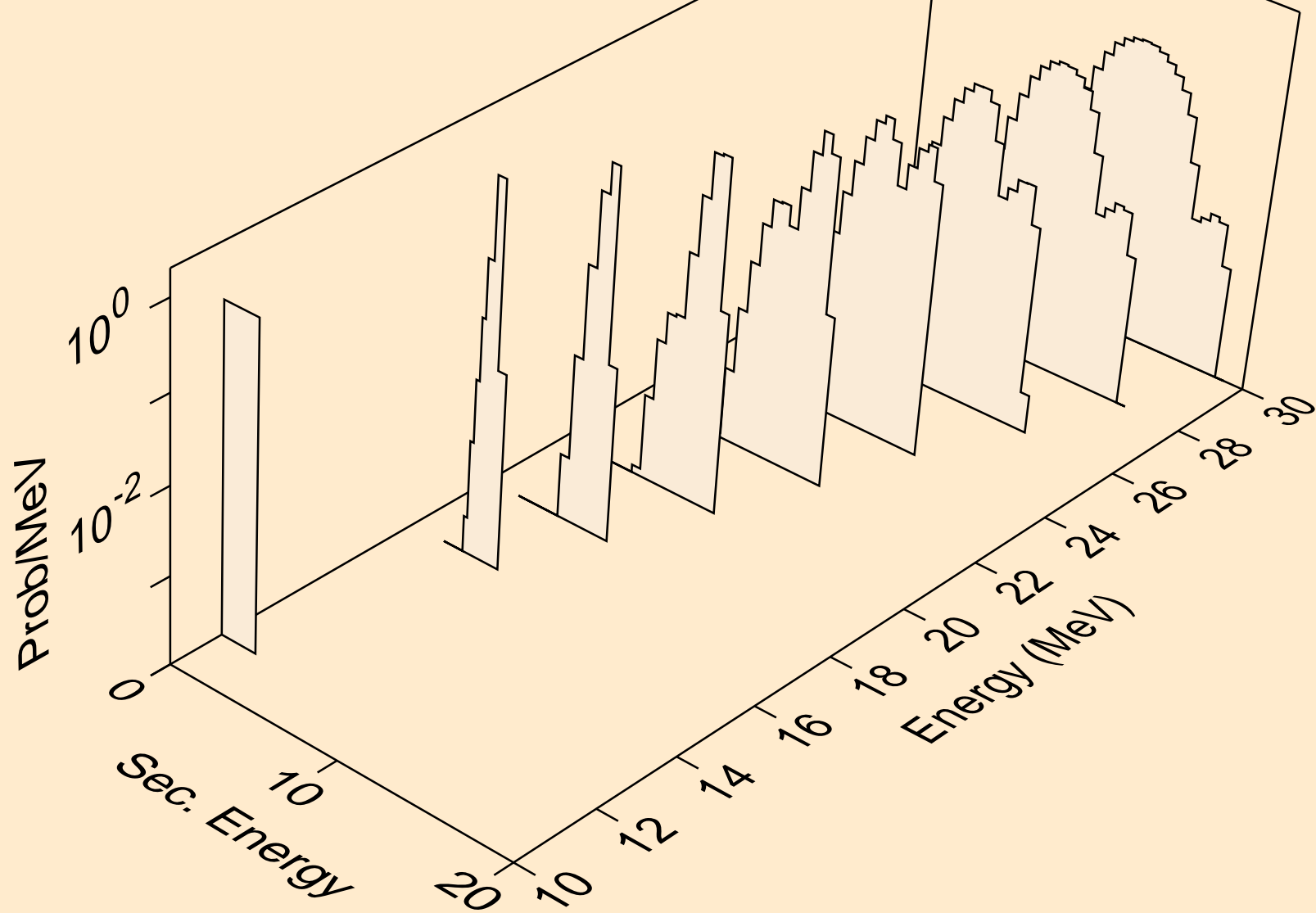

TL184 NEUTRON ACER TENDL-2023 LIBRARY; T=0.K
tritons from (n,t)

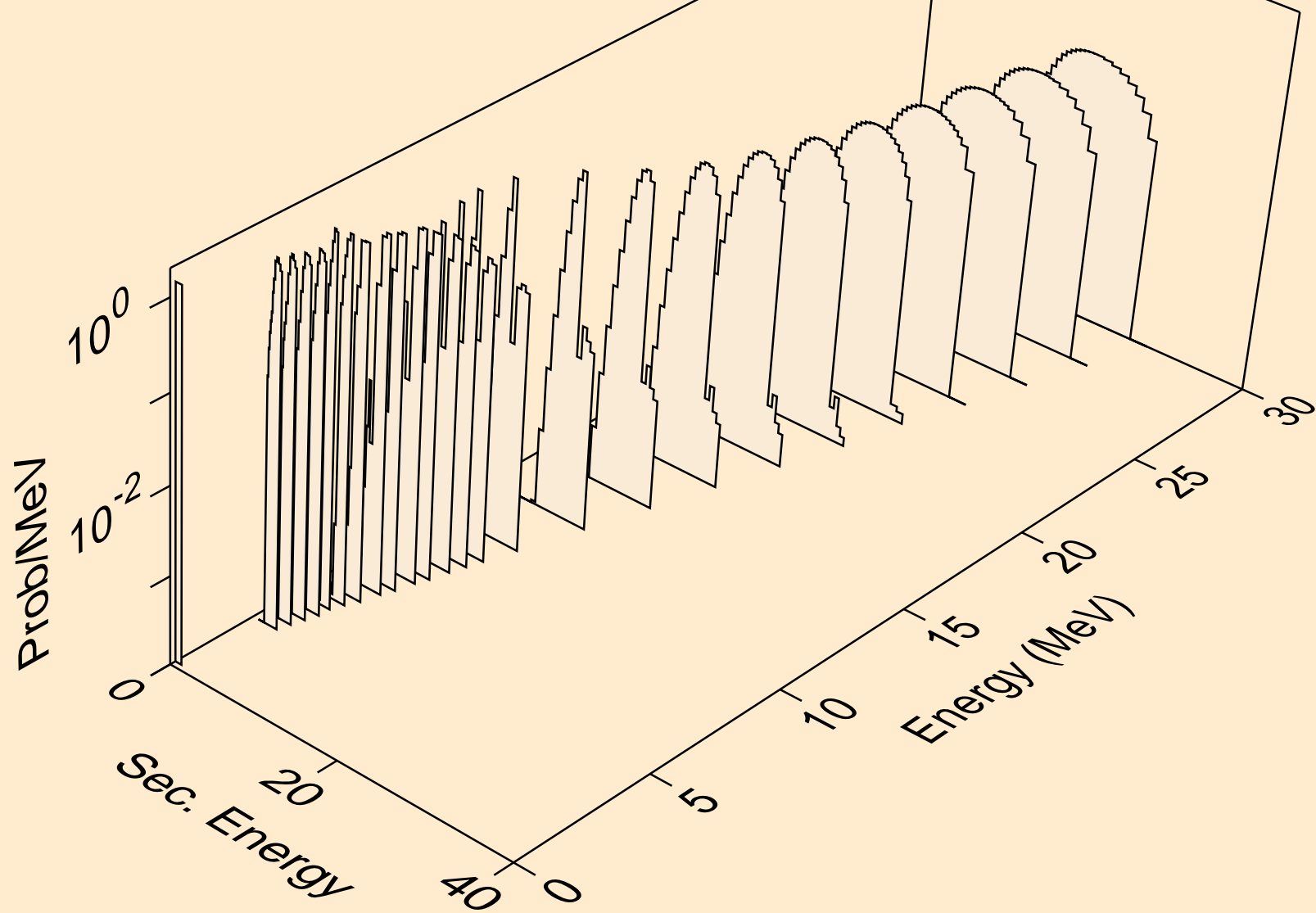

TL184 NEUTRON ACER TENDL-2023 LIBRARY; T=0.K
tritons from (n,t2a)

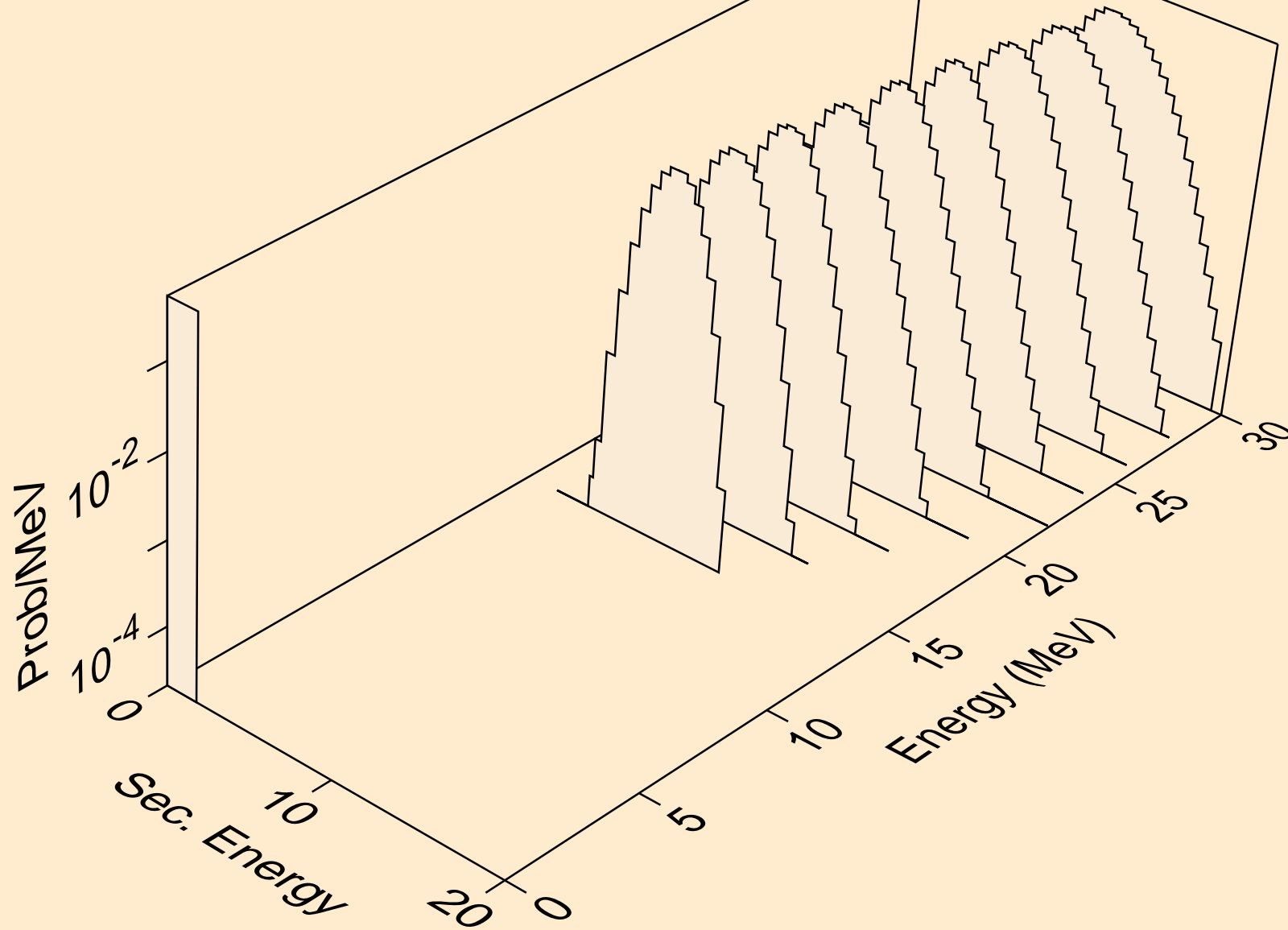

TL184 NEUTRON ACER TENDL-2023 LIBRARY; T=0.K
tritons from (n,pt)

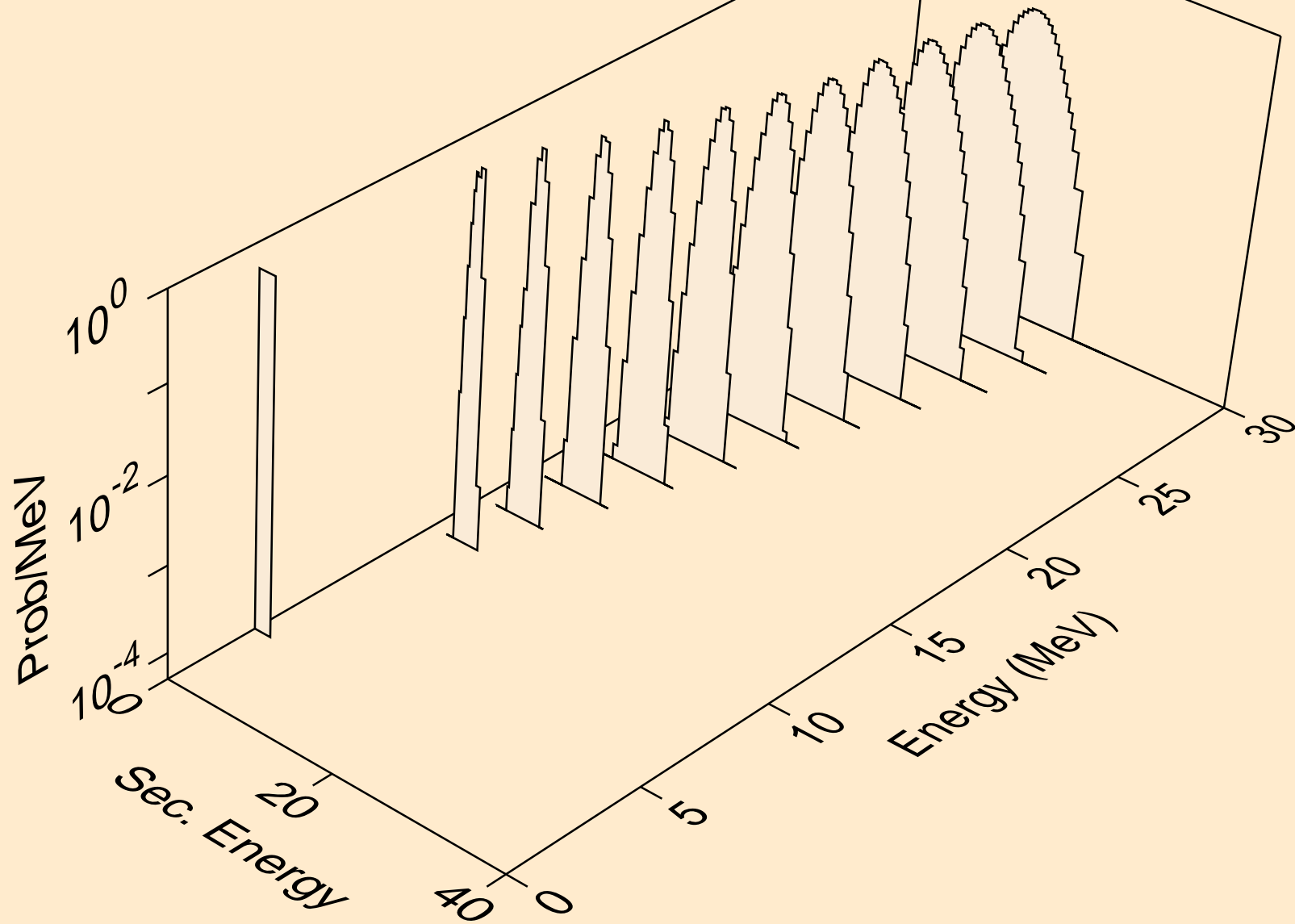

TL184 NEUTRON ACER TENDL-2023 LIBRARY; T=0.K
he3s from (n,x)

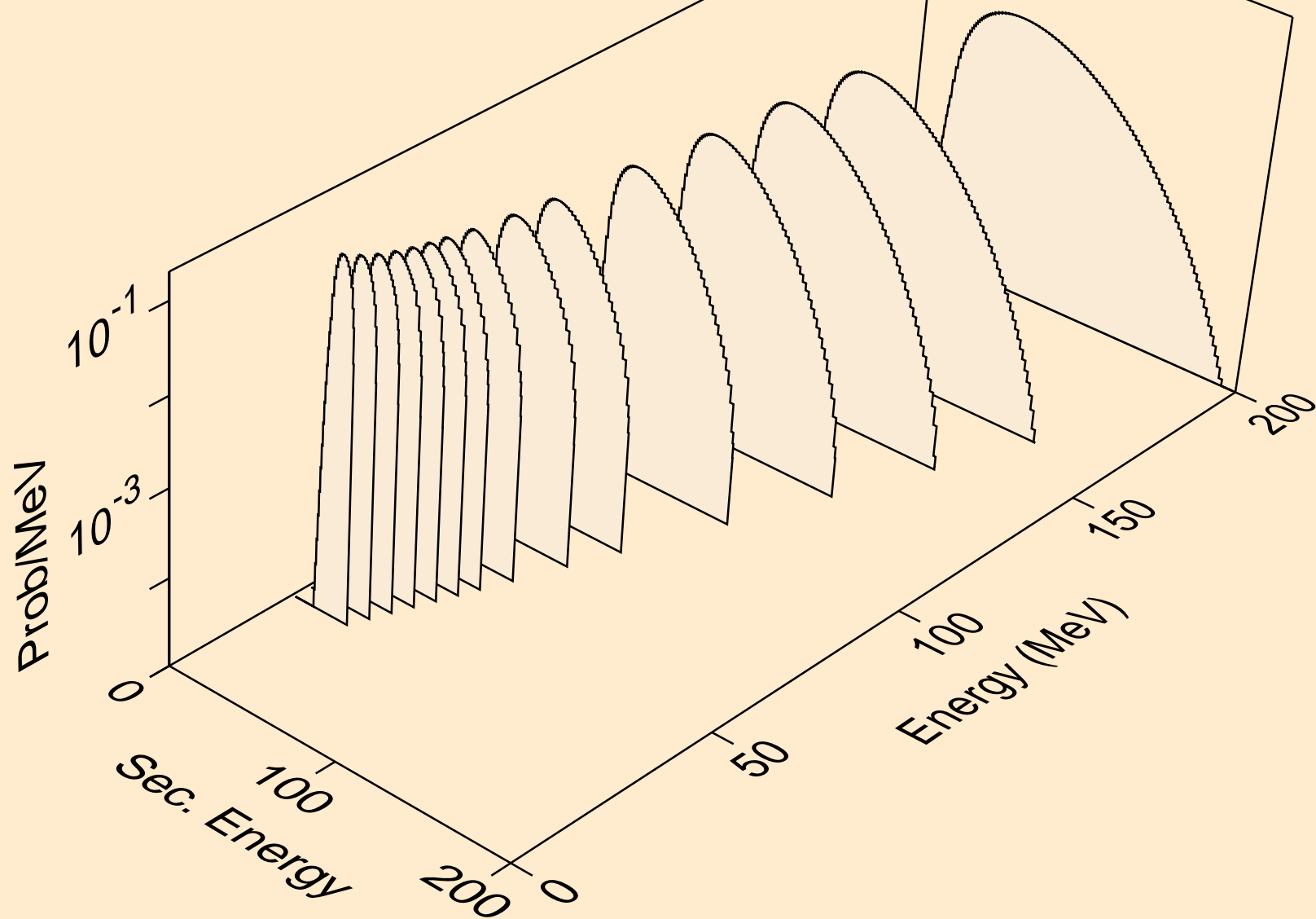

TL184 NEUTRON ACER TENDL-2023 LIBRARY; T=0.K
he3s from (n,n*)he3

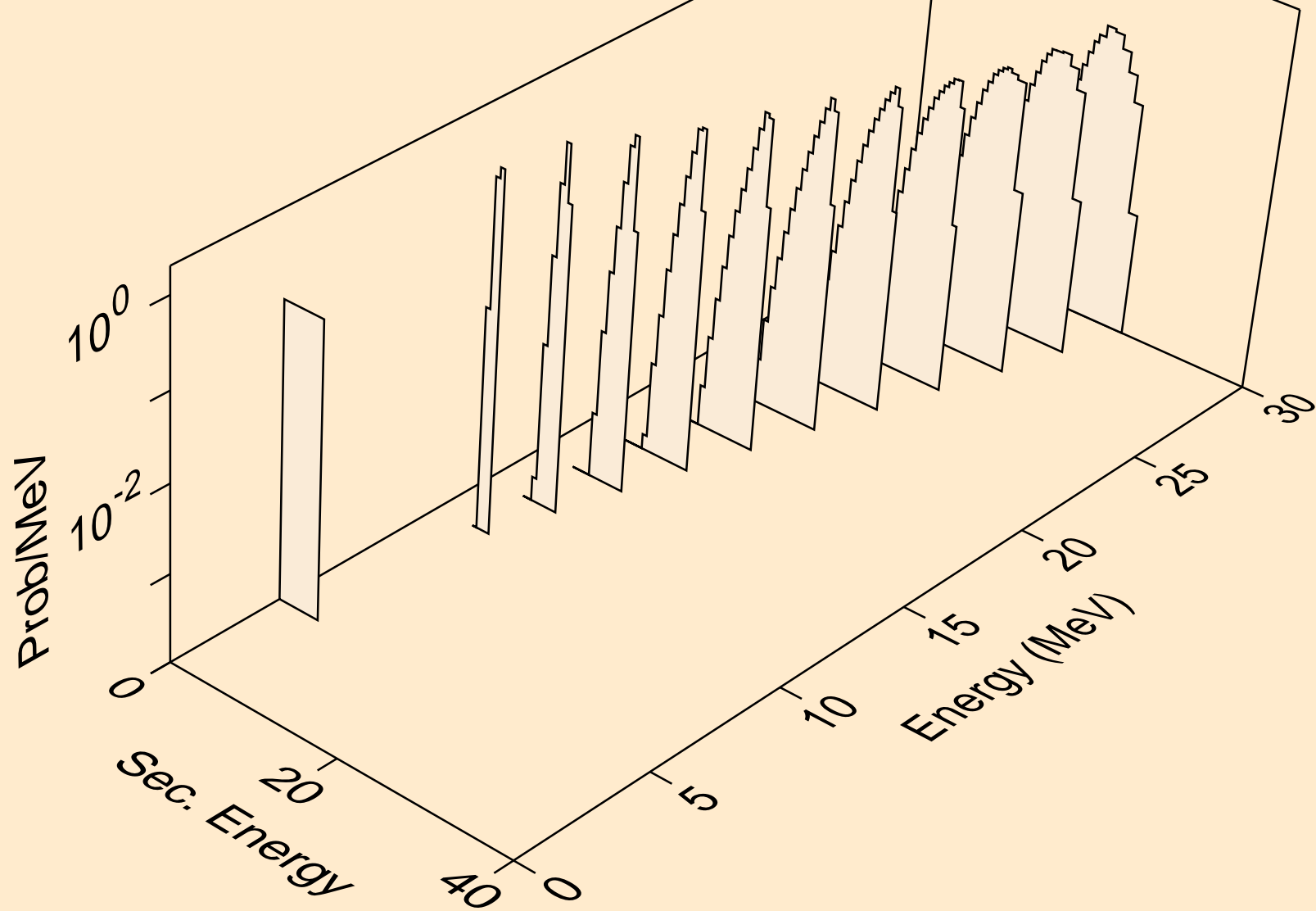

TL184 NEUTRON ACER TENDL-2023 LIBRARY; T=0.K
he3s from (n,he3)

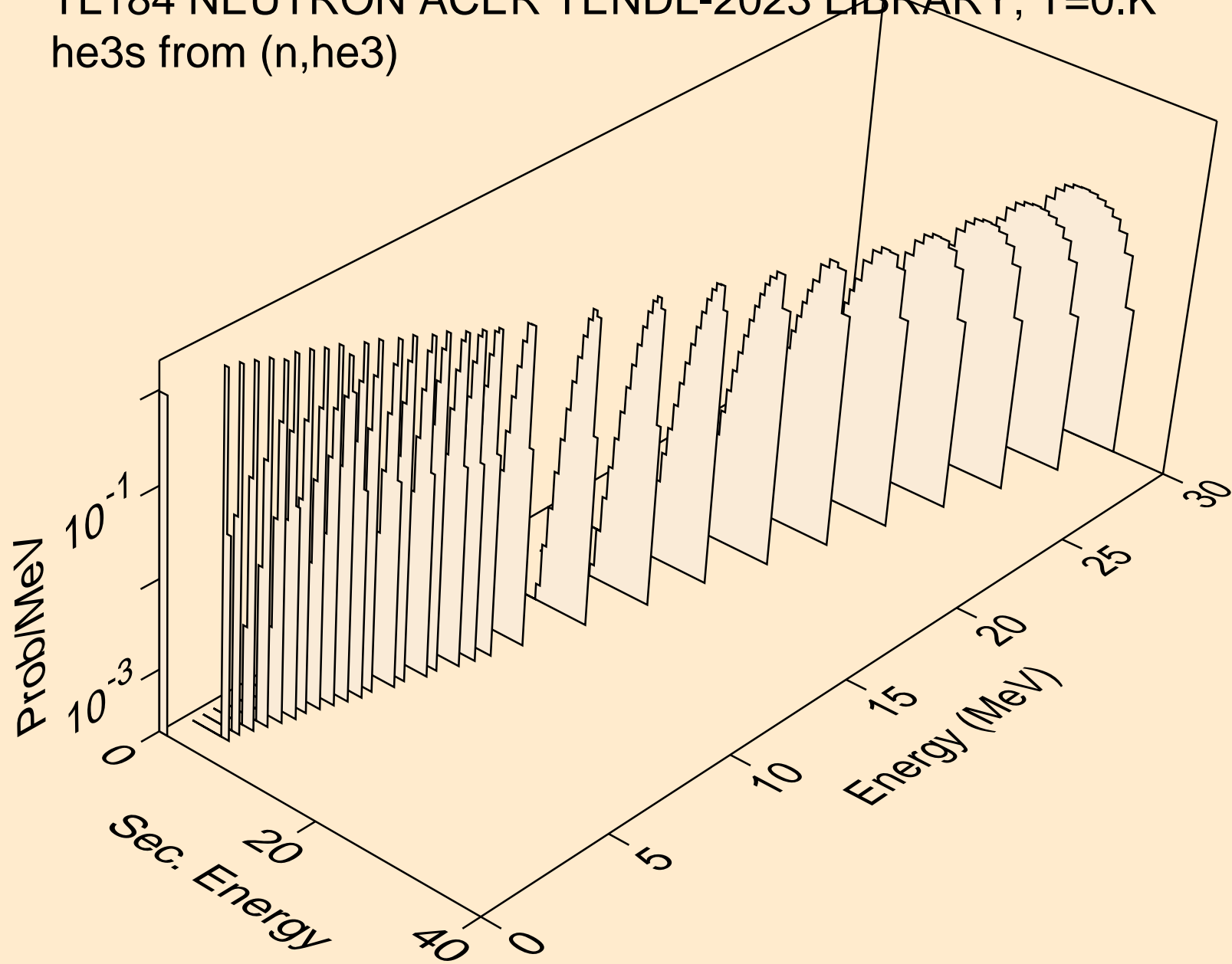

TL184 NEUTRON ACER TENDL-2023 LIBRARY; T=0.K
alphas from (n,x)

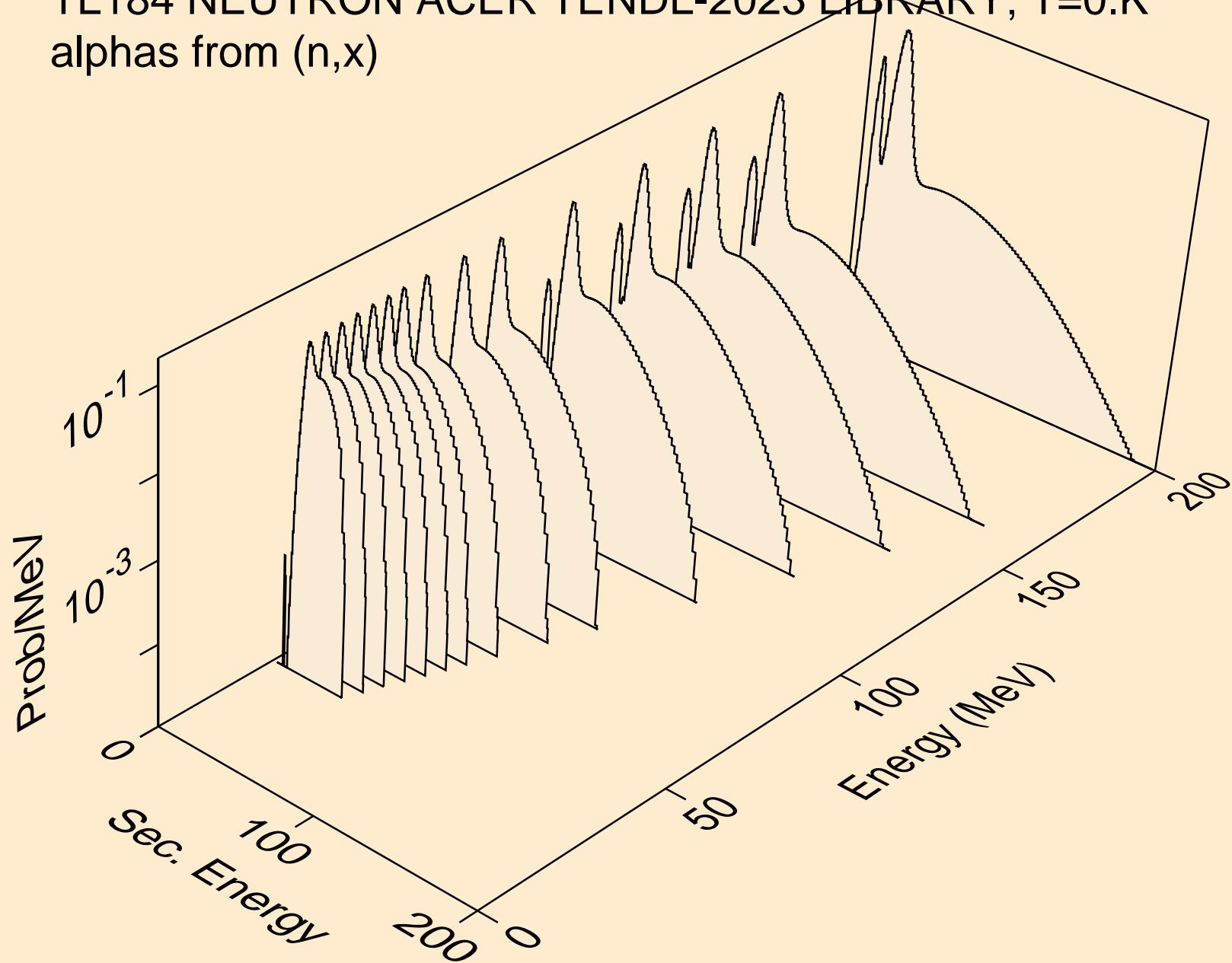

TL184 NEUTRON ACER TENDL-2023 LIBRARY; T=0.K
alphas from (n,n*)a

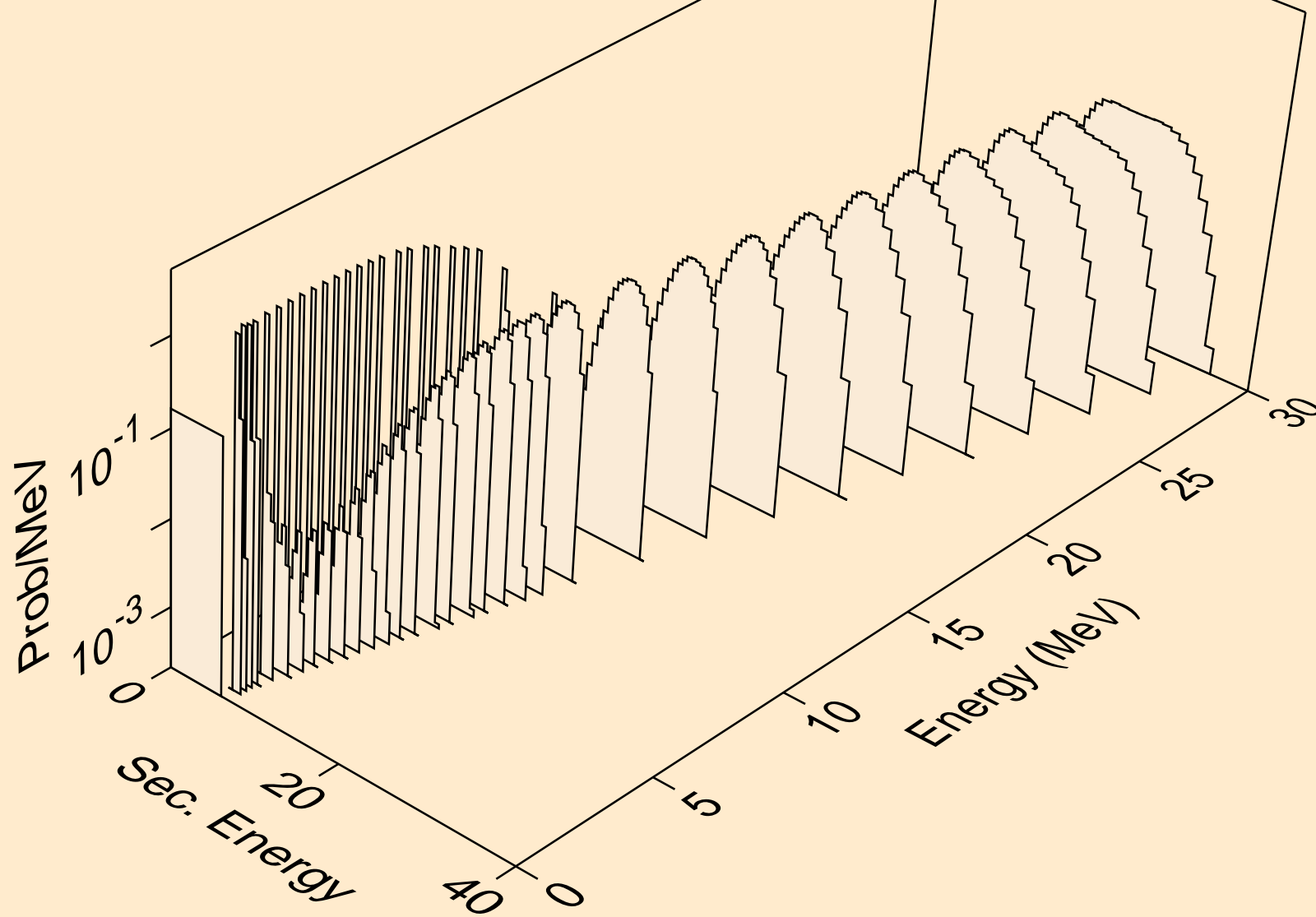

TL184 NEUTRON ACER TENDL-2023 LIBRARY; T=0.K
alphas from (n,n*)3a

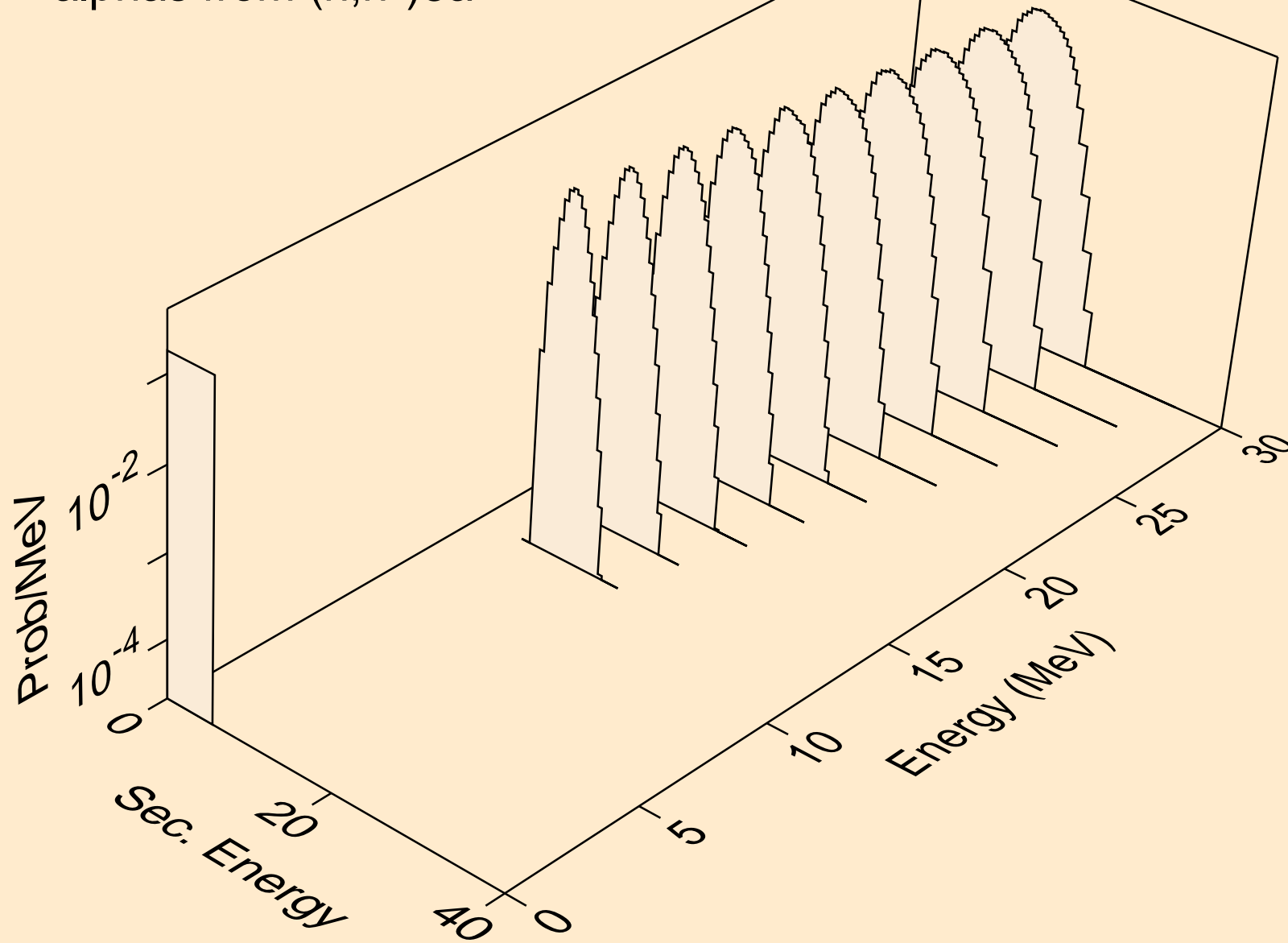

TL184 NEUTRON ACER TENDL-2023 LIBRARY; T=0.K
alphas from (n,2n)a

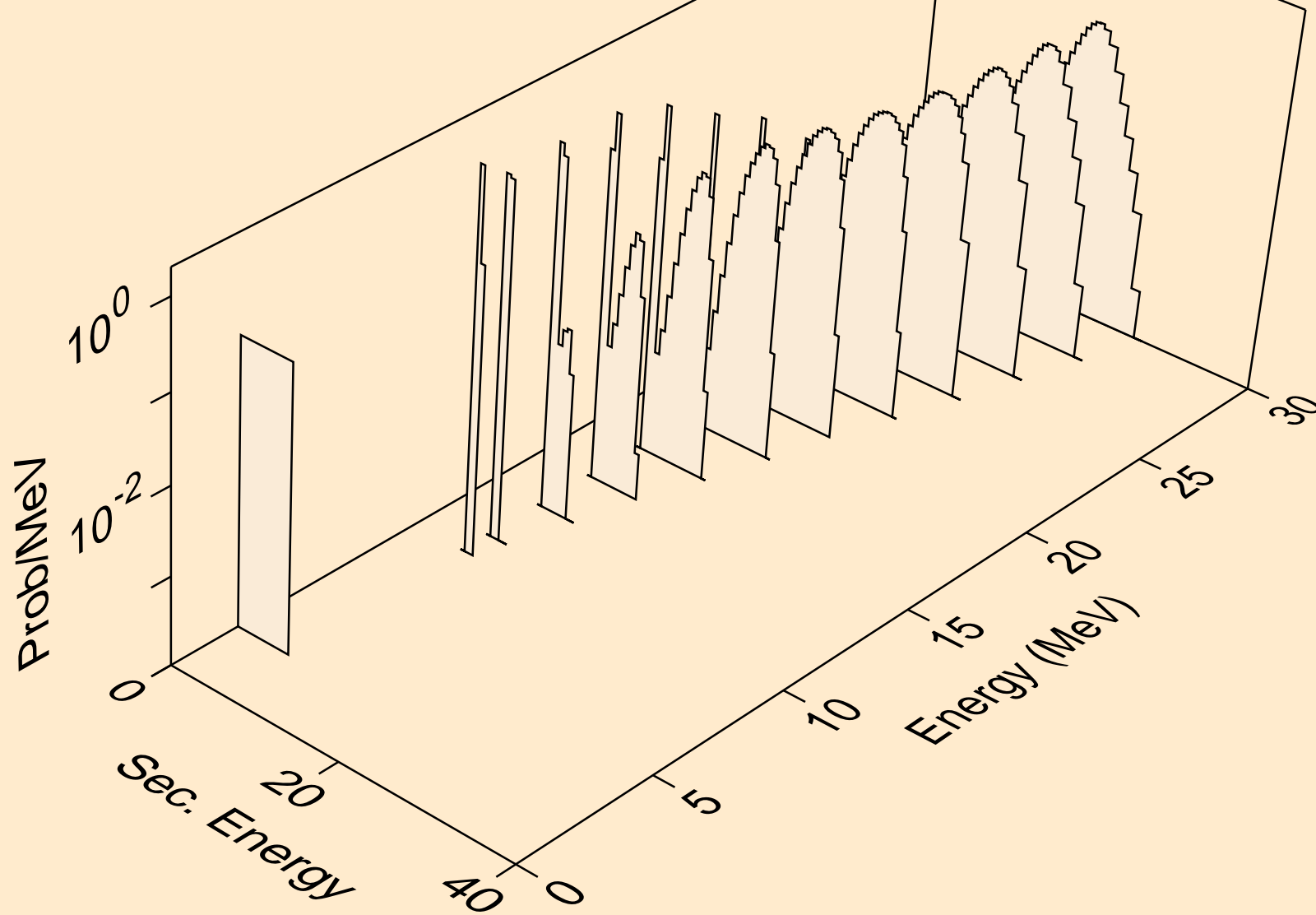

TL184 NEUTRON ACER TENDL-2023 LIBRARY; T=0.K
alphas from (n,3n)a

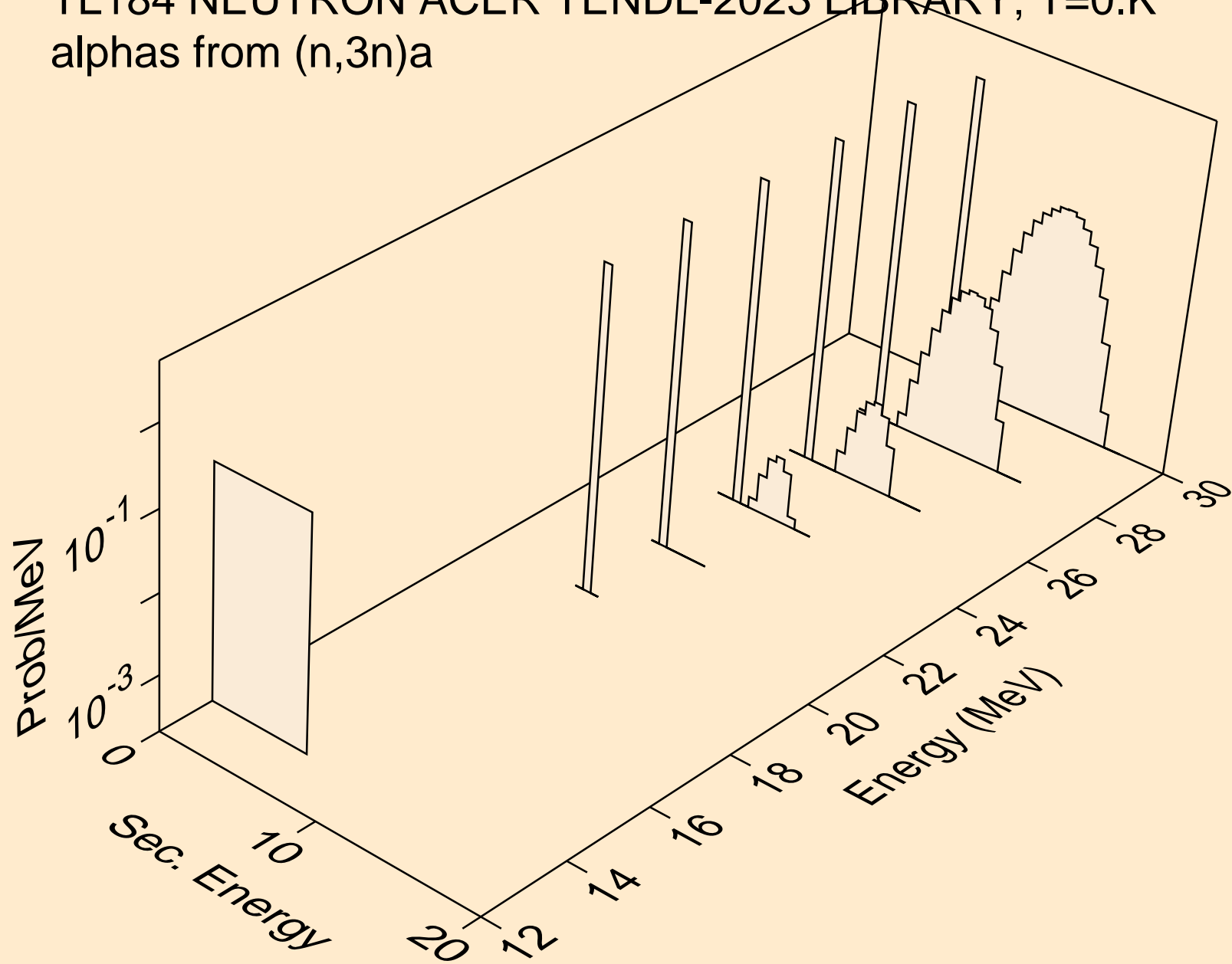

TL184 NEUTRON ACER TENDL-2023 LIBRARY; T=0.K
alphas from (n,n*)2a

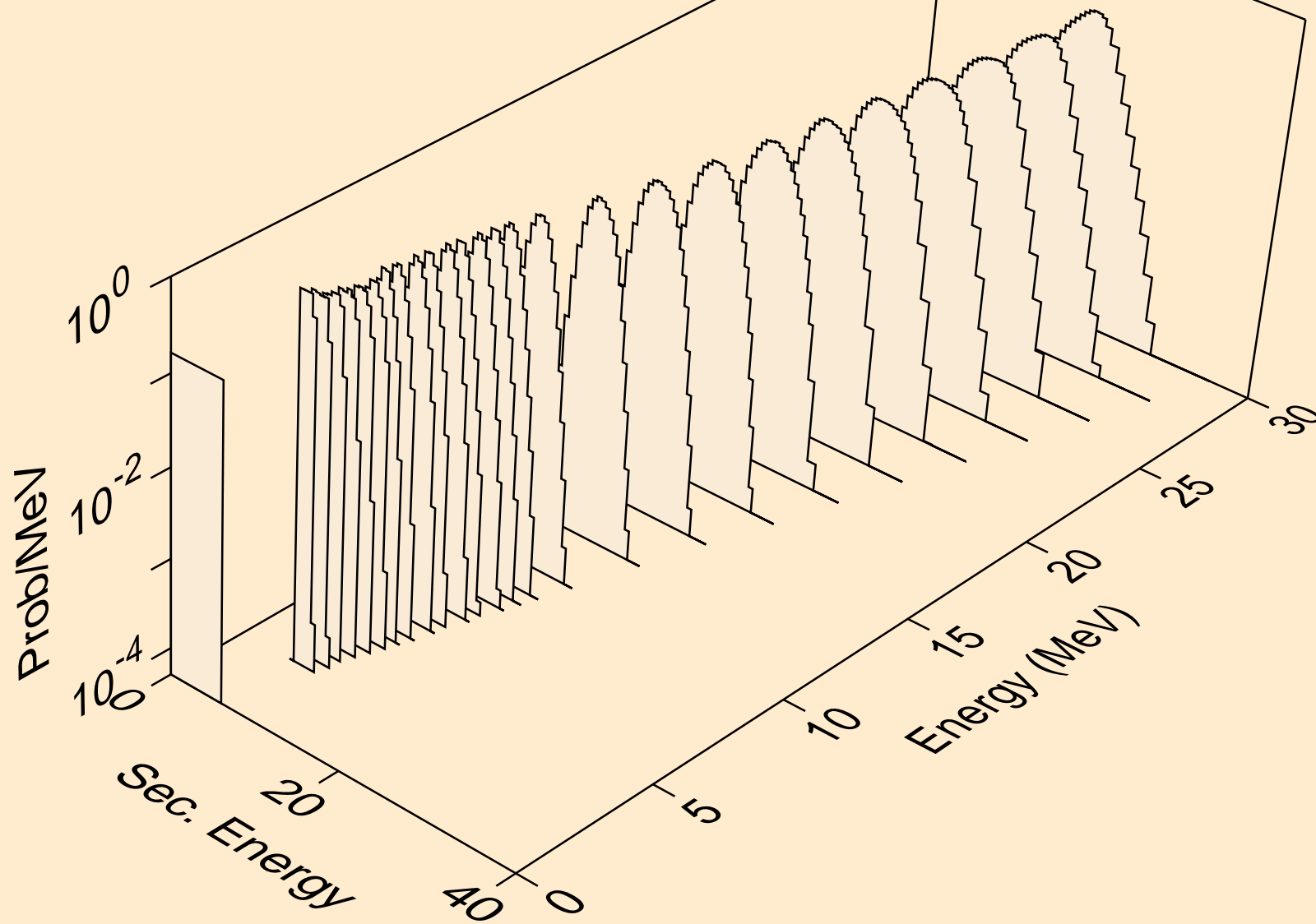

TL184 NEUTRON ACER TENDL-2023 LIBRARY; T=0.K
alphas from (n,2n)2a

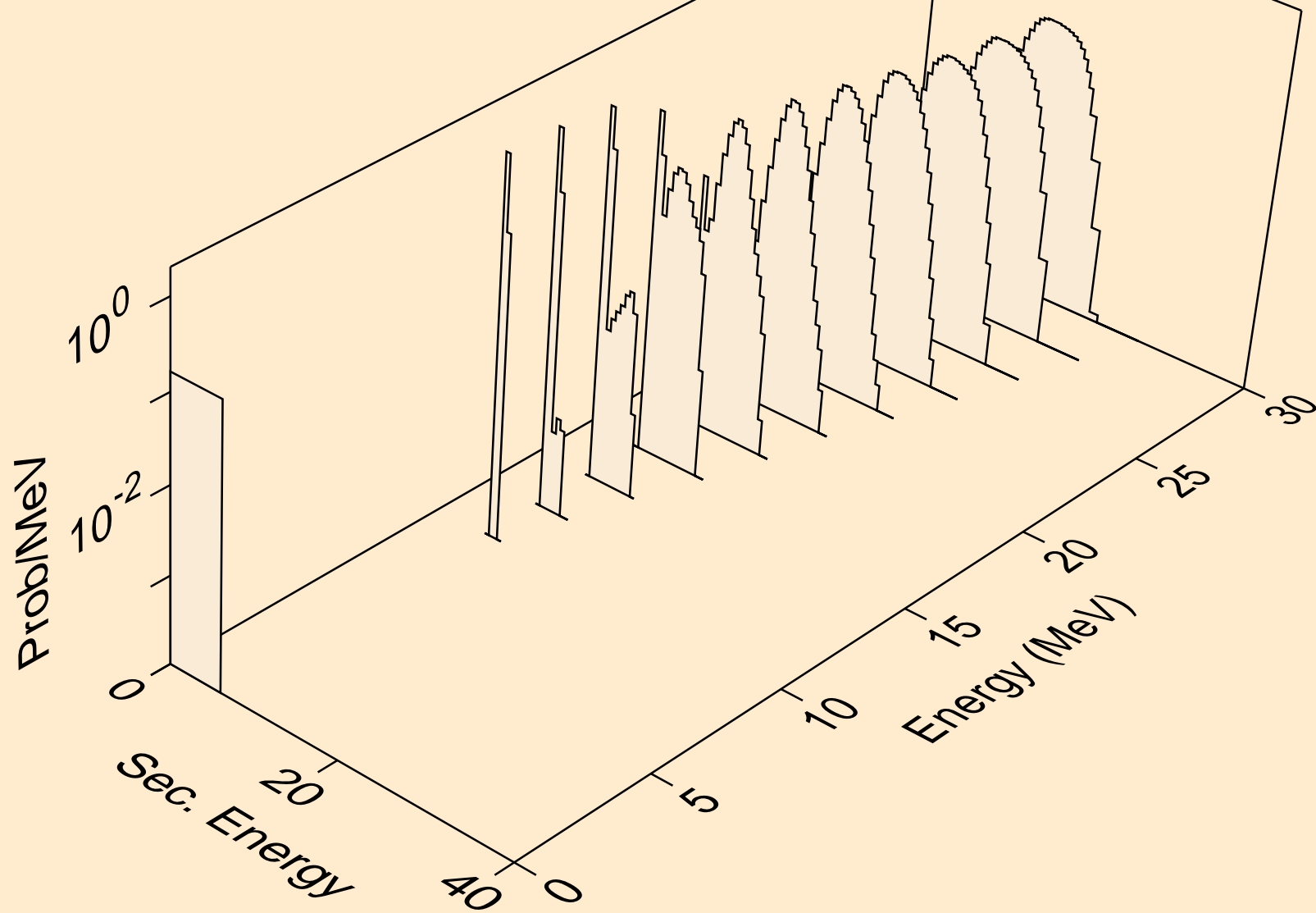

TL184 NEUTRON ACER TENDL-2023 LIBRARY; T=0.K
alphas from (n,npa)

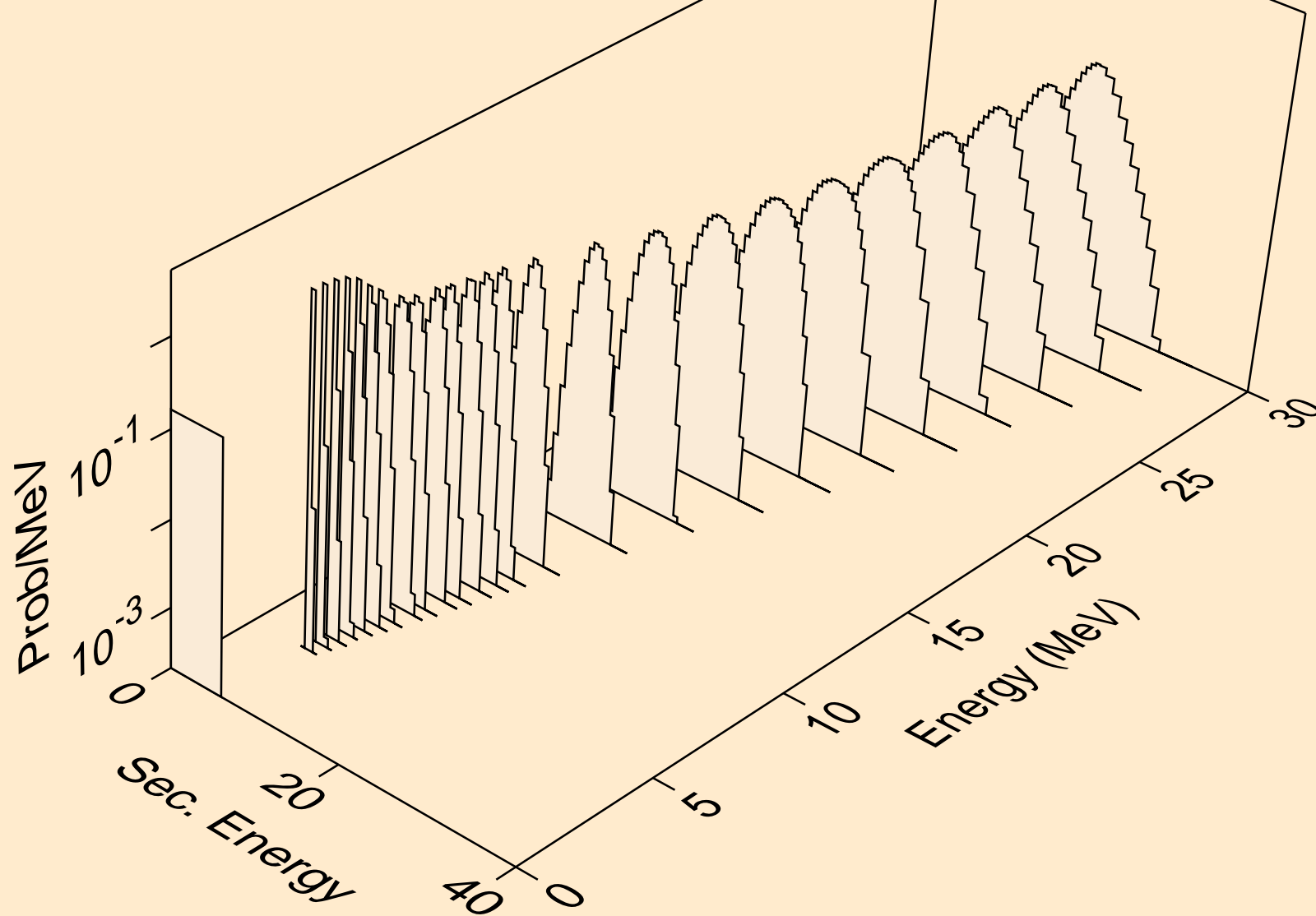

TL184 NEUTRON ACER TENDL-2023 LIBRARY; T=0.K
alphas from (n,a)

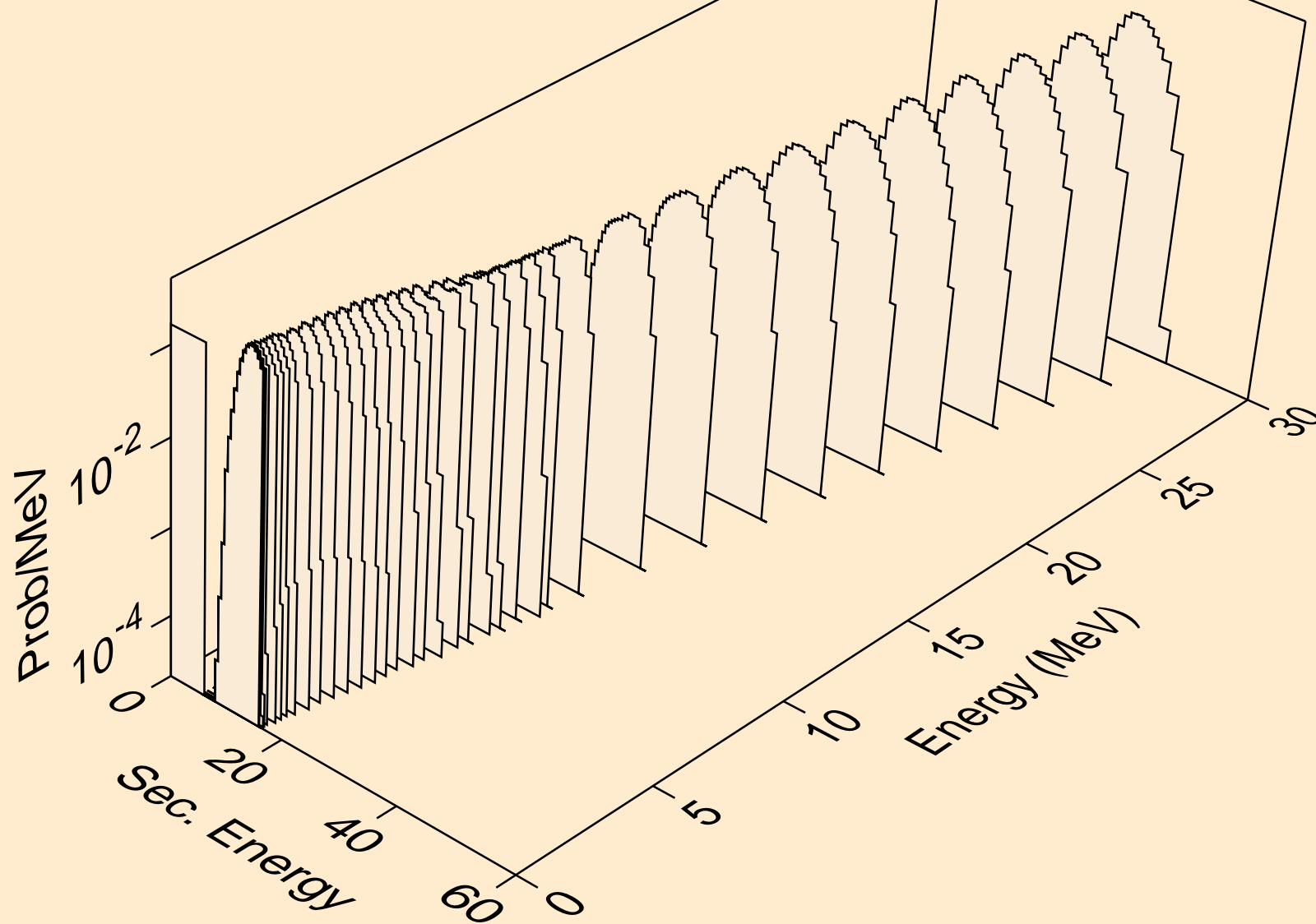

TL184 NEUTRON ACER TENDL-2023 LIBRARY; T=0.K
alphas from (n,2a)

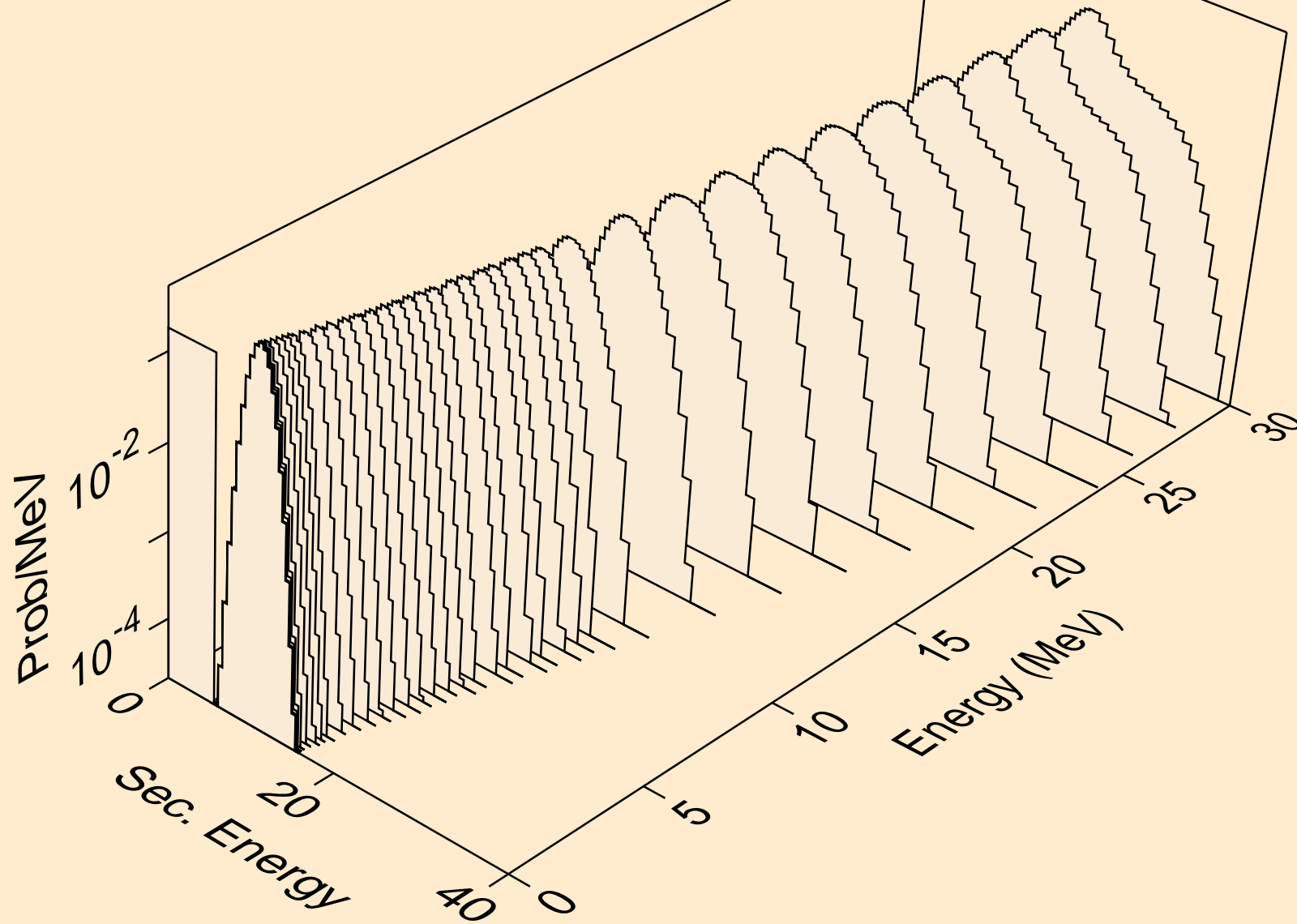

TL184 NEUTRON ACER TENDL-2023 LIBRARY; T=0.K
alphas from (n,3a)

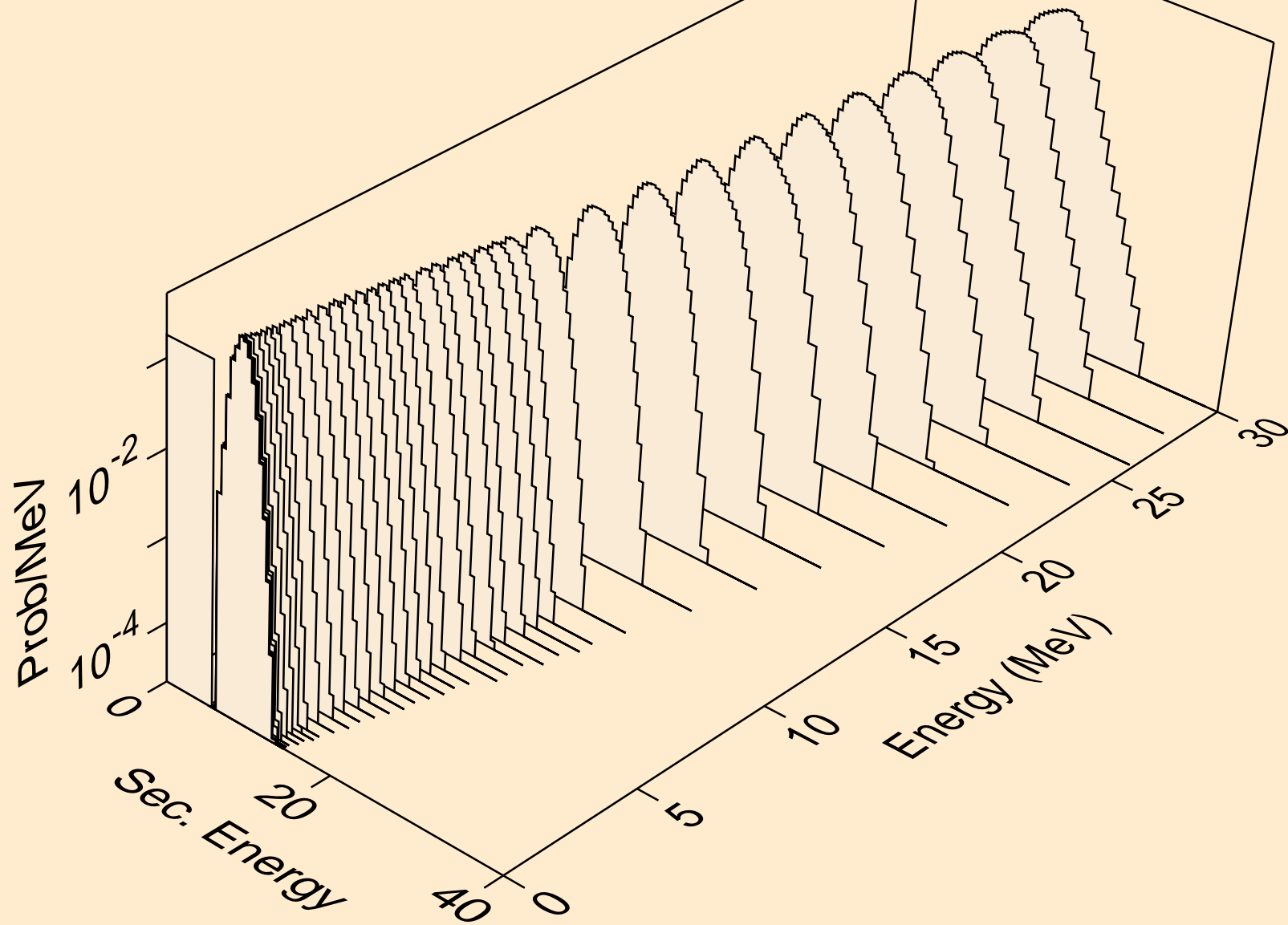

TL184 NEUTRON ACER TENDL-2023 LIBRARY; T=0.K
alphas from (n,pa)

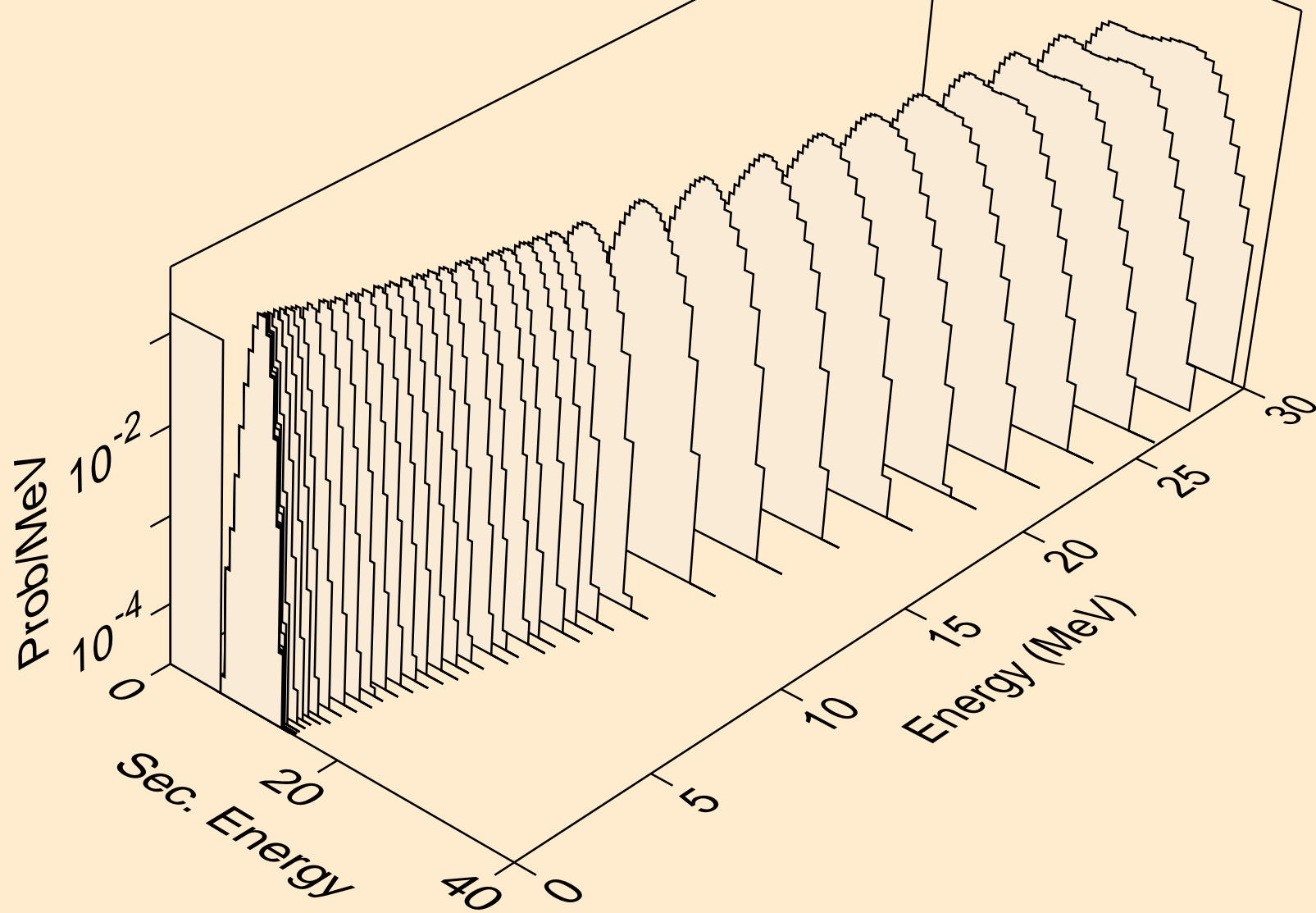

TL184 NEUTRON ACER TENDL-2023 LIBRARY; T=0.K
alphas from (n,t2a)

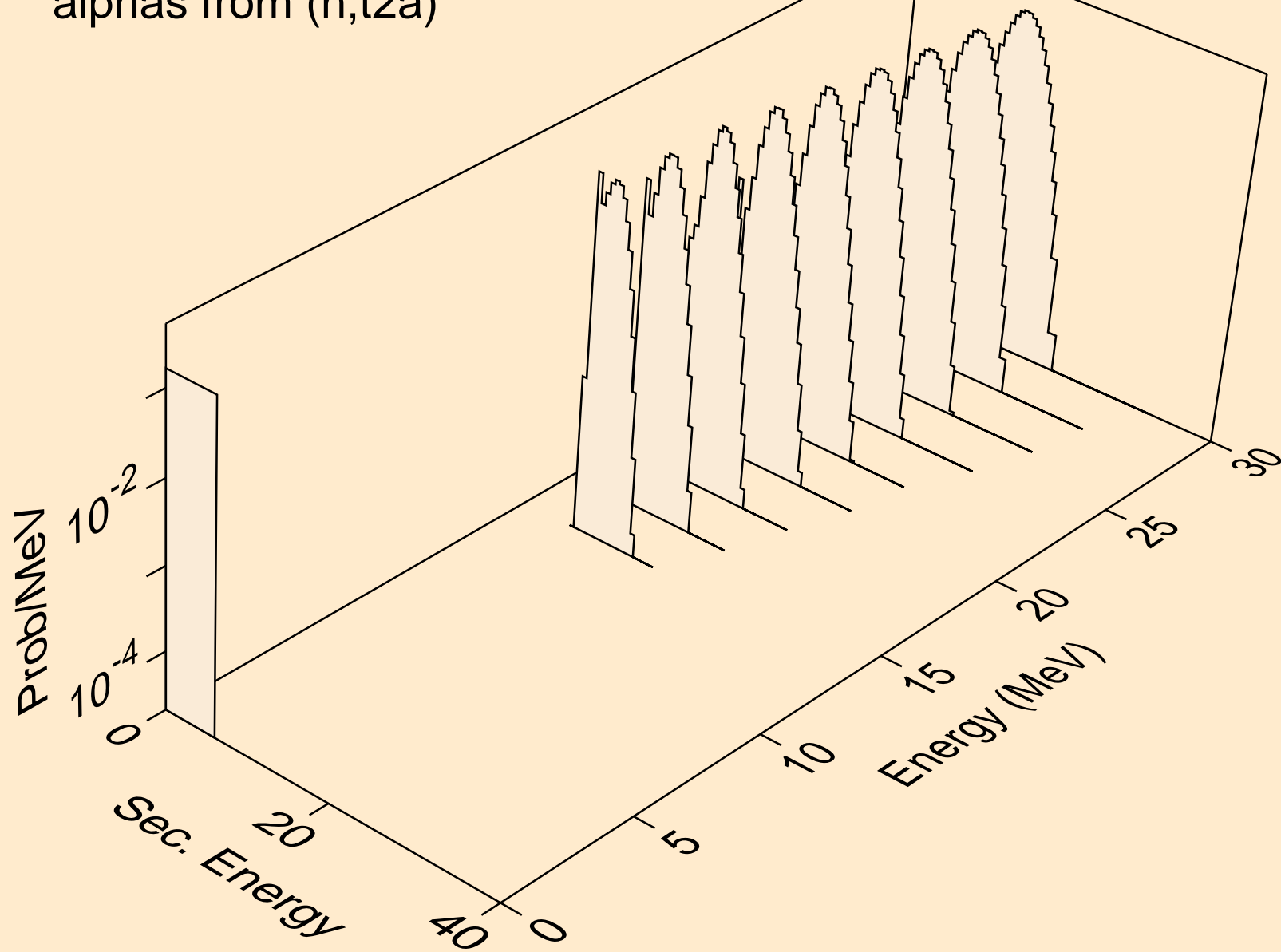

TL184 NEUTRON ACER TENDL-2023 LIBRARY; T=0.K
alphas from (n,d2a)

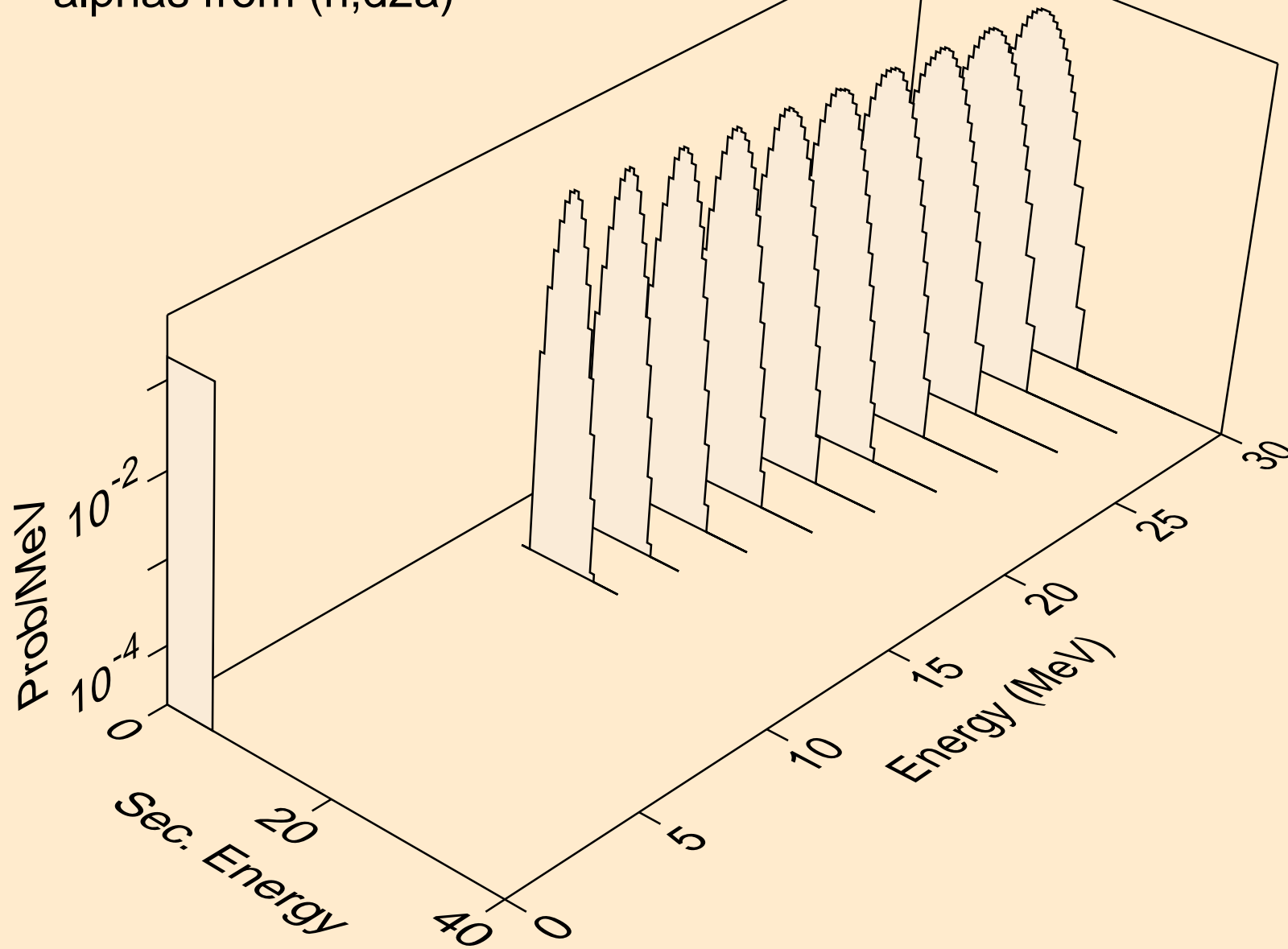

TL184 NEUTRON ACER TENDL-2023 LIBRARY; T=0.K
alphas from (n,da)

