

# YB160 NEUTRON ACER TENDL-2023 LIBRARY; T=0.K

## Principal cross sections

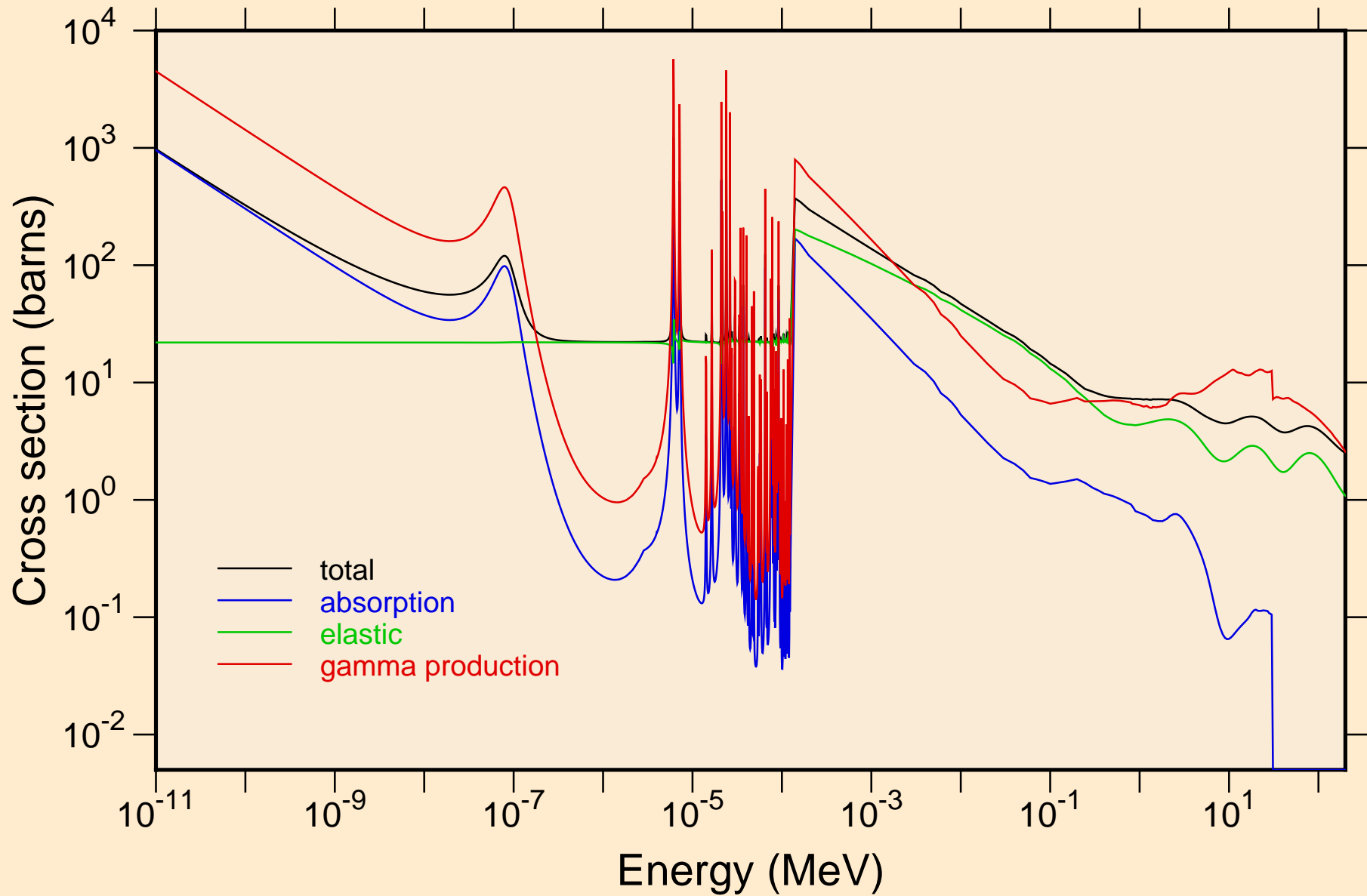

YB160 NEUTRON ACER TENDL-2023 LIBRARY; T=0.K  
resonance total cross section

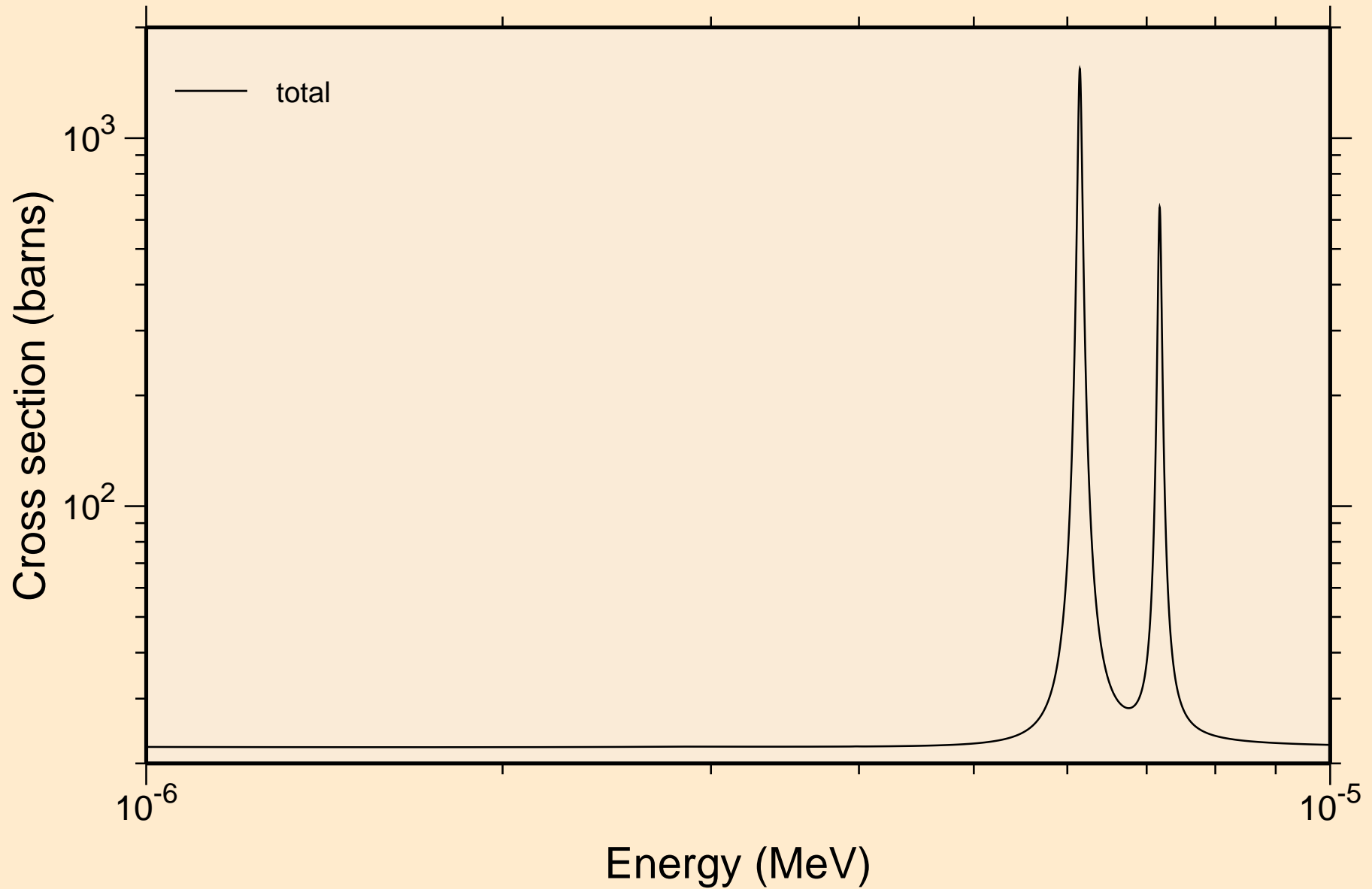

YB160 NEUTRON ACER TENDL-2023 LIBRARY; T=0.K  
resonance total cross section

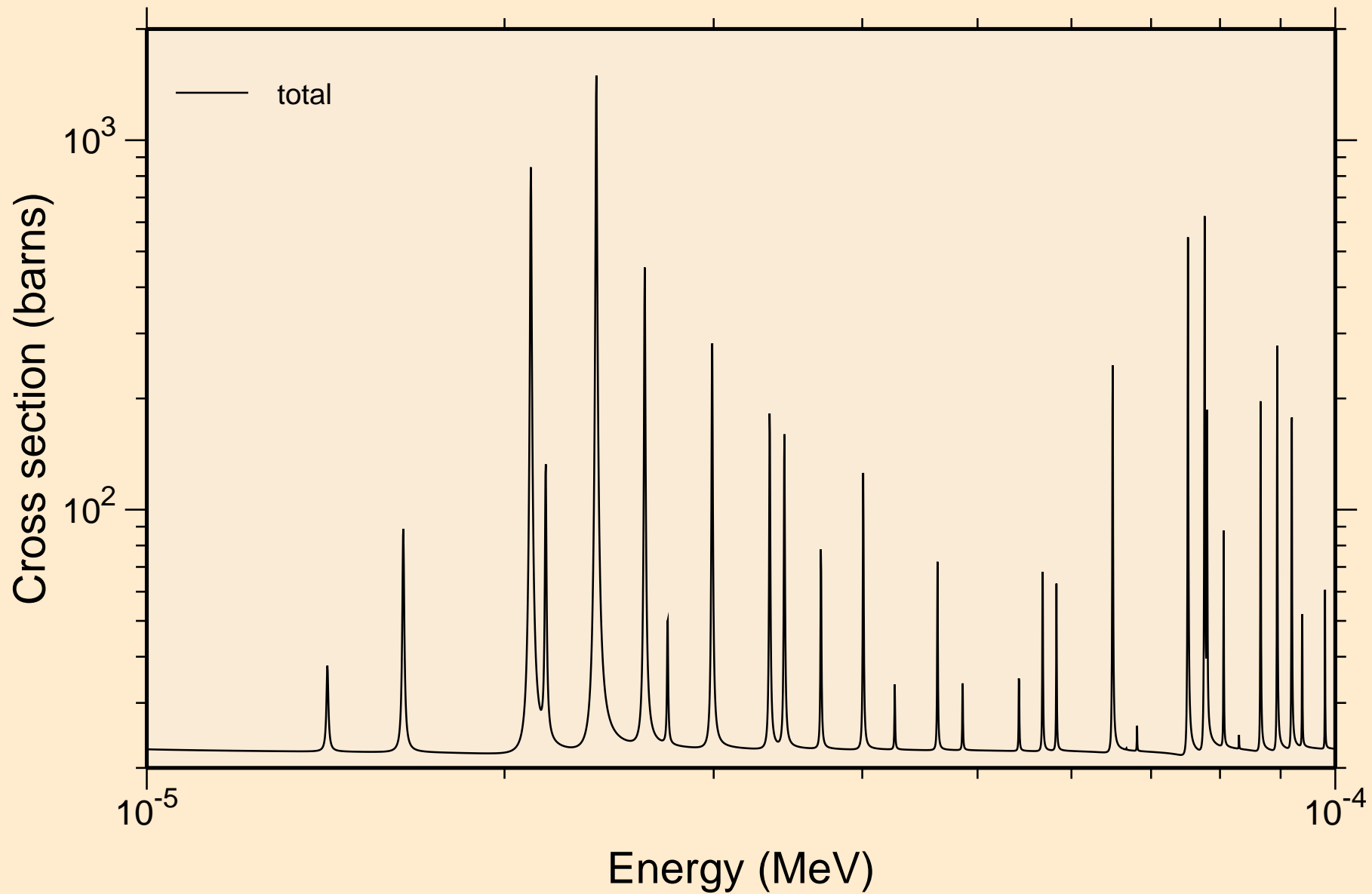

YB160 NEUTRON ACER TENDL-2023 LIBRARY; T=0.K  
resonance total cross section

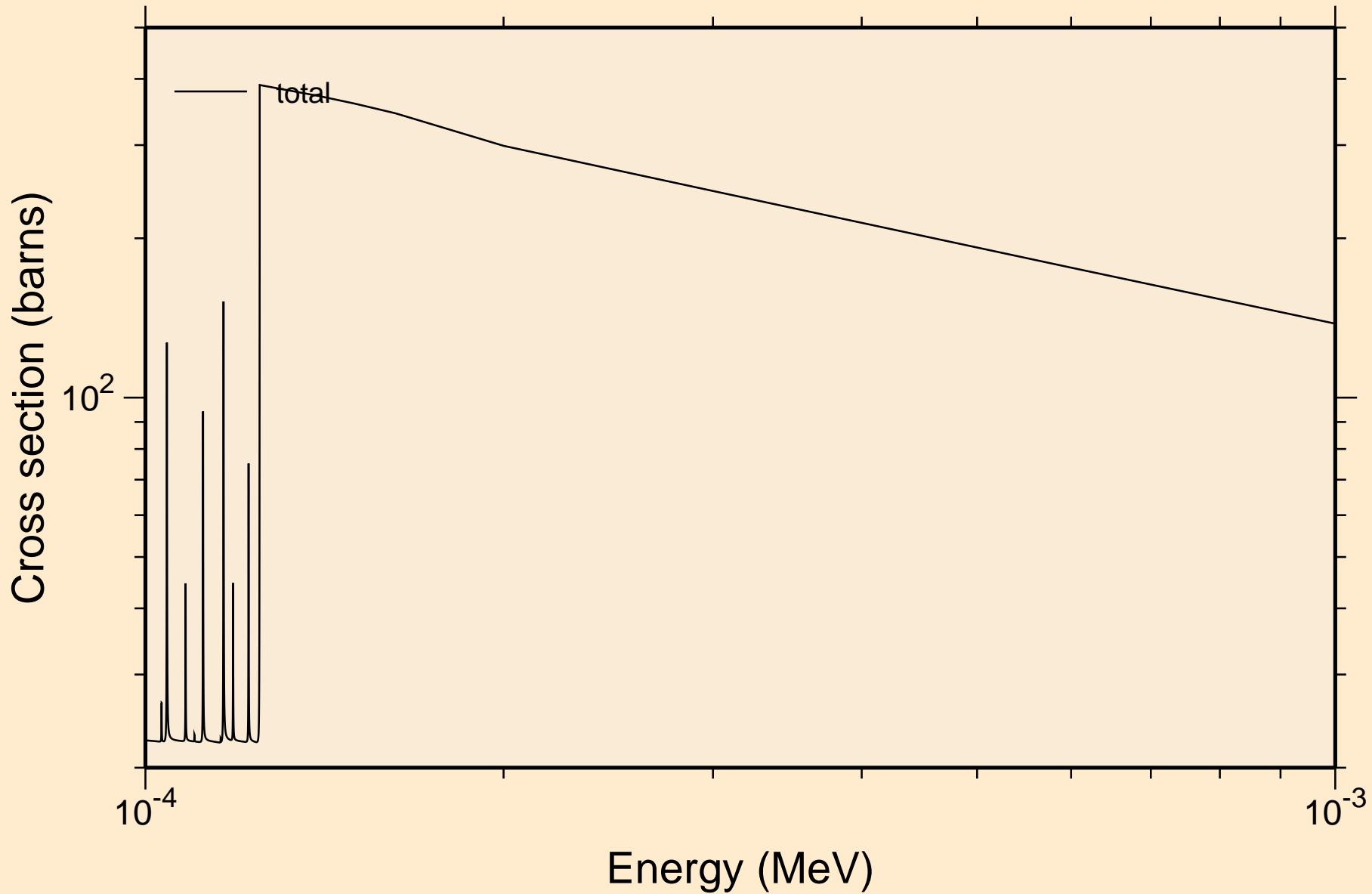

YB160 NEUTRON ACER TENDL-2023 LIBRARY; T=0.K  
resonance total cross section

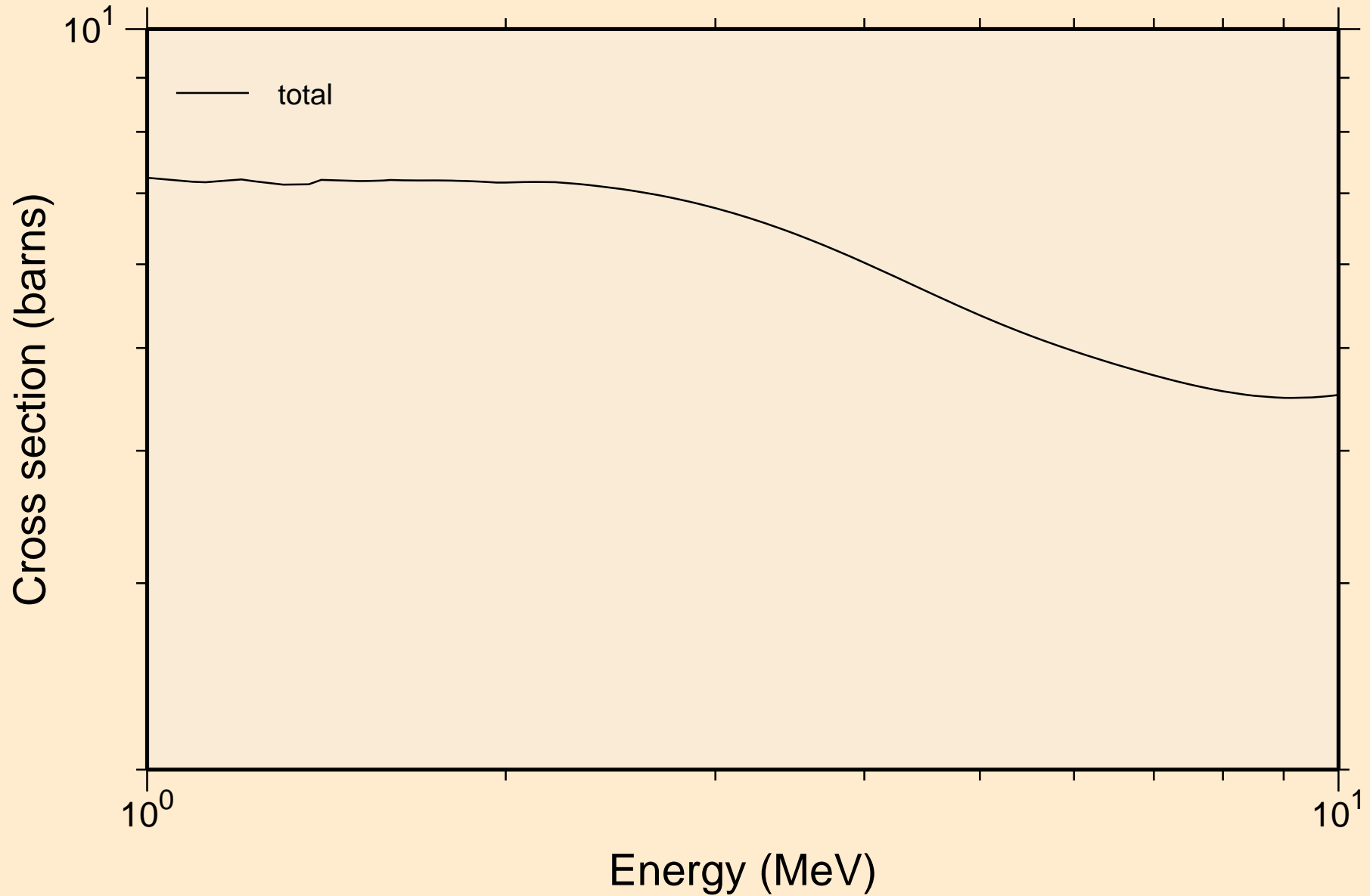

YB160 NEUTRON ACER TENDL-2023 LIBRARY; T=0.K  
resonance absorption cross sections

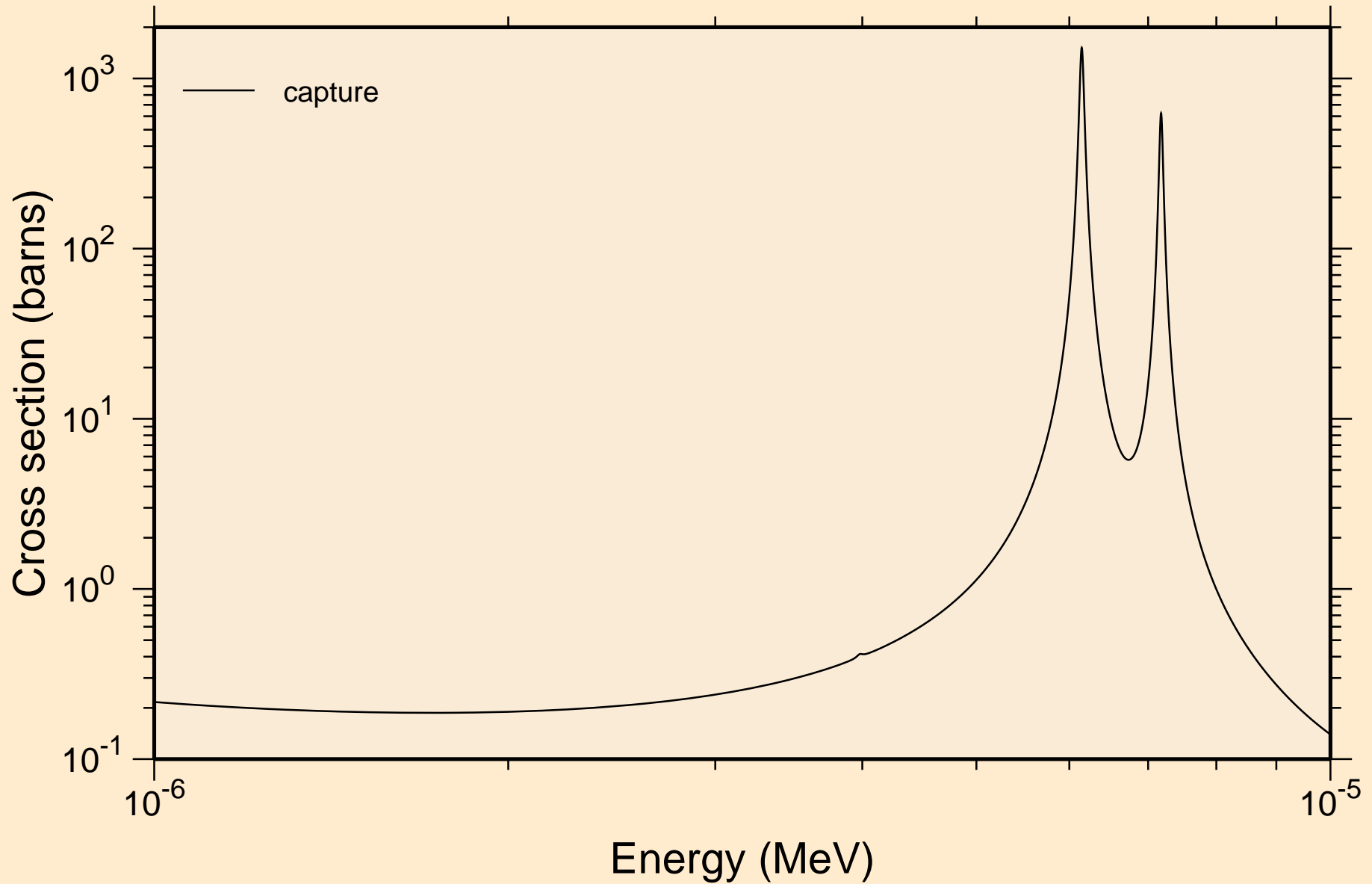

YB160 NEUTRON ACER TENDL-2023 LIBRARY; T=0.K  
resonance absorption cross sections

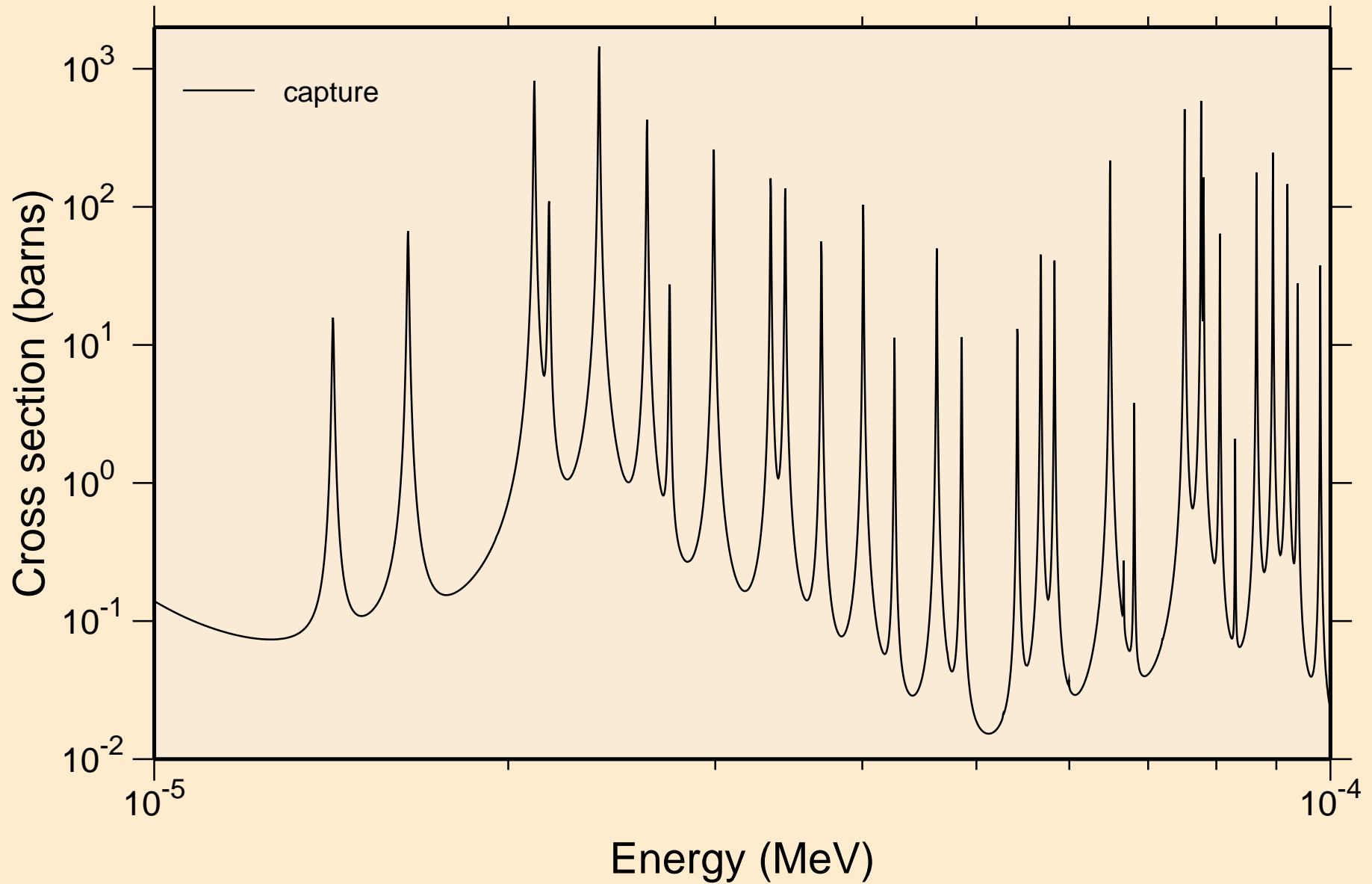

YB160 NEUTRON ACER TENDL-2023 LIBRARY; T=0.K  
resonance absorption cross sections

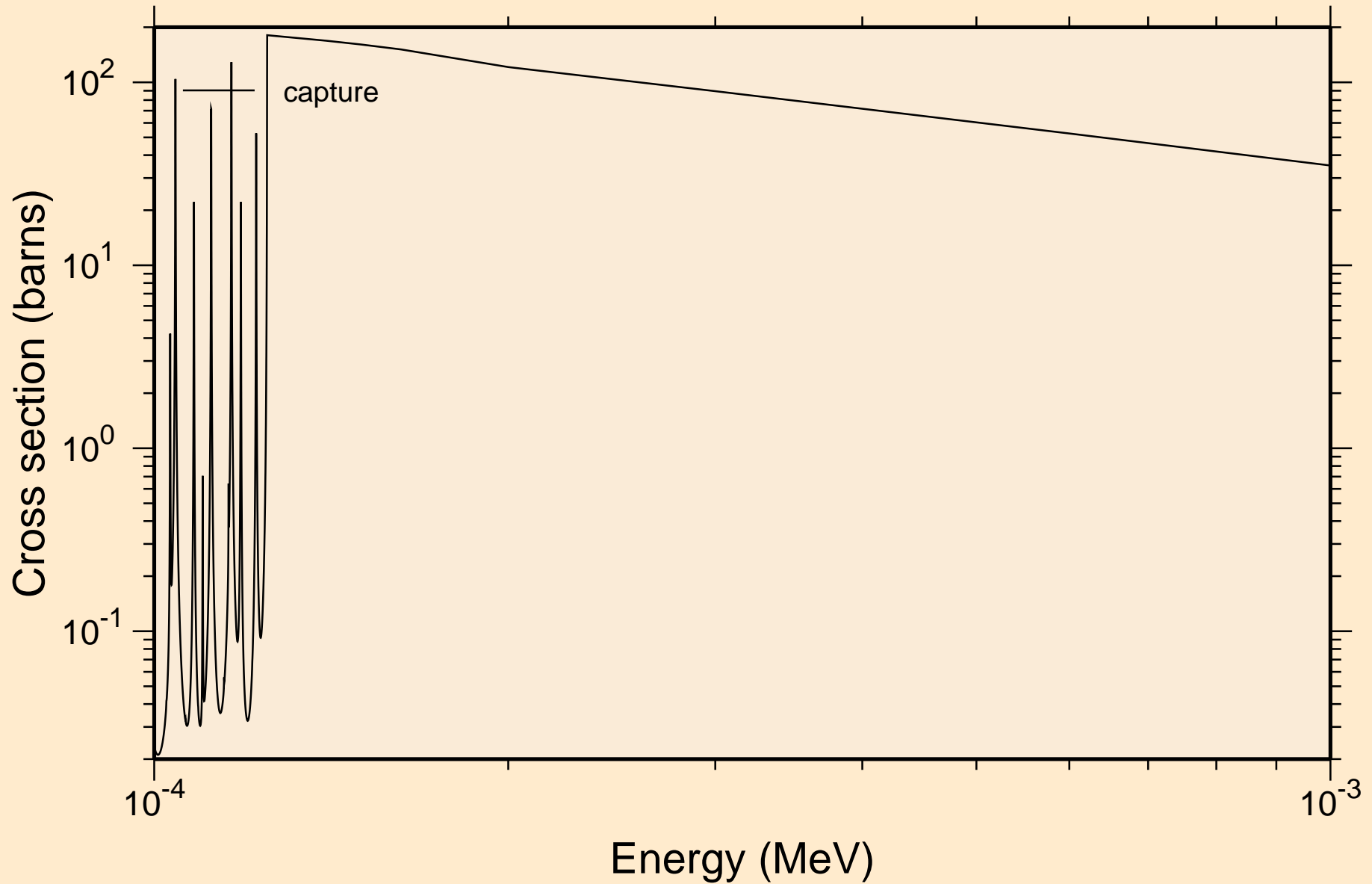

YB160 NEUTRON ACER TENDL-2023 LIBRARY; T=0.K  
resonance absorption cross sections

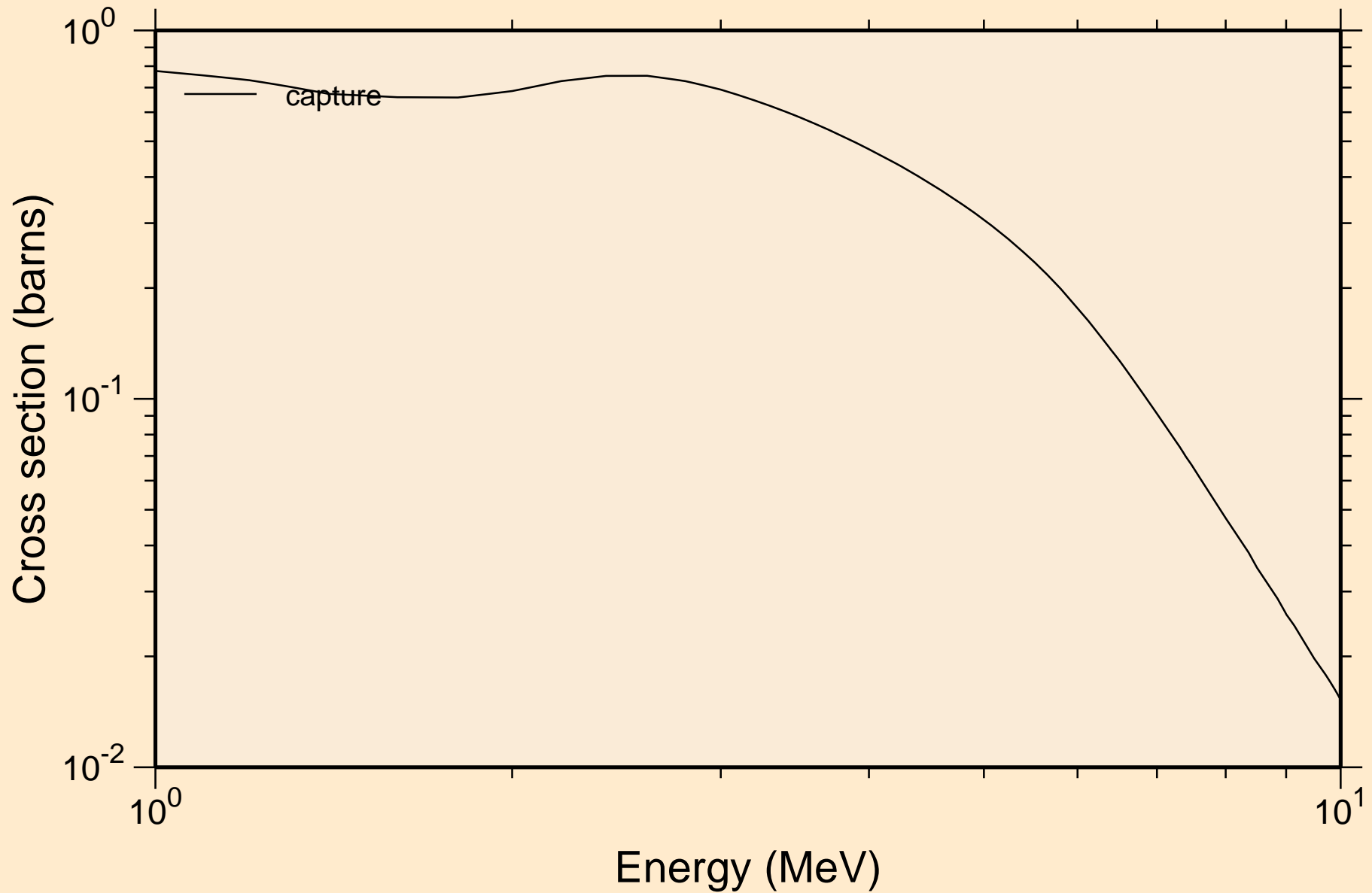

# YB160 NEUTRON ACER TENDL-2023 LIBRARY; T=0.K

## Heating

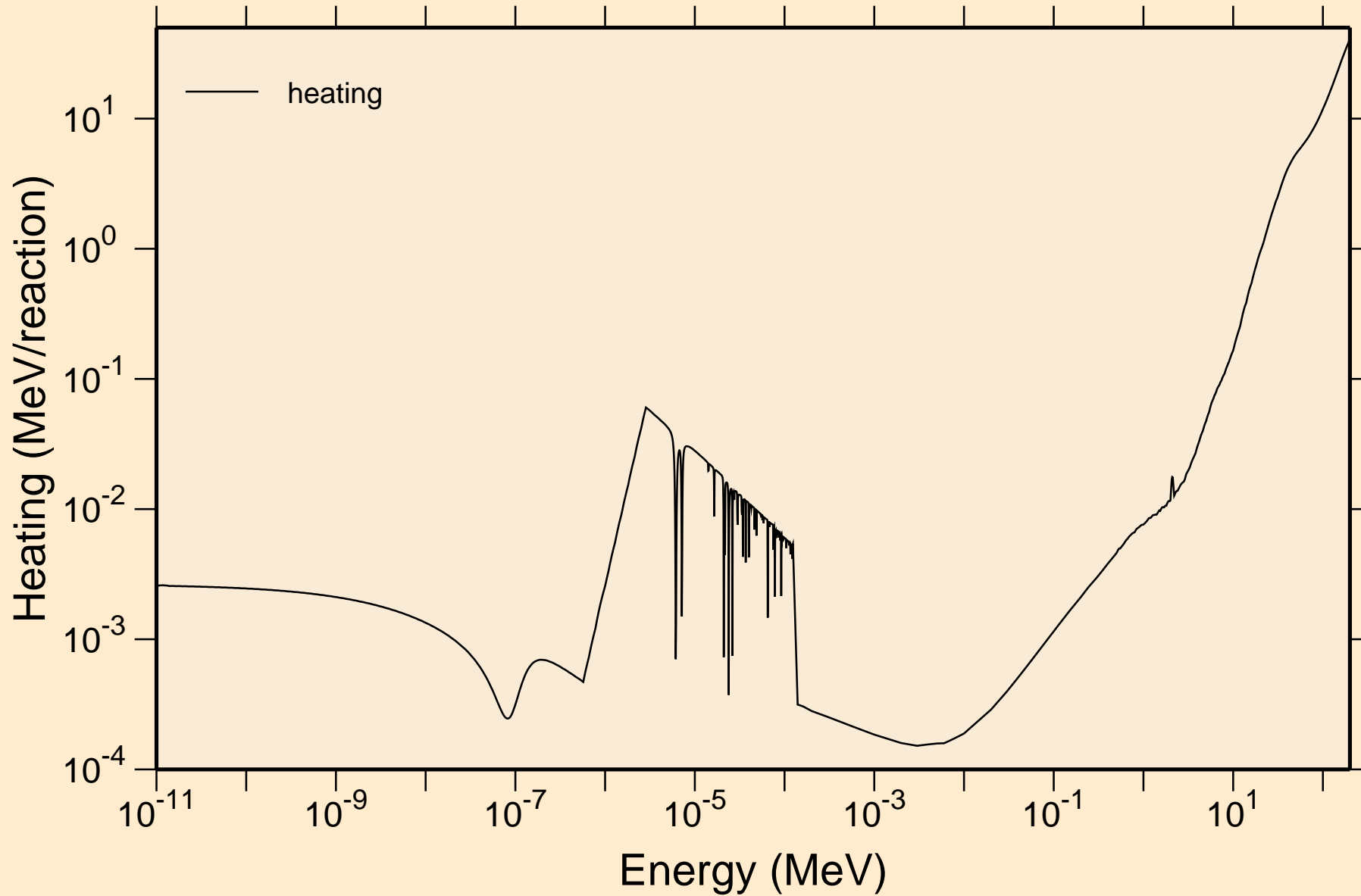

YB160 NEUTRON ACER TENDL-2023 LIBRARY; T=0.K  
Damage

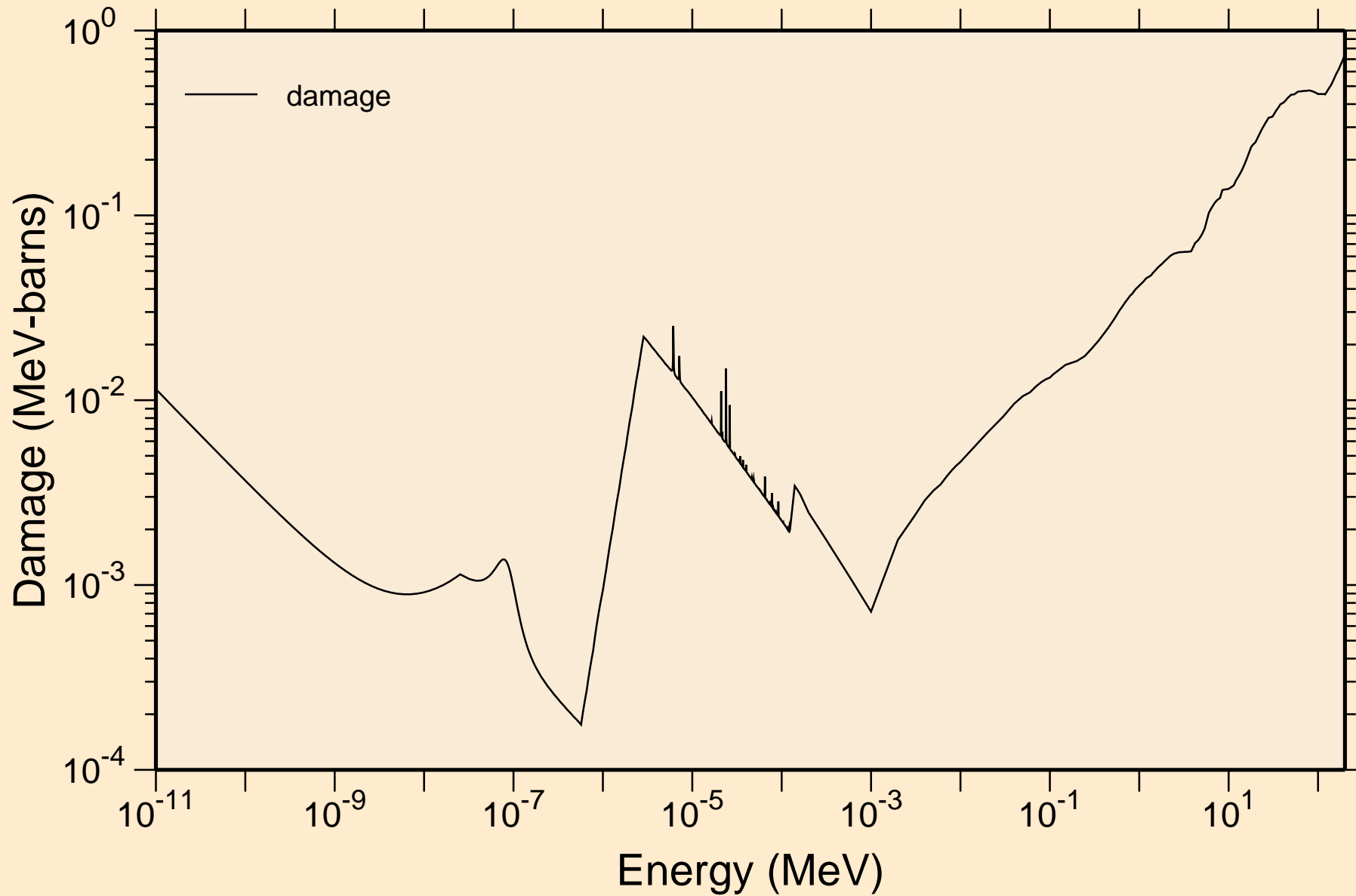

YB160 NEUTRON ACER TENDL-2023 LIBRARY; T=0.K  
Non-threshold reactions

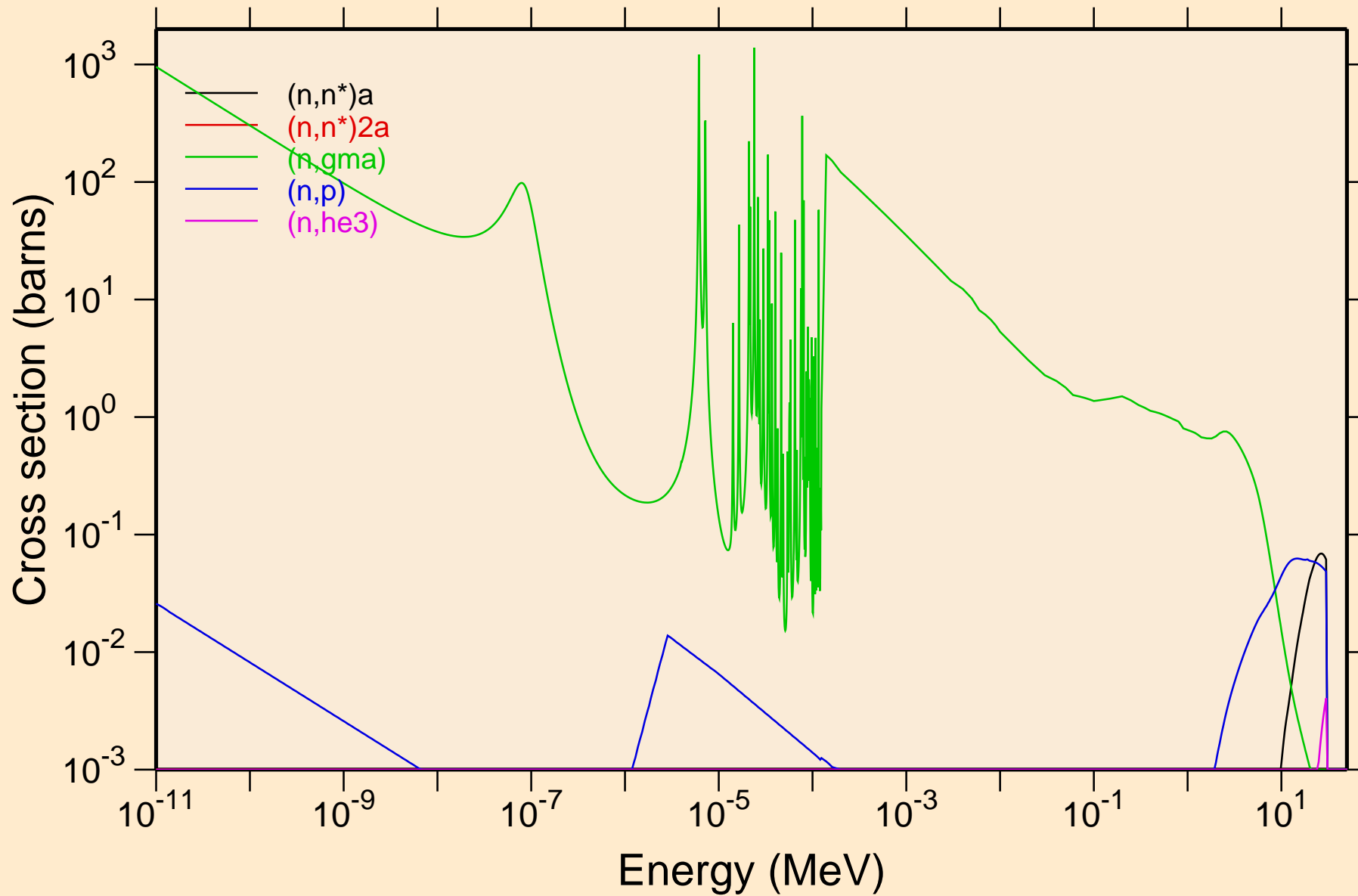

YB160 NEUTRON ACER TENDL-2023 LIBRARY; T=0.K  
Non-threshold reactions

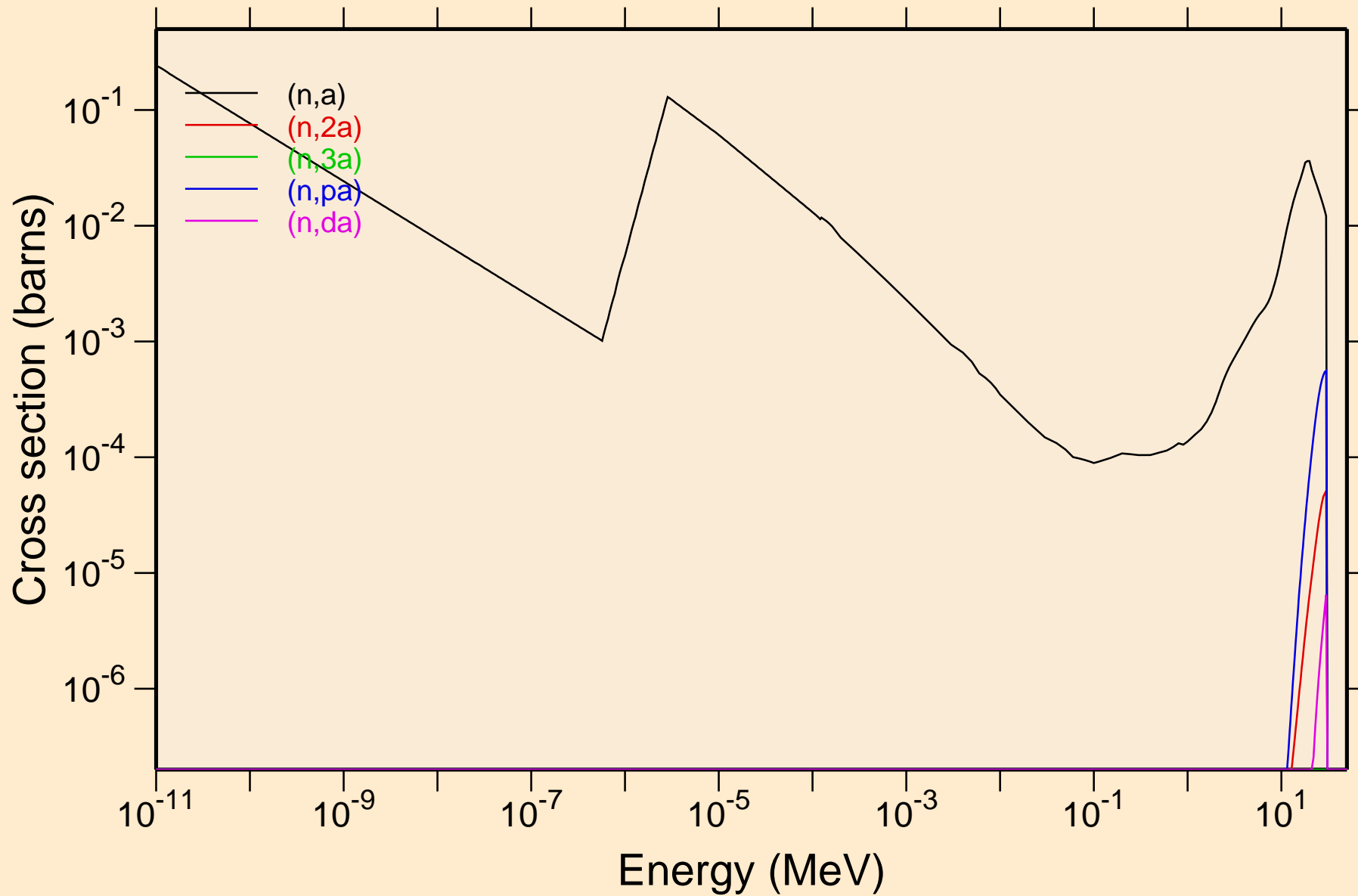

YB160 NEUTRON ACER TENDL-2023 LIBRARY; T=0.K  
Non-threshold reactions

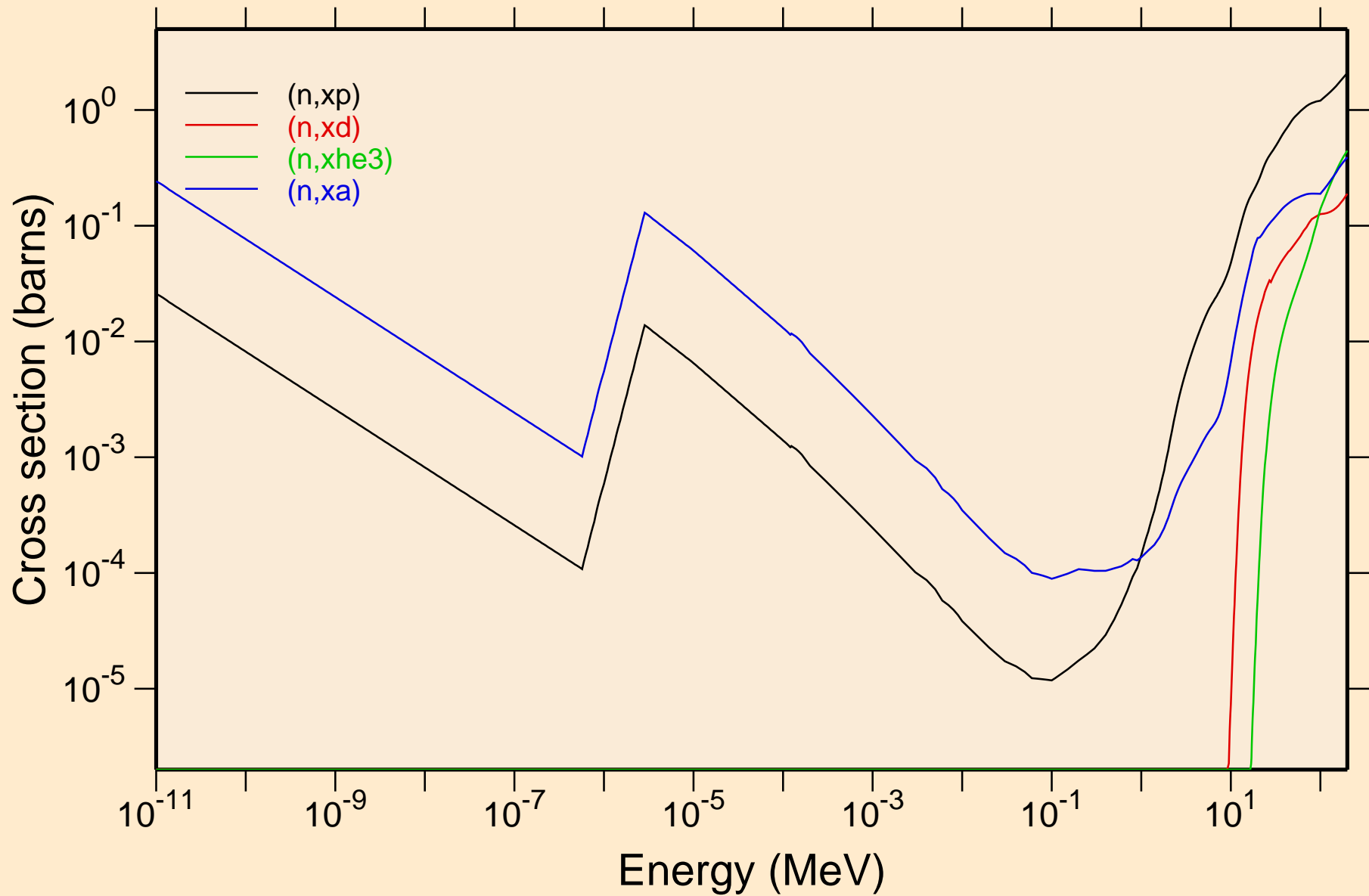

# YB160 NEUTRON ACER TENDL-2023 LIBRARY; T=0.K

## Principal cross sections

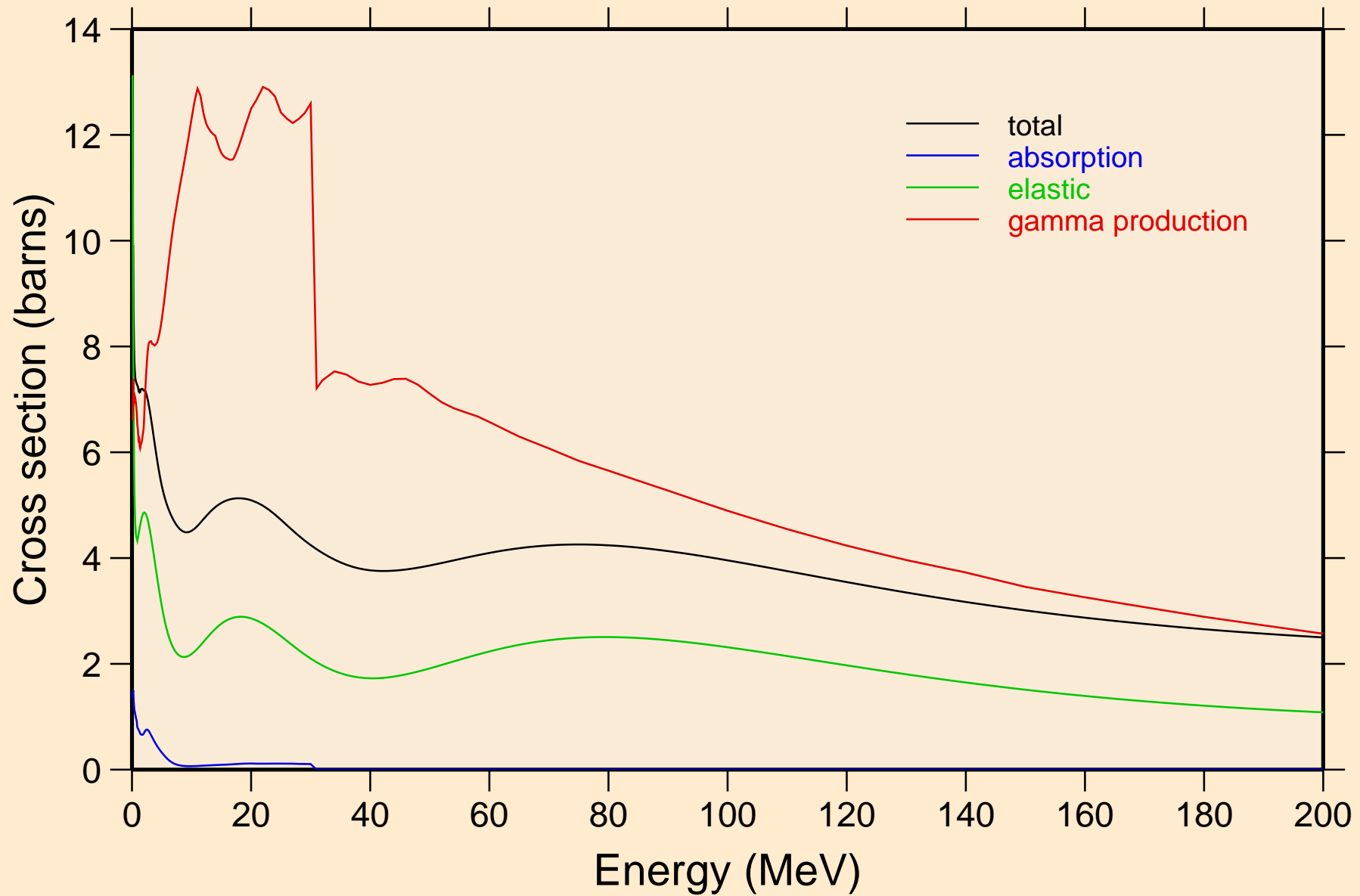

# YB160 NEUTRON ACER TENDL-2023 LIBRARY; T=0.K

## Heating

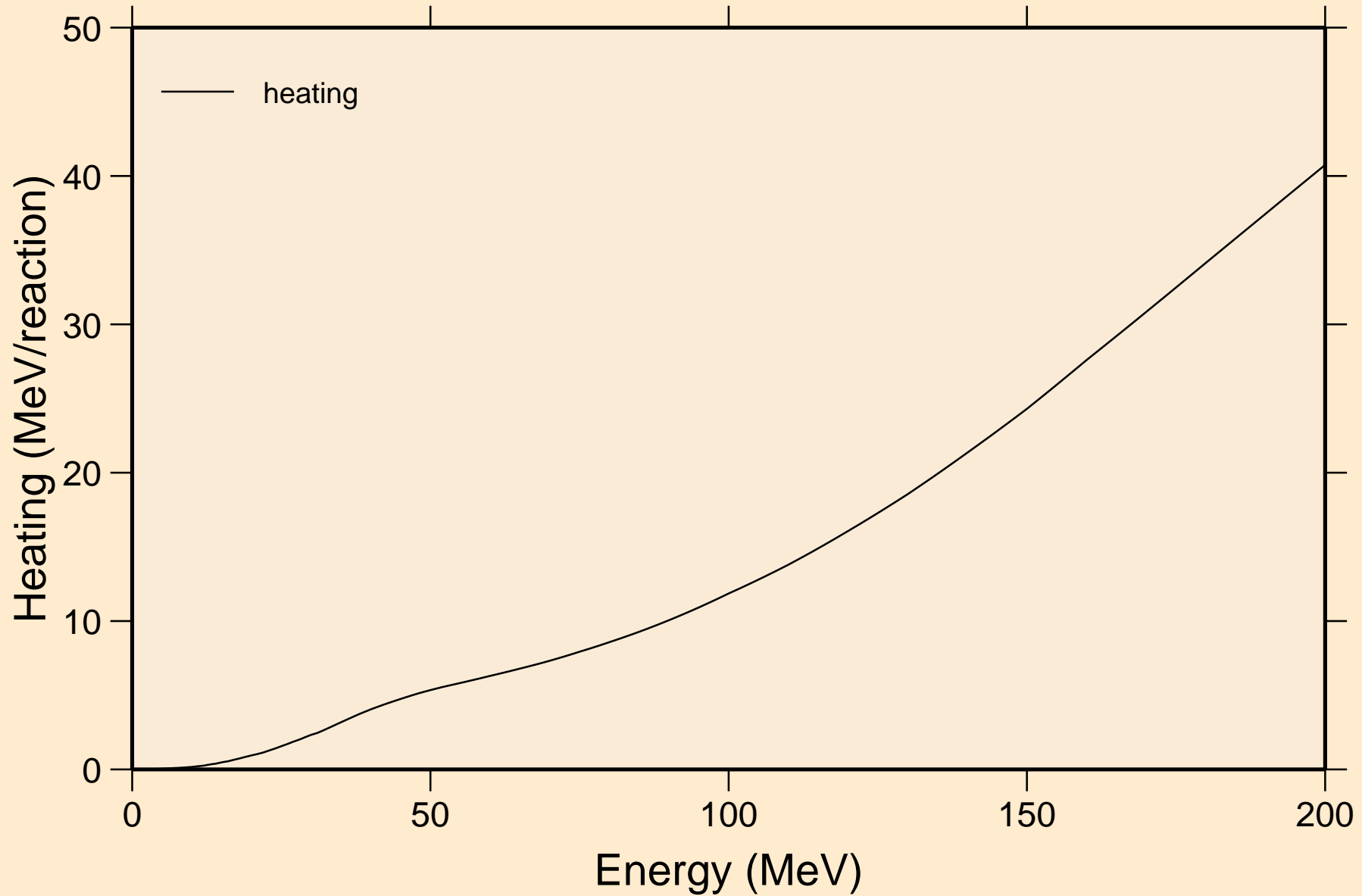

# YB160 NEUTRON ACER TENDL-2023 LIBRARY; T=0.K

## Damage

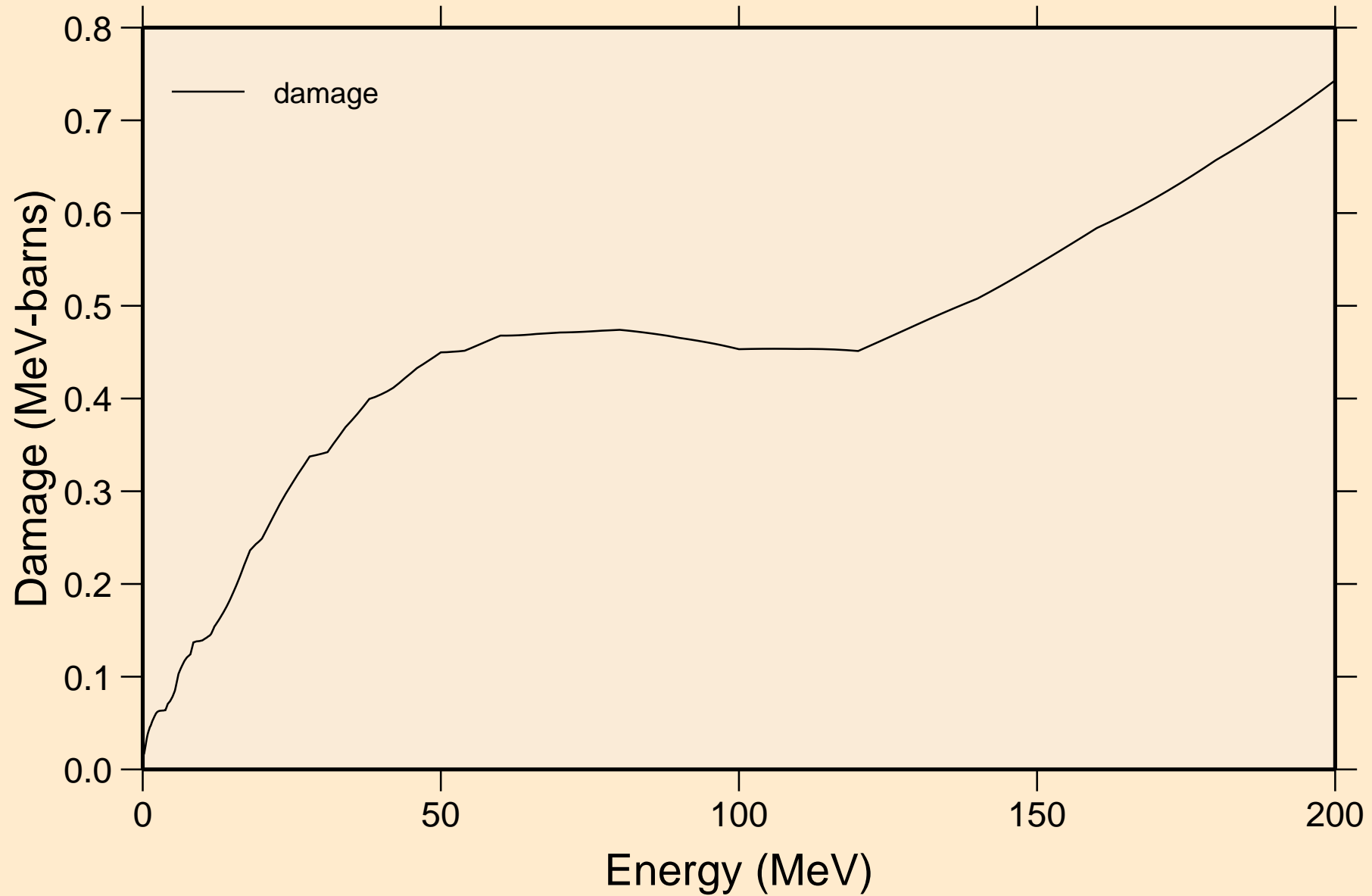

# YB160 NEUTRON ACER TENDL-2023 LIBRARY; T=0.K

## Non-threshold reactions

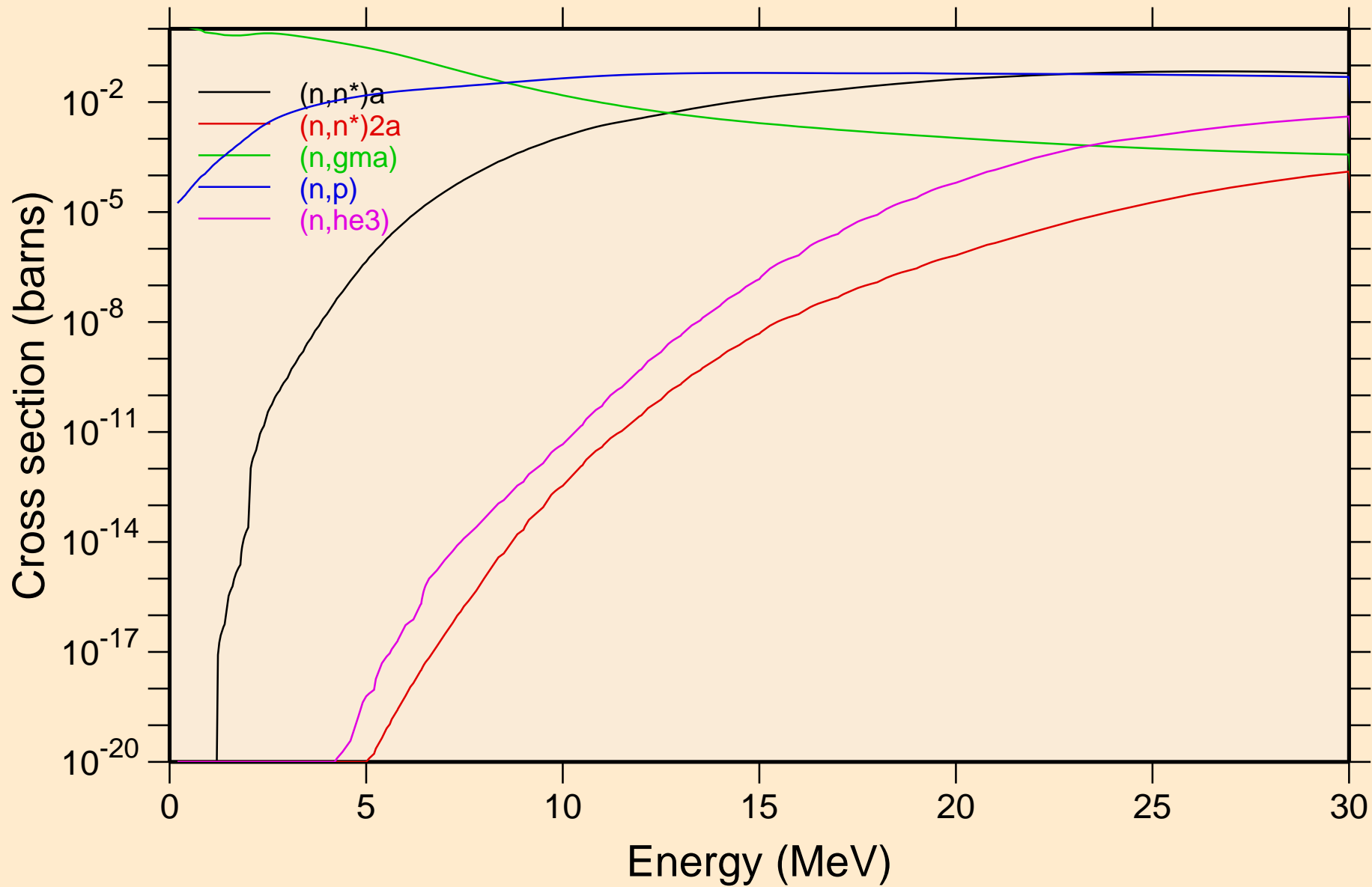

YB160 NEUTRON ACER TENDL-2023 LIBRARY; T=0.K  
Non-threshold reactions

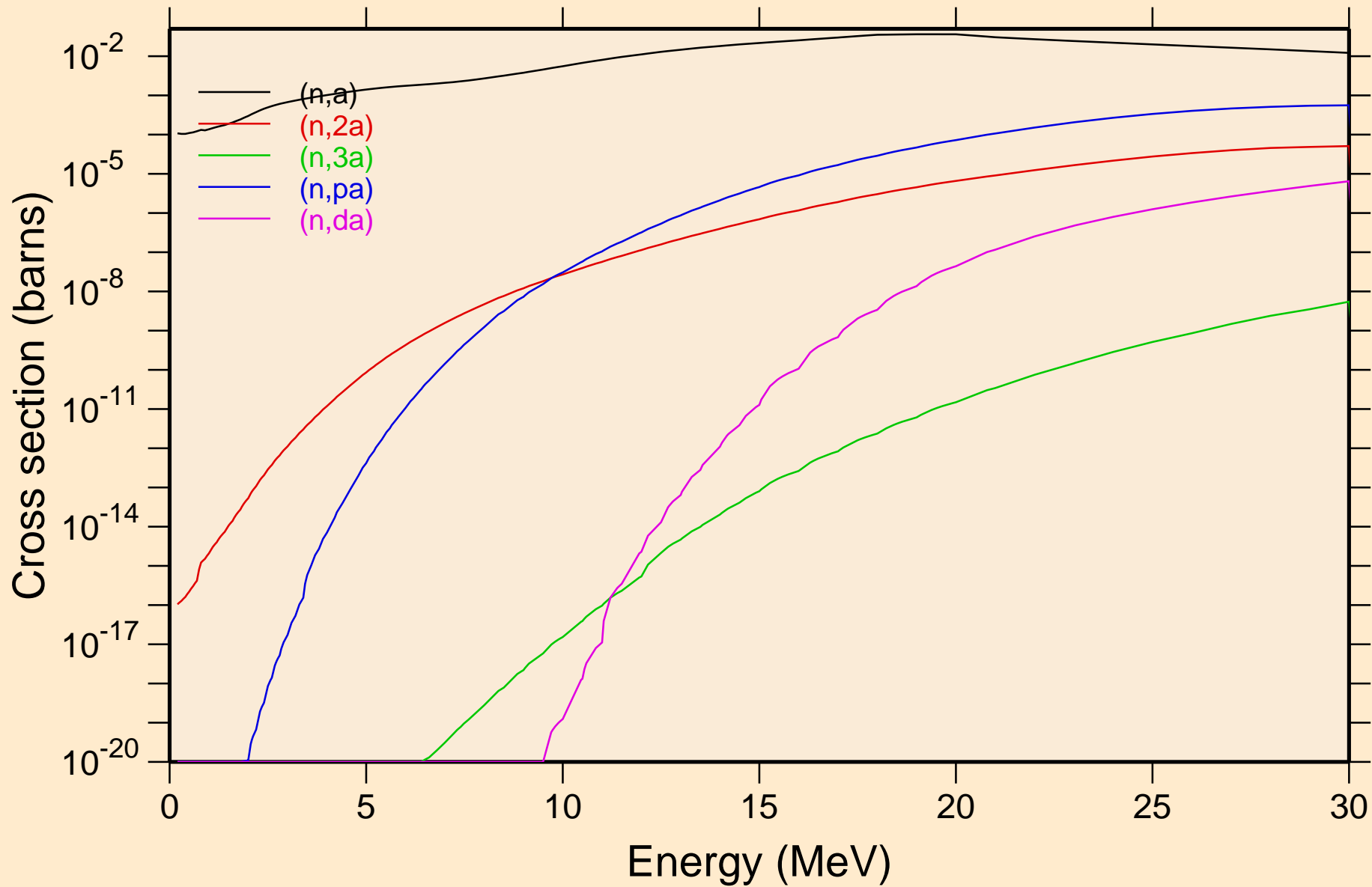

YB160 NEUTRON ACER TENDL-2023 LIBRARY; T=0.K  
Non-threshold reactions

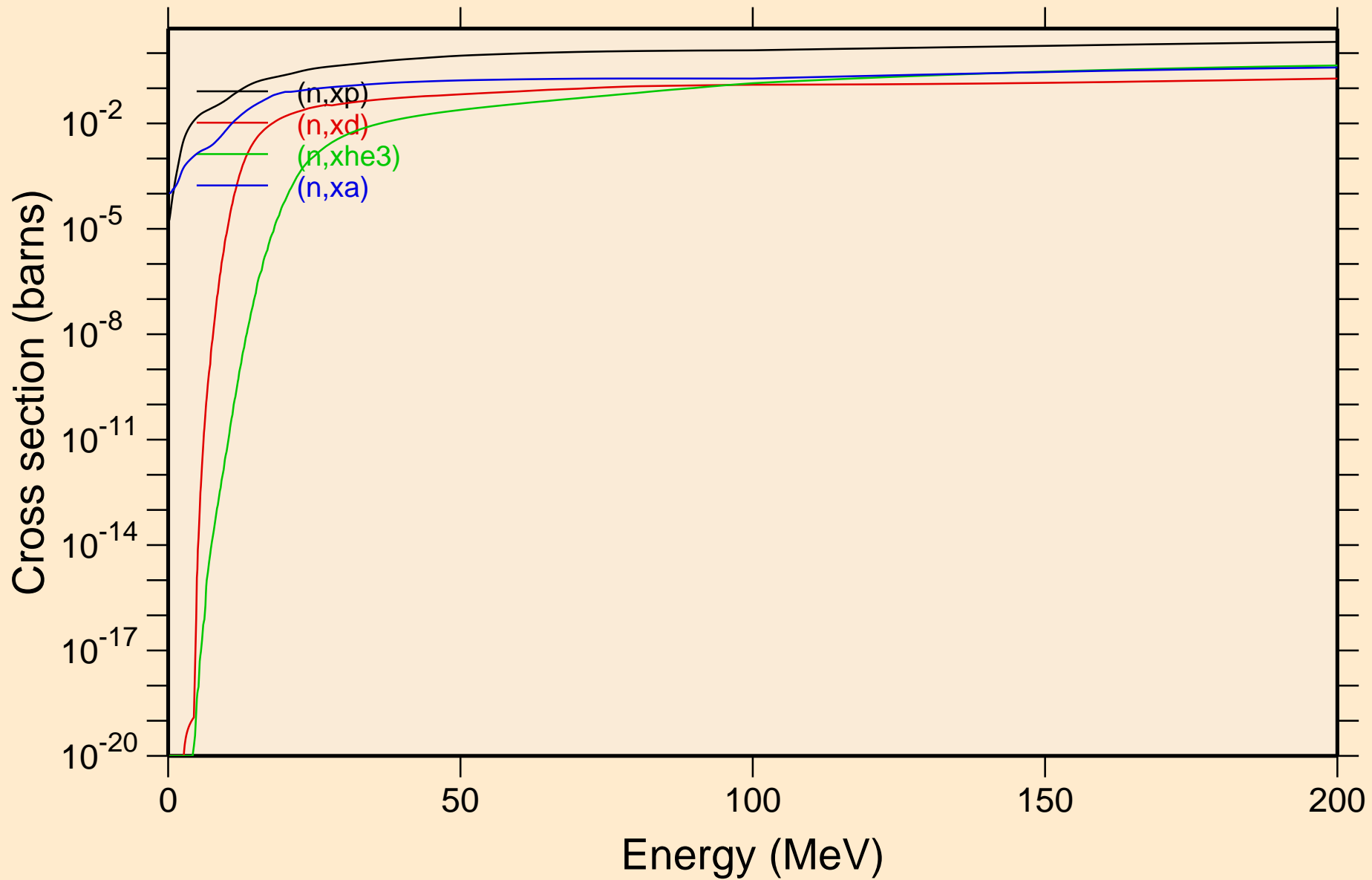

YB160 NEUTRON ACER TENDL-2023 LIBRARY; T=0.K  
Inelastic levels

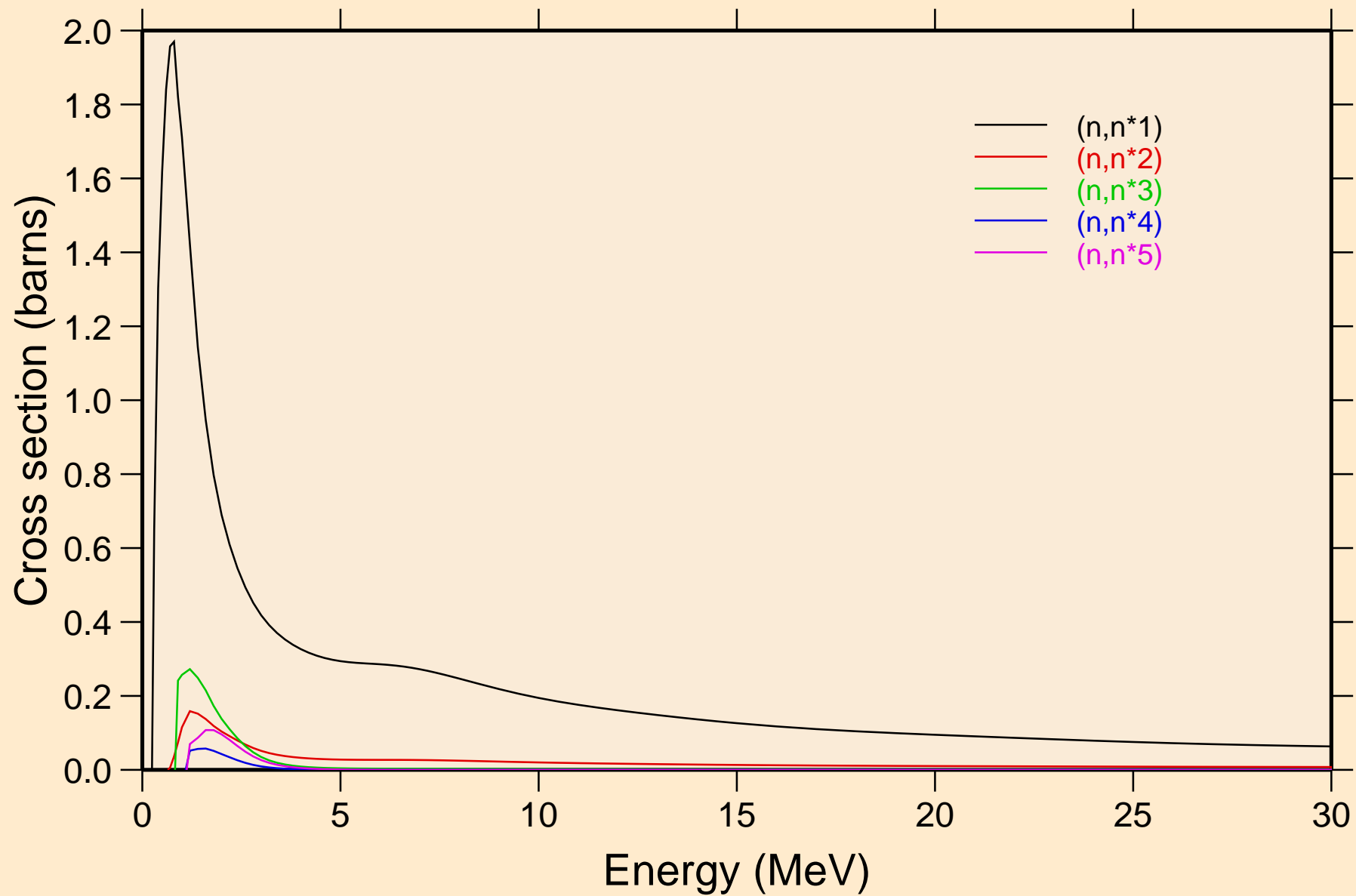

YB160 NEUTRON ACER TENDL-2023 LIBRARY; T=0.K  
Inelastic levels

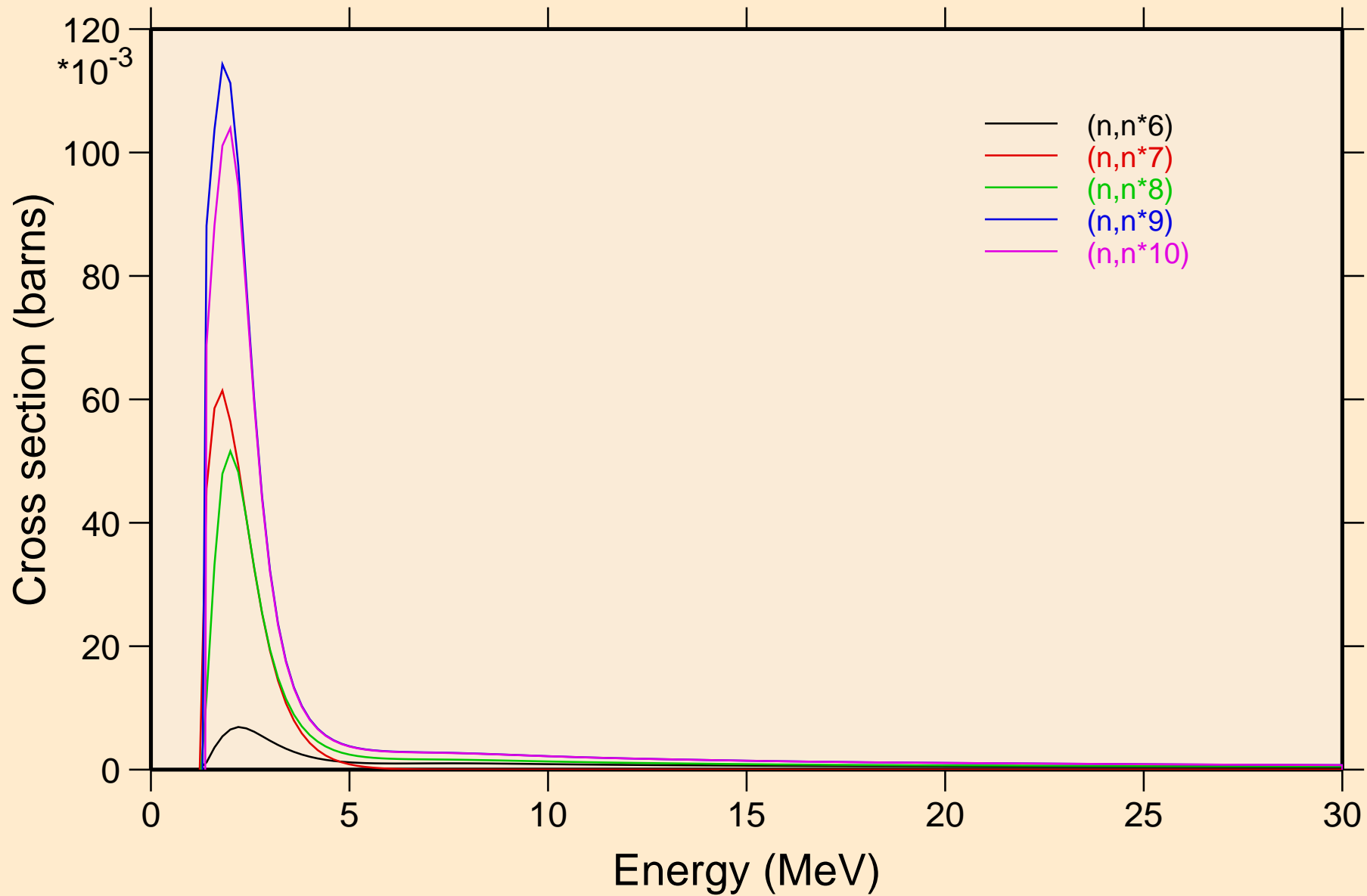

YB160 NEUTRON ACER TENDL-2023 LIBRARY; T=0.K  
Inelastic levels

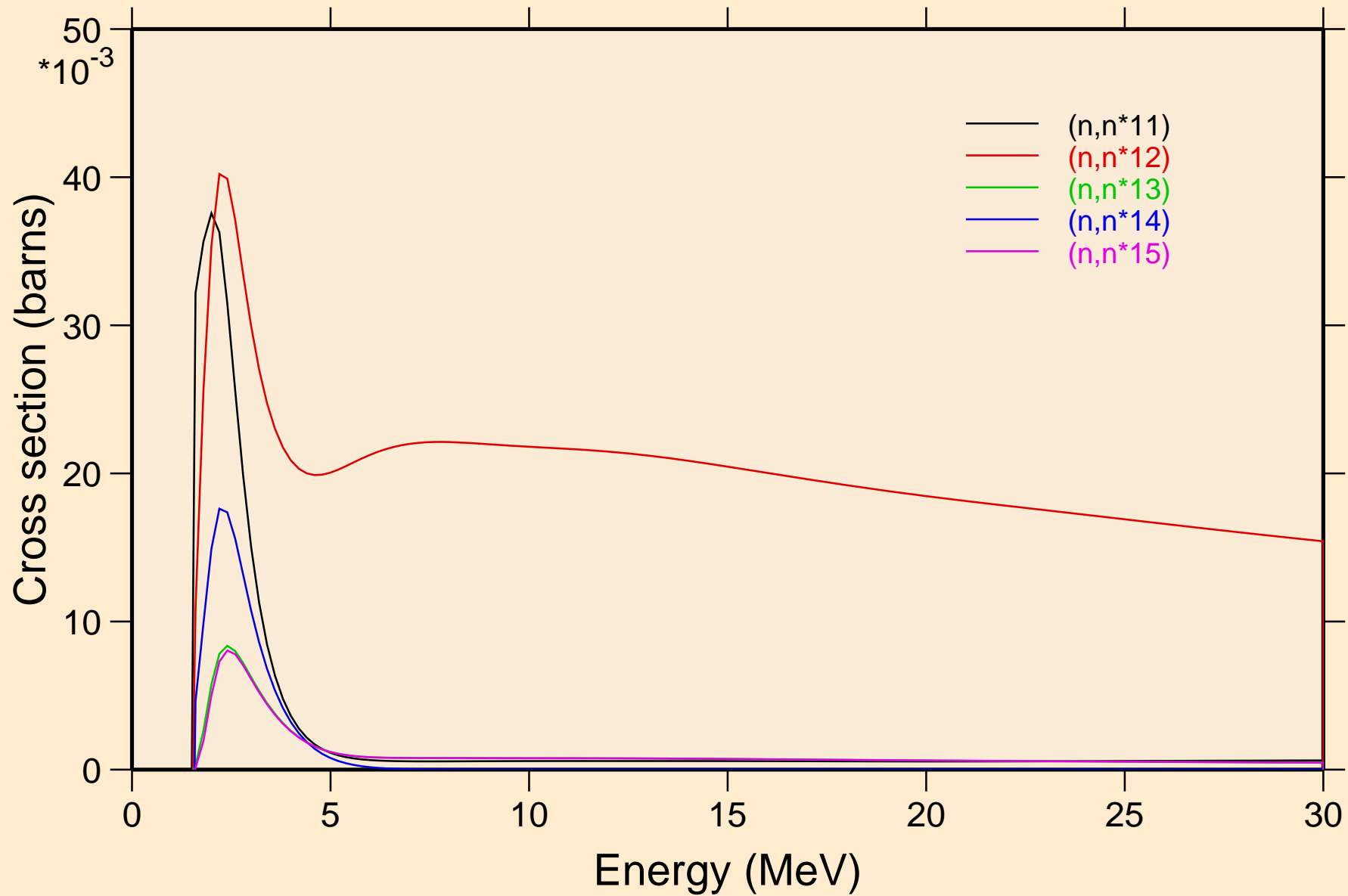

YB160 NEUTRON ACER TENDL-2023 LIBRARY; T=0.K  
Inelastic levels

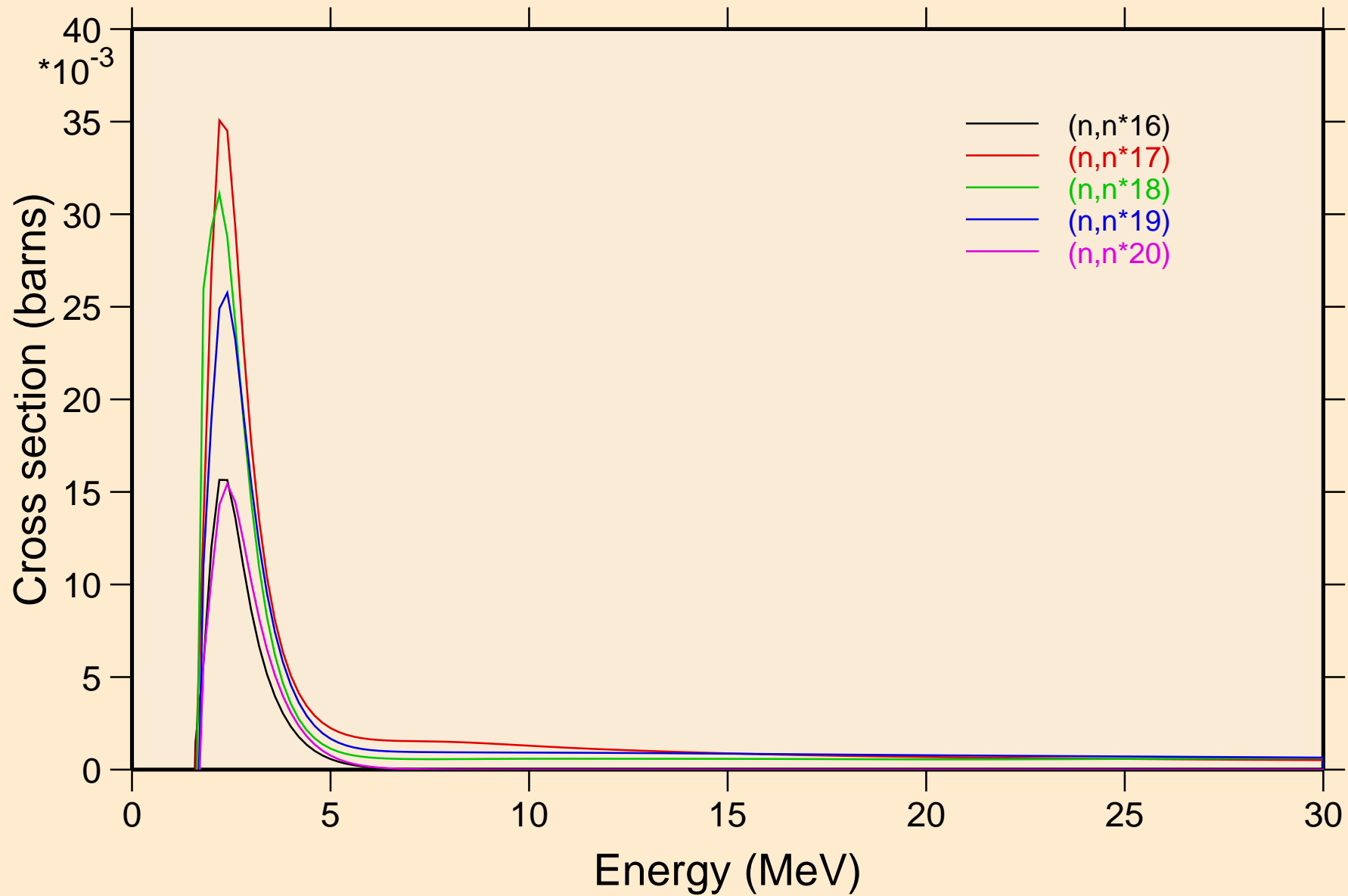

YB160 NEUTRON ACER TENDL-2023 LIBRARY; T=0.K  
Inelastic levels

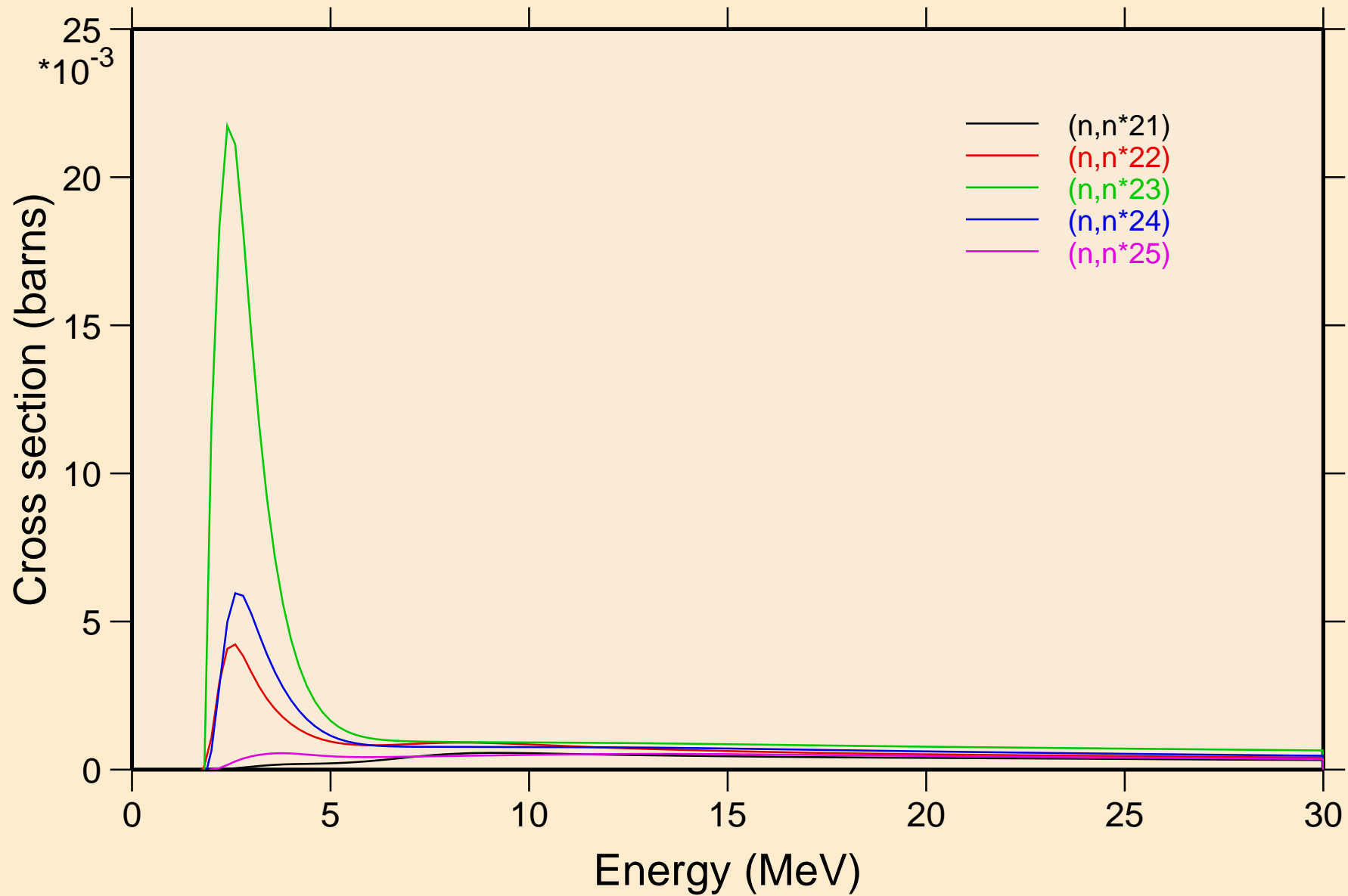

YB160 NEUTRON ACER TENDL-2023 LIBRARY; T=0.K  
Inelastic levels

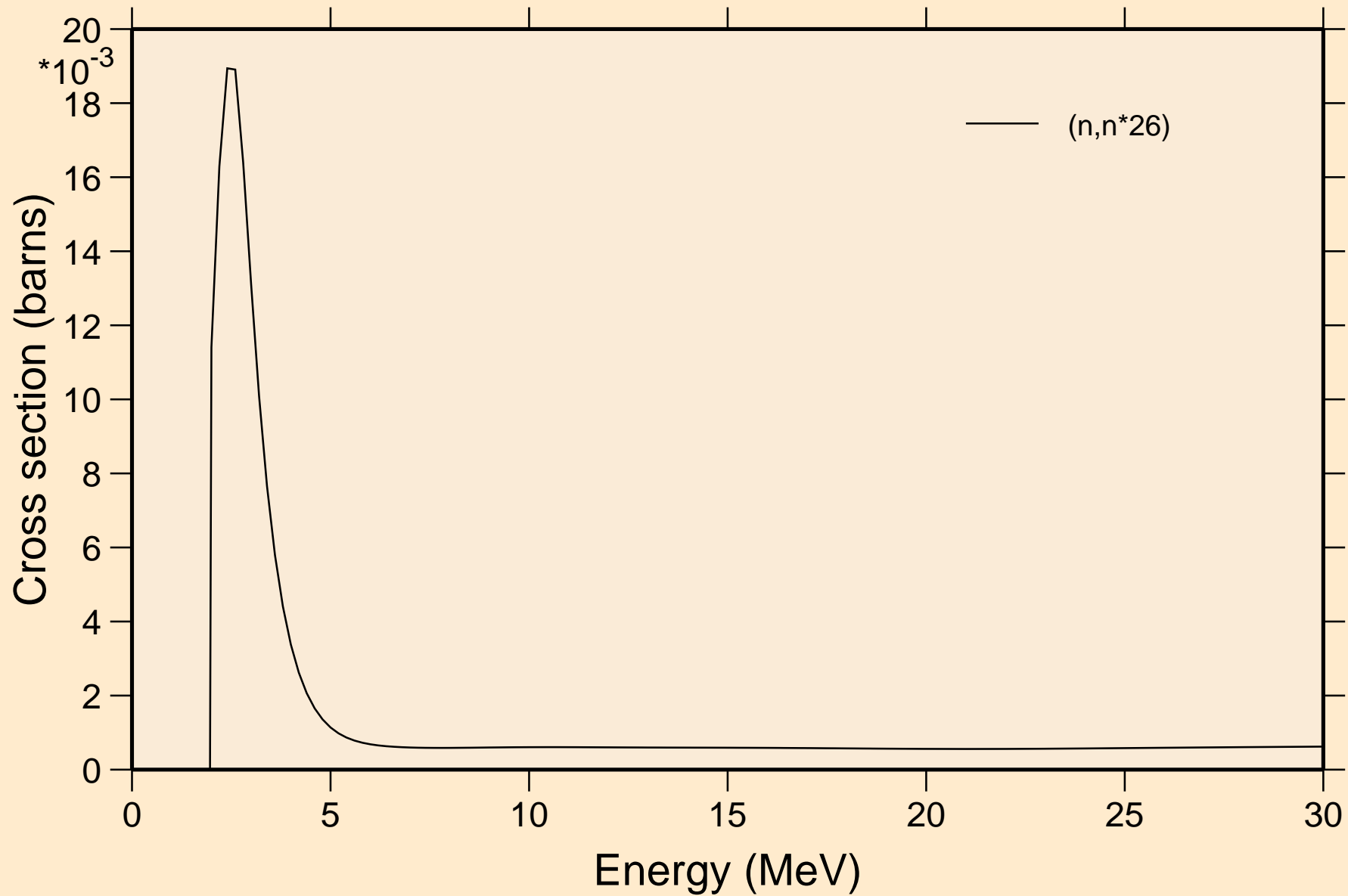

YB160 NEUTRON ACER TENDL-2023 LIBRARY; T=0.K  
Threshold reactions

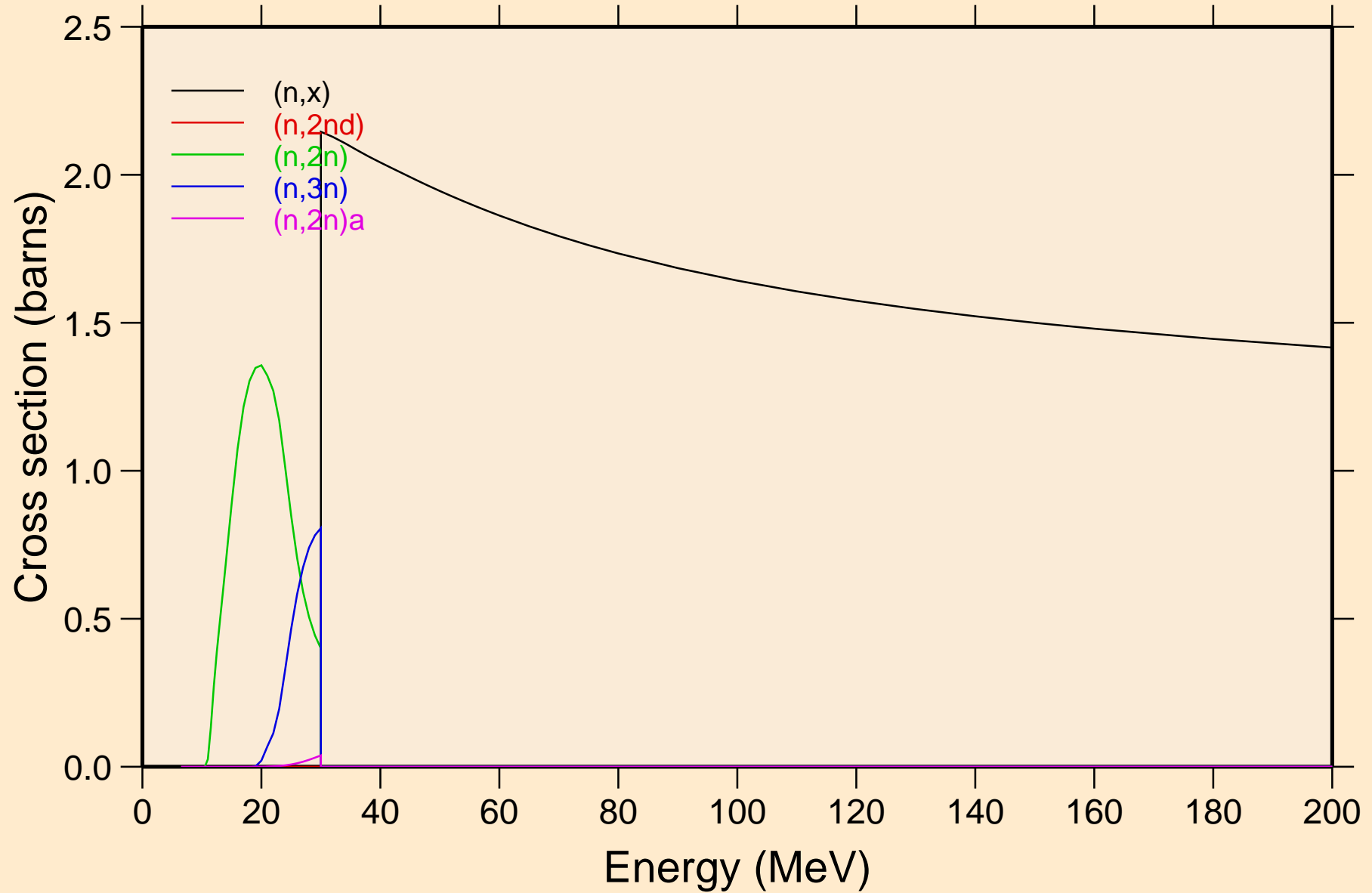

YB160 NEUTRON ACER TENDL-2023 LIBRARY; T=0.K  
Threshold reactions

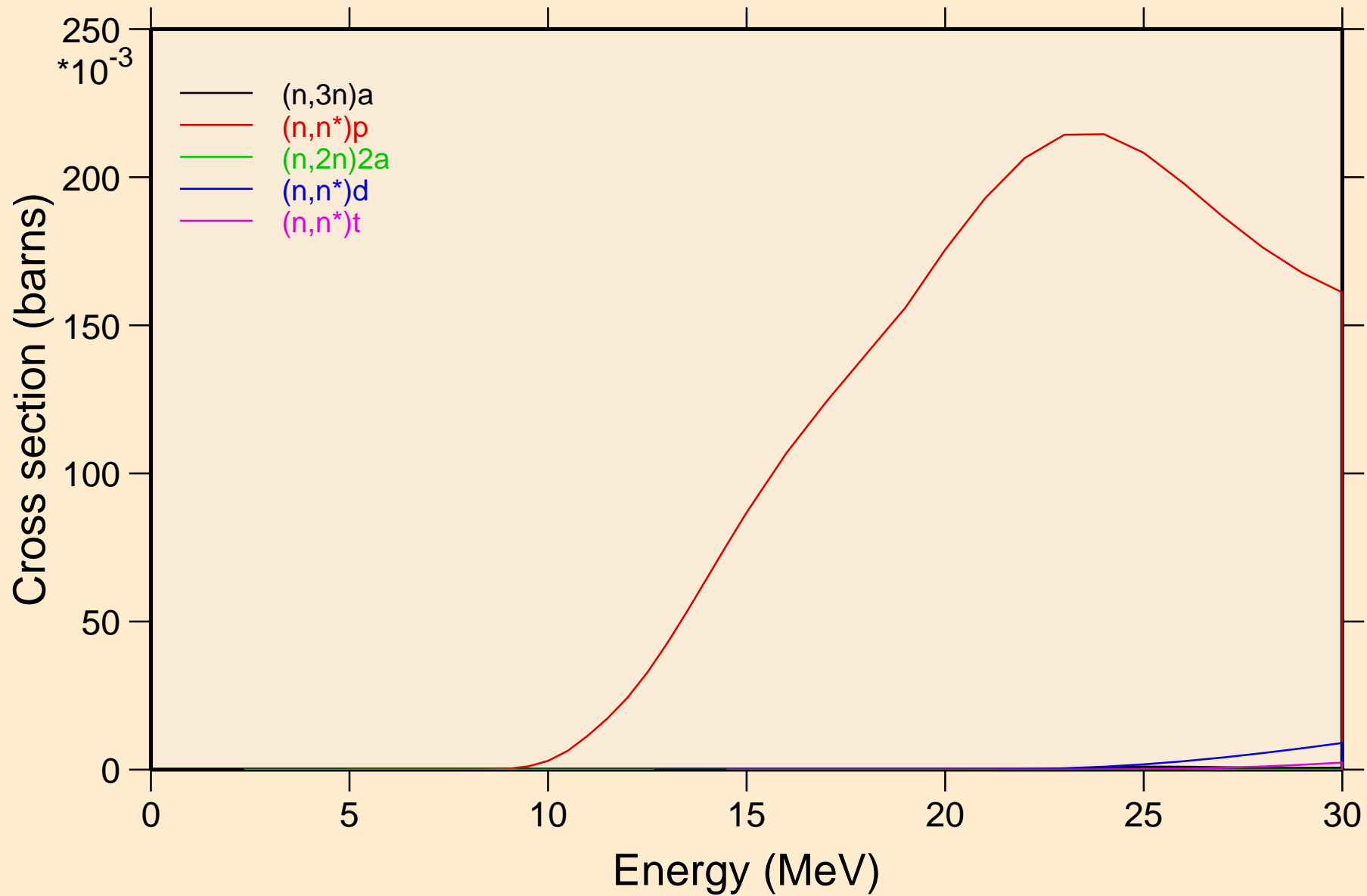

YB160 NEUTRON ACER TENDL-2023 LIBRARY; T=0.K  
Threshold reactions

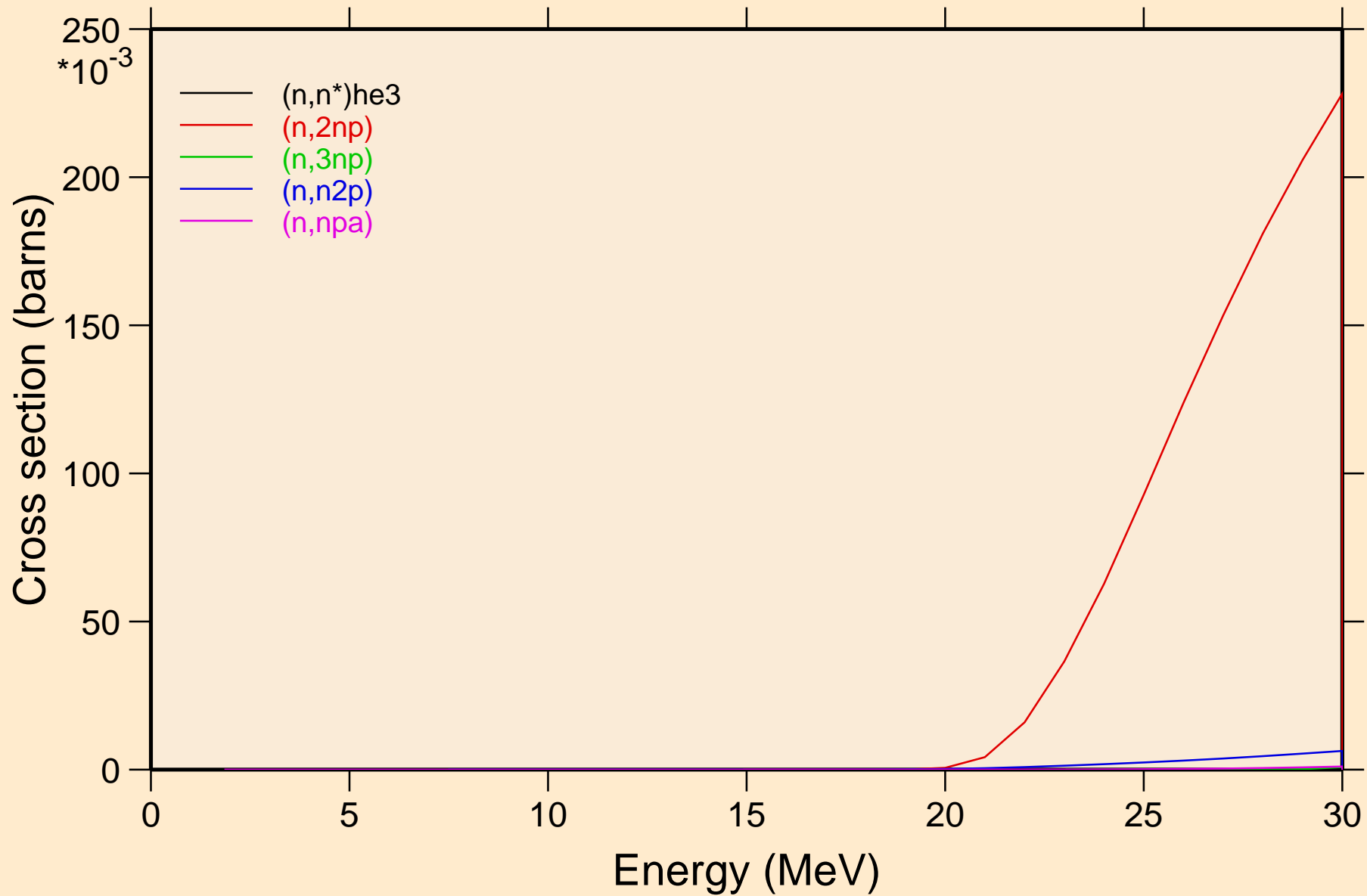

YB160 NEUTRON ACER TENDL-2023 LIBRARY; T=0.K  
Threshold reactions

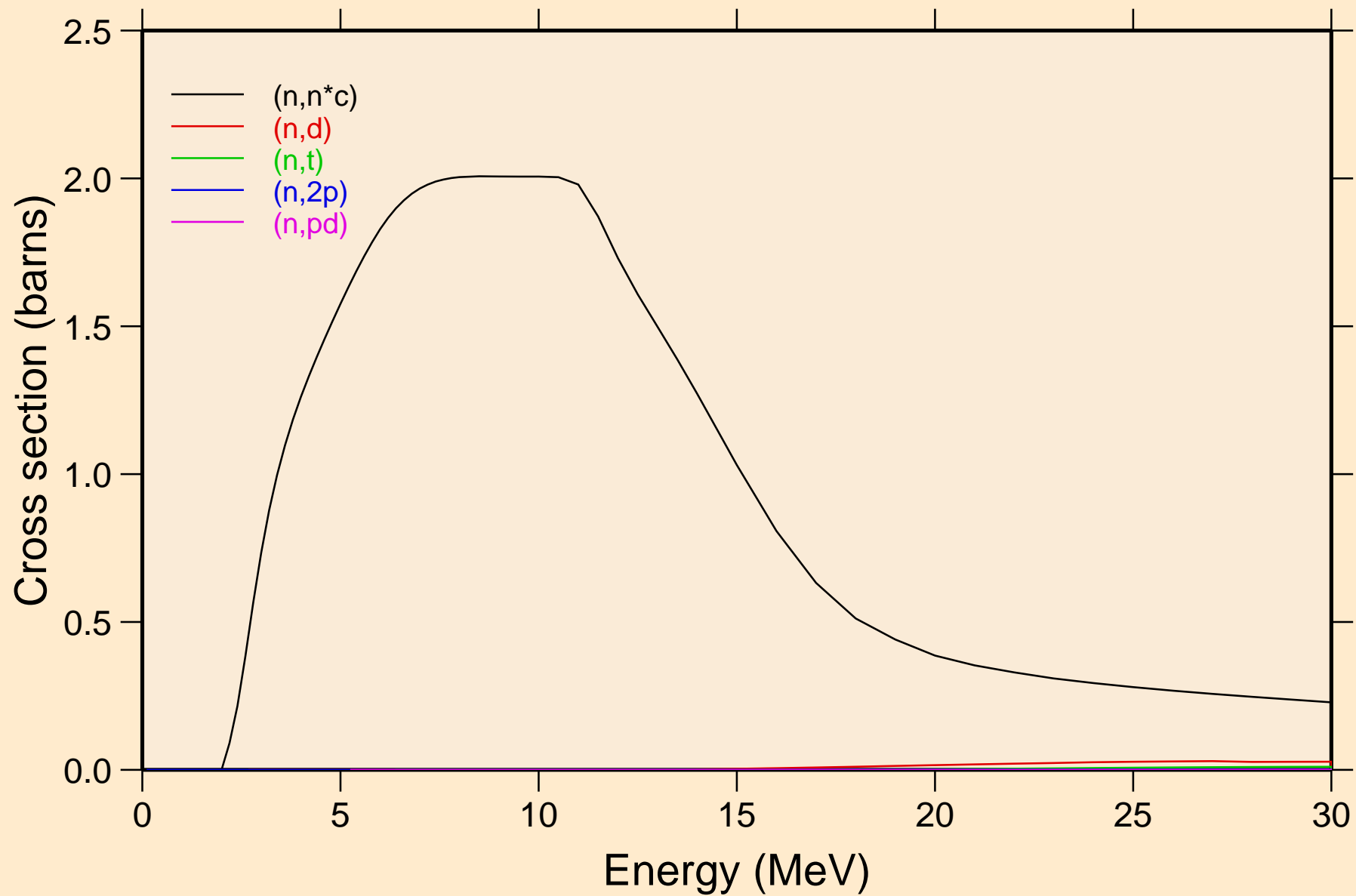

YB160 NEUTRON ACER TENDL-2023 LIBRARY; T=0.K  
Threshold reactions

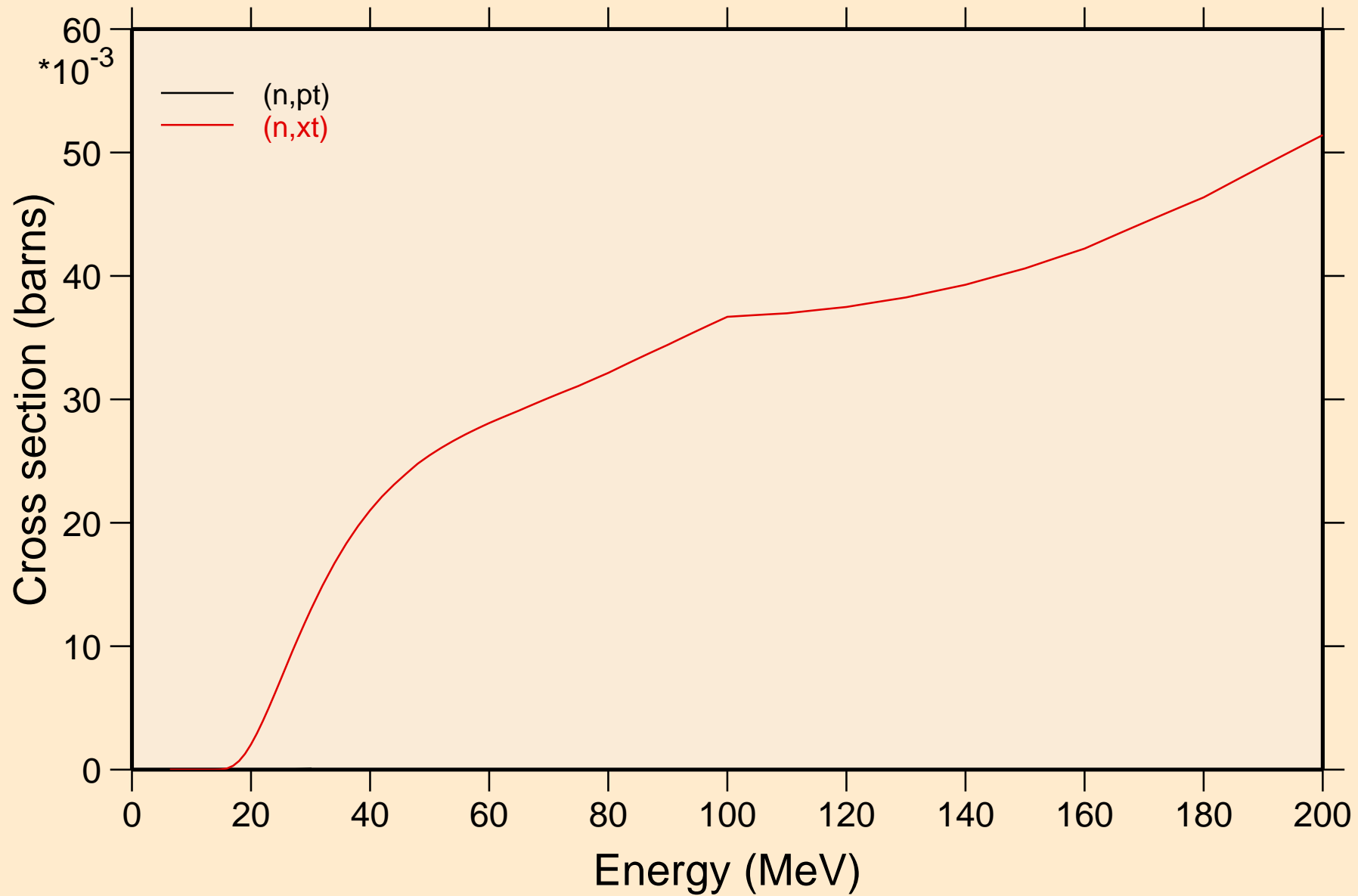

YB160 NEUTRON ACER TENDL-2023 LIBRARY; T=0.K  
angular distribution for elastic

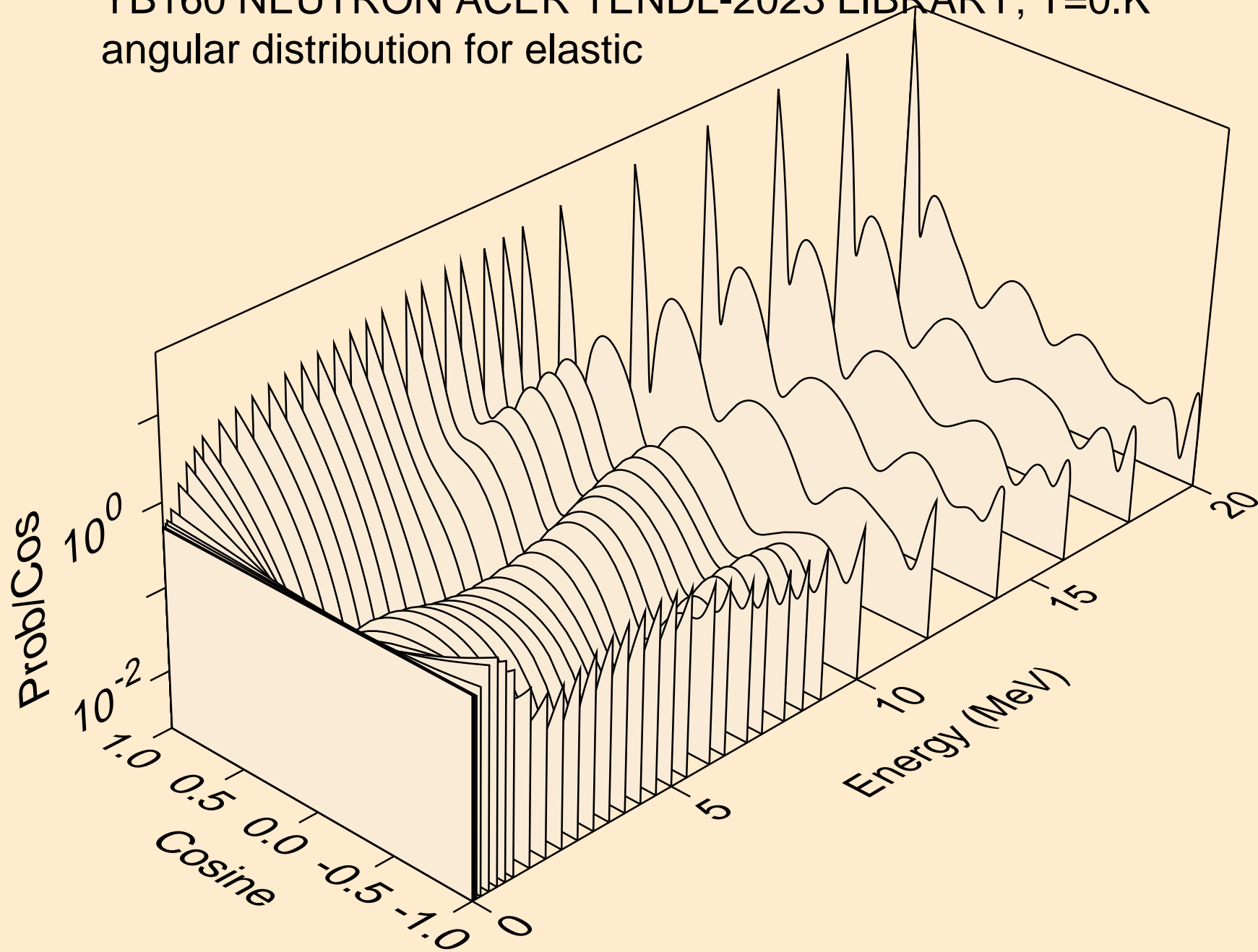

YB160 NEUTRON ACER TENDL-2023 LIBRARY; T=0.K  
angular distribution for elastic

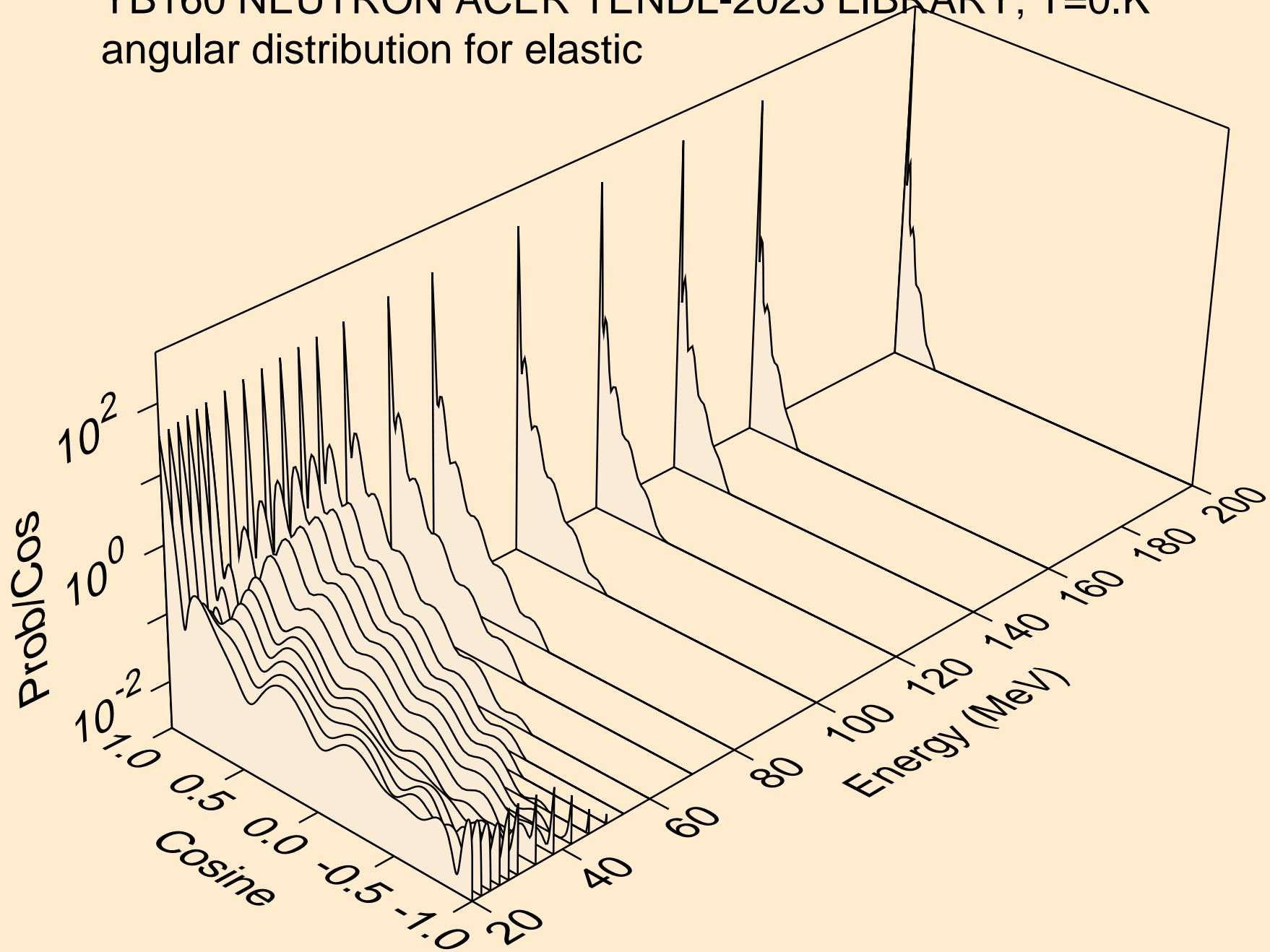

YB160 NEUTRON ACER TENDL-2023 LIBRARY; T=0.K  
angular distribution for (n,n\*1)

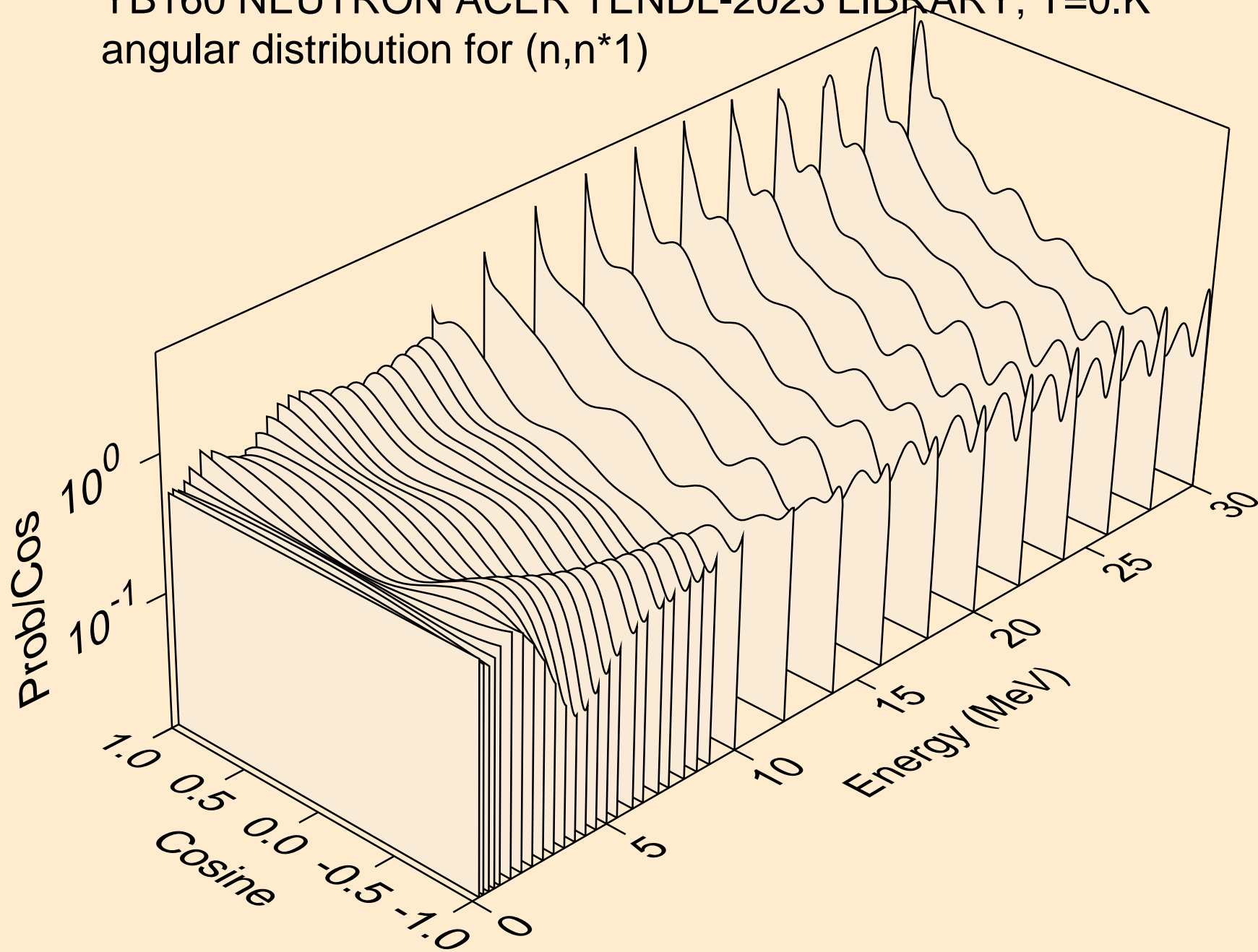

YB160 NEUTRON ACER TENDL-2023 LIBRARY; T=0.K  
angular distribution for (n,n\*2)

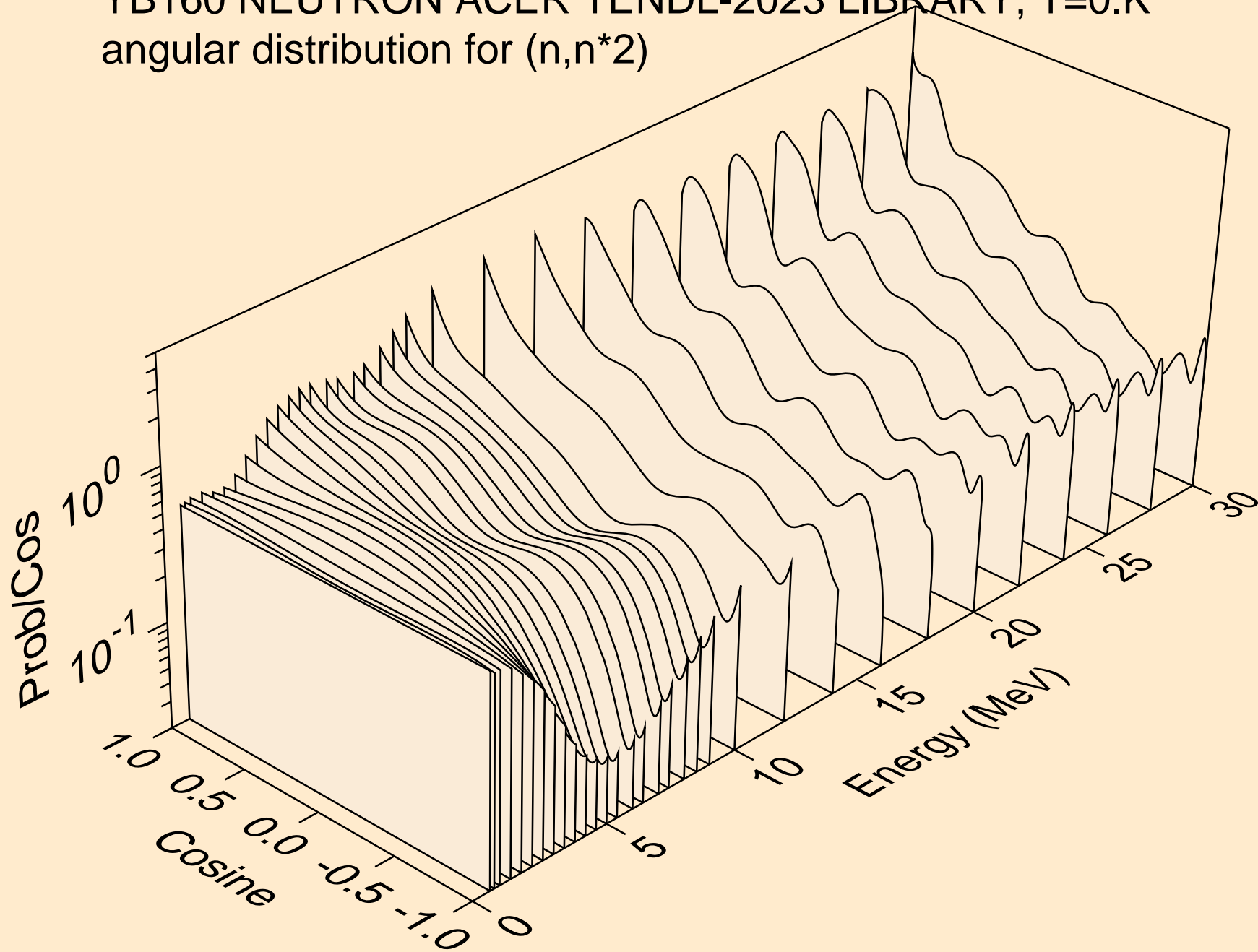

YB160 NEUTRON ACER TENDL-2023 LIBRARY; T=0.K  
angular distribution for (n,n\*3)

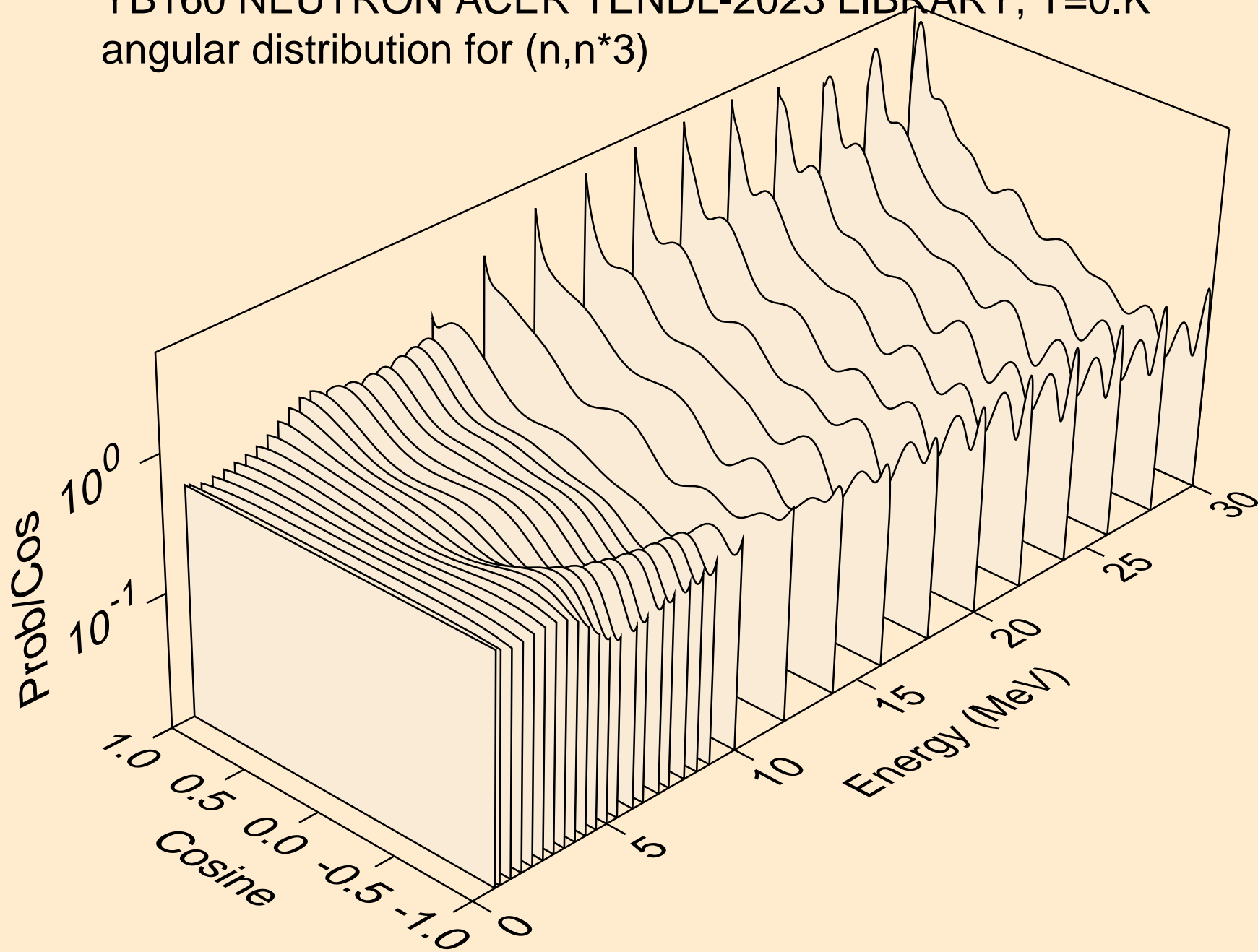

YB160 NEUTRON ACER TENDL-2023 LIBRARY; T=0.K  
angular distribution for (n,n\*4)

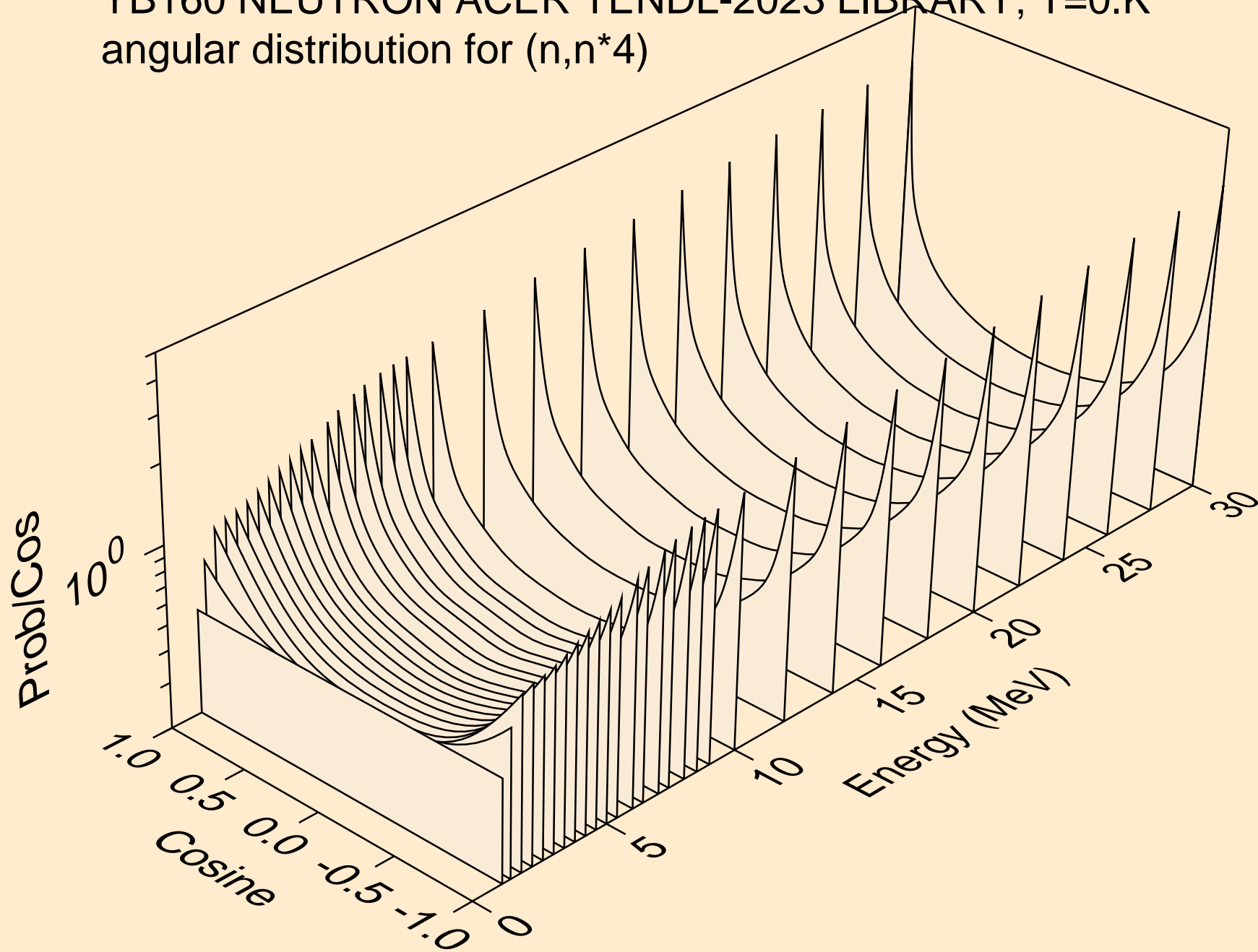

YB160 NEUTRON ACER TENDL-2023 LIBRARY; T=0.K  
angular distribution for (n,n\*5)

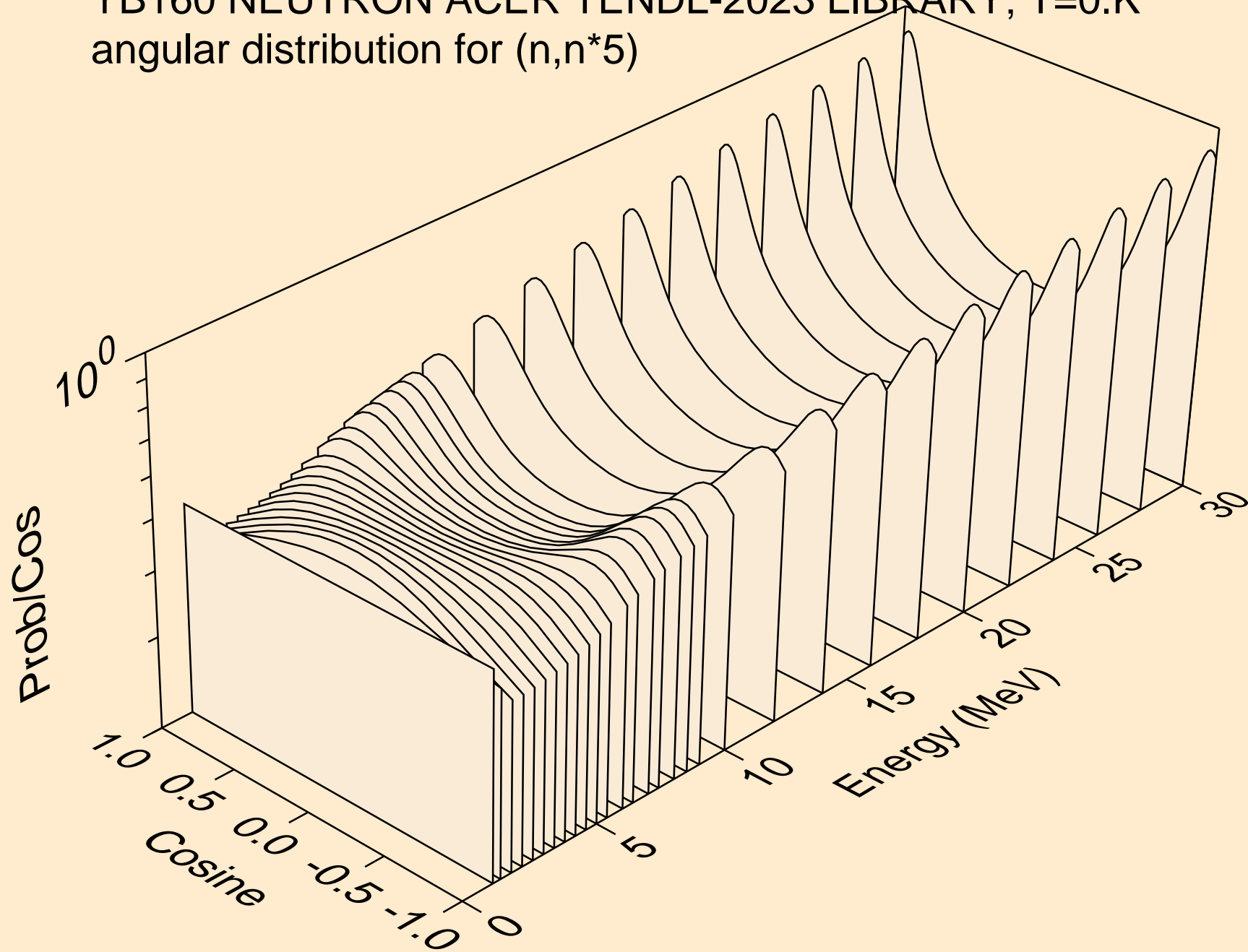

YB160 NEUTRON ACER TENDL-2023 LIBRARY; T=0.K  
angular distribution for (n,n\*6)

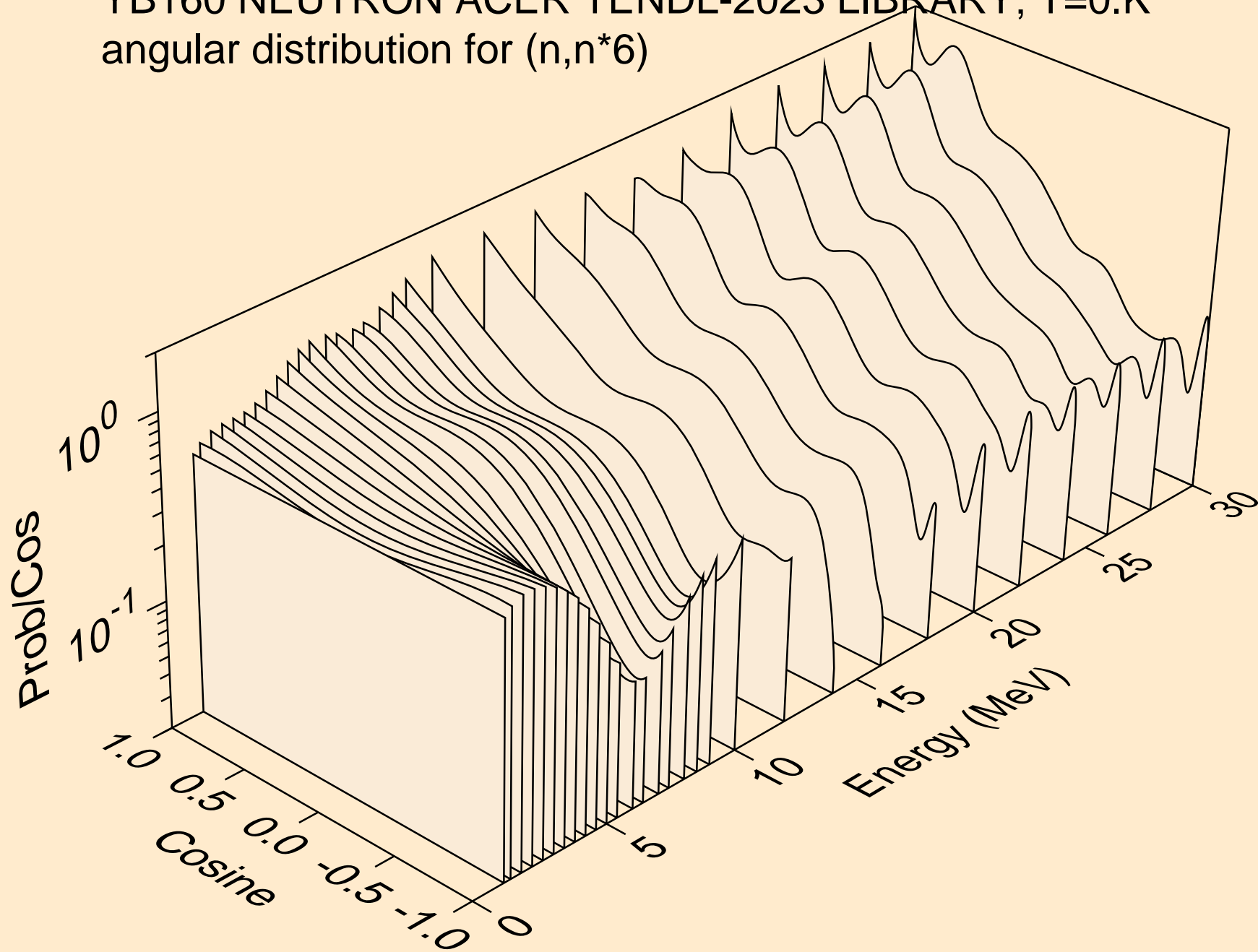

YB160 NEUTRON ACER TENDL-2023 LIBRARY; T=0.K  
angular distribution for (n,n\*7)

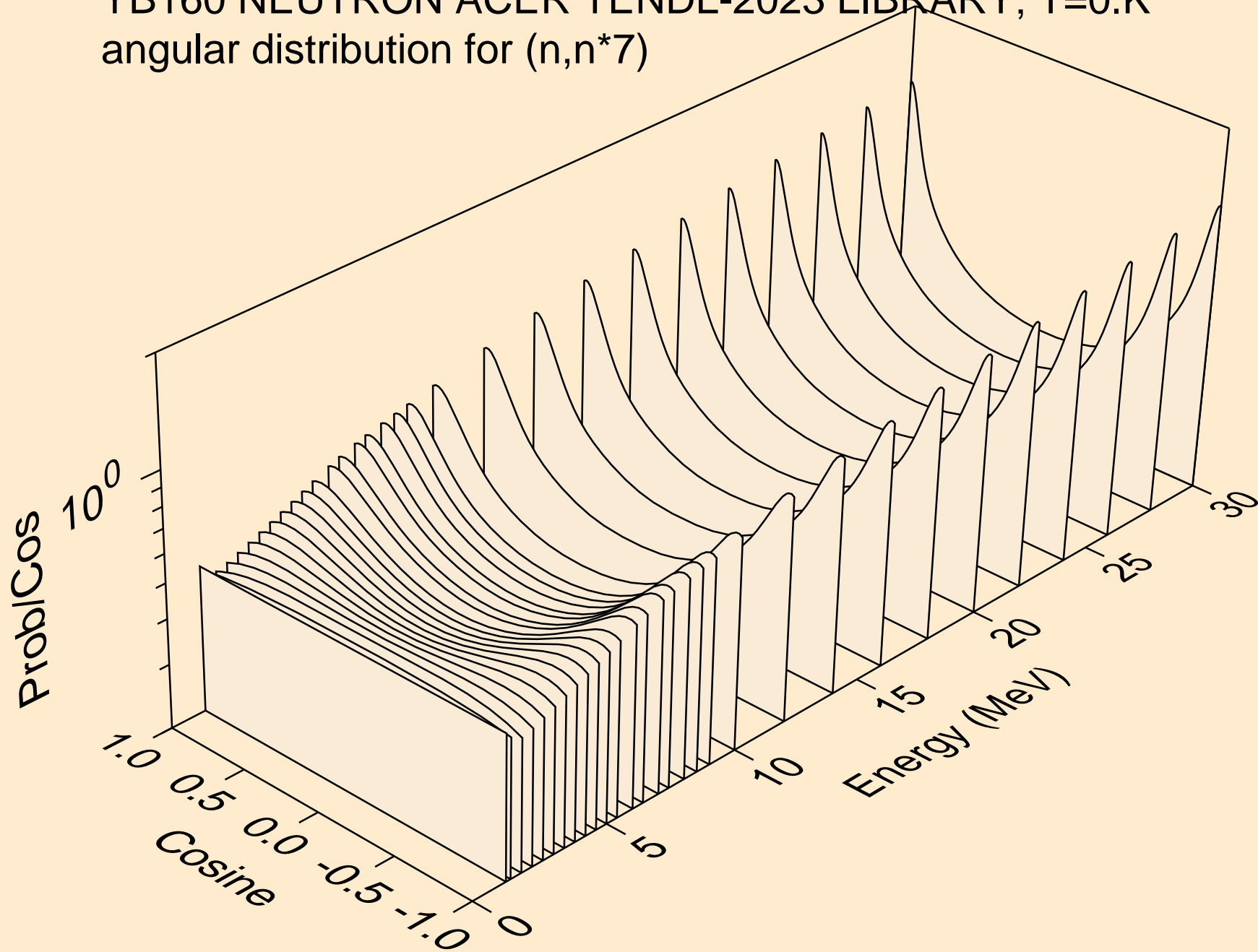

YB160 NEUTRON ACER TENDL-2023 LIBRARY; T=0.K  
angular distribution for (n,n\*8)

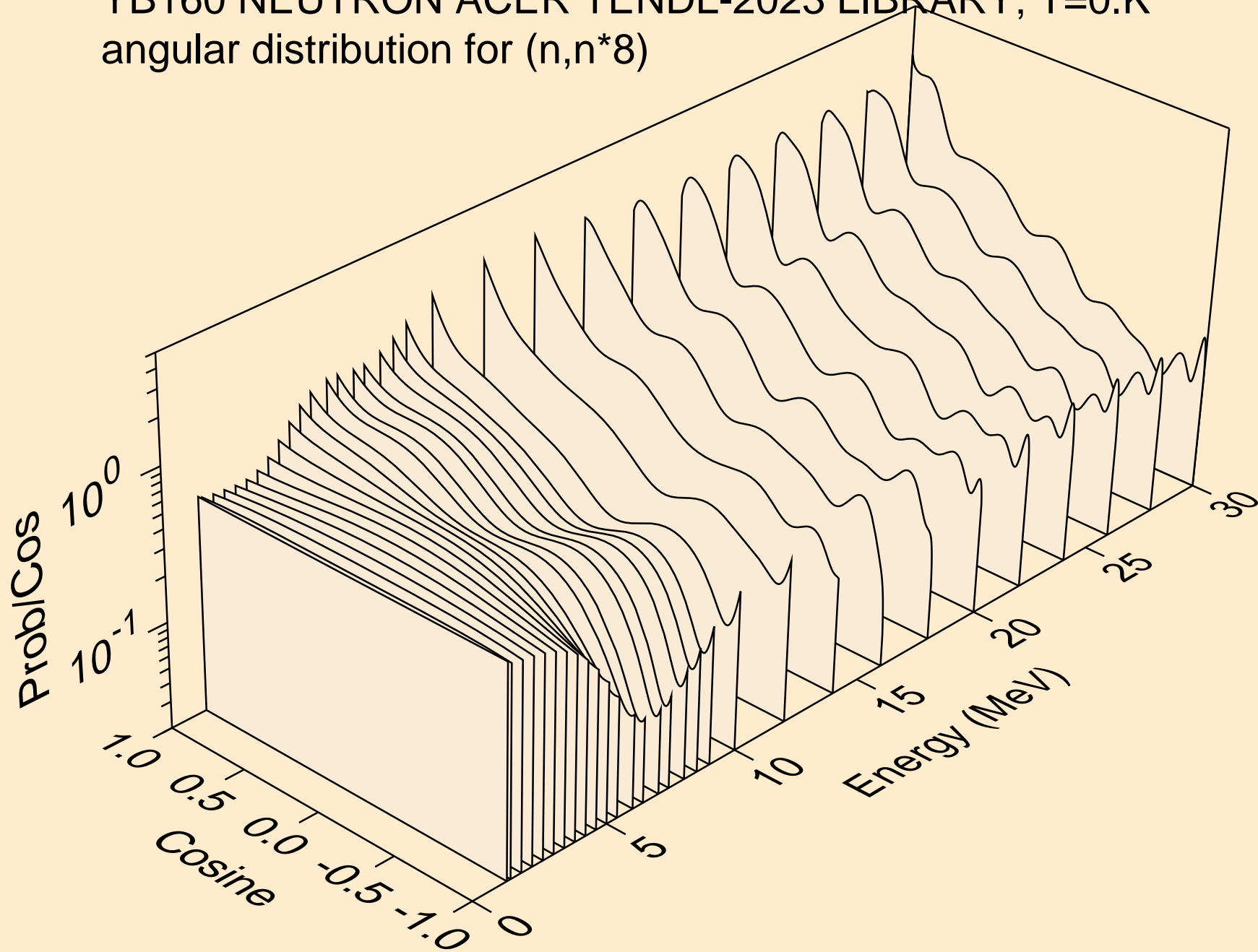

YB160 NEUTRON ACER TENDL-2023 LIBRARY; T=0.K  
angular distribution for (n,n\*9)

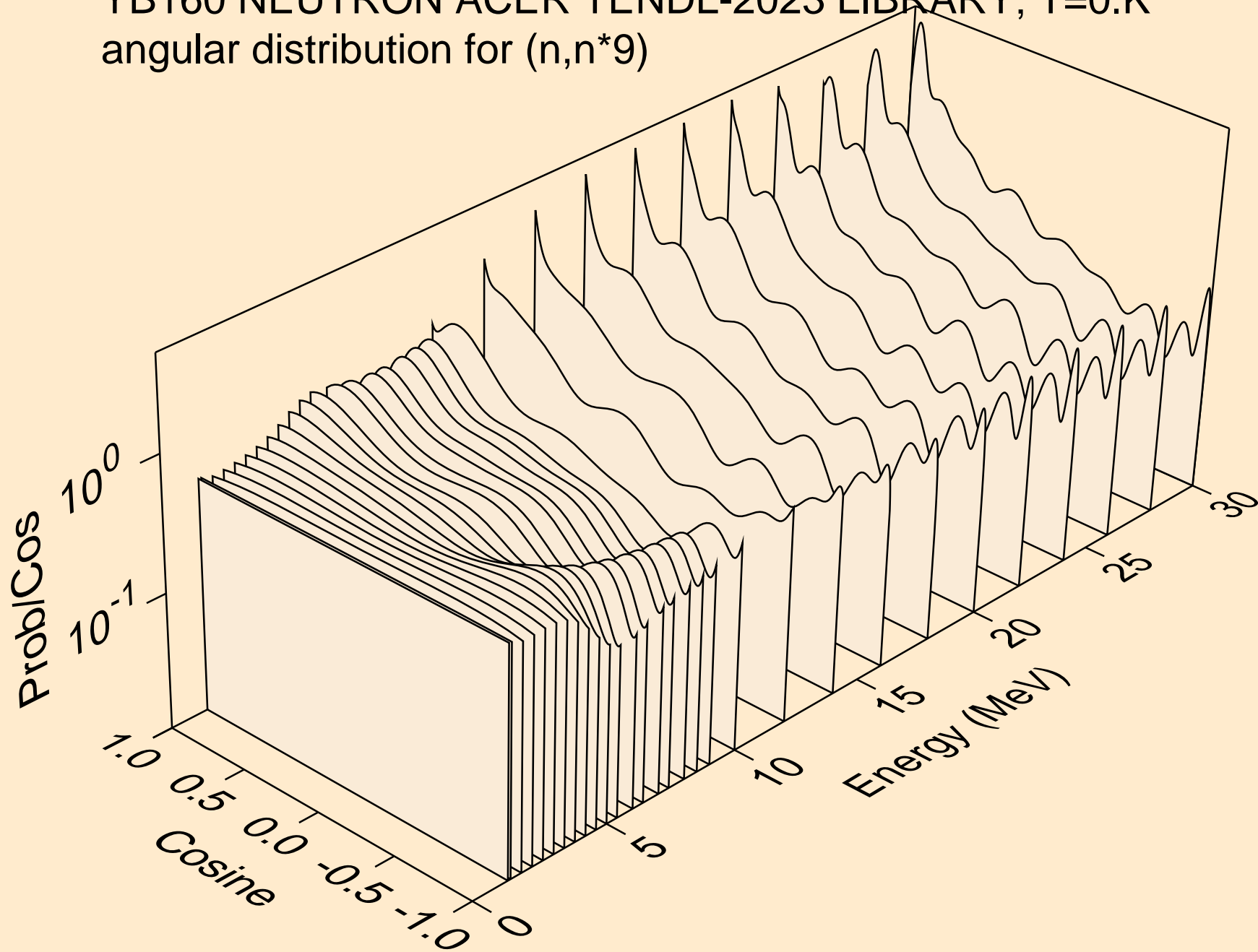

YB160 NEUTRON ACER TENDL-2023 LIBRARY; T=0.K  
angular distribution for (n,n\*10)

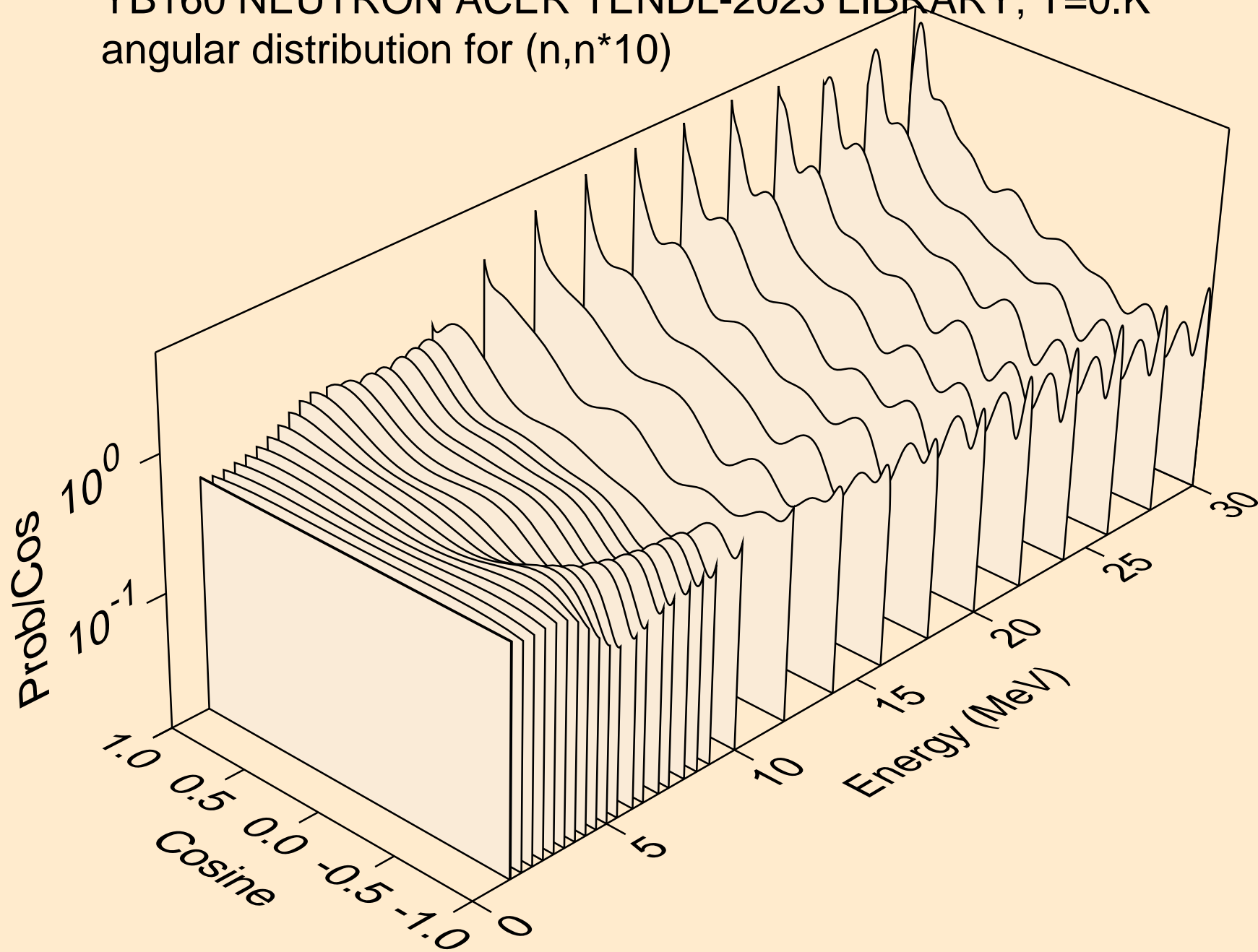

YB160 NEUTRON ACER TENDL-2023 LIBRARY; T=0.K  
angular distribution for (n,n\*11)

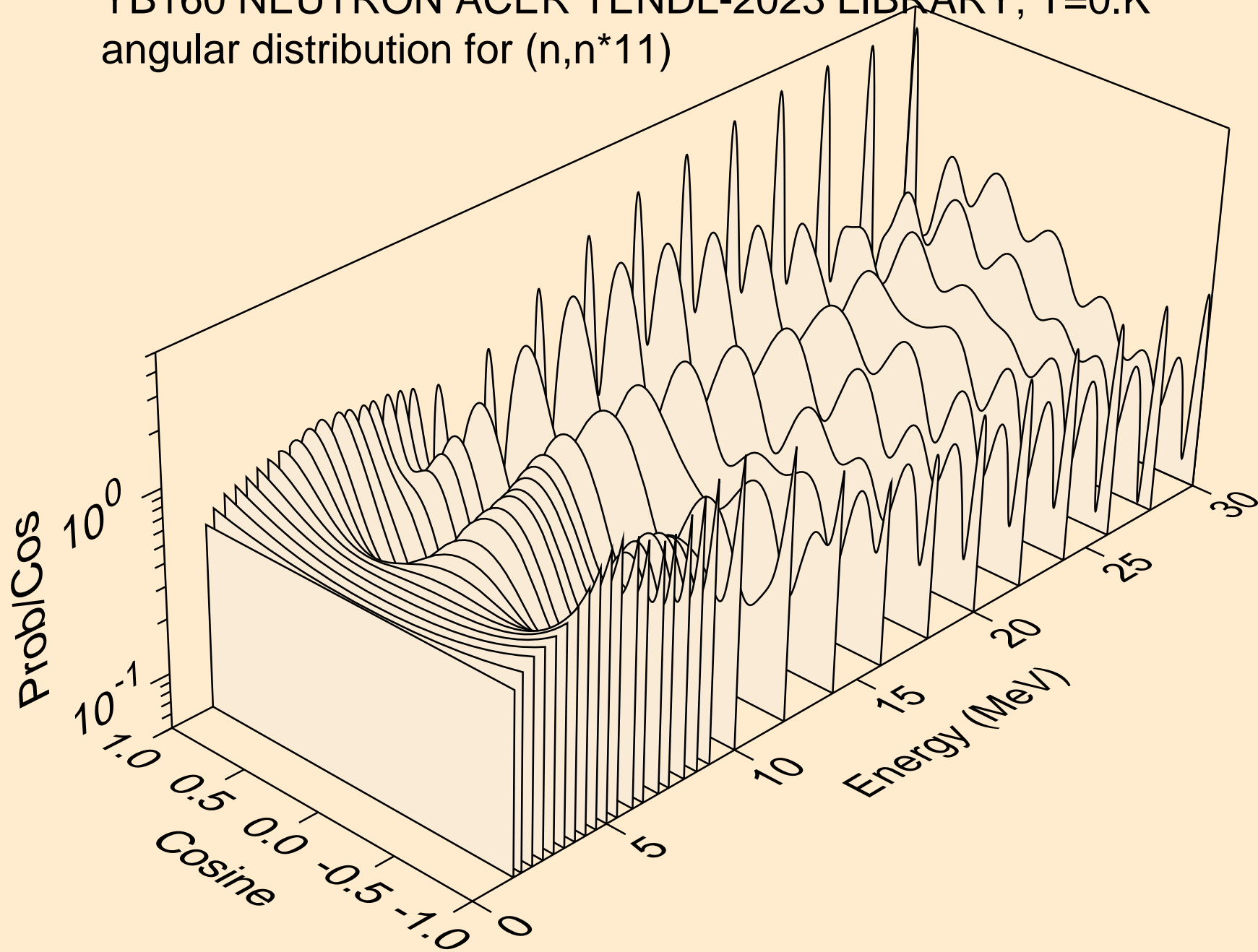

YB160 NEUTRON ACER TENDL-2023 LIBRARY; T=0.K  
angular distribution for (n,n\*12)

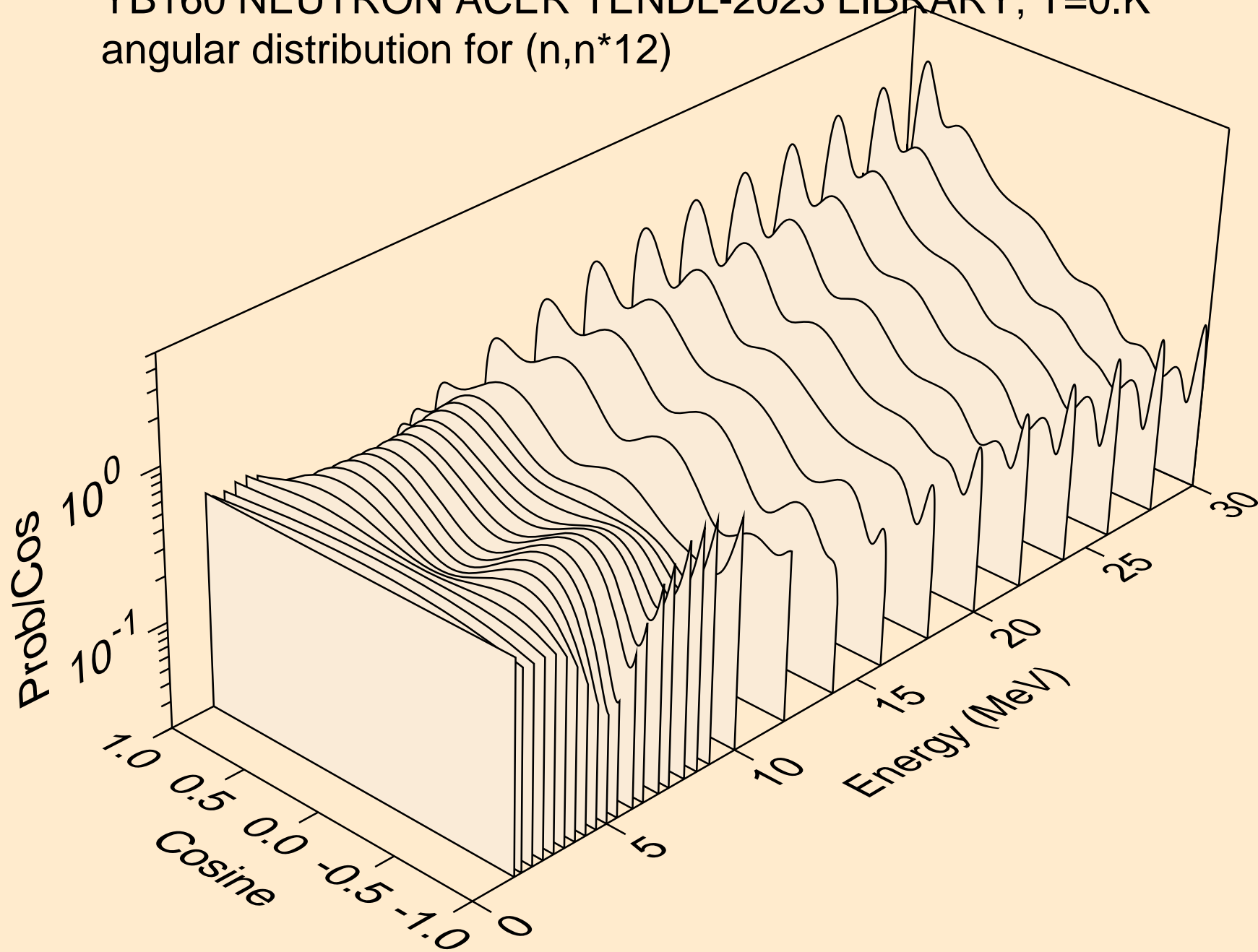

YB160 NEUTRON ACER TENDL-2023 LIBRARY; T=0.K  
angular distribution for (n,n\*13)

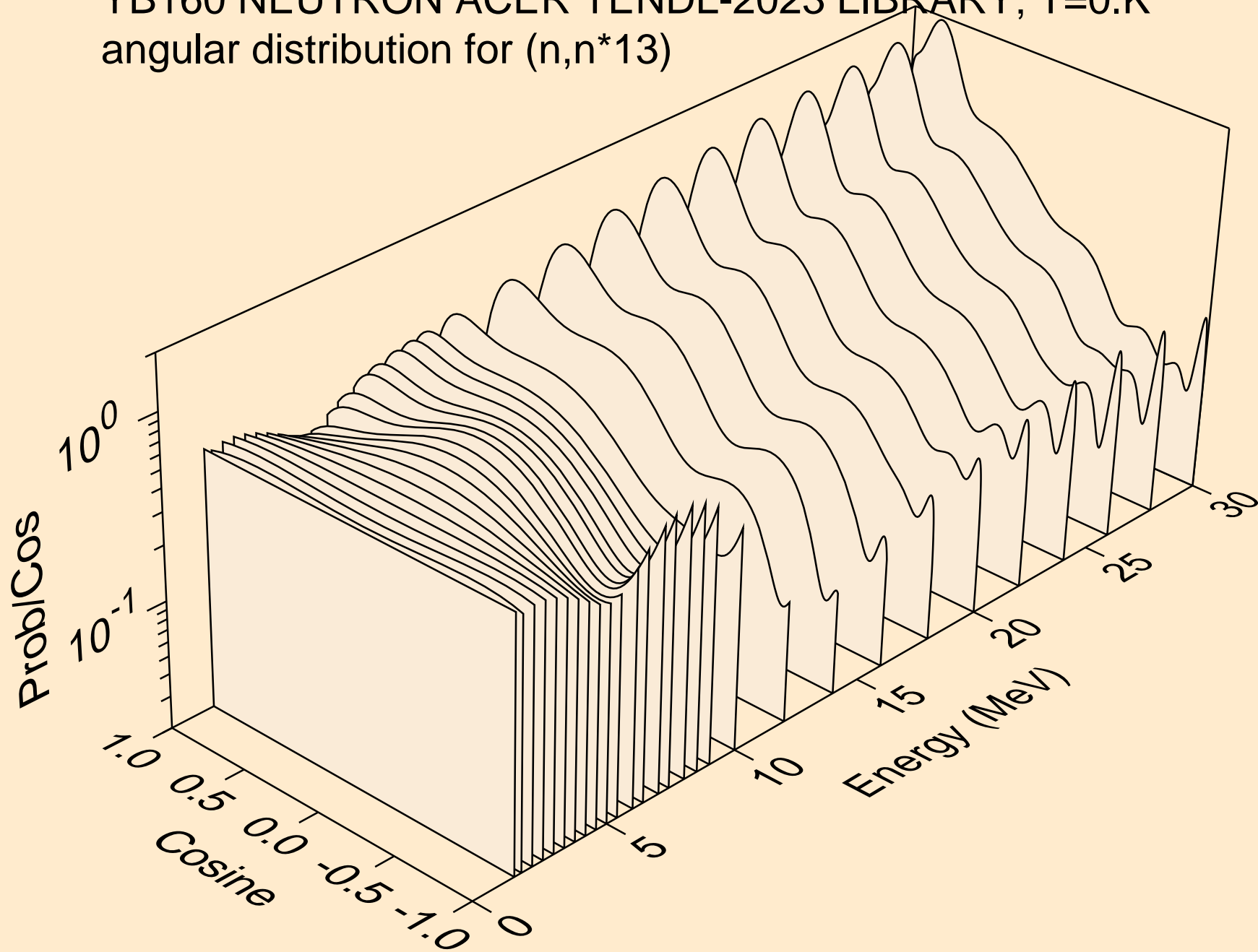

YB160 NEUTRON ACER TENDL-2023 LIBRARY; T=0.K  
angular distribution for (n,n\*14)

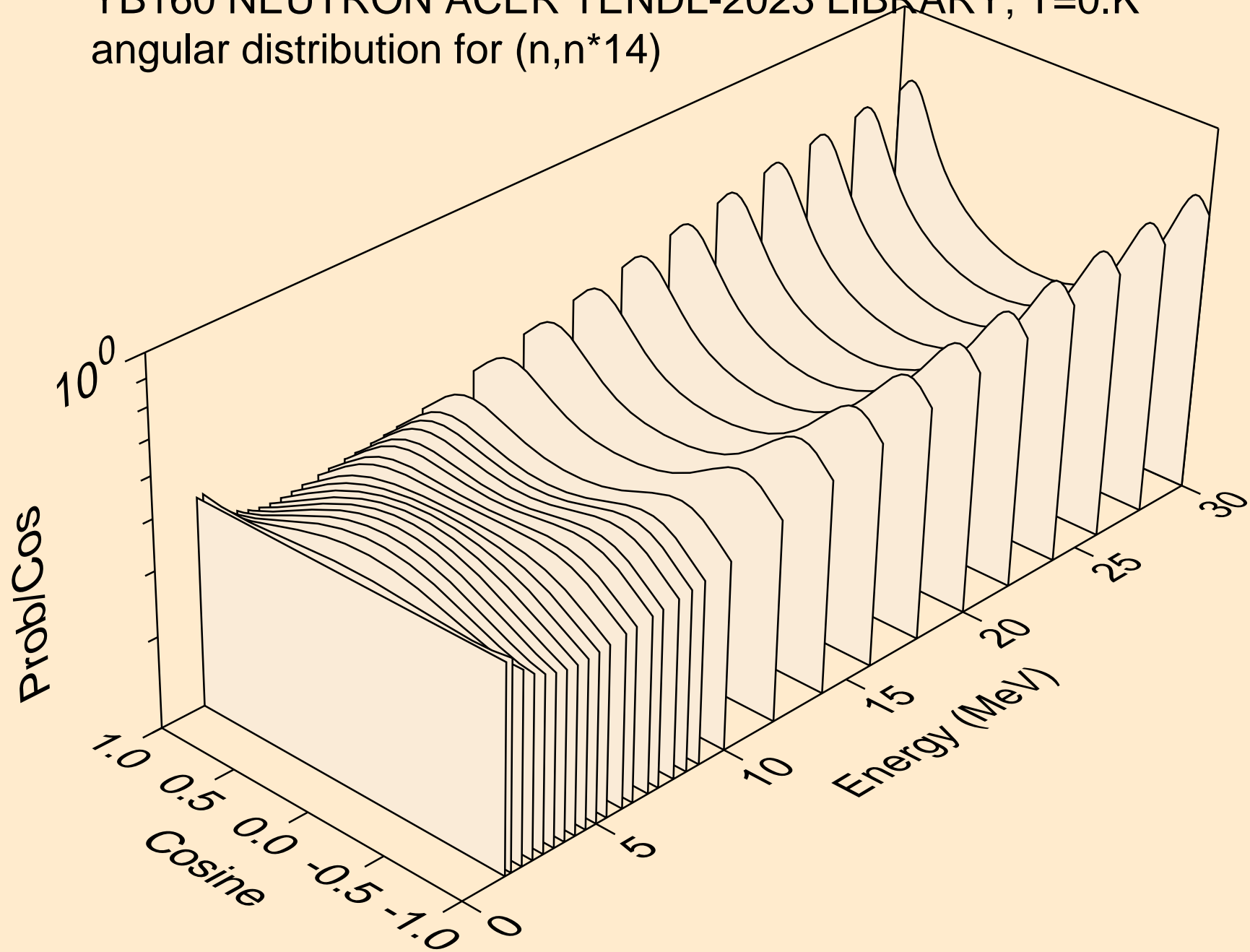

YB160 NEUTRON ACER TENDL-2023 LIBRARY; T=0.K  
angular distribution for (n,n\*15)

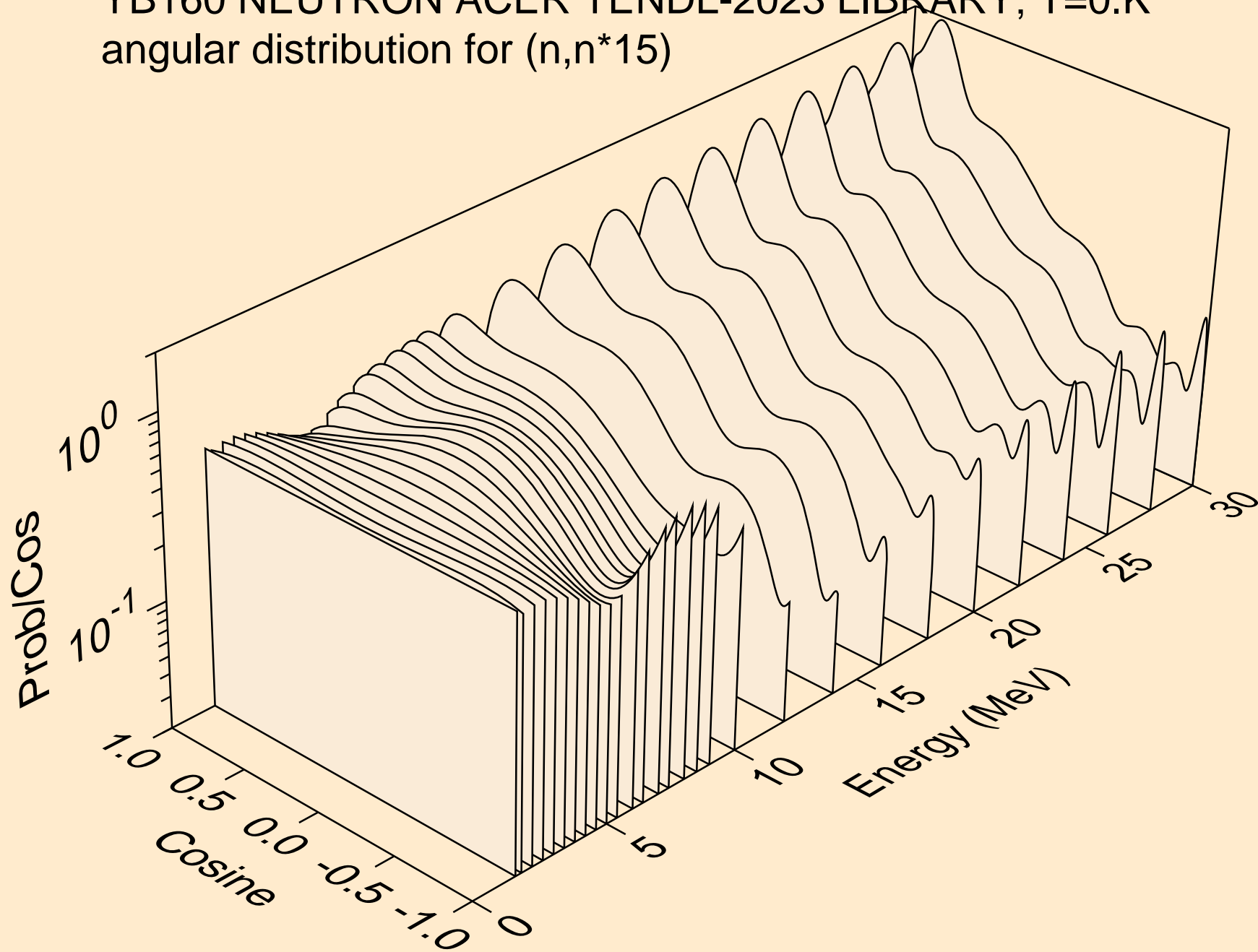

YB160 NEUTRON ACER TENDL-2023 LIBRARY; T=0.K  
angular distribution for (n,n\*16)

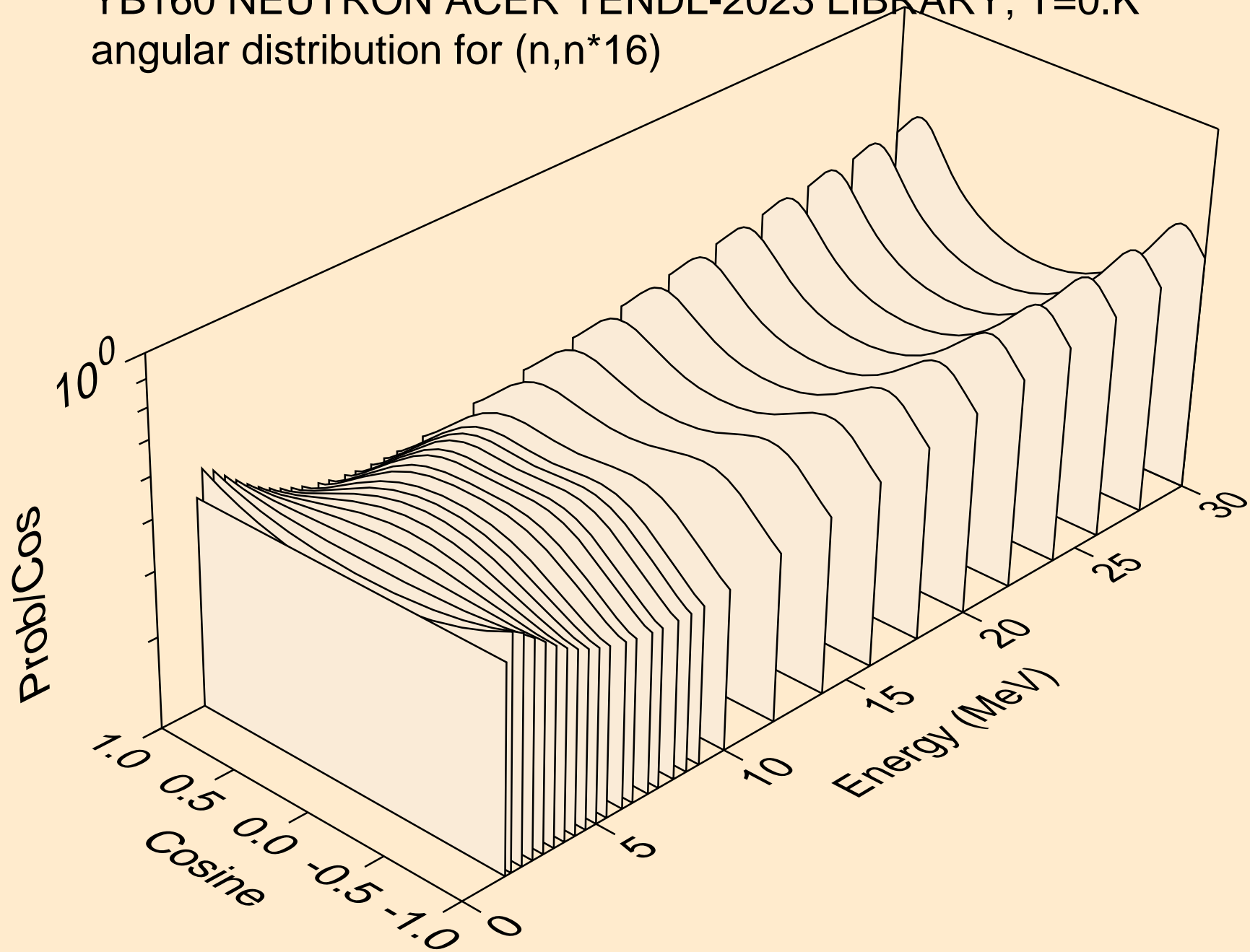

YB160 NEUTRON ACER TENDL-2023 LIBRARY; T=0.K  
angular distribution for (n,n\*17)

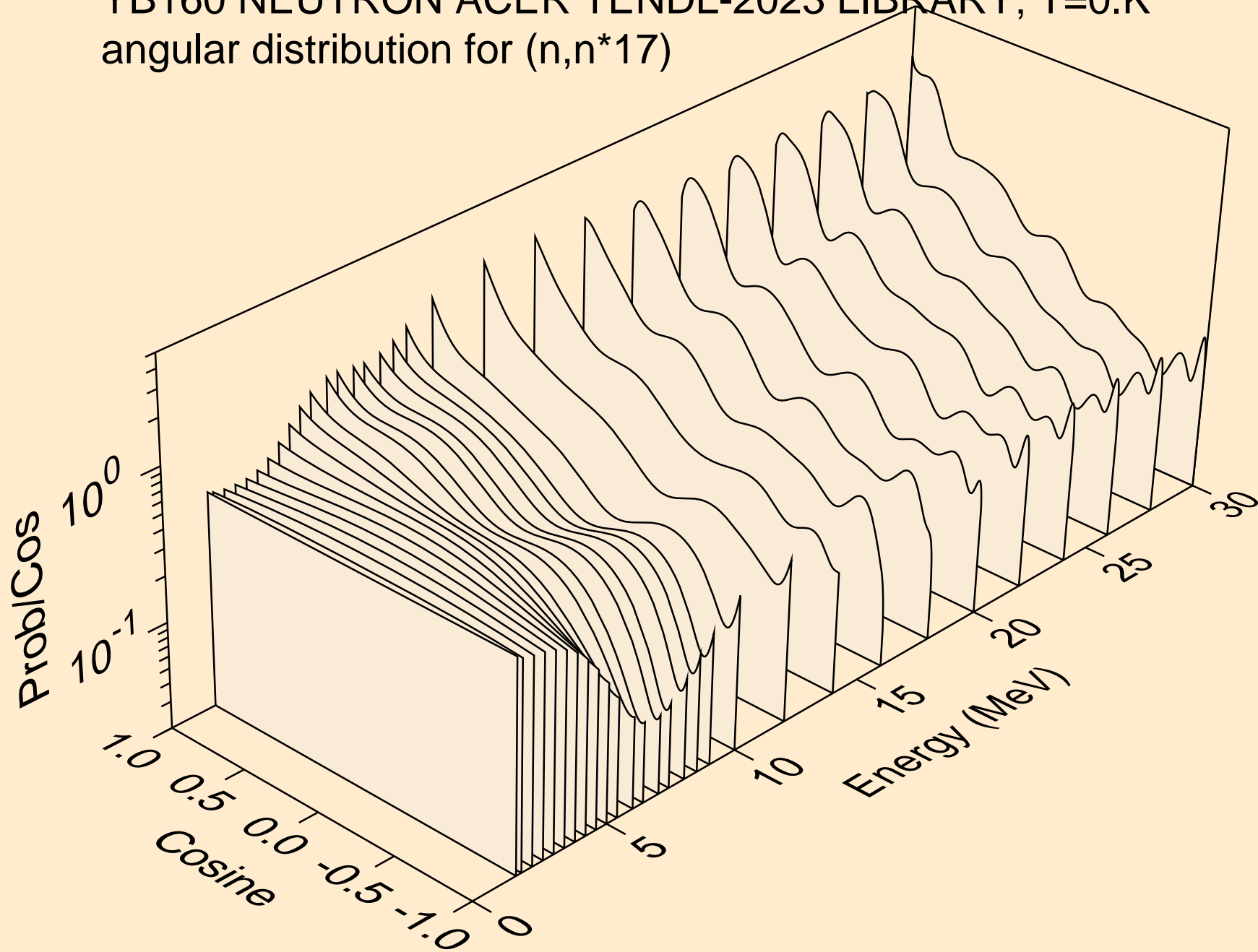

YB160 NEUTRON ACER TENDL-2023 LIBRARY; T=0.K  
angular distribution for (n,n\*18)

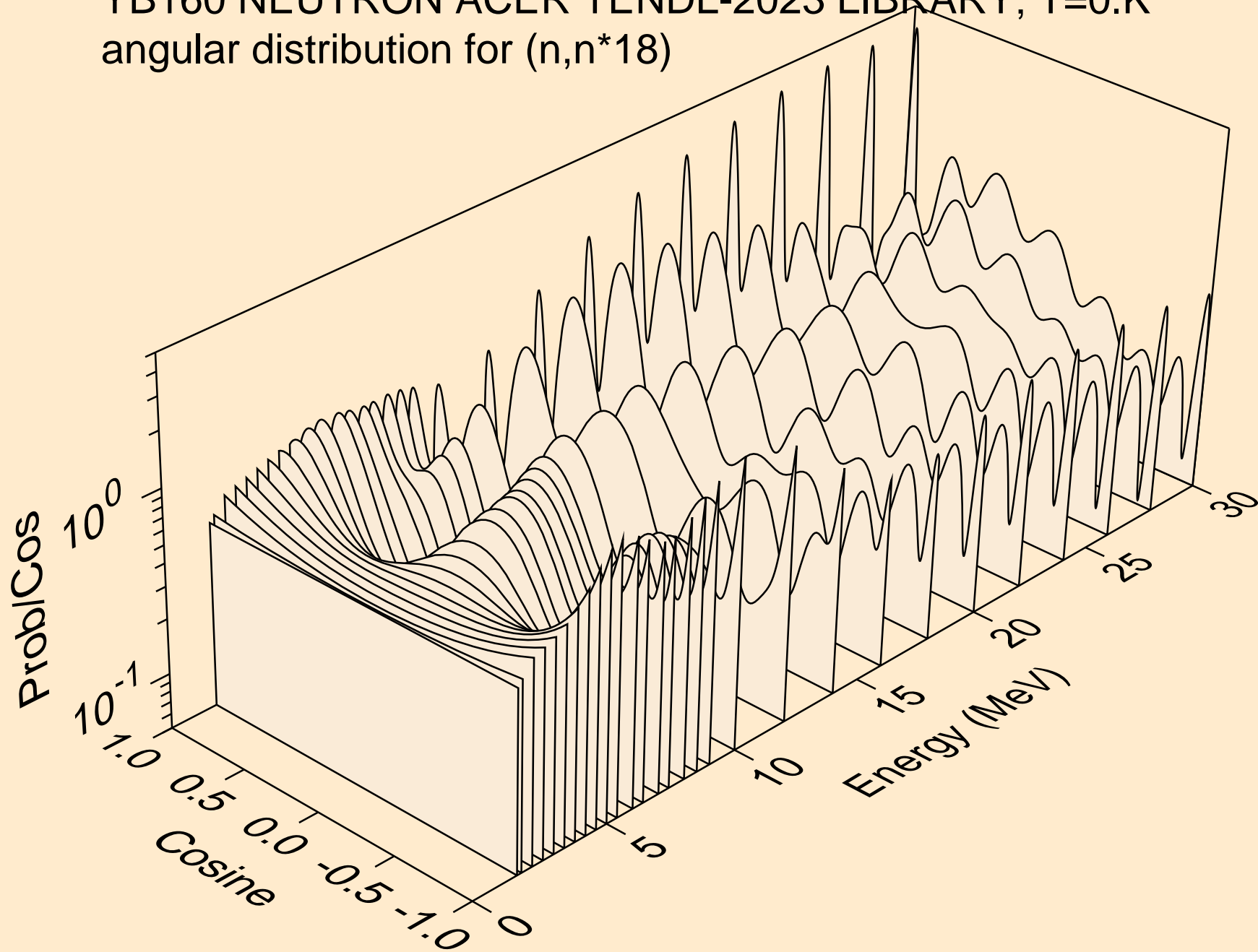

YB160 NEUTRON ACER TENDL-2023 LIBRARY; T=0.K  
angular distribution for (n,n\*19)

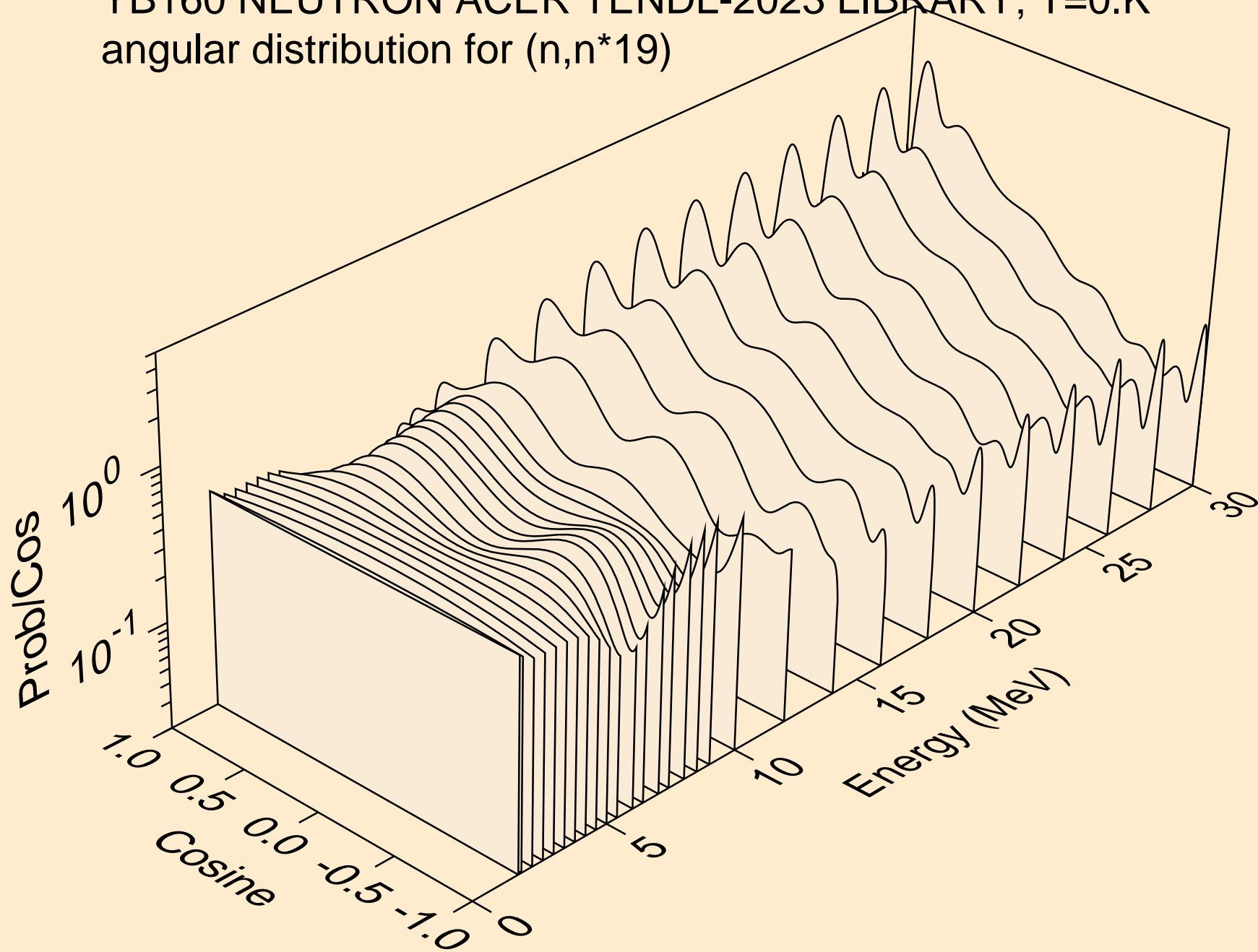

YB160 NEUTRON ACER TENDL-2023 LIBRARY; T=0.K  
angular distribution for (n,n\*20)

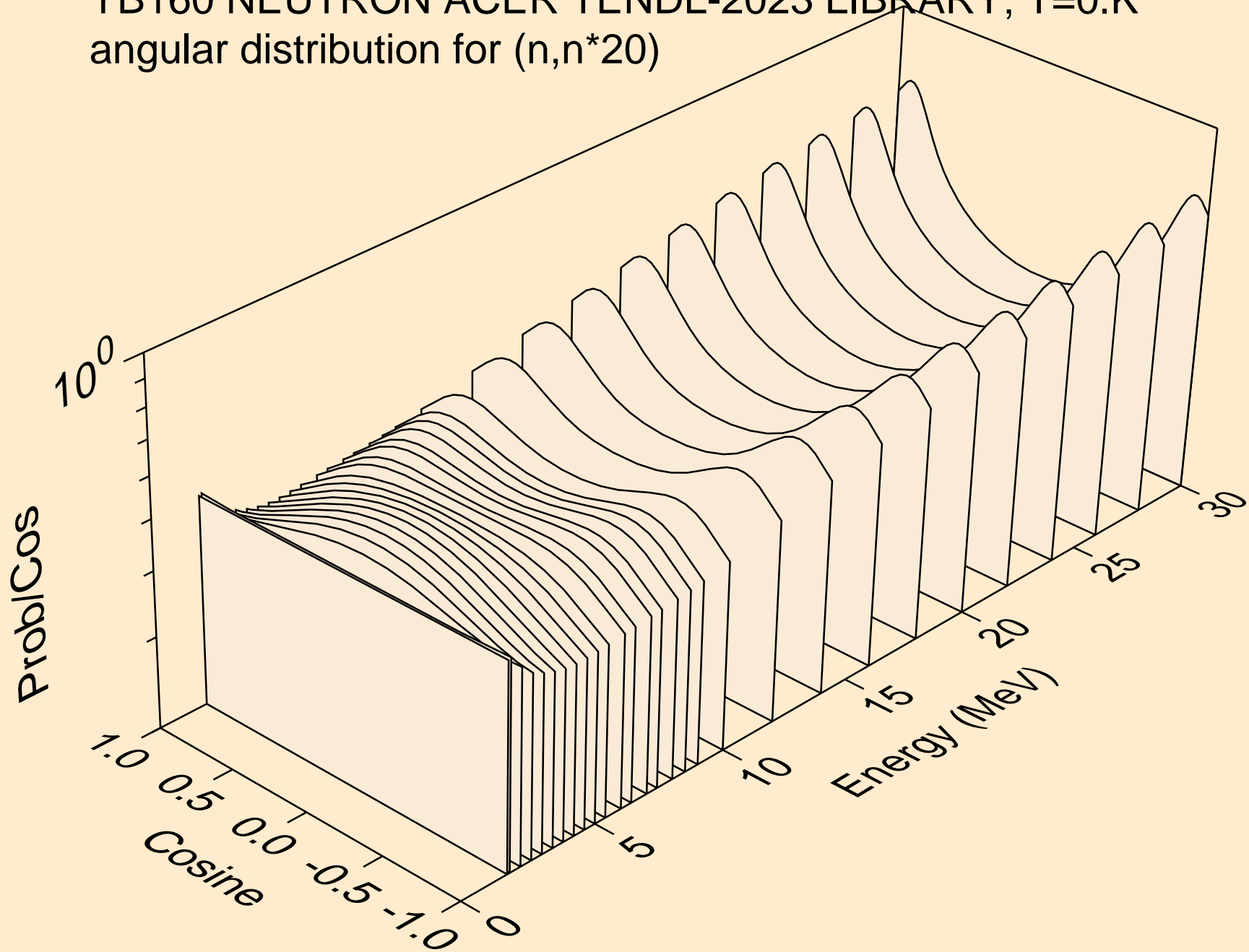

YB160 NEUTRON ACER TENDL-2023 LIBRARY; T=0.K  
angular distribution for (n,n\*21)

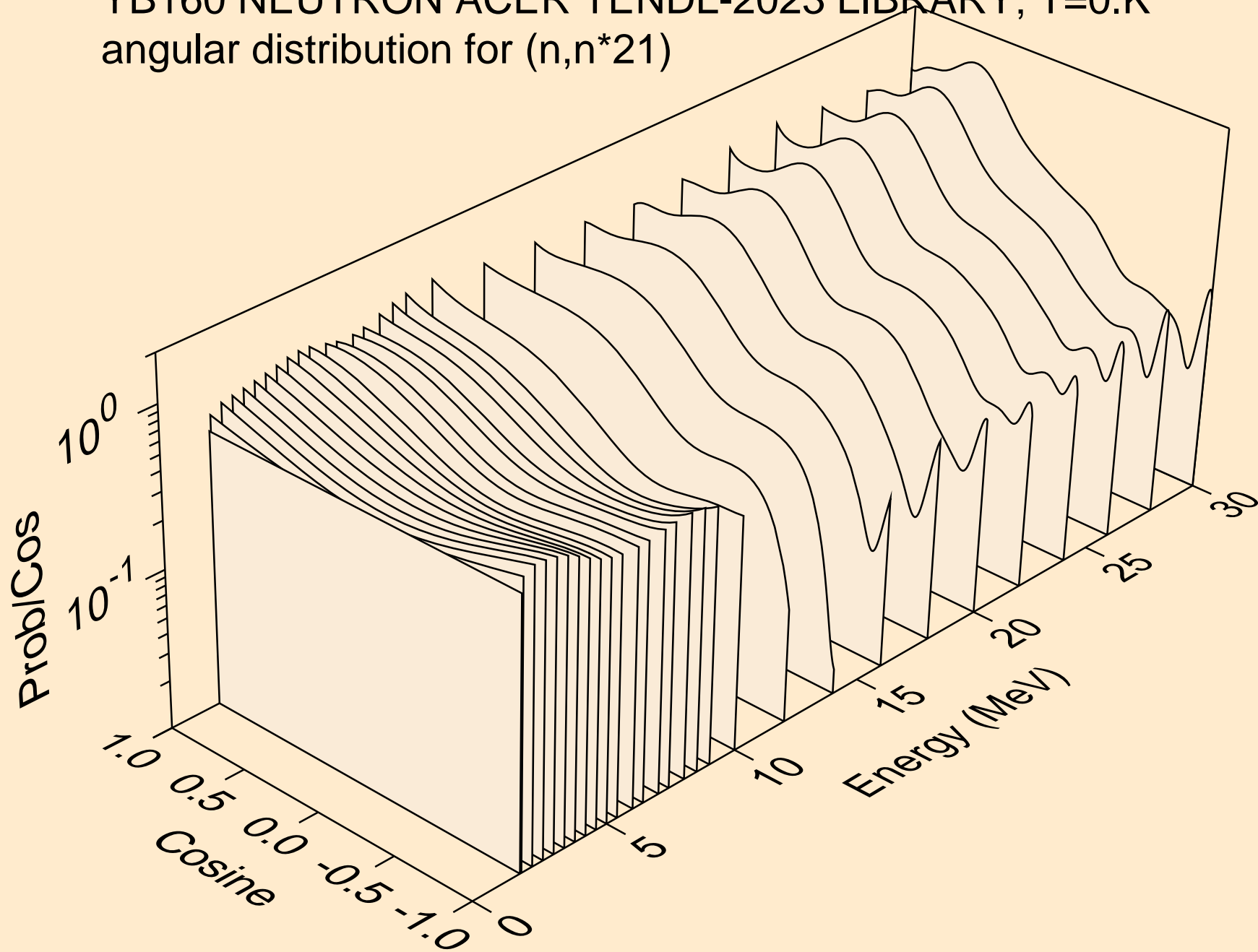

YB160 NEUTRON ACER TENDL-2023 LIBRARY; T=0.K  
angular distribution for (n,n\*22)

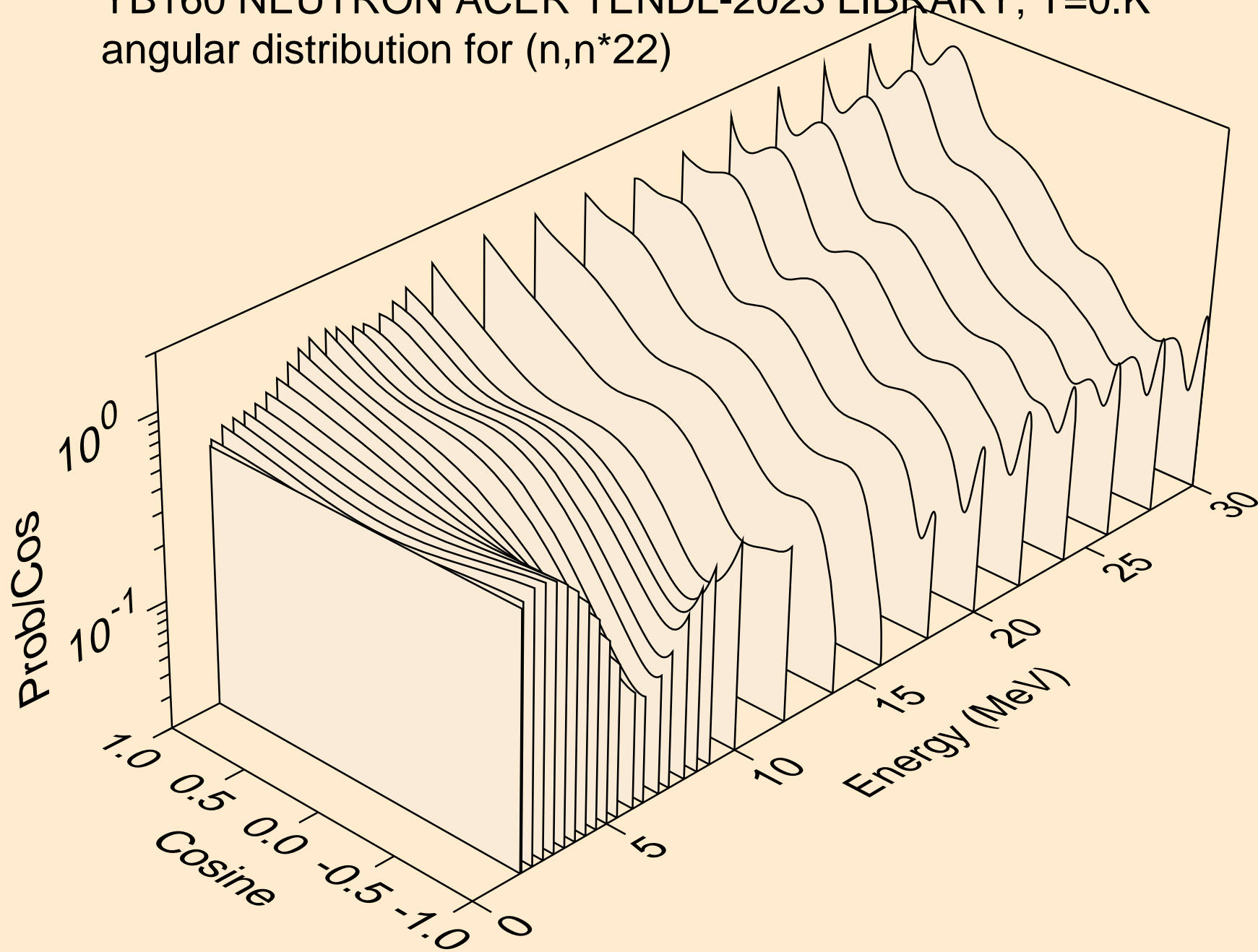

YB160 NEUTRON ACER TENDL-2023 LIBRARY; T=0.K  
angular distribution for (n,n\*23)

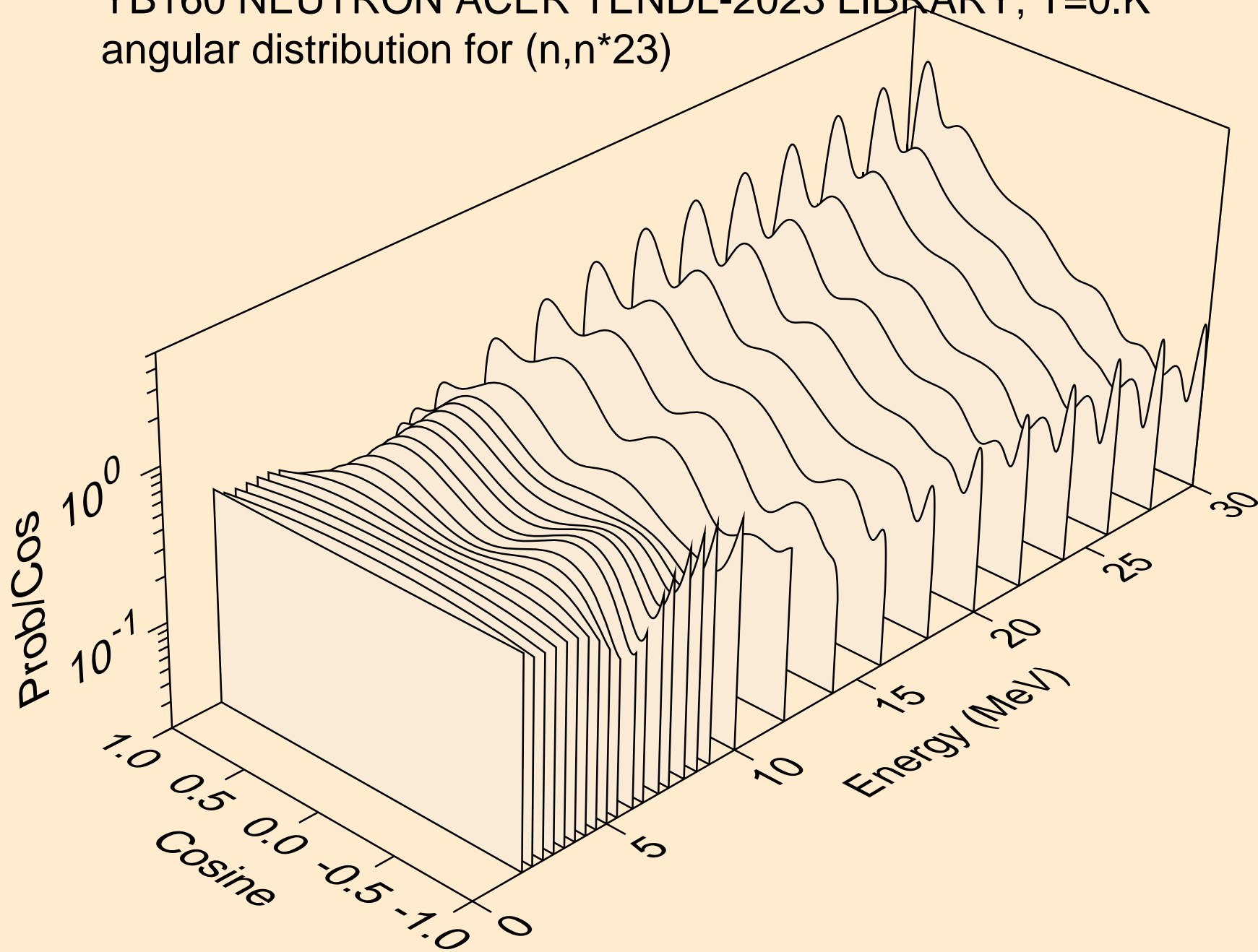

YB160 NEUTRON ACER TENDL-2023 LIBRARY; T=0.K  
angular distribution for (n,n\*24)

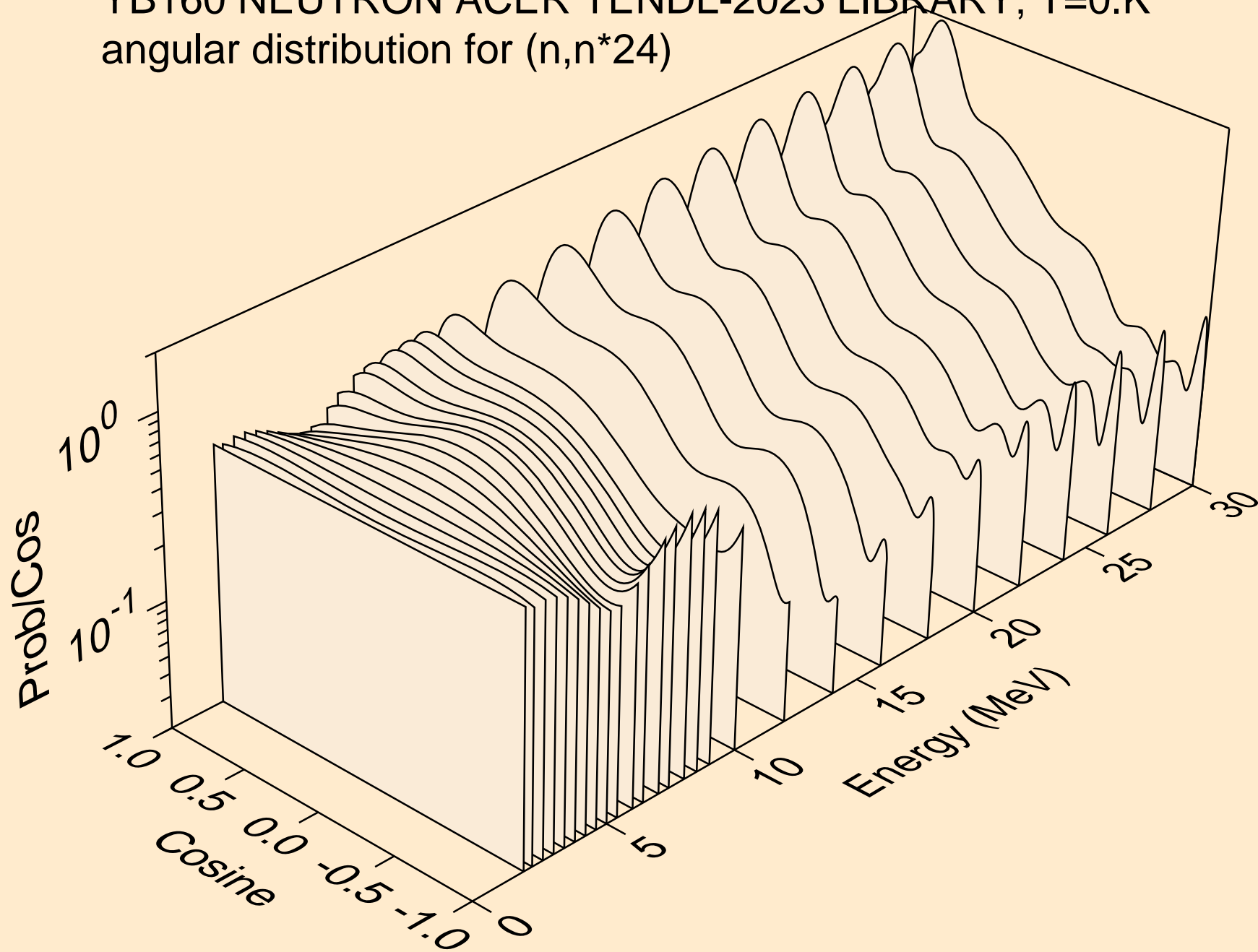

YB160 NEUTRON ACER TENDL-2023 LIBRARY; T=0.K  
angular distribution for (n,n\*25)

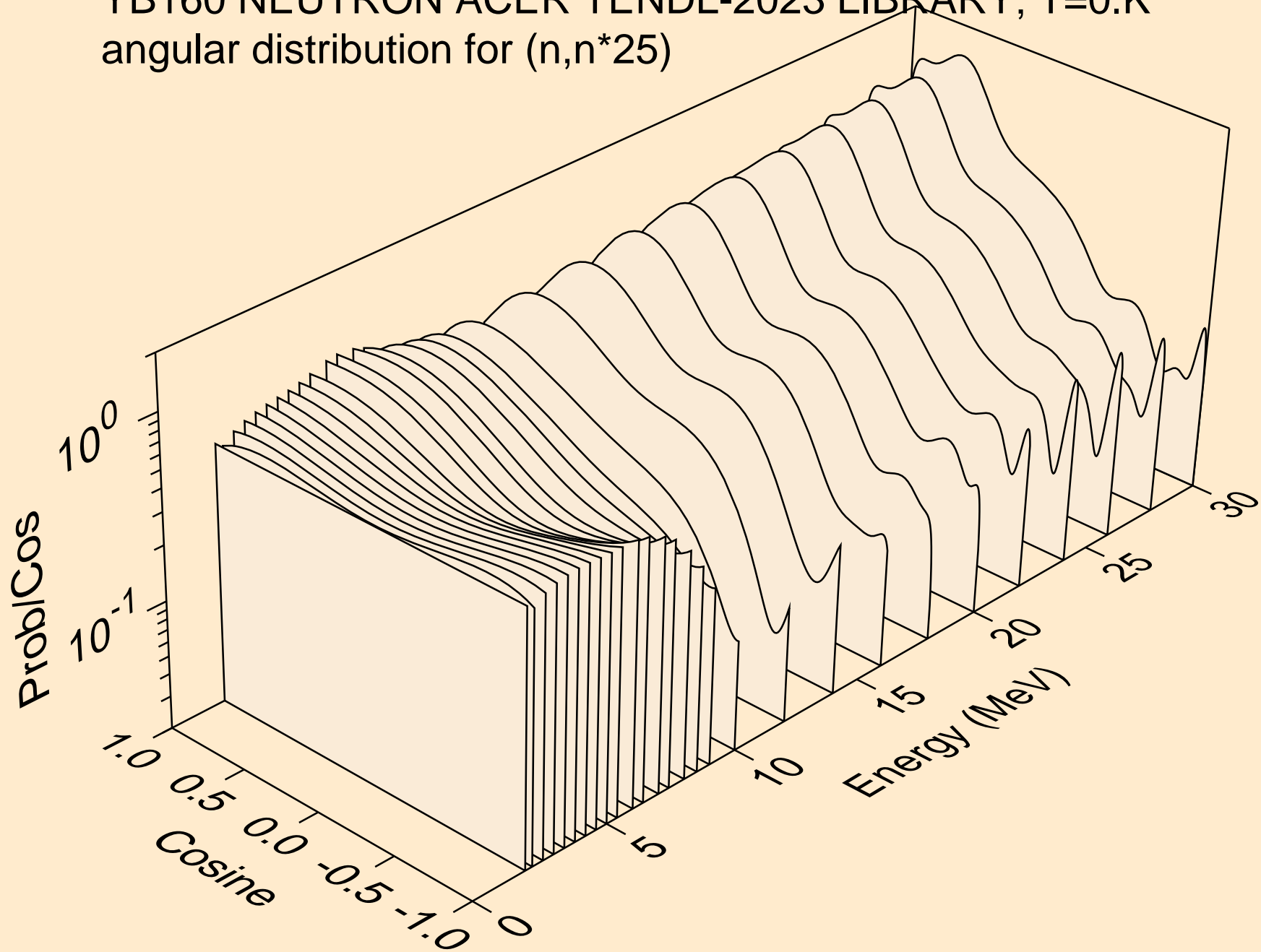

YB160 NEUTRON ACER TENDL-2023 LIBRARY; T=0.K  
angular distribution for (n,n\*26)

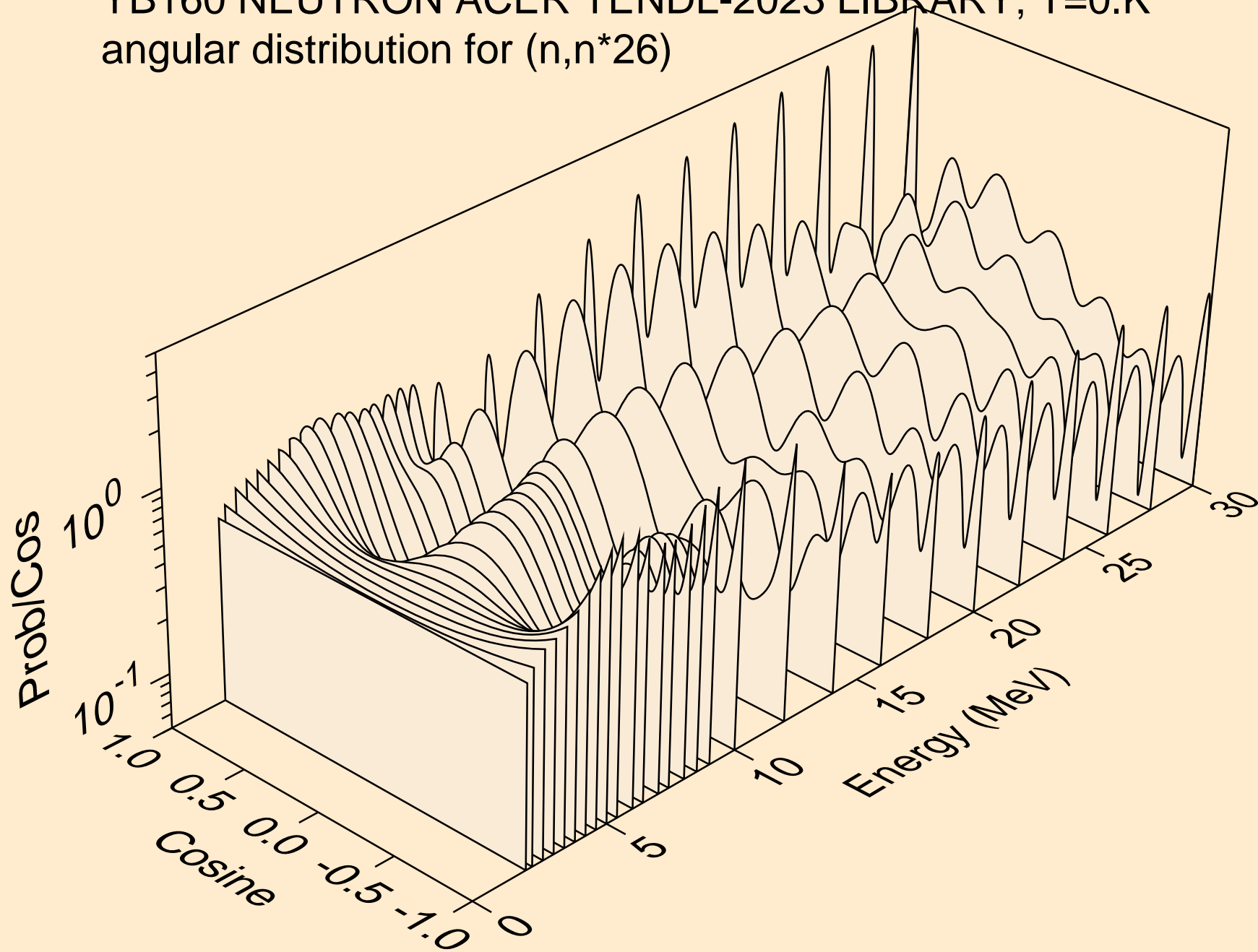

YB160 NEUTRON ACER TENDL-2023 LIBRARY; T=0.K  
Neutron emission for (n,x)

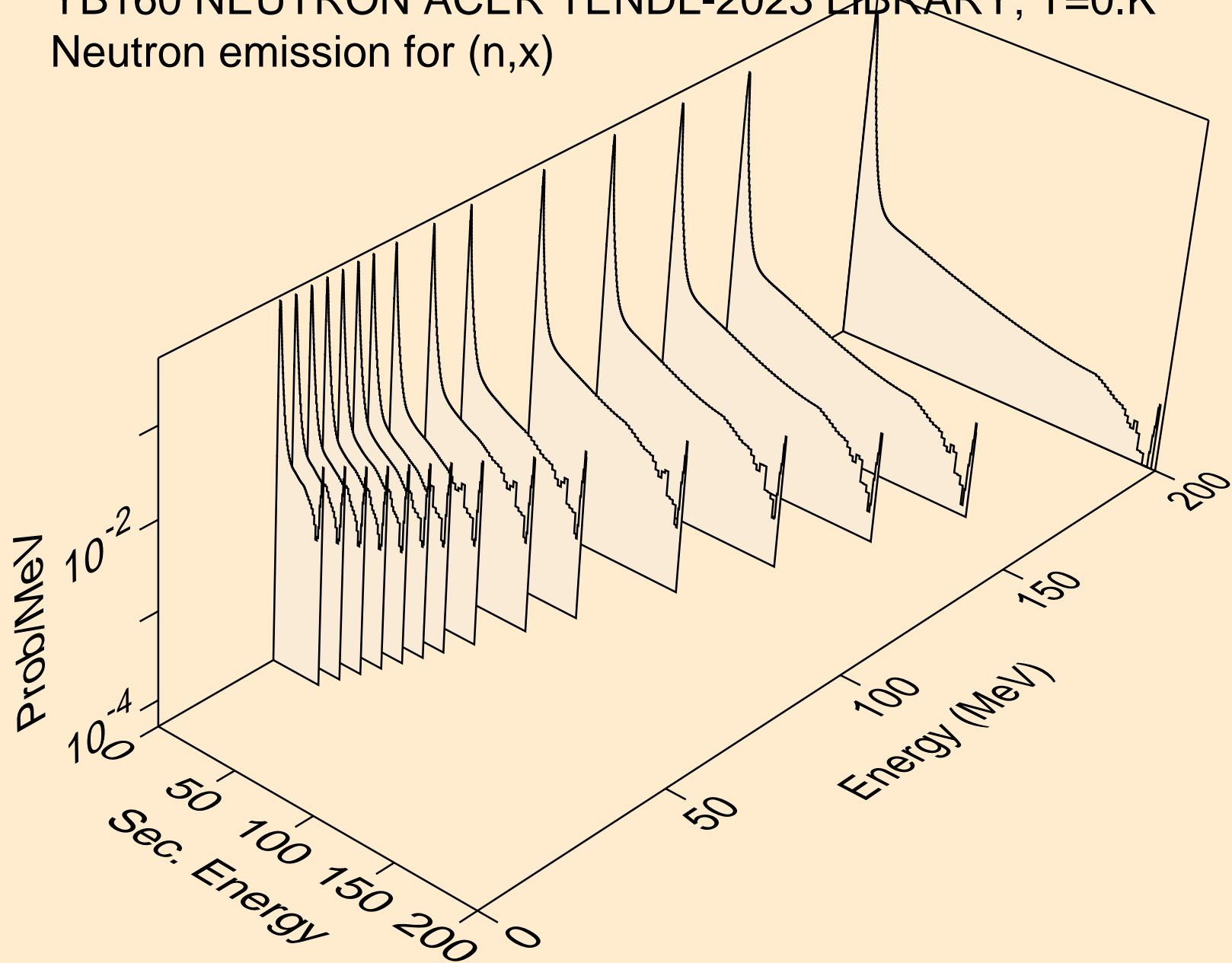

YB160 NEUTRON ACER TENDL-2023 LIBRARY; T=0.K  
Neutron emission for (n,2nd)

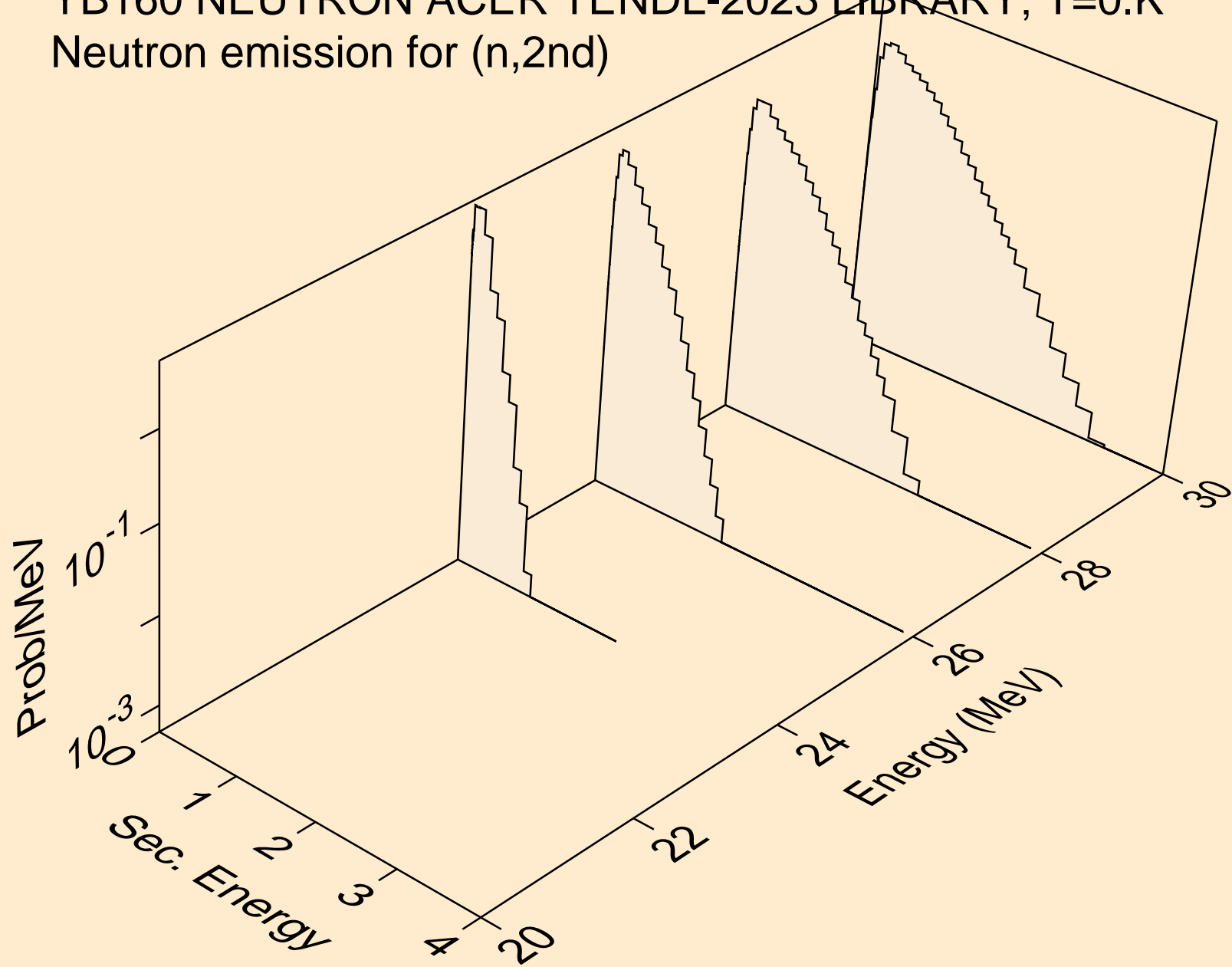

YB160 NEUTRON ACER TENDL-2023 LIBRARY; T=0.K  
Neutron emission for (n,2n)

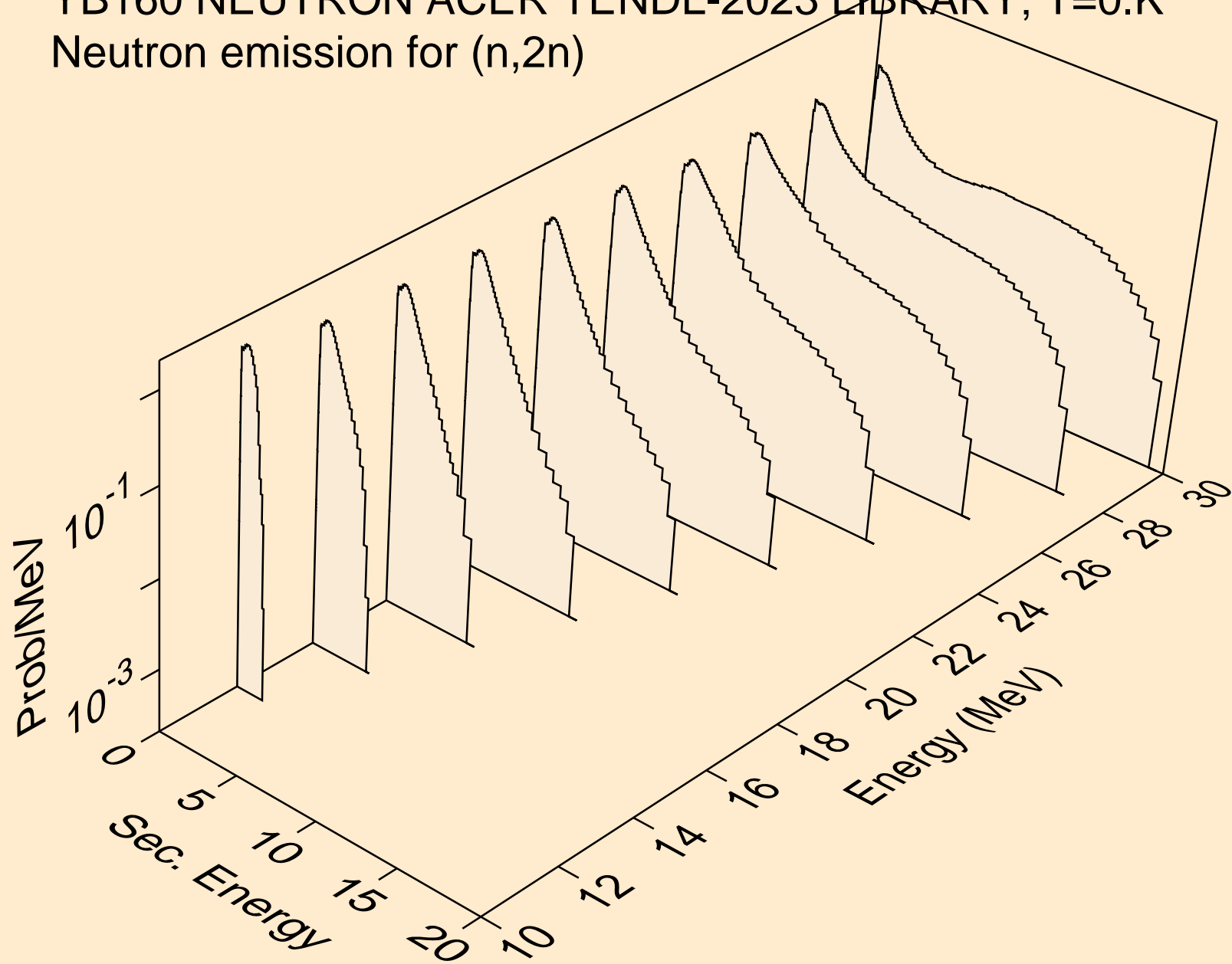

YB160 NEUTRON ACER TENDL-2023 LIBRARY; T=0.K  
Neutron emission for (n,3n)

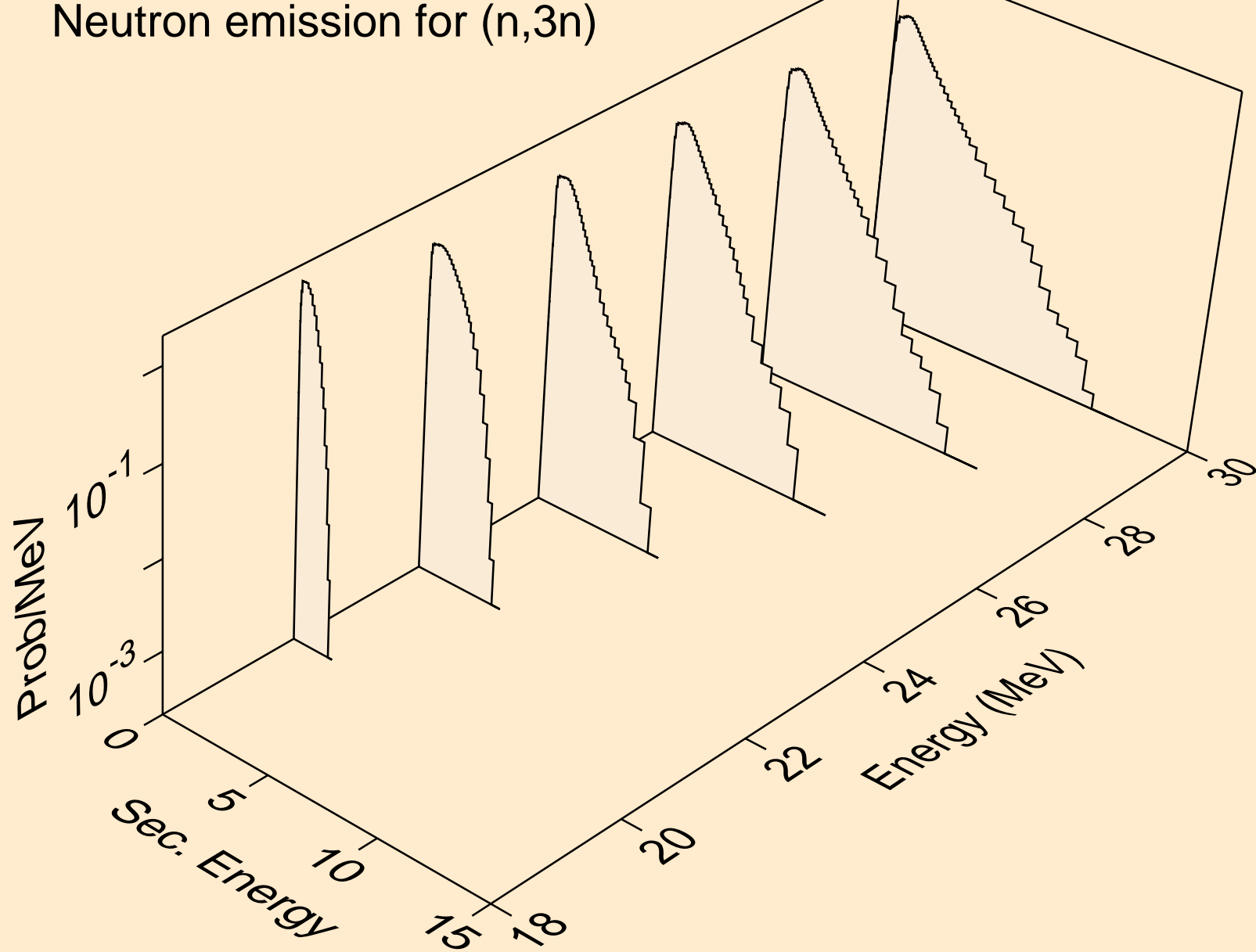

YB160 NEUTRON ACER TENDL-2023 LIBRARY; T=0.K  
Neutron emission for (n,n\*)a

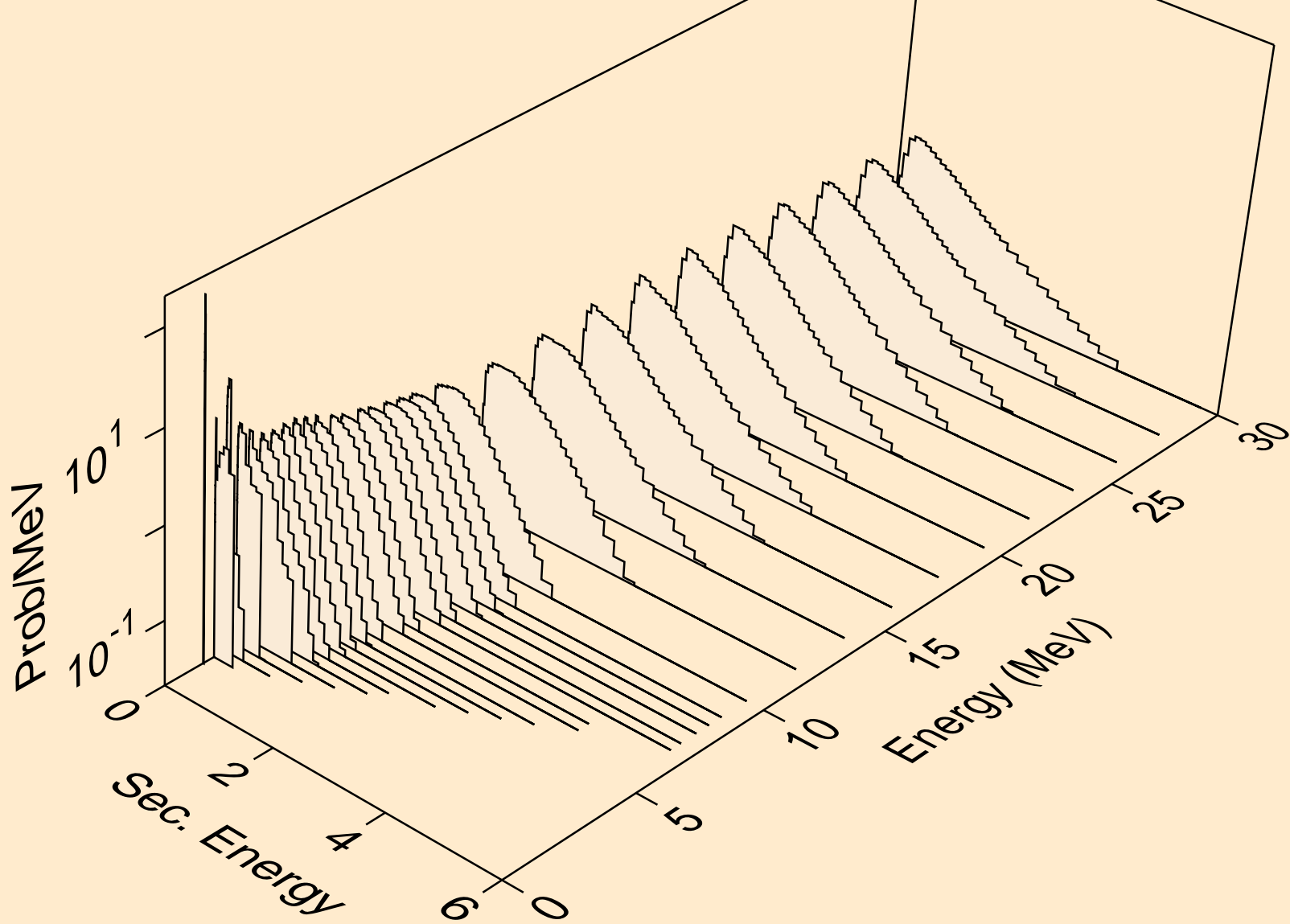

YB160 NEUTRON ACER TENDL-2023 LIBRARY; T=0.K  
Neutron emission for (n,2n)a

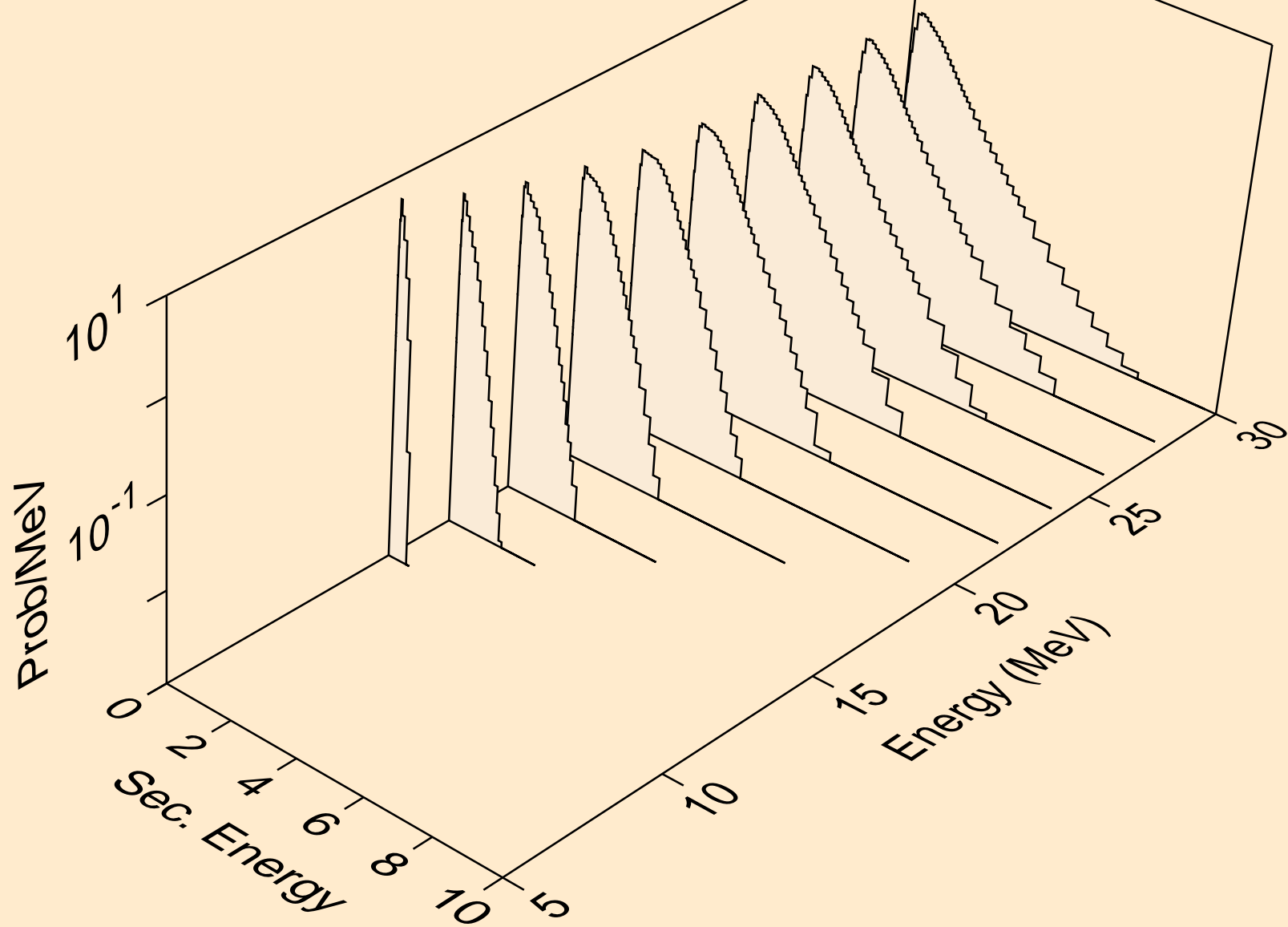

YB160 NEUTRON ACER TENDL-2023 LIBRARY; T=0.K  
Neutron emission for (n,3n)a

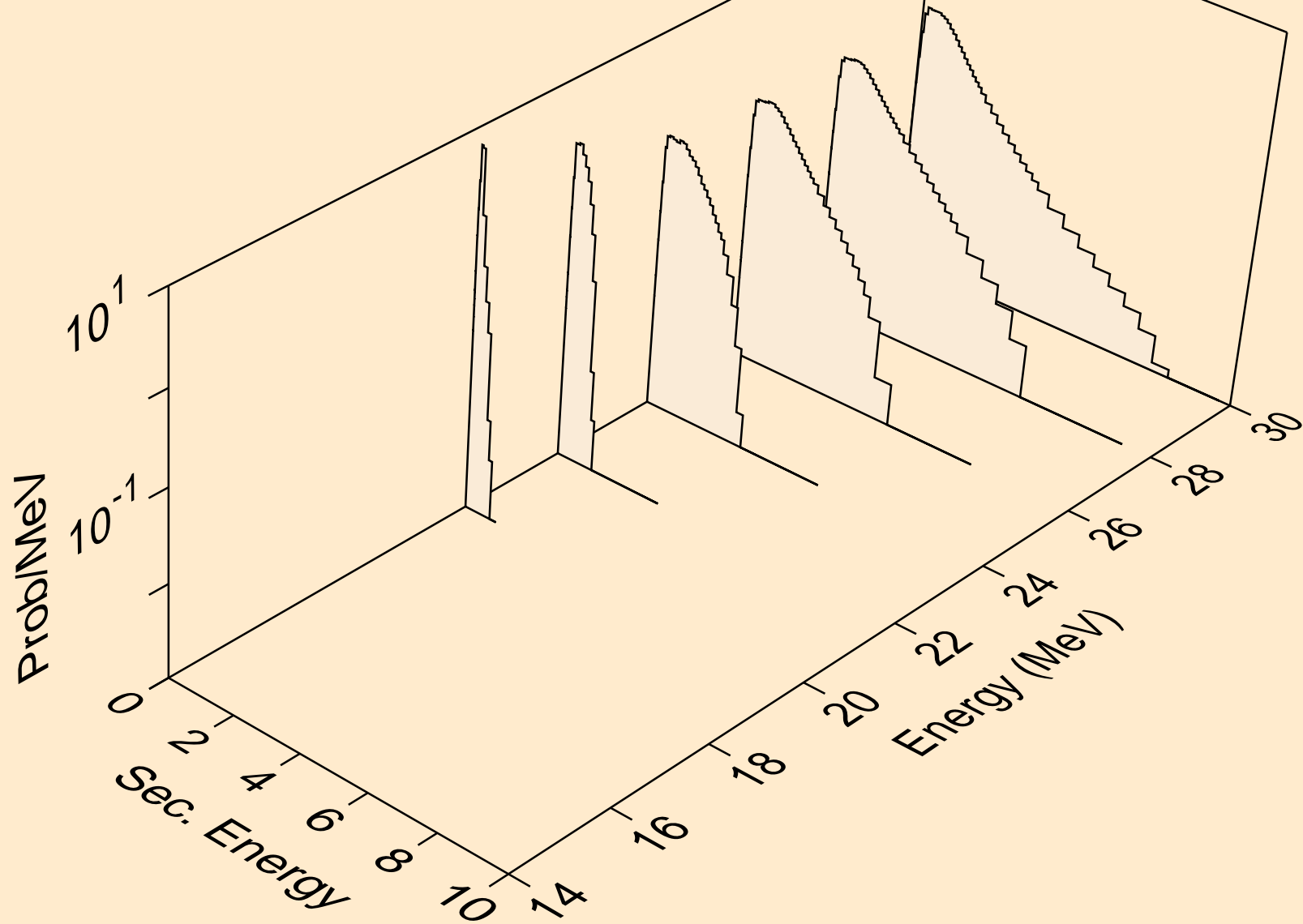

YB160 NEUTRON ACER TENDL-2023 LIBRARY; T=0.K  
Neutron emission for (n,n\*)p

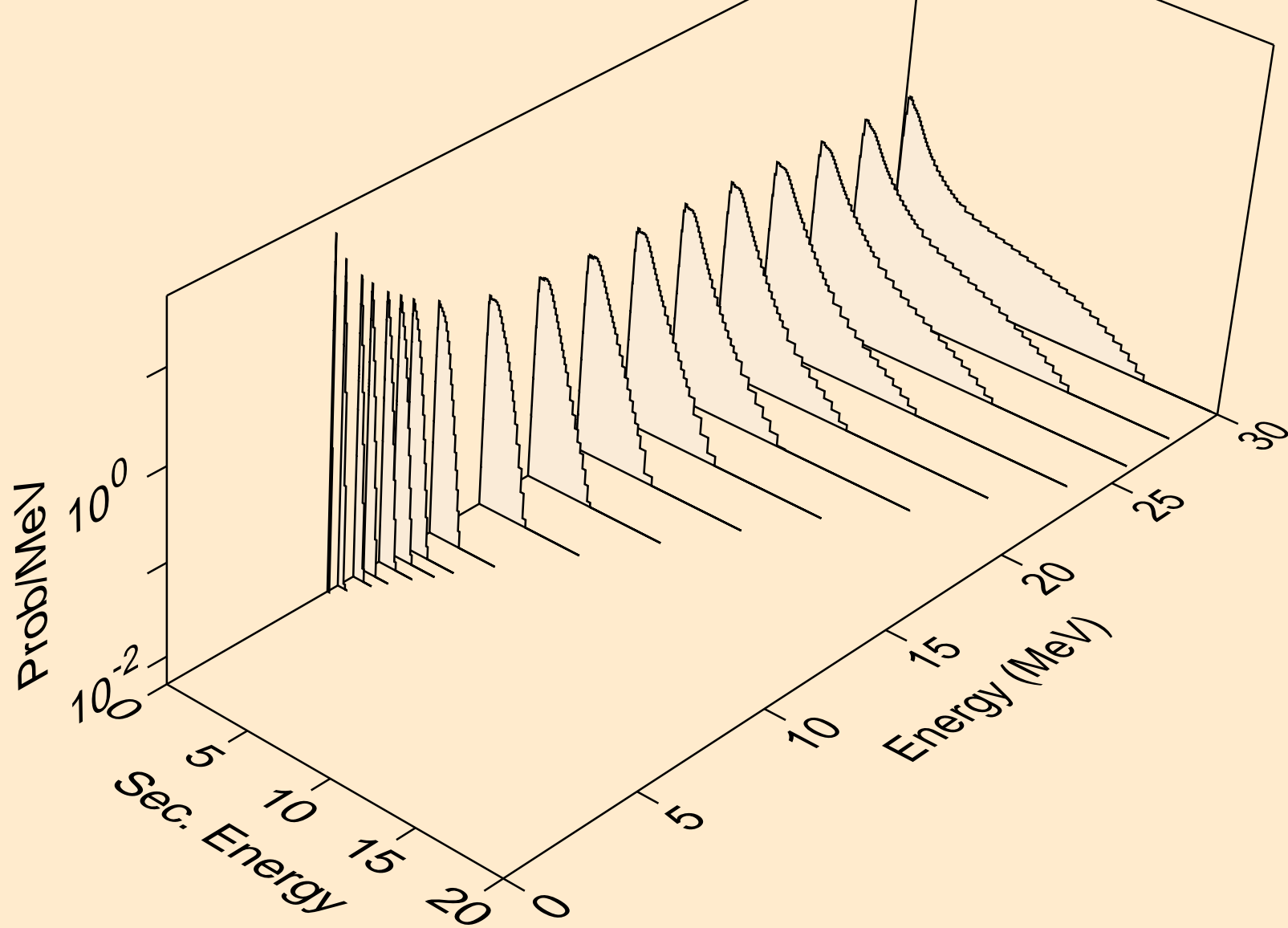

YB160 NEUTRON ACER TENDL-2023 LIBRARY; T=0.K  
Neutron emission for (n,n\*)2a

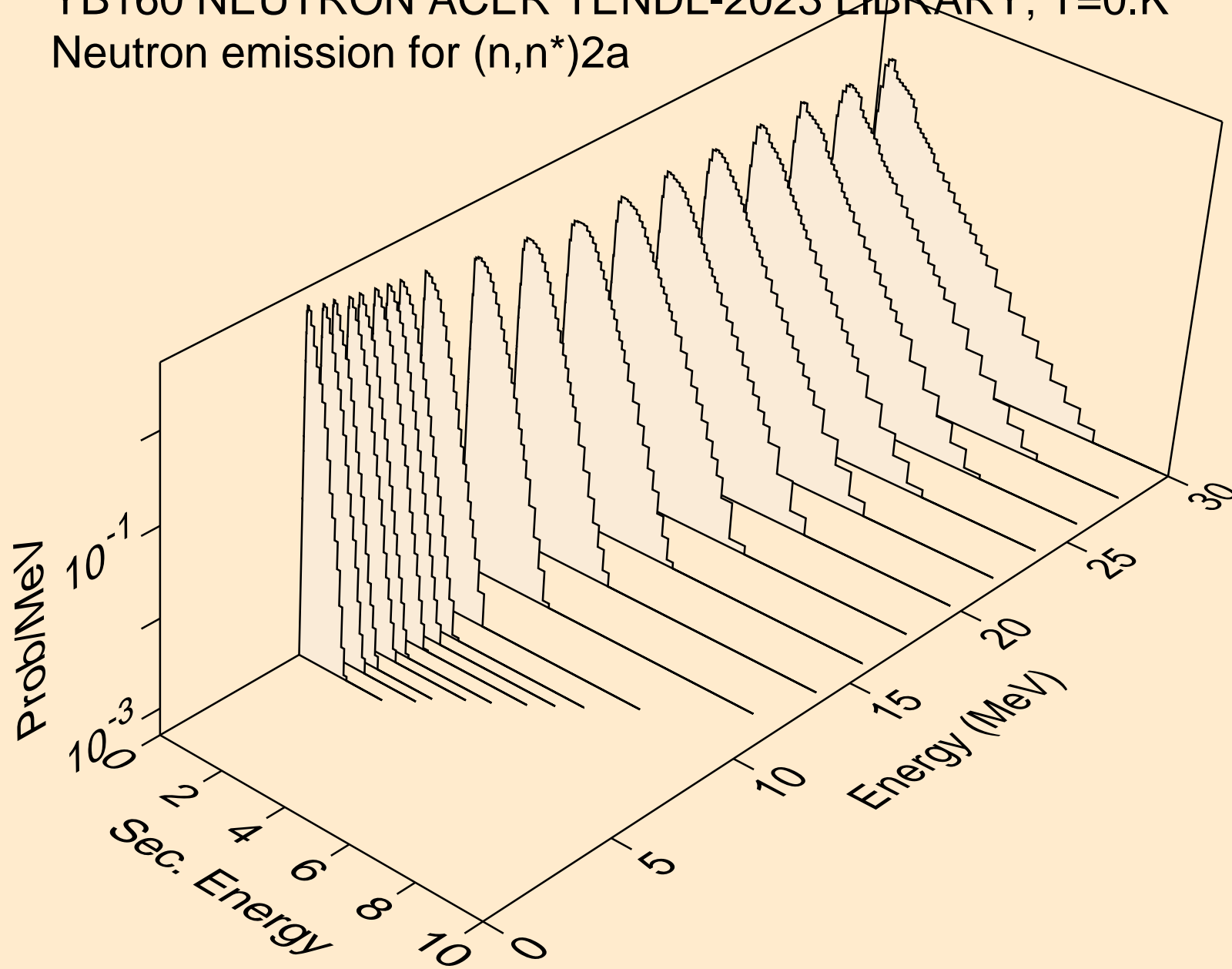

YB160 NEUTRON ACER TENDL-2023 LIBRARY; T=0.K  
Neutron emission for (n,2n)2a

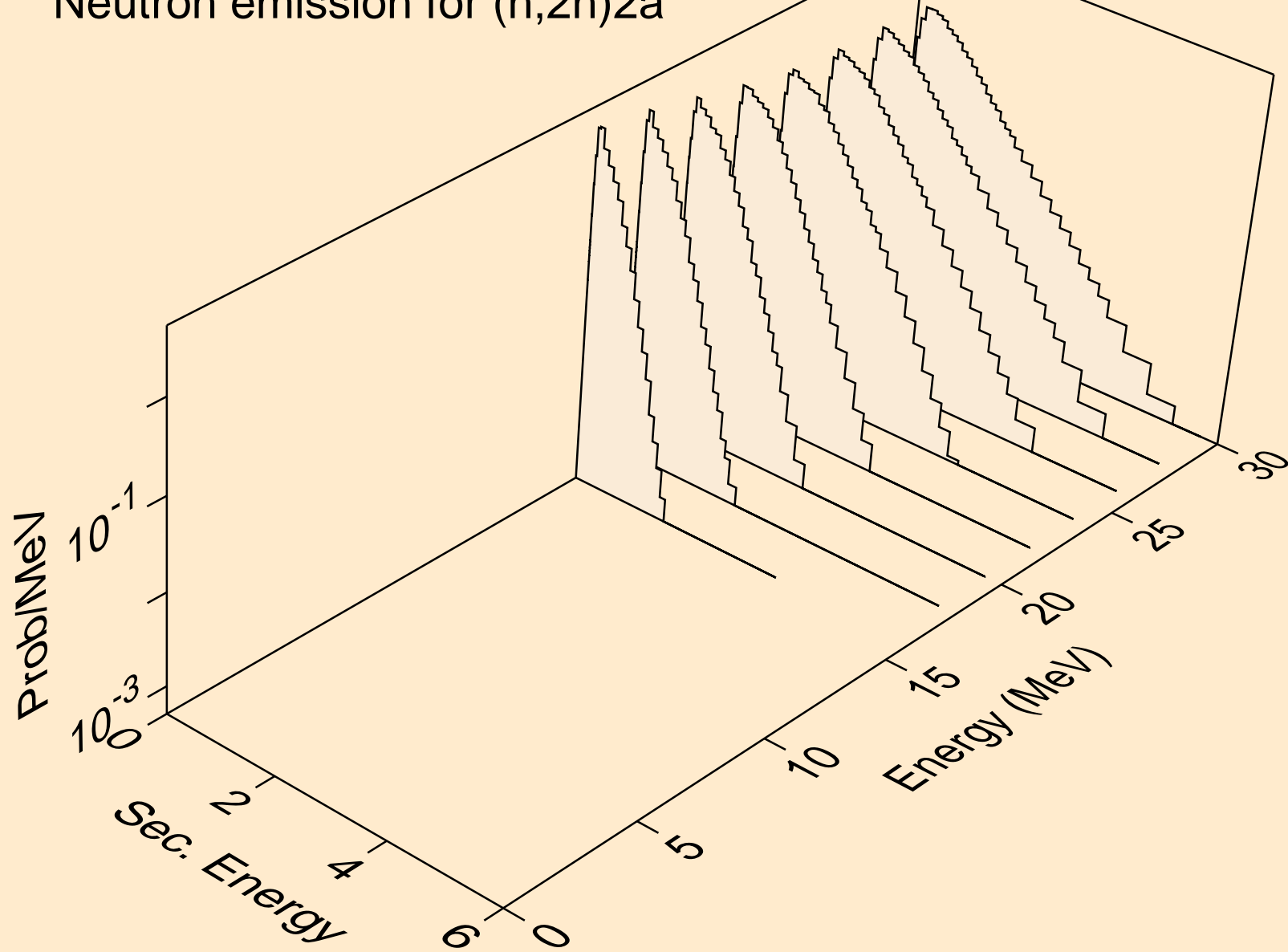

YB160 NEUTRON ACER TENDL-2023 LIBRARY; T=0.K  
Neutron emission for (n,n\*)d

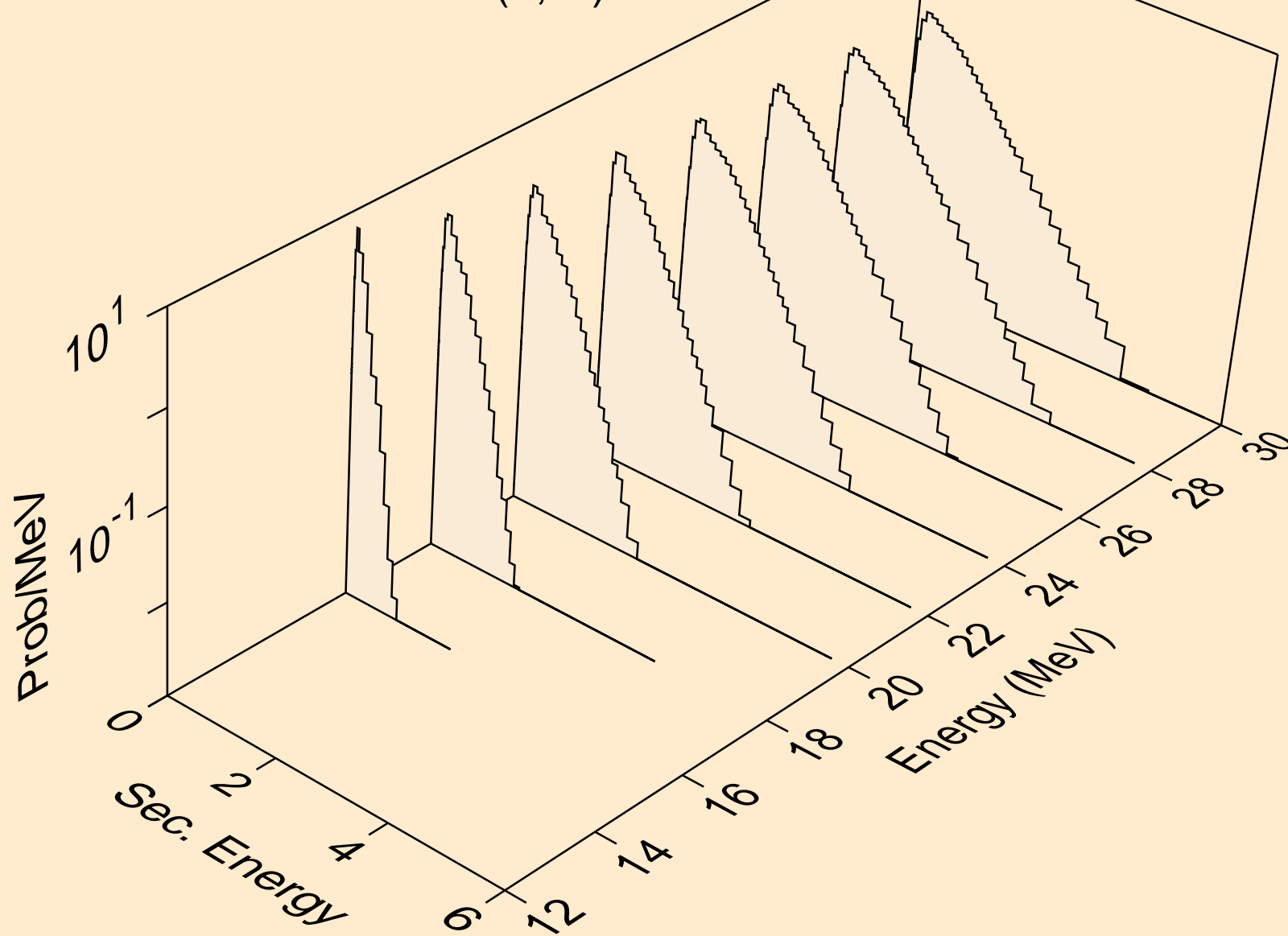

YB160 NEUTRON ACER TENDL-2023 LIBRARY; T=0.K  
Neutron emission for (n,n\*)t

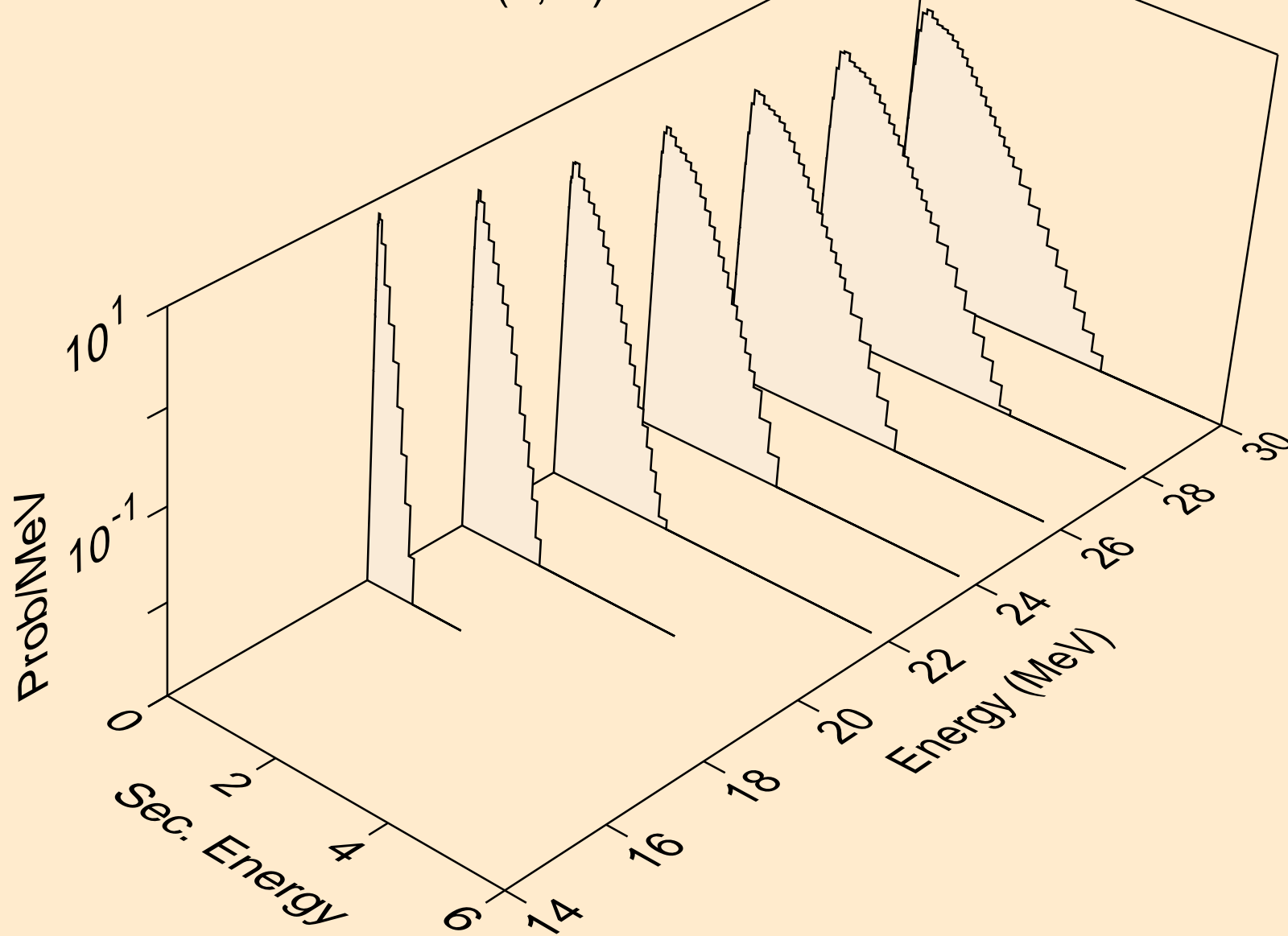

YB160 NEUTRON ACER TENDL-2023 LIBRARY; T=0.K  
Neutron emission for (n,n\*)he3

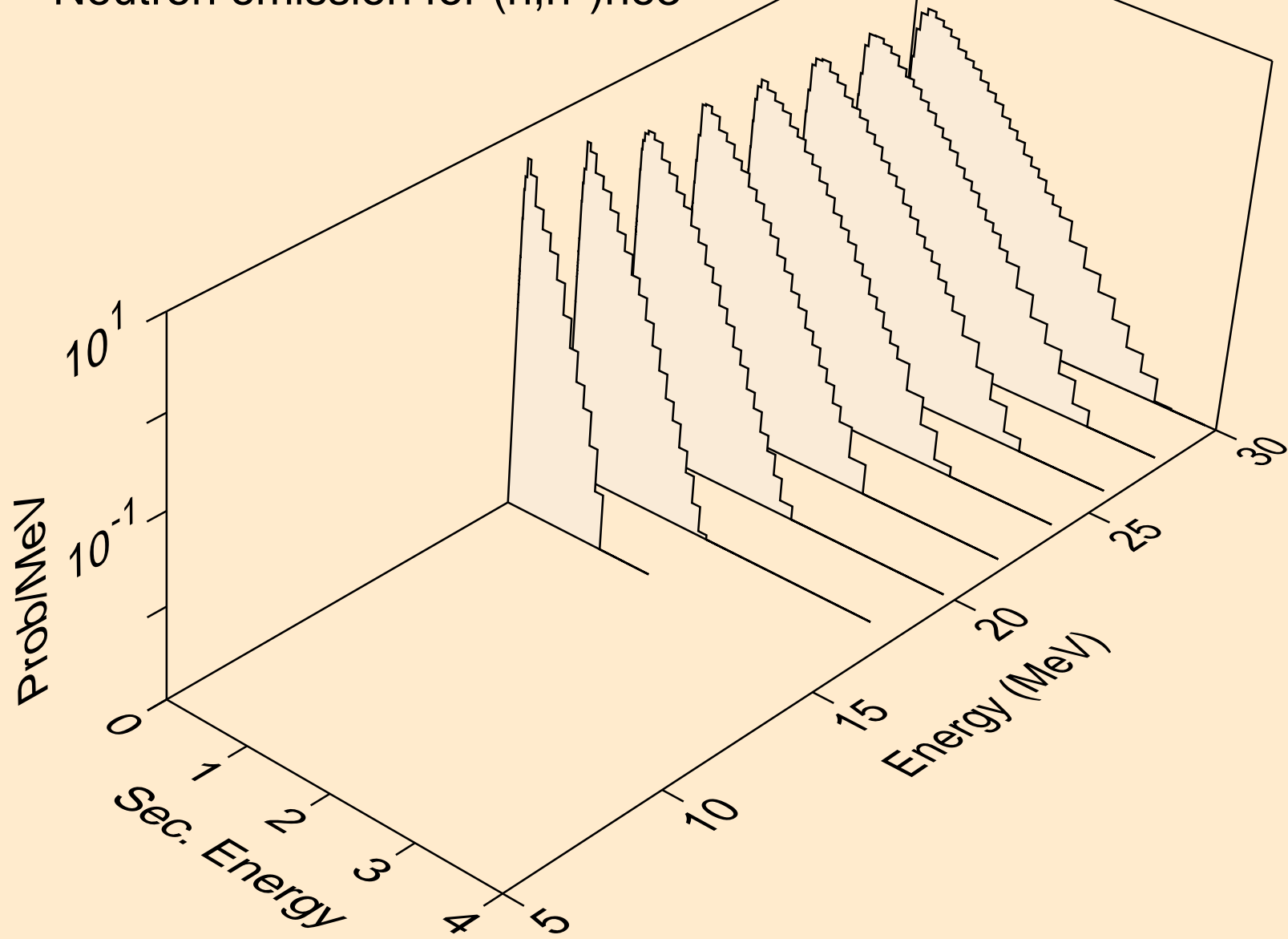

YB160 NEUTRON ACER TENDL-2023 LIBRARY; T=0.K  
Neutron emission for (n,2np)

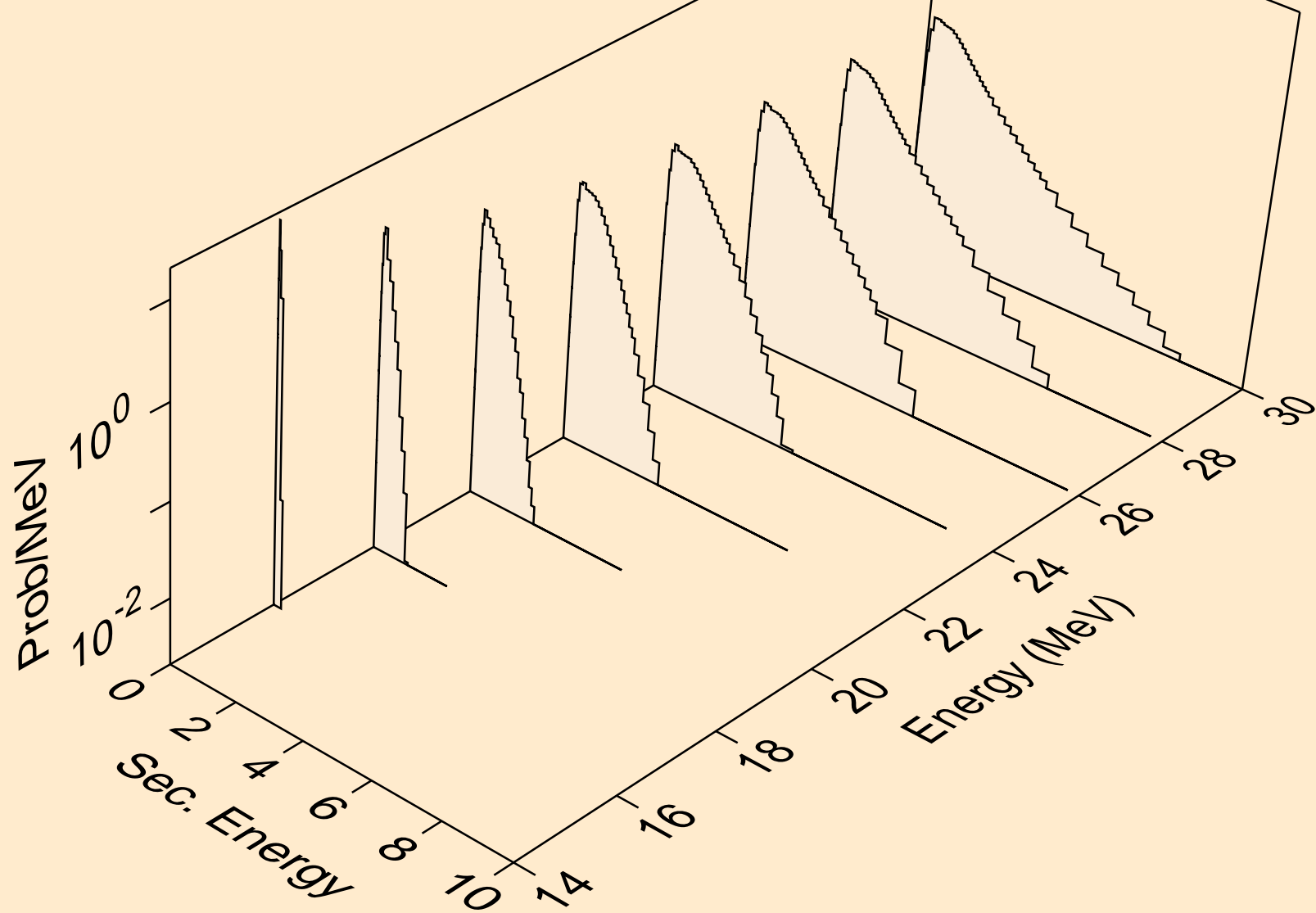

YB160 NEUTRON ACER TENDL-2023 LIBRARY; T=0.K  
Neutron emission for (n,3np)

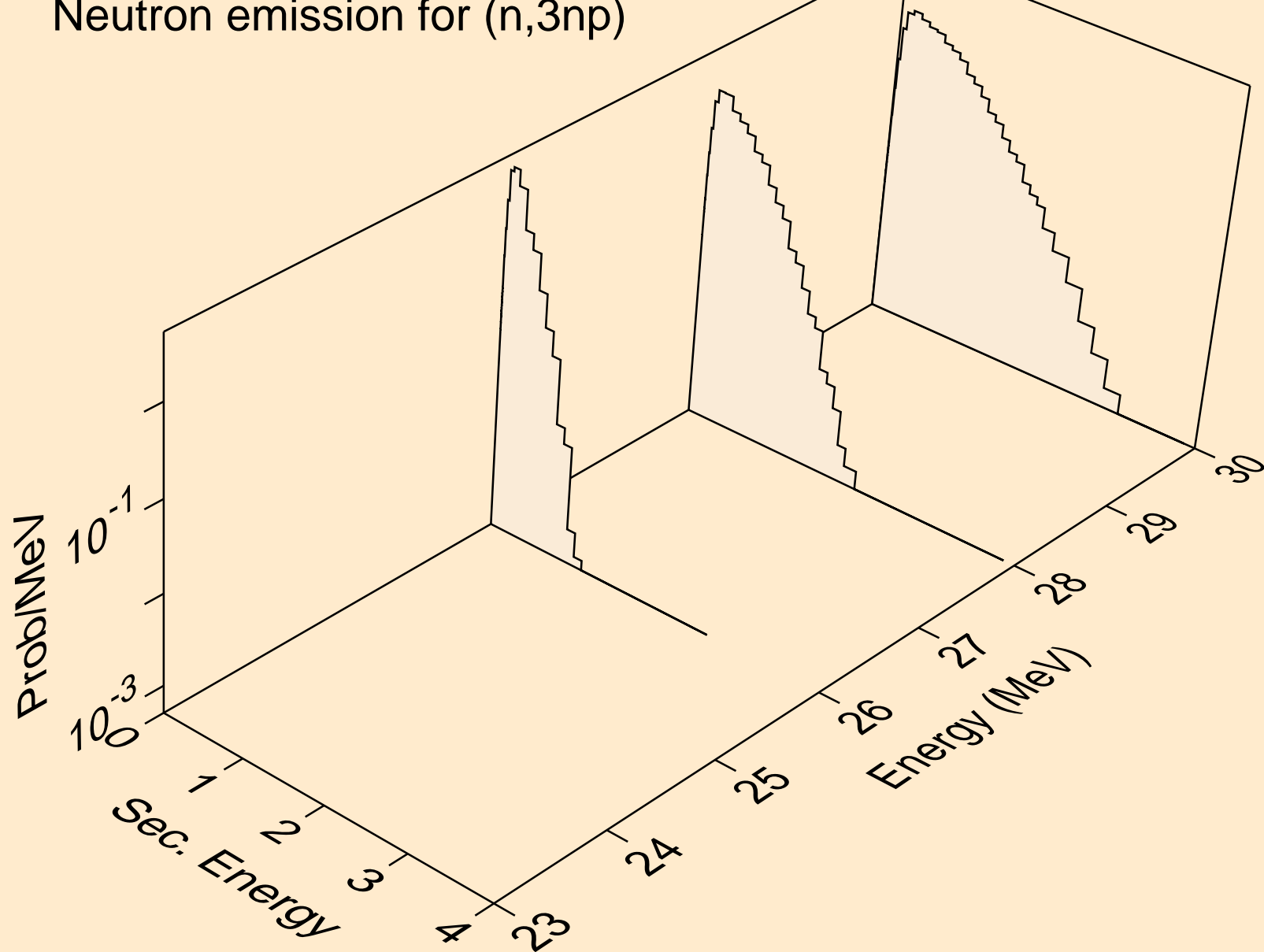

YB160 NEUTRON ACER TENDL-2023 LIBRARY; T=0.K  
Neutron emission for (n,n2p)

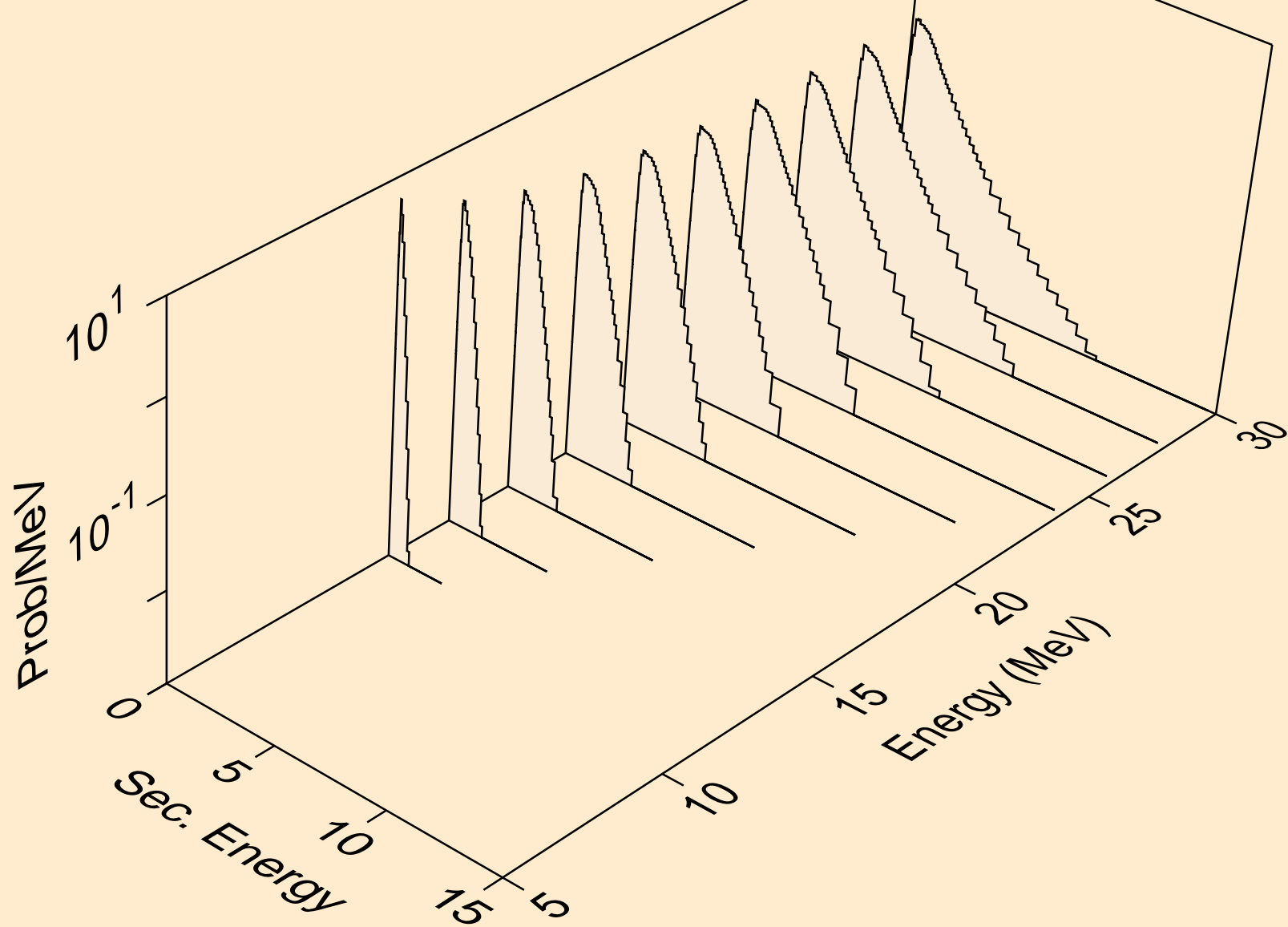

YB160 NEUTRON ACER TENDL-2023 LIBRARY; T=0.K  
Neutron emission for (n,npa)

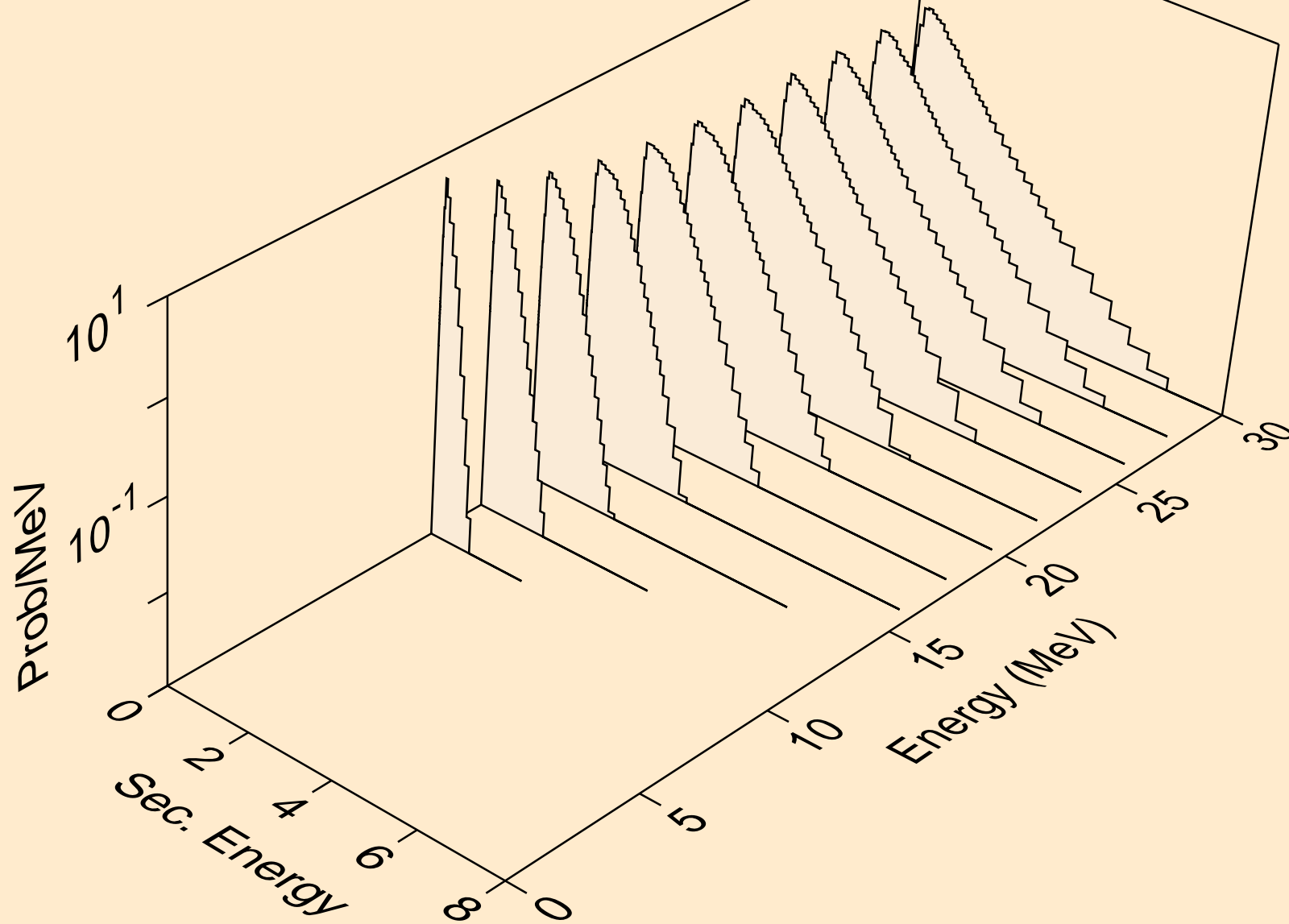

YB160 NEUTRON ACER TENDL-2023 LIBRARY; T=0.K  
Neutron emission for (n,n\*c)

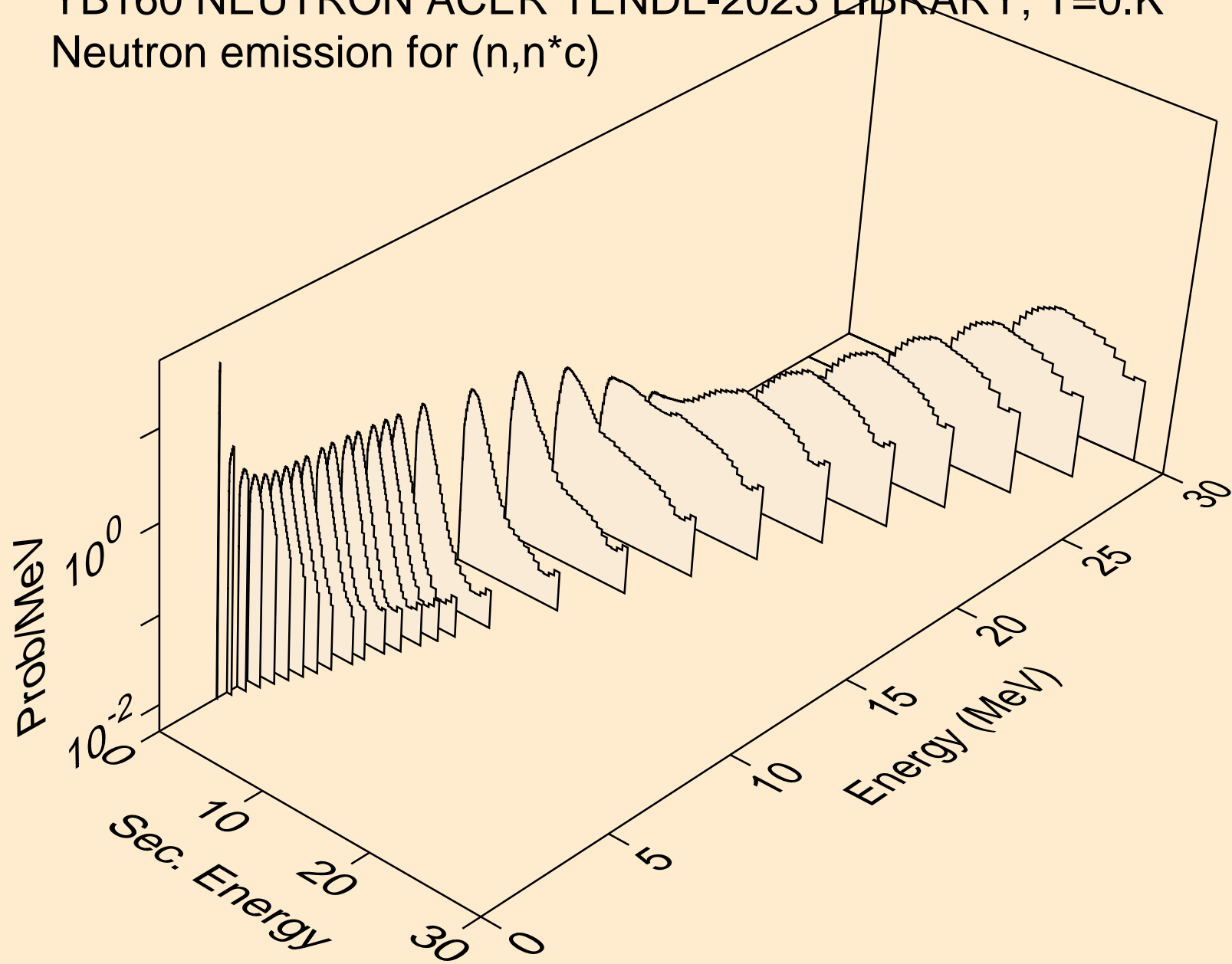

YB160 NEUTRON ACER TENDL-2023 LIBRARY; T=0.K  
Photon emission for (n,x)

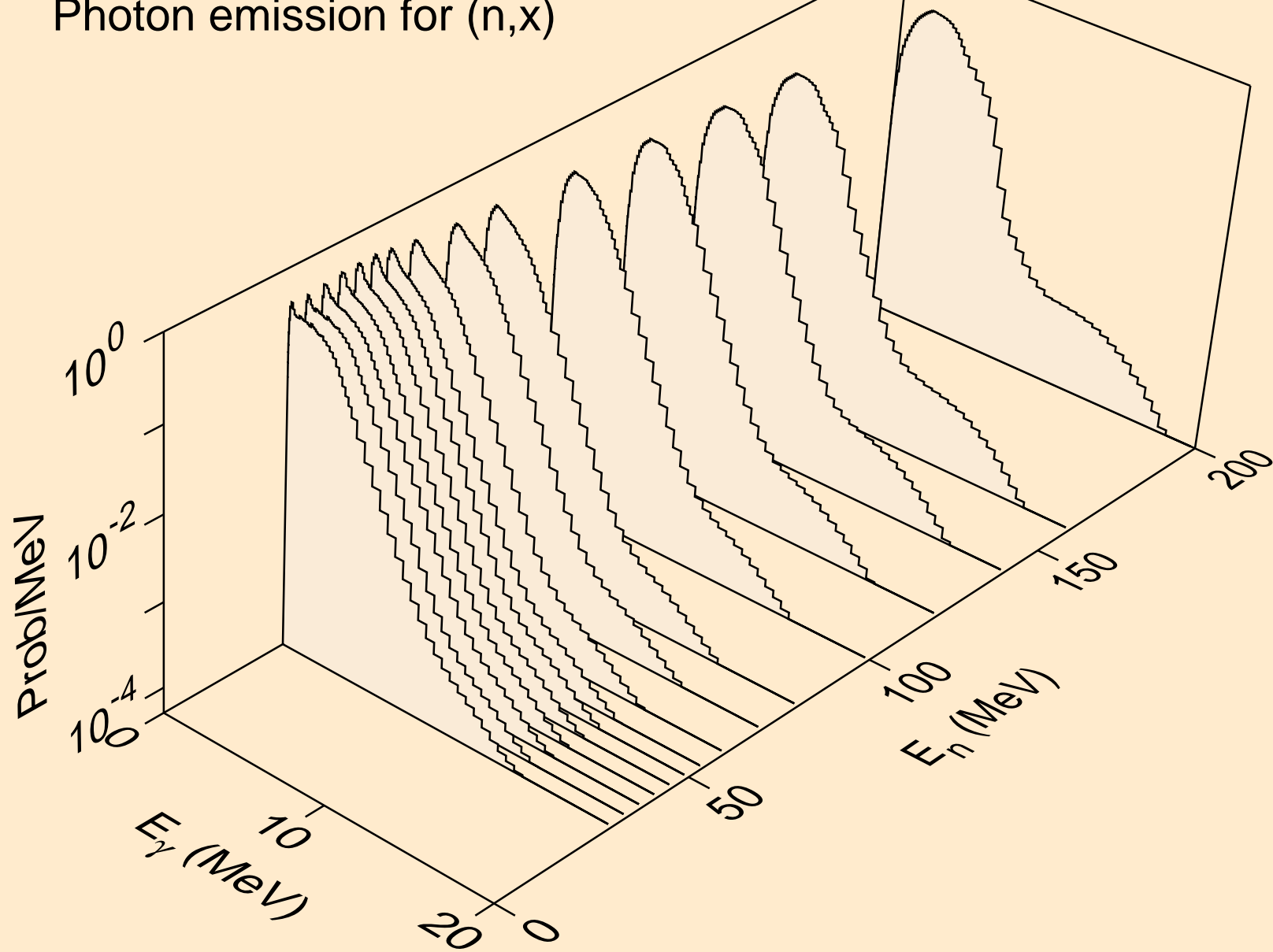

YB160 NEUTRON ACER TENDL-2023 LIBRARY; T=0.K  
Photon emission for (n,2nd)

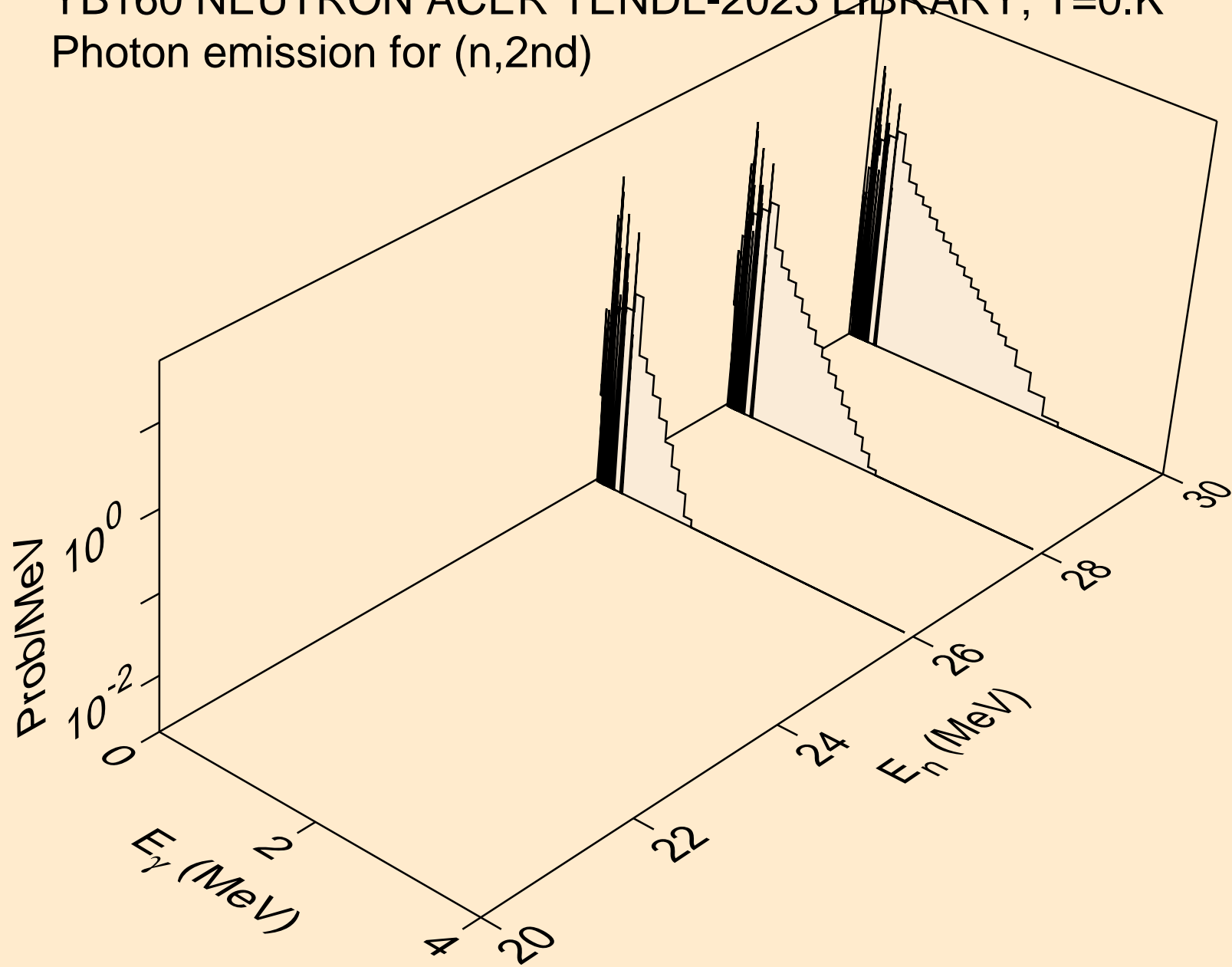

YB160 NEUTRON ACER TENDL-2023 LIBRARY; T=0.K  
Photon emission for (n,2n)

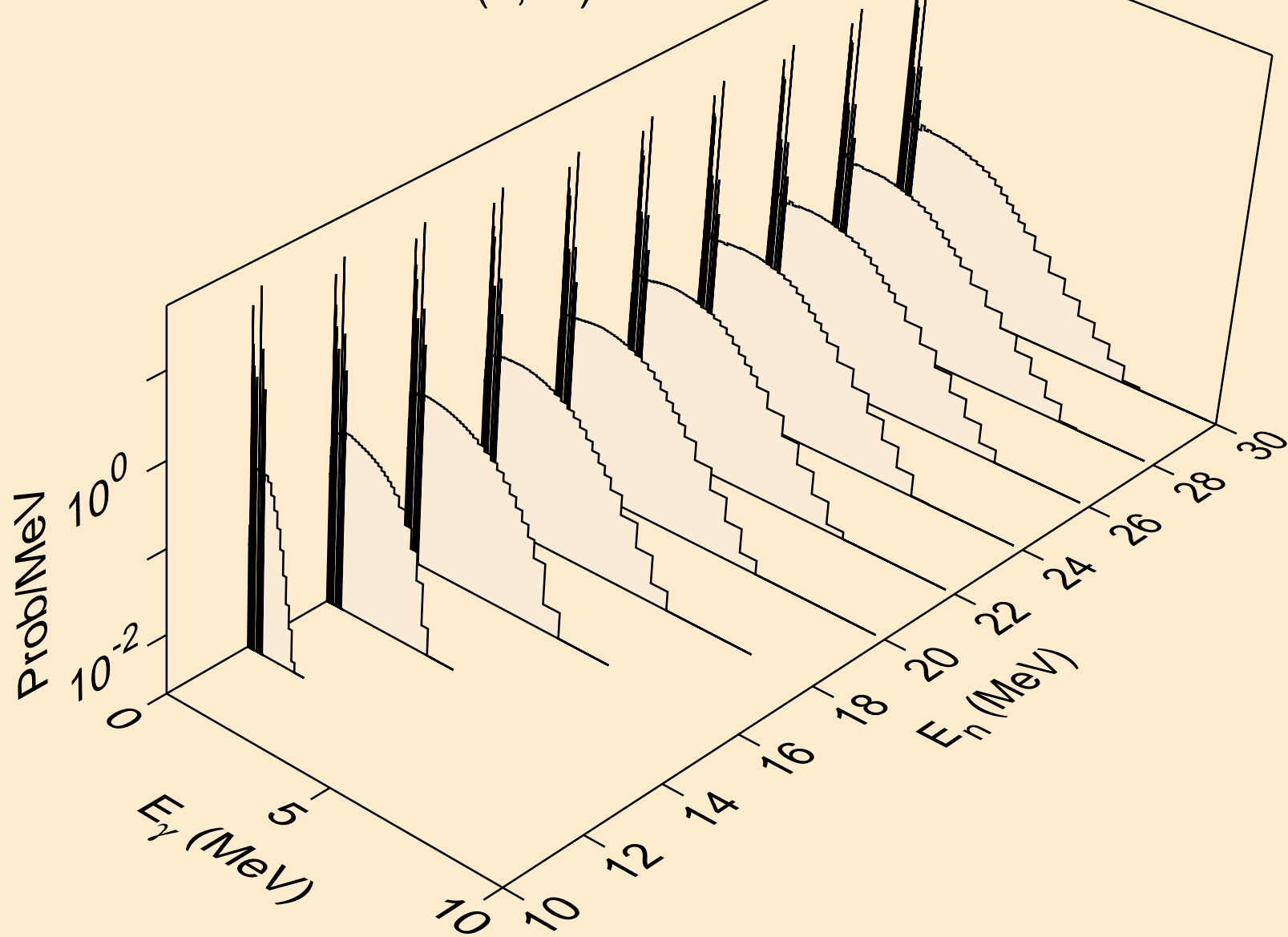

YB160 NEUTRON ACER TENDL-2023 LIBRARY; T=0.K  
Photon emission for (n,3n)

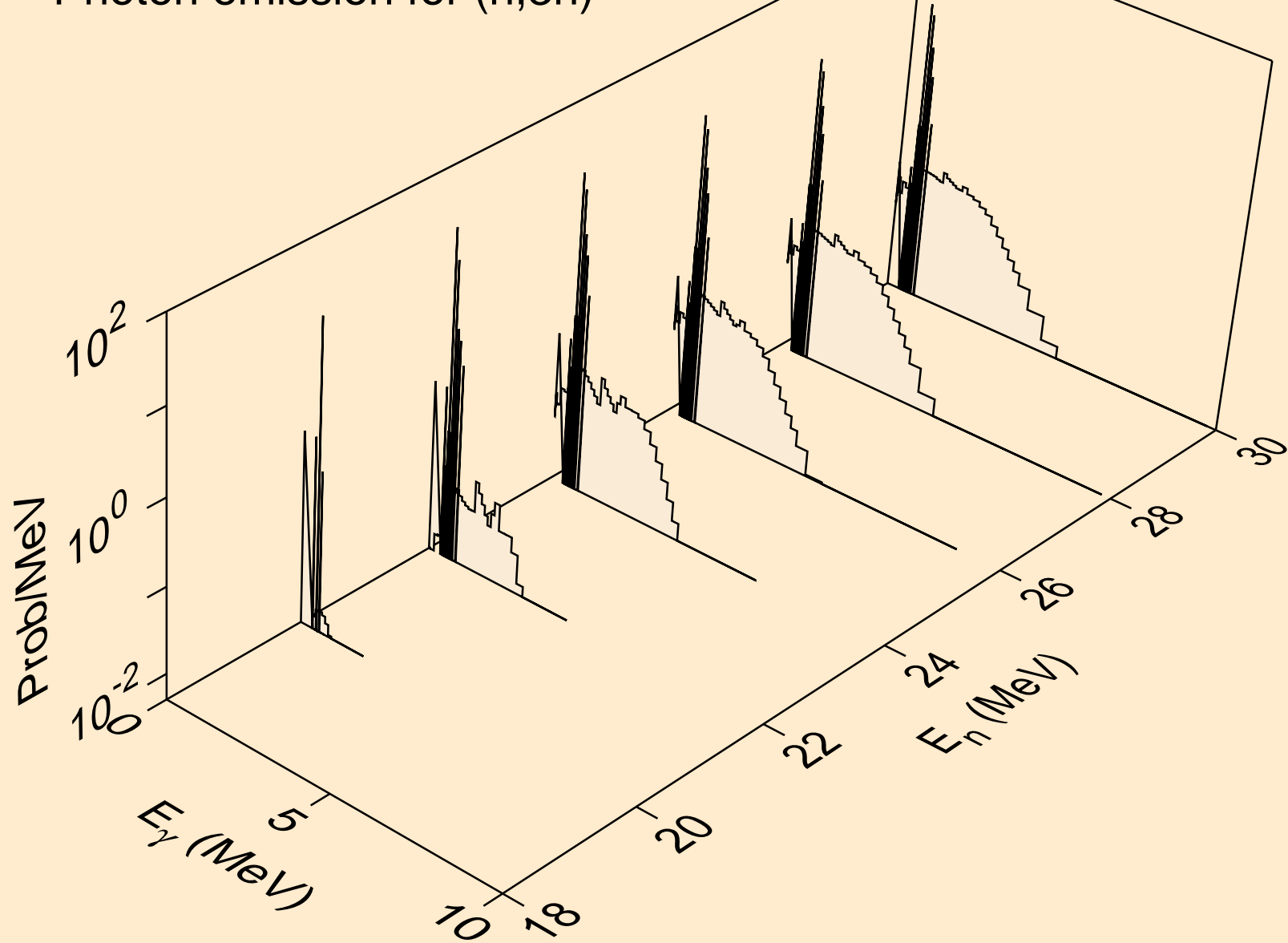

YB160 NEUTRON ACER TENDL-2023 LIBRARY; T=0.K  
Photon emission for (n,n\*)a

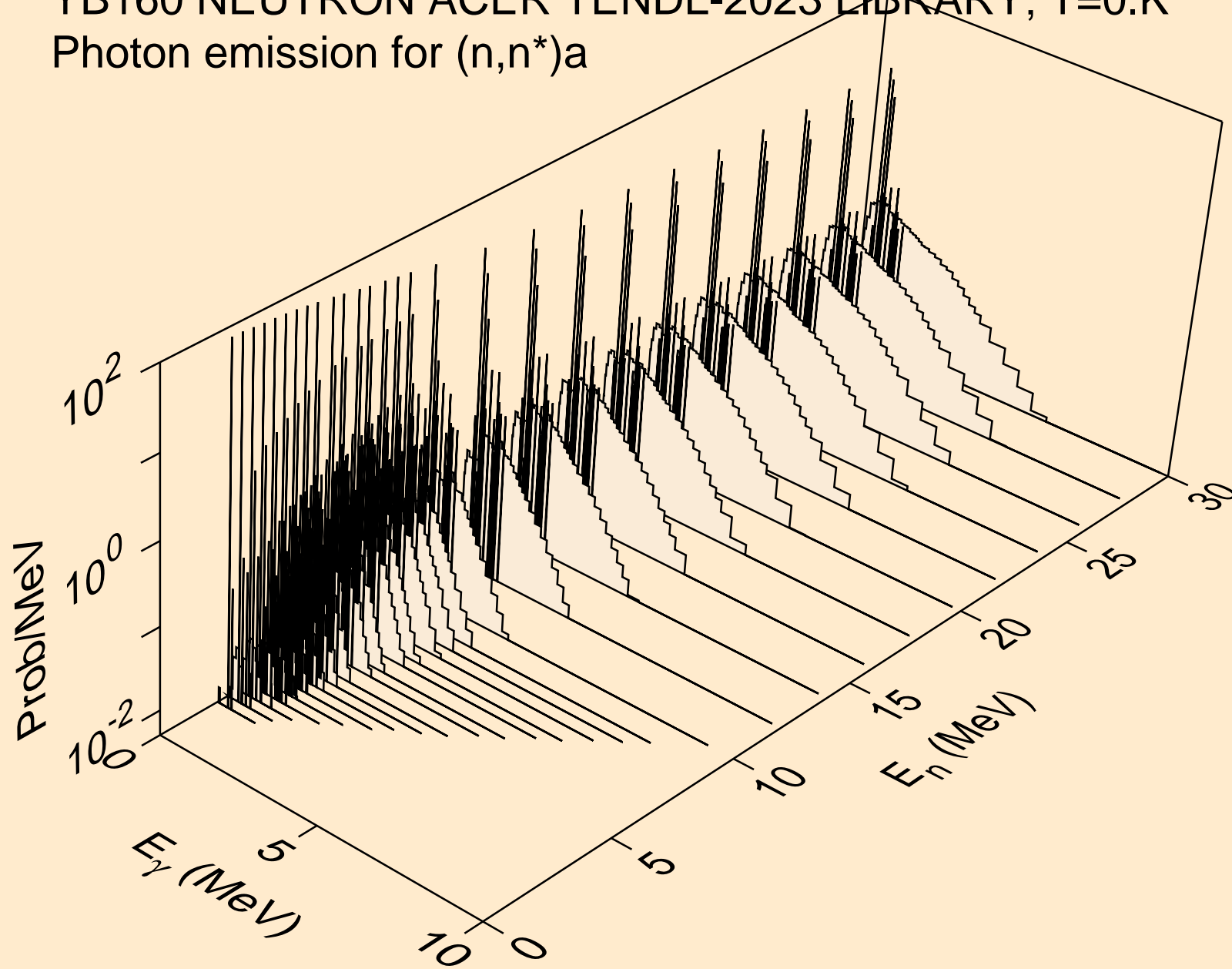

YB160 NEUTRON ACER TENDL-2023 LIBRARY; T=0.K  
Photon emission for (n,2n)a

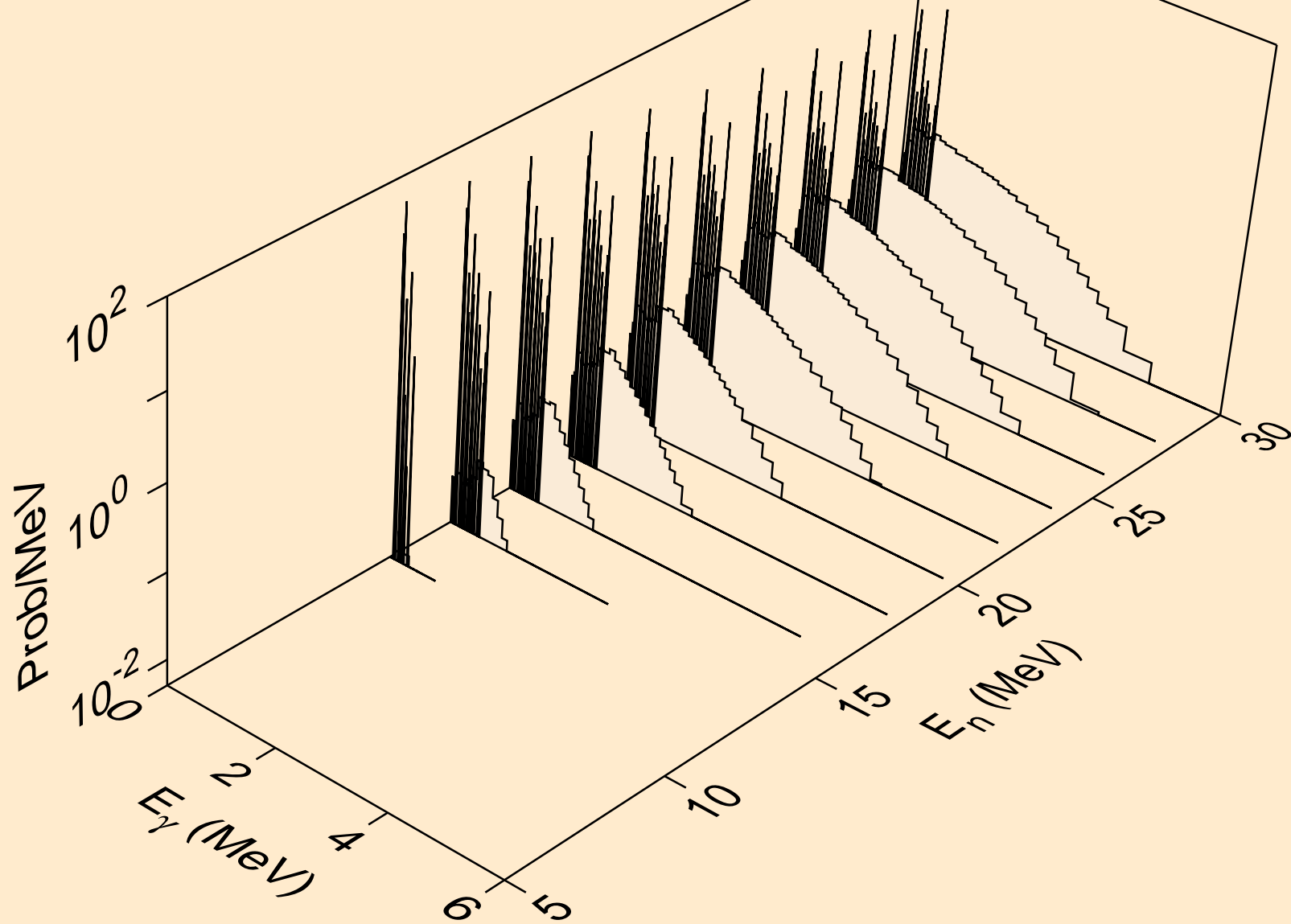

YB160 NEUTRON ACER TENDL-2023 LIBRARY; T=0.K  
Photon emission for (n,3n)a

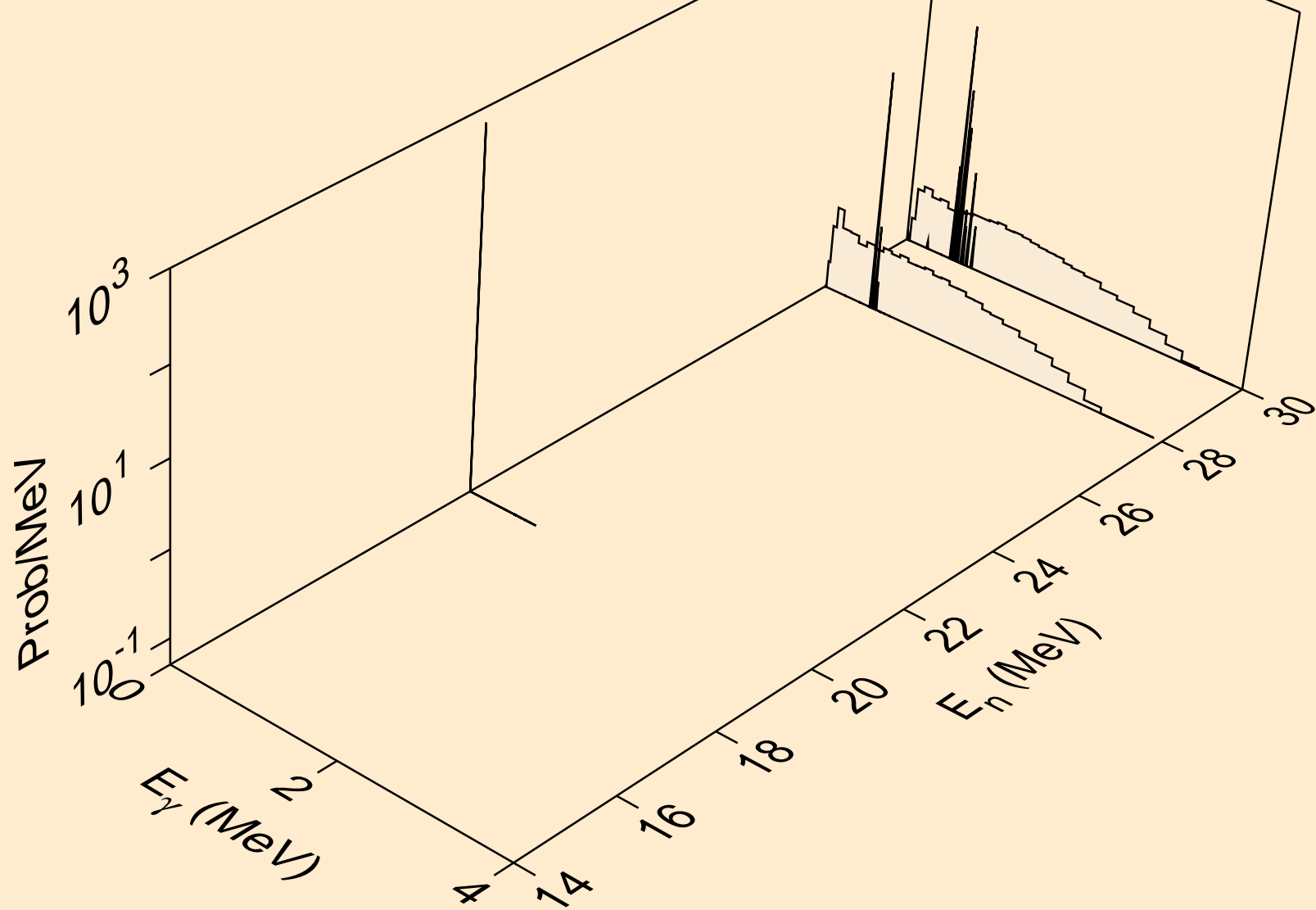

YB160 NEUTRON ACER TENDL-2023 LIBRARY; T=0.K  
Photon emission for (n,n\*)p

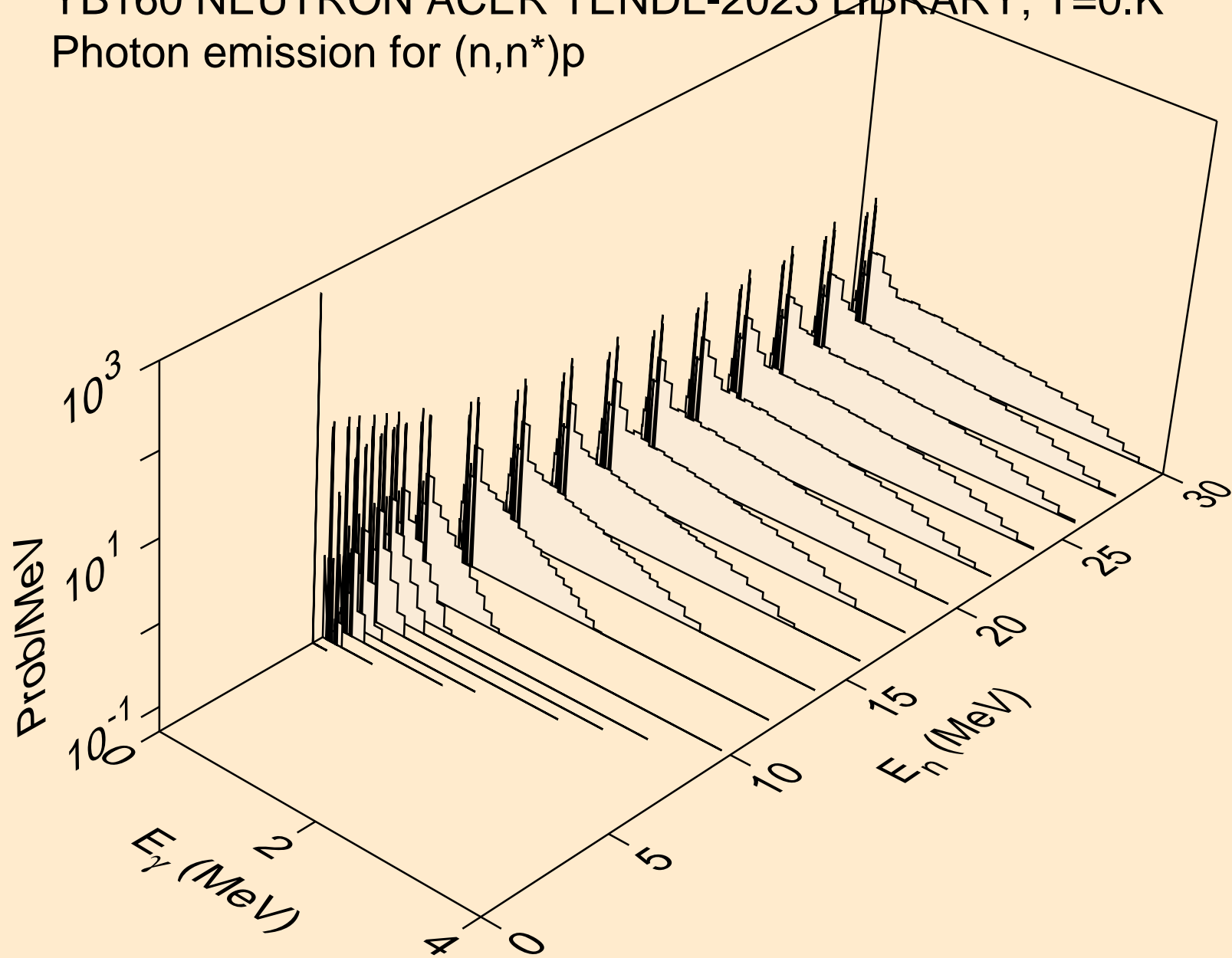

YB160 NEUTRON ACER TENDL-2023 LIBRARY; T=0.K  
Photon emission for (n,n\*)2a

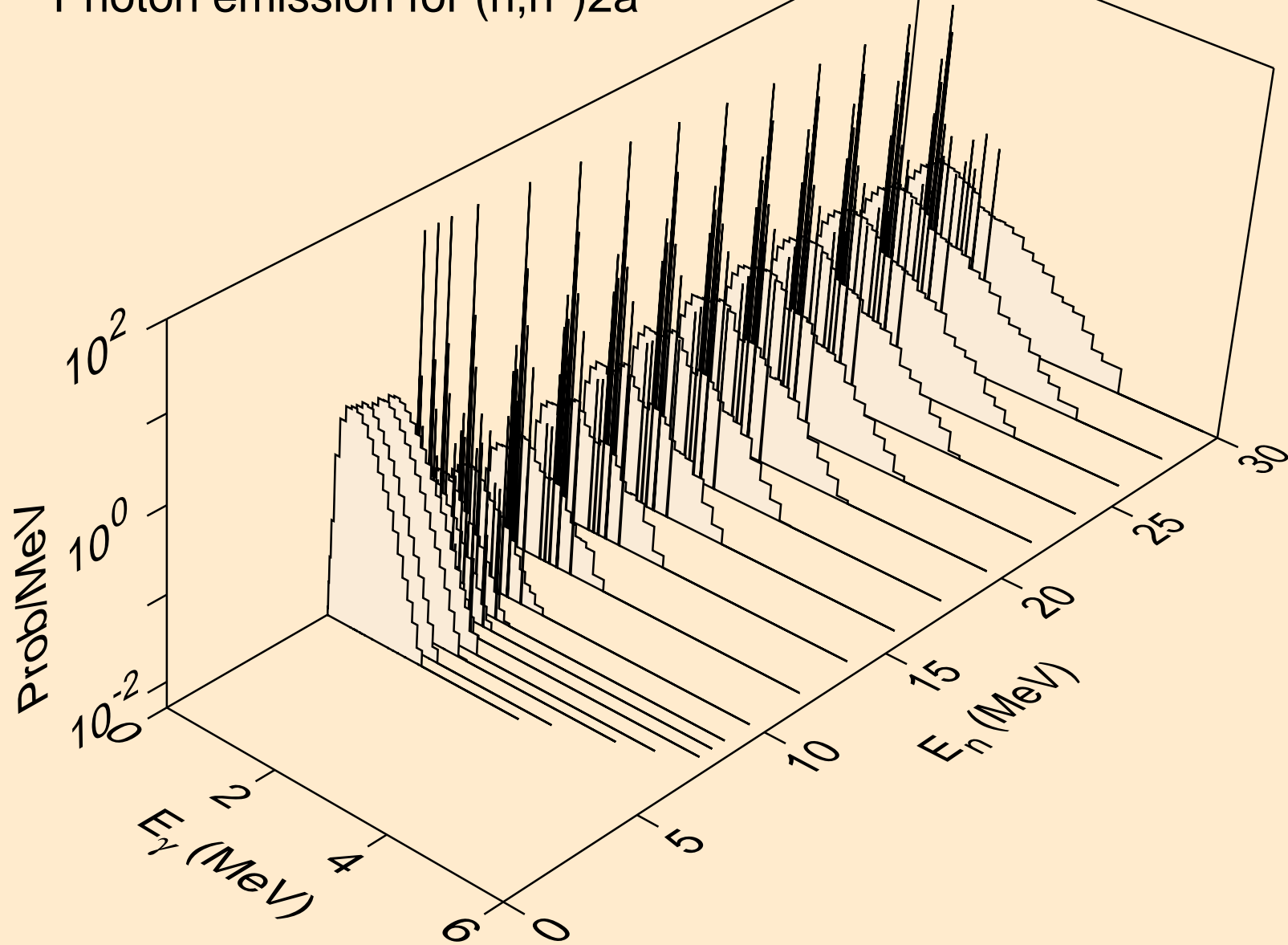

YB160 NEUTRON ACER TENDL-2023 LIBRARY; T=0.K  
Photon emission for (n,2n)2a

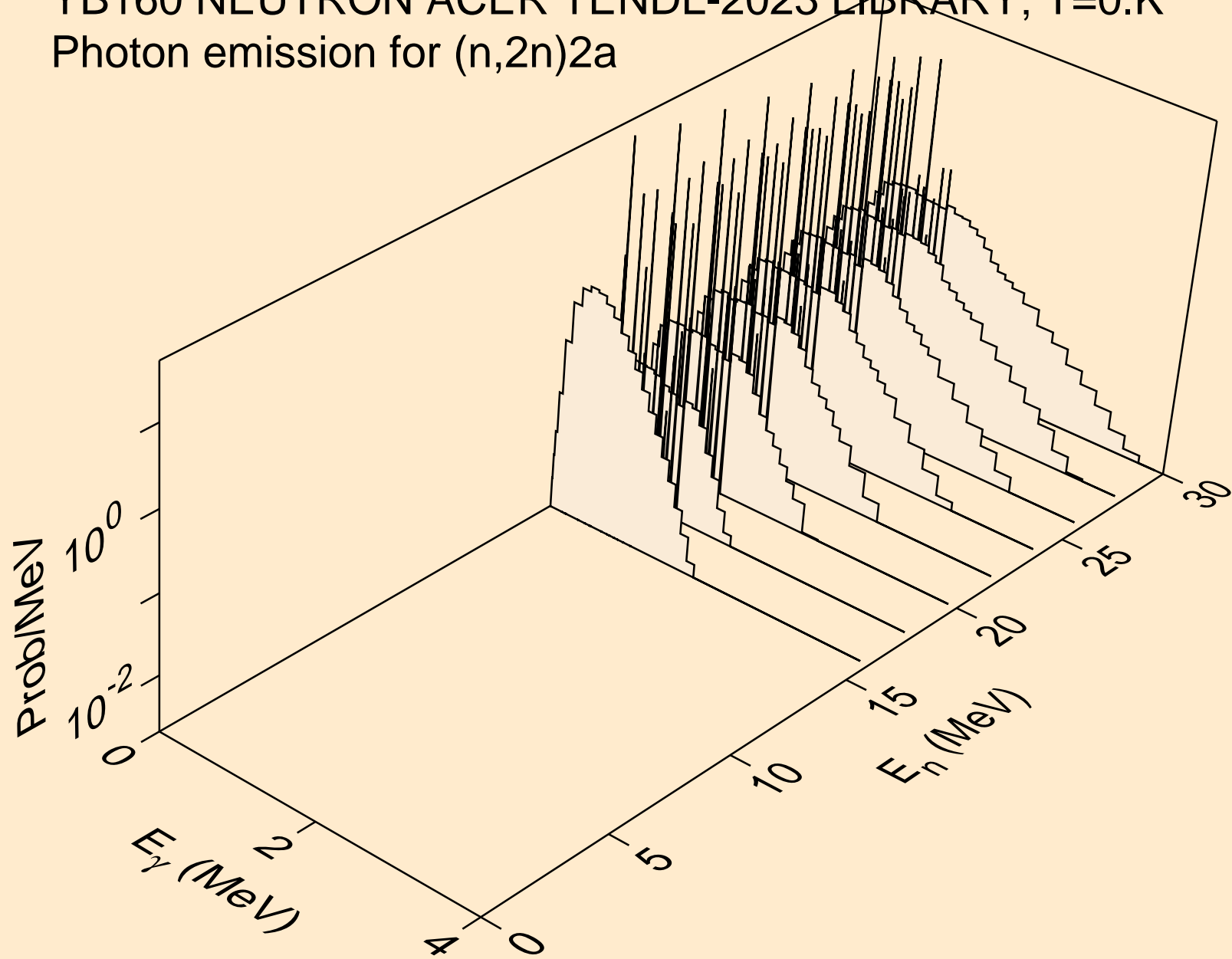

YB160 NEUTRON ACER TENDL-2023 LIBRARY; T=0.K  
Photon emission for (n,n\*)d

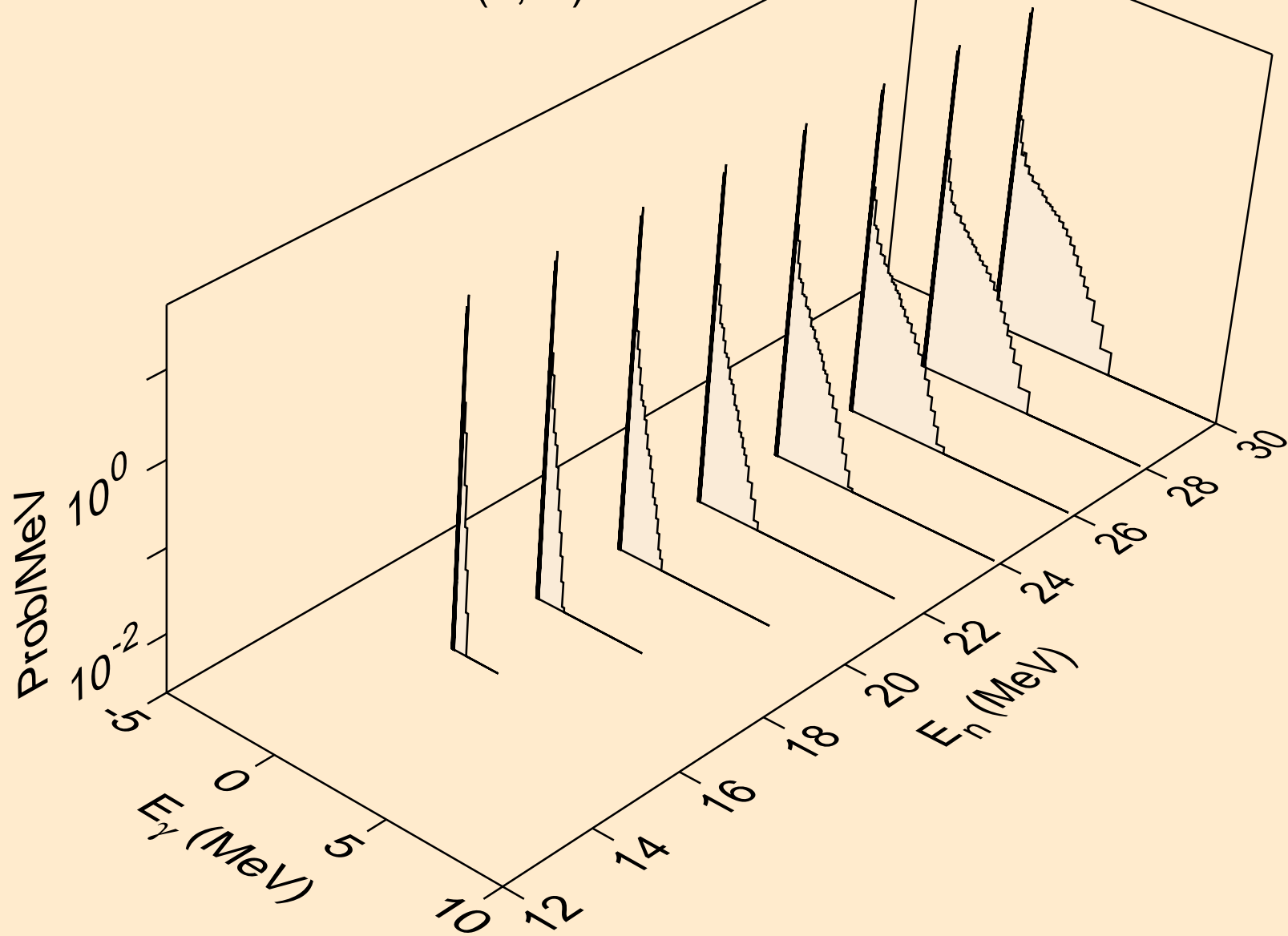

YB160 NEUTRON ACER TENDL-2023 LIBRARY; T=0.K  
Photon emission for (n,n\*)t

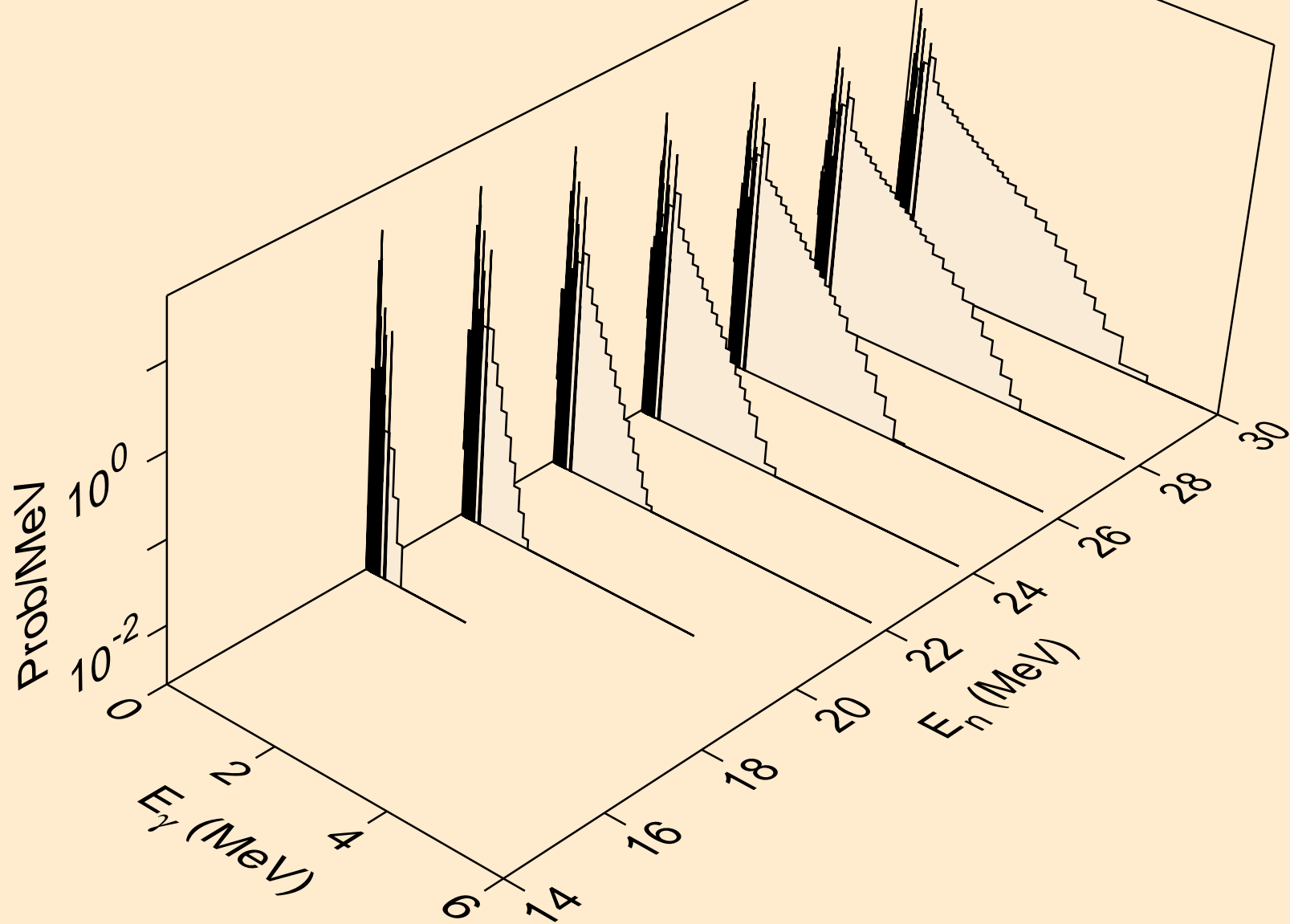

YB160 NEUTRON ACER TENDL-2023 LIBRARY; T=0.K  
Photon emission for (n,n\*)he3

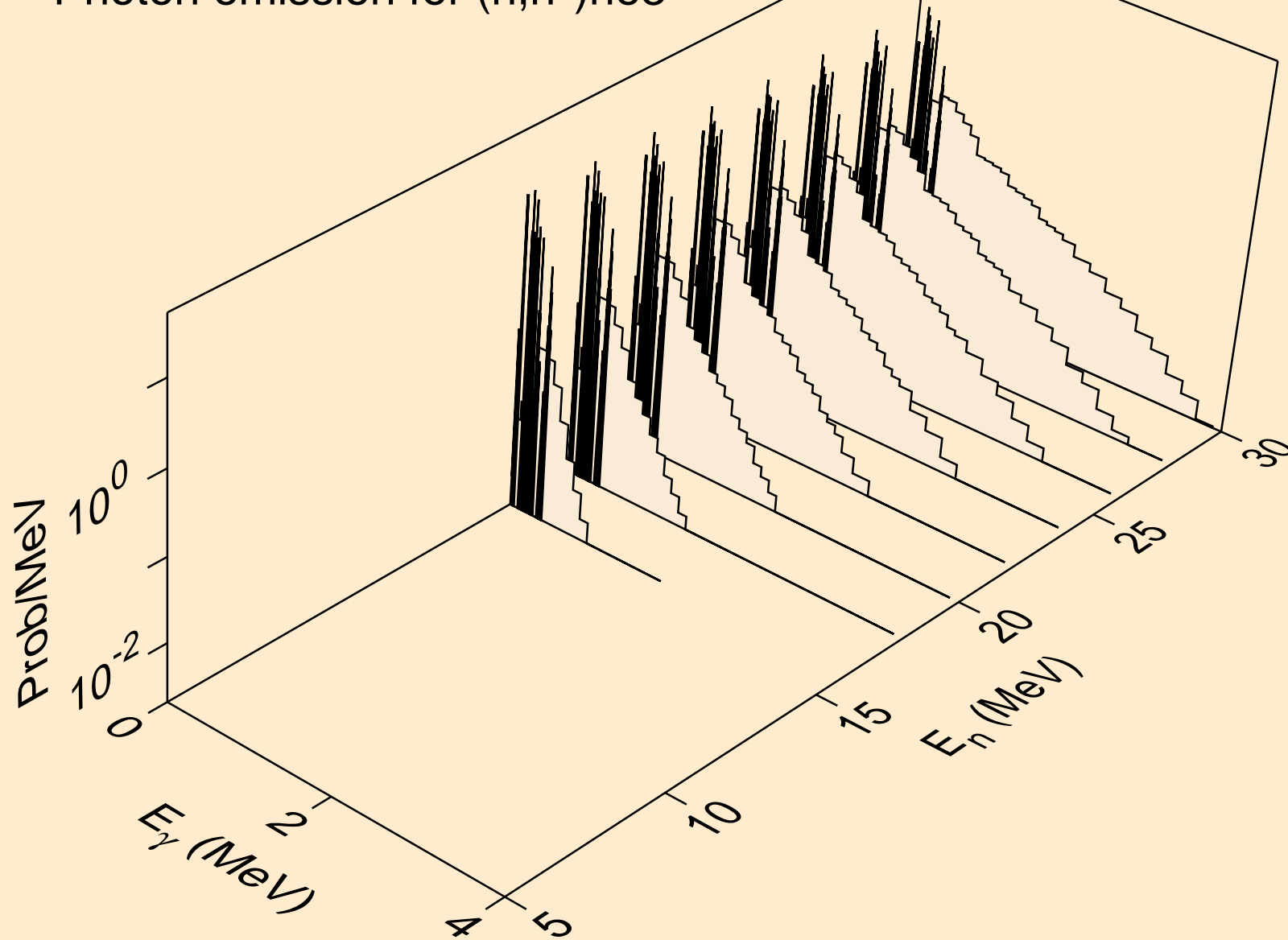

YB160 NEUTRON ACER TENDL-2023 LIBRARY; T=0.K  
Photon emission for (n,2np)

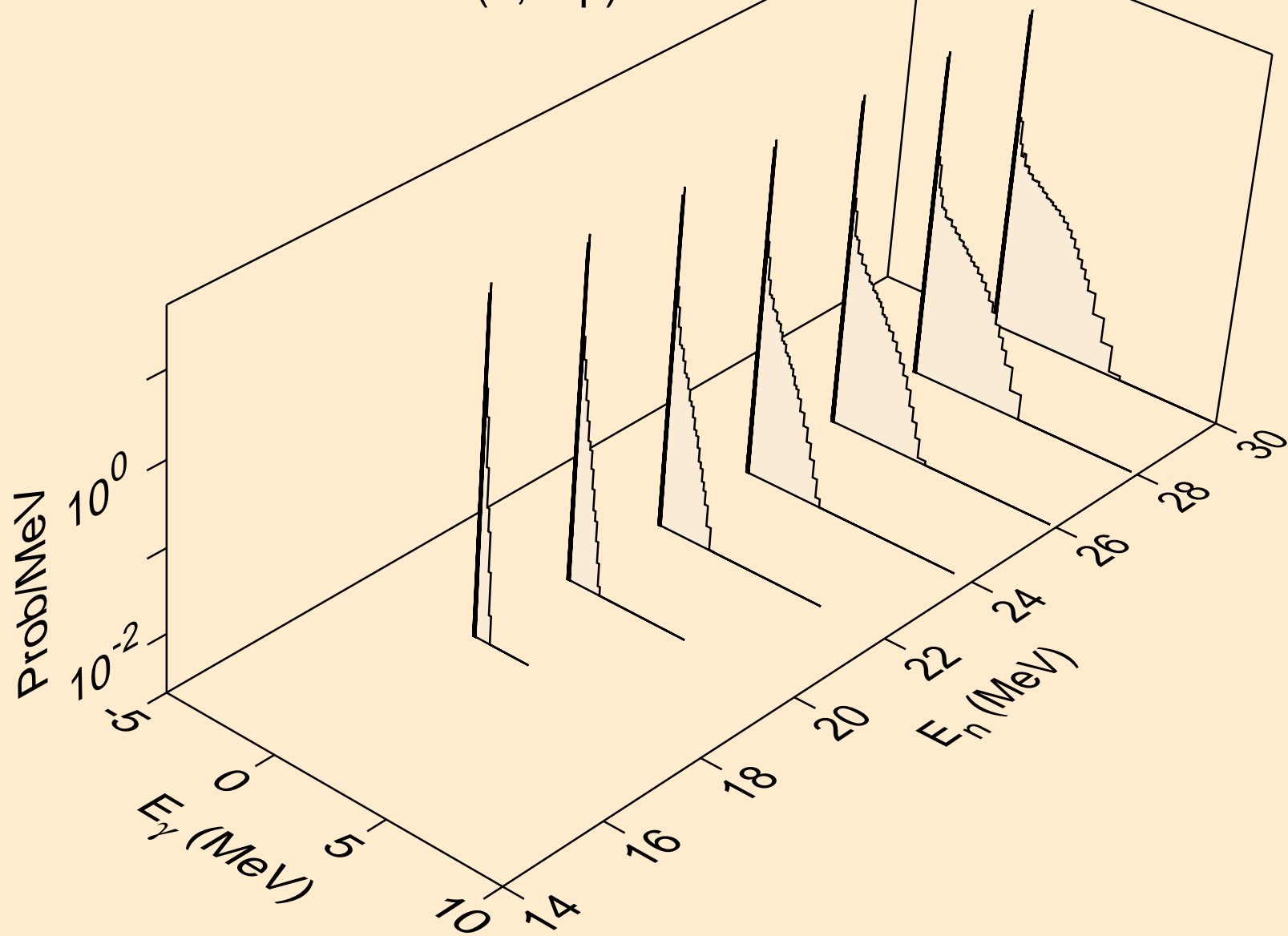

YB160 NEUTRON ACER TENDL-2023 LIBRARY; T=0.K  
Photon emission for (n,3np)

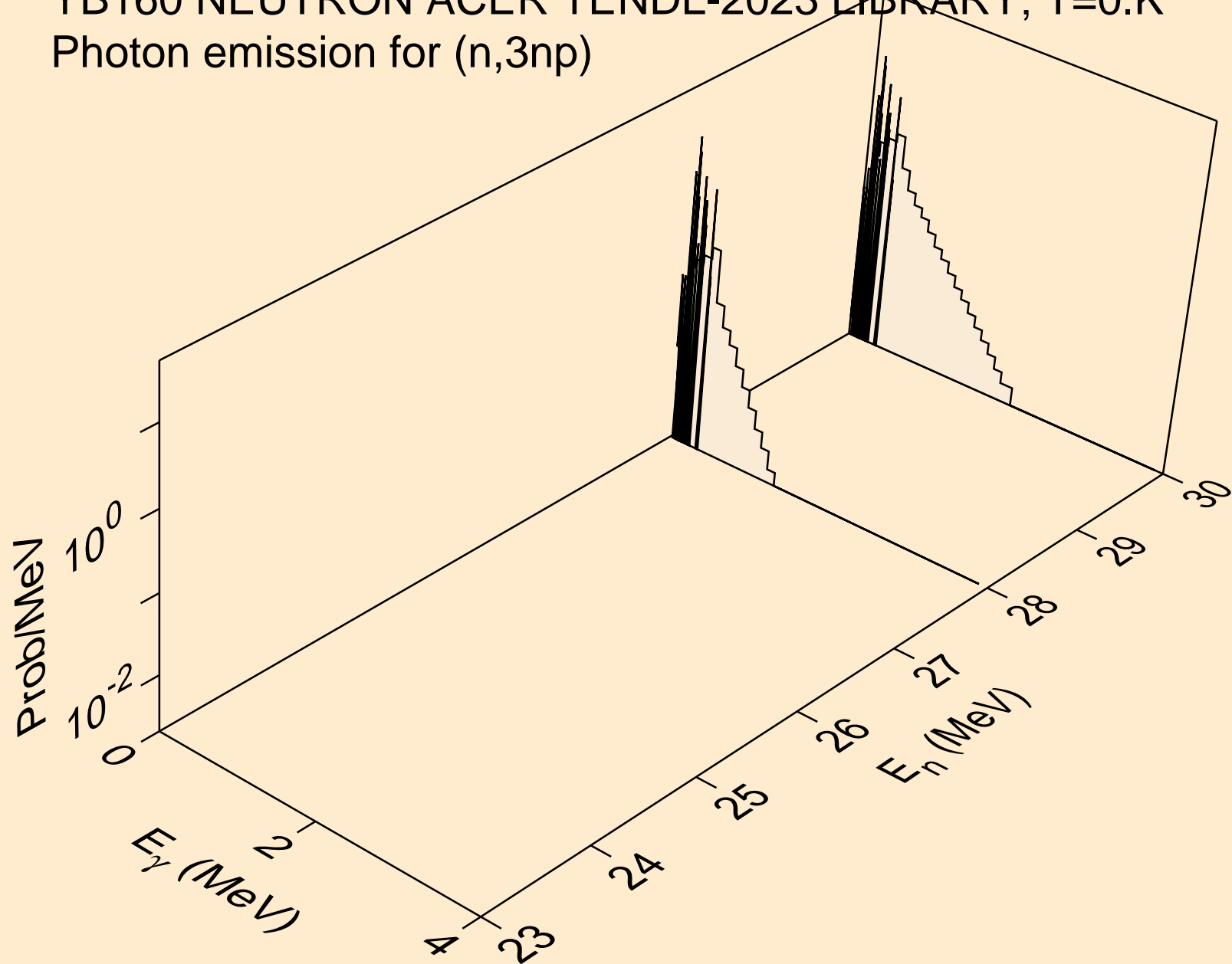

YB160 NEUTRON ACER TENDL-2023 LIBRARY; T=0.K  
Photon emission for (n,n2p)

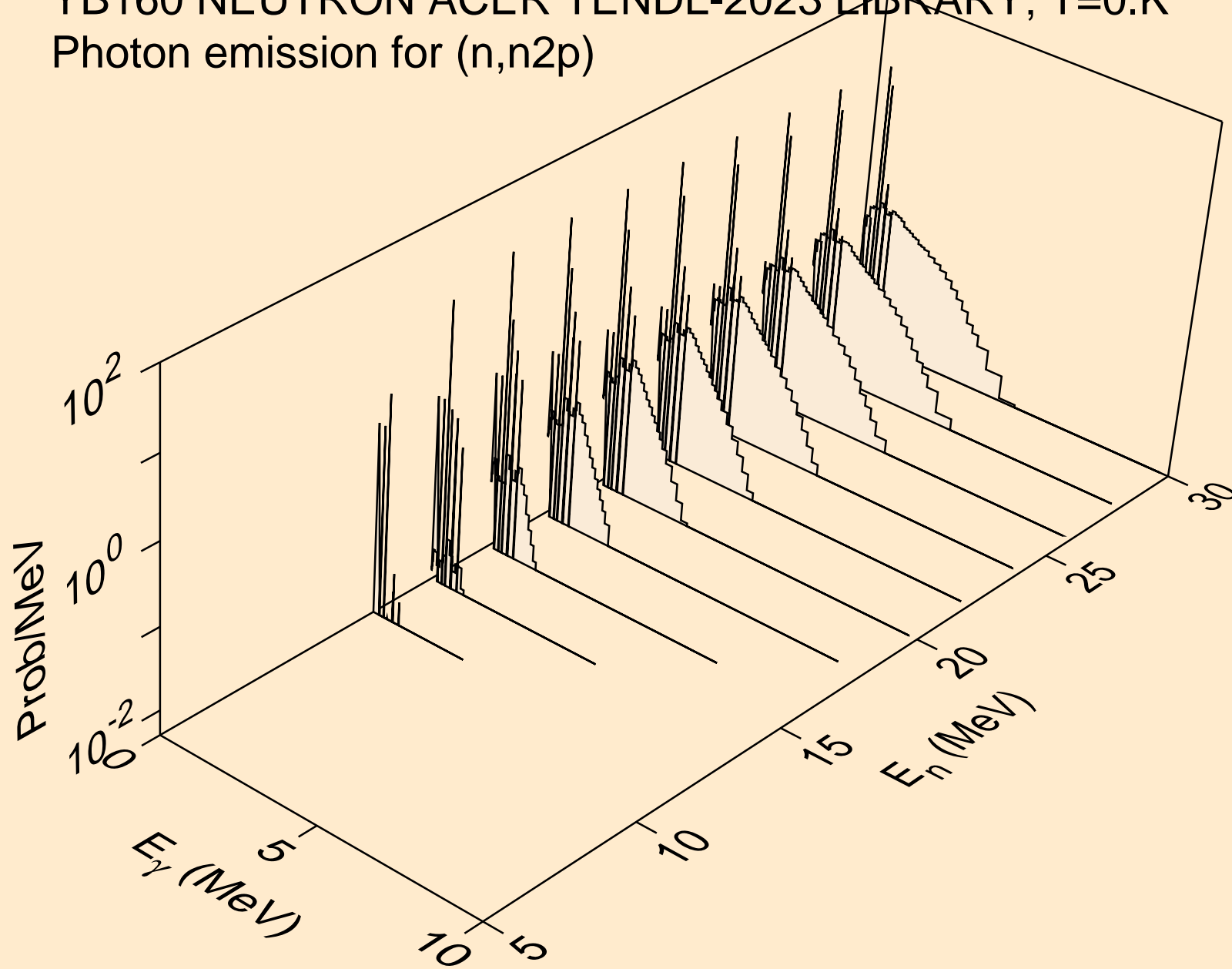

YB160 NEUTRON ACER TENDL-2023 LIBRARY; T=0.K  
Photon emission for (n,npa)

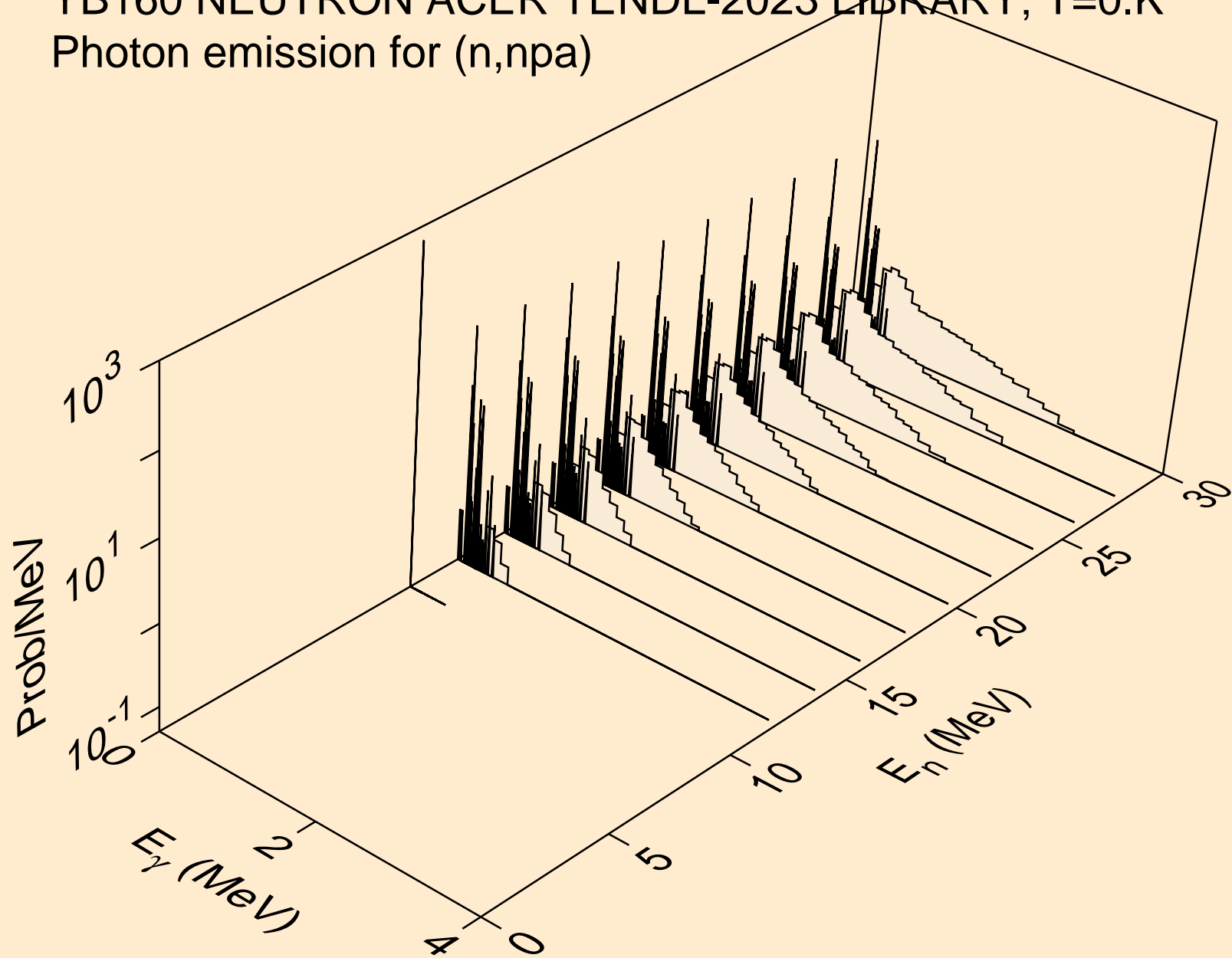

YB160 NEUTRON ACER TENDL-2023 LIBRARY; T=0.K  
Photon emission for (n,n\*c)

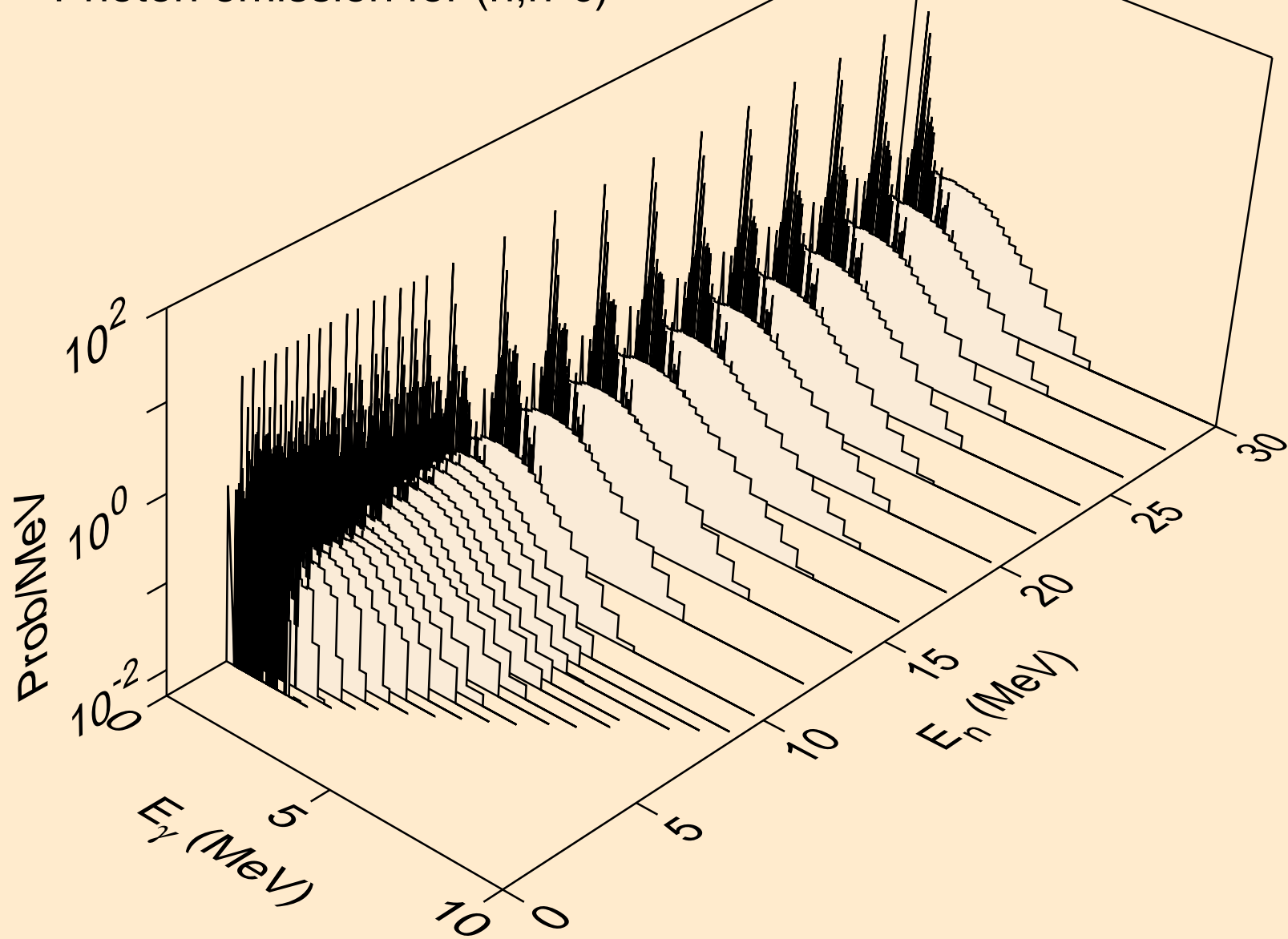

YB160 NEUTRON ACER TENDL-2023 LIBRARY; T=0.K  
Photon emission for (n,gma)

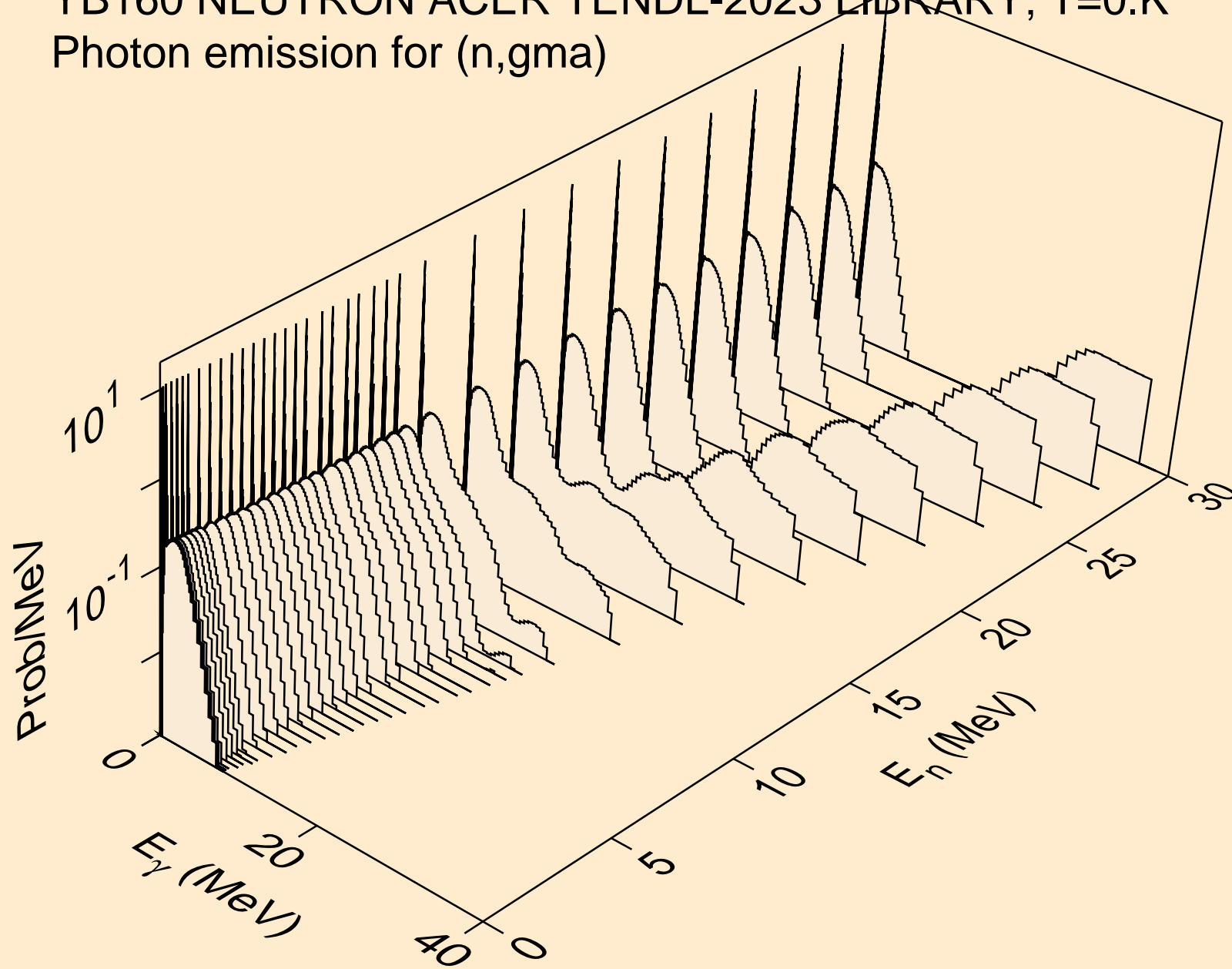

YB160 NEUTRON ACER TENDL-2023 LIBRARY; T=0.K  
Photon emission for (n,p)

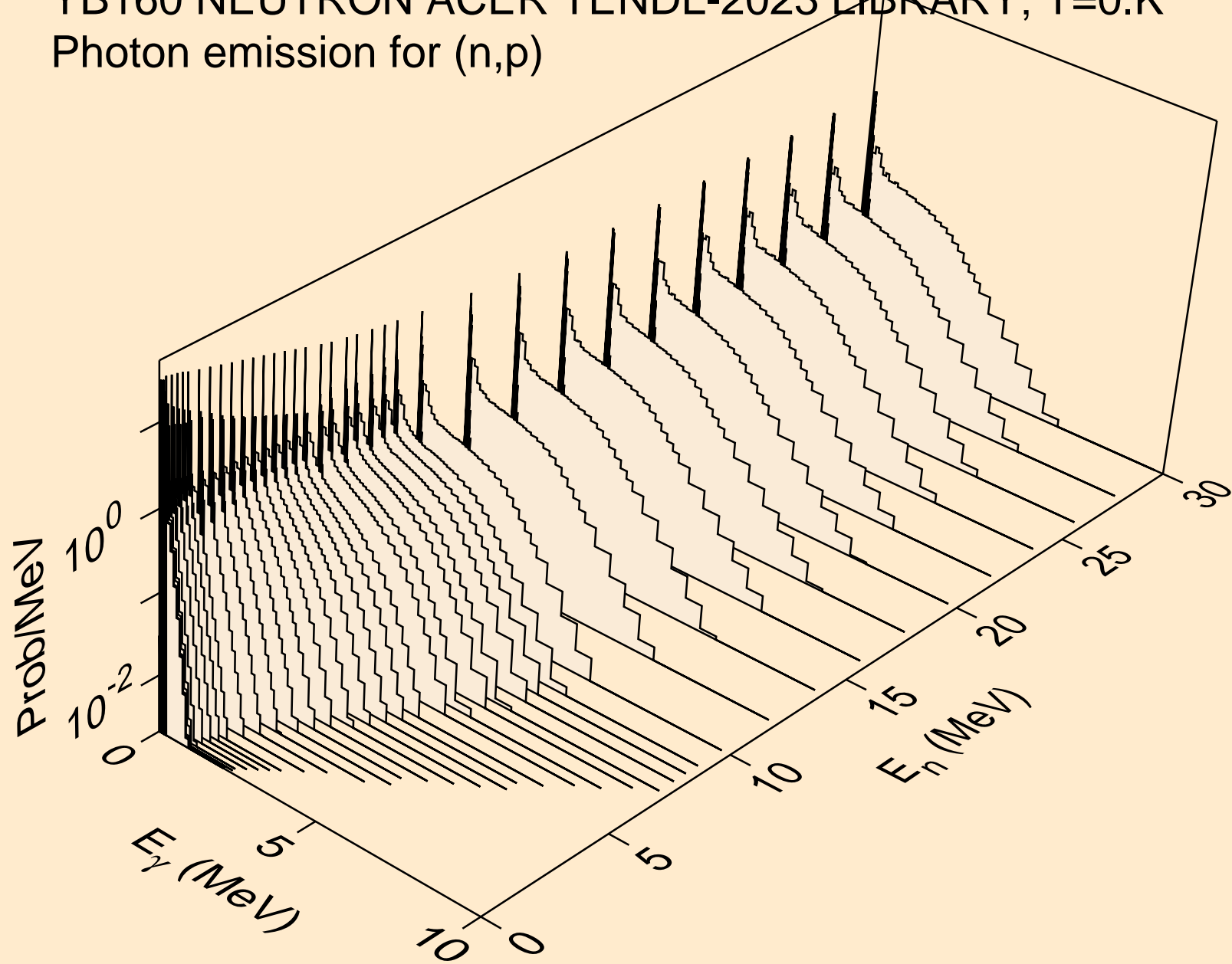

YB160 NEUTRON ACER TENDL-2023 LIBRARY; T=0.K  
Photon emission for (n,d)

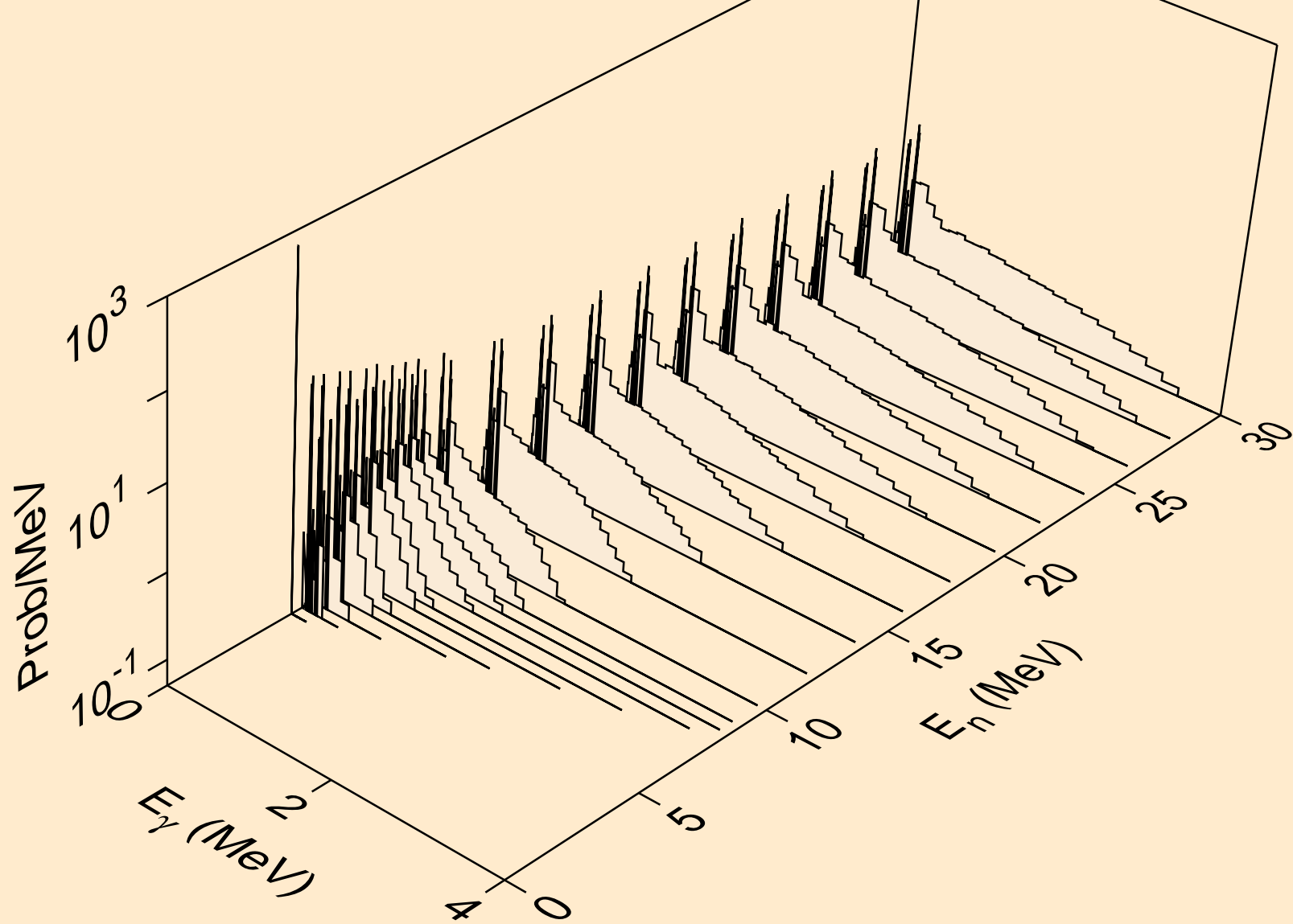

YB160 NEUTRON ACER TENDL-2023 LIBRARY; T=0.K  
Photon emission for (n,t)

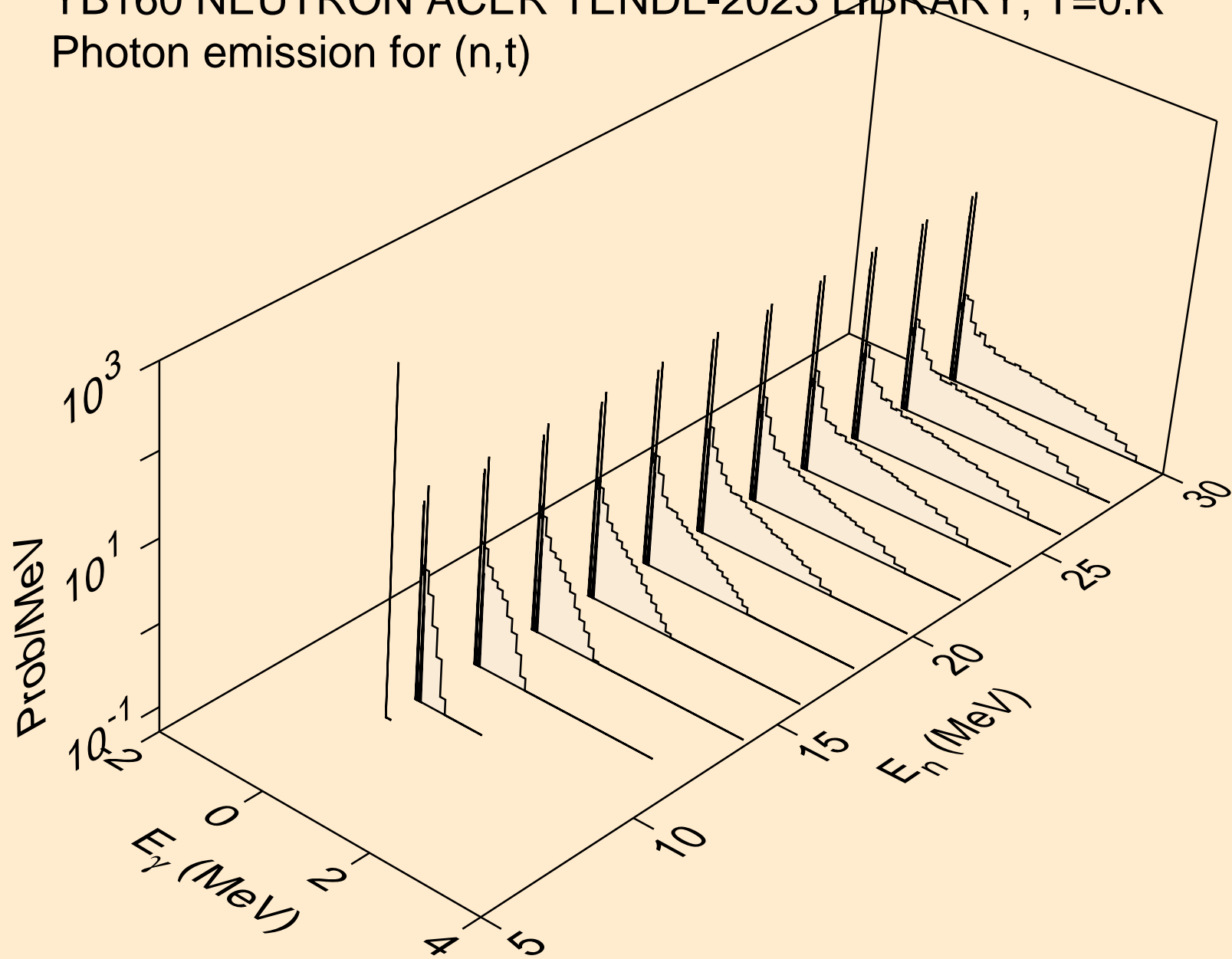

YB160 NEUTRON ACER TENDL-2023 LIBRARY; T=0.K  
Photon emission for (n,he3)

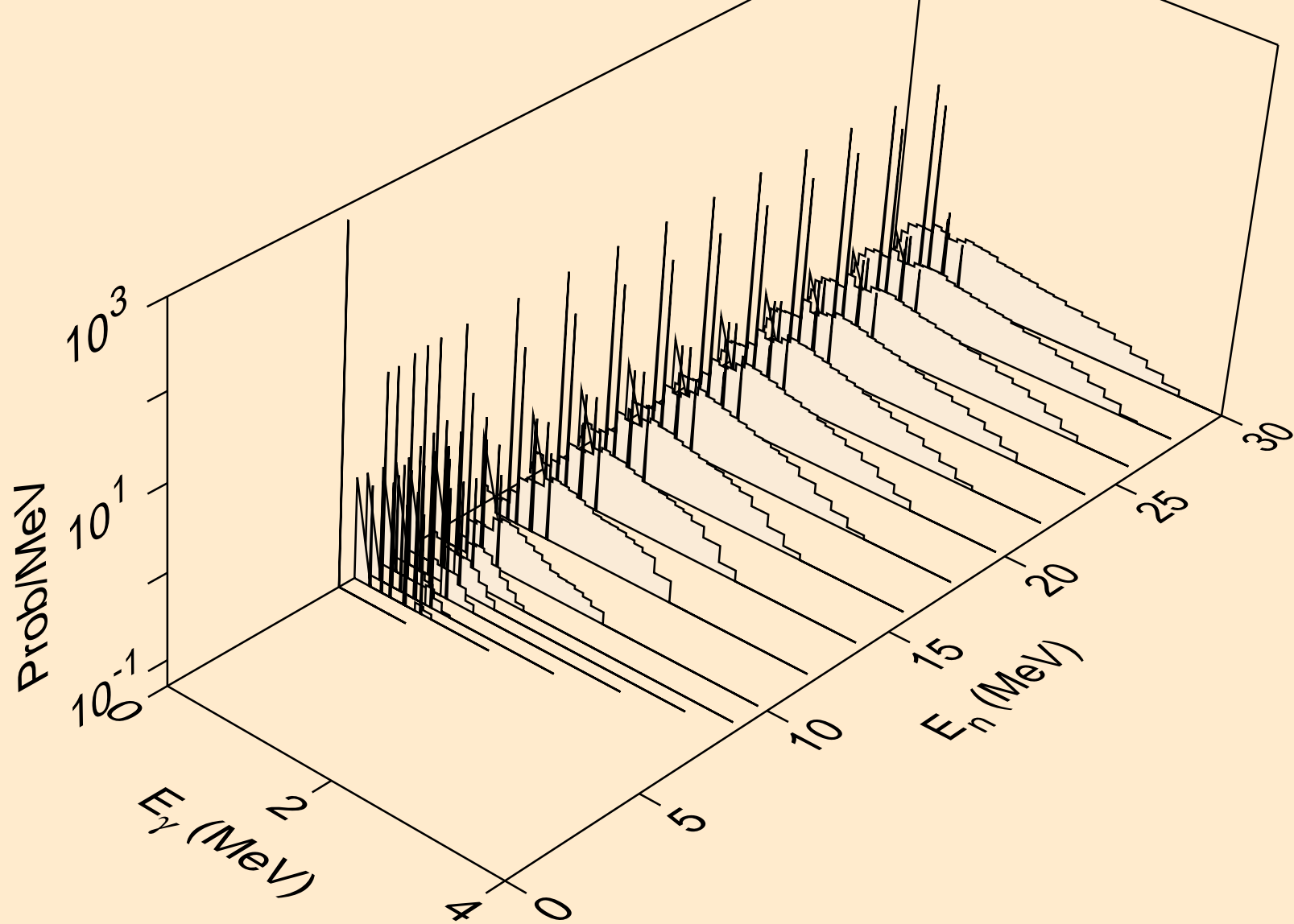

YB160 NEUTRON ACER TENDL-2023 LIBRARY; T=0.K  
Photon emission for (n,a)

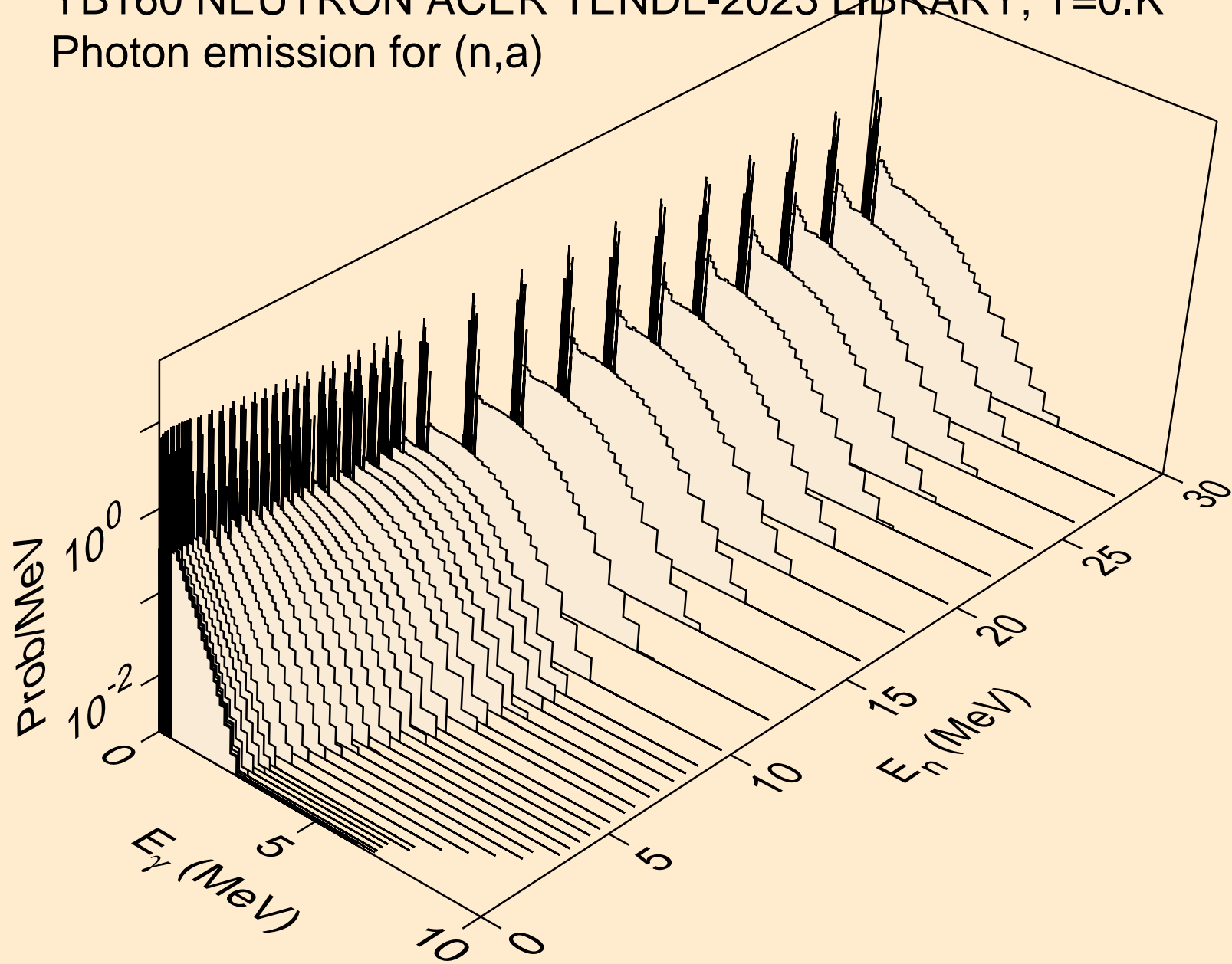

YB160 NEUTRON ACER TENDL-2023 LIBRARY; T=0.K  
Photon emission for (n,2a)

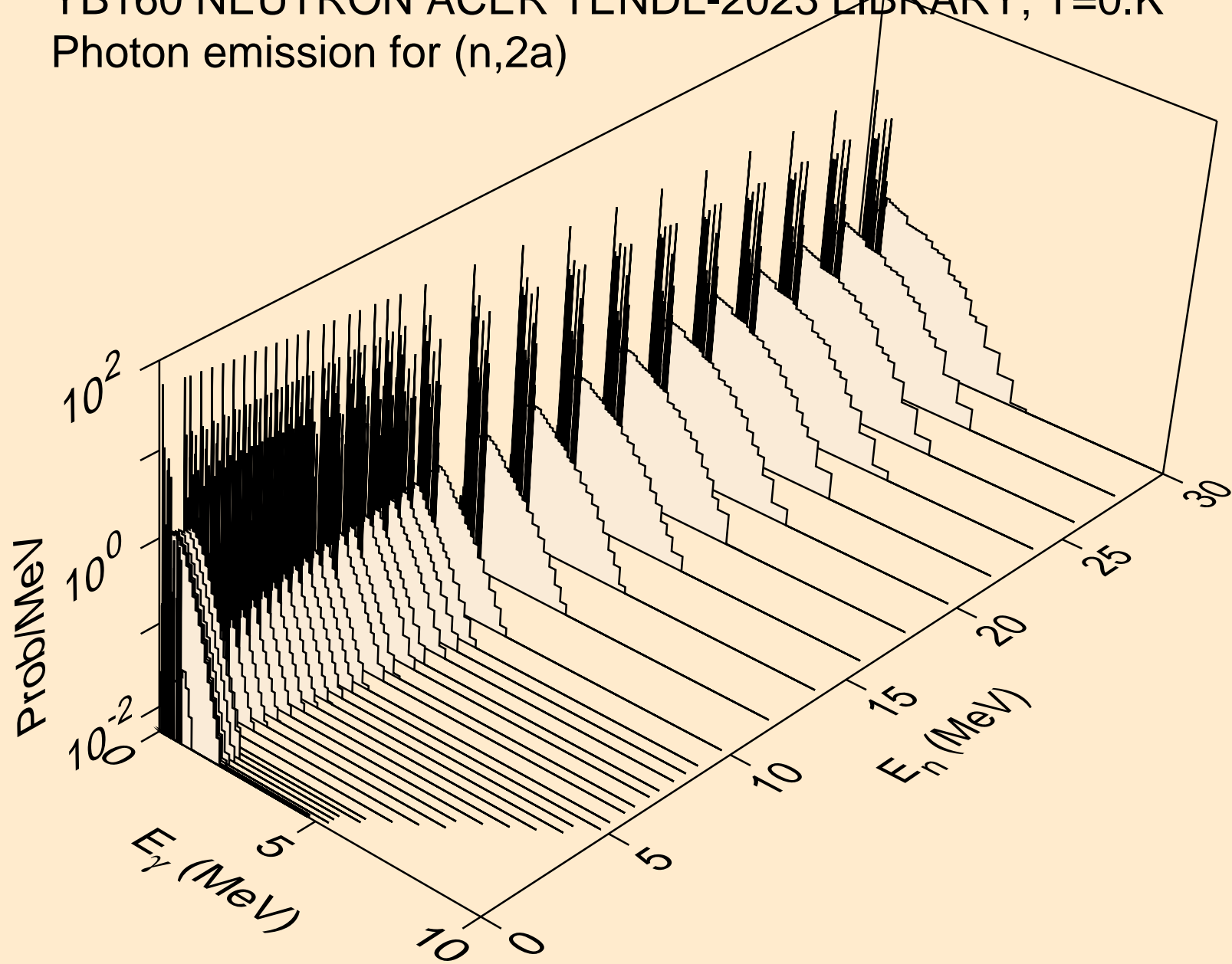

YB160 NEUTRON ACER TENDL-2023 LIBRARY; T=0.K  
Photon emission for (n,3a)

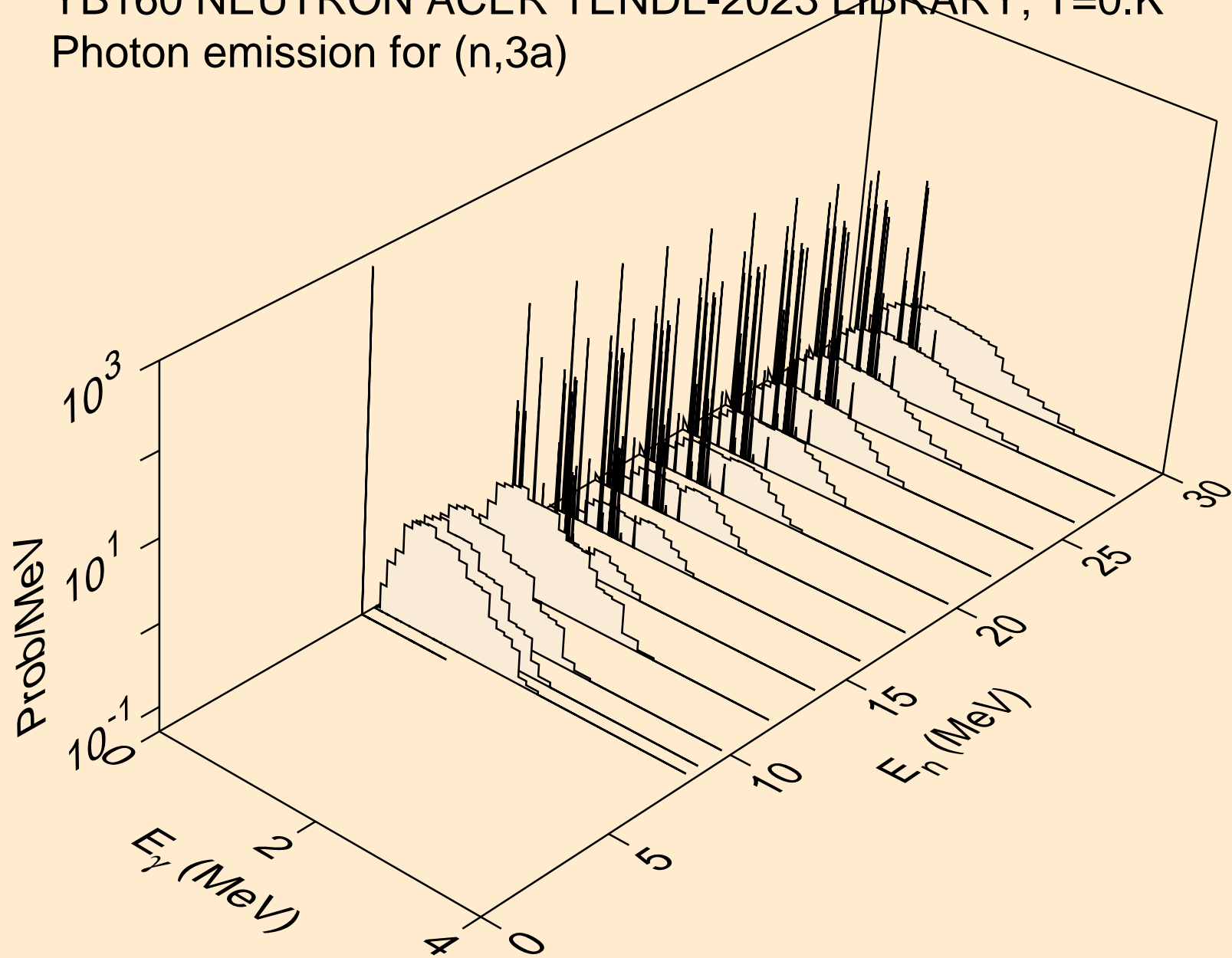

YB160 NEUTRON ACER TENDL-2023 LIBRARY; T=0.K  
Photon emission for (n,2p)

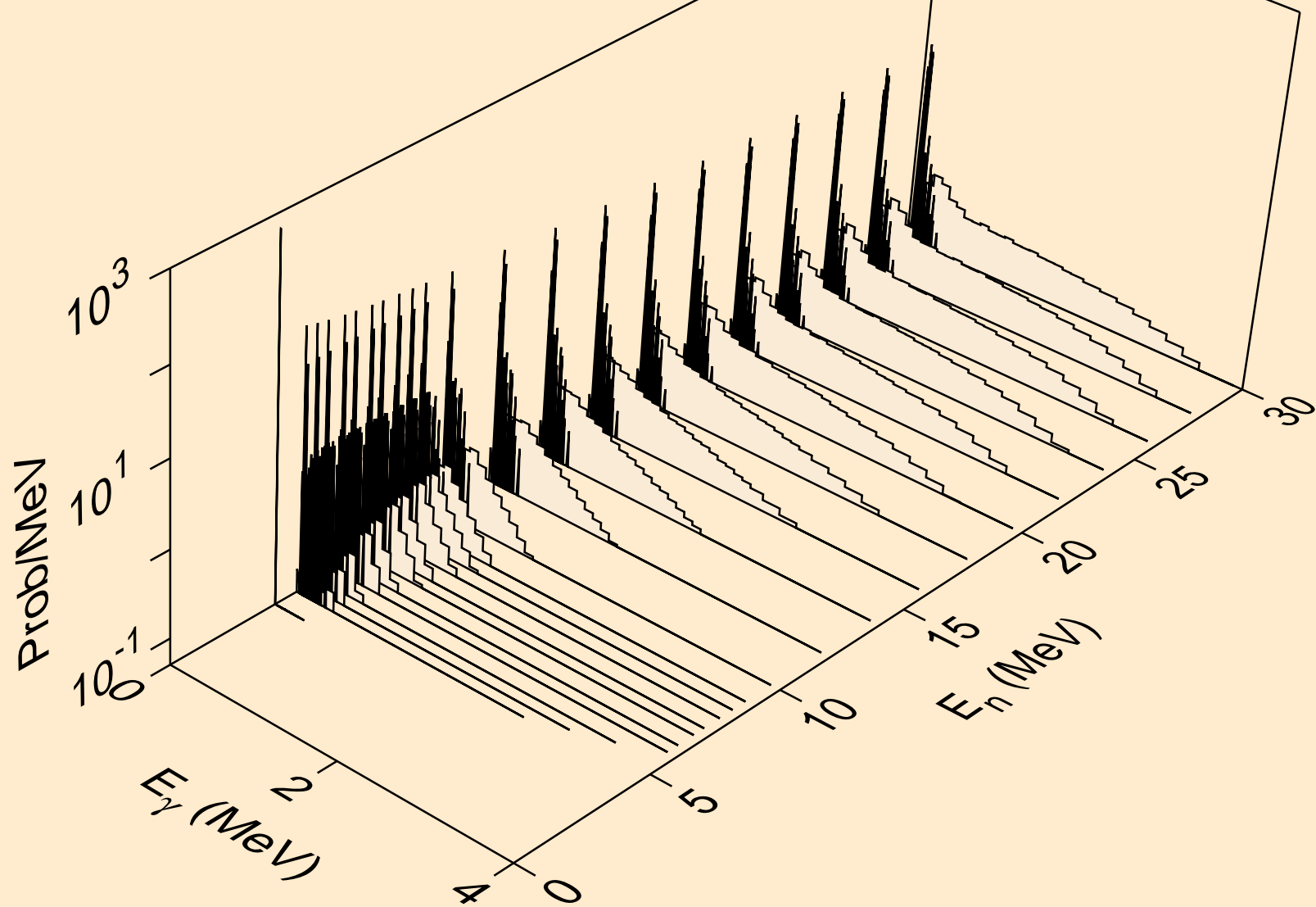

YB160 NEUTRON ACER TENDL-2023 LIBRARY; T=0.K  
Photon emission for (n,p $\alpha$ )

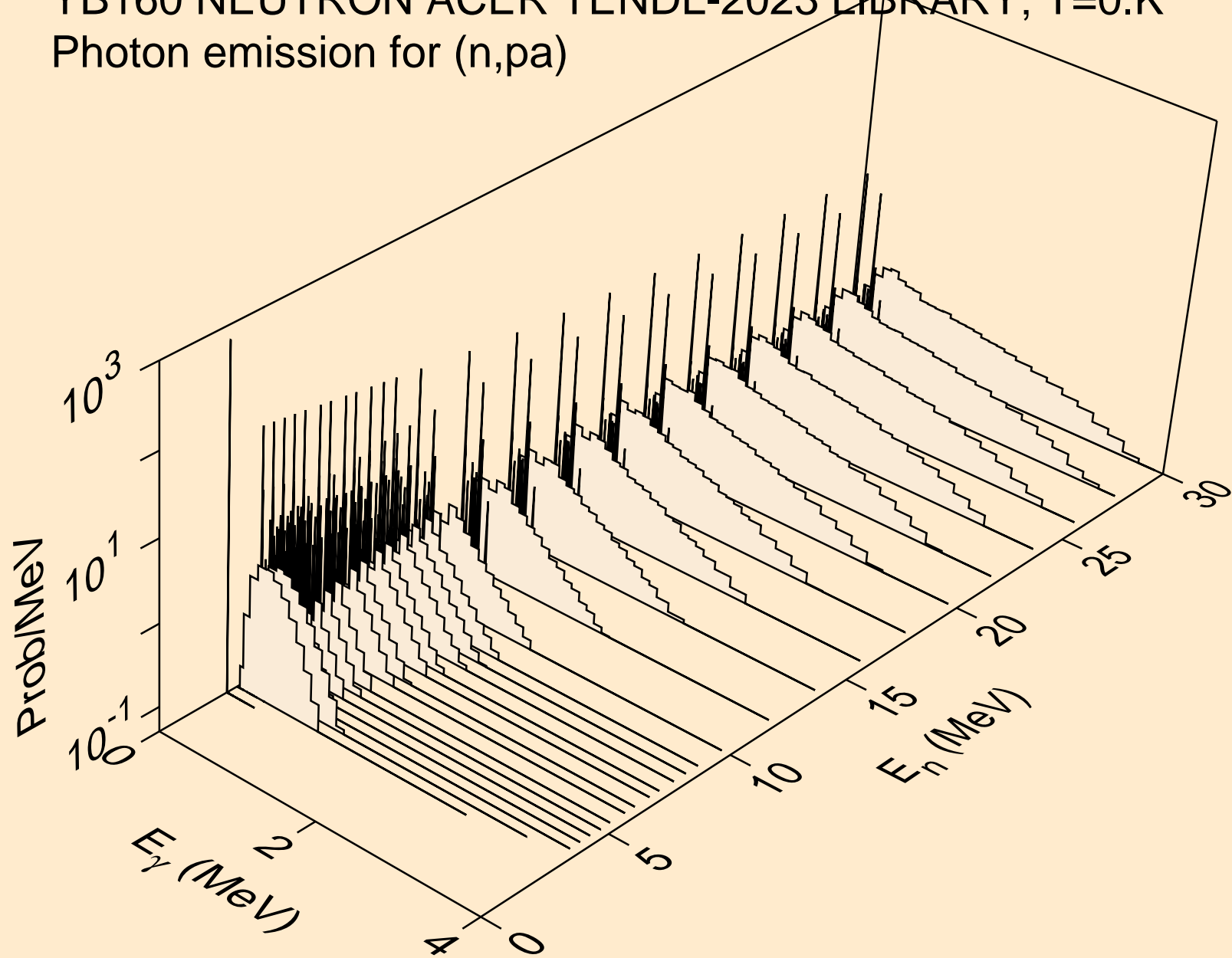

YB160 NEUTRON ACER TENDL-2023 LIBRARY; T=0.K  
Photon emission for (n,pd)

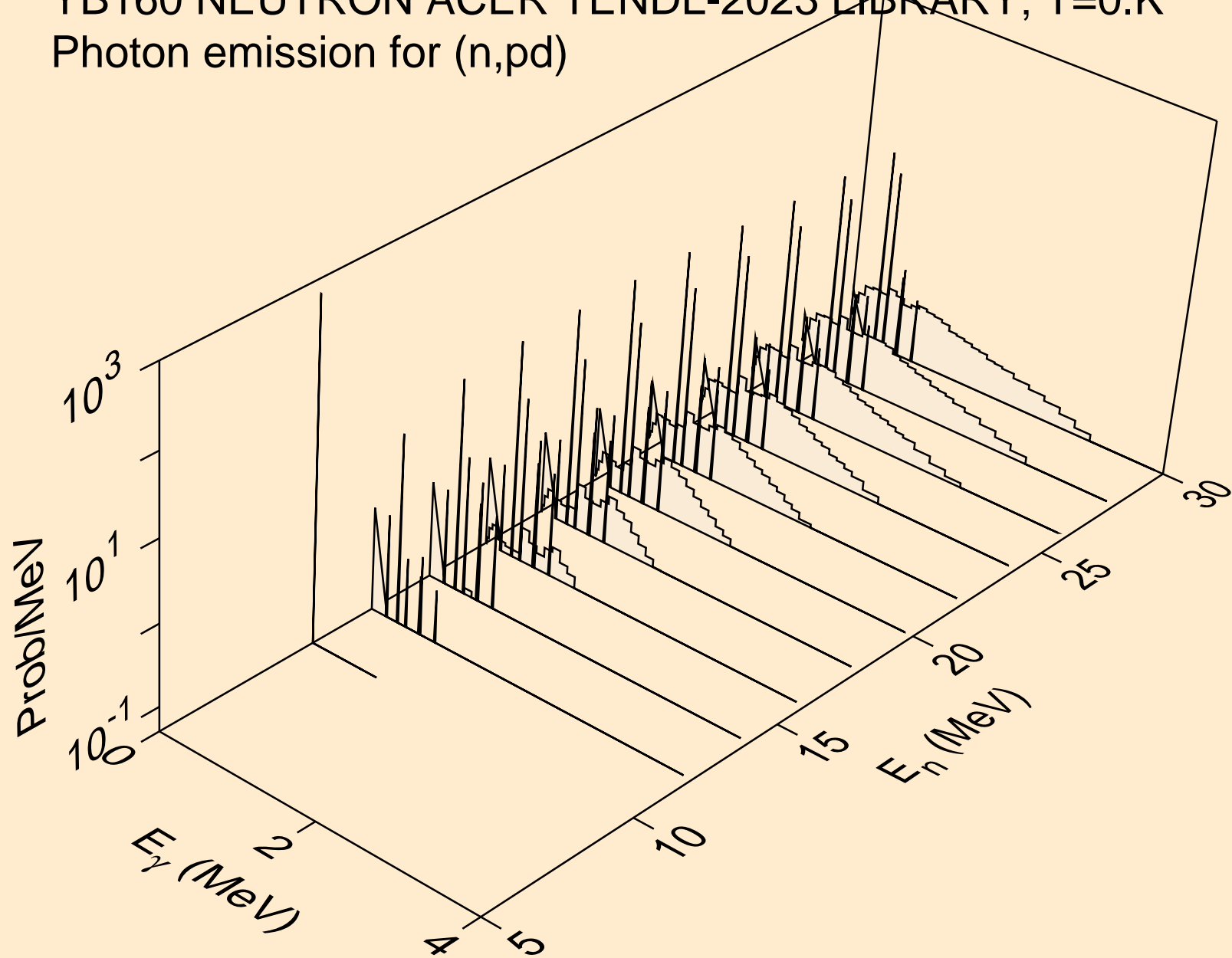

YB160 NEUTRON ACER TENDL-2023 LIBRARY; T=0.K  
Photon emission for (n,pt)

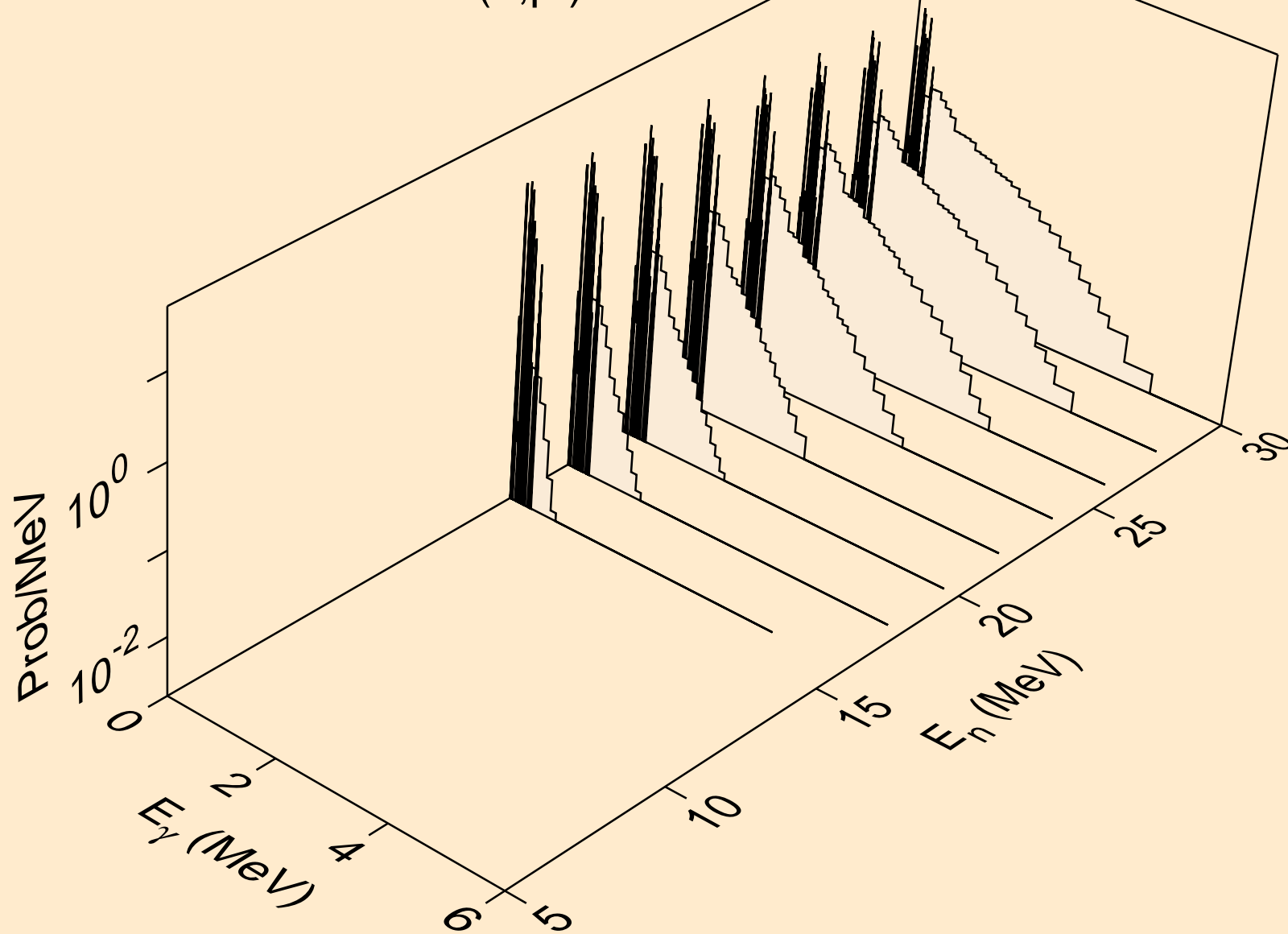

YB160 NEUTRON ACER TENDL-2023 LIBRARY; T=0.K  
Photon emission for (n,da)

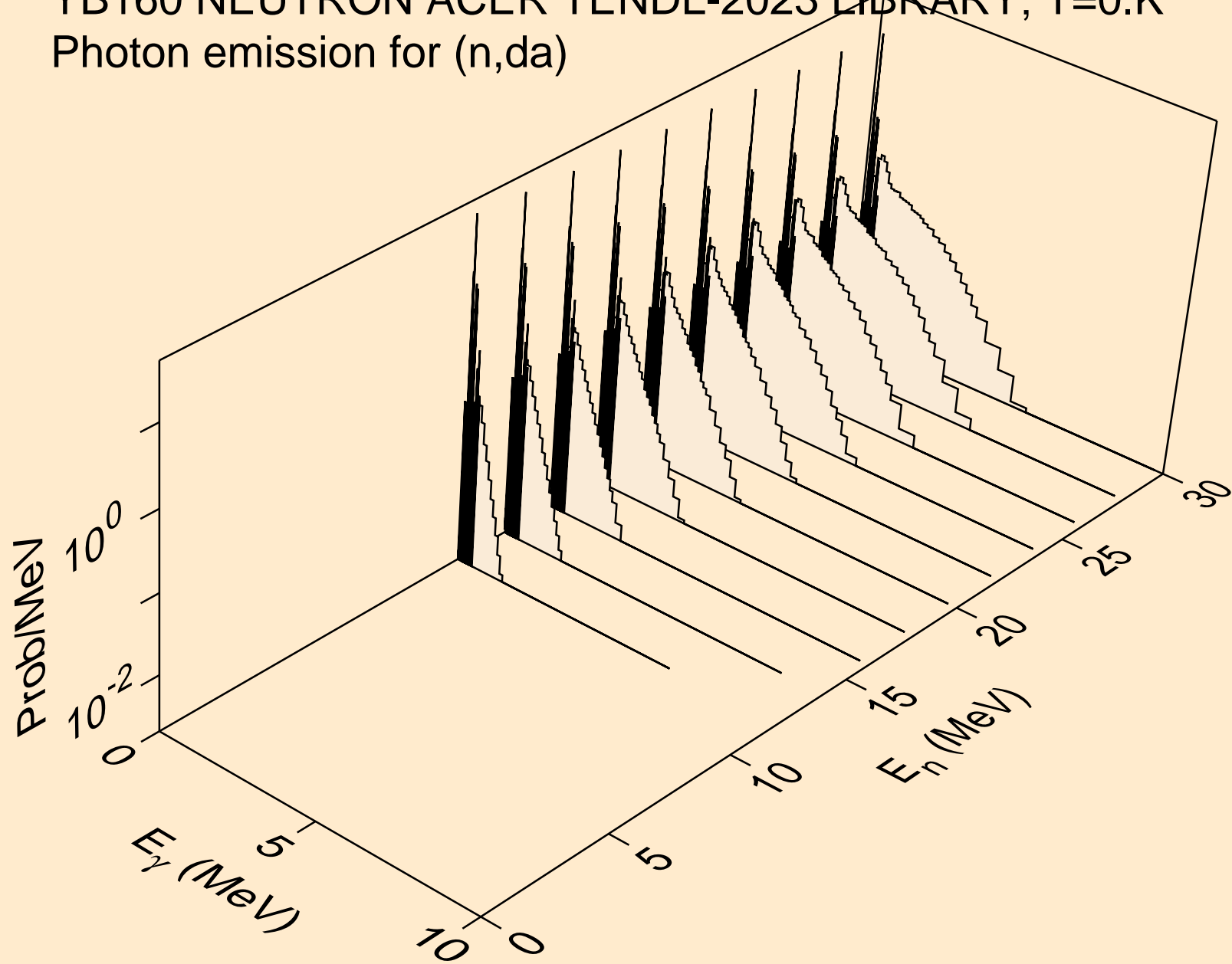

YB160 NEUTRON ACER TENDL-2023 LIBRARY; T=0.K  
thermal capture photon spectrum

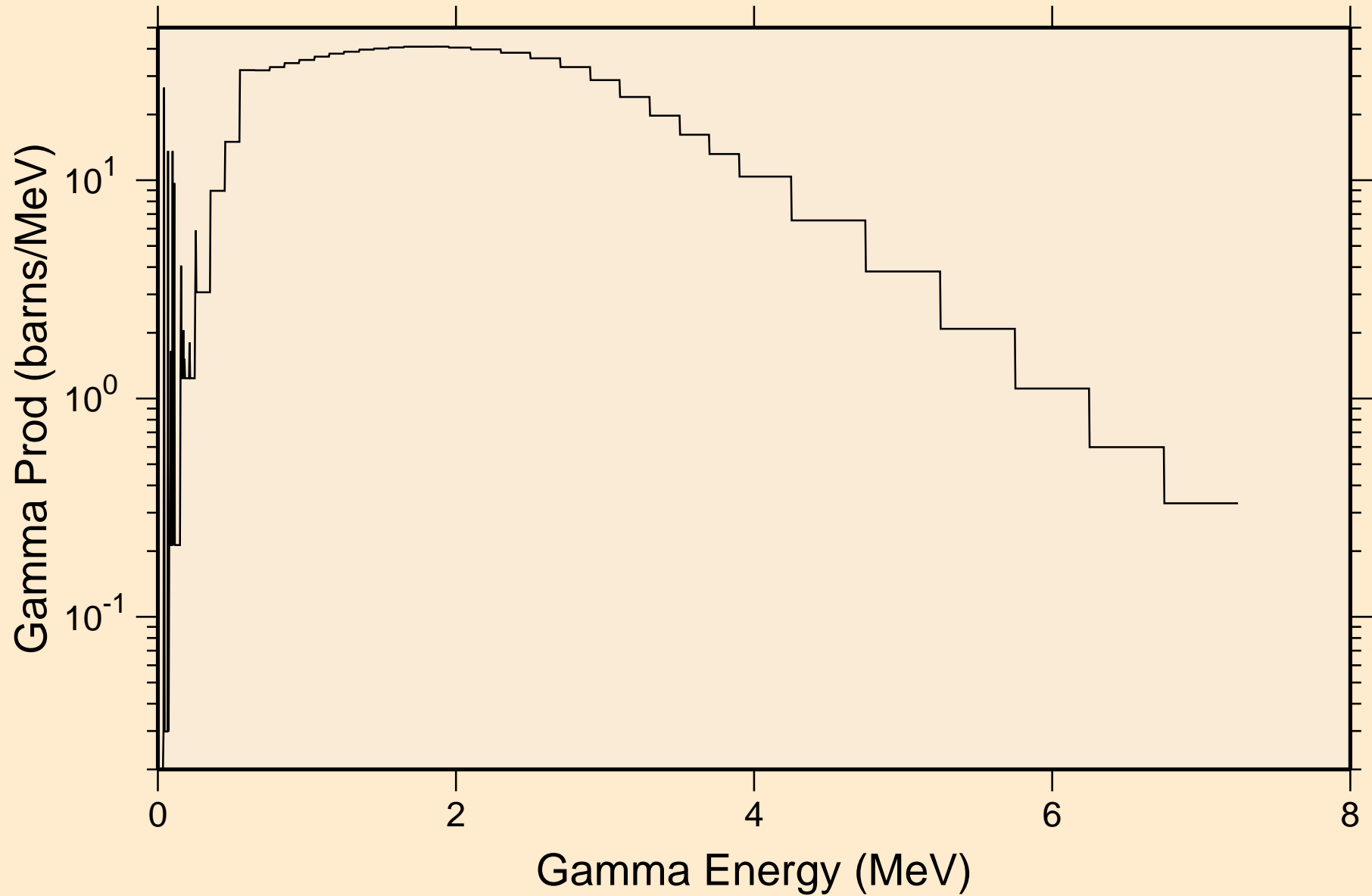

YB160 NEUTRON ACER TENDL-2023 LIBRARY; T=0.K  
14 MeV photon spectrum

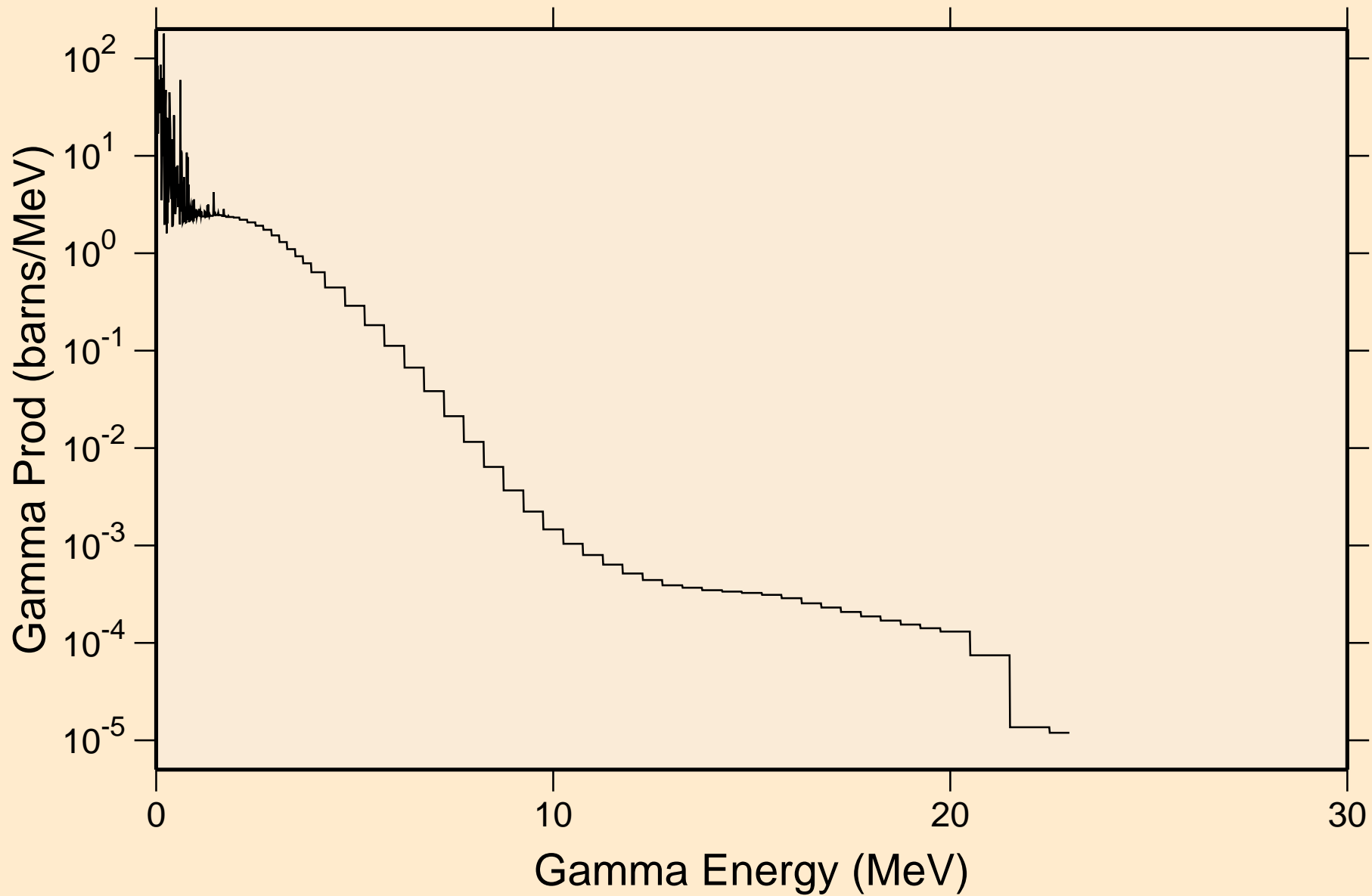

# YB160 NEUTRON ACER TENDL-2023 LIBRARY; T=0.K

## Particle heating contributions

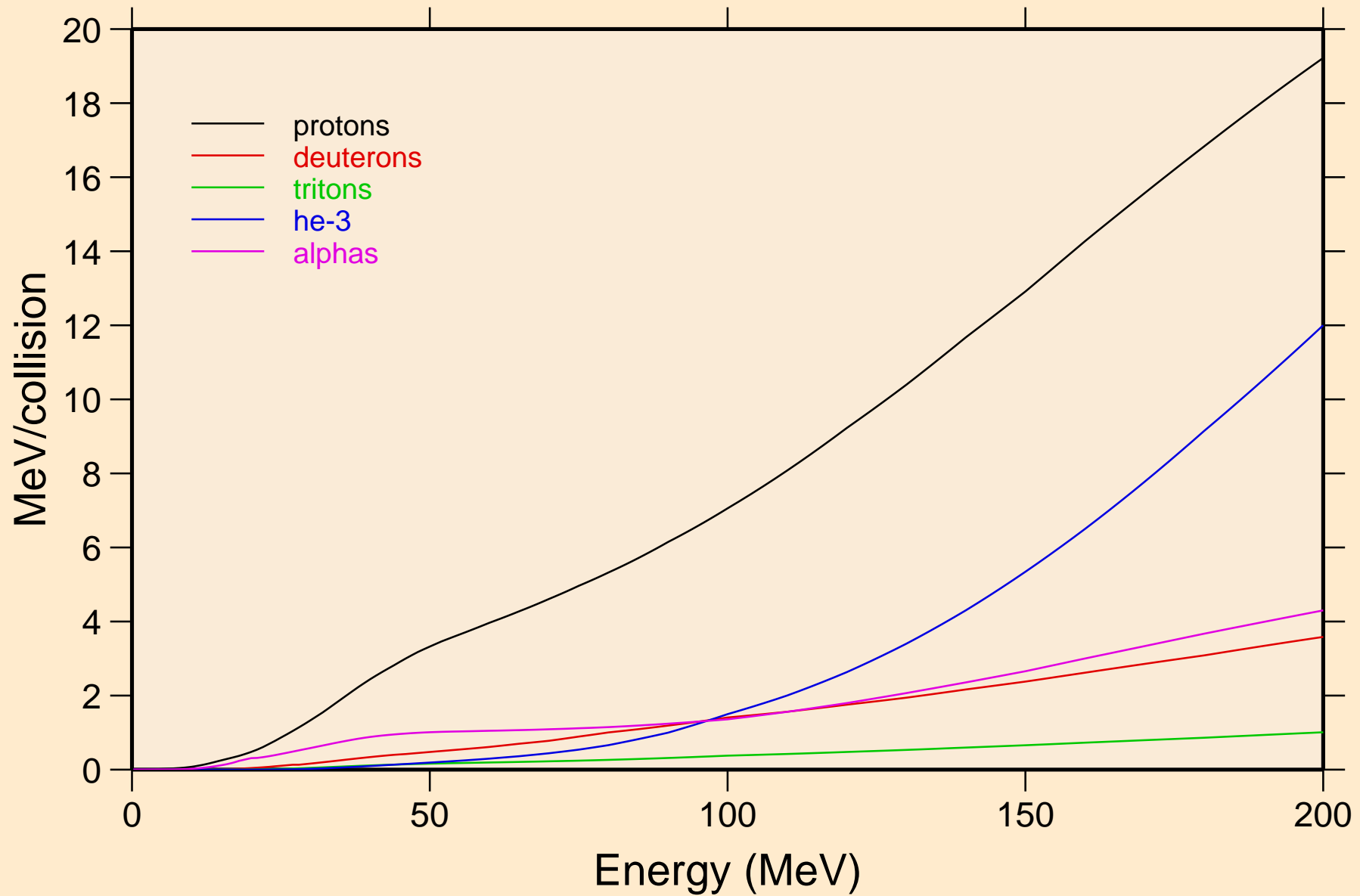

YB160 NEUTRON ACER TENDL-2023 LIBRARY; T=0.K  
Recoil Heating

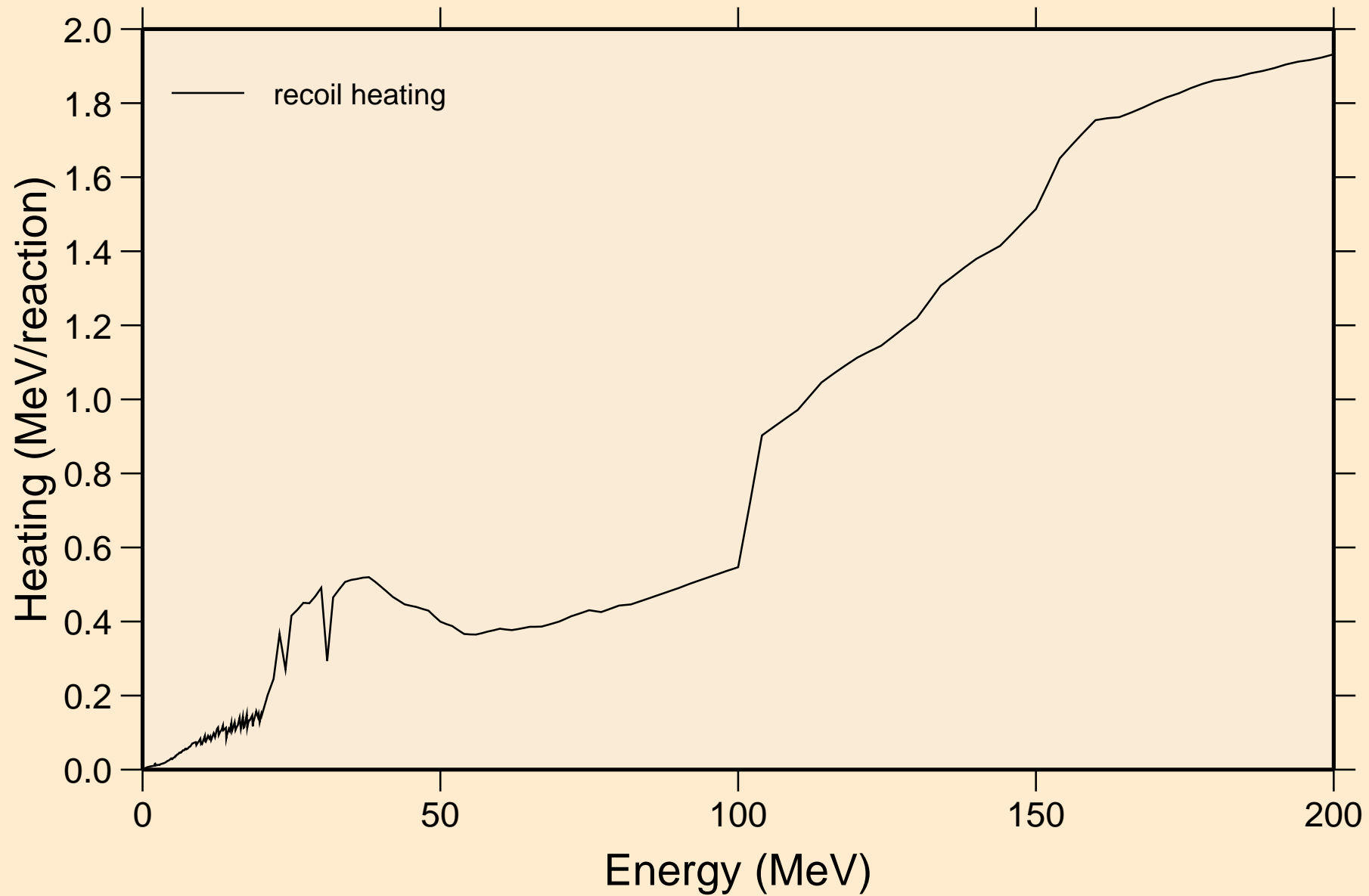

YB160 NEUTRON ACER TENDL-2023 LIBRARY; T=0.K  
Particle production cross sections

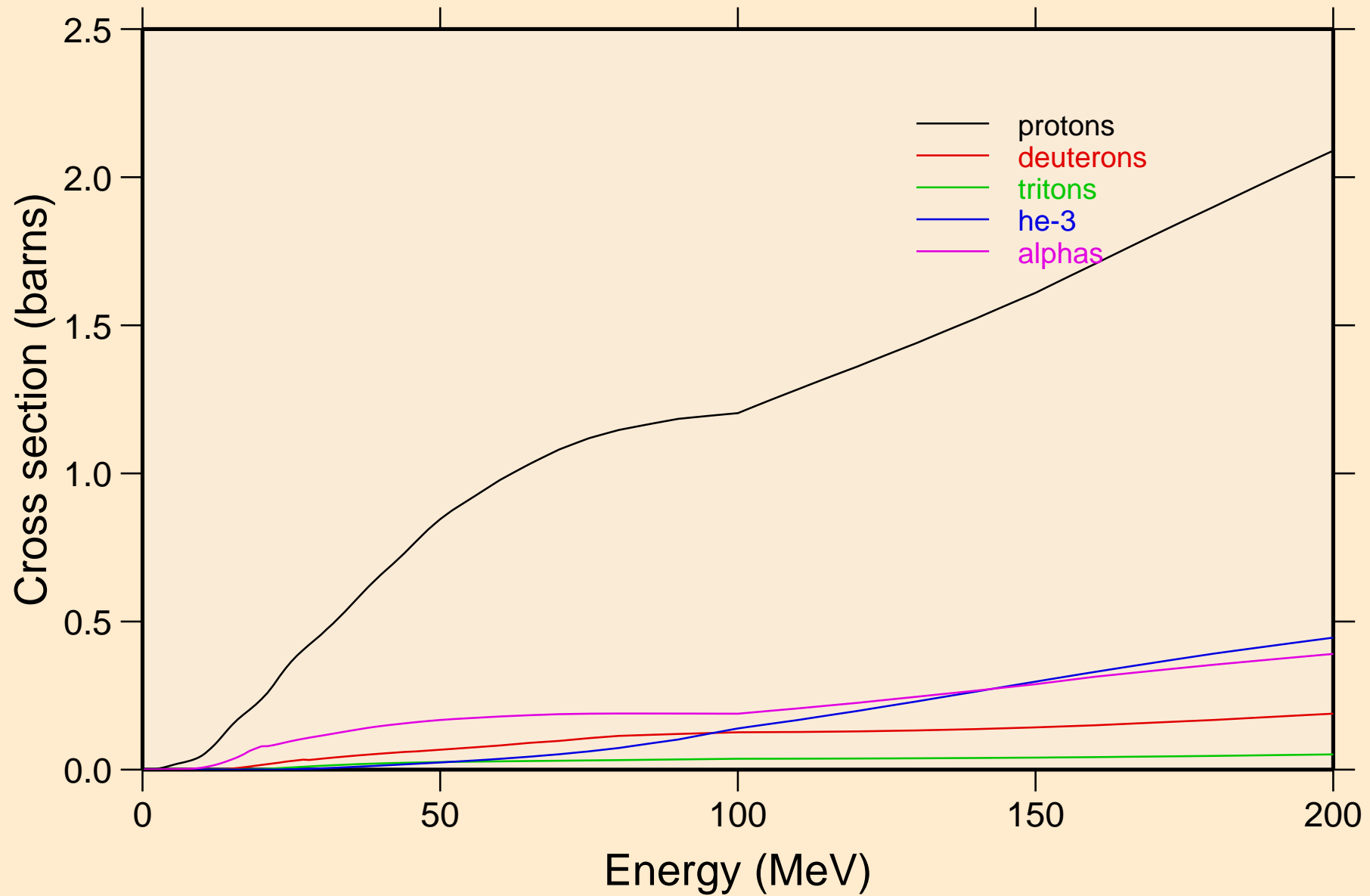

YB160 NEUTRON ACER TENDL-2023 LIBRARY; T=0.K  
protons from (n,x)

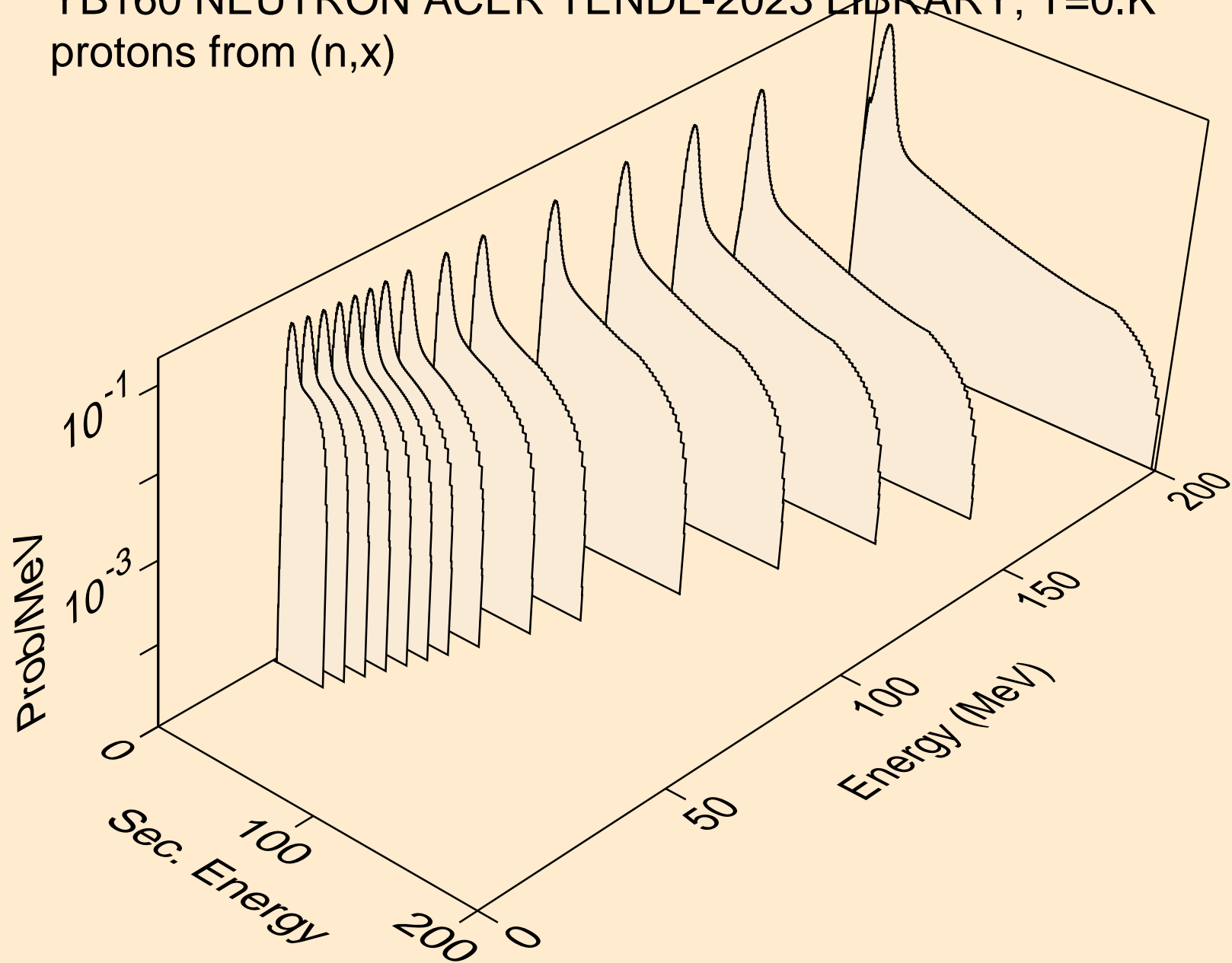

YB160 NEUTRON ACER TENDL-2023 LIBRARY; T=0.K  
protons from (n,n\*)p

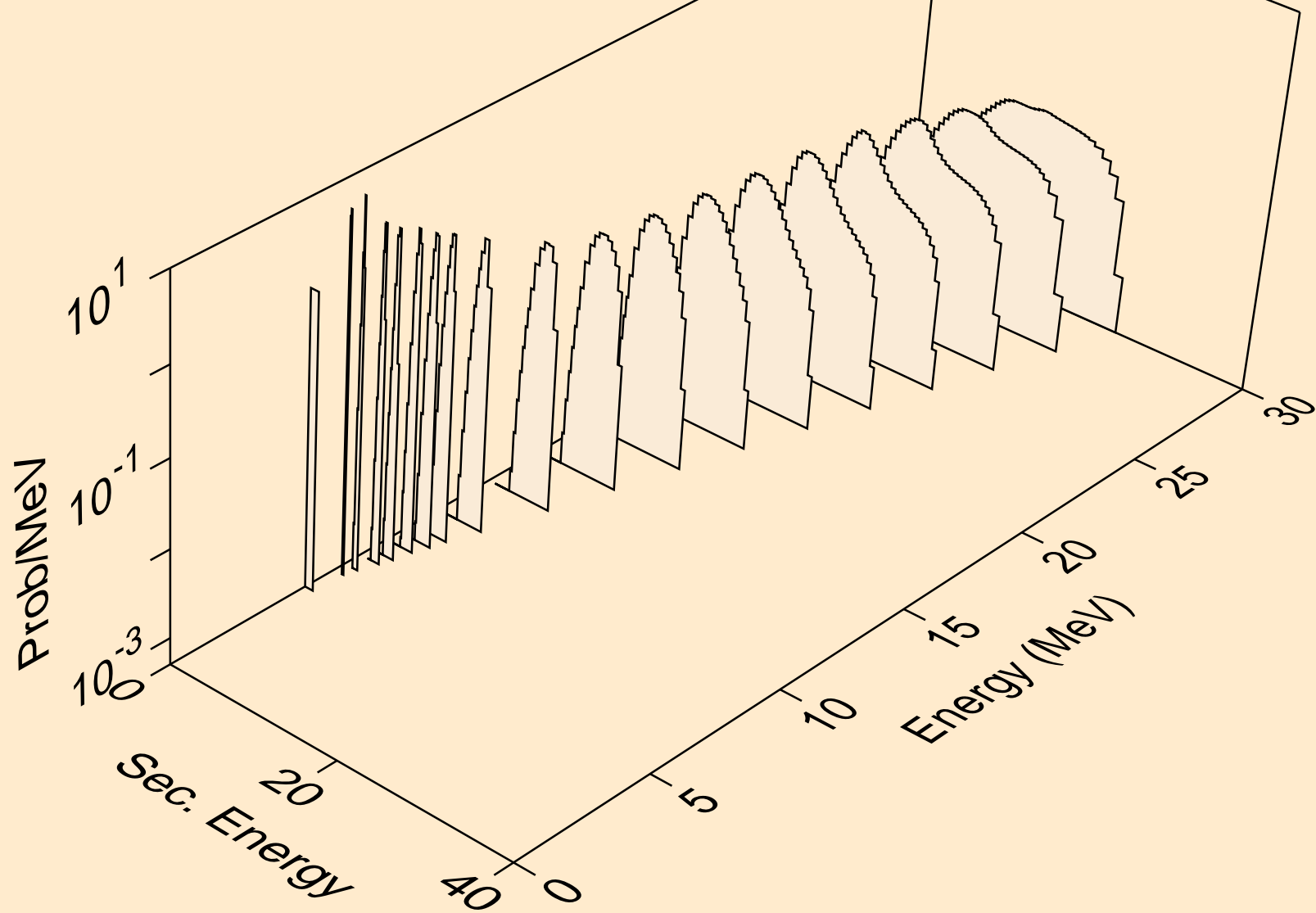

YB160 NEUTRON ACER TENDL-2023 LIBRARY; T=0.K  
protons from (n,2np)

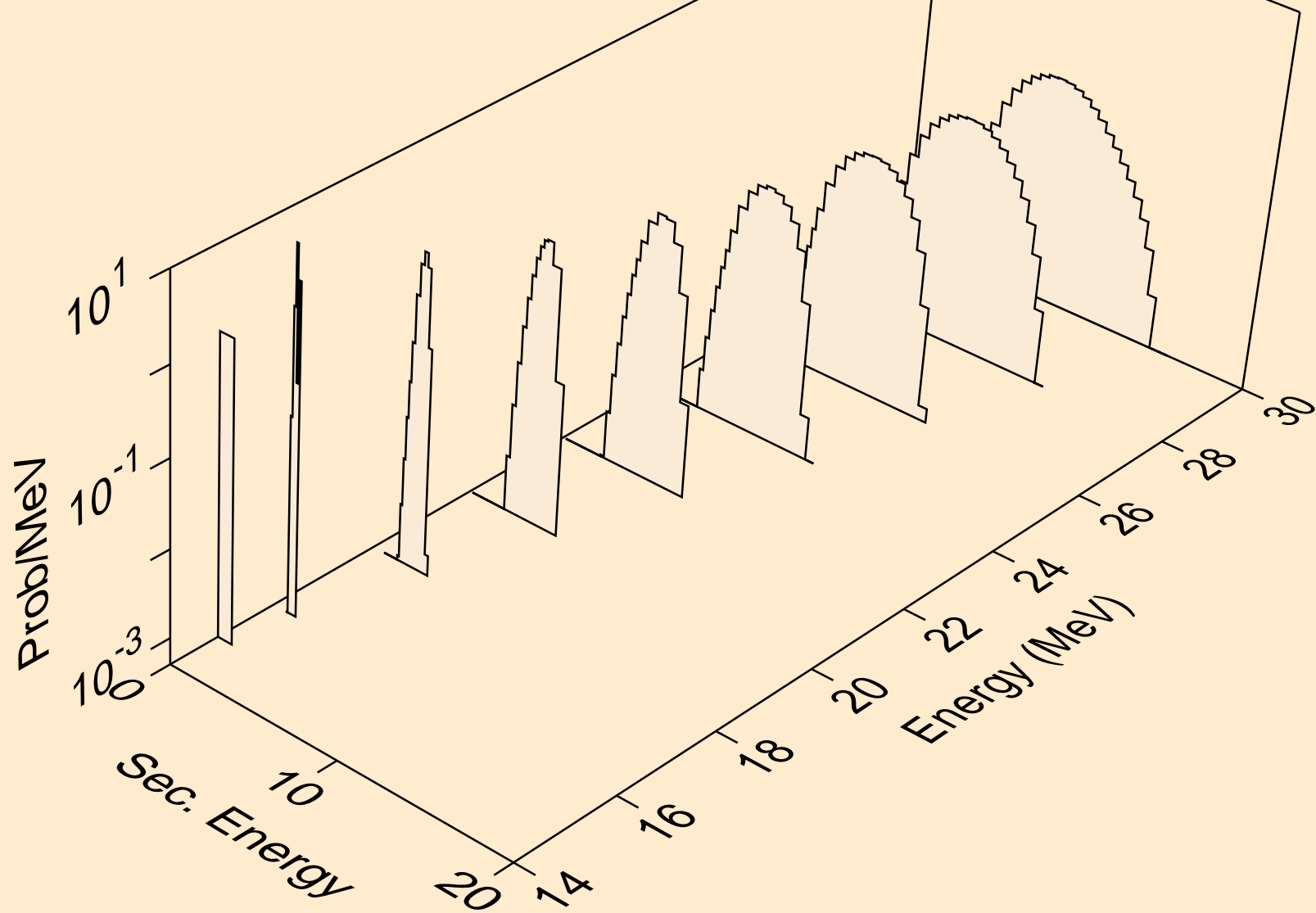

YB160 NEUTRON ACER TENDL-2023 LIBRARY; T=0.K  
protons from (n,3np)

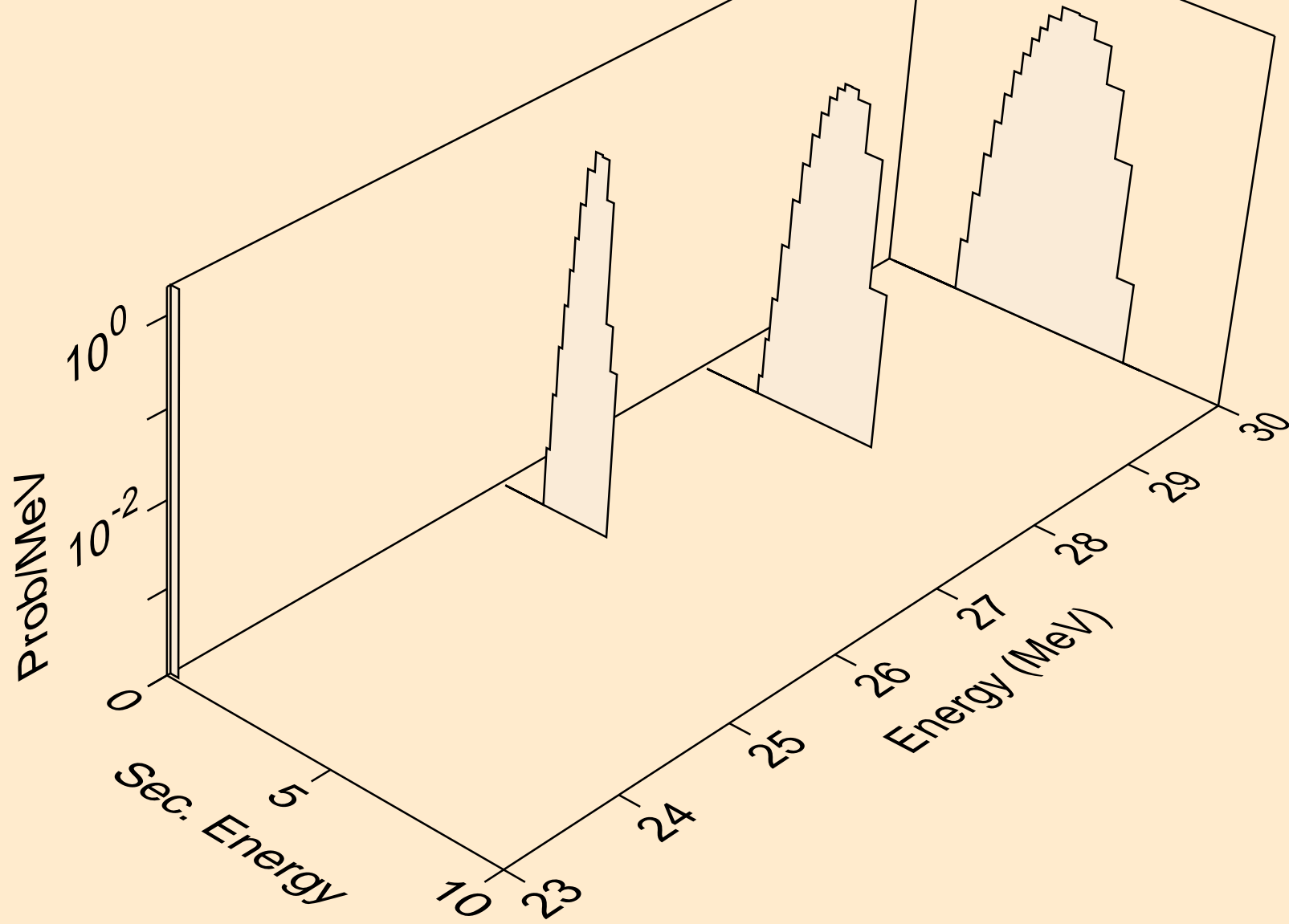

YB160 NEUTRON ACER TENDL-2023 LIBRARY; T=0.K  
protons from (n,n2p)

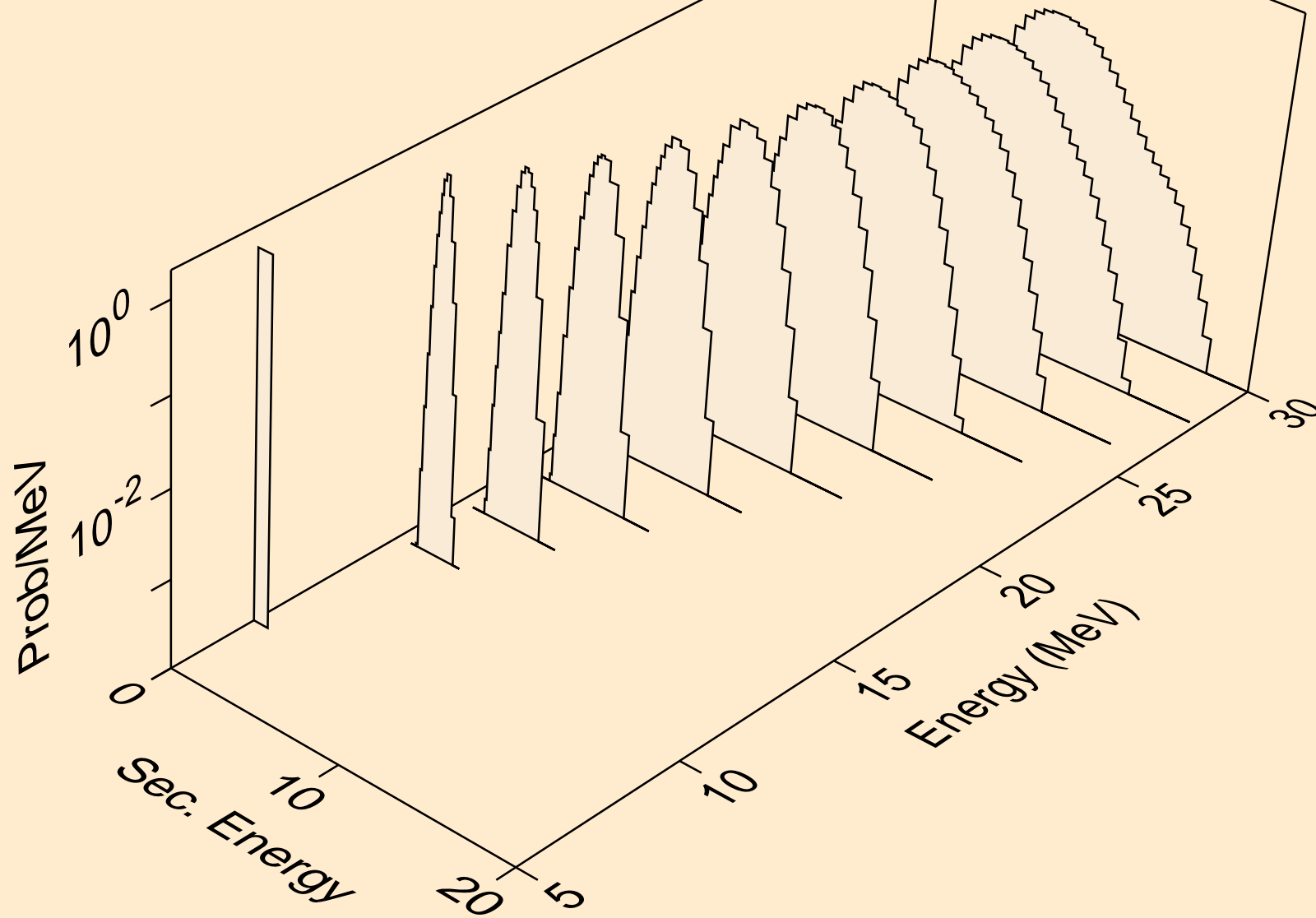

YB160 NEUTRON ACER TENDL-2023 LIBRARY; T=0.K  
protons from (n,npa)

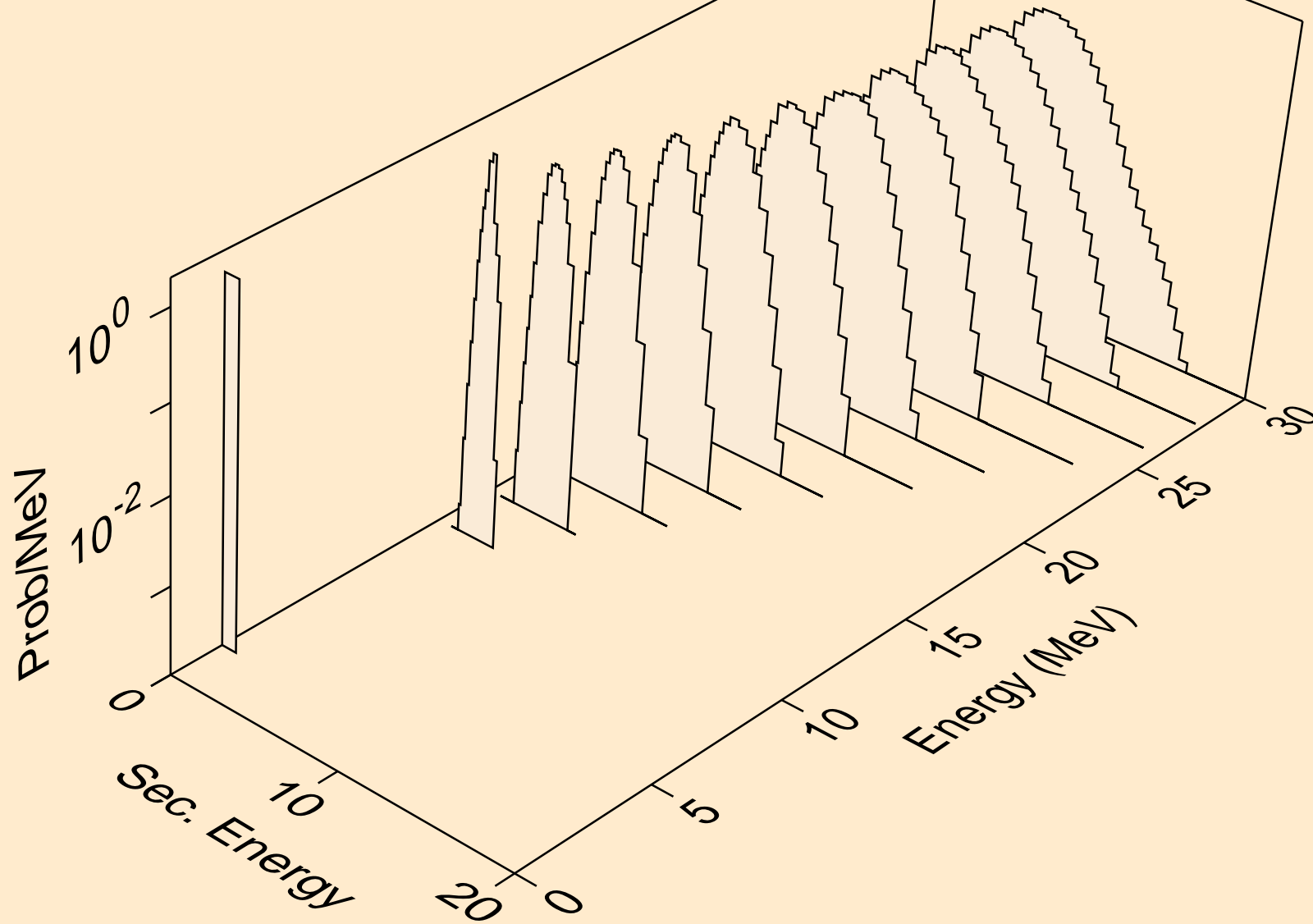

YB160 NEUTRON ACER TENDL-2023 LIBRARY; T=0.K  
protons from (n,p)

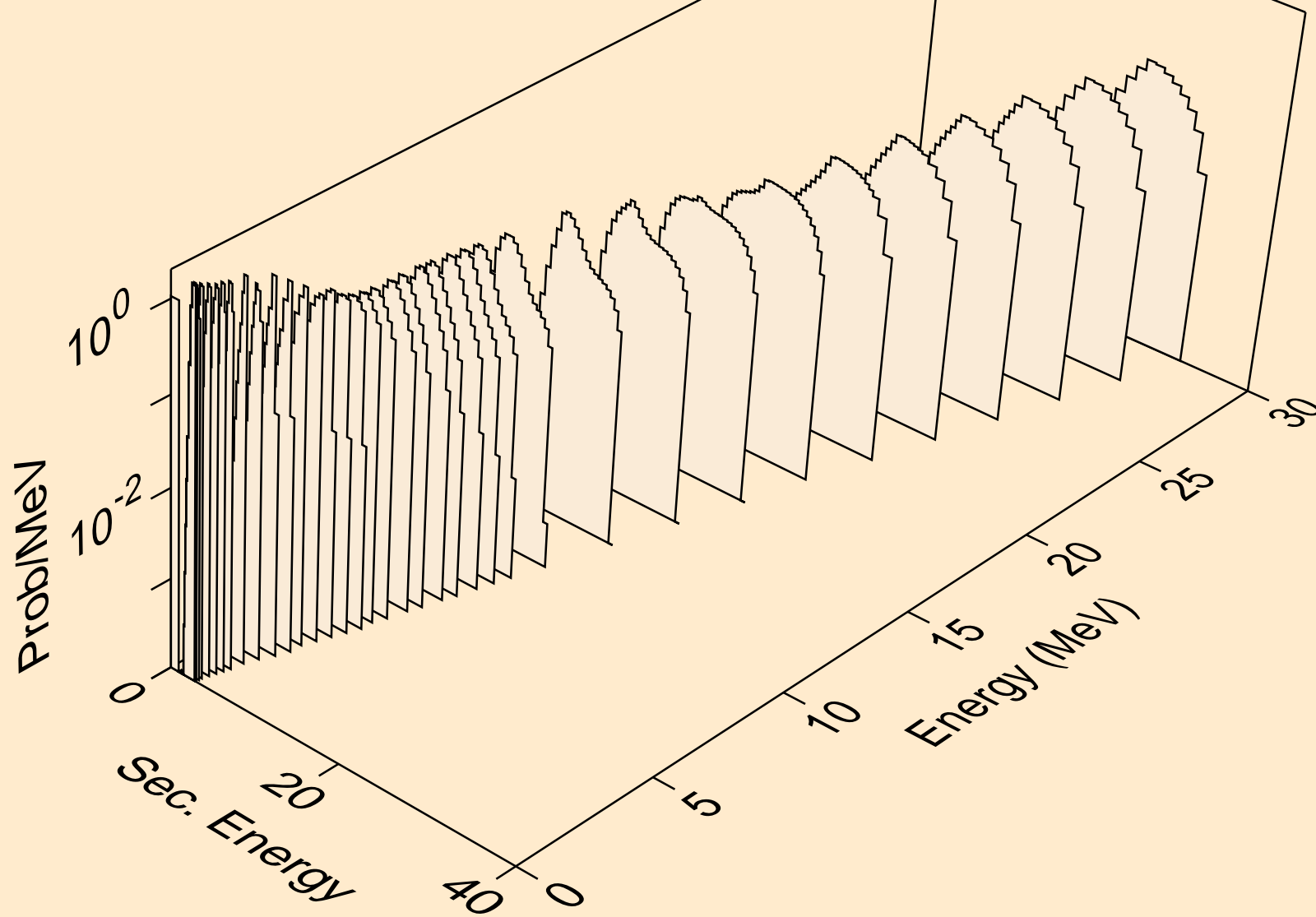

YB160 NEUTRON ACER TENDL-2023 LIBRARY; T=0.K  
protons from (n,2p)

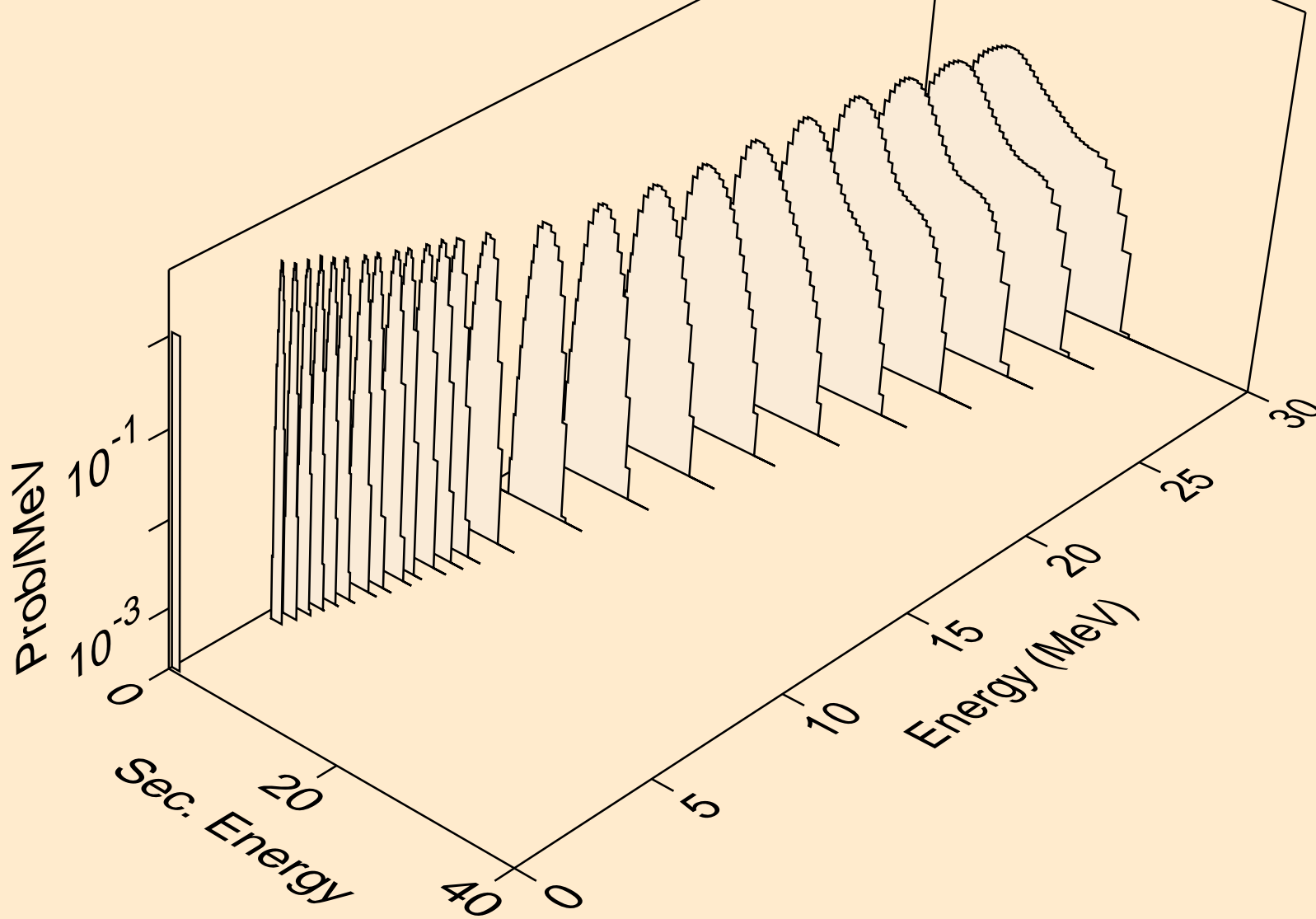

YB160 NEUTRON ACER TENDL-2023 LIBRARY; T=0.K  
protons from (n,p)

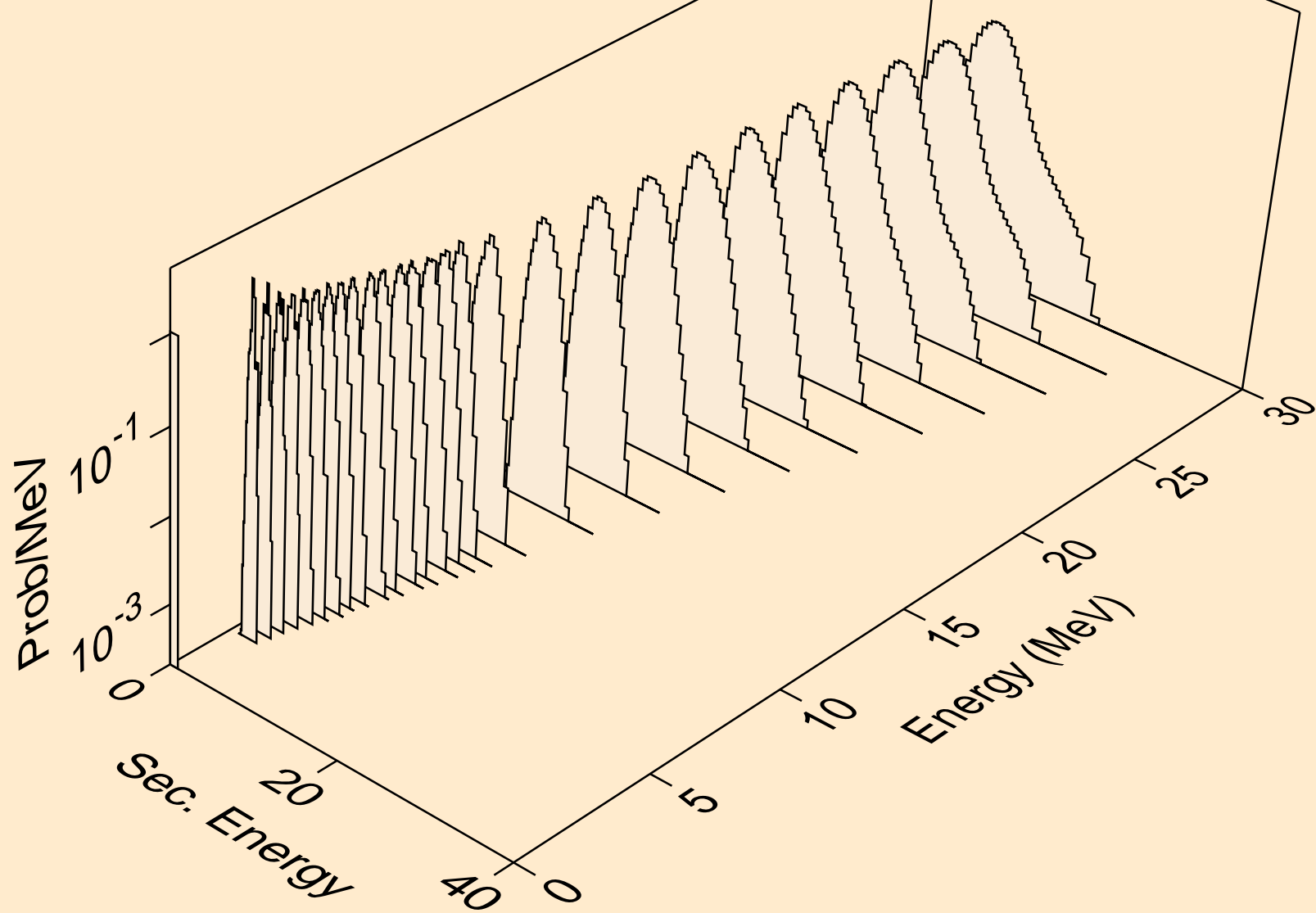

YB160 NEUTRON ACER TENDL-2023 LIBRARY; T=0.K  
protons from (n,pd)

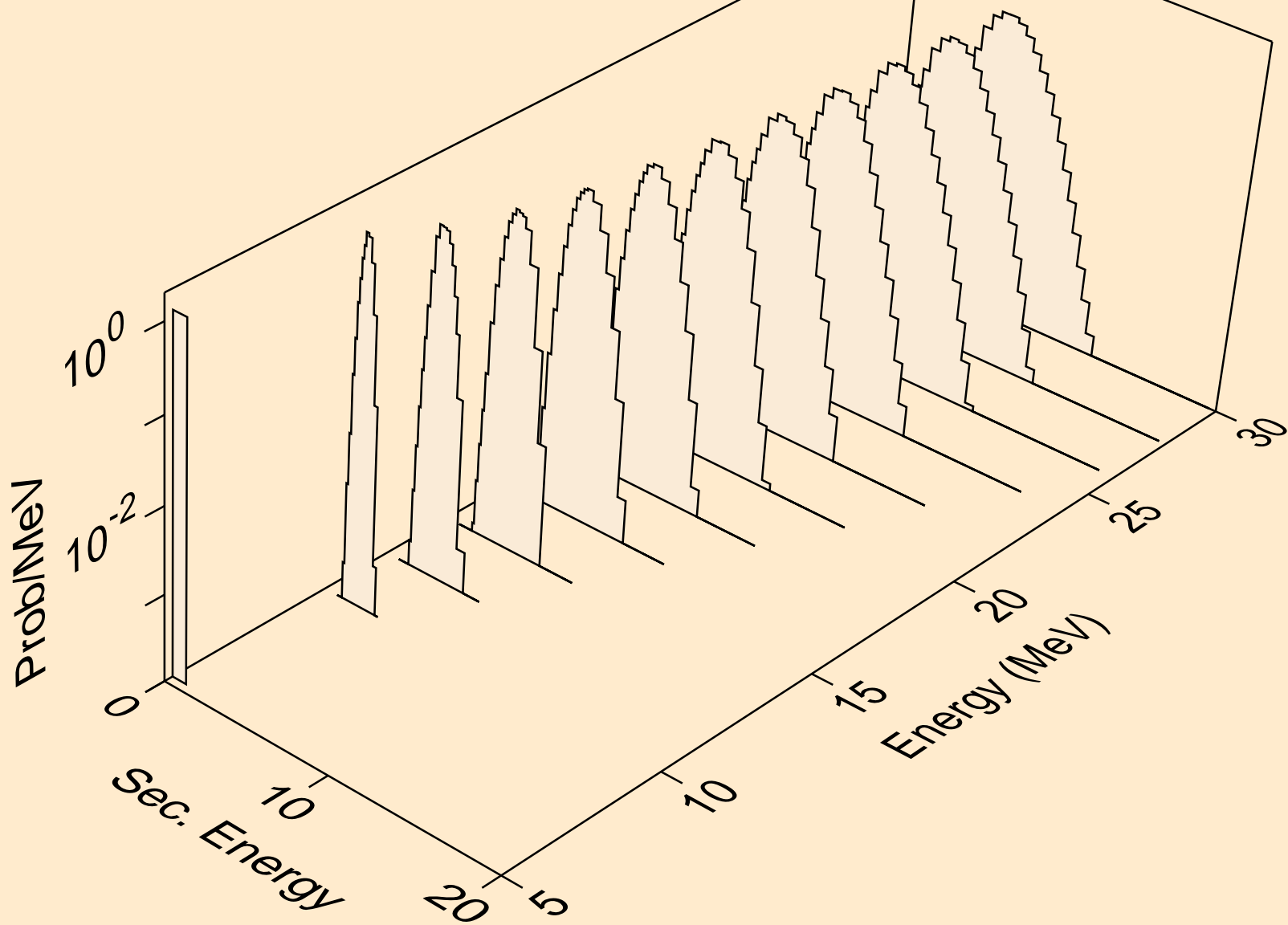

YB160 NEUTRON ACER TENDL-2023 LIBRARY; T=0.K  
protons from (n,pt)

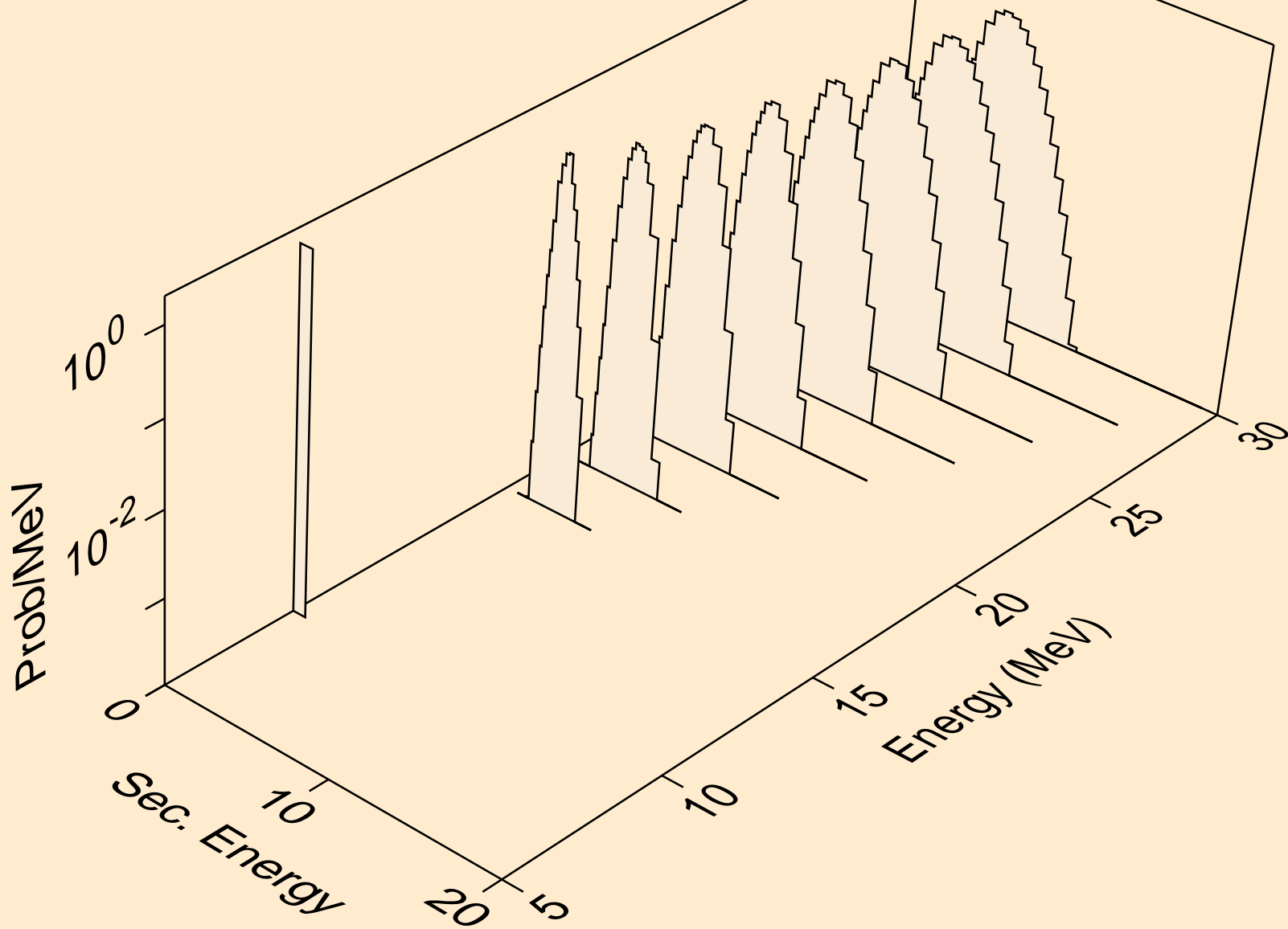

YB160 NEUTRON ACER TENDL-2023 LIBRARY; T=0.K  
deuterons from (n,x)

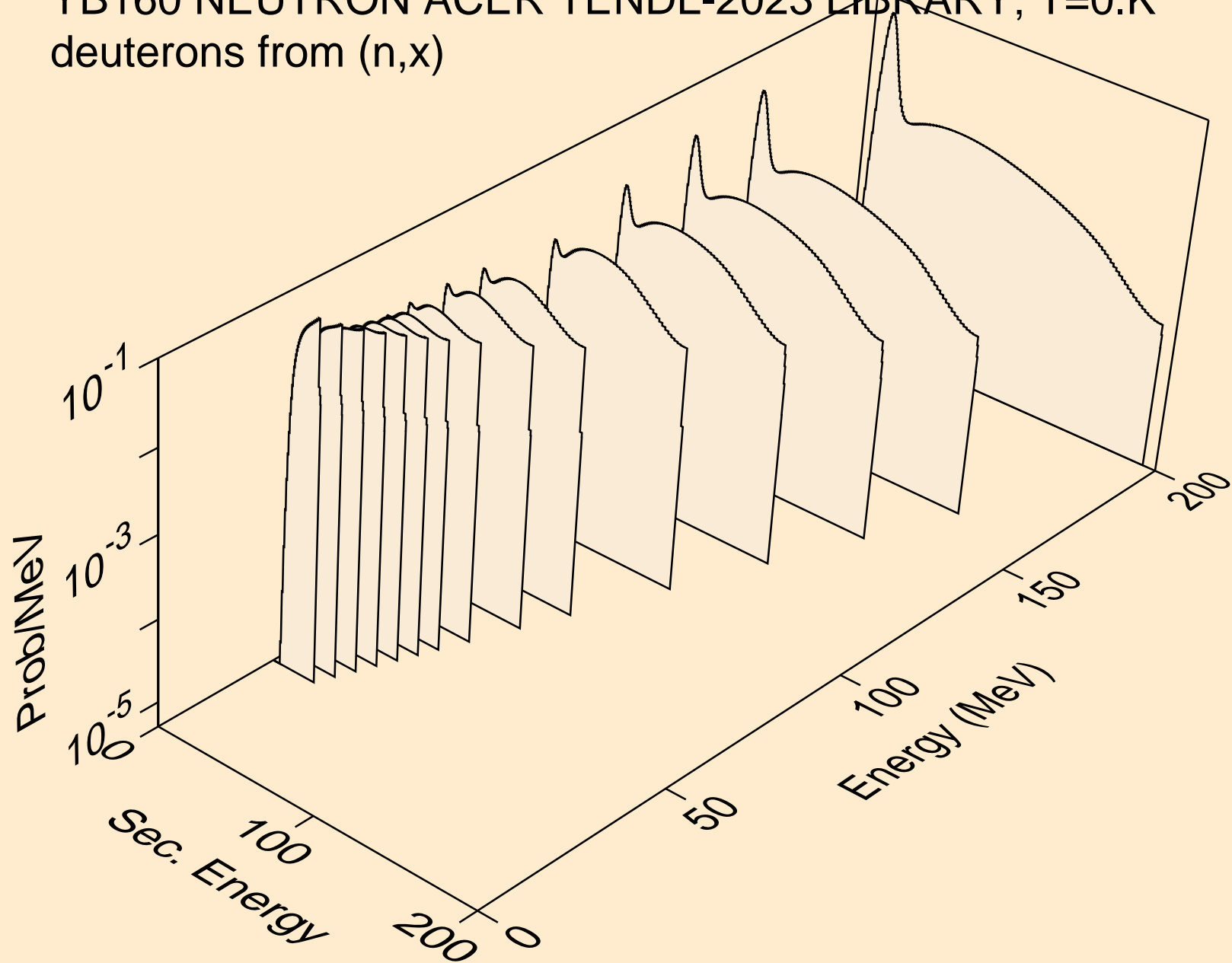

YB160 NEUTRON ACER TENDL-2023 LIBRARY; T=0.K  
deuterons from (n,2nd)

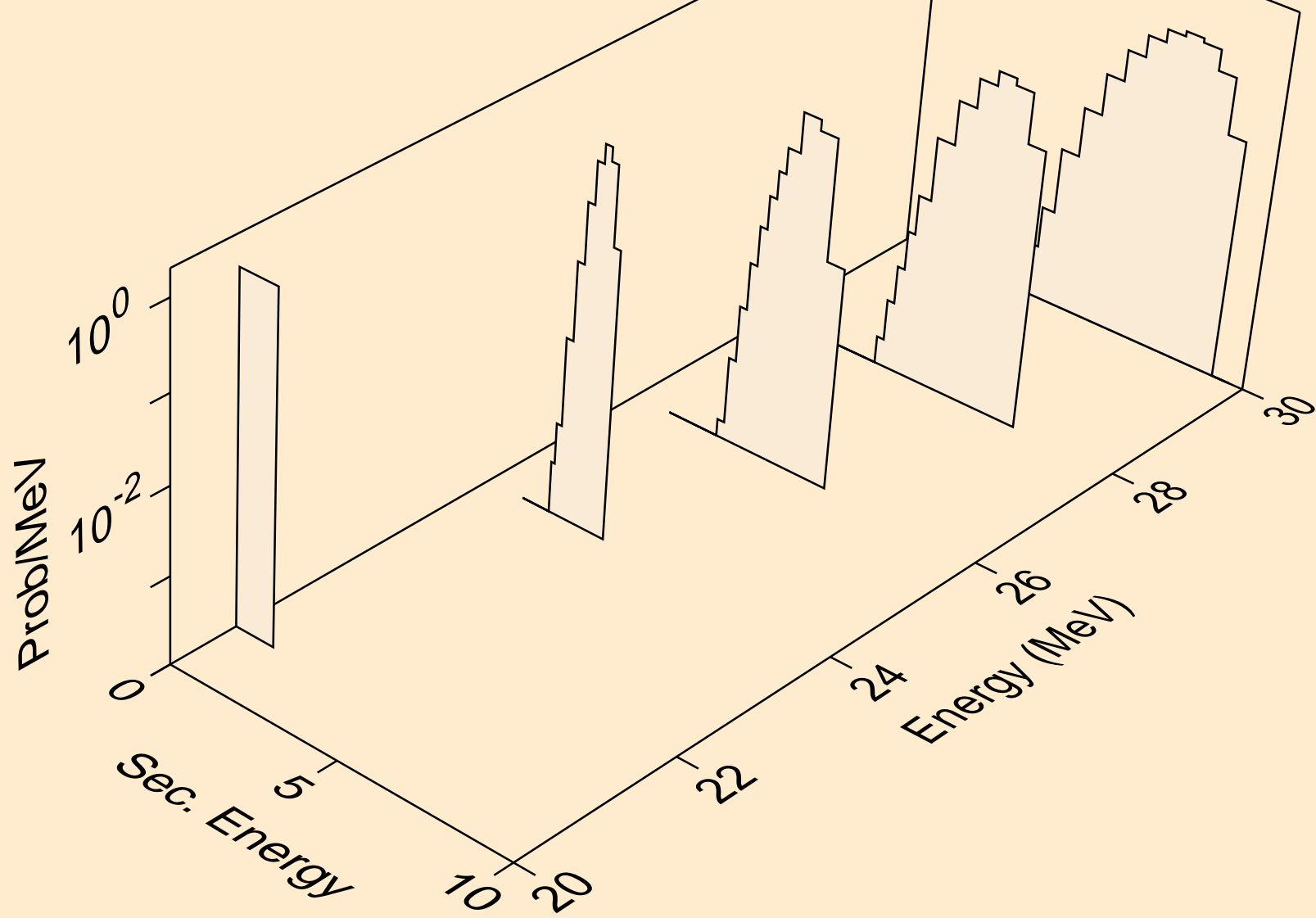

YB160 NEUTRON ACER TENDL-2023 LIBRARY; T=0.K  
deuterons from (n,n\*)d

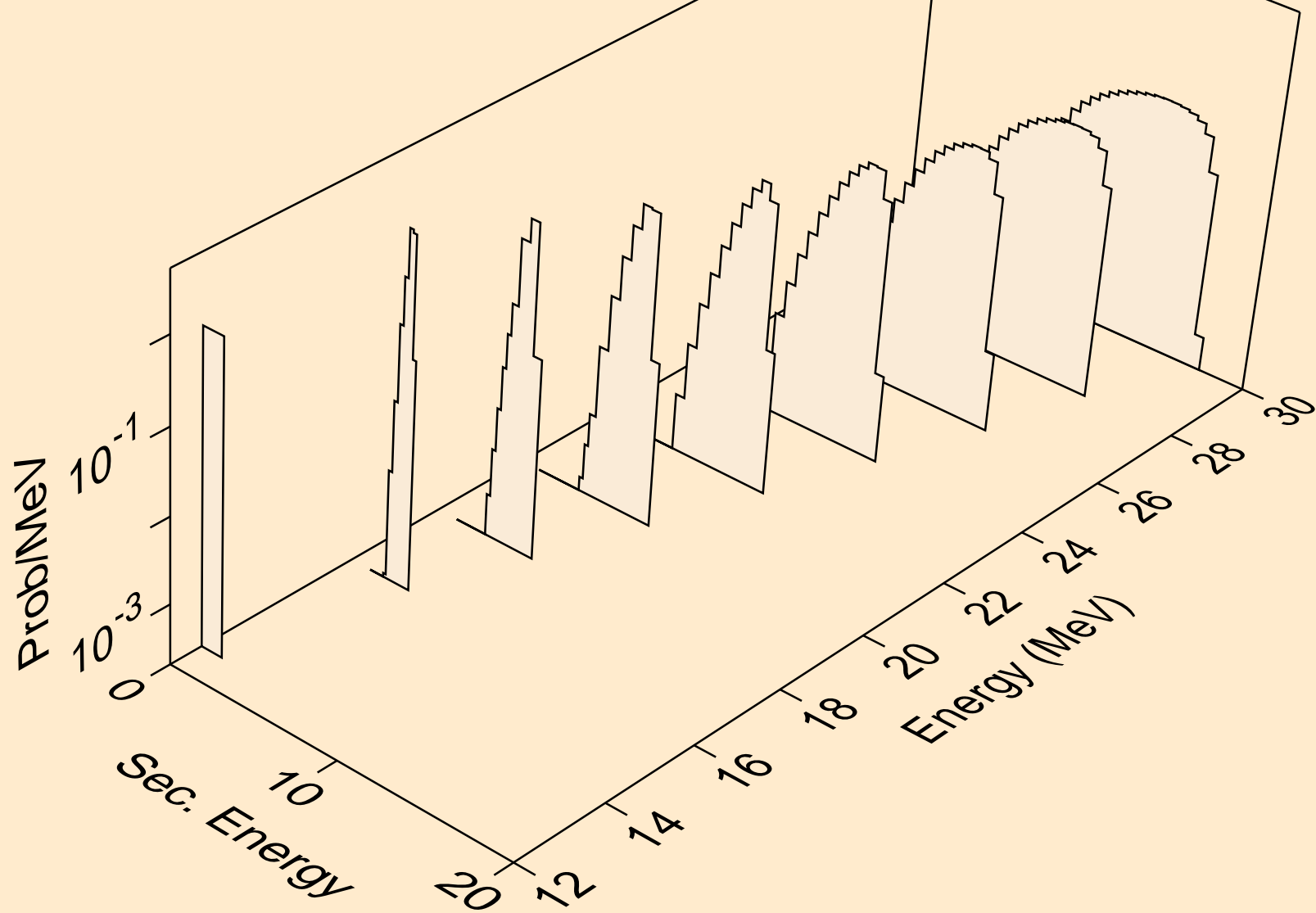

YB160 NEUTRON ACER TENDL-2023 LIBRARY; T=0.K  
deuterons from (n,d)

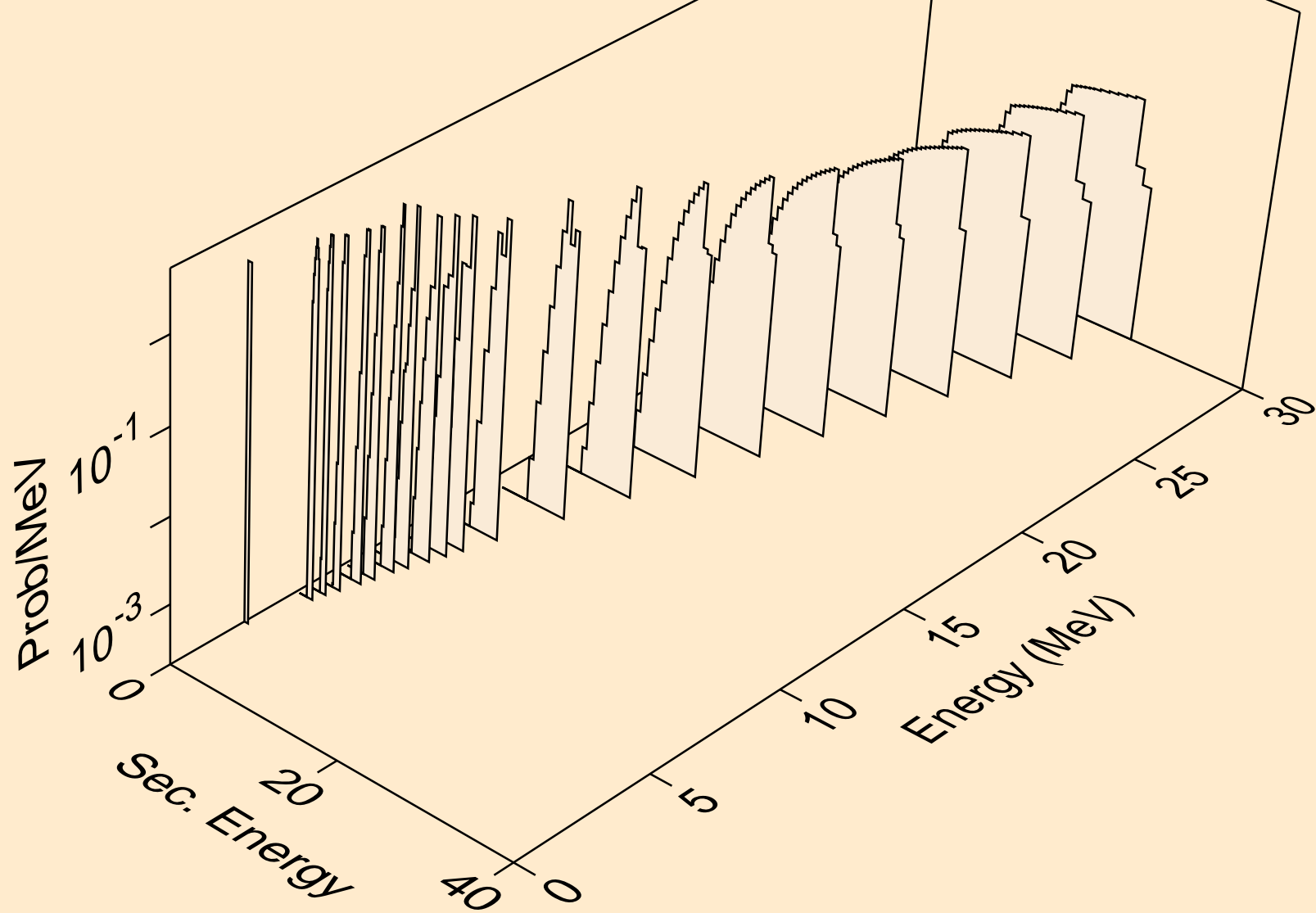

YB160 NEUTRON ACER TENDL-2023 LIBRARY; T=0.K  
deuterons from (n,pd)

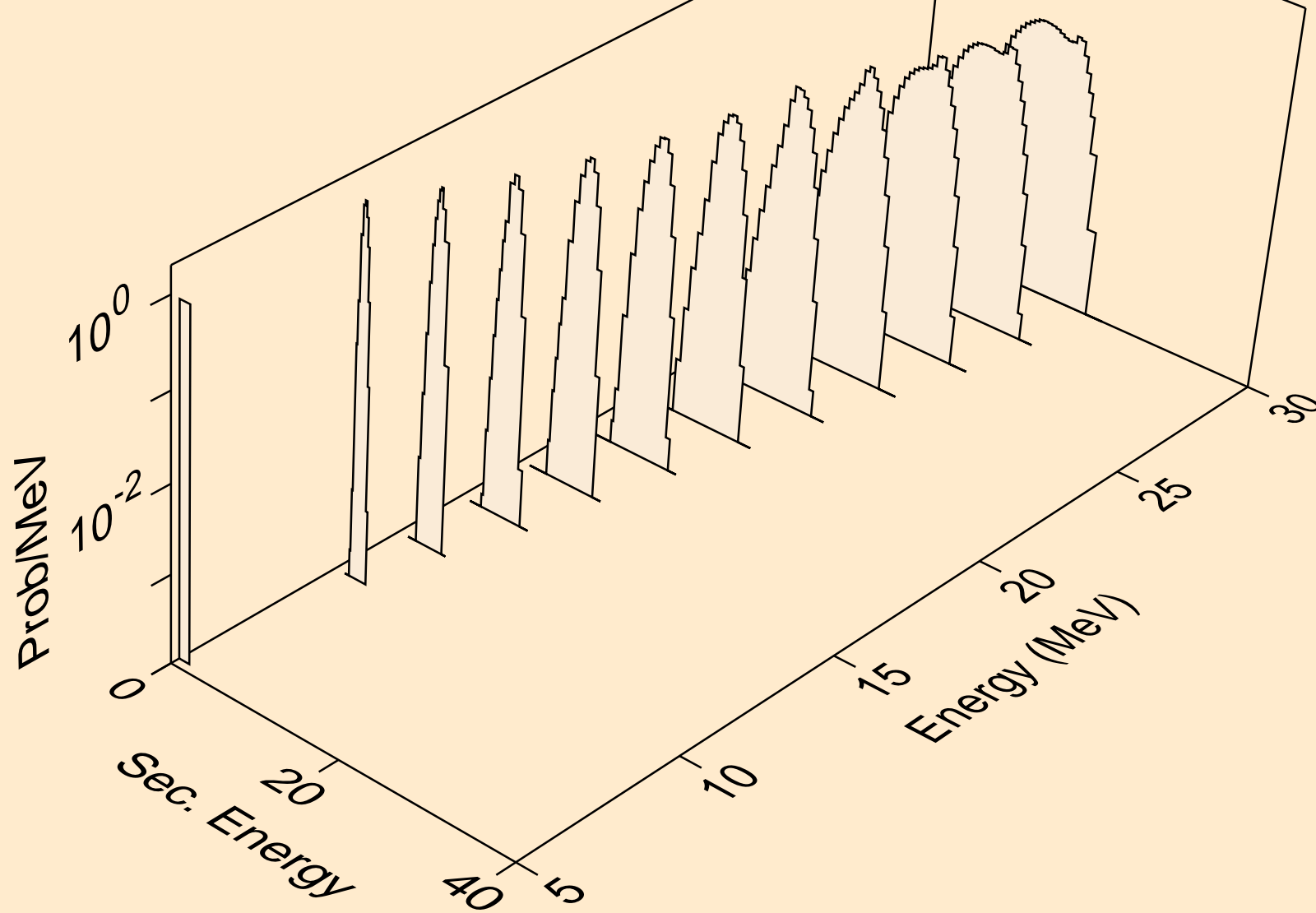

YB160 NEUTRON ACER TENDL-2023 LIBRARY; T=0.K  
deuterons from (n,da)

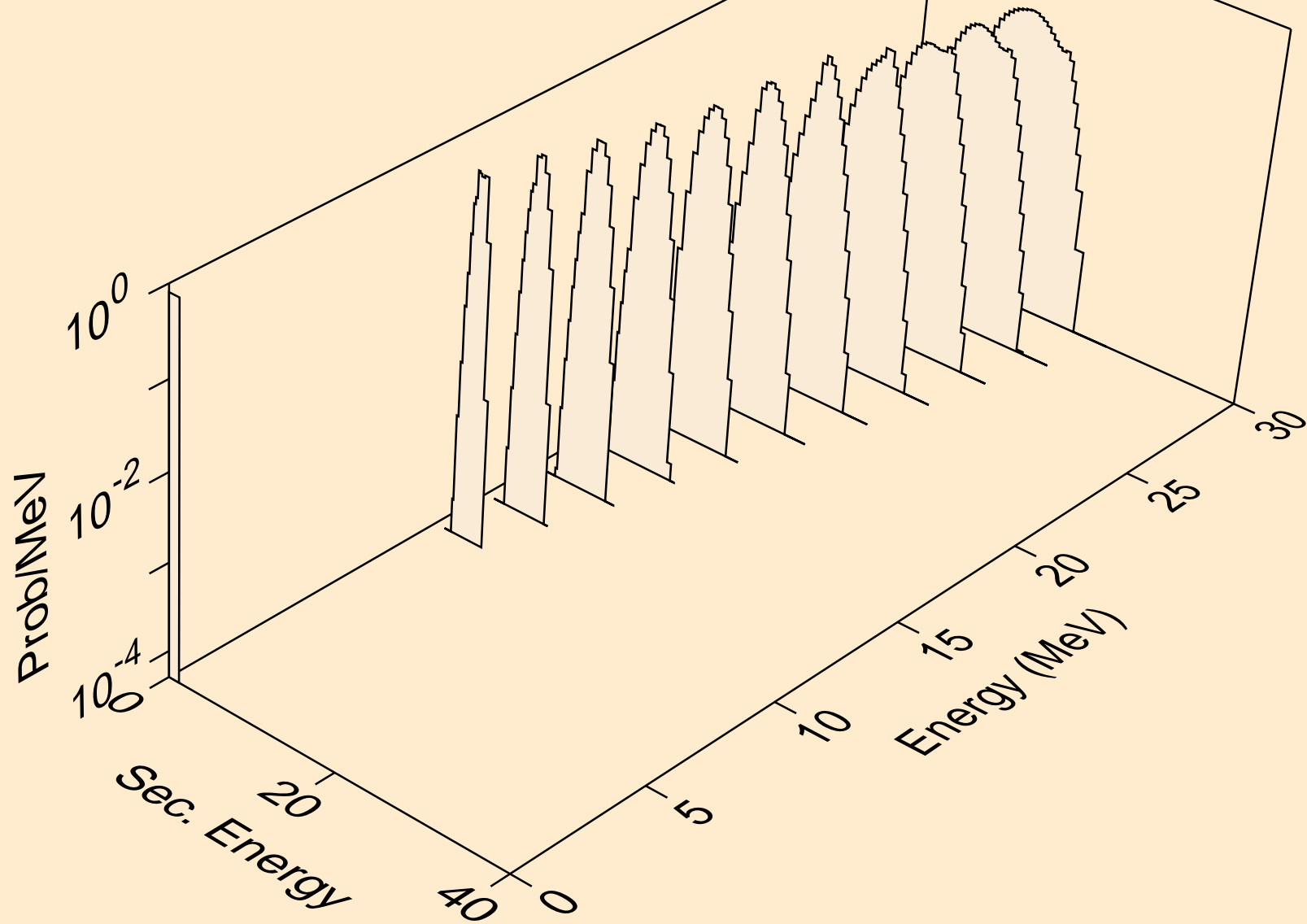

YB160 NEUTRON ACER TENDL-2023 LIBRARY; T=0.K  
tritons from (n,x)

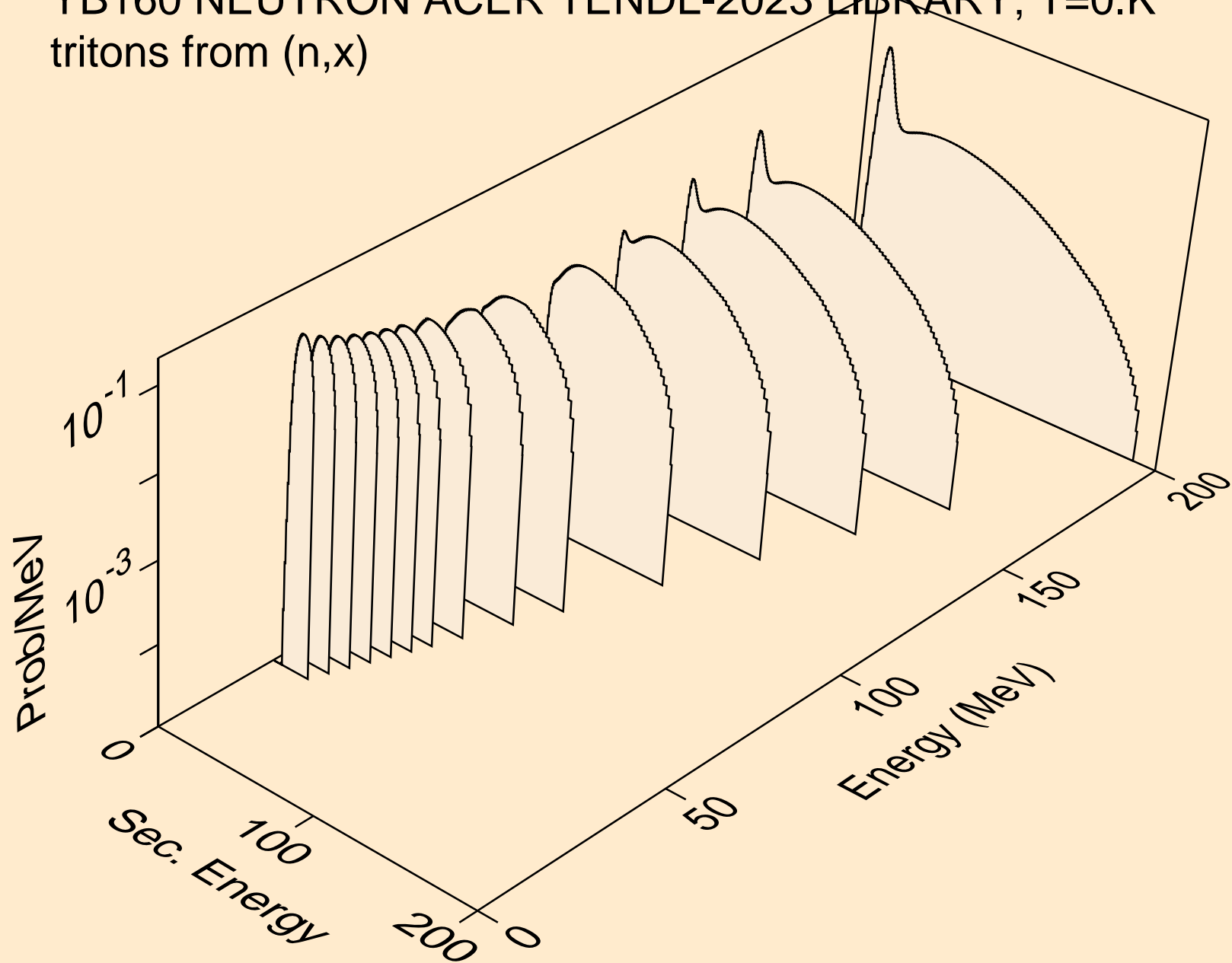

YB160 NEUTRON ACER TENDL-2023 LIBRARY; T=0.K  
tritons from (n,n\*)t

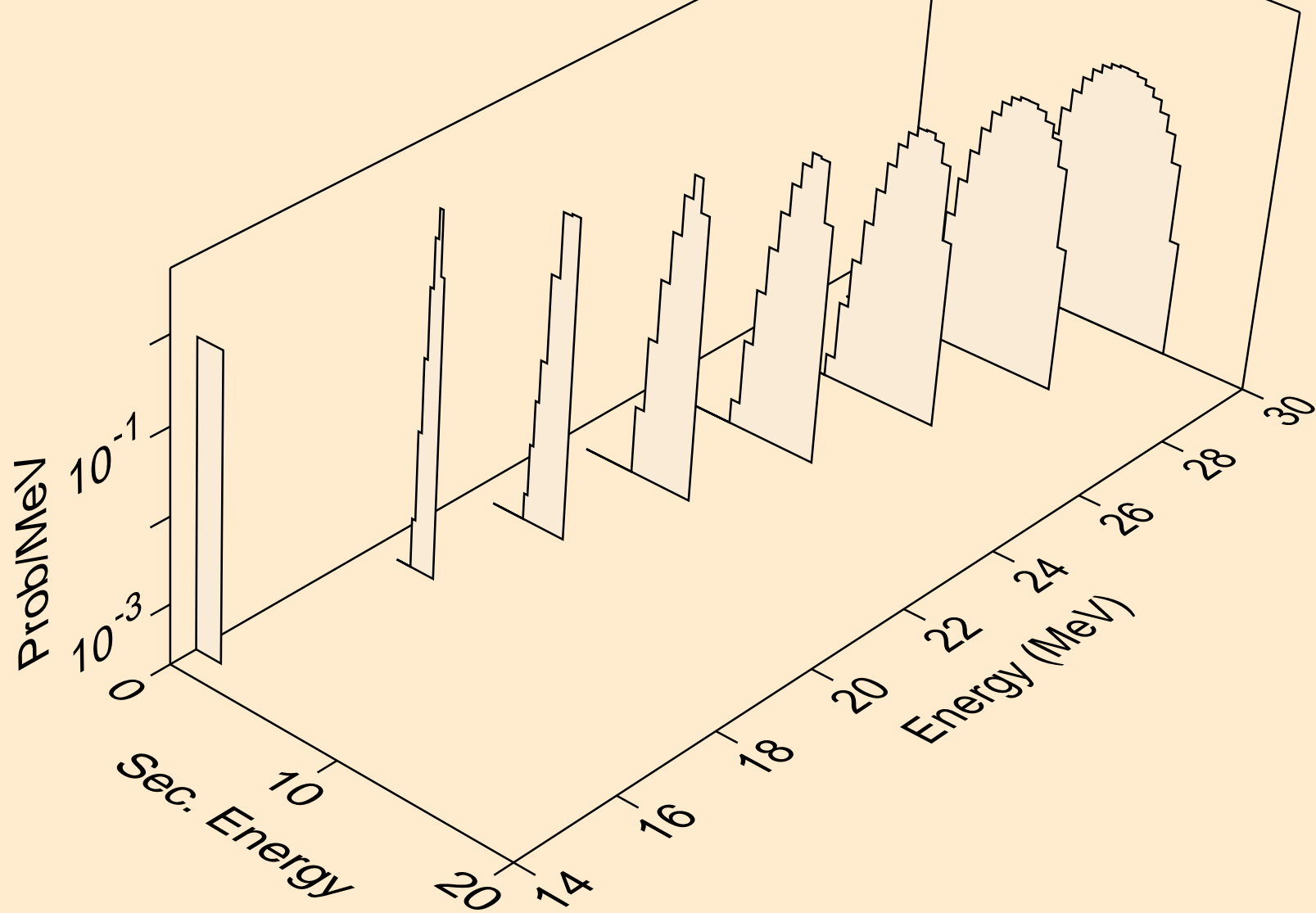

YB160 NEUTRON ACER TENDL-2023 LIBRARY; T=0.K  
tritons from (n,t)

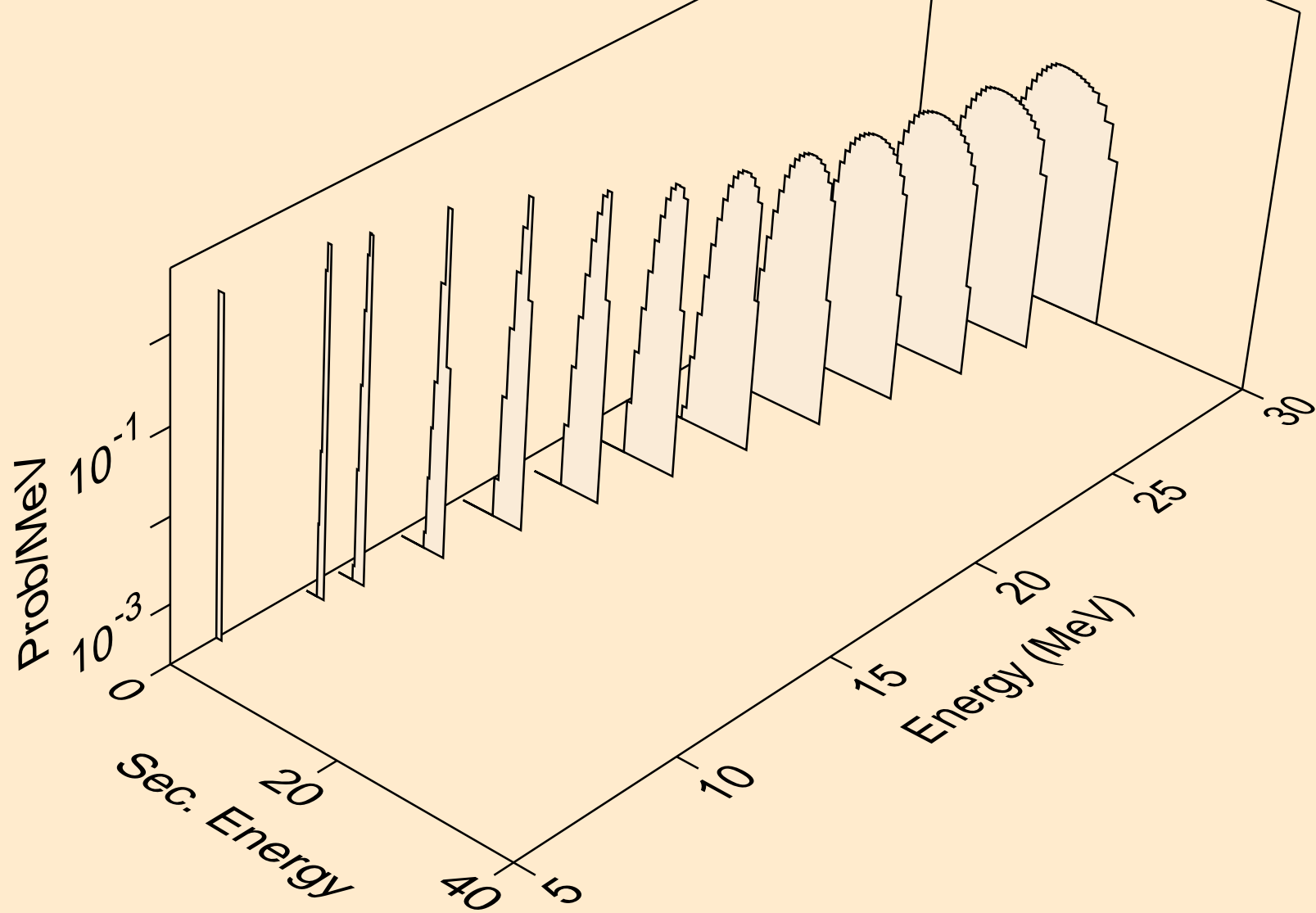

YB160 NEUTRON ACER TENDL-2023 LIBRARY; T=0.K  
tritons from (n,pt)

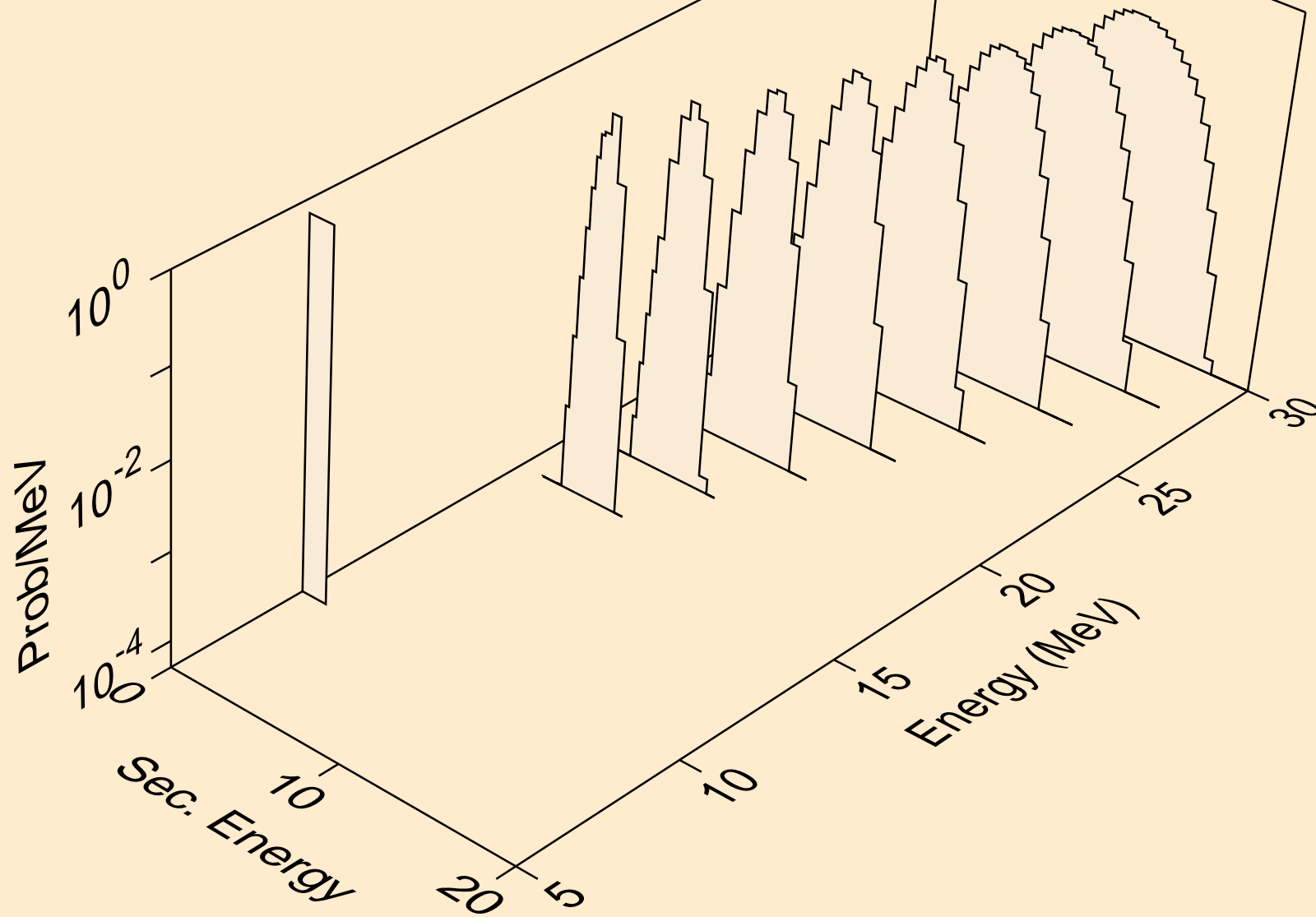

YB160 NEUTRON ACER TENDL-2023 LIBRARY; T=0.K  
he3s from (n,x)

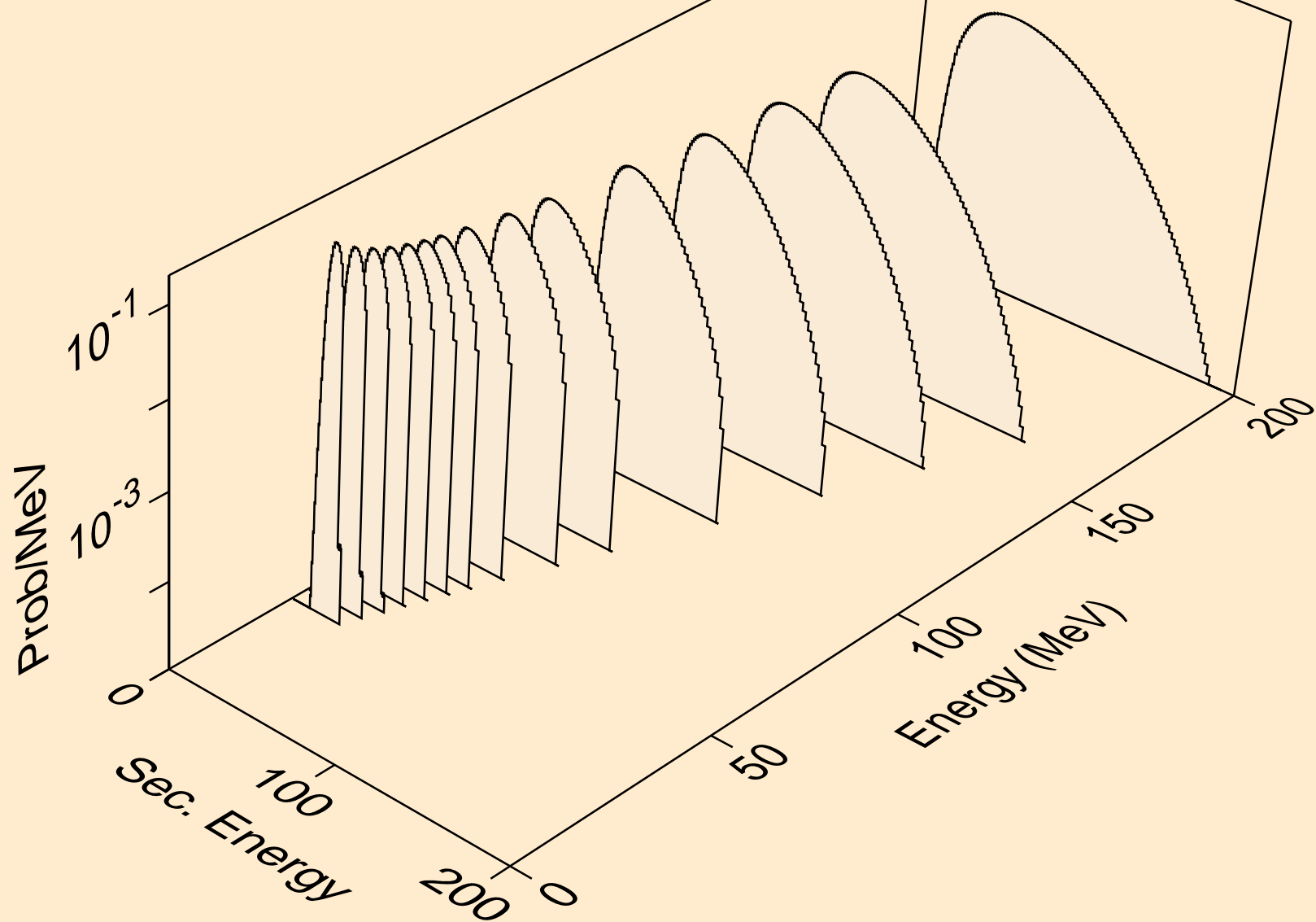

YB160 NEUTRON ACER TENDL-2023 LIBRARY; T=0.K  
he3s from (n,n\*)he3

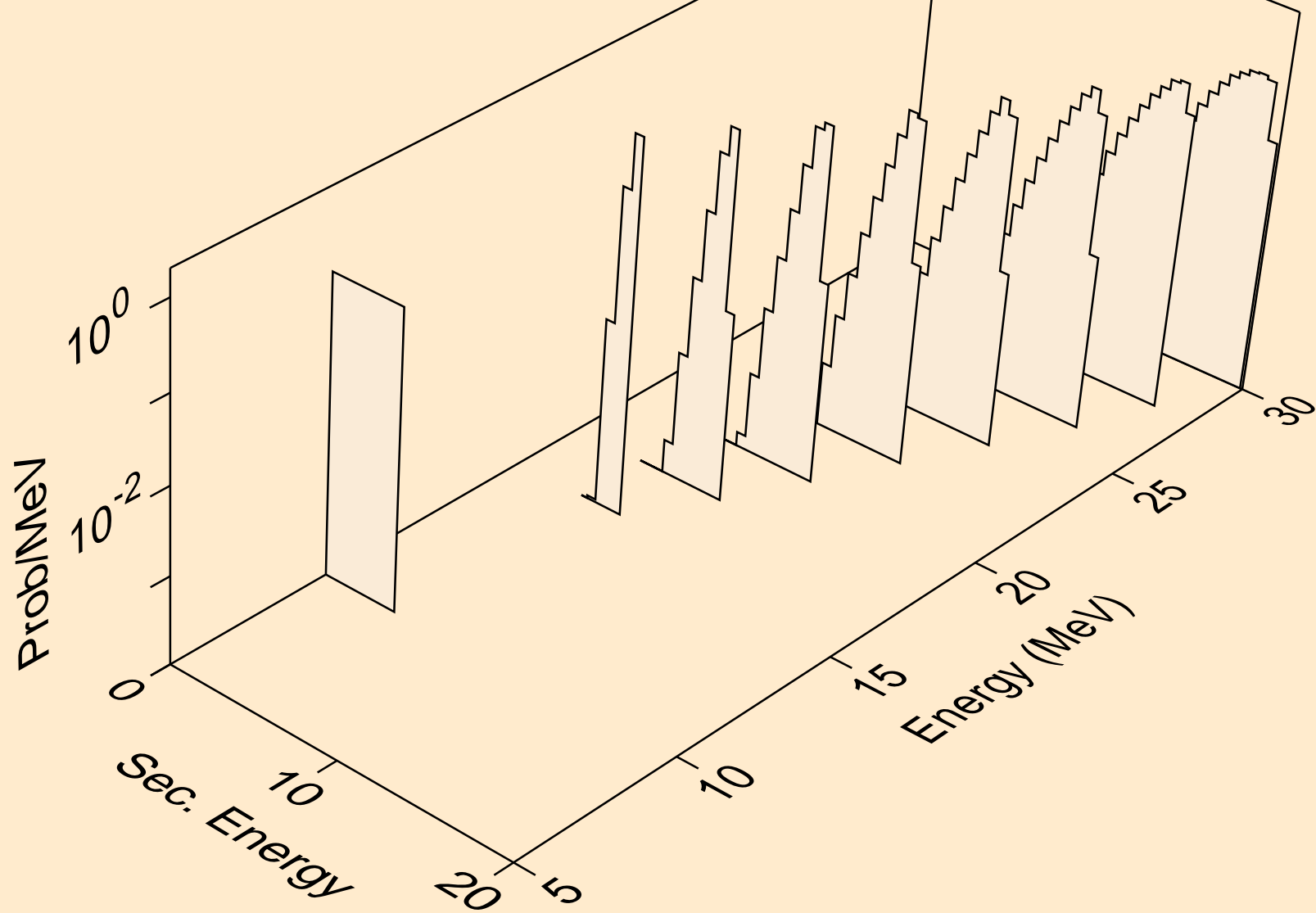

YB160 NEUTRON ACER TENDL-2023 LIBRARY; T=0.K  
he3s from (n,he3)

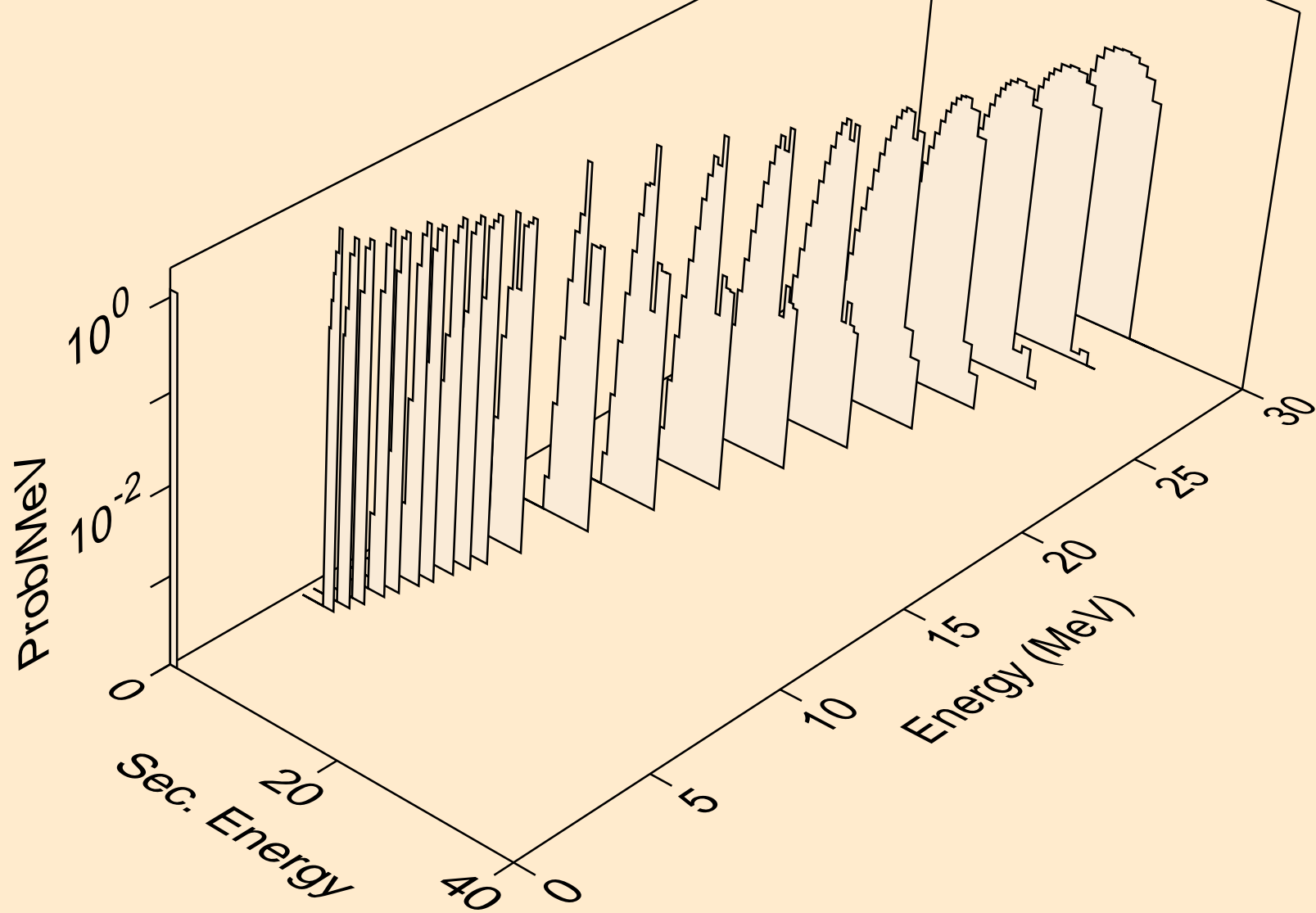

YB160 NEUTRON ACER TENDL-2023 LIBRARY; T=0.K  
alphas from (n,x)

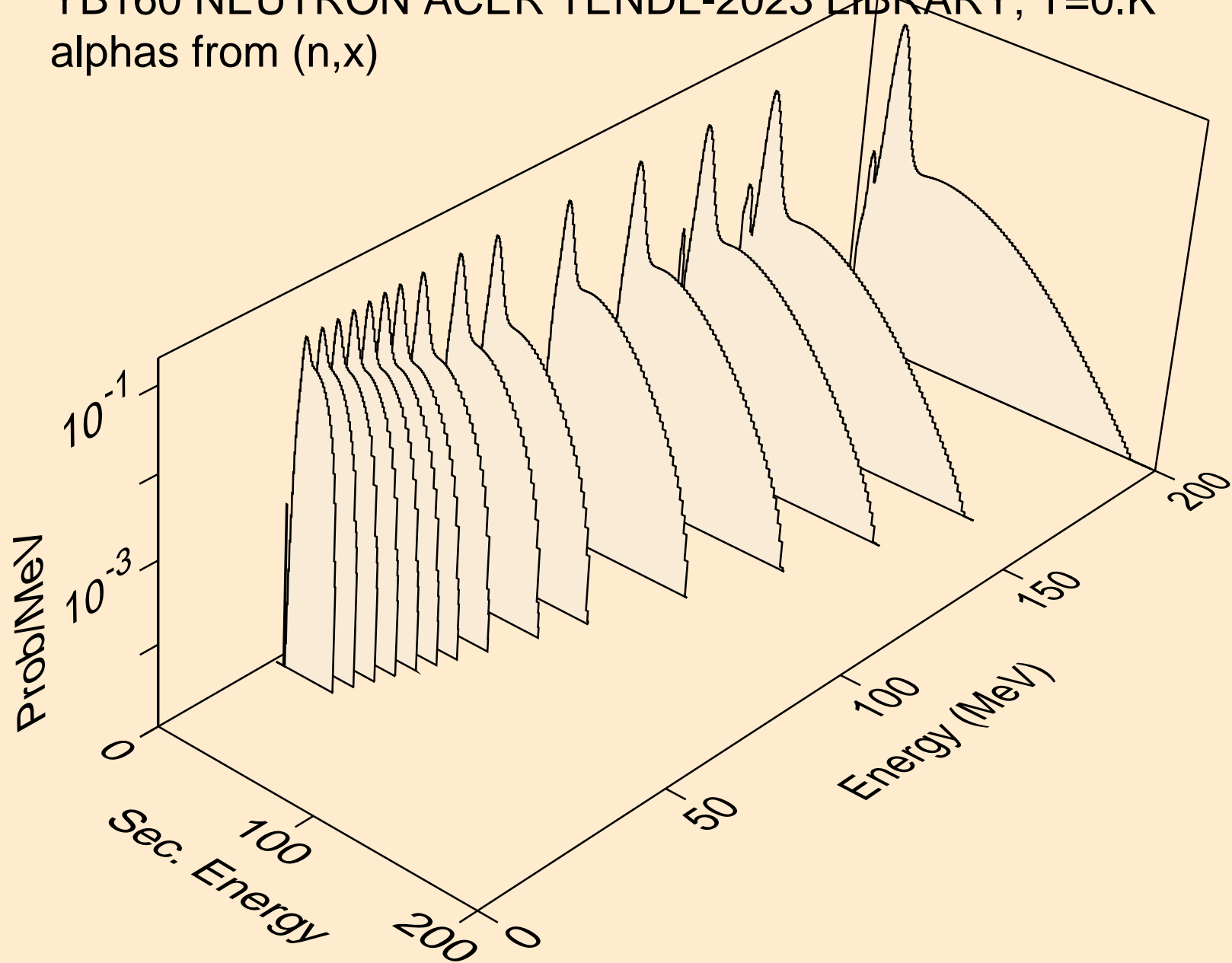

YB160 NEUTRON ACER TENDL-2023 LIBRARY; T=0.K  
alphas from (n,n\*)a

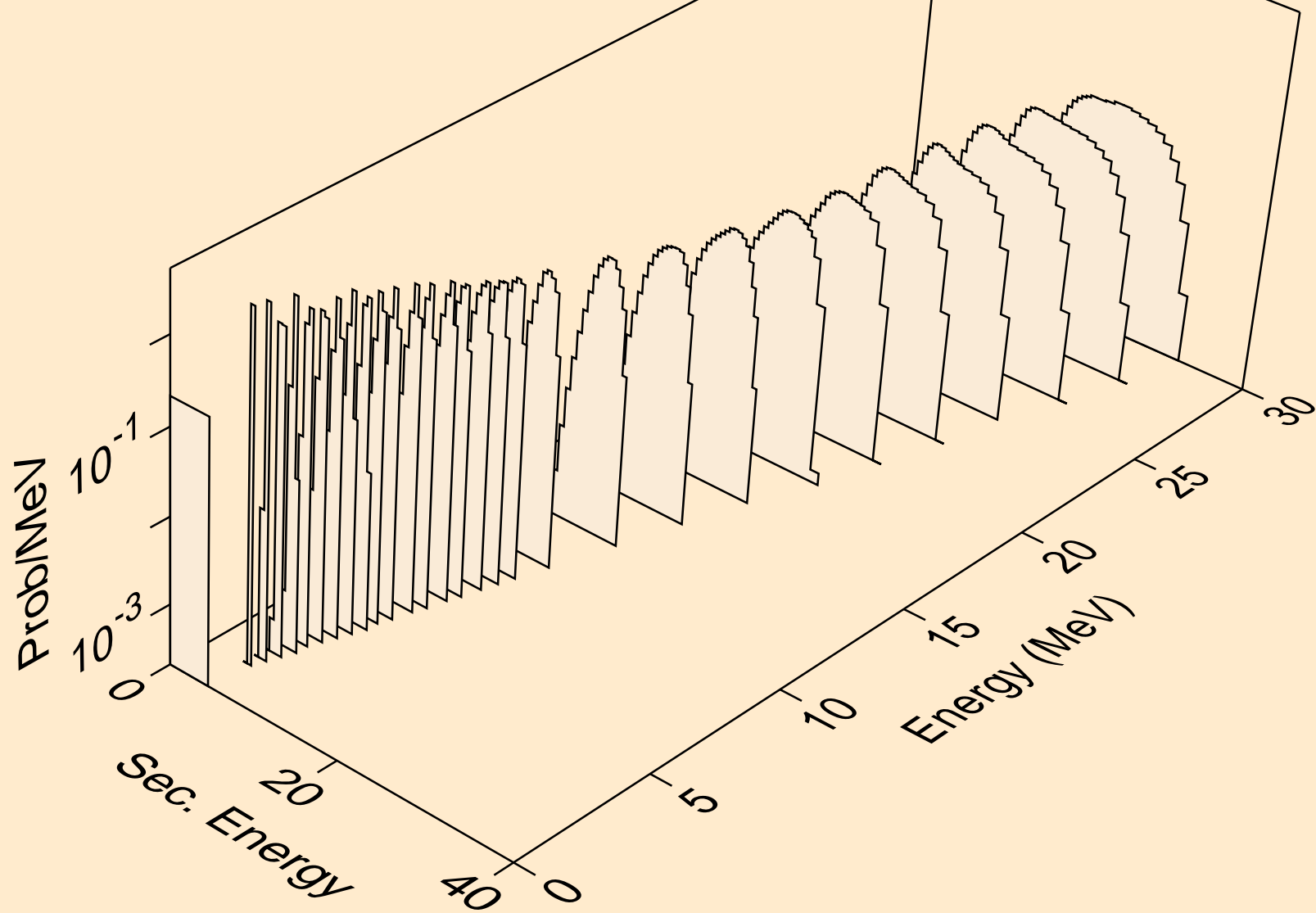

YB160 NEUTRON ACER TENDL-2023 LIBRARY; T=0.K  
alphas from (n,2n)a

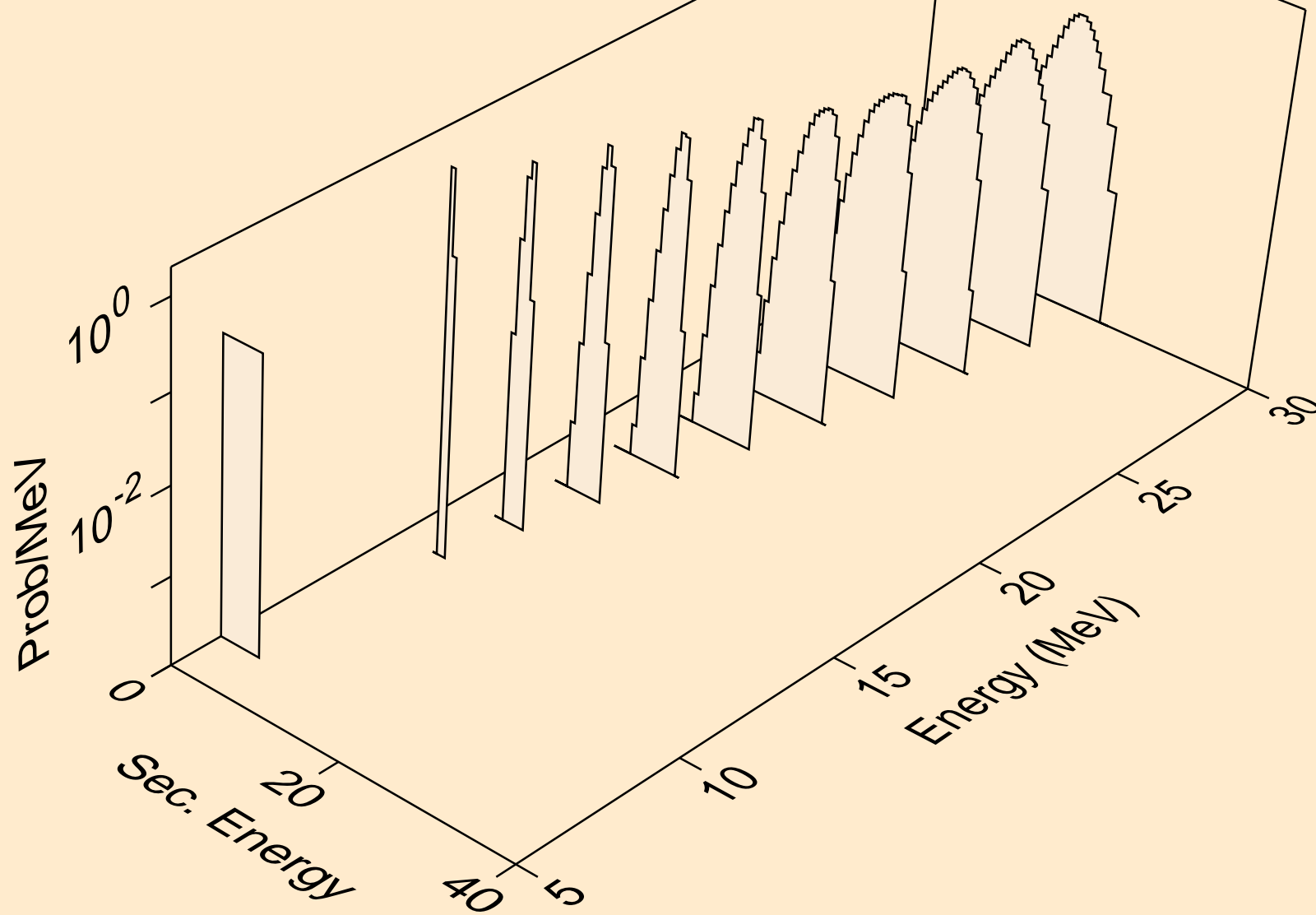

YB160 NEUTRON ACER TENDL-2023 LIBRARY; T=0.K  
alphas from (n,3n)a

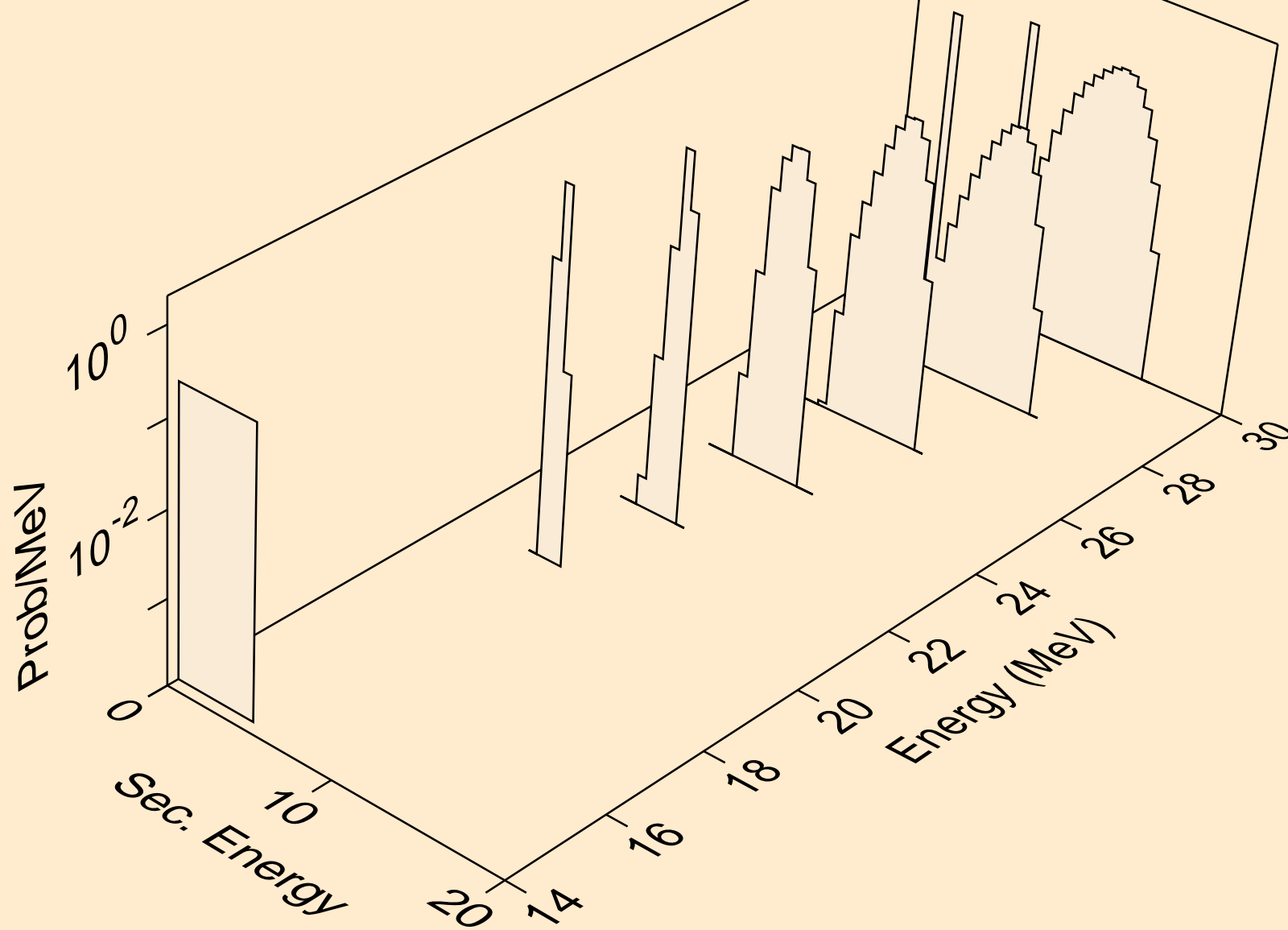

YB160 NEUTRON ACER TENDL-2023 LIBRARY; T=0.K  
alphas from (n,n\*)2a

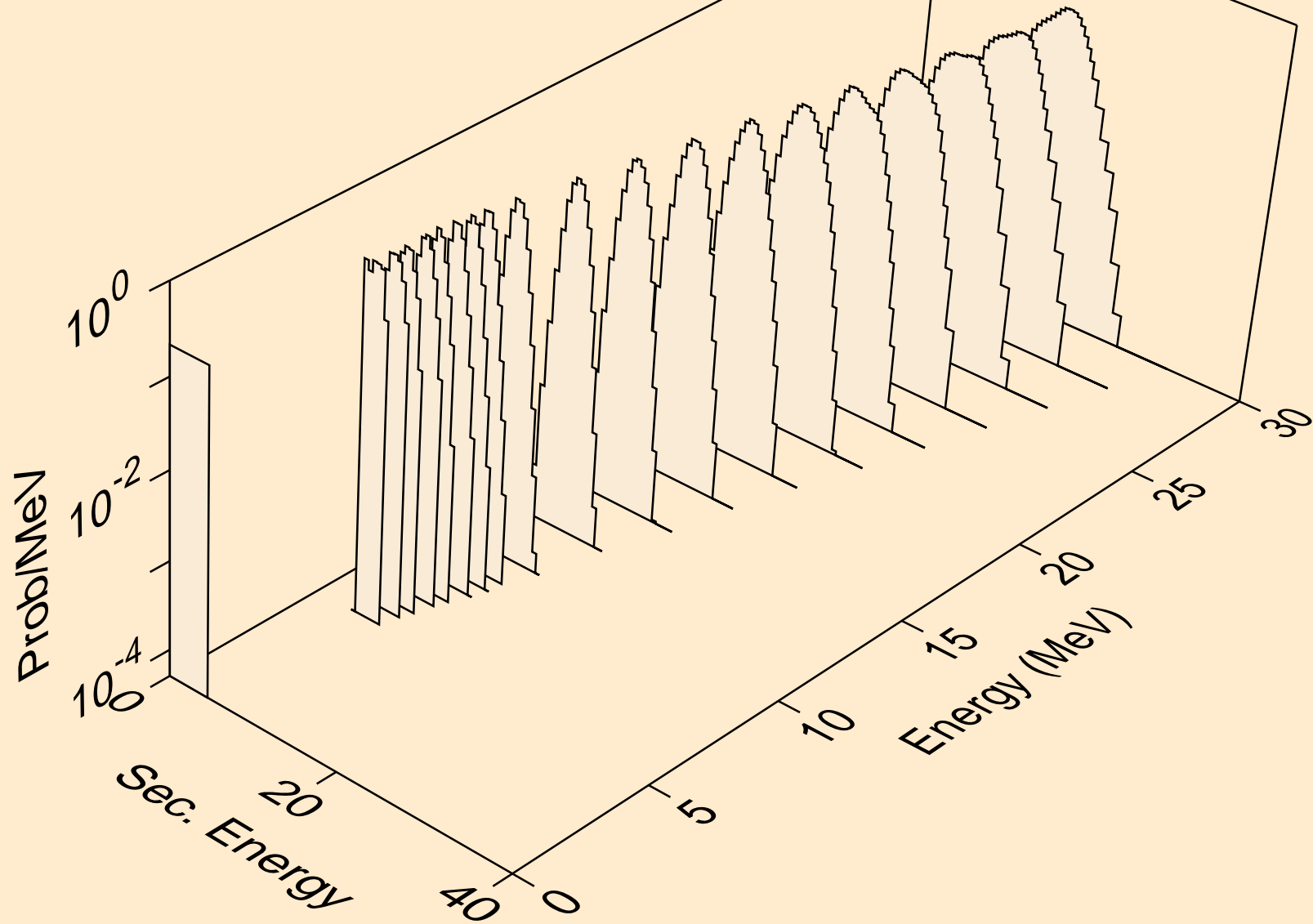

YB160 NEUTRON ACER TENDL-2023 LIBRARY; T=0.K  
alphas from (n,2n)2a

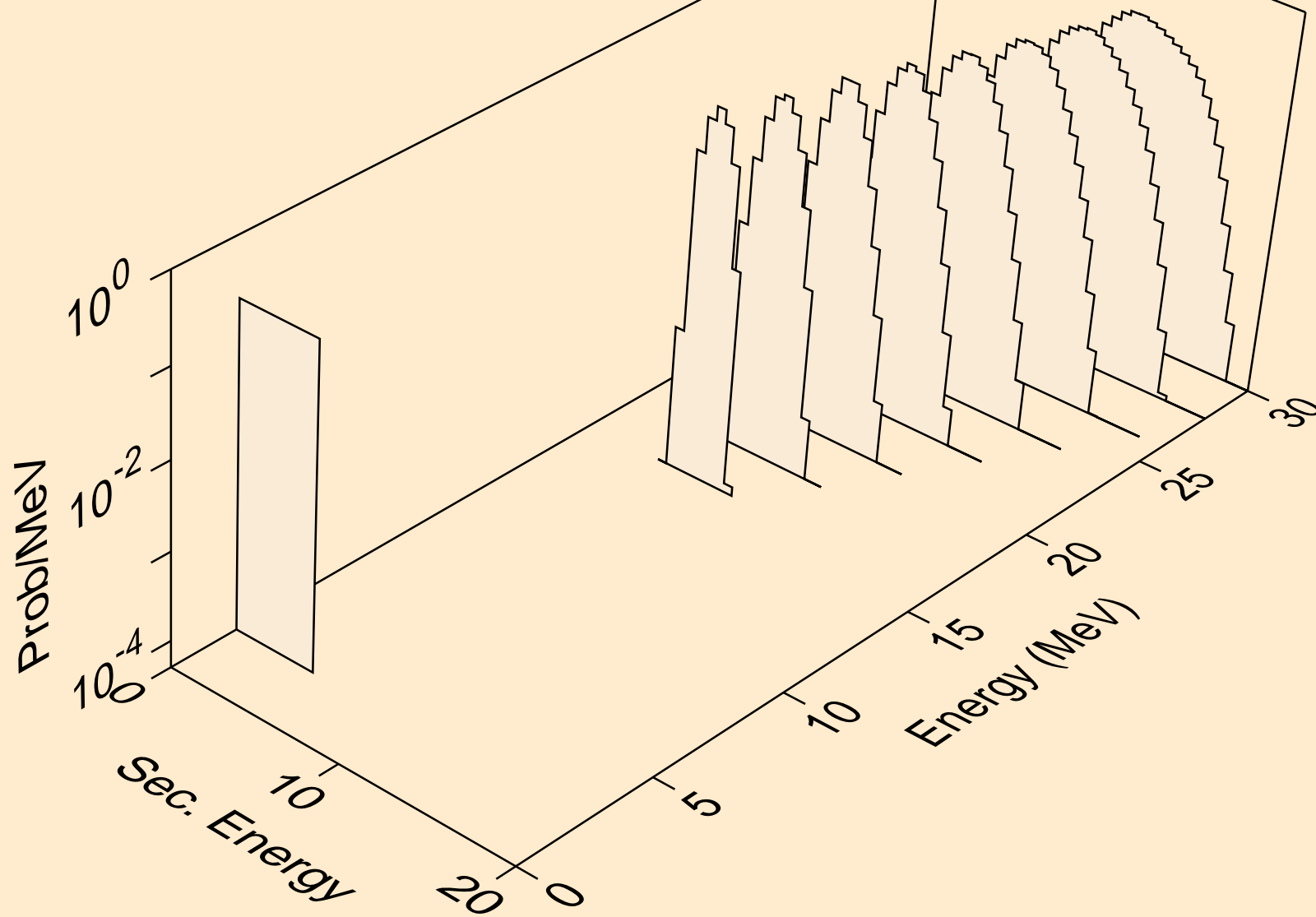

YB160 NEUTRON ACER TENDL-2023 LIBRARY; T=0.K  
alphas from (n,npa)

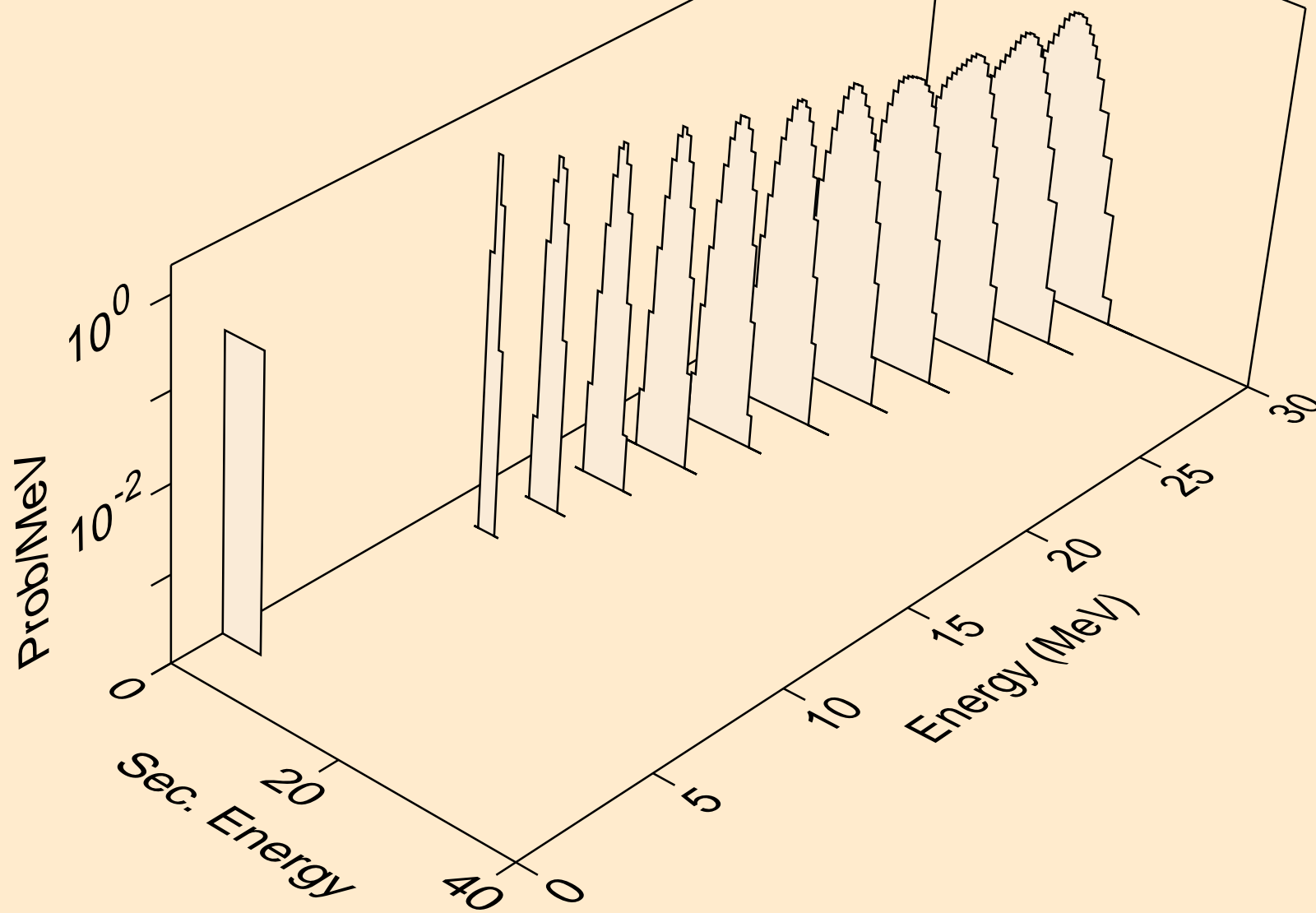

YB160 NEUTRON ACER TENDL-2023 LIBRARY; T=0.K  
alphas from (n,a)

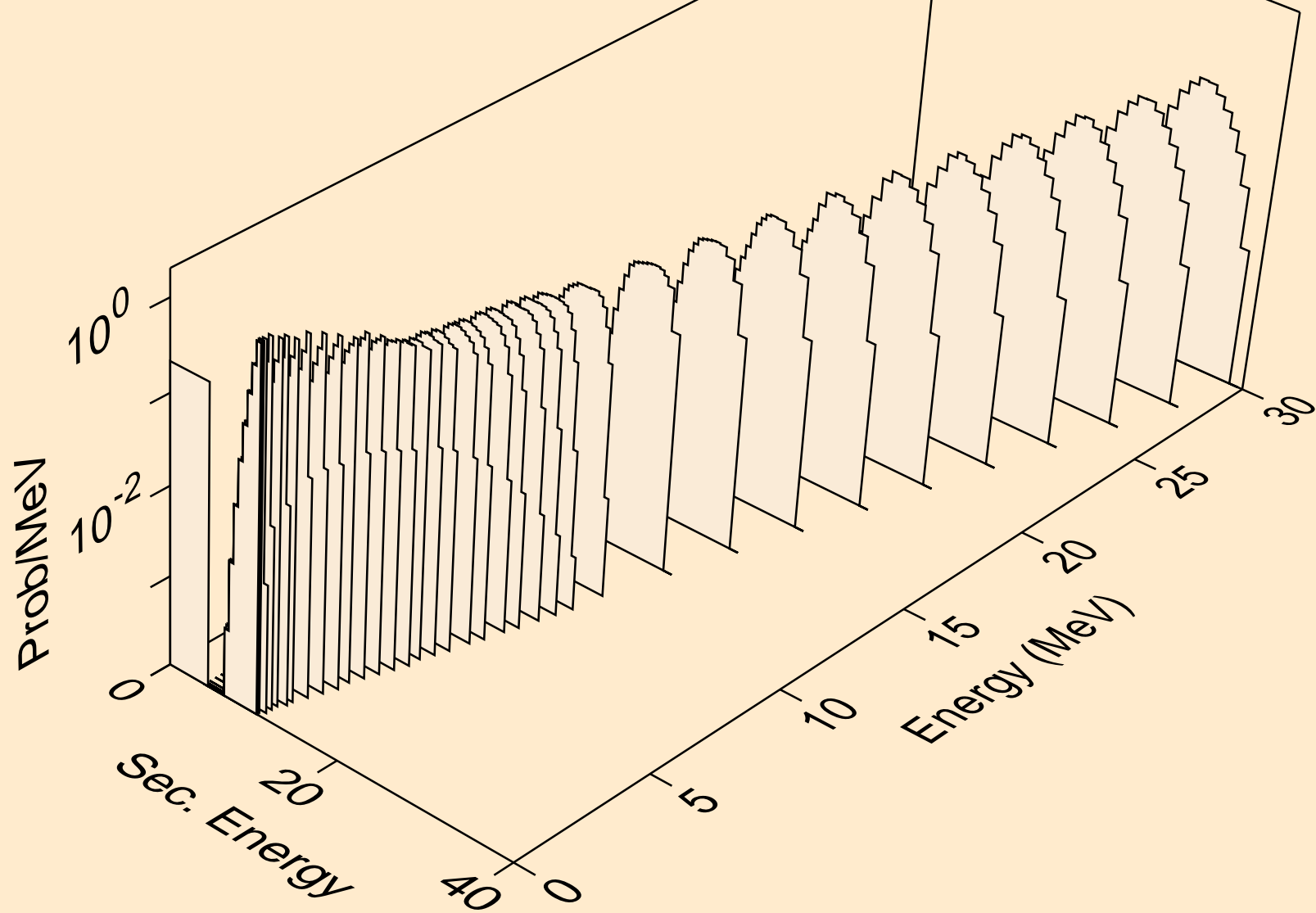

YB160 NEUTRON ACER TENDL-2023 LIBRARY; T=0.K  
alphas from (n,2a)

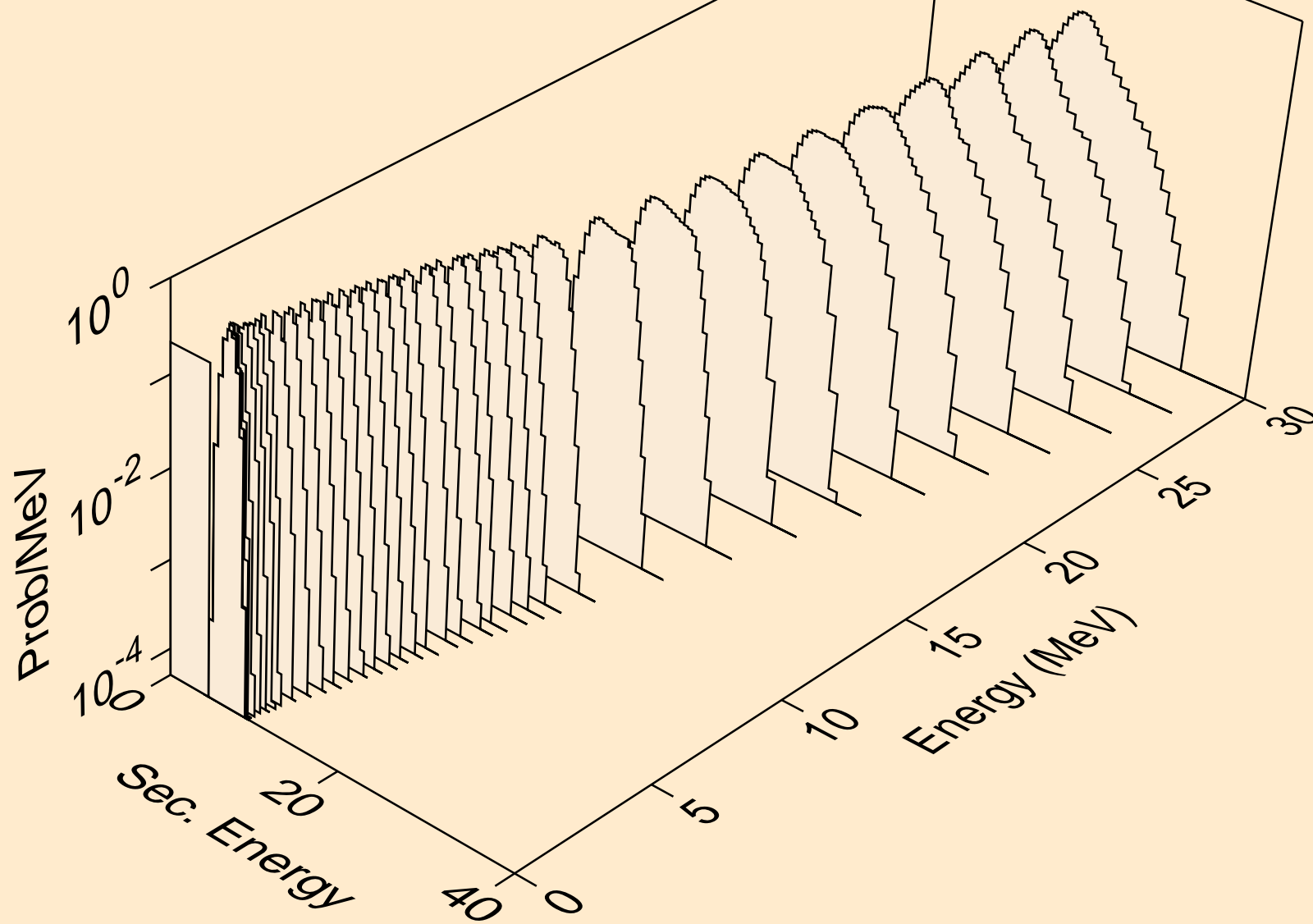

YB160 NEUTRON ACER TENDL-2023 LIBRARY; T=0.K  
alphas from (n,3a)

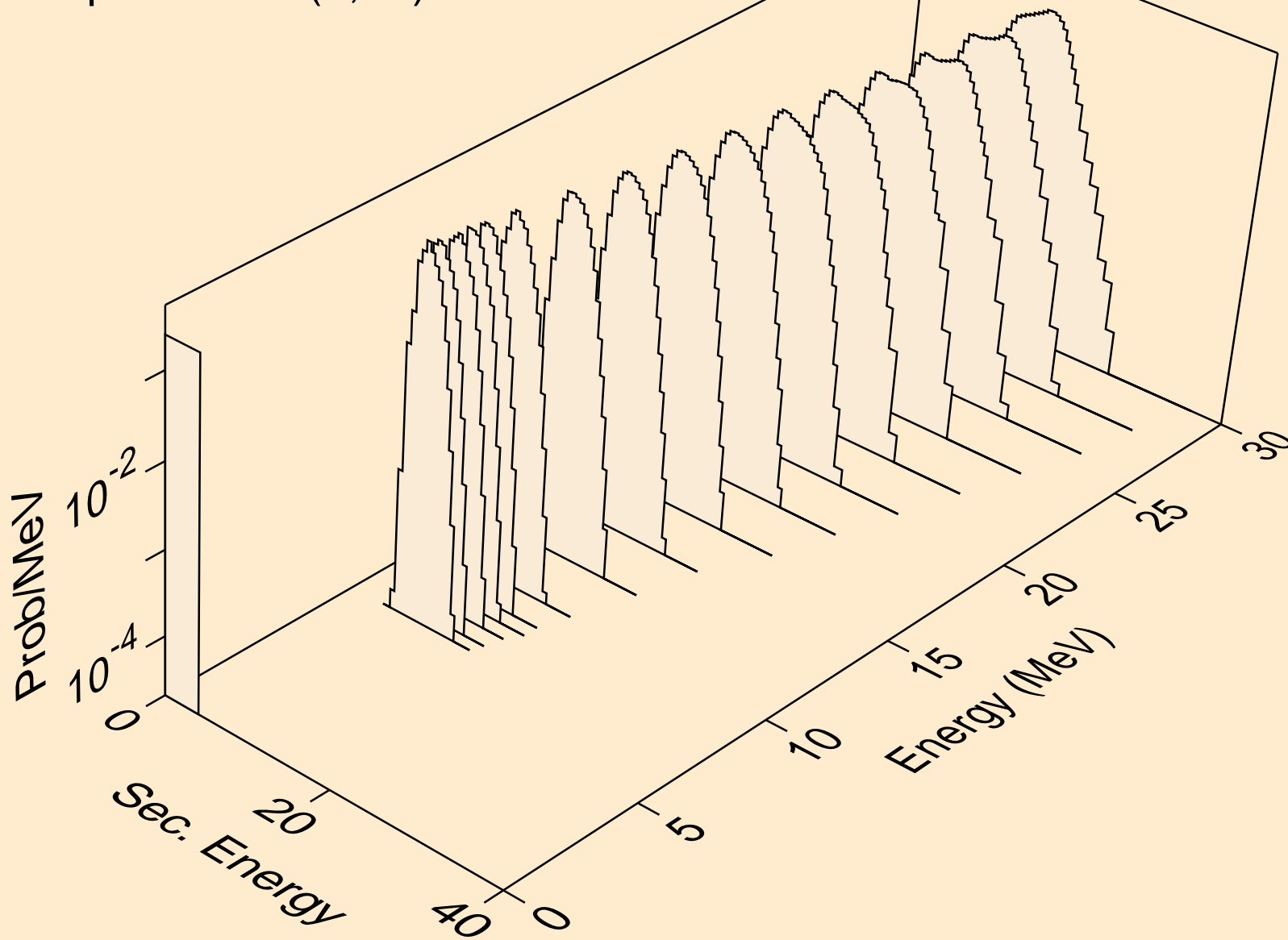

YB160 NEUTRON ACER TENDL-2023 LIBRARY; T=0.K  
alphas from (n,pa)

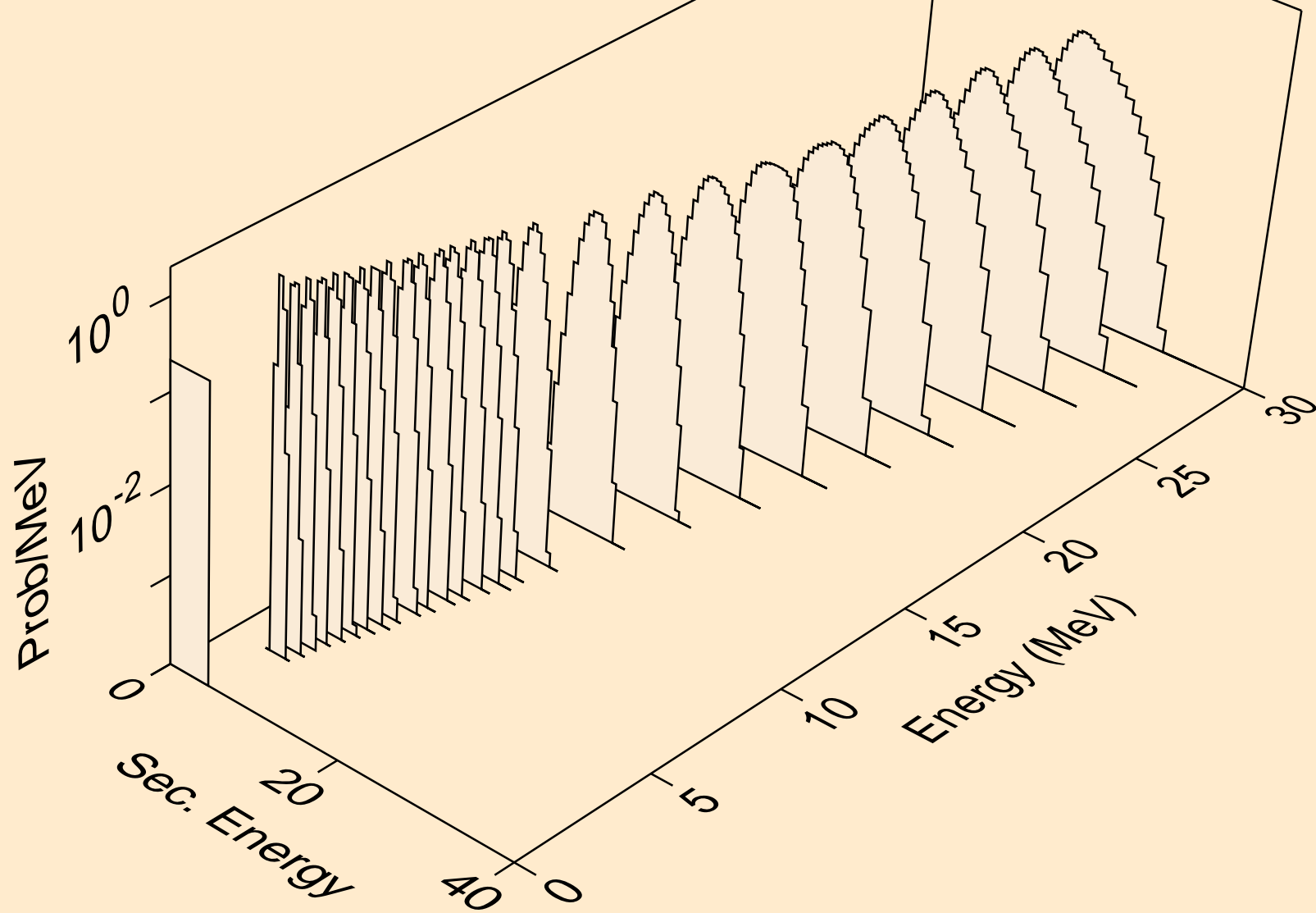

YB160 NEUTRON ACER TENDL-2023 LIBRARY; T=0.K  
alphas from (n,da)

