

# BK253 NEUTRON ACER TENDL-2024 LIBRARY; T=0.K

## Principal cross sections

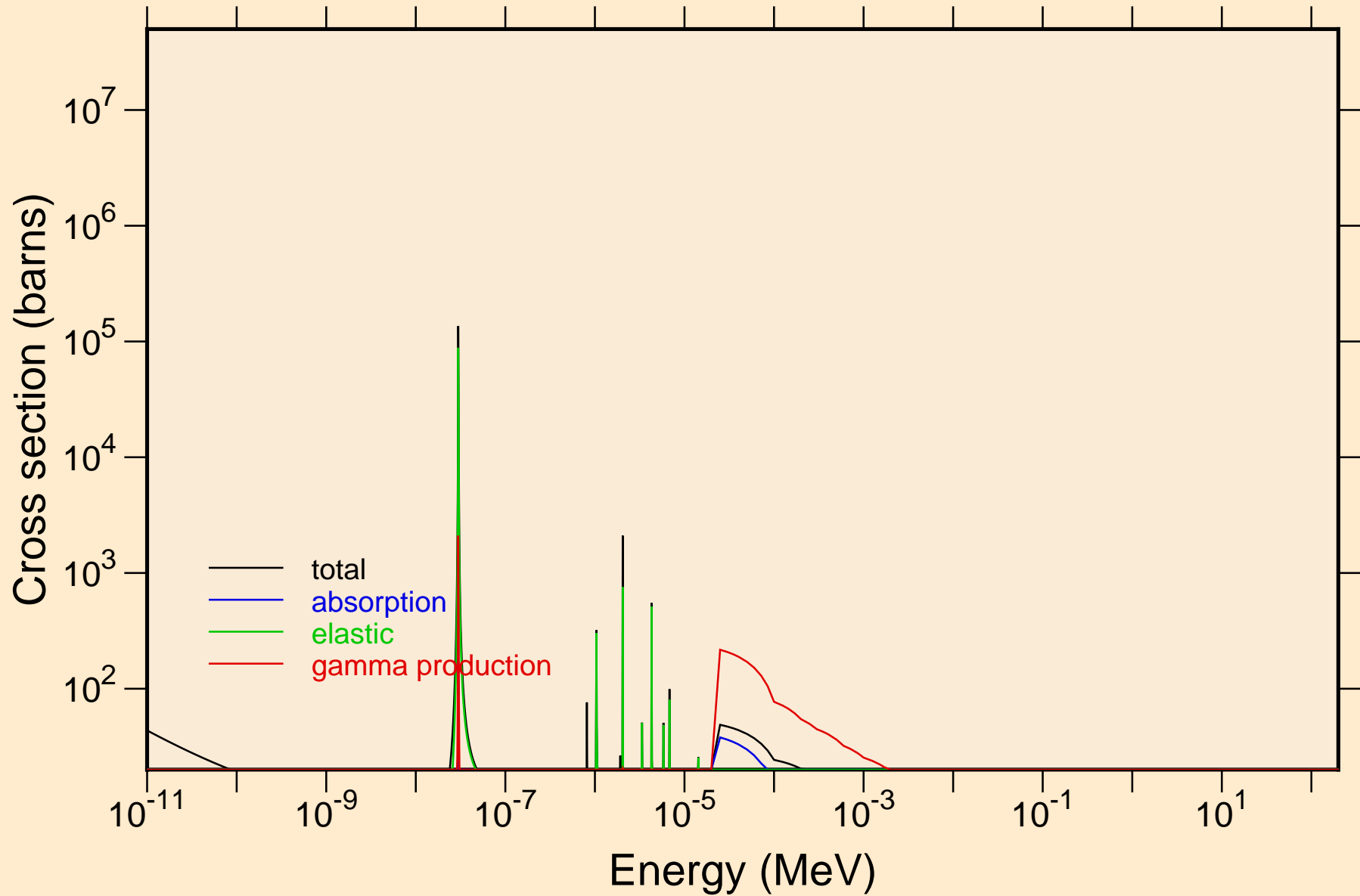

BK253 NEUTRON ACER TENDL-2024 LIBRARY; T=0.K  
resonance total cross section

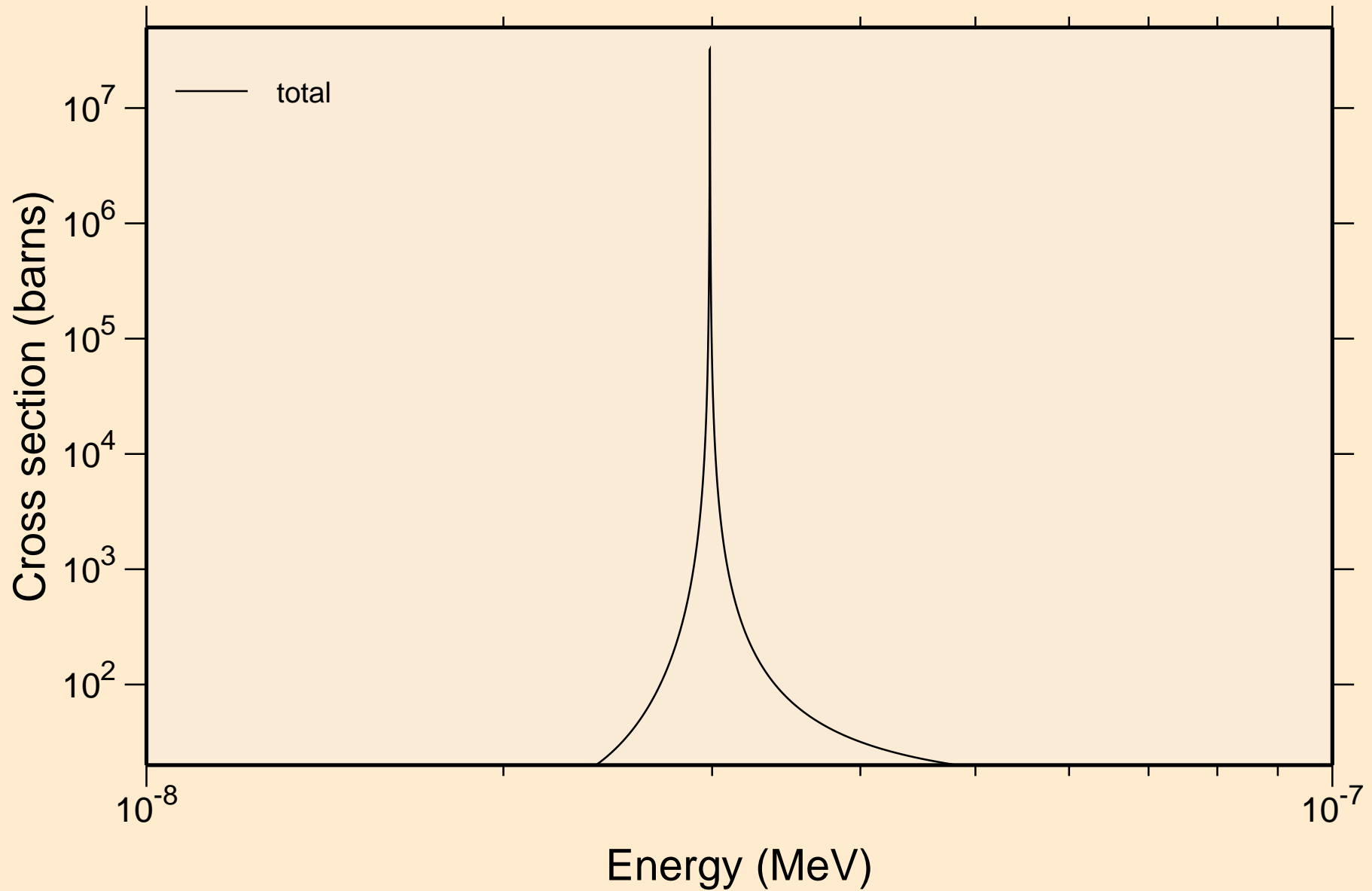

BK253 NEUTRON ACER TENDL-2024 LIBRARY; T=0.K  
resonance total cross section

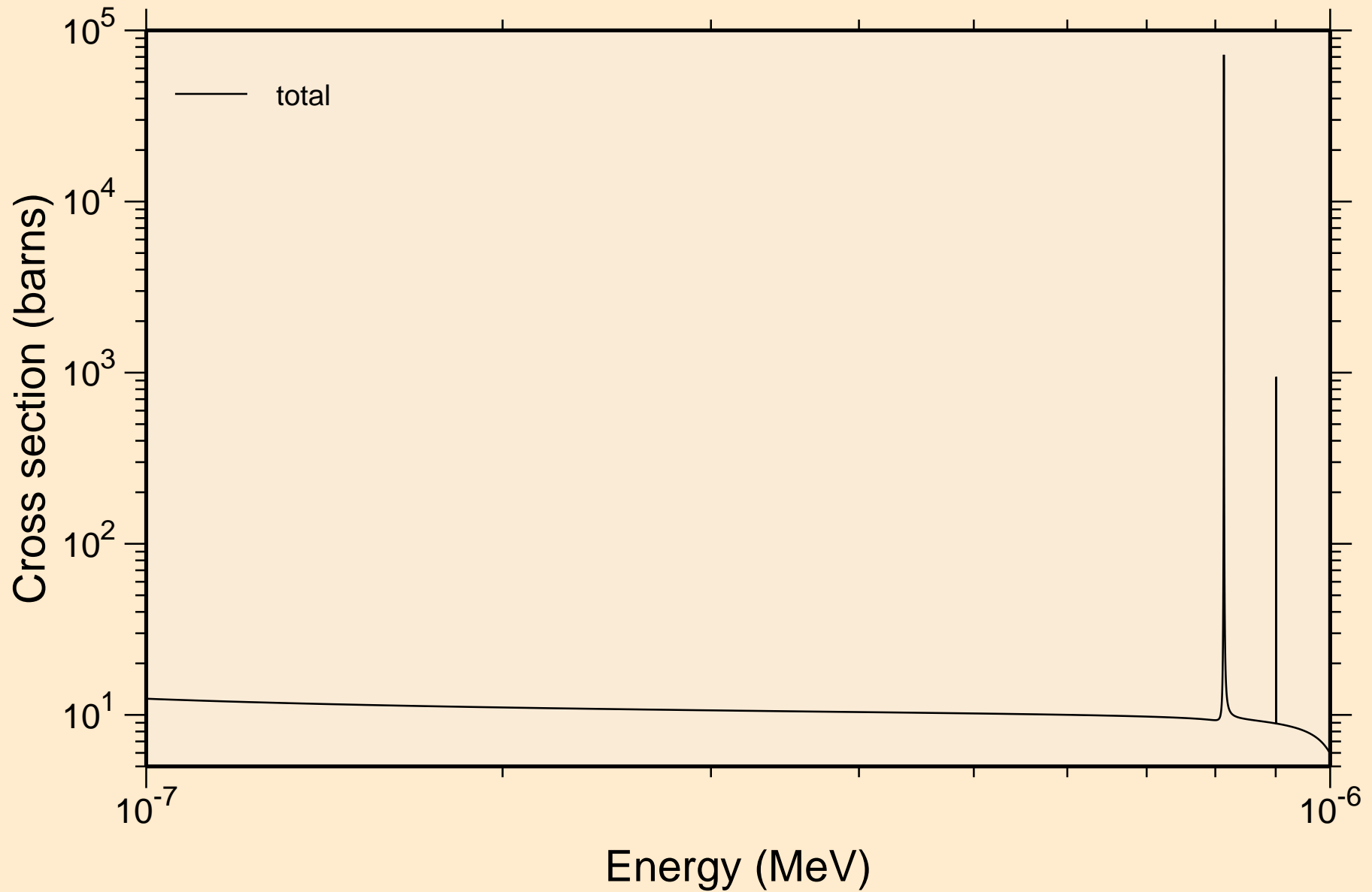

BK253 NEUTRON ACER TENDL-2024 LIBRARY; T=0.K  
resonance total cross section

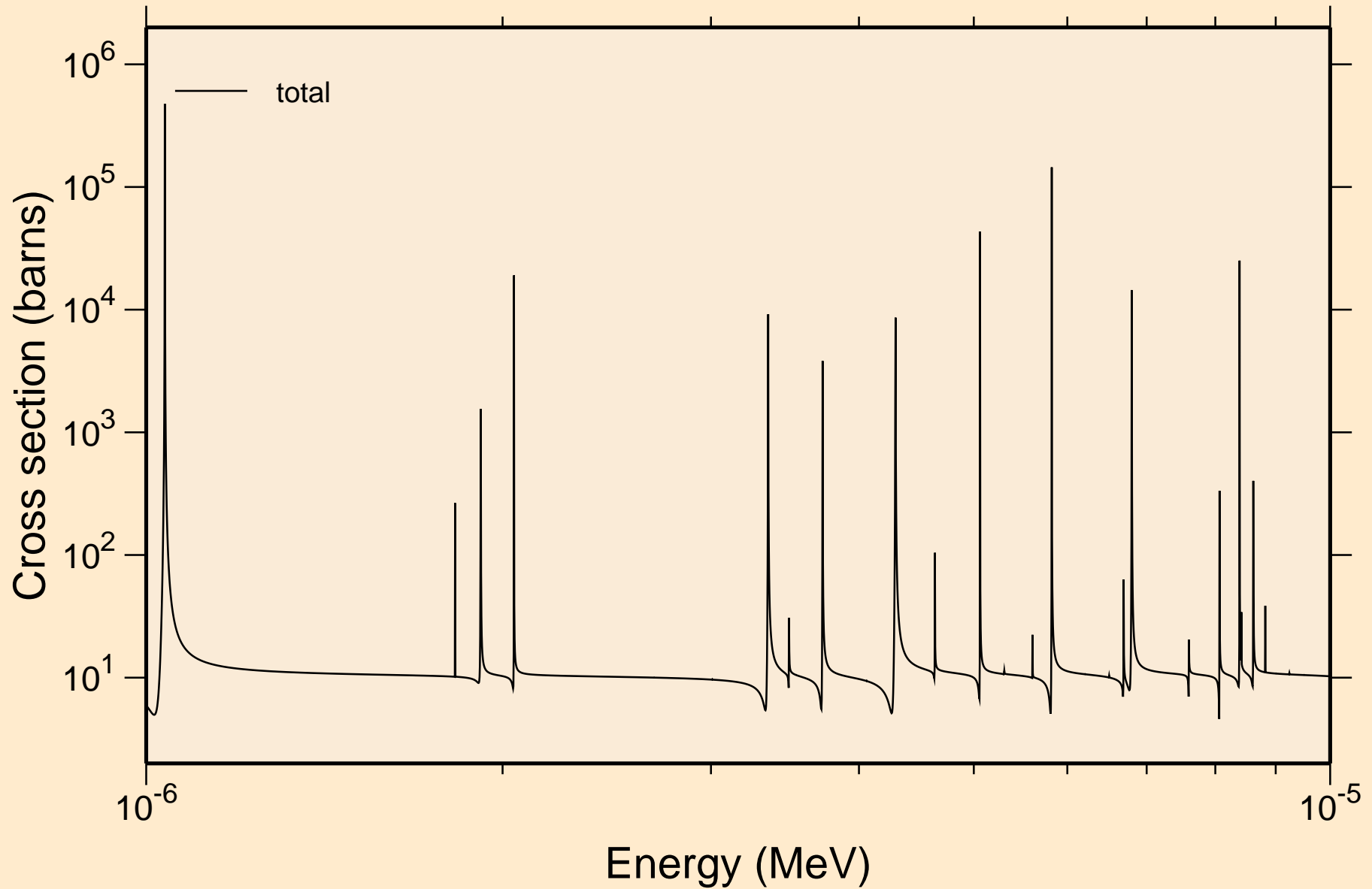

BK253 NEUTRON ACER TENDL-2024 LIBRARY; T=0.K  
resonance total cross section

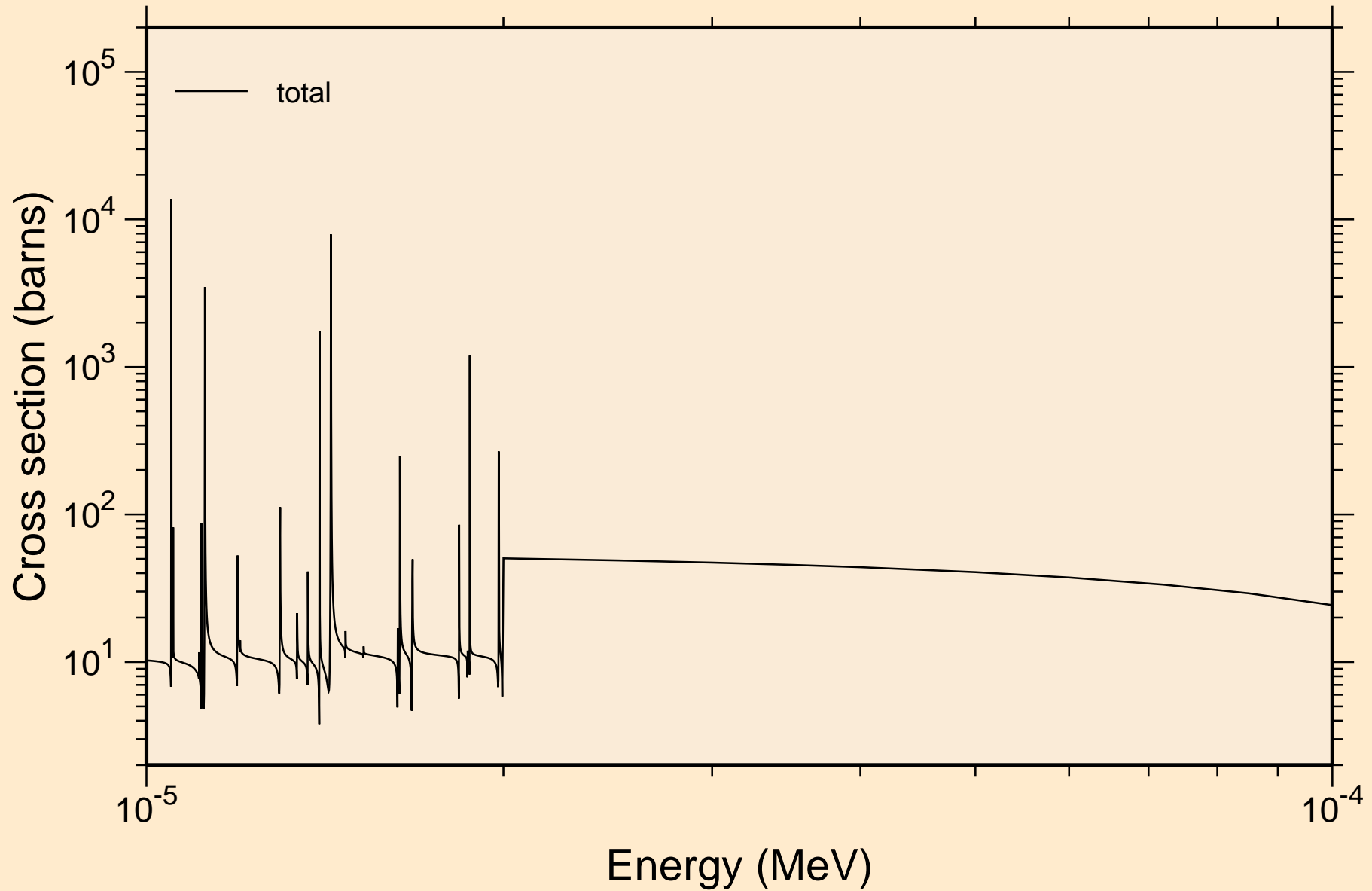

BK253 NEUTRON ACER TENDL-2024 LIBRARY; T=0.K  
resonance total cross section

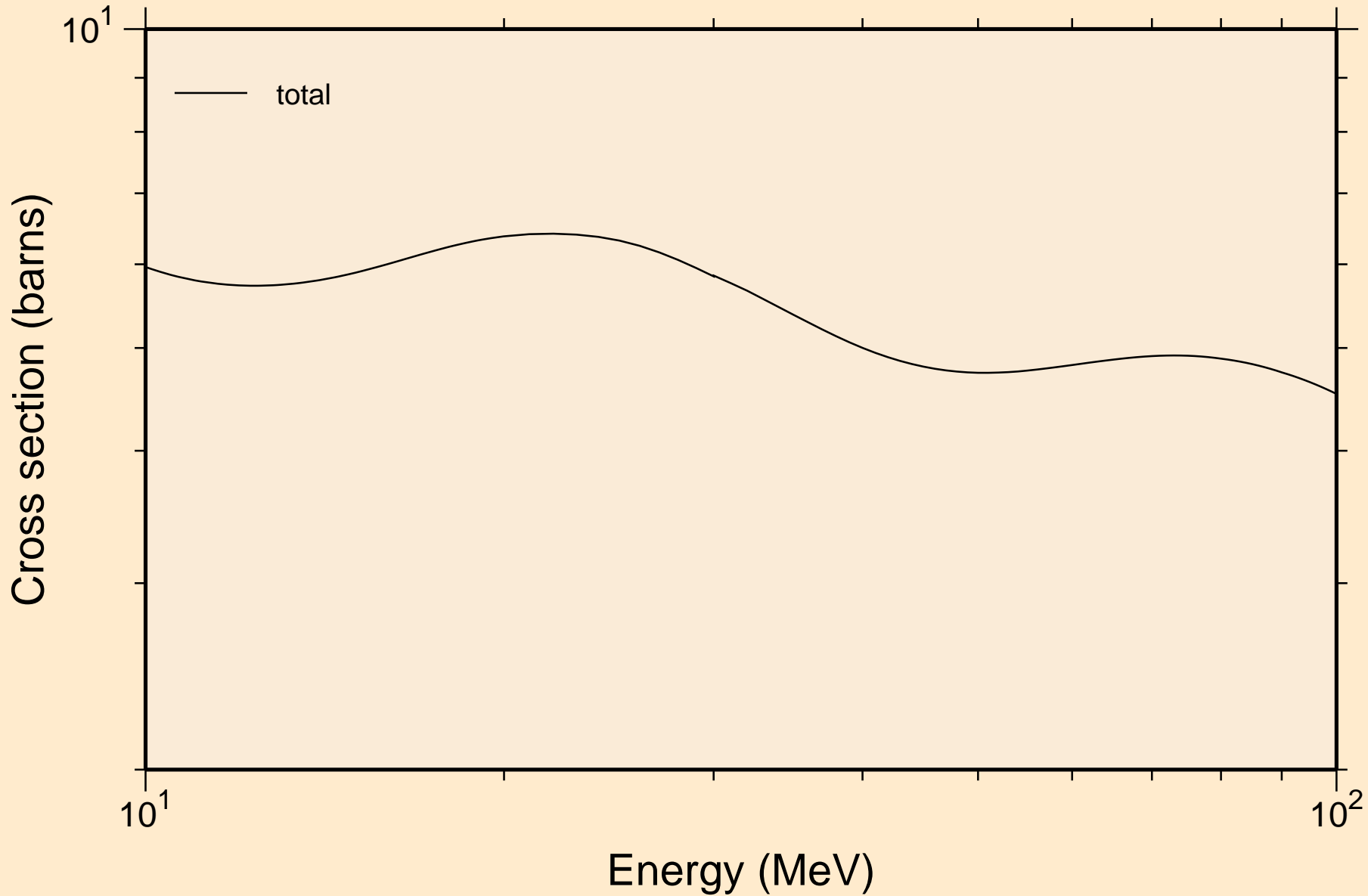

BK253 NEUTRON ACER TENDL-2024 LIBRARY; T=0.K  
resonance absorption cross sections

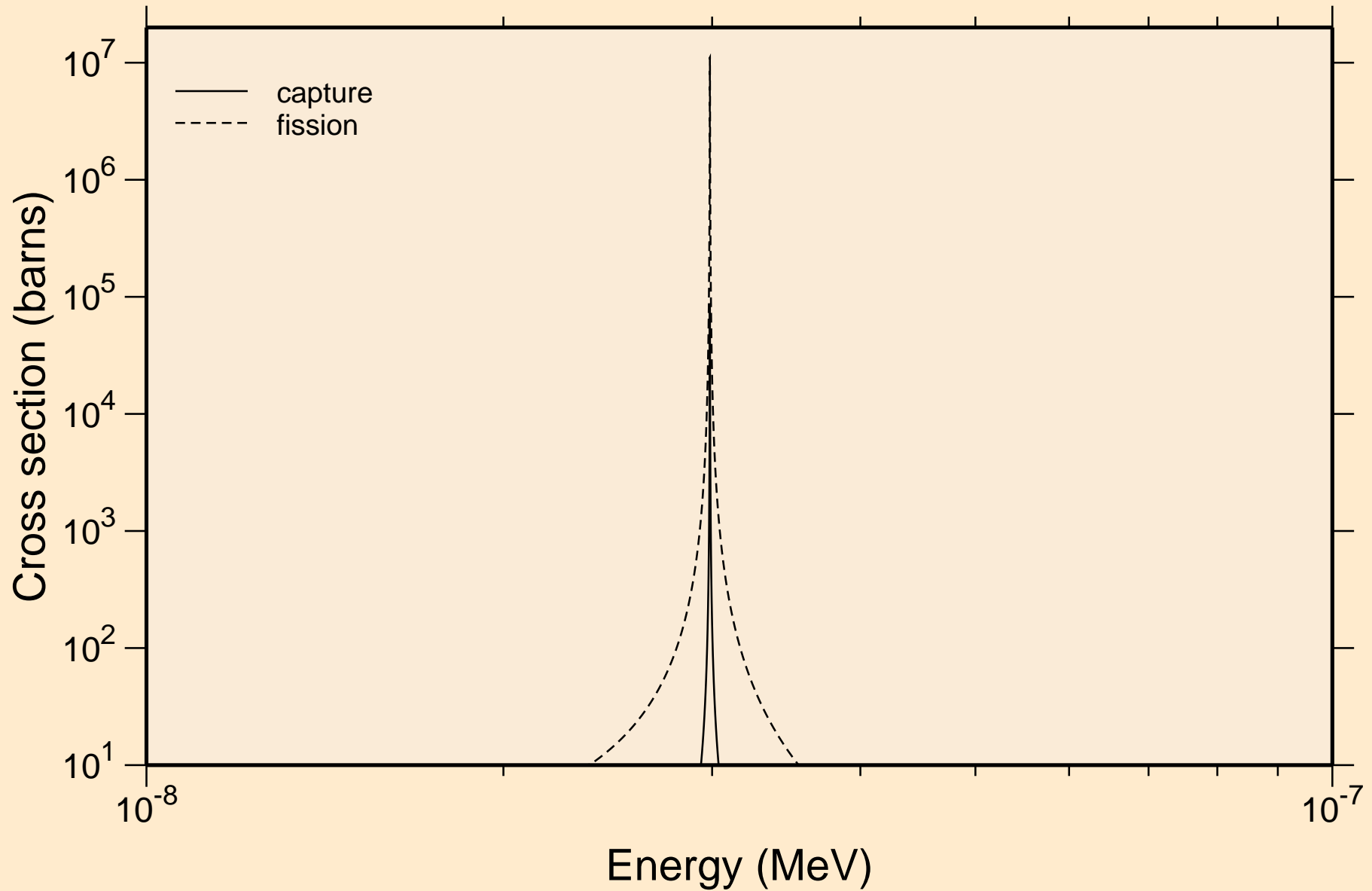



BK253 NEUTRON ACER TENDL-2024 LIBRARY; T=0.K  
resonance absorption cross sections

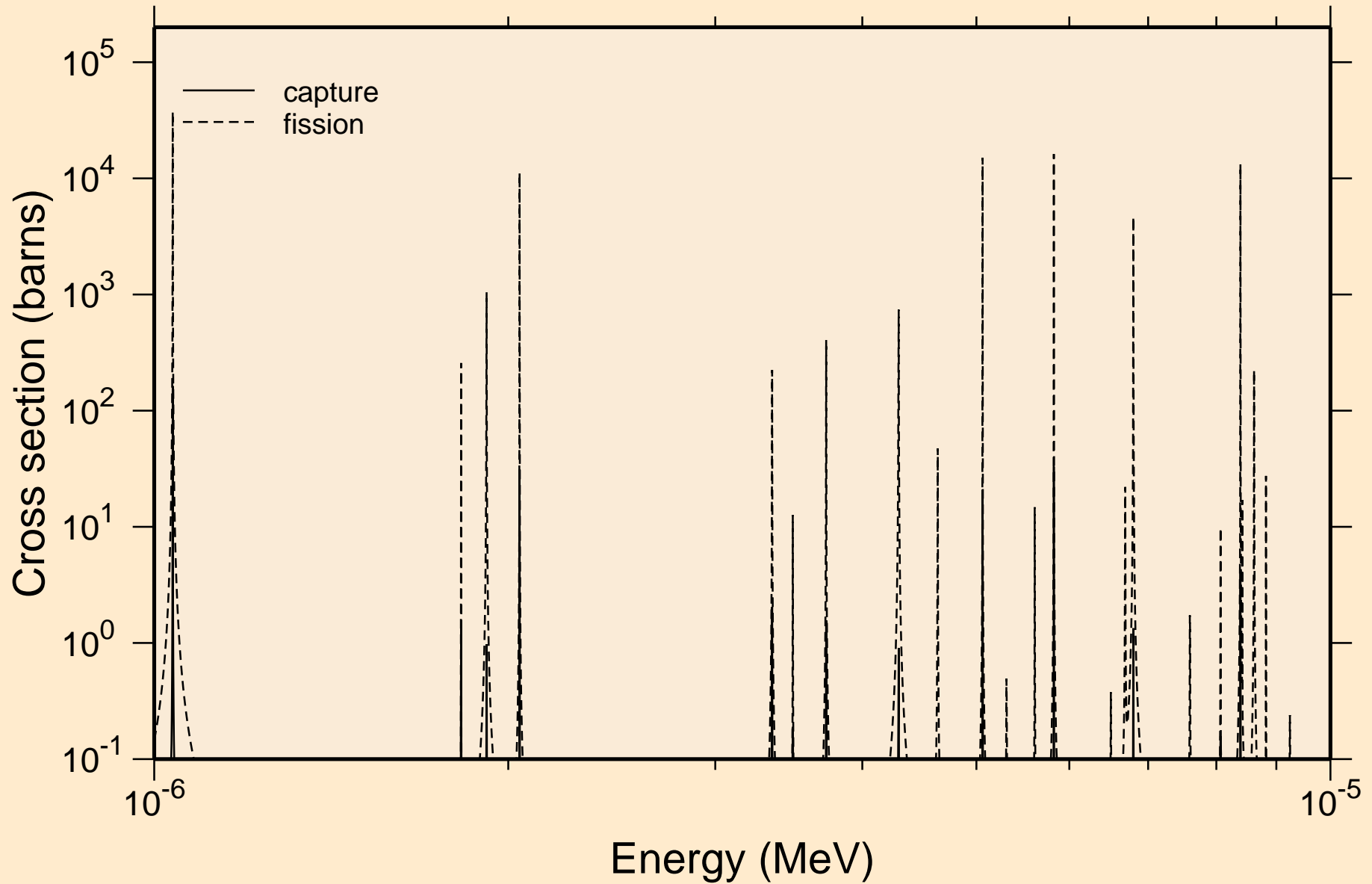

BK253 NEUTRON ACER TENDL-2024 LIBRARY; T=0.K  
resonance absorption cross sections

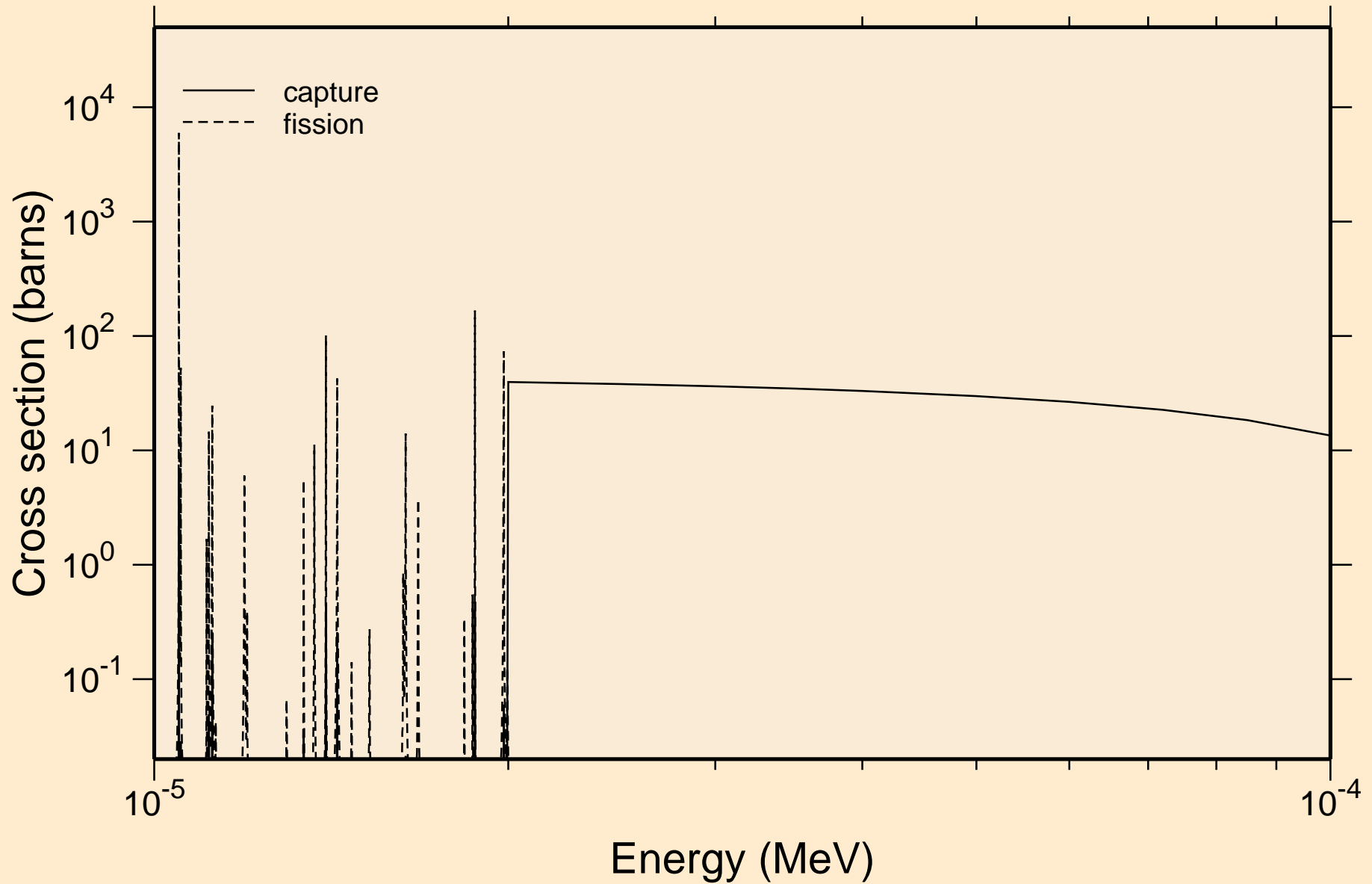

BK253 NEUTRON ACER TENDL-2024 LIBRARY; T=0.K  
resonance absorption cross sections

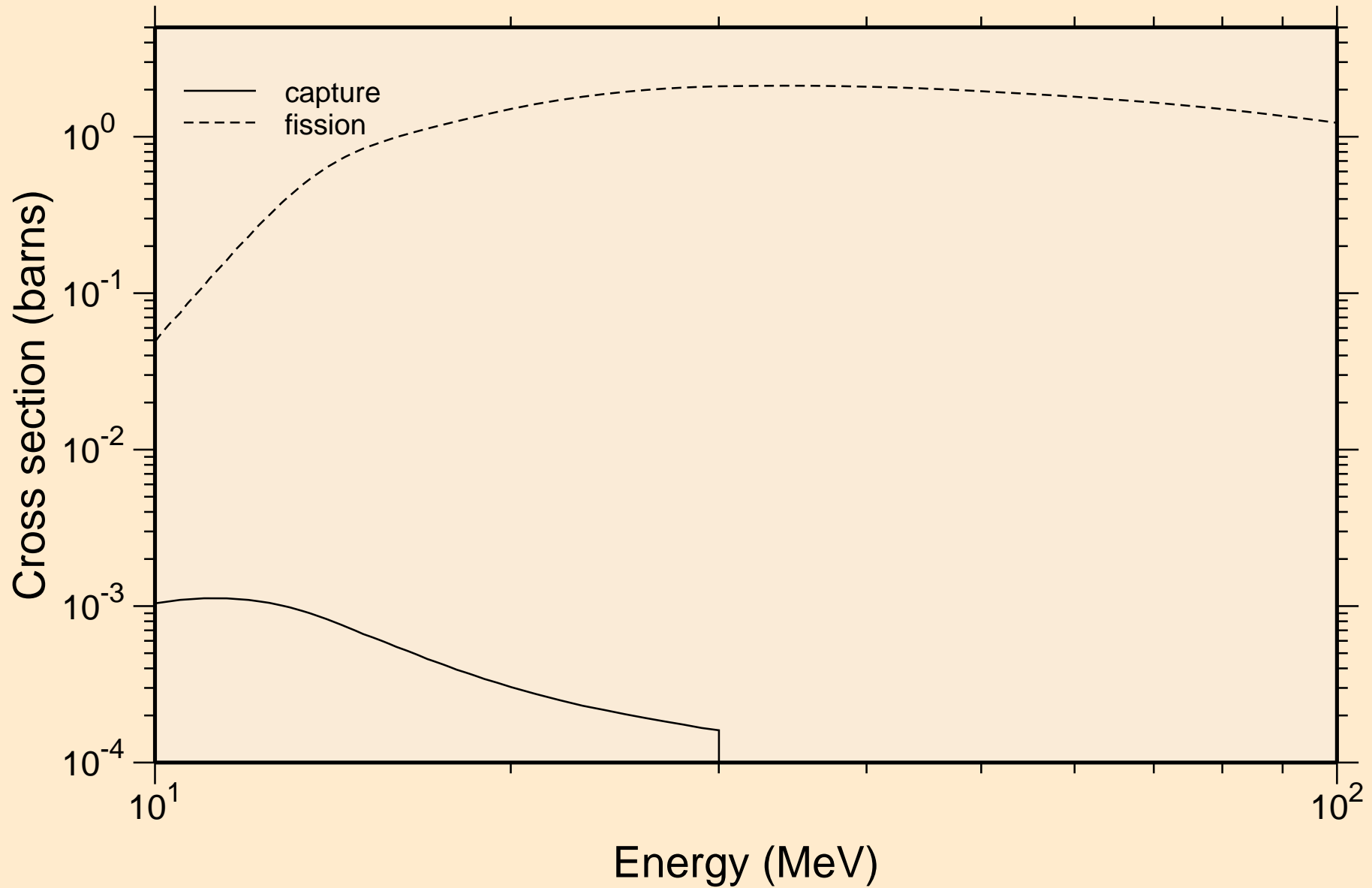

# BK253 NEUTRON ACER TENDL-2024 LIBRARY; T=0.K

## Heating

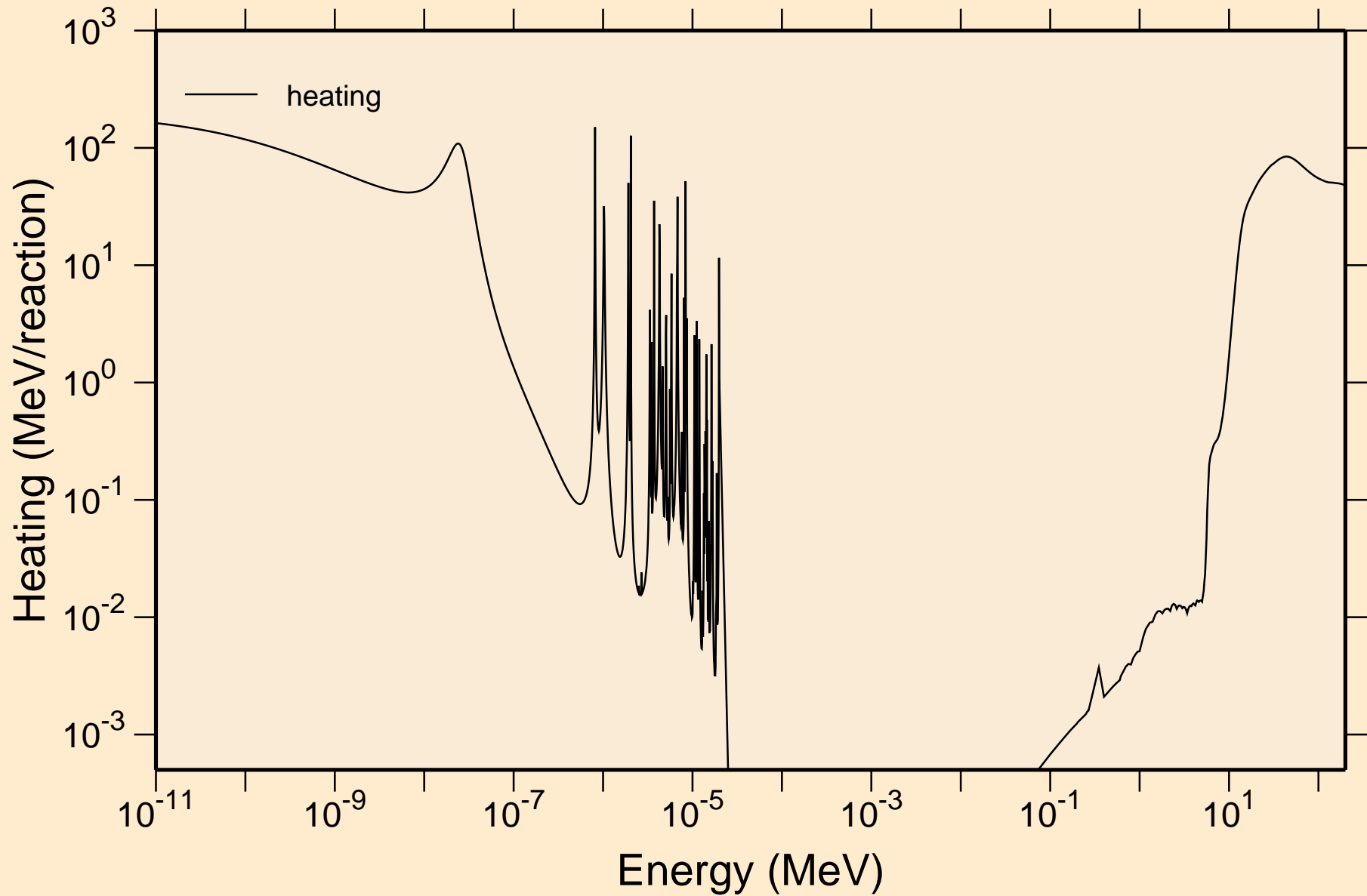

# BK253 NEUTRON ACER TENDL-2024 LIBRARY; T=0.K

## Damage

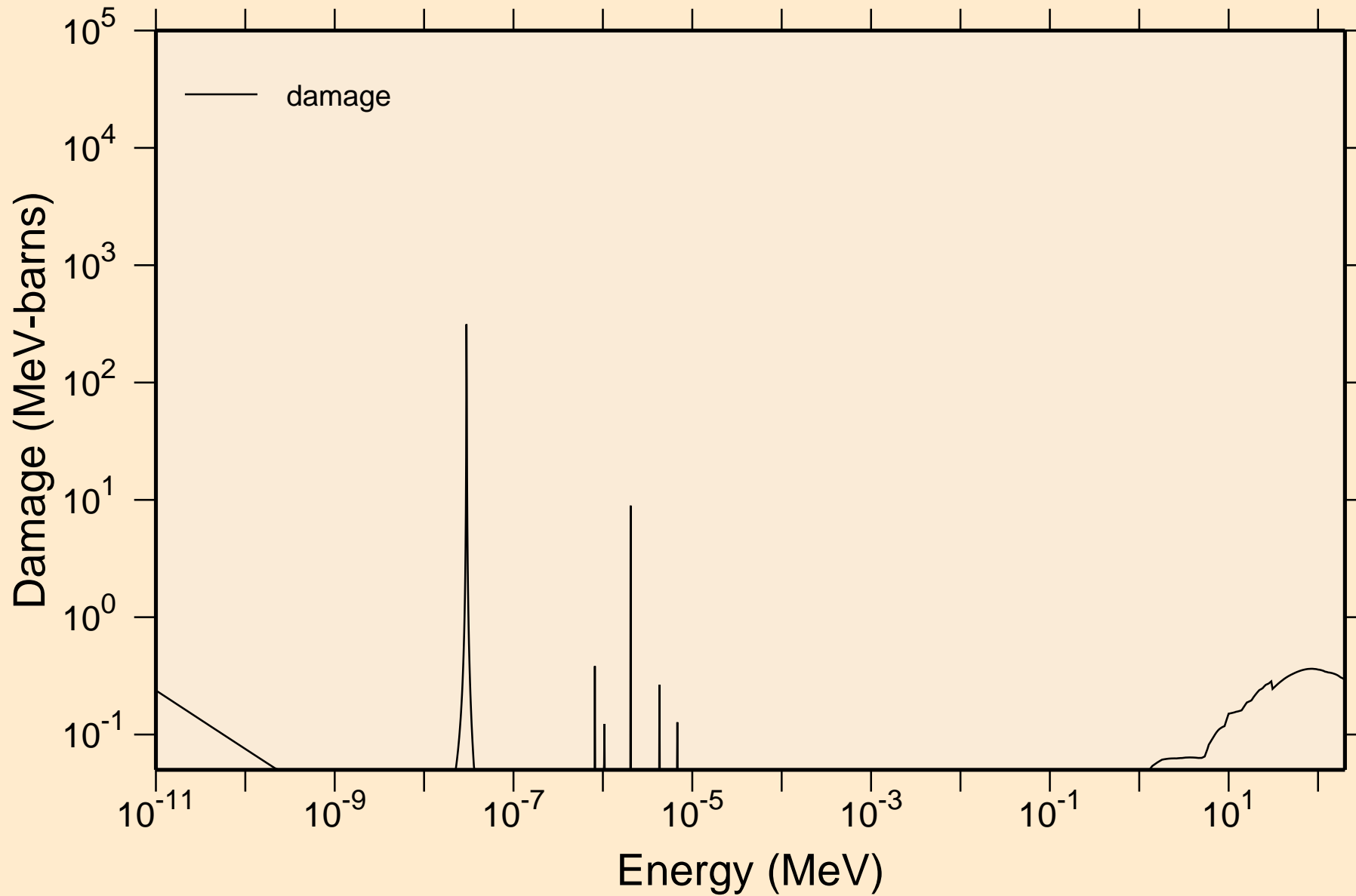

# BK253 NEUTRON ACER TENDL-2024 LIBRARY; T=0.K

## Non-threshold reactions

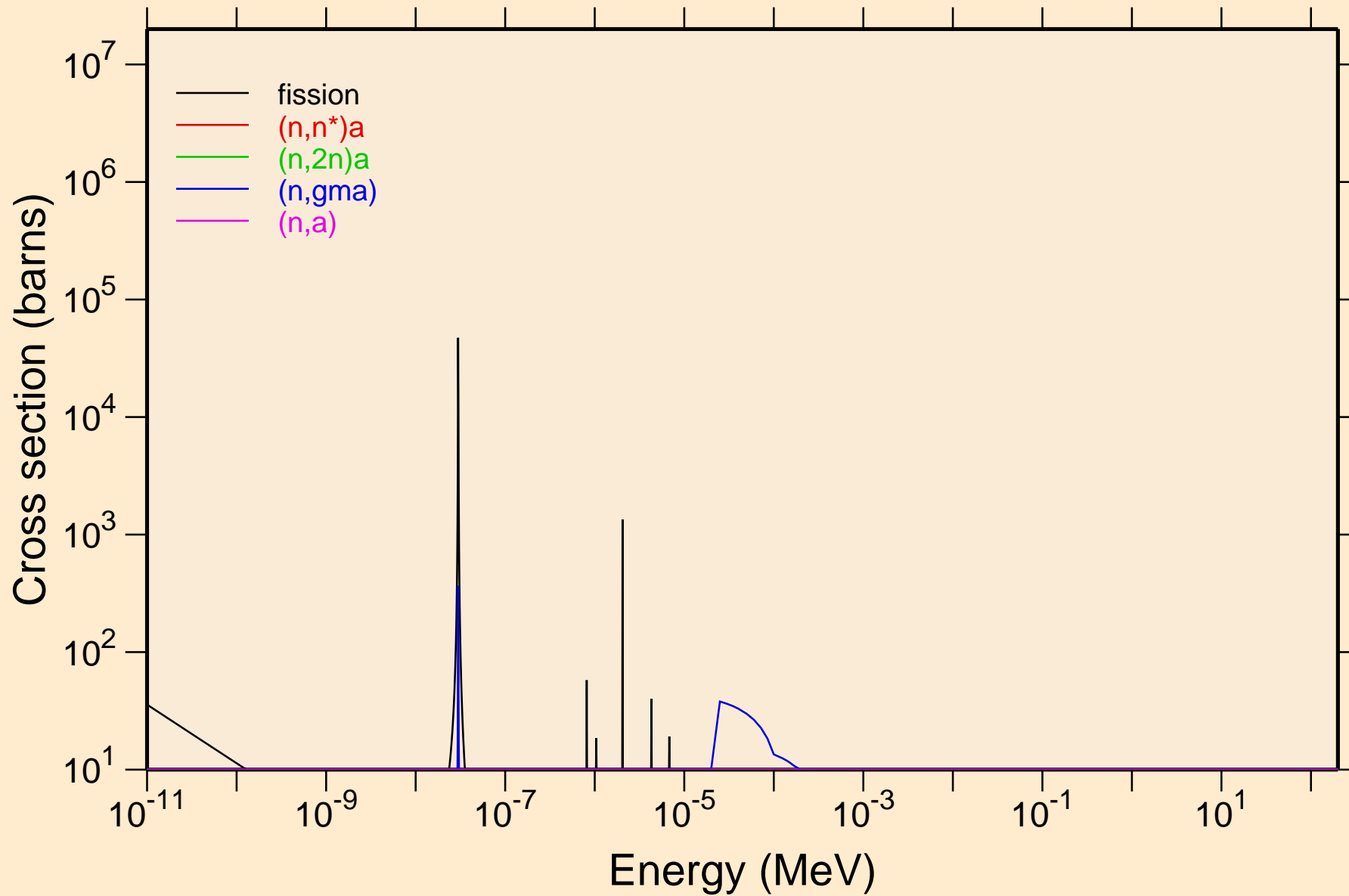

BK253 NEUTRON ACER TENDL-2024 LIBRARY; T=0.K  
Non-threshold reactions

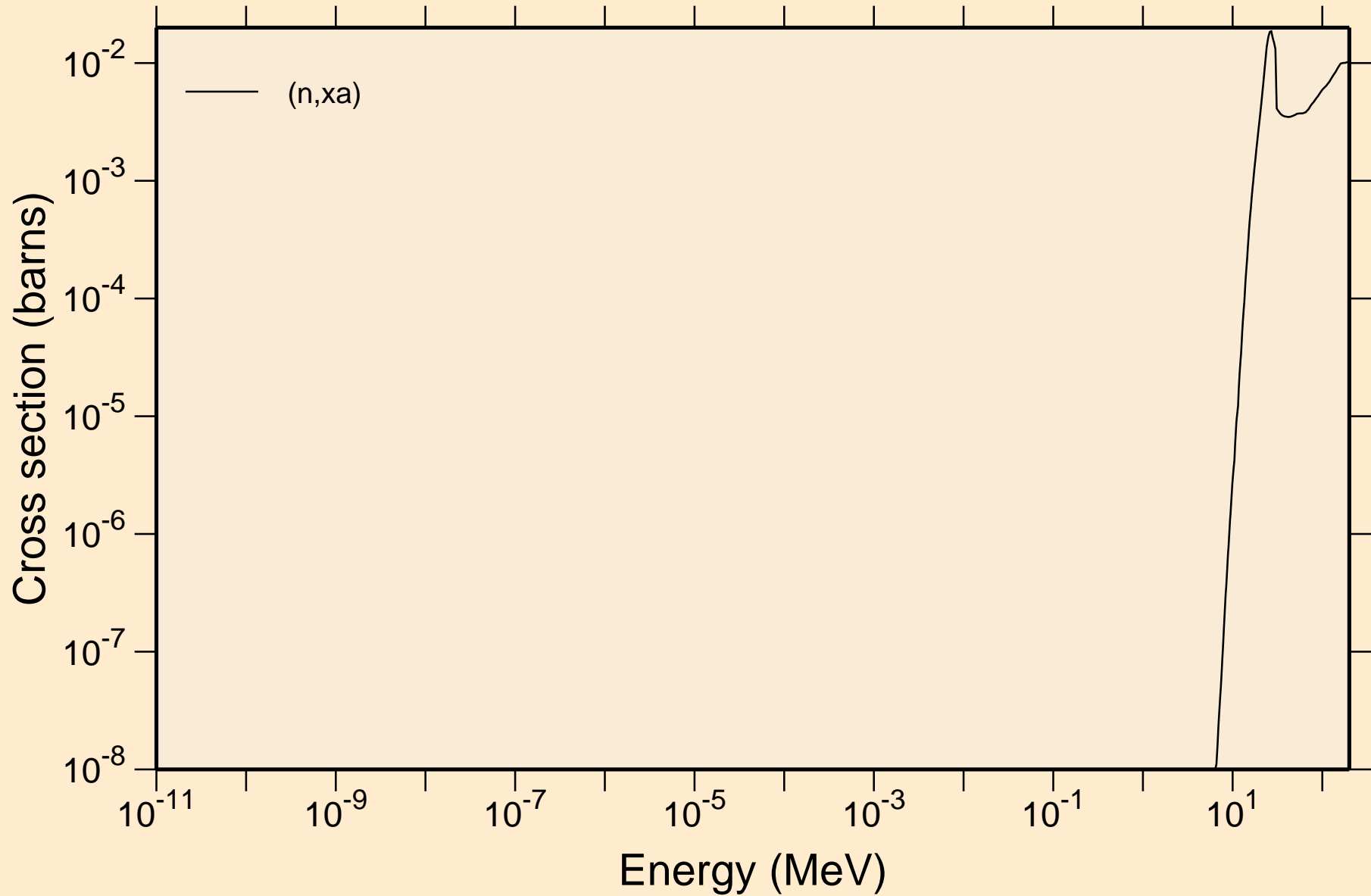

# BK253 NEUTRON ACER TENDL-2024 LIBRARY; T=0.K

## Principal cross sections

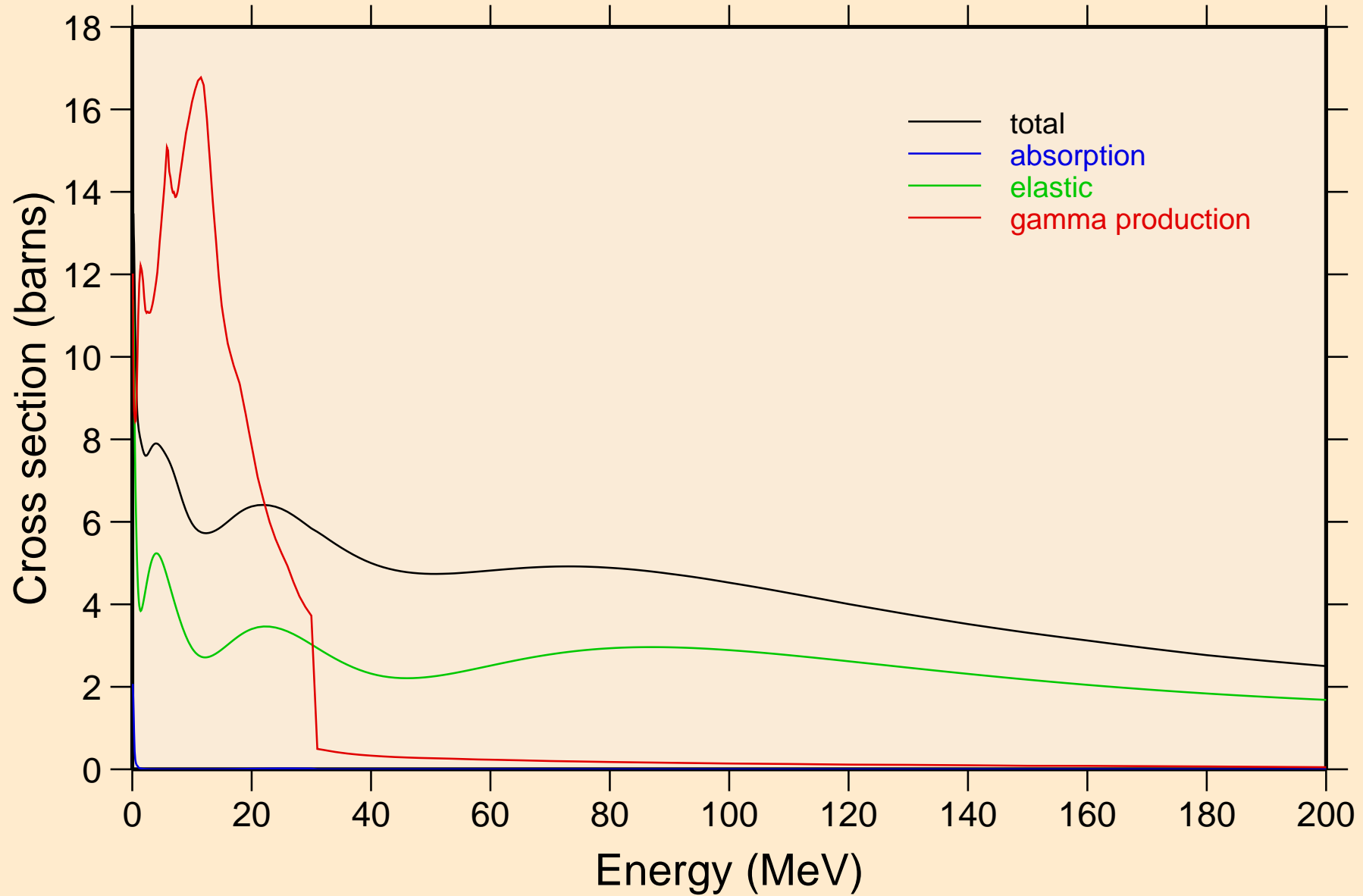

# BK253 NEUTRON ACER TENDL-2024 LIBRARY; T=0.K

## Heating

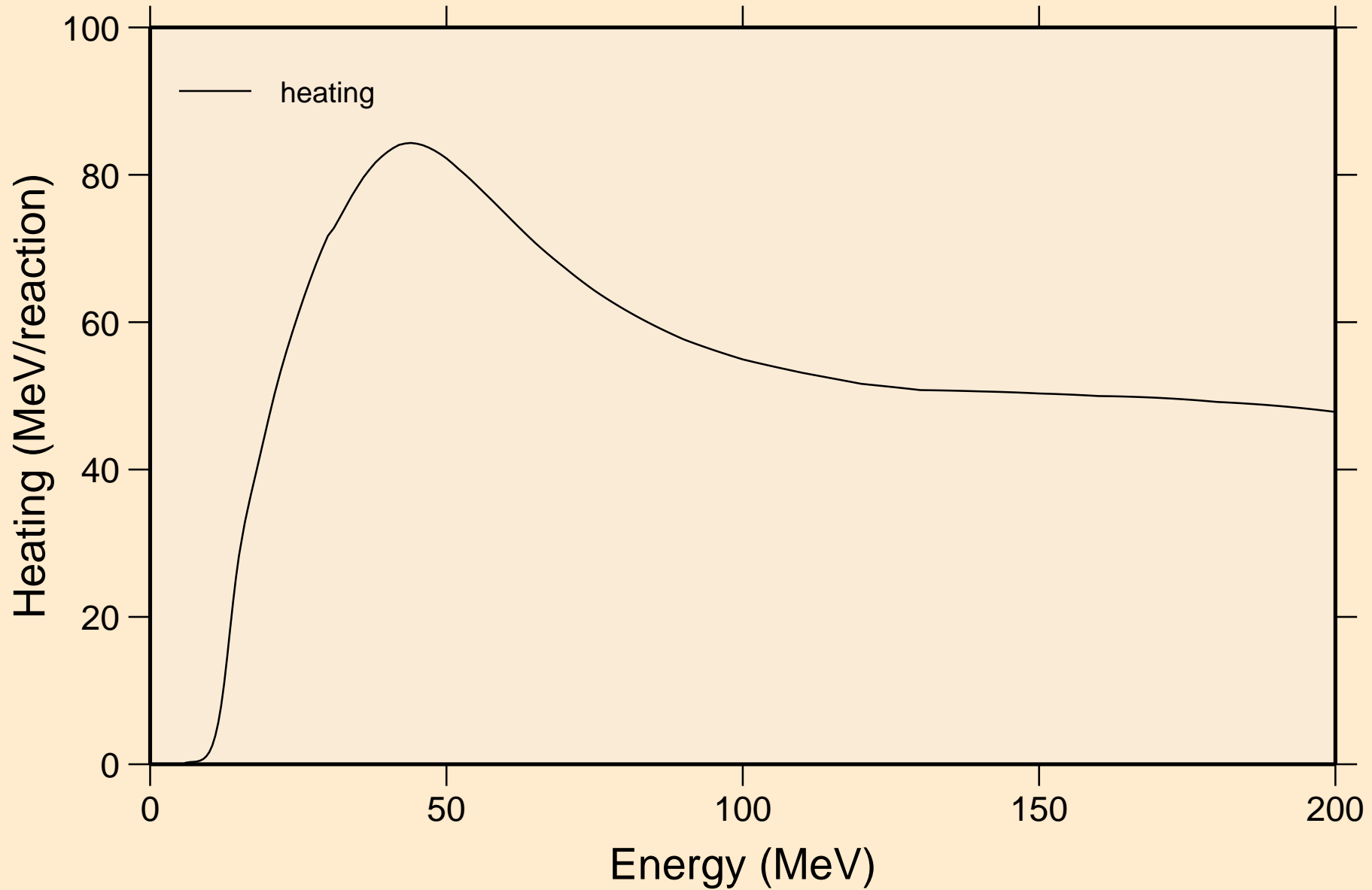

BK253 NEUTRON ACER TENDL-2024 LIBRARY; T=0.K  
Damage

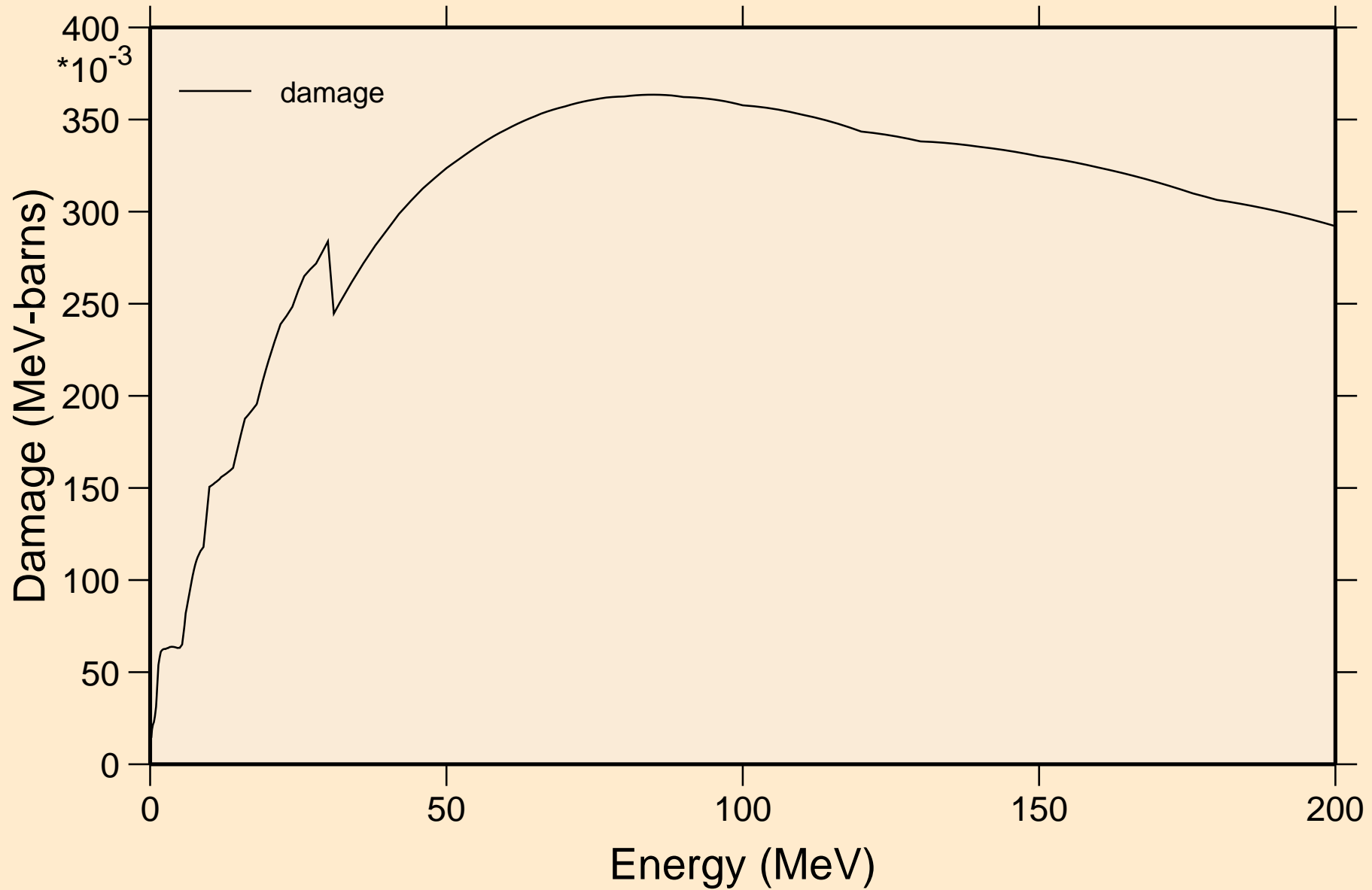

BK253 NEUTRON ACER TENDL-2024 LIBRARY; T=0.K  
Non-threshold reactions

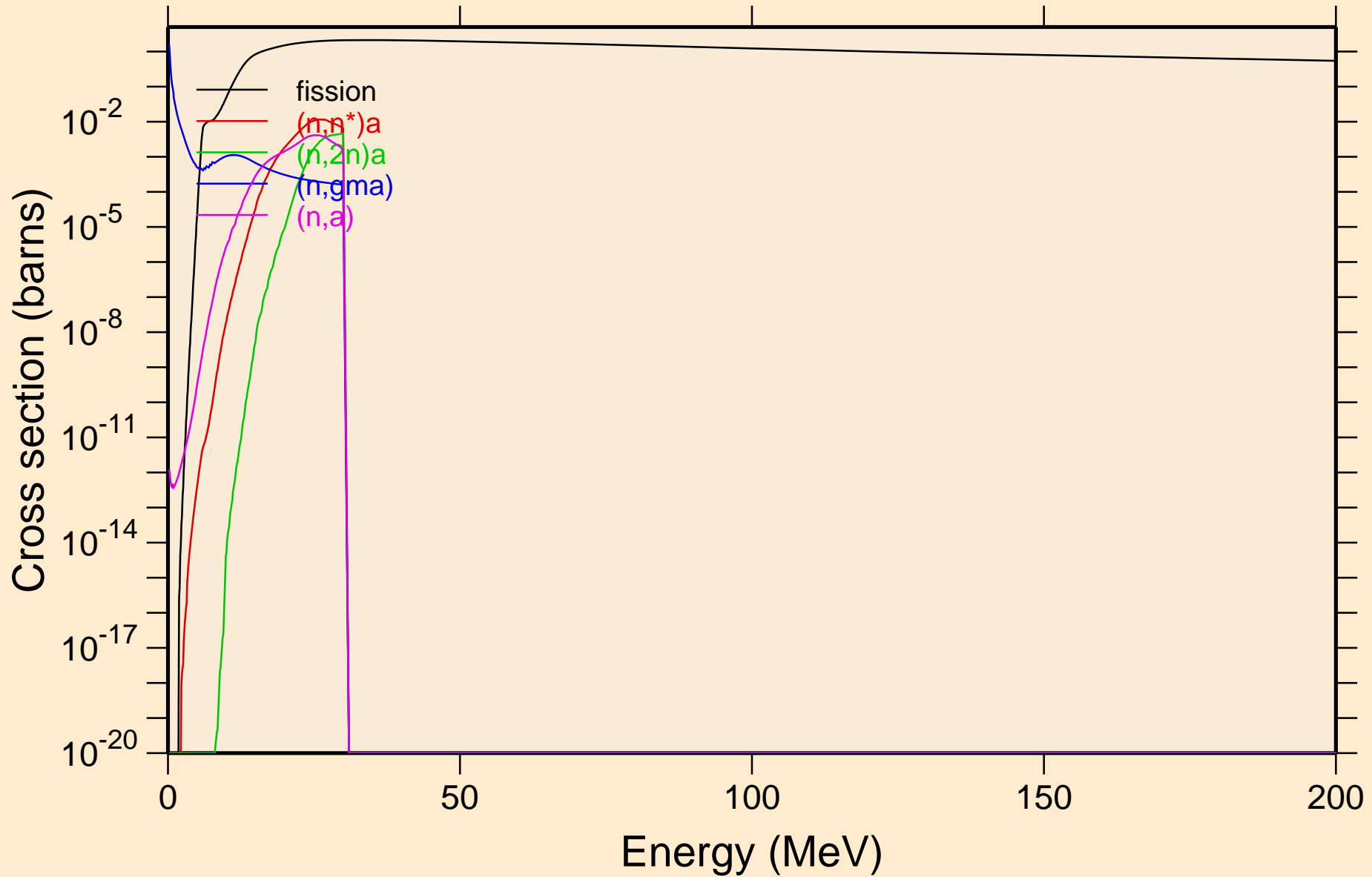

BK253 NEUTRON ACER TENDL-2024 LIBRARY; T=0.K  
Non-threshold reactions

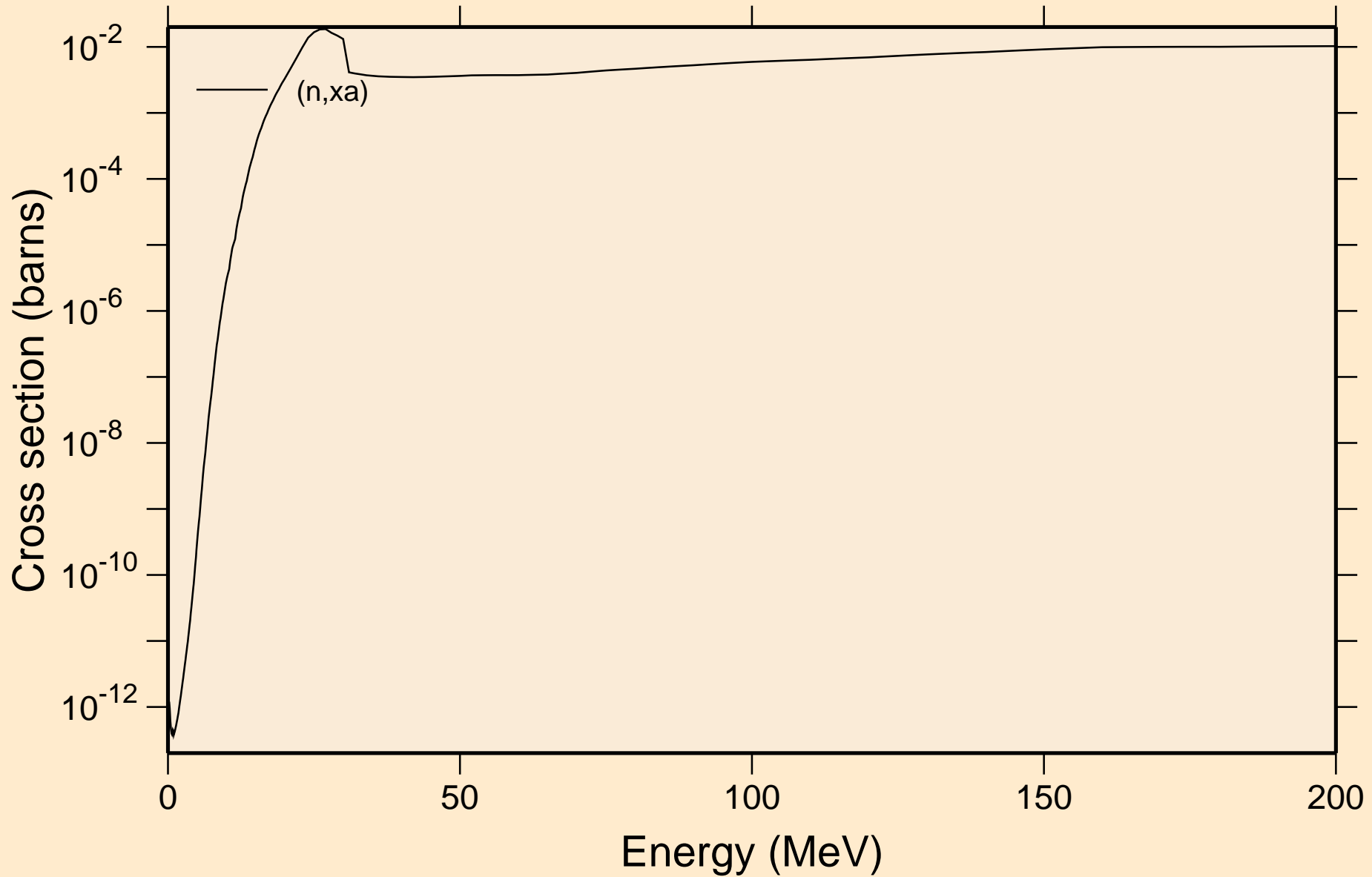

BK253 NEUTRON ACER TENDL-2024 LIBRARY; T=0.K  
Inelastic levels

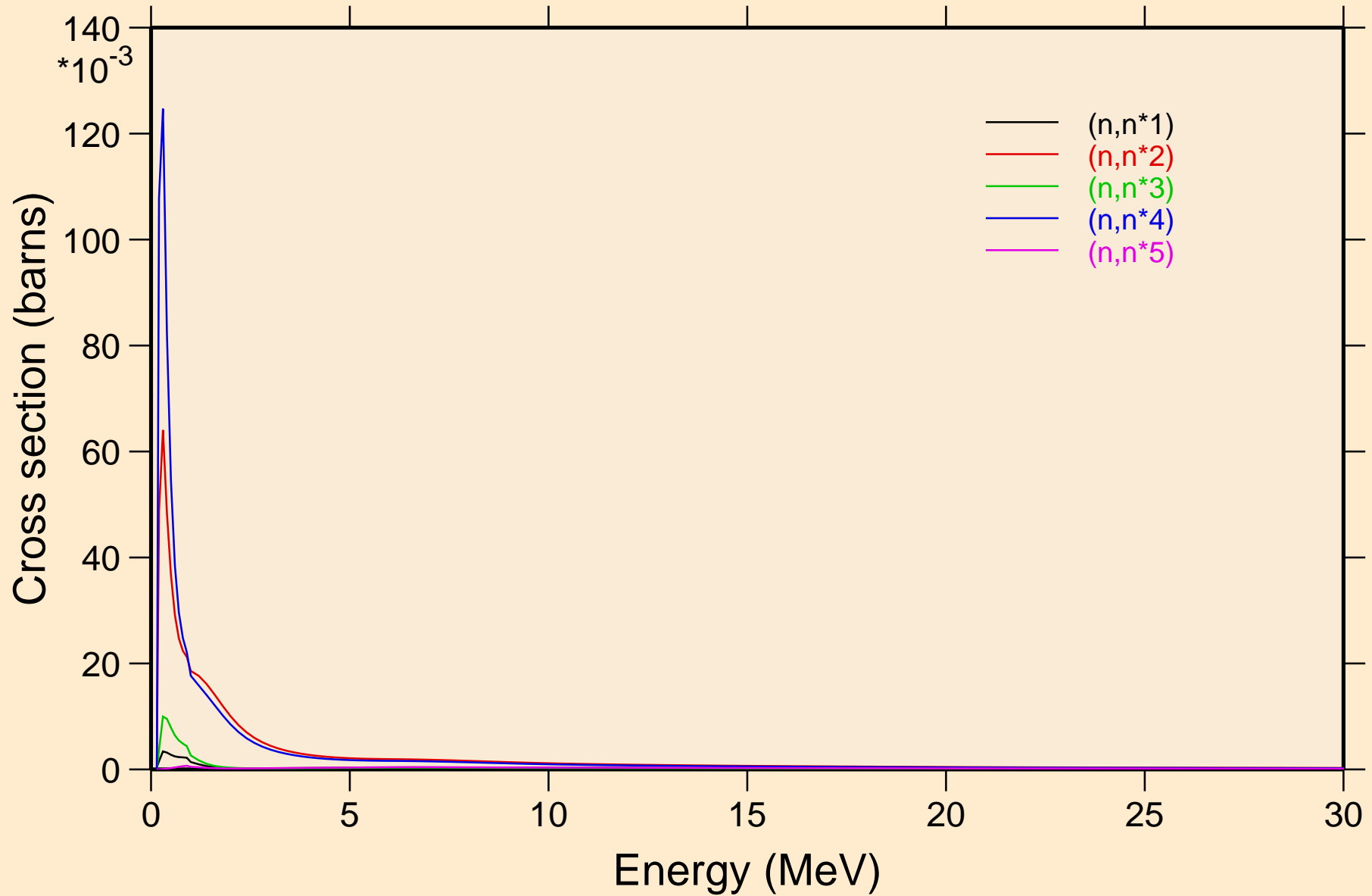

BK253 NEUTRON ACER TENDL-2024 LIBRARY; T=0.K  
Inelastic levels

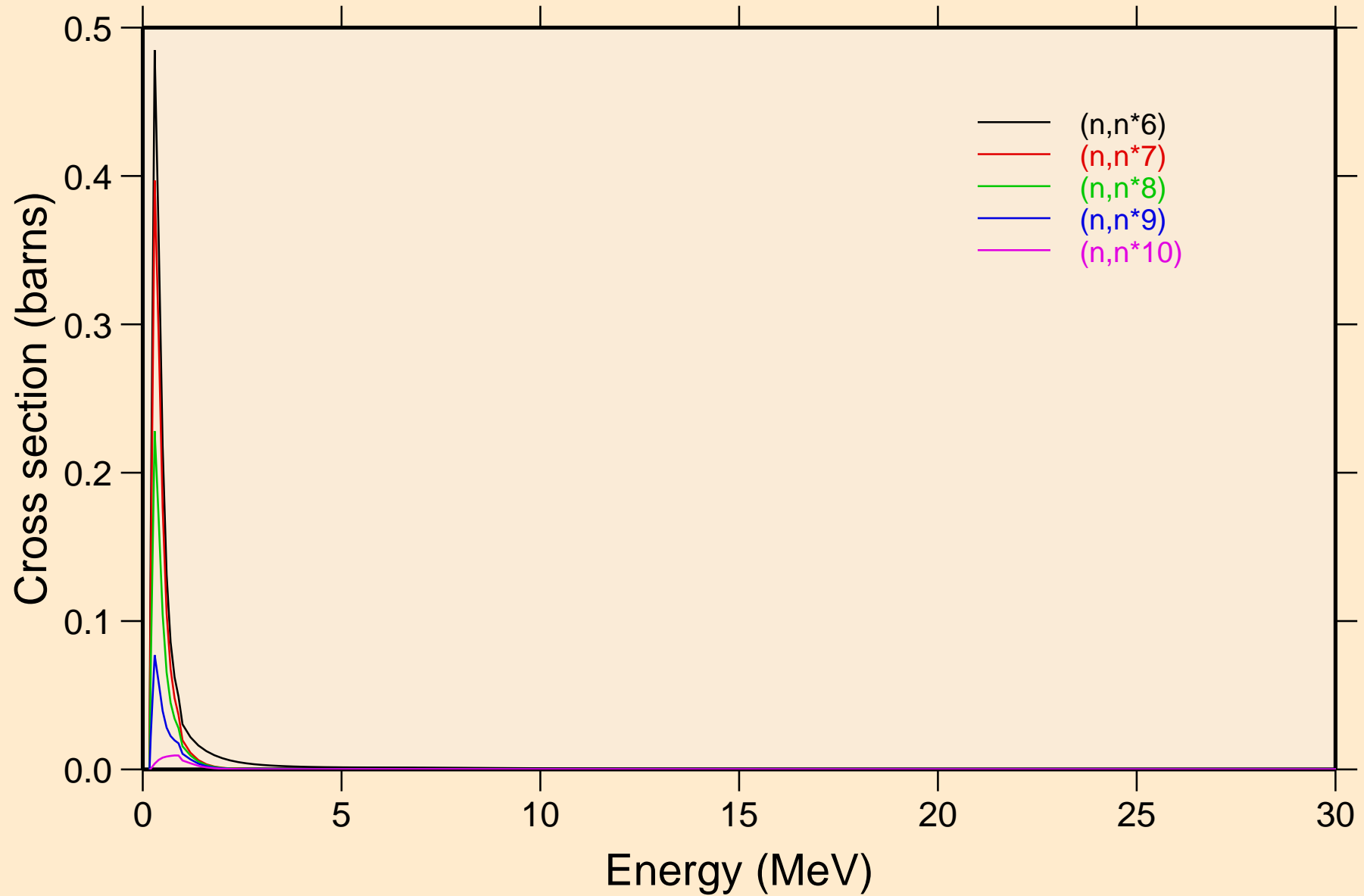

BK253 NEUTRON ACER TENDL-2024 LIBRARY; T=0.K  
Inelastic levels

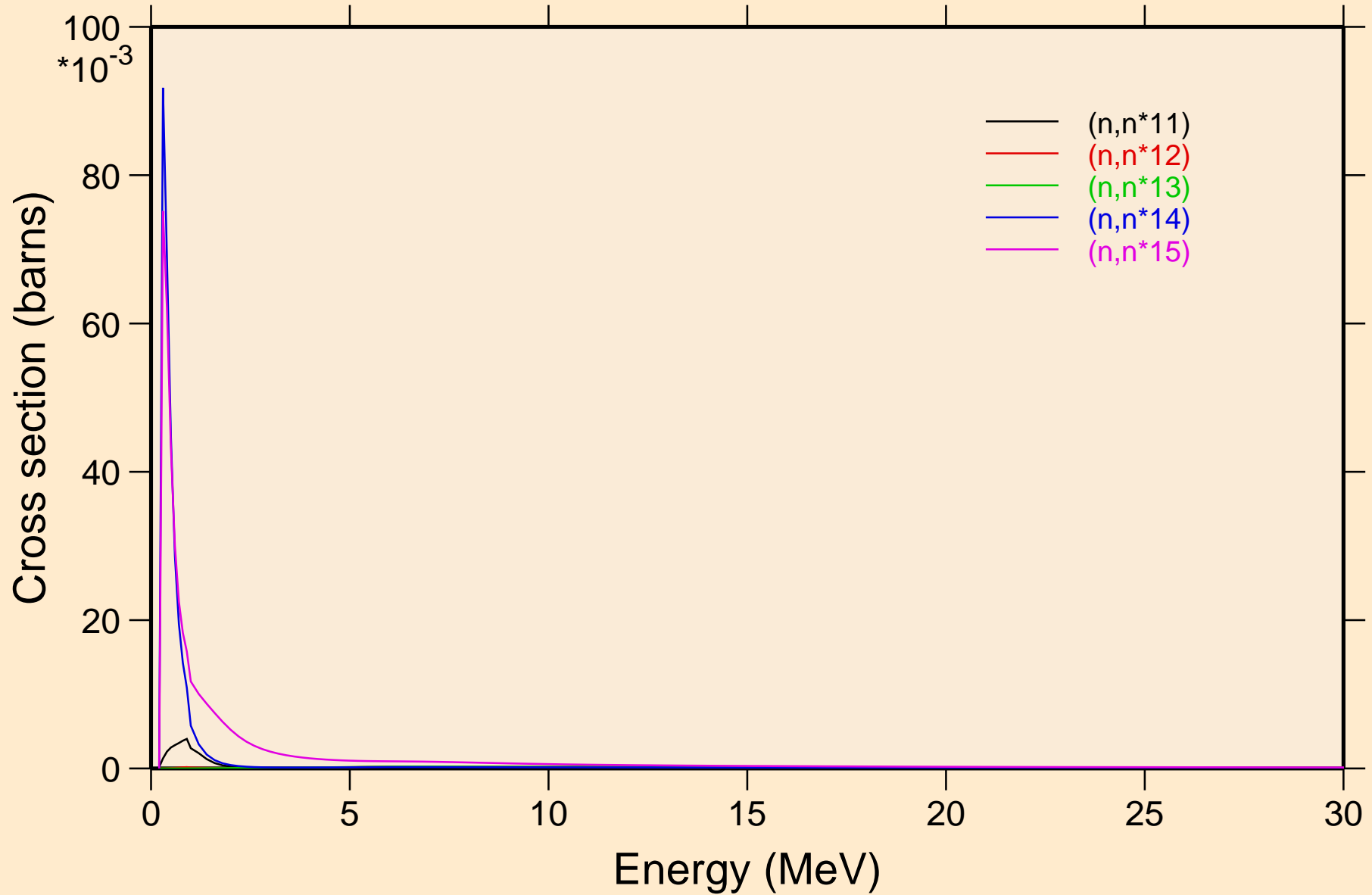

BK253 NEUTRON ACER TENDL-2024 LIBRARY; T=0.K  
Inelastic levels

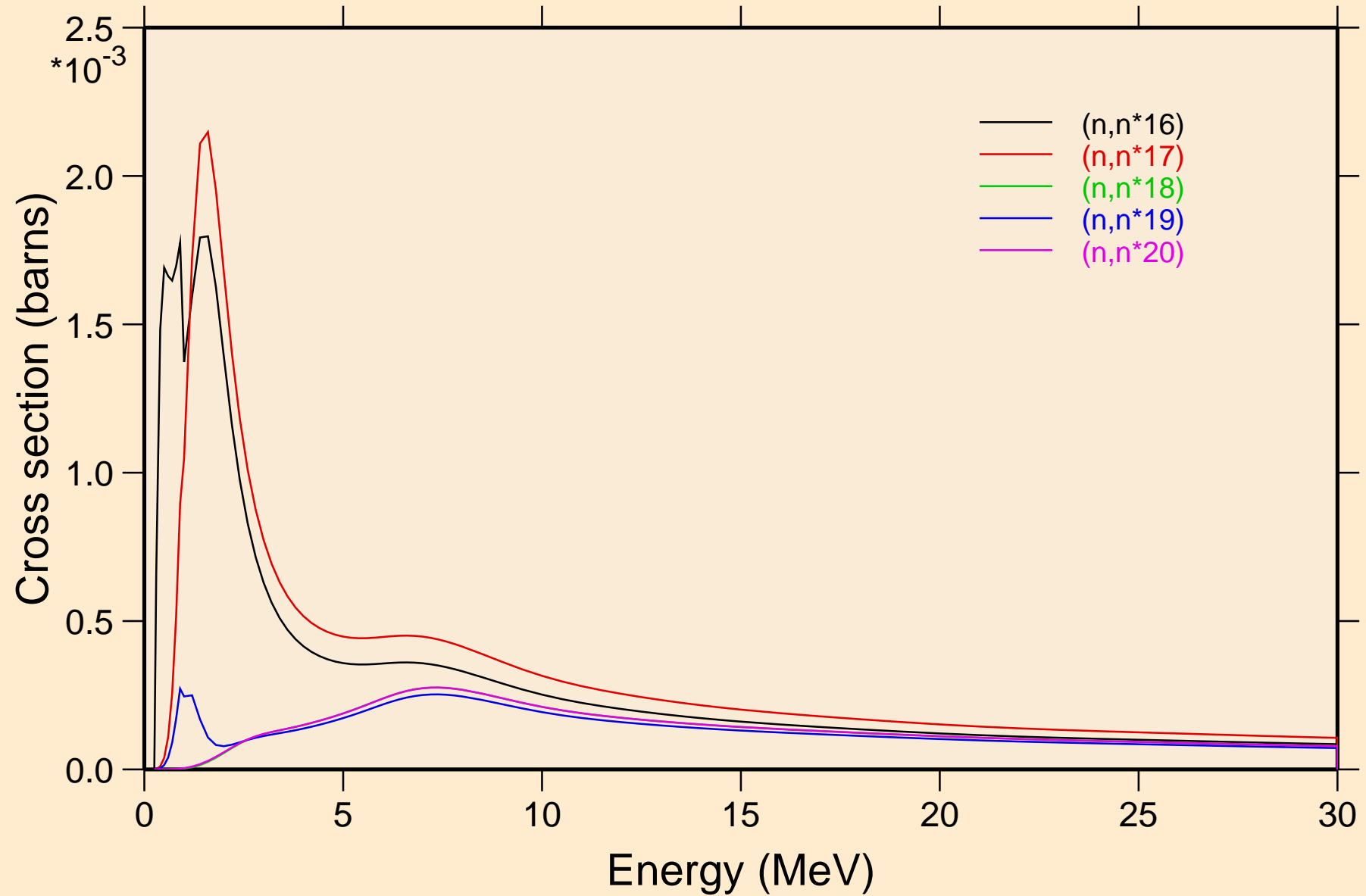

BK253 NEUTRON ACER TENDL-2024 LIBRARY; T=0.K  
Inelastic levels

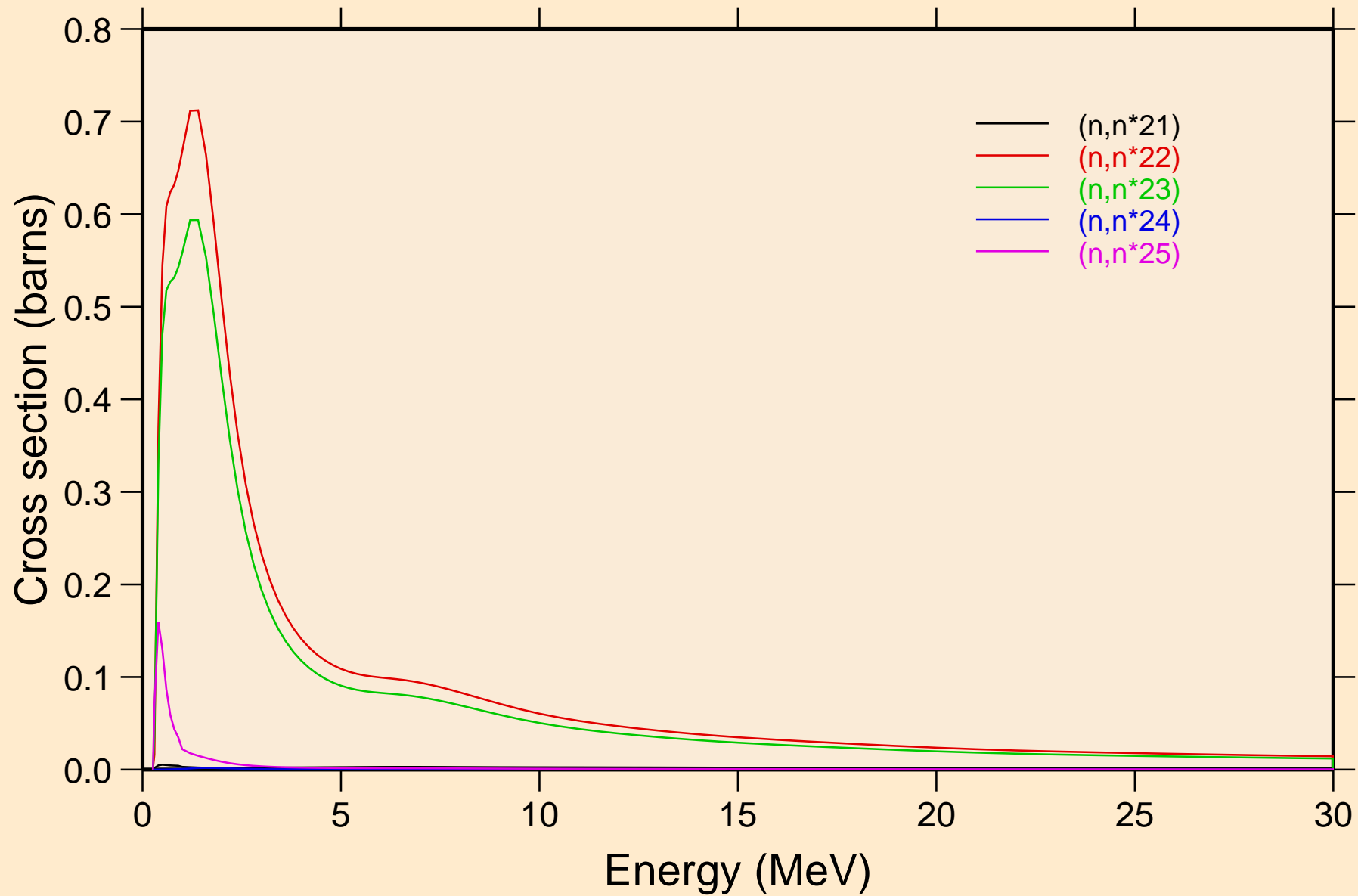

# BK253 NEUTRON ACER TENDL-2024 LIBRARY; T=0.K

## Inelastic levels

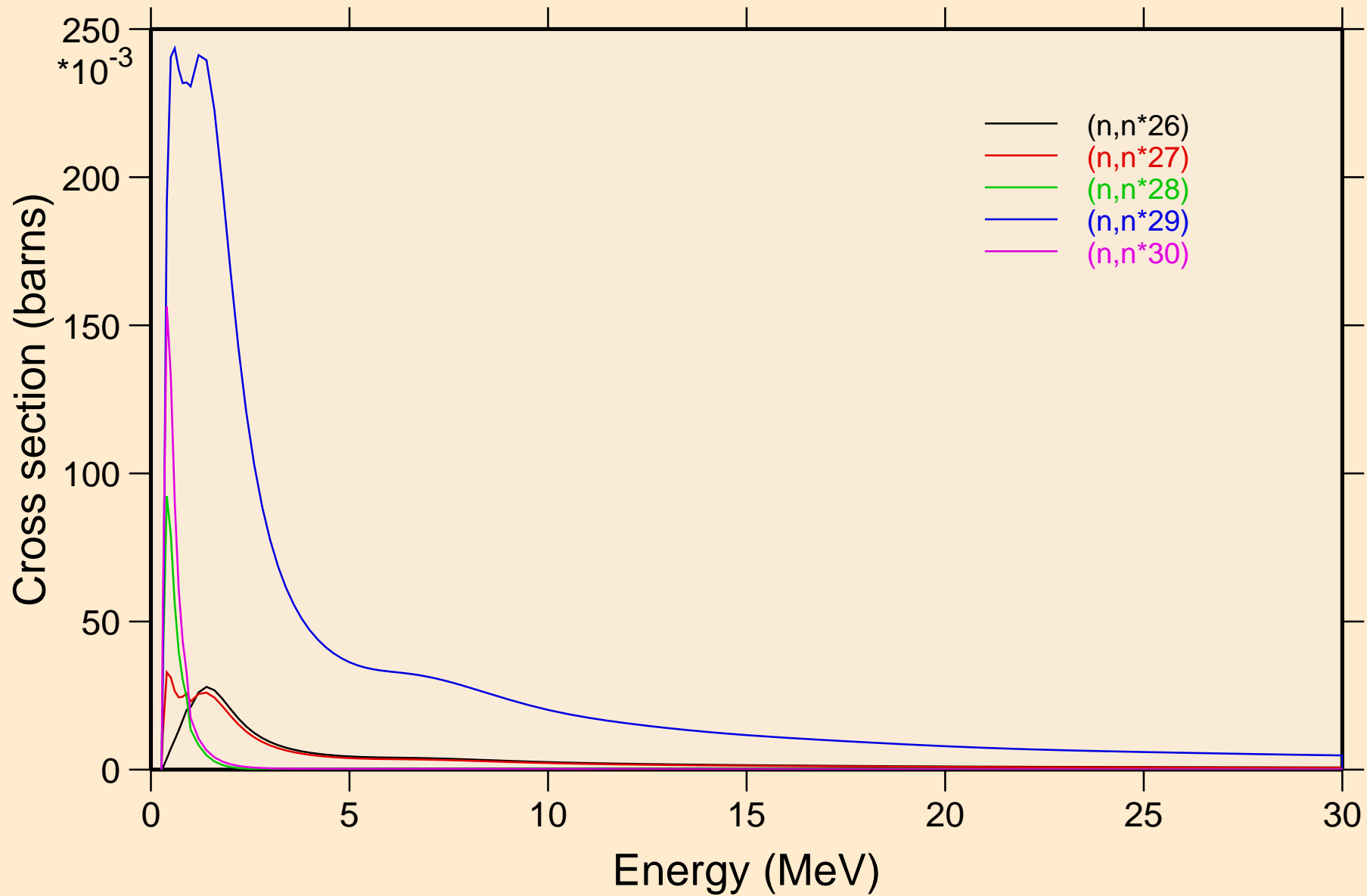

BK253 NEUTRON ACER TENDL-2024 LIBRARY; T=0.K  
Threshold reactions

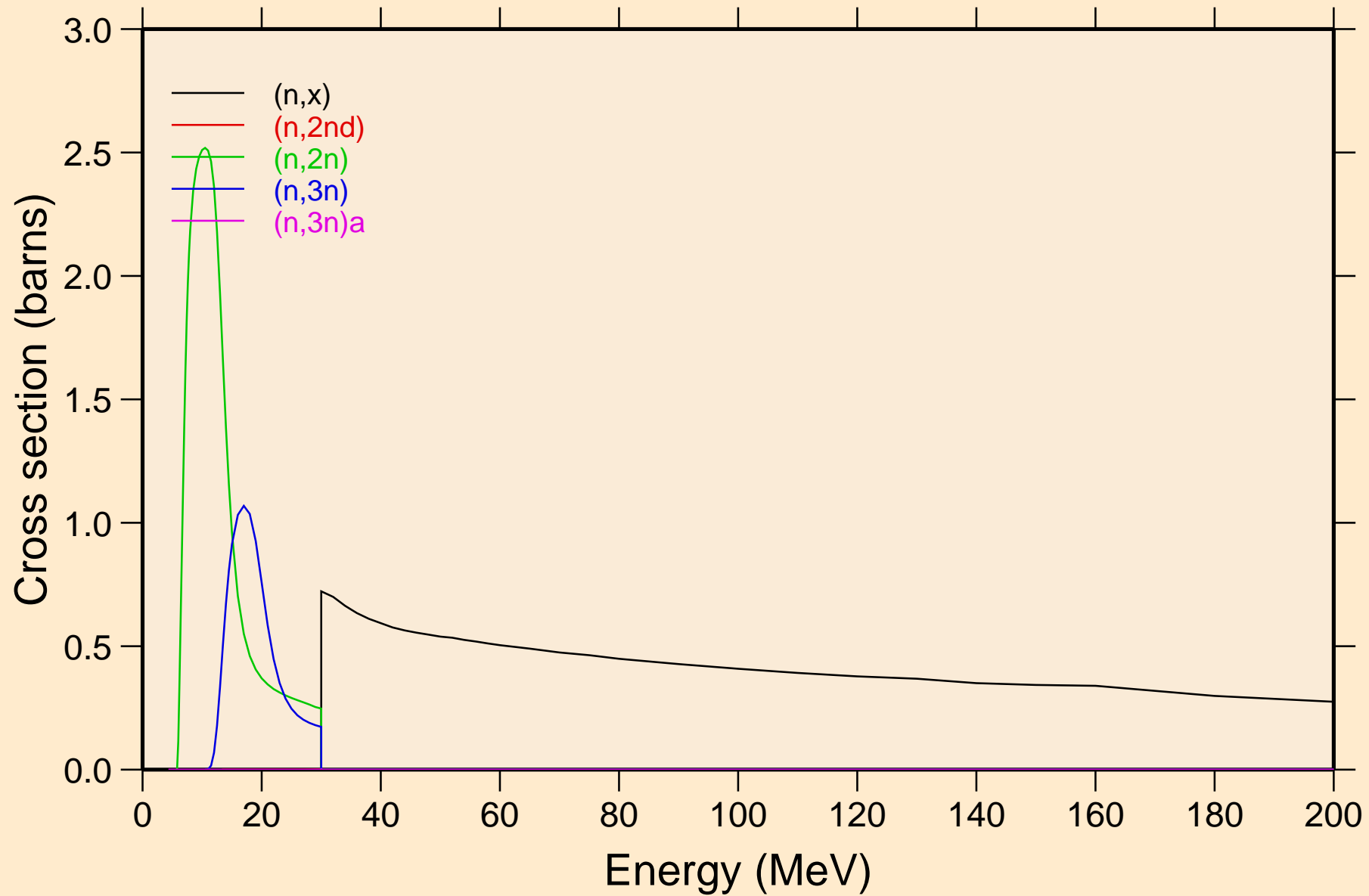

BK253 NEUTRON ACER TENDL-2024 LIBRARY; T=0.K  
Threshold reactions

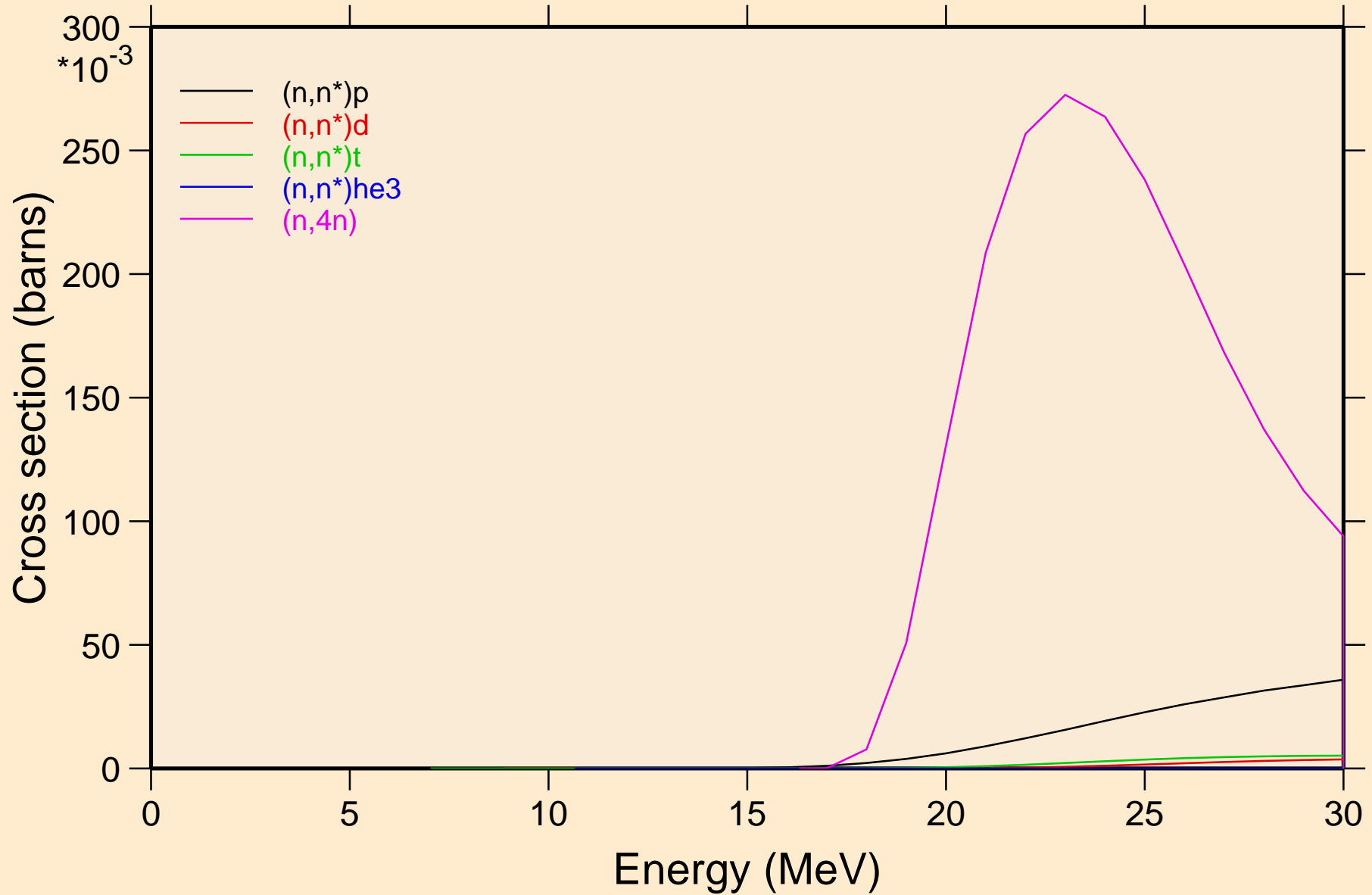

BK253 NEUTRON ACER TENDL-2024 LIBRARY; T=0.K  
Threshold reactions

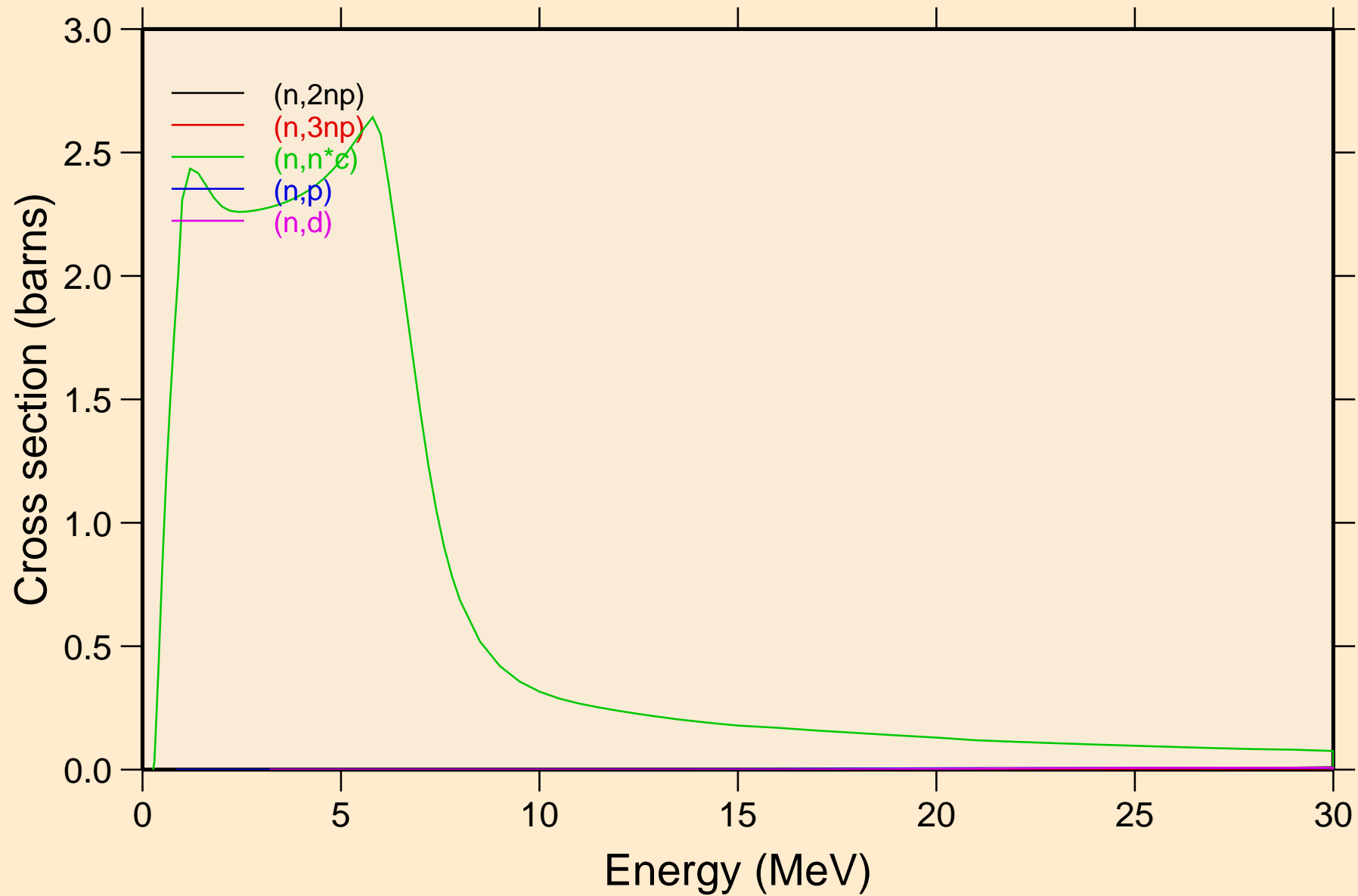

BK253 NEUTRON ACER TENDL-2024 LIBRARY; T=0.K  
Threshold reactions

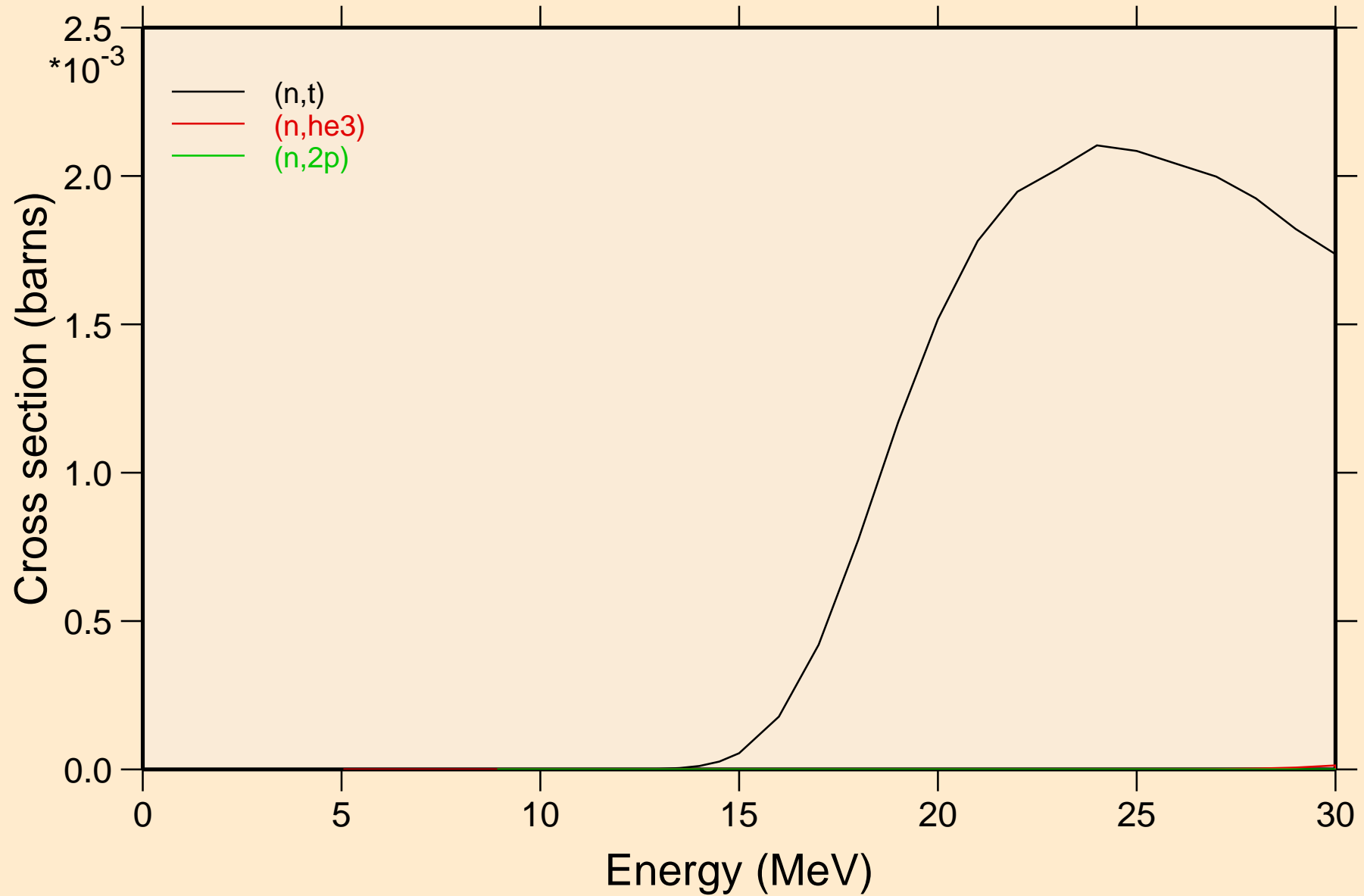

BK253 NEUTRON ACER TENDL-2024 LIBRARY; T=0.K  
Threshold reactions

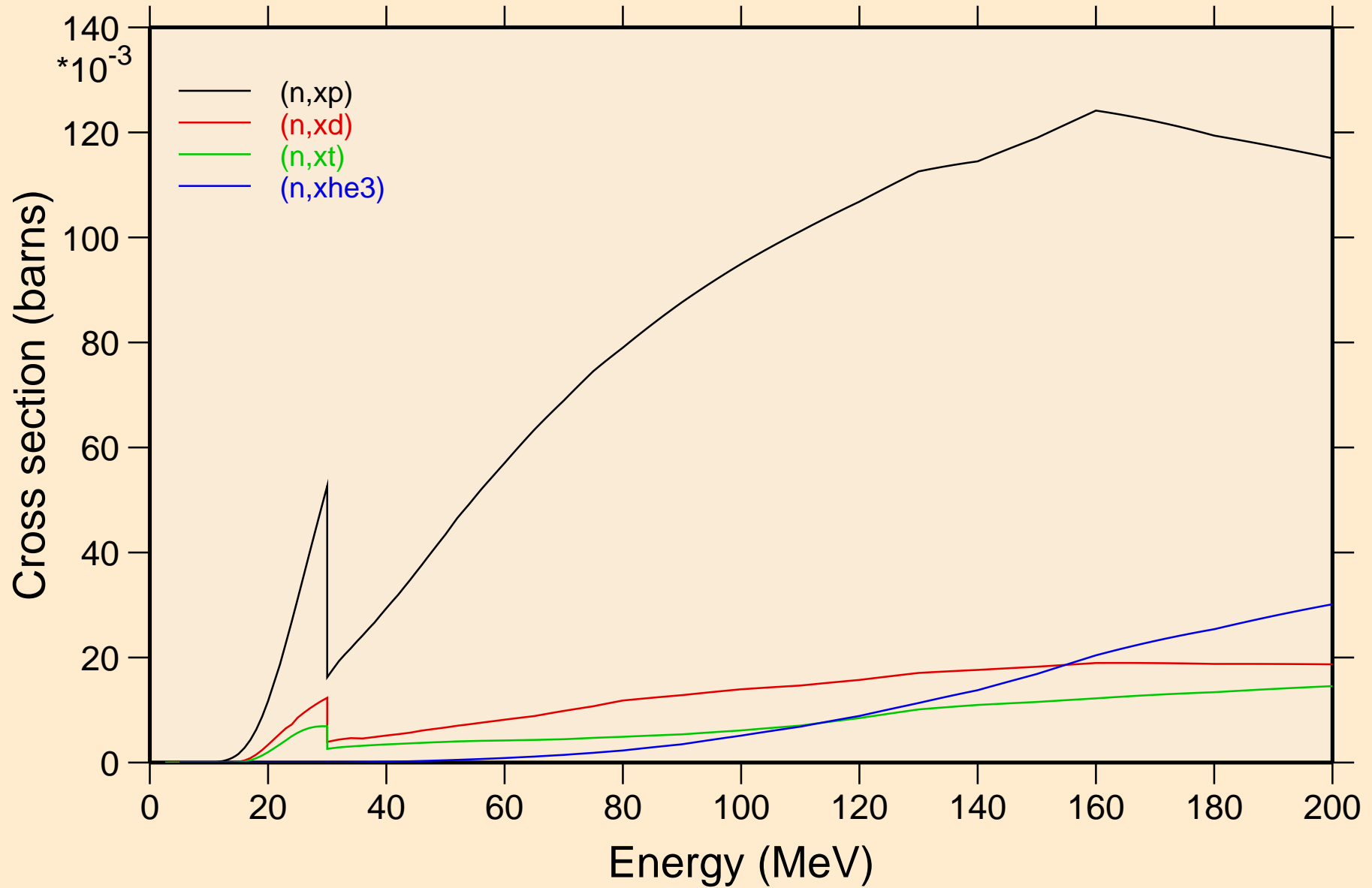

BK253 NEUTRON ACER TENDL-2024 LIBRARY; T=0.K  
angular distribution for elastic

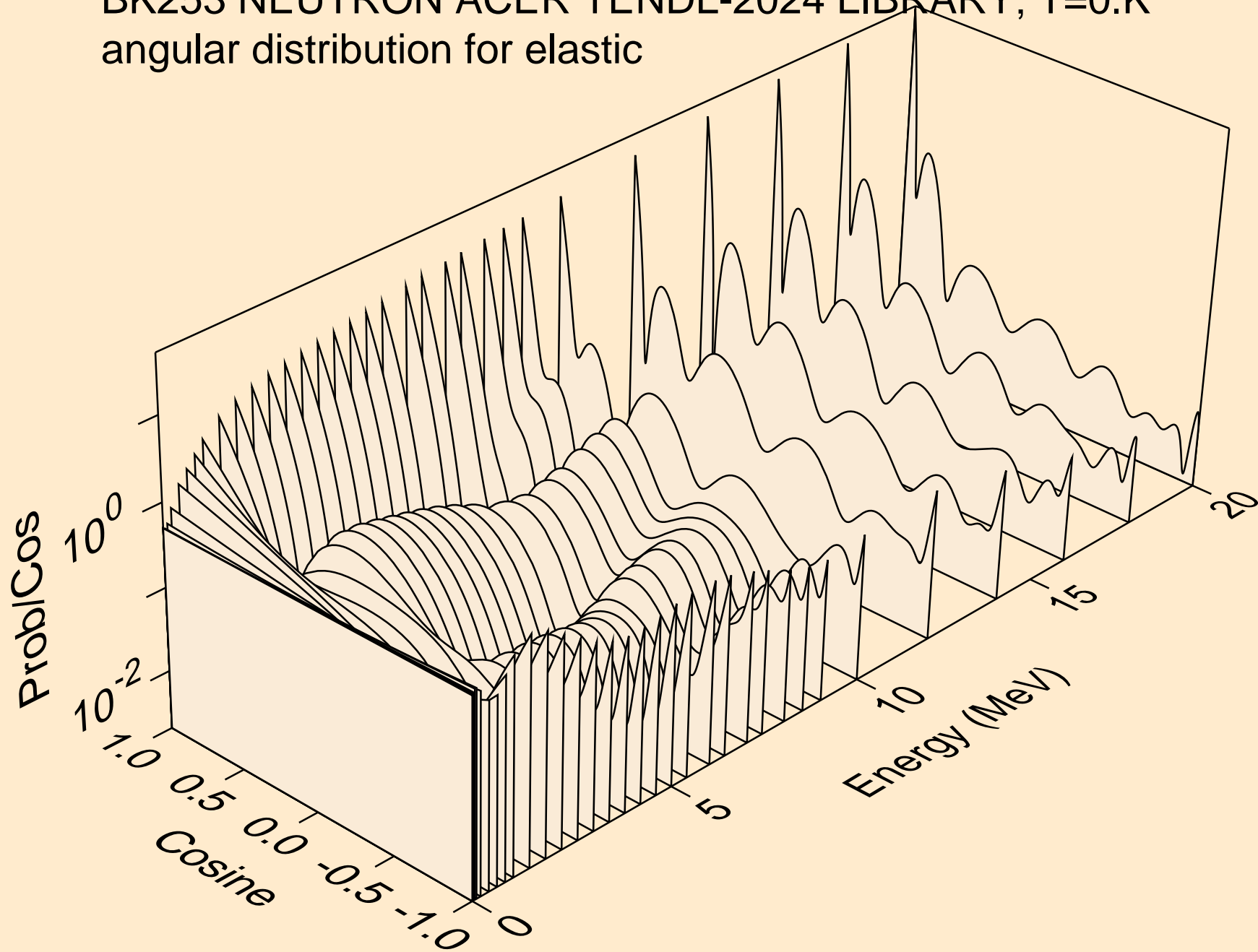

BK253 NEUTRON ACER TENDL-2024 LIBRARY; T=0.K  
angular distribution for elastic

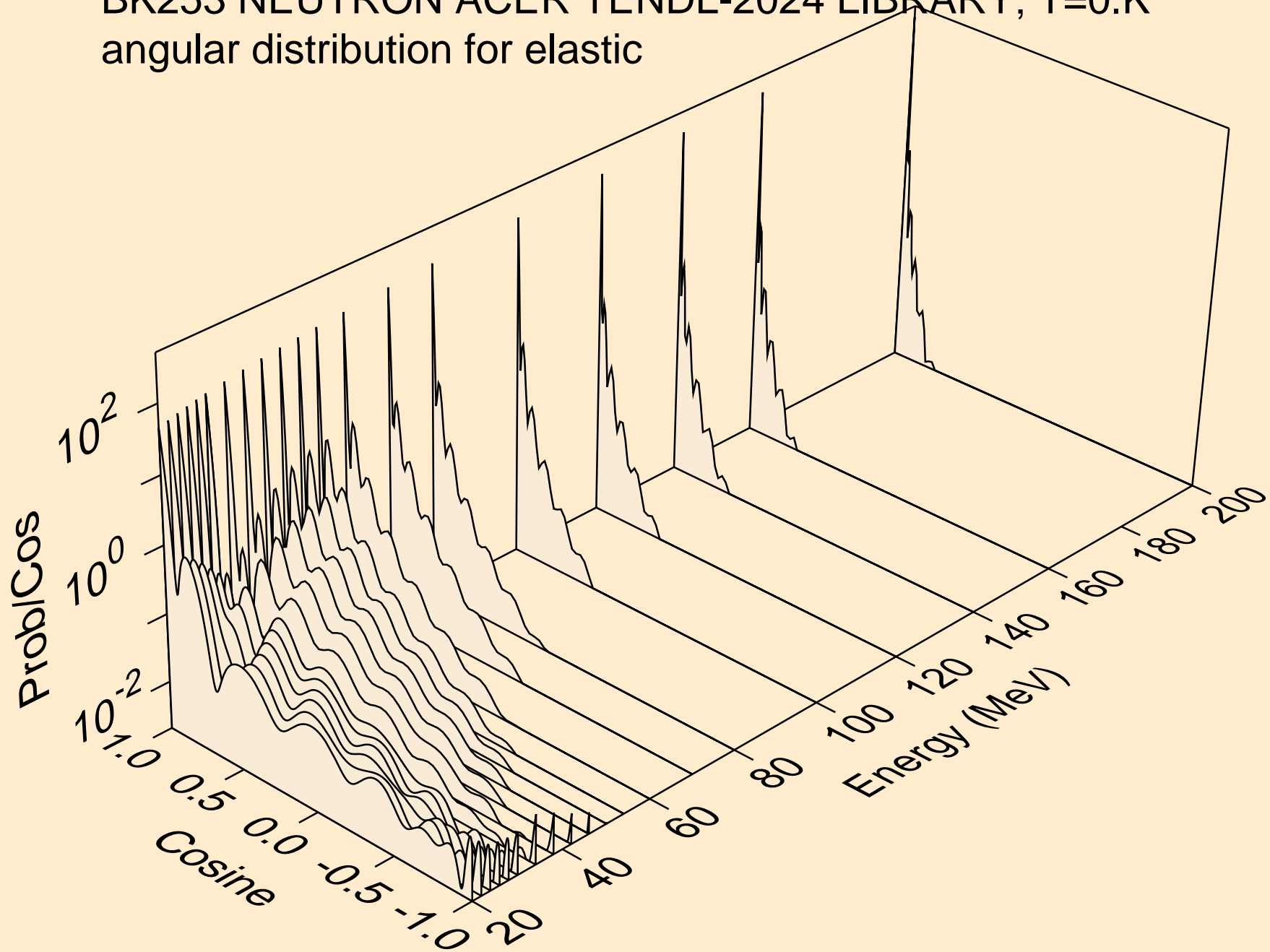

BK253 NEUTRON ACER TENDL-2024 LIBRARY; T=0.K  
angular distribution for (n,n\*1)

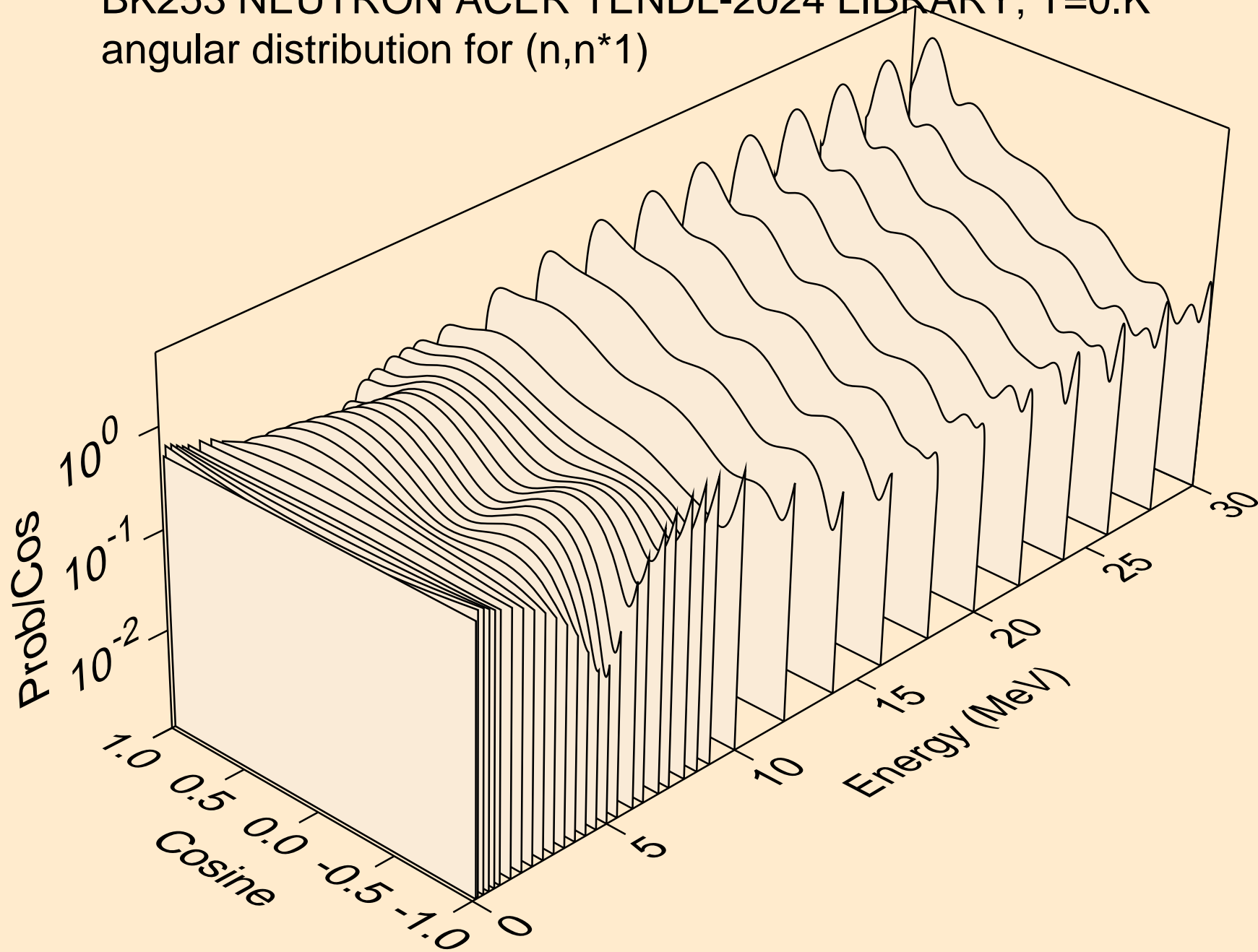

BK253 NEUTRON ACER TENDL-2024 LIBRARY; T=0.K  
angular distribution for (n,n\*2)

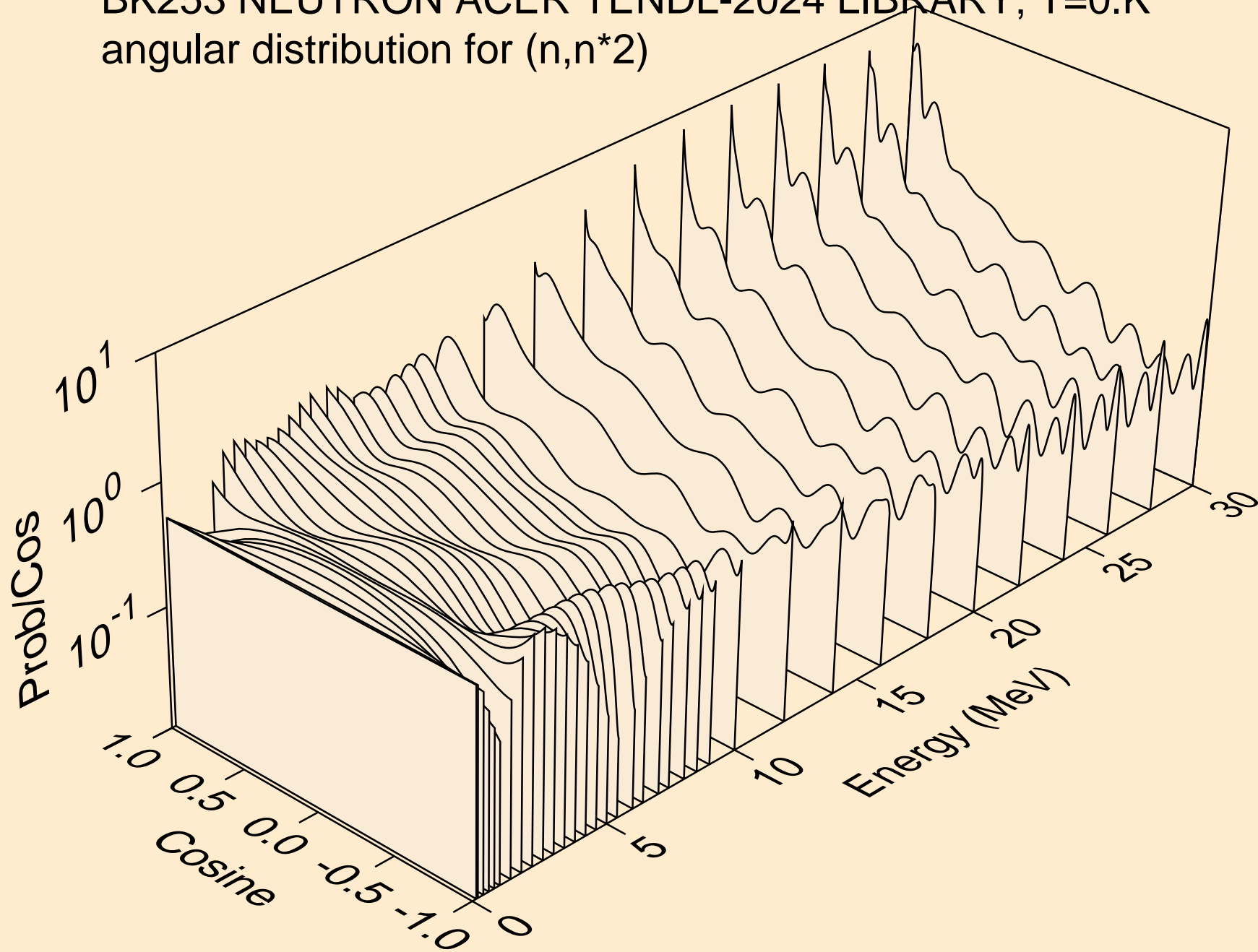

BK253 NEUTRON ACER TENDL-2024 LIBRARY; T=0.K  
angular distribution for (n,n\*3)

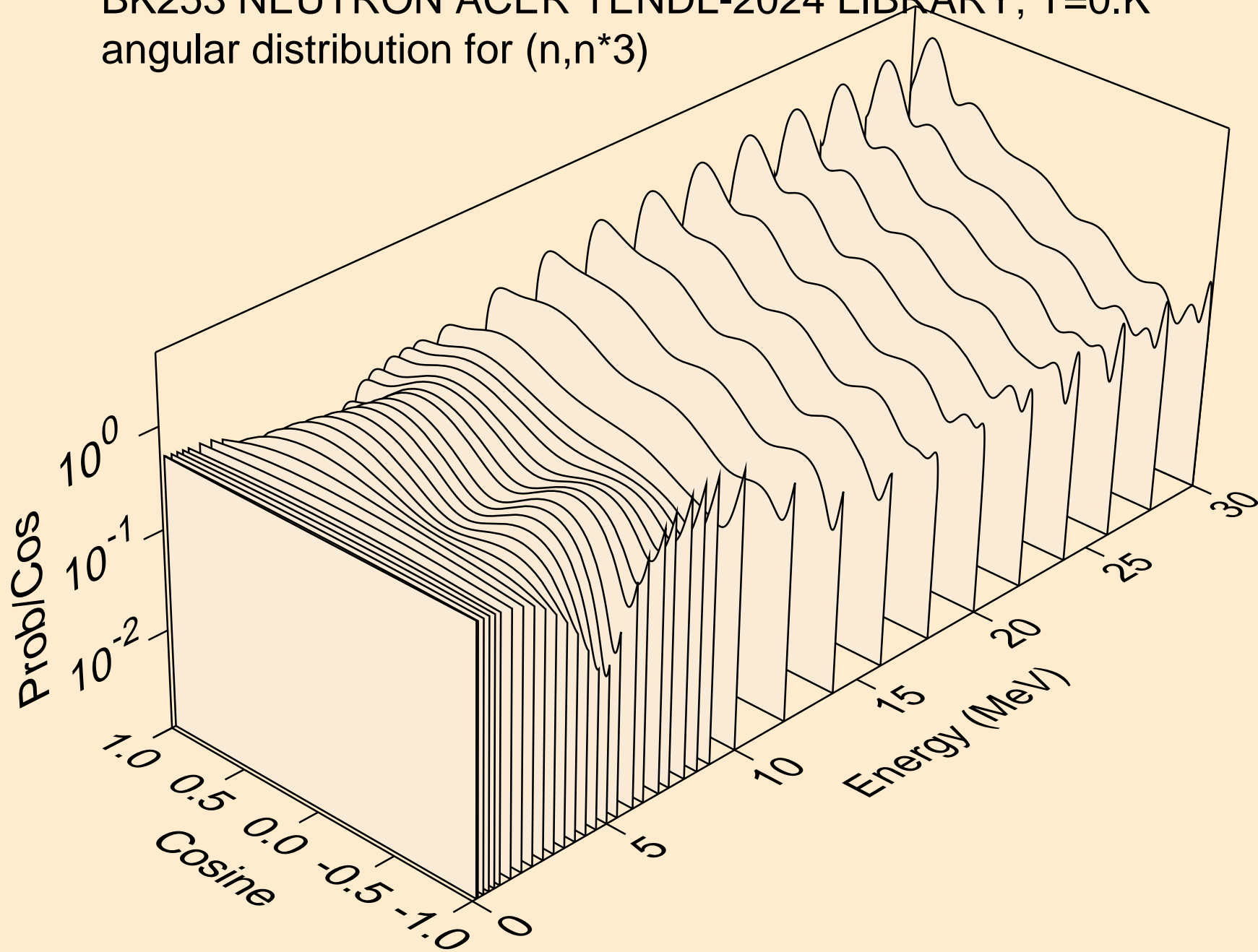

BK253 NEUTRON ACER TENDL-2024 LIBRARY; T=0.K  
angular distribution for (n,n\*4)

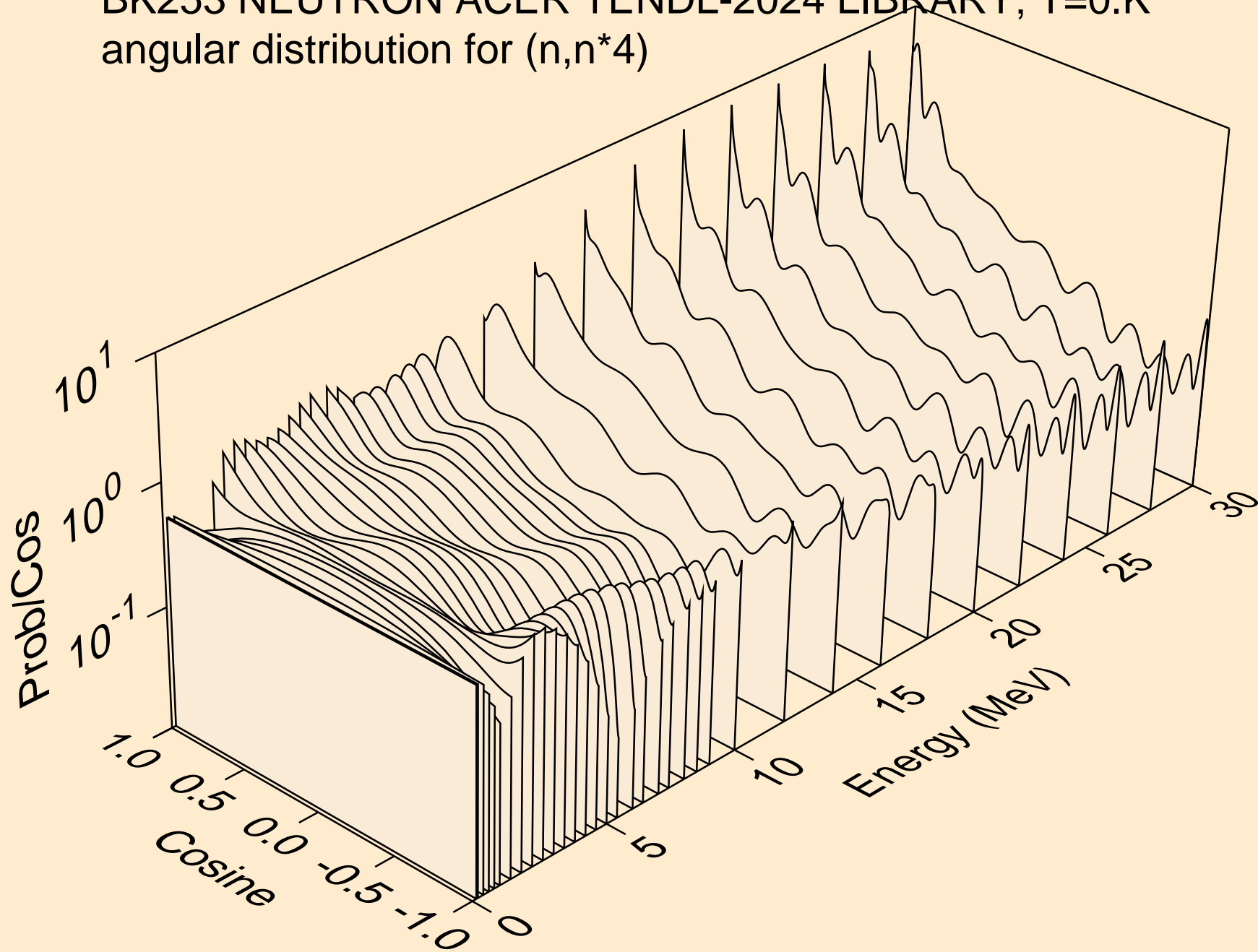

BK253 NEUTRON ACER TENDL-2024 LIBRARY; T=0.K  
angular distribution for (n,n\*5)

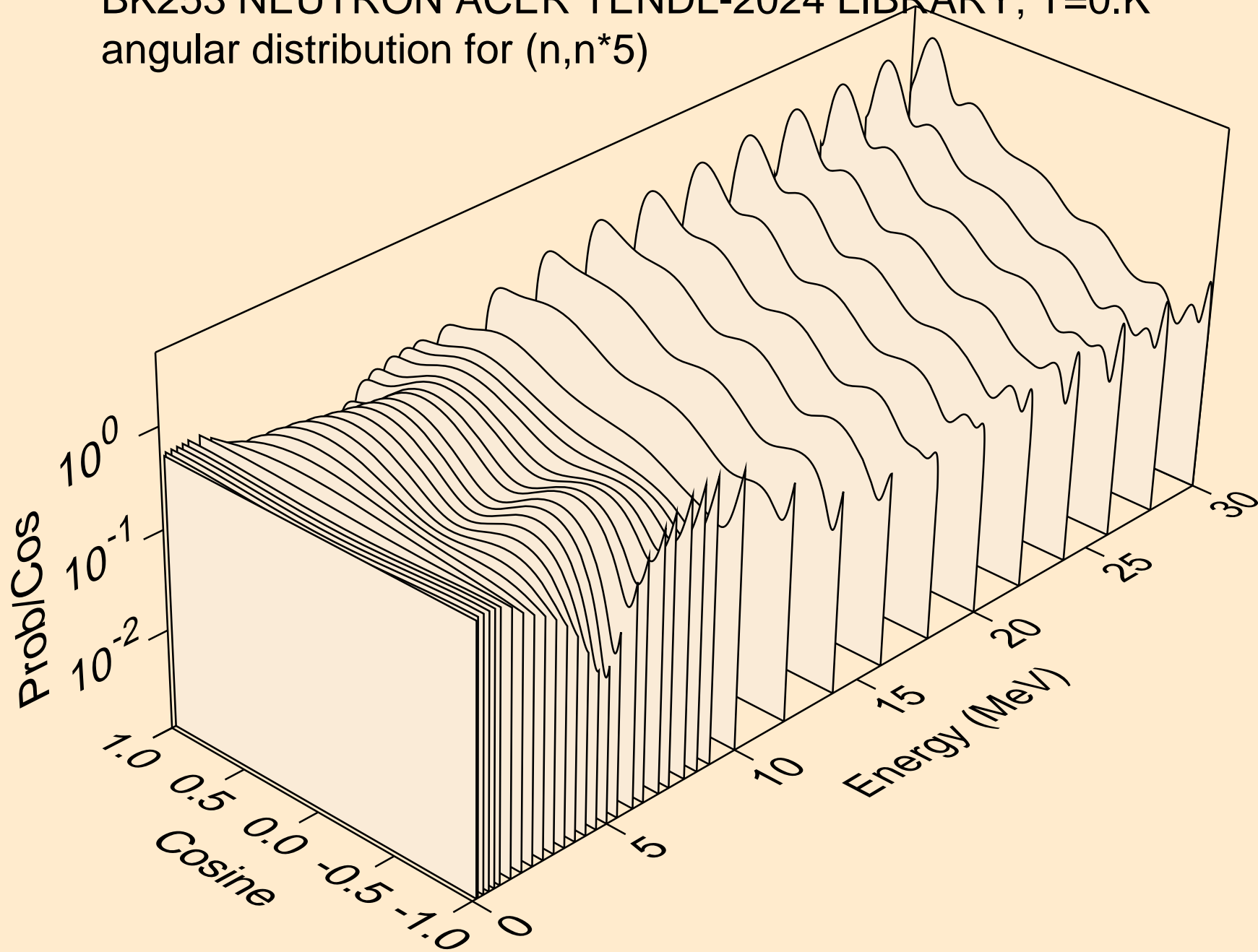

BK253 NEUTRON ACER TENDL-2024 LIBRARY; T=0.K  
angular distribution for (n,n\*6)

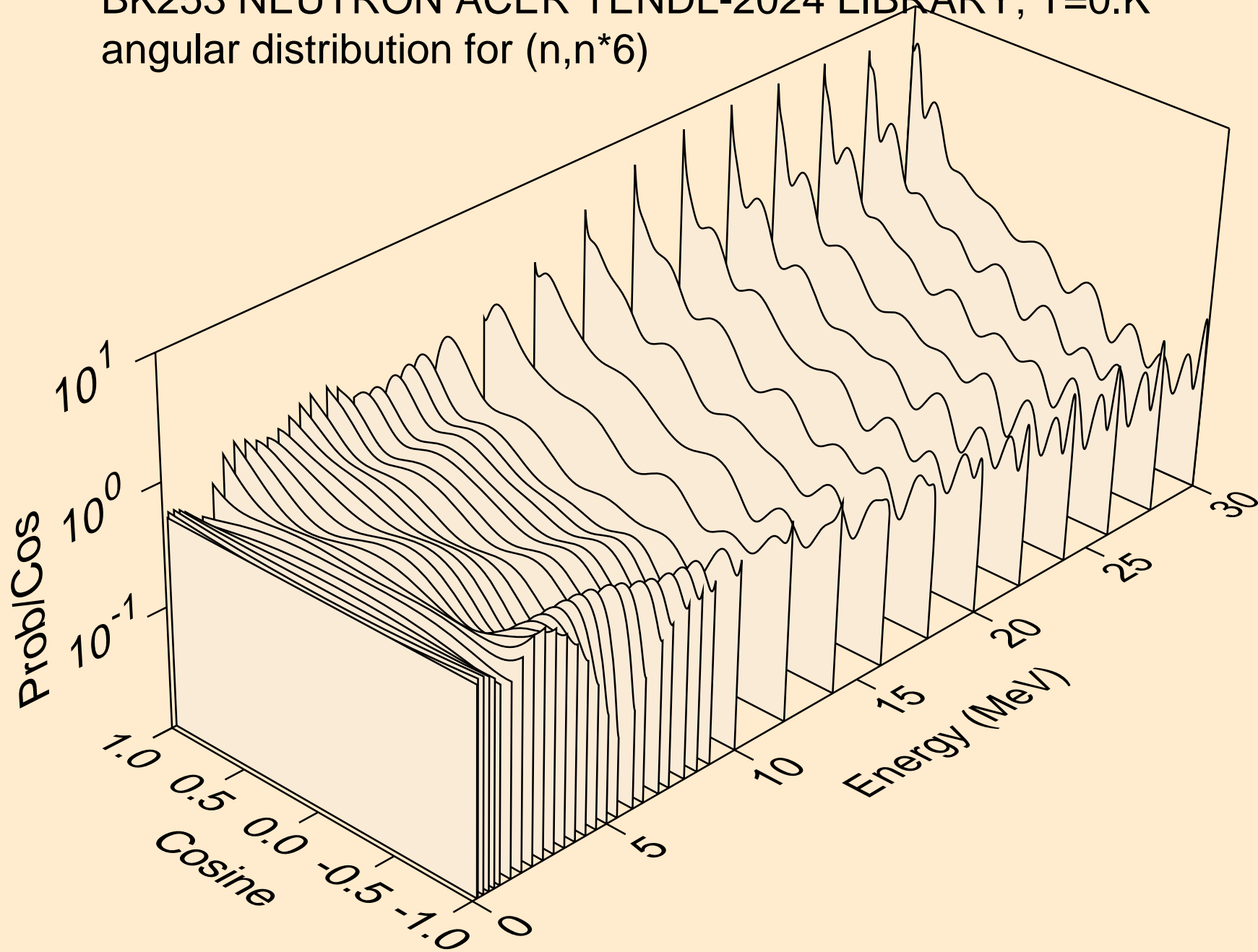

BK253 NEUTRON ACER TENDL-2024 LIBRARY; T=0.K  
angular distribution for (n,n\*7)

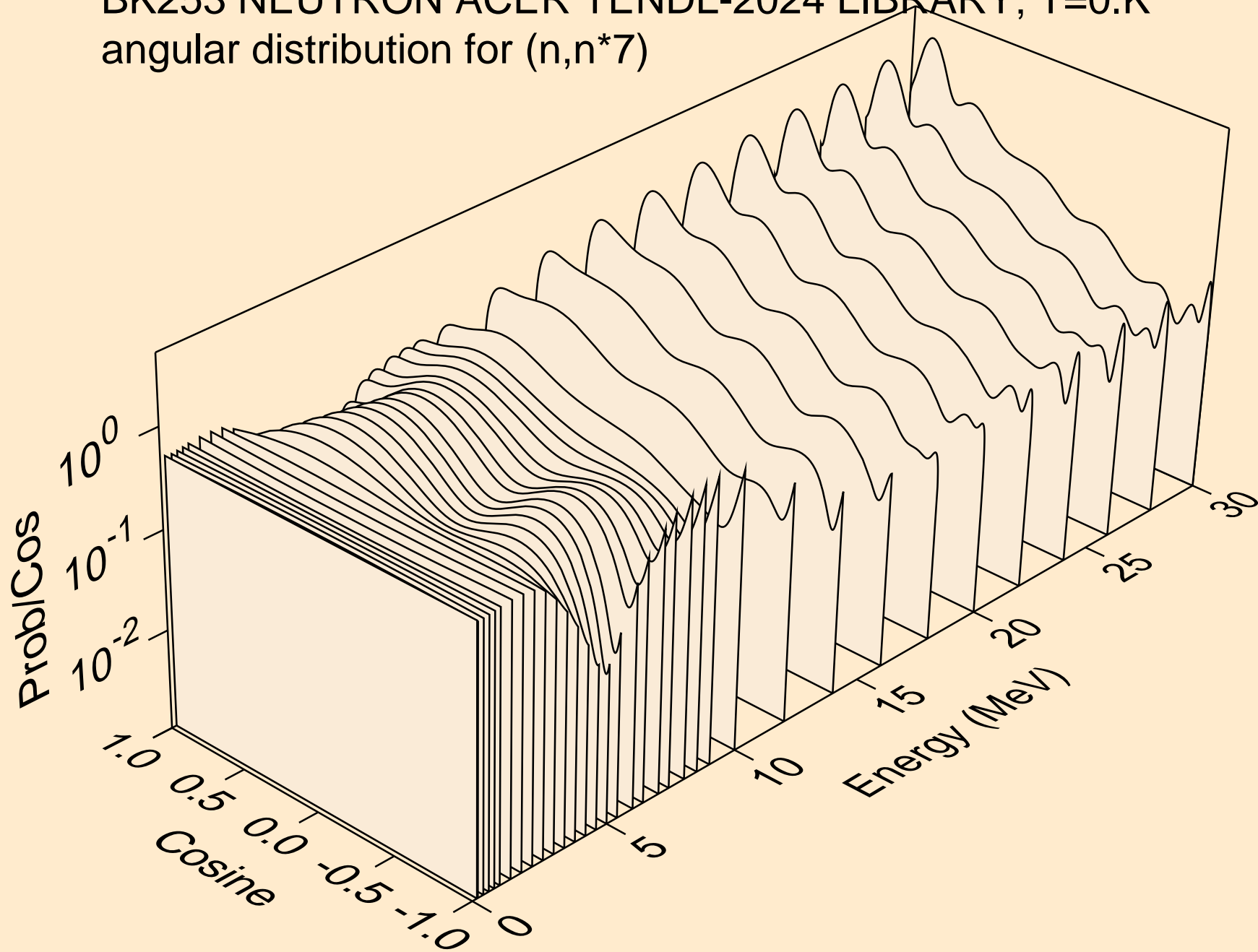

BK253 NEUTRON ACER TENDL-2024 LIBRARY; T=0.K  
angular distribution for (n,n\*8)

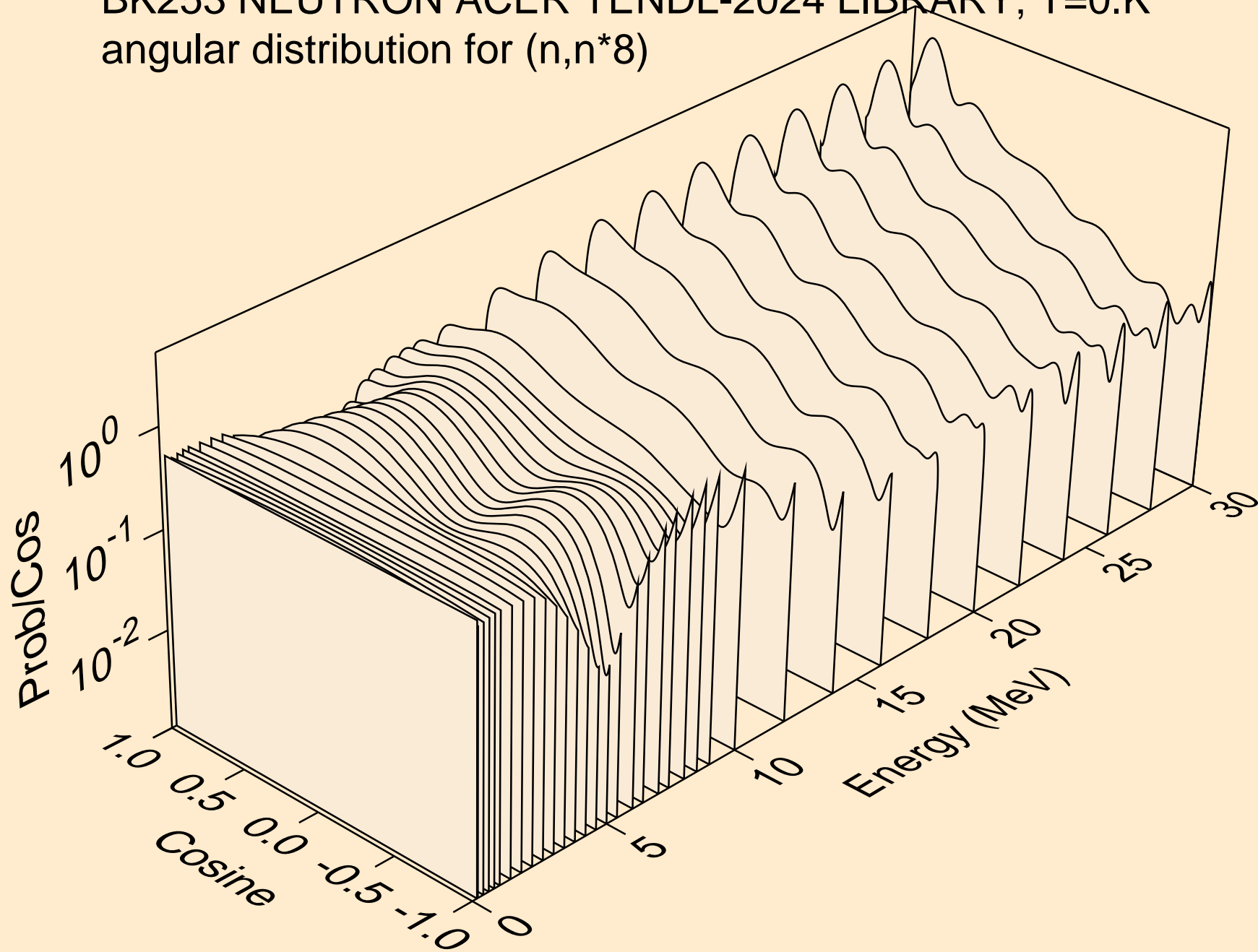

BK253 NEUTRON ACER TENDL-2024 LIBRARY; T=0.K  
angular distribution for (n,n\*9)

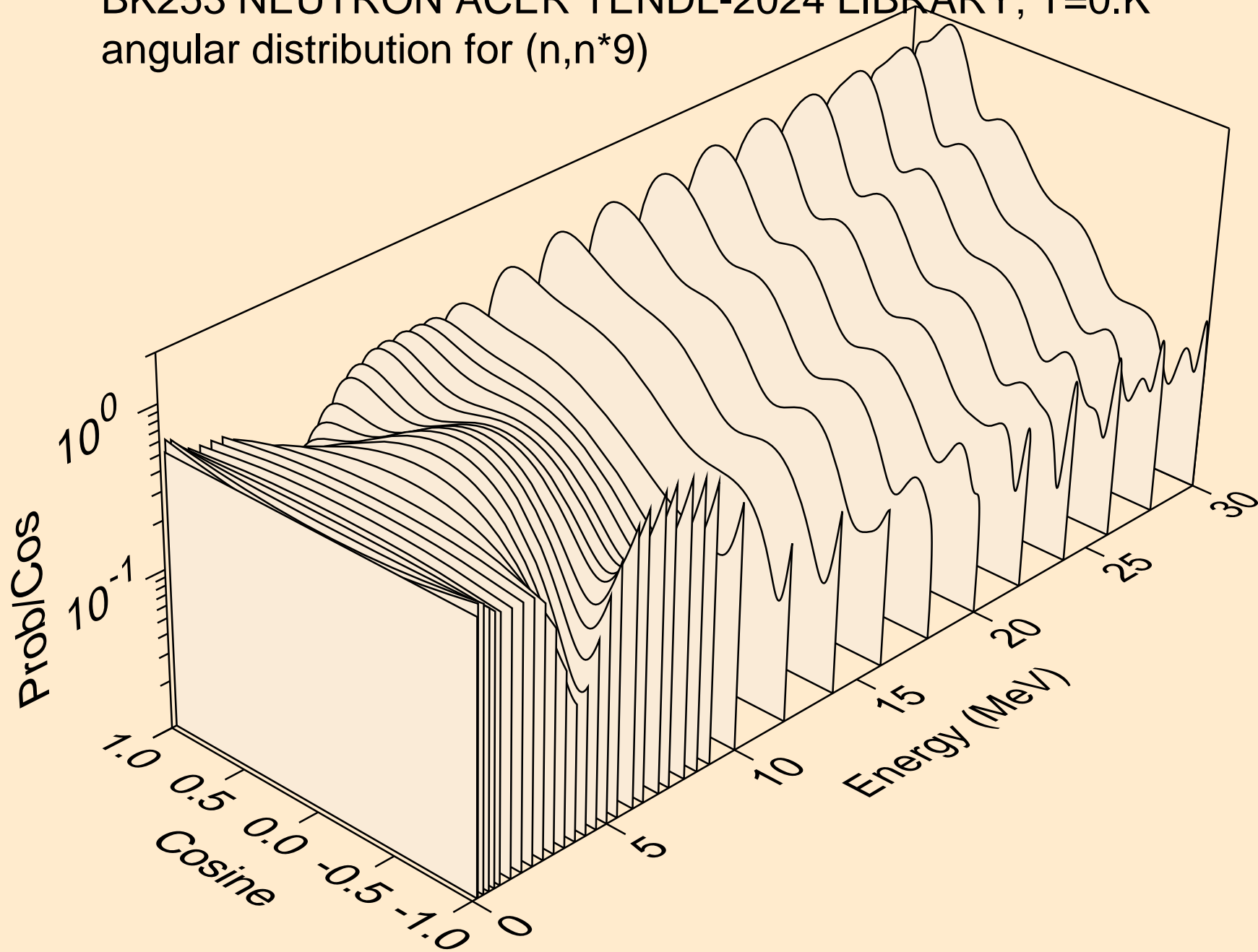

BK253 NEUTRON ACER TENDL-2024 LIBRARY; T=0.K  
angular distribution for (n,n\*10)

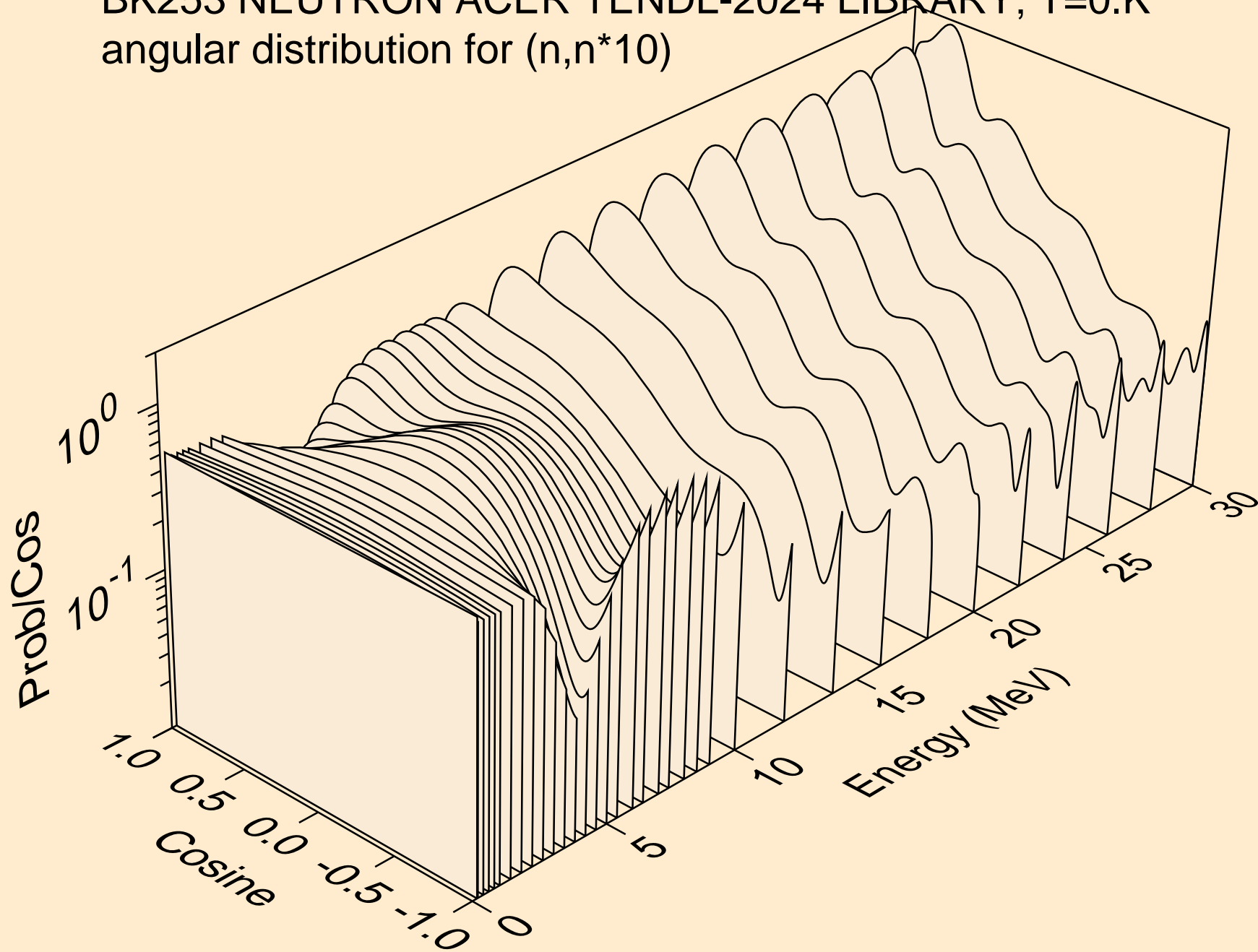

BK253 NEUTRON ACER TENDL-2024 LIBRARY; T=0.K  
angular distribution for (n,n\*11)

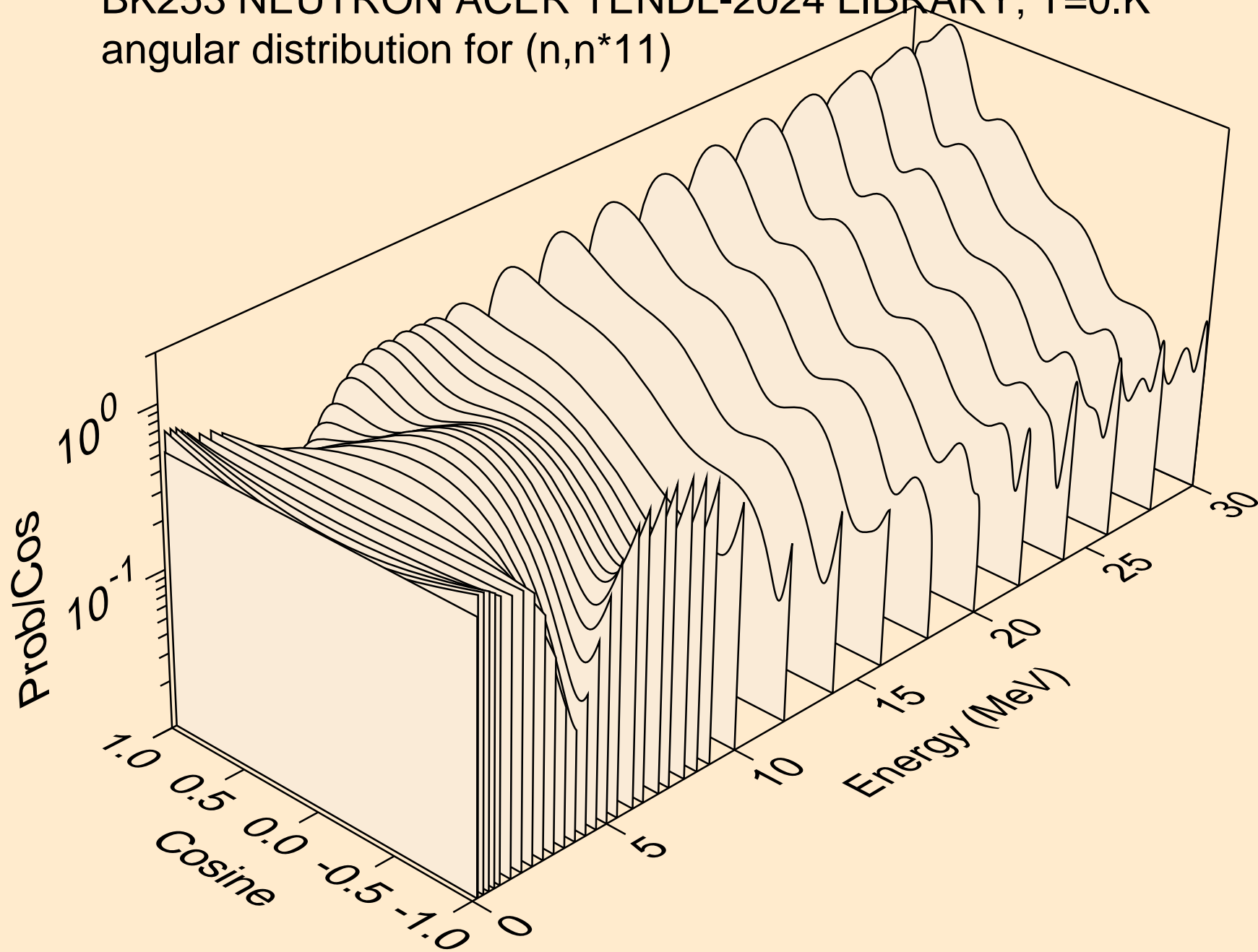

BK253 NEUTRON ACER TENDL-2024 LIBRARY; T=0.K  
angular distribution for (n,n\*12)

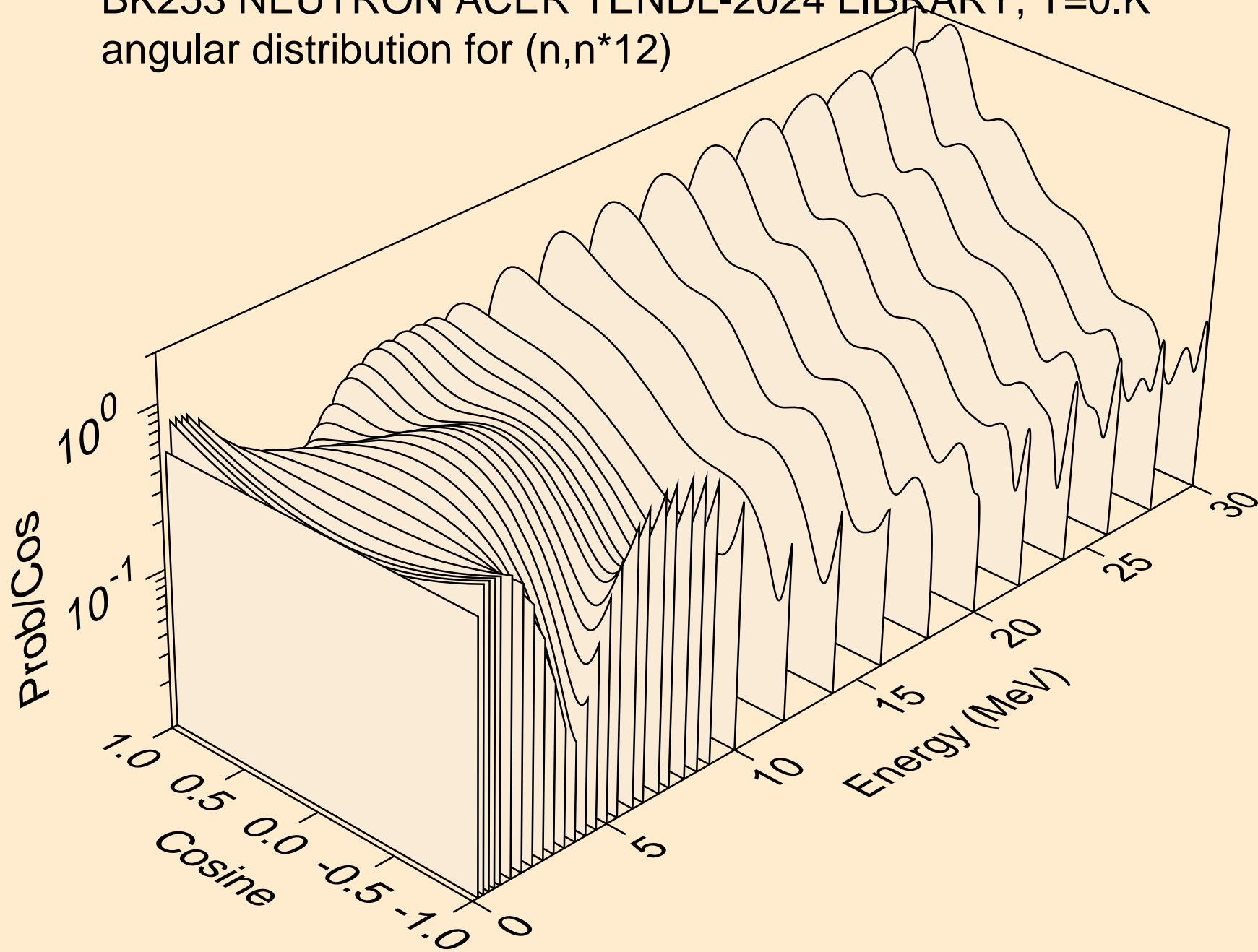

BK253 NEUTRON ACER TENDL-2024 LIBRARY; T=0.K  
angular distribution for (n,n\*13)

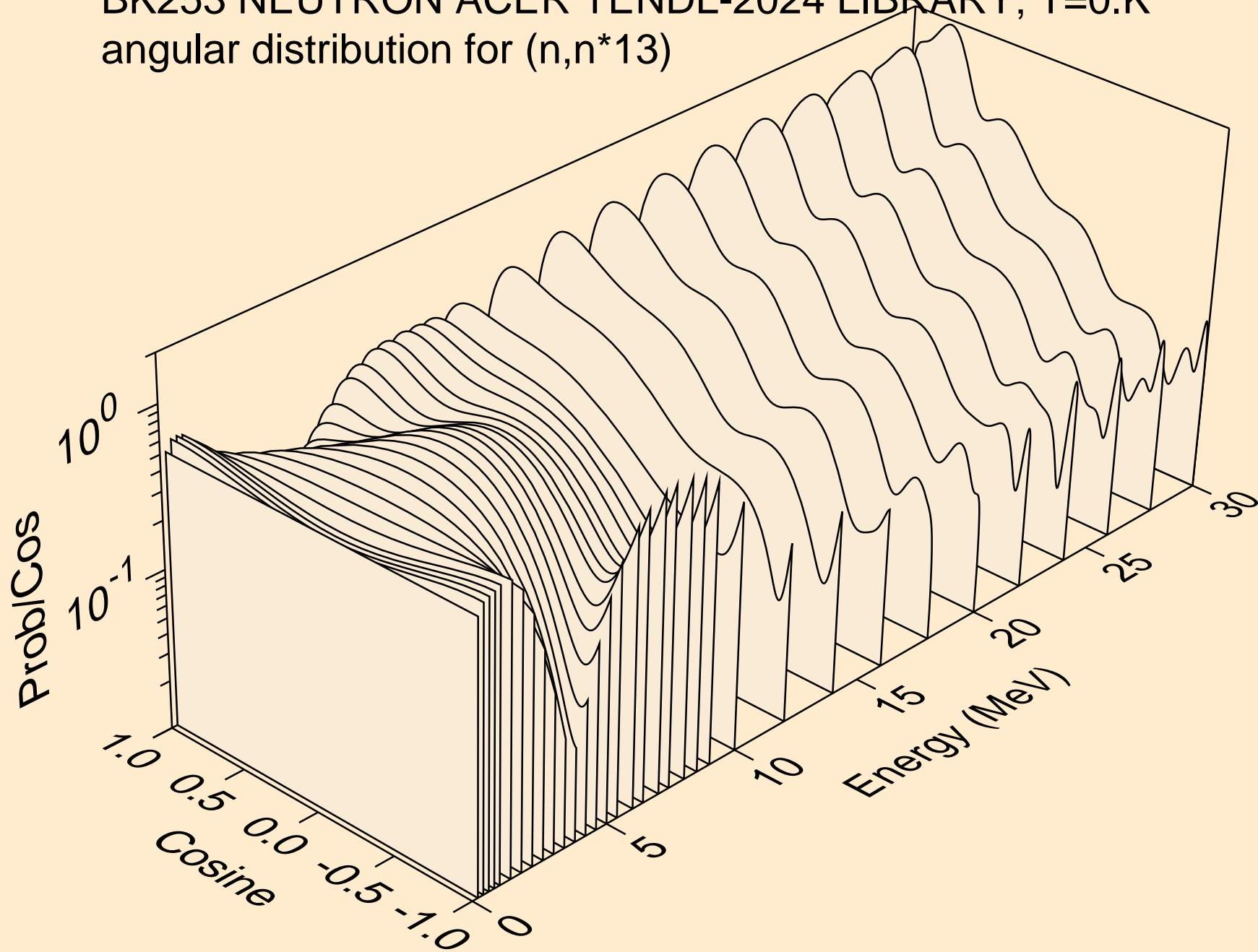

BK253 NEUTRON ACER TENDL-2024 LIBRARY; T=0.K  
angular distribution for (n,n\*14)

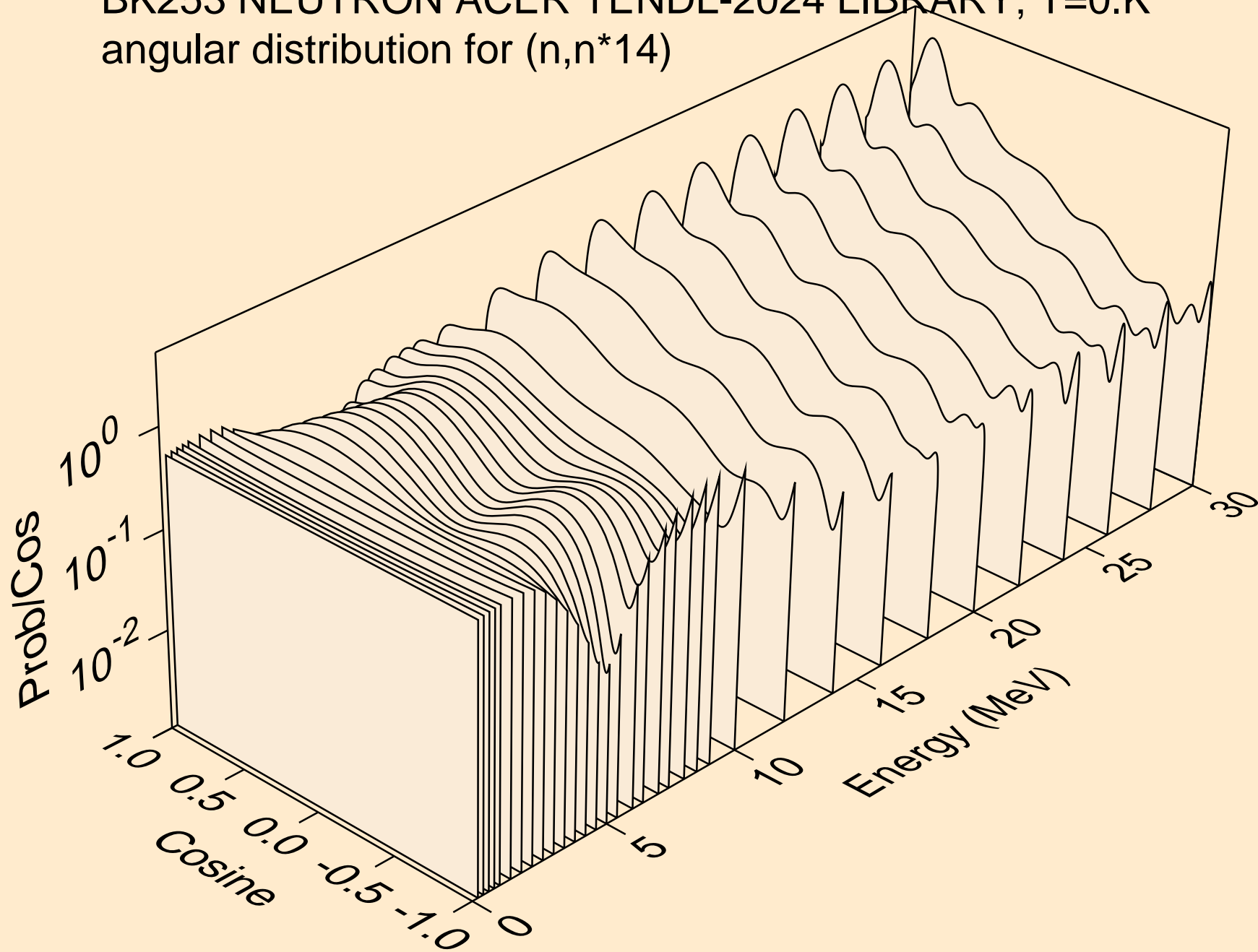

BK253 NEUTRON ACER TENDL-2024 LIBRARY; T=0.K  
angular distribution for (n,n\*15)

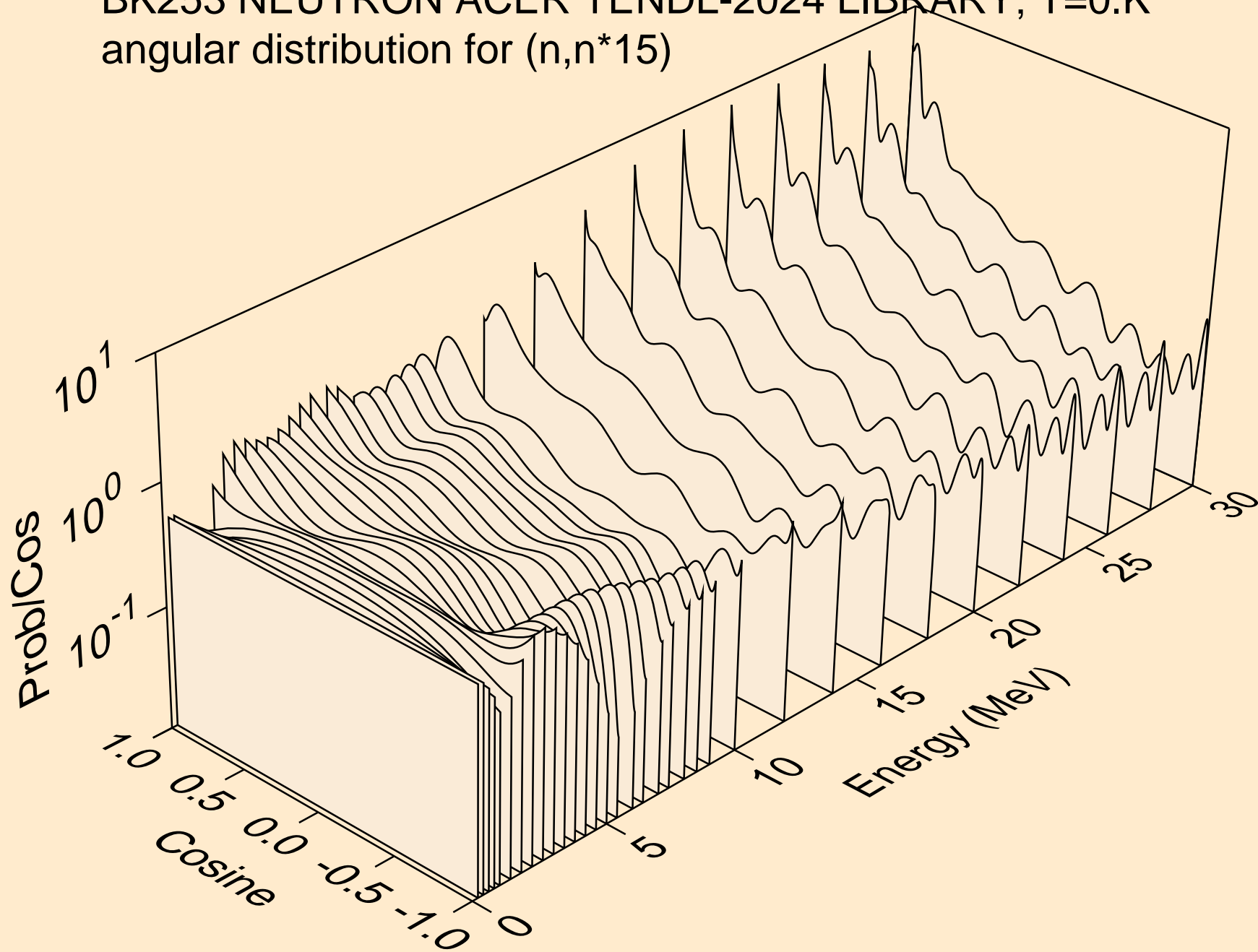

BK253 NEUTRON ACER TENDL-2024 LIBRARY; T=0.K  
angular distribution for (n,n\*16)

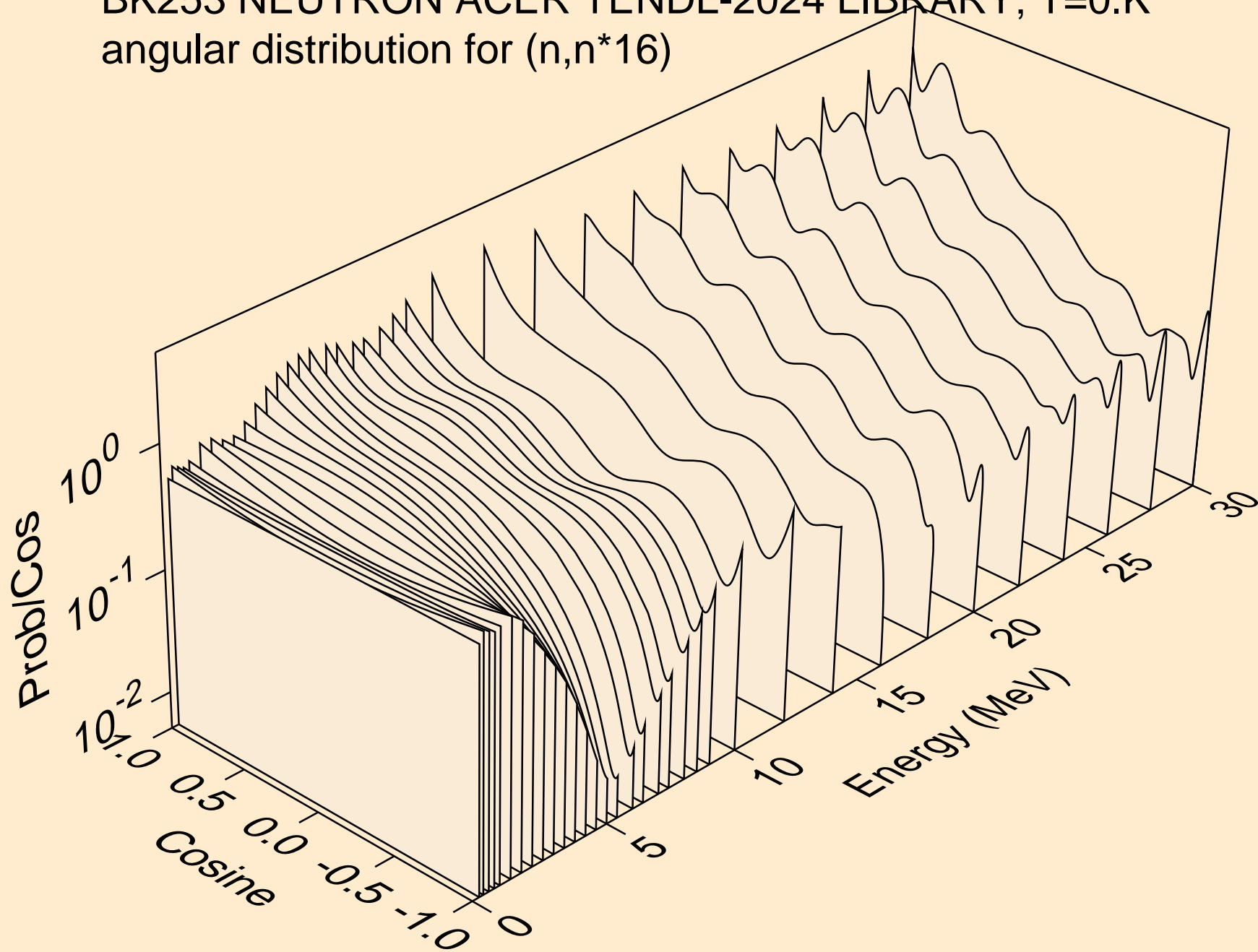

BK253 NEUTRON ACER TENDL-2024 LIBRARY; T=0.K  
angular distribution for (n,n\*17)

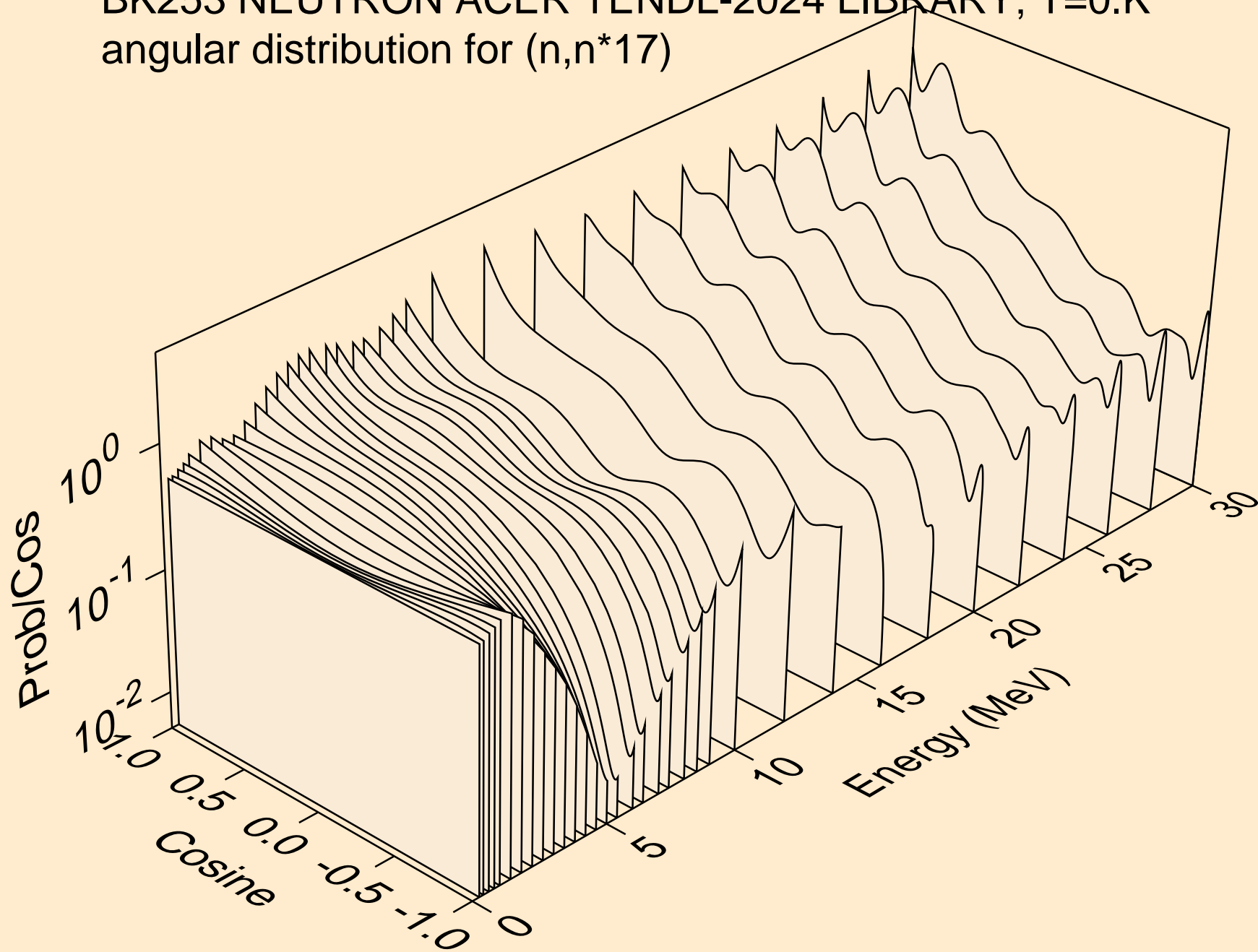

BK253 NEUTRON ACER TENDL-2024 LIBRARY; T=0.K  
angular distribution for (n,n\*18)

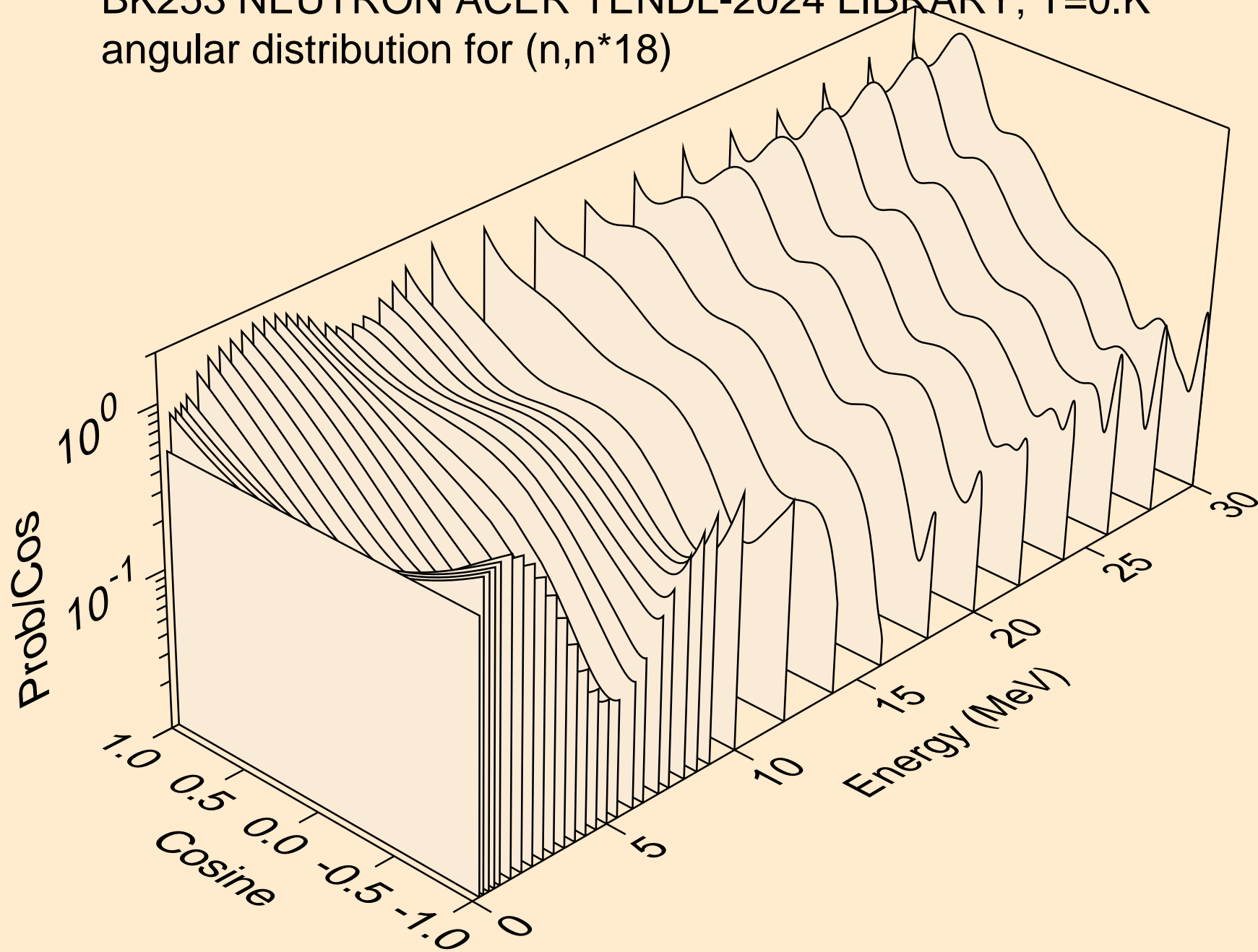

BK253 NEUTRON ACER TENDL-2024 LIBRARY; T=0.K  
angular distribution for (n,n\*19)

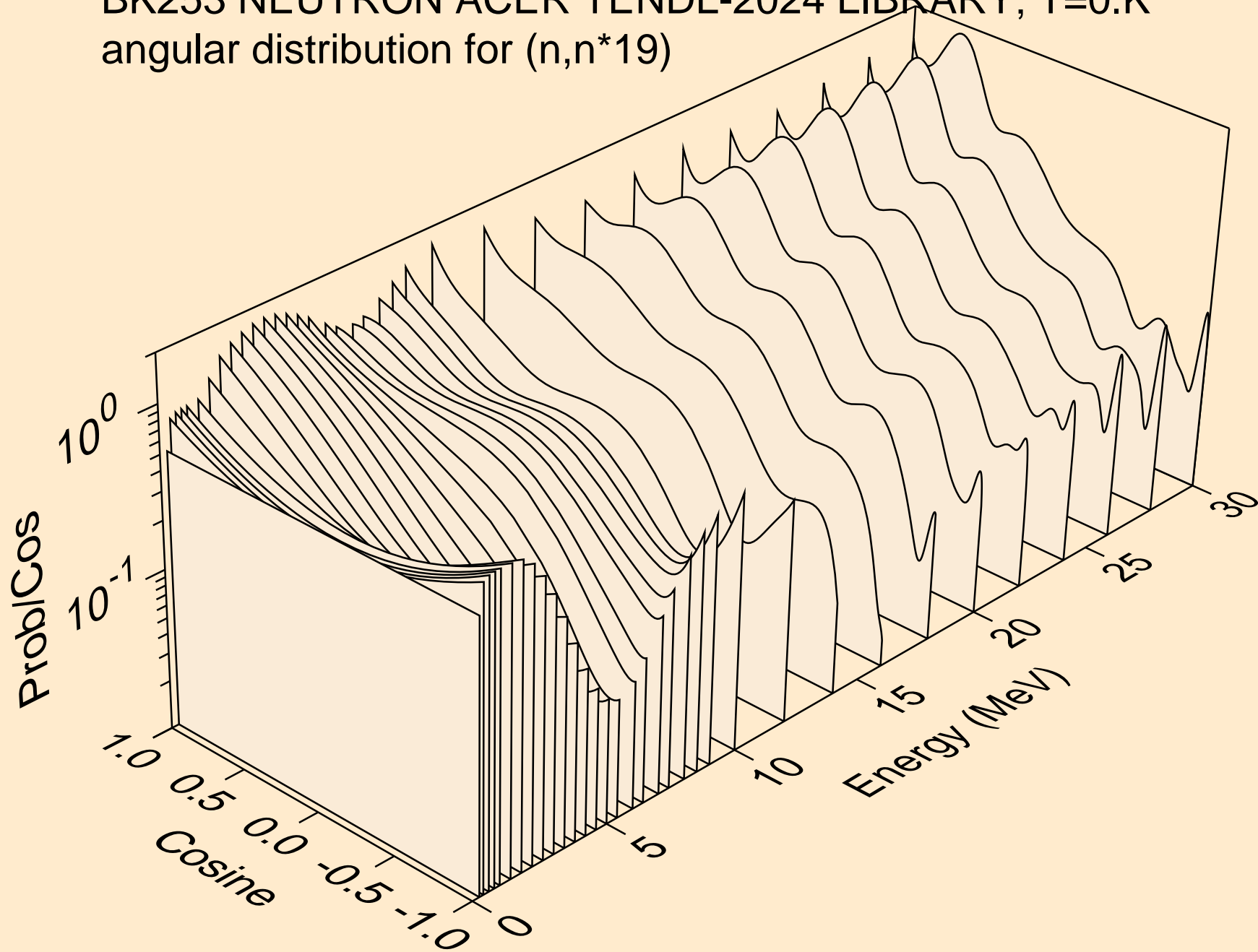

BK253 NEUTRON ACER TENDL-2024 LIBRARY; T=0.K  
angular distribution for (n,n\*20)

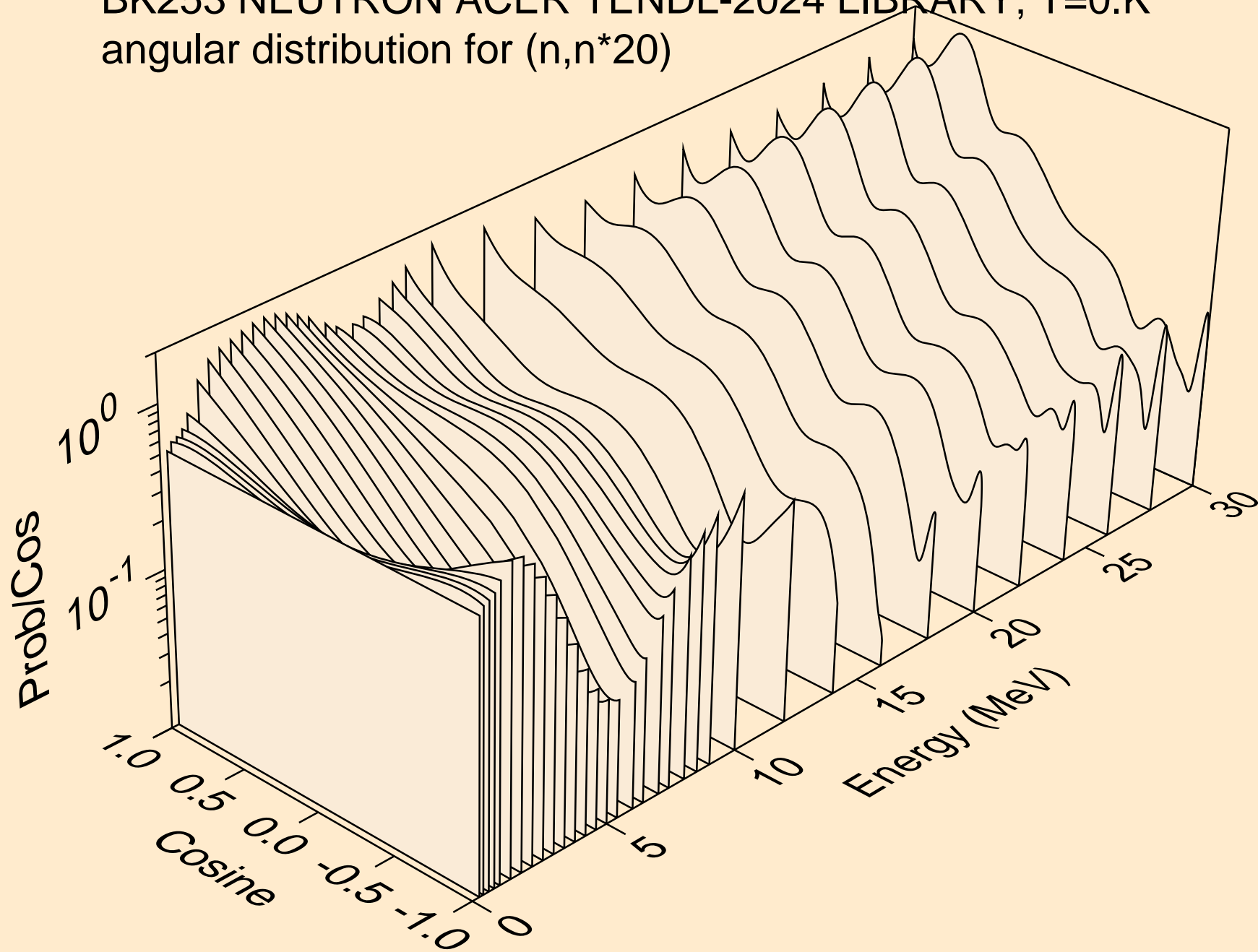

BK253 NEUTRON ACER TENDL-2024 LIBRARY; T=0.K  
angular distribution for (n,n\*21)

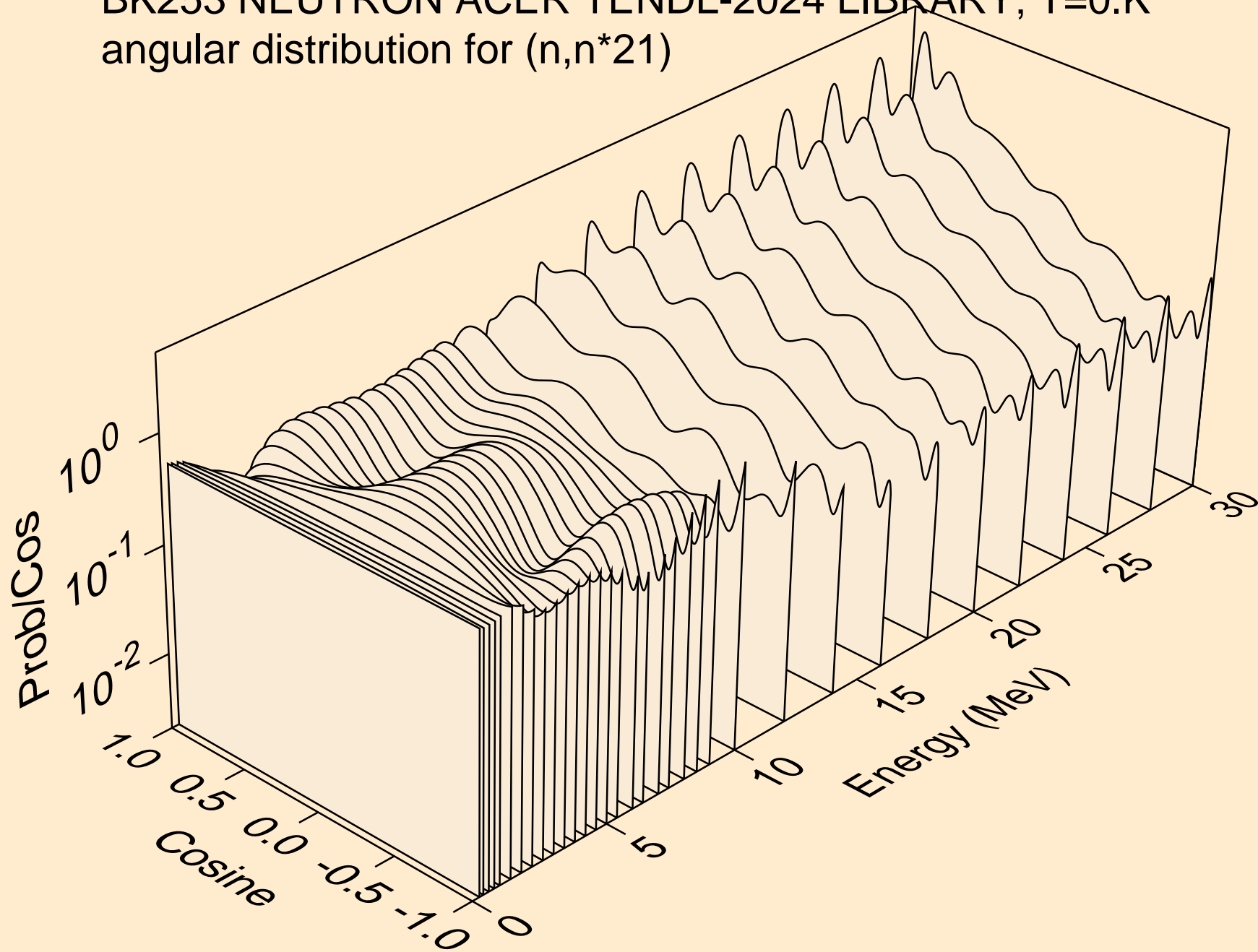

BK253 NEUTRON ACER TENDL-2024 LIBRARY; T=0.K  
angular distribution for (n,n\*22)

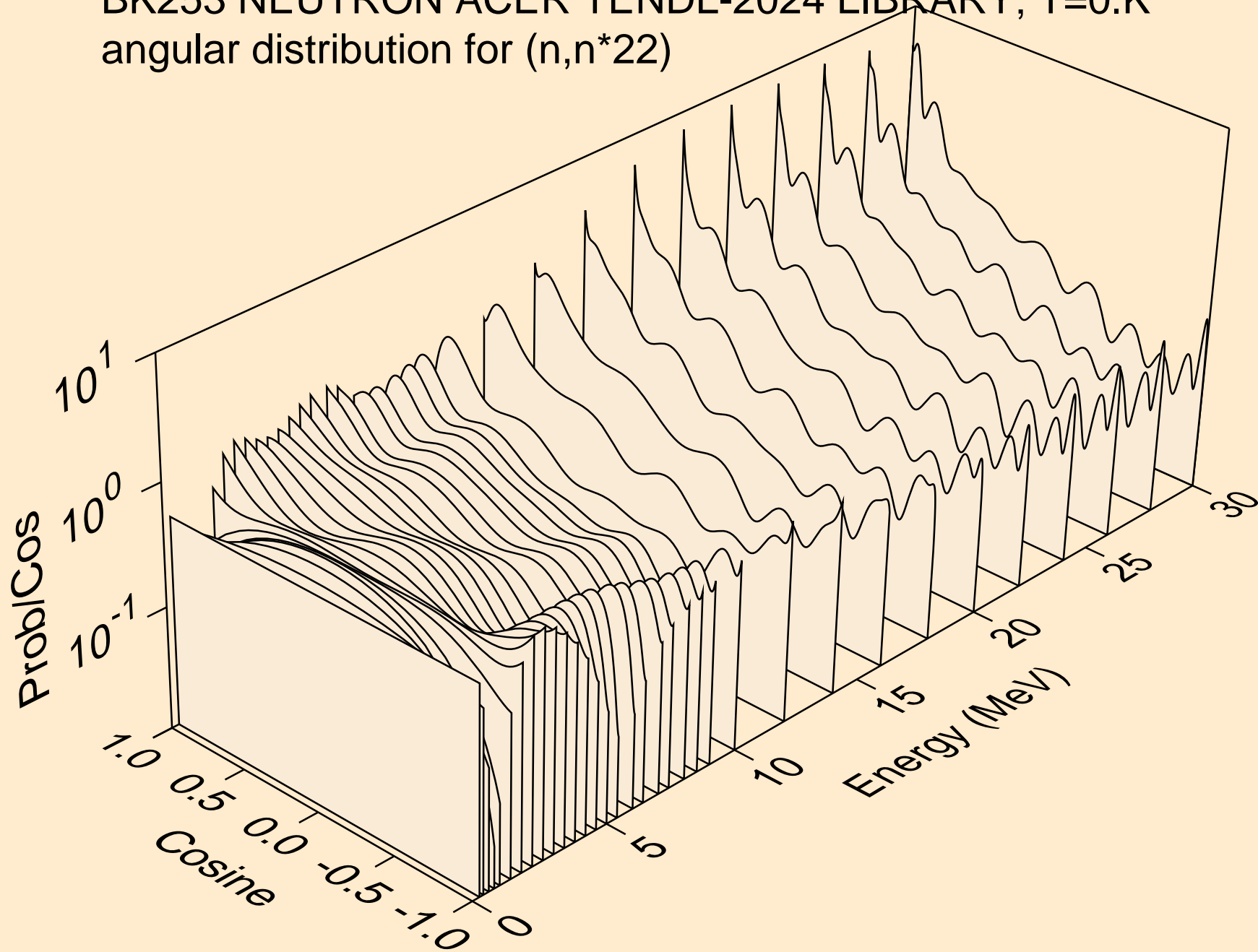

BK253 NEUTRON ACER TENDL-2024 LIBRARY; T=0.K  
angular distribution for (n,n\*23)

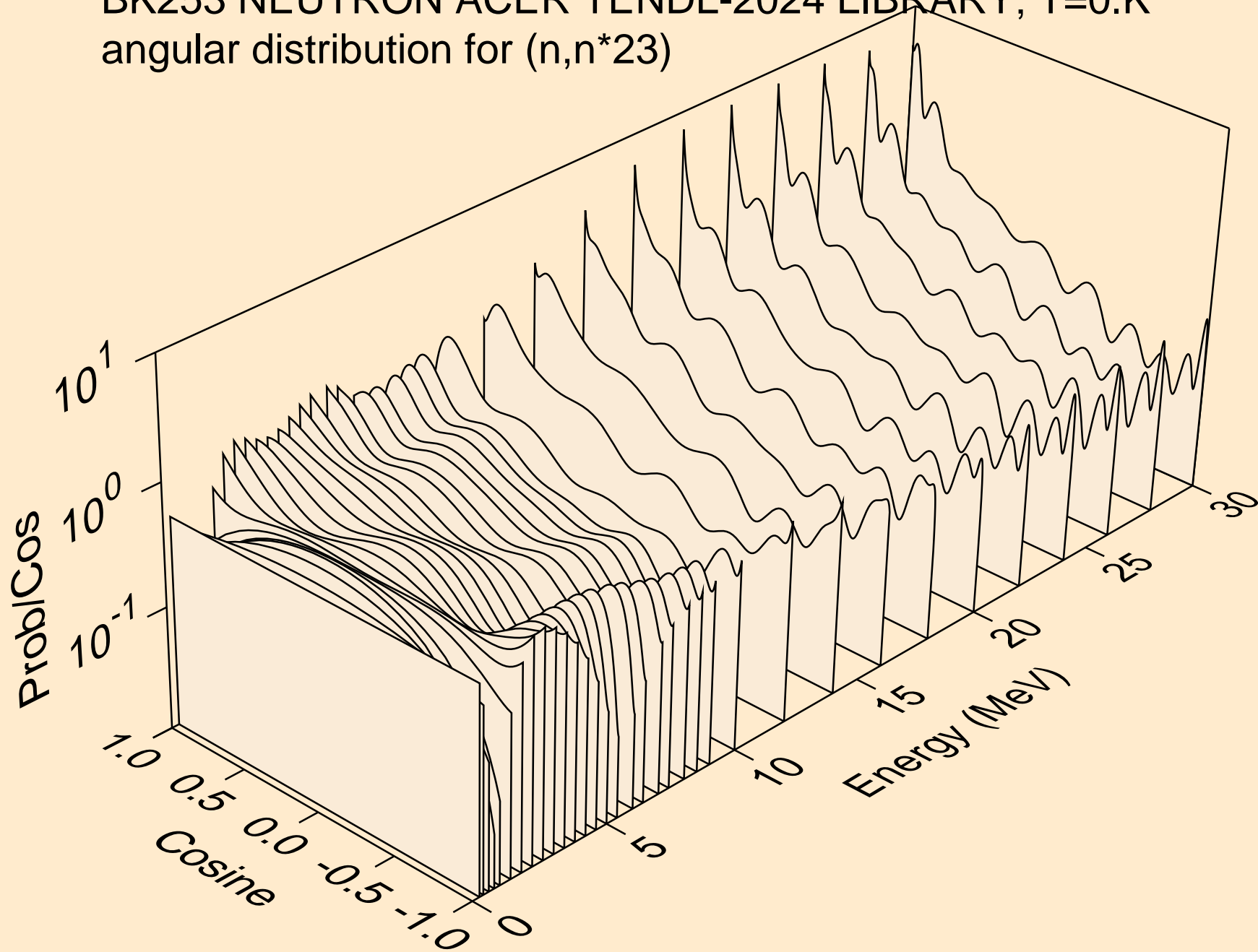

BK253 NEUTRON ACER TENDL-2024 LIBRARY; T=0.K  
angular distribution for (n,n\*24)

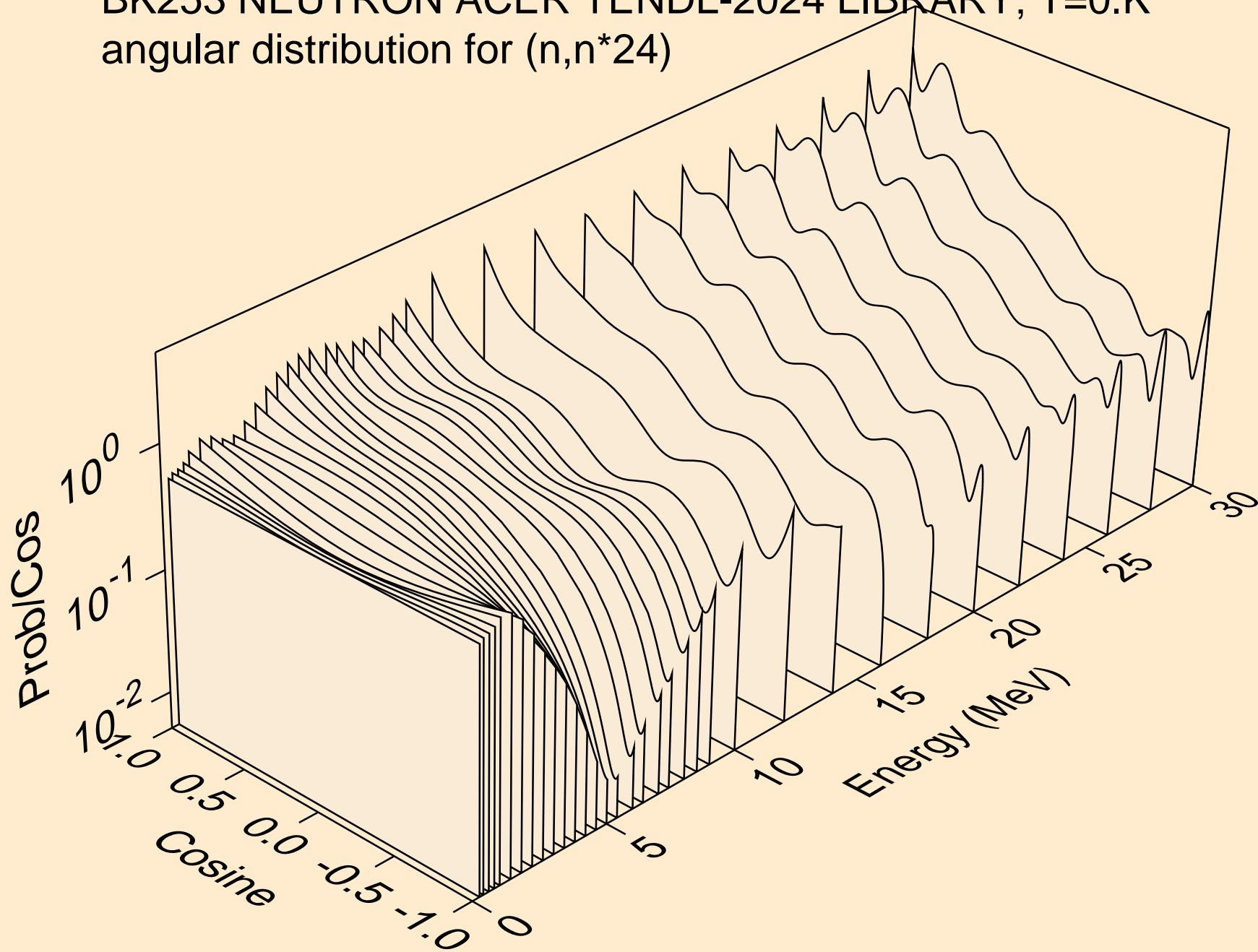

BK253 NEUTRON ACER TENDL-2024 LIBRARY; T=0.K  
angular distribution for (n,n\*25)

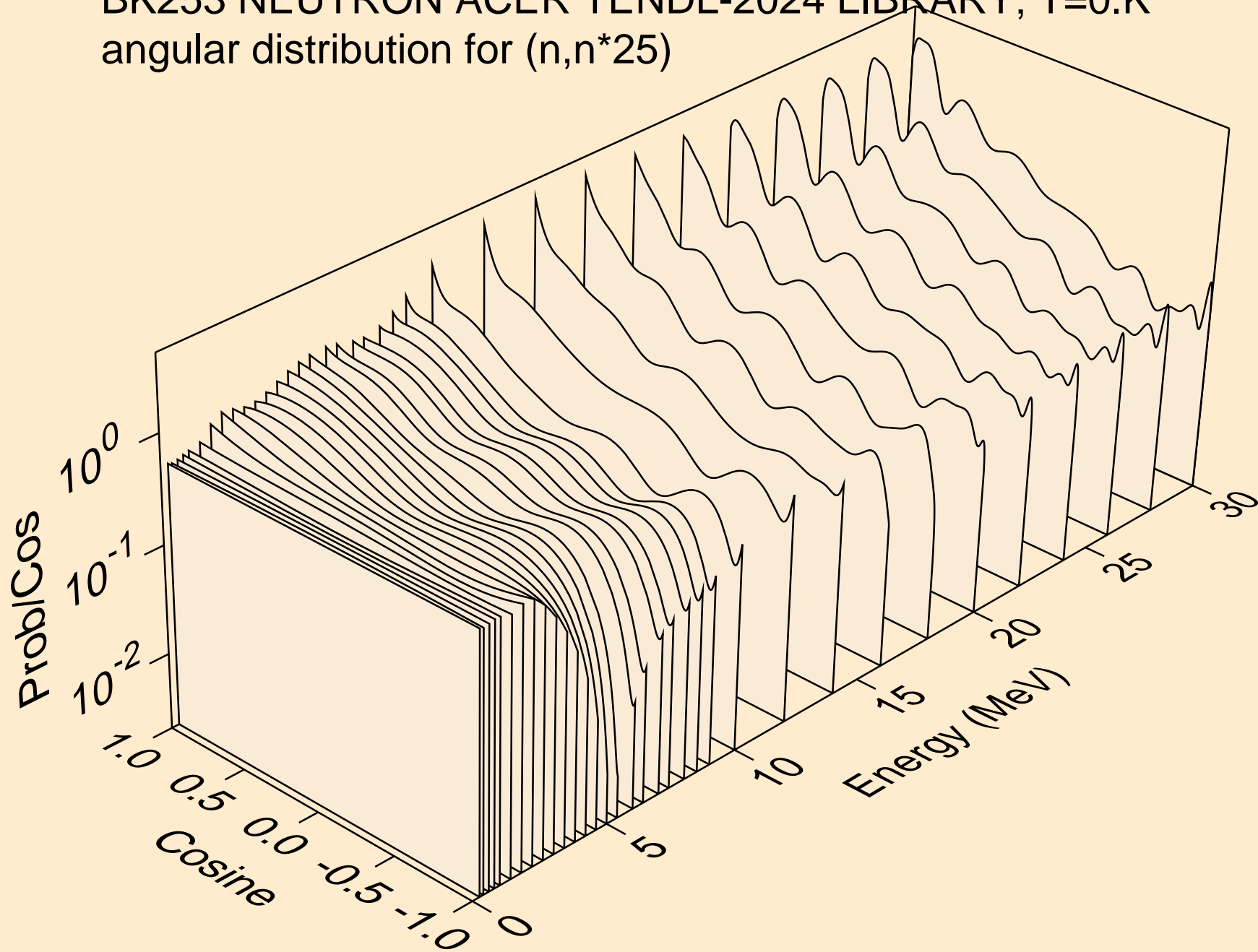

BK253 NEUTRON ACER TENDL-2024 LIBRARY; T=0.K  
angular distribution for (n,n\*26)

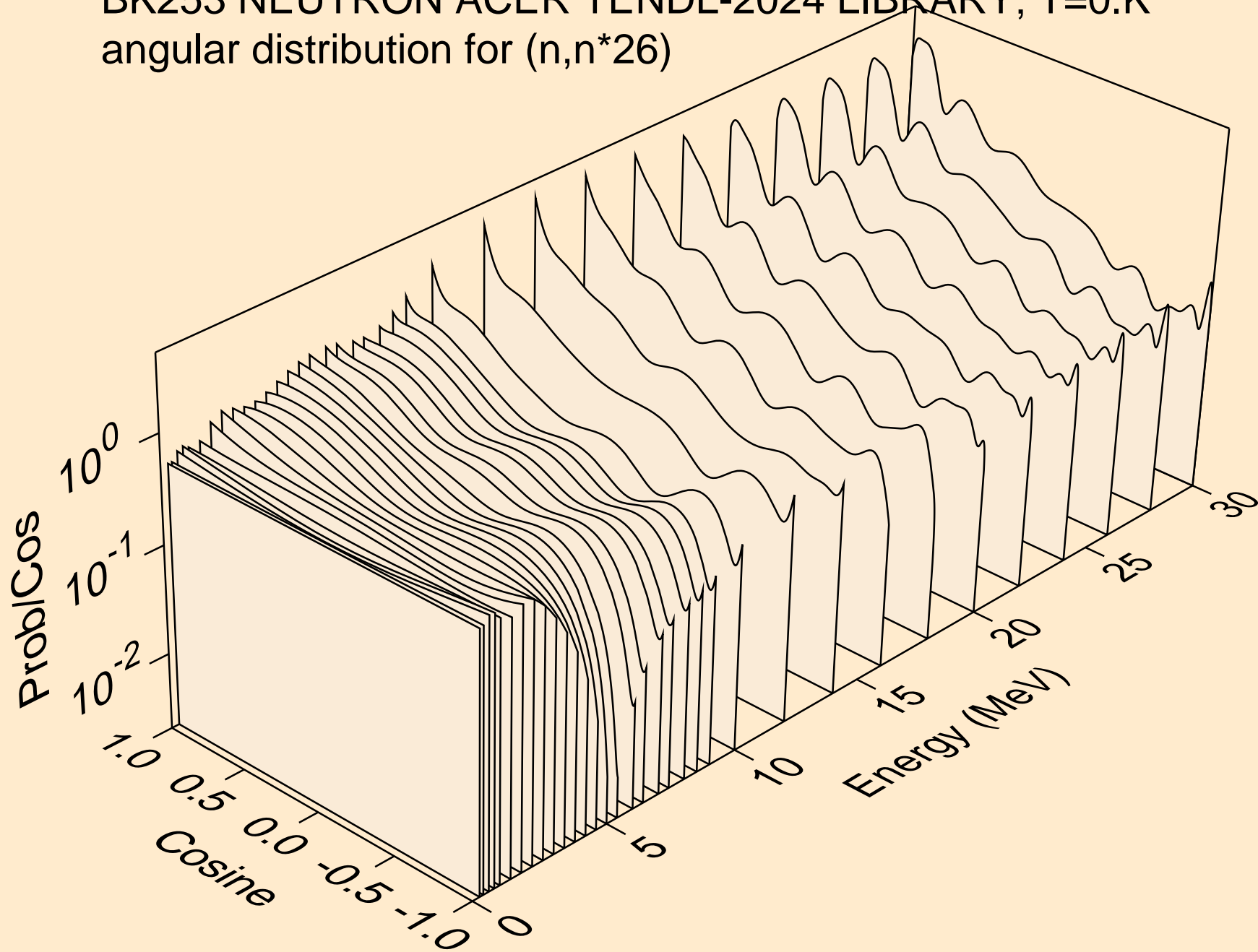

BK253 NEUTRON ACER TENDL-2024 LIBRARY; T=0.K  
angular distribution for (n,n\*27)

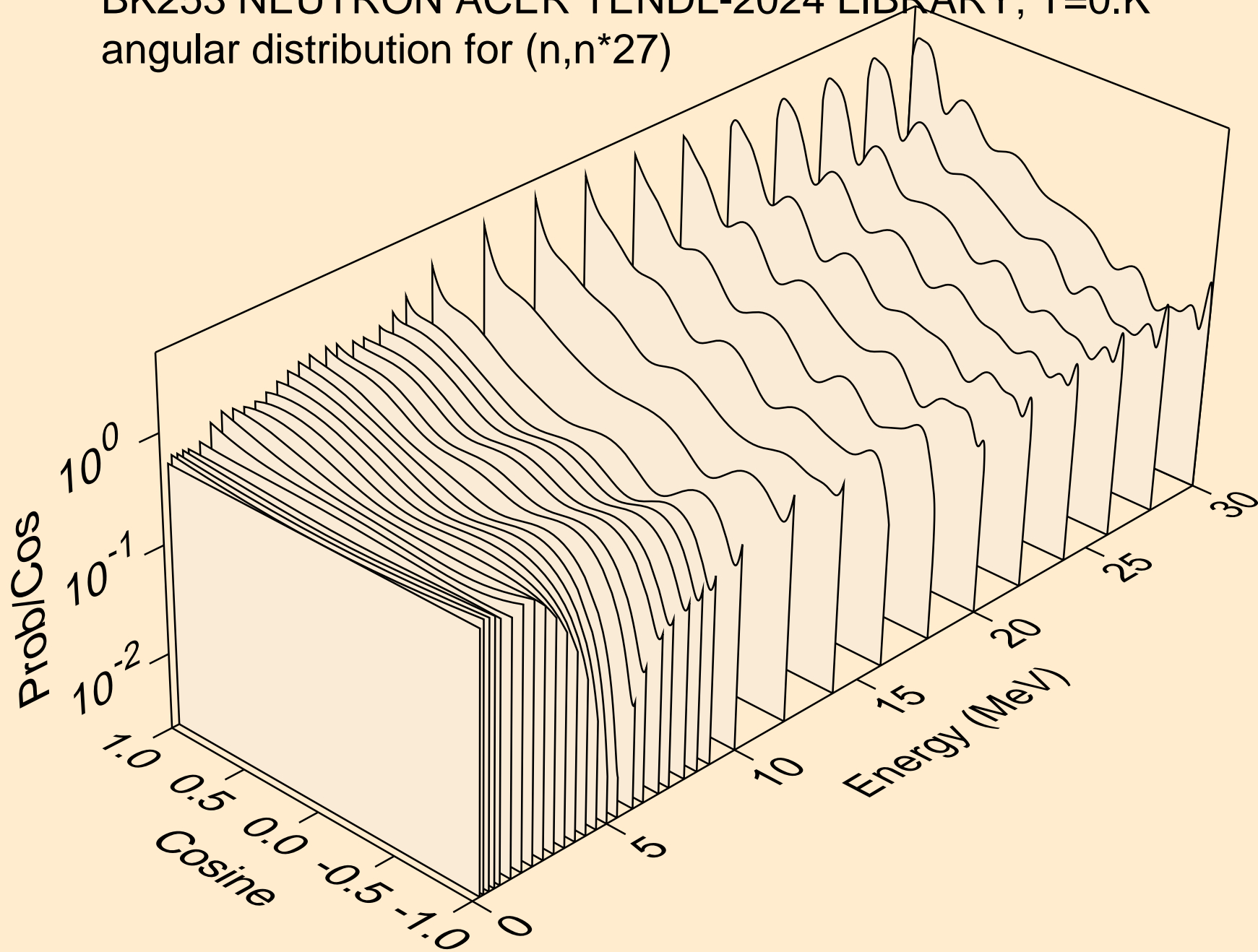

BK253 NEUTRON ACER TENDL-2024 LIBRARY; T=0.K  
angular distribution for (n,n\*28)

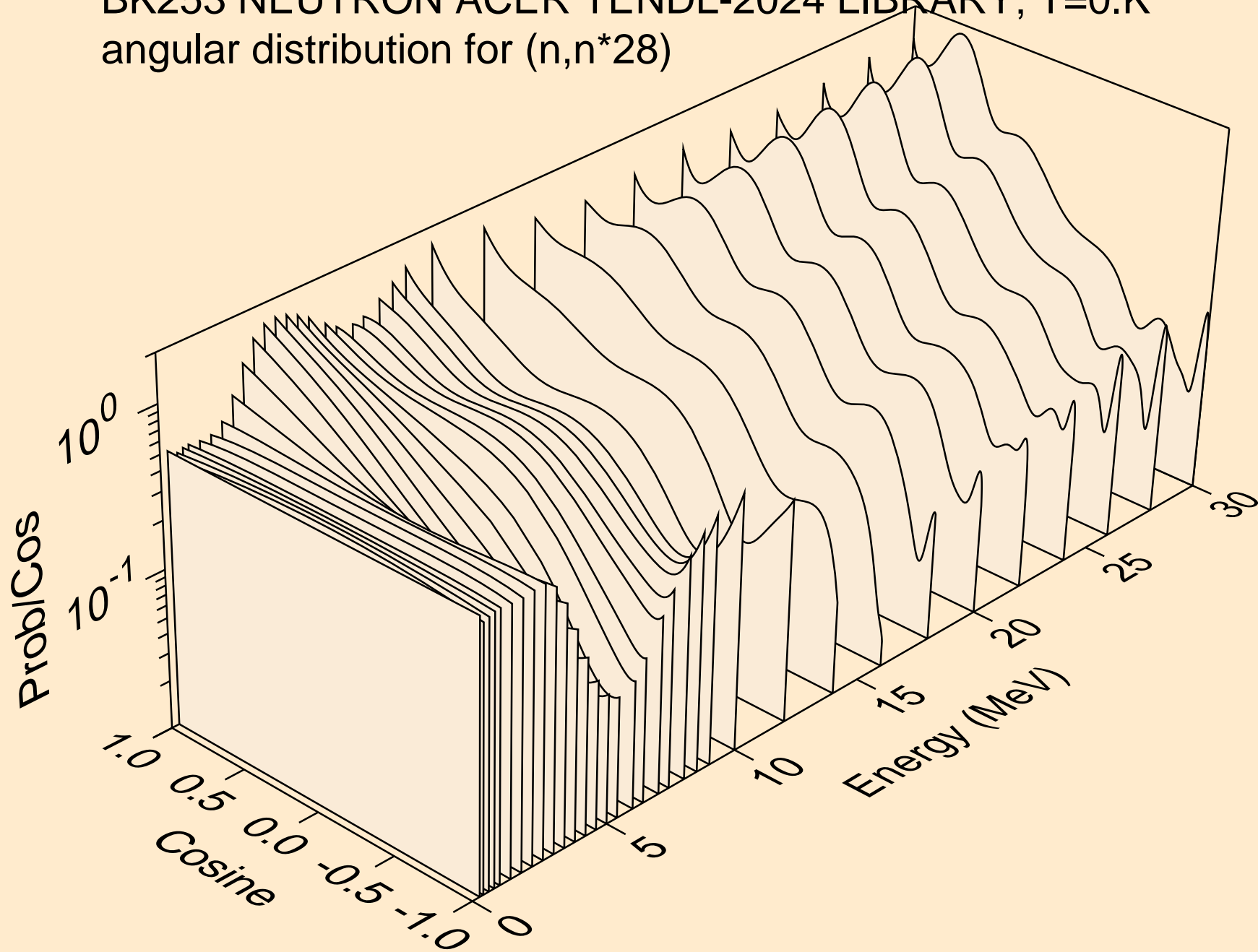

BK253 NEUTRON ACER TENDL-2024 LIBRARY; T=0.K  
angular distribution for (n,n\*29)

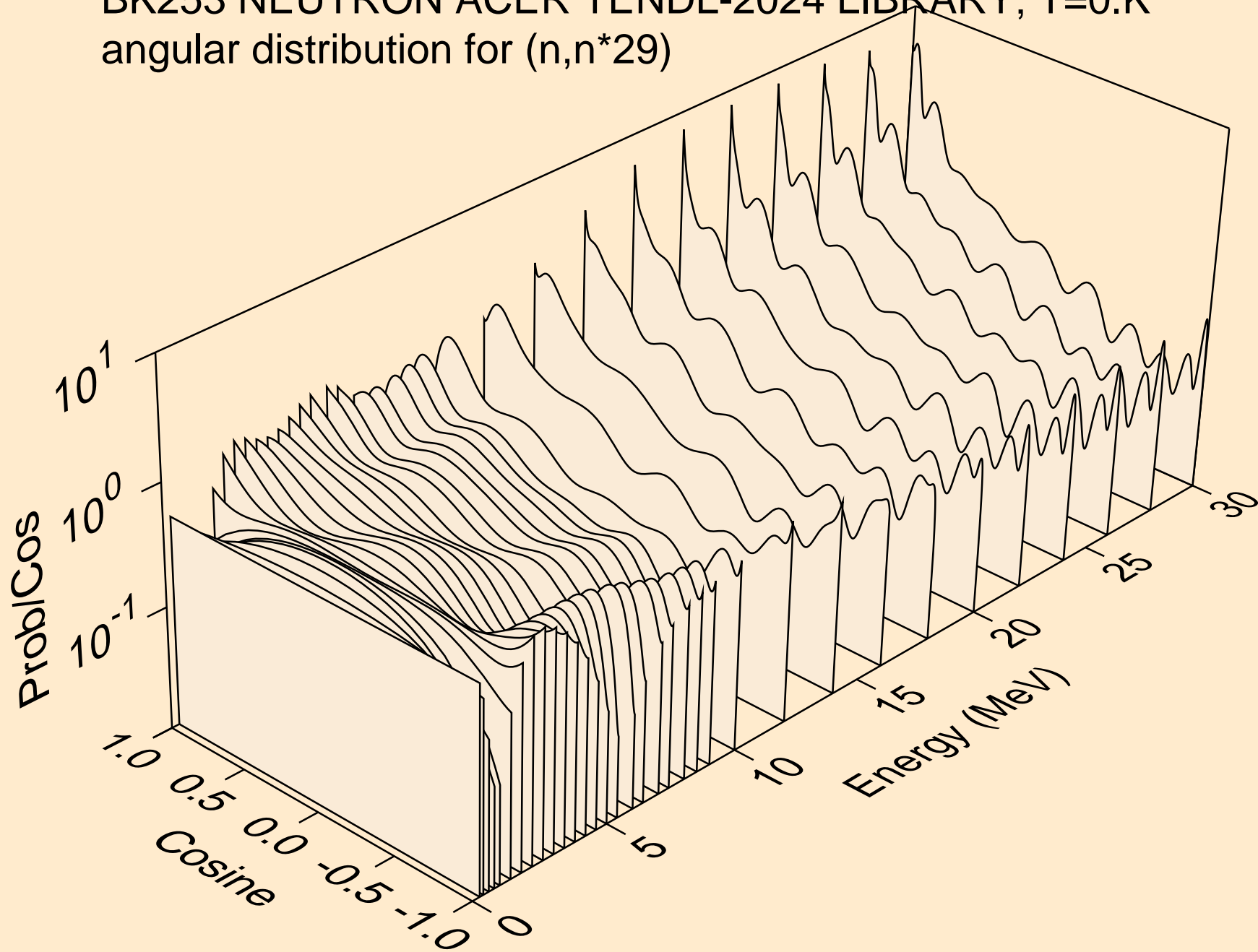

BK253 NEUTRON ACER TENDL-2024 LIBRARY; T=0.K  
angular distribution for (n,n\*30)

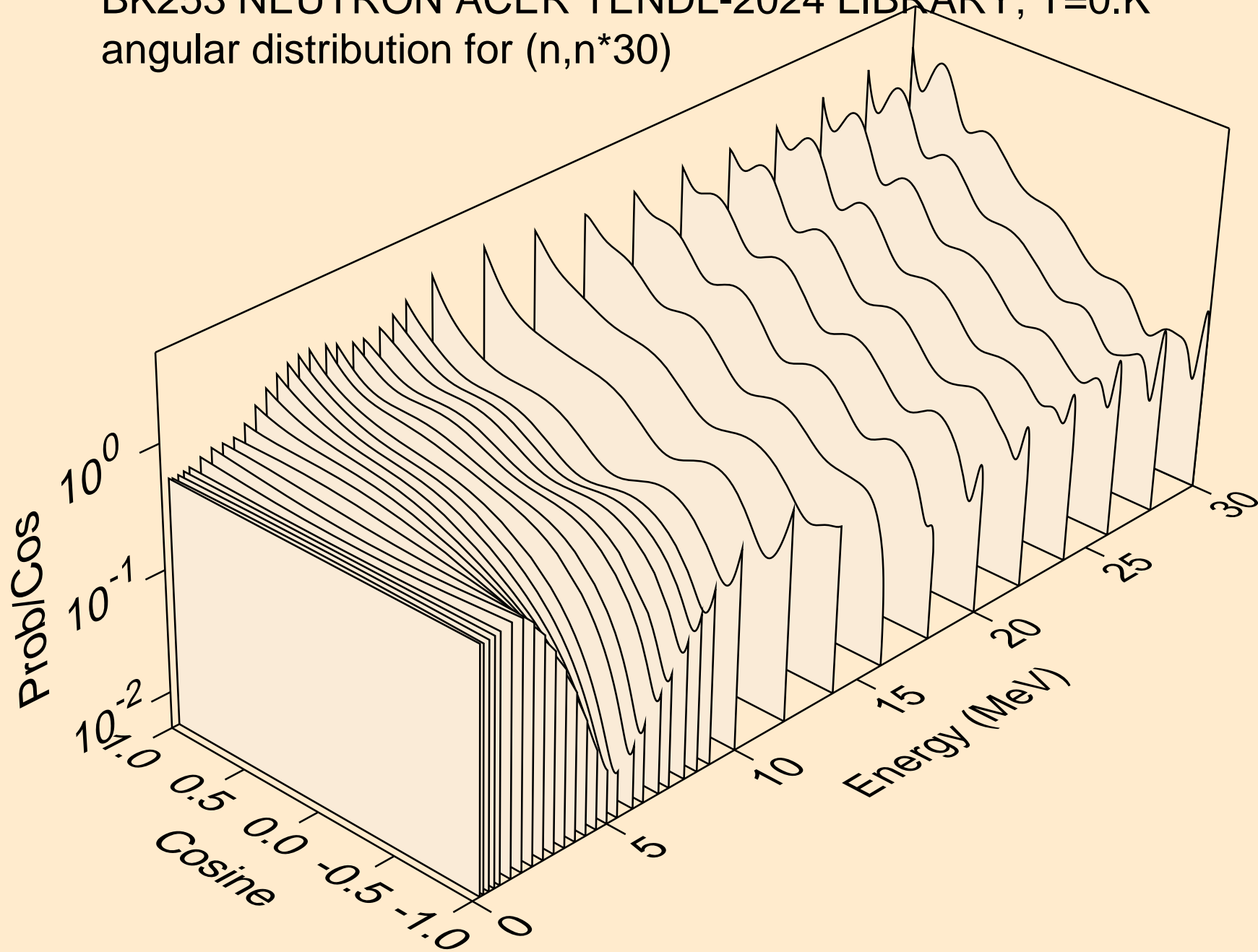

# BK253 NEUTRON ACER TENDL-2024 LIBRARY; T=0.K

## Total fission nubar

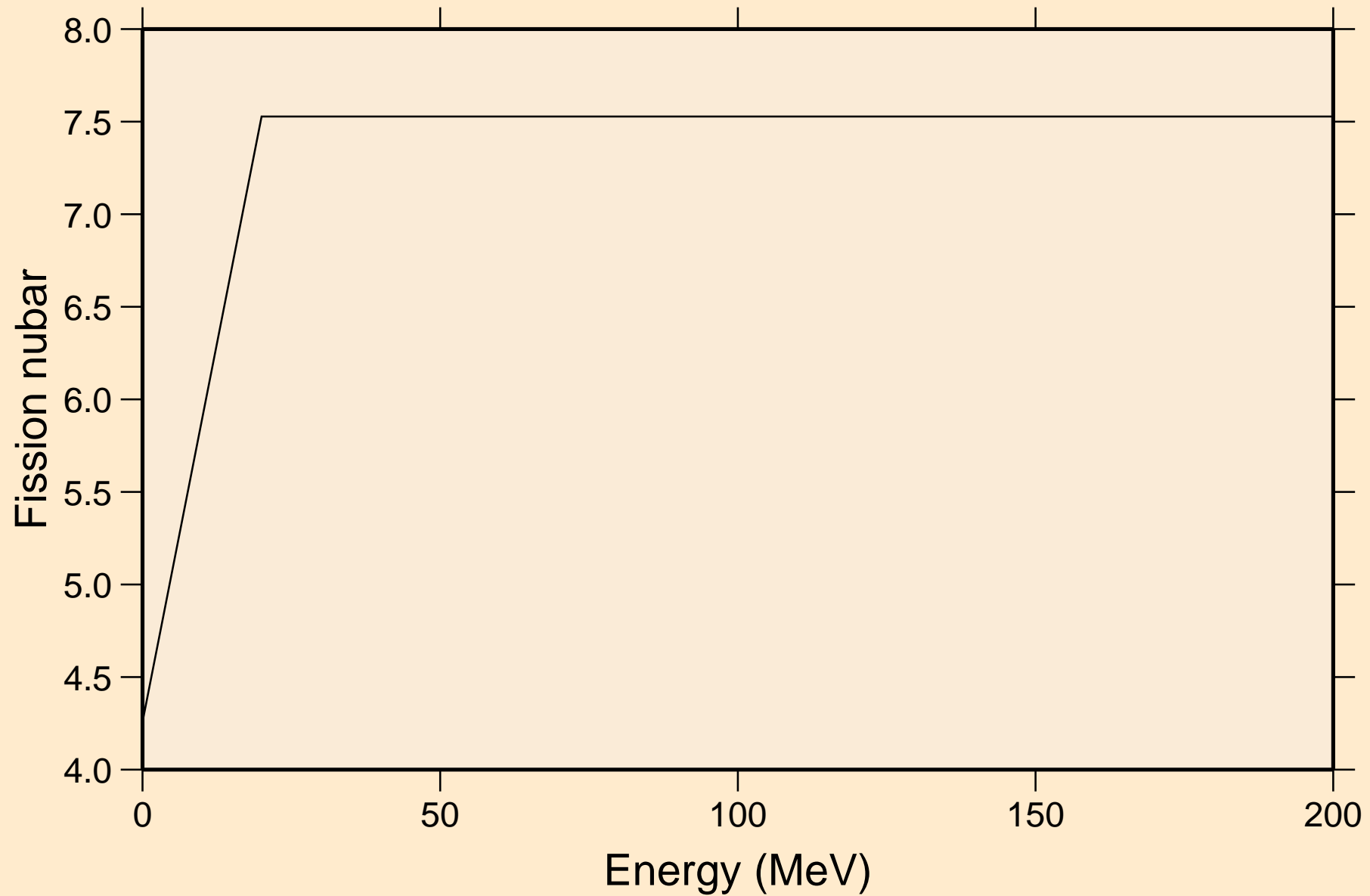

BK253 NEUTRON ACER TENDL-2024 LIBRARY; T=0.K  
Neutron emission for (n,x)

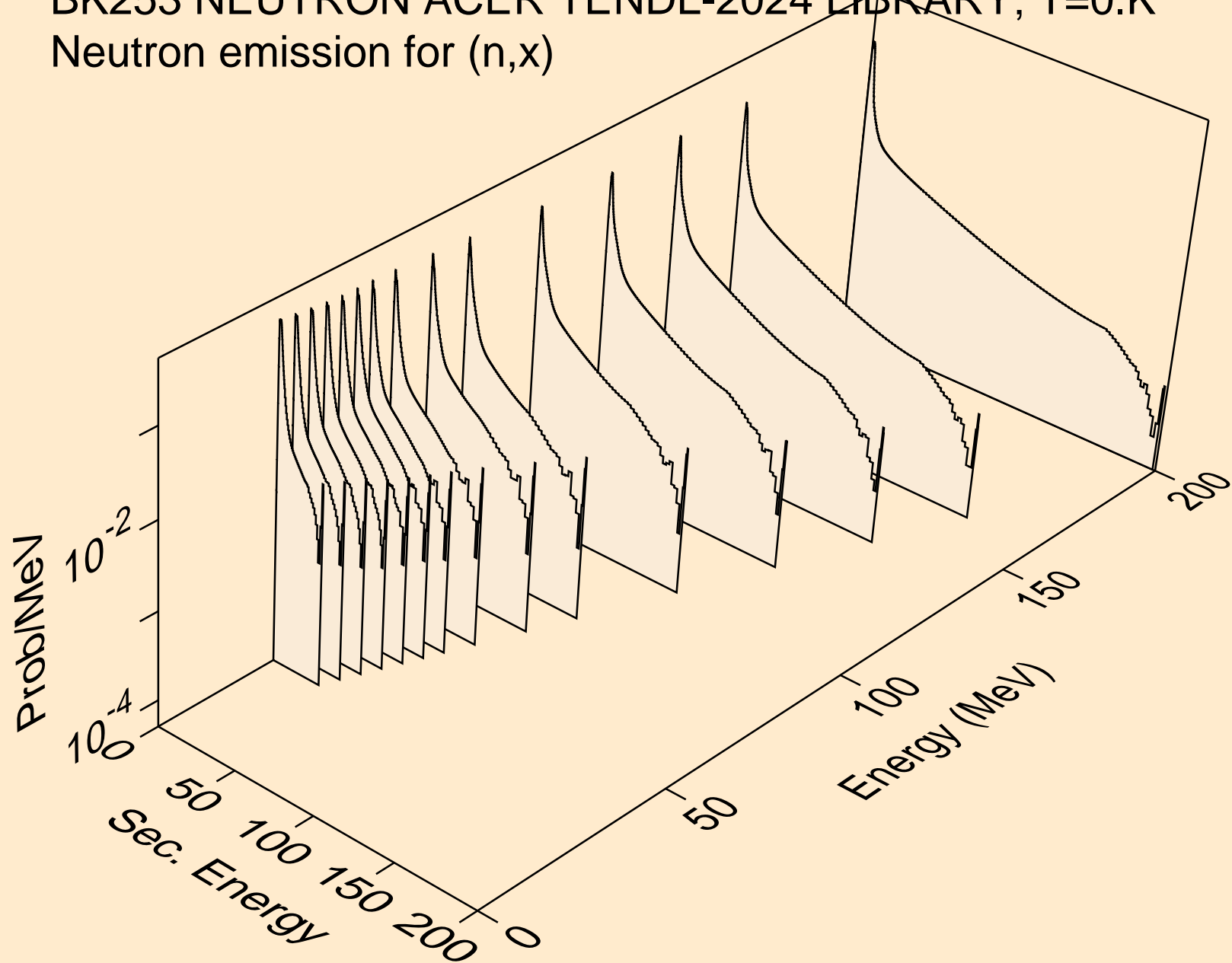

BK253 NEUTRON ACER TENDL-2024 LIBRARY; T=0.K  
Neutron emission for (n,2nd)

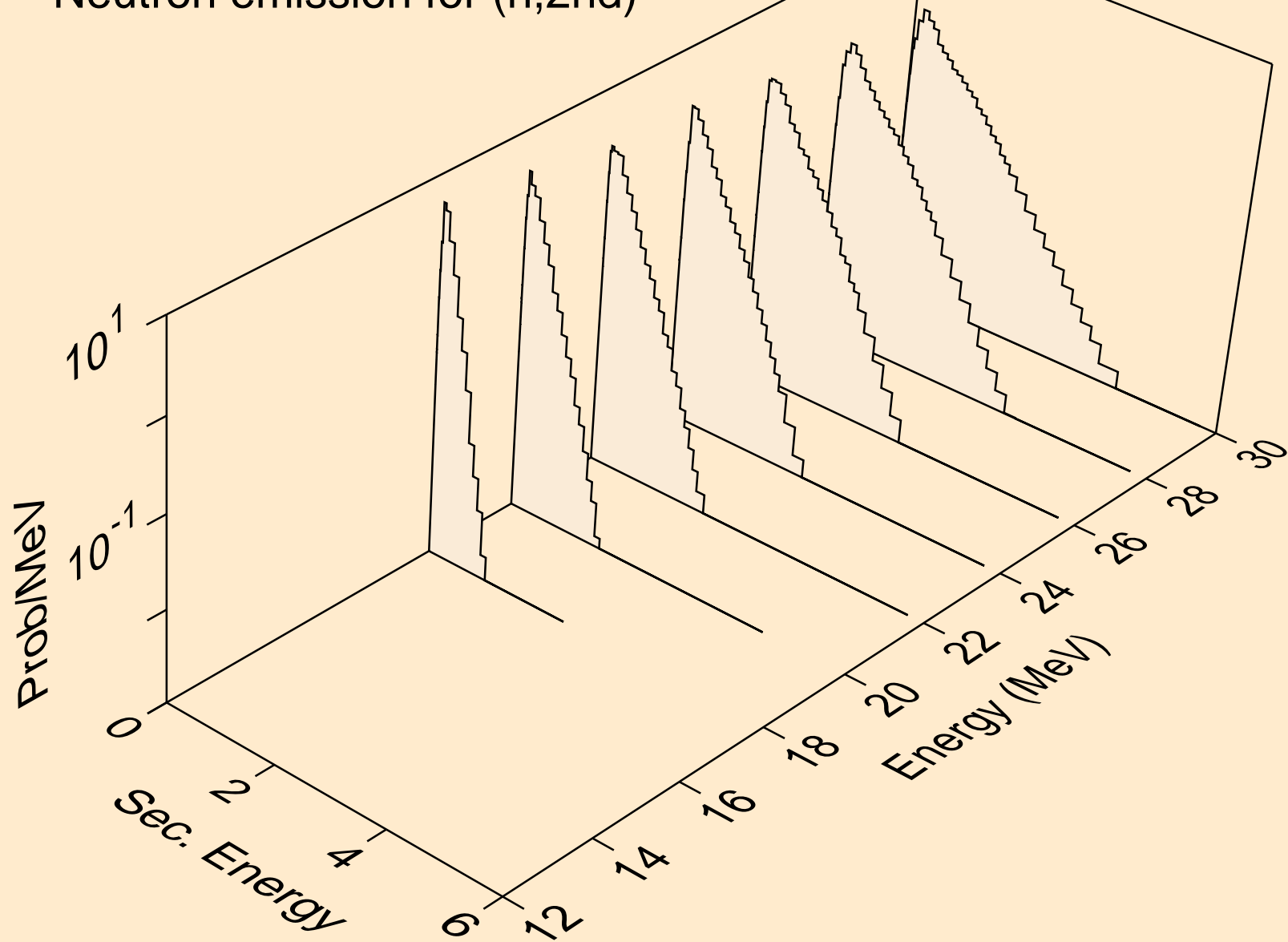

BK253 NEUTRON ACER TENDL-2024 LIBRARY; T=0.K  
Neutron emission for (n,2n)

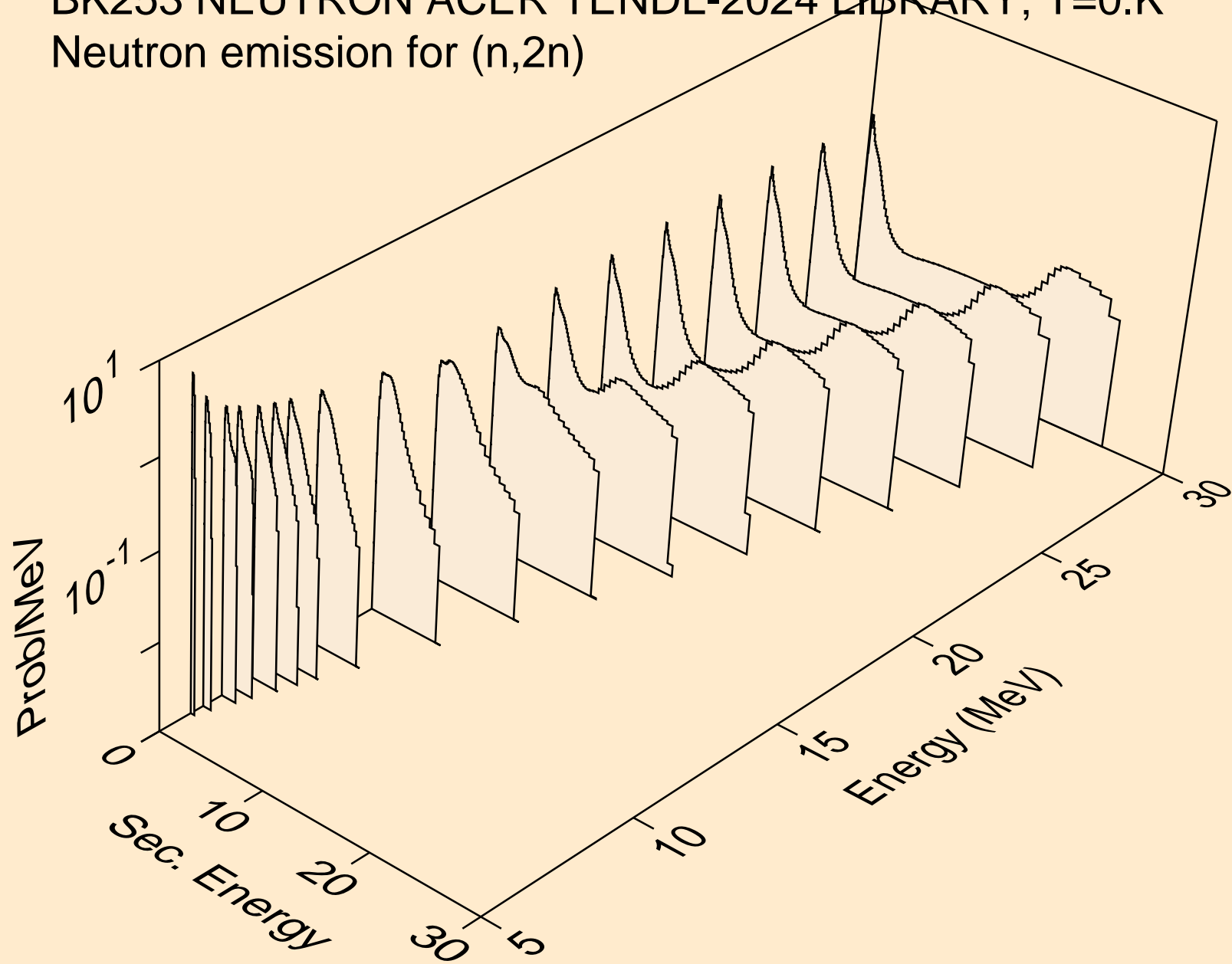

BK253 NEUTRON ACER TENDL-2024 LIBRARY; T=0.K  
Neutron emission for (n,3n)

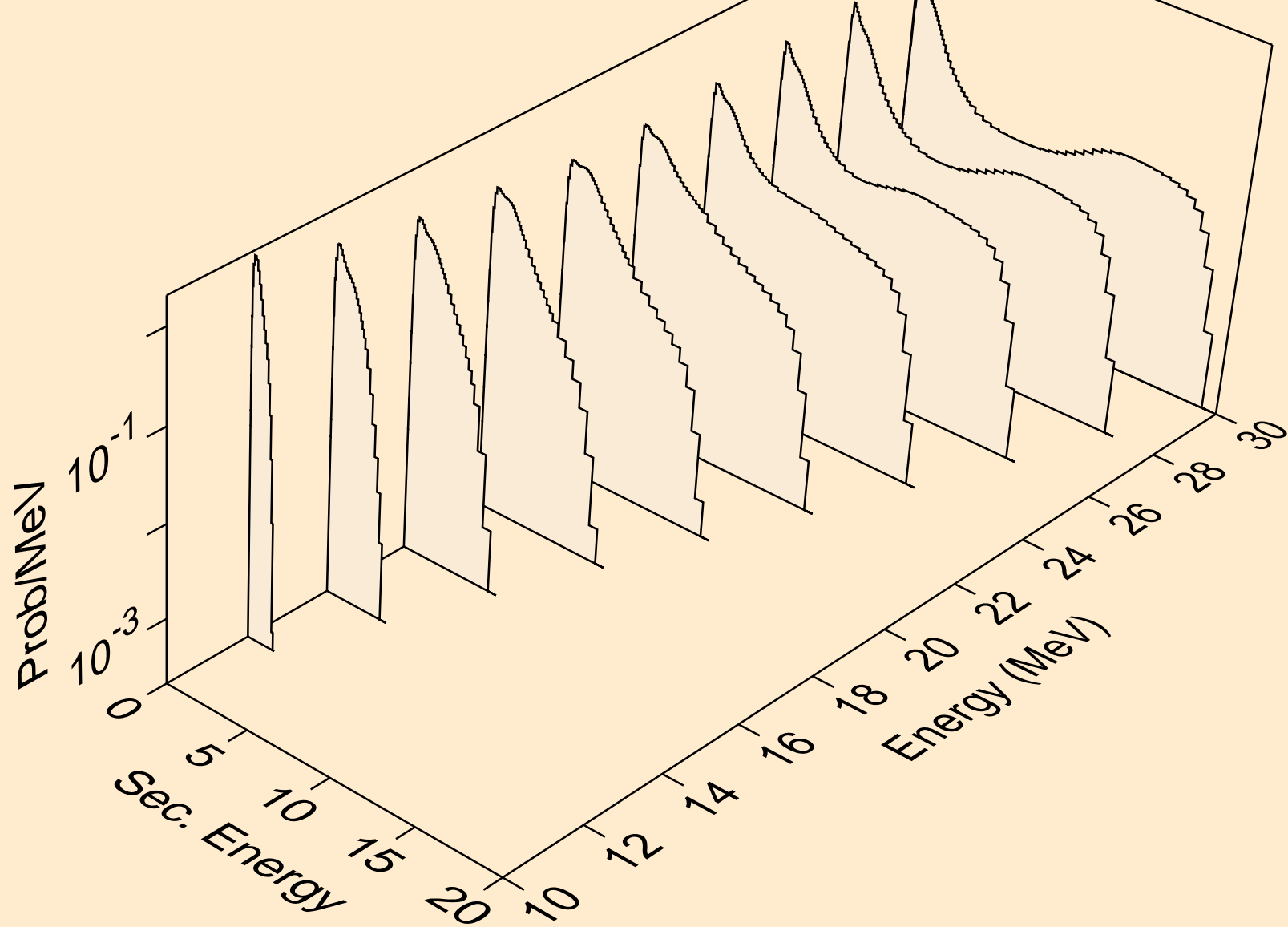

BK253 NEUTRON ACER TENDL-2024 LIBRARY; T=0.K  
Neutron emission for fission

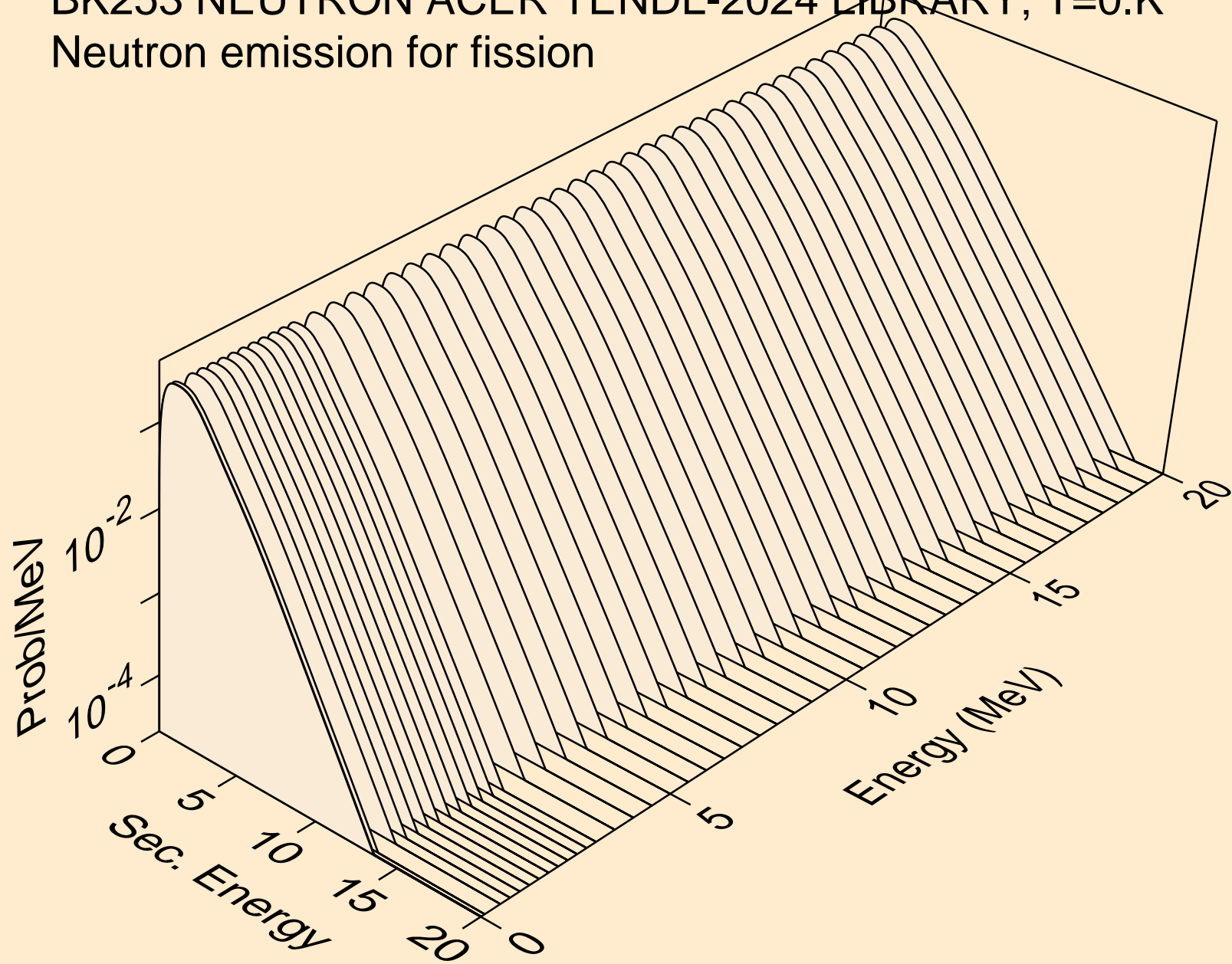

BK253 NEUTRON ACER TENDL-2024 LIBRARY; T=0.K  
Neutron emission for (n,n\*)a

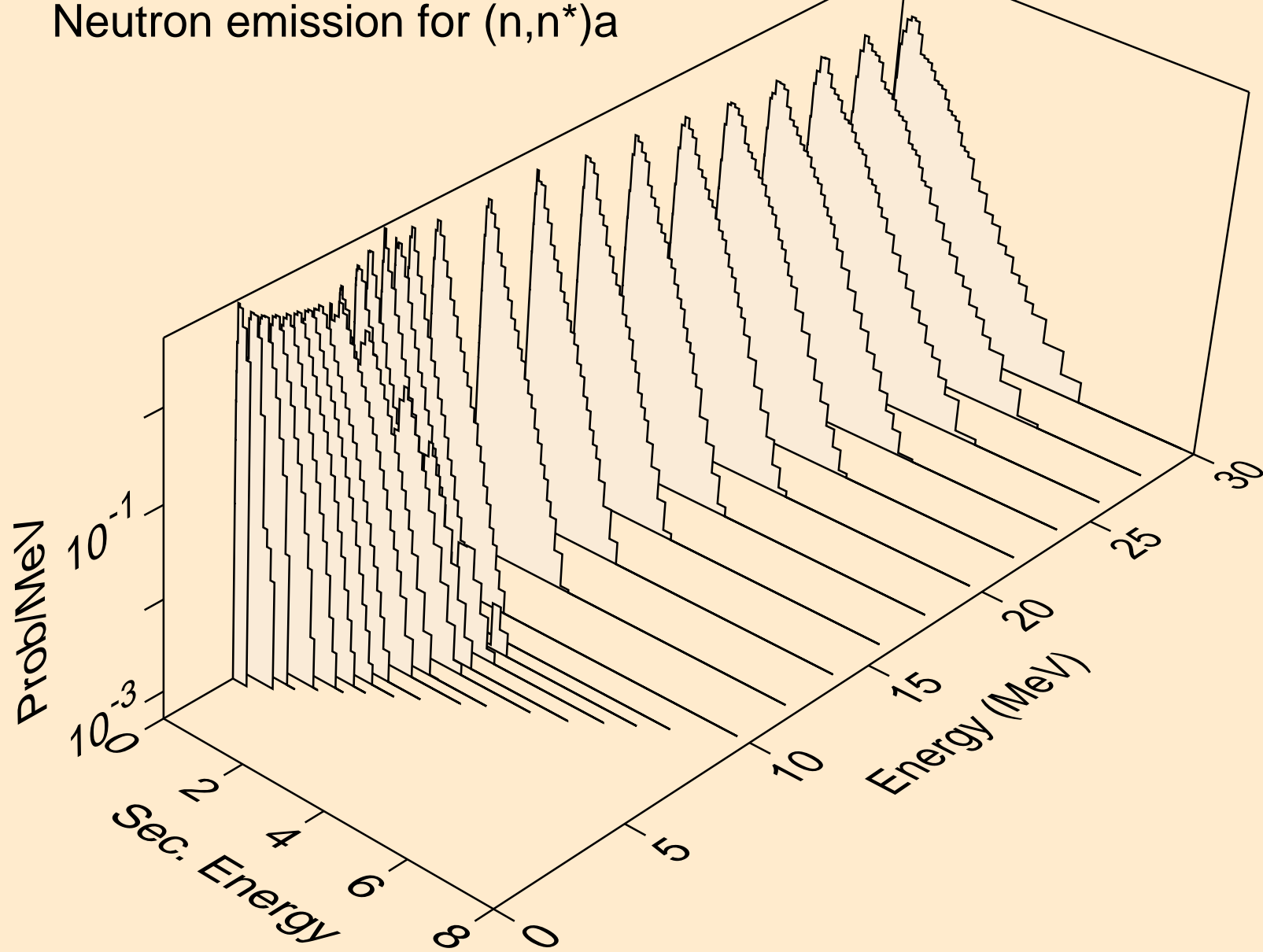

BK253 NEUTRON ACER TENDL-2024 LIBRARY; T=0.K  
Neutron emission for (n,2n)a

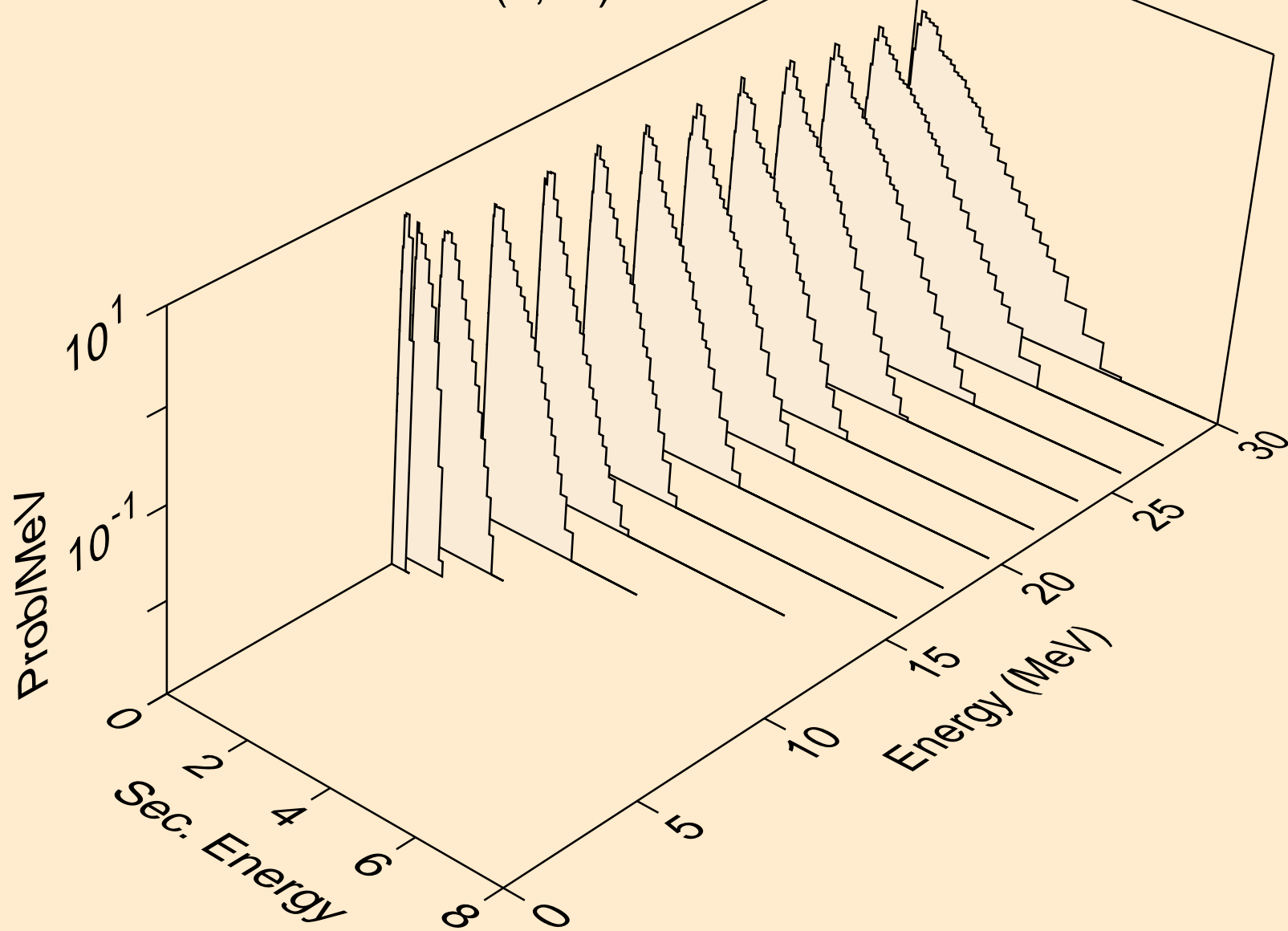

BK253 NEUTRON ACER TENDL-2024 LIBRARY; T=0.K  
Neutron emission for (n,3n)a

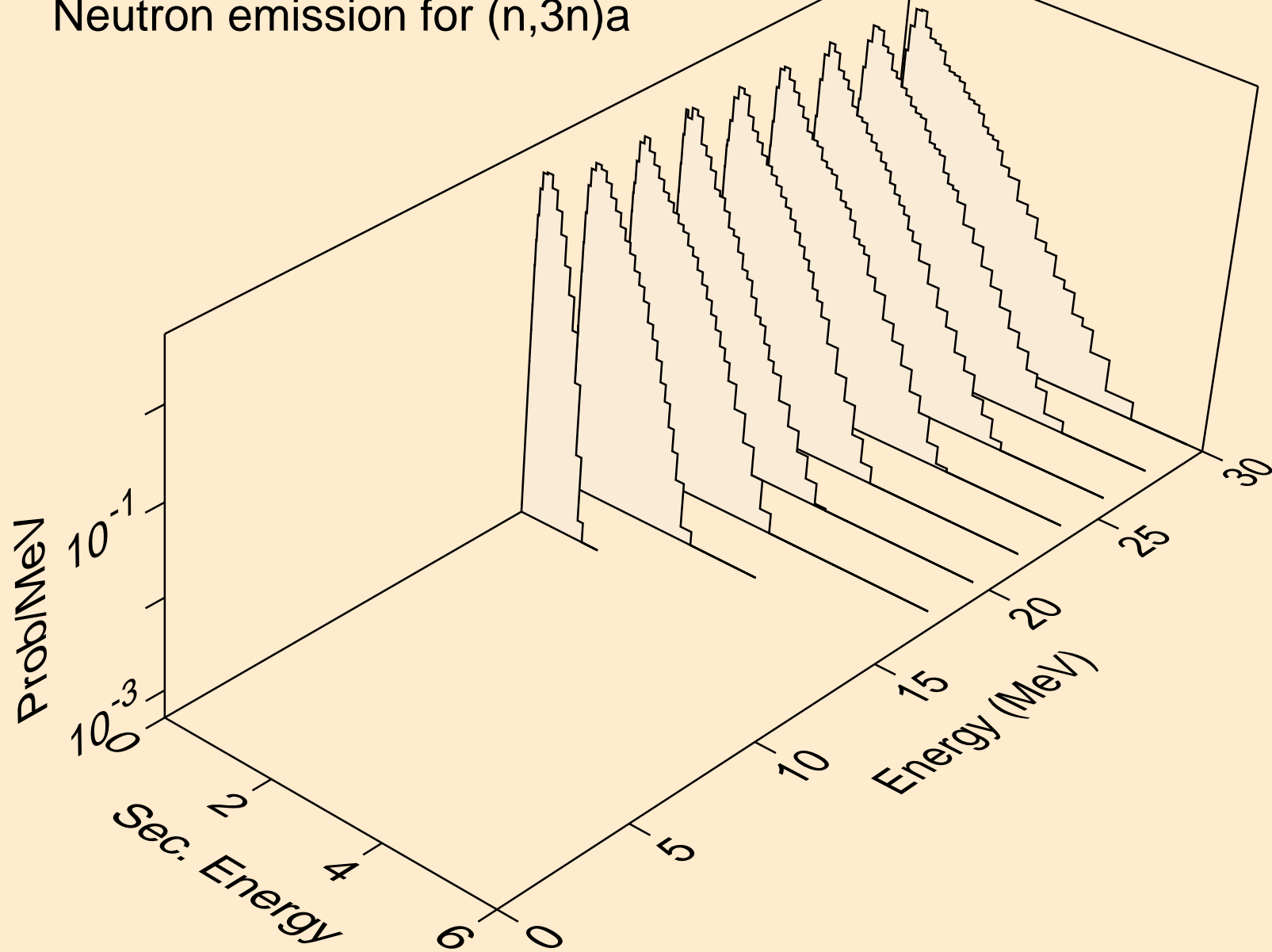

BK253 NEUTRON ACER TENDL-2024 LIBRARY; T=0.K  
Neutron emission for (n,n\*)p

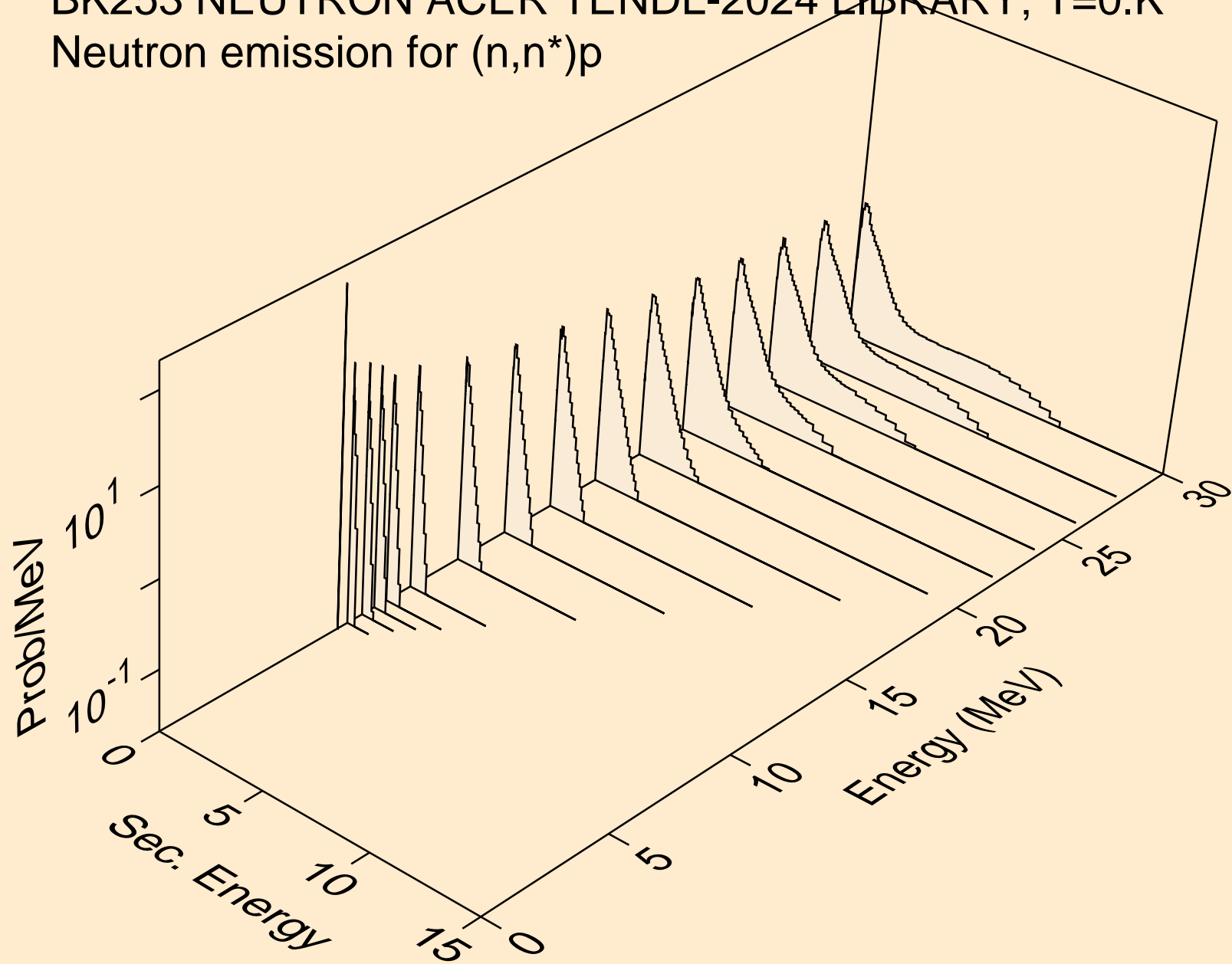

BK253 NEUTRON ACER TENDL-2024 LIBRARY; T=0.K  
Neutron emission for (n,n\*)d

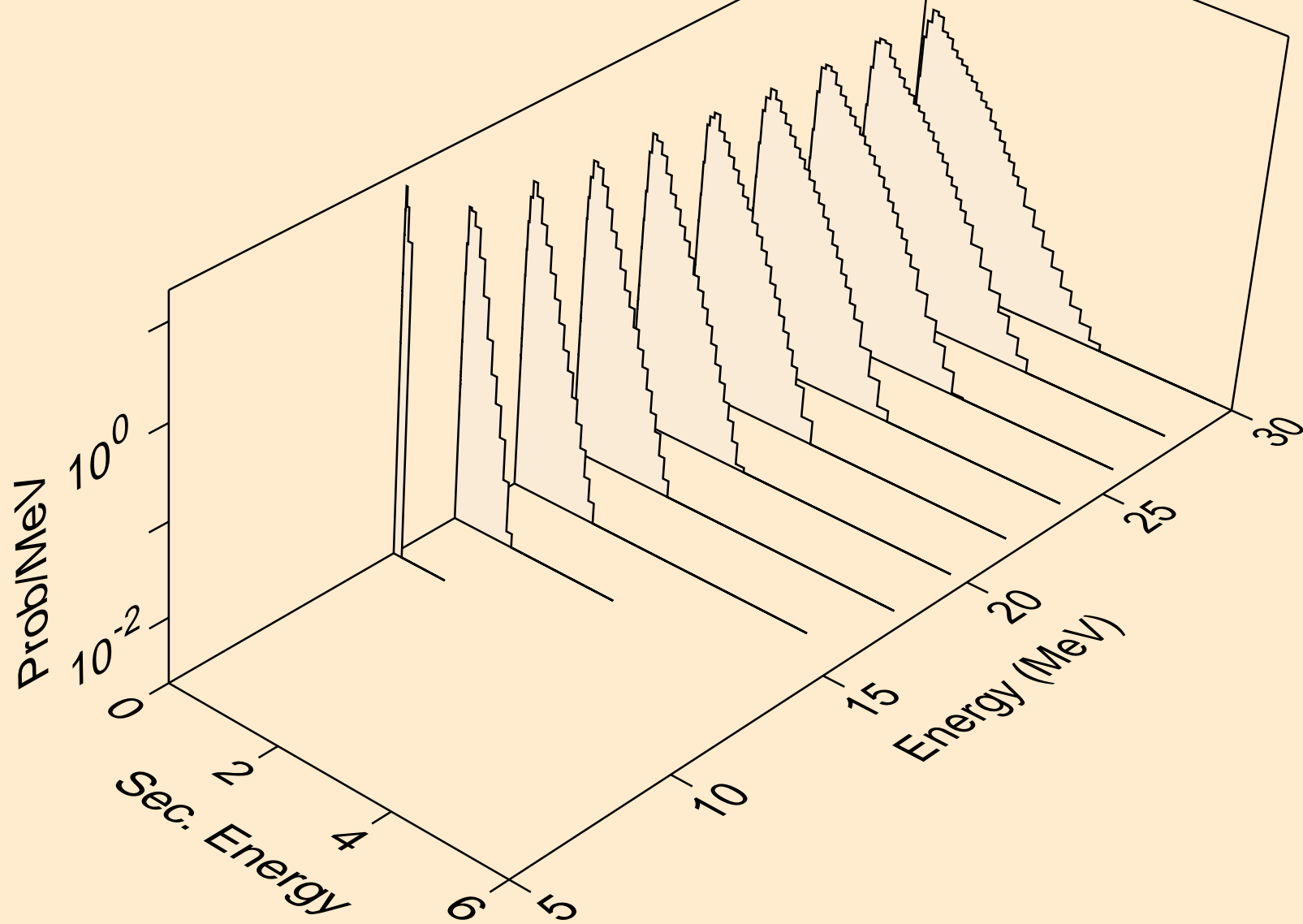

BK253 NEUTRON ACER TENDL-2024 LIBRARY; T=0.K  
Neutron emission for (n,n\*)t

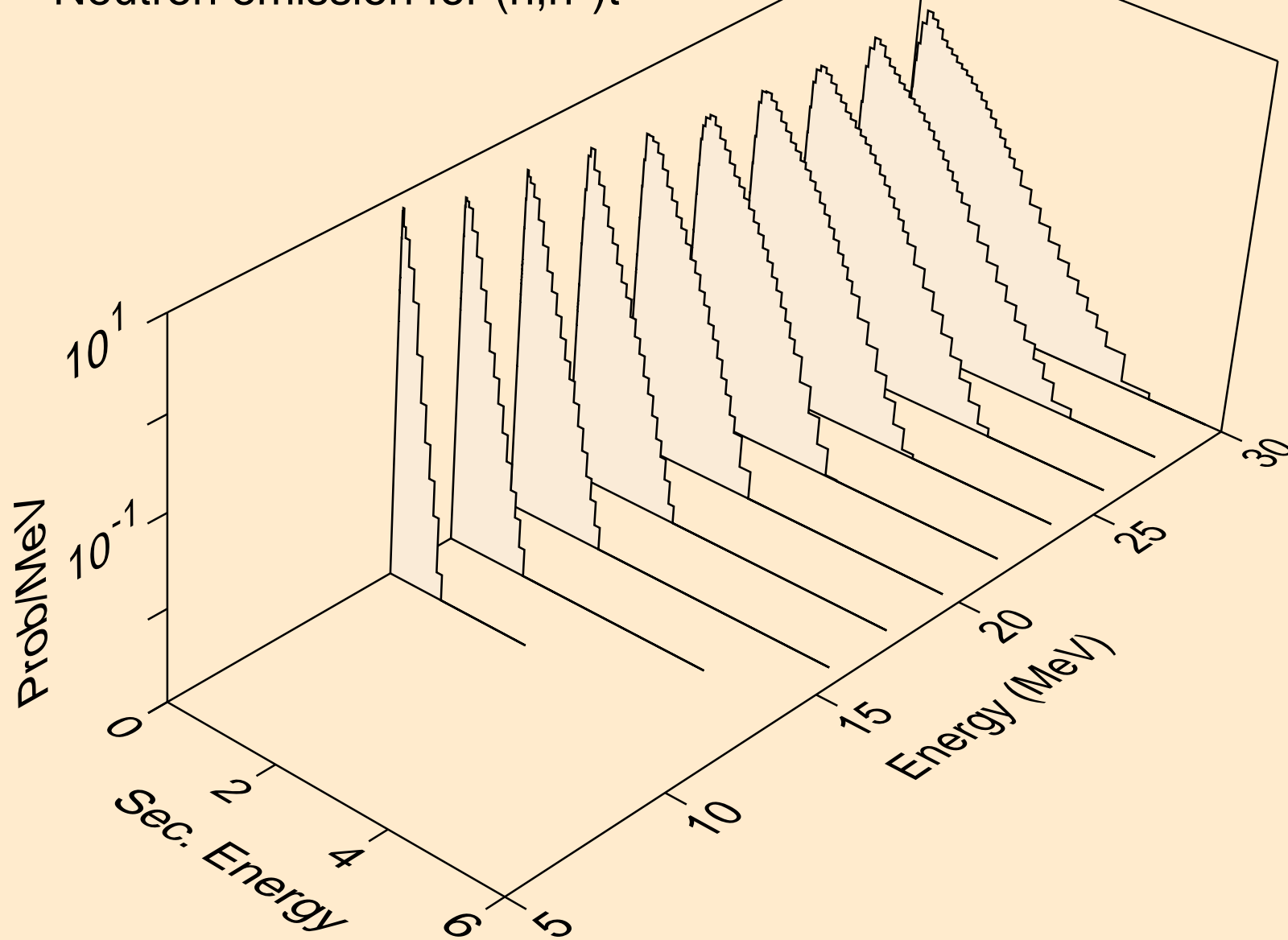

BK253 NEUTRON ACER TENDL-2024 LIBRARY; T=0.K  
Neutron emission for (n,n\*)he3

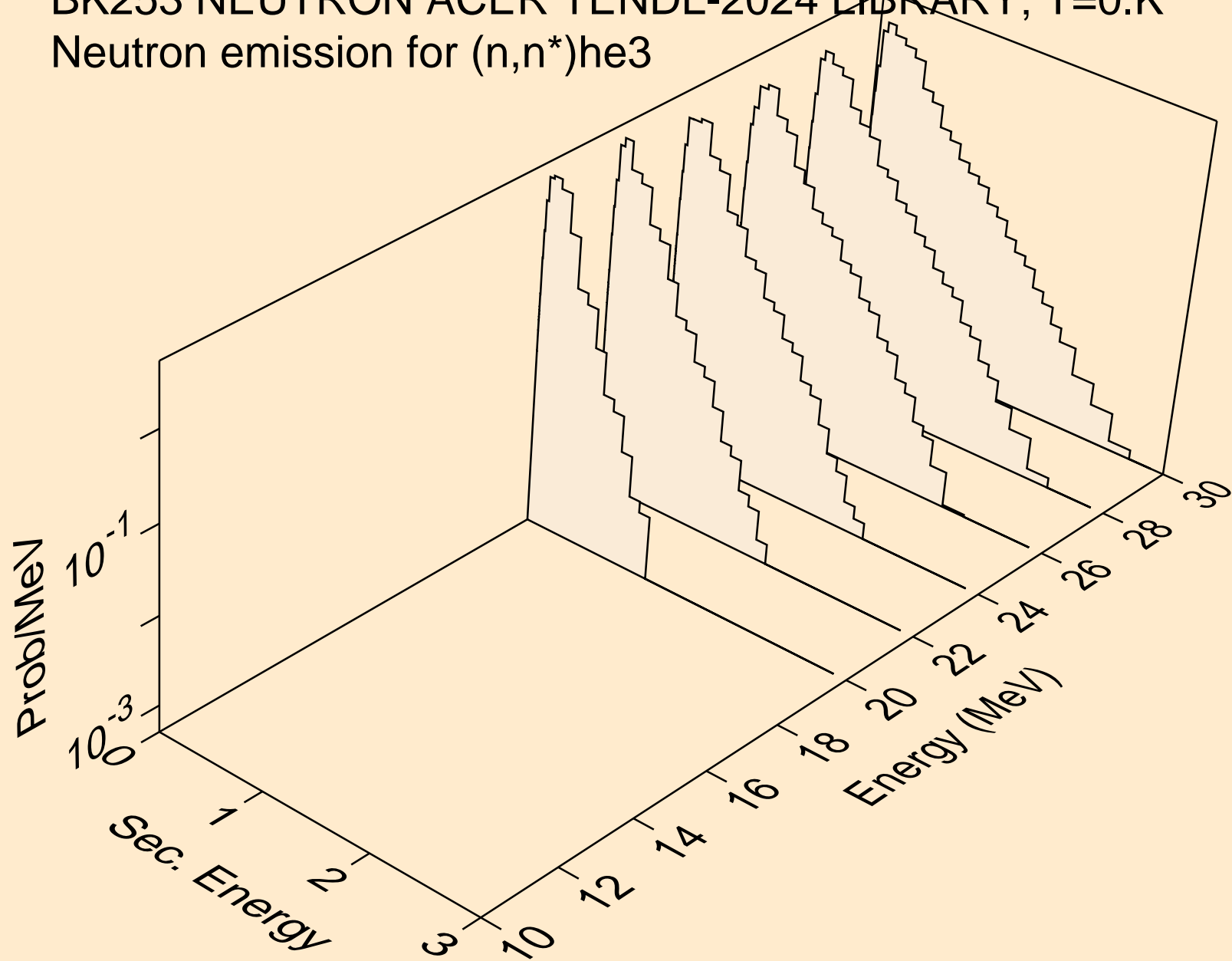

BK253 NEUTRON ACER TENDL-2024 LIBRARY; T=0.K  
Neutron emission for (n,4n)

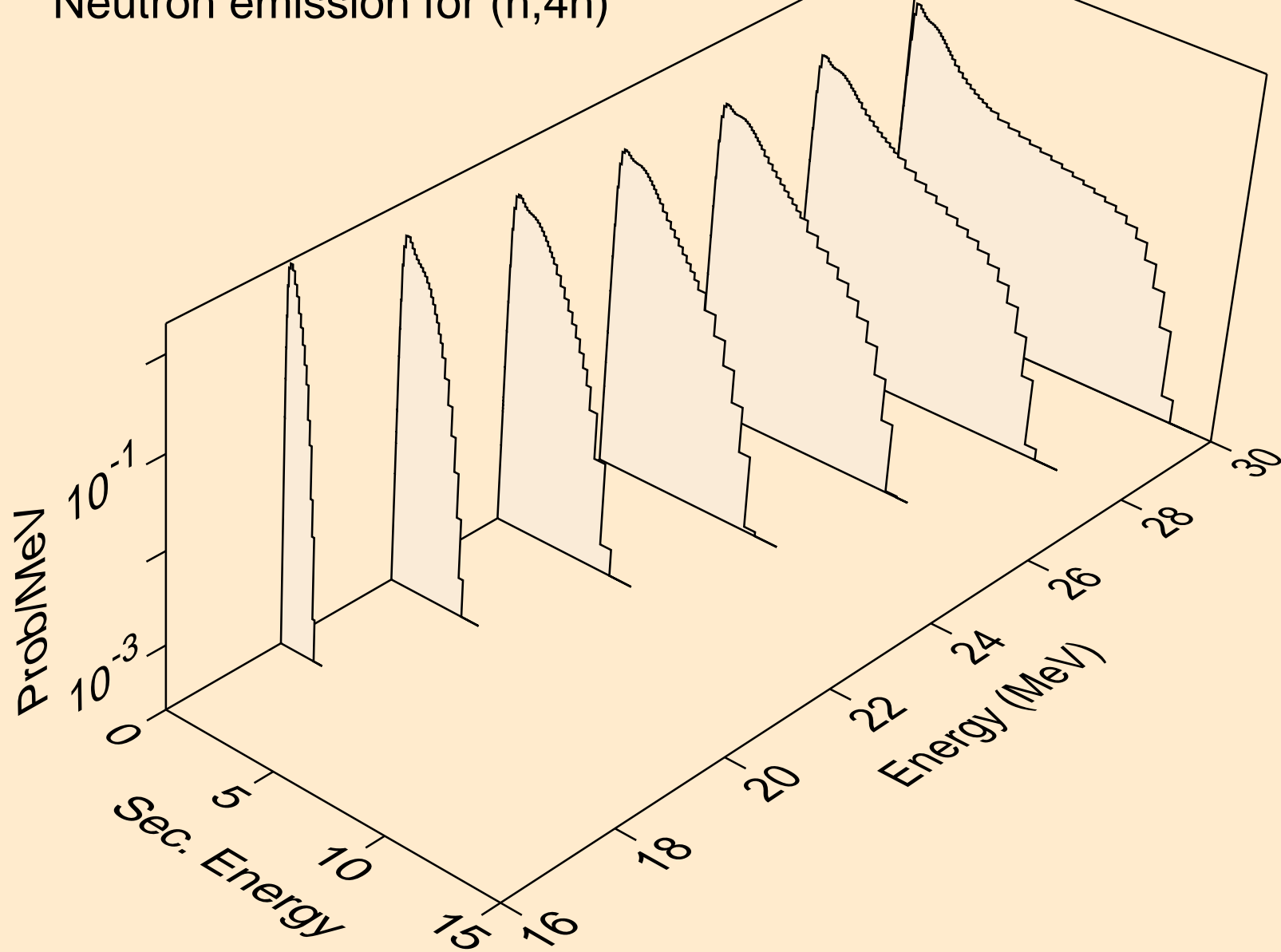

BK253 NEUTRON ACER TENDL-2024 LIBRARY; T=0.K  
Neutron emission for (n,2np)

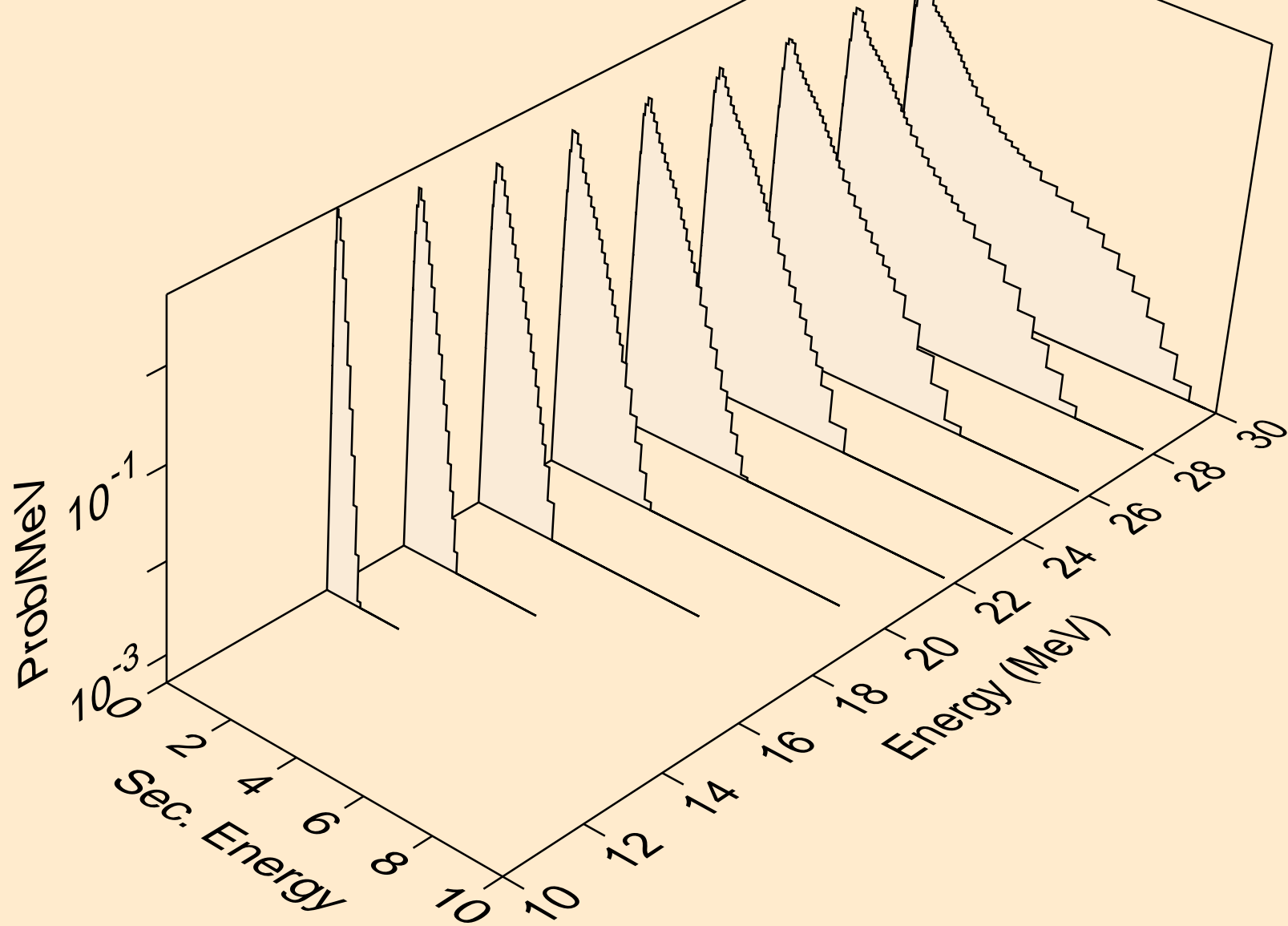

BK253 NEUTRON ACER TENDL-2024 LIBRARY; T=0.K  
Neutron emission for (n,3np)

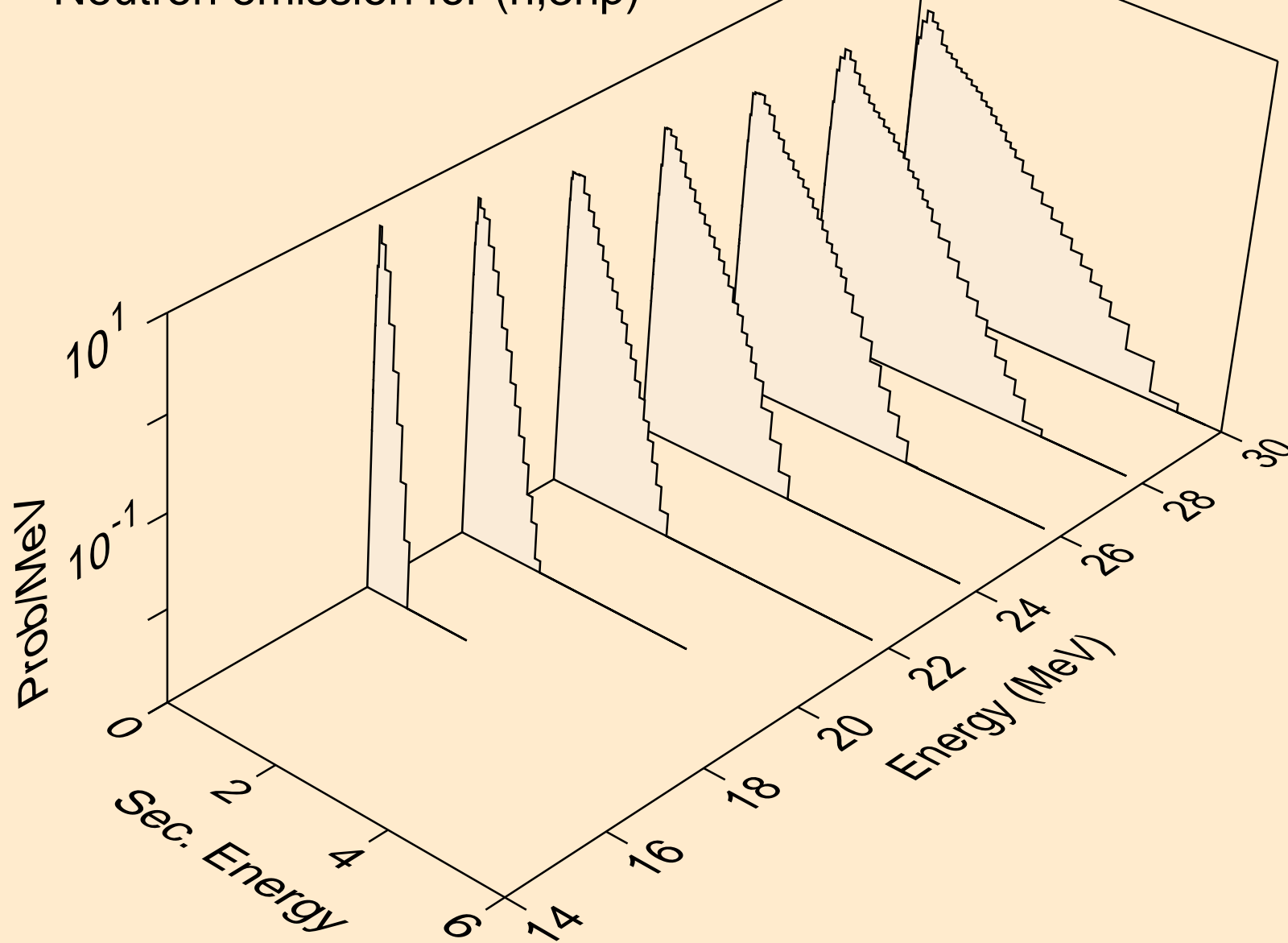

BK253 NEUTRON ACER TENDL-2024 LIBRARY; T=0.K  
Neutron emission for (n,n\*c)

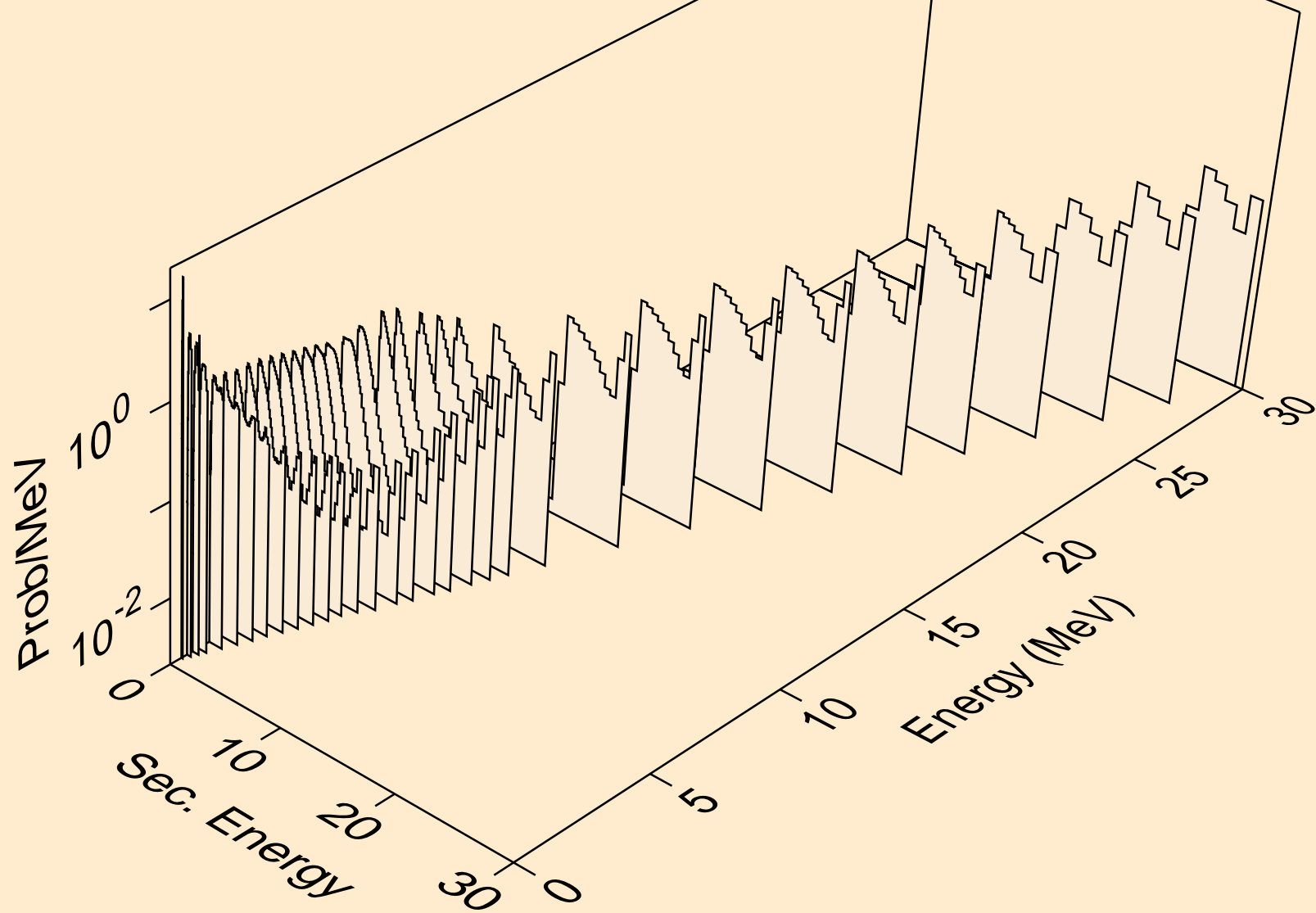

BK253 NEUTRON ACER TENDL-2024 LIBRARY; T=0.K

Delayed nubar

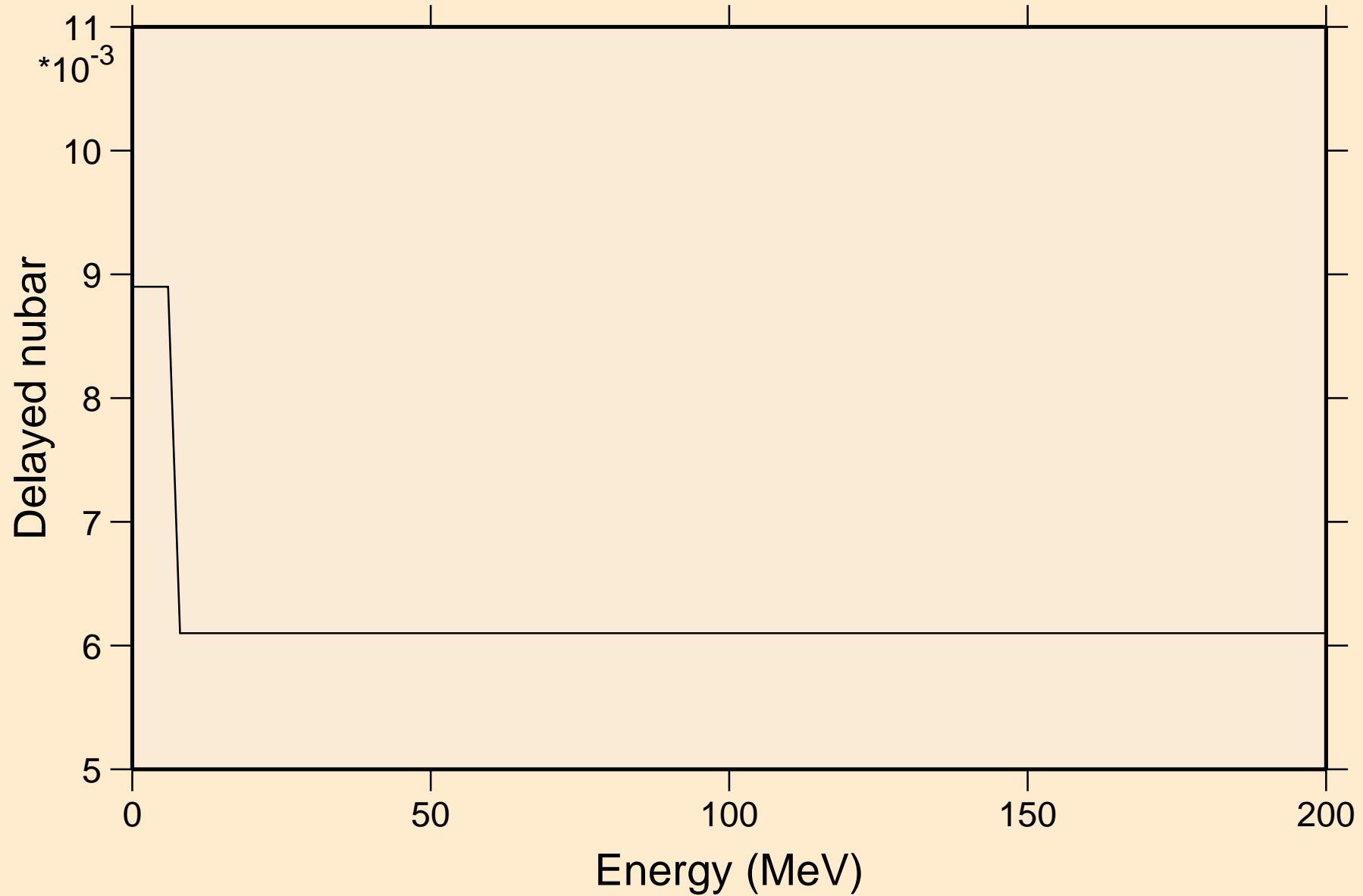

# BK253 NEUTRON ACER TENDL-2024 LIBRARY; T=0.K

## Delayed neutron spectra

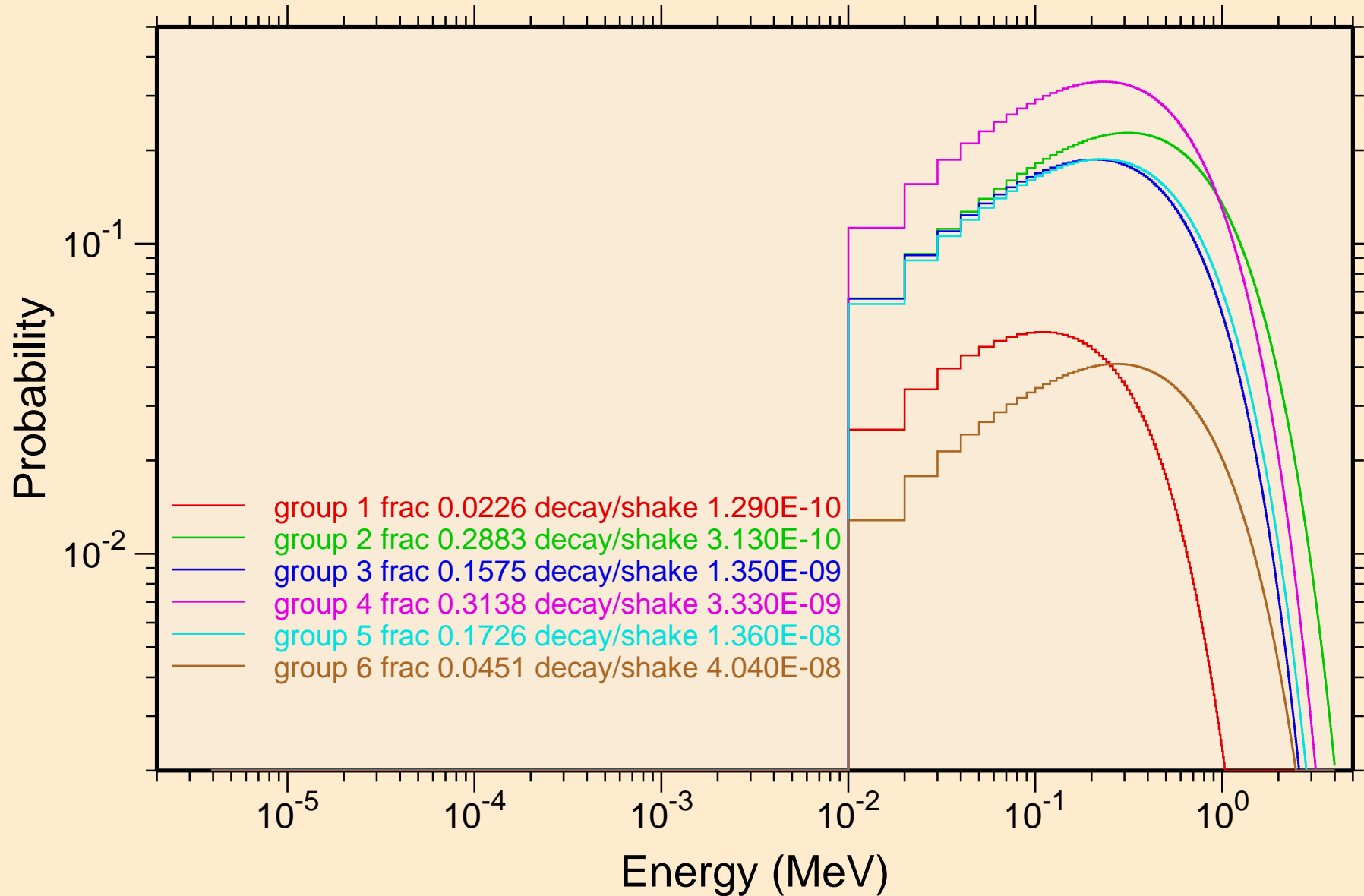

BK253 NEUTRON ACER TENDL-2024 LIBRARY; T=0.K  
Photon emission for (n,x)

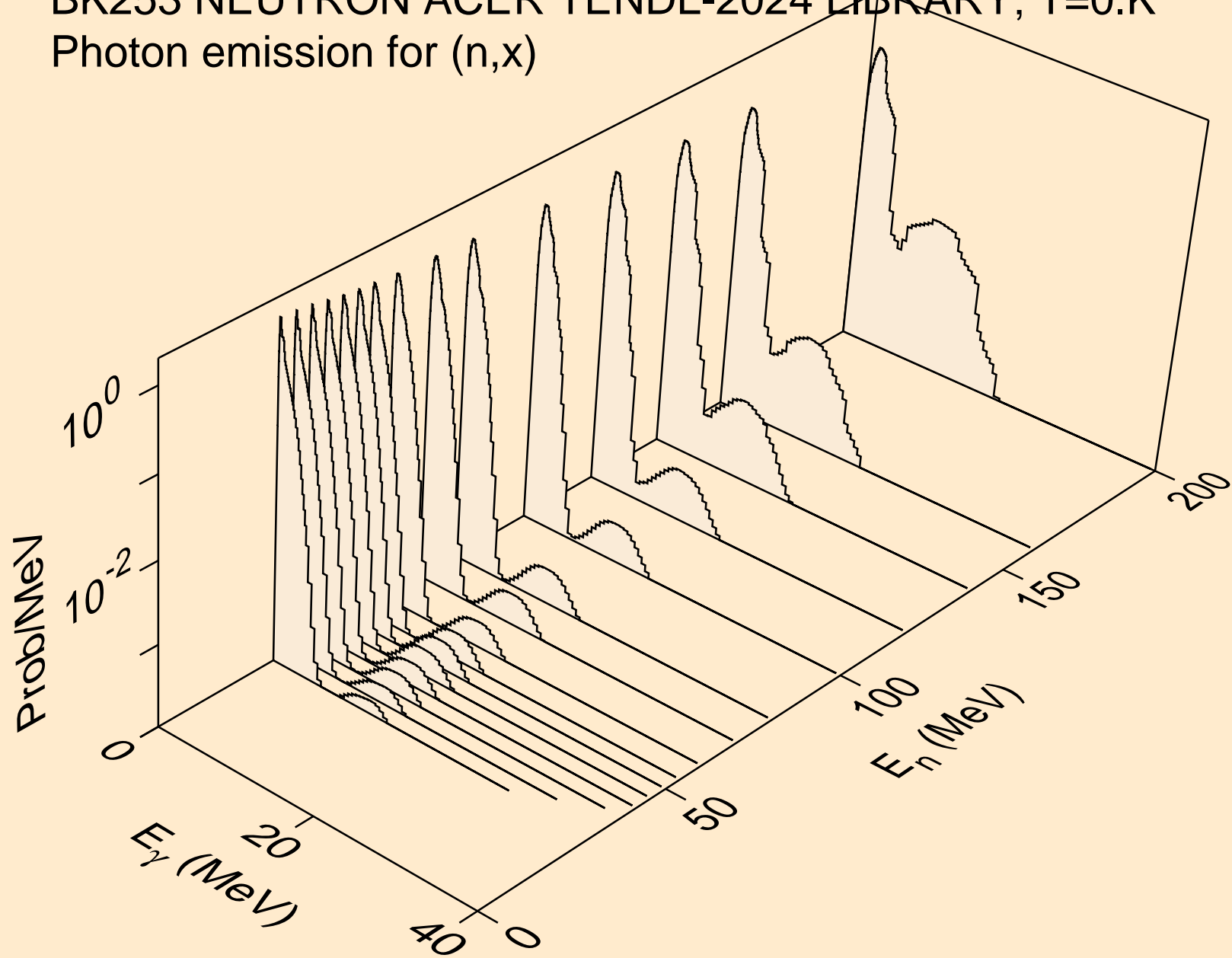

BK253 NEUTRON ACER TENDL-2024 LIBRARY; T=0.K  
Photon emission for (n,2nd)

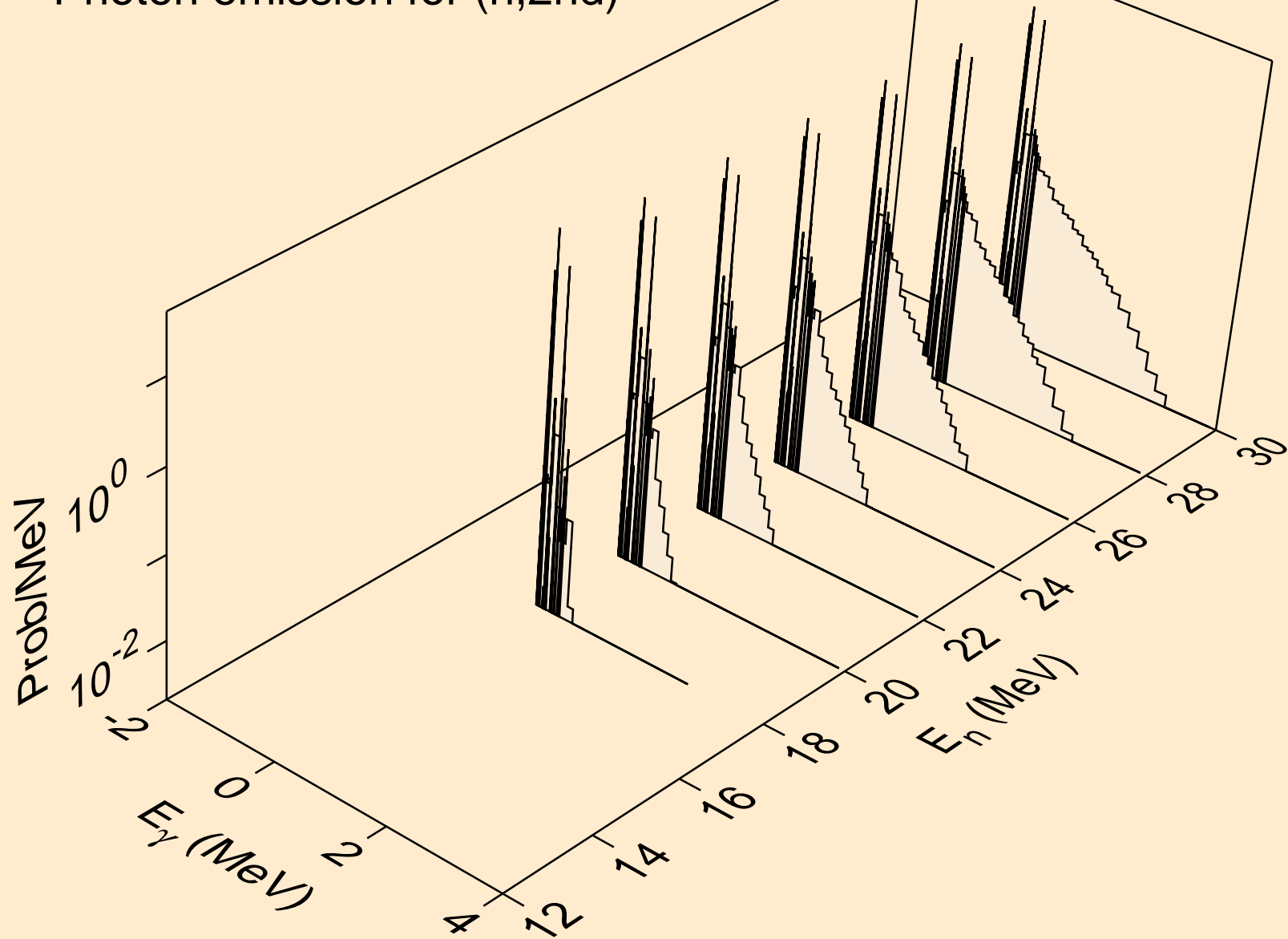

BK253 NEUTRON ACER TENDL-2024 LIBRARY; T=0.K  
Photon emission for (n,2n)

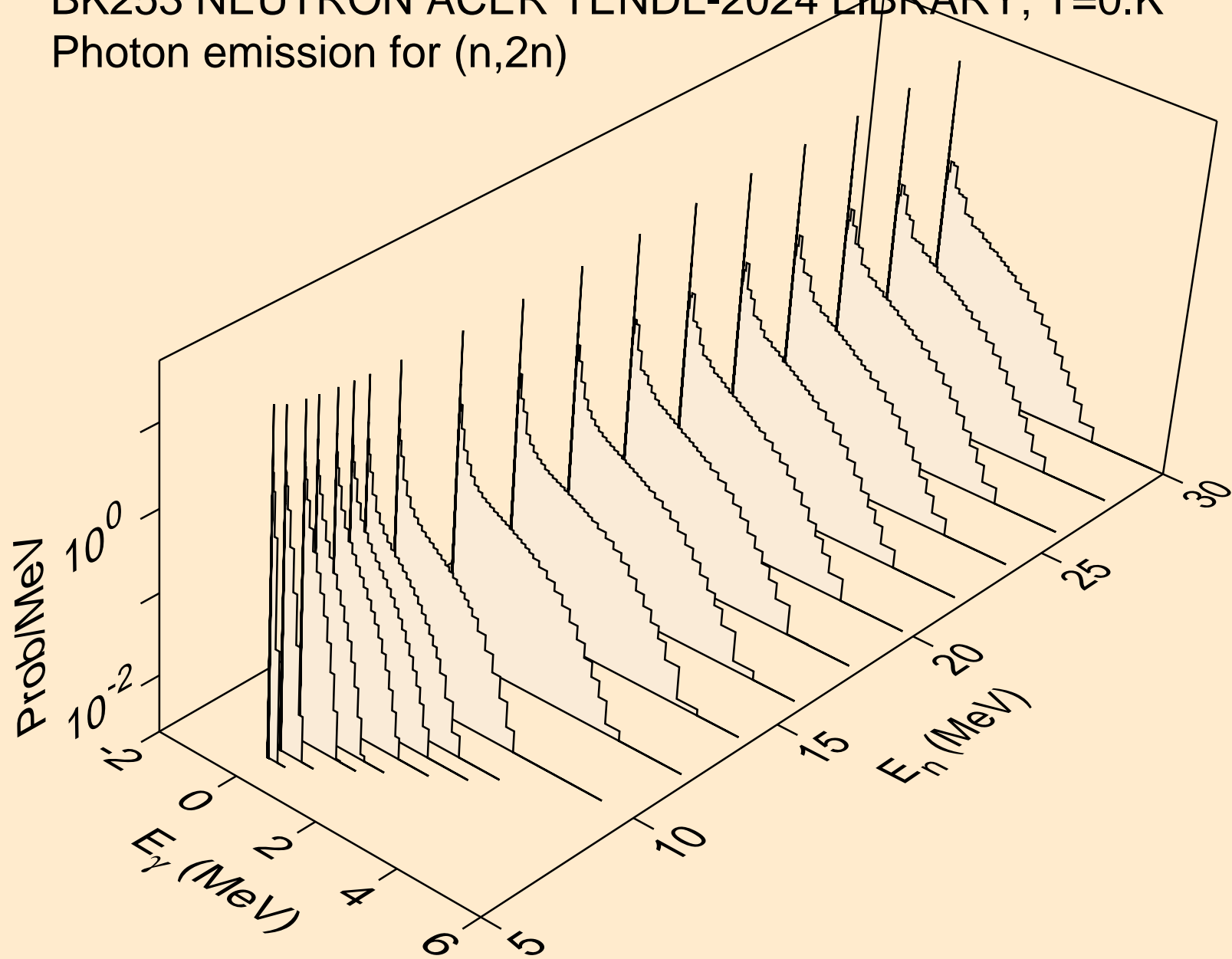

BK253 NEUTRON ACER TENDL-2024 LIBRARY; T=0.K  
Photon emission for (n,3n)

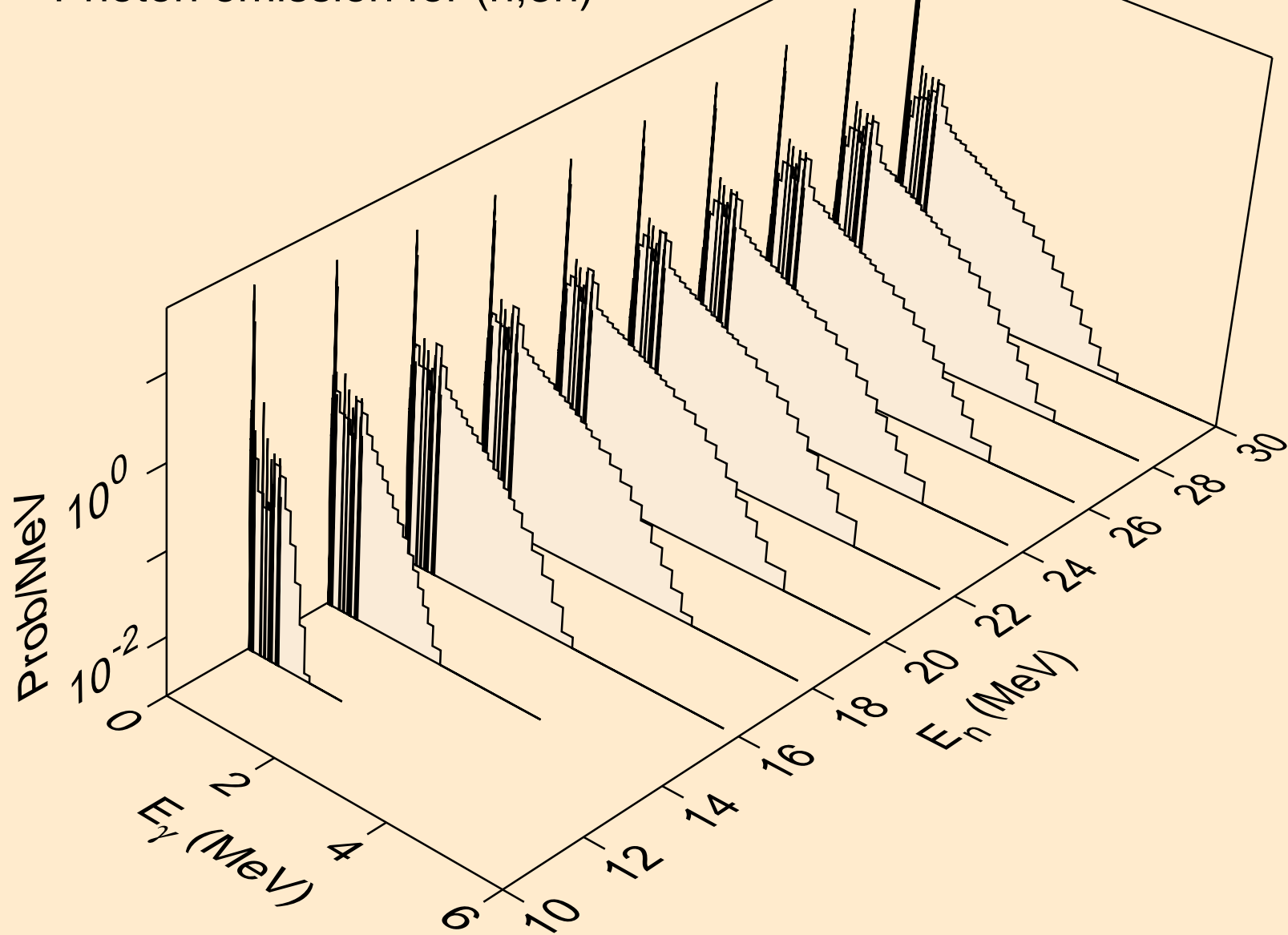

BK253 NEUTRON ACER TENDL-2024 LIBRARY; T=0.K  
Photon emission for (n,n\*)a

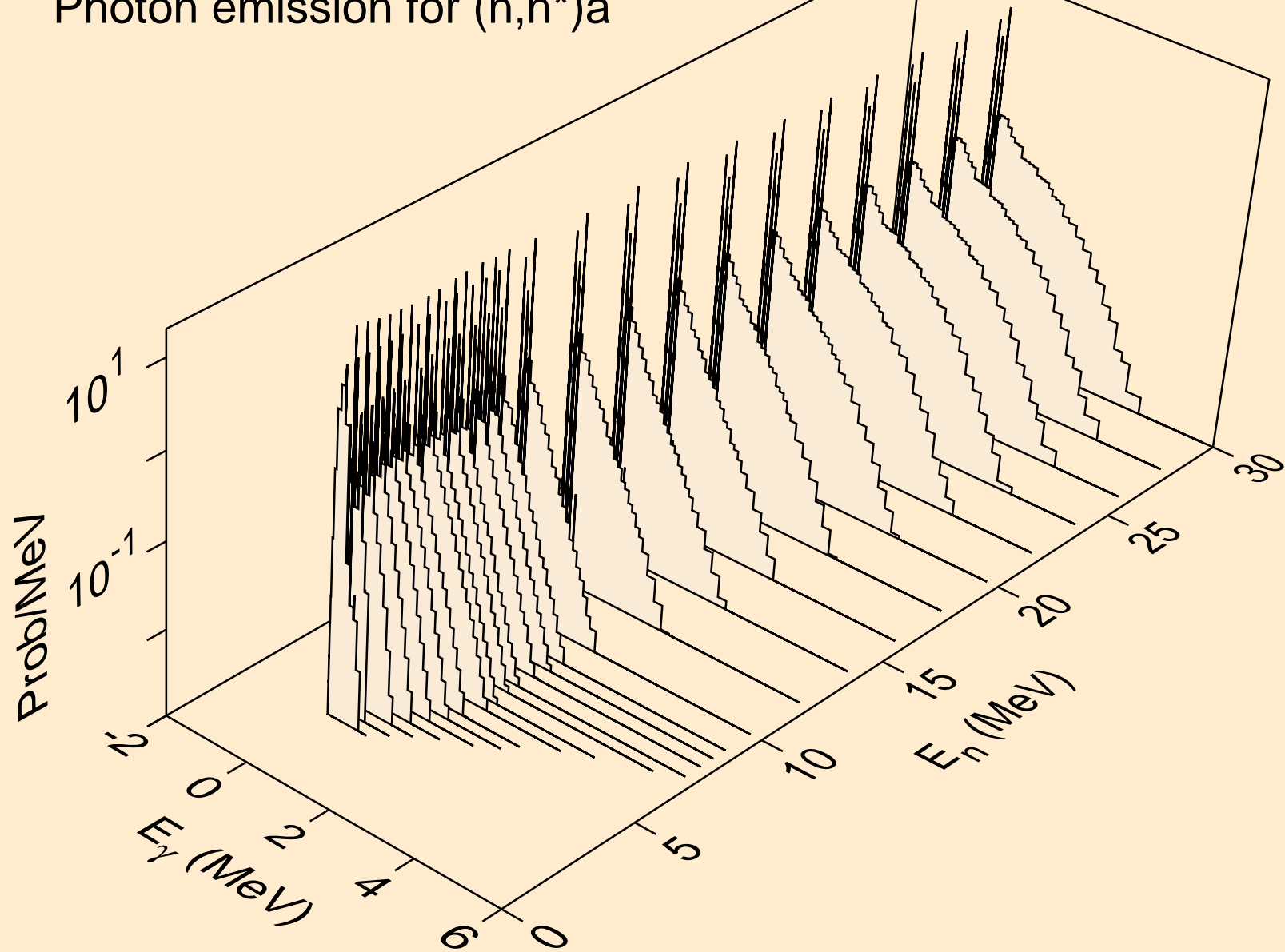

BK253 NEUTRON ACER TENDL-2024 LIBRARY; T=0.K  
Photon emission for (n,2n)a

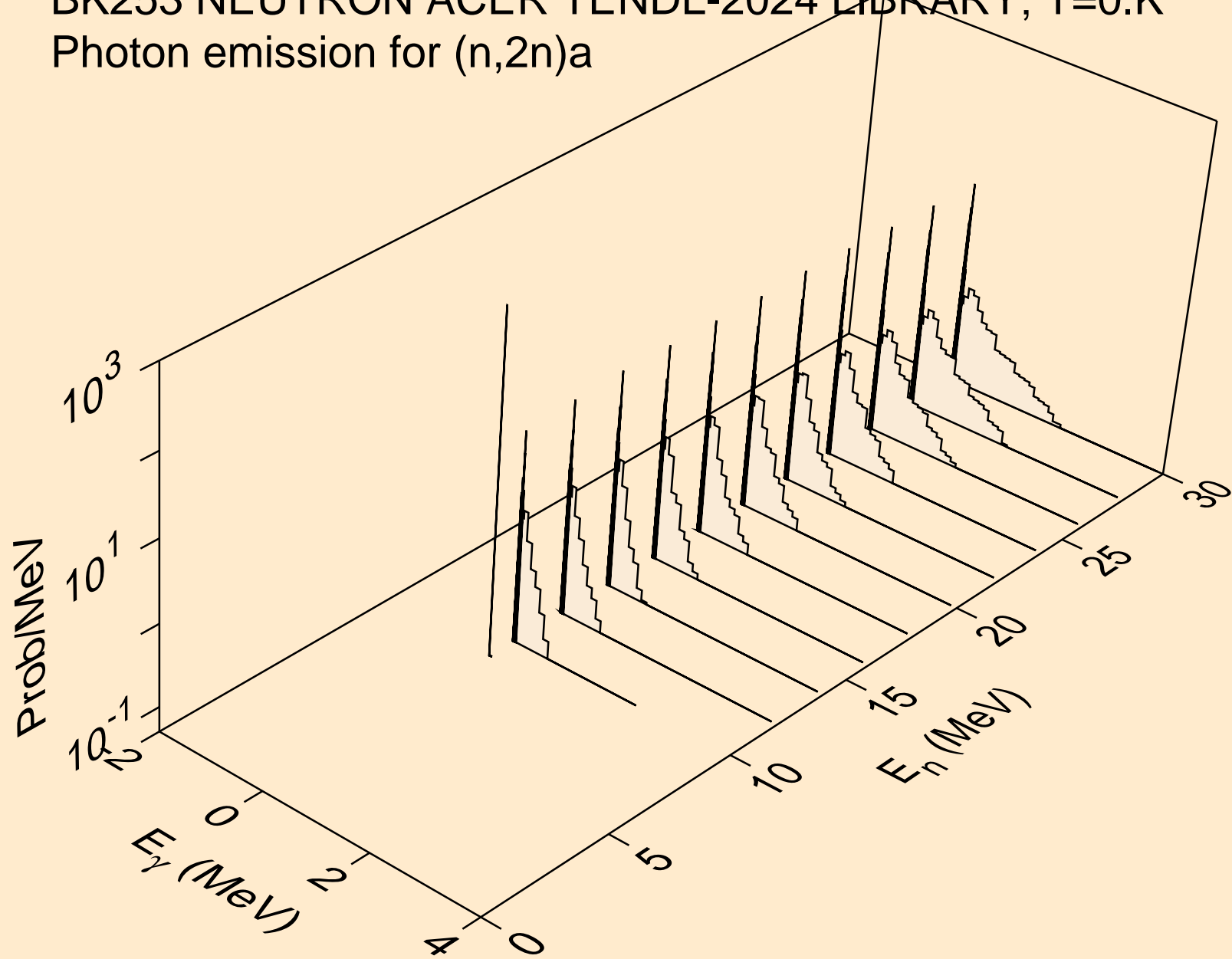

BK253 NEUTRON ACER TENDL-2024 LIBRARY; T=0.K  
Photon emission for (n,3n)a

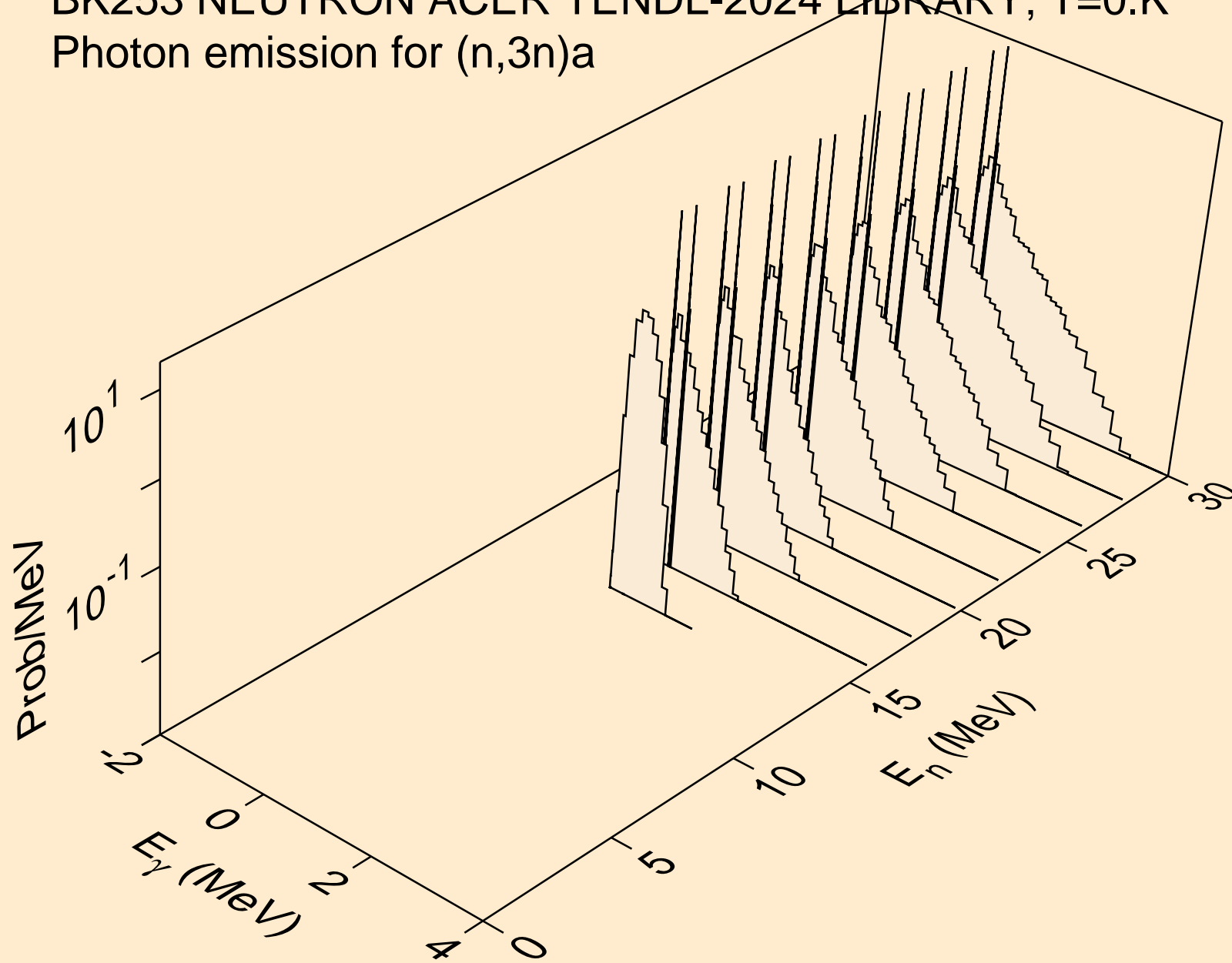

BK253 NEUTRON ACER TENDL-2024 LIBRARY; T=0.K  
Photon emission for (n,n\*)p

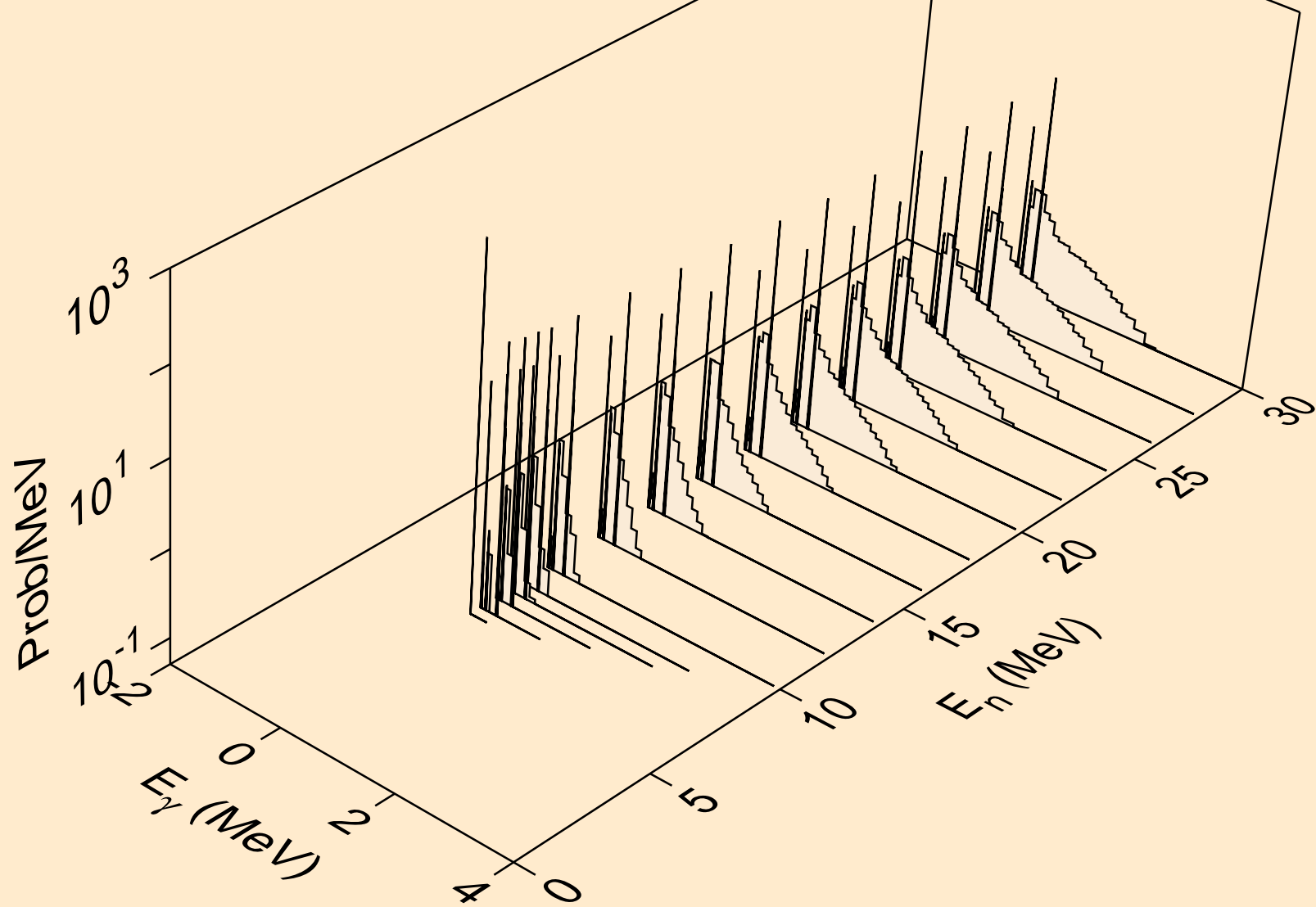

BK253 NEUTRON ACER TENDL-2024 LIBRARY; T=0.K  
Photon emission for (n,n\*)d

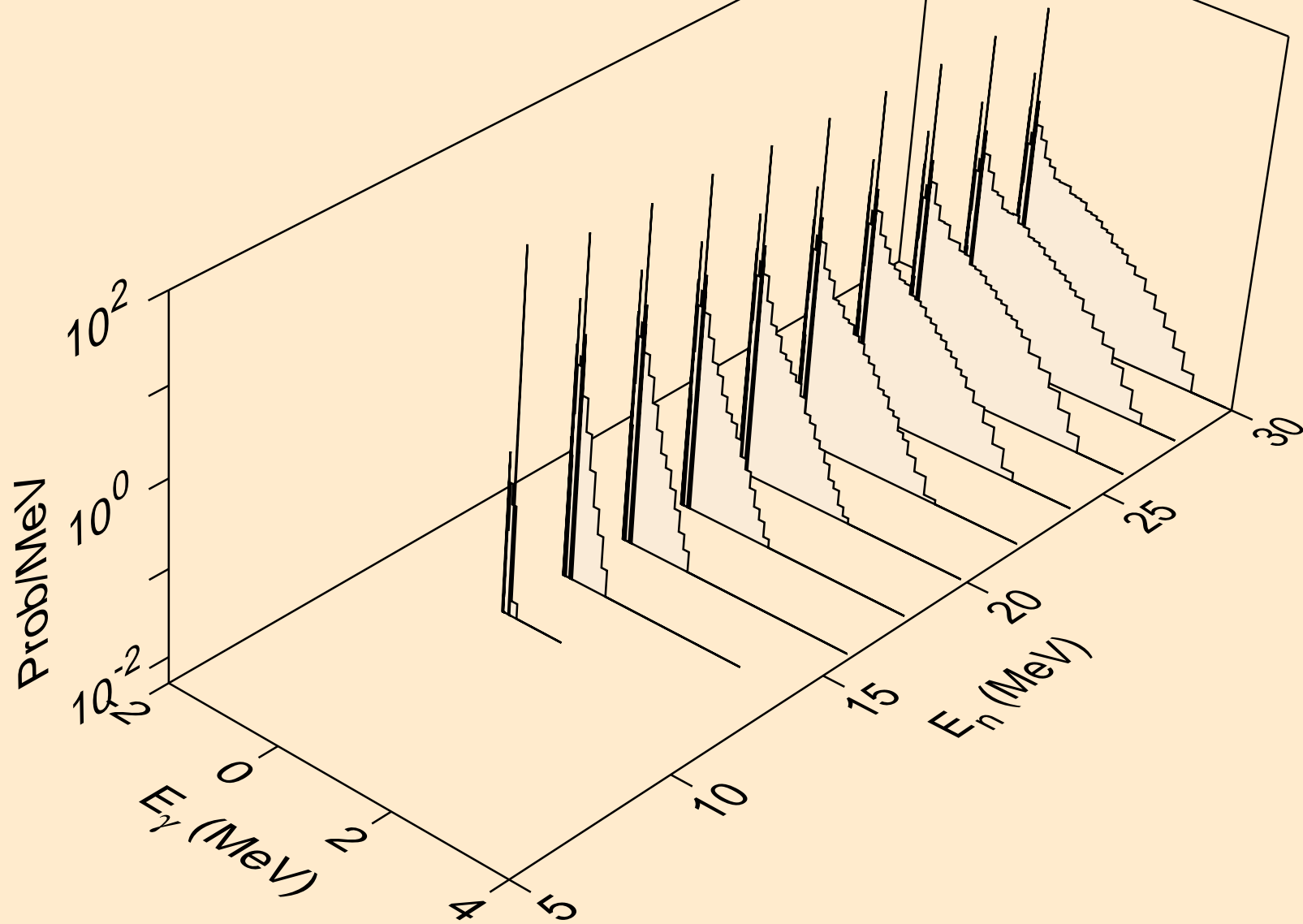

BK253 NEUTRON ACER TENDL-2024 LIBRARY; T=0.K  
Photon emission for (n,n\*)t

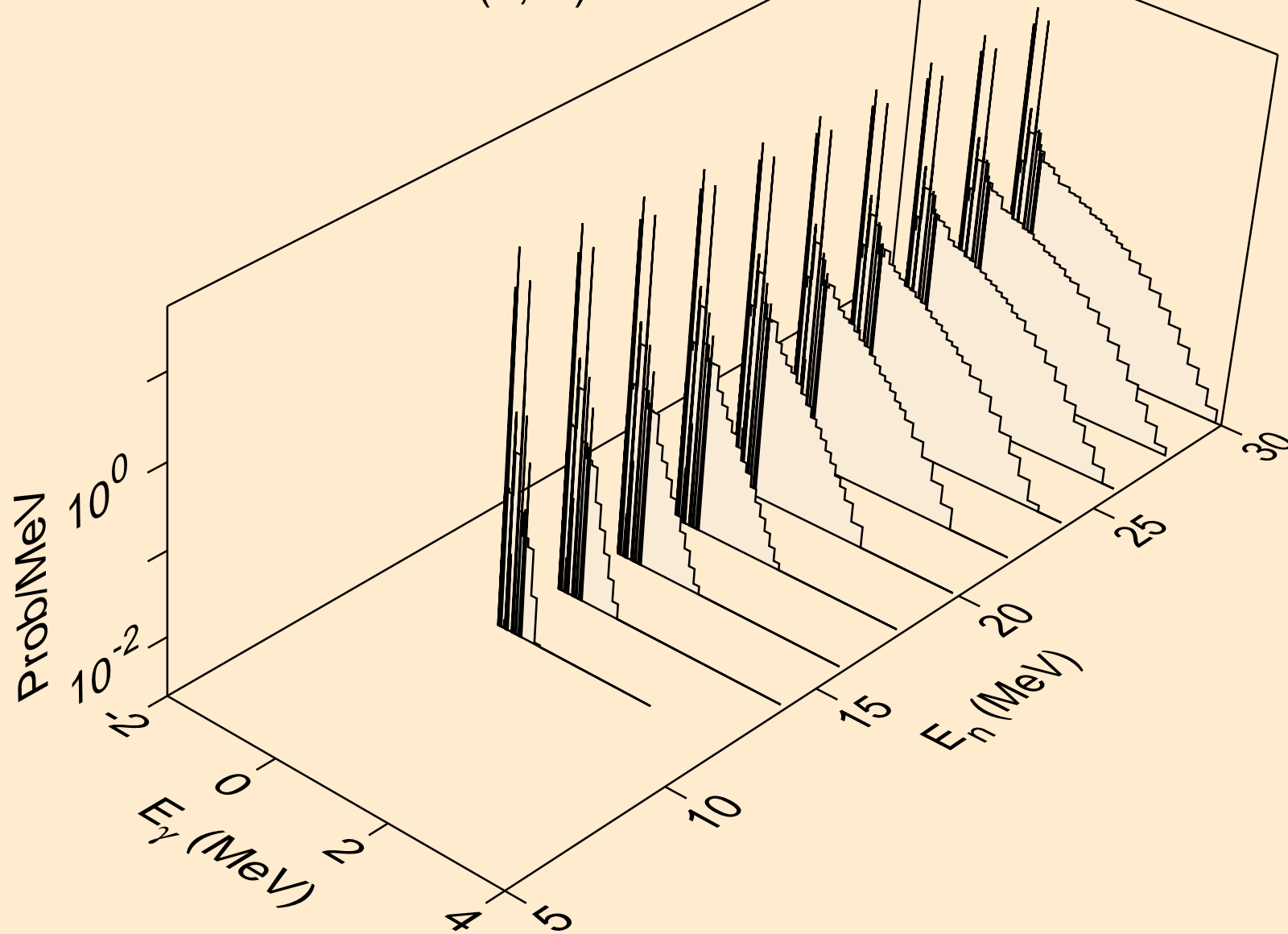

BK253 NEUTRON ACER TENDL-2024 LIBRARY; T=0.K  
Photon emission for (n,n\*)he3

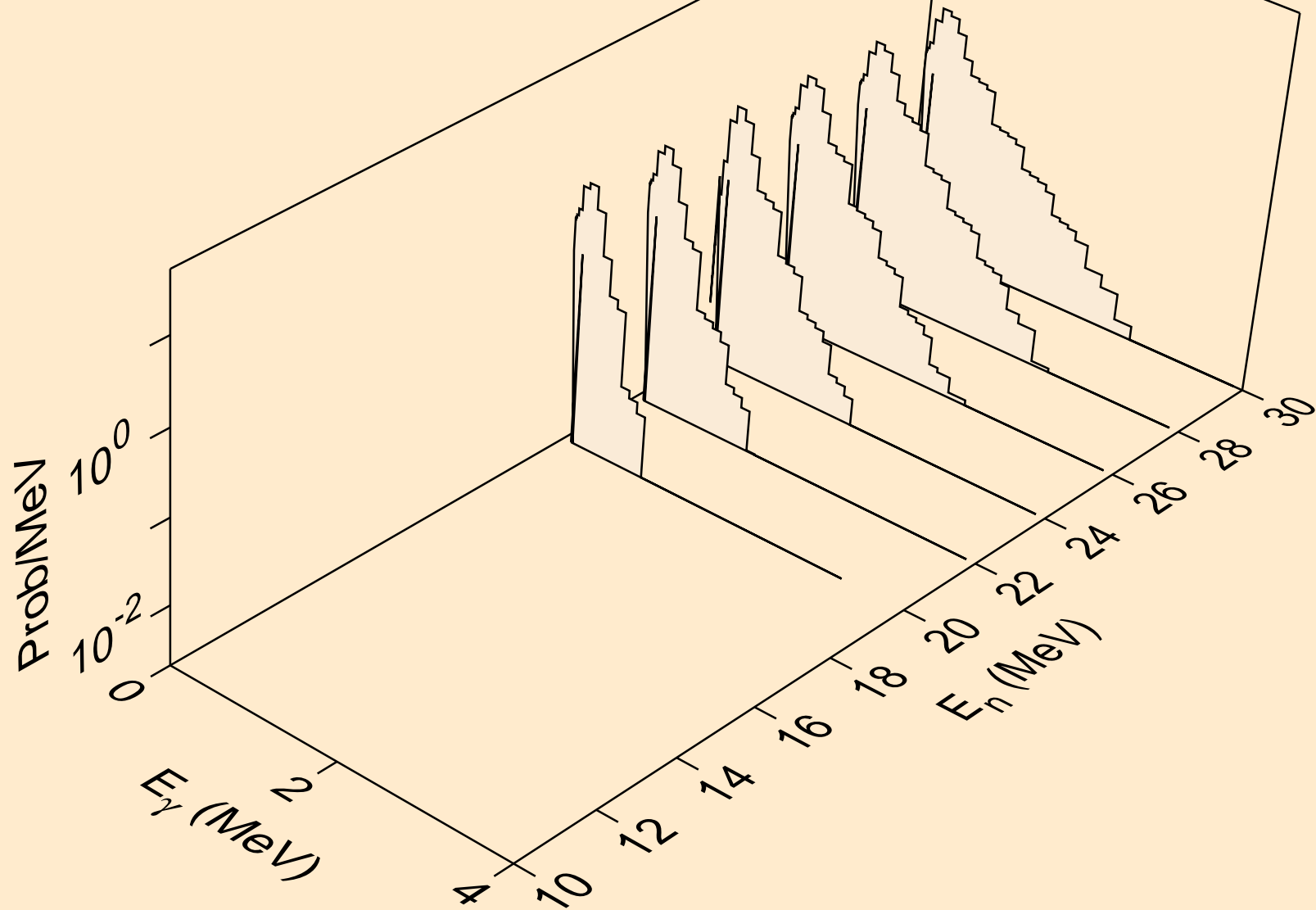

BK253 NEUTRON ACER TENDL-2024 LIBRARY; T=0.K  
Photon emission for (n,4n)

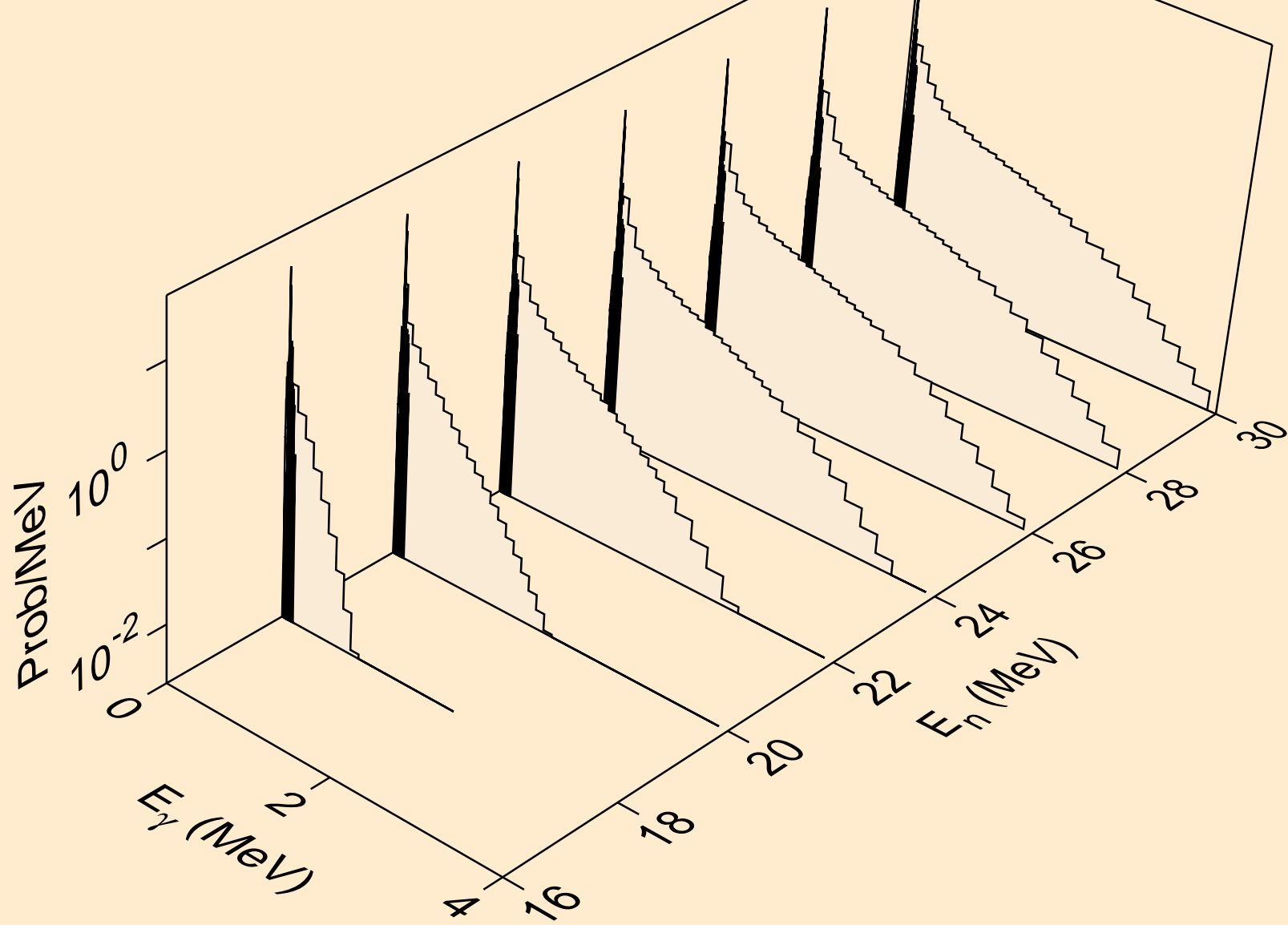

BK253 NEUTRON ACER TENDL-2024 LIBRARY; T=0.K  
Photon emission for (n,2np)

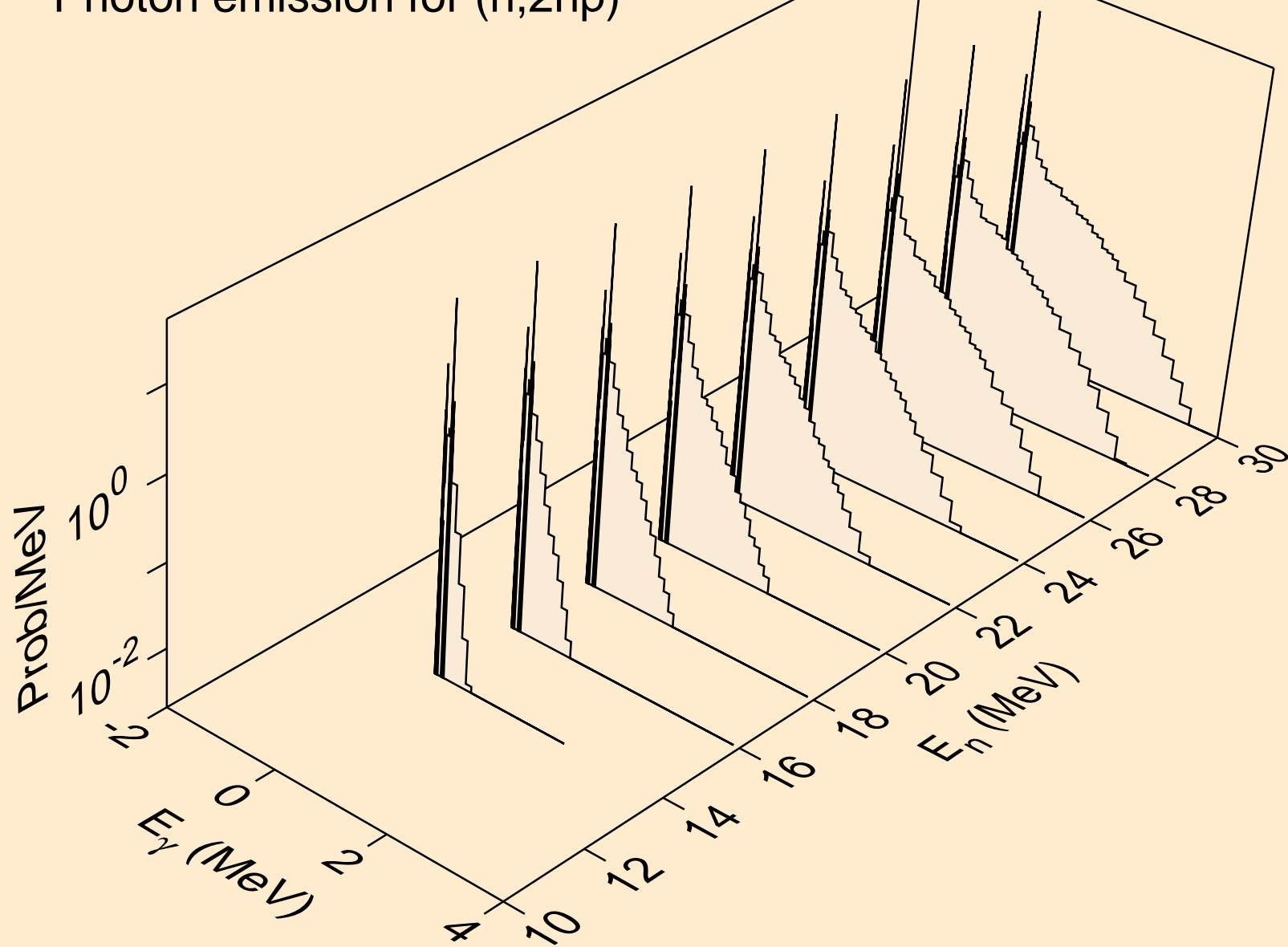

BK253 NEUTRON ACER TENDL-2024 LIBRARY; T=0.K  
Photon emission for (n,3np)

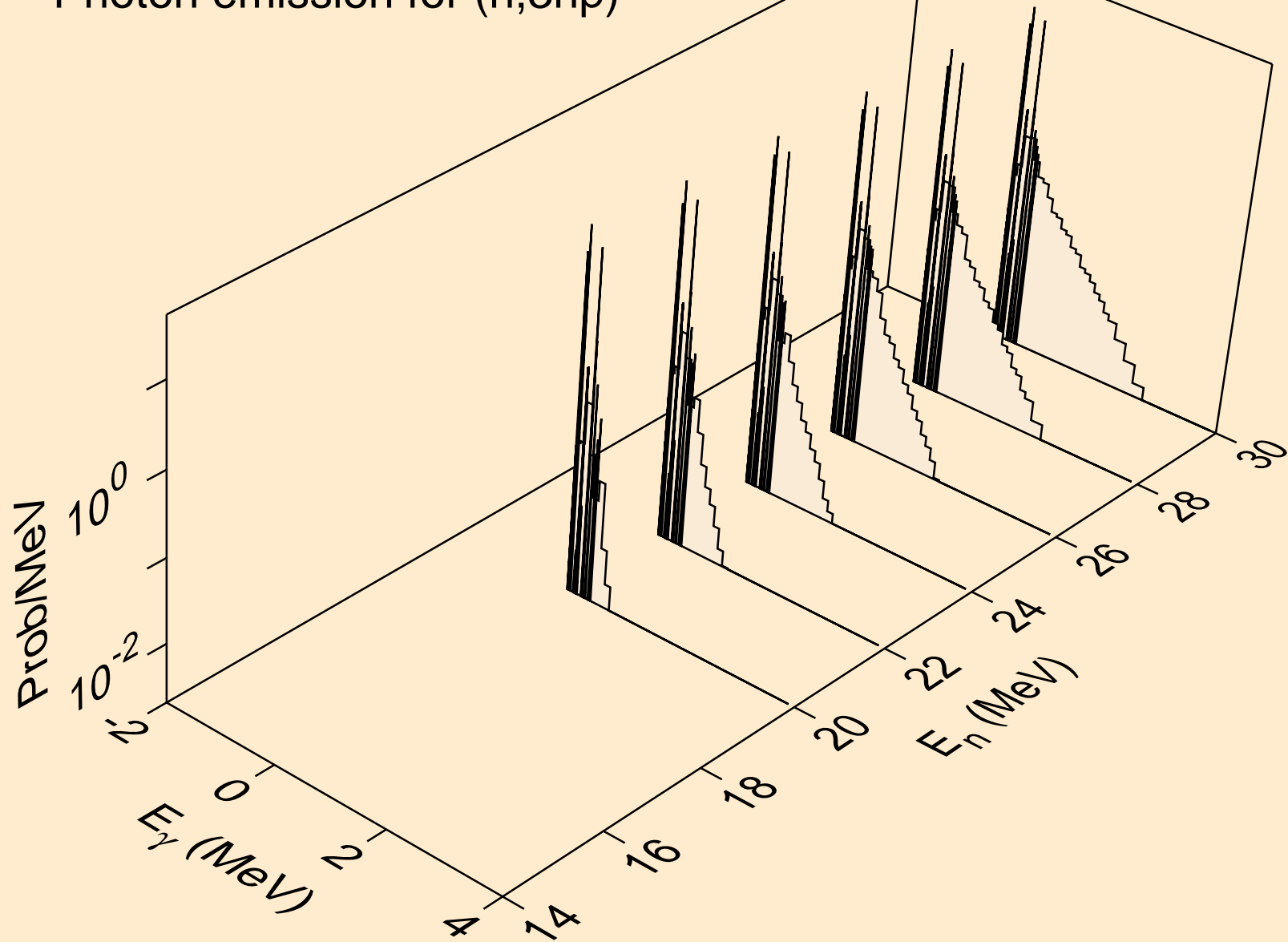

BK253 NEUTRON ACER TENDL-2024 LIBRARY; T=0.K  
Photon emission for (n,n\*c)

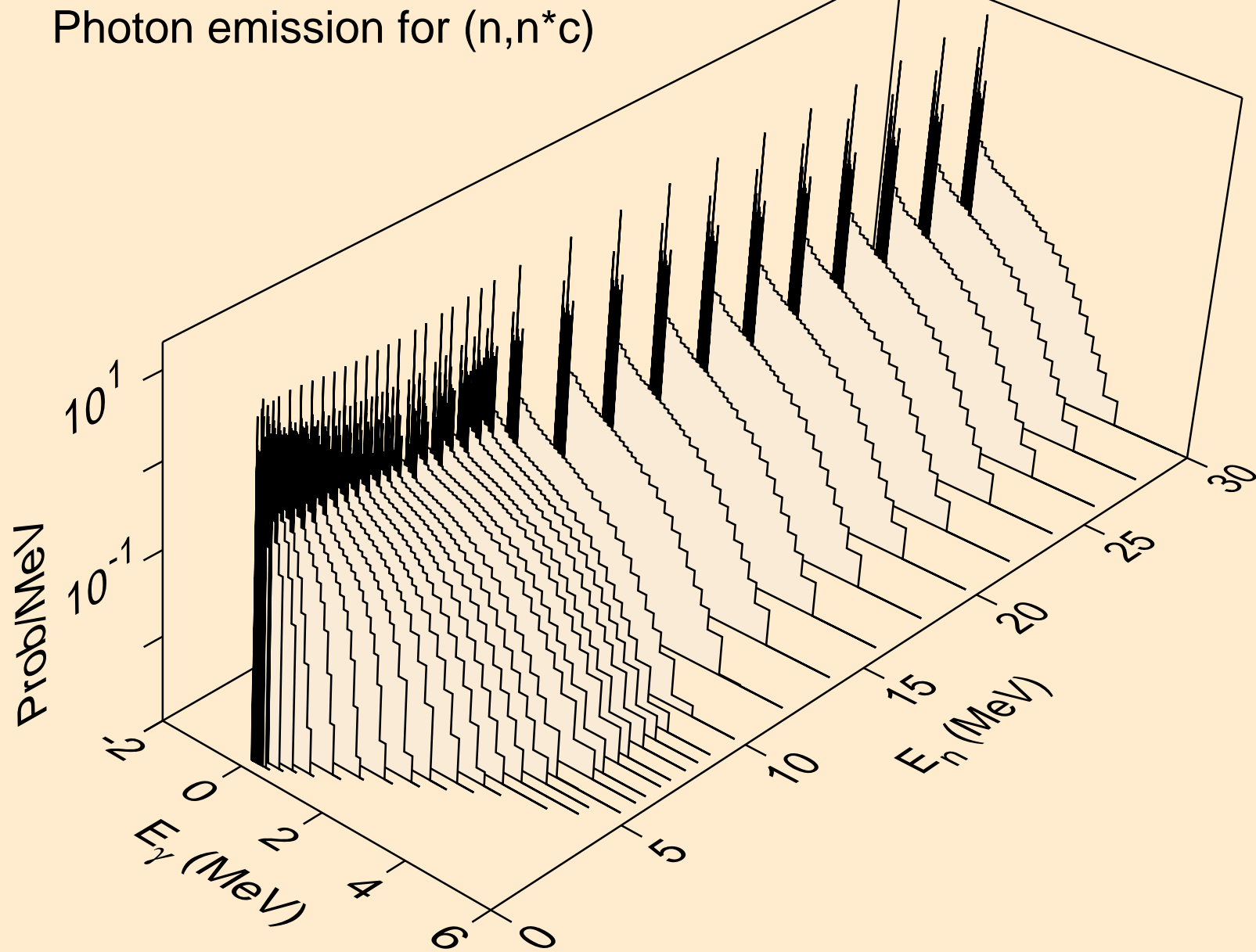

BK253 NEUTRON ACER TENDL-2024 LIBRARY; T=0.K  
Photon emission for (n,gma)

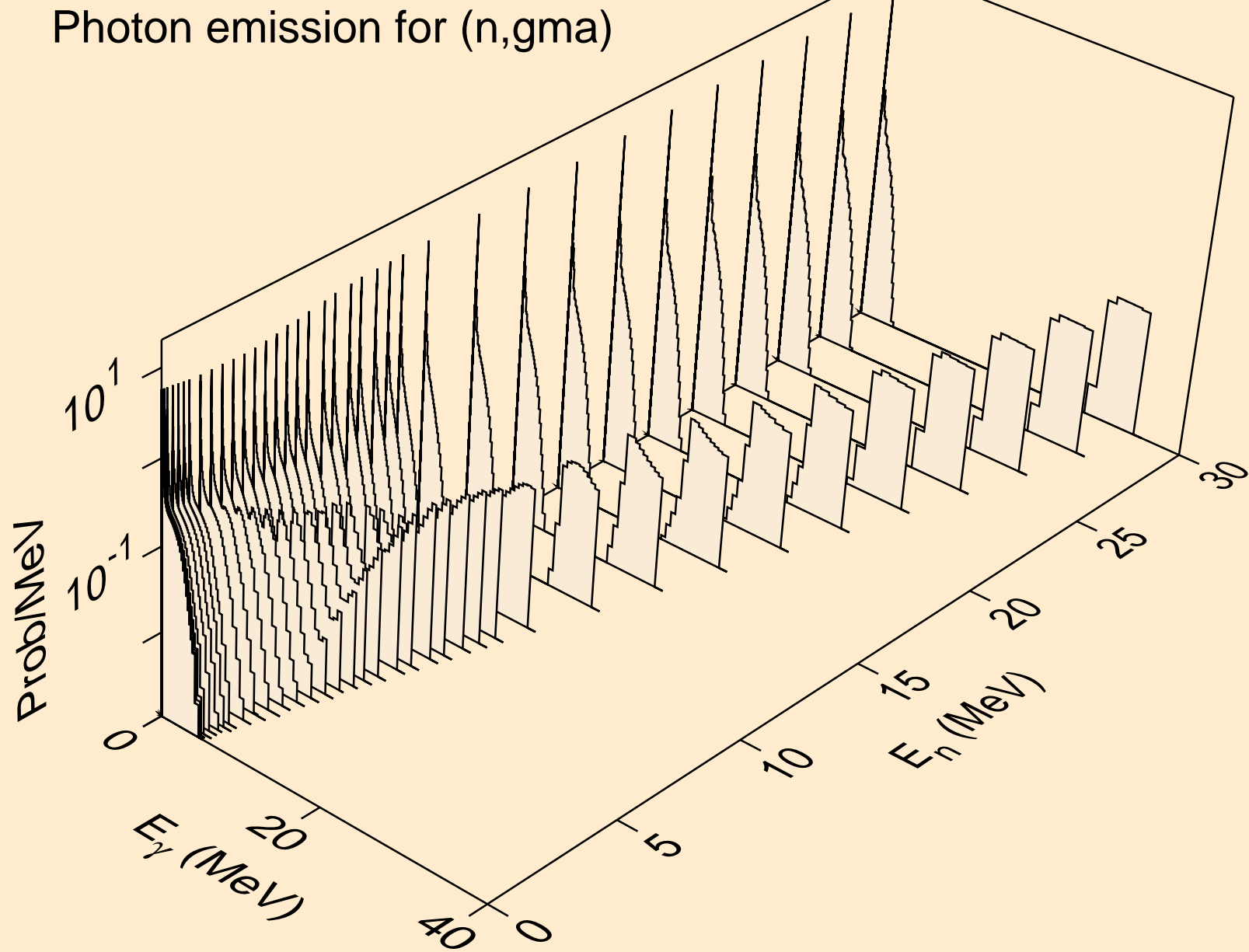

BK253 NEUTRON ACER TENDL-2024 LIBRARY; T=0.K  
Photon emission for (n,p)

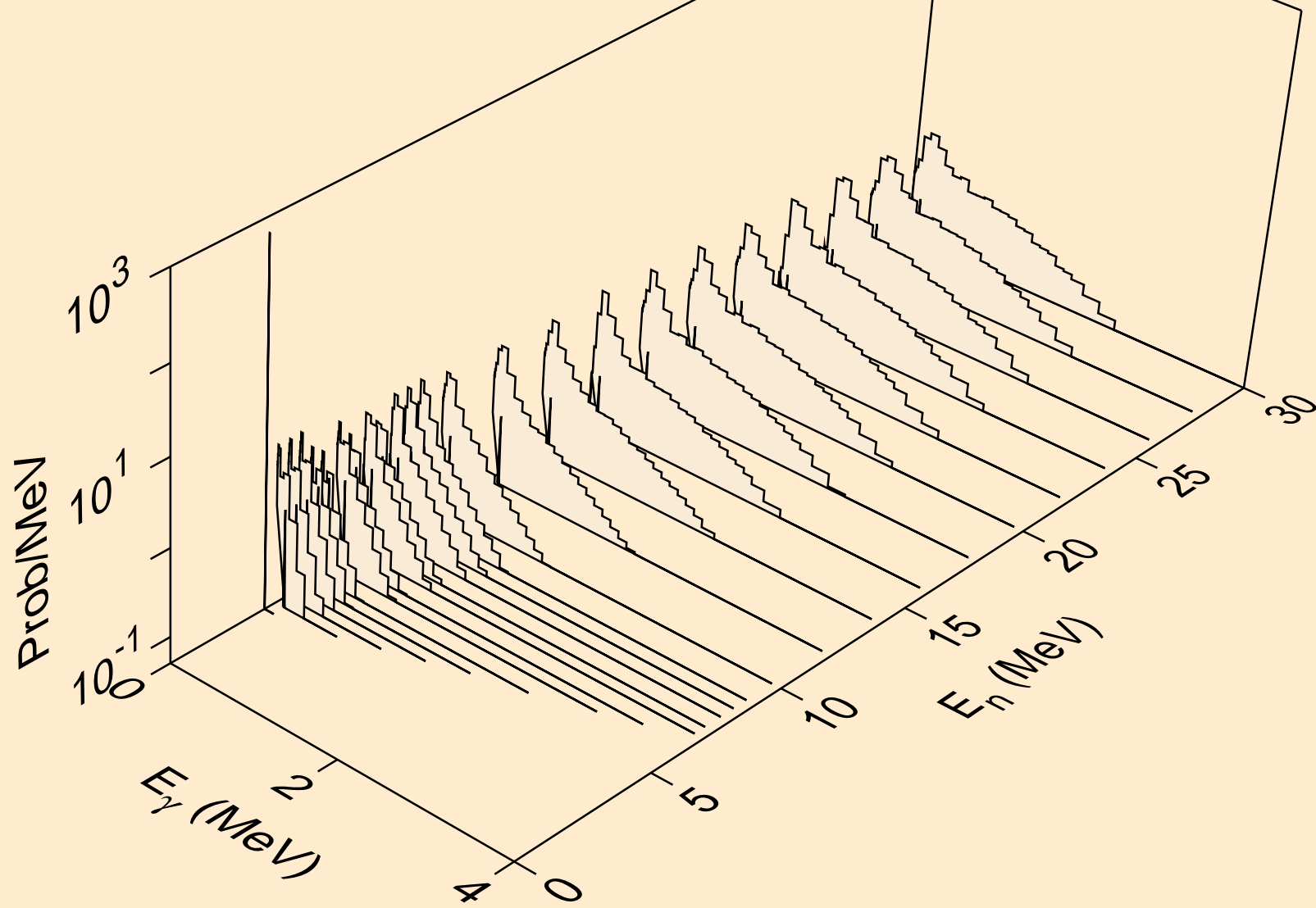

BK253 NEUTRON ACER TENDL-2024 LIBRARY; T=0.K  
Photon emission for (n,d)

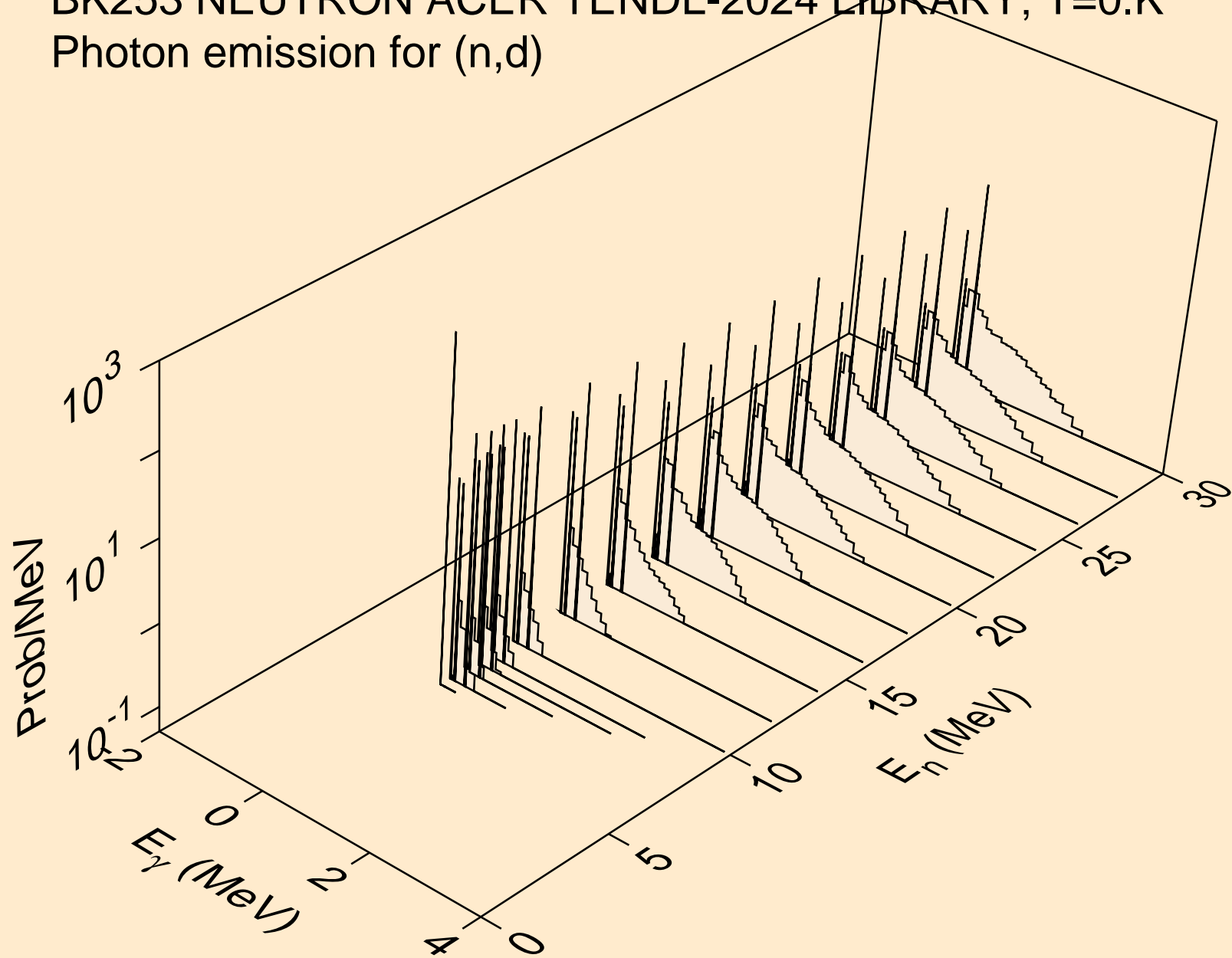

BK253 NEUTRON ACER TENDL-2024 LIBRARY; T=0.K  
Photon emission for (n,t)

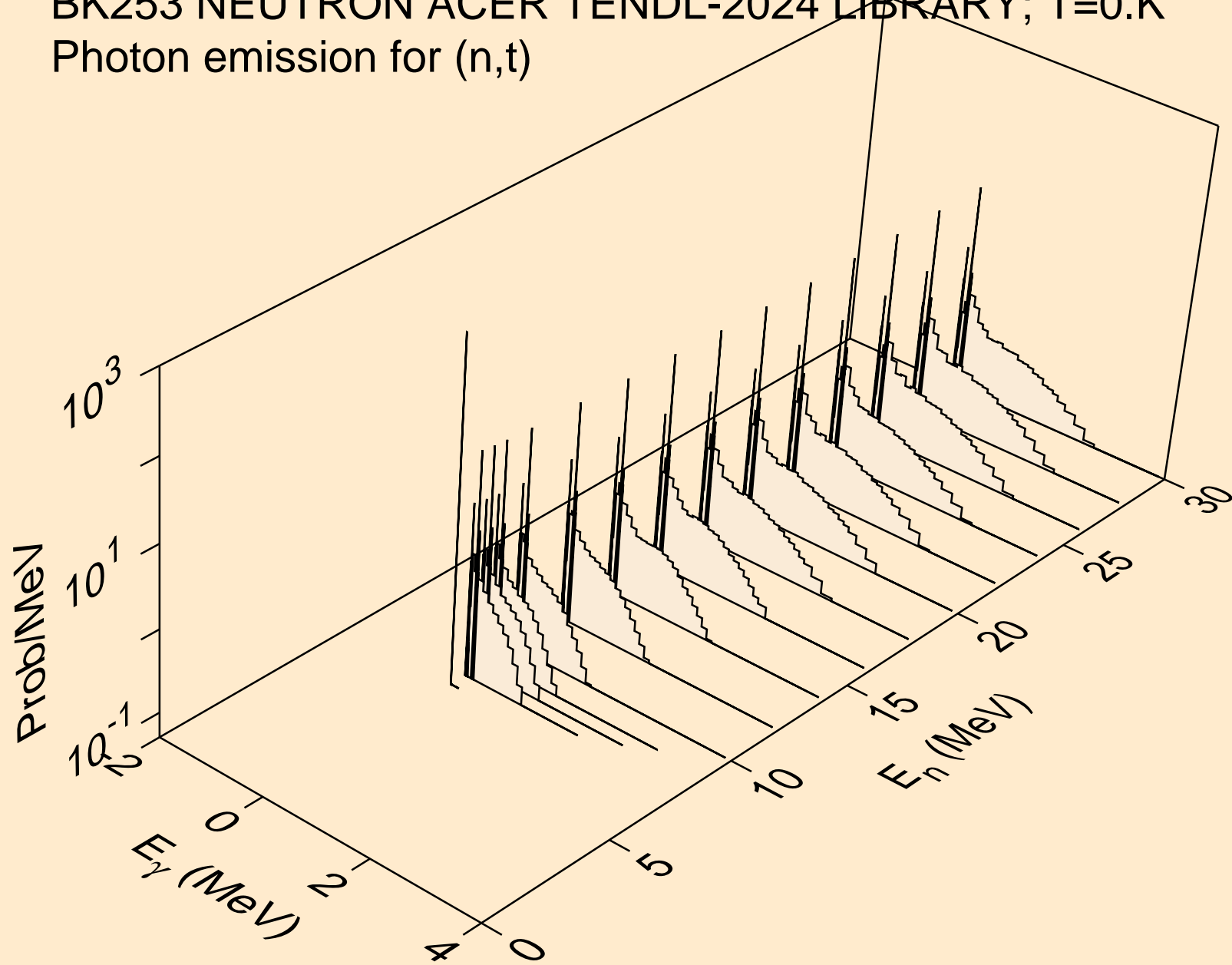

BK253 NEUTRON ACER TENDL-2024 LIBRARY; T=0.K  
Photon emission for (n,he3)

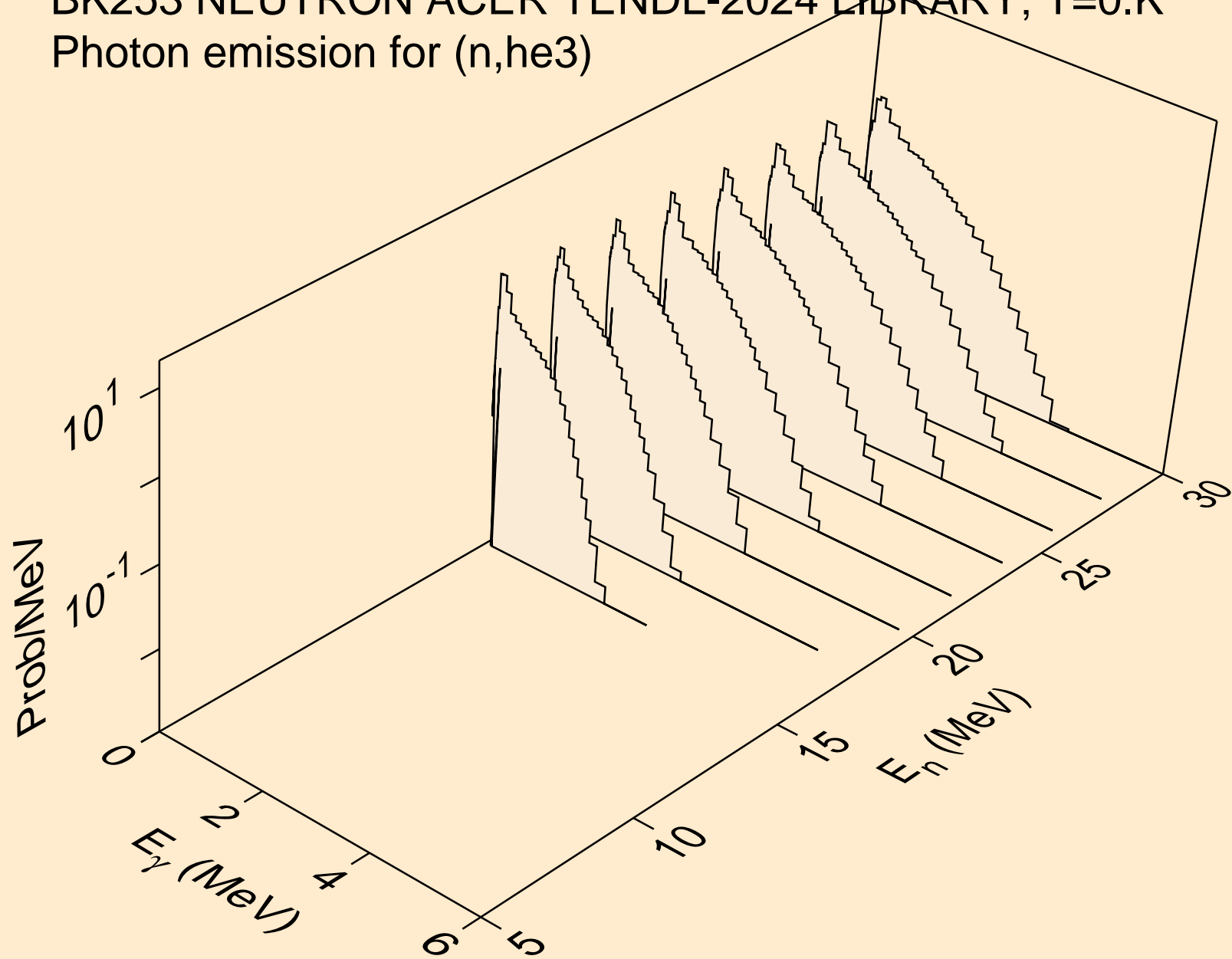

BK253 NEUTRON ACER TENDL-2024 LIBRARY; T=0.K  
Photon emission for (n,a)

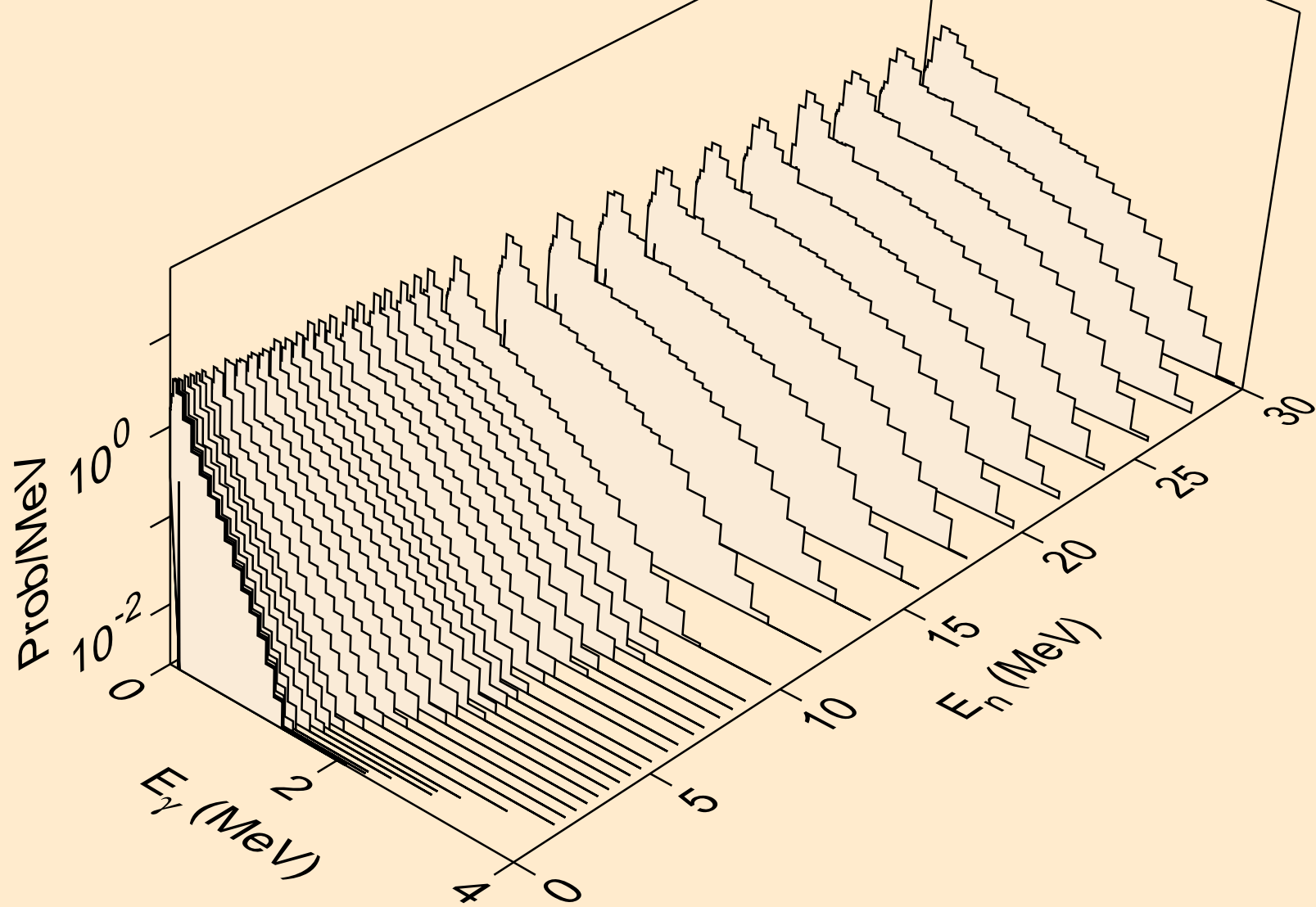

BK253 NEUTRON ACER TENDL-2024 LIBRARY; T=0.K  
Photon emission for (n,2p)

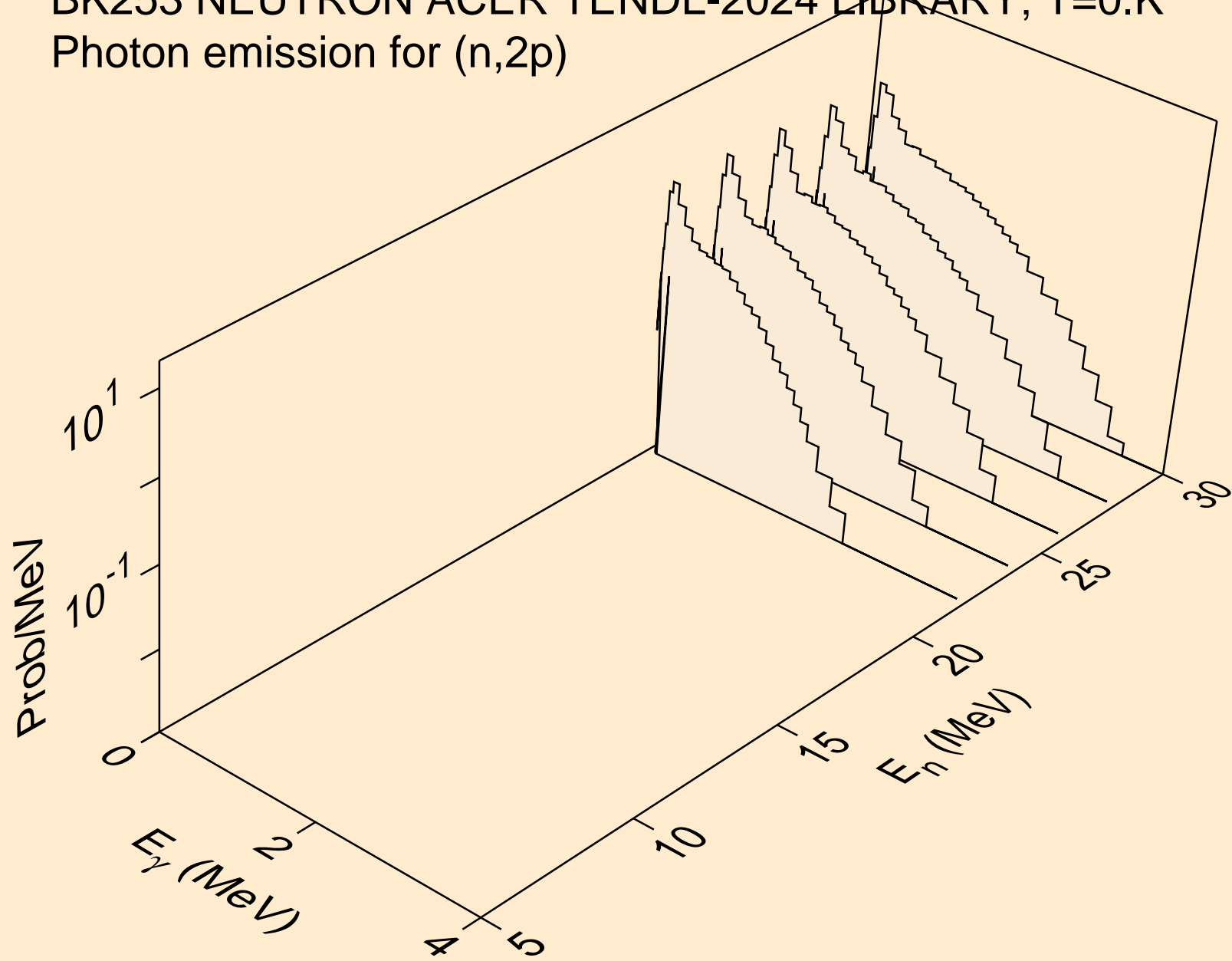

BK253 NEUTRON ACER TENDL-2024 LIBRARY; T=0.K  
thermal capture photon spectrum

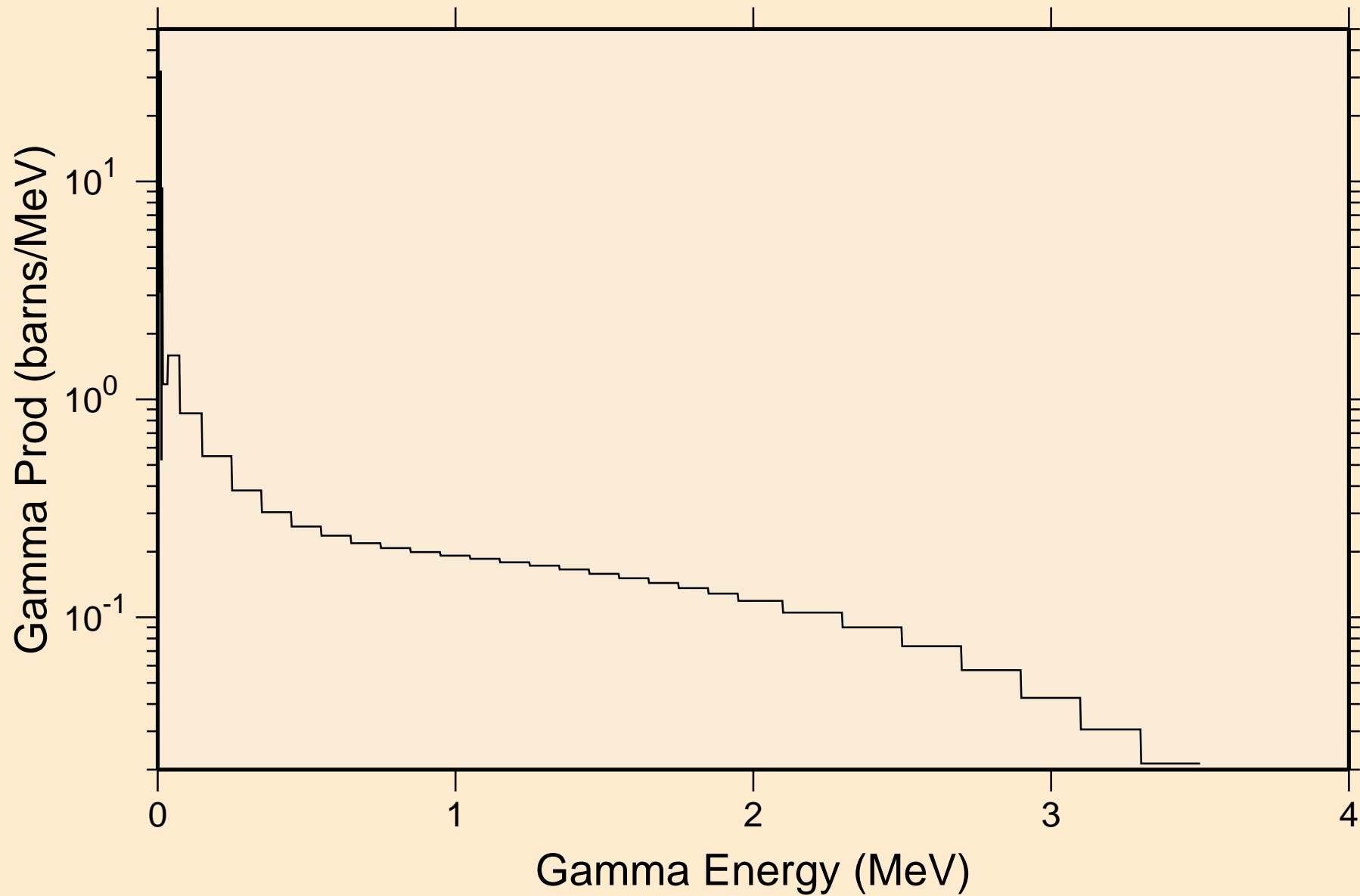

BK253 NEUTRON ACER TENDL-2024 LIBRARY; T=0.K  
14 MeV photon spectrum

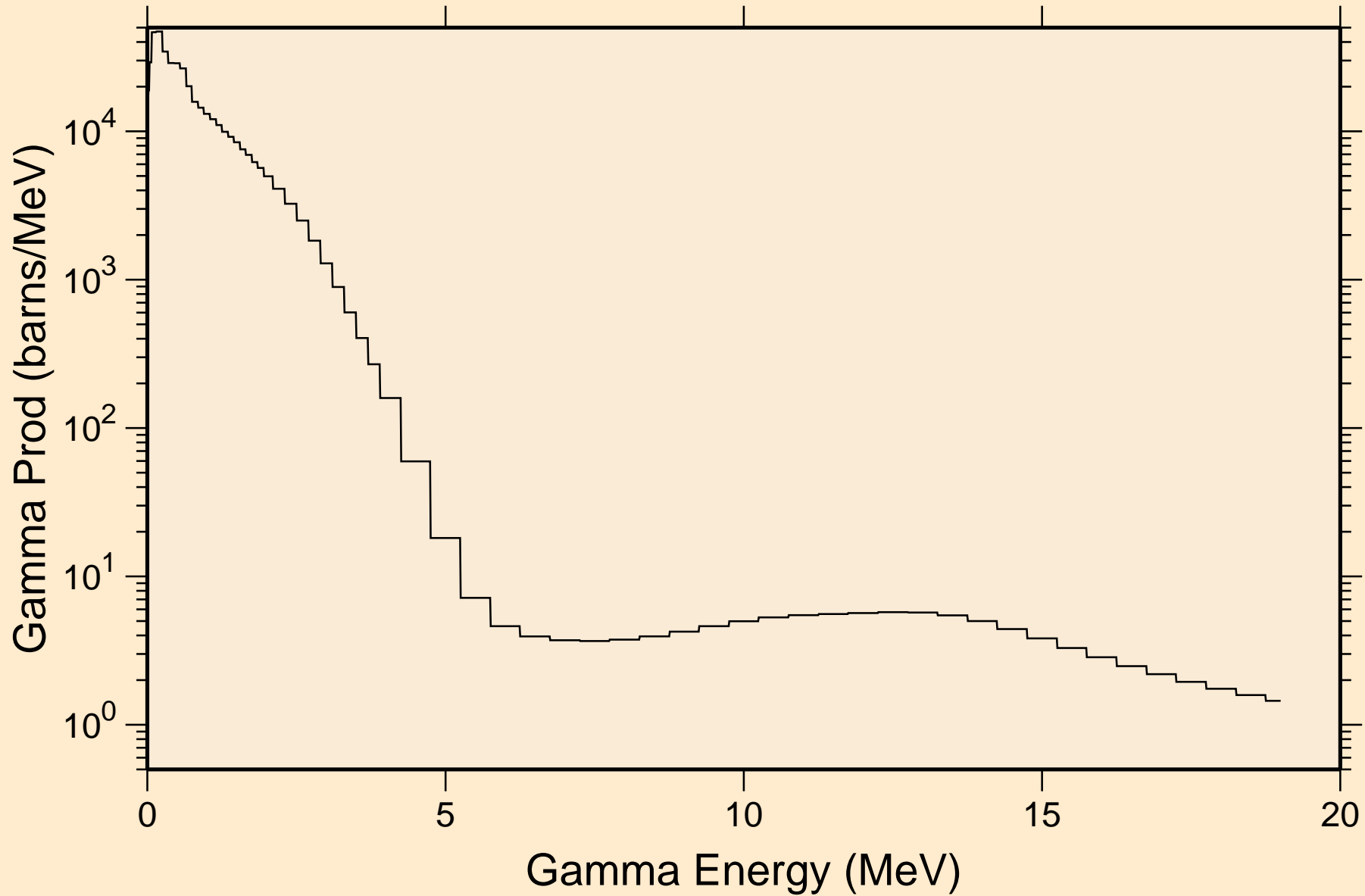

# BK253 NEUTRON ACER TENDL-2024 LIBRARY; T=0.K

## Particle heating contributions

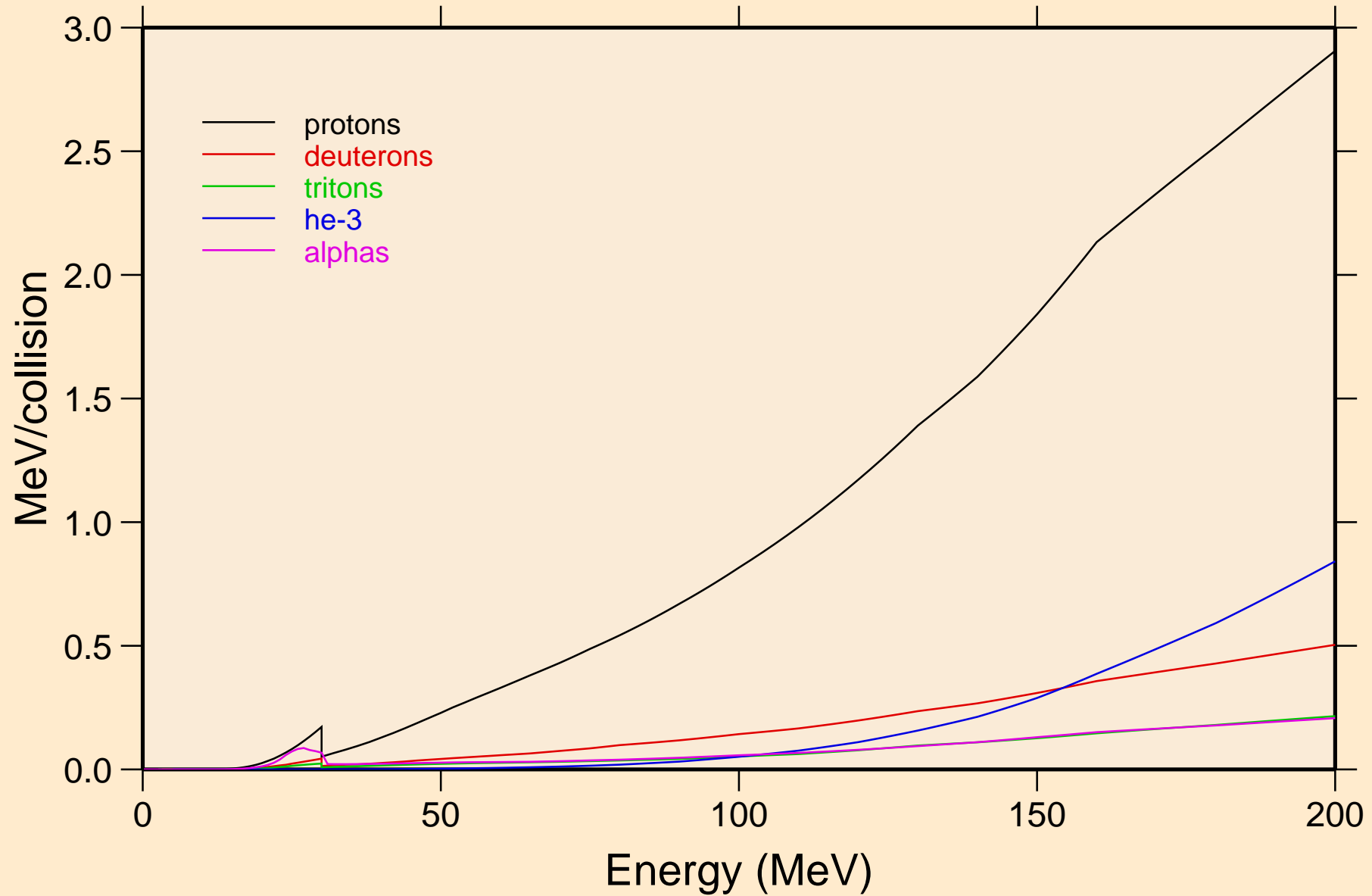

BK253 NEUTRON ACER TENDL-2024 LIBRARY; T=0.K  
Recoil Heating

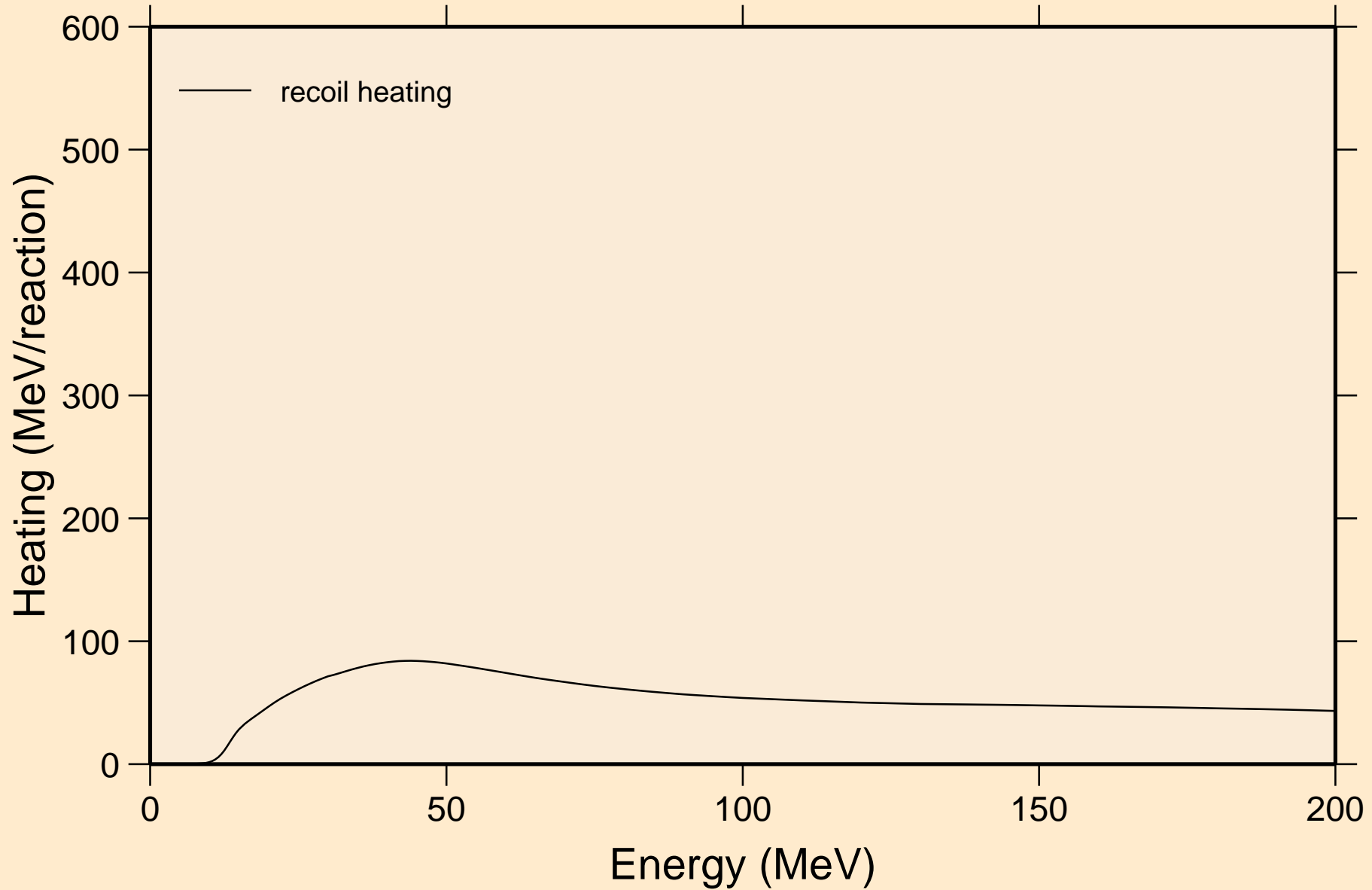

# BK253 NEUTRON ACER TENDL-2024 LIBRARY; T=0.K

## Particle production cross sections

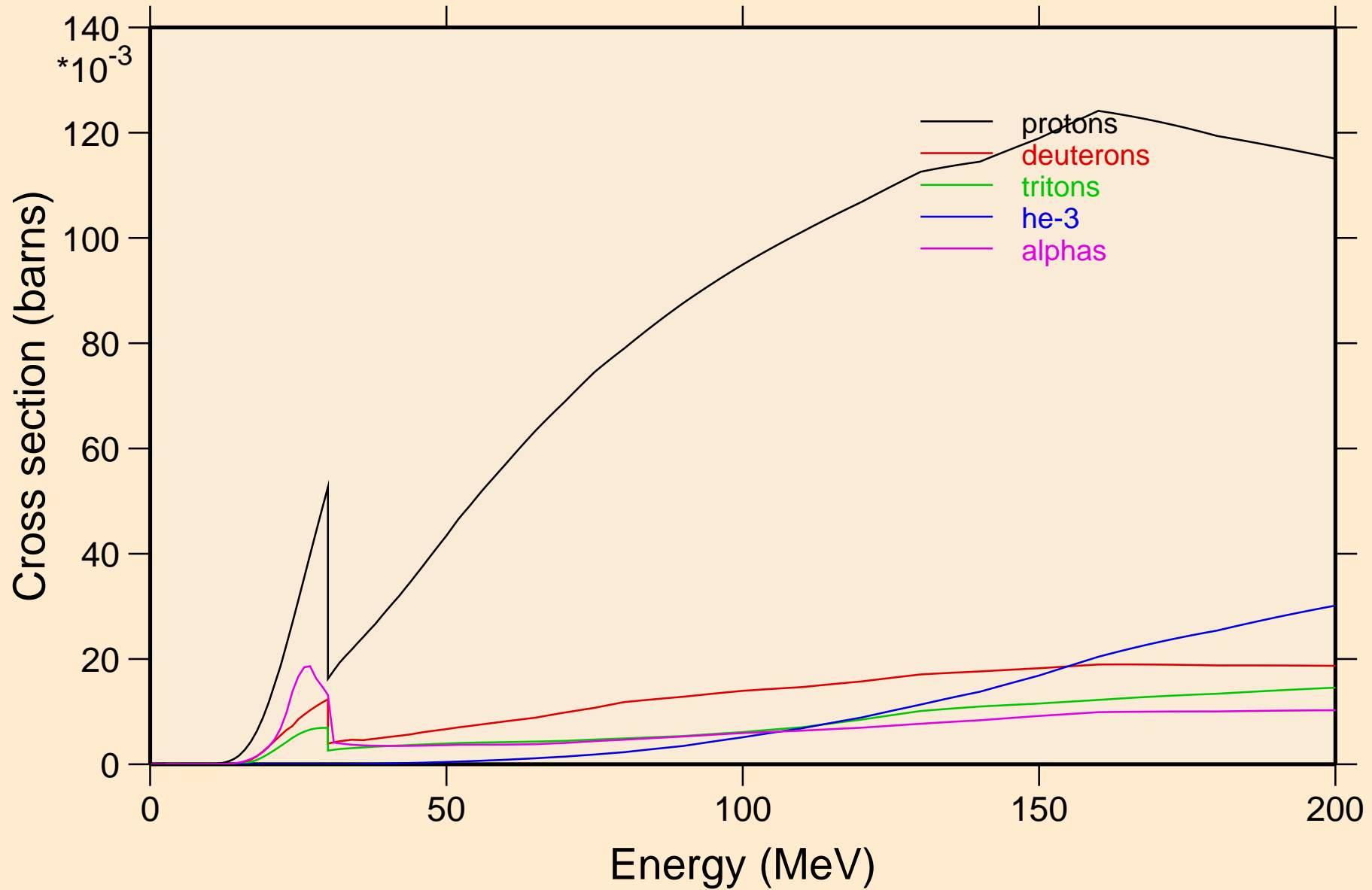

BK253 NEUTRON ACER TENDL-2024 LIBRARY; T=0.K  
protons from (n,x)

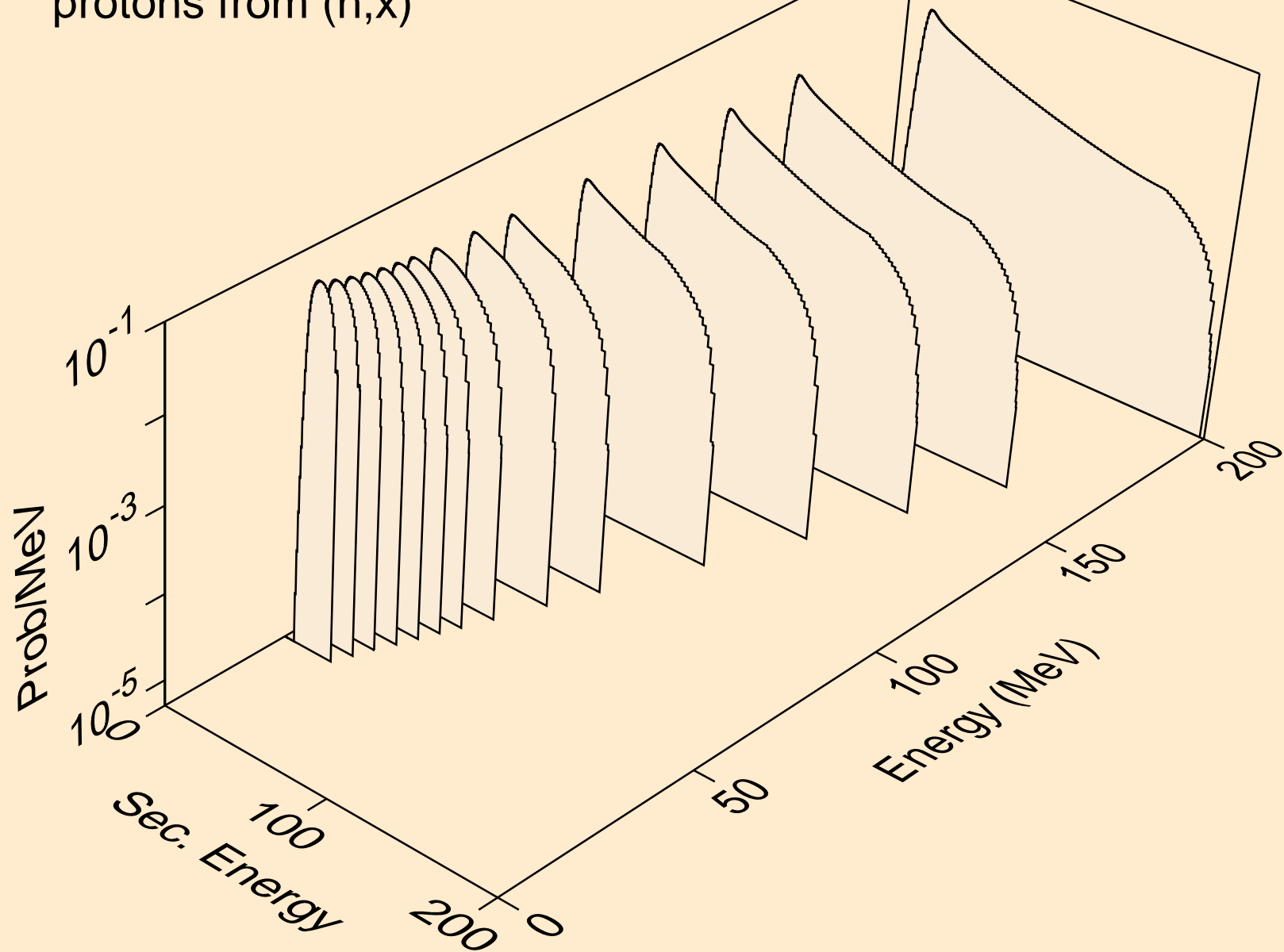

BK253 NEUTRON ACER TENDL-2024 LIBRARY; T=0.K  
protons from (n,n\*)p

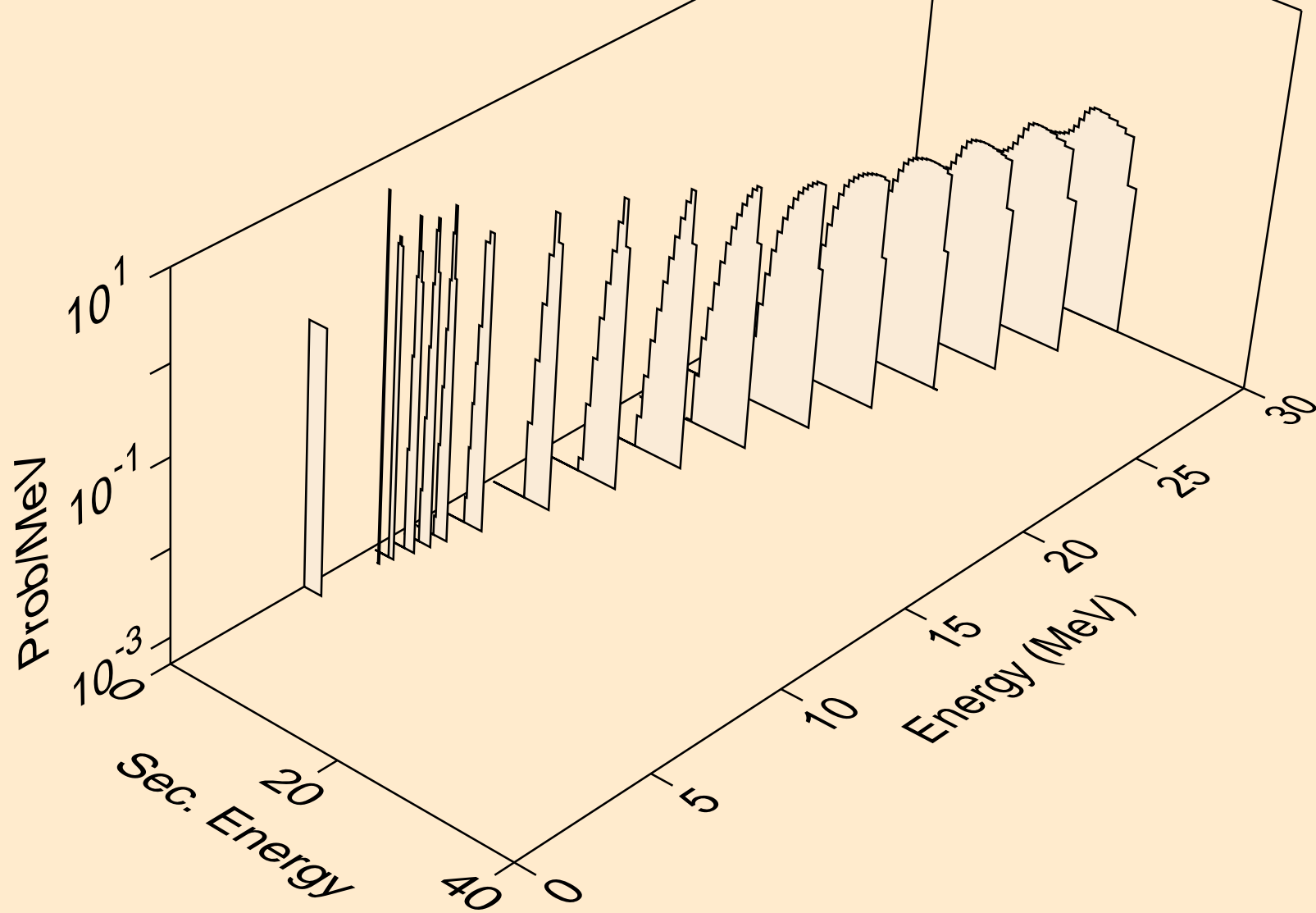

BK253 NEUTRON ACER TENDL-2024 LIBRARY; T=0.K  
protons from (n,2np)

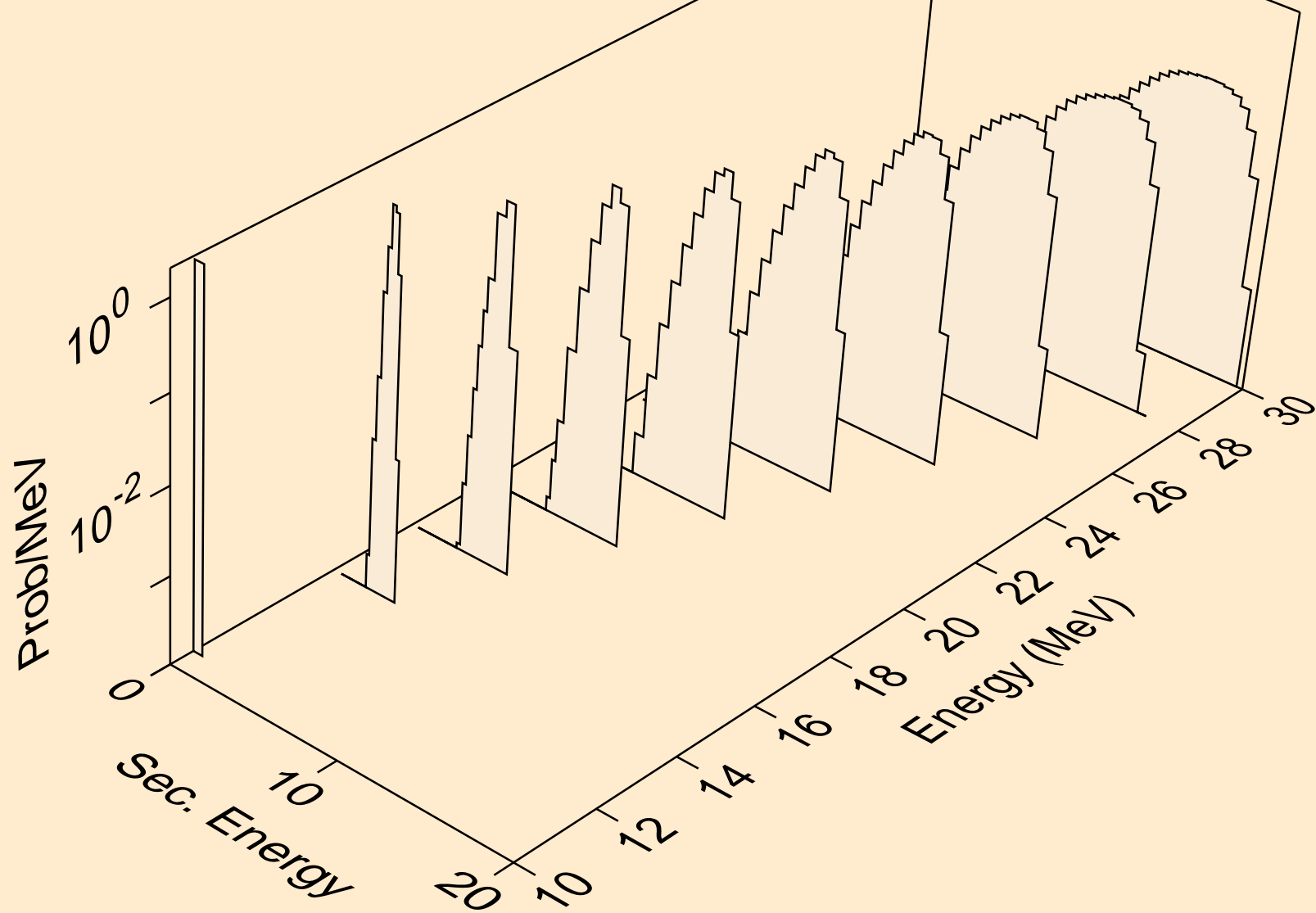

BK253 NEUTRON ACER TENDL-2024 LIBRARY; T=0.K  
protons from (n,3np)

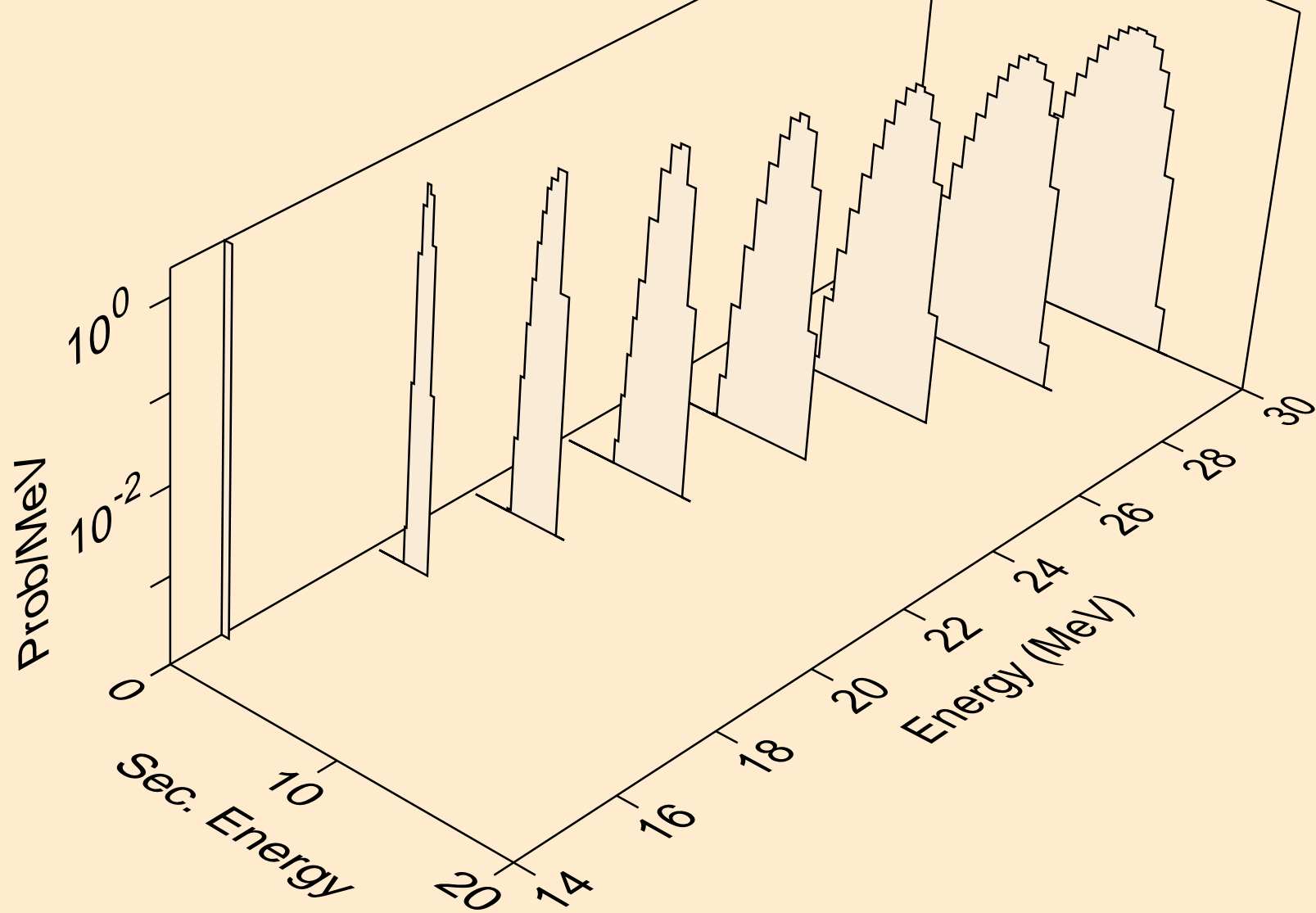

BK253 NEUTRON ACER TENDL-2024 LIBRARY; T=0.K  
protons from (n,p)

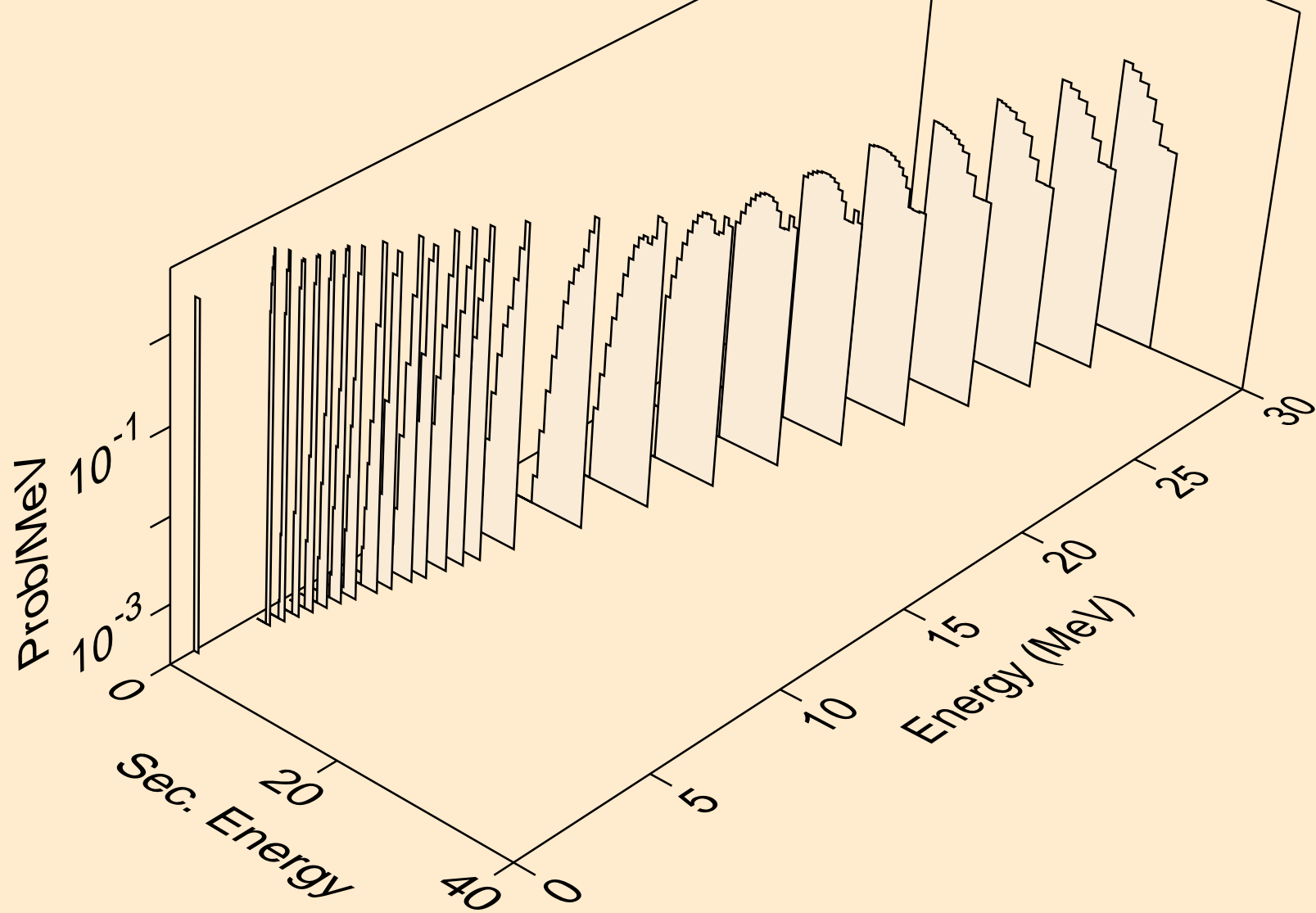

BK253 NEUTRON ACER TENDL-2024 LIBRARY; T=0.K  
protons from (n,2p)

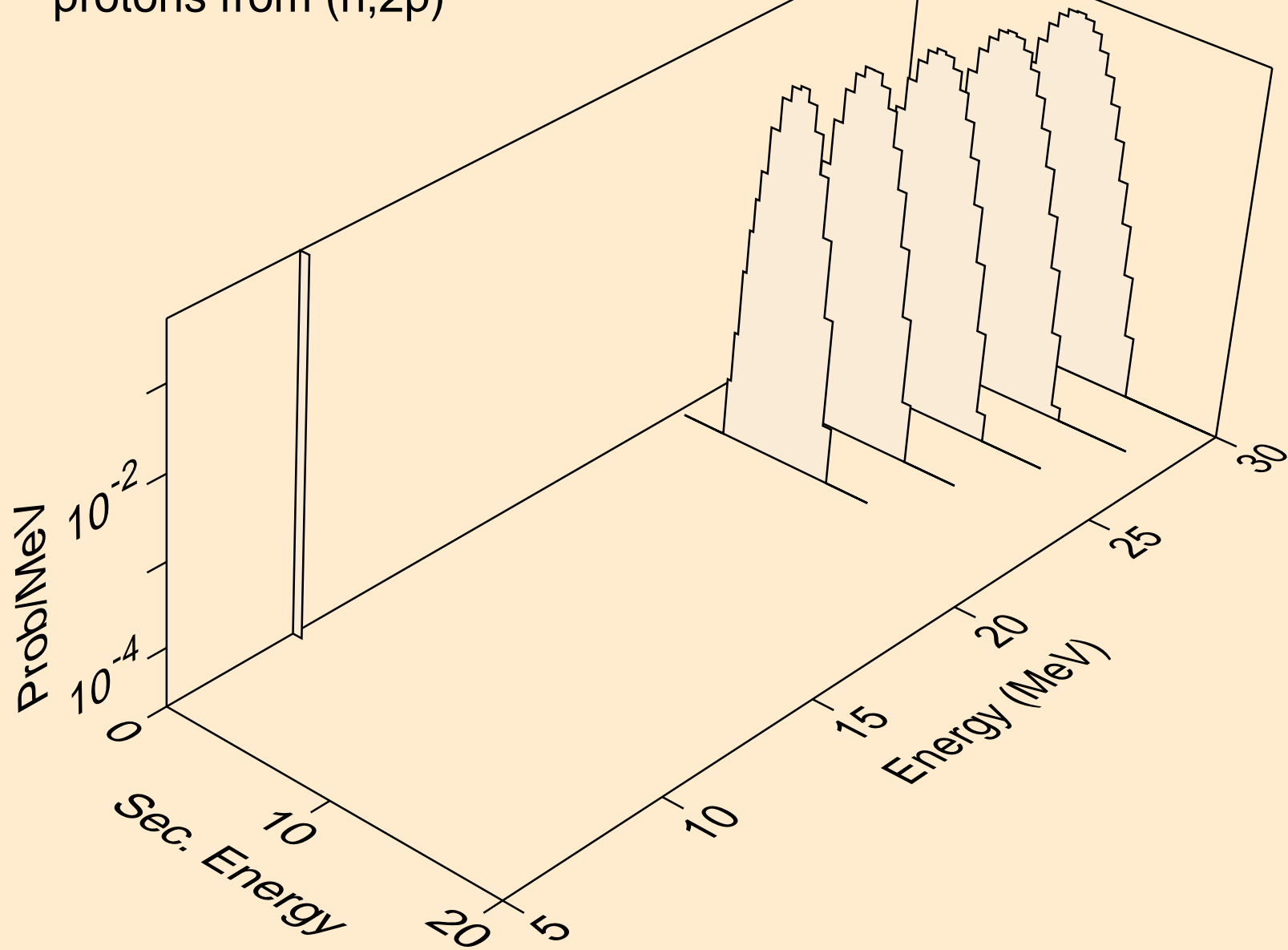

BK253 NEUTRON ACER TENDL-2024 LIBRARY; T=0.K  
deuterons from (n,x)

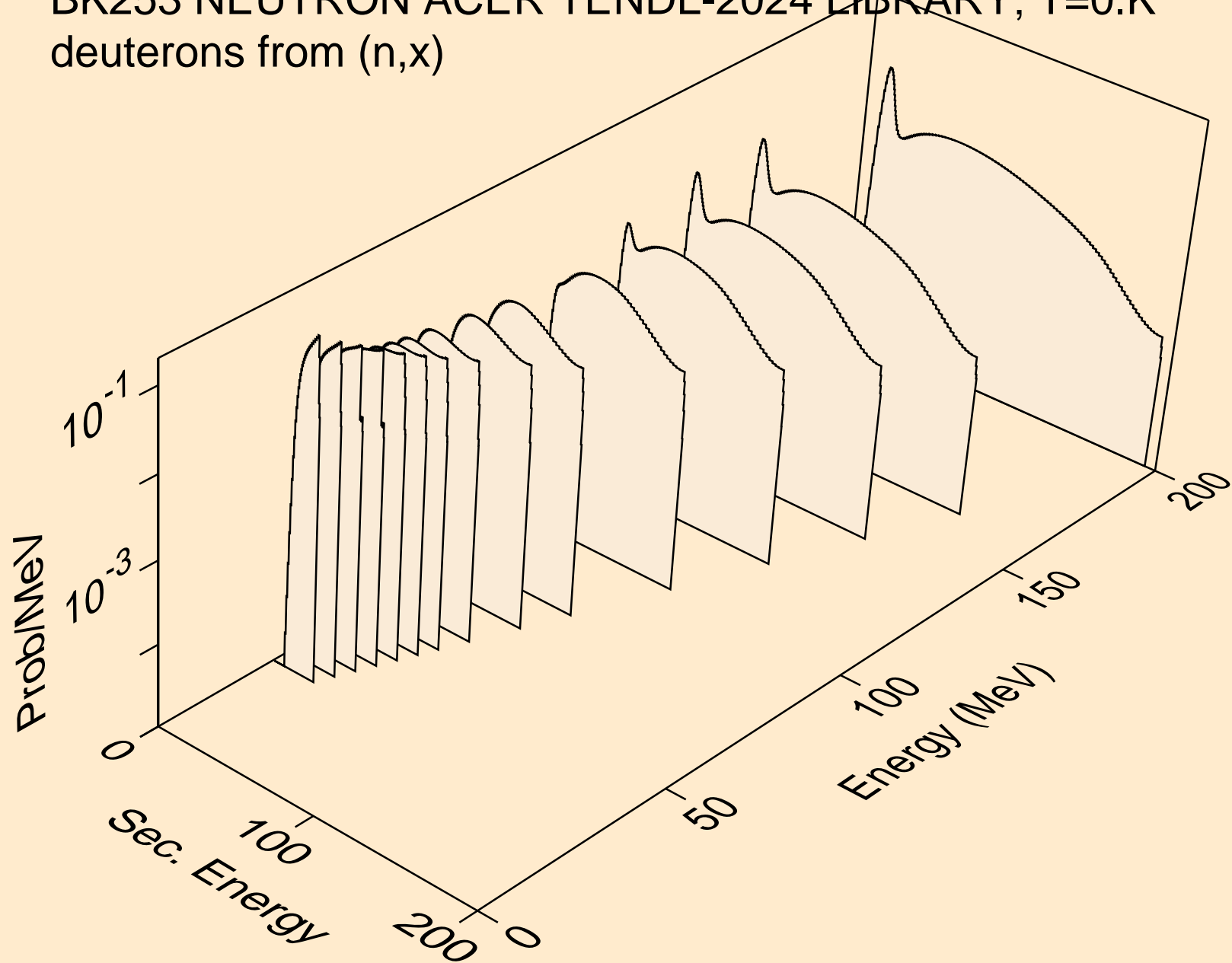

BK253 NEUTRON ACER TENDL-2024 LIBRARY; T=0.K  
deuterons from (n,2nd)

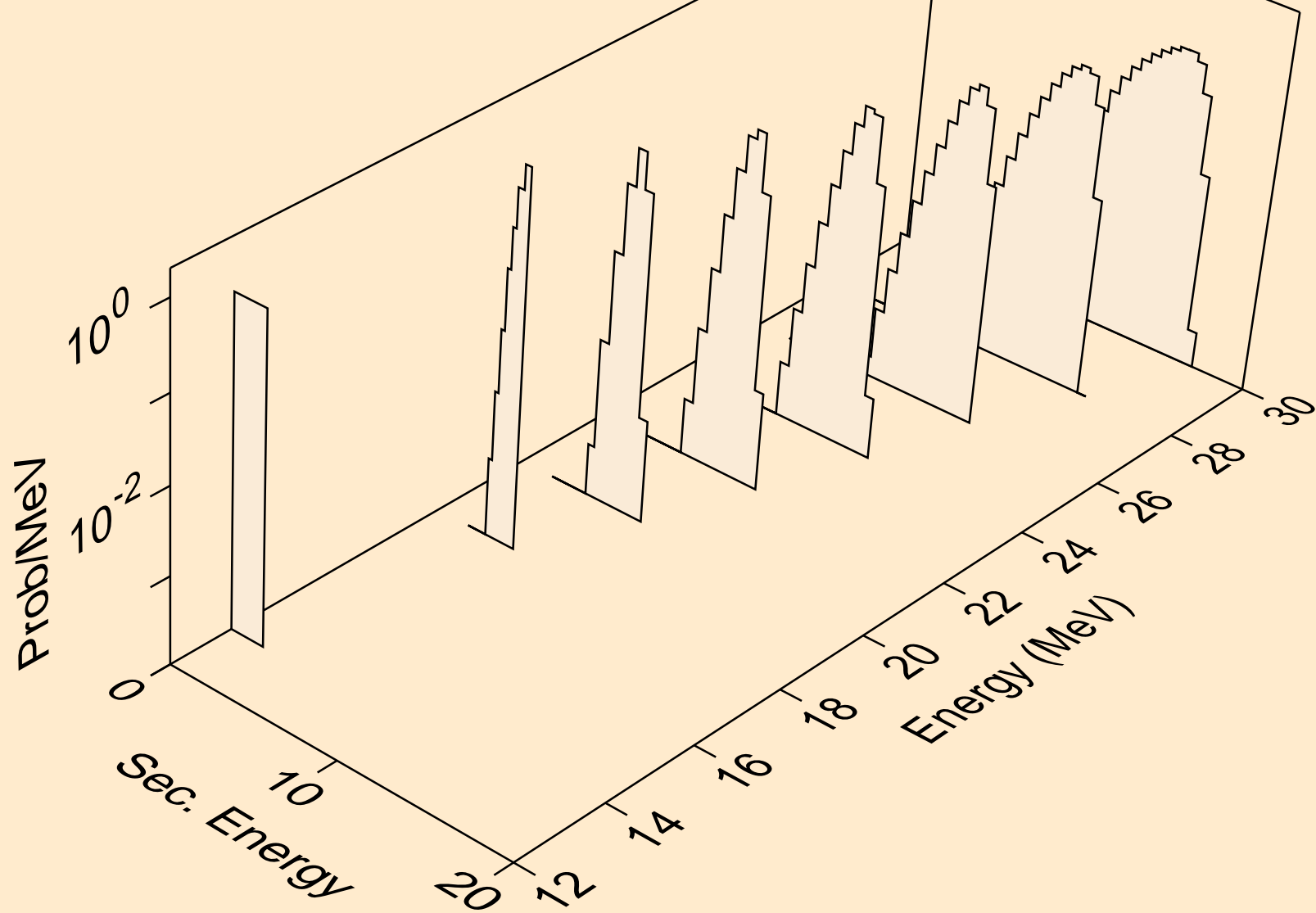

BK253 NEUTRON ACER TENDL-2024 LIBRARY; T=0.K  
deuterons from (n,n\*)d

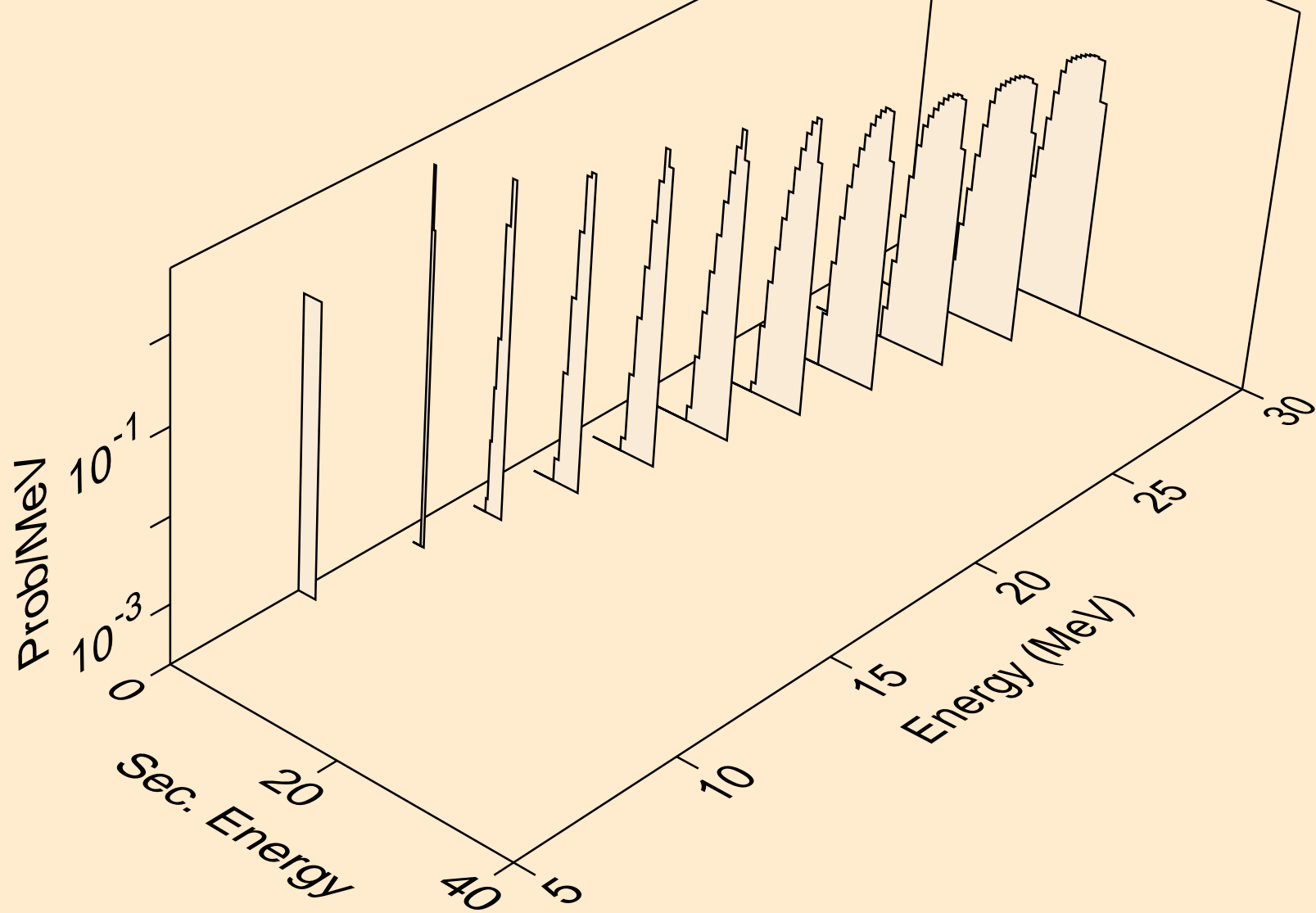

BK253 NEUTRON ACER TENDL-2024 LIBRARY; T=0.K  
deuterons from (n,d)

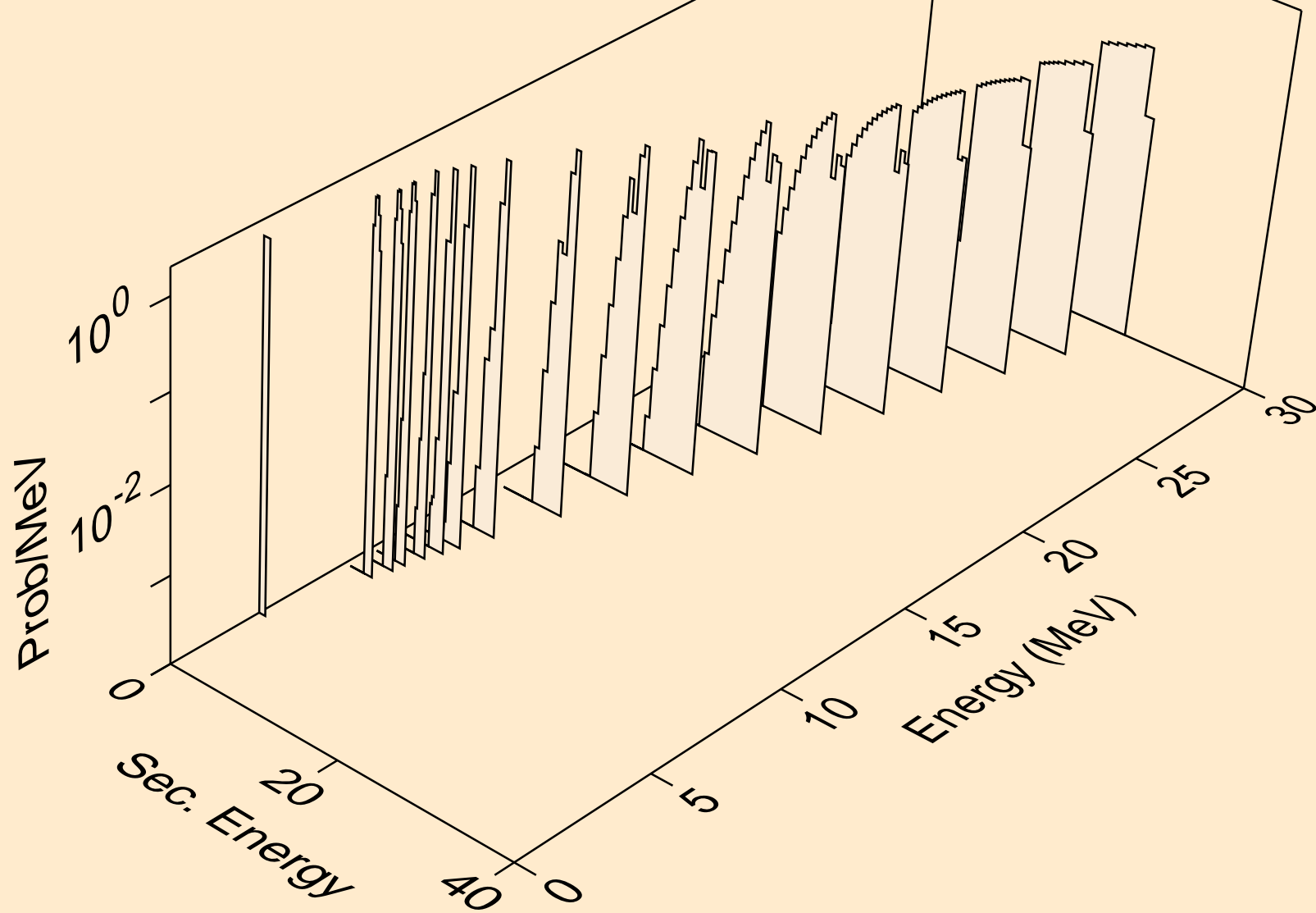

BK253 NEUTRON ACER TENDL-2024 LIBRARY; T=0.K  
tritons from (n,x)

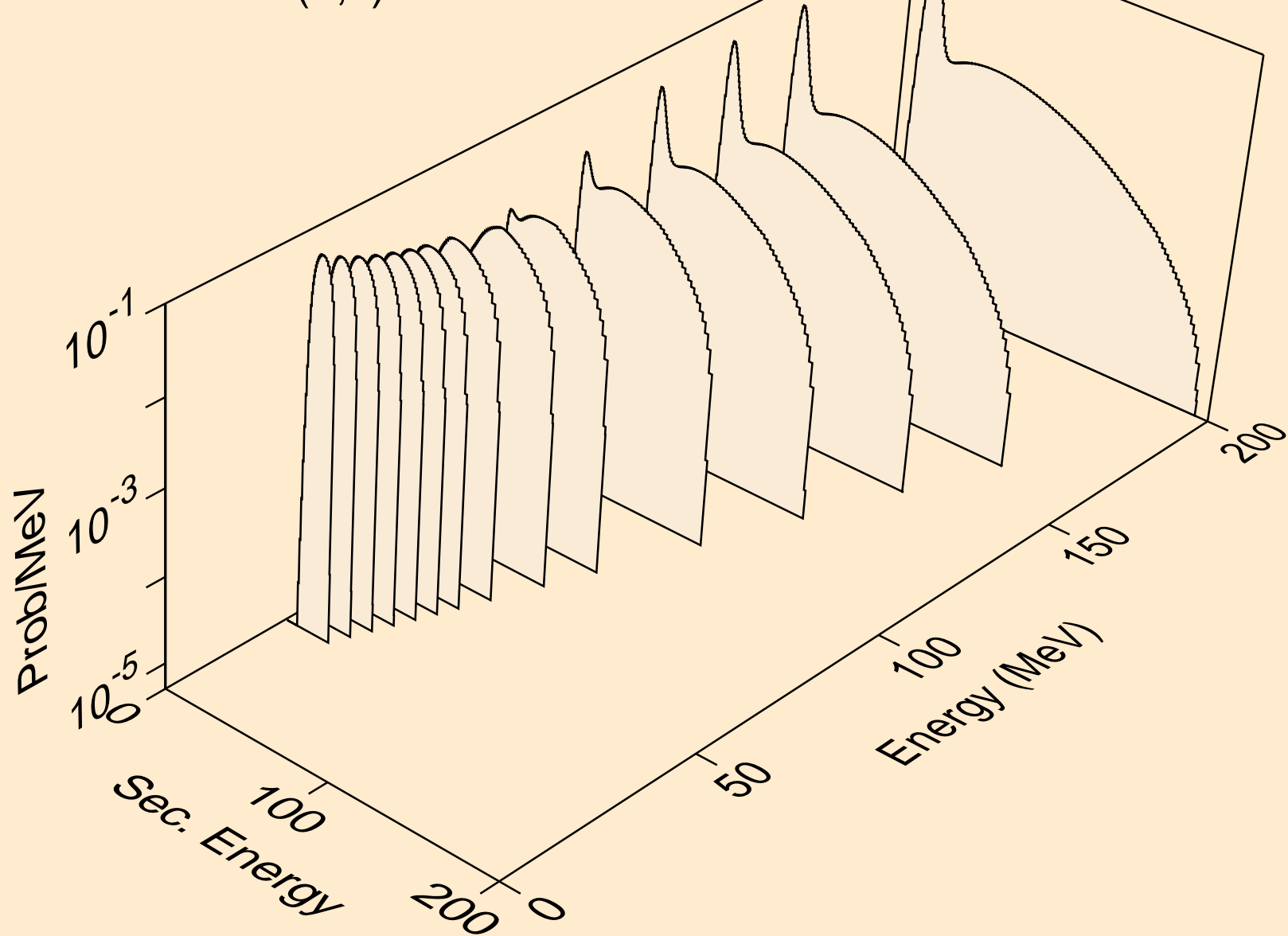

BK253 NEUTRON ACER TENDL-2024 LIBRARY; T=0.K  
tritons from (n,n\*)t

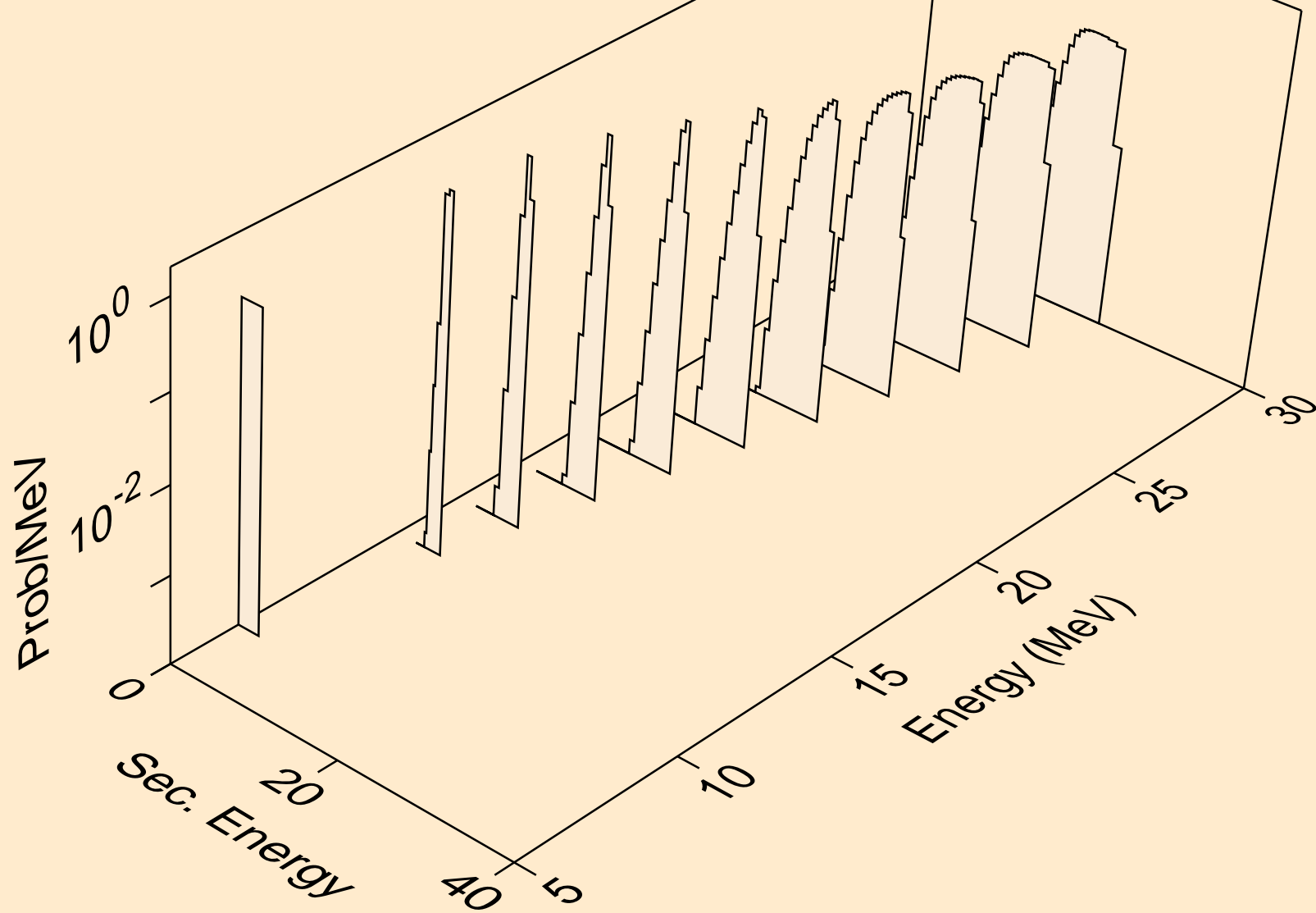

BK253 NEUTRON ACER TENDL-2024 LIBRARY; T=0.K  
tritons from (n,t)

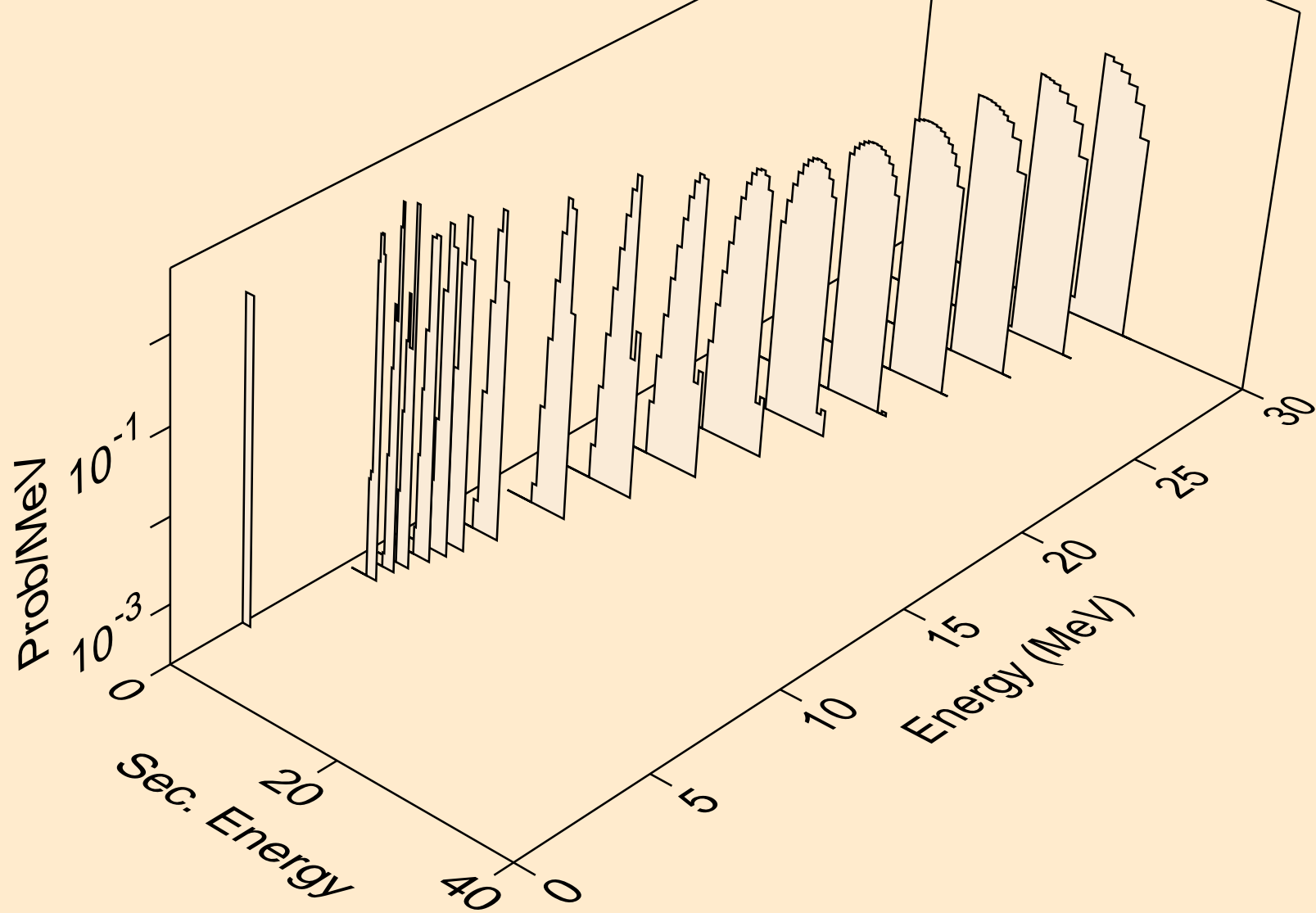

BK253 NEUTRON ACER TENDL-2024 LIBRARY; T=0.K  
he3s from (n,x)

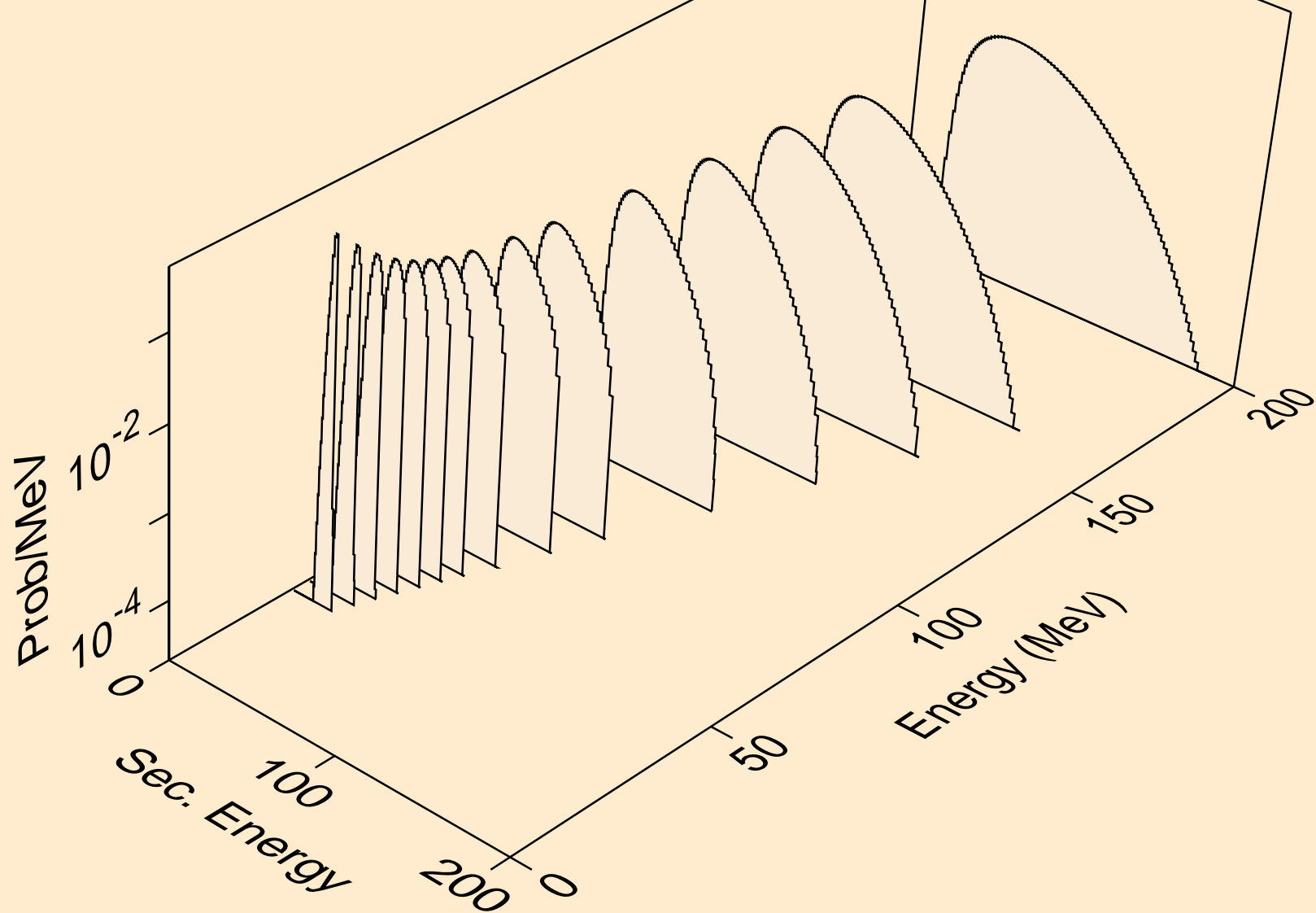

BK253 NEUTRON ACER TENDL-2024 LIBRARY; T=0.K  
he3s from (n,n\*)he3

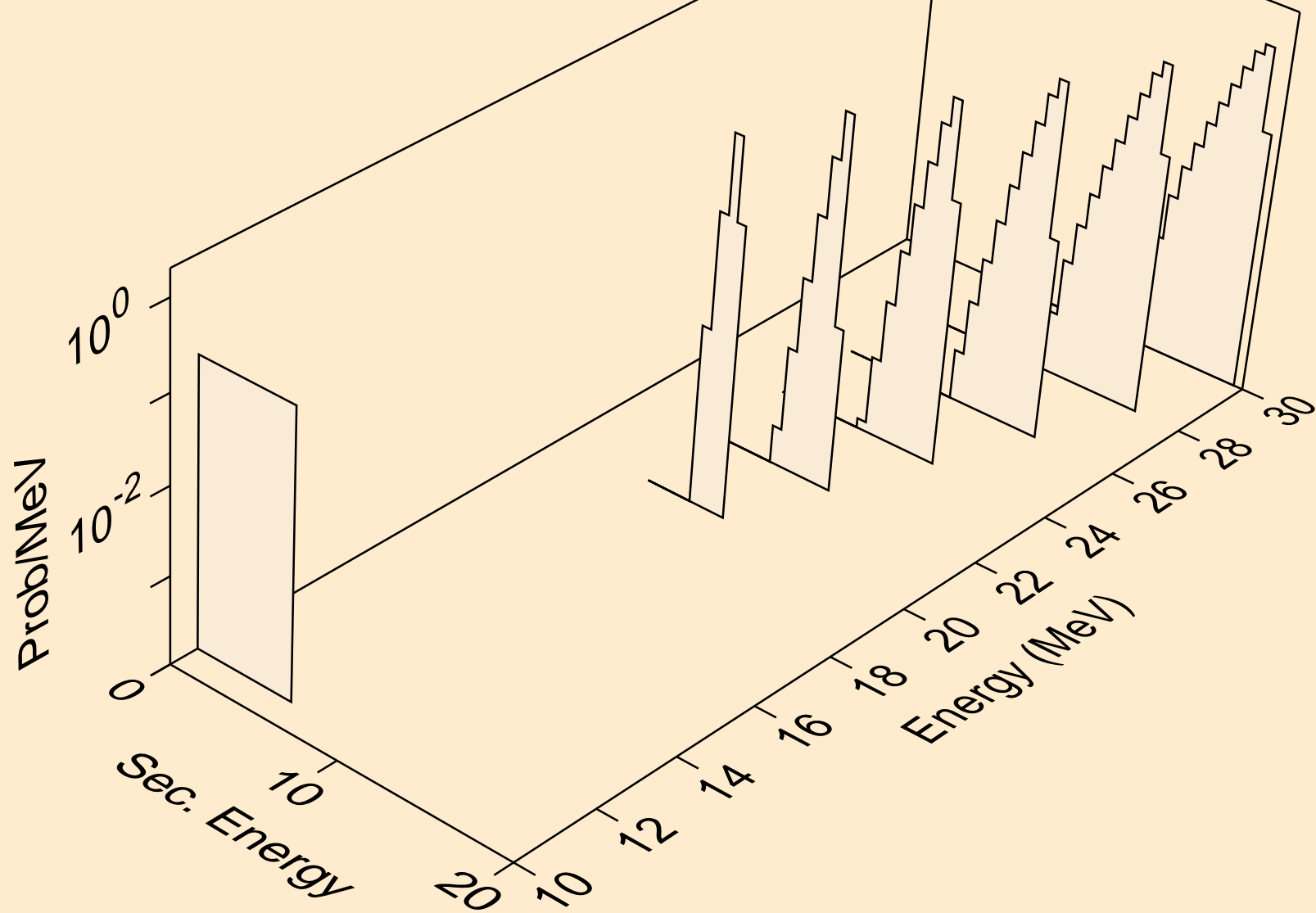

BK253 NEUTRON ACER TENDL-2024 LIBRARY; T=0.K  
he3s from (n,he3)

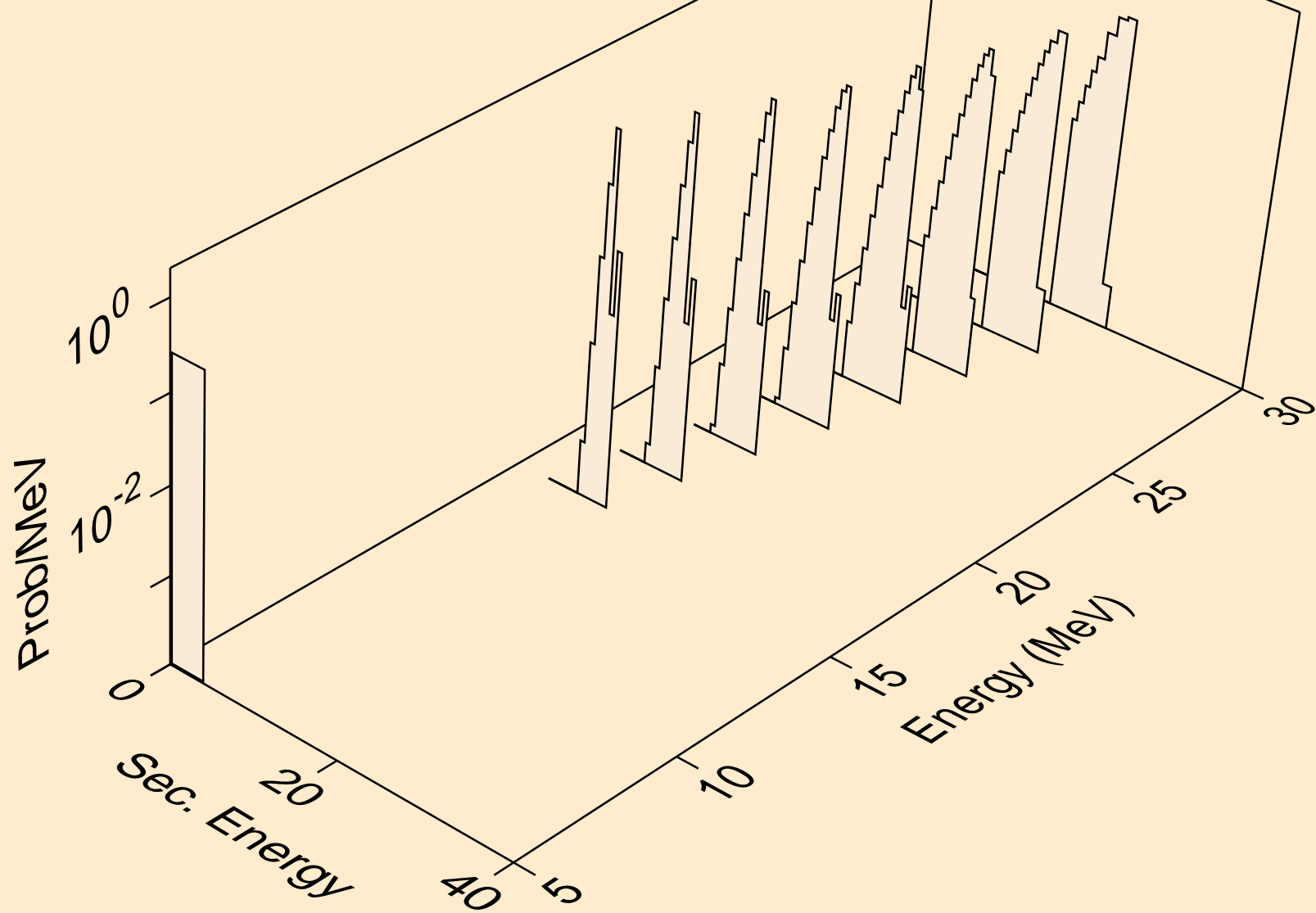

BK253 NEUTRON ACER TENDL-2024 LIBRARY; T=0.K  
alphas from (n,x)

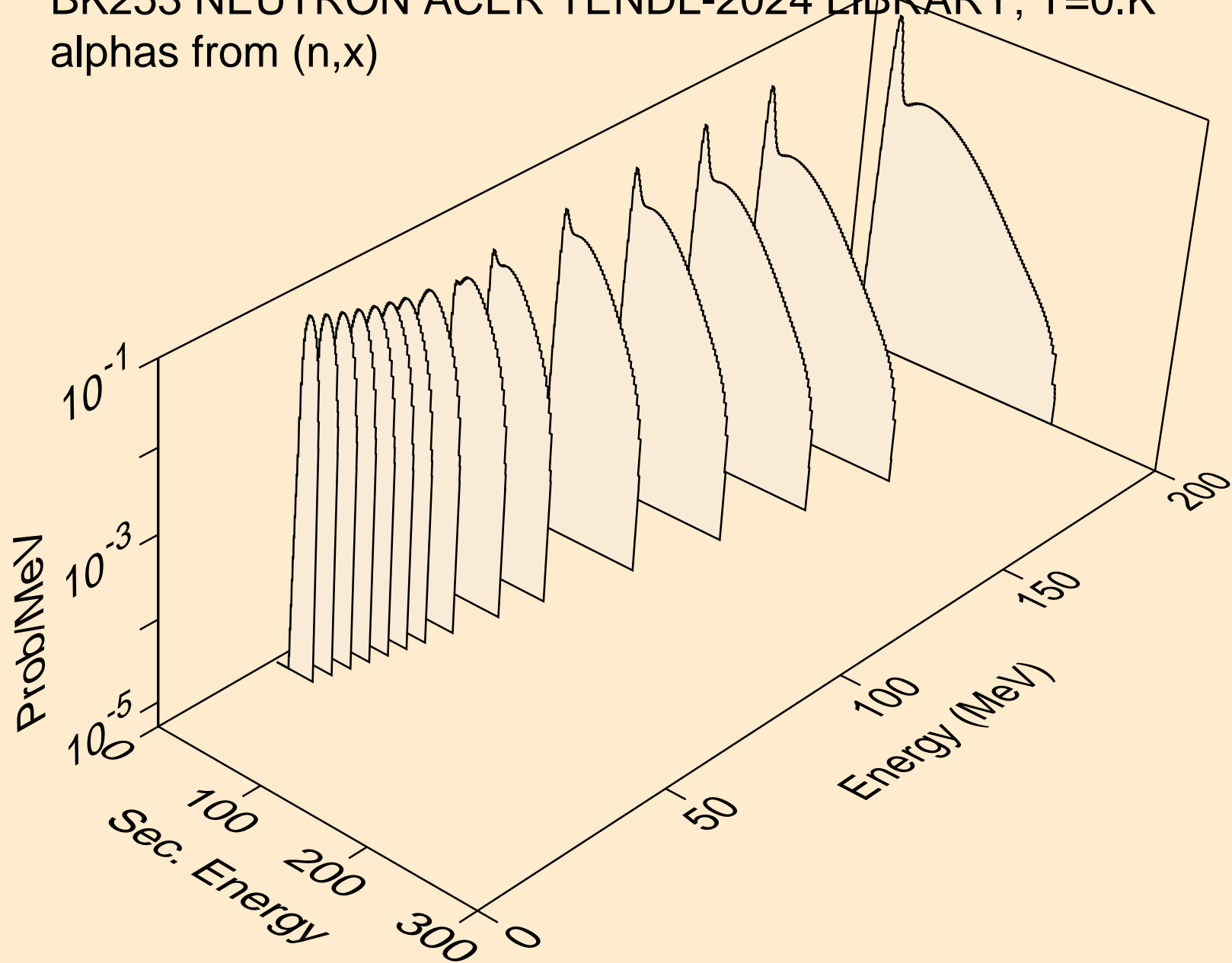

BK253 NEUTRON ACER TENDL-2024 LIBRARY; T=0.K  
alphas from (n,n\*)a

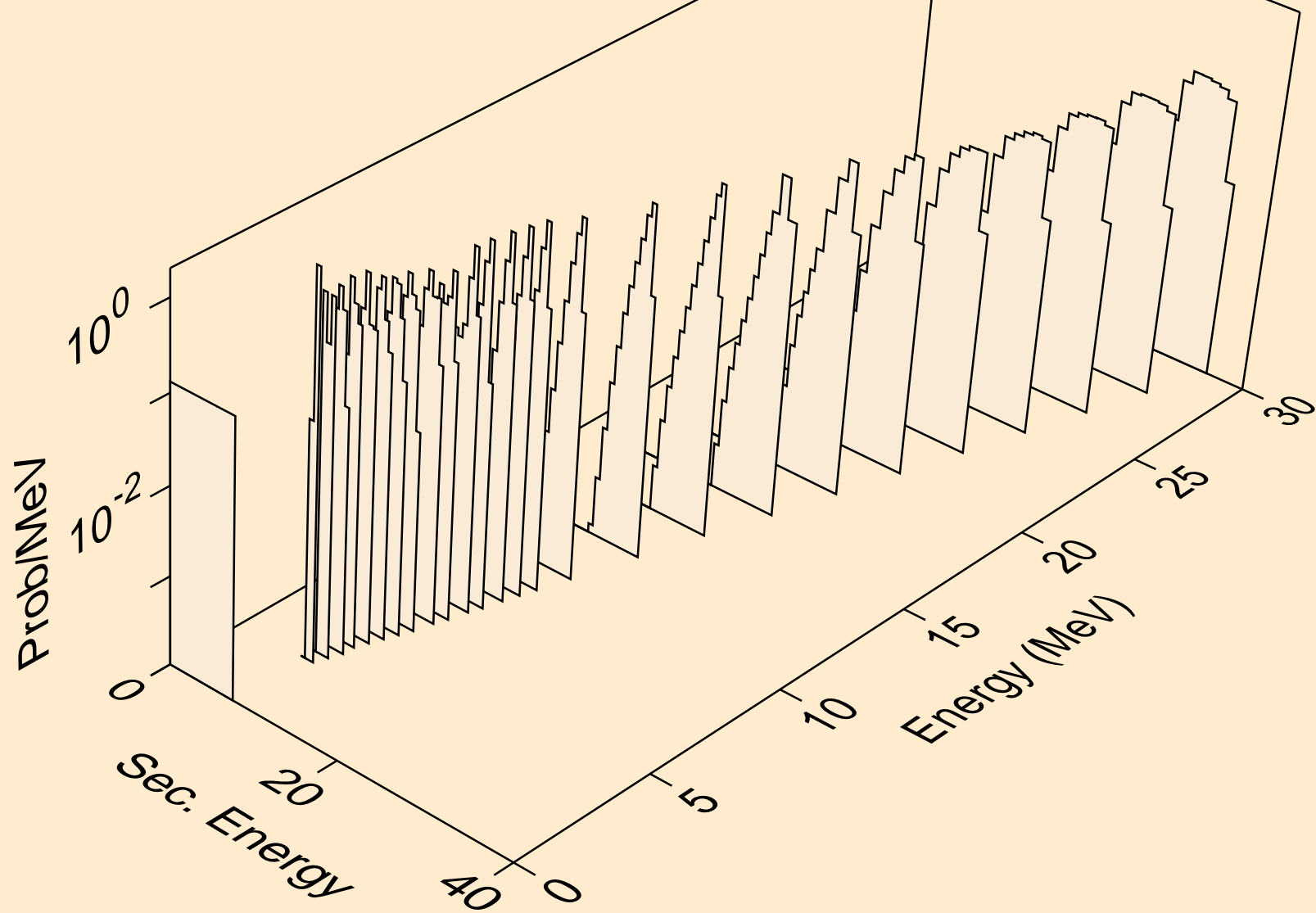

BK253 NEUTRON ACER TENDL-2024 LIBRARY; T=0.K  
alphas from (n,2n)a

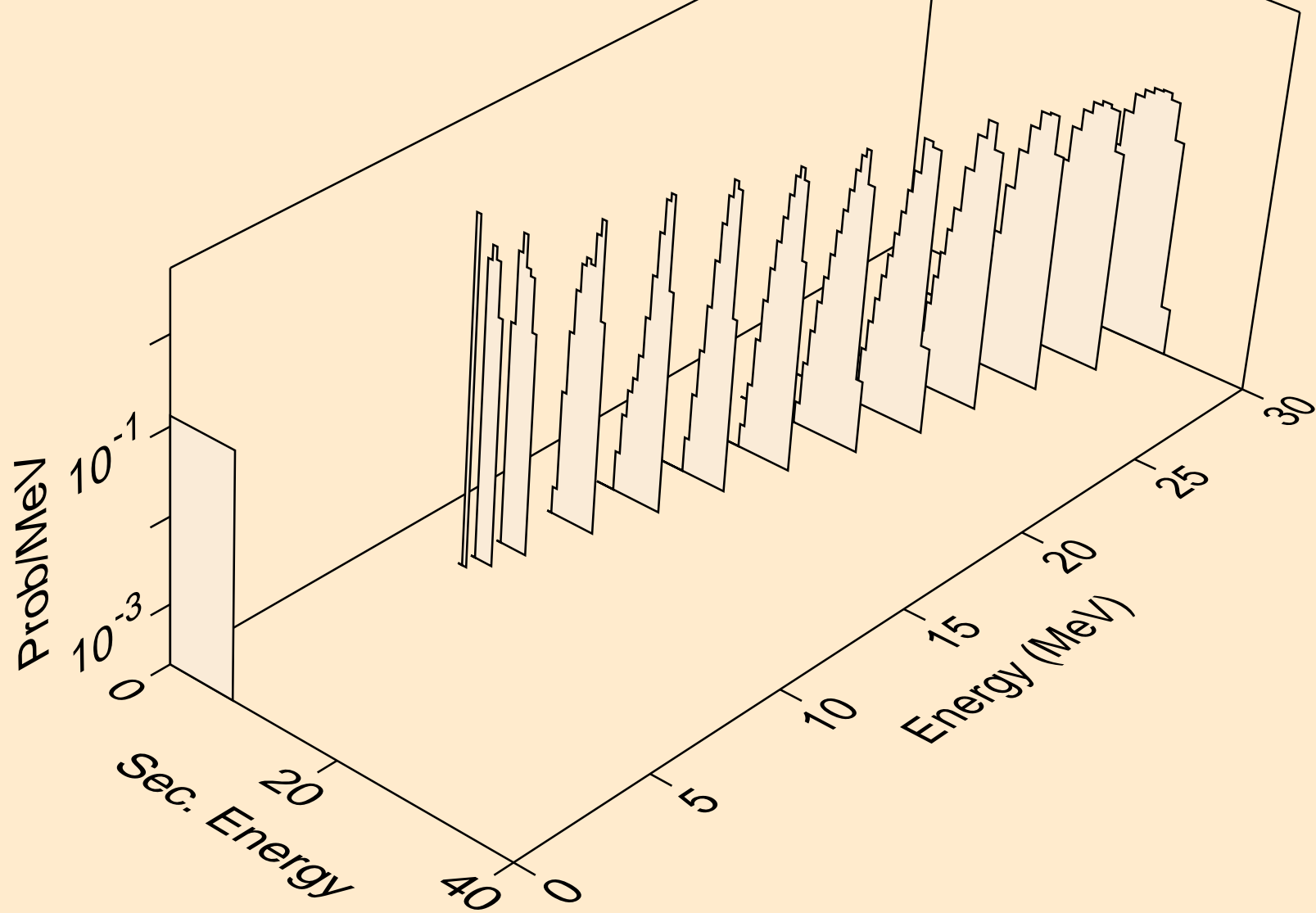

BK253 NEUTRON ACER TENDL-2024 LIBRARY; T=0.K  
alphas from (n,3n)a

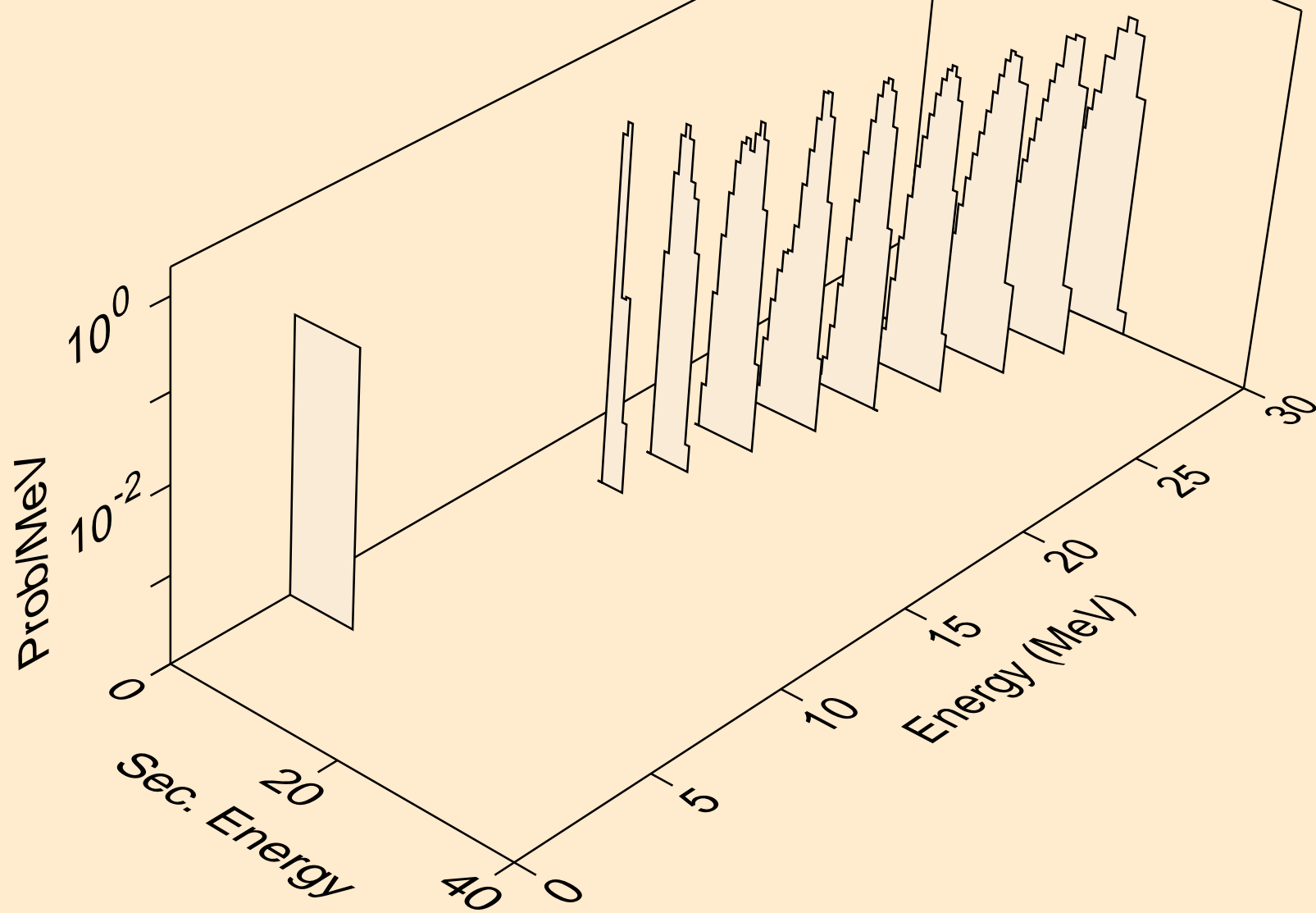

BK253 NEUTRON ACER TENDL-2024 LIBRARY; T=0.K  
alphas from (n,a)

