

FR232 NEUTRON ACER TENDL-2024 LIBRARY; T=0.K

Principal cross sections

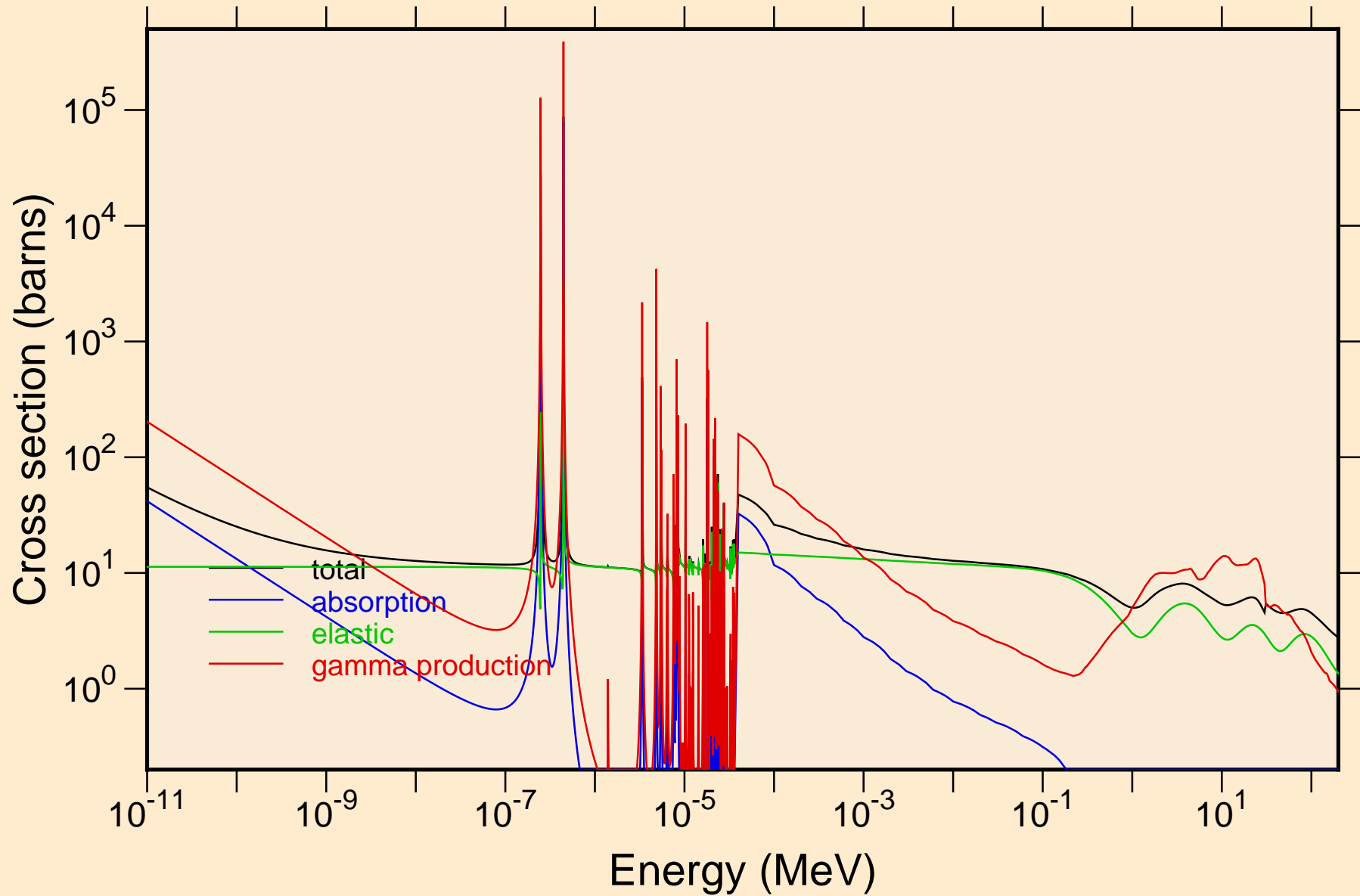

FR232 NEUTRON ACER TENDL-2024 LIBRARY; T=0.K
resonance total cross section

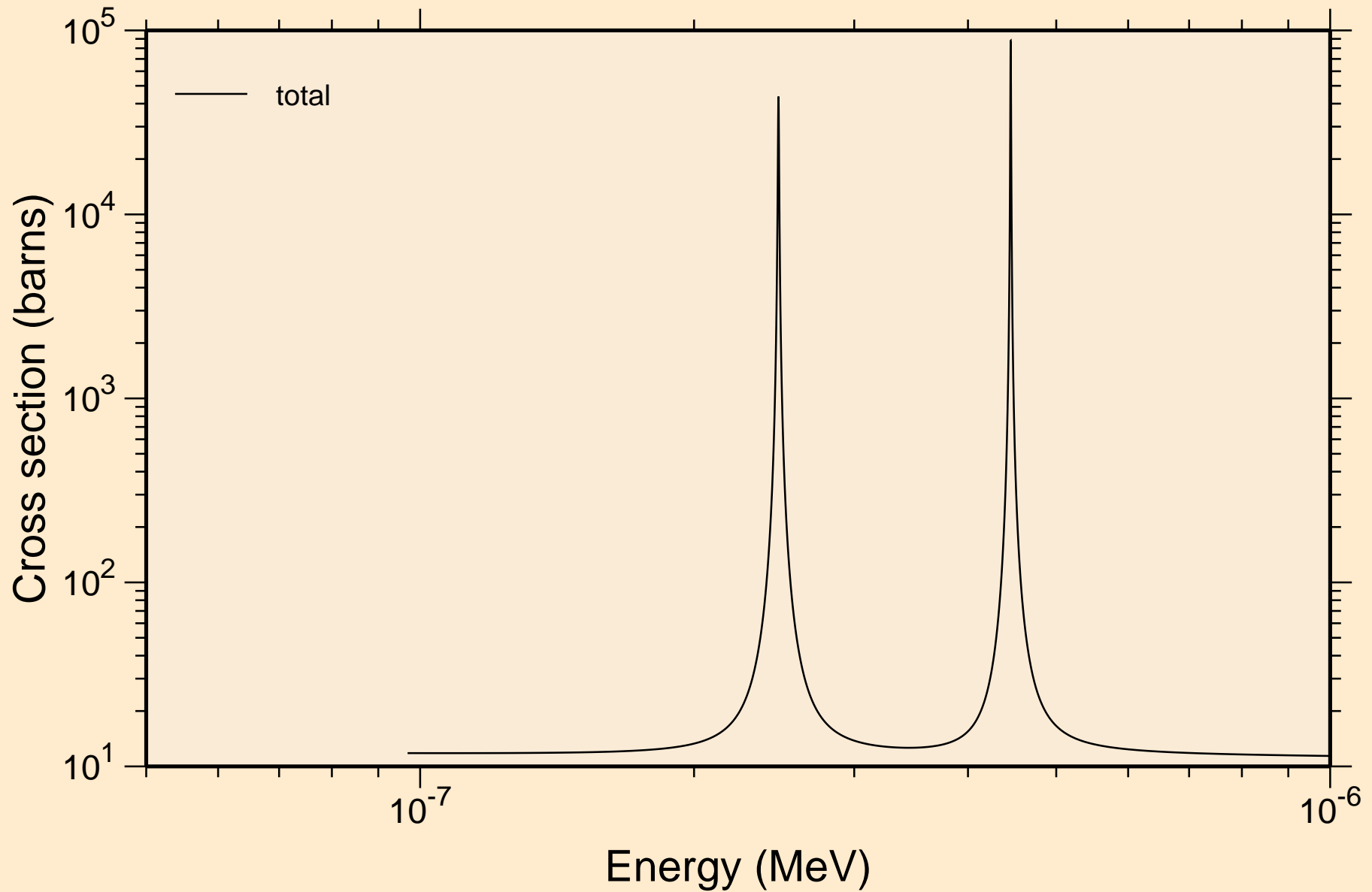

FR232 NEUTRON ACER TENDL-2024 LIBRARY; T=0.K
resonance total cross section

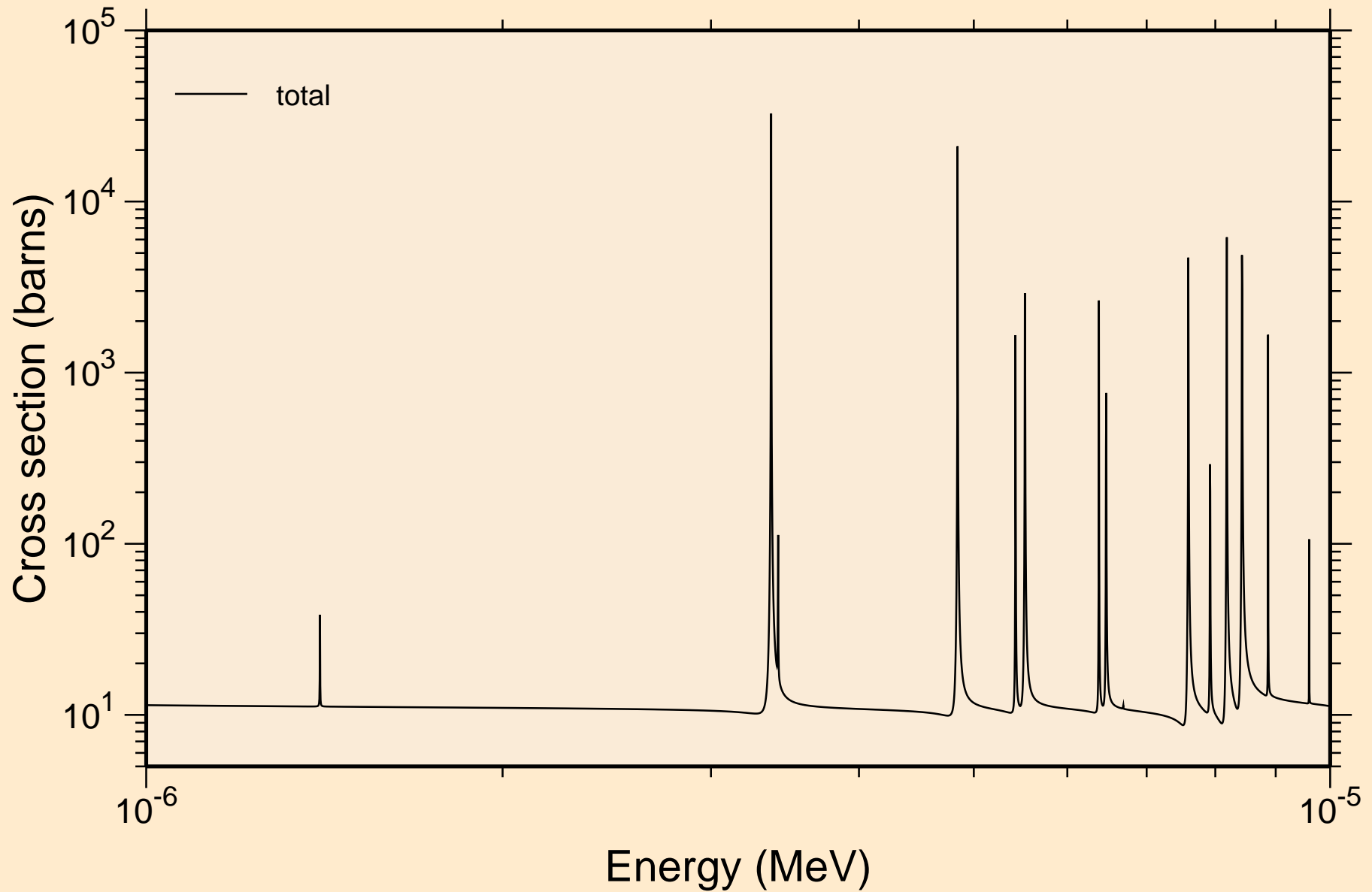

FR232 NEUTRON ACER TENDL-2024 LIBRARY; T=0.K
resonance total cross section

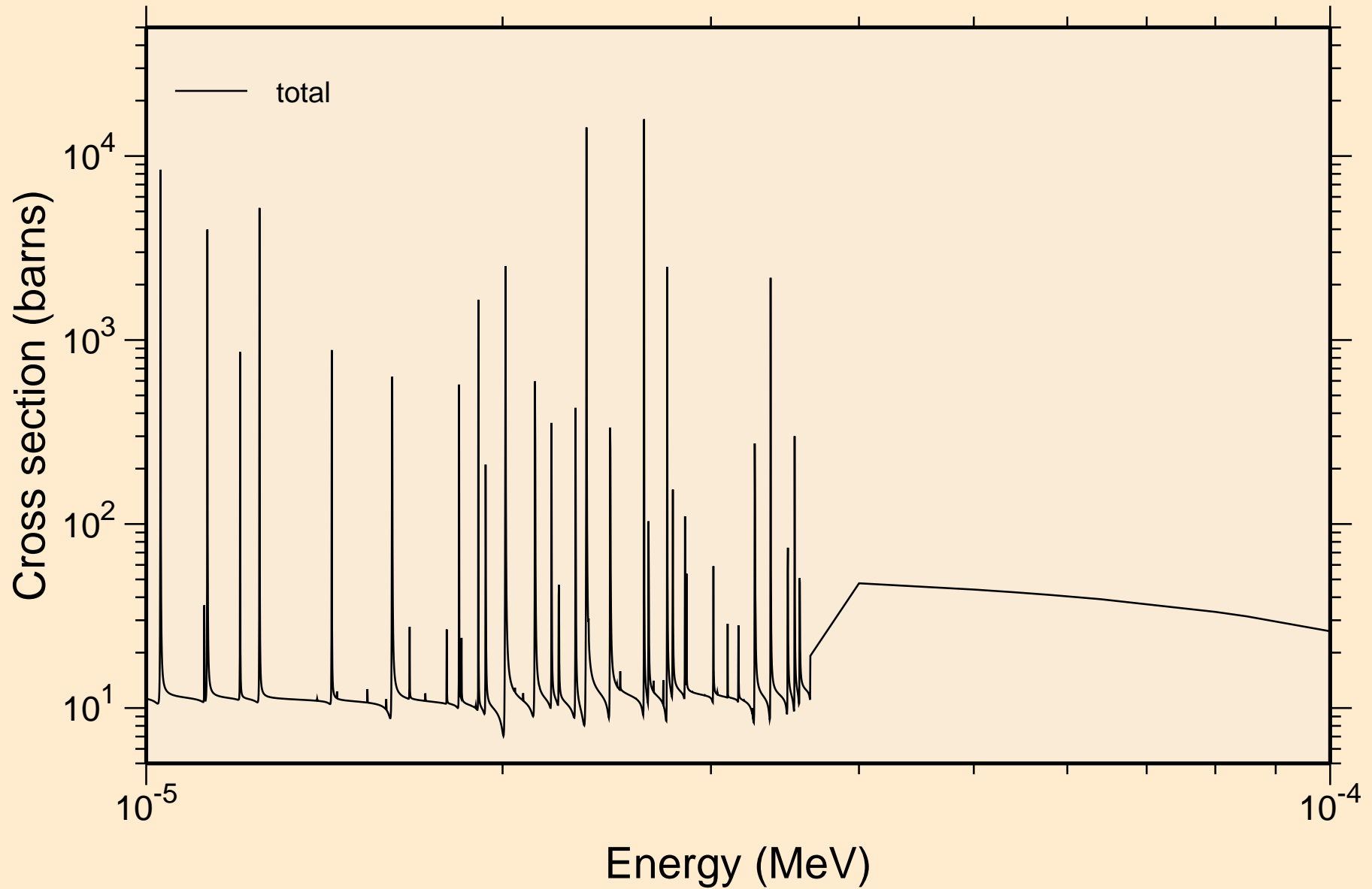

FR232 NEUTRON ACER TENDL-2024 LIBRARY; T=0.K
resonance total cross section

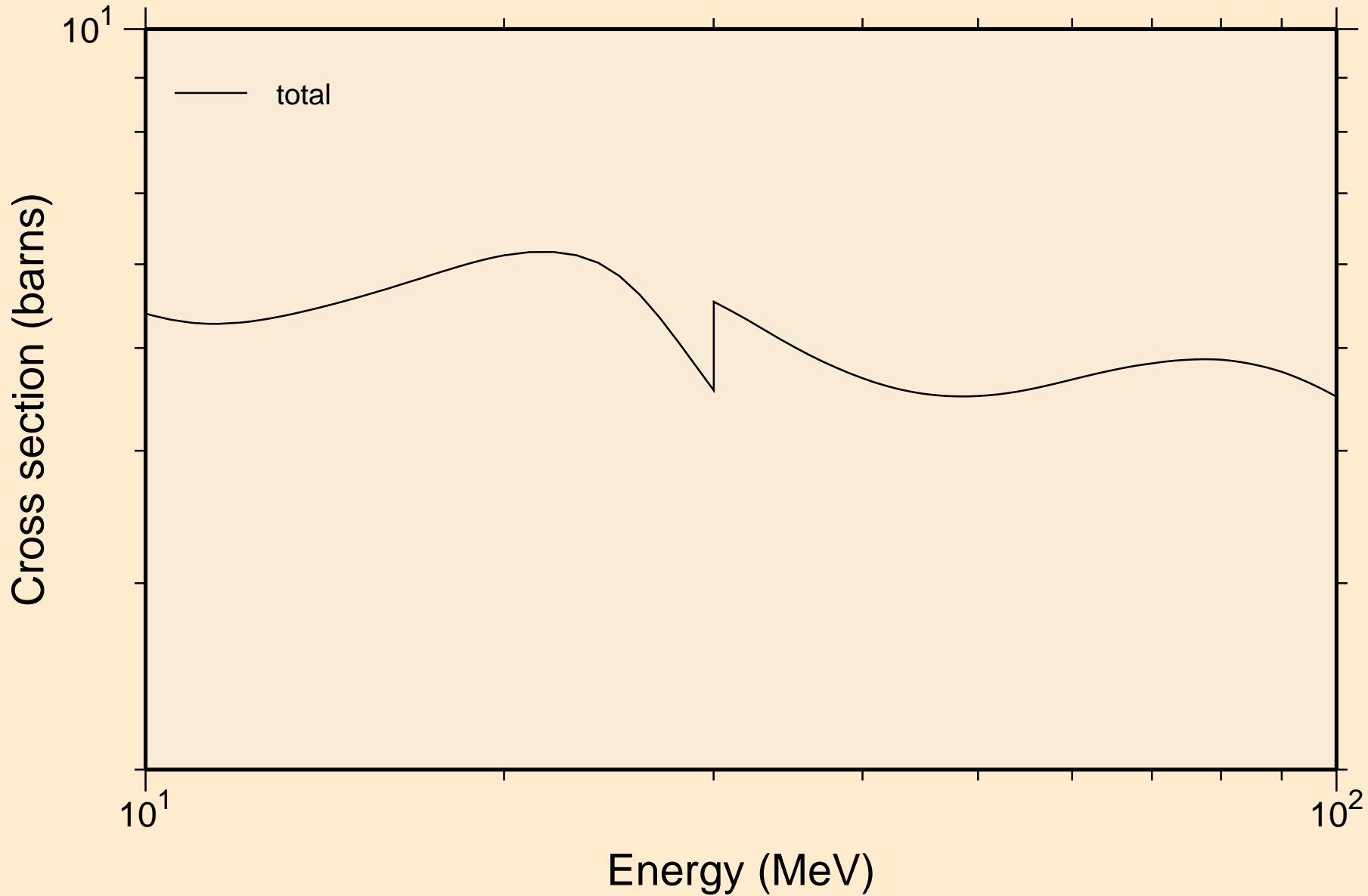

FR232 NEUTRON ACER TENDL-2024 LIBRARY; T=0.K
resonance absorption cross sections

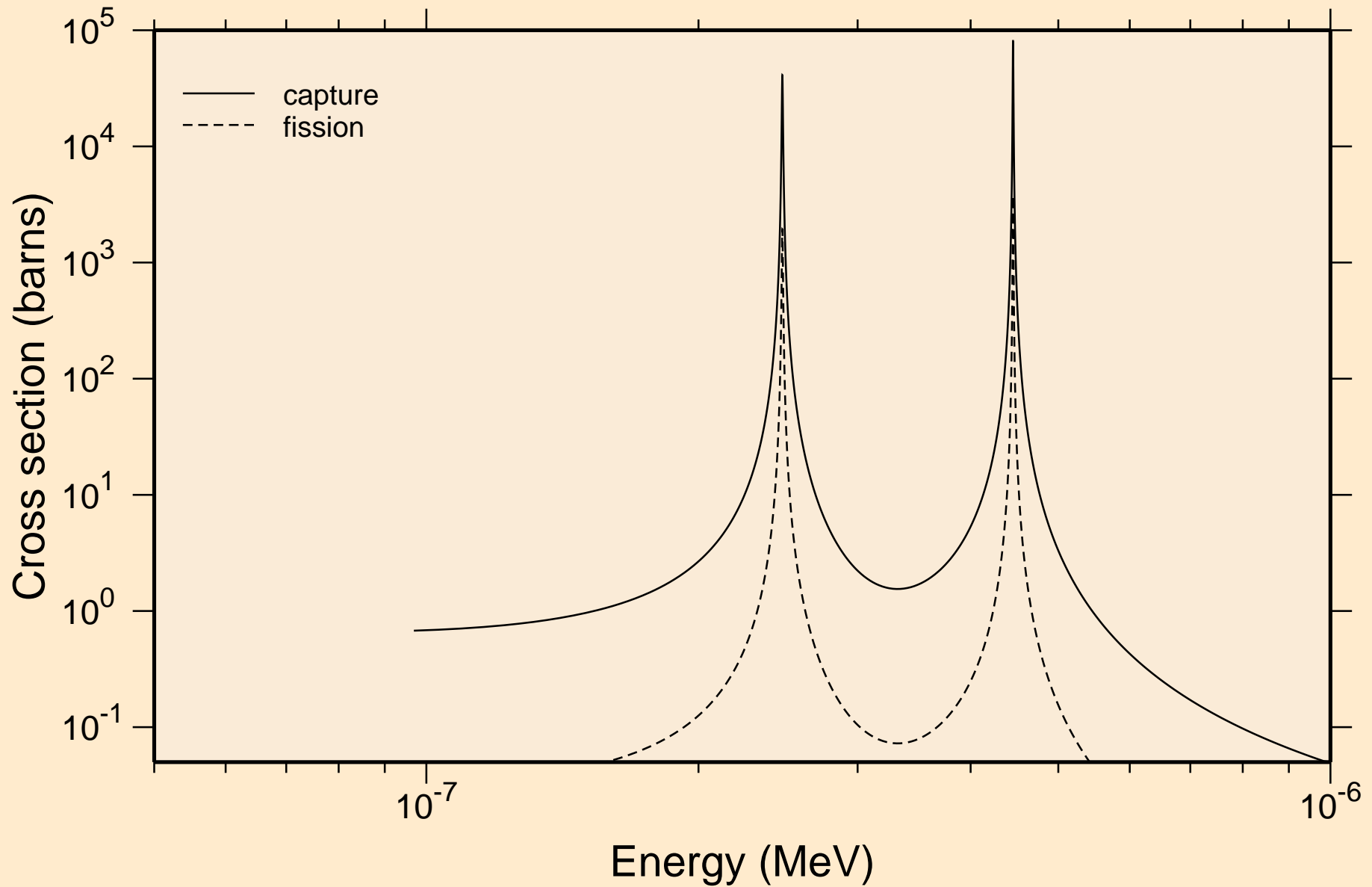

FR232 NEUTRON ACER TENDL-2024 LIBRARY; T=0.K
resonance absorption cross sections

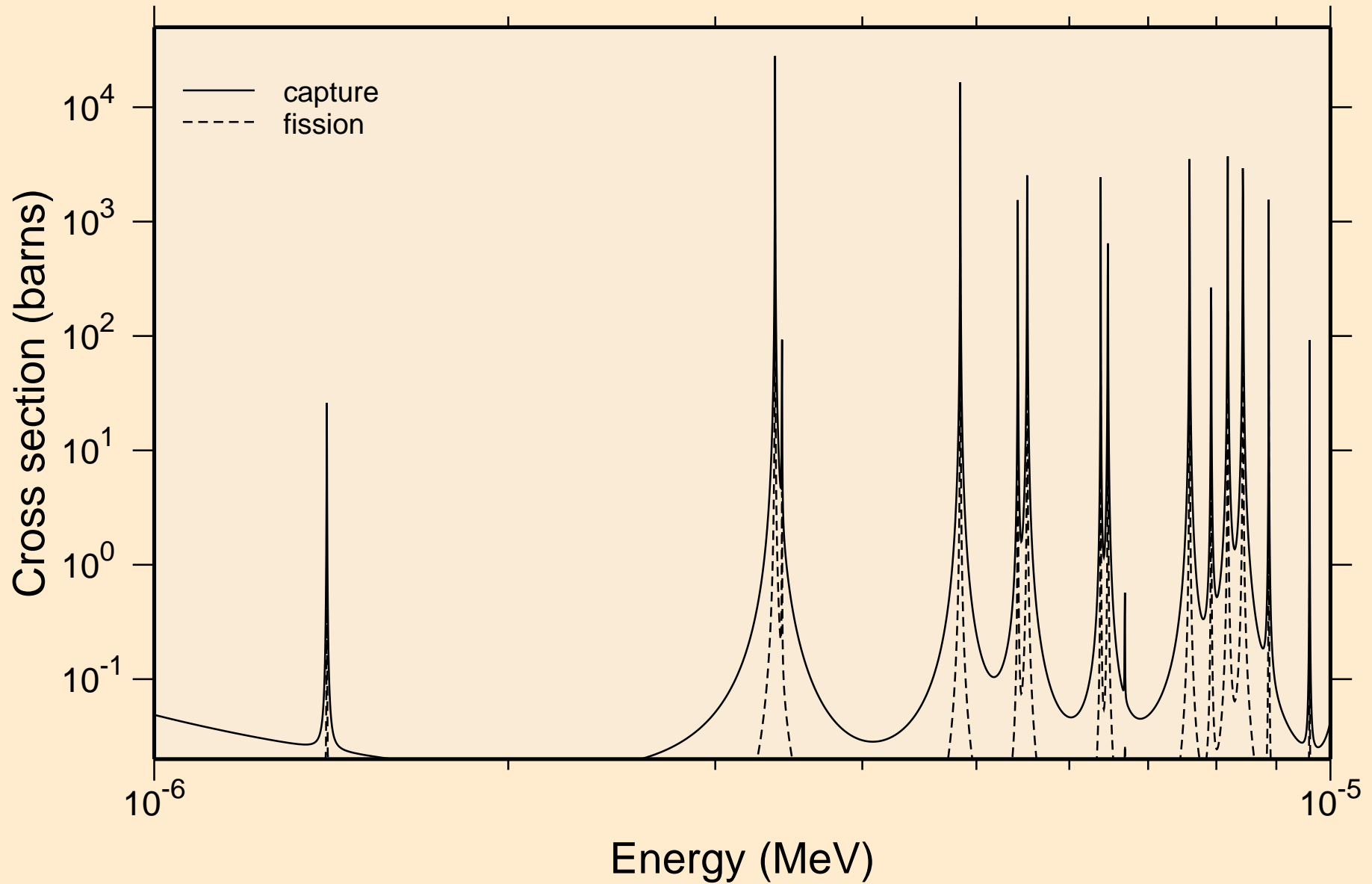

FR232 NEUTRON ACER TENDL-2024 LIBRARY; T=0.K
resonance absorption cross sections

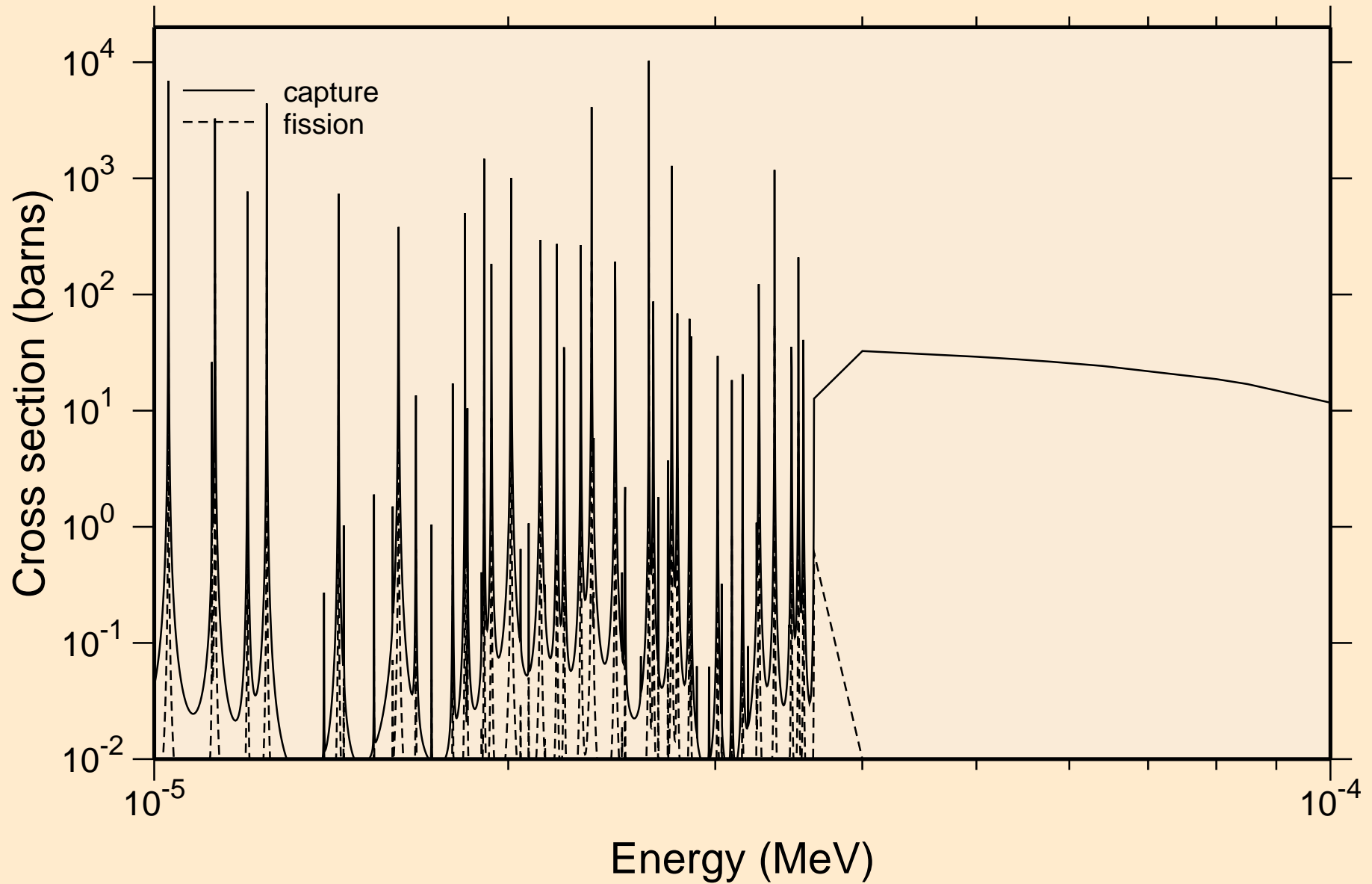

FR232 NEUTRON ACER TENDL-2024 LIBRARY; T=0.K
resonance absorption cross sections

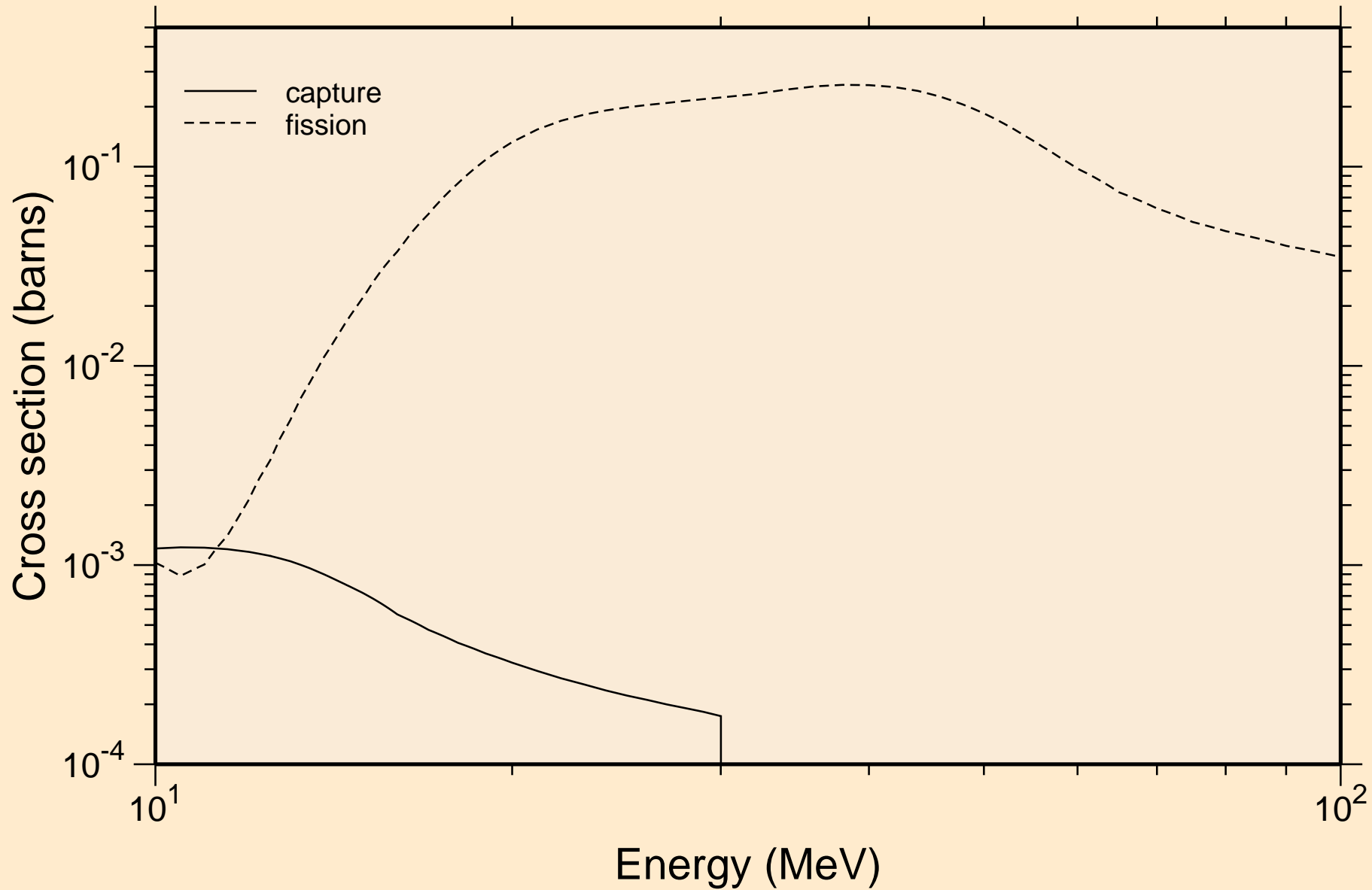

FR232 NEUTRON ACER TENDL-2024 LIBRARY; T=0.K

Heating

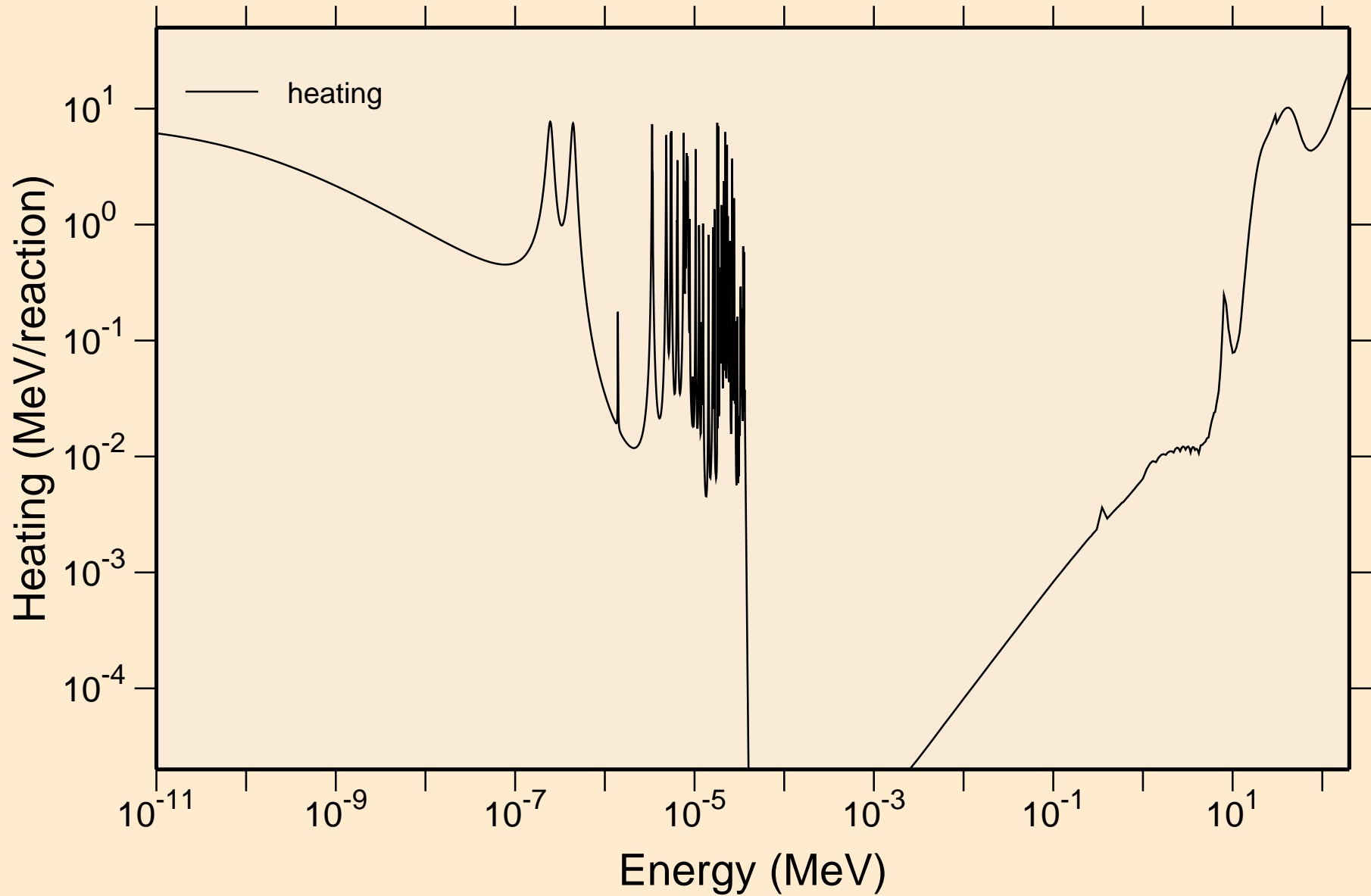

FR232 NEUTRON ACER TENDL-2024 LIBRARY; T=0.K

Damage

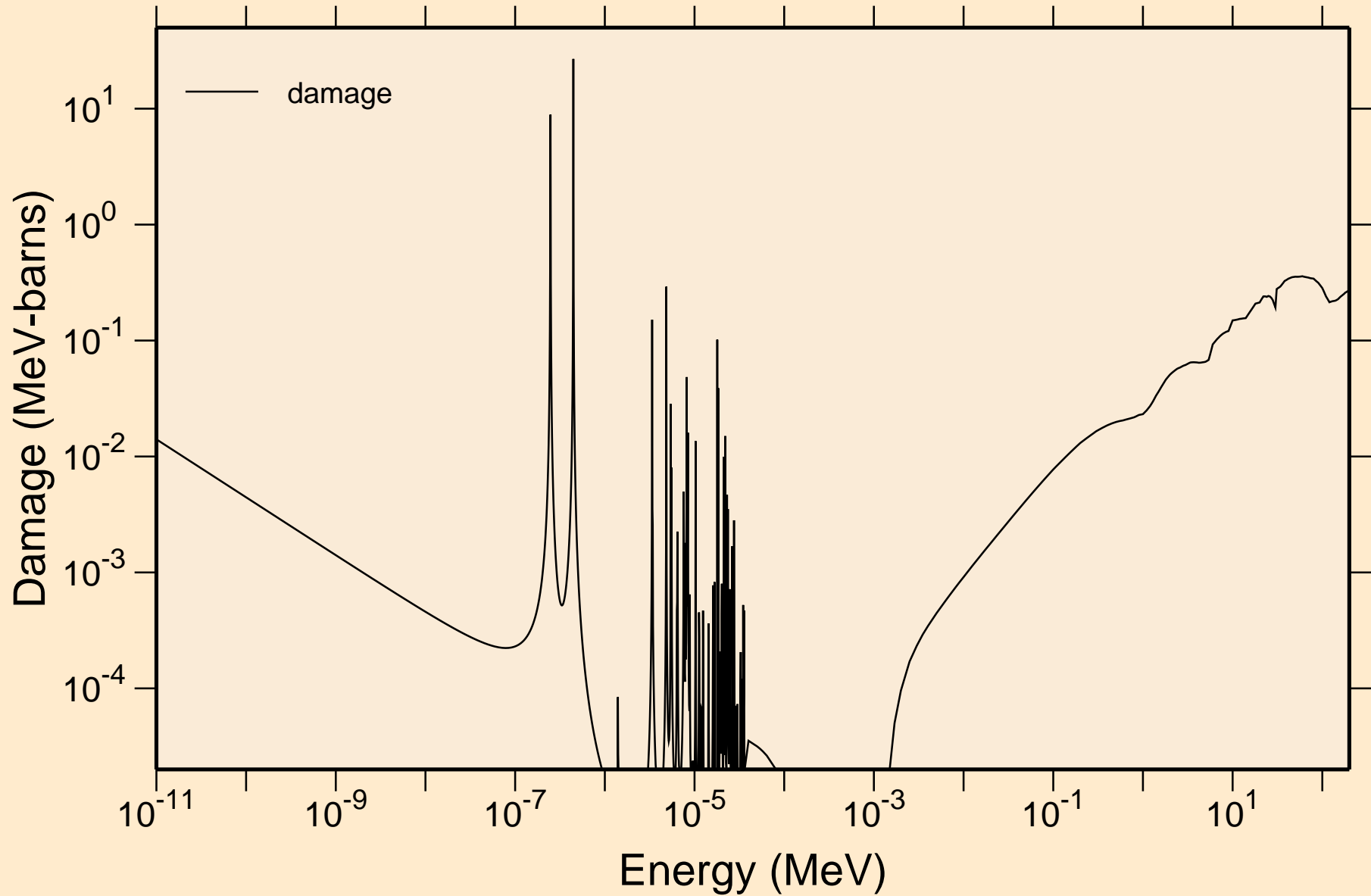

FR232 NEUTRON ACER TENDL-2024 LIBRARY; T=0.K

Non-threshold reactions

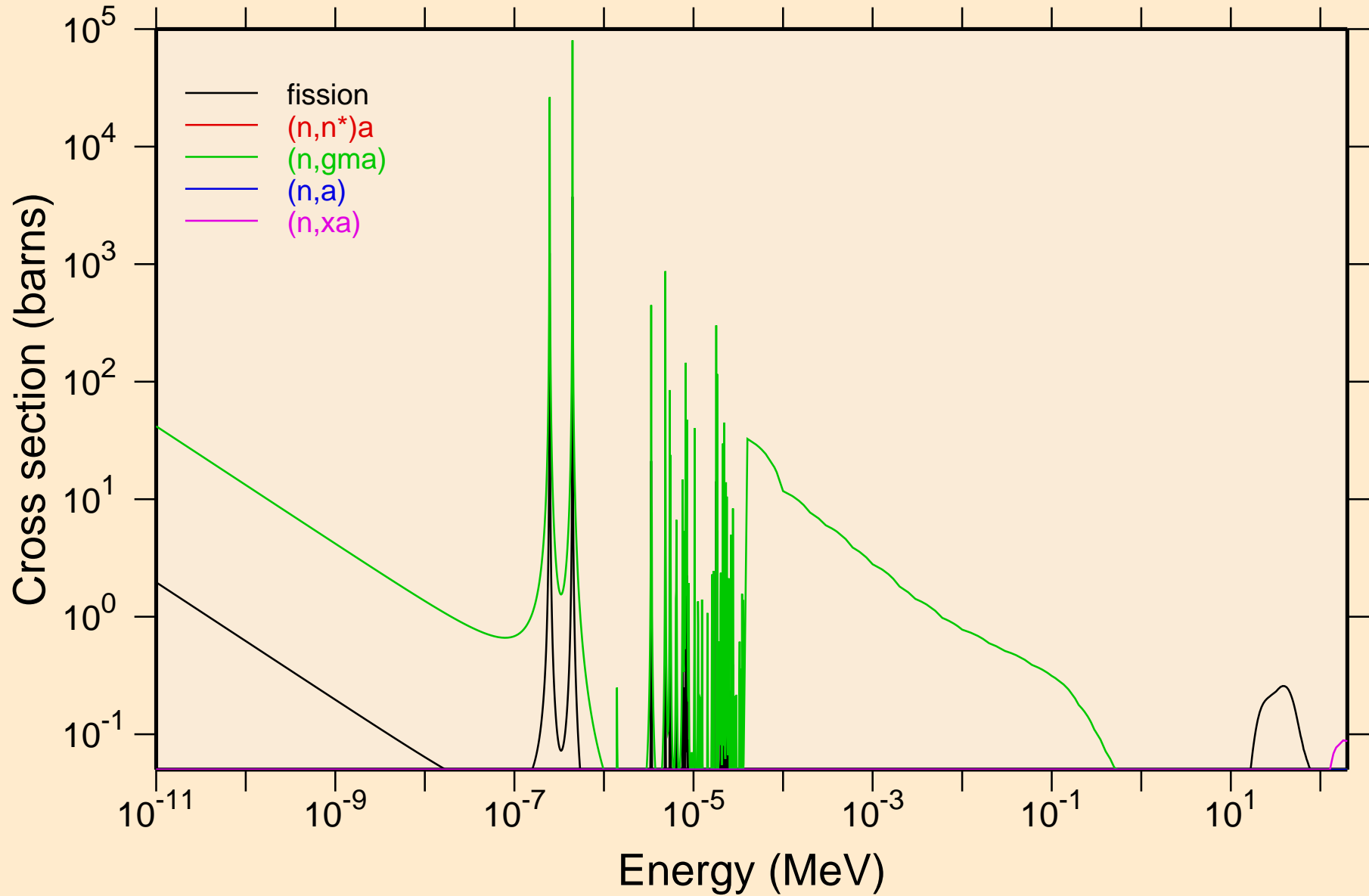

FR232 NEUTRON ACER TENDL-2024 LIBRARY; T=0.K

Principal cross sections

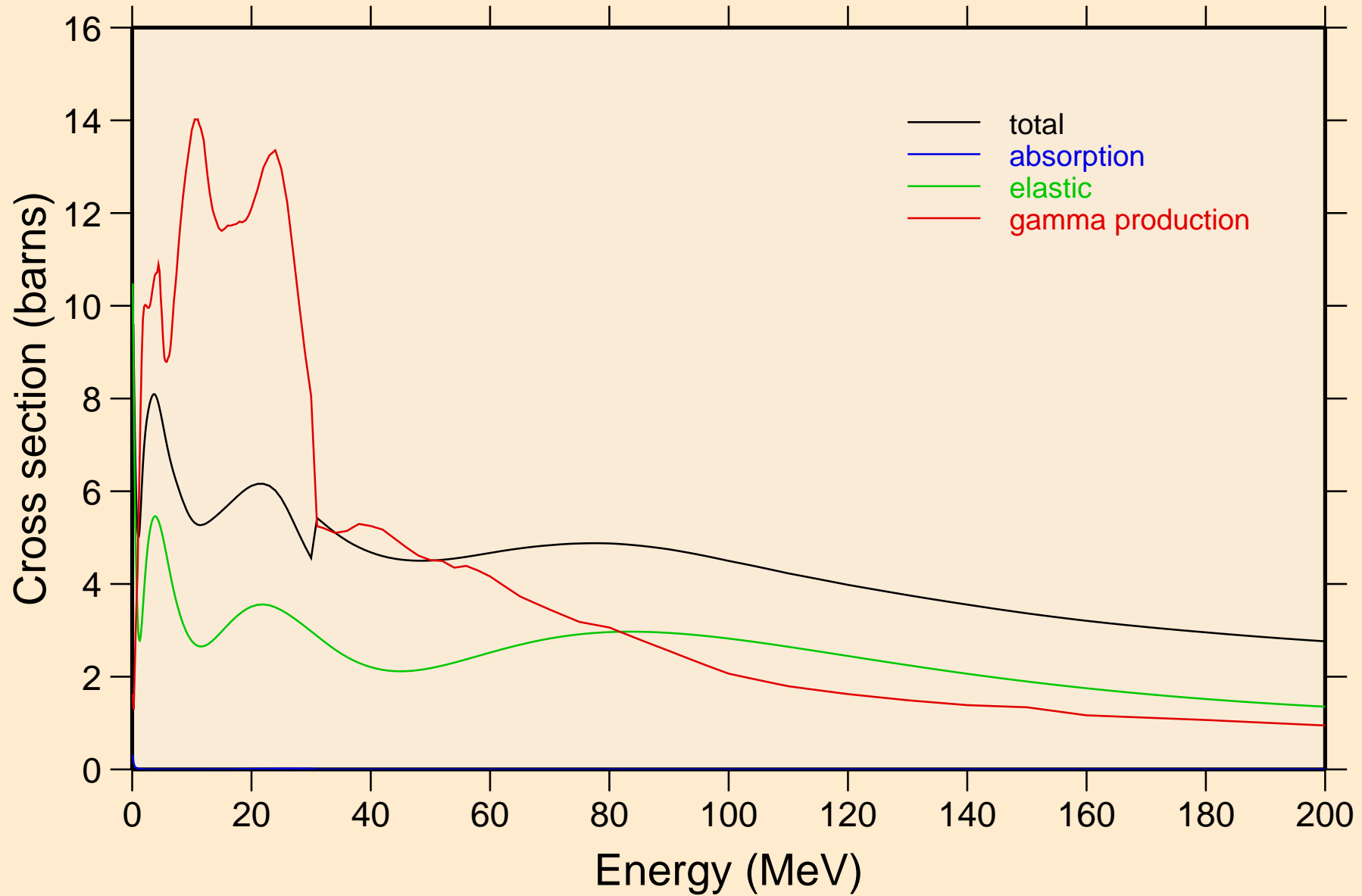

FR232 NEUTRON ACER TENDL-2024 LIBRARY; T=0.K

Heating

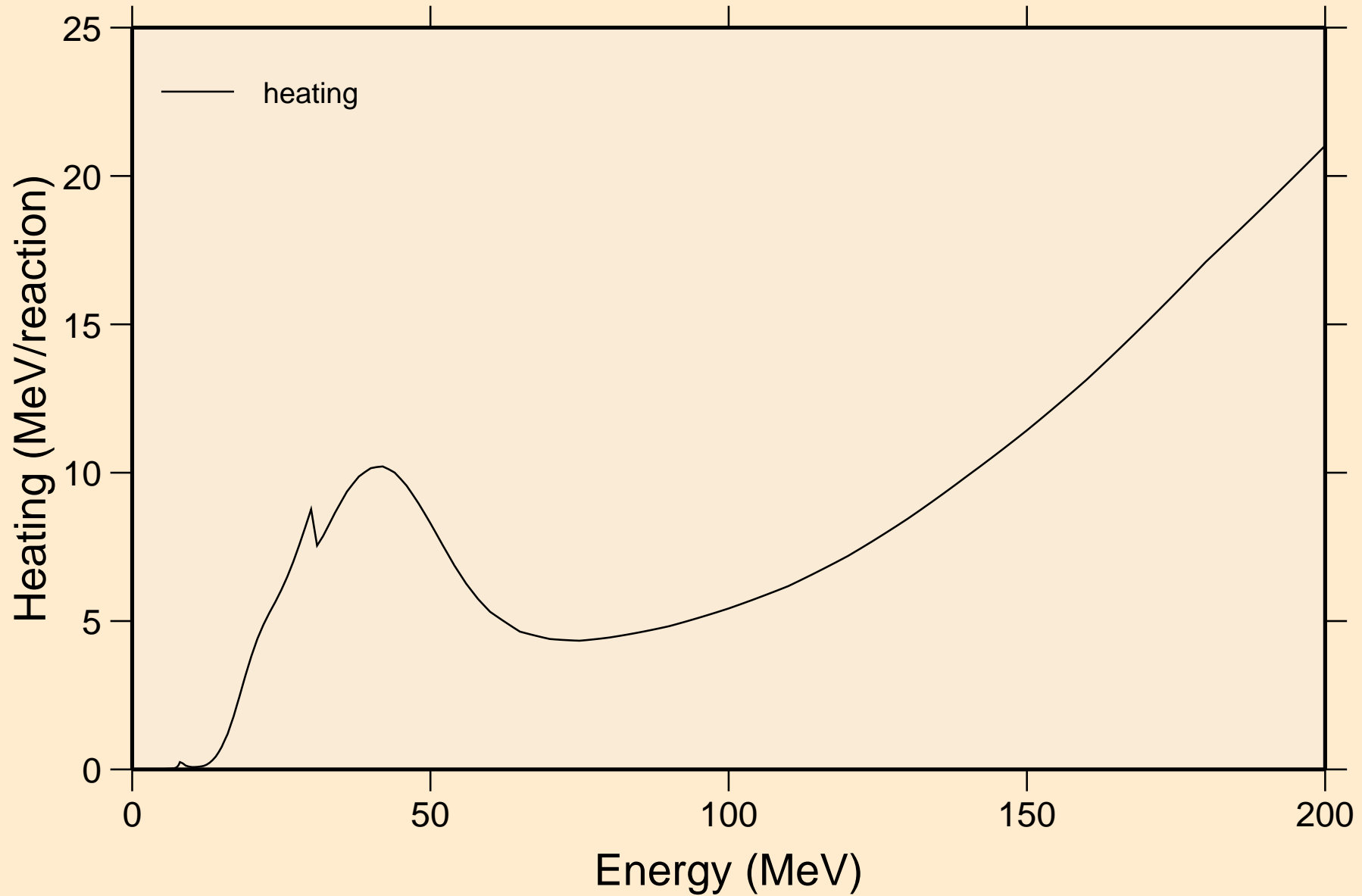

FR232 NEUTRON ACER TENDL-2024 LIBRARY; T=0.K
Damage

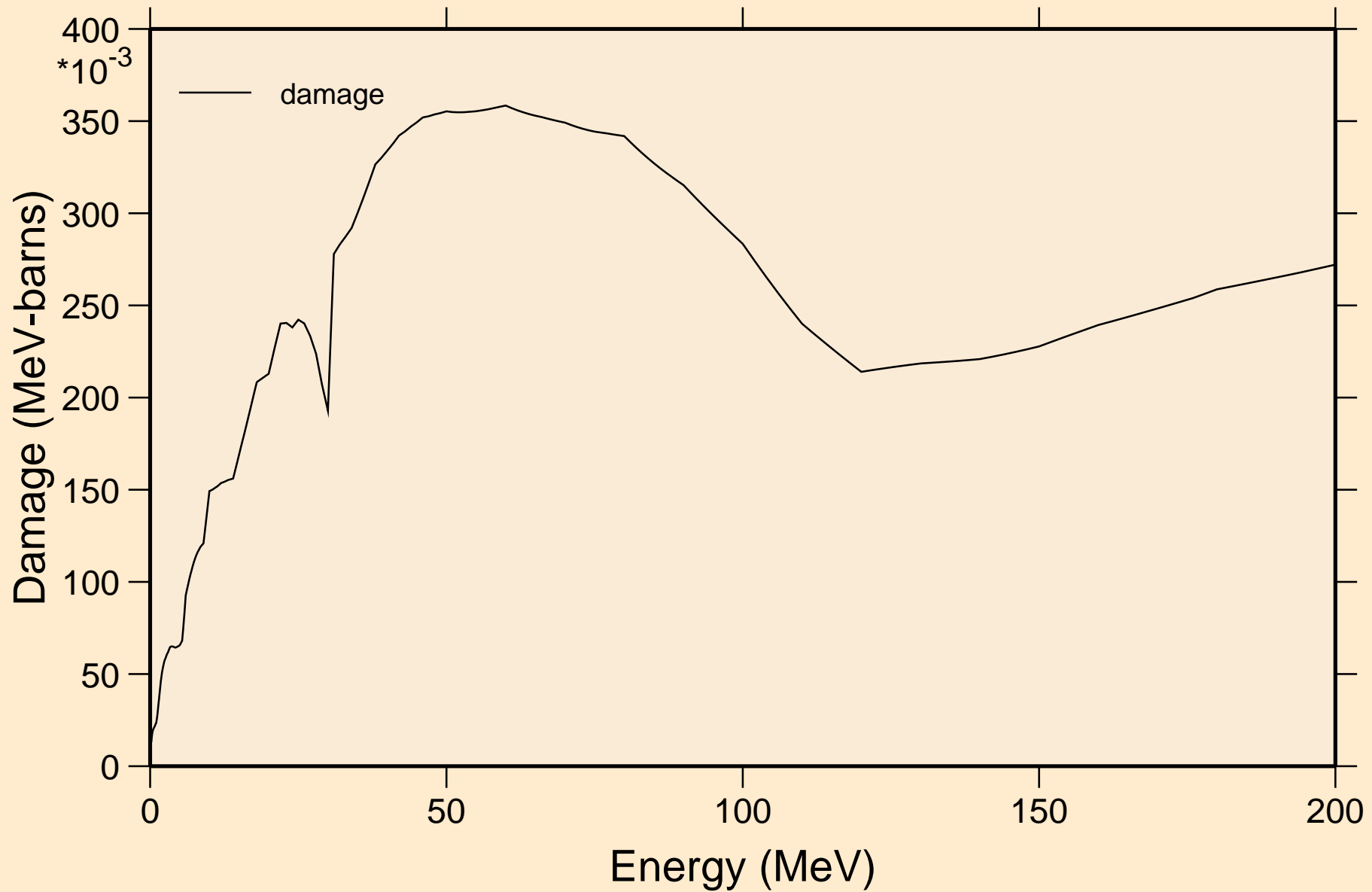

FR232 NEUTRON ACER TENDL-2024 LIBRARY; T=0.K

Non-threshold reactions

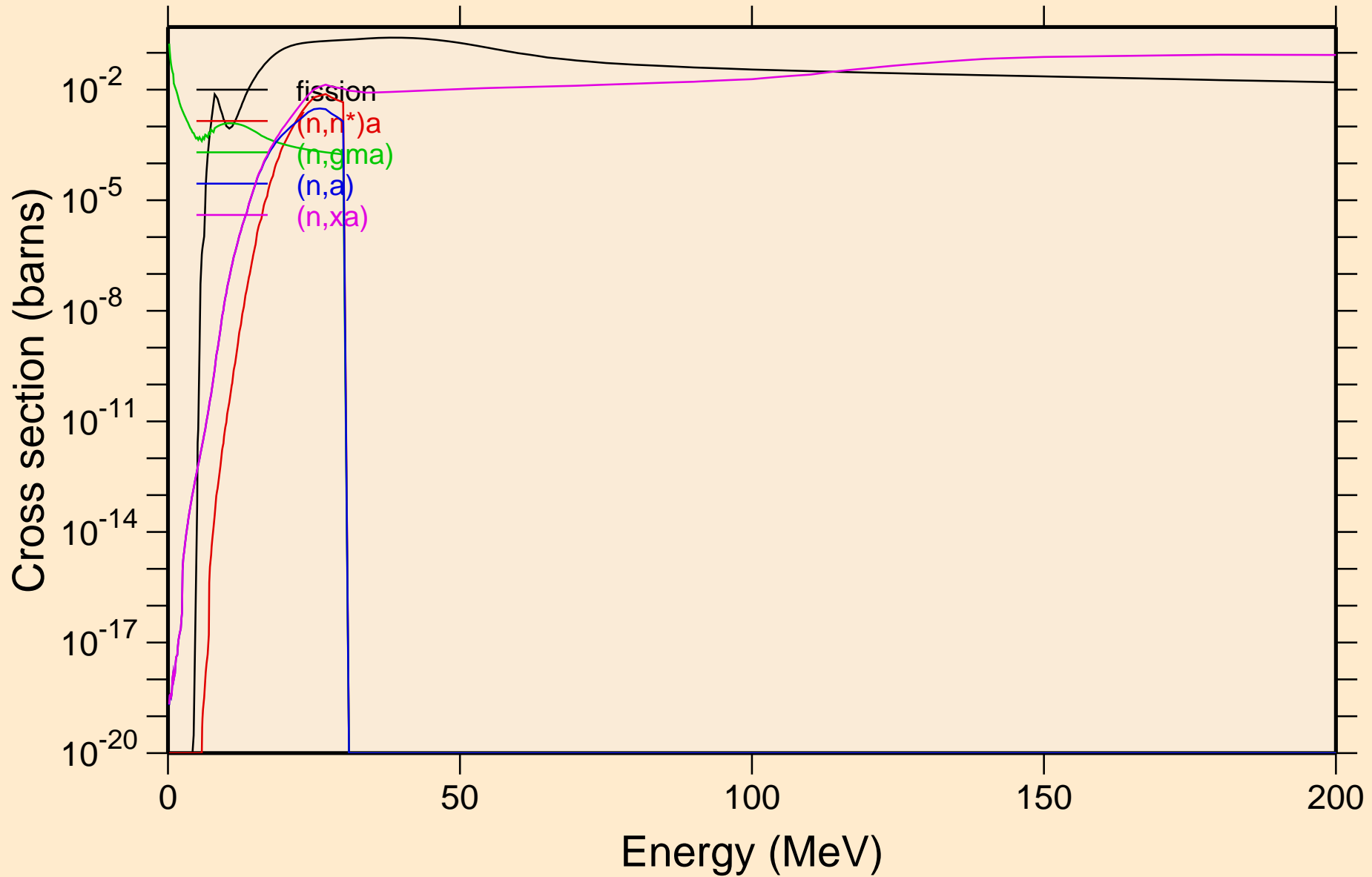

FR232 NEUTRON ACER TENDL-2024 LIBRARY; T=0.K
Inelastic levels

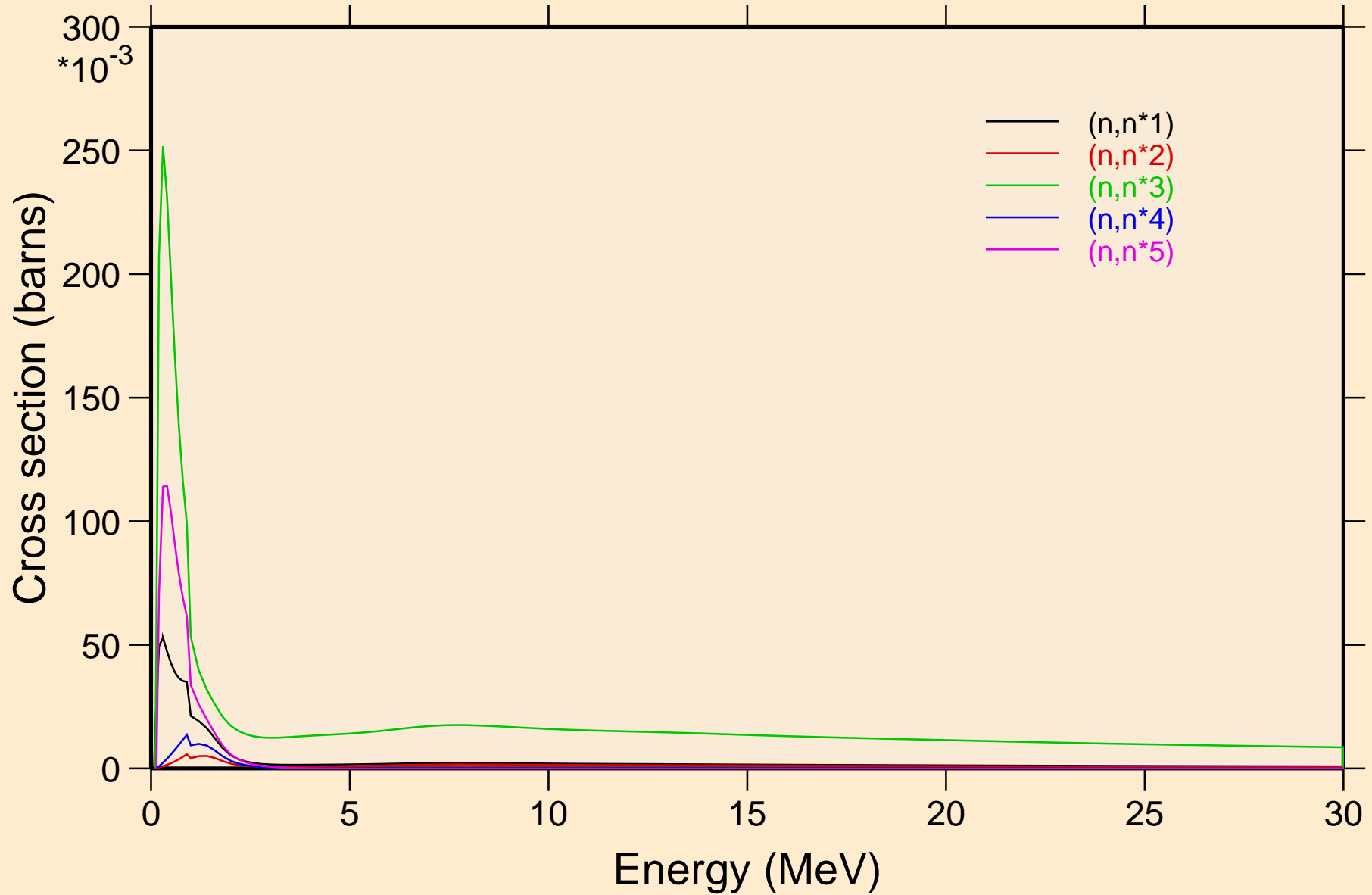

FR232 NEUTRON ACER TENDL-2024 LIBRARY; T=0.K
Inelastic levels

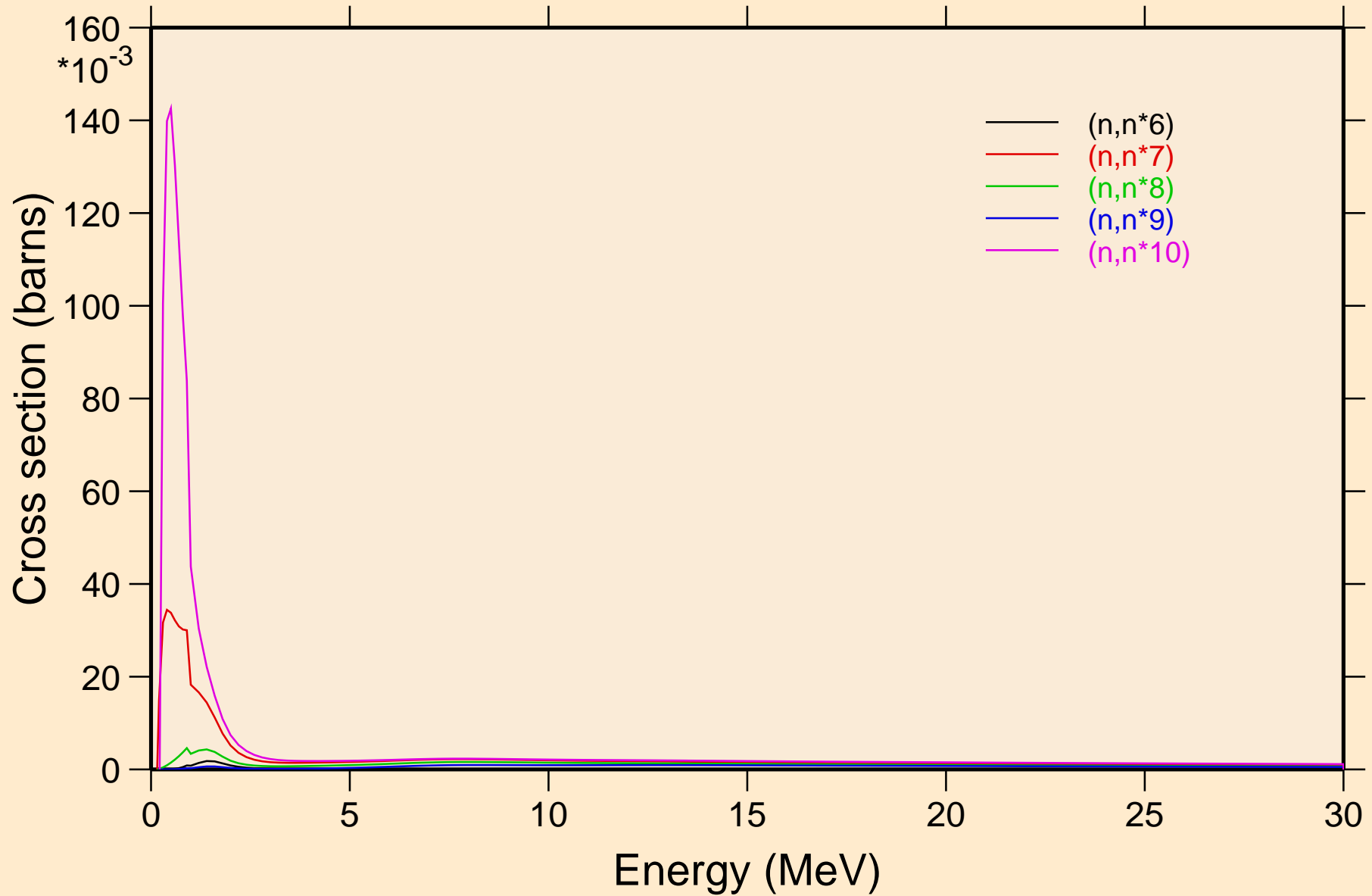

FR232 NEUTRON ACER TENDL-2024 LIBRARY; T=0.K
Inelastic levels

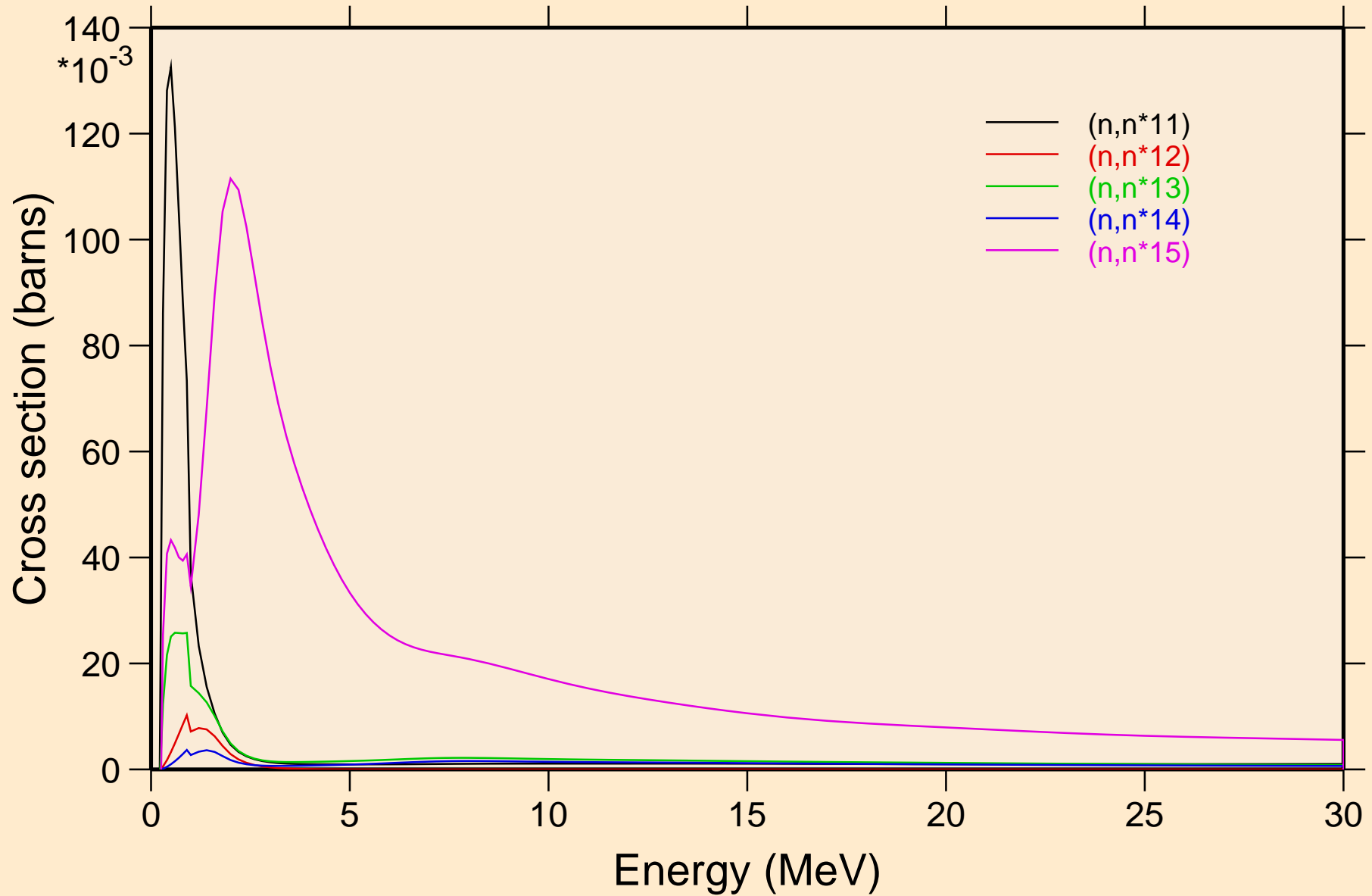

FR232 NEUTRON ACER TENDL-2024 LIBRARY; T=0.K
Inelastic levels

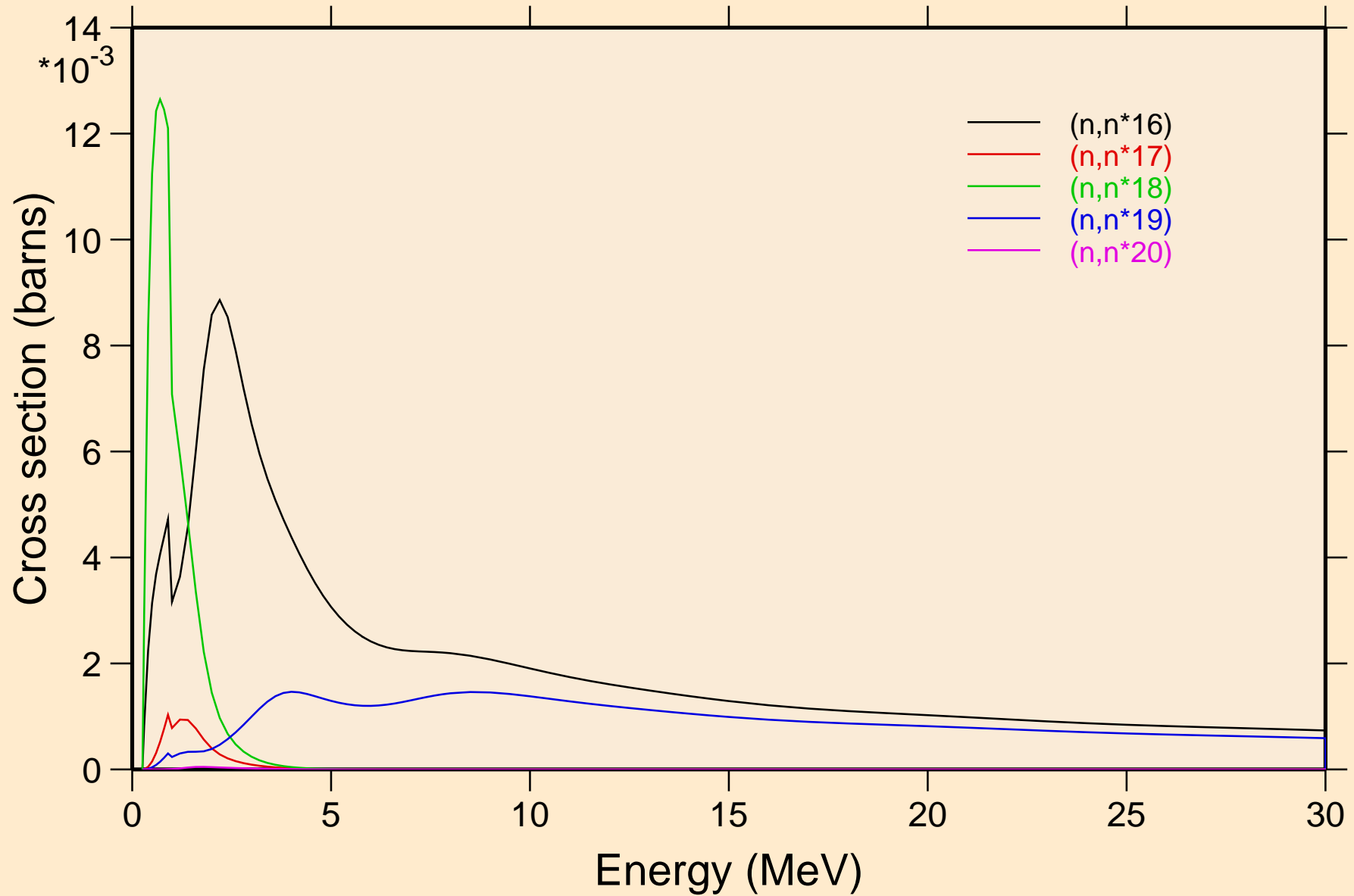

FR232 NEUTRON ACER TENDL-2024 LIBRARY; T=0.K
Inelastic levels

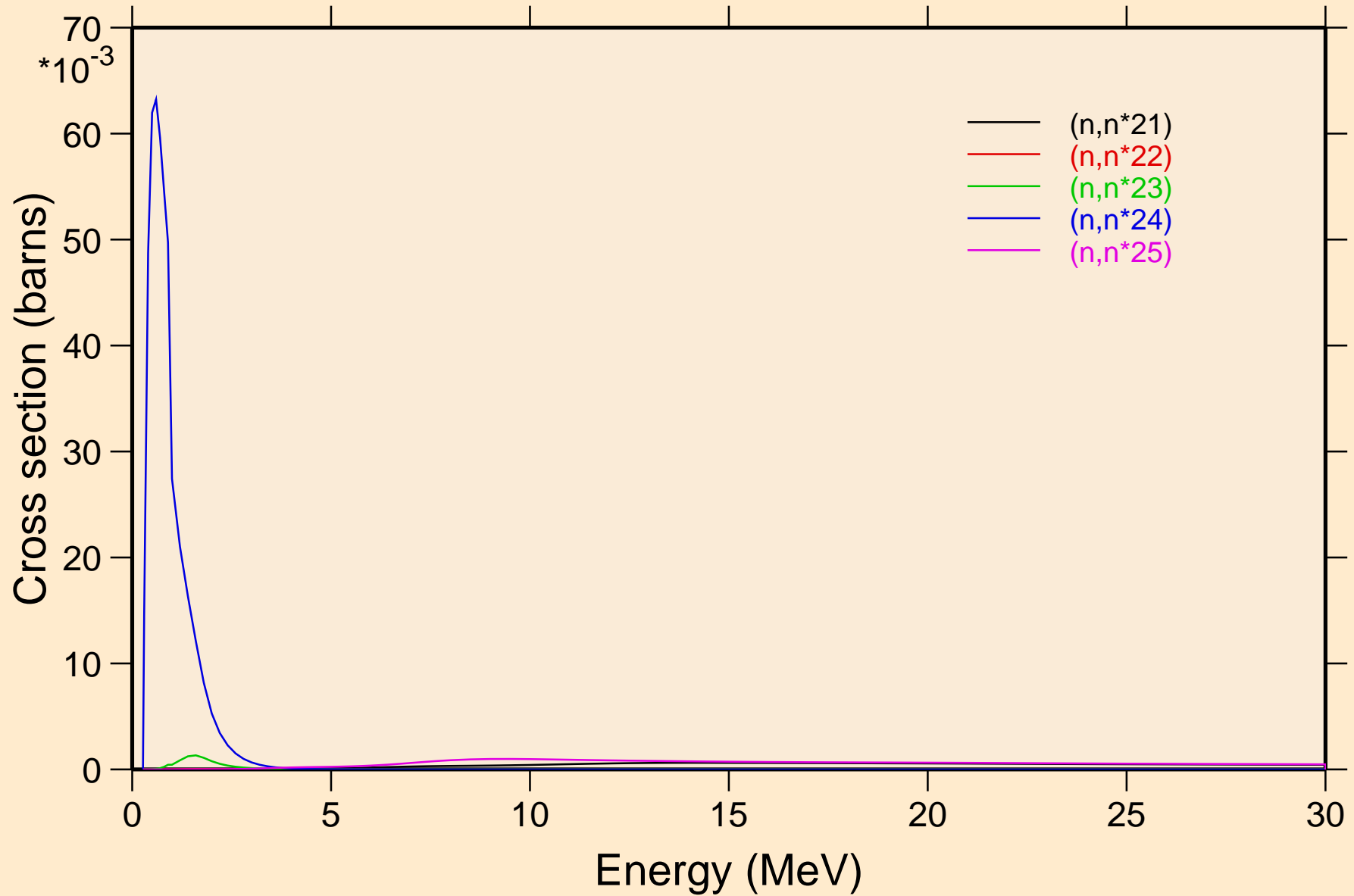

FR232 NEUTRON ACER TENDL-2024 LIBRARY; T=0.K
Inelastic levels

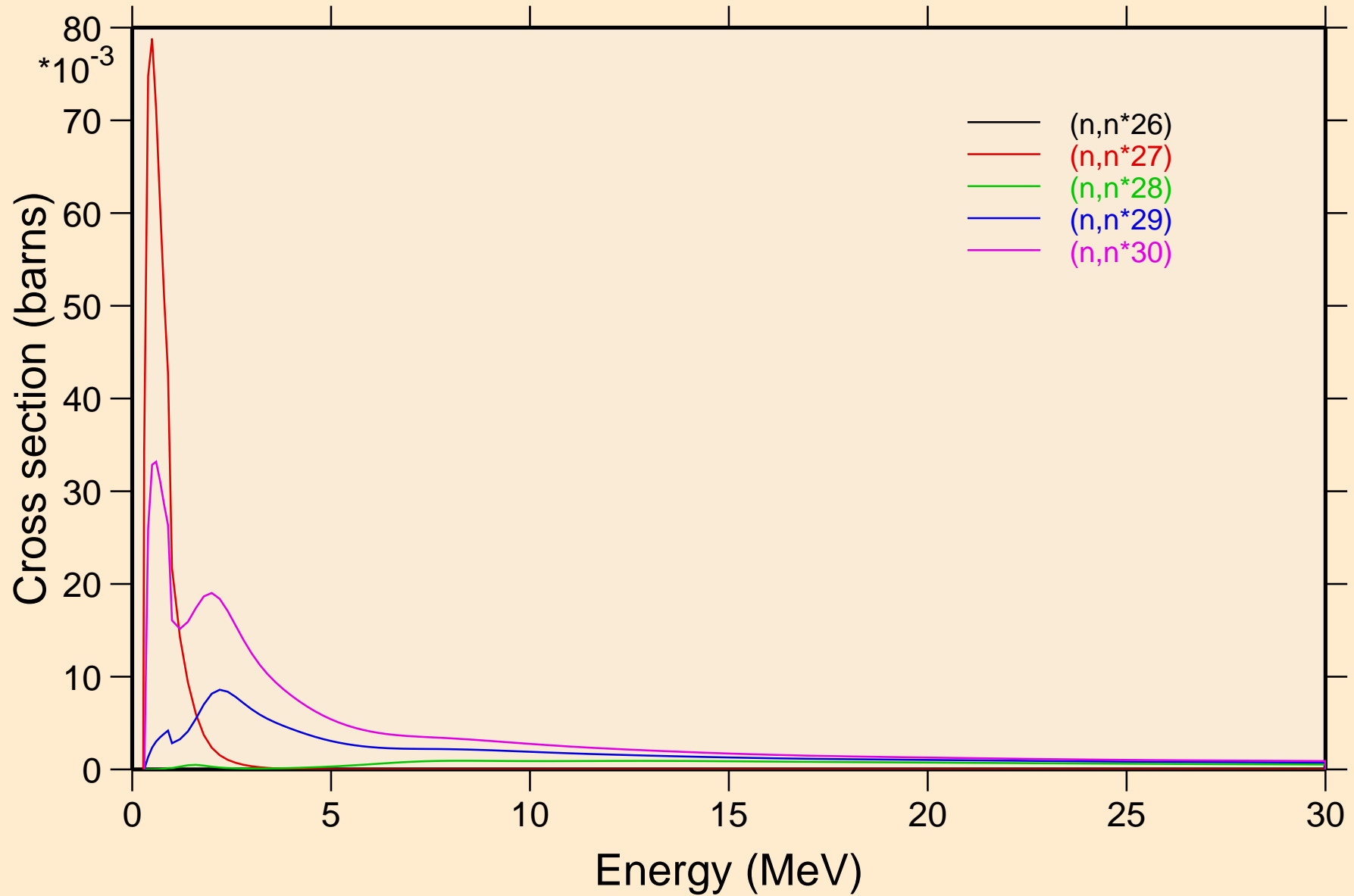

FR232 NEUTRON ACER TENDL-2024 LIBRARY; T=0.K
Threshold reactions

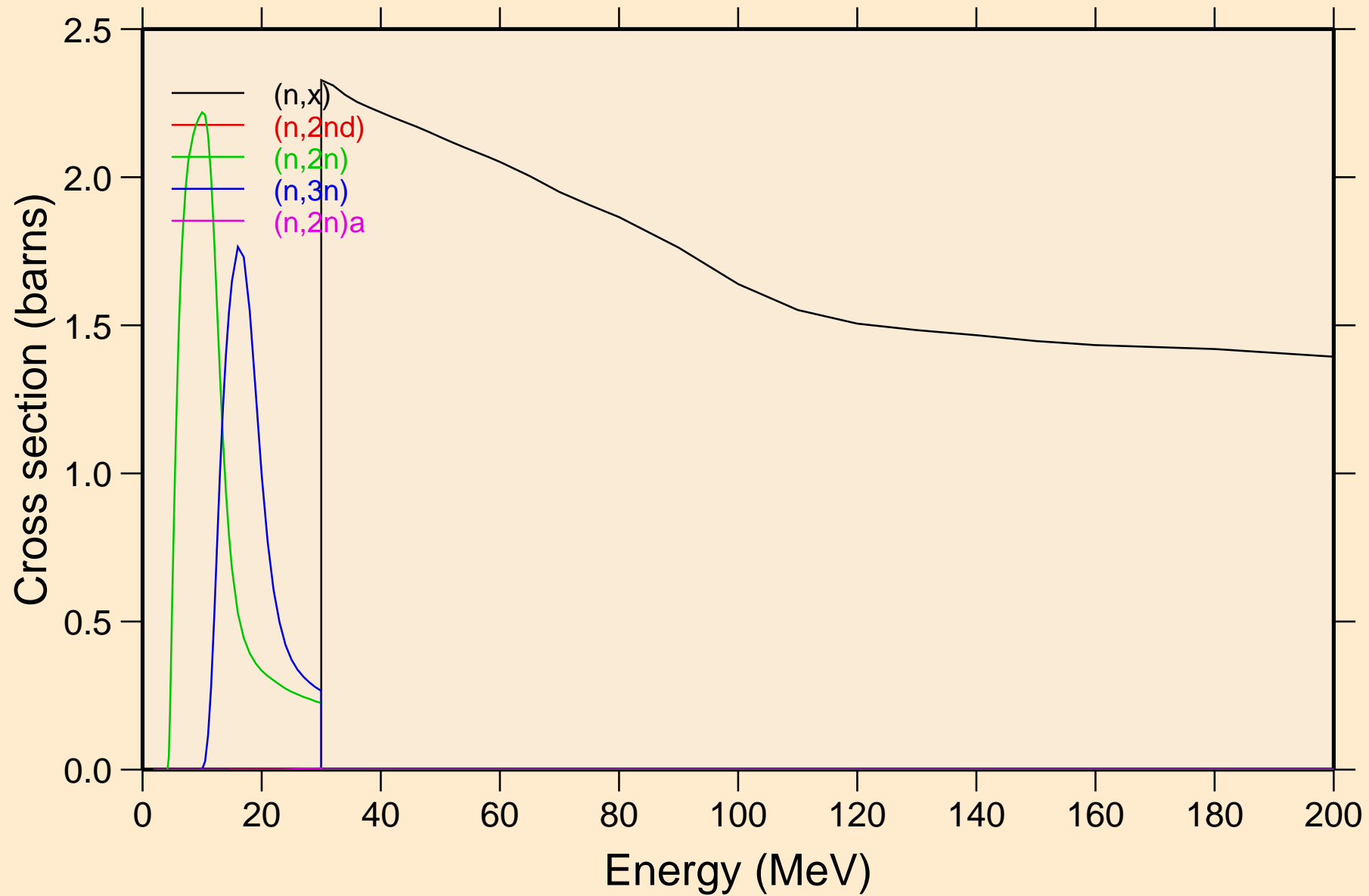

FR232 NEUTRON ACER TENDL-2024 LIBRARY; T=0.K
Threshold reactions

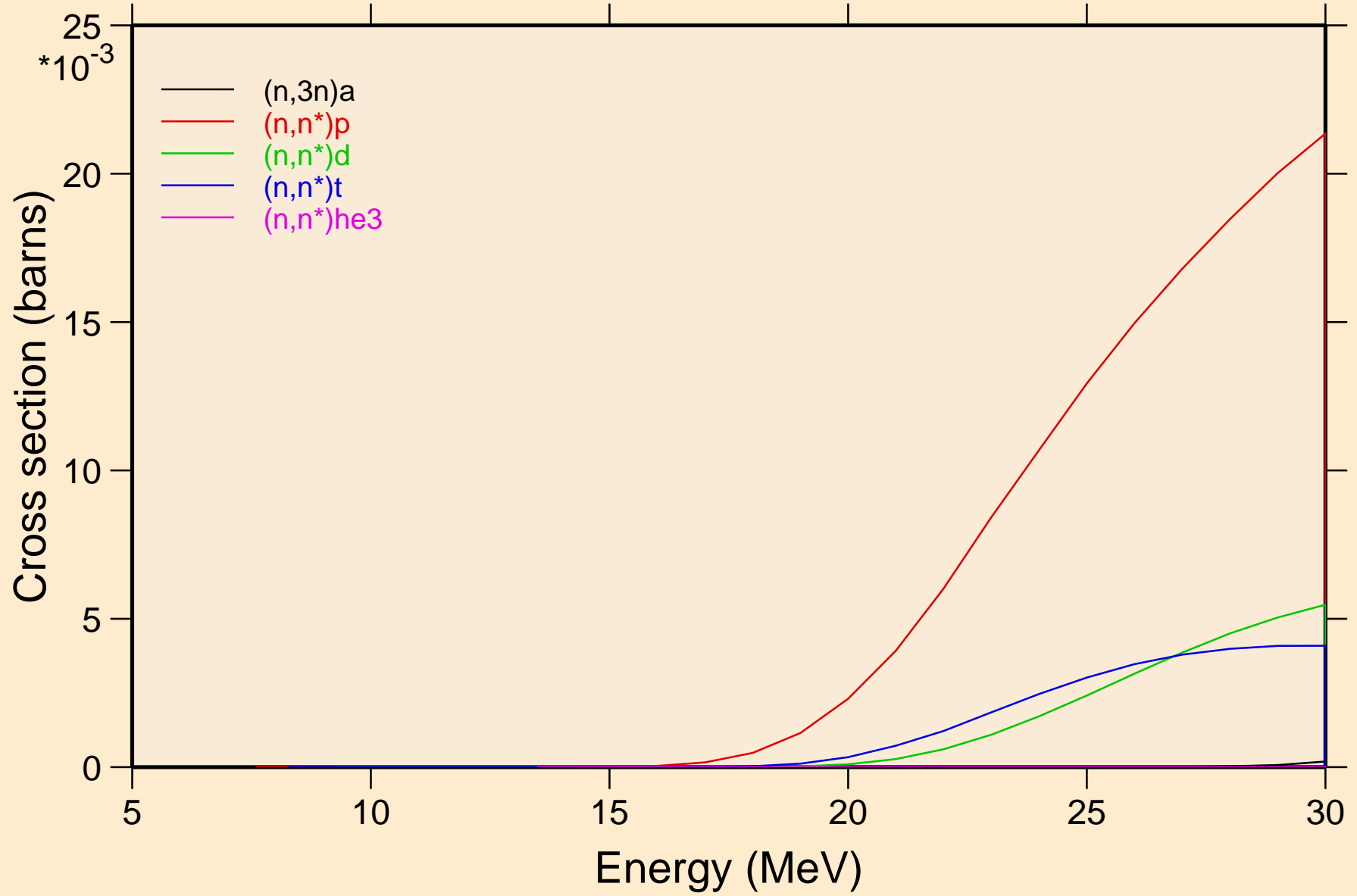

FR232 NEUTRON ACER TENDL-2024 LIBRARY; T=0.K
Threshold reactions

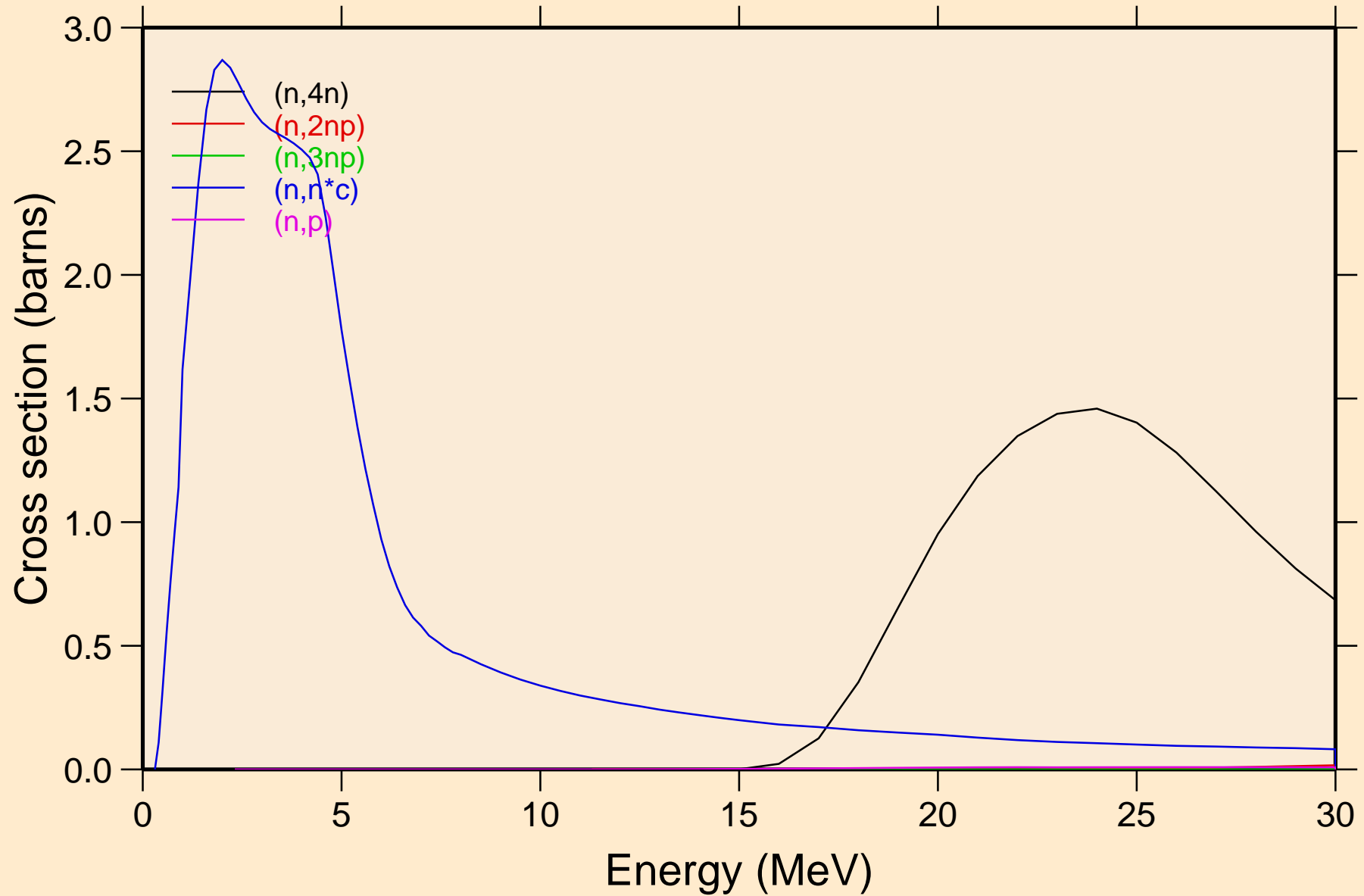

FR232 NEUTRON ACER TENDL-2024 LIBRARY; T=0.K
Threshold reactions

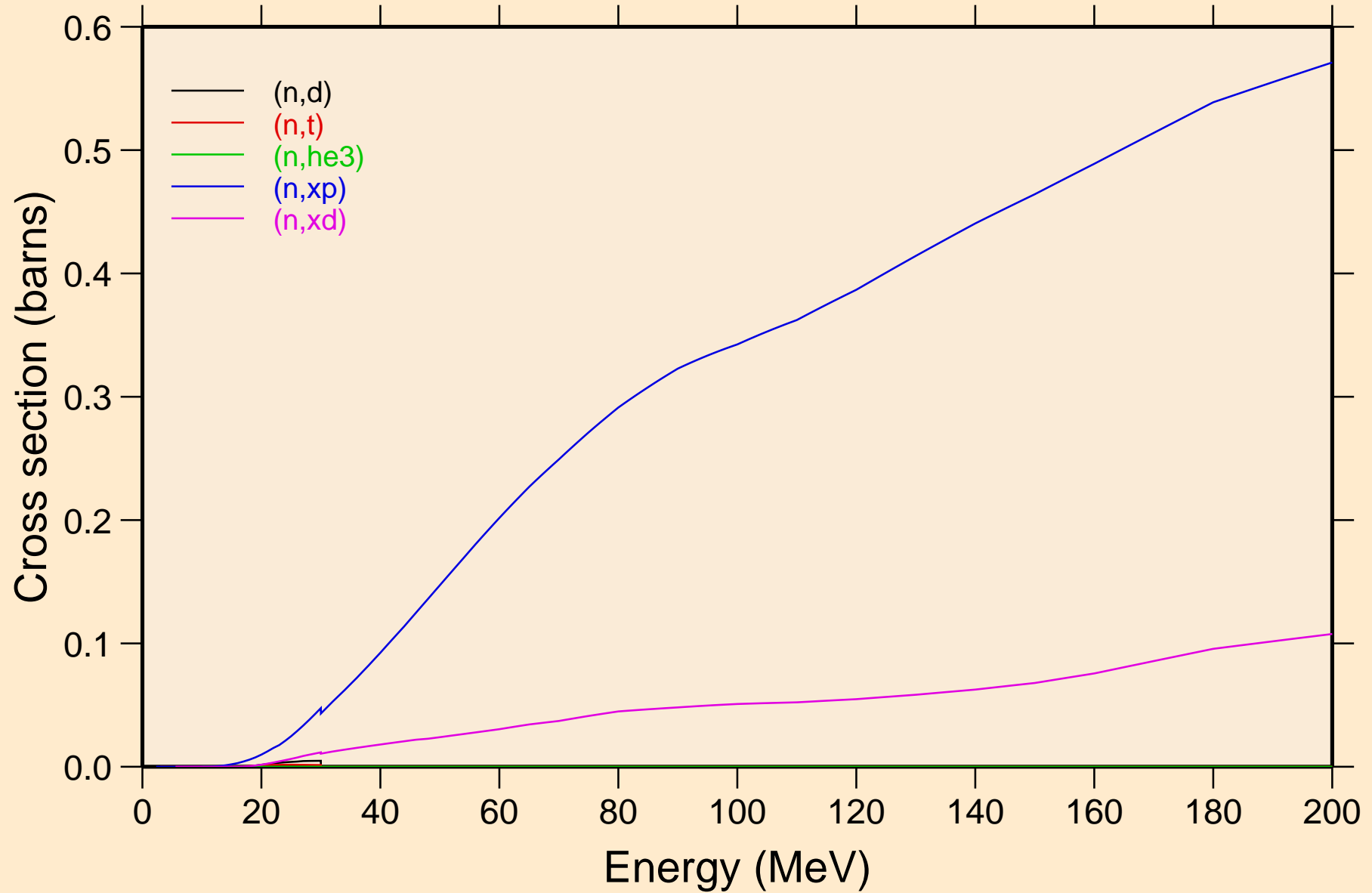

FR232 NEUTRON ACER TENDL-2024 LIBRARY; T=0.K
Threshold reactions

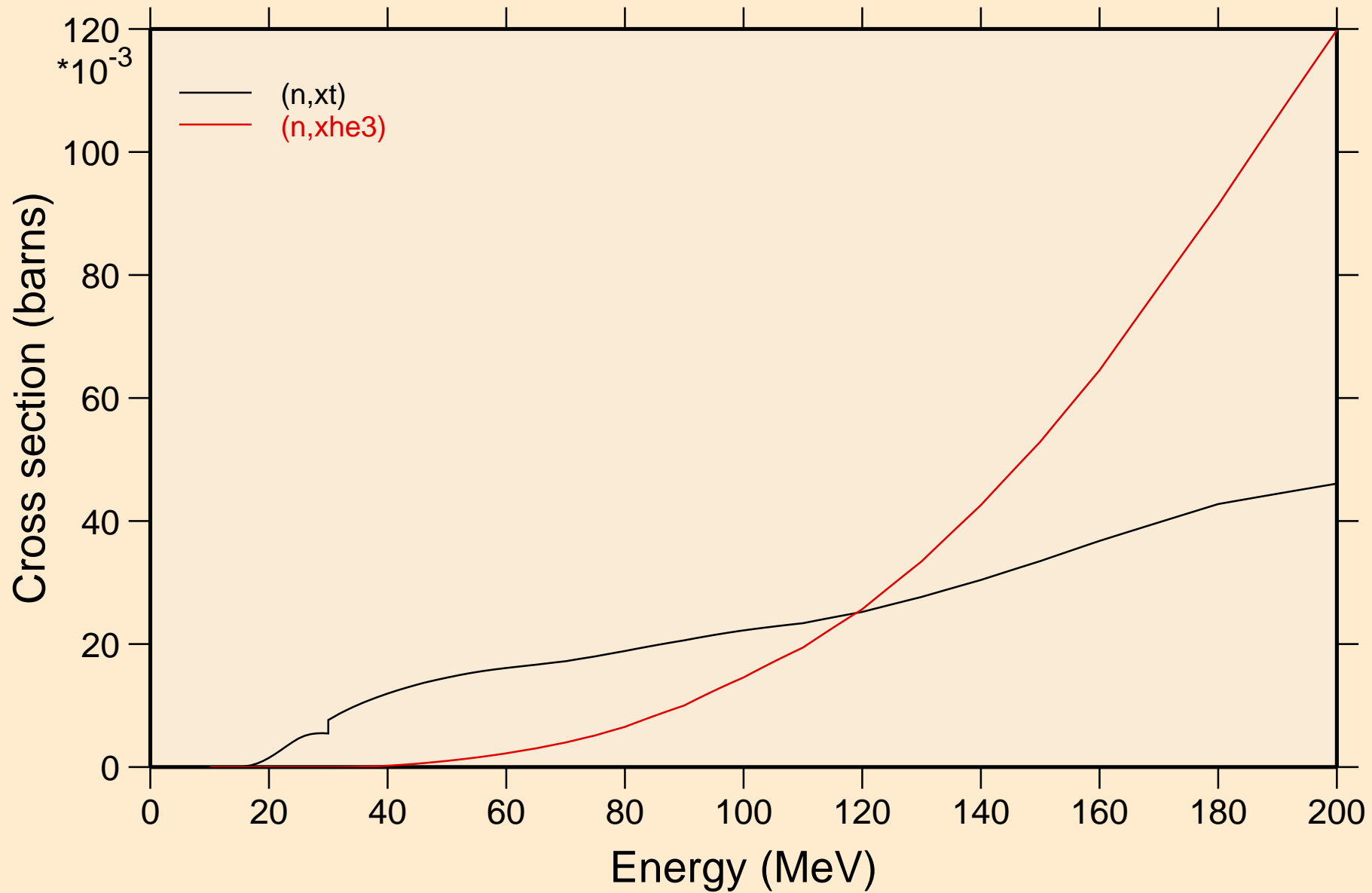

FR232 NEUTRON ACER TENDL-2024 LIBRARY; T=0.K
angular distribution for elastic

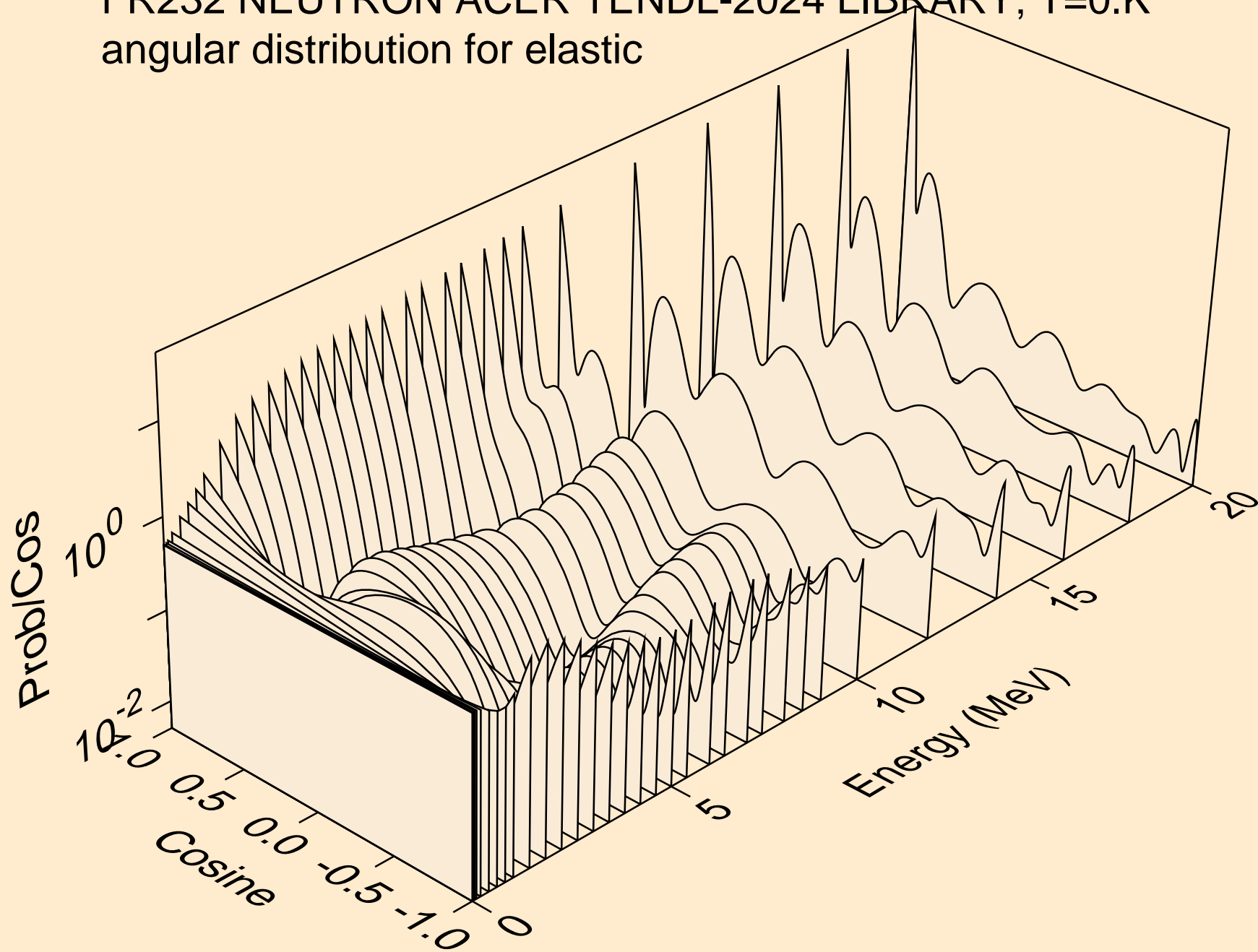

FR232 NEUTRON ACER TENDL-2024 LIBRARY; T=0.K
angular distribution for elastic

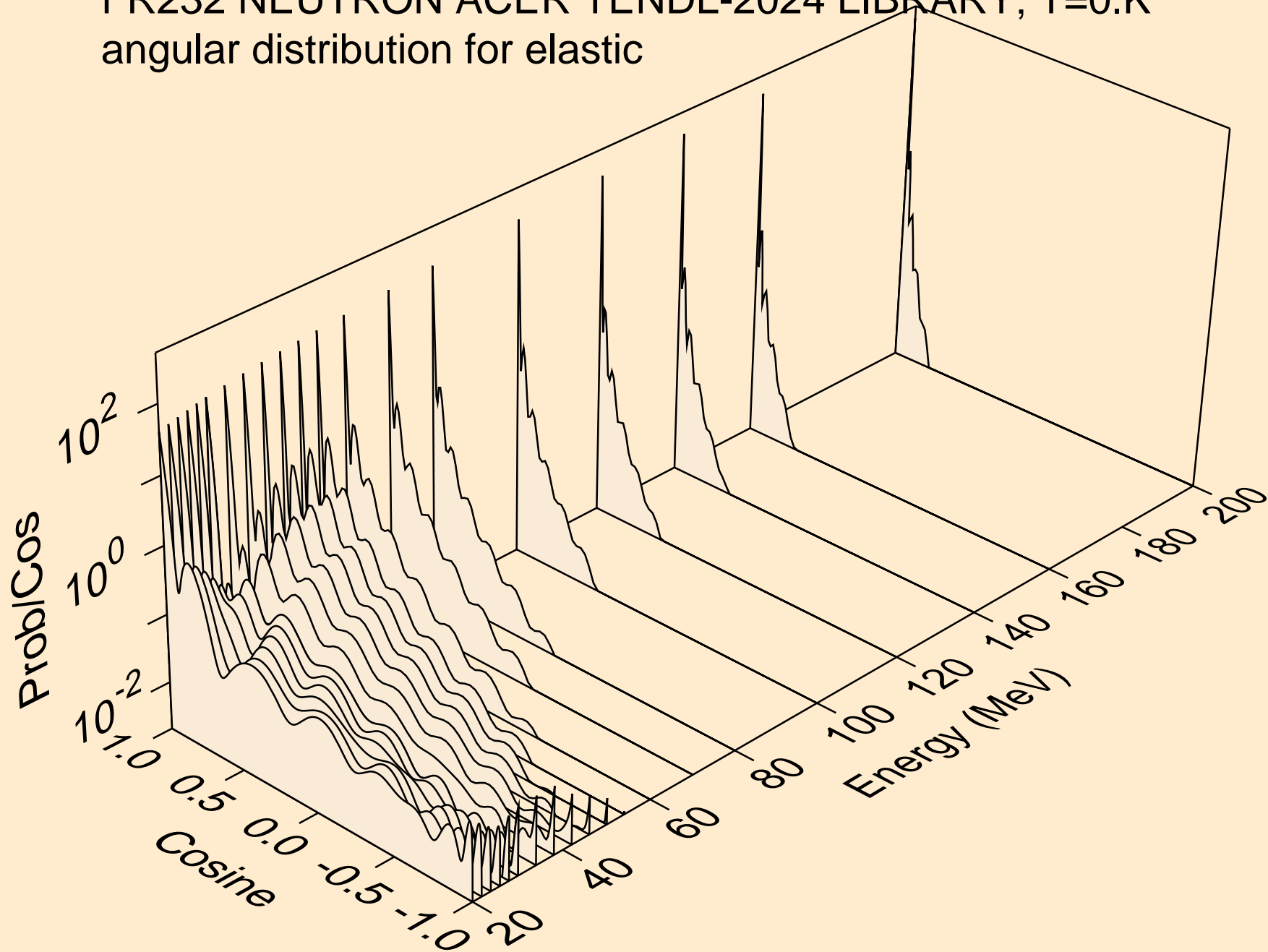

FR232 NEUTRON ACER TENDL-2024 LIBRARY; T=0.K
angular distribution for (n,n*1)

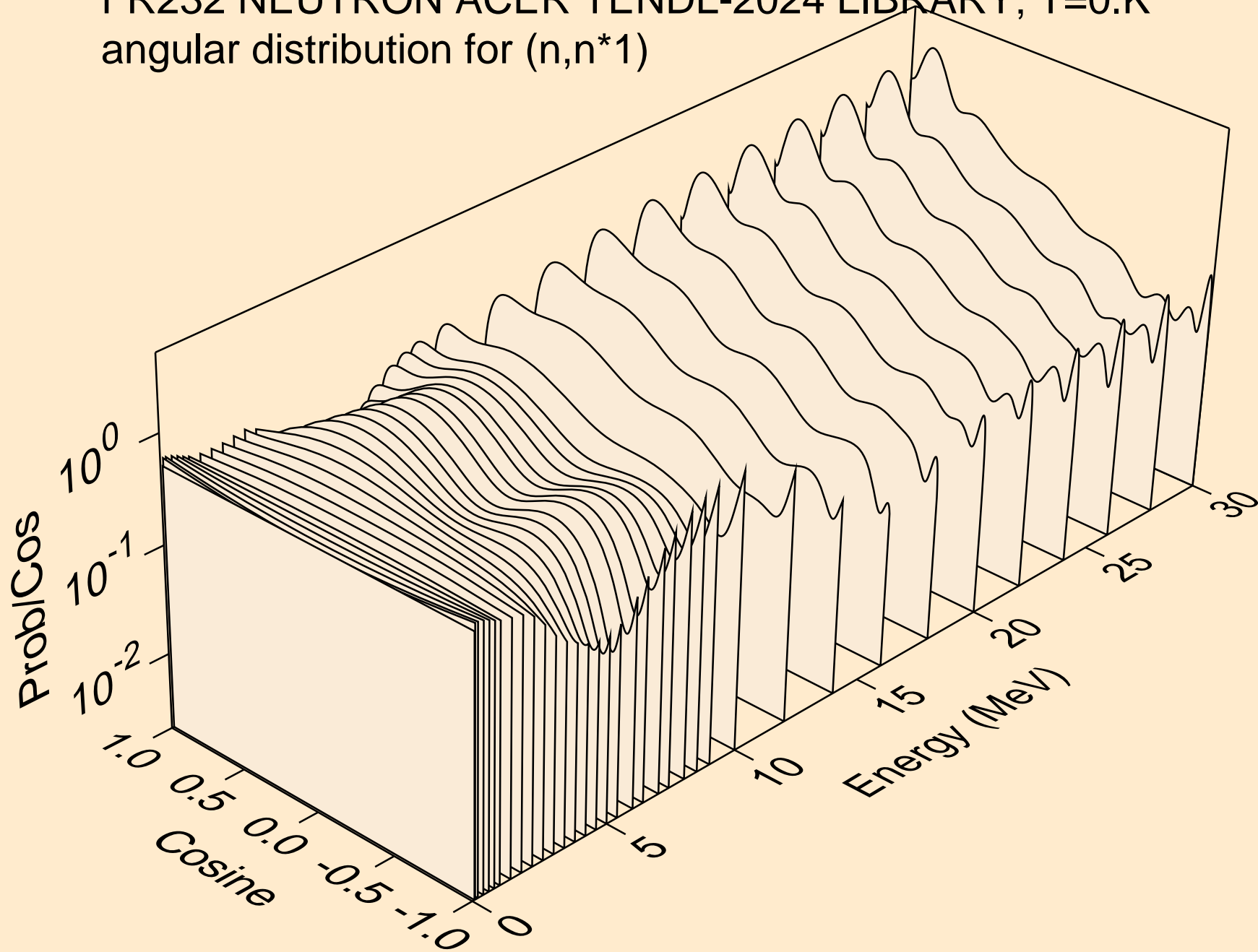

FR232 NEUTRON ACER TENDL-2024 LIBRARY; T=0.K
angular distribution for (n,n*2)

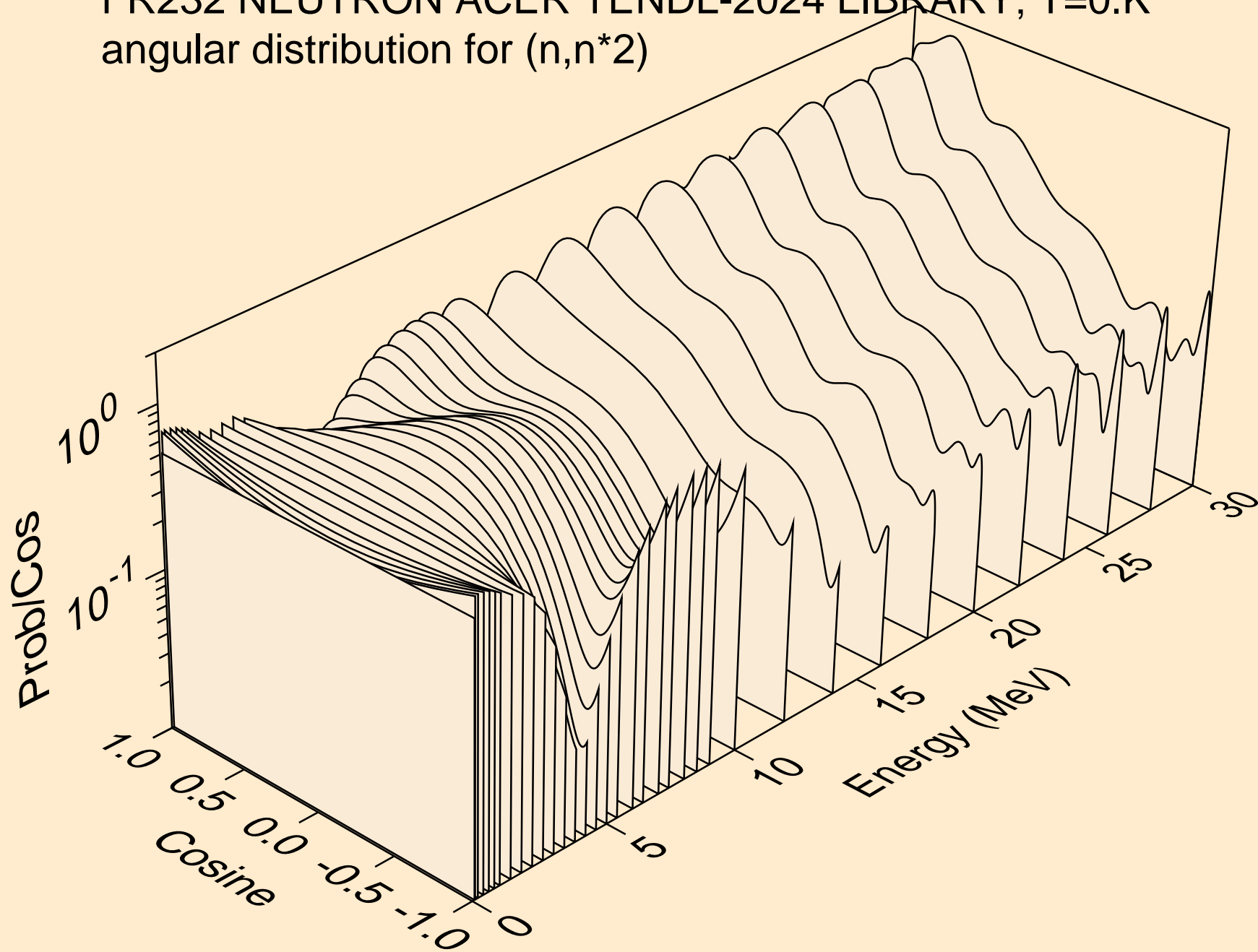

FR232 NEUTRON ACER TENDL-2024 LIBRARY; T=0.K
angular distribution for (n,n*3)

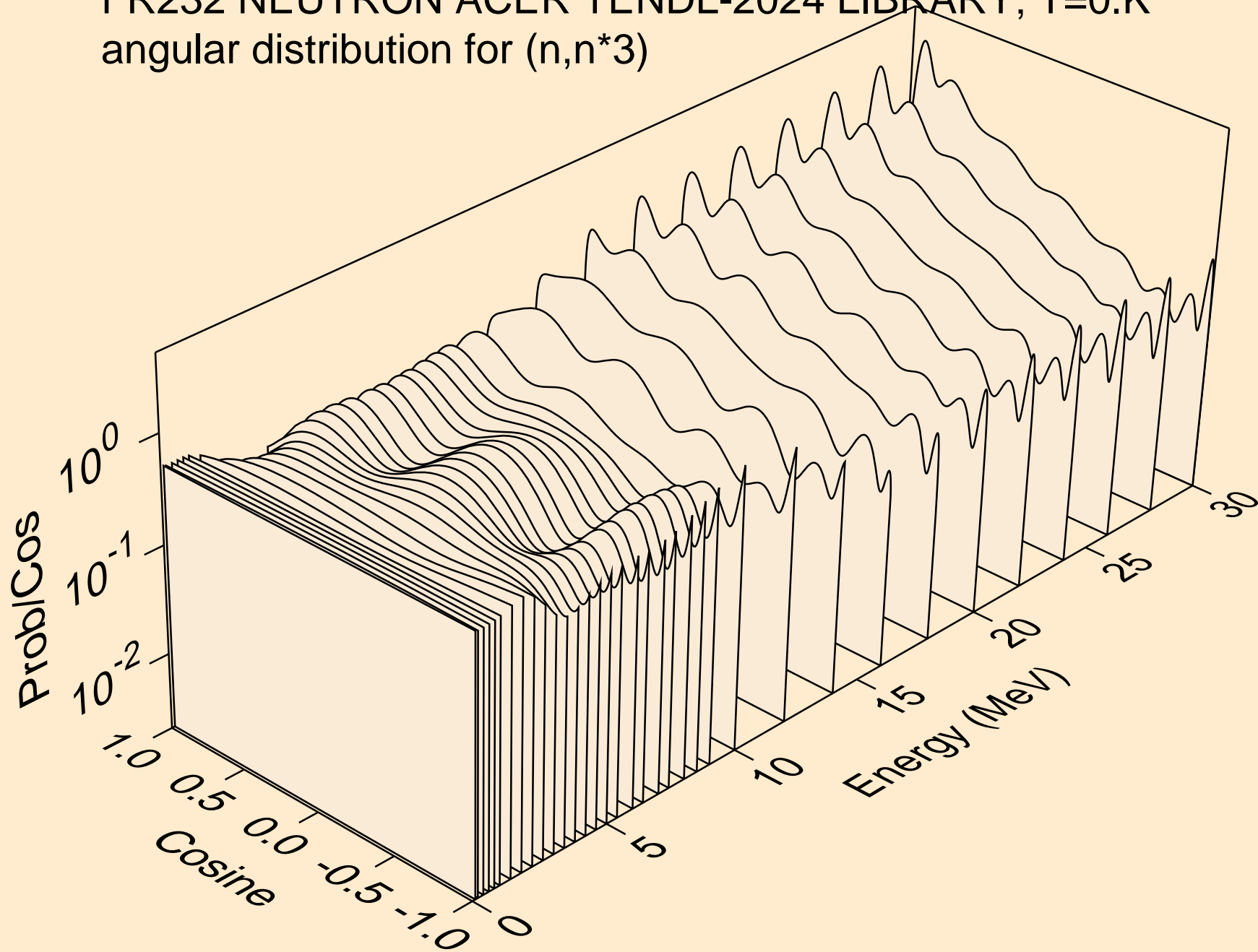

FR232 NEUTRON ACER TENDL-2024 LIBRARY; T=0.K
angular distribution for (n,n*4)

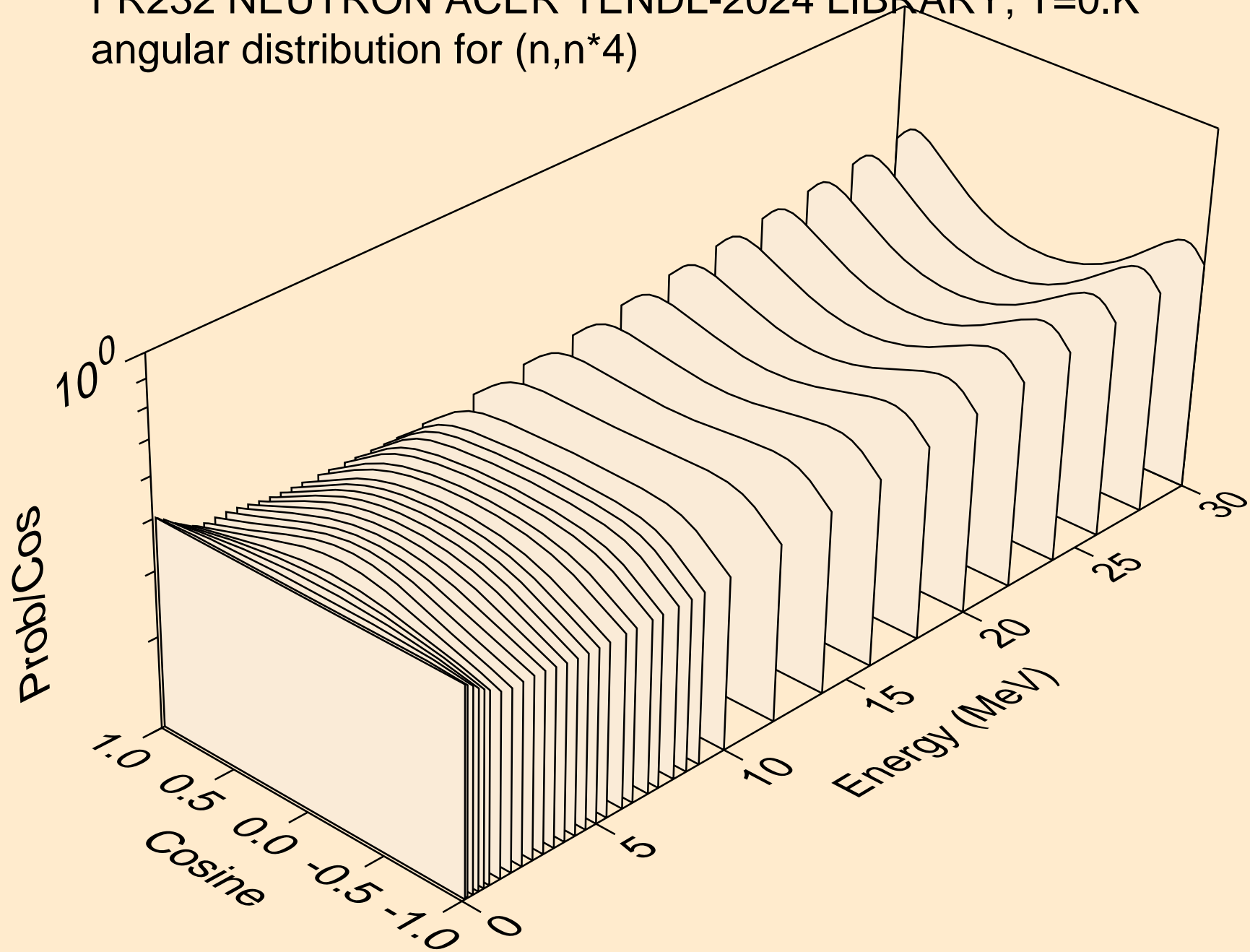

FR232 NEUTRON ACER TENDL-2024 LIBRARY; T=0.K
angular distribution for (n,n*5)

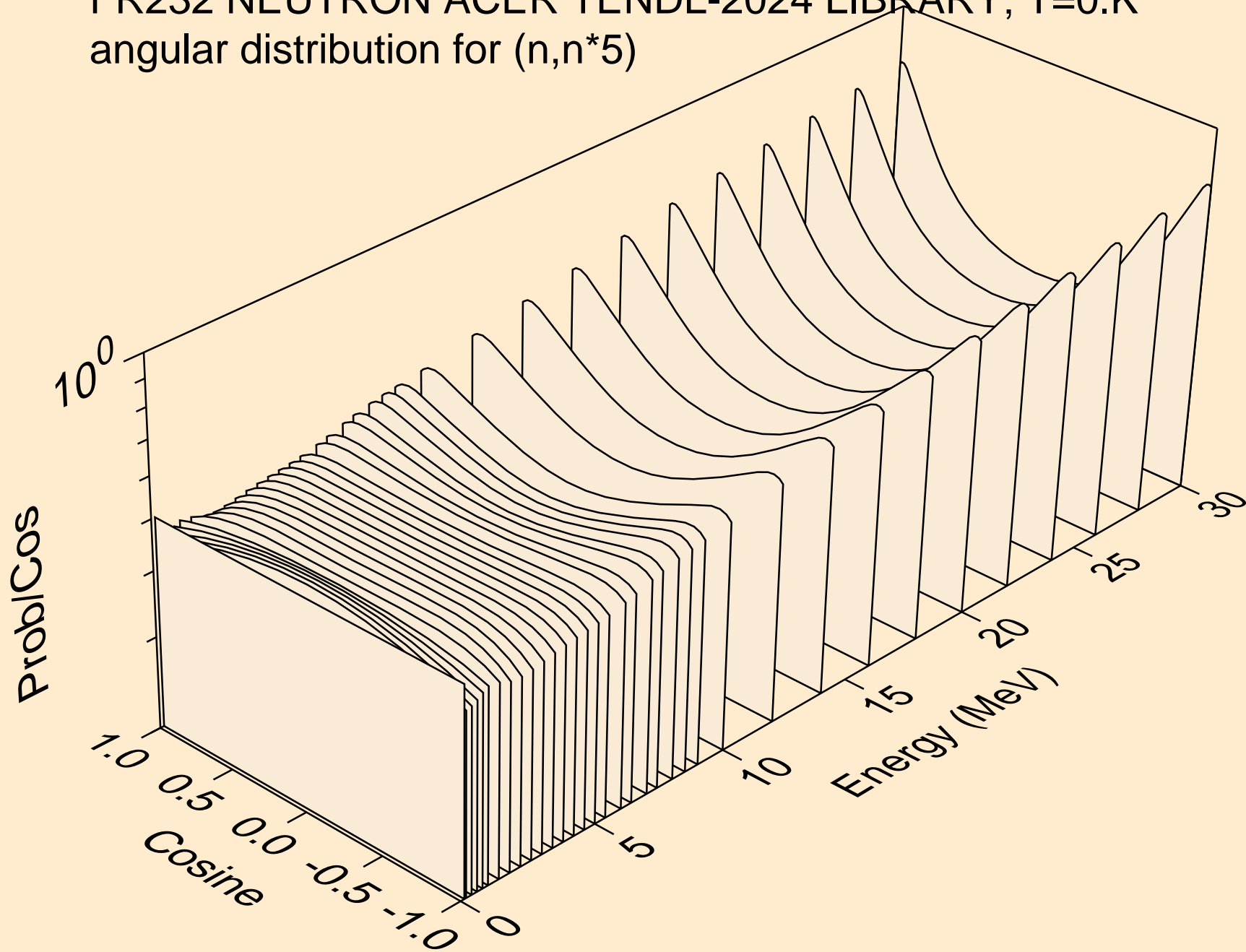

FR232 NEUTRON ACER TENDL-2024 LIBRARY; T=0.K
angular distribution for (n,n*6)

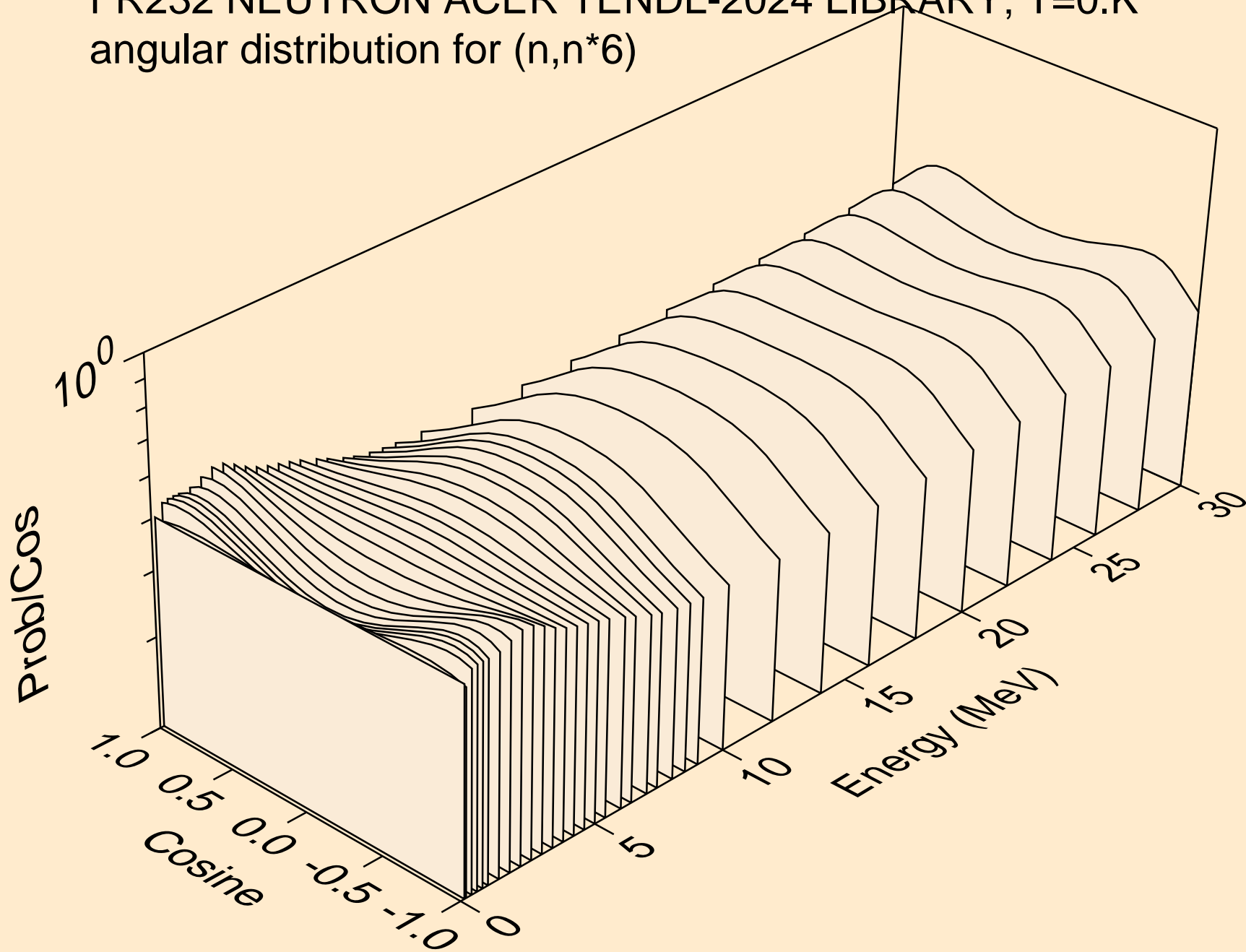

FR232 NEUTRON ACER TENDL-2024 LIBRARY; T=0.K
angular distribution for (n,n*7)

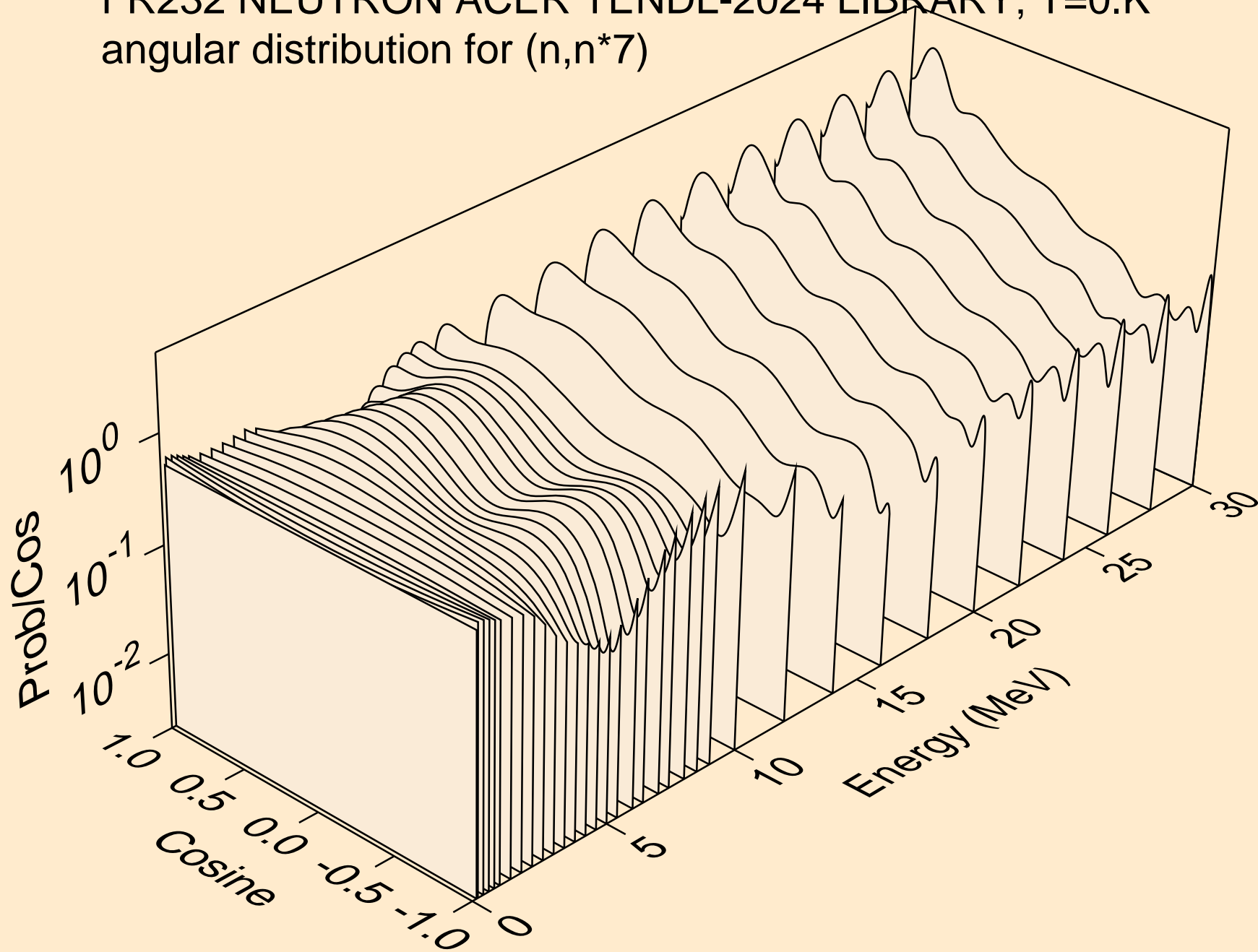

FR232 NEUTRON ACER TENDL-2024 LIBRARY; T=0.K
angular distribution for (n,n*8)

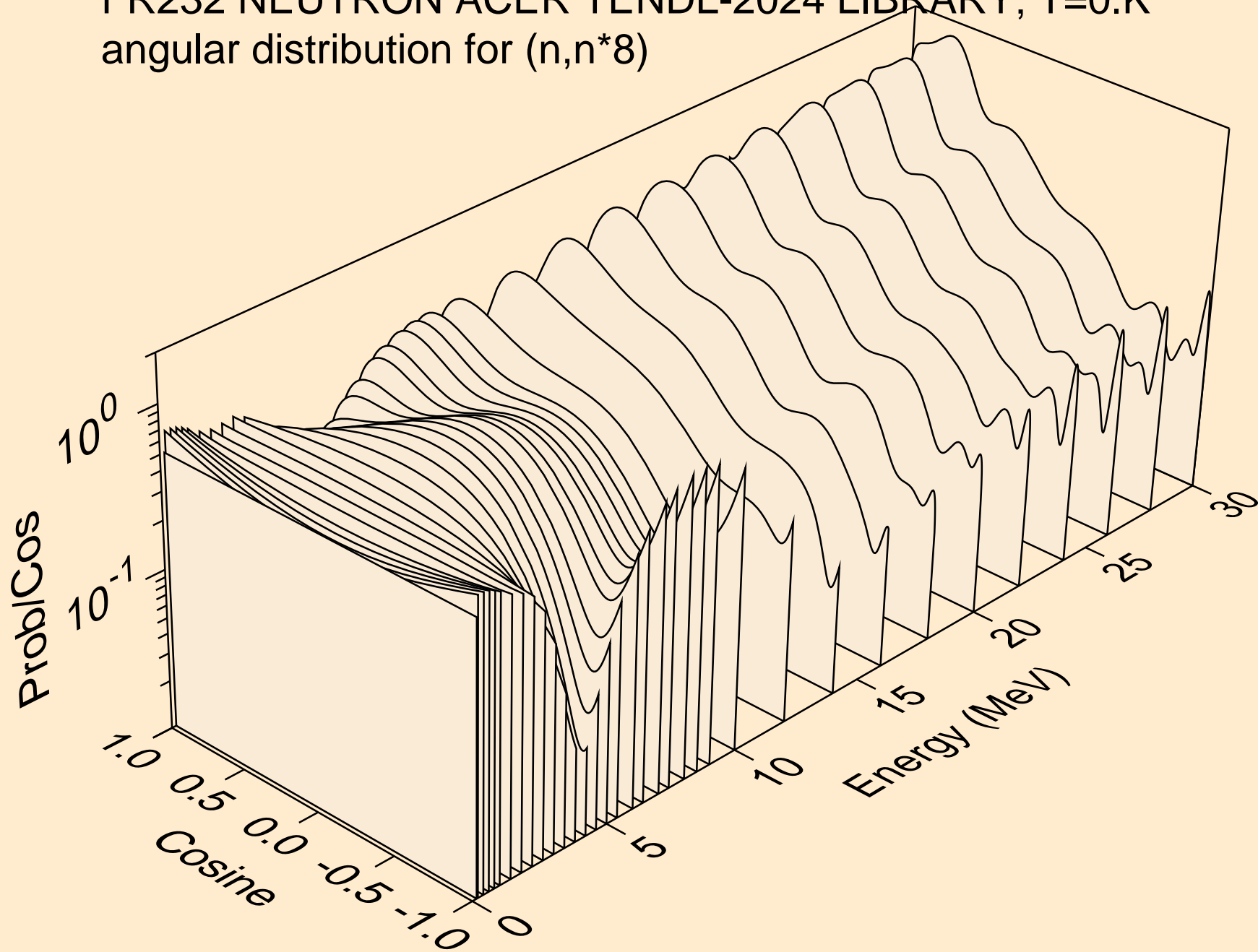

FR232 NEUTRON ACER TENDL-2024 LIBRARY; T=0.K
angular distribution for (n,n*9)

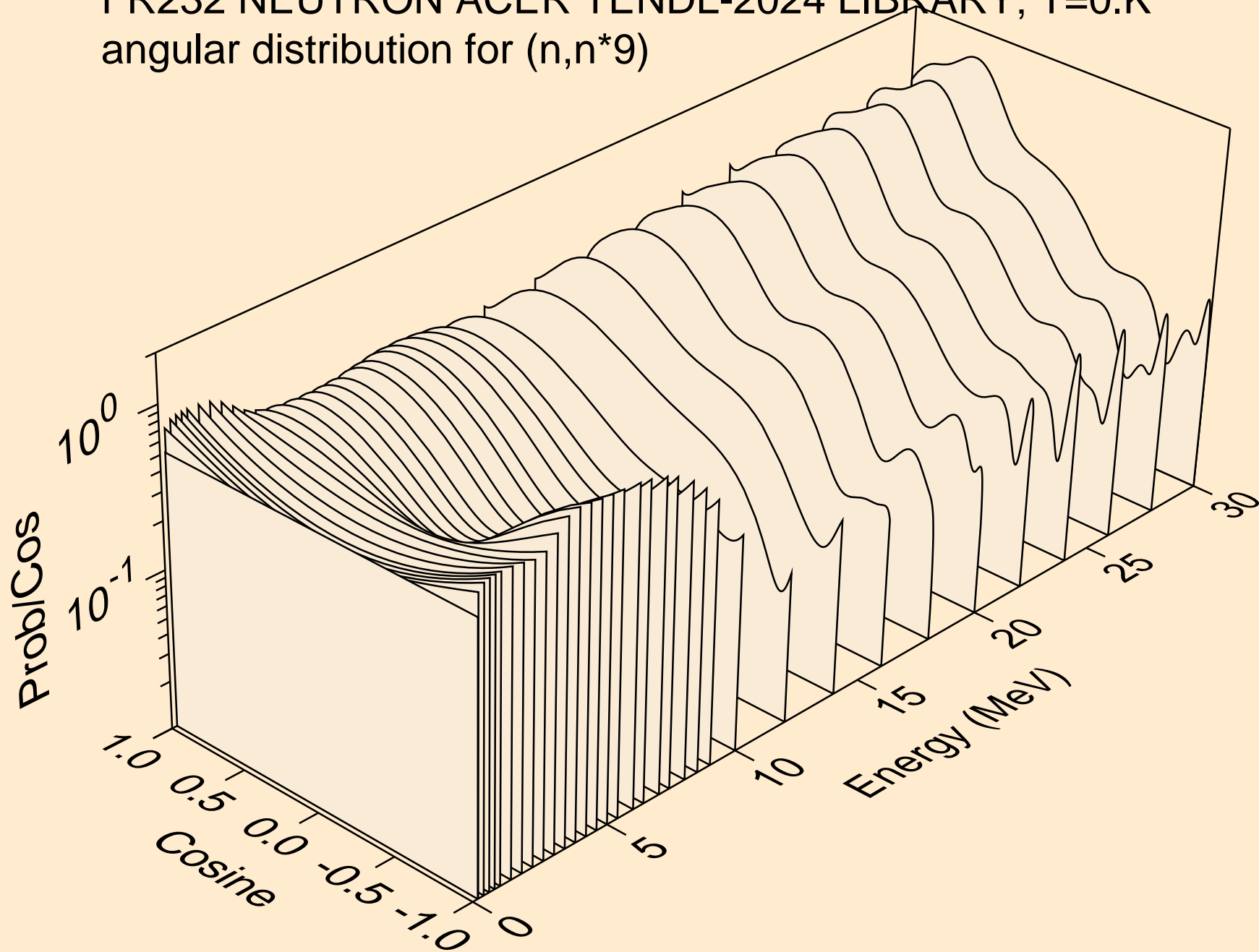

FR232 NEUTRON ACER TENDL-2024 LIBRARY; T=0.K
angular distribution for (n,n*10)

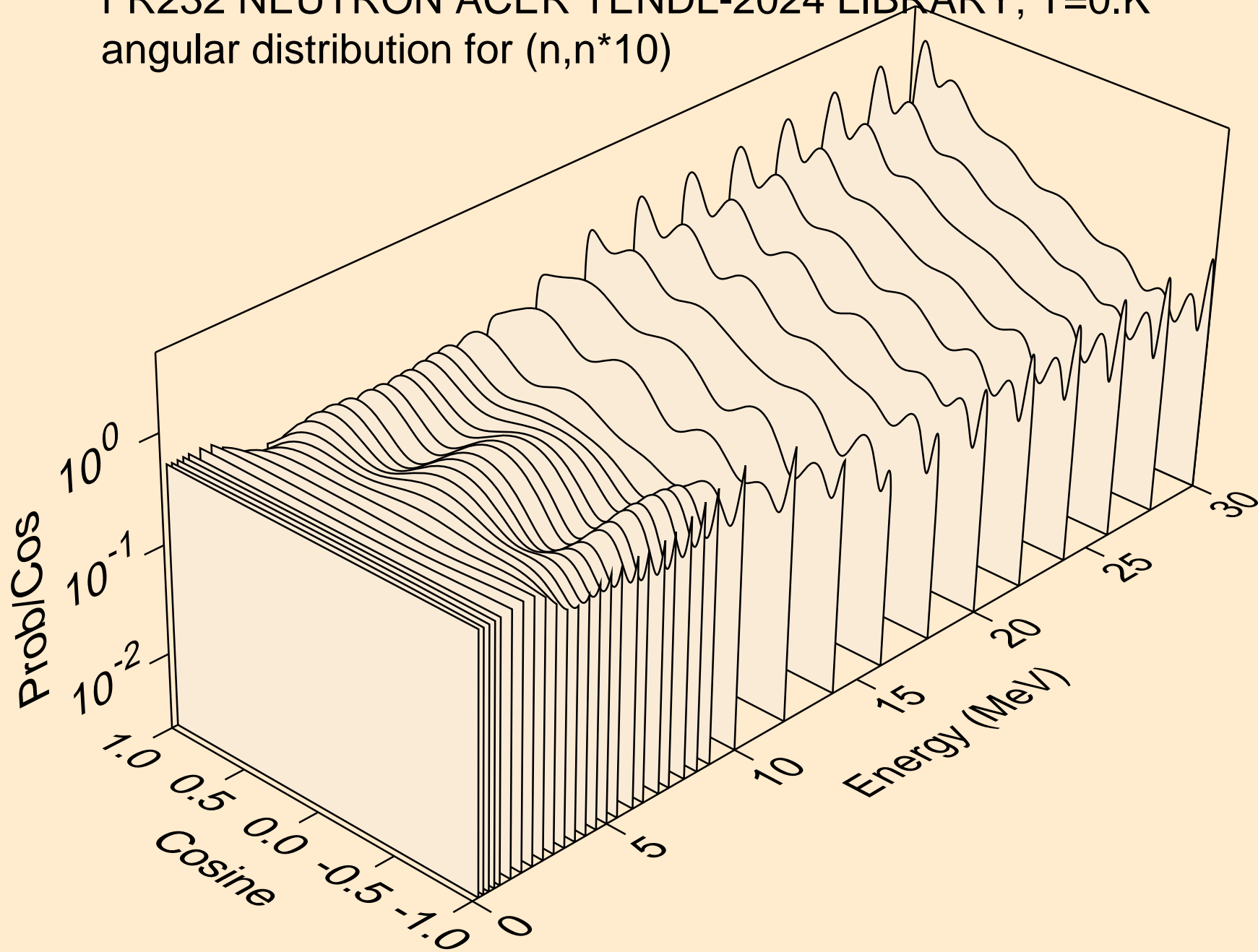

FR232 NEUTRON ACER TENDL-2024 LIBRARY; T=0.K
angular distribution for (n,n*11)

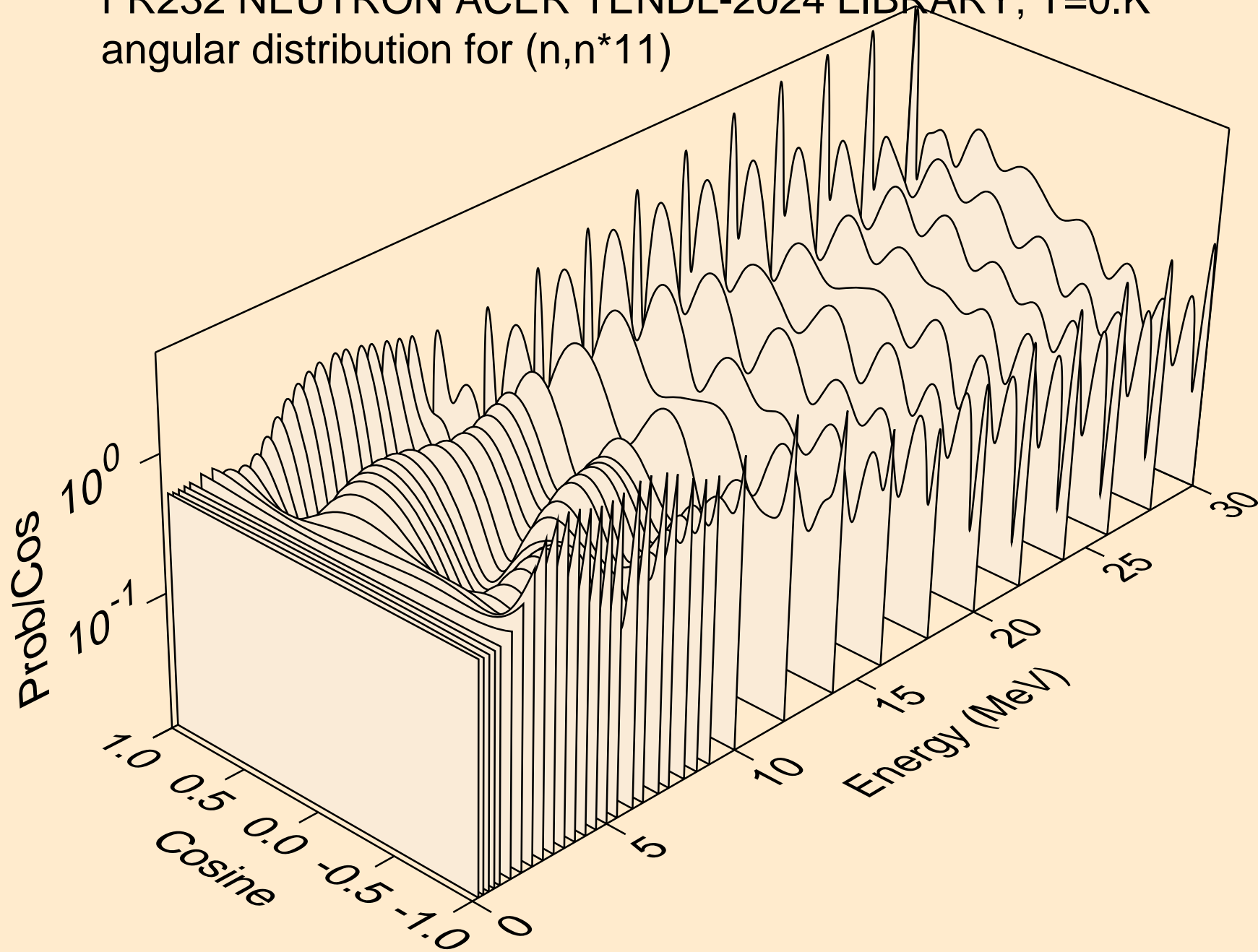

FR232 NEUTRON ACER TENDL-2024 LIBRARY; T=0.K
angular distribution for (n,n*12)

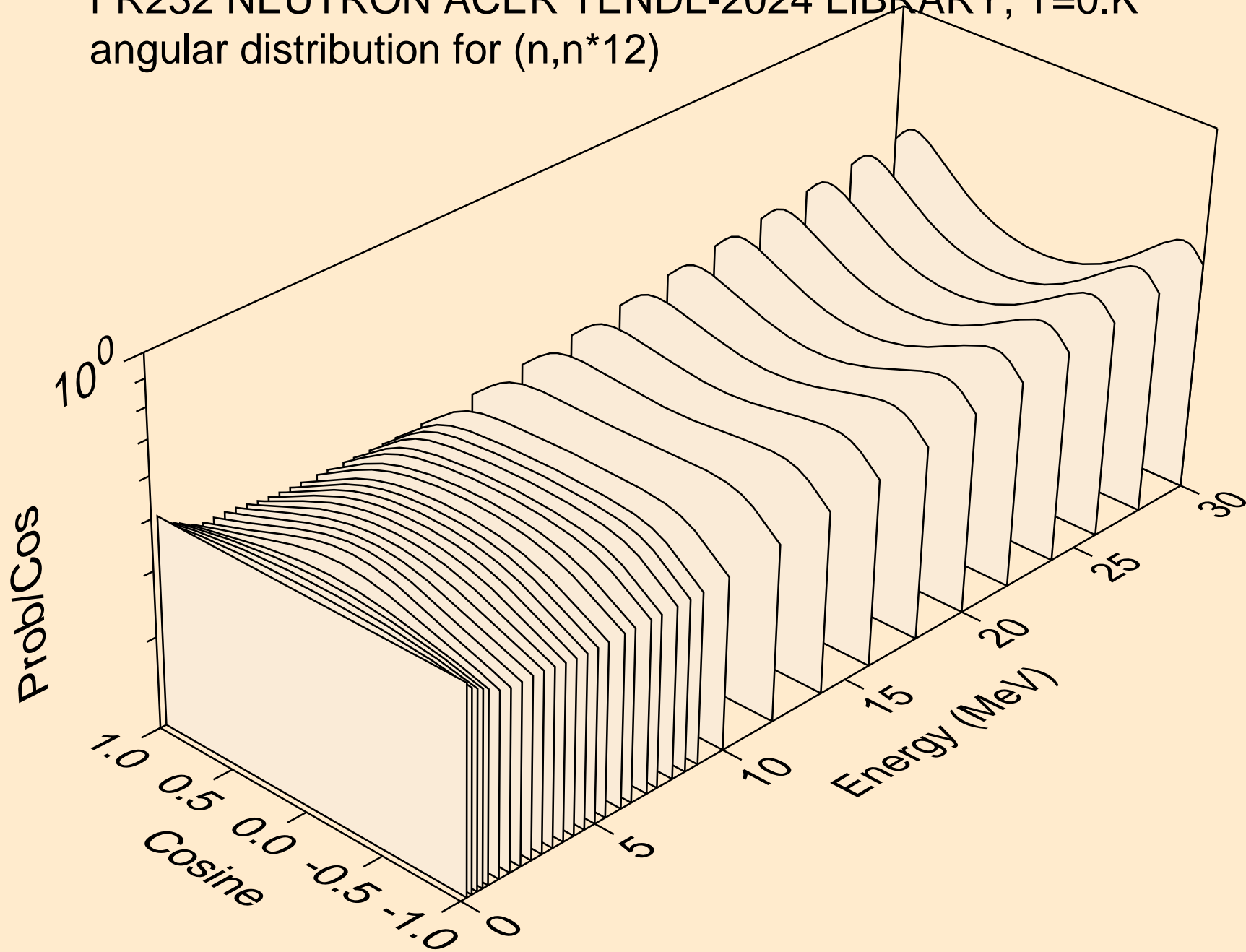

FR232 NEUTRON ACER TENDL-2024 LIBRARY; T=0.K
angular distribution for (n,n*13)

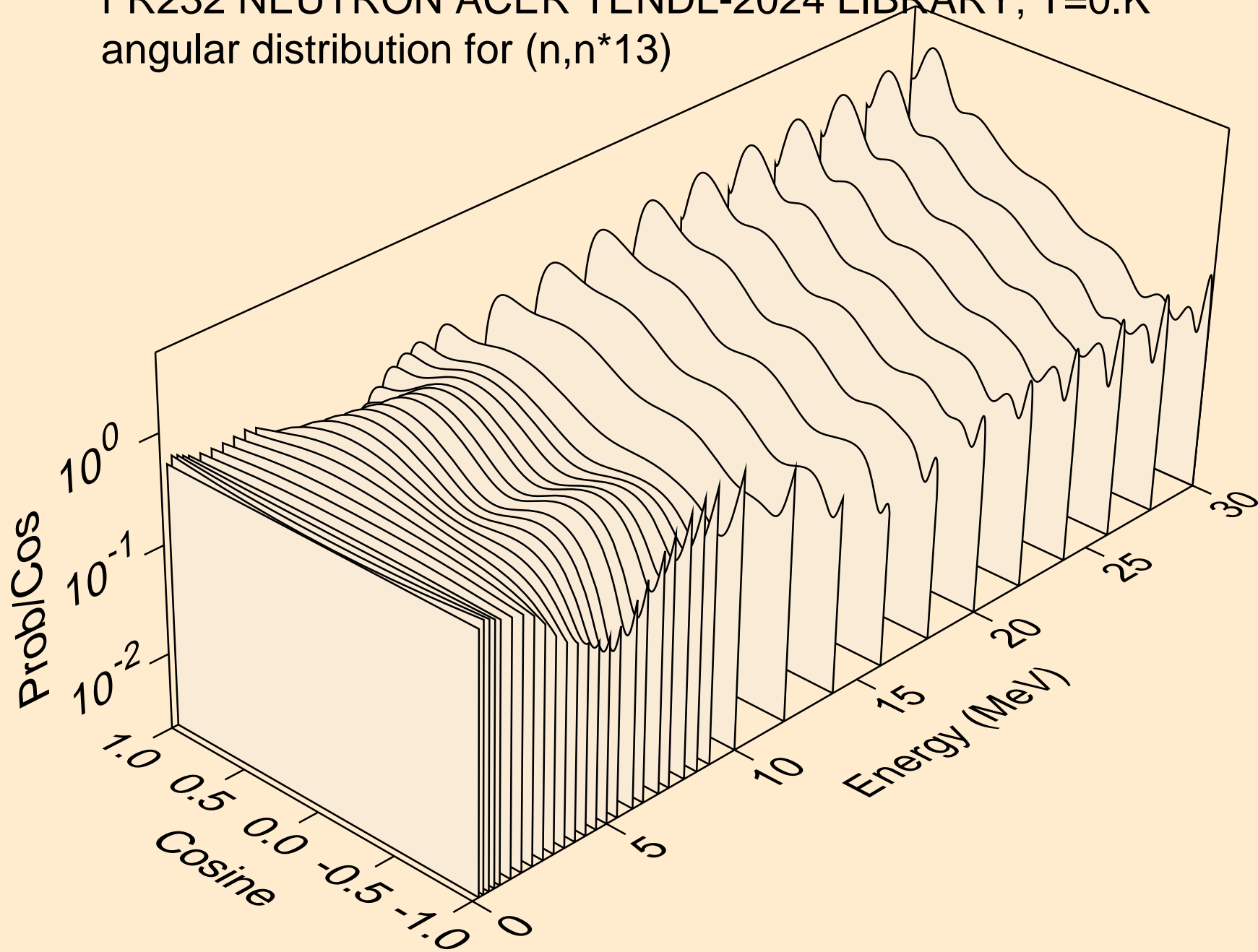

FR232 NEUTRON ACER TENDL-2024 LIBRARY; T=0.K
angular distribution for (n,n*14)

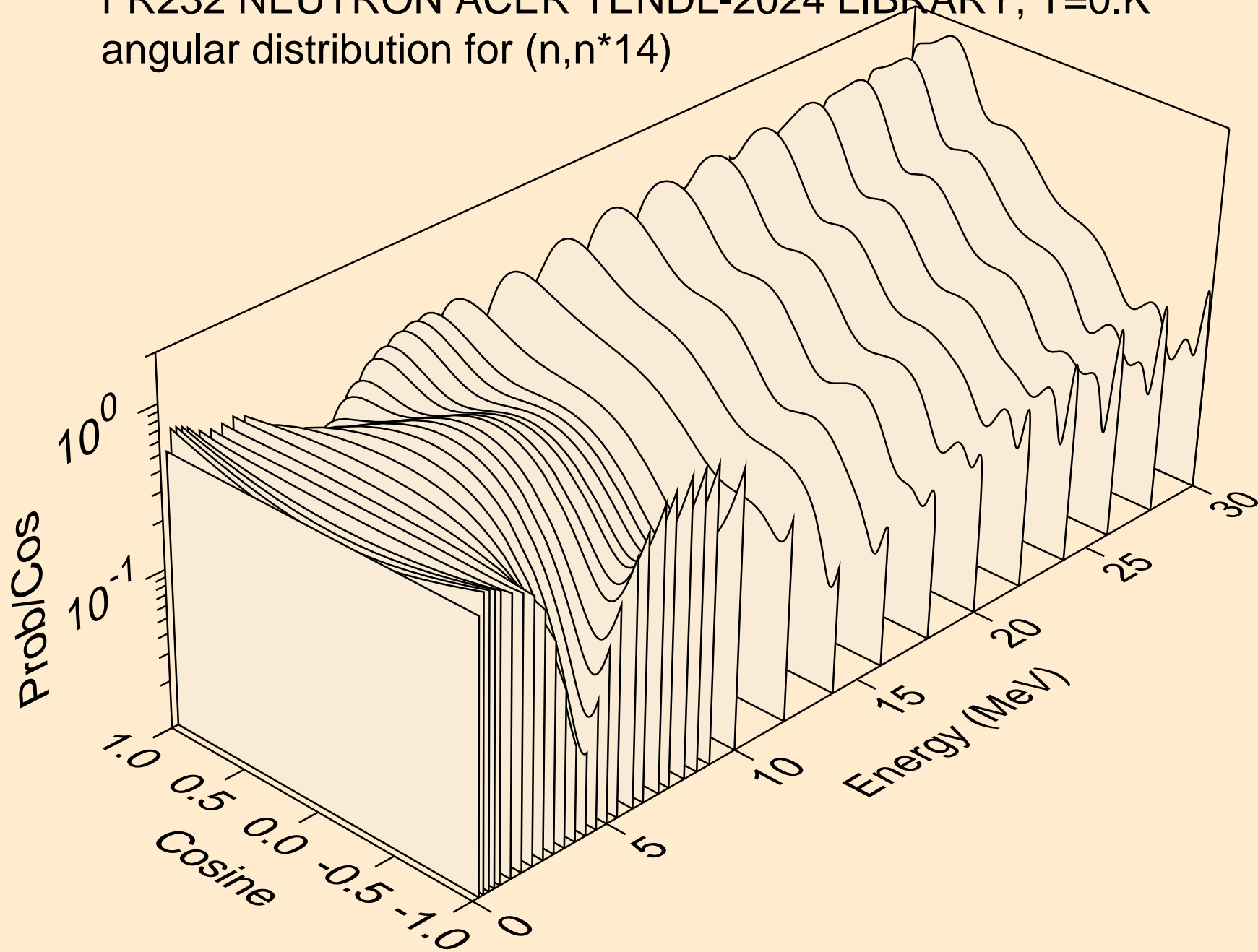

FR232 NEUTRON ACER TENDL-2024 LIBRARY; T=0.K
angular distribution for (n,n*15)

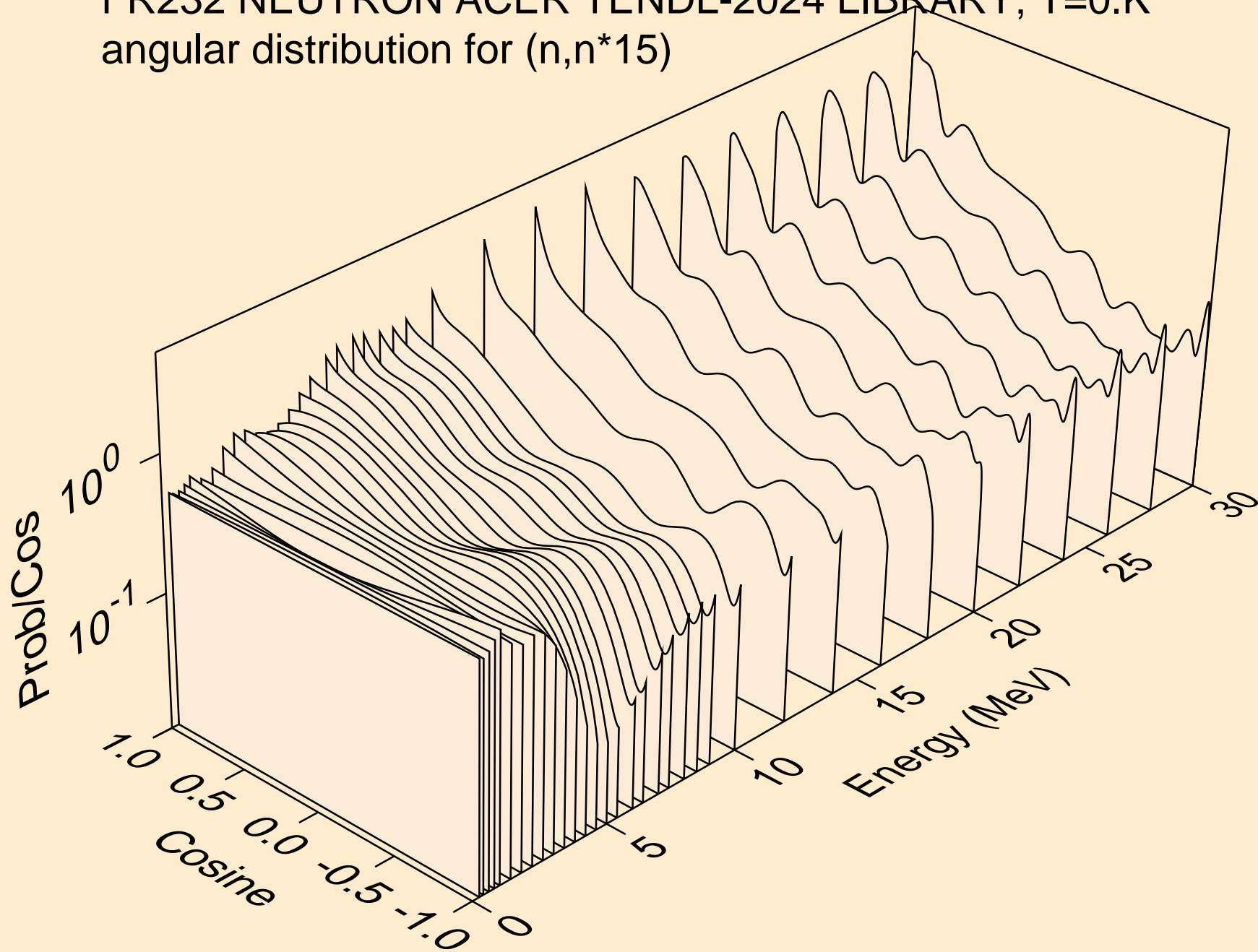

FR232 NEUTRON ACER TENDL-2024 LIBRARY; T=0.K
angular distribution for (n,n*16)

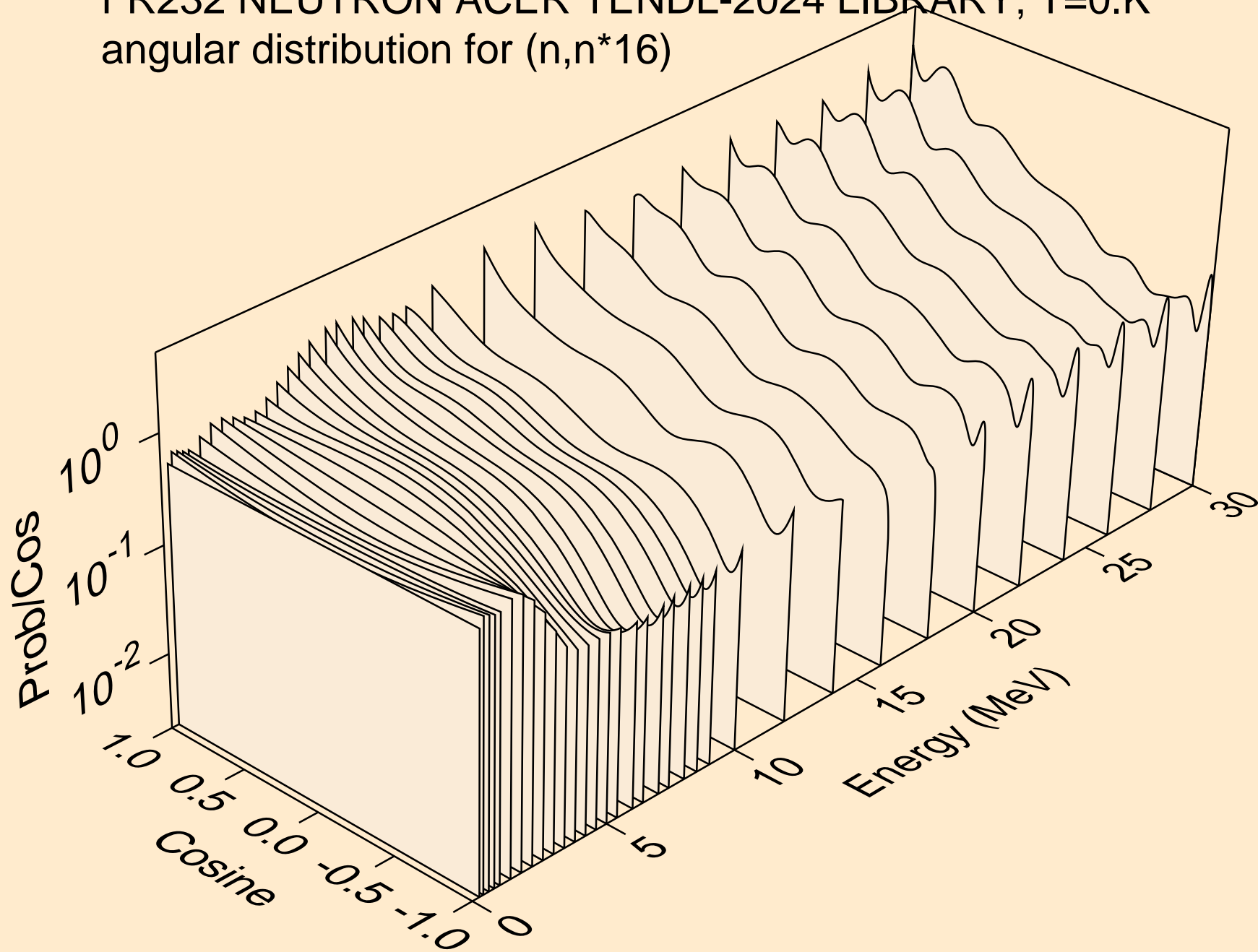

FR232 NEUTRON ACER TENDL-2024 LIBRARY; T=0.K
angular distribution for (n,n*17)

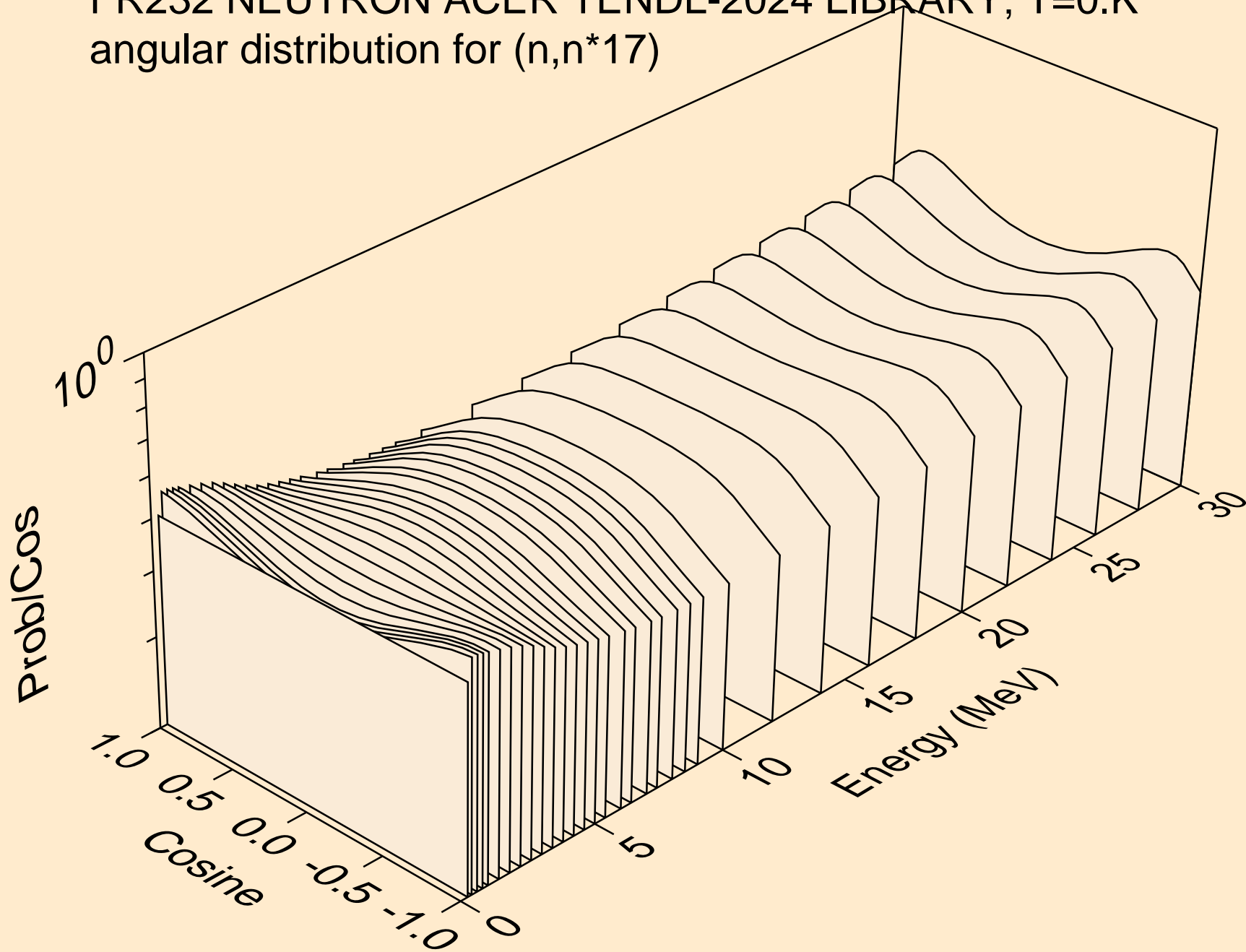

FR232 NEUTRON ACER TENDL-2024 LIBRARY; T=0.K
angular distribution for (n,n*18)

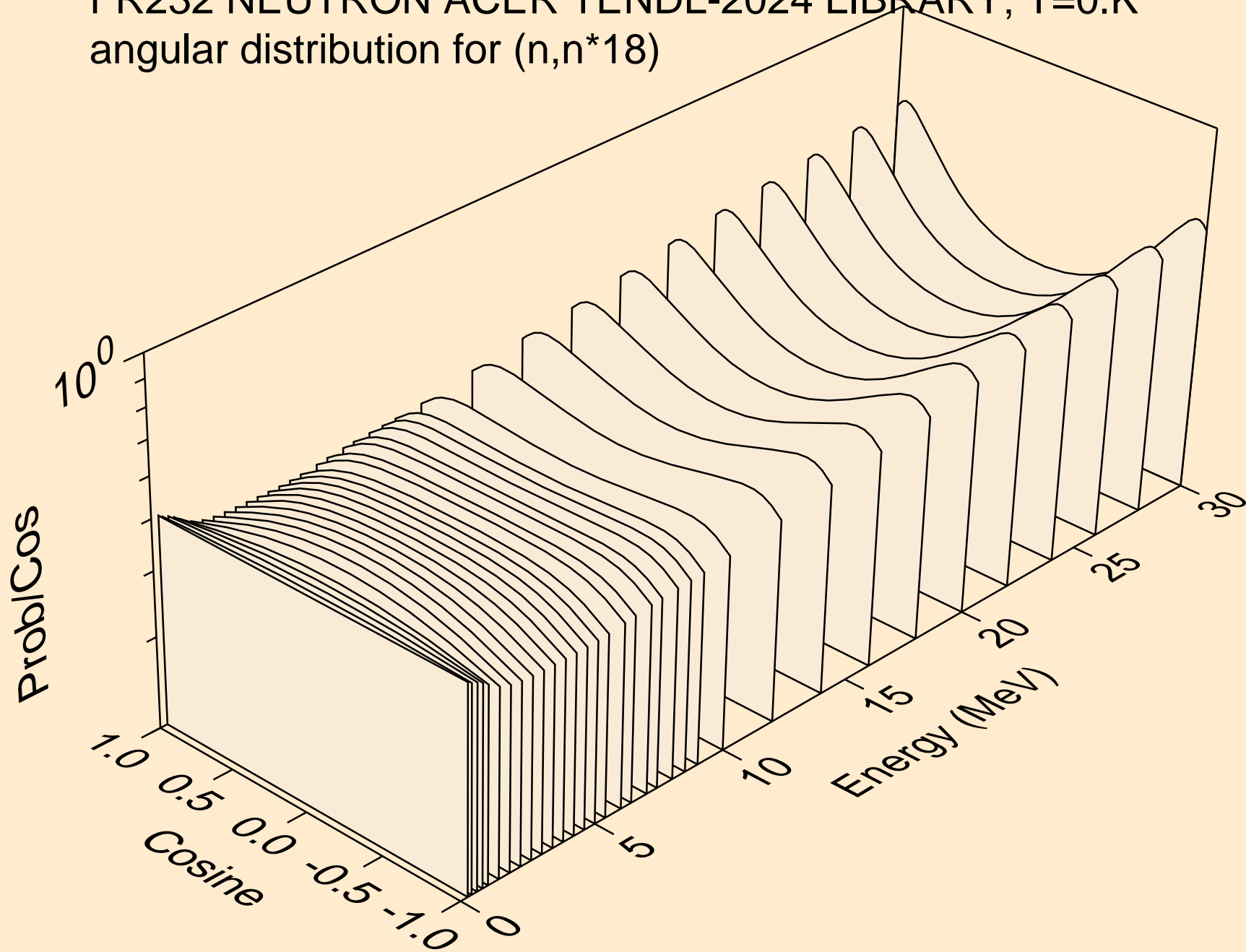

FR232 NEUTRON ACER TENDL-2024 LIBRARY; T=0.K
angular distribution for (n,n*19)

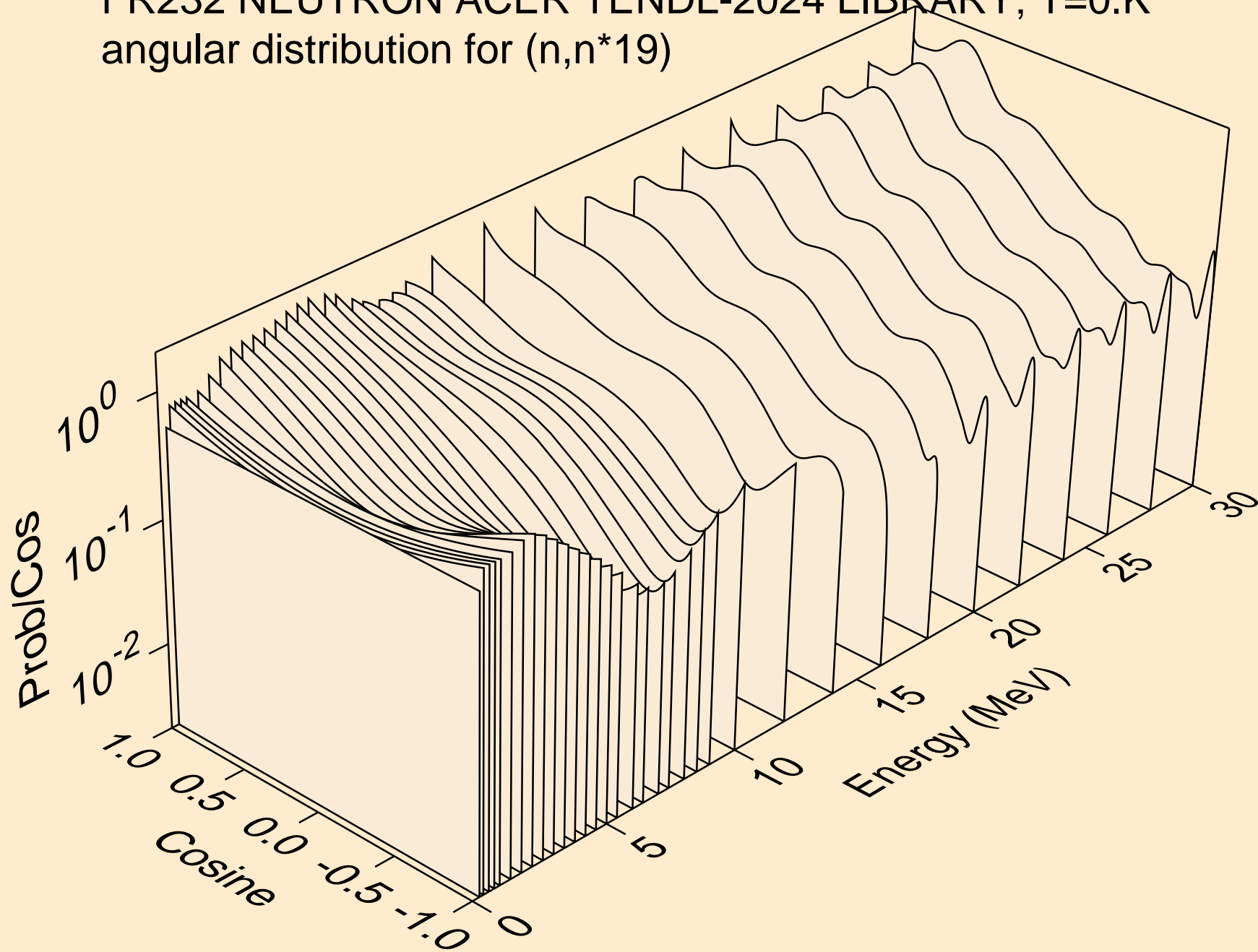

FR232 NEUTRON ACER TENDL-2024 LIBRARY; T=0.K
angular distribution for (n,n*20)

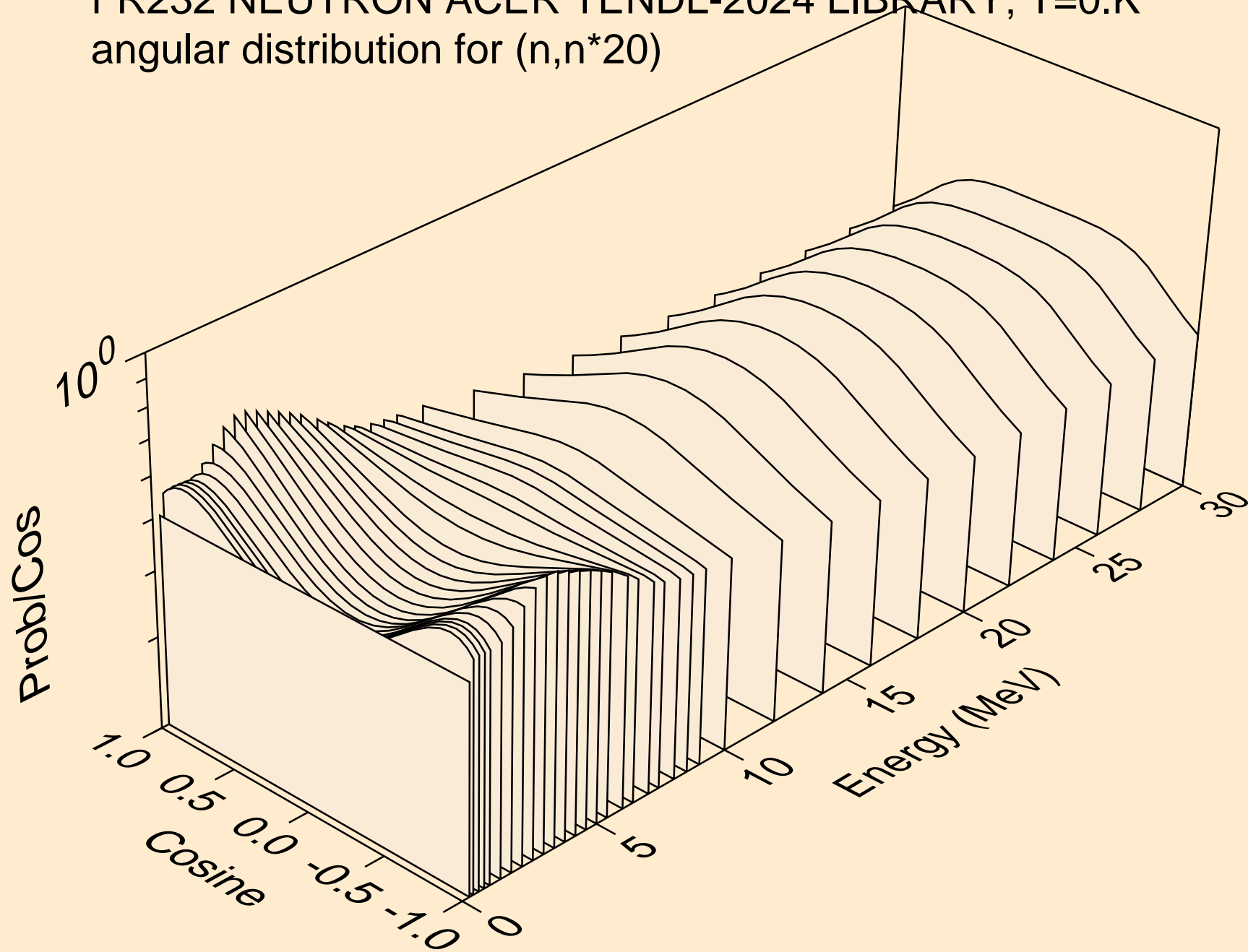

FR232 NEUTRON ACER TENDL-2024 LIBRARY; T=0.K
angular distribution for (n,n*21)

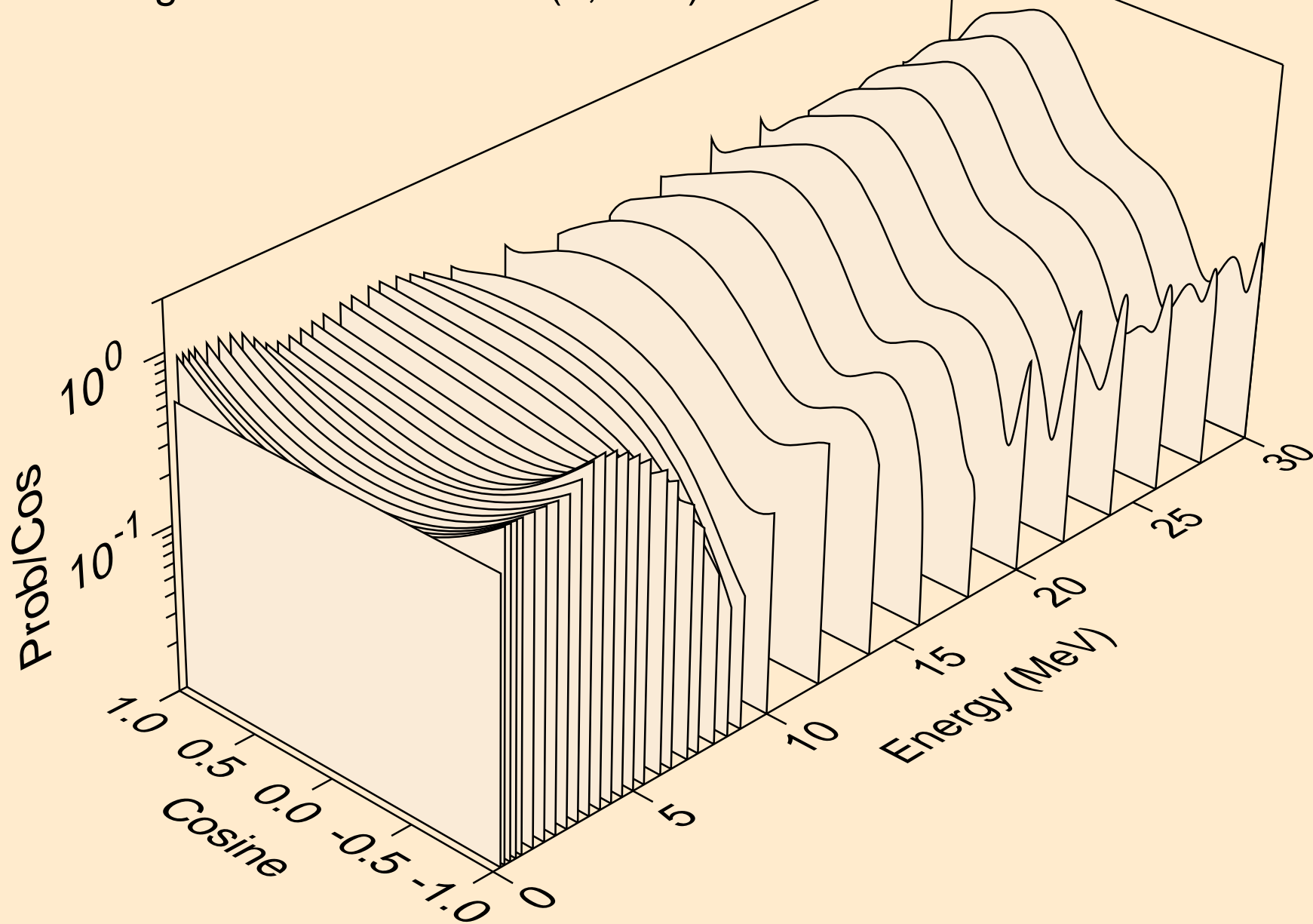

FR232 NEUTRON ACER TENDL-2024 LIBRARY; T=0.K
angular distribution for (n,n*22)

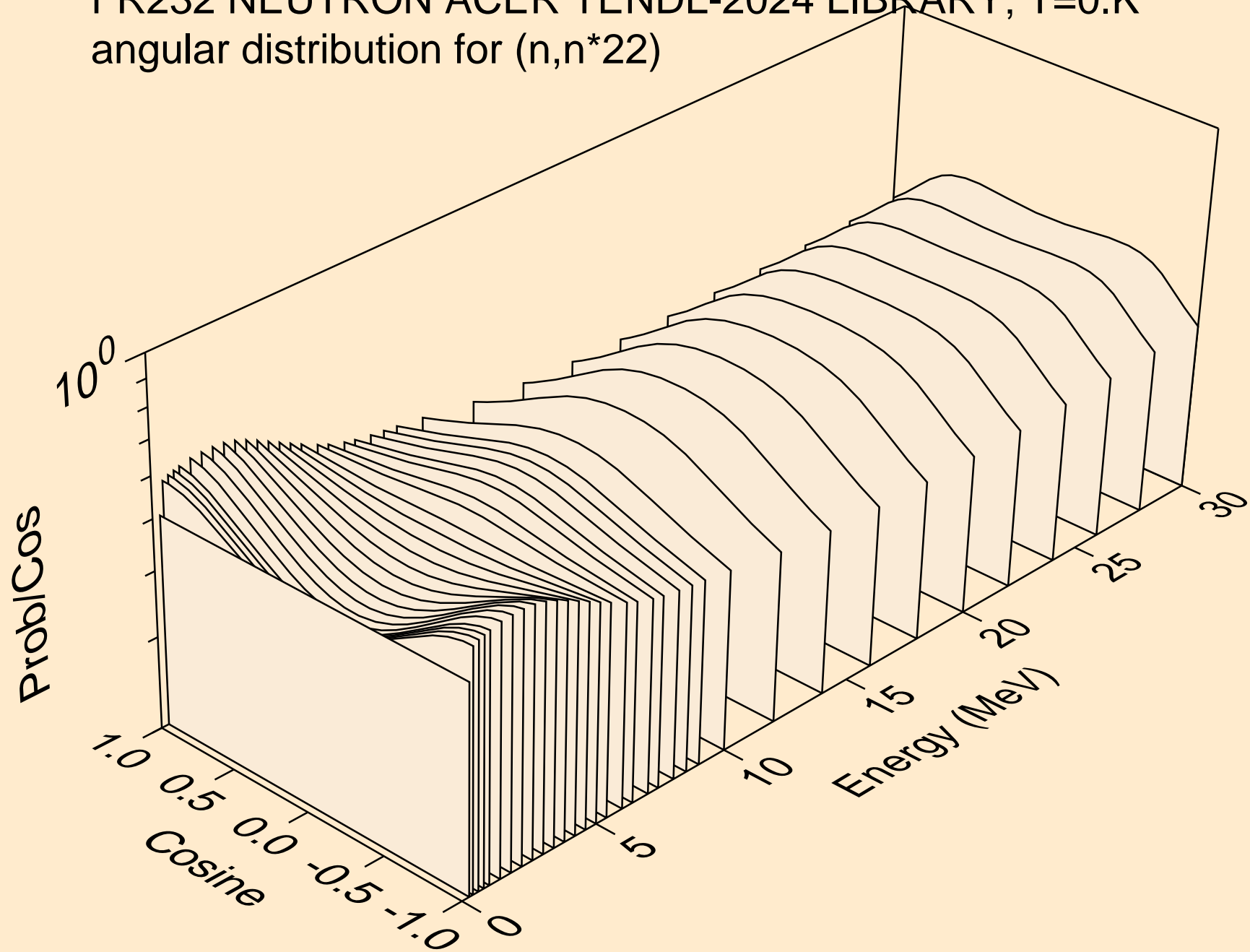

FR232 NEUTRON ACER TENDL-2024 LIBRARY; T=0.K
angular distribution for (n,n*23)

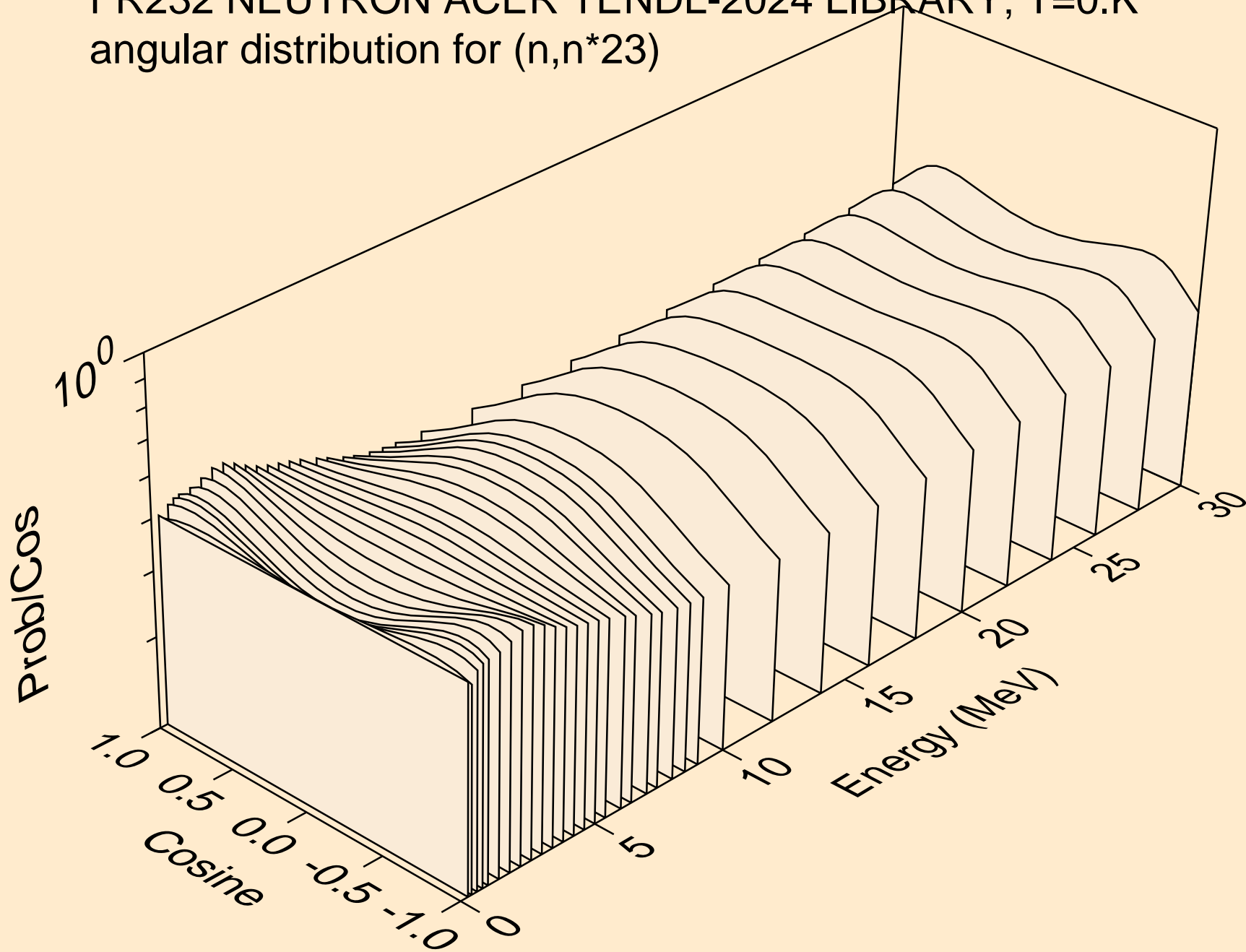

FR232 NEUTRON ACER TENDL-2024 LIBRARY; T=0.K
angular distribution for (n,n*24)

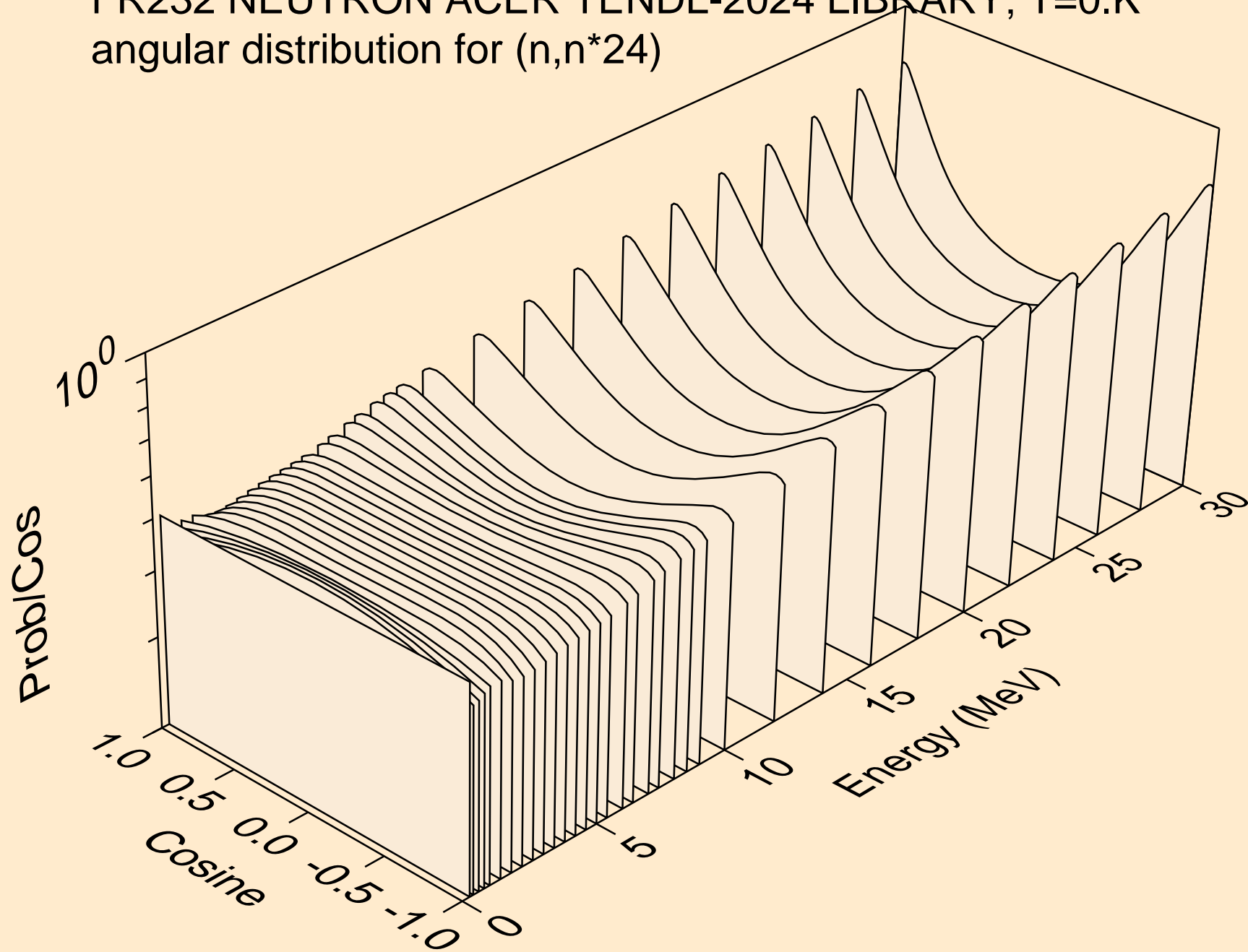

FR232 NEUTRON ACER TENDL-2024 LIBRARY; T=0.K
angular distribution for (n,n*25)

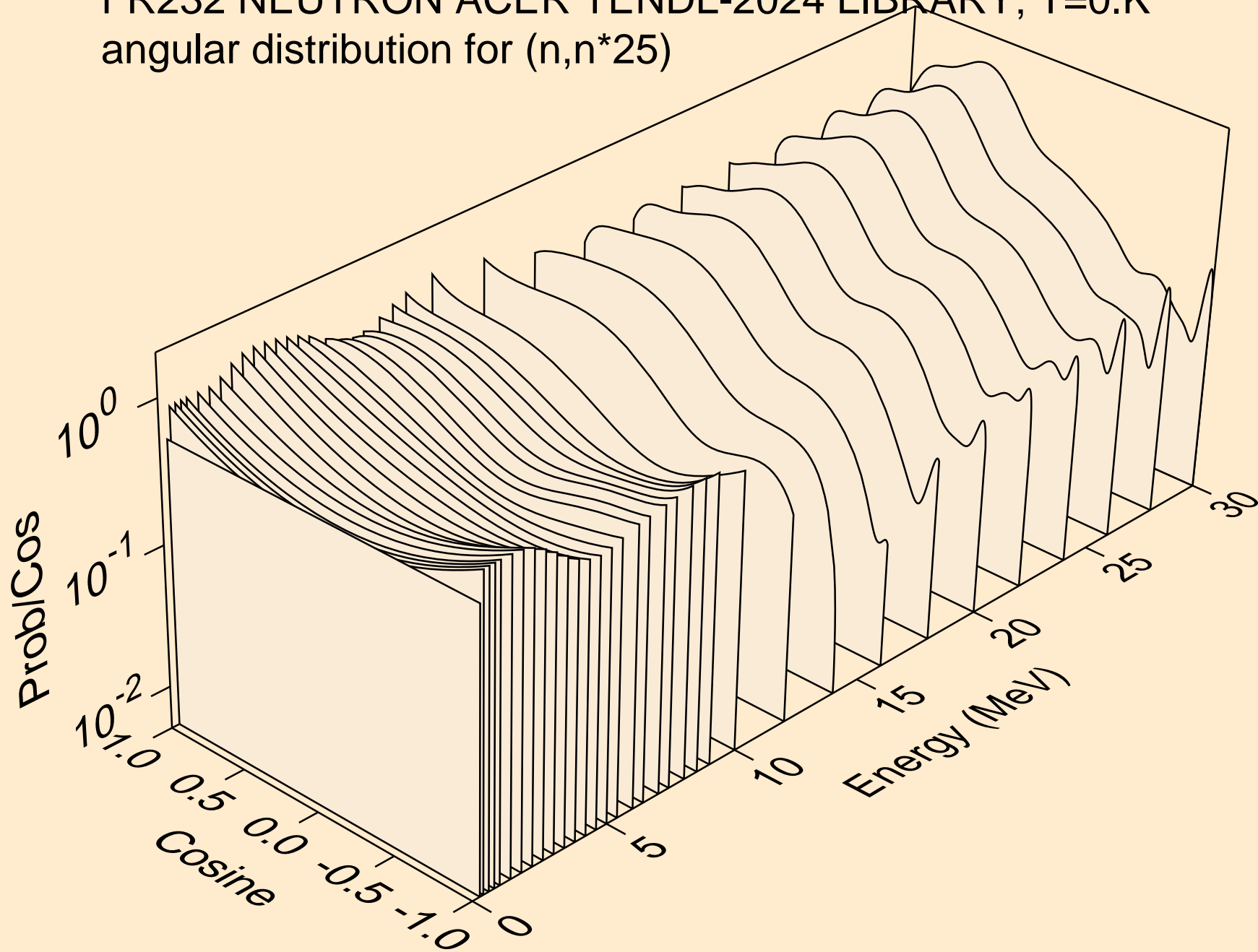

FR232 NEUTRON ACER TENDL-2024 LIBRARY; T=0.K
angular distribution for (n,n*26)

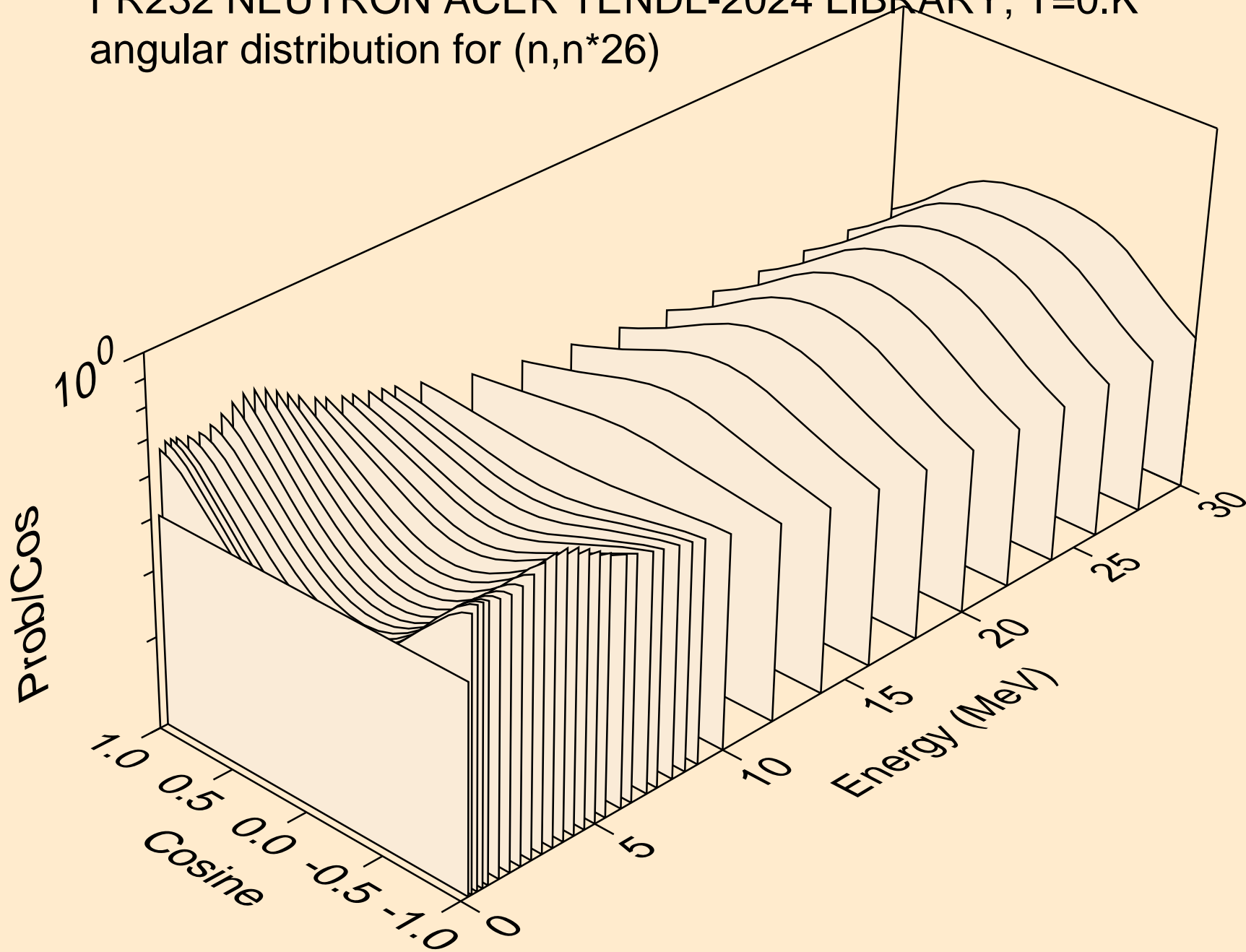

FR232 NEUTRON ACER TENDL-2024 LIBRARY; T=0.K
angular distribution for (n,n*27)

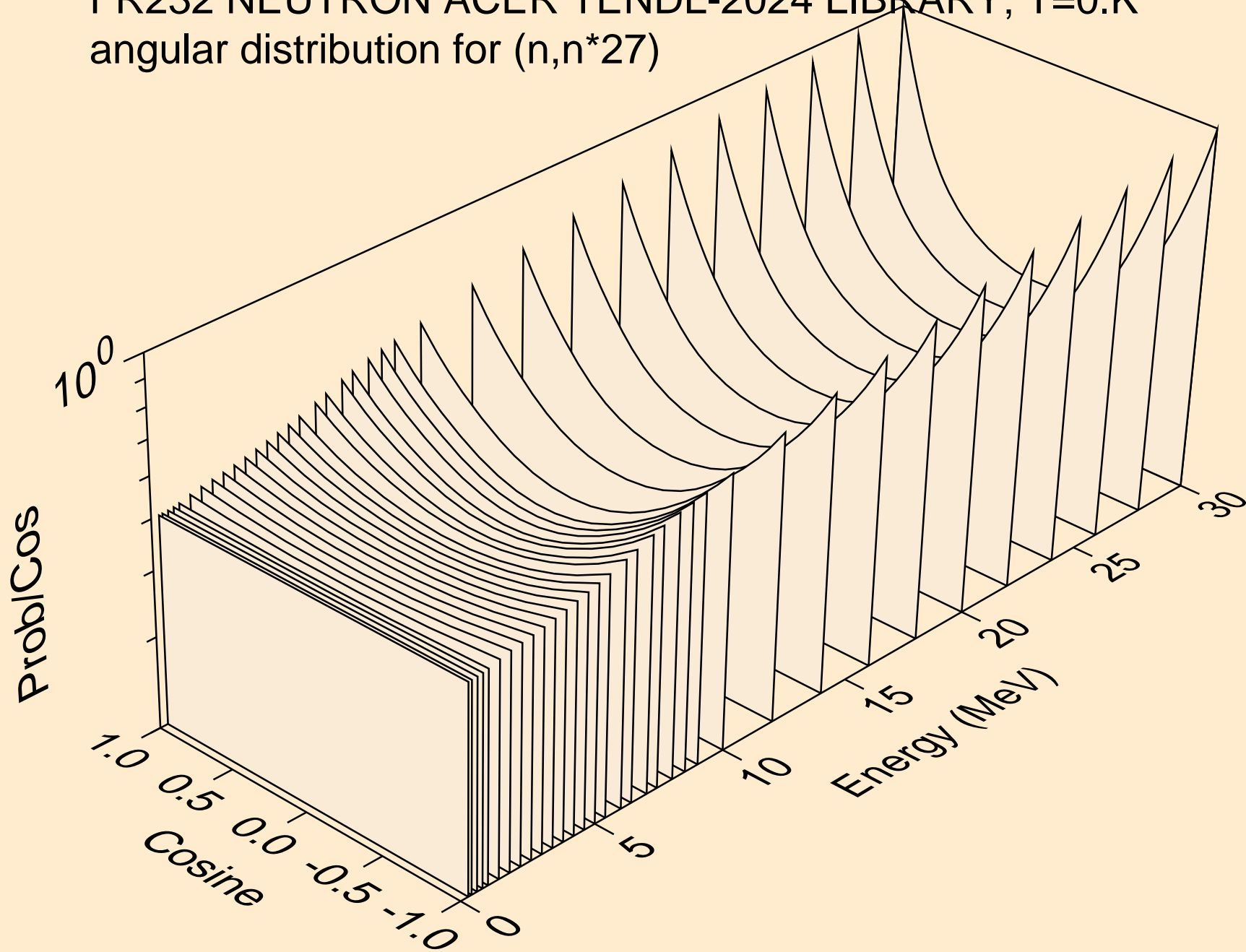

FR232 NEUTRON ACER TENDL-2024 LIBRARY; T=0.K
angular distribution for (n,n*28)

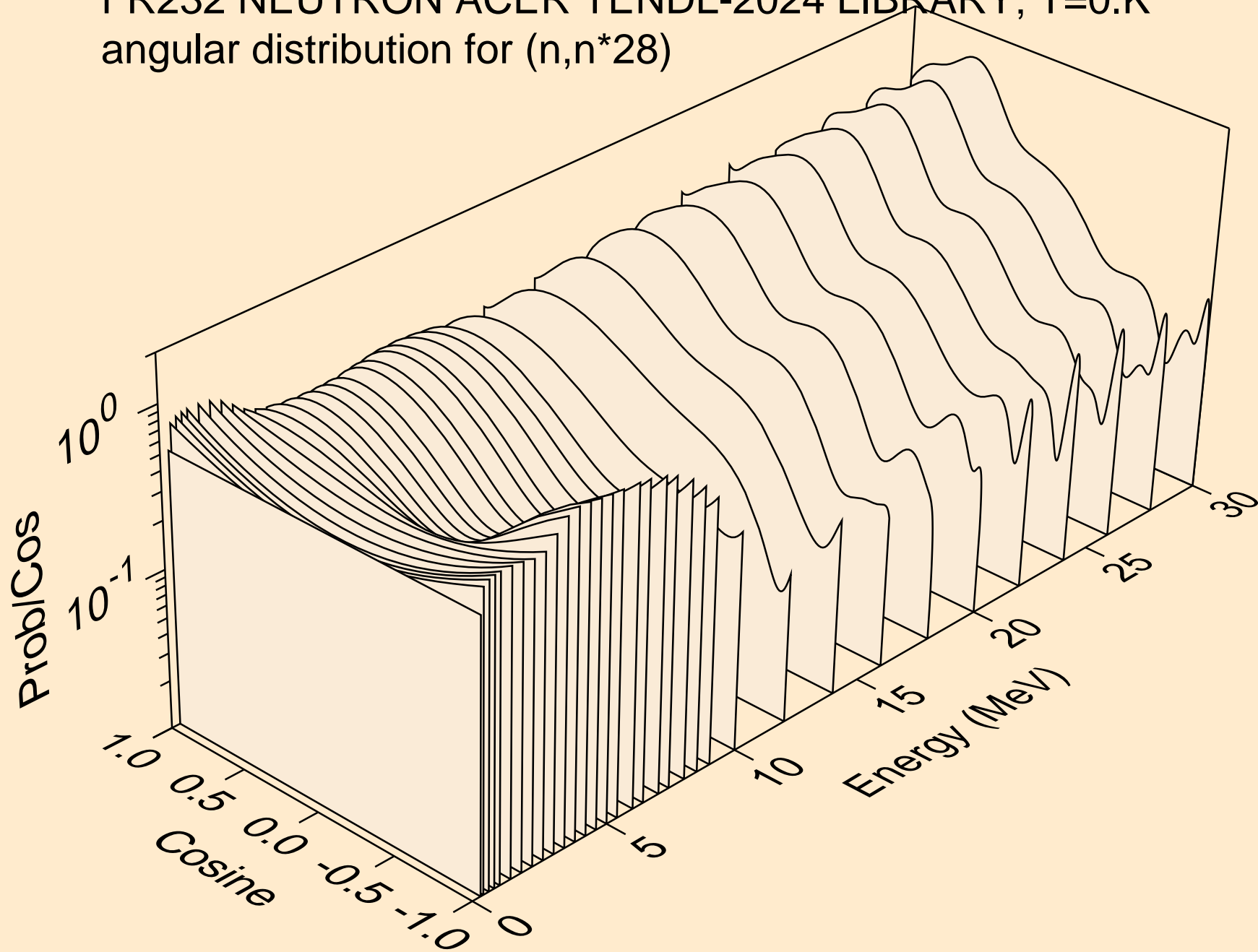

FR232 NEUTRON ACER TENDL-2024 LIBRARY; T=0.K
angular distribution for (n,n*29)

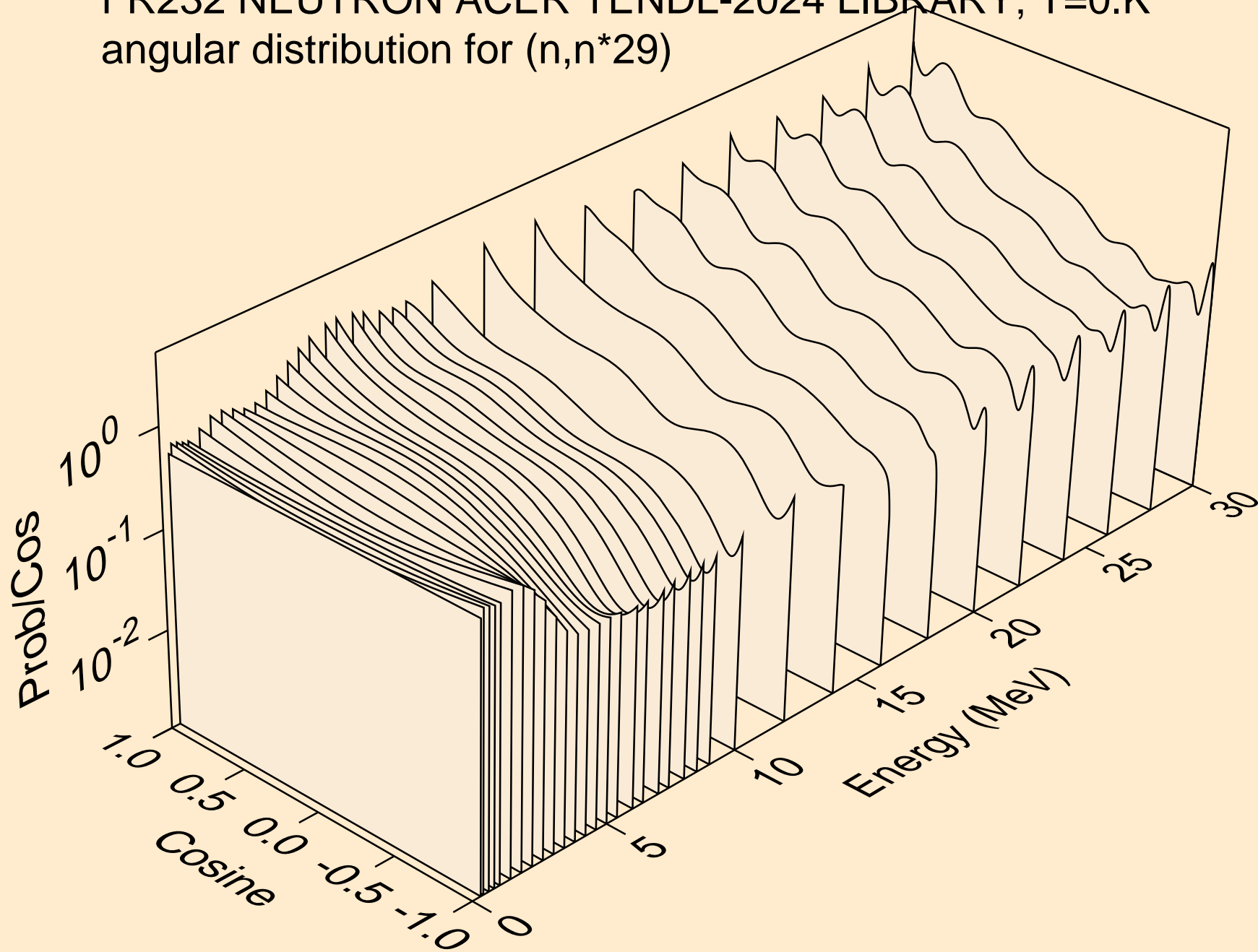

FR232 NEUTRON ACER TENDL-2024 LIBRARY; T=0.K
angular distribution for (n,n*30)

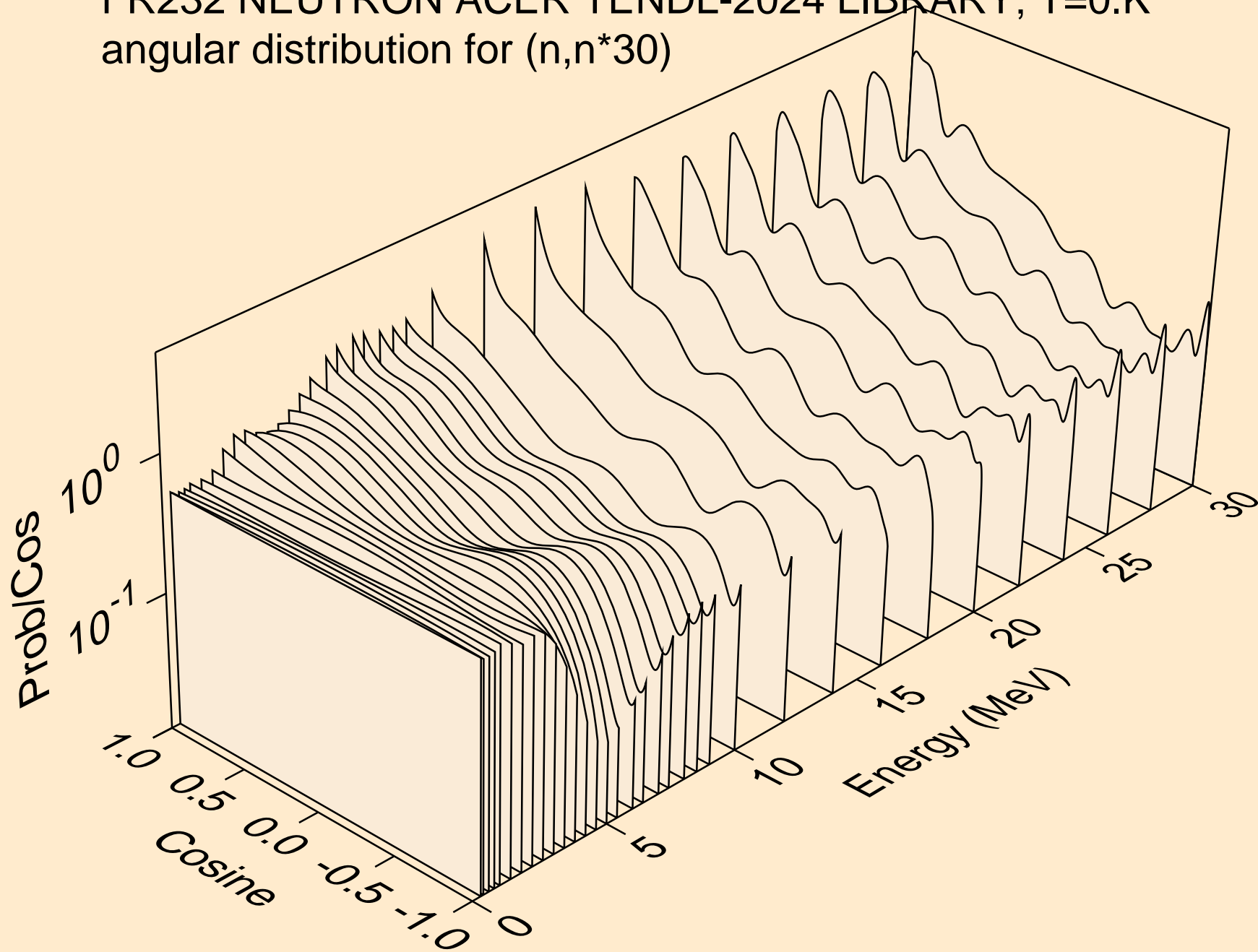

FR232 NEUTRON ACER TENDL-2024 LIBRARY; T=0.K

Total fission nubar

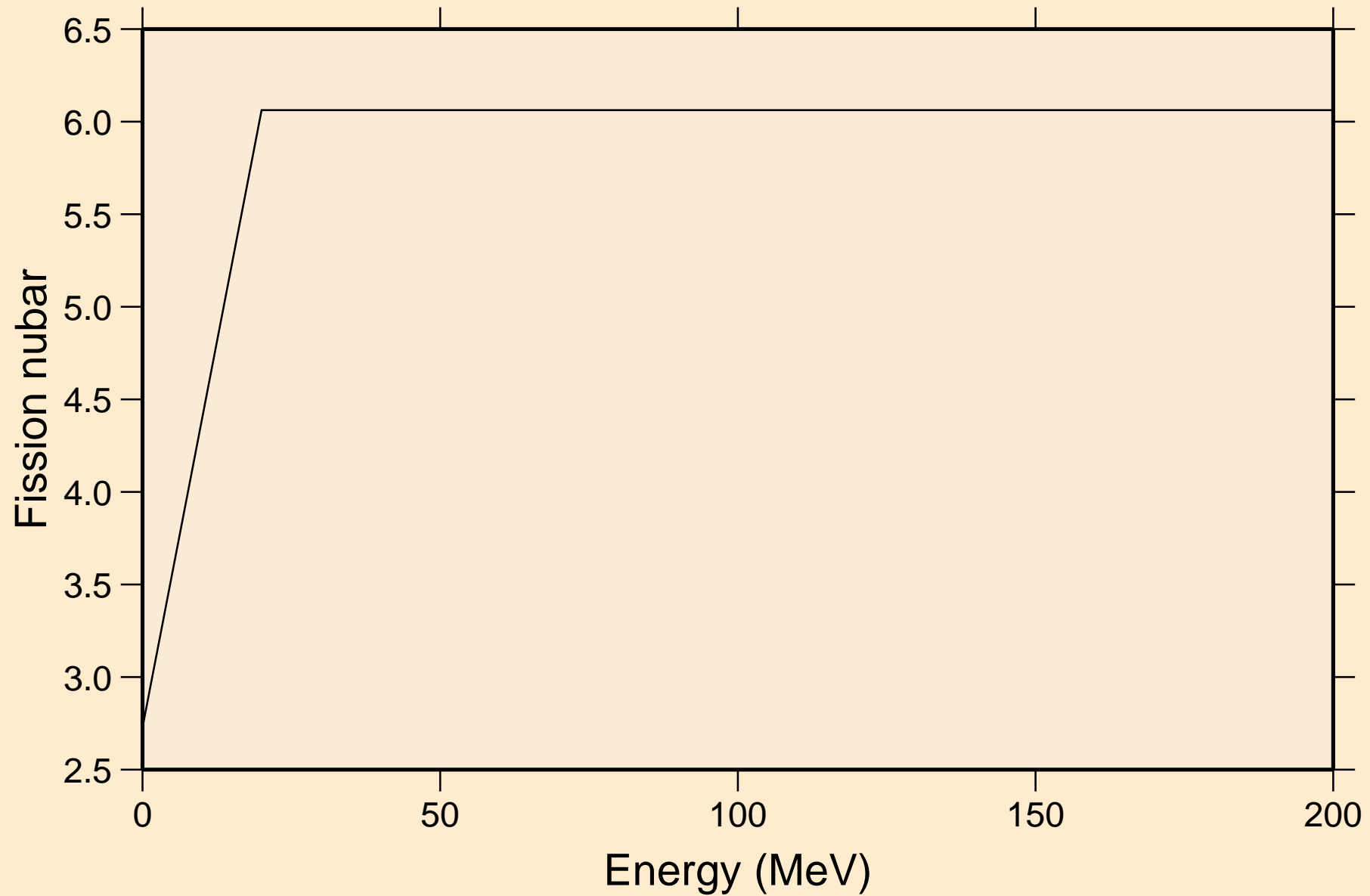

FR232 NEUTRON ACER TENDL-2024 LIBRARY; T=0.K
Neutron emission for (n,x)

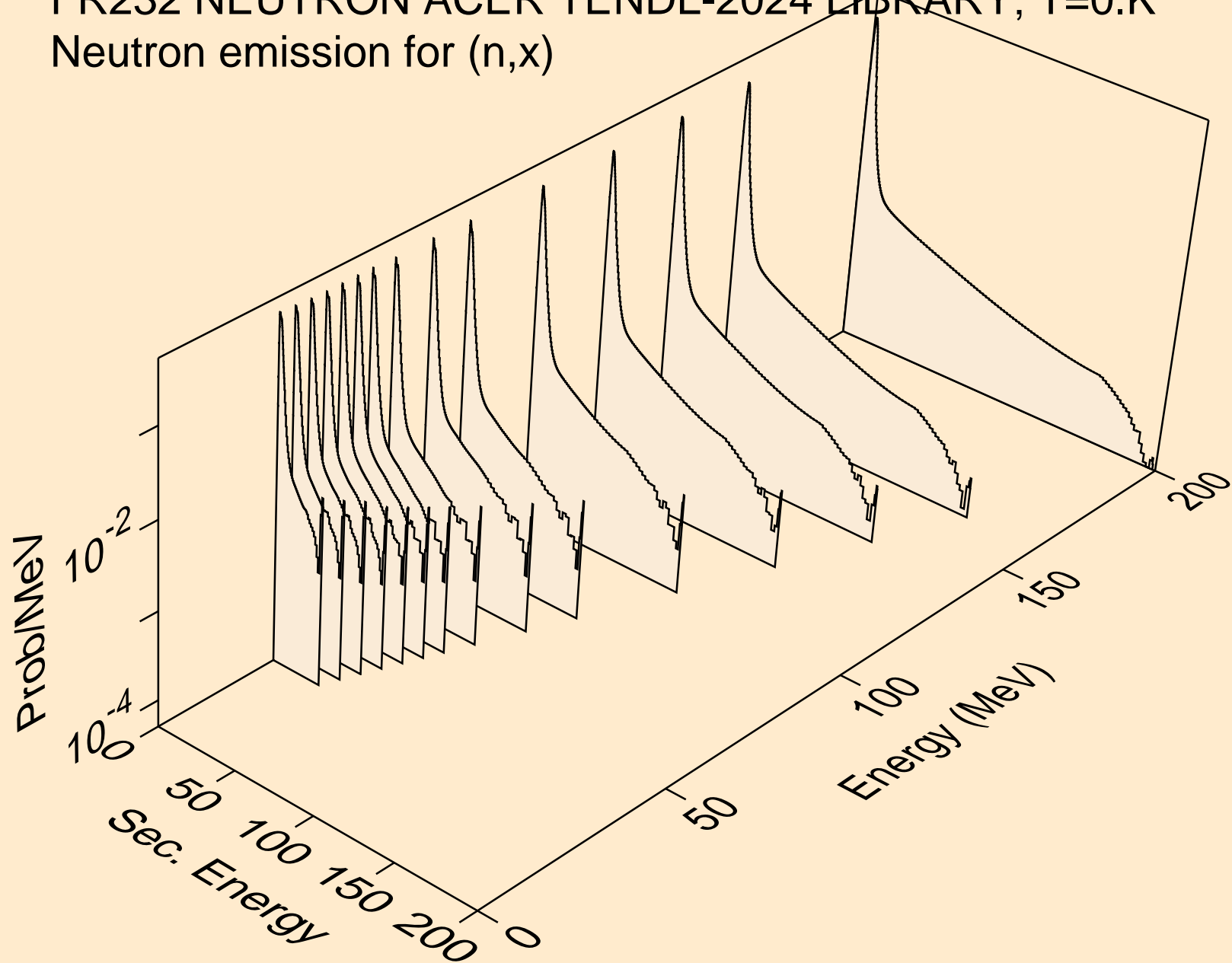

FR232 NEUTRON ACER TENDL-2024 LIBRARY; T=0.K
Neutron emission for (n,2nd)

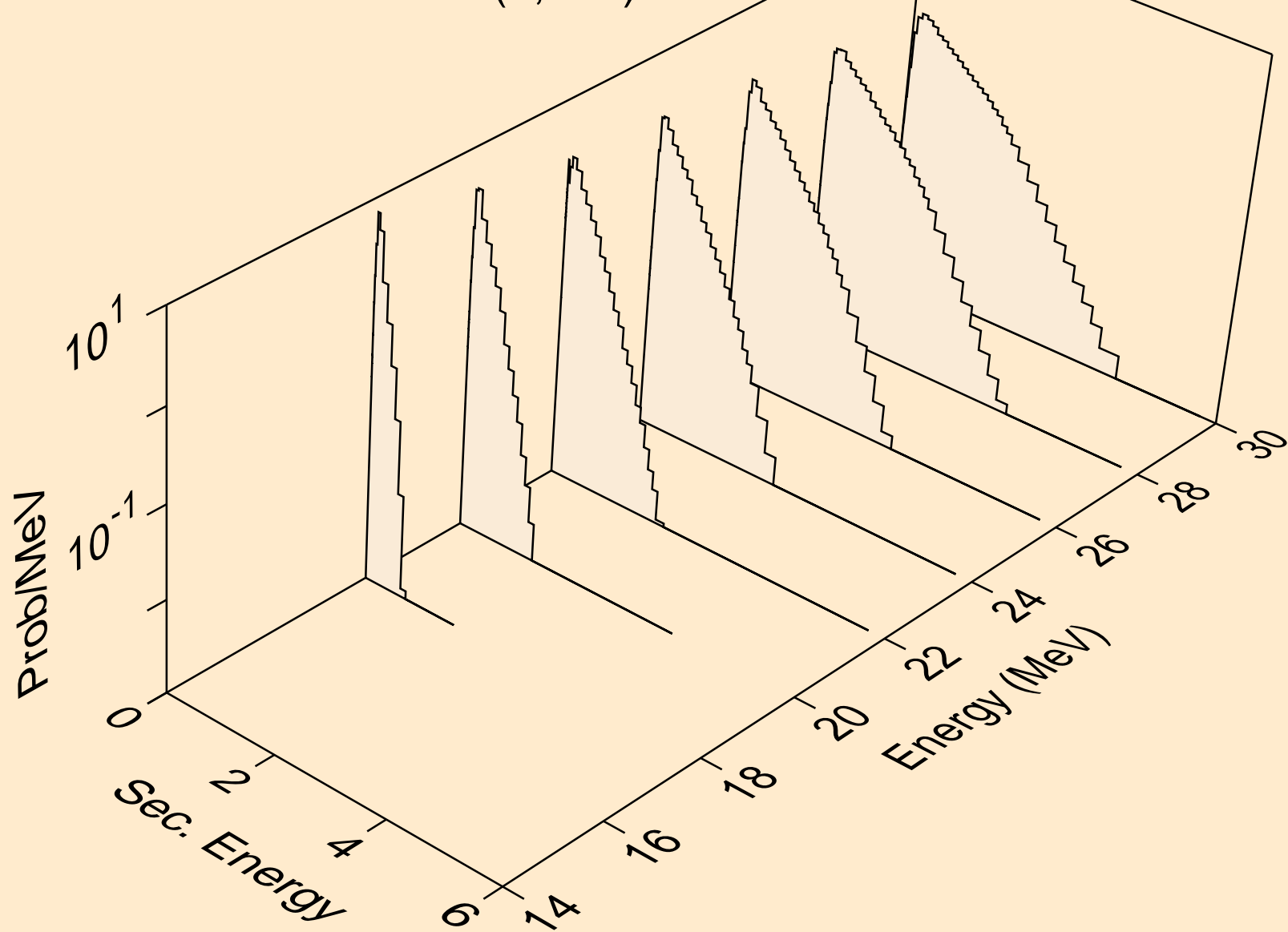

FR232 NEUTRON ACER TENDL-2024 LIBRARY; T=0.K
Neutron emission for (n,2n)

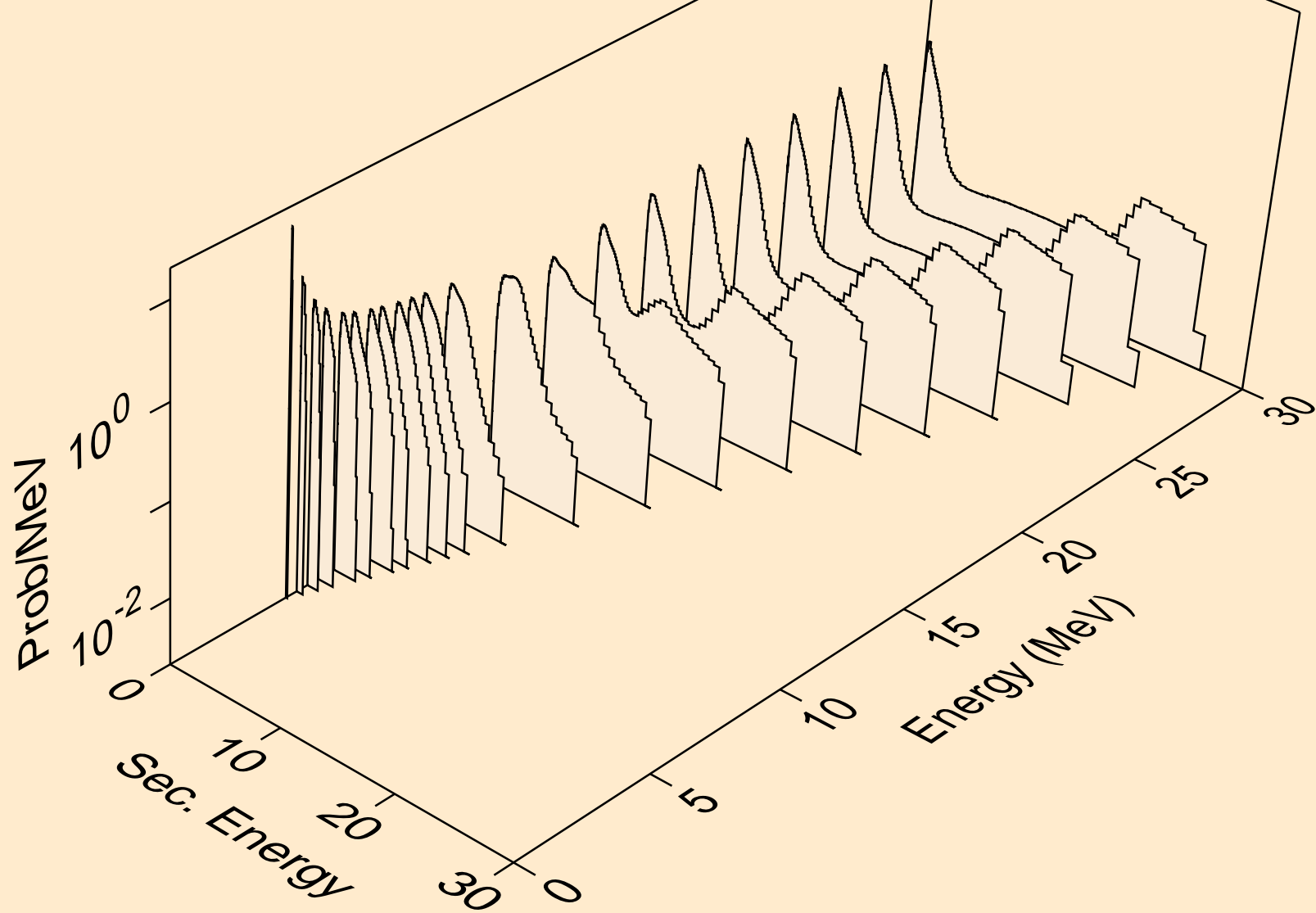

FR232 NEUTRON ACER TENDL-2024 LIBRARY; T=0.K
Neutron emission for (n,3n)

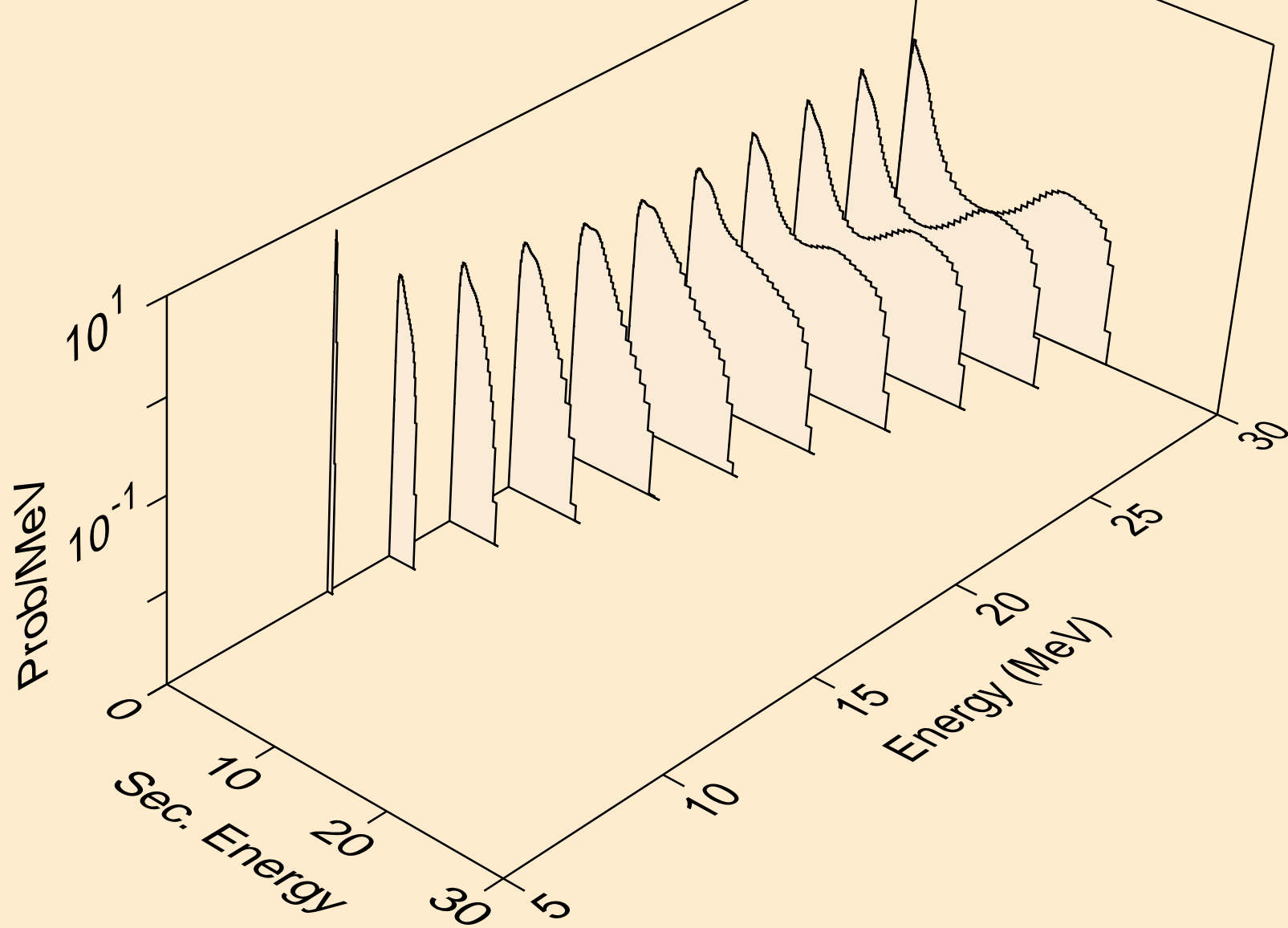

FR232 NEUTRON ACER TENDL-2024 LIBRARY; T=0.K
Neutron emission for fission

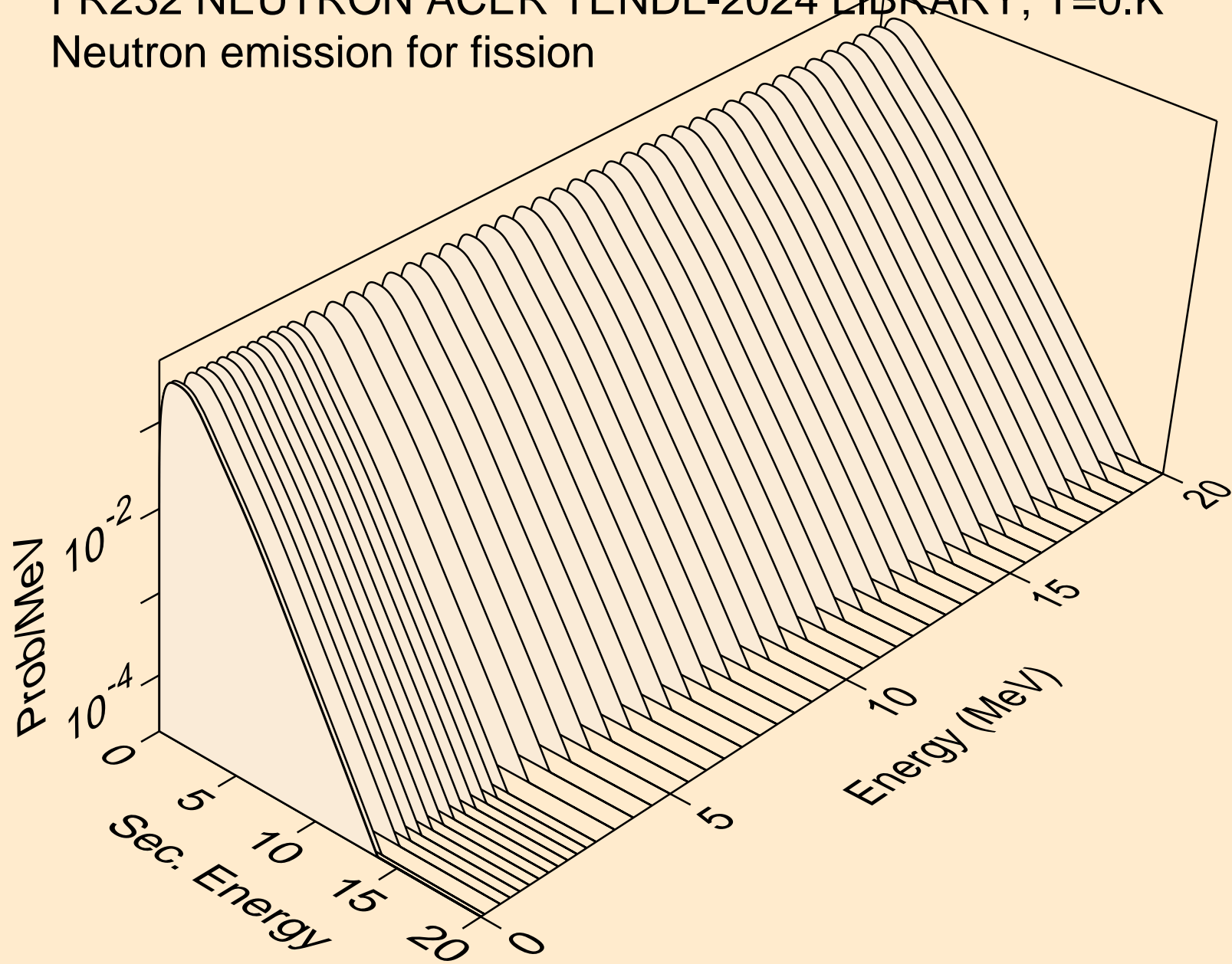

FR232 NEUTRON ACER TENDL-2024 LIBRARY; T=0.K
Neutron emission for (n,n*)a

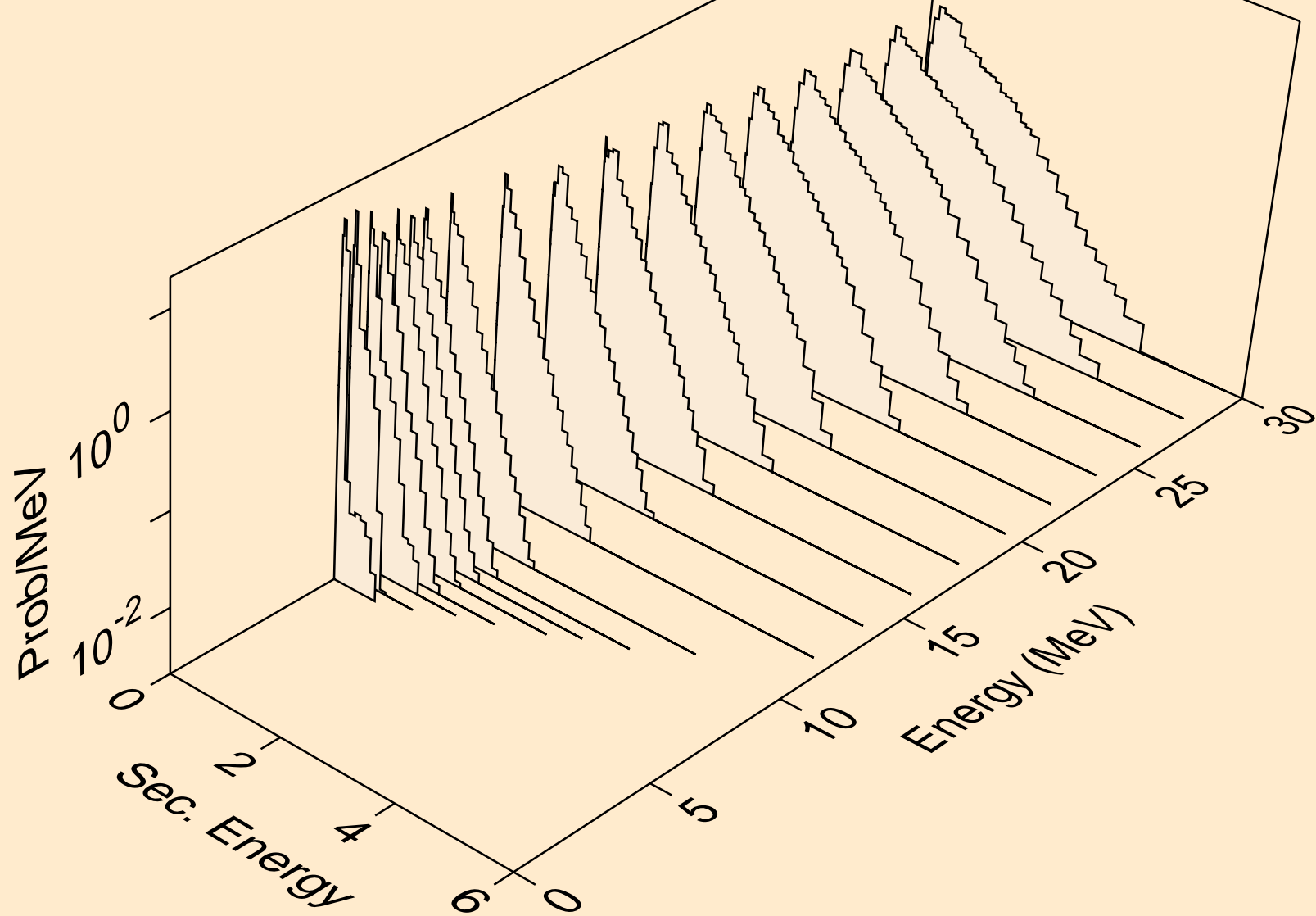

FR232 NEUTRON ACER TENDL-2024 LIBRARY; T=0.K
Neutron emission for (n,2n)a

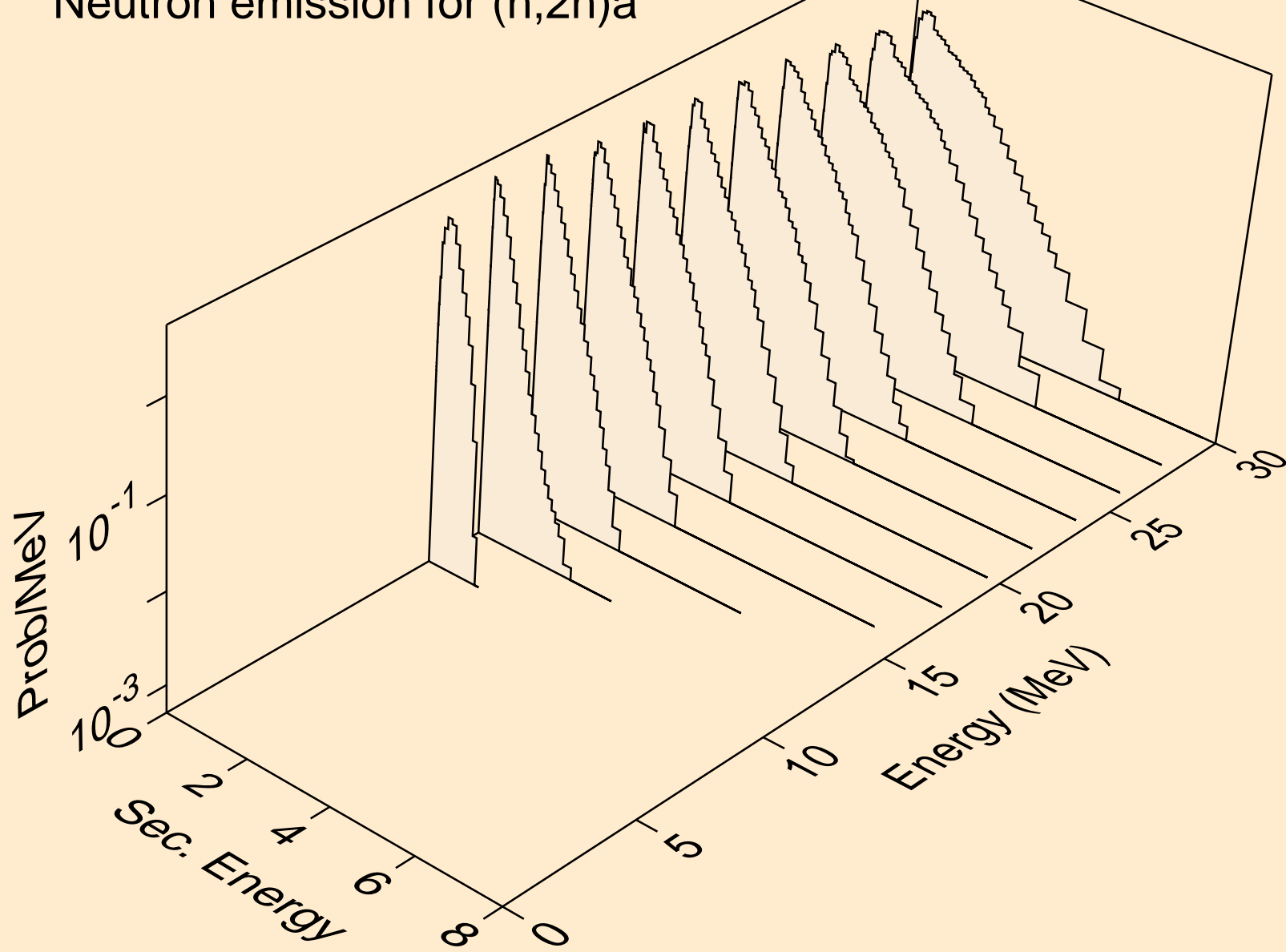

FR232 NEUTRON ACER TENDL-2024 LIBRARY; T=0.K
Neutron emission for (n,3n)a

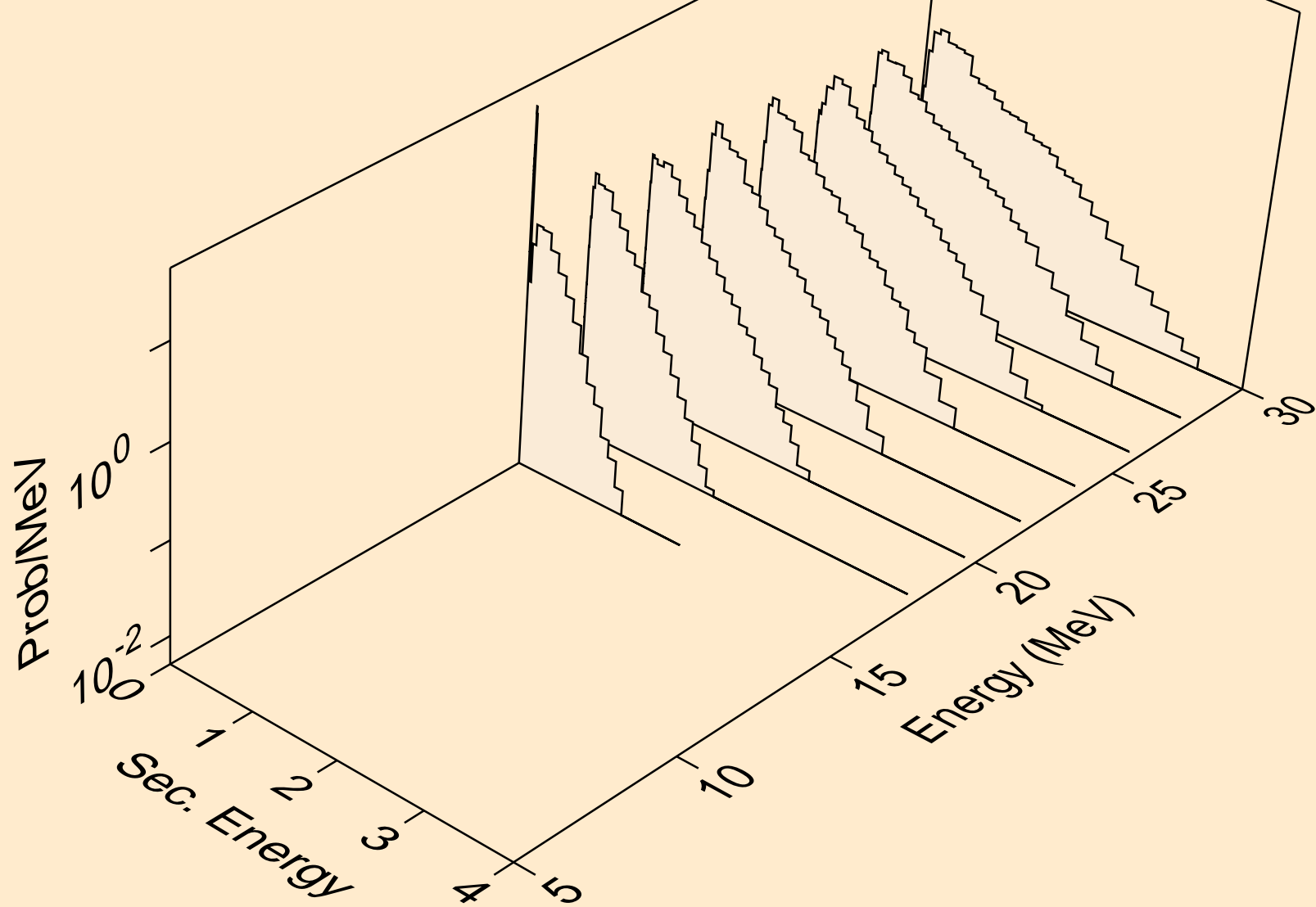

FR232 NEUTRON ACER TENDL-2024 LIBRARY; T=0.K
Neutron emission for (n,n*)p

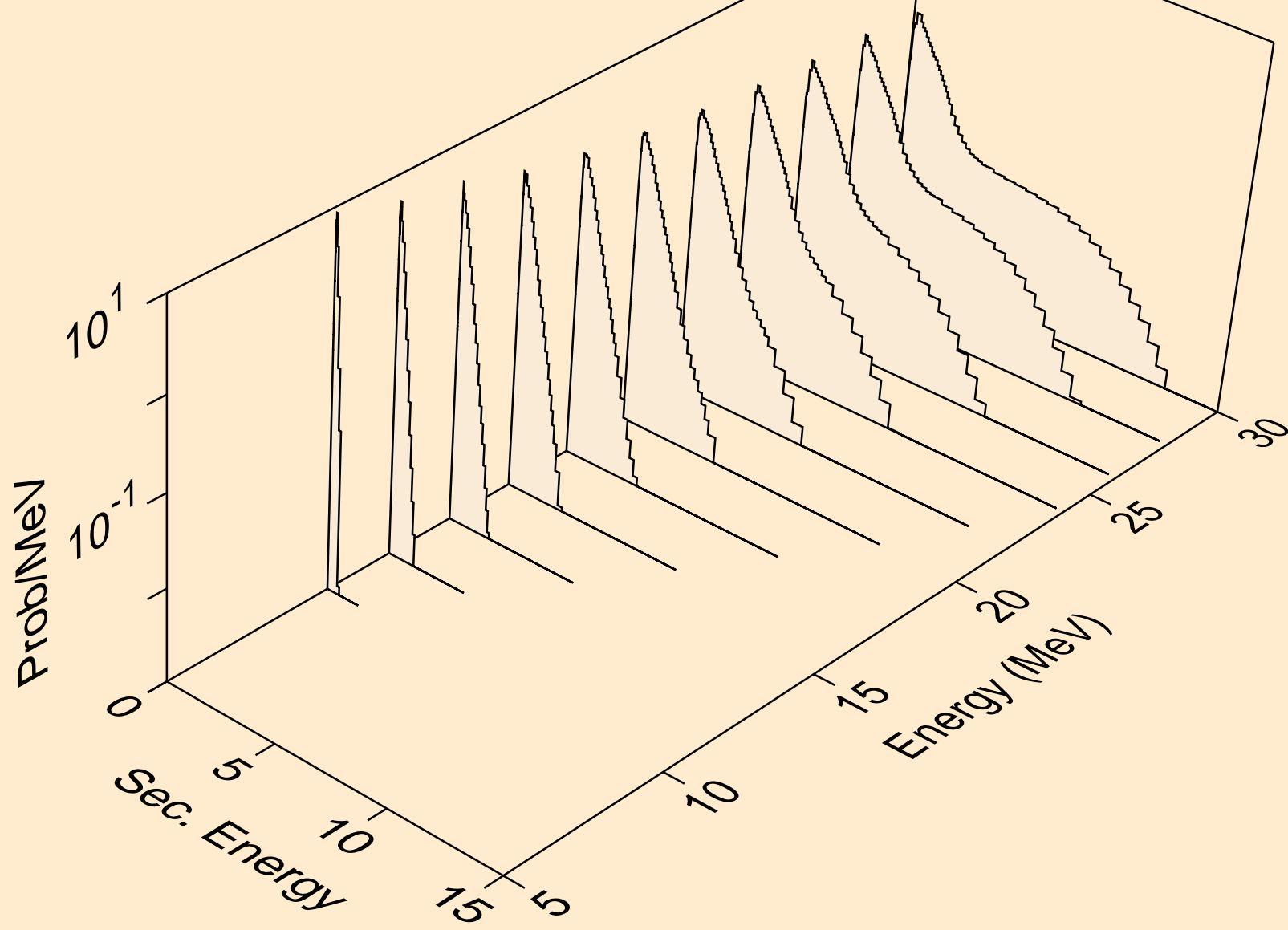

FR232 NEUTRON ACER TENDL-2024 LIBRARY; T=0.K
Neutron emission for (n,n*)d

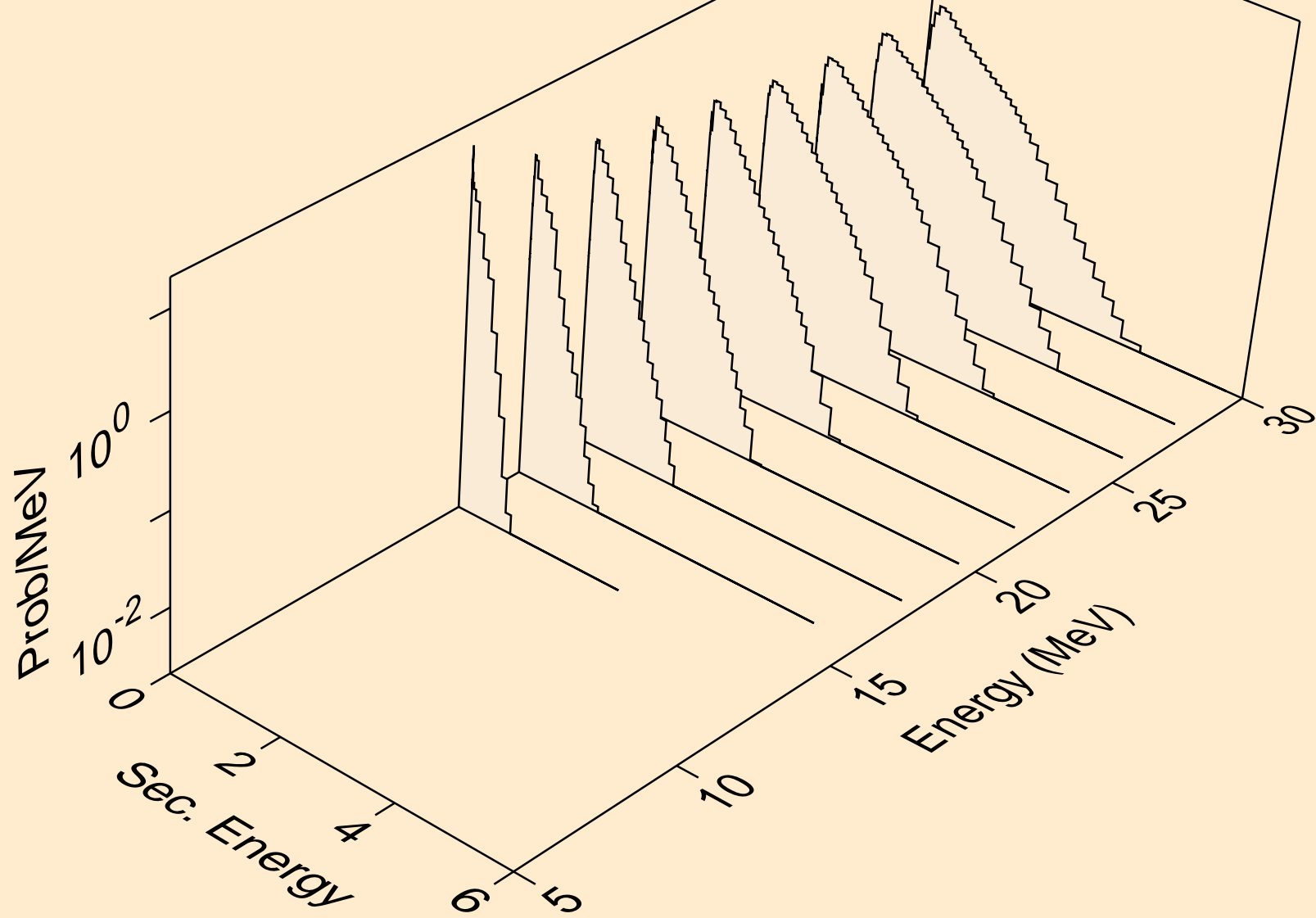

FR232 NEUTRON ACER TENDL-2024 LIBRARY; T=0.K
Neutron emission for (n,n*)t

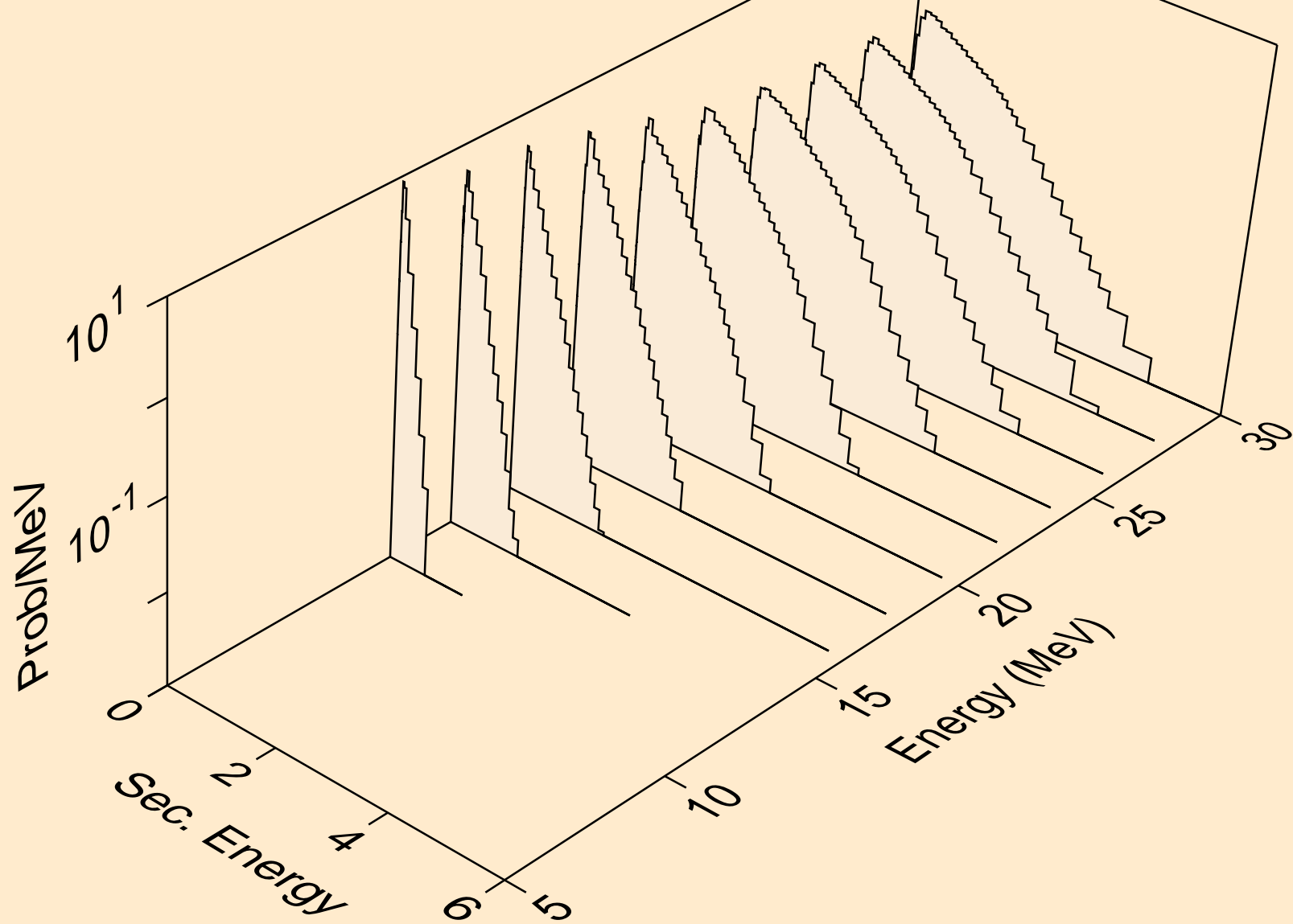

FR232 NEUTRON ACER TENDL-2024 LIBRARY; T=0.K
Neutron emission for (n,n*)he3

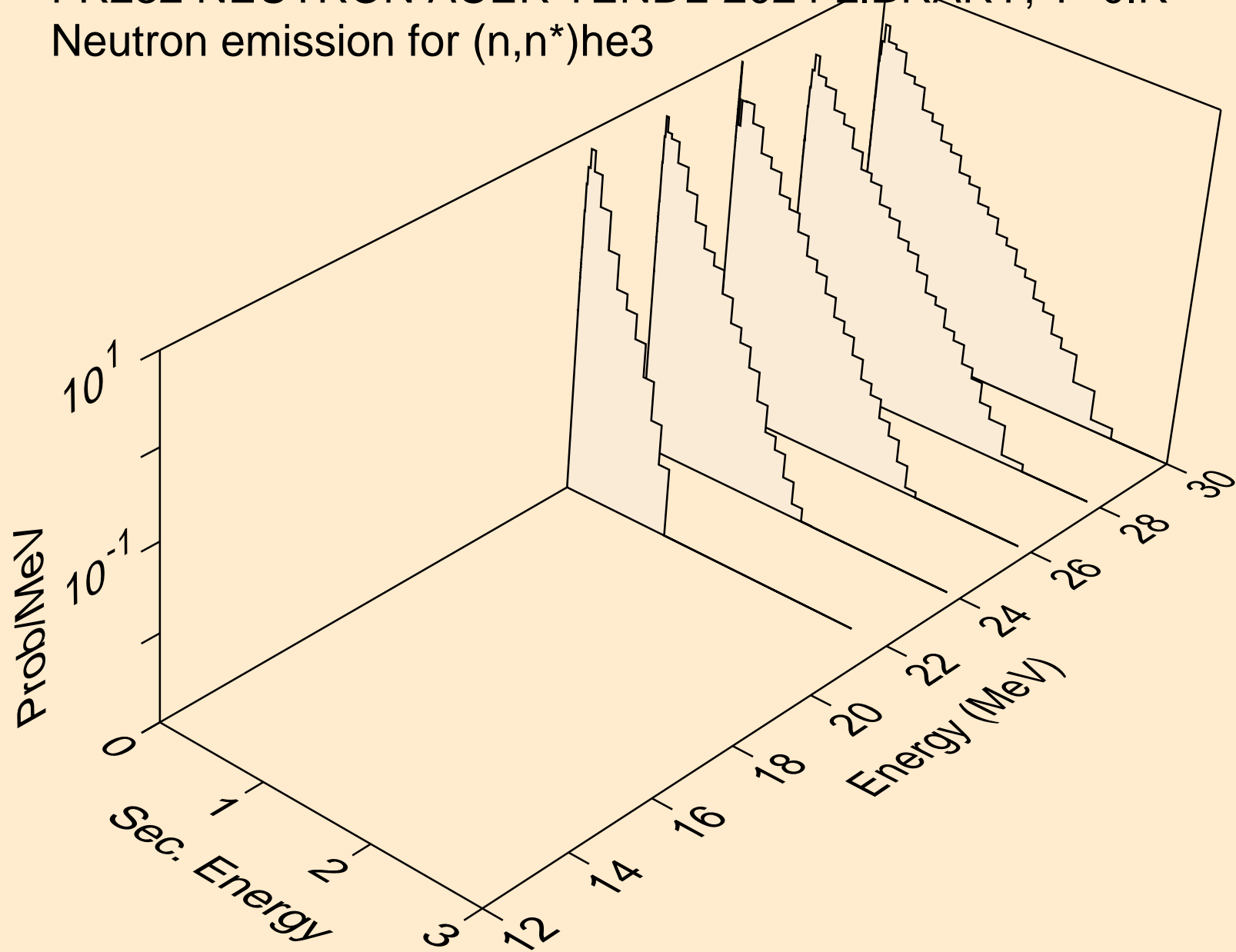

FR232 NEUTRON ACER TENDL-2024 LIBRARY; T=0.K
Neutron emission for (n,4n)

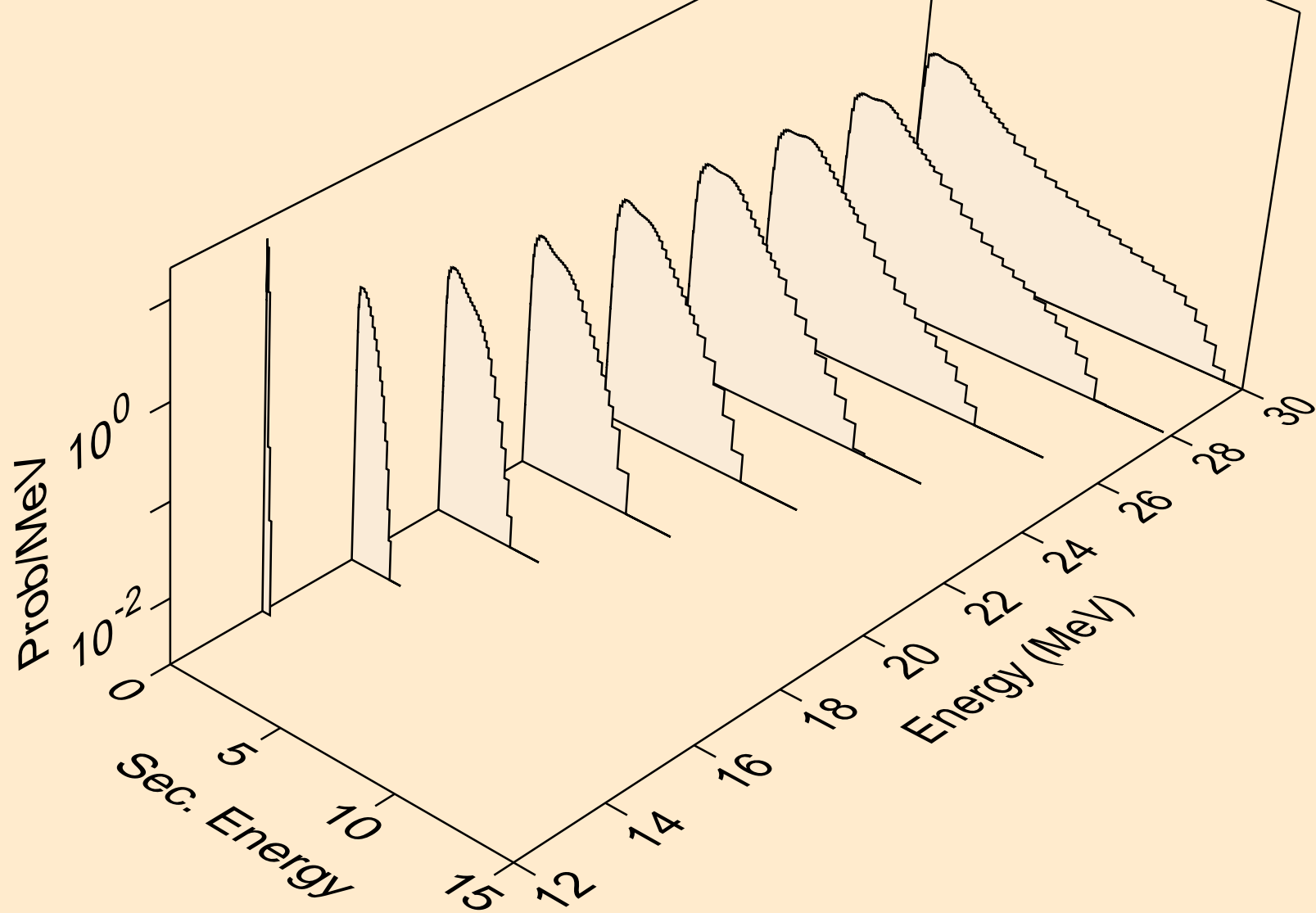

FR232 NEUTRON ACER TENDL-2024 LIBRARY; T=0.K
Neutron emission for (n,2np)

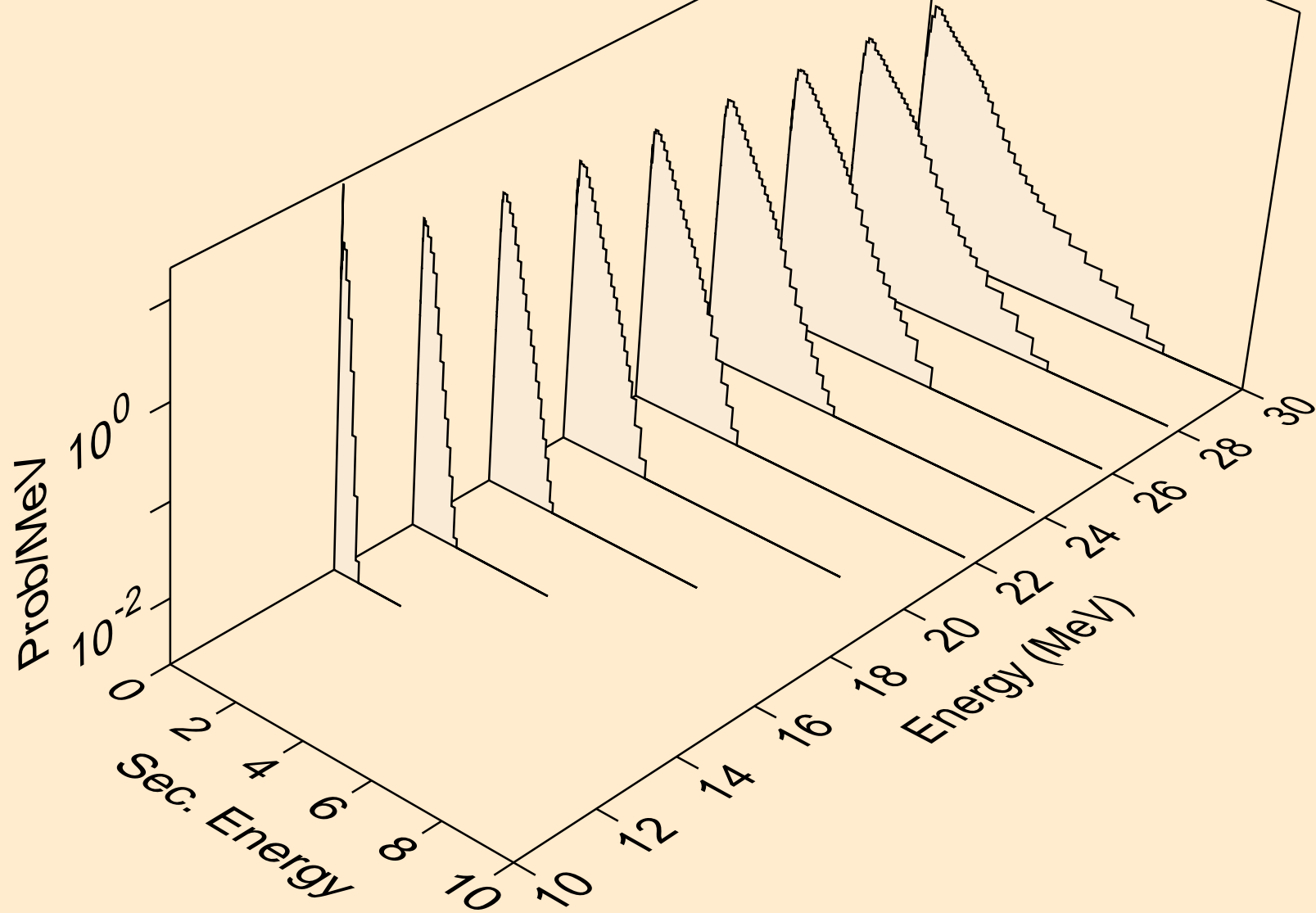

FR232 NEUTRON ACER TENDL-2024 LIBRARY; T=0.K
Neutron emission for (n,3np)

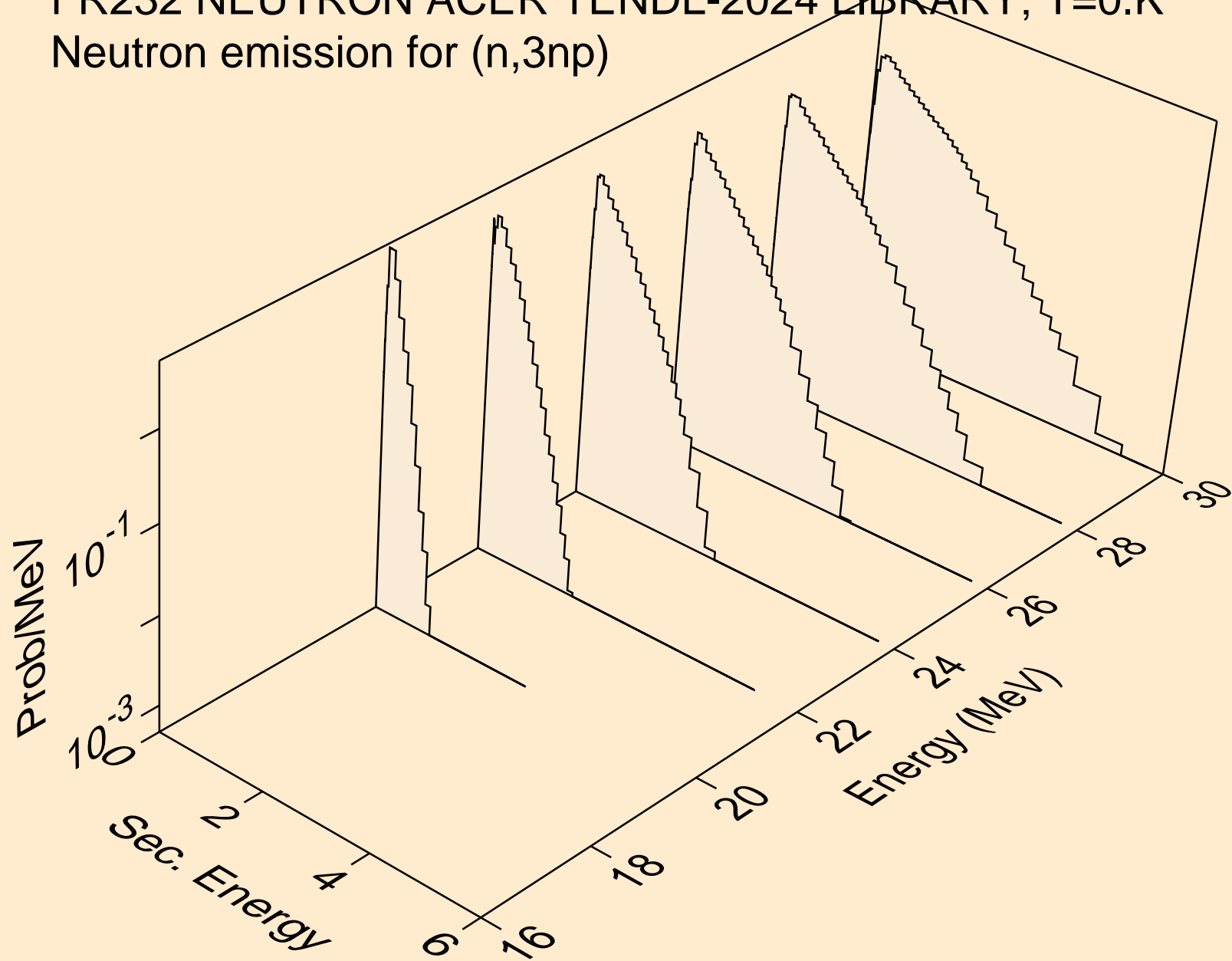

FR232 NEUTRON ACER TENDL-2024 LIBRARY; T=0.K
Neutron emission for (n,n*c)

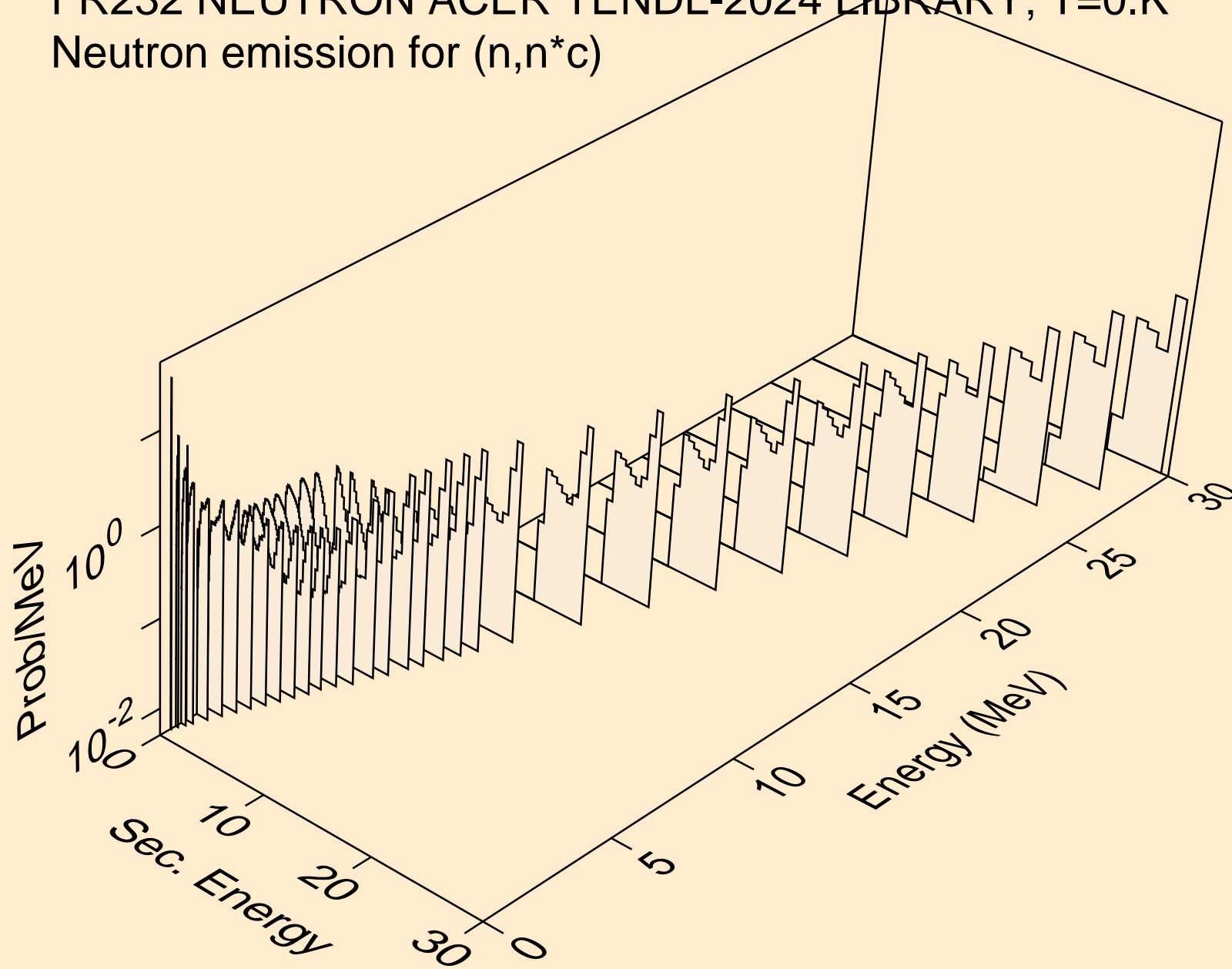

FR232 NEUTRON ACER TENDL-2024 LIBRARY; T=0.K

Delayed nubar

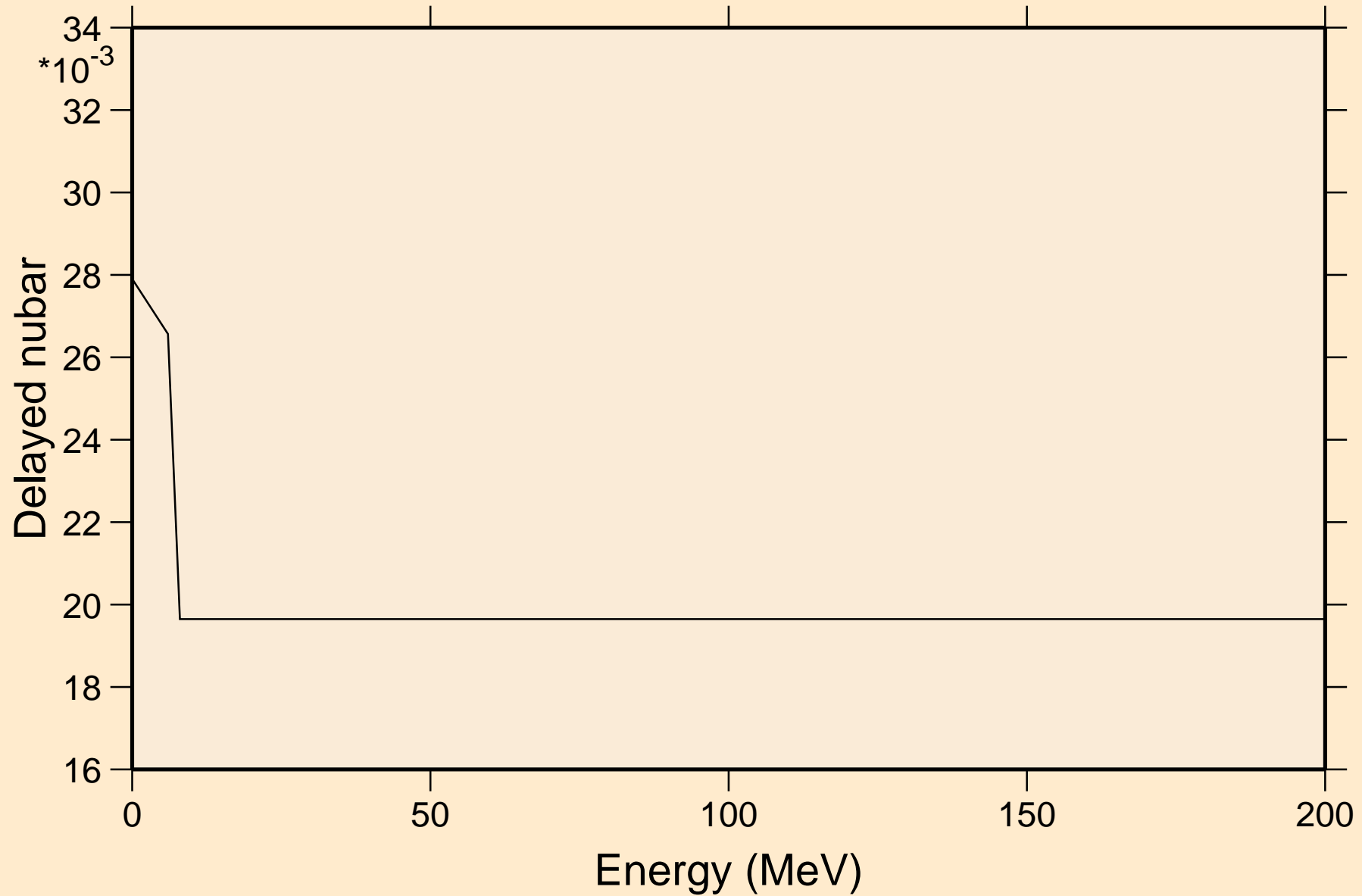

FR232 NEUTRON ACER TENDL-2024 LIBRARY; T=0.K

Delayed neutron spectra

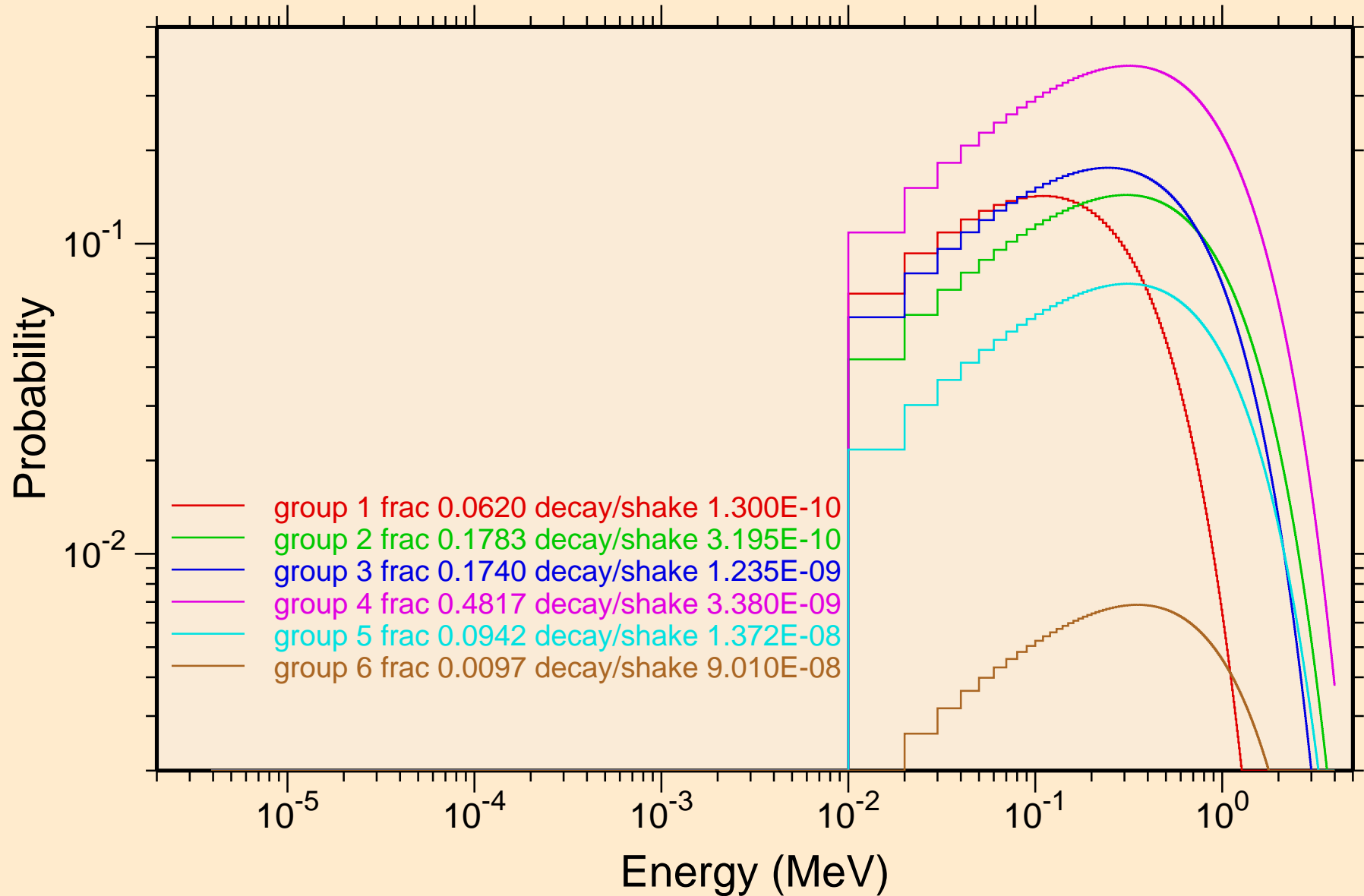

FR232 NEUTRON ACER TENDL-2024 LIBRARY; T=0.K
Photon emission for (n,x)

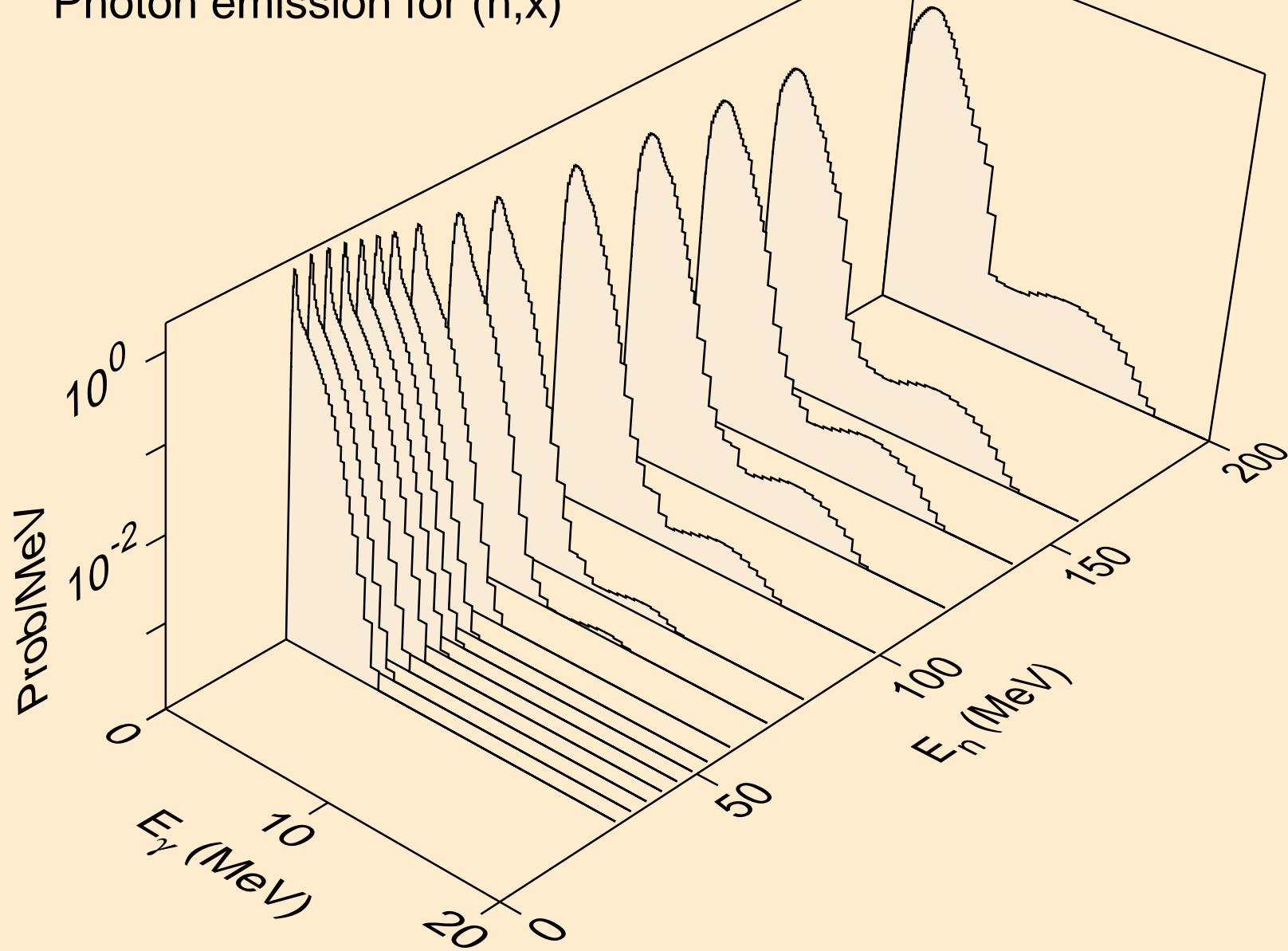

FR232 NEUTRON ACER TENDL-2024 LIBRARY; T=0.K
Photon emission for (n,2nd)

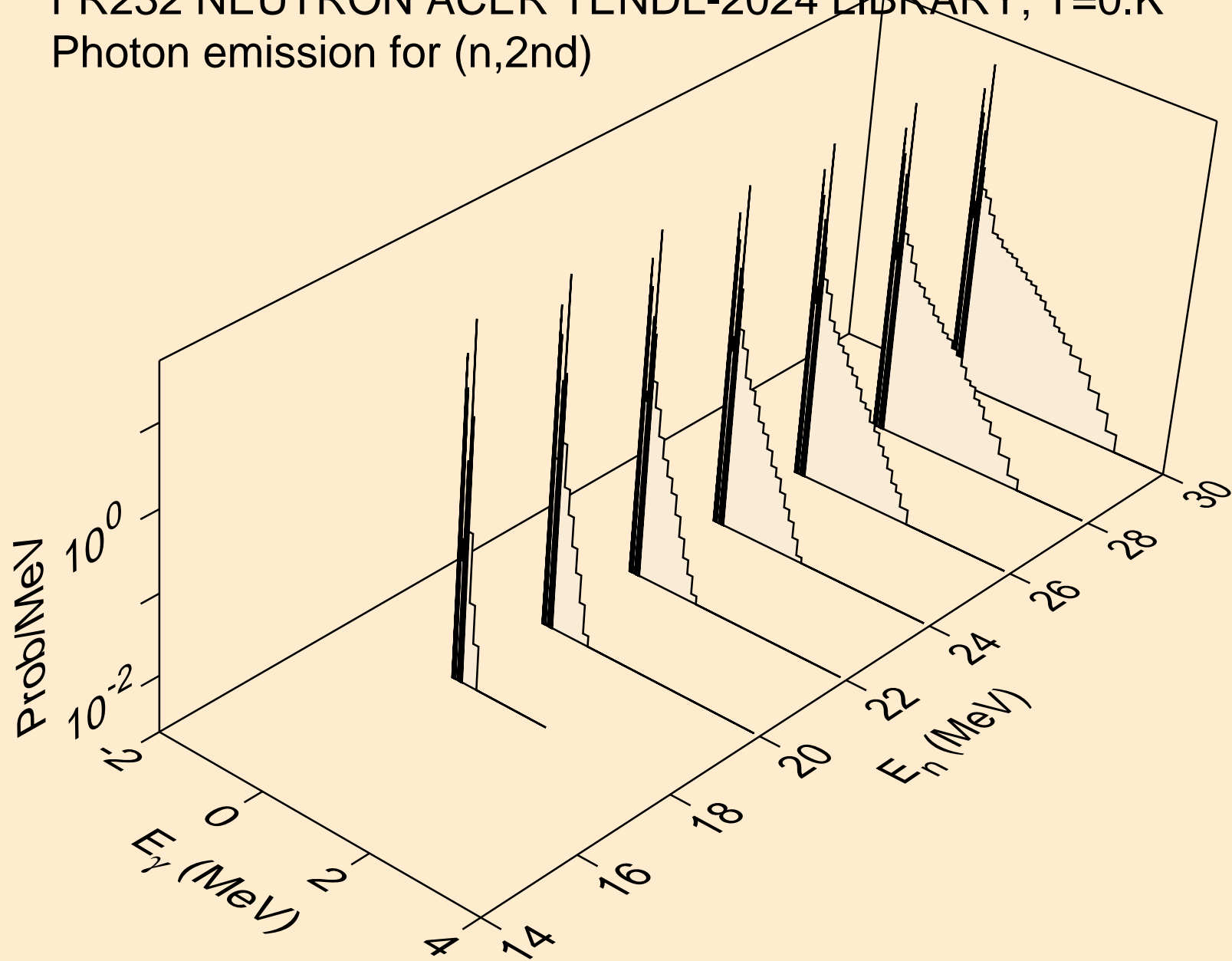

FR232 NEUTRON ACER TENDL-2024 LIBRARY; T=0.K
Photon emission for (n,2n)

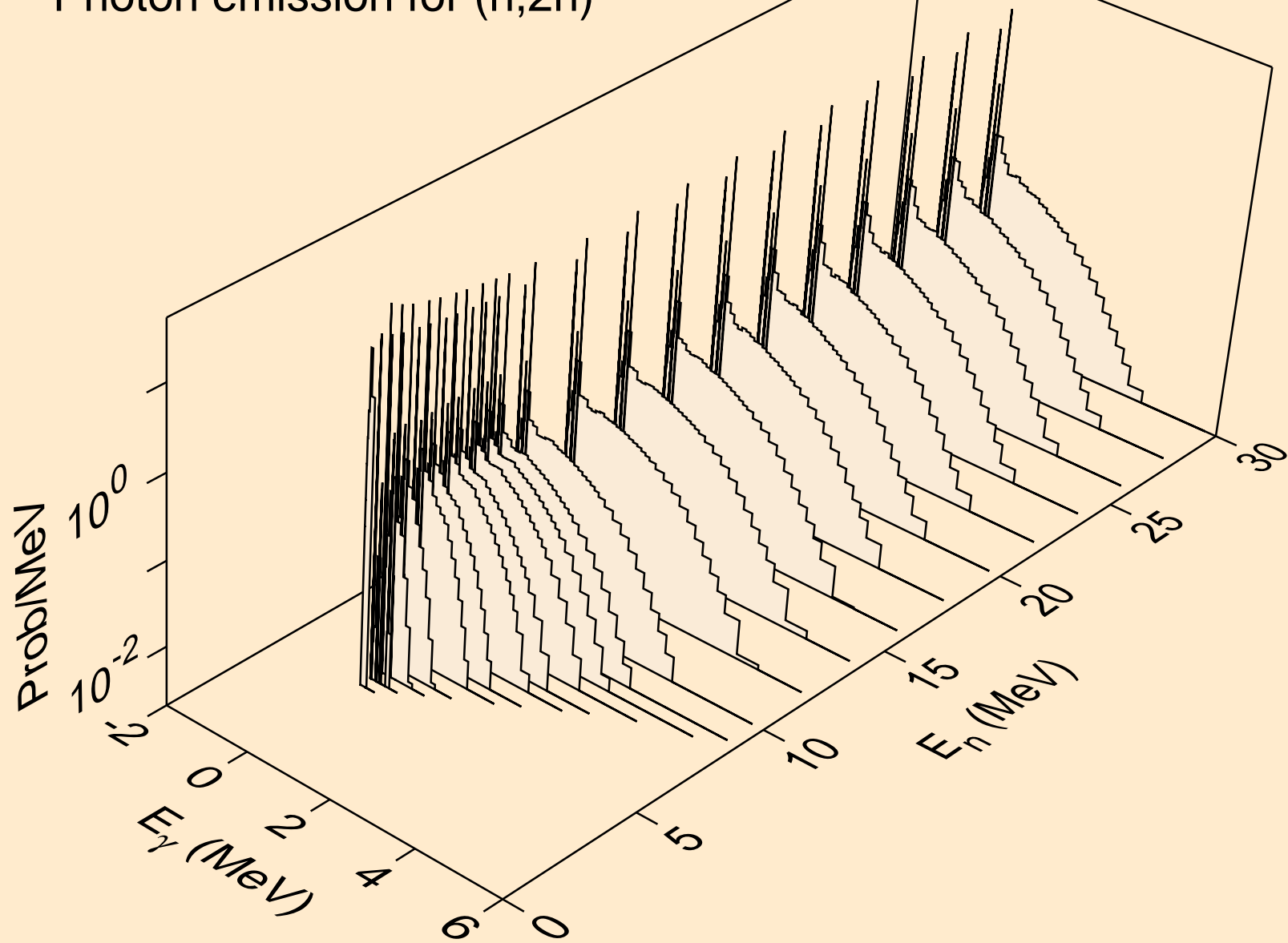

FR232 NEUTRON ACER TENDL-2024 LIBRARY; T=0.K
Photon emission for (n,3n)

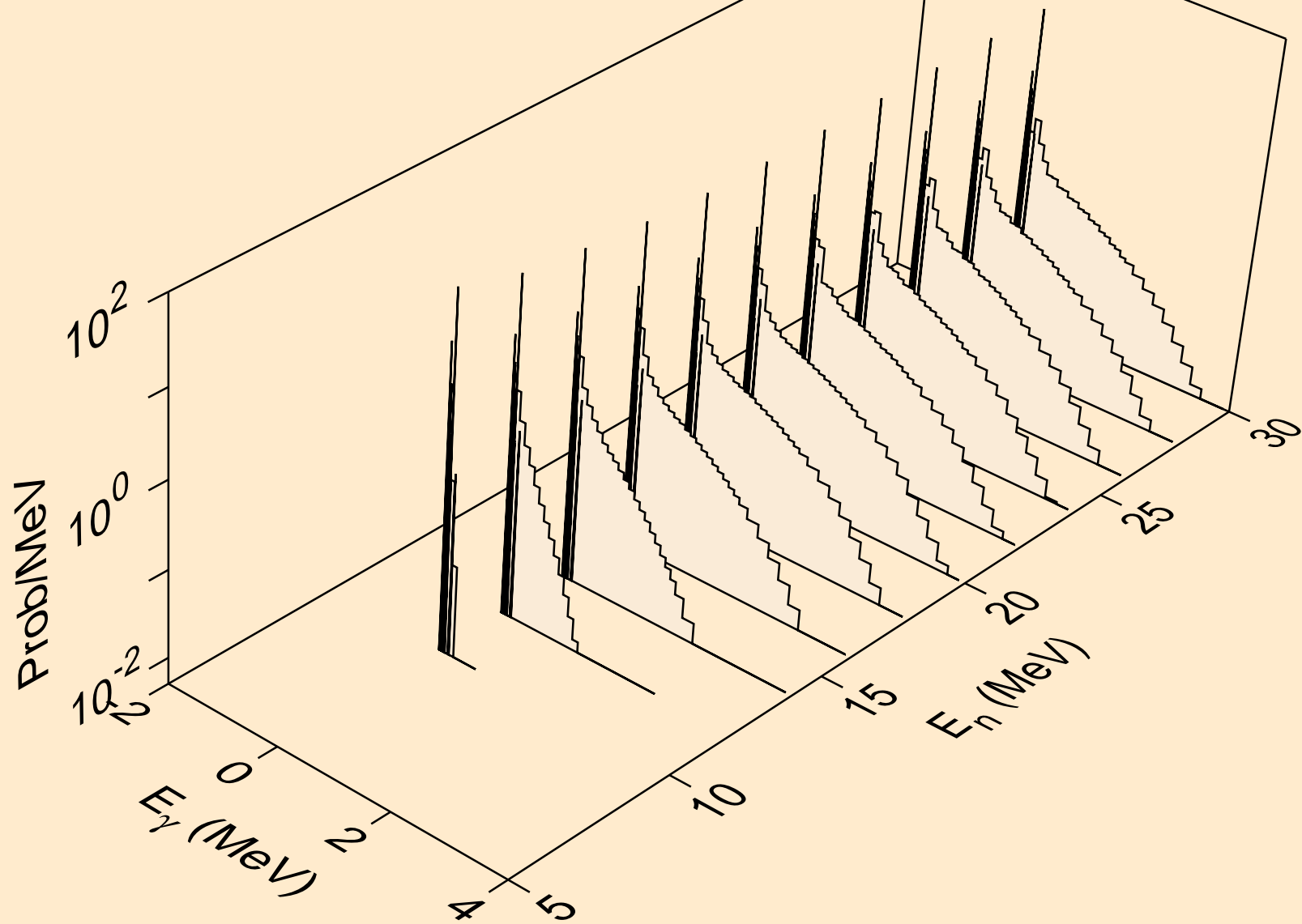

FR232 NEUTRON ACER TENDL-2024 LIBRARY; T=0.K
Photon emission for (n,n*)a

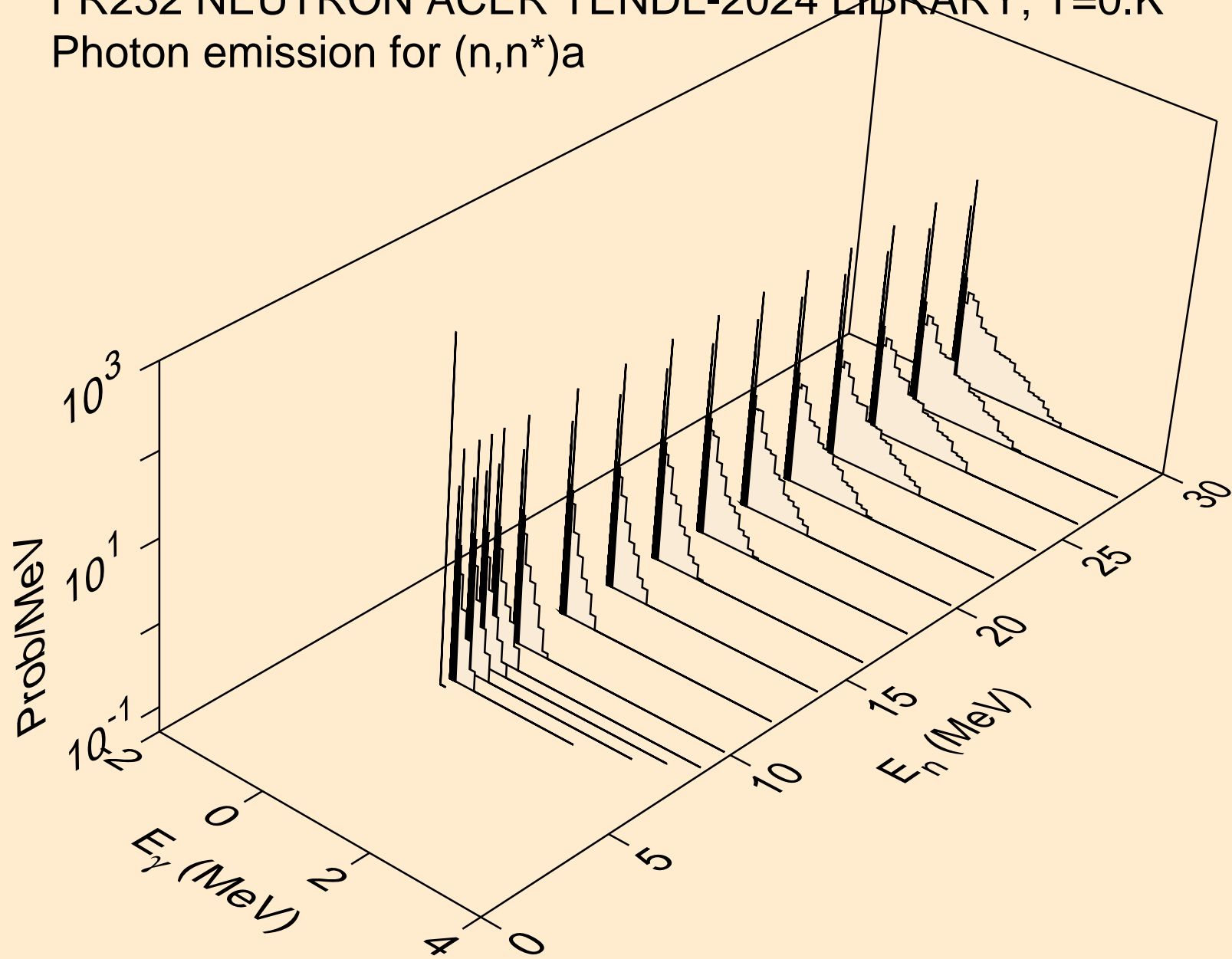

FR232 NEUTRON ACER TENDL-2024 LIBRARY; T=0.K
Photon emission for (n,2n)a

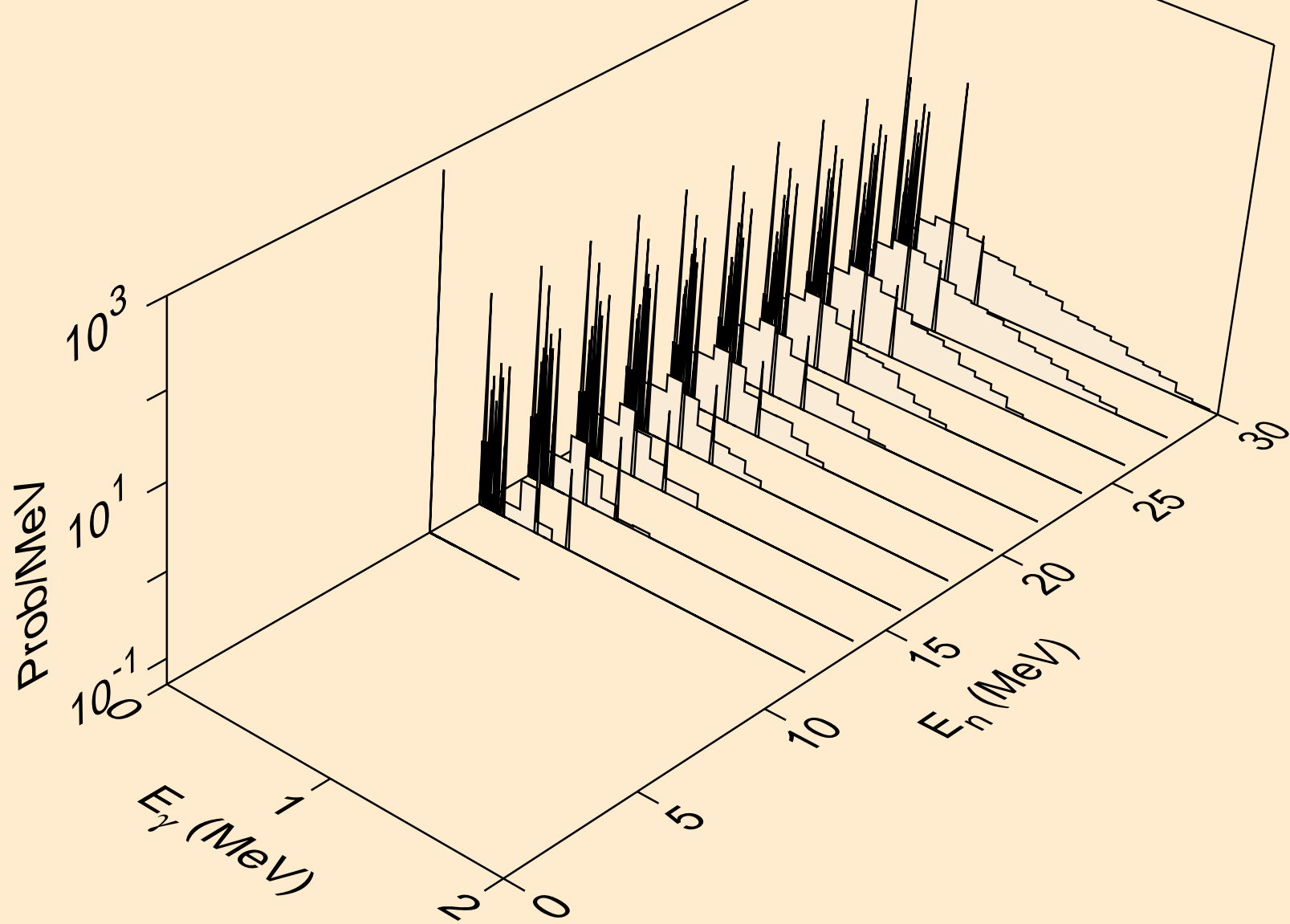

FR232 NEUTRON ACER TENDL-2024 LIBRARY; T=0.K
Photon emission for (n,3n)a

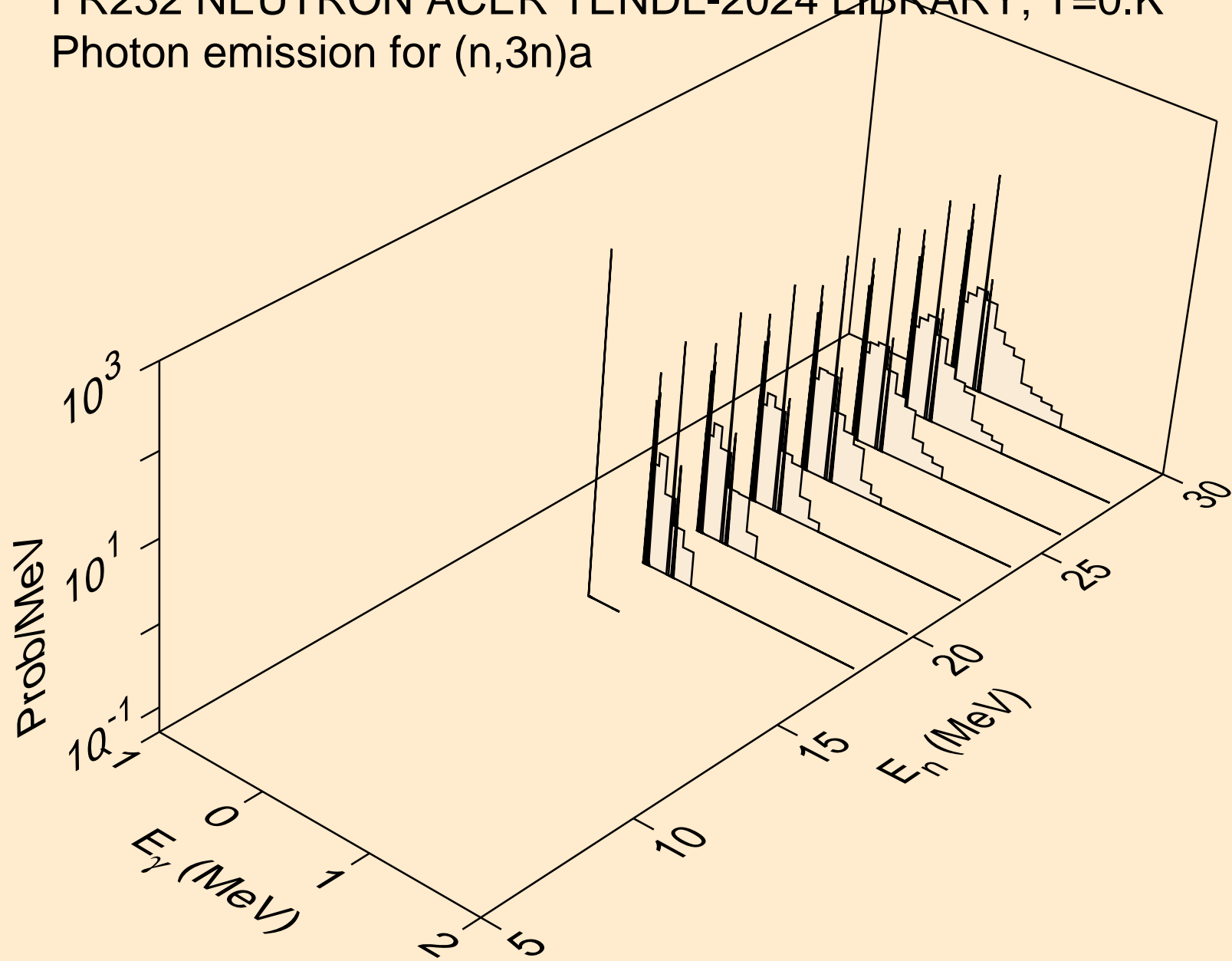

FR232 NEUTRON ACER TENDL-2024 LIBRARY; T=0.K
Photon emission for (n,n*)p

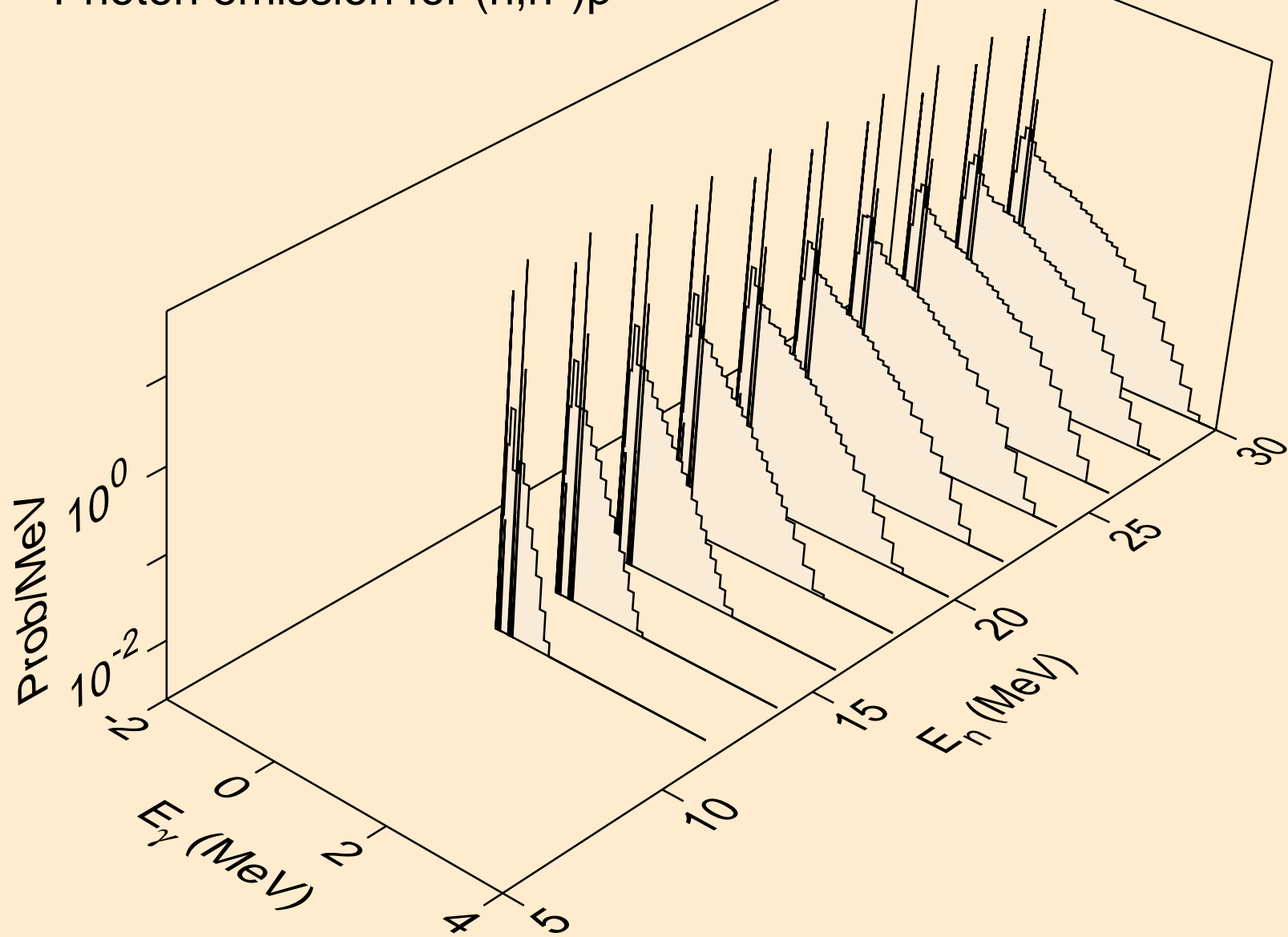

FR232 NEUTRON ACER TENDL-2024 LIBRARY; T=0.K
Photon emission for (n,n*)d

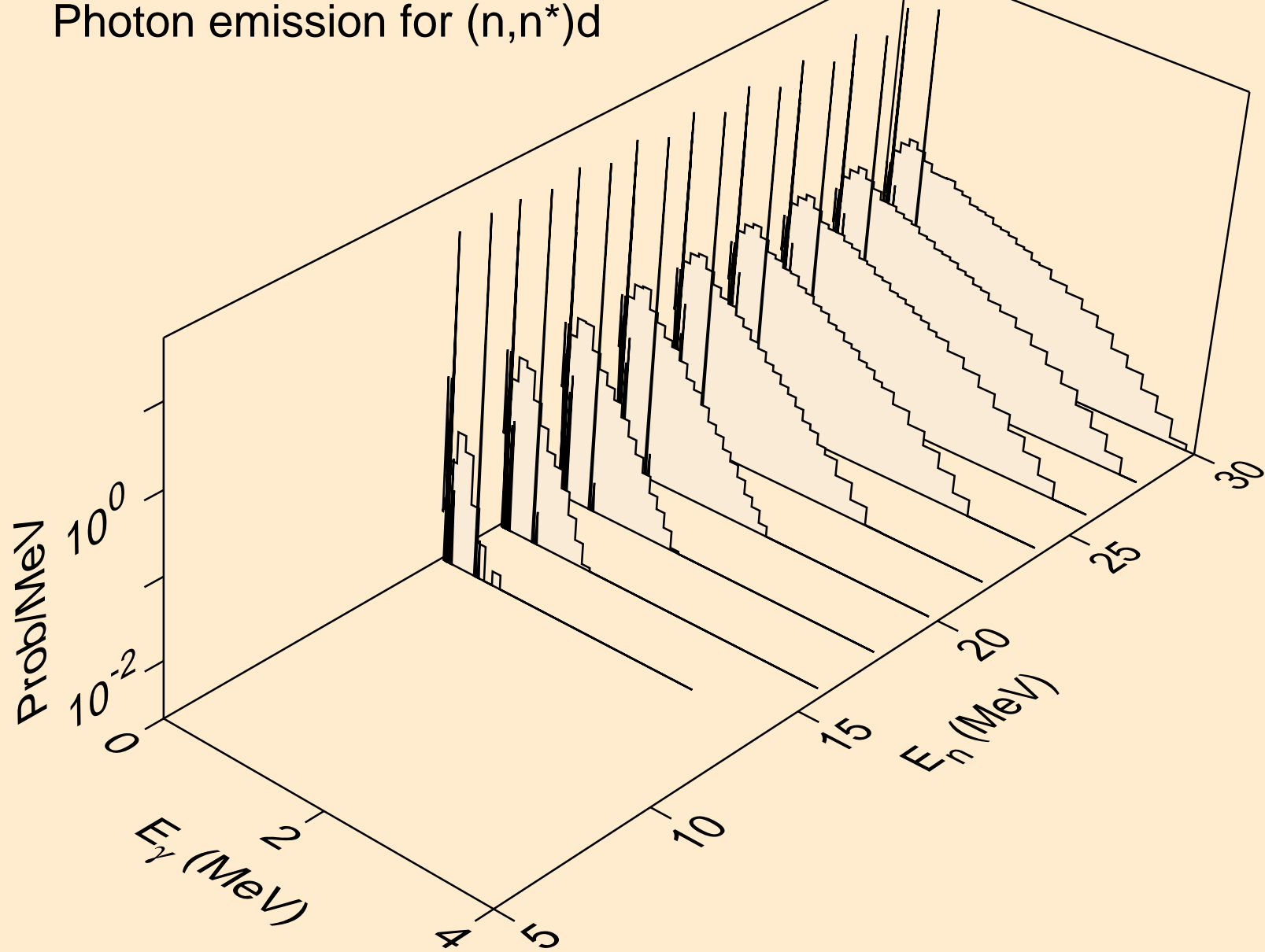

FR232 NEUTRON ACER TENDL-2024 LIBRARY; T=0.K
Photon emission for (n,n*)t

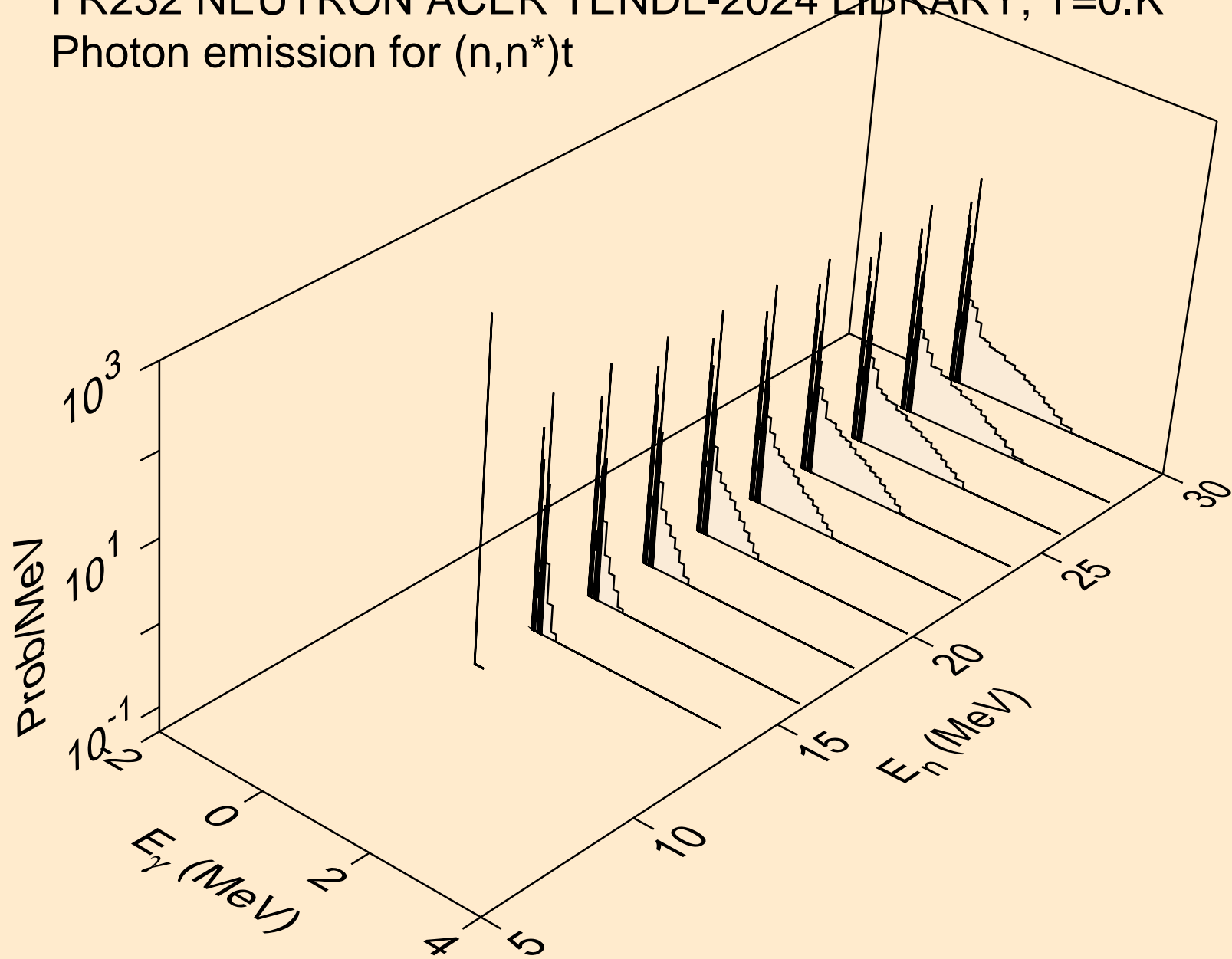

FR232 NEUTRON ACER TENDL-2024 LIBRARY; T=0.K
Photon emission for (n,n*)he3

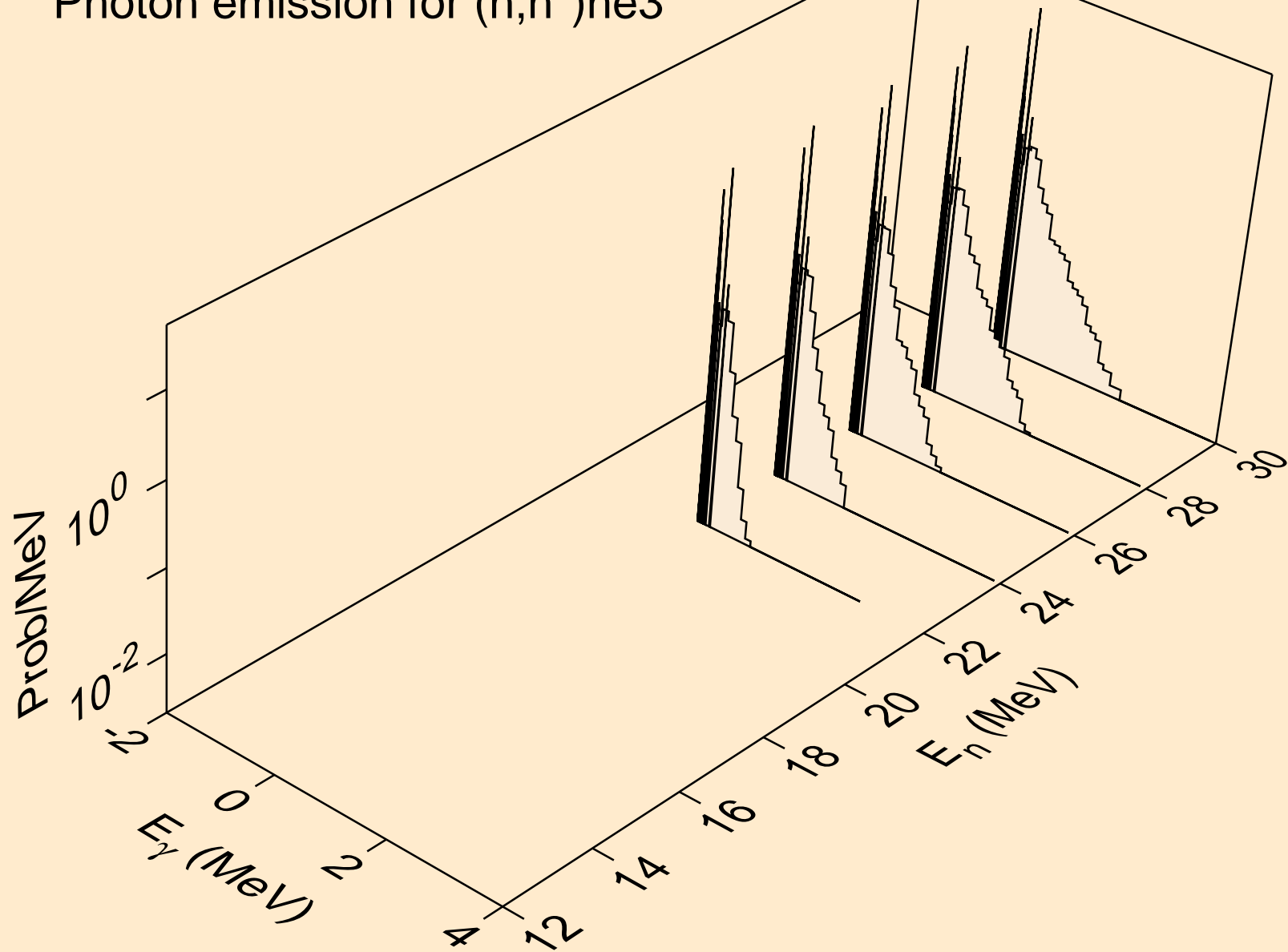

FR232 NEUTRON ACER TENDL-2024 LIBRARY; T=0.K
Photon emission for (n,4n)

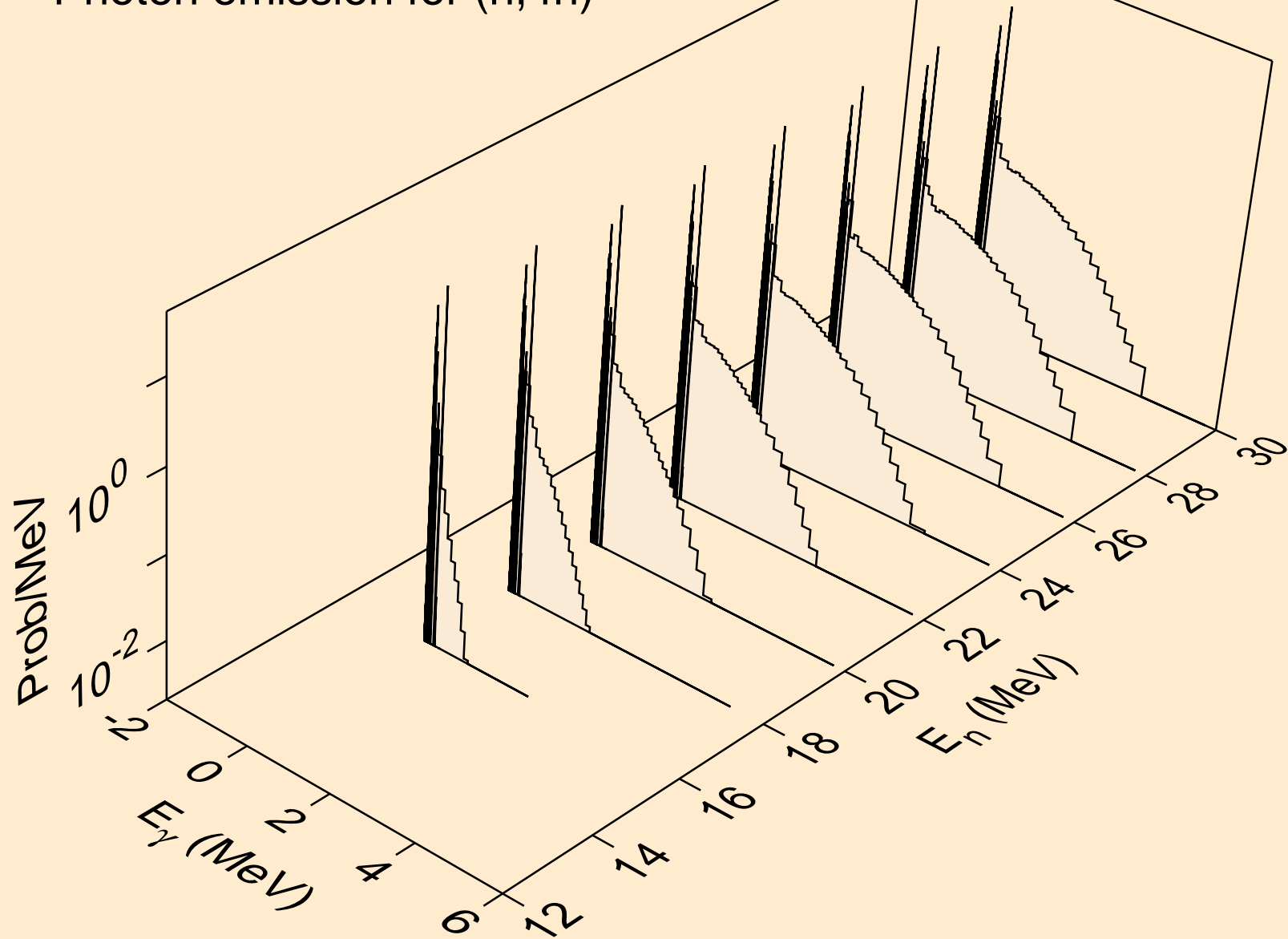

FR232 NEUTRON ACER TENDL-2024 LIBRARY; T=0.K
Photon emission for (n,2np)

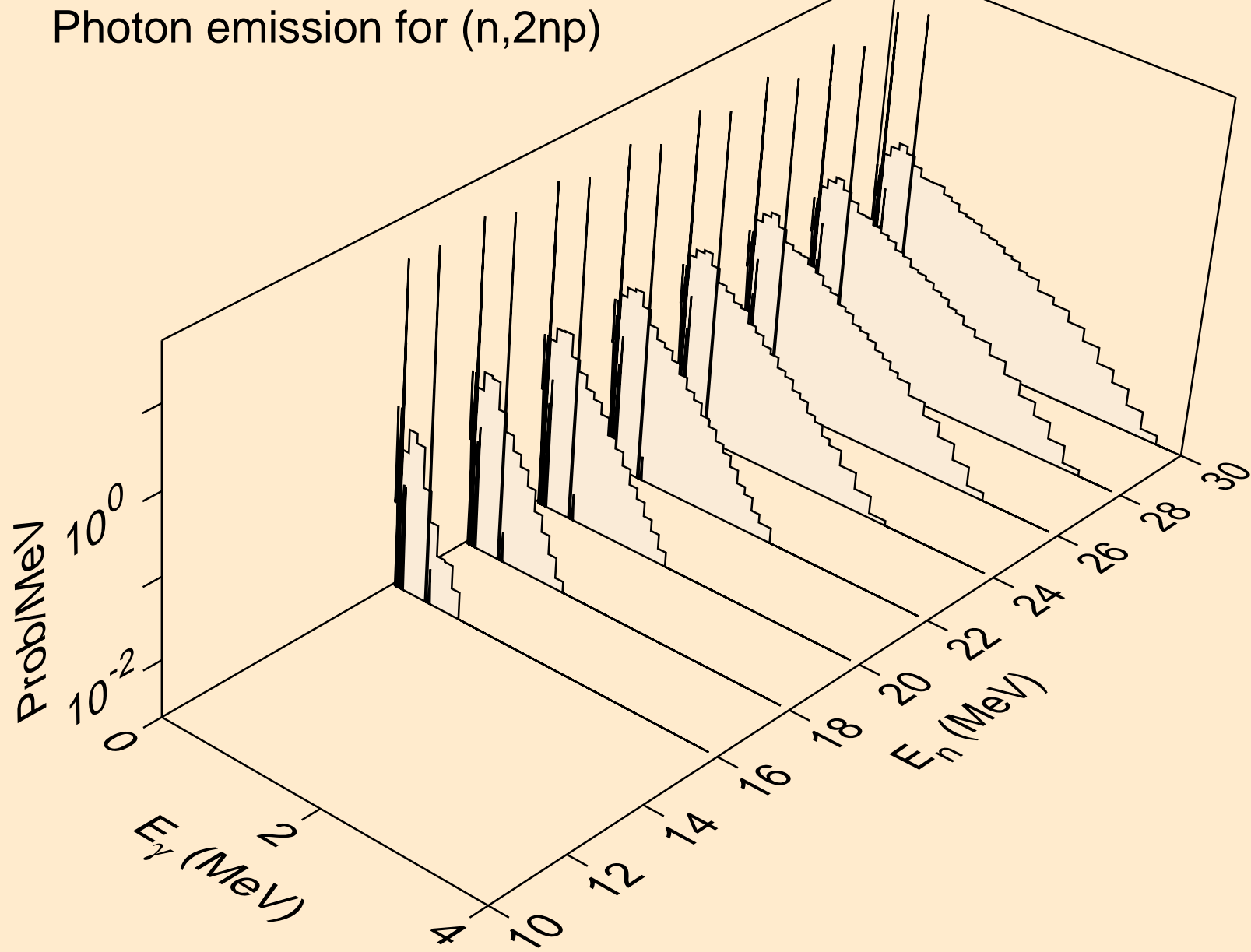

FR232 NEUTRON ACER TENDL-2024 LIBRARY; T=0.K
Photon emission for (n,3np)

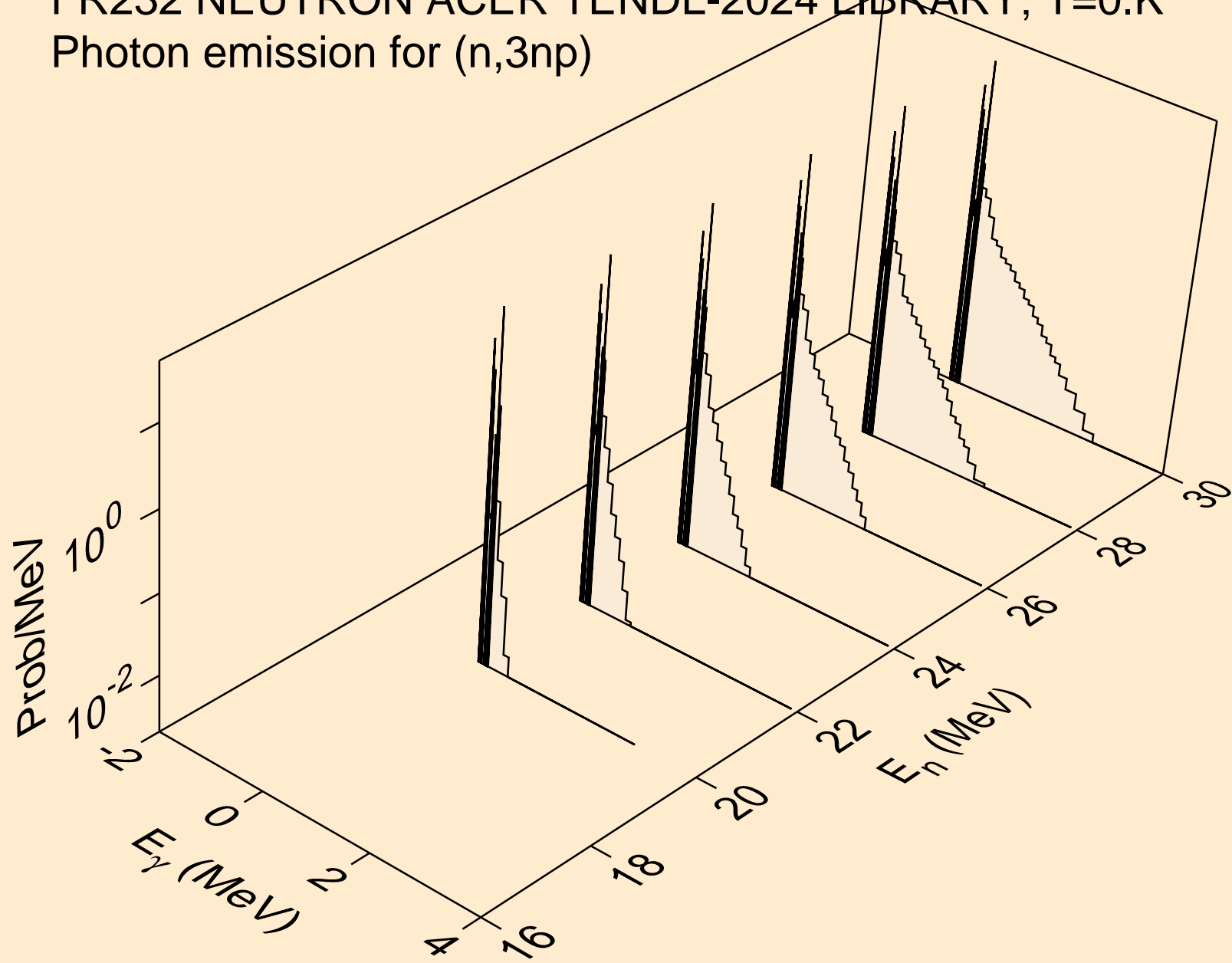

FR232 NEUTRON ACER TENDL-2024 LIBRARY; T=0.K
Photon emission for (n,n*c)

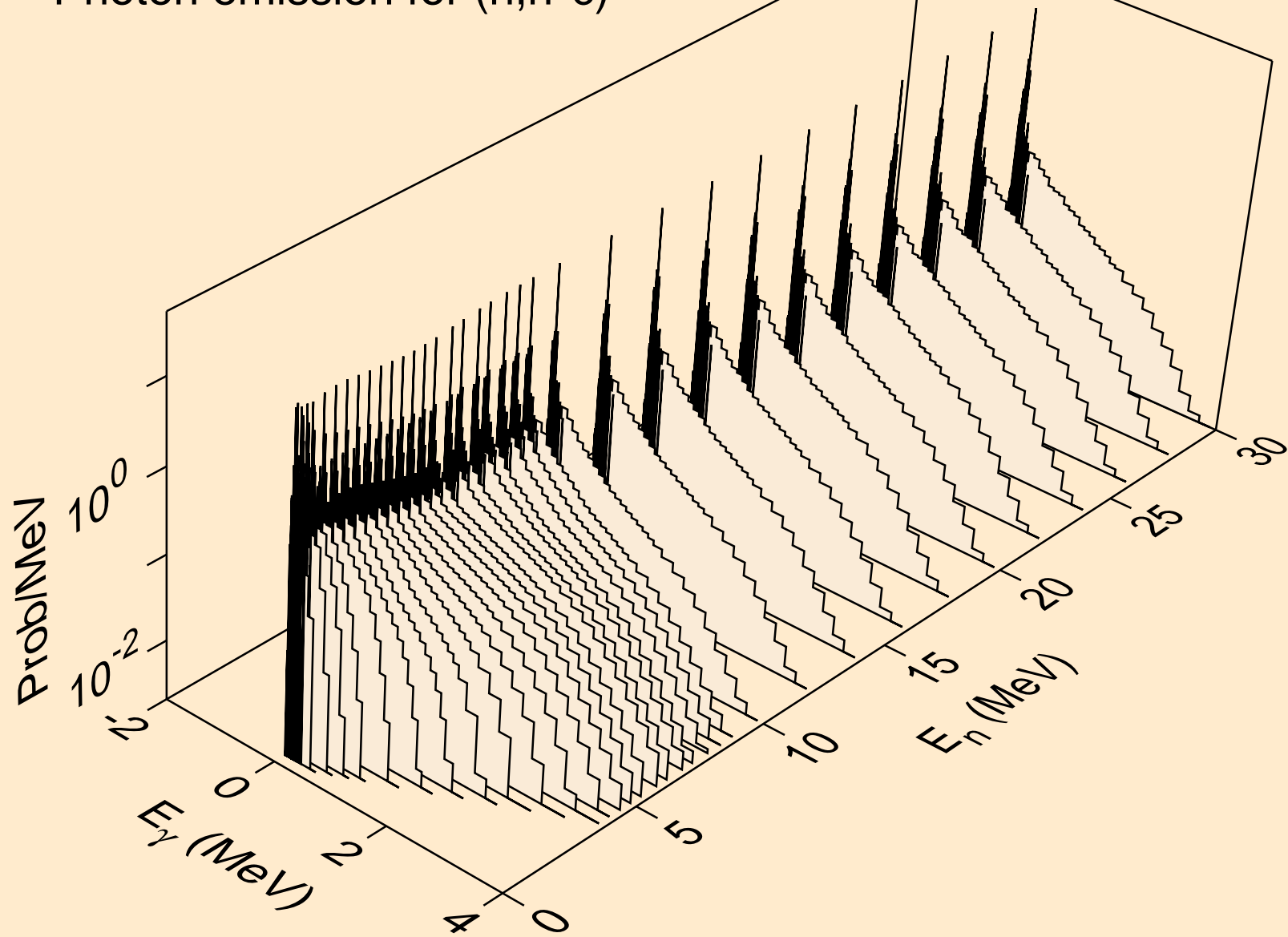

FR232 NEUTRON ACER TENDL-2024 LIBRARY; T=0.K
Photon emission for (n,gma)

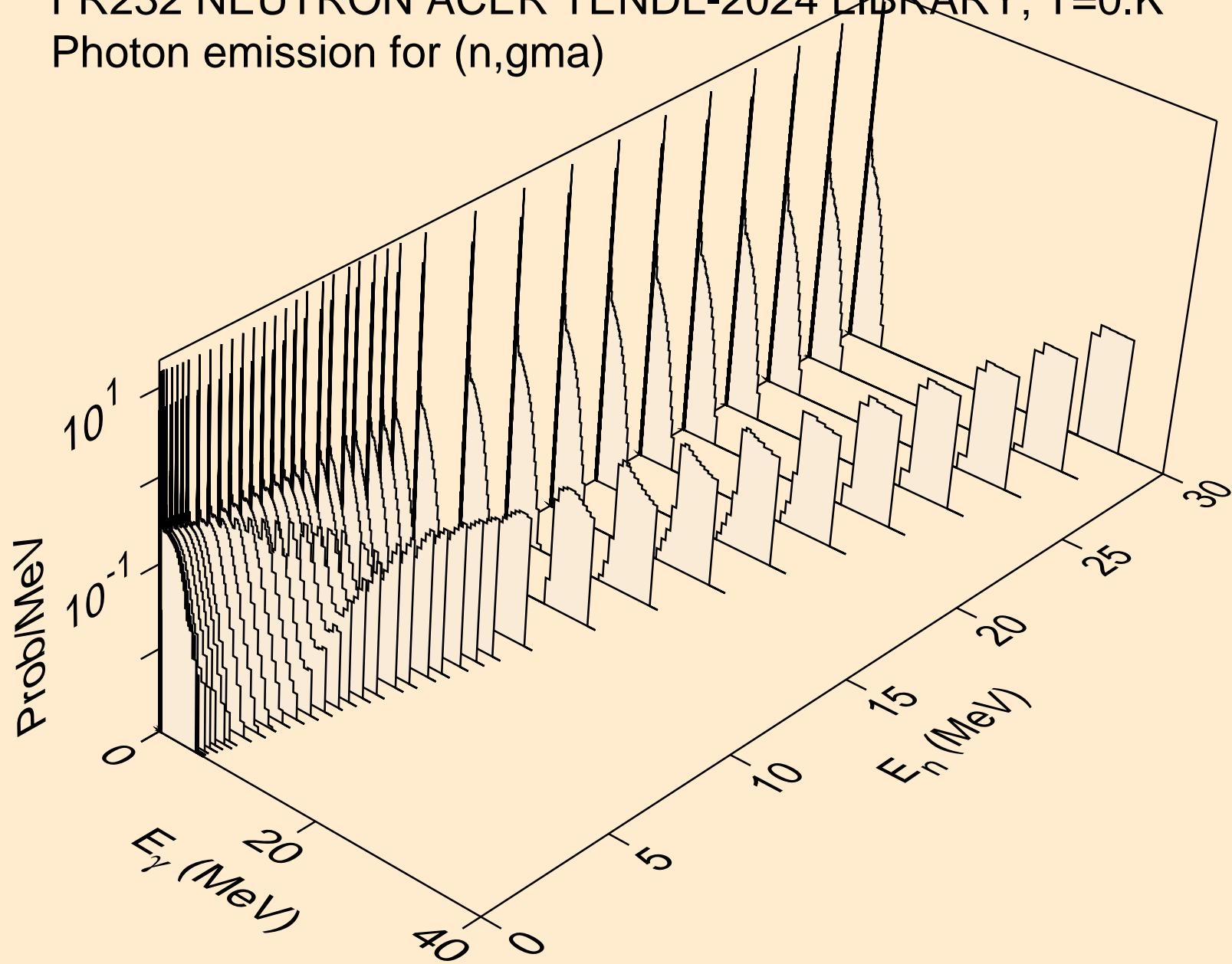

FR232 NEUTRON ACER TENDL-2024 LIBRARY; T=0.K
Photon emission for (n,p)

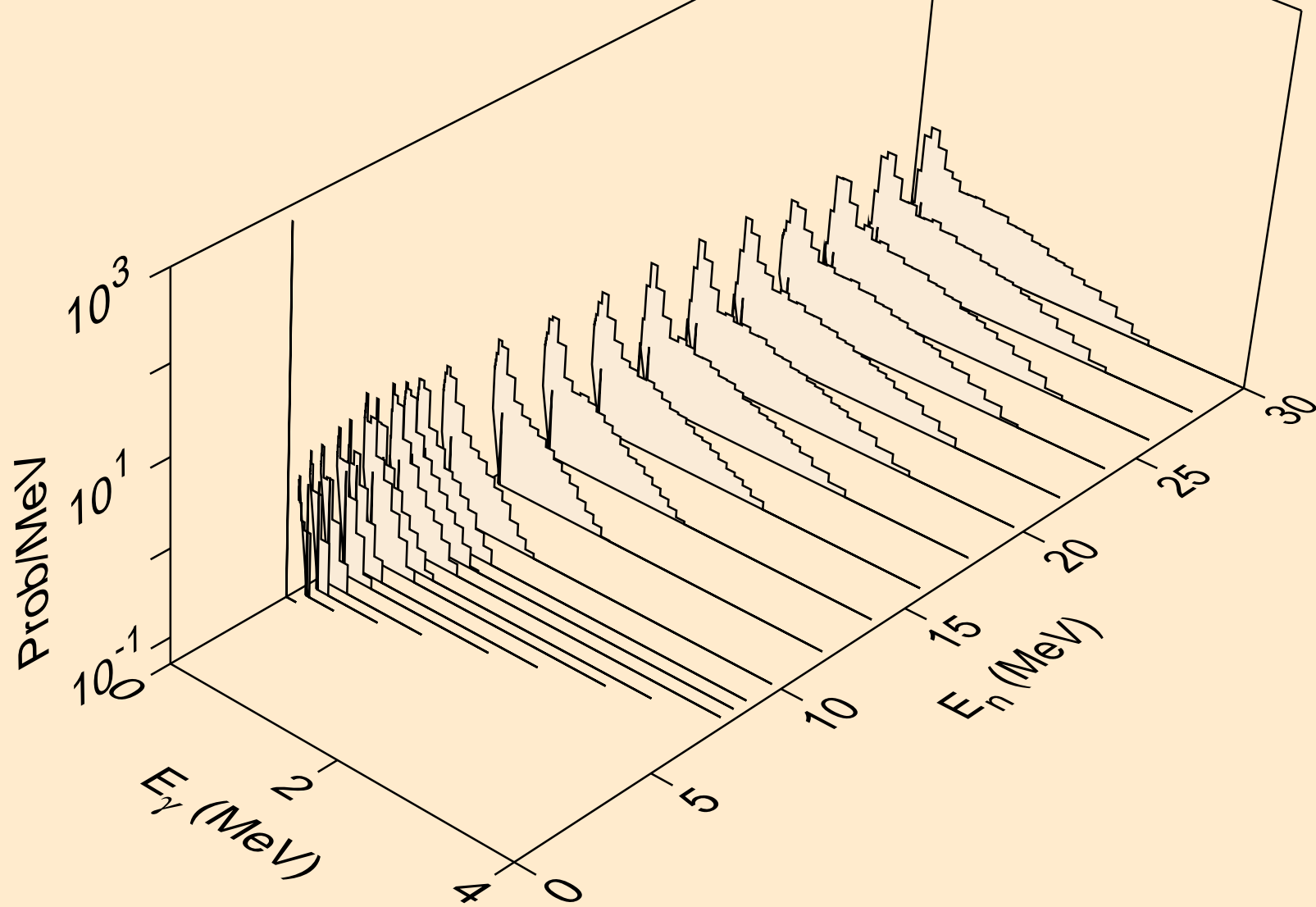

FR232 NEUTRON ACER TENDL-2024 LIBRARY; T=0.K
Photon emission for (n,d)

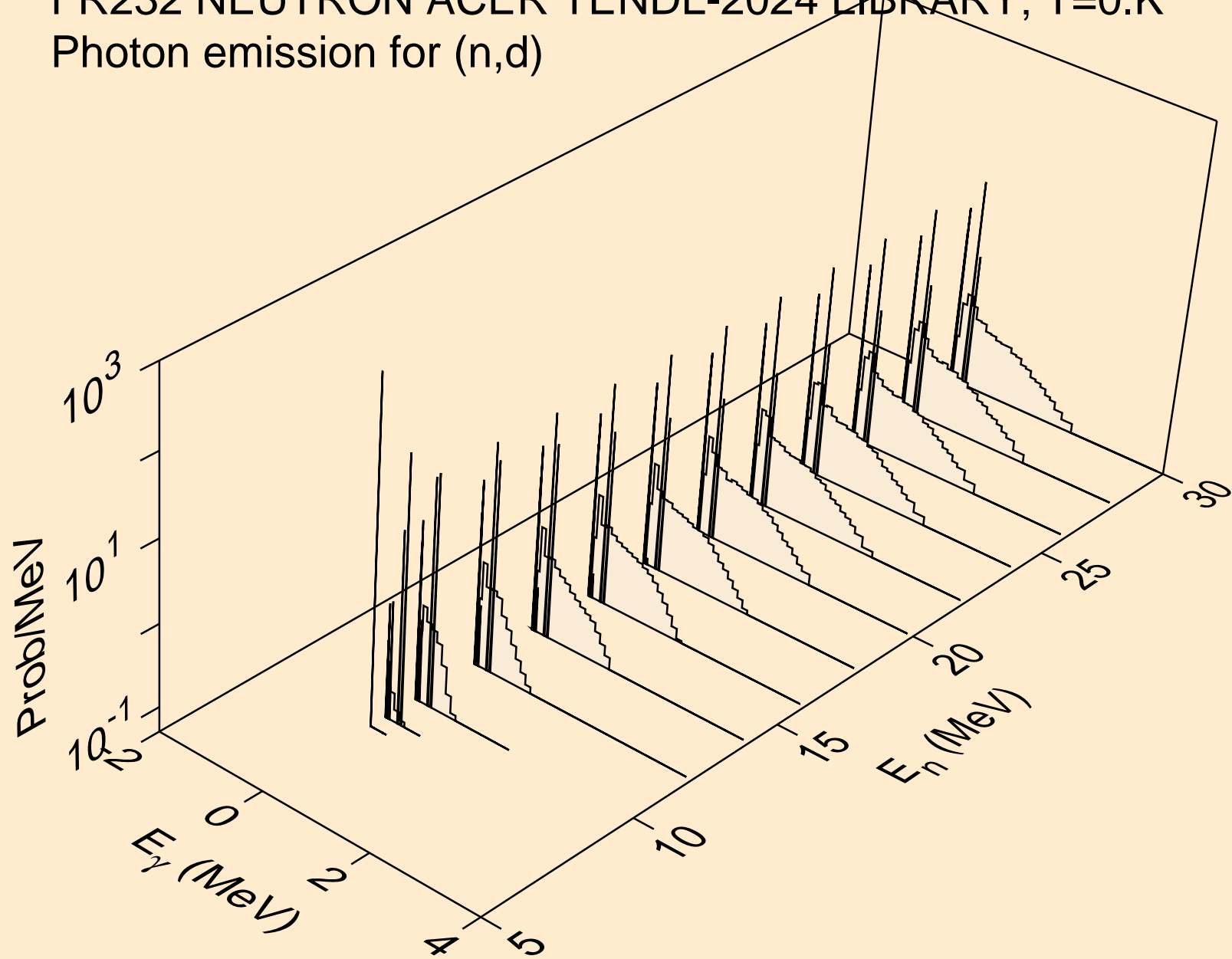

FR232 NEUTRON ACER TENDL-2024 LIBRARY; T=0.K
Photon emission for (n,t)

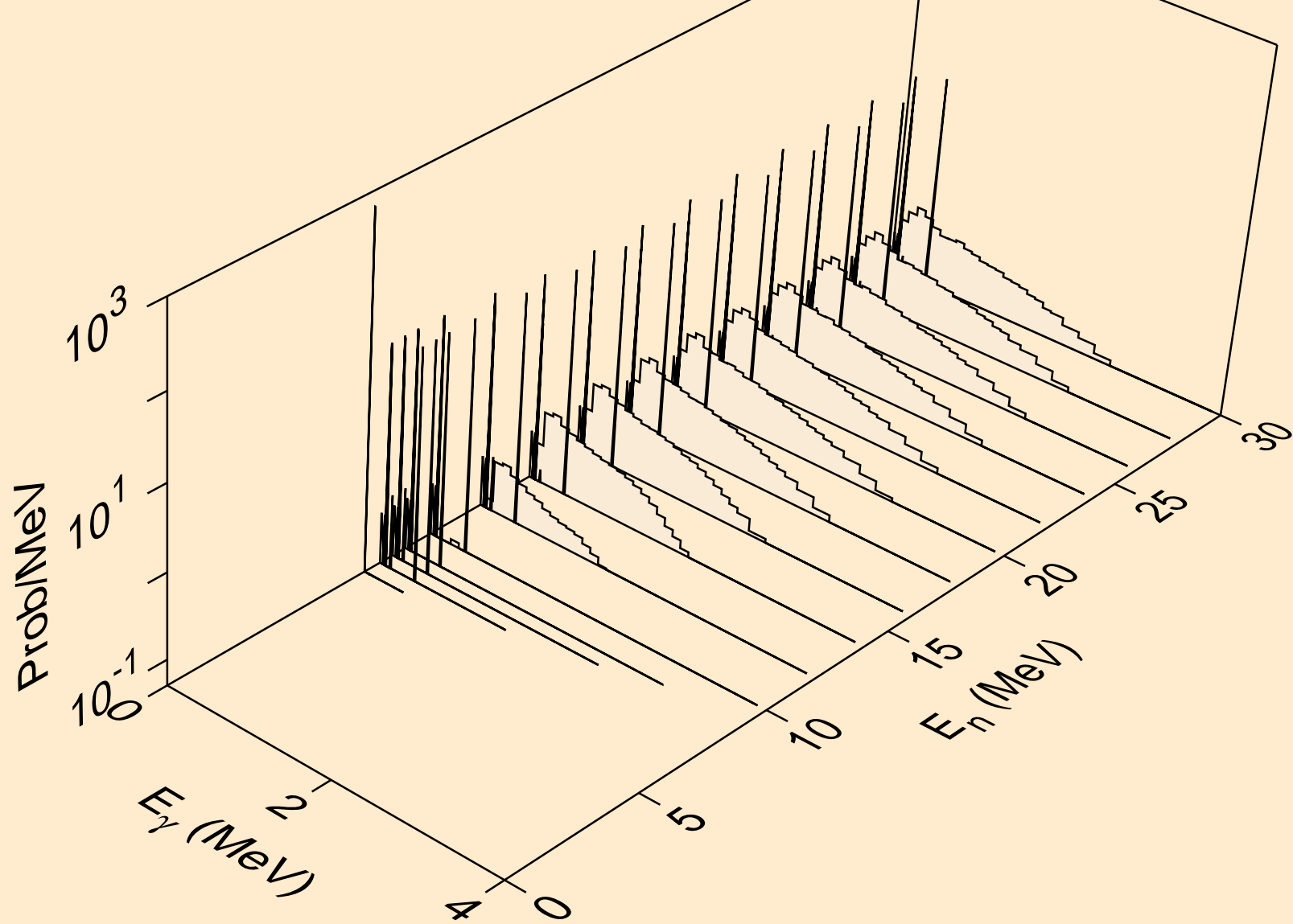

FR232 NEUTRON ACER TENDL-2024 LIBRARY; T=0.K
Photon emission for (n,he3)

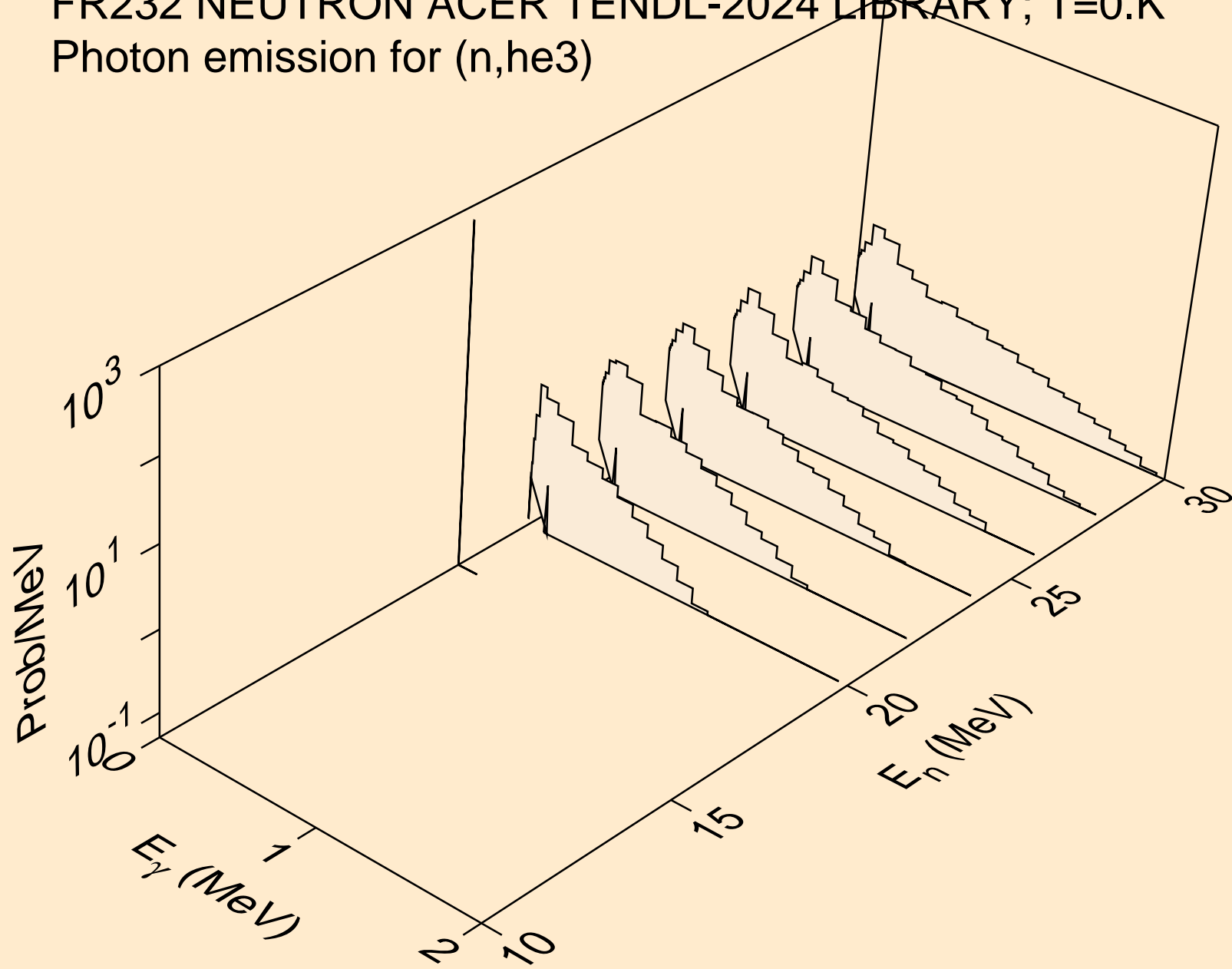

FR232 NEUTRON ACER TENDL-2024 LIBRARY; T=0.K
Photon emission for (n,a)

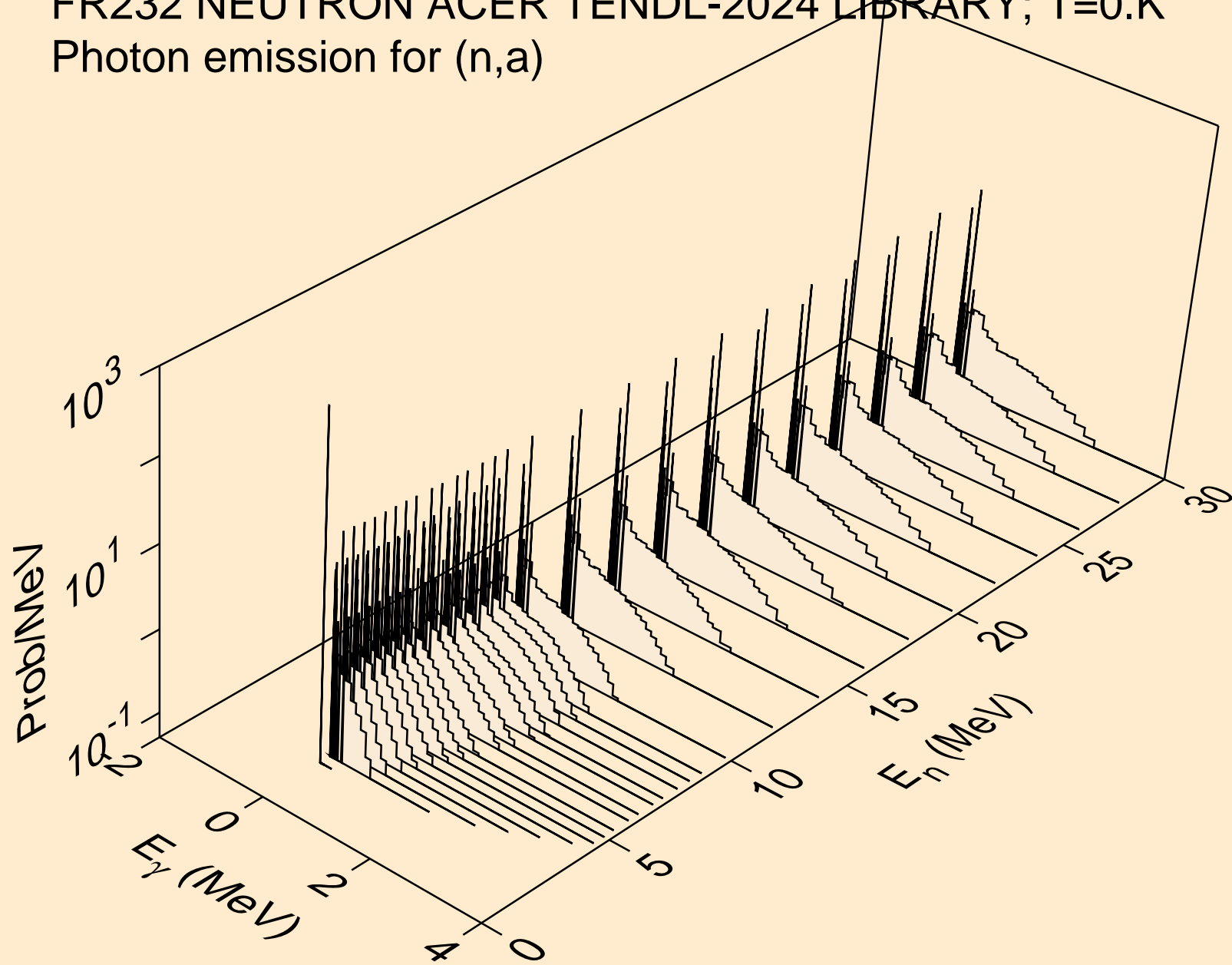

FR232 NEUTRON ACER TENDL-2024 LIBRARY; T=0.K
thermal capture photon spectrum

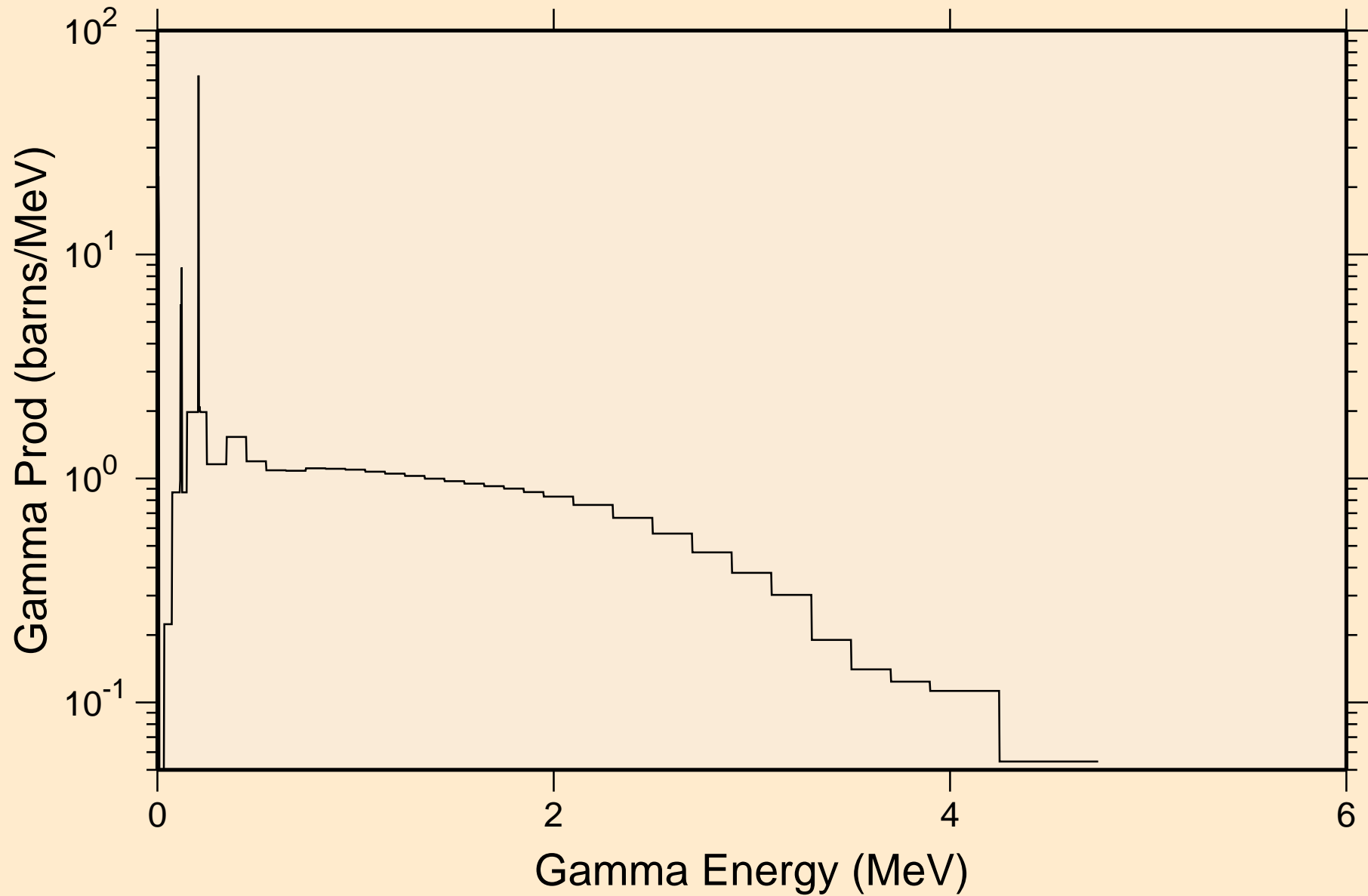

FR232 NEUTRON ACER TENDL-2024 LIBRARY; T=0.K
14 MeV photon spectrum

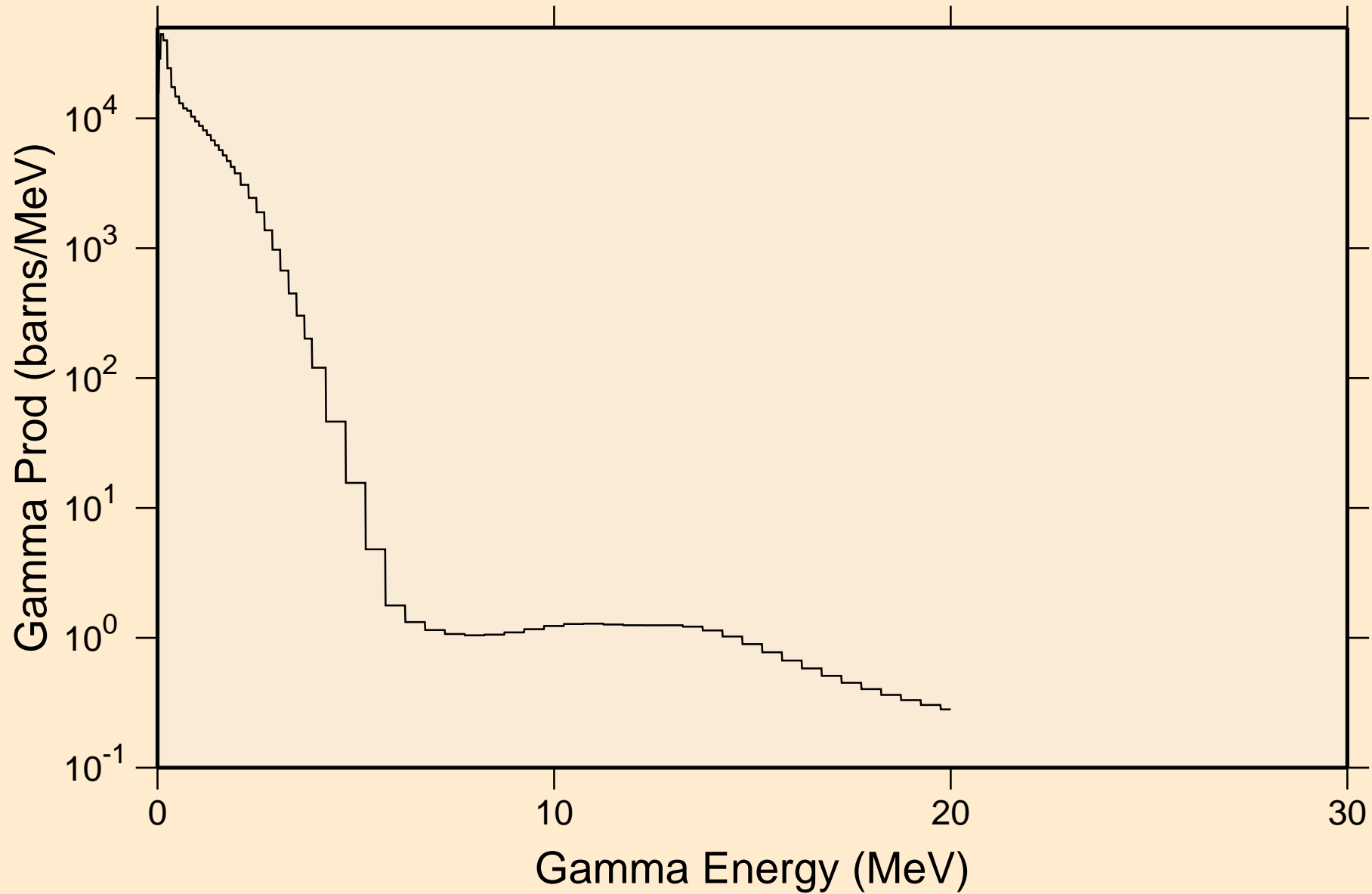

FR232 NEUTRON ACER TENDL-2024 LIBRARY; T=0.K
Particle heating contributions

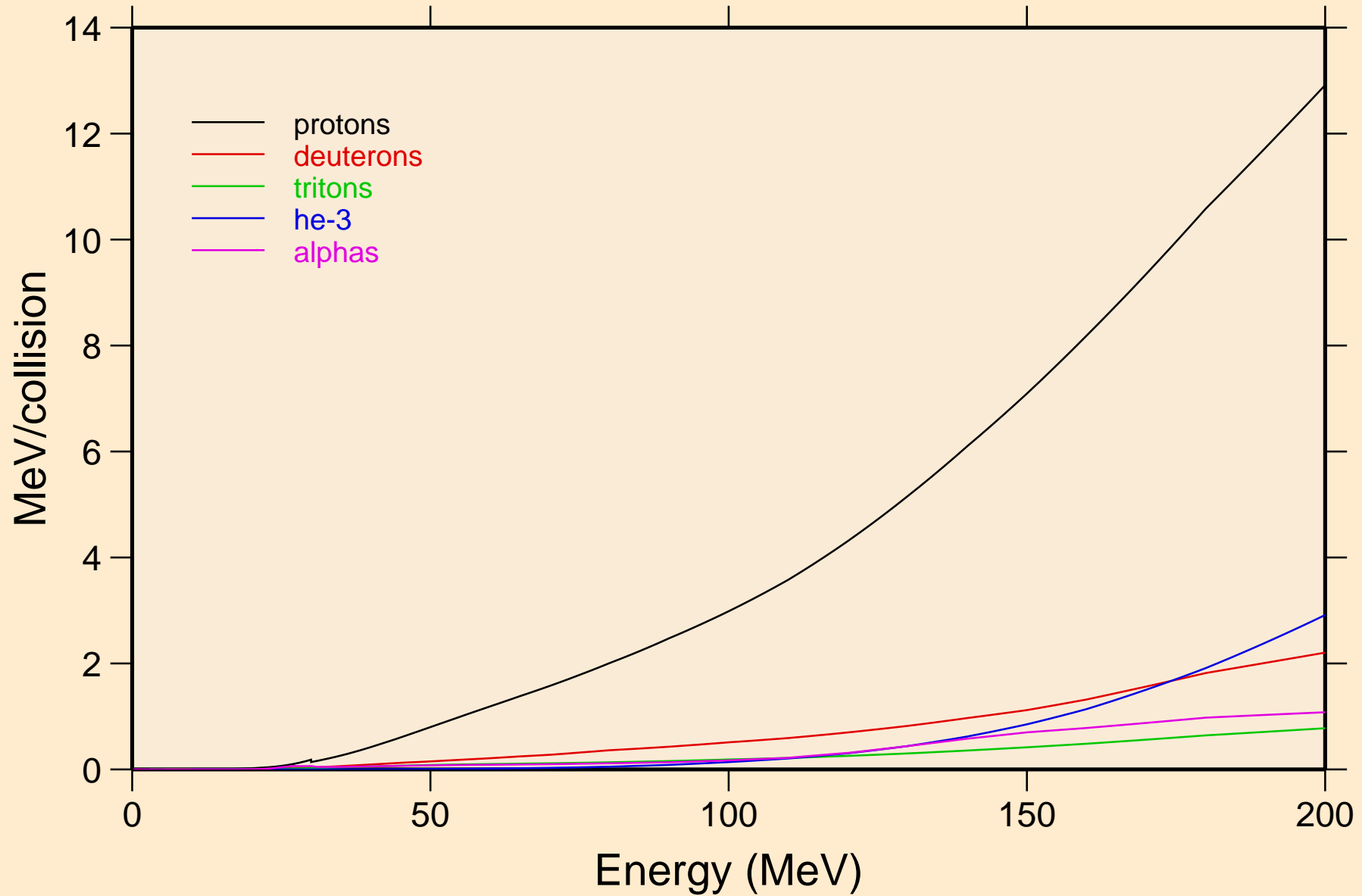

FR232 NEUTRON ACER TENDL-2024 LIBRARY; T=0.K
Recoil Heating

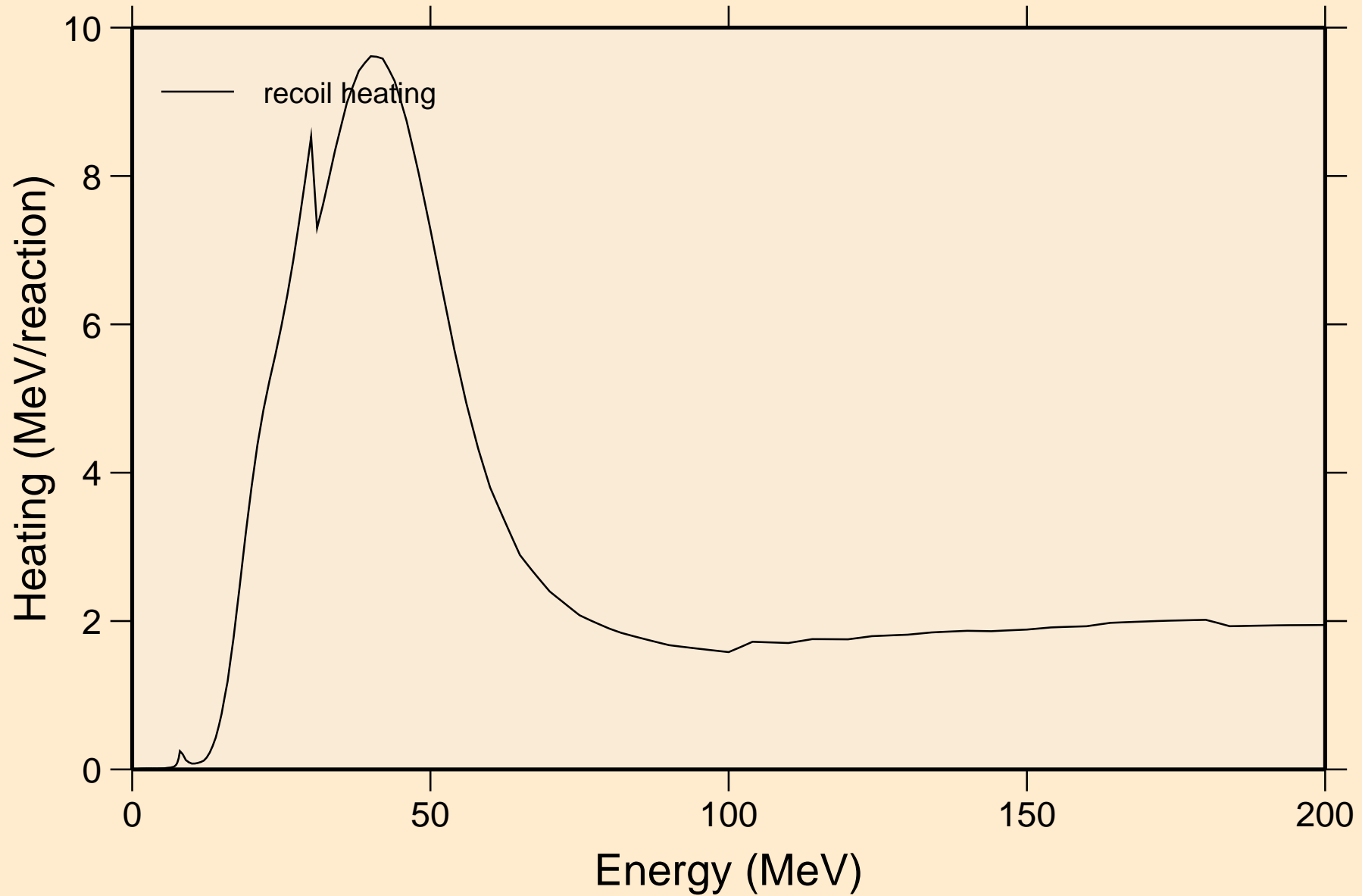

FR232 NEUTRON ACER TENDL-2024 LIBRARY; T=0.K

Particle production cross sections

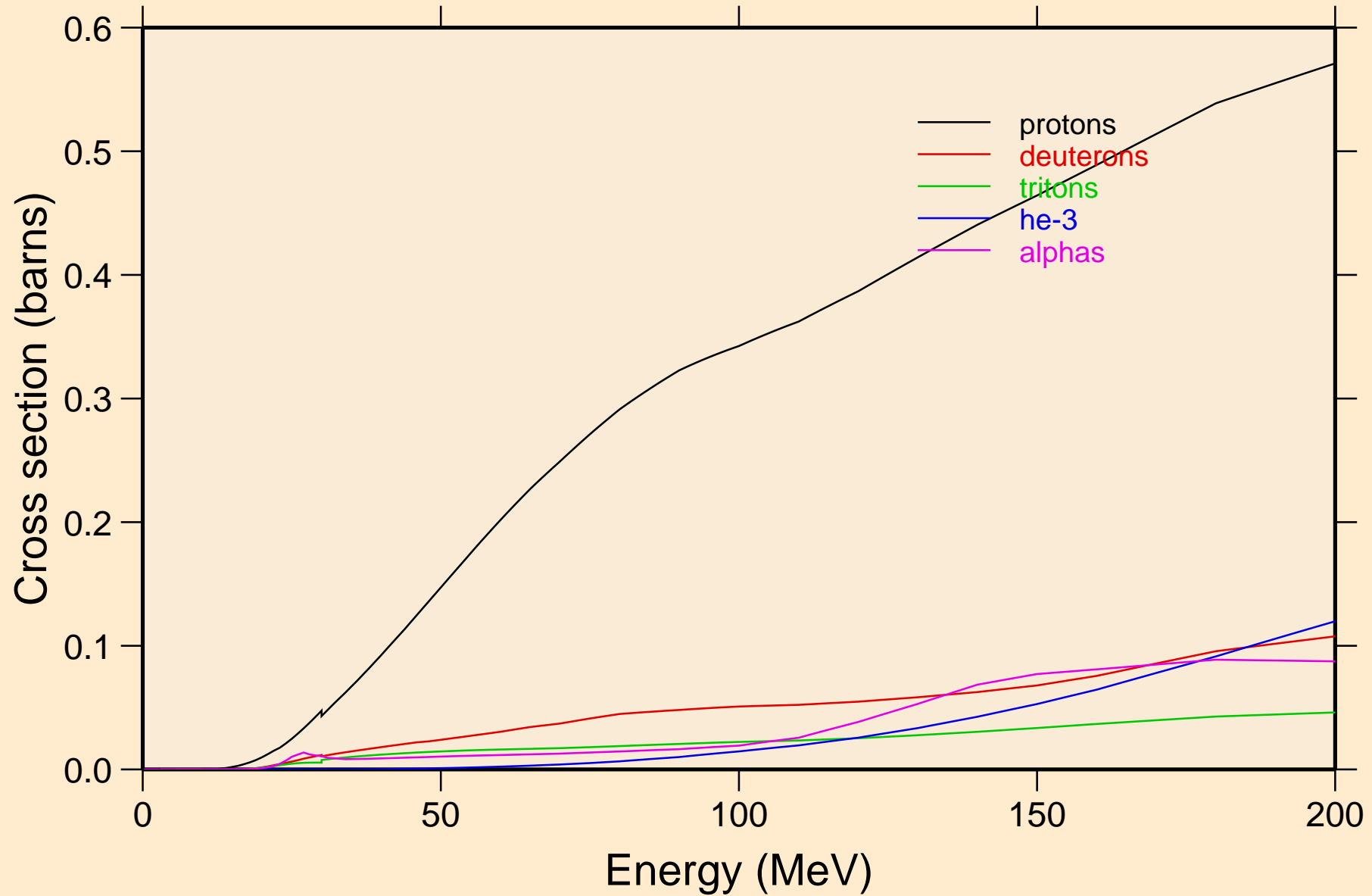

FR232 NEUTRON ACER TENDL-2024 LIBRARY; T=0.K
protons from (n,x)

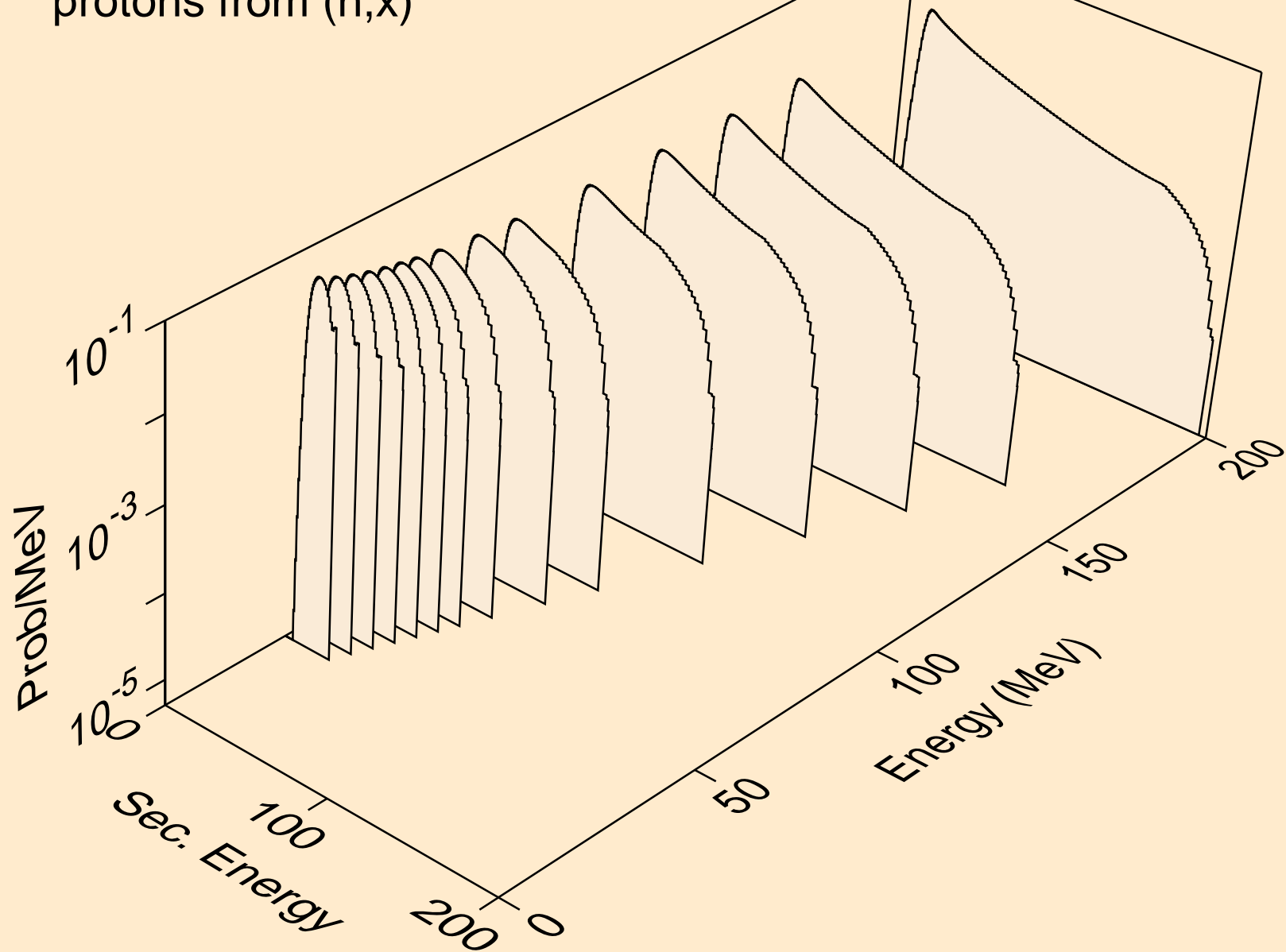

FR232 NEUTRON ACER TENDL-2024 LIBRARY; T=0.K
protons from (n,n*)p

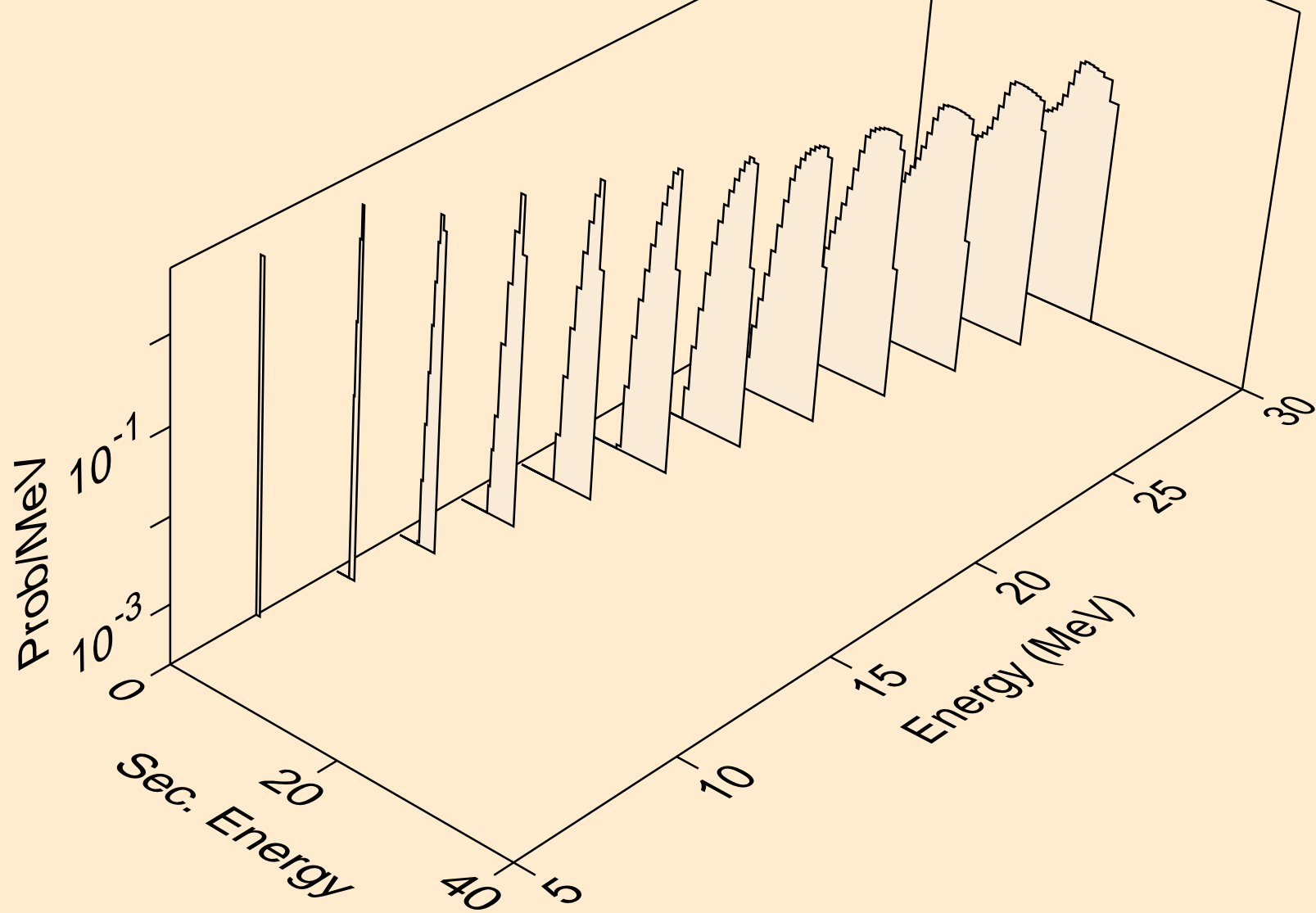

FR232 NEUTRON ACER TENDL-2024 LIBRARY; T=0.K
protons from (n,2np)

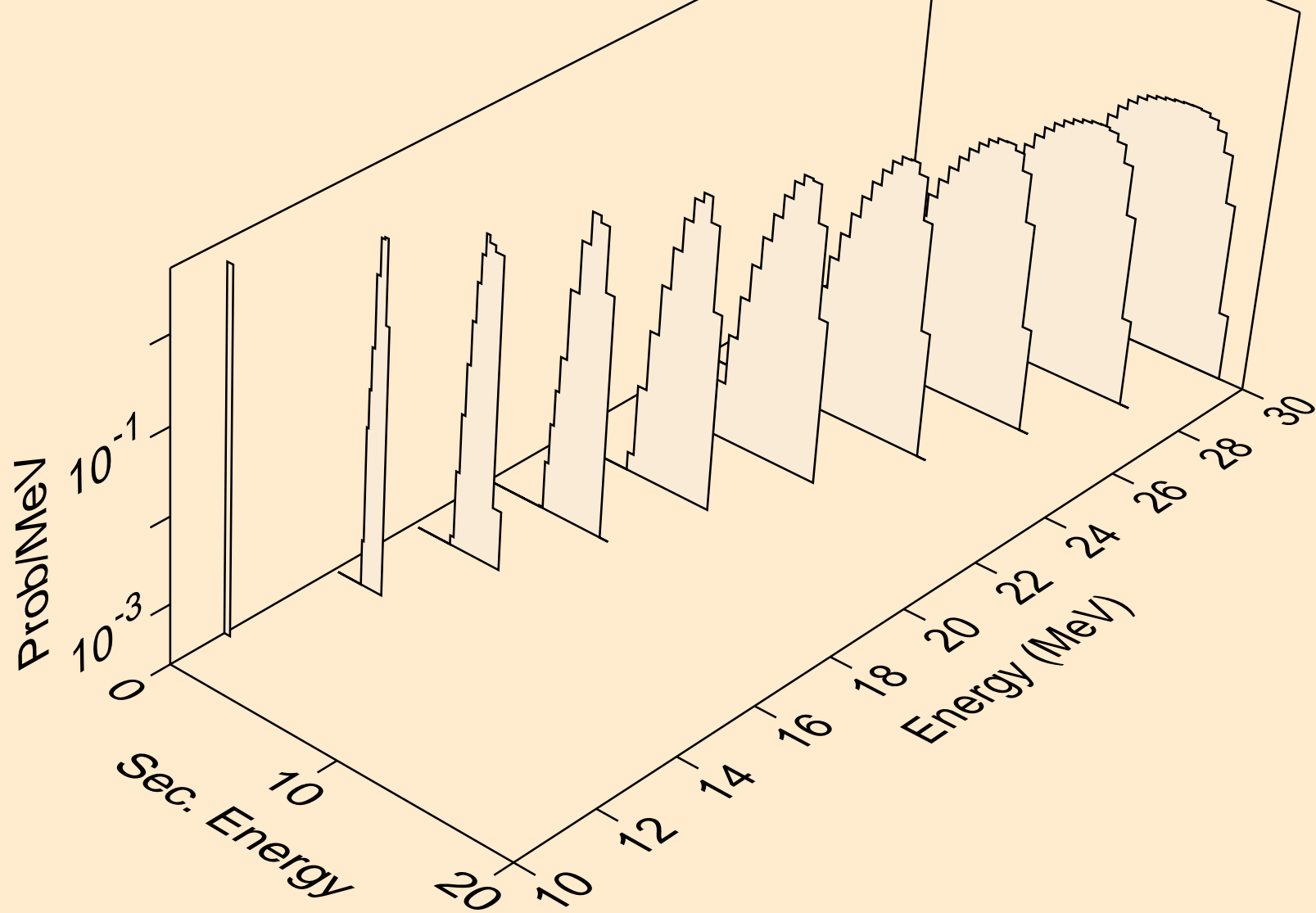

FR232 NEUTRON ACER TENDL-2024 LIBRARY; T=0.K
protons from (n,3np)

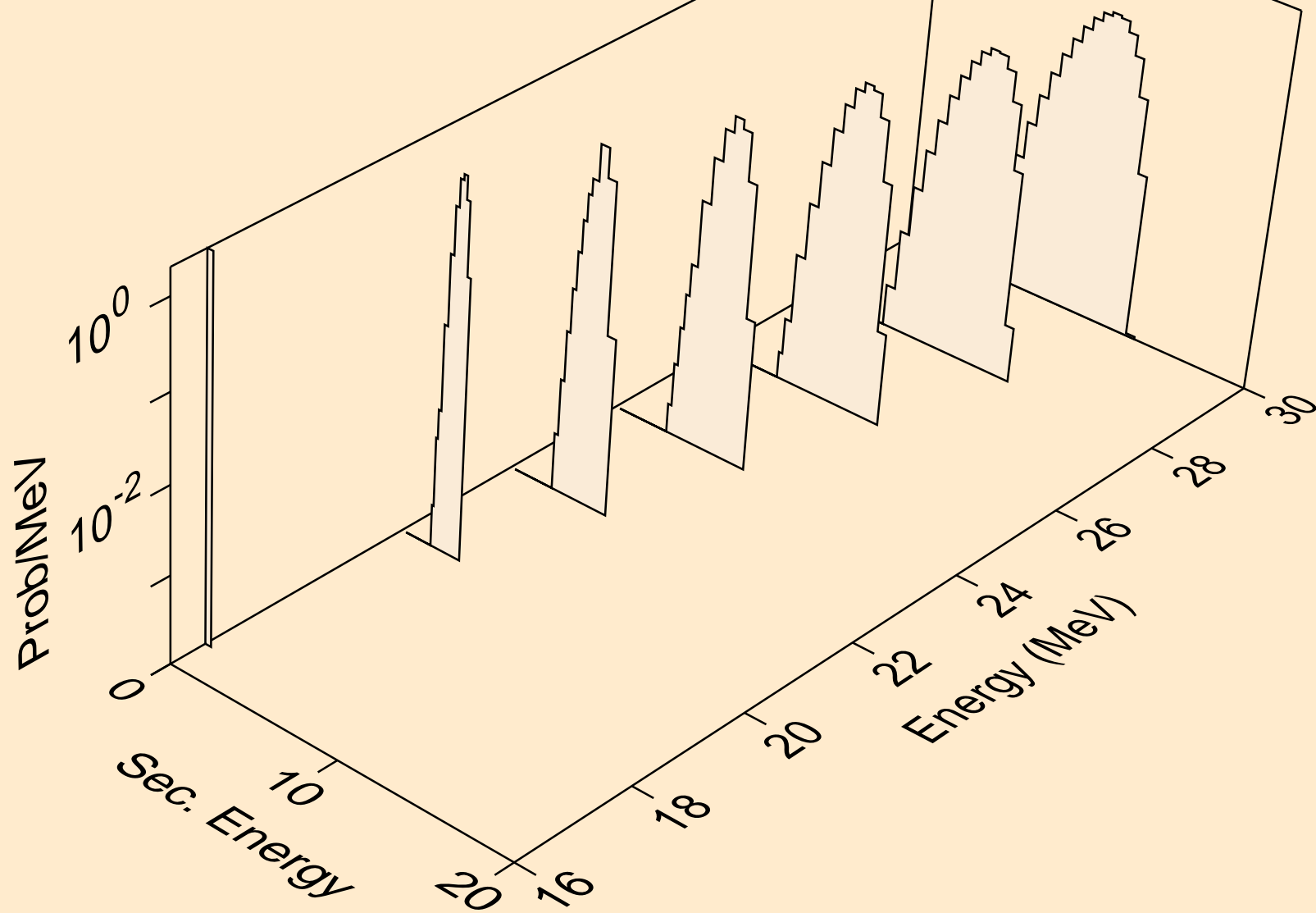

FR232 NEUTRON ACER TENDL-2024 LIBRARY; T=0.K
protons from (n,p)

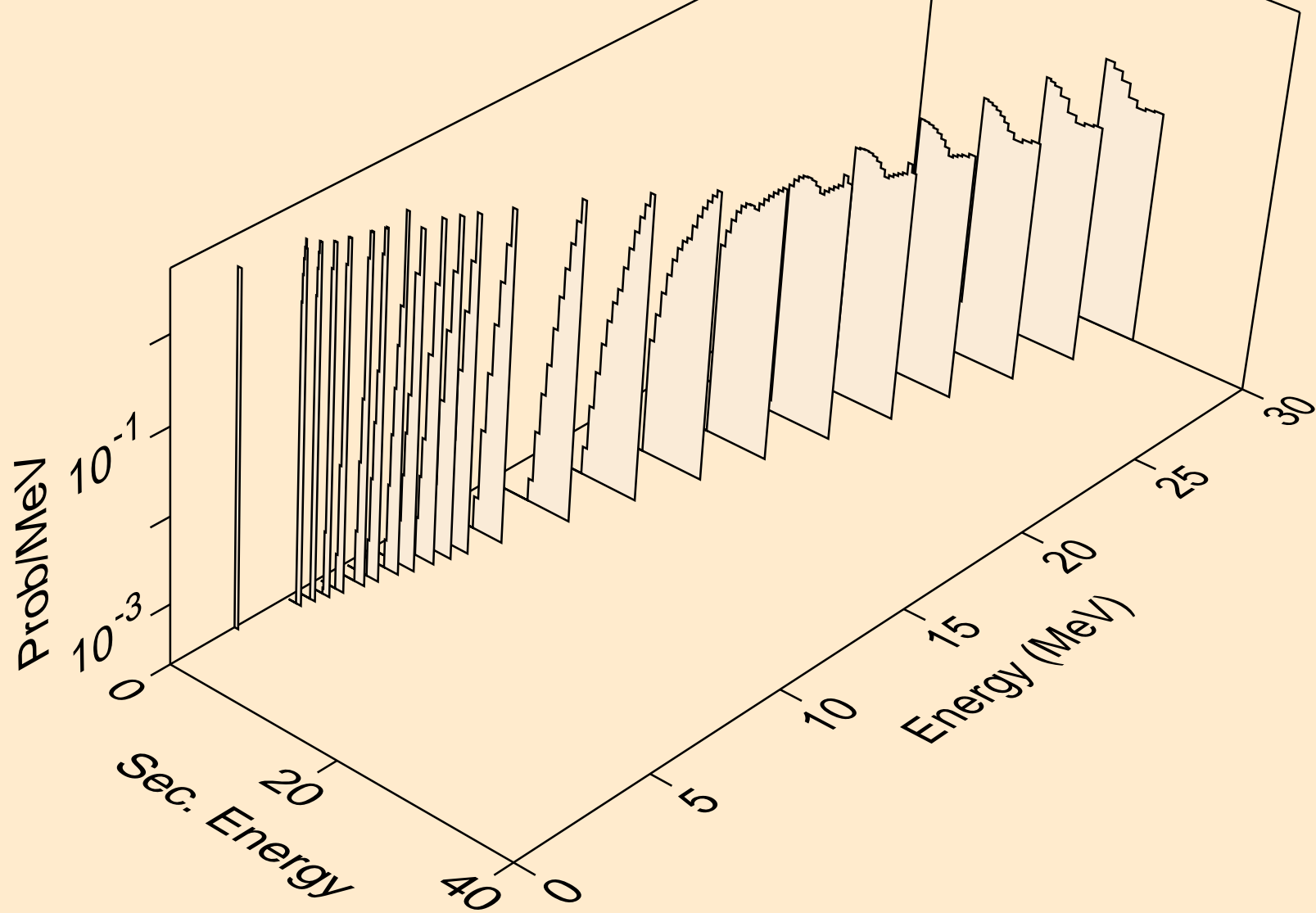

FR232 NEUTRON ACER TENDL-2024 LIBRARY; T=0.K
deuterons from (n,x)

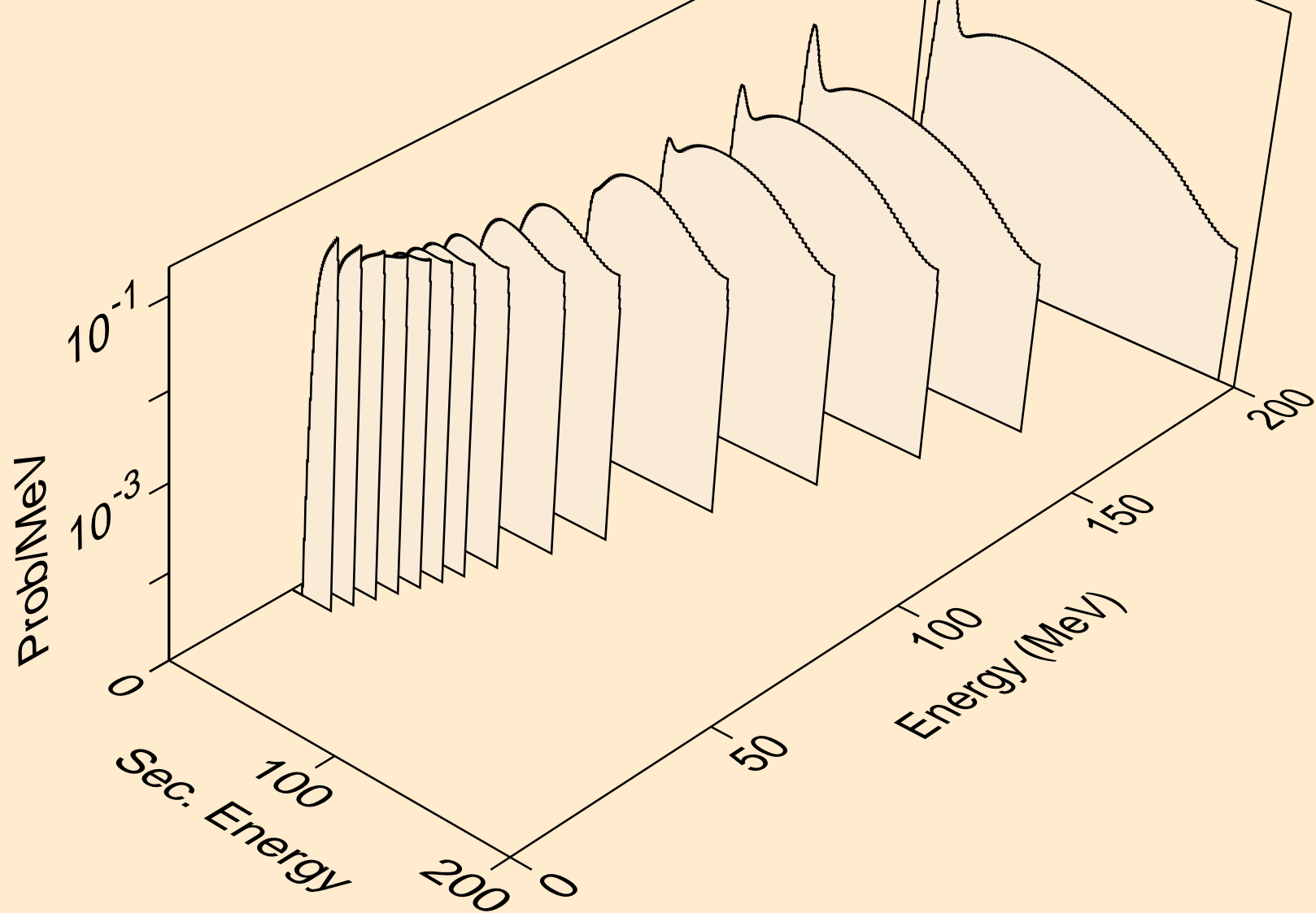

FR232 NEUTRON ACER TENDL-2024 LIBRARY; T=0.K
deuterons from (n,2nd)

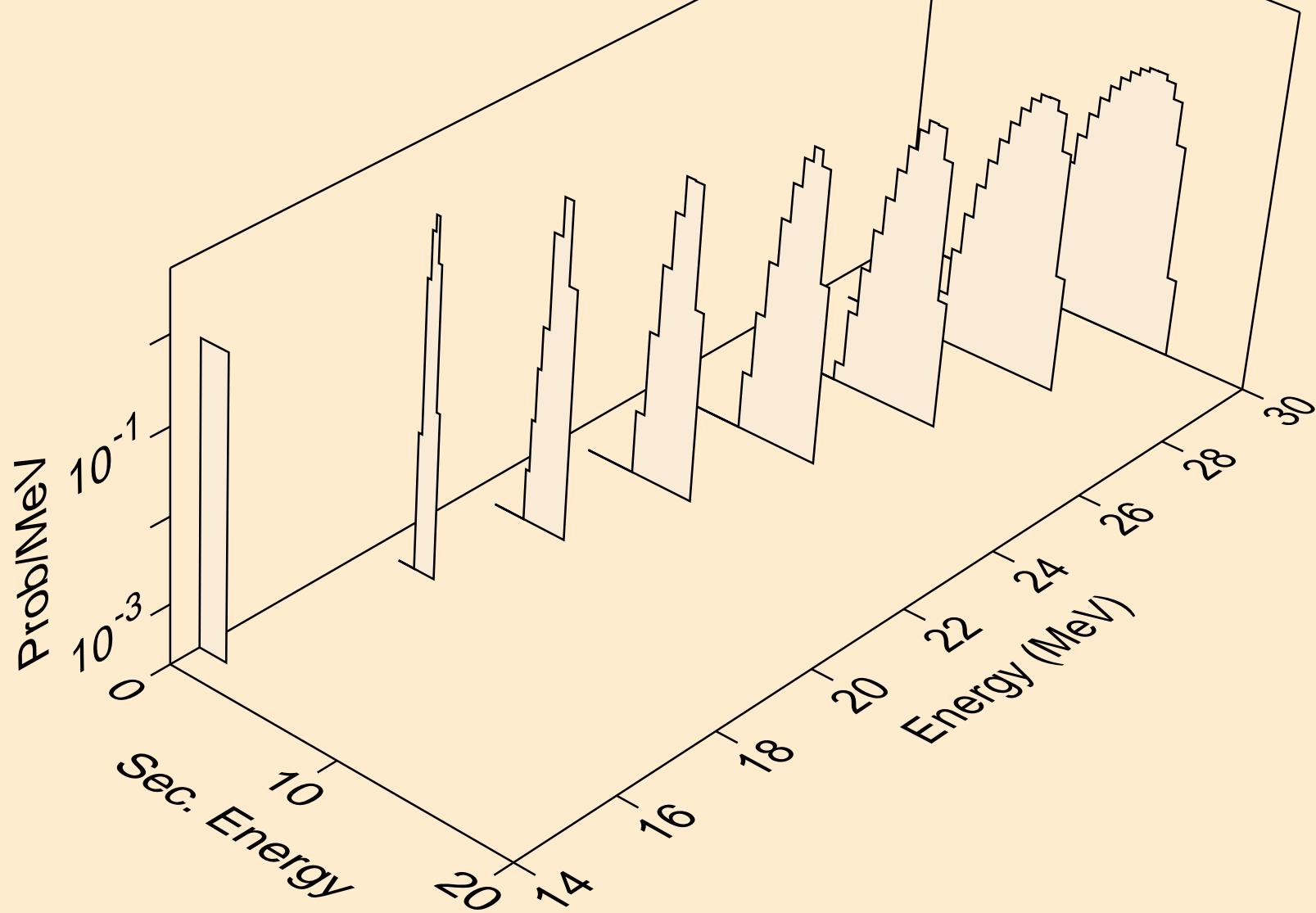

FR232 NEUTRON ACER TENDL-2024 LIBRARY; T=0.K
deuterons from (n,n*)d

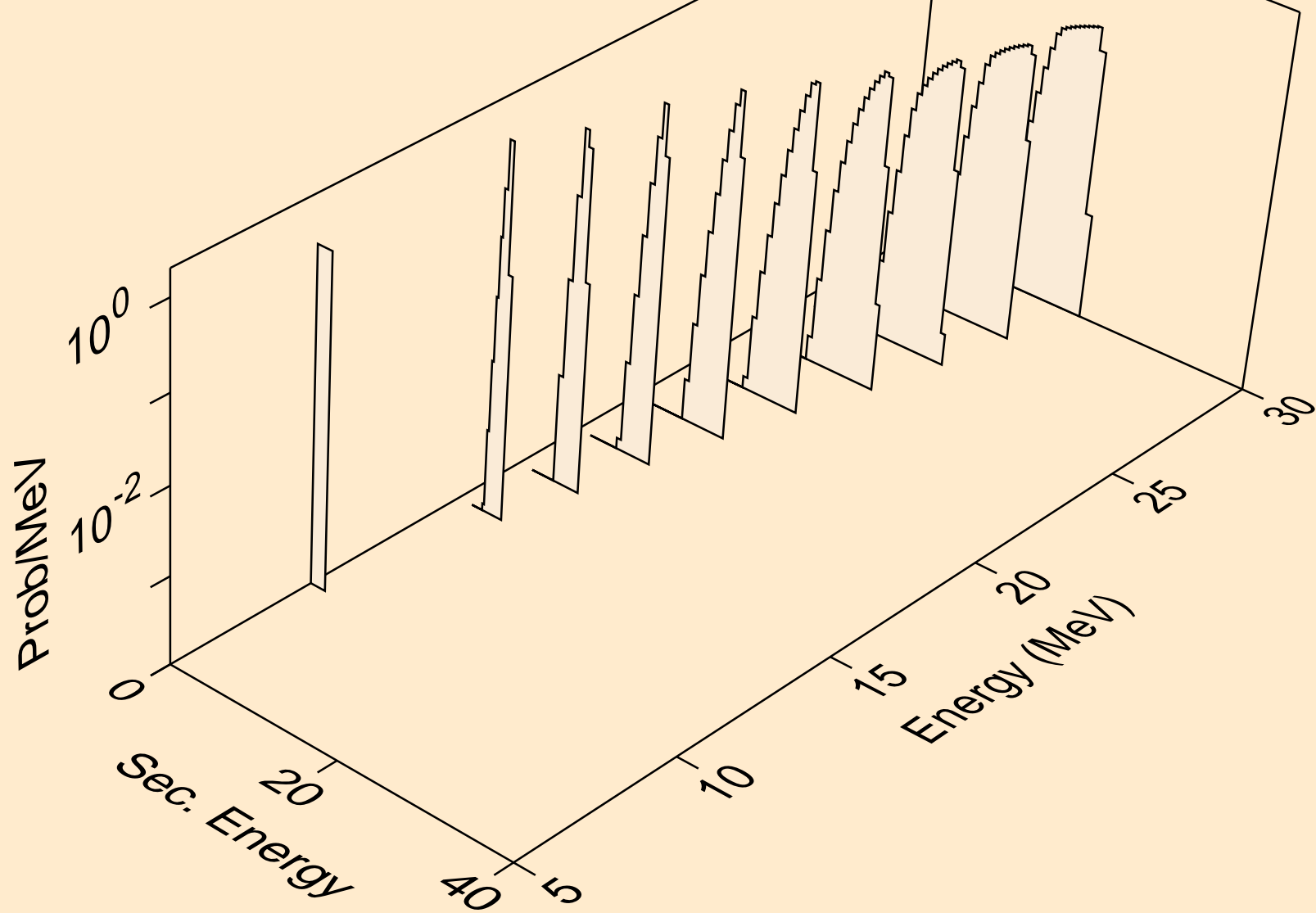

FR232 NEUTRON ACER TENDL-2024 LIBRARY; T=0.K
deuterons from (n,d)

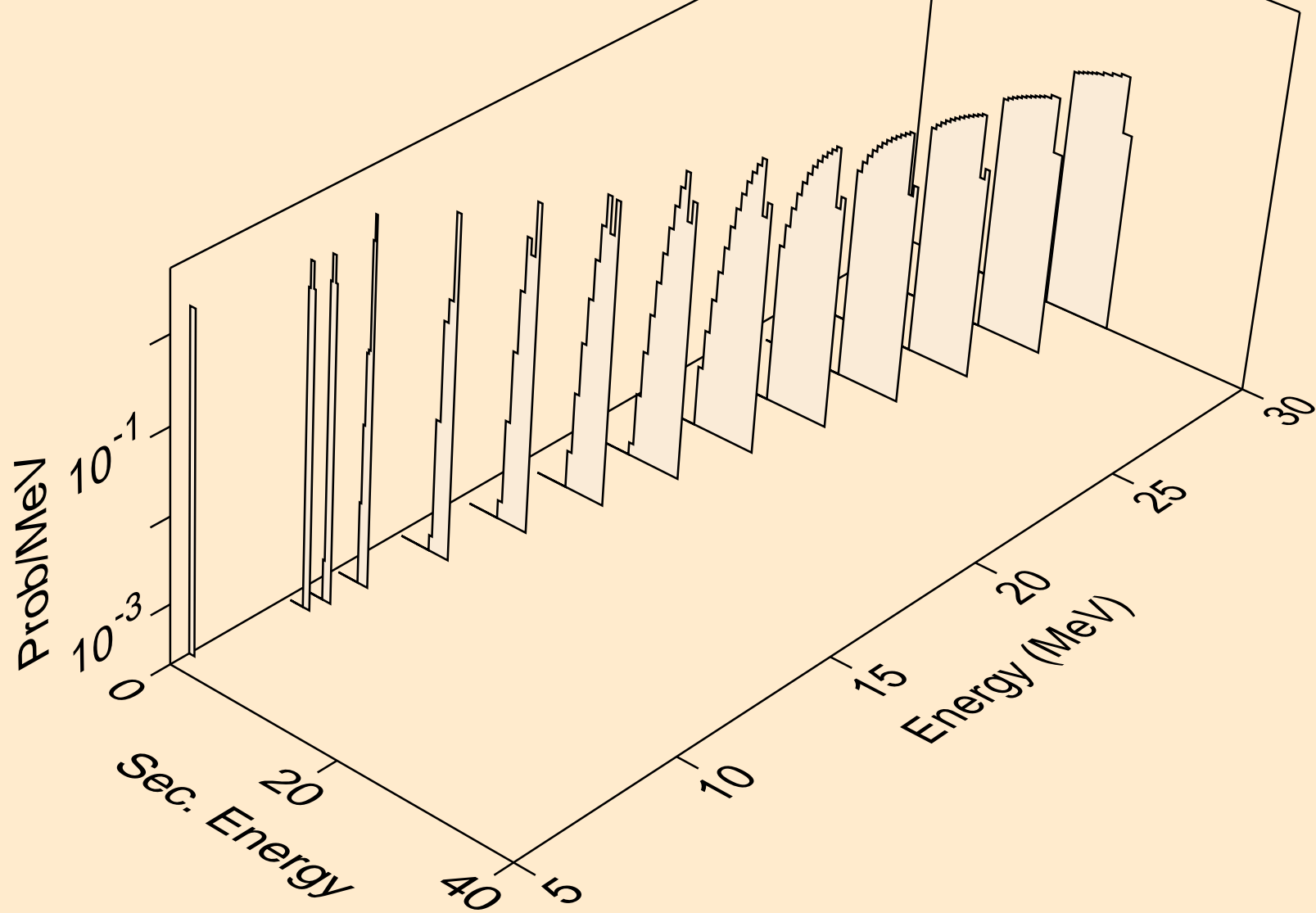

FR232 NEUTRON ACER TENDL-2024 LIBRARY; T=0.K
tritons from (n,x)

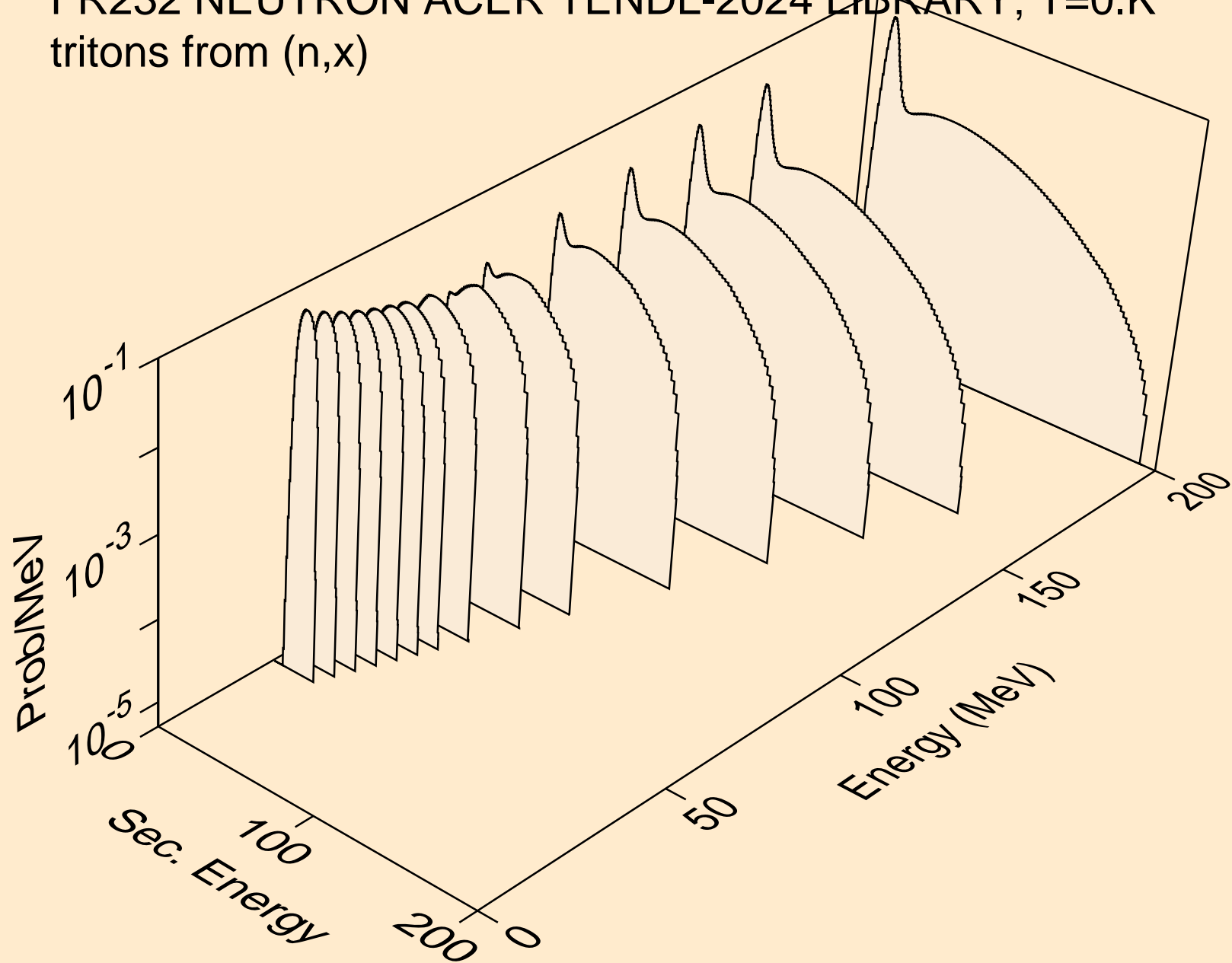

FR232 NEUTRON ACER TENDL-2024 LIBRARY; T=0.K
tritons from (n,n*)t

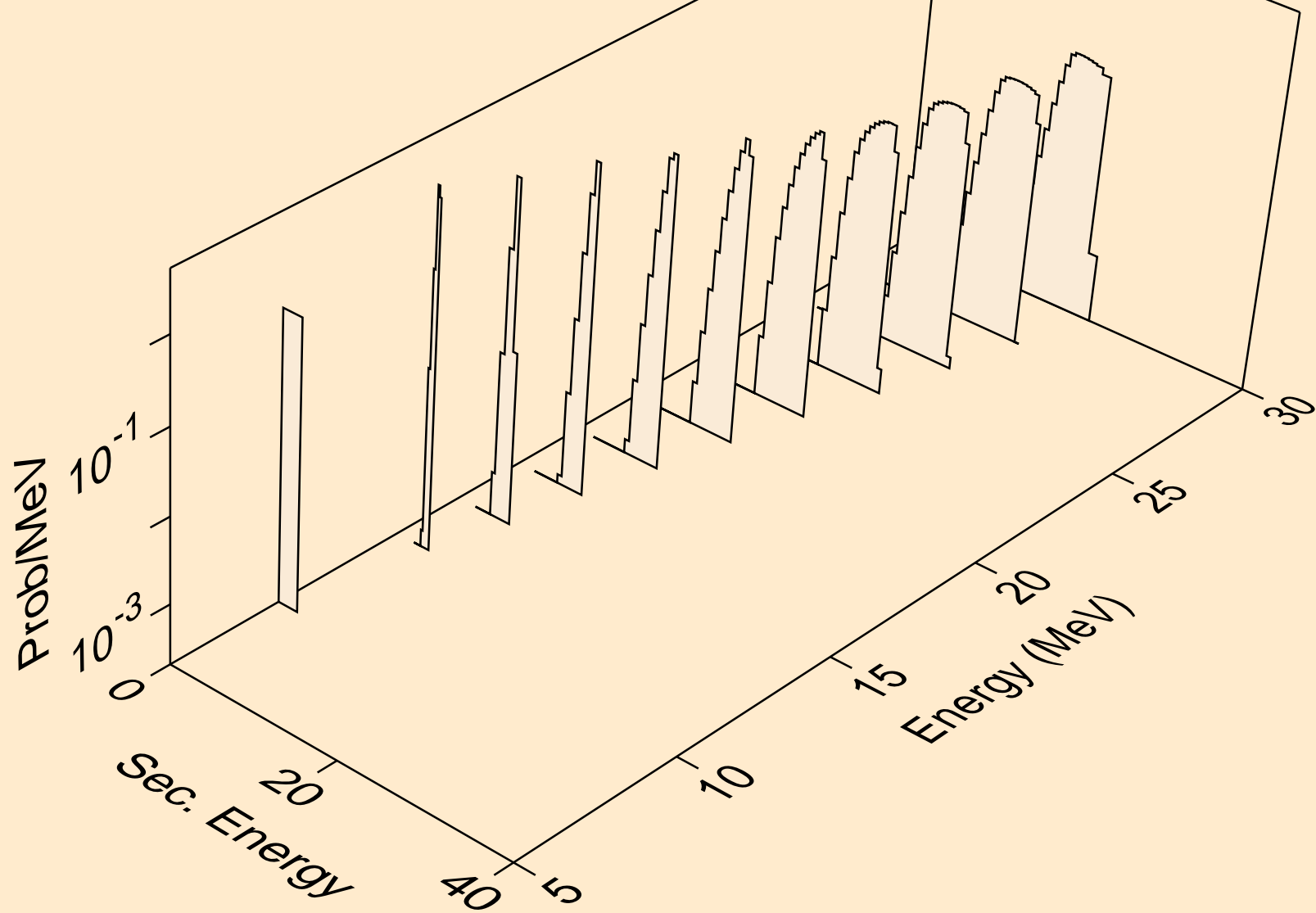

FR232 NEUTRON ACER TENDL-2024 LIBRARY; T=0.K
tritons from (n,t)

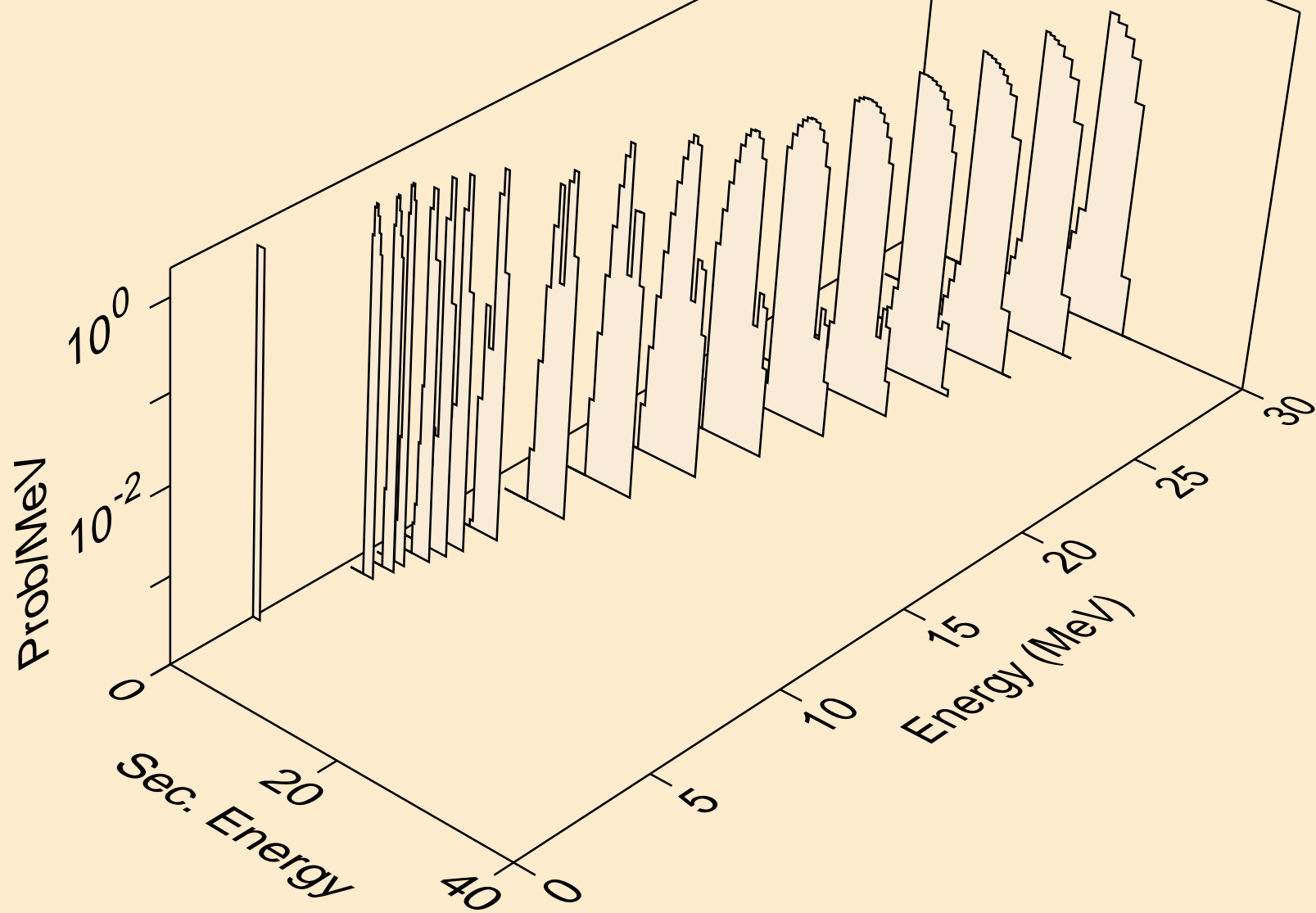

FR232 NEUTRON ACER TENDL-2024 LIBRARY; T=0.K
he3s from (n,x)

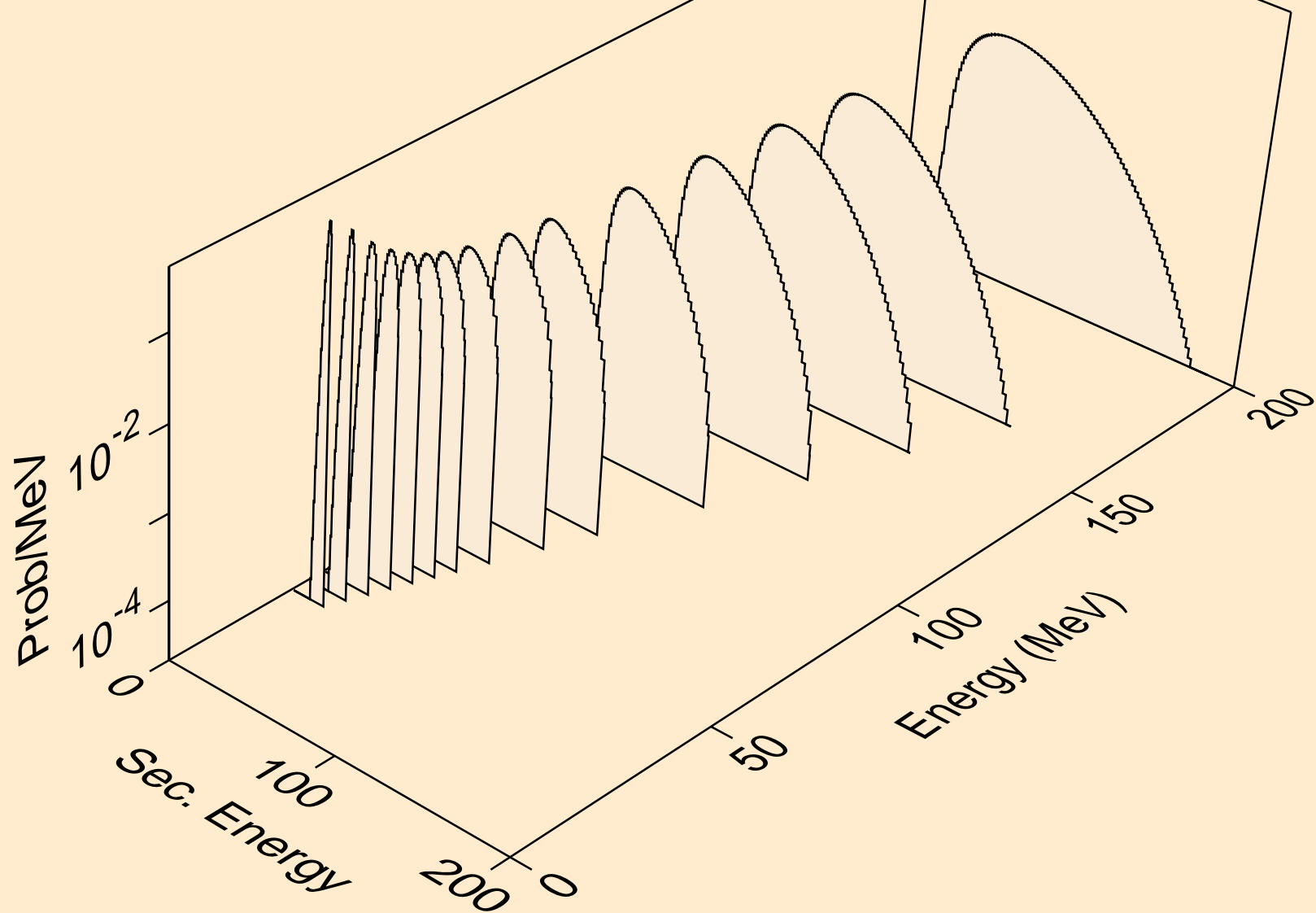

FR232 NEUTRON ACER TENDL-2024 LIBRARY; T=0.K
he3s from (n,n*)he3

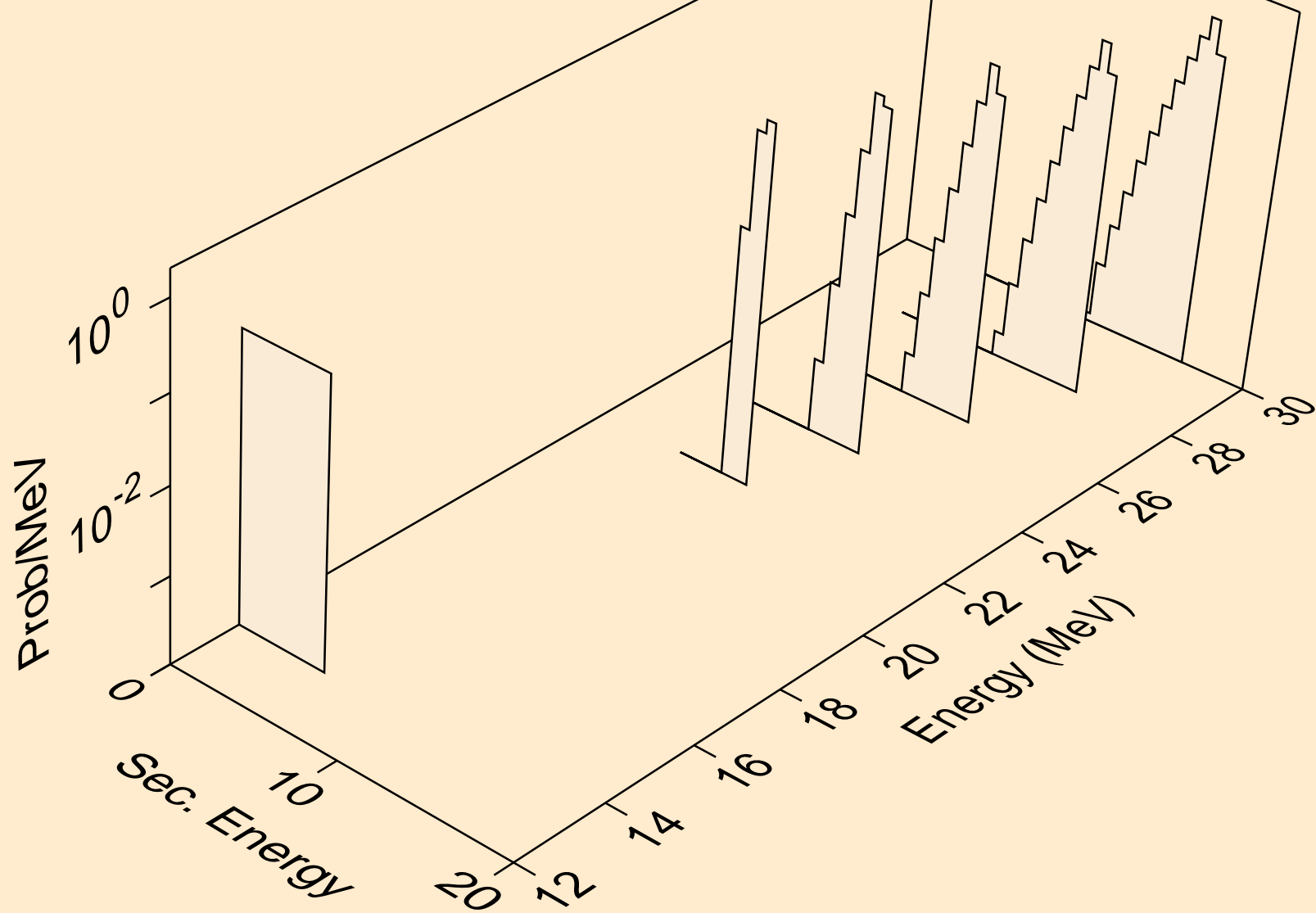

FR232 NEUTRON ACER TENDL-2024 LIBRARY; T=0.K
he3s from (n,he3)

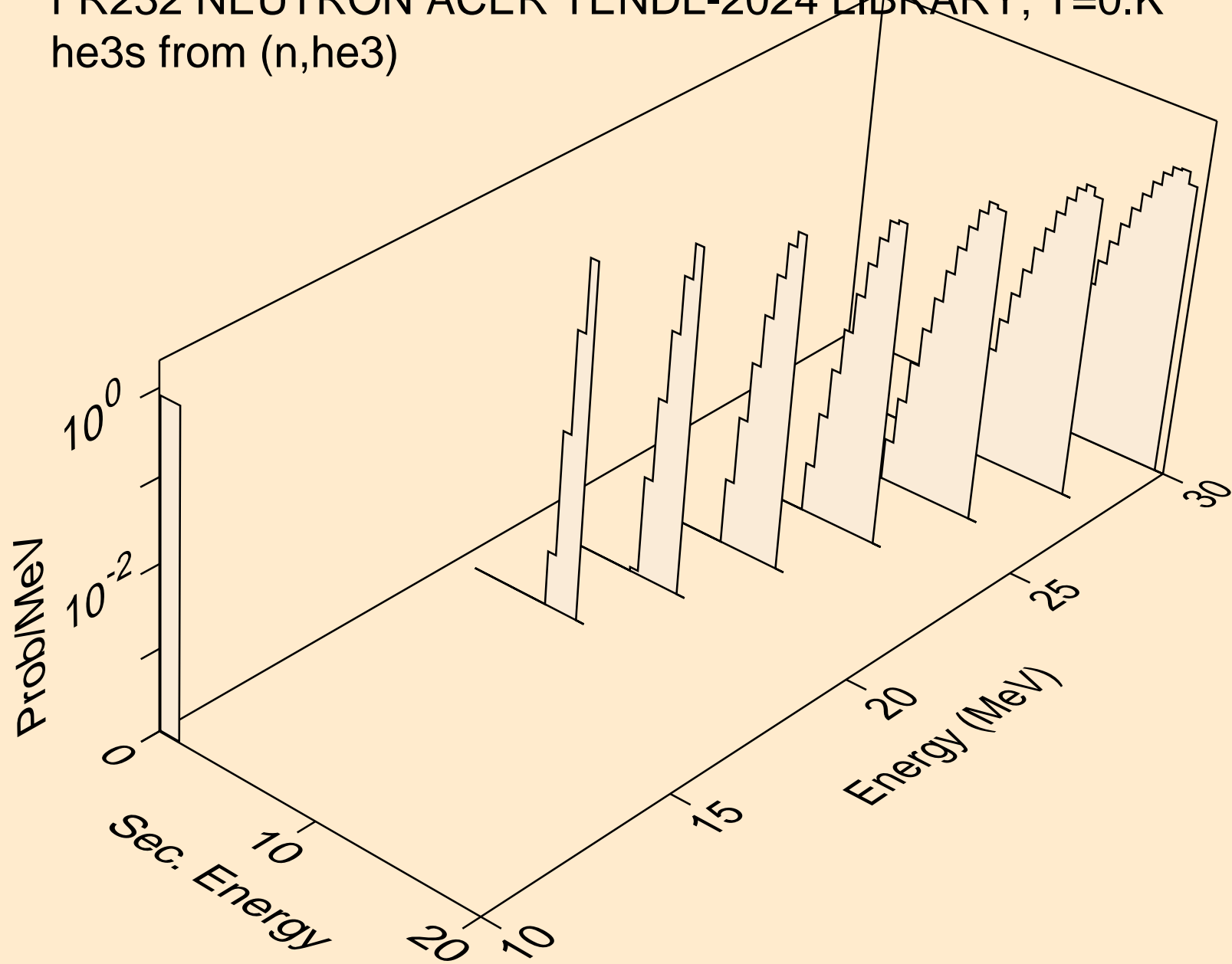

FR232 NEUTRON ACER TENDL-2024 LIBRARY; T=0.K
alphas from (n,x)

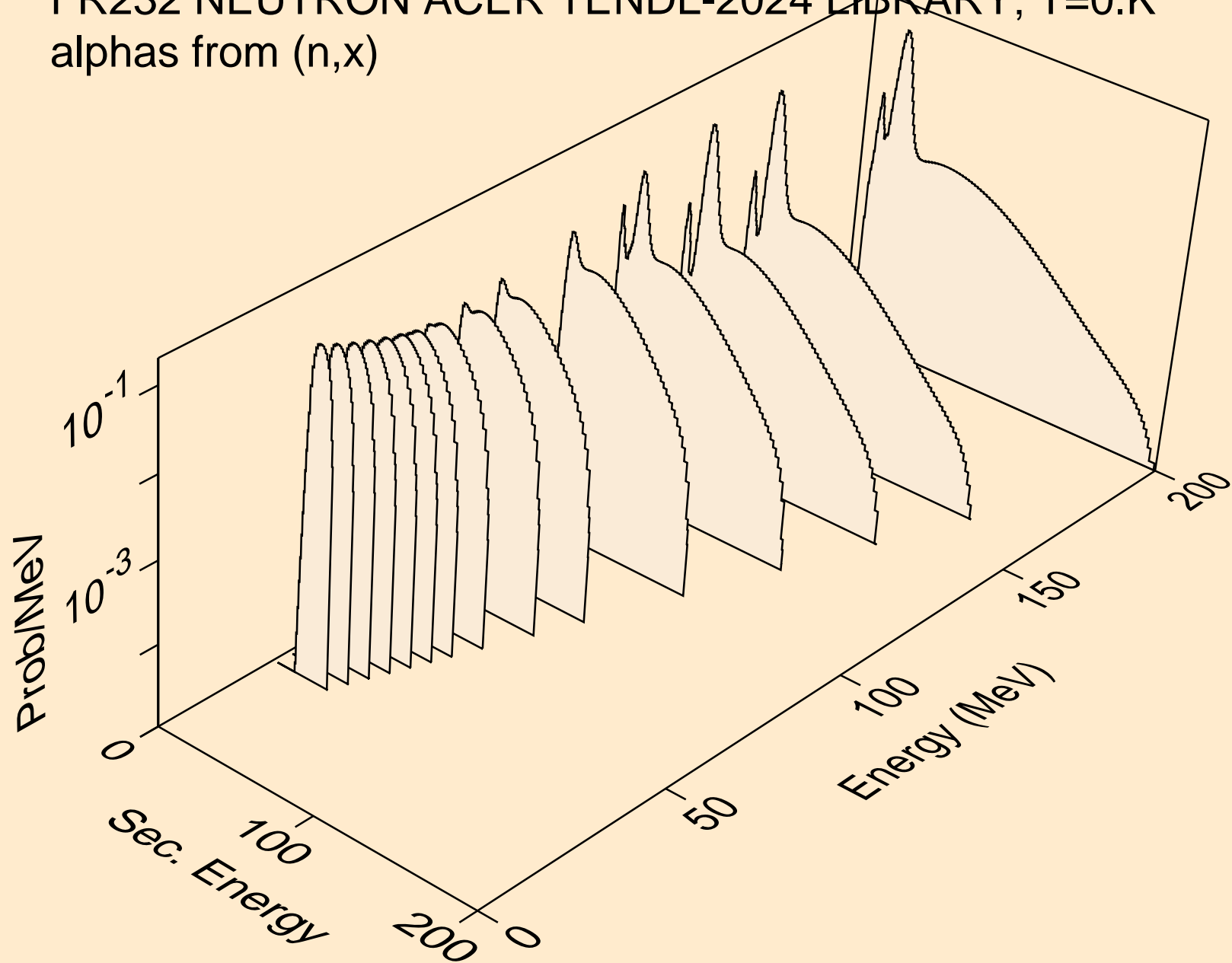

FR232 NEUTRON ACER TENDL-2024 LIBRARY; T=0.K
alphas from (n,n*)a

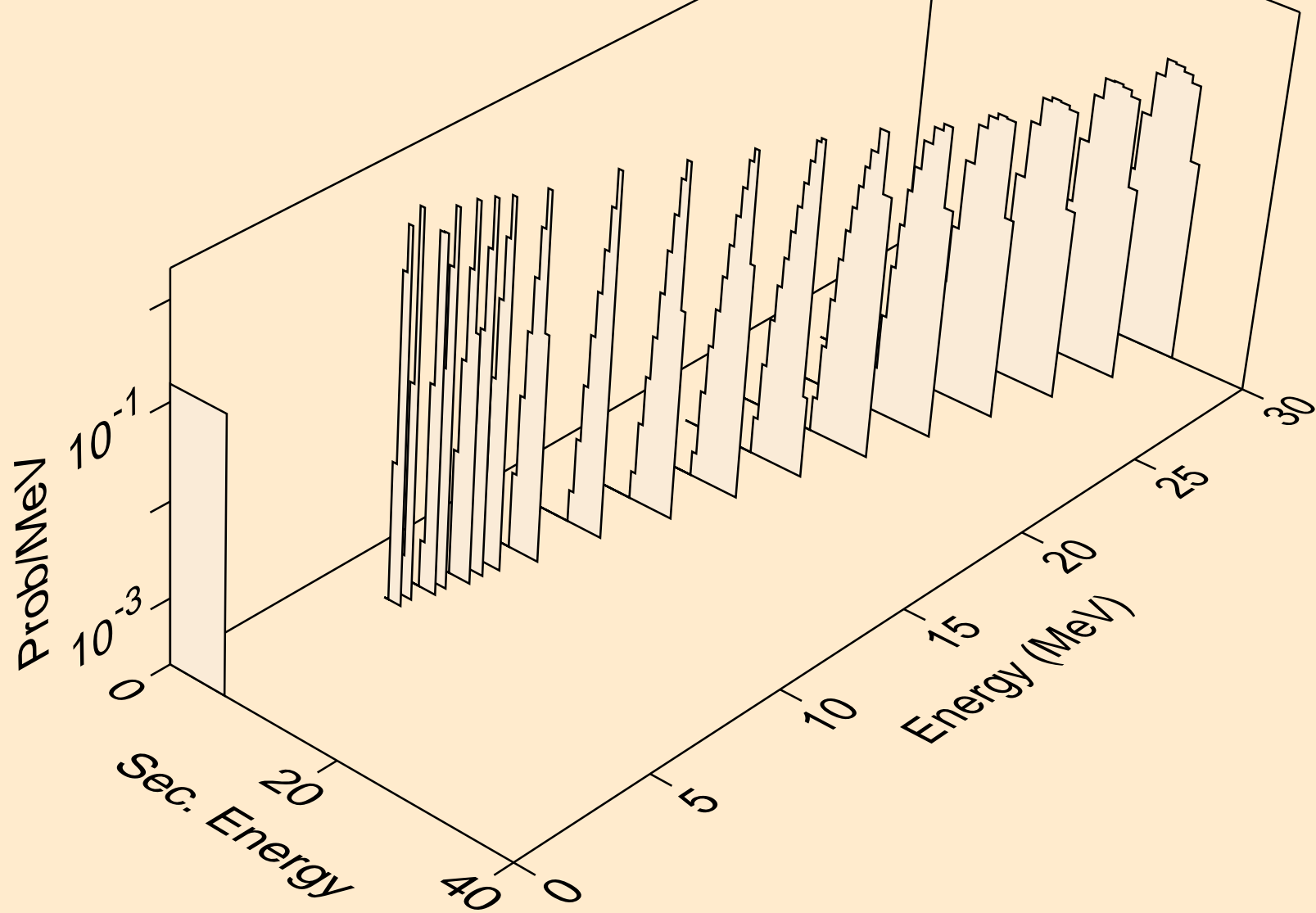

FR232 NEUTRON ACER TENDL-2024 LIBRARY; T=0.K
alphas from (n,2n)a

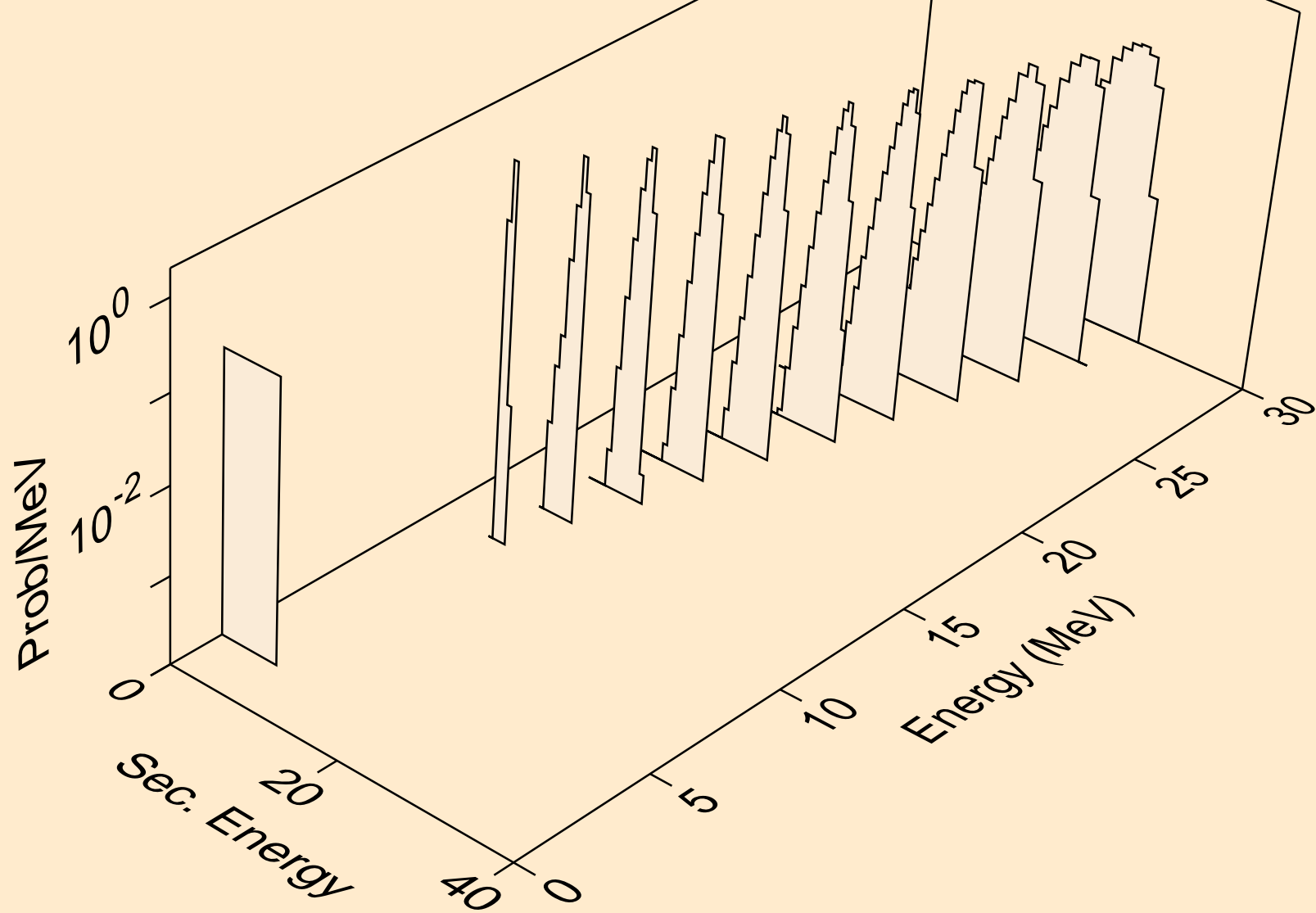

FR232 NEUTRON ACER TENDL-2024 LIBRARY; T=0.K
alphas from (n,3n)a

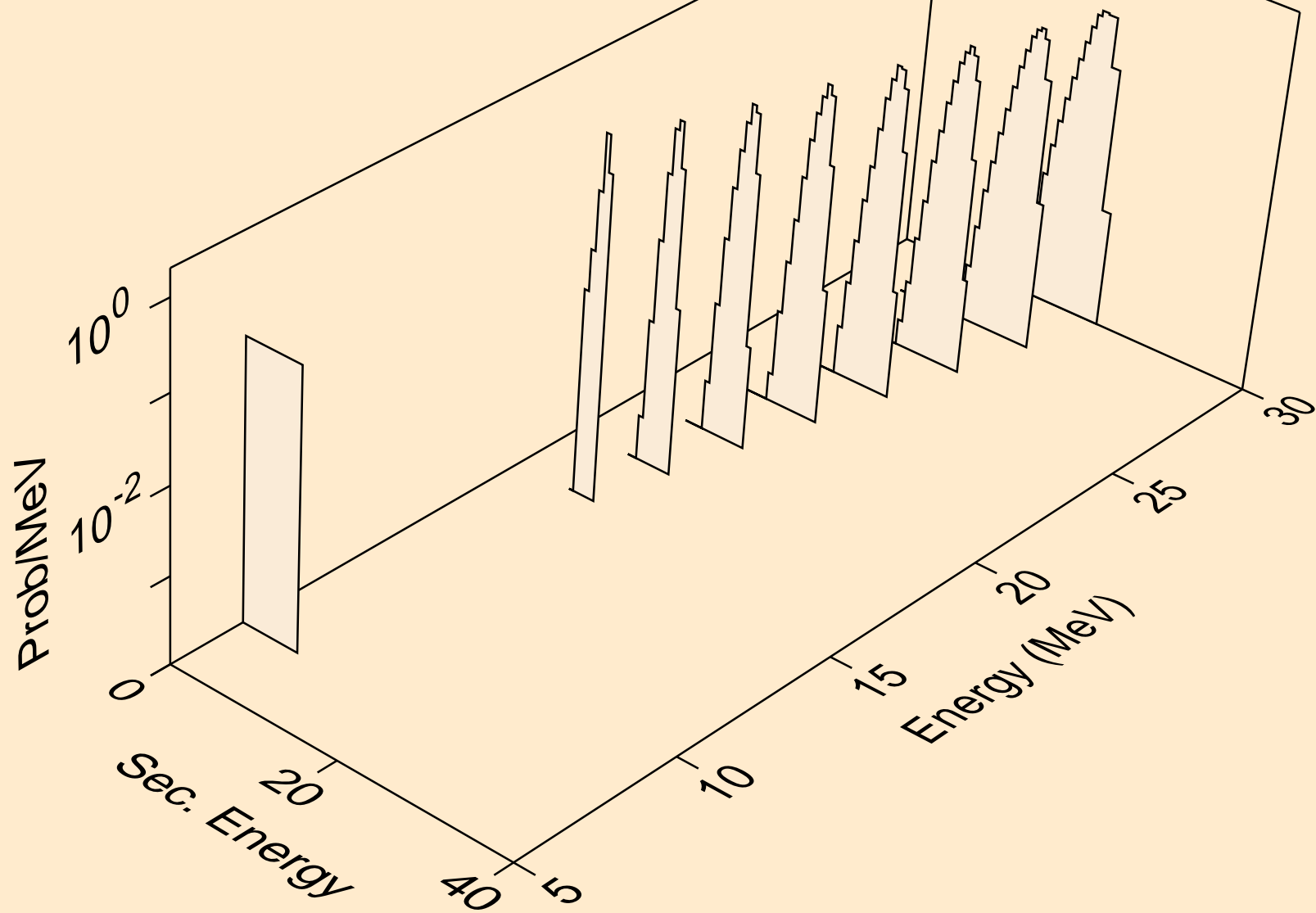

FR232 NEUTRON ACER TENDL-2024 LIBRARY; T=0.K
alphas from (n,a)

