

# RN205M NEUTRON ACER TENDL-2024 LIBRARY; T=0.K

## Principal cross sections

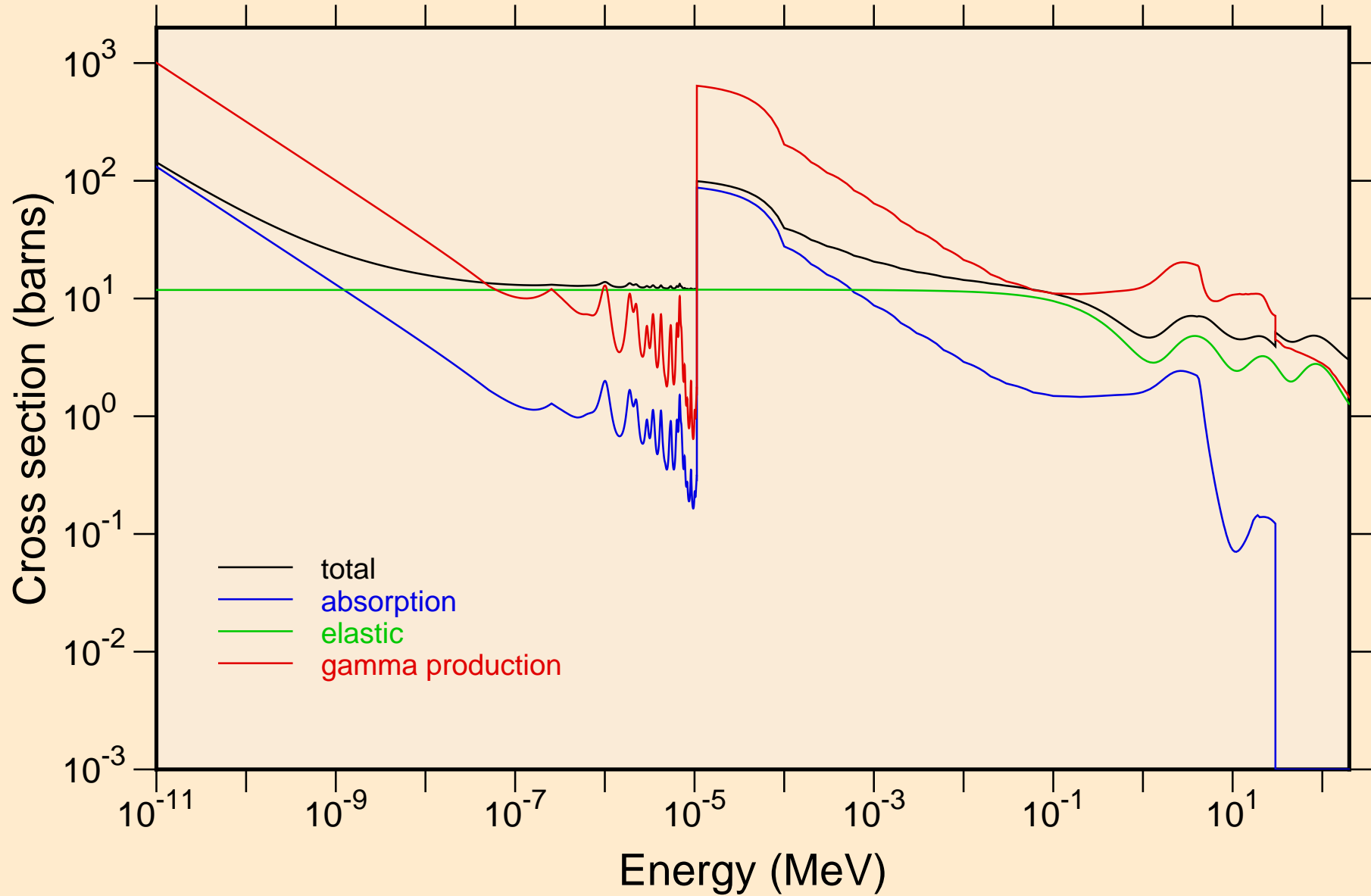

RN205M NEUTRON ACER TENDL-2024 LIBRARY; T=0.K  
Heating

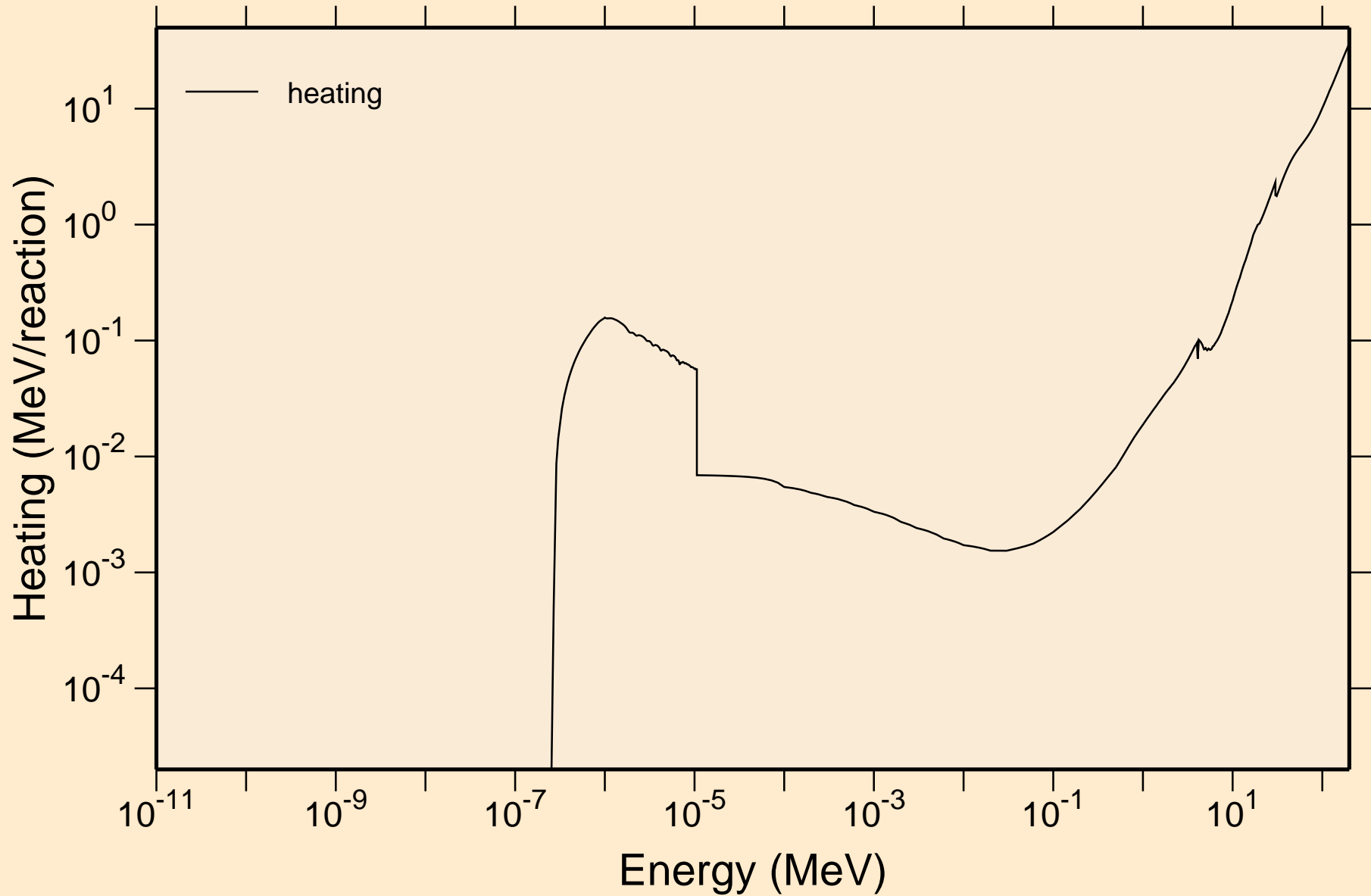

RN205M NEUTRON ACER TENDL-2024 LIBRARY; T=0.K  
Damage

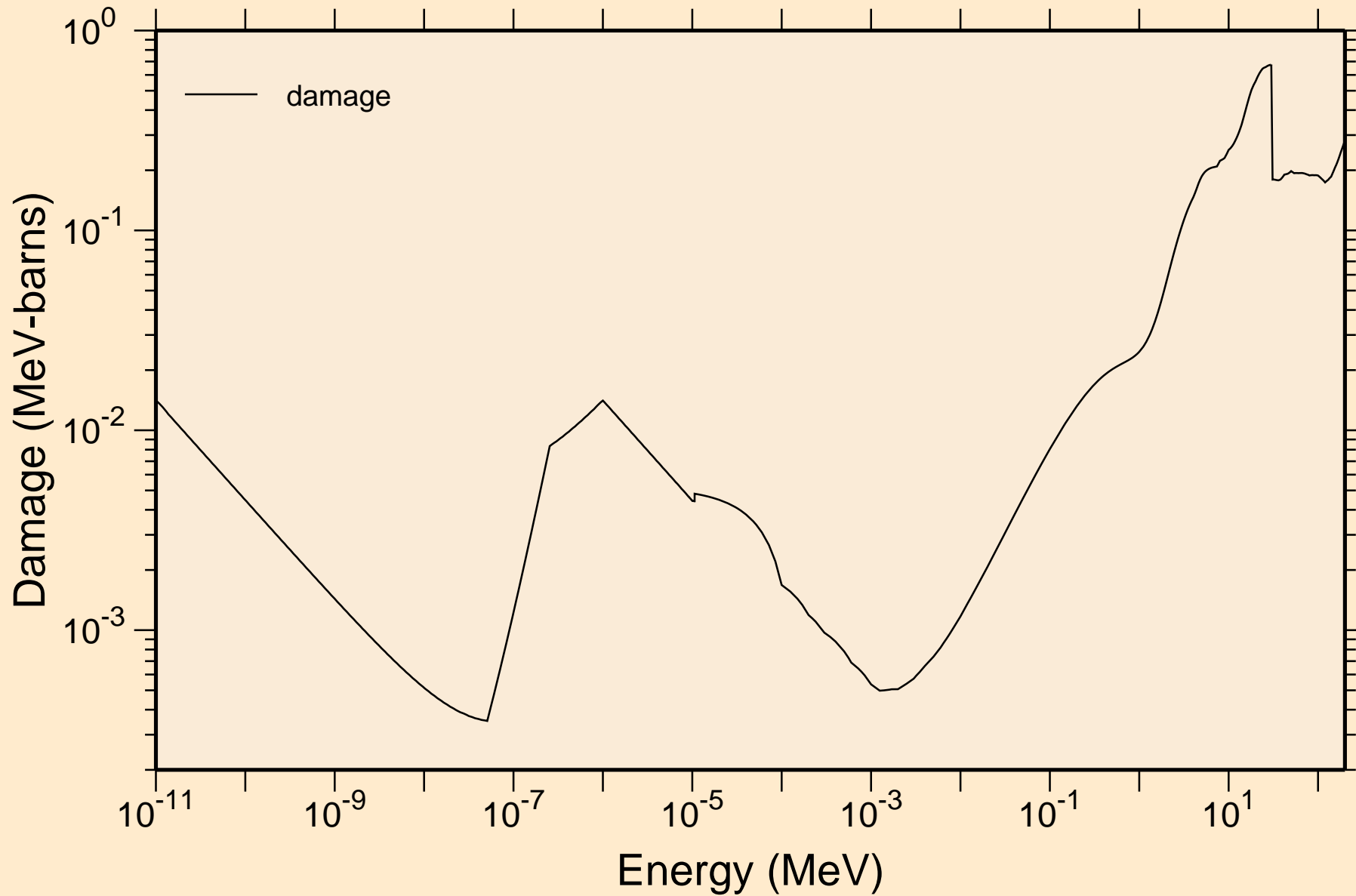

RN205M NEUTRON ACER TENDL-2024 LIBRARY; T=0.K  
Non-threshold reactions

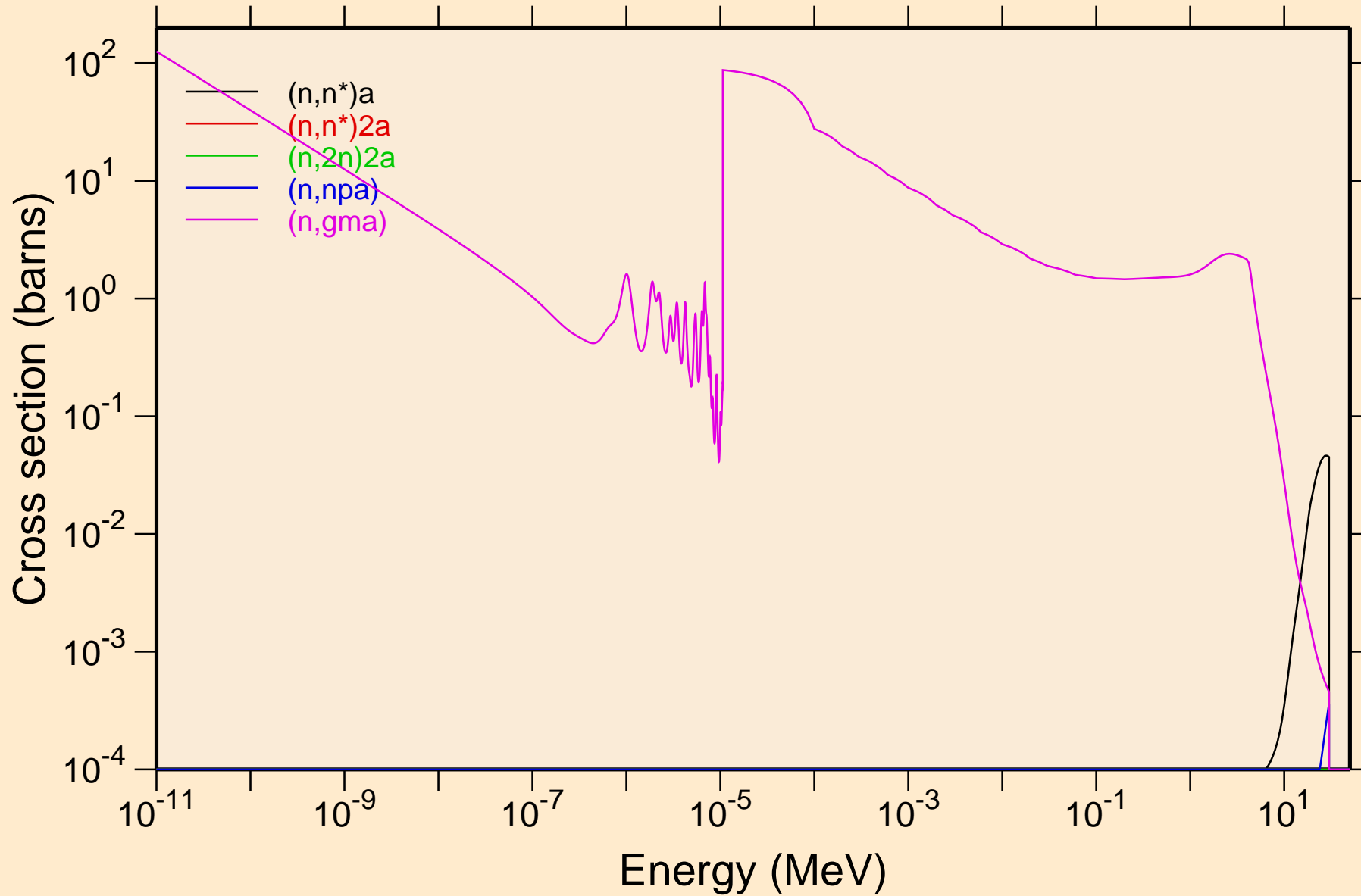

RN205M NEUTRON ACER TENDL-2024 LIBRARY; T=0.K  
Non-threshold reactions

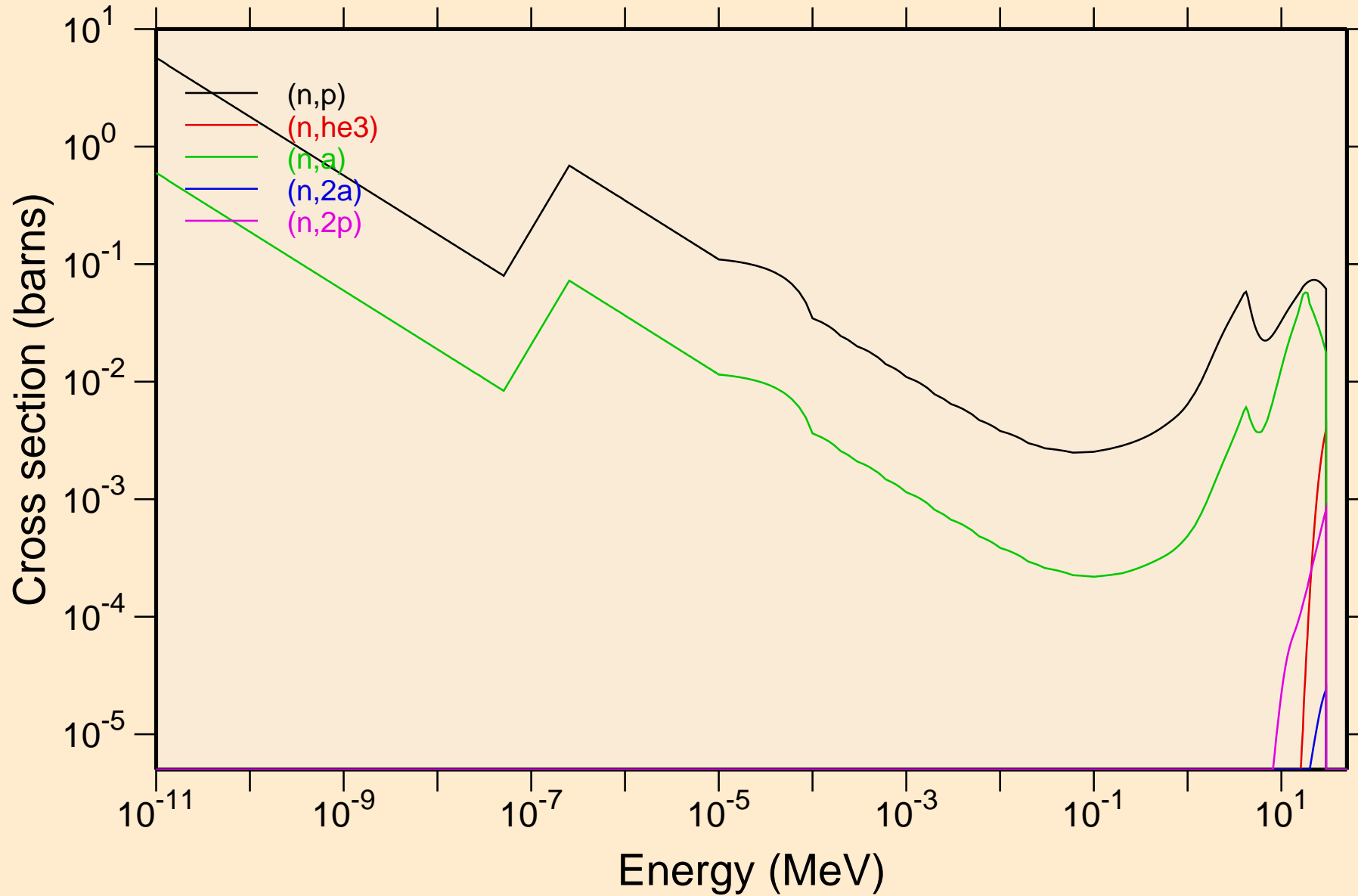

# RN205M NEUTRON ACER TENDL-2024 LIBRARY; T=0.K

## Non-threshold reactions

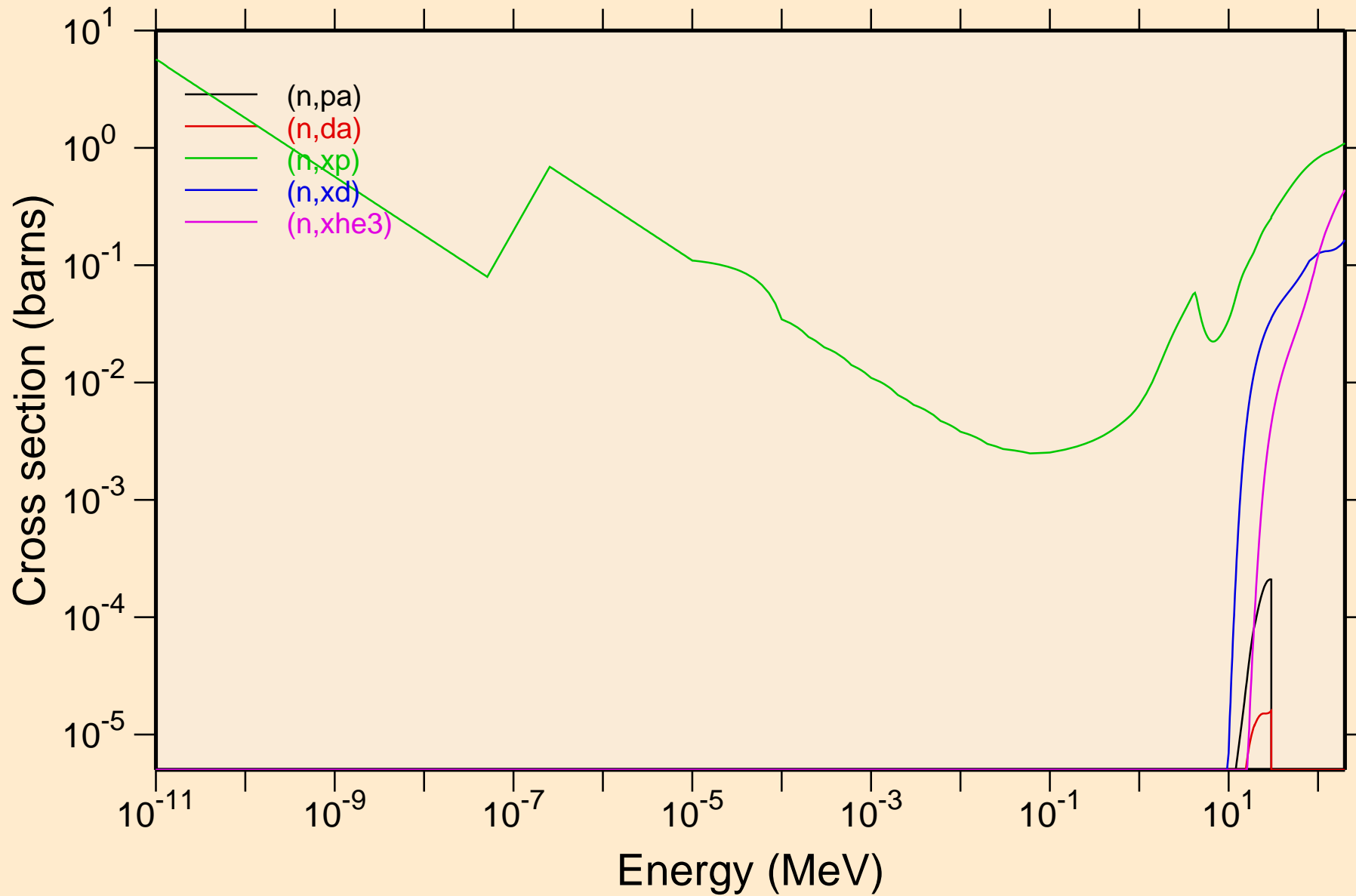

RN205M NEUTRON ACER TENDL-2024 LIBRARY; T=0.K  
Non-threshold reactions

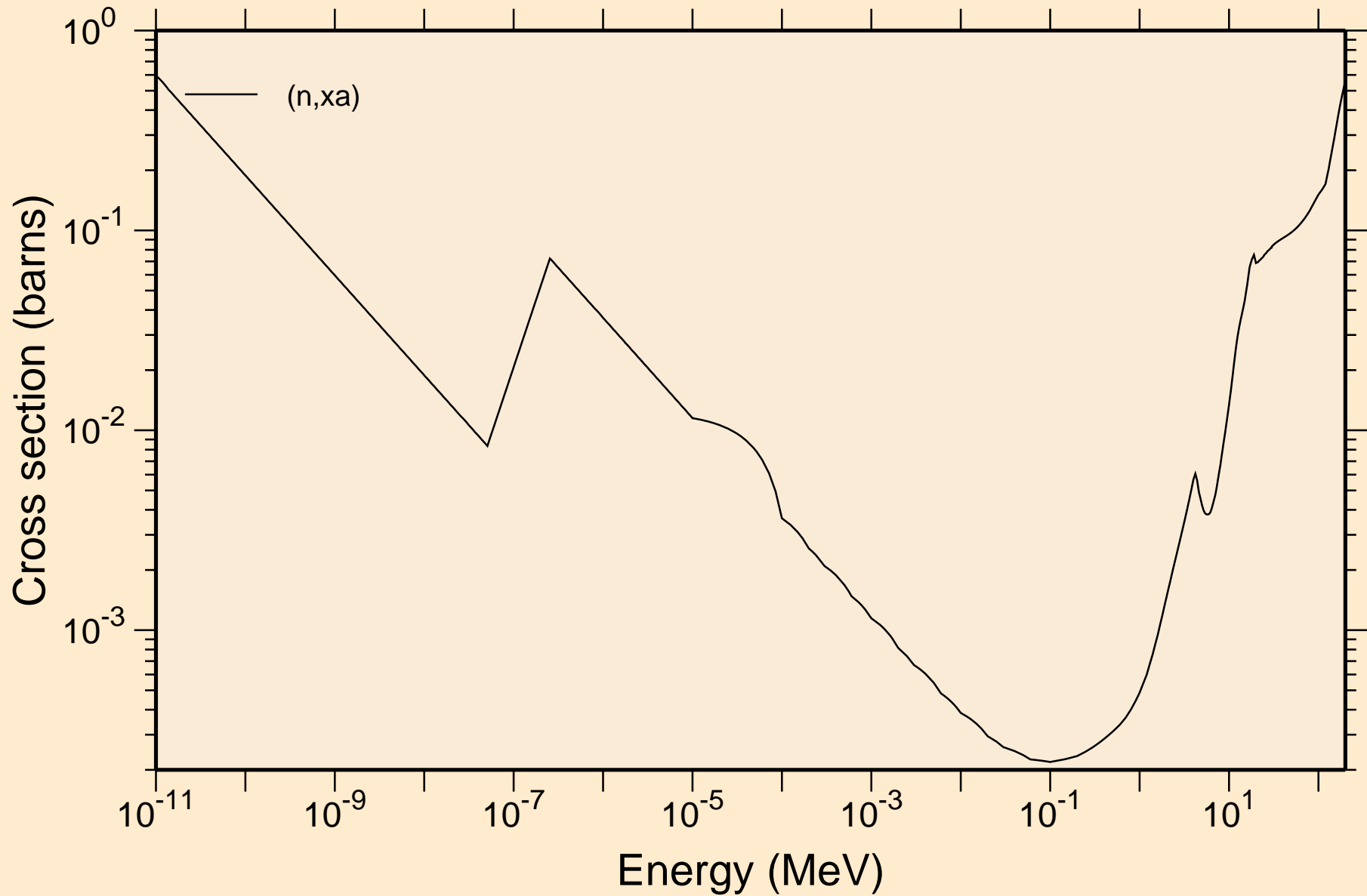

# RN205M NEUTRON ACER TENDL-2024 LIBRARY; T=0.K

## Principal cross sections

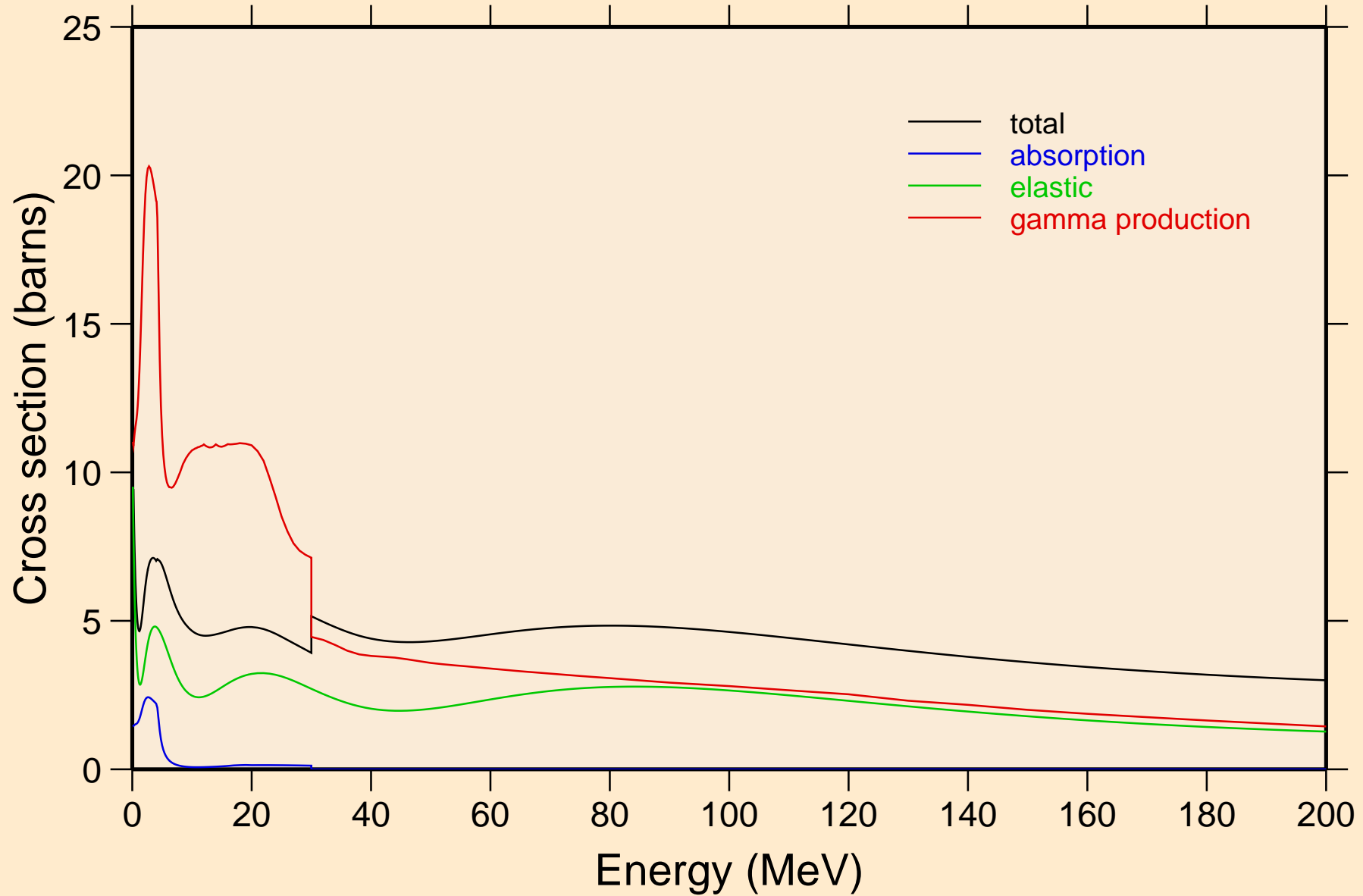

# RN205M NEUTRON ACER TENDL-2024 LIBRARY; T=0.K

## Heating

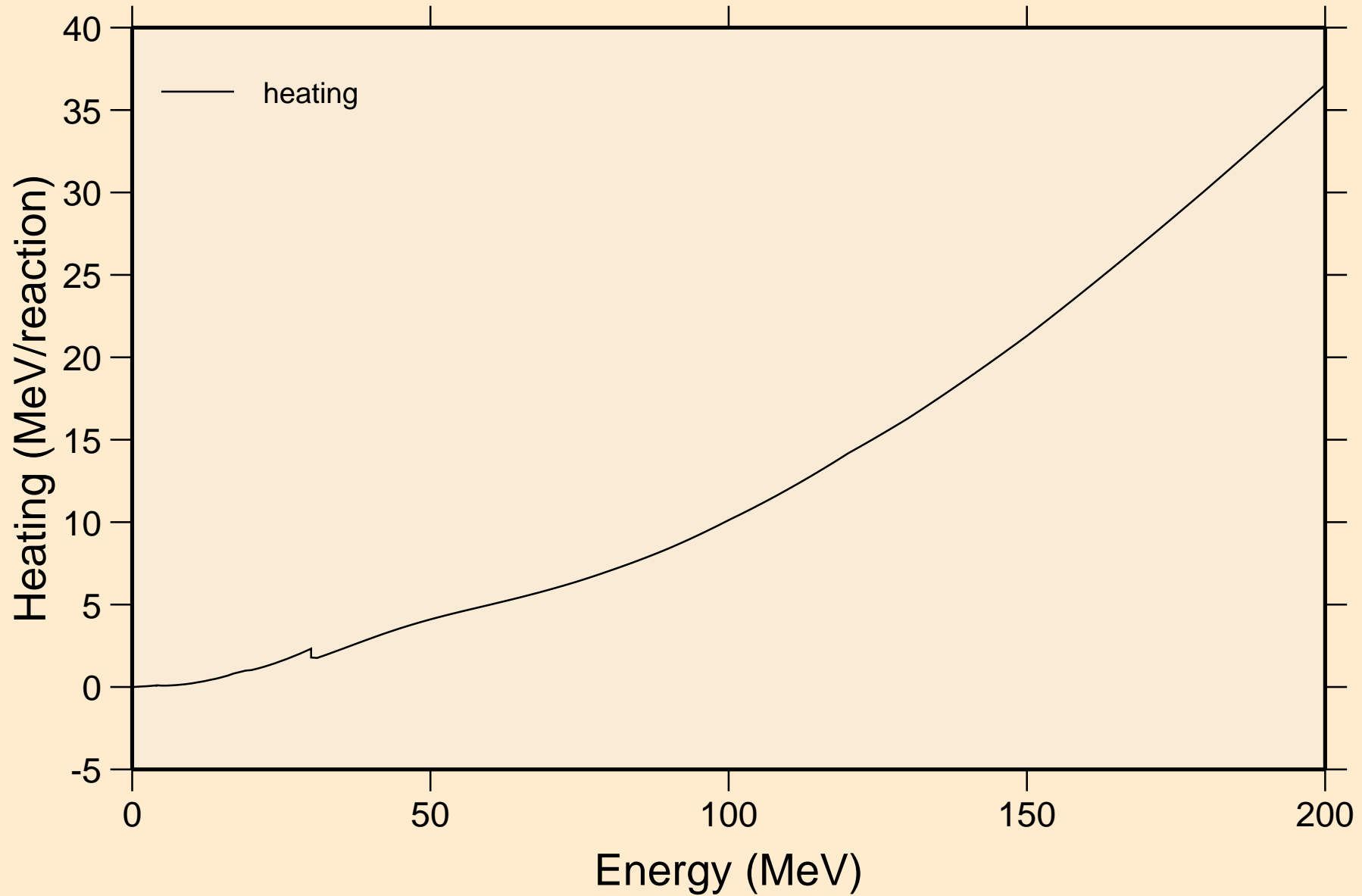

# RN205M NEUTRON ACER TENDL-2024 LIBRARY; T=0.K

## Damage

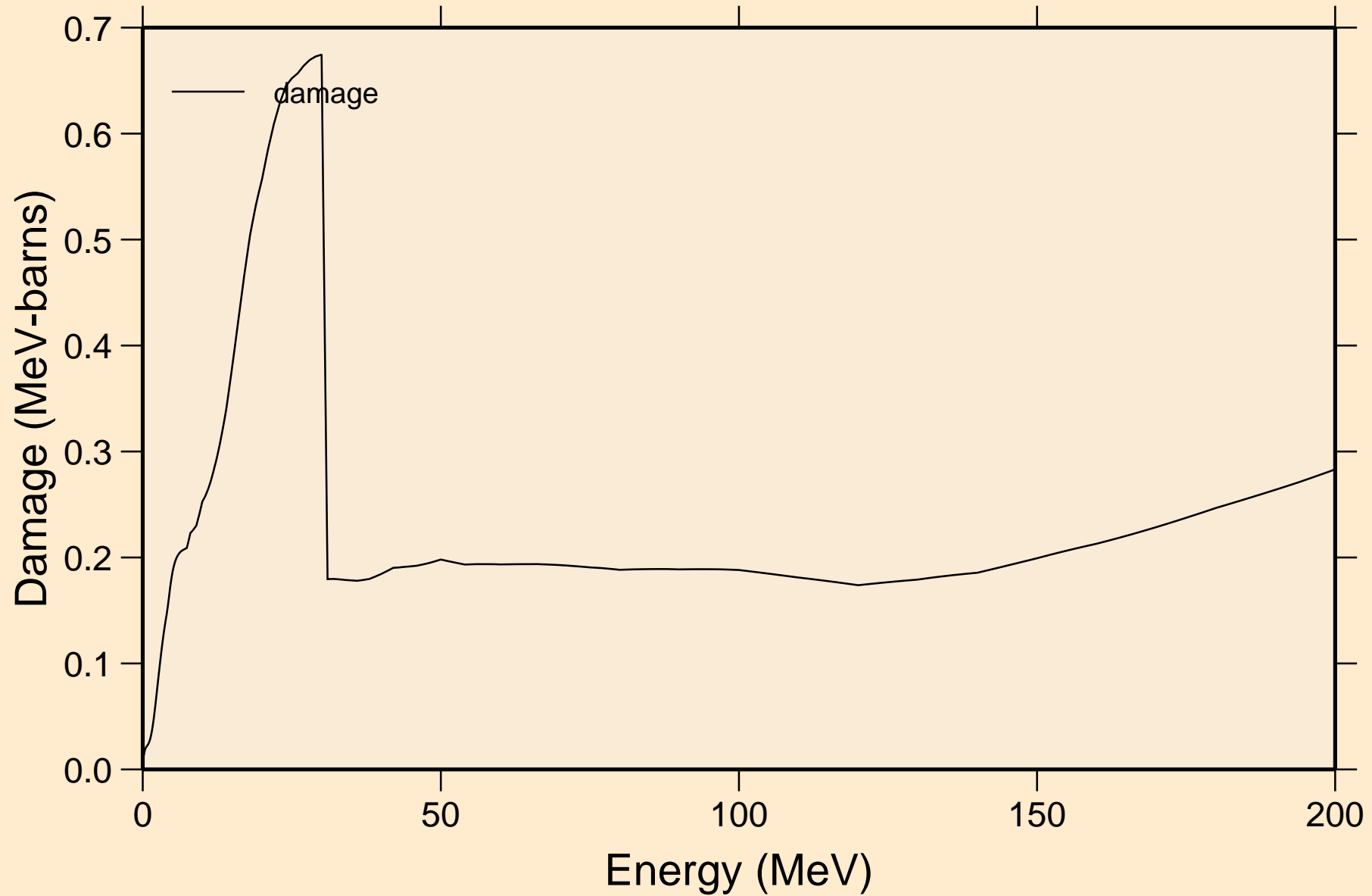

RN205M NEUTRON ACER TENDL-2024 LIBRARY; T=0.K  
Non-threshold reactions

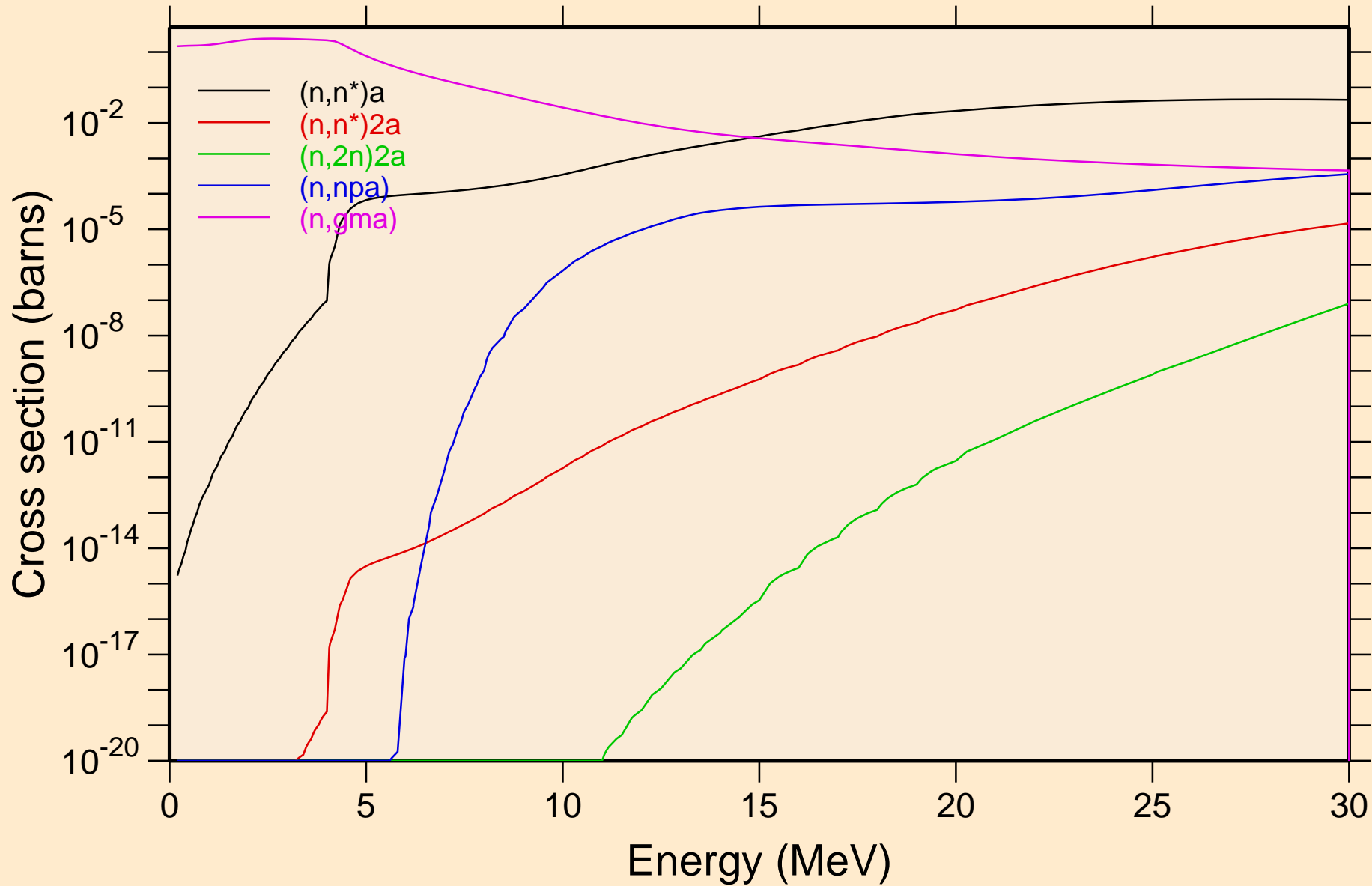

RN205M NEUTRON ACER TENDL-2024 LIBRARY; T=0.K  
Non-threshold reactions

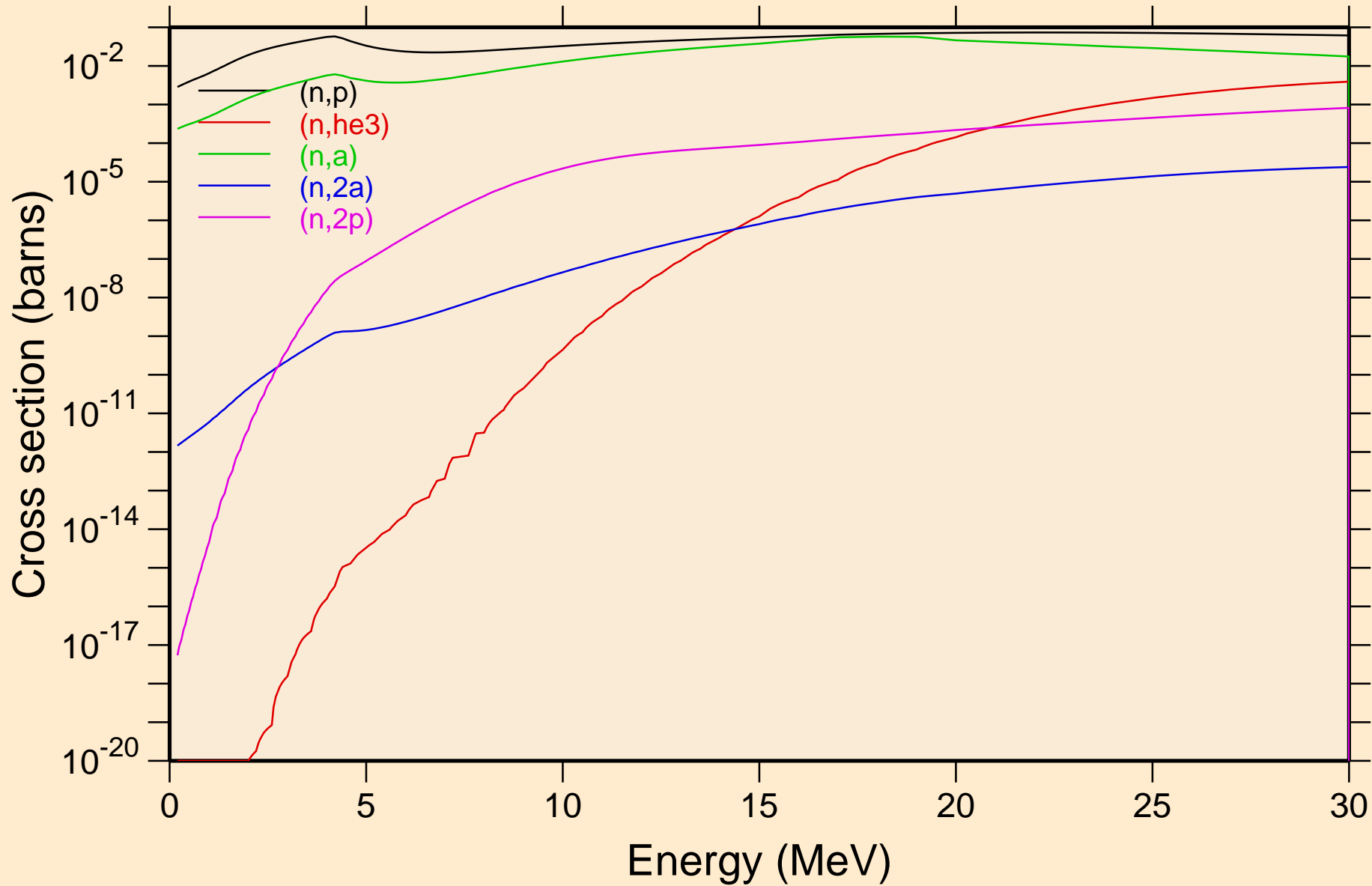

RN205M NEUTRON ACER TENDL-2024 LIBRARY; T=0.K  
Non-threshold reactions

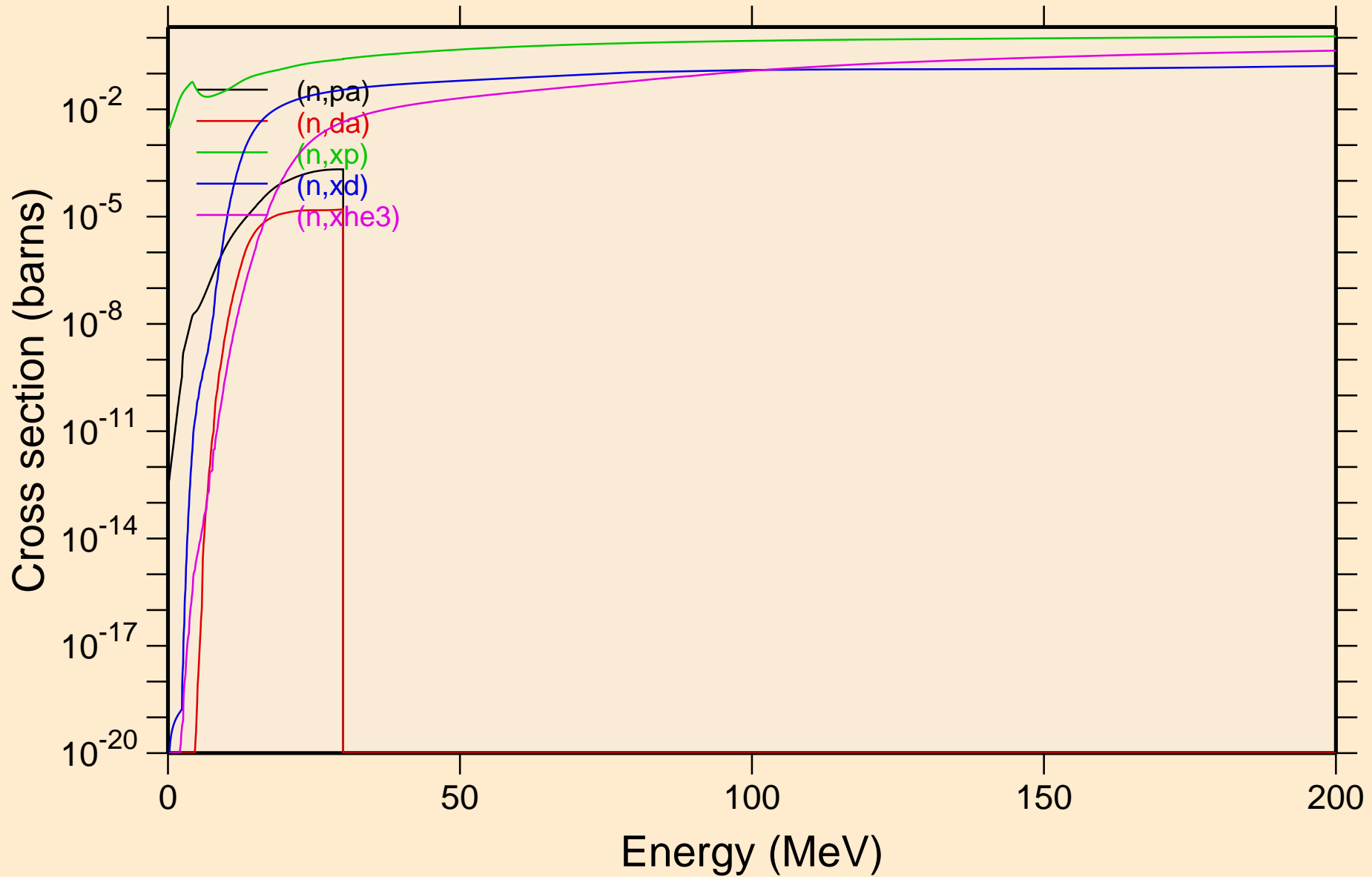

RN205M NEUTRON ACER TENDL-2024 LIBRARY; T=0.K  
Non-threshold reactions

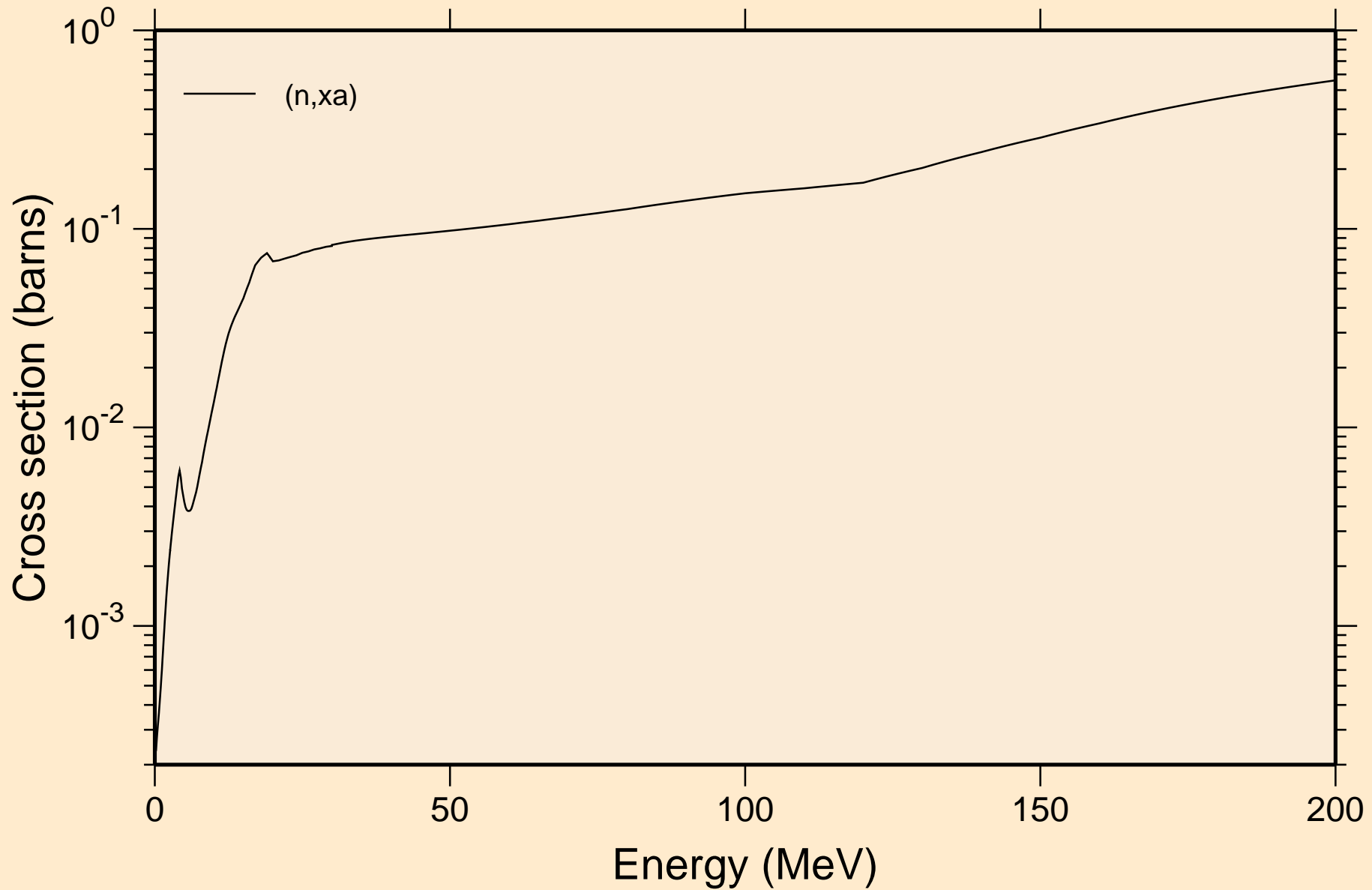

RN205M NEUTRON ACER TENDL-2024 LIBRARY; T=0.K  
Inelastic levels

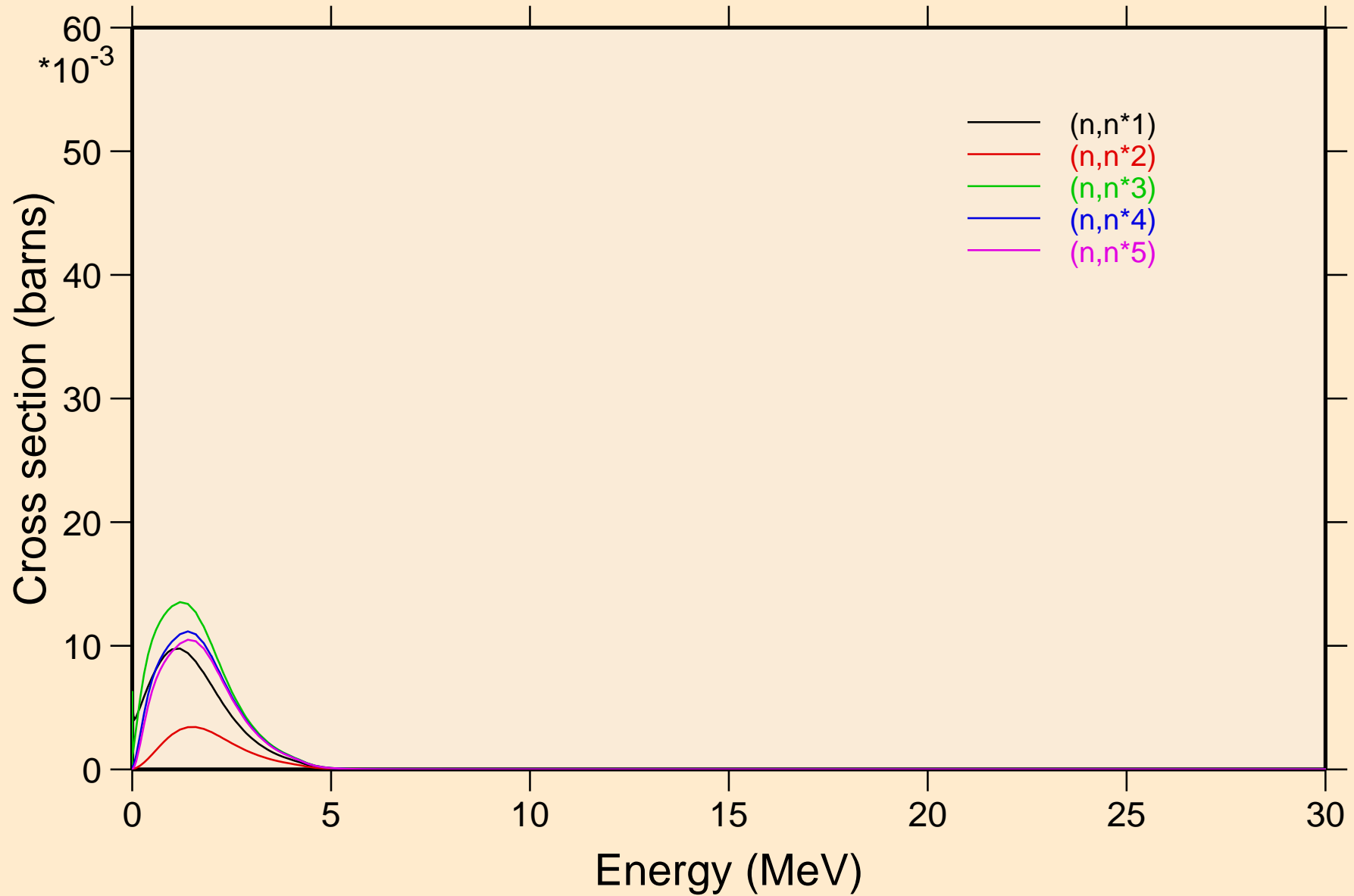

RN205M NEUTRON ACER TENDL-2024 LIBRARY; T=0.K  
Inelastic levels

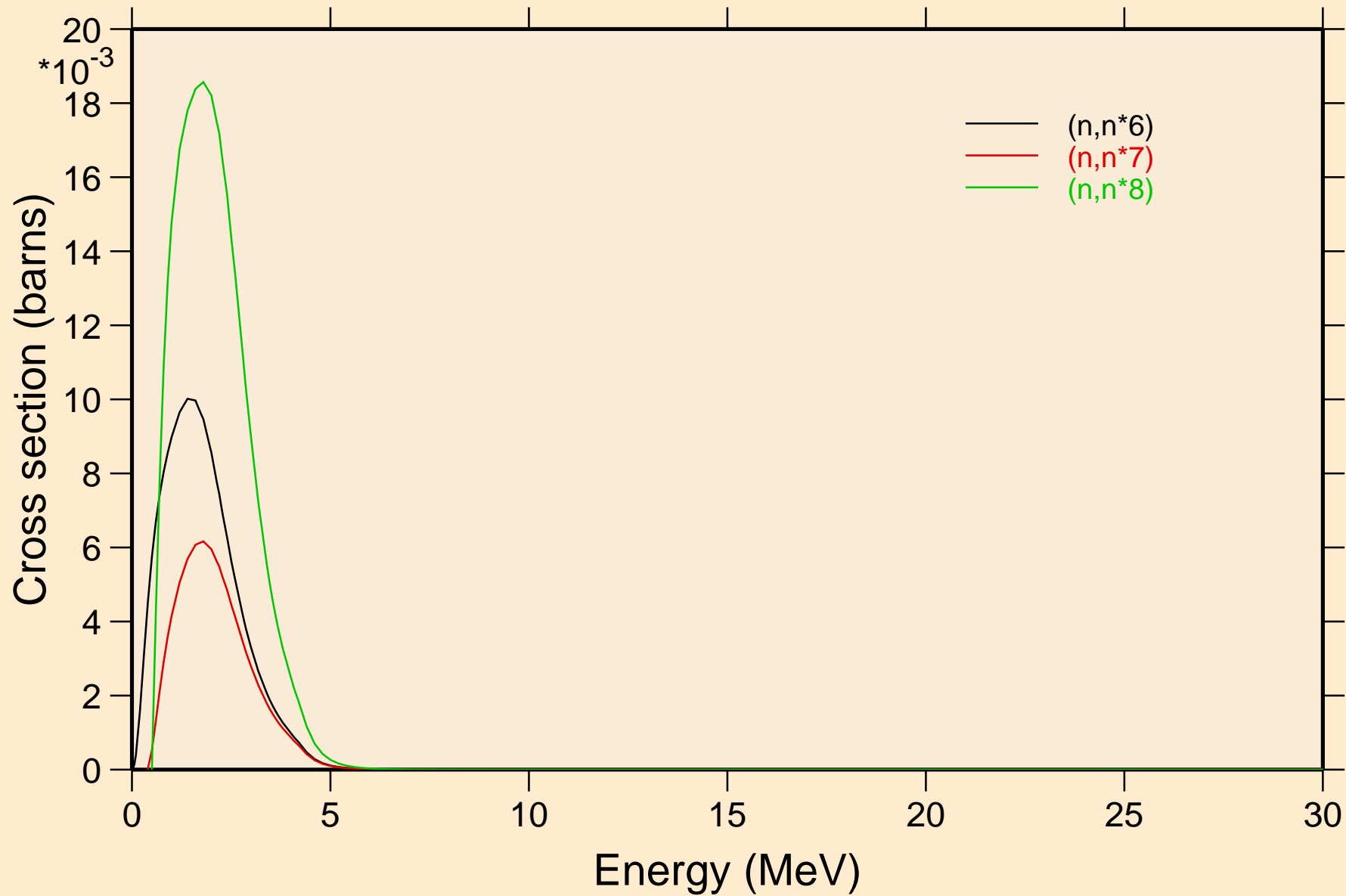

RN205M NEUTRON ACER TENDL-2024 LIBRARY; T=0.K  
Threshold reactions

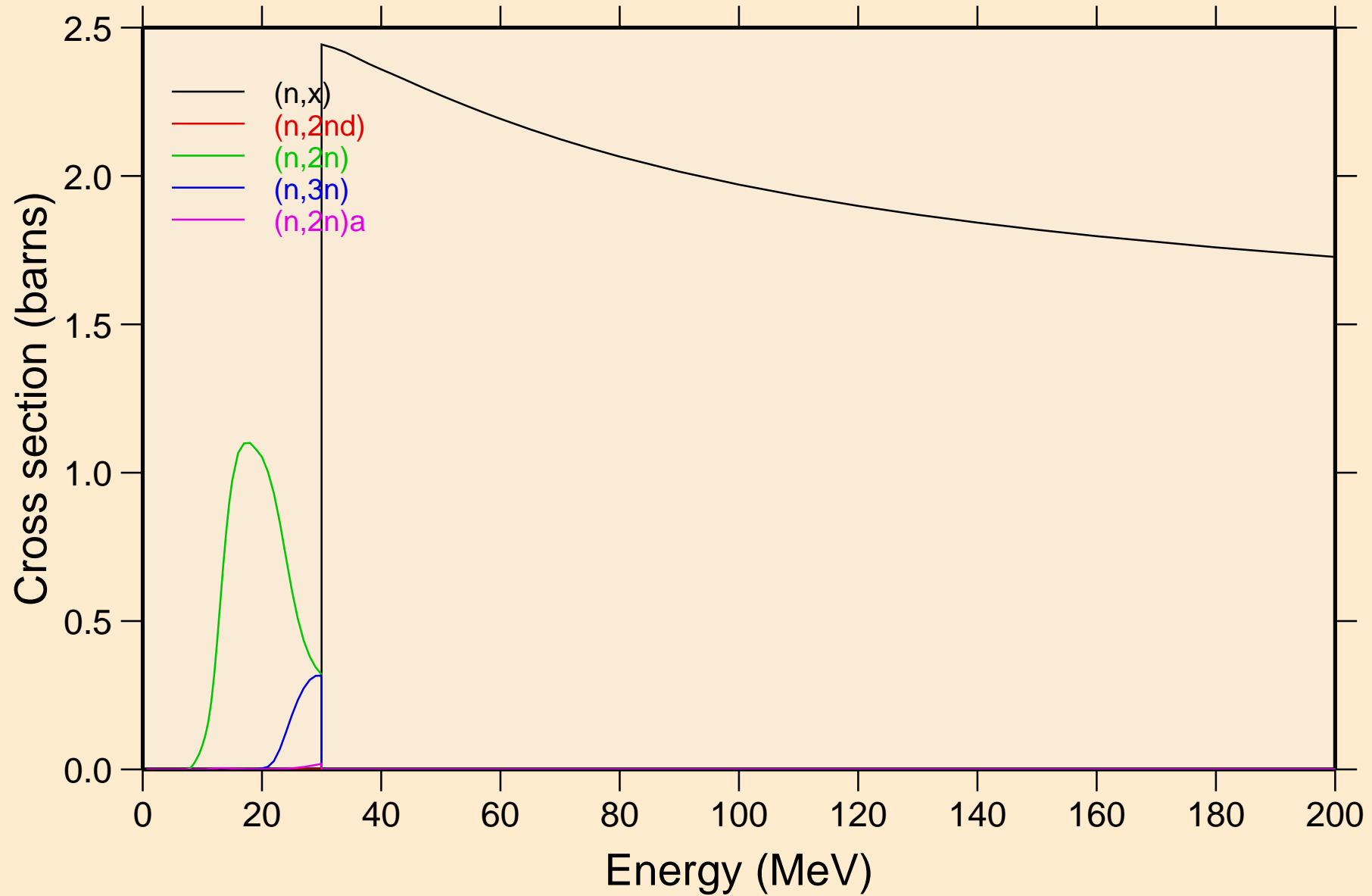

# RN205M NEUTRON ACER TENDL-2024 LIBRARY; T=0.K

## Threshold reactions

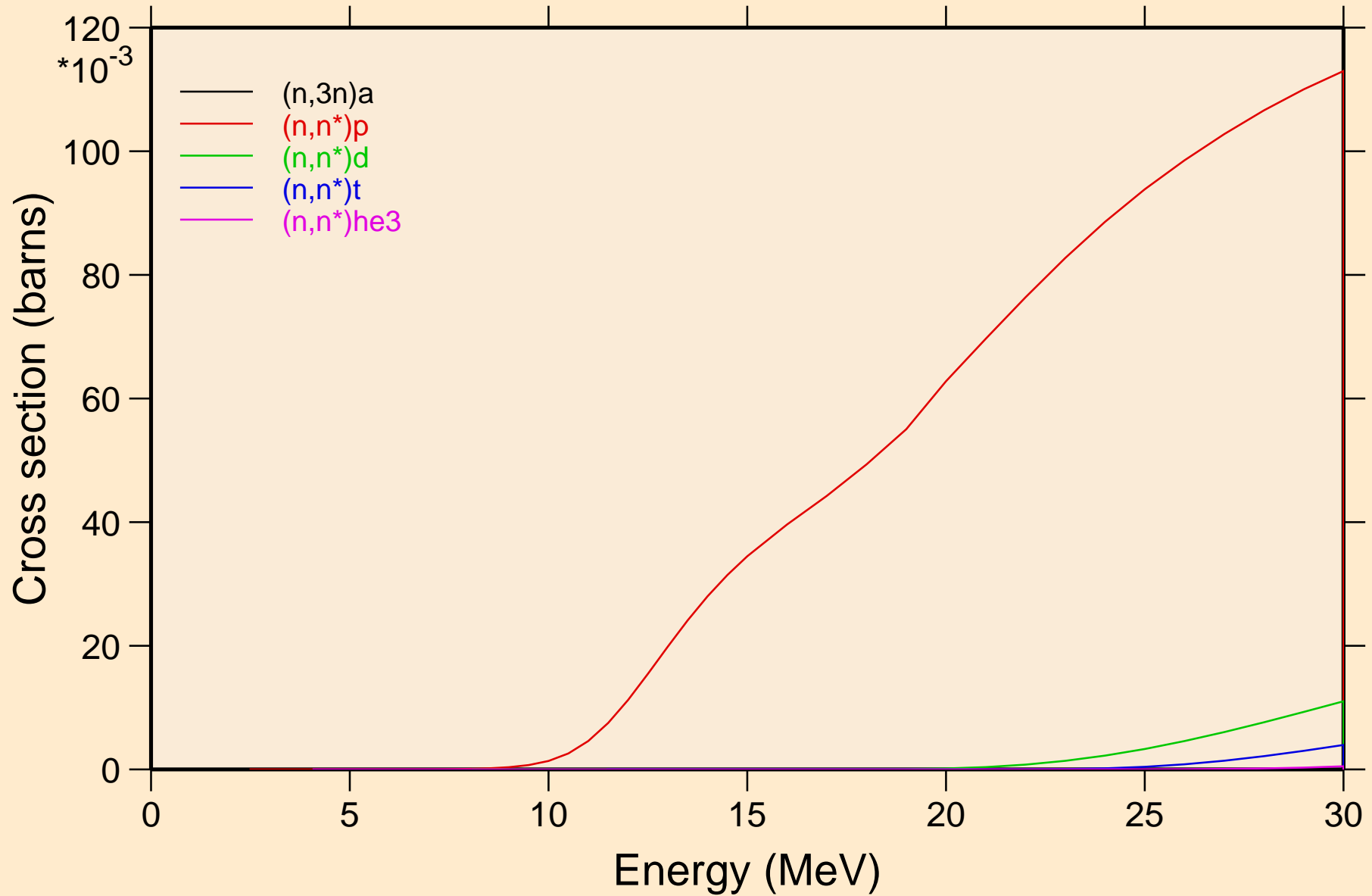

RN205M NEUTRON ACER TENDL-2024 LIBRARY; T=0.K  
Threshold reactions

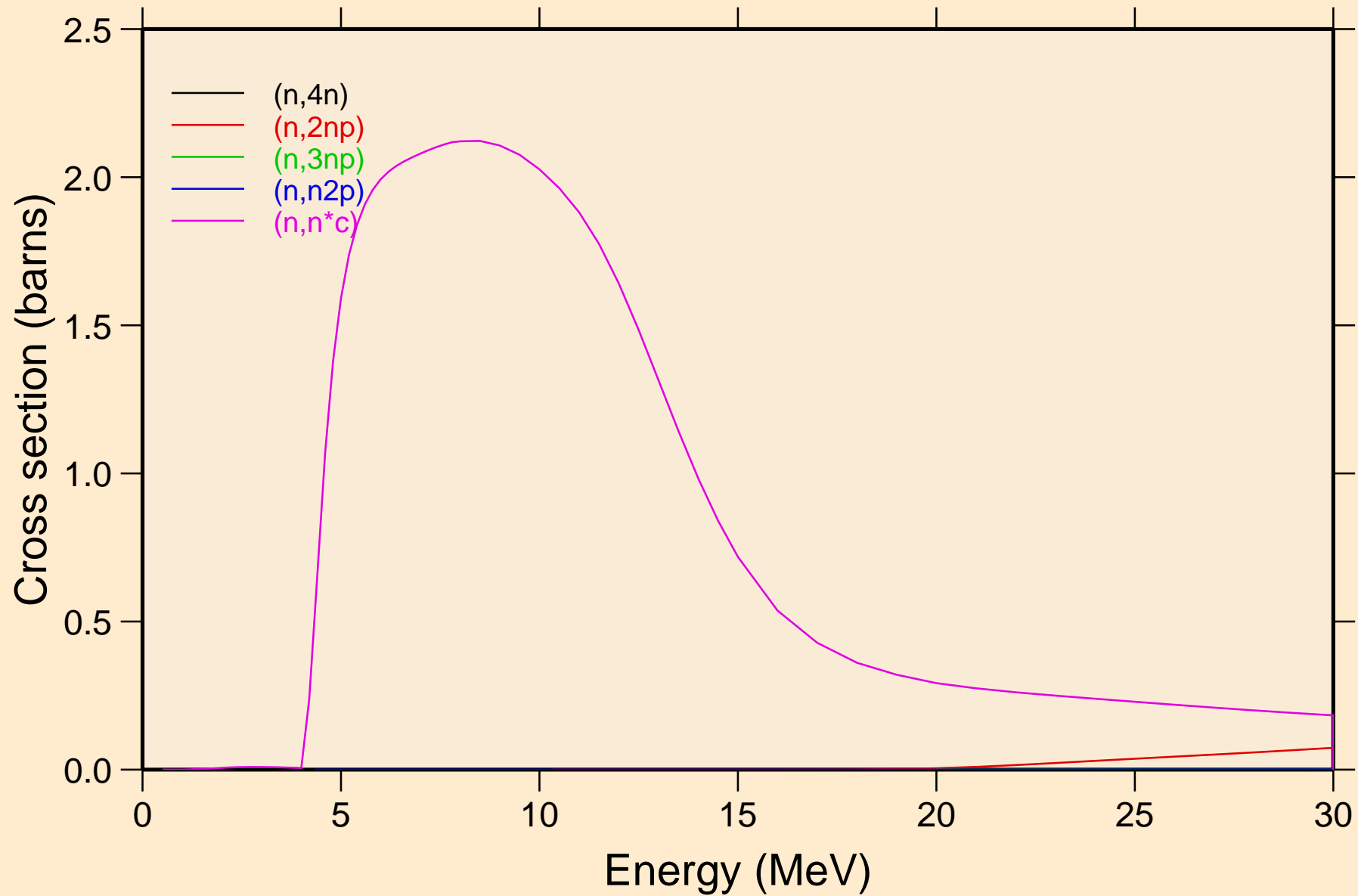

# RN205M NEUTRON ACER TENDL-2024 LIBRARY; T=0.K

## Threshold reactions

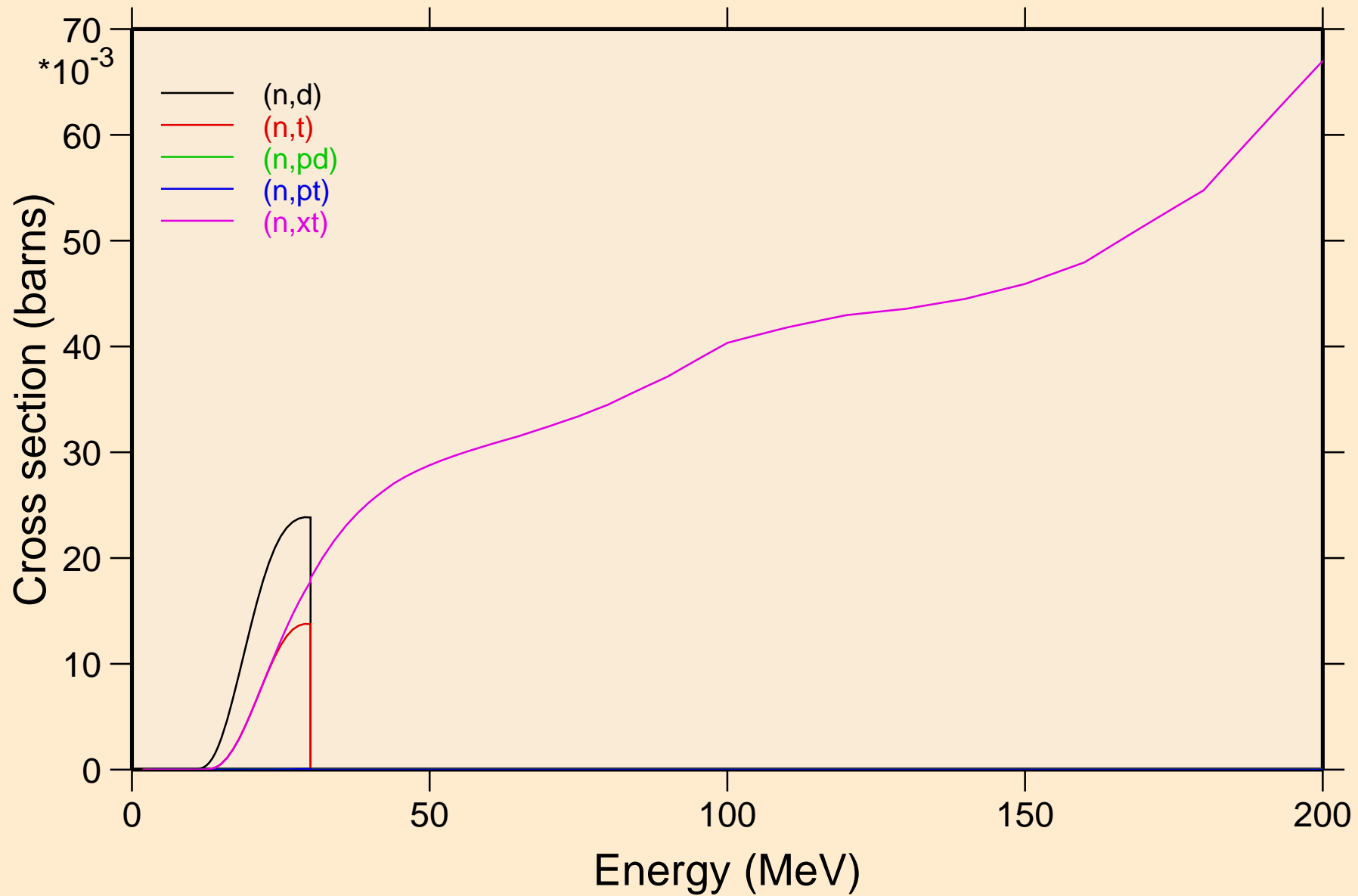

RN205M NEUTRON ACER TENDL-2024 LIBRARY; T=0.K  
angular distribution for elastic

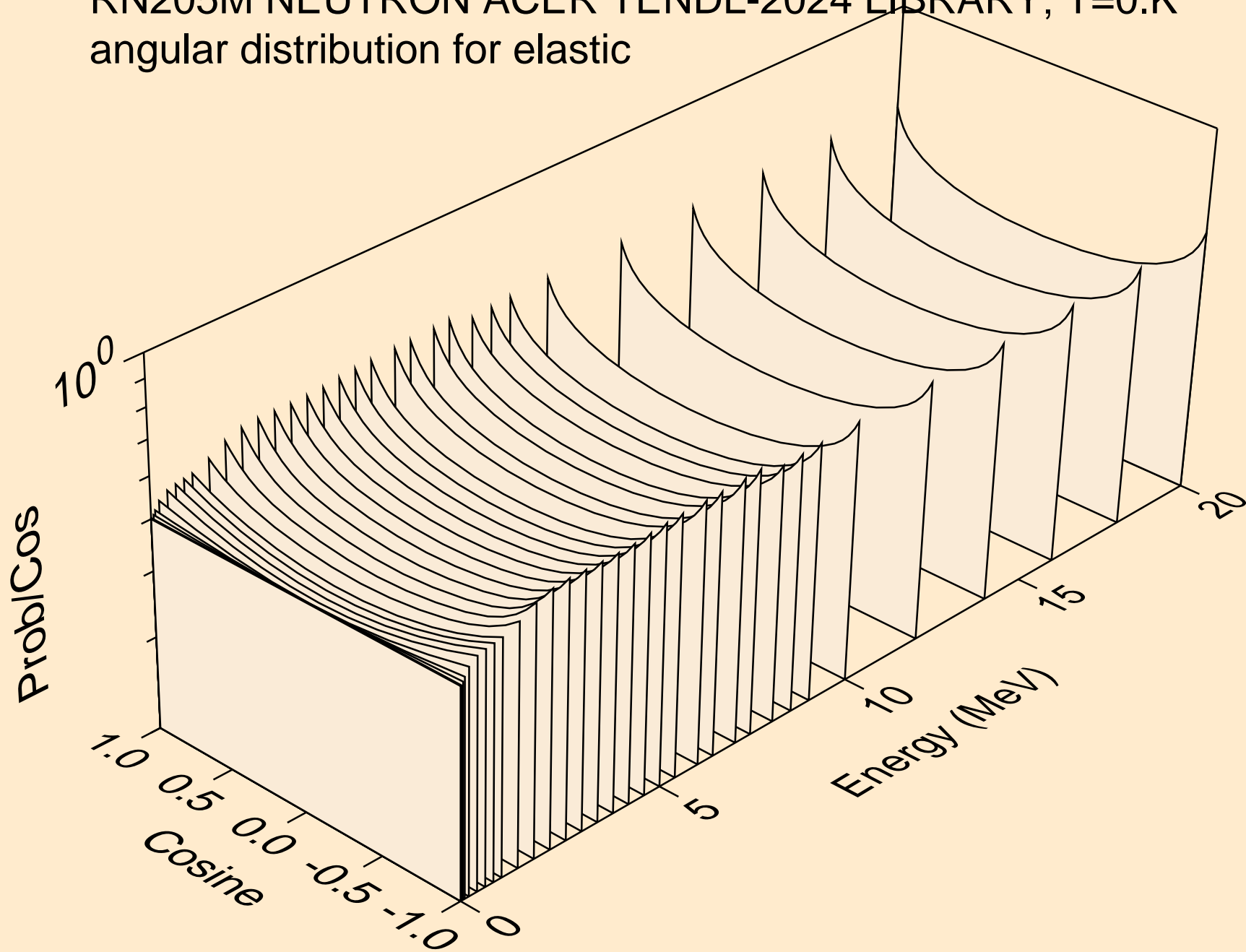

RN205M NEUTRON ACER TENDL-2024 LIBRARY; T=0.K  
angular distribution for elastic

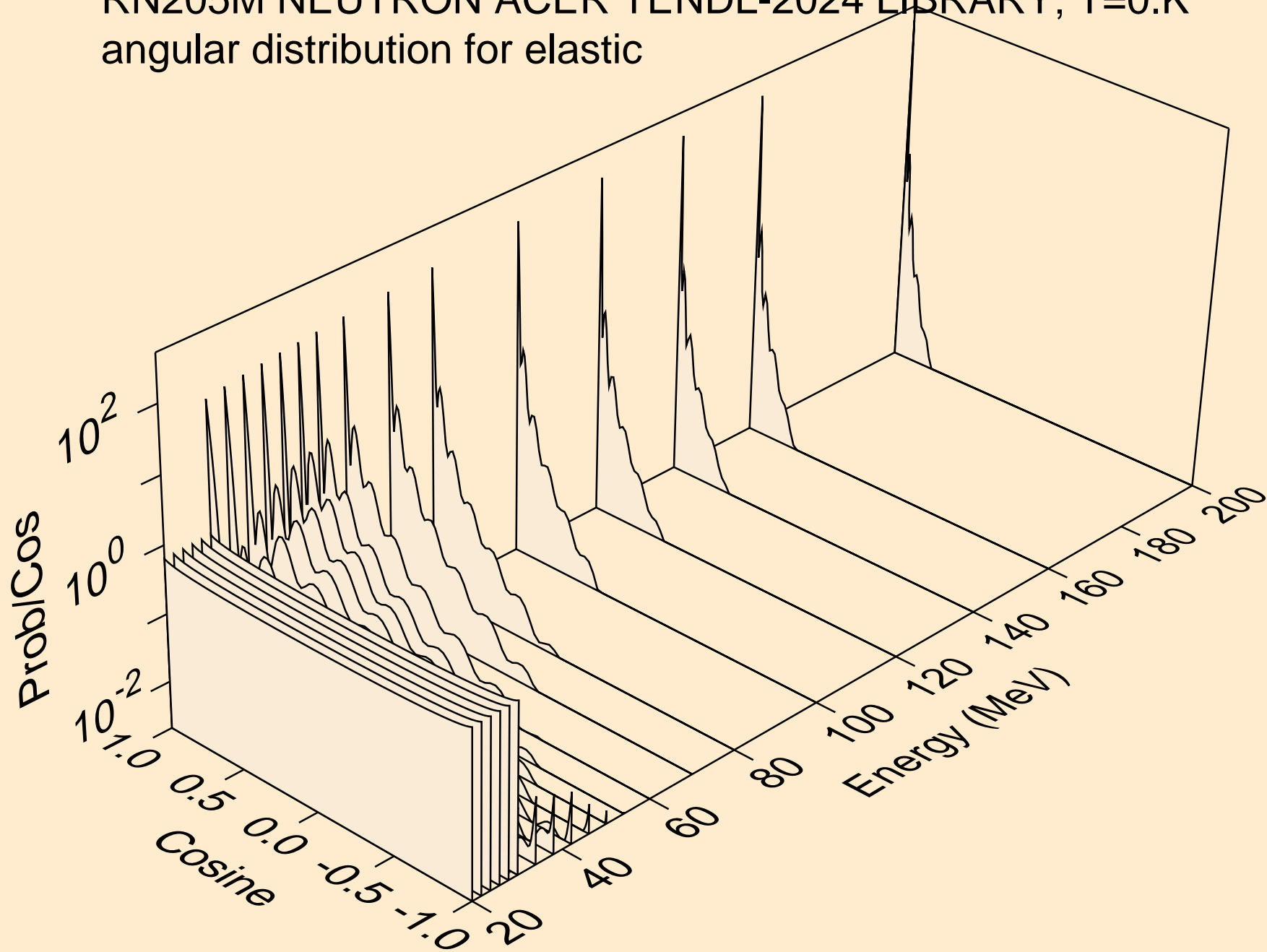

RN205M NEUTRON ACER TENDL-2024 LIBRARY; T=0.K  
angular distribution for (n,n\*1)

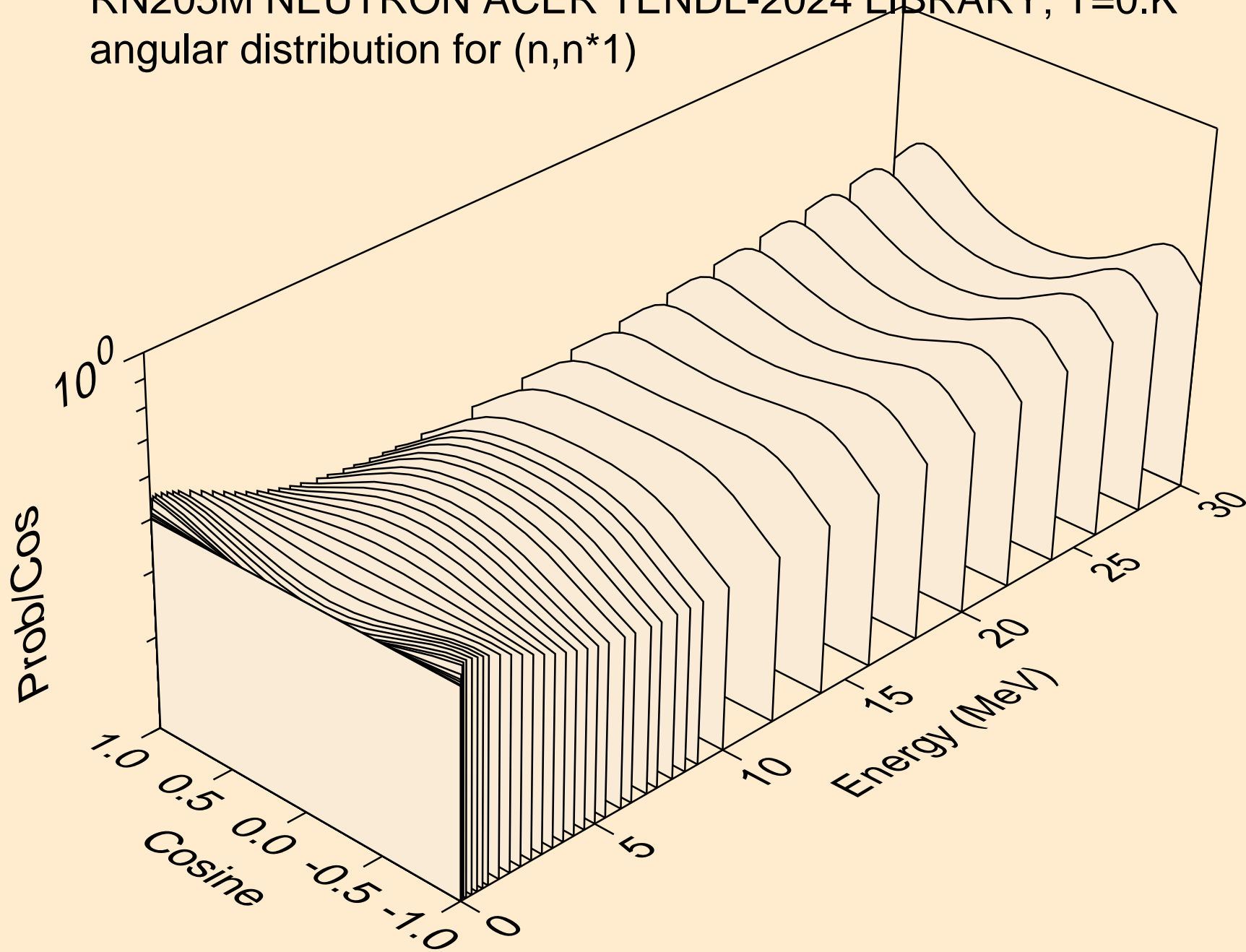

RN205M NEUTRON ACER TENDL-2024 LIBRARY; T=0.K  
angular distribution for (n,n\*2)

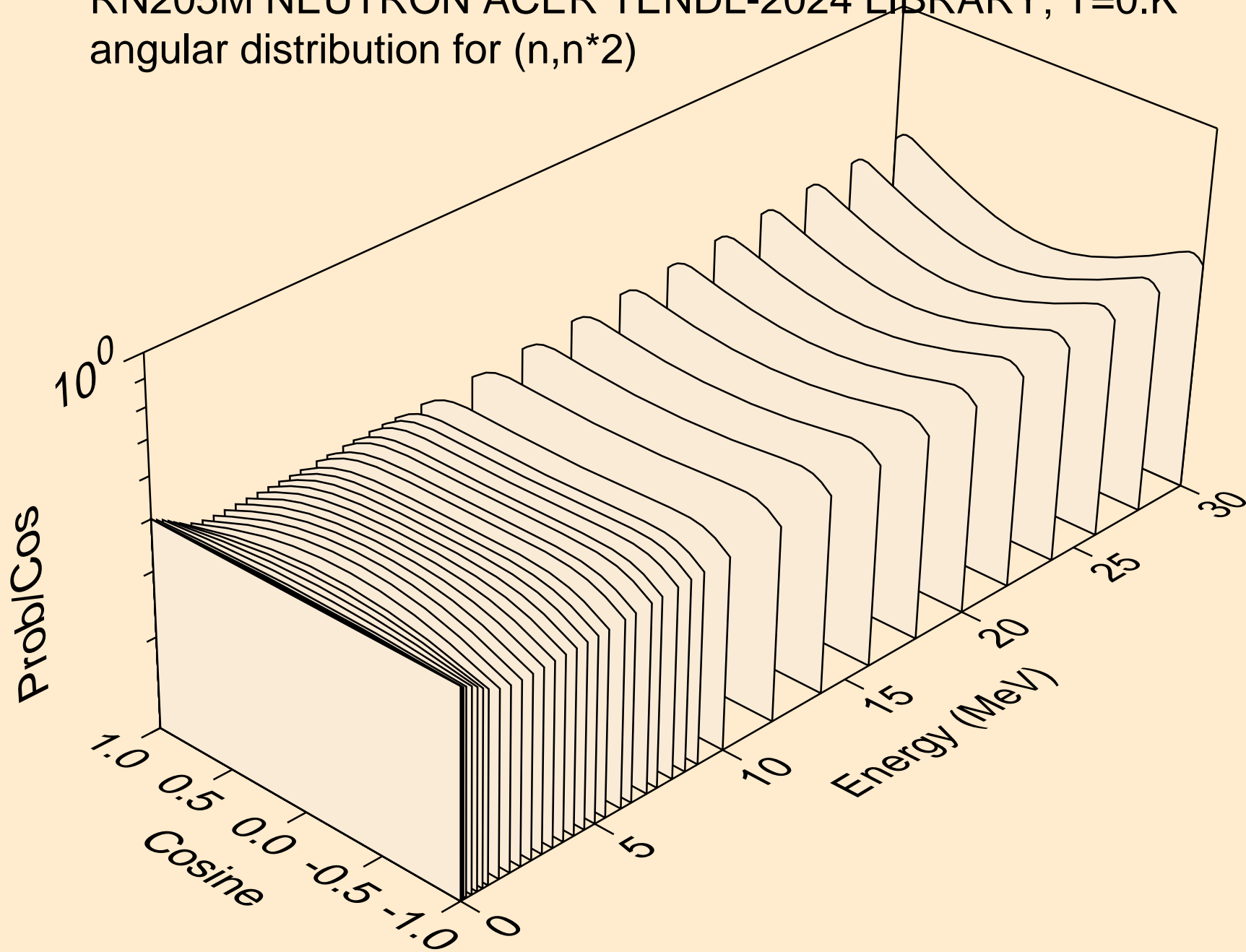

RN205M NEUTRON ACER TENDL-2024 LIBRARY; T=0.K  
angular distribution for (n,n\*3)

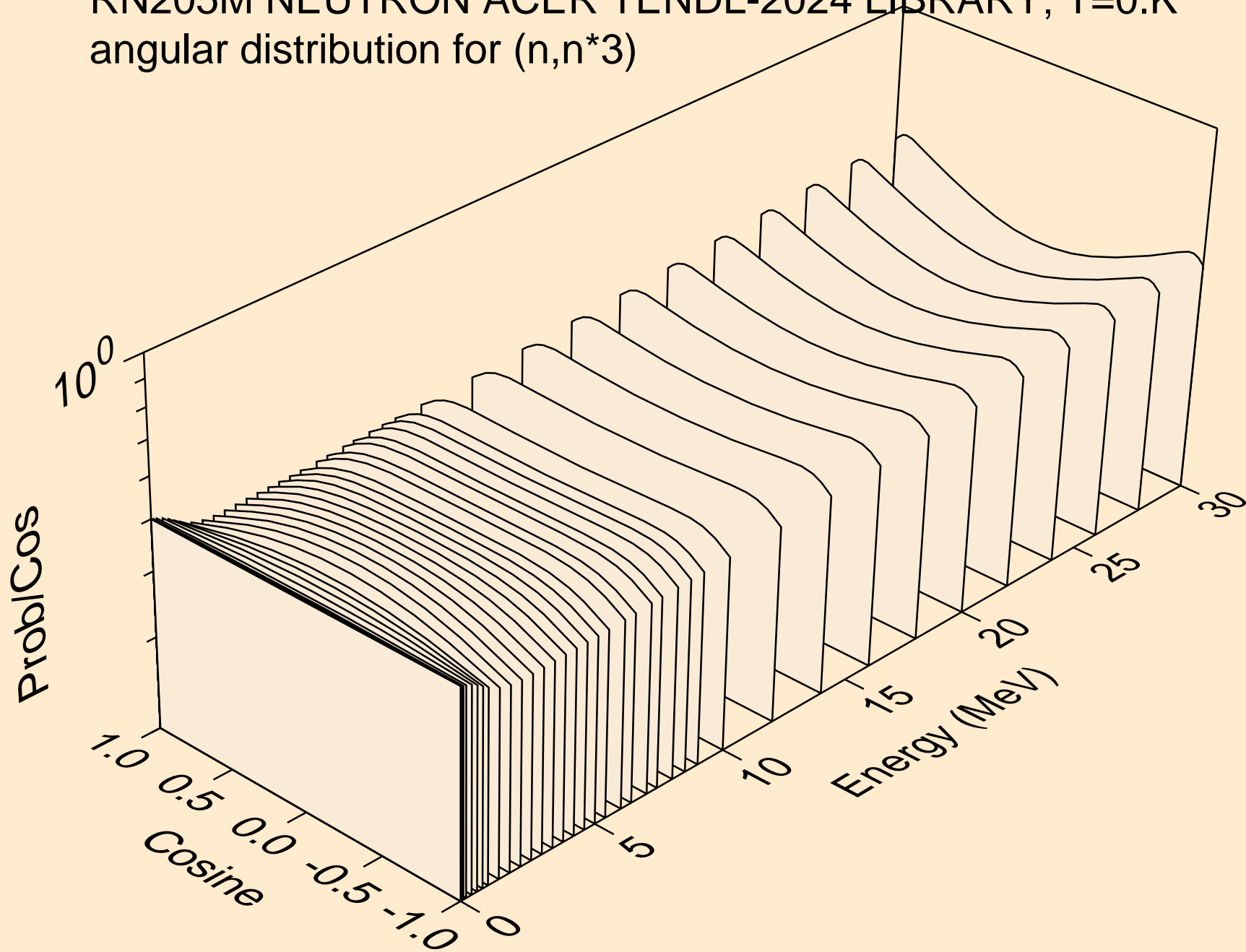

RN205M NEUTRON ACER TENDL-2024 LIBRARY; T=0.K  
angular distribution for (n,n\*4)

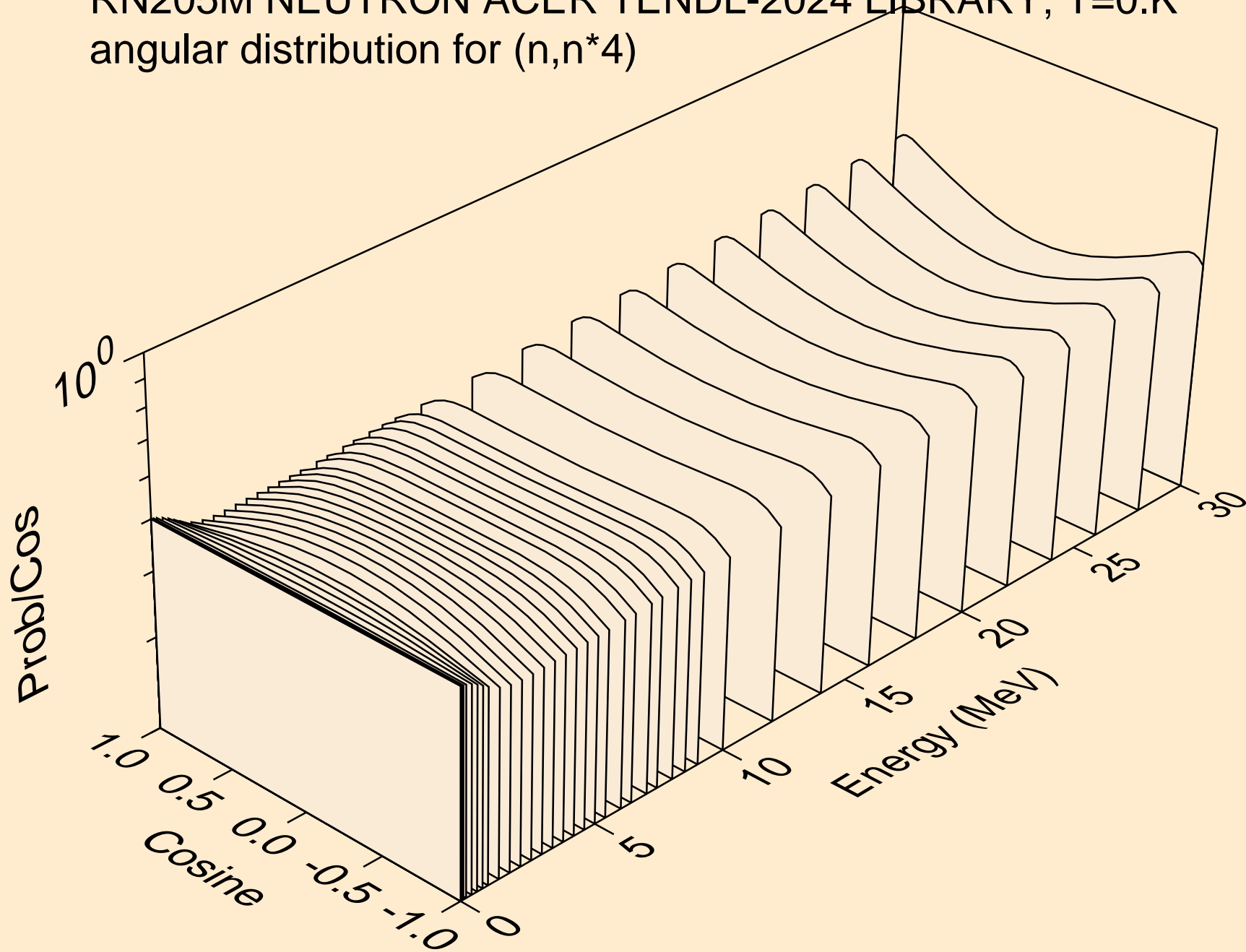

RN205M NEUTRON ACER TENDL-2024 LIBRARY; T=0.K  
angular distribution for (n,n\*5)

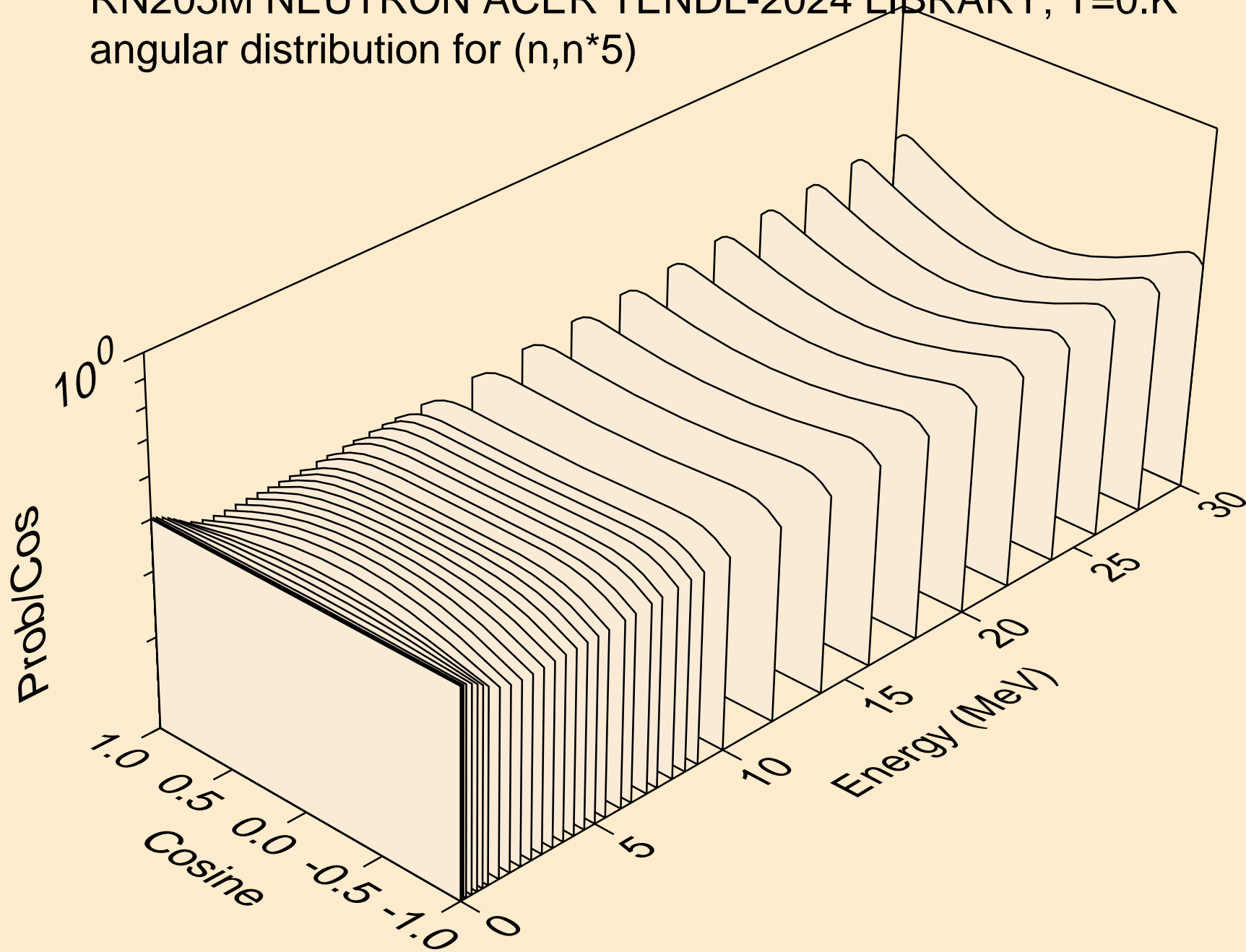

RN205M NEUTRON ACER TENDL-2024 LIBRARY; T=0.K  
angular distribution for (n,n\*6)

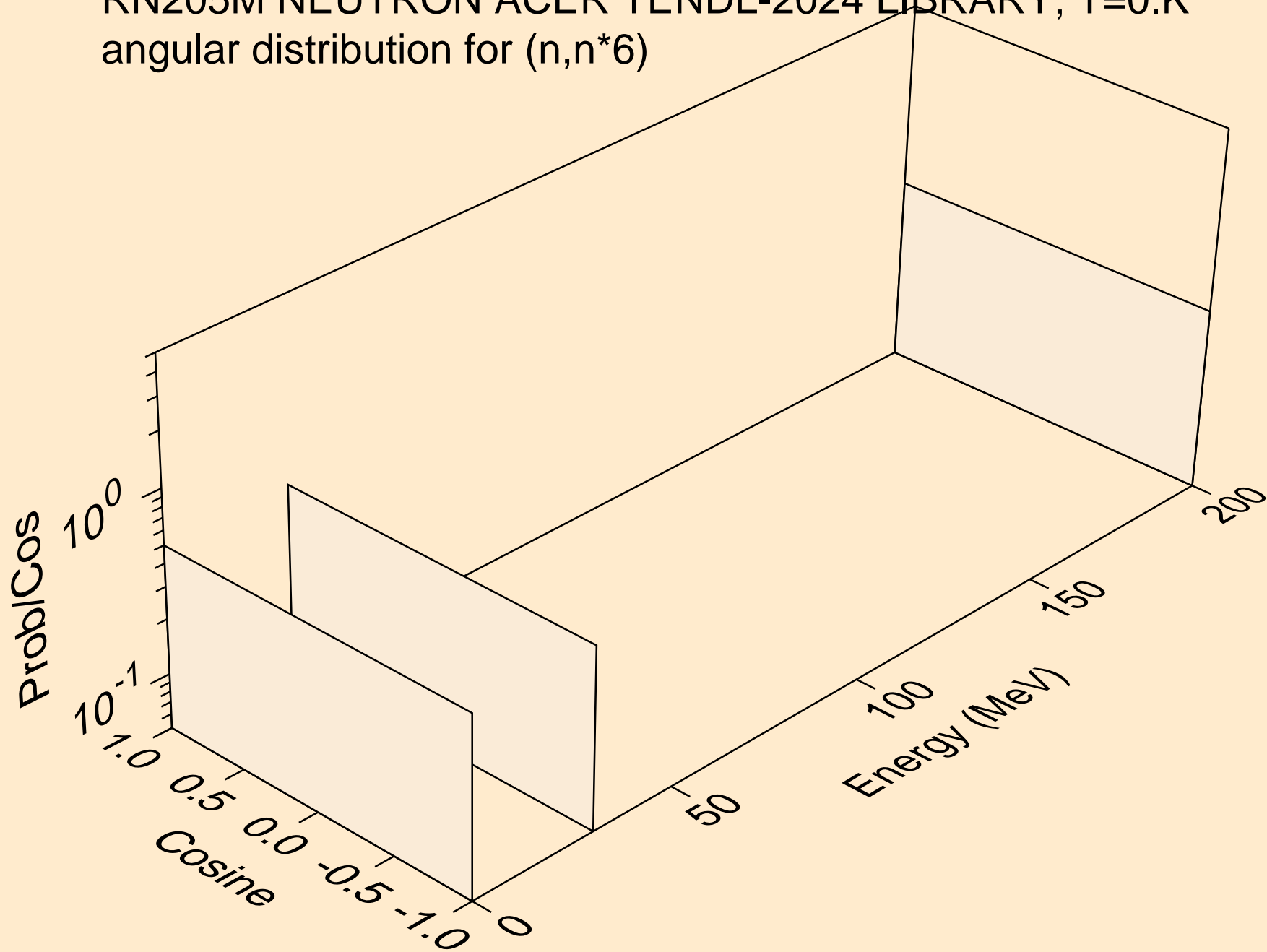

RN205M NEUTRON ACER TENDL-2024 LIBRARY; T=0.K  
angular distribution for (n,n\*7)

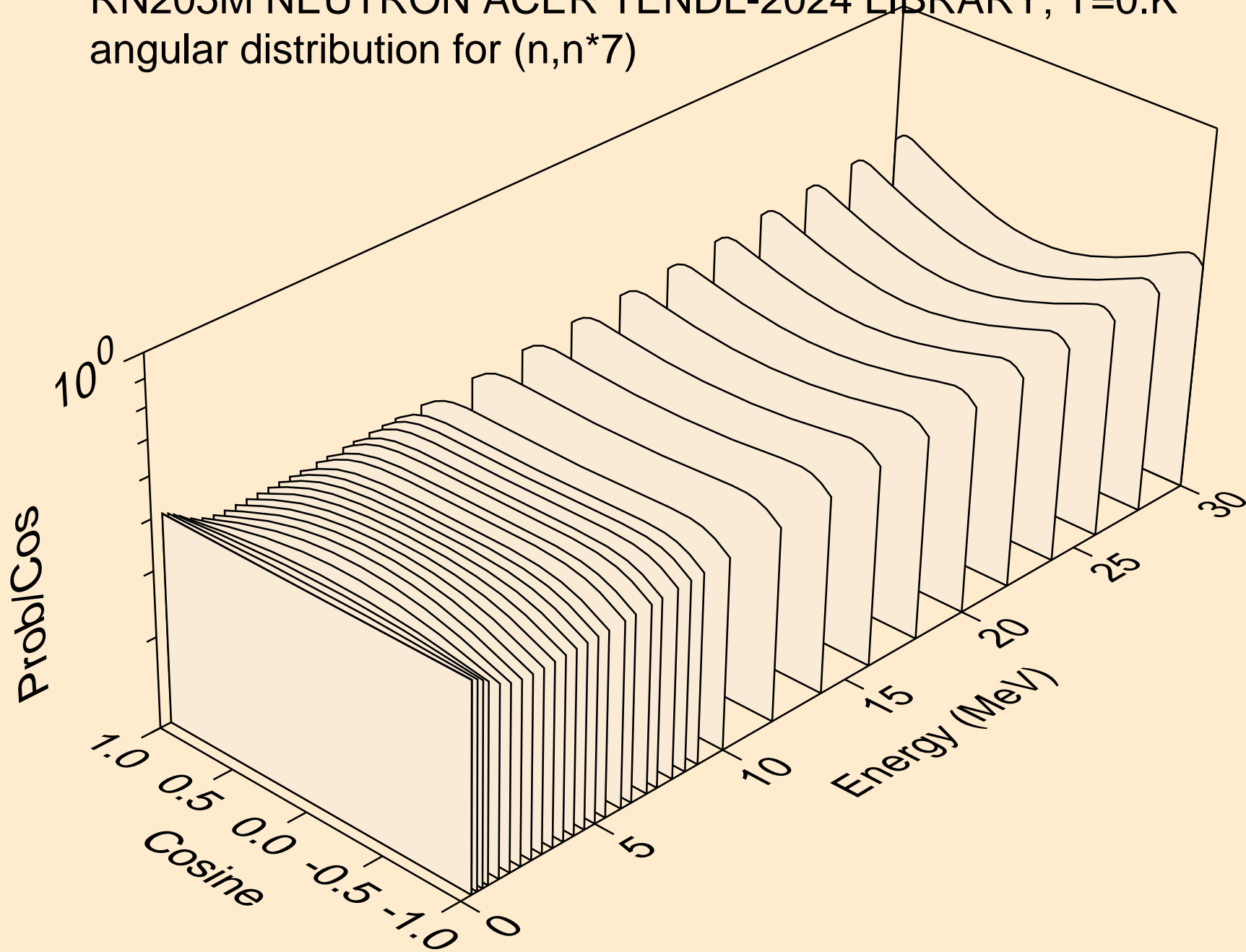

RN205M NEUTRON ACER TENDL-2024 LIBRARY; T=0.K  
angular distribution for (n,n\*8)

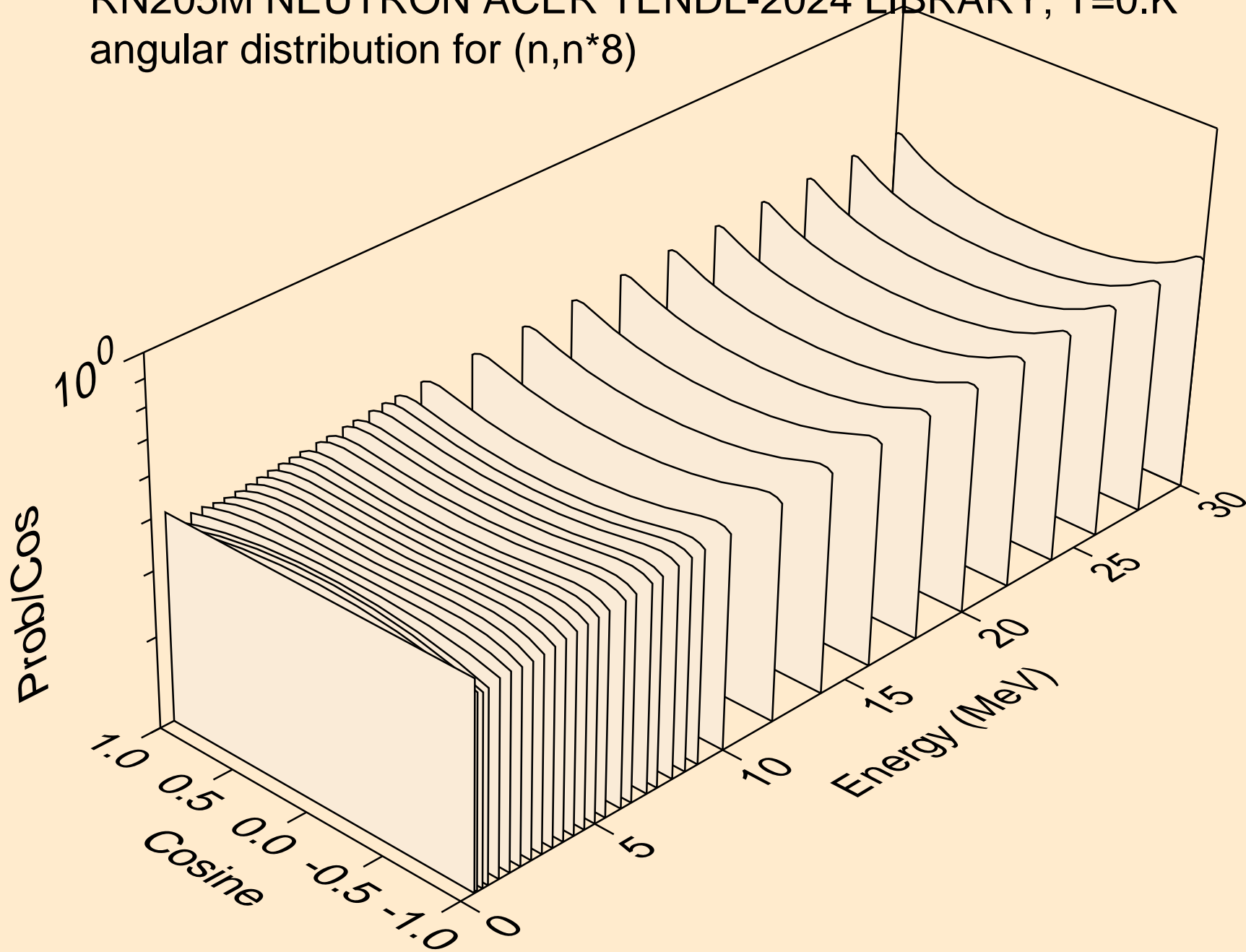

RN205M NEUTRON ACER TENDL-2024 LIBRARY; T=0.K  
Neutron emission for (n,x)

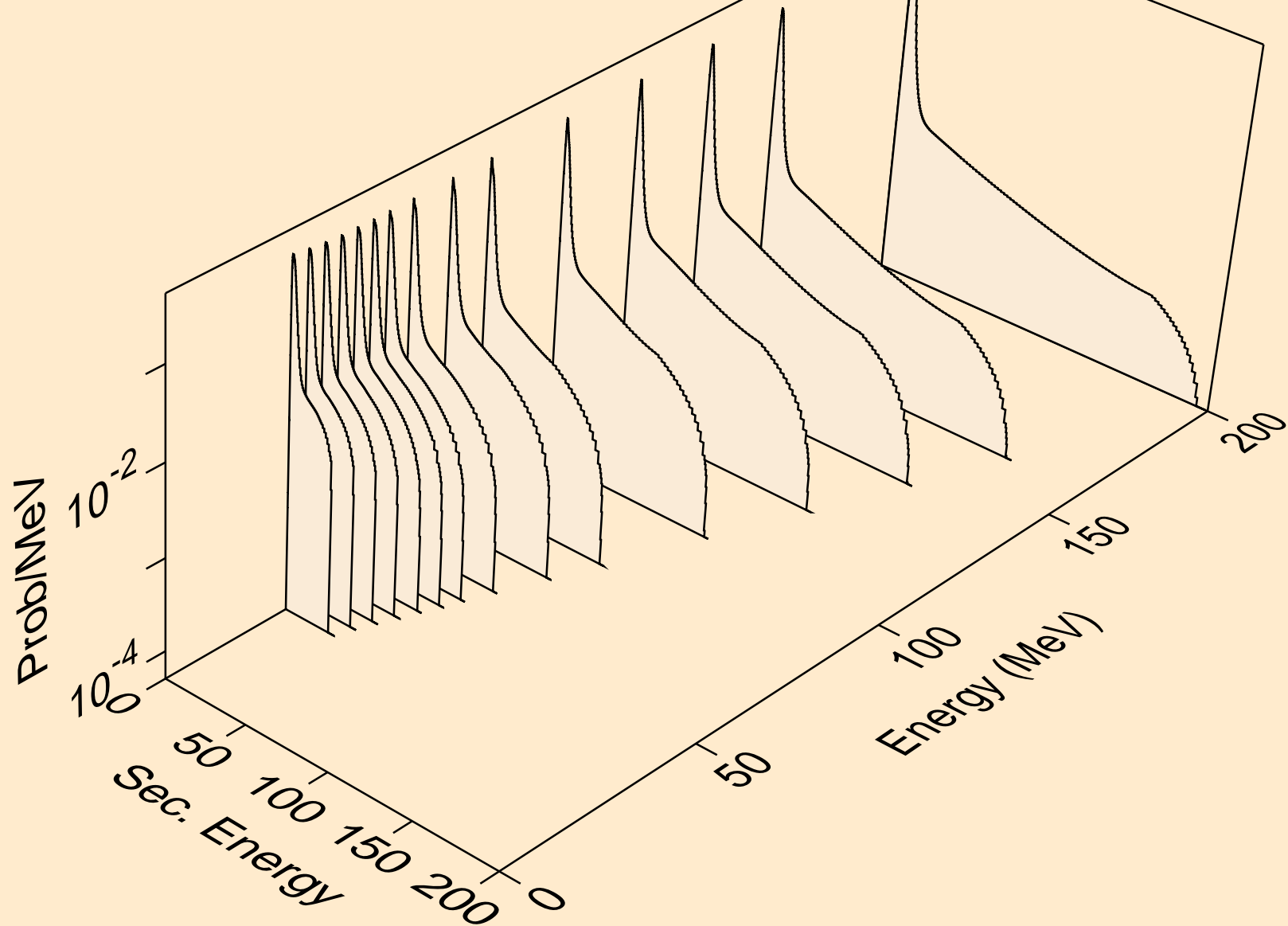

RN205M NEUTRON ACER TENDL-2024 LIBRARY; T=0.K  
Neutron emission for (n,2nd)

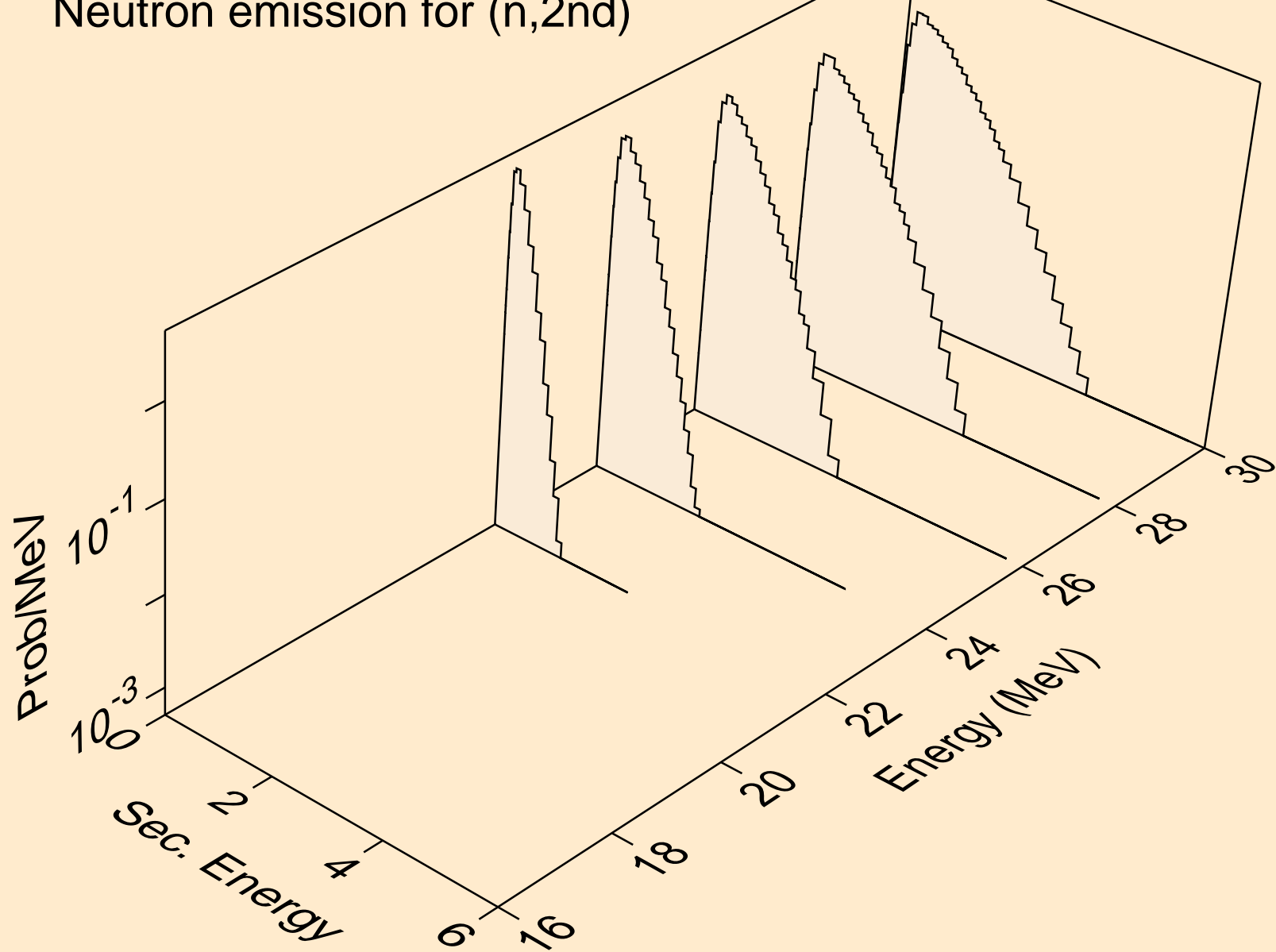

RN205M NEUTRON ACER TENDL-2024 LIBRARY; T=0.K  
Neutron emission for (n,2n)

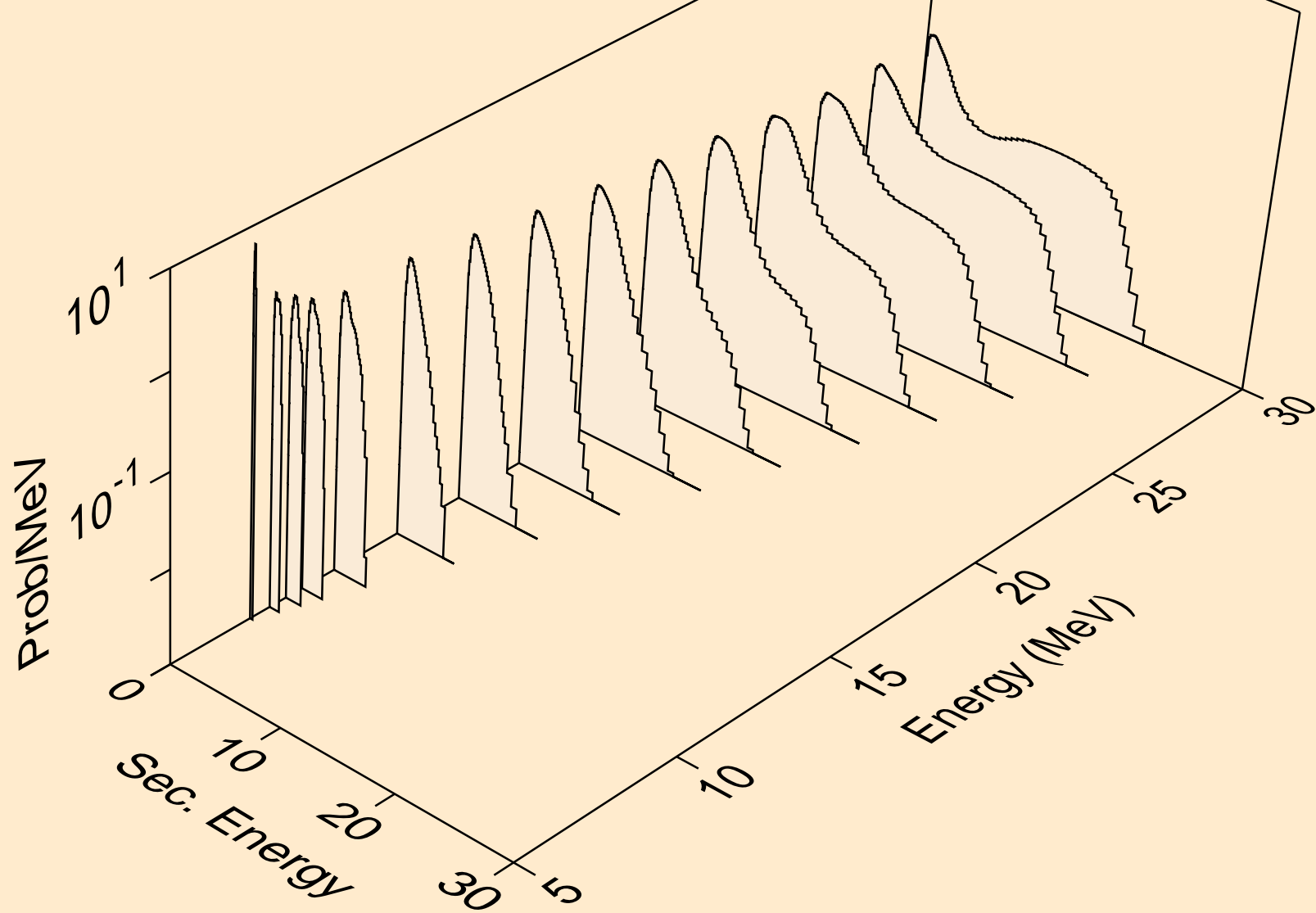

RN205M NEUTRON ACER TENDL-2024 LIBRARY; T=0.K  
Neutron emission for (n,3n)

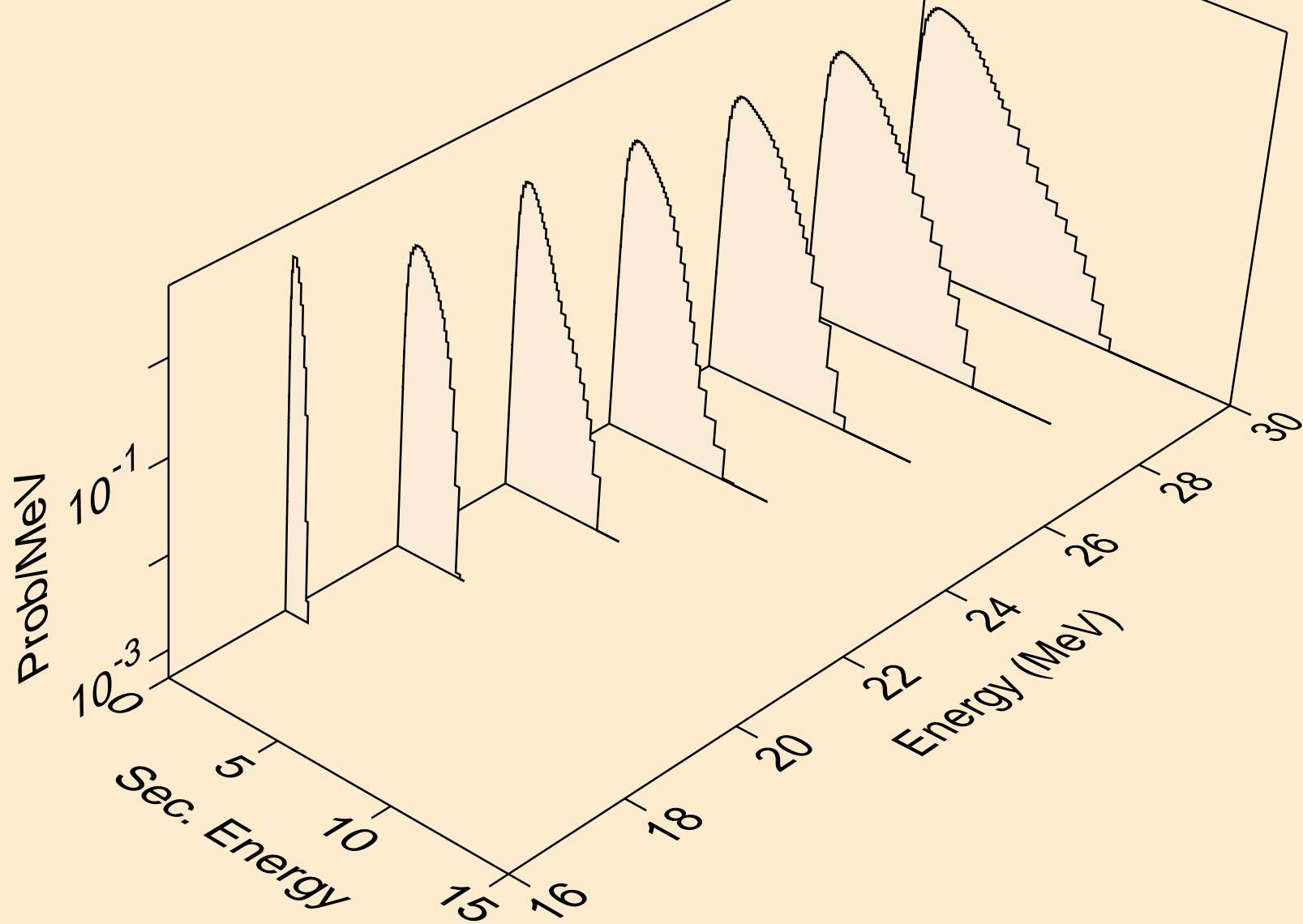

RN205M NEUTRON ACER TENDL-2024 LIBRARY; T=0.K  
Neutron emission for (n,n\*)a

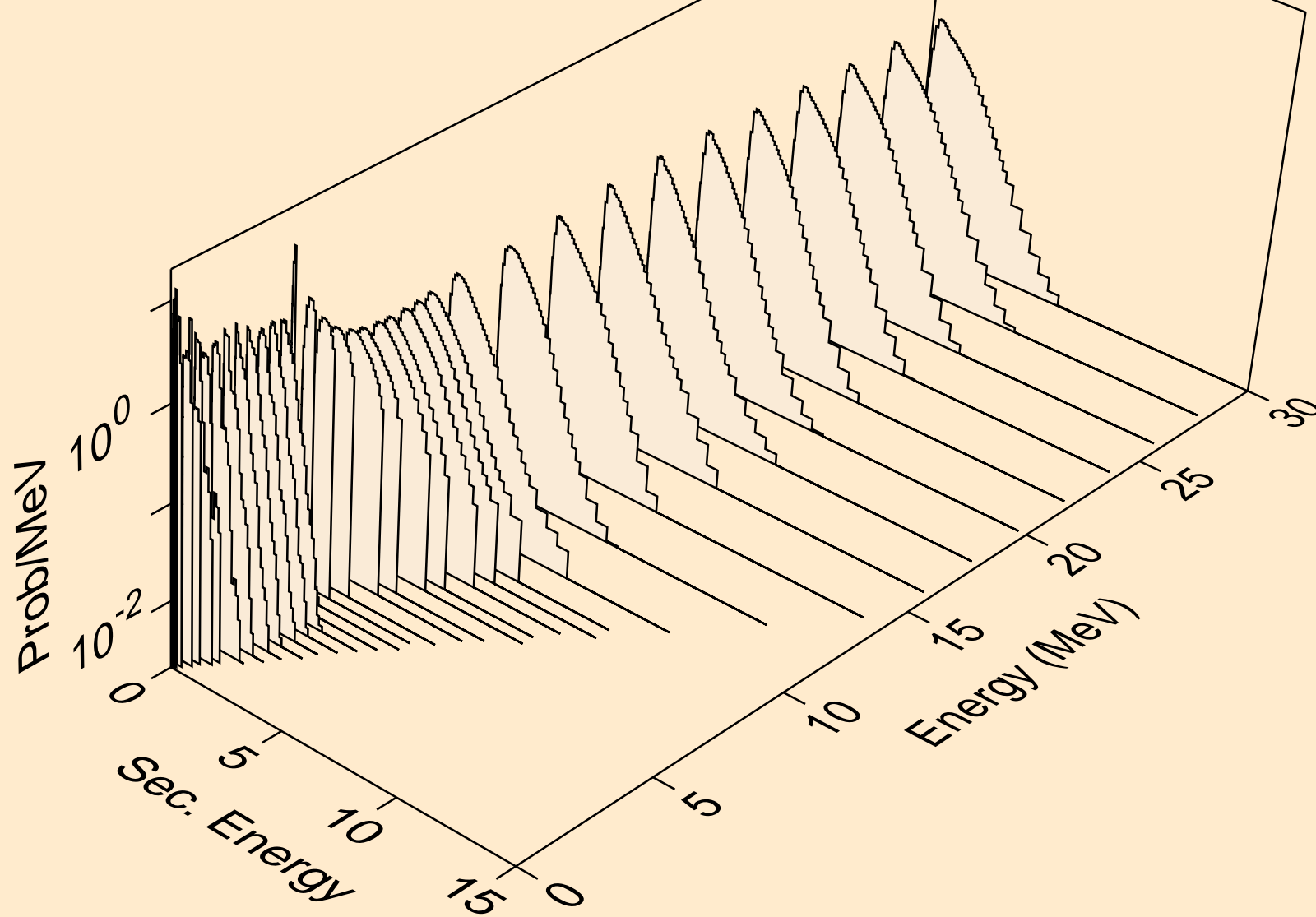

RN205M NEUTRON ACER TENDL-2024 LIBRARY; T=0.K  
Neutron emission for (n,2n)a

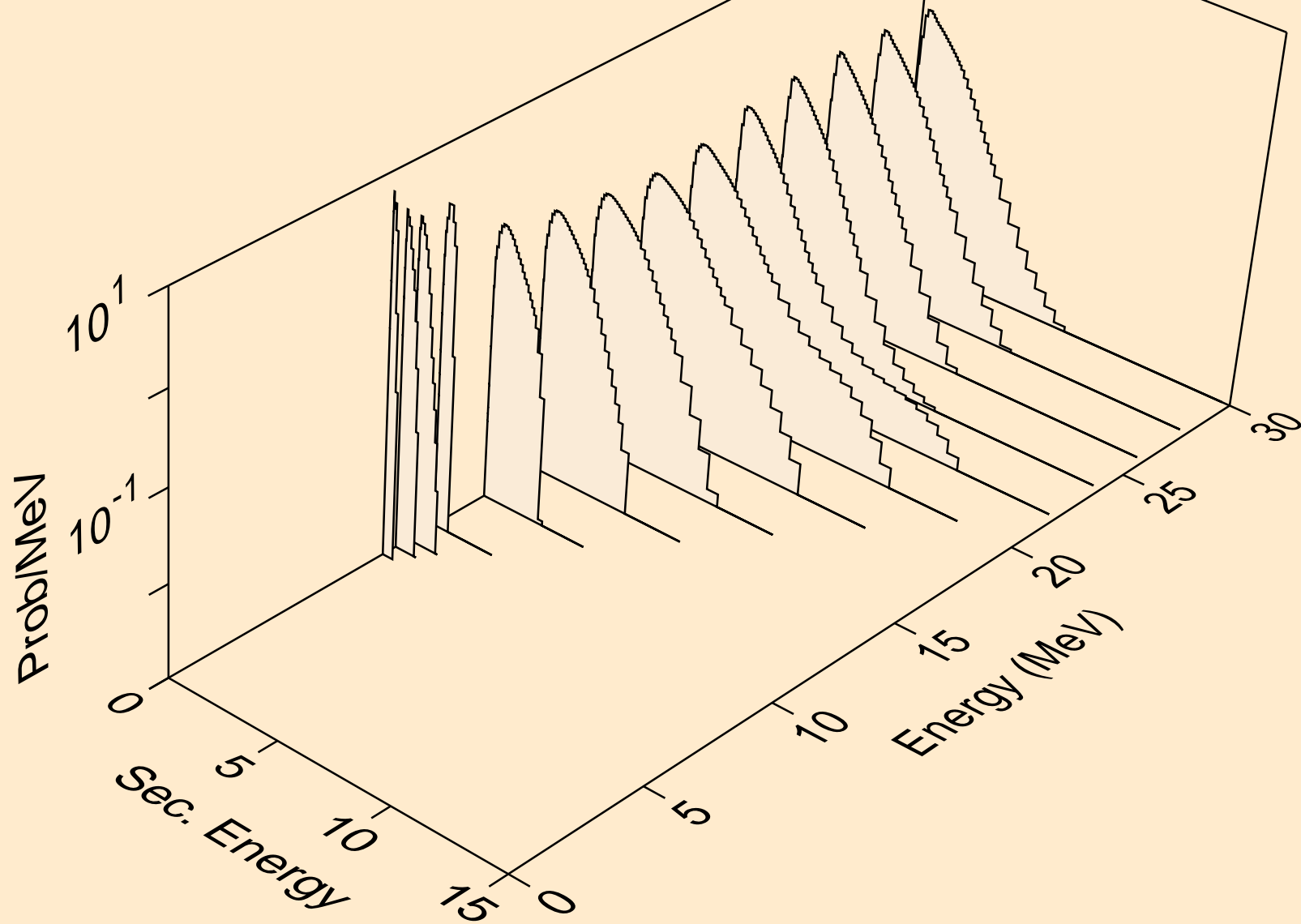

RN205M NEUTRON ACER TENDL-2024 LIBRARY; T=0.K  
Neutron emission for (n,3n)a

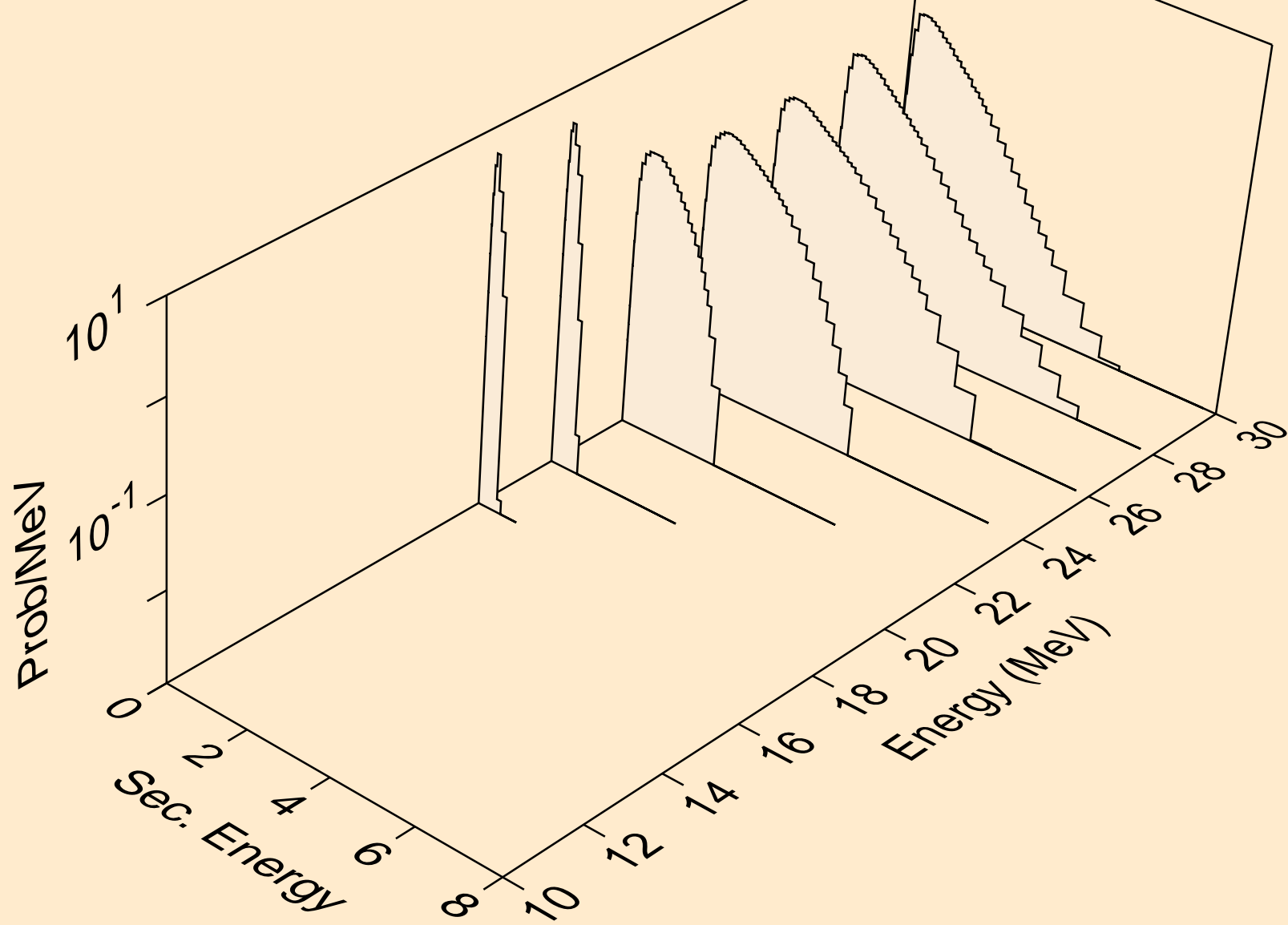

RN205M NEUTRON ACER TENDL-2024 LIBRARY; T=0.K  
Neutron emission for (n,n\*)p

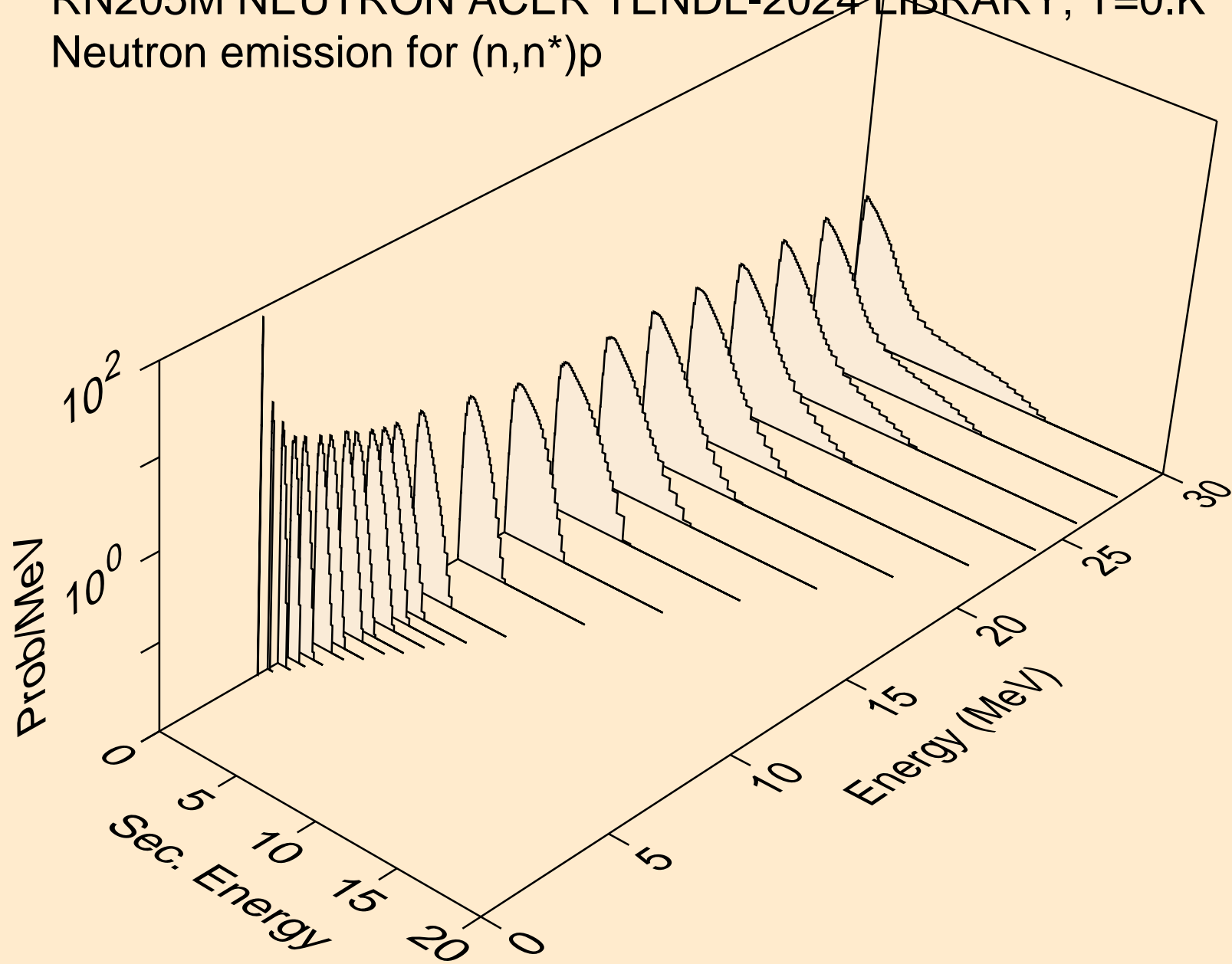

RN205M NEUTRON ACER TENDL-2024 LIBRARY; T=0.K  
Neutron emission for (n,n\*)2a

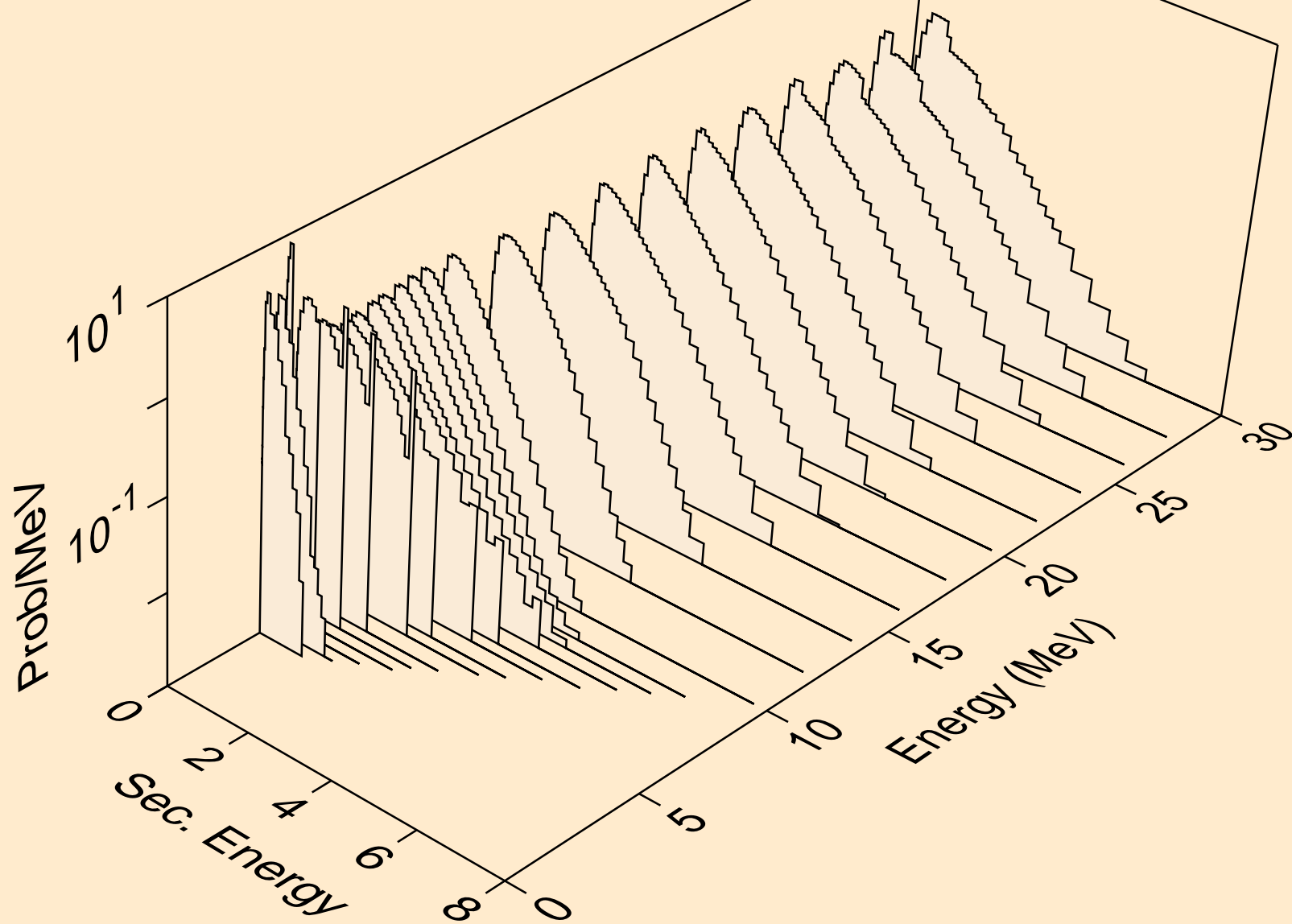

RN205M NEUTRON ACER TENDL-2024 LIBRARY; T=0.K  
Neutron emission for (n,2n)2a

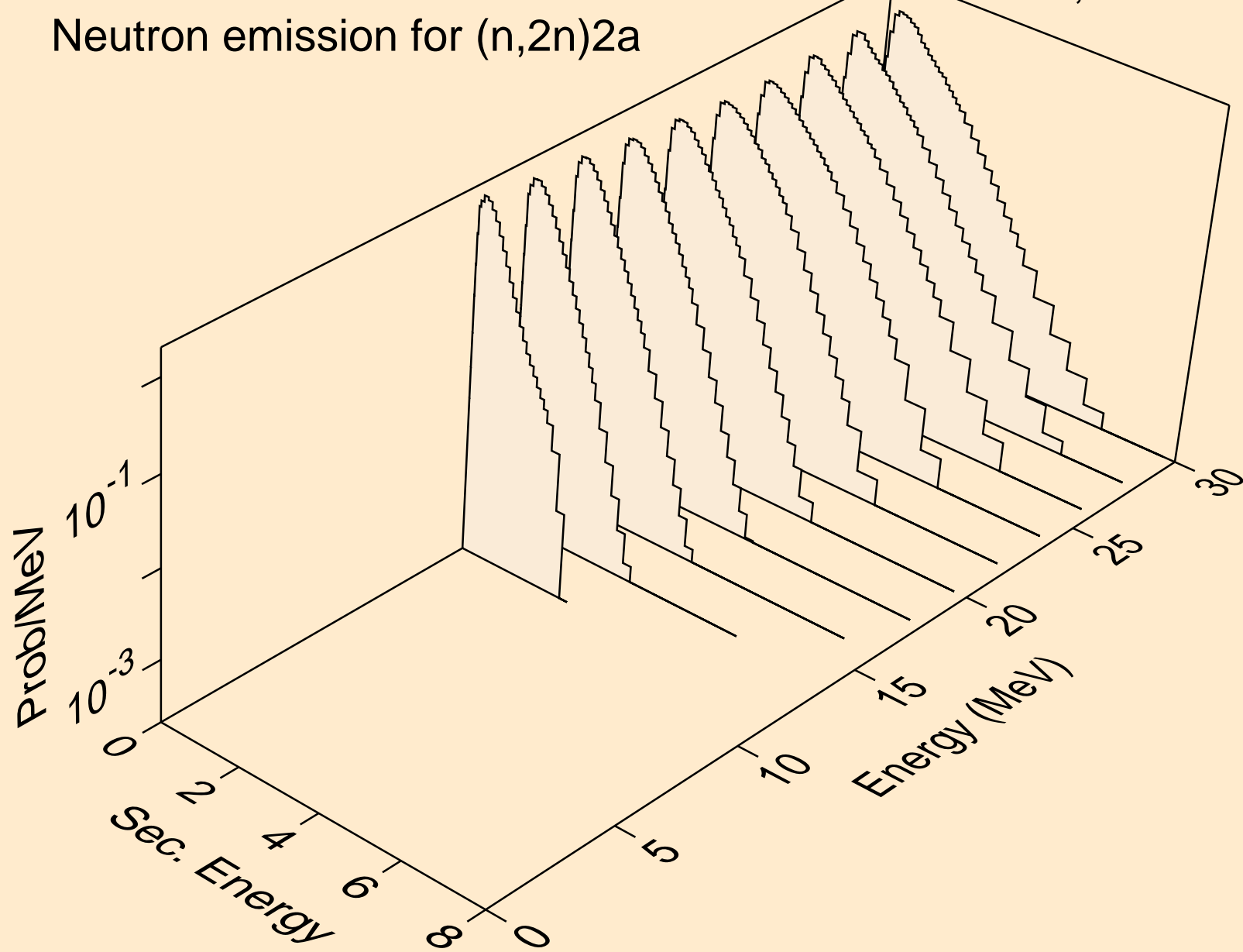

RN205M NEUTRON ACER TENDL-2024 LIBRARY; T=0.K  
Neutron emission for (n,n\*)d

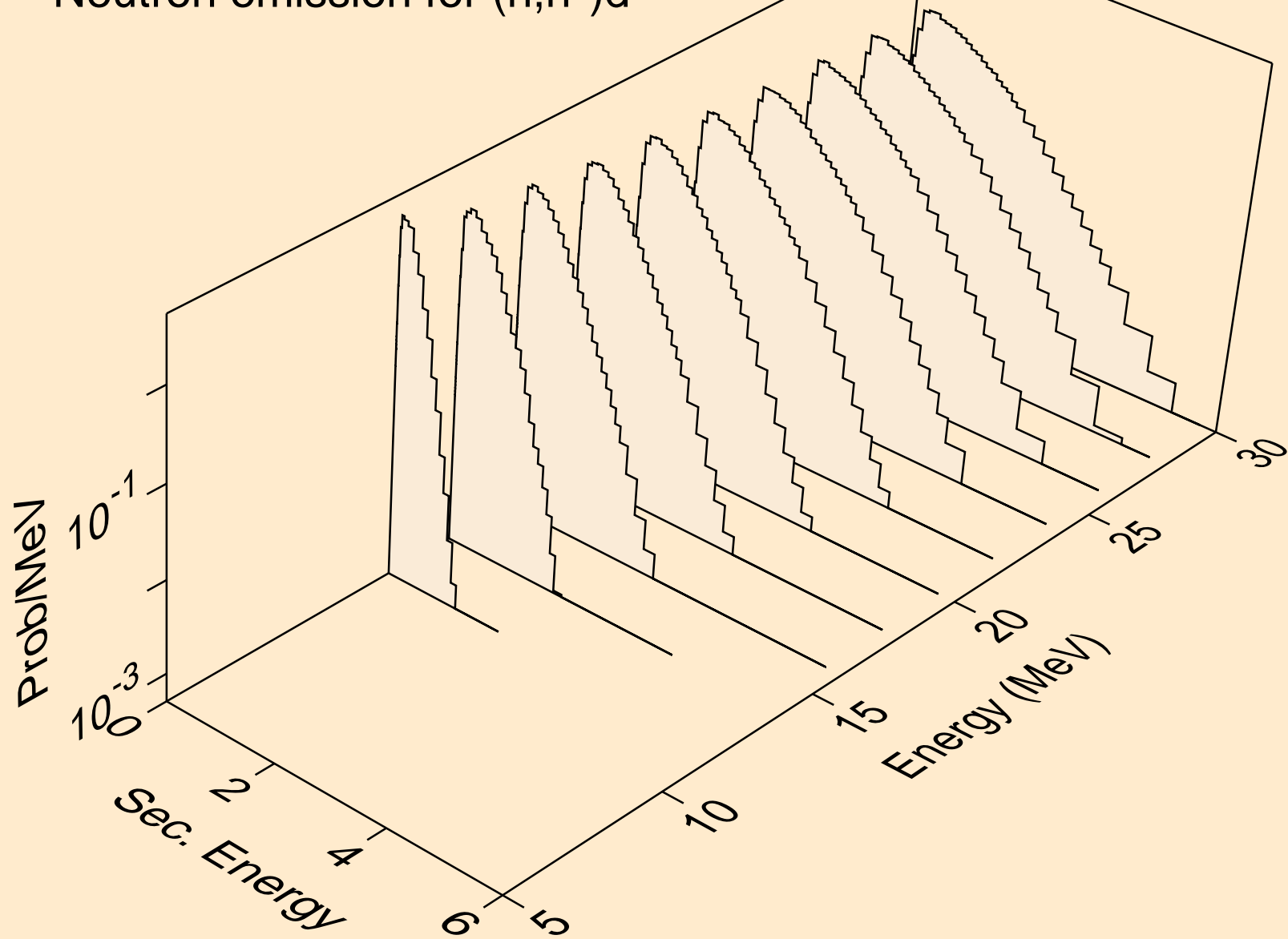

RN205M NEUTRON ACER TENDL-2024 LIBRARY; T=0.K  
Neutron emission for (n,n\*)t

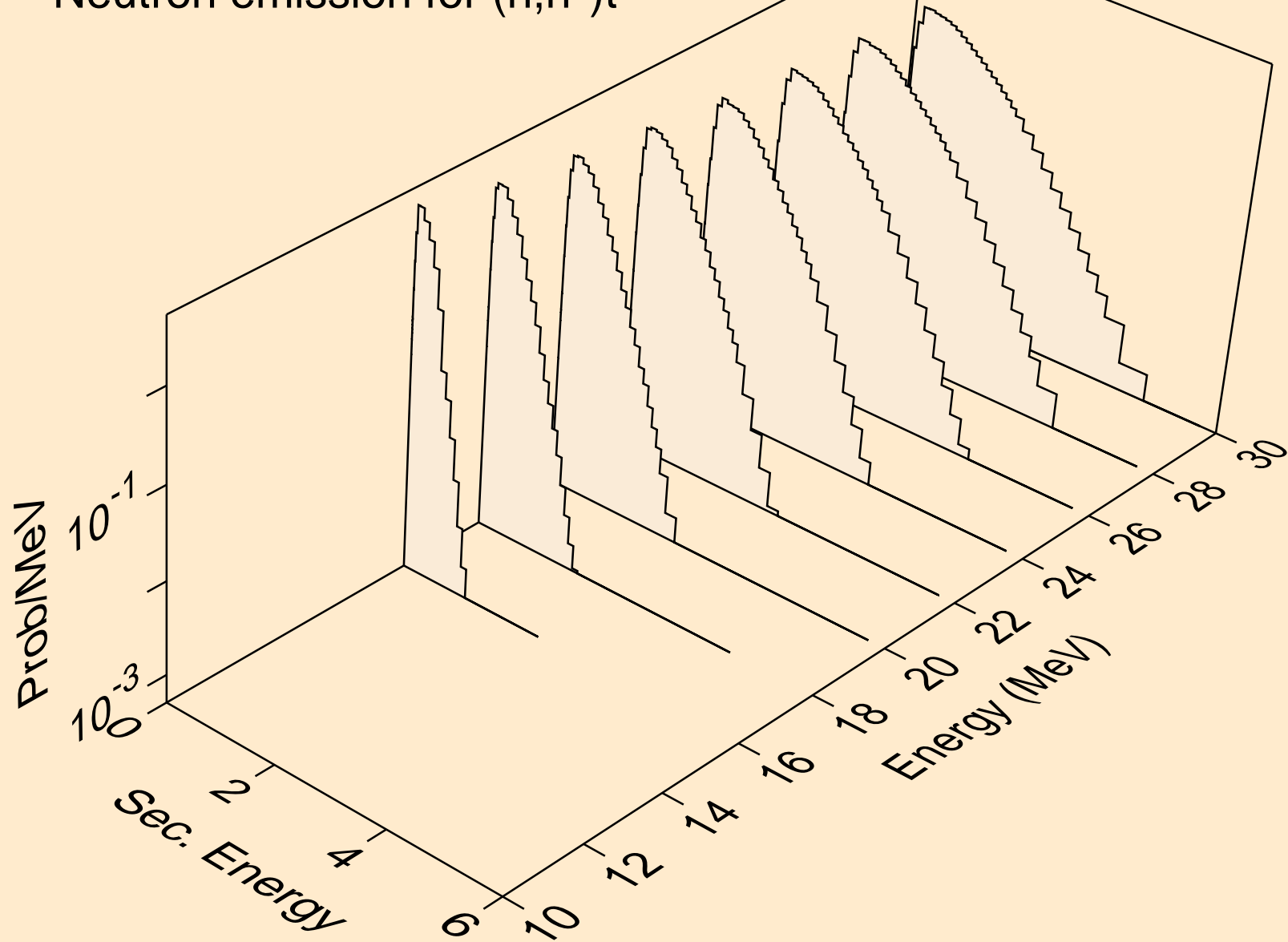

RN205M NEUTRON ACER TENDL-2024 LIBRARY; T=0.K  
Neutron emission for (n,n\*)he3

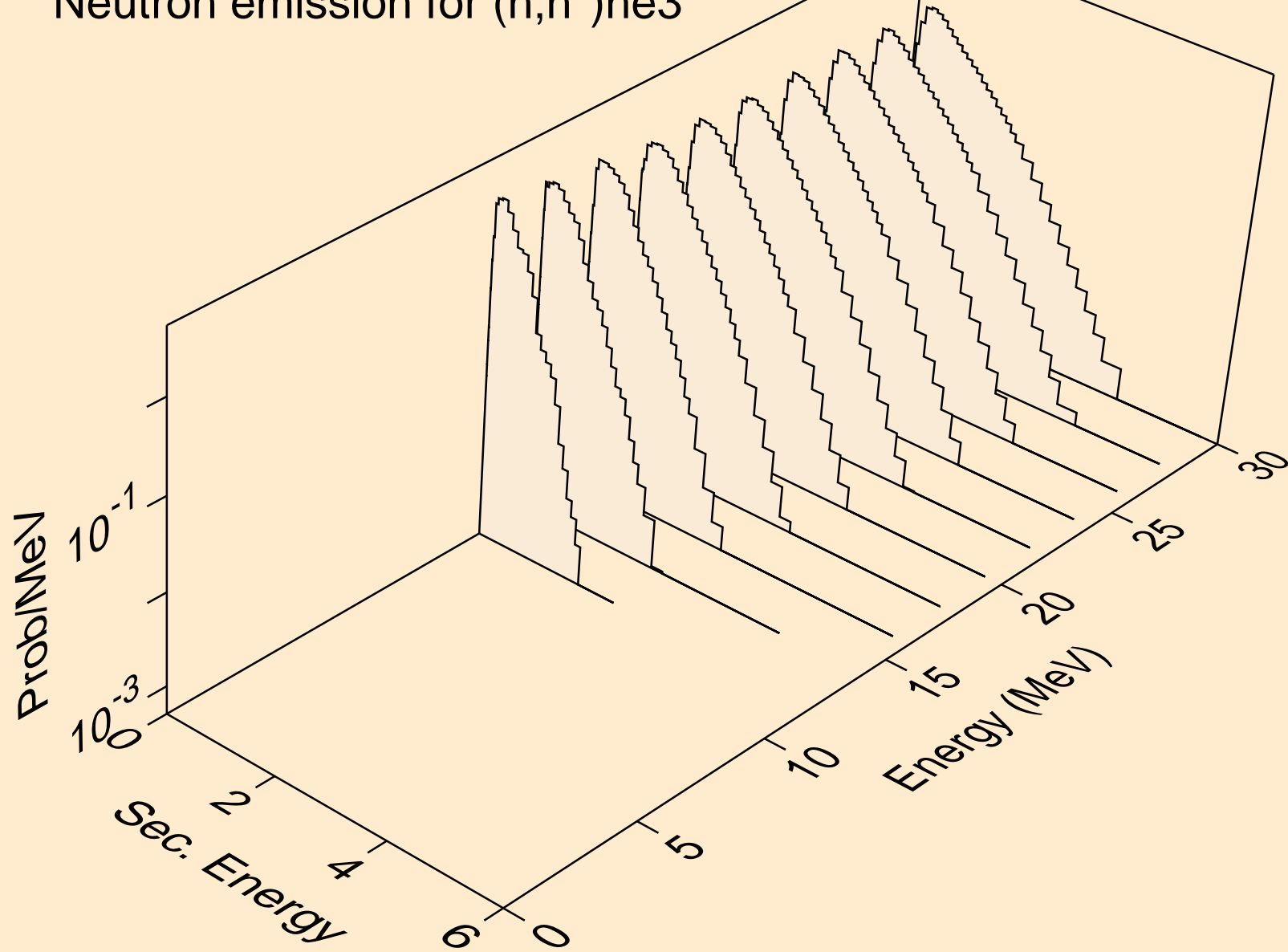

RN205M NEUTRON ACER TENDL-2024 LIBRARY; T=0.K  
Neutron emission for (n,4n)

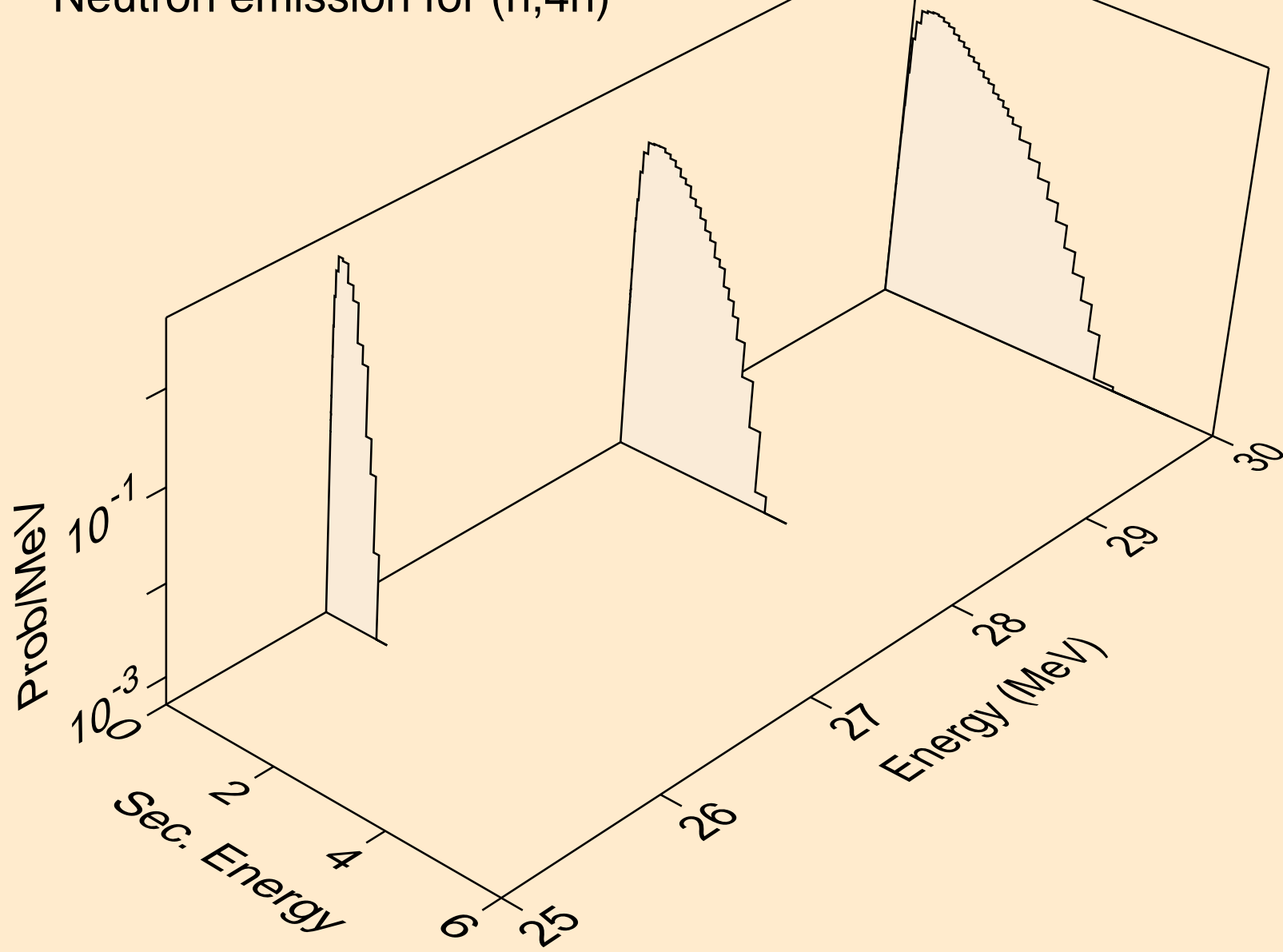

RN205M NEUTRON ACER TENDL-2024 LIBRARY; T=0.K  
Neutron emission for (n,2np)

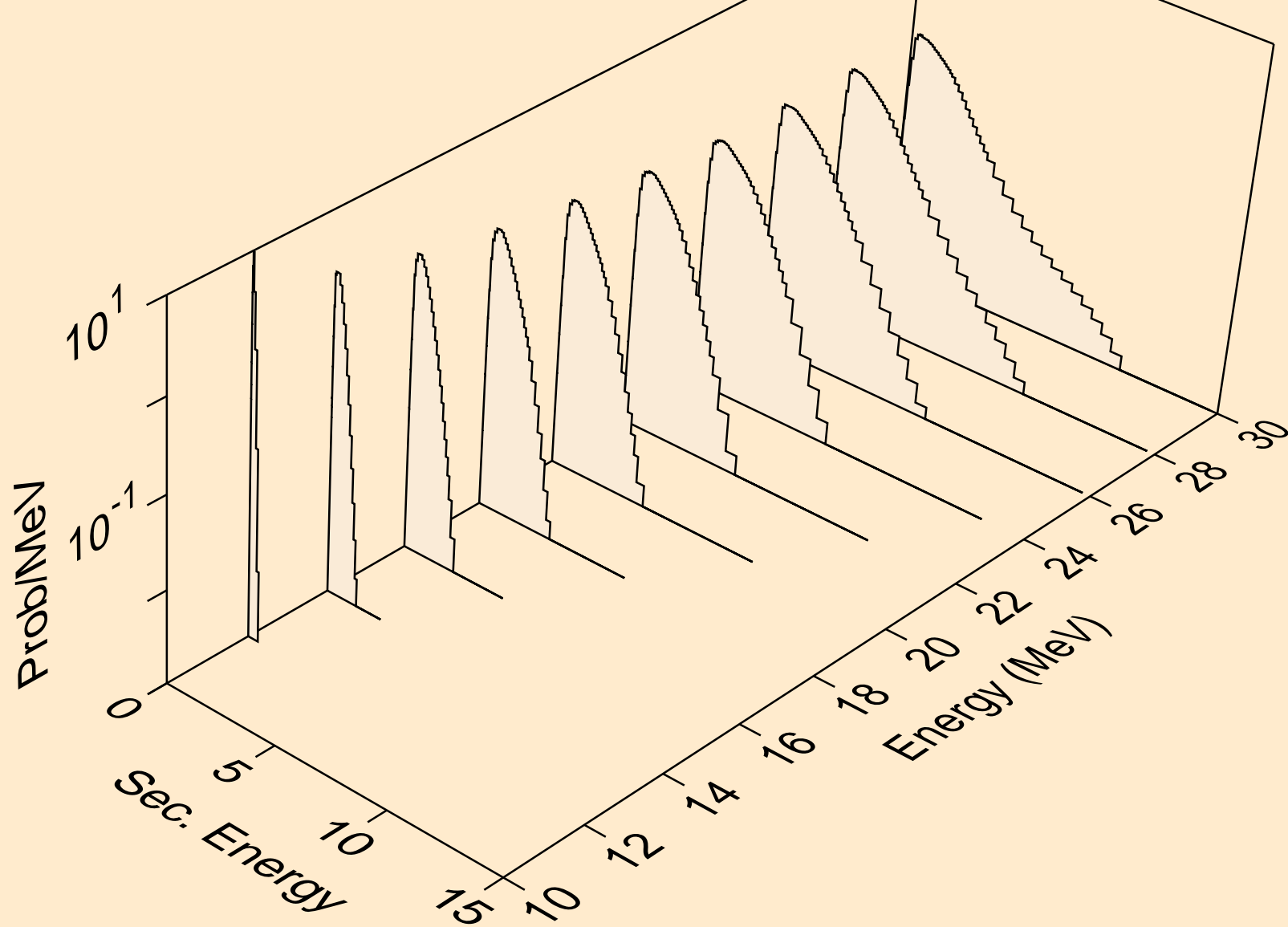

RN205M NEUTRON ACER TENDL-2024 LIBRARY; T=0.K  
Neutron emission for (n,3np)

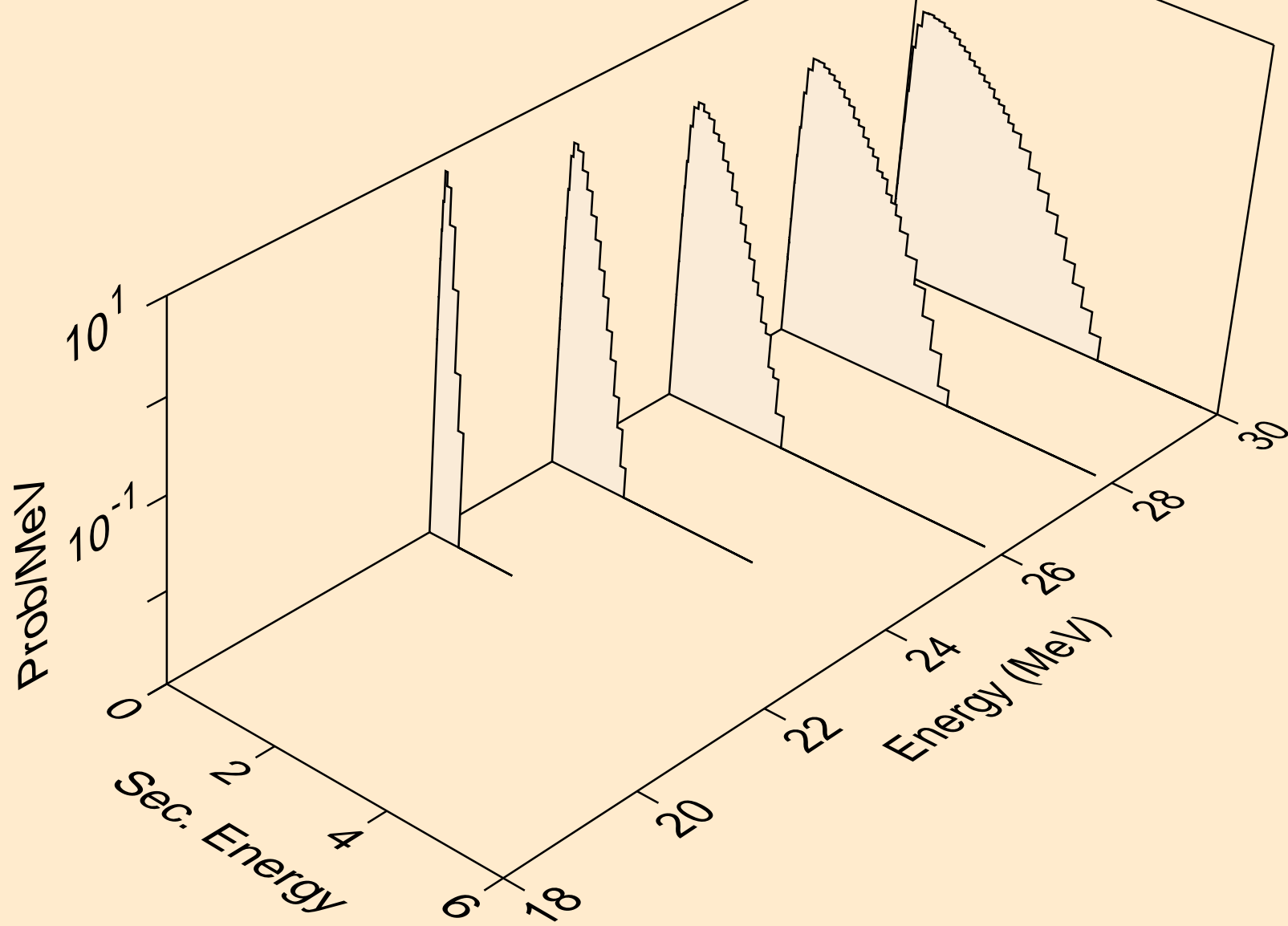

RN205M NEUTRON ACER TENDL-2024 LIBRARY; T=0.K  
Neutron emission for (n,n2p)

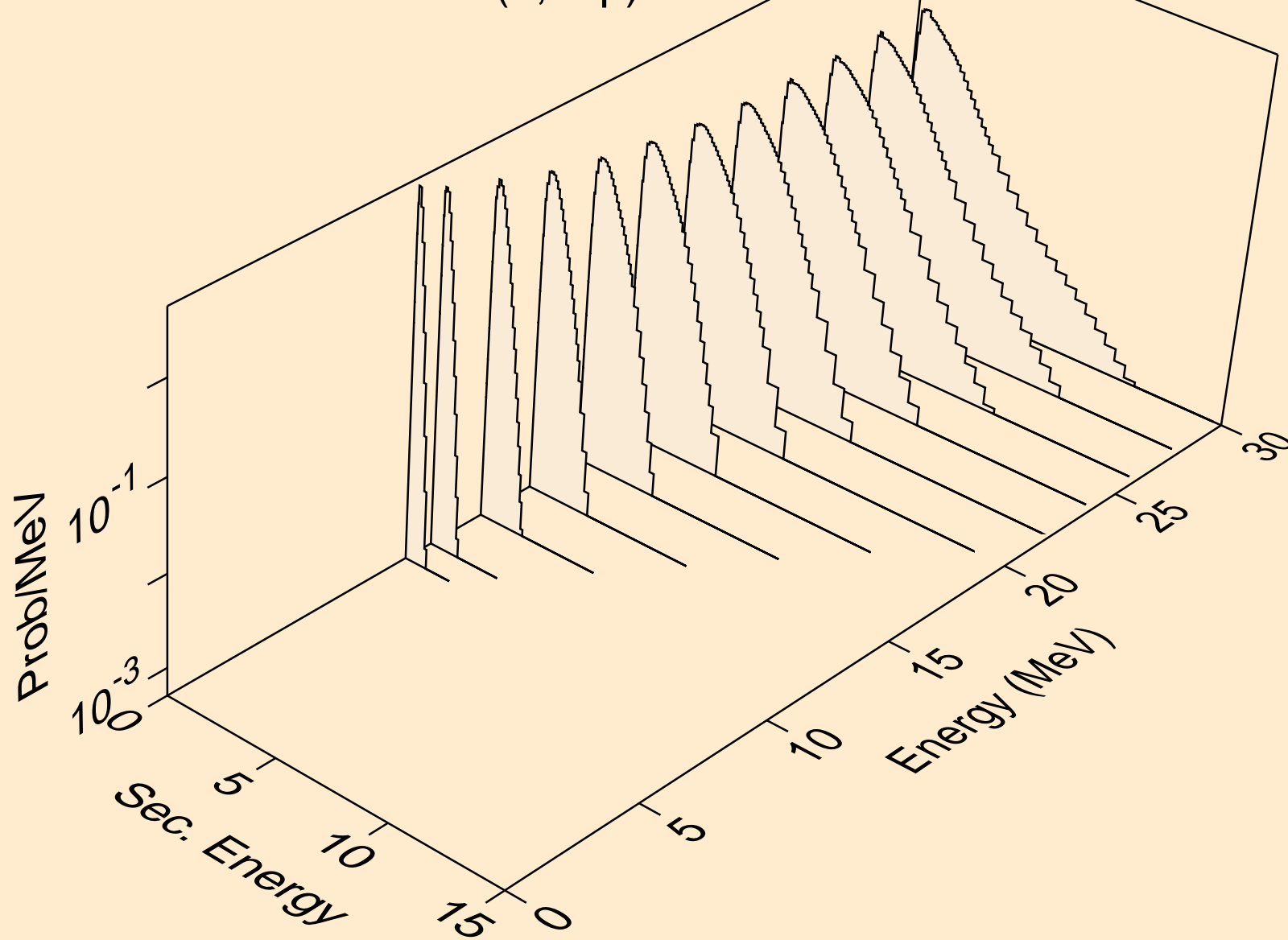

RN205M NEUTRON ACER TENDL-2024 LIBRARY; T=0.K  
Neutron emission for (n,npa)

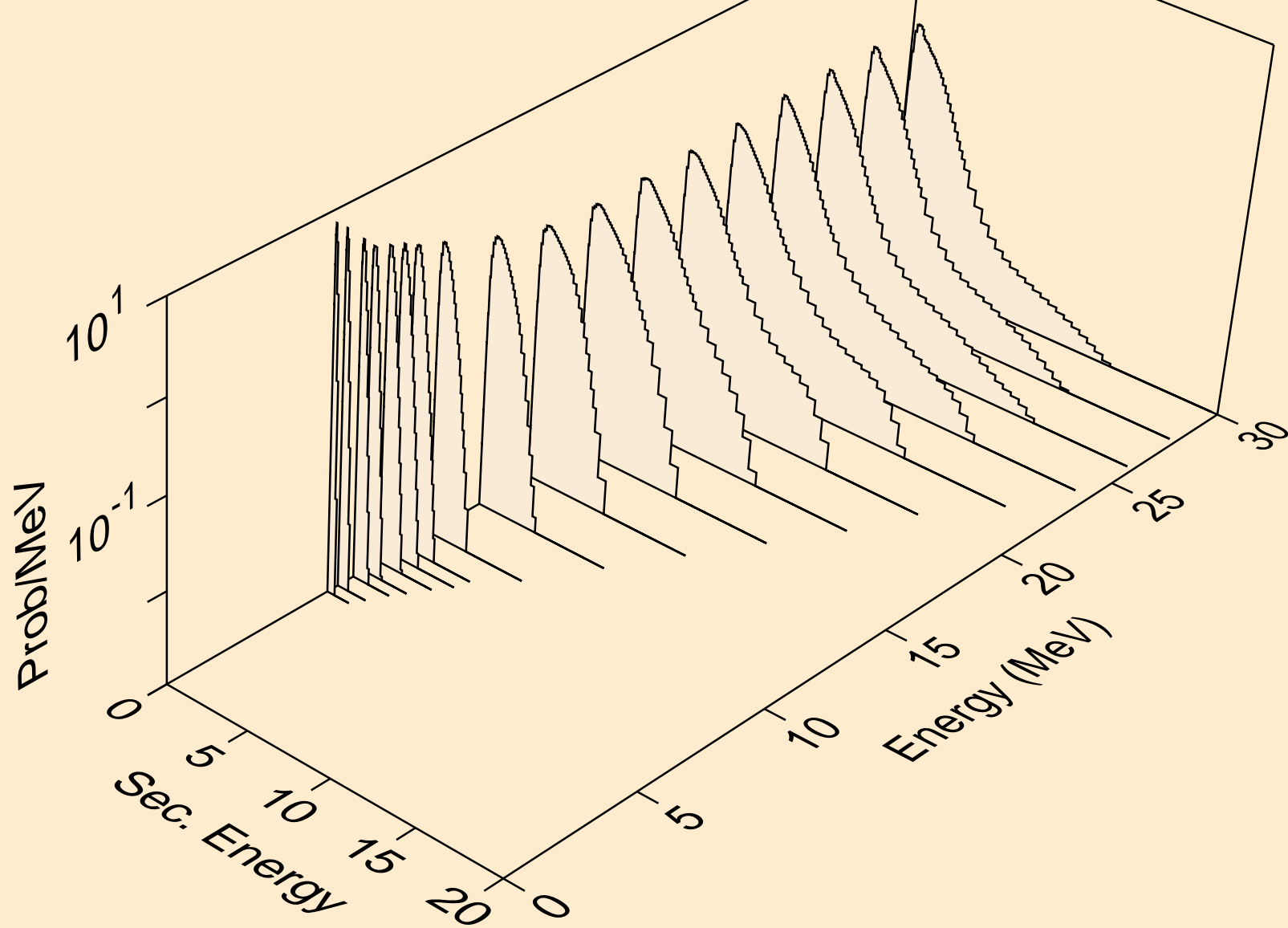

RN205M NEUTRON ACER TENDL-2024 LIBRARY; T=0.K  
Neutron emission for (n,n\*c)

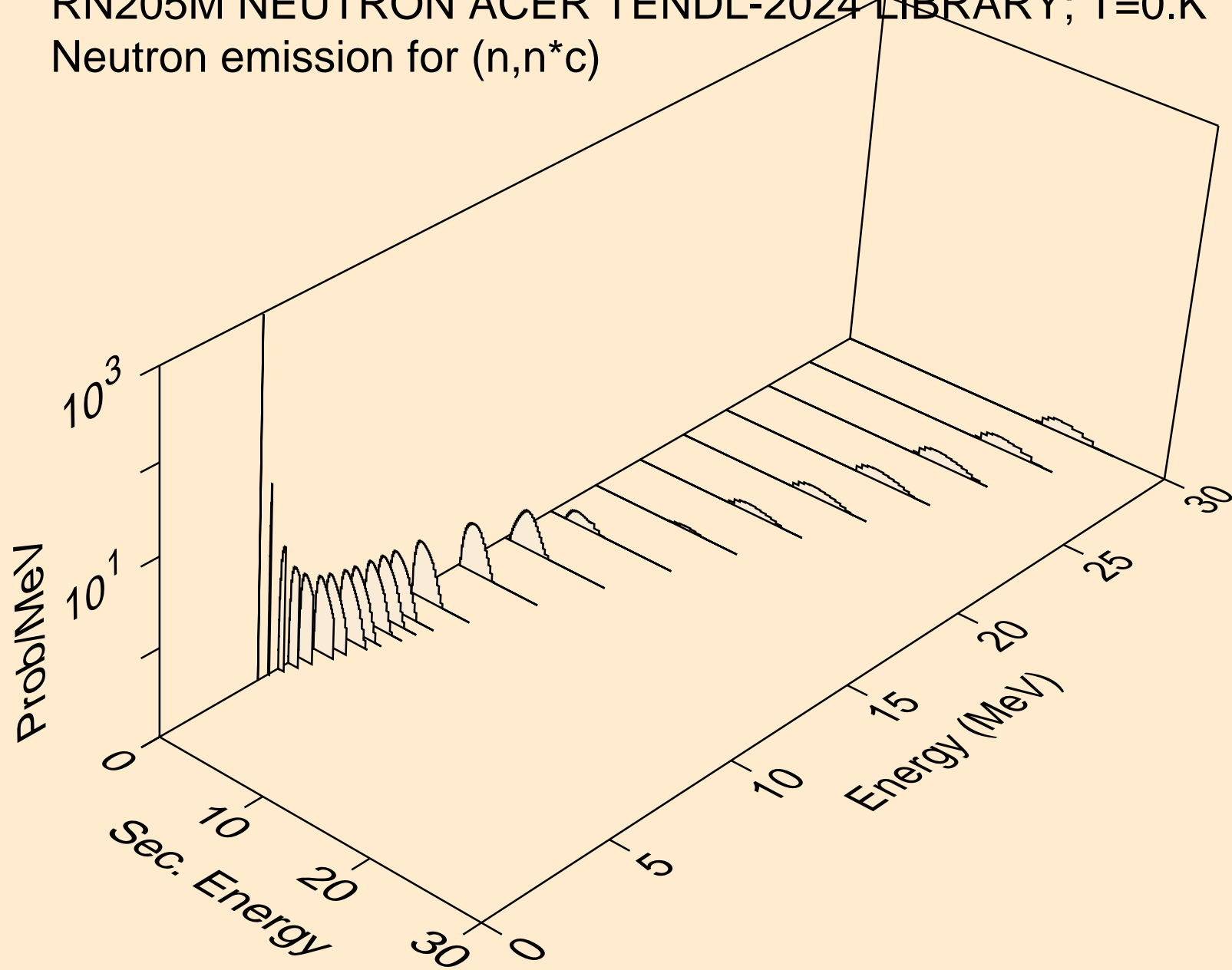

RN205M NEUTRON ACER TENDL-2024 LIBRARY; T=0.K  
Photon emission for (n,x)

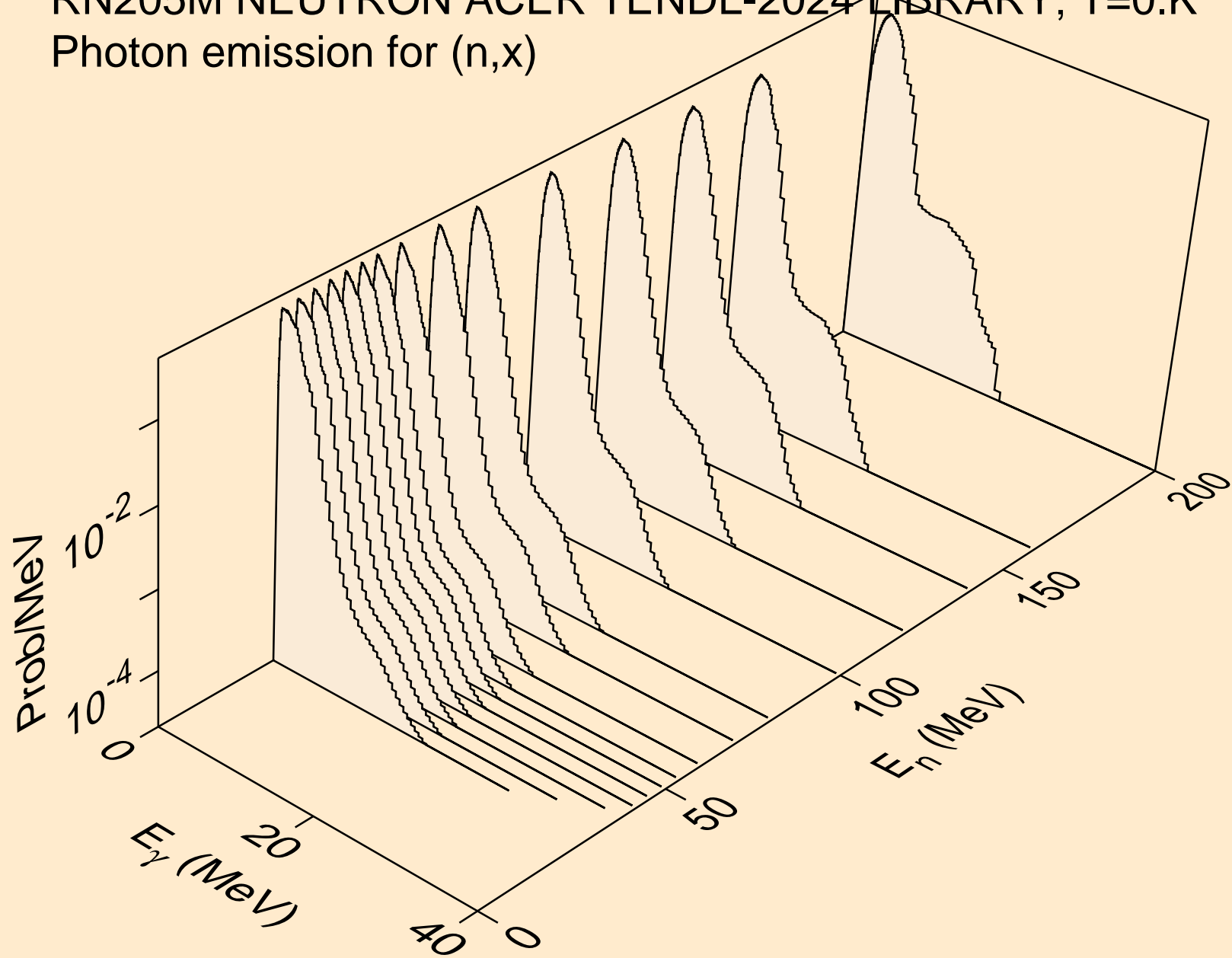

RN205M NEUTRON ACER TENDL-2024 LIBRARY; T=0.K  
Photon emission for (n,2nd)

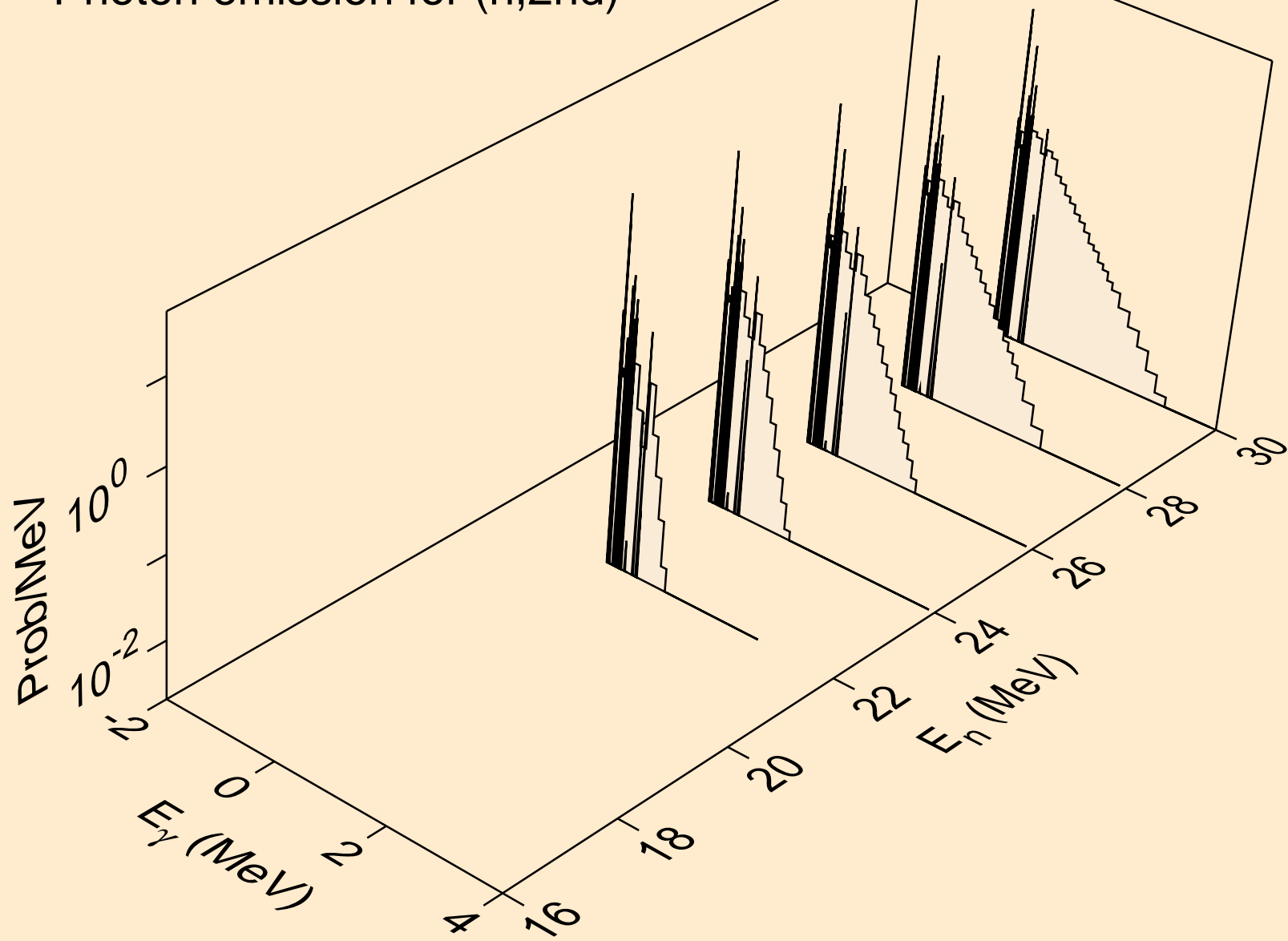

RN205M NEUTRON ACER TENDL-2024 LIBRARY; T=0.K  
Photon emission for (n,2n)

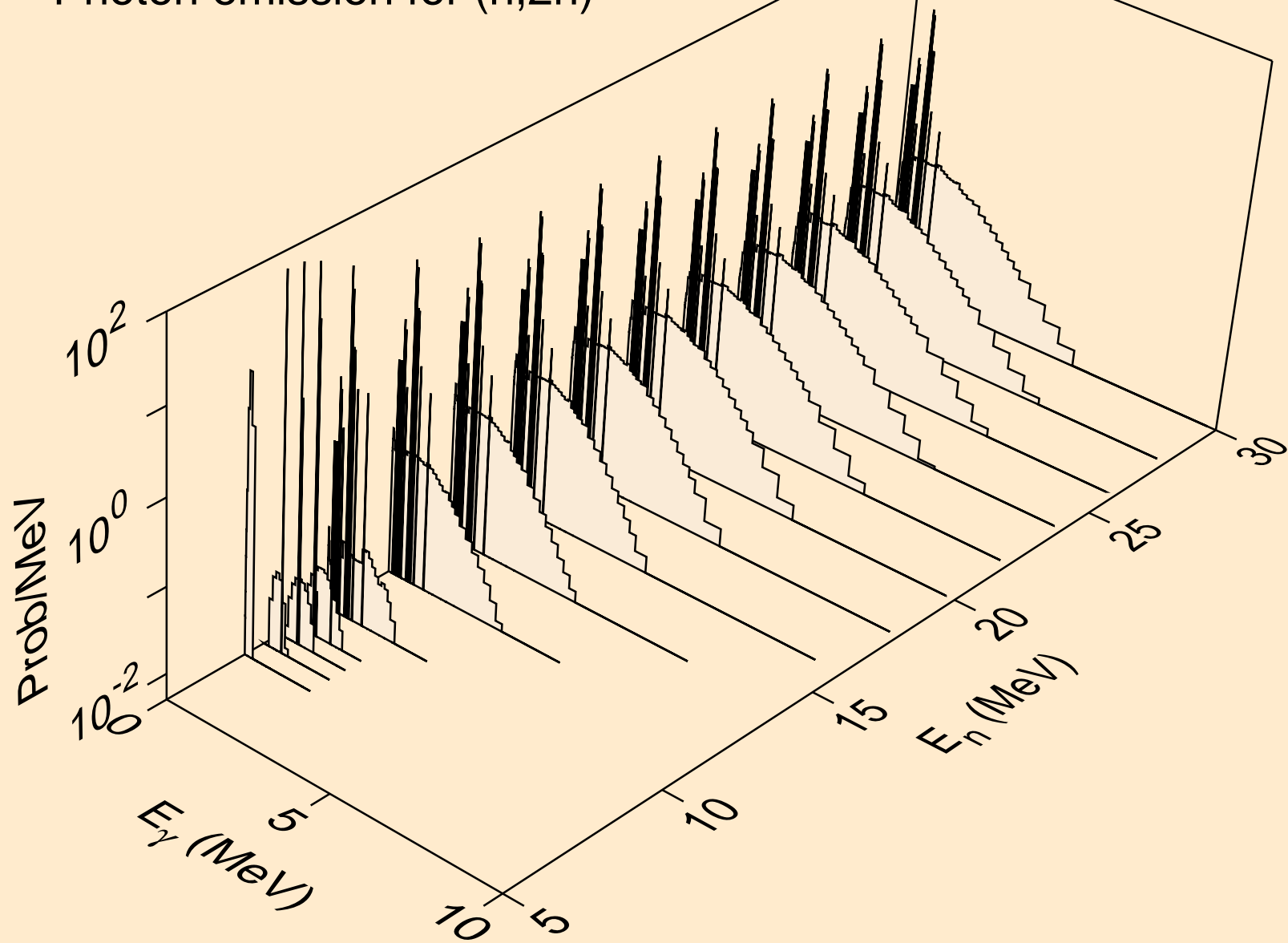

RN205M NEUTRON ACER TENDL-2024 LIBRARY; T=0.K  
Photon emission for (n,3n)

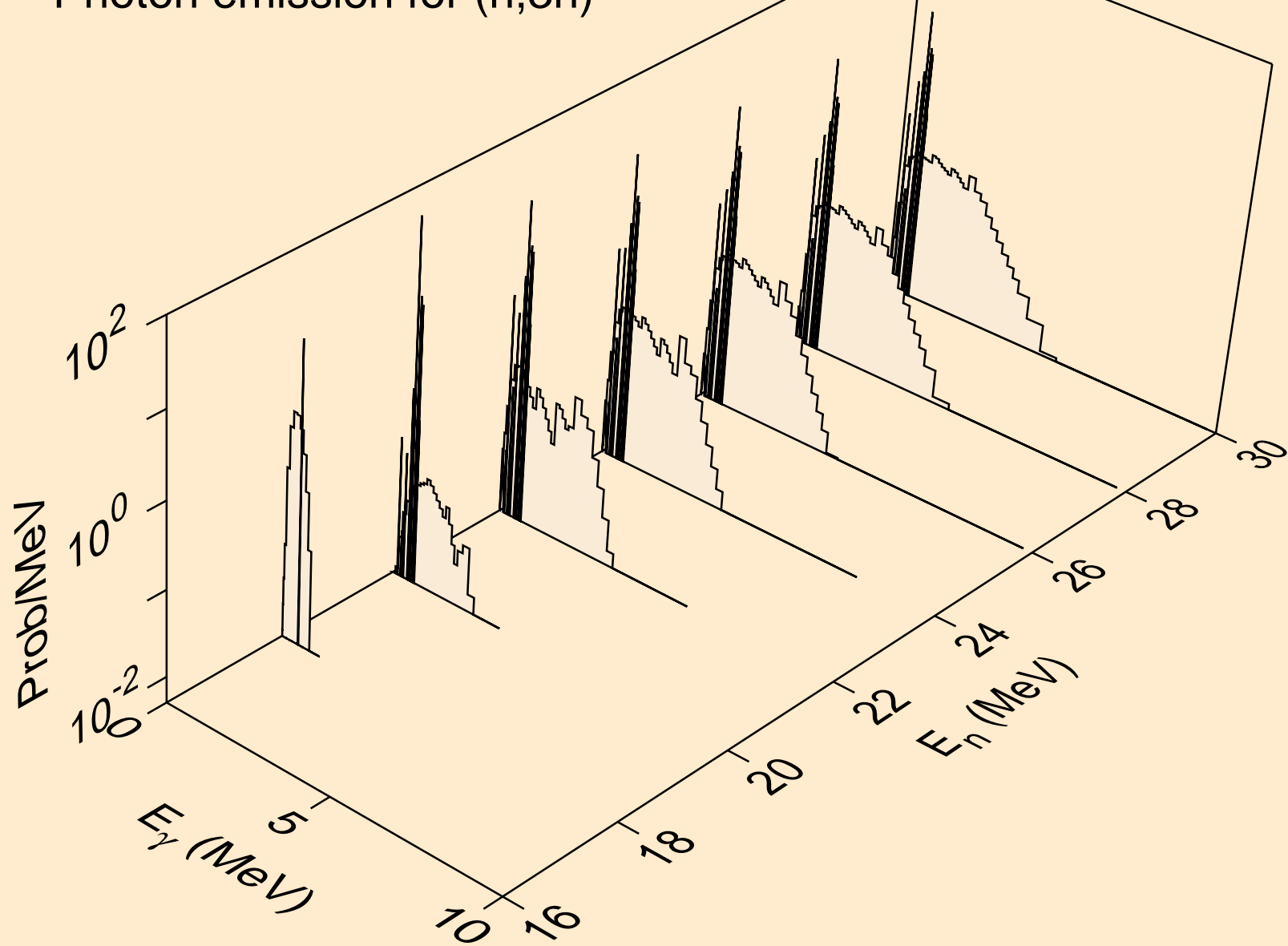

RN205M NEUTRON ACER TENDL-2024 LIBRARY; T=0.K  
Photon emission for (n,n\*)a

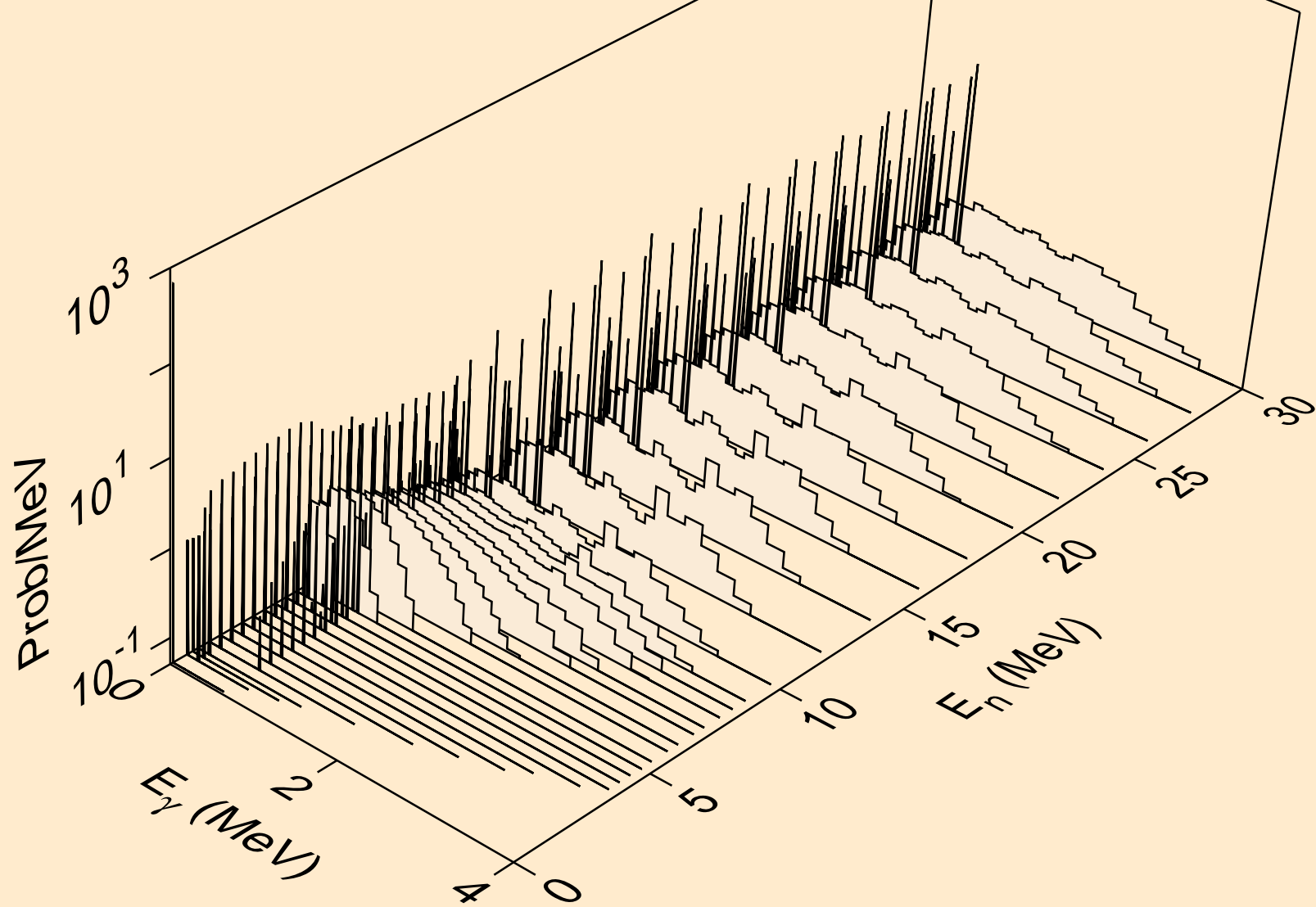

RN205M NEUTRON ACER TENDL-2024 LIBRARY; T=0.K  
Photon emission for (n,2n)a

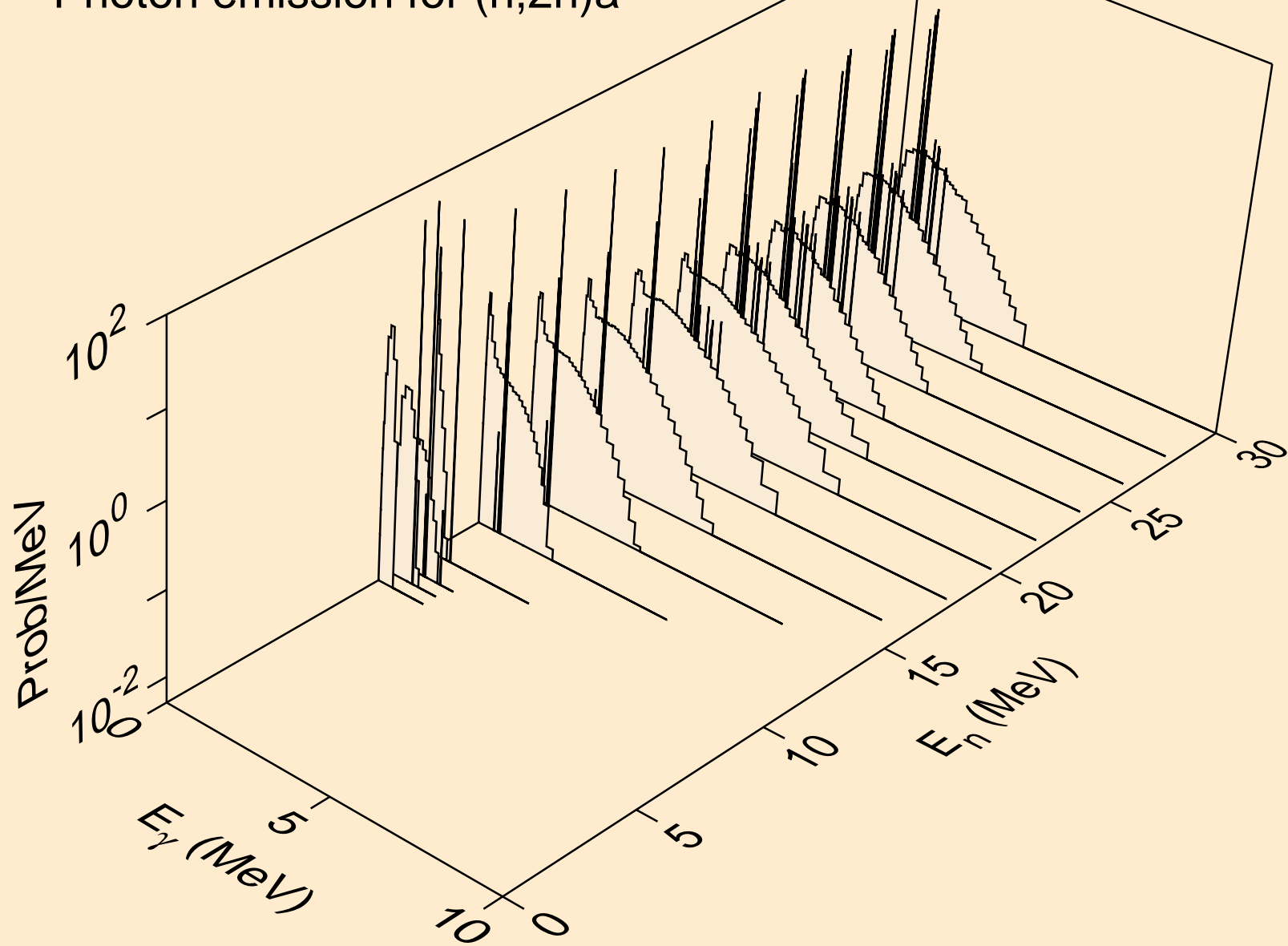

RN205M NEUTRON ACER TENDL-2024 LIBRARY; T=0.K  
Photon emission for (n,3n)a

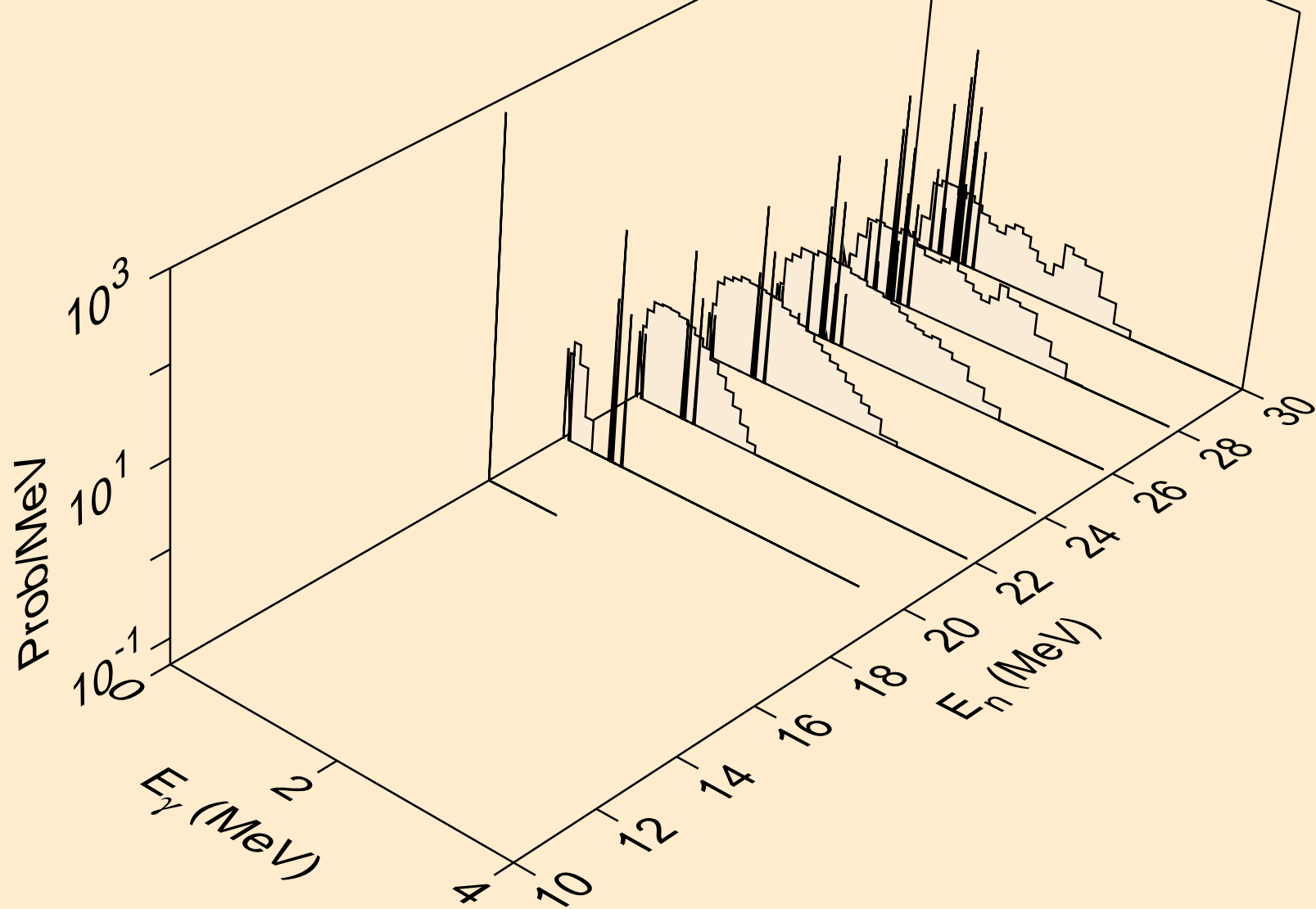

RN205M NEUTRON ACER TENDL-2024 LIBRARY; T=0.K  
Photon emission for (n,n\*)p

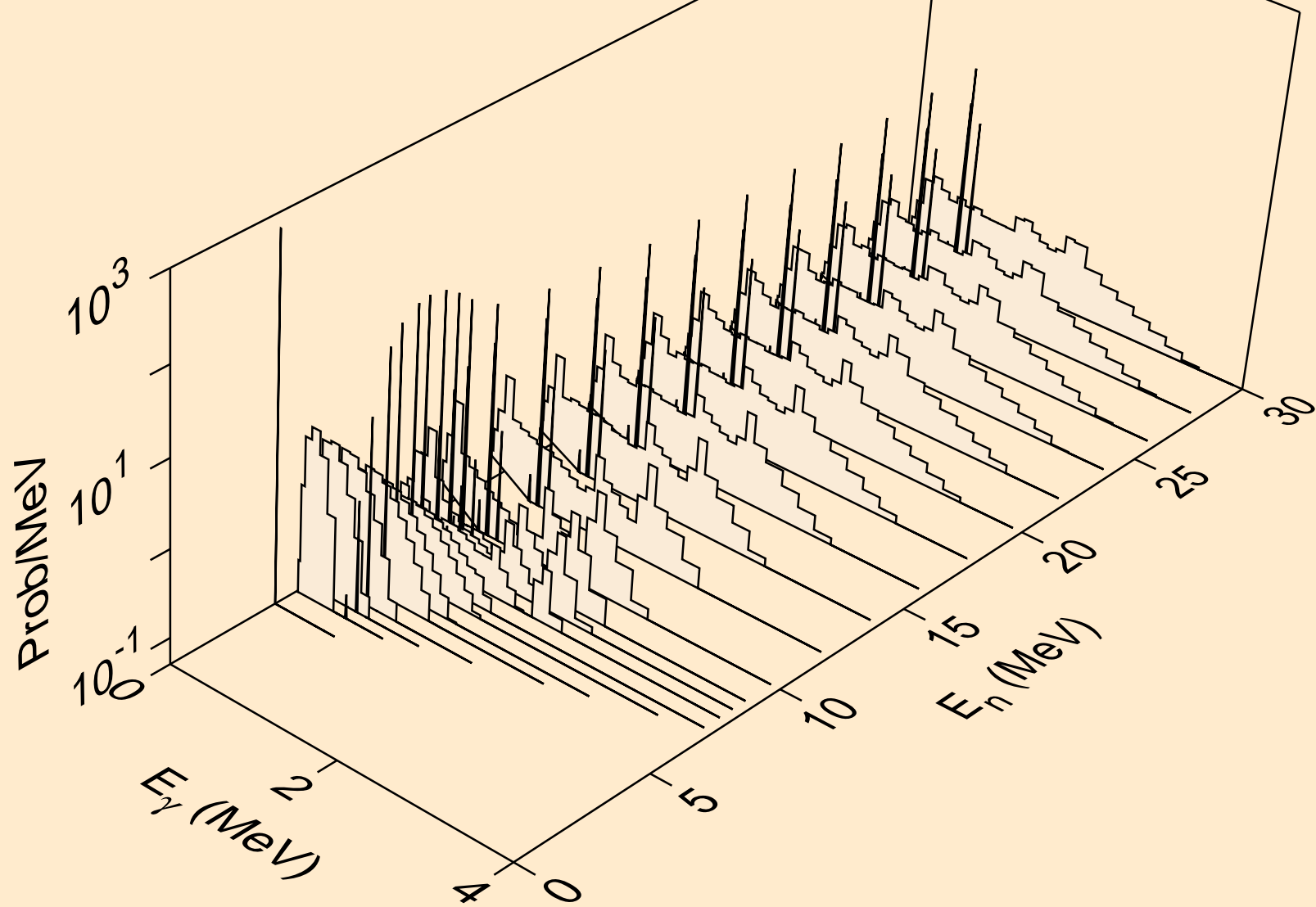

RN205M NEUTRON ACER TENDL-2024 LIBRARY; T=0.K  
Photon emission for (n,n\*)2a

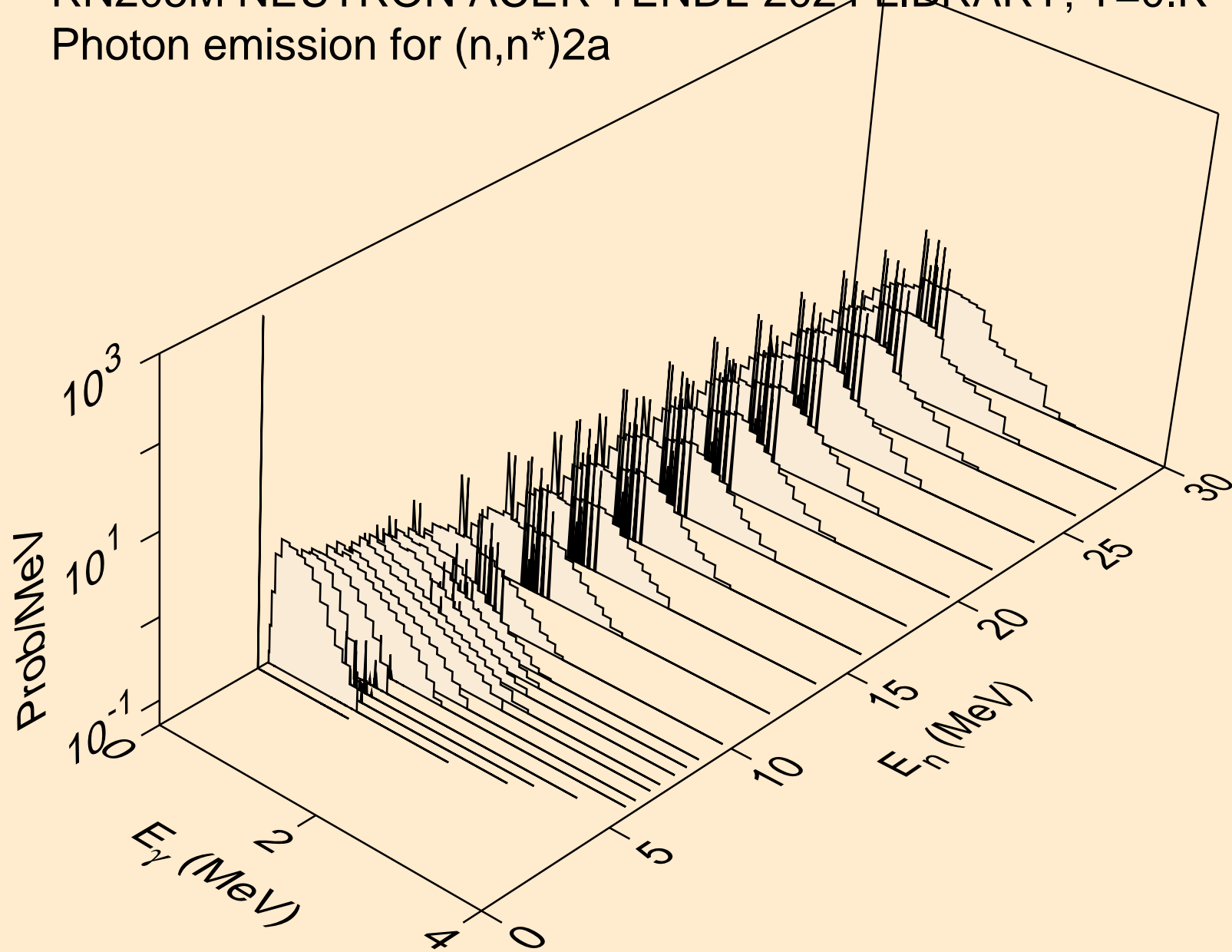

RN205M NEUTRON ACER TENDL-2024 LIBRARY; T=0.K  
Photon emission for (n,2n)2a

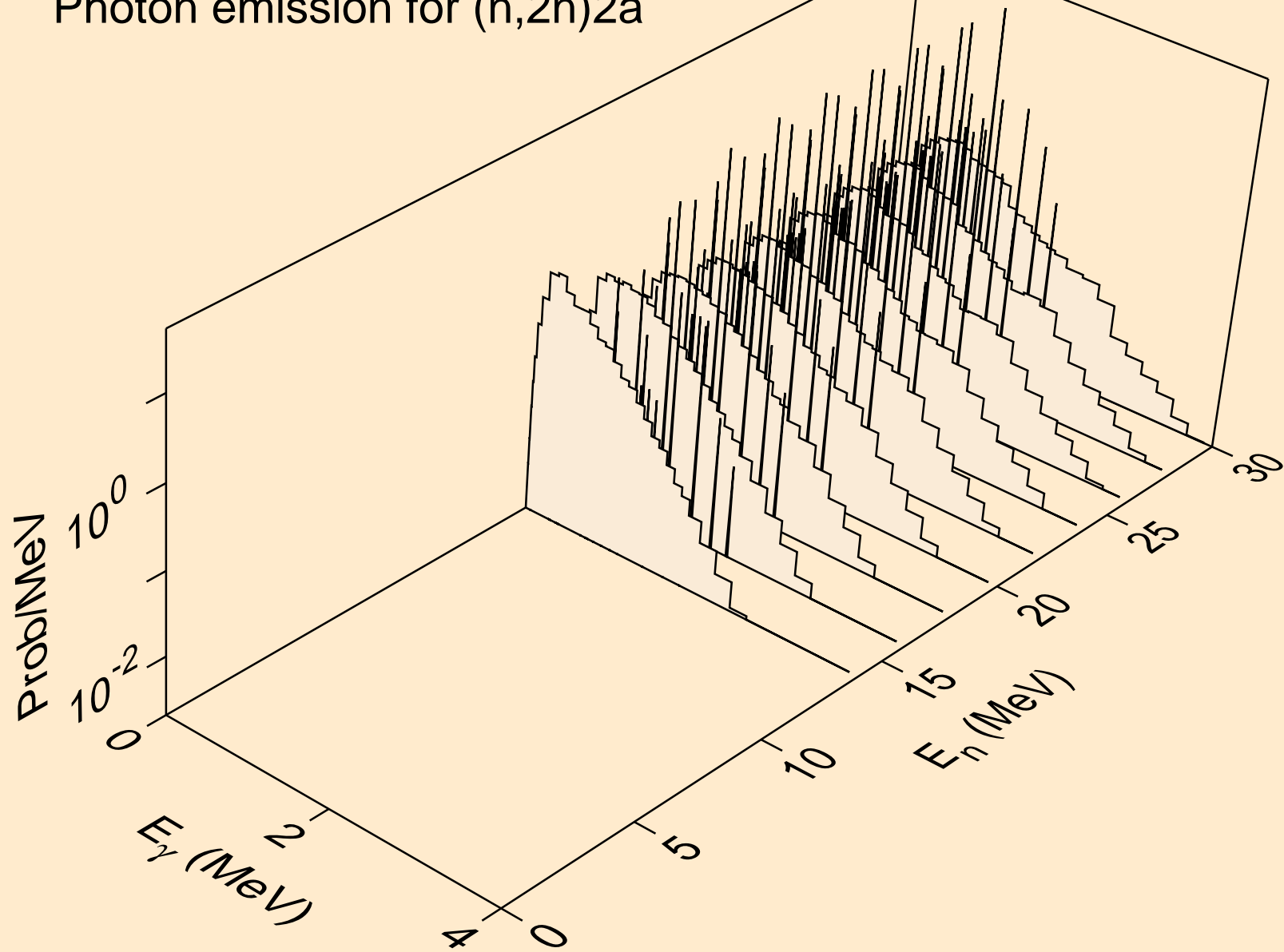

RN205M NEUTRON ACER TENDL-2024 LIBRARY; T=0.K  
Photon emission for (n,n\*)d

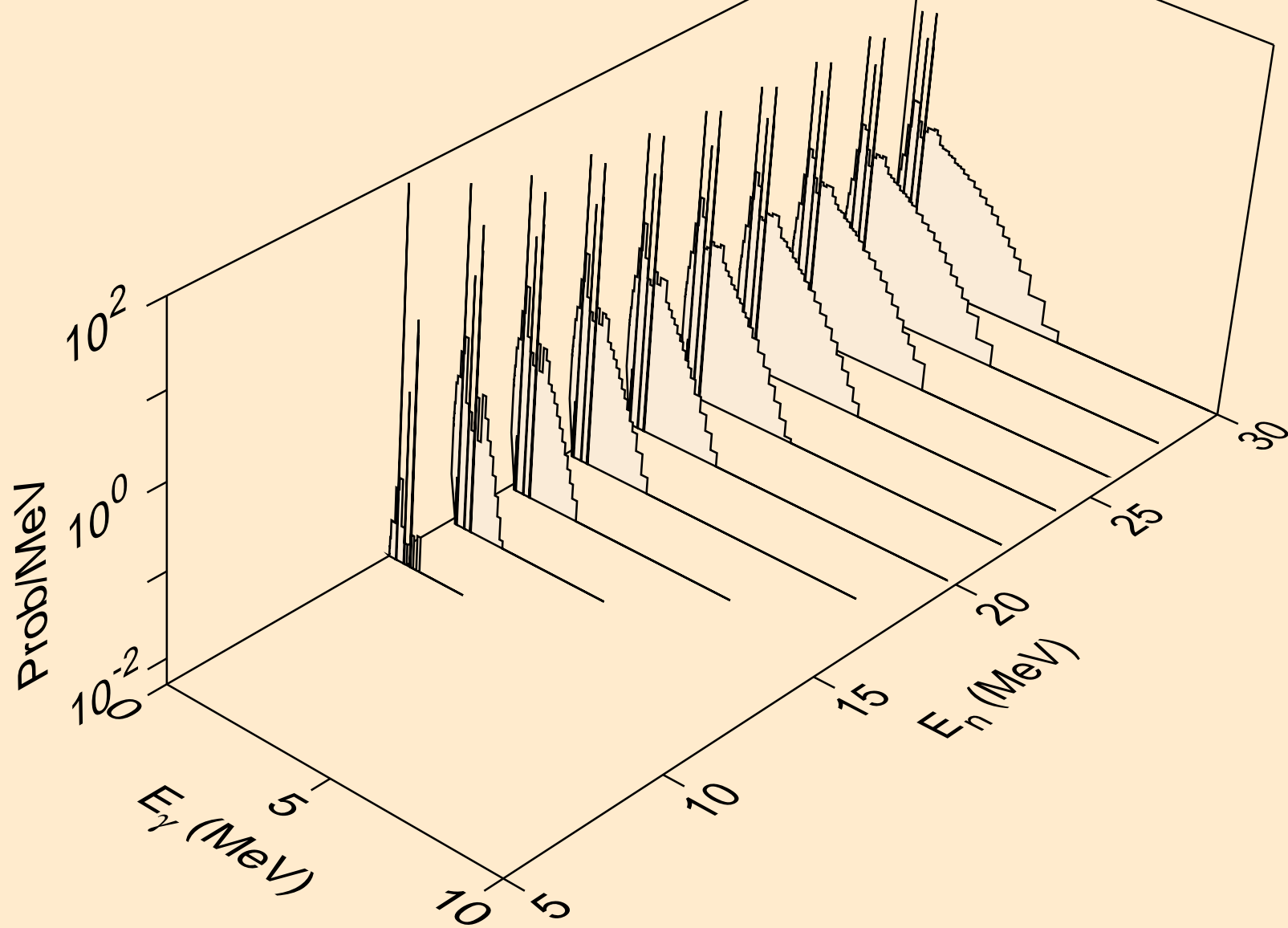

RN205M NEUTRON ACER TENDL-2024 LIBRARY; T=0.K  
Photon emission for (n,n\*)t

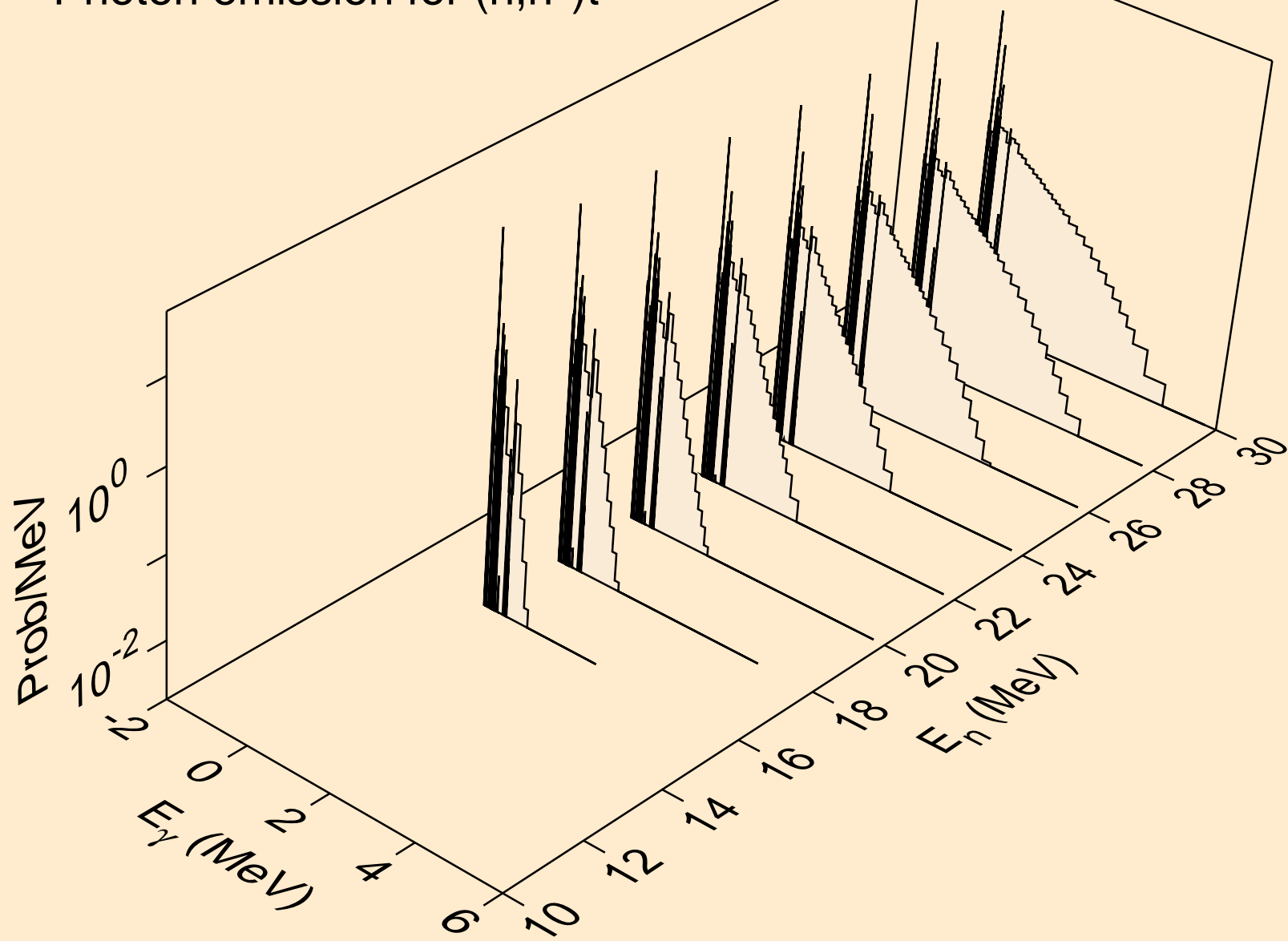

RN205M NEUTRON ACER TENDL-2024 LIBRARY; T=0.K  
Photon emission for (n,n\*)he3

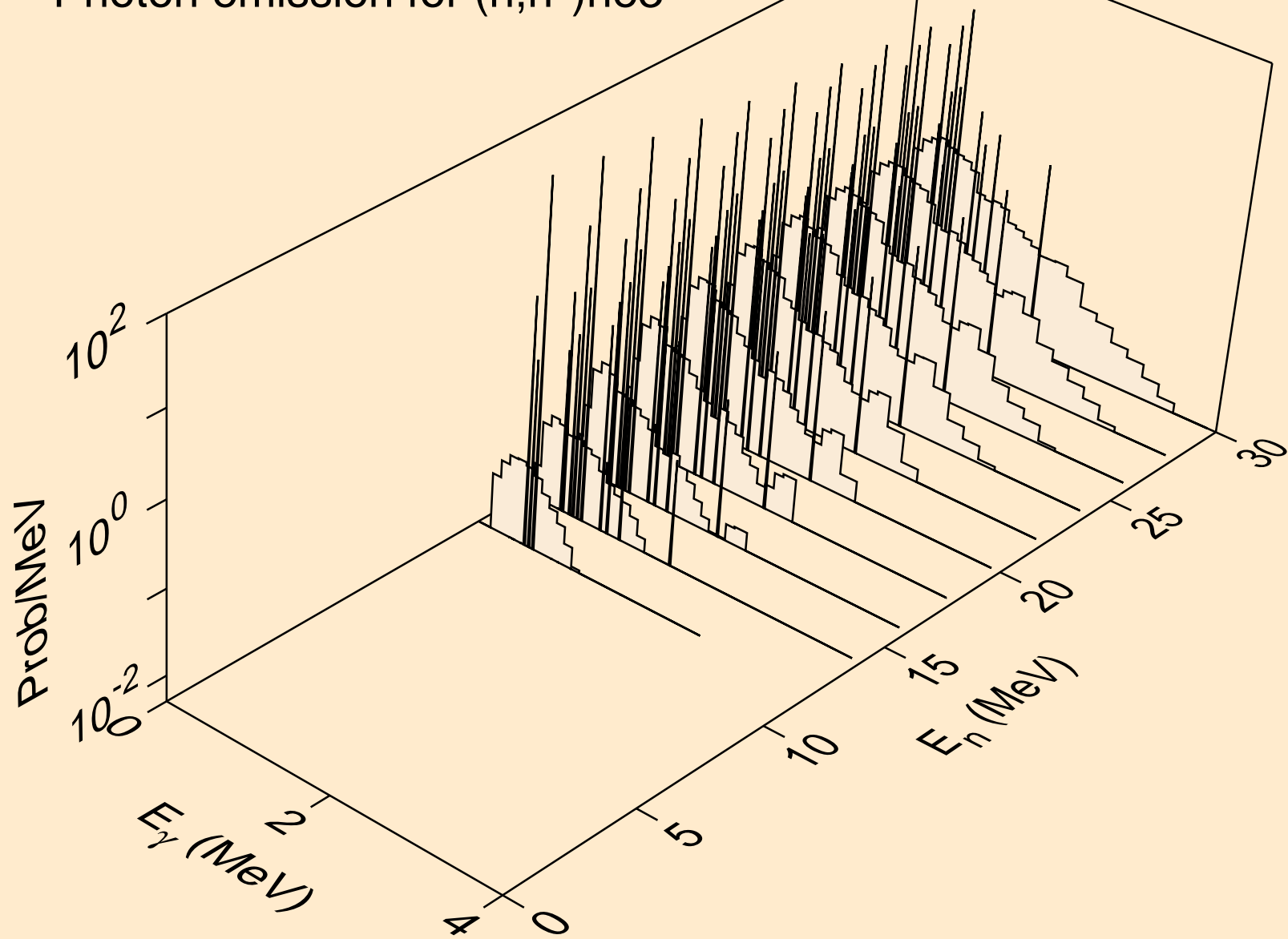

RN205M NEUTRON ACER TENDL-2024 LIBRARY; T=0.K  
Photon emission for (n,4n)

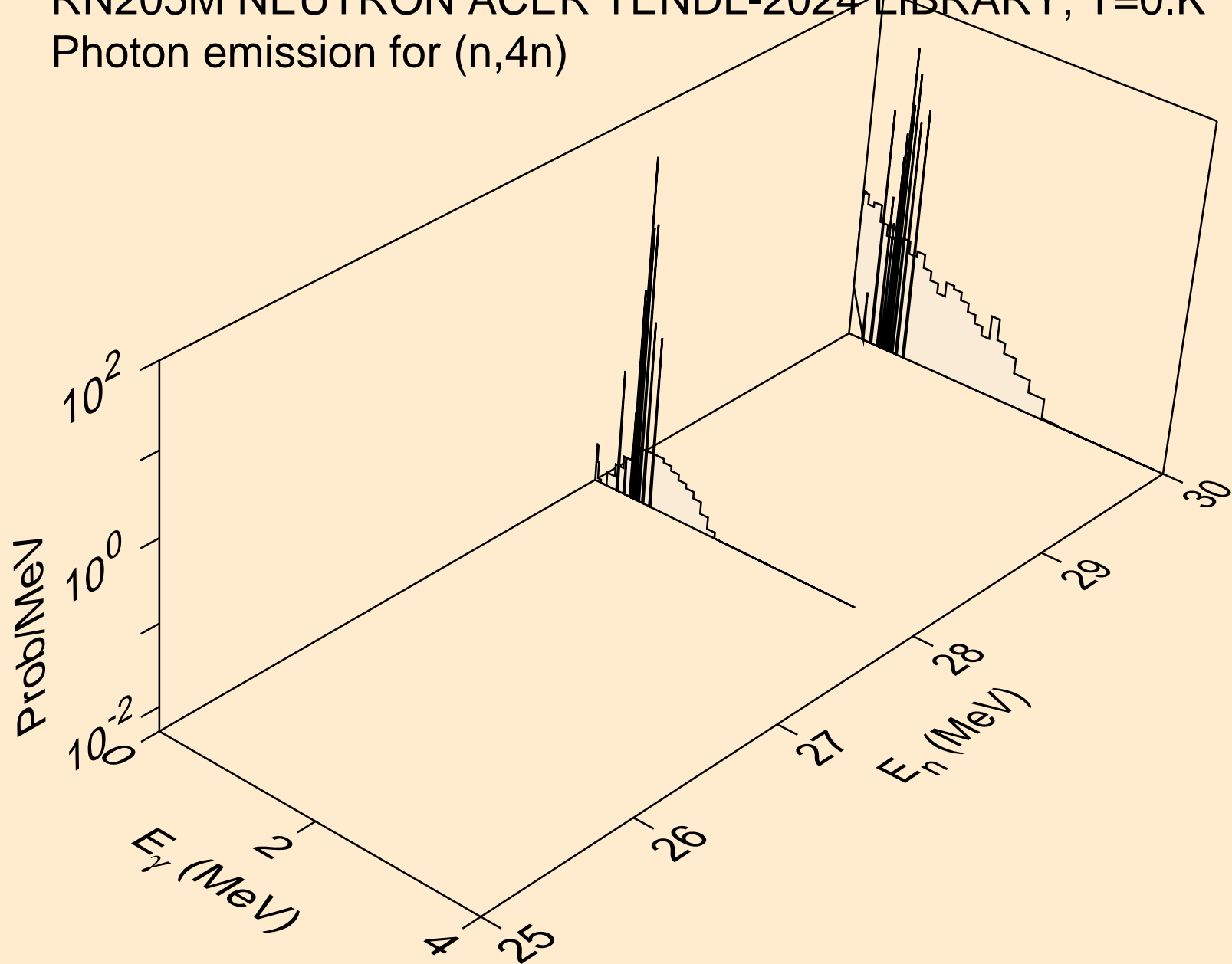

RN205M NEUTRON ACER TENDL-2024 LIBRARY; T=0.K  
Photon emission for (n,2np)

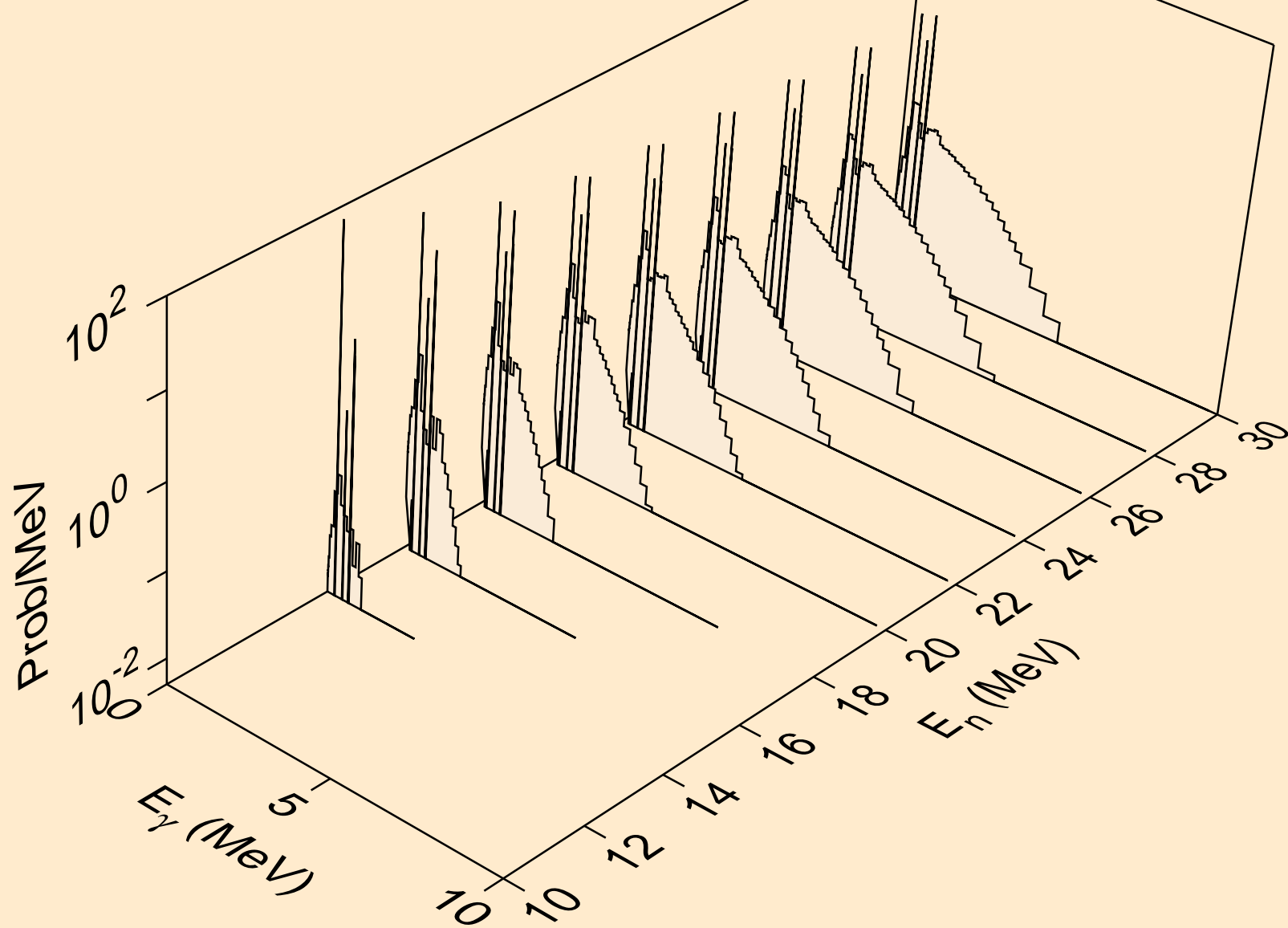

RN205M NEUTRON ACER TENDL-2024 LIBRARY; T=0.K  
Photon emission for (n,3np)

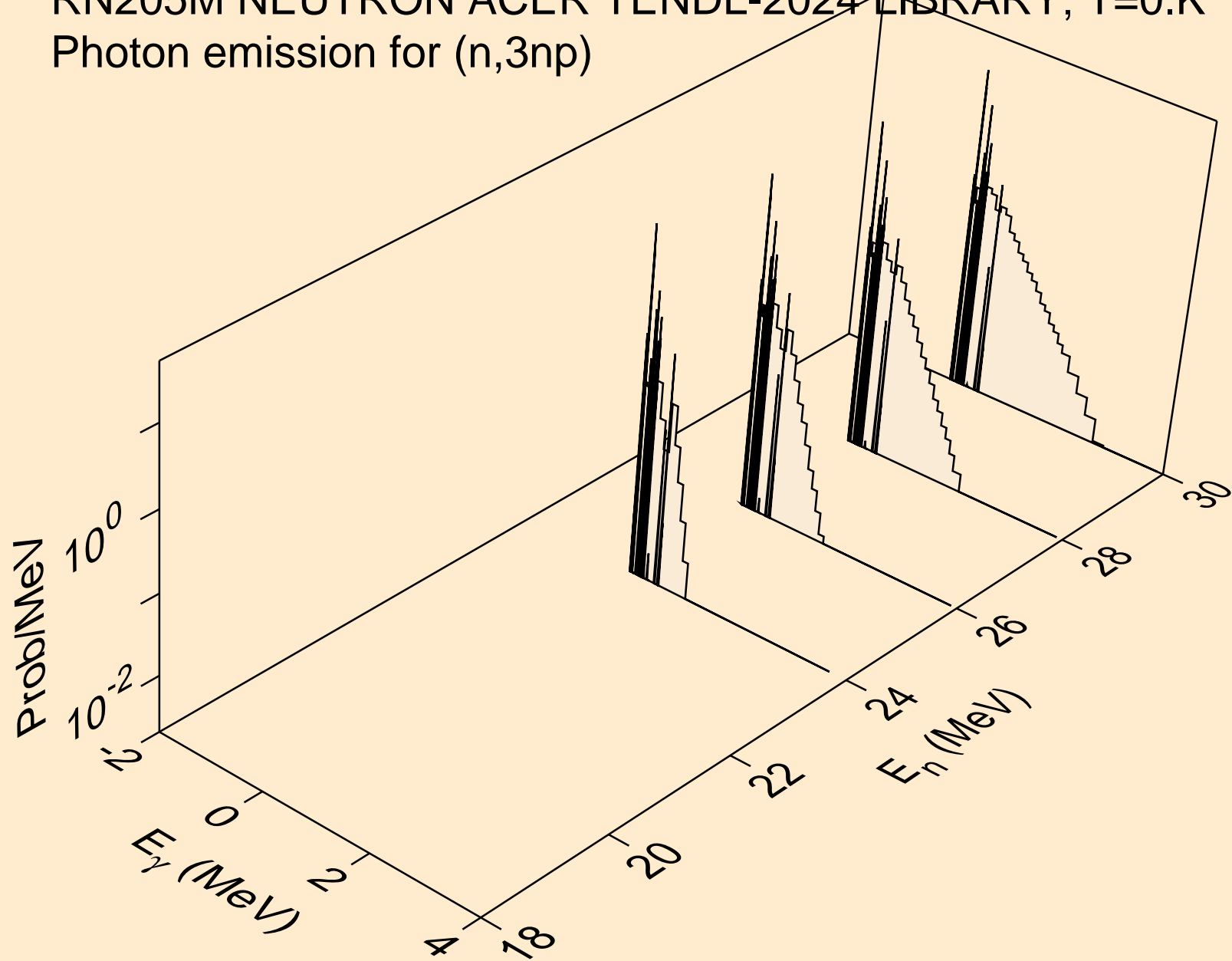

RN205M NEUTRON ACER TENDL-2024 LIBRARY; T=0.K  
Photon emission for (n,n2p)

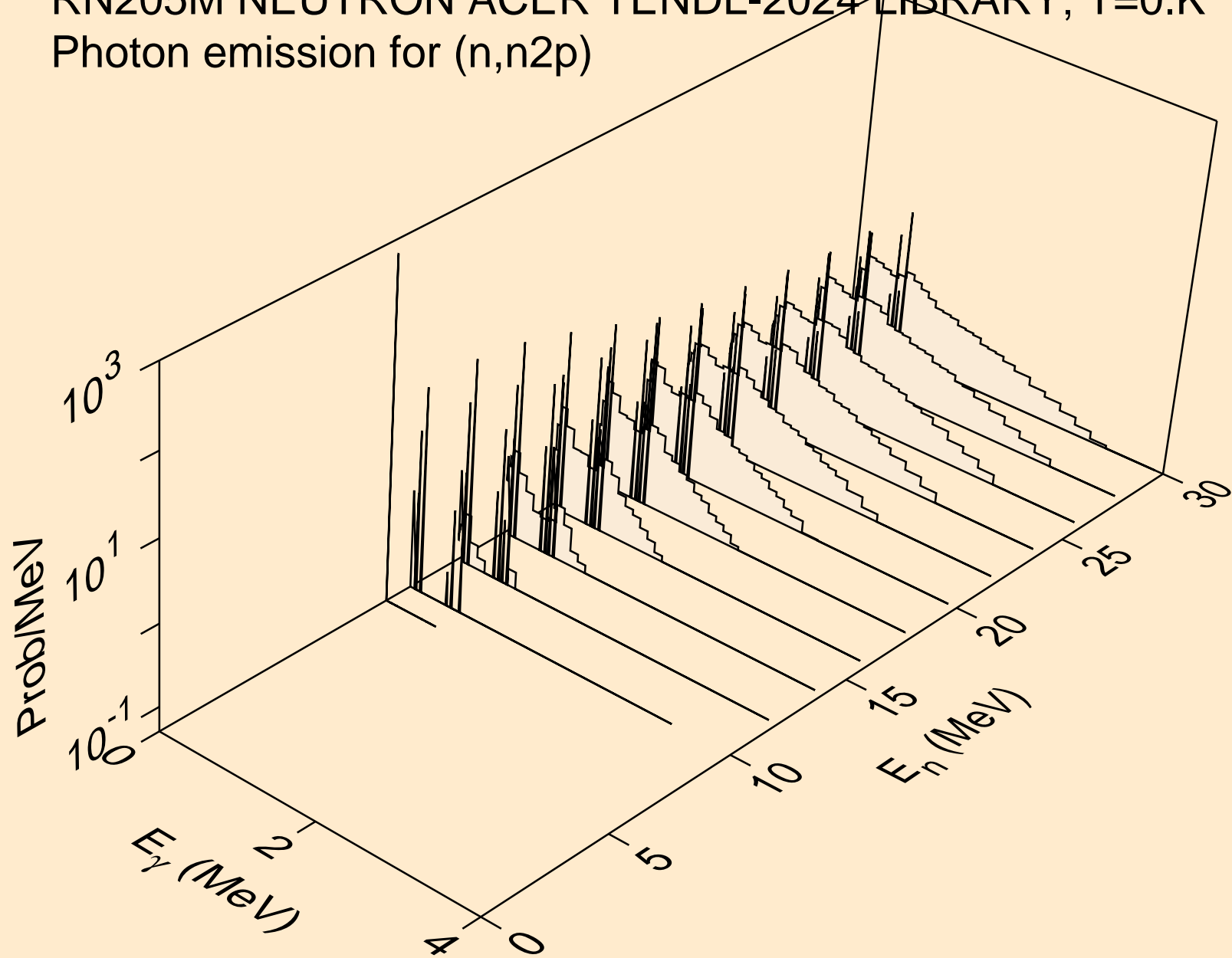

RN205M NEUTRON ACER TENDL-2024 LIBRARY; T=0.K  
Photon emission for (n,npa)

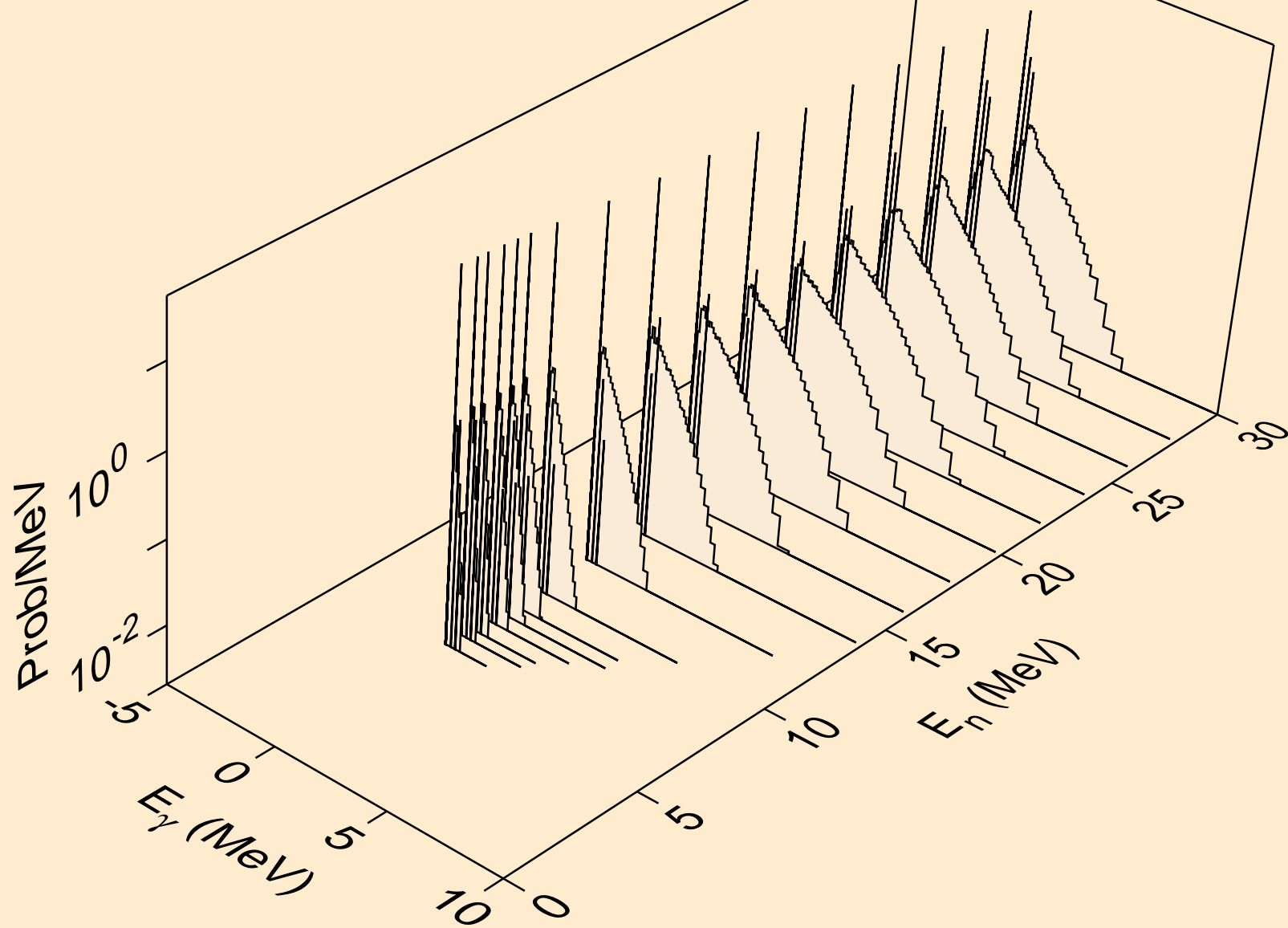

RN205M NEUTRON ACER TENDL-2024 LIBRARY; T=0.K  
Photon emission for (n,n\*1)

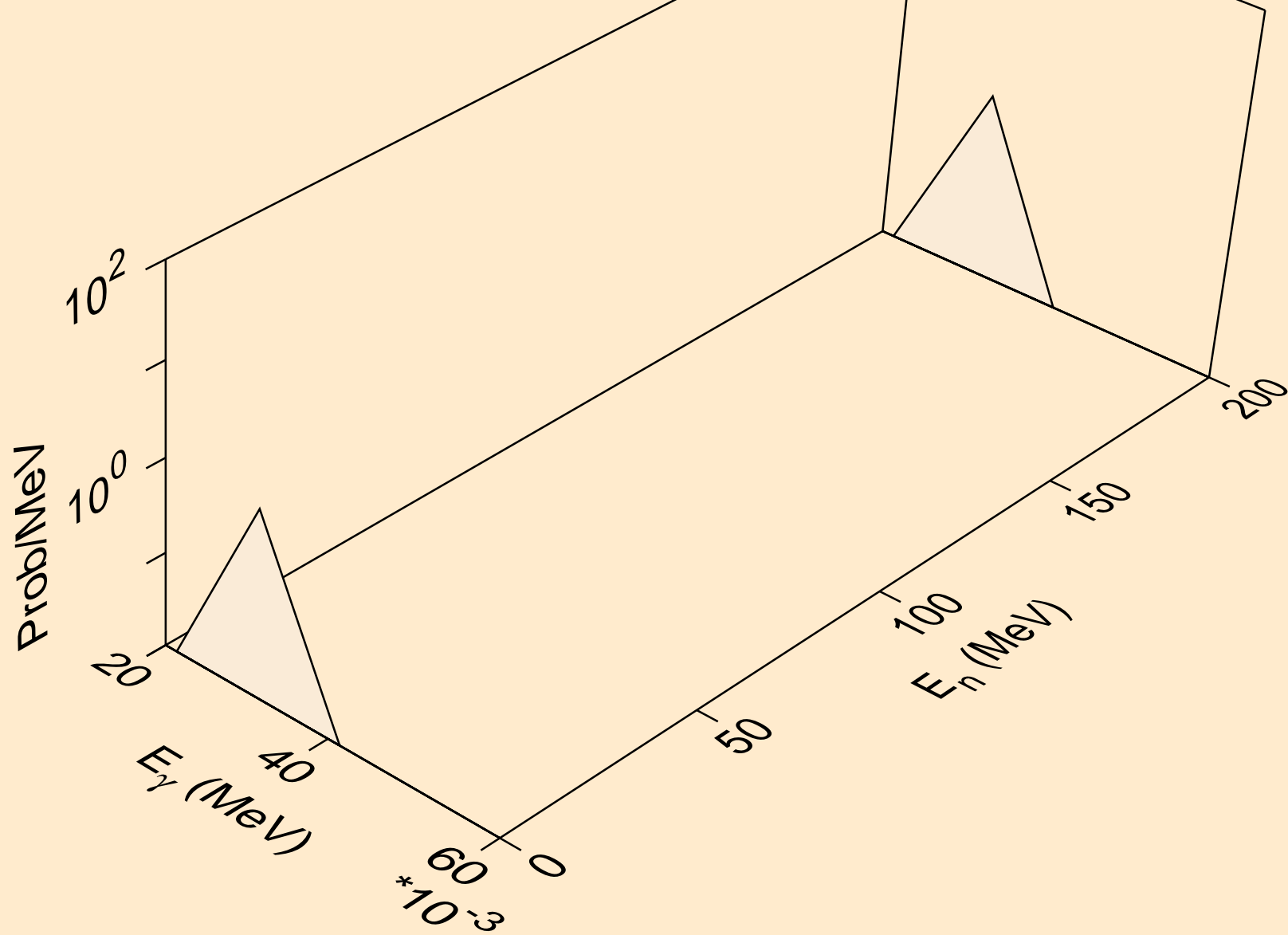

RN205M NEUTRON ACER TENDL-2024 LIBRARY; T=0.K  
Photon emission for (n,n\*2)

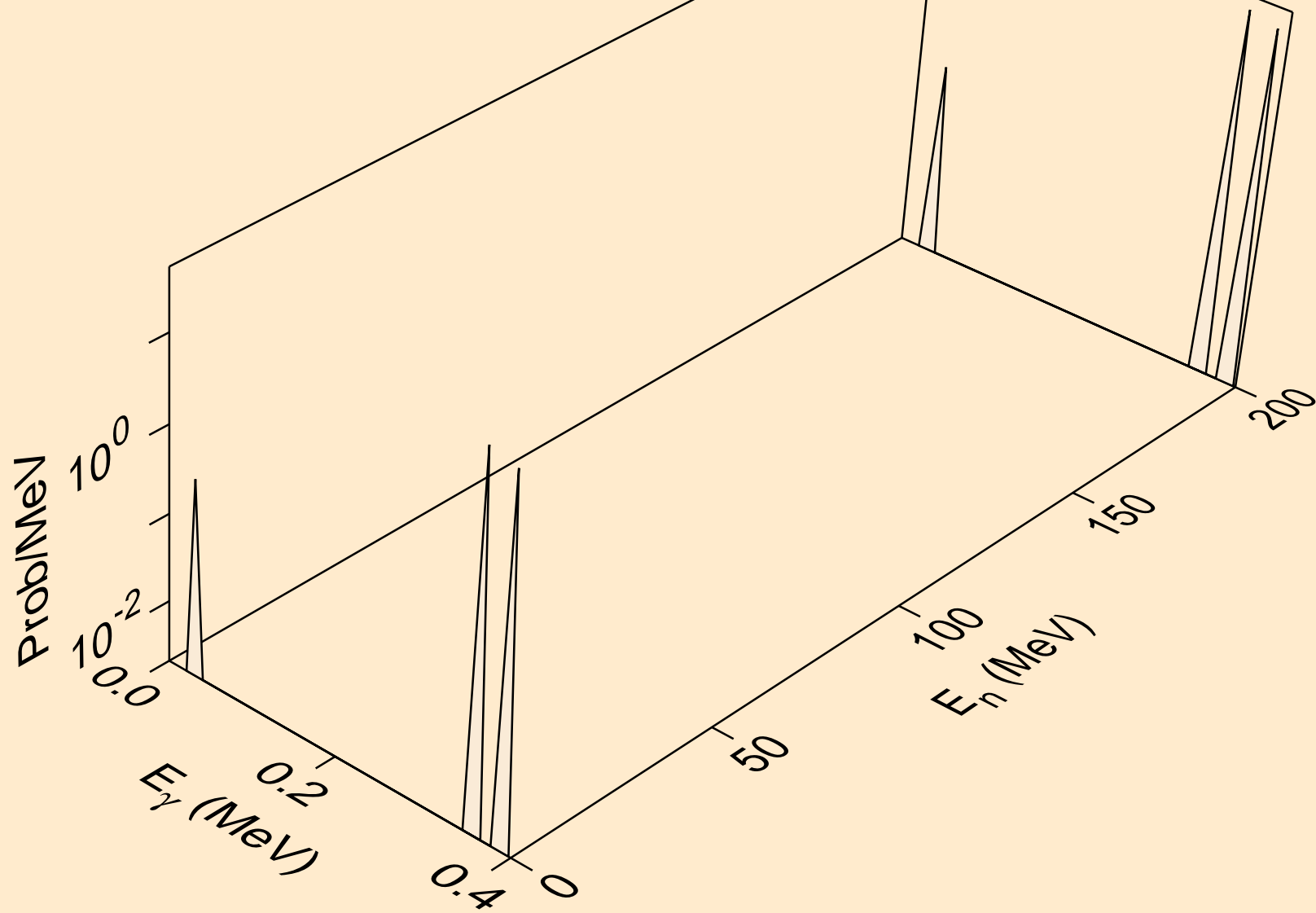

RN205M NEUTRON ACER TENDL-2024 LIBRARY; T=0.K  
Photon emission for (n,n\*3)

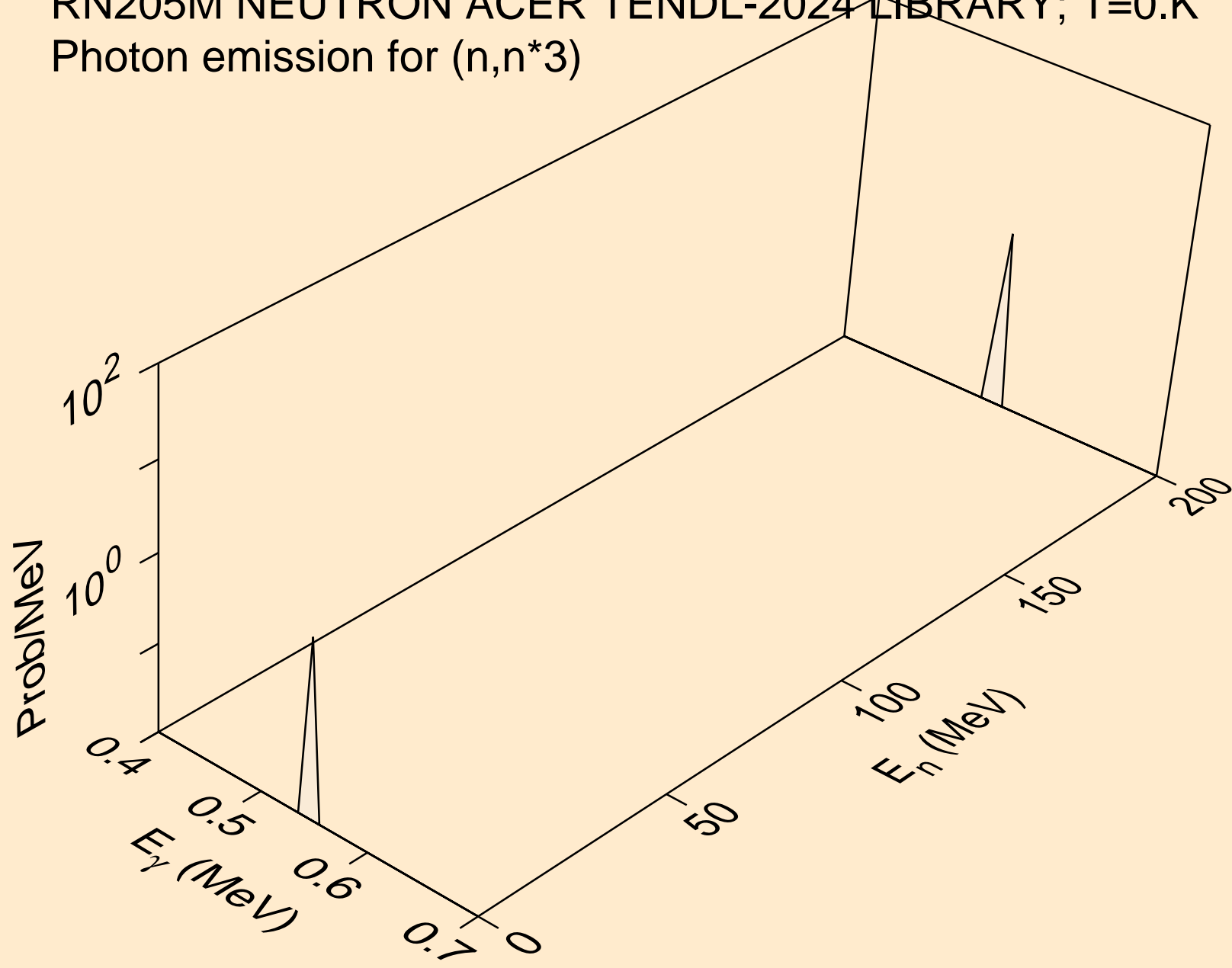

RN205M NEUTRON ACER TENDL-2024 LIBRARY; T=0.K  
Photon emission for (n,n\*4)

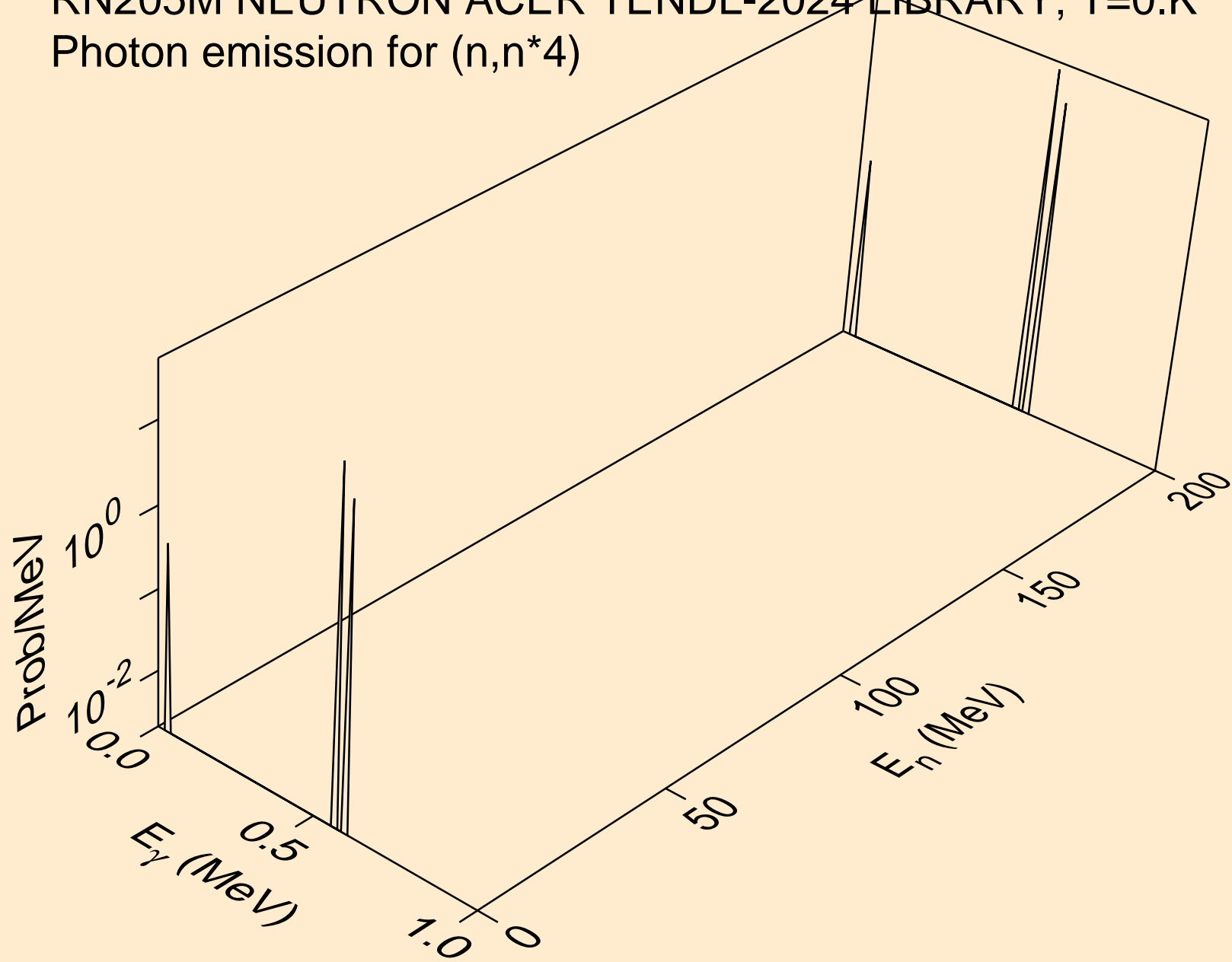

RN205M NEUTRON ACER TENDL-2024 LIBRARY; T=0.K  
Photon emission for (n,n\*5)

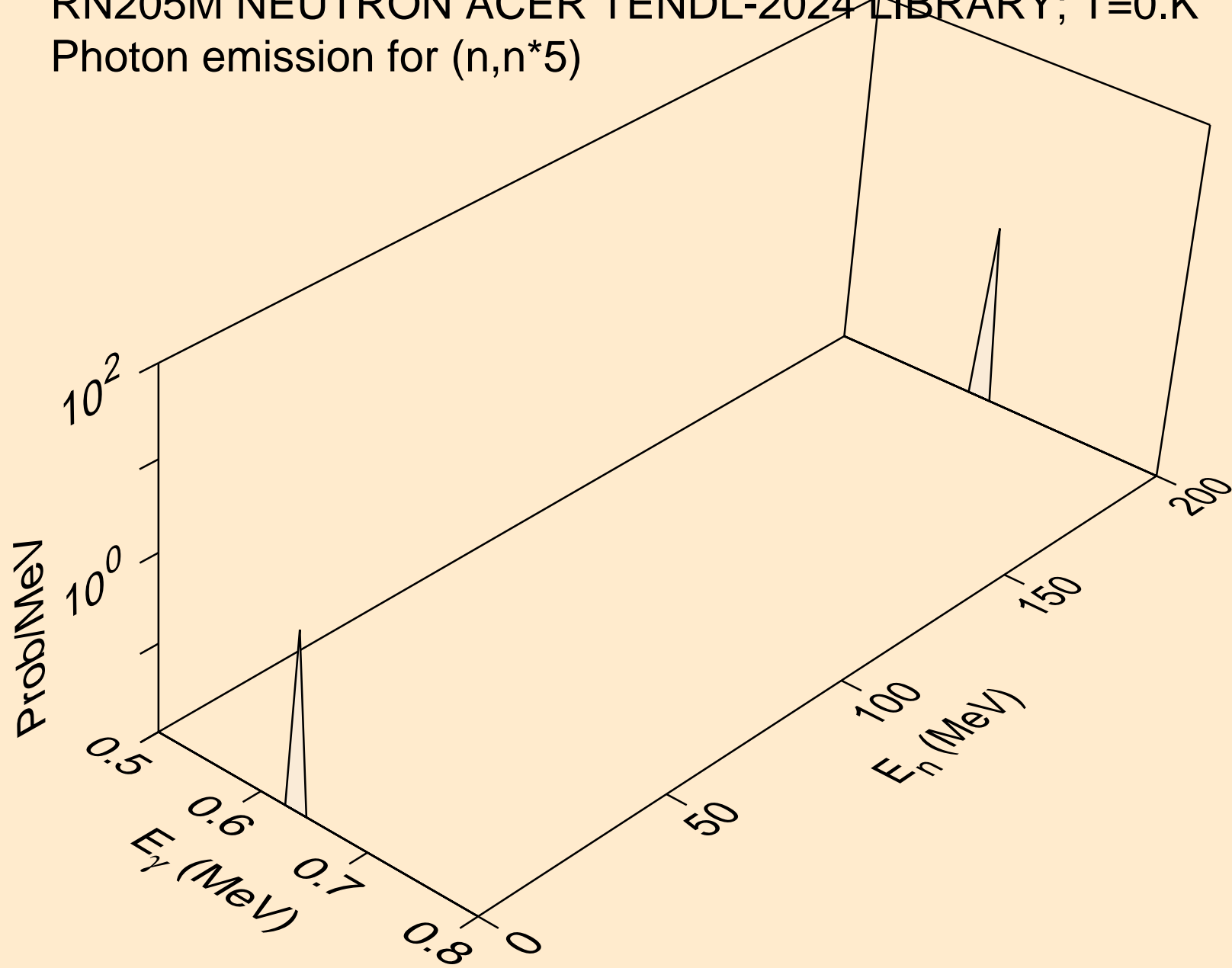

RN205M NEUTRON ACER TENDL-2024 LIBRARY; T=0.K  
Photon emission for (n,n\*7)

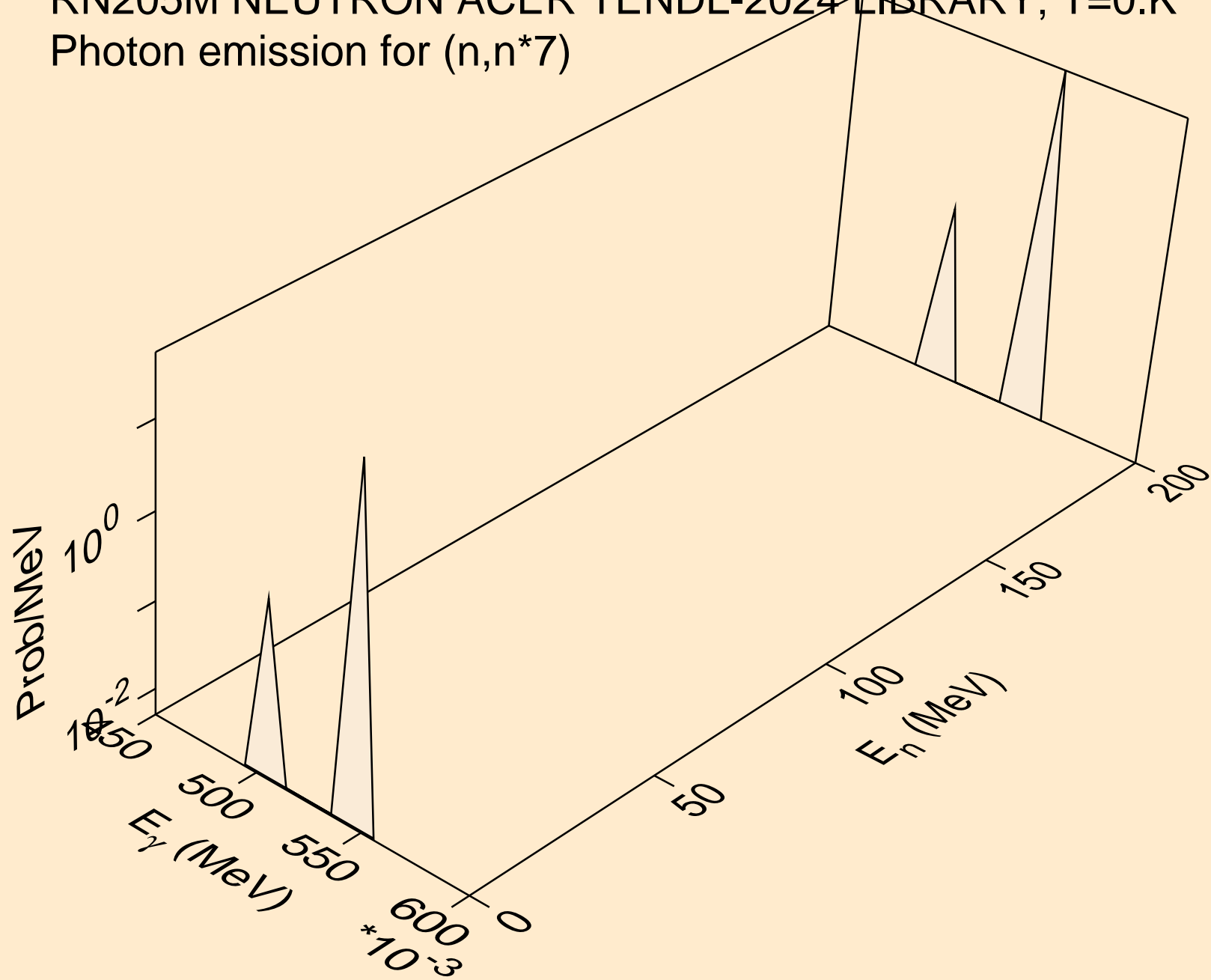

RN205M NEUTRON ACER TENDL-2024 LIBRARY; T=0.K  
Photon emission for (n,n\*8)

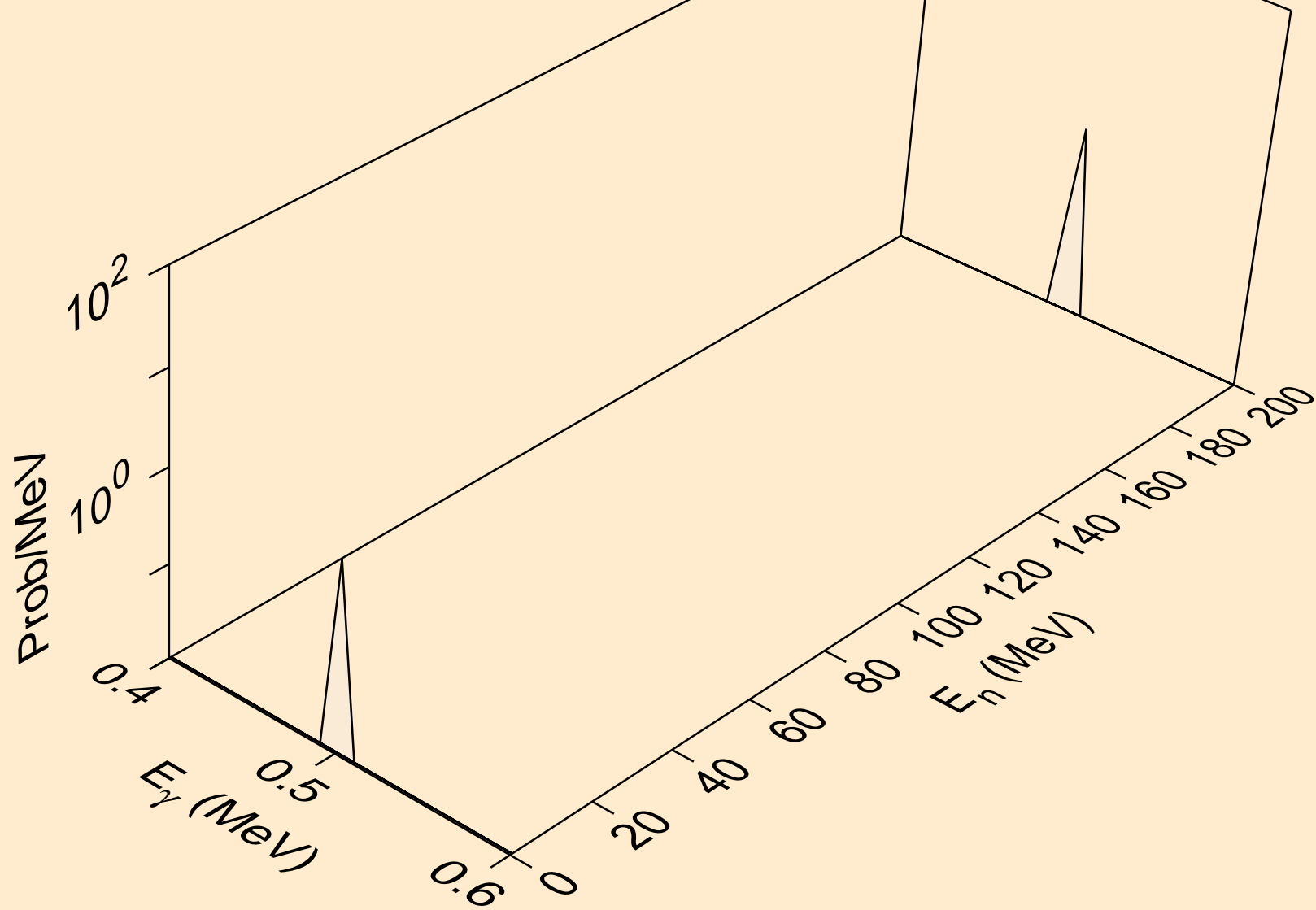

RN205M NEUTRON ACER TENDL-2024 LIBRARY; T=0.K  
Photon emission for (n,n\*c)

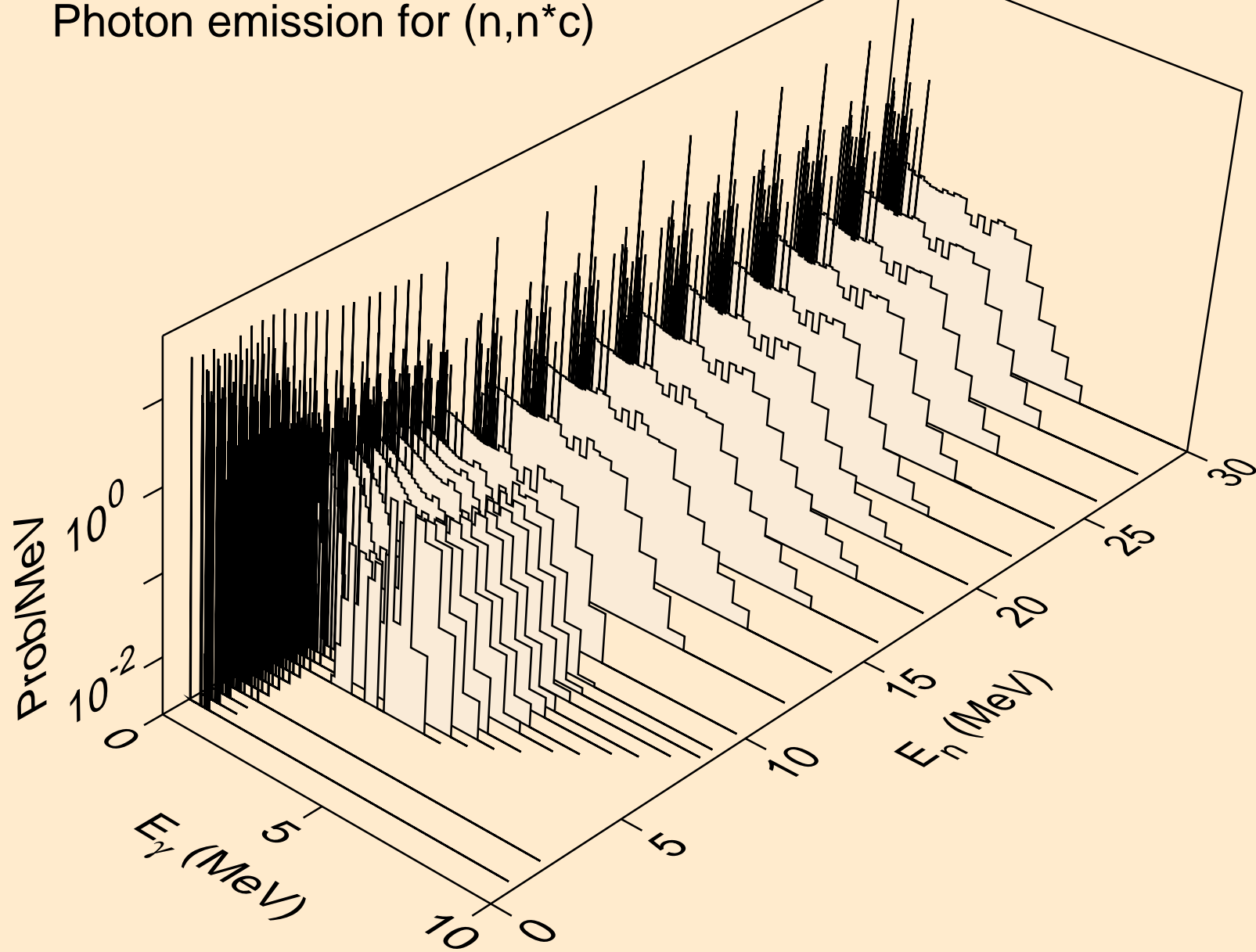

RN205M NEUTRON ACER TENDL-2024 LIBRARY; T=0.K  
Photon emission for (n,gma)

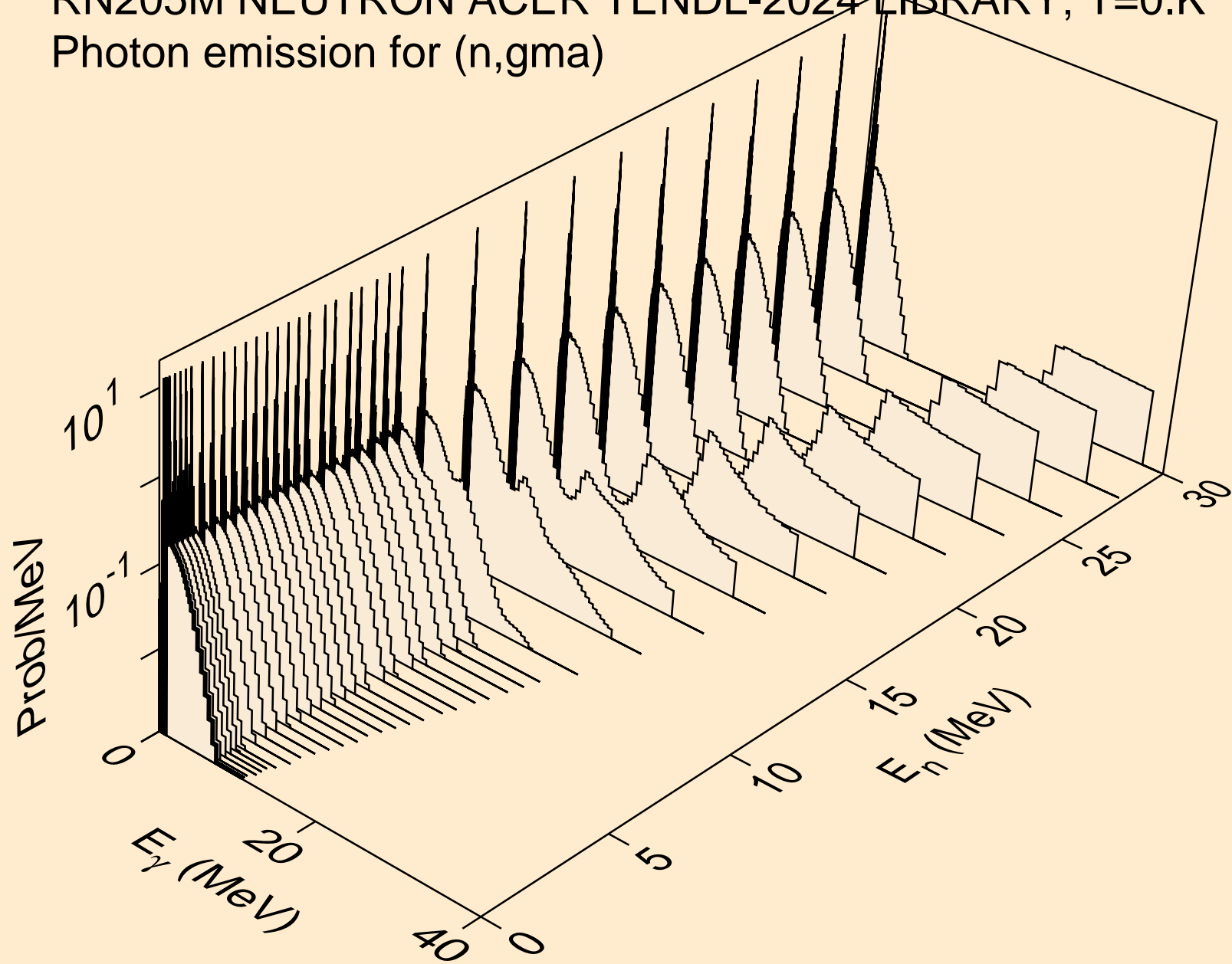

RN205M NEUTRON ACER TENDL-2024 LIBRARY; T=0.K  
Photon emission for (n,p)

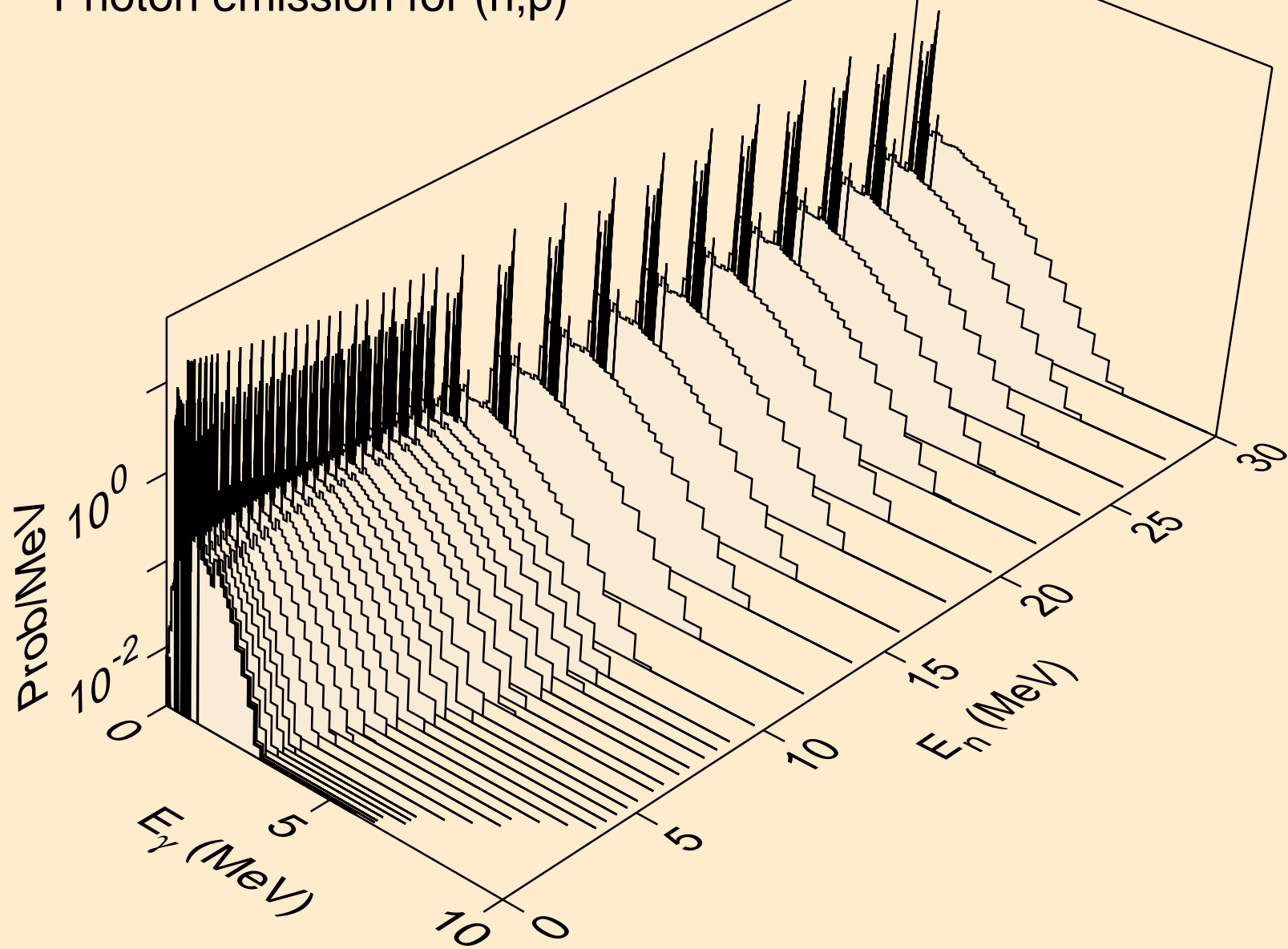

RN205M NEUTRON ACER TENDL-2024 LIBRARY; T=0.K  
Photon emission for (n,d)

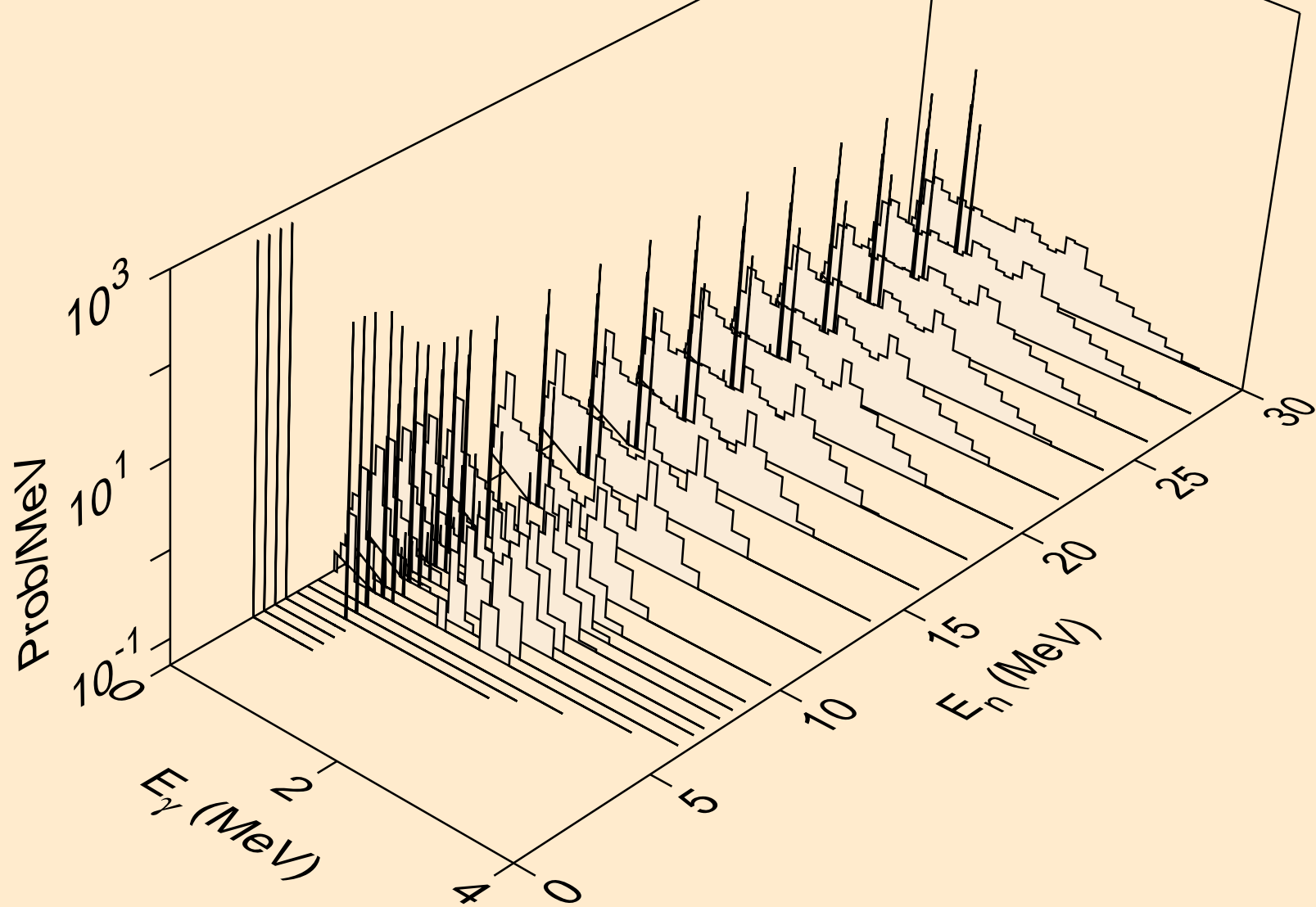

RN205M NEUTRON ACER TENDL-2024 LIBRARY; T=0.K  
Photon emission for (n,t)

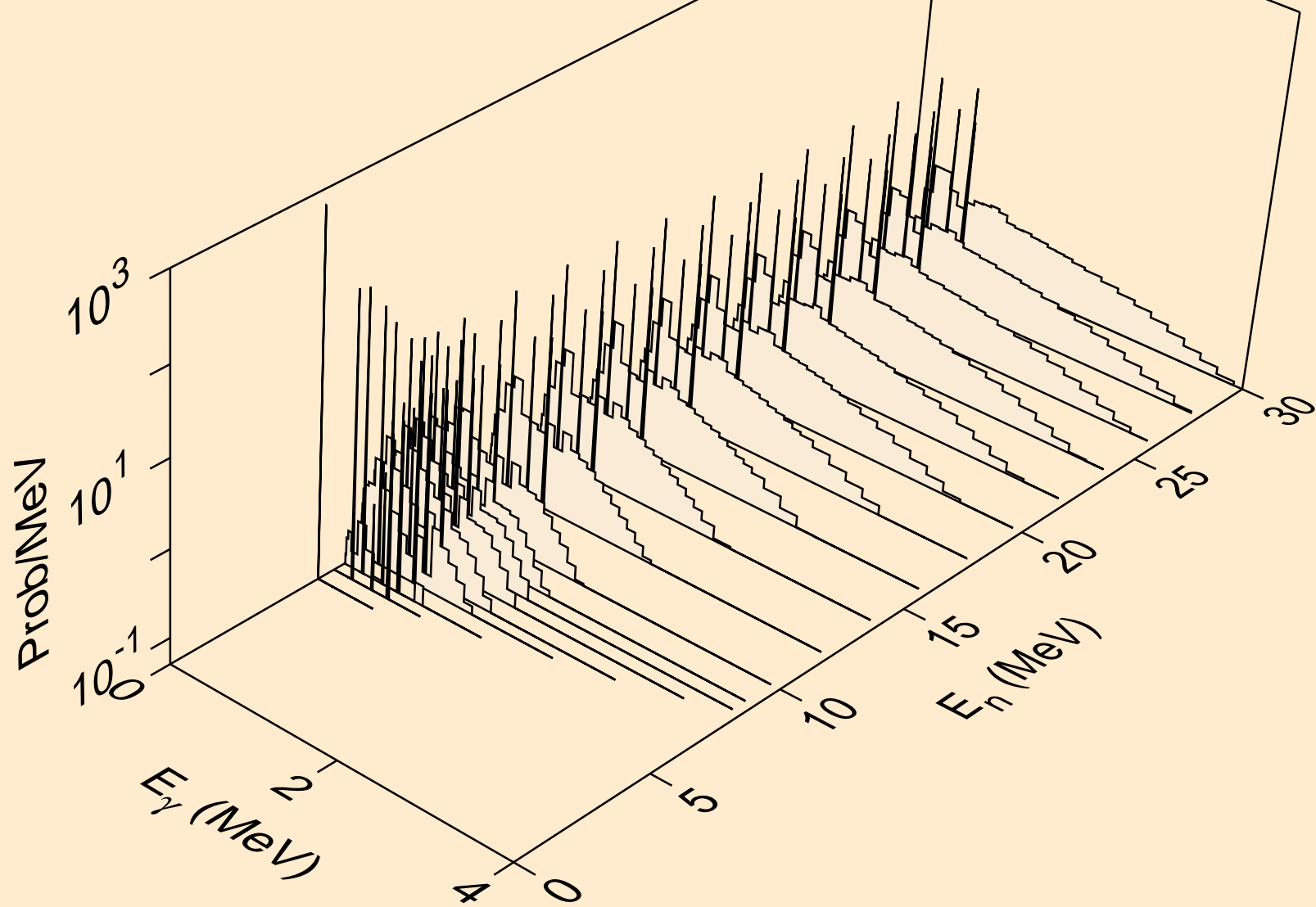

RN205M NEUTRON ACER TENDL-2024 LIBRARY; T=0.K  
Photon emission for (n,he3)

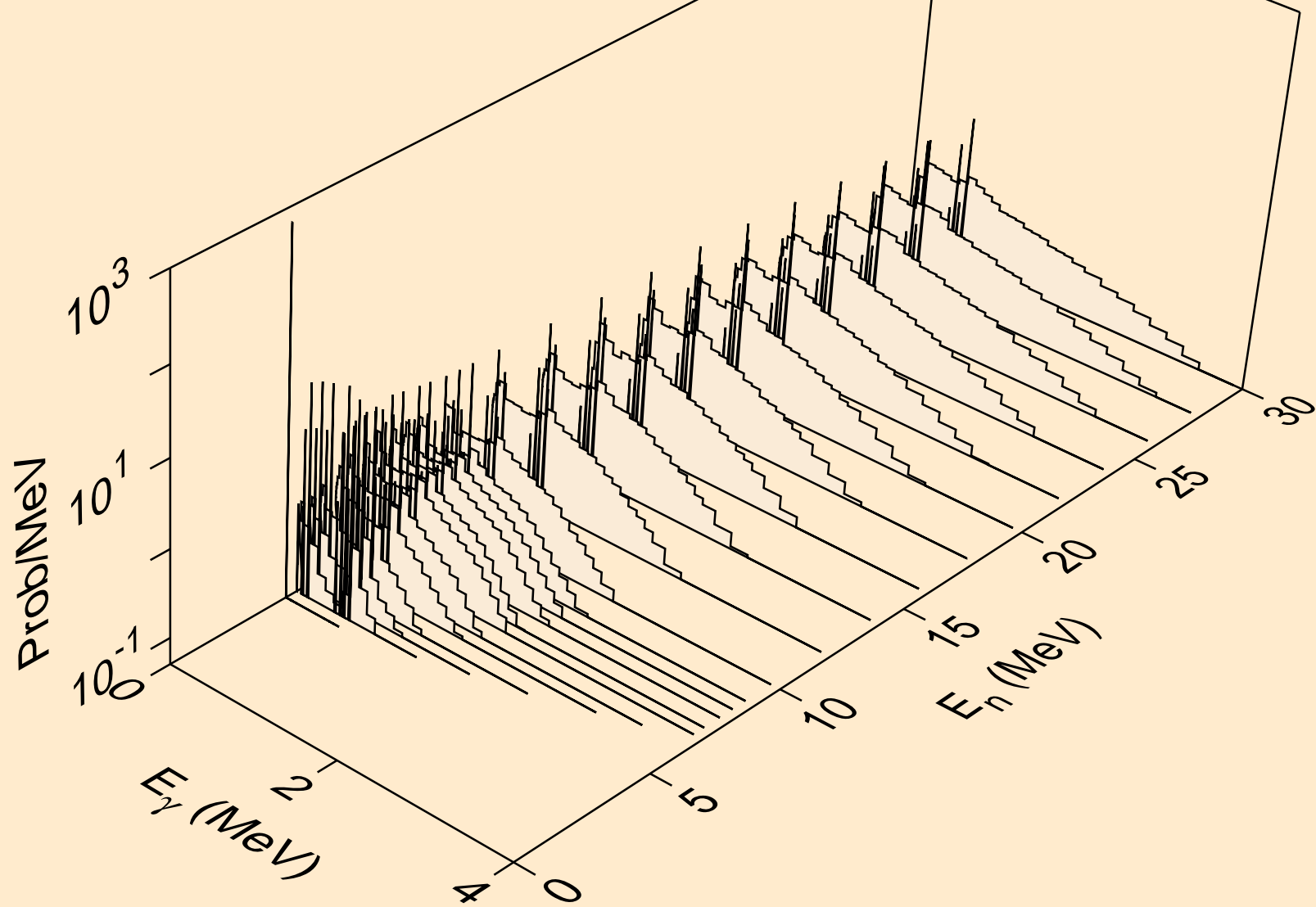

RN205M NEUTRON ACER TENDL-2024 LIBRARY; T=0.K  
Photon emission for (n,a)

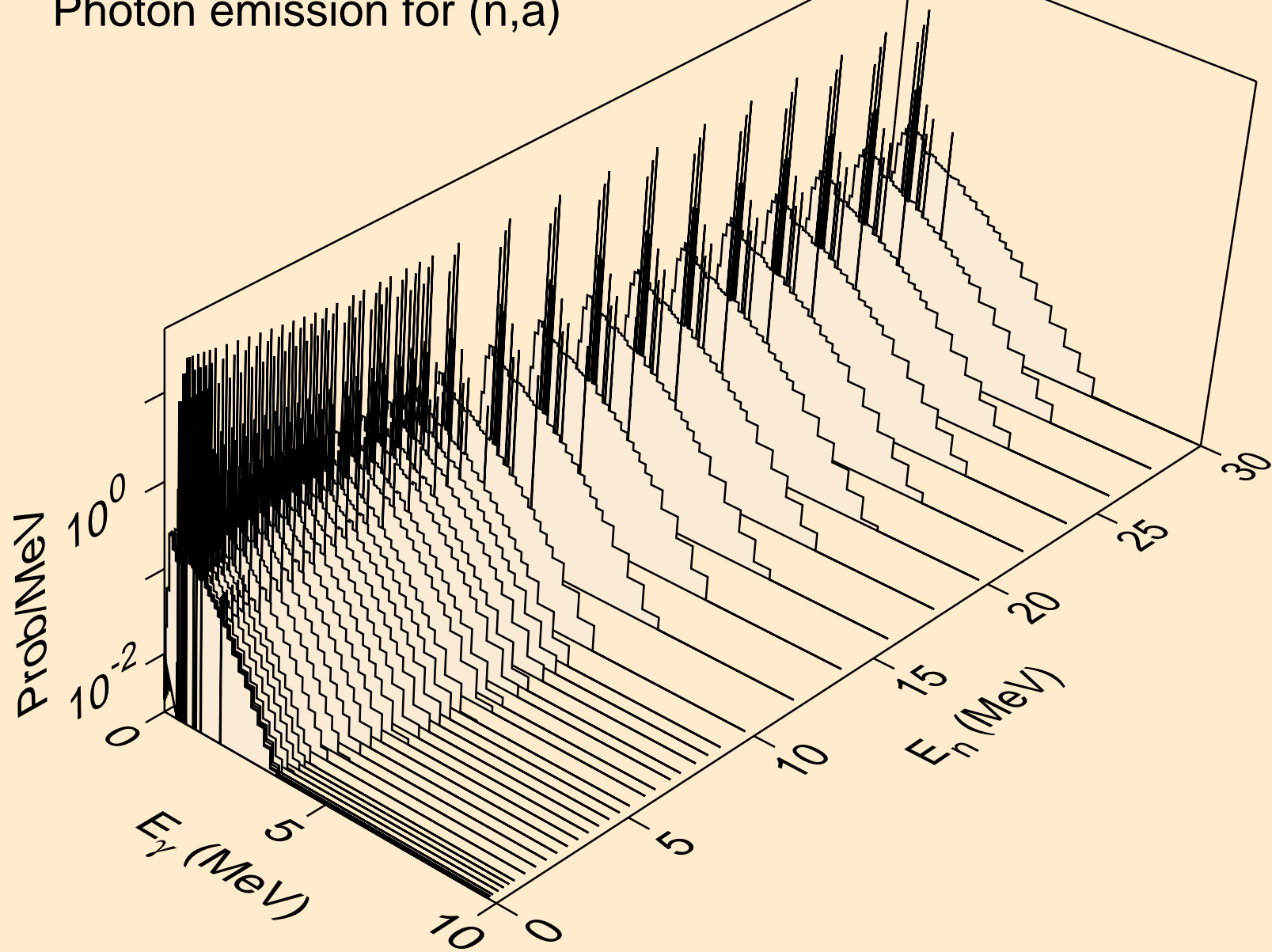

RN205M NEUTRON ACER TENDL-2024 LIBRARY; T=0.K  
Photon emission for (n,2a)

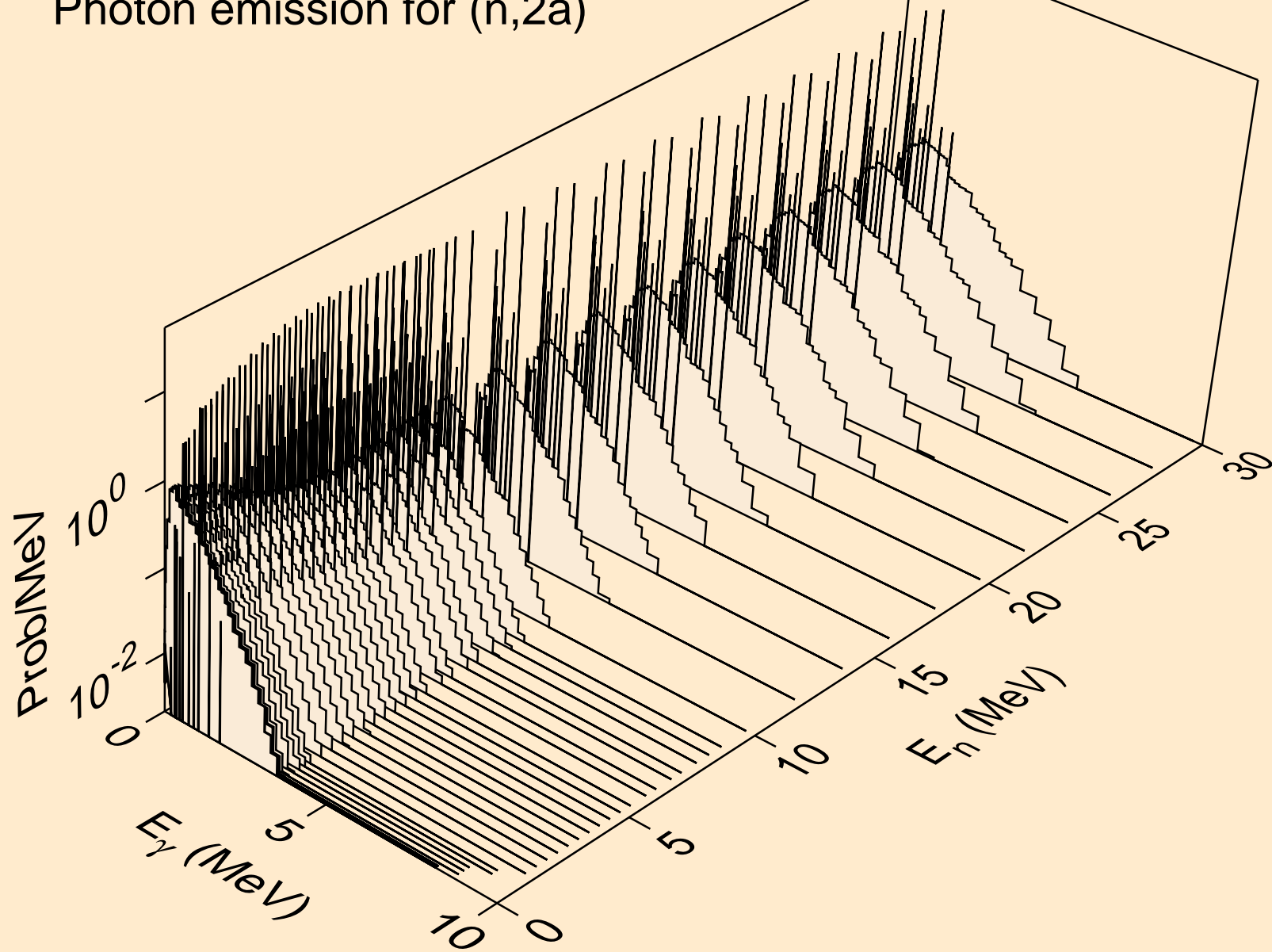

RN205M NEUTRON ACER TENDL-2024 LIBRARY; T=0.K  
Photon emission for (n,2p)

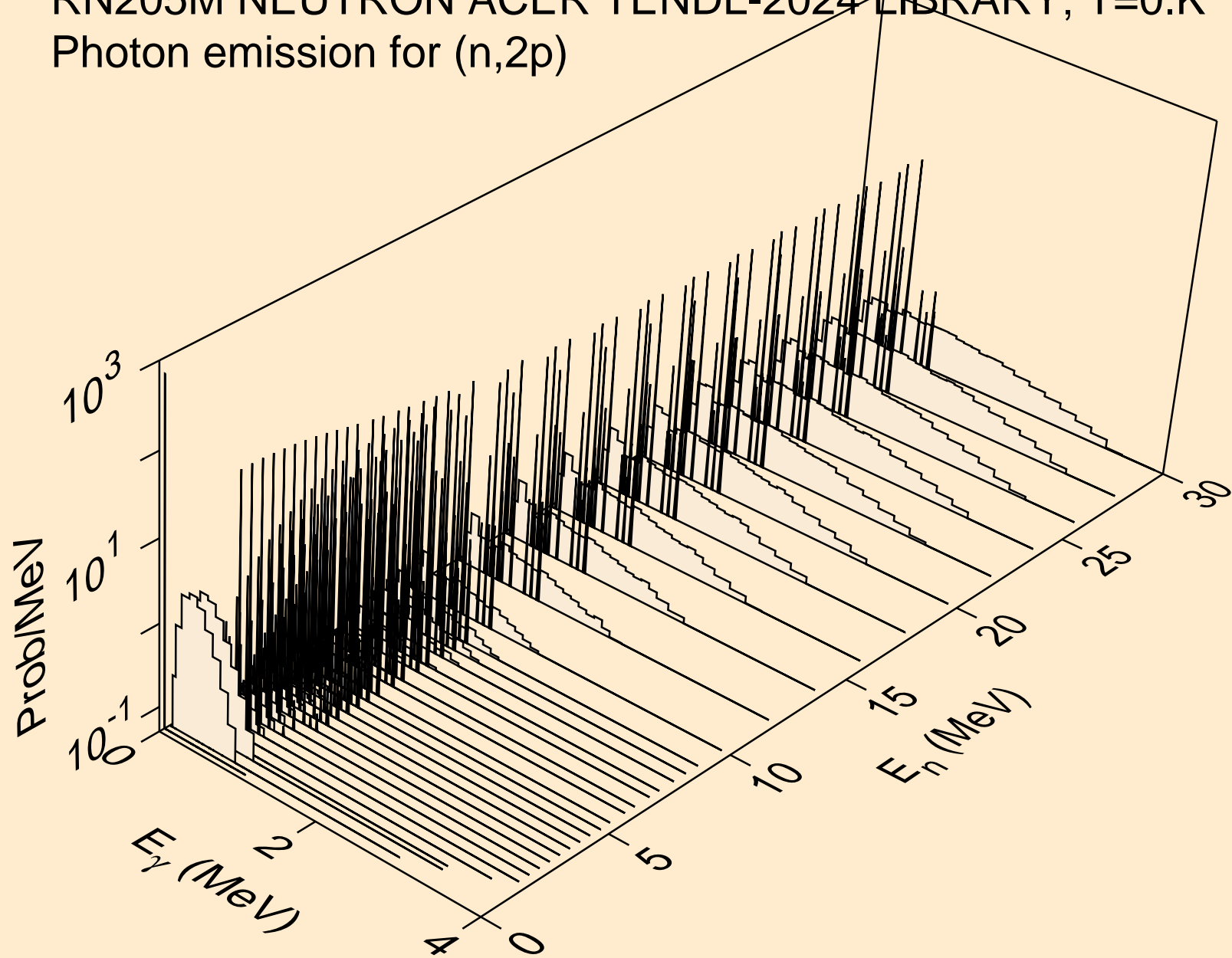

RN205M NEUTRON ACER TENDL-2024 LIBRARY; T=0.K  
Photon emission for (n,p $\alpha$ )

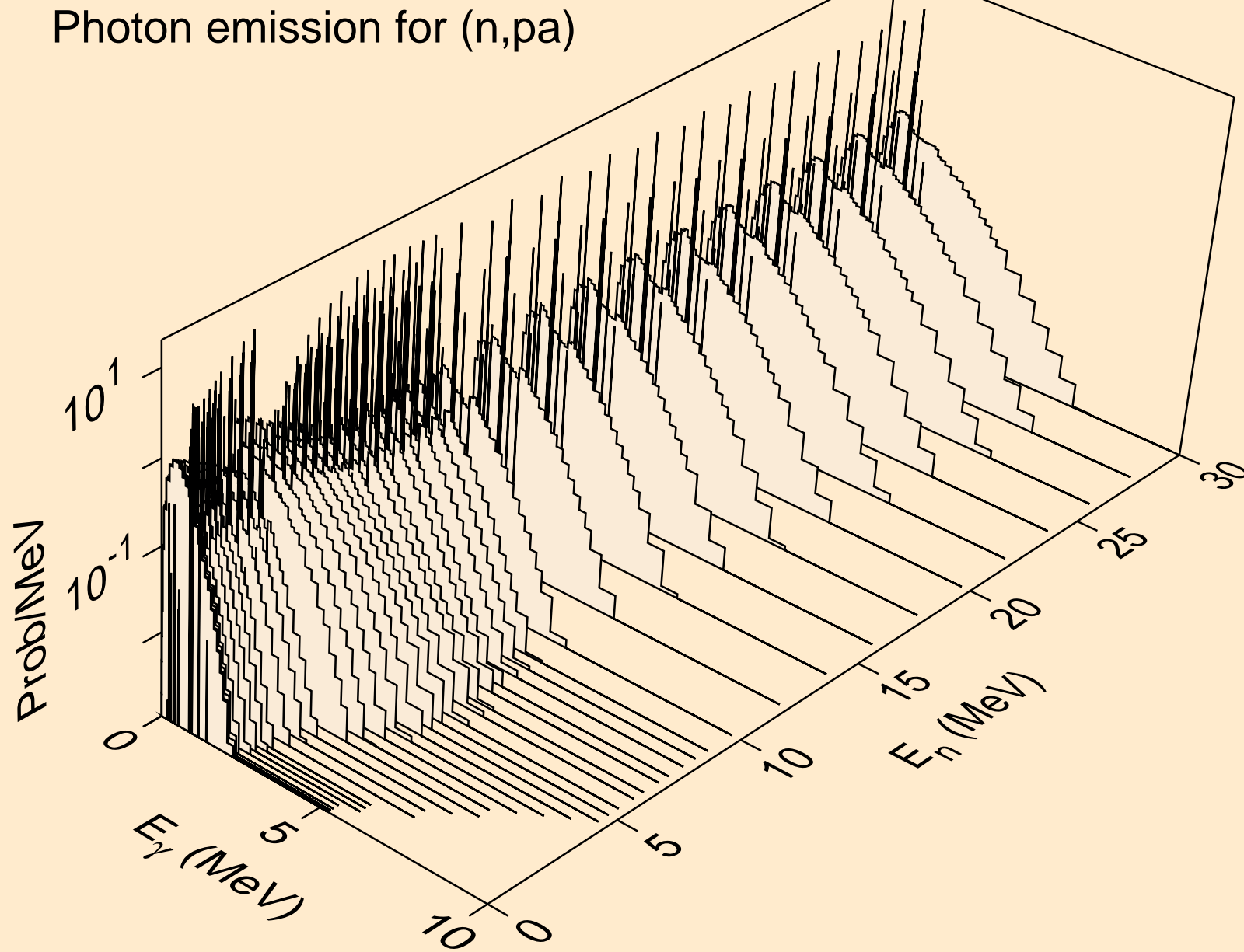

RN205M NEUTRON ACER TENDL-2024 LIBRARY; T=0.K  
Photon emission for (n,pd)

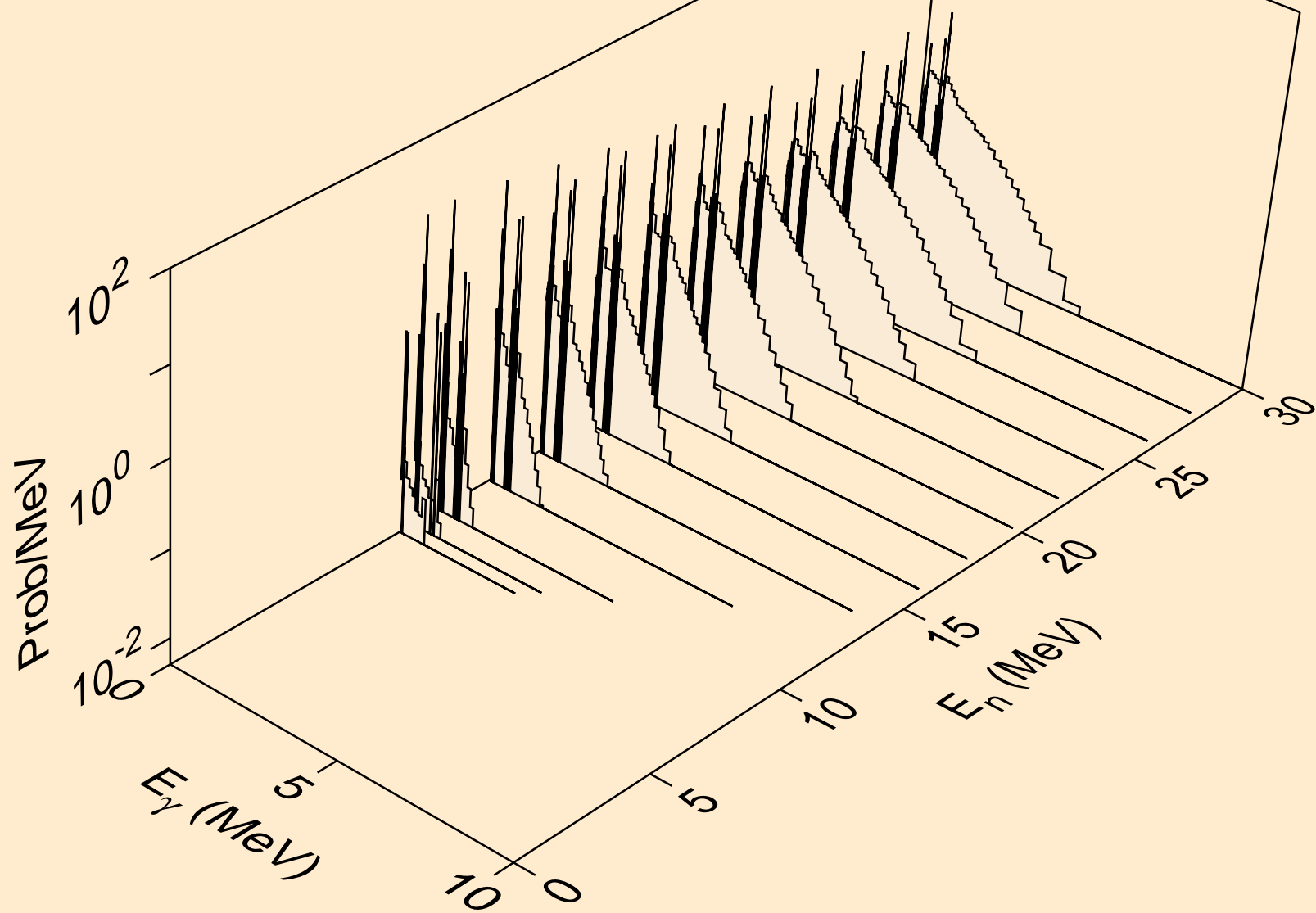

RN205M NEUTRON ACER TENDL-2024 LIBRARY; T=0.K  
Photon emission for (n,pt)

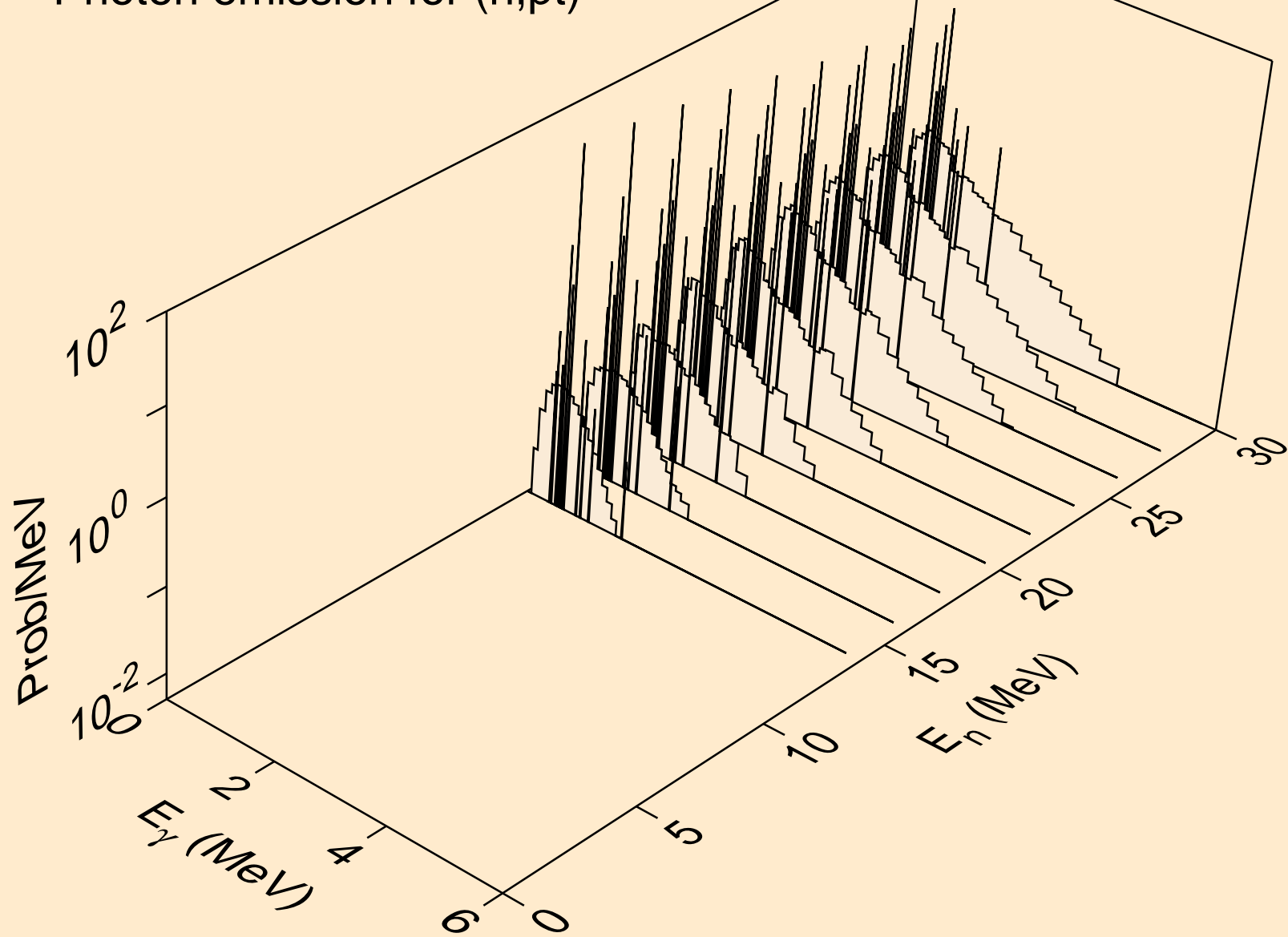

RN205M NEUTRON ACER TENDL-2024 LIBRARY; T=0.K  
Photon emission for (n,da)

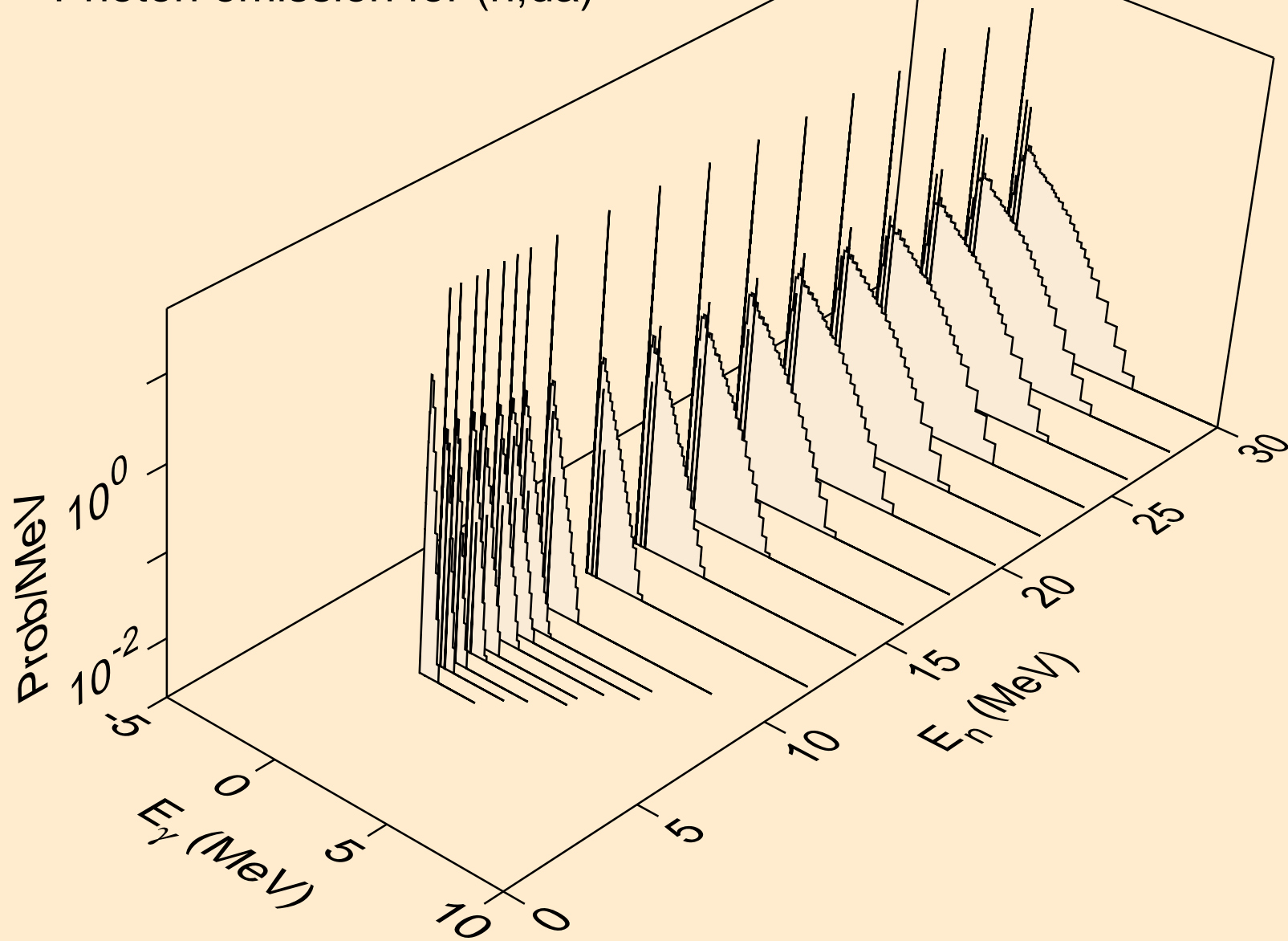

RN205M NEUTRON ACER TENDL-2024 LIBRARY; T=0.K  
thermal capture photon spectrum

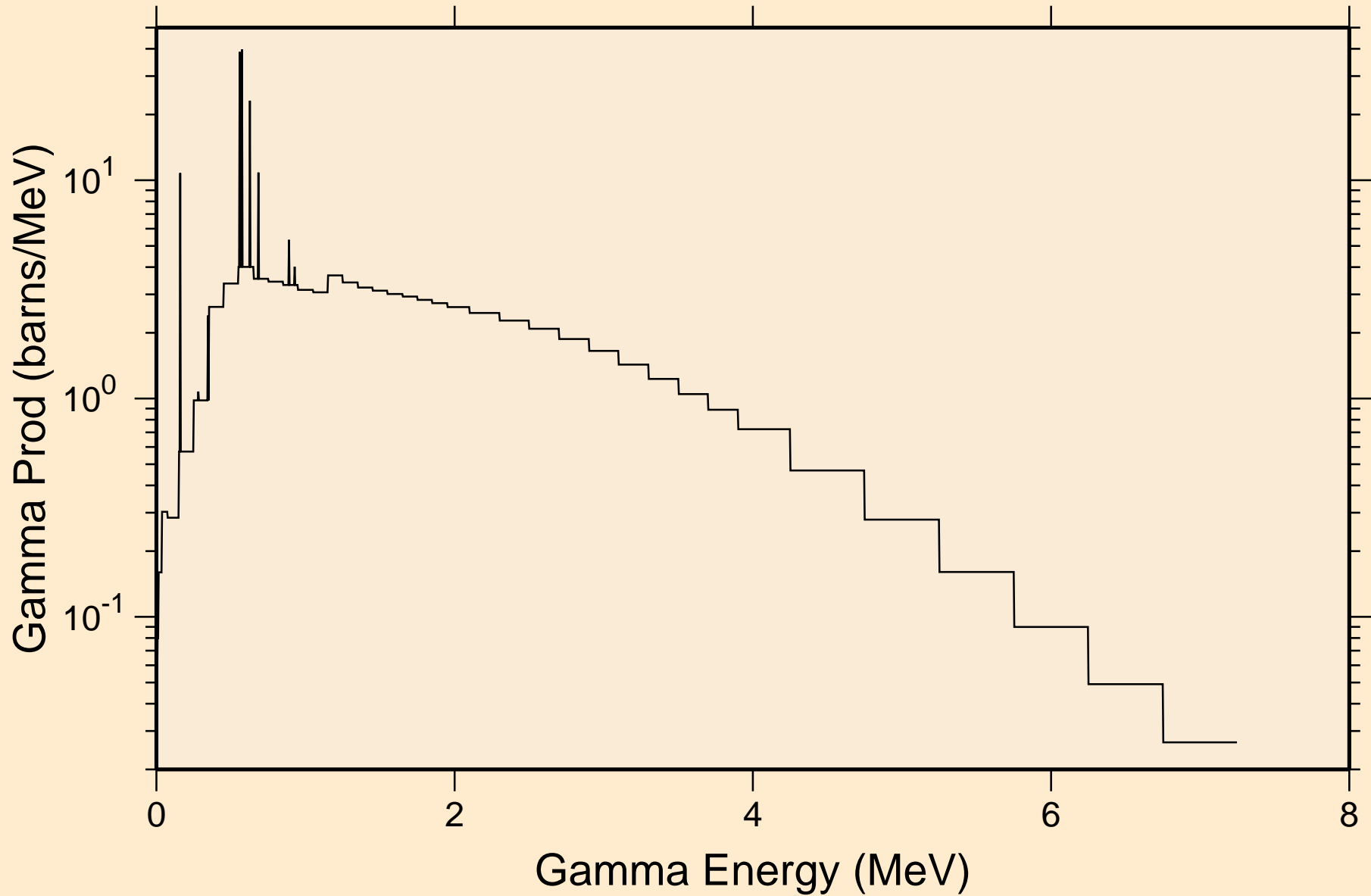

RN205M NEUTRON ACER TENDL-2024 LIBRARY; T=0.K  
14 MeV photon spectrum

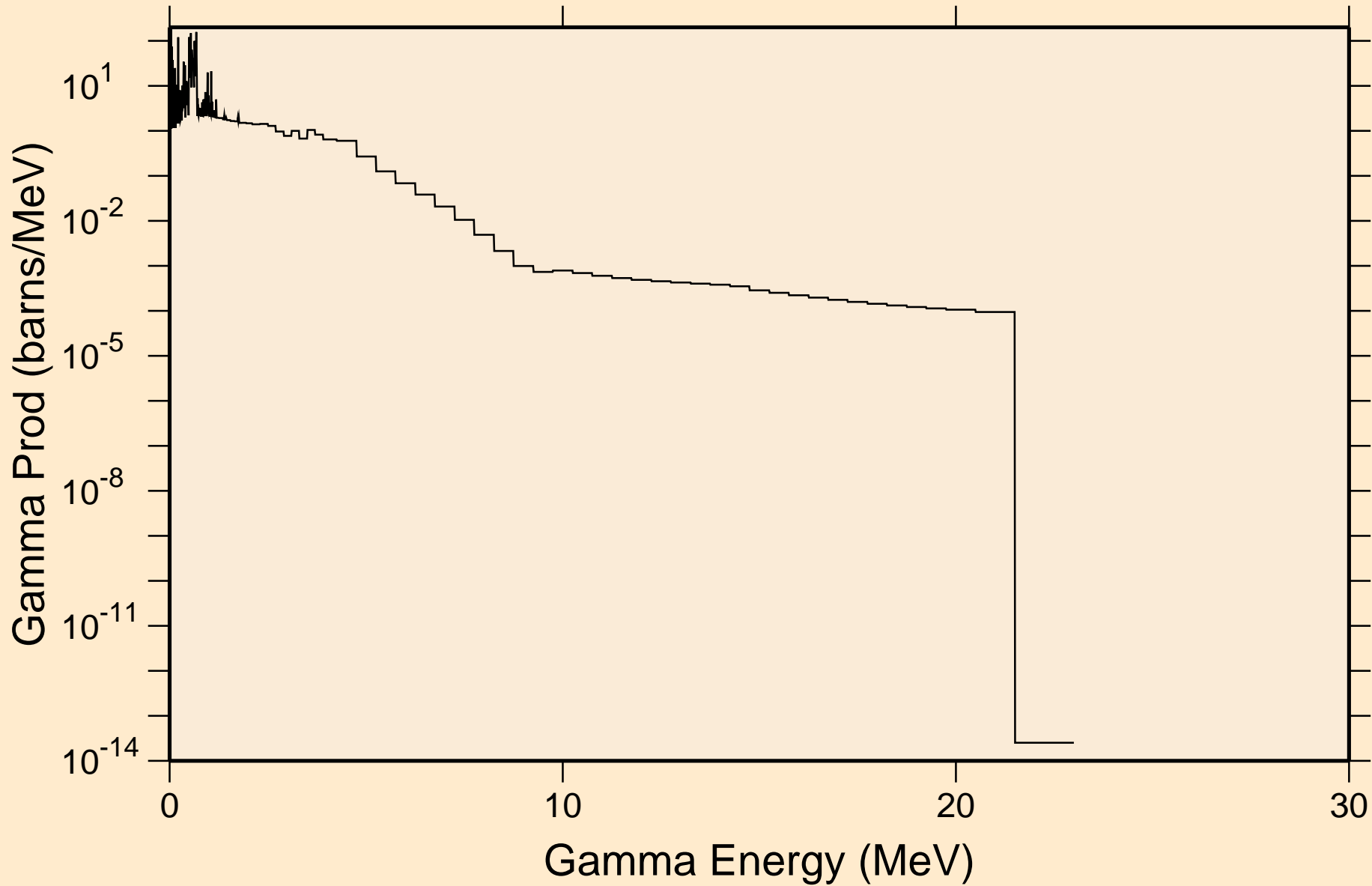

# RN205M NEUTRON ACER TENDL-2024 LIBRARY; T=0.K

## Particle heating contributions

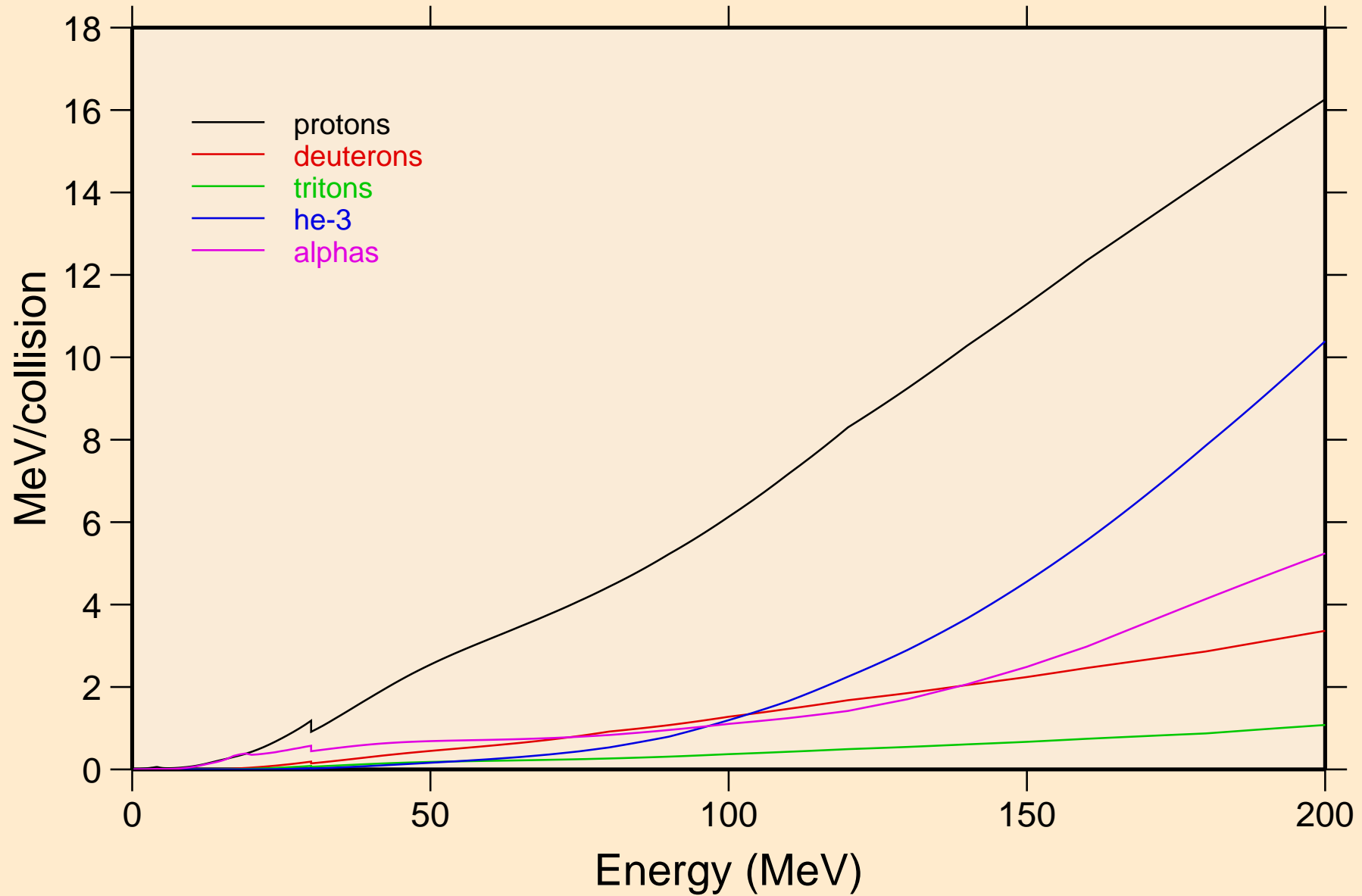

RN205M NEUTRON ACER TENDL-2024 LIBRARY; T=0.K  
Recoil Heating

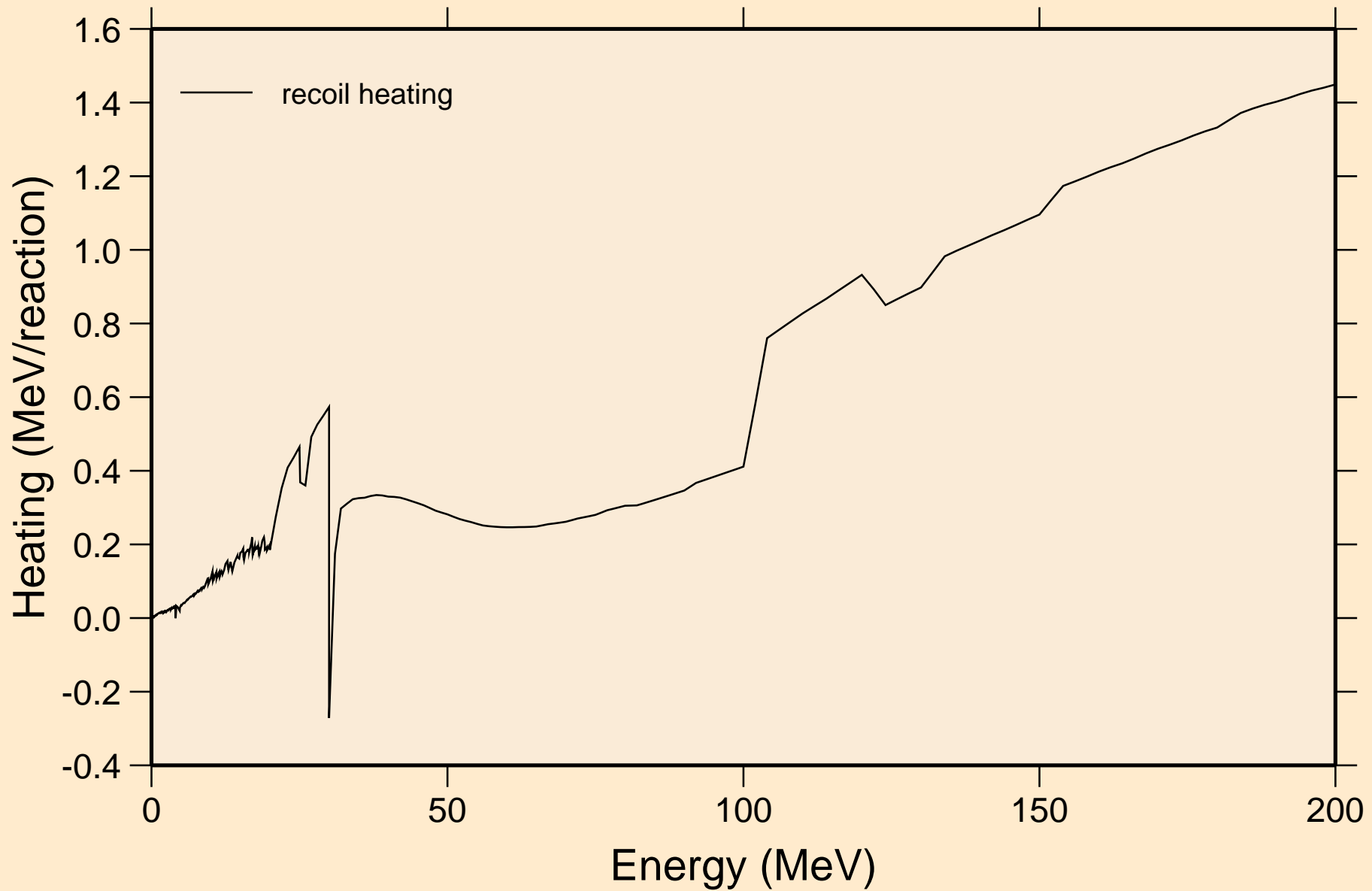

RN205M NEUTRON ACER TENDL-2024 LIBRARY; T=0.K  
Particle production cross sections

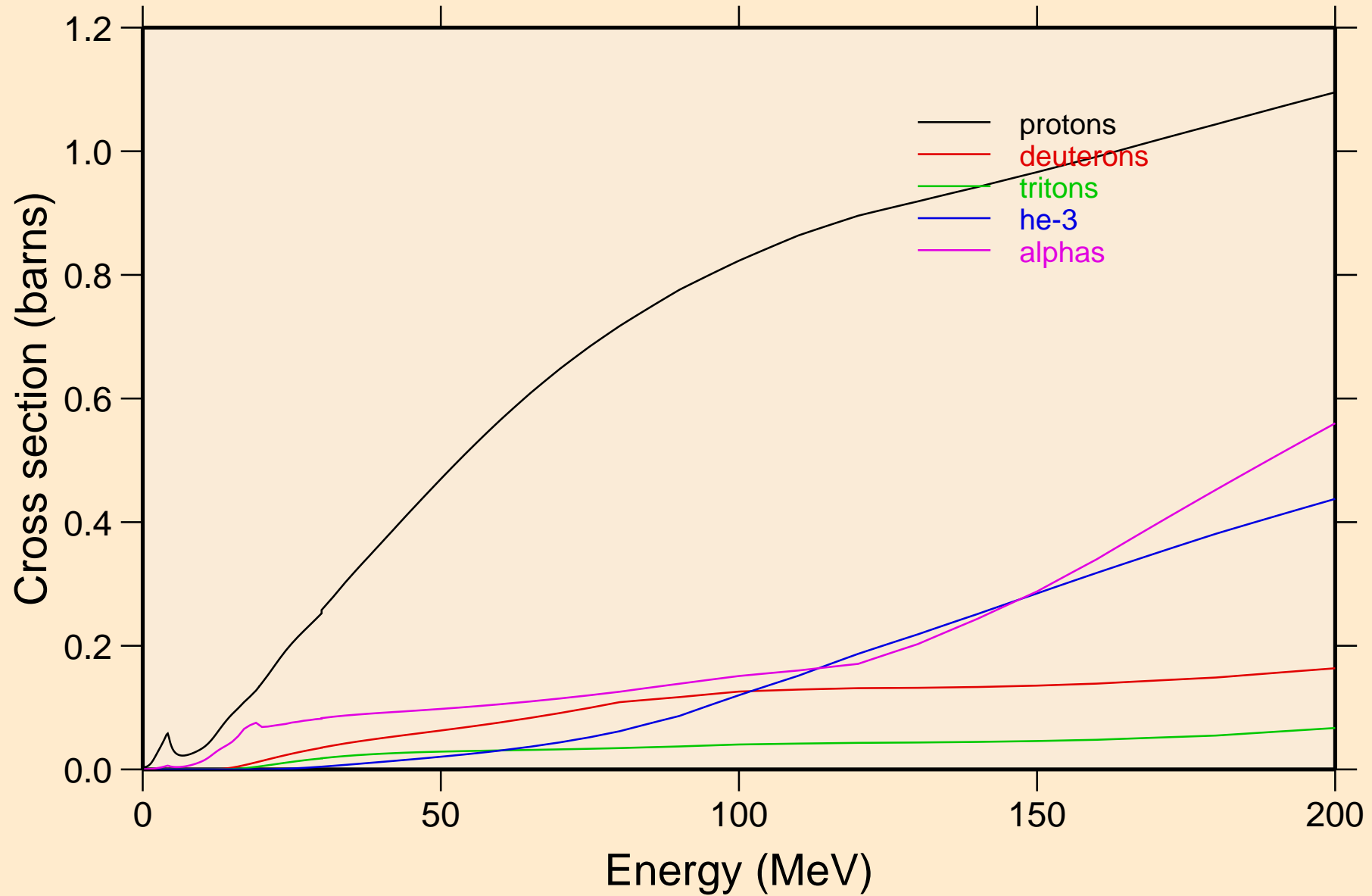

RN205M NEUTRON ACER TENDL-2024 LIBRARY; T=0.K  
protons from (n,x)

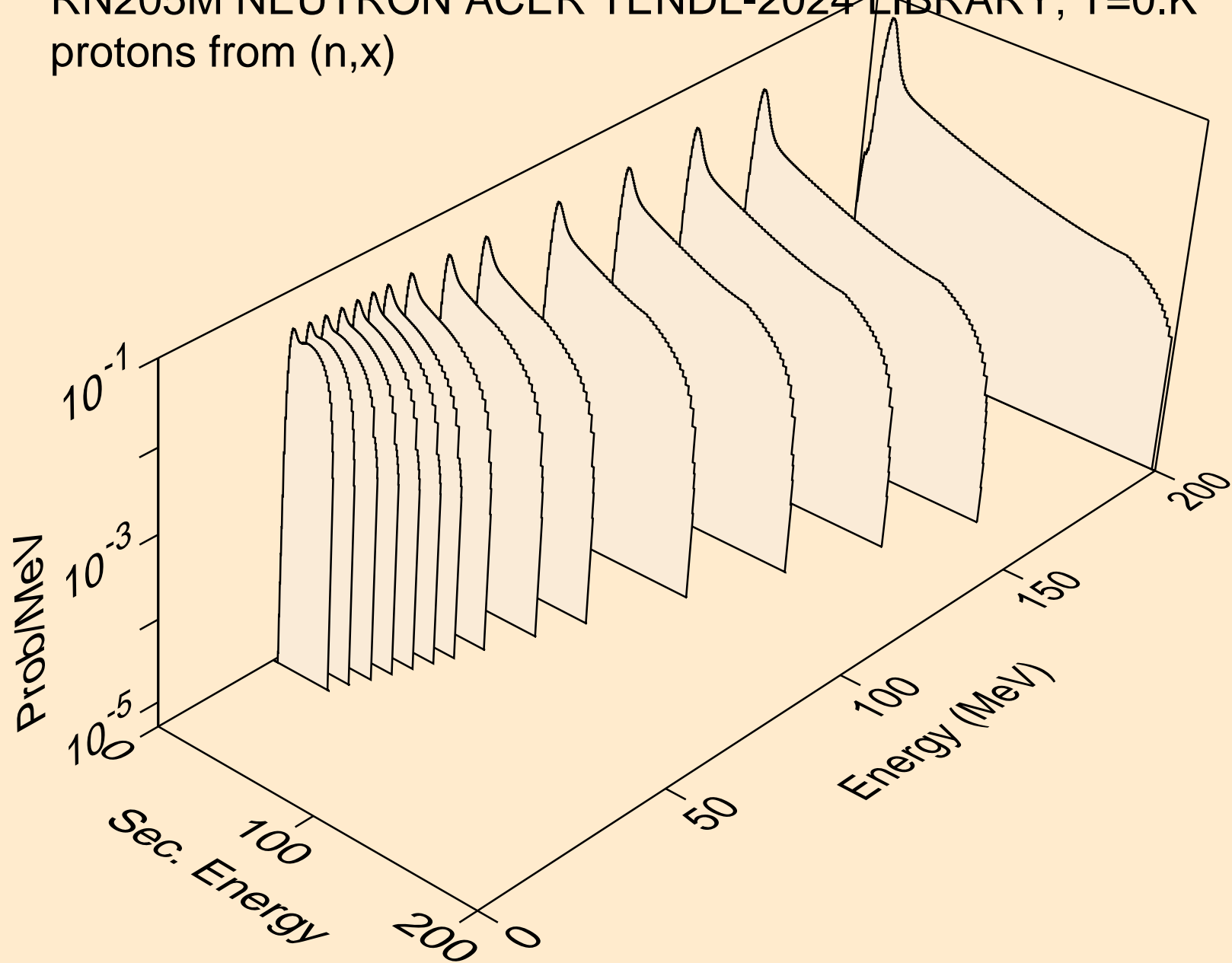

RN205M NEUTRON ACER TENDL-2024 LIBRARY; T=0.K  
protons from (n,n\*)p

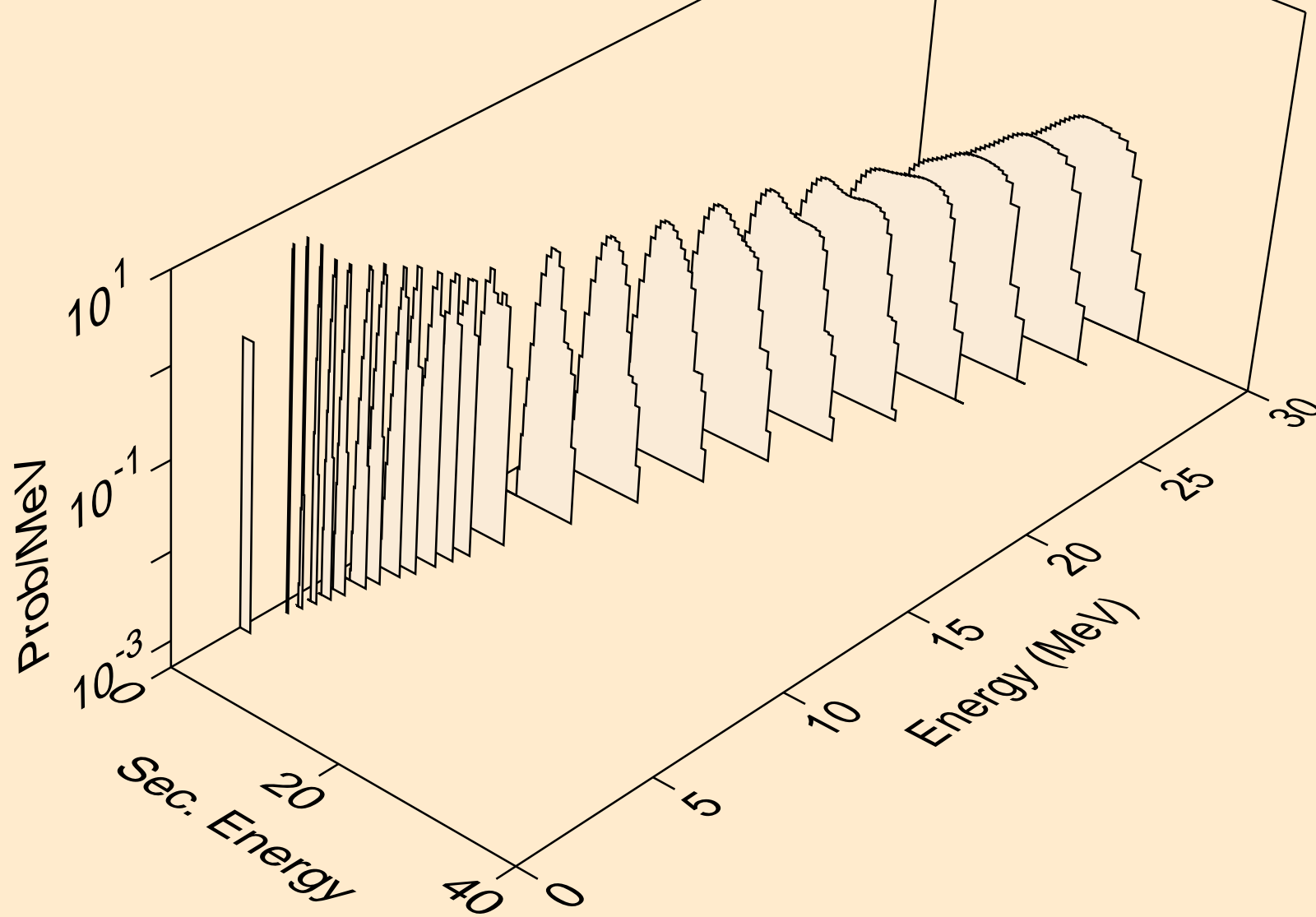

RN205M NEUTRON ACER TENDL-2024 LIBRARY; T=0.K  
protons from (n,2np)

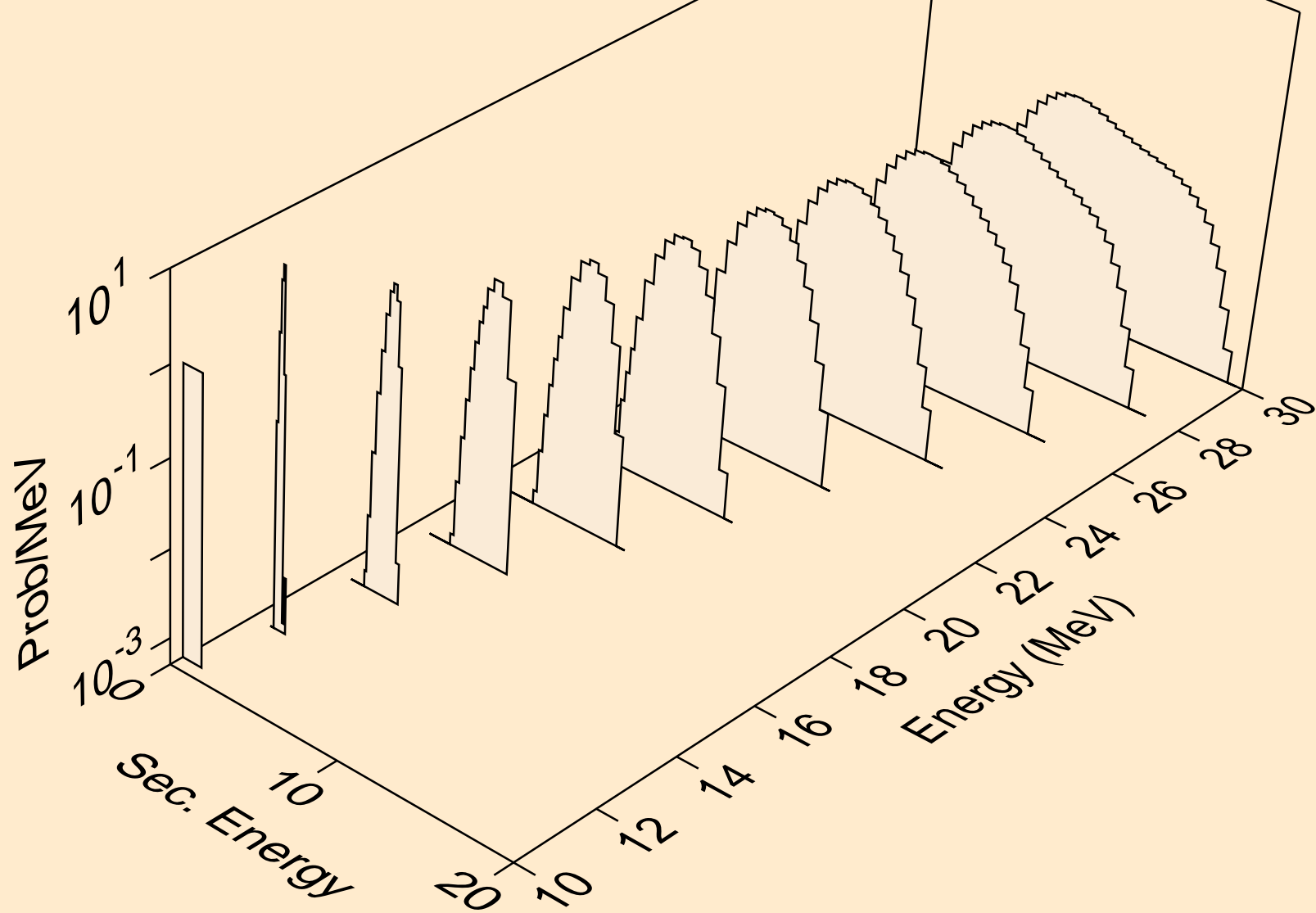

RN205M NEUTRON ACER TENDL-2024 LIBRARY; T=0.K  
protons from (n,3np)

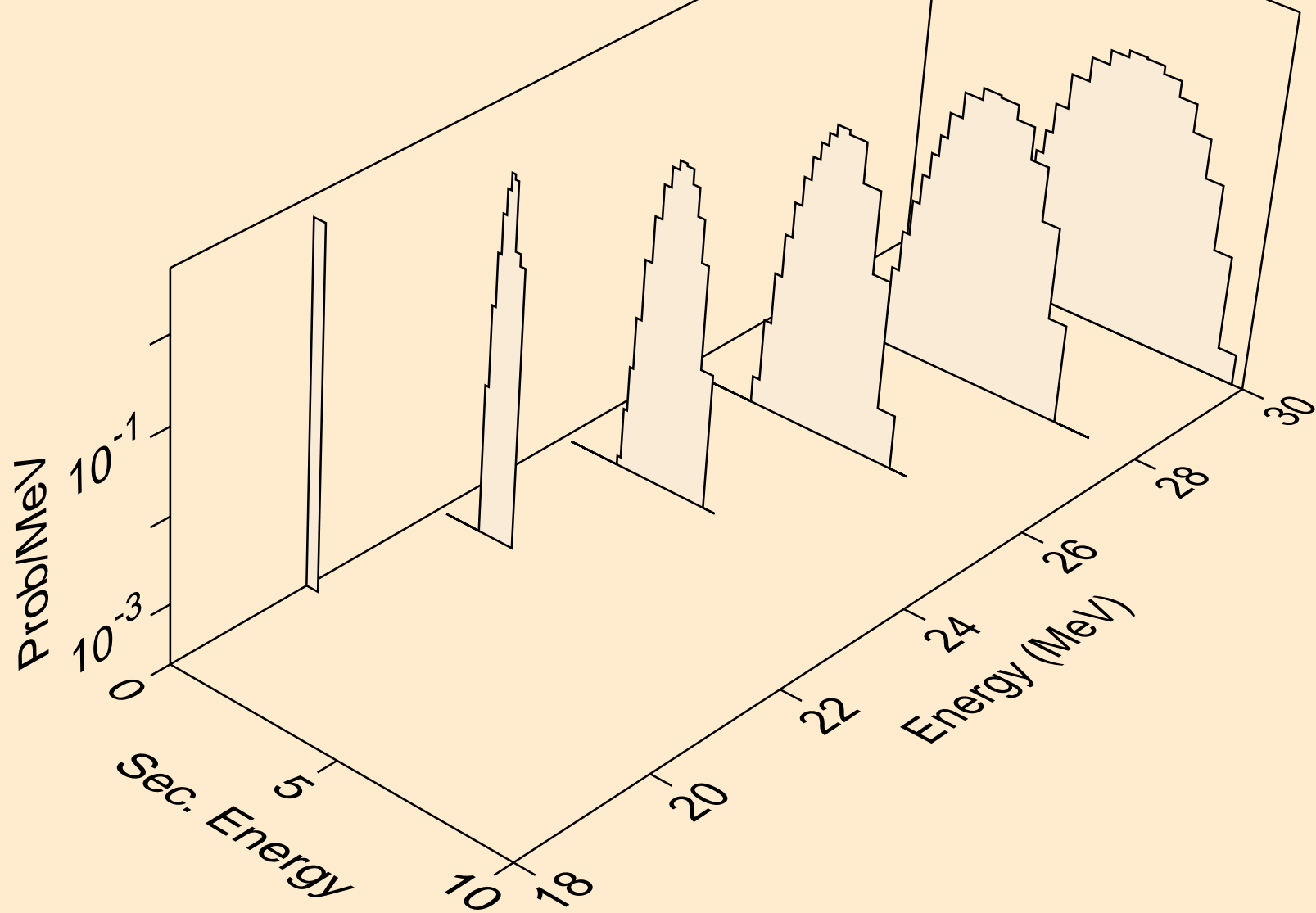

RN205M NEUTRON ACER TENDL-2024 LIBRARY; T=0.K  
protons from (n,n2p)

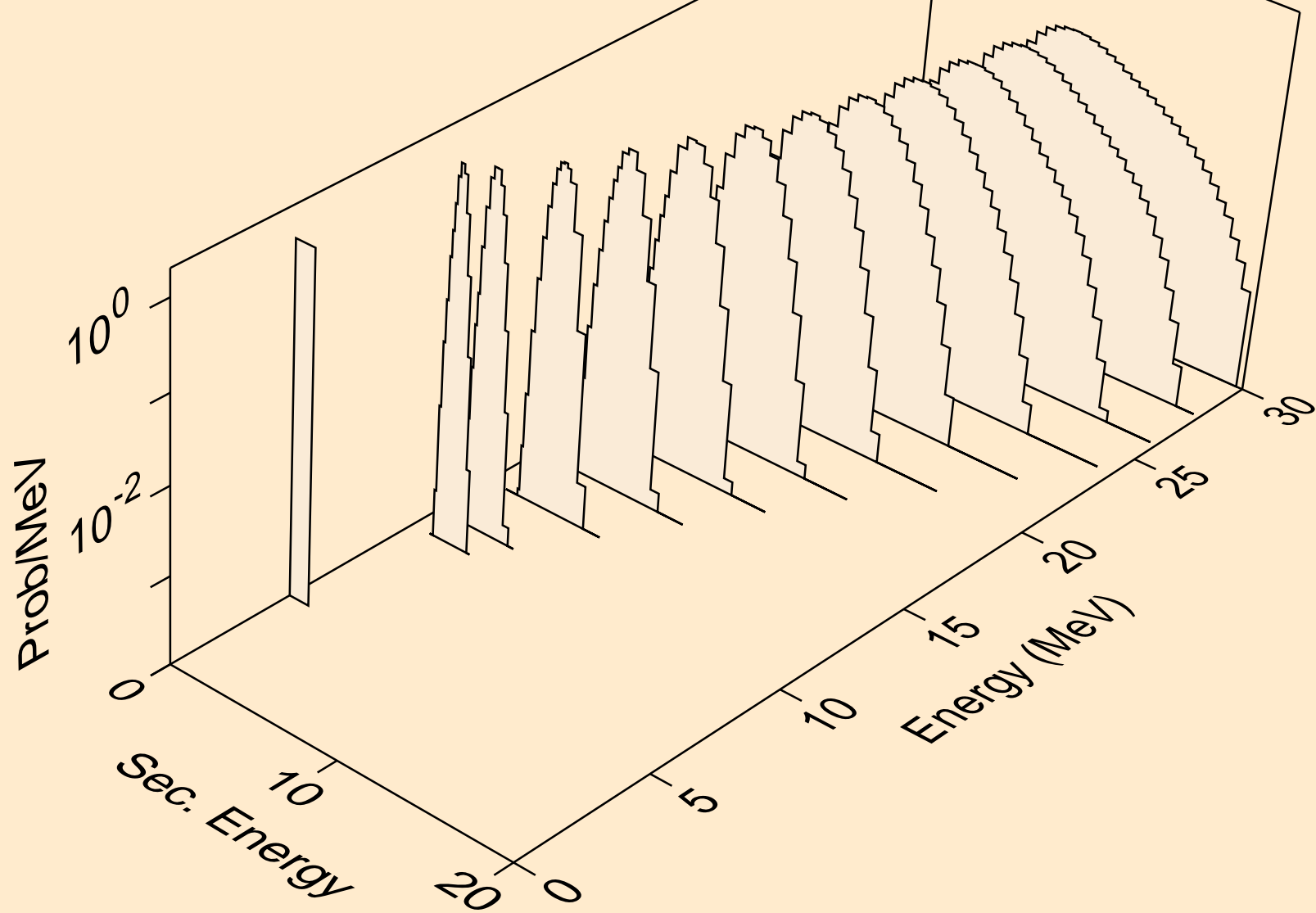

RN205M NEUTRON ACER TENDL-2024 LIBRARY; T=0.K  
protons from (n,npa)

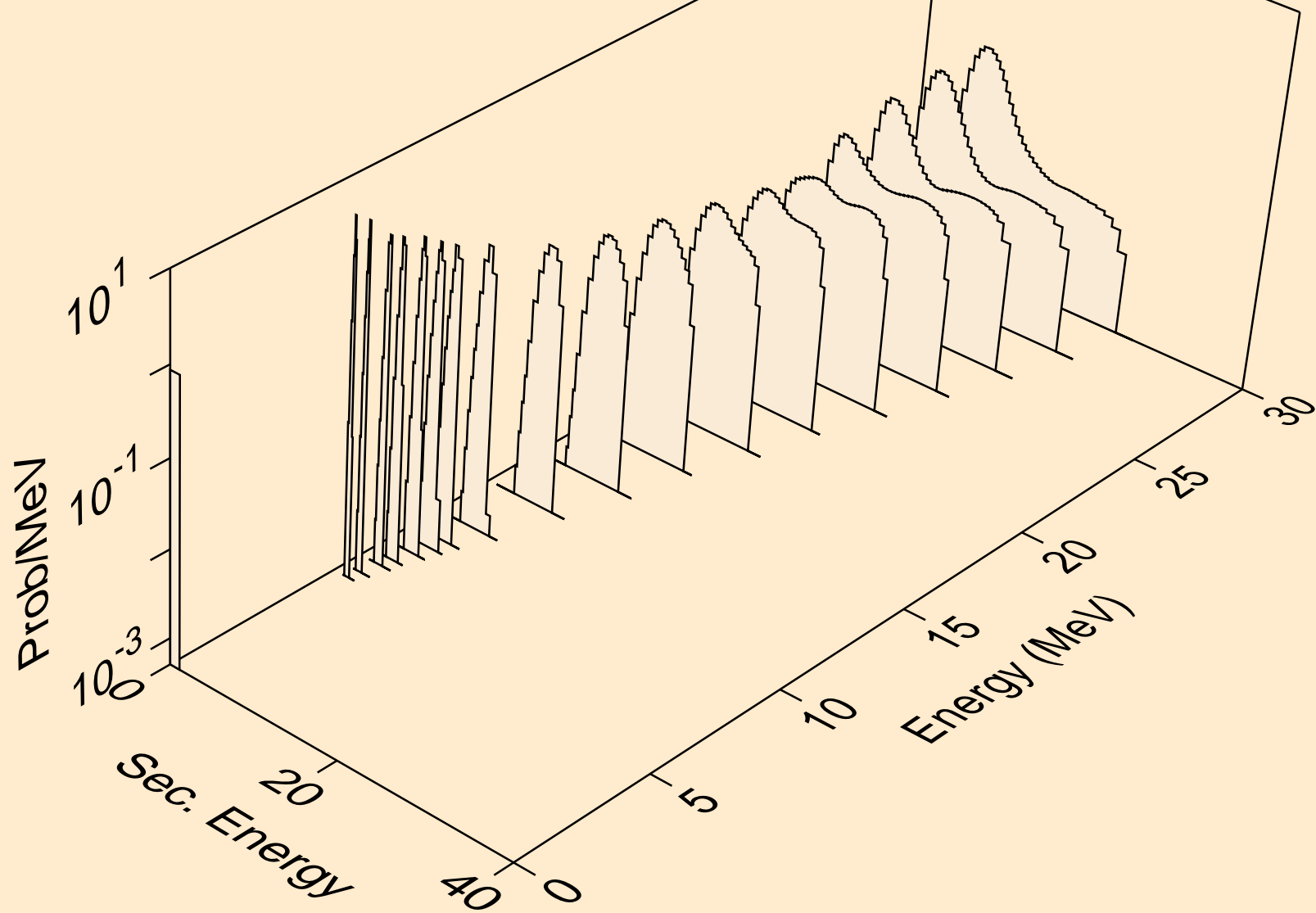

RN205M NEUTRON ACER TENDL-2024 LIBRARY; T=0.K  
protons from (n,p)

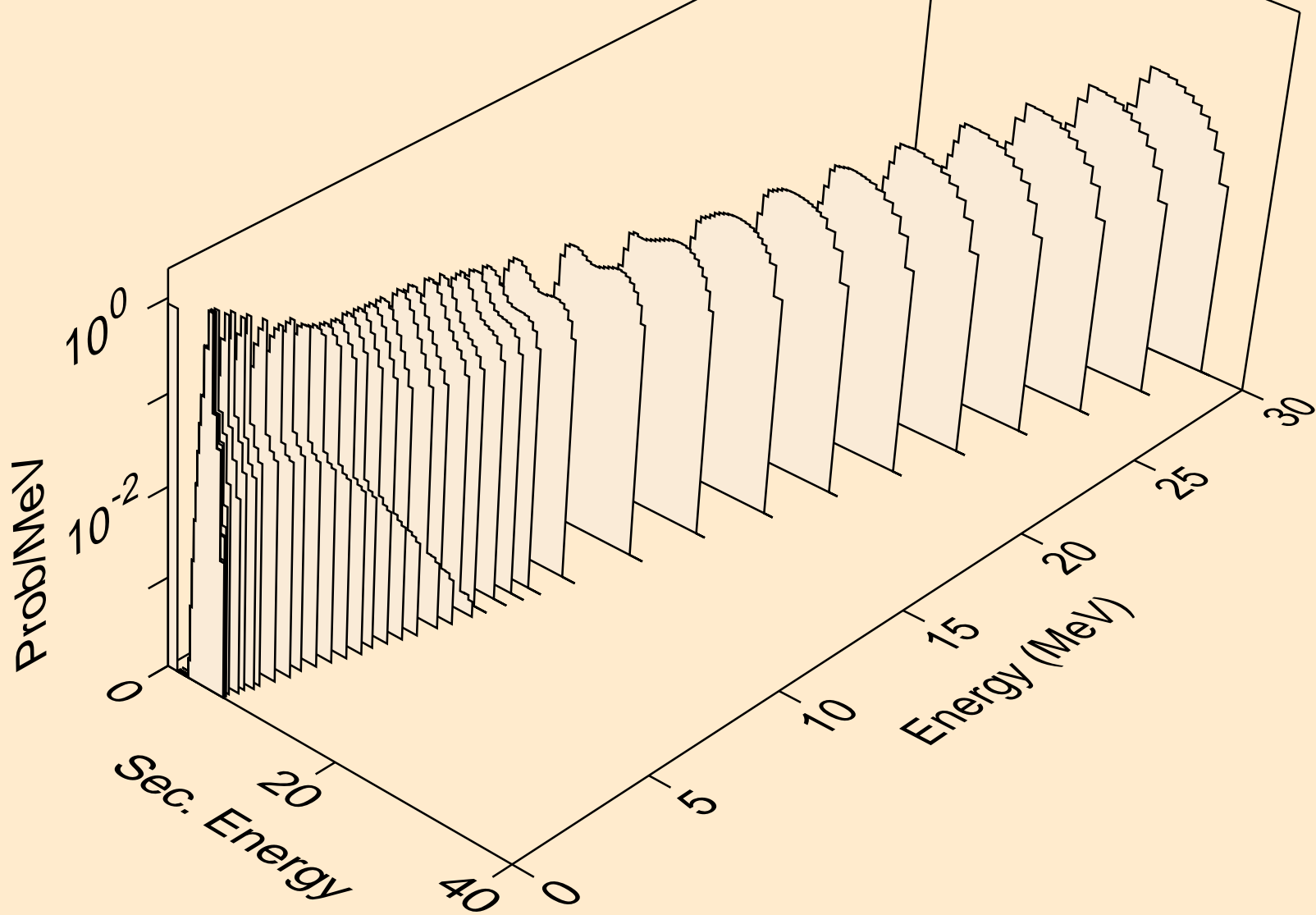

RN205M NEUTRON ACER TENDL-2024 LIBRARY; T=0.K  
protons from (n,2p)

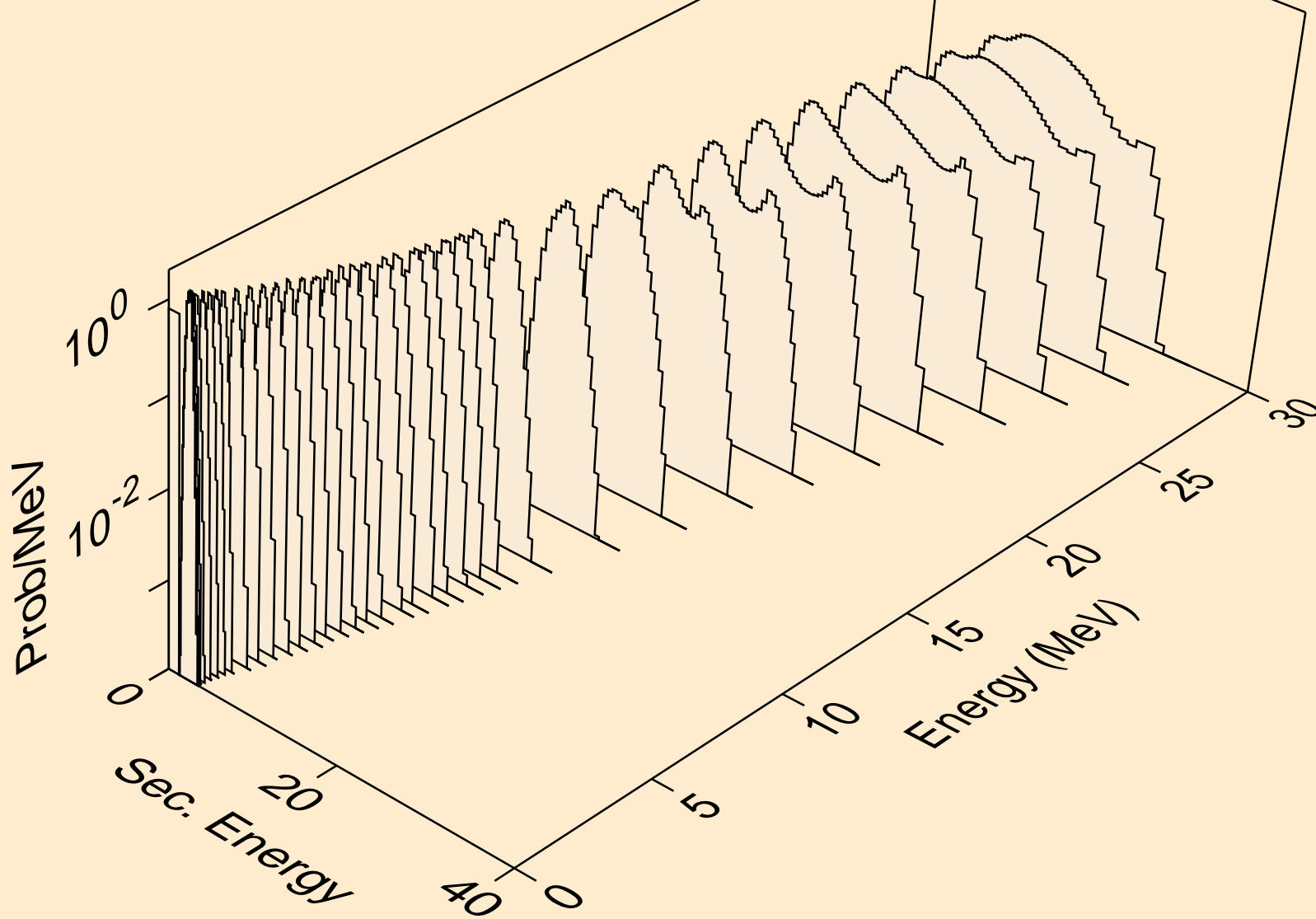

RN205M NEUTRON ACER TENDL-2024 LIBRARY; T=0.K  
protons from (n,p)

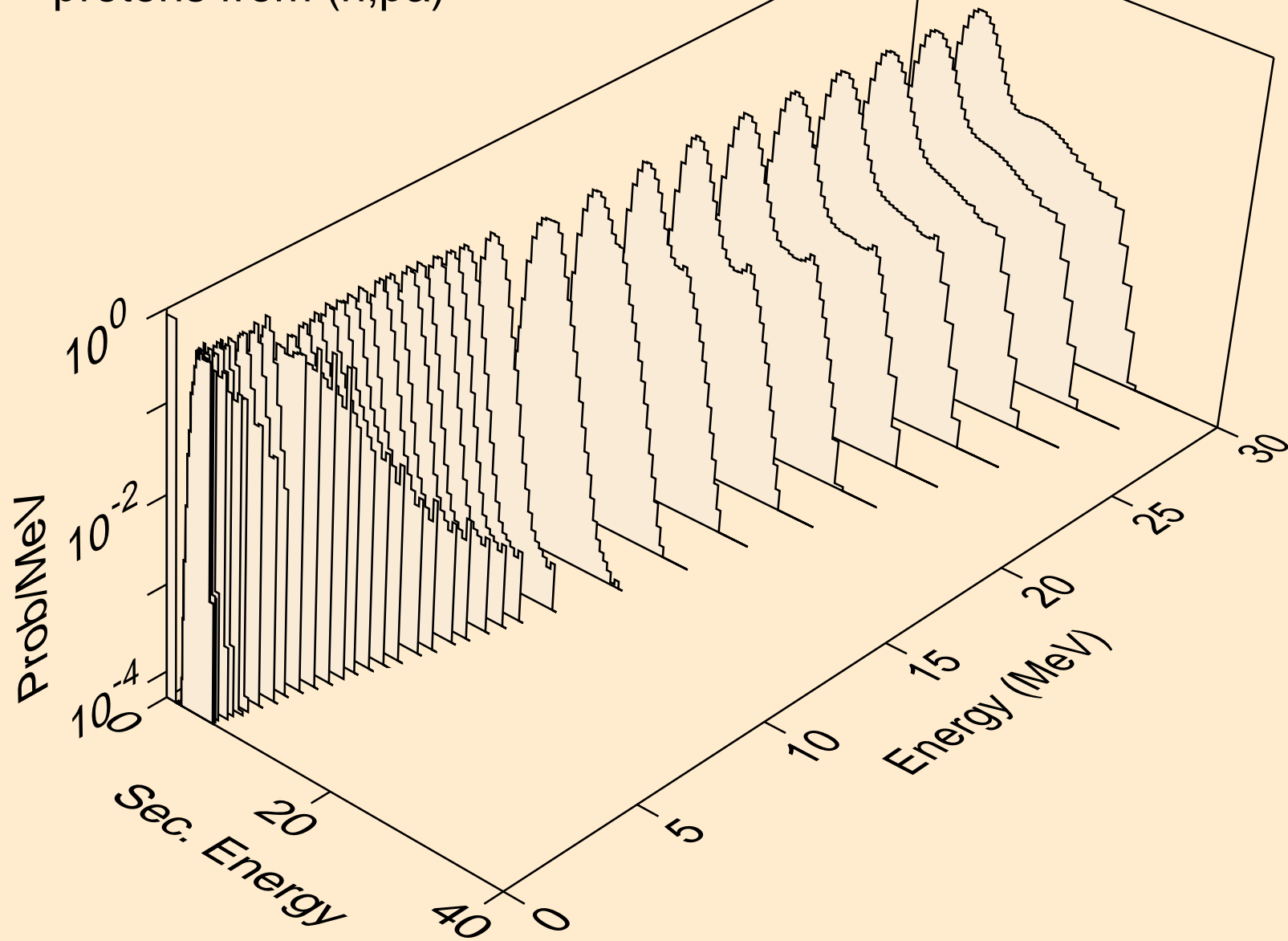

RN205M NEUTRON ACER TENDL-2024 LIBRARY; T=0.K  
protons from (n,pd)

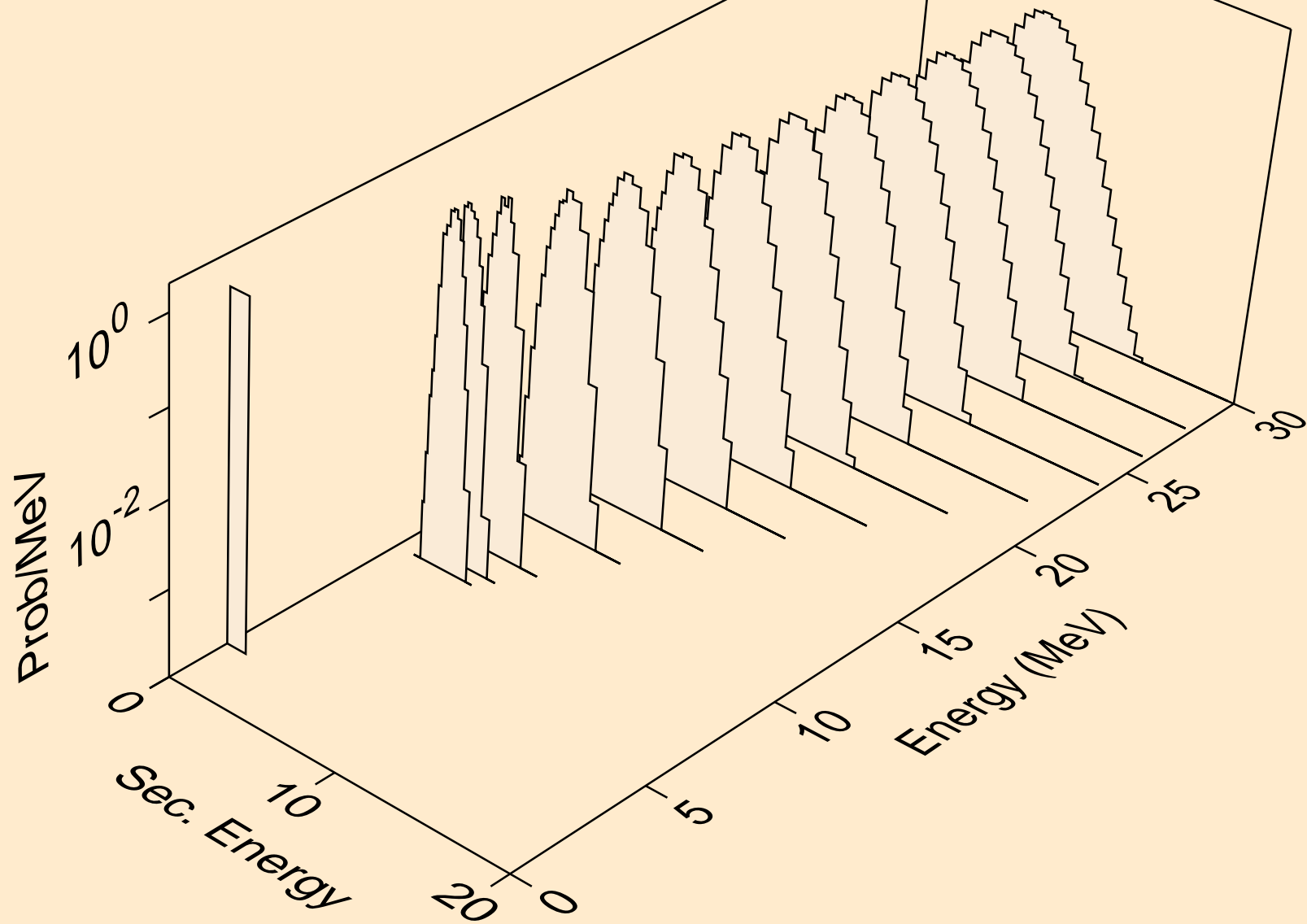

RN205M NEUTRON ACER TENDL-2024 LIBRARY; T=0.K  
protons from (n,pt)

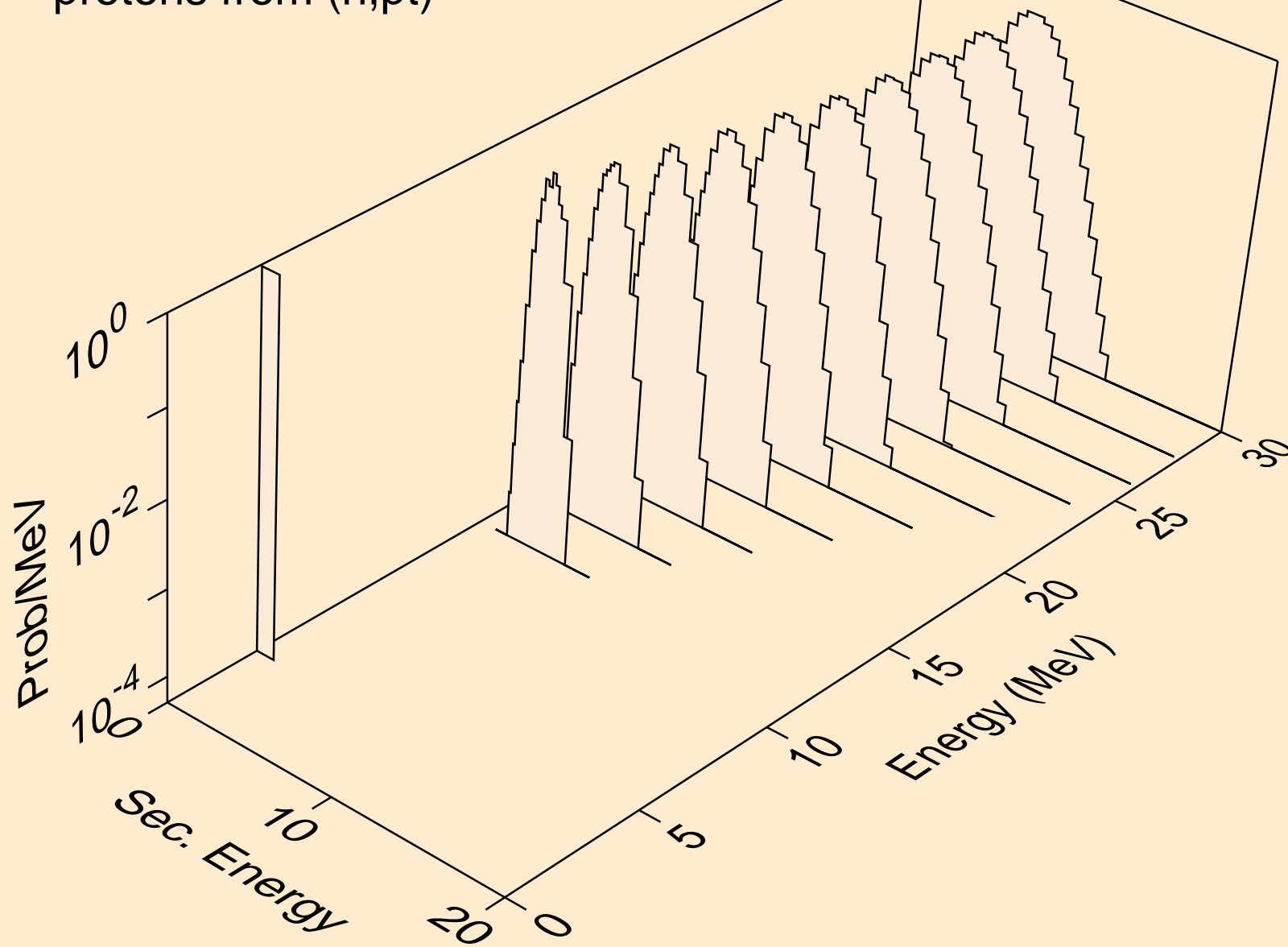

RN205M NEUTRON ACER TENDL-2024 LIBRARY; T=0.K  
deuterons from (n,x)

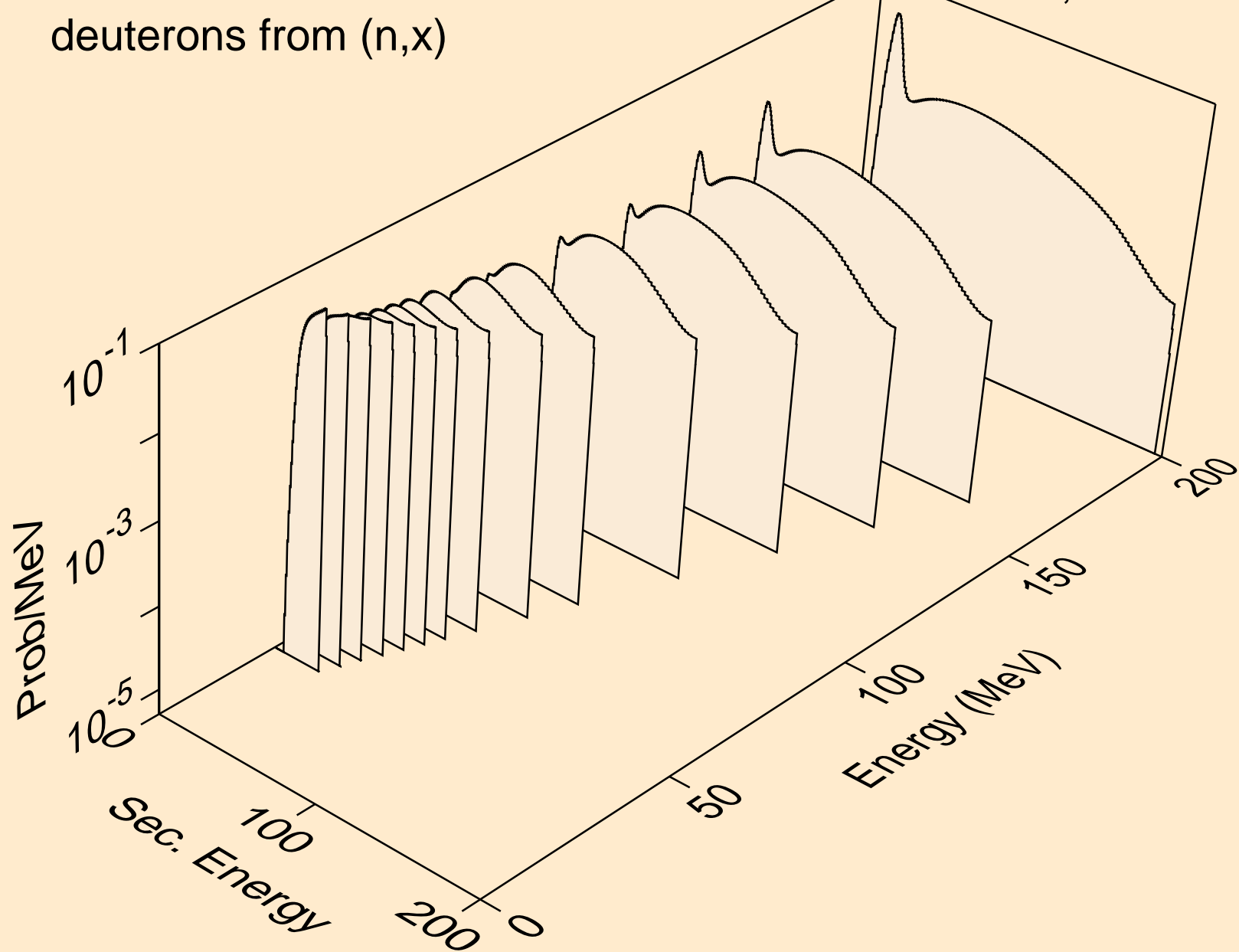

RN205M NEUTRON ACER TENDL-2024 LIBRARY; T=0.K  
deuterons from (n,2nd)

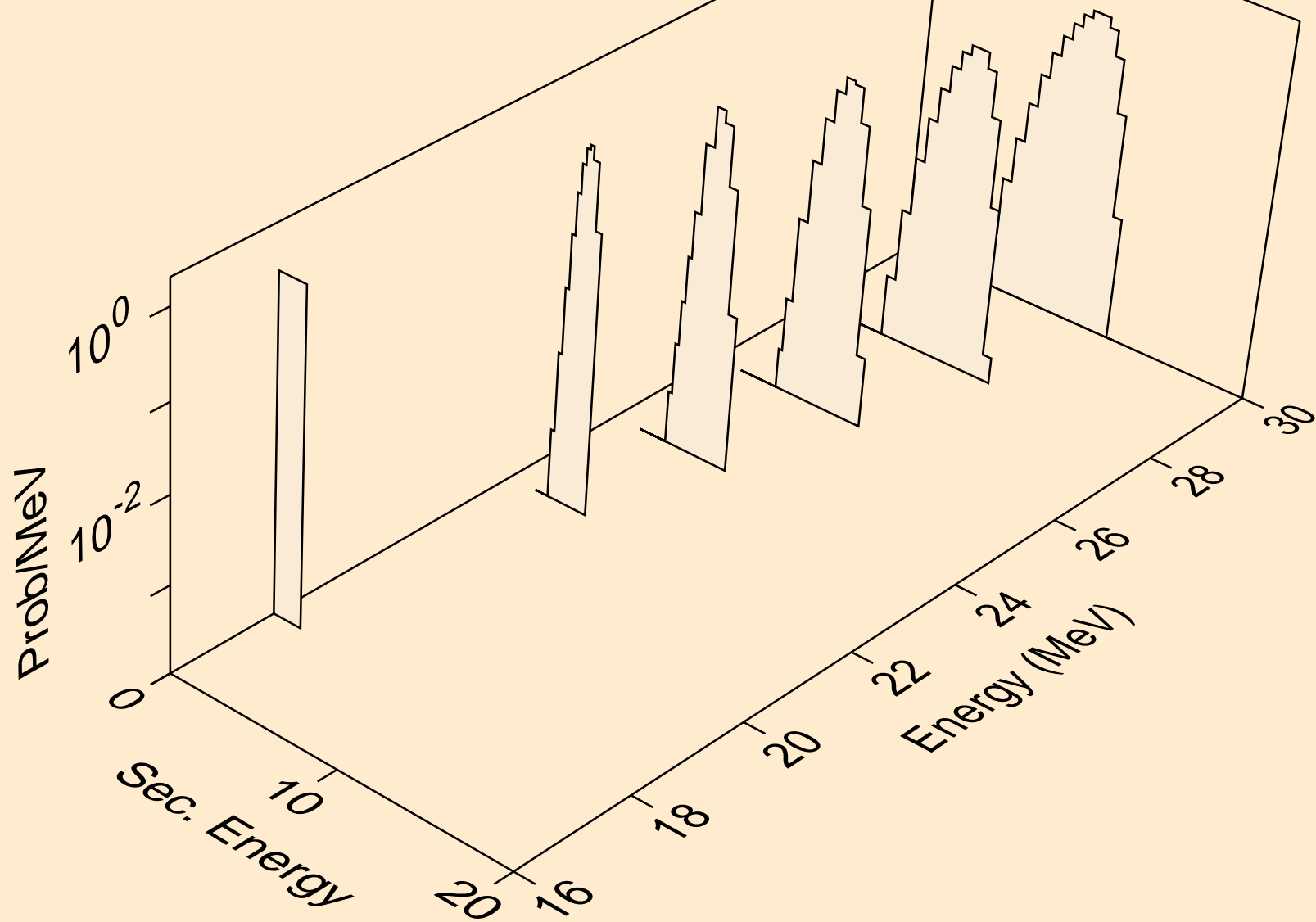

RN205M NEUTRON ACER TENDL-2024 LIBRARY; T=0.K  
deuterons from (n,n\*)d

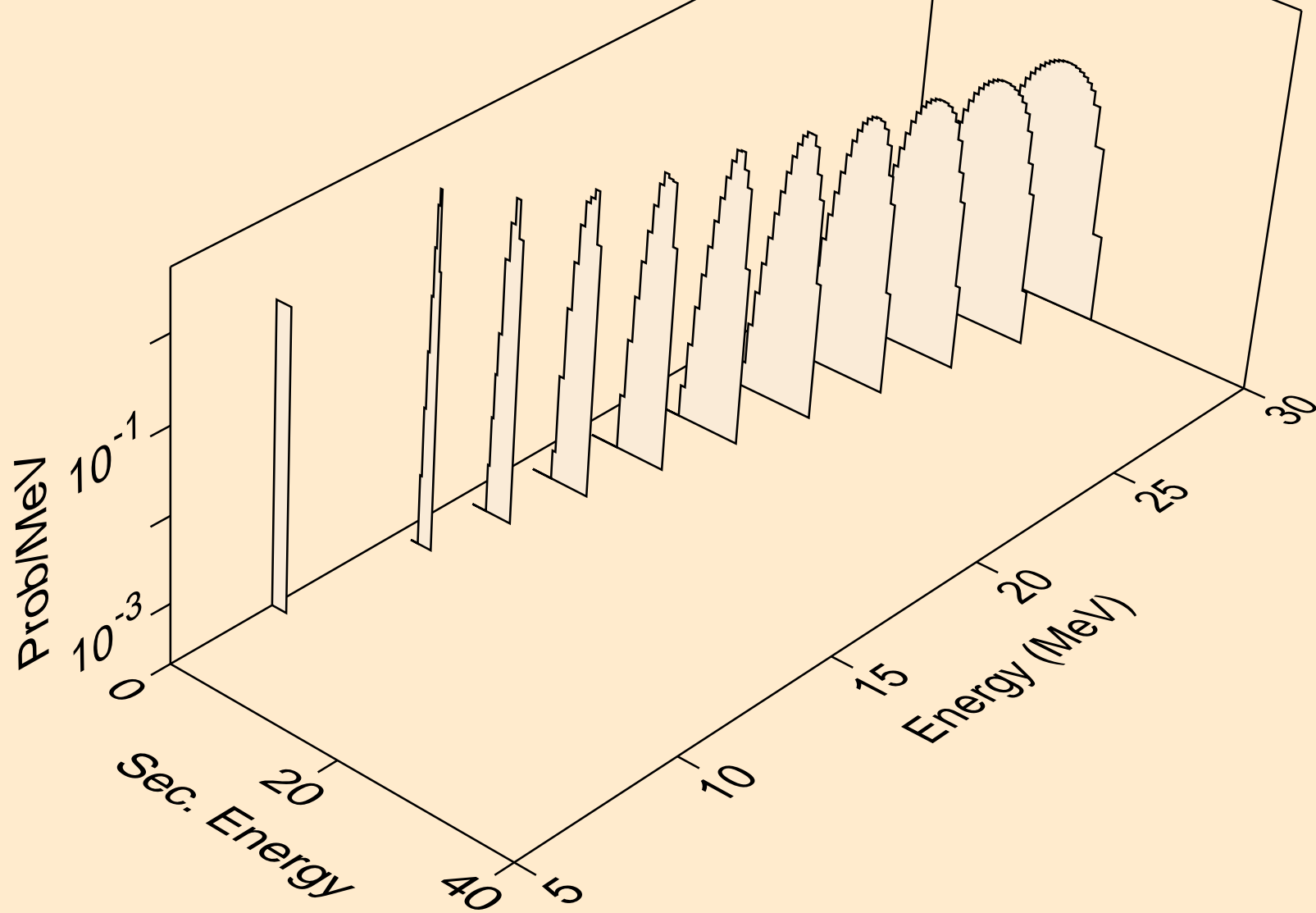

RN205M NEUTRON ACER TENDL-2024 LIBRARY; T=0.K  
deuterons from (n,d)

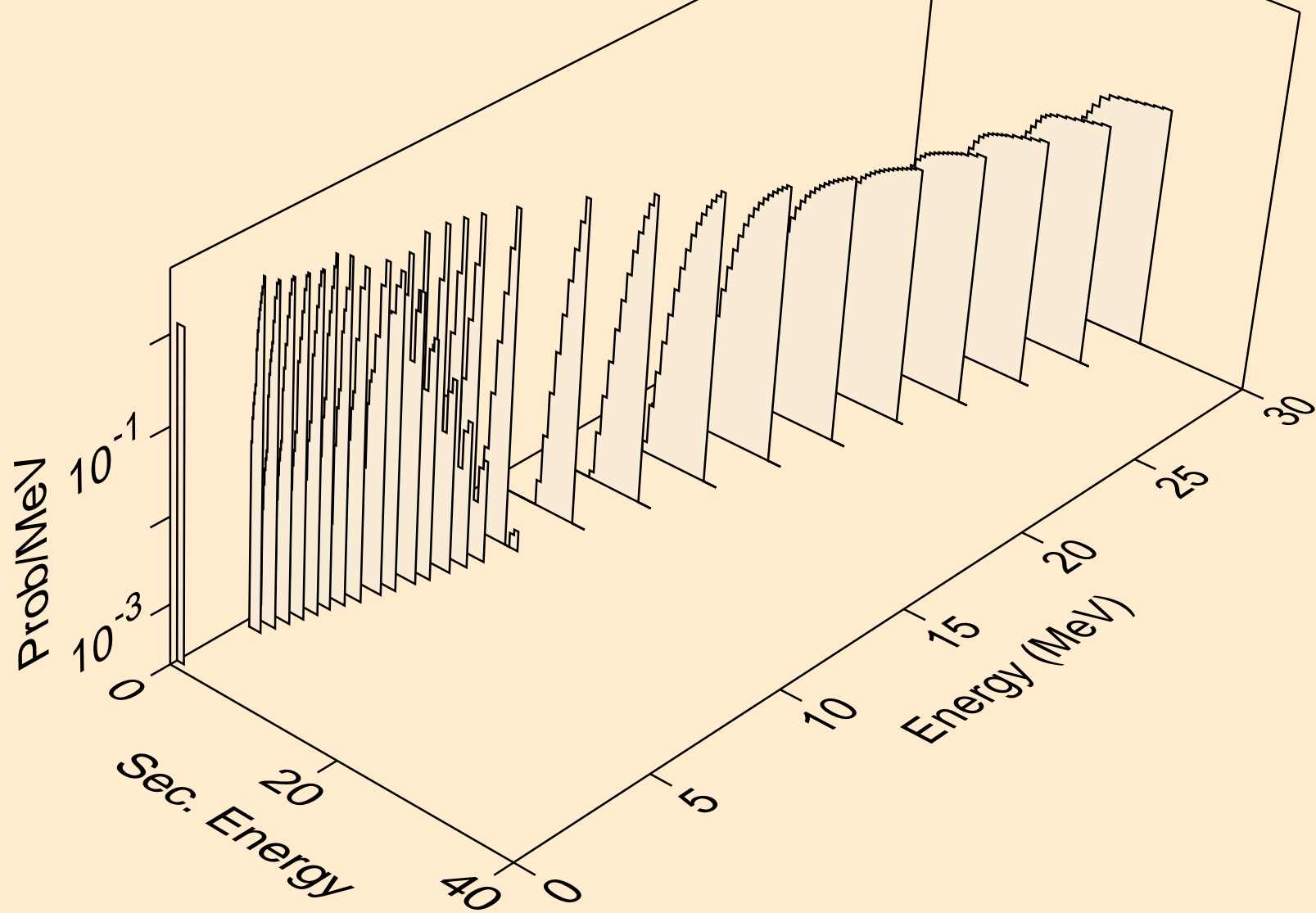

RN205M NEUTRON ACER TENDL-2024 LIBRARY; T=0.K  
deuterons from (n,pd)

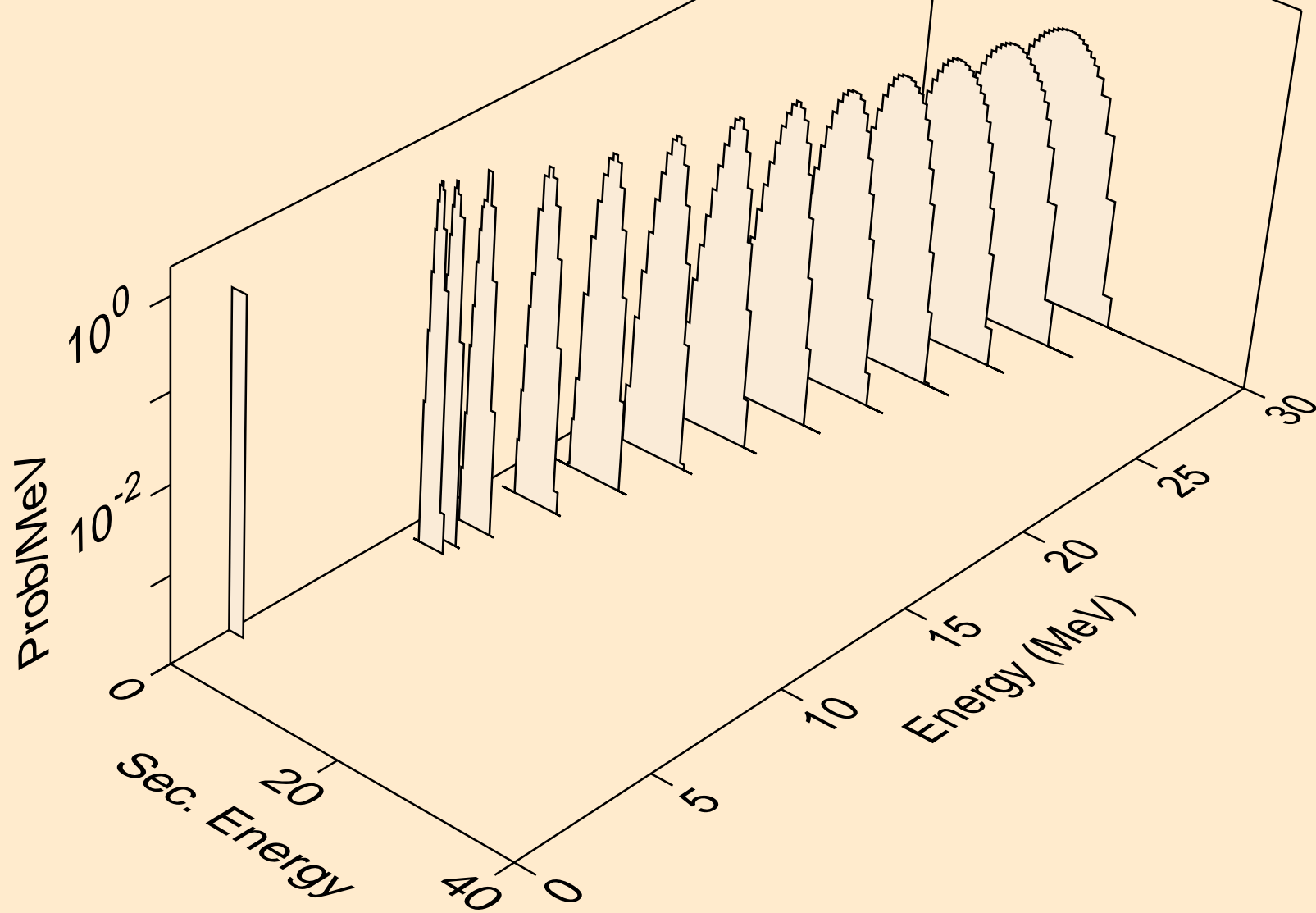

RN205M NEUTRON ACER TENDL-2024 LIBRARY; T=0.K  
deuterons from (n,da)

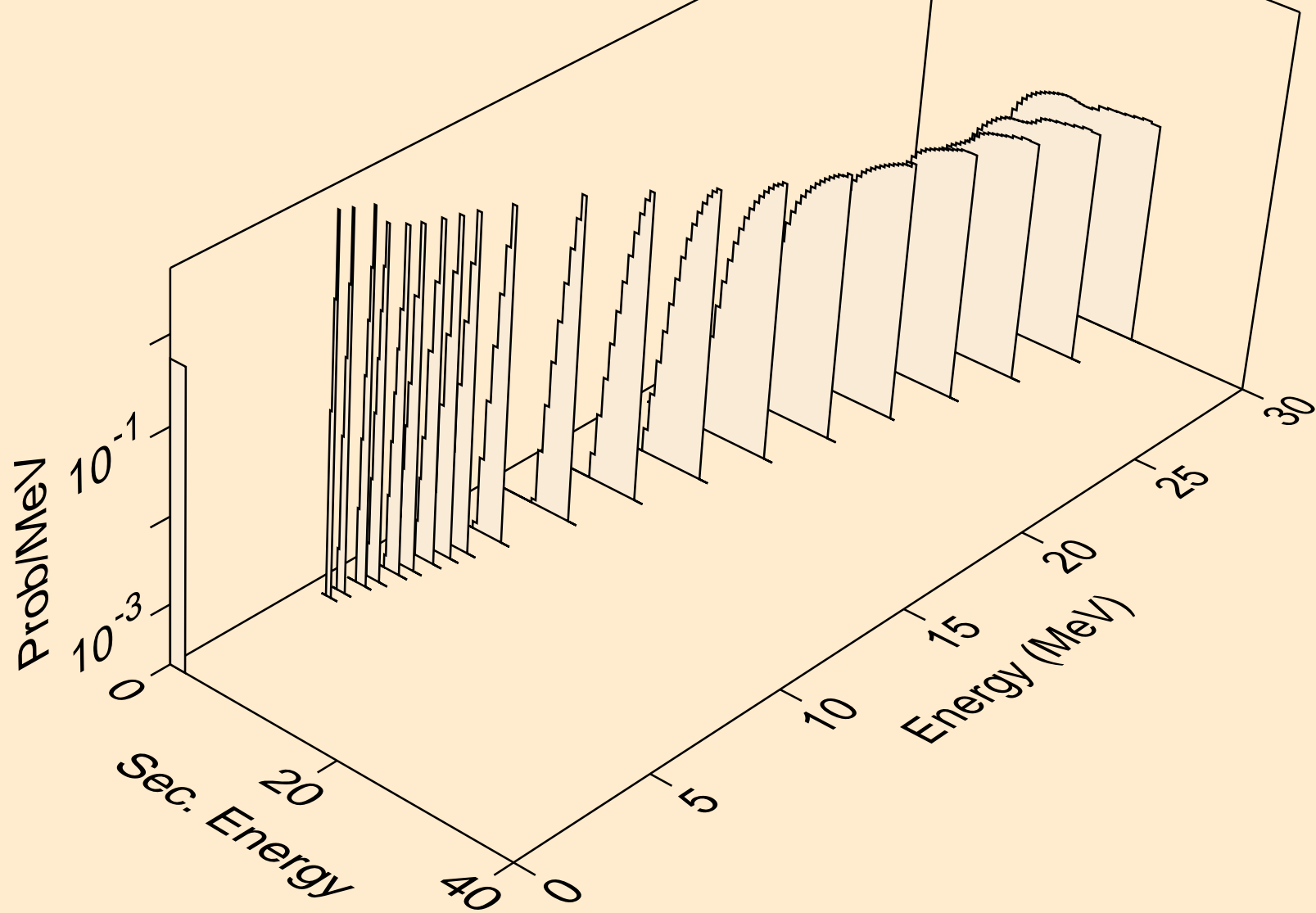

RN205M NEUTRON ACER TENDL-2024 LIBRARY; T=0.K  
tritons from (n,x)

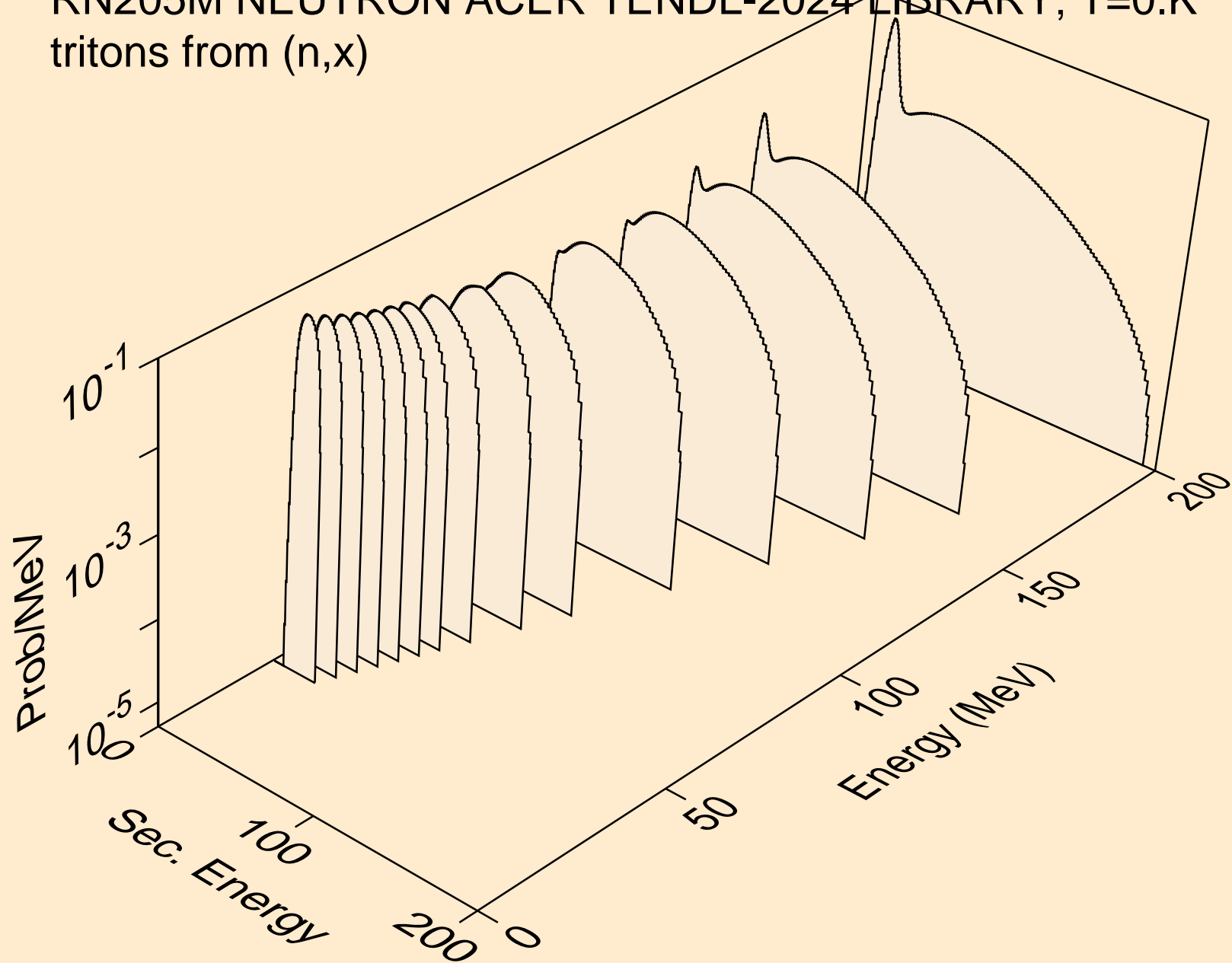

RN205M NEUTRON ACER TENDL-2024 LIBRARY; T=0.K  
tritons from (n,n\*)t

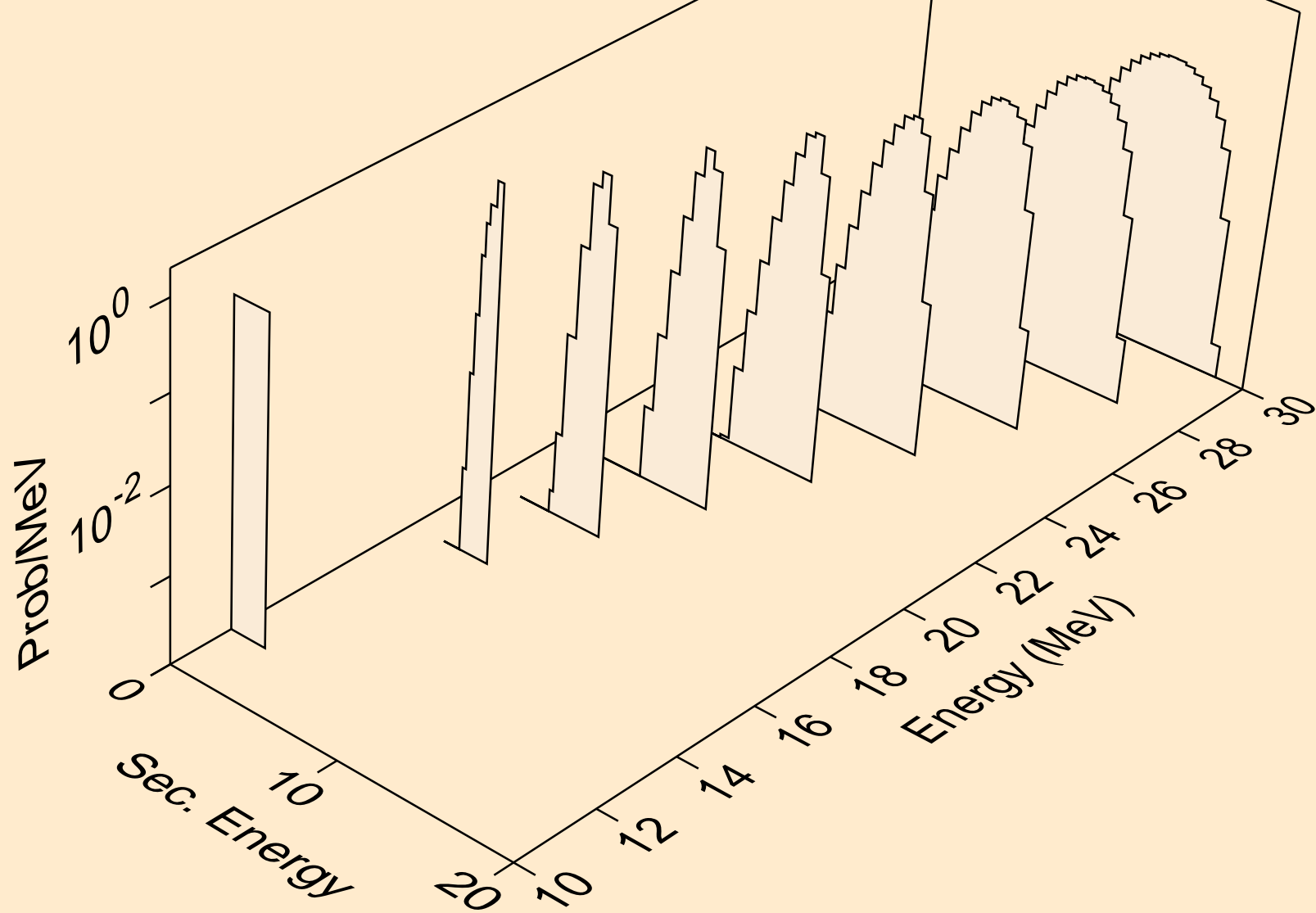

RN205M NEUTRON ACER TENDL-2024 LIBRARY; T=0.K  
tritons from (n,t)

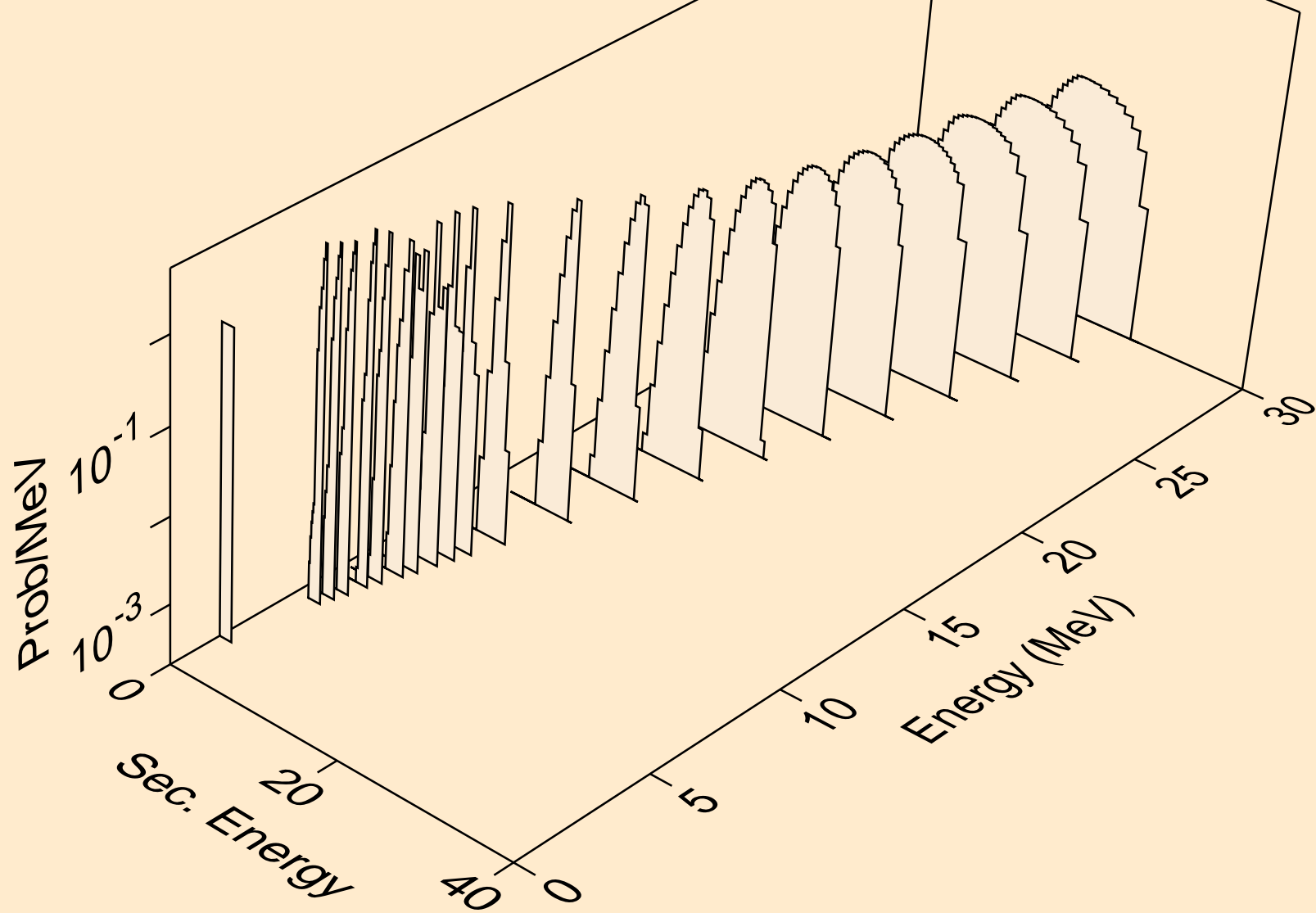

RN205M NEUTRON ACER TENDL-2024 LIBRARY; T=0.K  
tritons from (n,pt)

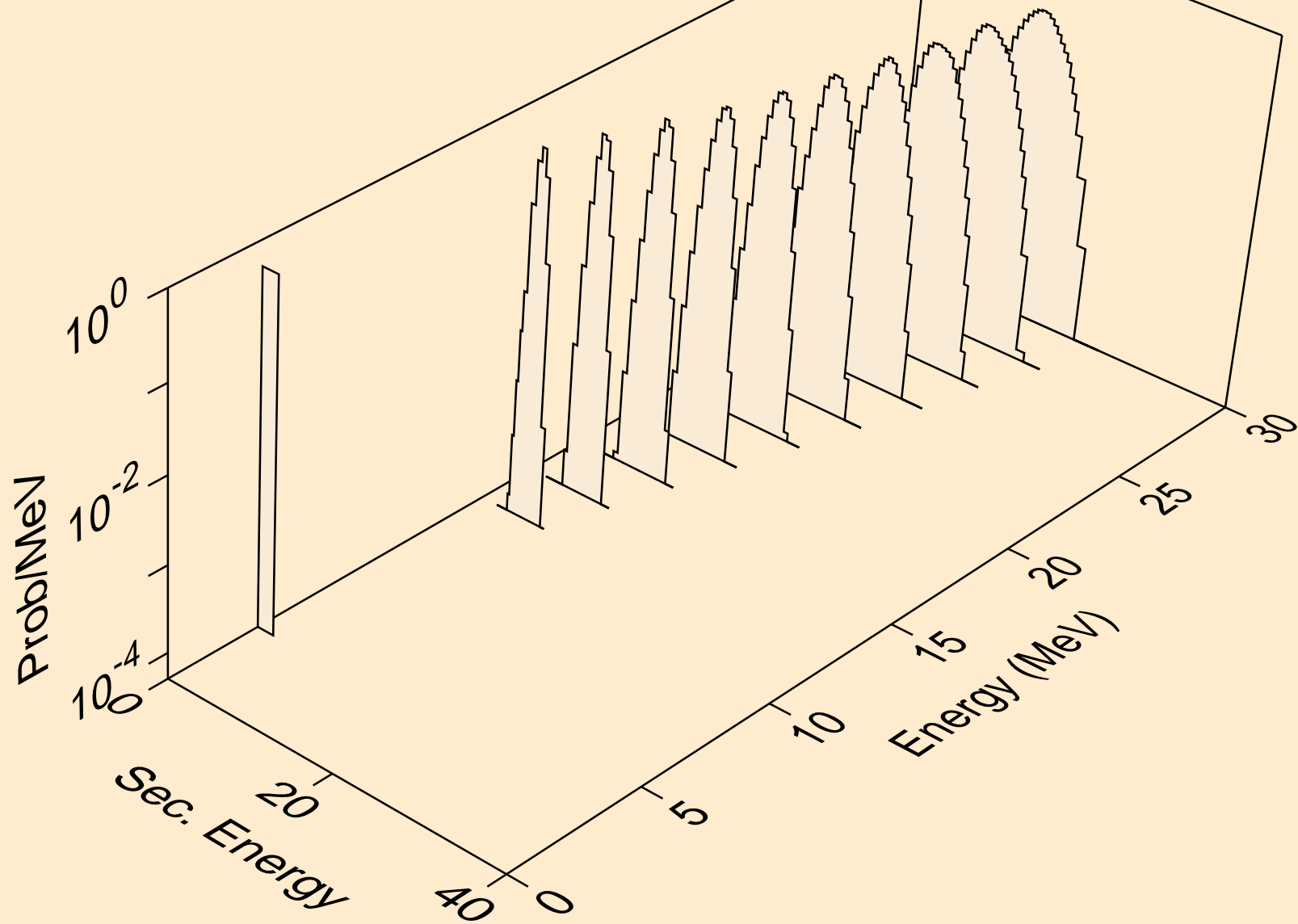

RN205M NEUTRON ACER TENDL-2024 LIBRARY; T=0.K  
he3s from (n,x)

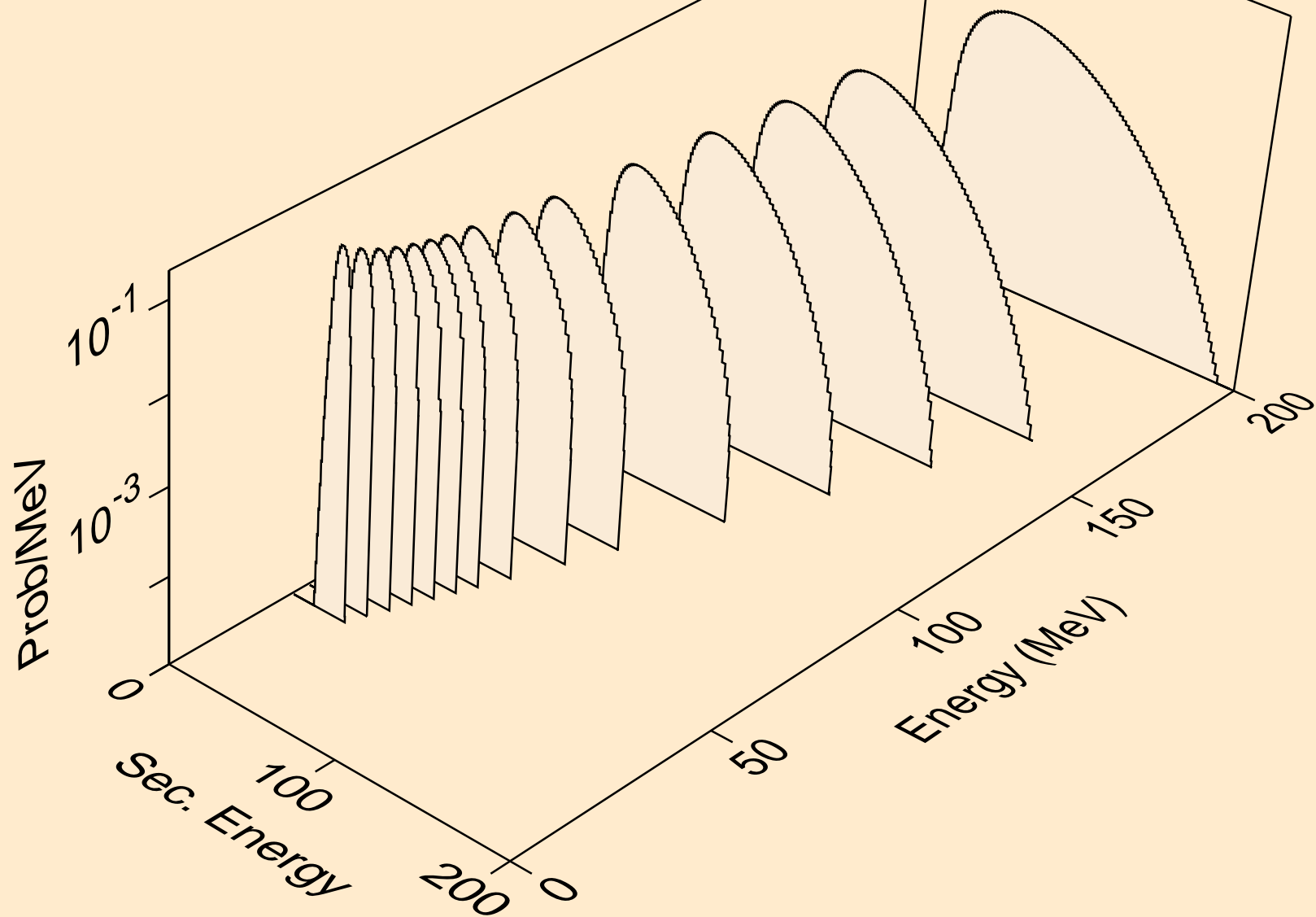

RN205M NEUTRON ACER TENDL-2024 LIBRARY; T=0.K  
he3s from (n,n\*)he3

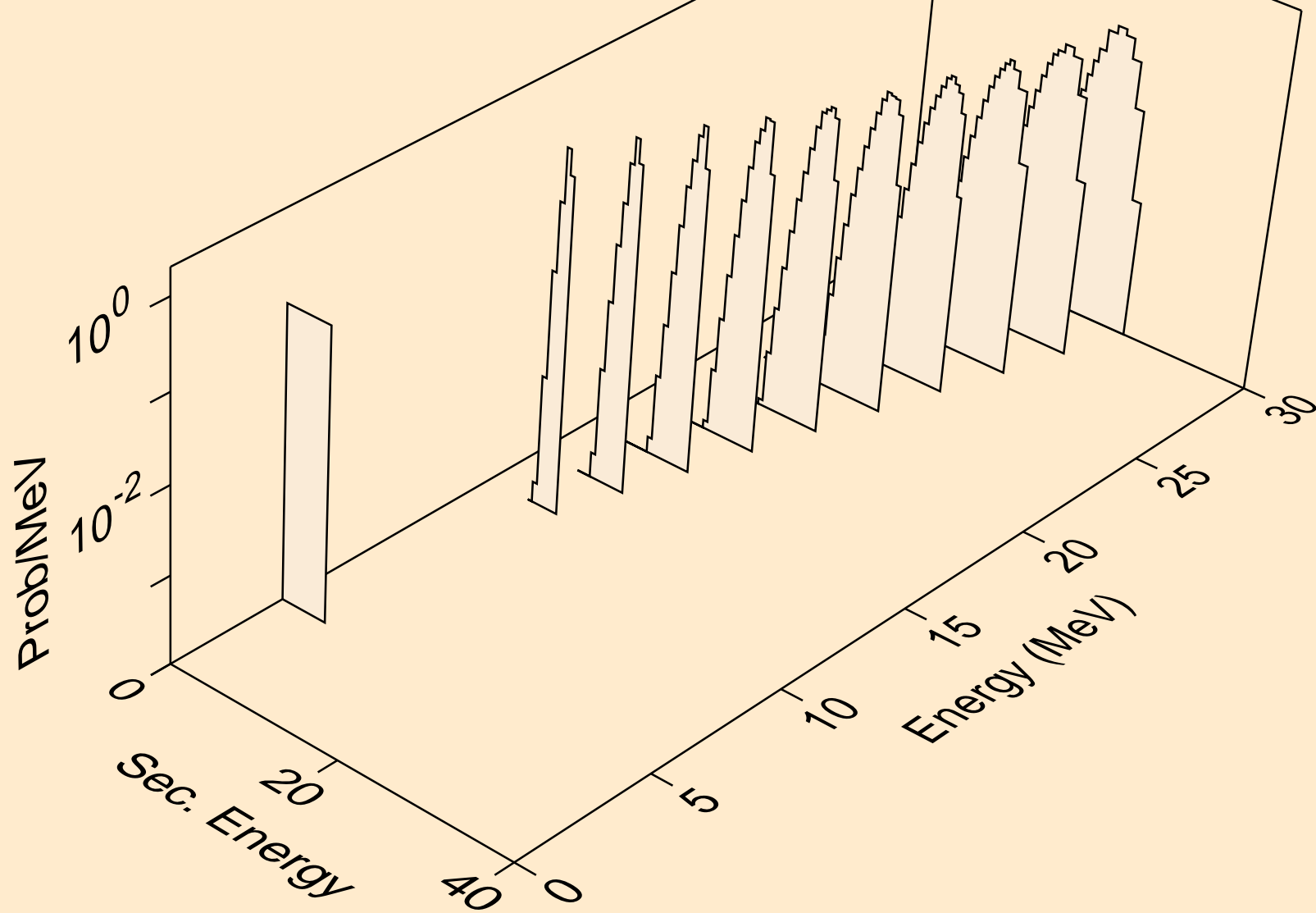

RN205M NEUTRON ACER TENDL-2024 LIBRARY; T=0.K  
he3s from (n,he3)

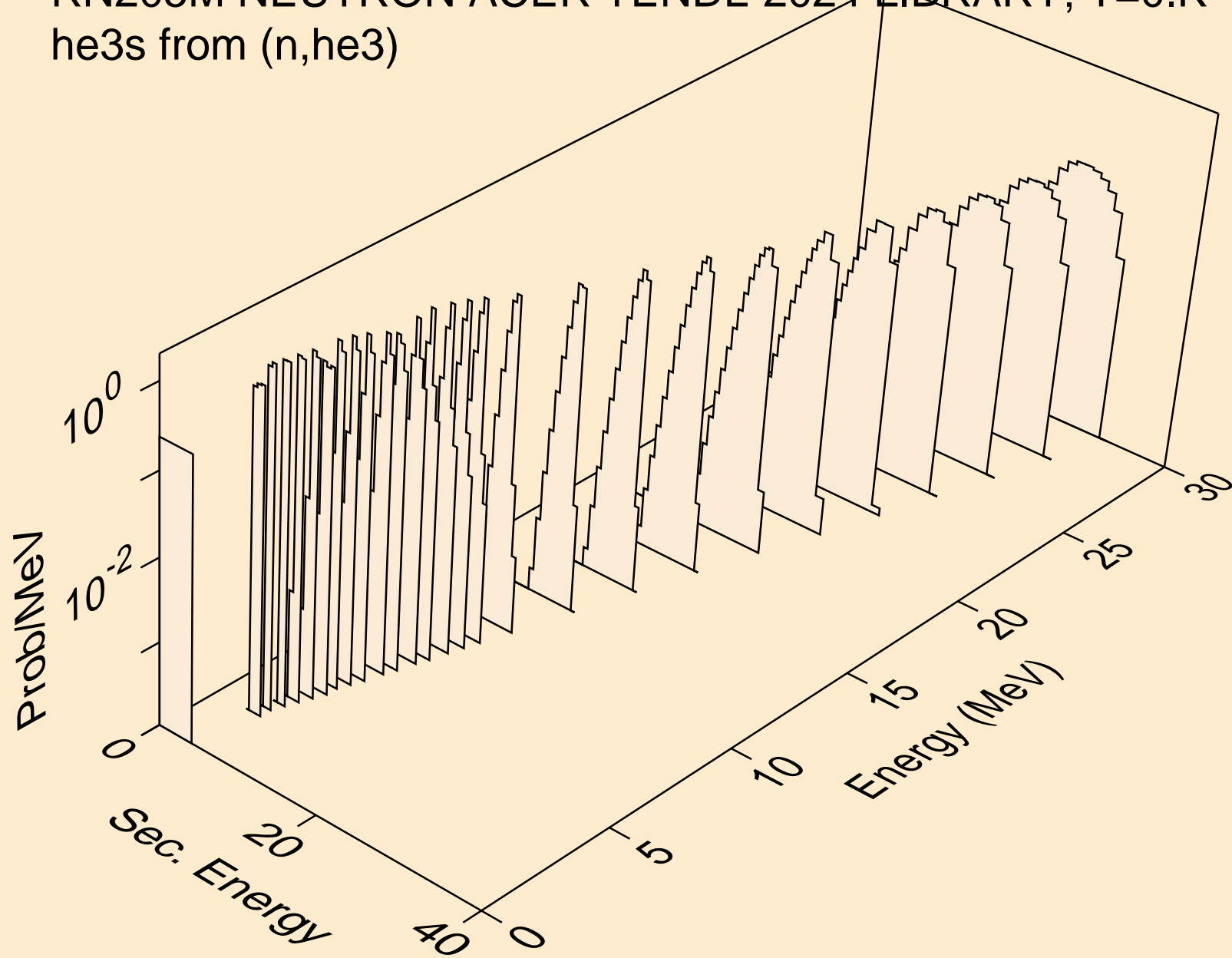

RN205M NEUTRON ACER TENDL-2024 LIBRARY; T=0.K  
alphas from (n,x)

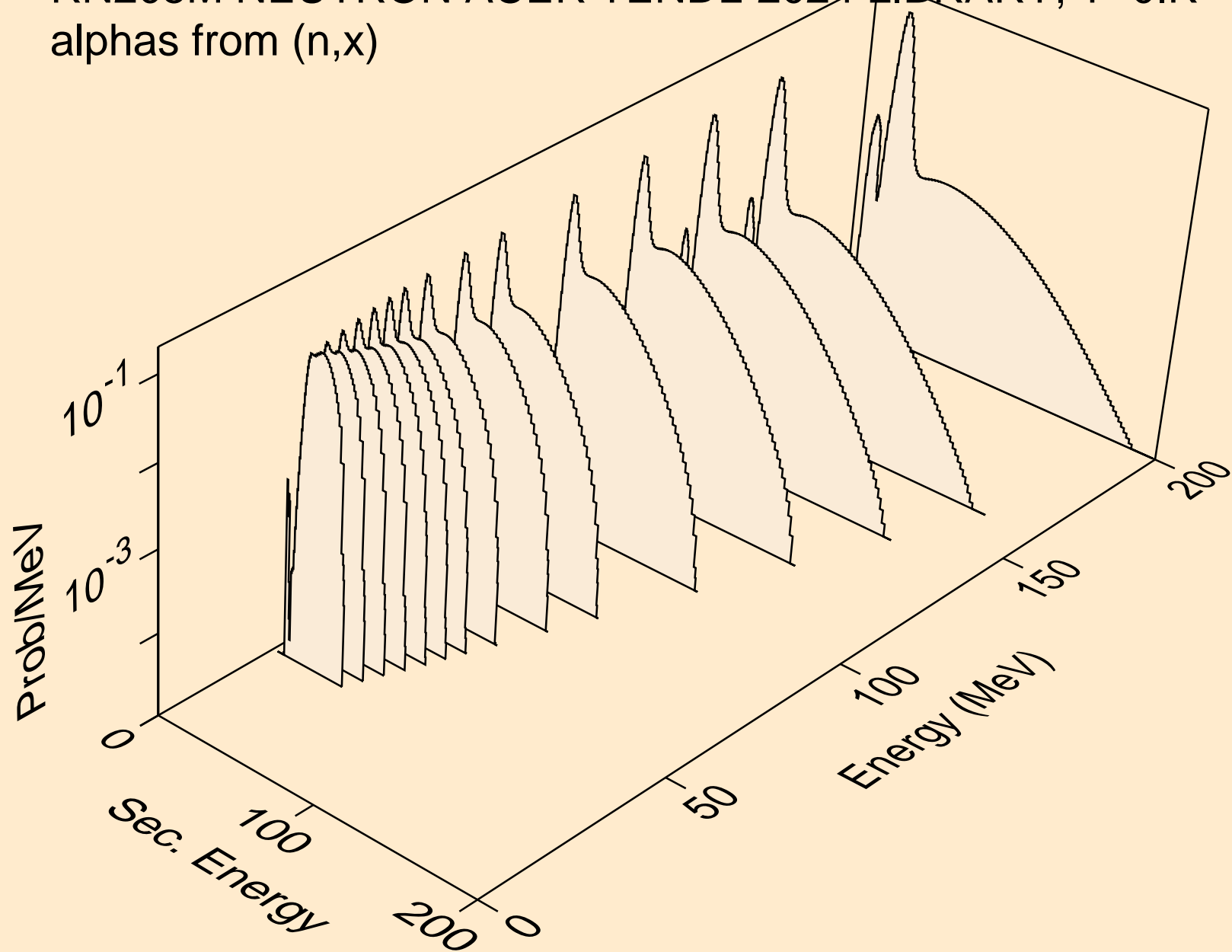

RN205M NEUTRON ACER TENDL-2024 LIBRARY; T=0.K  
alphas from (n,n\*)a

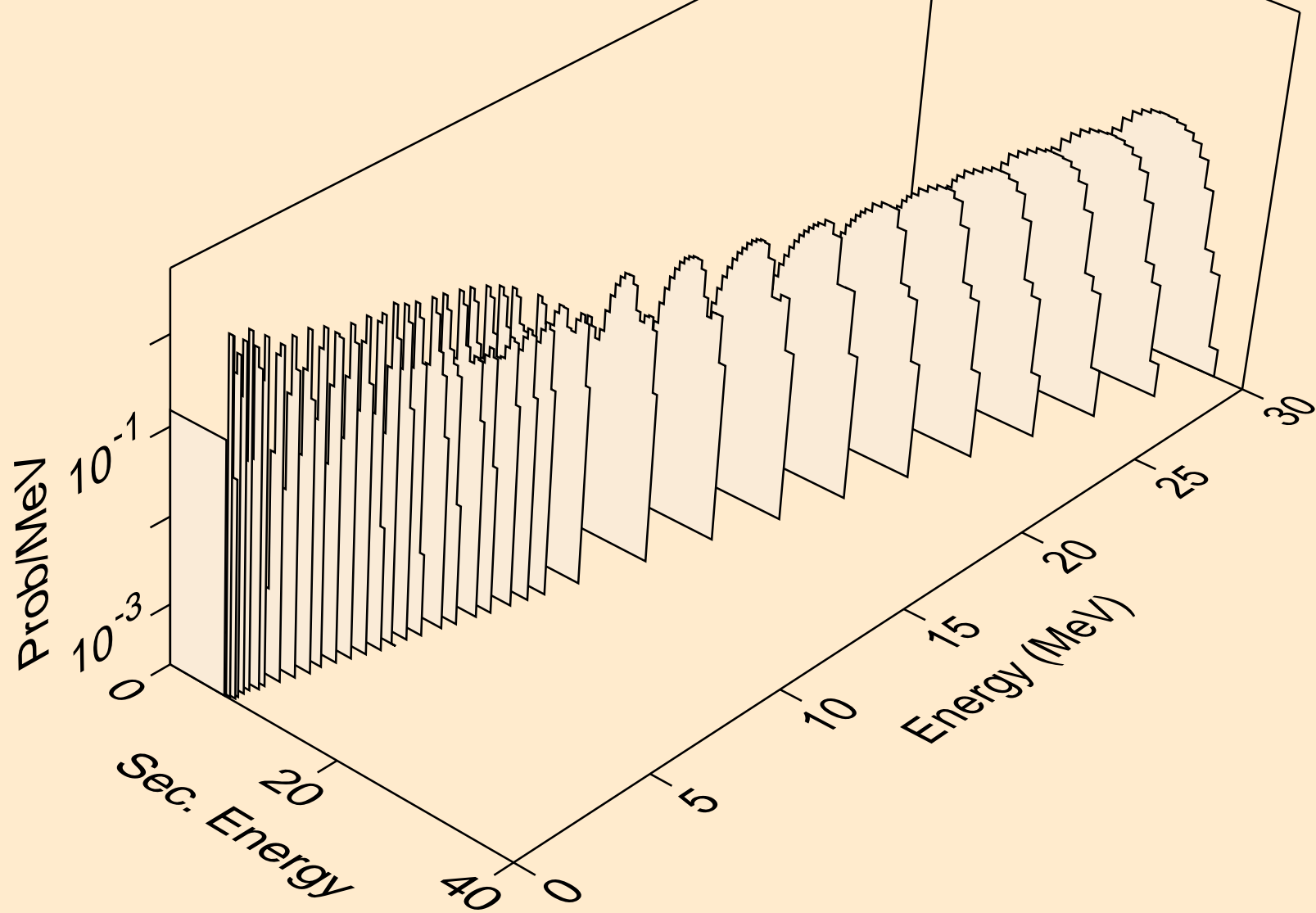

RN205M NEUTRON ACER TENDL-2024 LIBRARY; T=0.K  
alphas from (n,2n)a

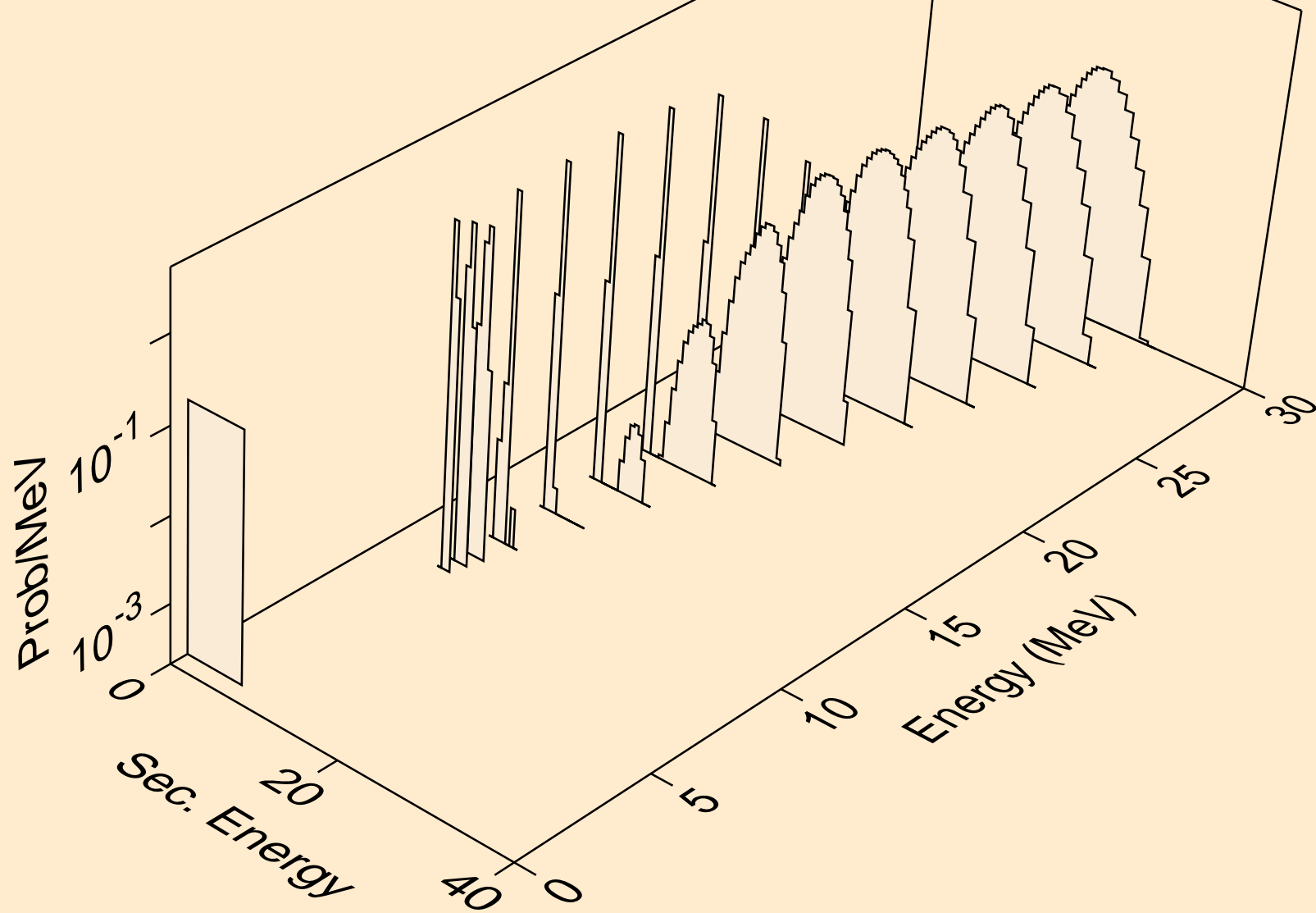

RN205M NEUTRON ACER TENDL-2024 LIBRARY; T=0.K  
alphas from (n,3n)a

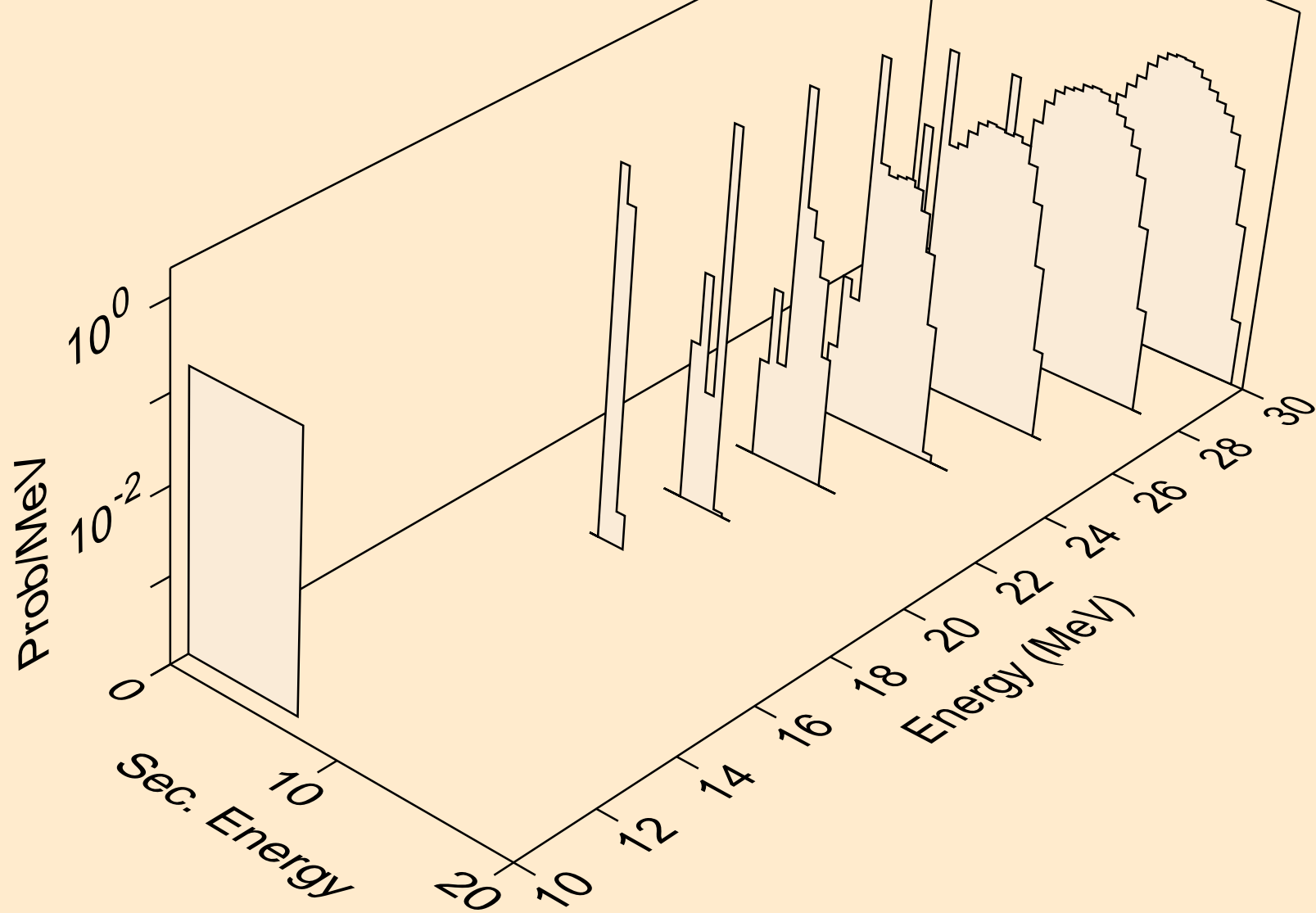

RN205M NEUTRON ACER TENDL-2024 LIBRARY; T=0.K  
alphas from (n,n\*)2a

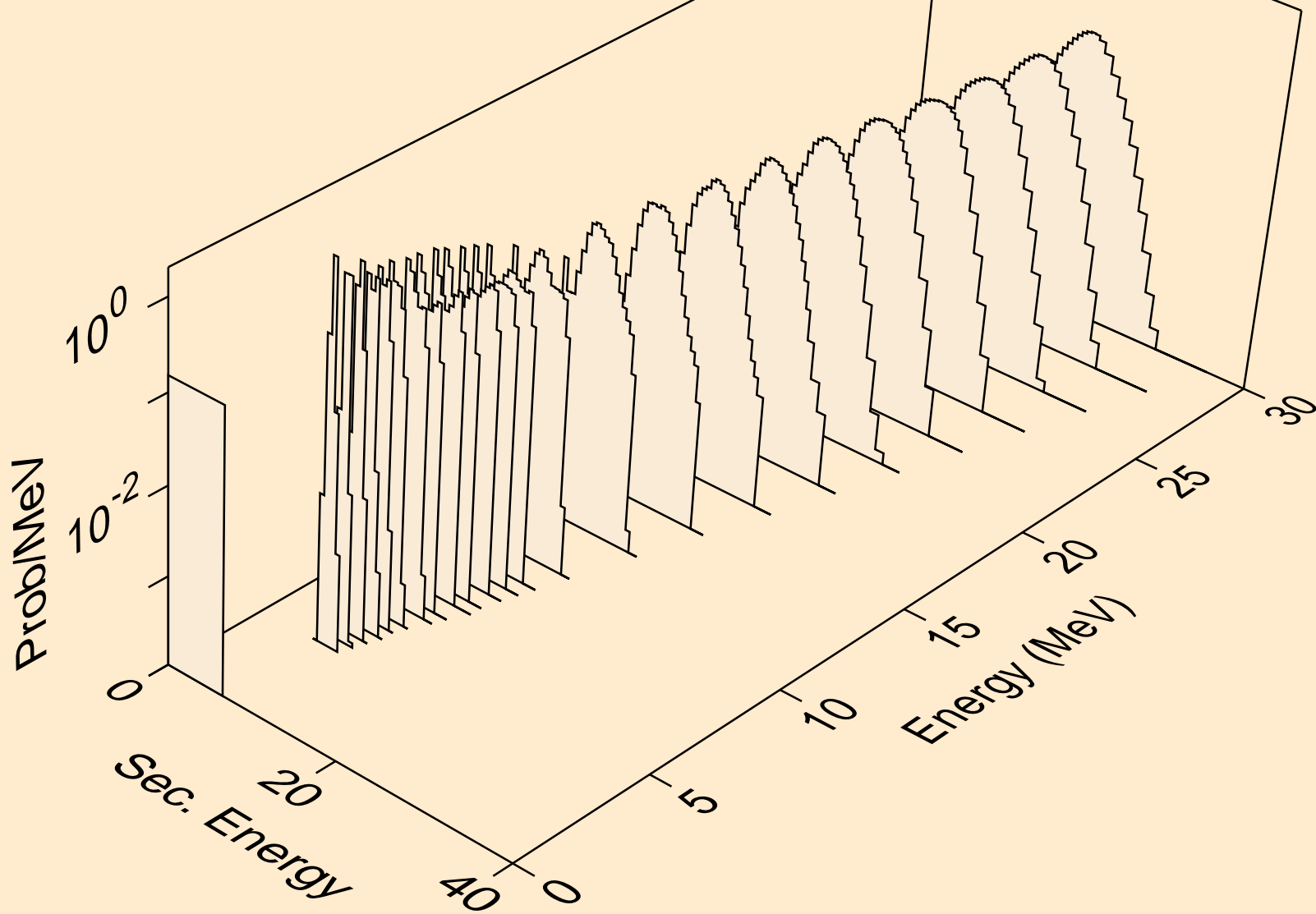

RN205M NEUTRON ACER TENDL-2024 LIBRARY; T=0.K  
alphas from (n,2n)2a

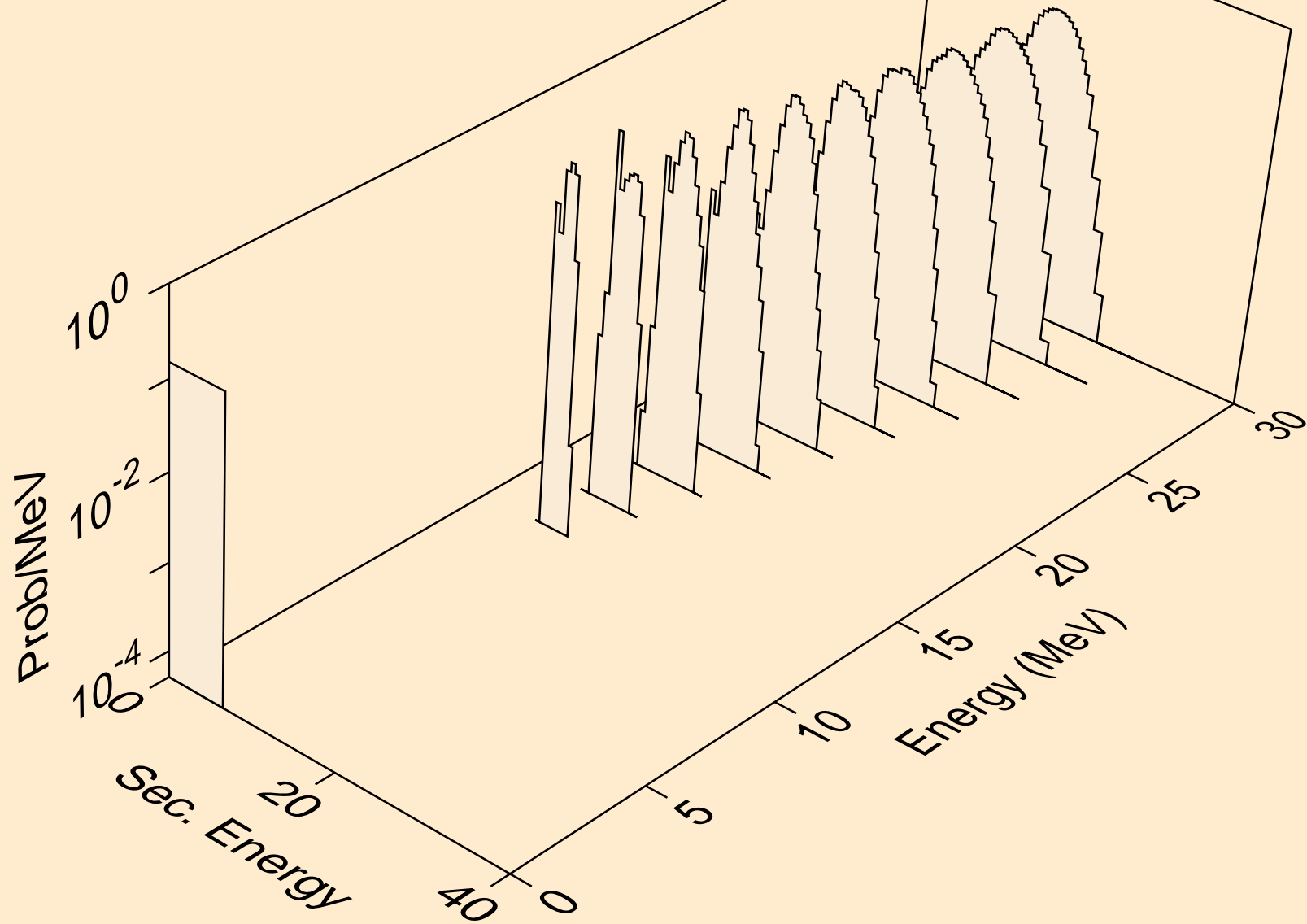

RN205M NEUTRON ACER TENDL-2024 LIBRARY; T=0.K  
alphas from (n,npa)

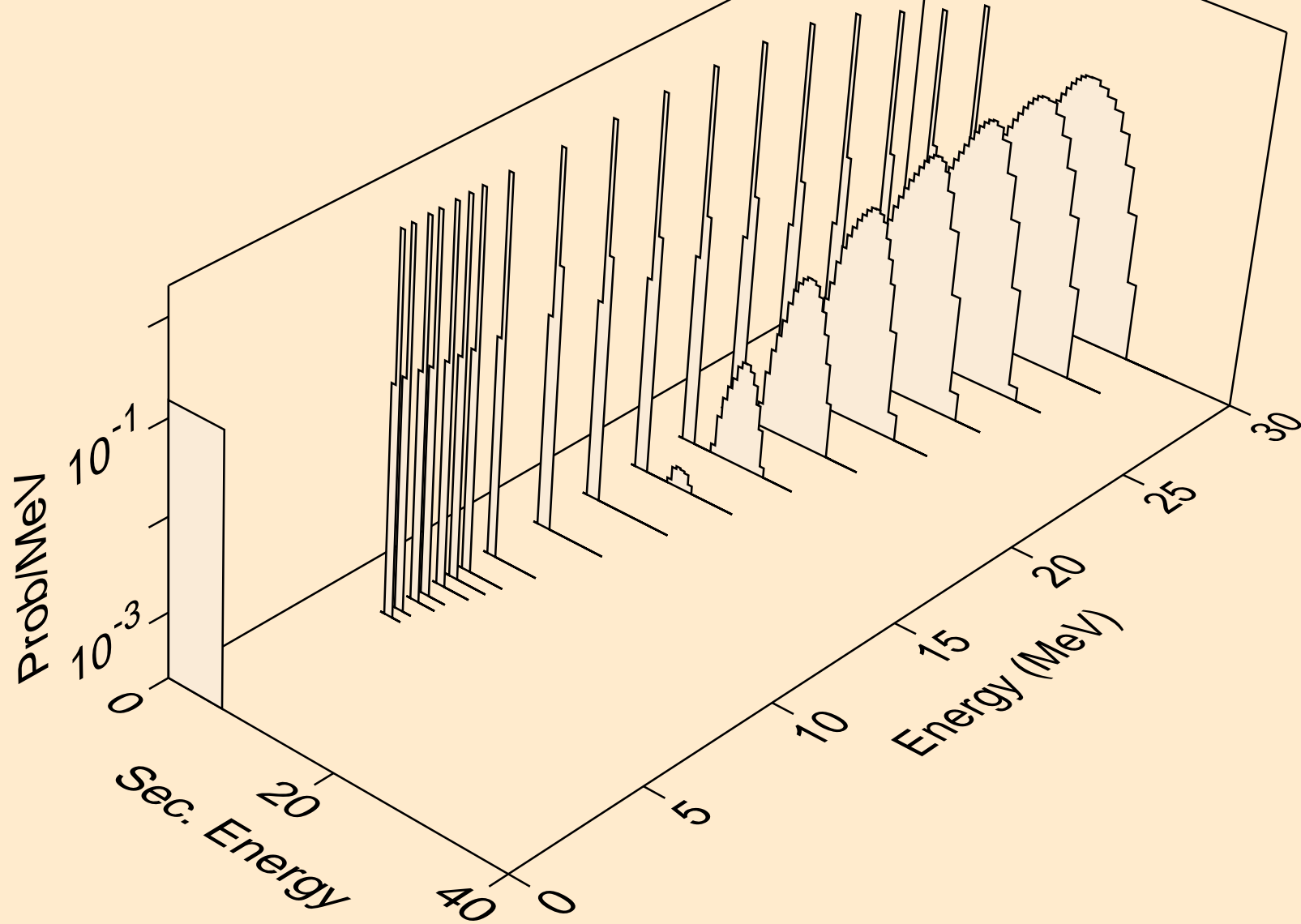

RN205M NEUTRON ACER TENDL-2024 LIBRARY; T=0.K  
alphas from (n,a)

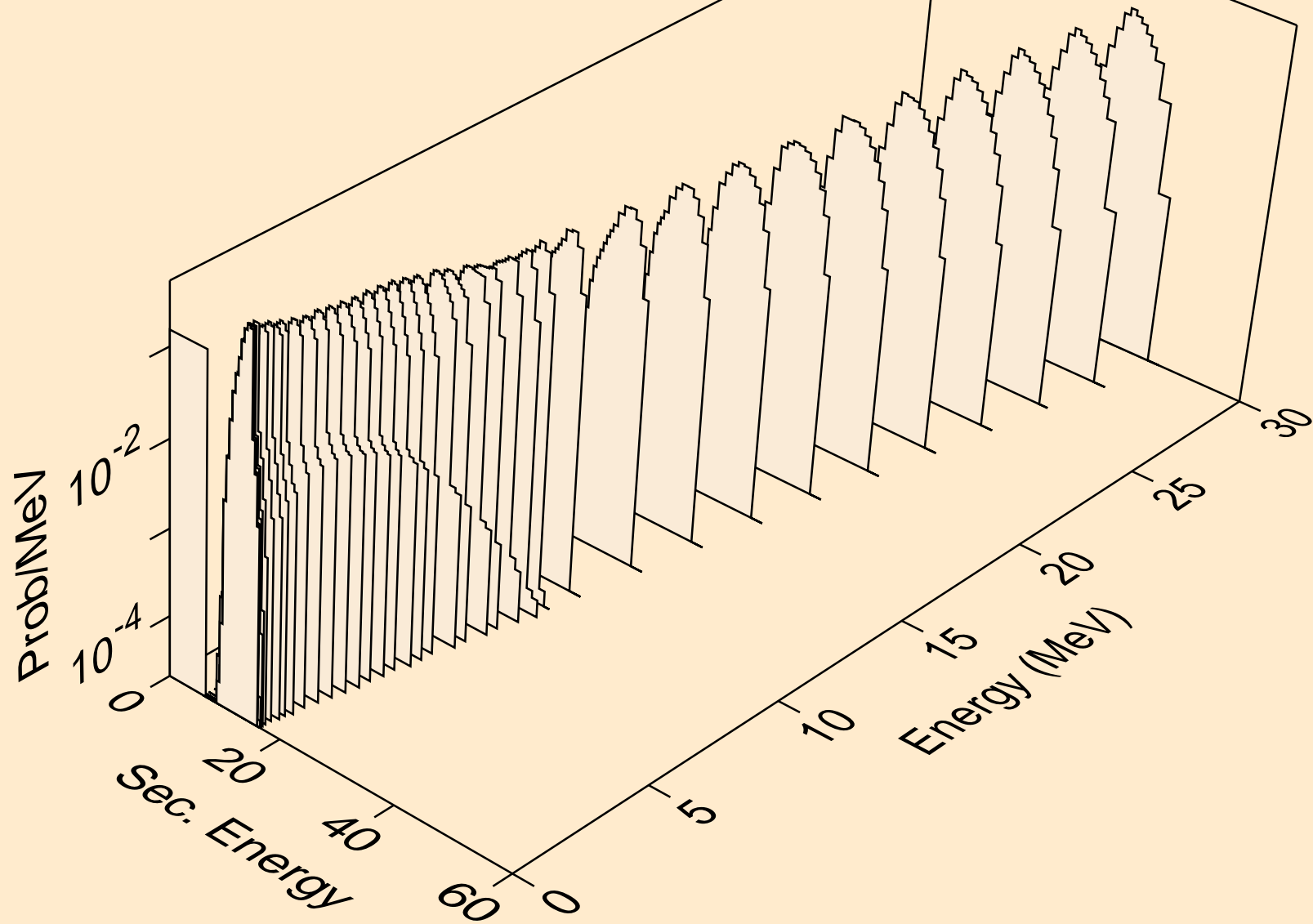

RN205M NEUTRON ACER TENDL-2024 LIBRARY; T=0.K  
alphas from (n,2a)

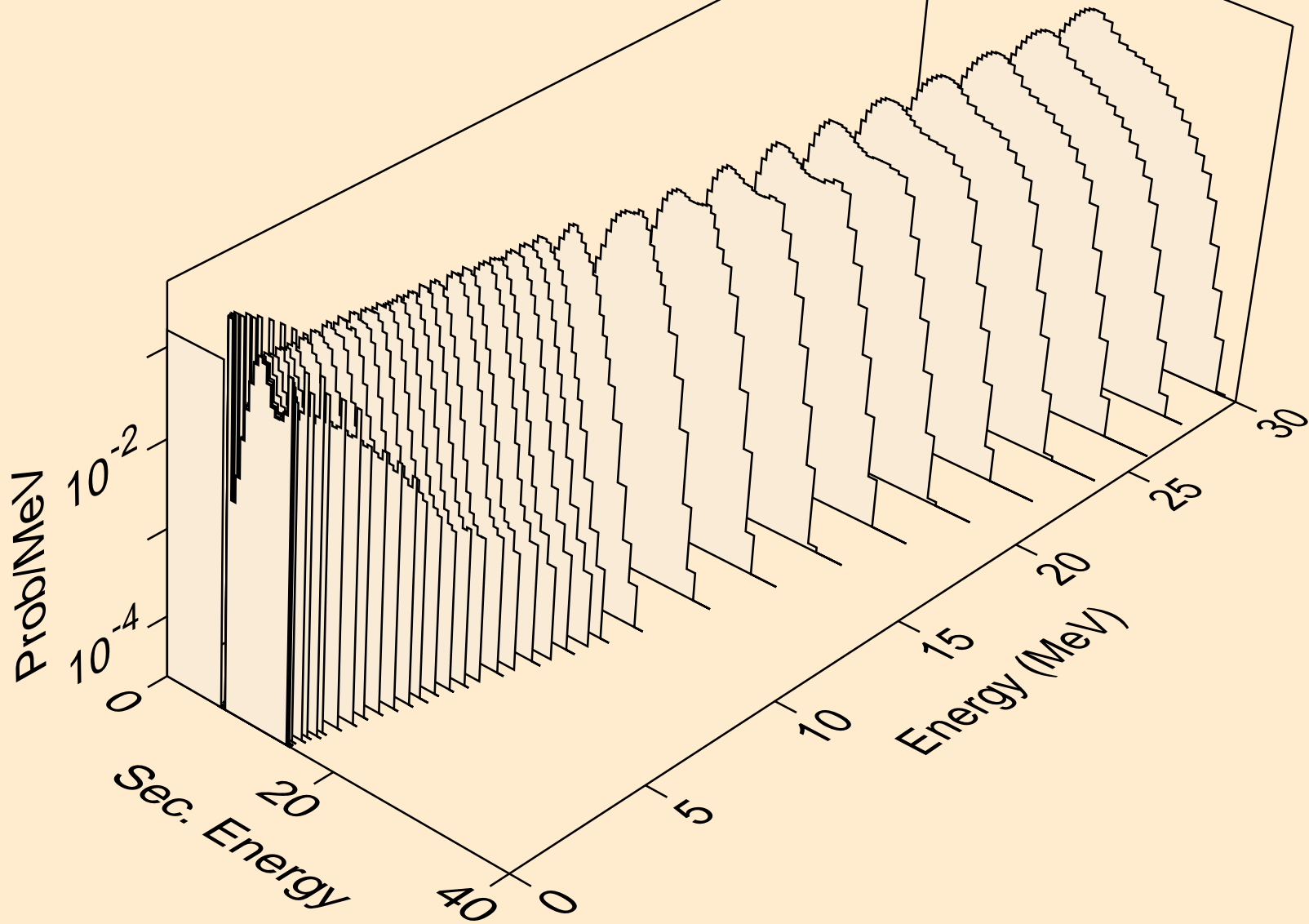

RN205M NEUTRON ACER TENDL-2024 LIBRARY; T=0.K  
alphas from (n,pa)

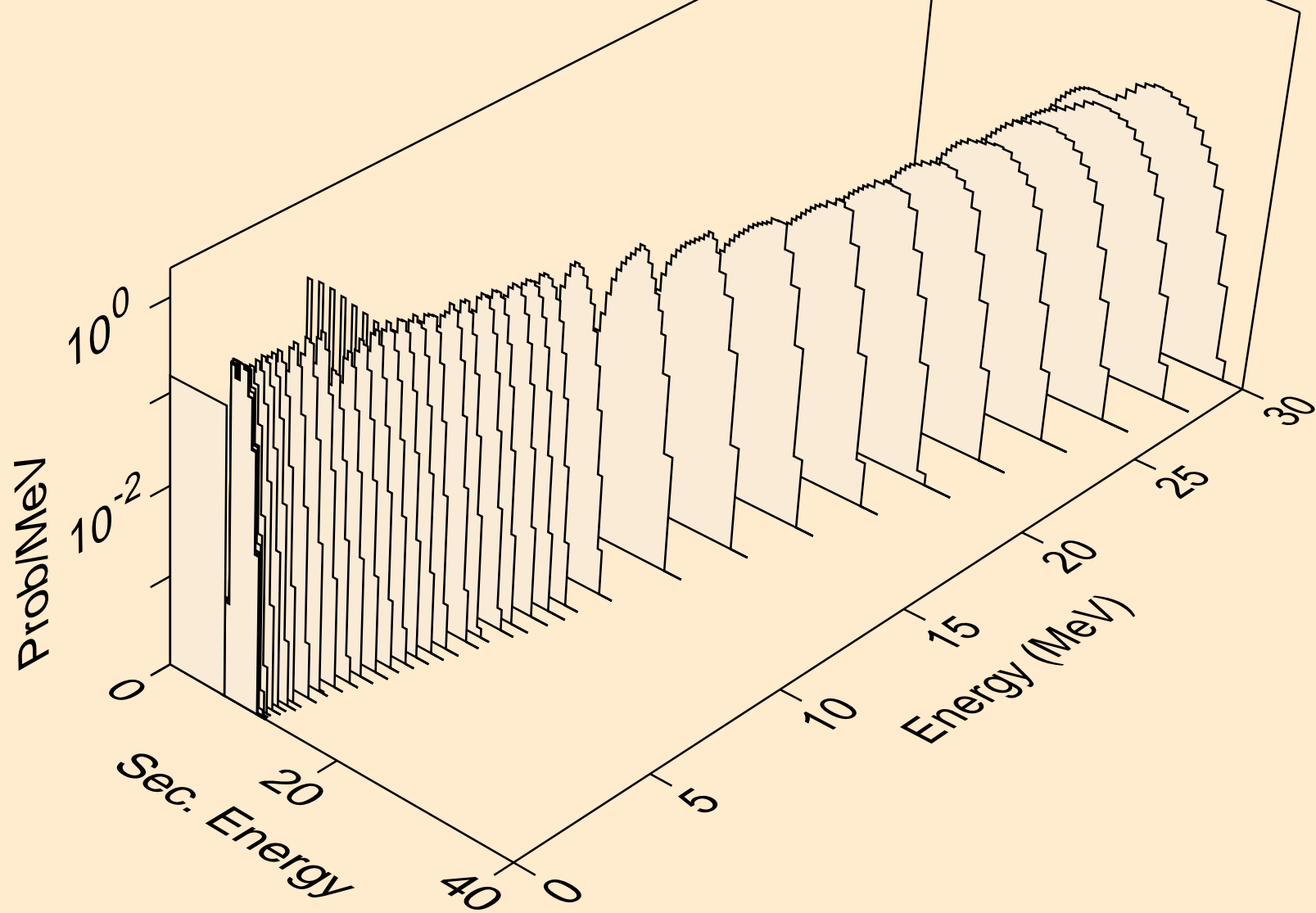

RN205M NEUTRON ACER TENDL-2024 LIBRARY; T=0.K  
alphas from (n,da)

