

TC102M NEUTRON ACER TENDL-2024 LIBRARY; T=0.K

Principal cross sections

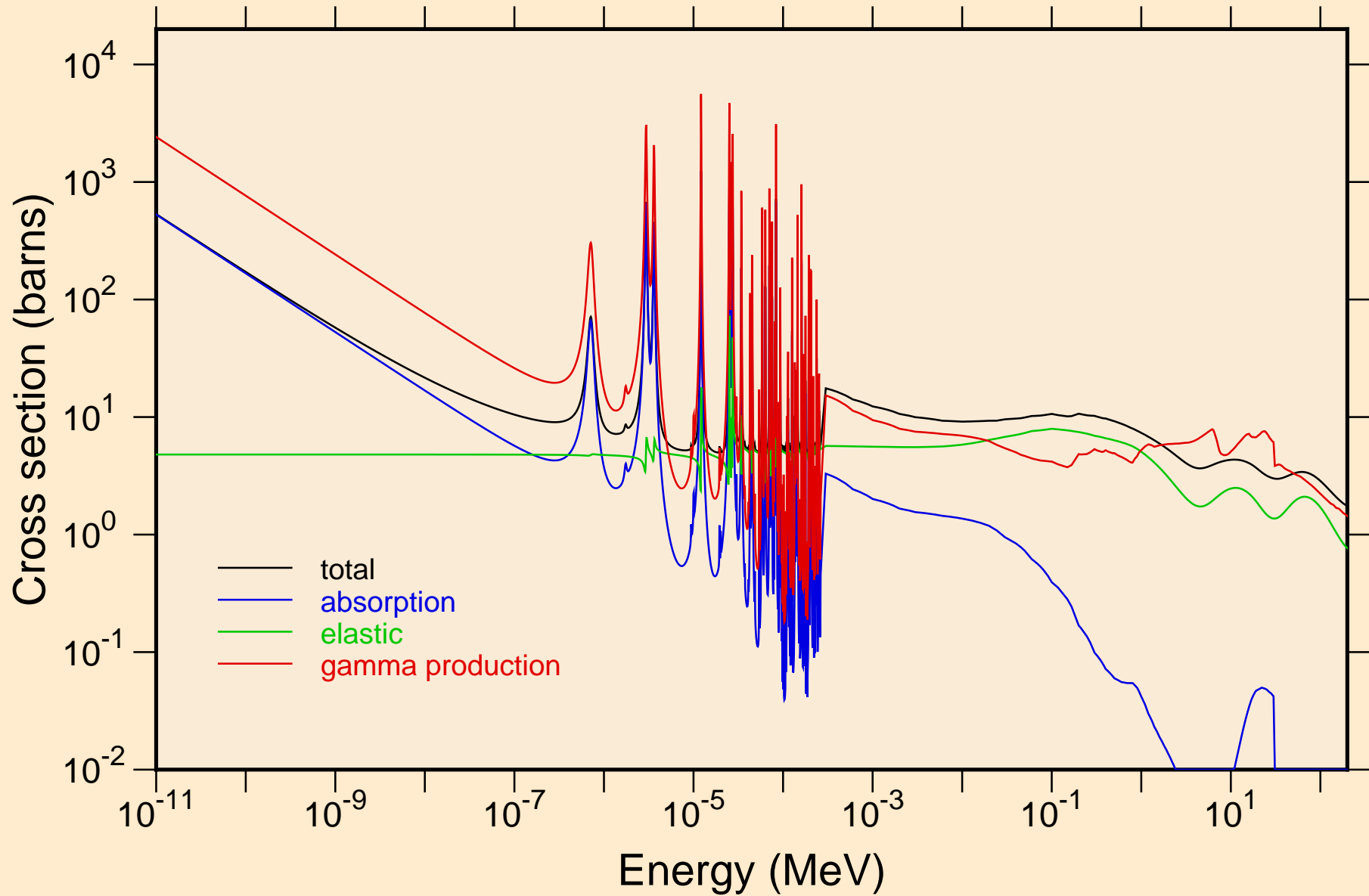

TC102M NEUTRON ACER TENDL-2024 LIBRARY; T=0.K
resonance total cross section

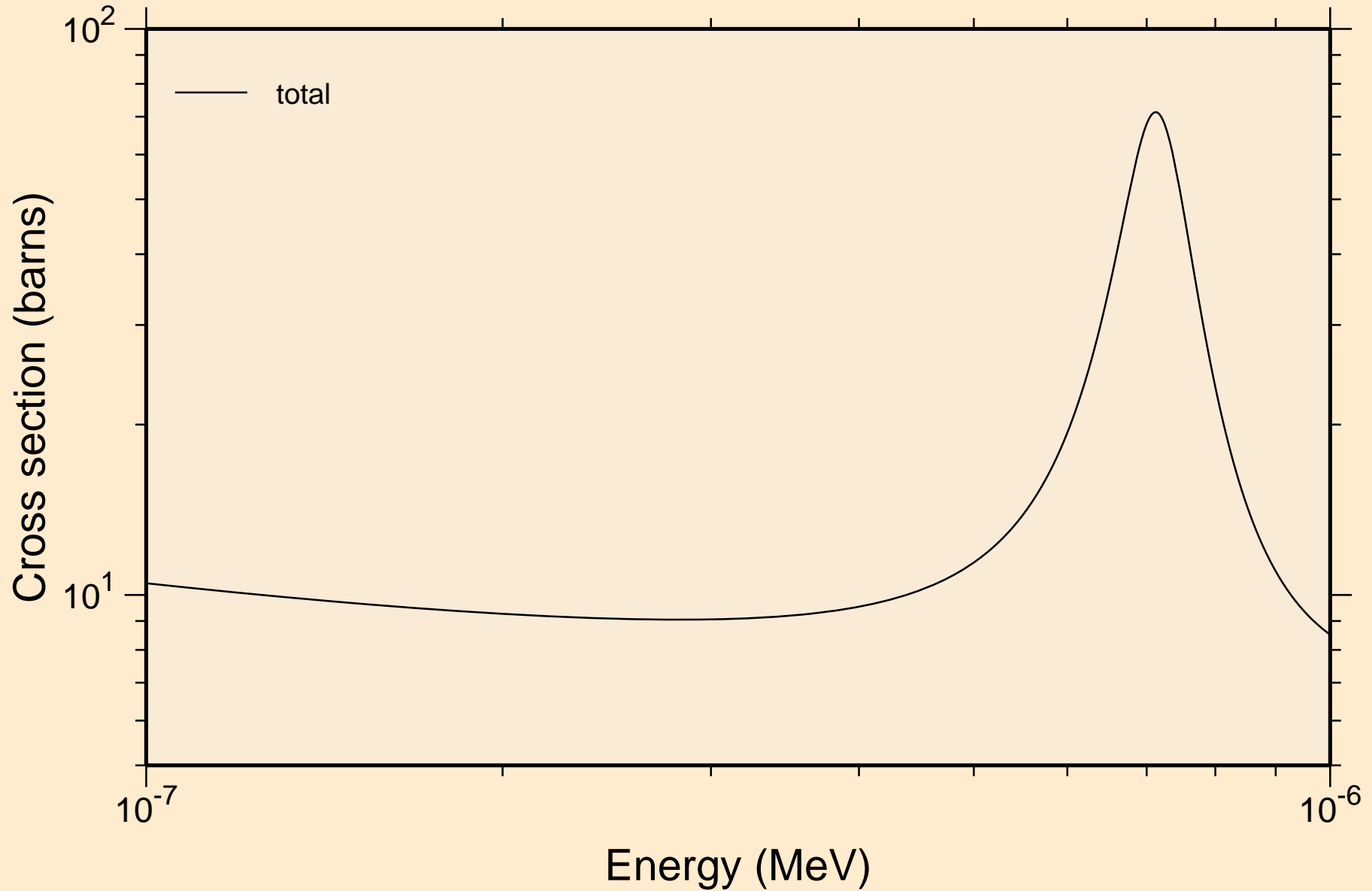

TC102M NEUTRON ACER TENDL-2024 LIBRARY; T=0.K
resonance total cross section

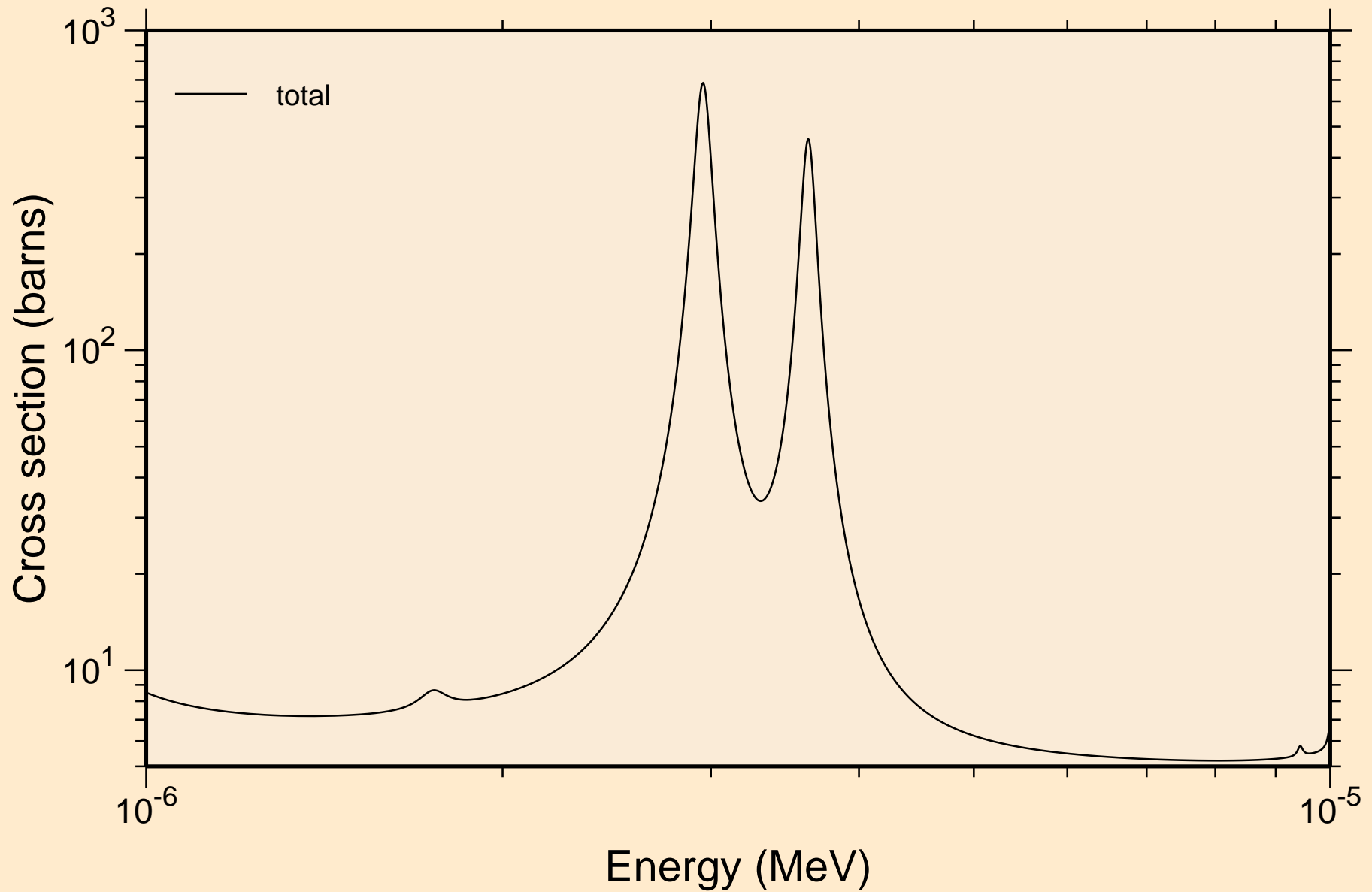

TC102M NEUTRON ACER TENDL-2024 LIBRARY; T=0.K
resonance total cross section

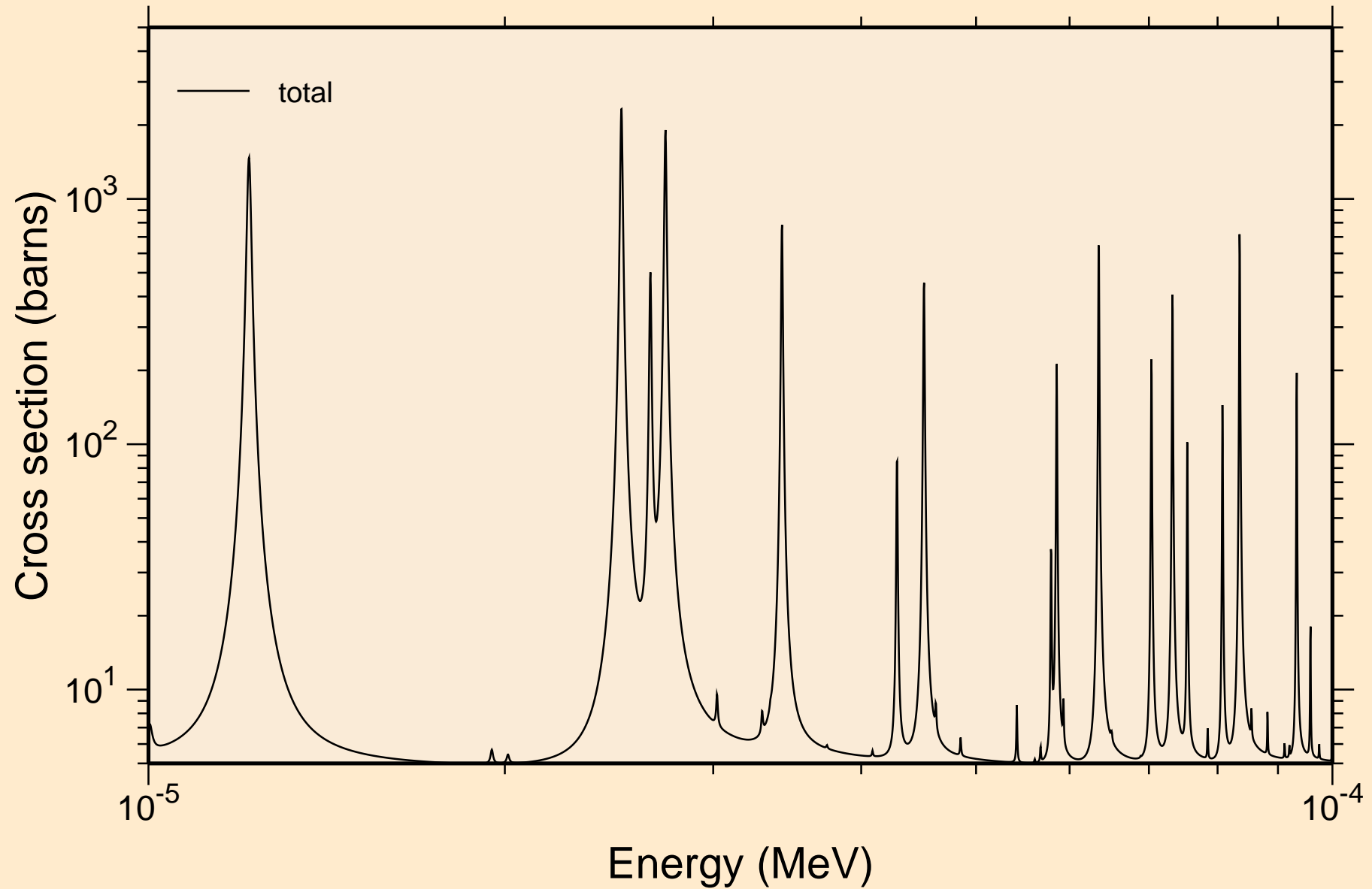

TC102M NEUTRON ACER TENDL-2024 LIBRARY; T=0.K
resonance total cross section

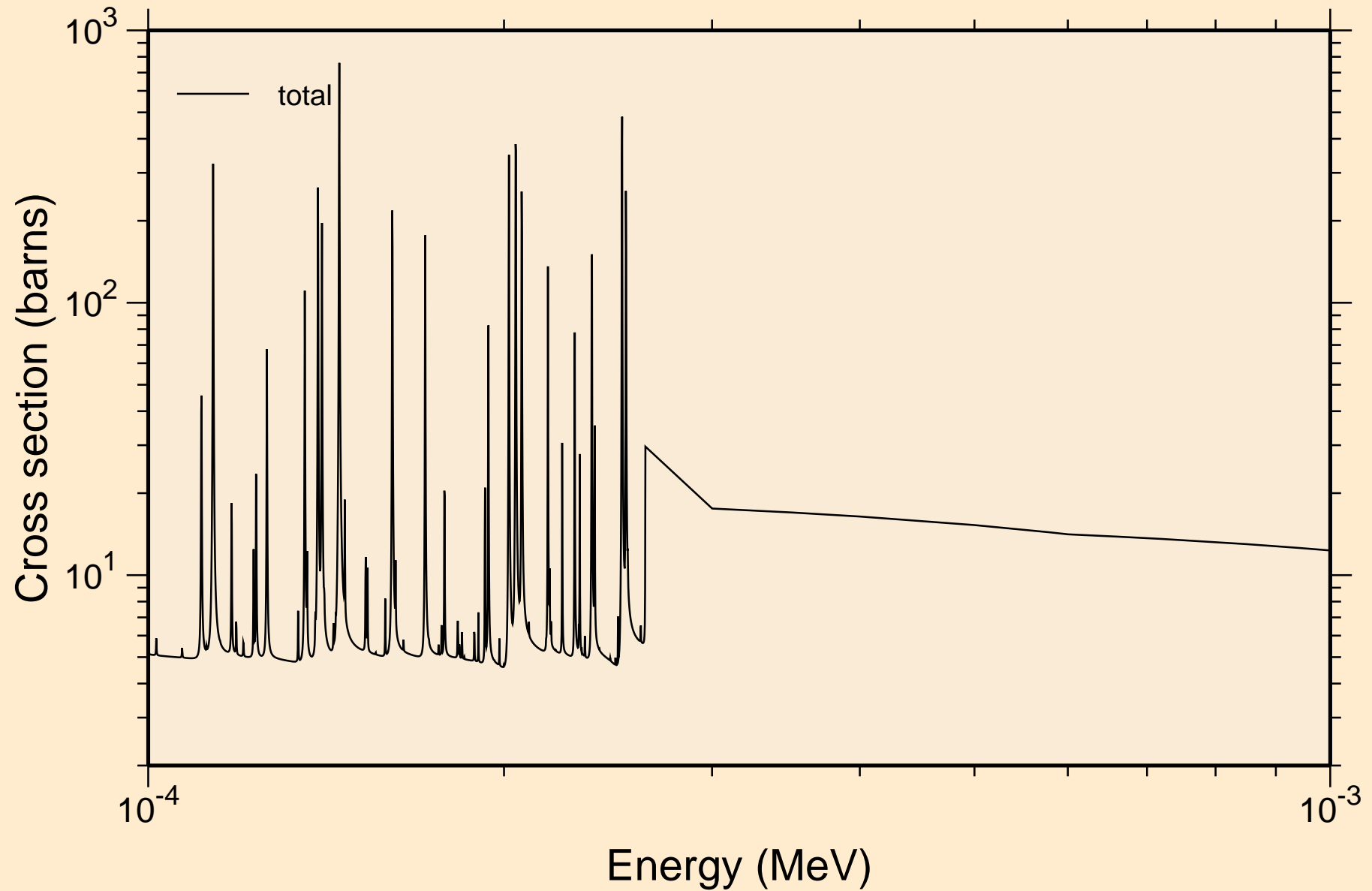

T̄C102M NEUTRON ACER TENDL-2024 LIBRARY; T=0.K
resonance total cross section

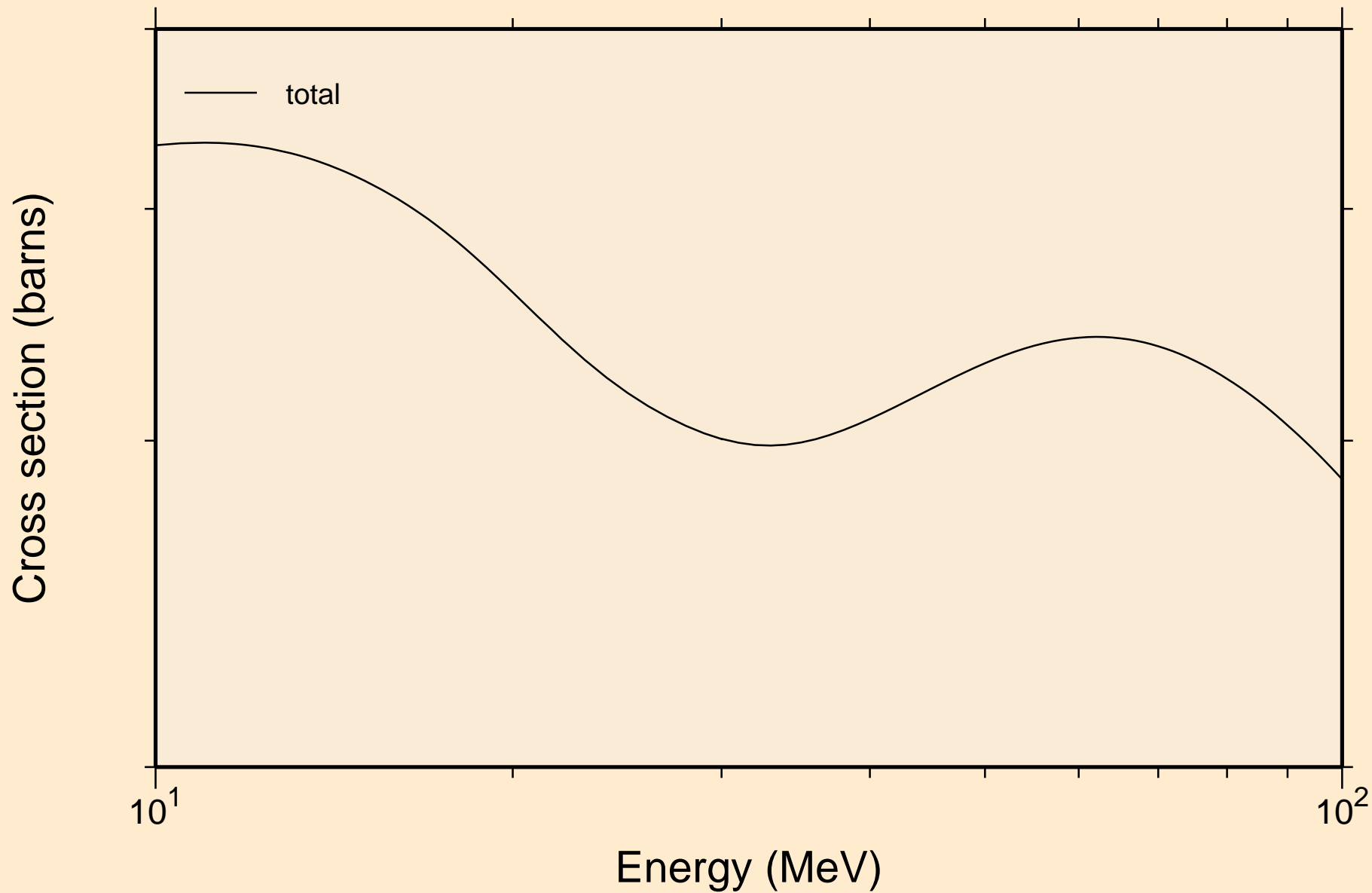

TC102M NEUTRON ACER TENDL-2024 LIBRARY; T=0.K
resonance absorption cross sections

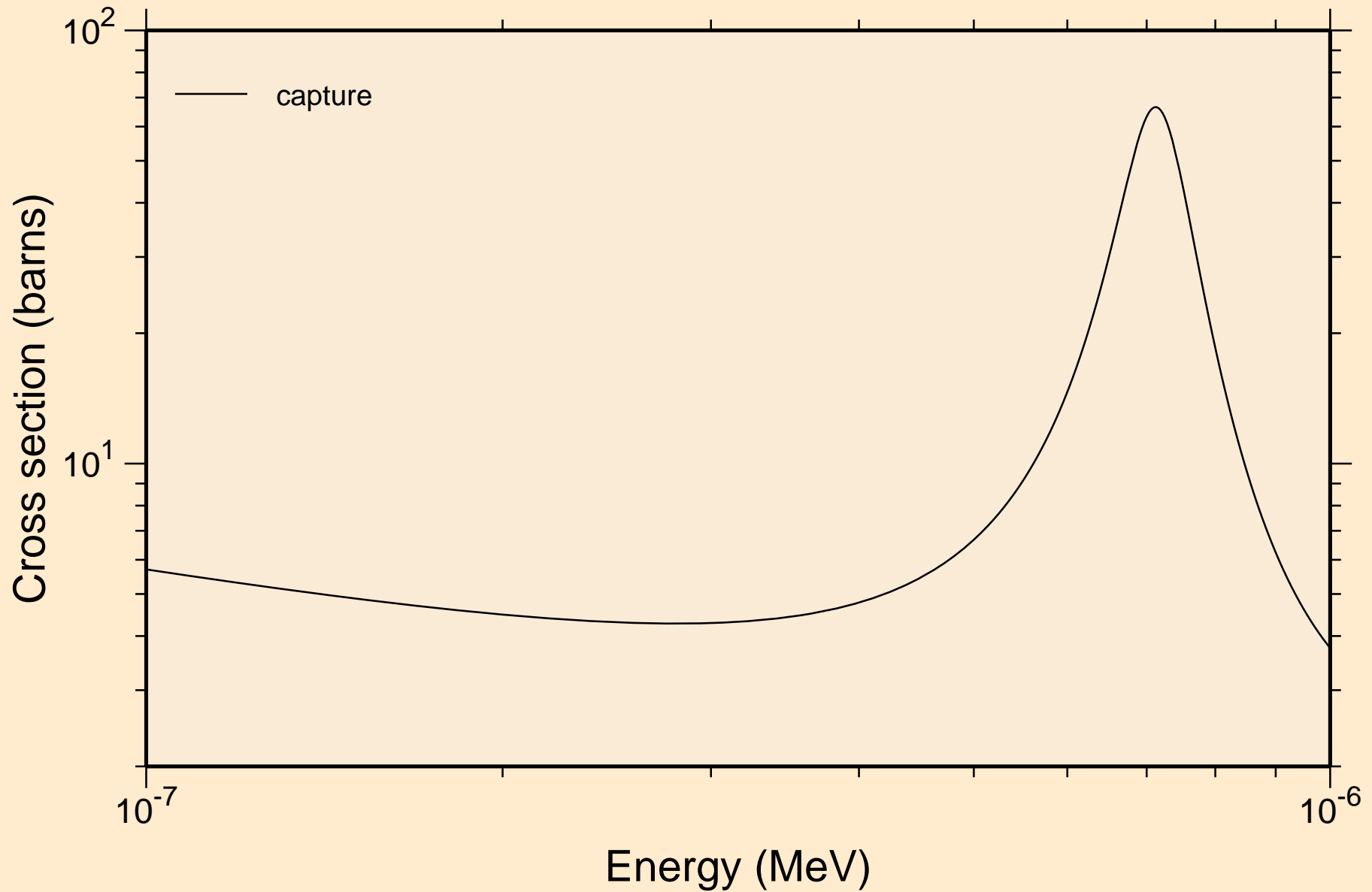

TC102M NEUTRON ACER TENDL-2024 LIBRARY; T=0.K
resonance absorption cross sections

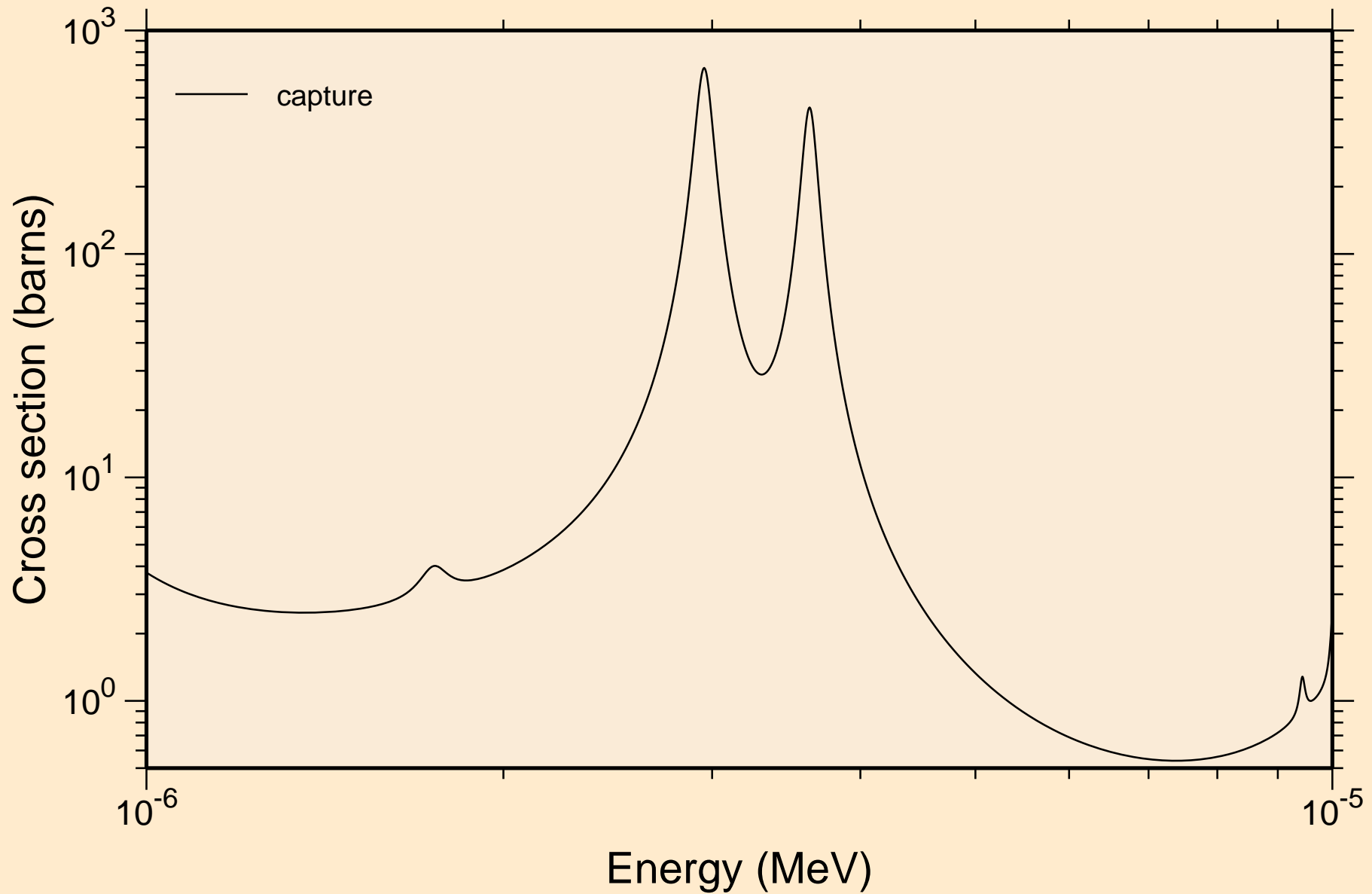

TC102M NEUTRON ACER TENDL-2024 LIBRARY; T=0.K
resonance absorption cross sections

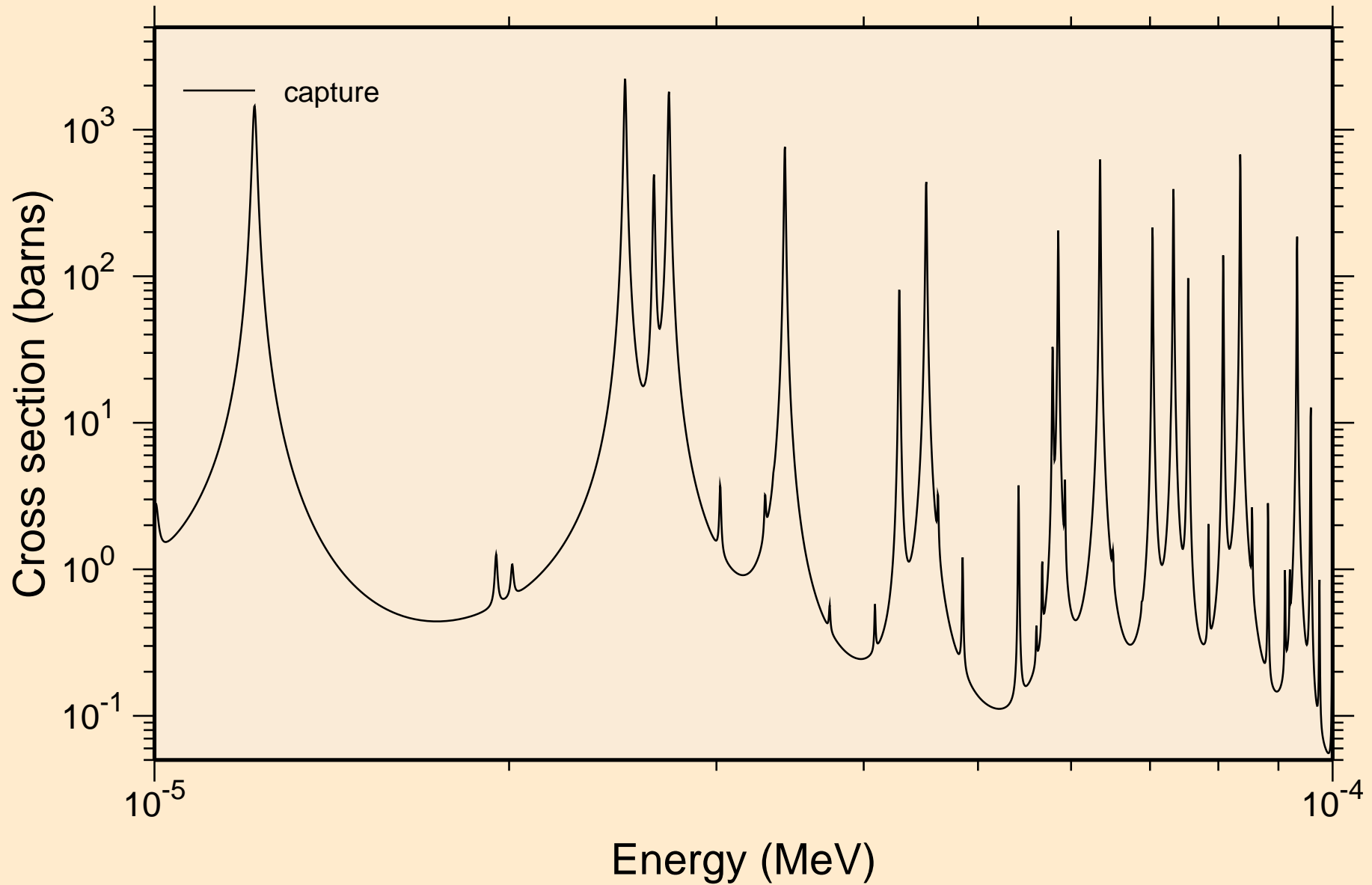

TC102M NEUTRON ACER TENDL-2024 LIBRARY; T=0.K
resonance absorption cross sections

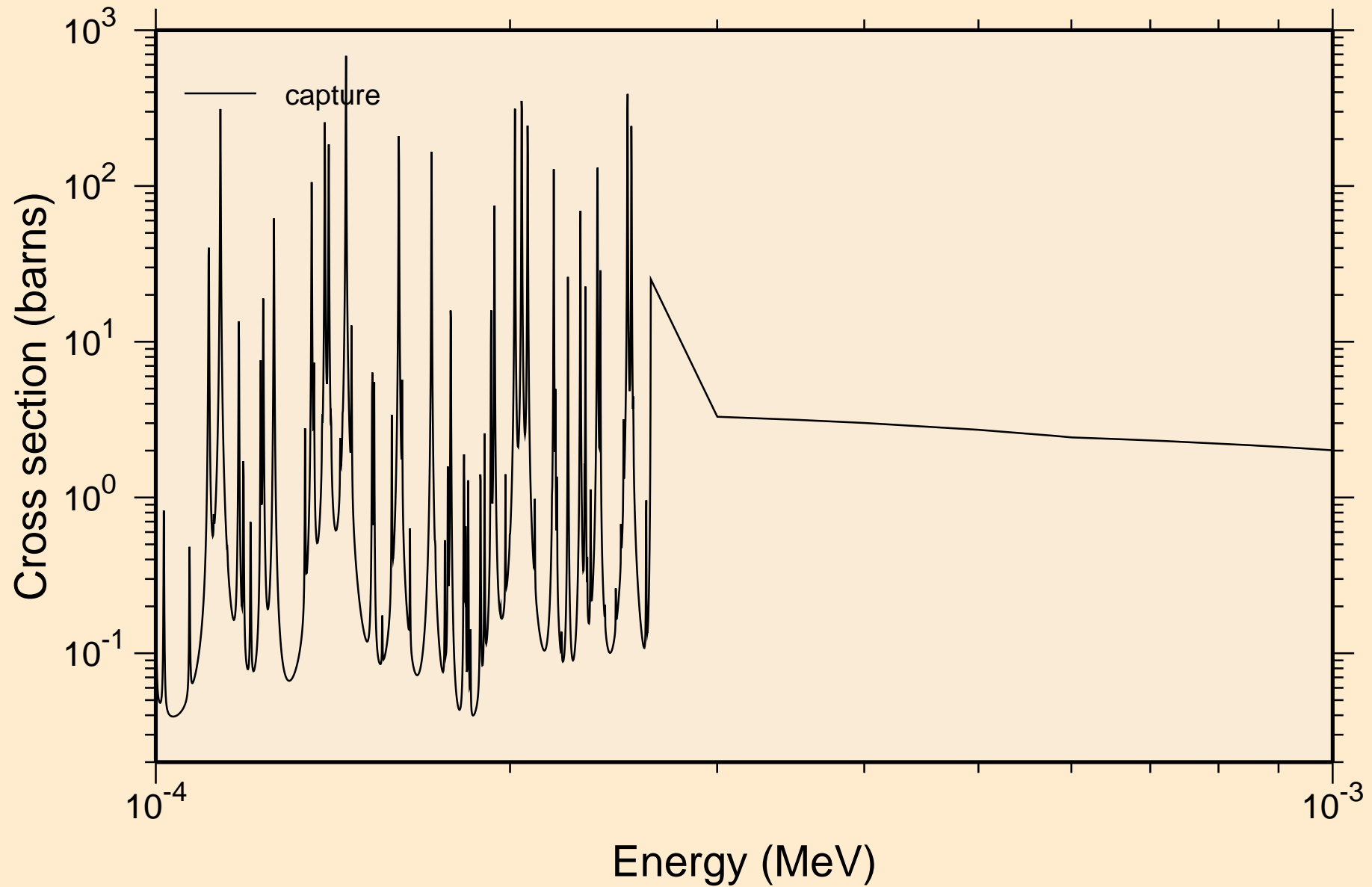

TC102M NEUTRON ACER TENDL-2024 LIBRARY; T=0.K
resonance absorption cross sections

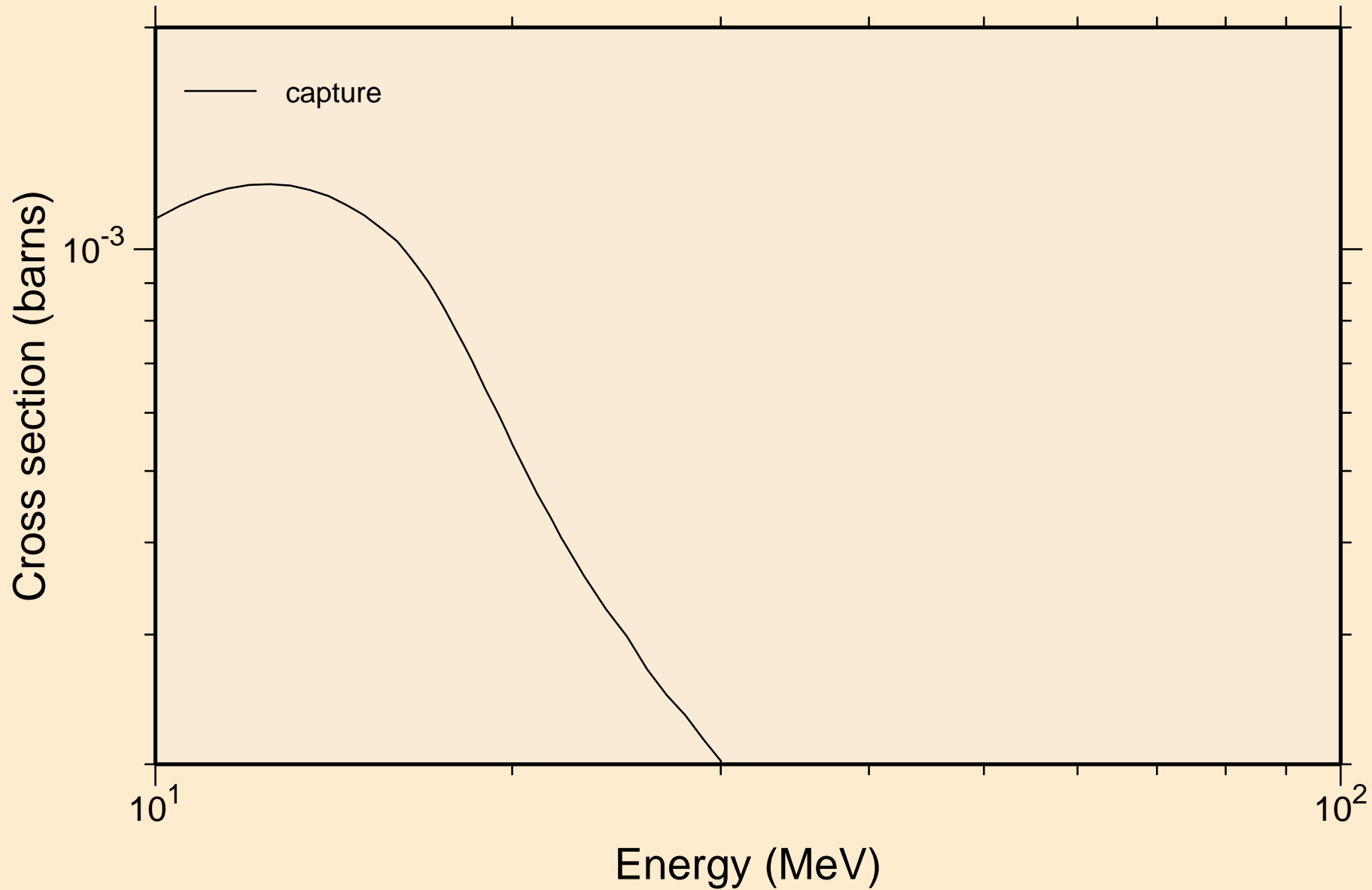

TC102M NEUTRON ACER TENDL-2024 LIBRARY; T=0.K
Heating

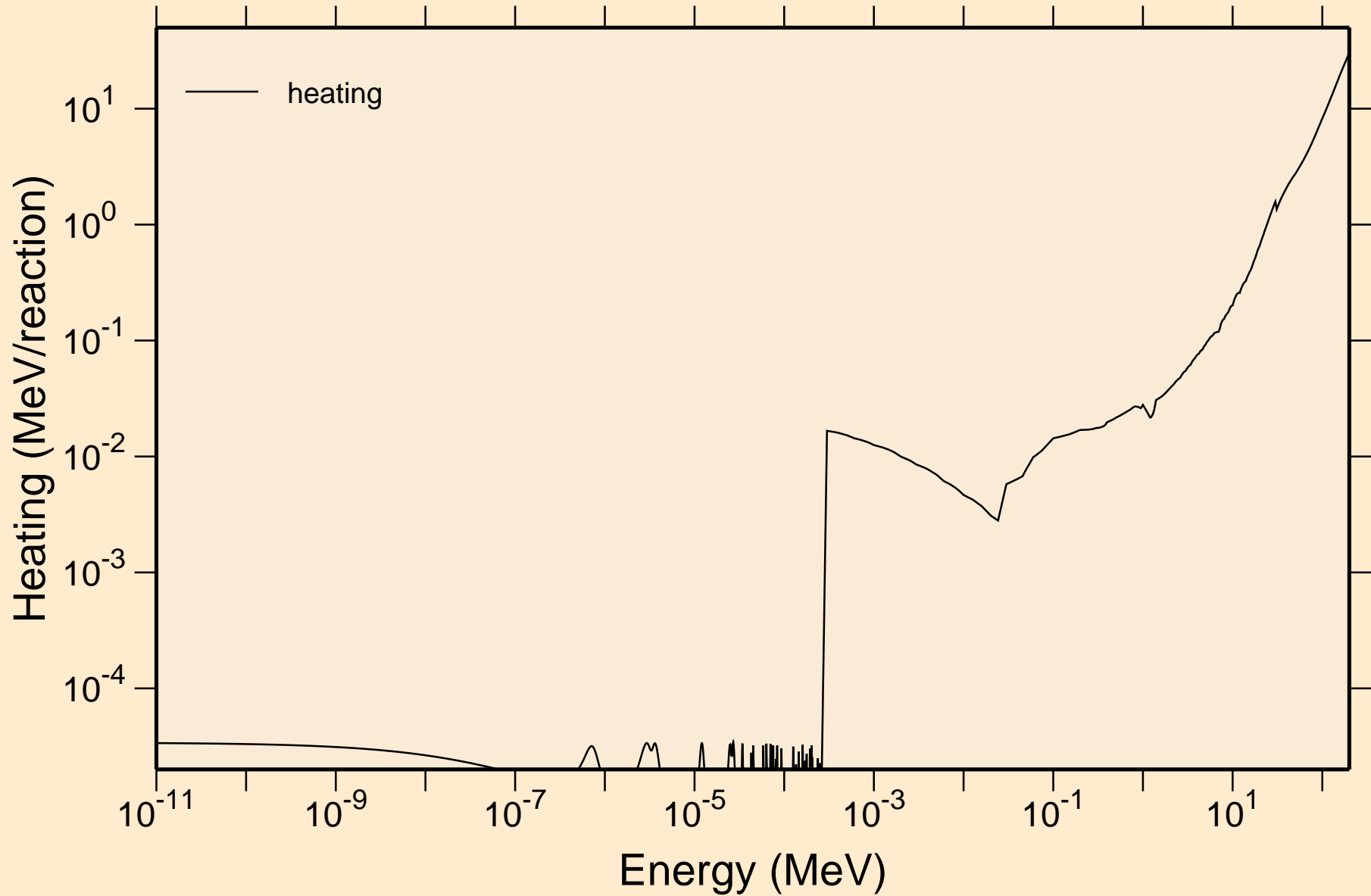

TC102M NEUTRON ACER TENDL-2024 LIBRARY; T=0.K
Damage

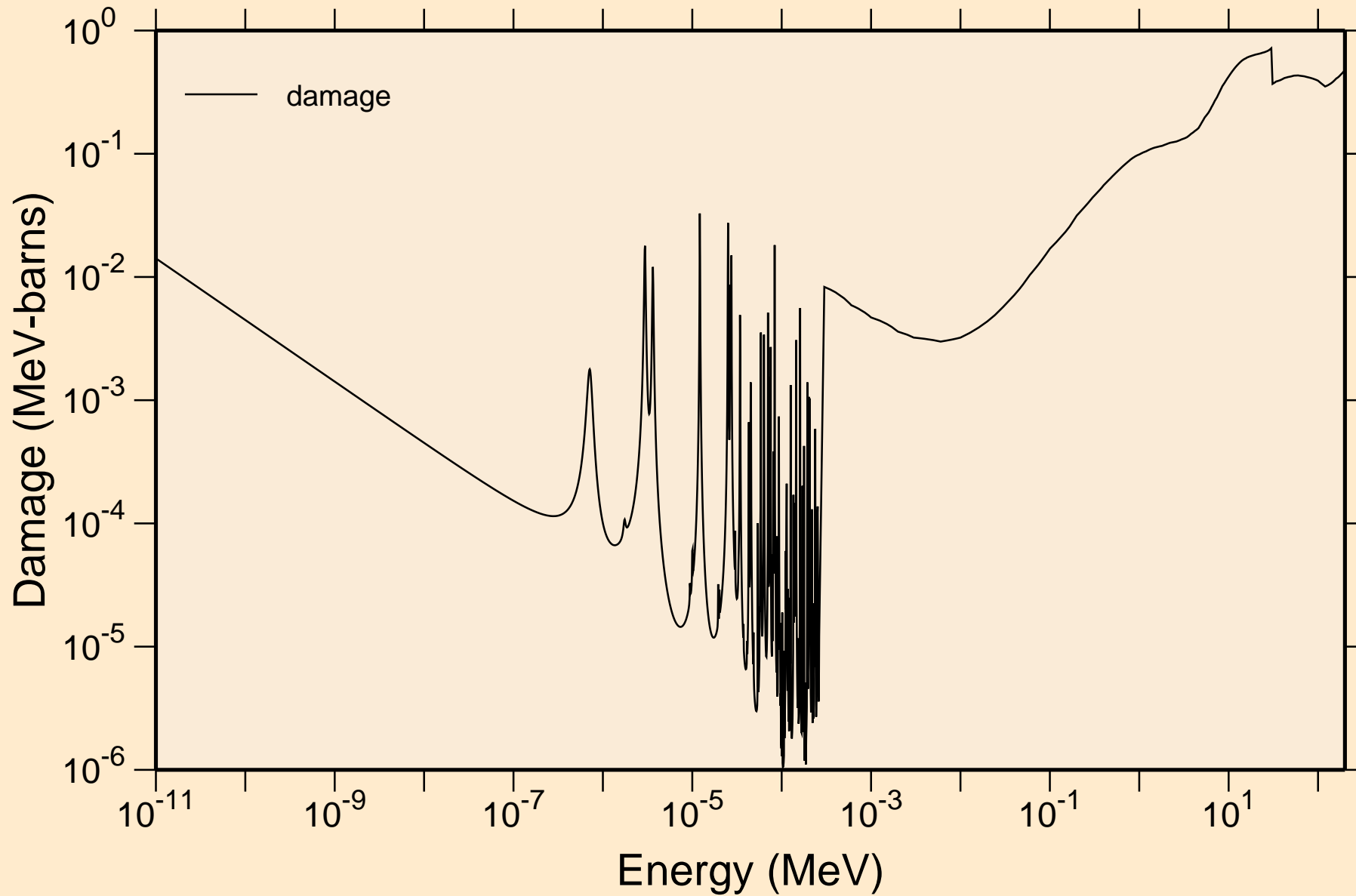

TC102M NEUTRON ACER TENDL-2024 LIBRARY; T=0.K
Non-threshold reactions

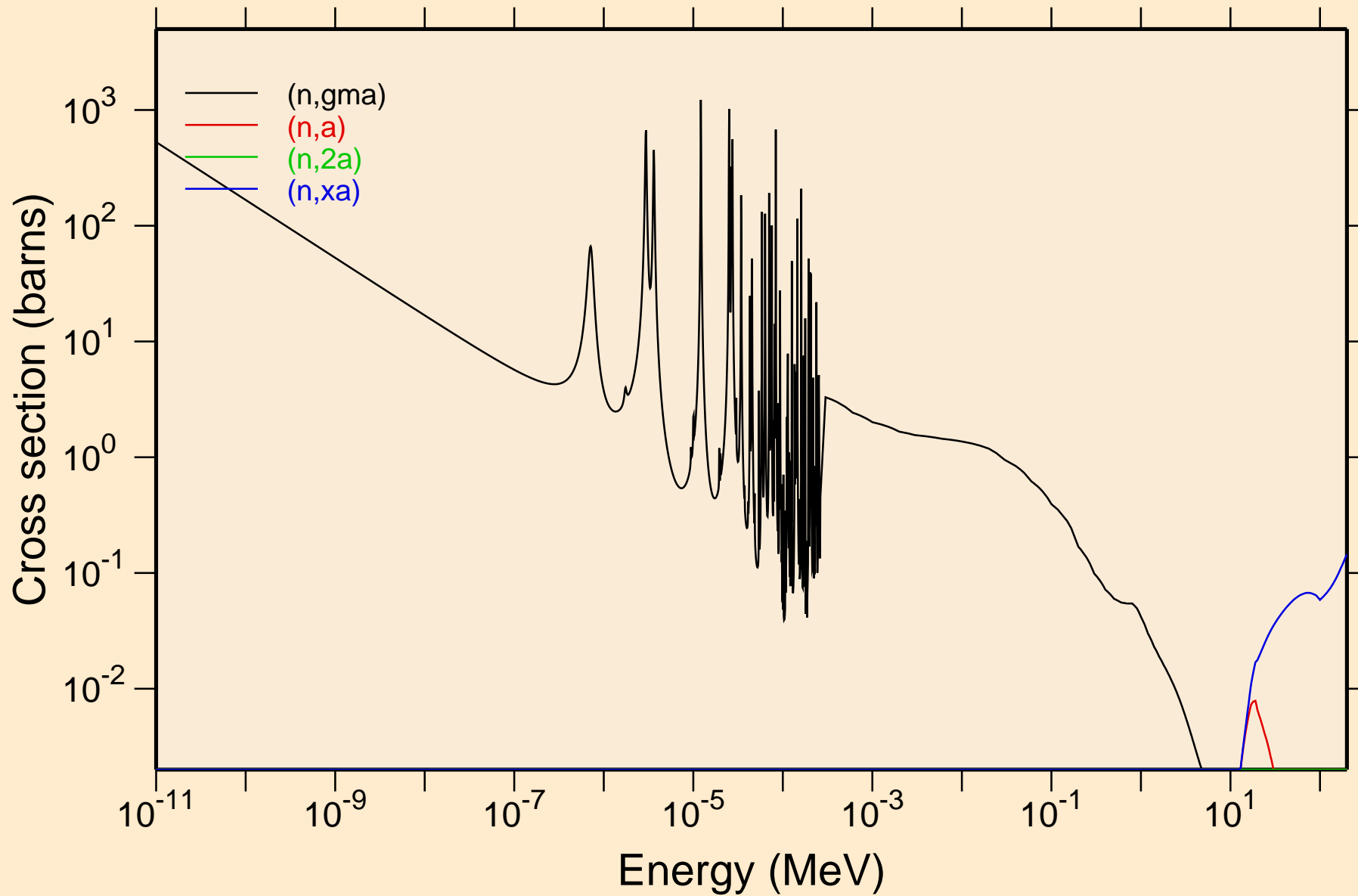

TC102M NEUTRON ACER TENDL-2024 LIBRARY; T=0.K
Principal cross sections

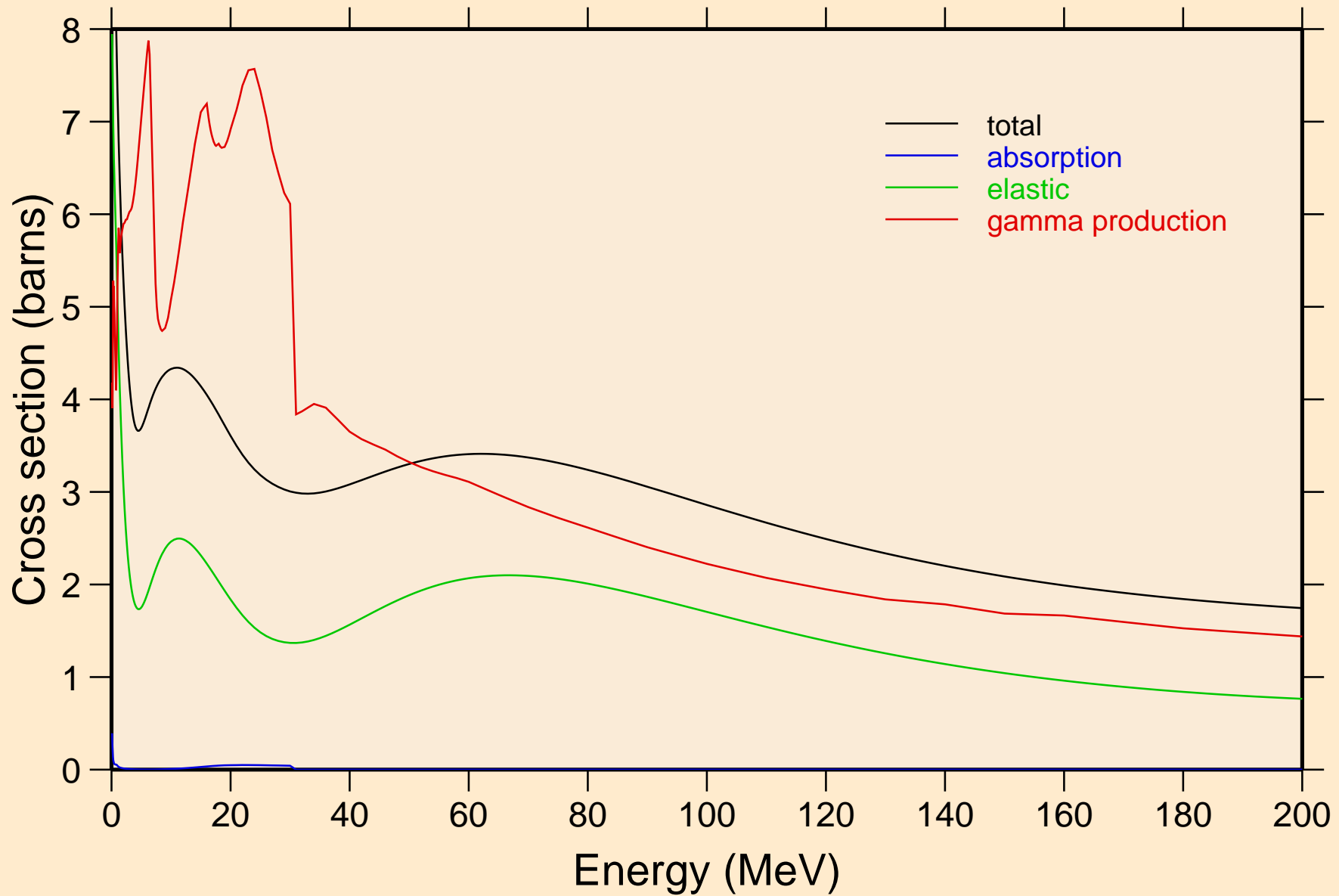

TC102M NEUTRON ACER TENDL-2024 LIBRARY; T=0.K

Heating

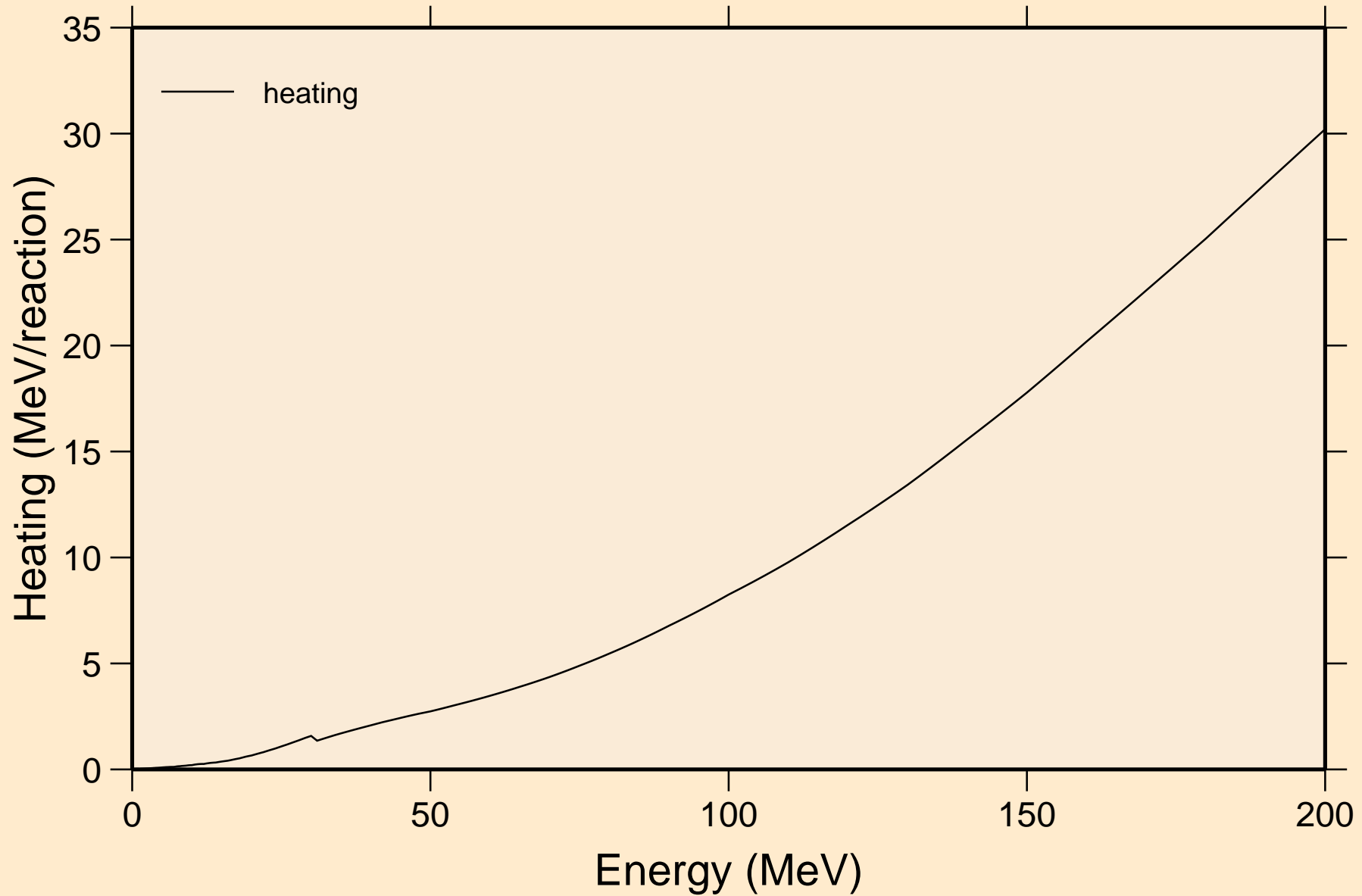

TC102M NEUTRON ACER TENDL-2024 LIBRARY; T=0.K
Damage

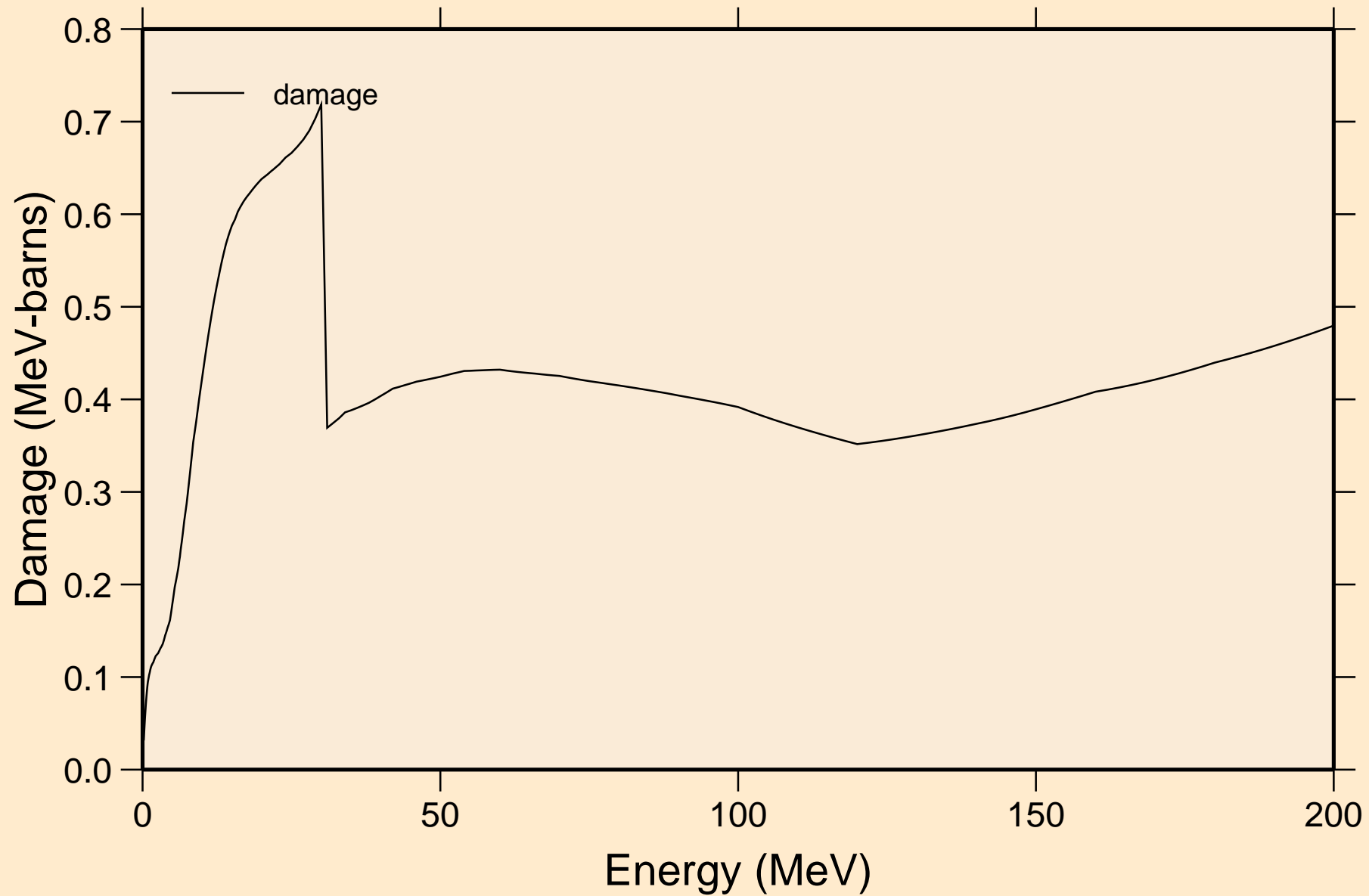

TC102M NEUTRON ACER TENDL-2024 LIBRARY; T=0.K
Non-threshold reactions

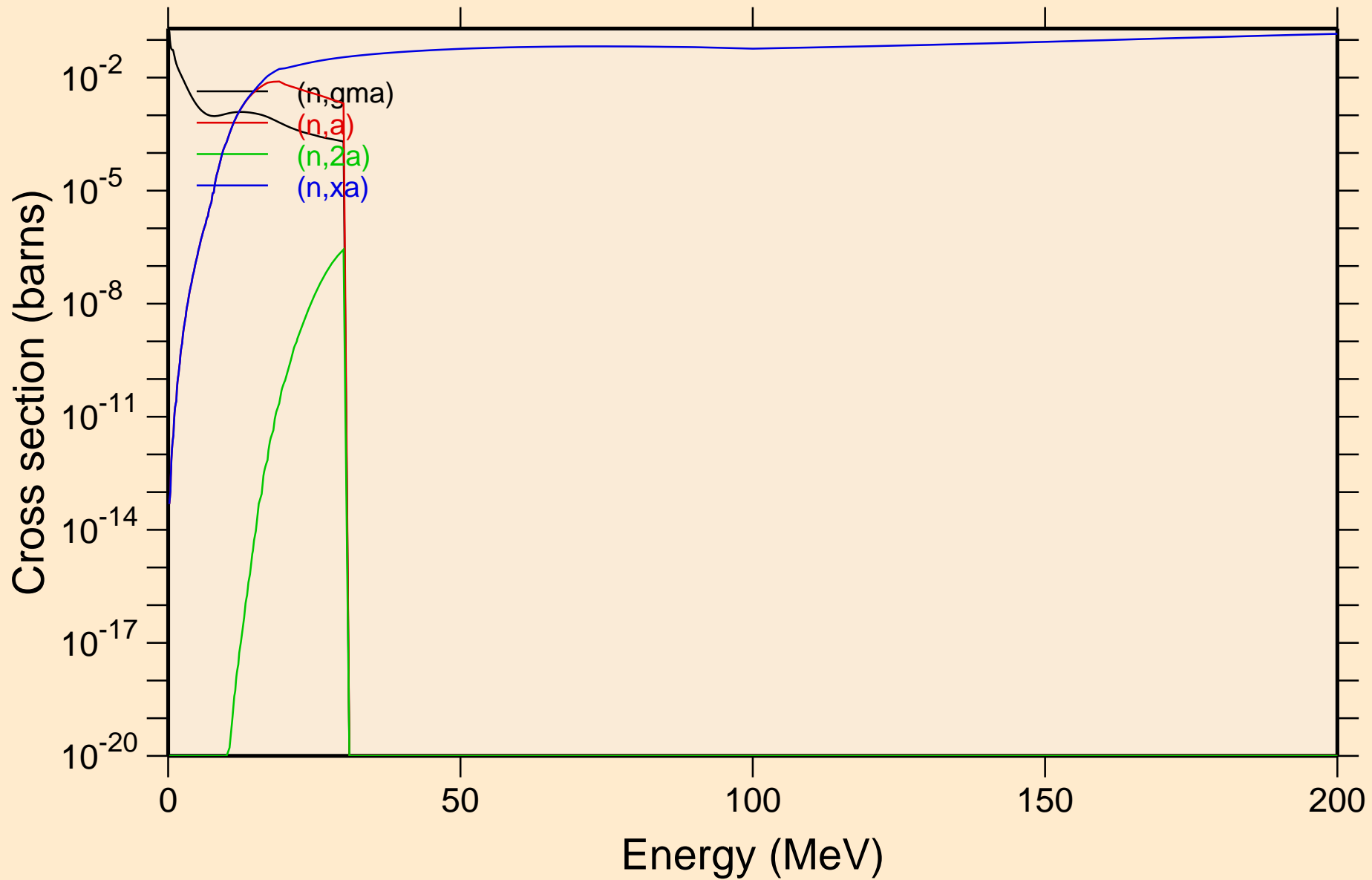

TC102M NEUTRON ACER TENDL-2024 LIBRARY; T=0.K
Inelastic levels

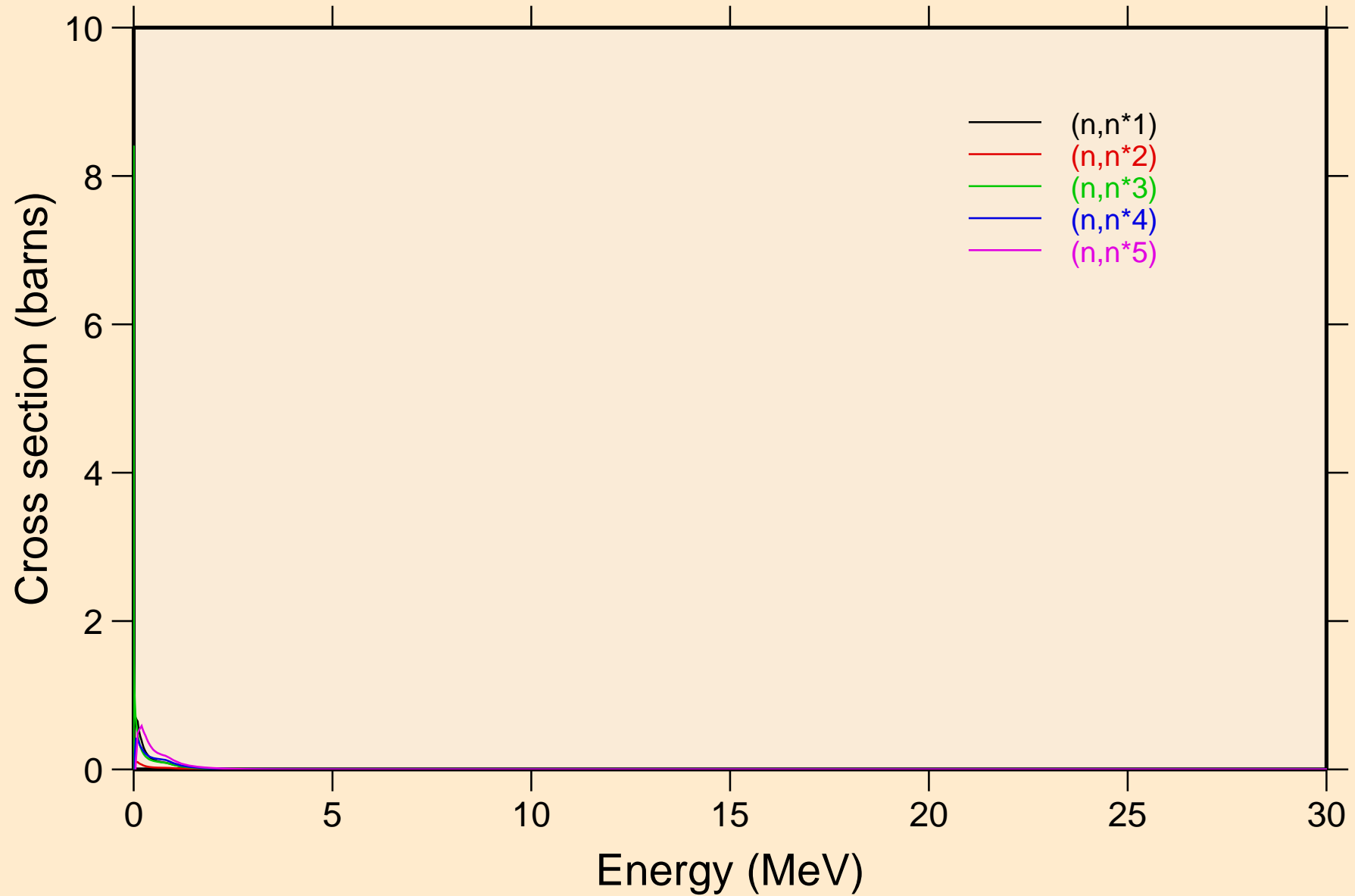

TC102M NEUTRON ACER TENDL-2024 LIBRARY; T=0.K
Inelastic levels

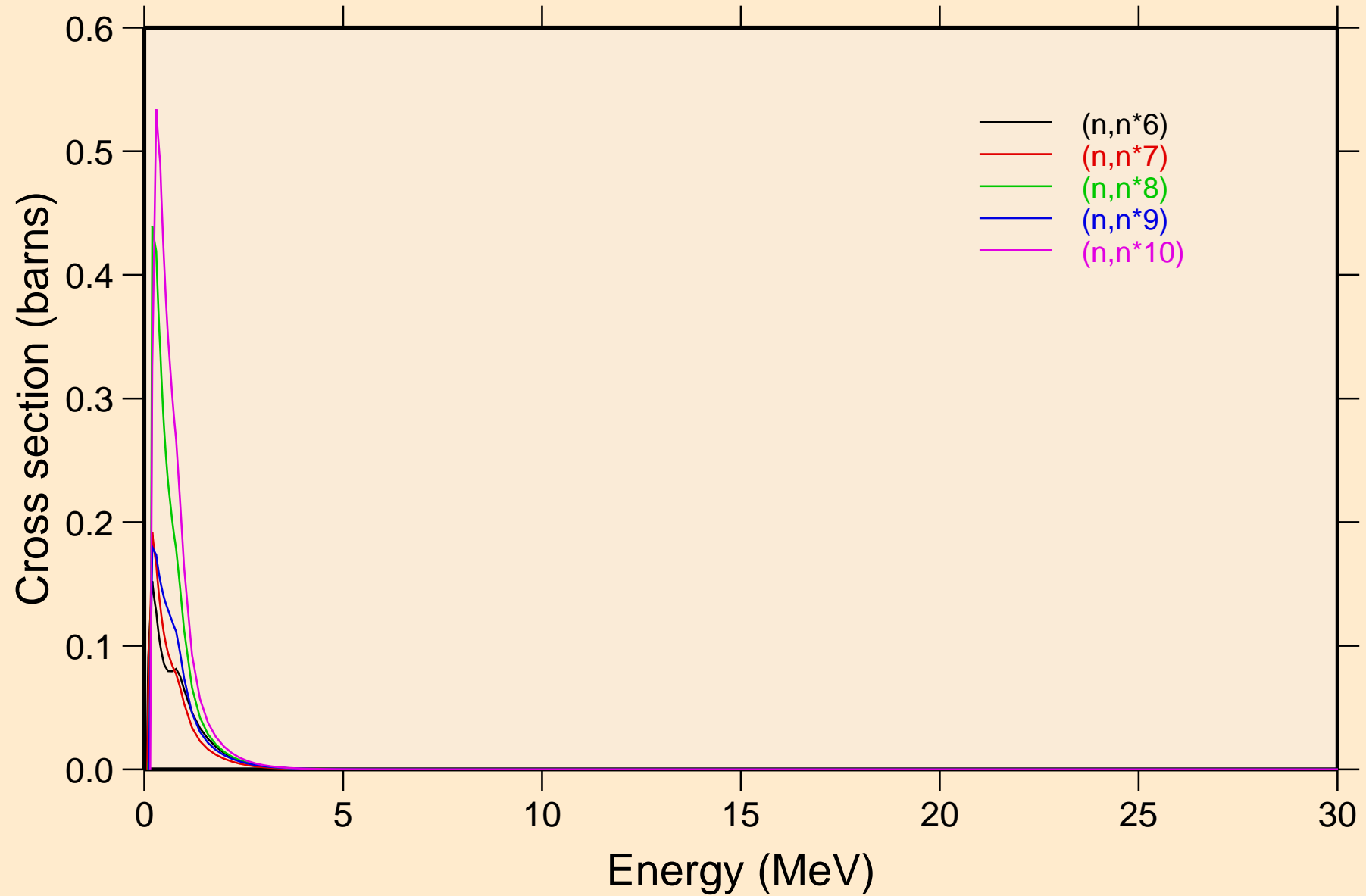

TC102M NEUTRON ACER TENDL-2024 LIBRARY; T=0.K
Inelastic levels

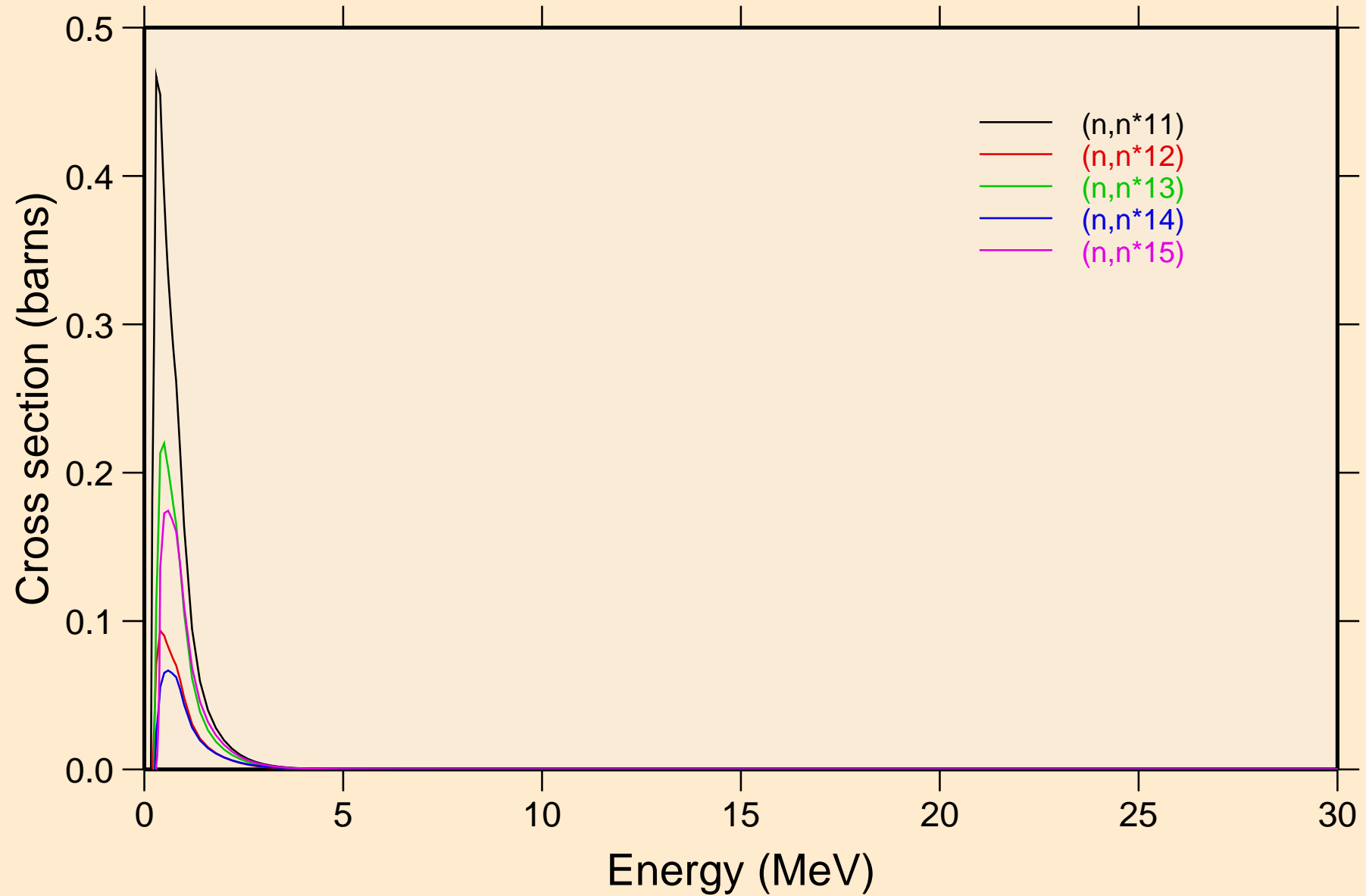

TC102M NEUTRON ACER TENDL-2024 LIBRARY; T=0.K
Inelastic levels

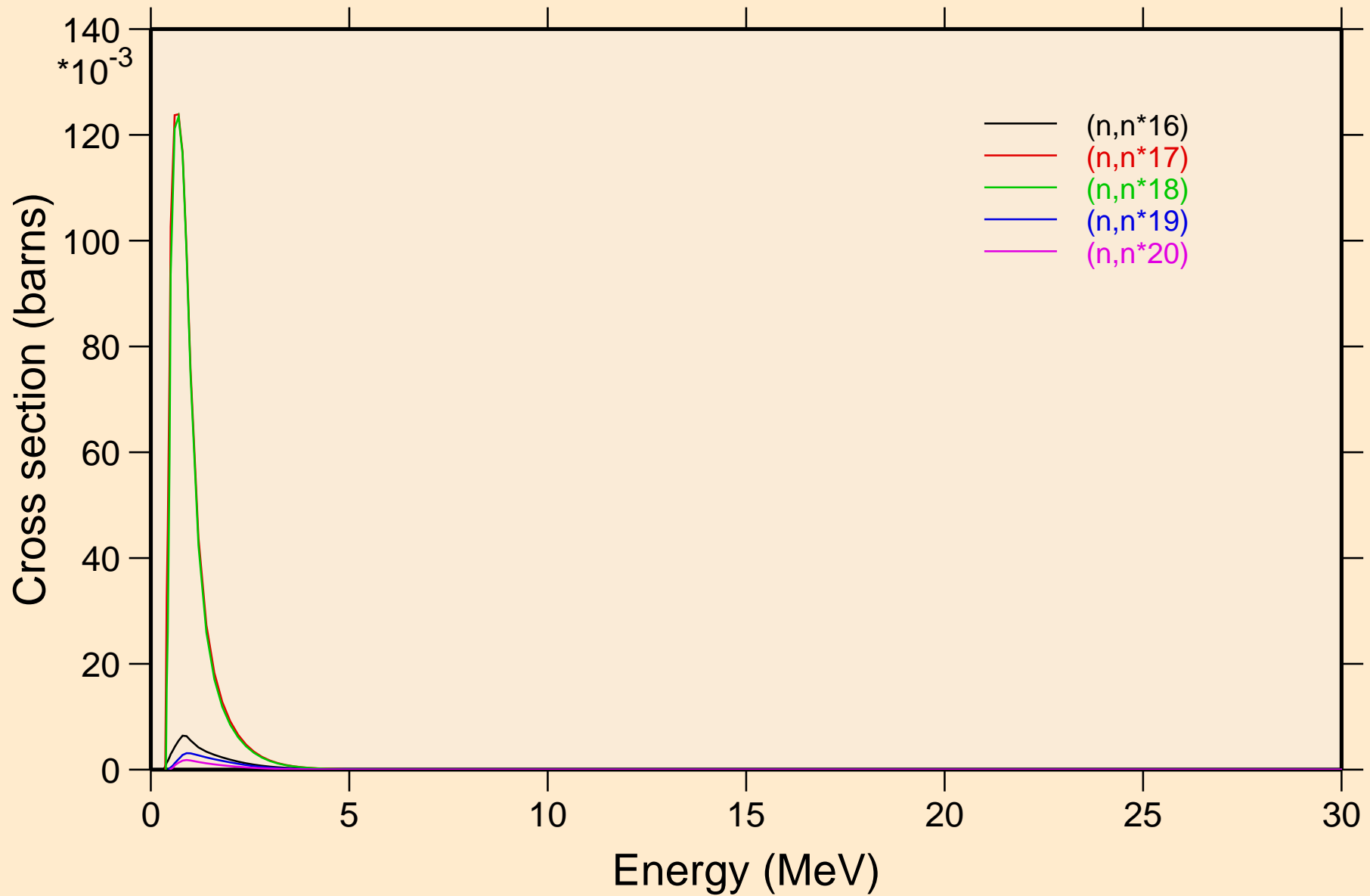

TC102M NEUTRON ACER TENDL-2024 LIBRARY; T=0.K
Inelastic levels

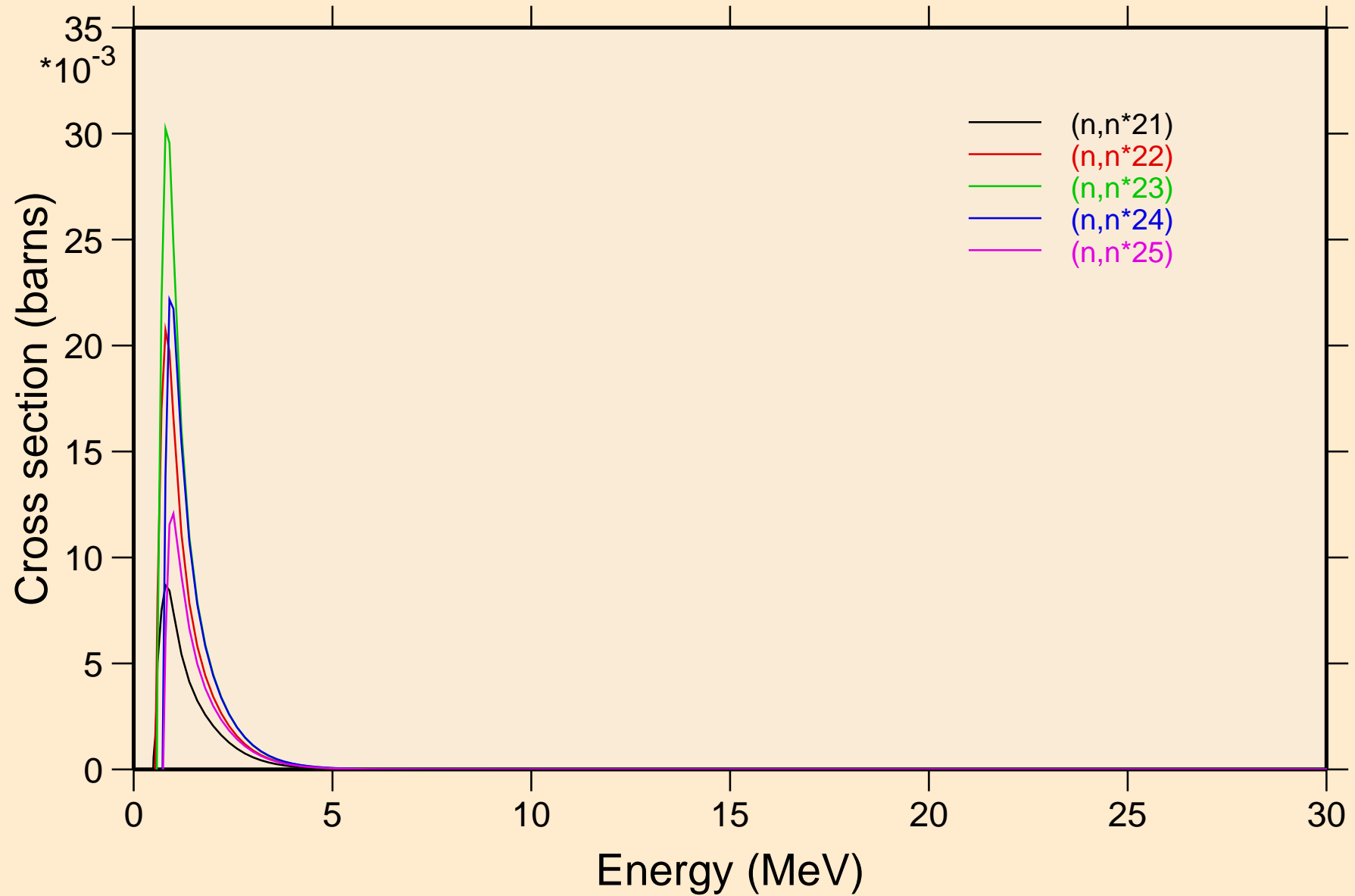

TC102M NEUTRON ACER TENDL-2024 LIBRARY; T=0.K
Inelastic levels

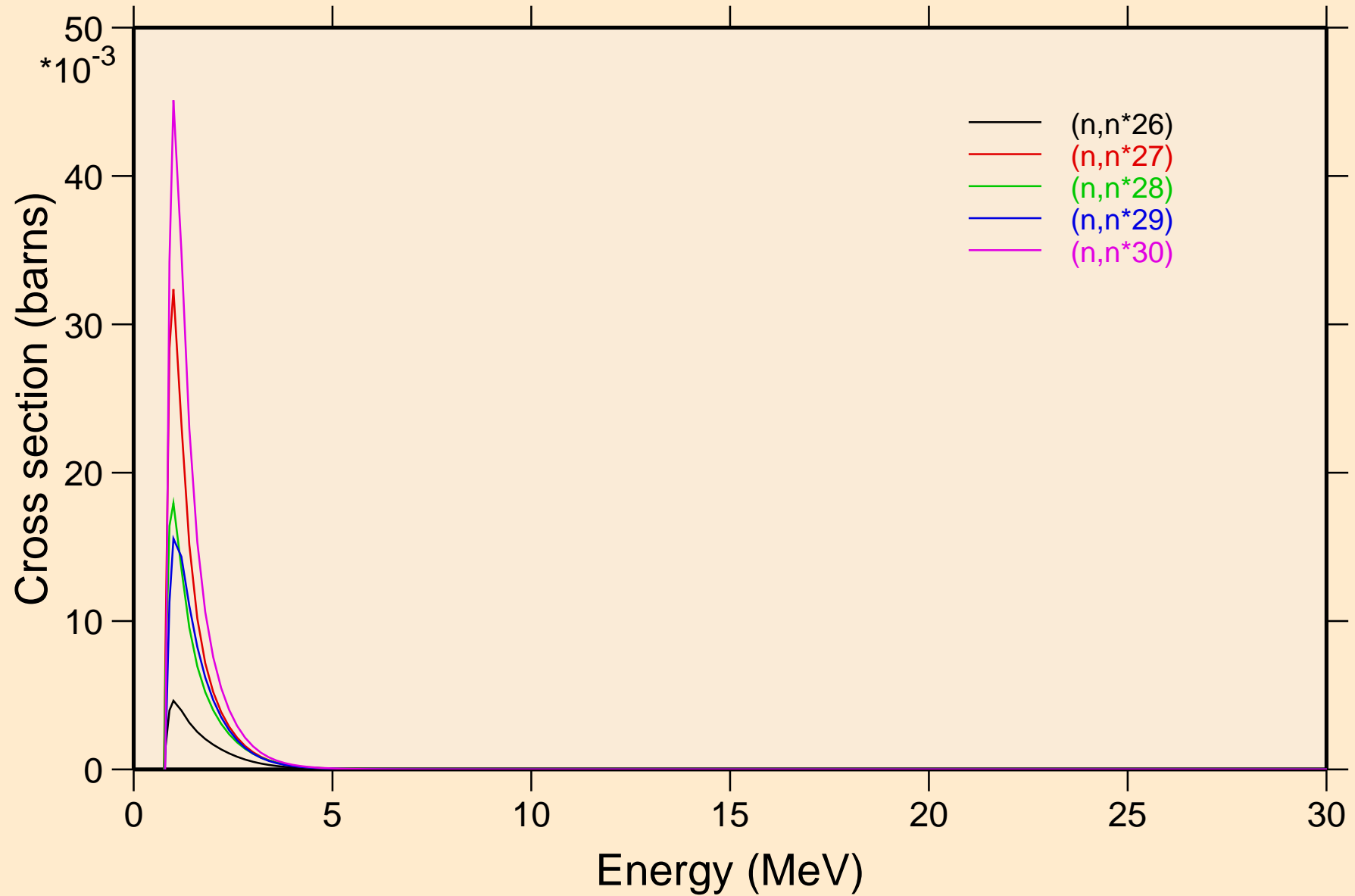

TC102M NEUTRON ACER TENDL-2024 LIBRARY; T=0.K
Threshold reactions

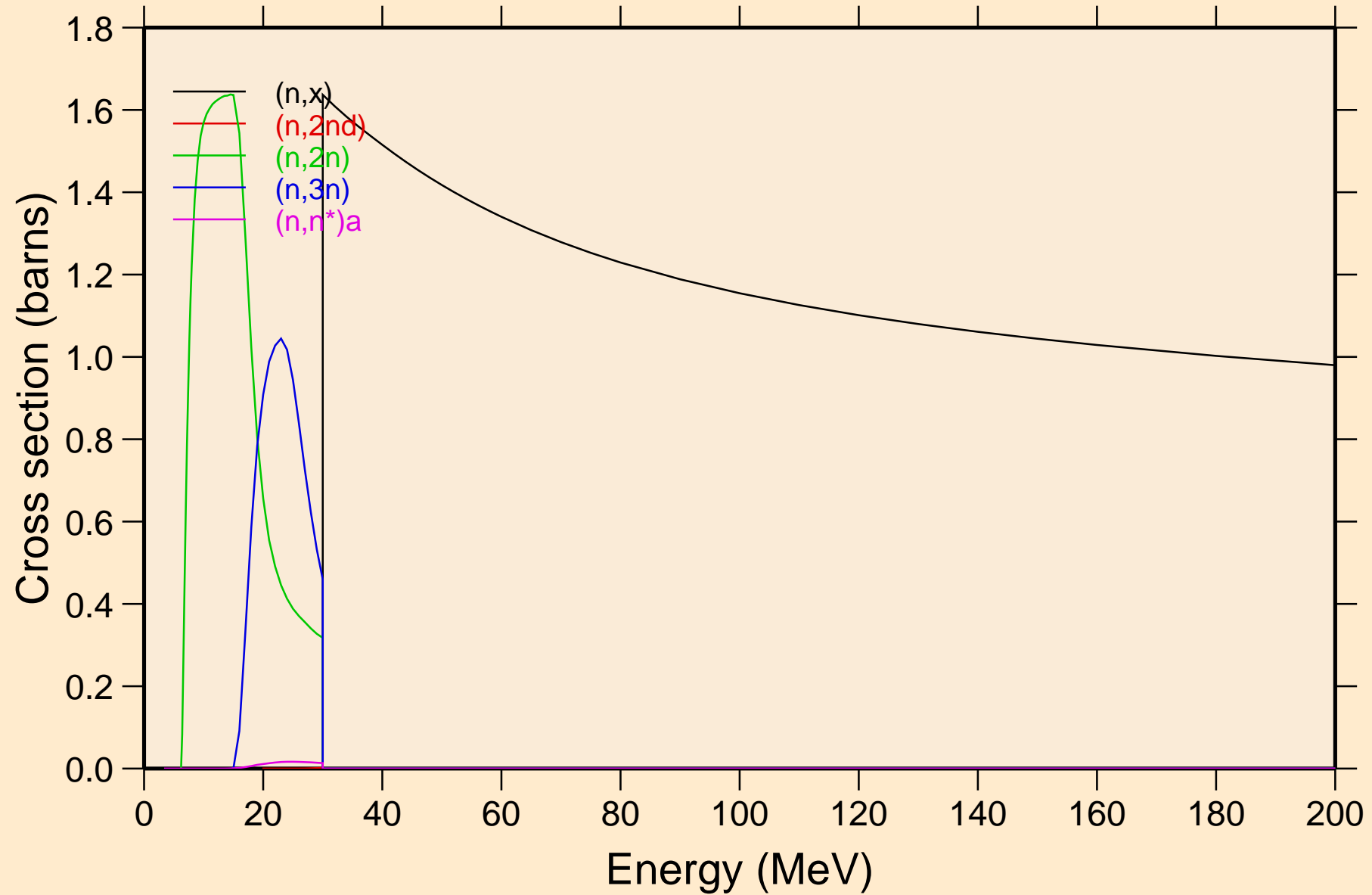

TC102M NEUTRON ACER TENDL-2024 LIBRARY; T=0.K
Threshold reactions

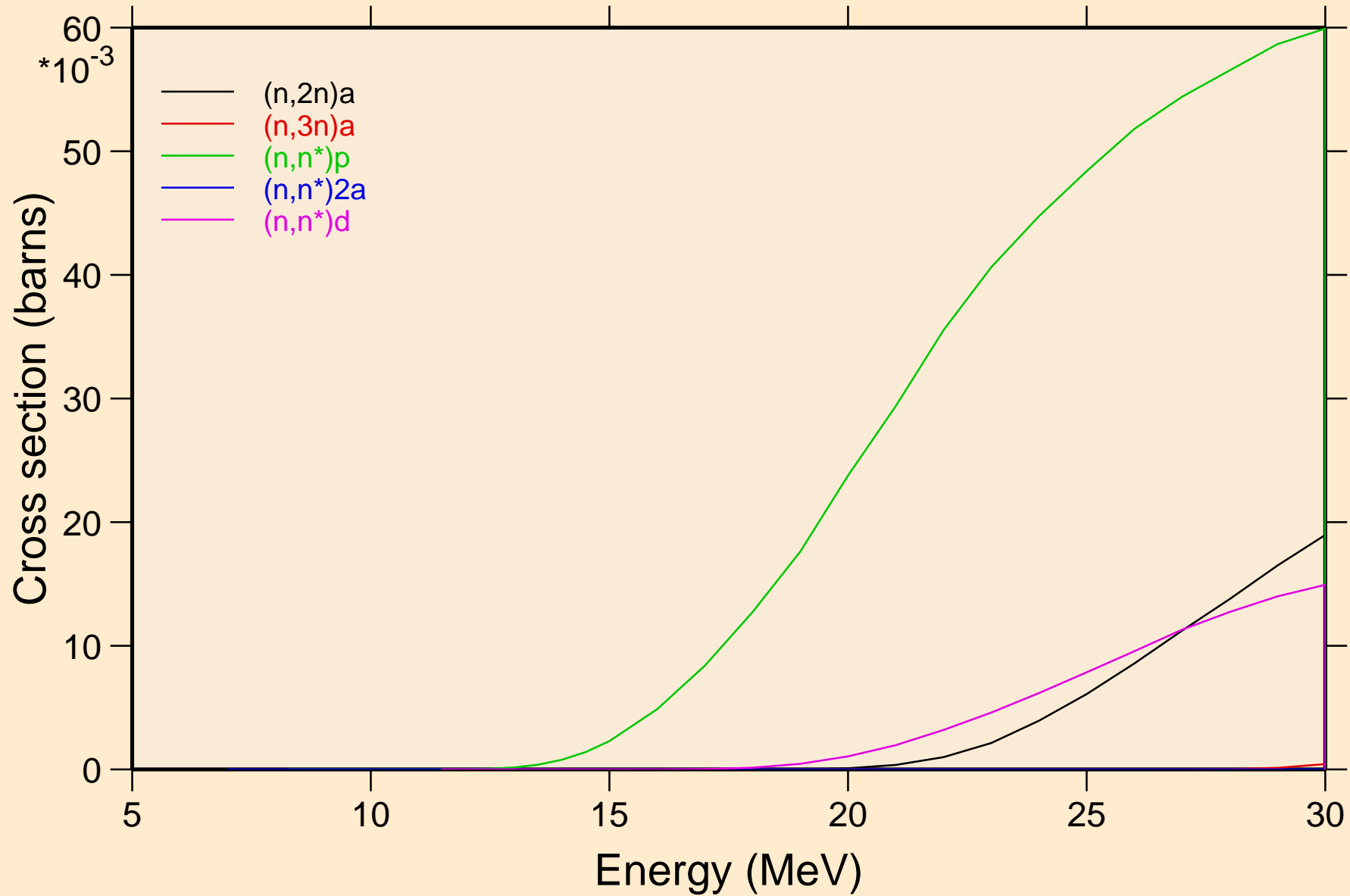

TC102M NEUTRON ACER TENDL-2024 LIBRARY; T=0.K
Threshold reactions

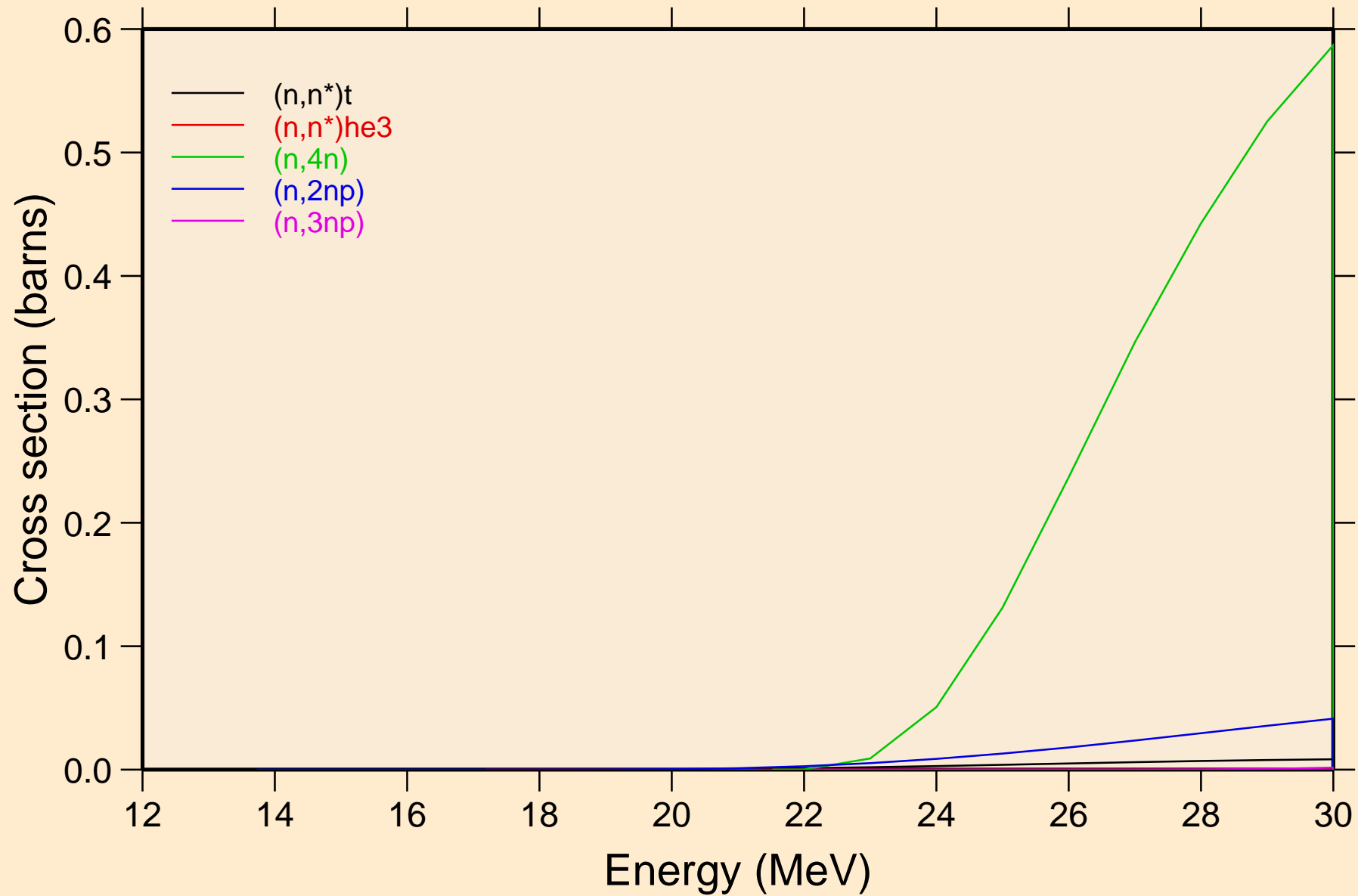

TC102M NEUTRON ACER TENDL-2024 LIBRARY; T=0.K
Threshold reactions

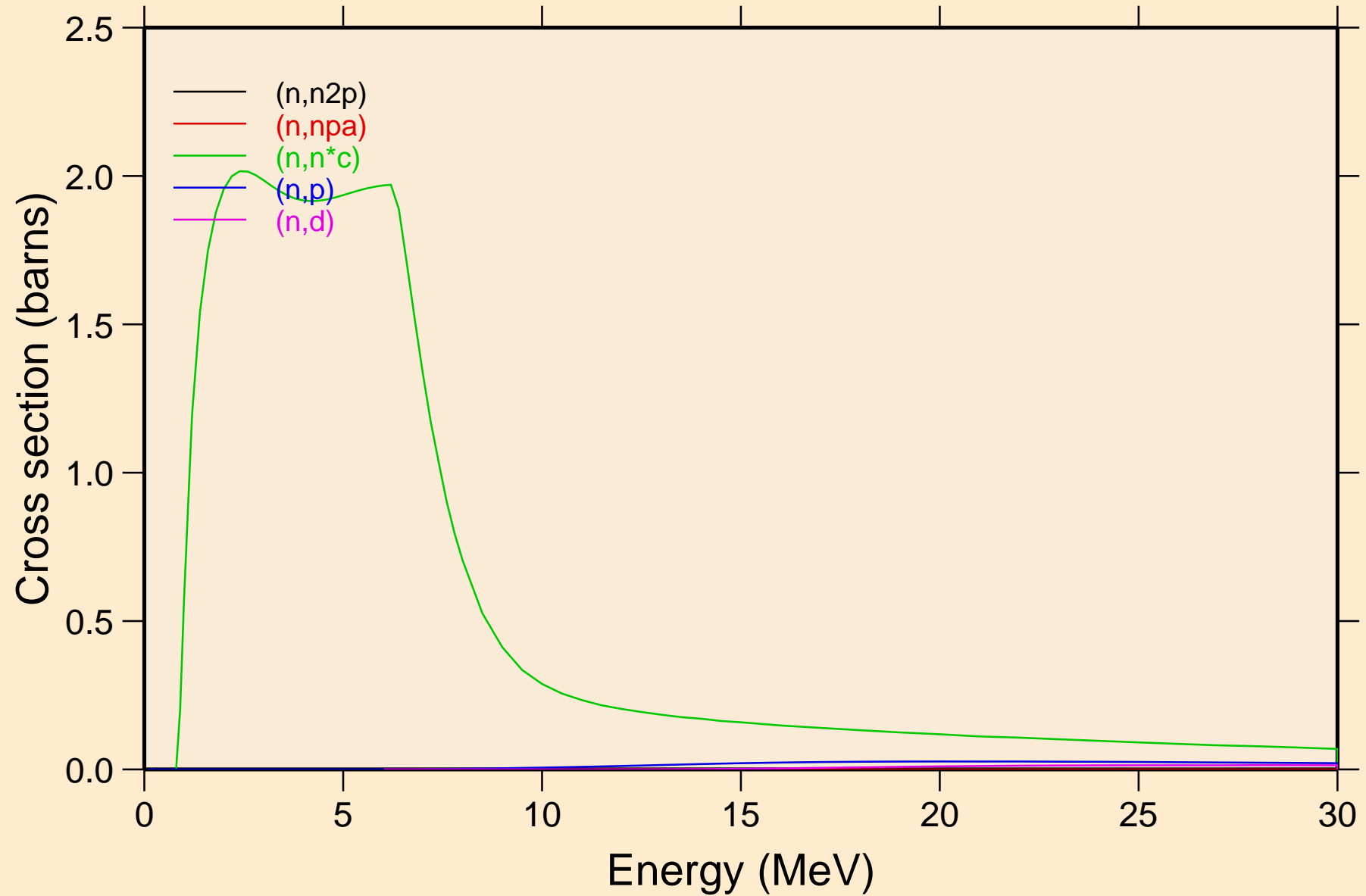

TC102M NEUTRON ACER TENDL-2024 LIBRARY; T=0.K
Threshold reactions

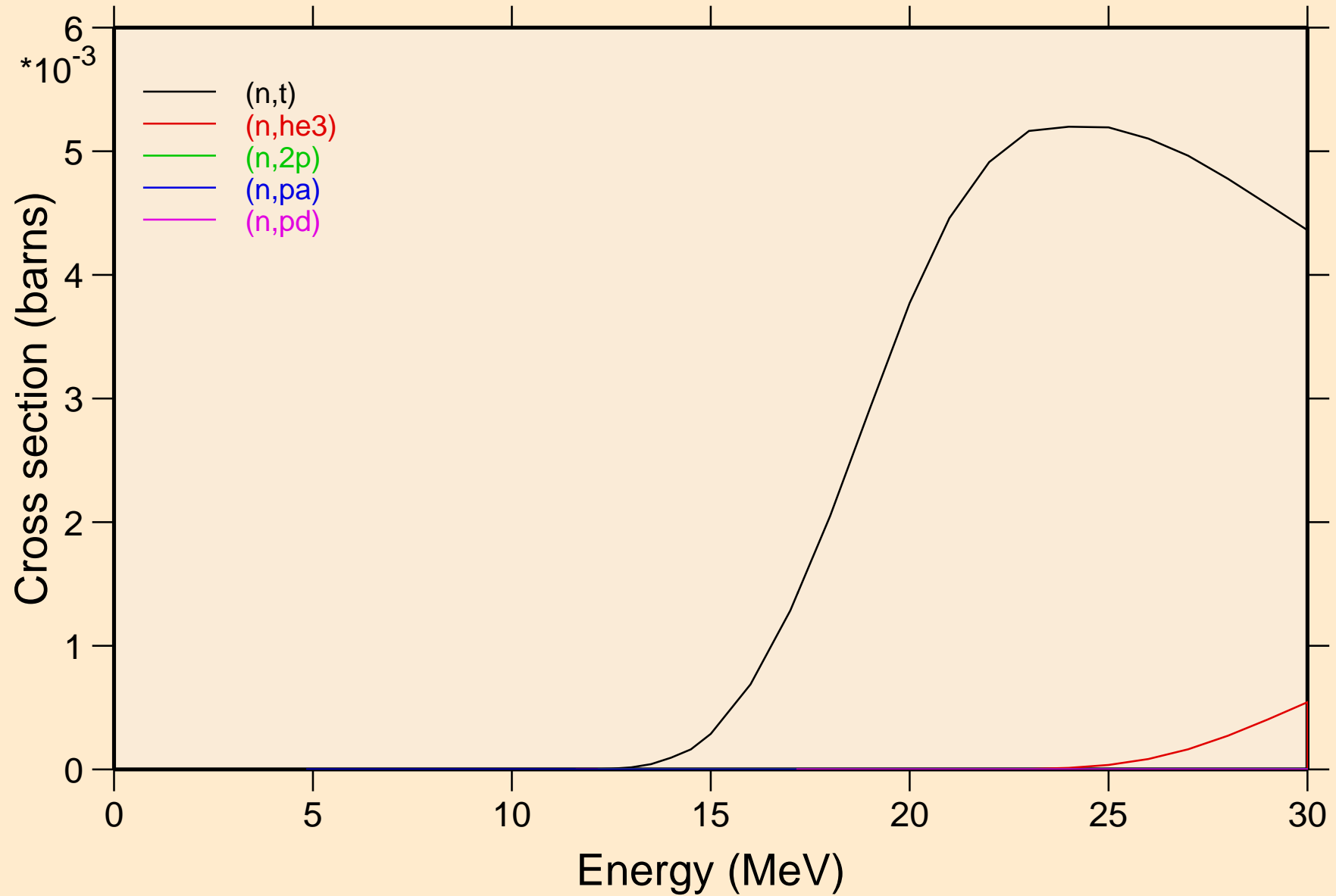

TC102M NEUTRON ACER TENDL-2024 LIBRARY; T=0.K
Threshold reactions

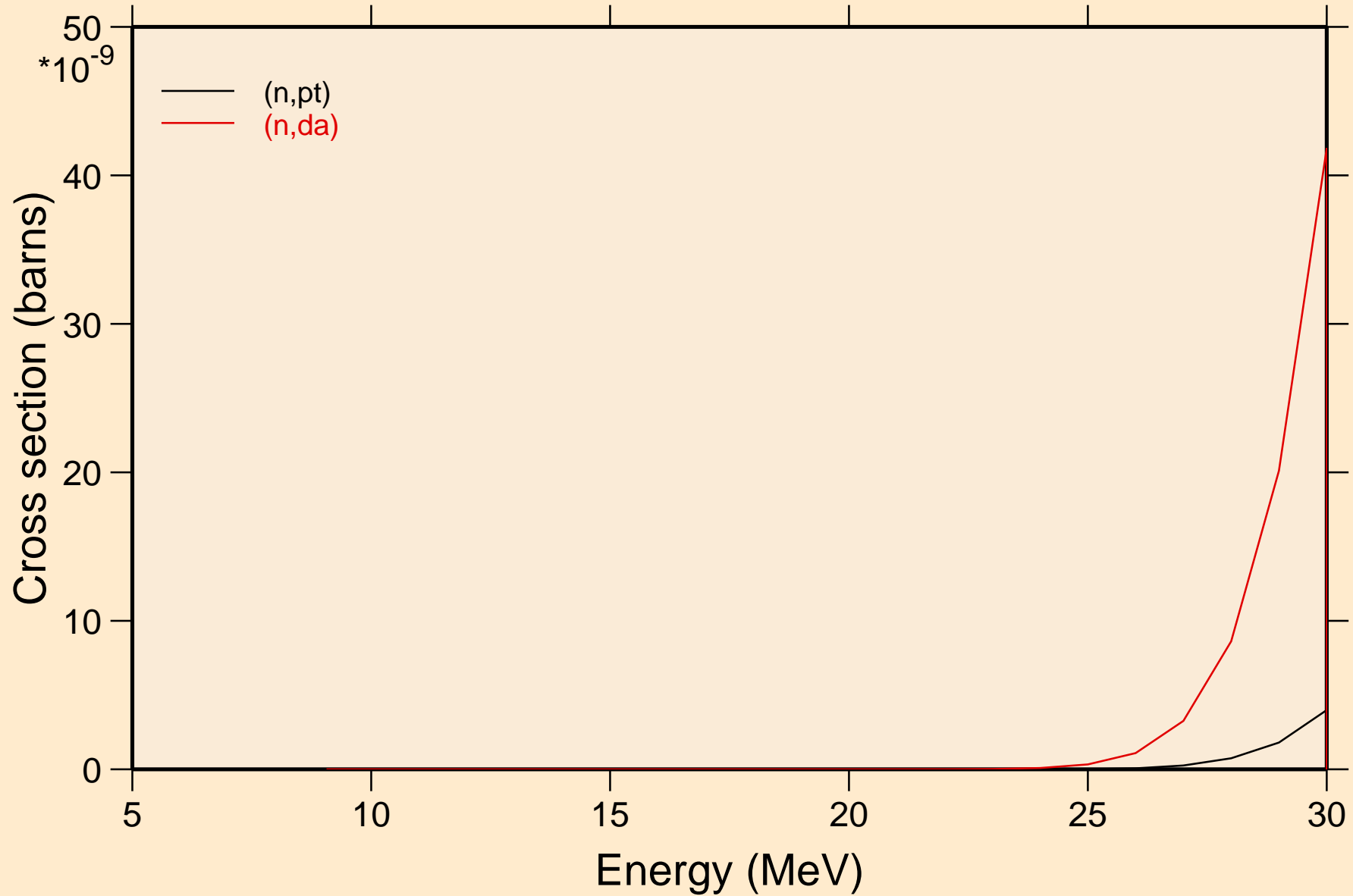

TC102M NEUTRON ACER TENDL-2024 LIBRARY; T=0.K
Threshold reactions

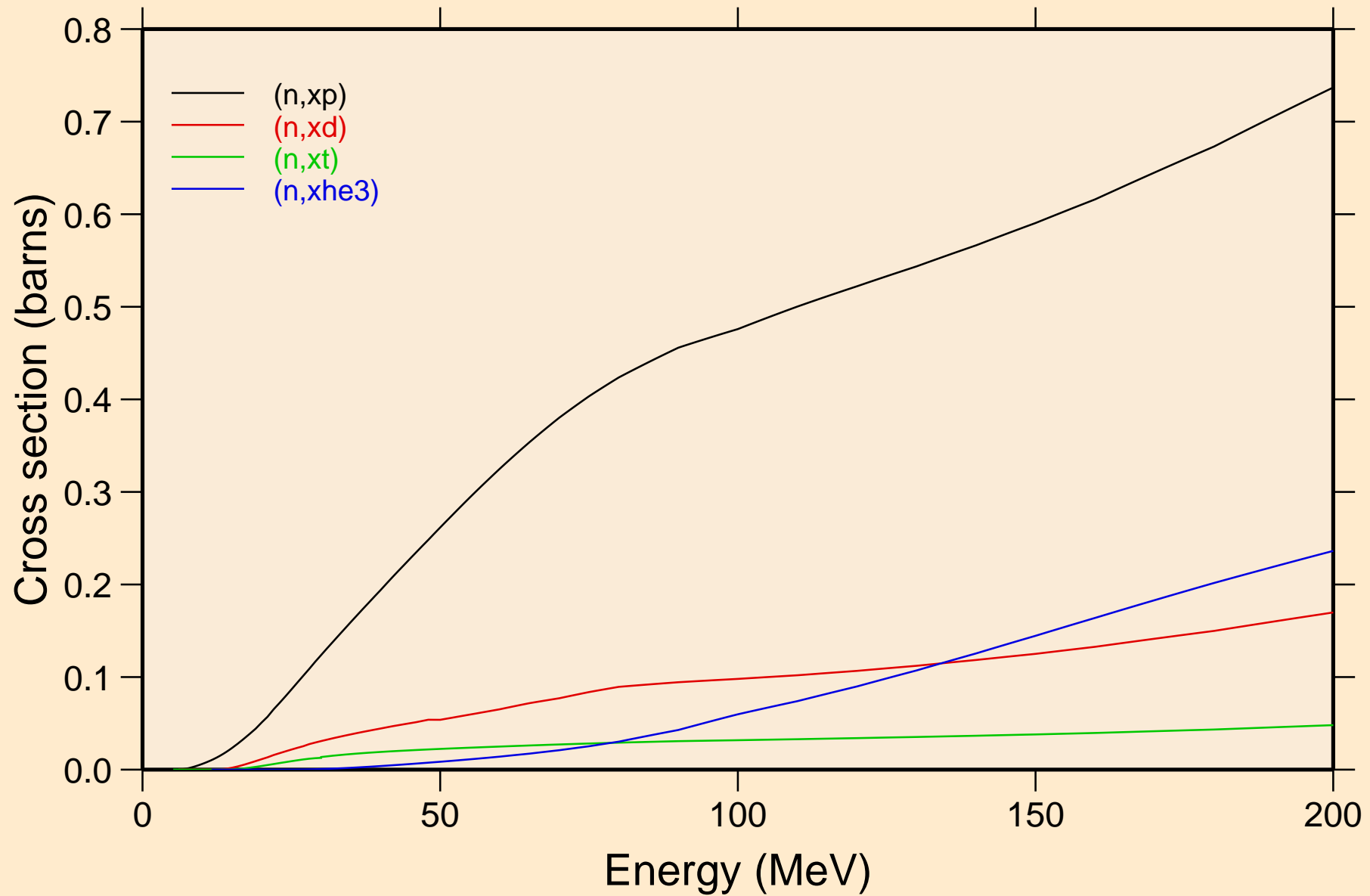

TC102M NEUTRON ACER TENDL-2024 LIBRARY; T=0.K
angular distribution for elastic

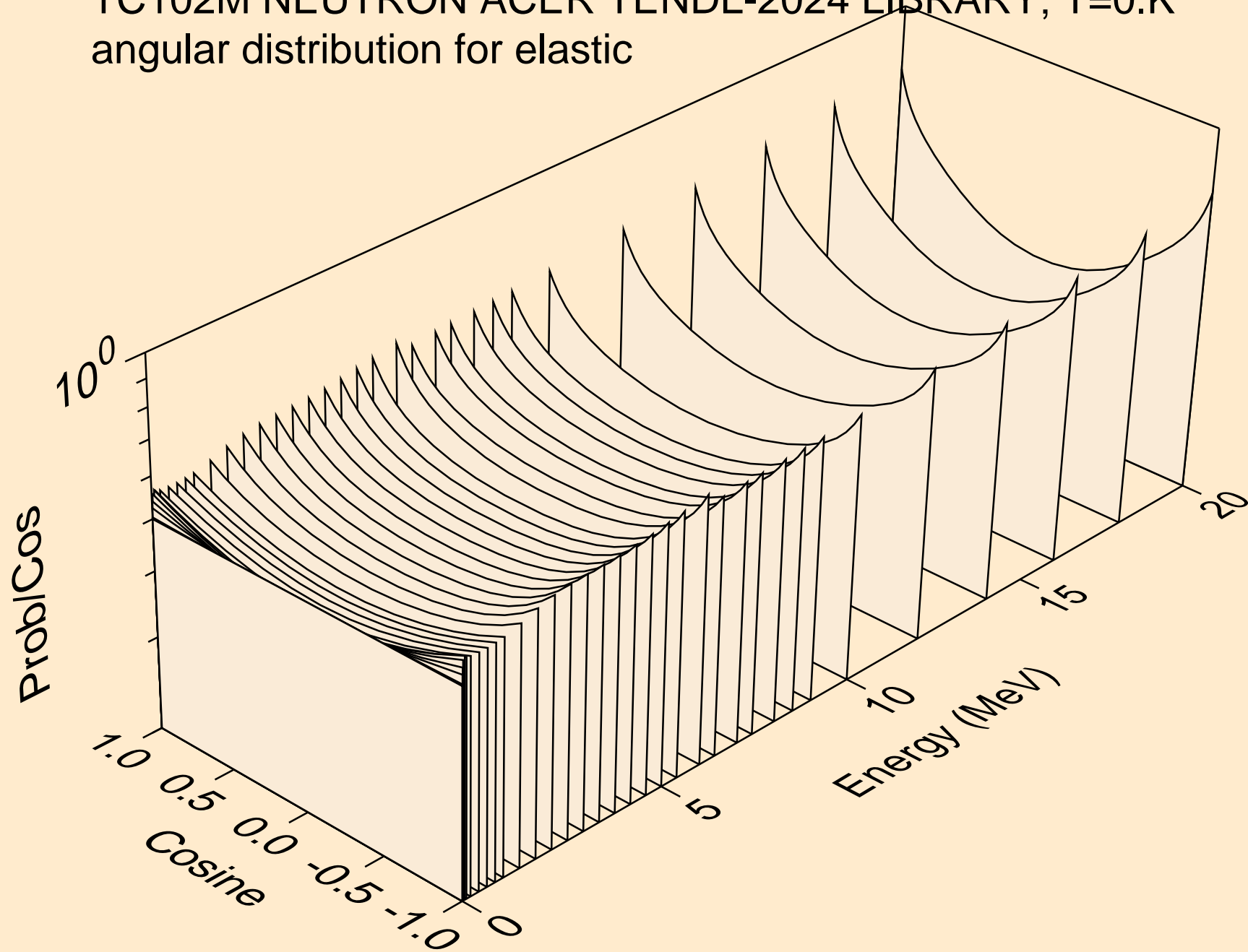

TC102M NEUTRON ACER TENDL-2024 LIBRARY; T=0.K
angular distribution for elastic

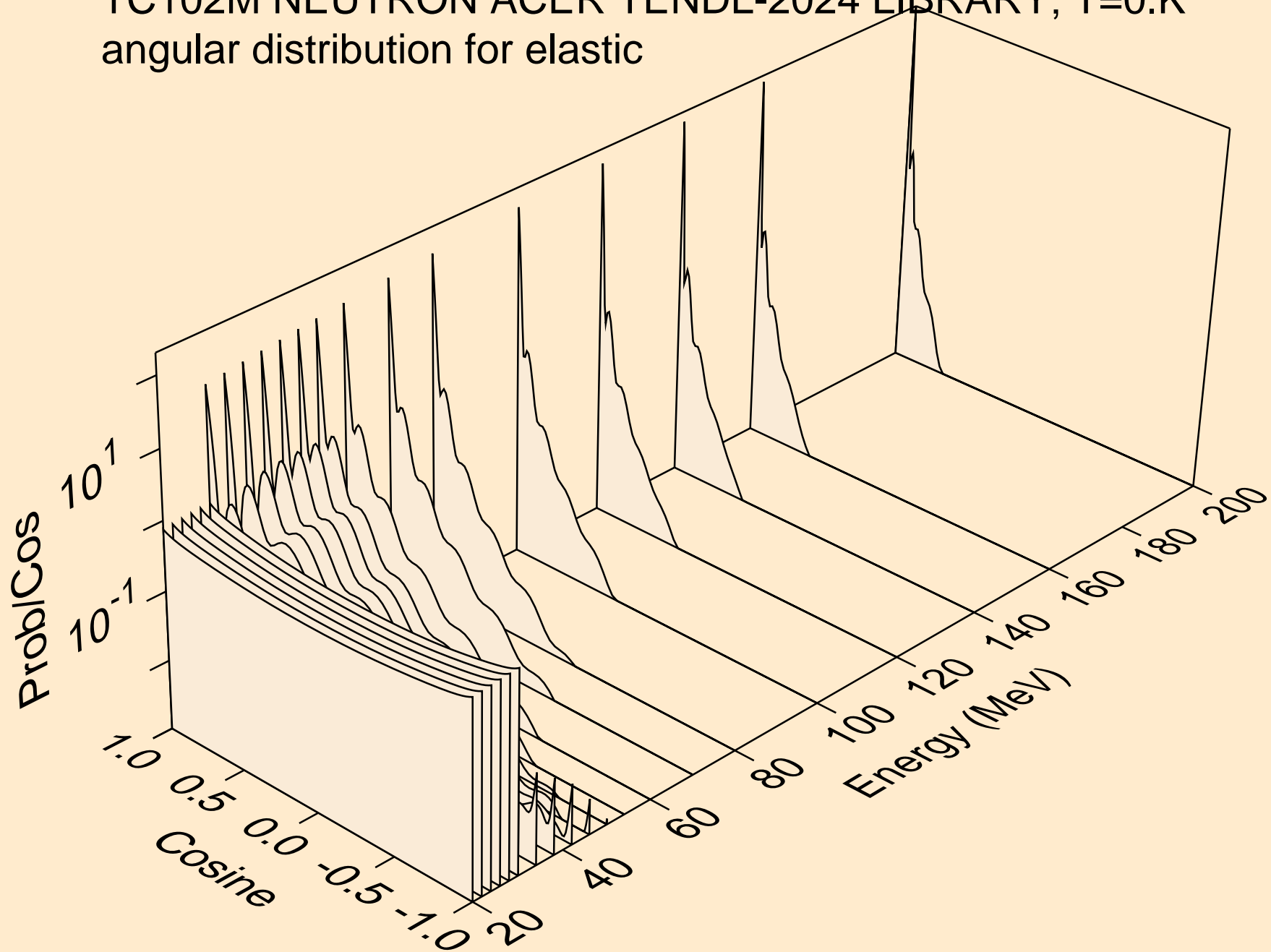

TC102M NEUTRON ACER TENDL-2024 LIBRARY; T=0.K
angular distribution for (n,n*1)

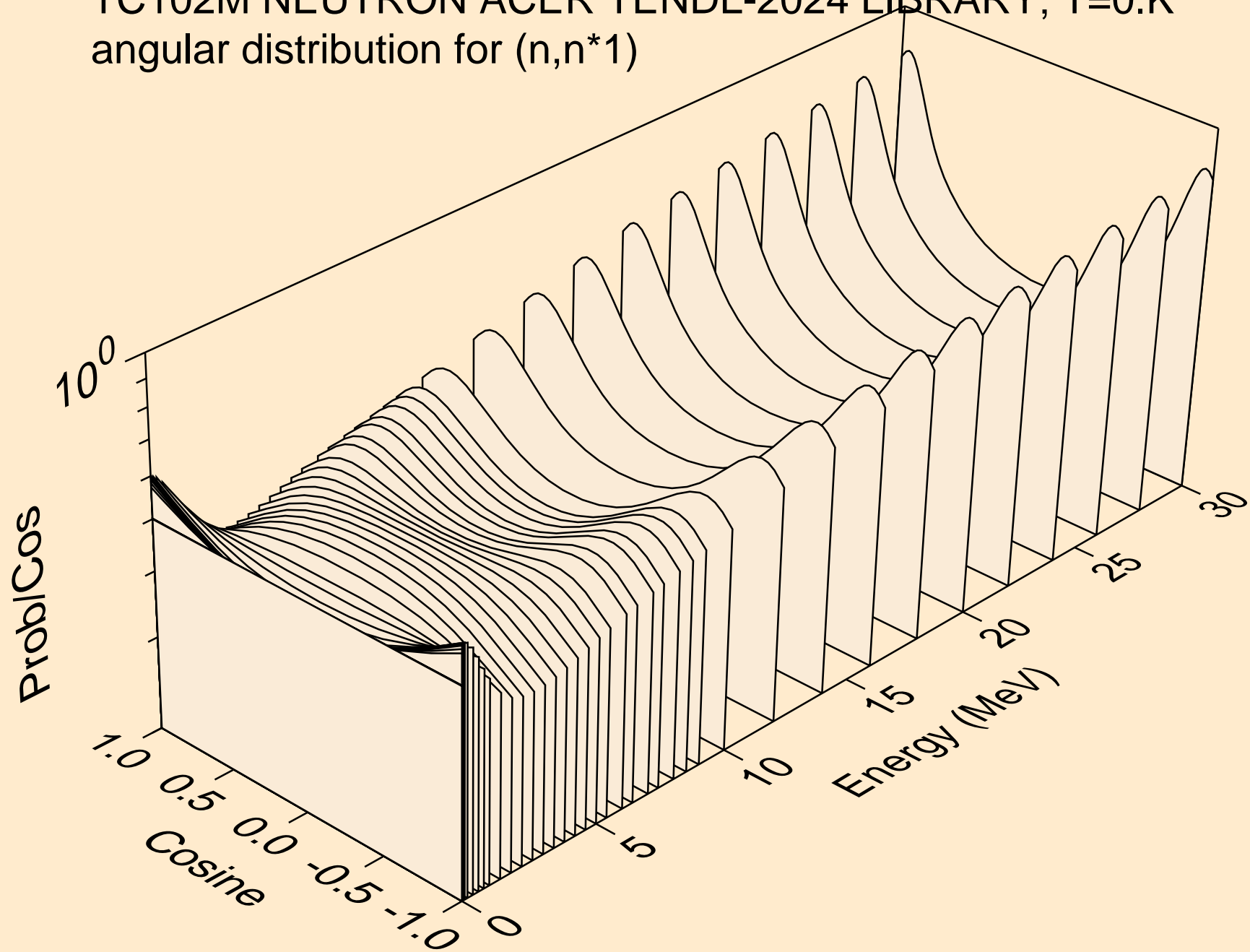

TC102M NEUTRON ACER TENDL-2024 LIBRARY; T=0.K
angular distribution for (n,n*2)

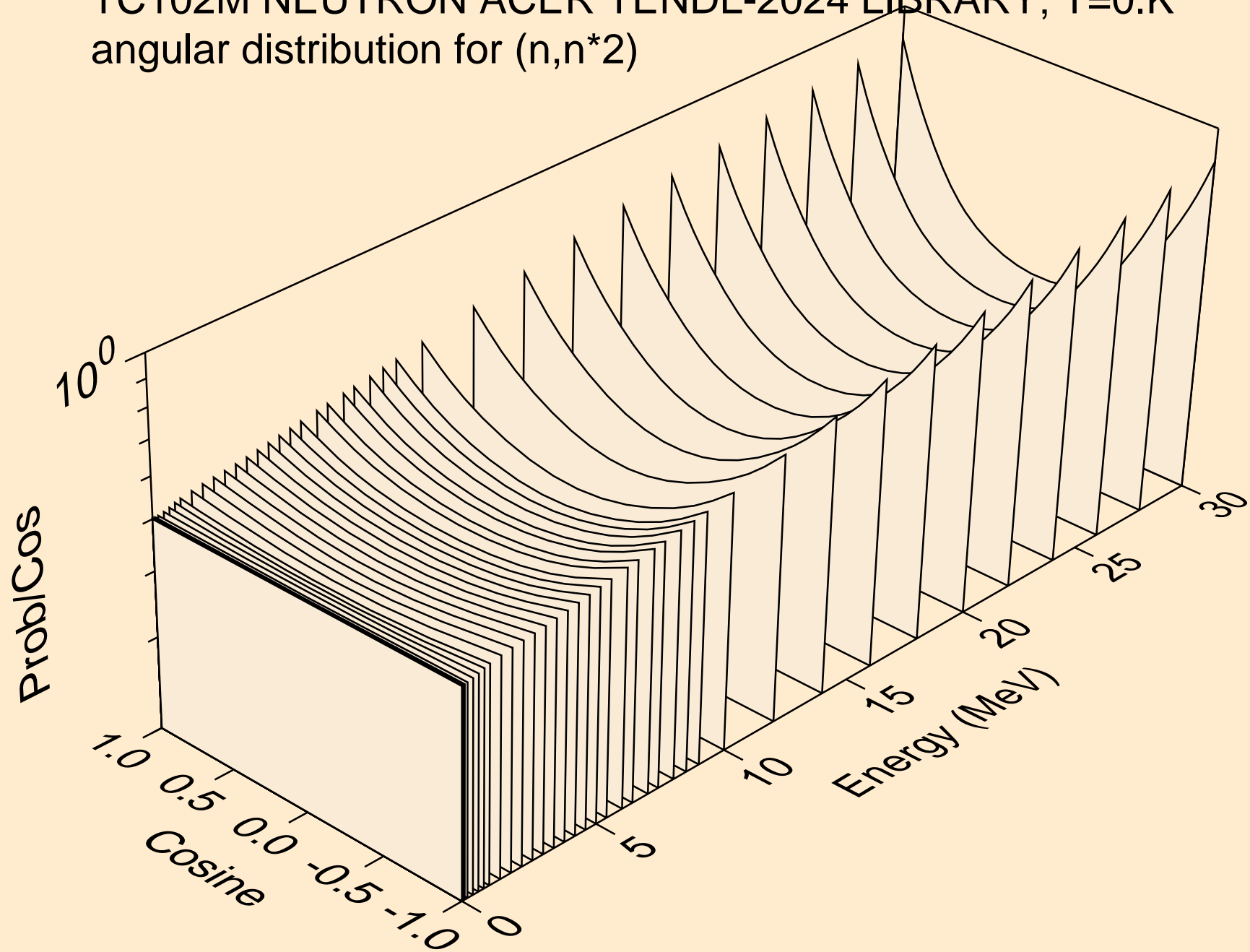

TC102M NEUTRON ACER TENDL-2024 LIBRARY; T=0.K
angular distribution for (n,n*3)

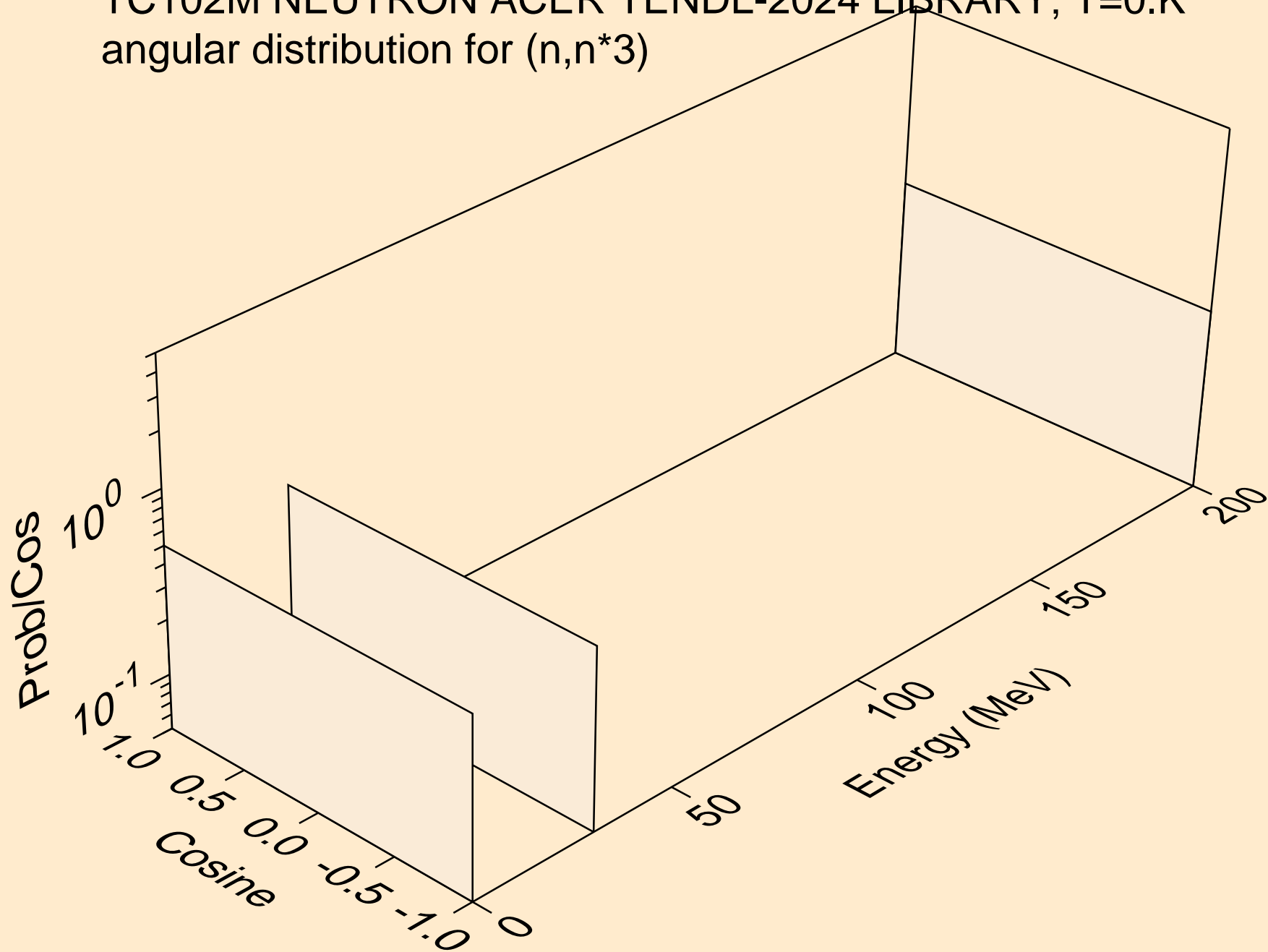

TC102M NEUTRON ACER TENDL-2024 LIBRARY; T=0.K
angular distribution for (n,n*4)

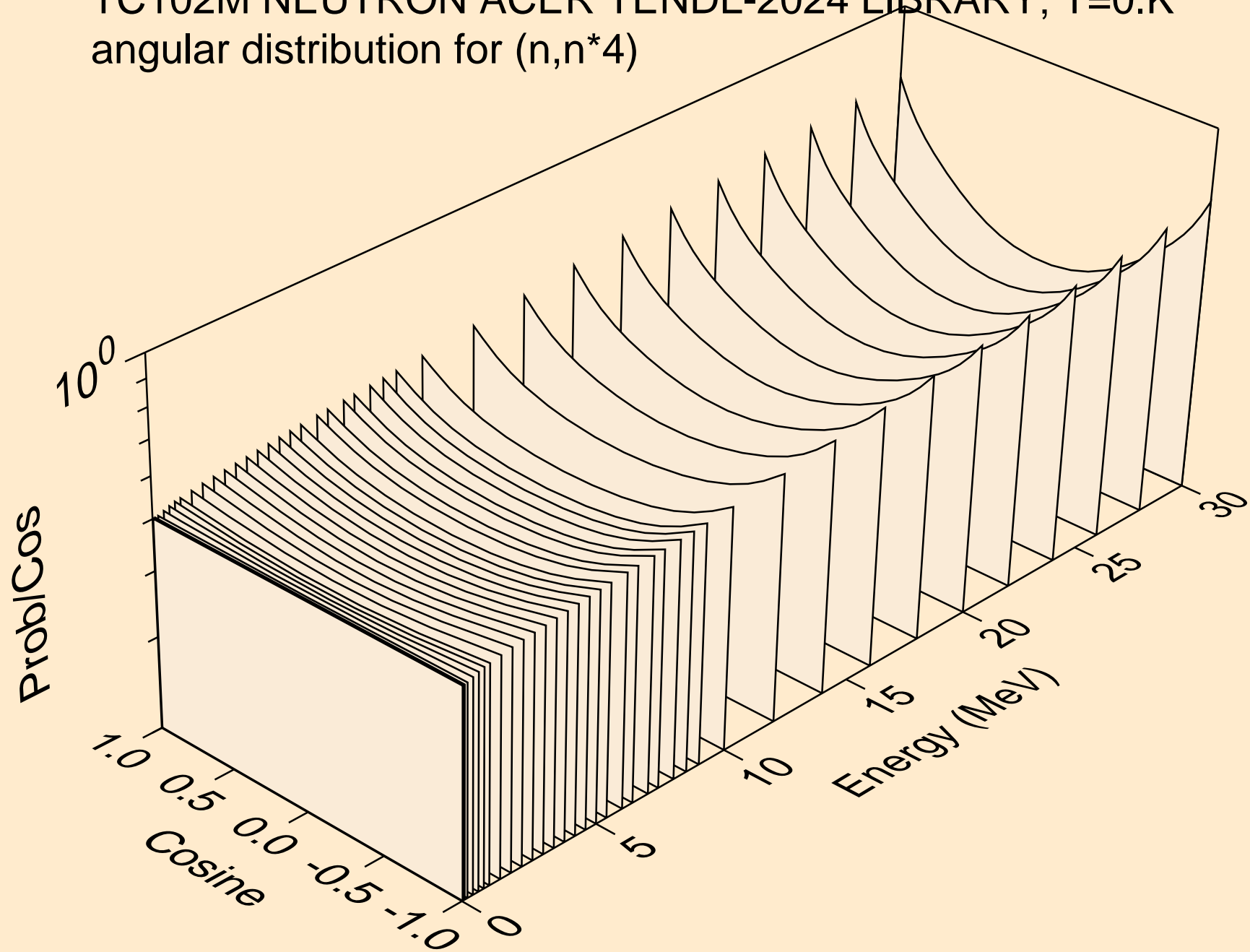

TC102M NEUTRON ACER TENDL-2024 LIBRARY; T=0.K
angular distribution for (n,n*5)

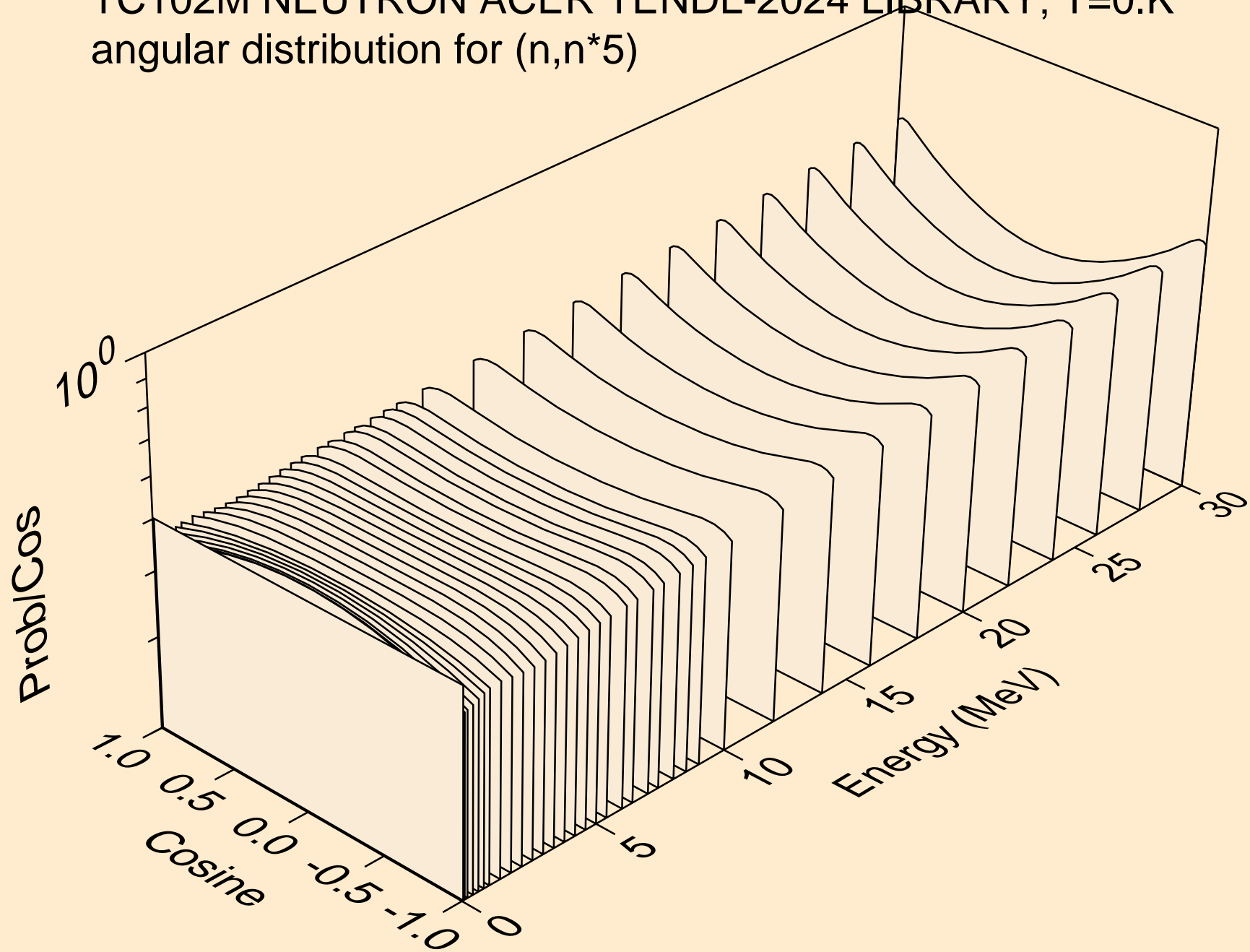

TC102M NEUTRON ACER TENDL-2024 LIBRARY; T=0.K
angular distribution for (n,n*6)

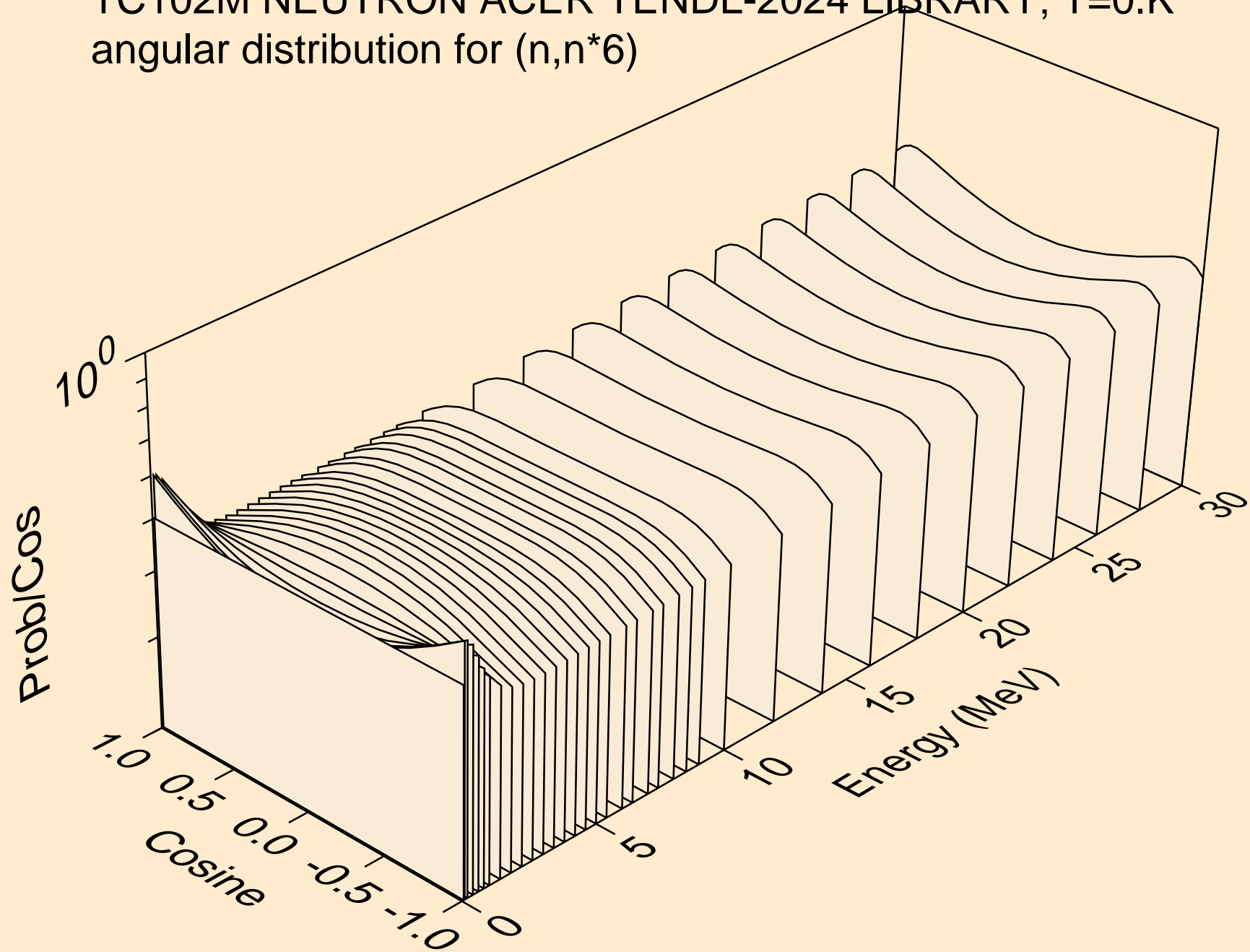

TC102M NEUTRON ACER TENDL-2024 LIBRARY; T=0.K
angular distribution for (n,n*7)

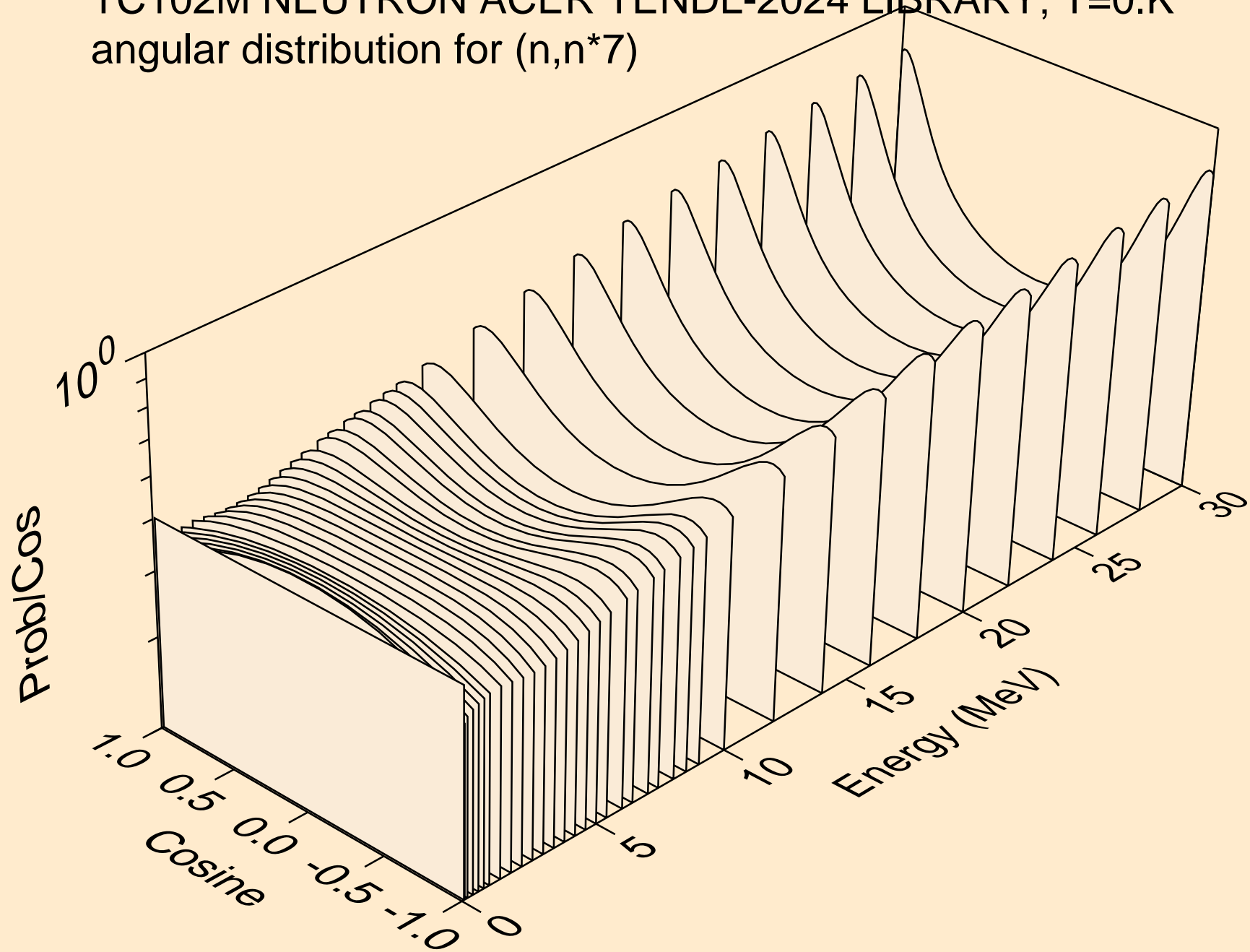

TC102M NEUTRON ACER TENDL-2024 LIBRARY; T=0.K
angular distribution for (n,n*8)

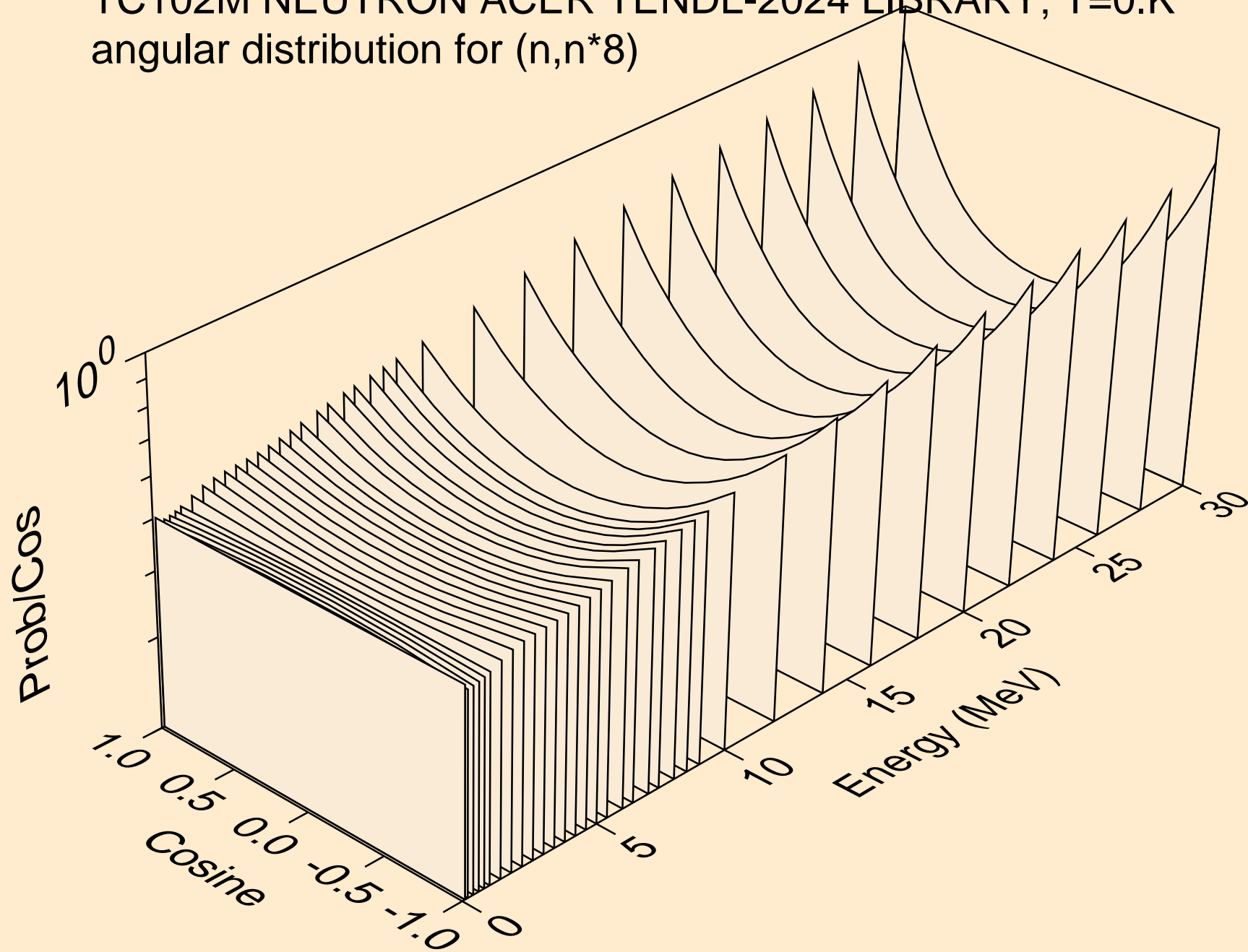

TC102M NEUTRON ACER TENDL-2024 LIBRARY; T=0.K
angular distribution for (n,n*9)

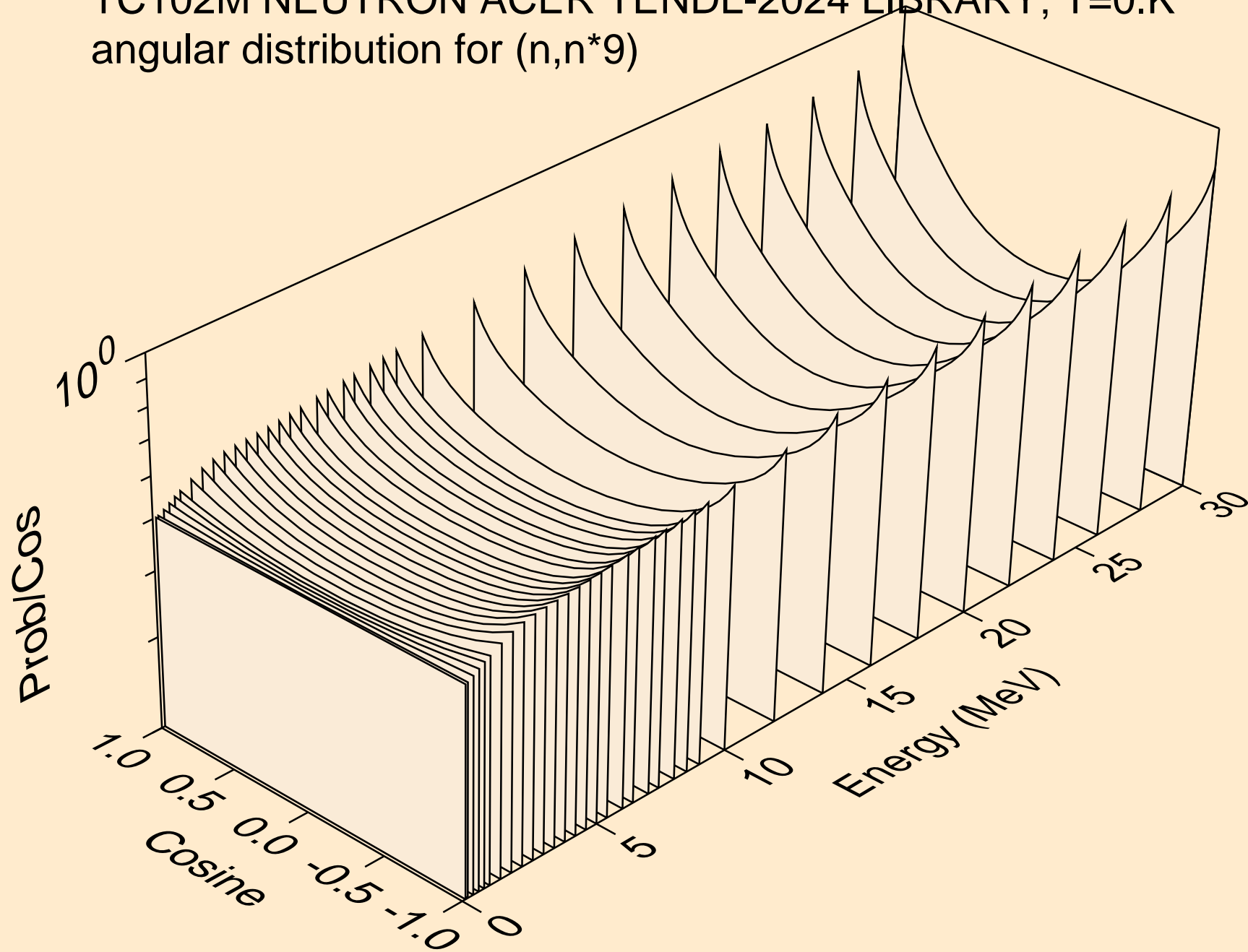

TC102M NEUTRON ACER TENDL-2024 LIBRARY; T=0.K
angular distribution for (n,n*10)

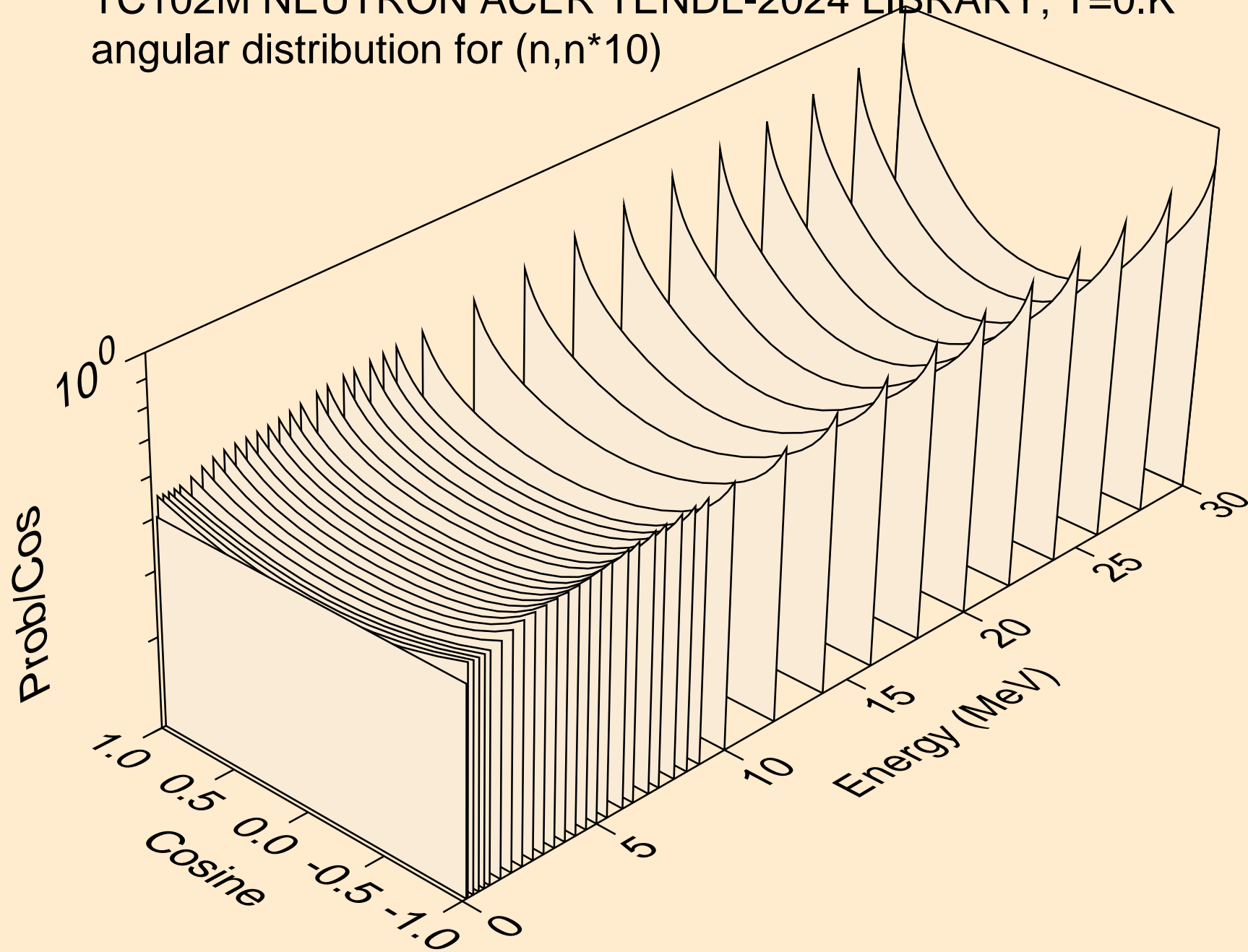

TC102M NEUTRON ACER TENDL-2024 LIBRARY; T=0.K
angular distribution for (n,n*11)

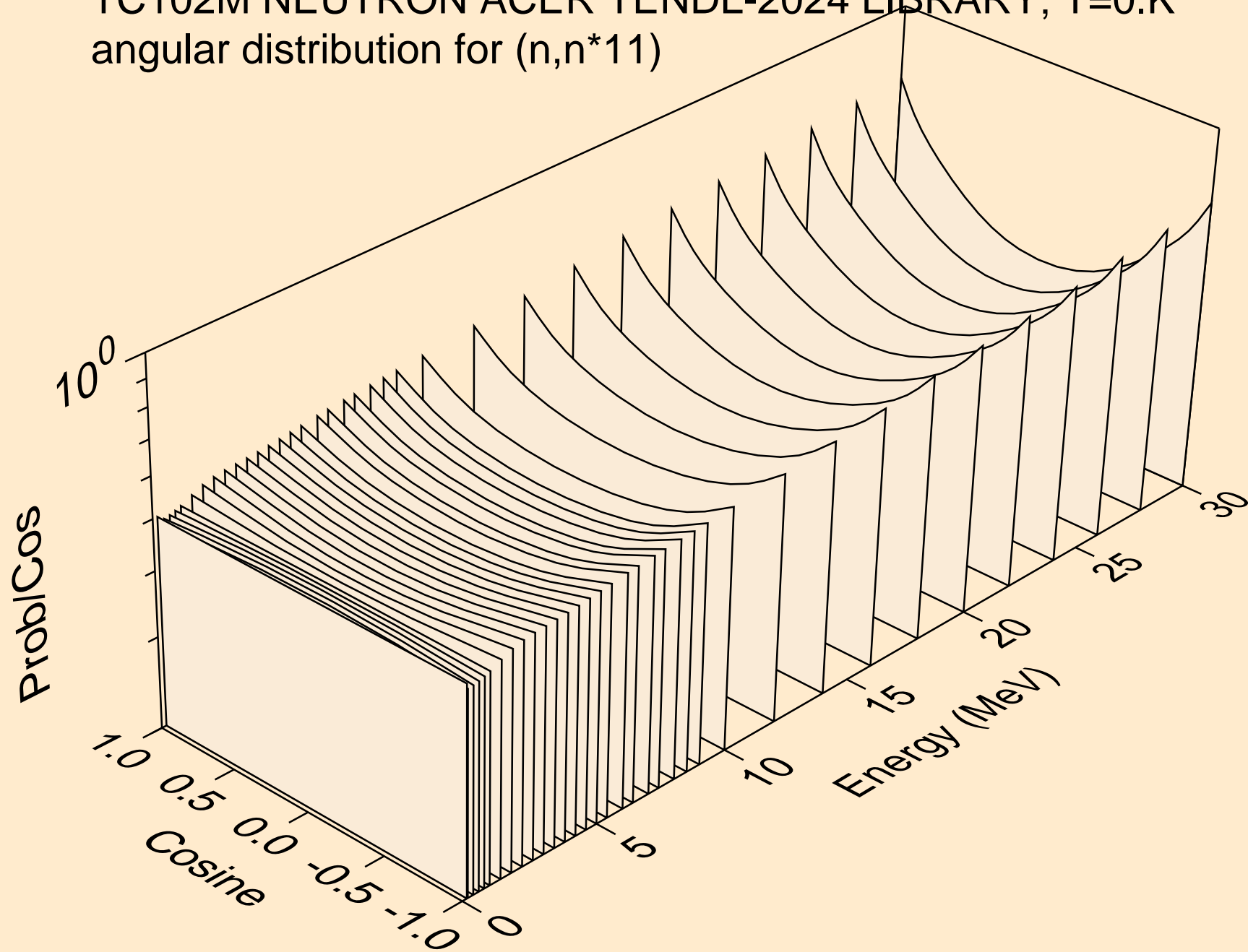

TC102M NEUTRON ACER TENDL-2024 LIBRARY; T=0.K
angular distribution for (n,n*12)

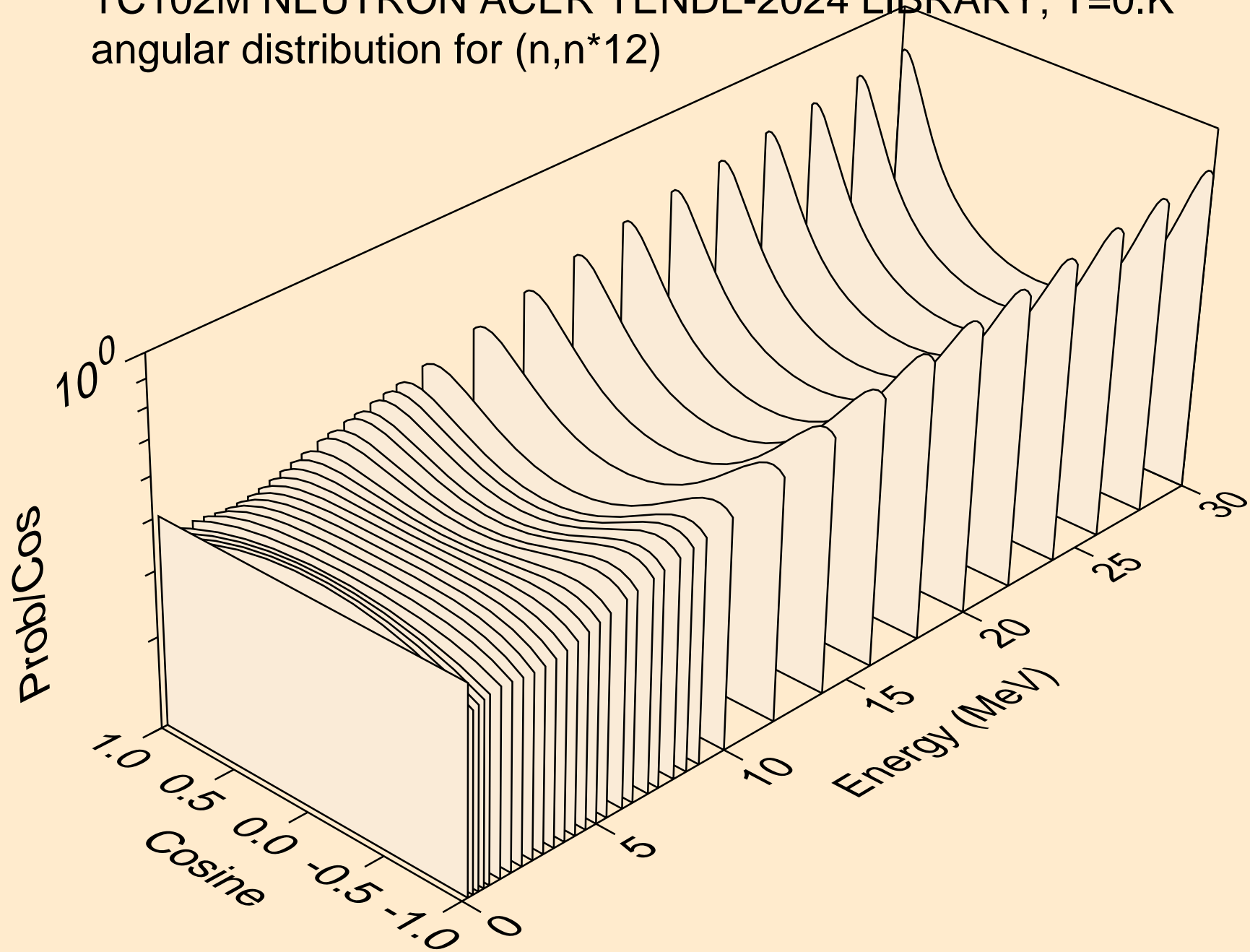

TC102M NEUTRON ACER TENDL-2024 LIBRARY; T=0.K
angular distribution for (n,n*13)

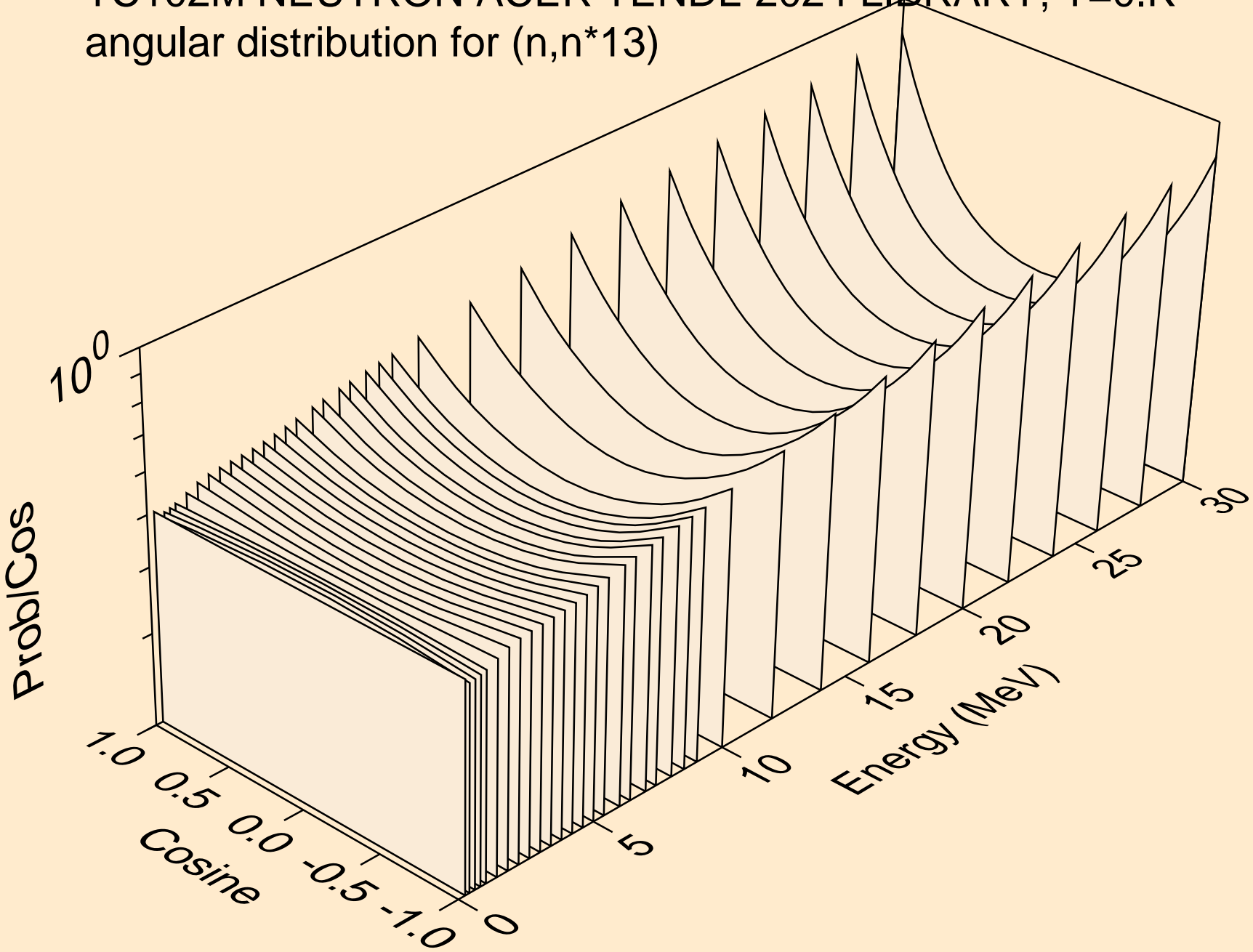

TC102M NEUTRON ACER TENDL-2024 LIBRARY; T=0.K
angular distribution for (n,n*14)

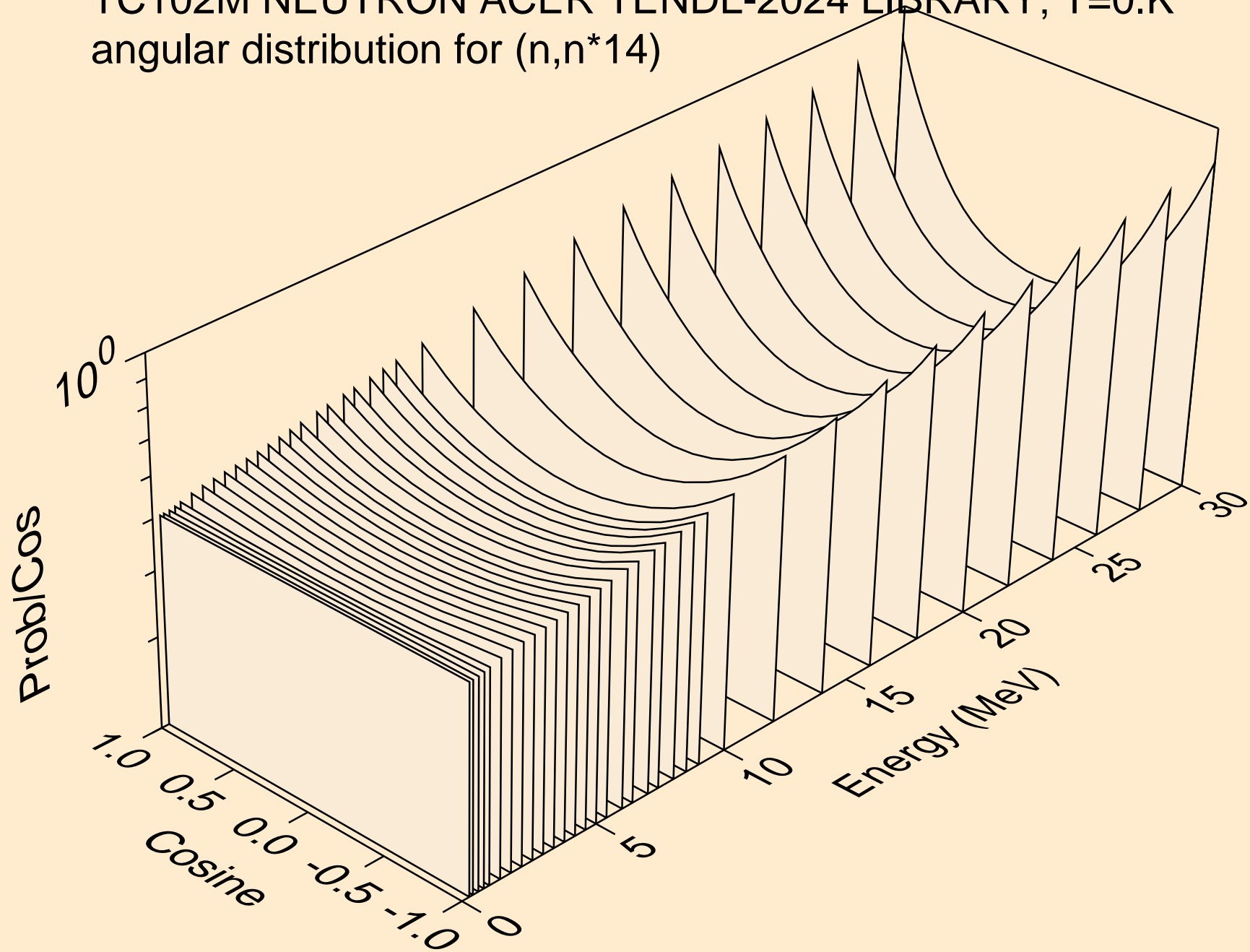

TC102M NEUTRON ACER TENDL-2024 LIBRARY; T=0.K
angular distribution for (n,n*15)

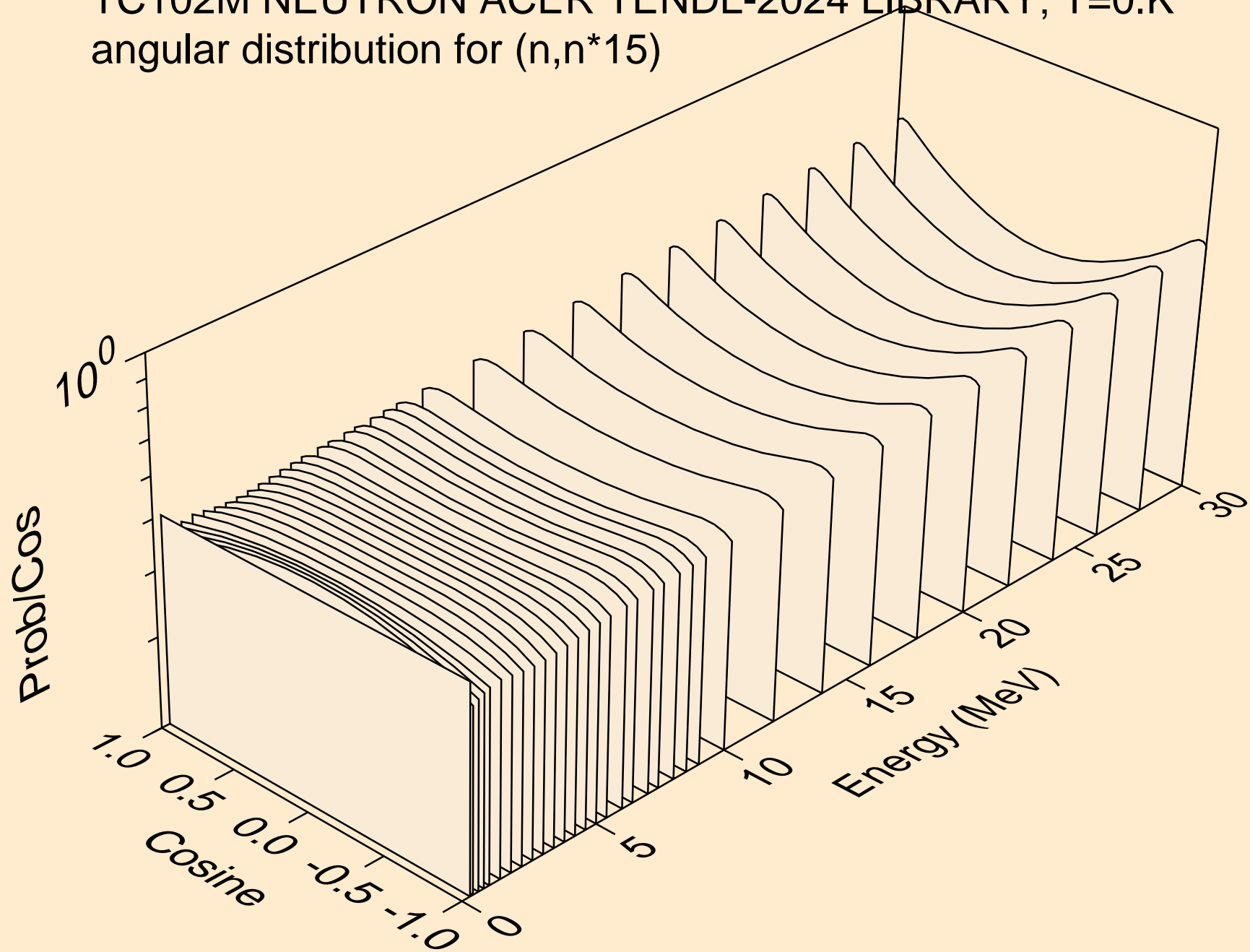

TC102M NEUTRON ACER TENDL-2024 LIBRARY; T=0.K
angular distribution for (n,n*16)

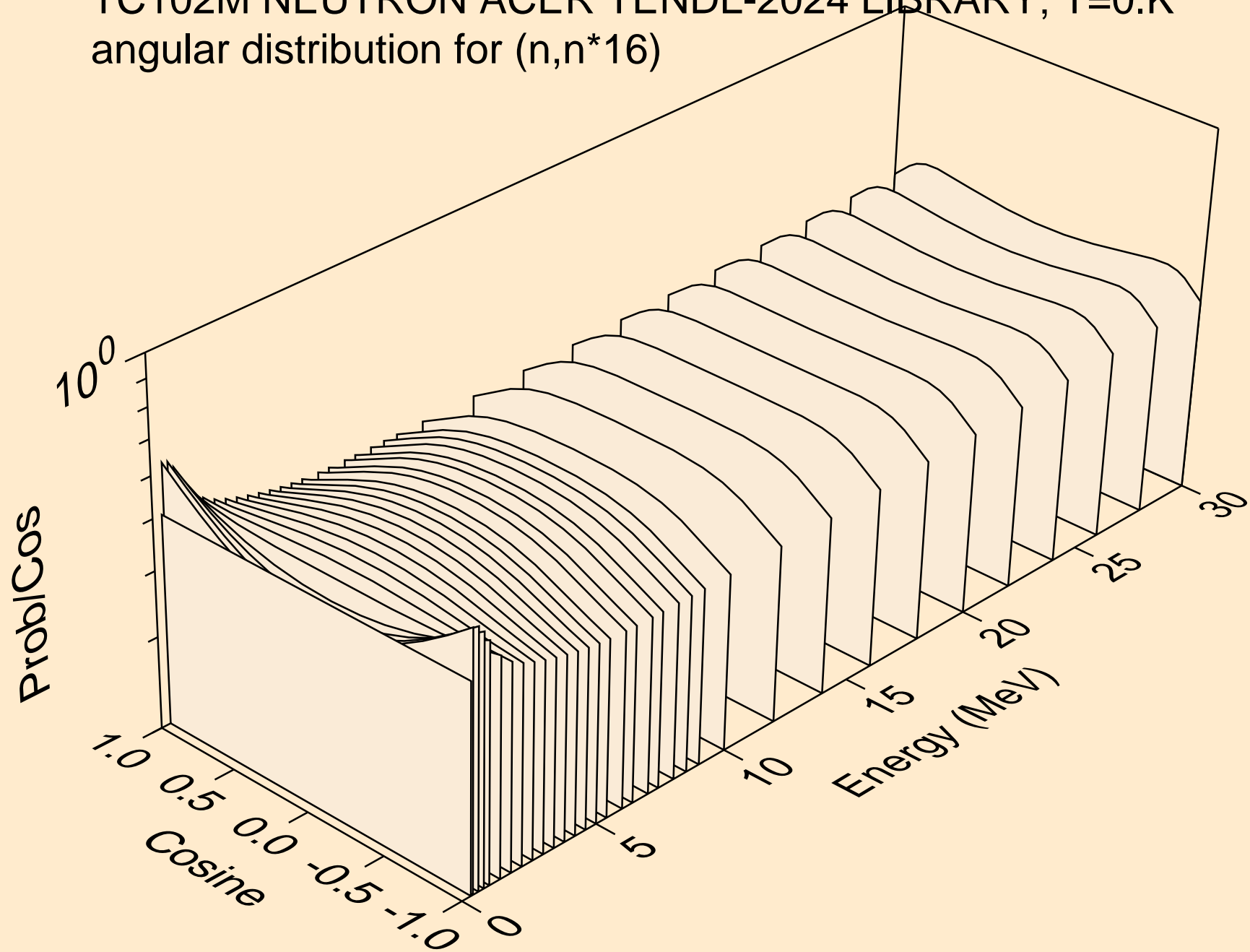

TC102M NEUTRON ACER TENDL-2024 LIBRARY; T=0.K
angular distribution for (n,n*17)

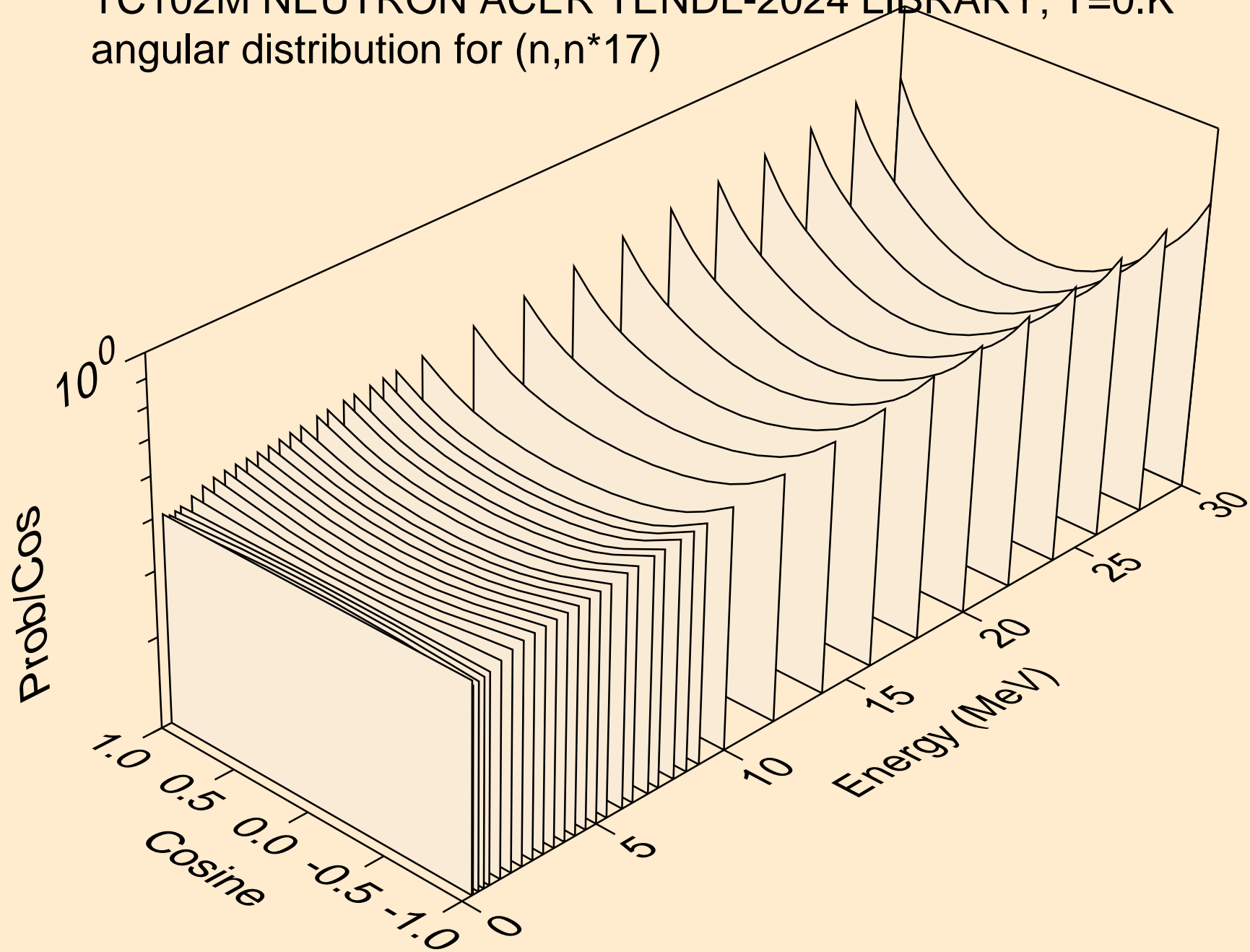

TC102M NEUTRON ACER TENDL-2024 LIBRARY; T=0.K
angular distribution for (n,n*18)

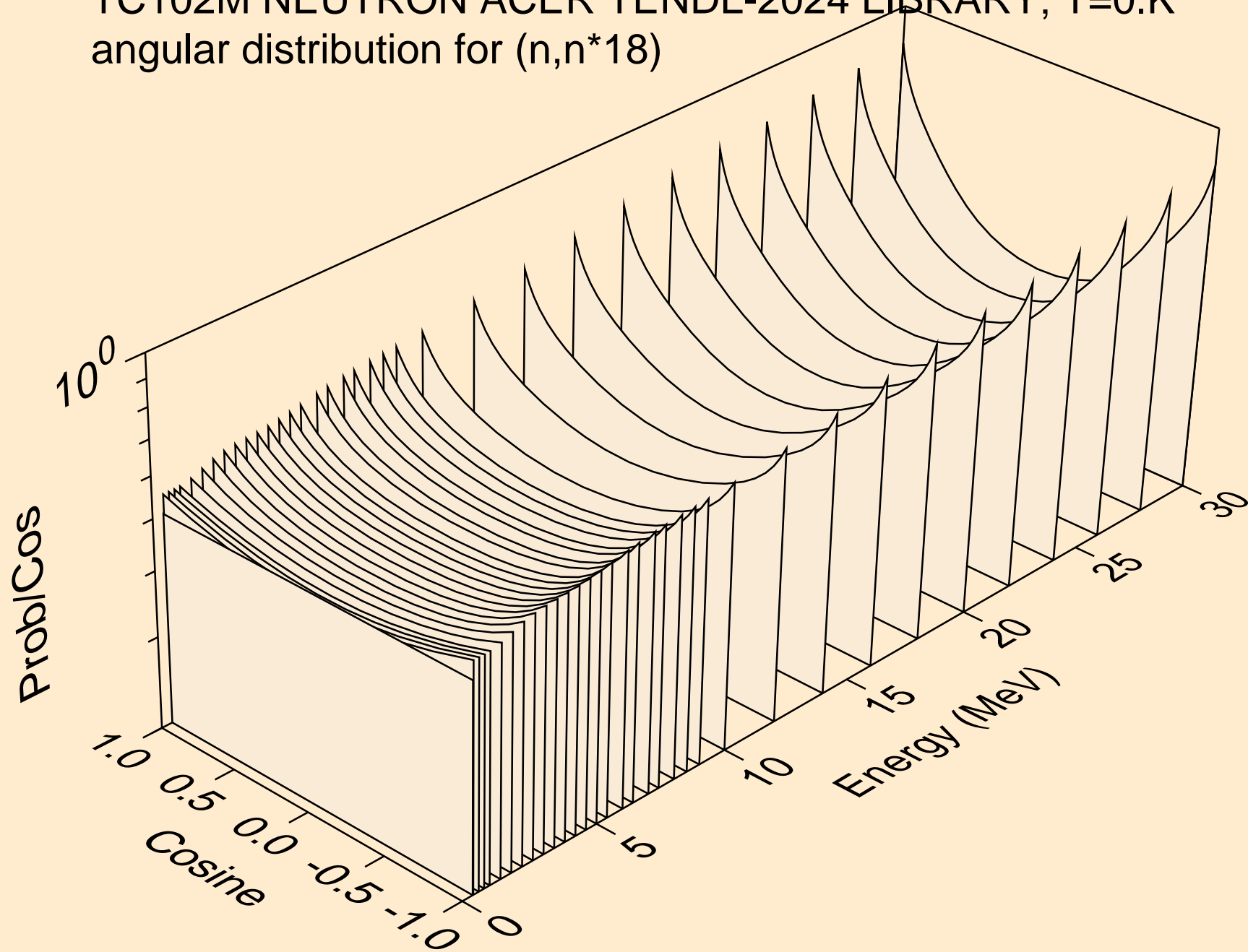

TC102M NEUTRON ACER TENDL-2024 LIBRARY; T=0.K
angular distribution for (n,n*19)

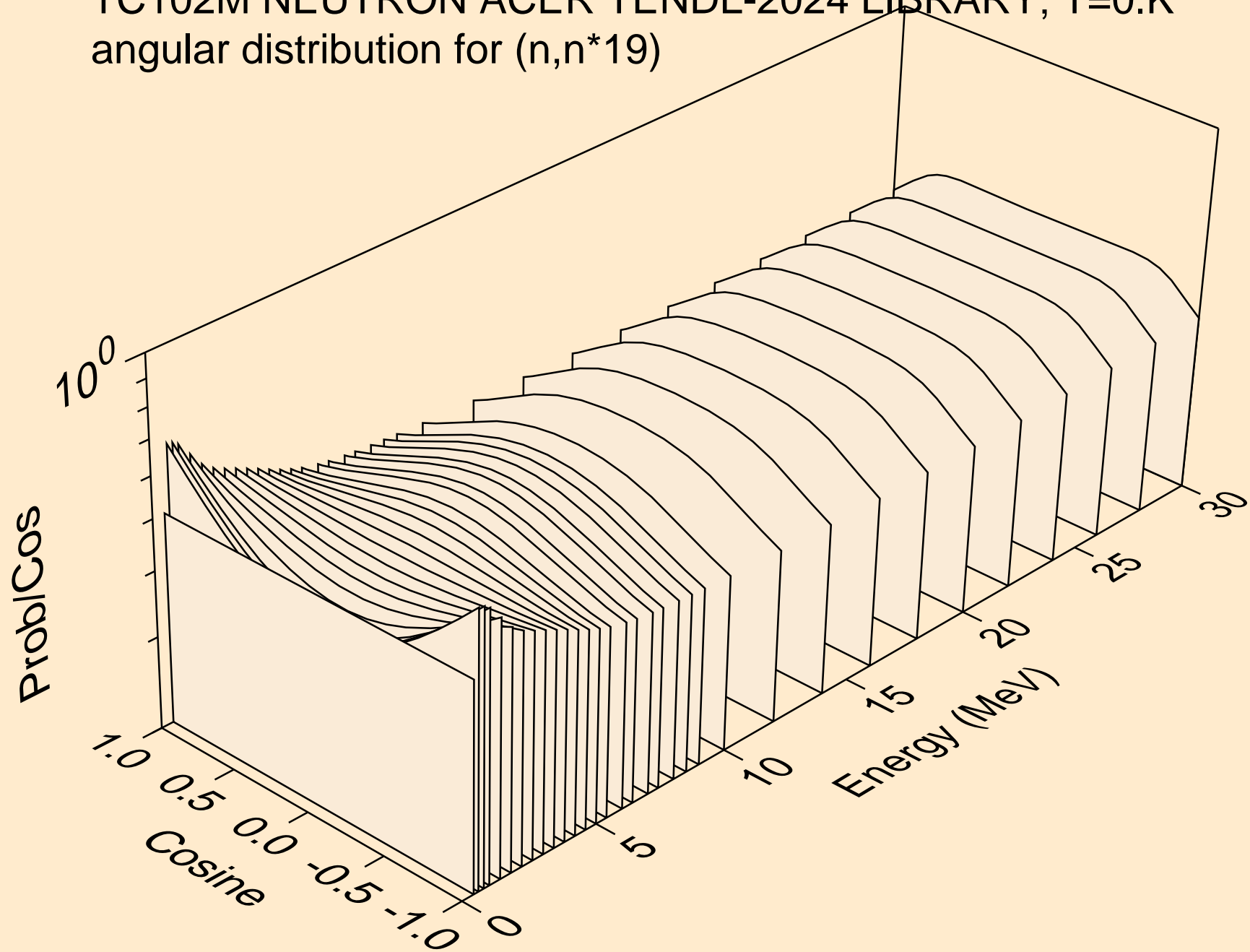

TC102M NEUTRON ACER TENDL-2024 LIBRARY; T=0.K
angular distribution for (n,n*20)

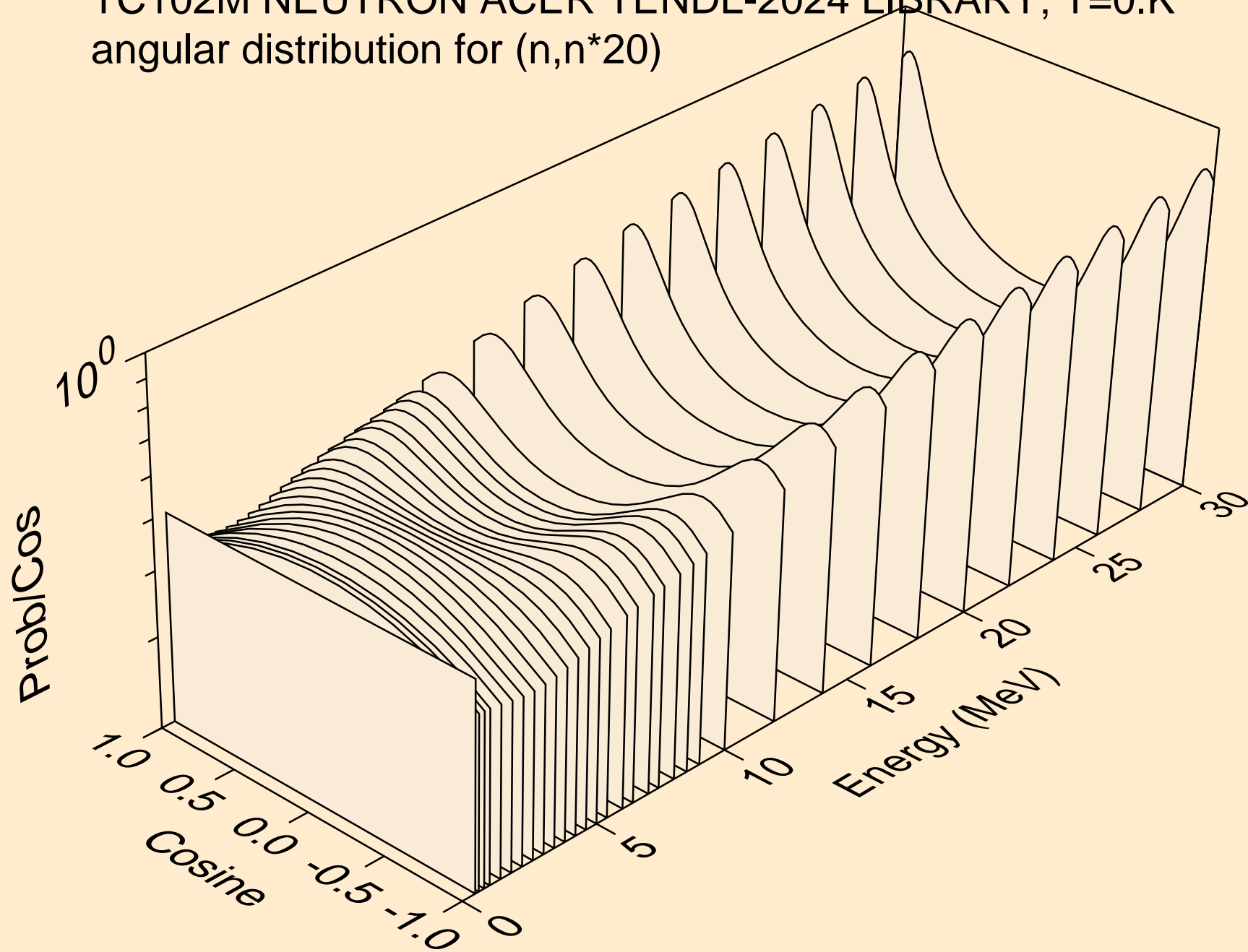

TC102M NEUTRON ACER TENDL-2024 LIBRARY; T=0.K
angular distribution for (n,n*21)

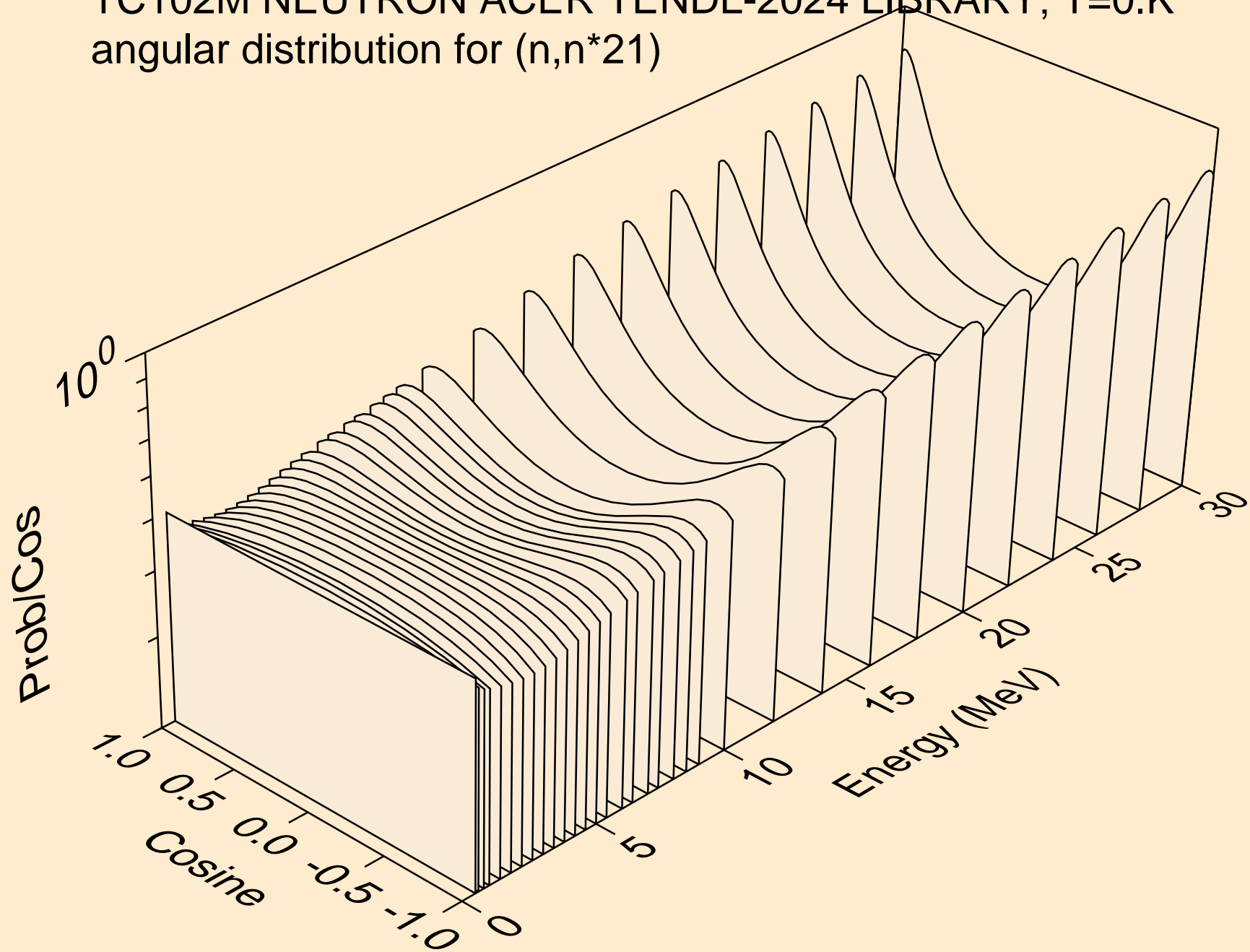

TC102M NEUTRON ACER TENDL-2024 LIBRARY; T=0.K
angular distribution for (n,n*22)

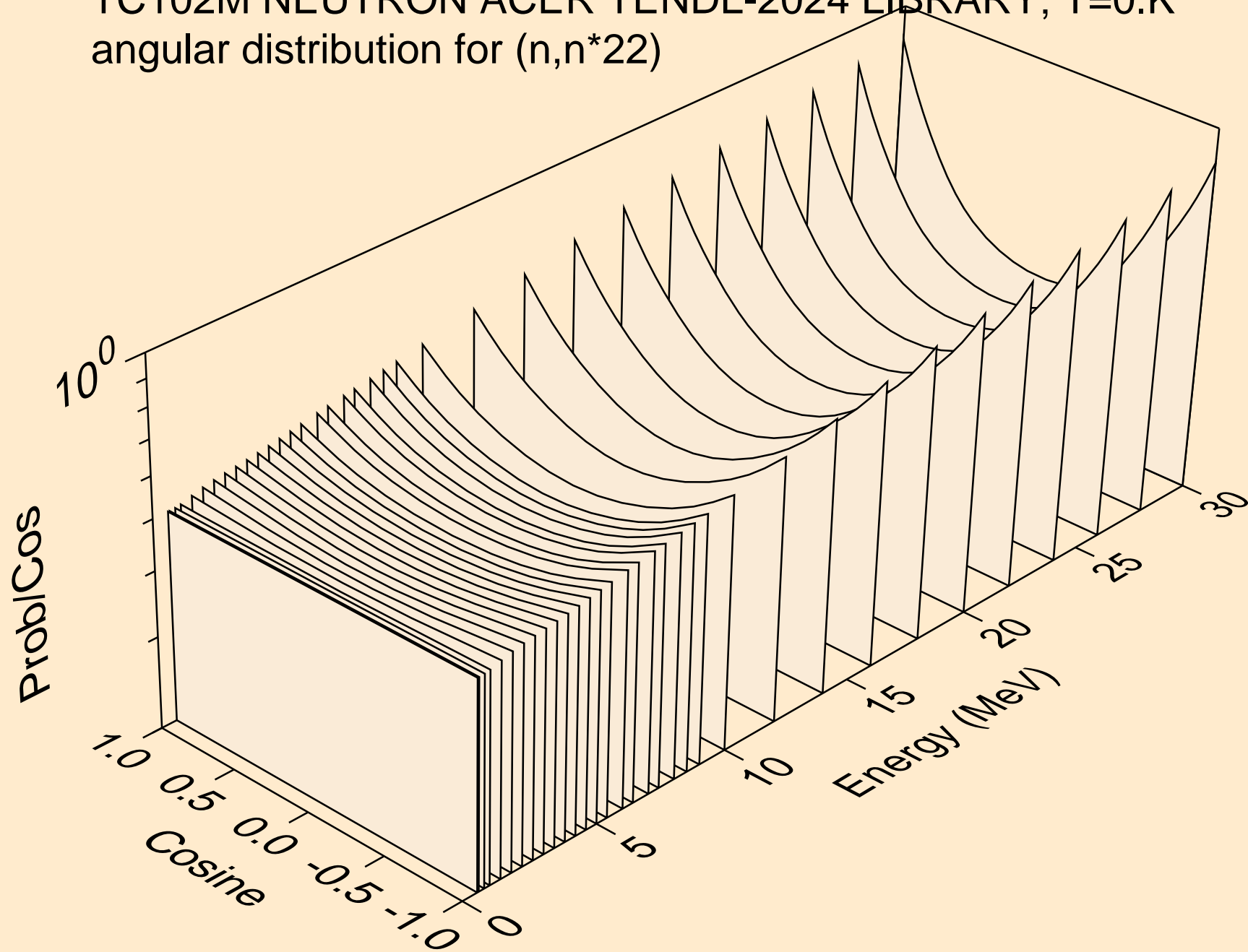

TC102M NEUTRON ACER TENDL-2024 LIBRARY; T=0.K
angular distribution for (n,n*23)

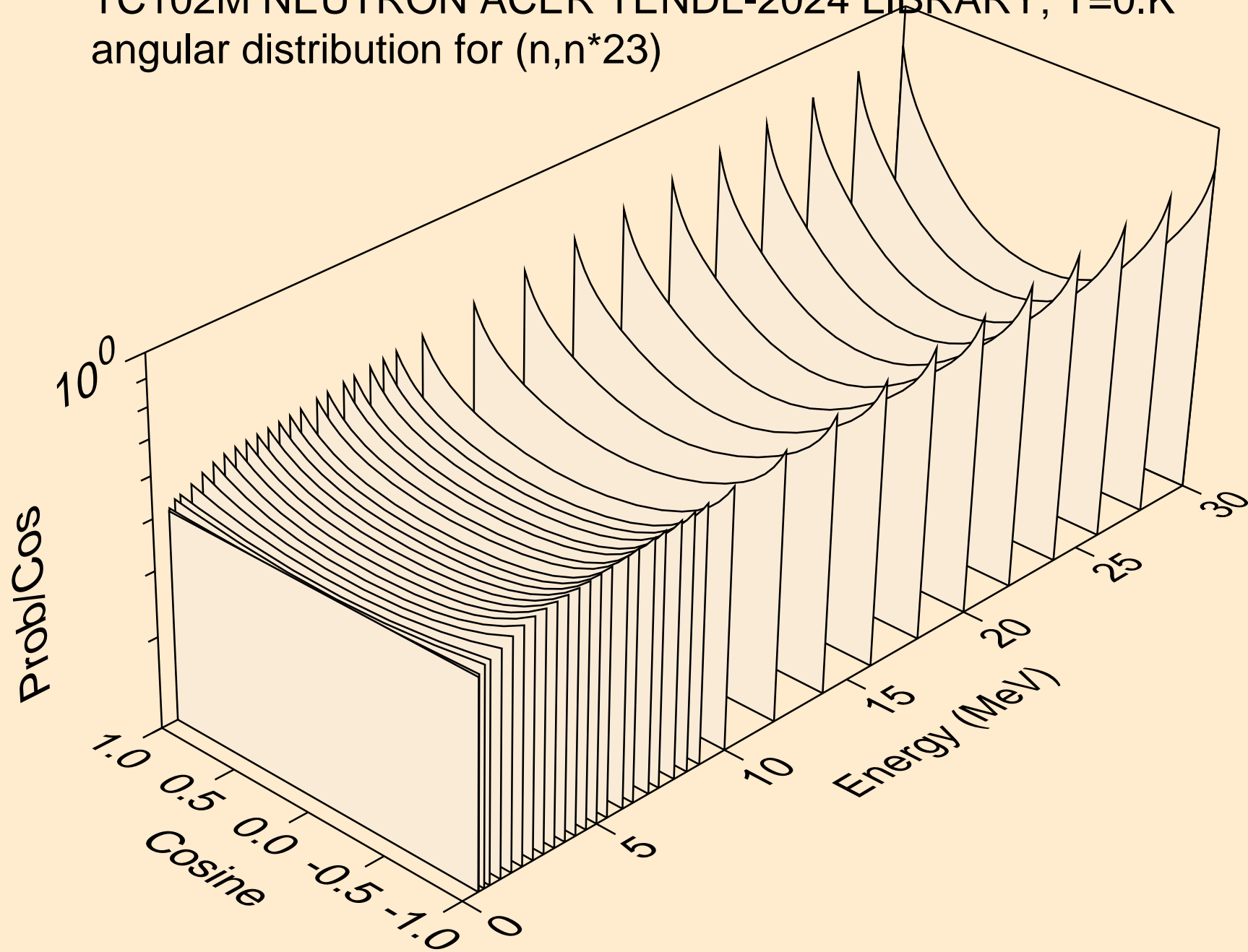

TC102M NEUTRON ACER TENDL-2024 LIBRARY; T=0.K
angular distribution for (n,n*24)

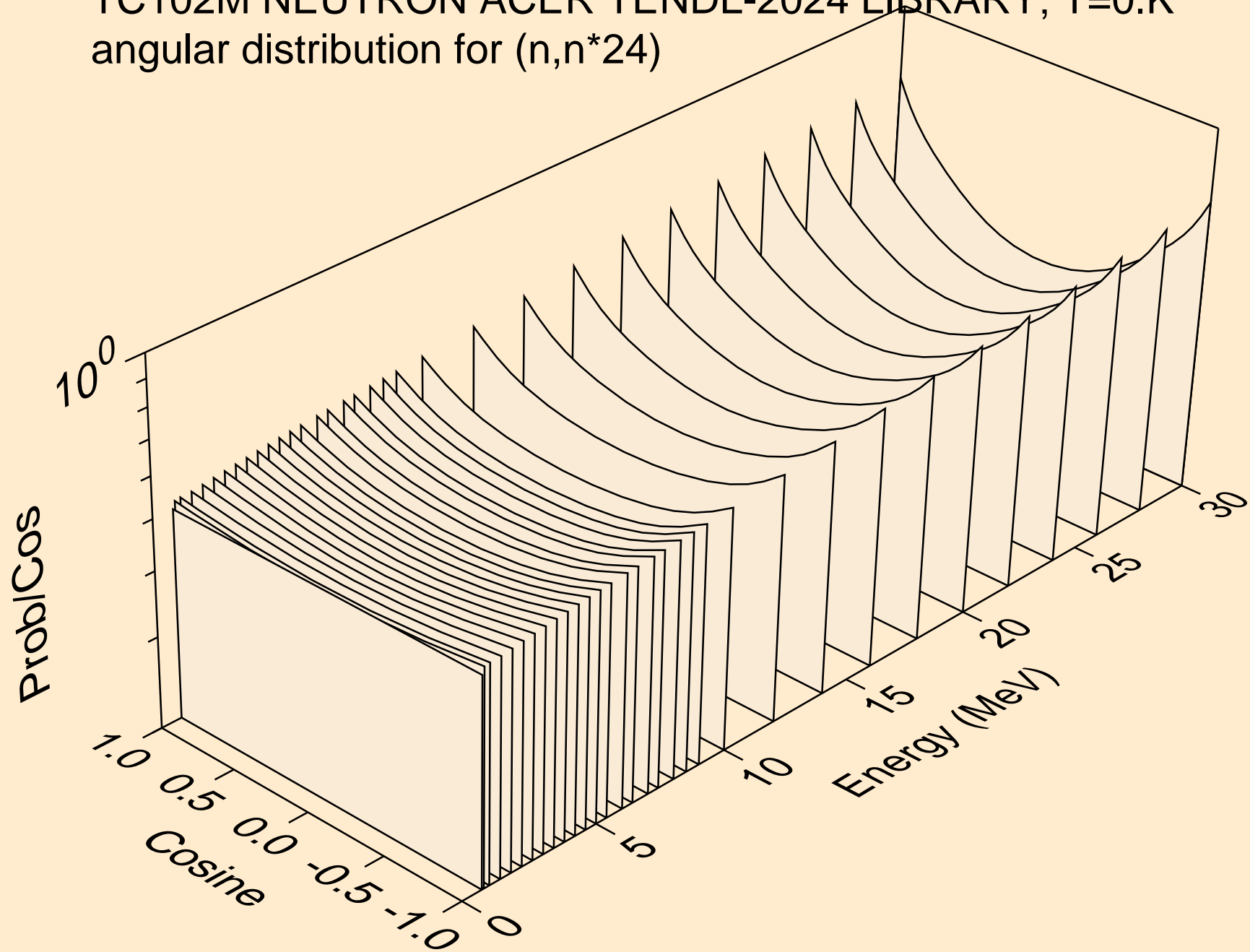

TC102M NEUTRON ACER TENDL-2024 LIBRARY; T=0.K
angular distribution for (n,n*25)

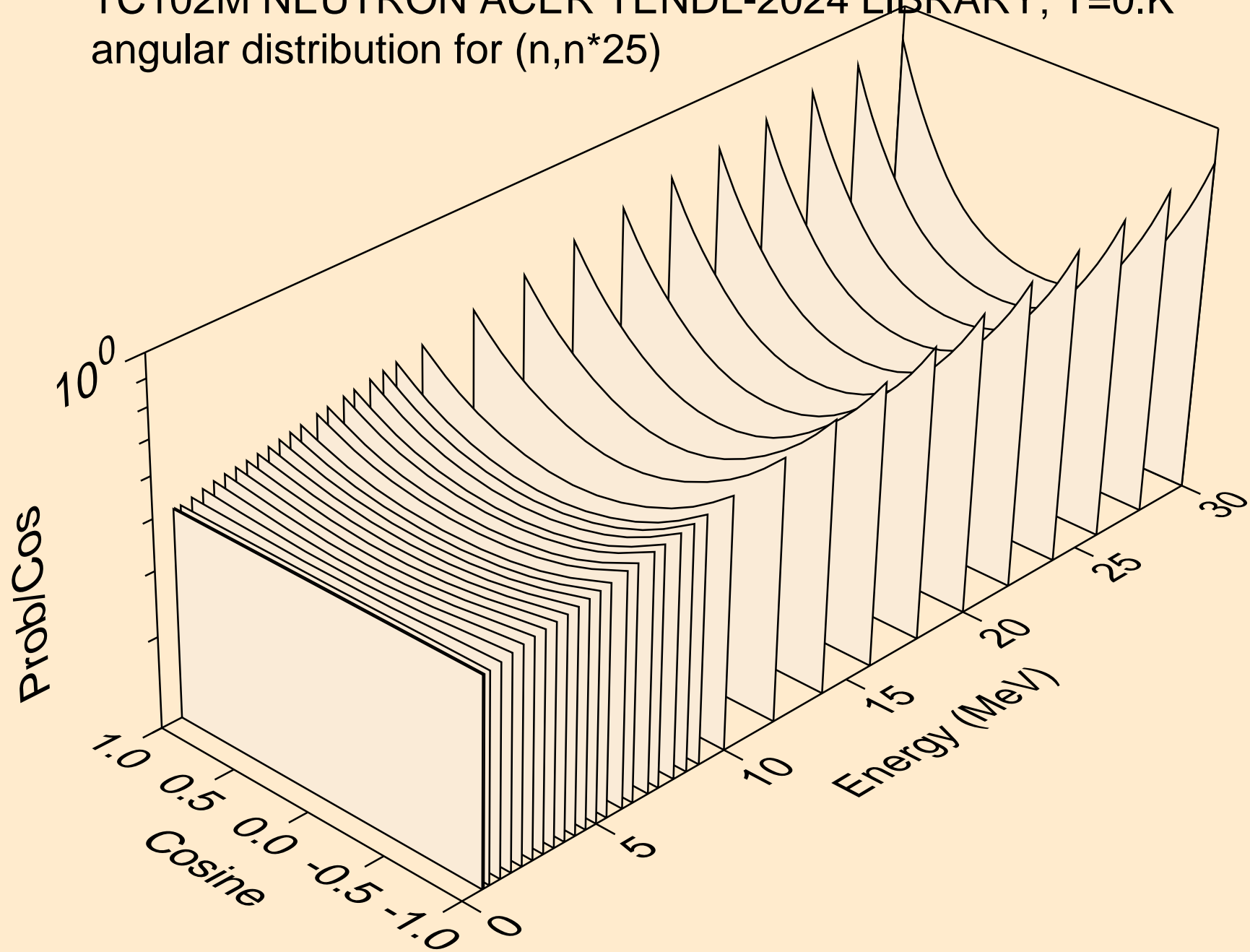

TC102M NEUTRON ACER TENDL-2024 LIBRARY; T=0.K
angular distribution for (n,n*26)

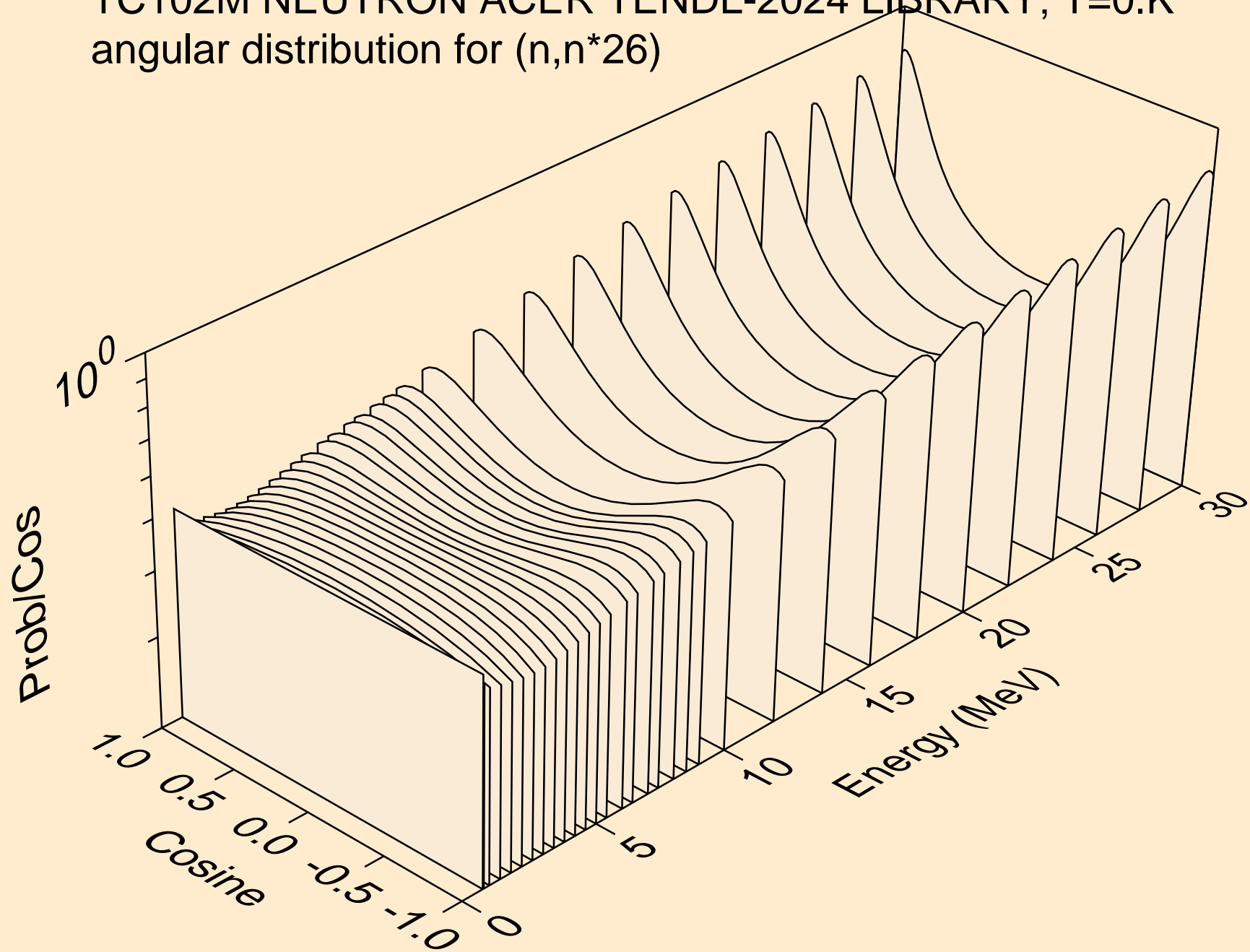

TC102M NEUTRON ACER TENDL-2024 LIBRARY; T=0.K
angular distribution for (n,n*27)

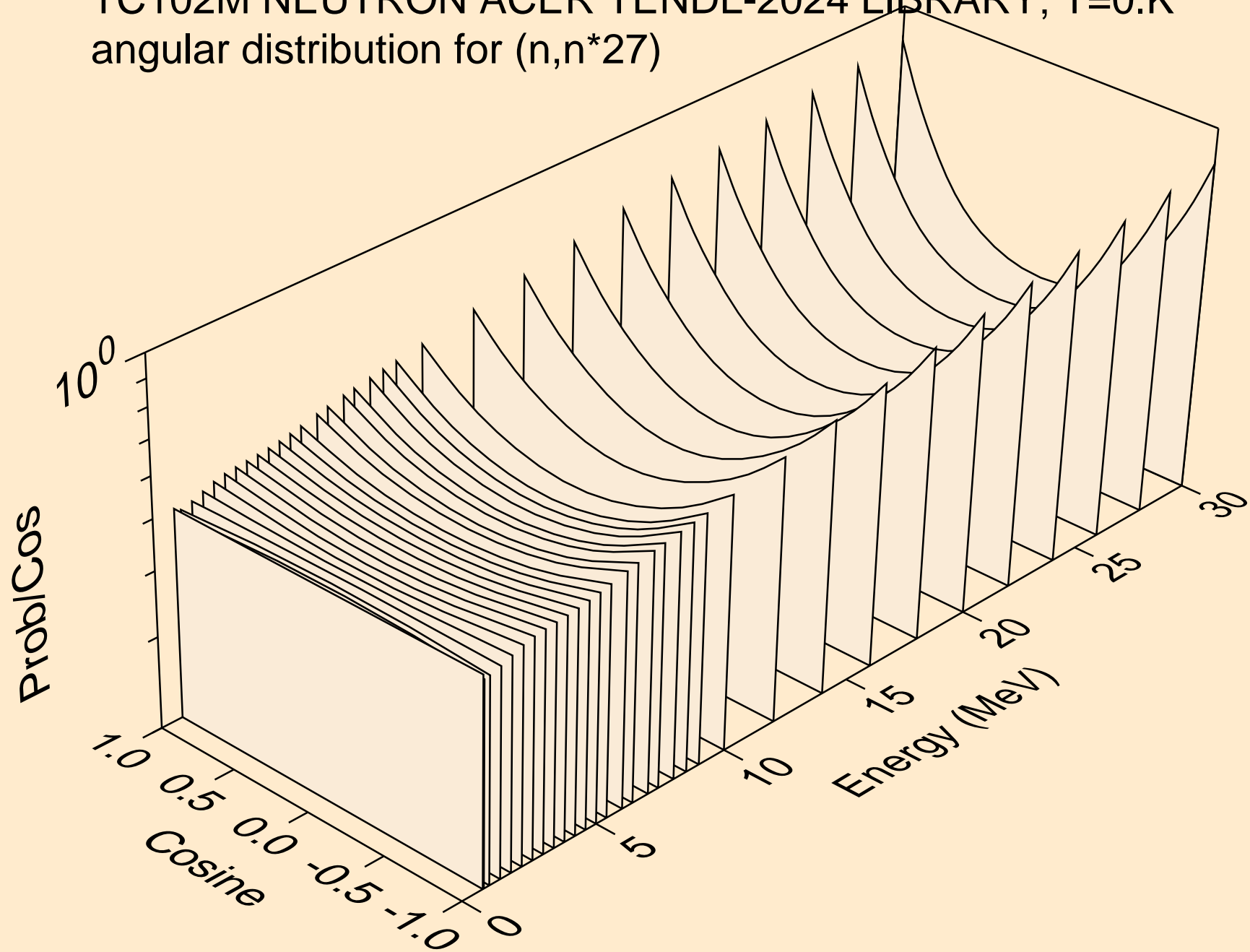

TC102M NEUTRON ACER TENDL-2024 LIBRARY; T=0.K
angular distribution for (n,n*28)

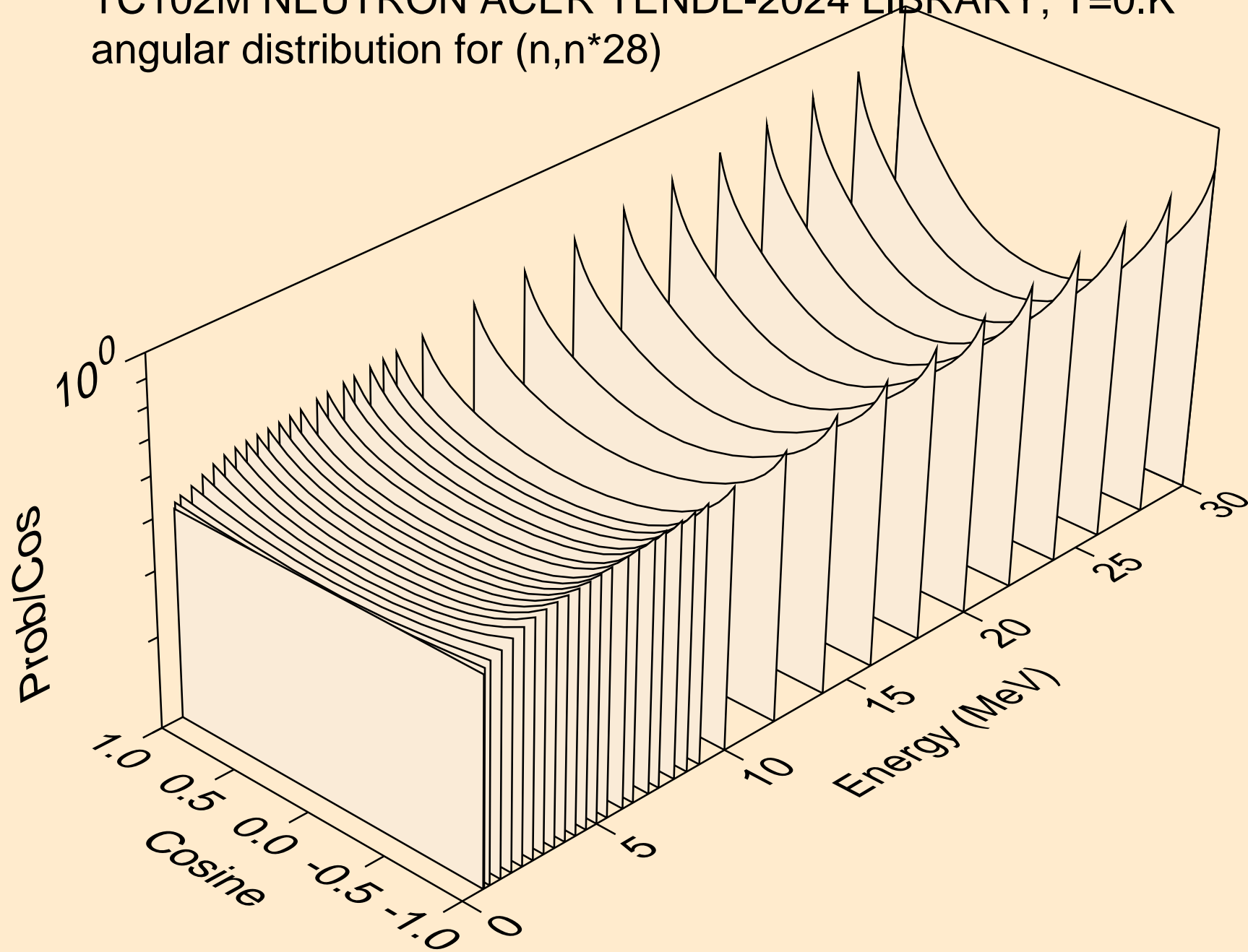

TC102M NEUTRON ACER TENDL-2024 LIBRARY; T=0.K
angular distribution for (n,n*29)

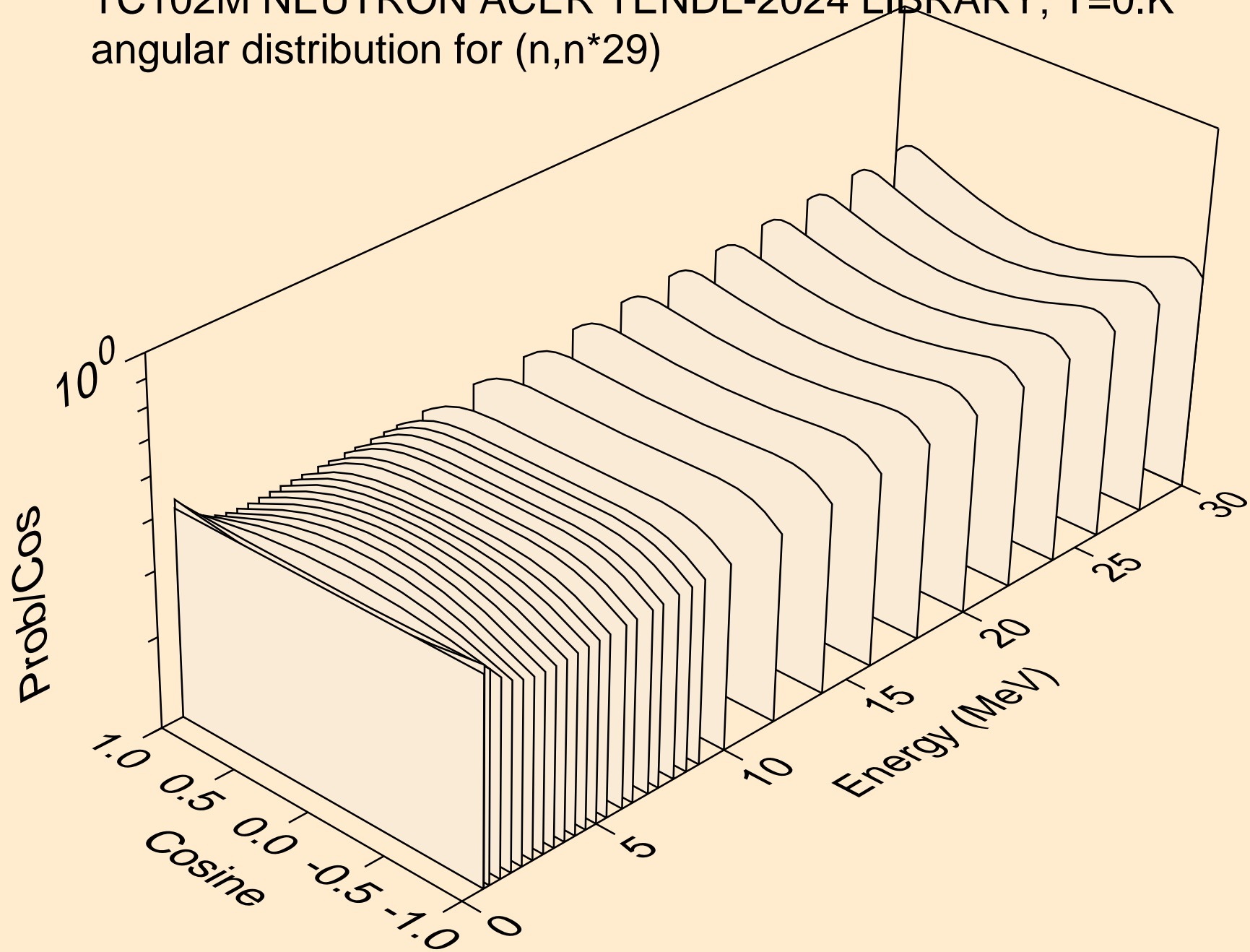

TC102M NEUTRON ACER TENDL-2024 LIBRARY; T=0.K
angular distribution for (n,n*30)

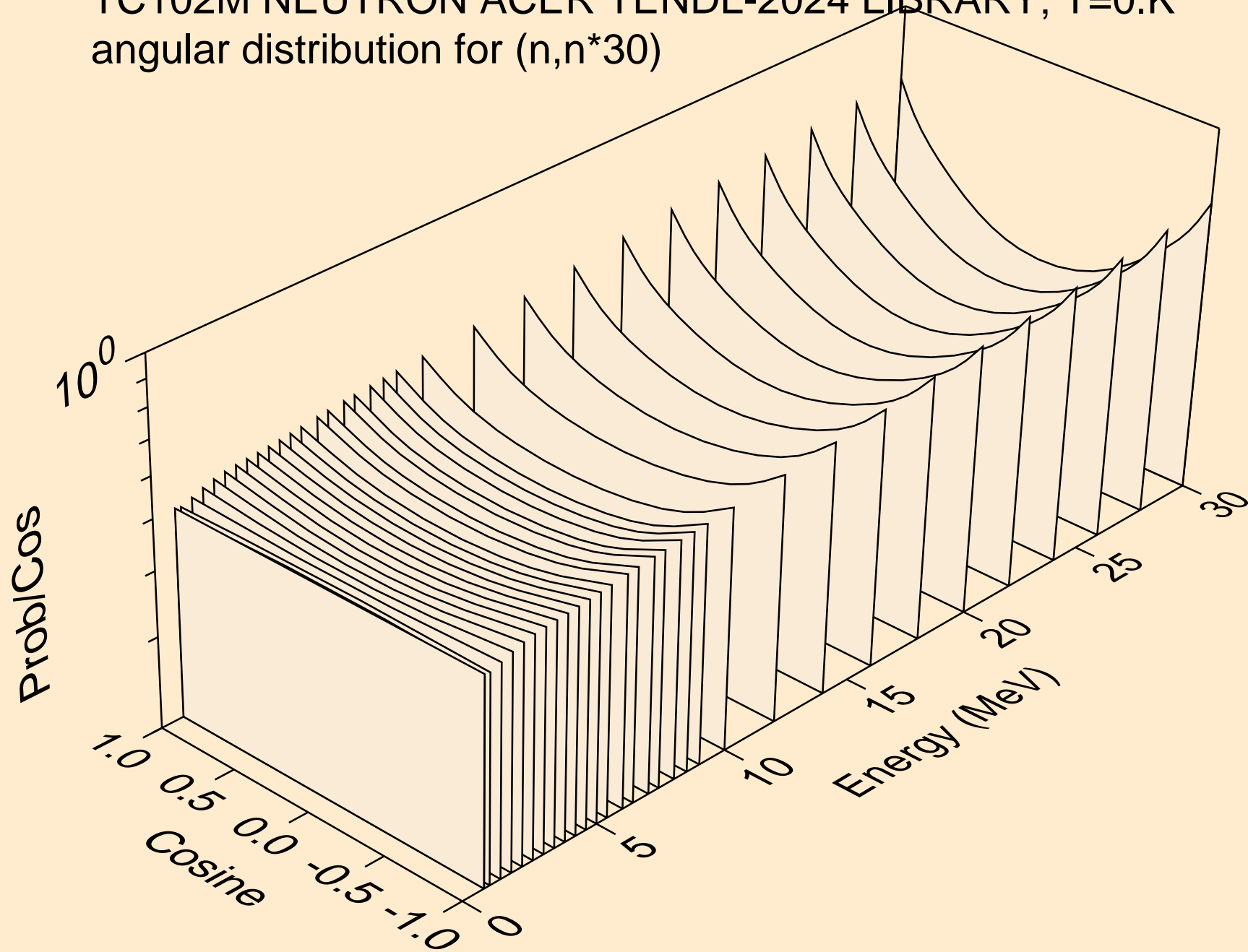

TC102M NEUTRON ACER TENDL-2024 LIBRARY; T=0.K
Neutron emission for (n,x)

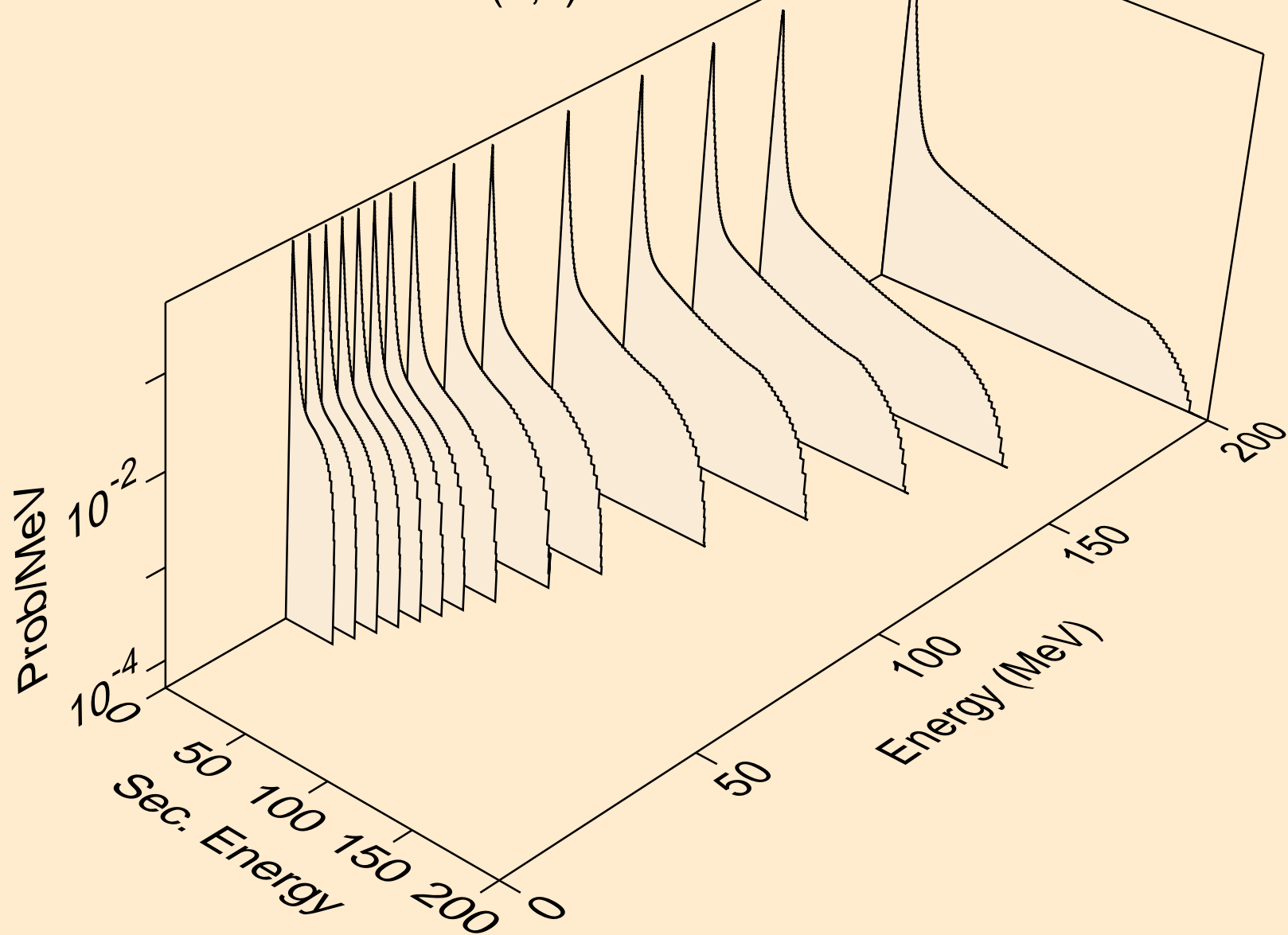

TC102M NEUTRON ACER TENDL-2024 LIBRARY; T=0.K
Neutron emission for (n,2nd)

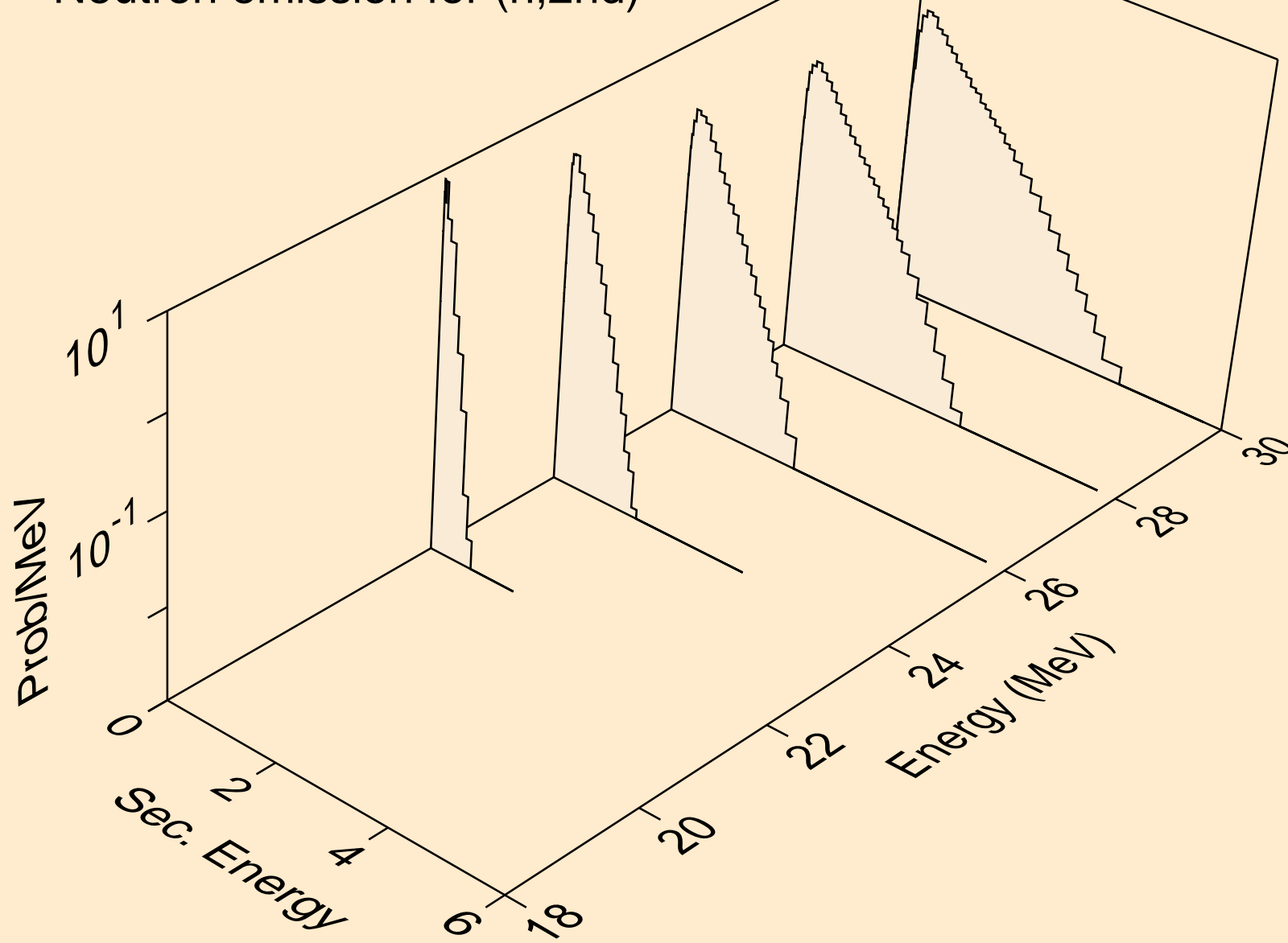

TC102M NEUTRON ACER TENDL-2024 LIBRARY; T=0.K
Neutron emission for (n,2n)

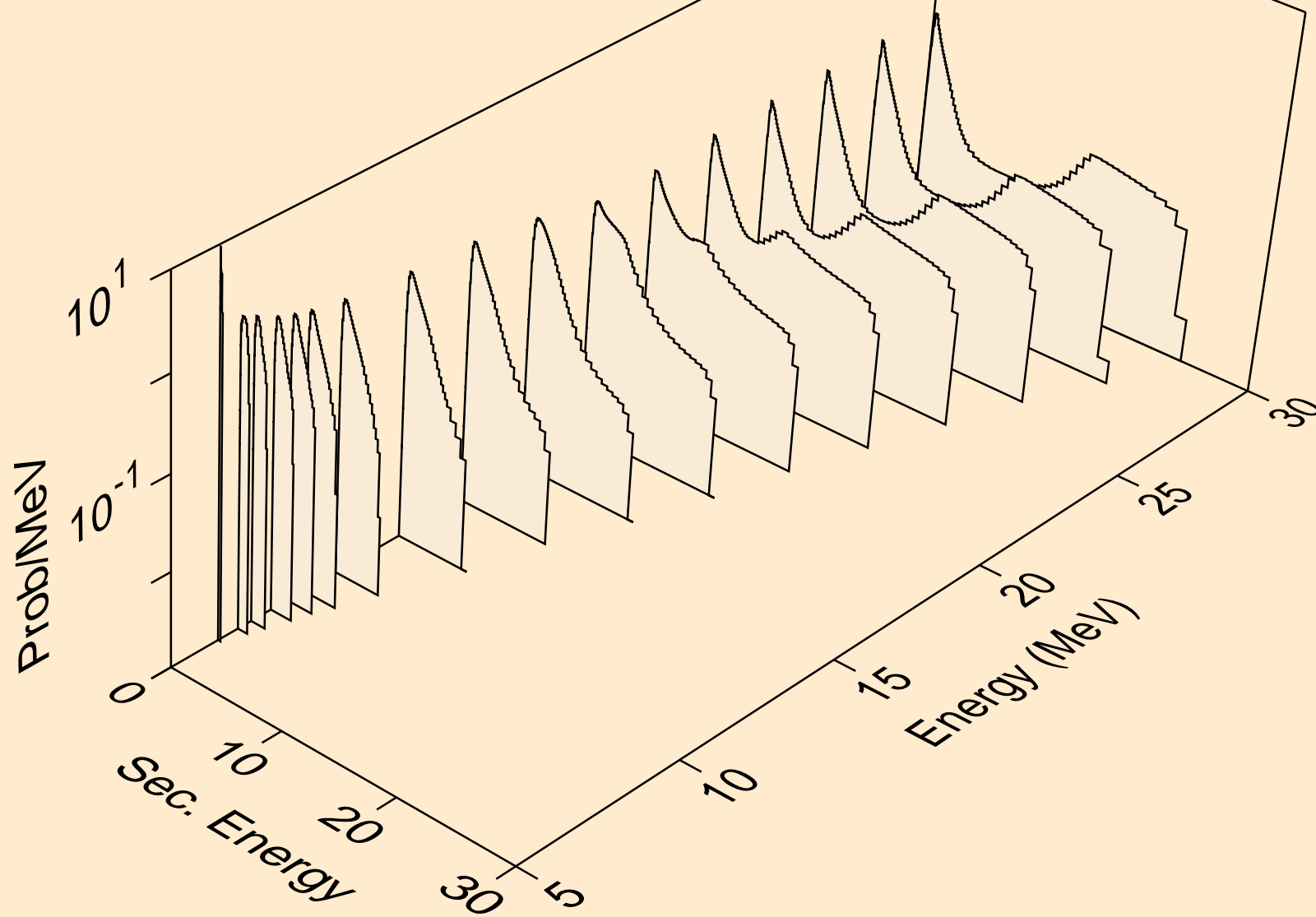

TC102M NEUTRON ACER TENDL-2024 LIBRARY; T=0.K
Neutron emission for (n,3n)

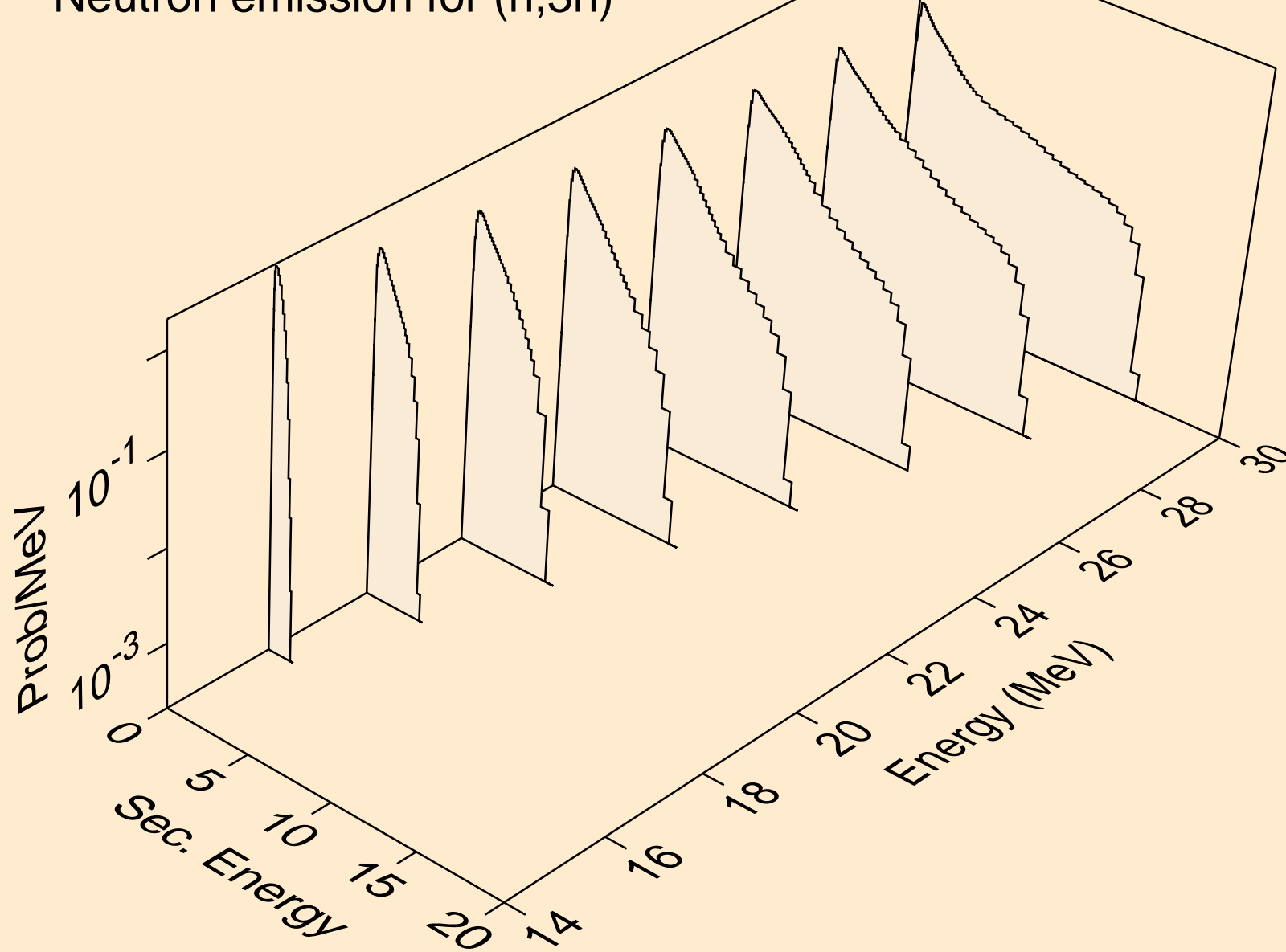

TC102M NEUTRON ACER TENDL-2024 LIBRARY; T=0.K
Neutron emission for (n,n*)a

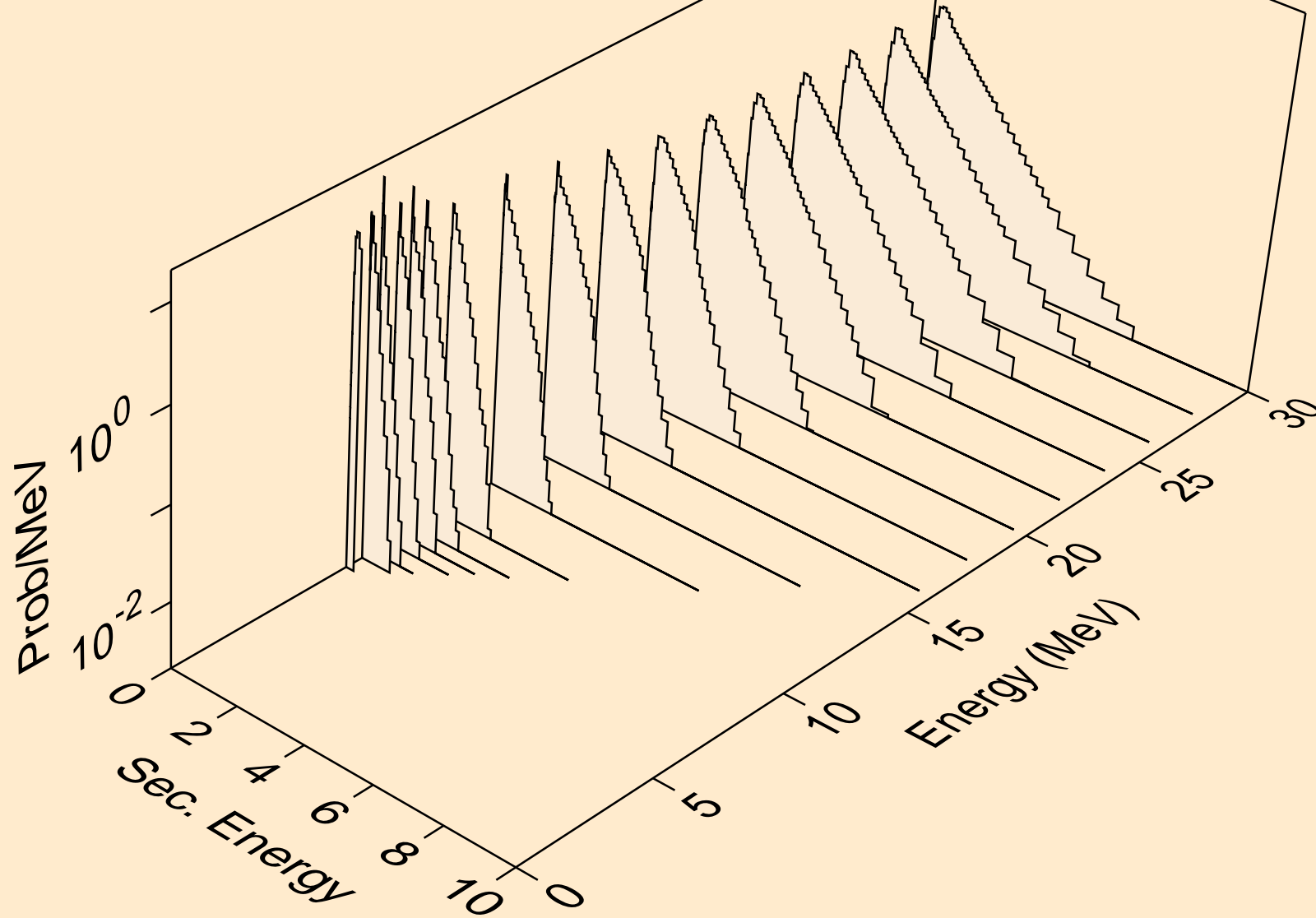

TC102M NEUTRON ACER TENDL-2024 LIBRARY; T=0.K
Neutron emission for (n,2n)a

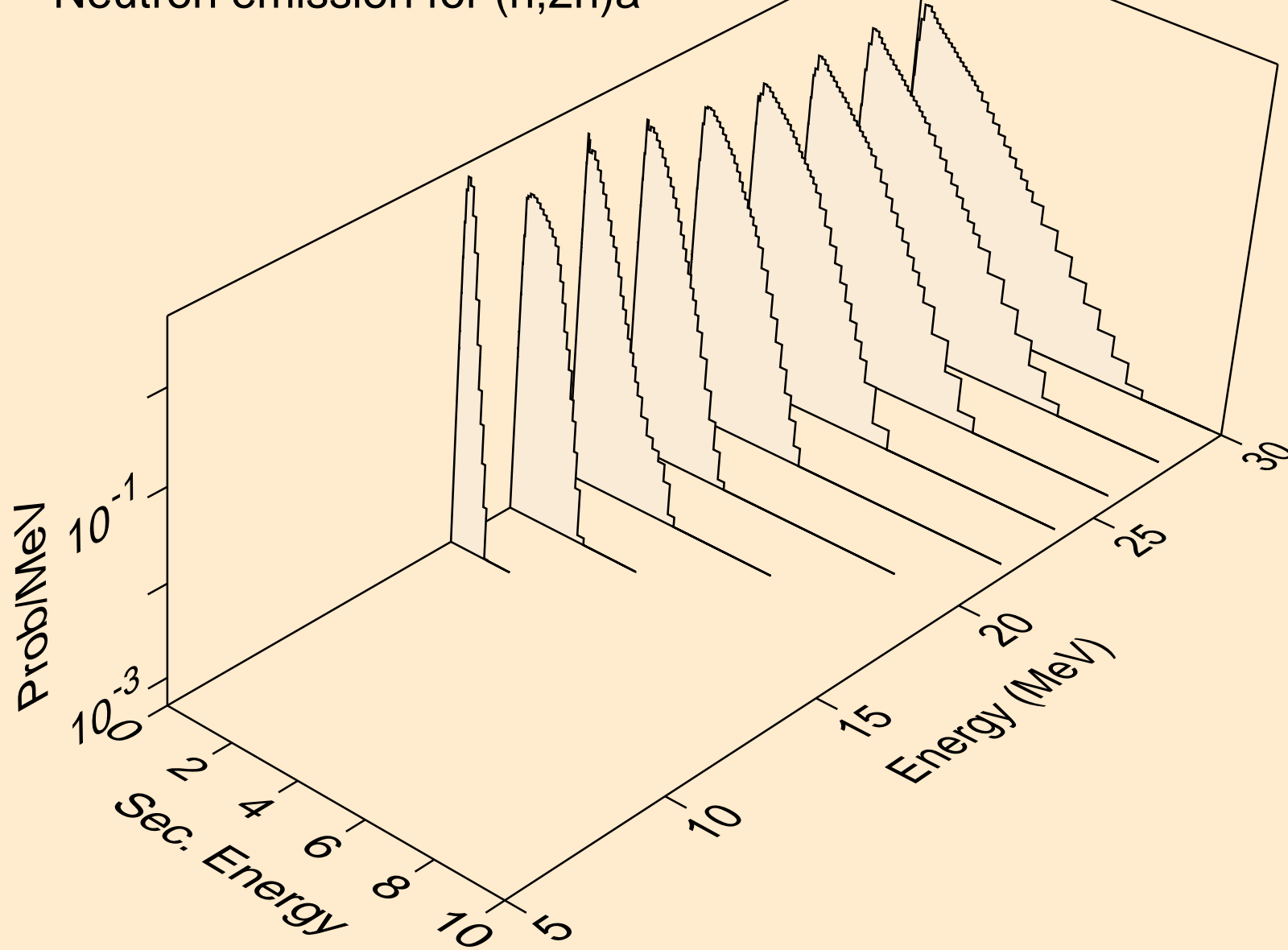

TC102M NEUTRON ACER TENDL-2024 LIBRARY; T=0.K
Neutron emission for (n,3n)a

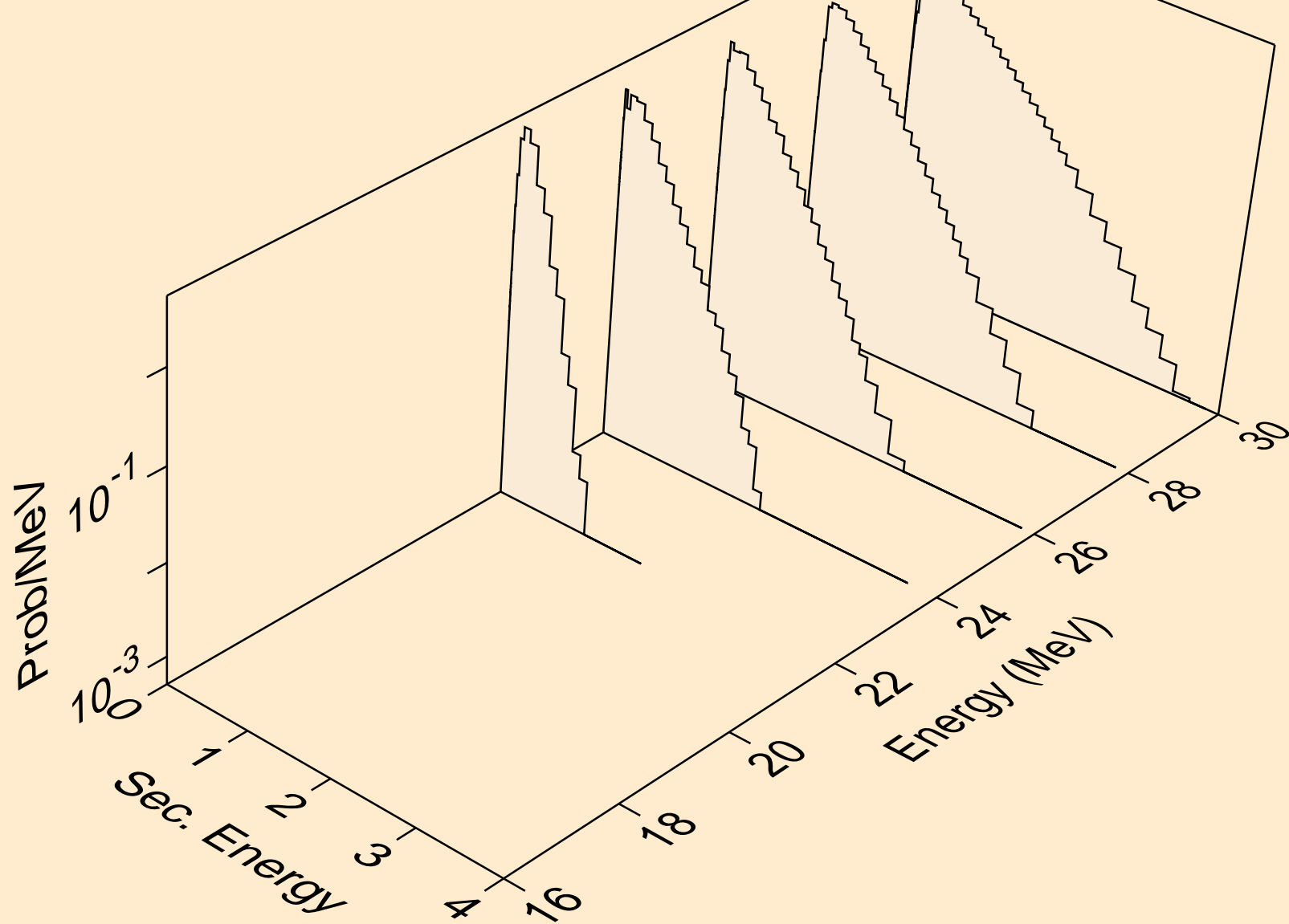

TC102M NEUTRON ACER TENDL-2024 LIBRARY; T=0.K
Neutron emission for (n,n*)p

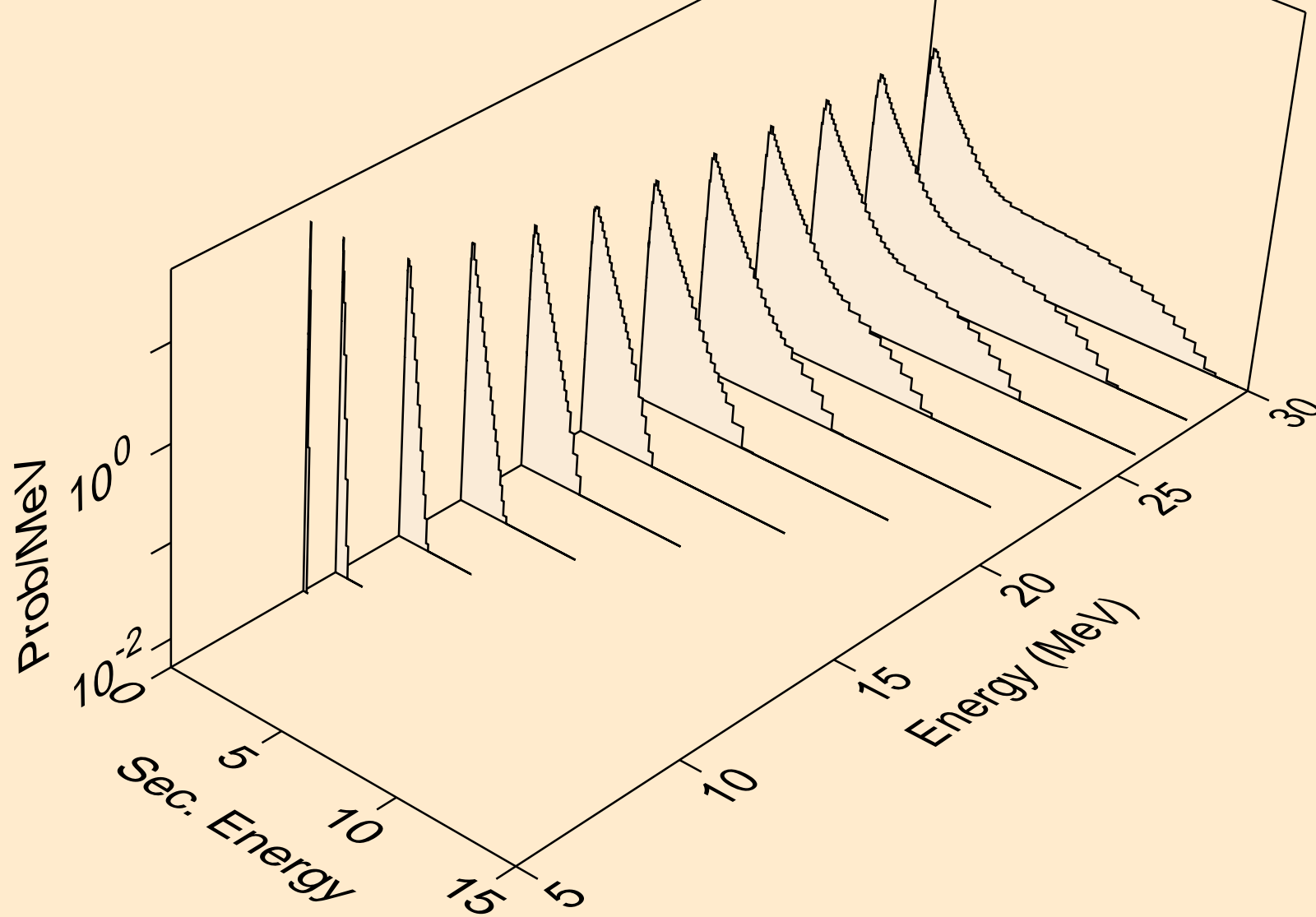

TC102M NEUTRON ACER TENDL-2024 LIBRARY; T=0.K
Neutron emission for (n,n*)2a

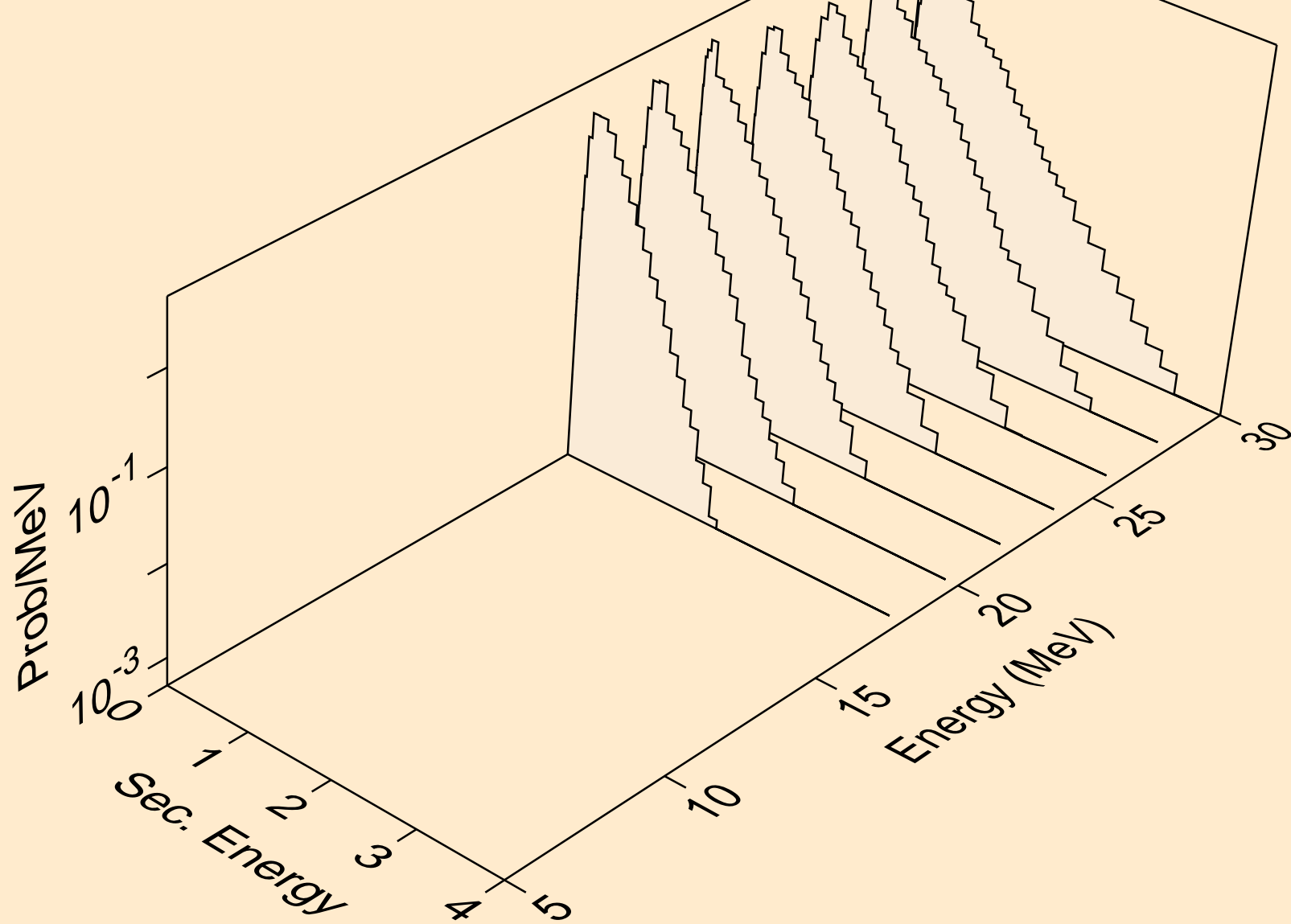

TC102M NEUTRON ACER TENDL-2024 LIBRARY; T=0.K
Neutron emission for (n,n*)d

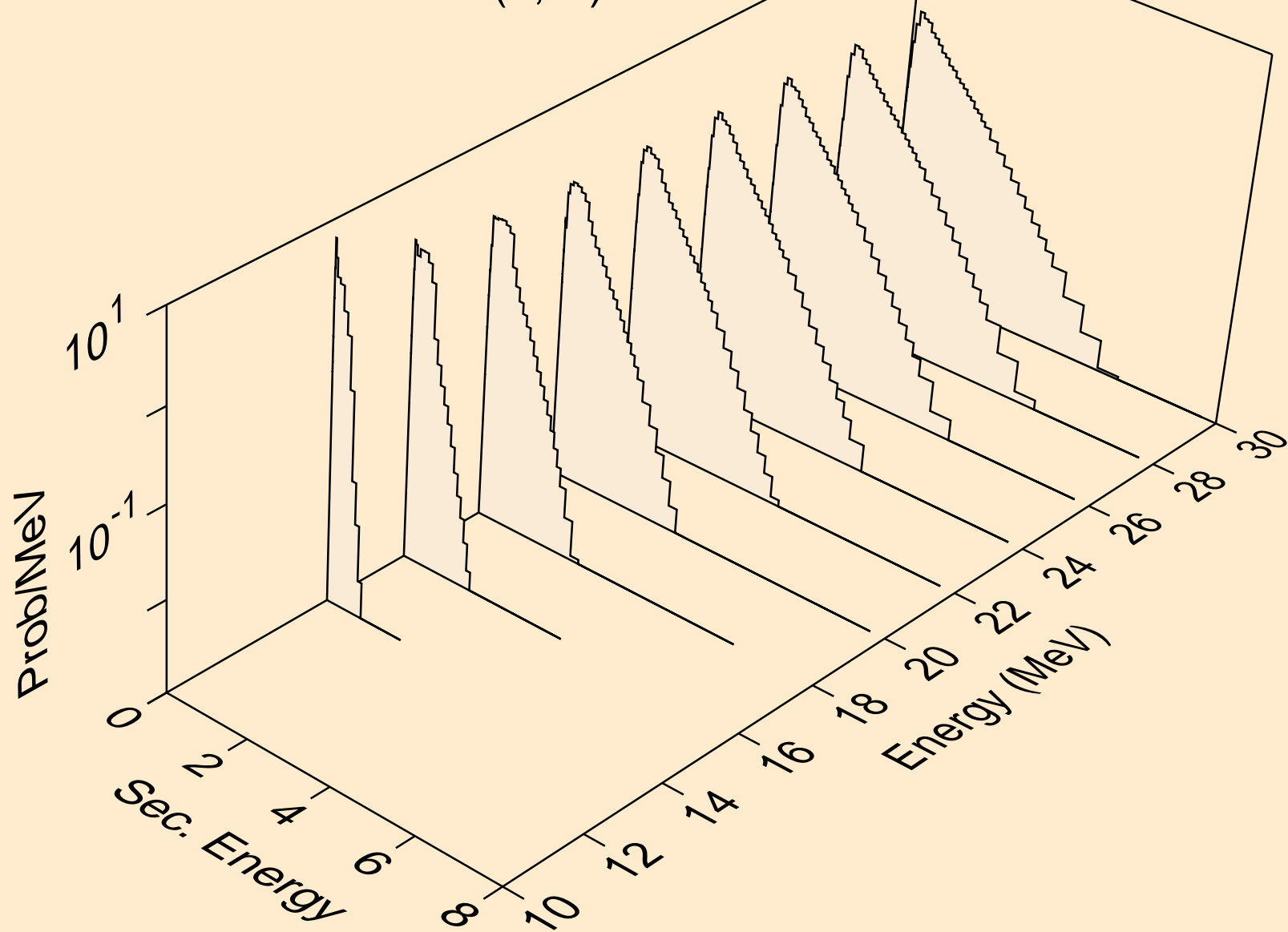

TC102M NEUTRON ACER TENDL-2024 LIBRARY; T=0.K
Neutron emission for (n,n*)t

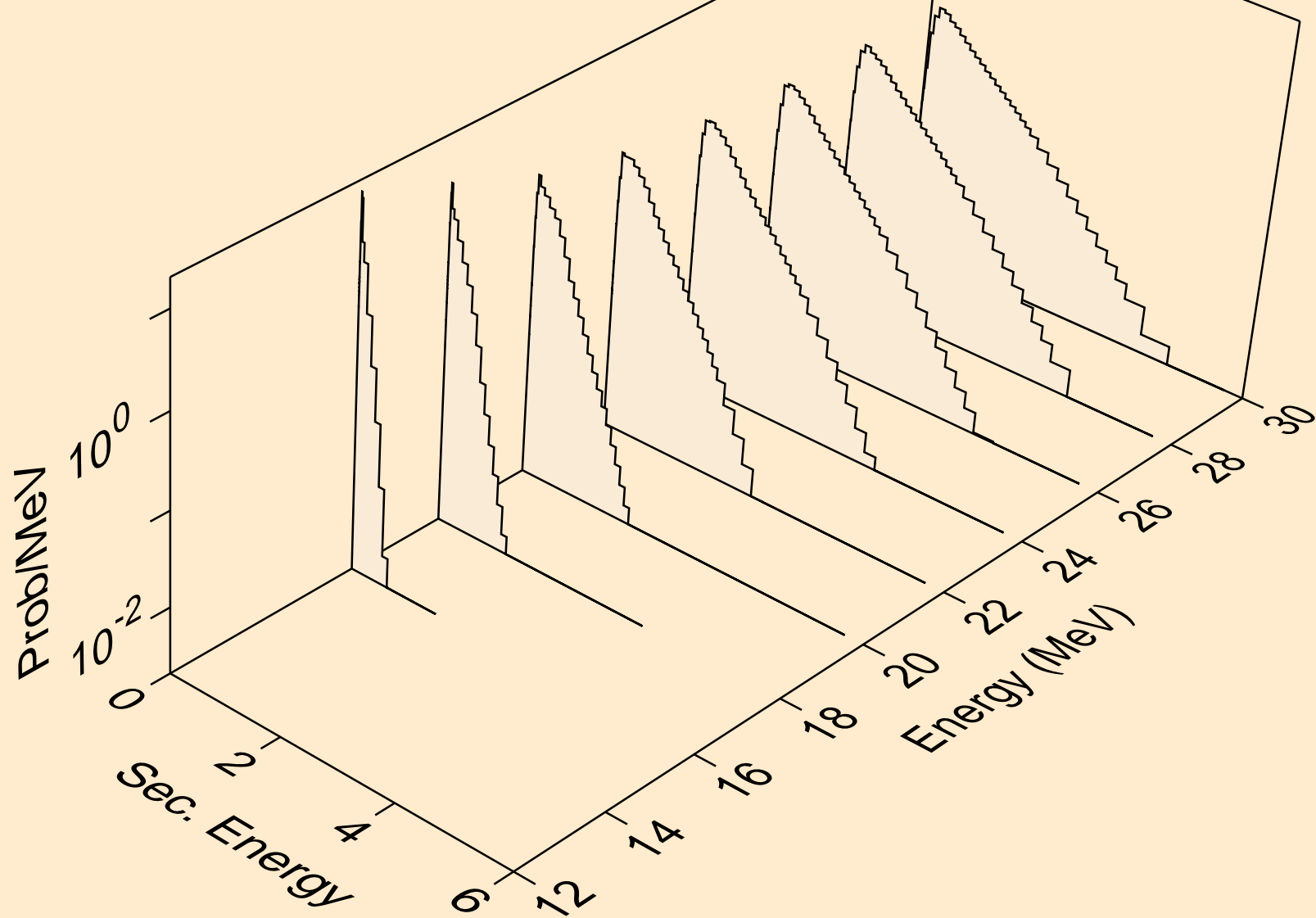

TC102M NEUTRON ACER TENDL-2024 LIBRARY; T=0.K
Neutron emission for (n,n*)he3

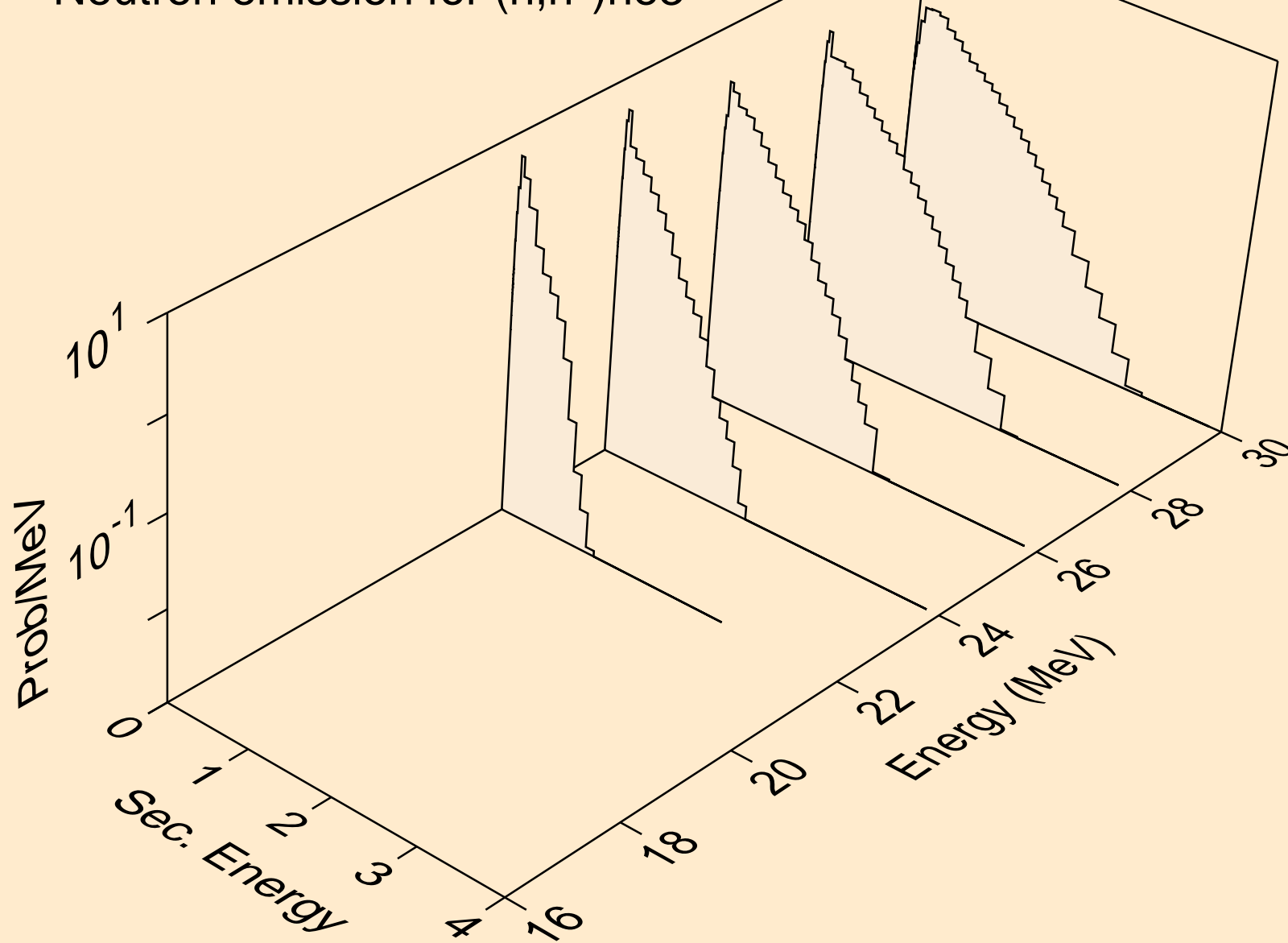

TC102M NEUTRON ACER TENDL-2024 LIBRARY; T=0.K
Neutron emission for (n,4n)

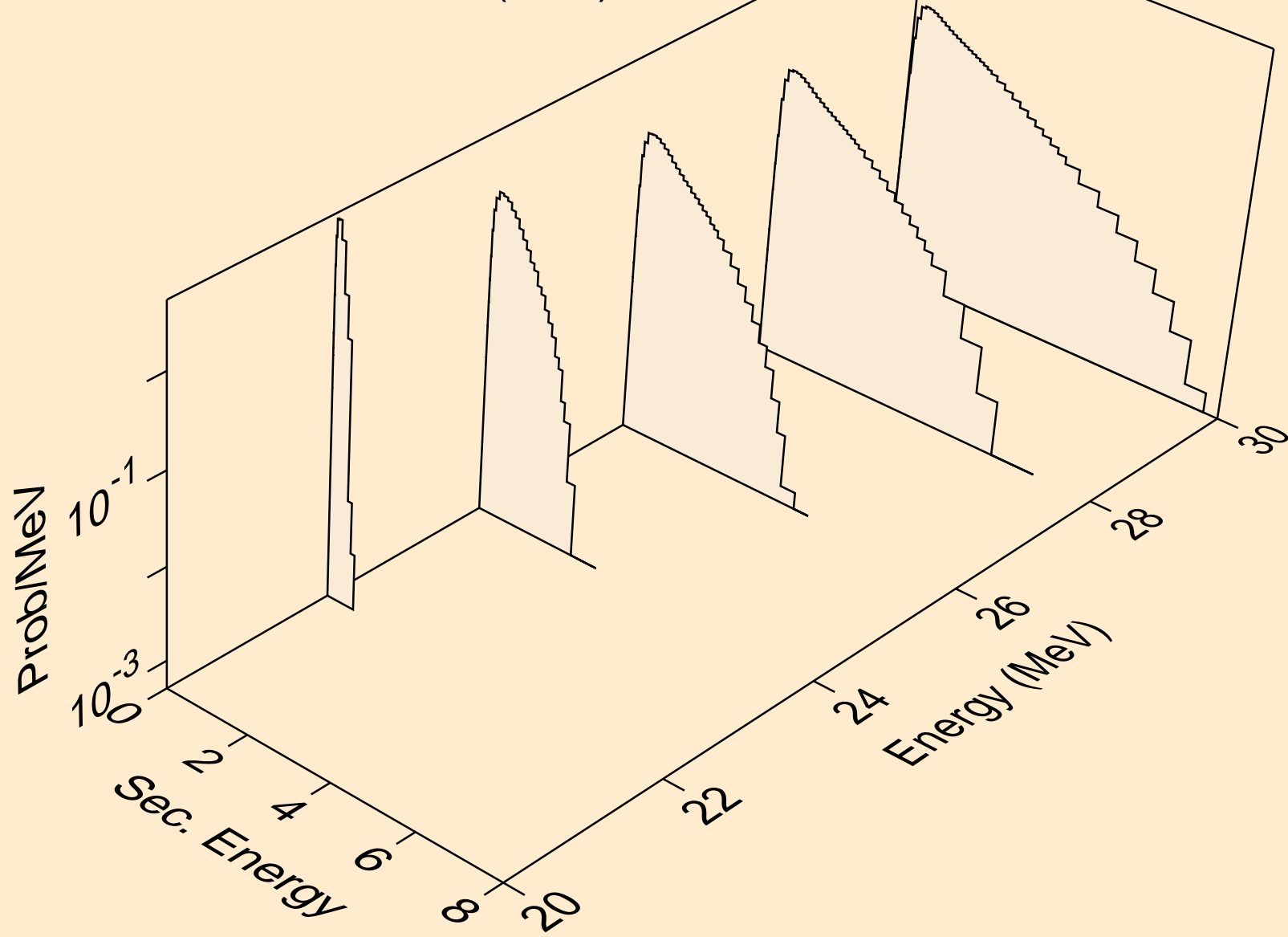

TC102M NEUTRON ACER TENDL-2024 LIBRARY; T=0.K
Neutron emission for (n,2np)

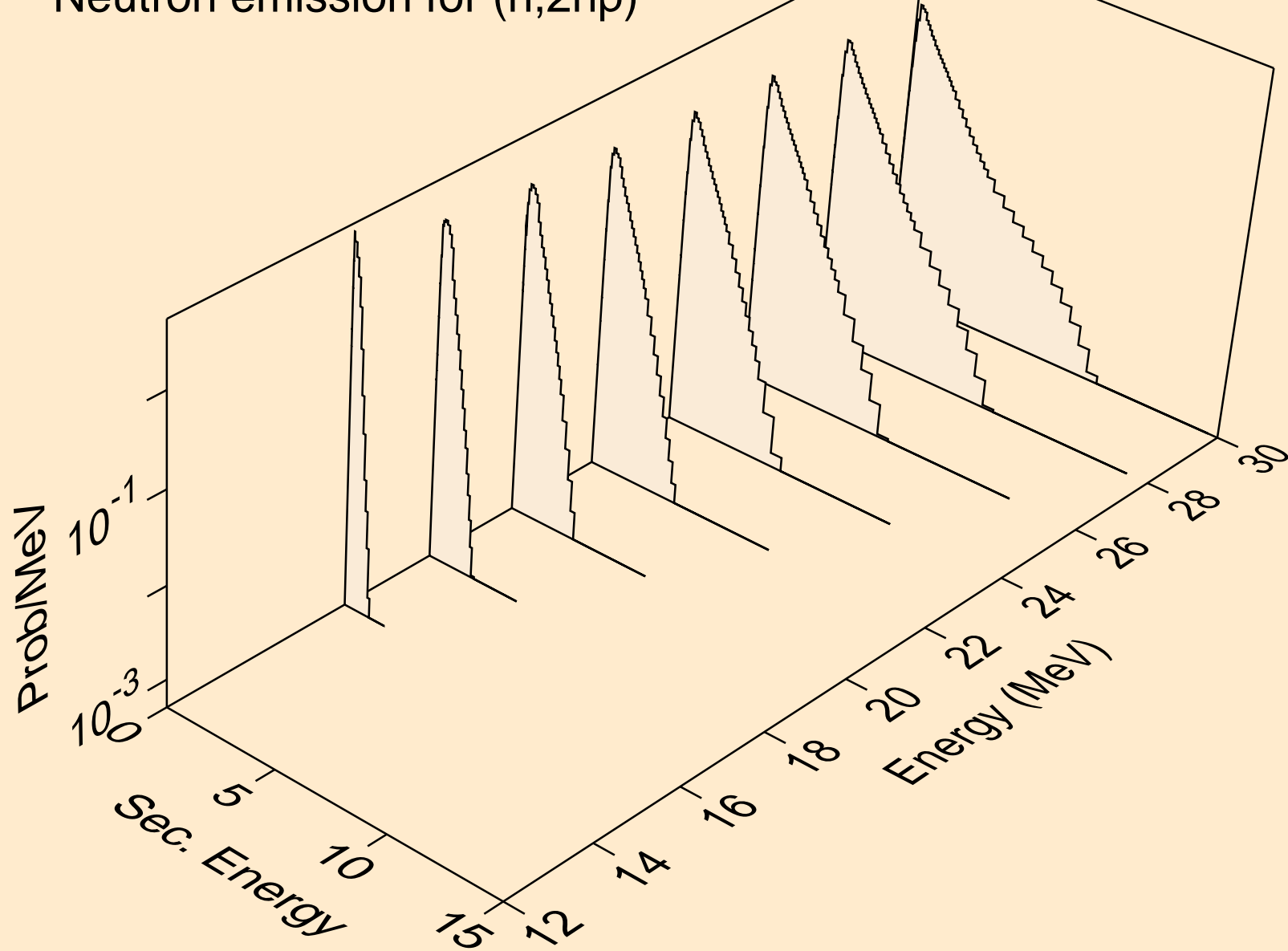

TC102M NEUTRON ACER TENDL-2024 LIBRARY; T=0.K
Neutron emission for (n,3np)

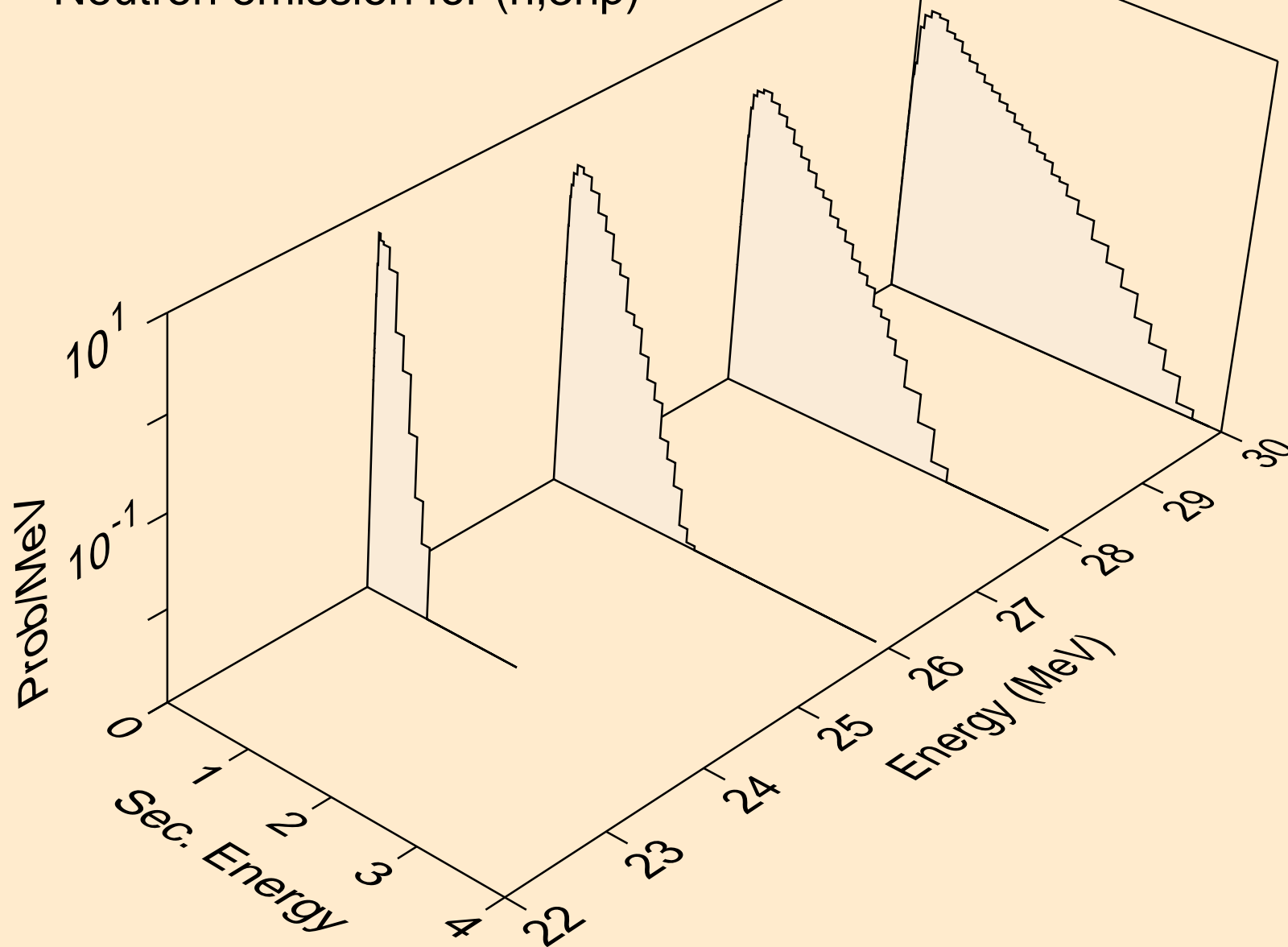

TC102M NEUTRON ACER TENDL-2024 LIBRARY; T=0.K
Neutron emission for (n,n2p)

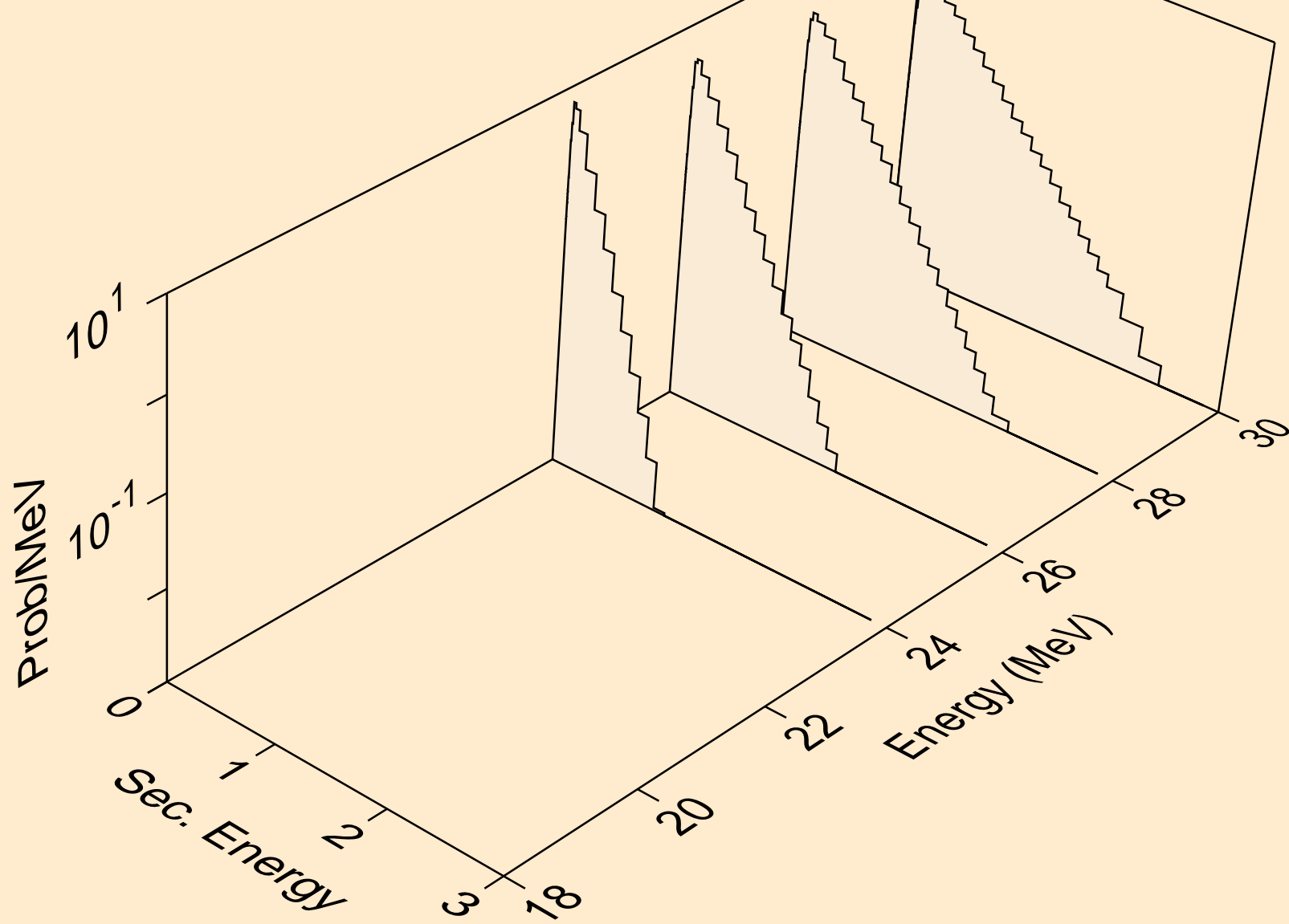

TC102M NEUTRON ACER TENDL-2024 LIBRARY; T=0.K
Neutron emission for (n,npa)

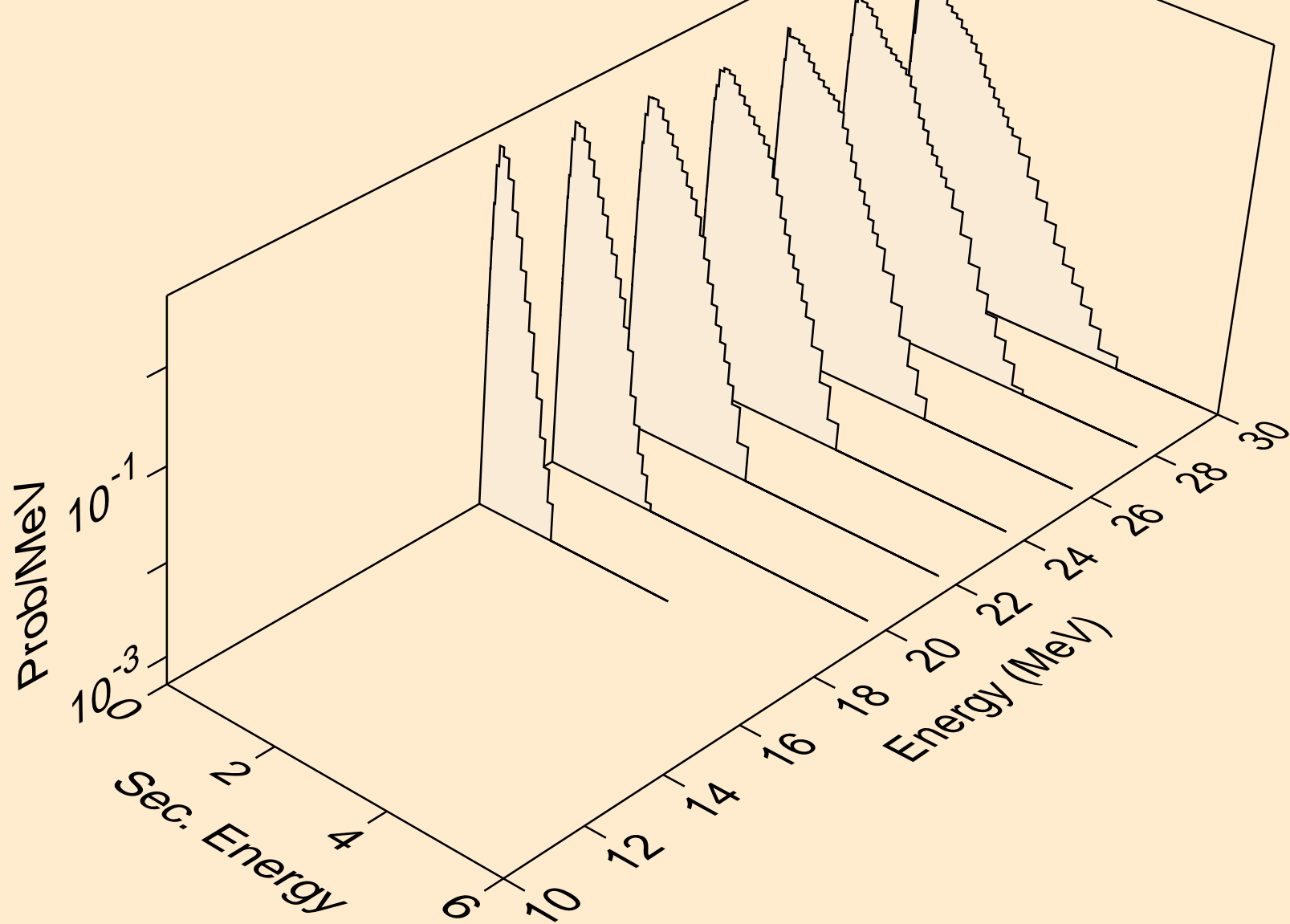

TC102M NEUTRON ACER TENDL-2024 LIBRARY; T=0.K
Neutron emission for (n,n*c)

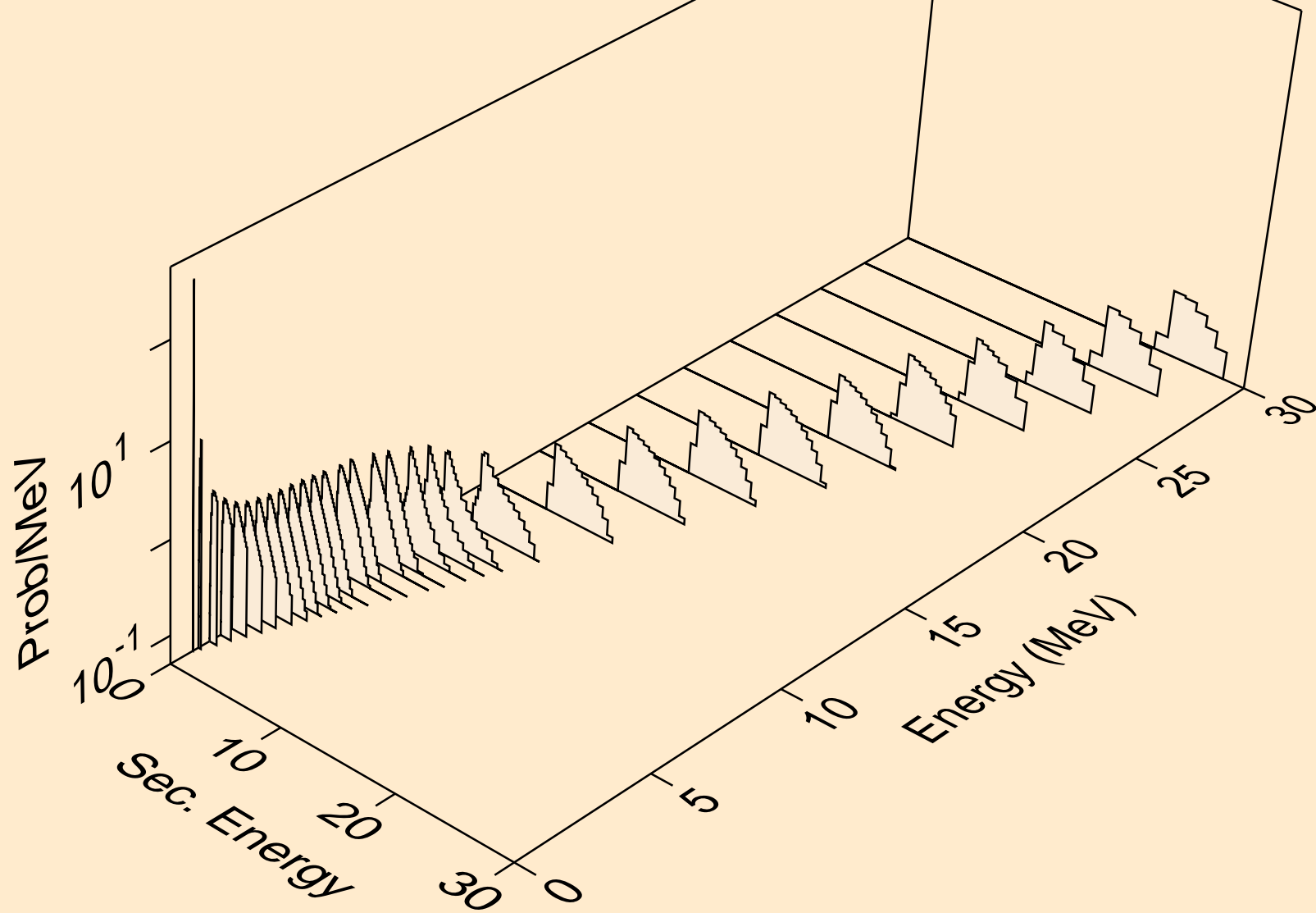

TC102M NEUTRON ACER TENDL-2024 LIBRARY; T=0.K
Photon emission for (n,x)

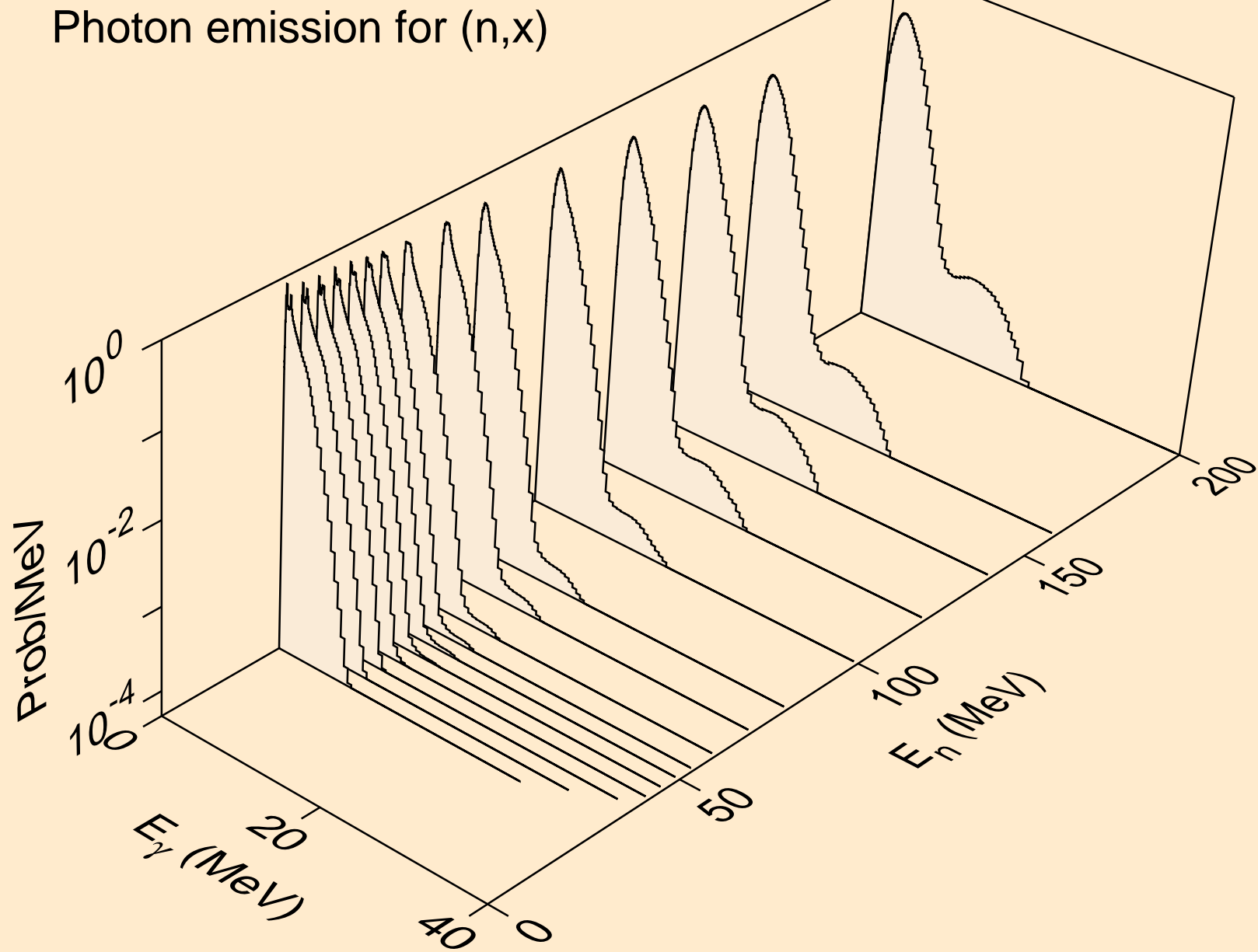

TC102M NEUTRON ACER TENDL-2024 LIBRARY; T=0.K
Photon emission for (n,2nd)

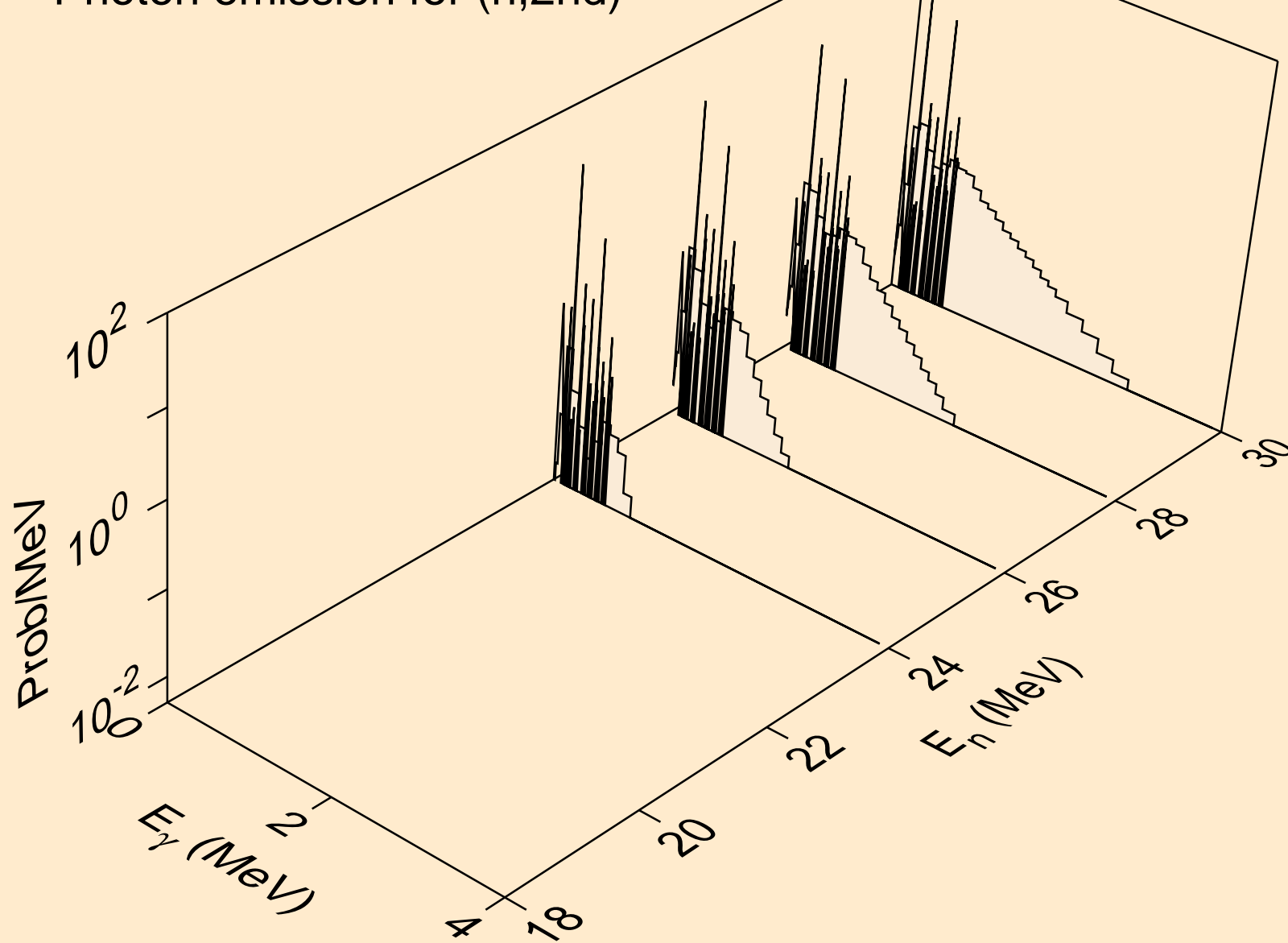

TC102M NEUTRON ACER TENDL-2024 LIBRARY; T=0.K
Photon emission for (n,2n)

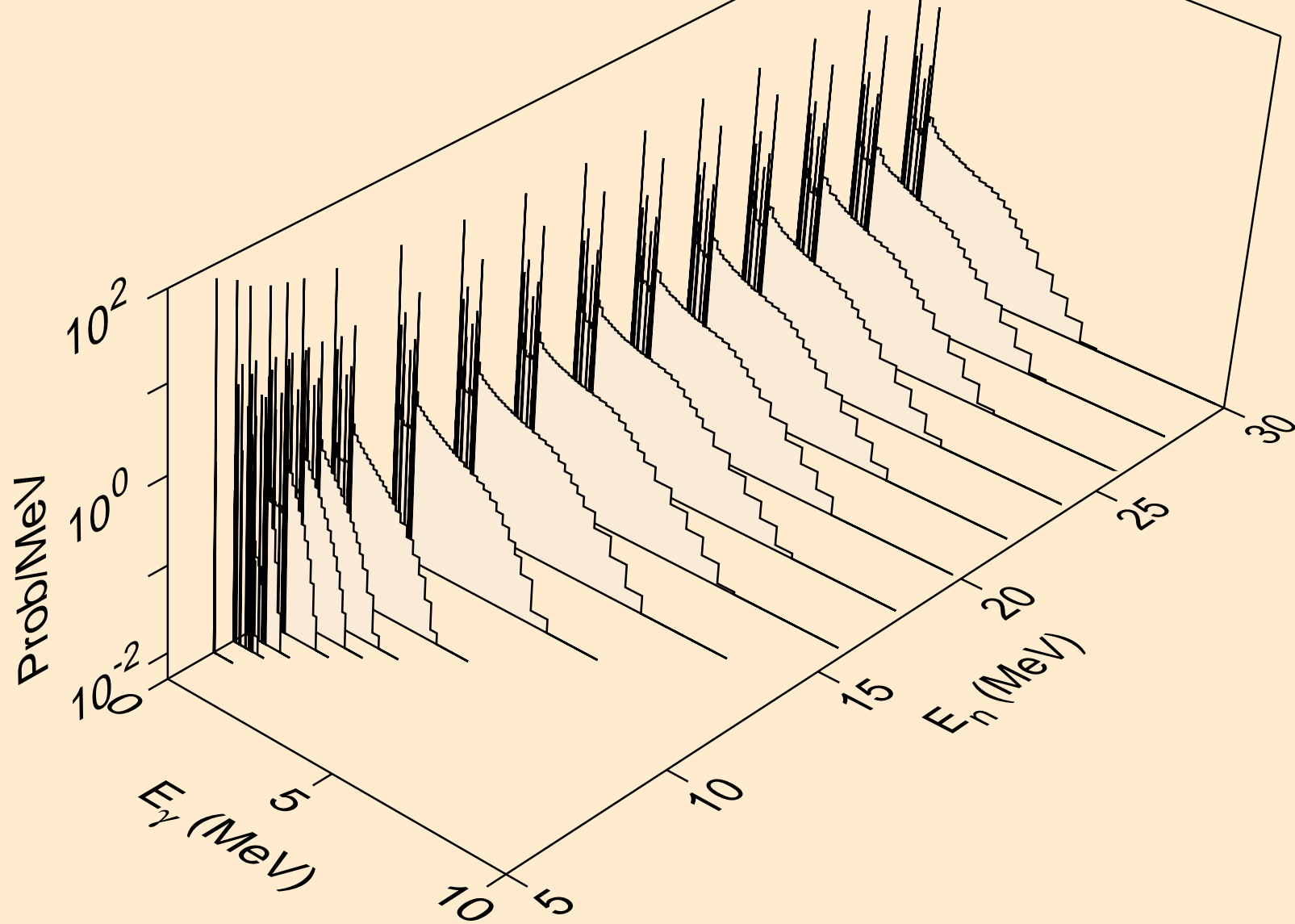

TC102M NEUTRON ACER TENDL-2024 LIBRARY; T=0.K
Photon emission for (n,3n)

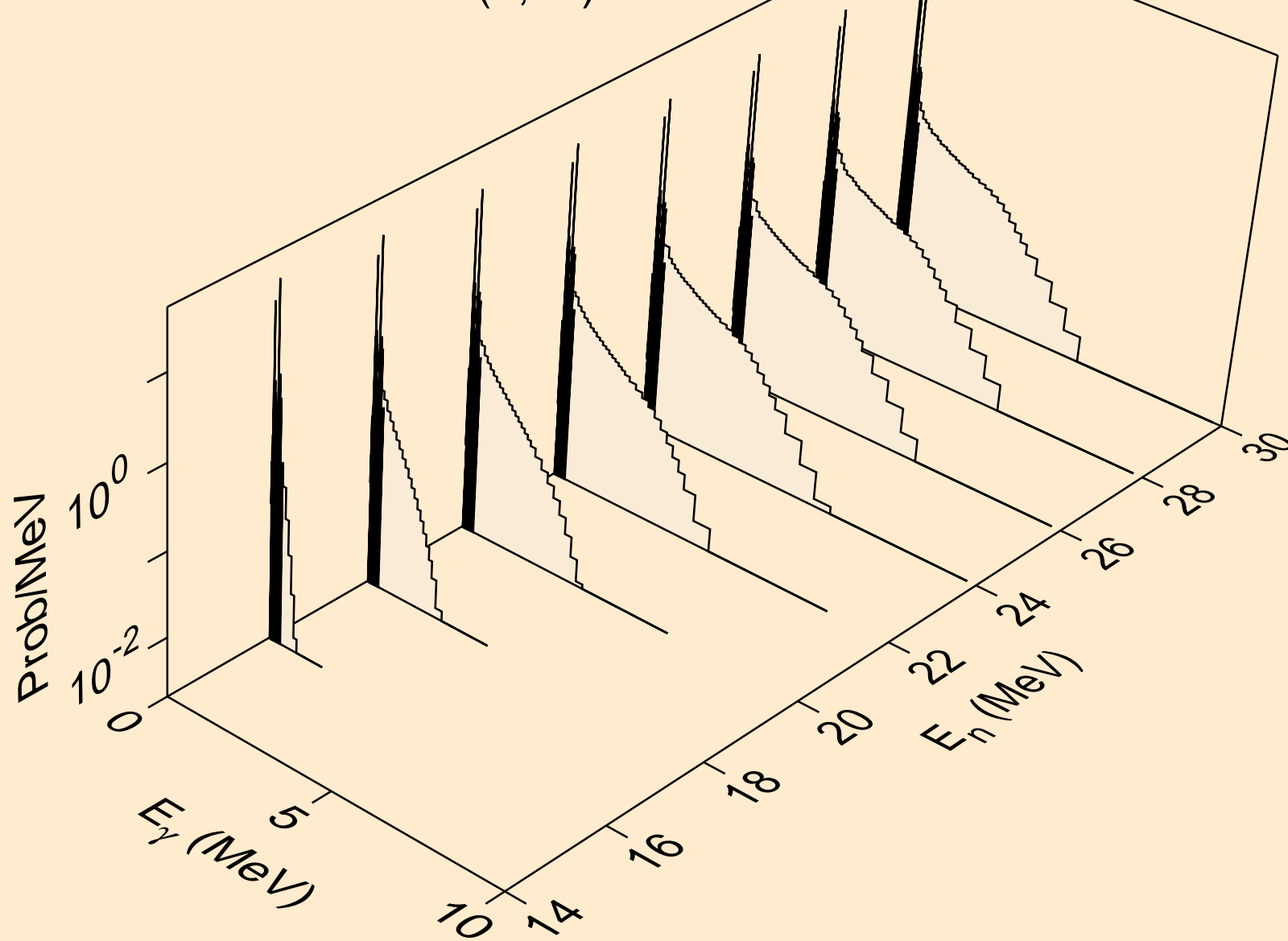

TC102M NEUTRON ACER TENDL-2024 LIBRARY; T=0.K
Photon emission for (n,n*)a

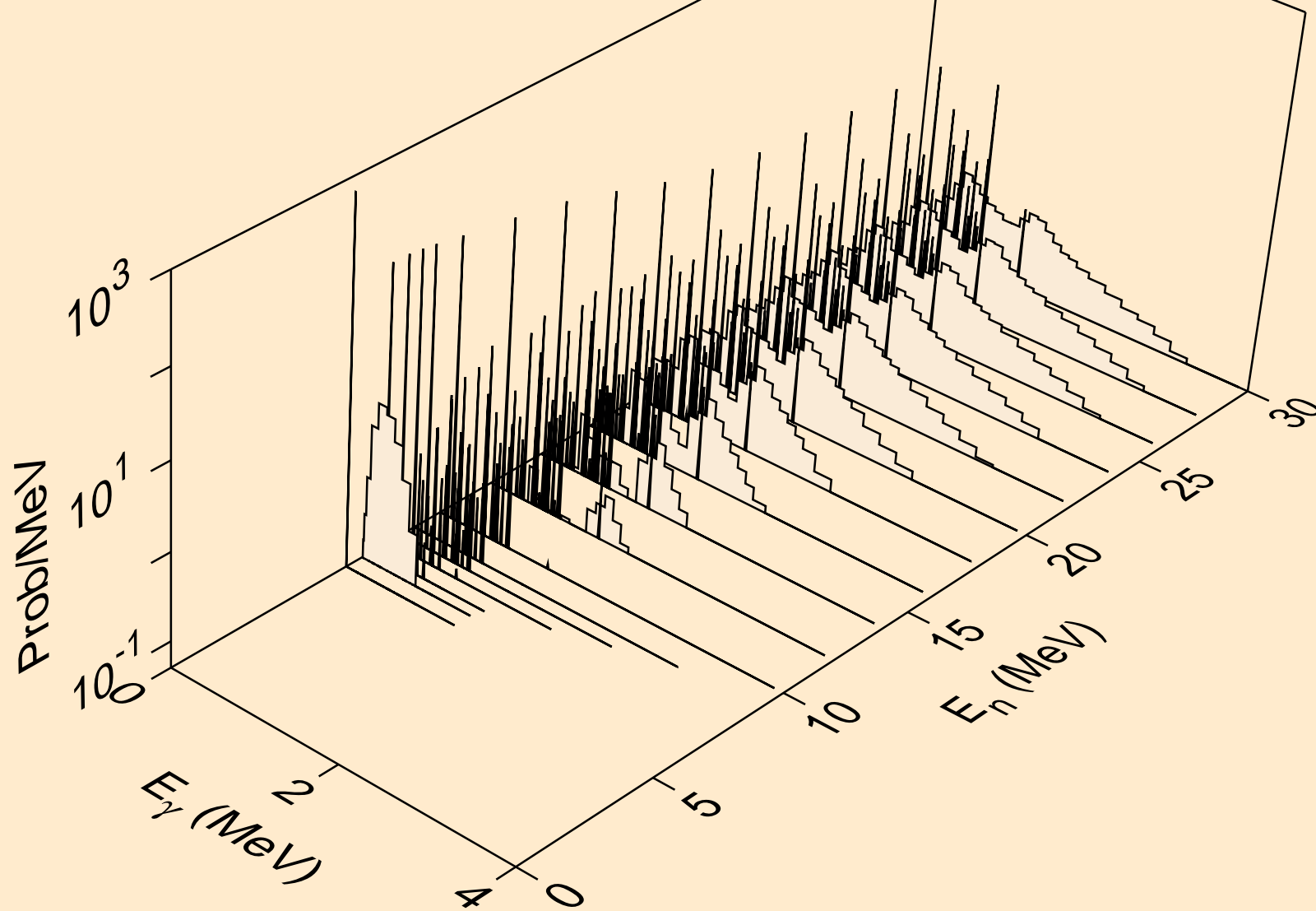

TC102M NEUTRON ACER TENDL-2024 LIBRARY; T=0.K
Photon emission for (n,2n)a

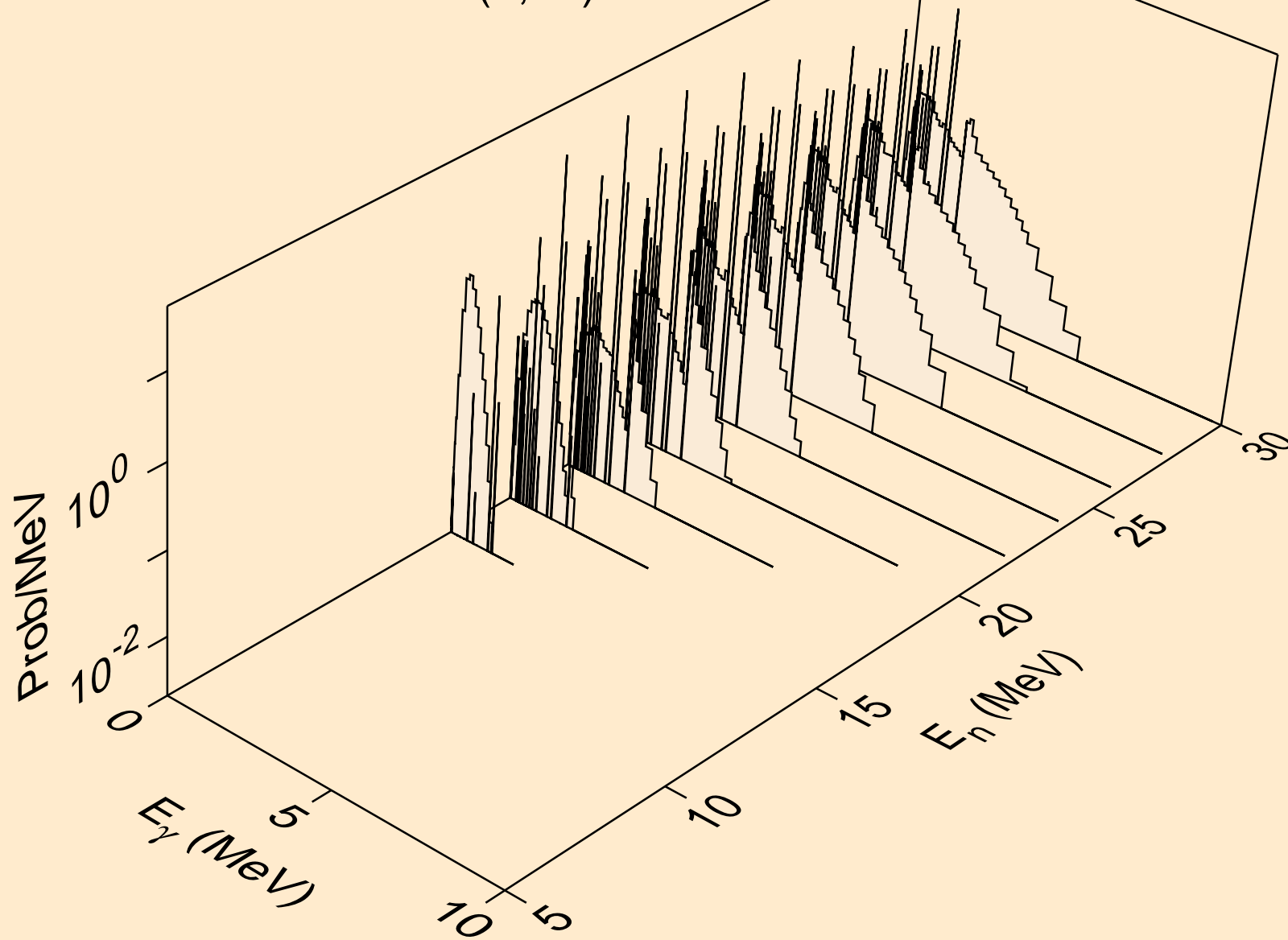

TC102M NEUTRON ACER TENDL-2024 LIBRARY; T=0.K
Photon emission for (n,3n)a

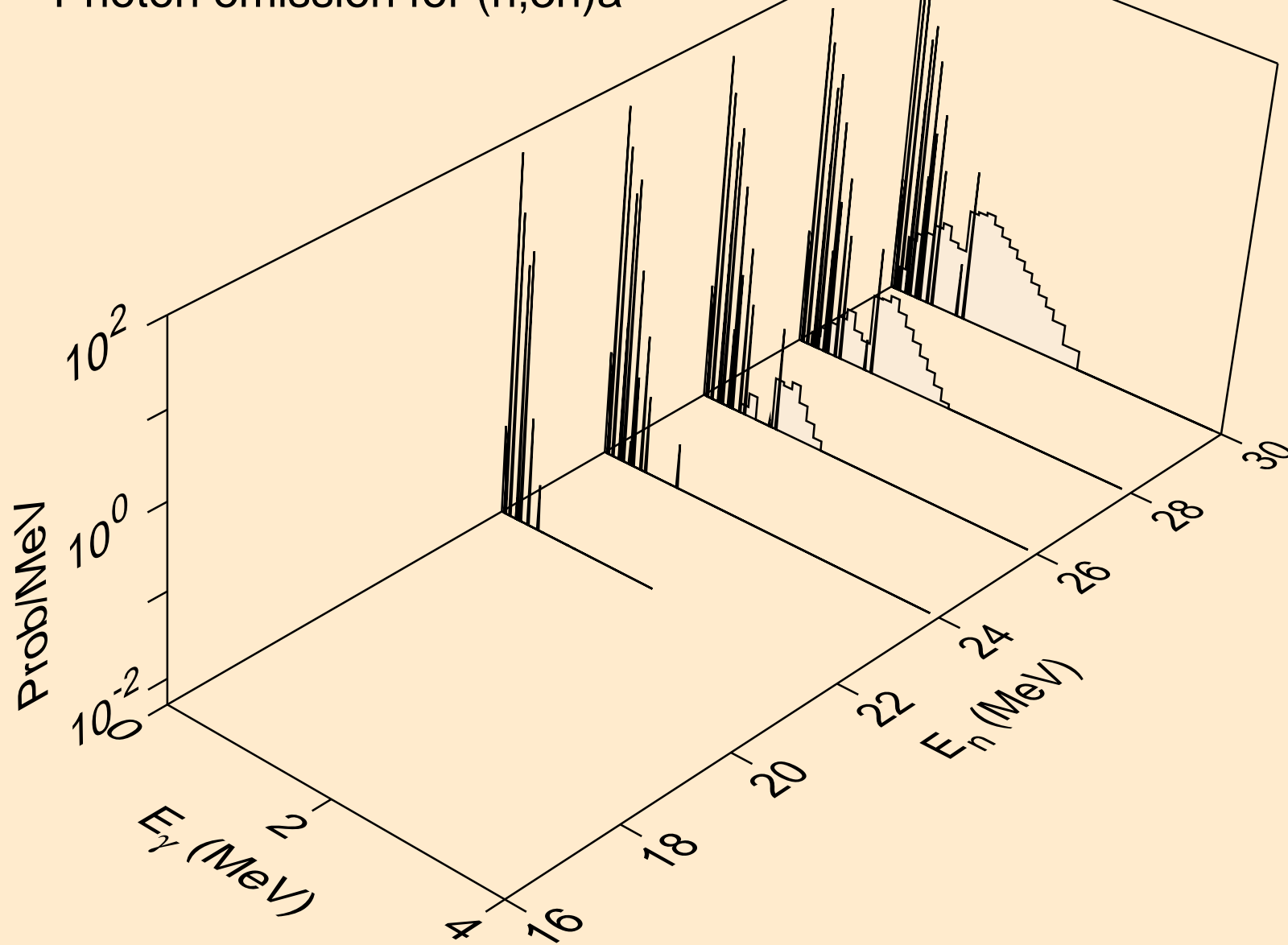

TC102M NEUTRON ACER TENDL-2024 LIBRARY; T=0.K
Photon emission for (n,n*)p

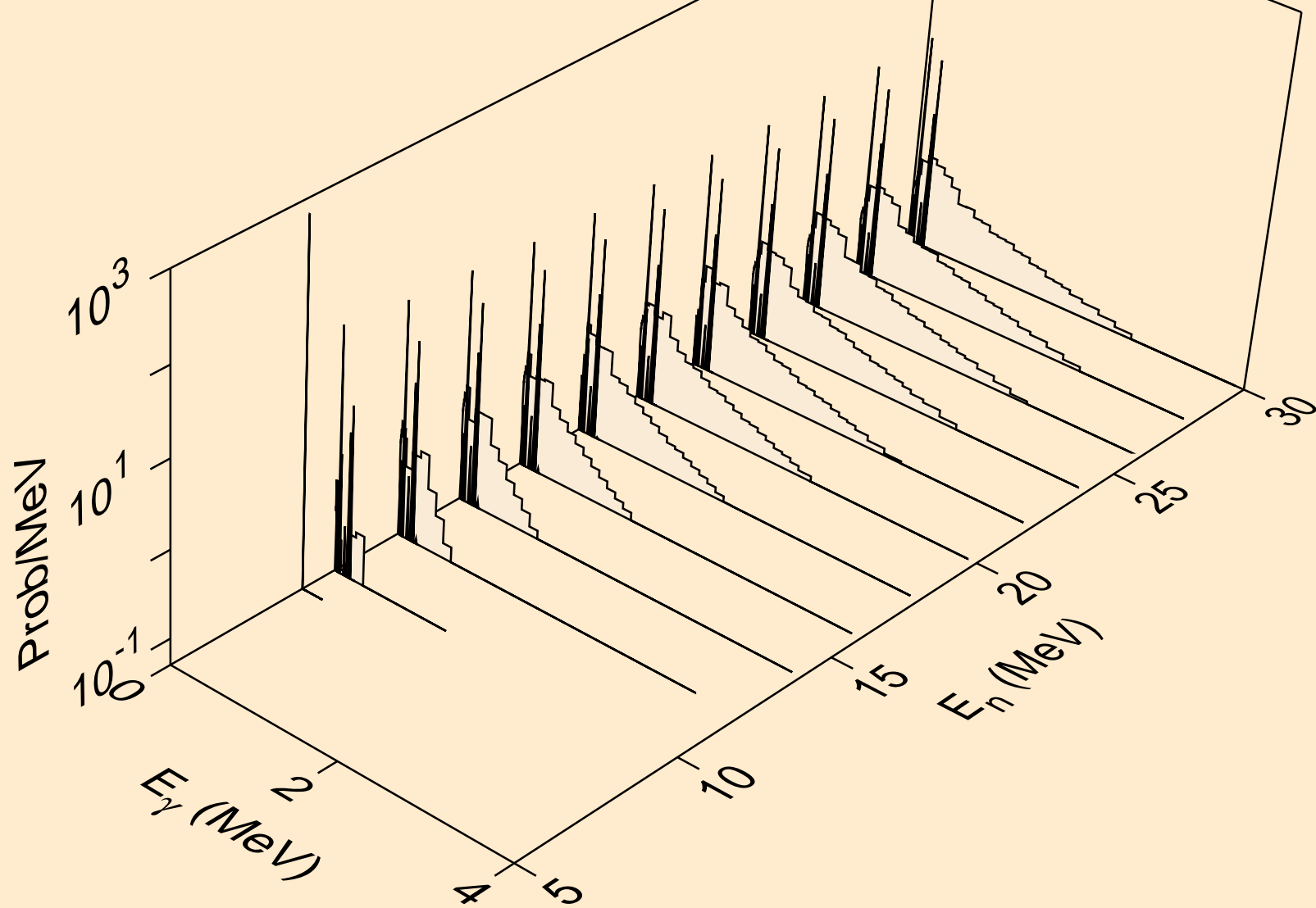

TC102M NEUTRON ACER TENDL-2024 LIBRARY; T=0.K
Photon emission for (n,n*)2a

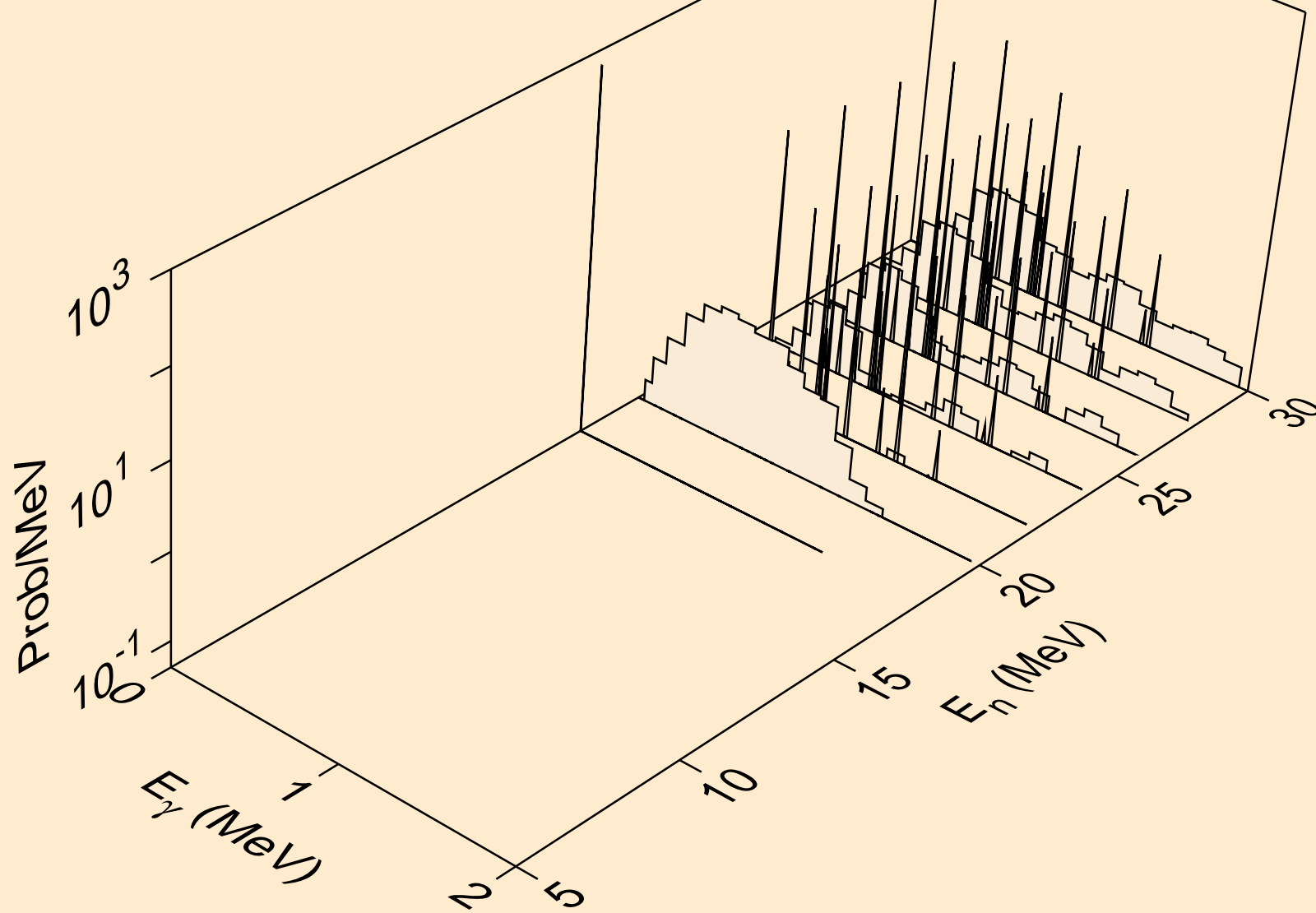

TC102M NEUTRON ACER TENDL-2024 LIBRARY; T=0.K
Photon emission for (n,n*)d

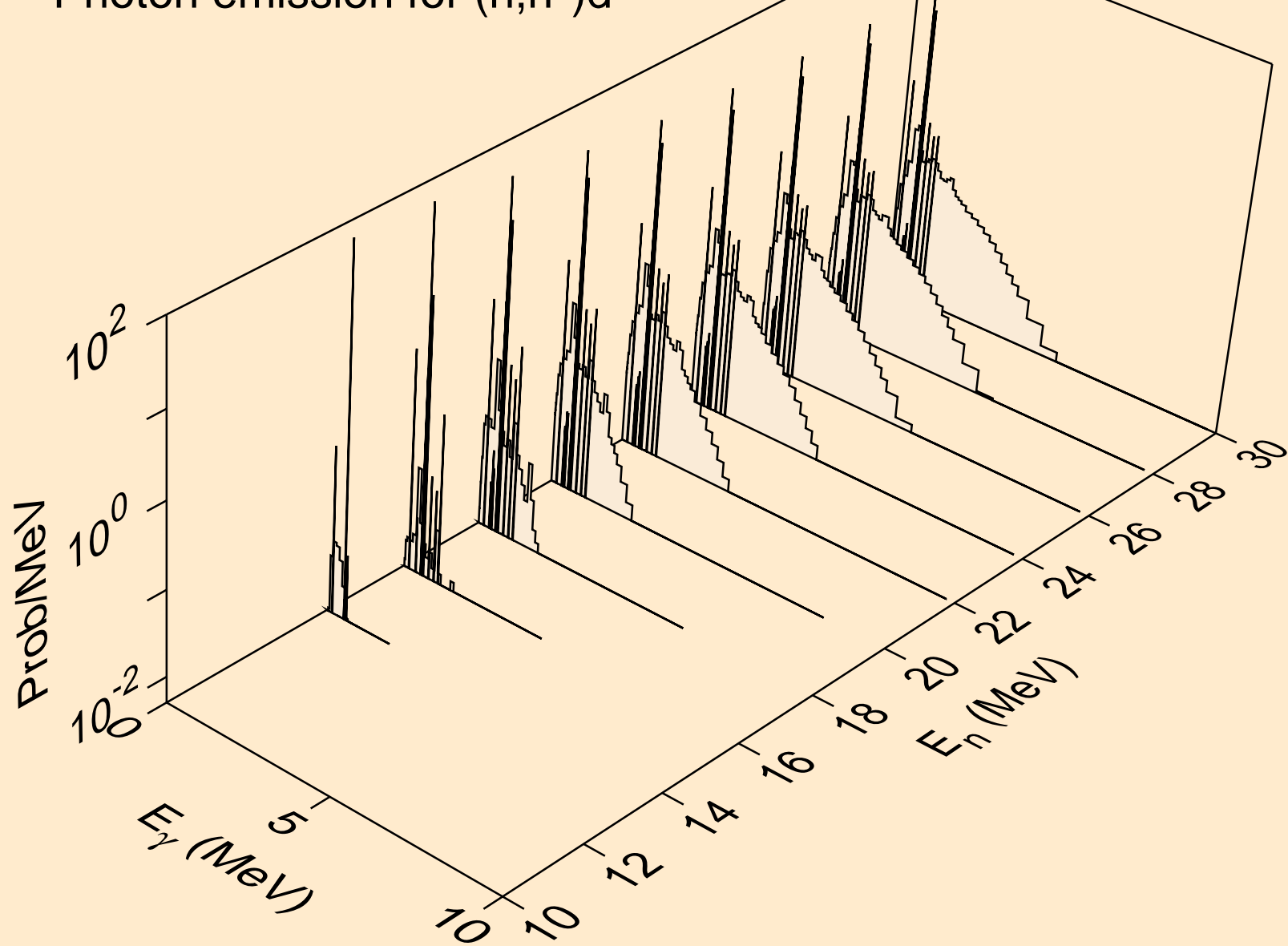

TC102M NEUTRON ACER TENDL-2024 LIBRARY; T=0.K
Photon emission for (n,n*)t

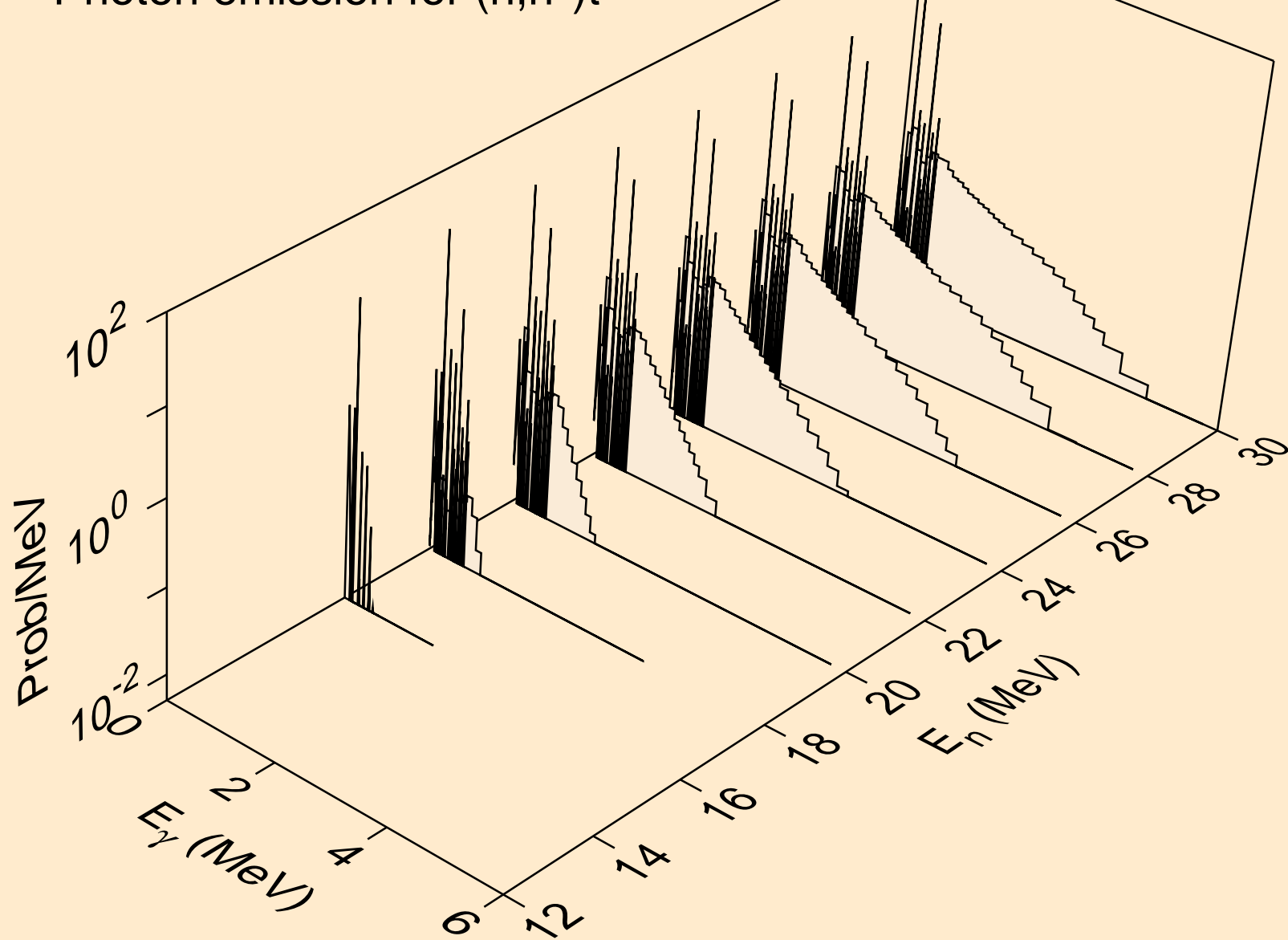

TC102M NEUTRON ACER TENDL-2024 LIBRARY; T=0.K
Photon emission for (n,n*)he3

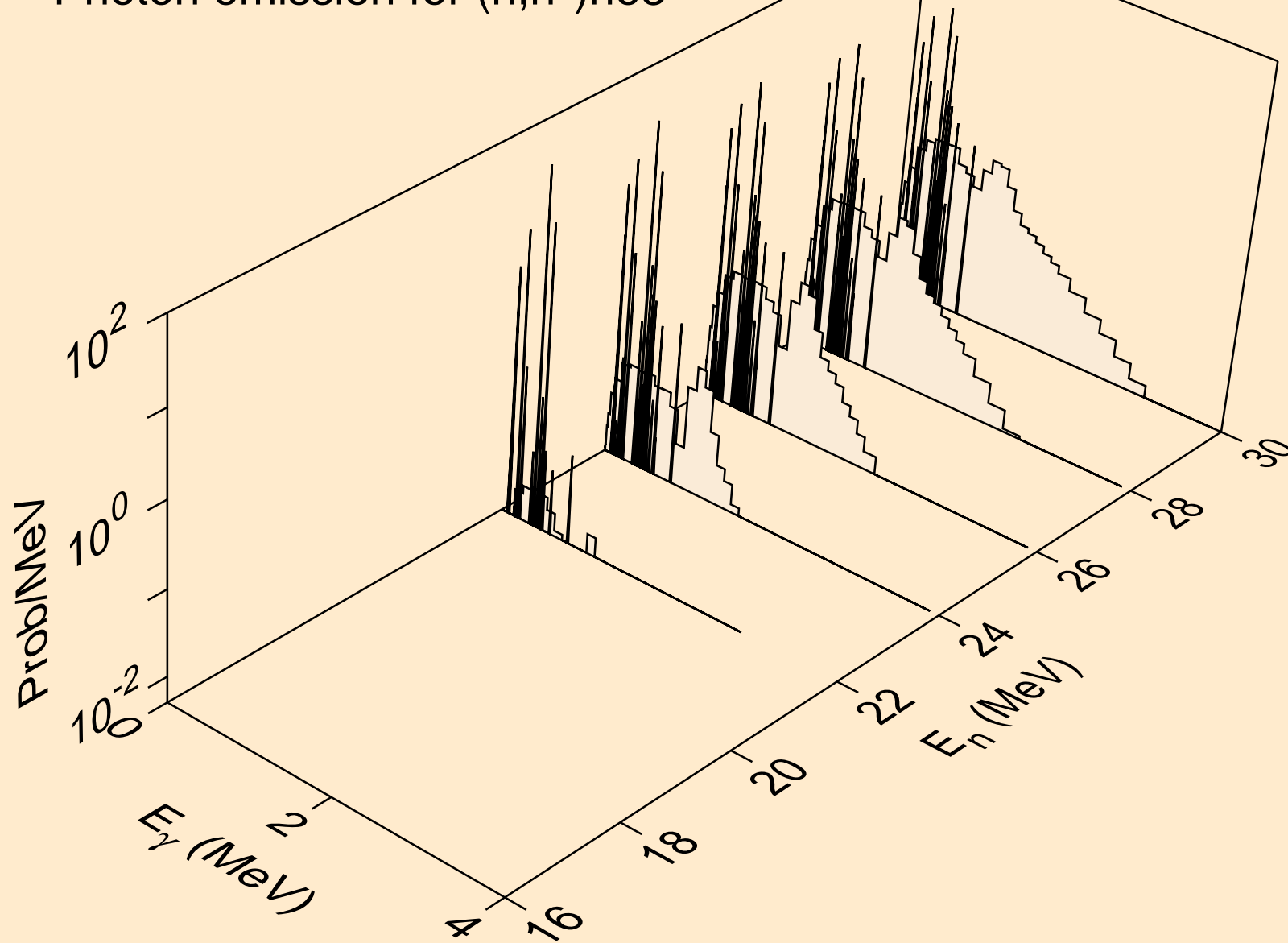

TC102M NEUTRON ACER TENDL-2024 LIBRARY; T=0.K
Photon emission for (n,4n)

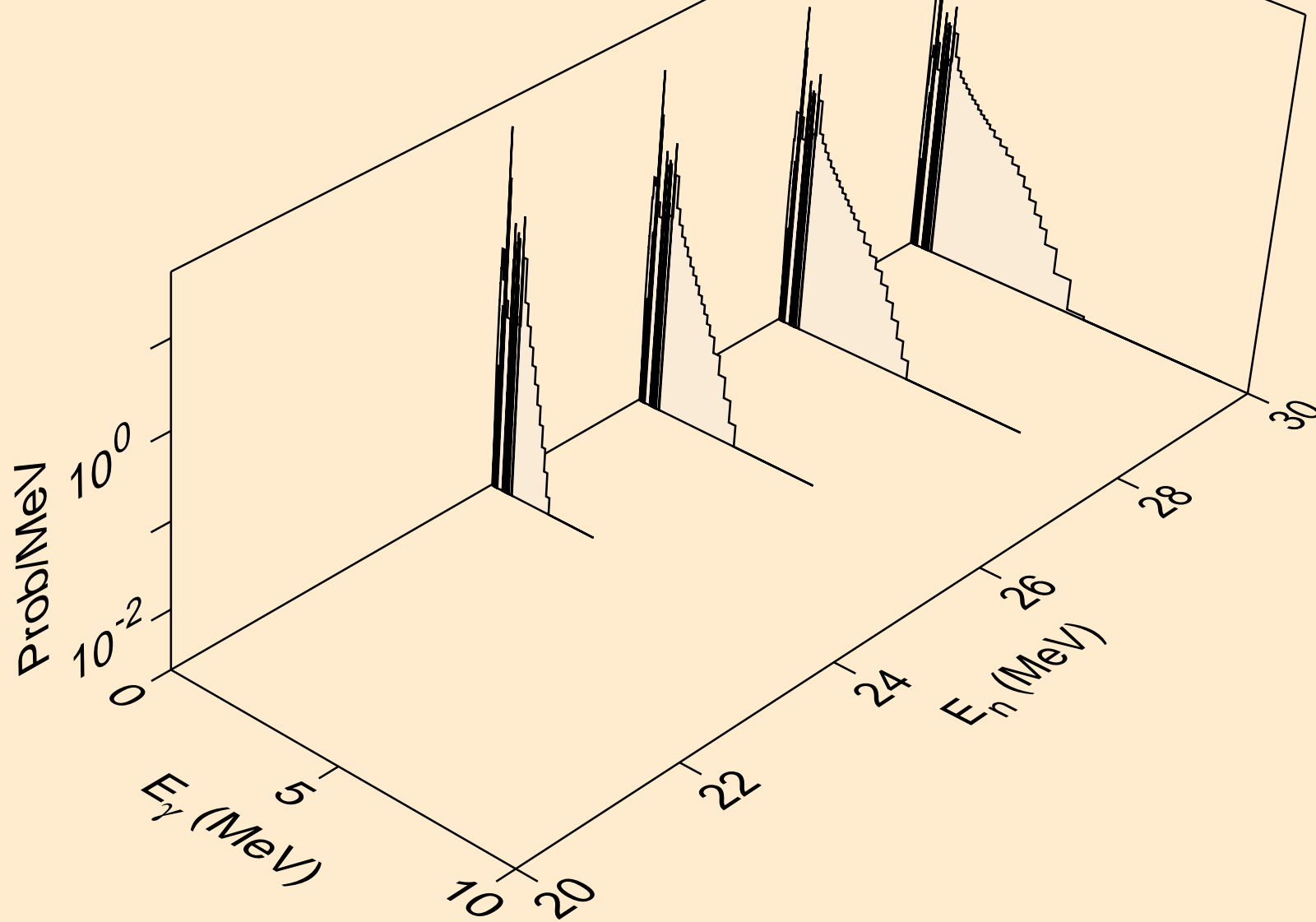

TC102M NEUTRON ACER TENDL-2024 LIBRARY; T=0.K
Photon emission for (n,2np)

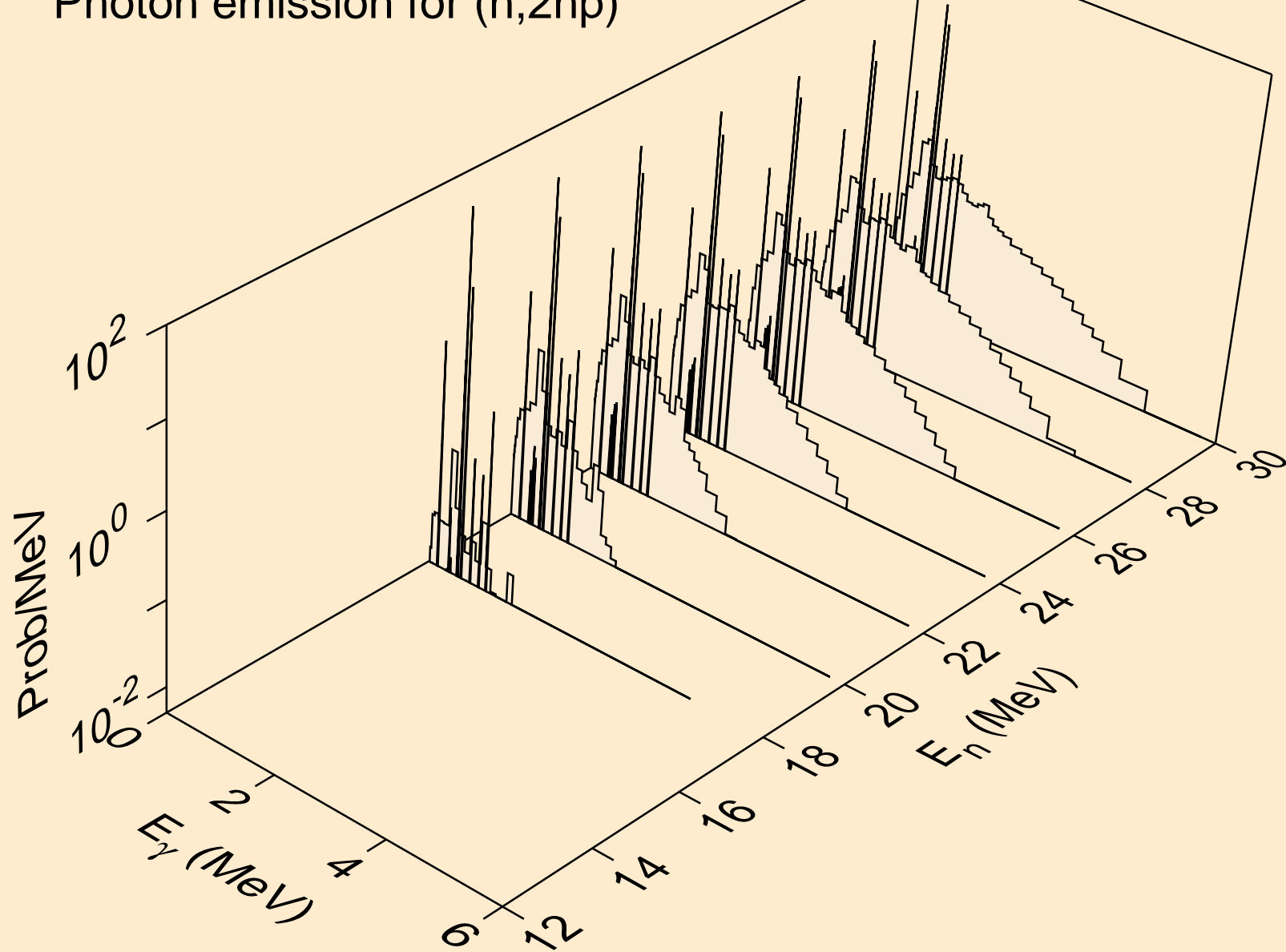

TC102M NEUTRON ACER TENDL-2024 LIBRARY; T=0.K
Photon emission for (n,3np)

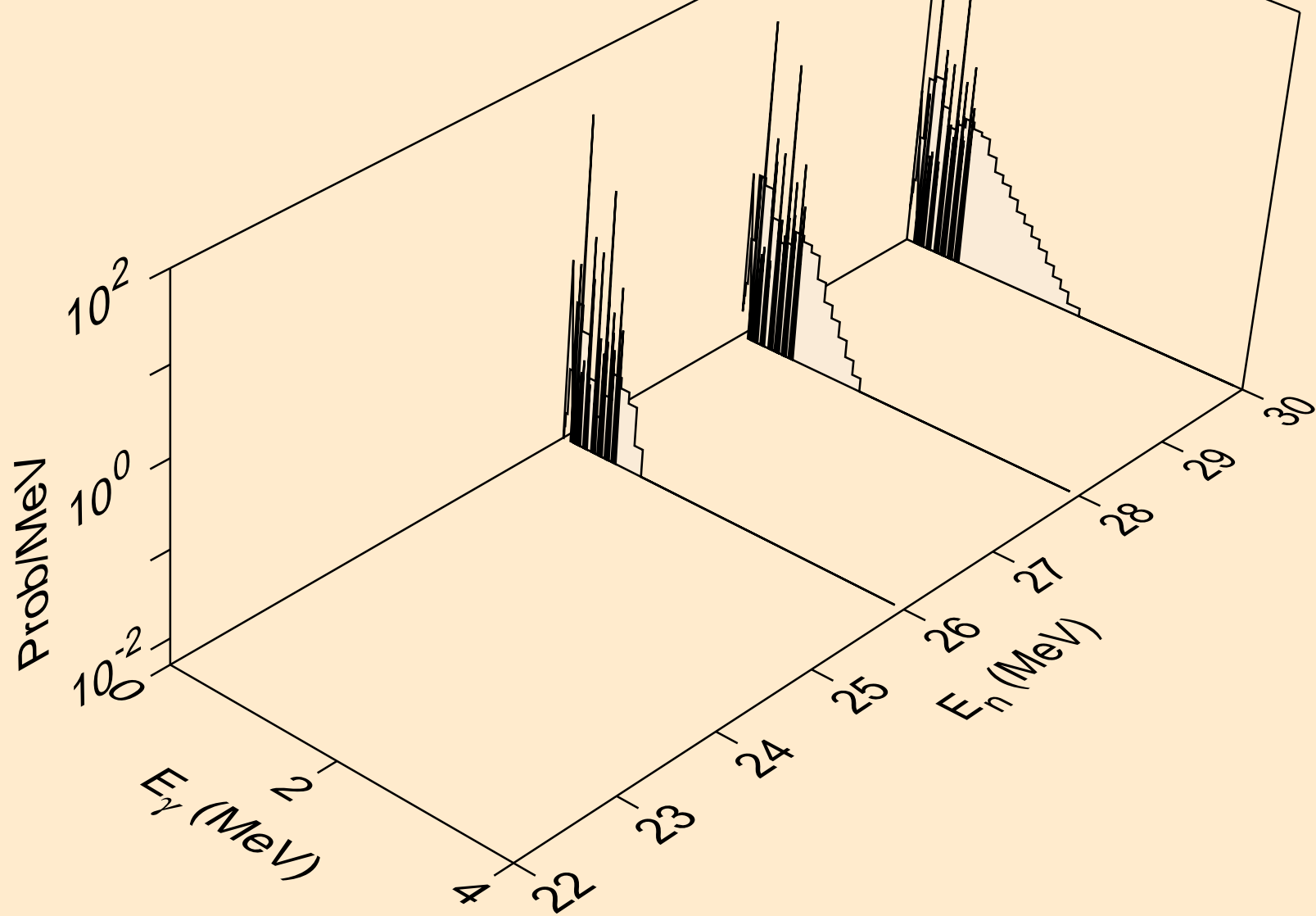

TC102M NEUTRON ACER TENDL-2024 LIBRARY; T=0.K
Photon emission for (n,n2p)

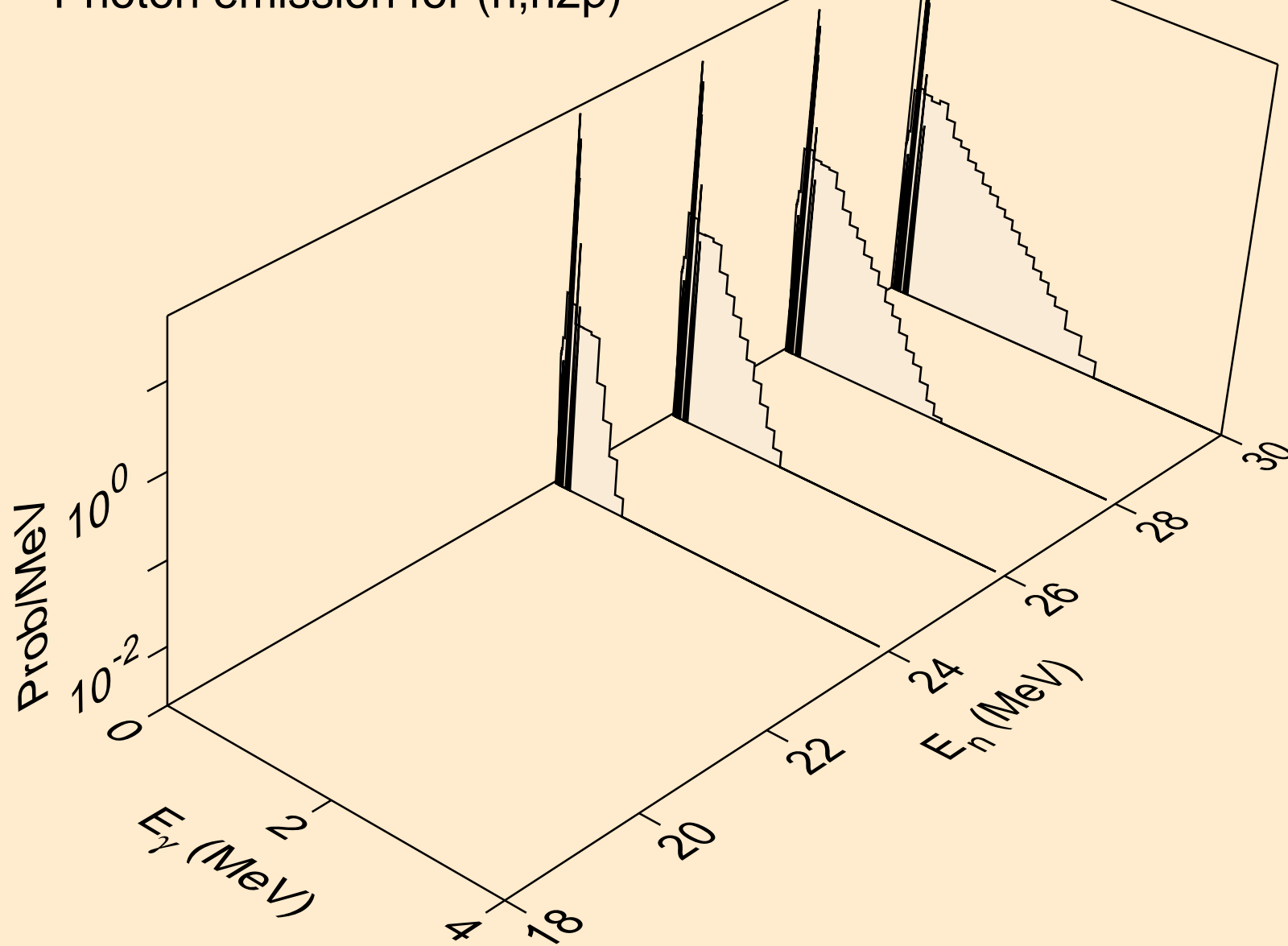

TC102M NEUTRON ACER TENDL-2024 LIBRARY; T=0.K
Photon emission for (n,npa)

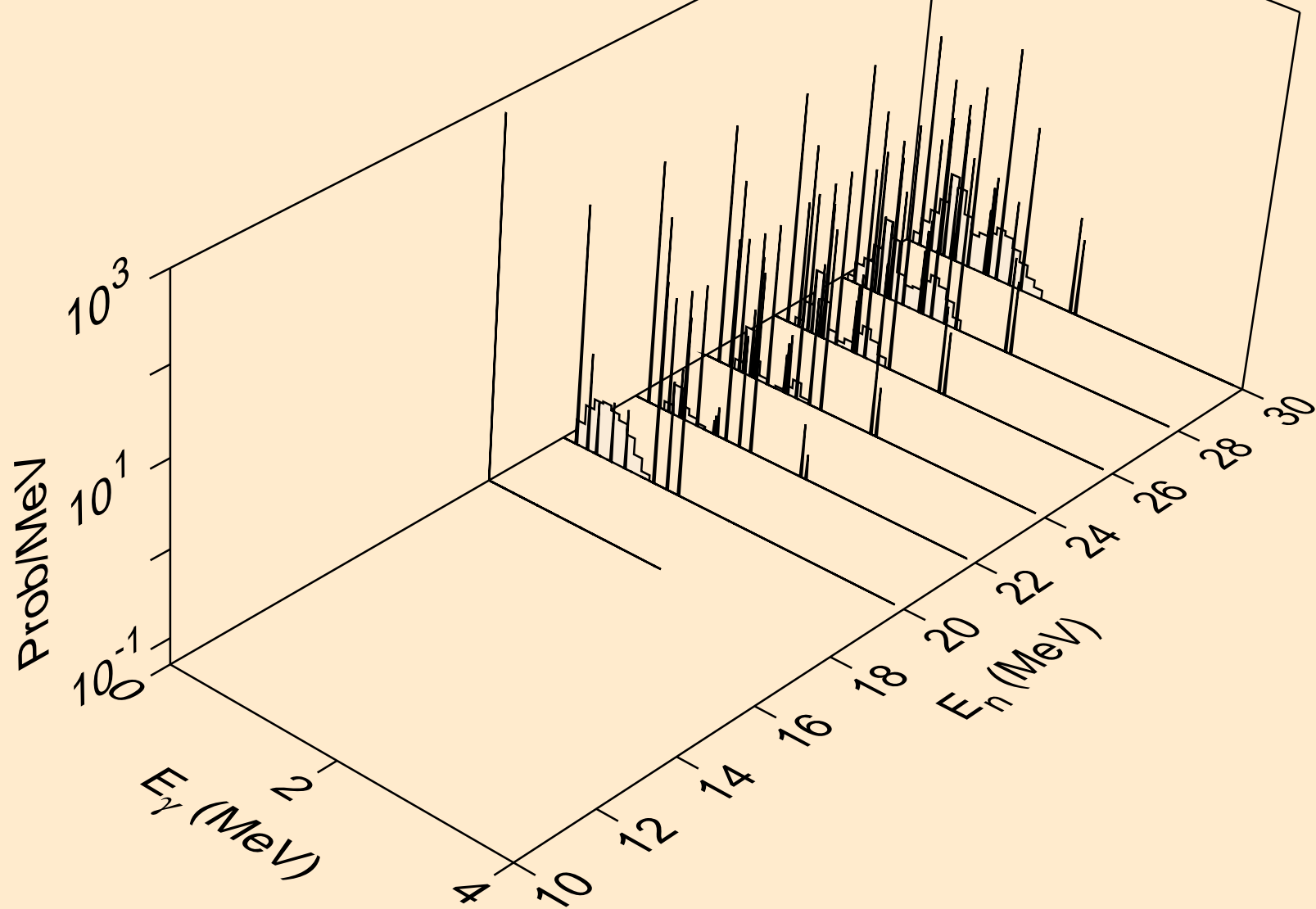

TC102M NEUTRON ACER TENDL-2024 LIBRARY; T=0.K
Photon emission for (n,n*1)

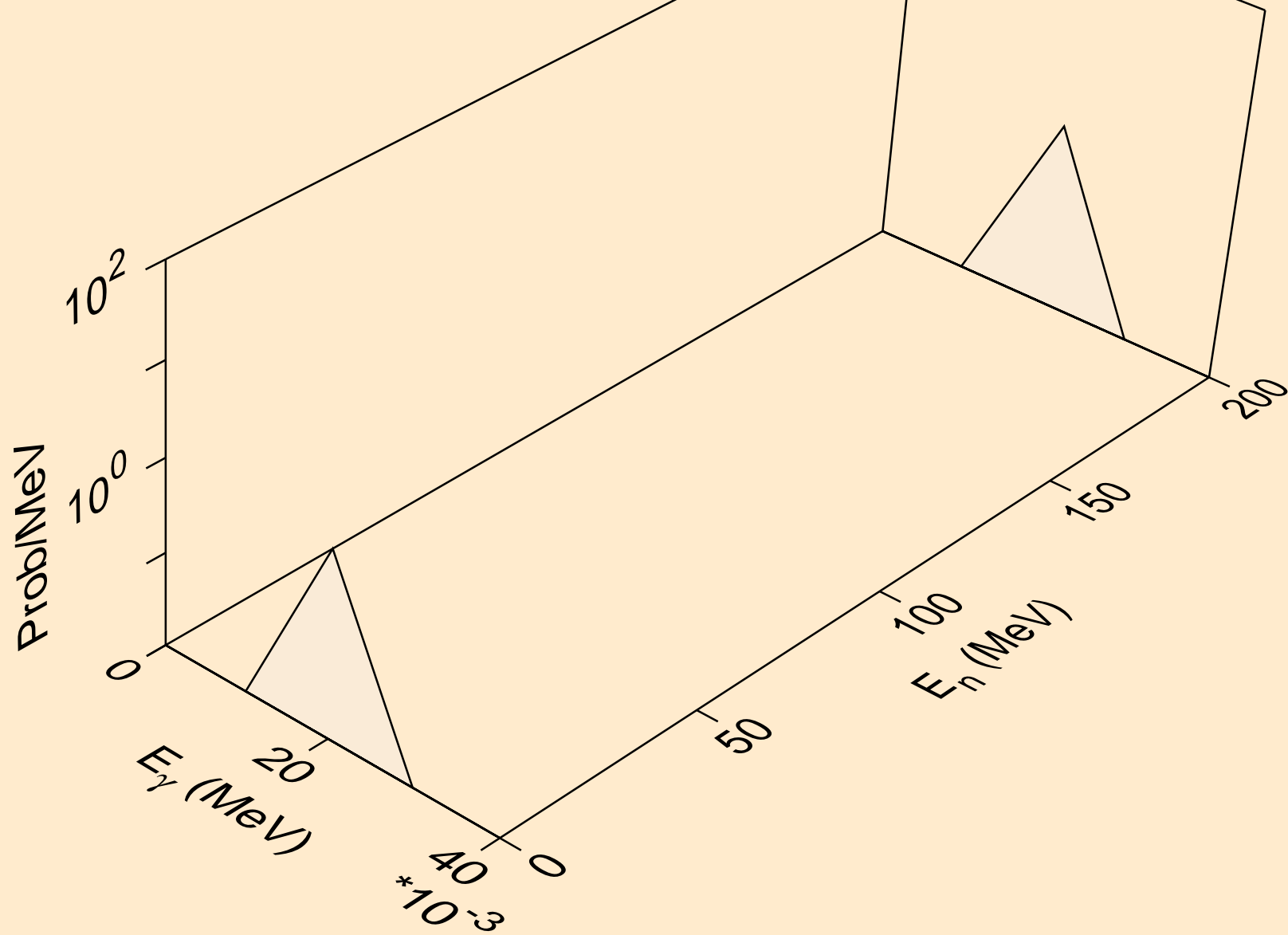

TC102M NEUTRON ACER TENDL-2024 LIBRARY; T=0.K
Photon emission for (n,n*2)

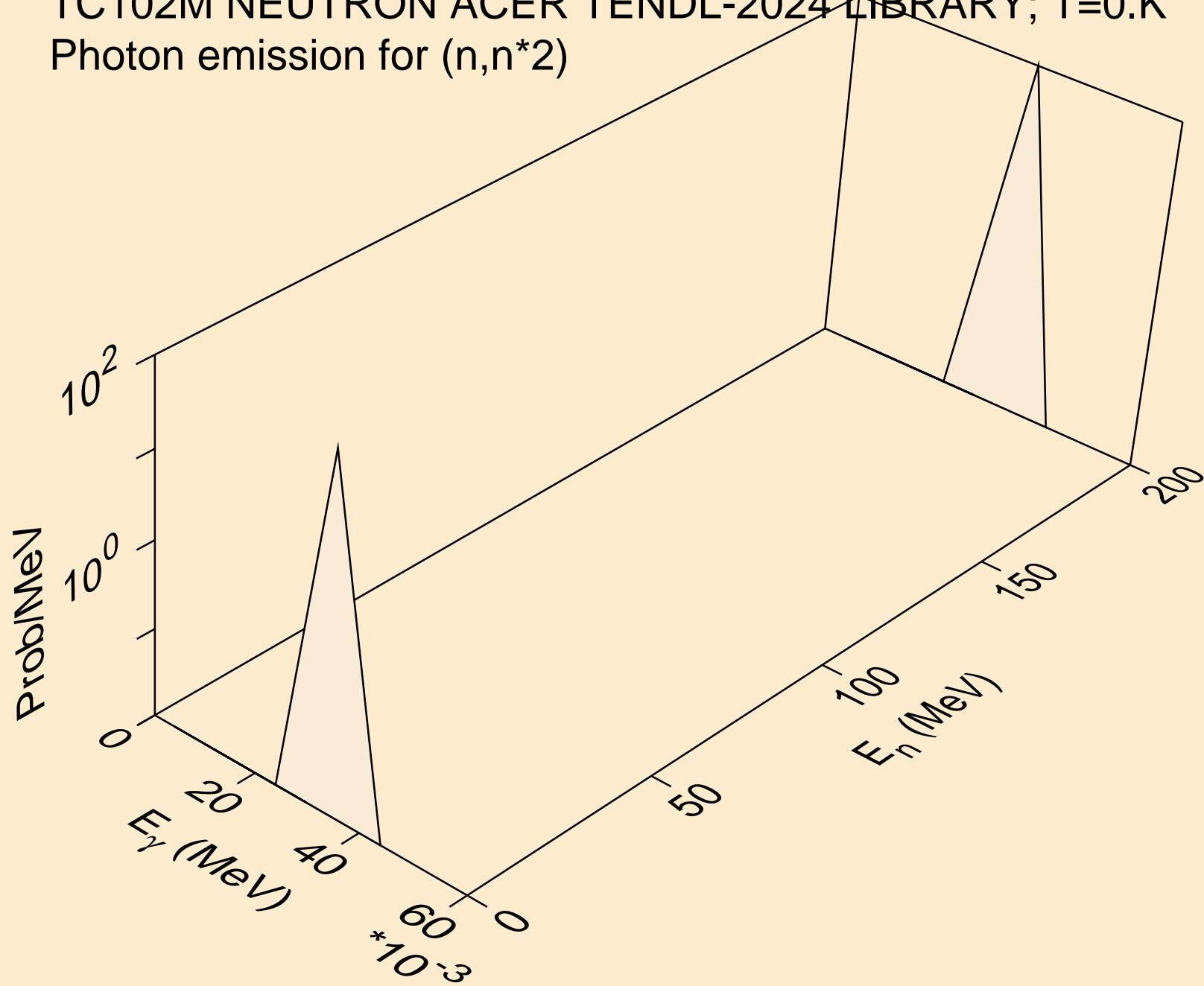

TC102M NEUTRON ACER TENDL-2024 LIBRARY; T=0.K
Photon emission for (n,n*4)

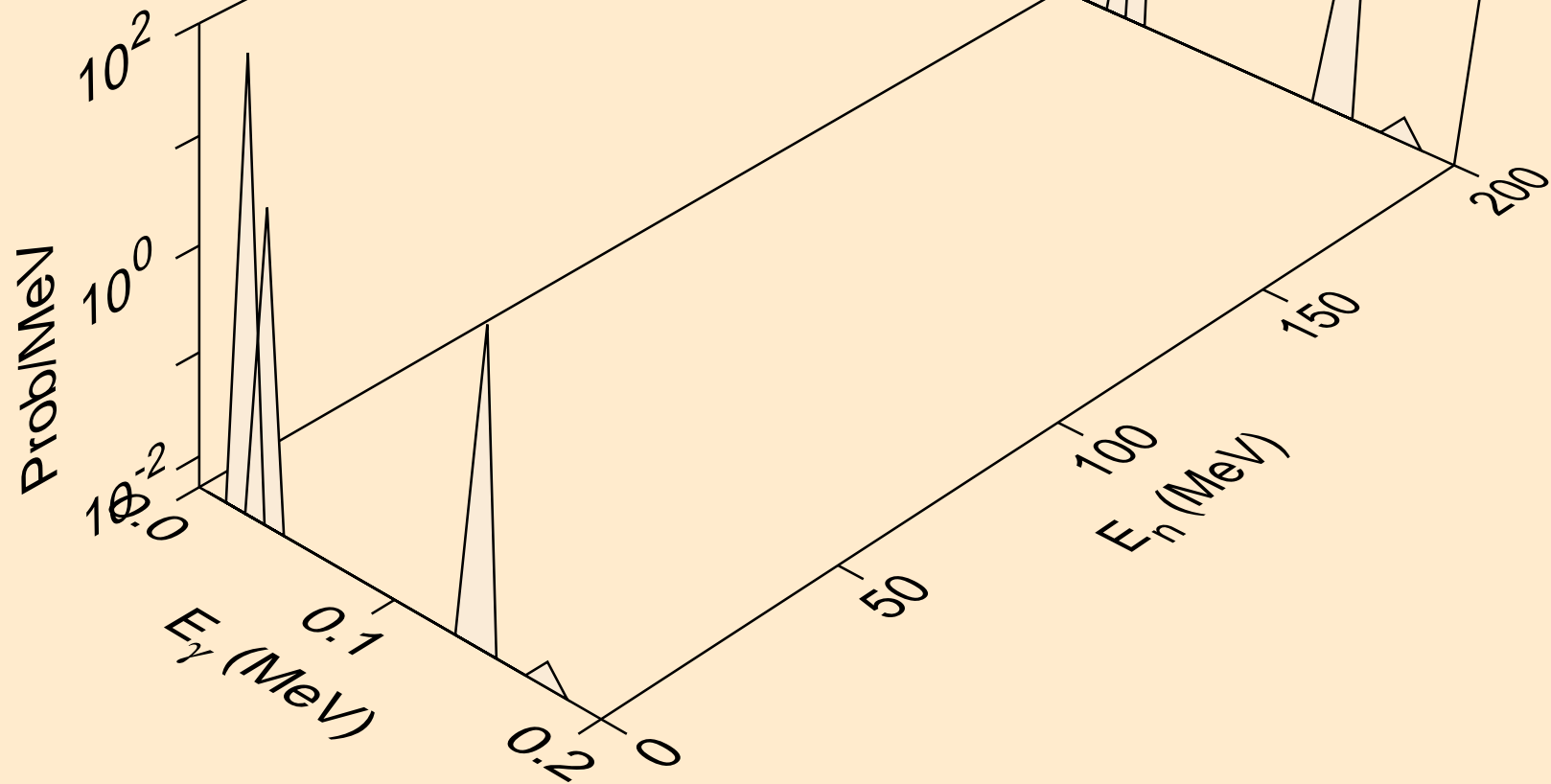

TC102M NEUTRON ACER TENDL-2024 LIBRARY; T=0.K
Photon emission for (n,n*5)

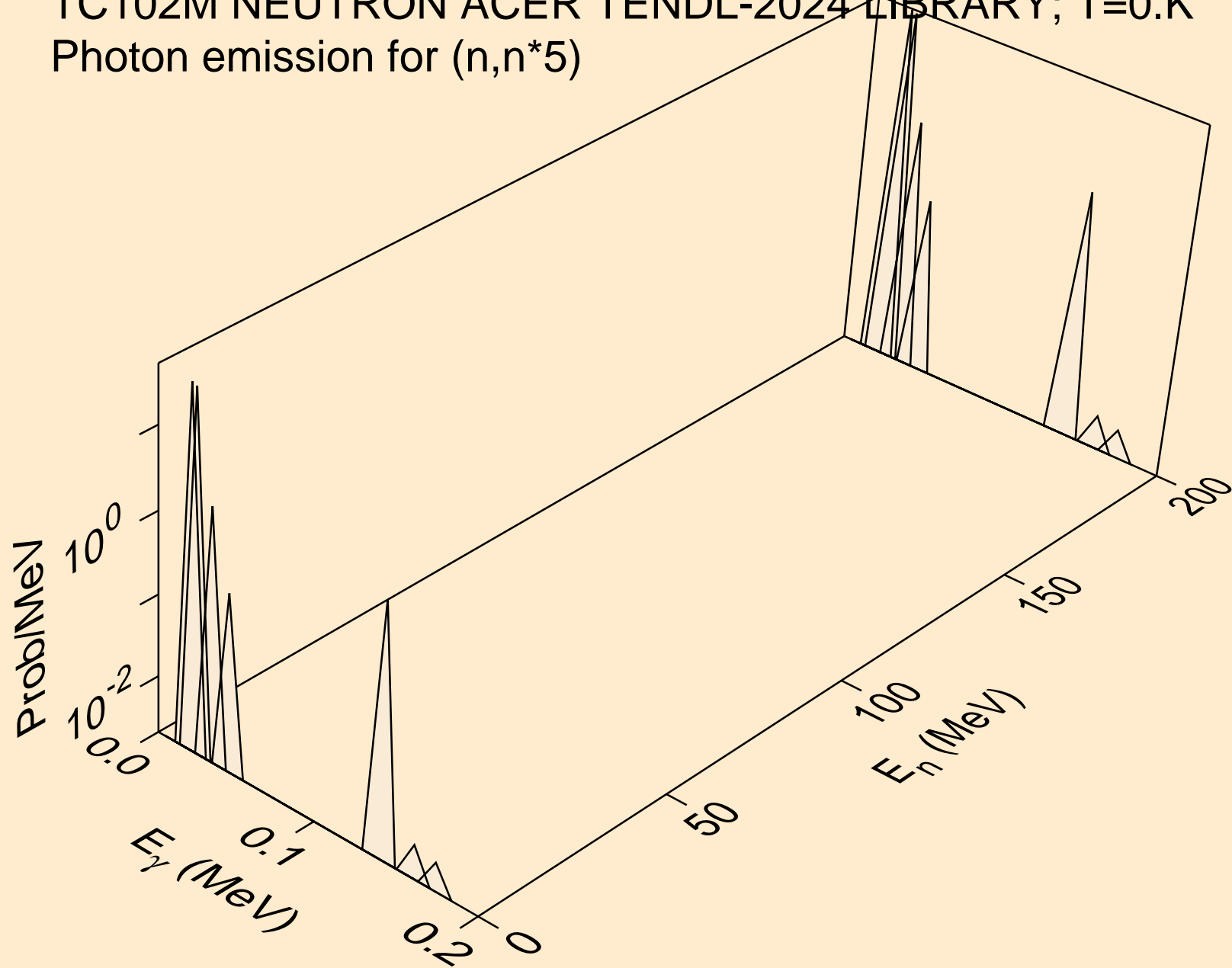

TC102M NEUTRON ACER TENDL-2024 LIBRARY; T=0.K
Photon emission for (n,n*6)

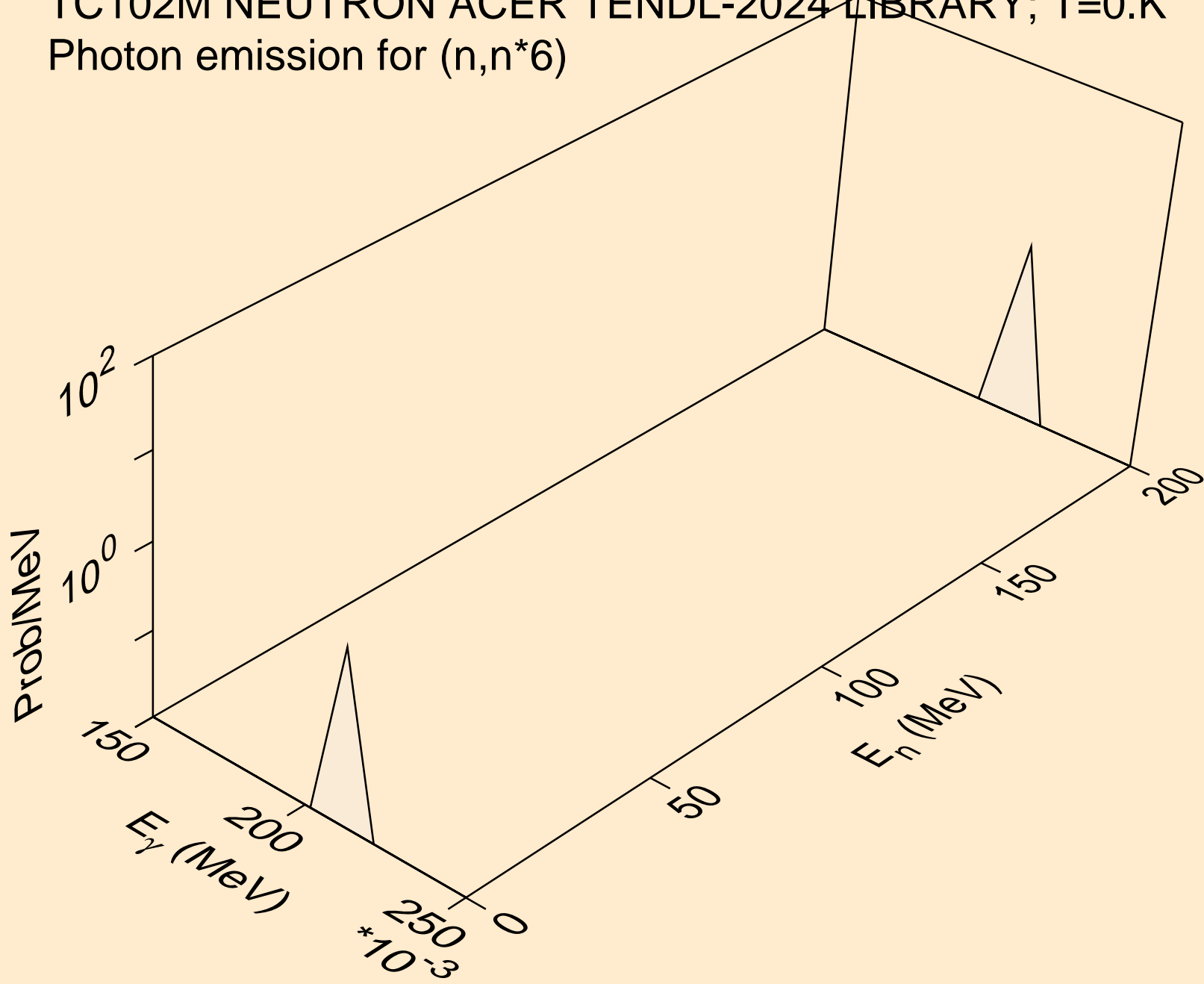

TC102M NEUTRON ACER TENDL-2024 LIBRARY; T=0.K
Photon emission for (n,n*7)

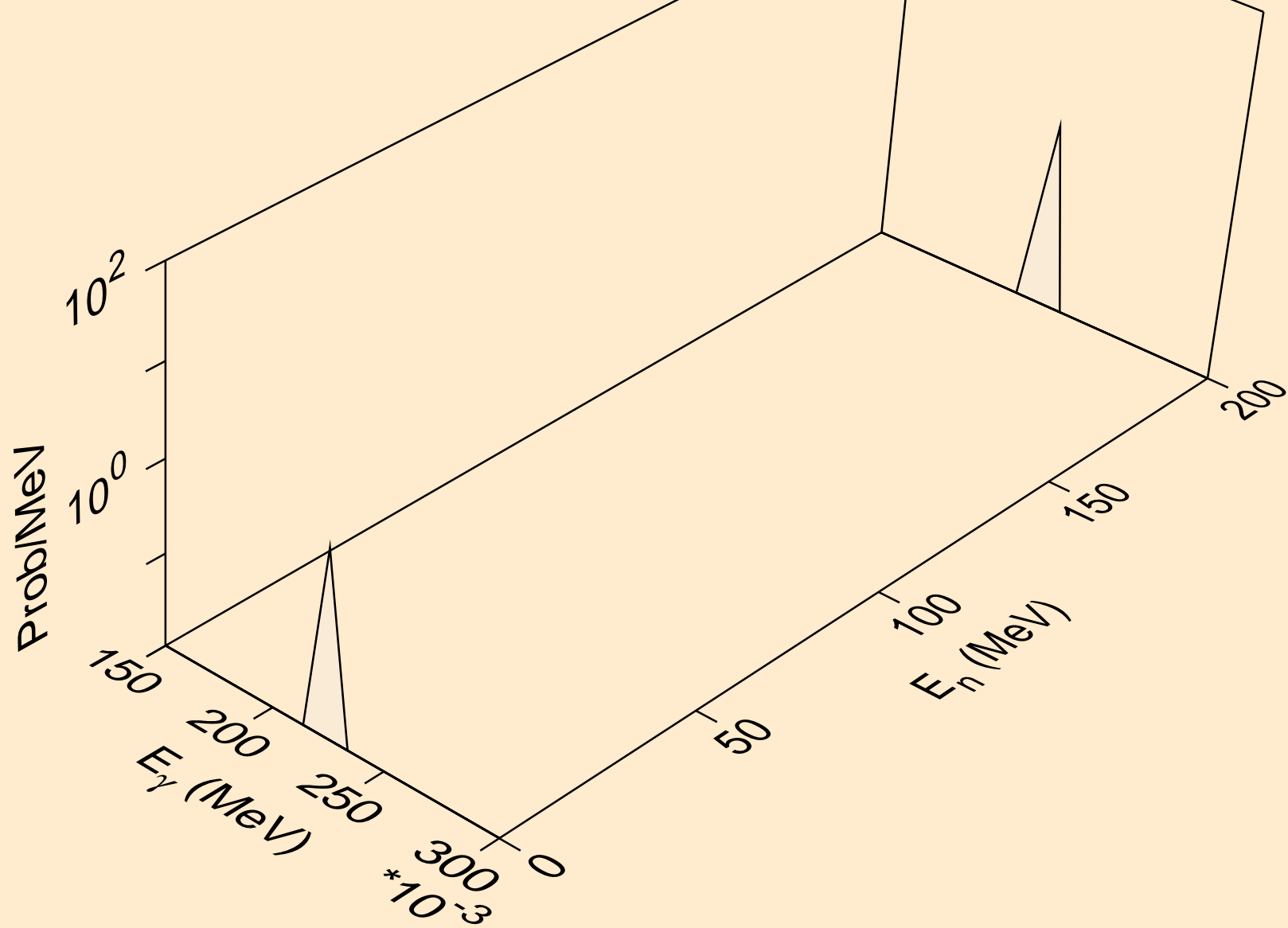

TC102M NEUTRON ACER TENDL-2024 LIBRARY; T=0.K
Photon emission for (n,n*8)

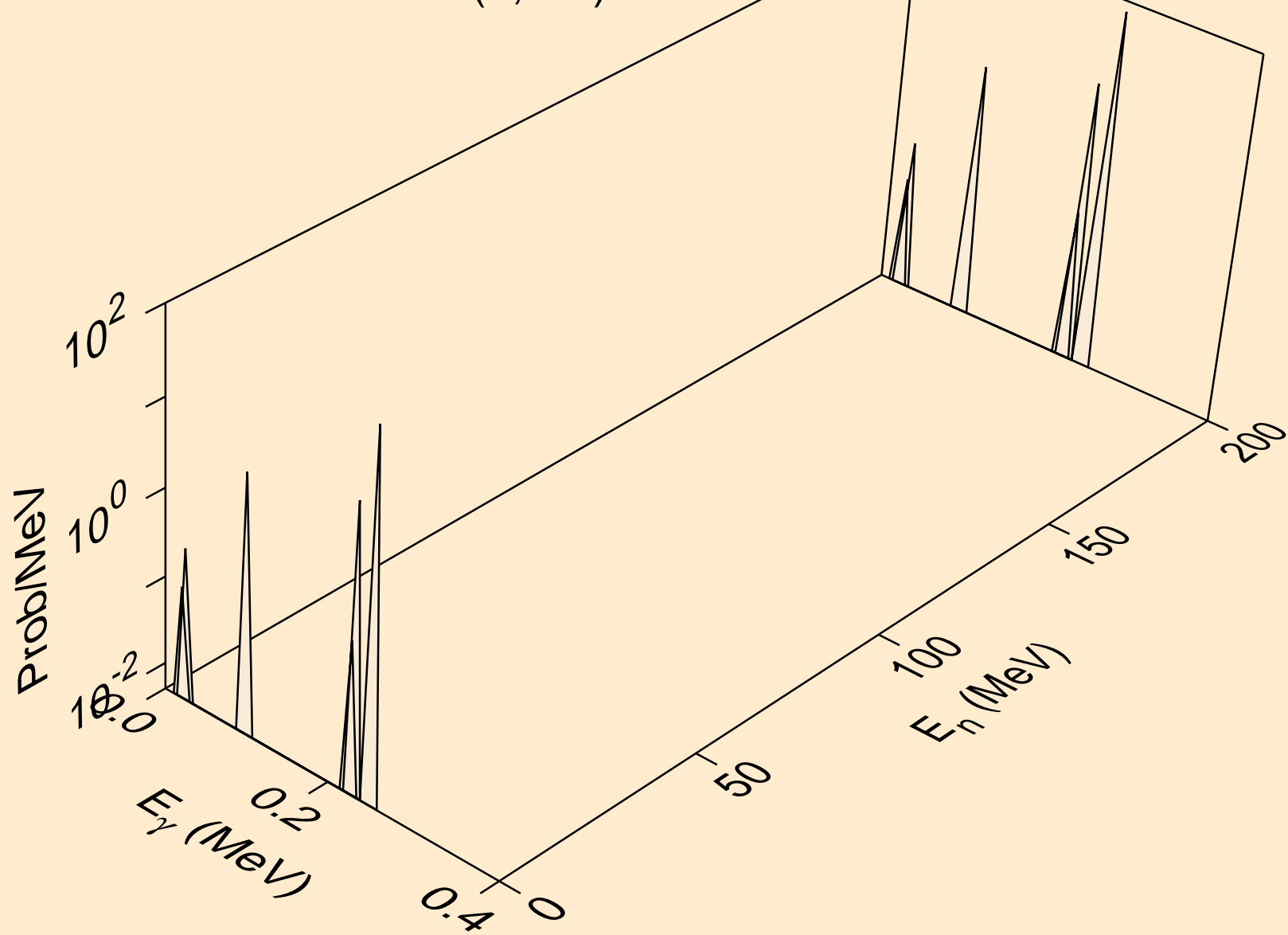

TC102M NEUTRON ACER TENDL-2024 LIBRARY; T=0.K
Photon emission for (n,n*9)

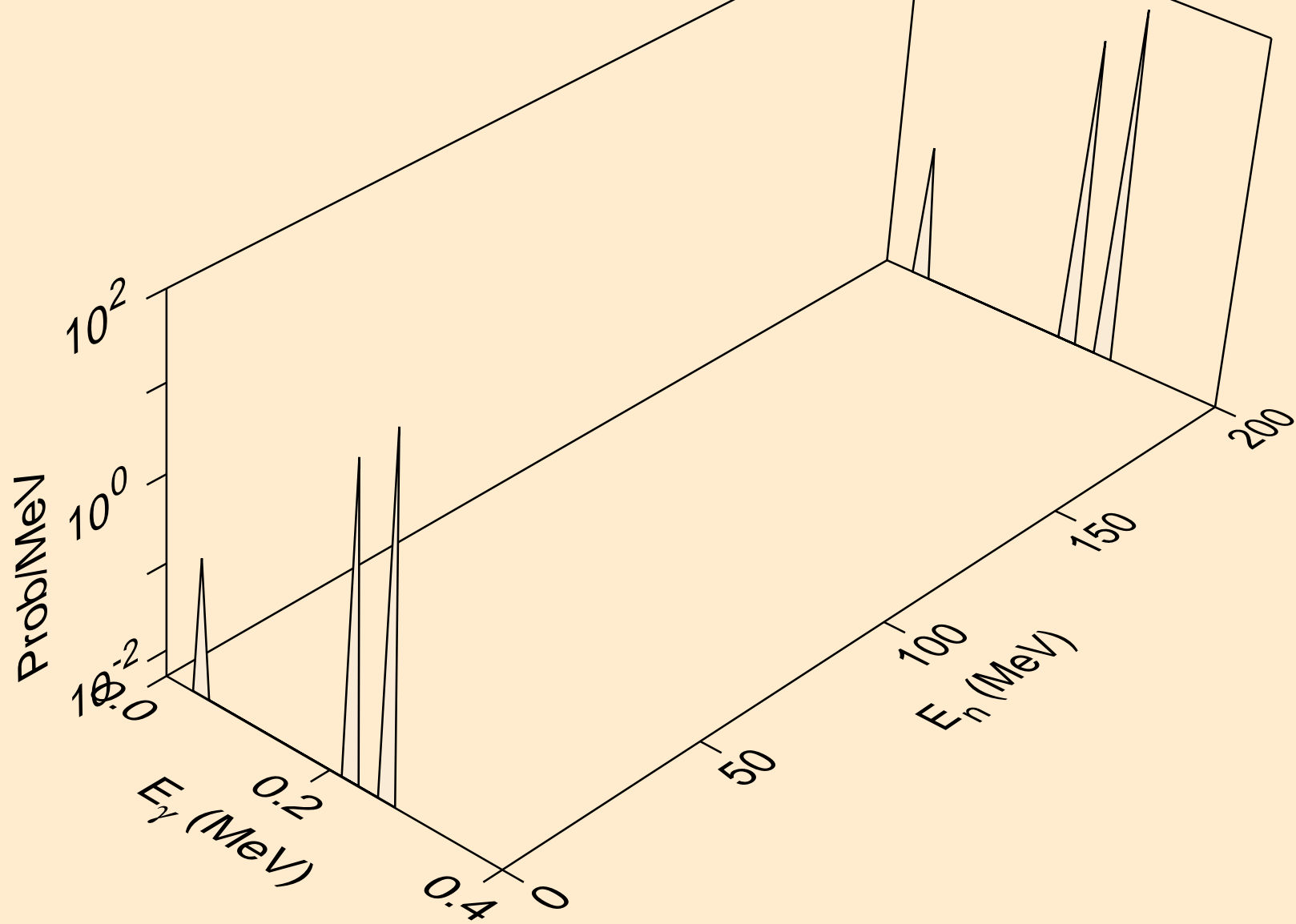

TC102M NEUTRON ACER TENDL-2024 LIBRARY; T=0.K
Photon emission for (n,n*10)

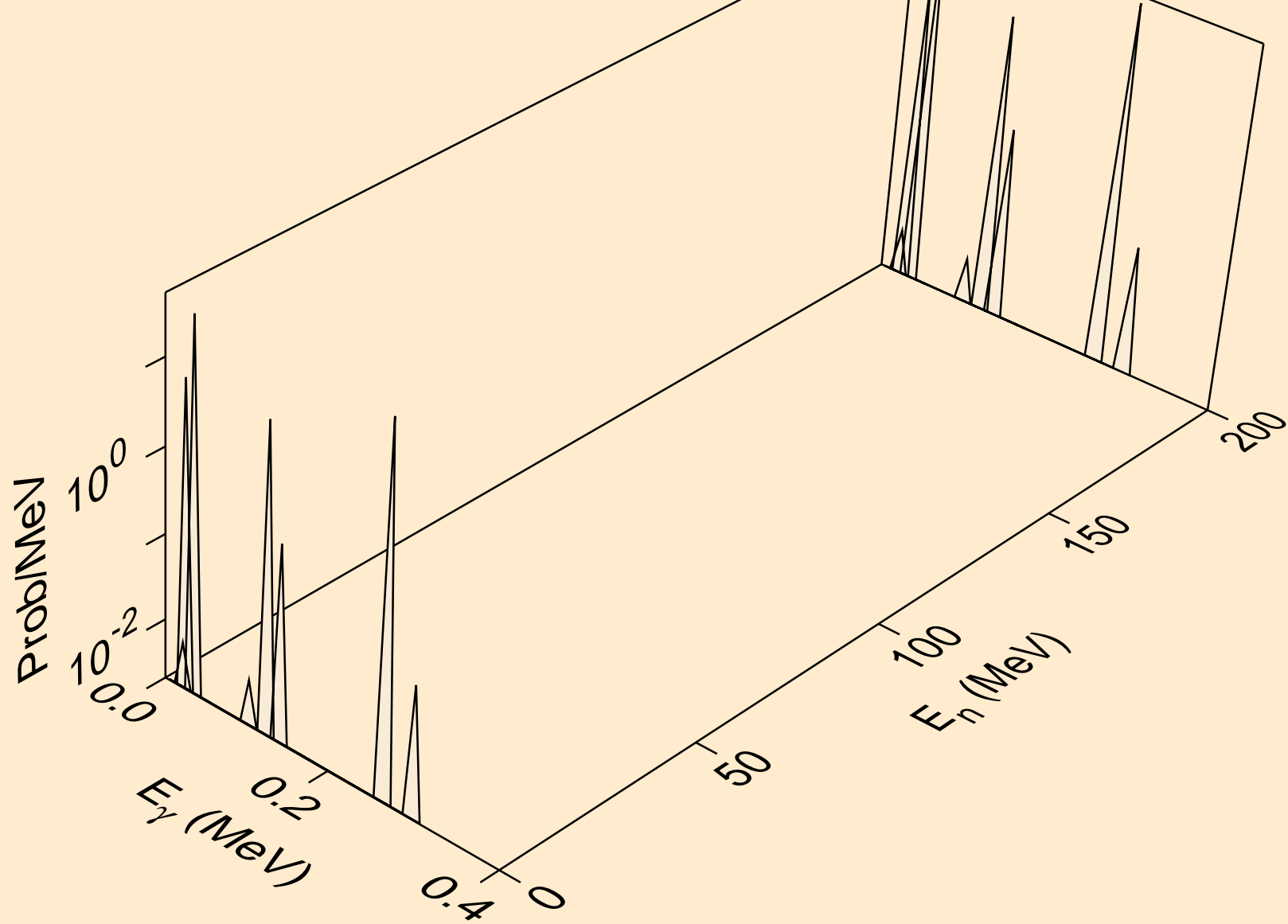

TC102M NEUTRON ACER TENDL-2024 LIBRARY; T=0.K
Photon emission for (n,n*11)

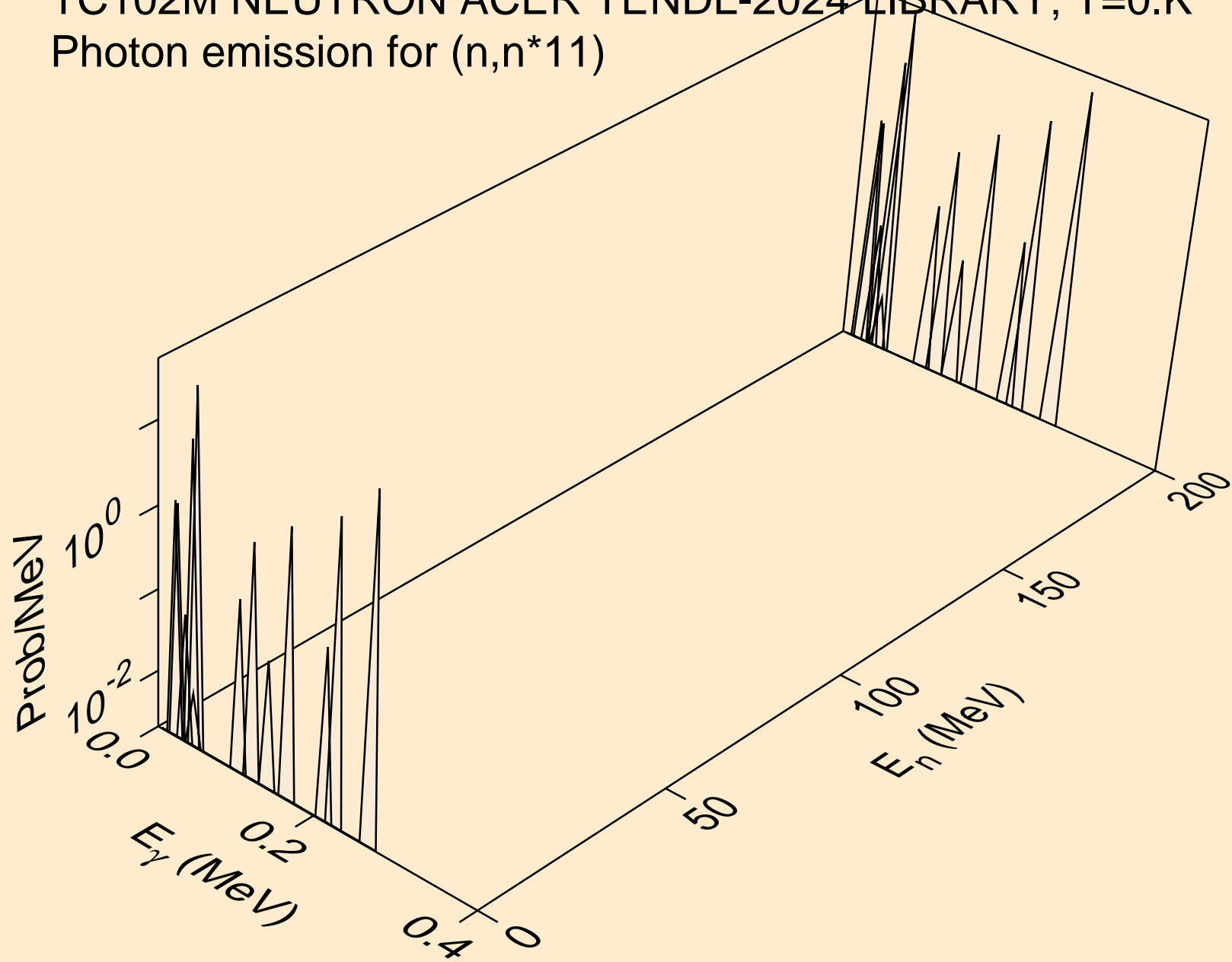

TC102M NEUTRON ACER TENDL-2024 LIBRARY; T=0.K
Photon emission for (n,n*12)

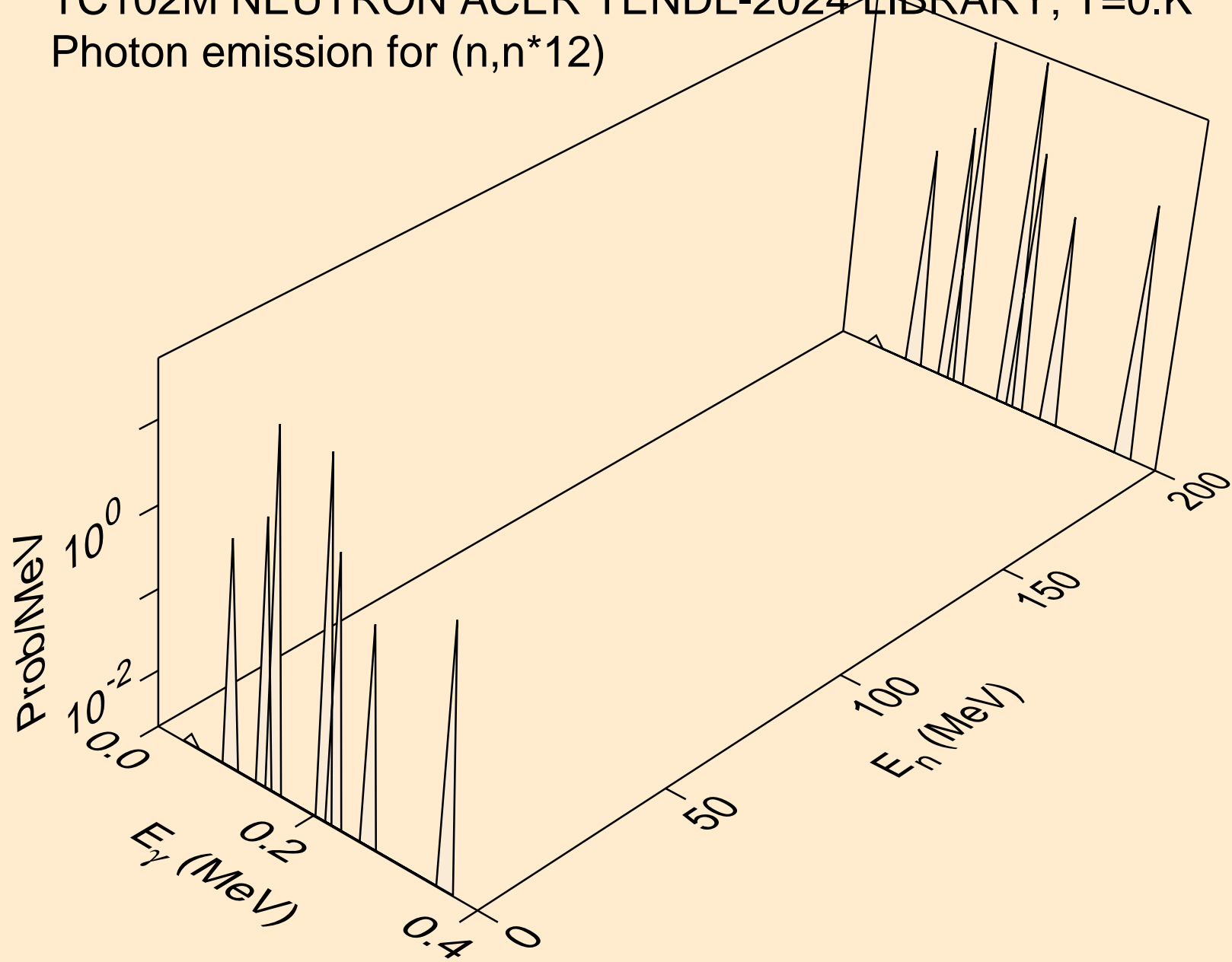

TC102M NEUTRON ACER TENDL-2024 LIBRARY; T=0.K
Photon emission for (n,n*13)

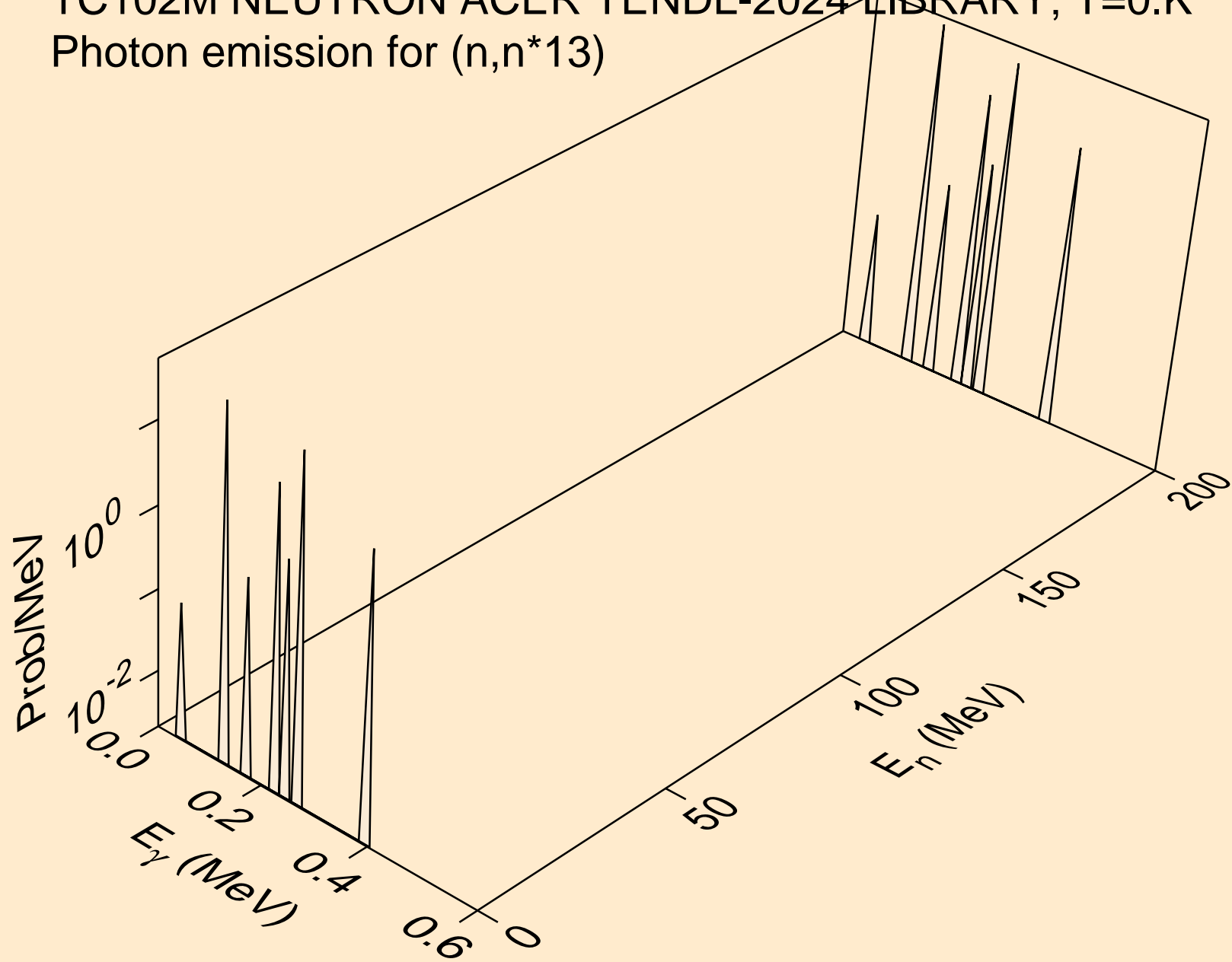

TC102M NEUTRON ACER TENDL-2024 LIBRARY; T=0.K
Photon emission for (n,n*14)

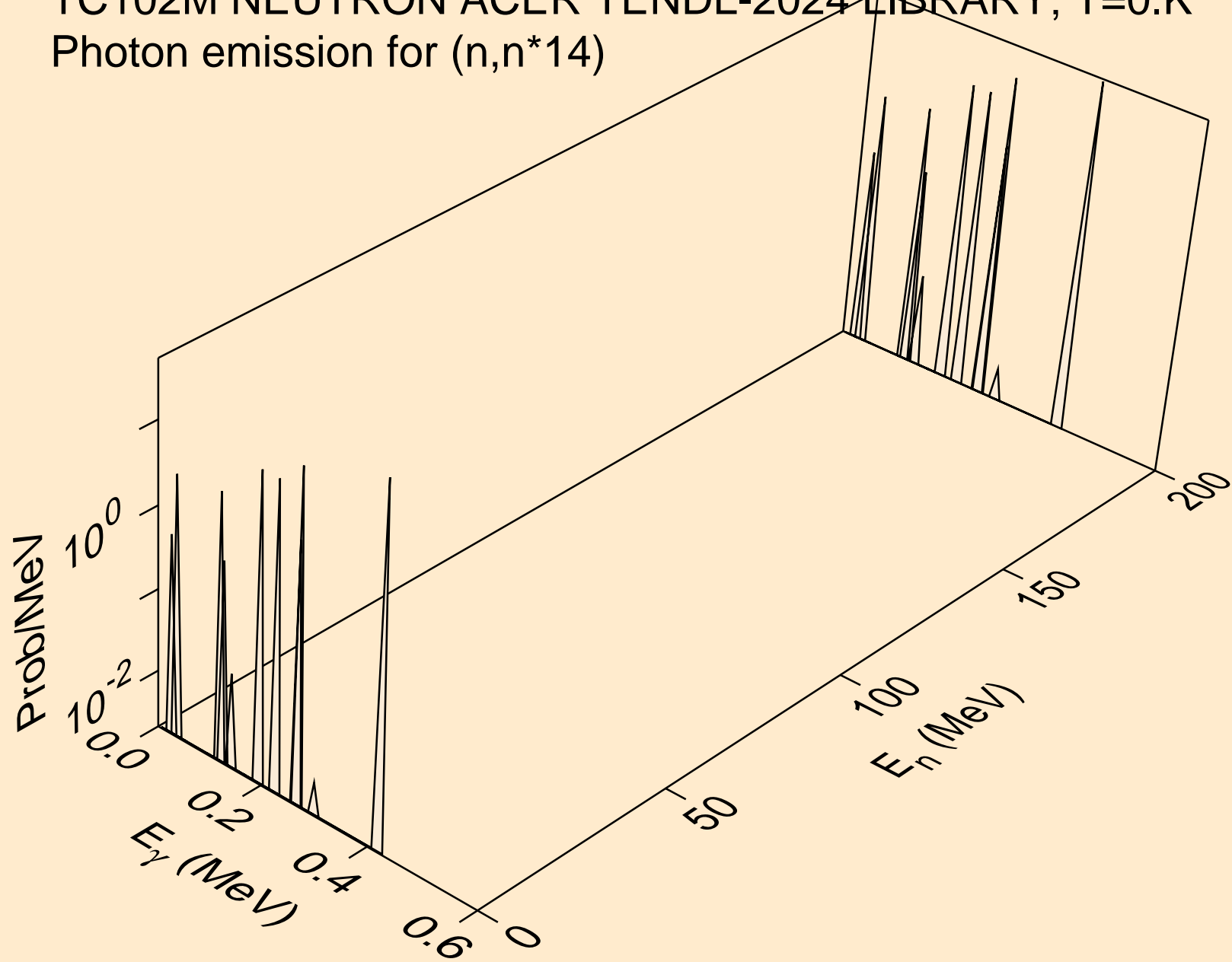

TC102M NEUTRON ACER TENDL-2024 LIBRARY; T=0.K
Photon emission for (n,n*15)

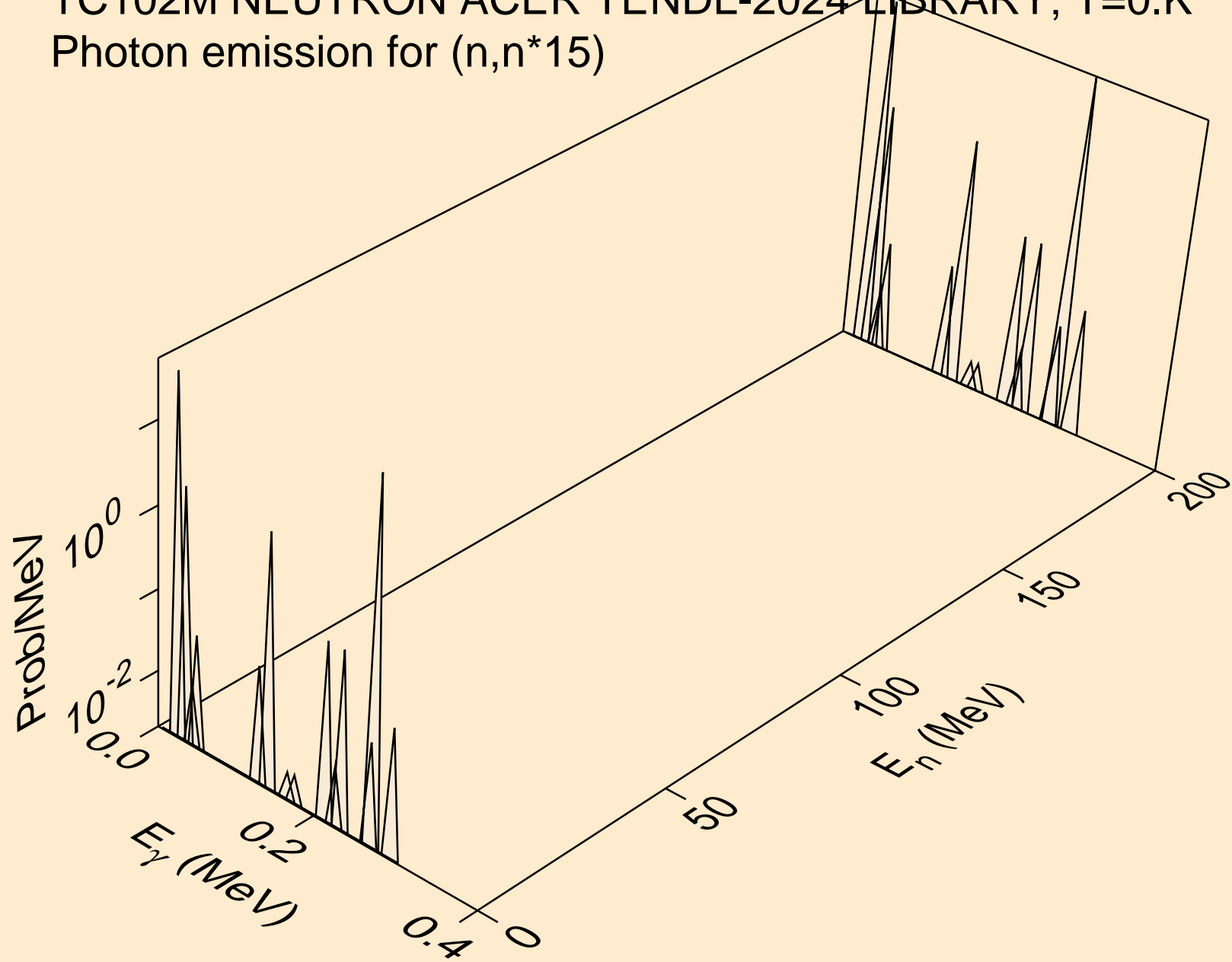

TC102M NEUTRON ACER TENDL-2024 LIBRARY; T=0.K
Photon emission for (n,n*16)

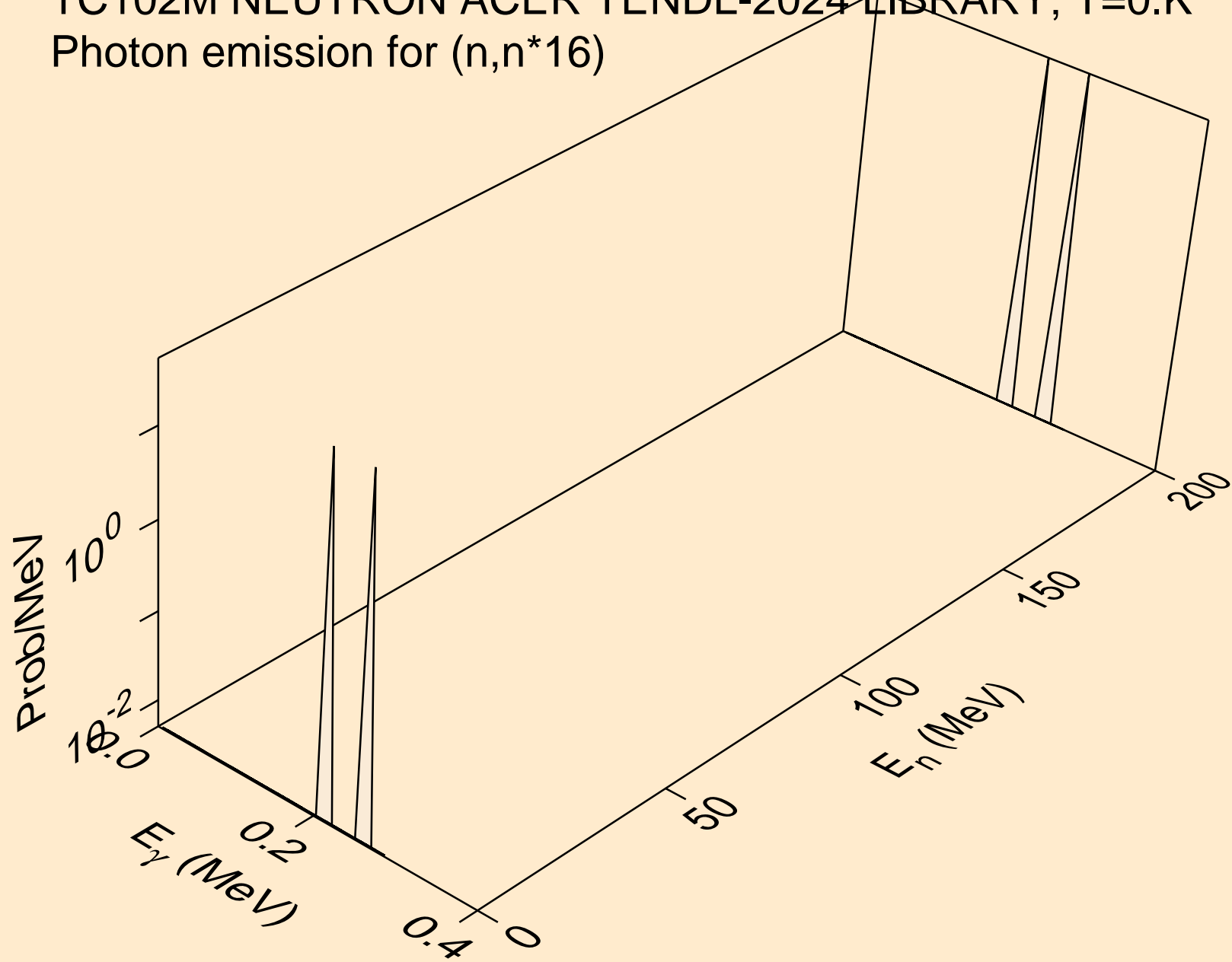

TC102M NEUTRON ACER TENDL-2024 LIBRARY; T=0.K
Photon emission for (n,n*17)

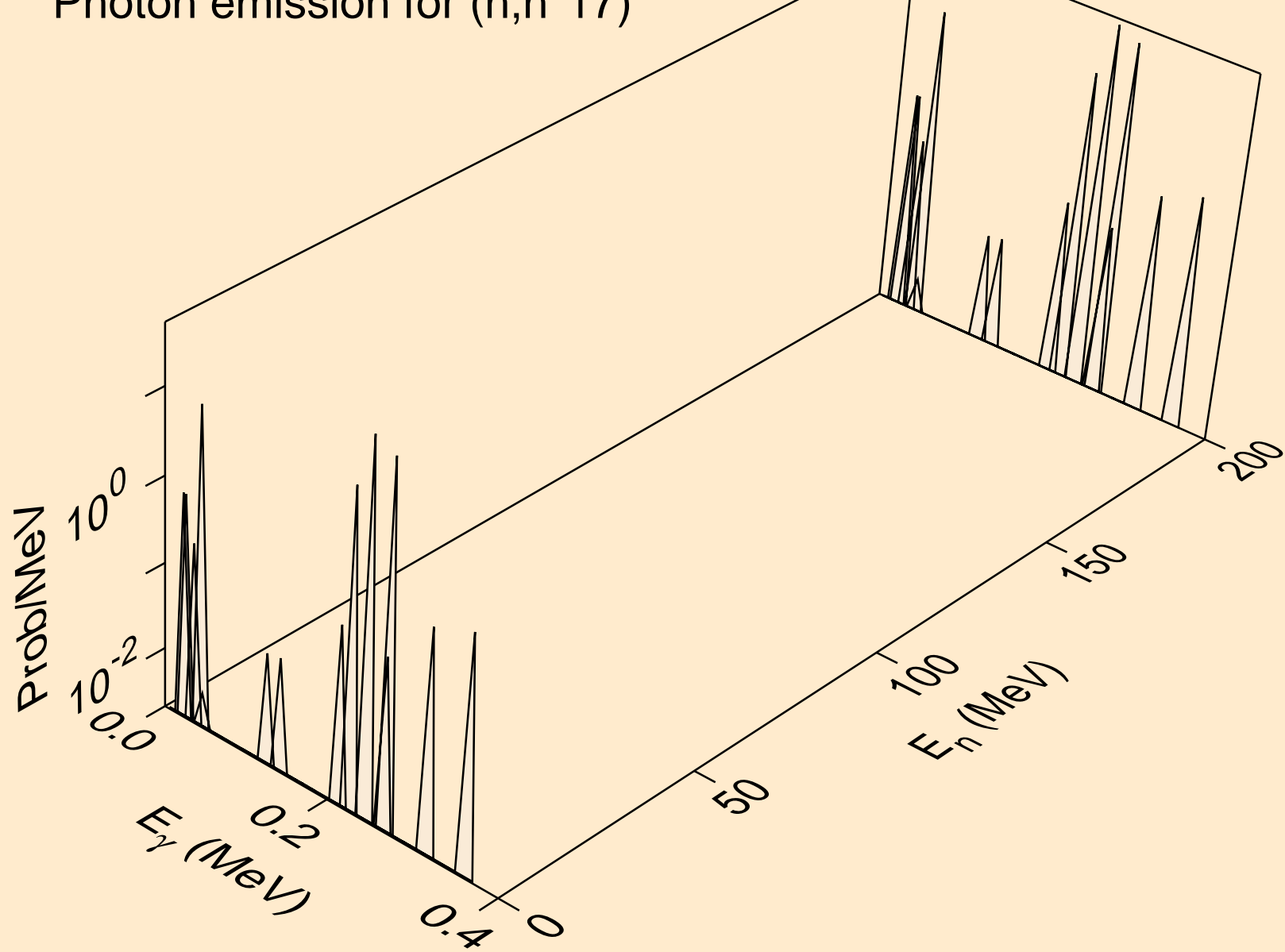

TC102M NEUTRON ACER TENDL-2024 LIBRARY; T=0.K
Photon emission for (n,n*18)

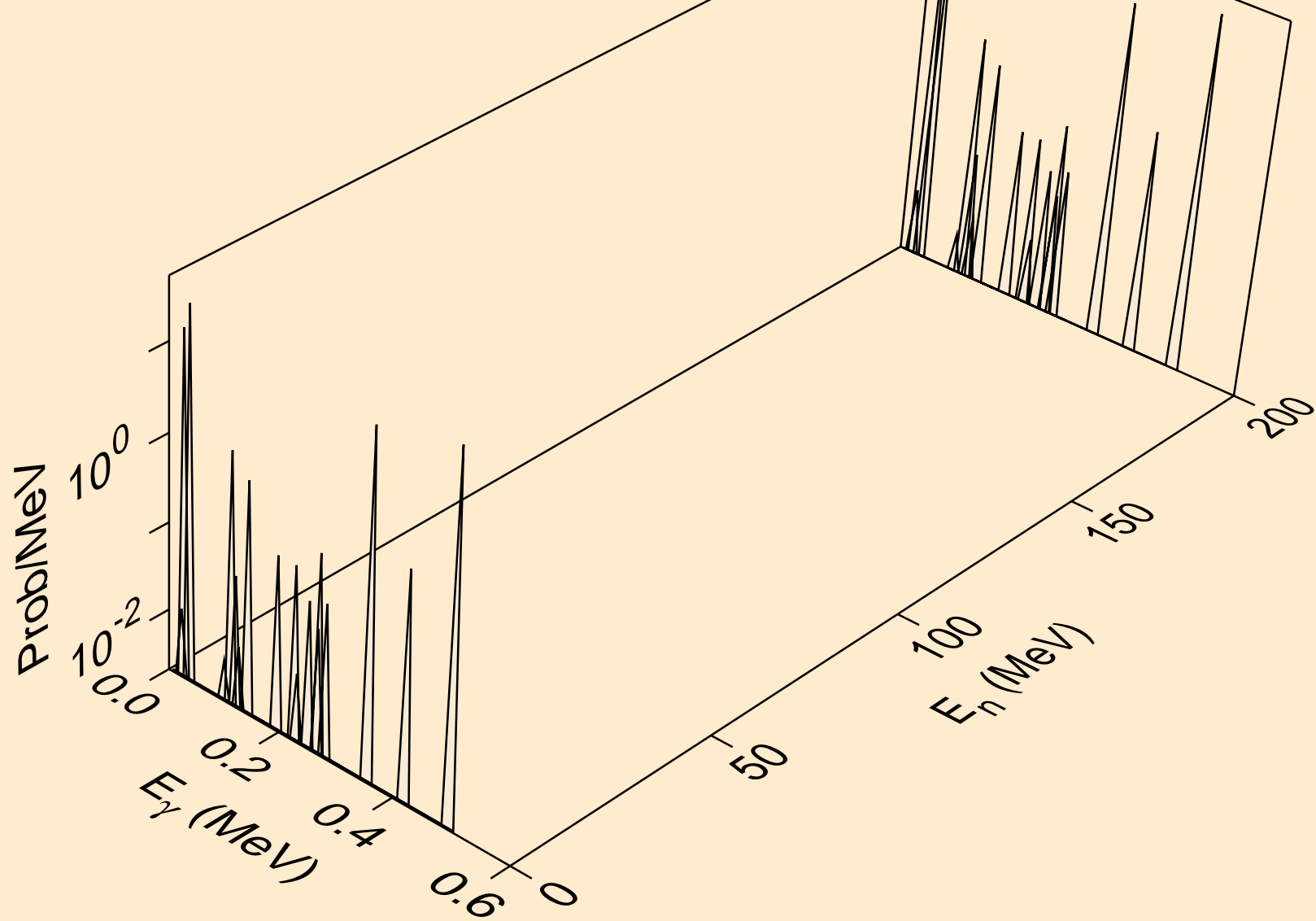

TC102M NEUTRON ACER TENDL-2024 LIBRARY; T=0.K
Photon emission for (n,n*19)

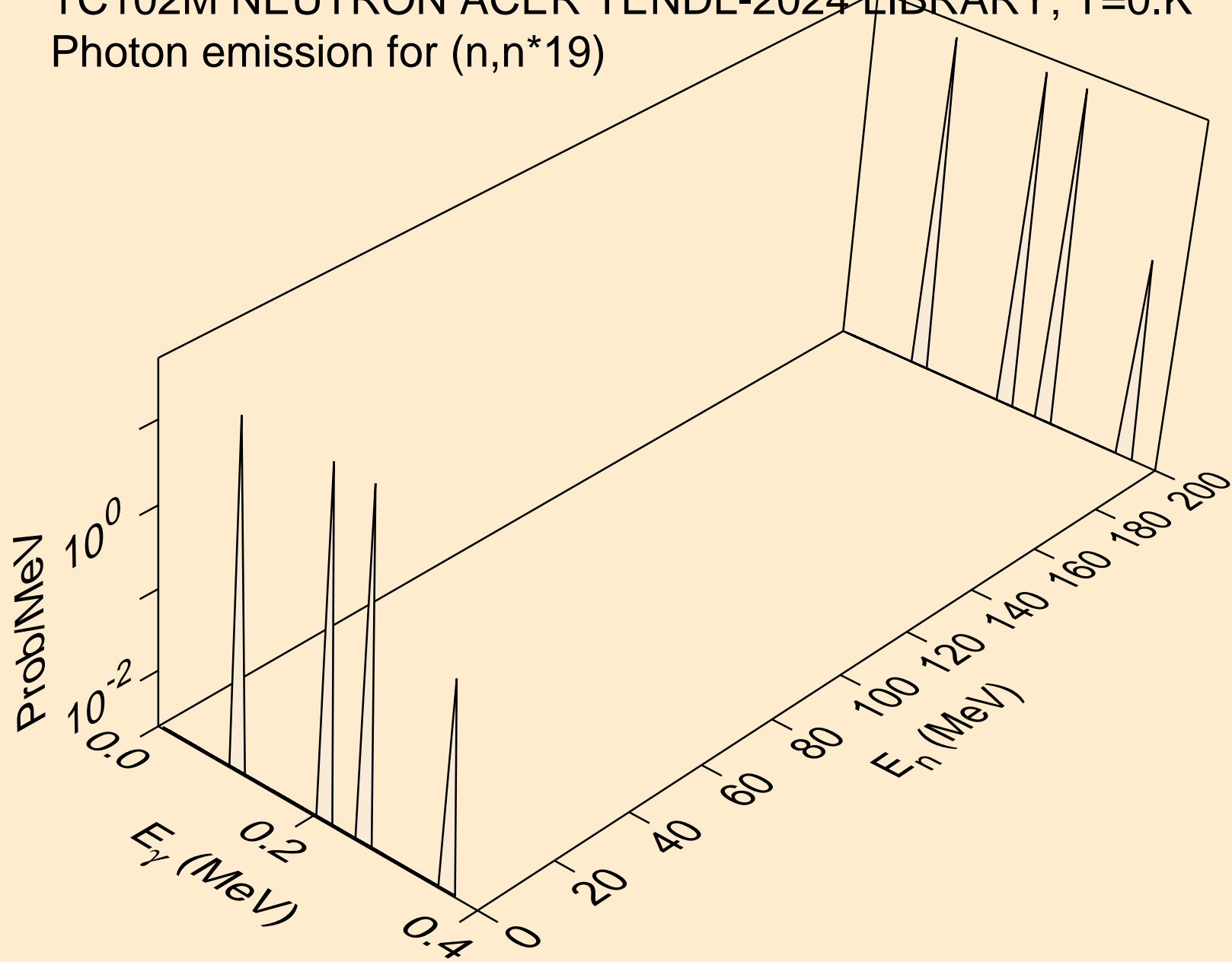

TC102M NEUTRON ACER TENDL-2024 LIBRARY; T=0.K
Photon emission for (n,n*20)

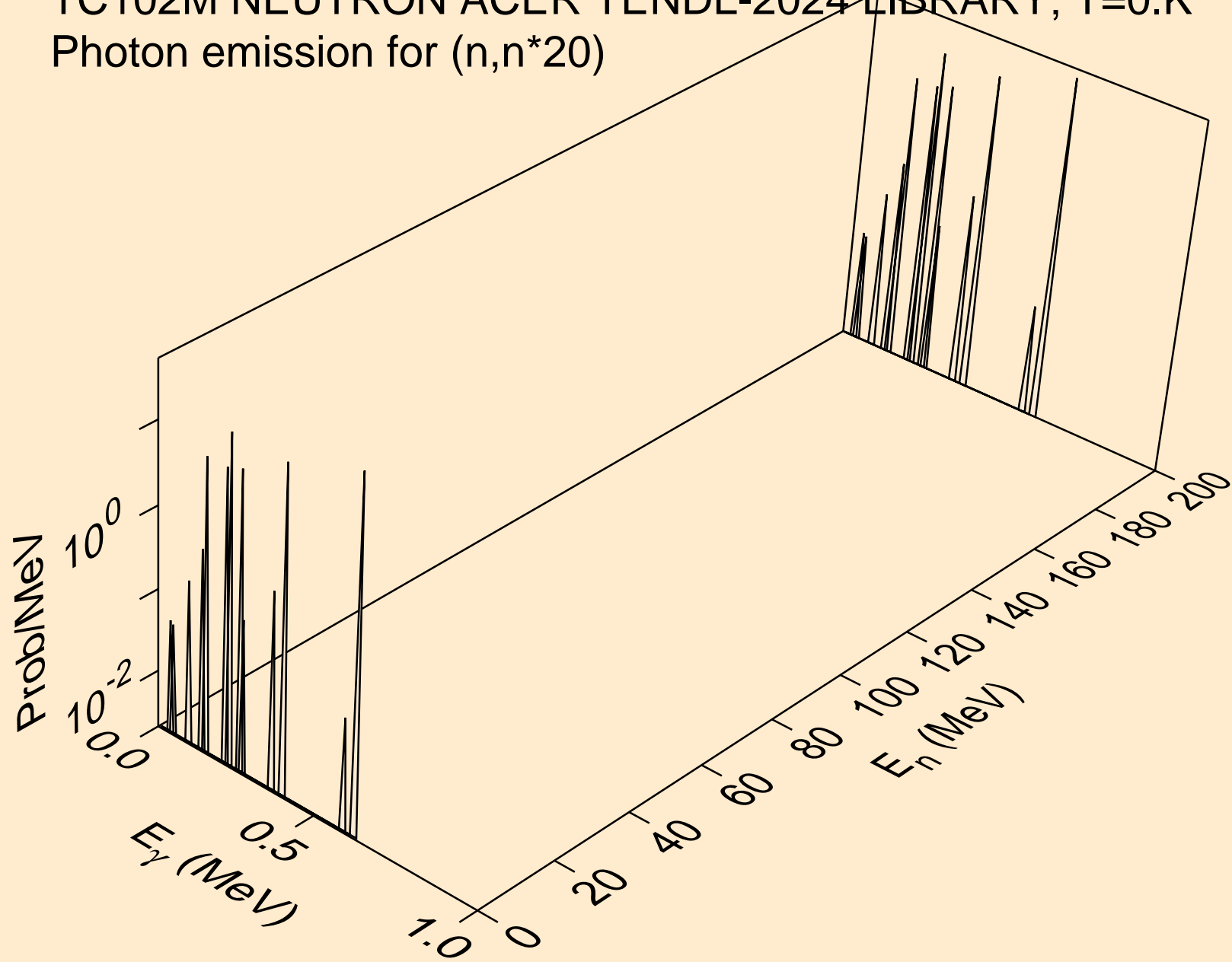

TC102M NEUTRON ACER TENDL-2024 LIBRARY; T=0.K
Photon emission for (n,n*21)

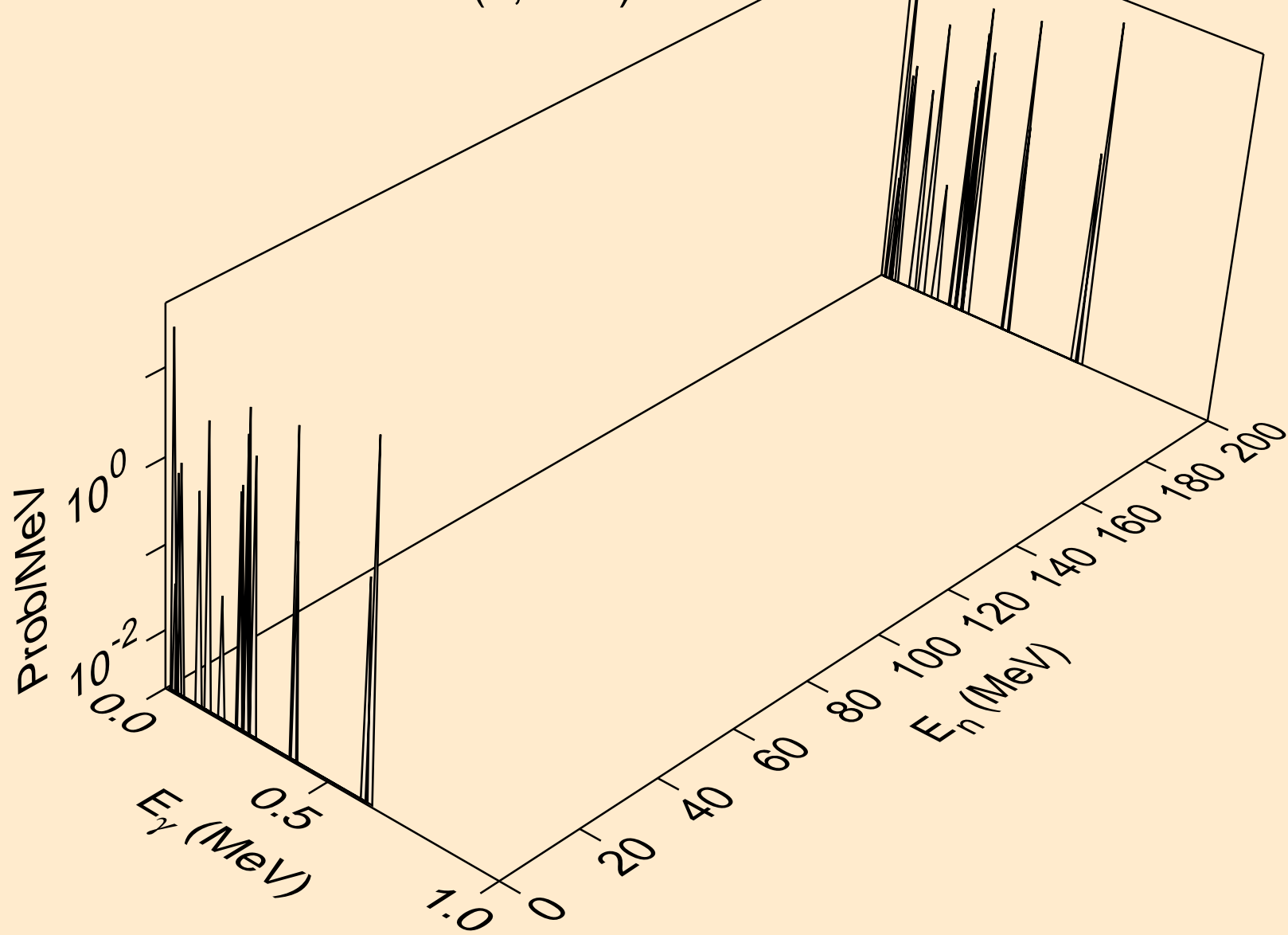

TC102M NEUTRON ACER TENDL-2024 LIBRARY; T=0.K
Photon emission for (n,n*22)

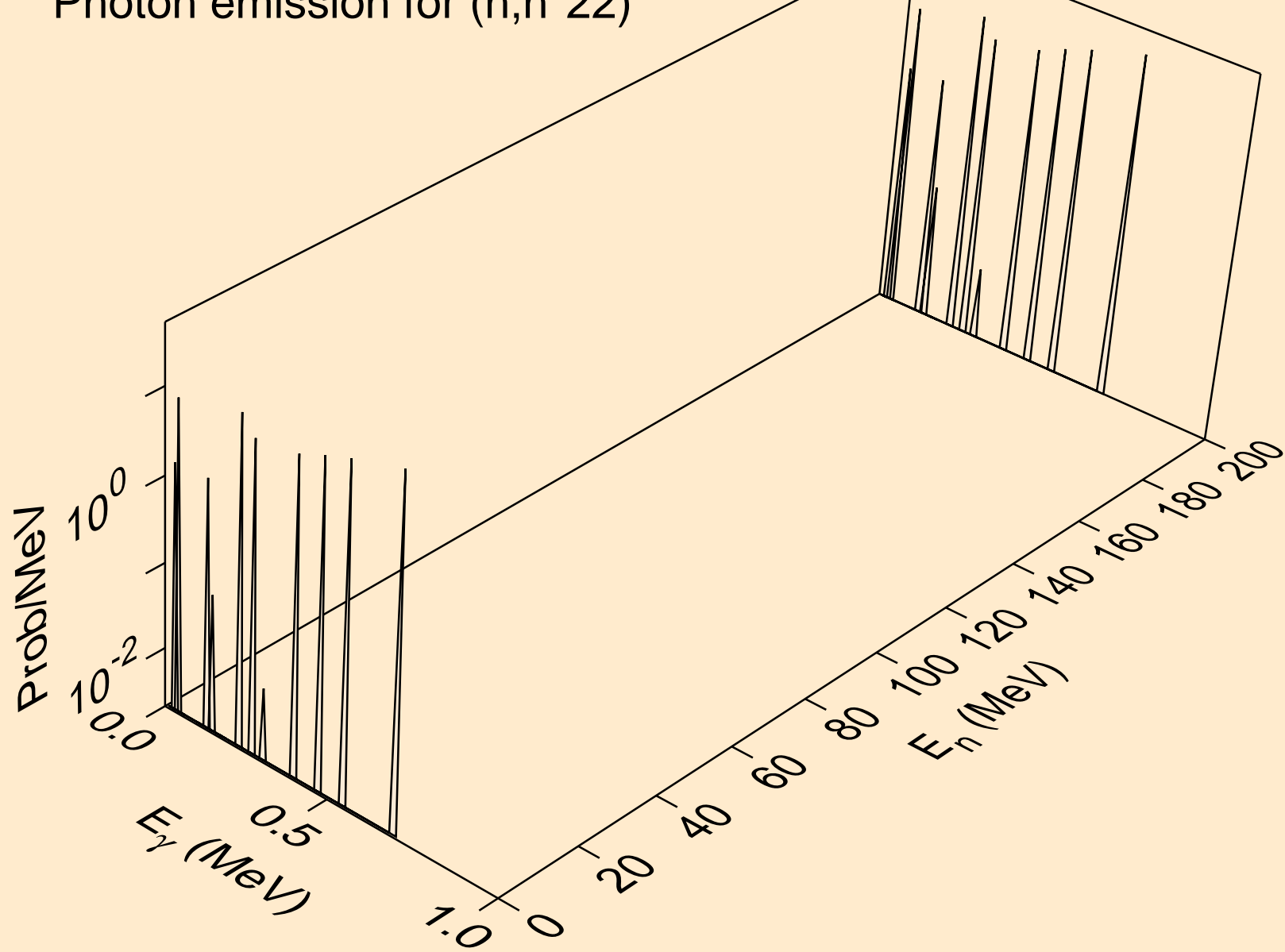

TC102M NEUTRON ACER TENDL-2024 LIBRARY; T=0.K
Photon emission for (n,n*23)

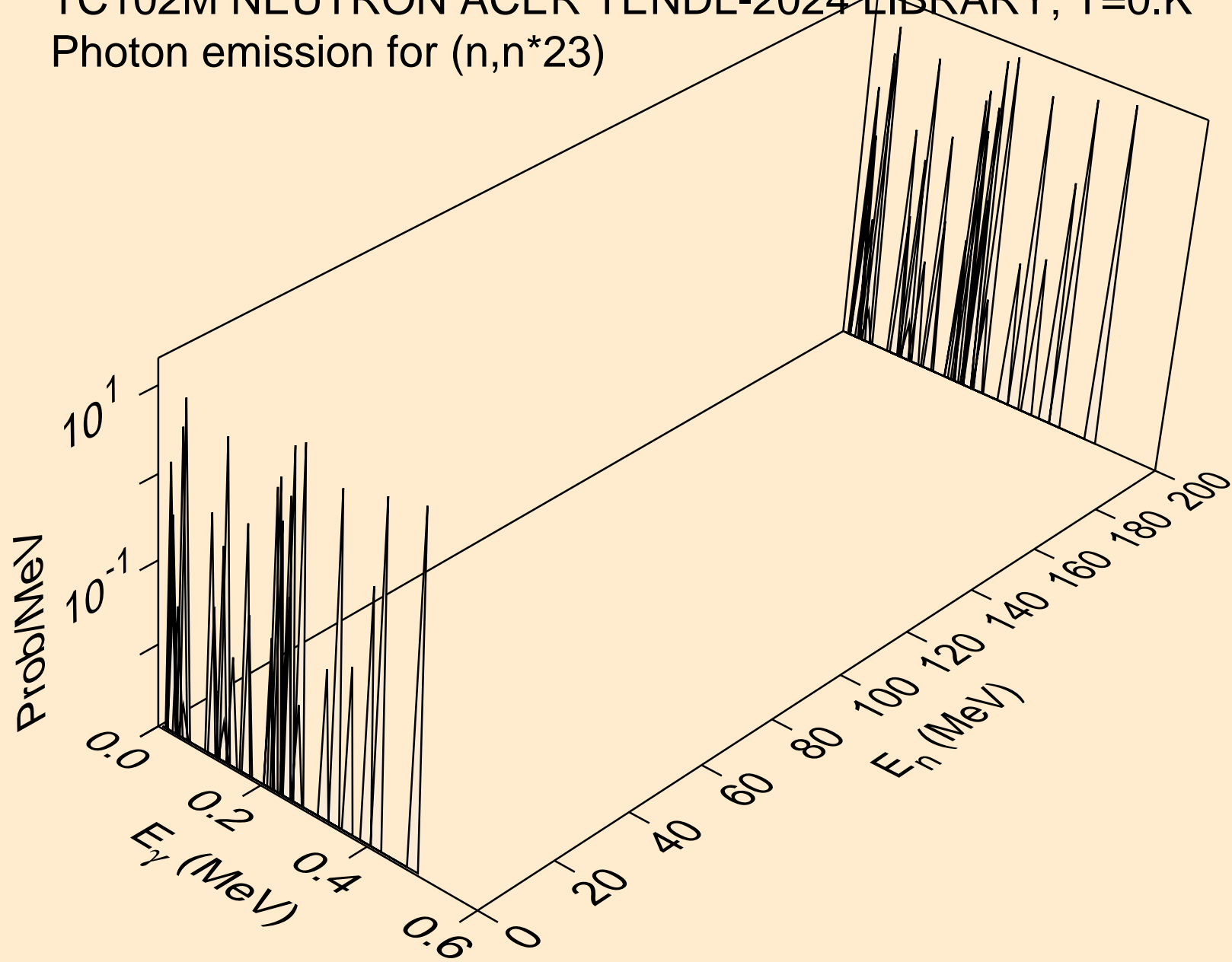

TC102M NEUTRON ACER TENDL-2024 LIBRARY; T=0.K
Photon emission for (n,n*24)

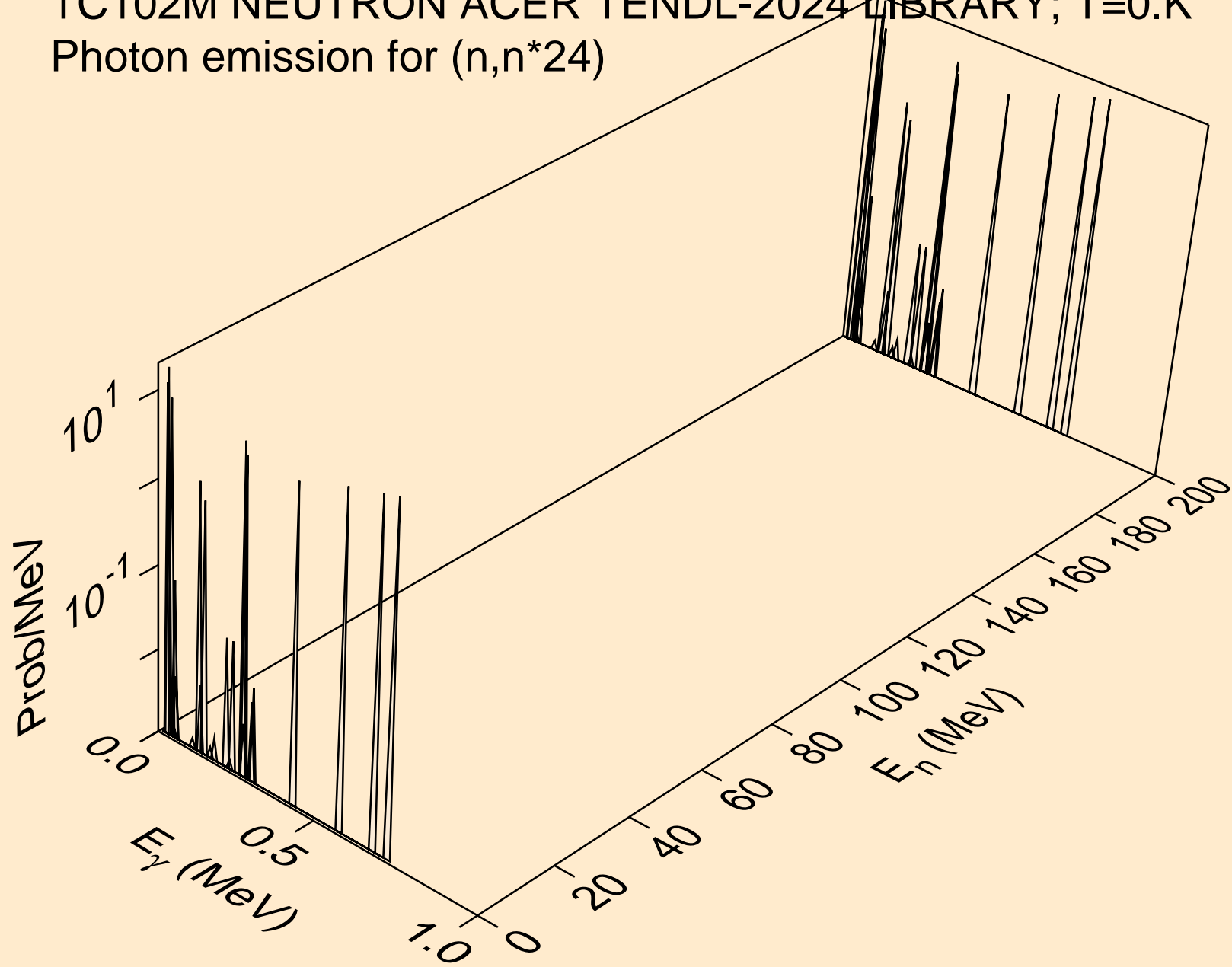

TC102M NEUTRON ACER TENDL-2024 LIBRARY; T=0.K
Photon emission for (n,n*25)

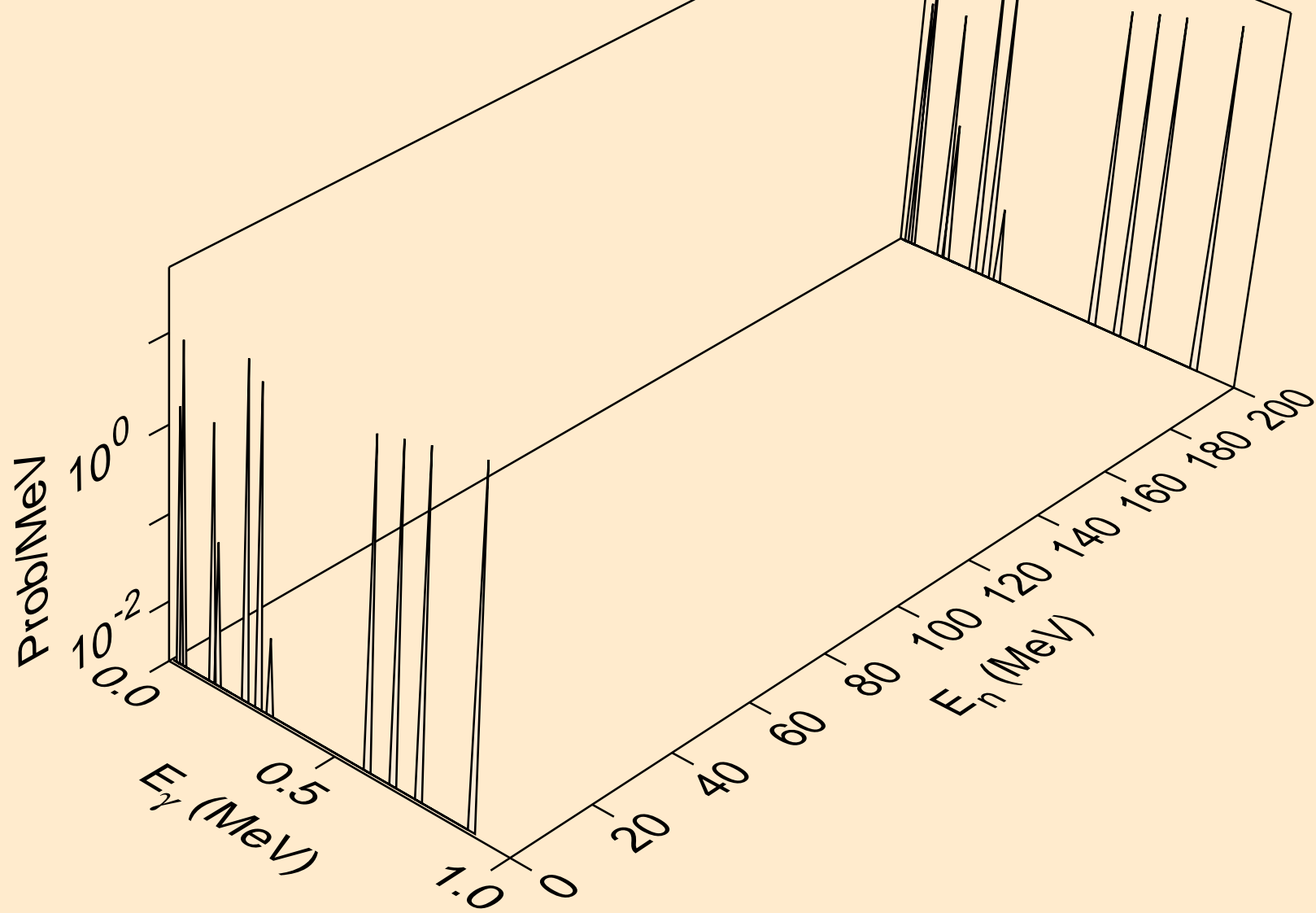

TC102M NEUTRON ACER TENDL-2024 LIBRARY; T=0.K
Photon emission for (n,n*26)

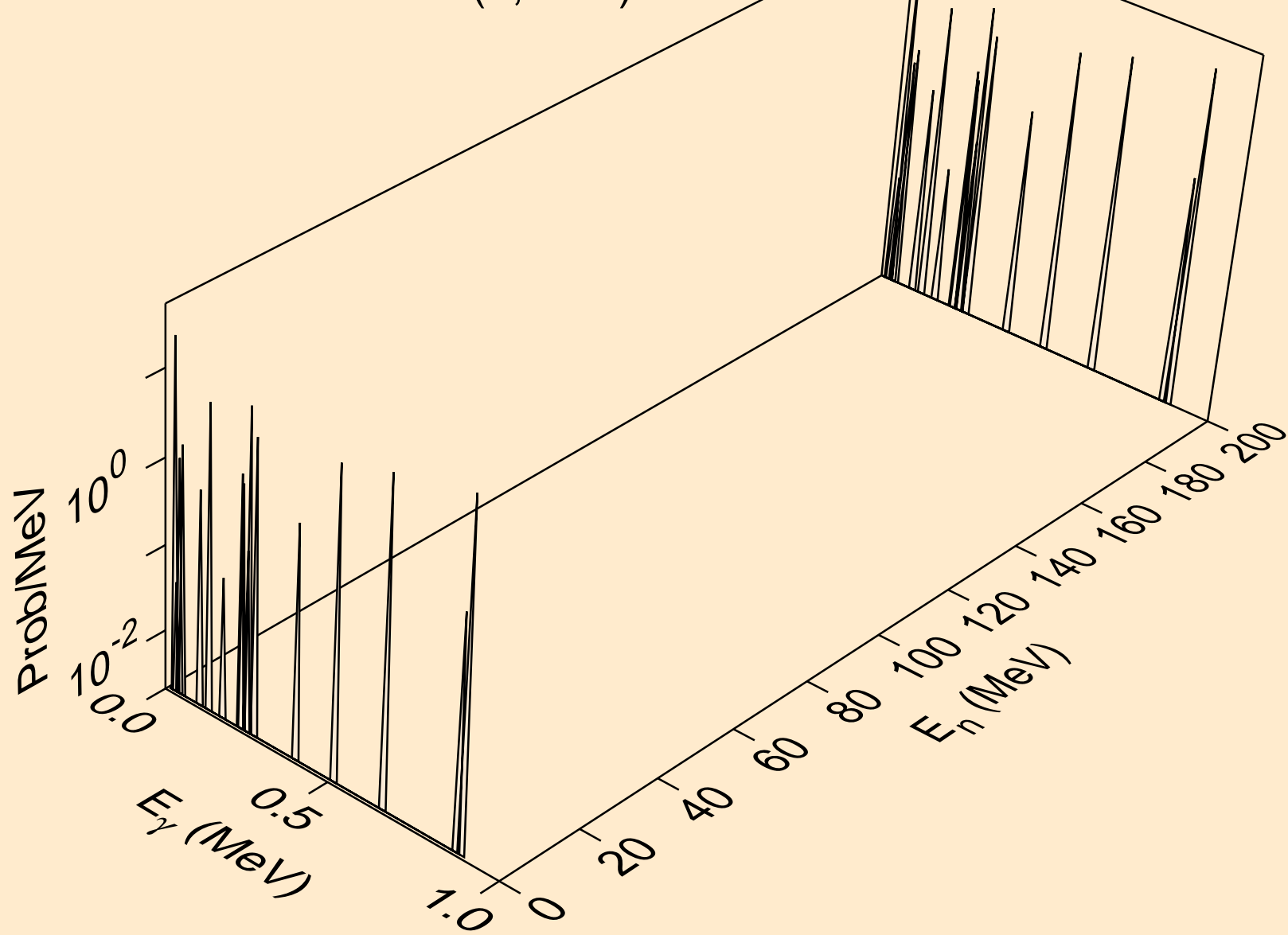

TC102M NEUTRON ACER TENDL-2024 LIBRARY; T=0.K
Photon emission for (n,n*27)

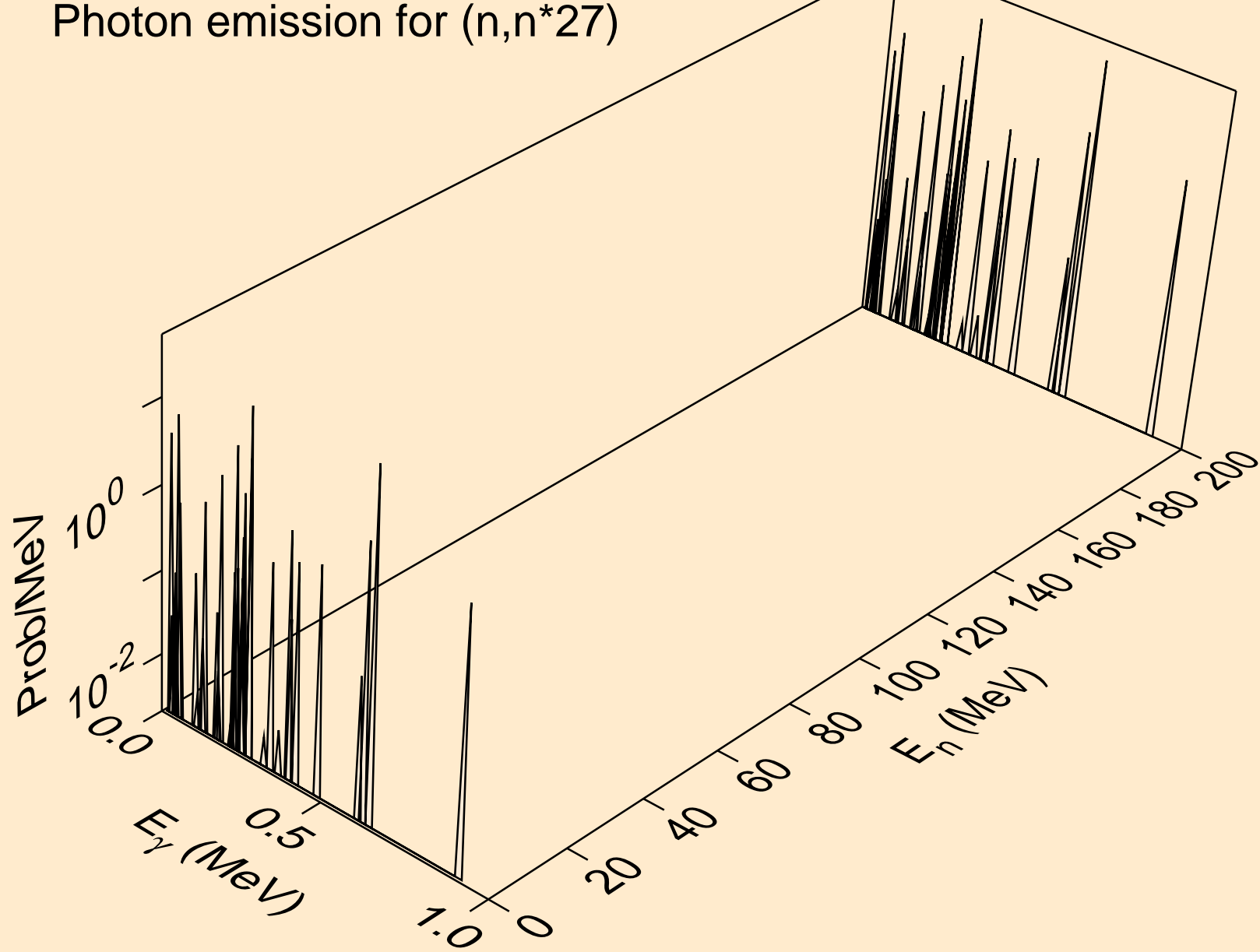

TC102M NEUTRON ACER TENDL-2024 LIBRARY; T=0.K
Photon emission for (n,n*28)

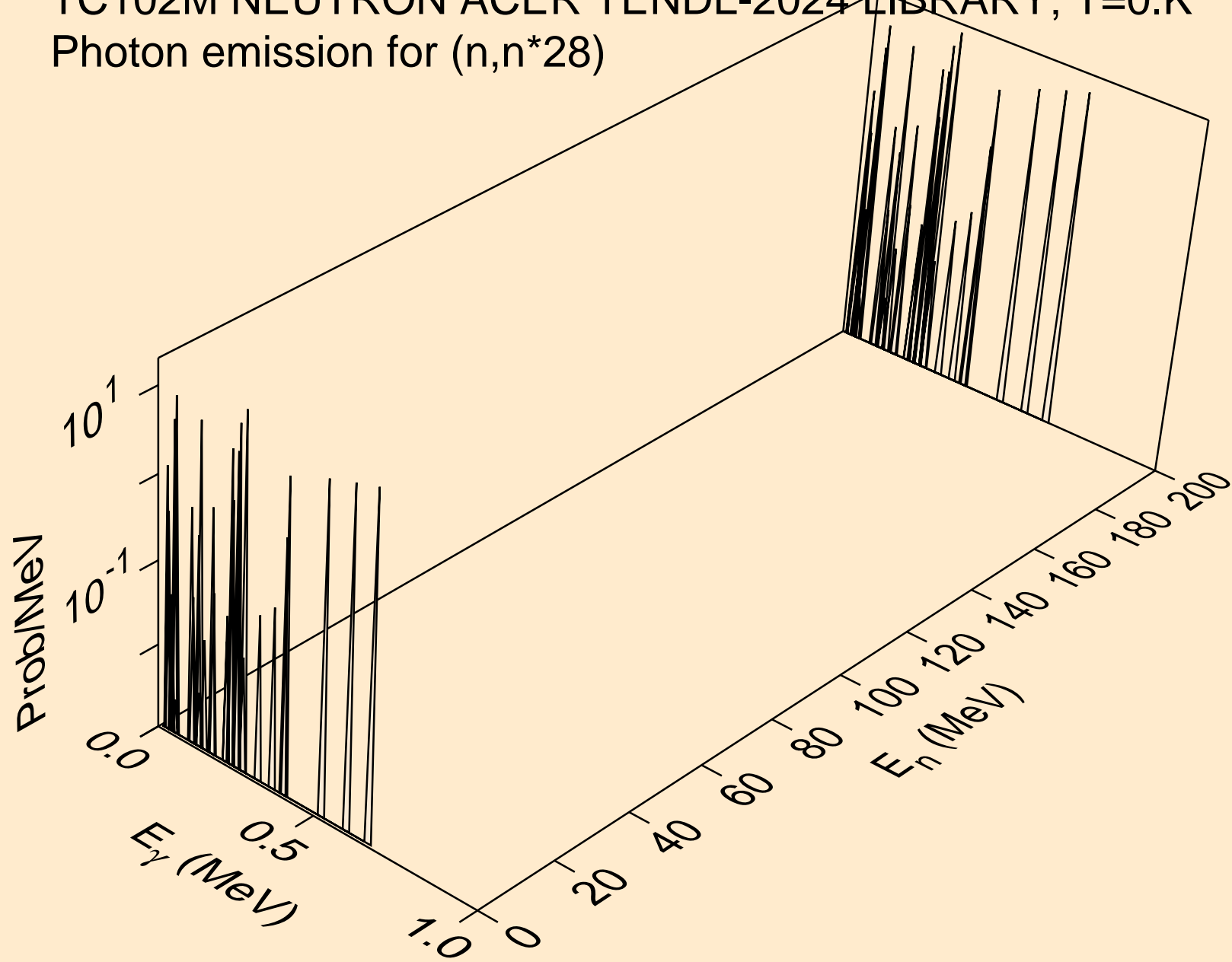

TC102M NEUTRON ACER TENDL-2024 LIBRARY; T=0.K
Photon emission for (n,n*29)

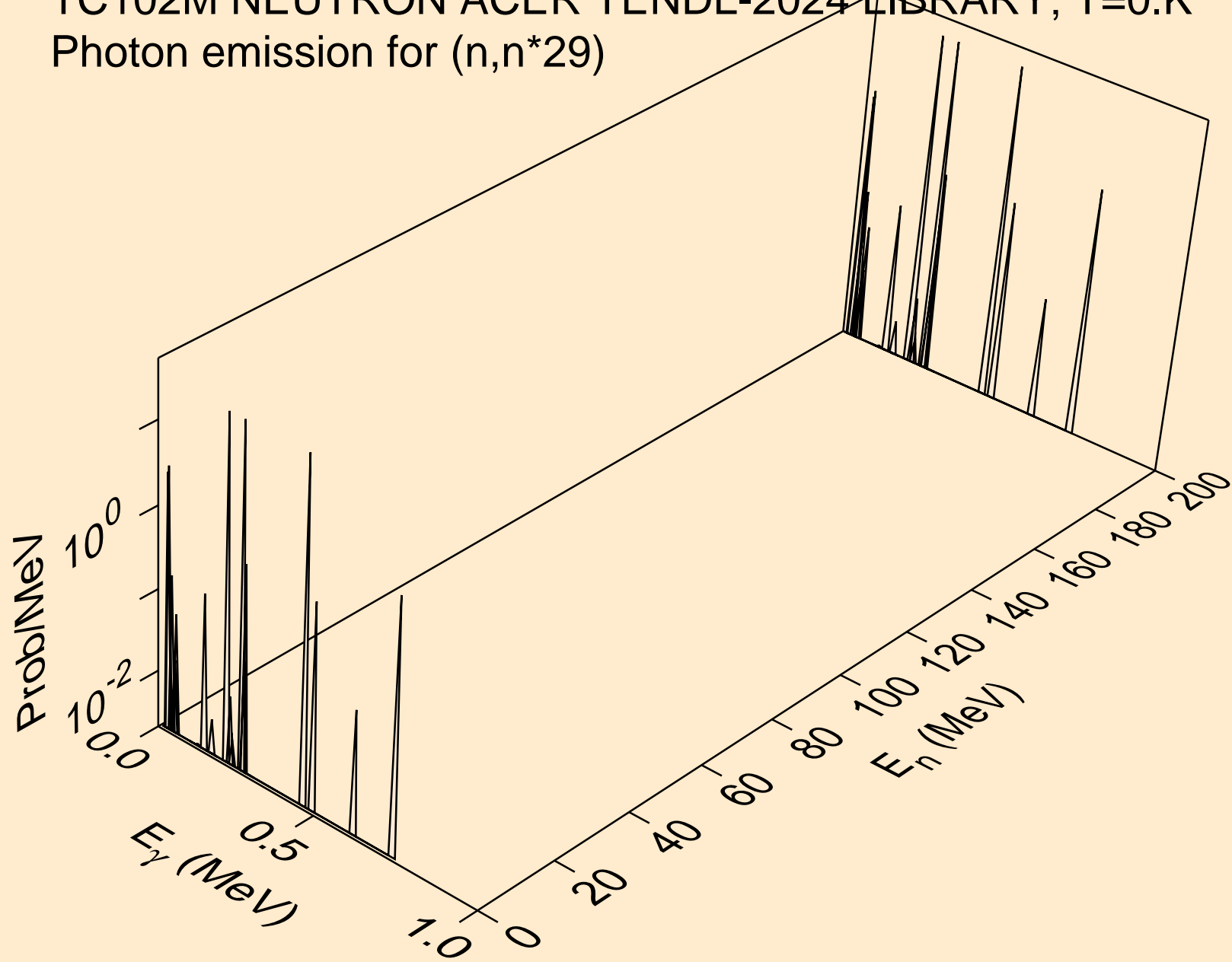

TC102M NEUTRON ACER TENDL-2024 LIBRARY; T=0.K
Photon emission for (n,n*30)

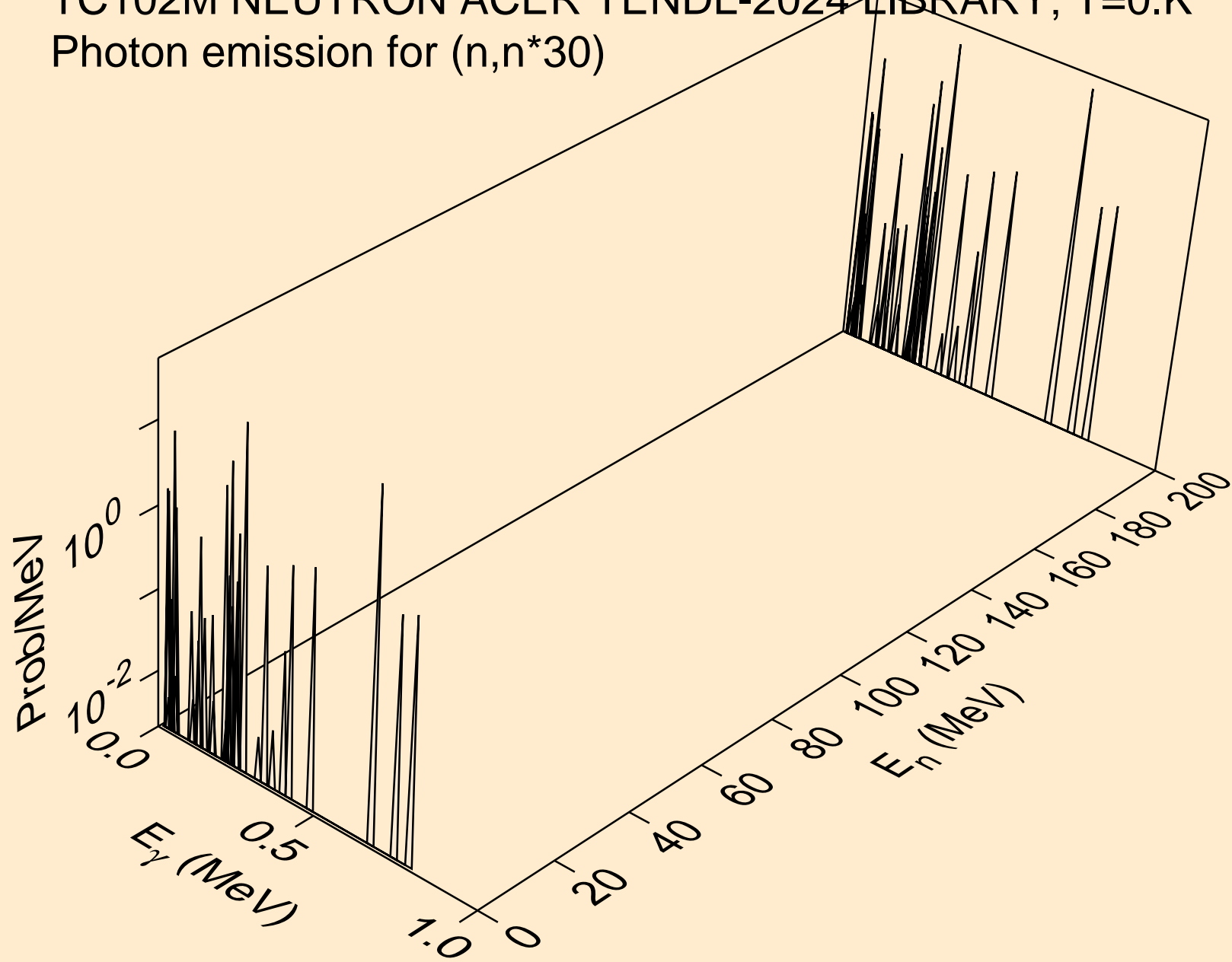

TC102M NEUTRON ACER TENDL-2024 LIBRARY; T=0.K
Photon emission for (n,n*c)

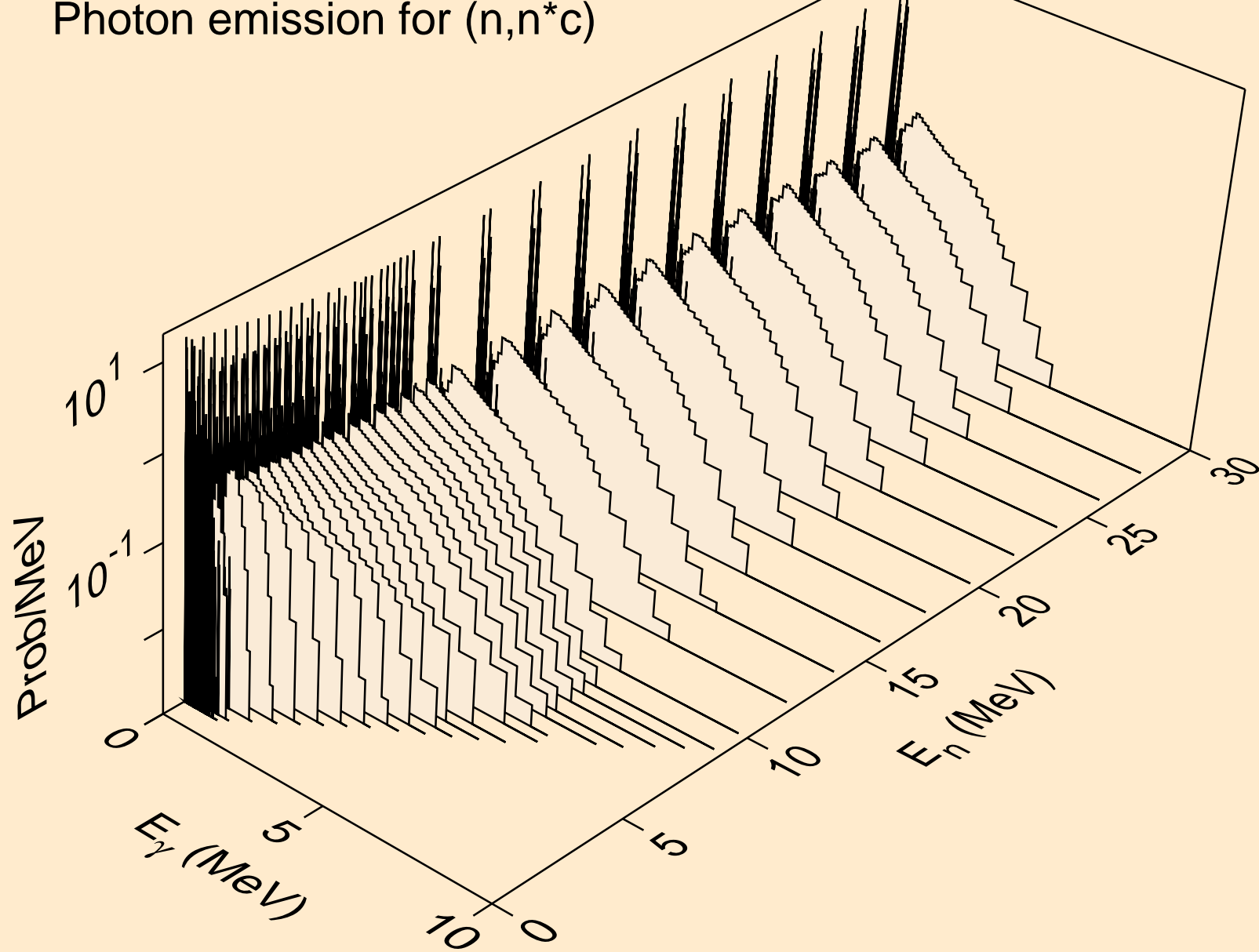

TC102M NEUTRON ACER TENDL-2024 LIBRARY; T=0.K
Photon emission for (n,gma)

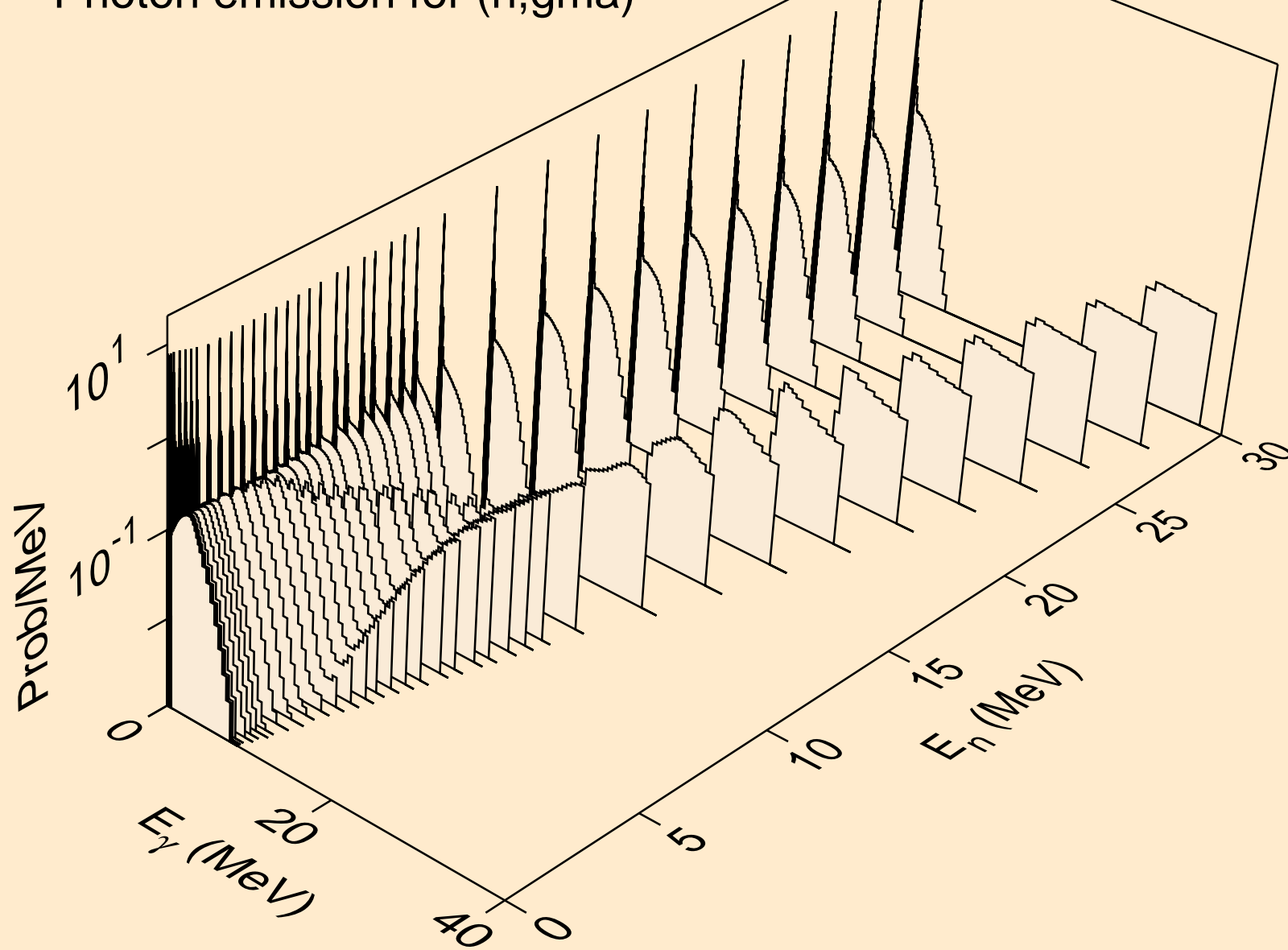

TC102M NEUTRON ACER TENDL-2024 LIBRARY; T=0.K
Photon emission for (n,p)

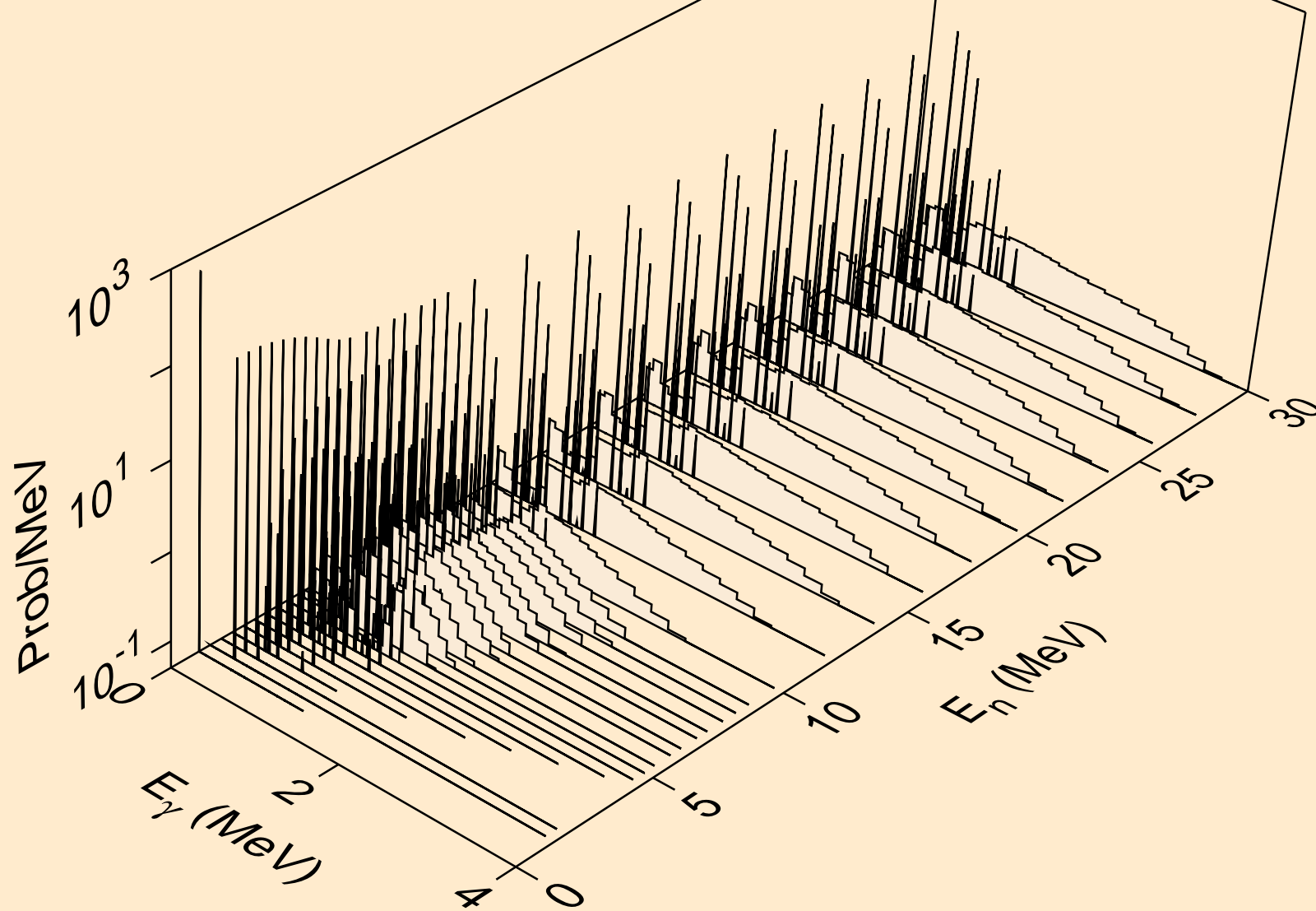

TC102M NEUTRON ACER TENDL-2024 LIBRARY; T=0.K
Photon emission for (n,d)

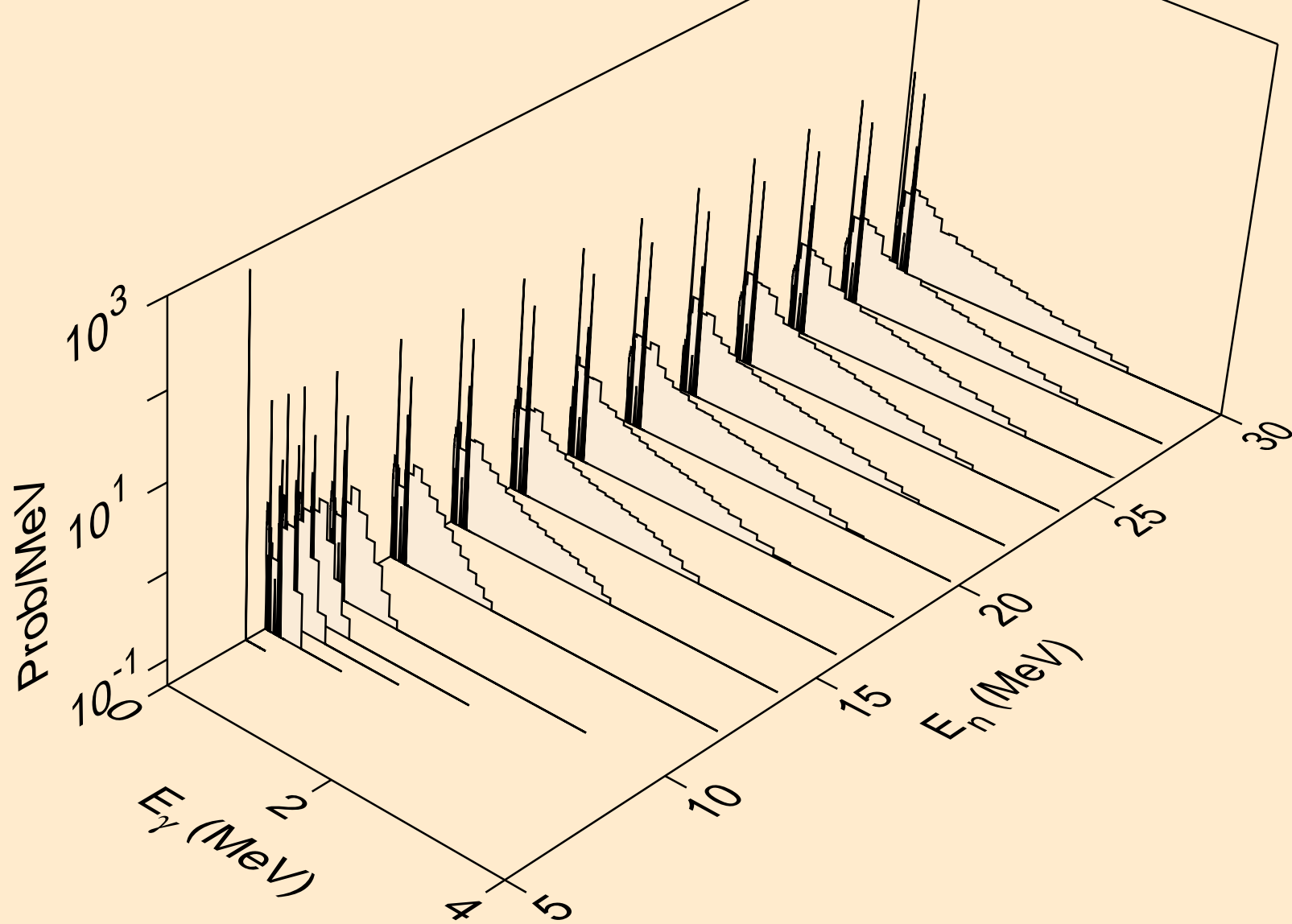

TC102M NEUTRON ACER TENDL-2024 LIBRARY; T=0.K
Photon emission for (n,t)

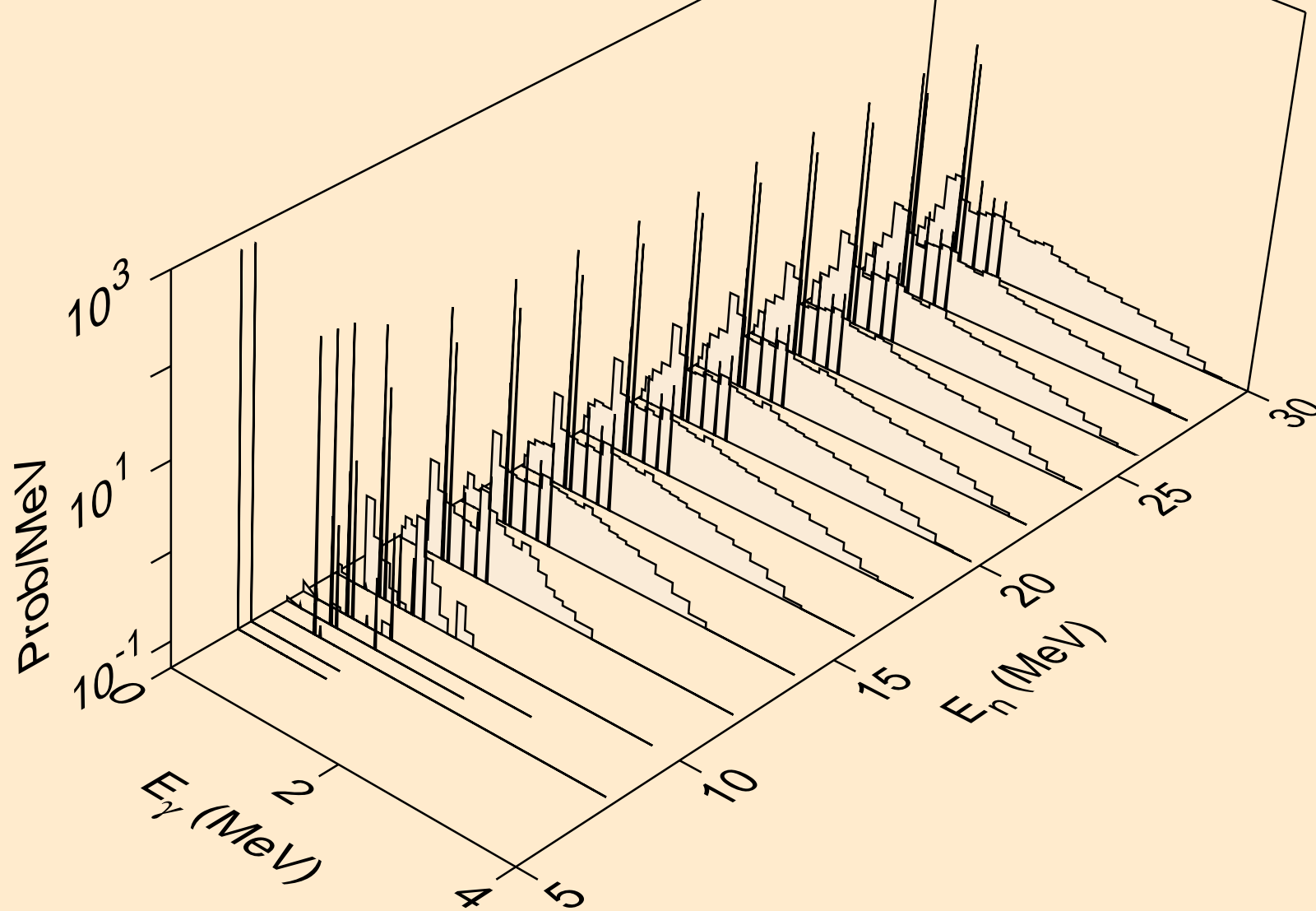

TC102M NEUTRON ACER TENDL-2024 LIBRARY; T=0.K
Photon emission for (n,he3)

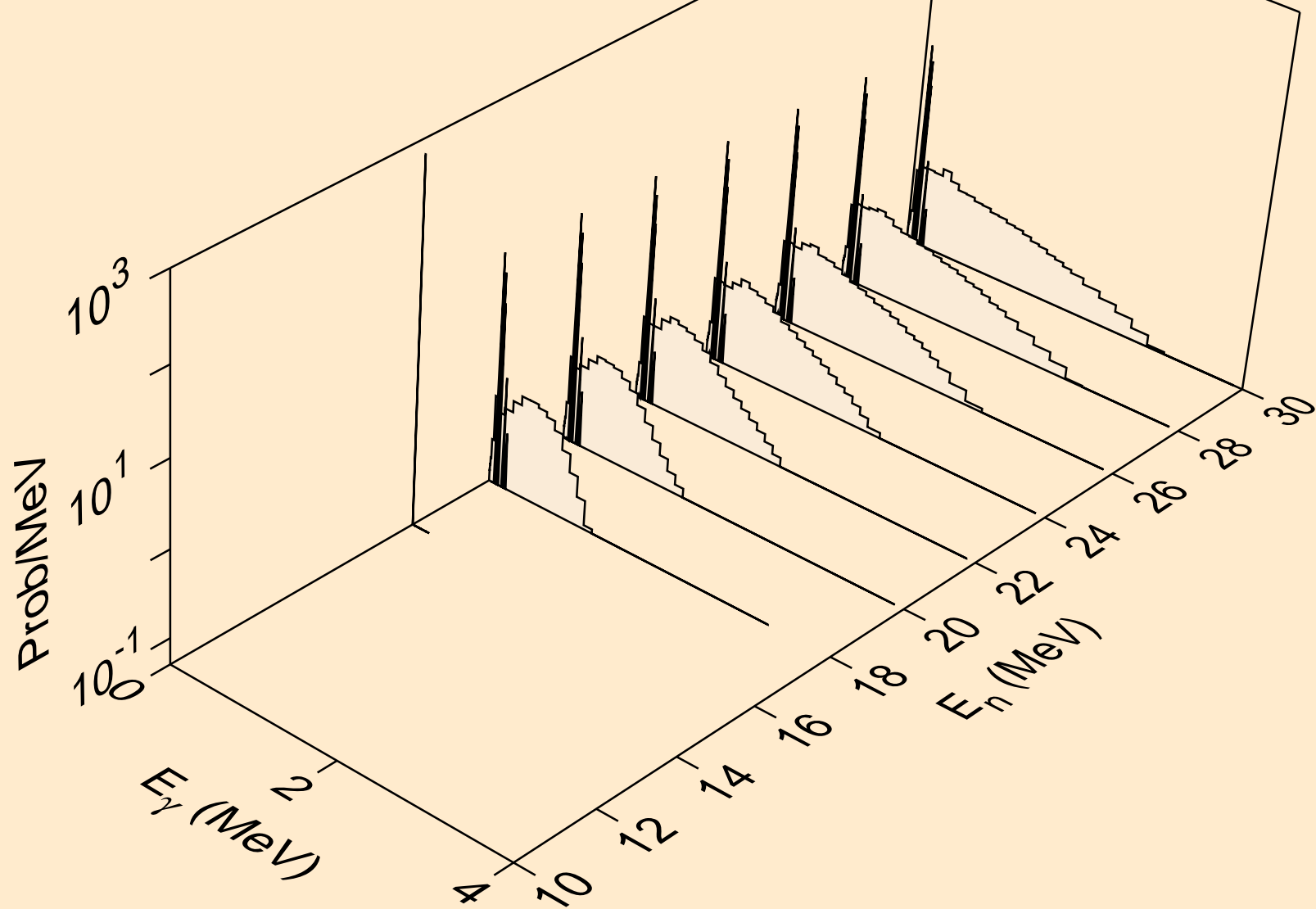

TC102M NEUTRON ACER TENDL-2024 LIBRARY; T=0.K
Photon emission for (n,a)

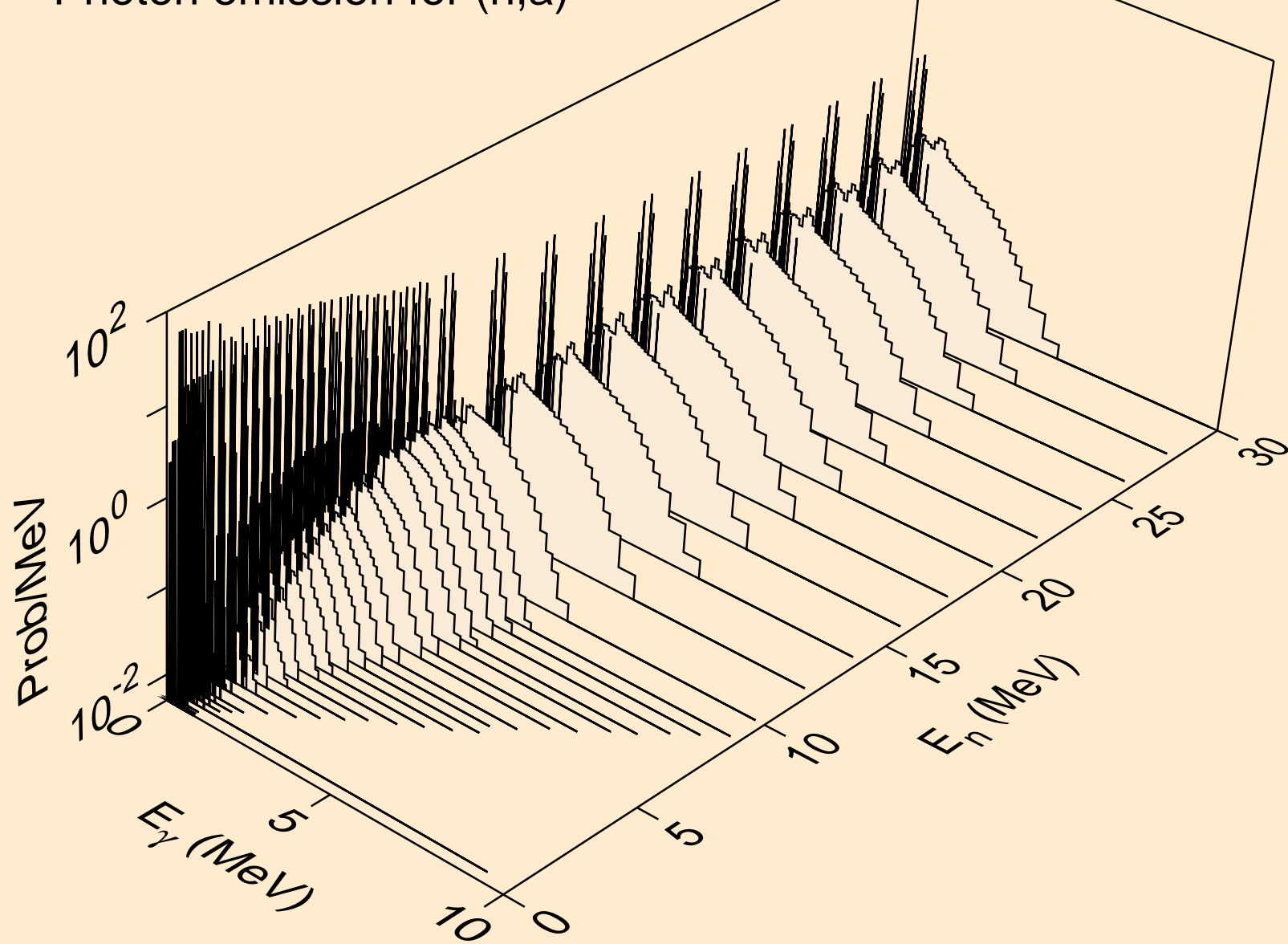

TC102M NEUTRON ACER TENDL-2024 LIBRARY; T=0.K
Photon emission for (n,2a)

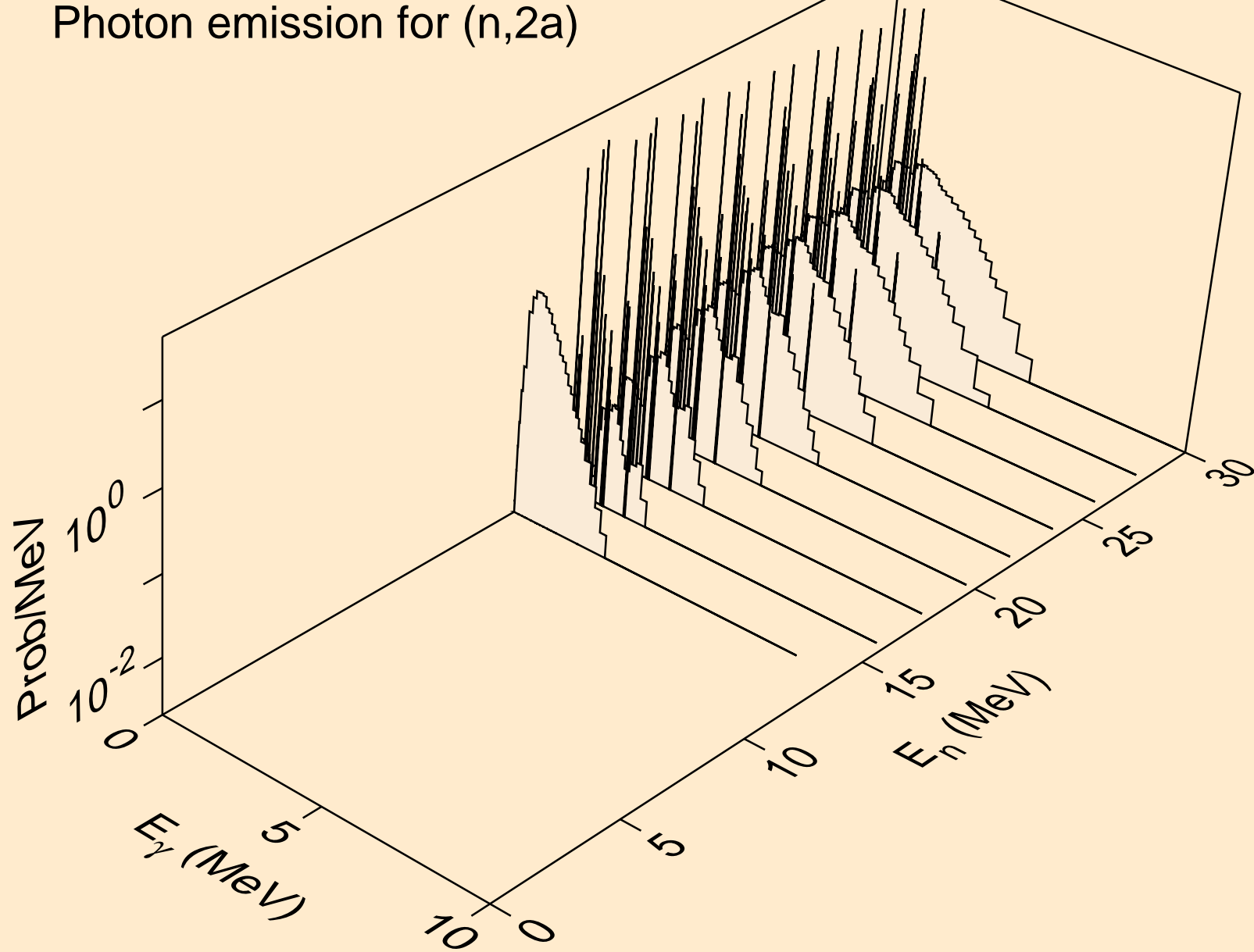

TC102M NEUTRON ACER TENDL-2024 LIBRARY; T=0.K
Photon emission for (n,2p)

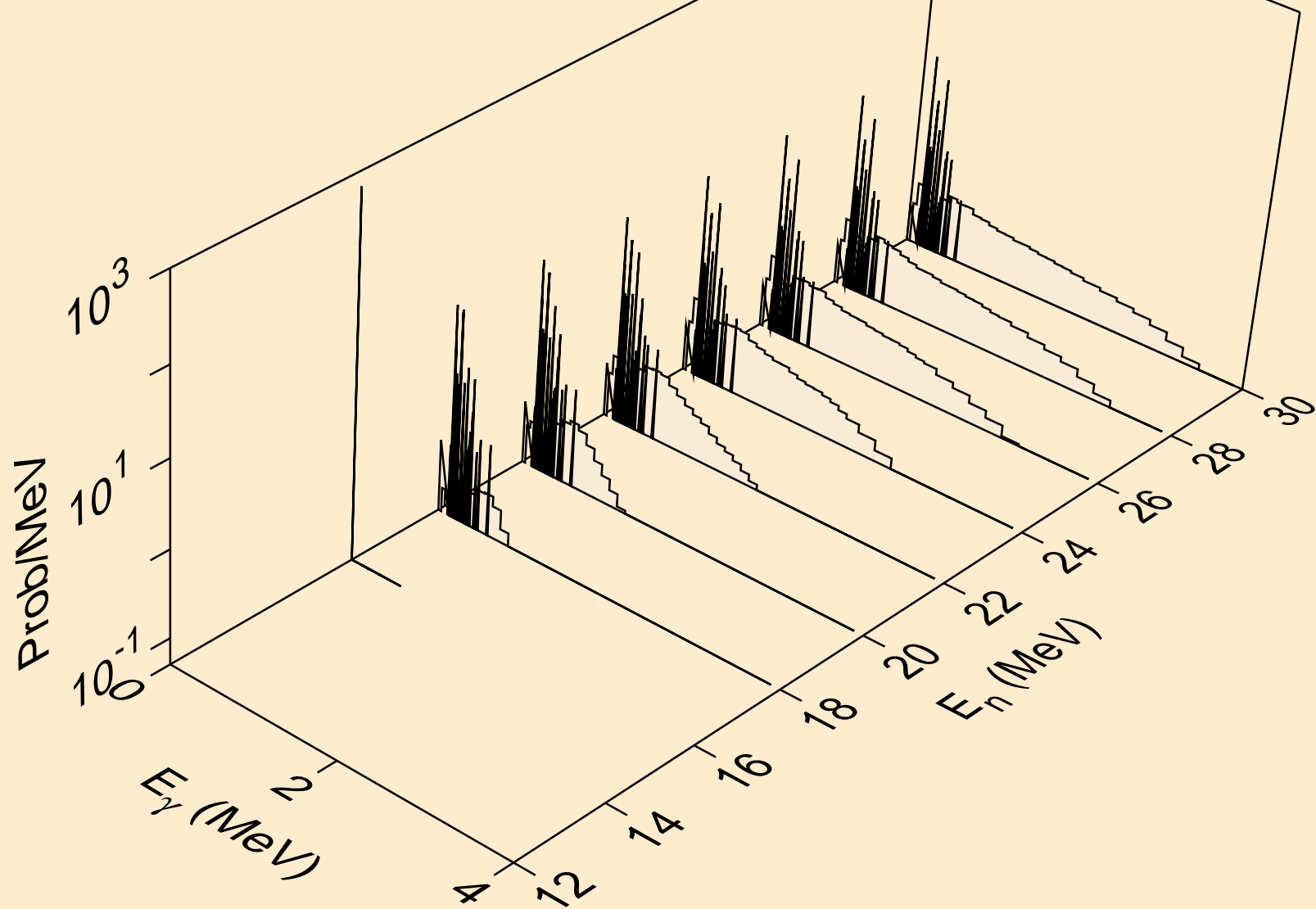

TC102M NEUTRON ACER TENDL-2024 LIBRARY; T=0.K
Photon emission for (n,p α)

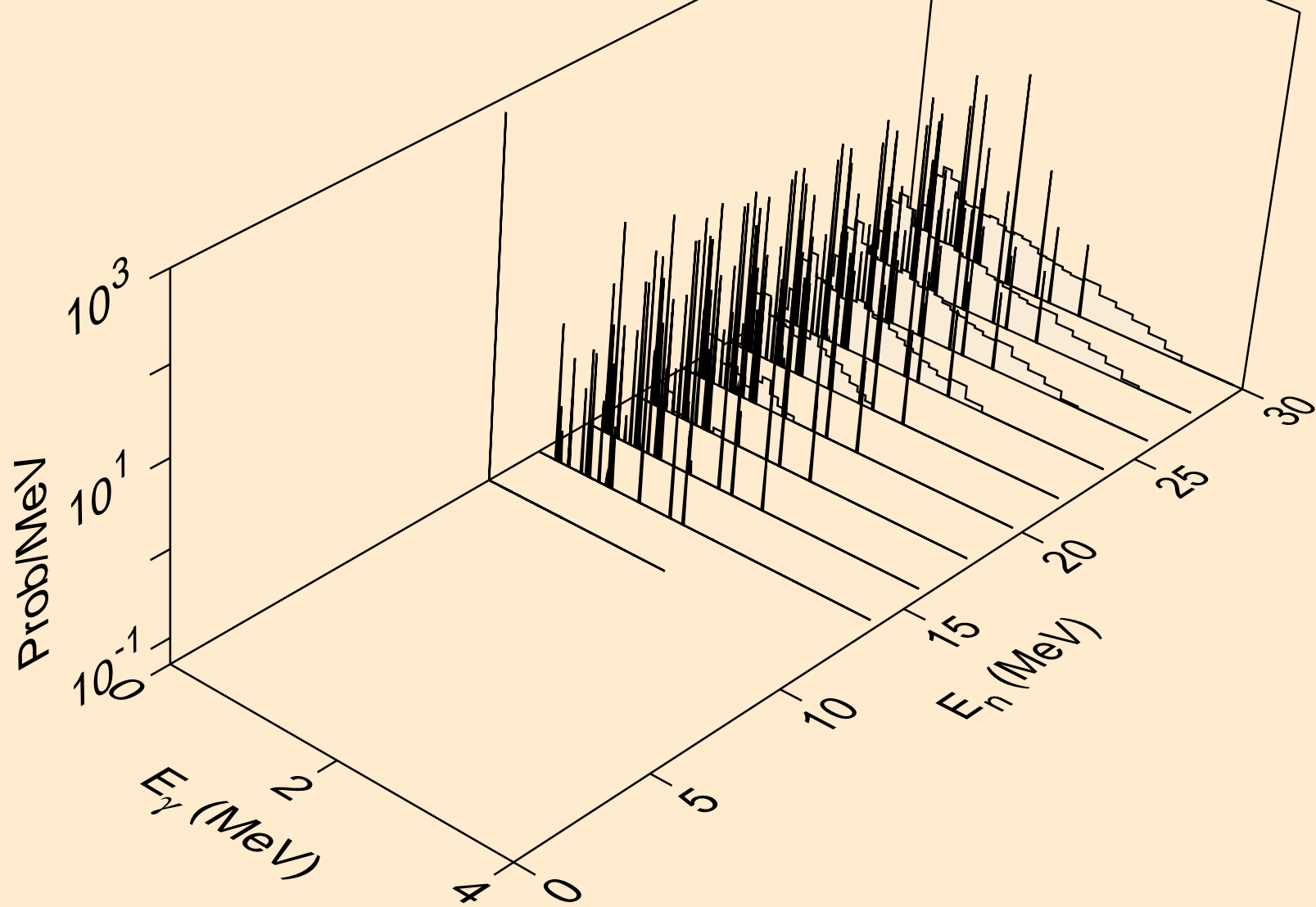

TC102M NEUTRON ACER TENDL-2024 LIBRARY; T=0.K
Photon emission for (n,pd)

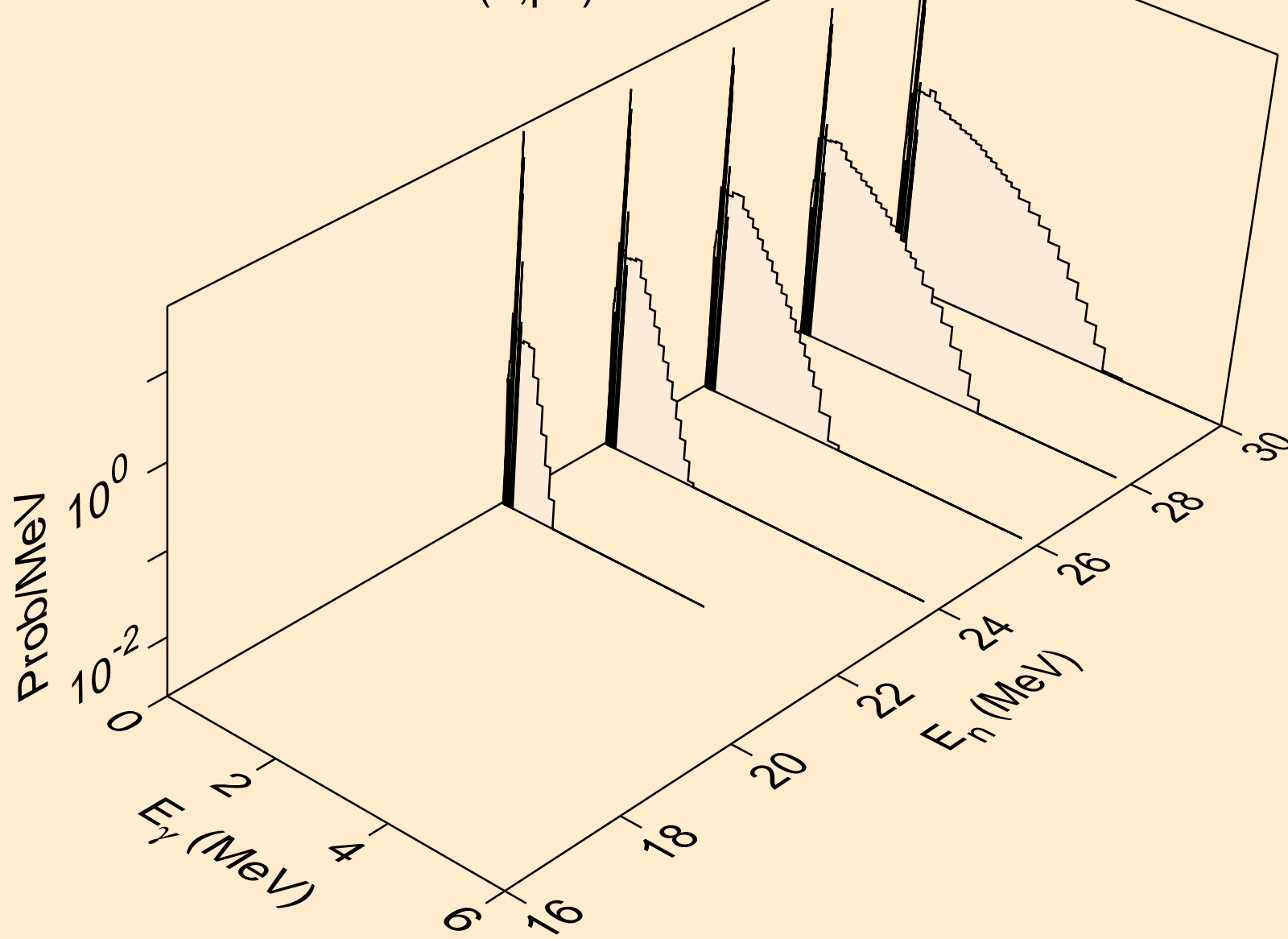

TC102M NEUTRON ACER TENDL-2024 LIBRARY; T=0.K
Photon emission for (n,pt)

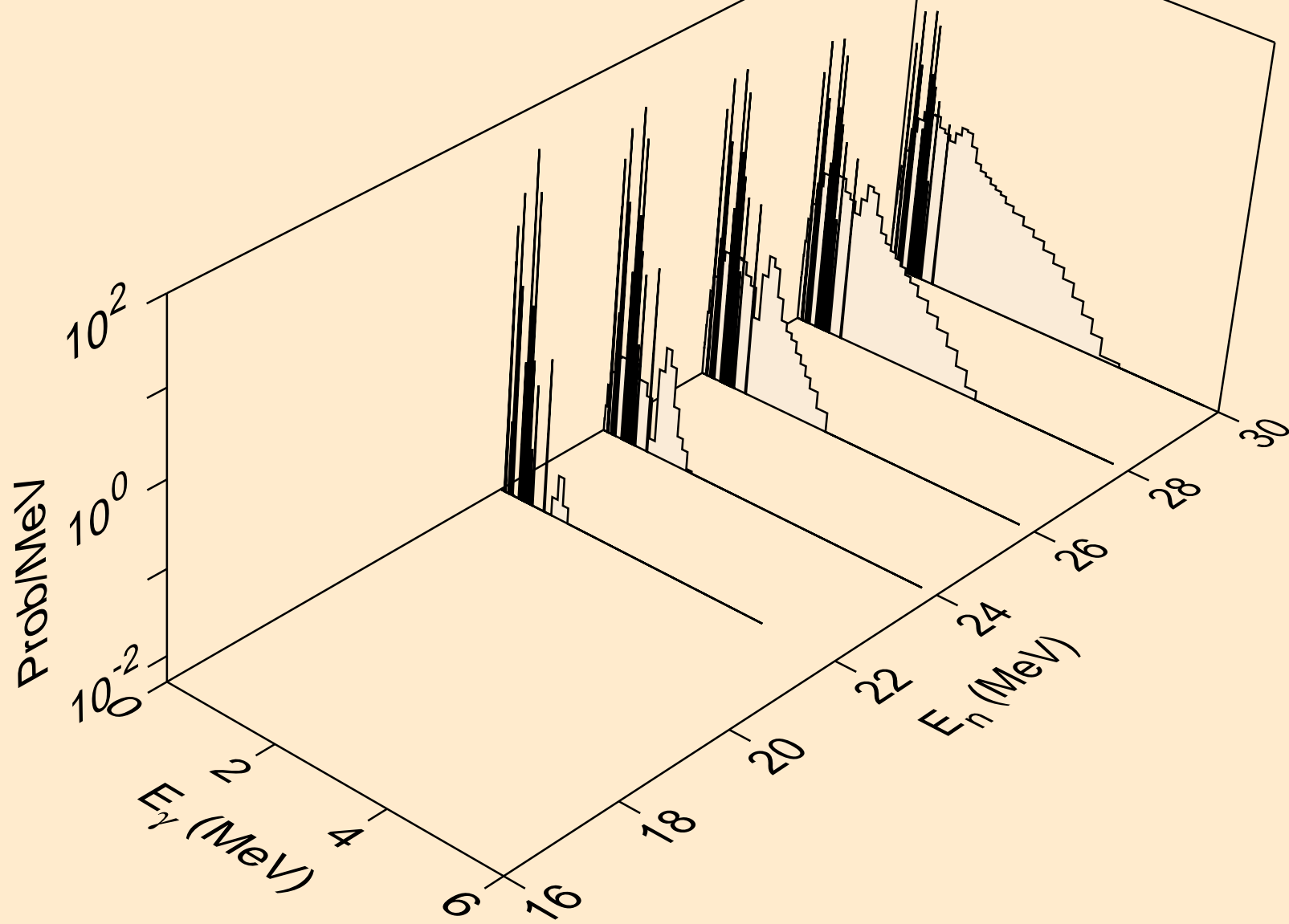

TC102M NEUTRON ACER TENDL-2024 LIBRARY; T=0.K
Photon emission for (n,da)

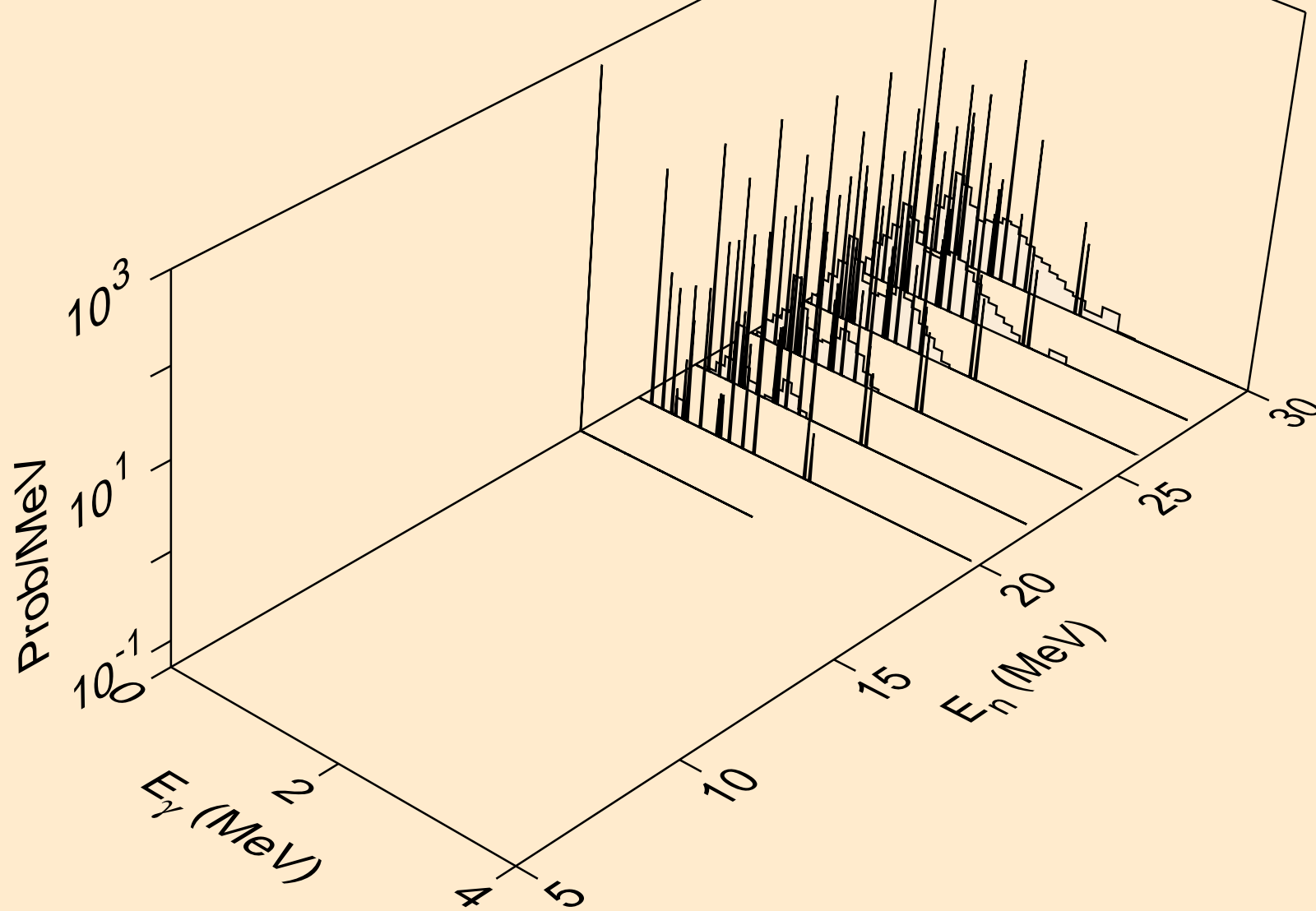

TC102M NEUTRON ACER TENDL-2024 LIBRARY; T=0.K
thermal capture photon spectrum

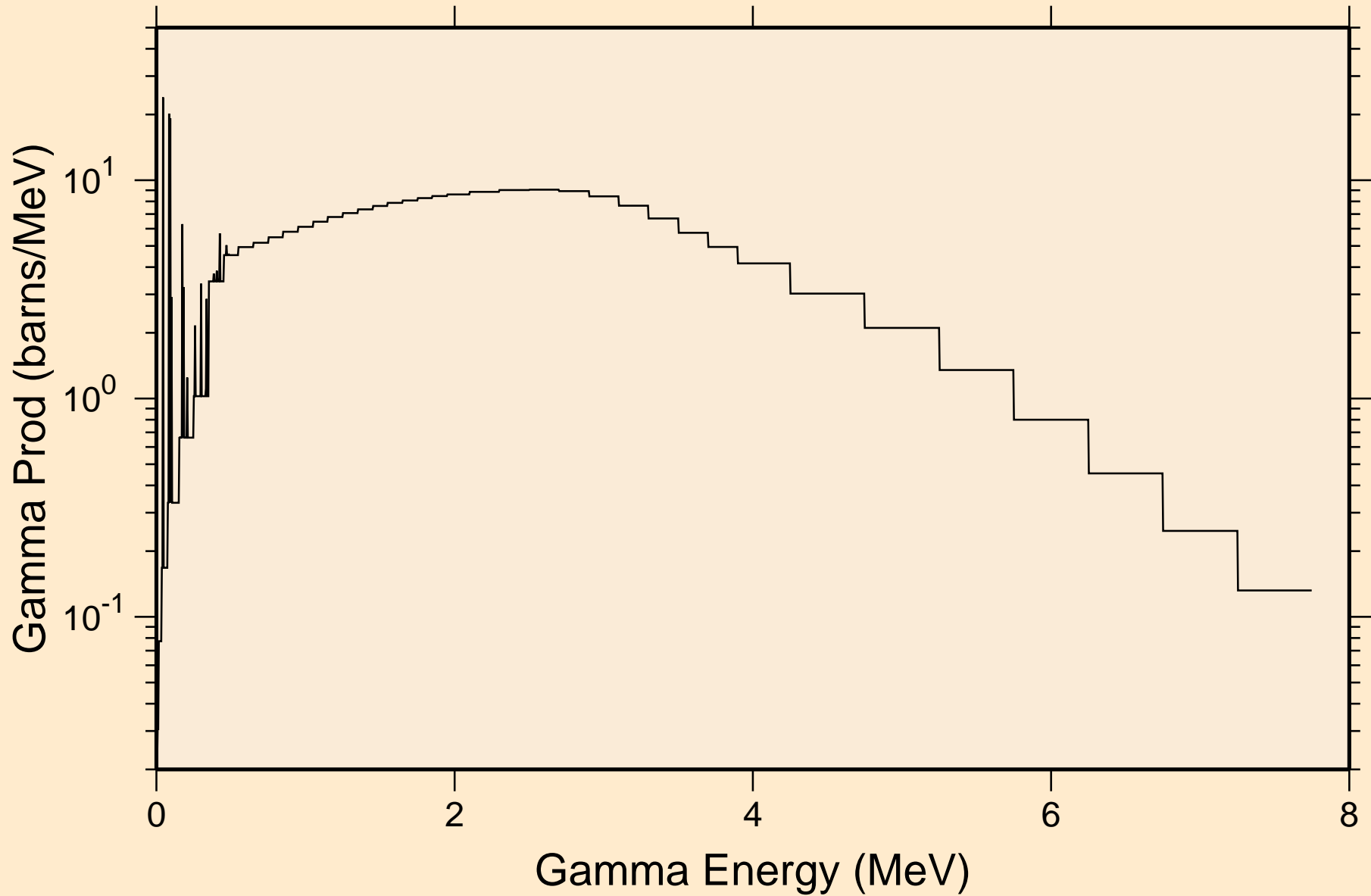

TC102M NEUTRON ACER TENDL-2024 LIBRARY; T=0.K
14 MeV photon spectrum



TC102M NEUTRON ACER TENDL-2024 LIBRARY; T=0.K

Particle heating contributions

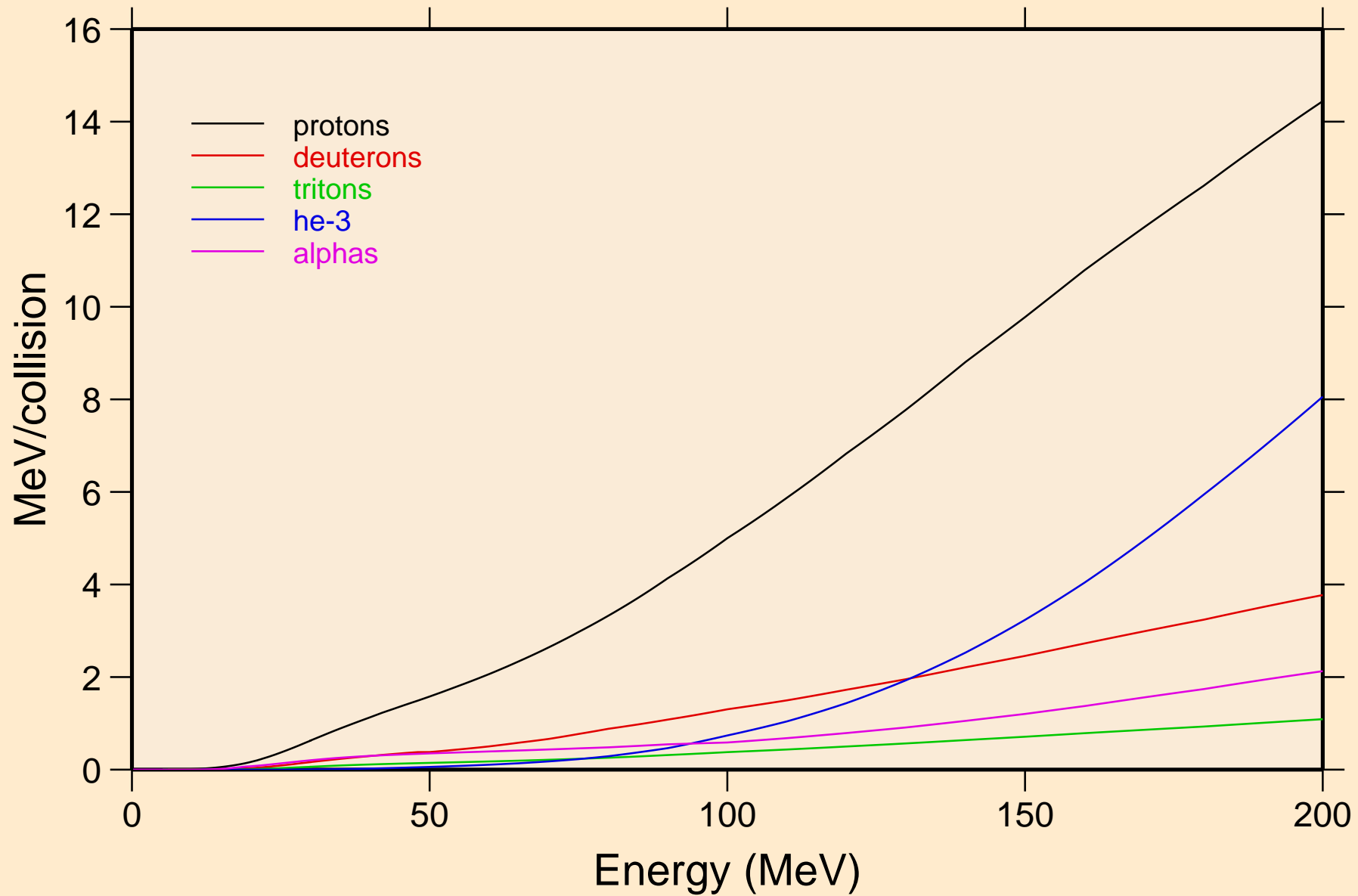

TC102M NEUTRON ACER TENDL-2024 LIBRARY; T=0.K
Recoil Heating

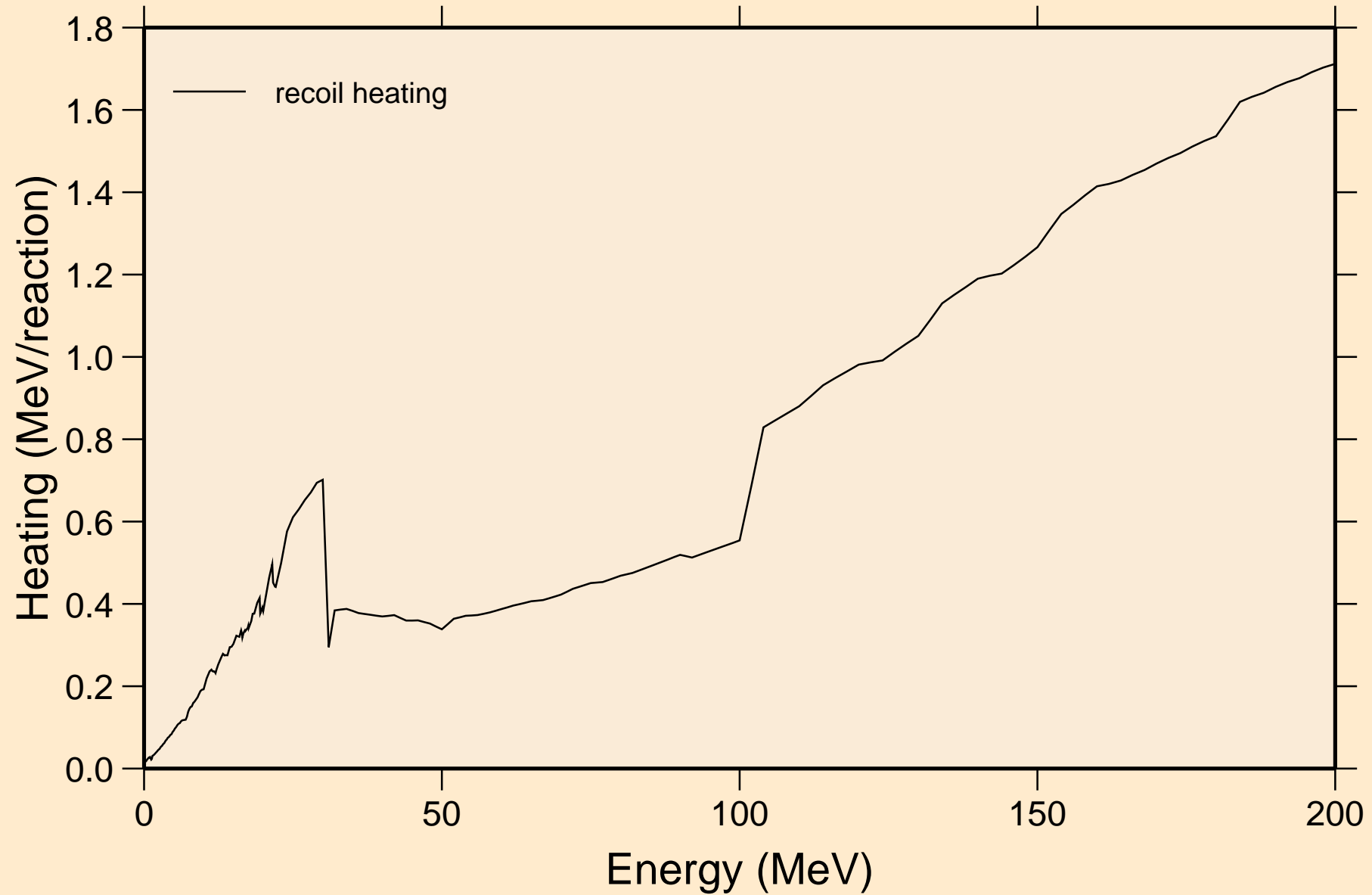

TC102M NEUTRON ACER TENDL-2024 LIBRARY; T=0.K

Particle production cross sections

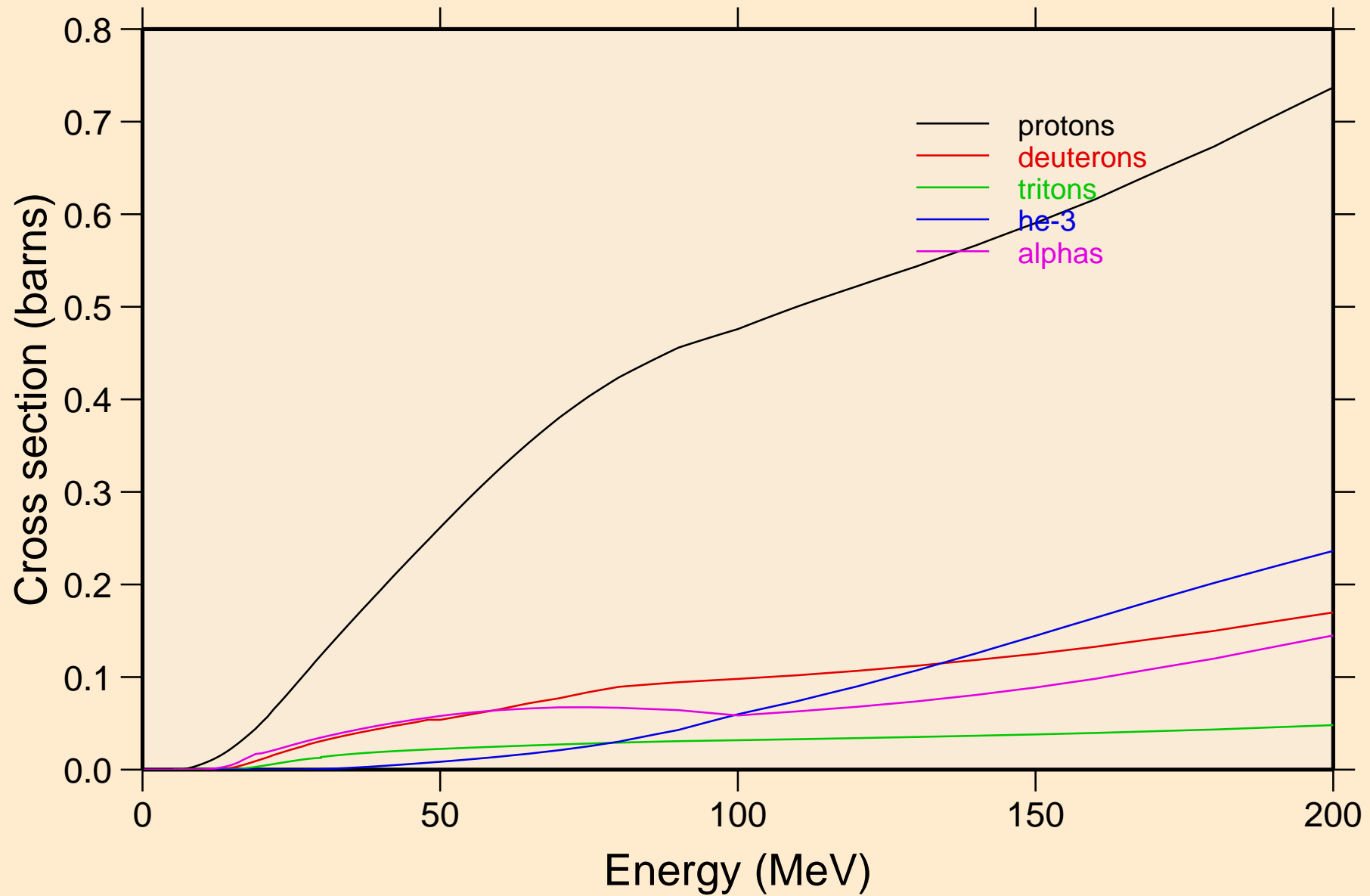

TC102M NEUTRON ACER TENDL-2024 LIBRARY; T=0.K
protons from (n,x)

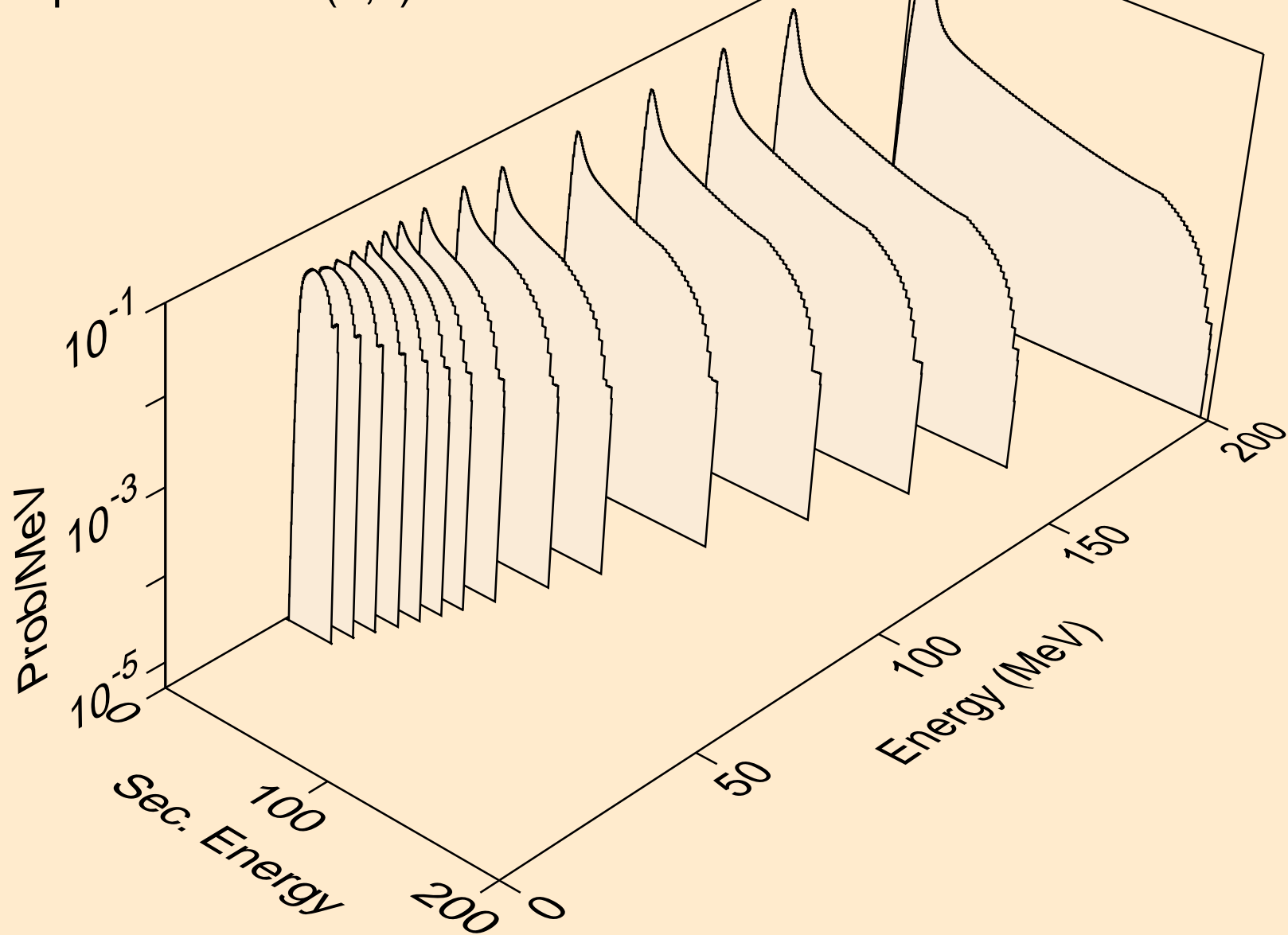

TC102M NEUTRON ACER TENDL-2024 LIBRARY; T=0.K
protons from (n,n*)p

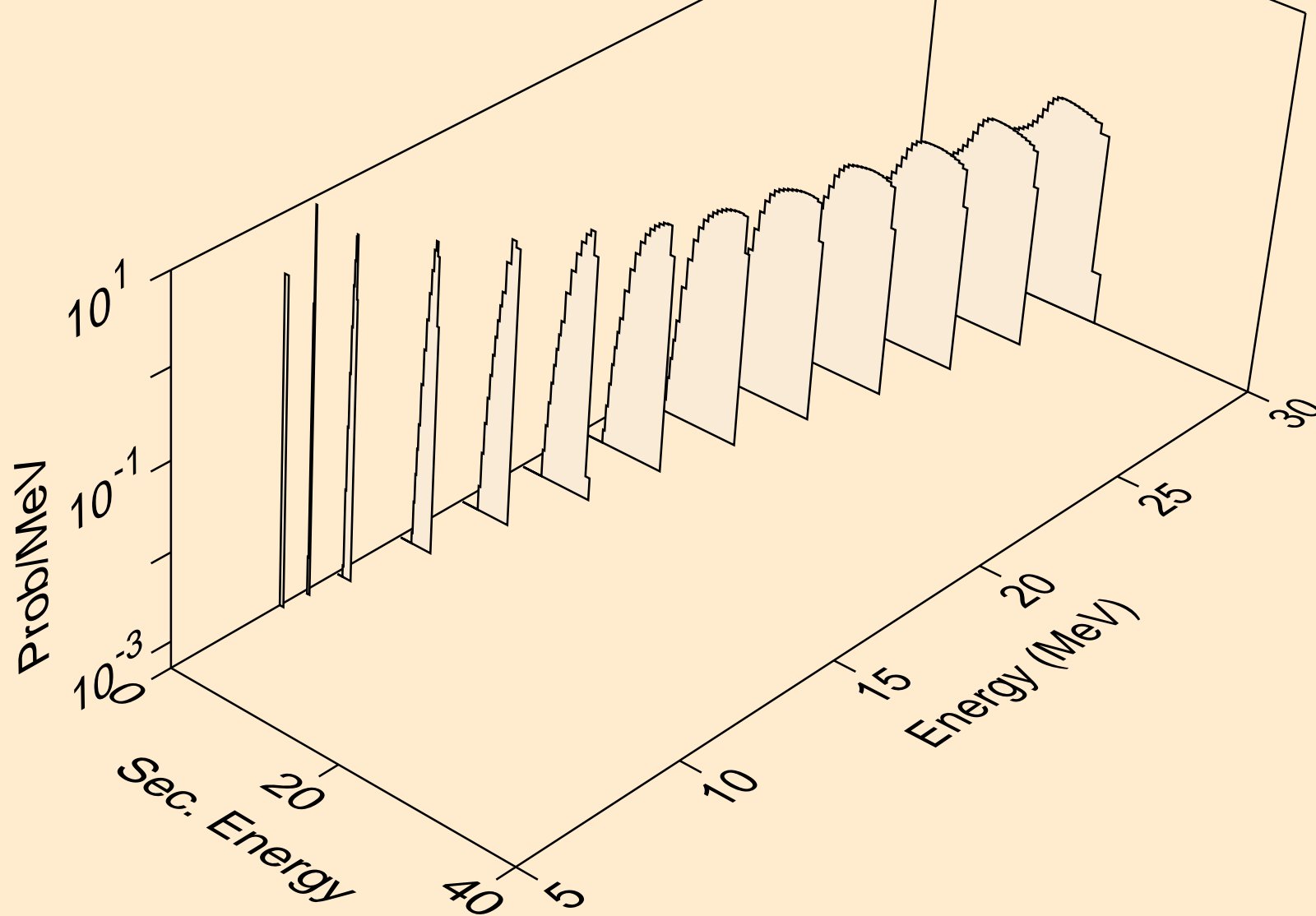

TC102M NEUTRON ACER TENDL-2024 LIBRARY; T=0.K
protons from (n,2np)

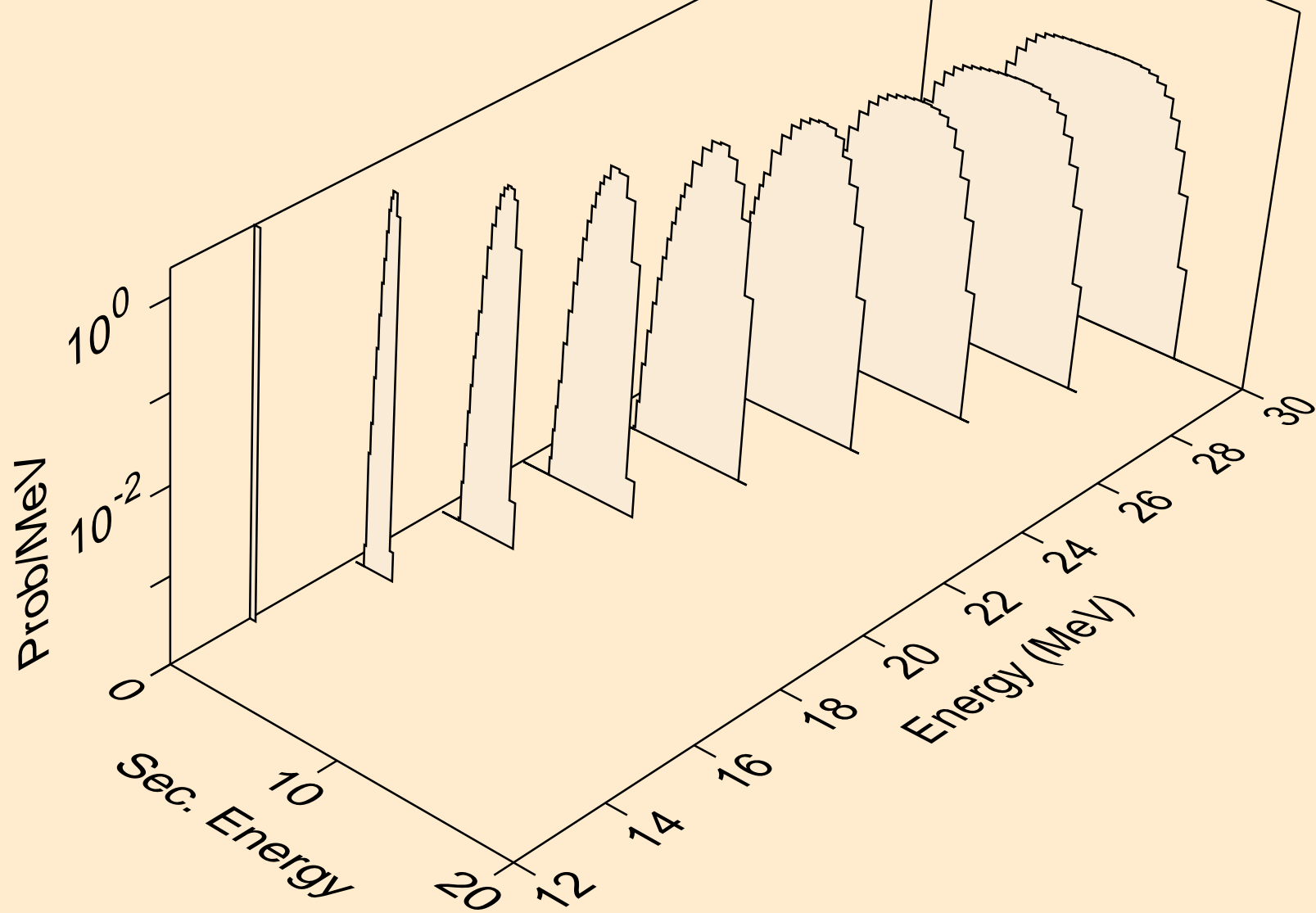

TC102M NEUTRON ACER TENDL-2024 LIBRARY; T=0.K
protons from (n,3np)

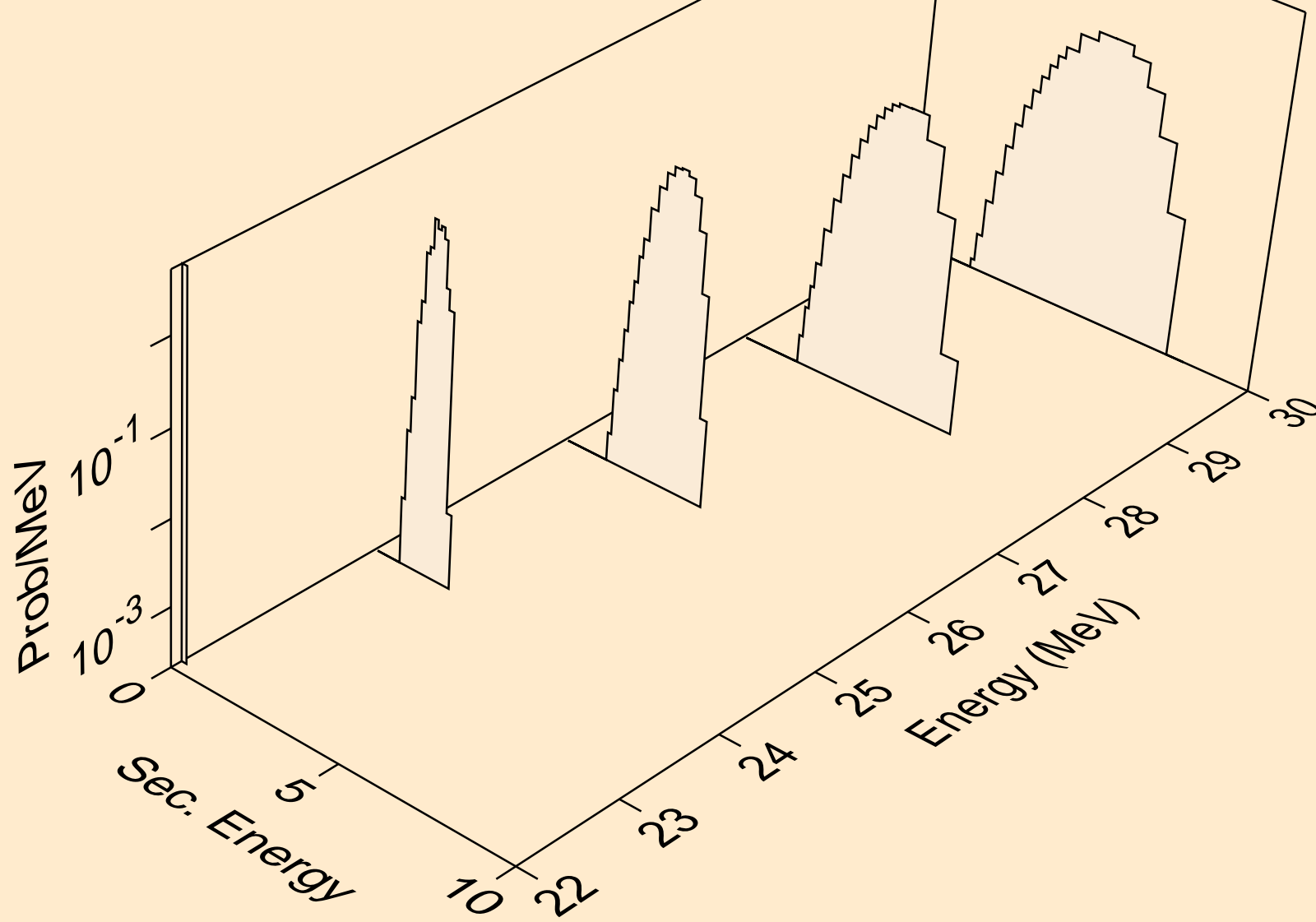

TC102M NEUTRON ACER TENDL-2024 LIBRARY; T=0.K
protons from (n,n2p)

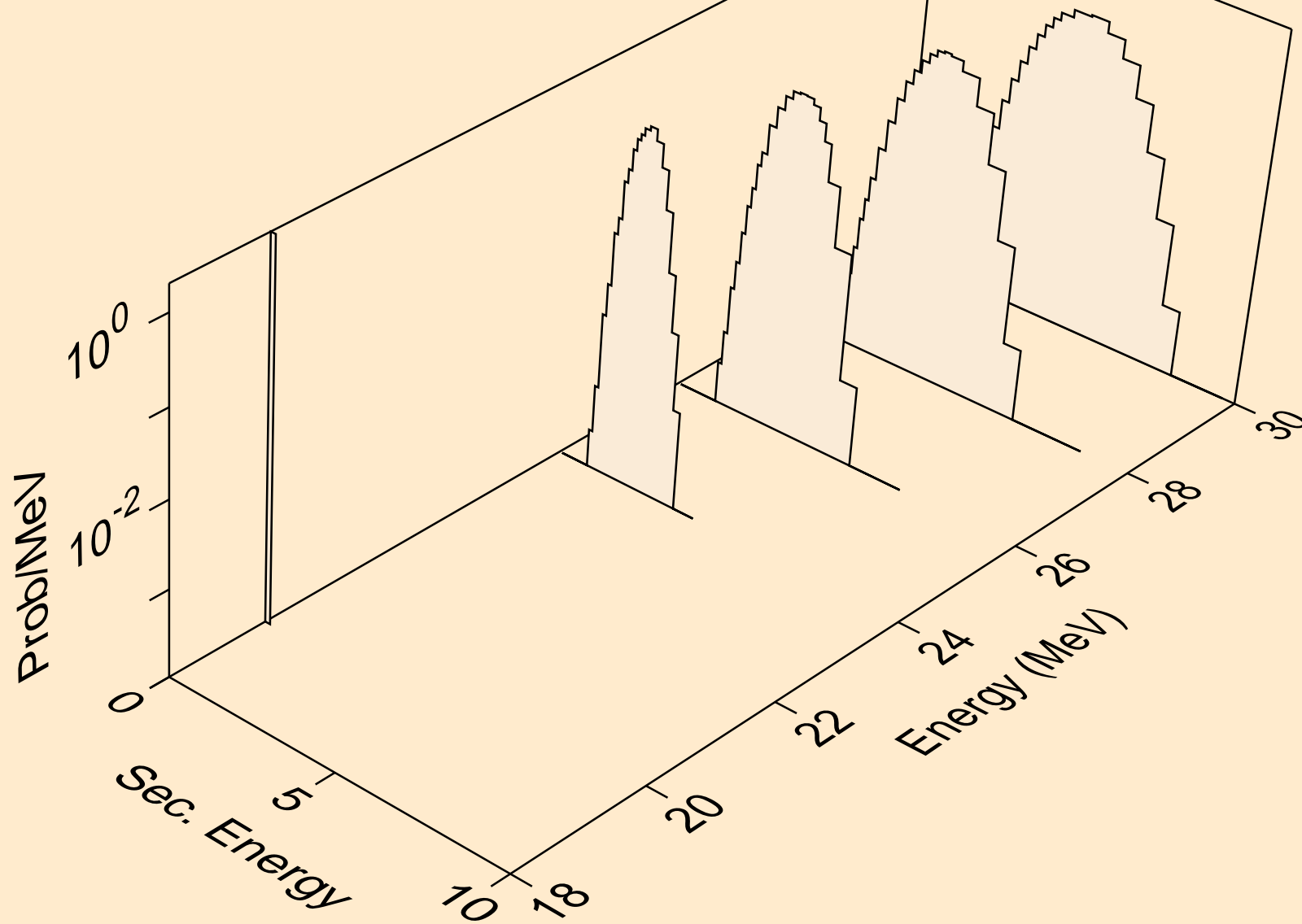

TC102M NEUTRON ACER TENDL-2024 LIBRARY; T=0.K
protons from (n,npa)

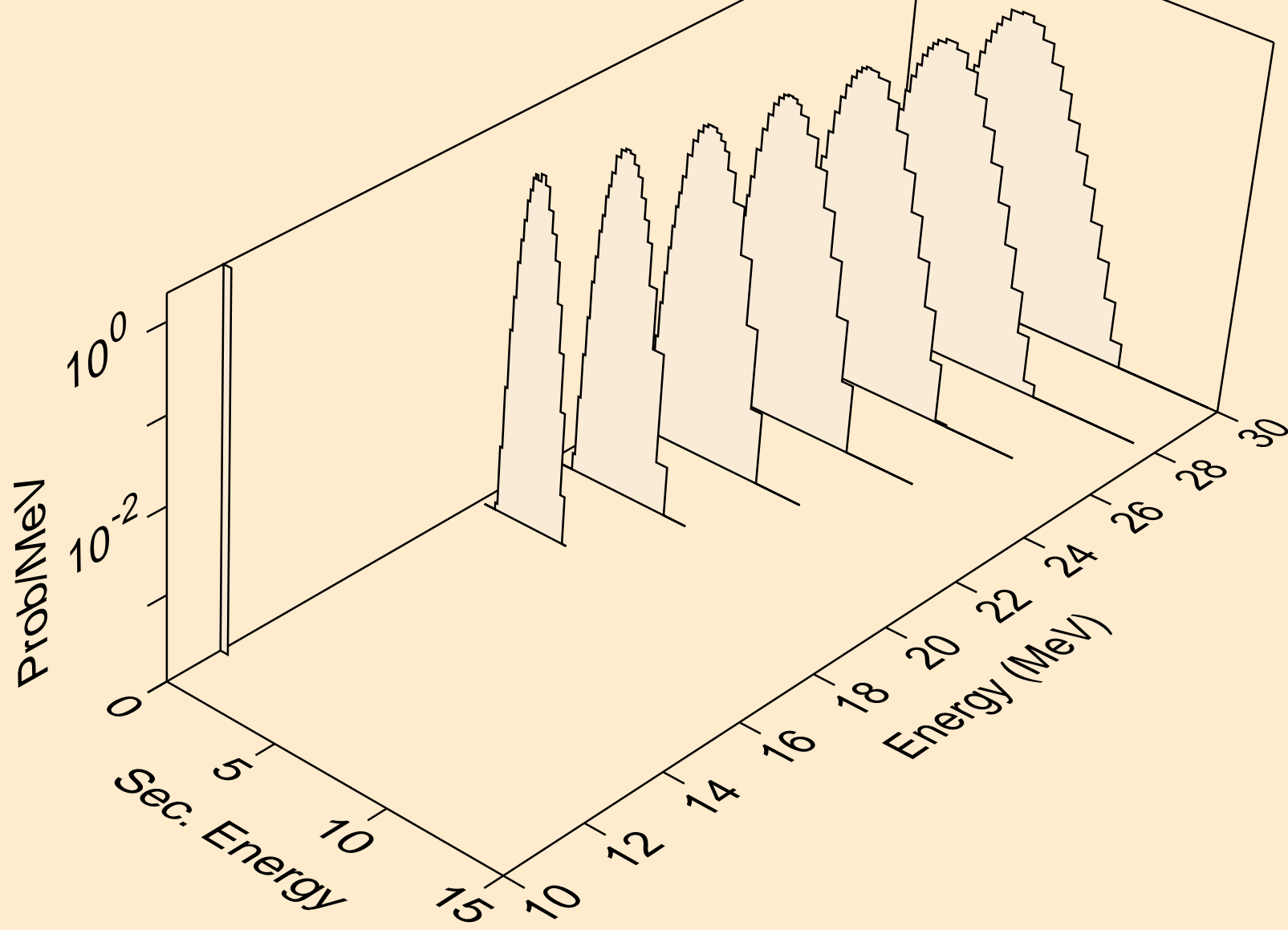

TC102M NEUTRON ACER TENDL-2024 LIBRARY; T=0.K
protons from (n,p)

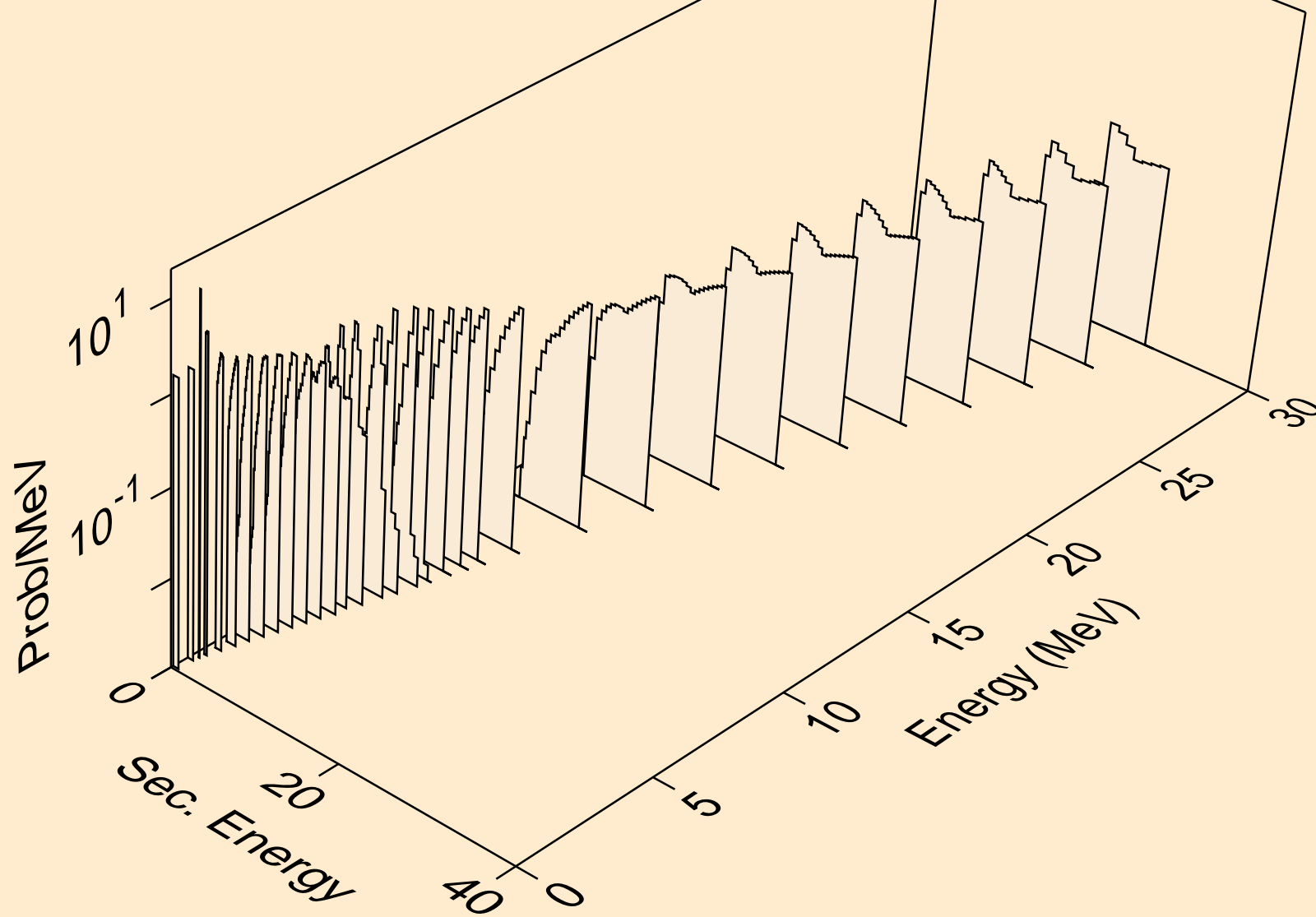

TC102M NEUTRON ACER TENDL-2024 LIBRARY; T=0.K
protons from (n,2p)

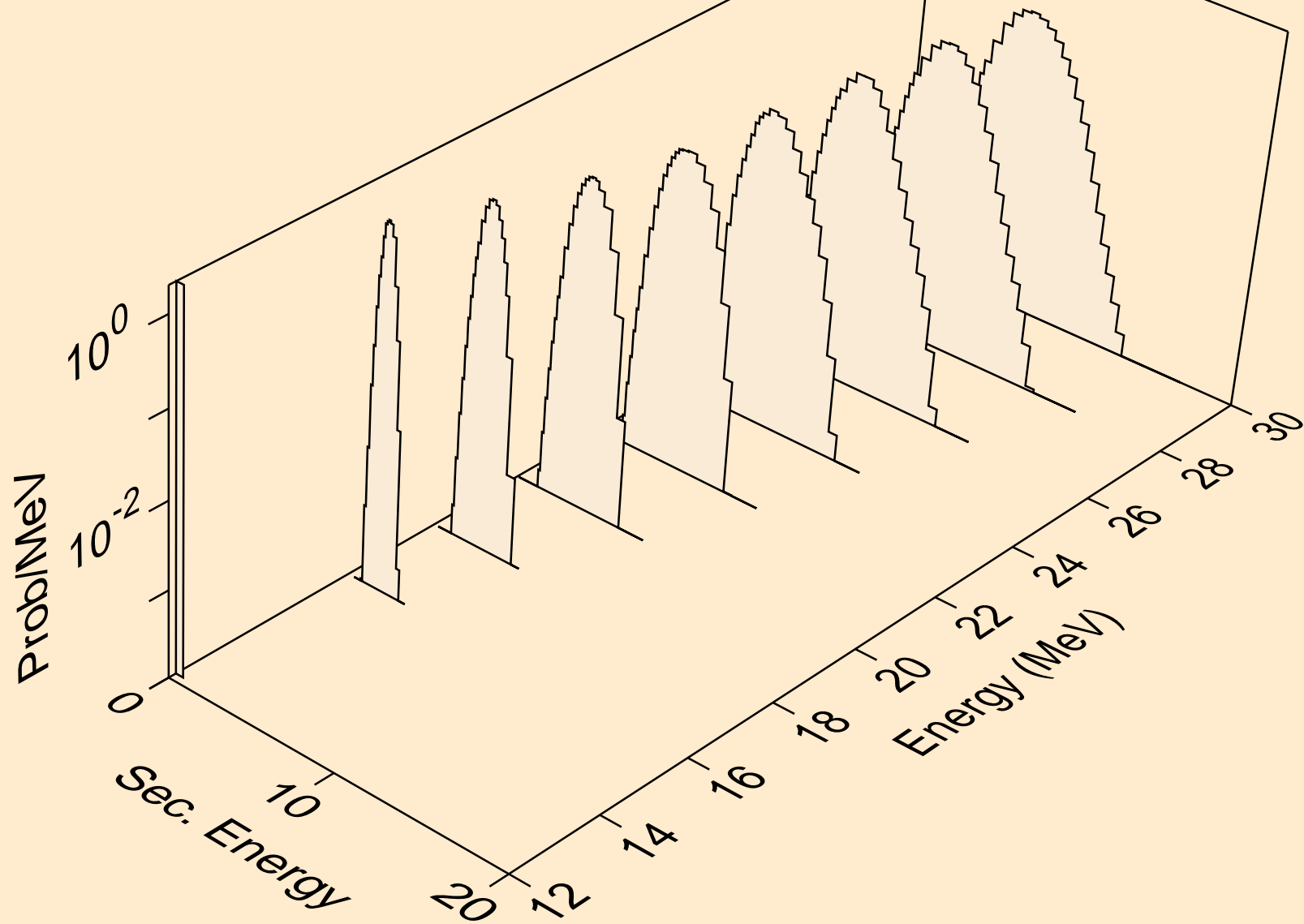

TC102M NEUTRON ACER TENDL-2024 LIBRARY; T=0.K
protons from (n,p)

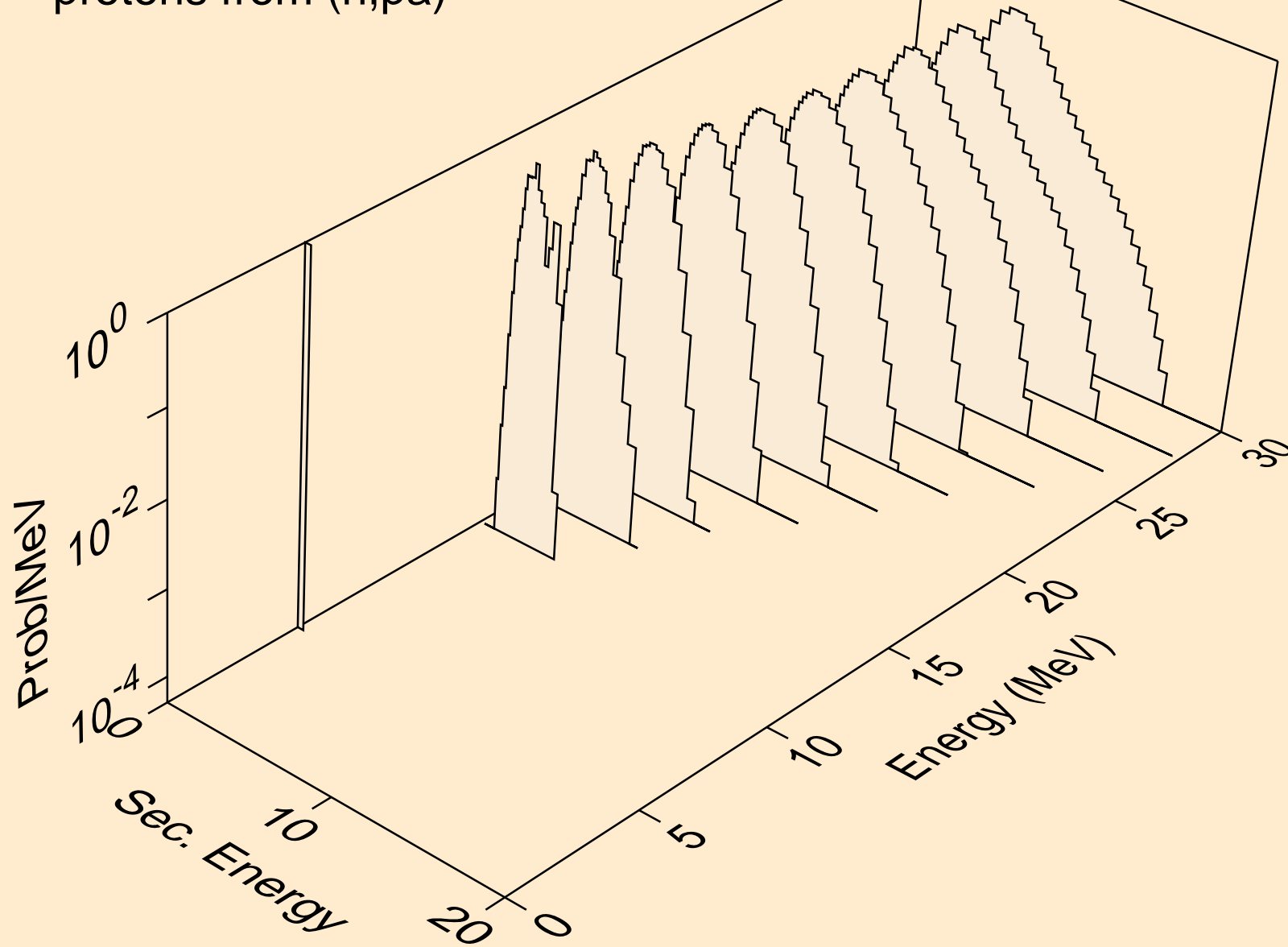

TC102M NEUTRON ACER TENDL-2024 LIBRARY; T=0.K
protons from (n,pd)

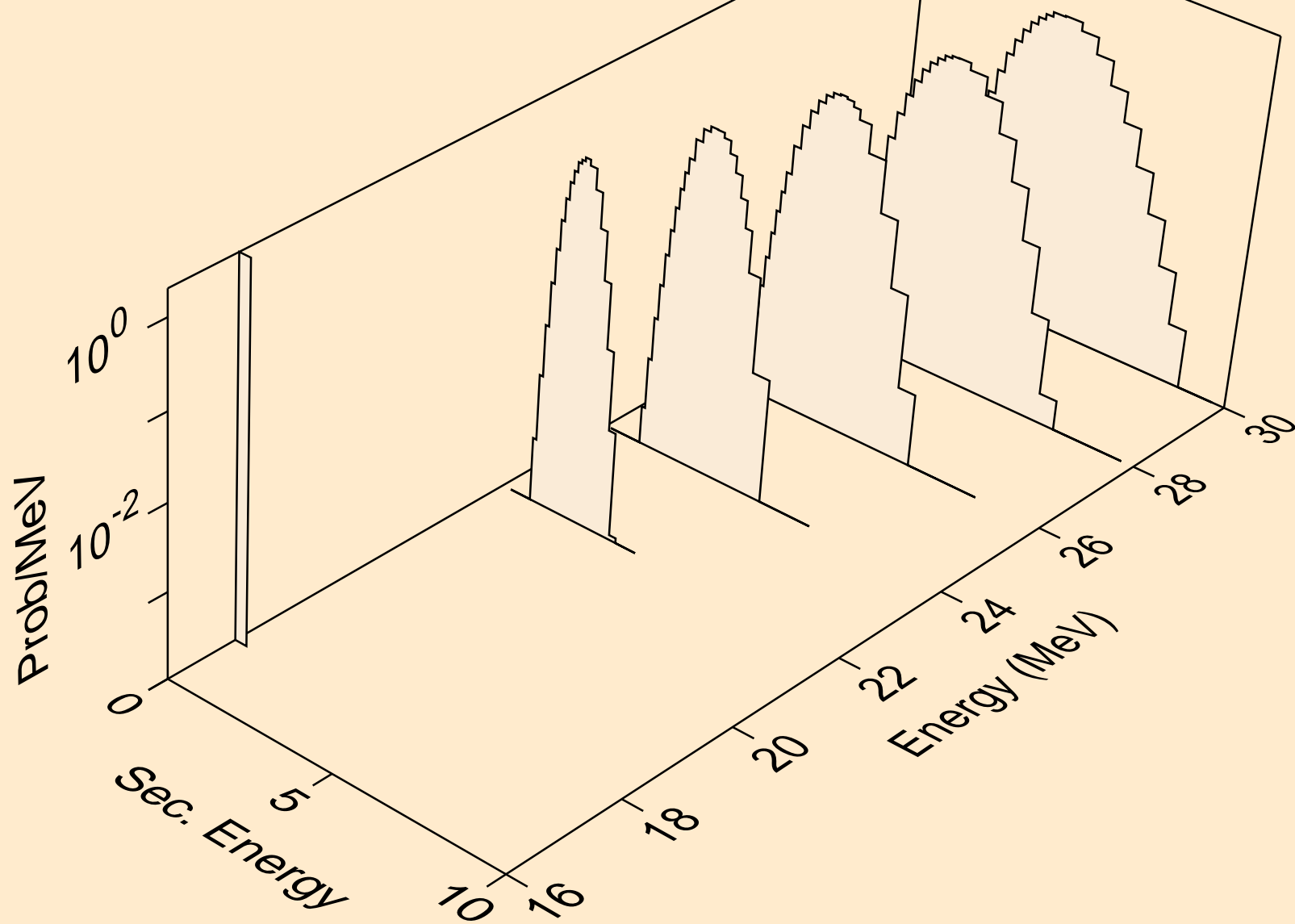

TC102M NEUTRON ACER TENDL-2024 LIBRARY; T=0.K
protons from (n,pt)

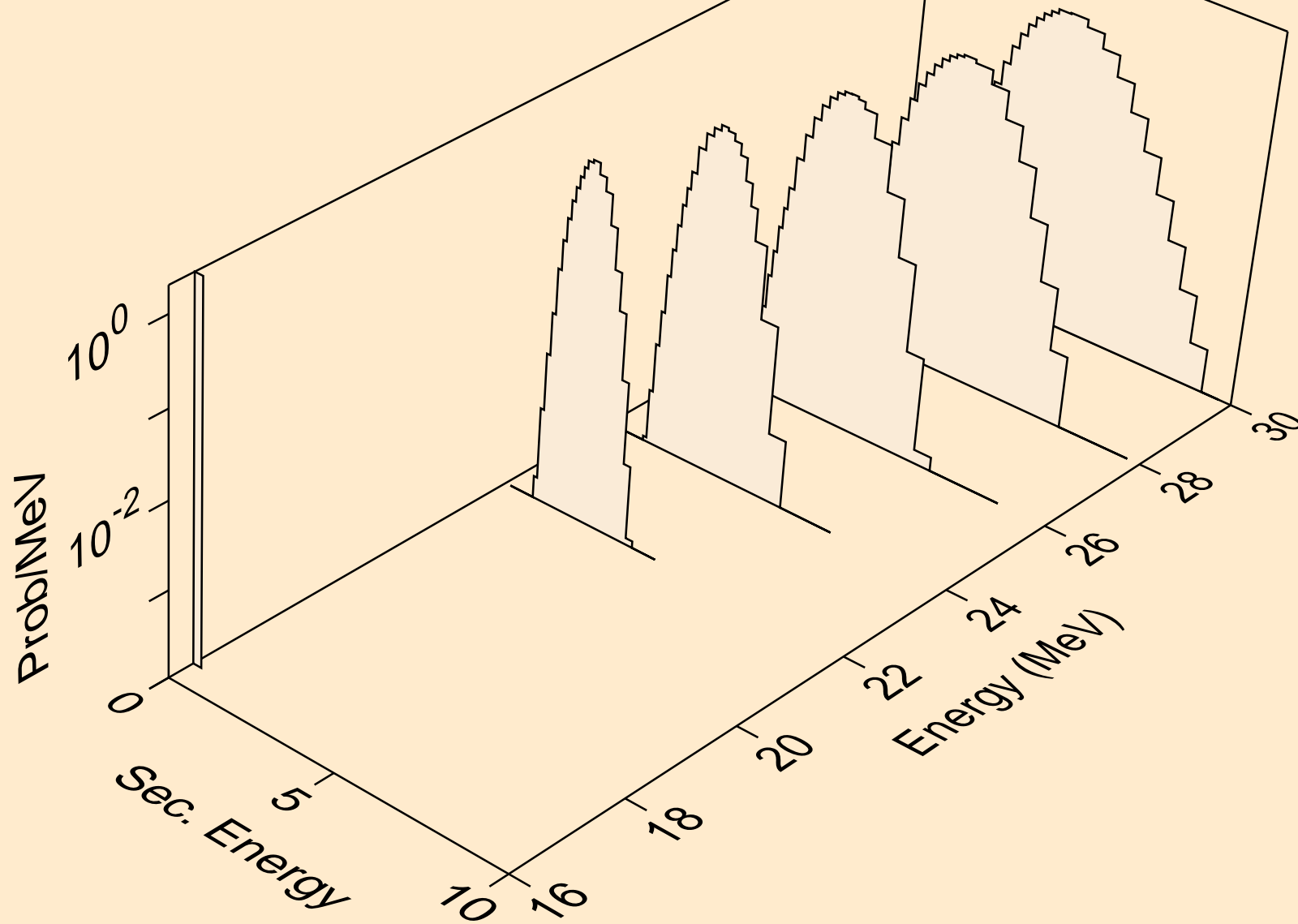

TC102M NEUTRON ACER TENDL-2024 LIBRARY; T=0.K
deuterons from (n,x)

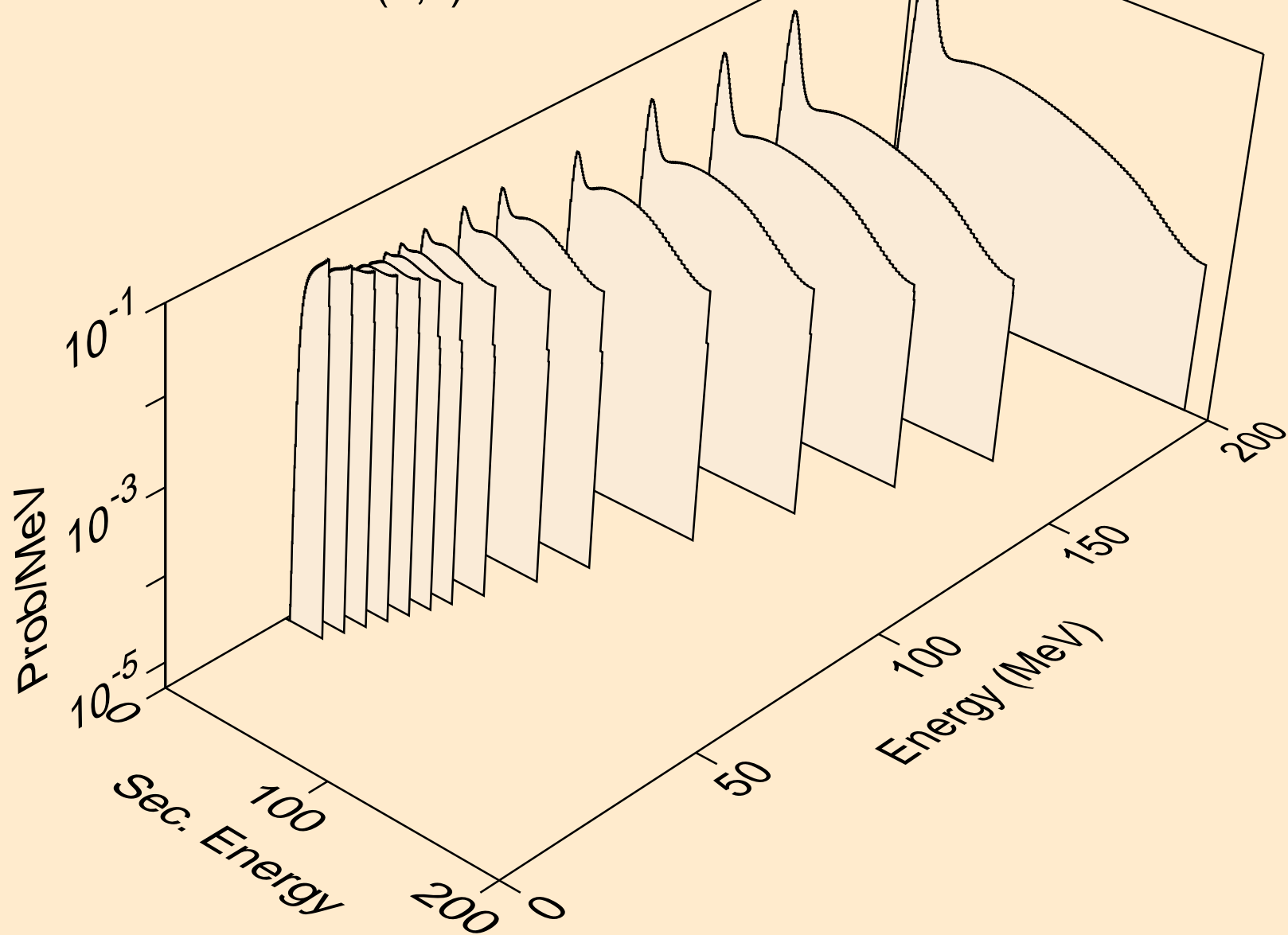

TC102M NEUTRON ACER TENDL-2024 LIBRARY; T=0.K
deuterons from (n,2nd)

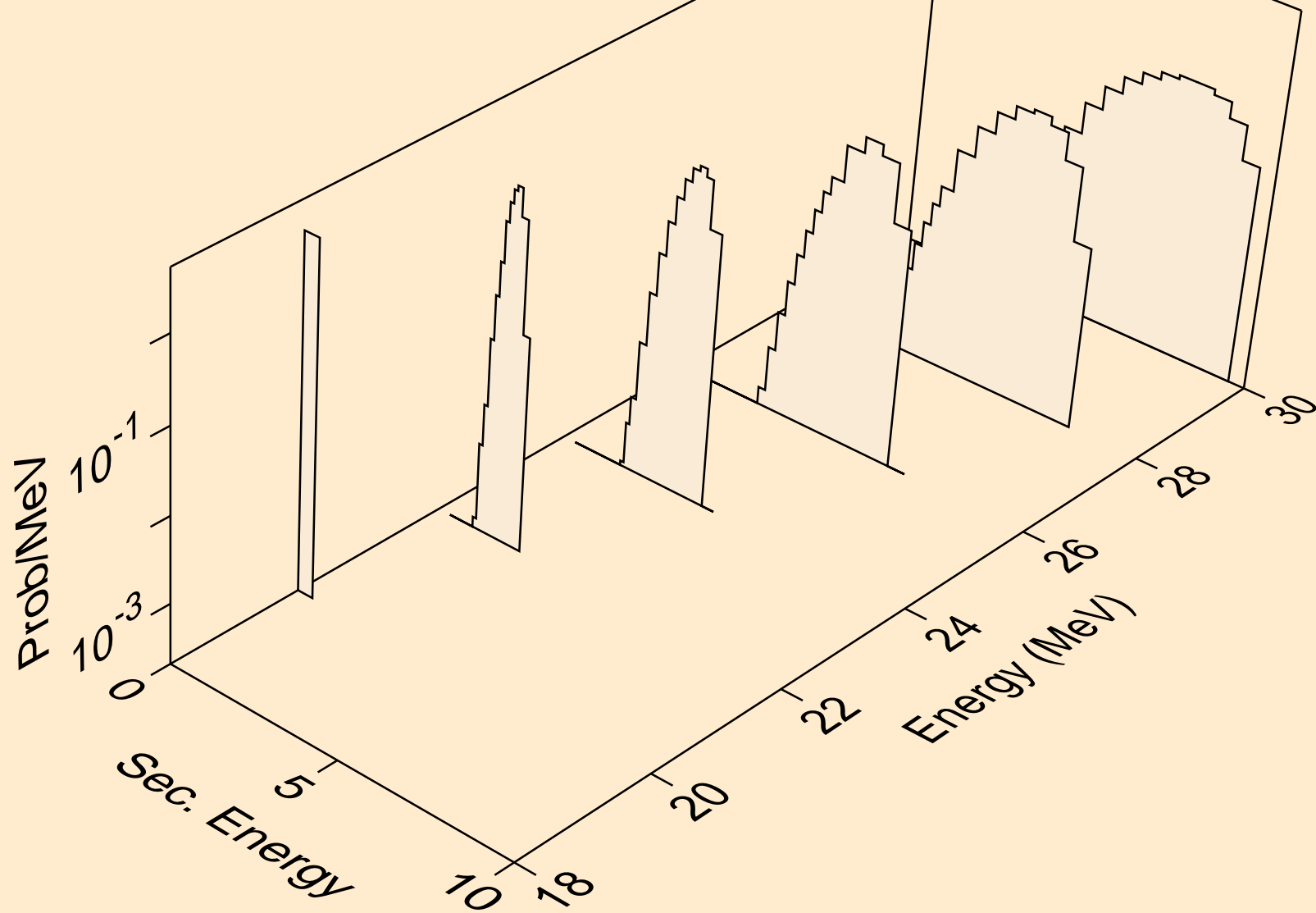

TC102M NEUTRON ACER TENDL-2024 LIBRARY; T=0.K
deuterons from (n,n*)d

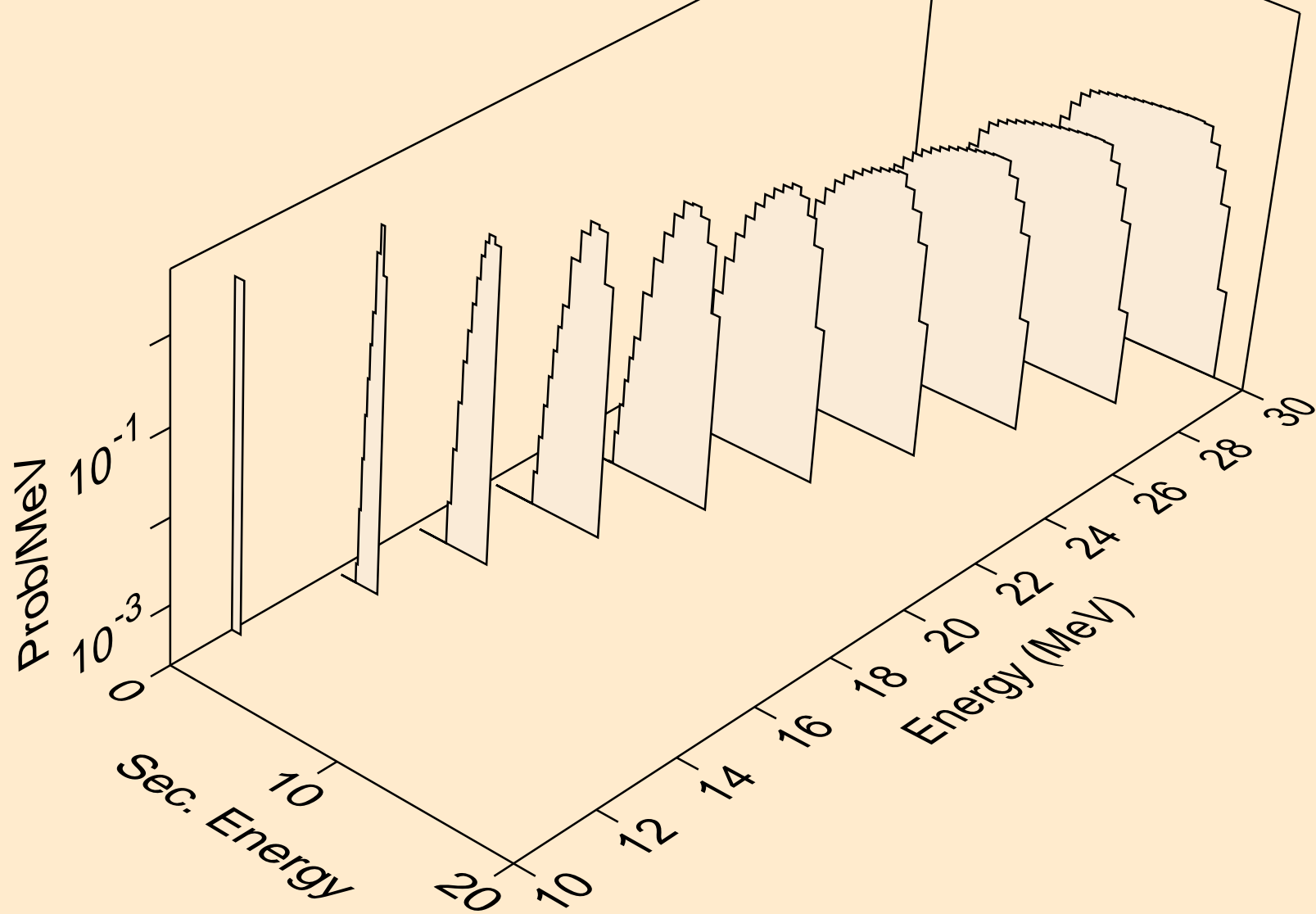

TC102M NEUTRON ACER TENDL-2024 LIBRARY; T=0.K
deuterons from (n,d)

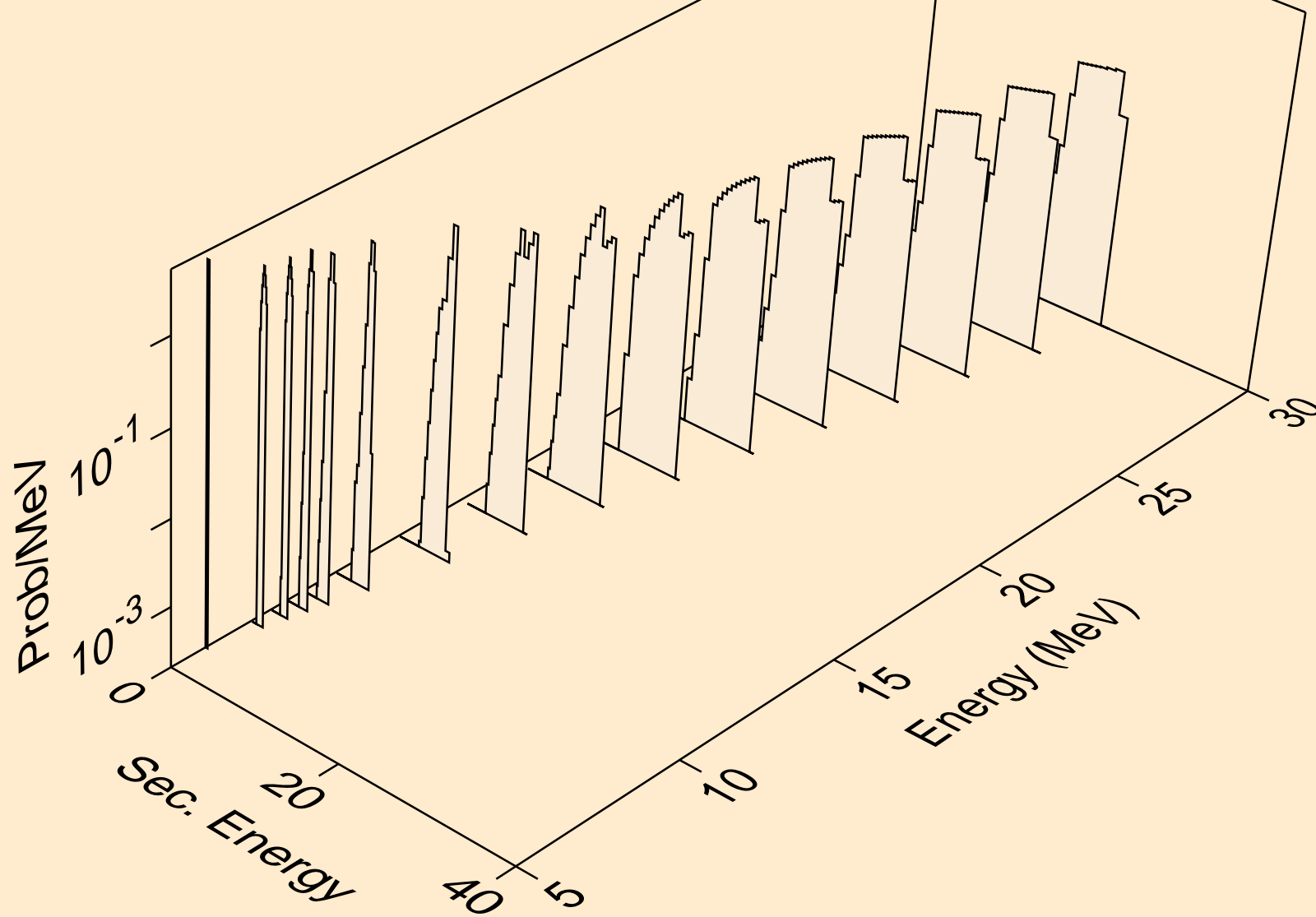

TC102M NEUTRON ACER TENDL-2024 LIBRARY; T=0.K
deuterons from (n,pd)

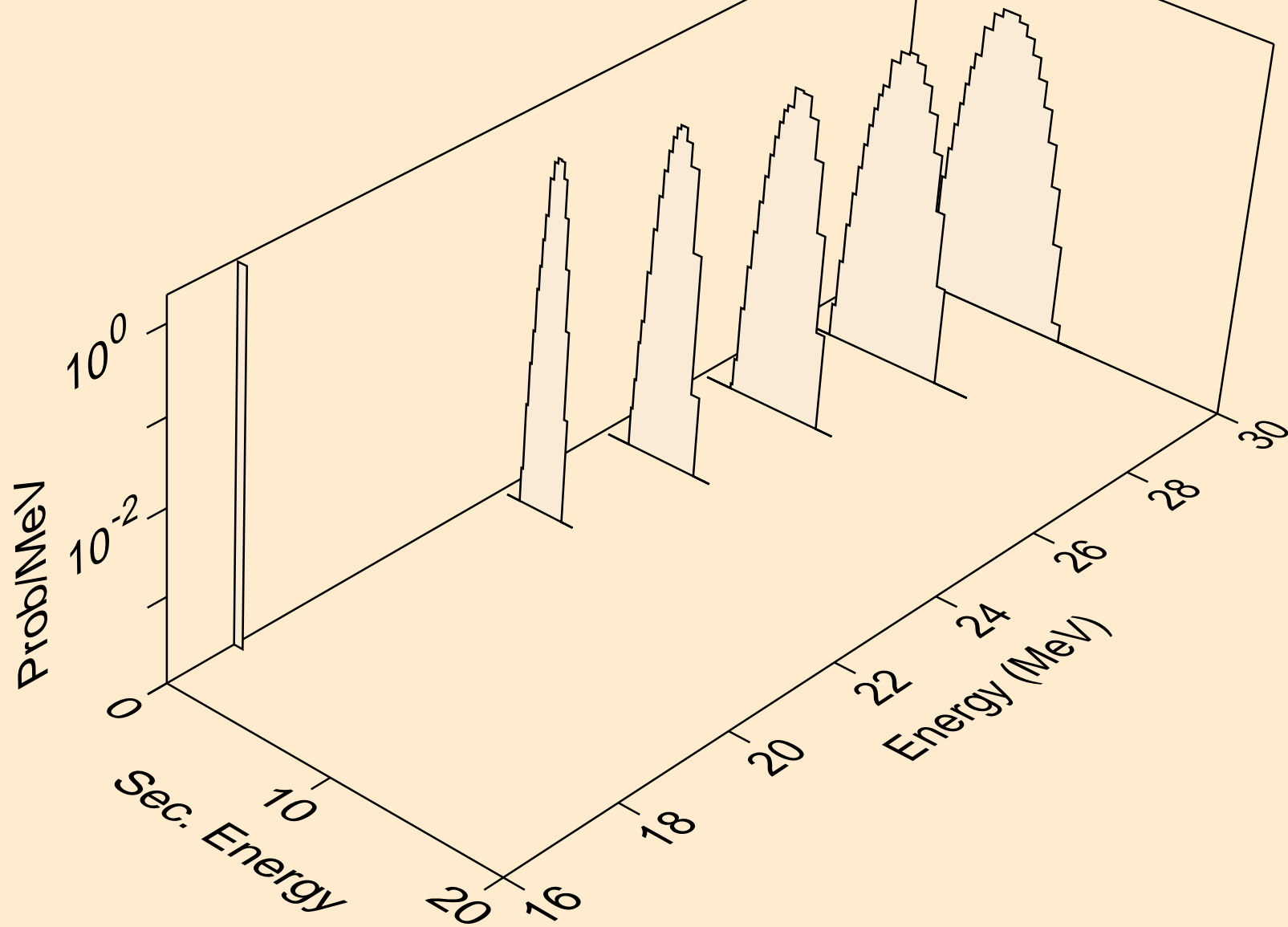

TC102M NEUTRON ACER TENDL-2024 LIBRARY; T=0.K
deuterons from (n,da)

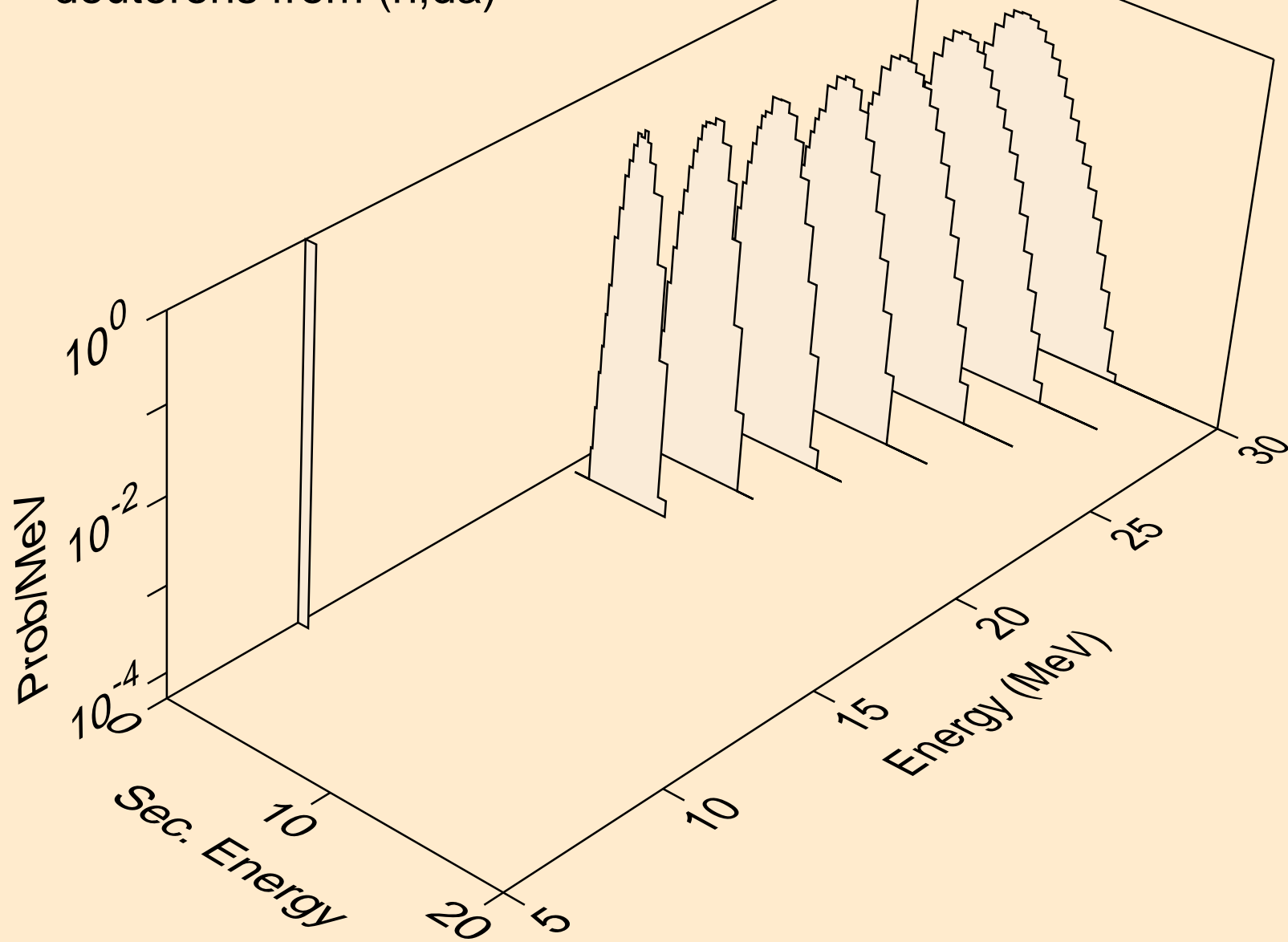

TC102M NEUTRON ACER TENDL-2024 LIBRARY; T=0.K
tritons from (n,x)

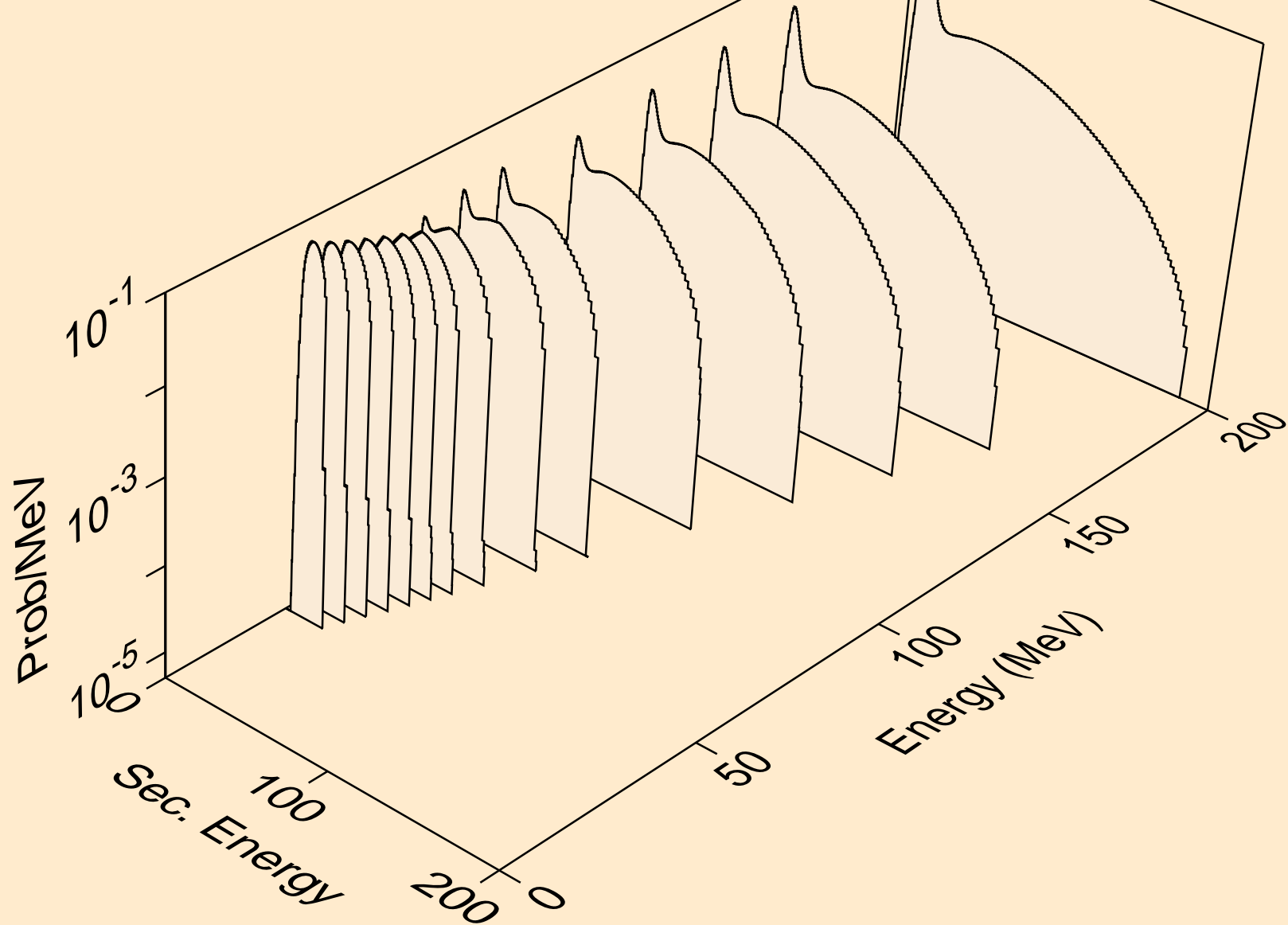

TC102M NEUTRON ACER TENDL-2024 LIBRARY; T=0.K
tritons from (n,n*)t

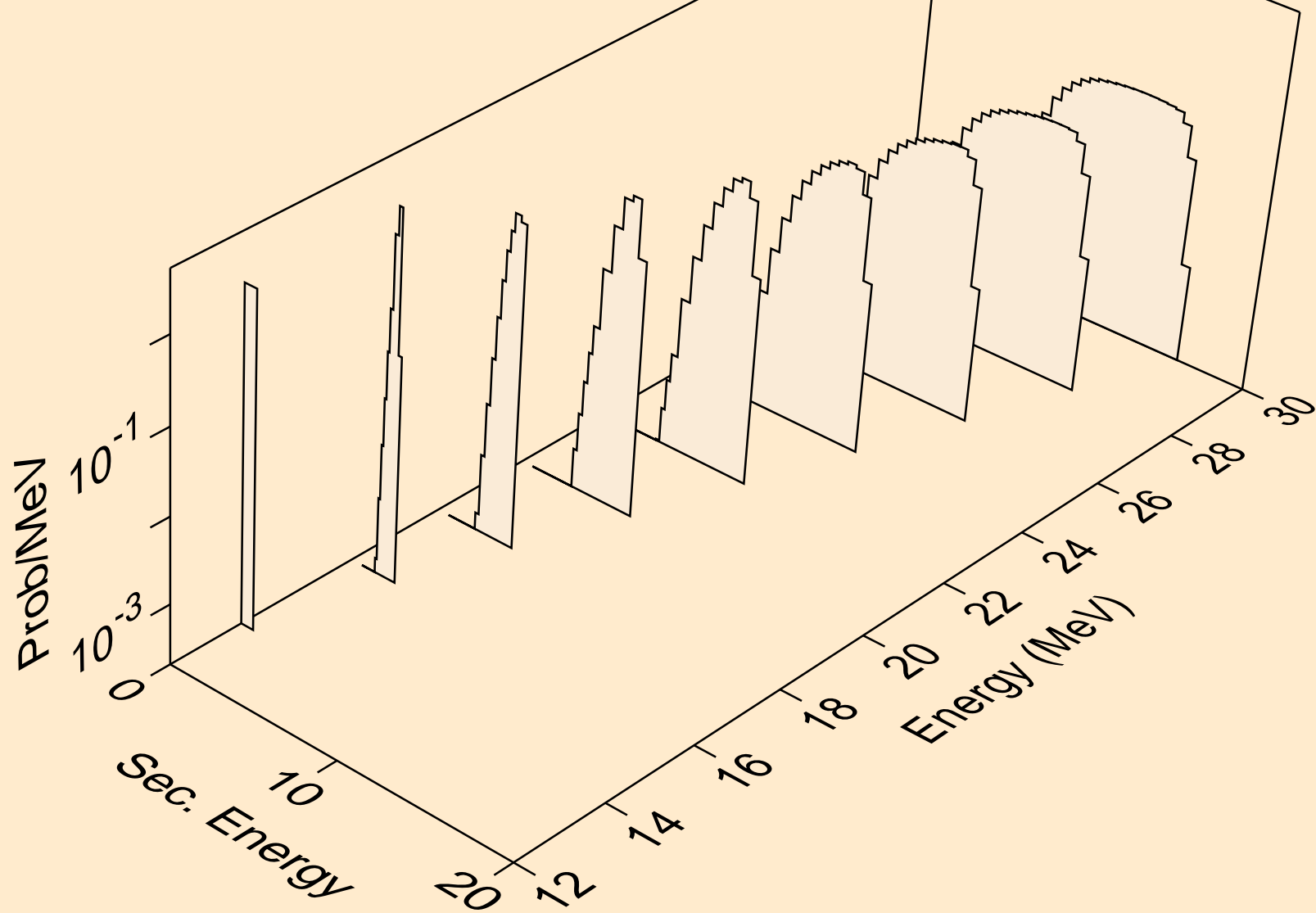

TC102M NEUTRON ACER TENDL-2024 LIBRARY; T=0.K
tritons from (n,t)

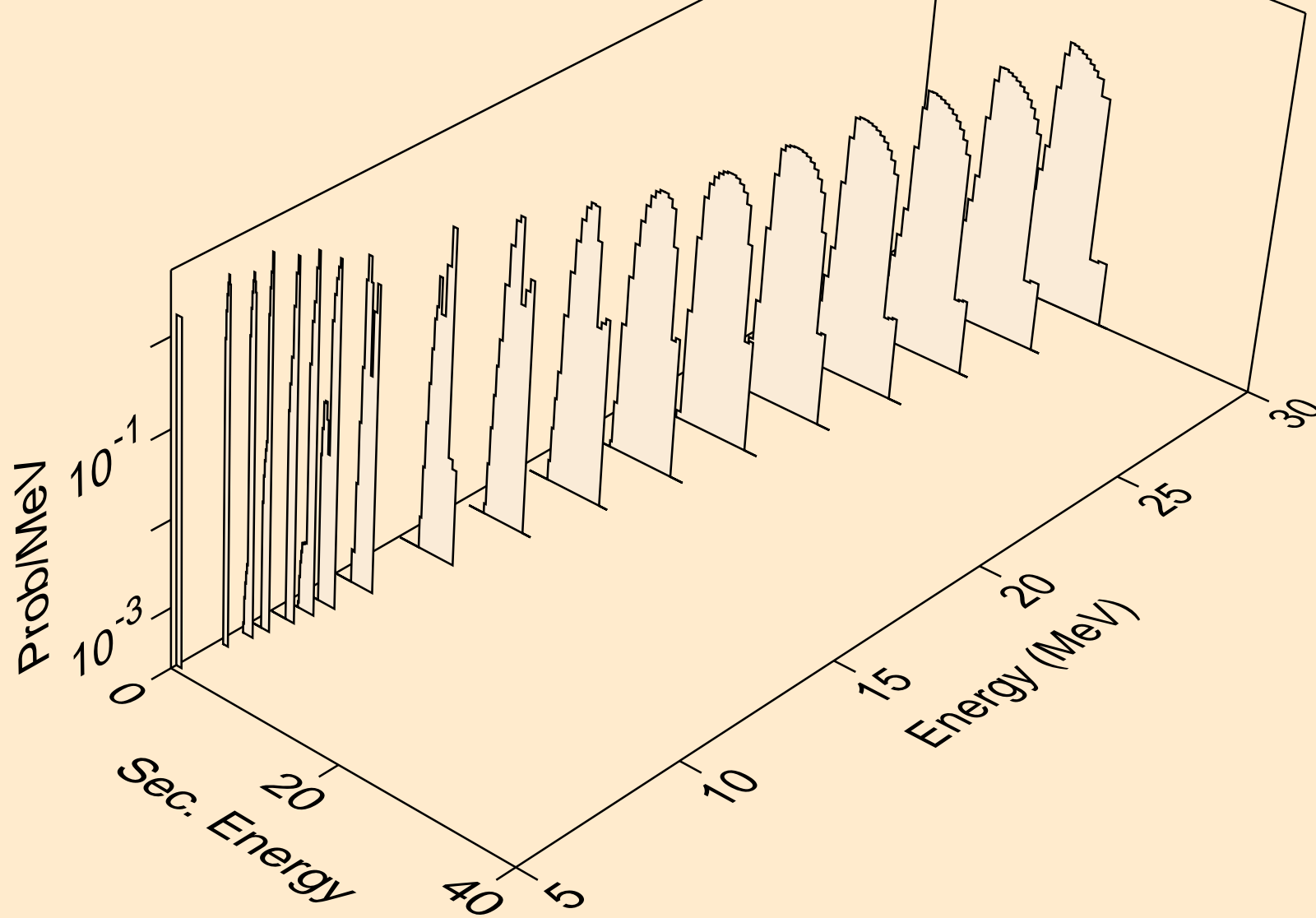

TC102M NEUTRON ACER TENDL-2024 LIBRARY; T=0.K
tritons from (n,pt)

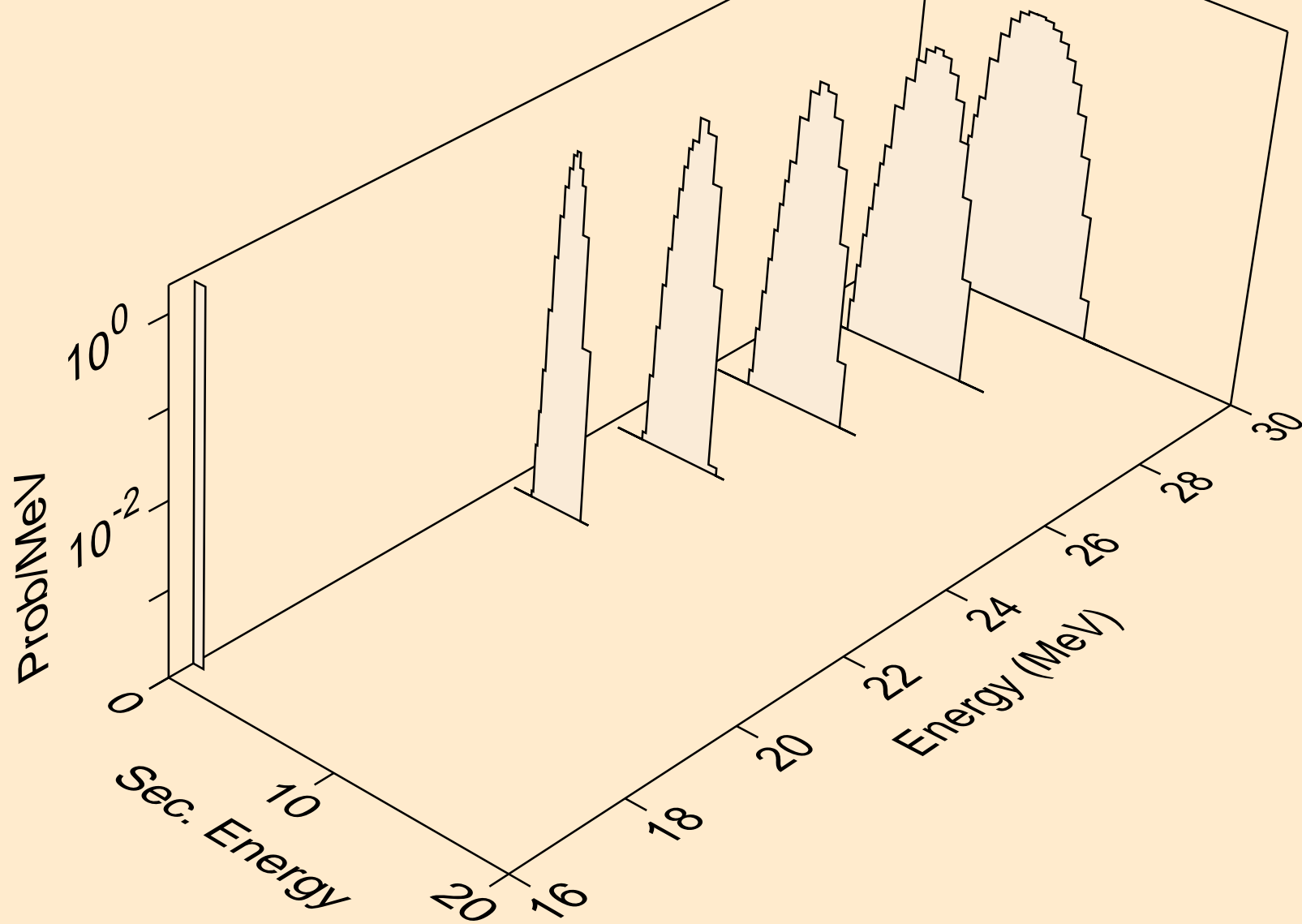

TC102M NEUTRON ACER TENDL-2024 LIBRARY; T=0.K
he3s from (n,x)

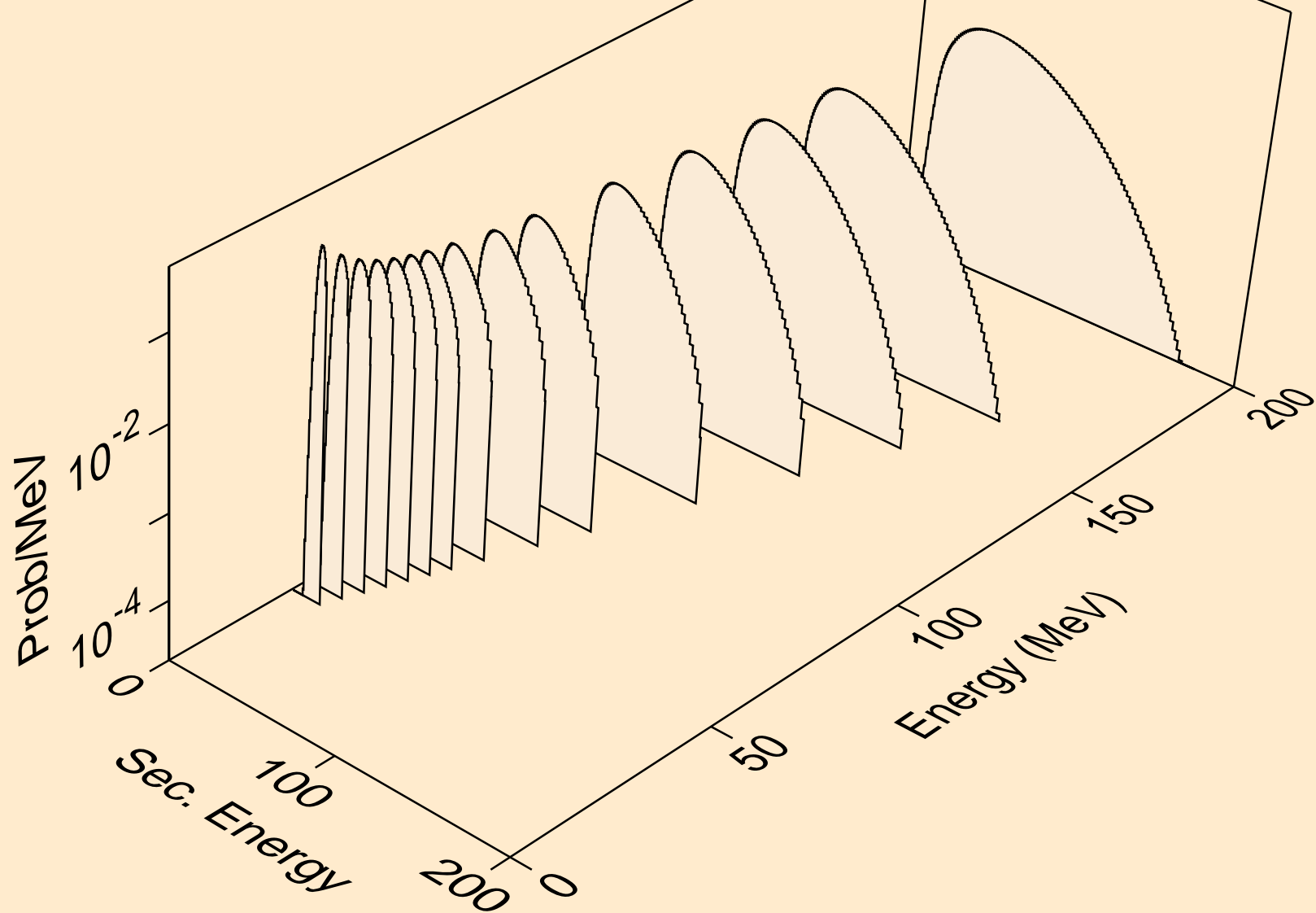

TC102M NEUTRON ACER TENDL-2024 LIBRARY; T=0.K
he3s from (n,n*)he3

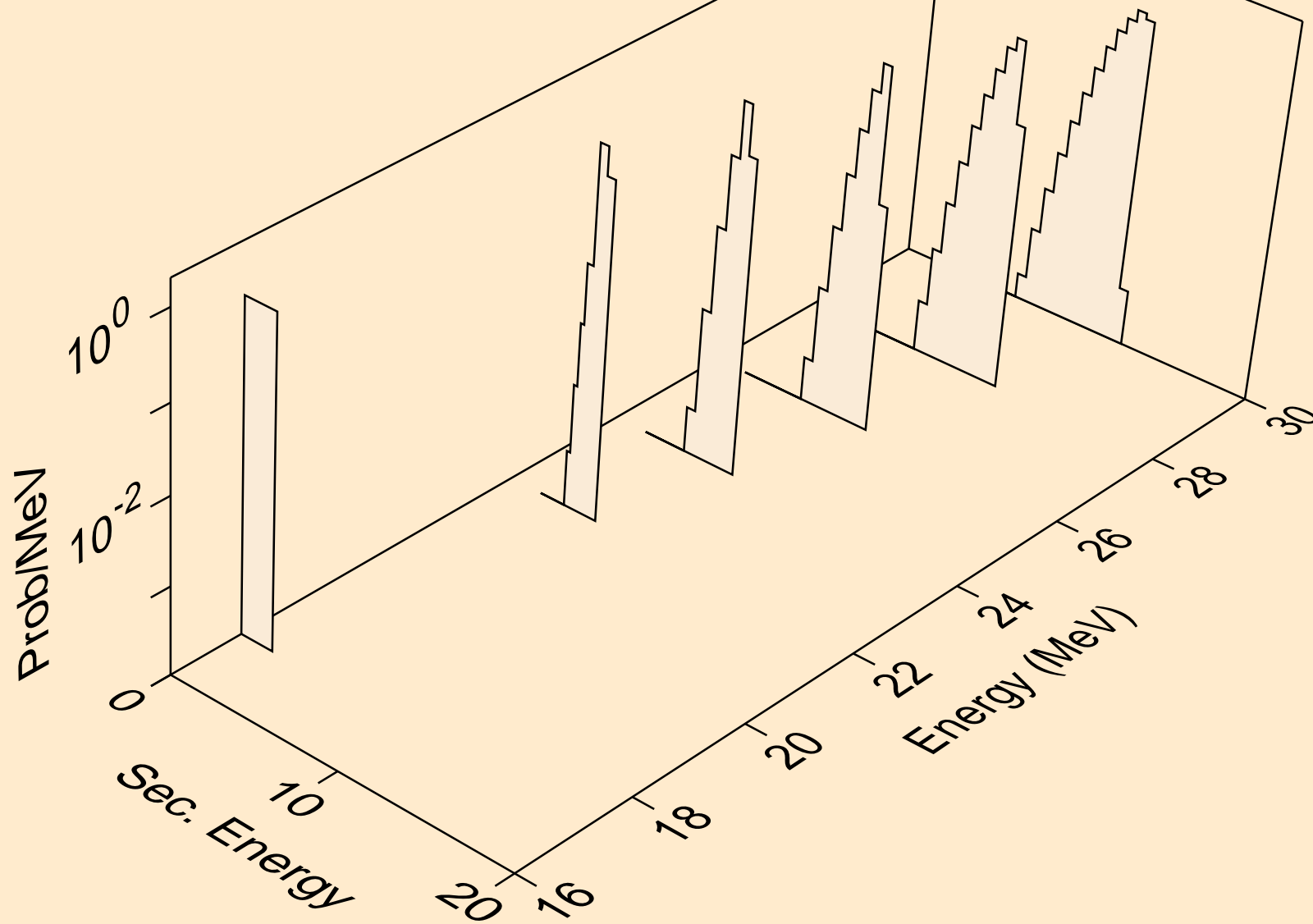

TC102M NEUTRON ACER TENDL-2024 LIBRARY; T=0.K
he3s from (n,he3)

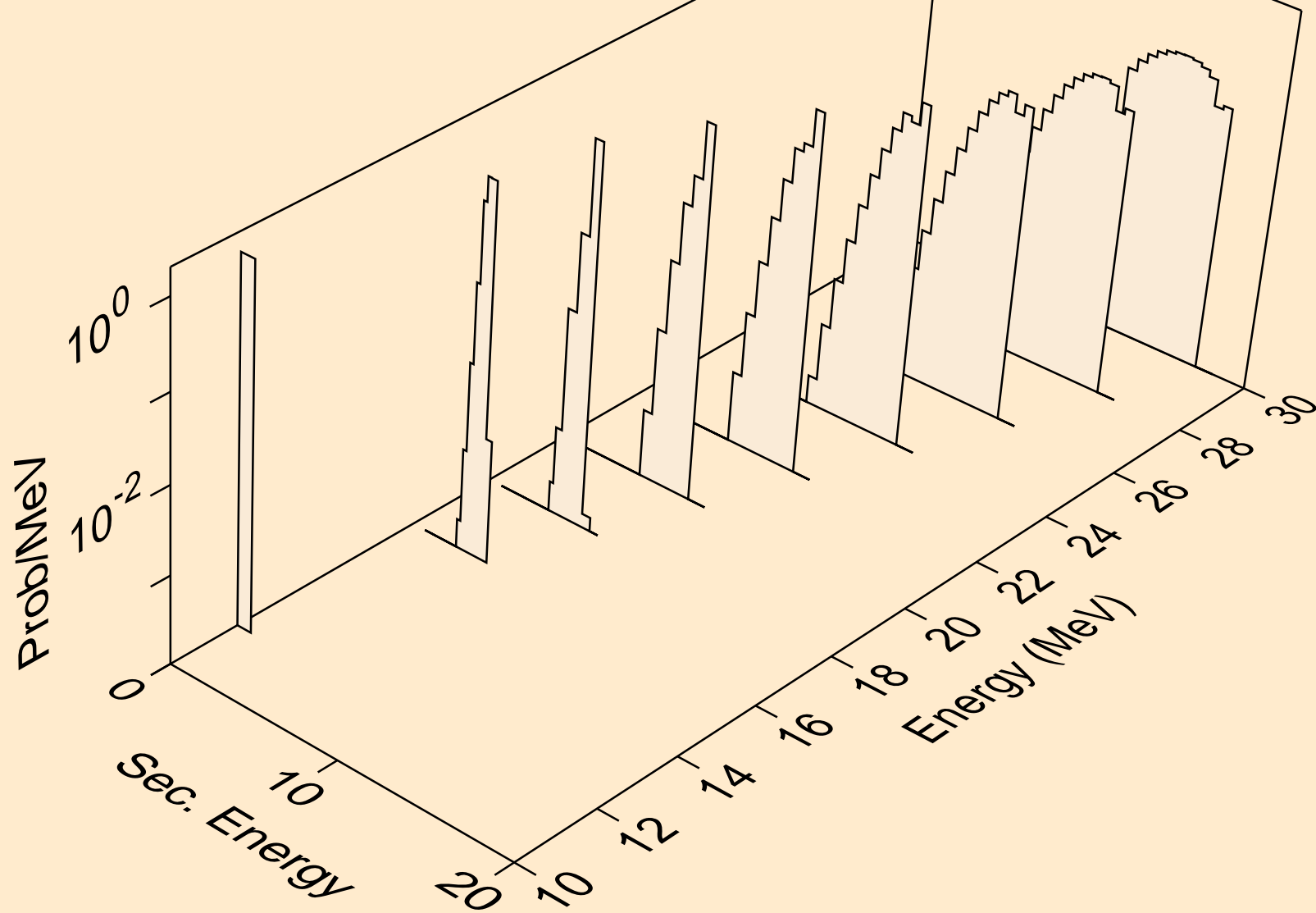

TC102M NEUTRON ACER TENDL-2024 LIBRARY; T=0.K
alphas from (n,x)

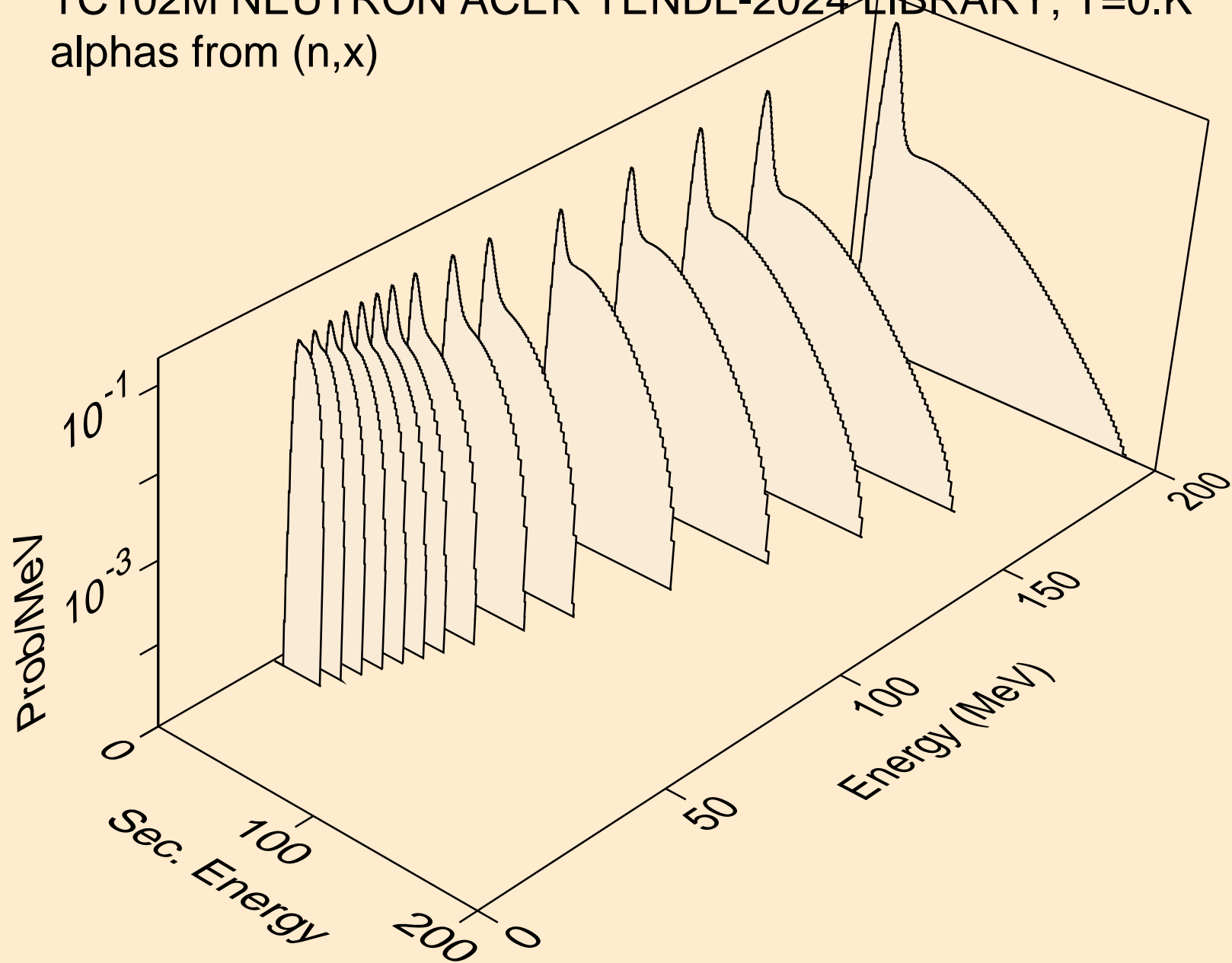

TC102M NEUTRON ACER TENDL-2024 LIBRARY; T=0.K
alphas from (n,n*)a

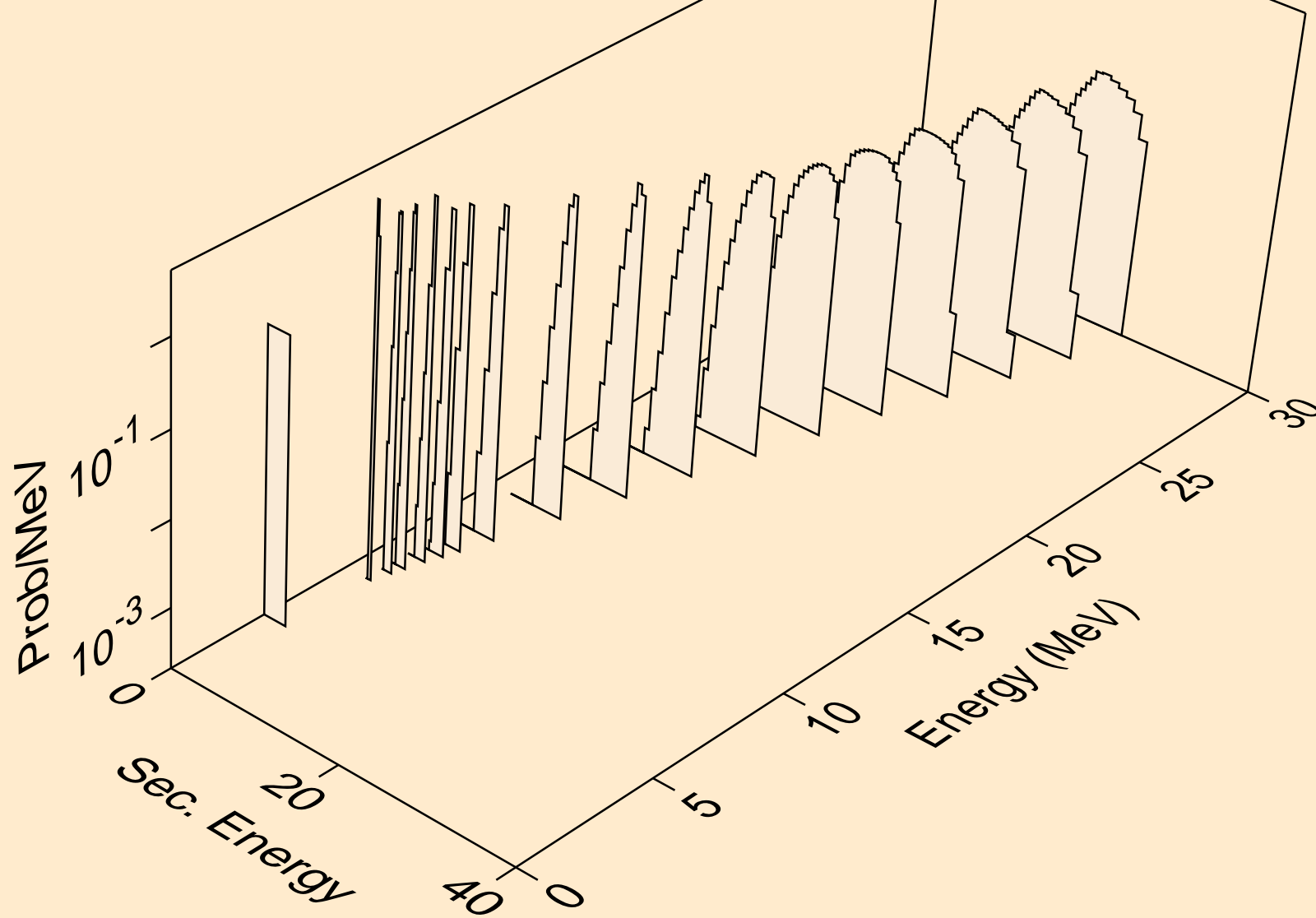

TC102M NEUTRON ACER TENDL-2024 LIBRARY; T=0.K
alphas from (n,2n)a

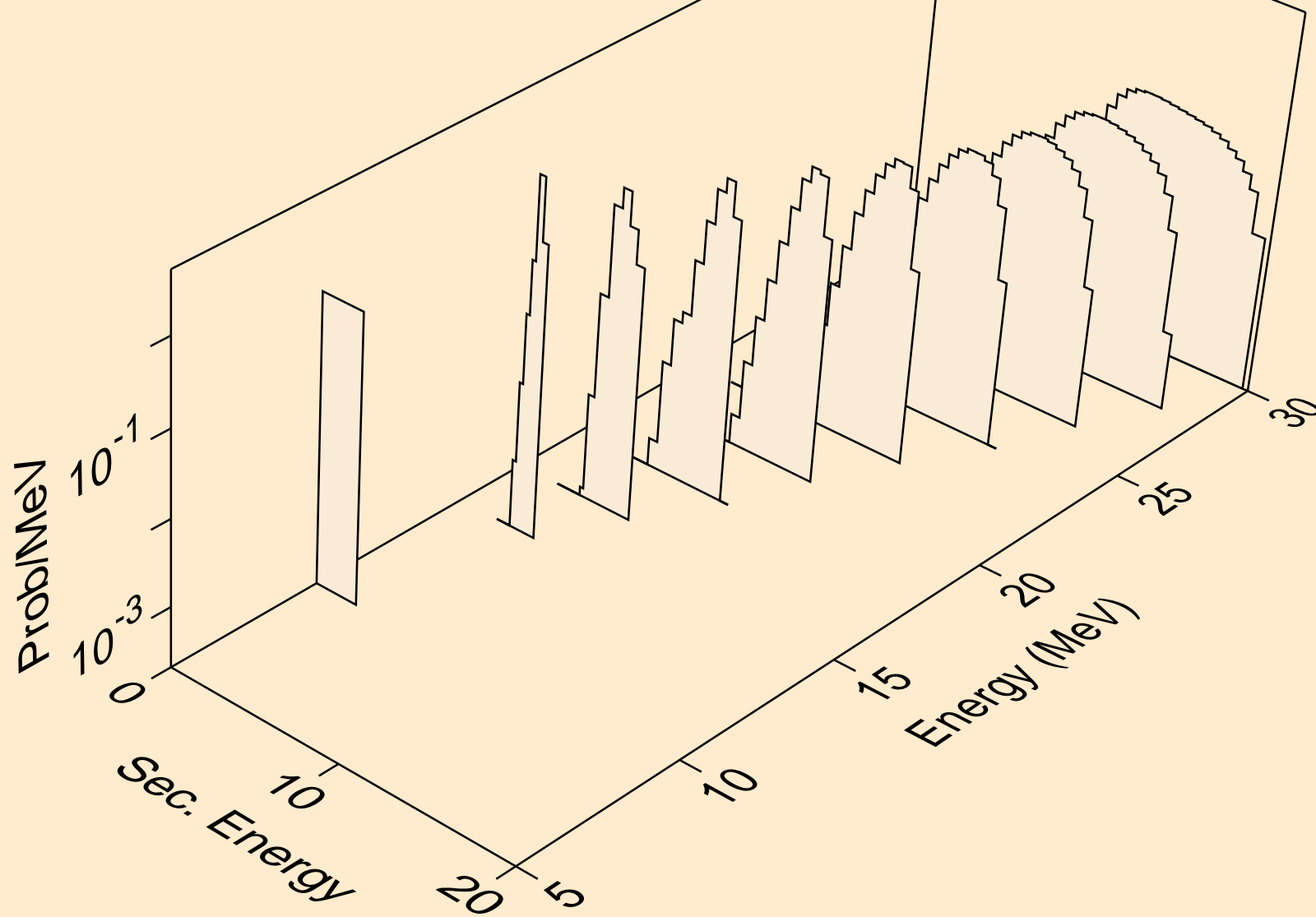

TC102M NEUTRON ACER TENDL-2024 LIBRARY; T=0.K
alphas from (n,3n)a

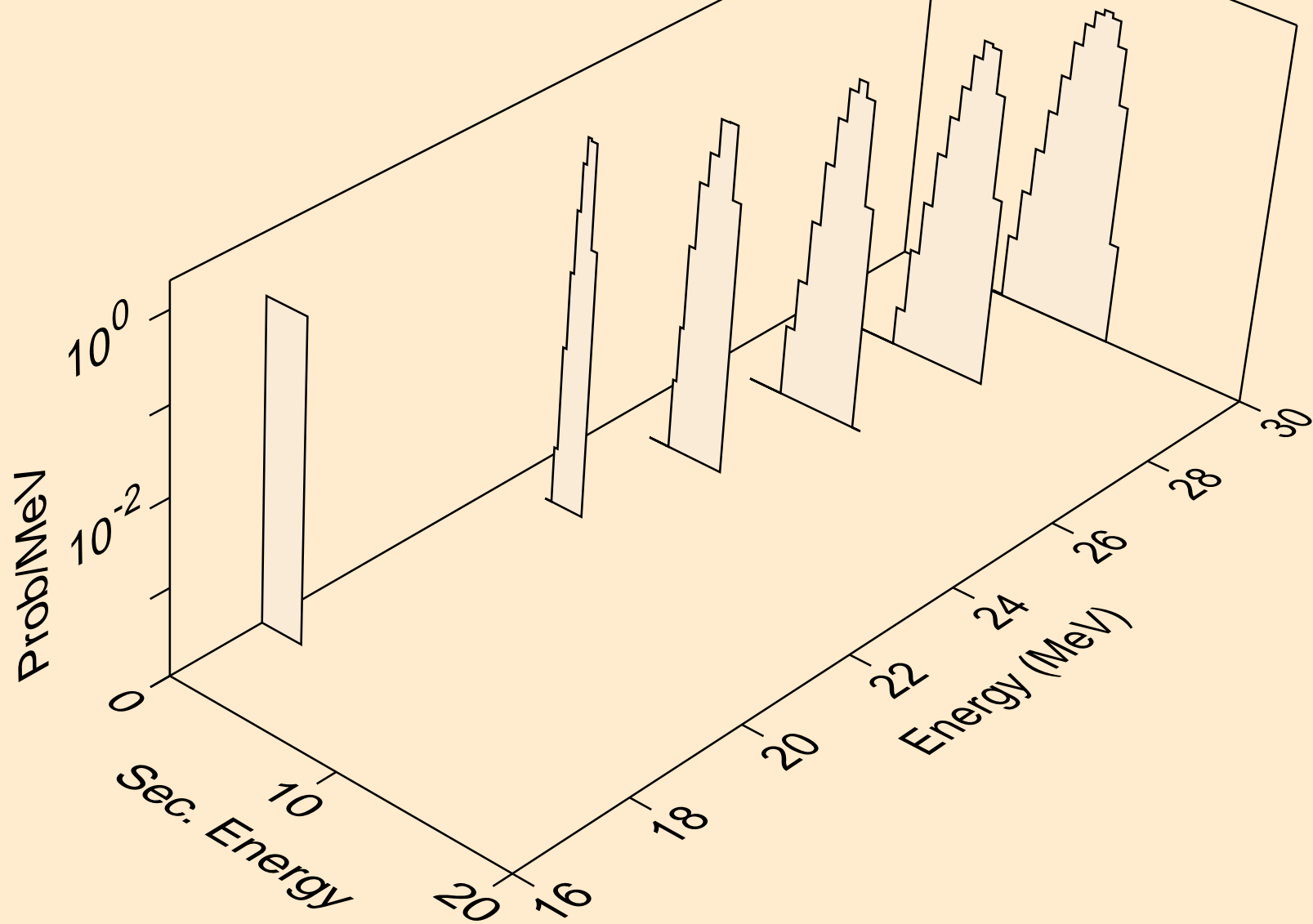

TC102M NEUTRON ACER TENDL-2024 LIBRARY; T=0.K
alphas from (n,n*)2a

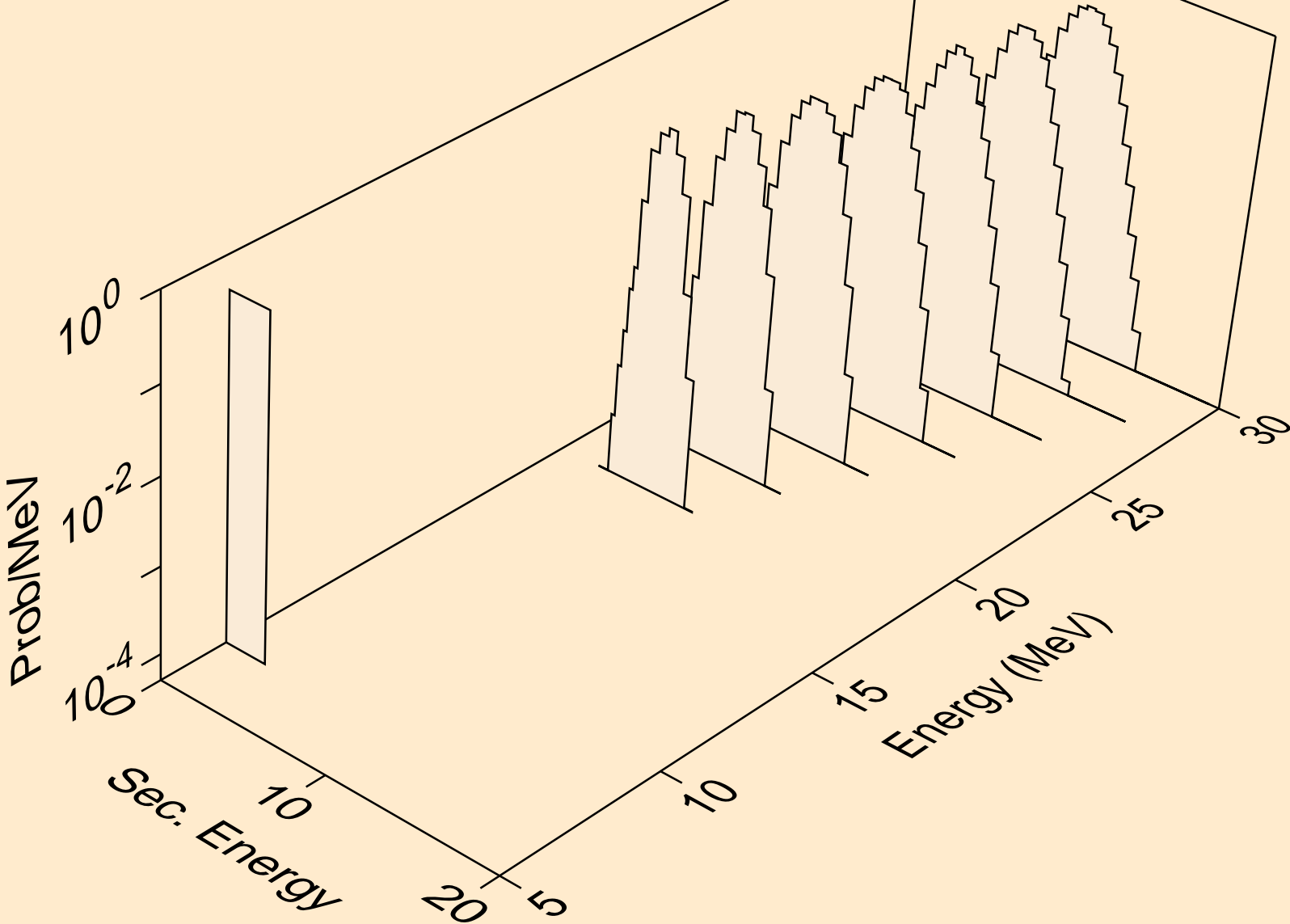

TC102M NEUTRON ACER TENDL-2024 LIBRARY; T=0.K
alphas from (n,npa)

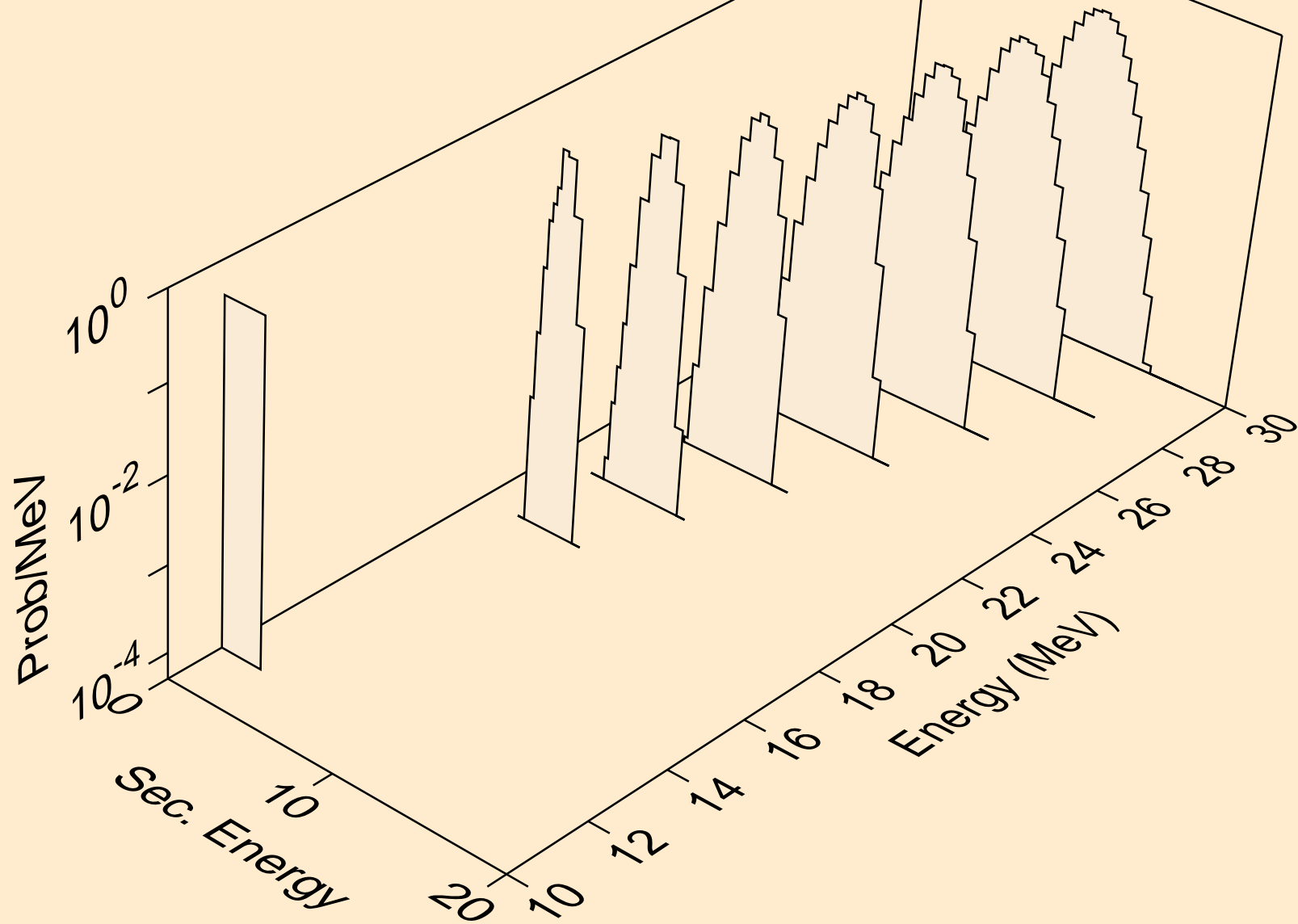

TC102M NEUTRON ACER TENDL-2024 LIBRARY; T=0.K
alphas from (n,a)

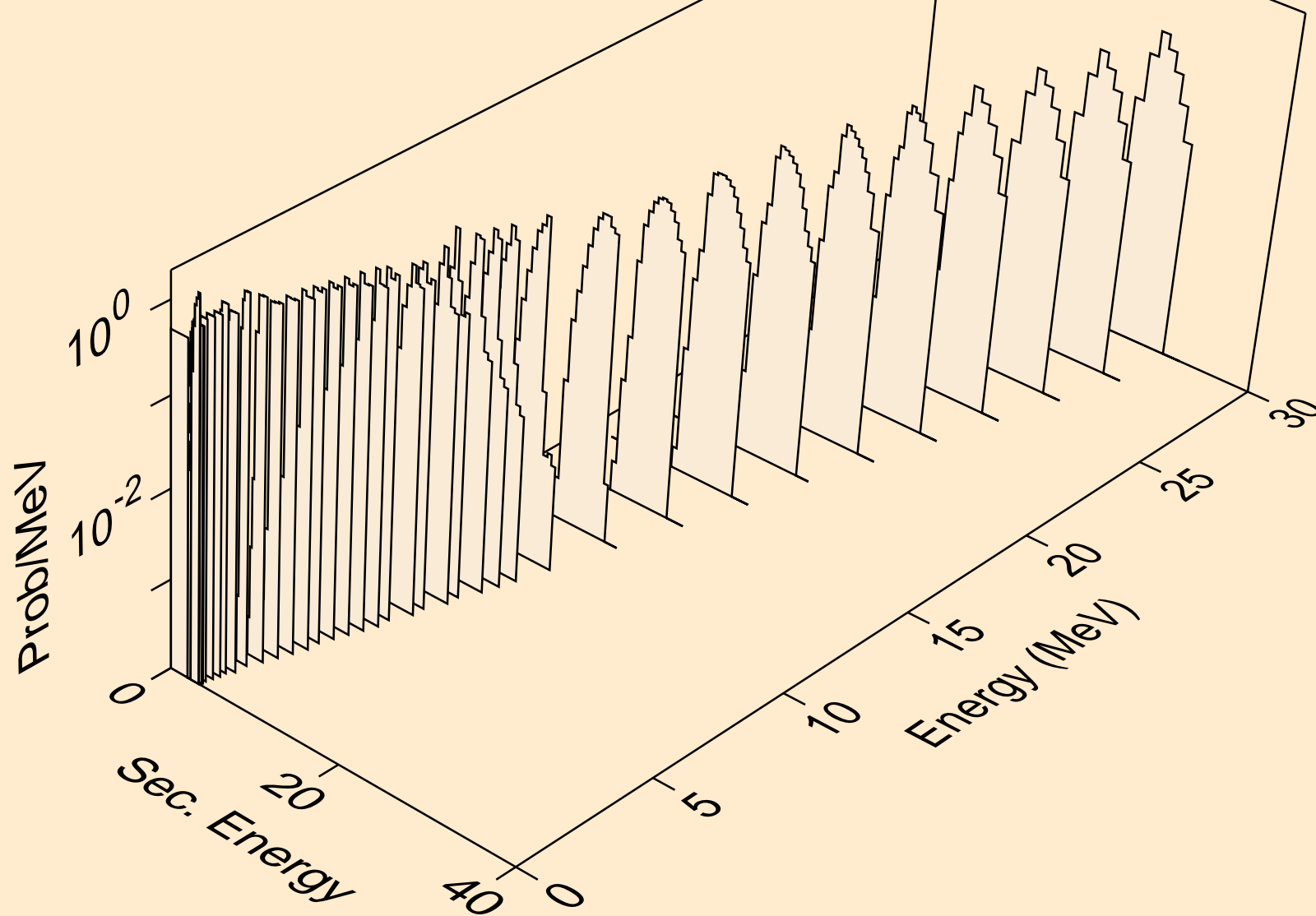

TC102M NEUTRON ACER TENDL-2024 LIBRARY; T=0.K
alphas from (n,2a)

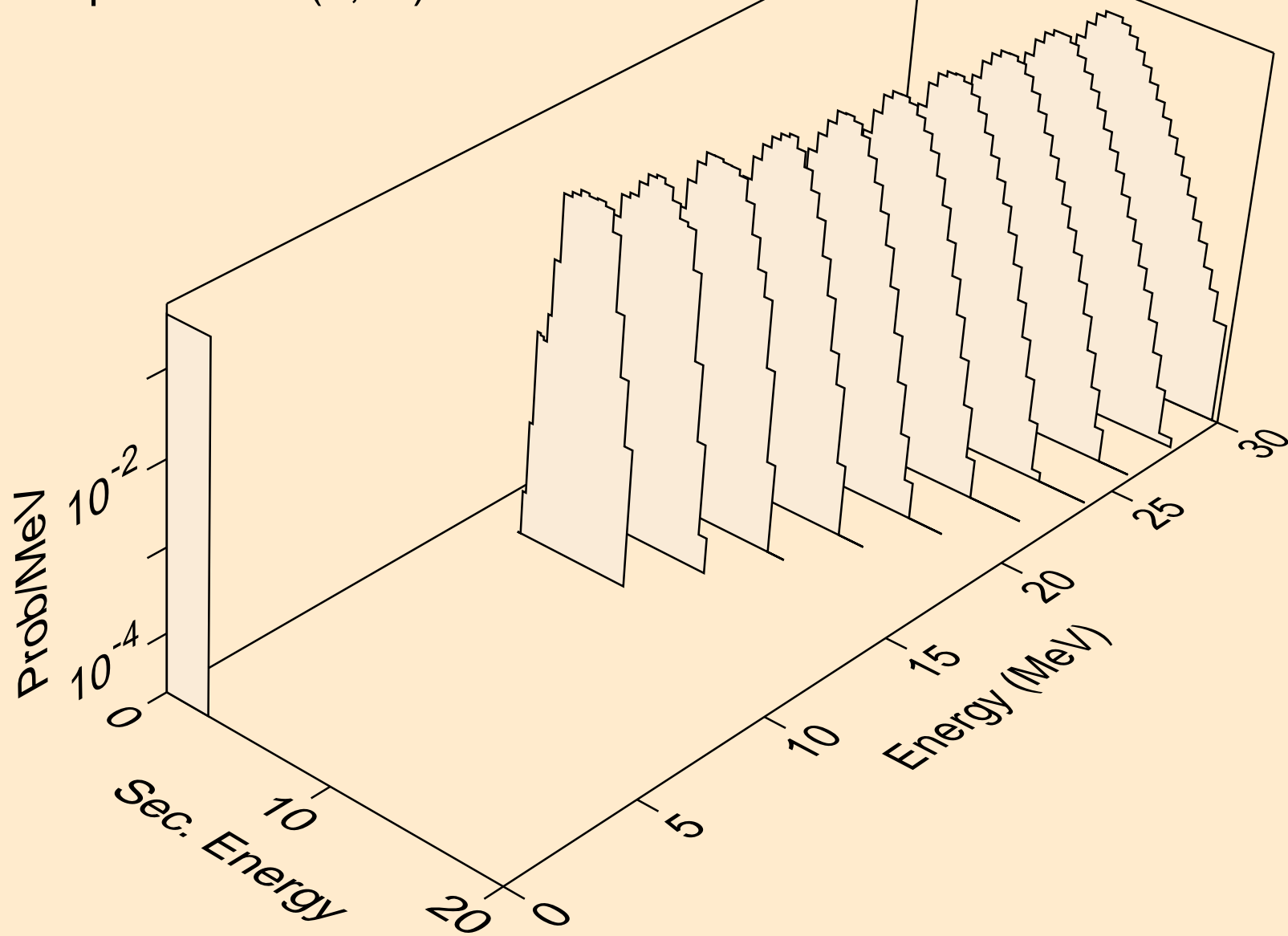

TC102M NEUTRON ACER TENDL-2024 LIBRARY; T=0.K
alphas from (n,pa)

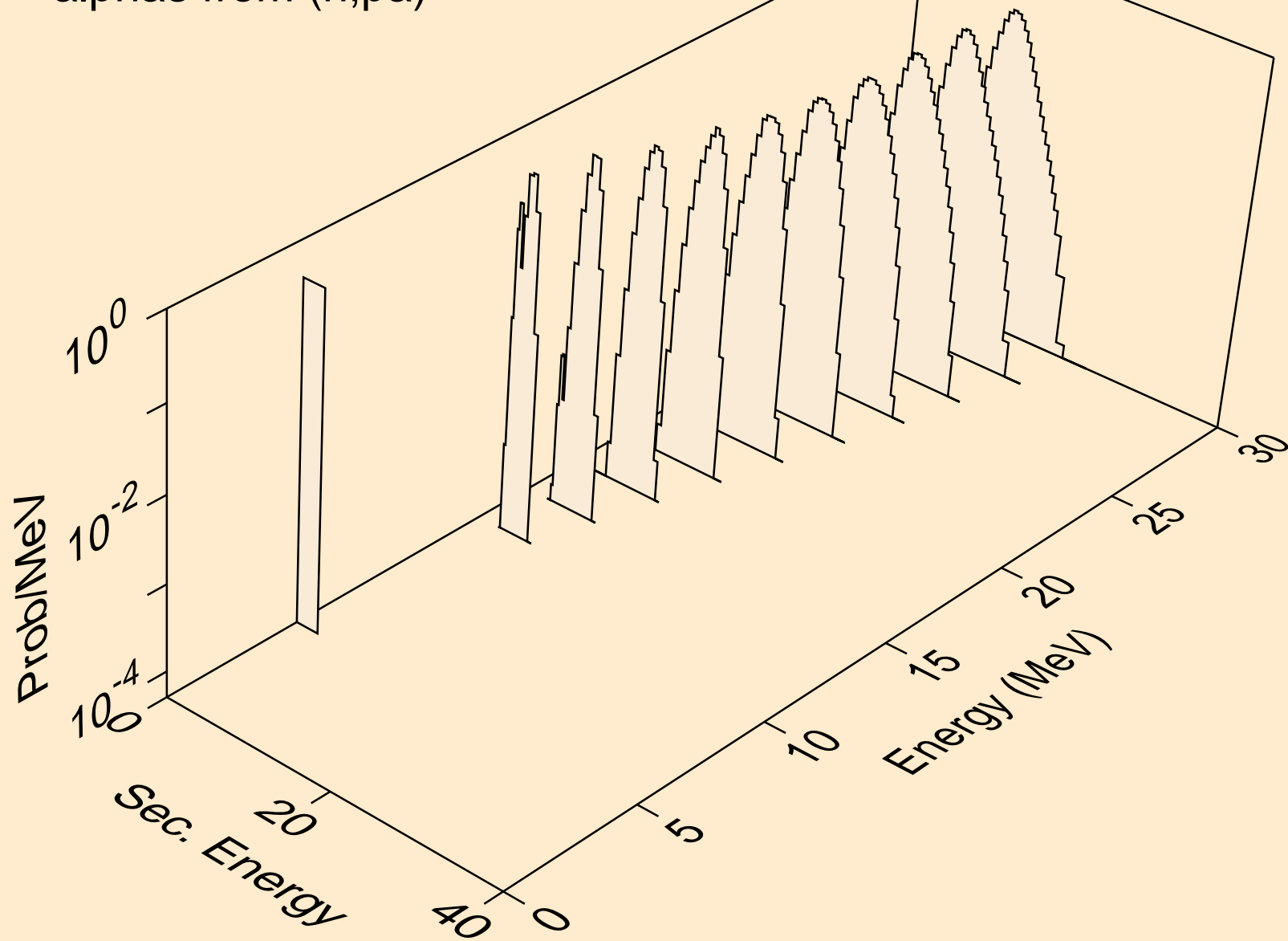

TC102M NEUTRON ACER TENDL-2024 LIBRARY; T=0.K
alphas from (n,da)

