

# TM156 NEUTRON ACER TENDL-2024 LIBRARY; T=0.K

## Principal cross sections

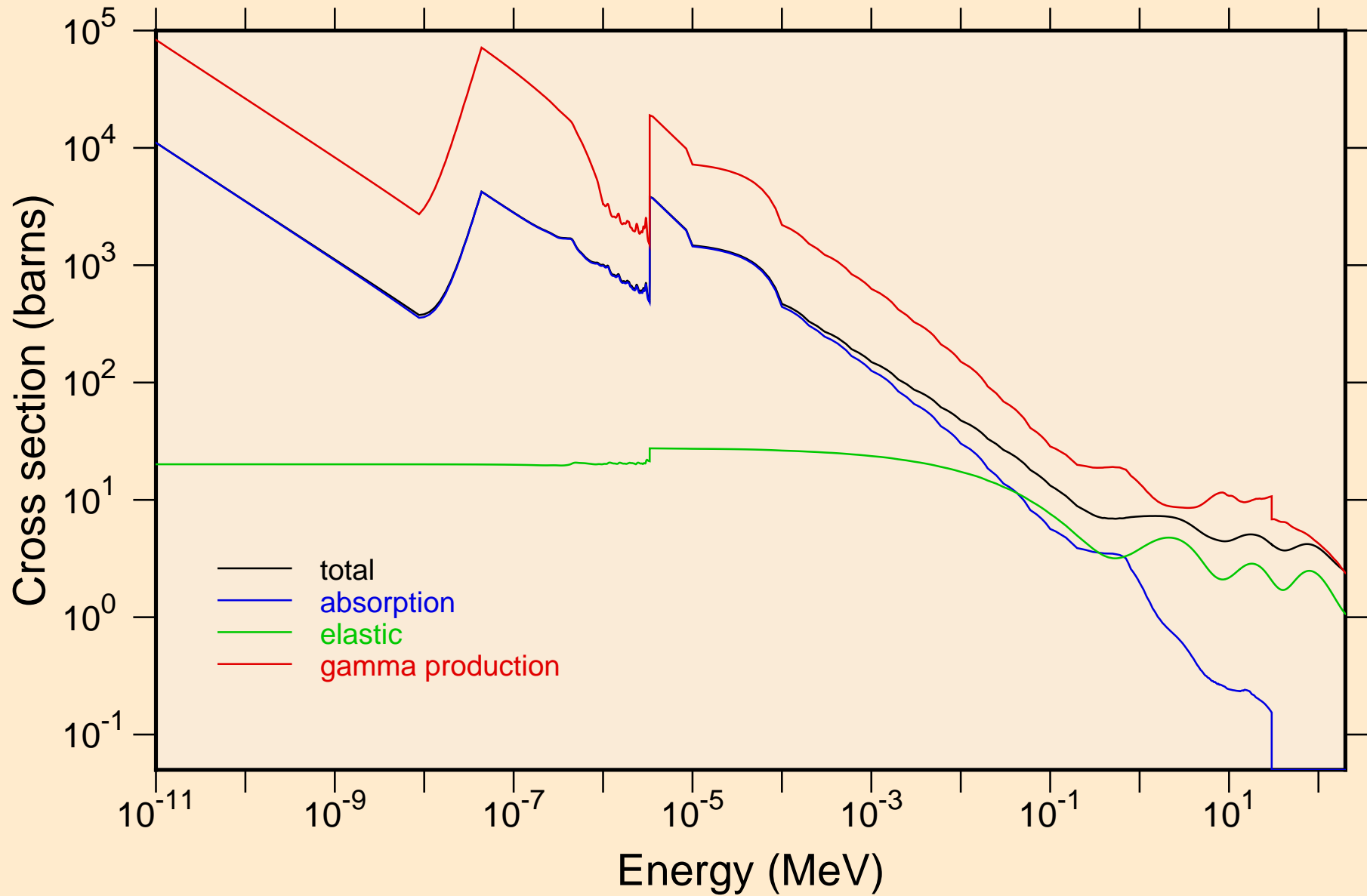

TM156 NEUTRON ACER TENDL-2024 LIBRARY; T=0.K  
Heating

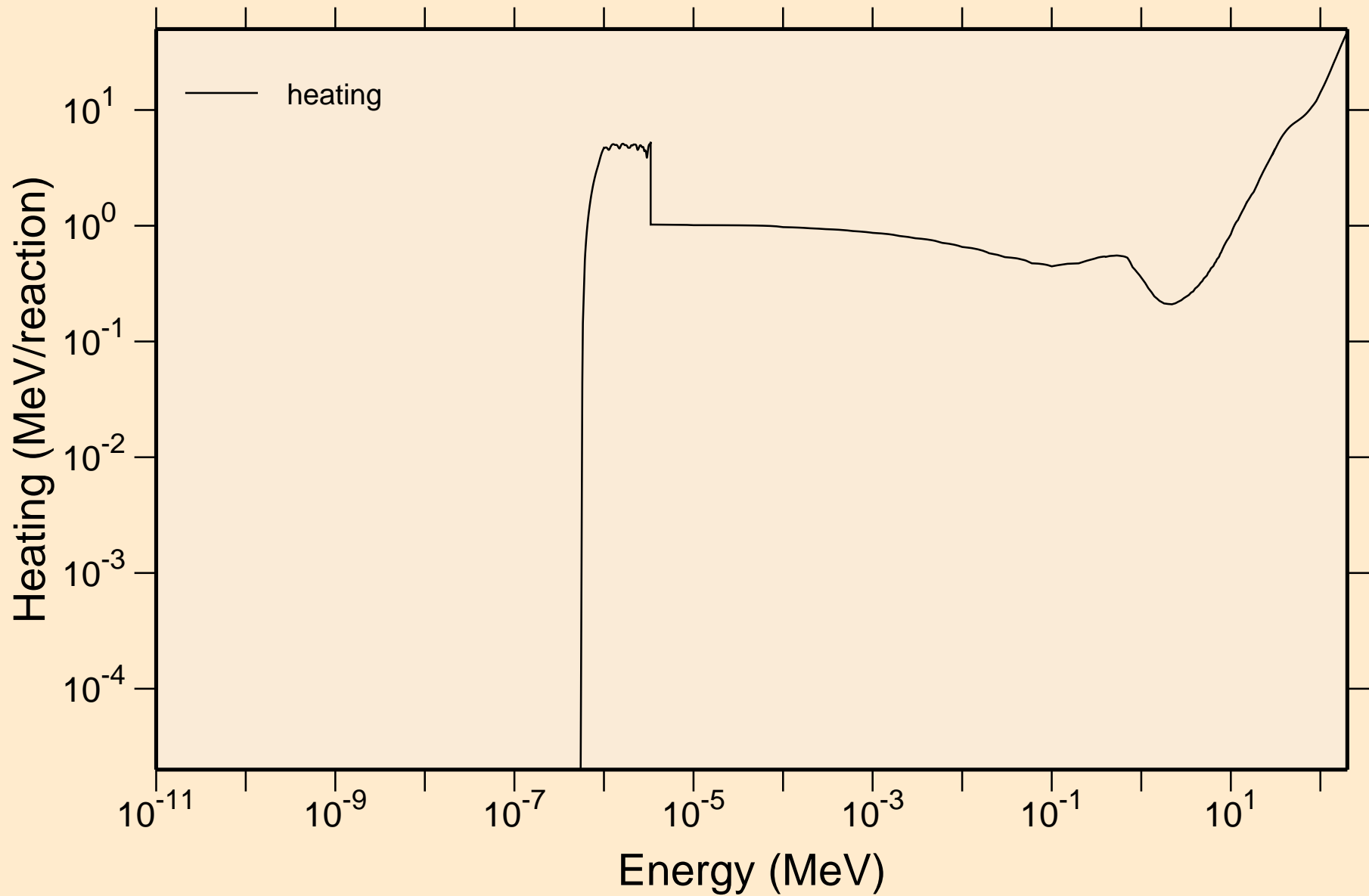

# TM156 NEUTRON ACER TENDL-2024 LIBRARY; T=0.K

## Damage

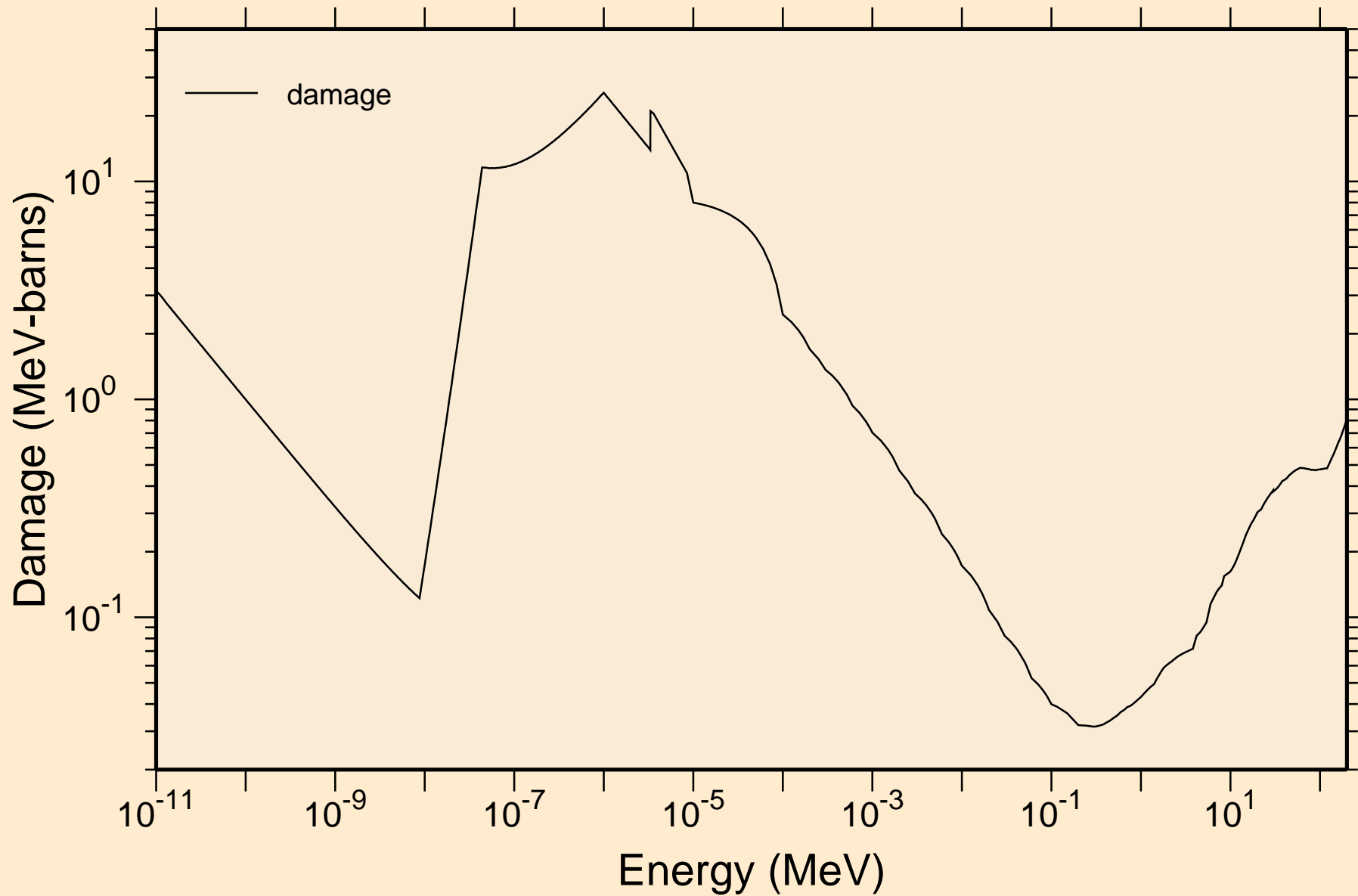

TM156 NEUTRON ACER TENDL-2024 LIBRARY; T=0.K  
Non-threshold reactions

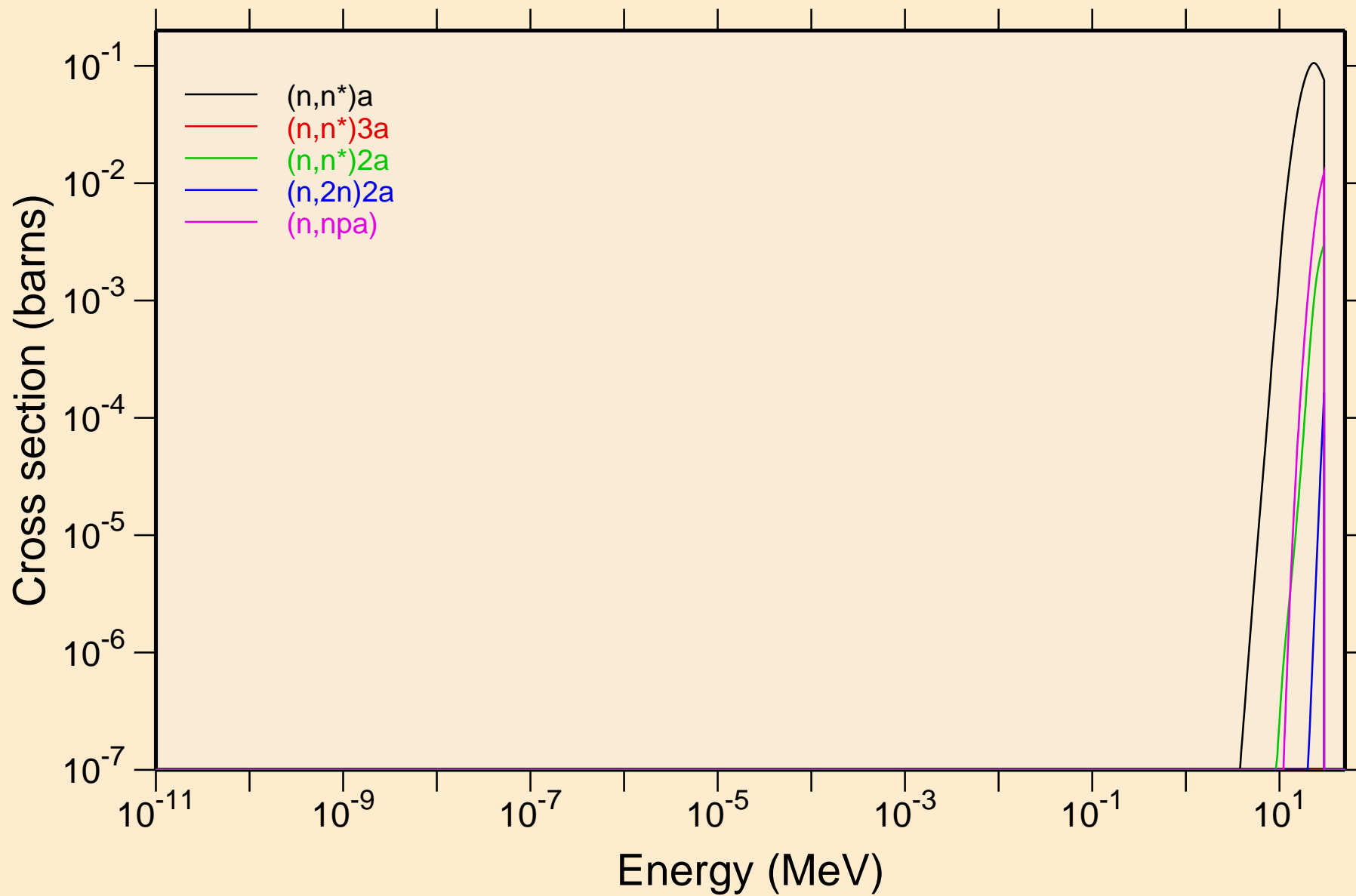

# TM156 NEUTRON ACER TENDL-2024 LIBRARY; T=0.K

## Non-threshold reactions

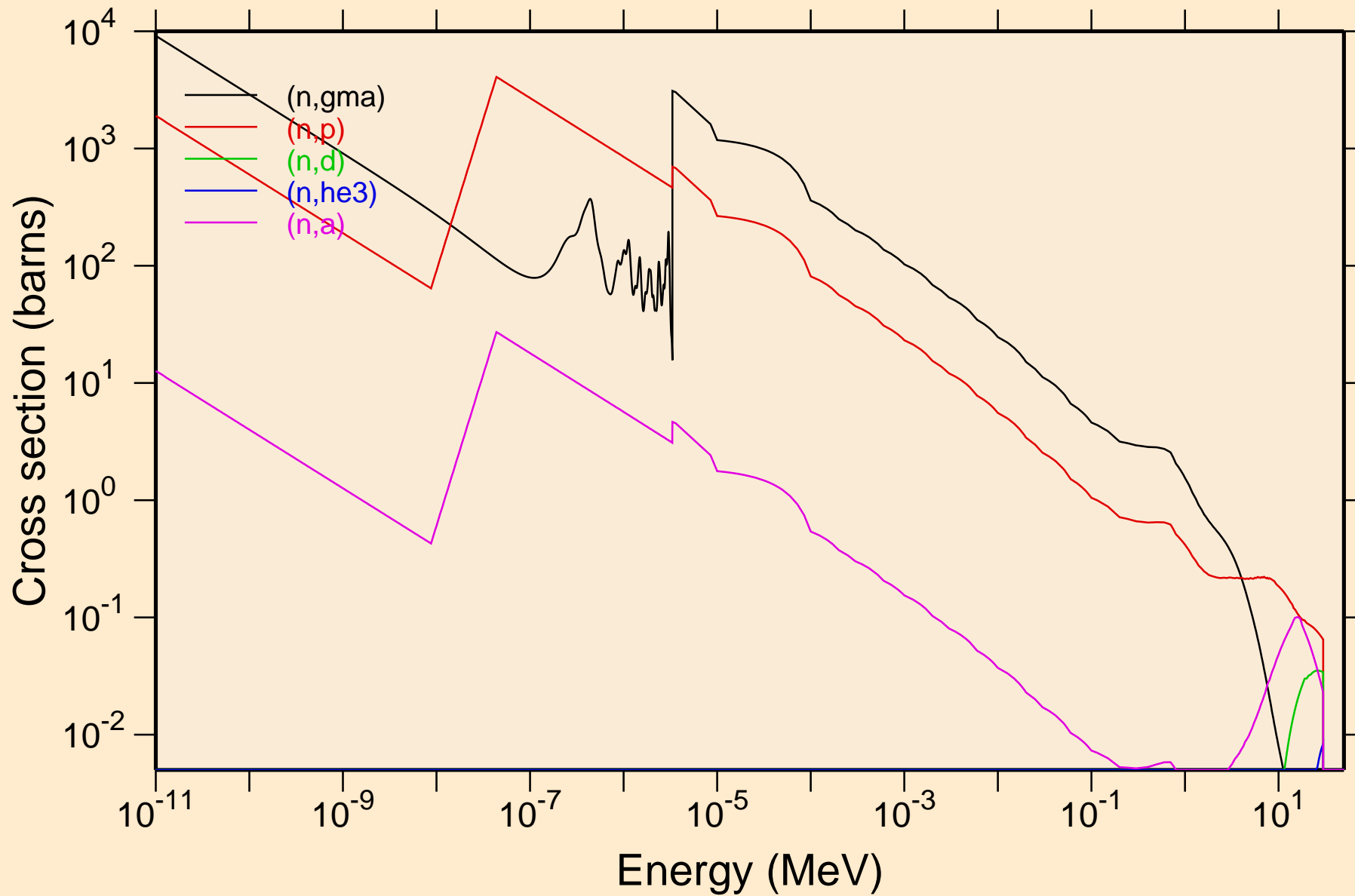

TM156 NEUTRON ACER TENDL-2024 LIBRARY; T=0.K  
Non-threshold reactions

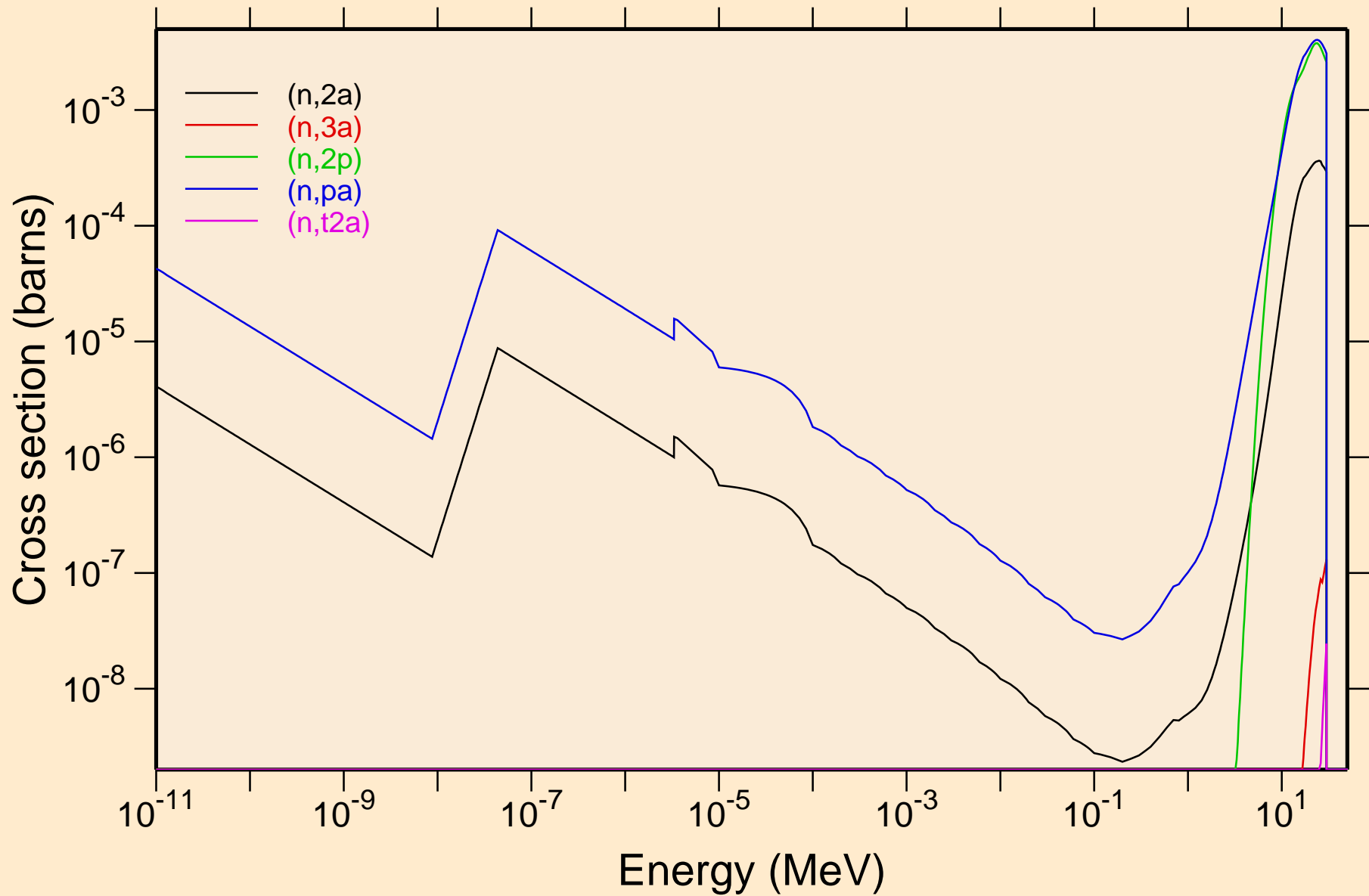

TM156 NEUTRON ACER TENDL-2024 LIBRARY; T=0.K  
Non-threshold reactions

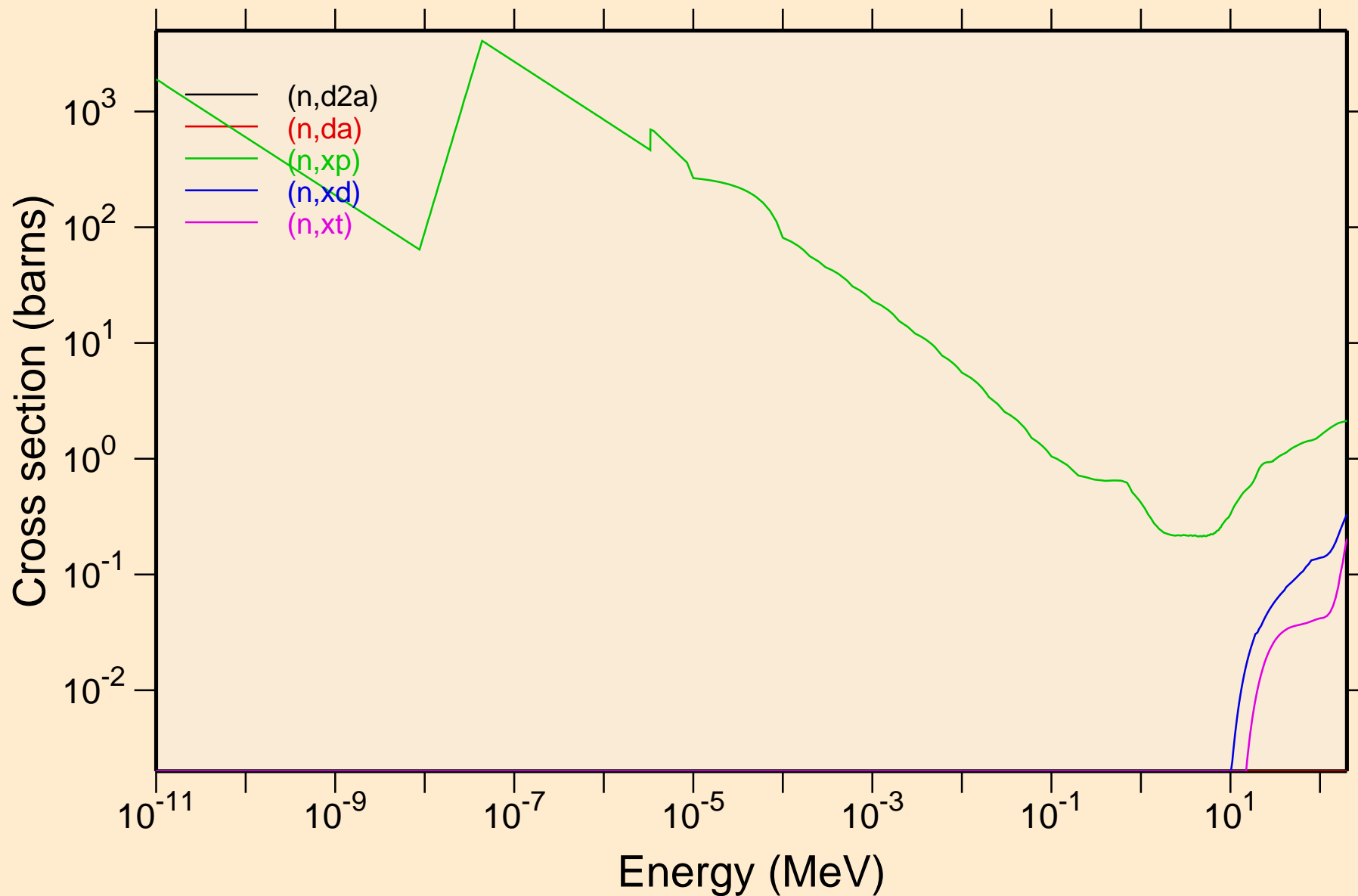

TM156 NEUTRON ACER TENDL-2024 LIBRARY; T=0.K  
Non-threshold reactions

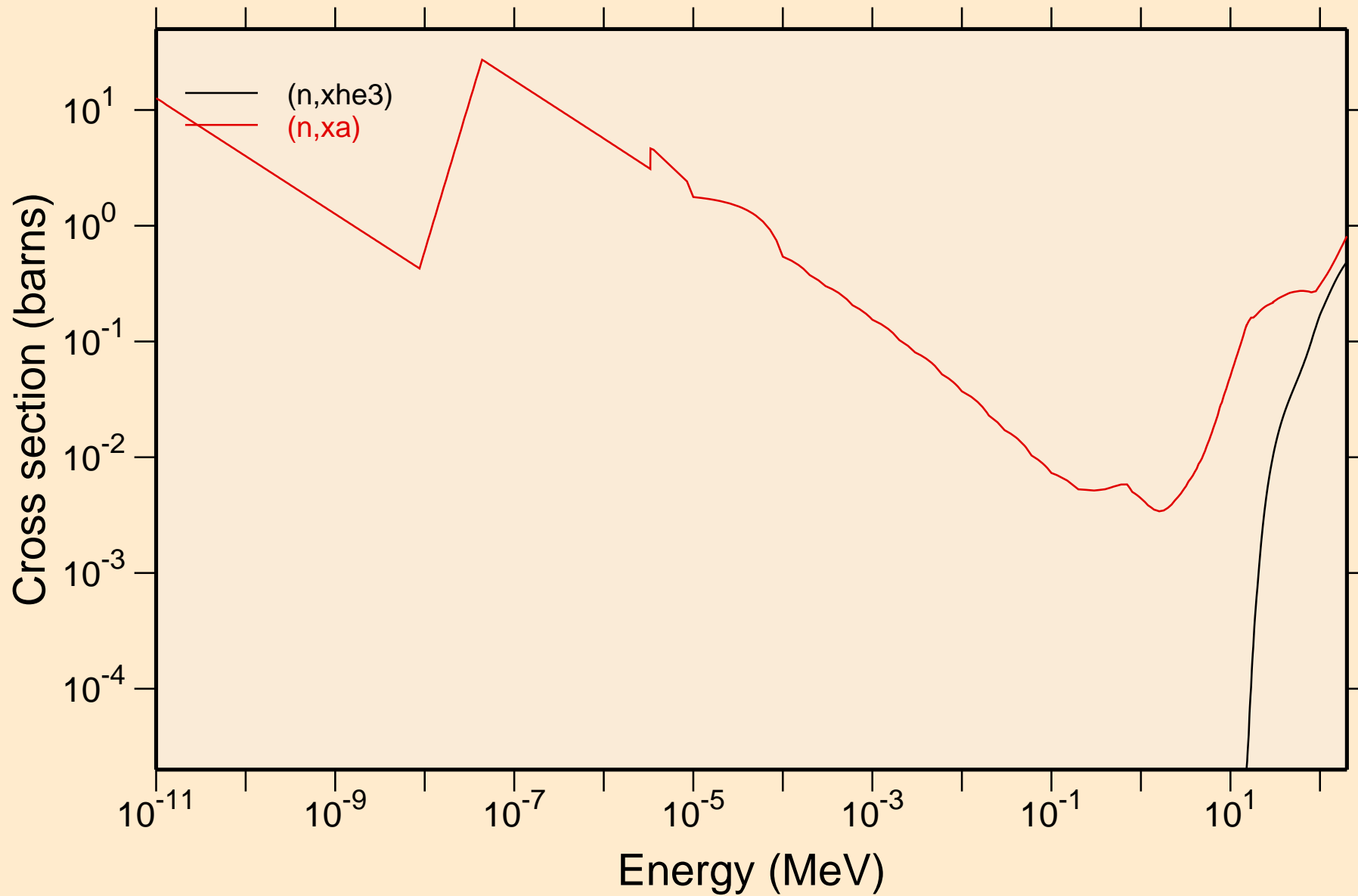

# TM156 NEUTRON ACER TENDL-2024 LIBRARY; T=0.K

## Principal cross sections

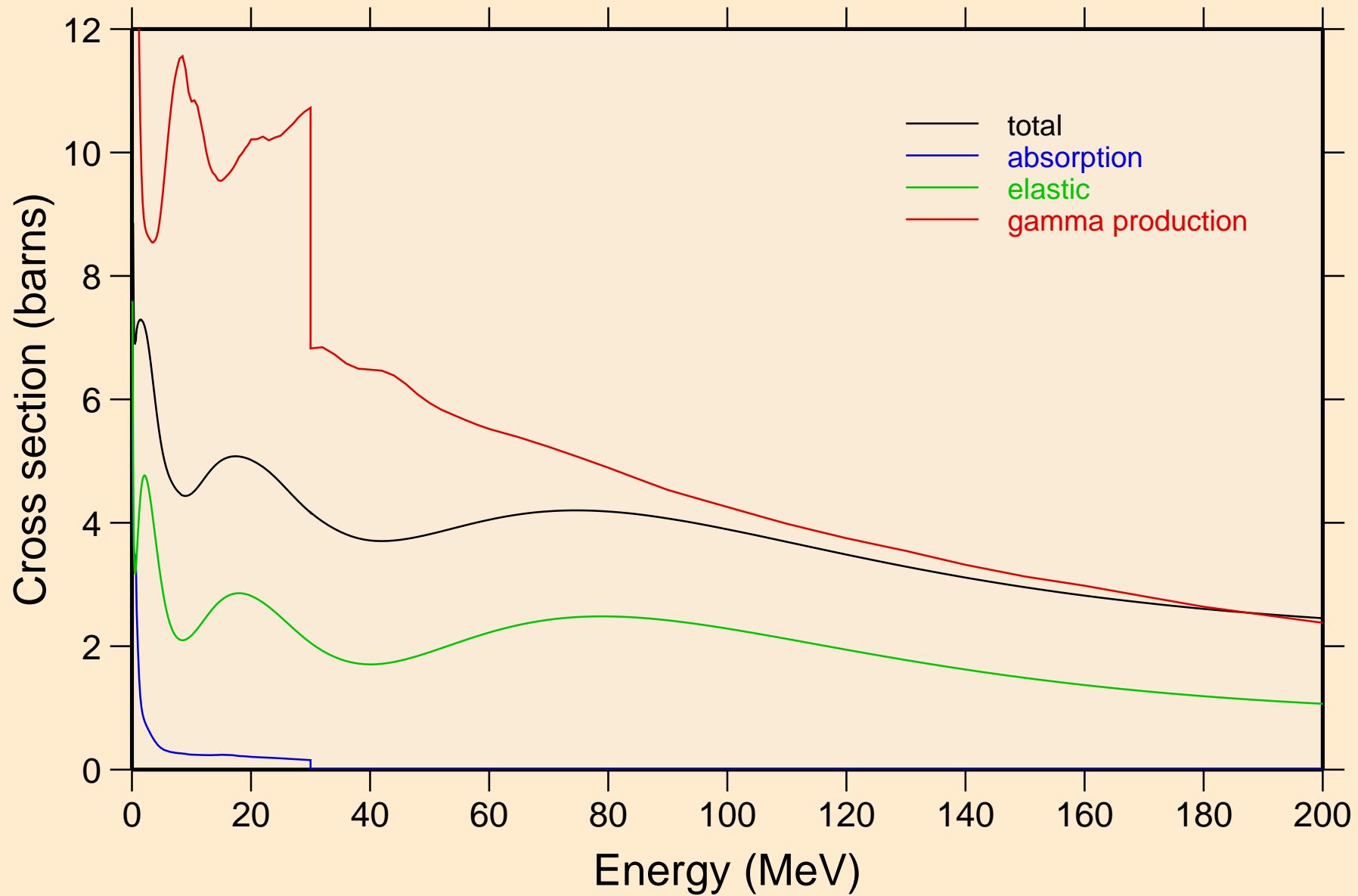

# TM156 NEUTRON ACER TENDL-2024 LIBRARY; T=0.K

## Heating

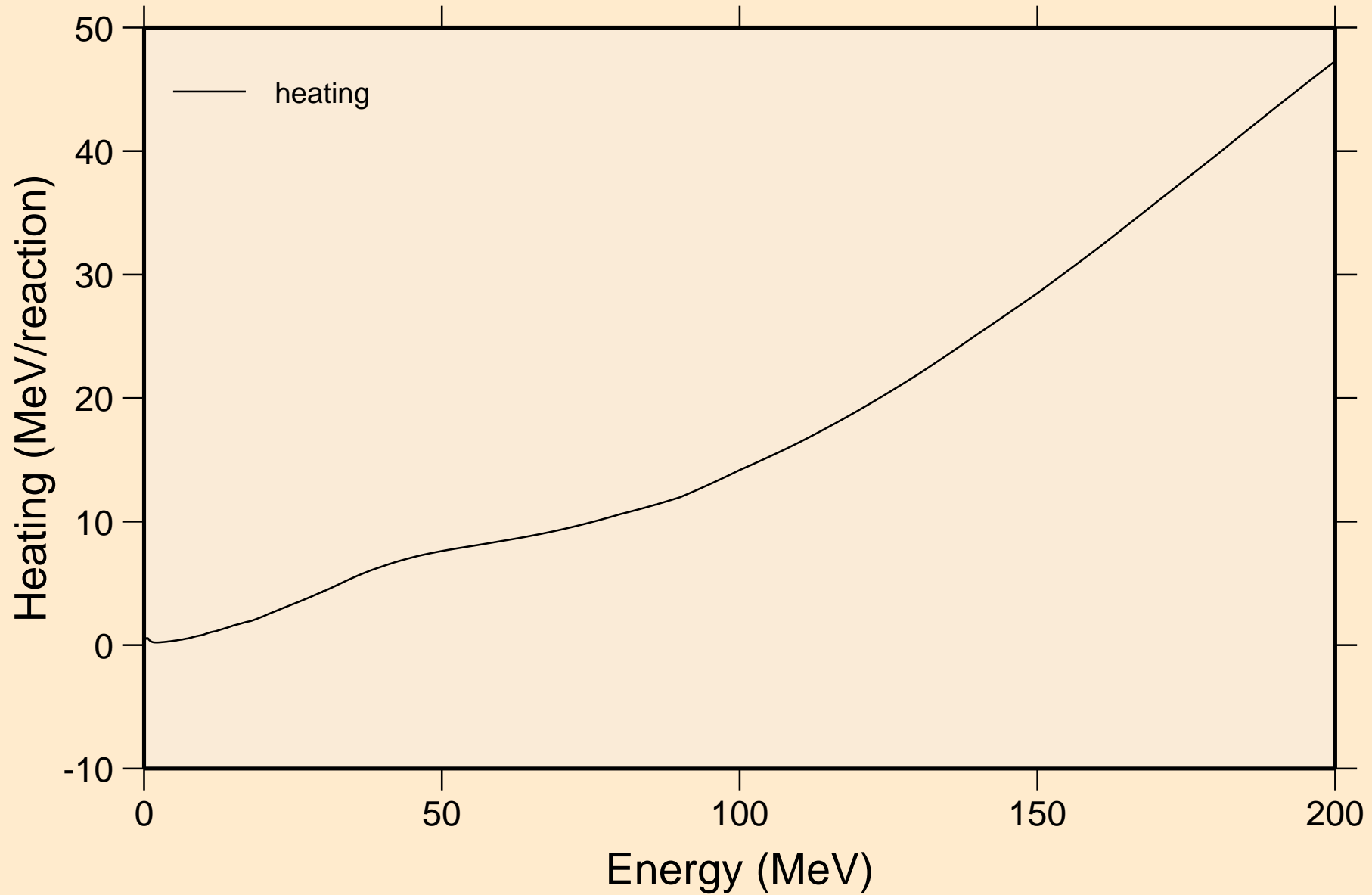

# TM156 NEUTRON ACER TENDL-2024 LIBRARY; T=0.K

## Damage

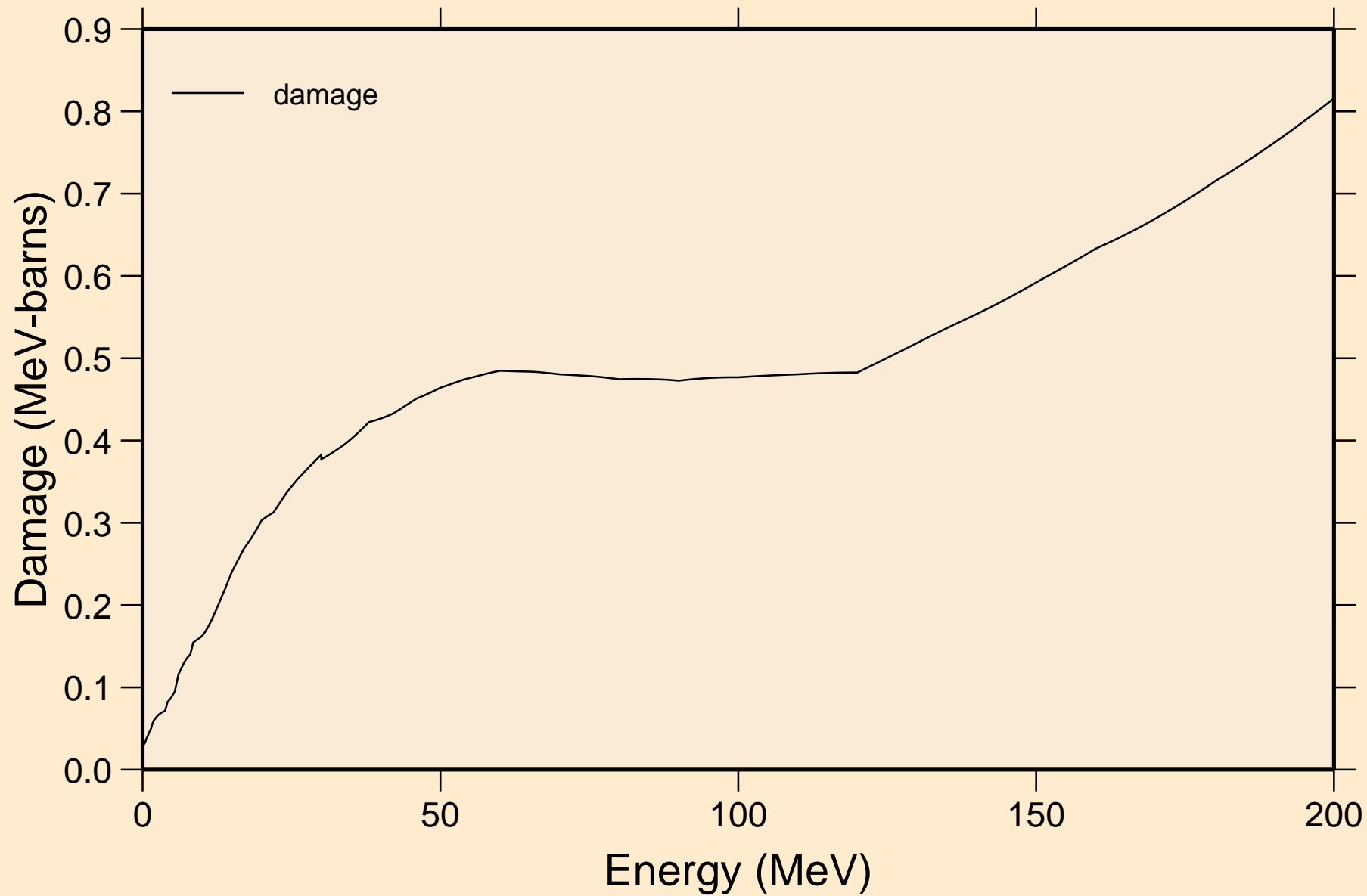

TM156 NEUTRON ACER TENDL-2024 LIBRARY; T=0.K  
Non-threshold reactions

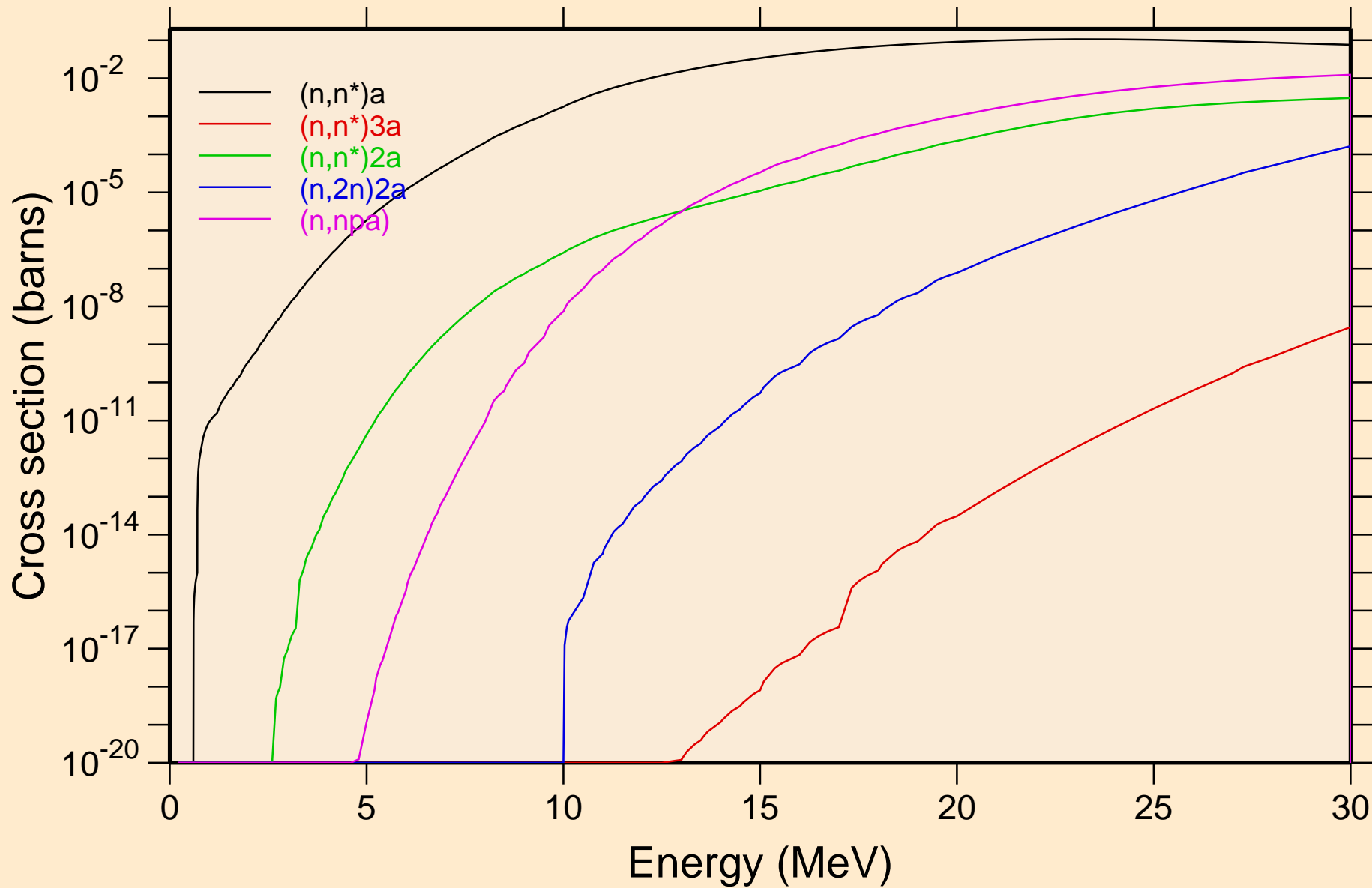

# TM156 NEUTRON ACER TENDL-2024 LIBRARY; T=0.K

## Non-threshold reactions

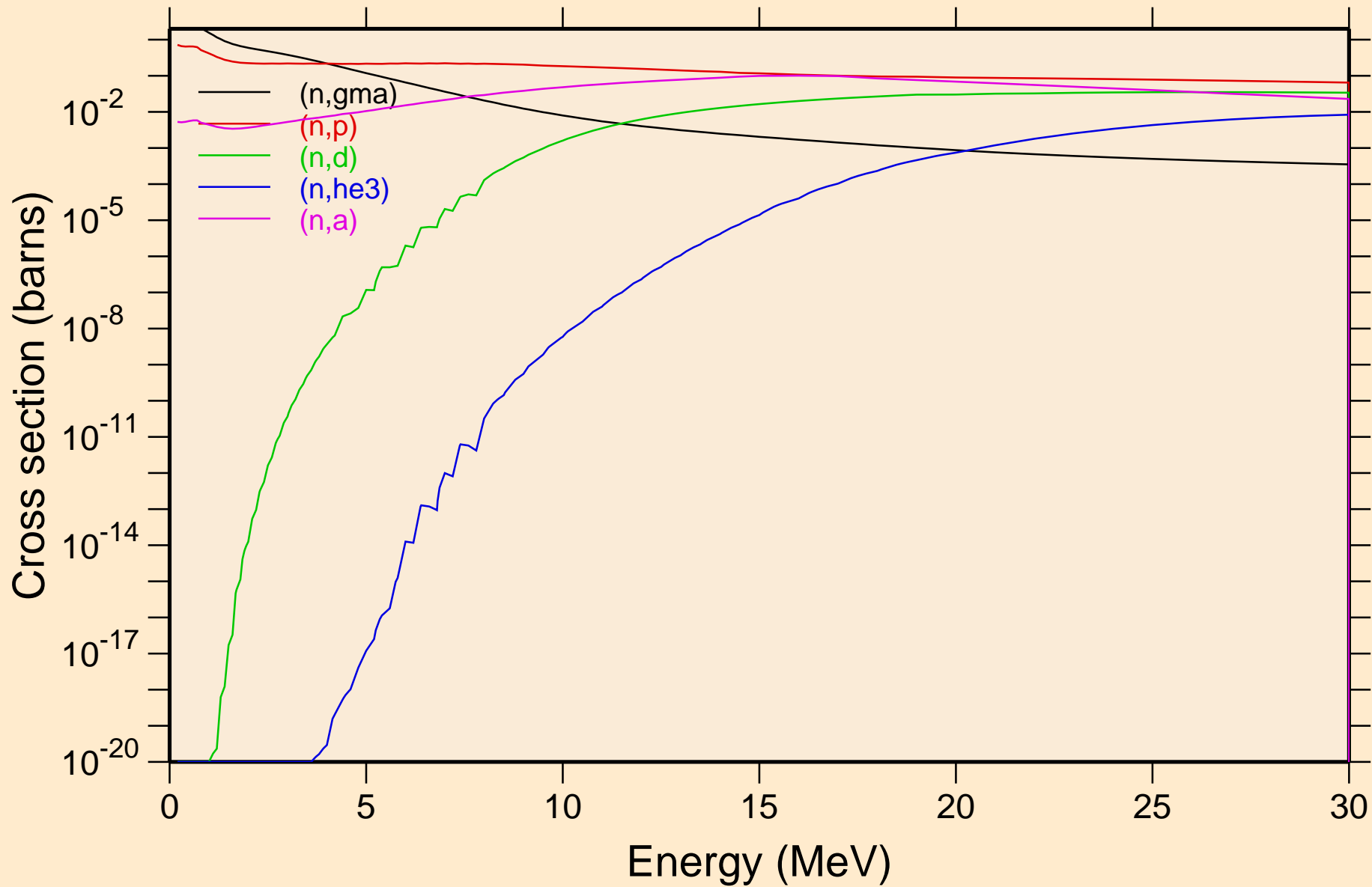

TM156 NEUTRON ACER TENDL-2024 LIBRARY; T=0.K  
Non-threshold reactions

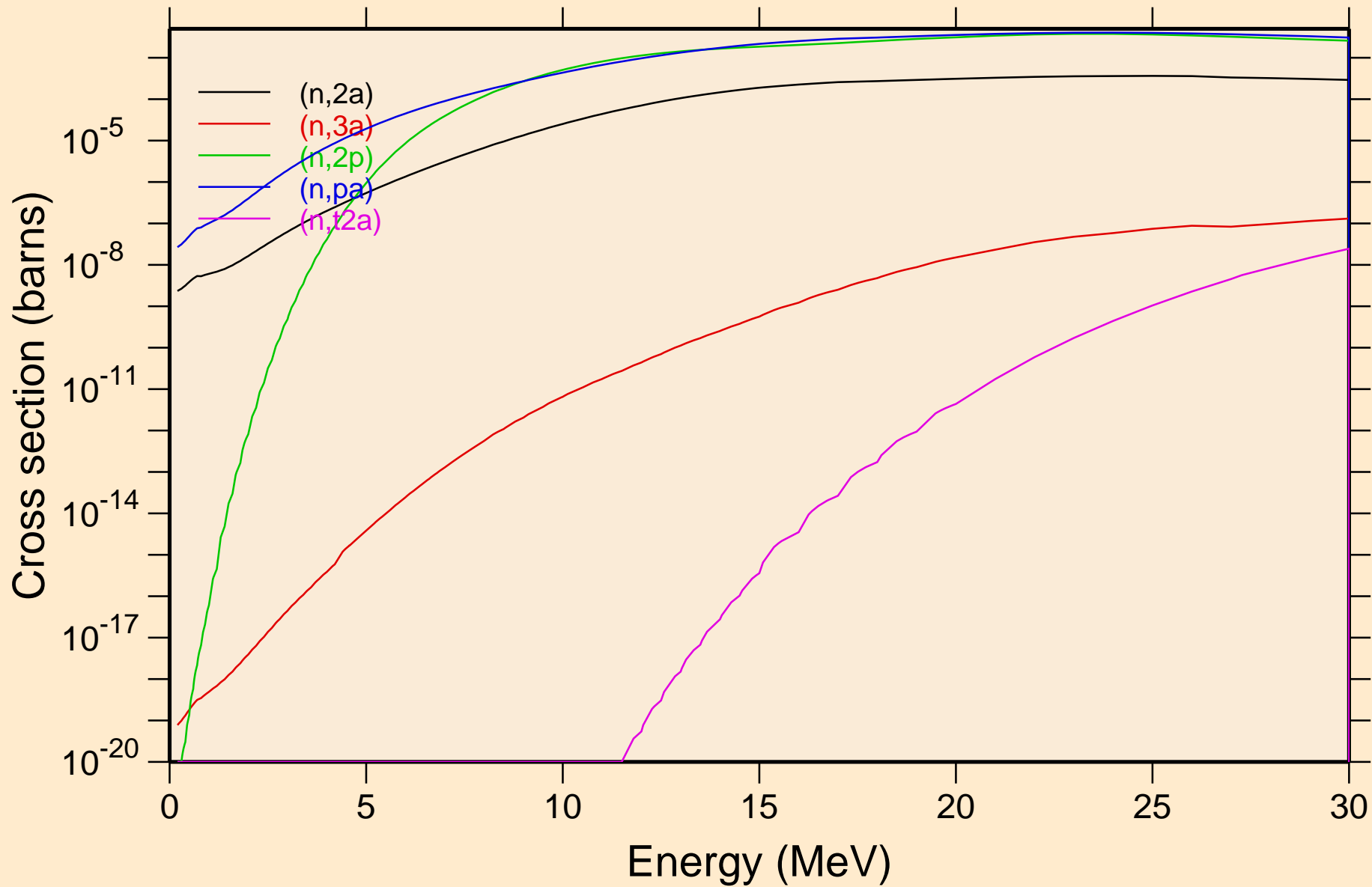

TM156 NEUTRON ACER TENDL-2024 LIBRARY; T=0.K  
Non-threshold reactions

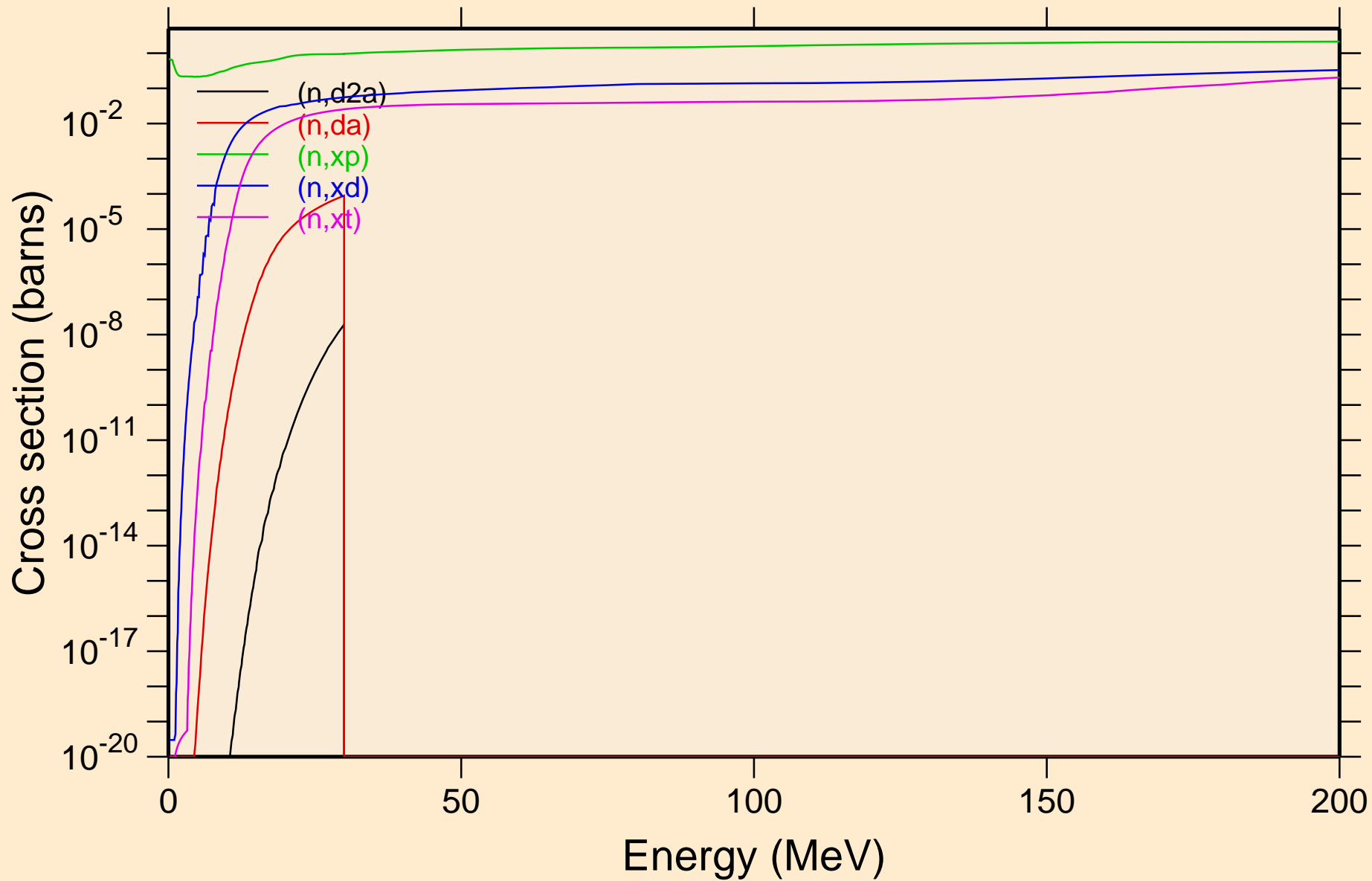

TM156 NEUTRON ACER TENDL-2024 LIBRARY; T=0.K  
Non-threshold reactions

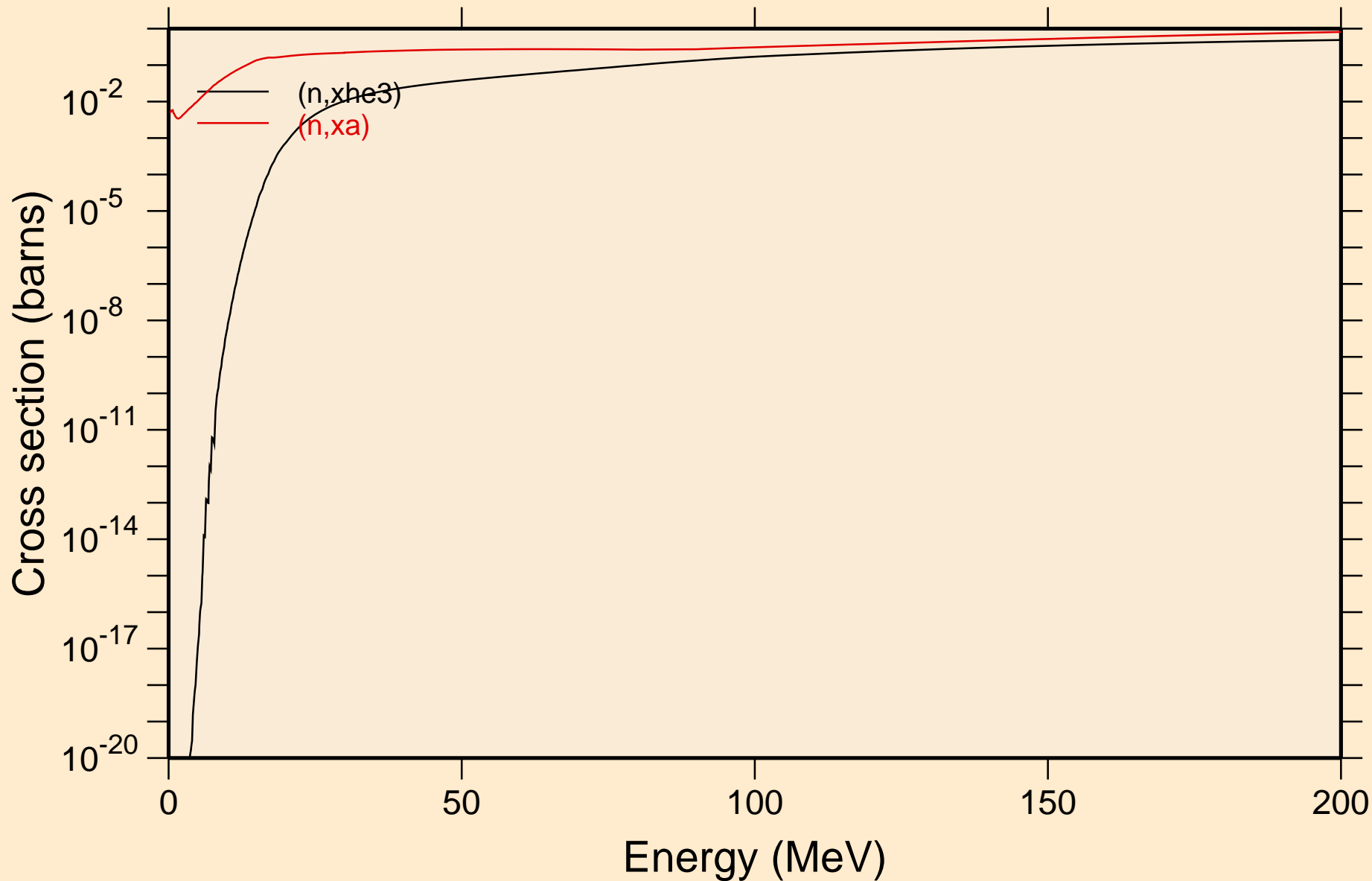

# TM156 NEUTRON ACER TENDL-2024 LIBRARY; T=0.K

## Inelastic levels

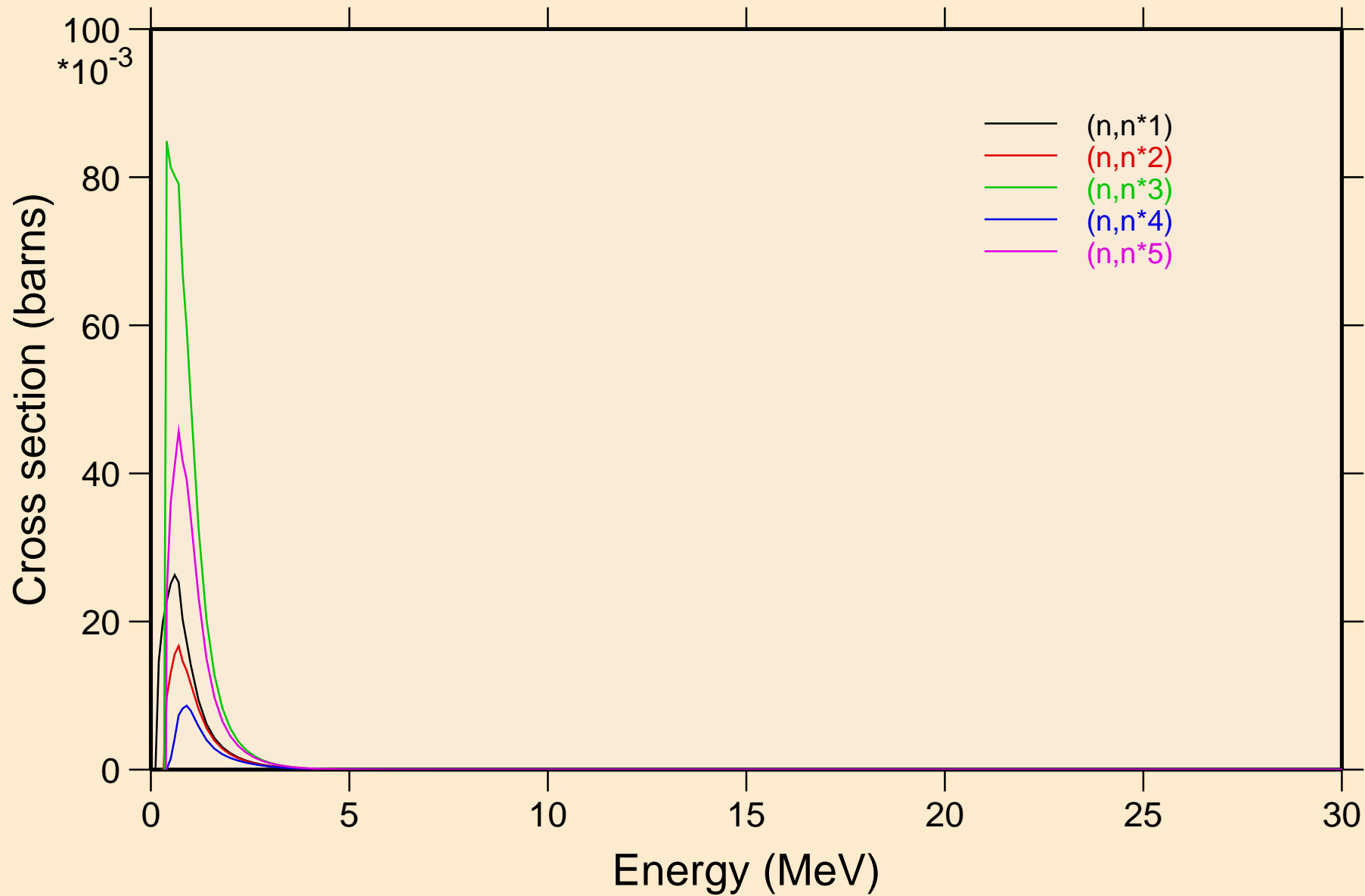

TM156 NEUTRON ACER TENDL-2024 LIBRARY; T=0.K  
Inelastic levels

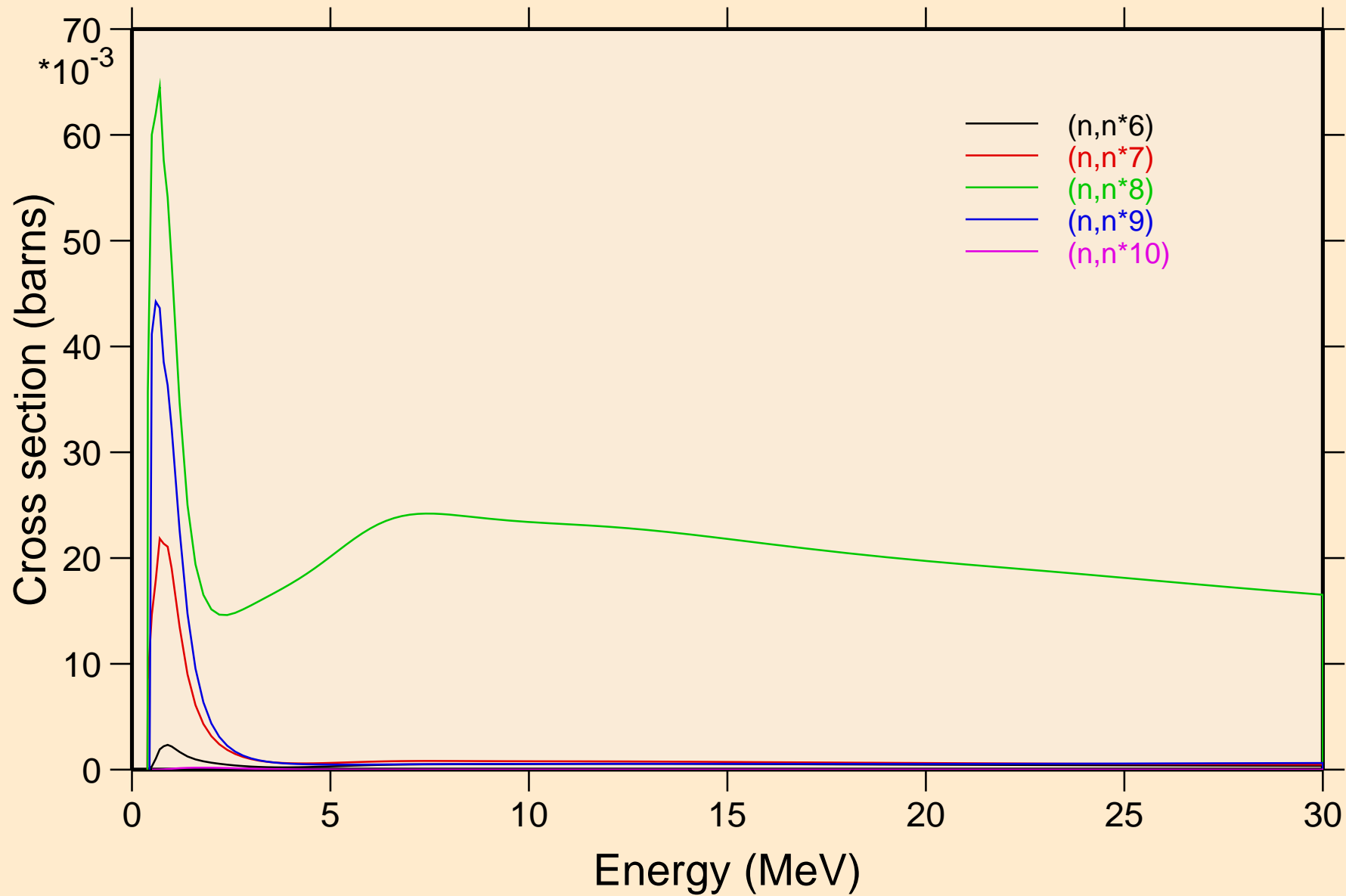

TM156 NEUTRON ACER TENDL-2024 LIBRARY; T=0.K  
Inelastic levels

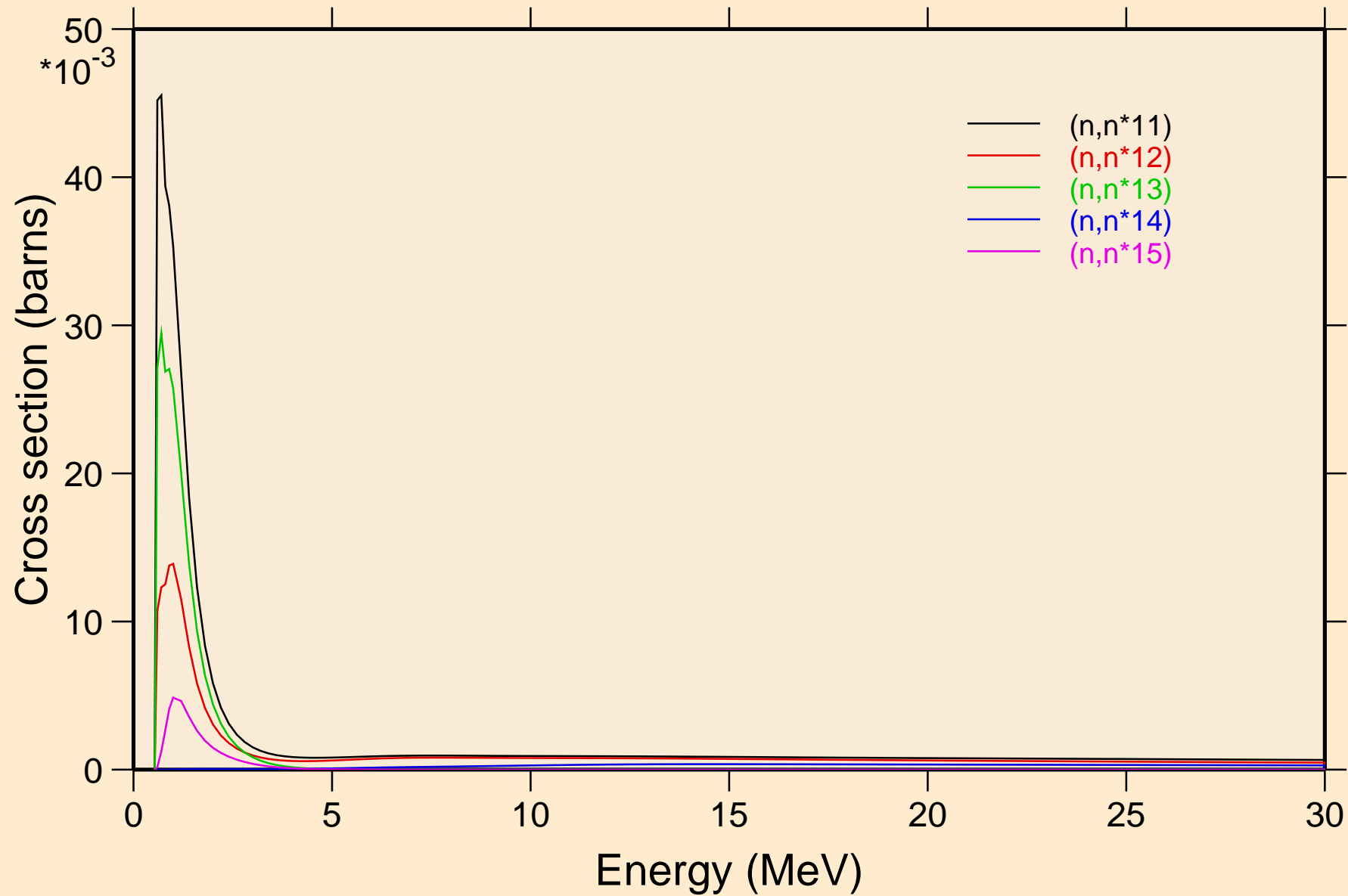

TM156 NEUTRON ACER TENDL-2024 LIBRARY; T=0.K  
Inelastic levels

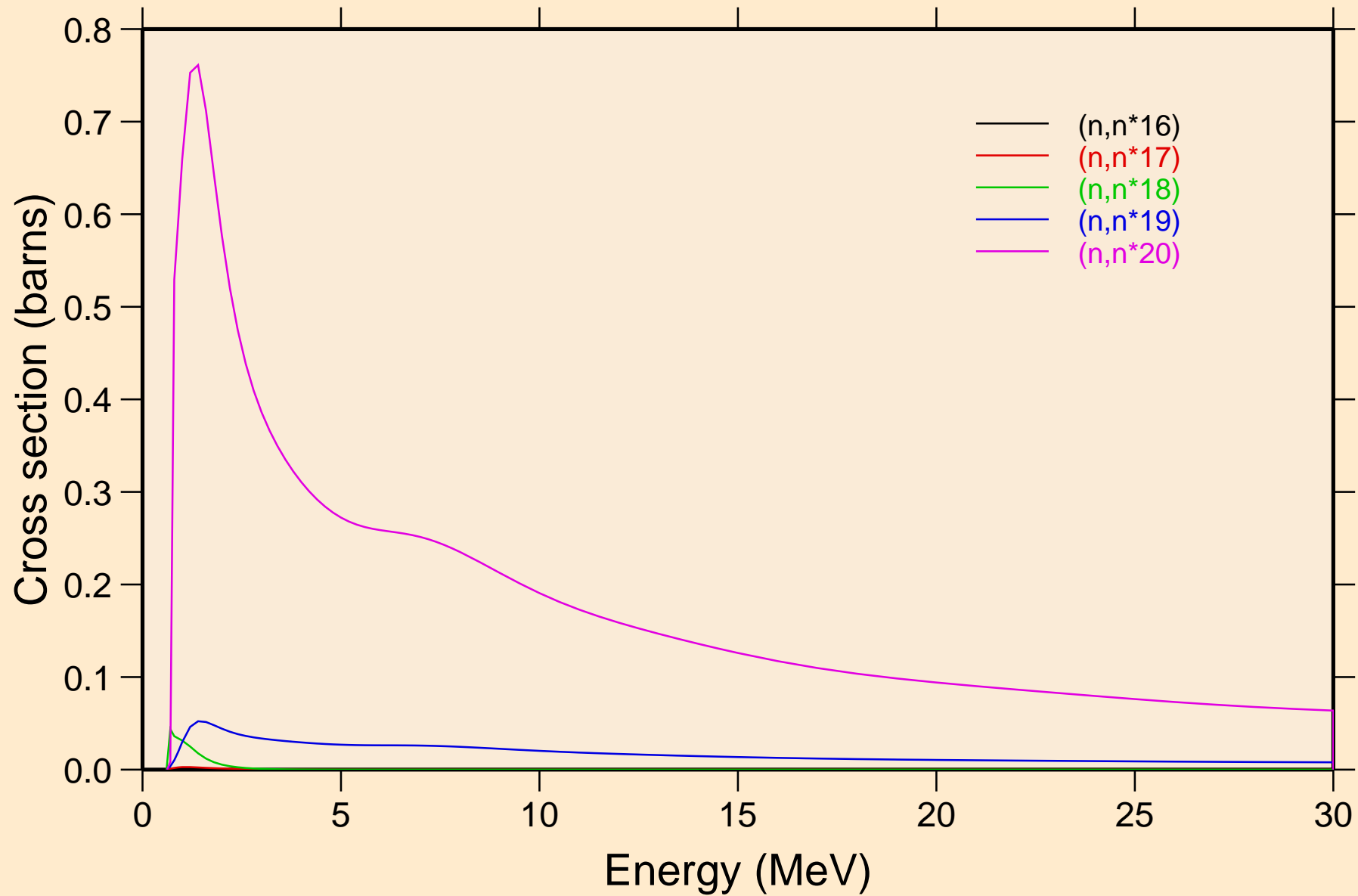

TM156 NEUTRON ACER TENDL-2024 LIBRARY; T=0.K  
Inelastic levels

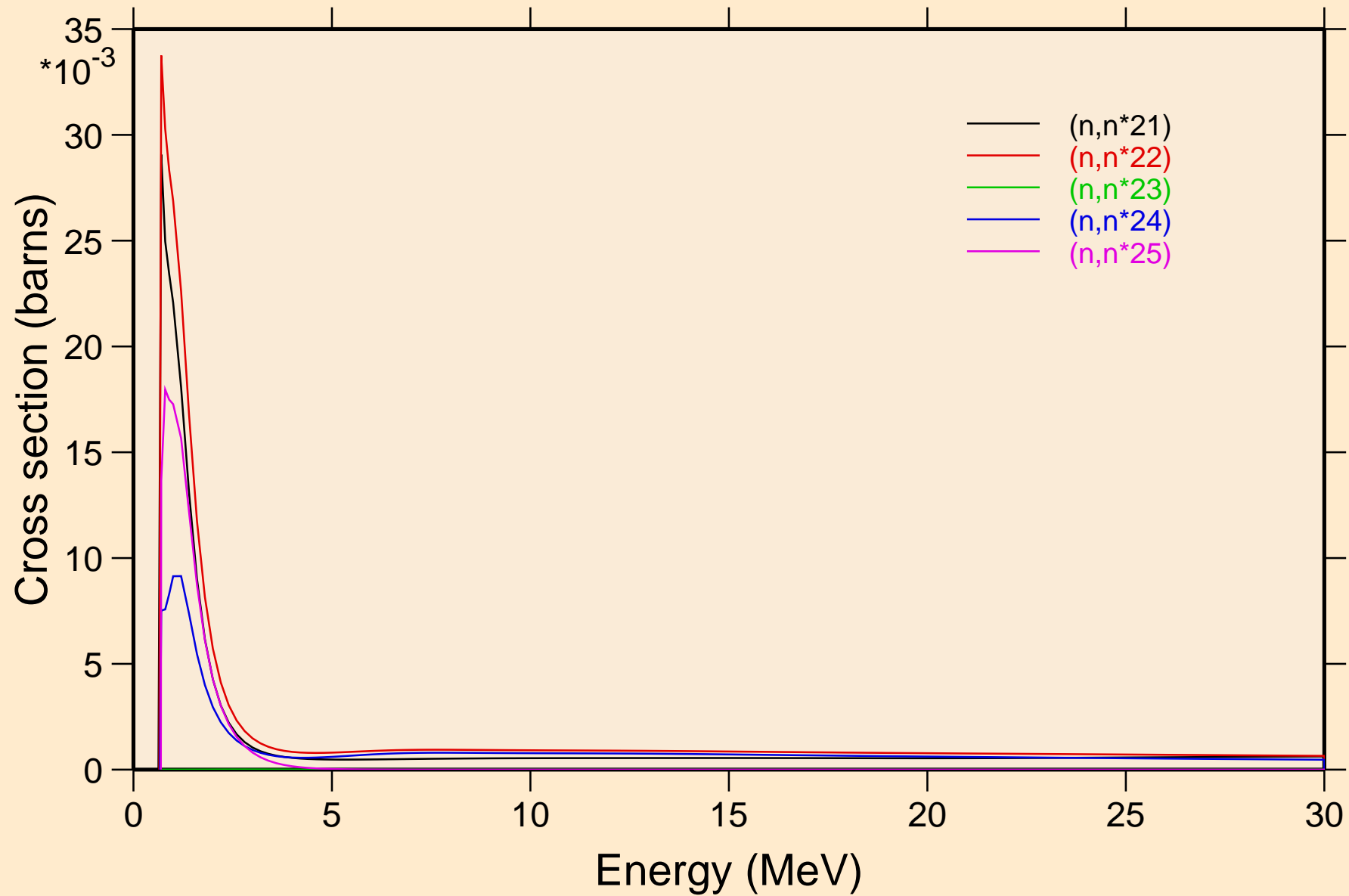

TM156 NEUTRON ACER TENDL-2024 LIBRARY; T=0.K  
Threshold reactions

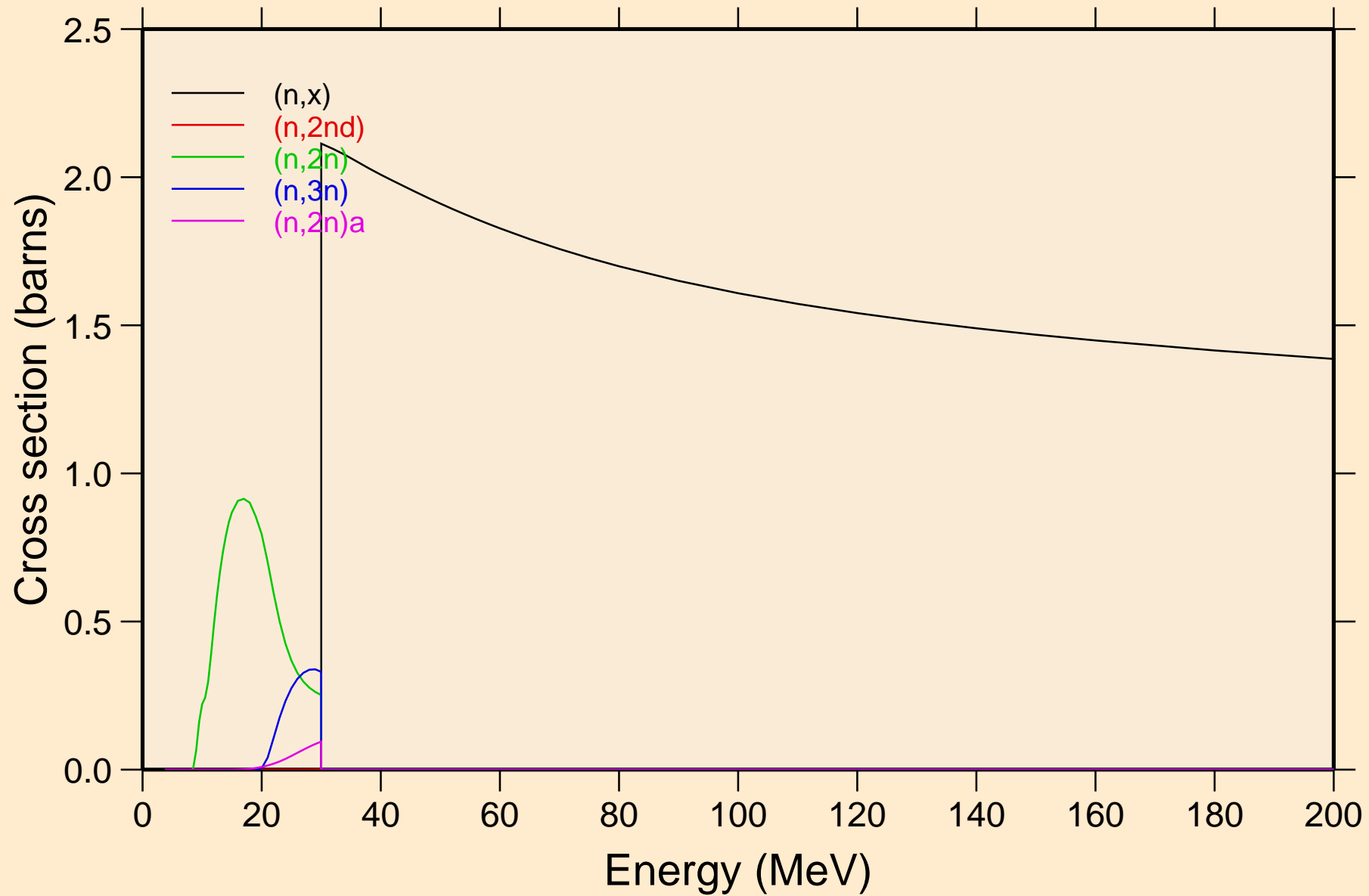

TM156 NEUTRON ACER TENDL-2024 LIBRARY; T=0.K  
Threshold reactions

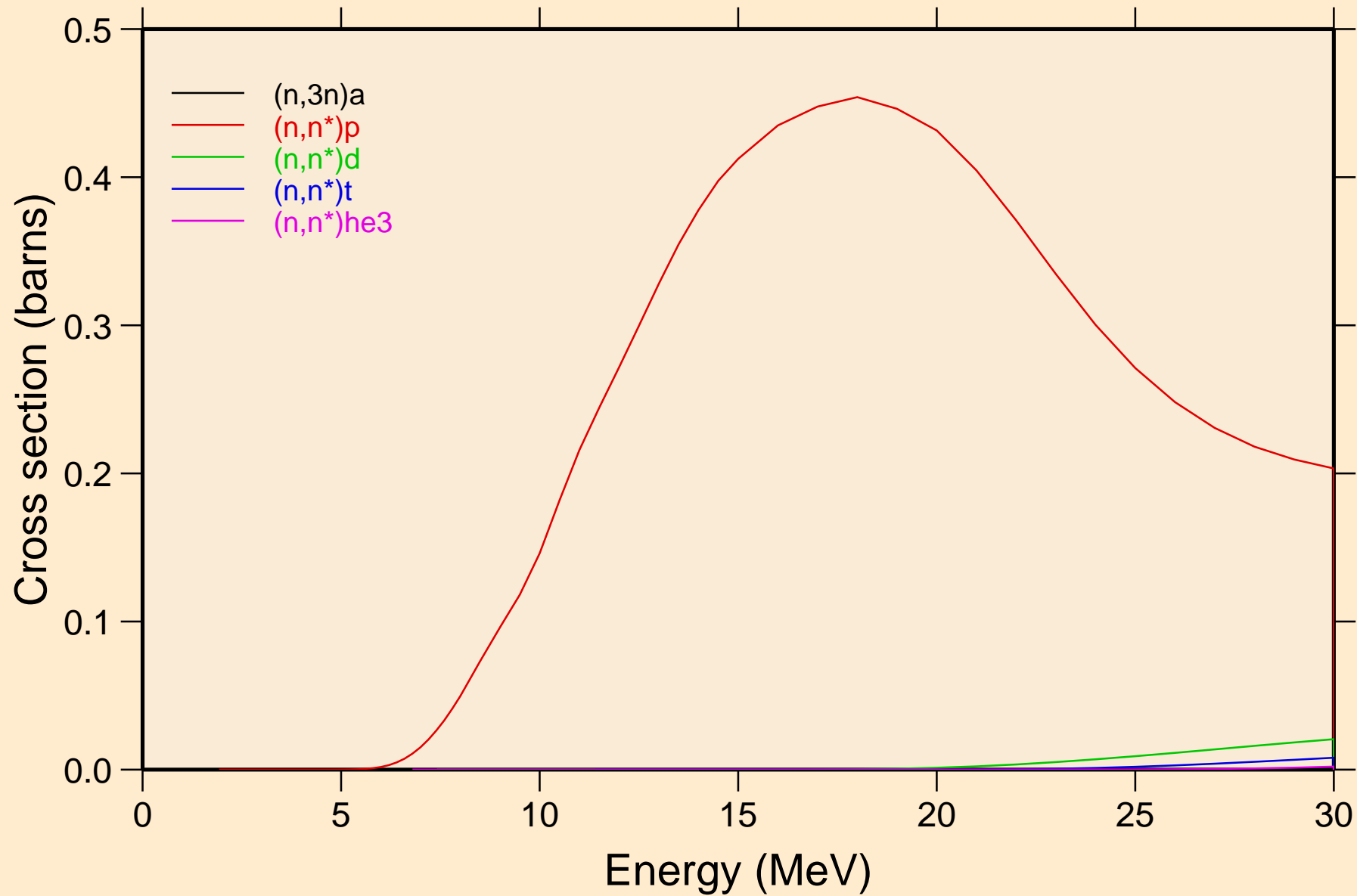

TM156 NEUTRON ACER TENDL-2024 LIBRARY; T=0.K  
Threshold reactions

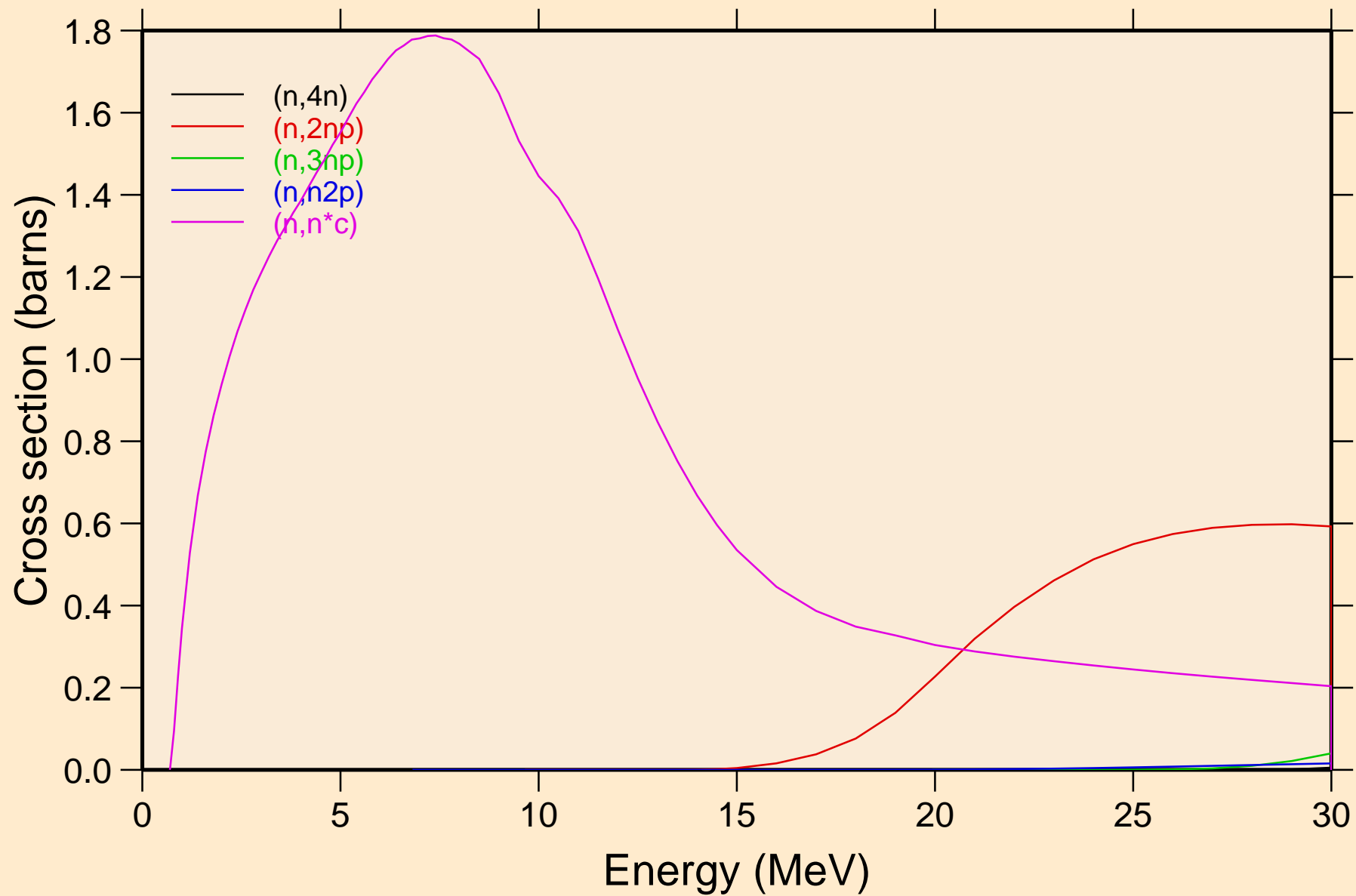

TM156 NEUTRON ACER TENDL-2024 LIBRARY; T=0.K  
Threshold reactions

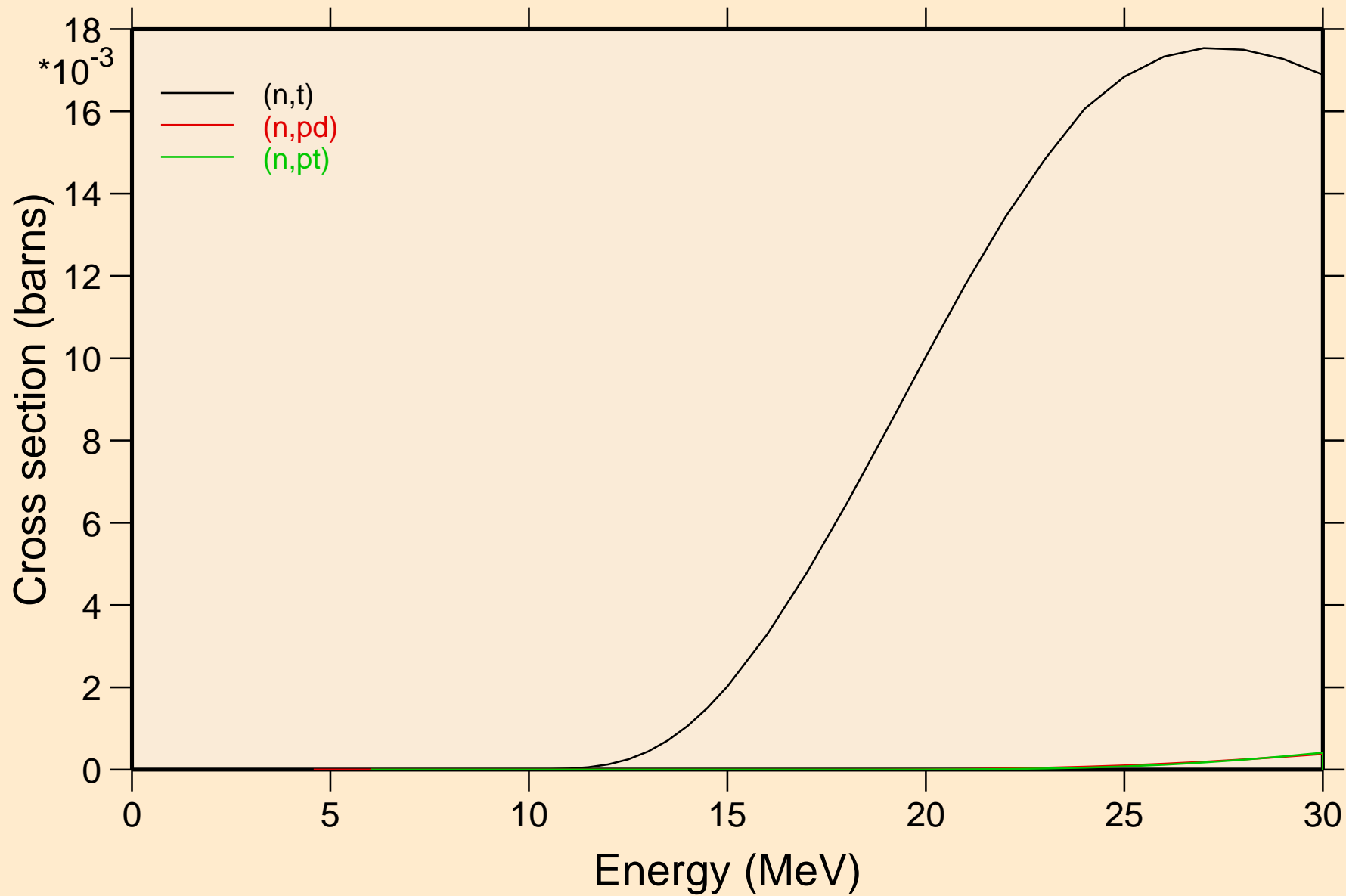

TM156 NEUTRON ACER TENDL-2024 LIBRARY; T=0.K  
angular distribution for elastic

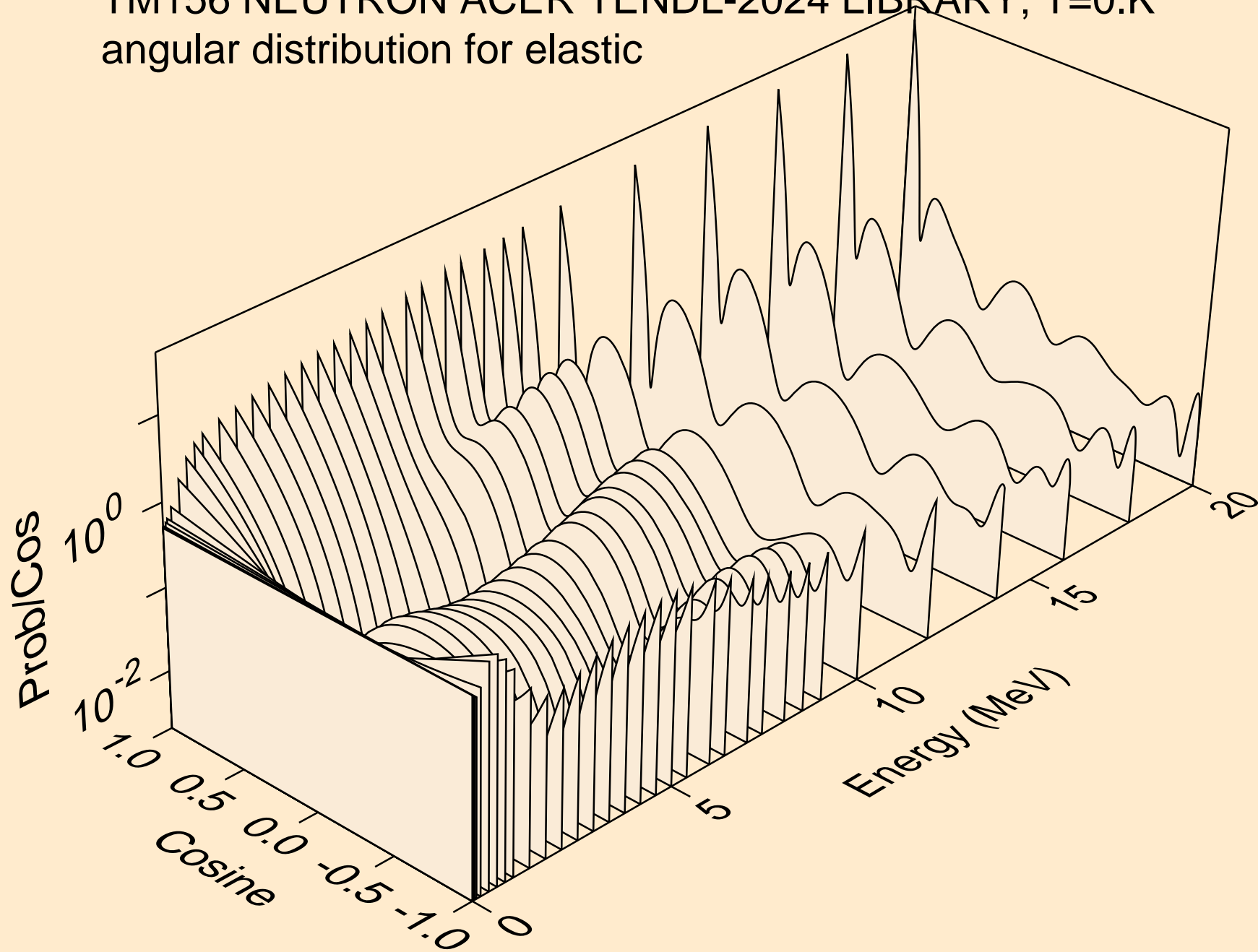

TM156 NEUTRON ACER TENDL-2024 LIBRARY; T=0.K  
angular distribution for elastic

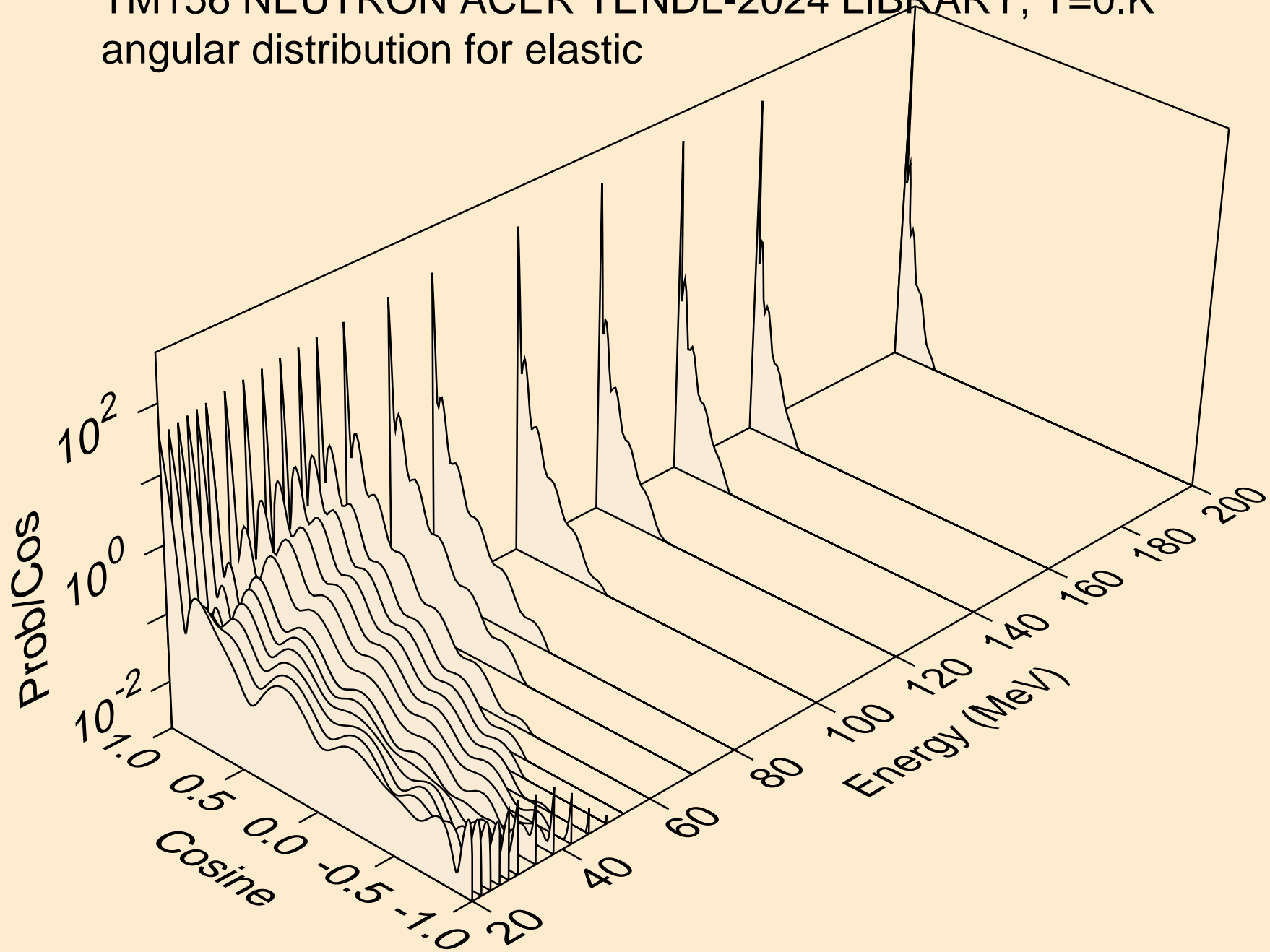

TM156 NEUTRON ACER TENDL-2024 LIBRARY; T=0.K  
angular distribution for (n,n\*1)

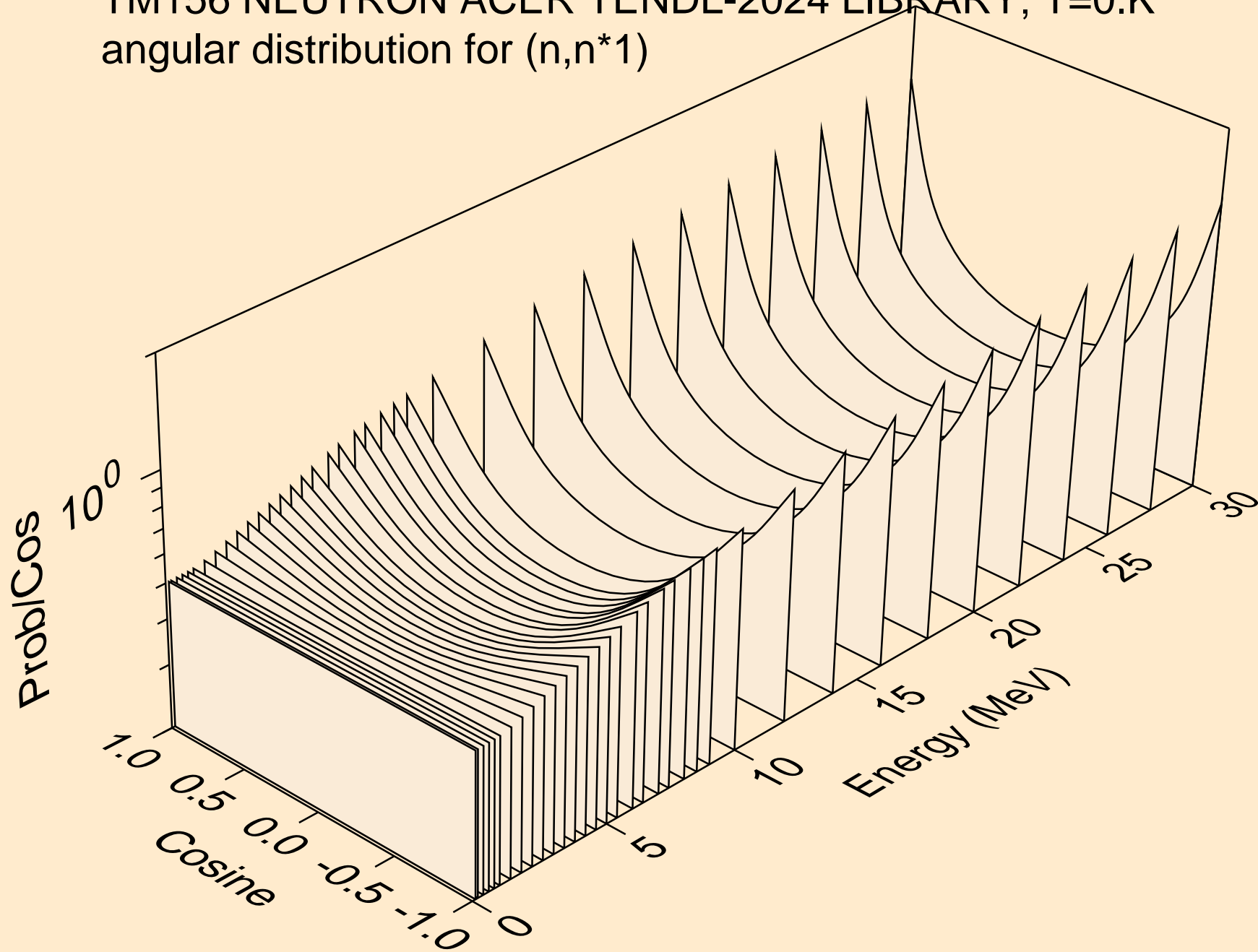

TM156 NEUTRON ACER TENDL-2024 LIBRARY; T=0.K  
angular distribution for (n,n\*2)

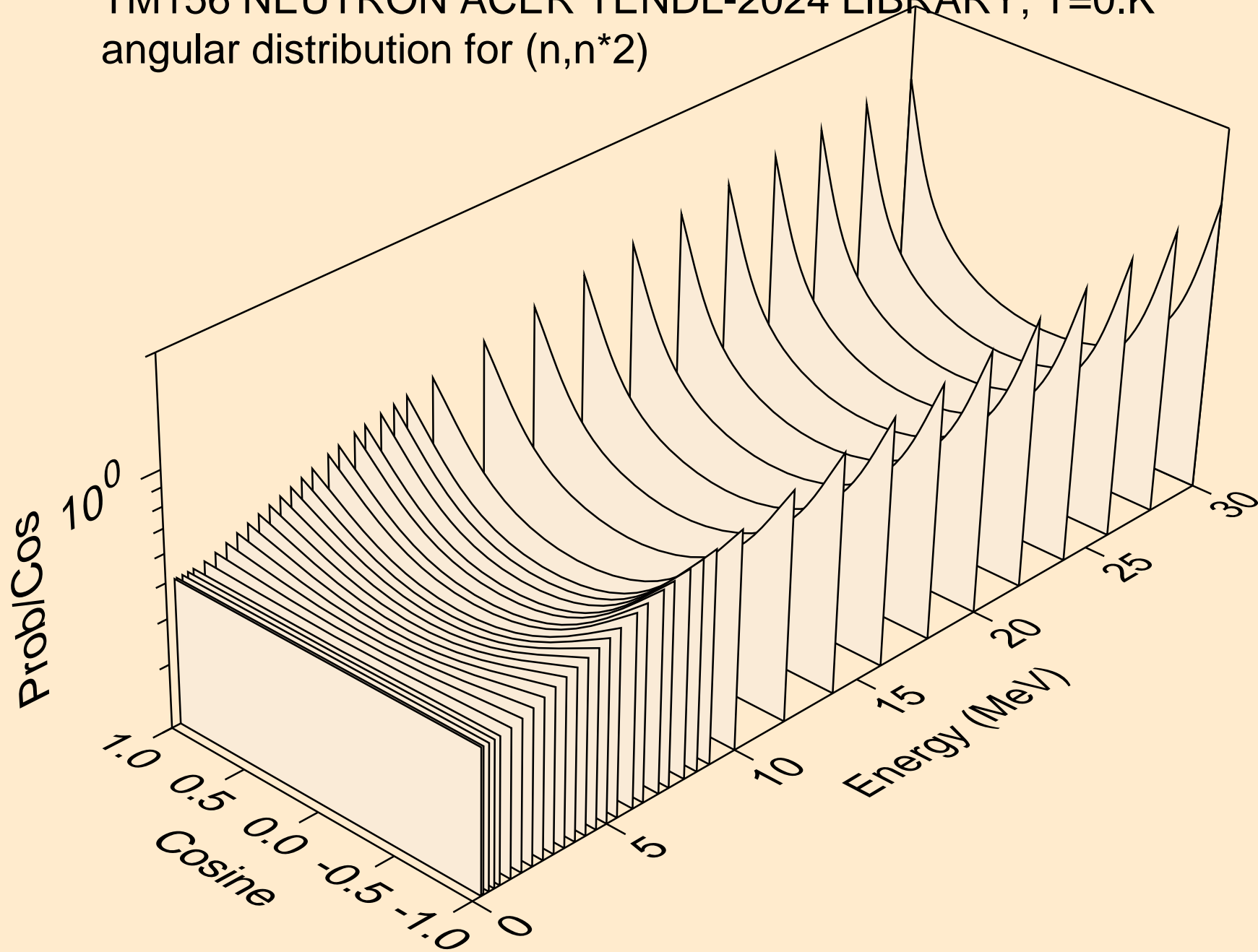

TM156 NEUTRON ACER TENDL-2024 LIBRARY; T=0.K  
angular distribution for (n,n\*3)

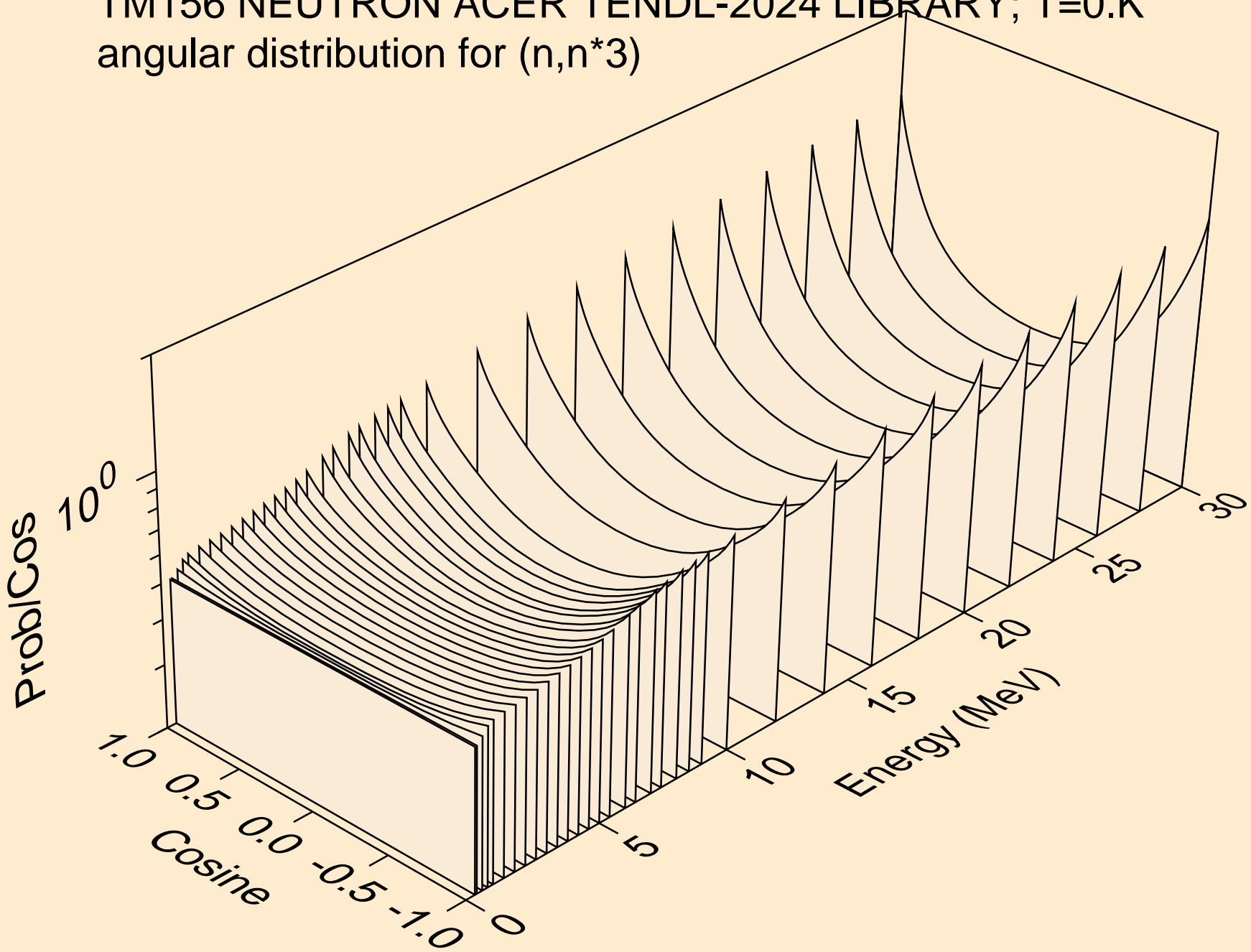

TM156 NEUTRON ACER TENDL-2024 LIBRARY; T=0.K  
angular distribution for (n,n\*4)

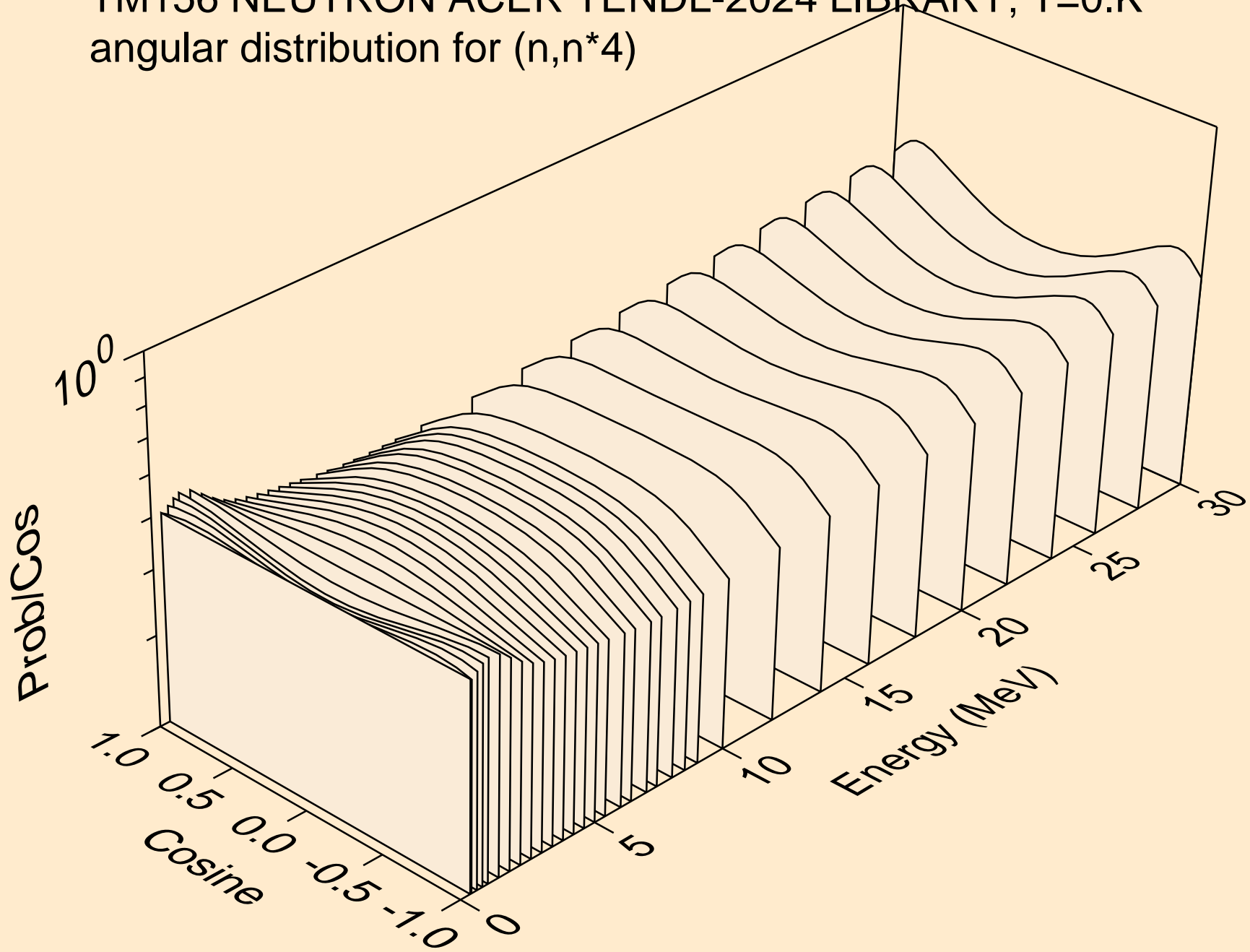

TM156 NEUTRON ACER TENDL-2024 LIBRARY; T=0.K  
angular distribution for (n,n\*5)

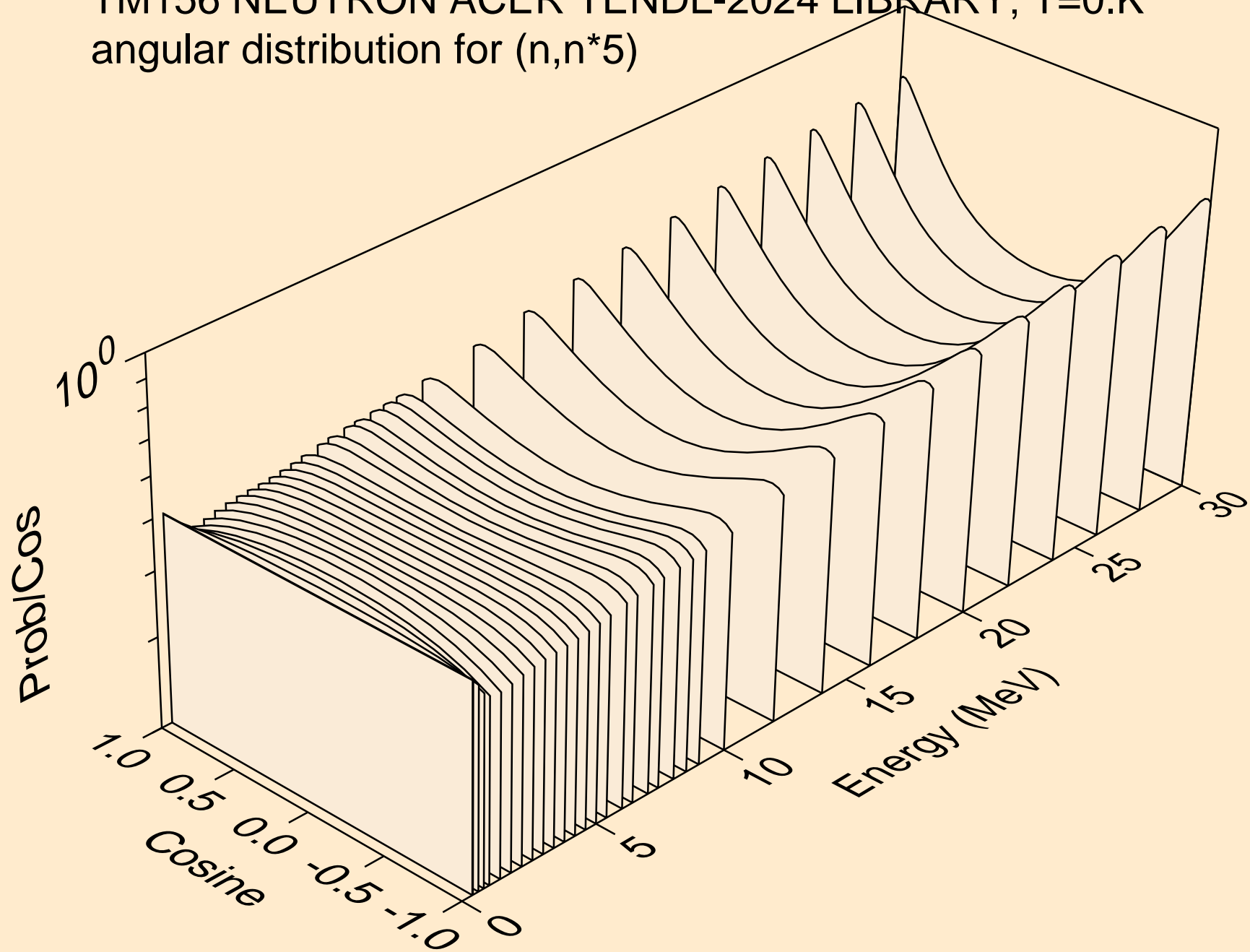

TM156 NEUTRON ACER TENDL-2024 LIBRARY; T=0.K  
angular distribution for (n,n\*6)

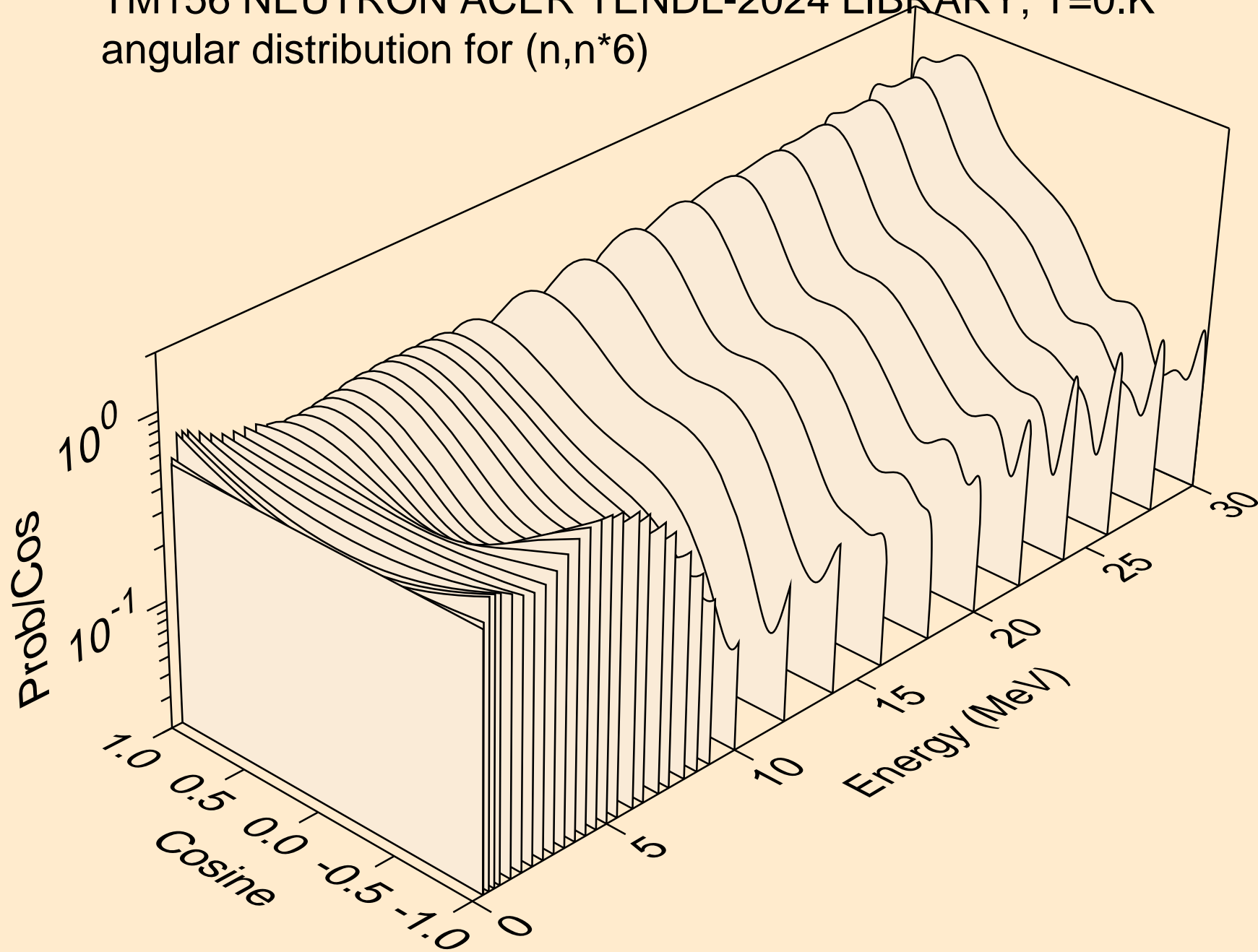

TM156 NEUTRON ACER TENDL-2024 LIBRARY; T=0.K  
angular distribution for (n,n\*7)

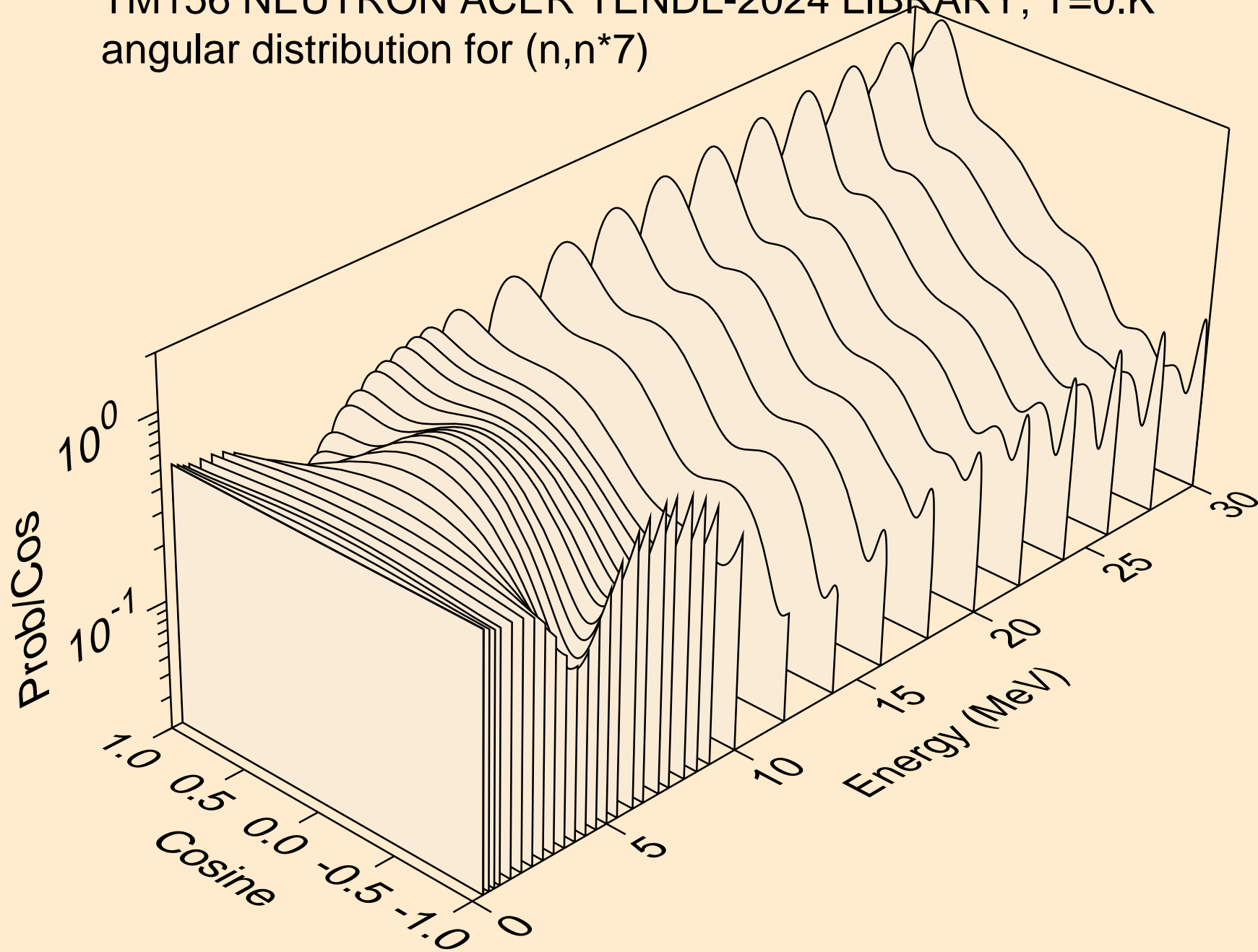

TM156 NEUTRON ACER TENDL-2024 LIBRARY; T=0.K  
angular distribution for (n,n\*8)

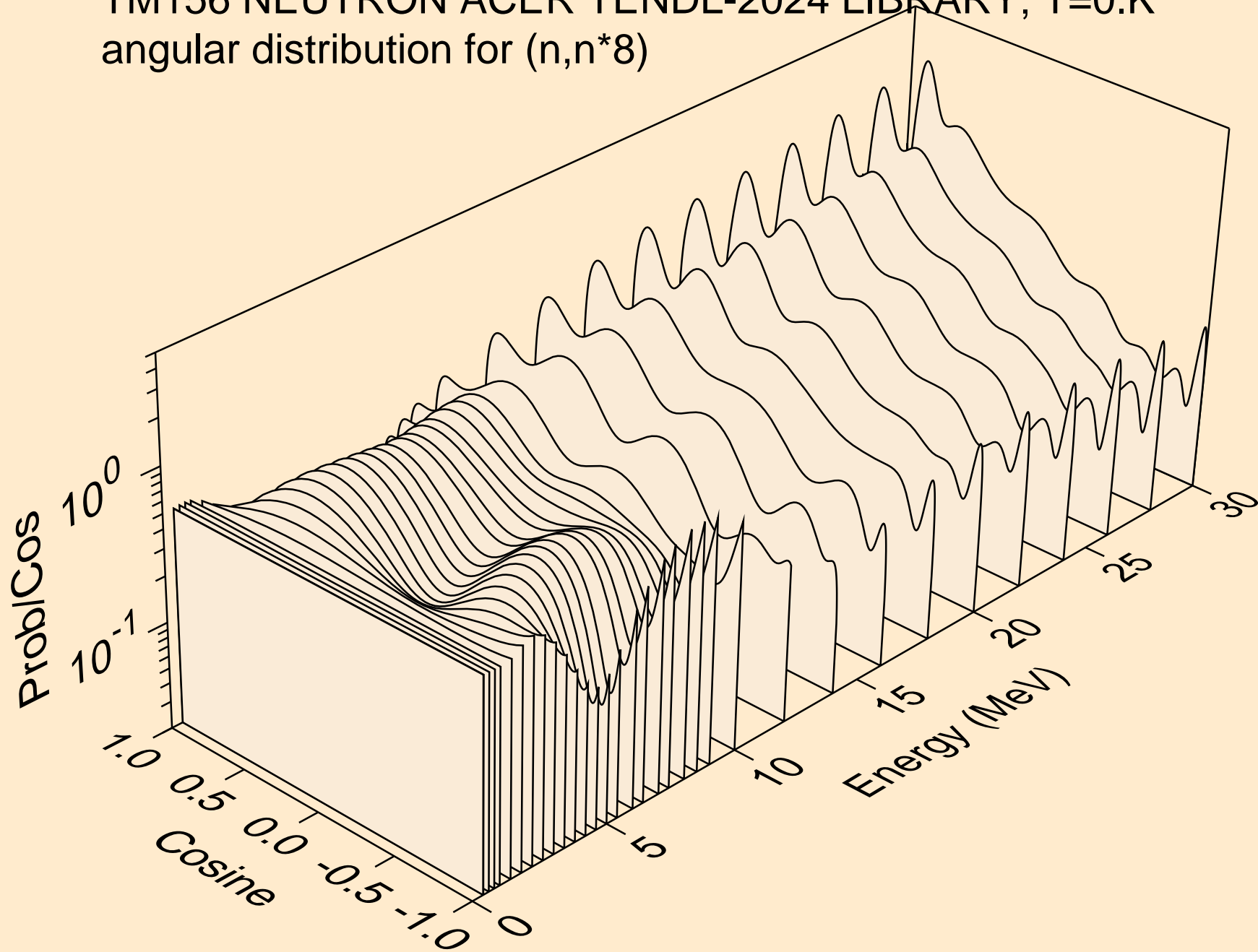

TM156 NEUTRON ACER TENDL-2024 LIBRARY; T=0.K  
angular distribution for (n,n\*9)

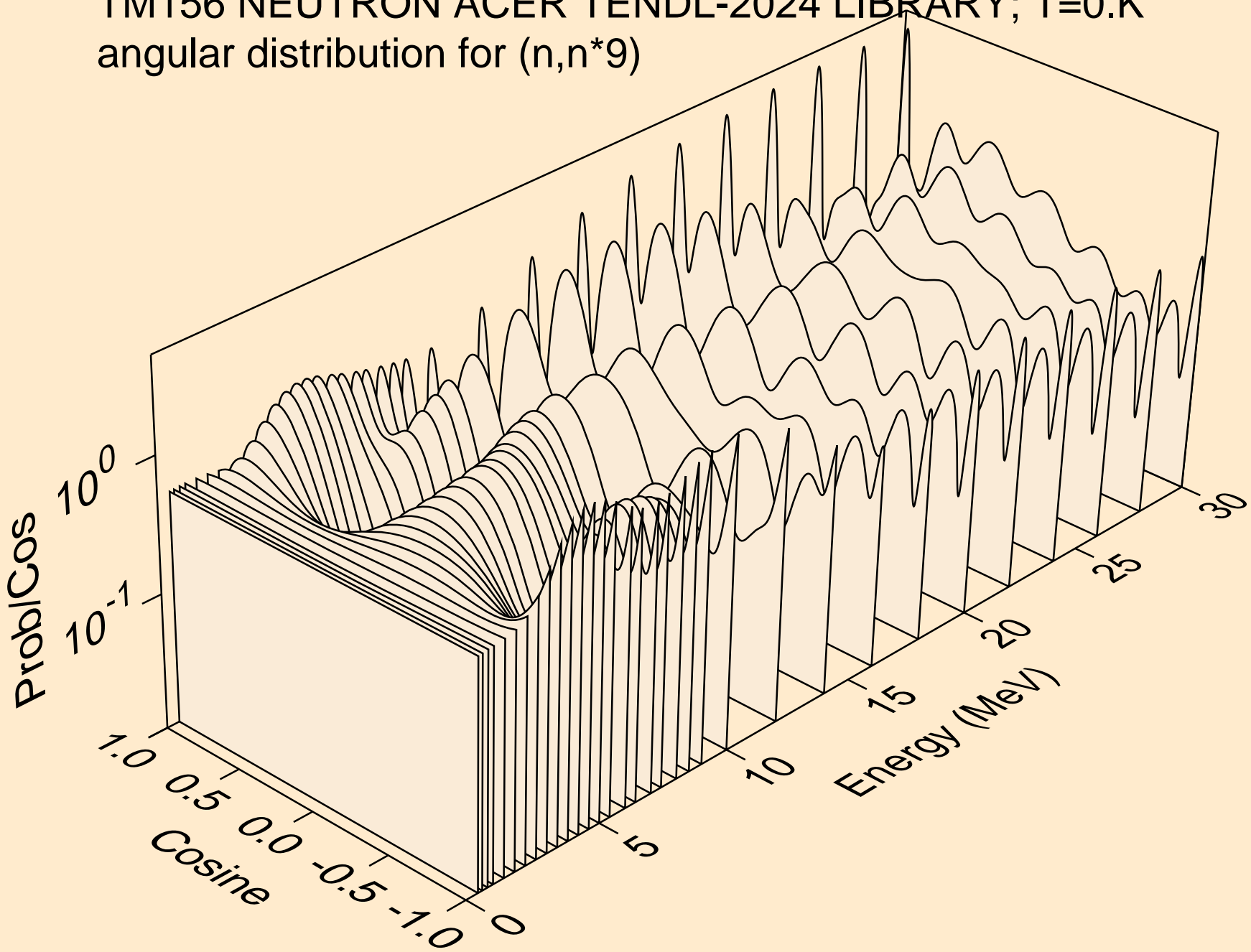

TM156 NEUTRON ACER TENDL-2024 LIBRARY; T=0.K  
angular distribution for (n,n\*10)

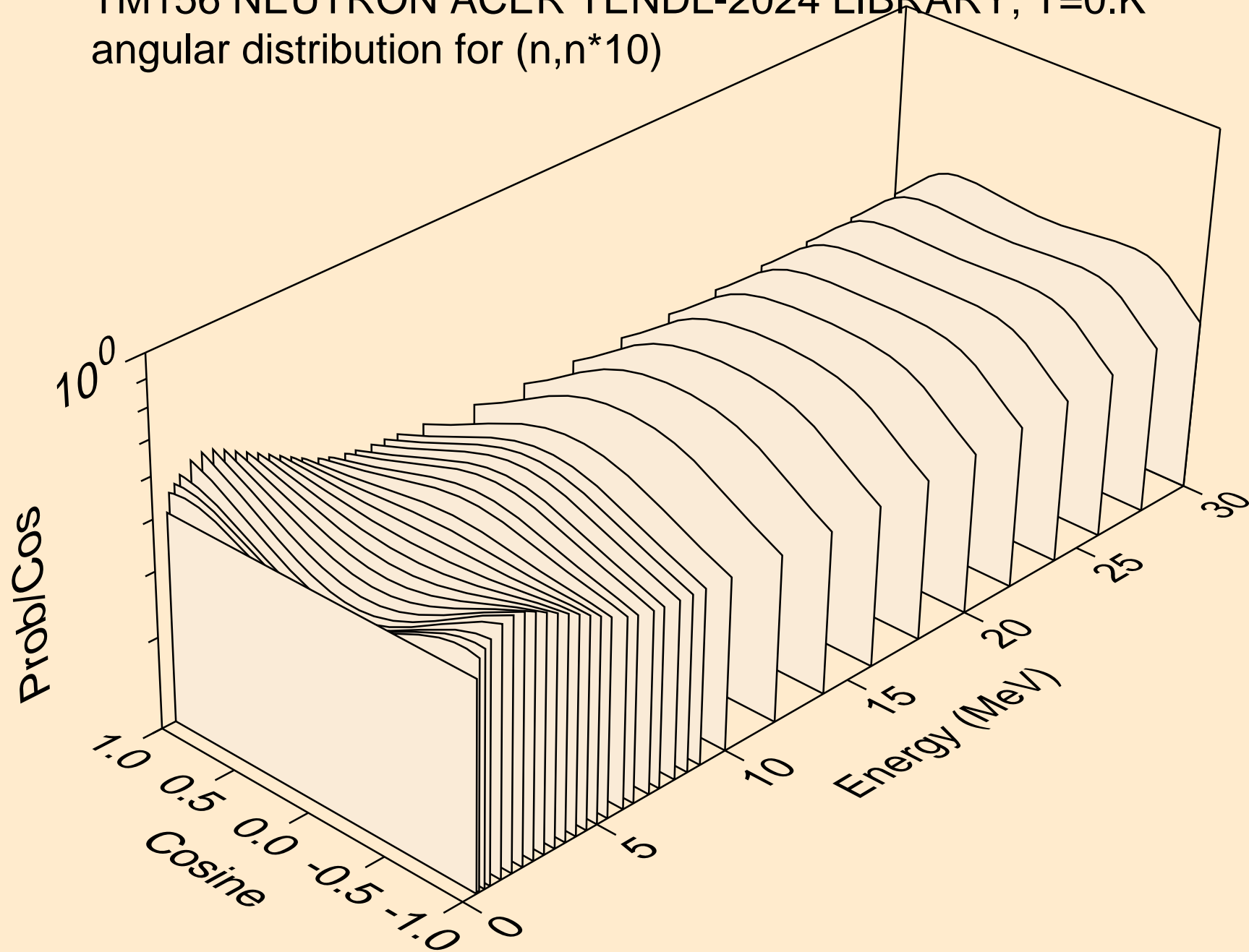

TM156 NEUTRON ACER TENDL-2024 LIBRARY; T=0.K  
angular distribution for (n,n\*11)

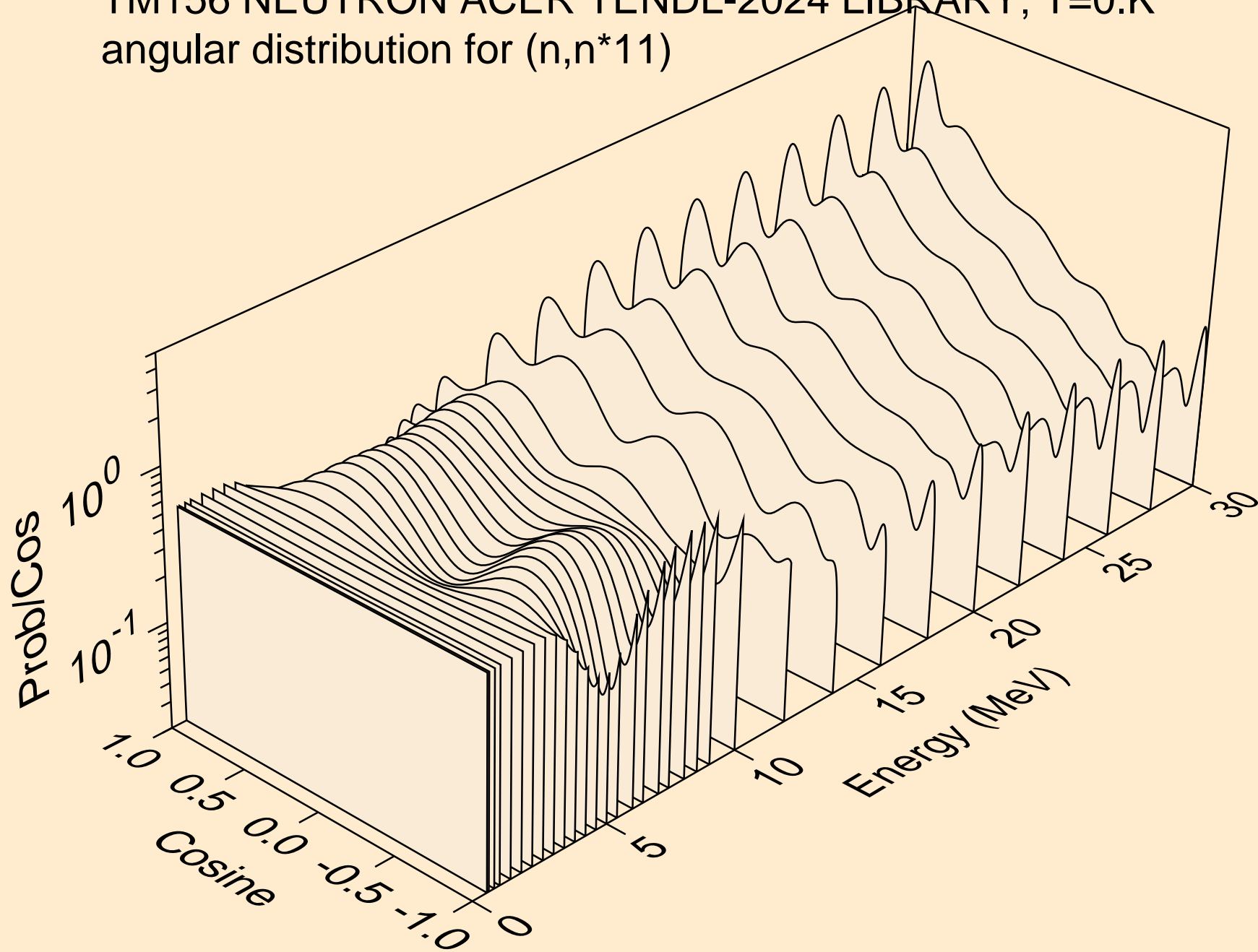

TM156 NEUTRON ACER TENDL-2024 LIBRARY; T=0.K  
angular distribution for (n,n\*12)

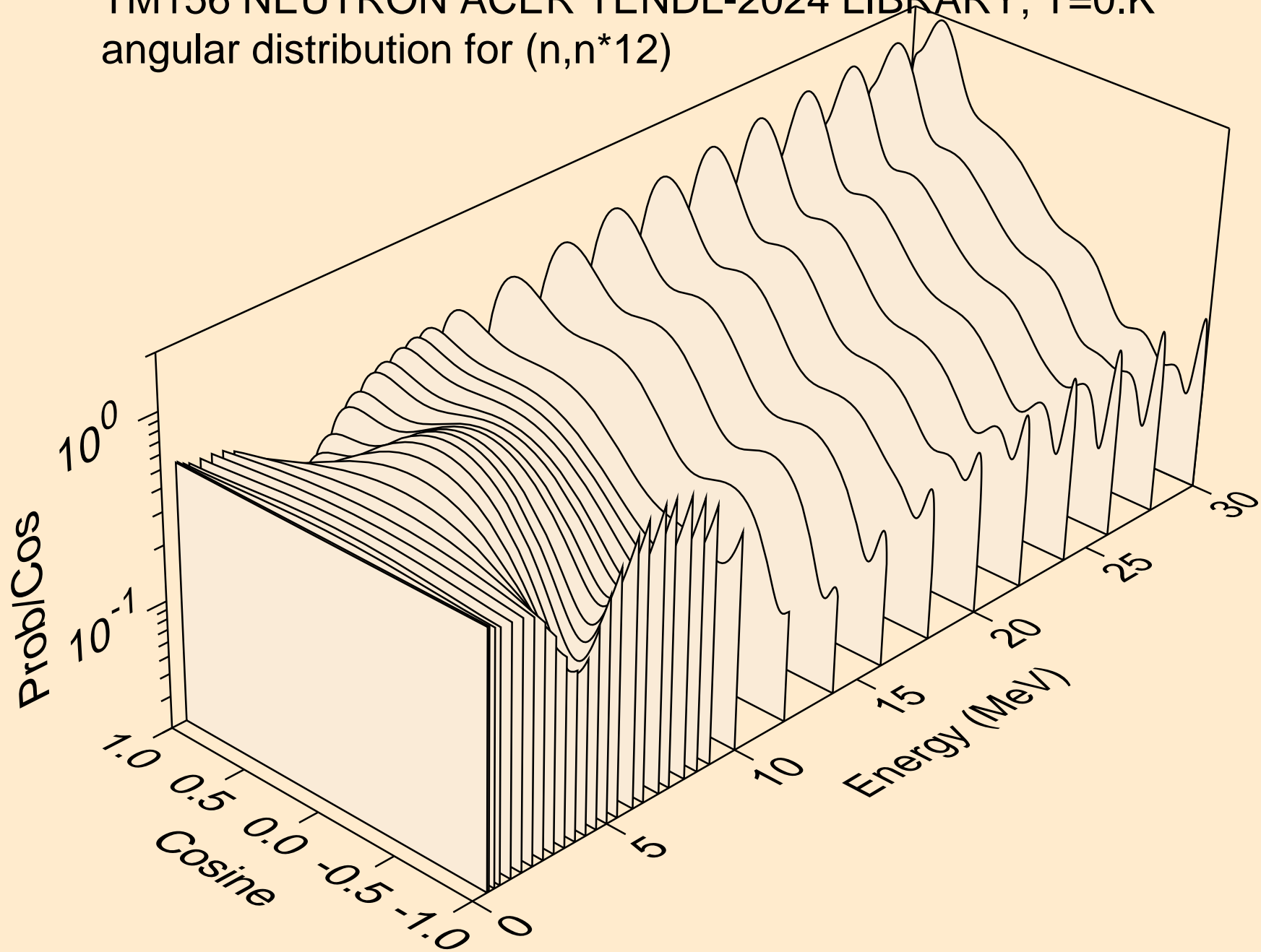

TM156 NEUTRON ACER TENDL-2024 LIBRARY; T=0.K  
angular distribution for (n,n\*13)

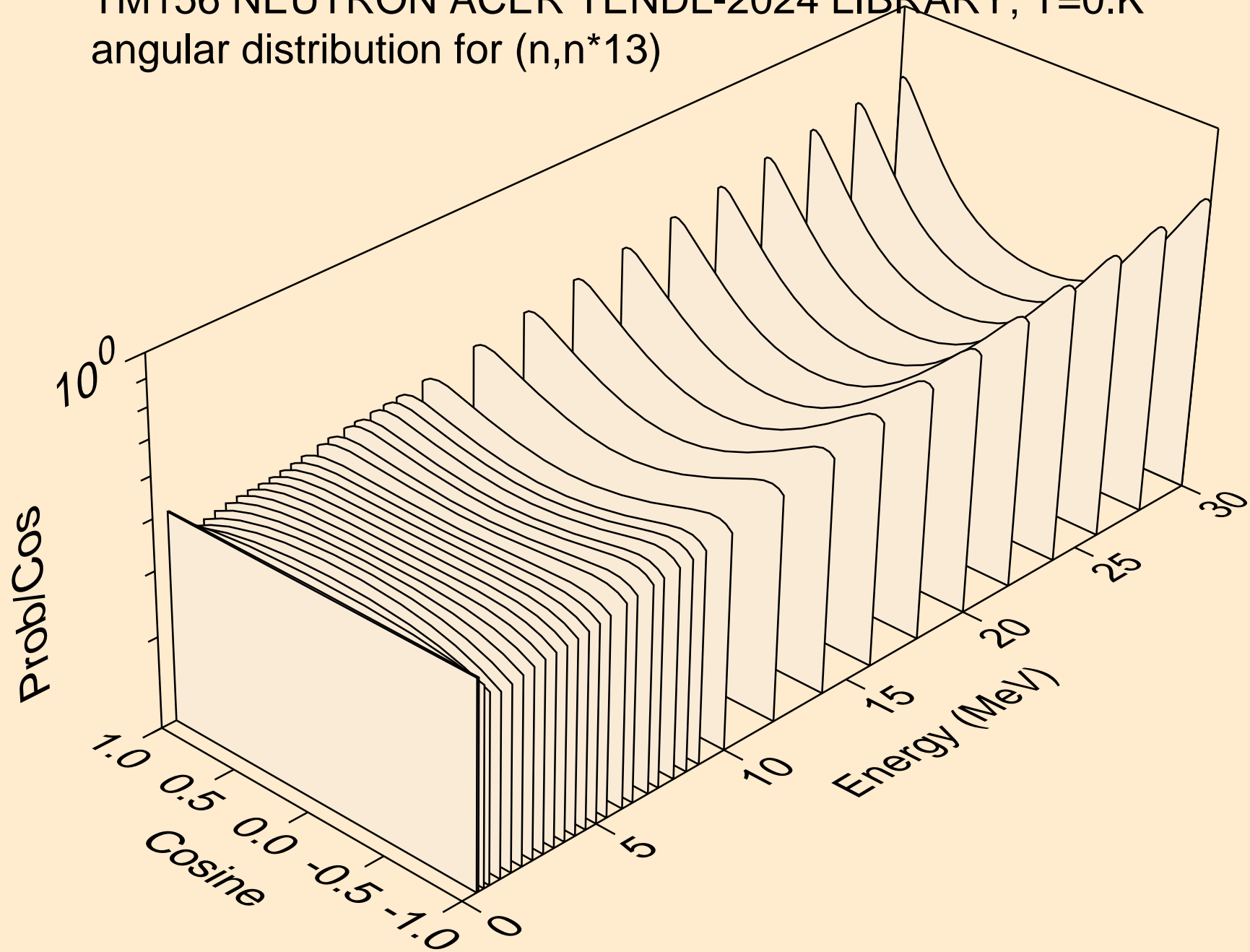

TM156 NEUTRON ACER TENDL-2024 LIBRARY; T=0.K  
angular distribution for (n,n\*14)

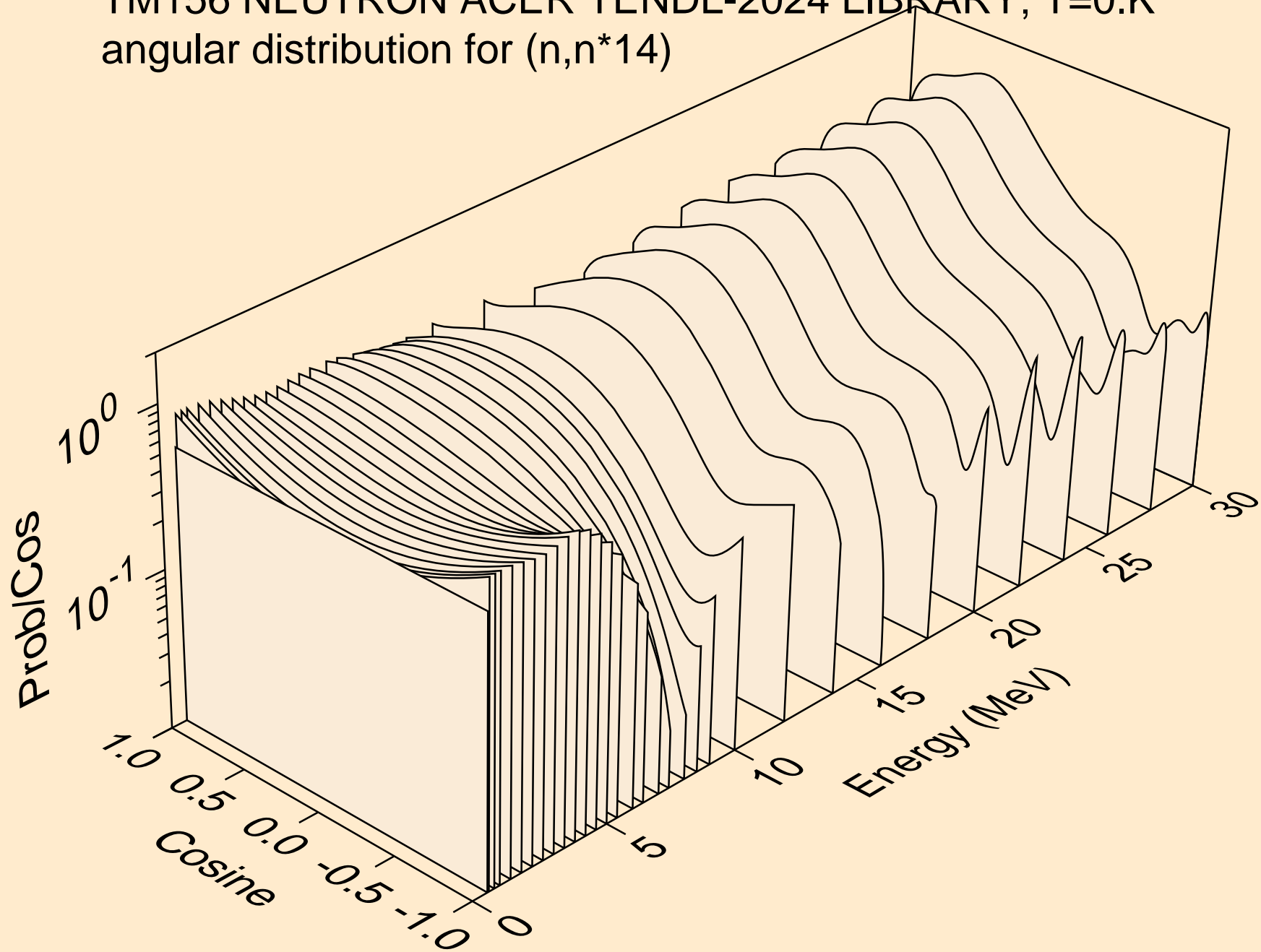

TM156 NEUTRON ACER TENDL-2024 LIBRARY; T=0.K  
angular distribution for (n,n\*15)

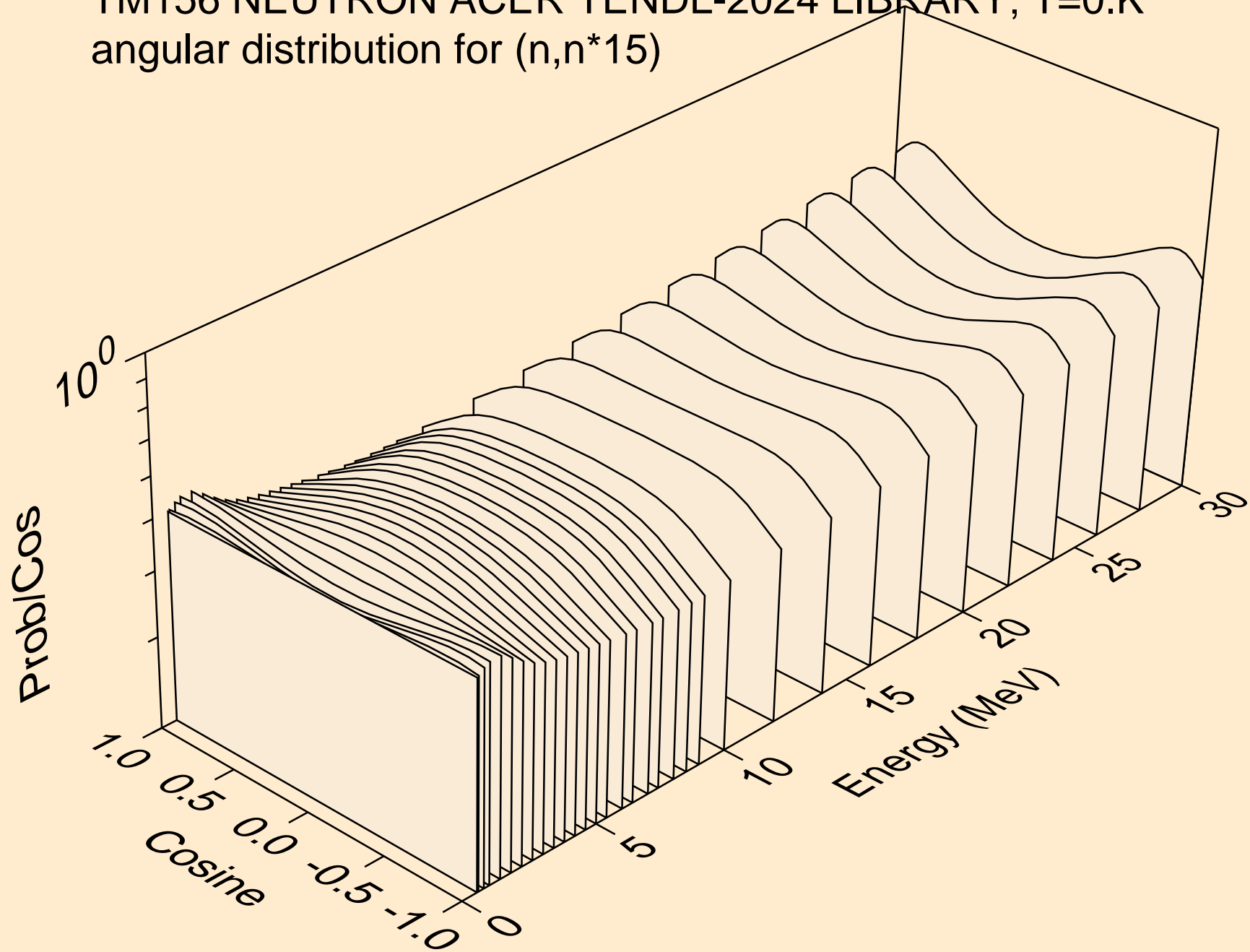

TM156 NEUTRON ACER TENDL-2024 LIBRARY; T=0.K  
angular distribution for (n,n\*16)

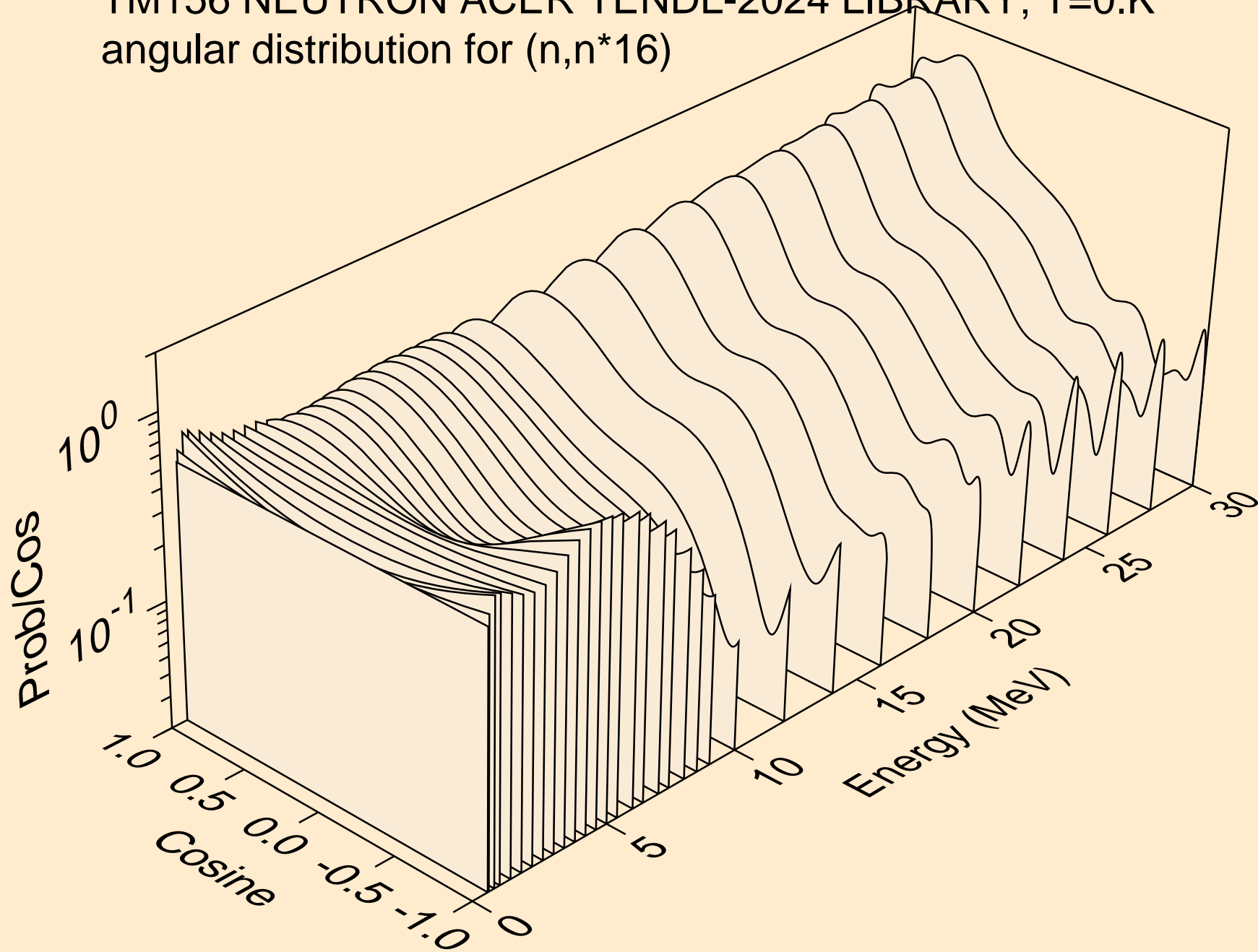

TM156 NEUTRON ACER TENDL-2024 LIBRARY; T=0.K  
angular distribution for (n,n\*17)

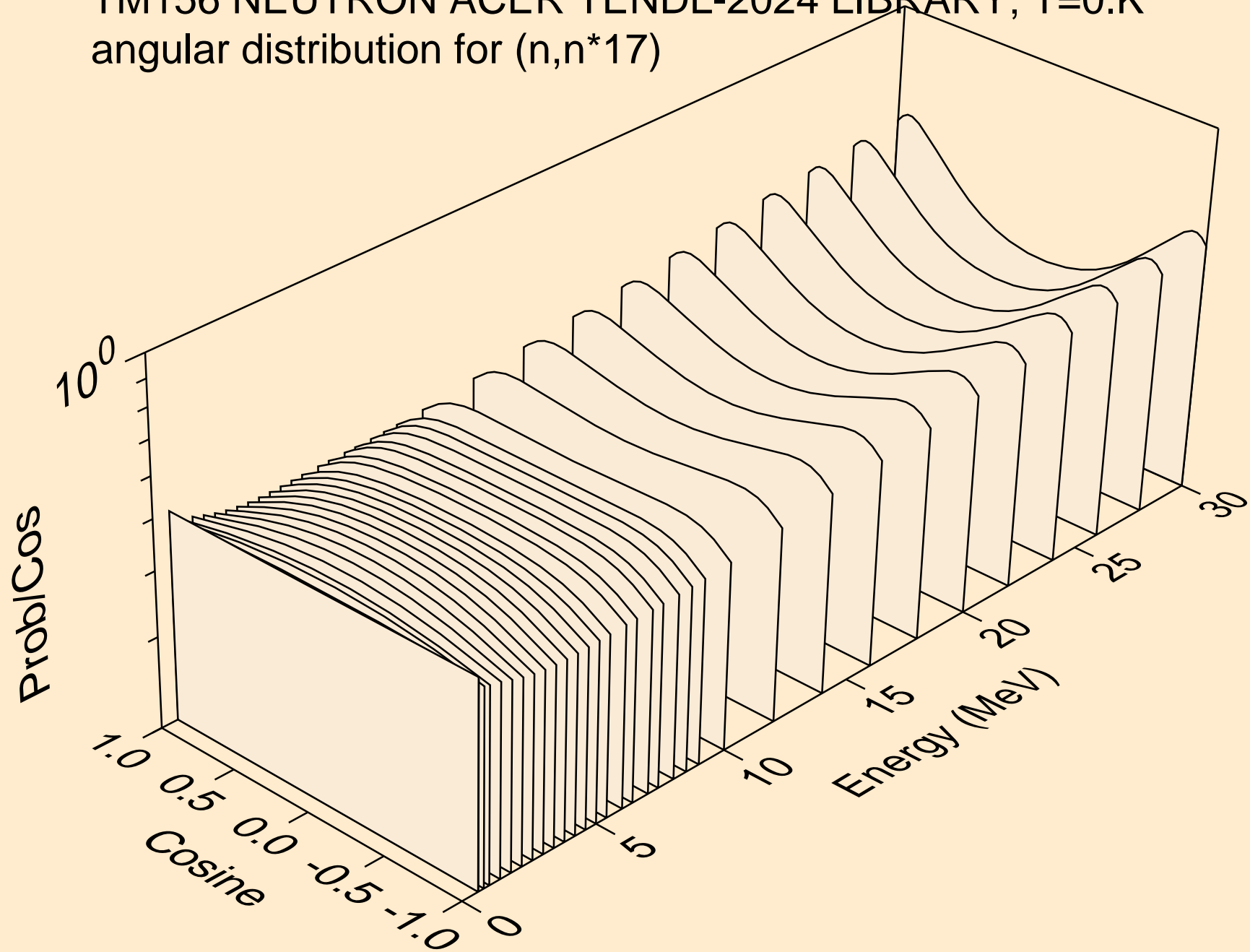

TM156 NEUTRON ACER TENDL-2024 LIBRARY; T=0.K  
angular distribution for (n,n\*18)

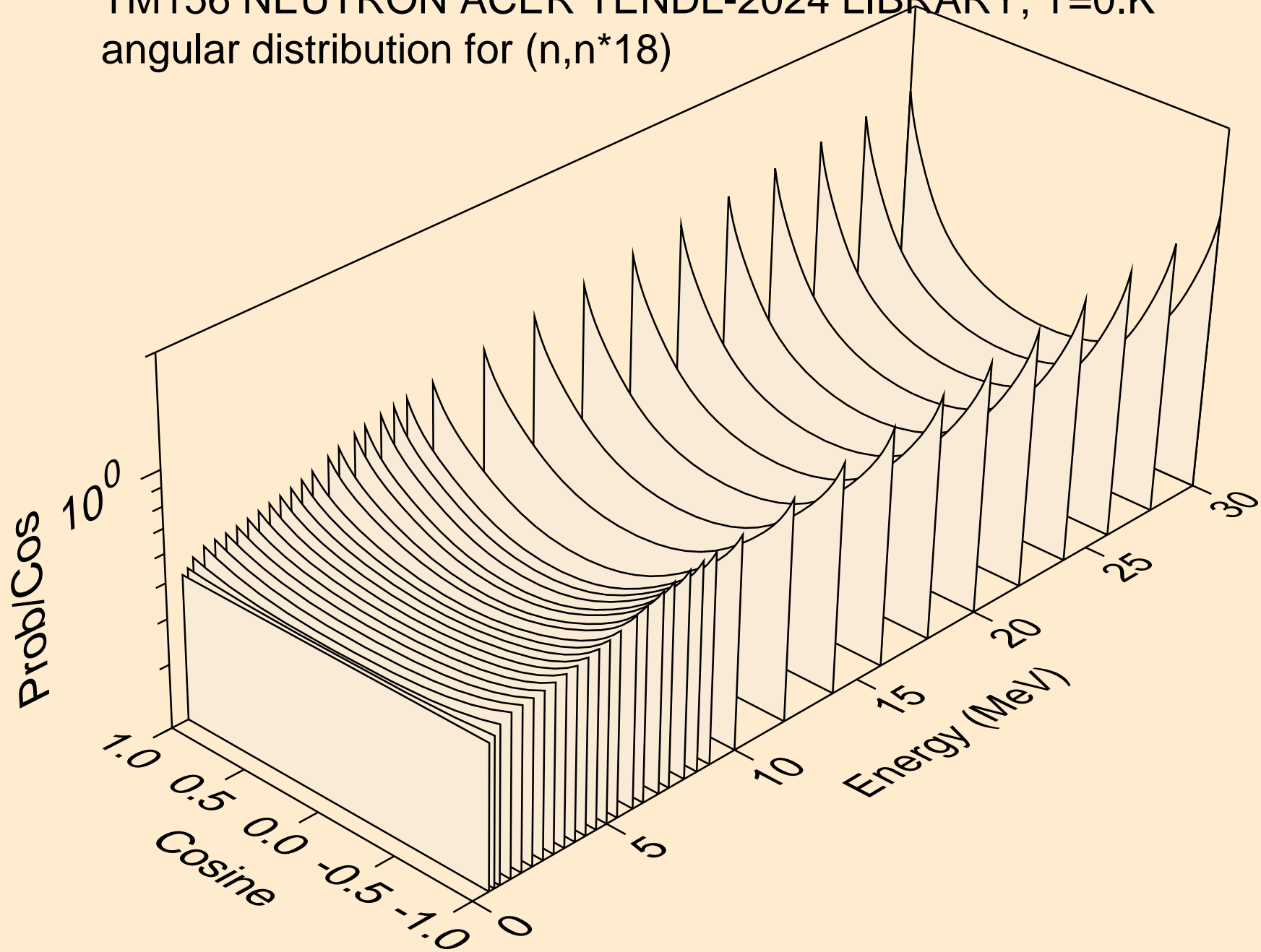

TM156 NEUTRON ACER TENDL-2024 LIBRARY; T=0.K  
angular distribution for (n,n\*19)

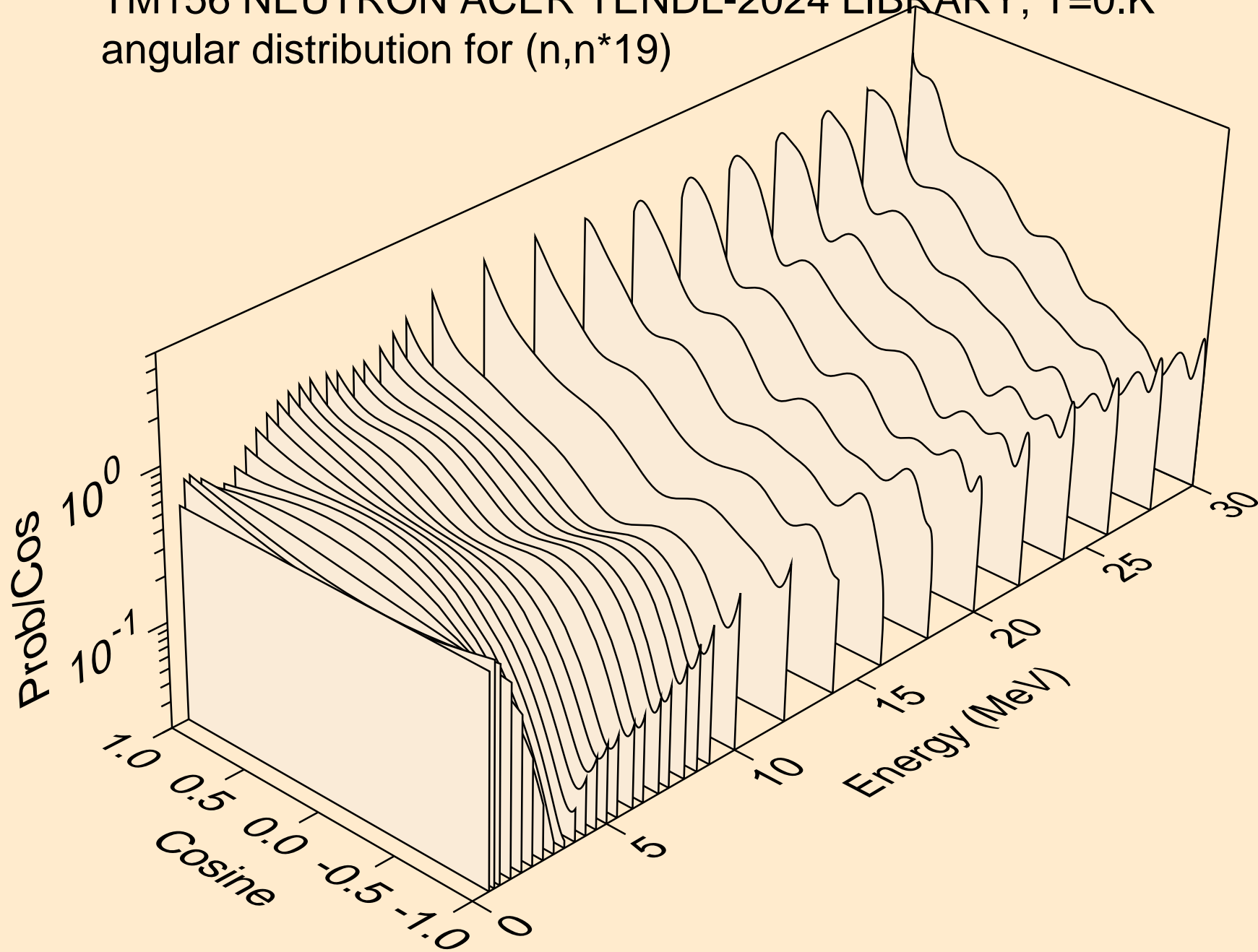

TM156 NEUTRON ACER TENDL-2024 LIBRARY; T=0.K  
angular distribution for (n,n\*20)

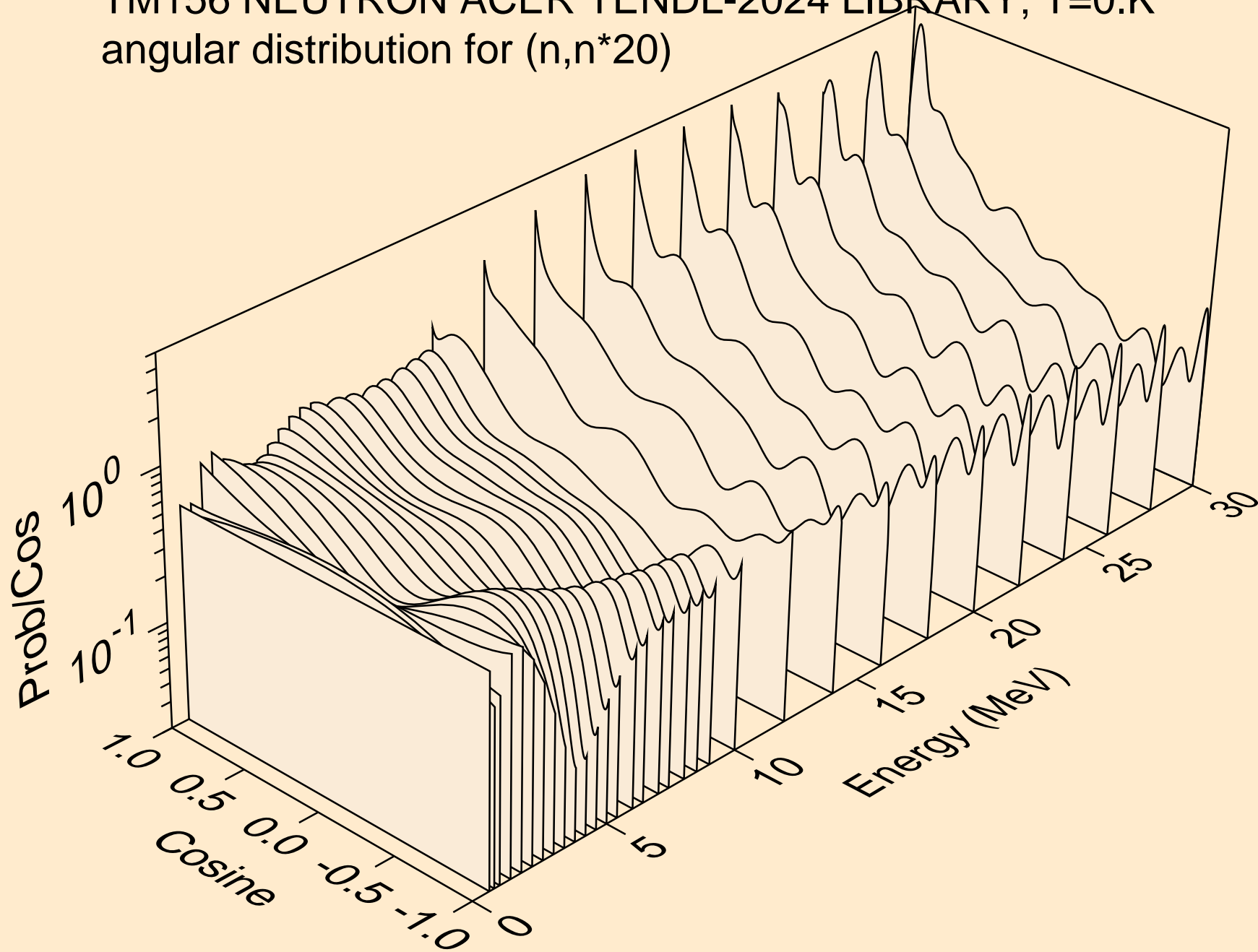

TM156 NEUTRON ACER TENDL-2024 LIBRARY; T=0.K  
angular distribution for (n,n\*21)

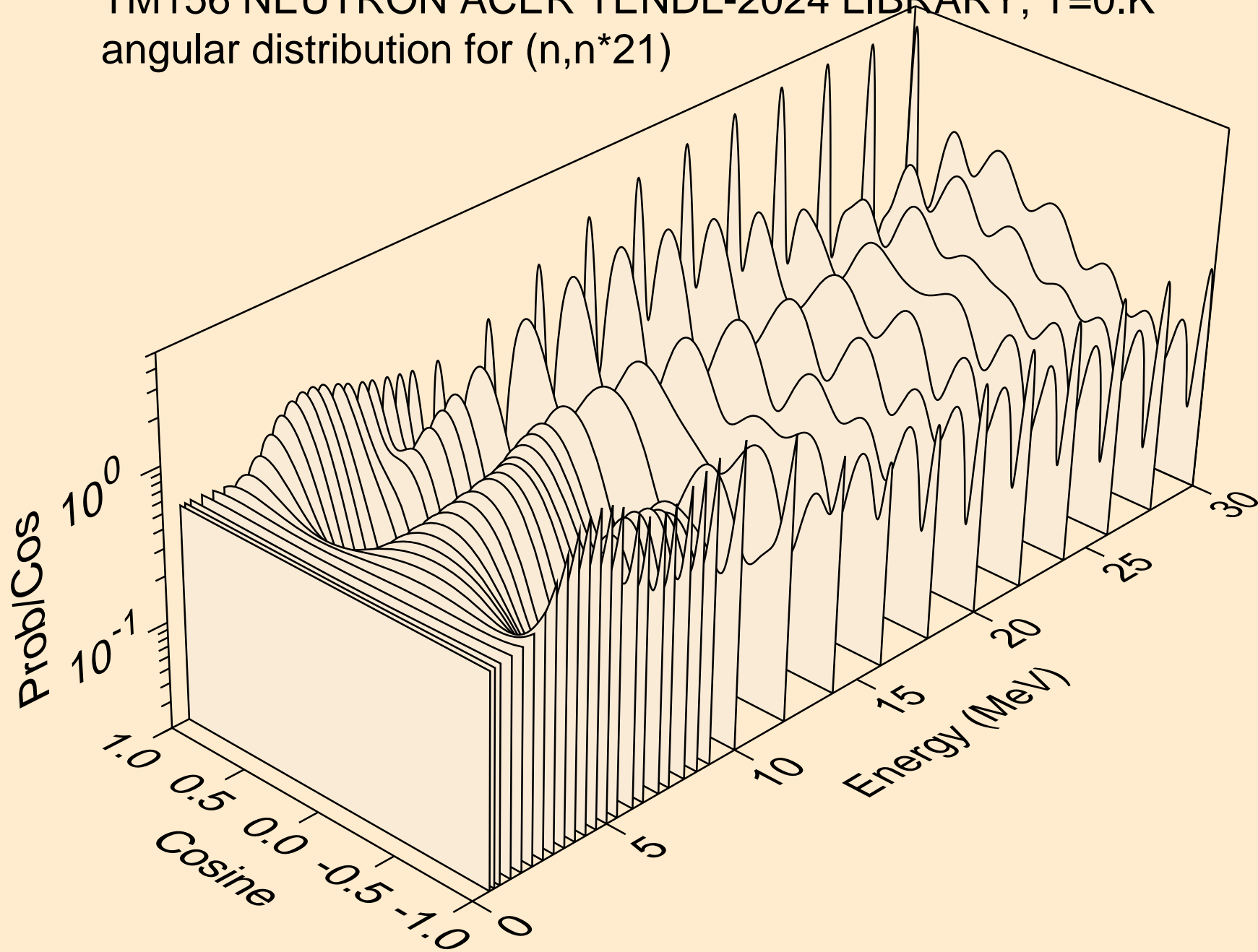

TM156 NEUTRON ACER TENDL-2024 LIBRARY; T=0.K  
angular distribution for (n,n\*22)

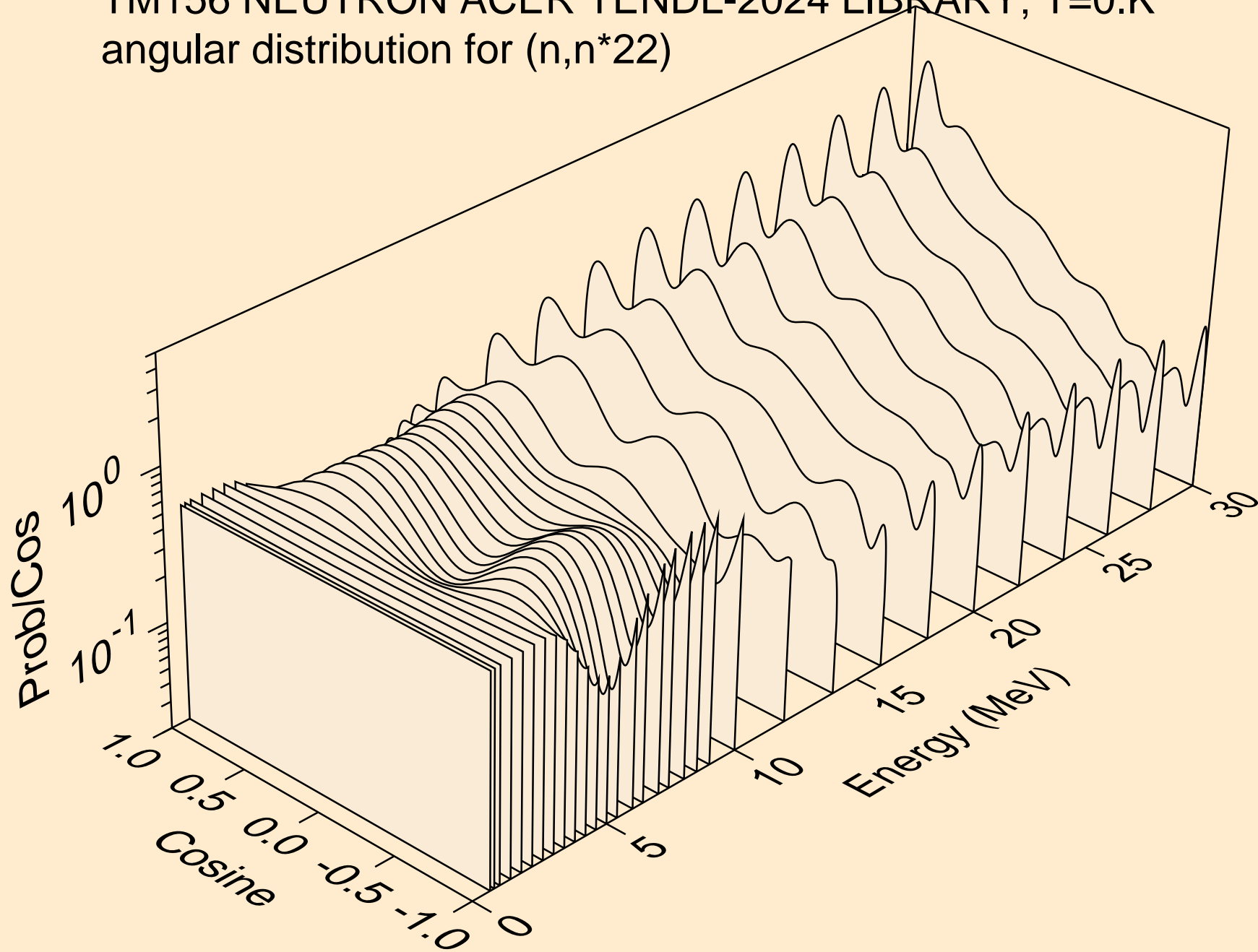

TM156 NEUTRON ACER TENDL-2024 LIBRARY; T=0.K  
angular distribution for (n,n\*23)

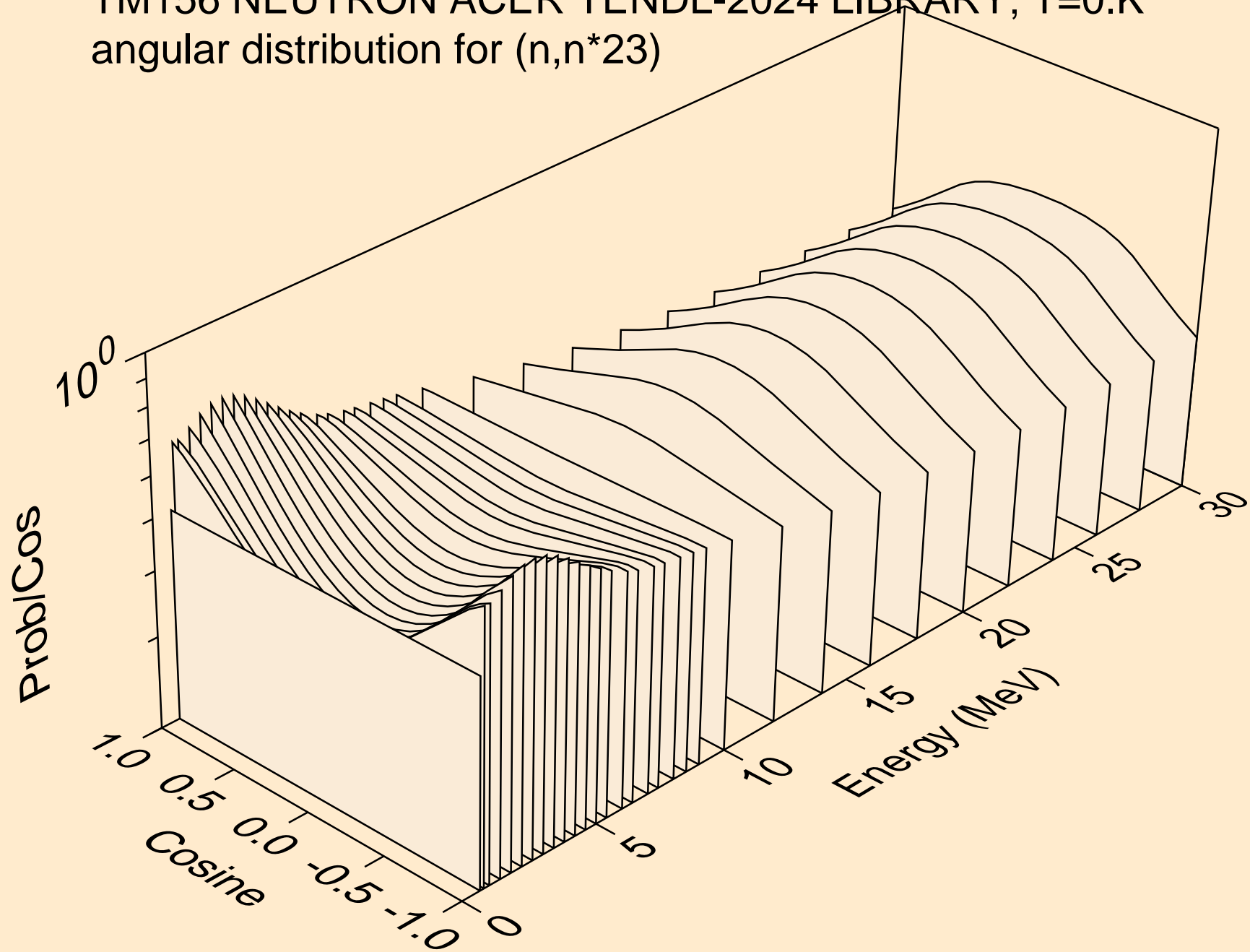

TM156 NEUTRON ACER TENDL-2024 LIBRARY; T=0.K  
angular distribution for (n,n\*24)

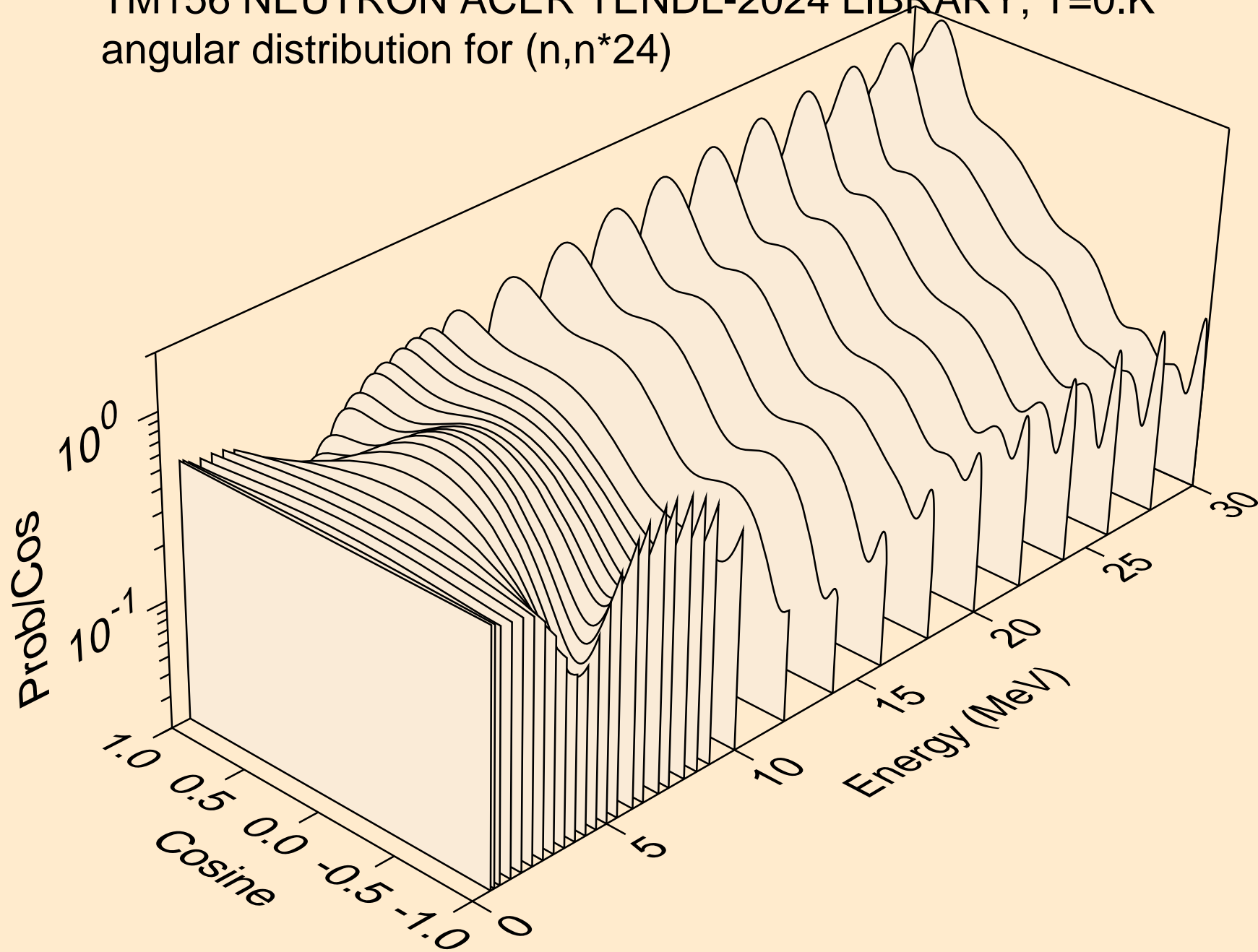

TM156 NEUTRON ACER TENDL-2024 LIBRARY; T=0.K  
angular distribution for (n,n\*25)

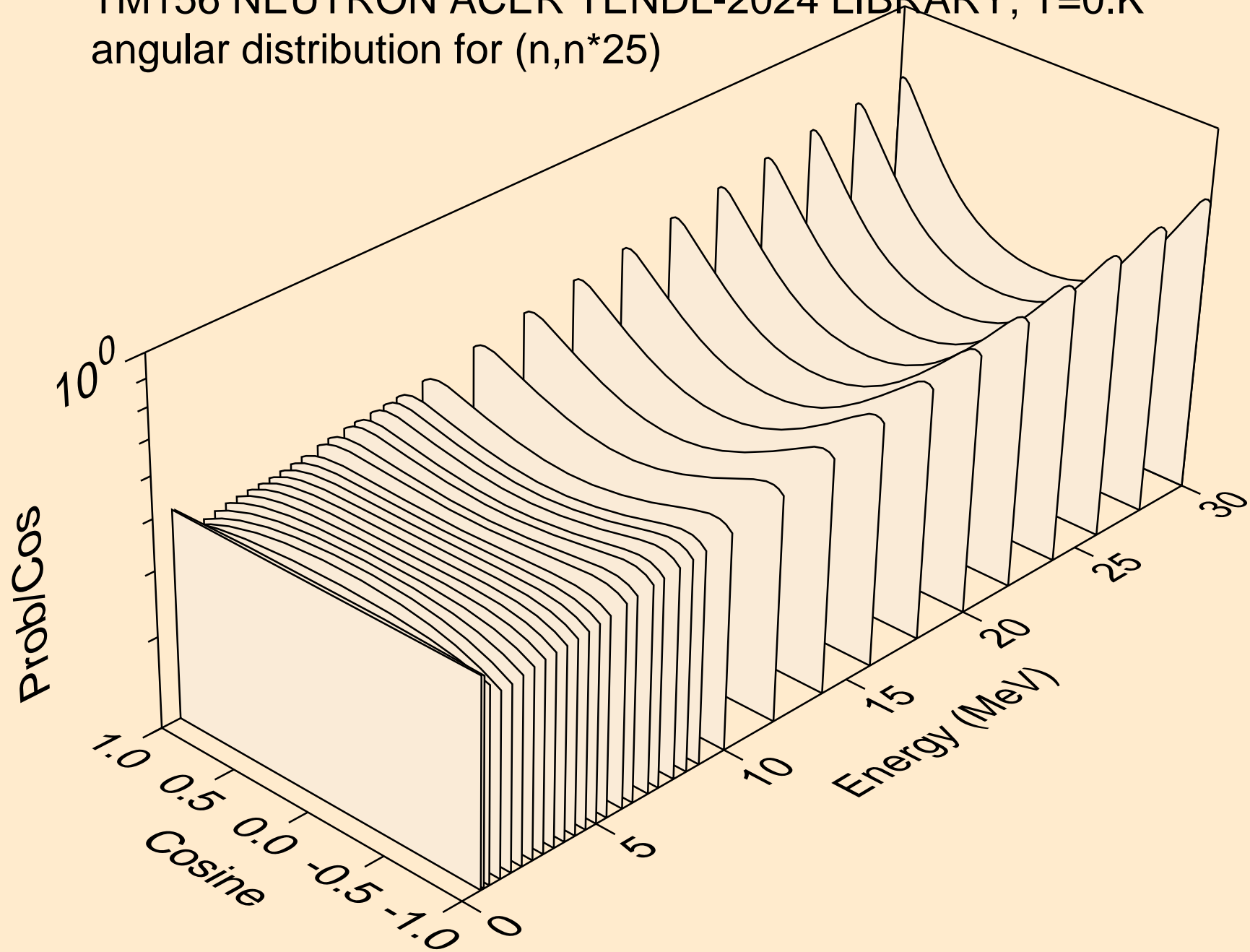

TM156 NEUTRON ACER TENDL-2024 LIBRARY; T=0.K  
Neutron emission for (n,x)

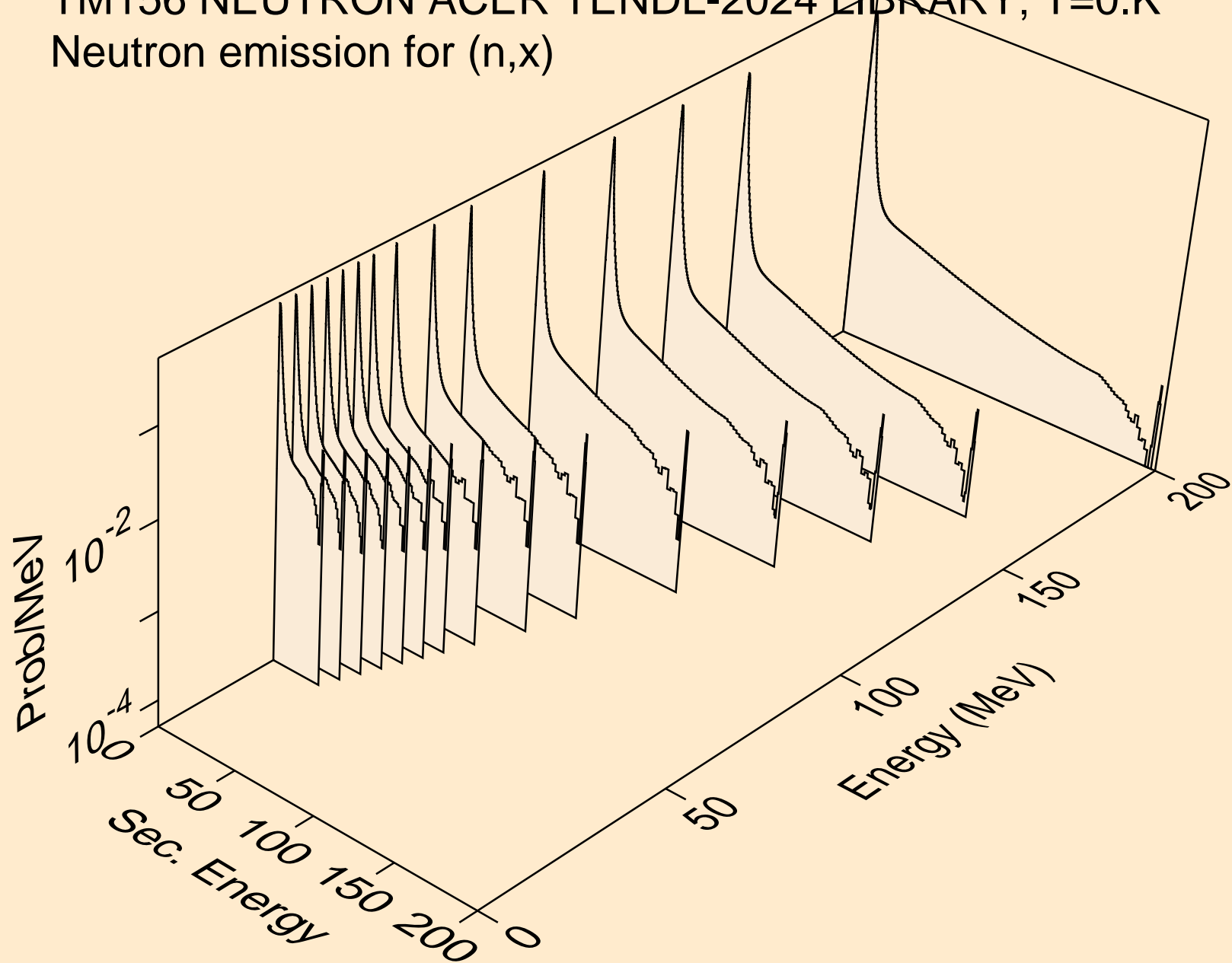

TM156 NEUTRON ACER TENDL-2024 LIBRARY; T=0.K  
Neutron emission for (n,2nd)

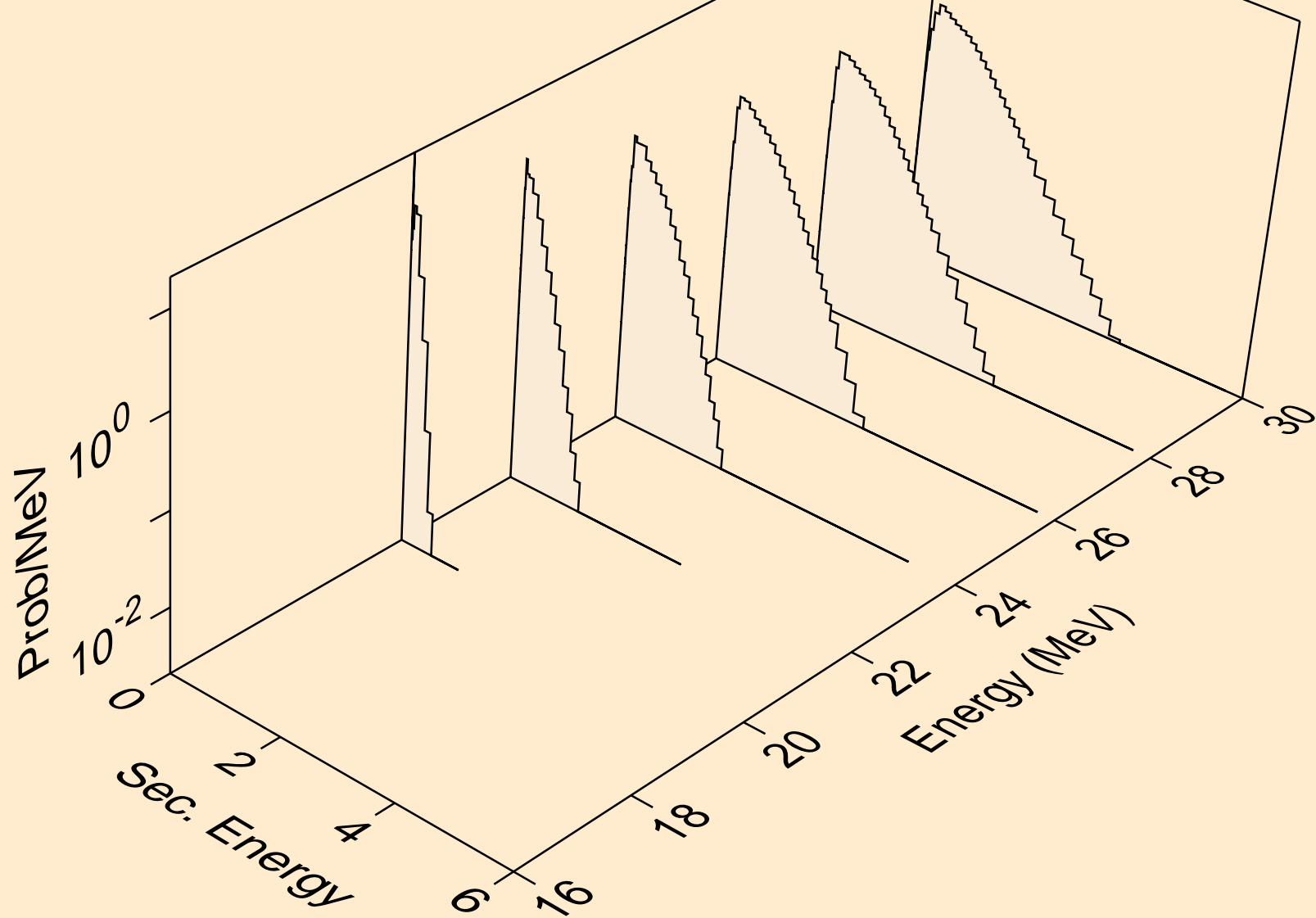

TM156 NEUTRON ACER TENDL-2024 LIBRARY; T=0.K  
Neutron emission for (n,2n)

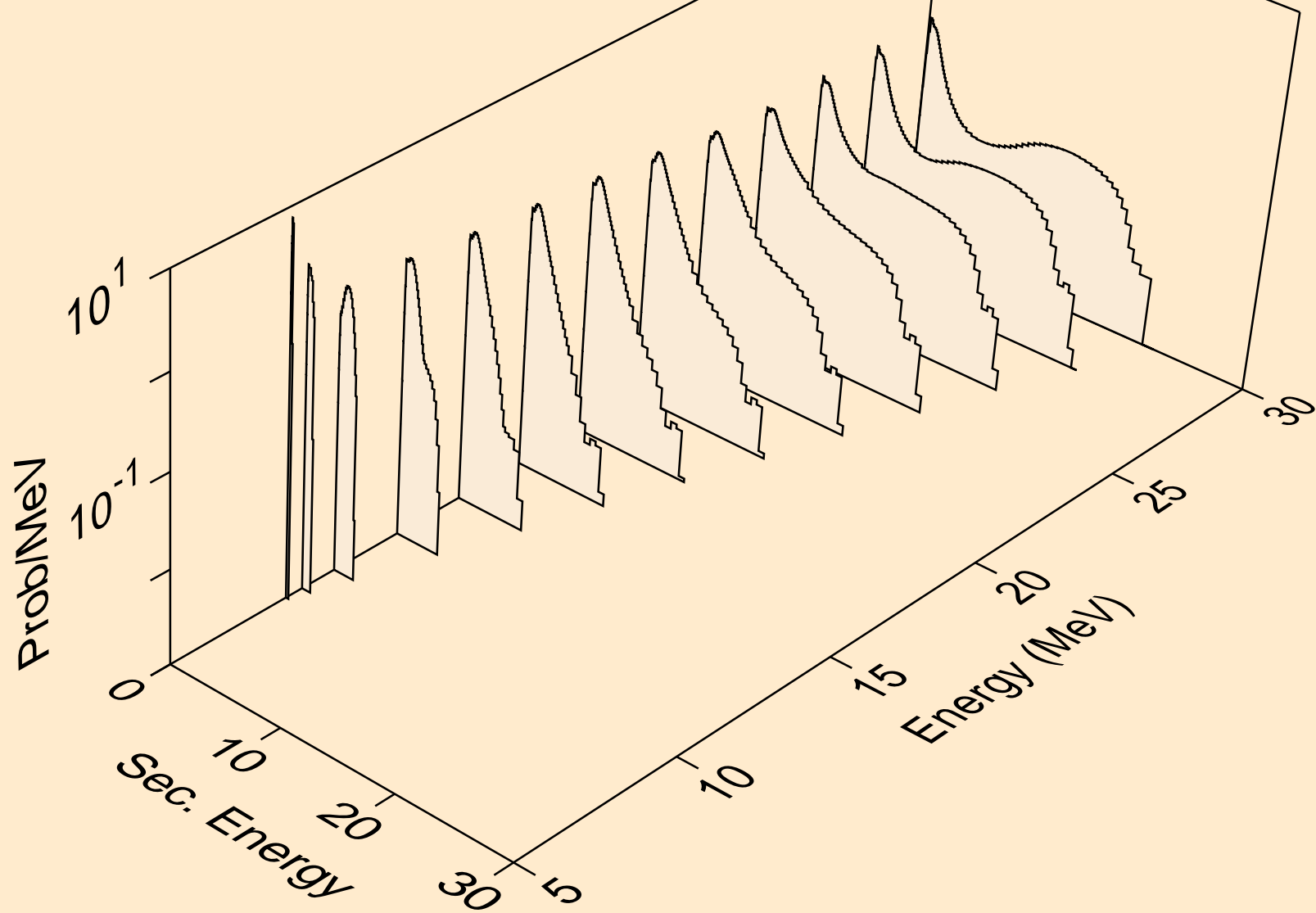

TM156 NEUTRON ACER TENDL-2024 LIBRARY; T=0.K  
Neutron emission for (n,3n)

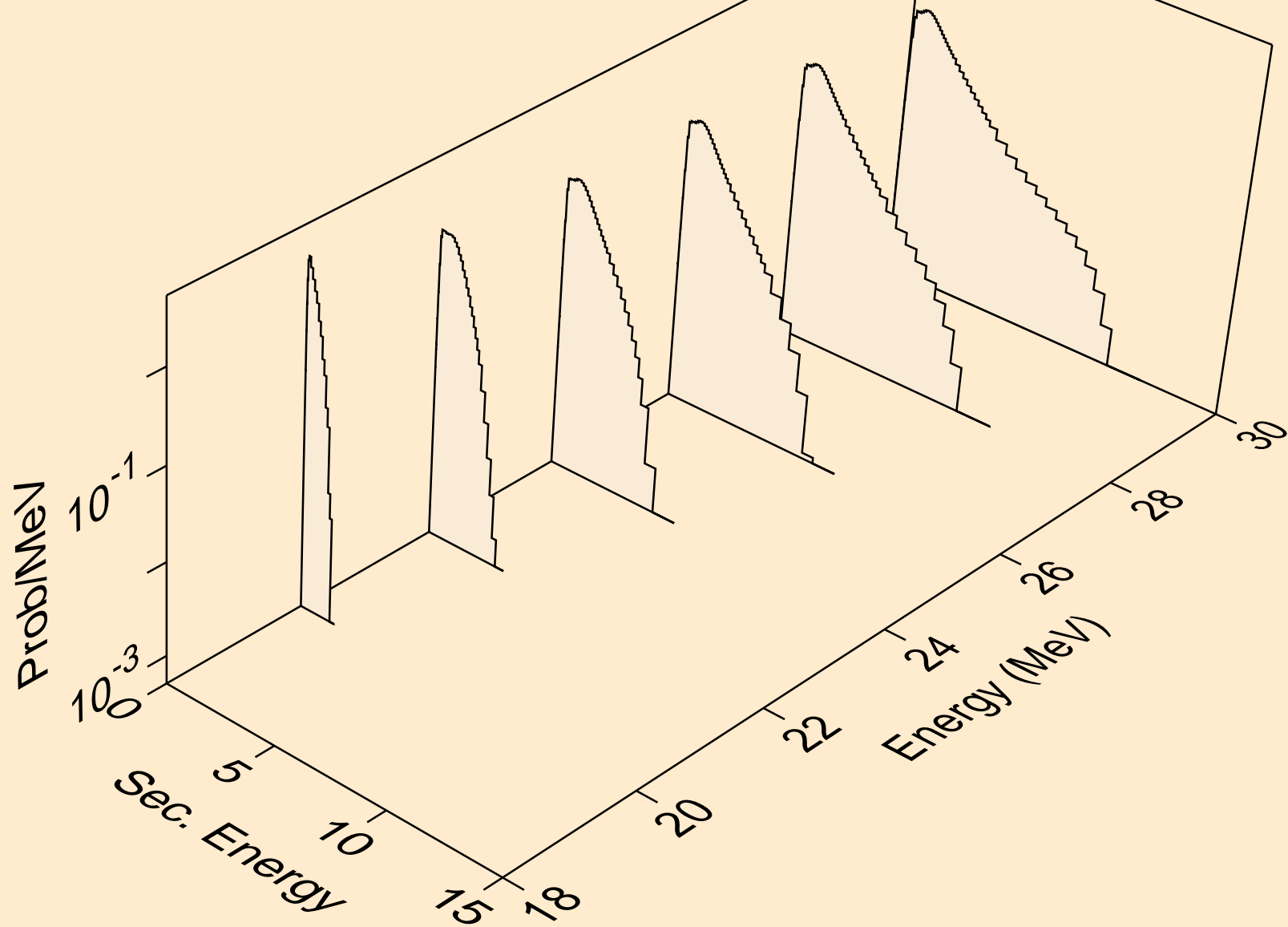

TM156 NEUTRON ACER TENDL-2024 LIBRARY; T=0.K  
Neutron emission for (n,n\*)a

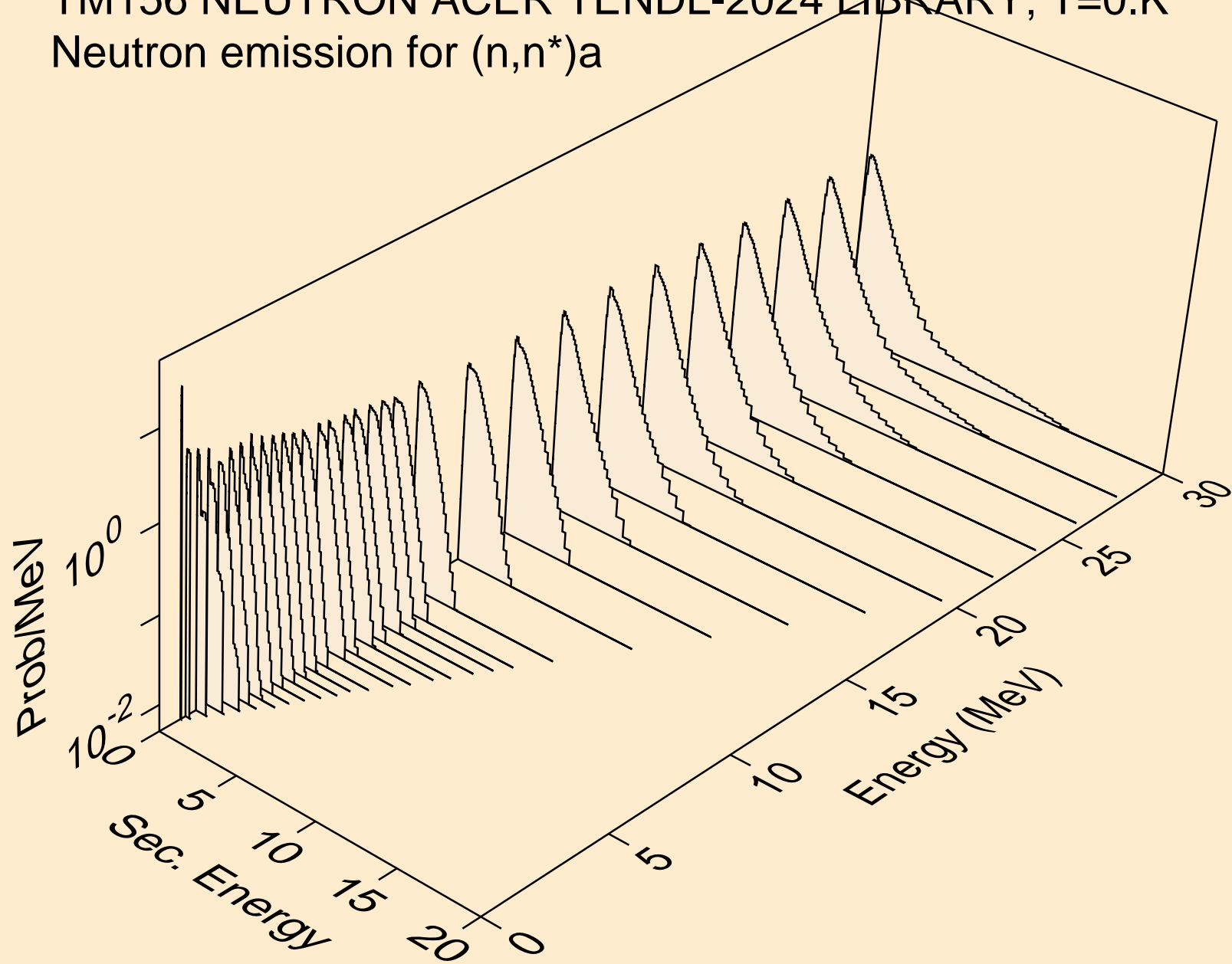

TM156 NEUTRON ACER TENDL-2024 LIBRARY; T=0.K  
Neutron emission for (n,n\*)3a

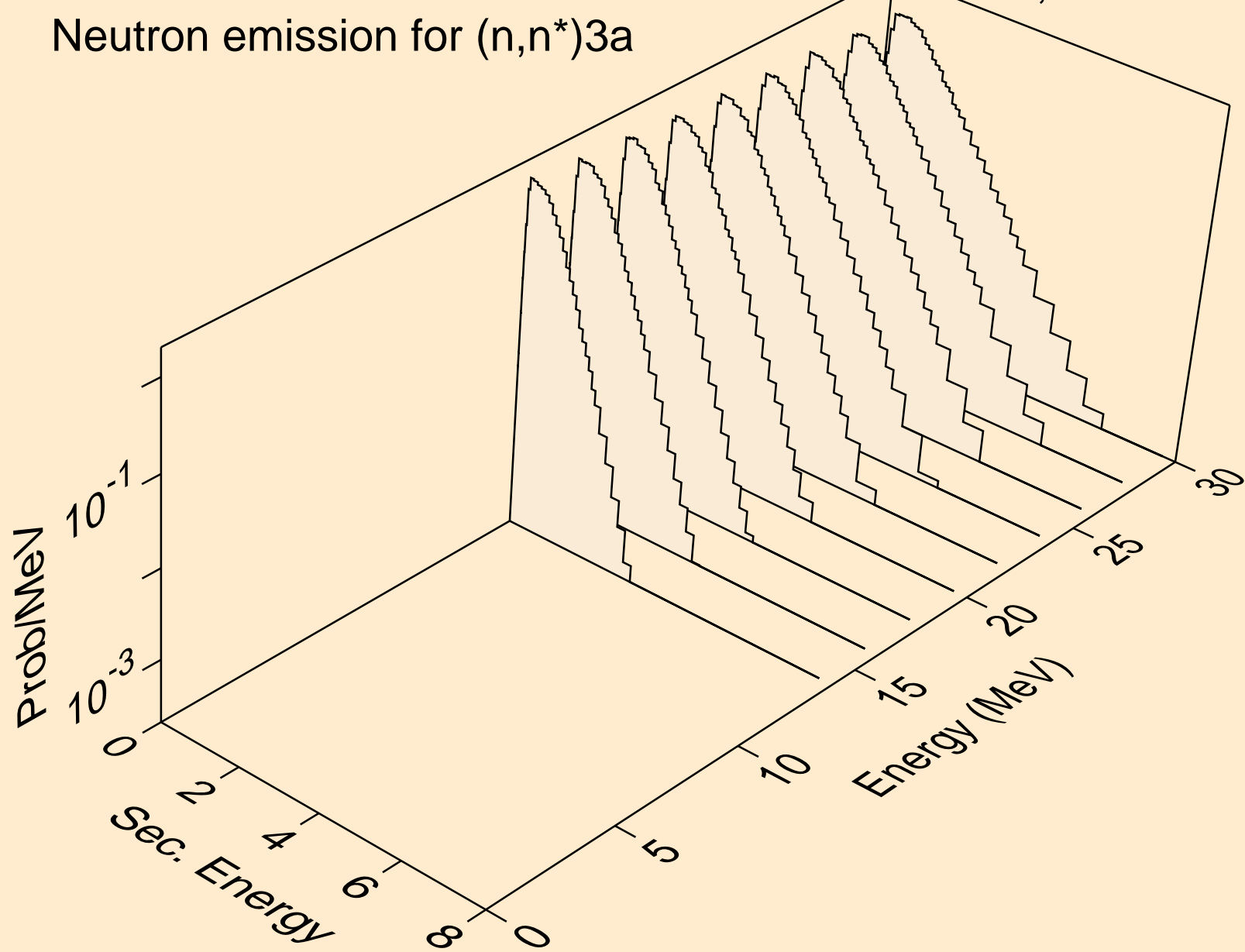

TM156 NEUTRON ACER TENDL-2024 LIBRARY; T=0.K  
Neutron emission for (n,2n)a

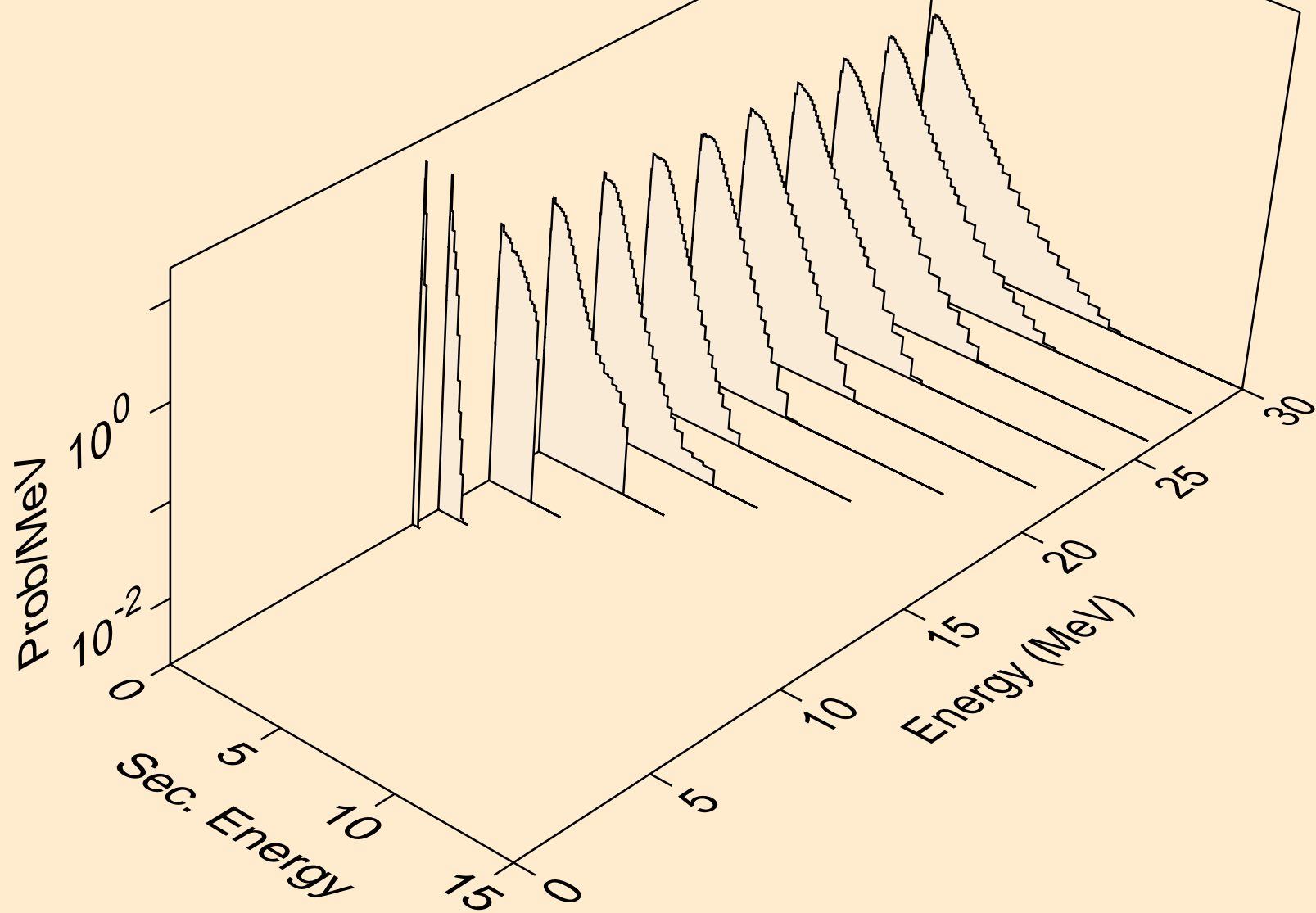

TM156 NEUTRON ACER TENDL-2024 LIBRARY; T=0.K  
Neutron emission for (n,3n)a

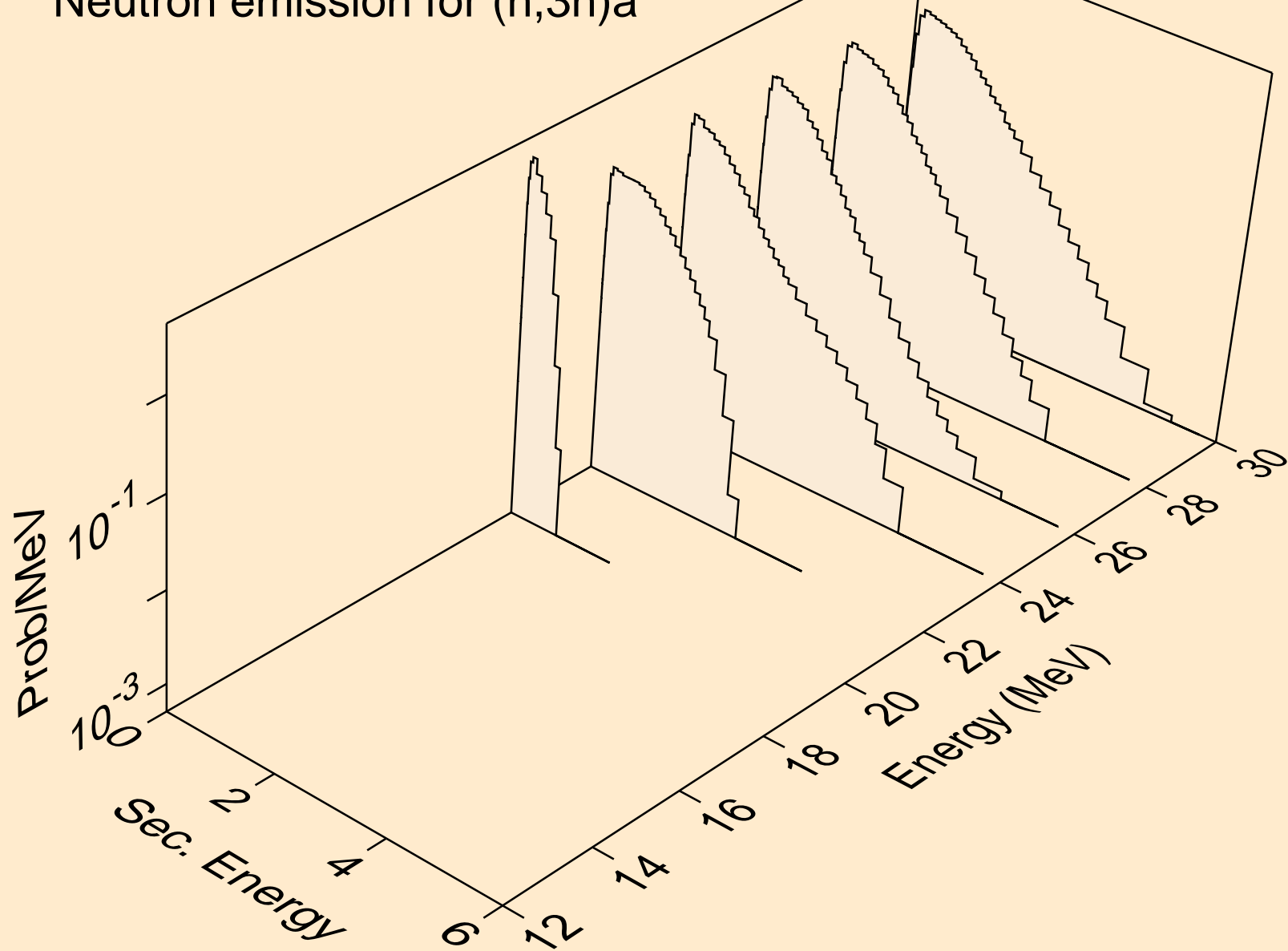

TM156 NEUTRON ACER TENDL-2024 LIBRARY; T=0.K  
Neutron emission for (n,n\*)p

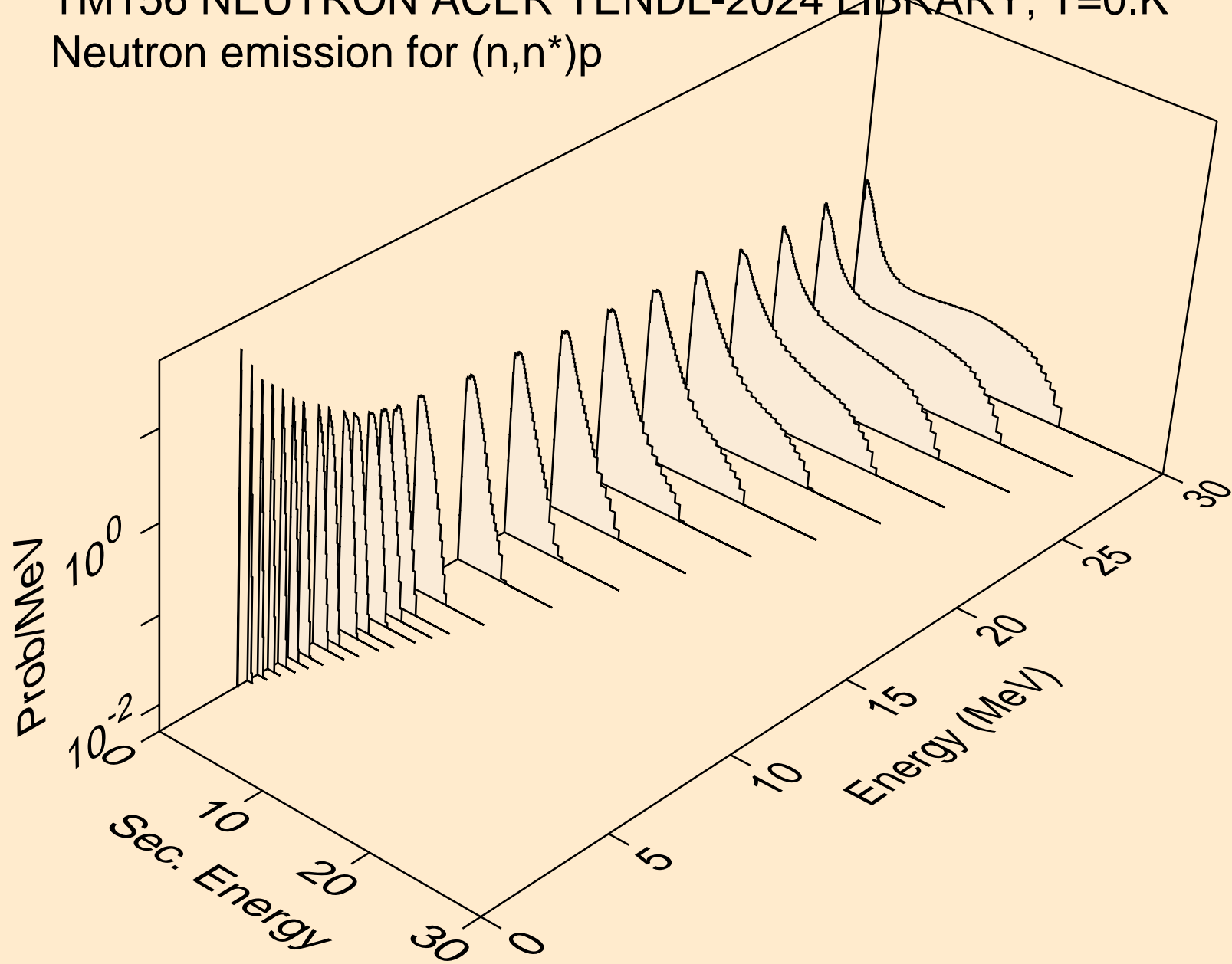

TM156 NEUTRON ACER TENDL-2024 LIBRARY; T=0.K  
Neutron emission for (n,n\*)2a

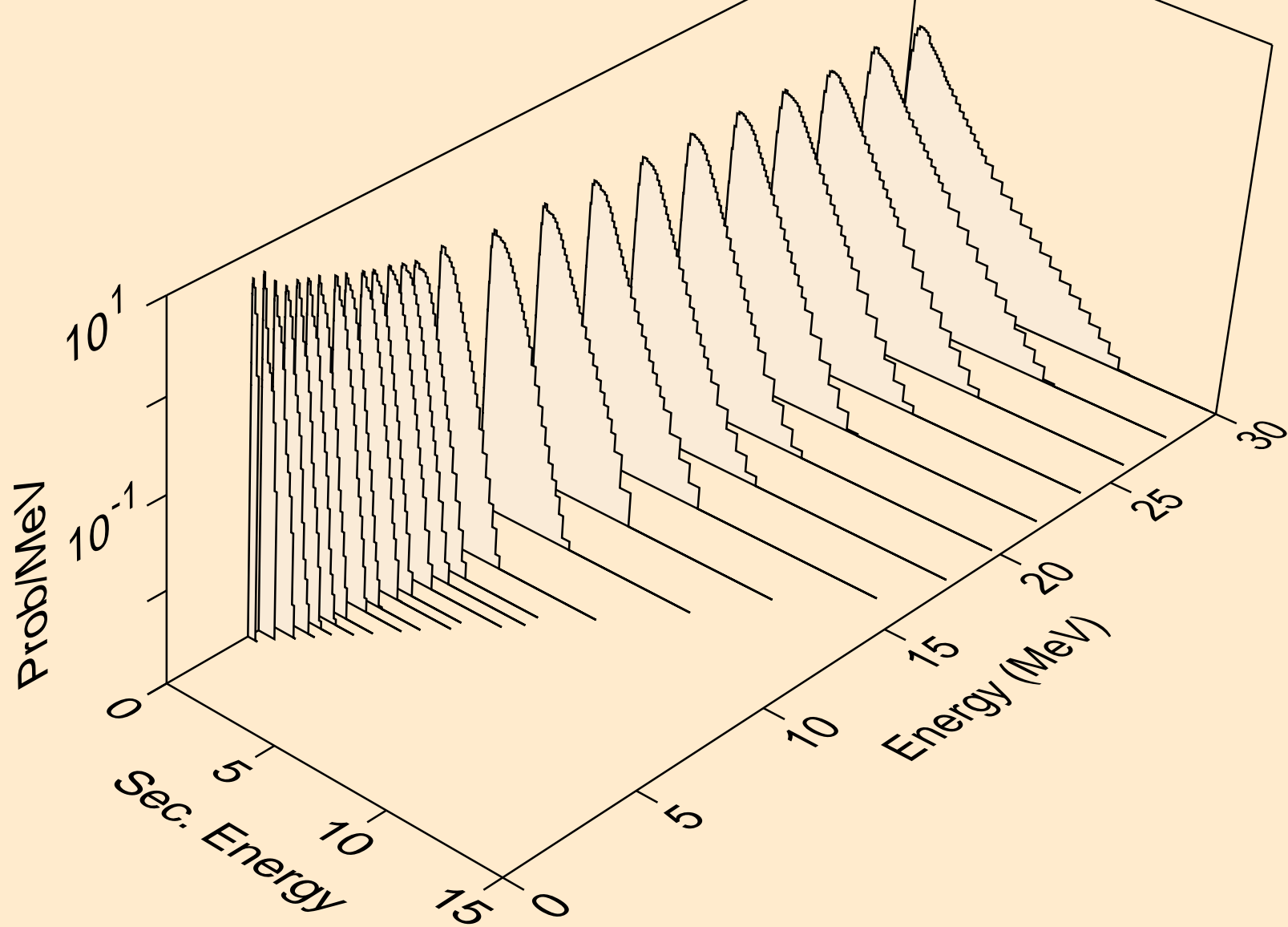

TM156 NEUTRON ACER TENDL-2024 LIBRARY; T=0.K  
Neutron emission for (n,2n)2a

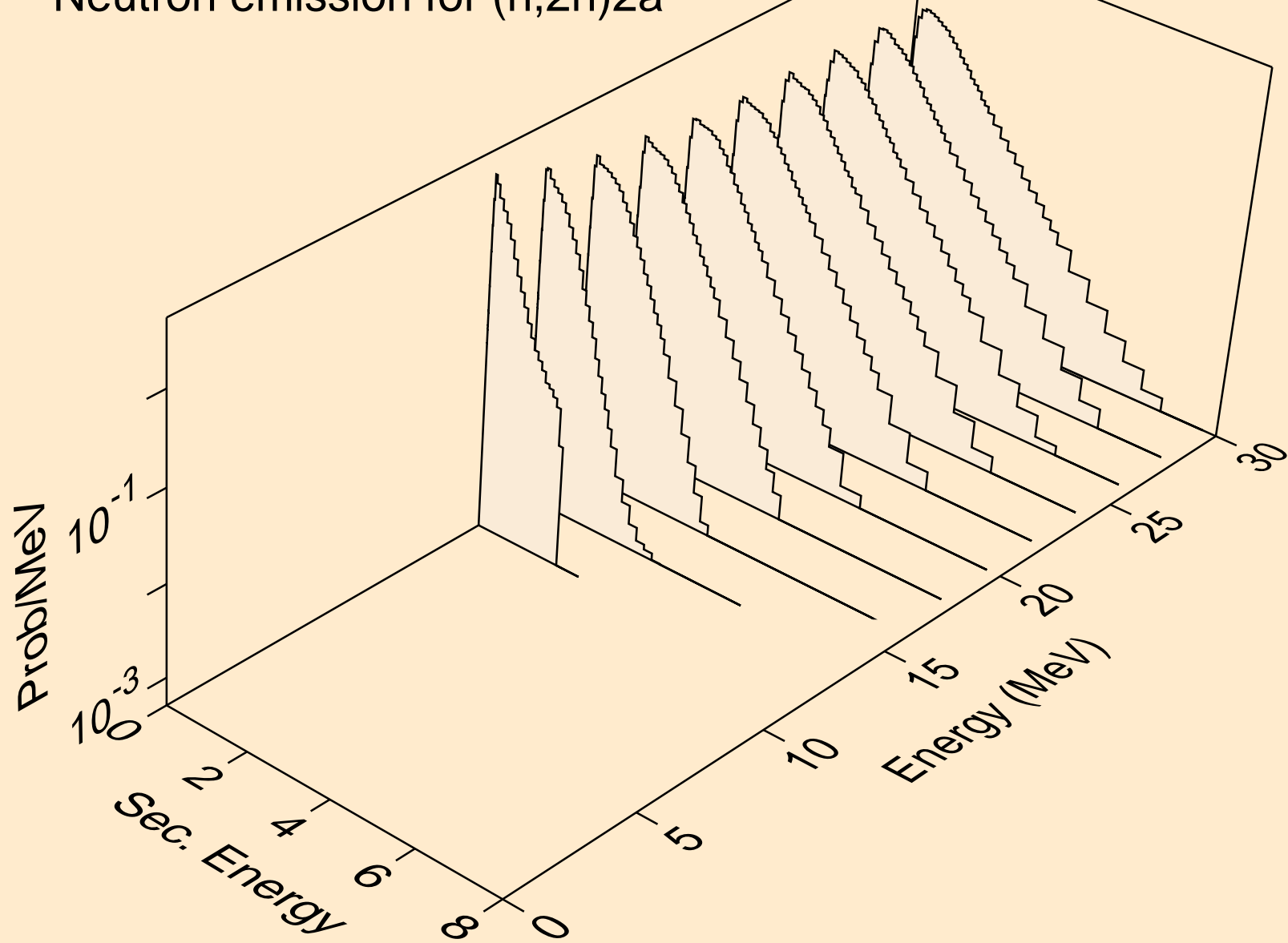

TM156 NEUTRON ACER TENDL-2024 LIBRARY; T=0.K  
Neutron emission for (n,n\*)d

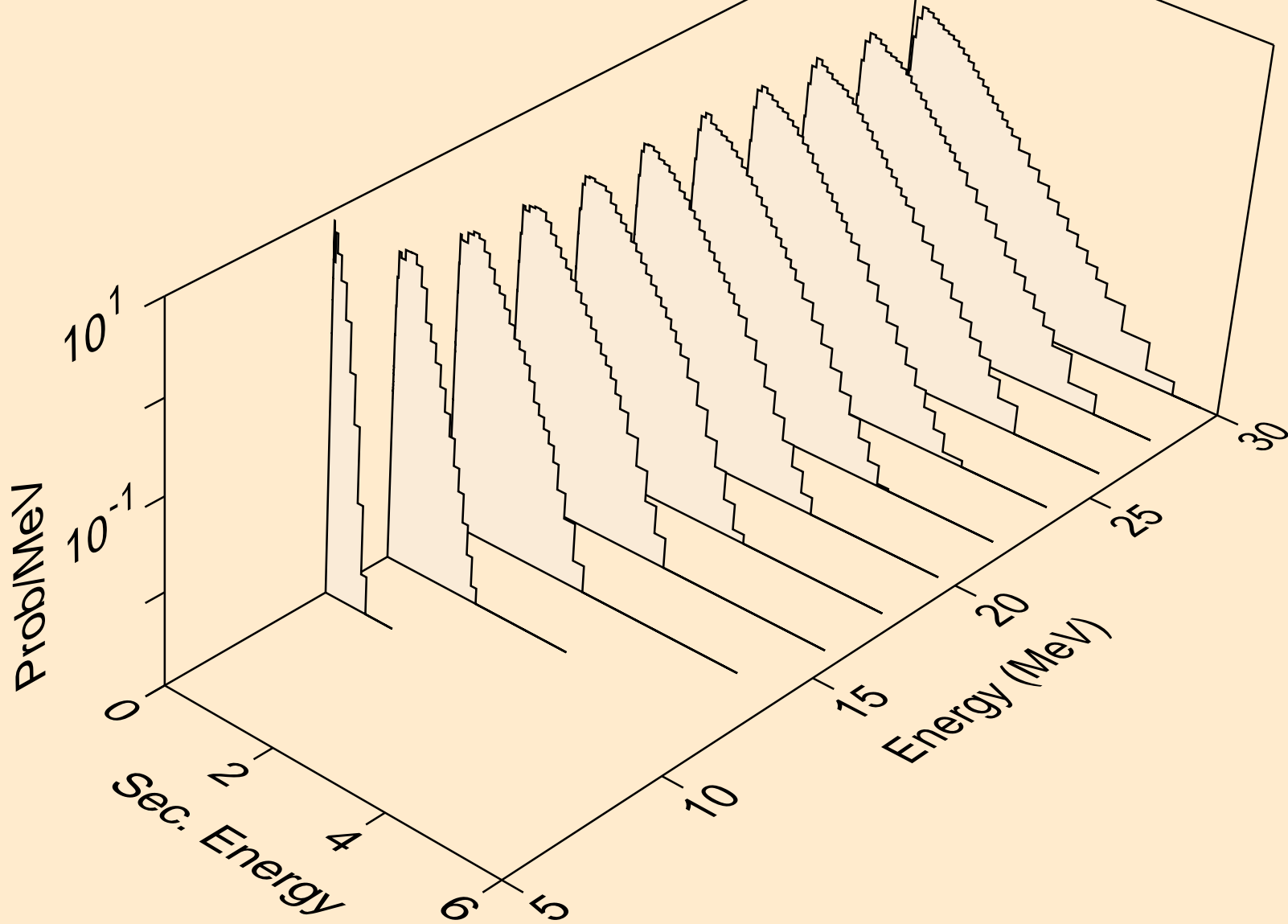

TM156 NEUTRON ACER TENDL-2024 LIBRARY; T=0.K  
Neutron emission for (n,n\*)t

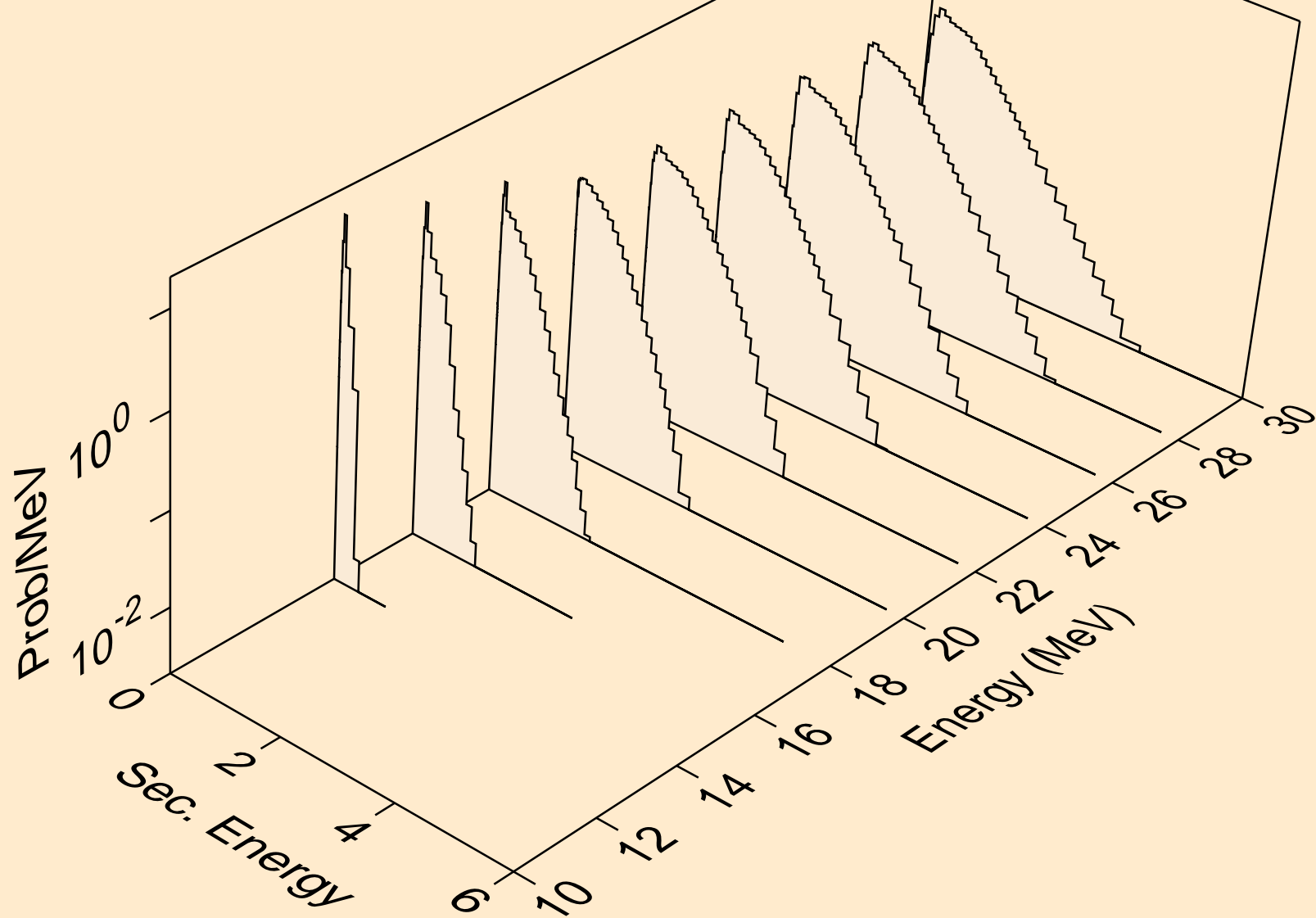

TM156 NEUTRON ACER TENDL-2024 LIBRARY; T=0.K  
Neutron emission for (n,n\*)he3

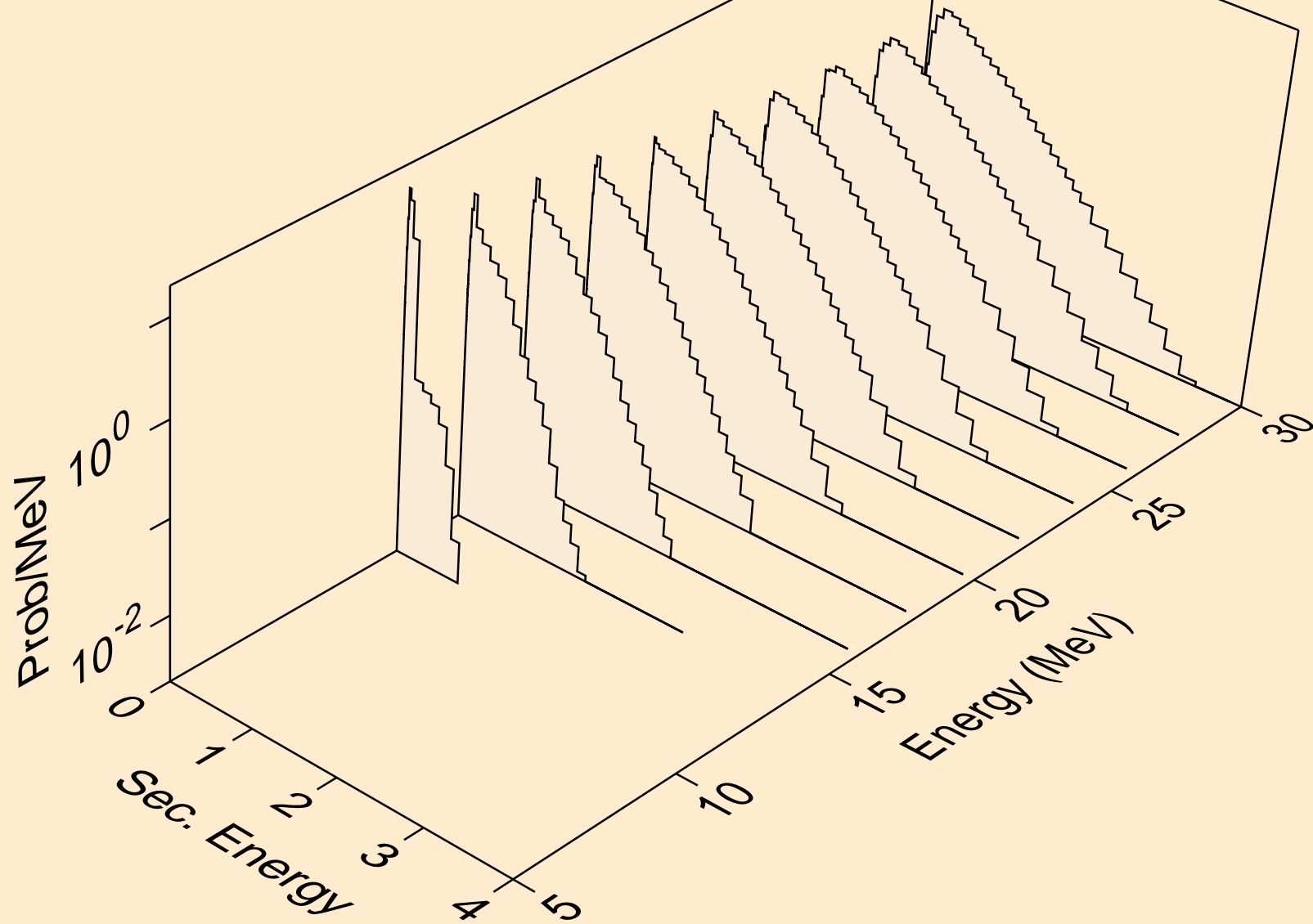

TM156 NEUTRON ACER TENDL-2024 LIBRARY; T=0.K  
Neutron emission for (n,4n)

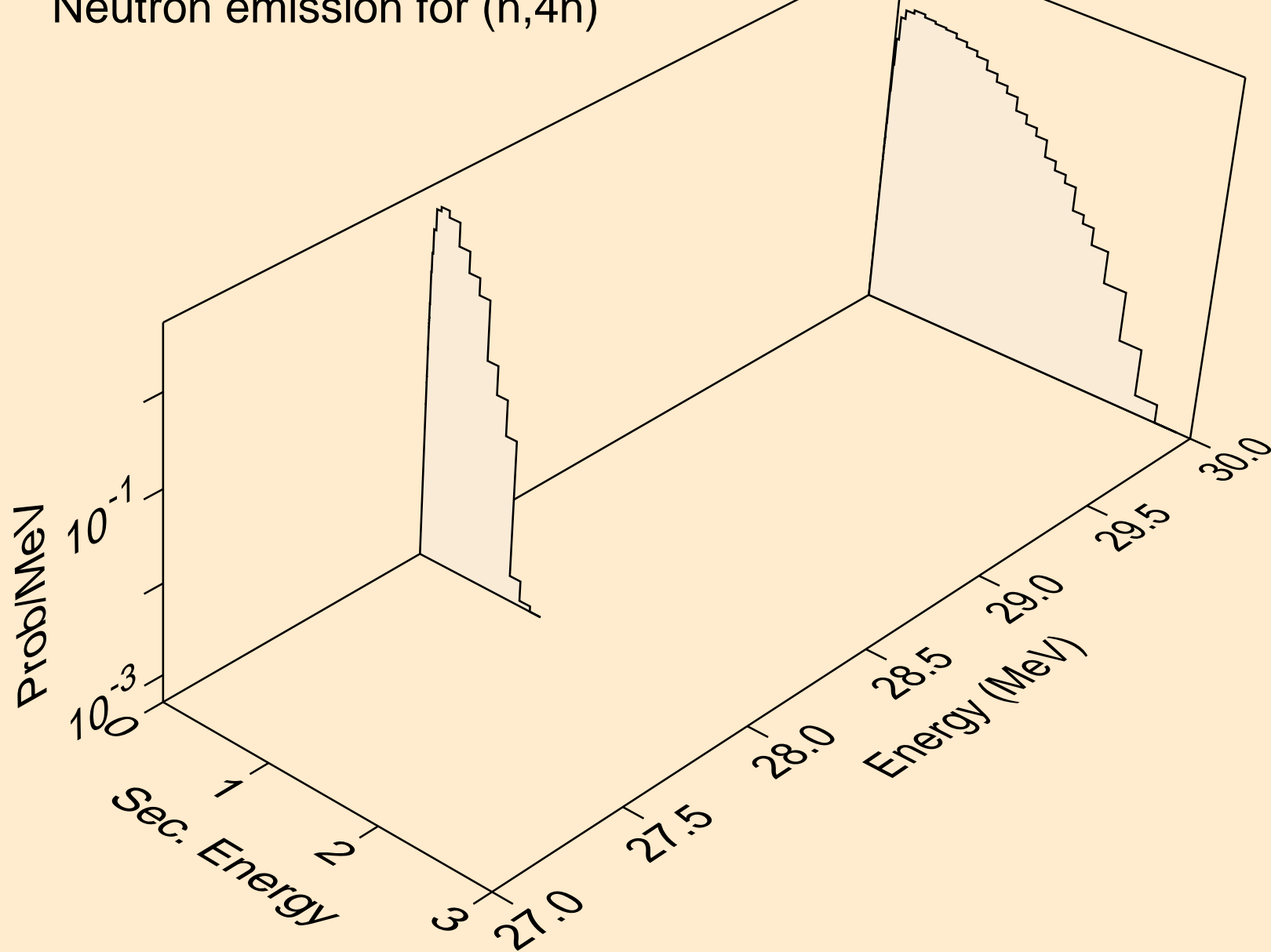

TM156 NEUTRON ACER TENDL-2024 LIBRARY; T=0.K  
Neutron emission for (n,2np)

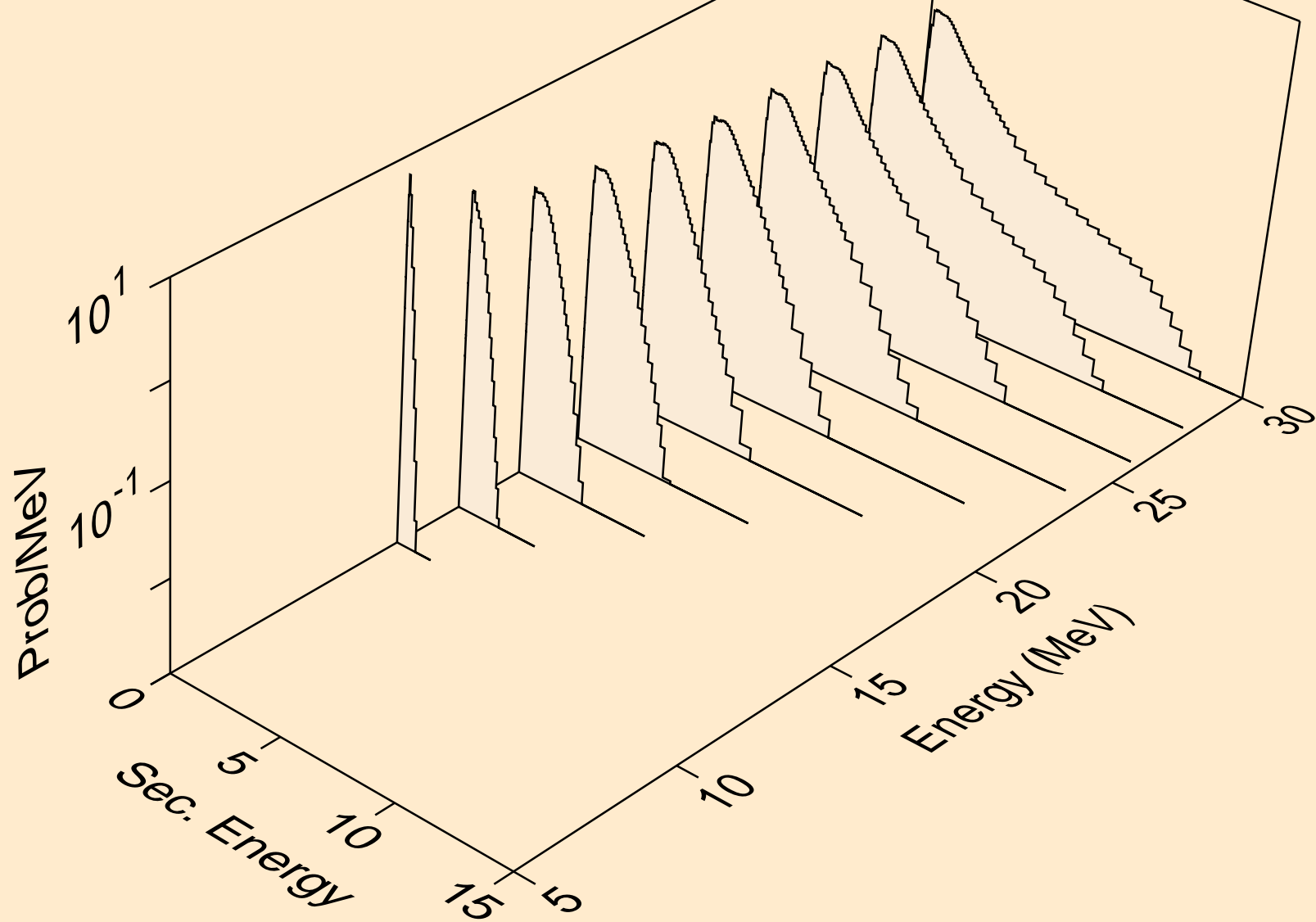

TM156 NEUTRON ACER TENDL-2024 LIBRARY; T=0.K  
Neutron emission for (n,3np)

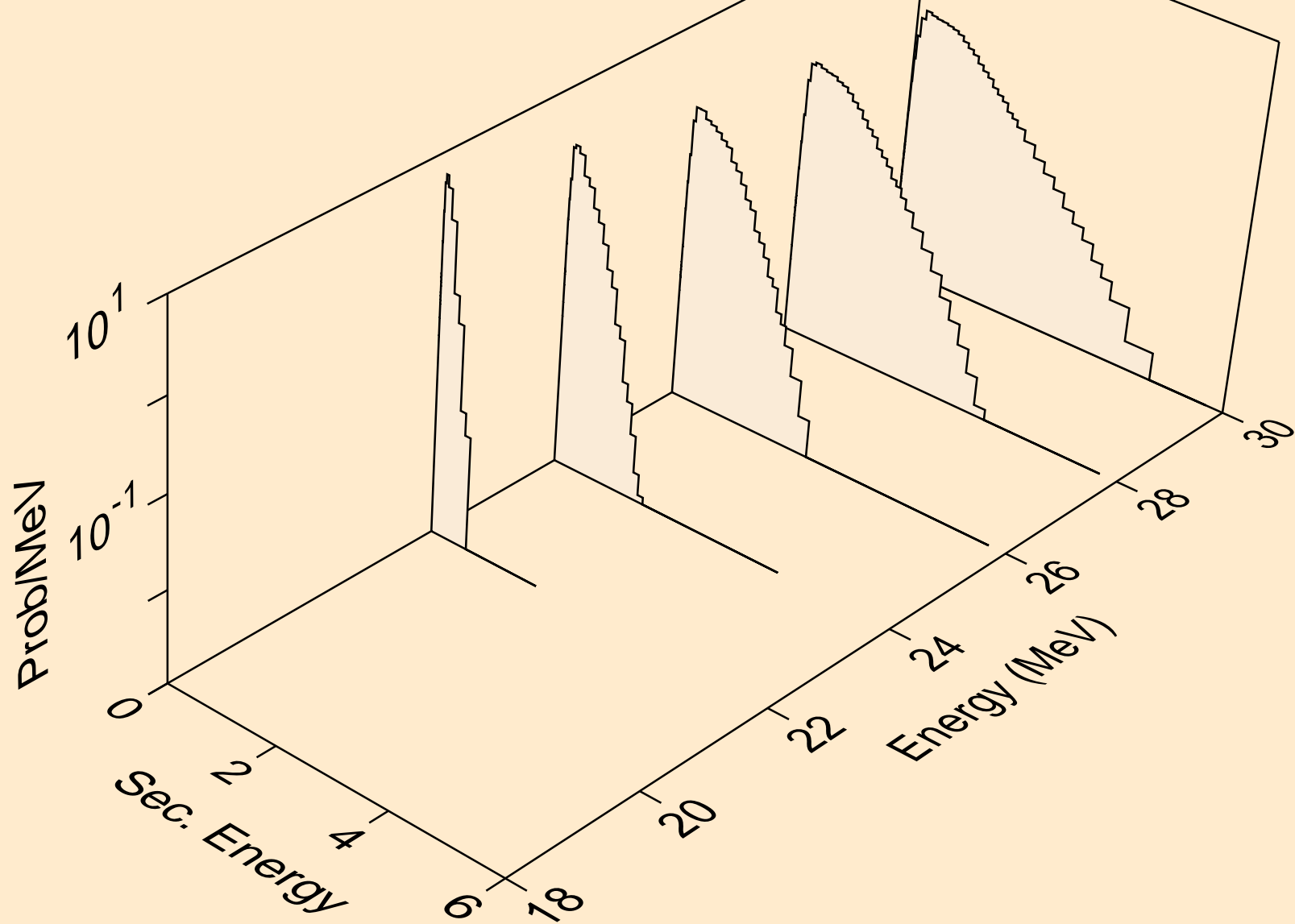

TM156 NEUTRON ACER TENDL-2024 LIBRARY; T=0.K  
Neutron emission for (n,n2p)

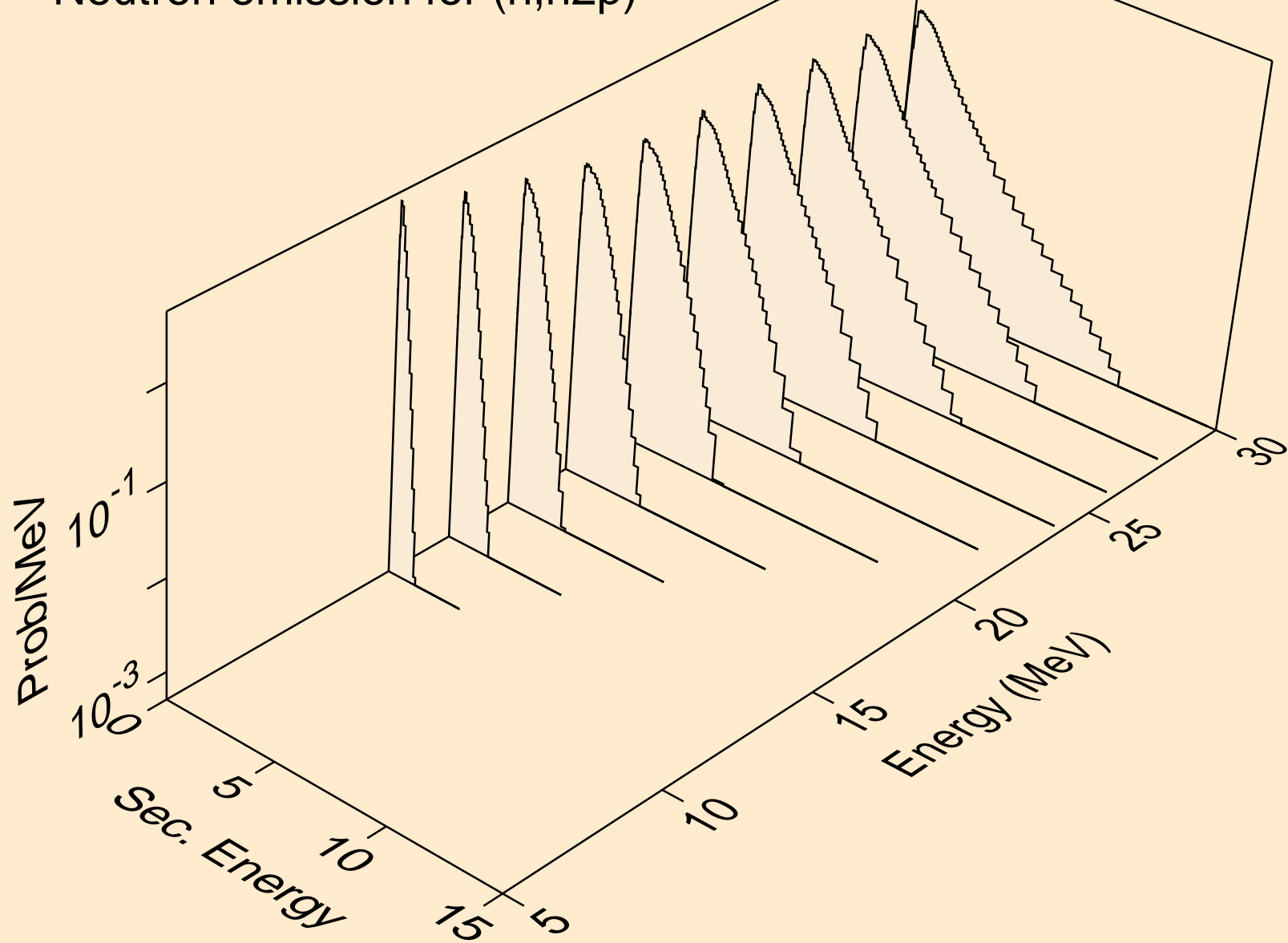

TM156 NEUTRON ACER TENDL-2024 LIBRARY; T=0.K  
Neutron emission for (n,npa)

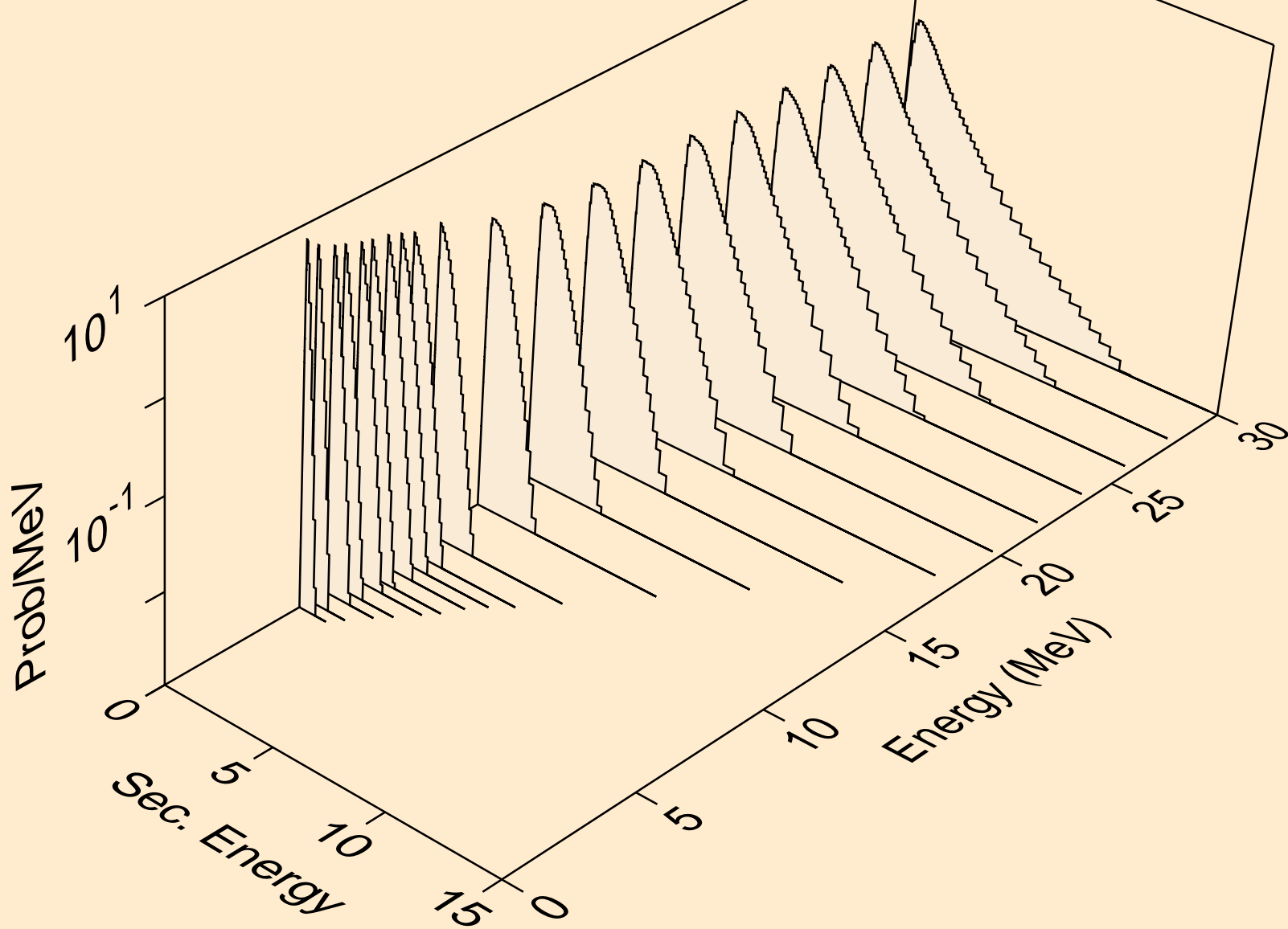

TM156 NEUTRON ACER TENDL-2024 LIBRARY; T=0.K  
Neutron emission for (n,n\*c)

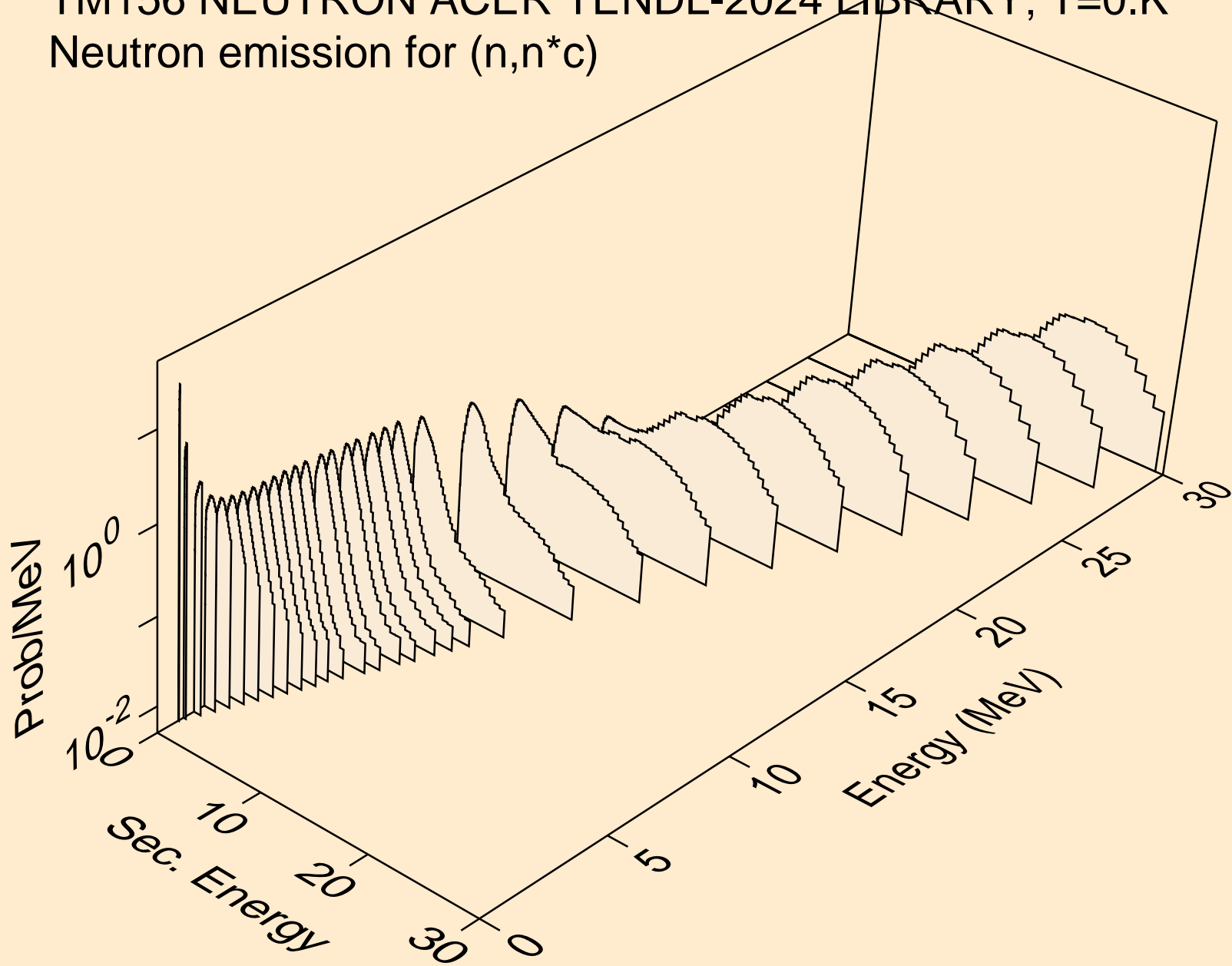

TM156 NEUTRON ACER TENDL-2024 LIBRARY; T=0.K  
Photon emission for (n,x)

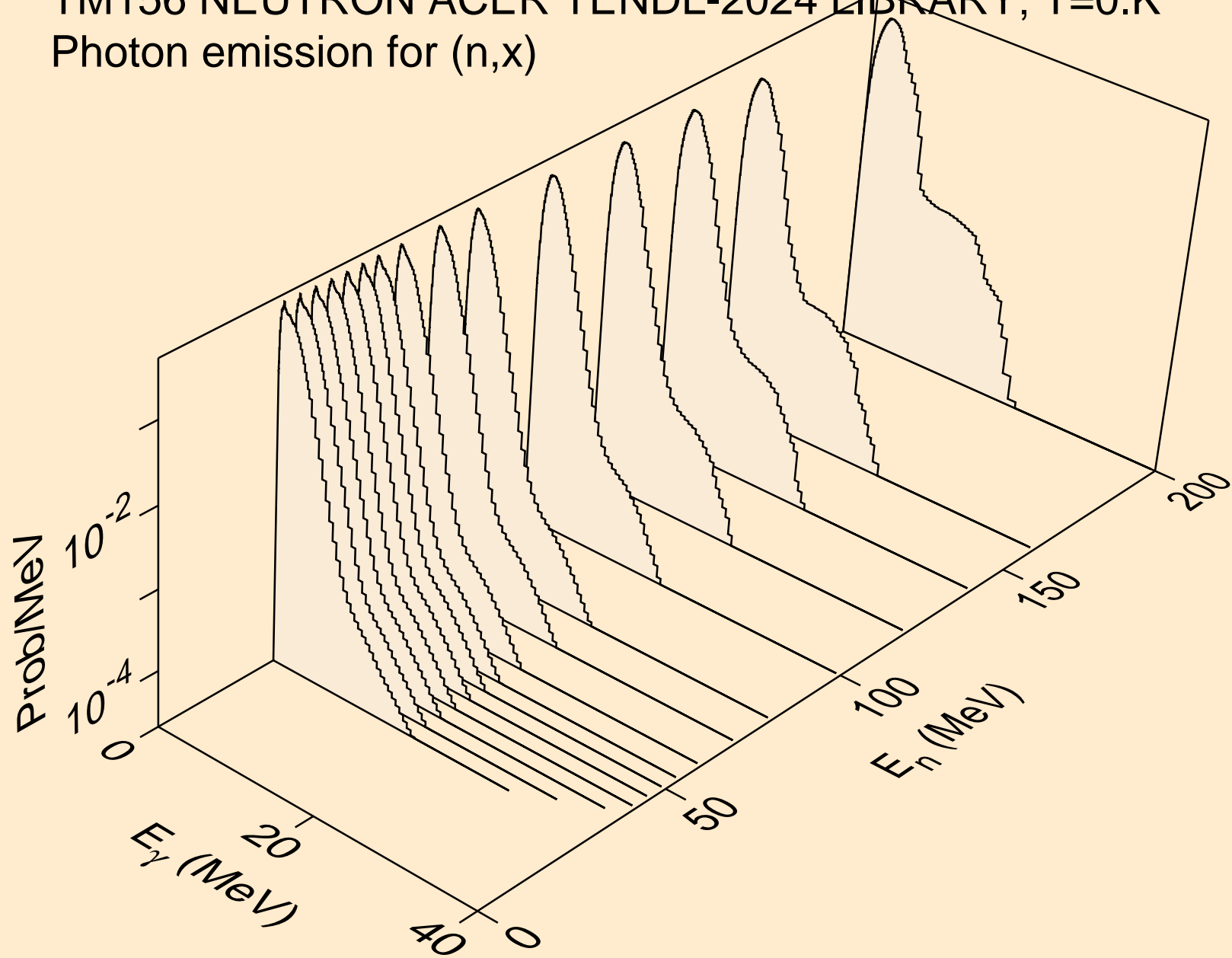

TM156 NEUTRON ACER TENDL-2024 LIBRARY; T=0.K  
Photon emission for (n,2nd)

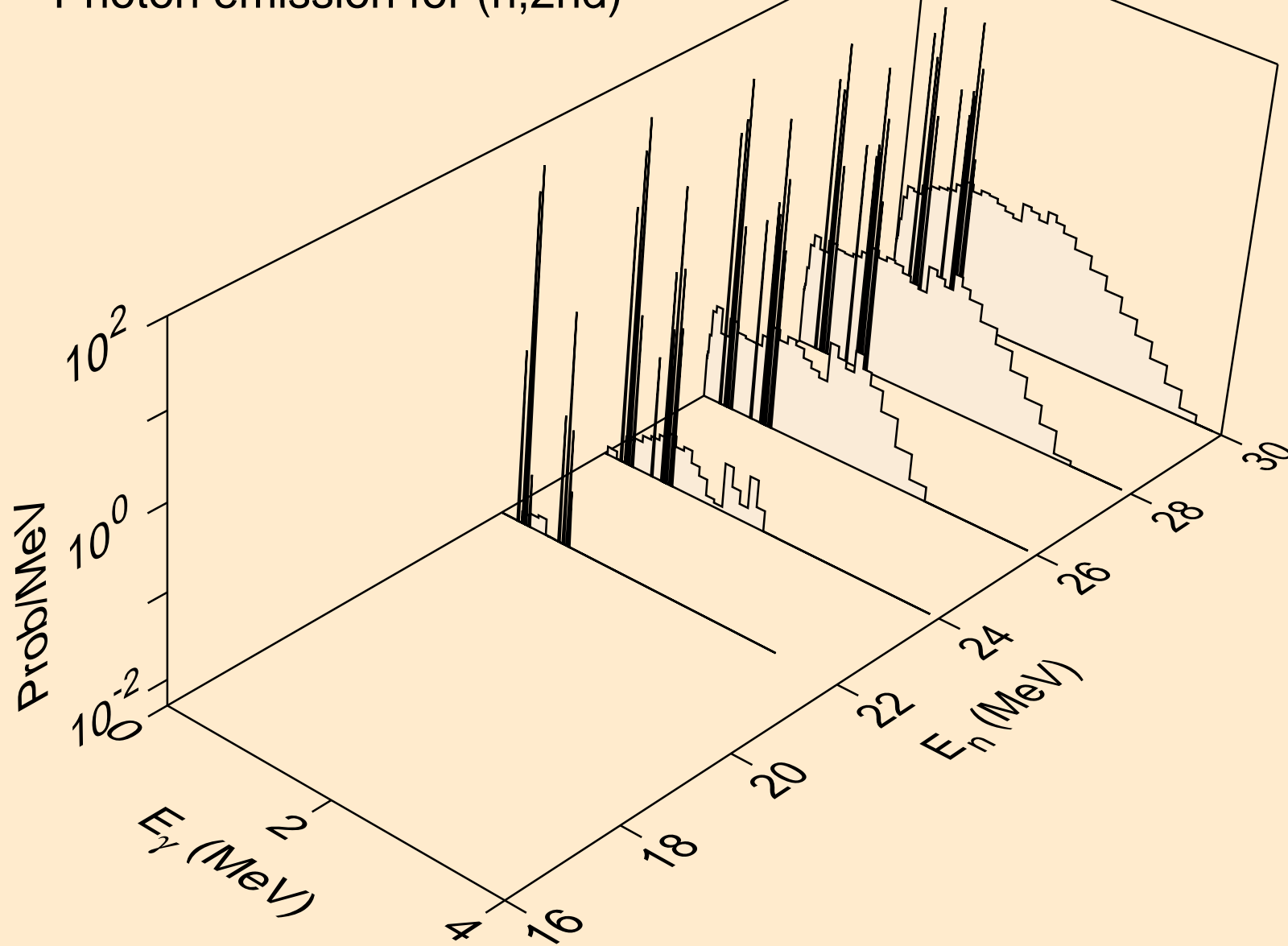

TM156 NEUTRON ACER TENDL-2024 LIBRARY; T=0.K  
Photon emission for (n,2n)

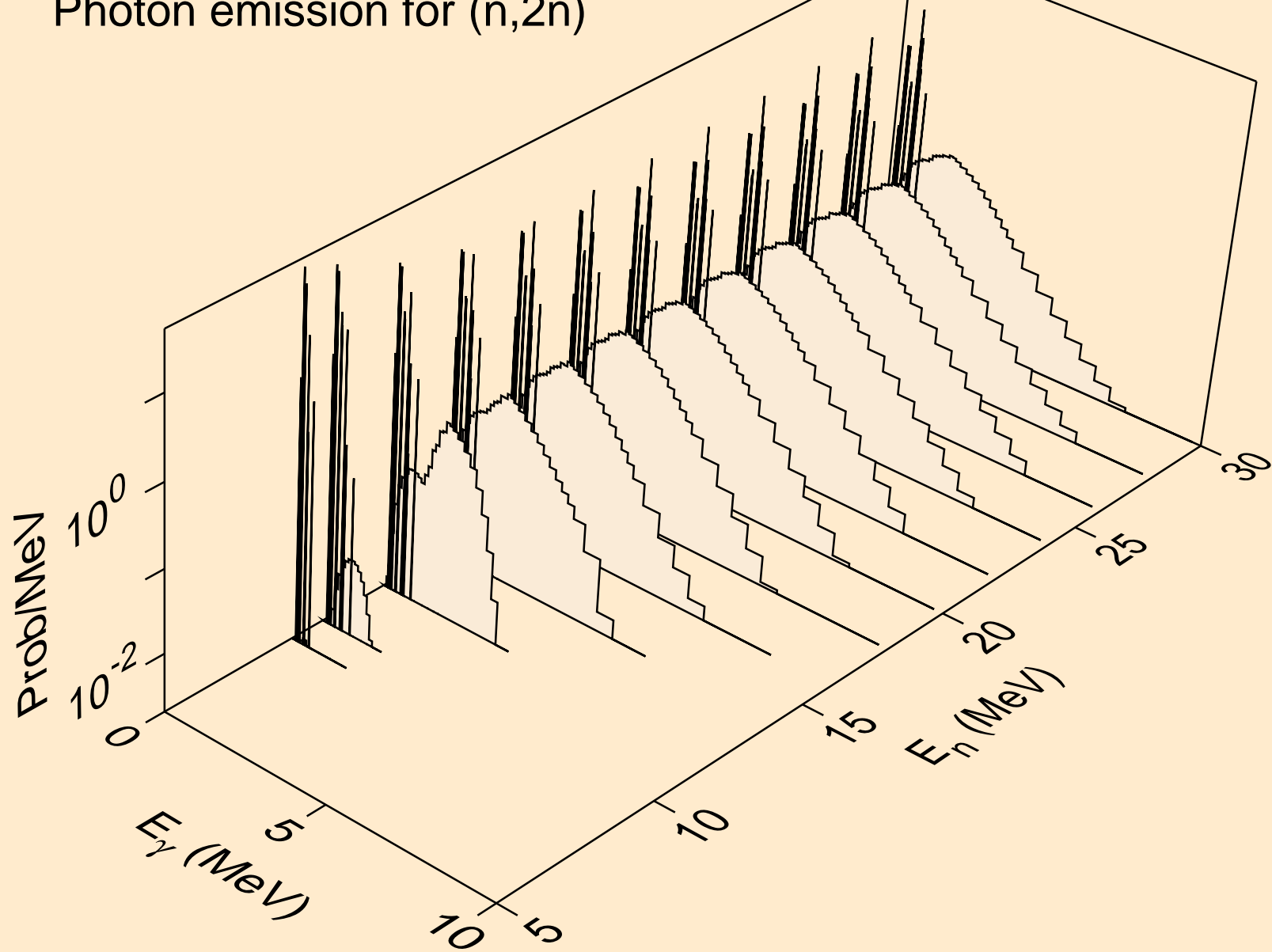

TM156 NEUTRON ACER TENDL-2024 LIBRARY; T=0.K  
Photon emission for (n,3n)

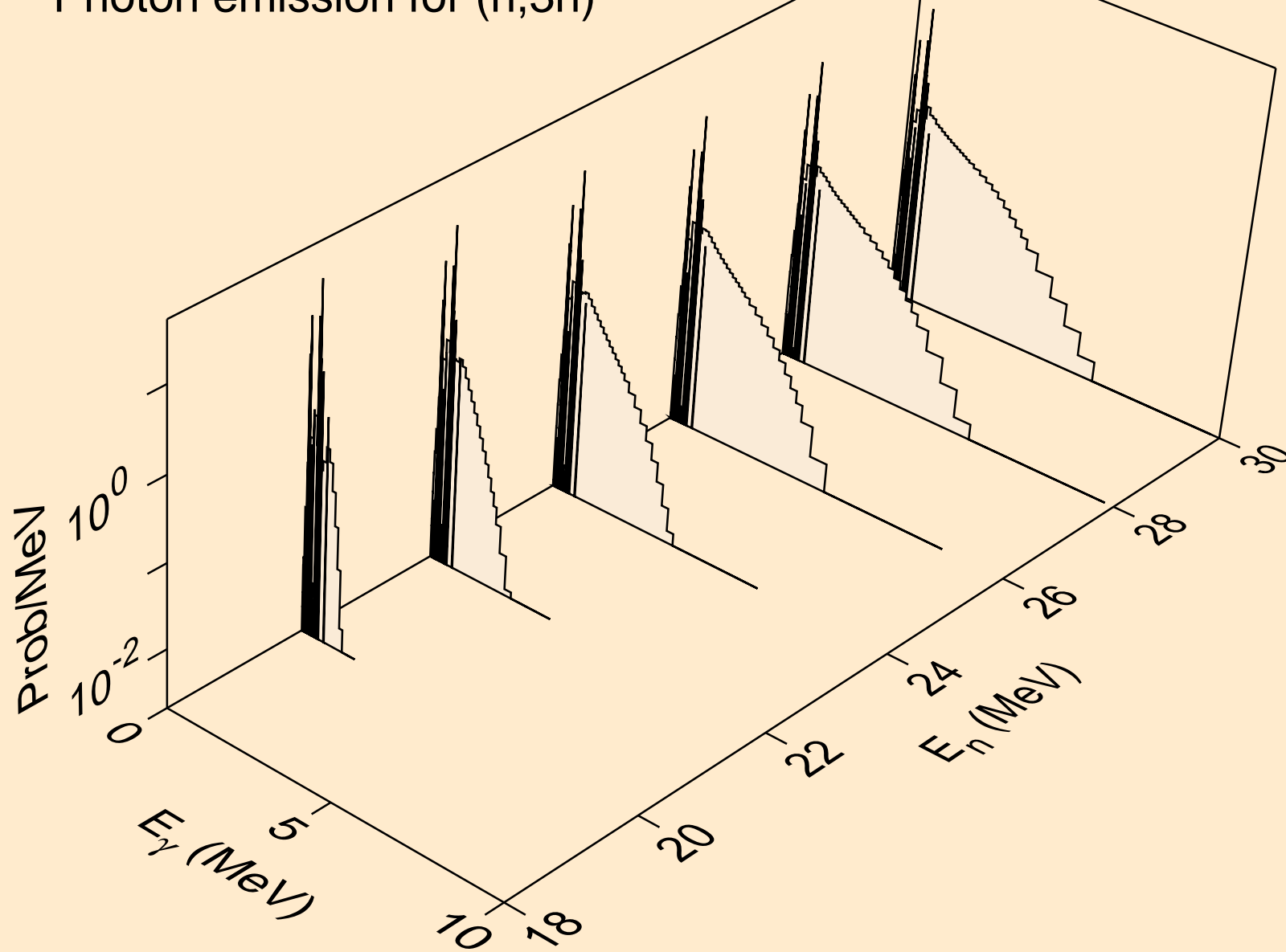

TM156 NEUTRON ACER TENDL-2024 LIBRARY; T=0.K  
Photon emission for (n,n\*)a

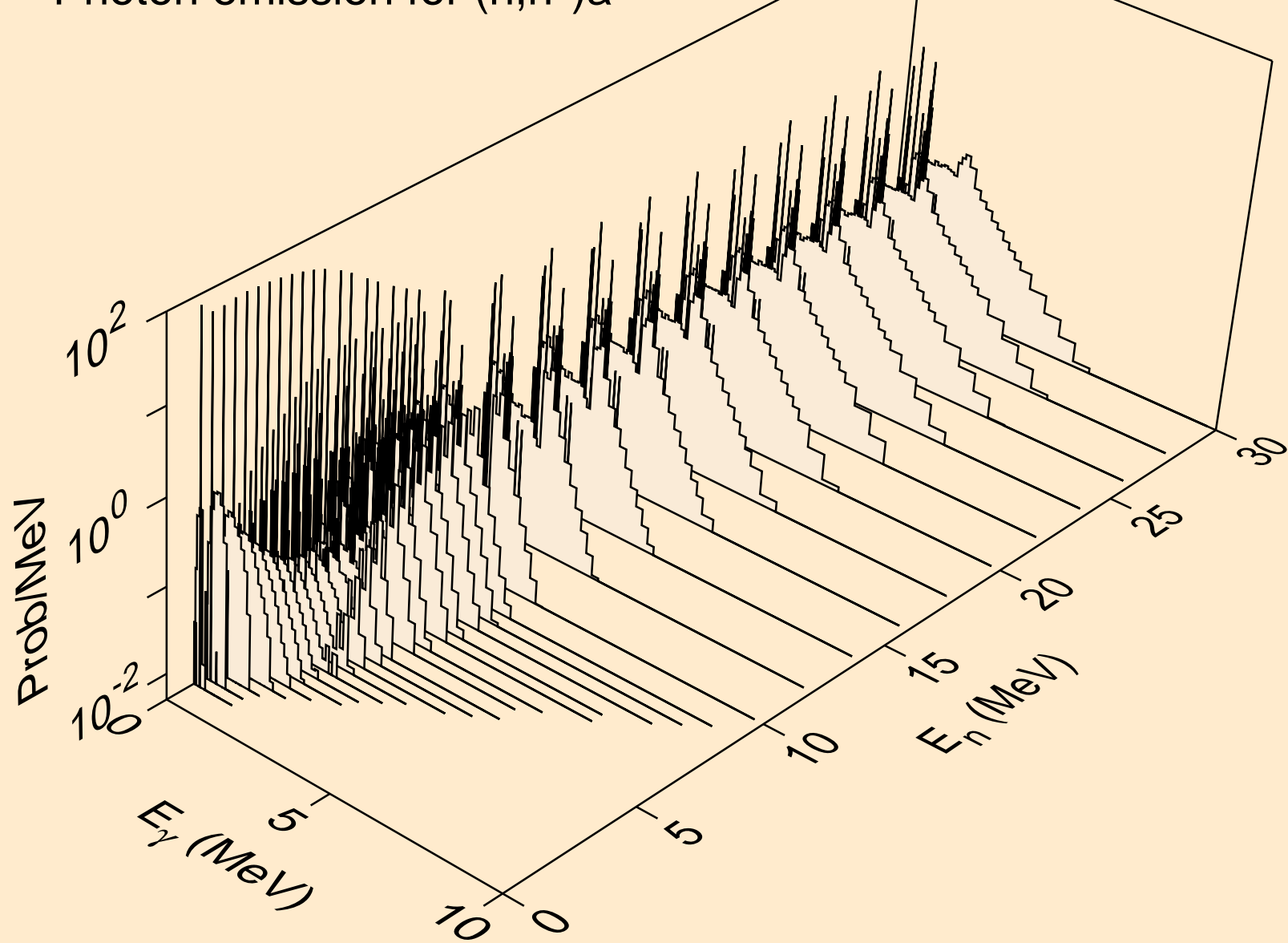

TM156 NEUTRON ACER TENDL-2024 LIBRARY; T=0.K  
Photon emission for (n,n\*)3a

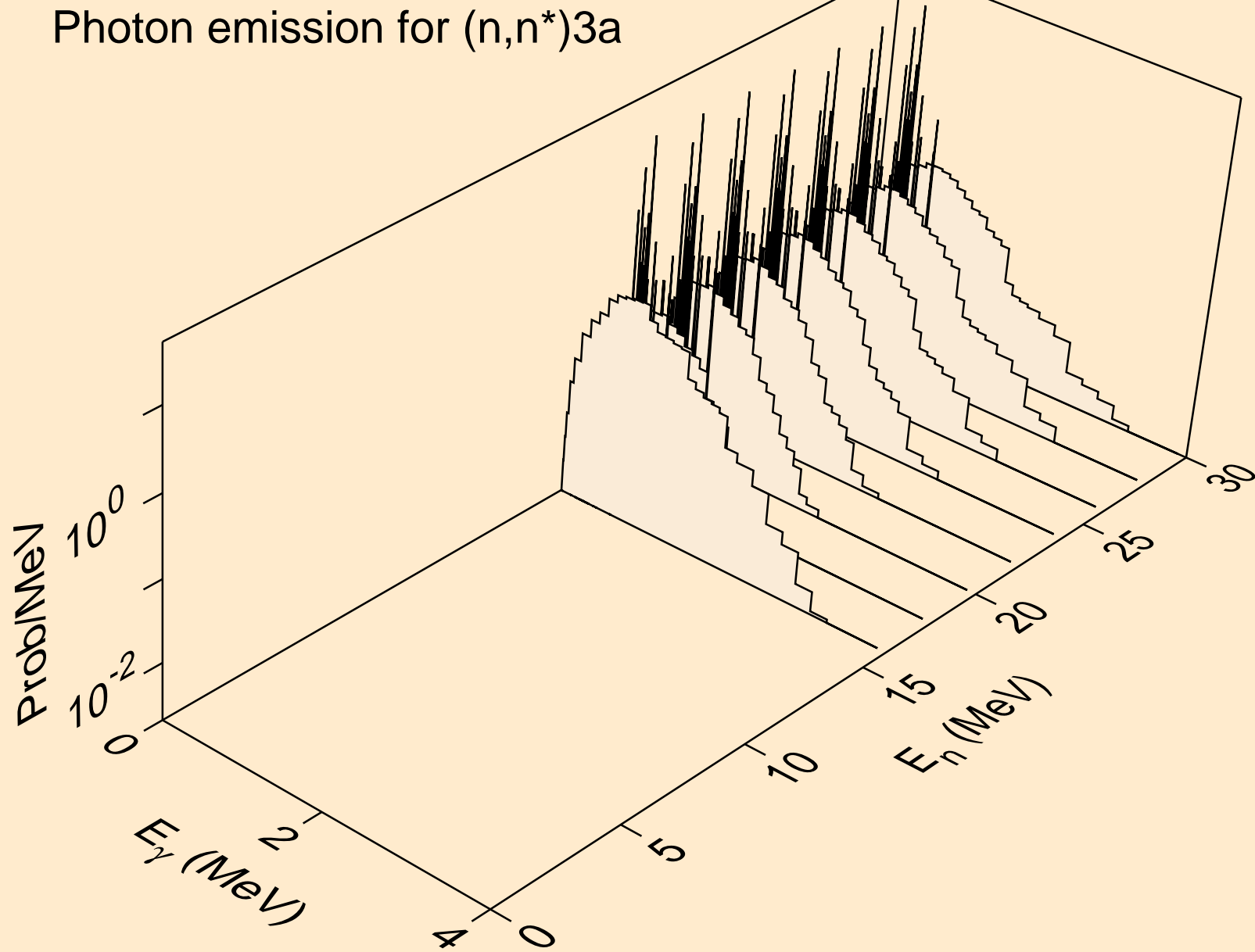

TM156 NEUTRON ACER TENDL-2024 LIBRARY; T=0.K  
Photon emission for (n,2n)a

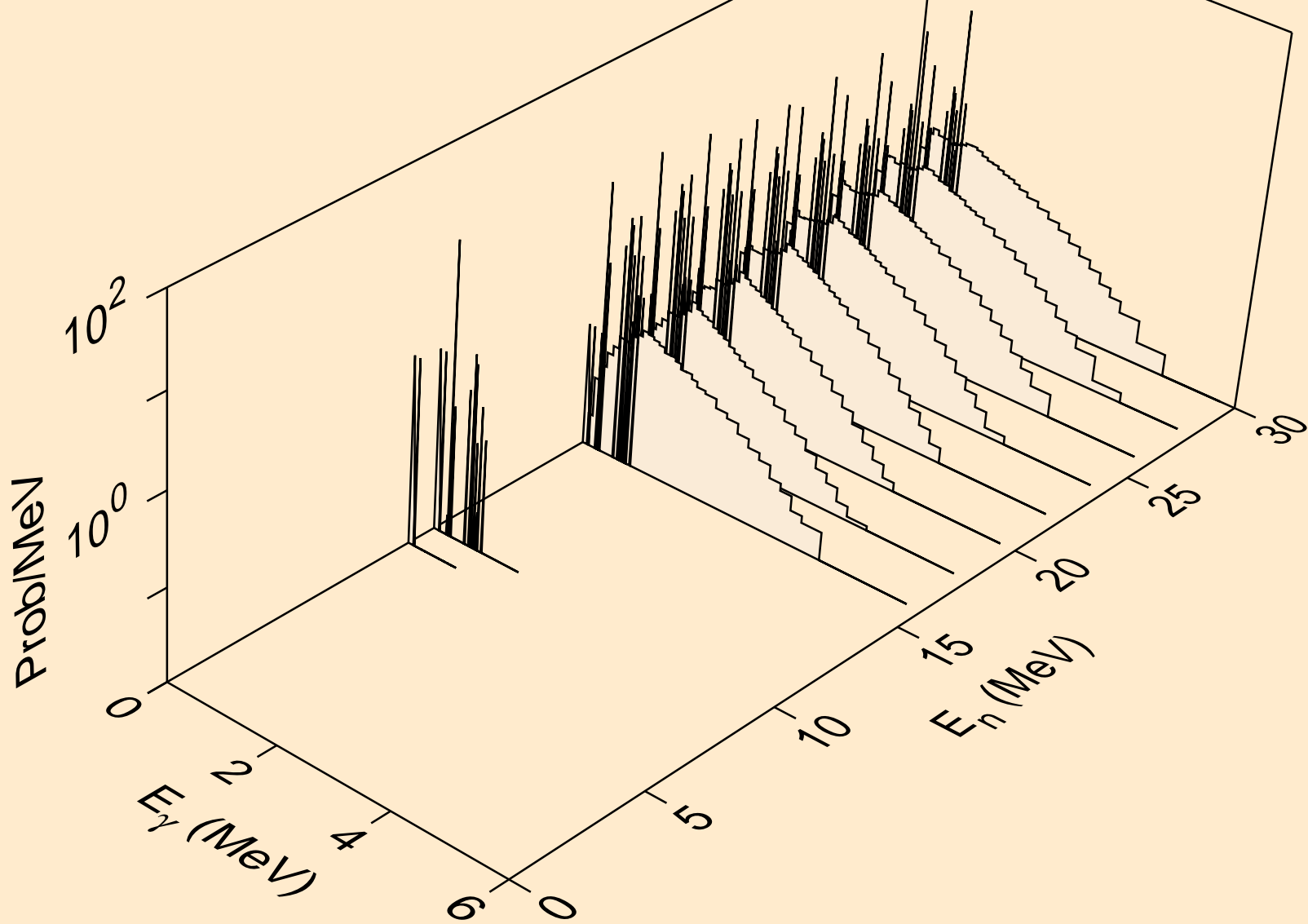

TM156 NEUTRON ACER TENDL-2024 LIBRARY; T=0.K  
Photon emission for (n,3n)a

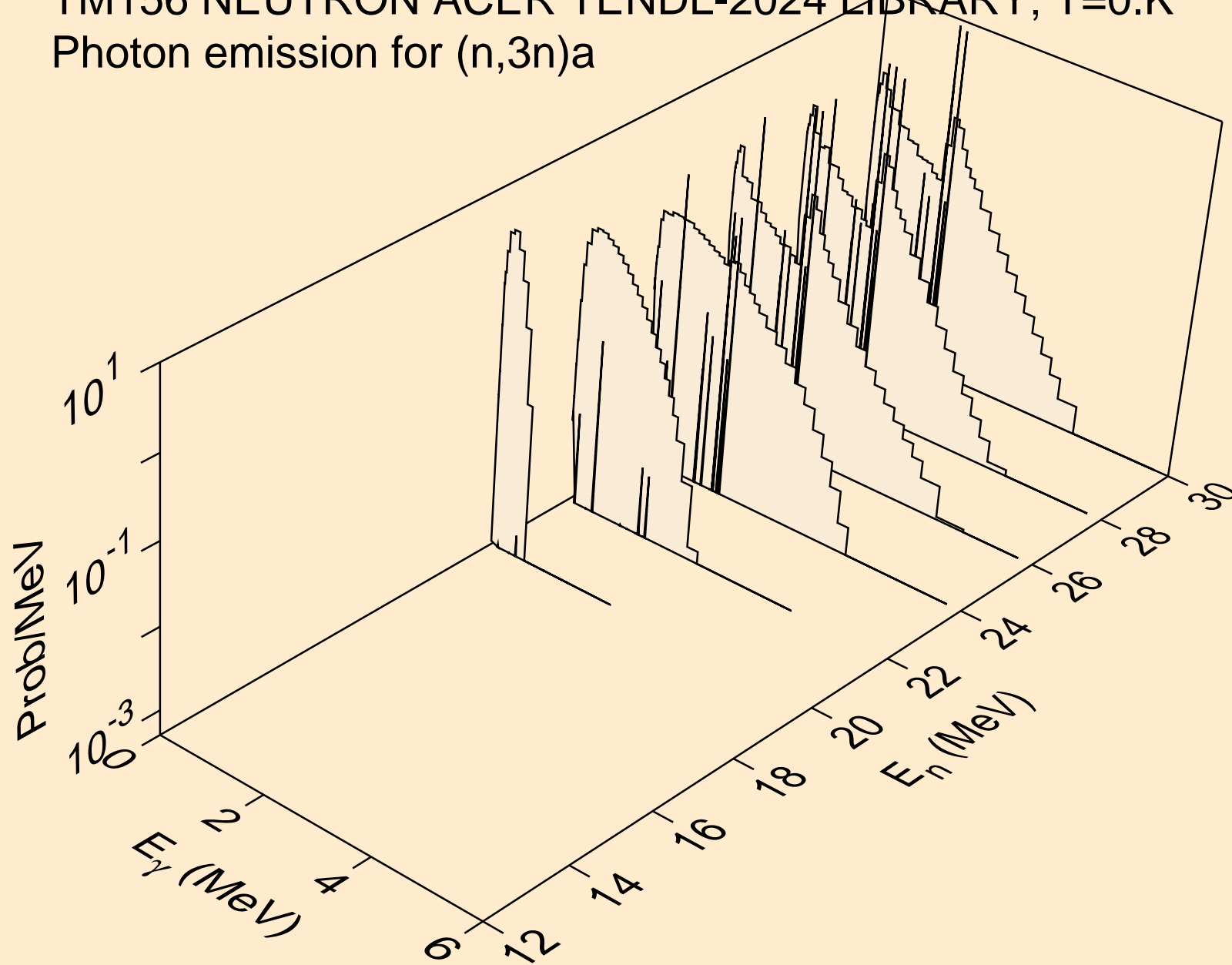

TM156 NEUTRON ACER TENDL-2024 LIBRARY; T=0.K  
Photon emission for (n,n\*)p

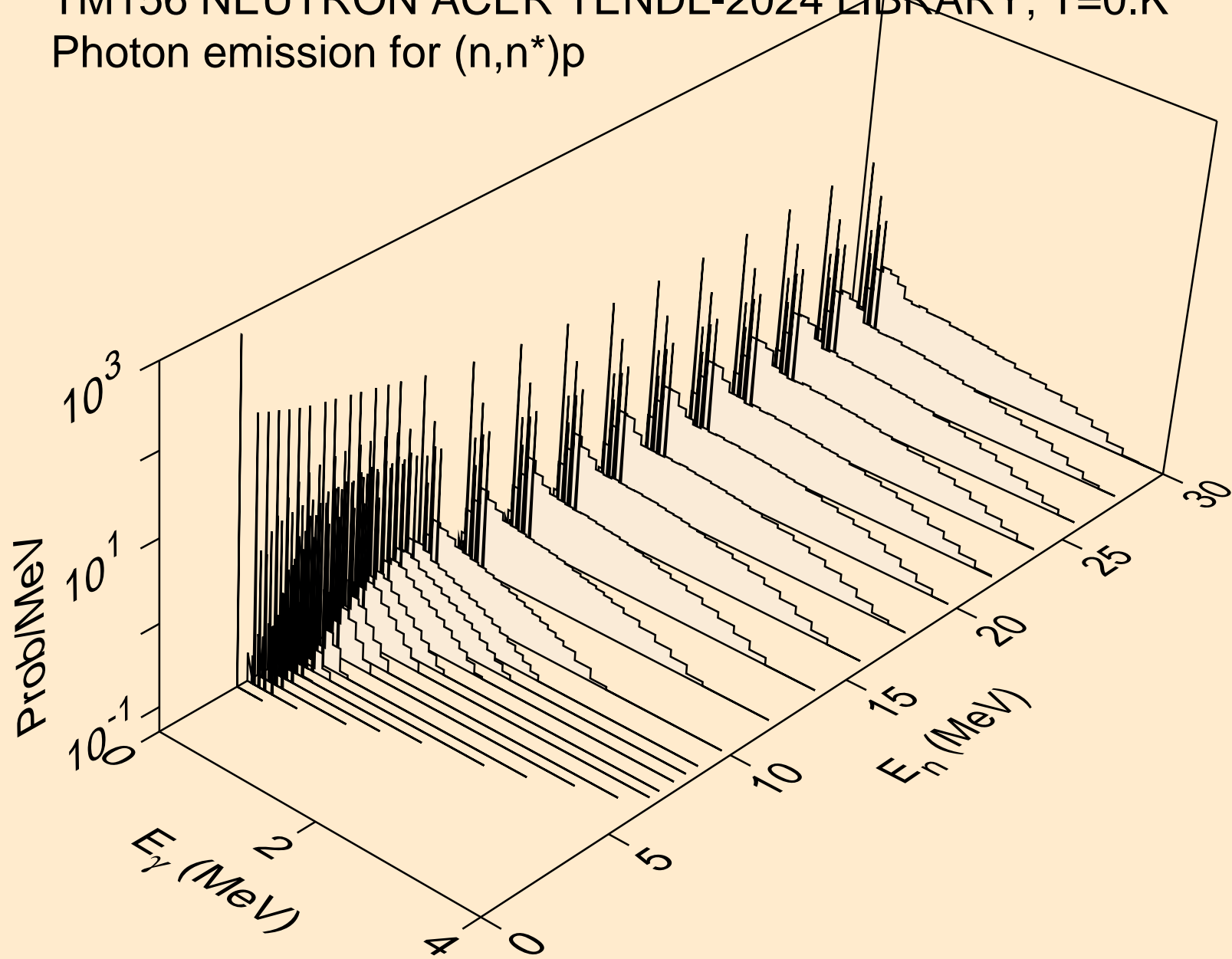

TM156 NEUTRON ACER TENDL-2024 LIBRARY; T=0.K  
Photon emission for (n,n\*)2a

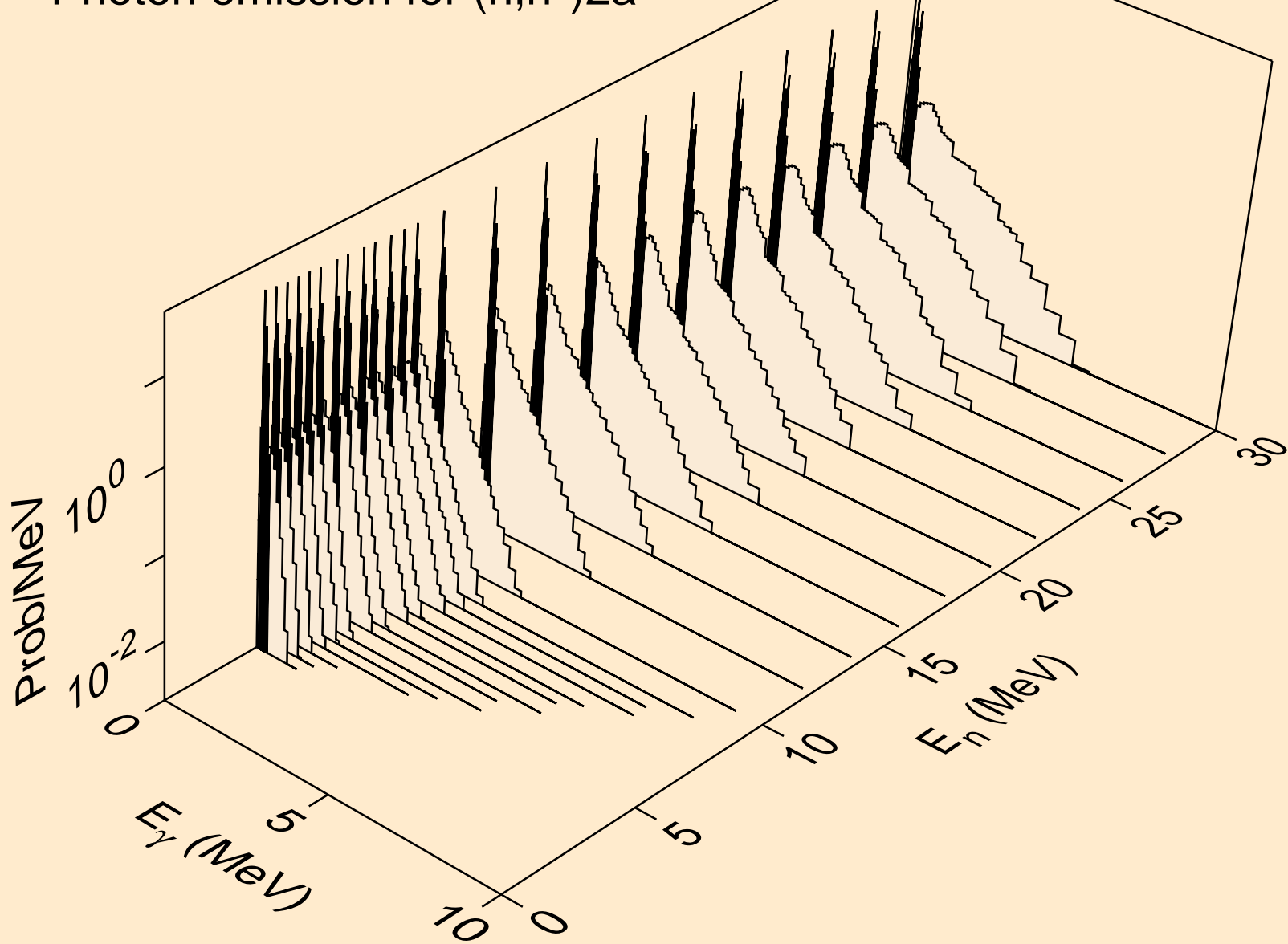

TM156 NEUTRON ACER TENDL-2024 LIBRARY; T=0.K  
Photon emission for (n,2n)2a

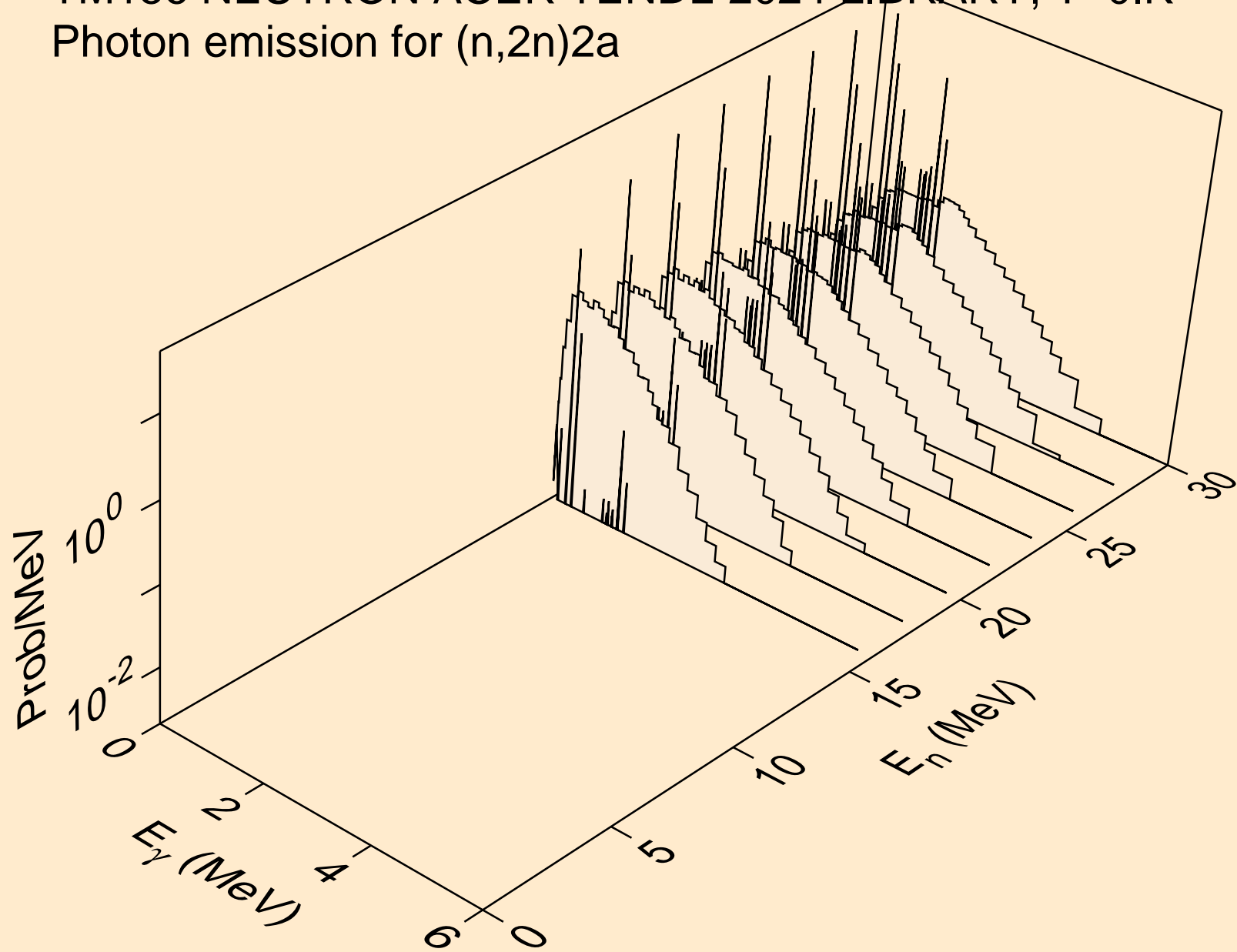

TM156 NEUTRON ACER TENDL-2024 LIBRARY; T=0.K  
Photon emission for (n,n\*)d

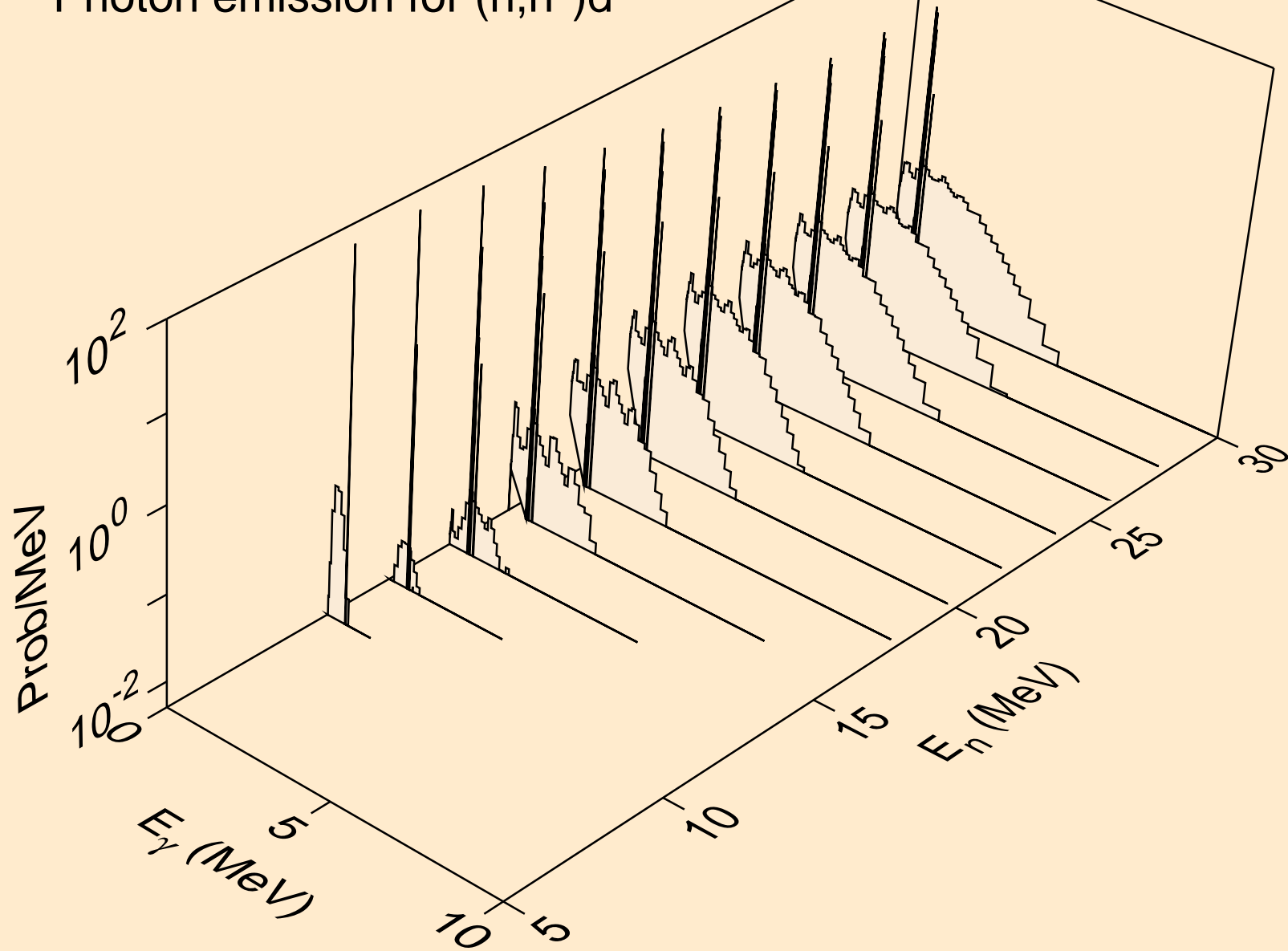

TM156 NEUTRON ACER TENDL-2024 LIBRARY; T=0.K  
Photon emission for (n,n\*)t

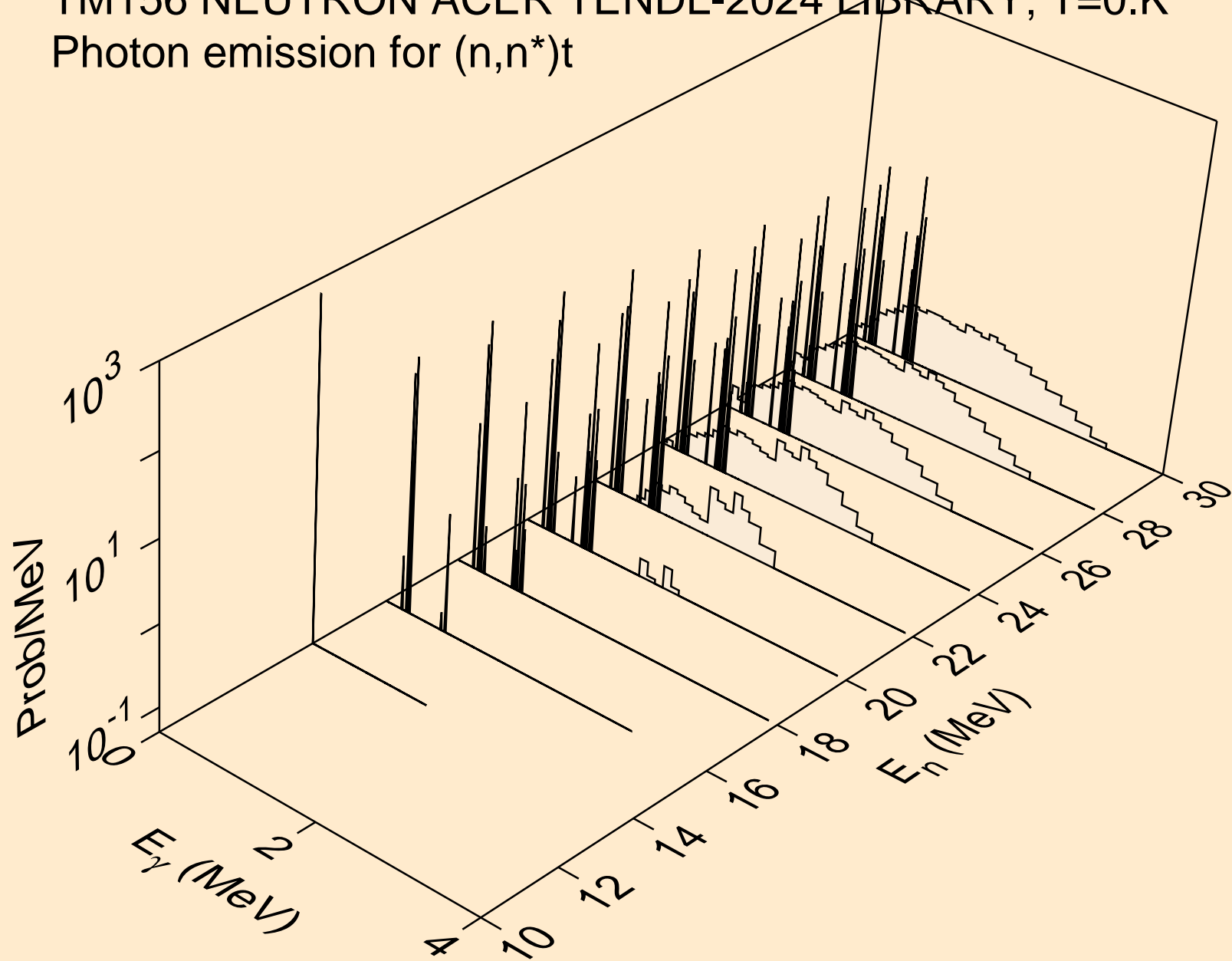

TM156 NEUTRON ACER TENDL-2024 LIBRARY; T=0.K  
Photon emission for (n,n\*)he3

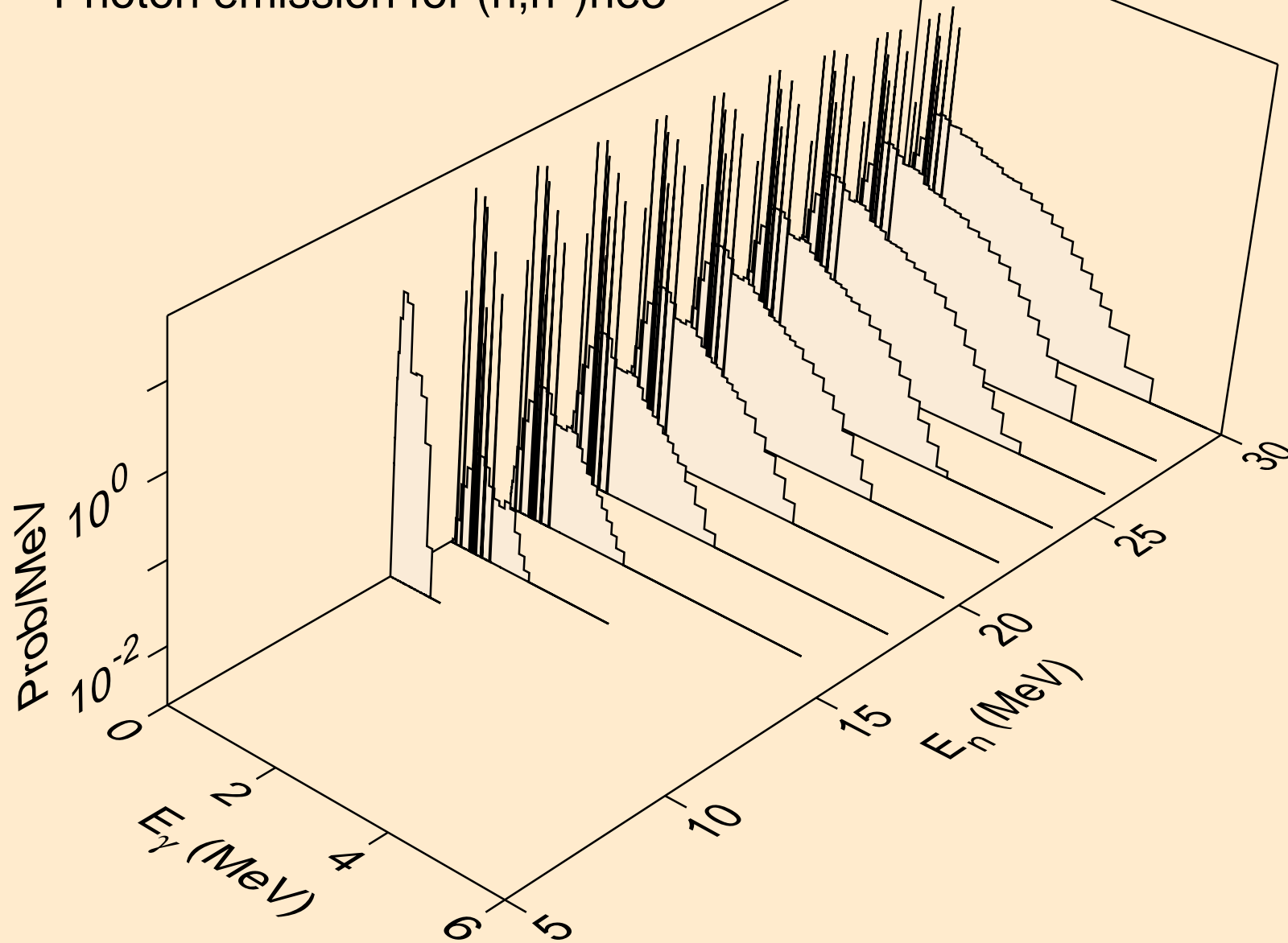

TM156 NEUTRON ACER TENDL-2024 LIBRARY; T=0.K  
Photon emission for (n,4n)

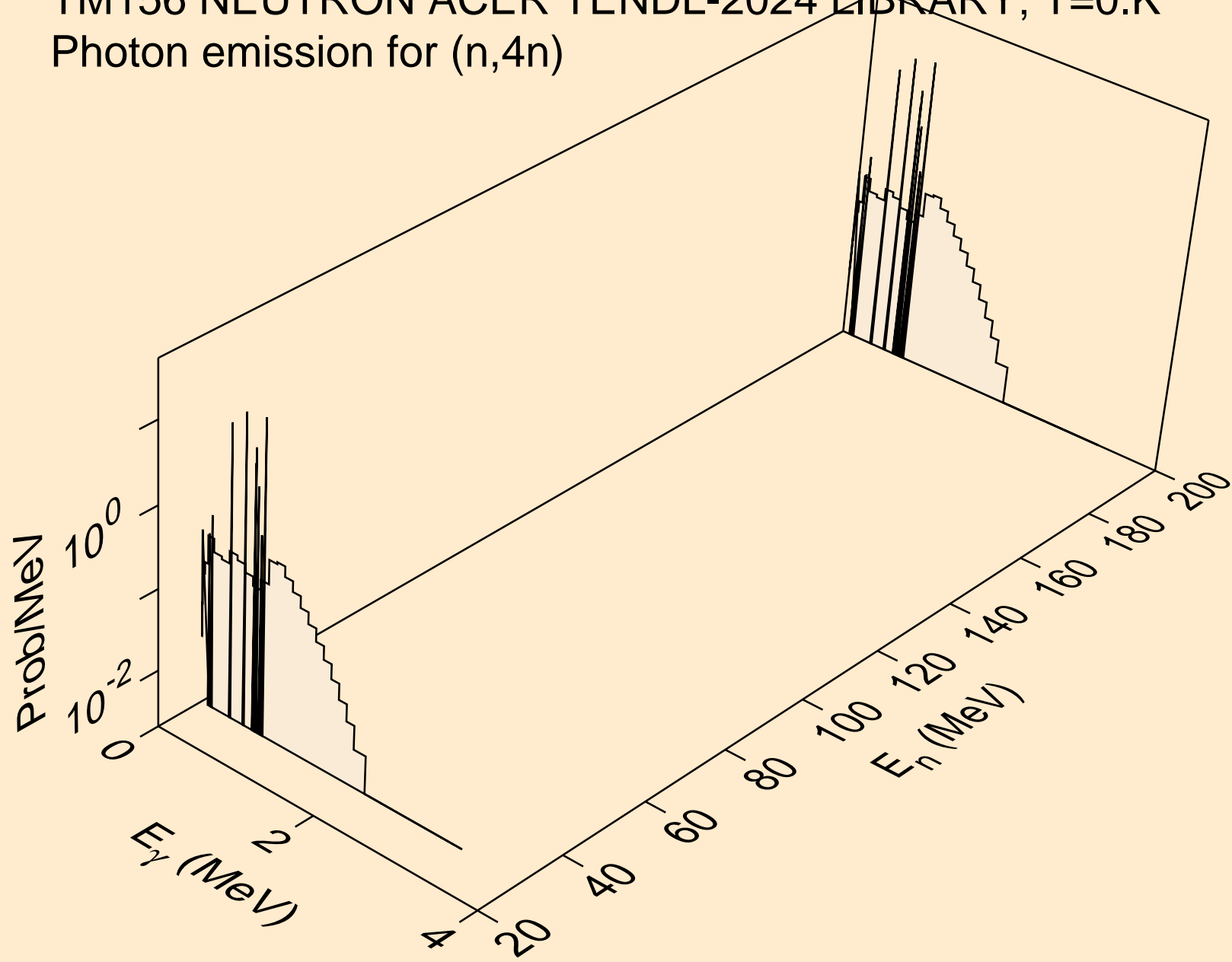

TM156 NEUTRON ACER TENDL-2024 LIBRARY; T=0.K  
Photon emission for (n,2np)

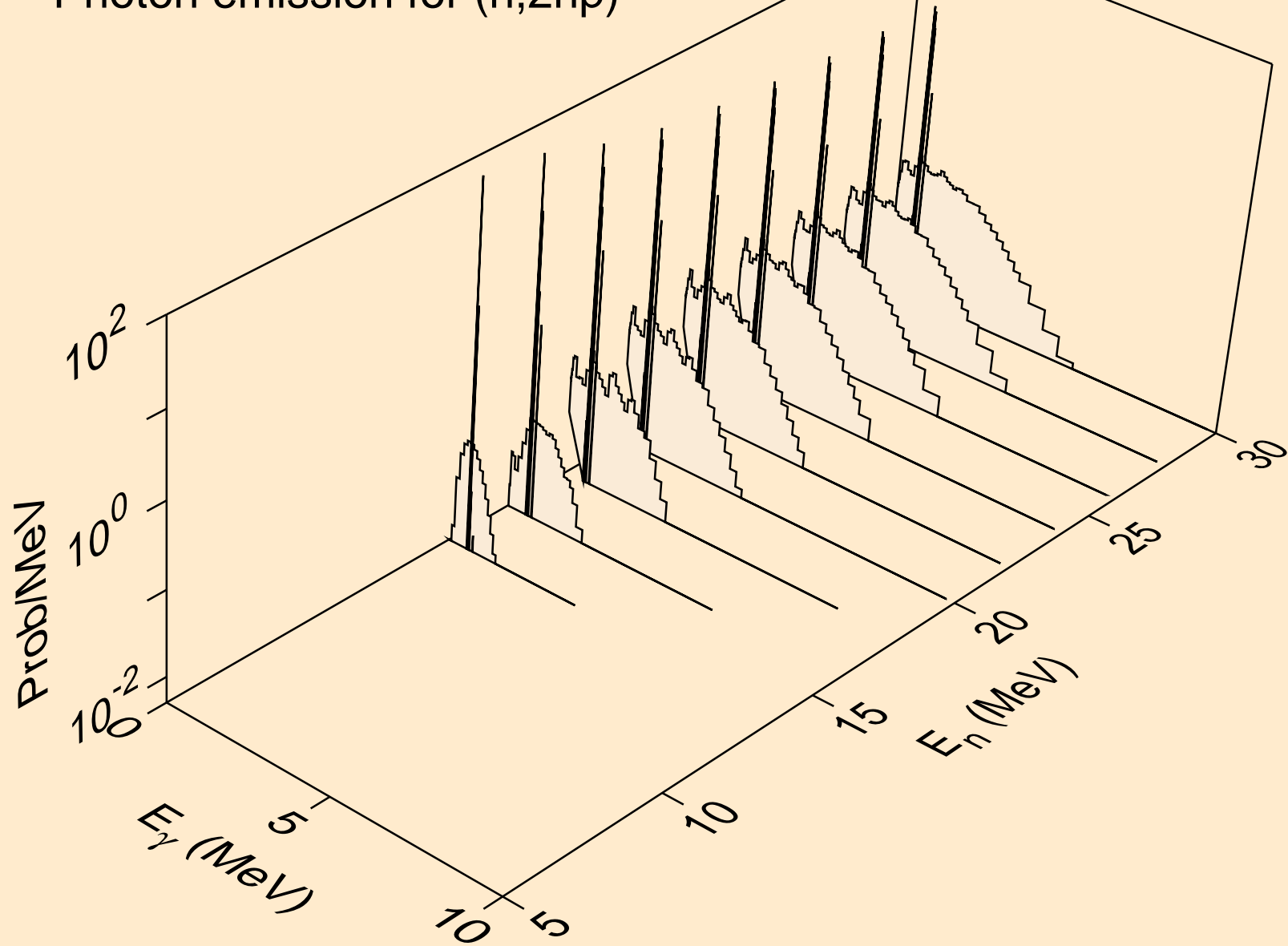

TM156 NEUTRON ACER TENDL-2024 LIBRARY; T=0.K  
Photon emission for (n,3np)

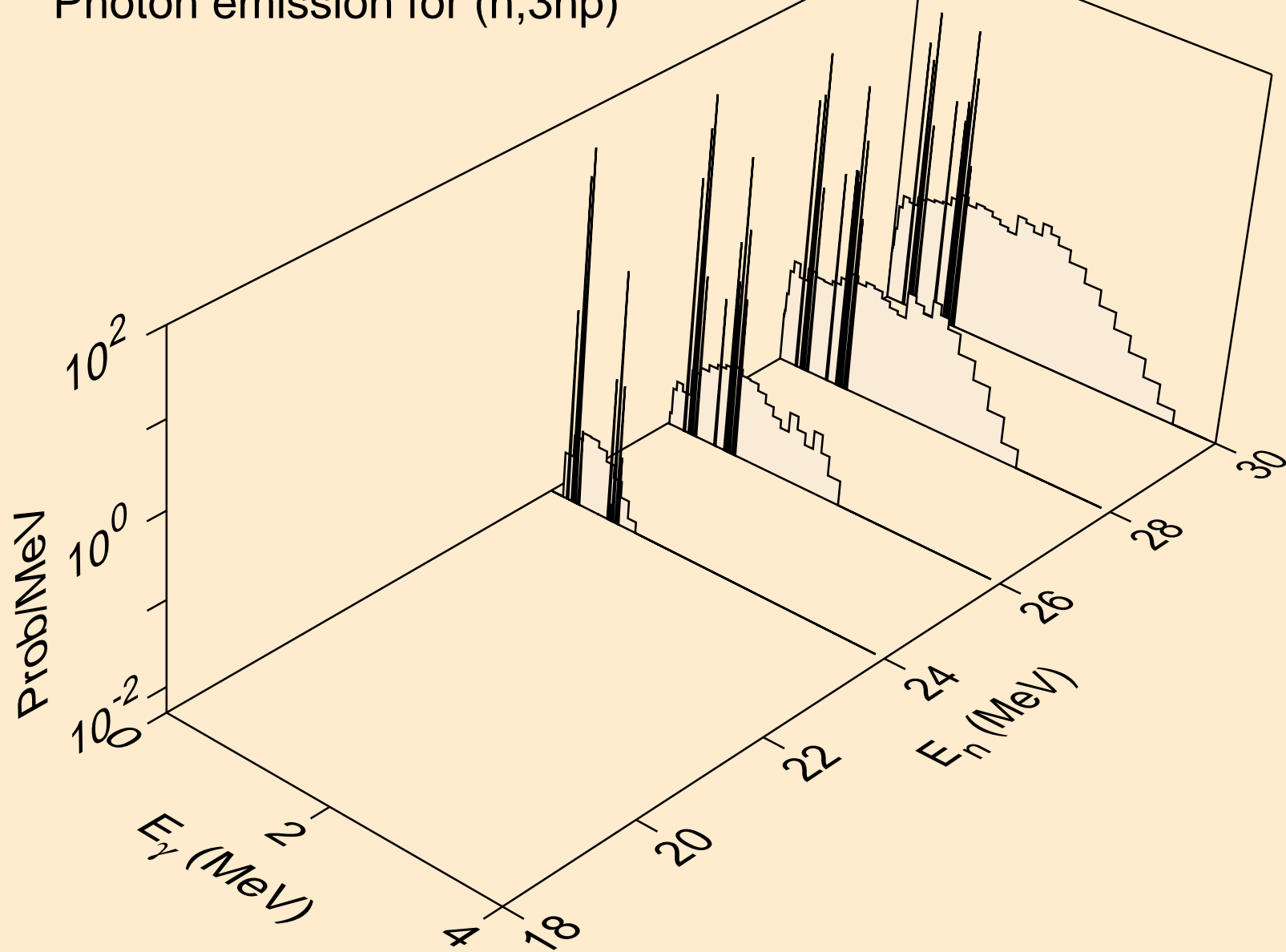

TM156 NEUTRON ACER TENDL-2024 LIBRARY; T=0.K  
Photon emission for (n,n2p)

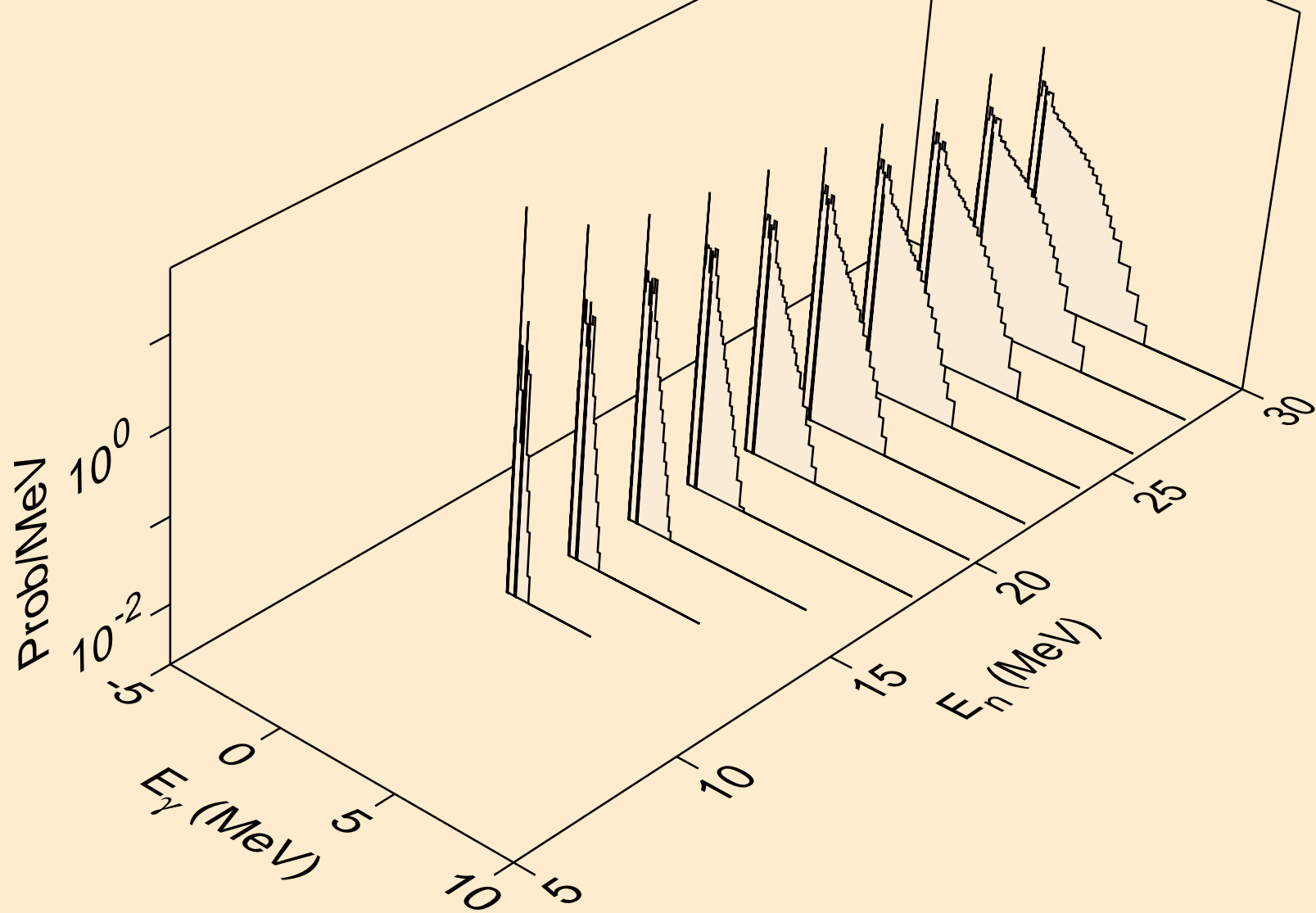

TM156 NEUTRON ACER TENDL-2024 LIBRARY; T=0.K  
Photon emission for (n,npa)

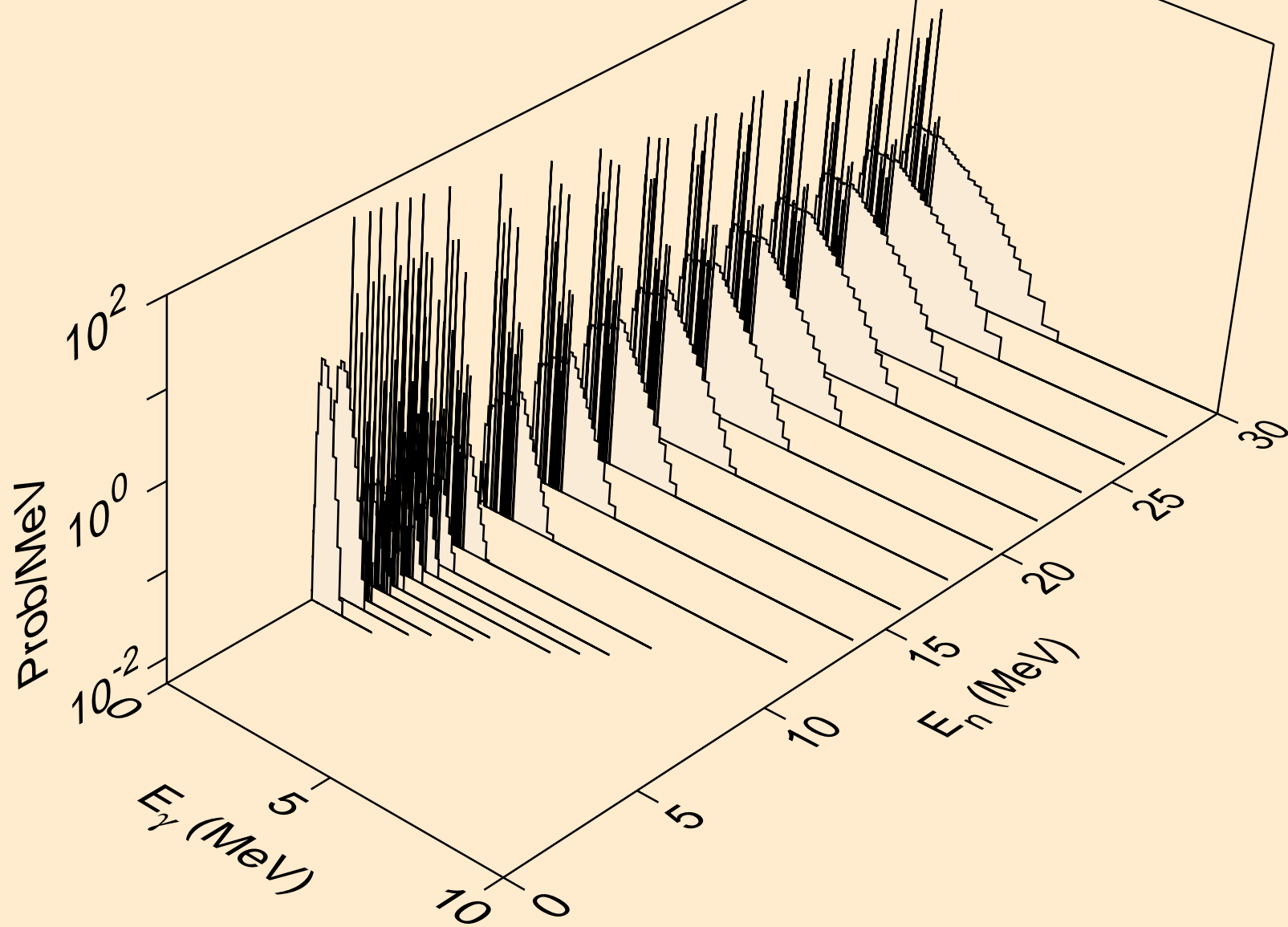

TM156 NEUTRON ACER TENDL-2024 LIBRARY; T=0.K  
Photon emission for (n,n\*c)

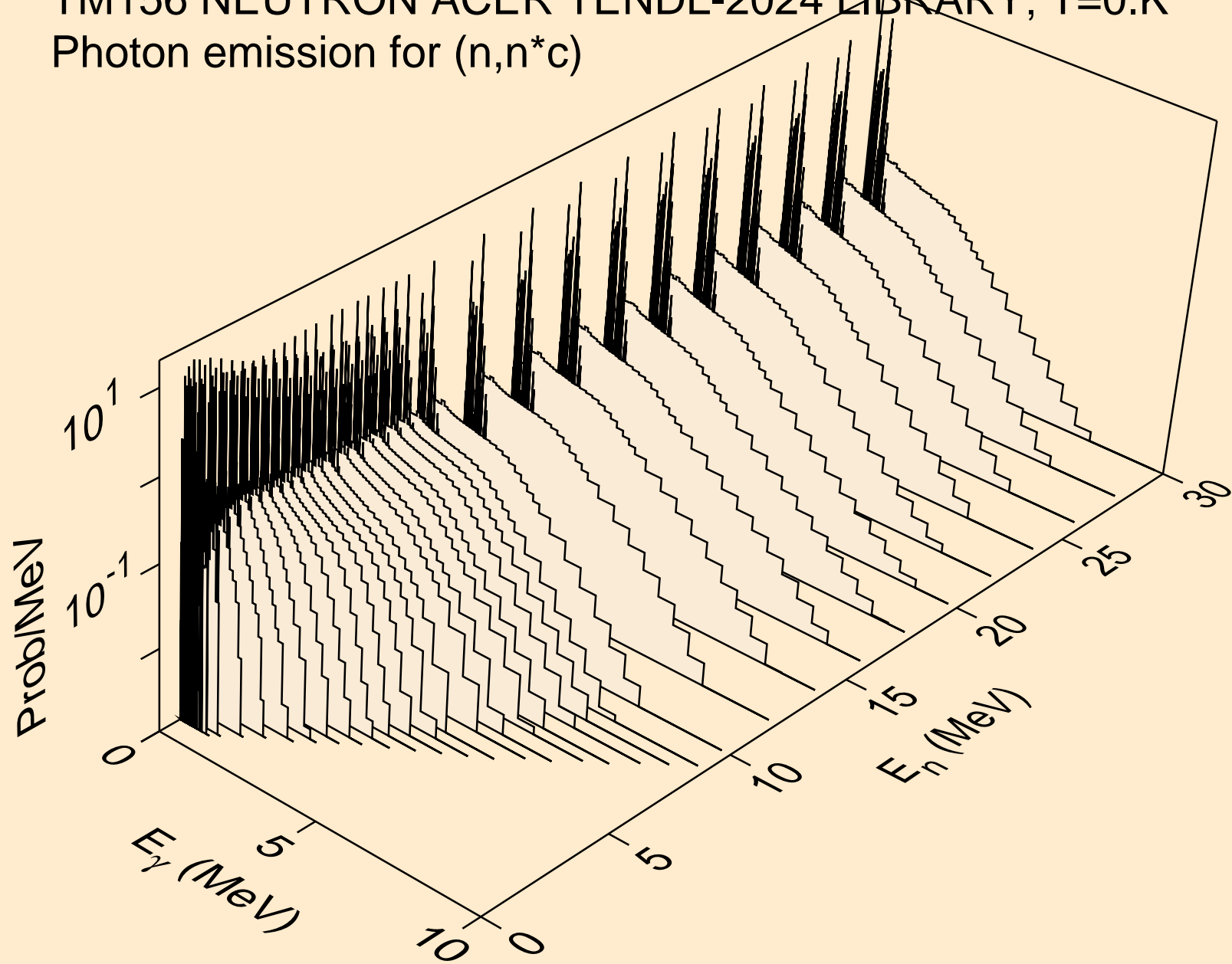

TM156 NEUTRON ACER TENDL-2024 LIBRARY; T=0.K  
Photon emission for (n,gma)

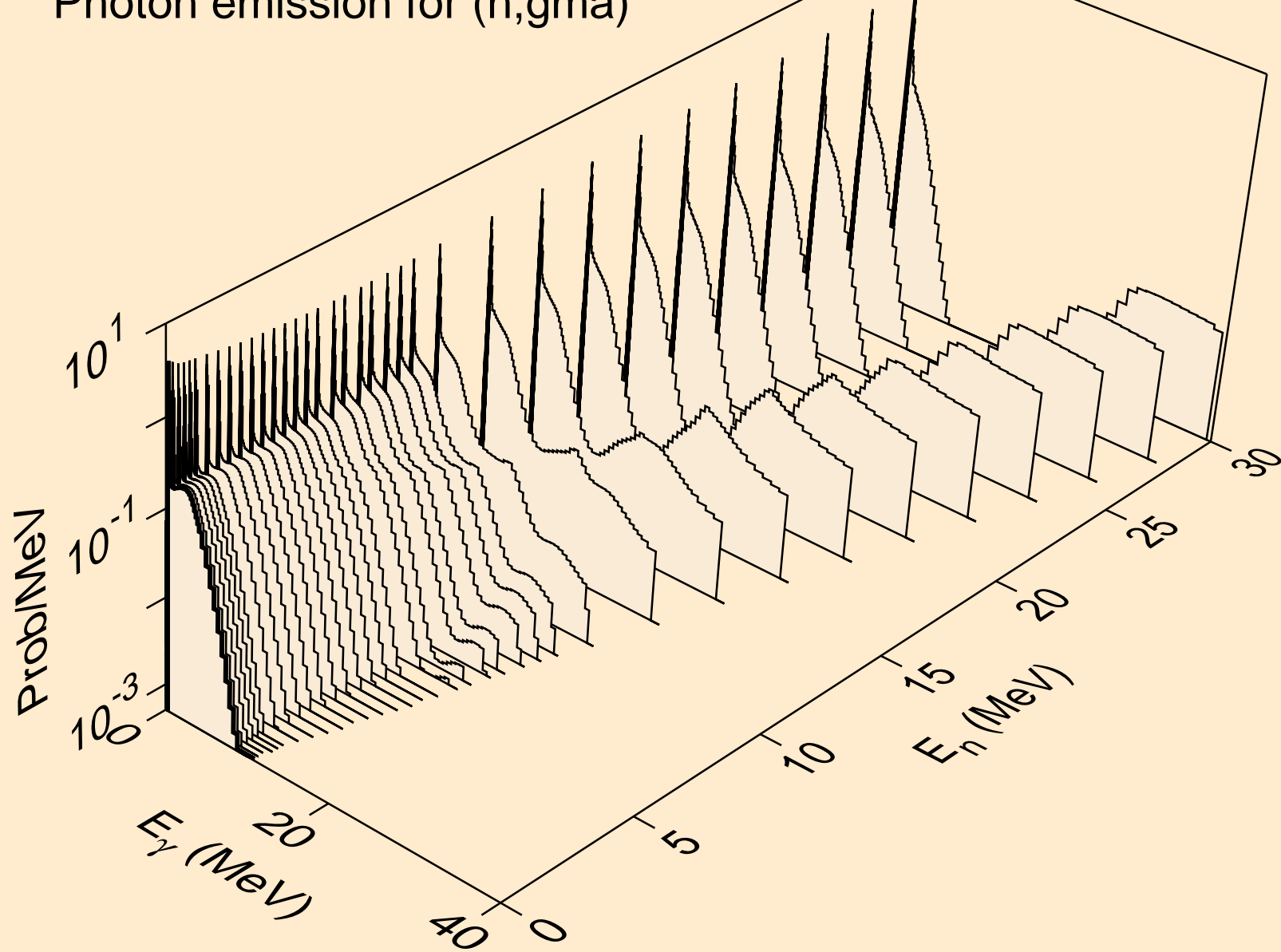

TM156 NEUTRON ACER TENDL-2024 LIBRARY; T=0.K  
Photon emission for (n,p)

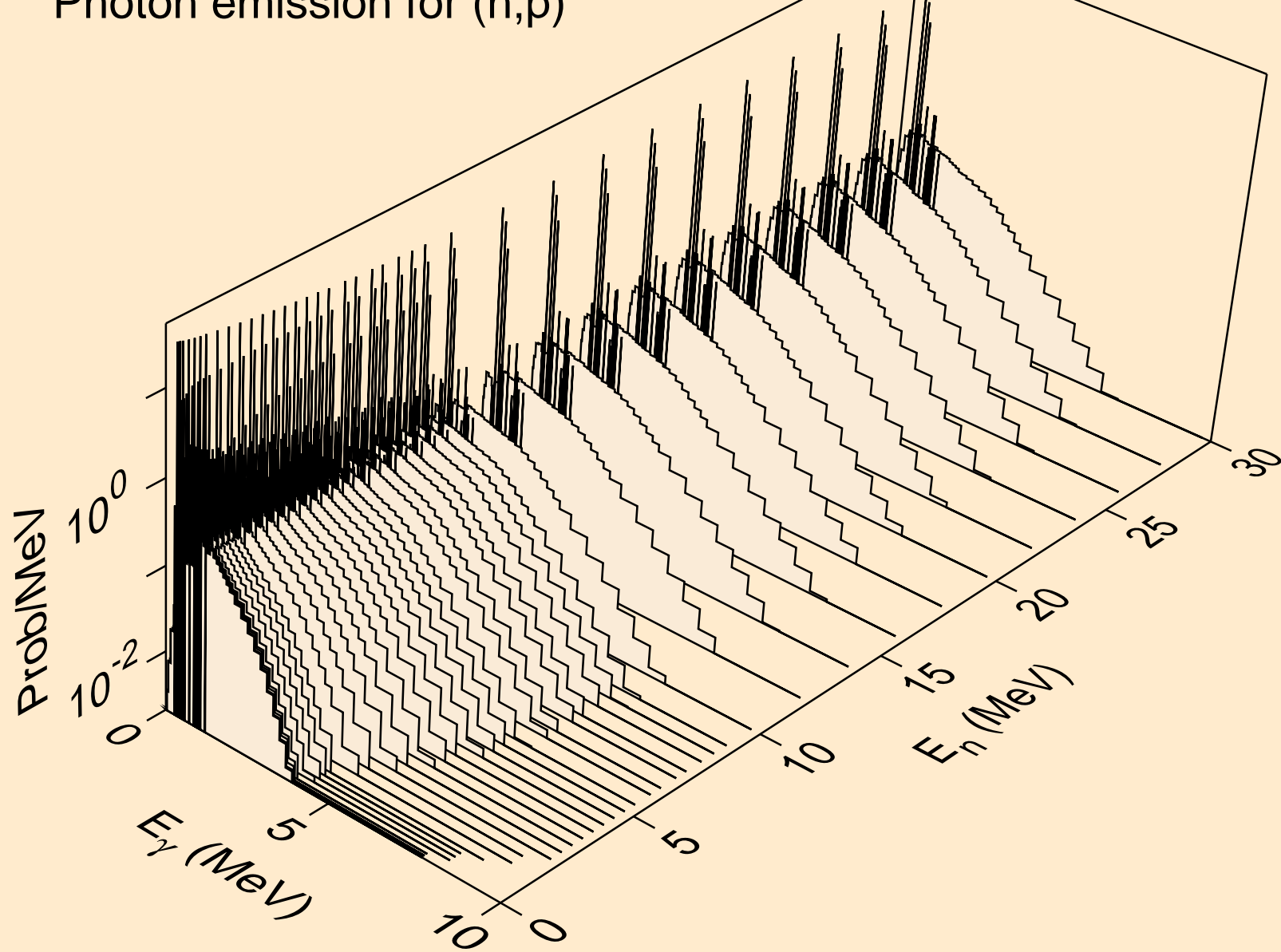

TM156 NEUTRON ACER TENDL-2024 LIBRARY; T=0.K  
Photon emission for (n,d)

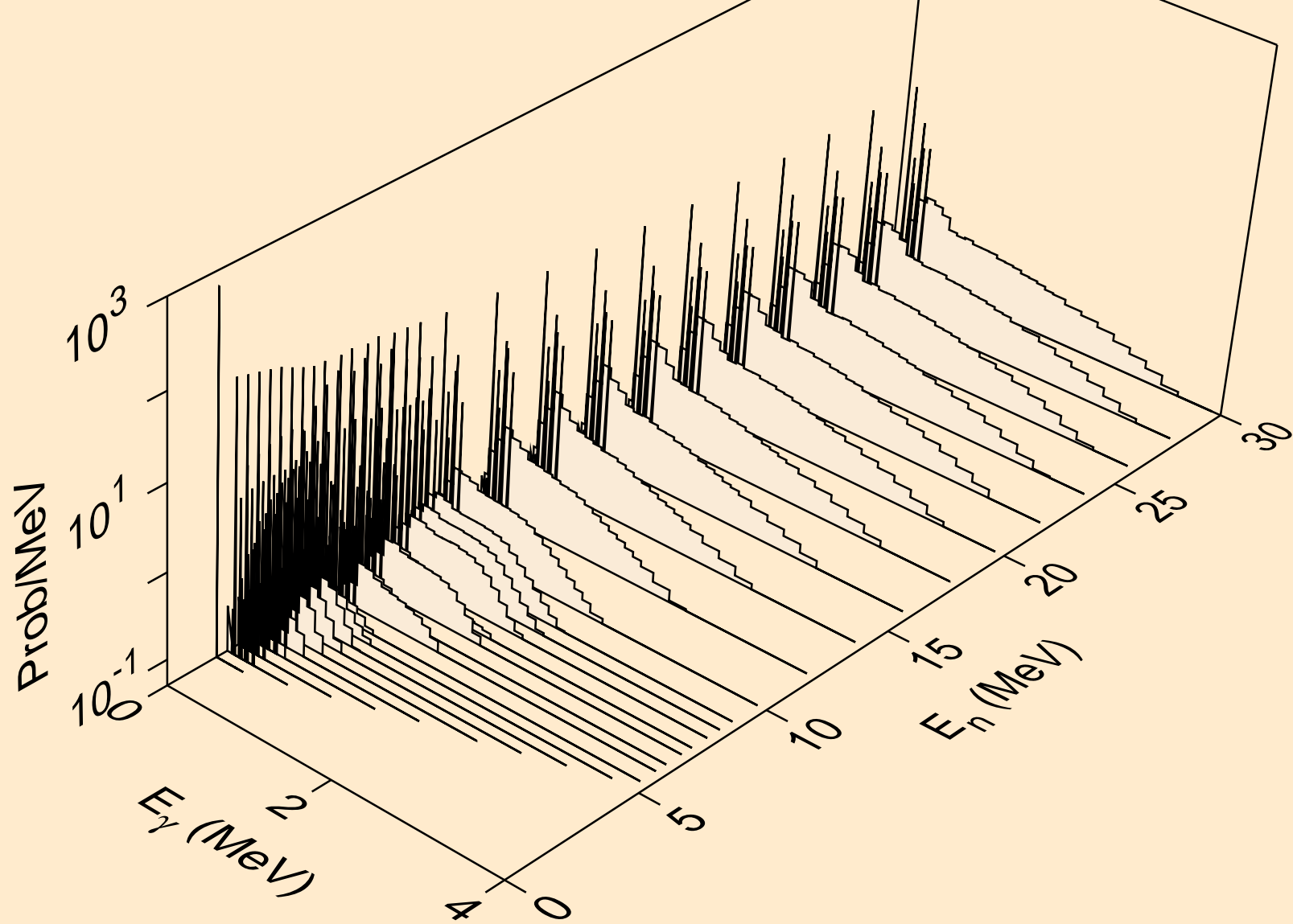

TM156 NEUTRON ACER TENDL-2024 LIBRARY; T=0.K  
Photon emission for (n,t)

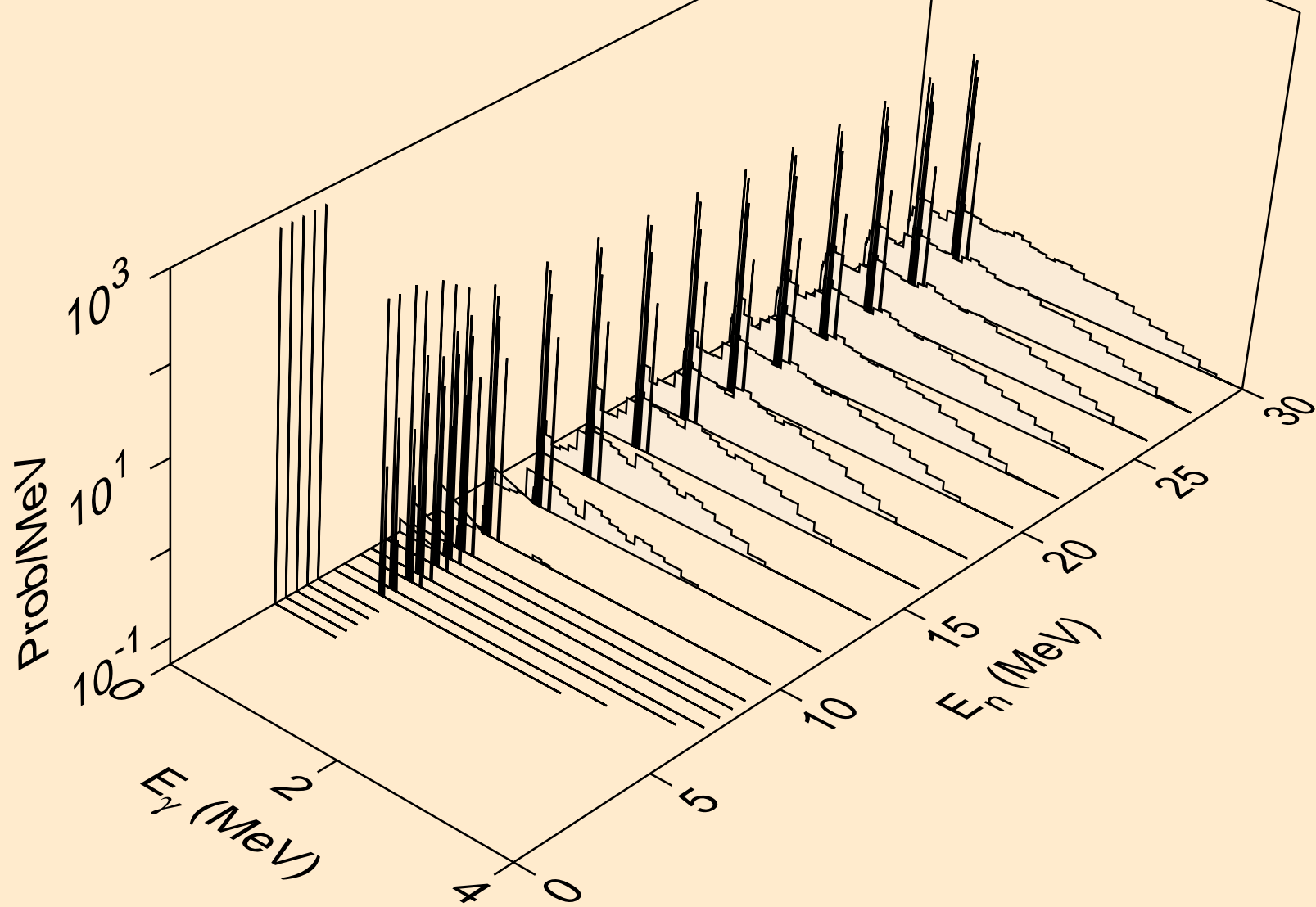

TM156 NEUTRON ACER TENDL-2024 LIBRARY; T=0.K  
Photon emission for (n,he3)

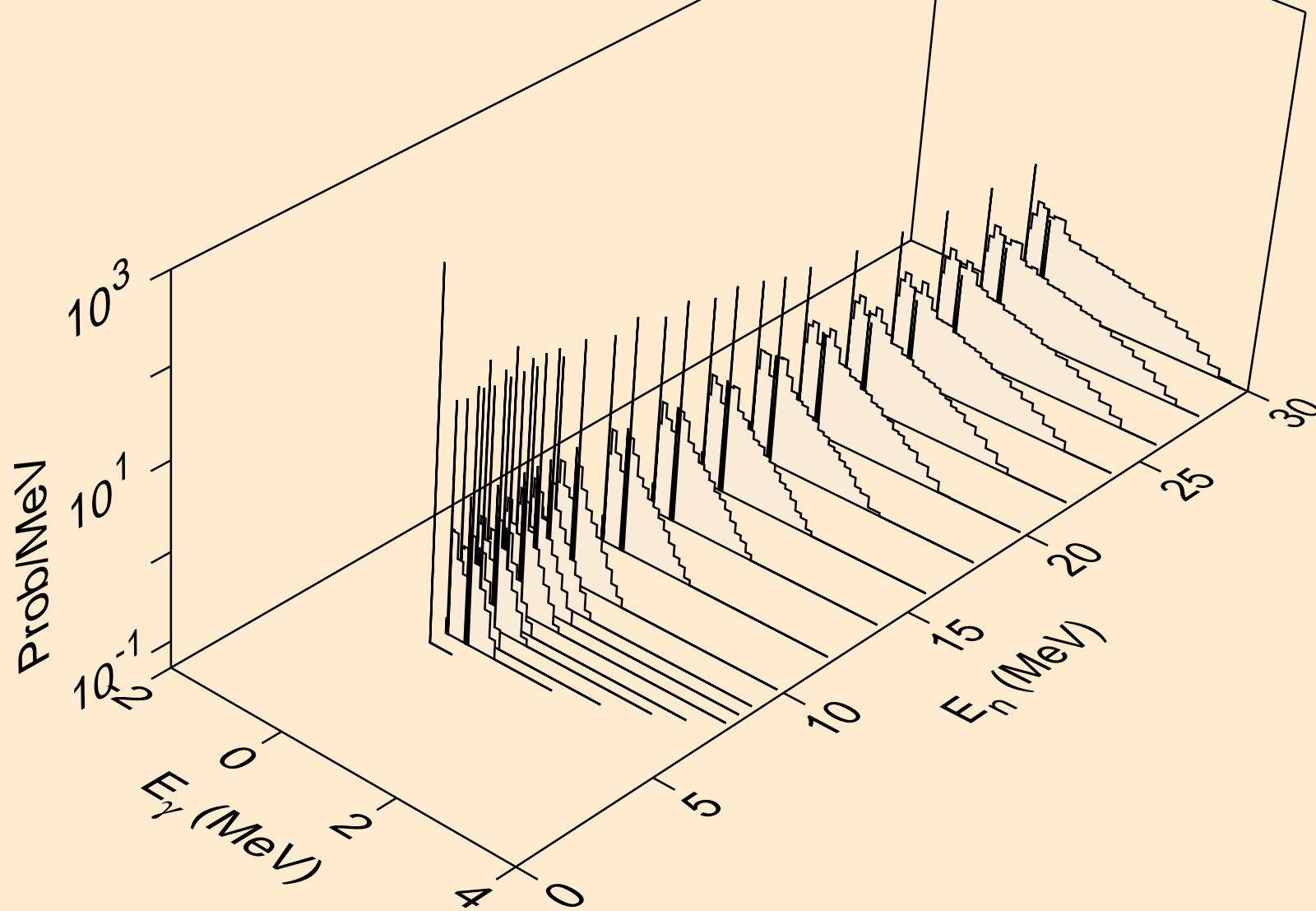

TM156 NEUTRON ACER TENDL-2024 LIBRARY; T=0.K  
Photon emission for (n,a)

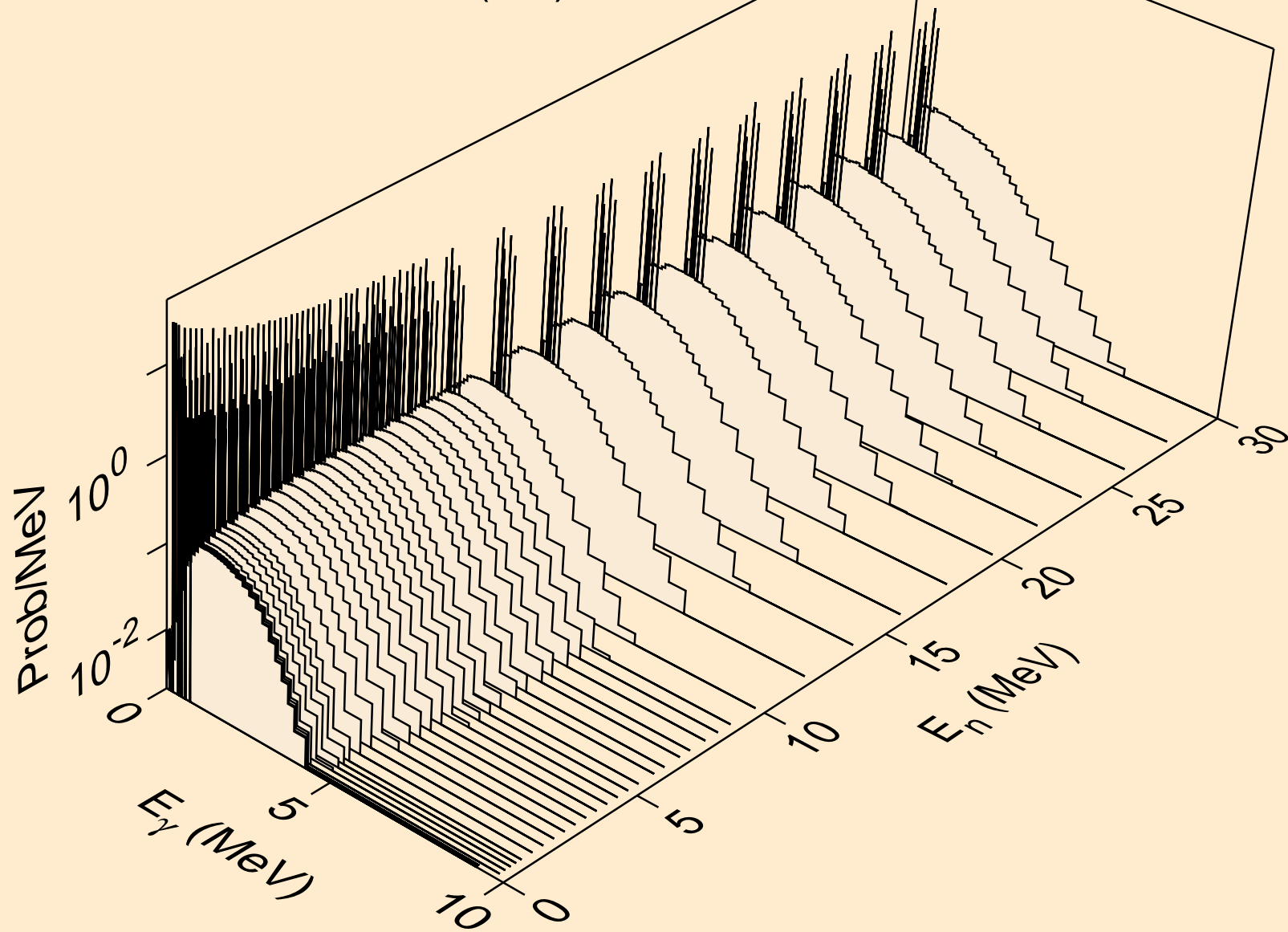

TM156 NEUTRON ACER TENDL-2024 LIBRARY; T=0.K  
Photon emission for (n,2a)

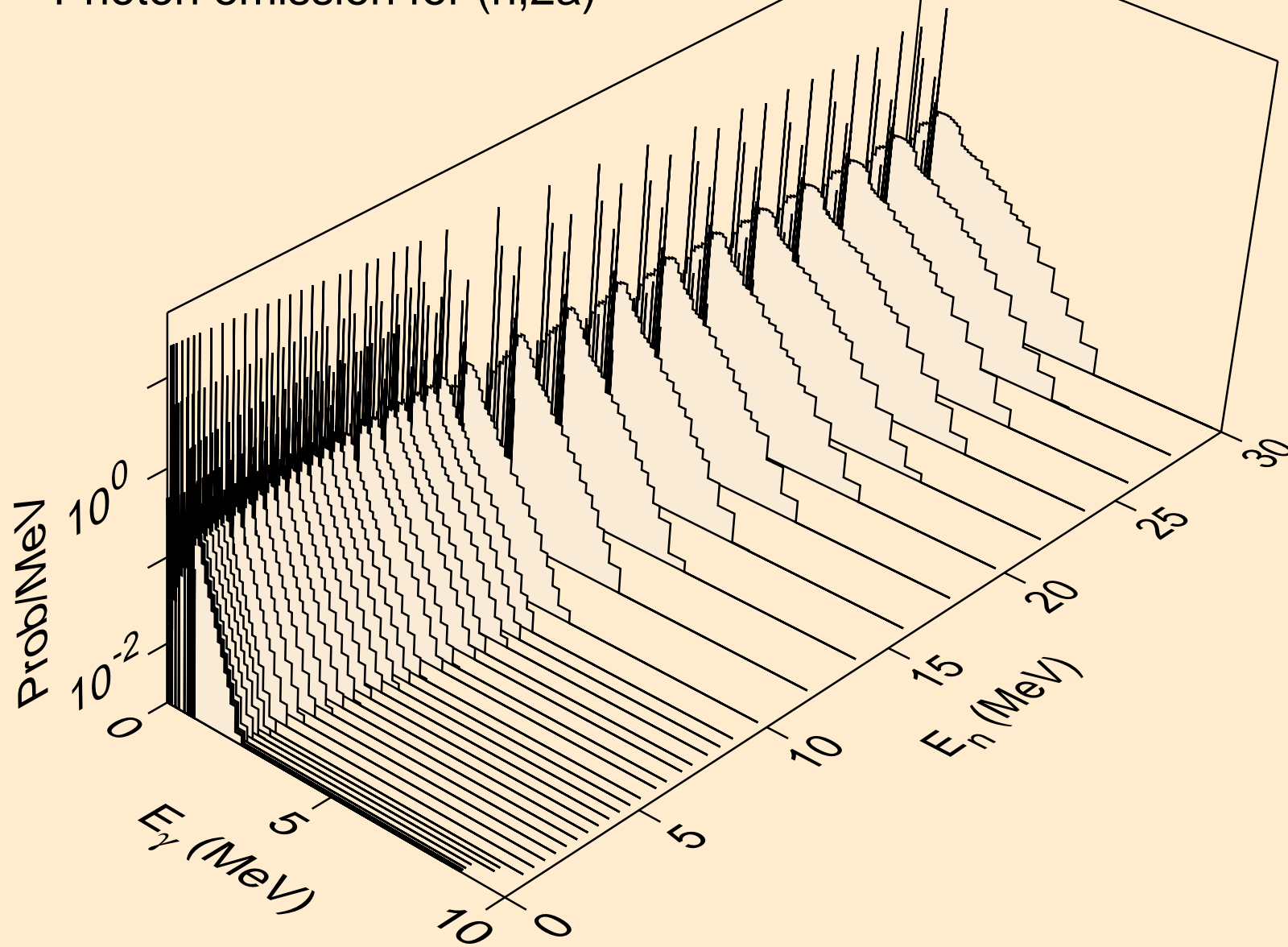

TM156 NEUTRON ACER TENDL-2024 LIBRARY; T=0.K  
Photon emission for (n,3a)

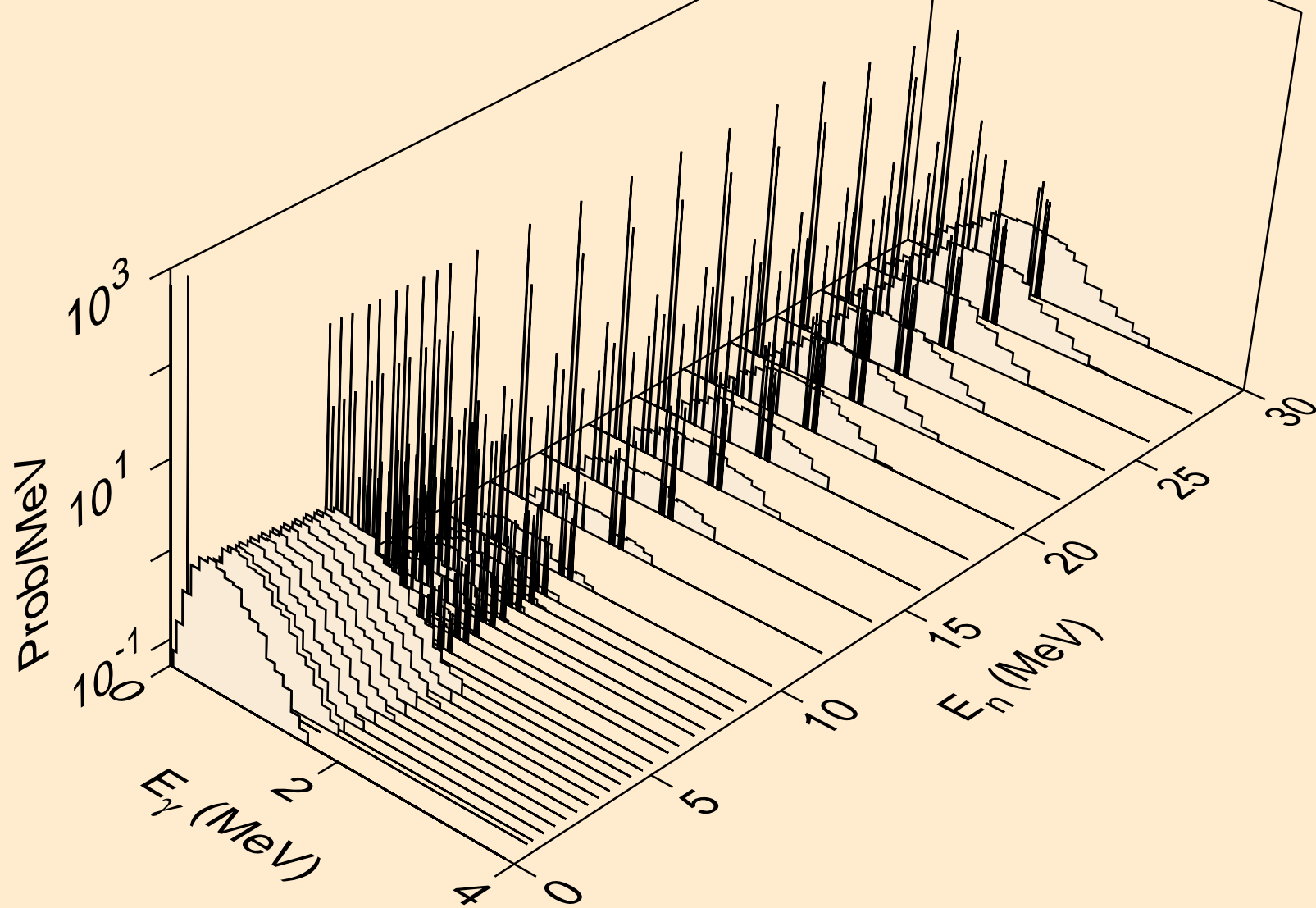

TM156 NEUTRON ACER TENDL-2024 LIBRARY; T=0.K  
Photon emission for (n,2p)

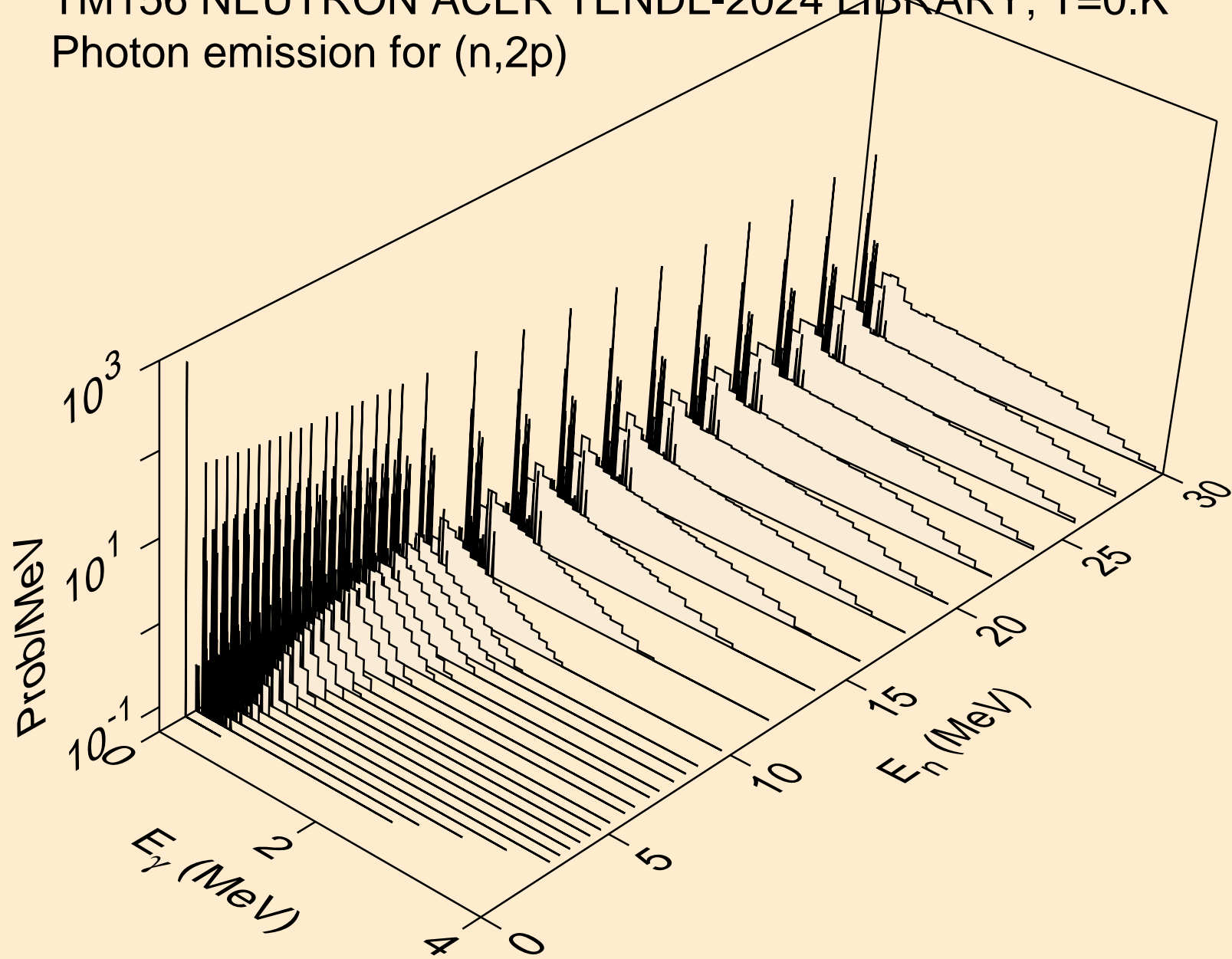

TM156 NEUTRON ACER TENDL-2024 LIBRARY; T=0.K  
Photon emission for (n,p)

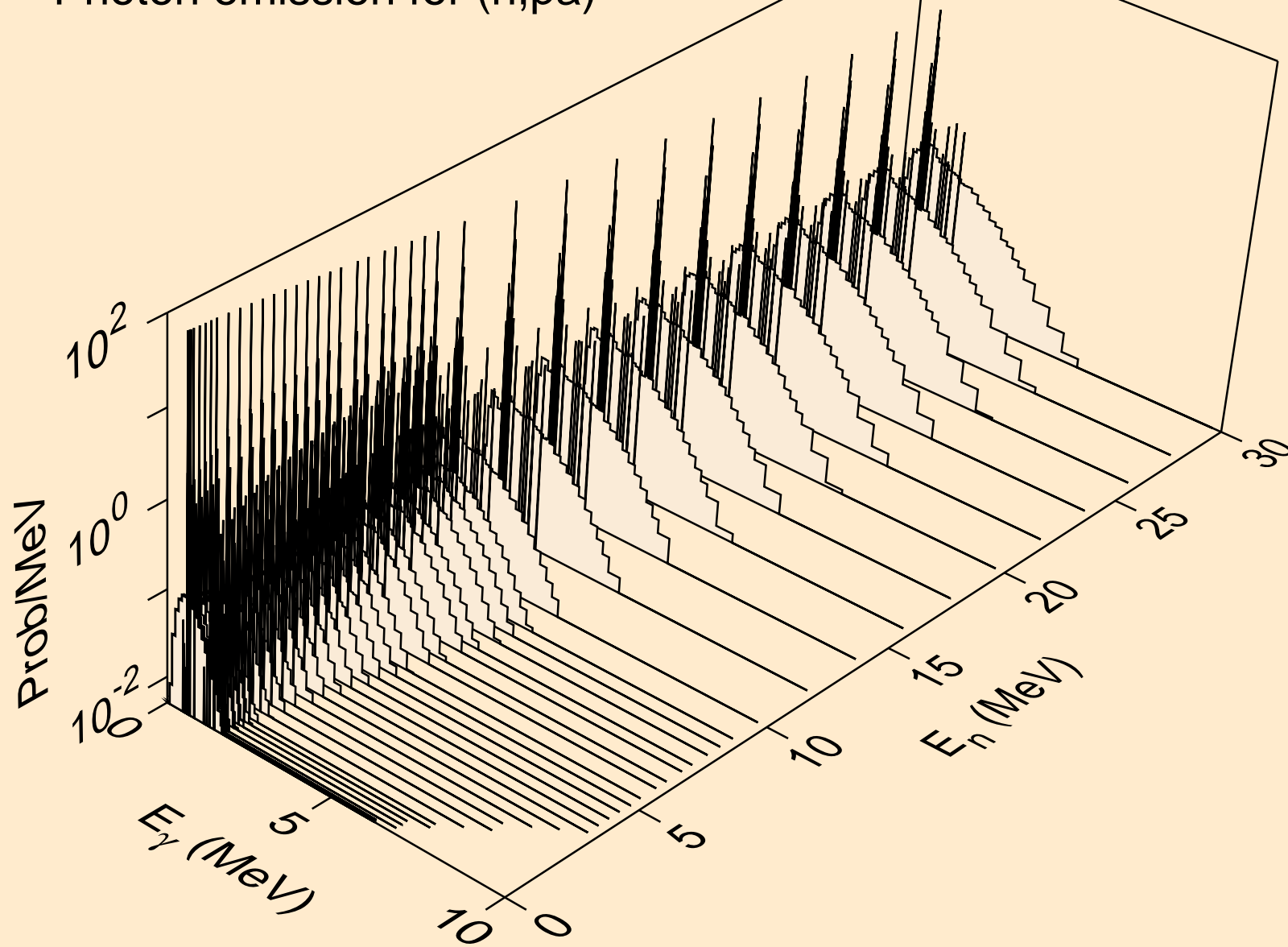

TM156 NEUTRON ACER TENDL-2024 LIBRARY; T=0.K  
Photon emission for (n,t2a)

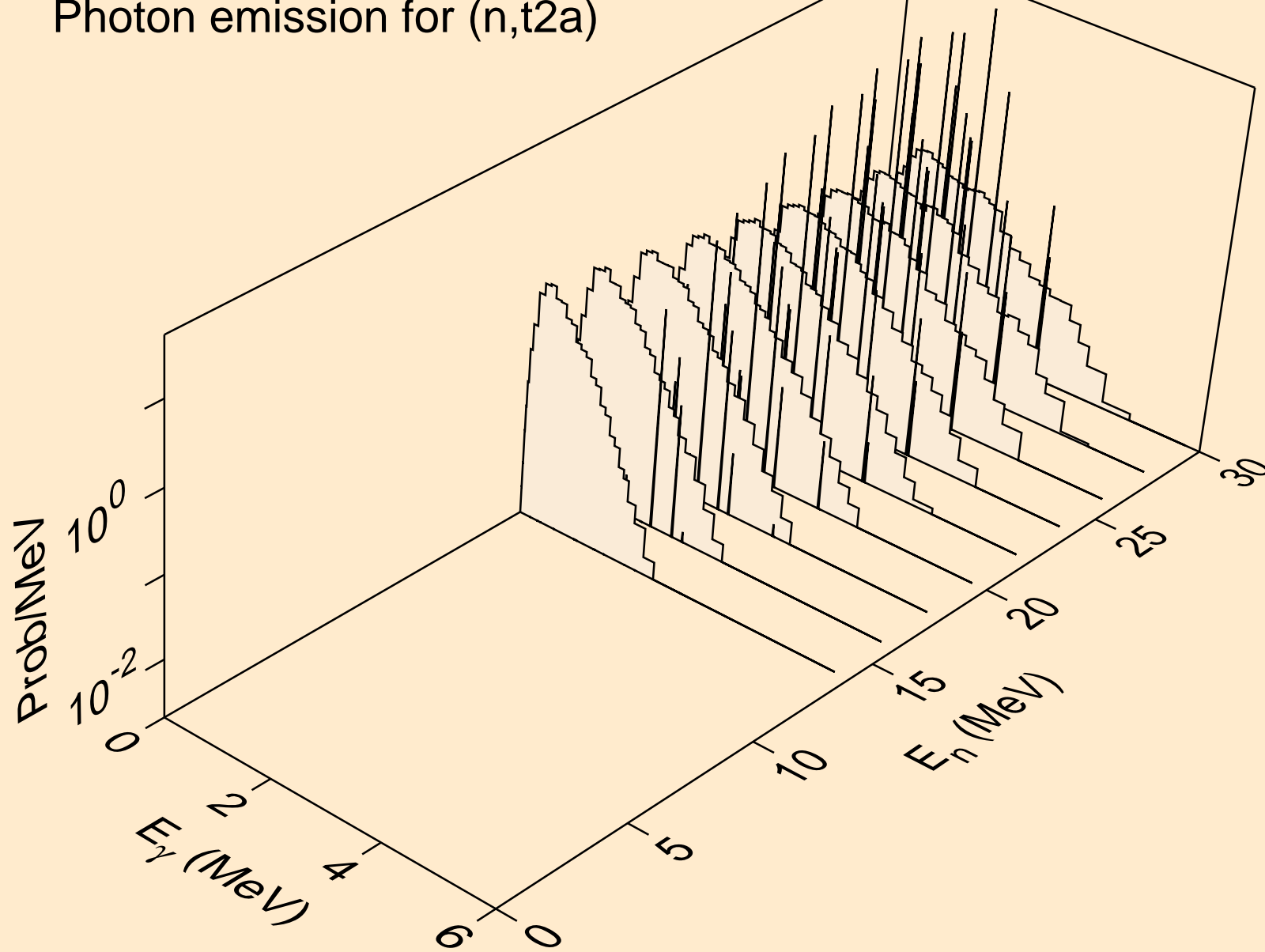

TM156 NEUTRON ACER TENDL-2024 LIBRARY; T=0.K  
Photon emission for (n,d2a)

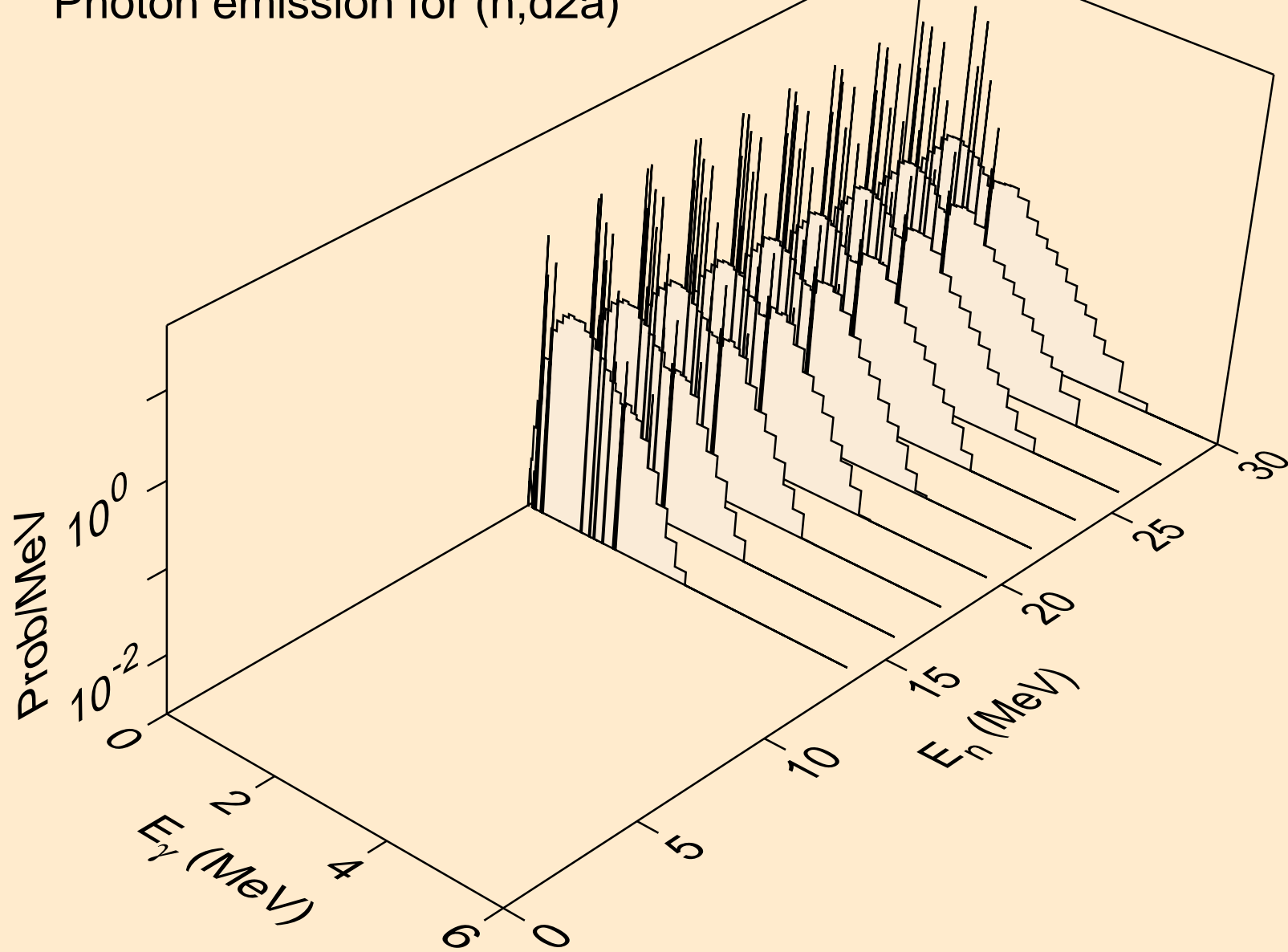

TM156 NEUTRON ACER TENDL-2024 LIBRARY; T=0.K  
Photon emission for (n,pd)

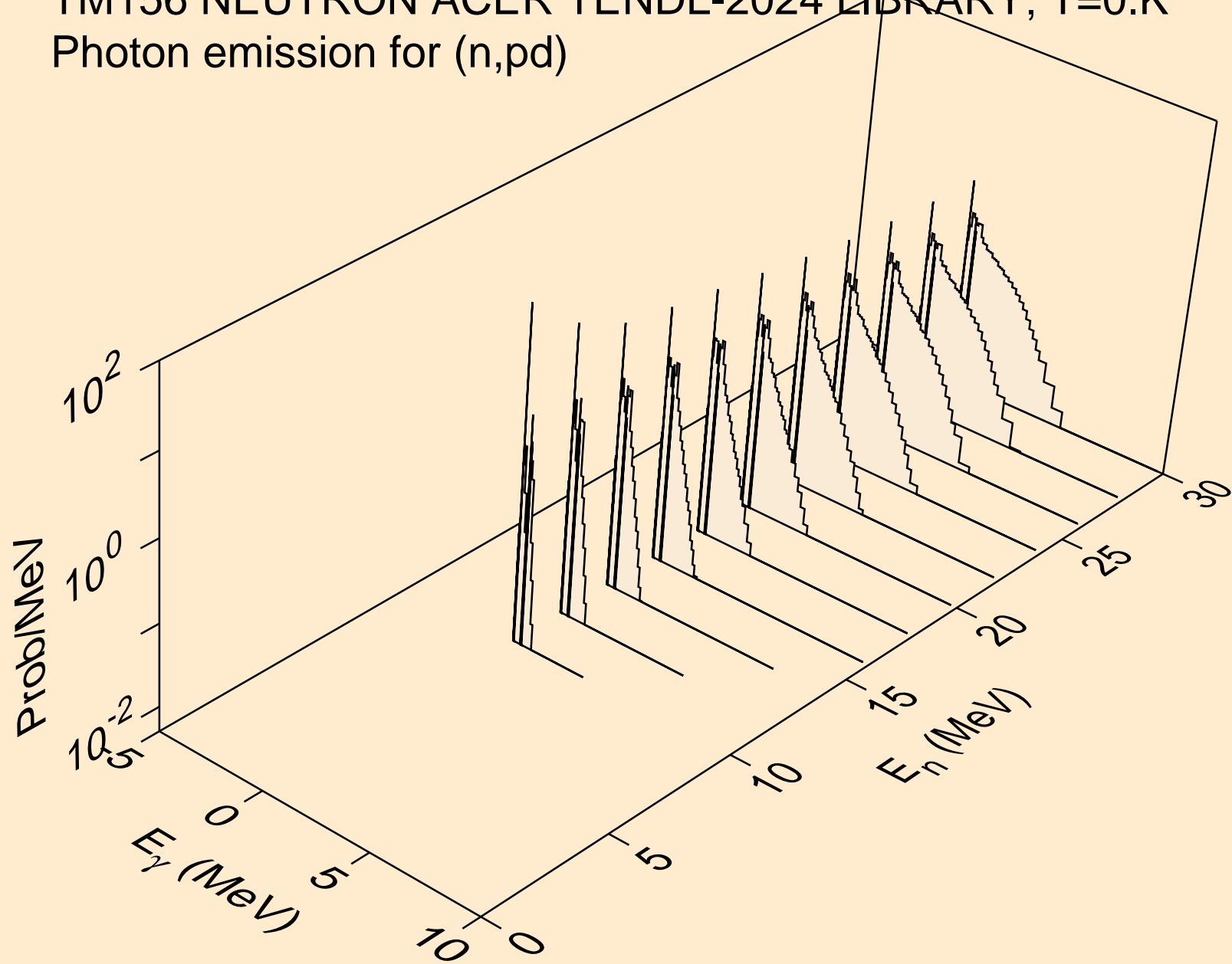

TM156 NEUTRON ACER TENDL-2024 LIBRARY; T=0.K  
Photon emission for (n,pt)

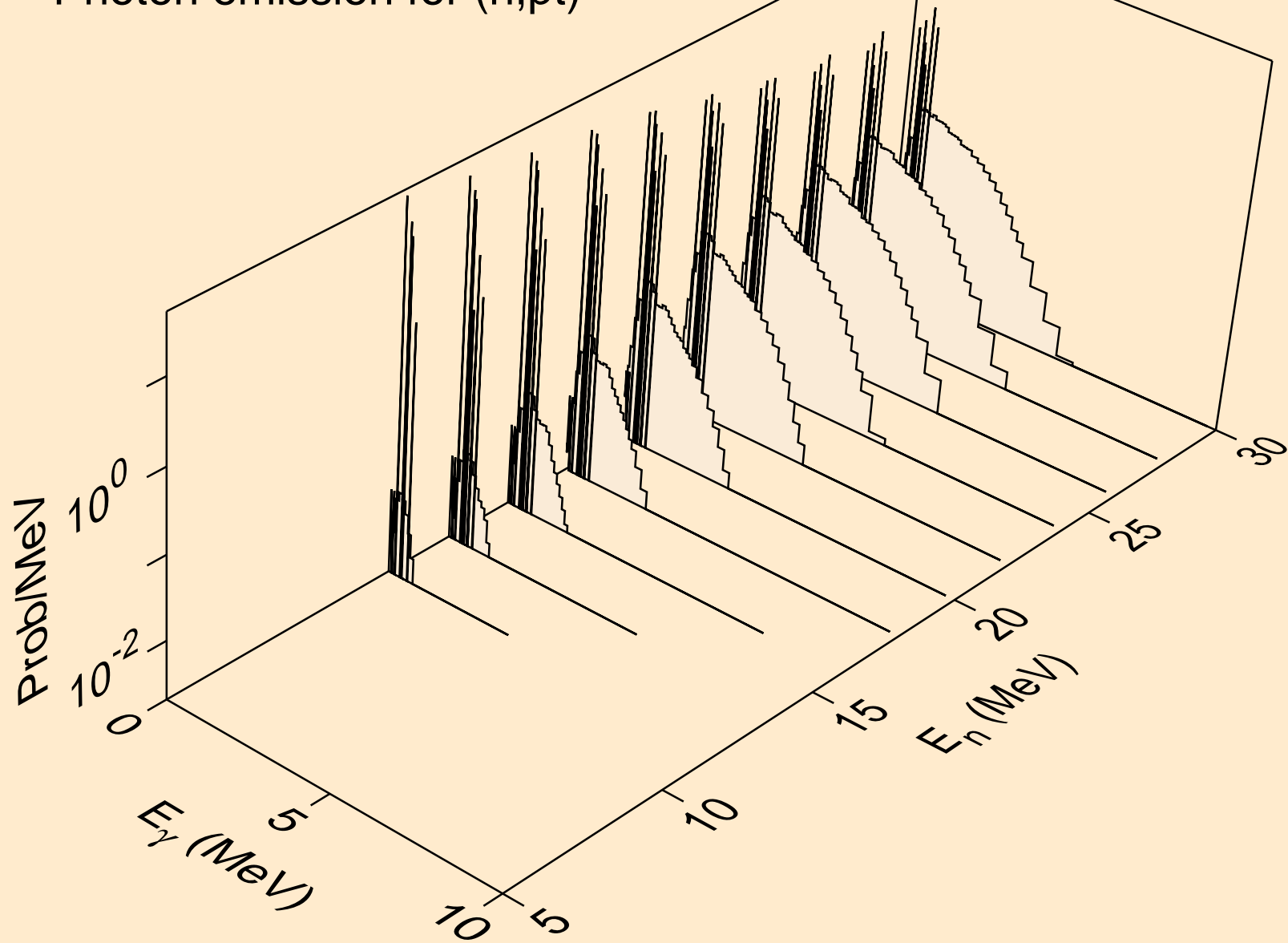

TM156 NEUTRON ACER TENDL-2024 LIBRARY; T=0.K  
Photon emission for (n,da)

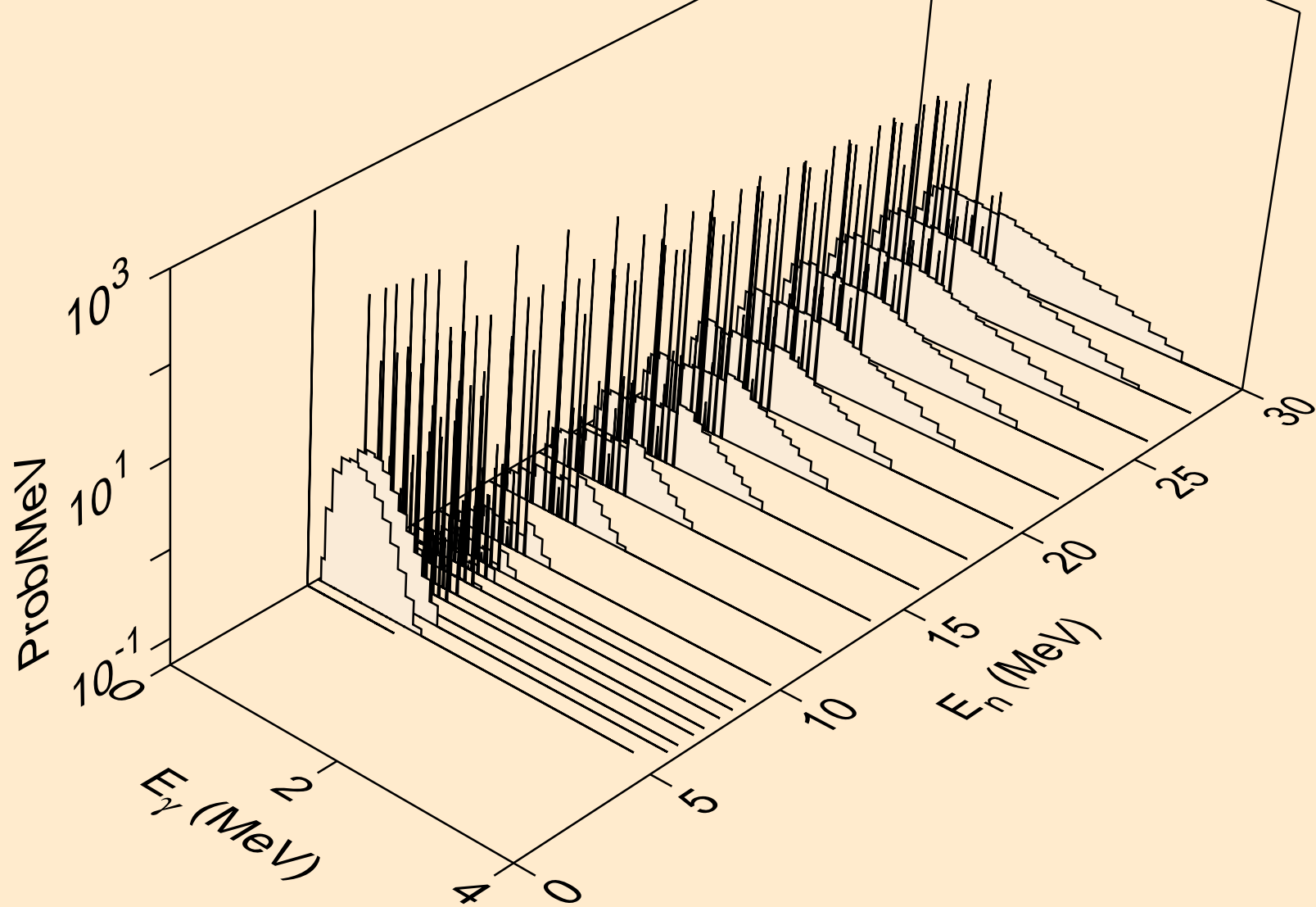

TM156 NEUTRON ACER TENDL-2024 LIBRARY; T=0.K  
thermal capture photon spectrum

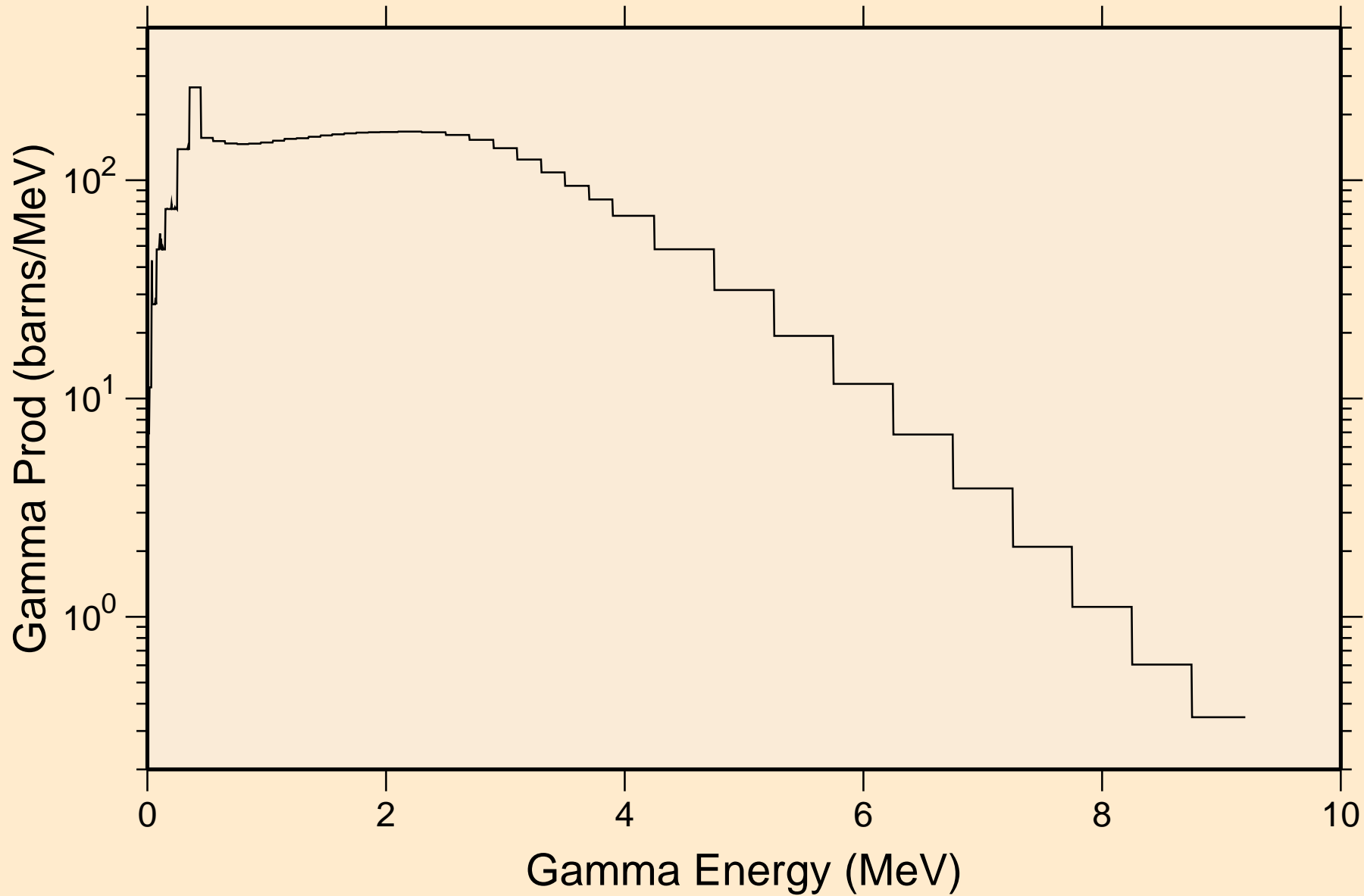

TM156 NEUTRON ACER TENDL-2024 LIBRARY; T=0.K  
14 MeV photon spectrum

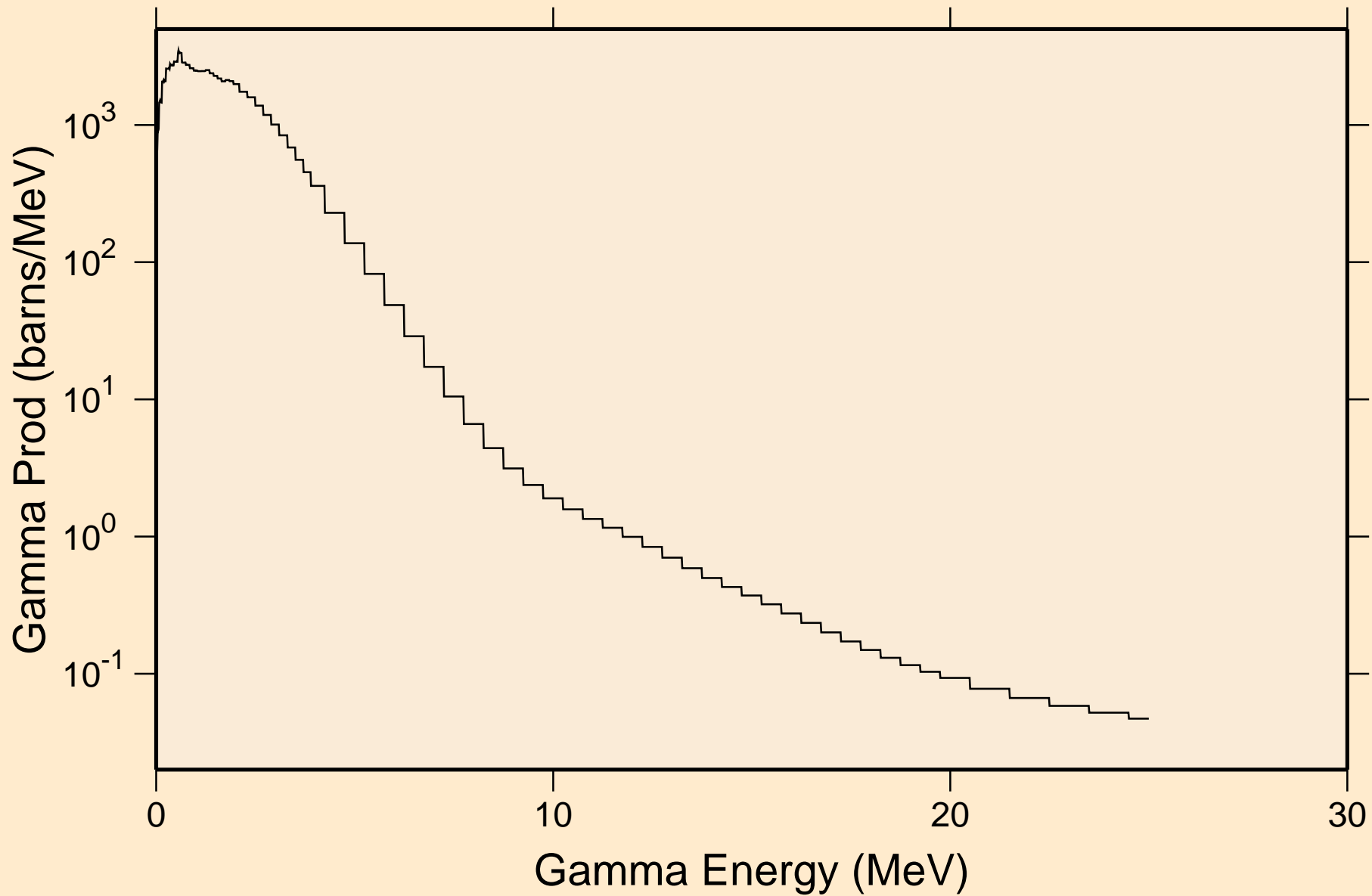

# TM156 NEUTRON ACER TENDL-2024 LIBRARY; T=0.K

## Particle heating contributions

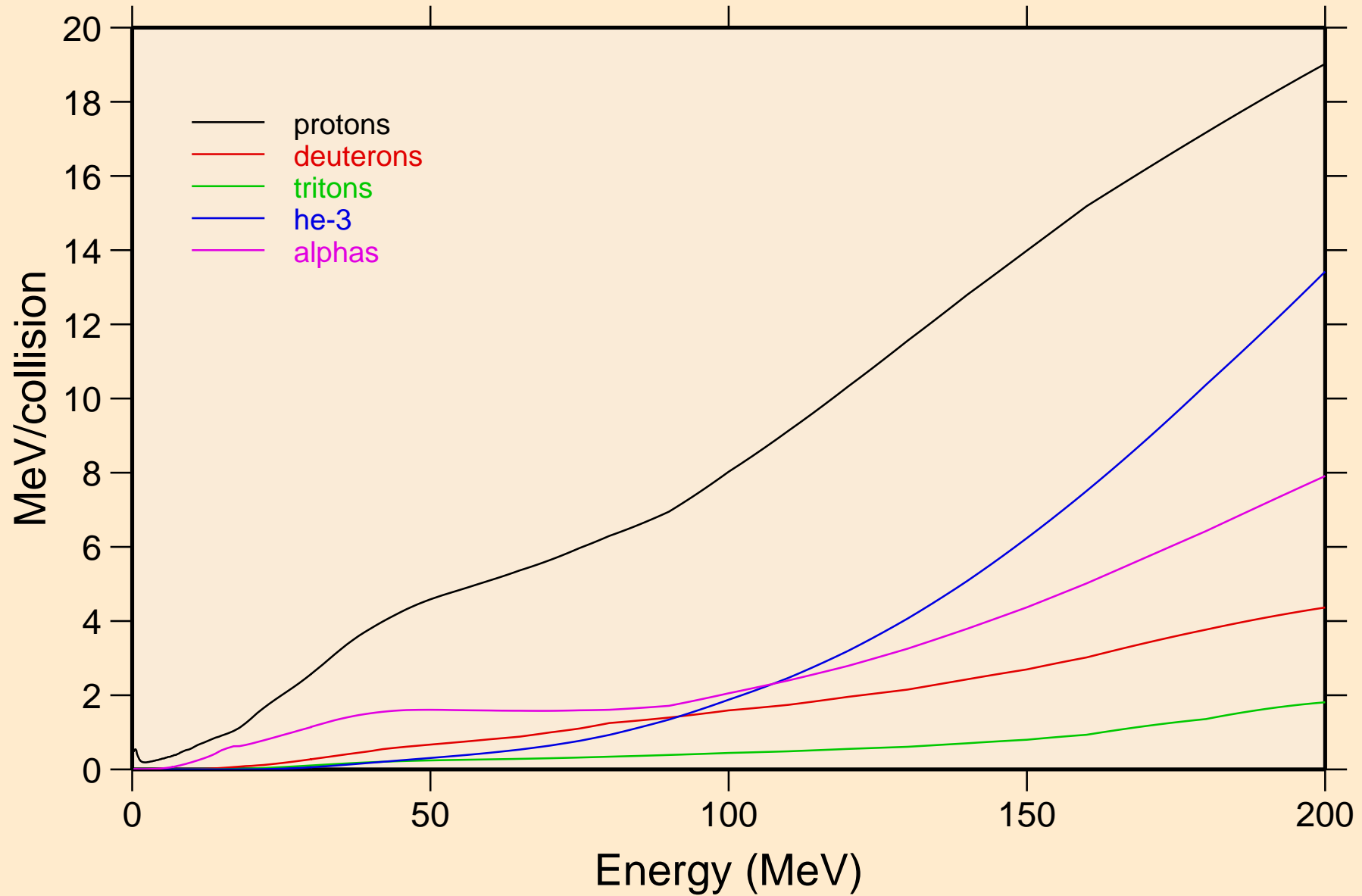

TM156 NEUTRON ACER TENDL-2024 LIBRARY; T=0.K  
Recoil Heating

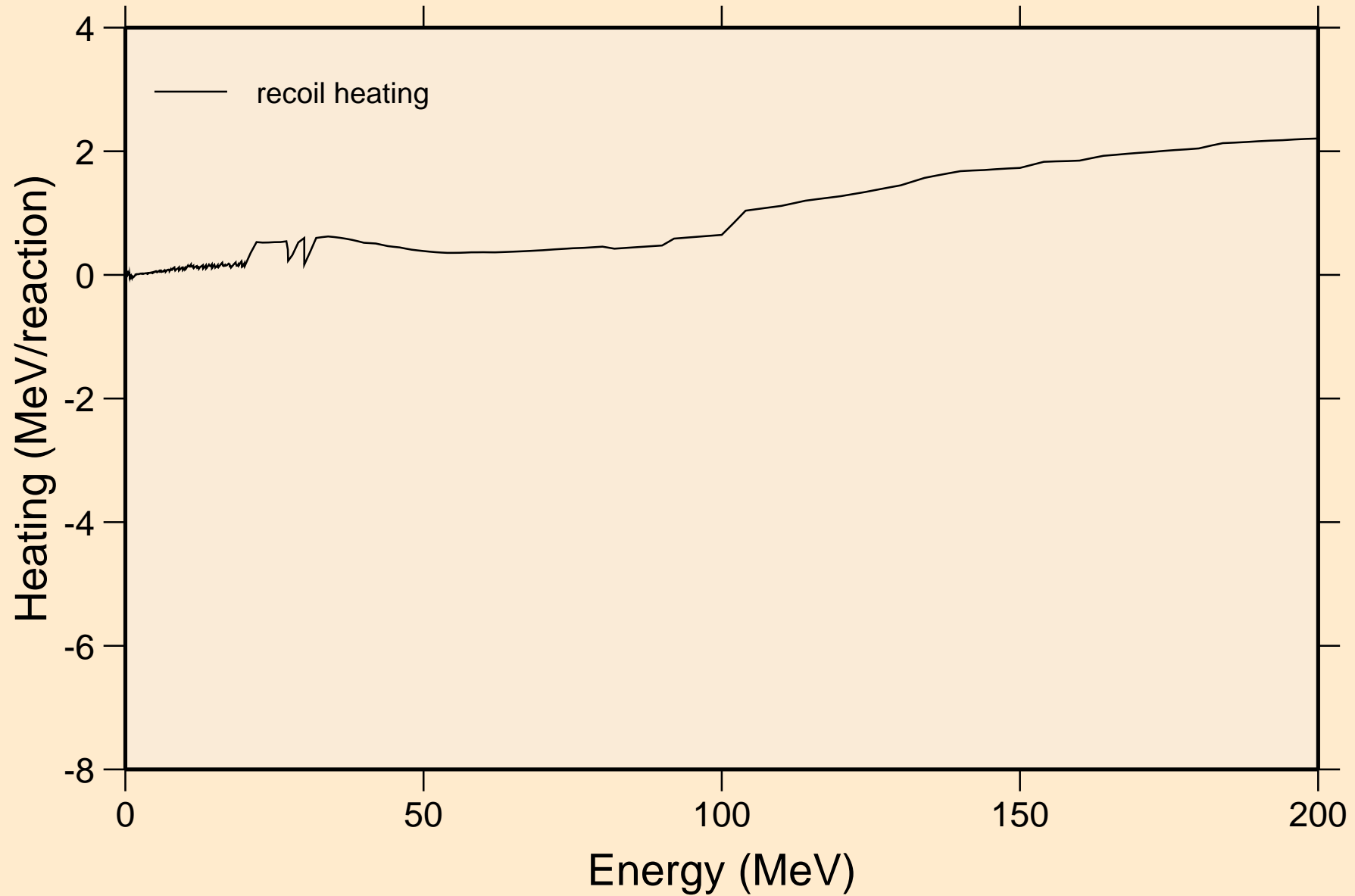

# TM156 NEUTRON ACER TENDL-2024 LIBRARY; T=0.K

## Particle production cross sections

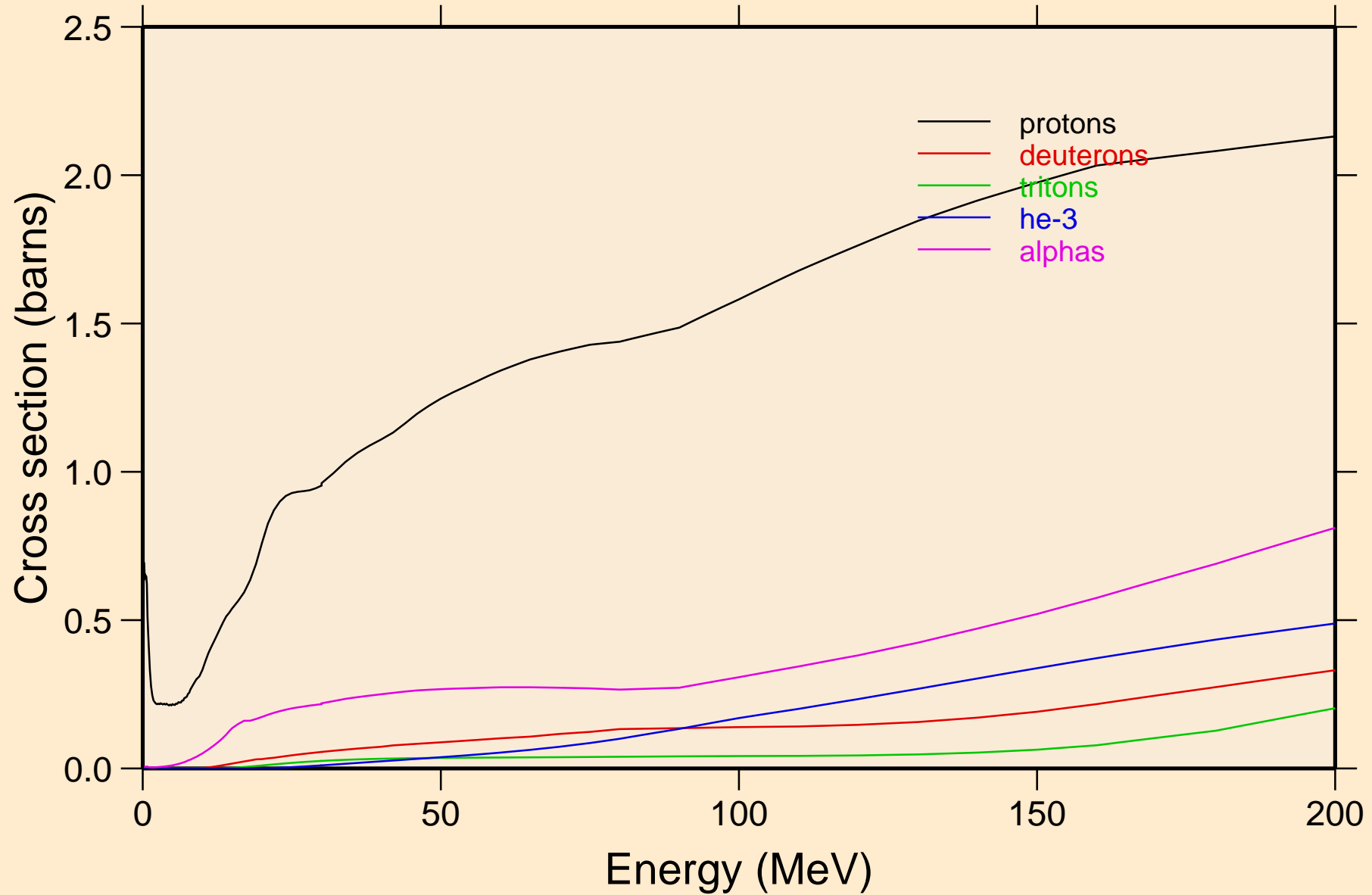

TM156 NEUTRON ACER TENDL-2024 LIBRARY; T=0.K  
protons from (n,x)

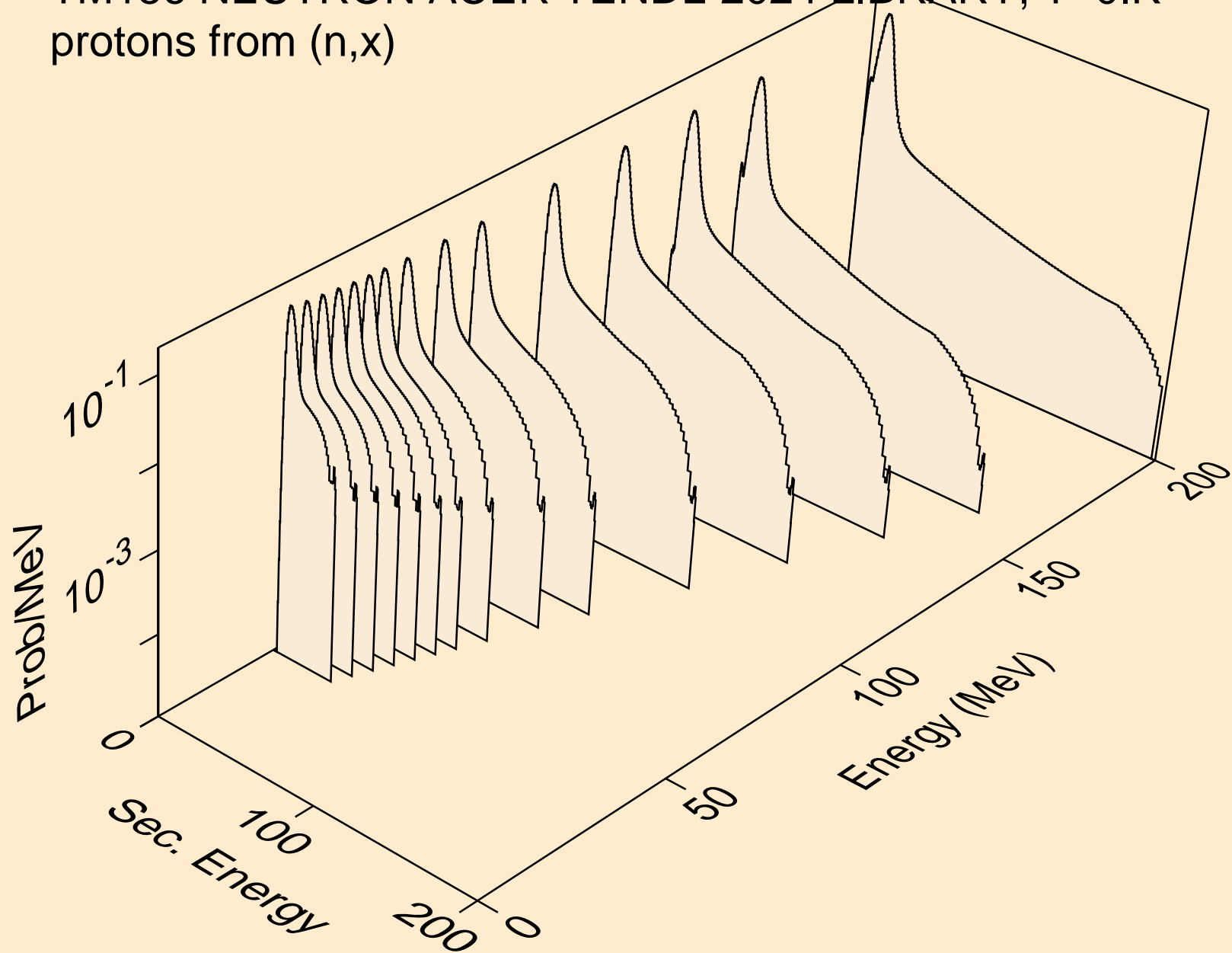

TM156 NEUTRON ACER TENDL-2024 LIBRARY; T=0.K  
protons from (n,n\*)p

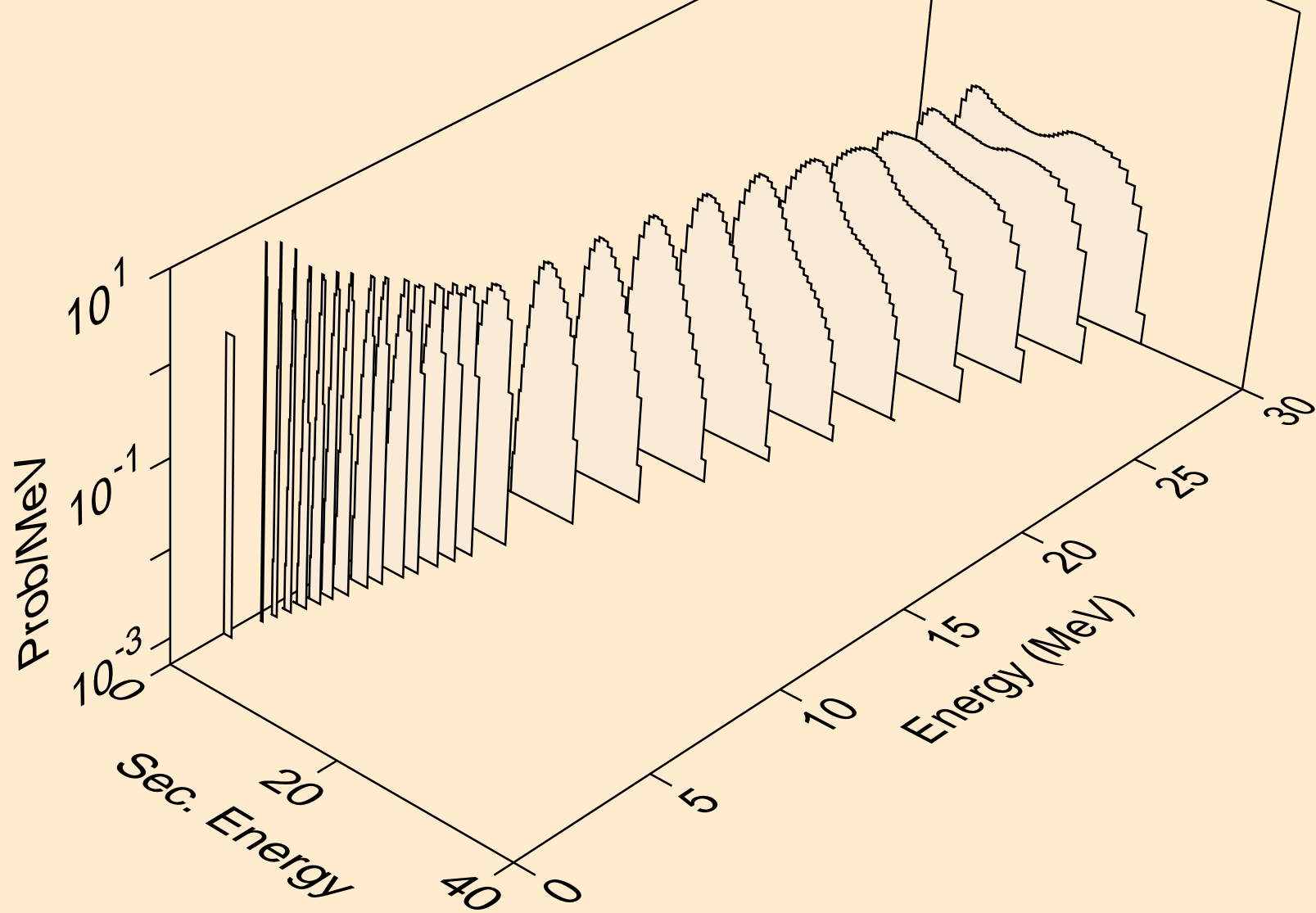

TM156 NEUTRON ACER TENDL-2024 LIBRARY; T=0.K  
protons from (n,2np)

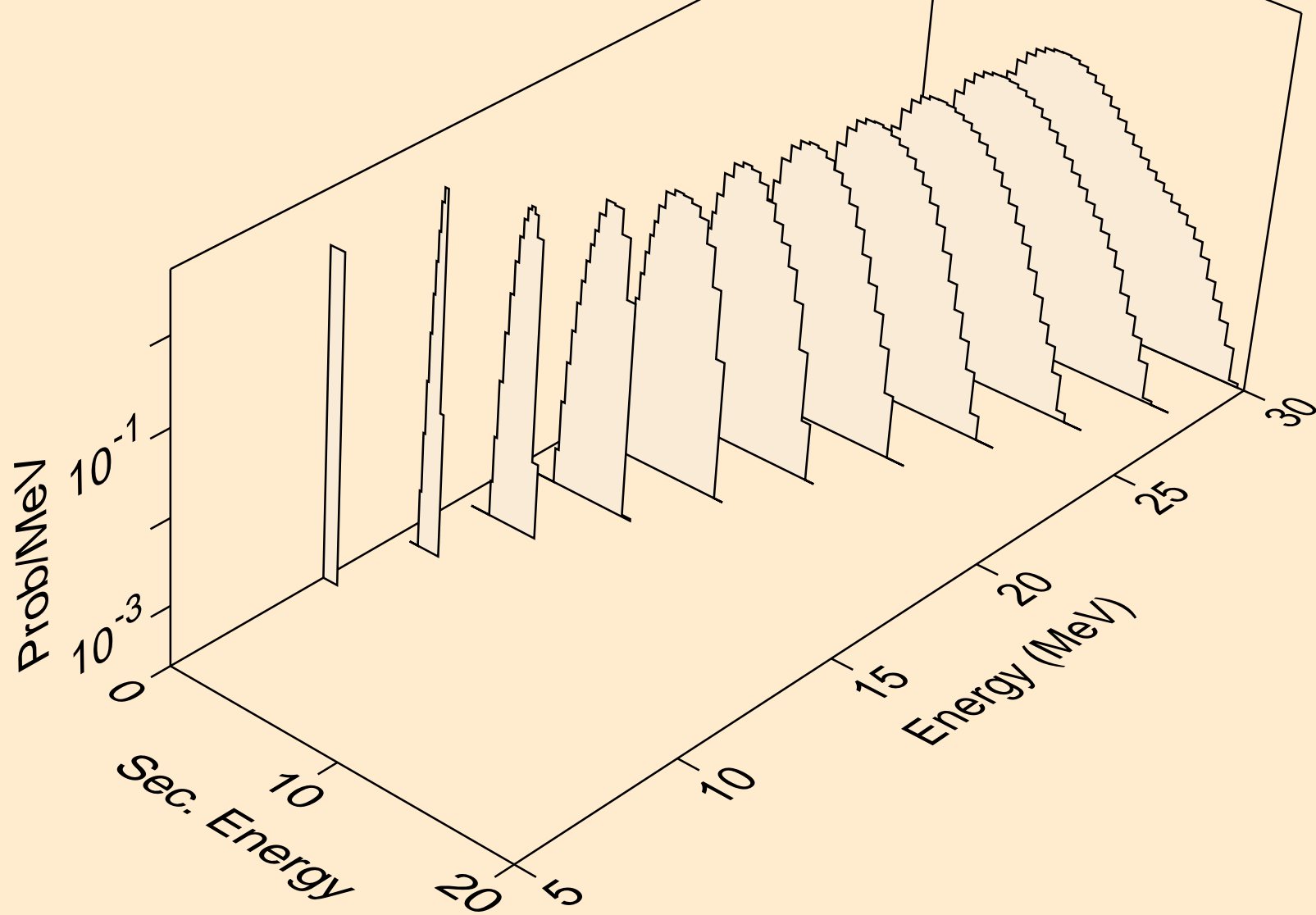

TM156 NEUTRON ACER TENDL-2024 LIBRARY; T=0.K  
protons from (n,3np)

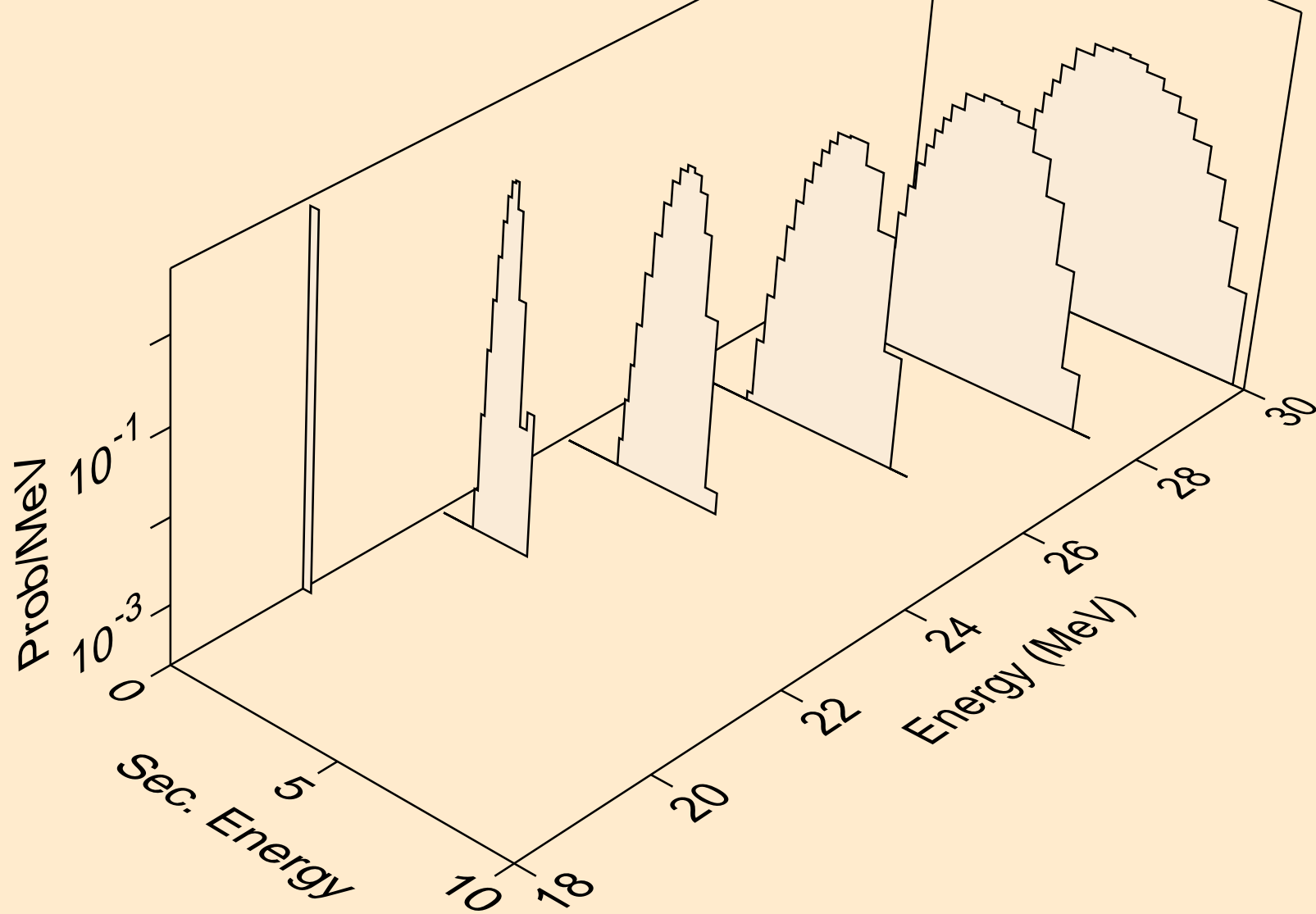

TM156 NEUTRON ACER TENDL-2024 LIBRARY; T=0.K  
protons from (n,n2p)

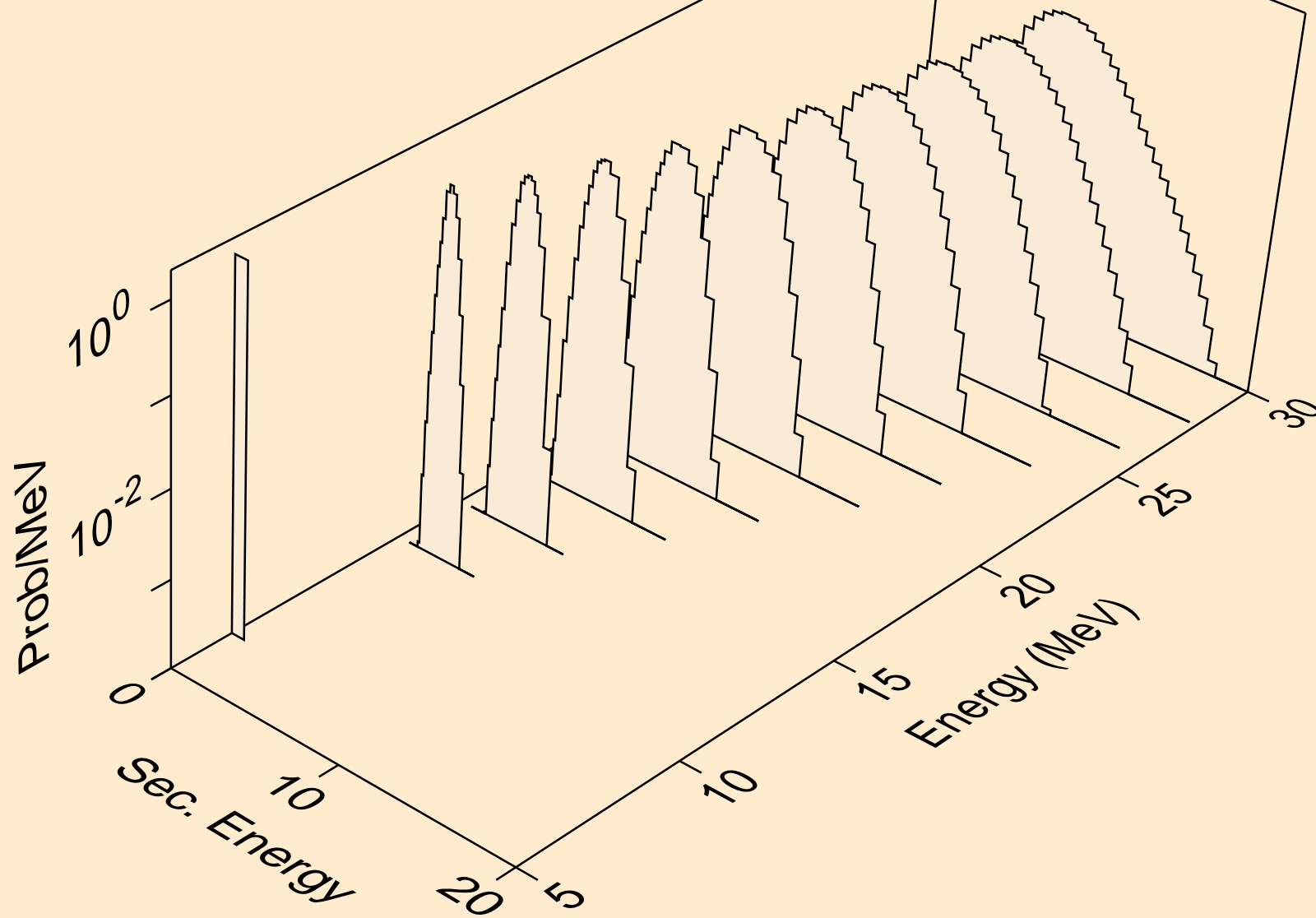

TM156 NEUTRON ACER TENDL-2024 LIBRARY; T=0.K  
protons from (n,npa)

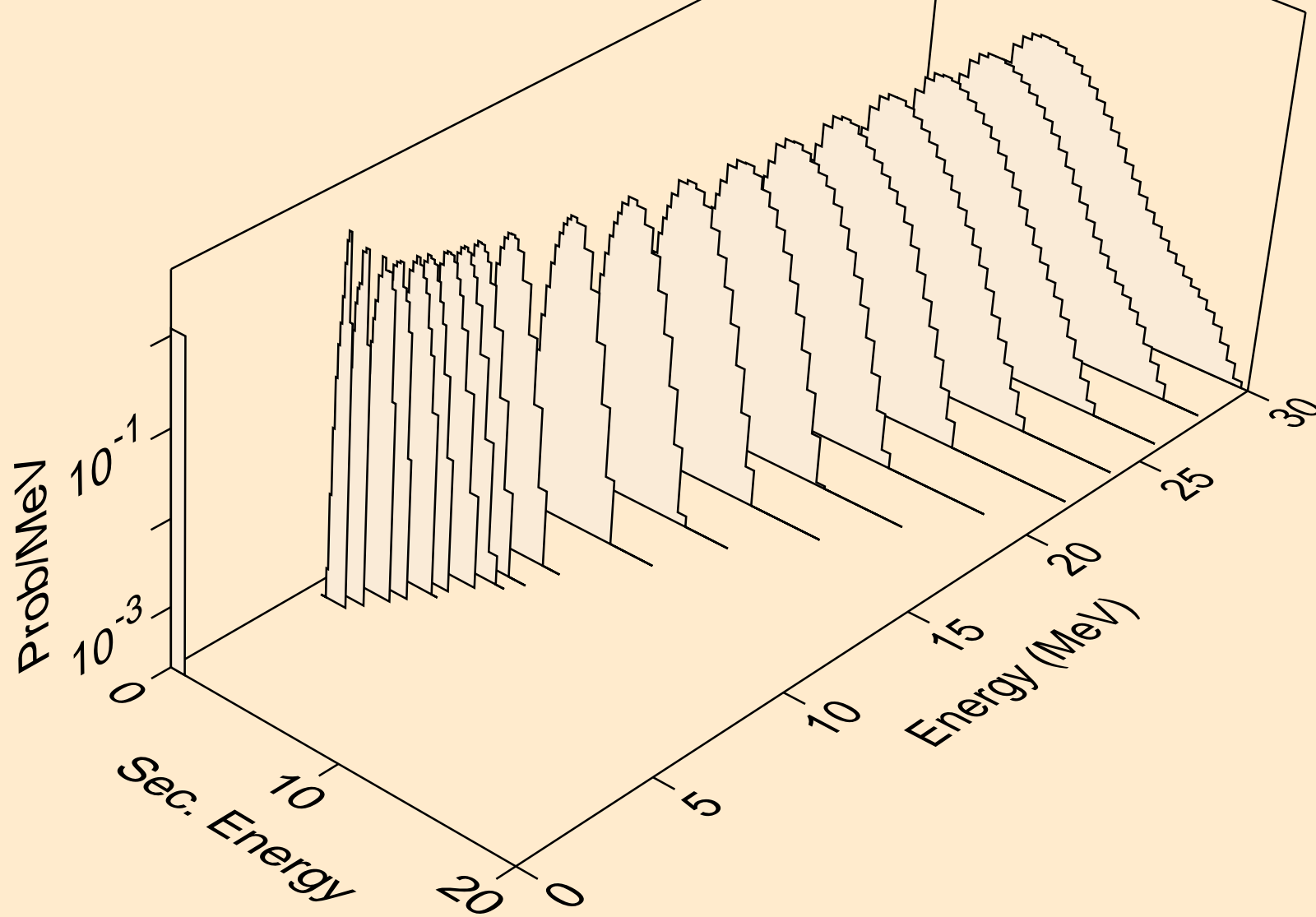

TM156 NEUTRON ACER TENDL-2024 LIBRARY; T=0.K  
protons from (n,p)

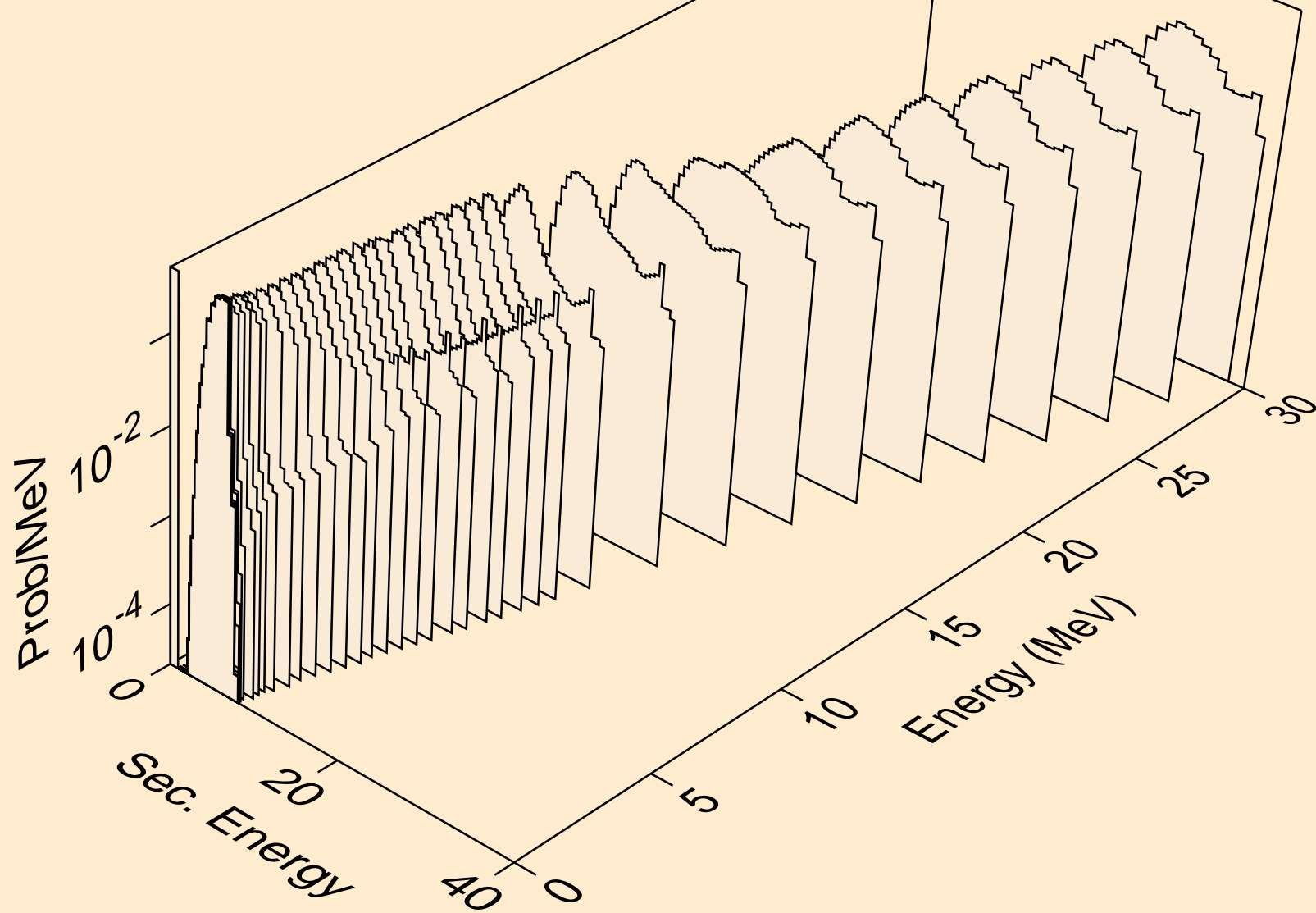

TM156 NEUTRON ACER TENDL-2024 LIBRARY; T=0.K  
protons from (n,2p)

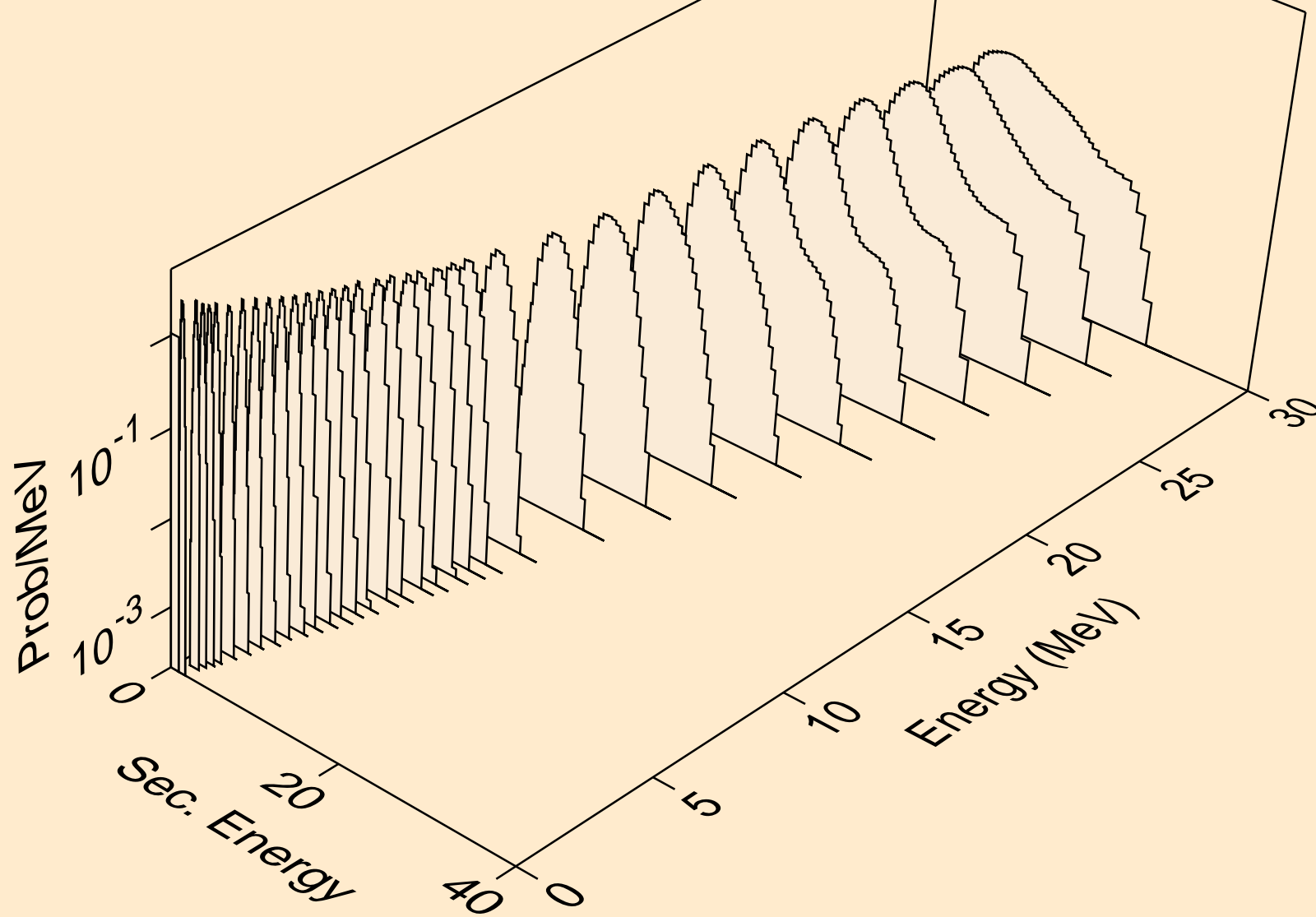

TM156 NEUTRON ACER TENDL-2024 LIBRARY; T=0.K  
protons from (n,p)

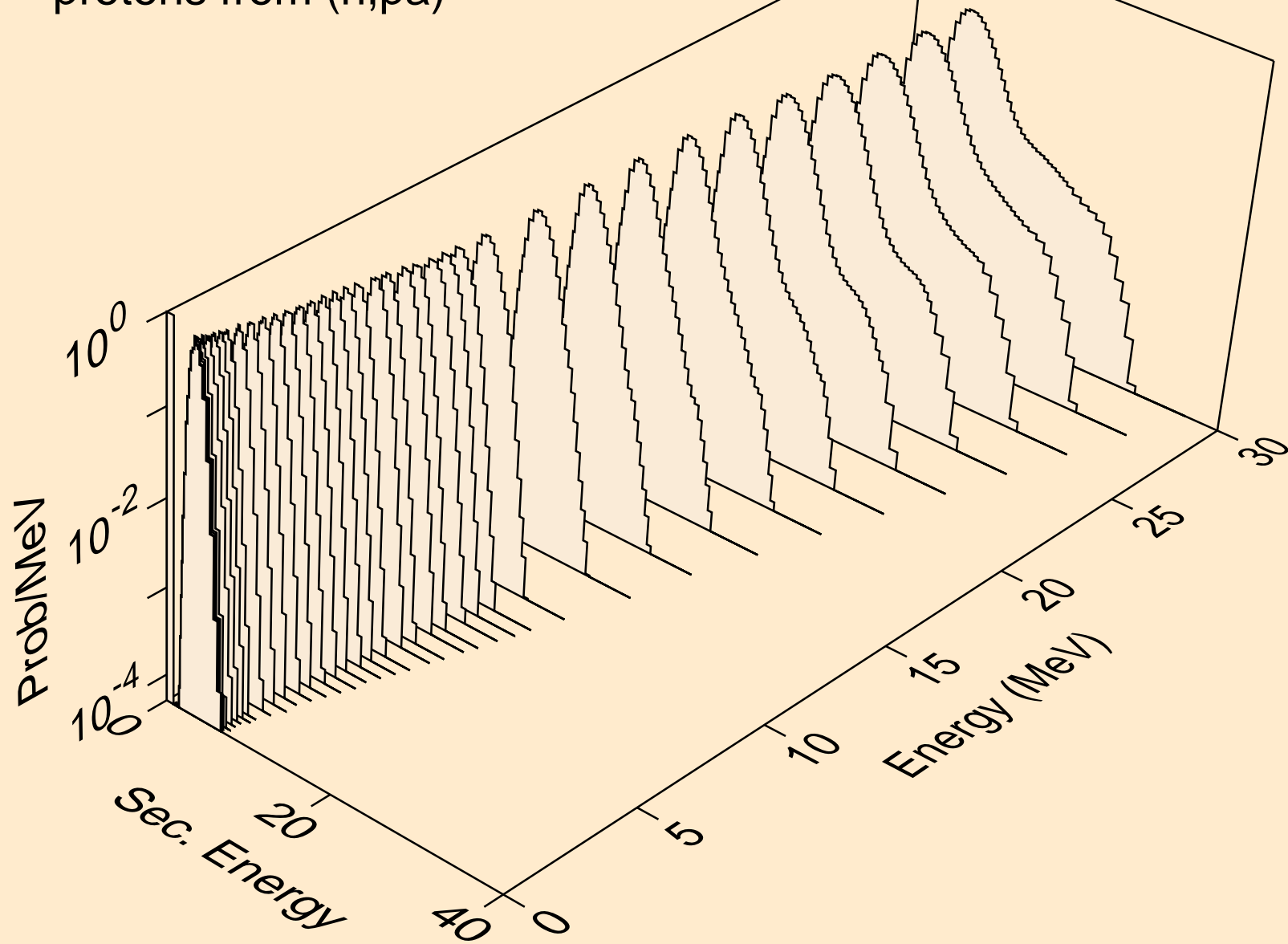

TM156 NEUTRON ACER TENDL-2024 LIBRARY; T=0.K  
protons from (n,pd)

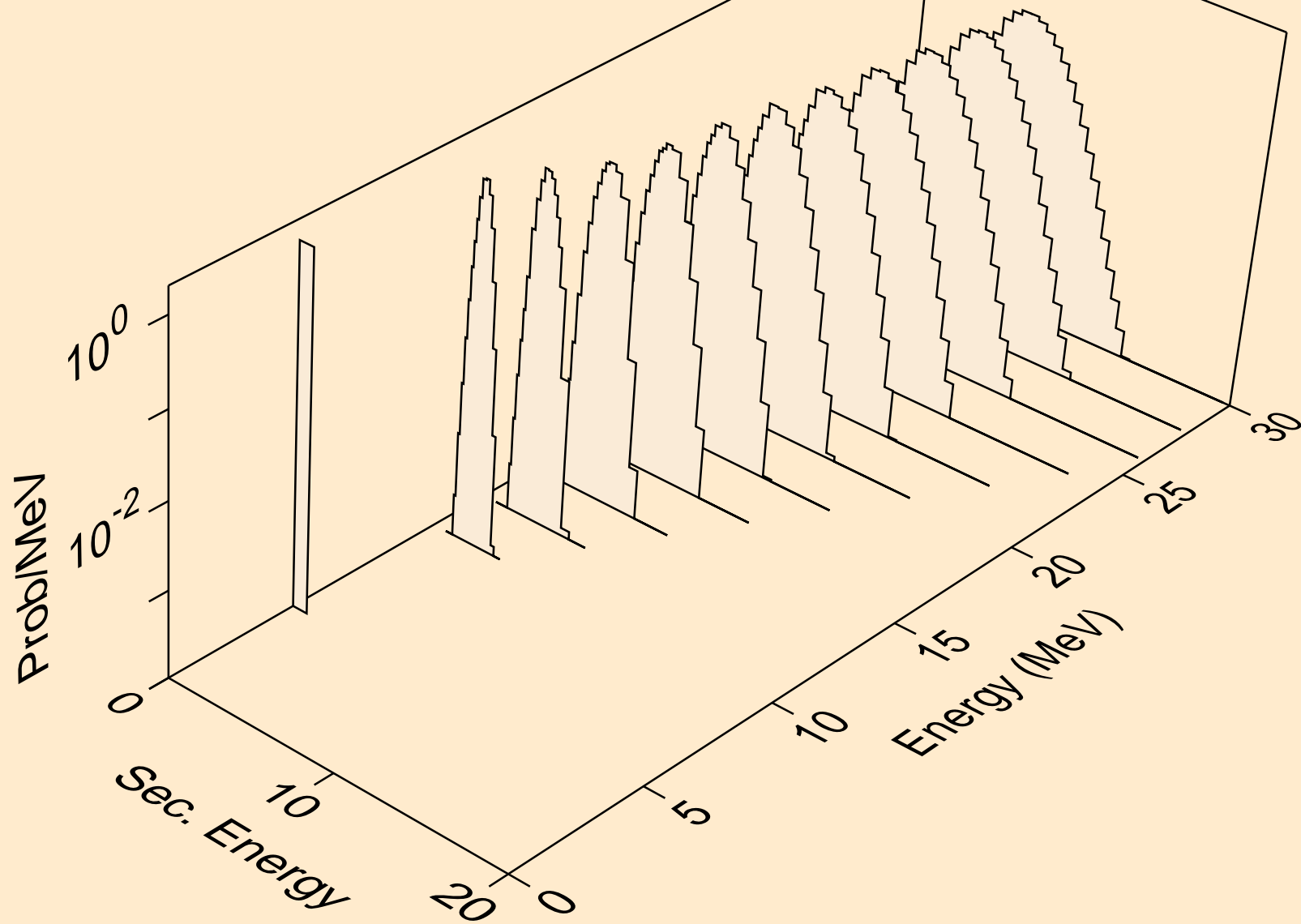

TM156 NEUTRON ACER TENDL-2024 LIBRARY; T=0.K  
protons from (n,pt)

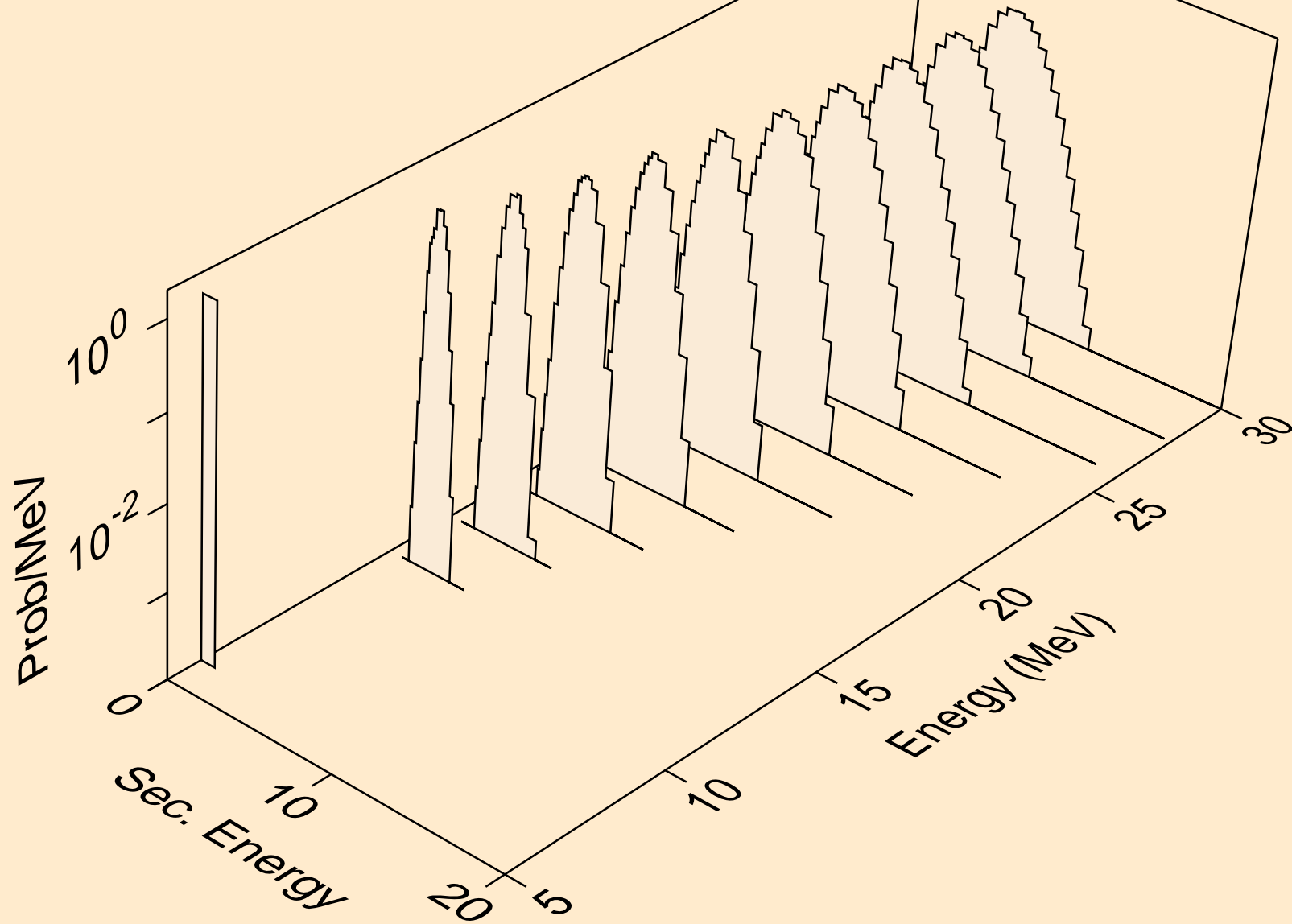

TM156 NEUTRON ACER TENDL-2024 LIBRARY; T=0.K  
deuterons from (n,x)

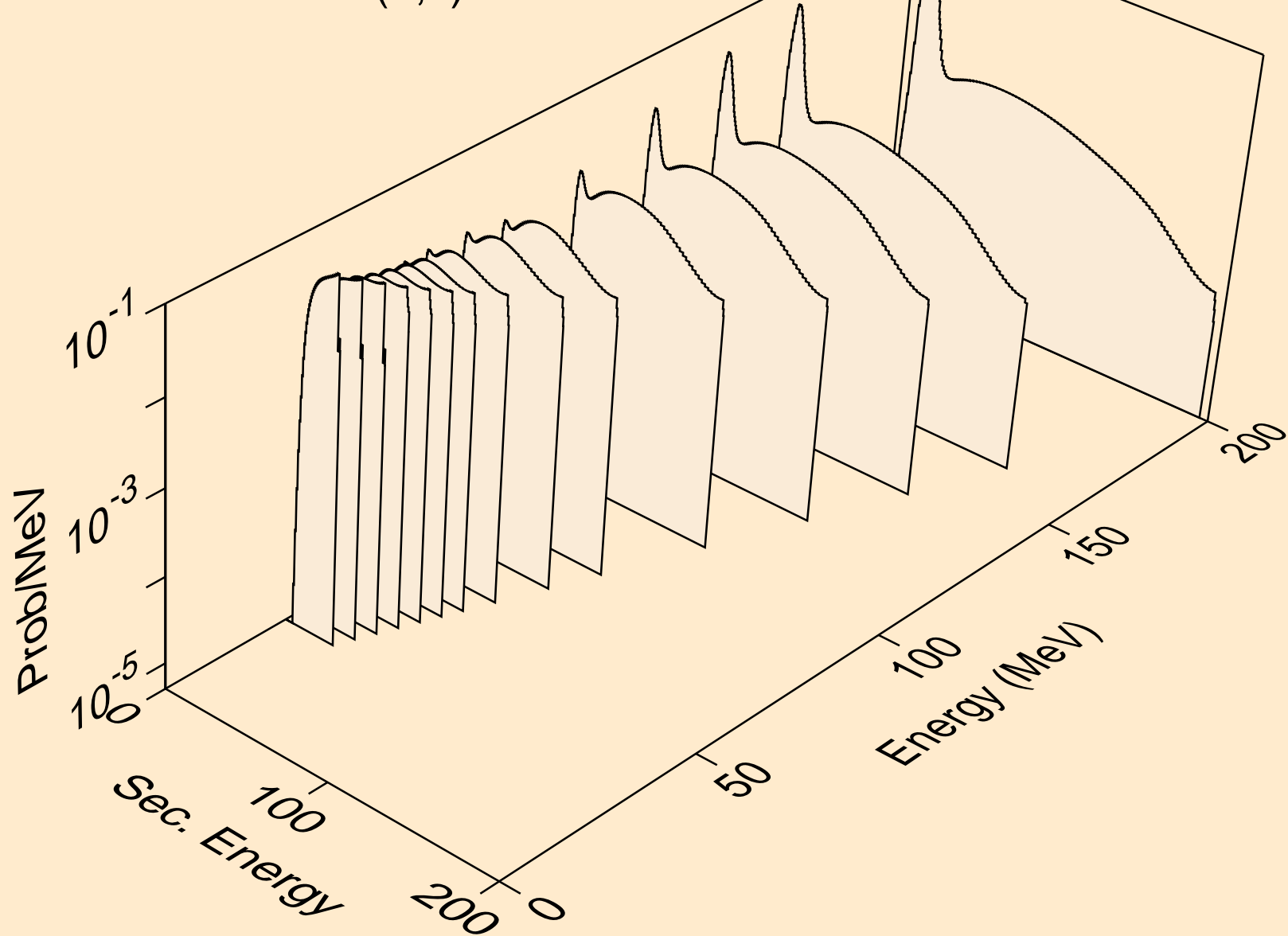

TM156 NEUTRON ACER TENDL-2024 LIBRARY; T=0.K  
deuterons from (n,2nd)

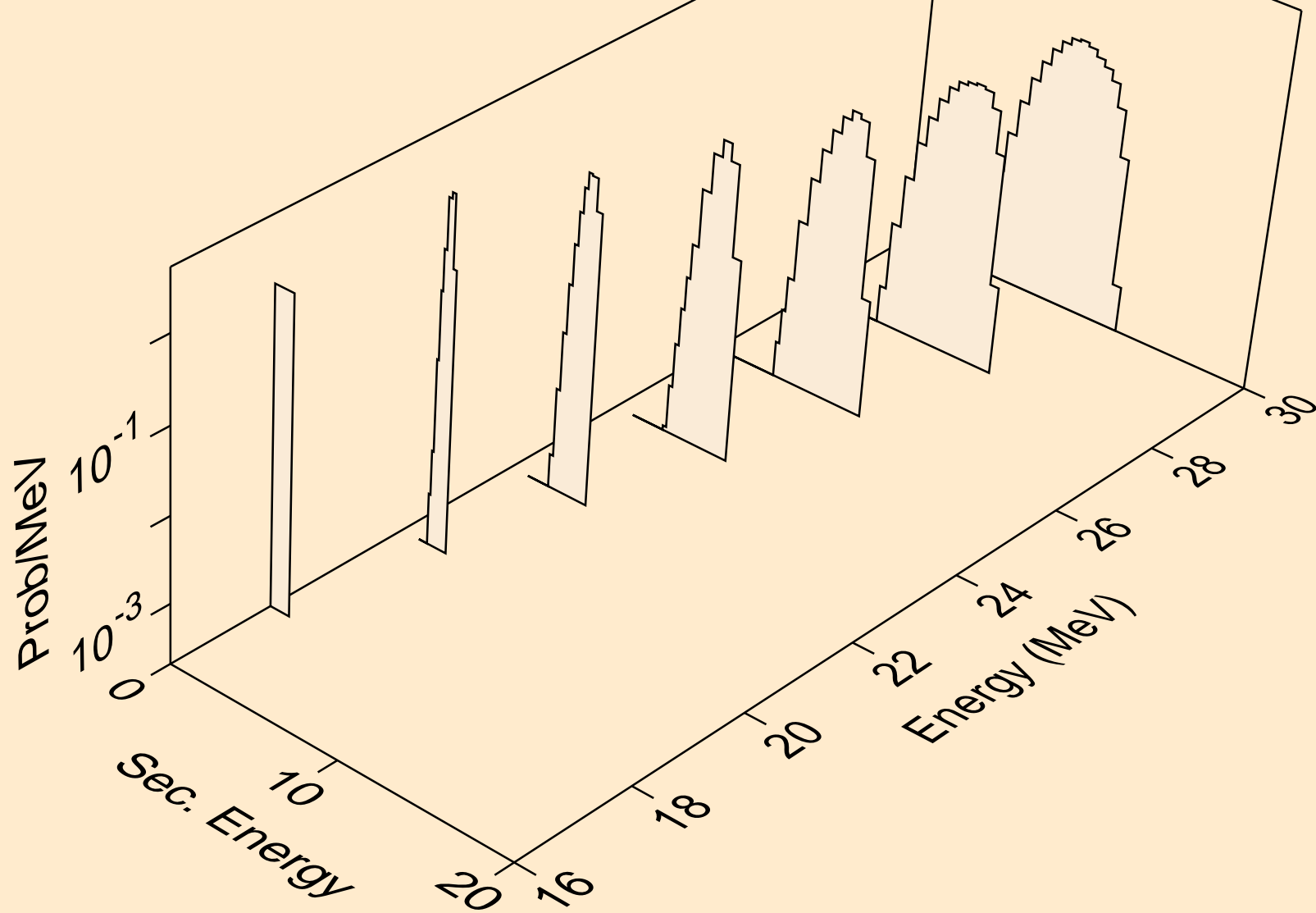

TM156 NEUTRON ACER TENDL-2024 LIBRARY; T=0.K  
deuterons from (n,n\*)d

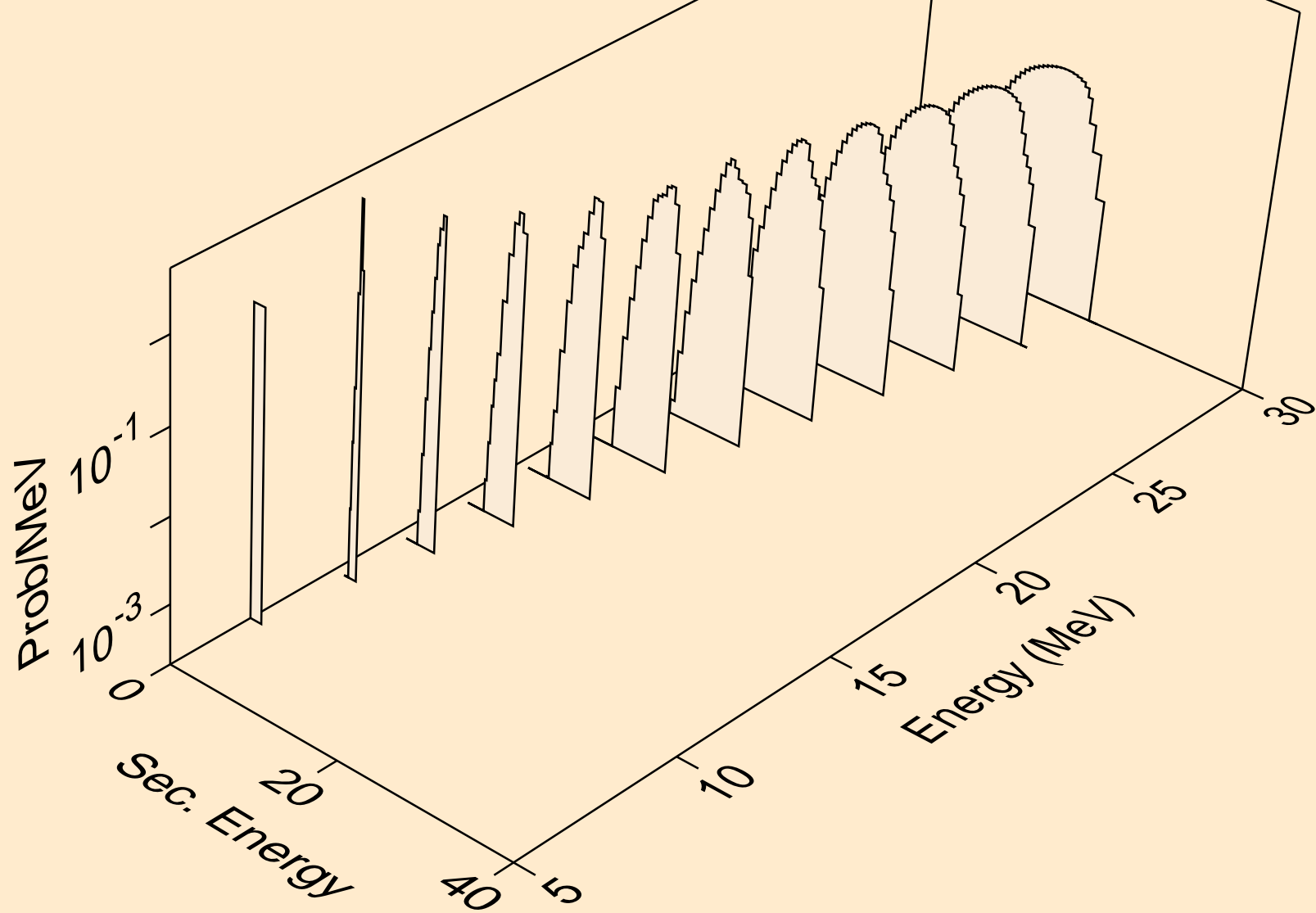

TM156 NEUTRON ACER TENDL-2024 LIBRARY; T=0.K  
deuterons from (n,d)

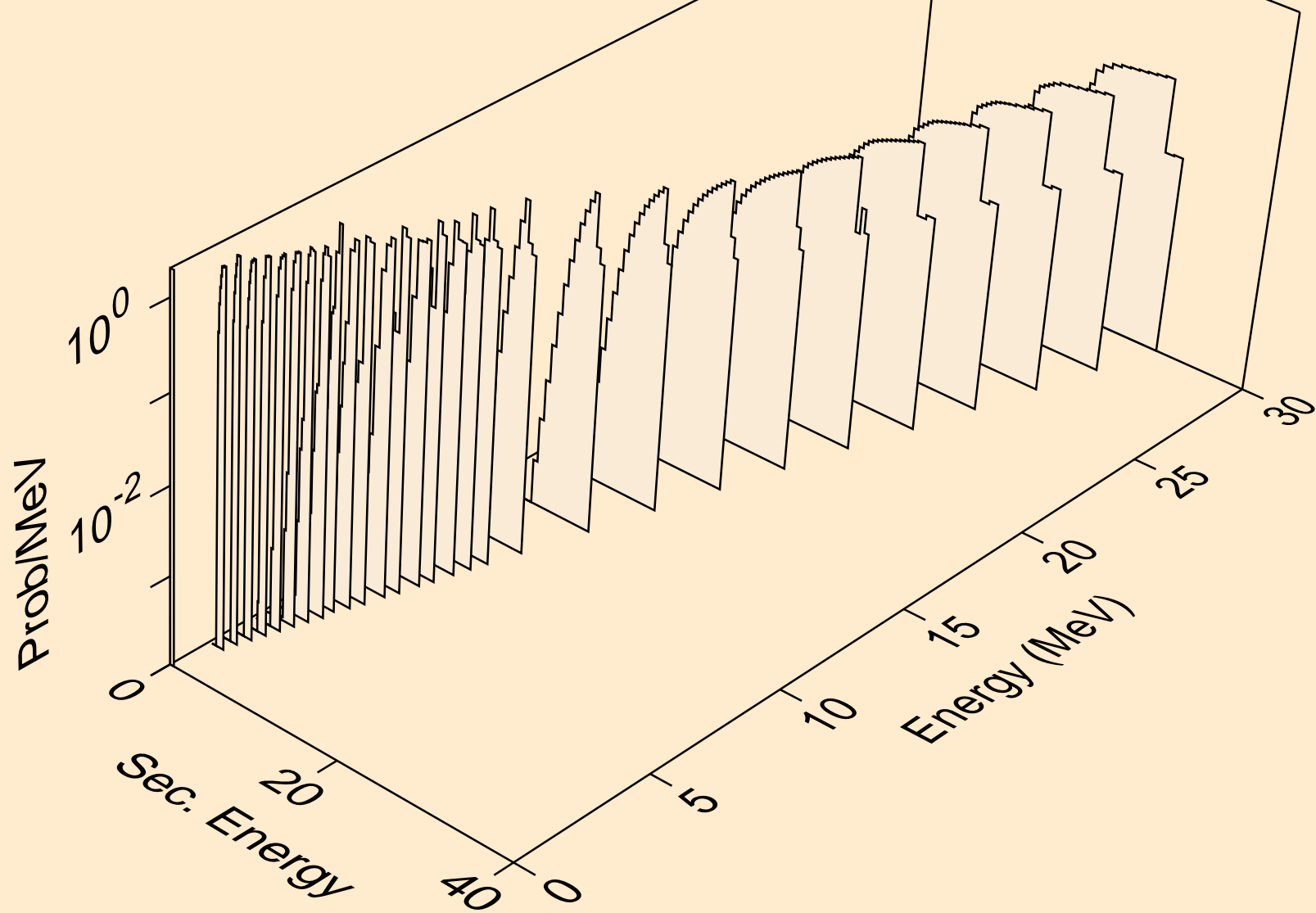

TM156 NEUTRON ACER TENDL-2024 LIBRARY; T=0.K  
deuterons from (n,d2a)

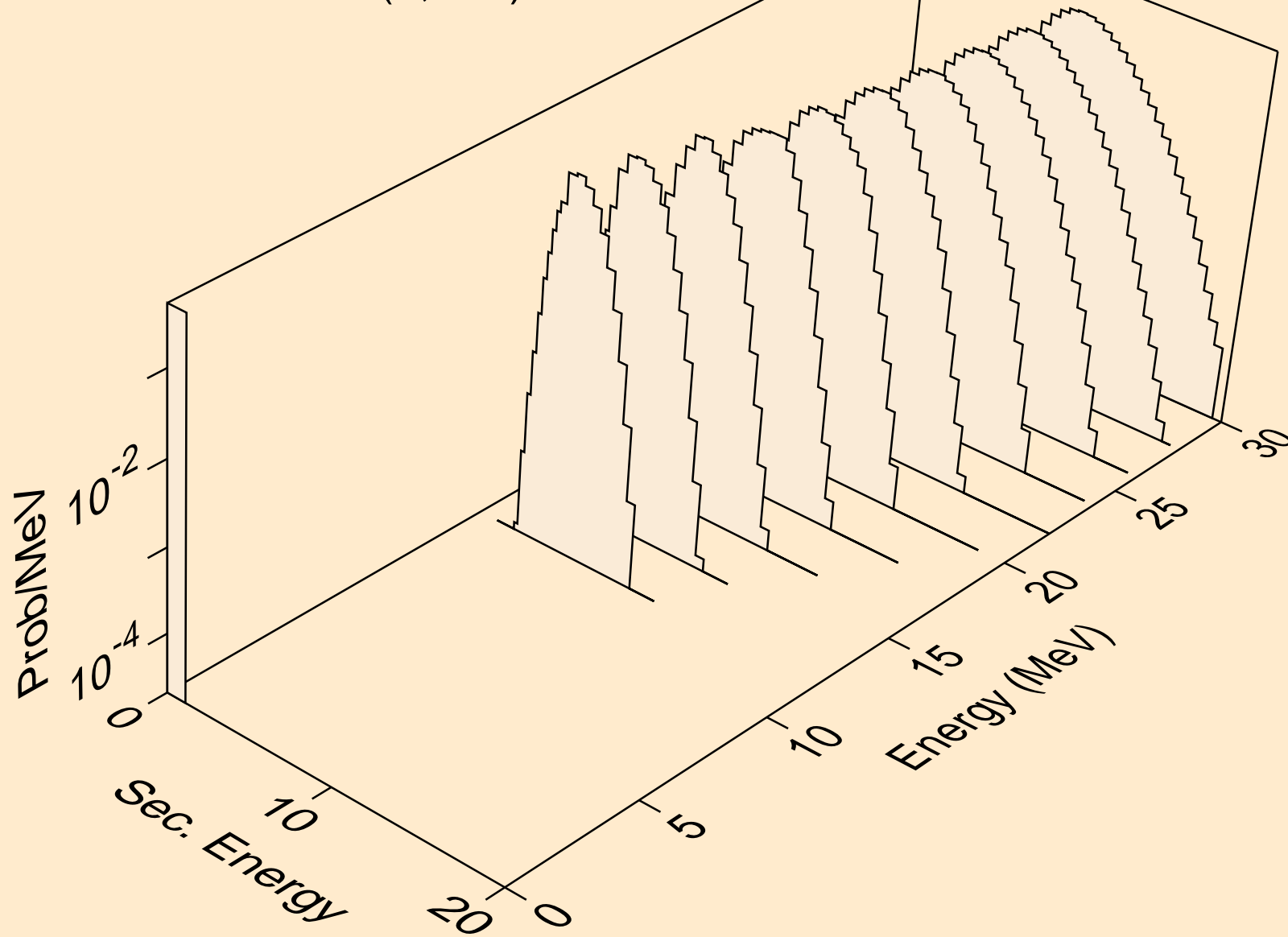

TM156 NEUTRON ACER TENDL-2024 LIBRARY; T=0.K  
deuterons from (n,pd)

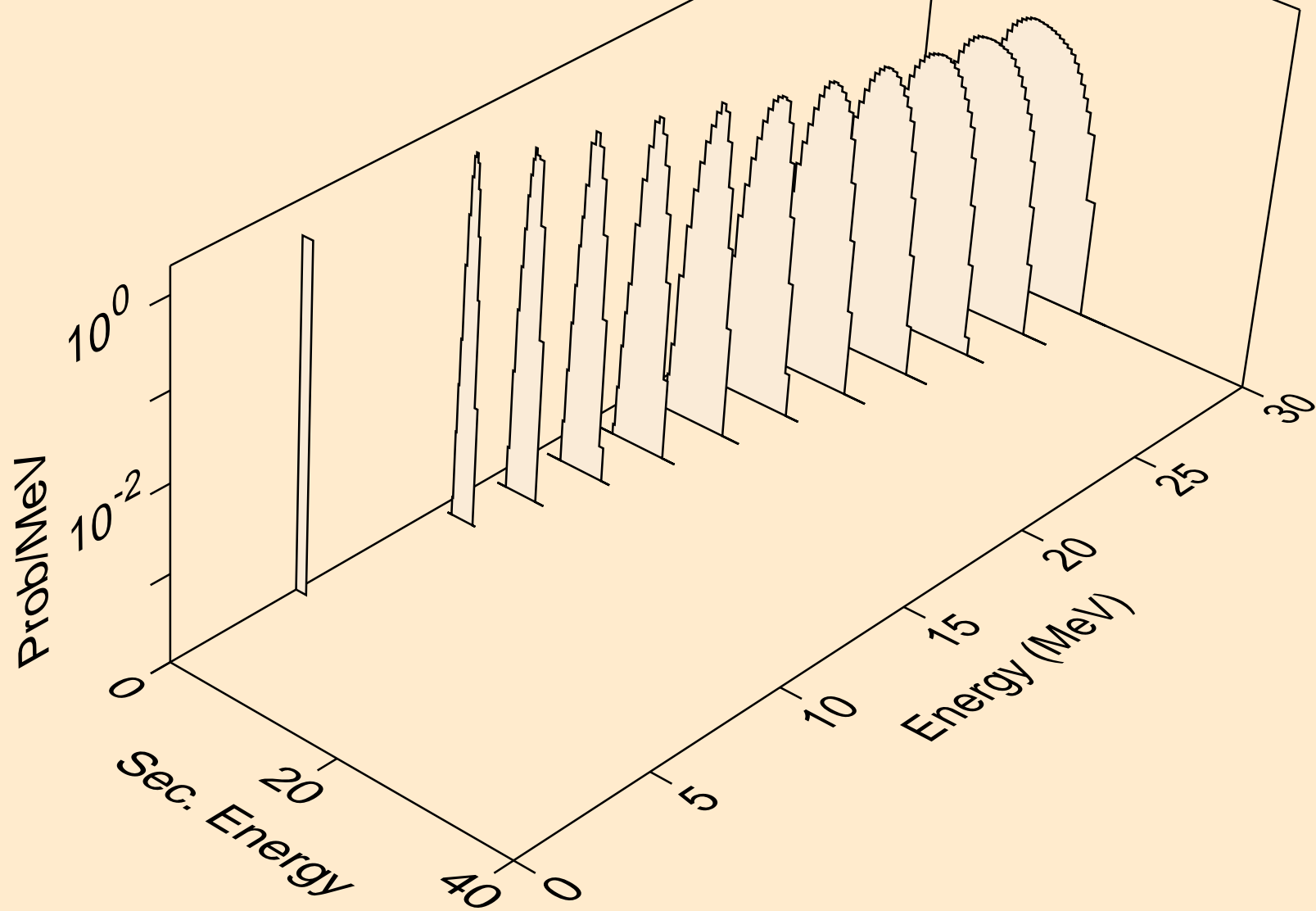

TM156 NEUTRON ACER TENDL-2024 LIBRARY; T=0.K  
deuterons from (n,da)

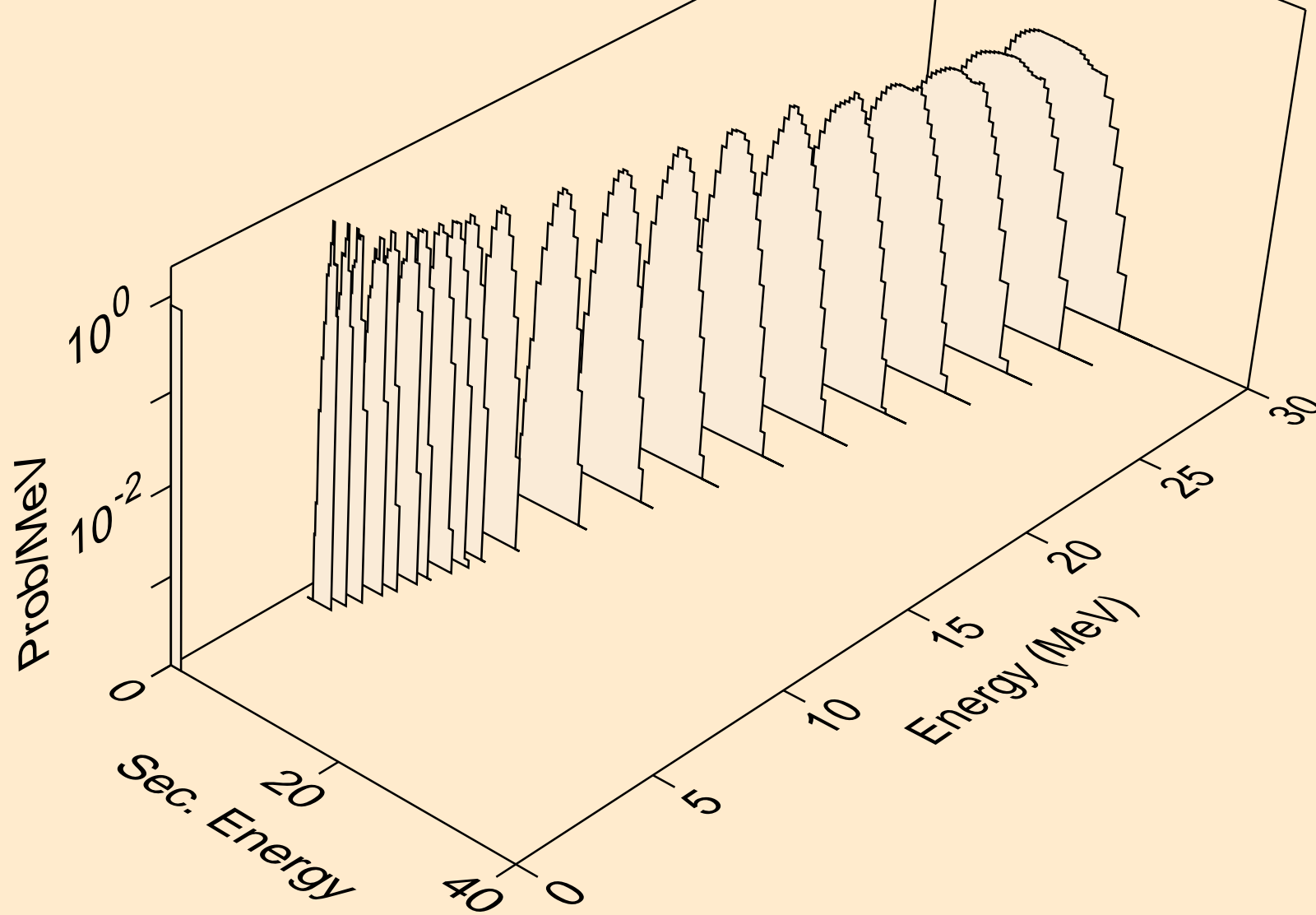

TM156 NEUTRON ACER TENDL-2024 LIBRARY; T=0.K  
tritons from (n,x)

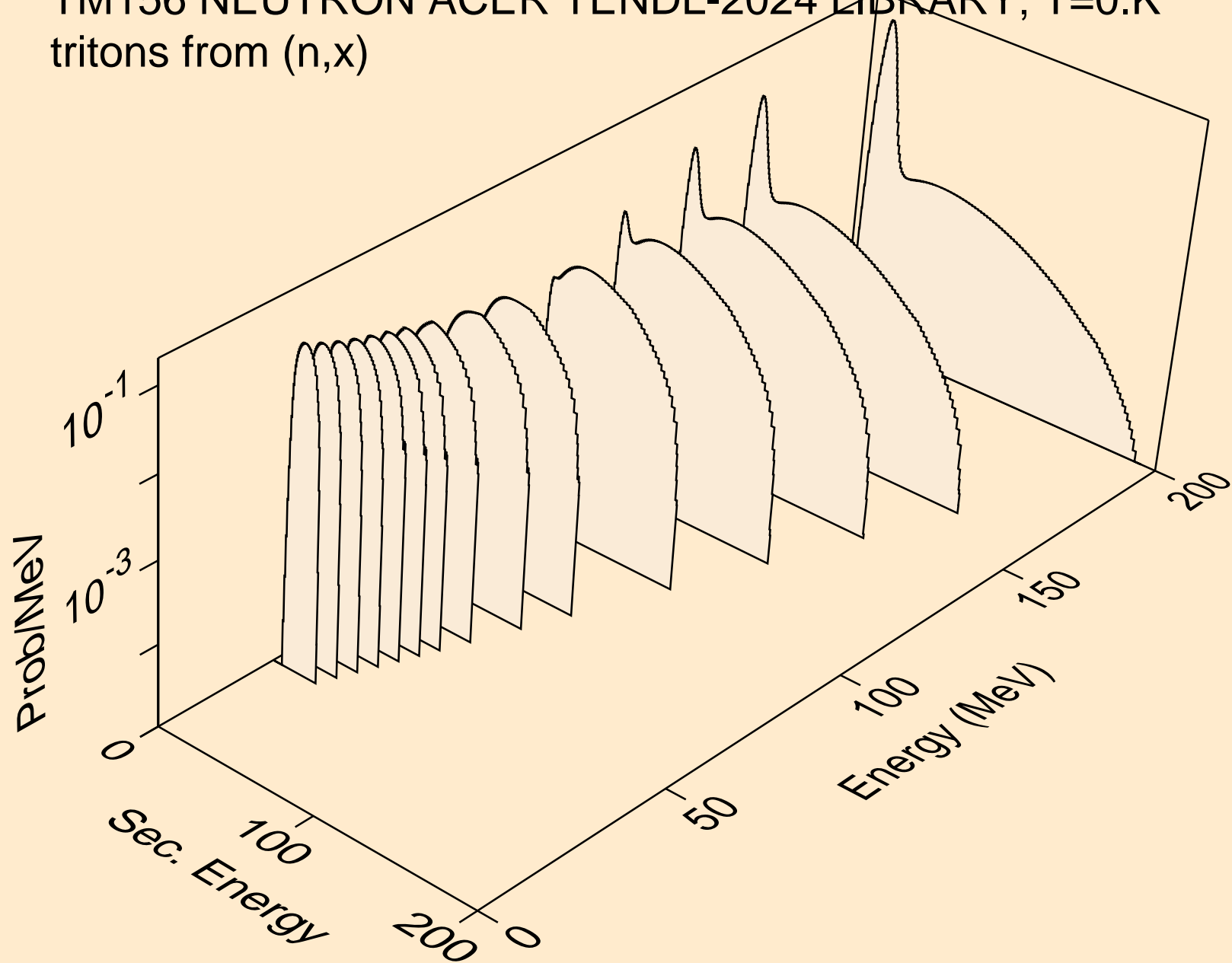

TM156 NEUTRON ACER TENDL-2024 LIBRARY; T=0.K  
tritons from (n,n\*)t

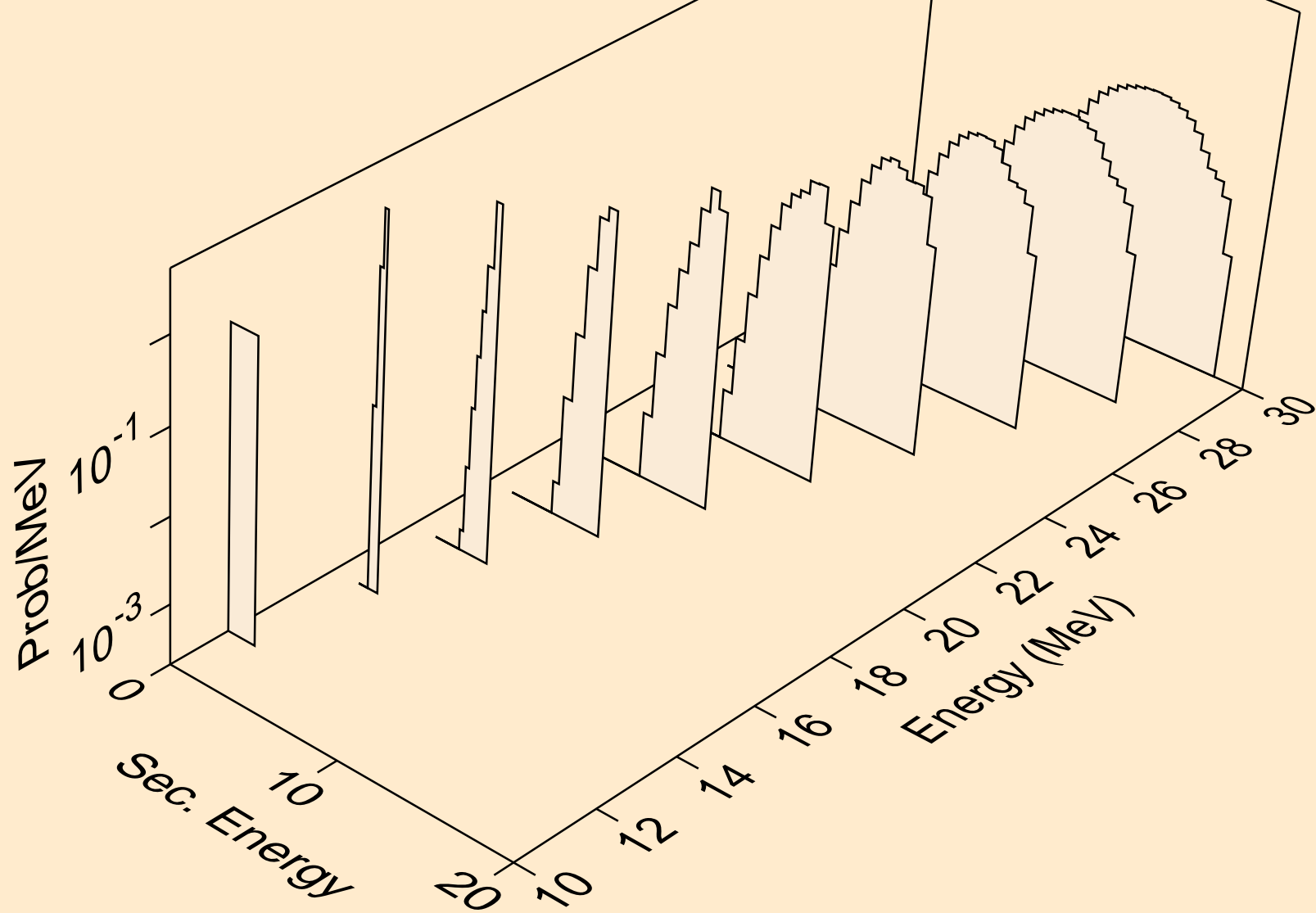

TM156 NEUTRON ACER TENDL-2024 LIBRARY; T=0.K  
tritons from (n,t)

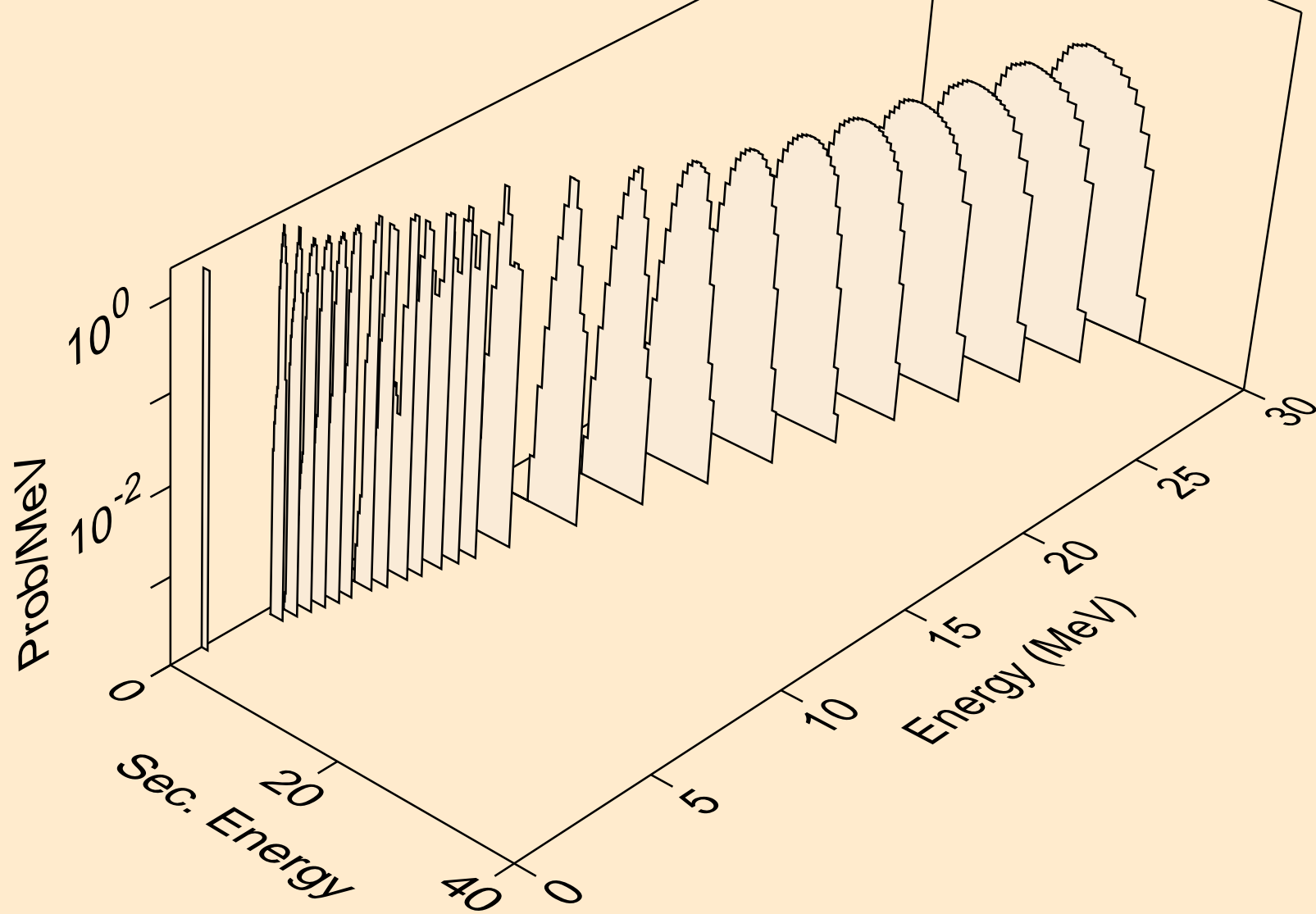

TM156 NEUTRON ACER TENDL-2024 LIBRARY; T=0.K  
tritons from (n,t2a)

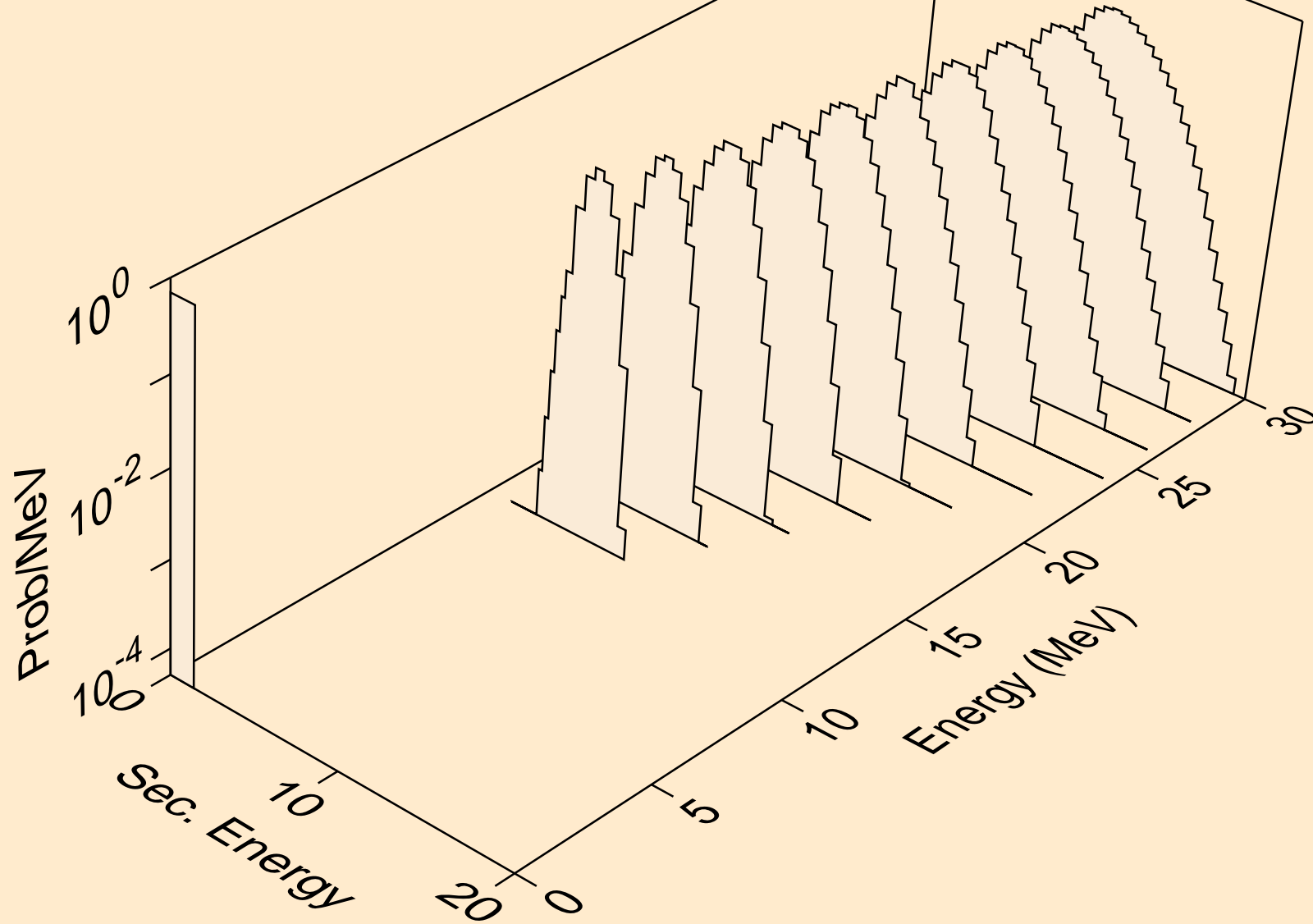

TM156 NEUTRON ACER TENDL-2024 LIBRARY; T=0.K  
tritons from (n,pt)

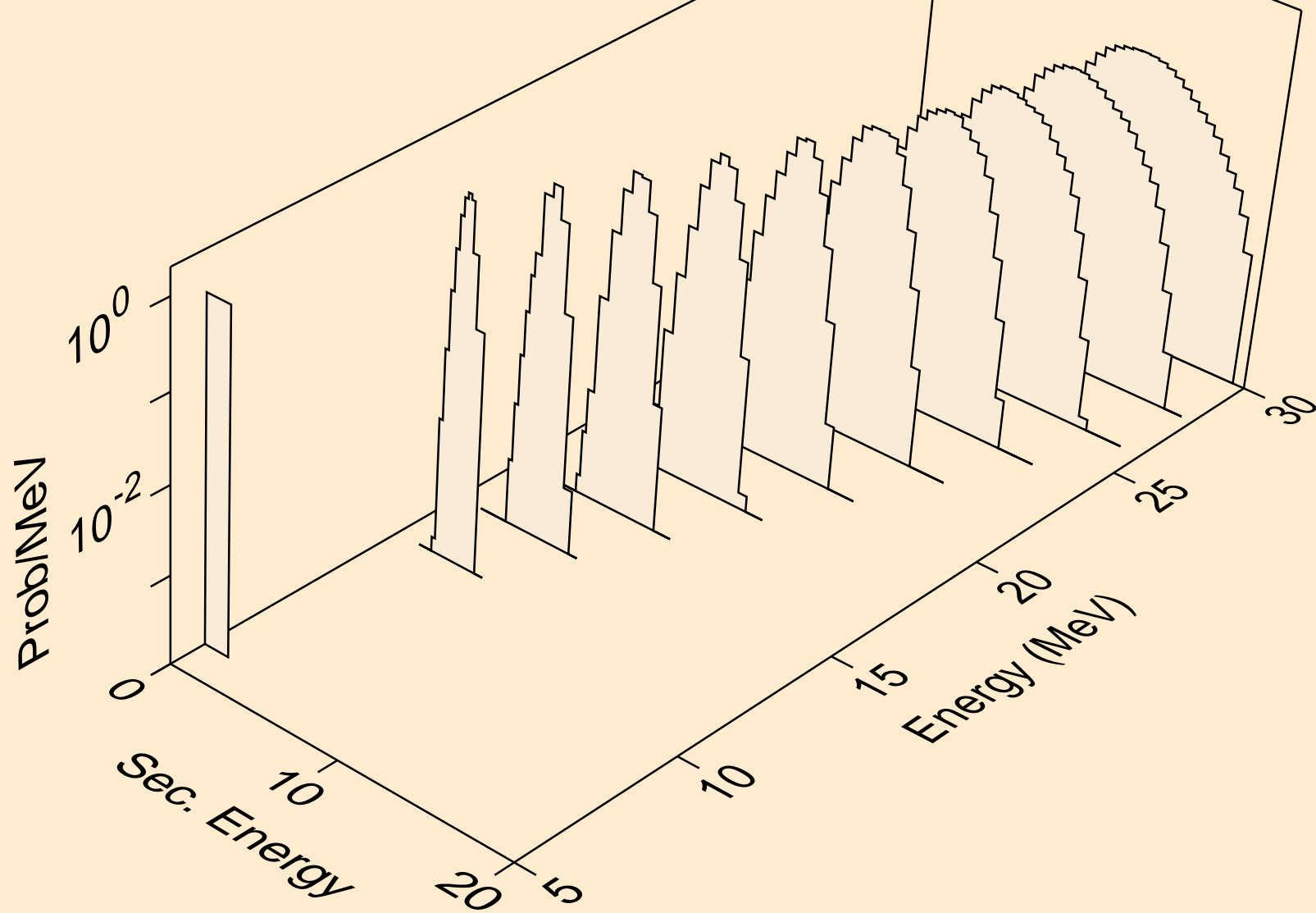

TM156 NEUTRON ACER TENDL-2024 LIBRARY; T=0.K  
he3s from (n,x)

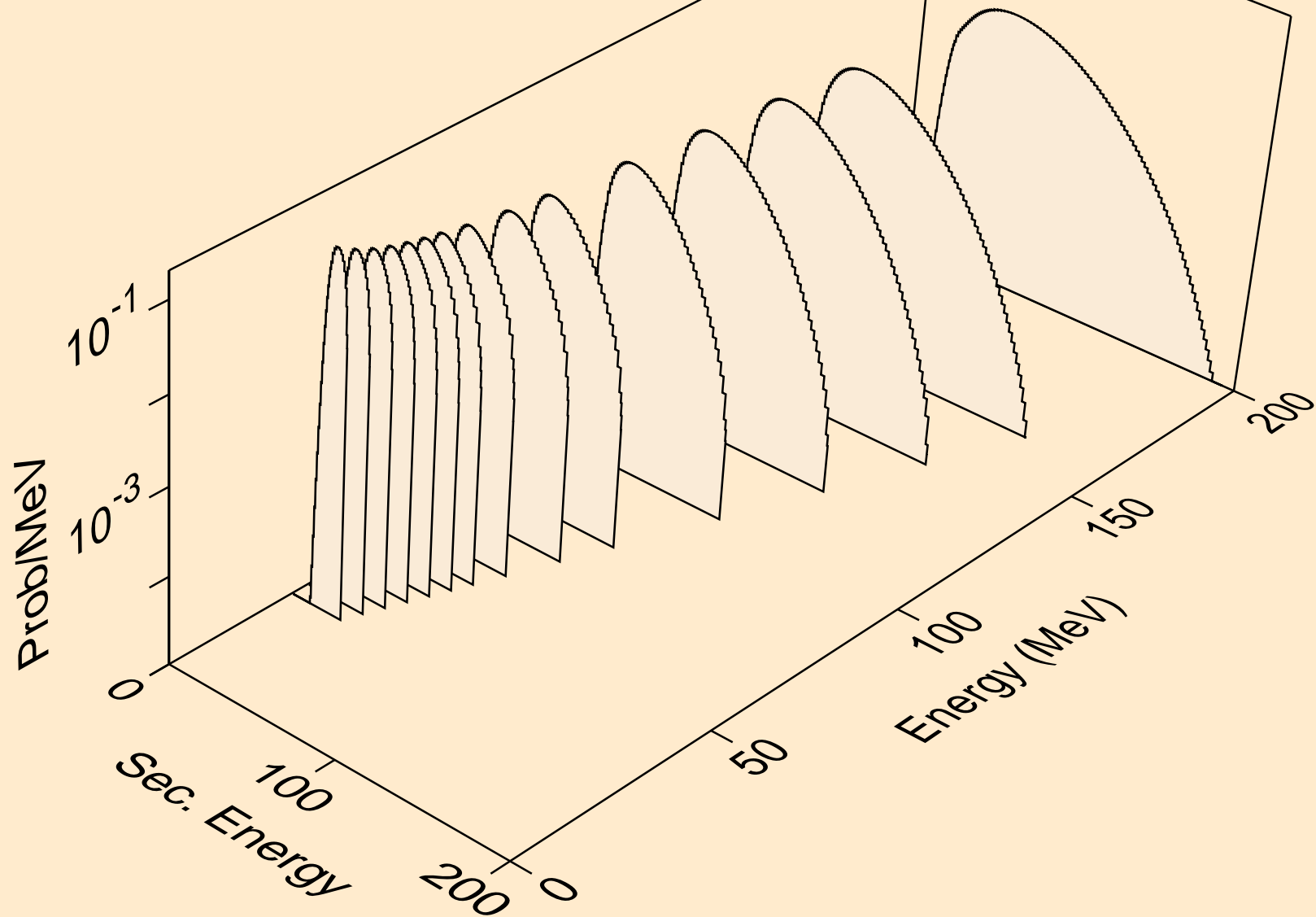

TM156 NEUTRON ACER TENDL-2024 LIBRARY; T=0.K  
he3s from (n,n\*)he3

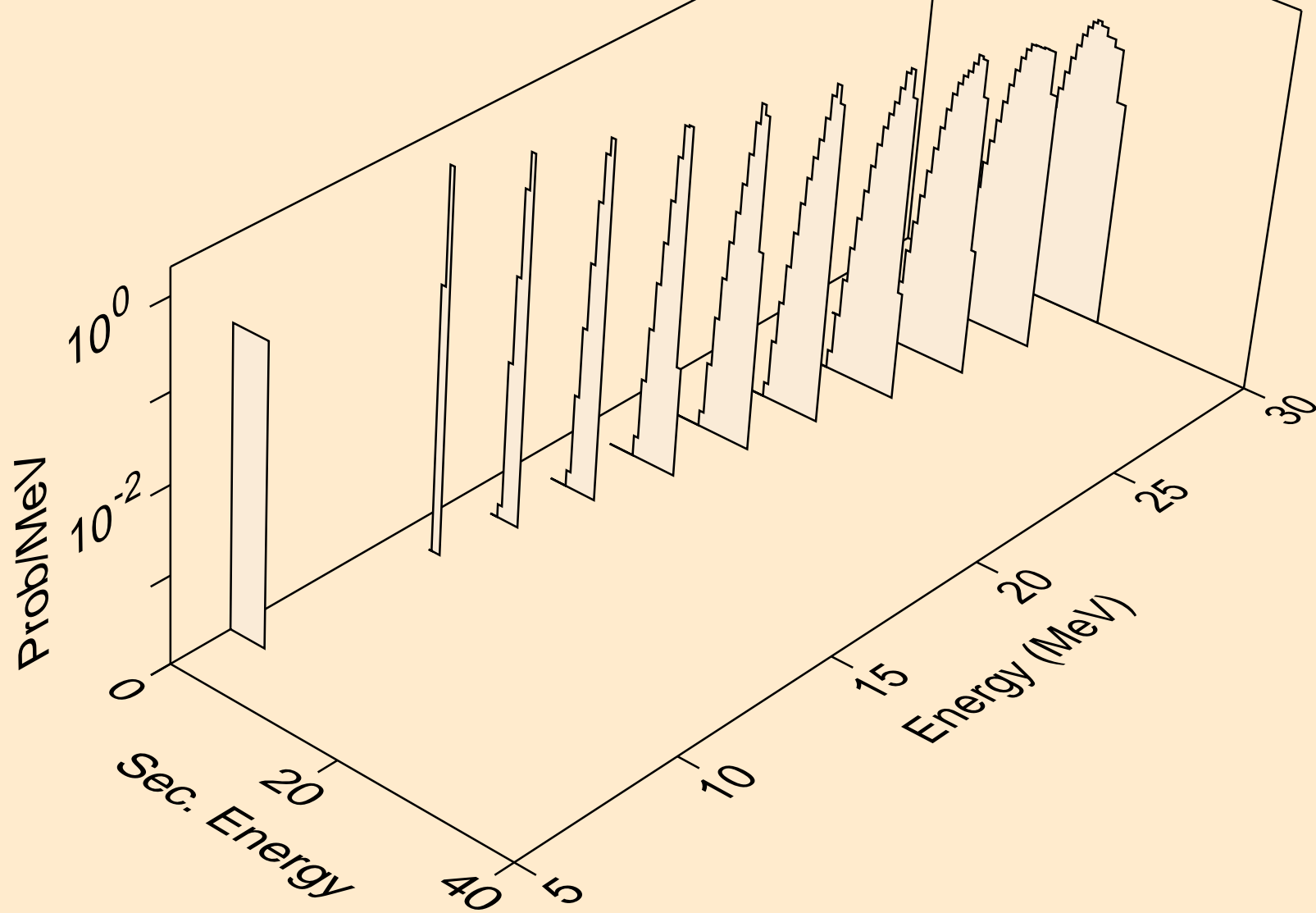

TM156 NEUTRON ACER TENDL-2024 LIBRARY; T=0.K  
he3s from (n,he3)

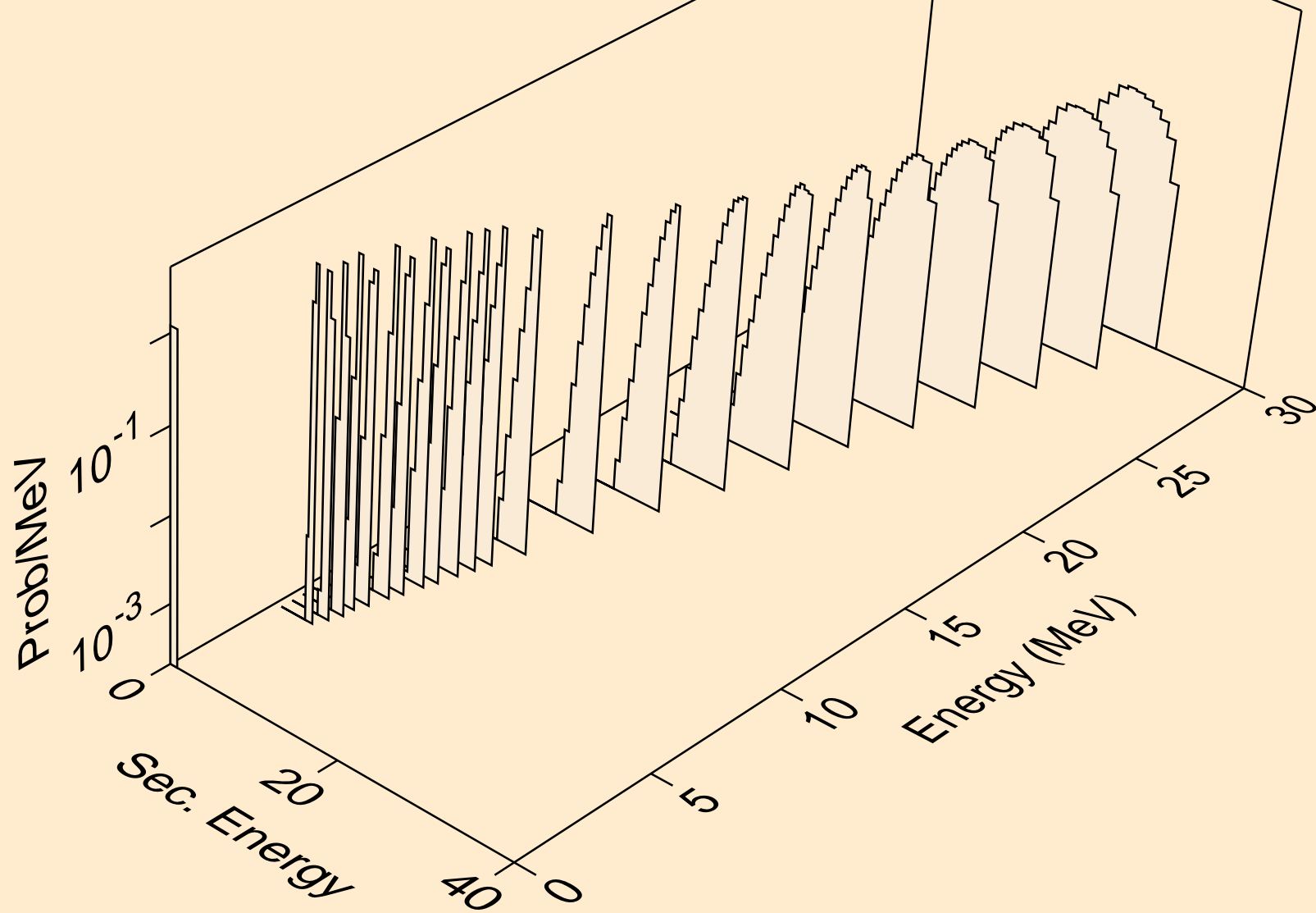

TM156 NEUTRON ACER TENDL-2024 LIBRARY; T=0.K  
alphas from (n,x)

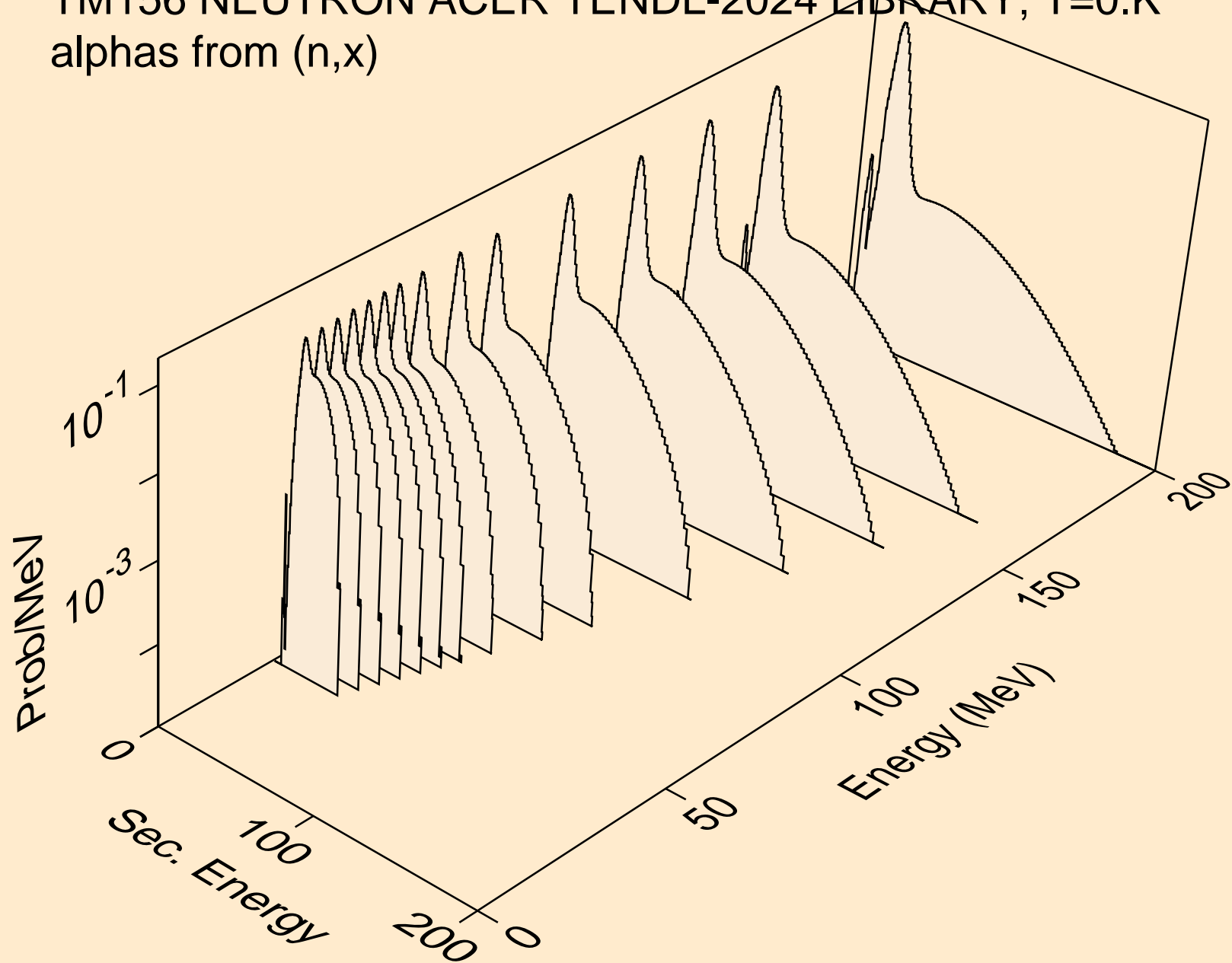

TM156 NEUTRON ACER TENDL-2024 LIBRARY; T=0.K  
alphas from (n,n\*)a

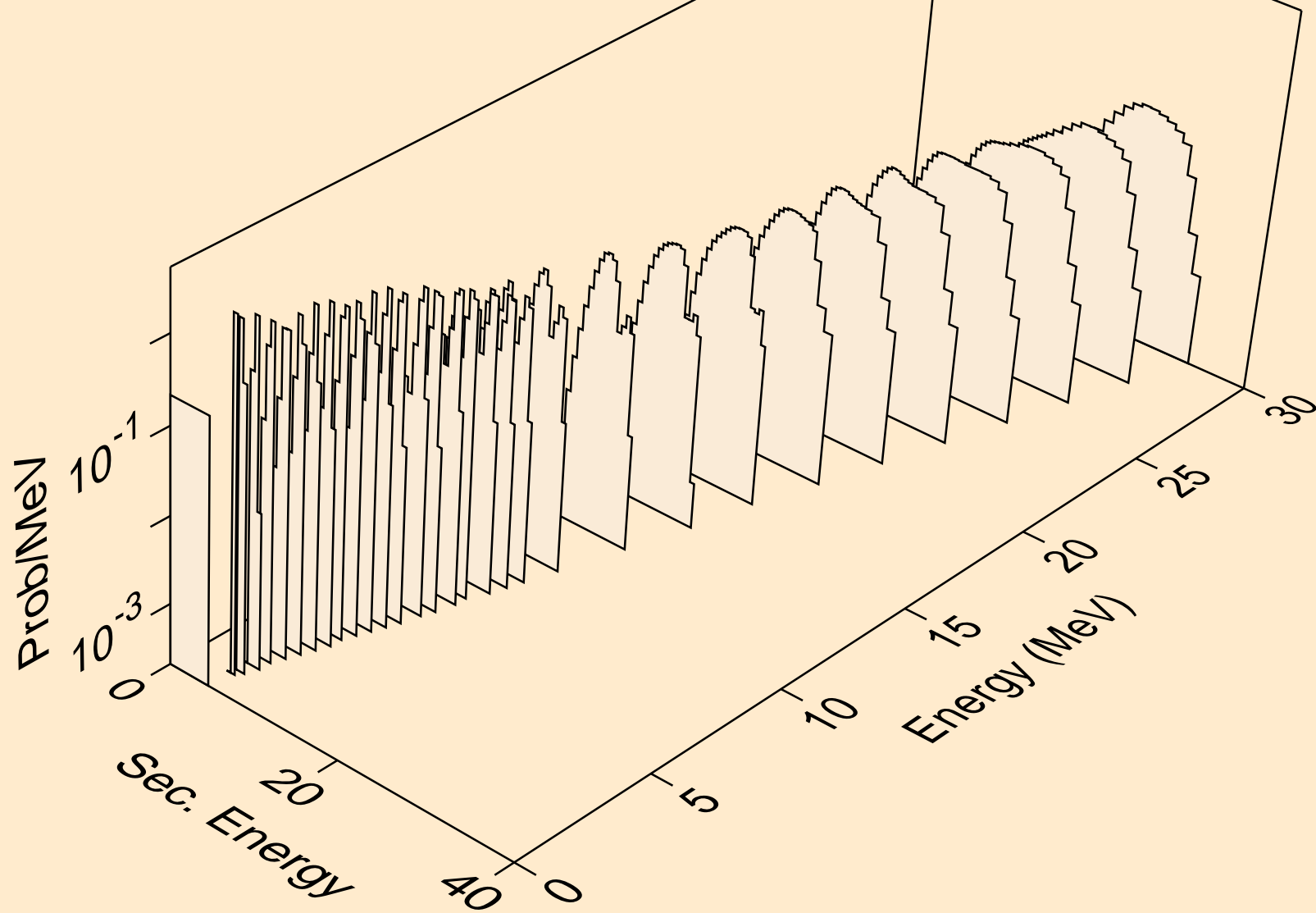

TM156 NEUTRON ACER TENDL-2024 LIBRARY; T=0.K  
alphas from (n,n\*)3a

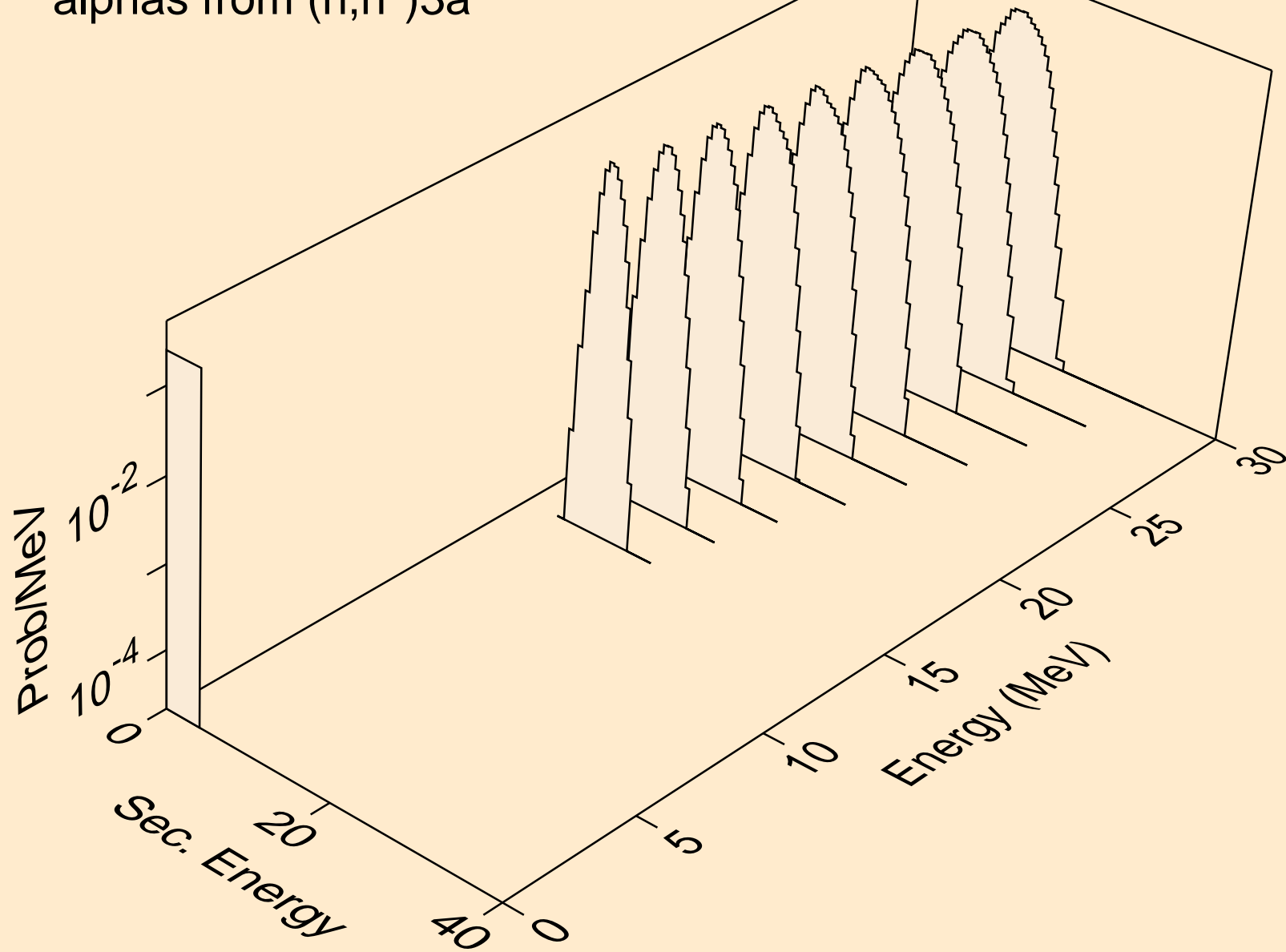

TM156 NEUTRON ACER TENDL-2024 LIBRARY; T=0.K  
alphas from (n,2n)a

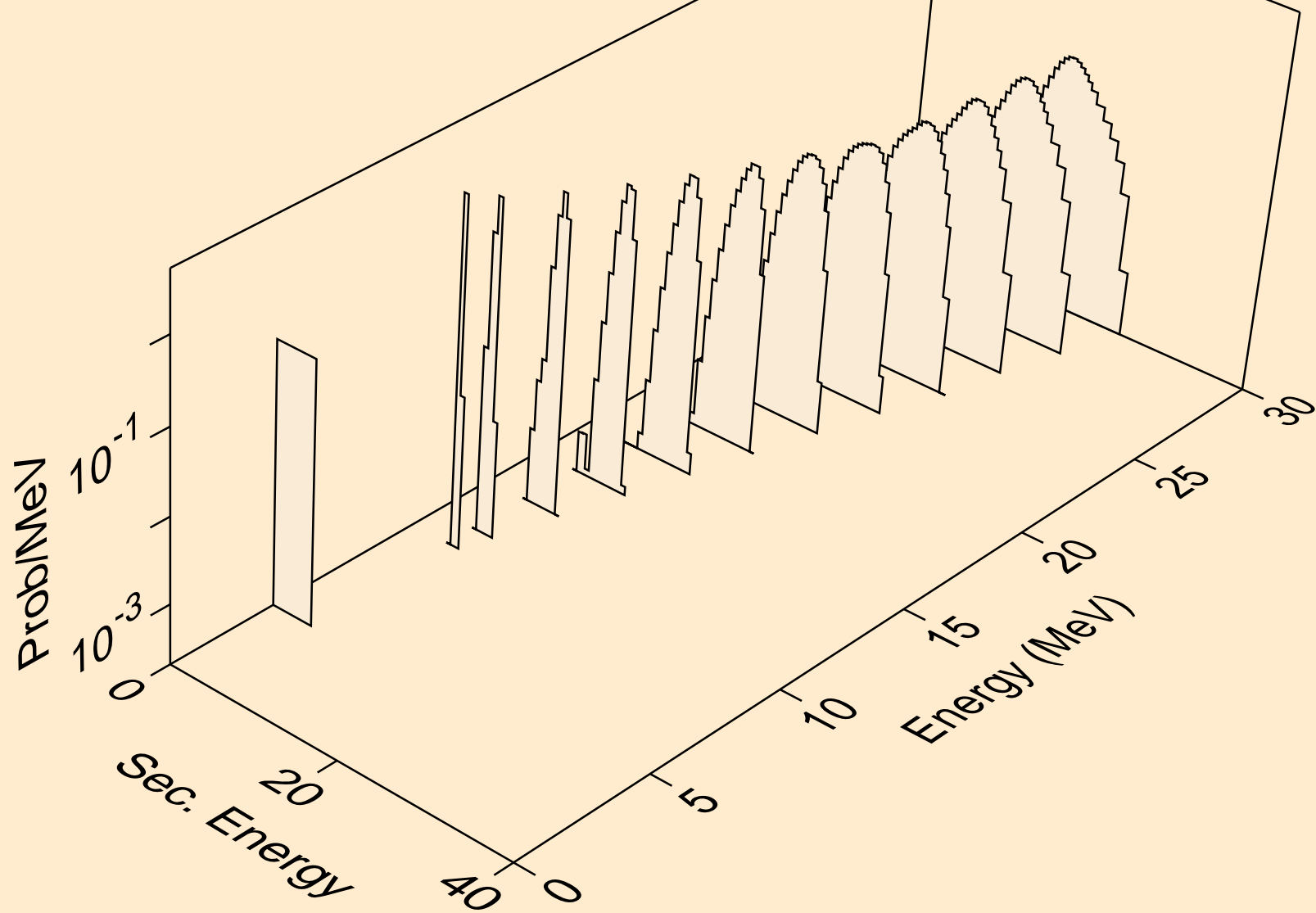

TM156 NEUTRON ACER TENDL-2024 LIBRARY; T=0.K  
alphas from (n,3n)a

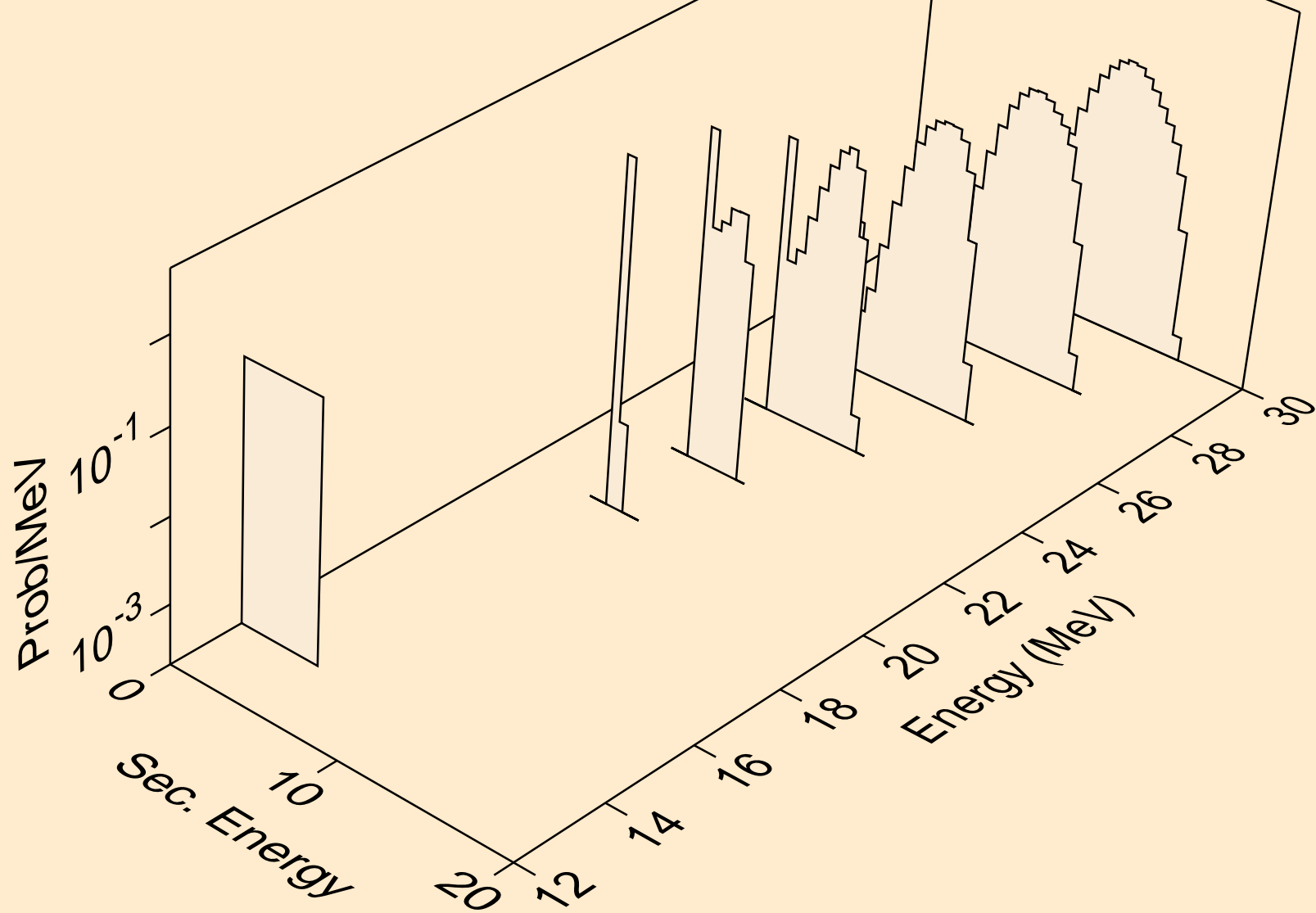

TM156 NEUTRON ACER TENDL-2024 LIBRARY; T=0.K  
alphas from (n,n\*)2a

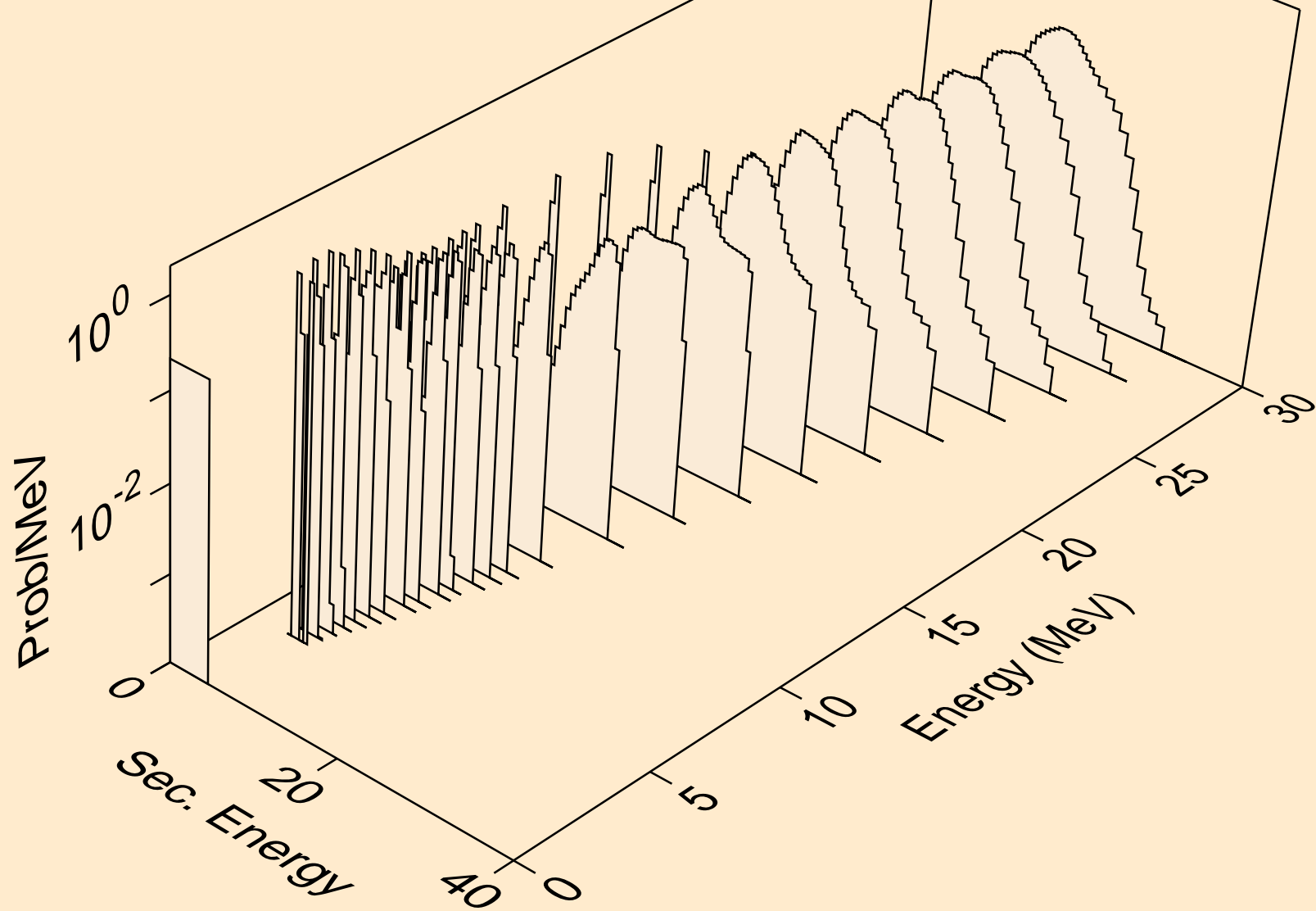

TM156 NEUTRON ACER TENDL-2024 LIBRARY; T=0.K  
alphas from (n,2n)2a

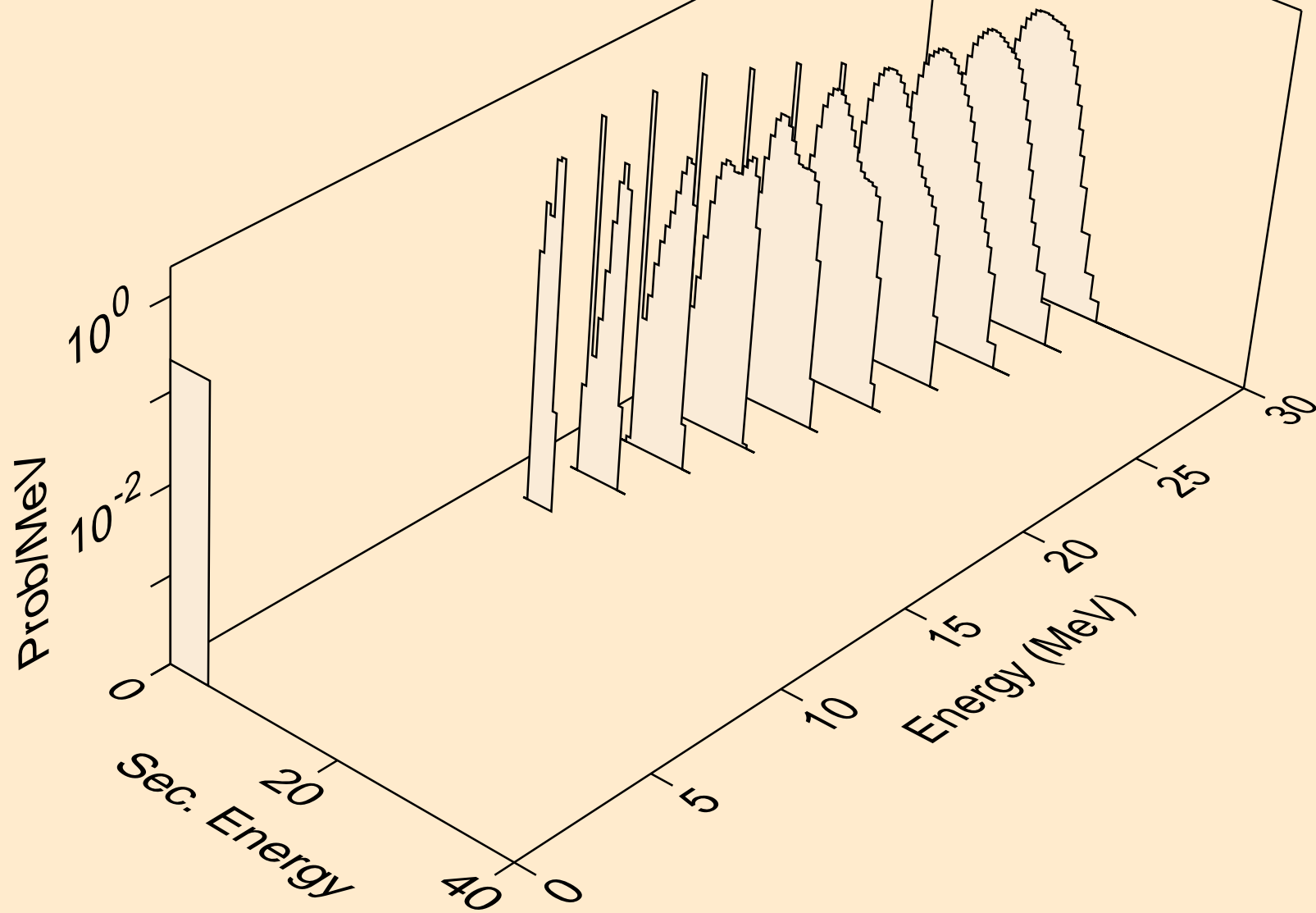

TM156 NEUTRON ACER TENDL-2024 LIBRARY; T=0.K  
alphas from (n,npa)

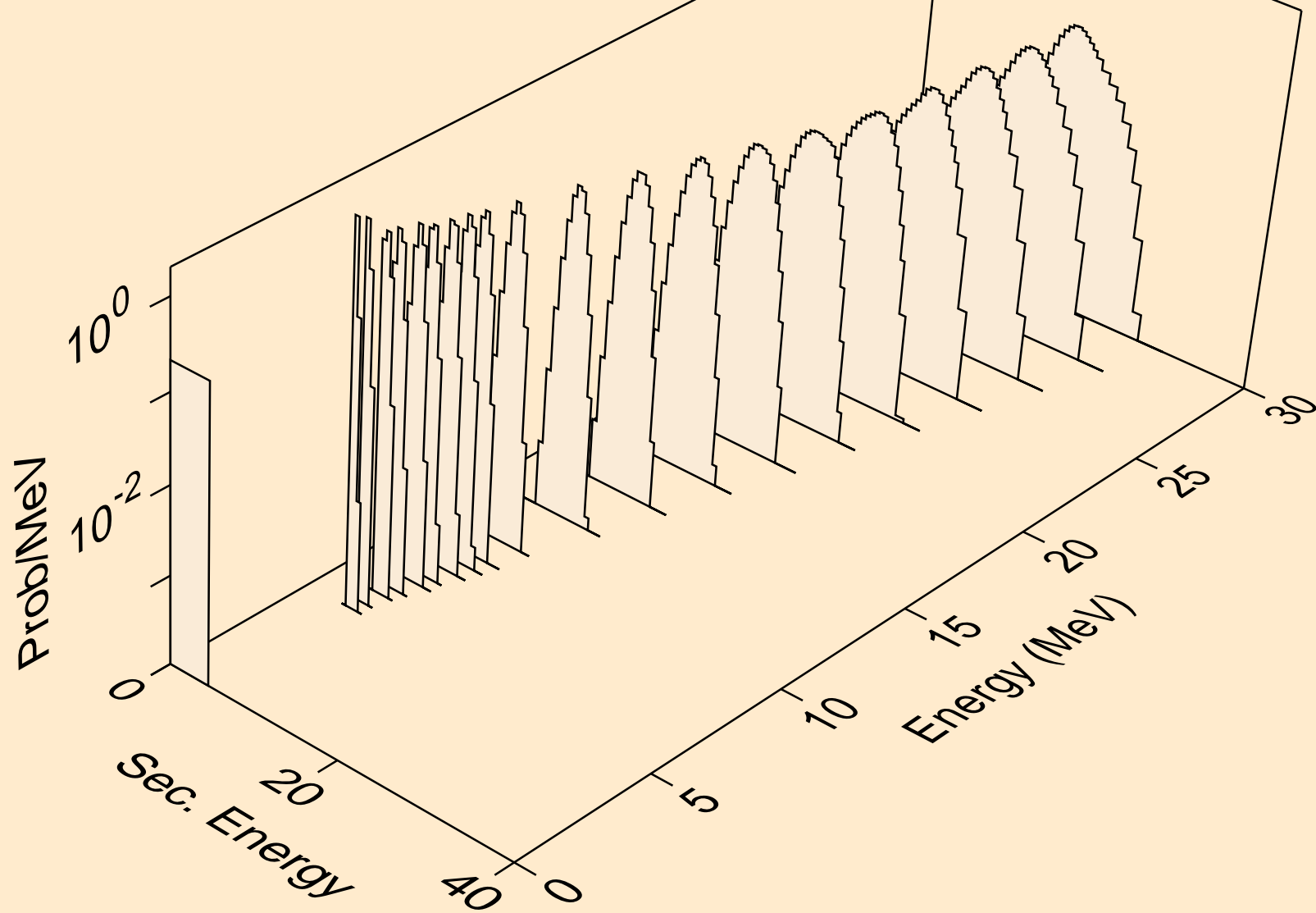

TM156 NEUTRON ACER TENDL-2024 LIBRARY; T=0.K  
alphas from (n,a)

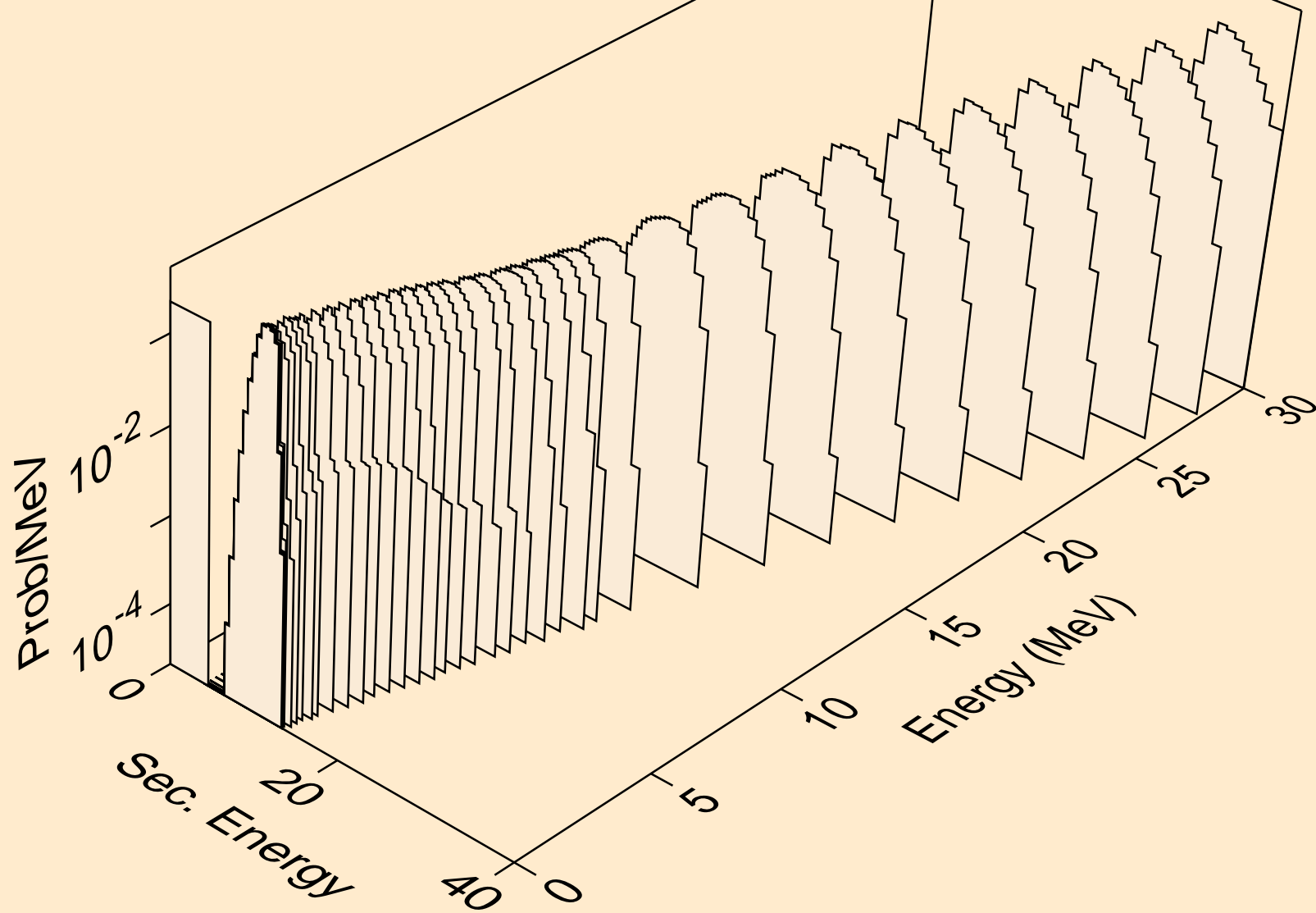

TM156 NEUTRON ACER TENDL-2024 LIBRARY; T=0.K  
alphas from (n,2a)

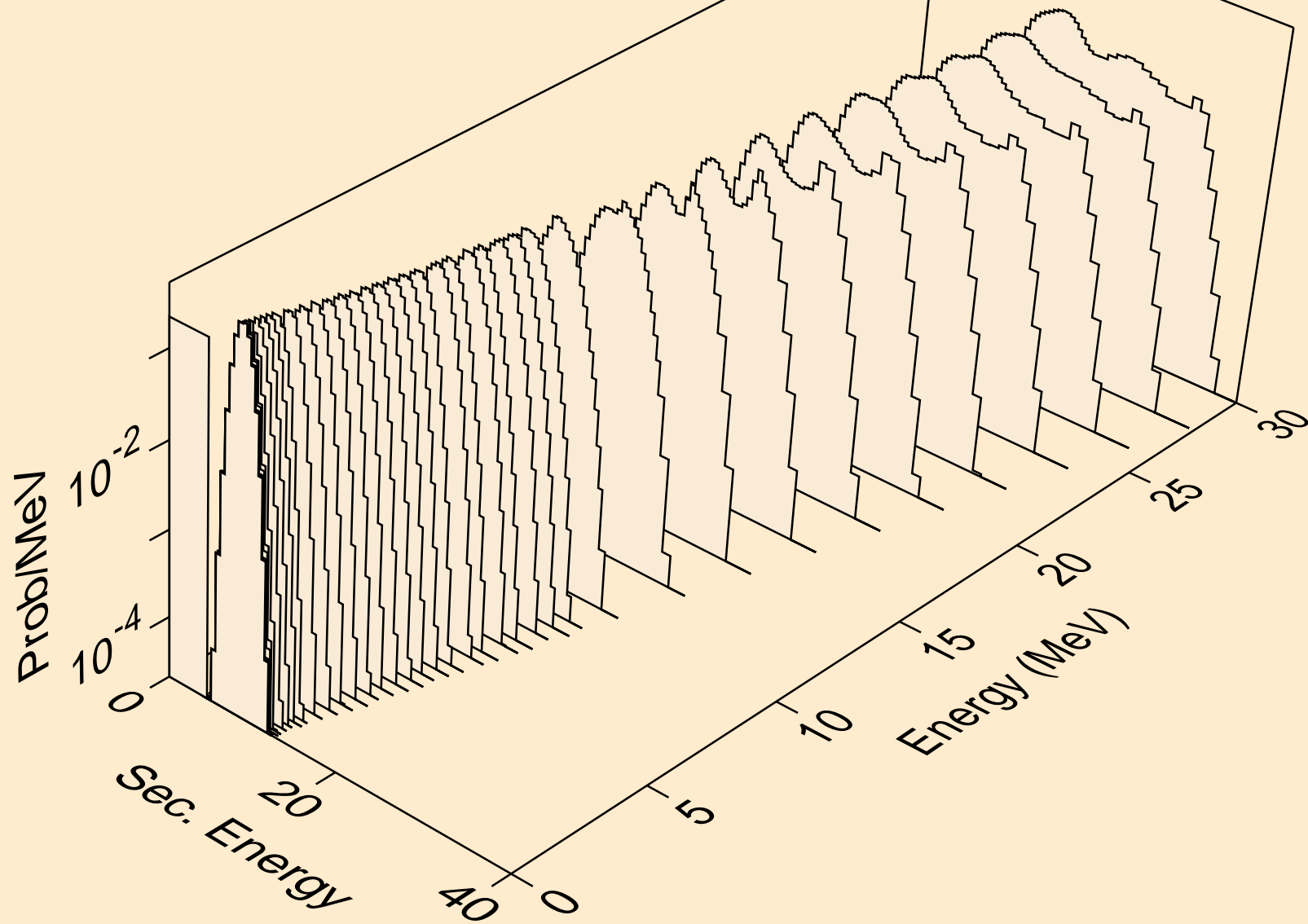

TM156 NEUTRON ACER TENDL-2024 LIBRARY; T=0.K  
alphas from (n,3a)

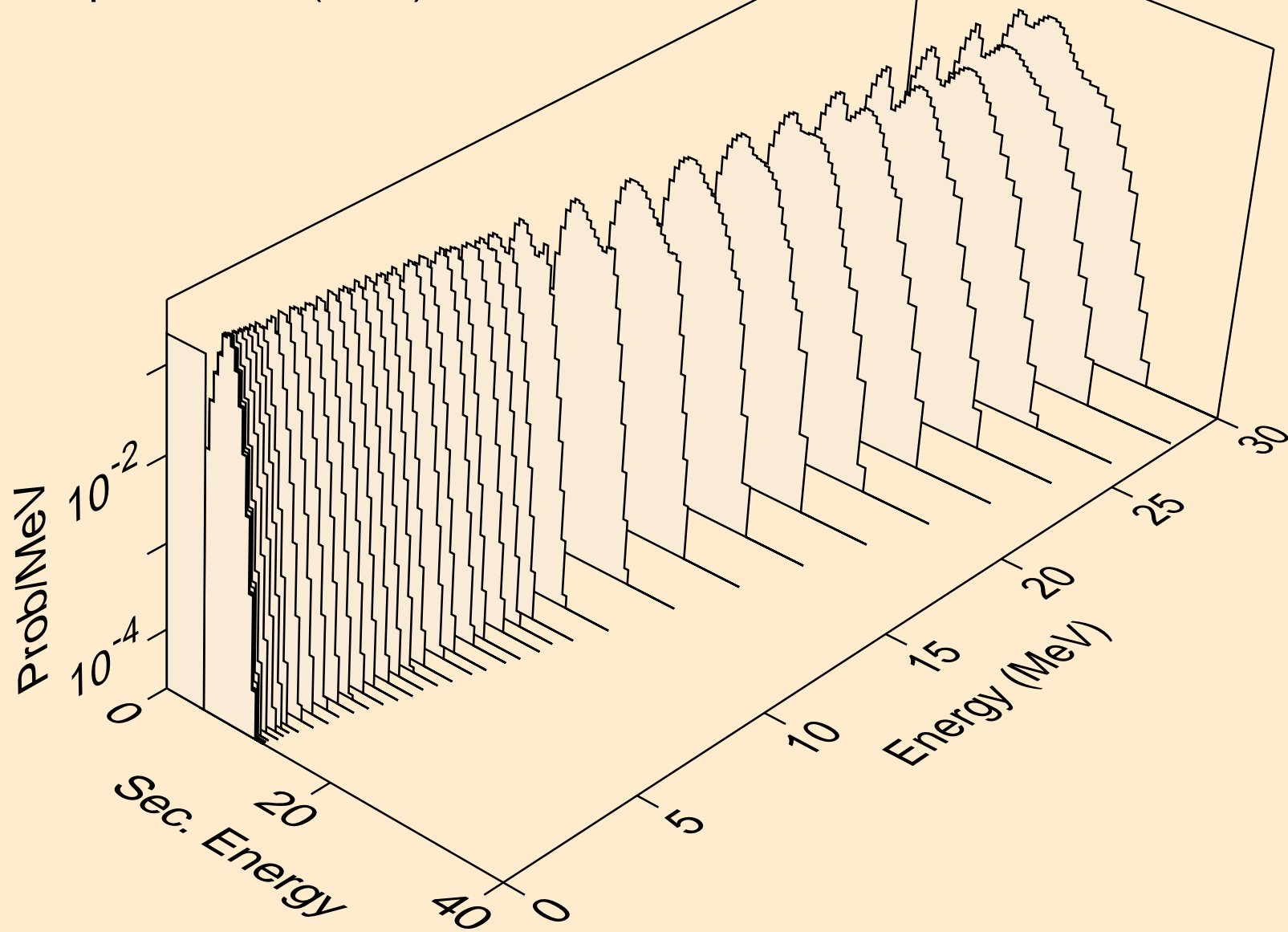

TM156 NEUTRON ACER TENDL-2024 LIBRARY; T=0.K  
alphas from (n,pa)

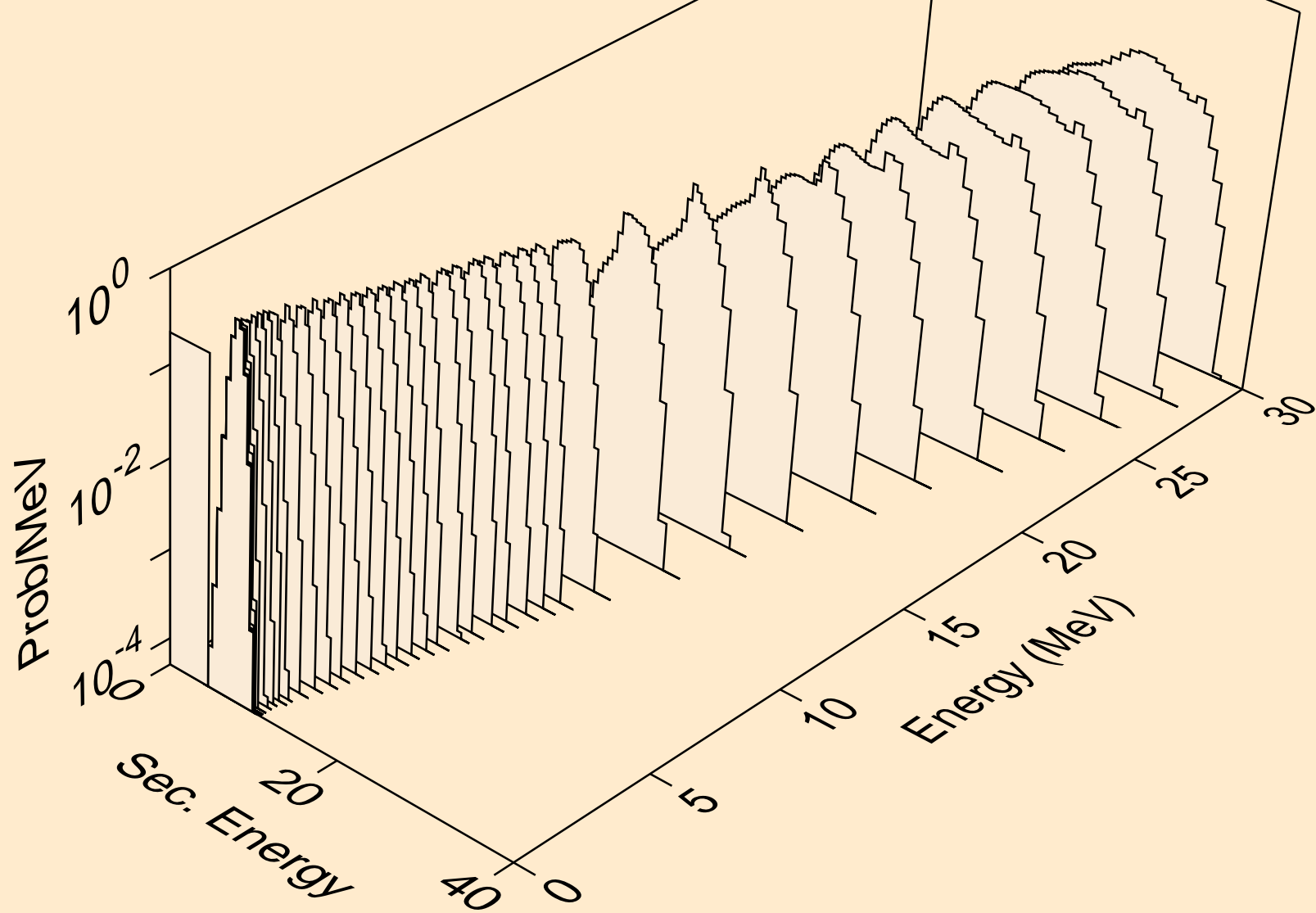

TM156 NEUTRON ACER TENDL-2024 LIBRARY; T=0.K  
alphas from (n,t2a)

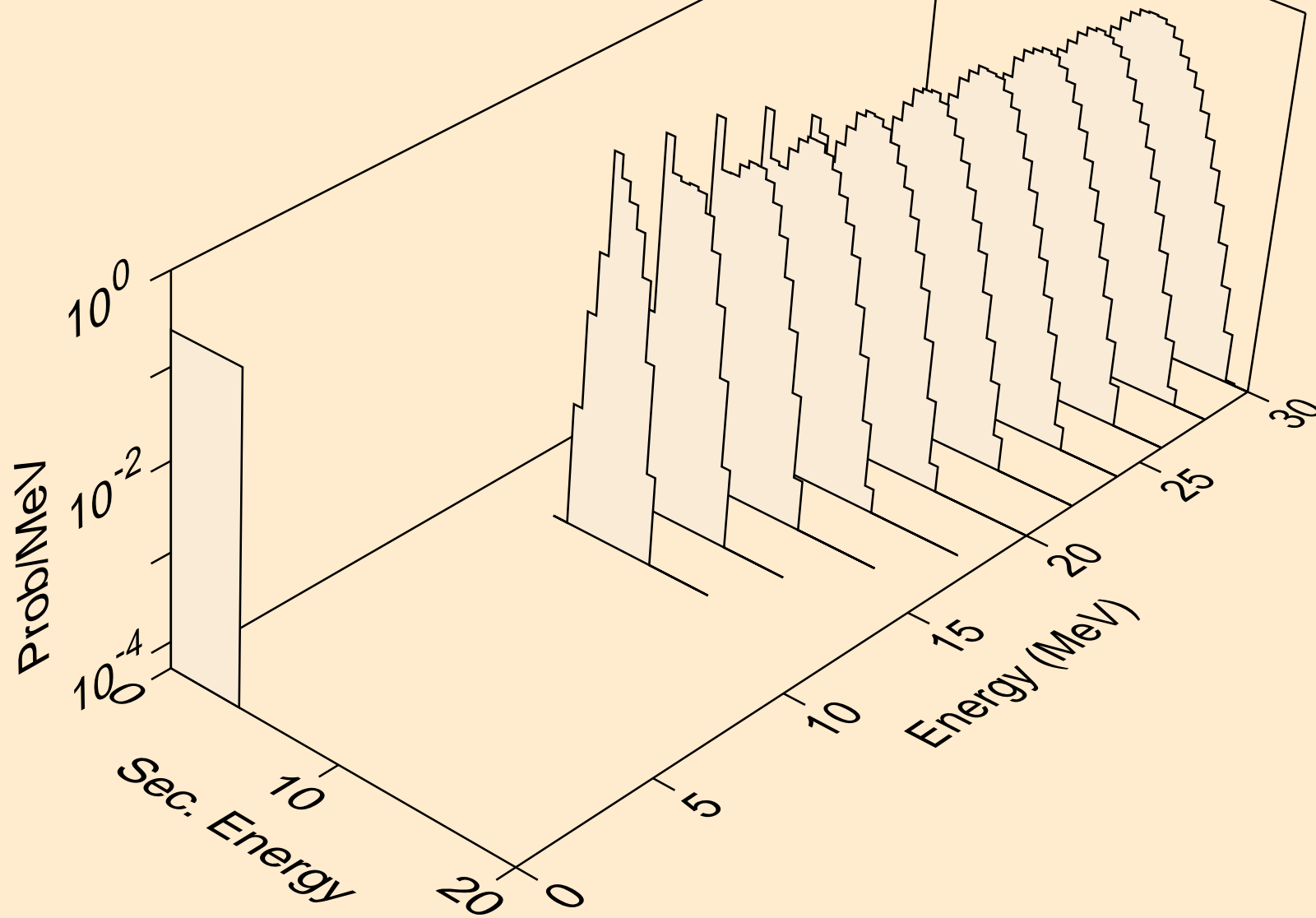

TM156 NEUTRON ACER TENDL-2024 LIBRARY; T=0.K  
alphas from (n,d2a)

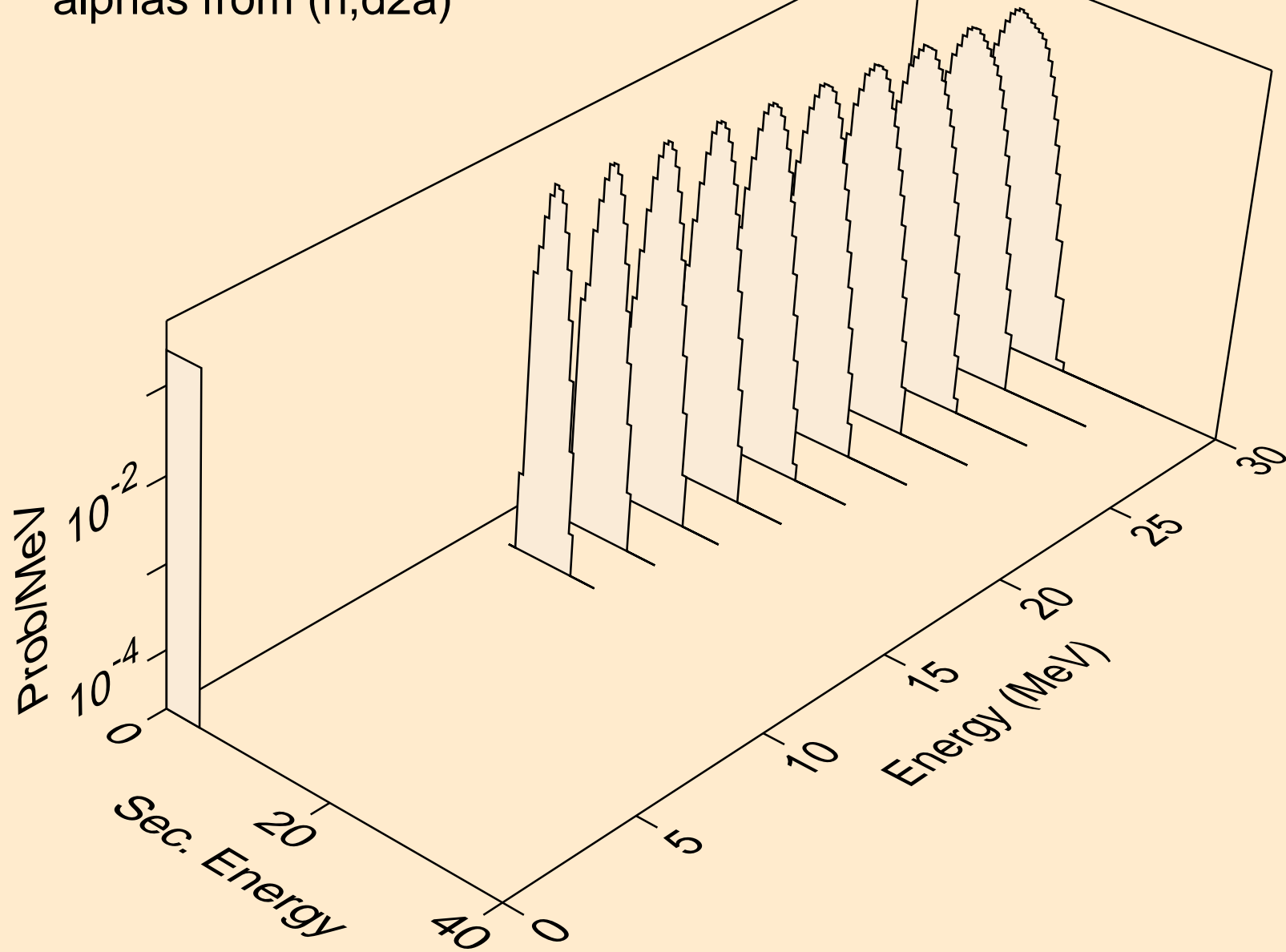

TM156 NEUTRON ACER TENDL-2024 LIBRARY; T=0.K  
alphas from (n,da)

