

# W197 NEUTRON ACER TENDL-2024 LIBRARY; T=0.K

## Principal cross sections

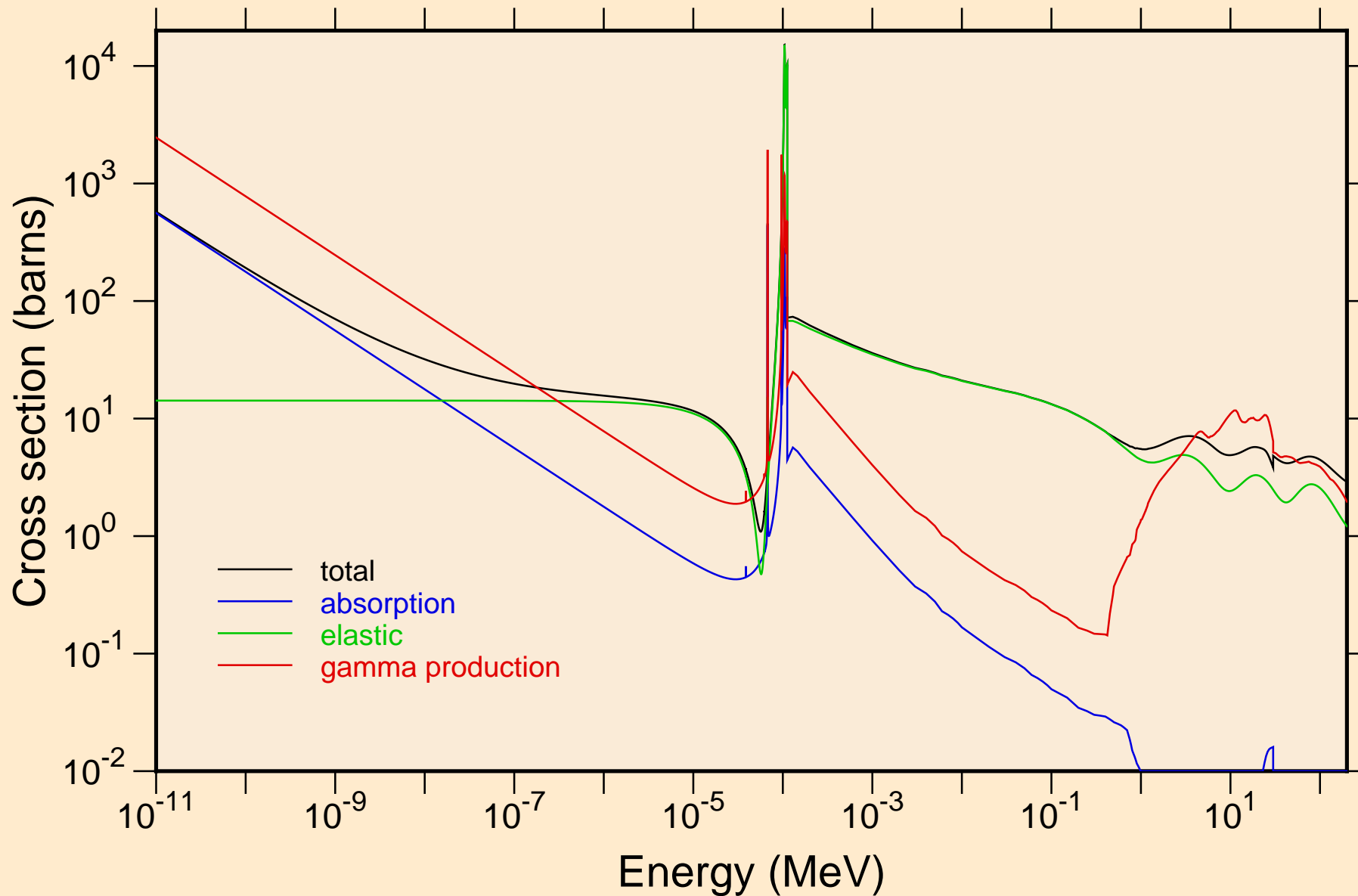

# W197 NEUTRON ACER TENDL-2024 LIBRARY; T=0.K

## Heating

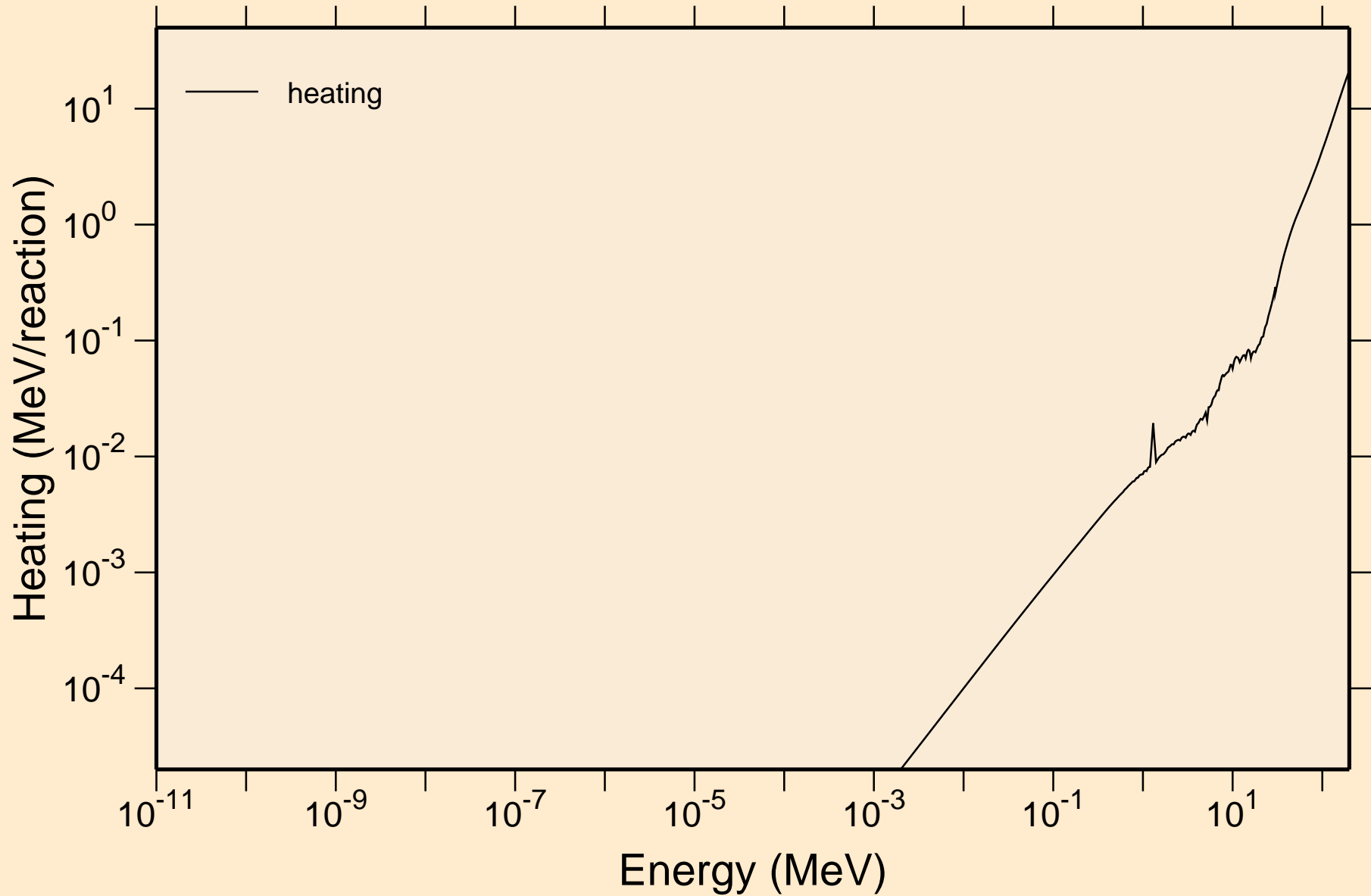

# W197 NEUTRON ACER TENDL-2024 LIBRARY; T=0.K

## Damage

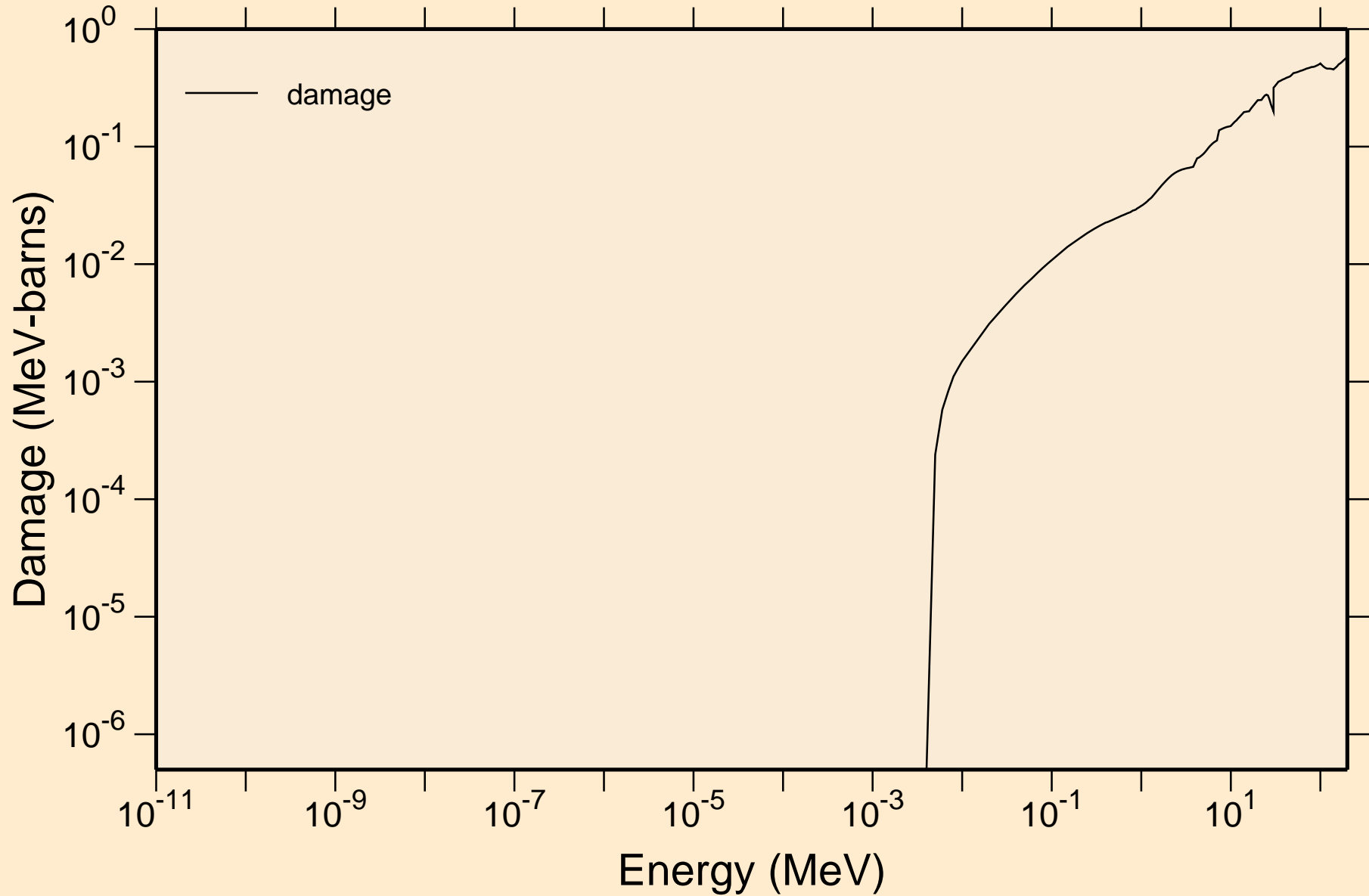

W197 NEUTRON ACER TENDL-2024 LIBRARY; T=0.K  
Non-threshold reactions

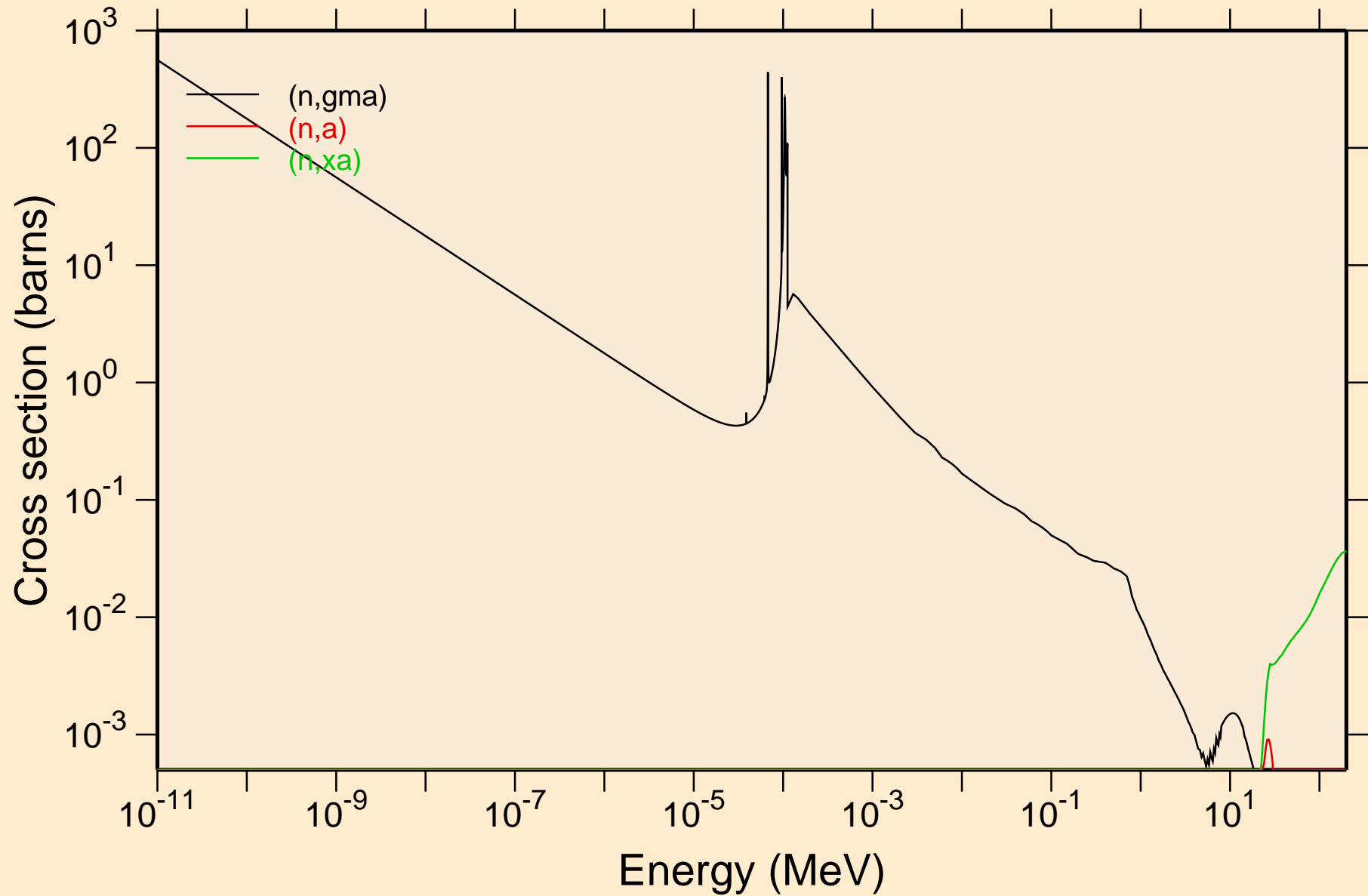

# W197 NEUTRON ACER TENDL-2024 LIBRARY; T=0.K

## Principal cross sections

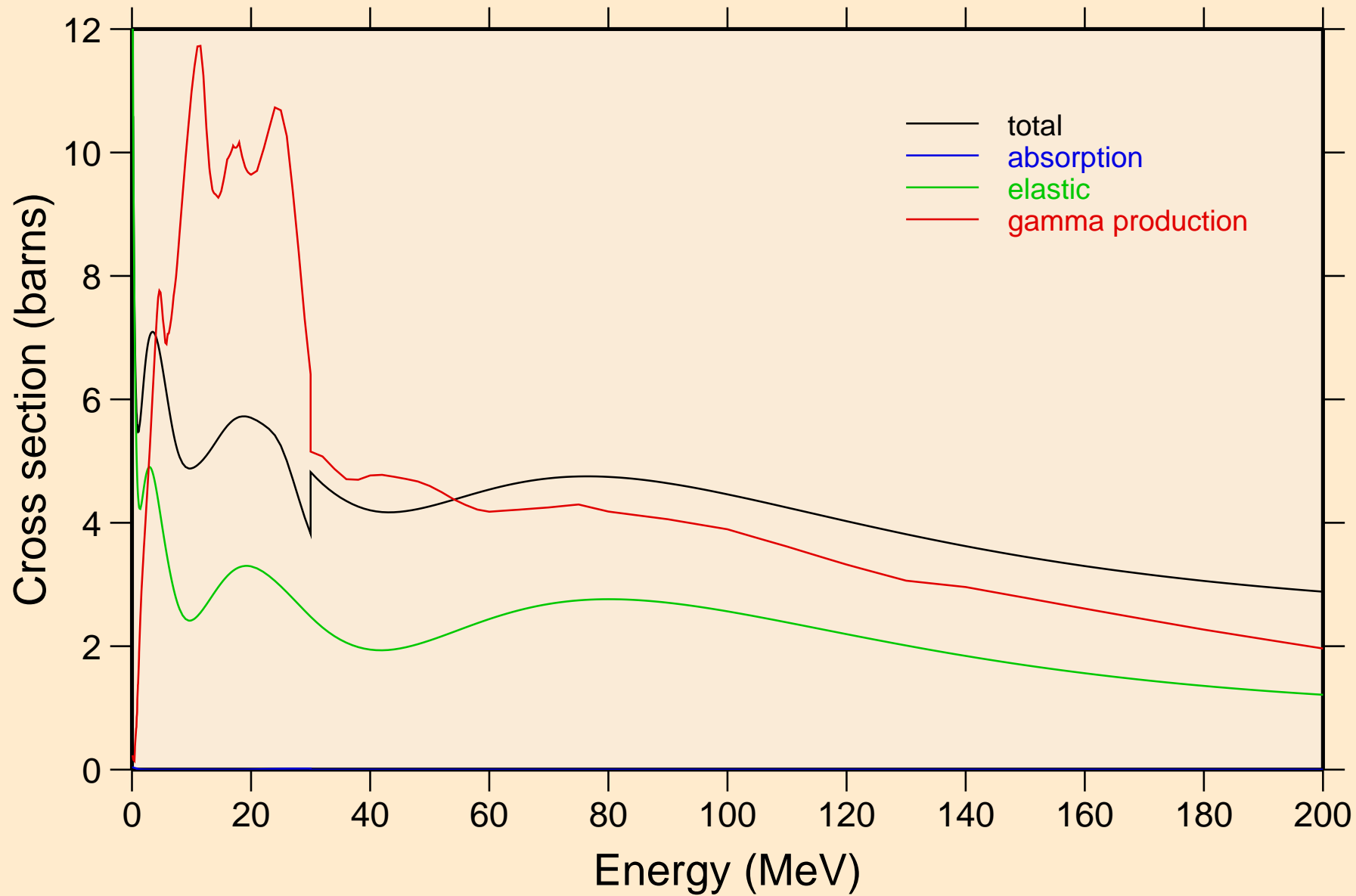

# W197 NEUTRON ACER TENDL-2024 LIBRARY; T=0.K

## Heating

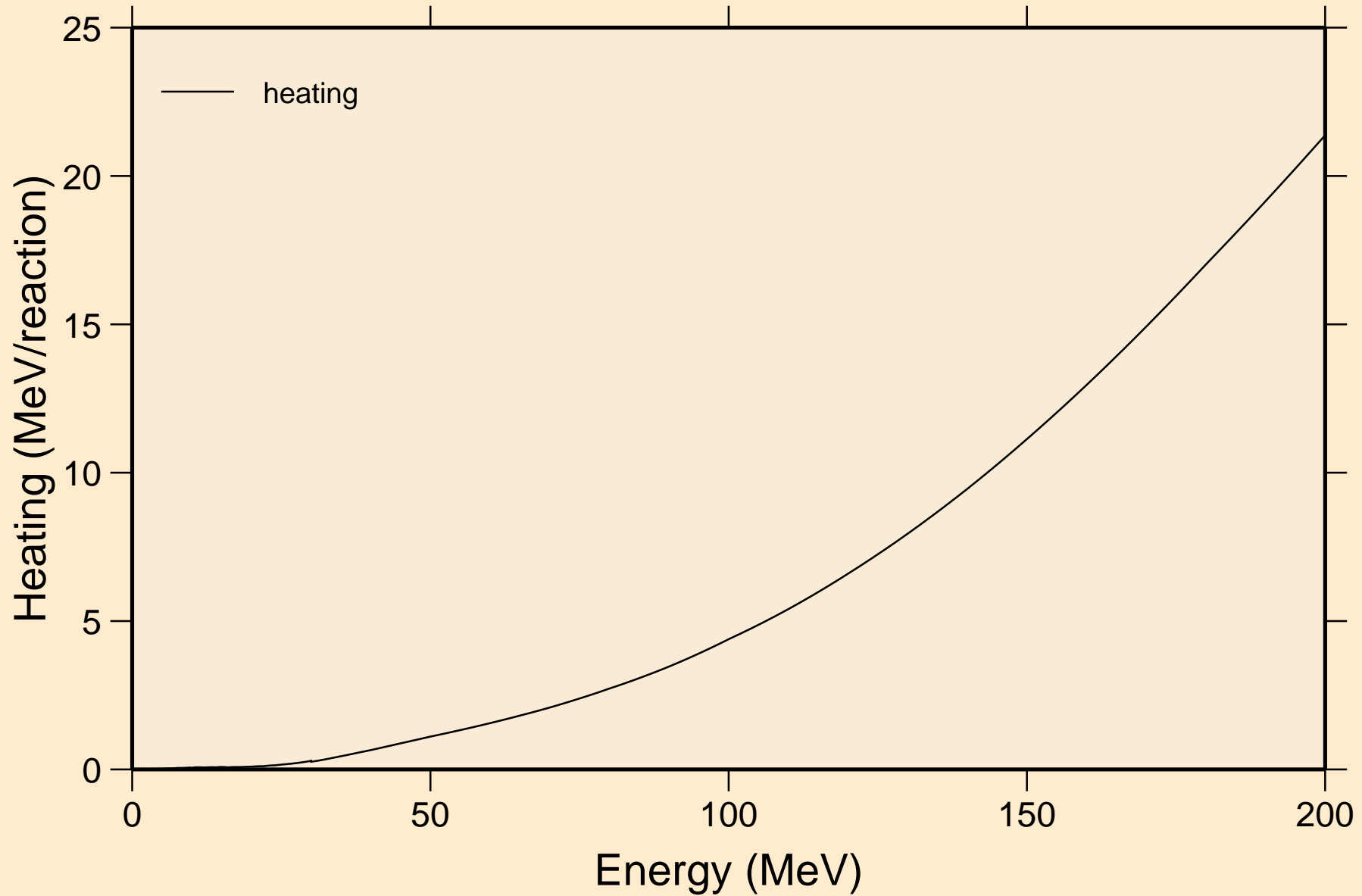

W197 NEUTRON ACER TENDL-2024 LIBRARY; T=0.K  
Damage

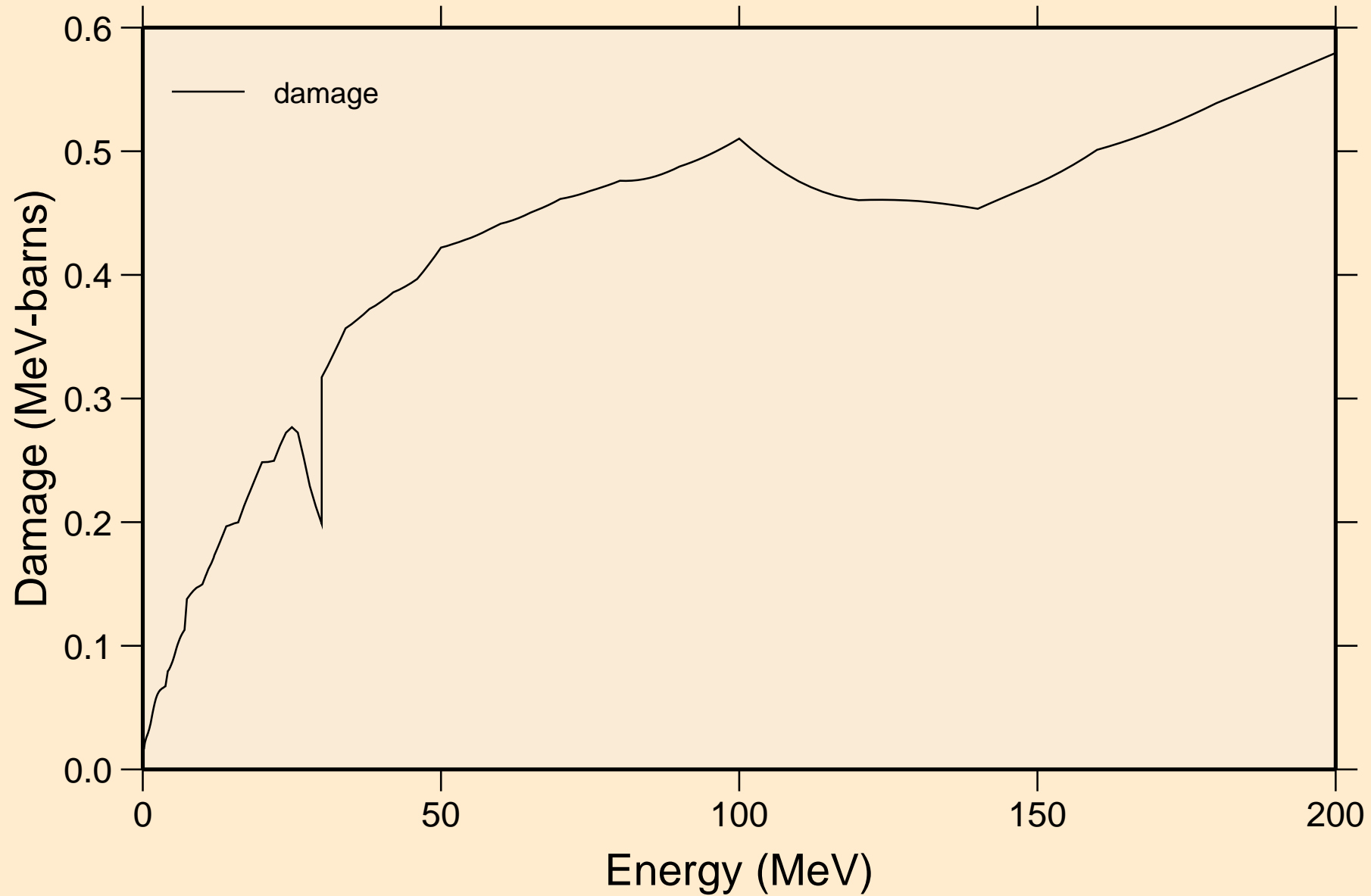

W197 NEUTRON ACER TENDL-2024 LIBRARY; T=0.K  
Non-threshold reactions

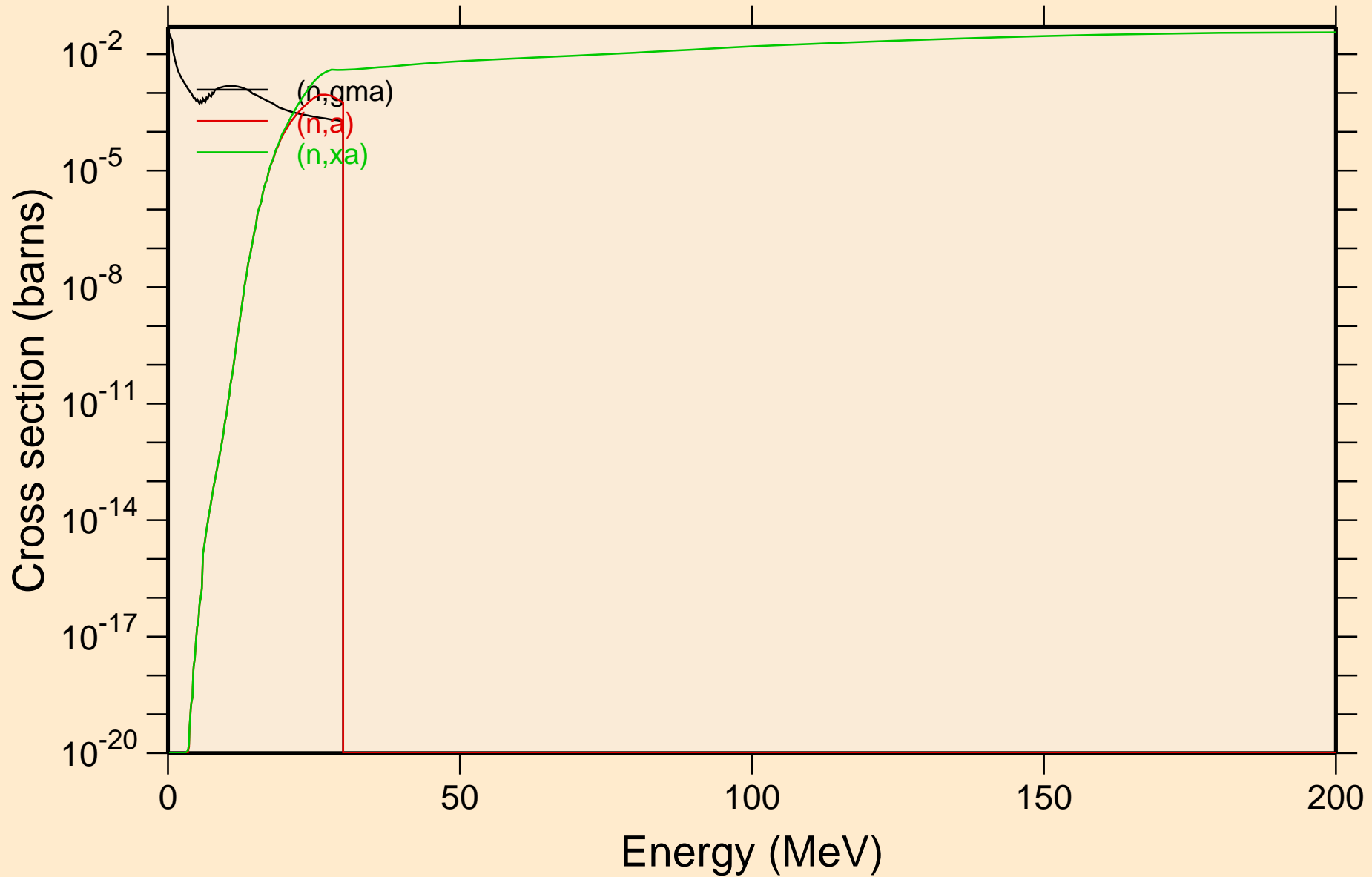

W197 NEUTRON ACER TENDL-2024 LIBRARY; T=0.K  
Inelastic levels

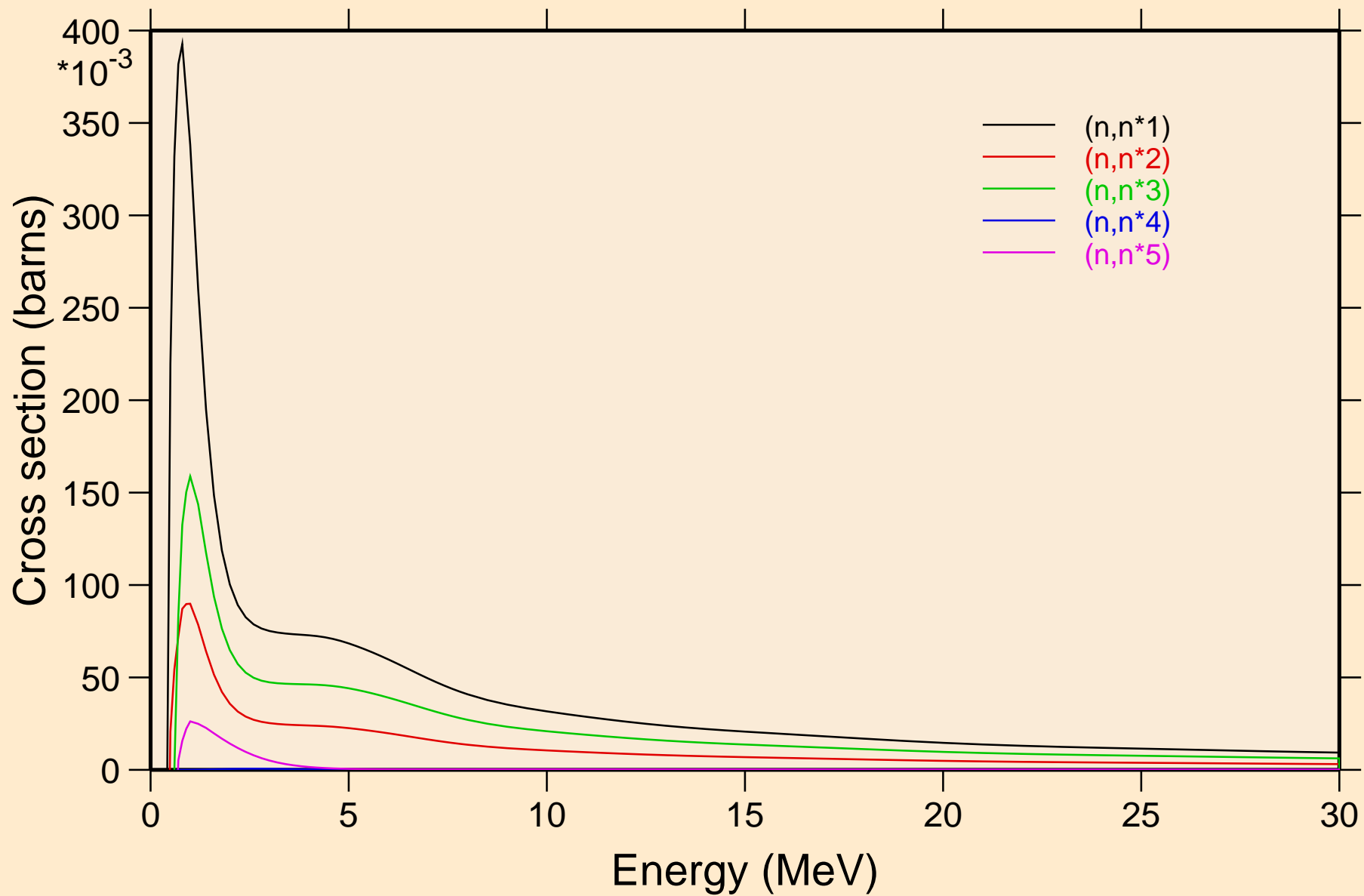

W197 NEUTRON ACER TENDL-2024 LIBRARY; T=0.K  
Inelastic levels

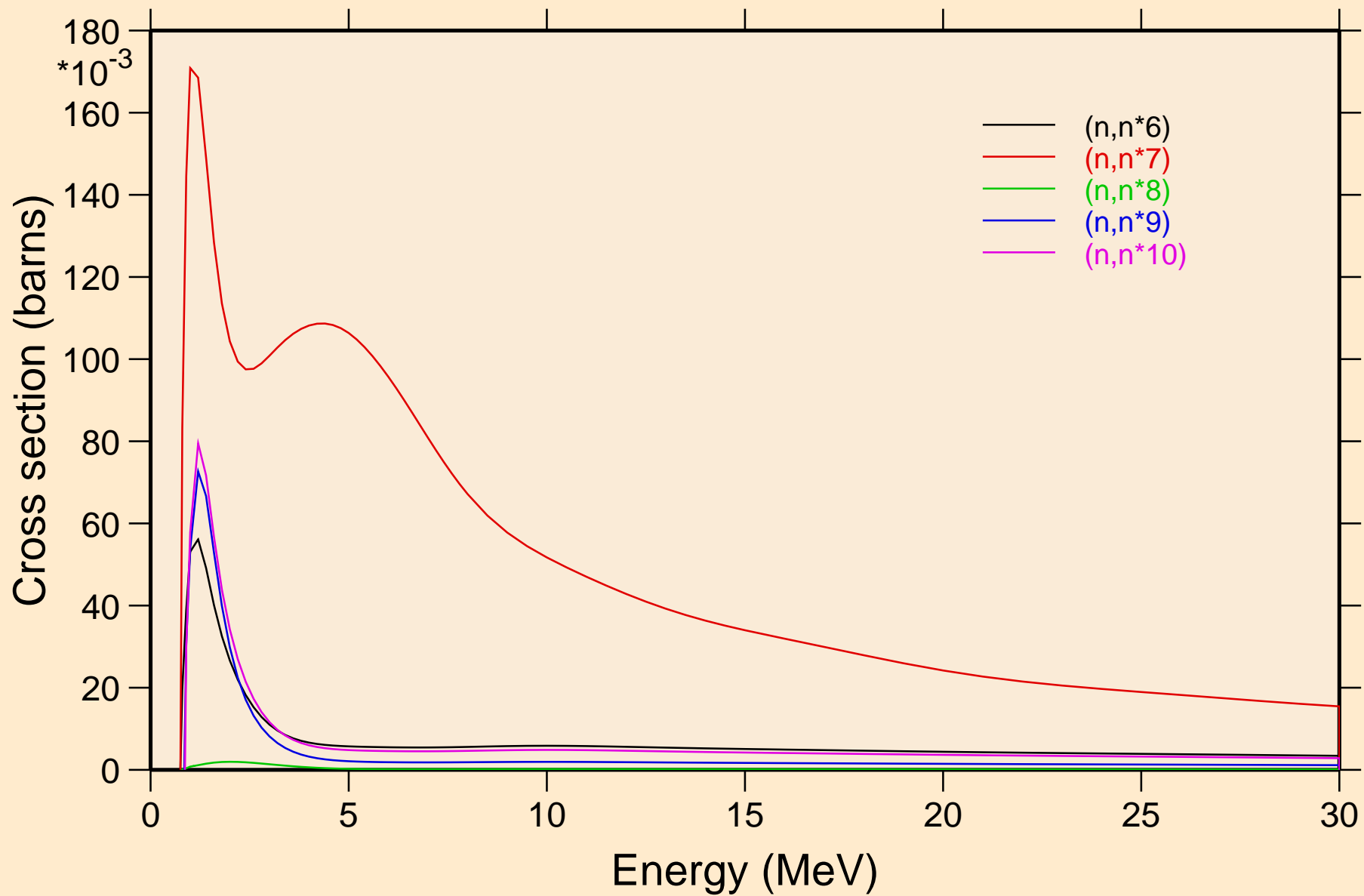

W197 NEUTRON ACER TENDL-2024 LIBRARY; T=0.K  
Inelastic levels

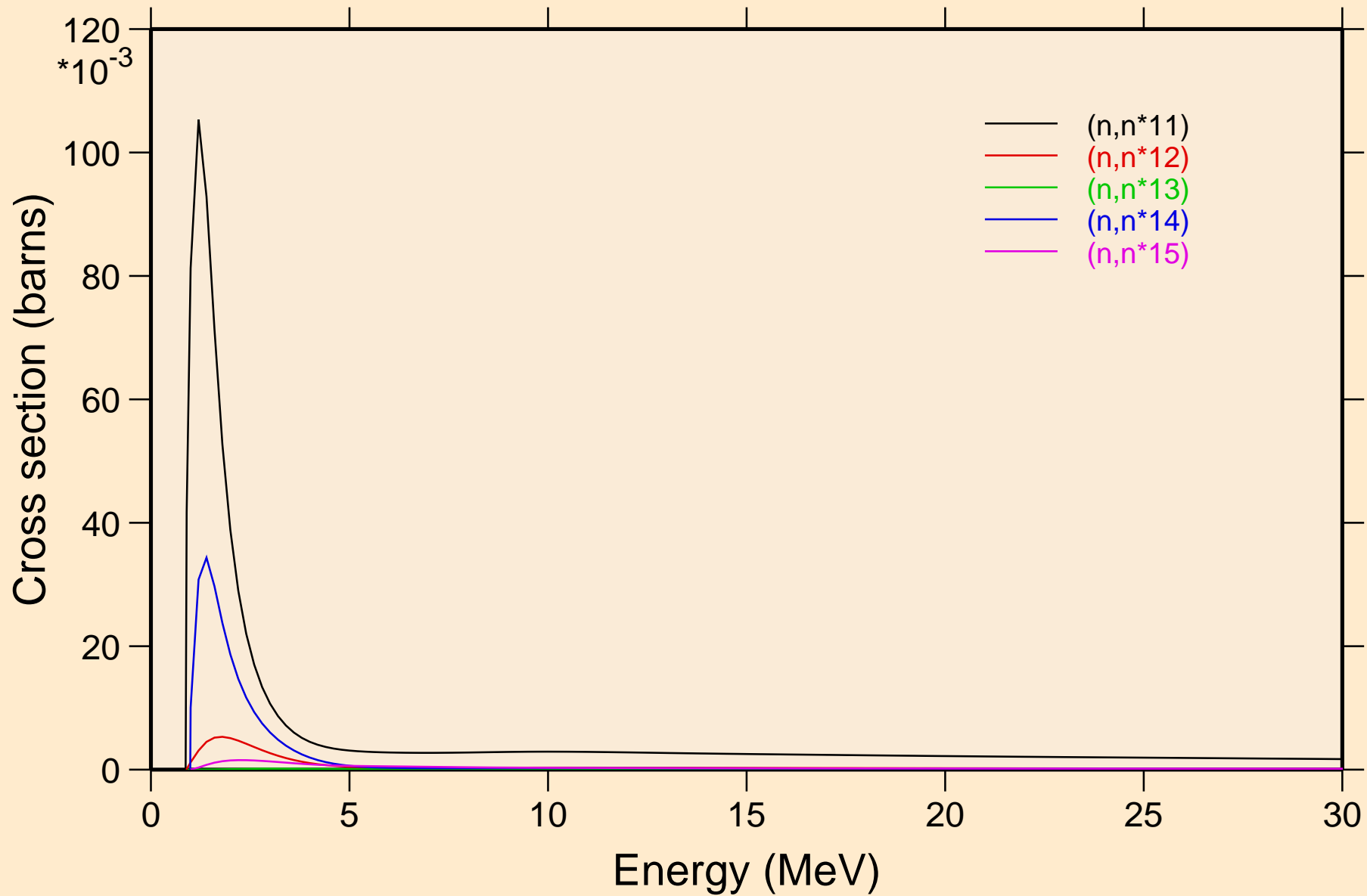

W197 NEUTRON ACER TENDL-2024 LIBRARY; T=0.K  
Inelastic levels

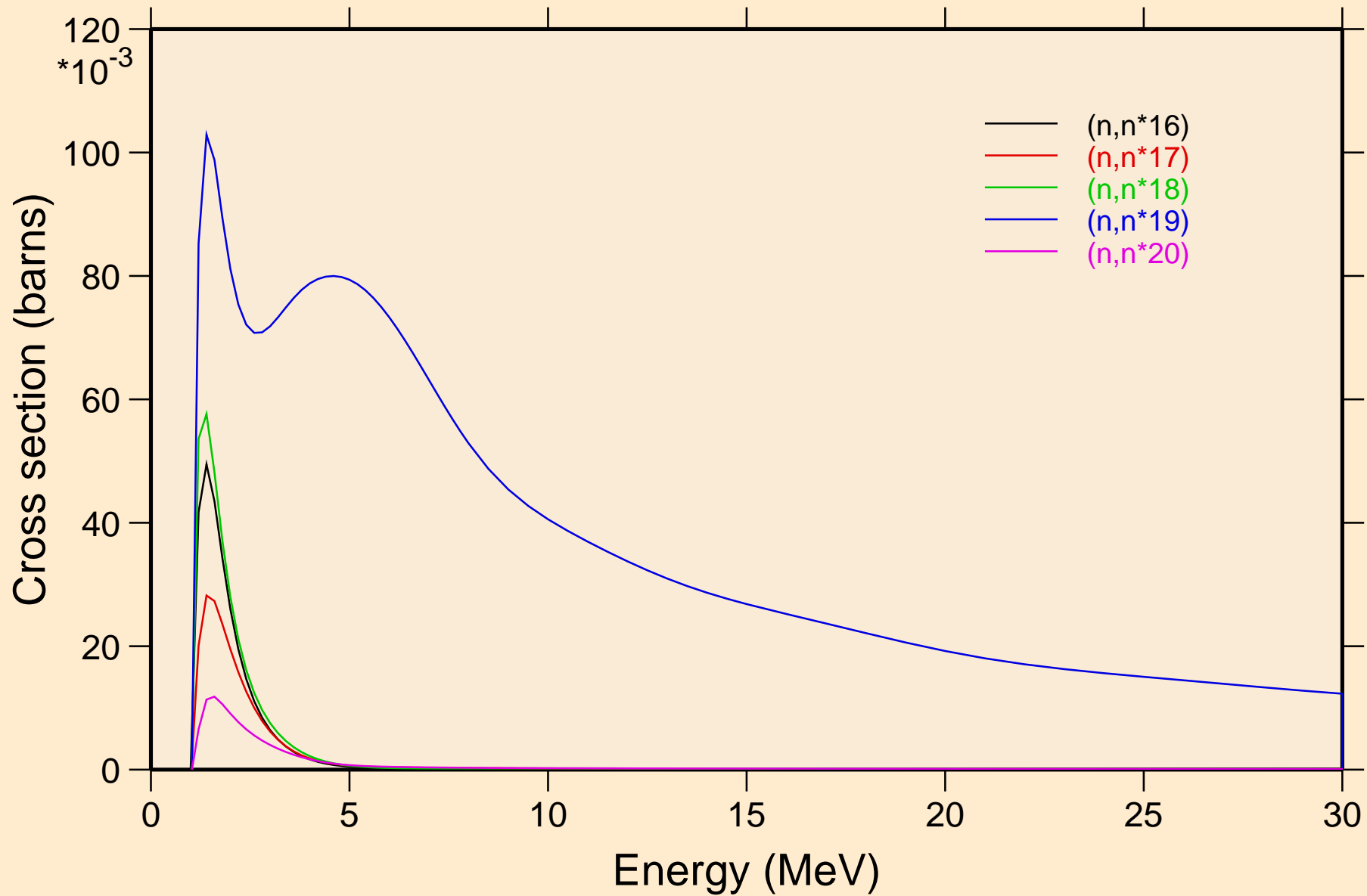

W197 NEUTRON ACER TENDL-2024 LIBRARY; T=0.K  
Inelastic levels

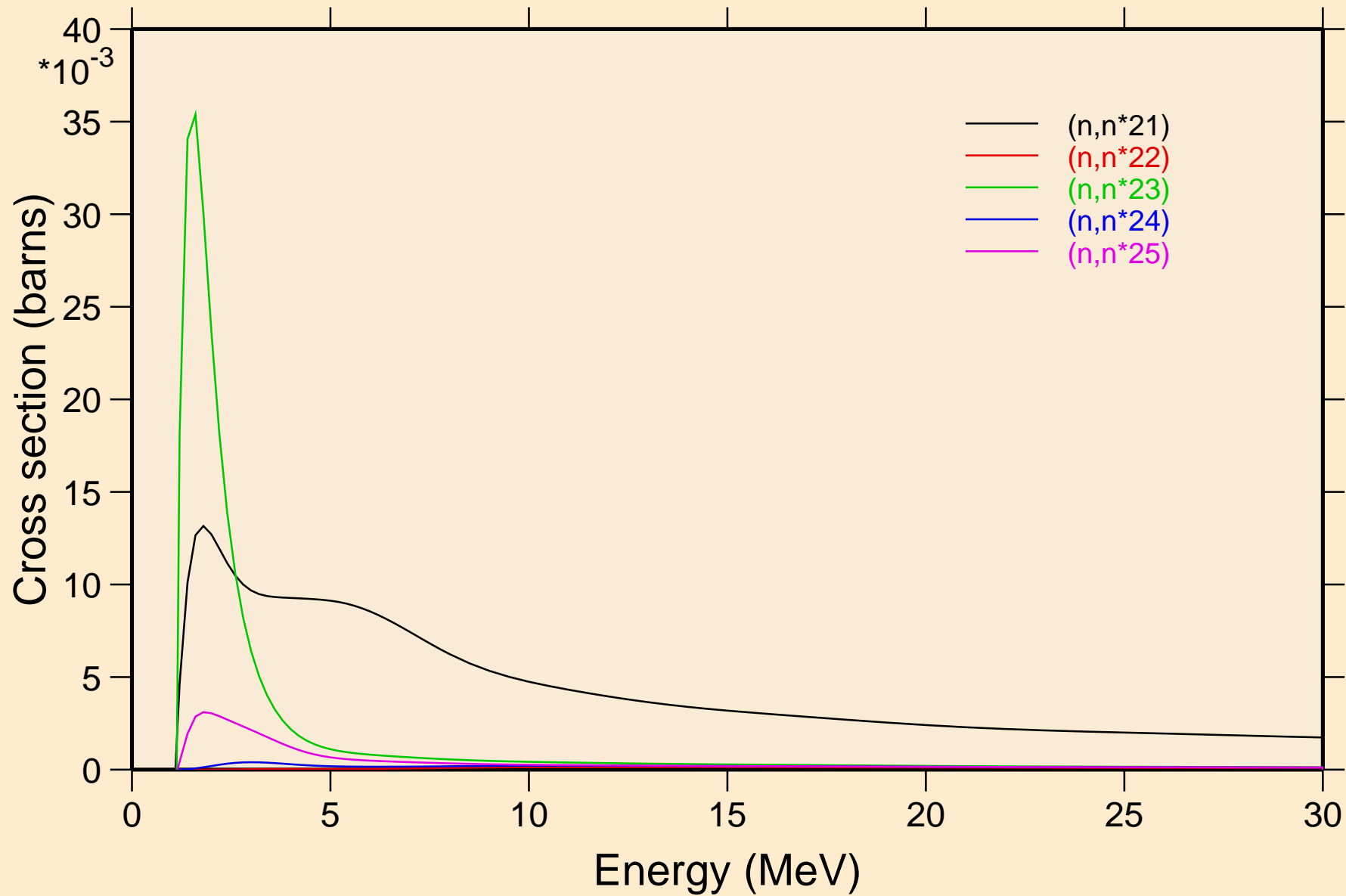

W197 NEUTRON ACER TENDL-2024 LIBRARY; T=0.K  
Inelastic levels

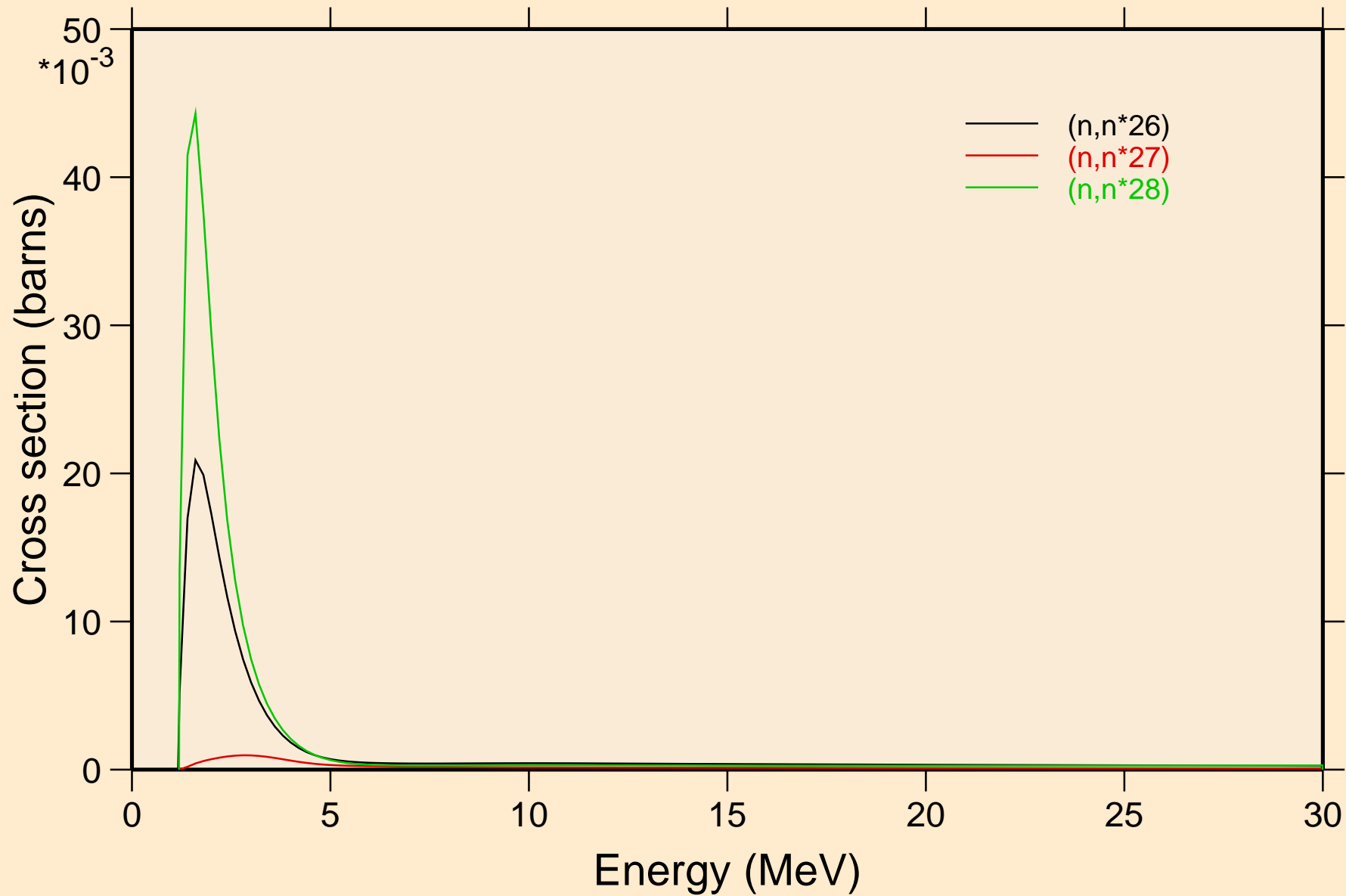

W197 NEUTRON ACER TENDL-2024 LIBRARY; T=0.K  
Threshold reactions

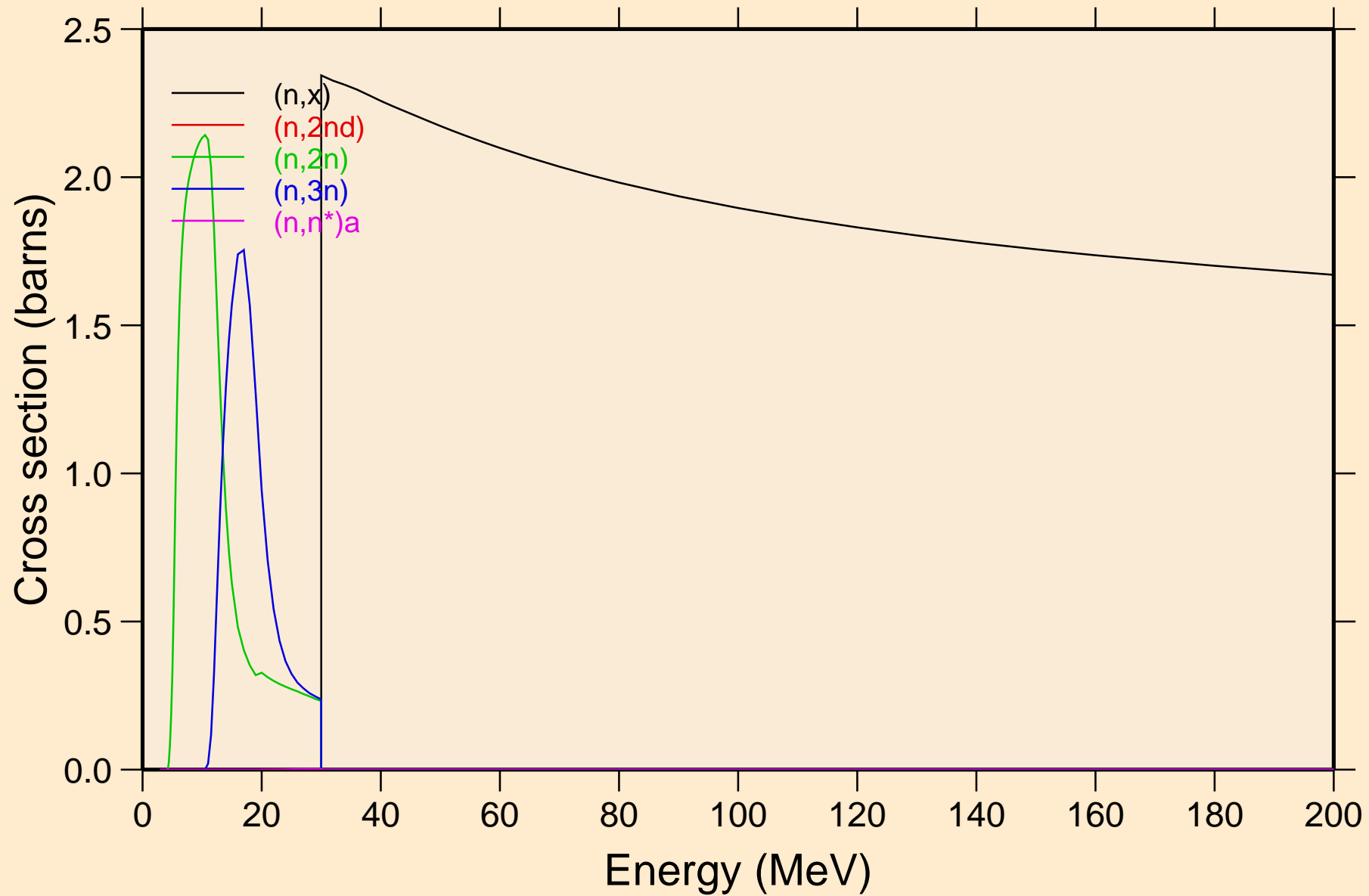

W197 NEUTRON ACER TENDL-2024 LIBRARY; T=0.K  
Threshold reactions

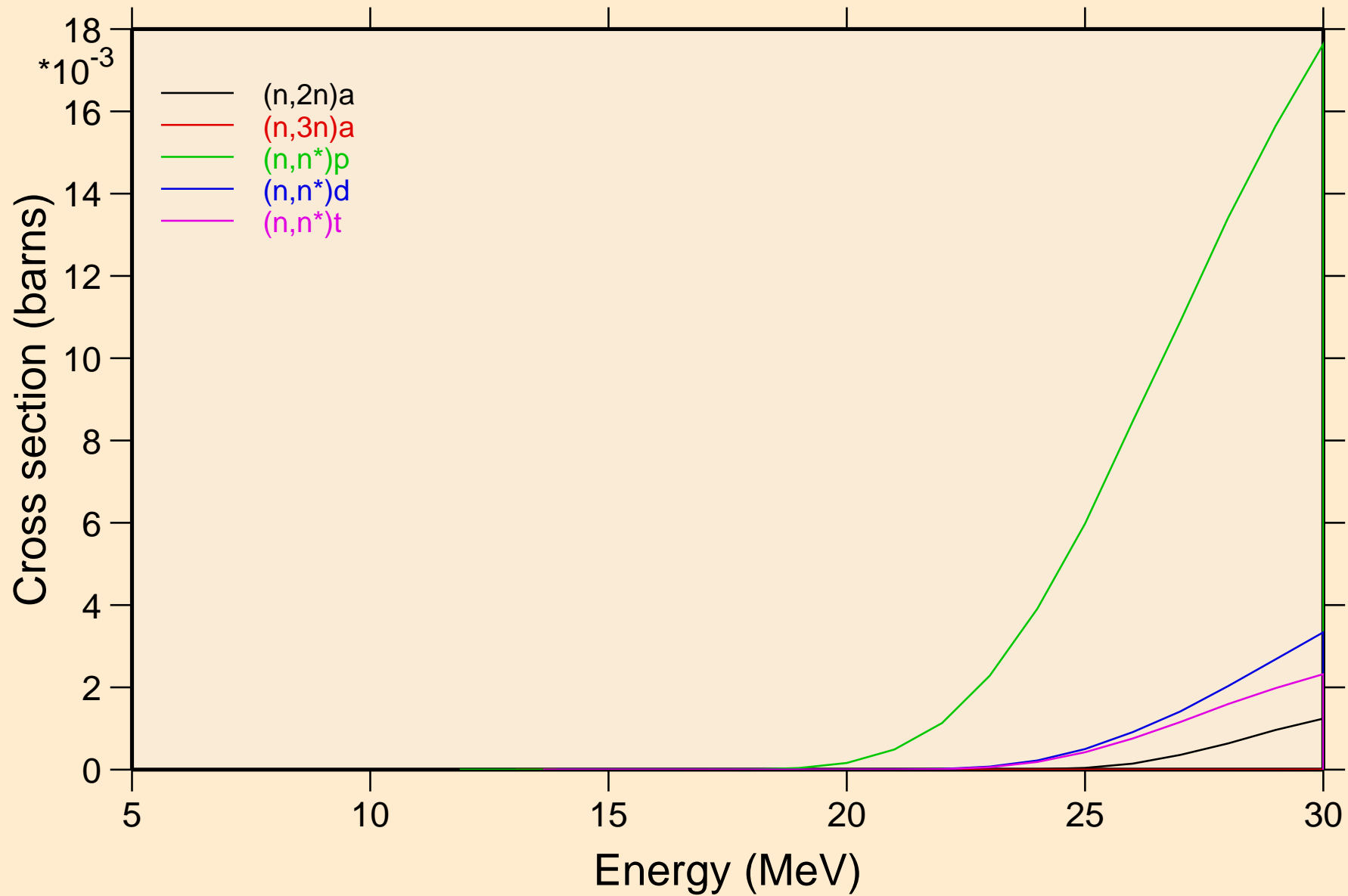

W197 NEUTRON ACER TENDL-2024 LIBRARY; T=0.K  
Threshold reactions

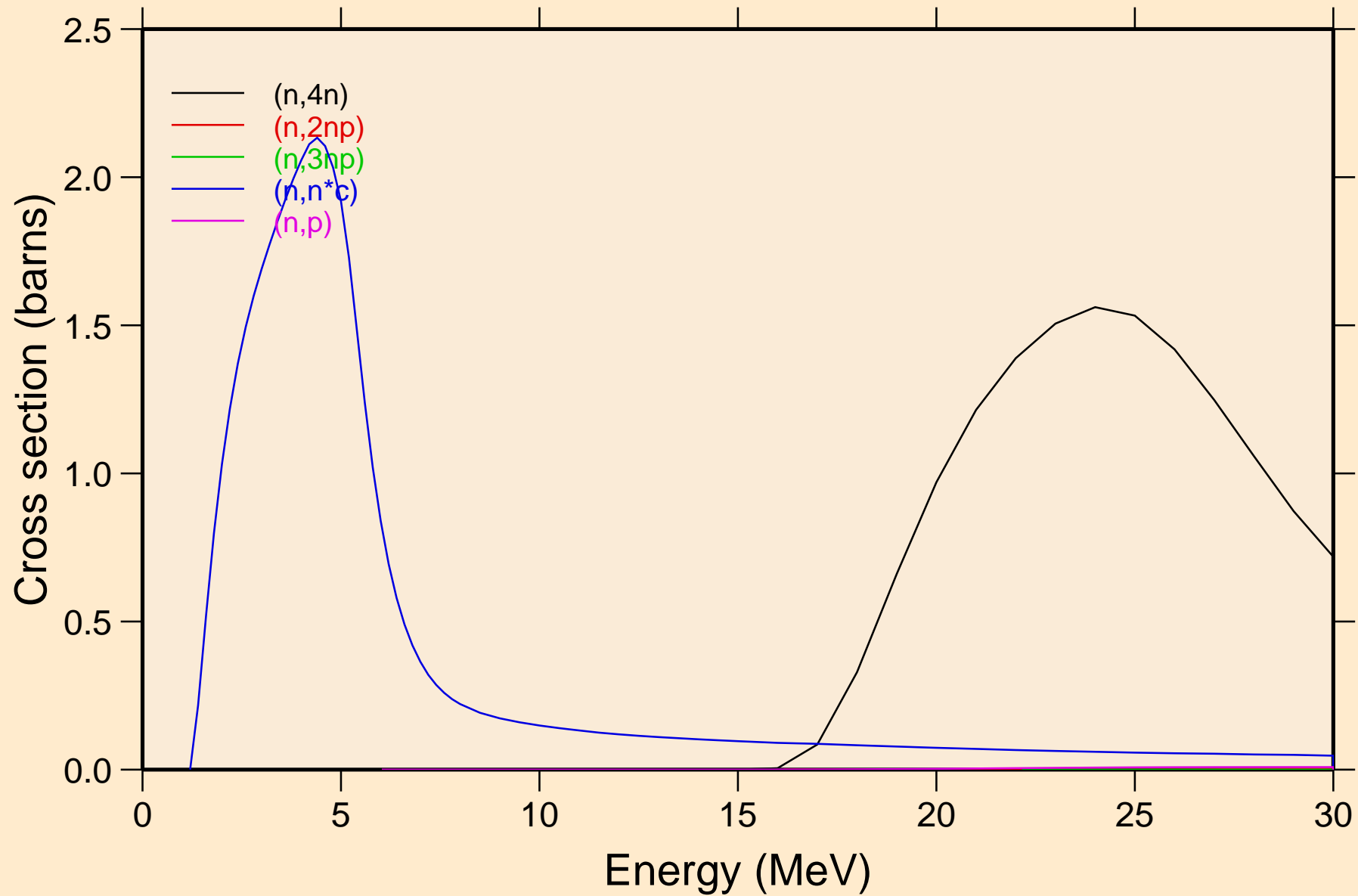

W197 NEUTRON ACER TENDL-2024 LIBRARY; T=0.K  
Threshold reactions

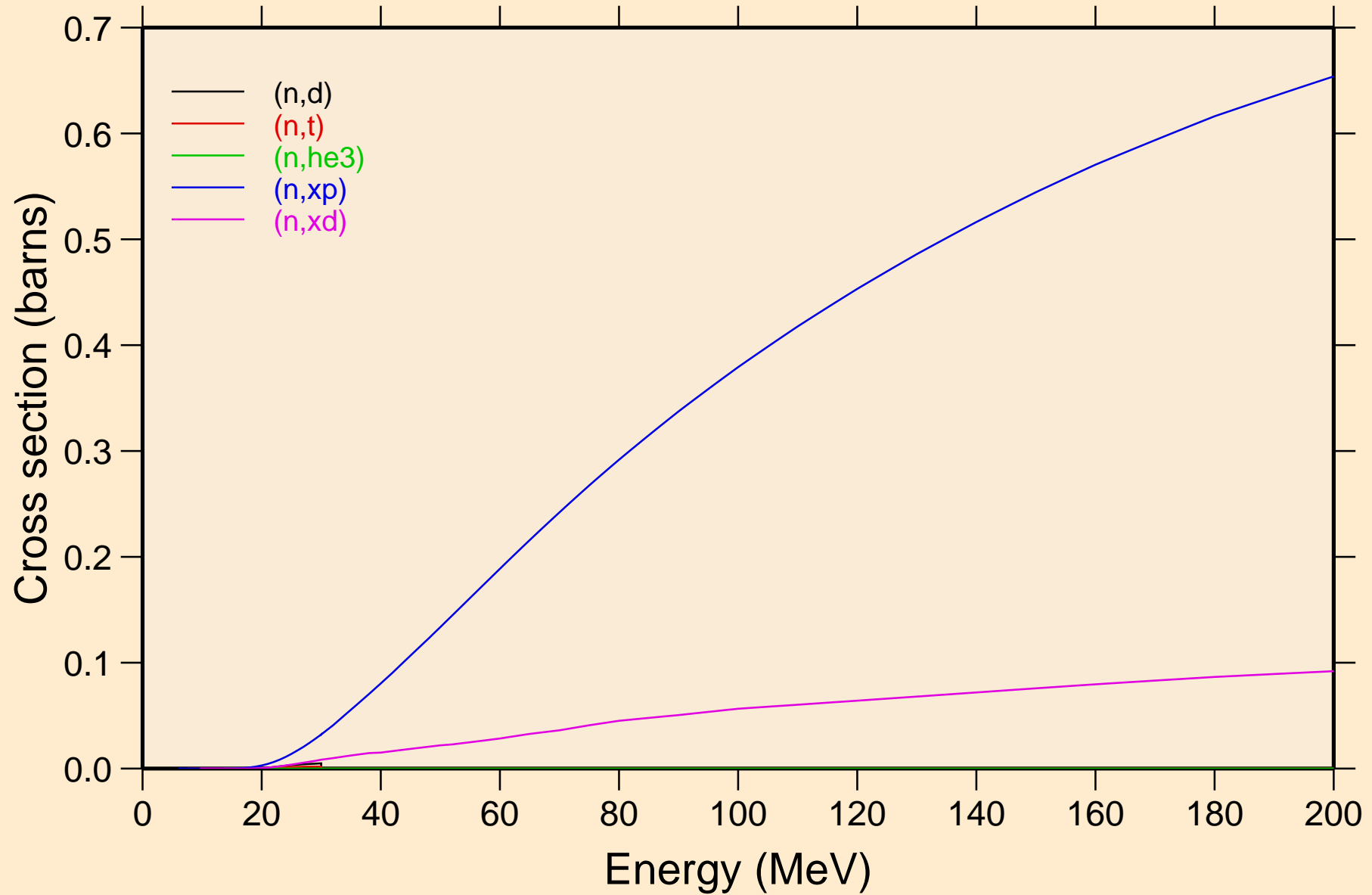

W197 NEUTRON ACER TENDL-2024 LIBRARY; T=0.K  
Threshold reactions

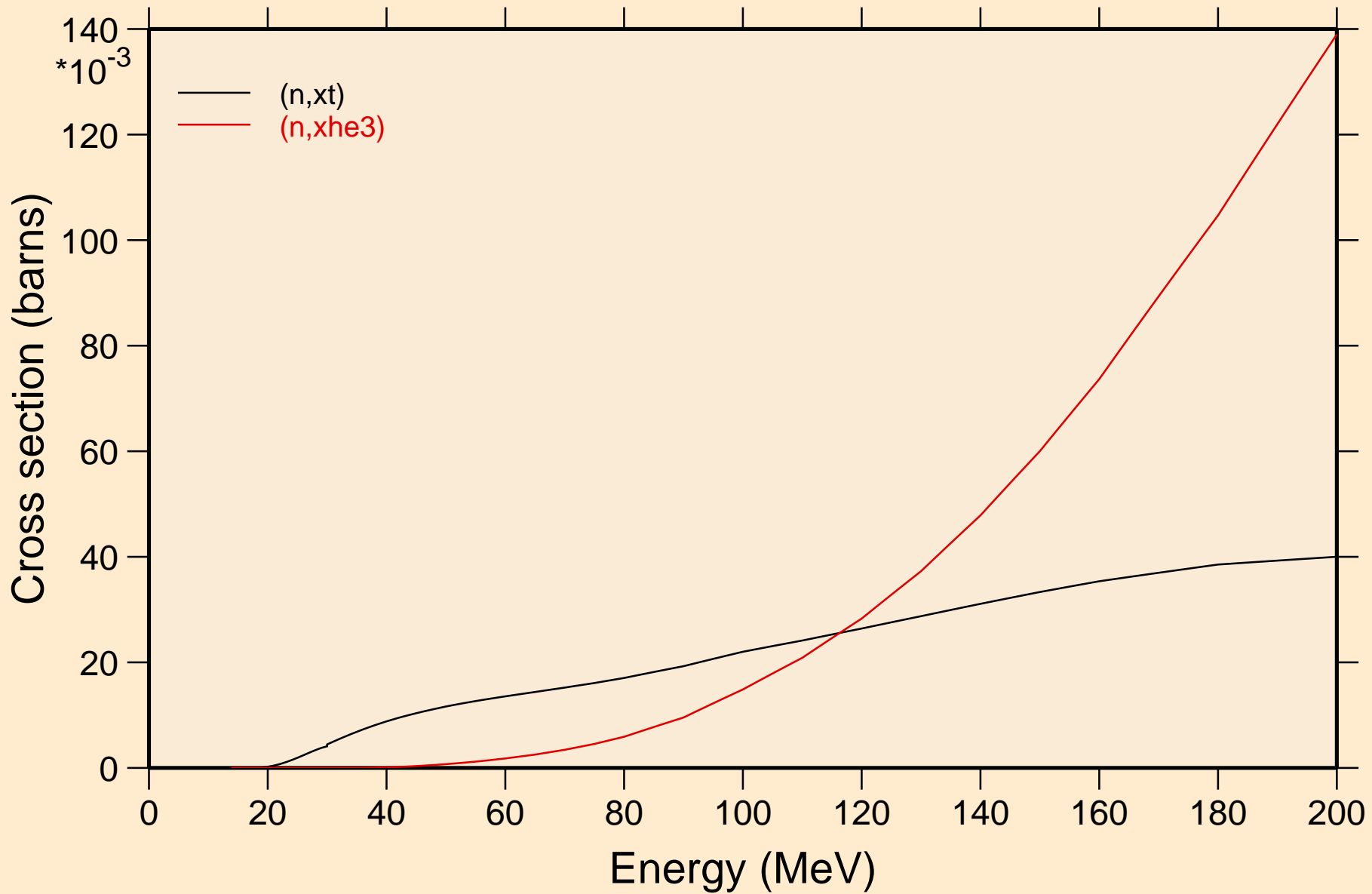

W197 NEUTRON ACER TENDL-2024 LIBRARY; T=0.K  
angular distribution for elastic

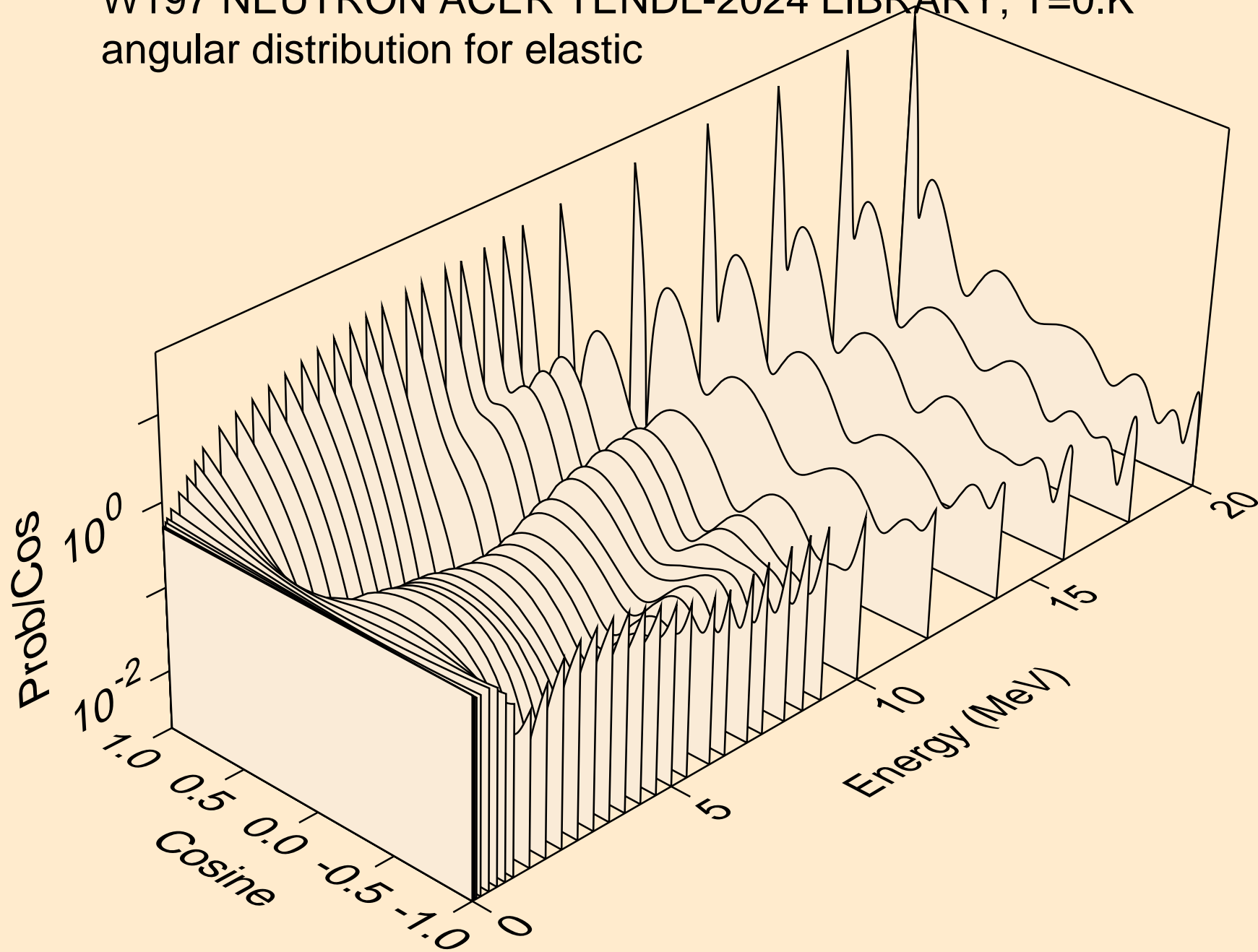

W197 NEUTRON ACER TENDL-2024 LIBRARY; T=0.K  
angular distribution for elastic

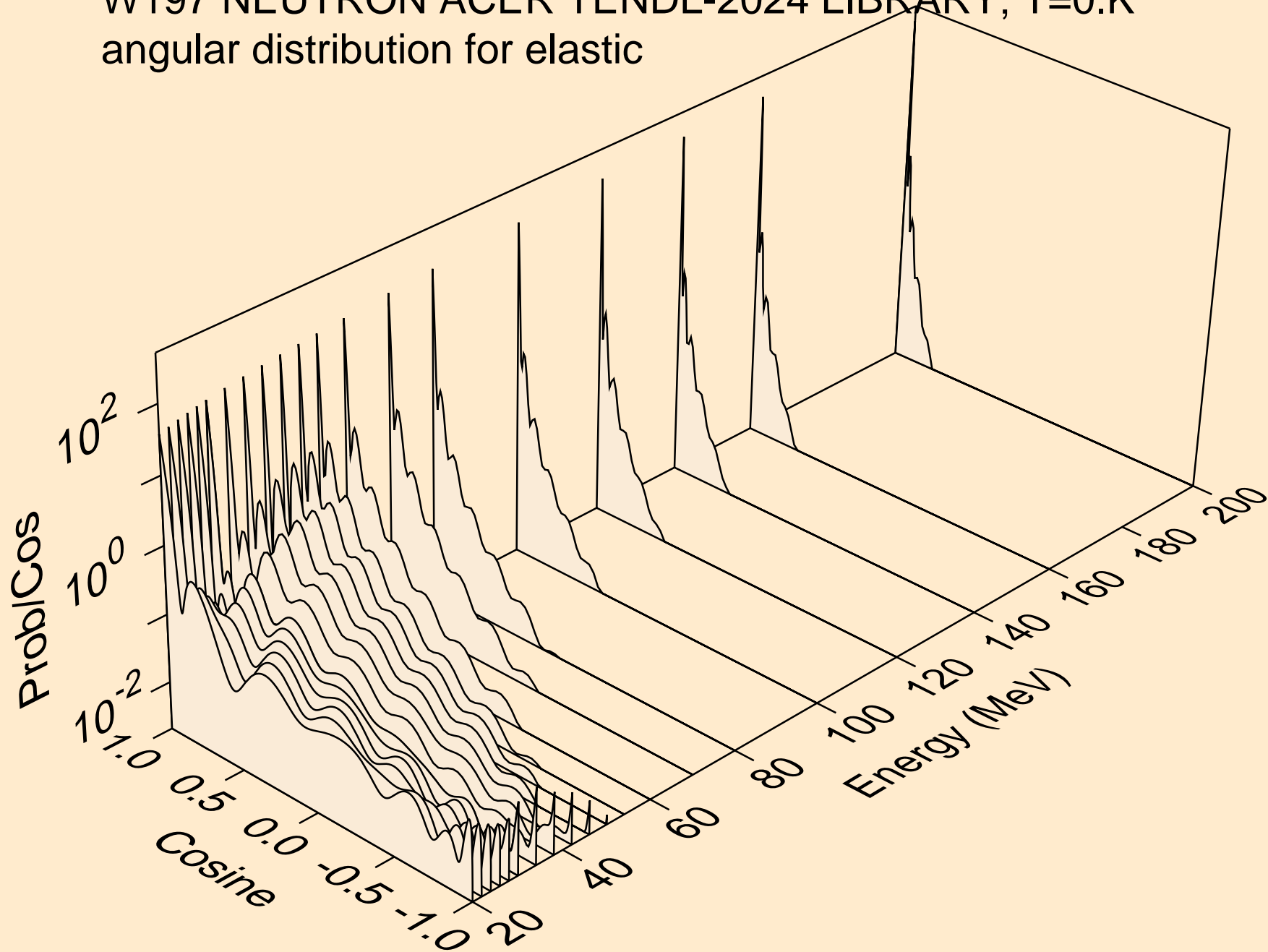

W197 NEUTRON ACER TENDL-2024 LIBRARY; T=0.K  
angular distribution for (n,n\*1)

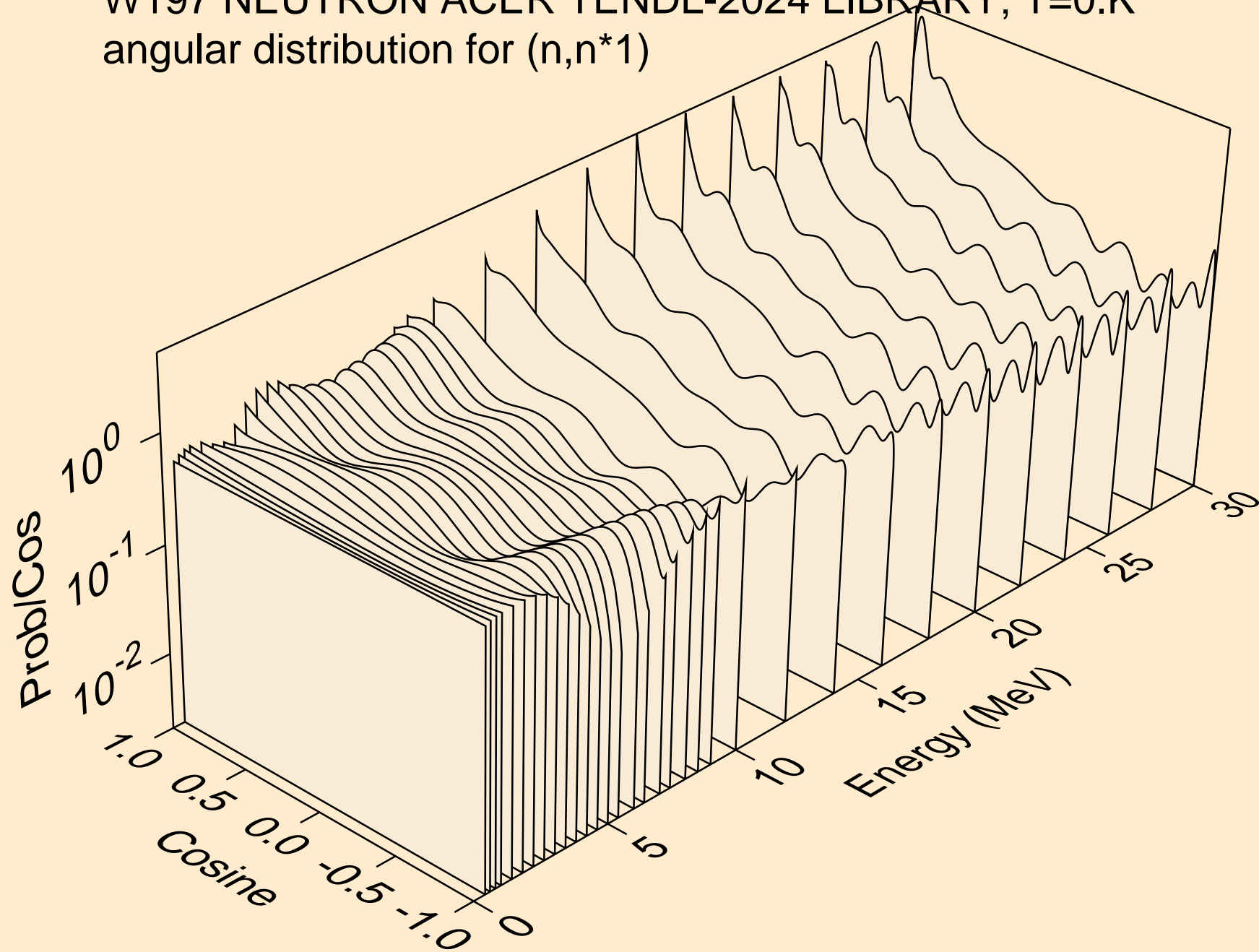

W197 NEUTRON ACER TENDL-2024 LIBRARY; T=0.K  
angular distribution for (n,n\*2)

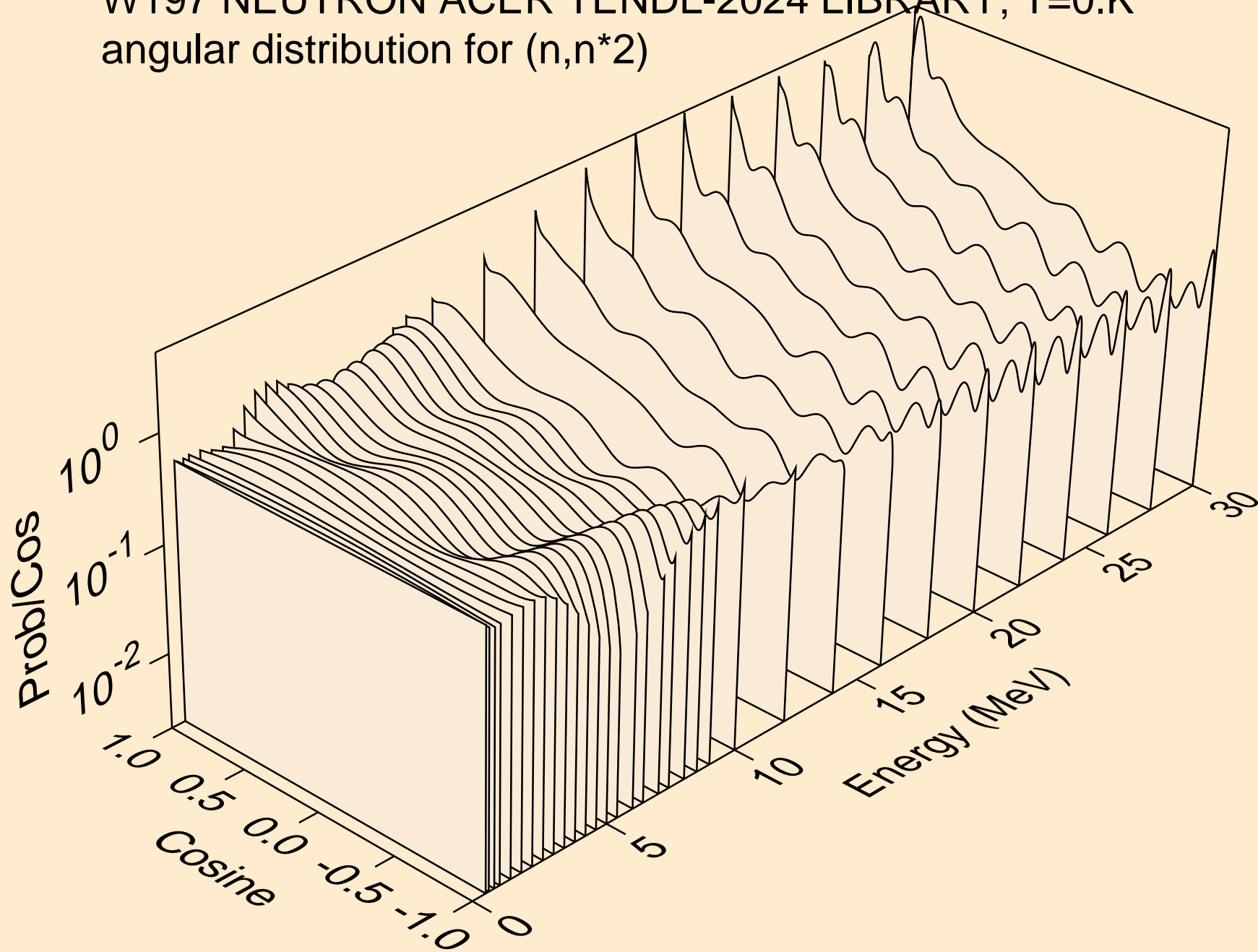

W197 NEUTRON ACER TENDL-2024 LIBRARY; T=0.K  
angular distribution for (n,n\*3)

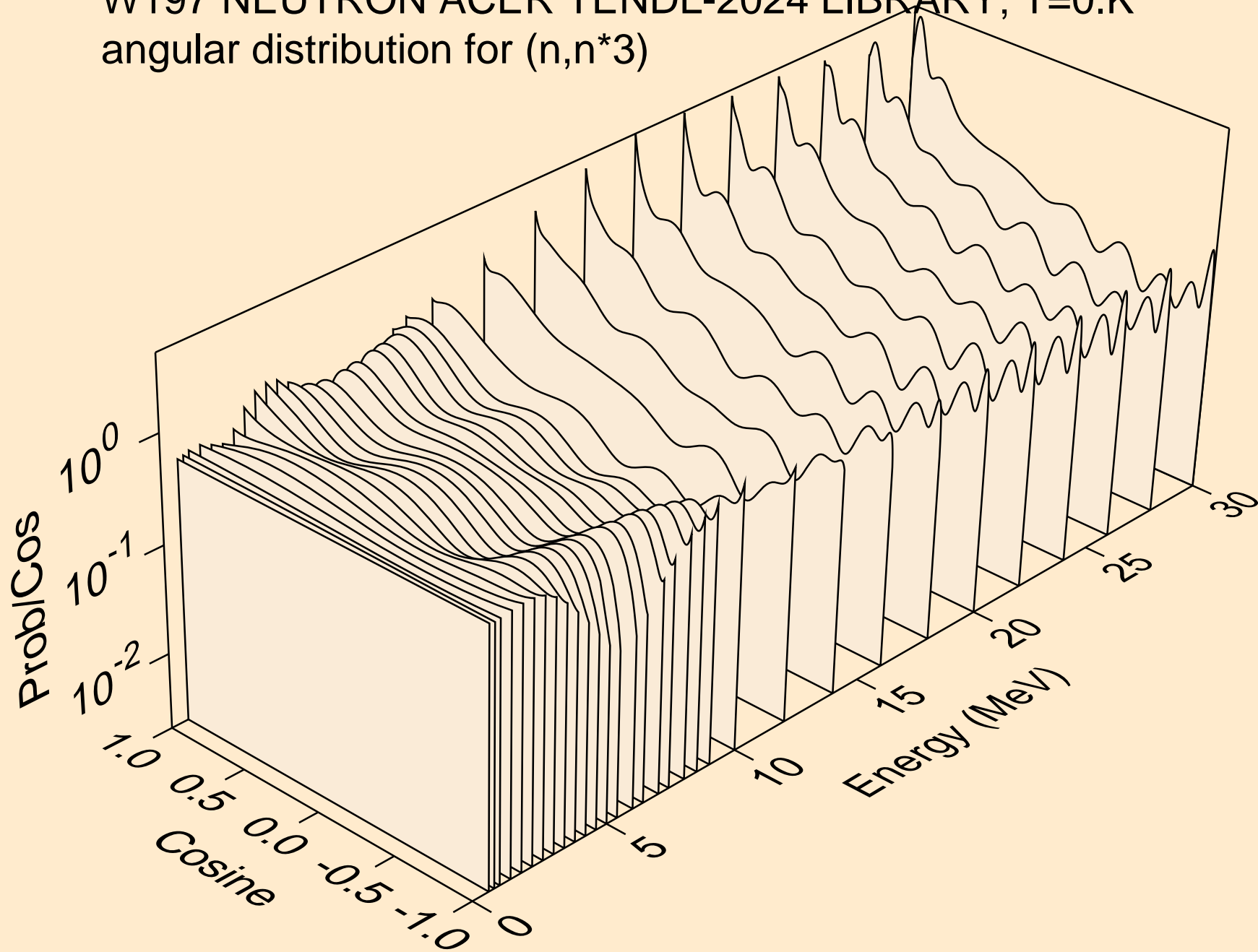

W197 NEUTRON ACER TENDL-2024 LIBRARY; T=0.K  
angular distribution for (n,n\*4)

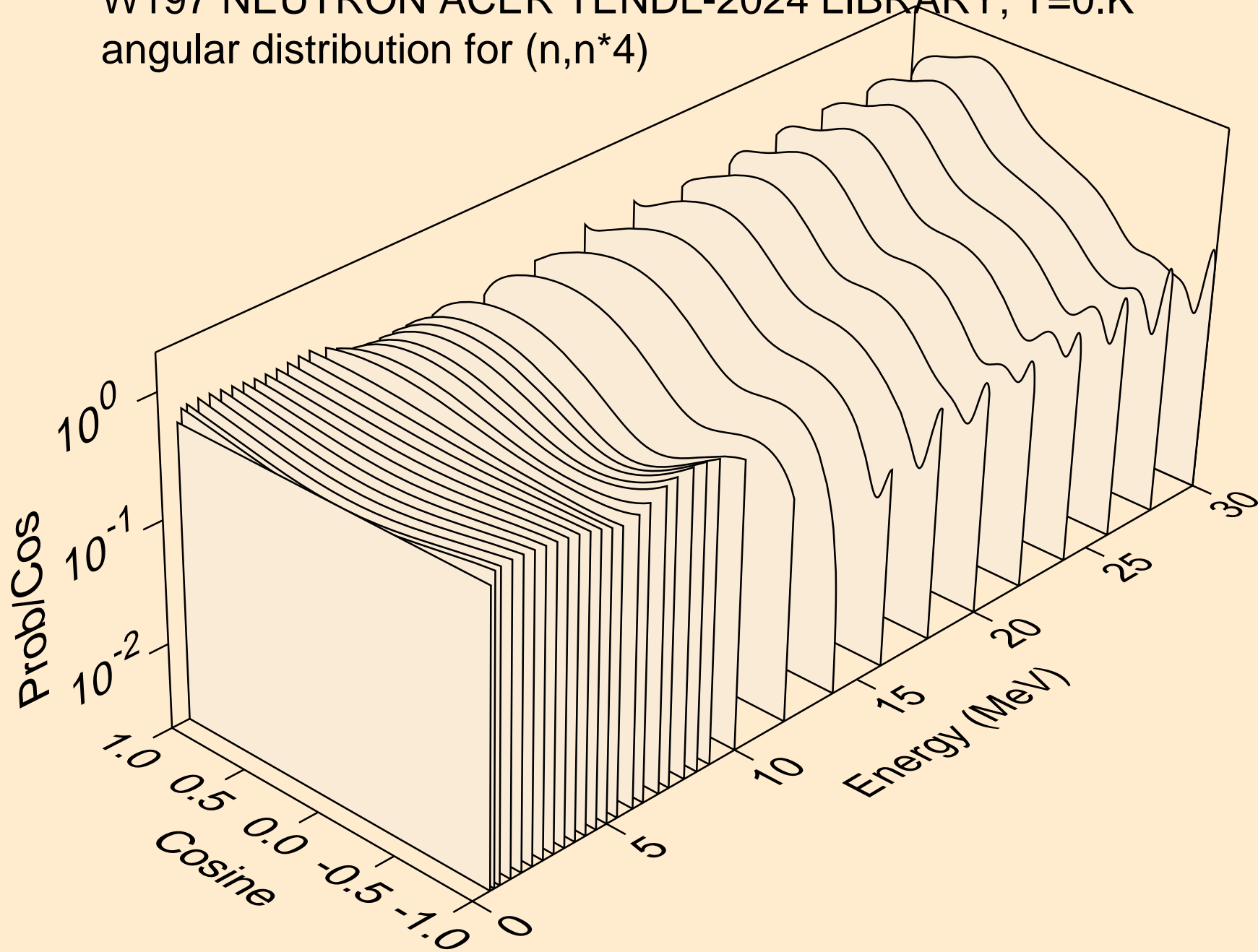

W197 NEUTRON ACER TENDL-2024 LIBRARY; T=0.K  
angular distribution for (n,n\*5)

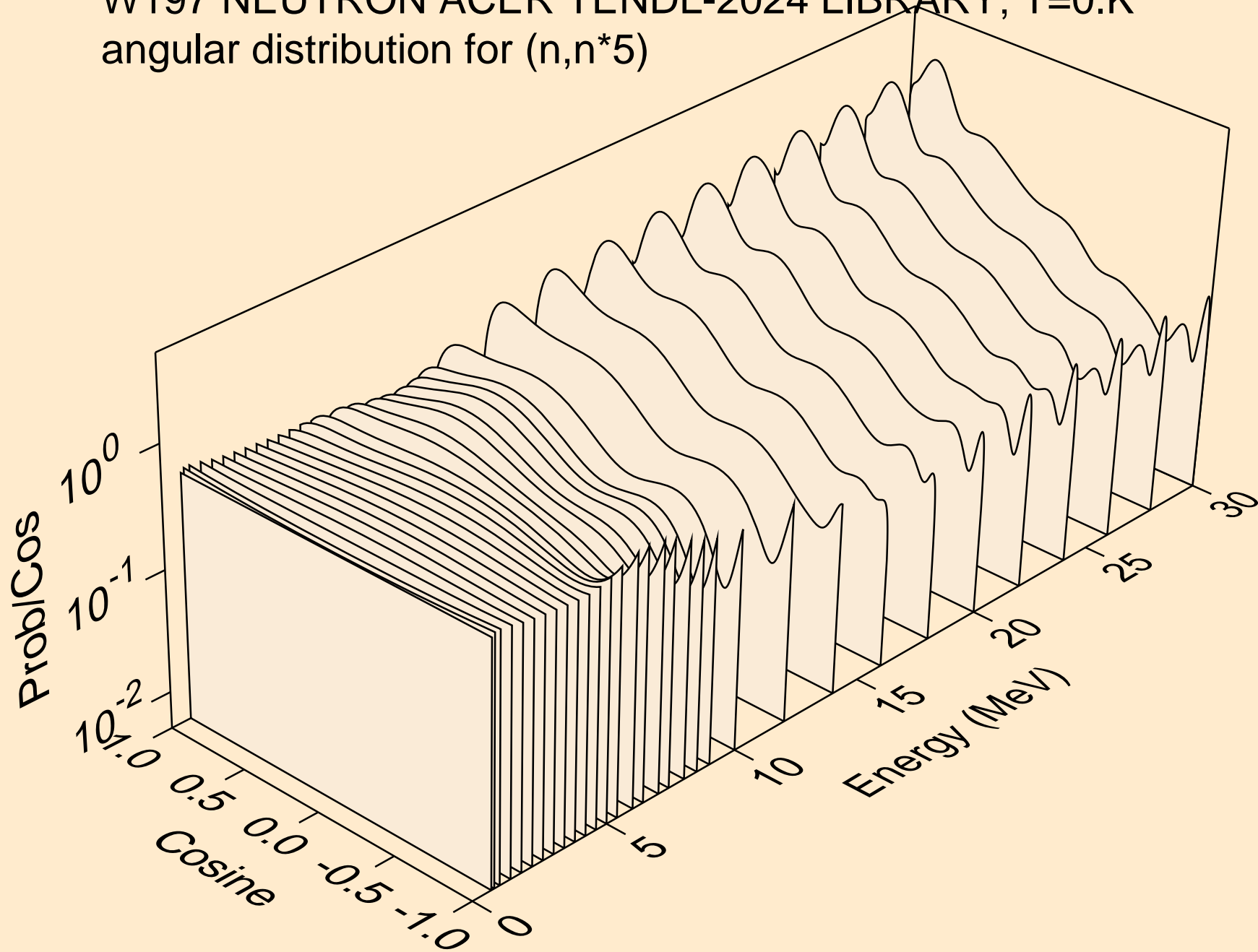

W197 NEUTRON ACER TENDL-2024 LIBRARY; T=0.K  
angular distribution for (n,n\*6)

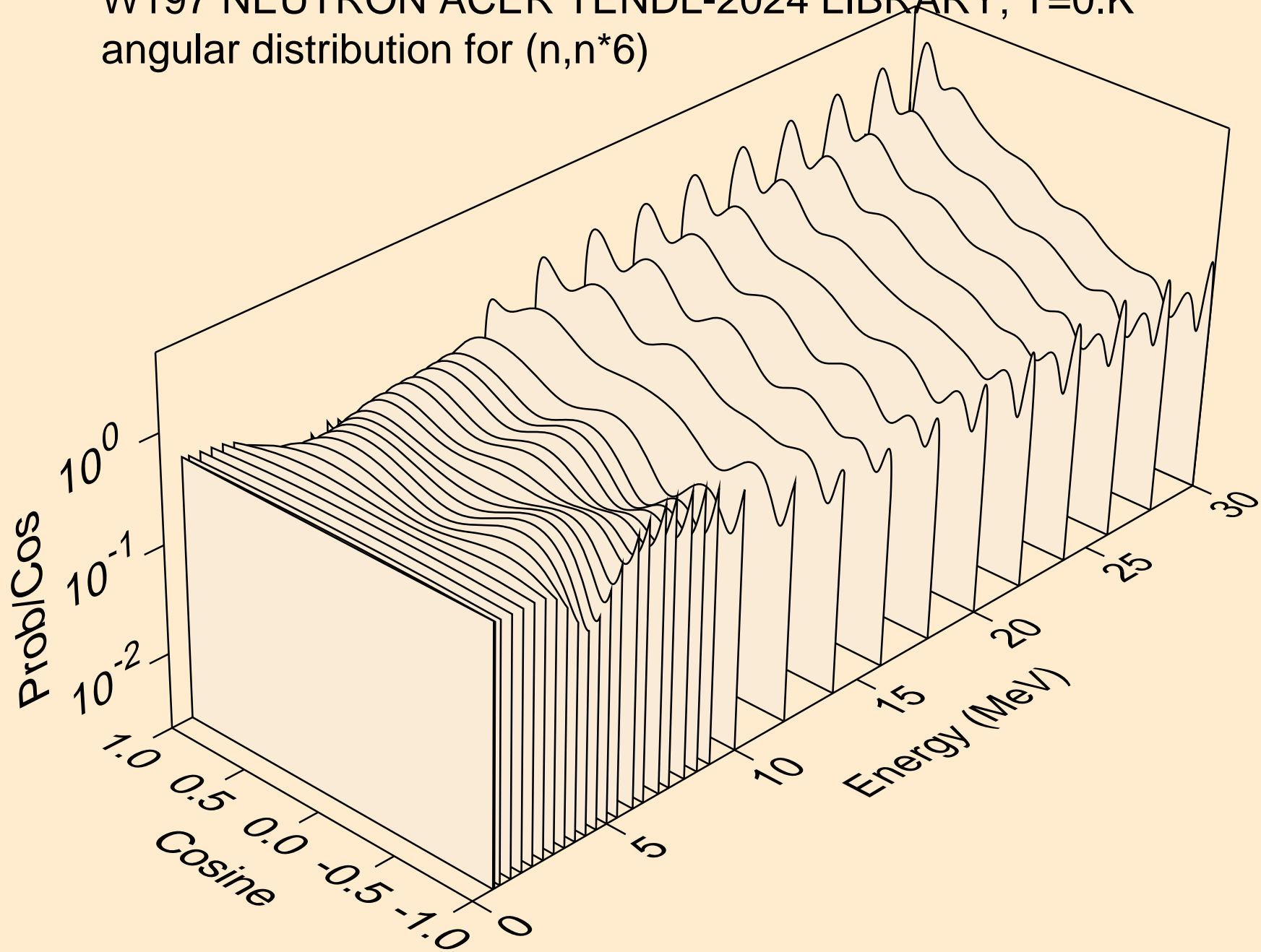

W197 NEUTRON ACER TENDL-2024 LIBRARY; T=0.K  
angular distribution for (n,n\*7)

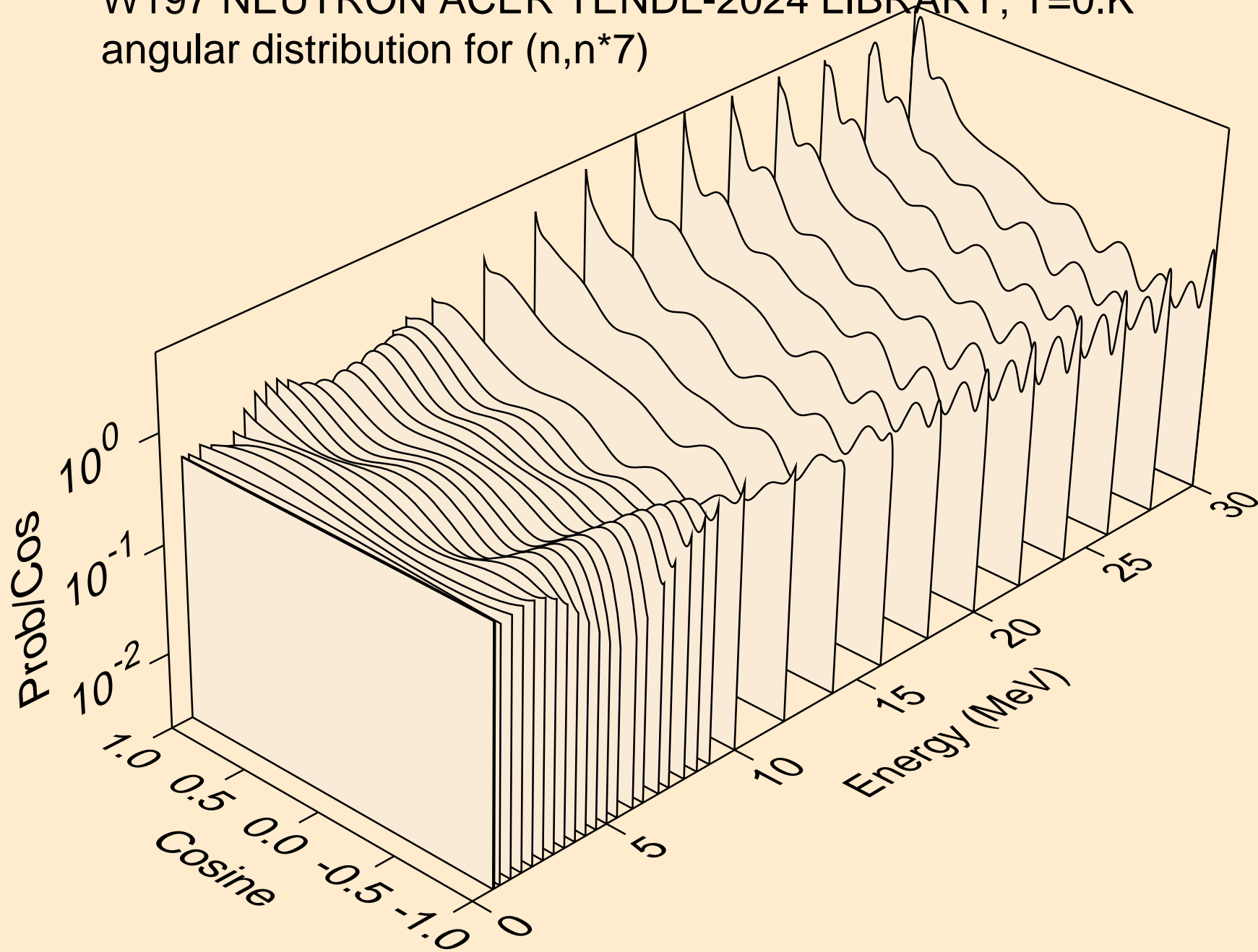

W197 NEUTRON ACER TENDL-2024 LIBRARY; T=0.K  
angular distribution for (n,n\*8)

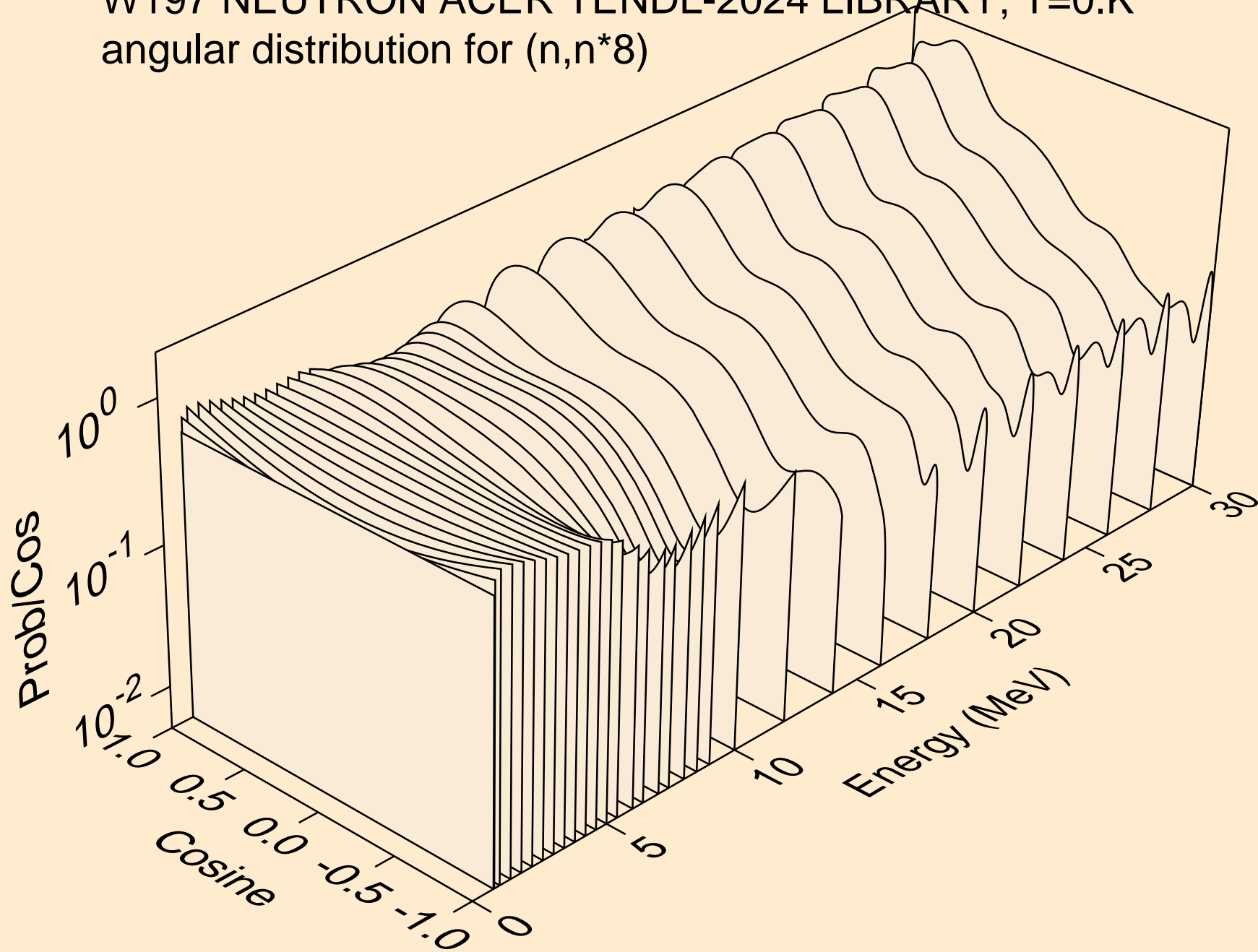

W197 NEUTRON ACER TENDL-2024 LIBRARY; T=0.K  
angular distribution for (n,n\*9)

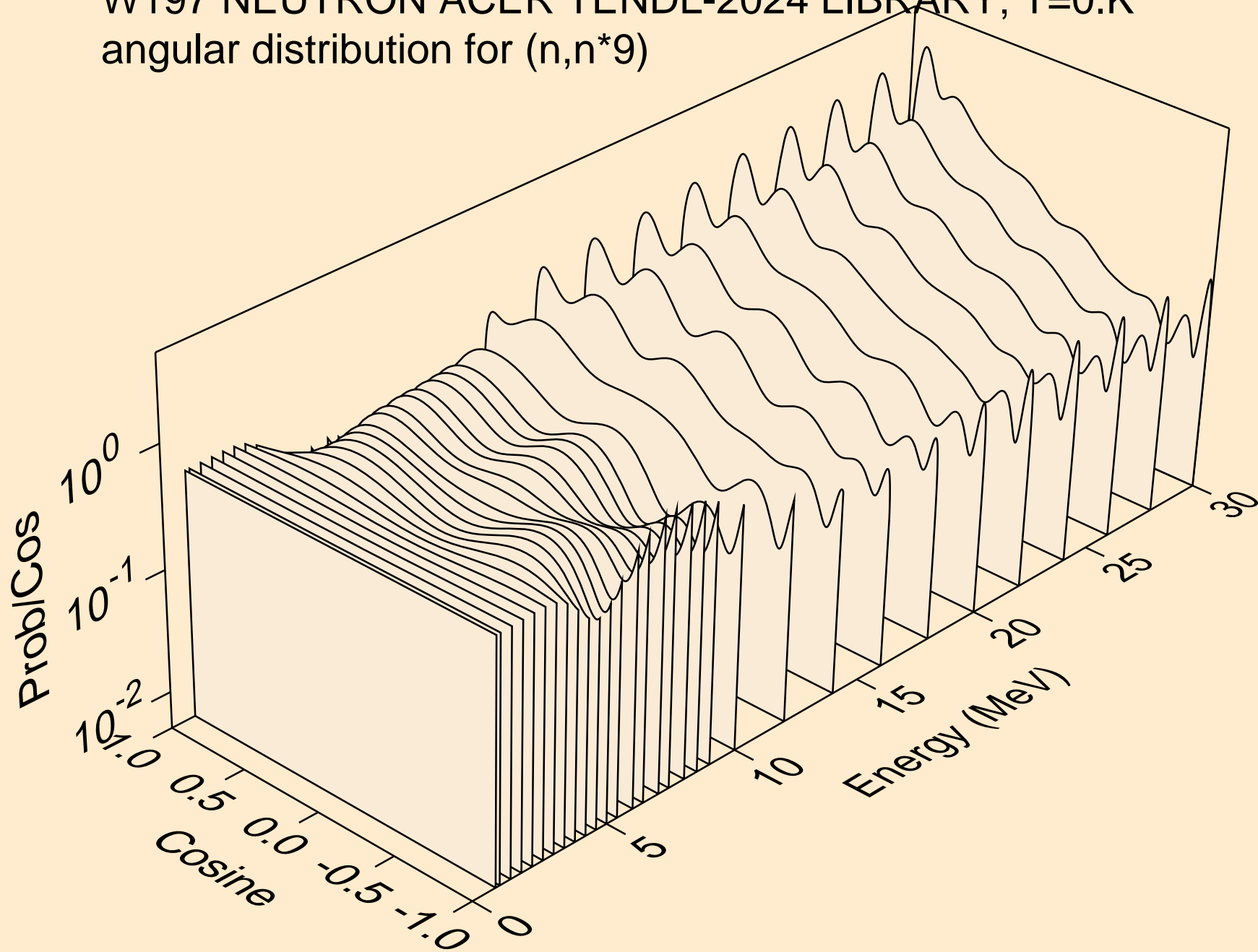

W197 NEUTRON ACER TENDL-2024 LIBRARY; T=0.K  
angular distribution for (n,n\*10)

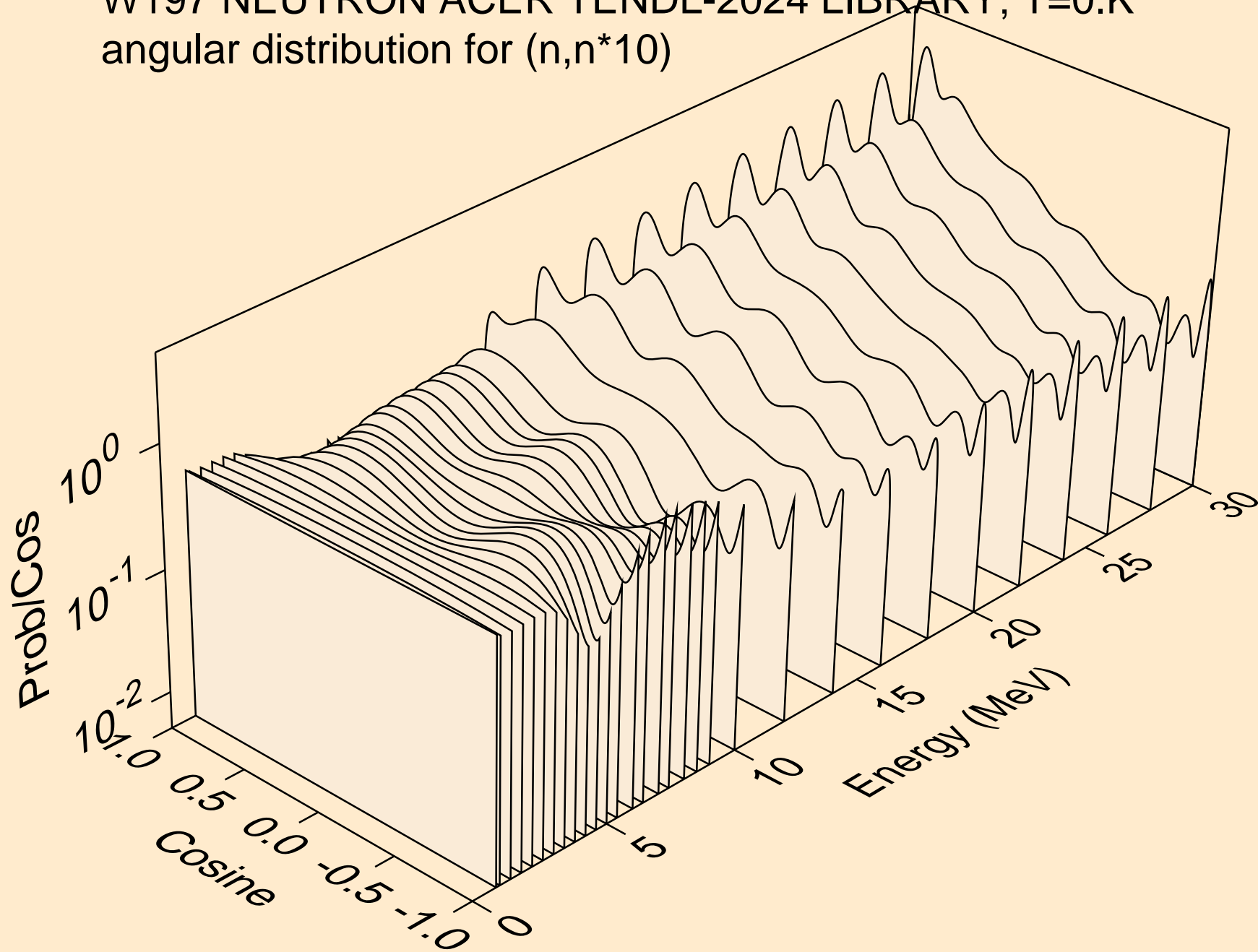

W197 NEUTRON ACER TENDL-2024 LIBRARY; T=0.K  
angular distribution for (n,n\*11)

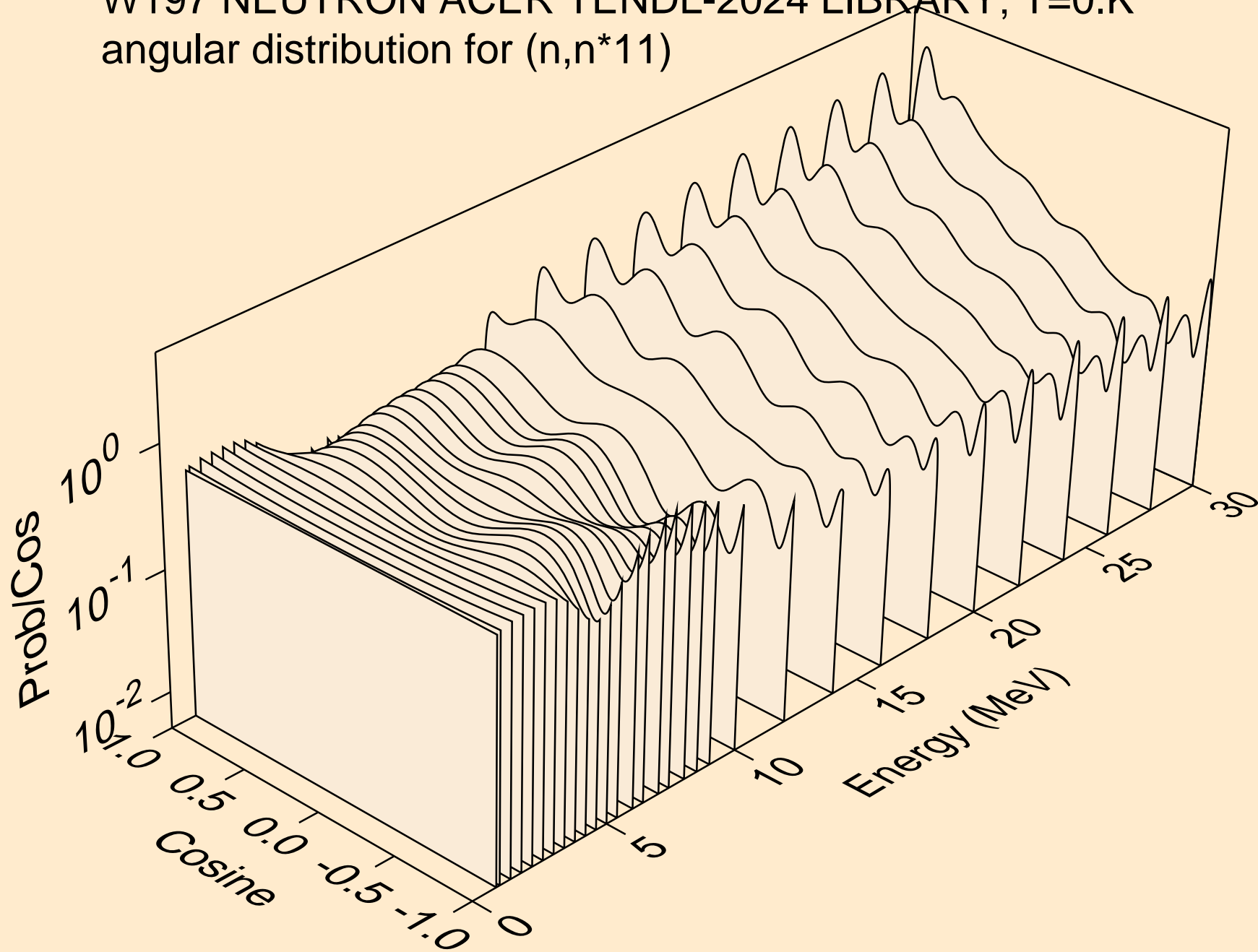

W197 NEUTRON ACER TENDL-2024 LIBRARY; T=0.K  
angular distribution for (n,n\*12)

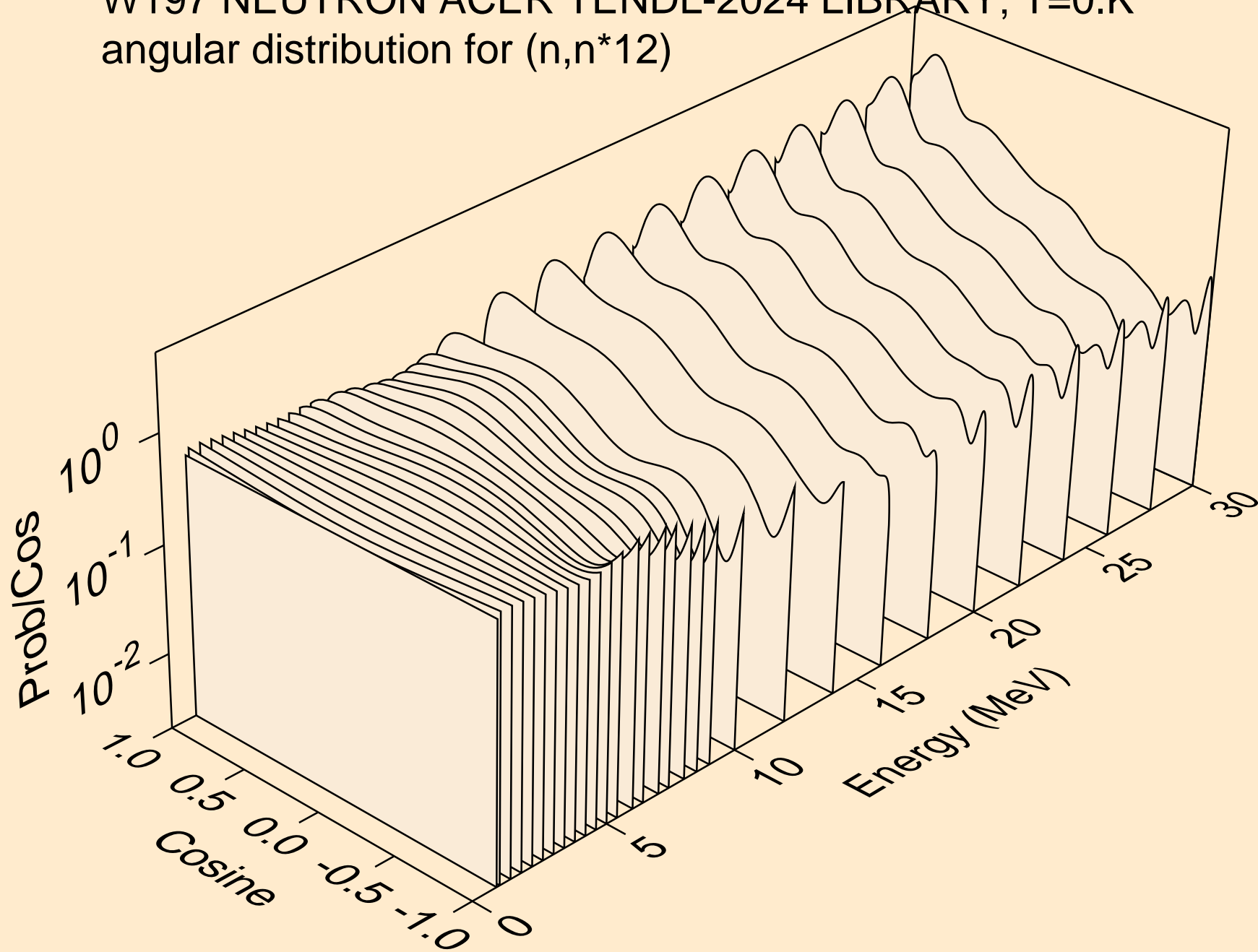

W197 NEUTRON ACER TENDL-2024 LIBRARY; T=0.K  
angular distribution for (n,n\*13)

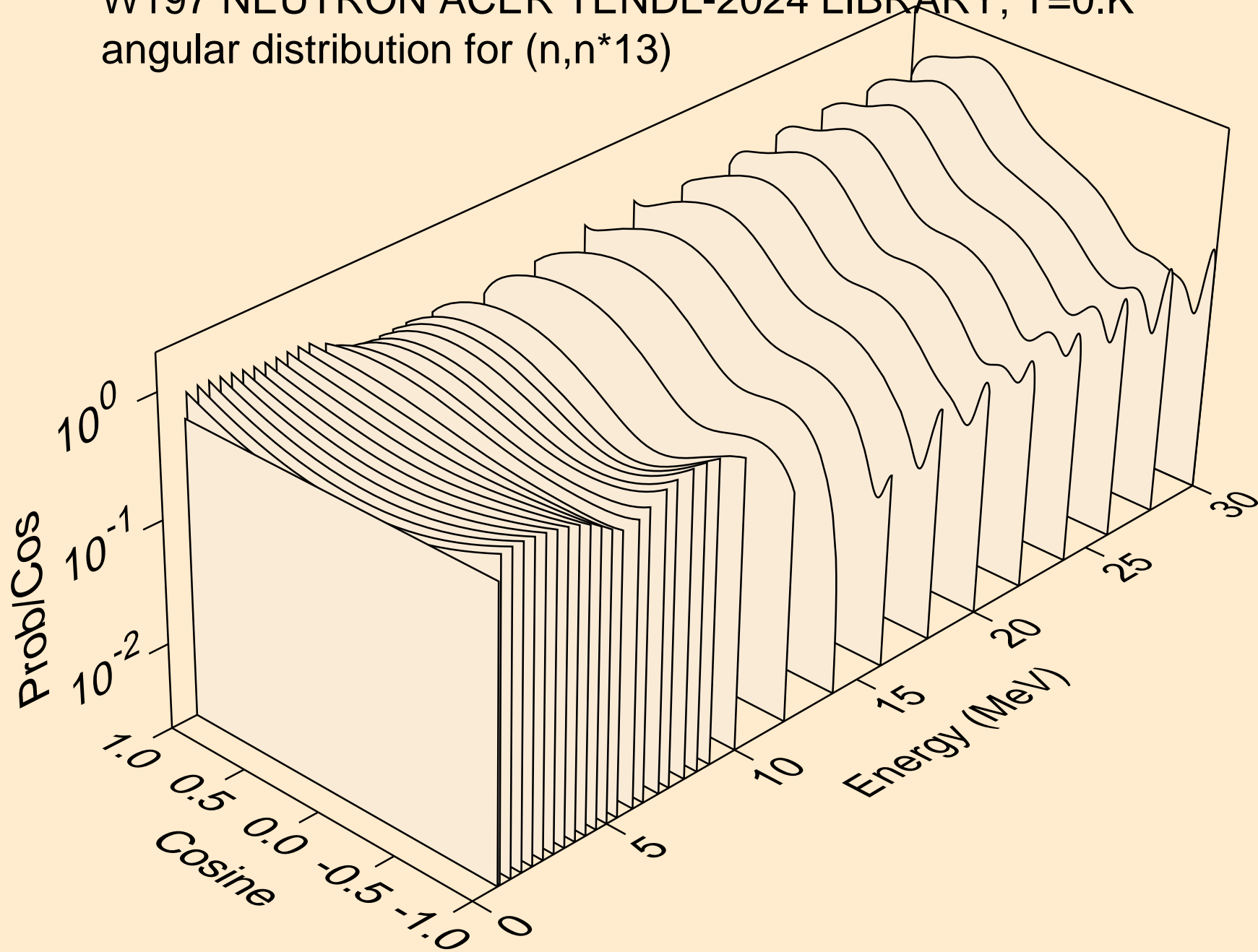

W197 NEUTRON ACER TENDL-2024 LIBRARY; T=0.K  
angular distribution for (n,n\*14)

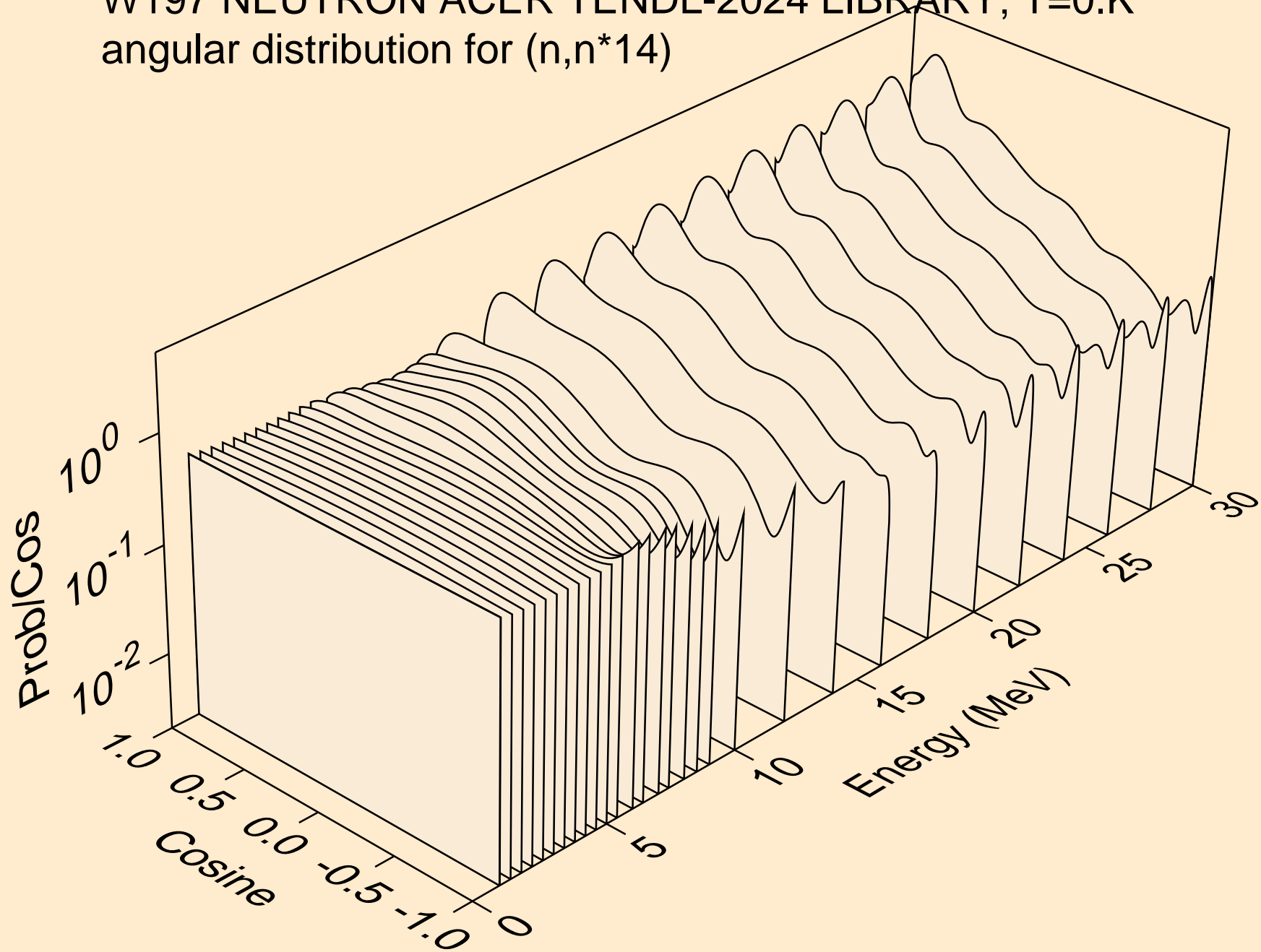

W197 NEUTRON ACER TENDL-2024 LIBRARY; T=0.K  
angular distribution for (n,n\*15)

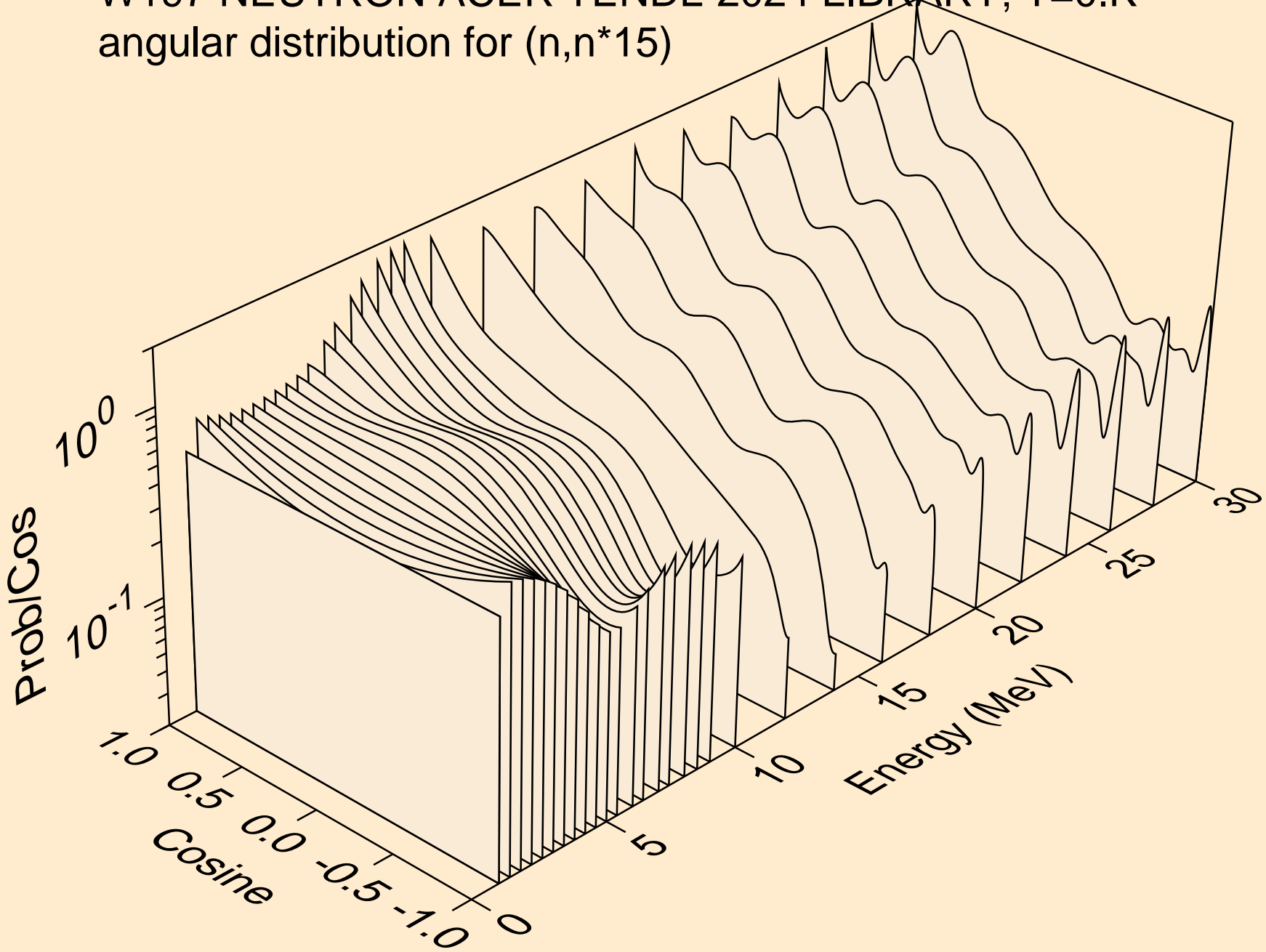

W197 NEUTRON ACER TENDL-2024 LIBRARY; T=0.K  
angular distribution for (n,n\*16)

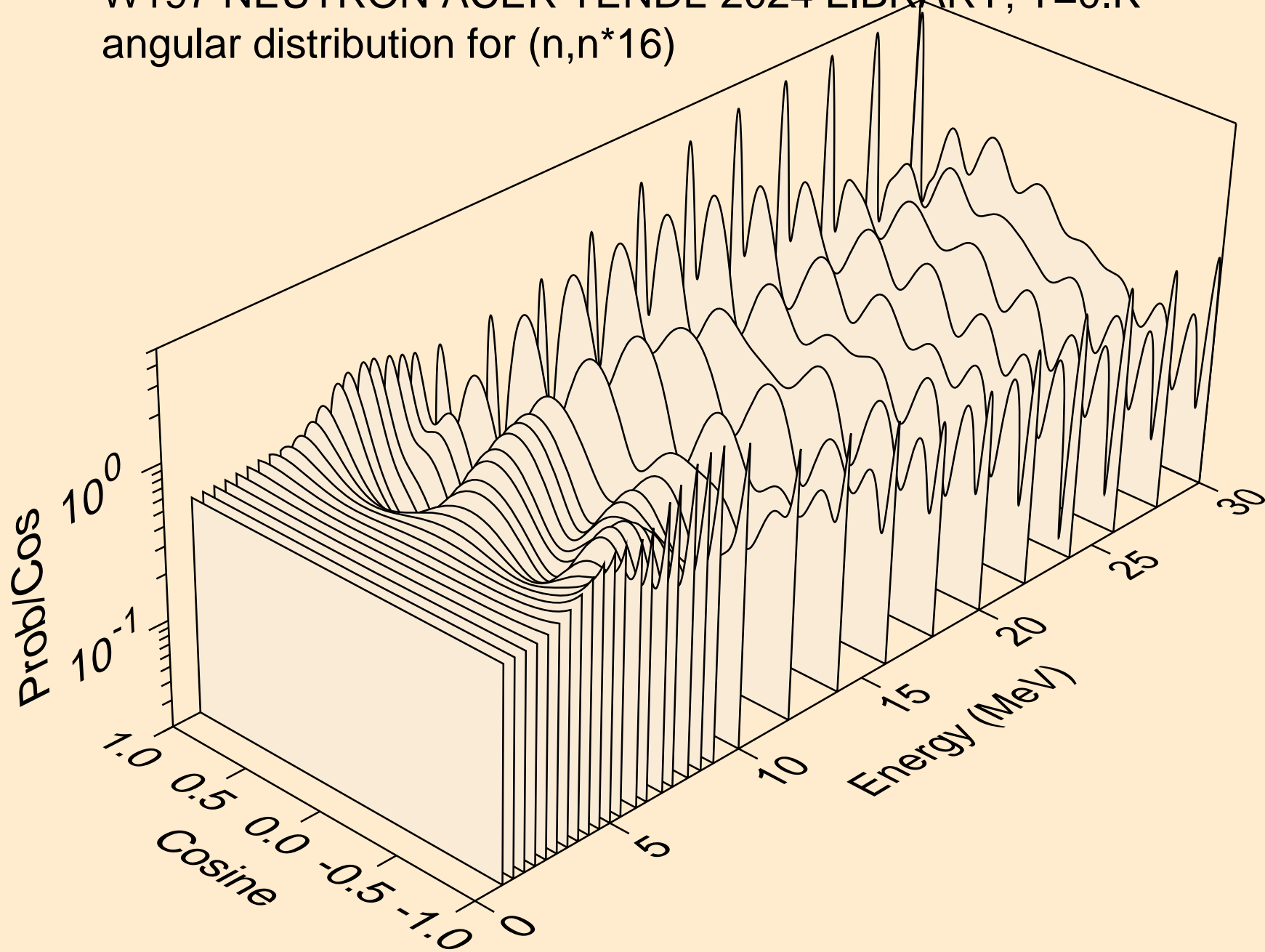

W197 NEUTRON ACER TENDL-2024 LIBRARY; T=0.K  
angular distribution for (n,n\*17)

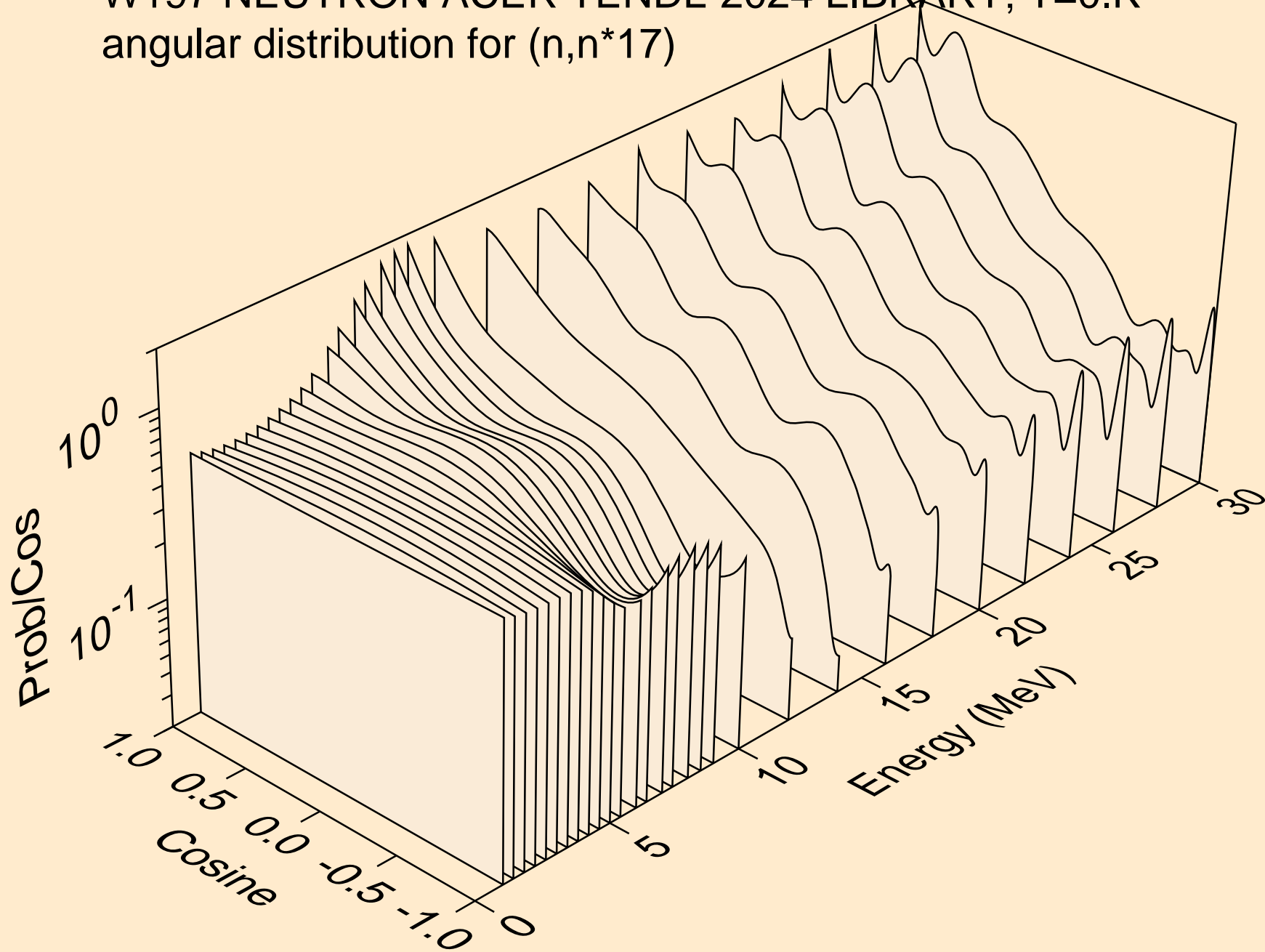

W197 NEUTRON ACER TENDL-2024 LIBRARY; T=0.K  
angular distribution for (n,n\*18)

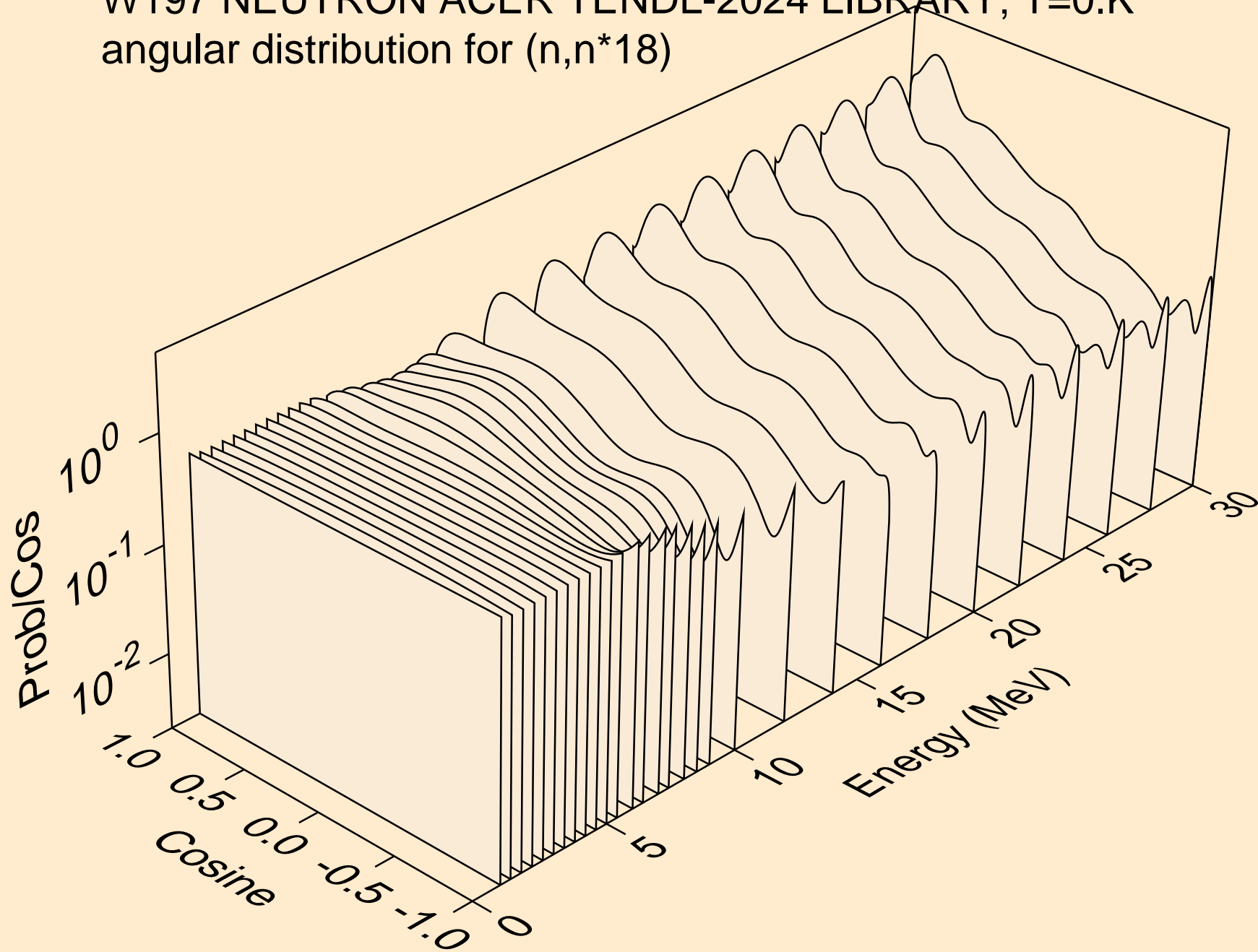

W197 NEUTRON ACER TENDL-2024 LIBRARY; T=0.K  
angular distribution for (n,n\*19)

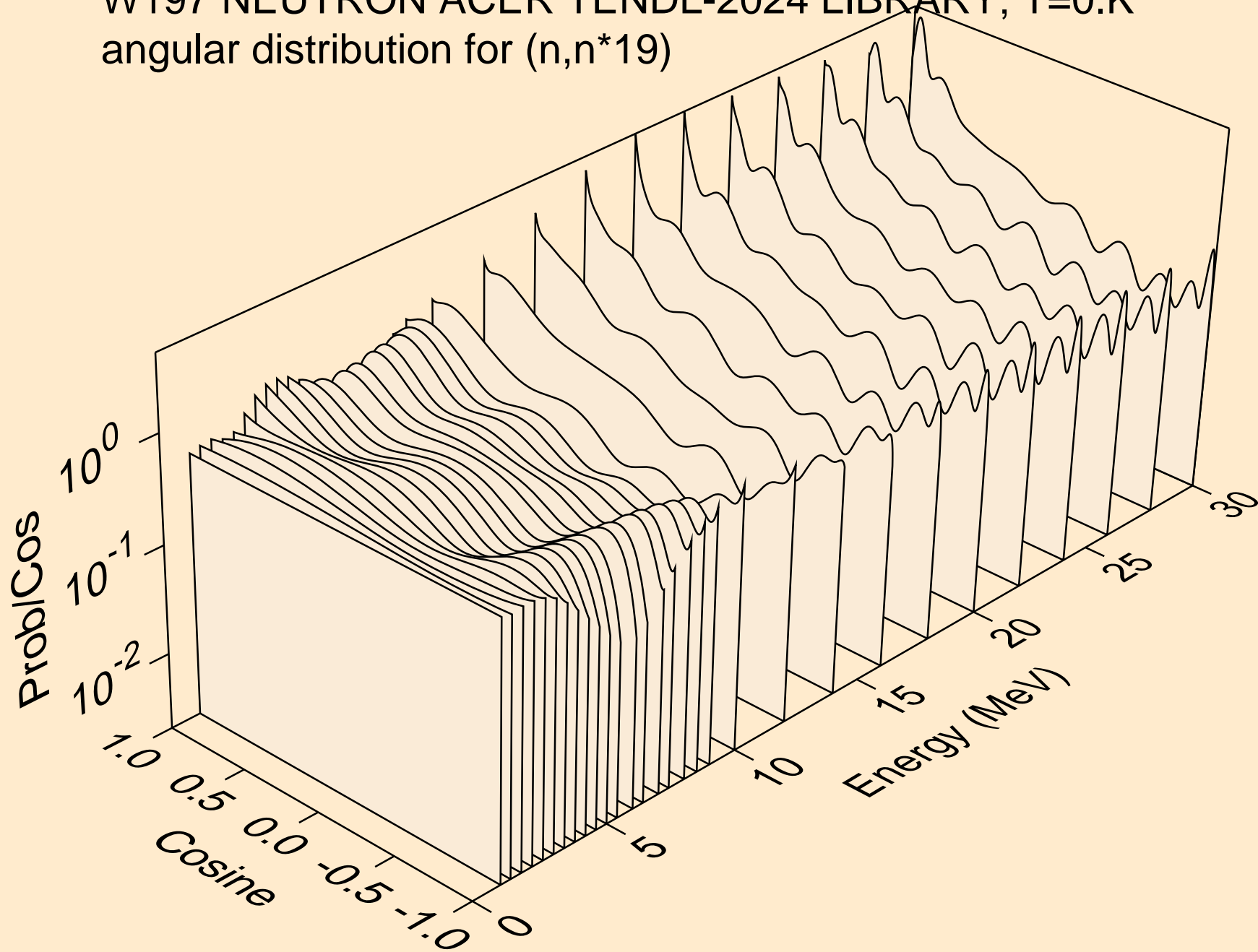

W197 NEUTRON ACER TENDL-2024 LIBRARY; T=0.K  
angular distribution for (n,n\*20)

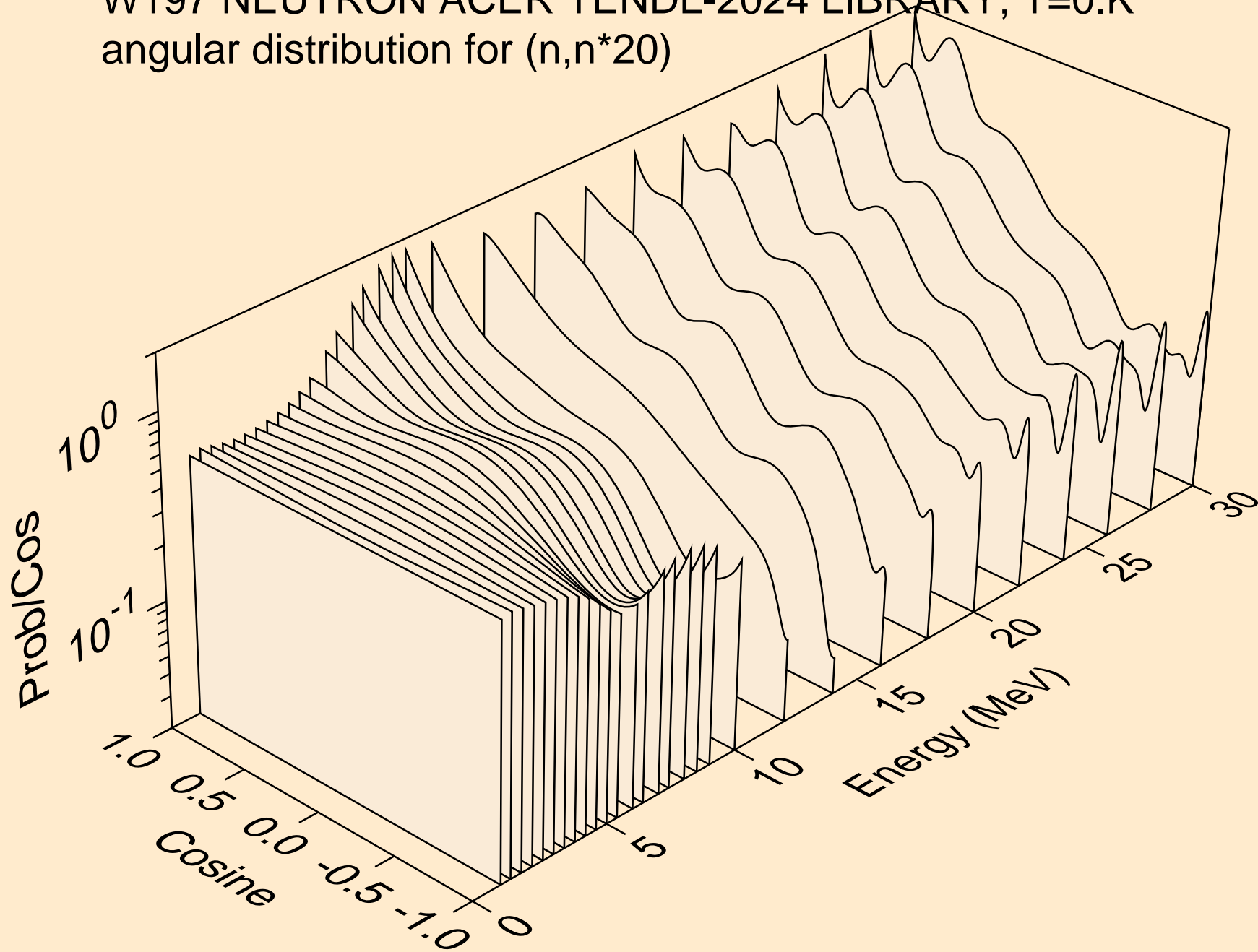

W197 NEUTRON ACER TENDL-2024 LIBRARY; T=0.K  
angular distribution for (n,n\*21)

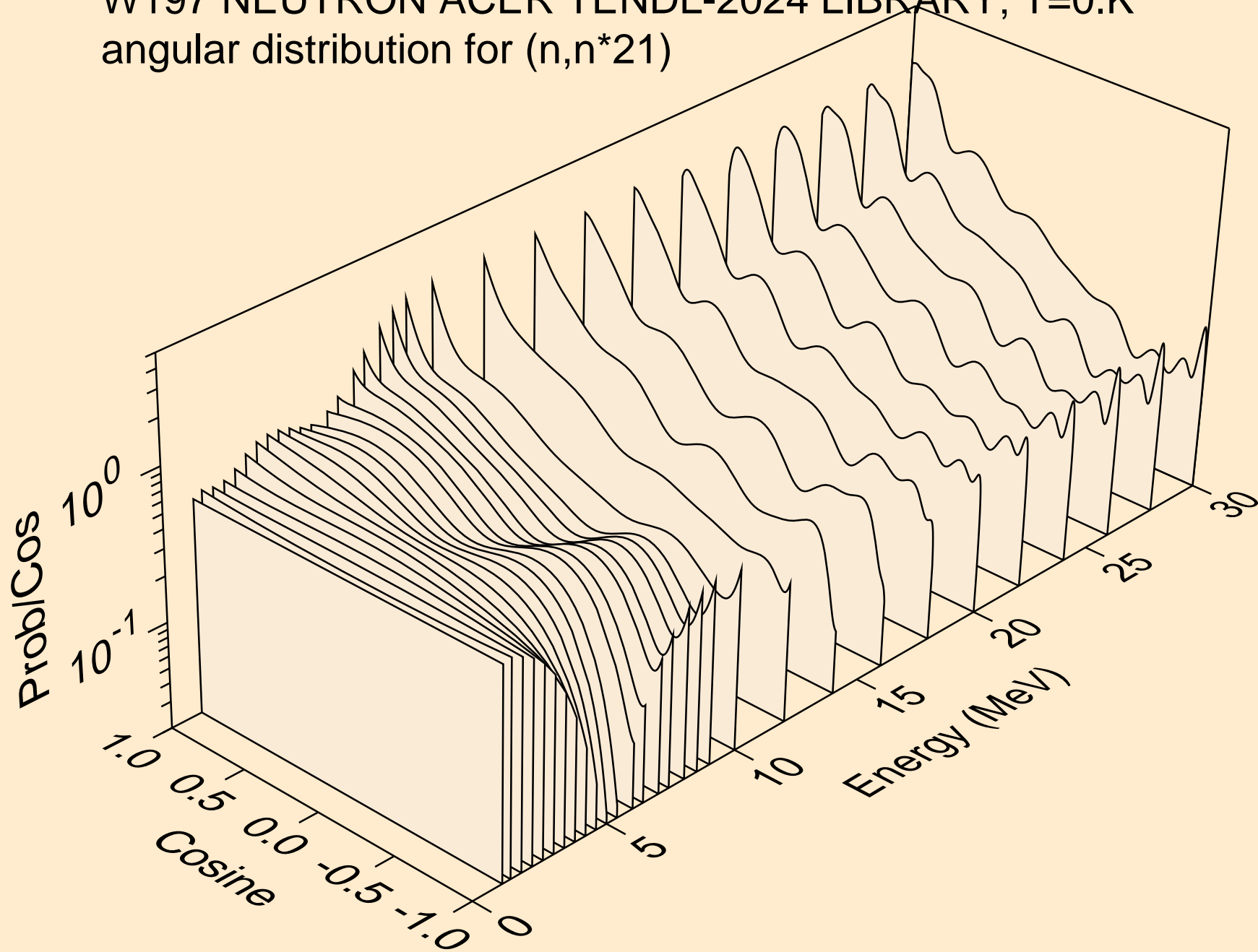

W197 NEUTRON ACER TENDL-2024 LIBRARY; T=0.K  
angular distribution for (n,n\*22)

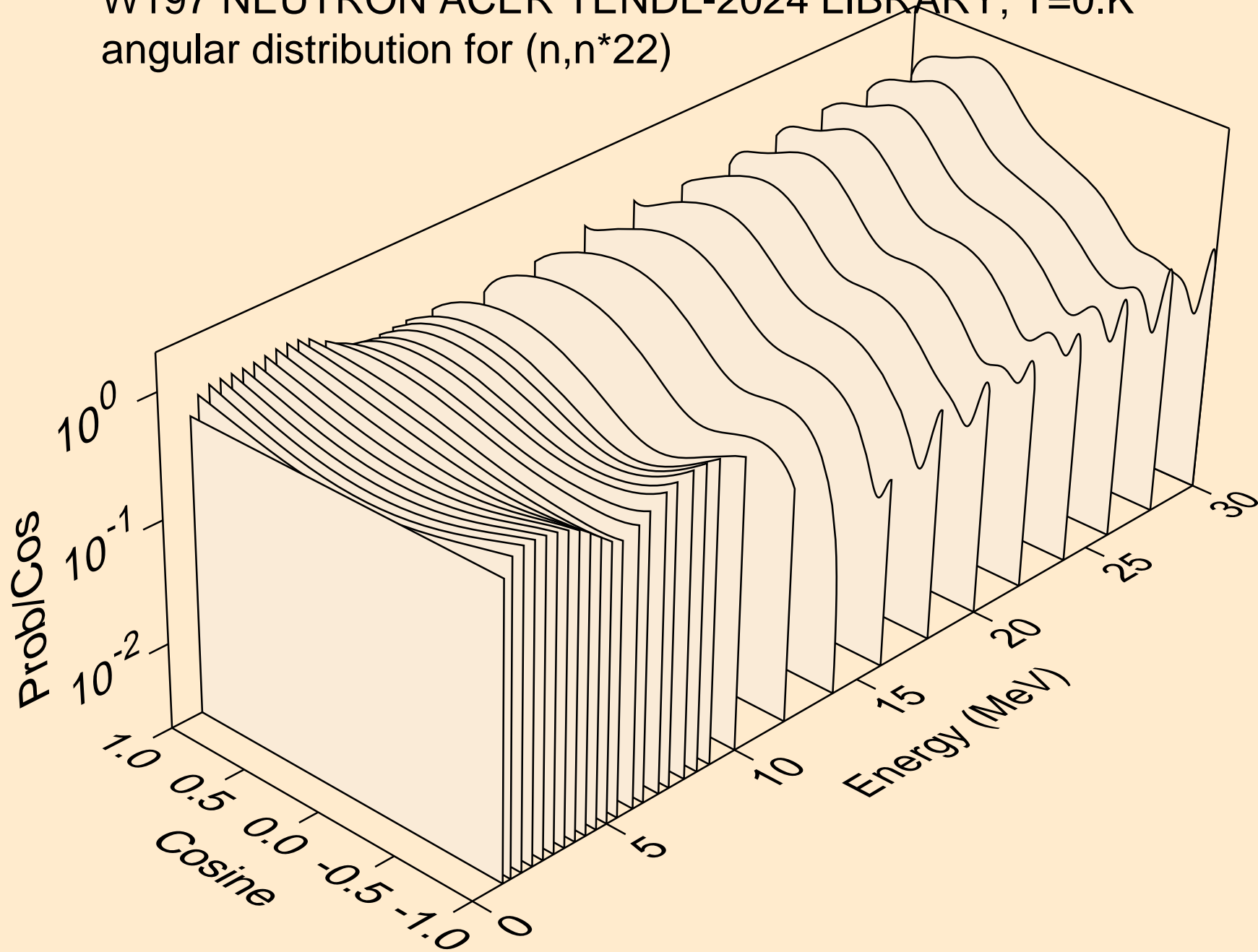

W197 NEUTRON ACER TENDL-2024 LIBRARY; T=0.K  
angular distribution for (n,n\*23)

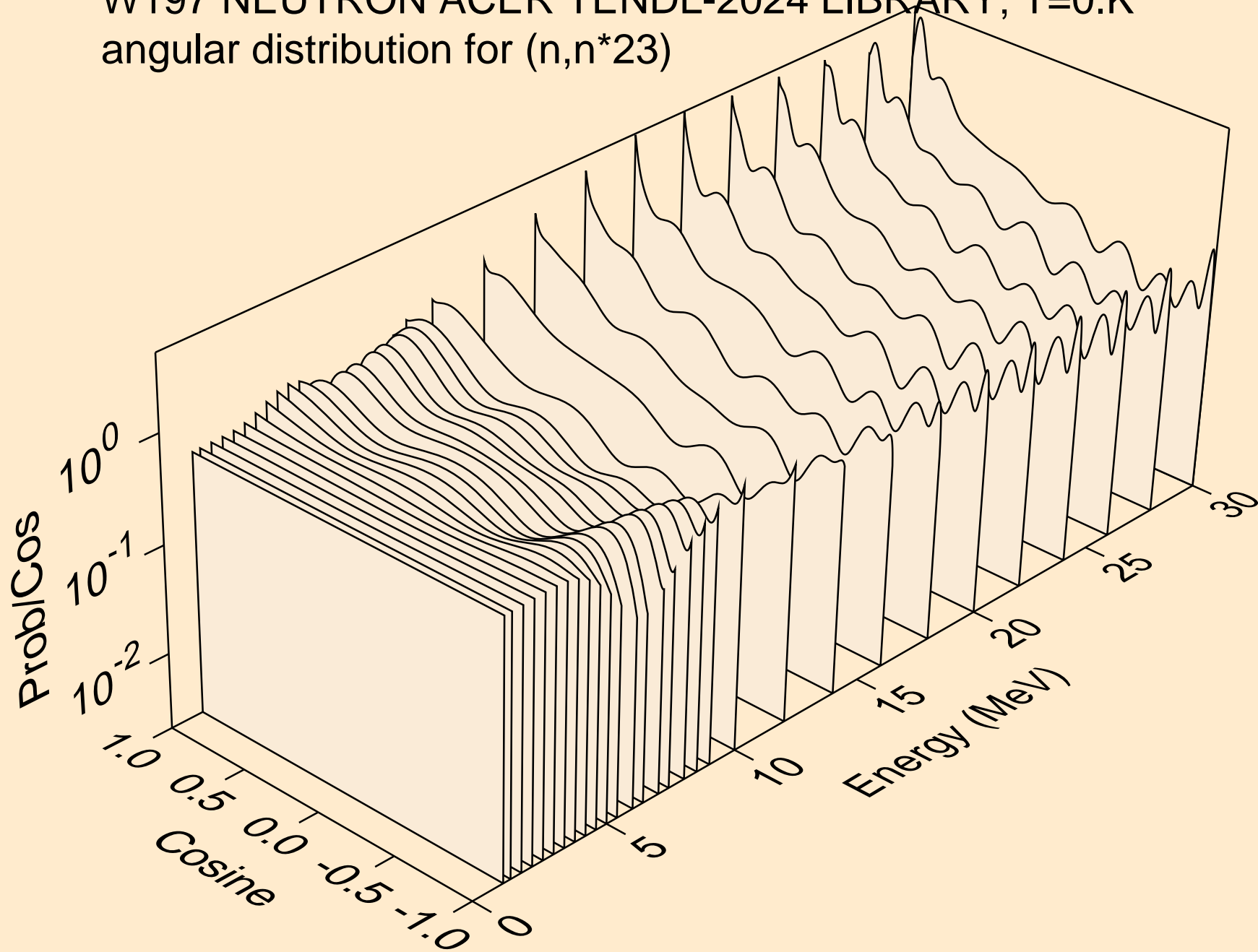

W197 NEUTRON ACER TENDL-2024 LIBRARY; T=0.K  
angular distribution for (n,n\*24)

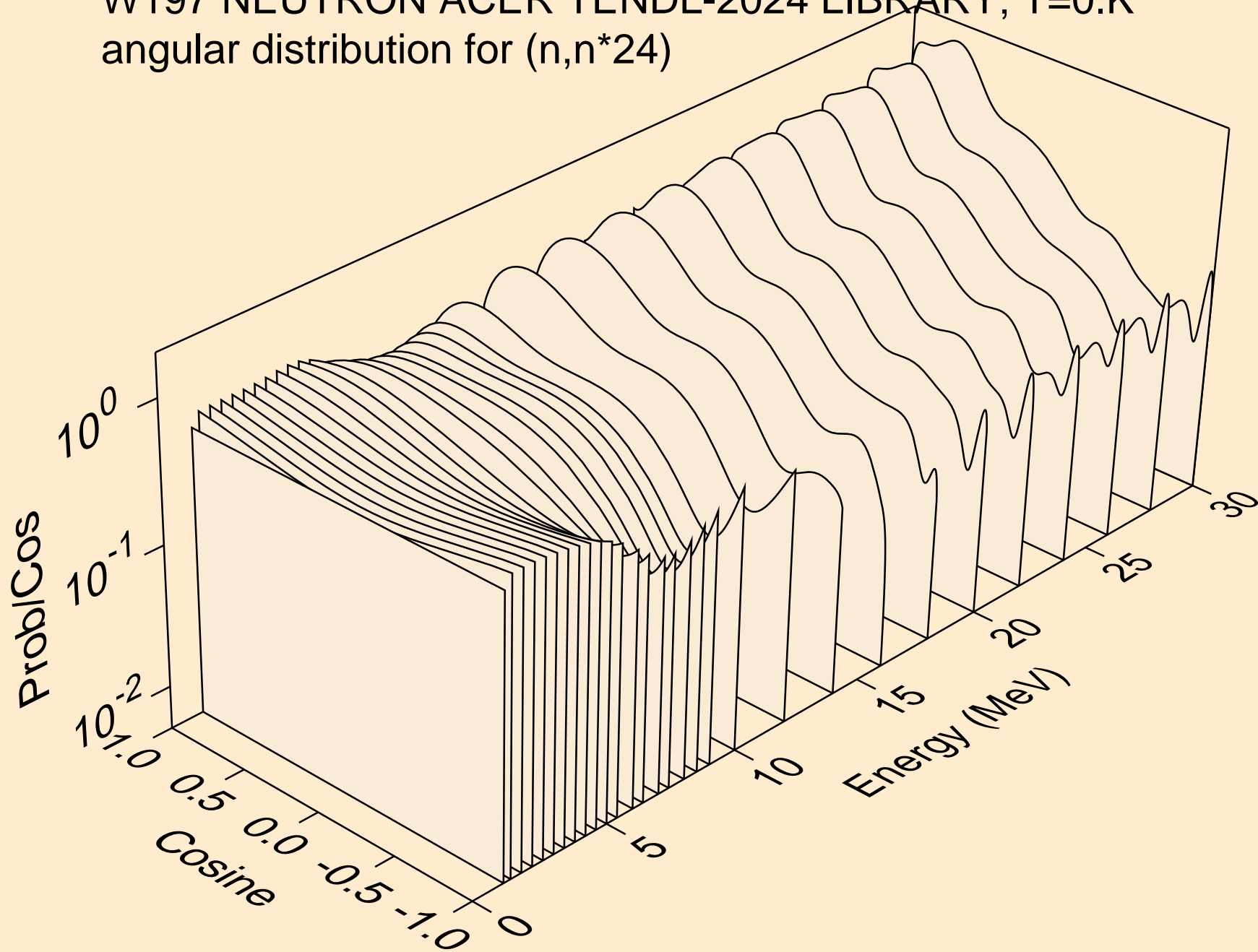

W197 NEUTRON ACER TENDL-2024 LIBRARY; T=0.K  
angular distribution for (n,n\*25)

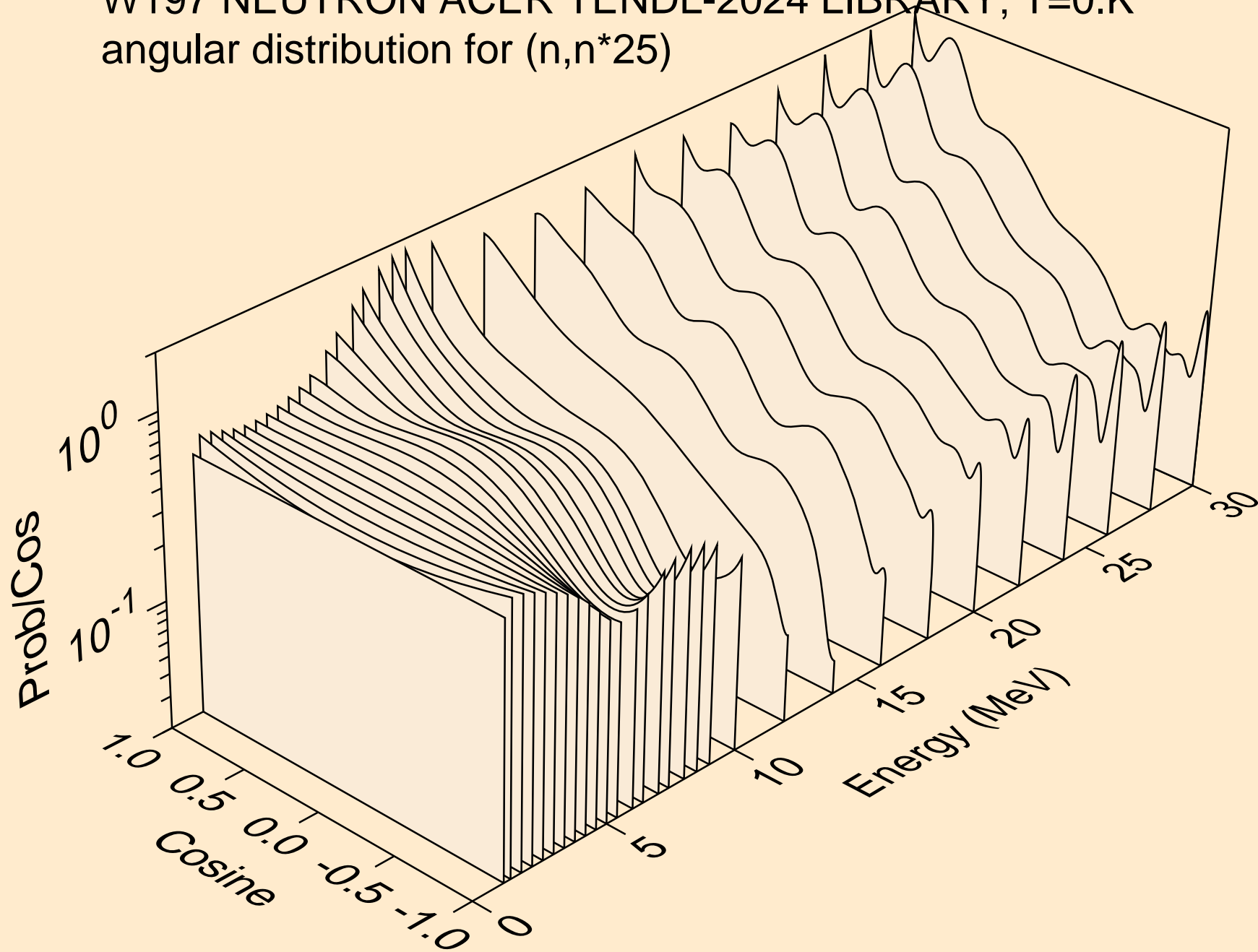

W197 NEUTRON ACER TENDL-2024 LIBRARY; T=0.K  
angular distribution for (n,n\*26)

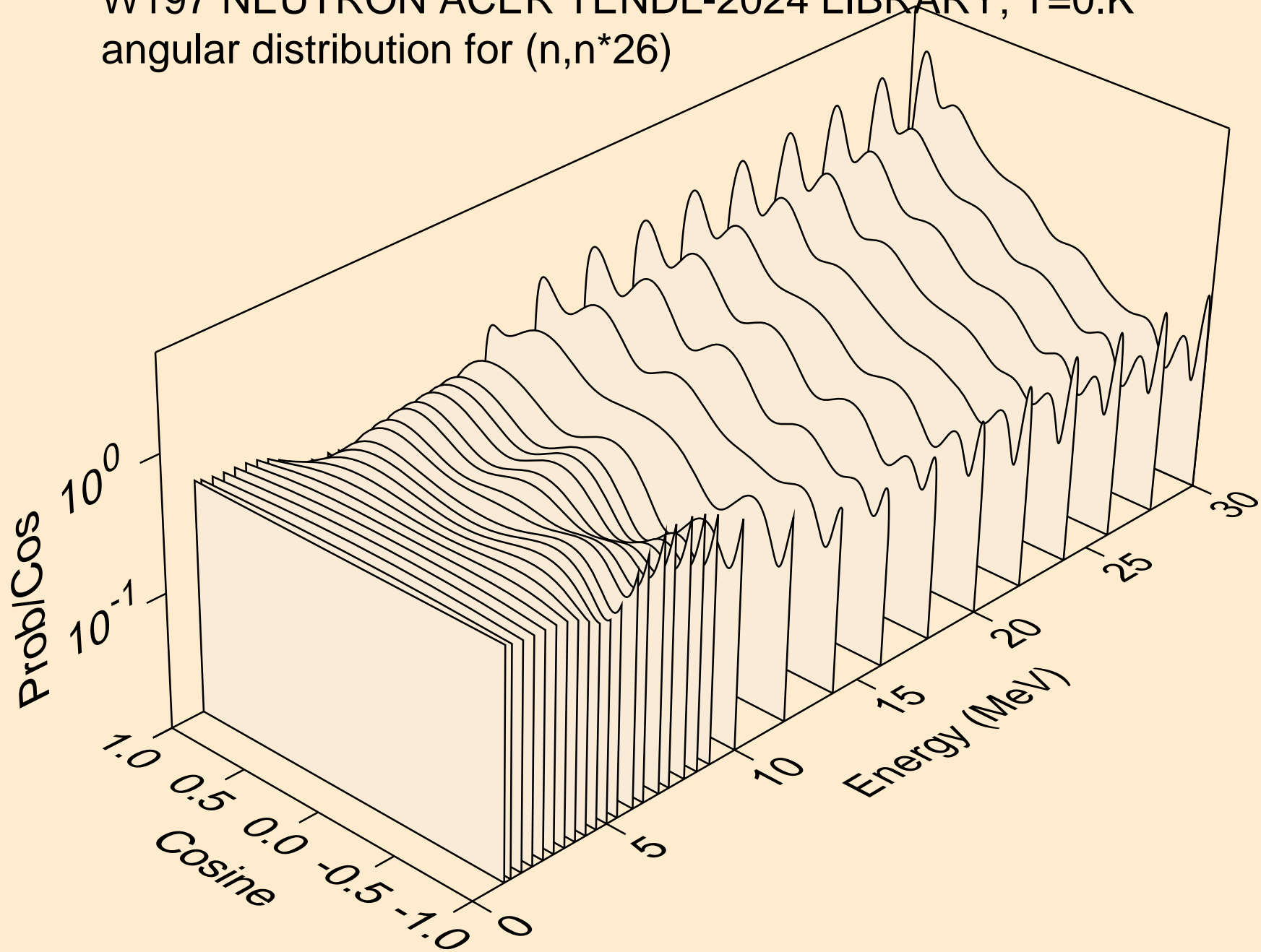

W197 NEUTRON ACER TENDL-2024 LIBRARY; T=0.K  
angular distribution for (n,n\*27)

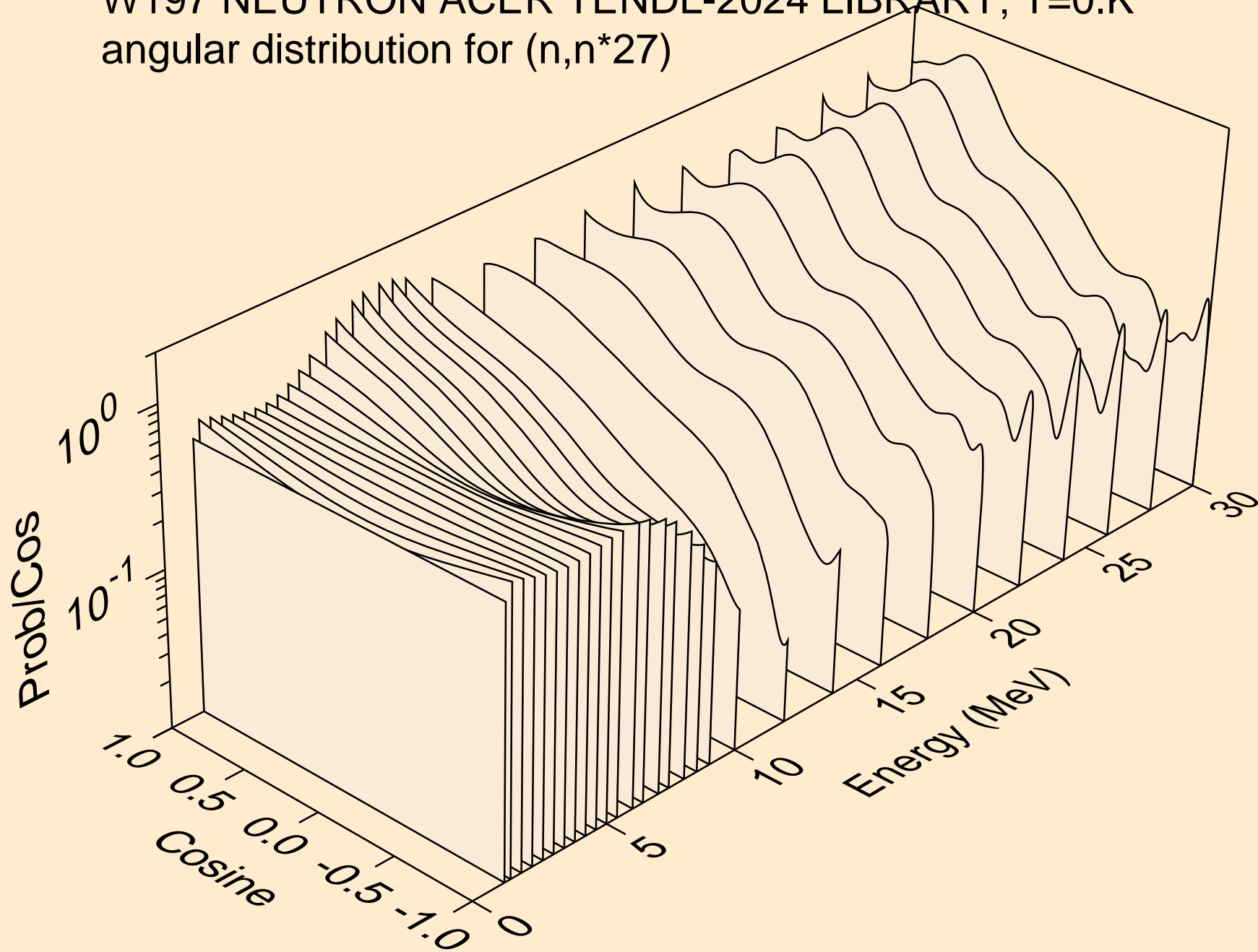

W197 NEUTRON ACER TENDL-2024 LIBRARY; T=0.K  
angular distribution for (n,n\*28)

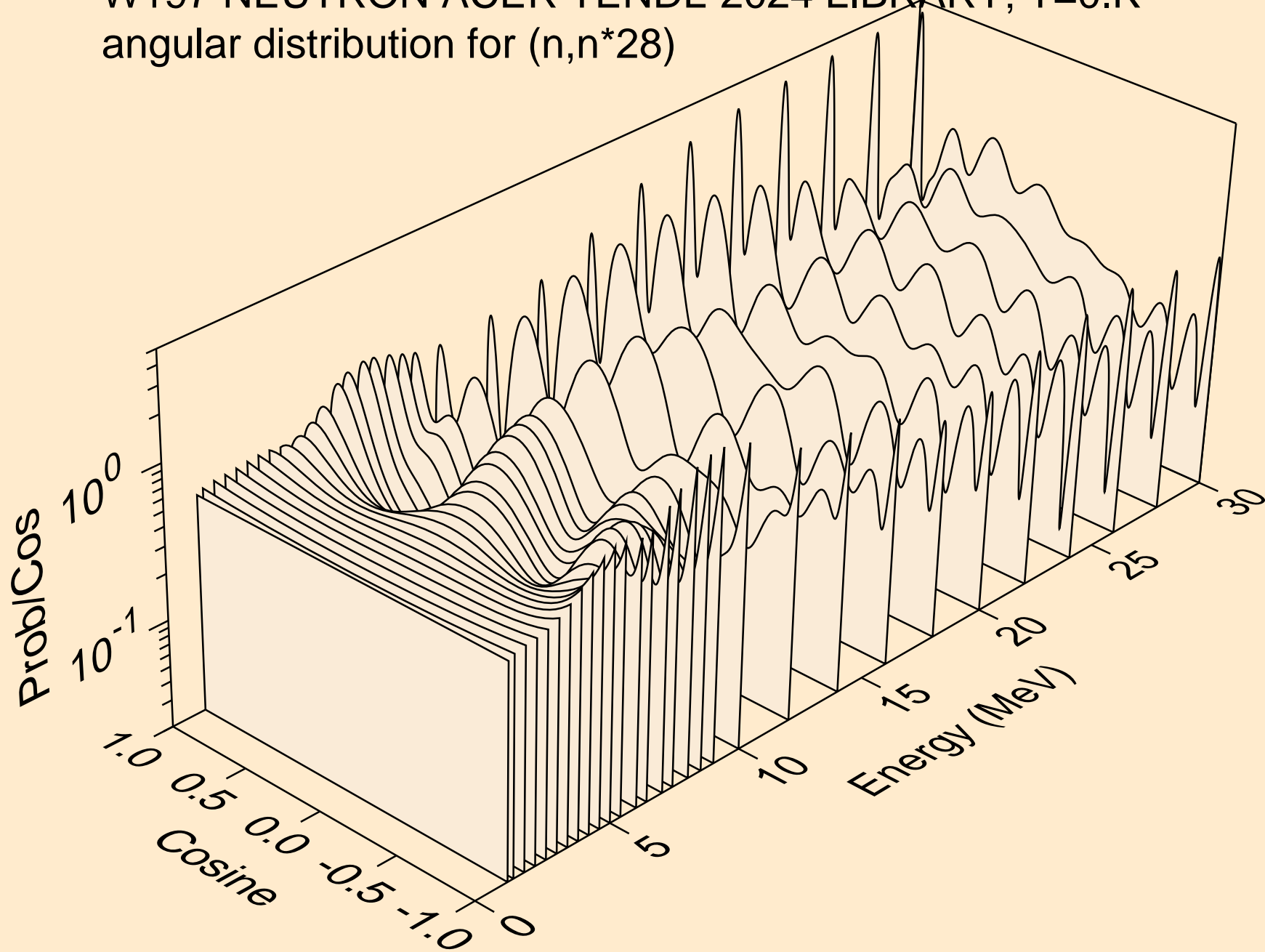

W197 NEUTRON ACER TENDL-2024 LIBRARY; T=0.K  
Neutron emission for (n,x)

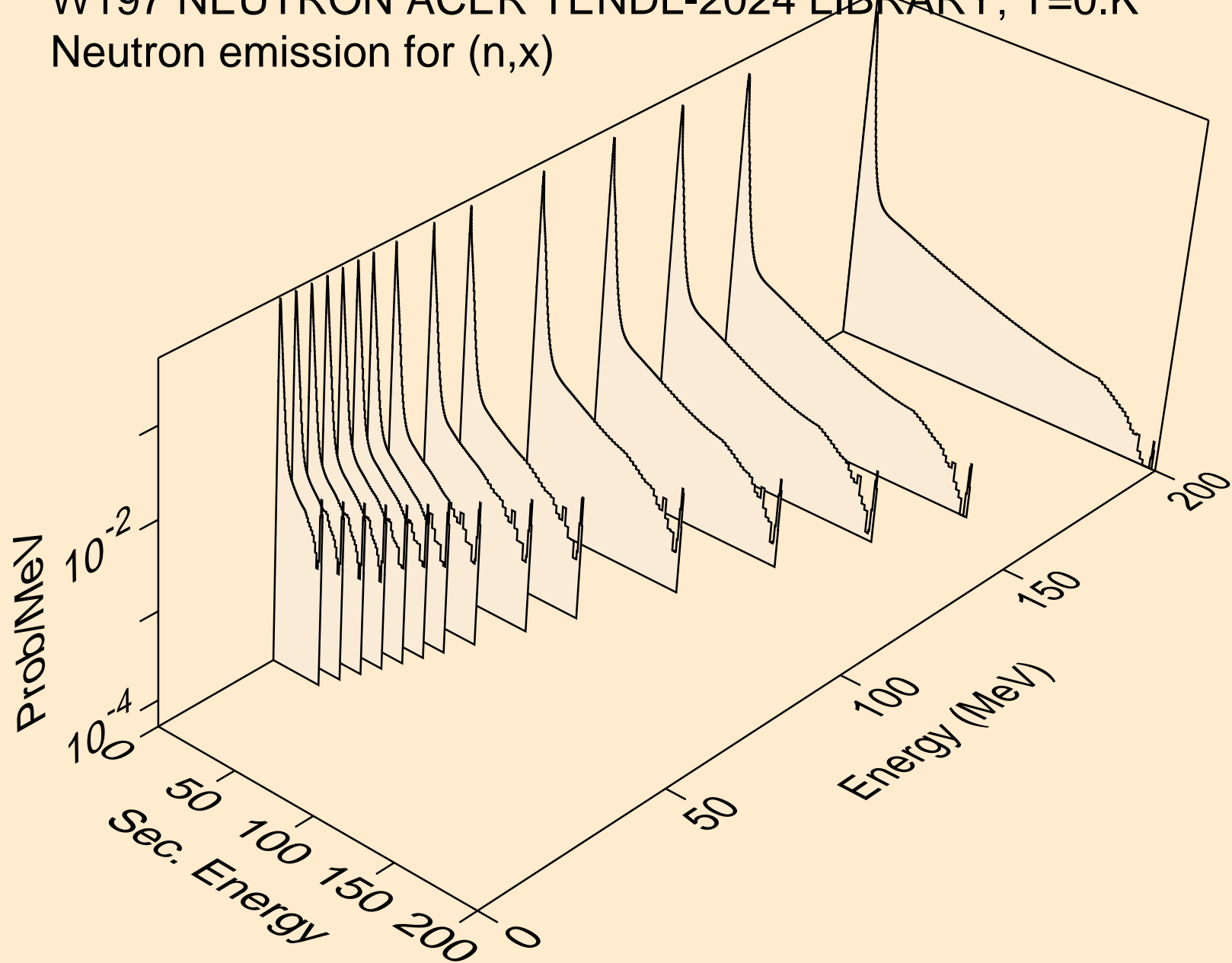

W197 NEUTRON ACER TENDL-2024 LIBRARY; T=0.K  
Neutron emission for (n,2nd)

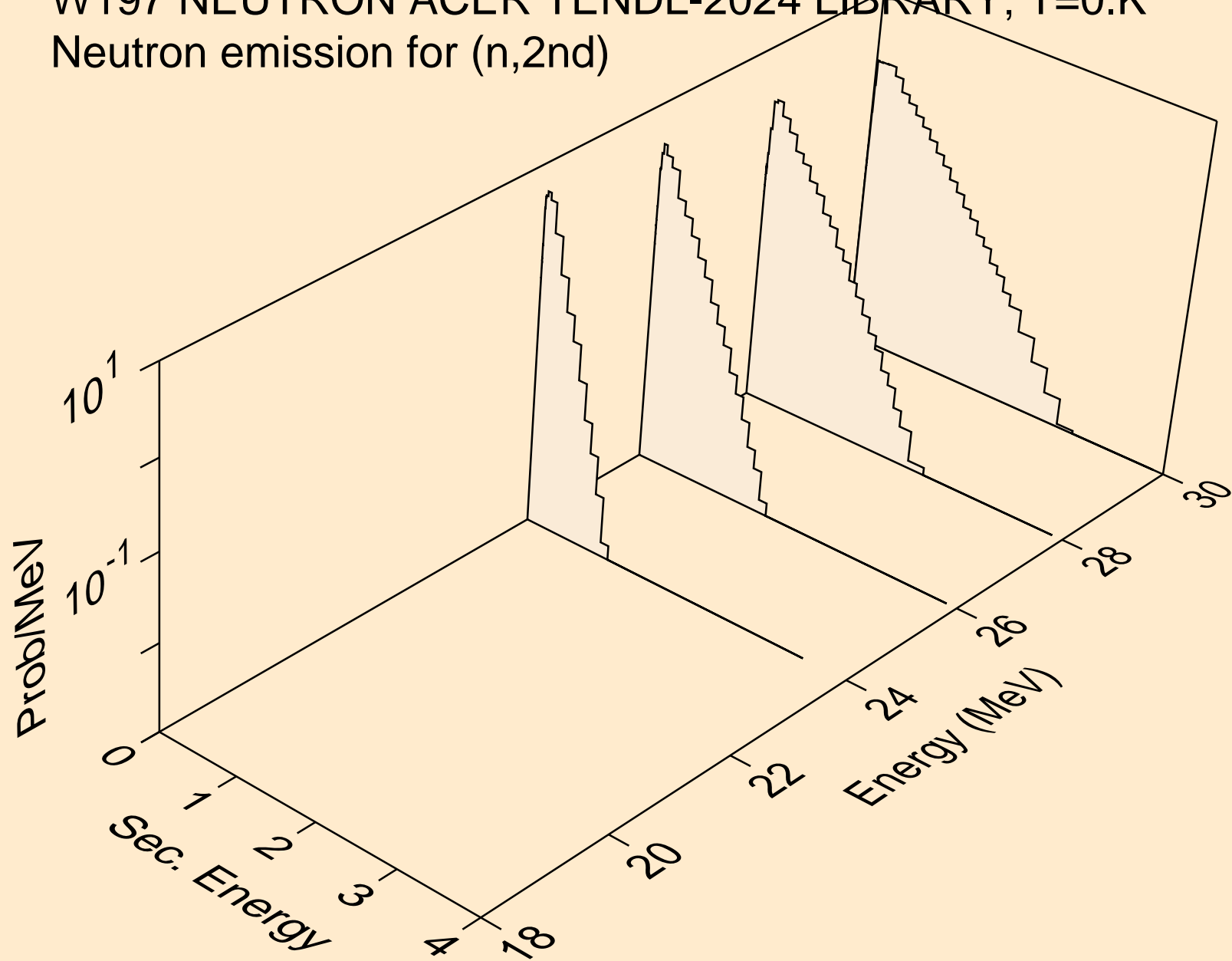

W197 NEUTRON ACER TENDL-2024 LIBRARY; T=0.K  
Neutron emission for (n,2n)

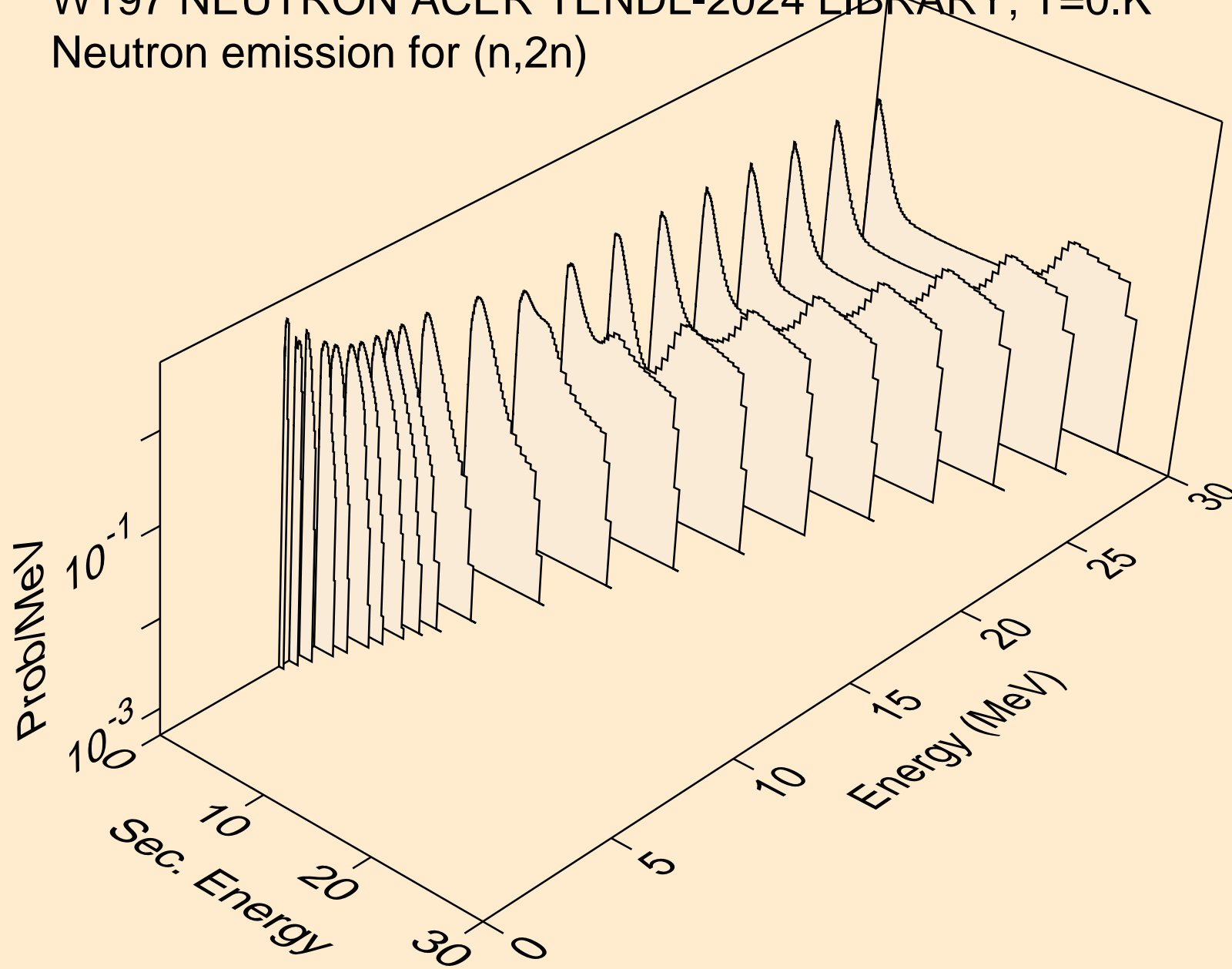

W197 NEUTRON ACER TENDL-2024 LIBRARY; T=0.K  
Neutron emission for (n,3n)

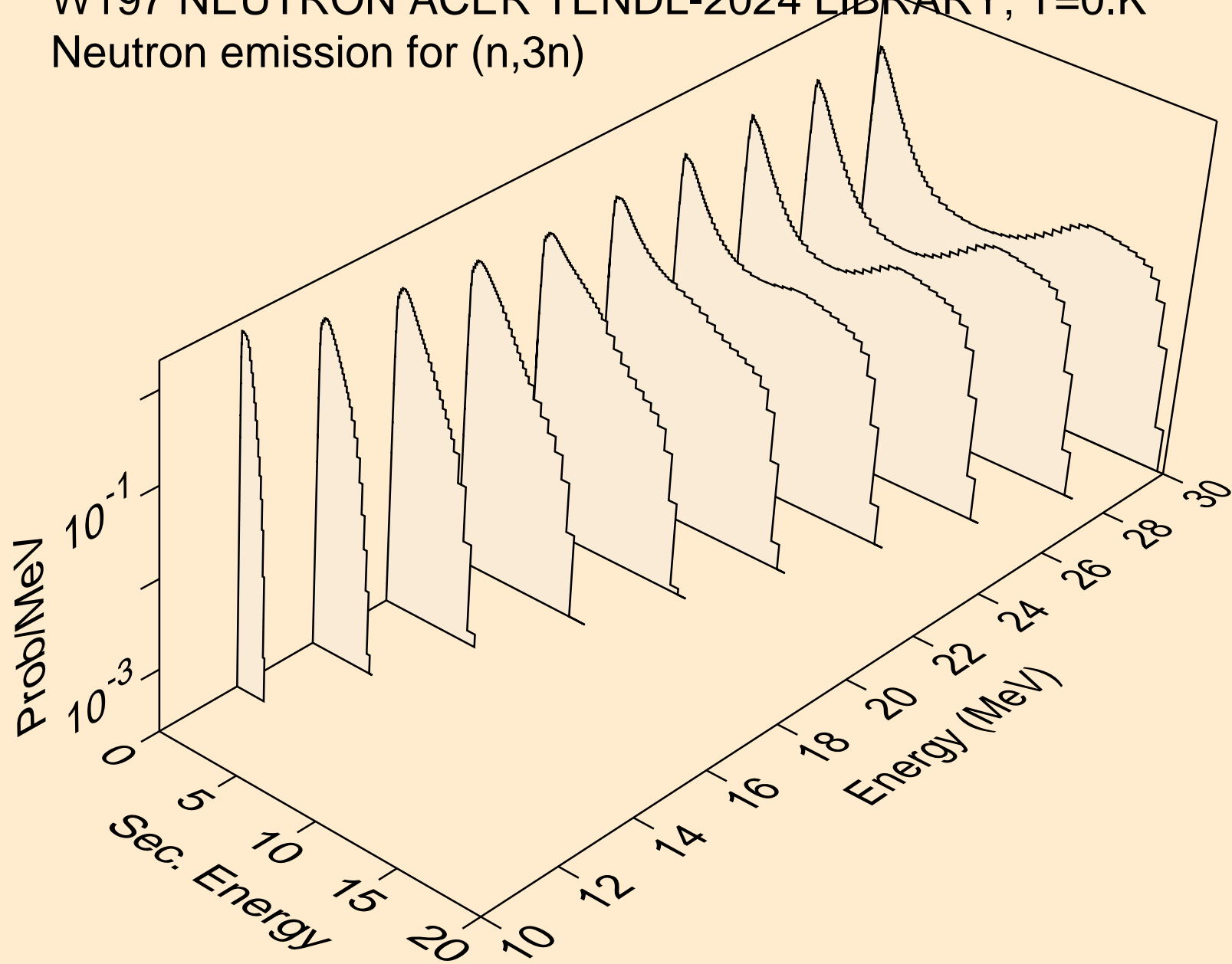

W197 NEUTRON ACER TENDL-2024 LIBRARY; T=0.K  
Neutron emission for (n,n\*)a

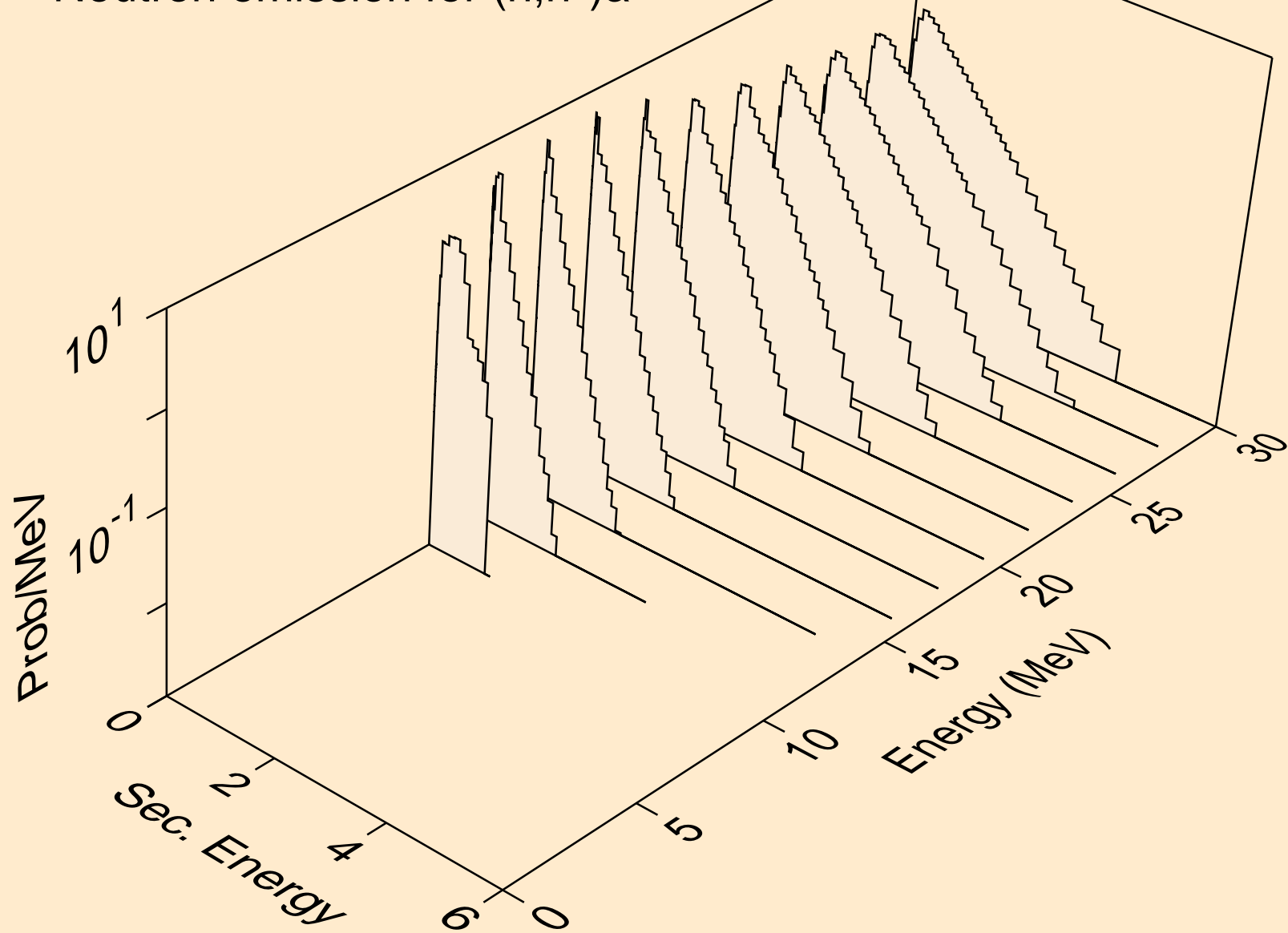

W197 NEUTRON ACER TENDL-2024 LIBRARY; T=0.K  
Neutron emission for (n,2n)a

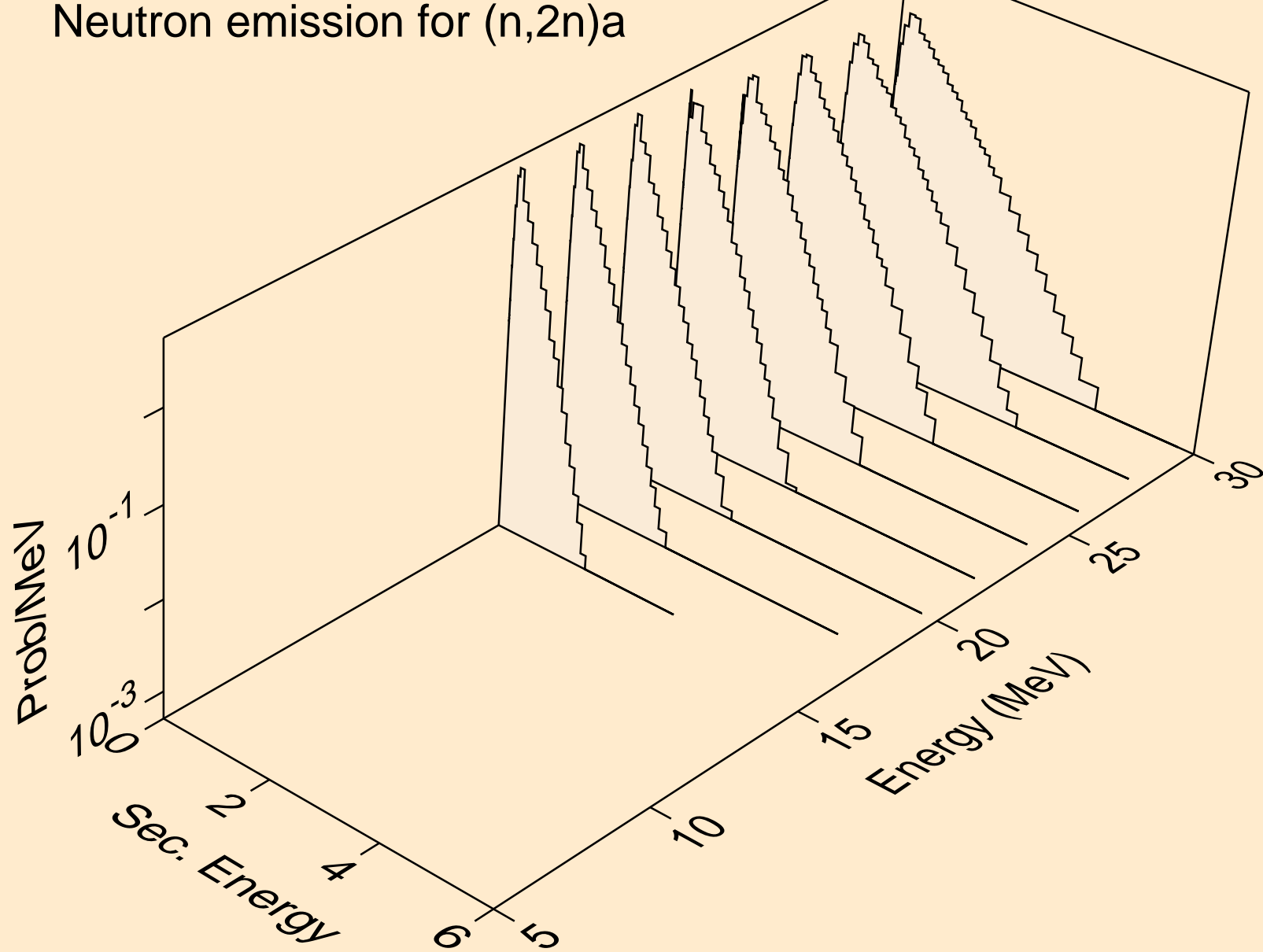

W197 NEUTRON ACER TENDL-2024 LIBRARY; T=0.K  
Neutron emission for (n,3n)a

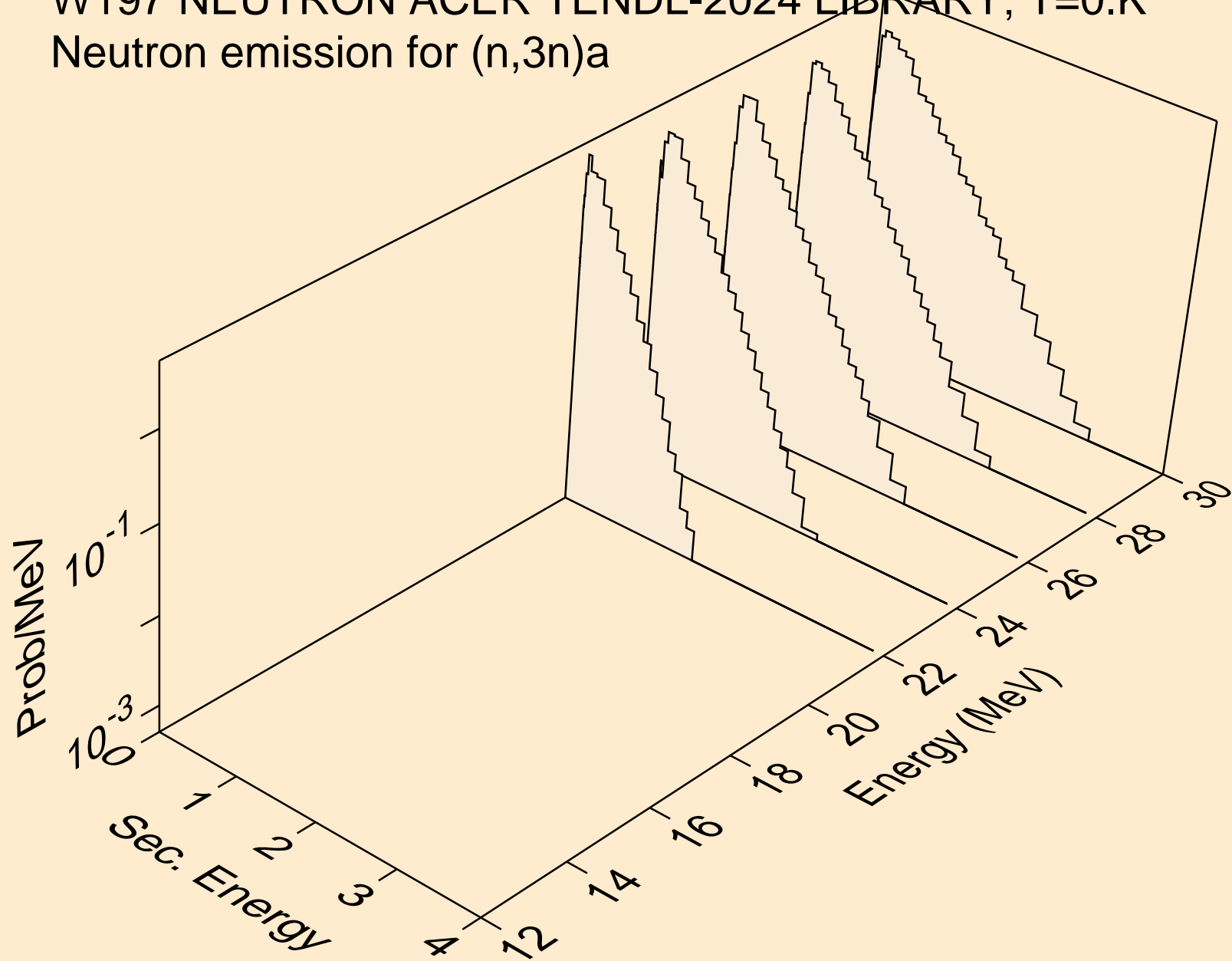

W197 NEUTRON ACER TENDL-2024 LIBRARY; T=0.K  
Neutron emission for (n,n\*)p

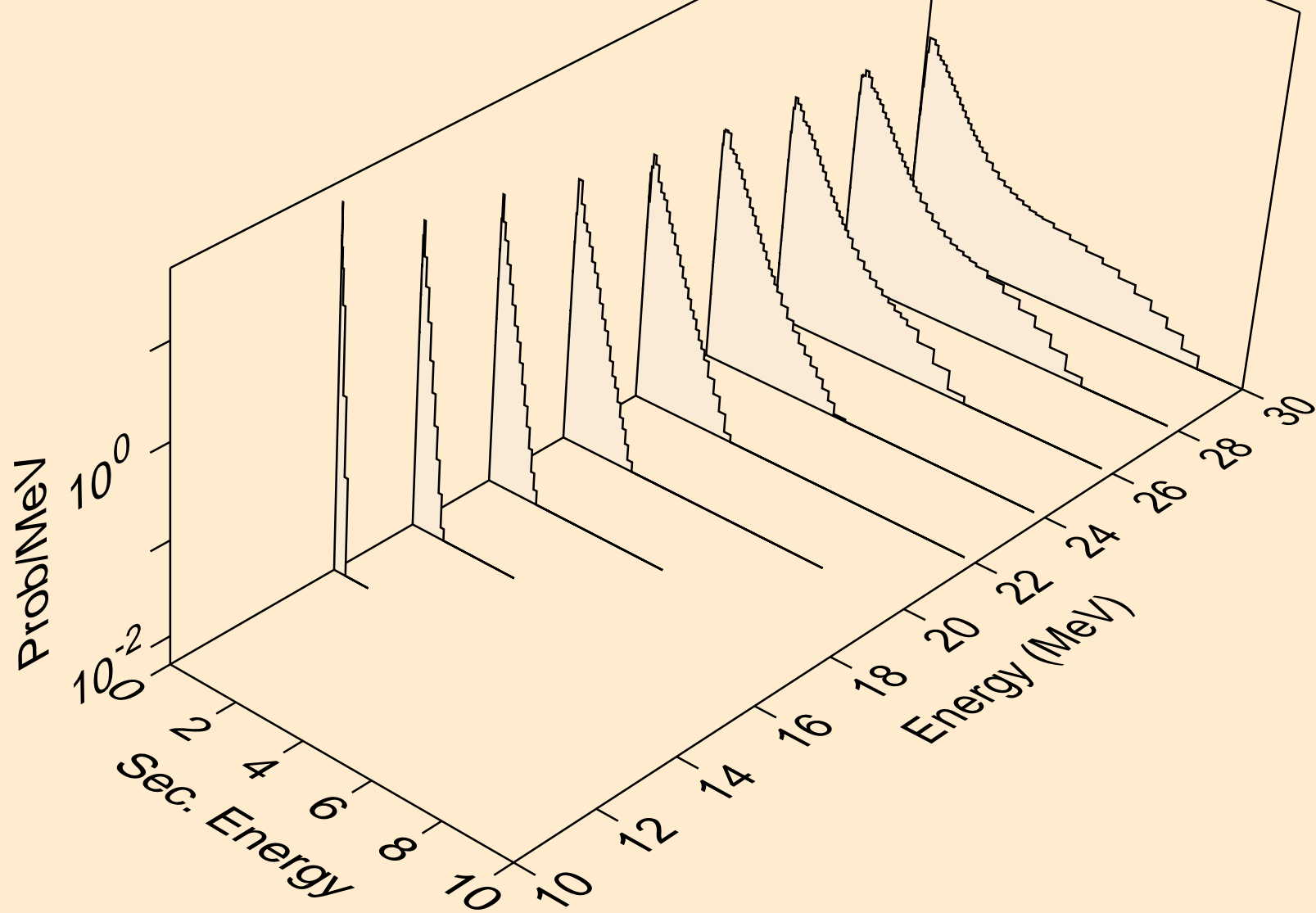

W197 NEUTRON ACER TENDL-2024 LIBRARY; T=0.K  
Neutron emission for (n,n\*)d

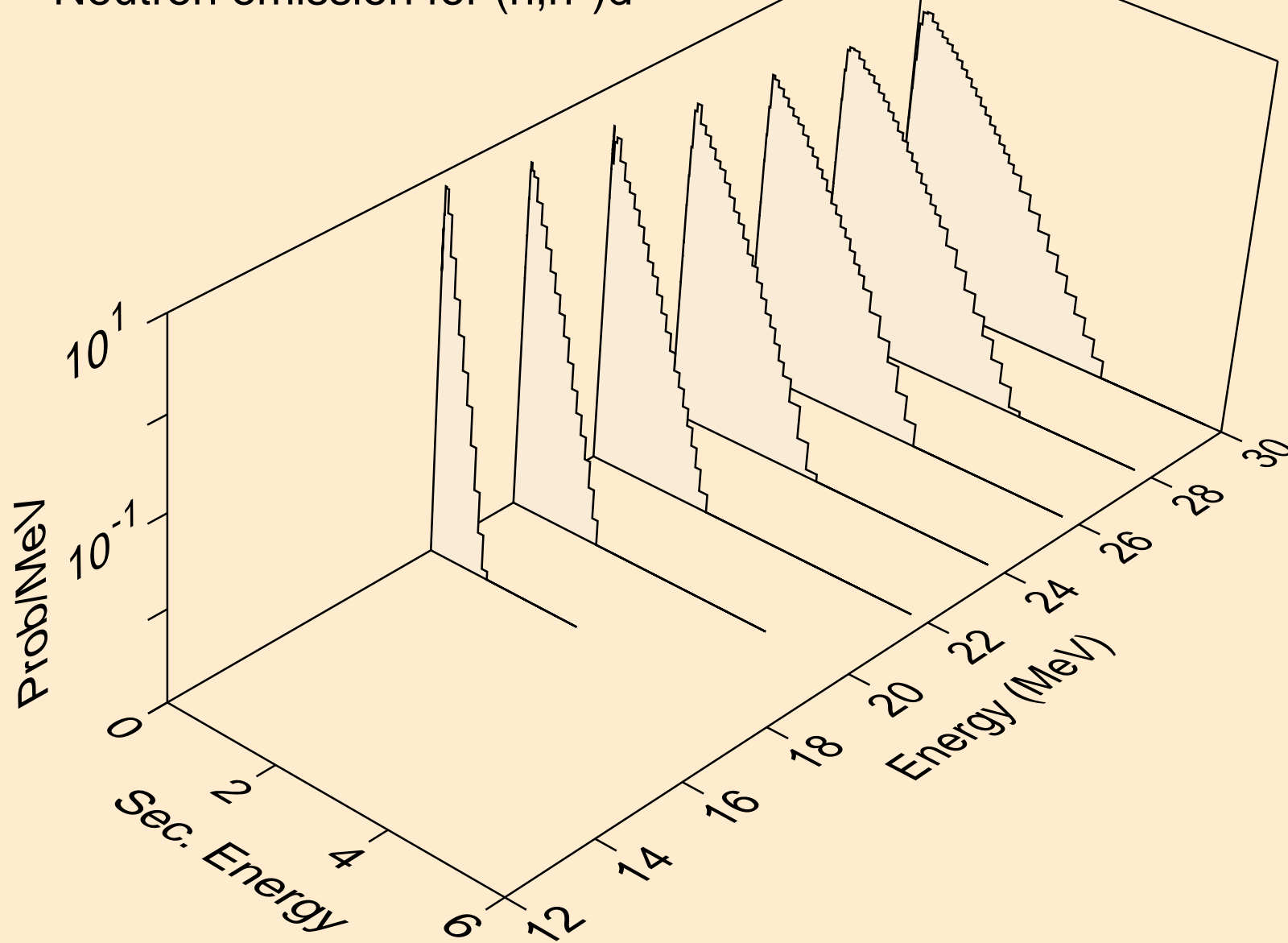

W197 NEUTRON ACER TENDL-2024 LIBRARY; T=0.K  
Neutron emission for (n,n\*)t

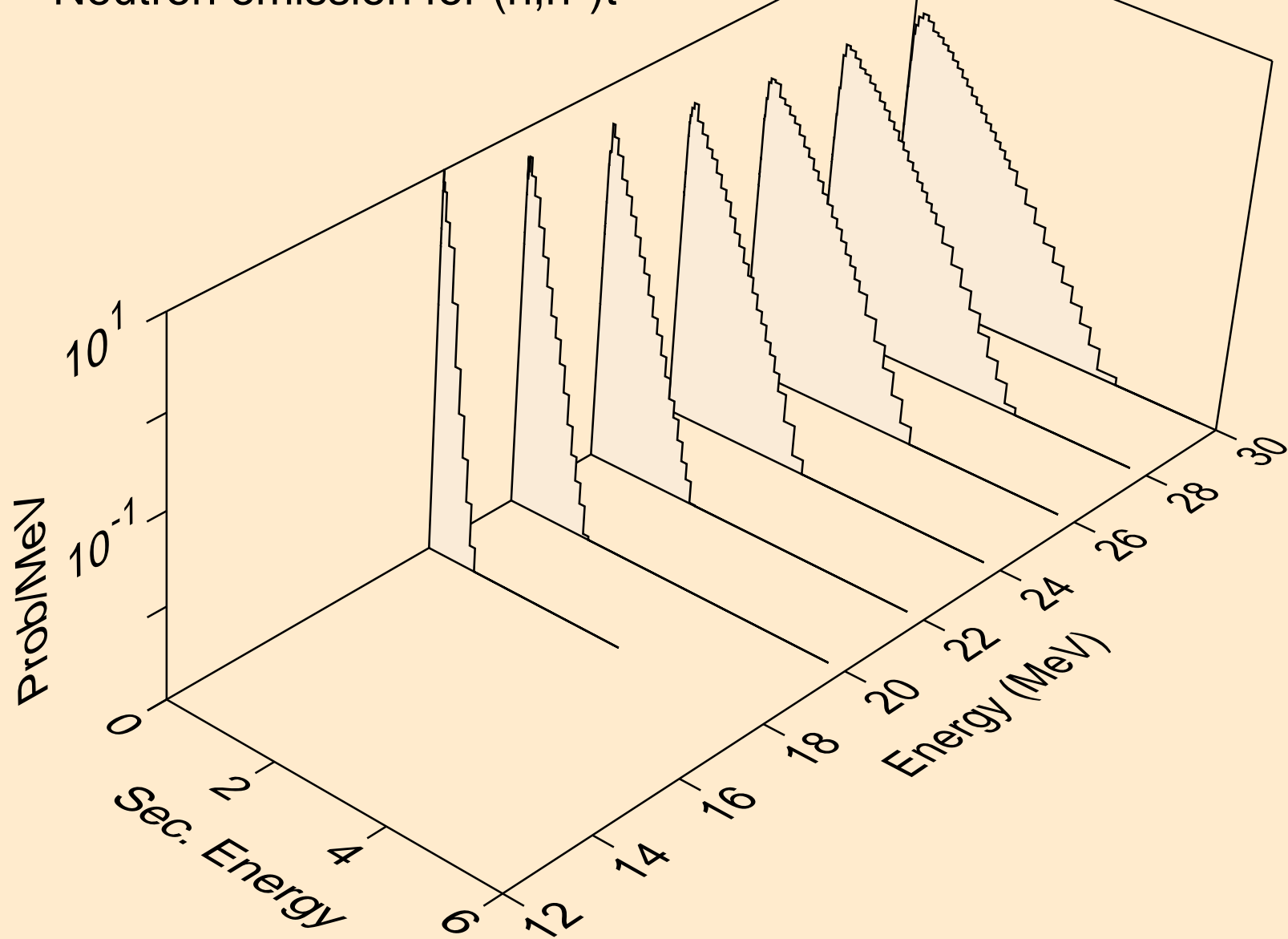

W197 NEUTRON ACER TENDL-2024 LIBRARY; T=0.K  
Neutron emission for (n,4n)

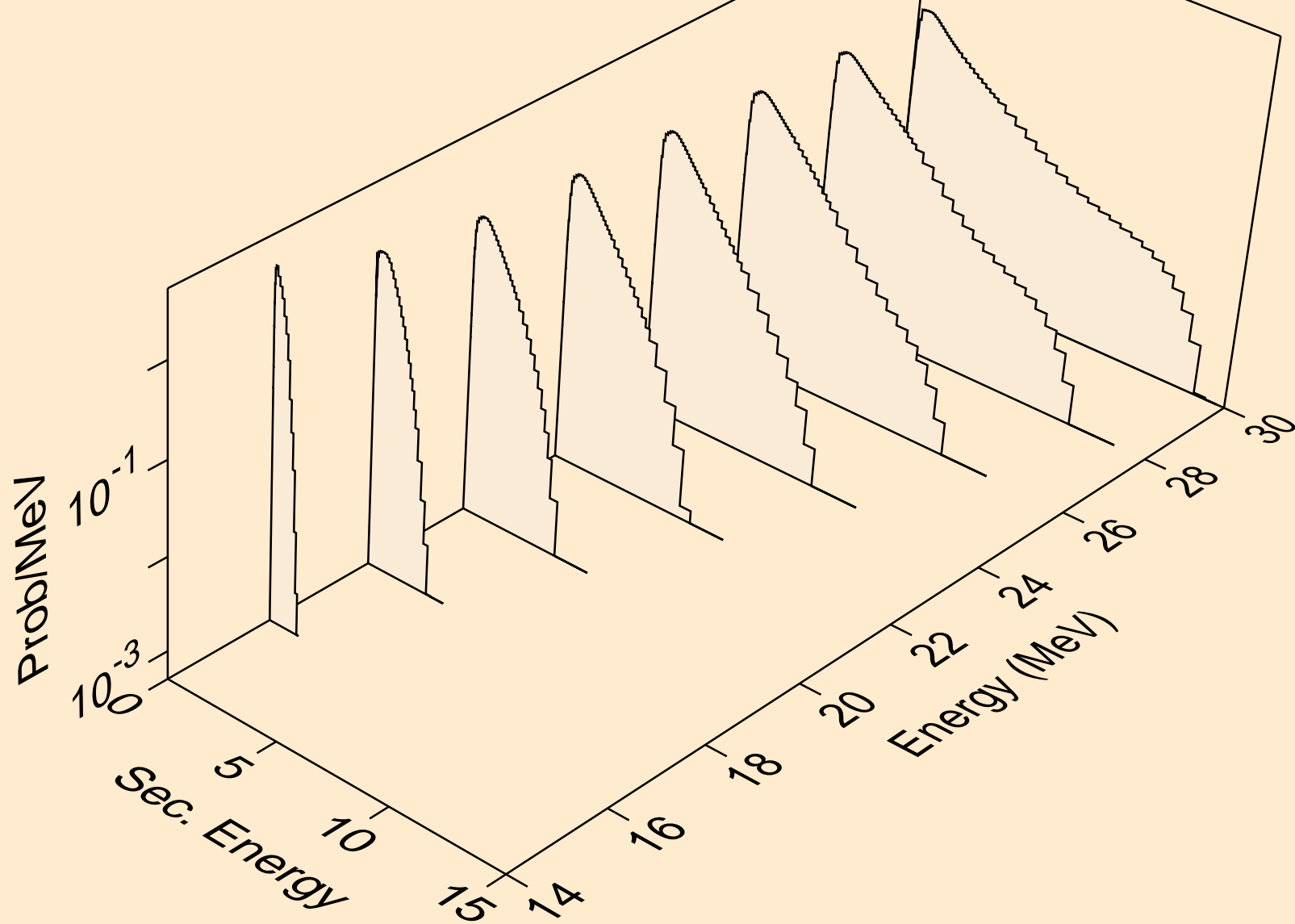

W197 NEUTRON ACER TENDL-2024 LIBRARY; T=0.K  
Neutron emission for (n,2np)

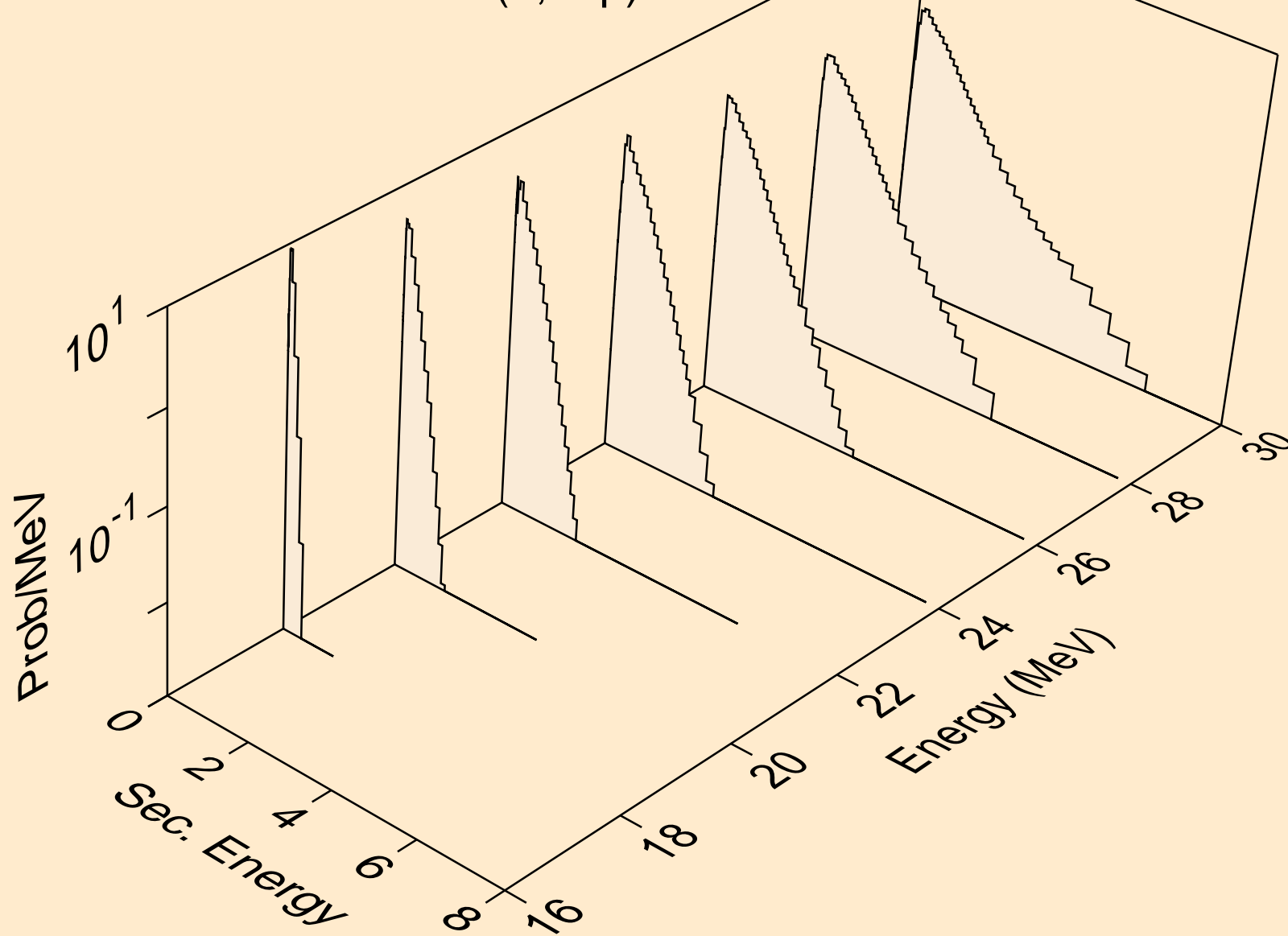

W197 NEUTRON ACER TENDL-2024 LIBRARY; T=0.K  
Neutron emission for (n,3np)

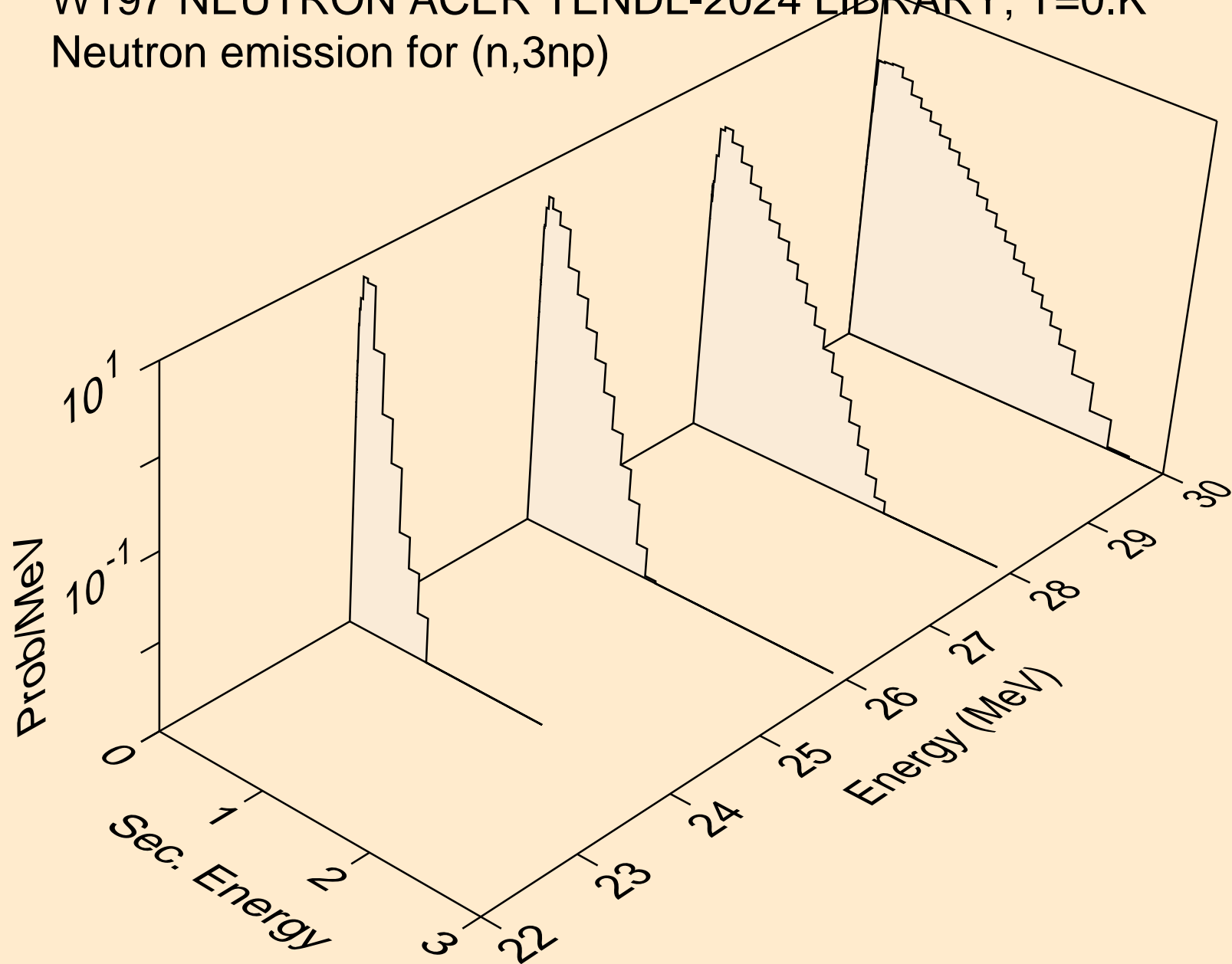

W197 NEUTRON ACER TENDL-2024 LIBRARY; T=0.K  
Neutron emission for (n,n\*c)

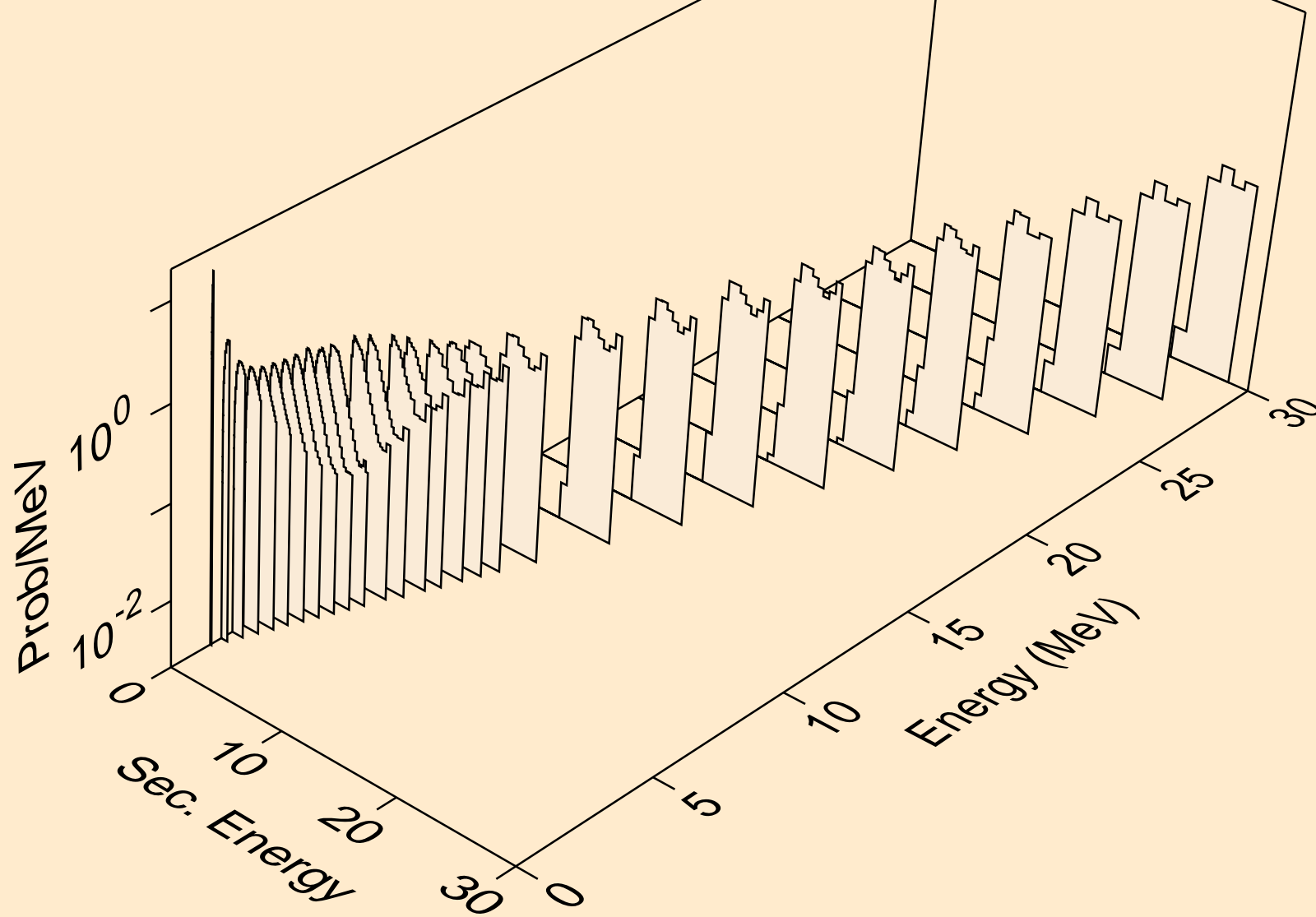

W197 NEUTRON ACER TENDL-2024 LIBRARY; T=0.K  
Photon emission for (n,x)

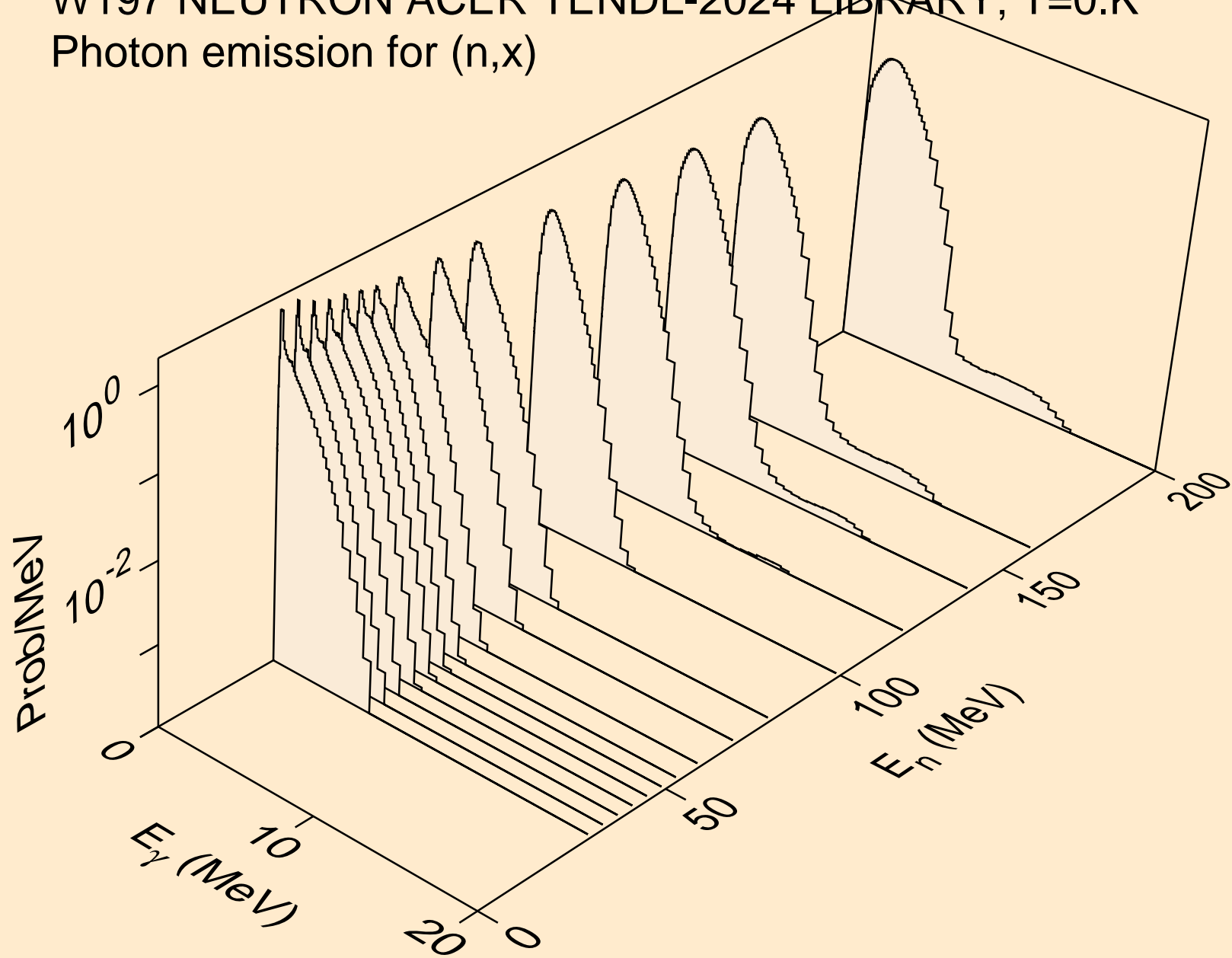

W197 NEUTRON ACER TENDL-2024 LIBRARY; T=0.K  
Photon emission for (n,2nd)

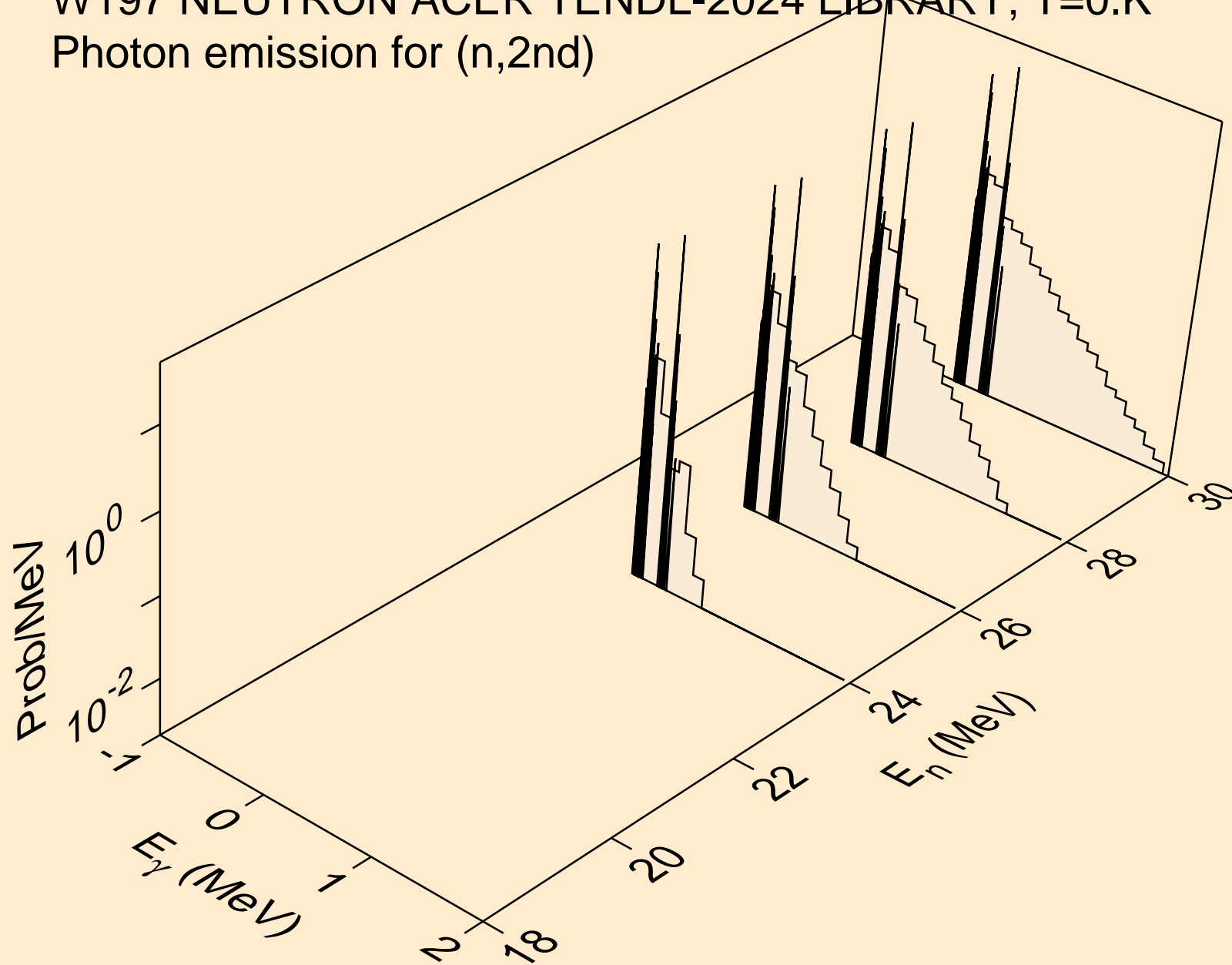

W197 NEUTRON ACER TENDL-2024 LIBRARY; T=0.K  
Photon emission for (n,2n)

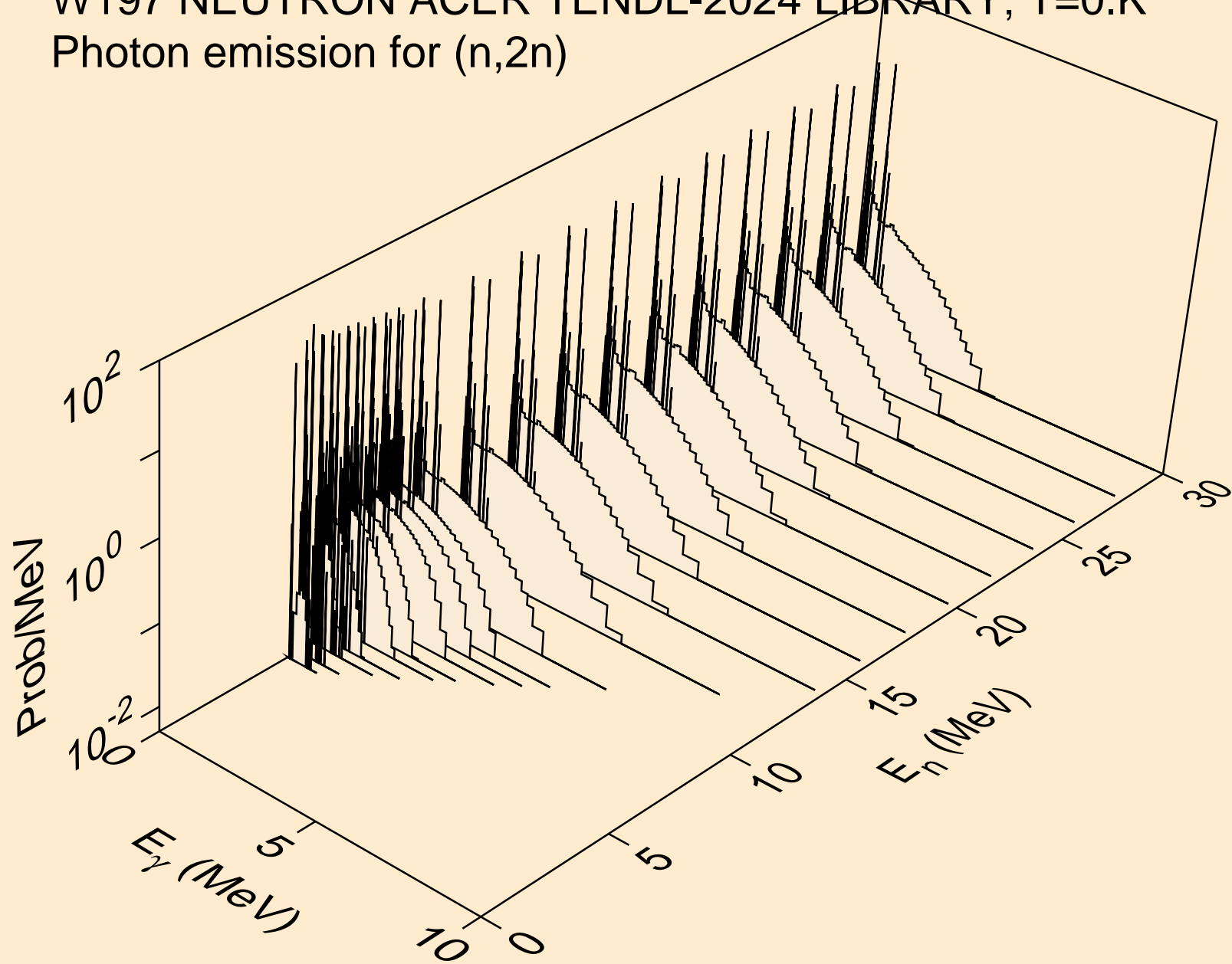

W197 NEUTRON ACER TENDL-2024 LIBRARY; T=0.K  
Photon emission for (n,3n)

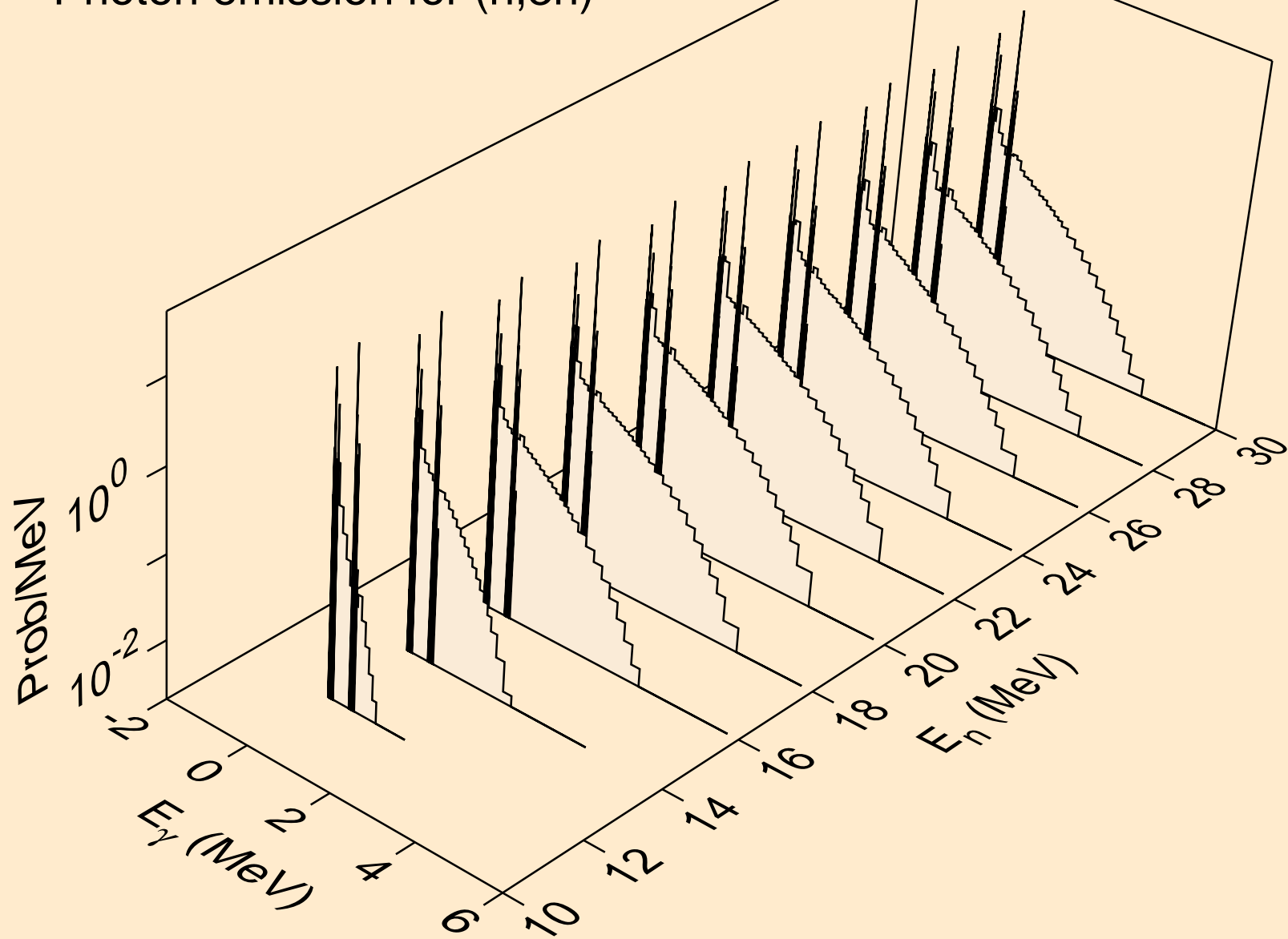

W197 NEUTRON ACER TENDL-2024 LIBRARY; T=0.K  
Photon emission for (n,n\*)a

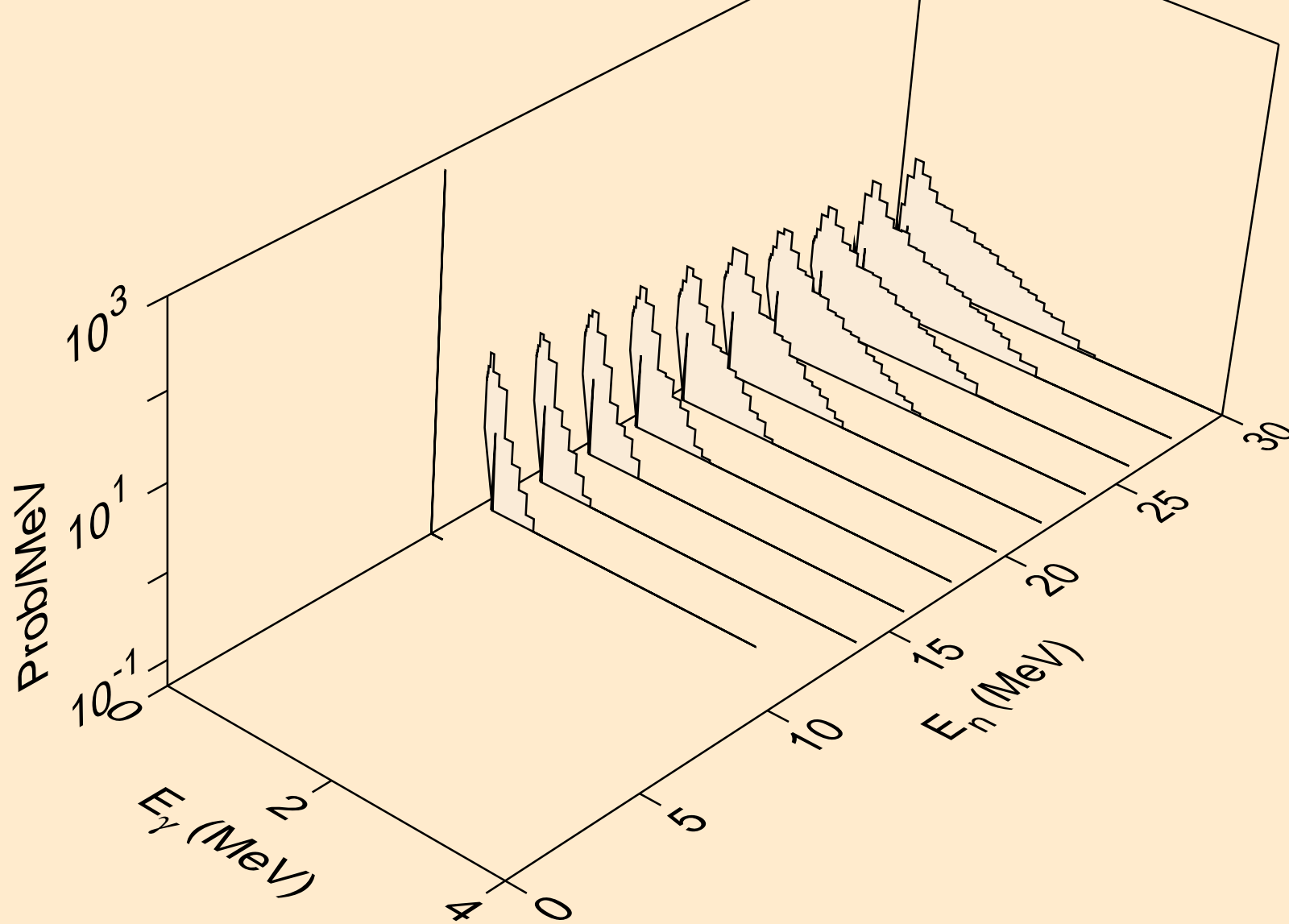

W197 NEUTRON ACER TENDL-2024 LIBRARY; T=0.K  
Photon emission for (n,2n)a

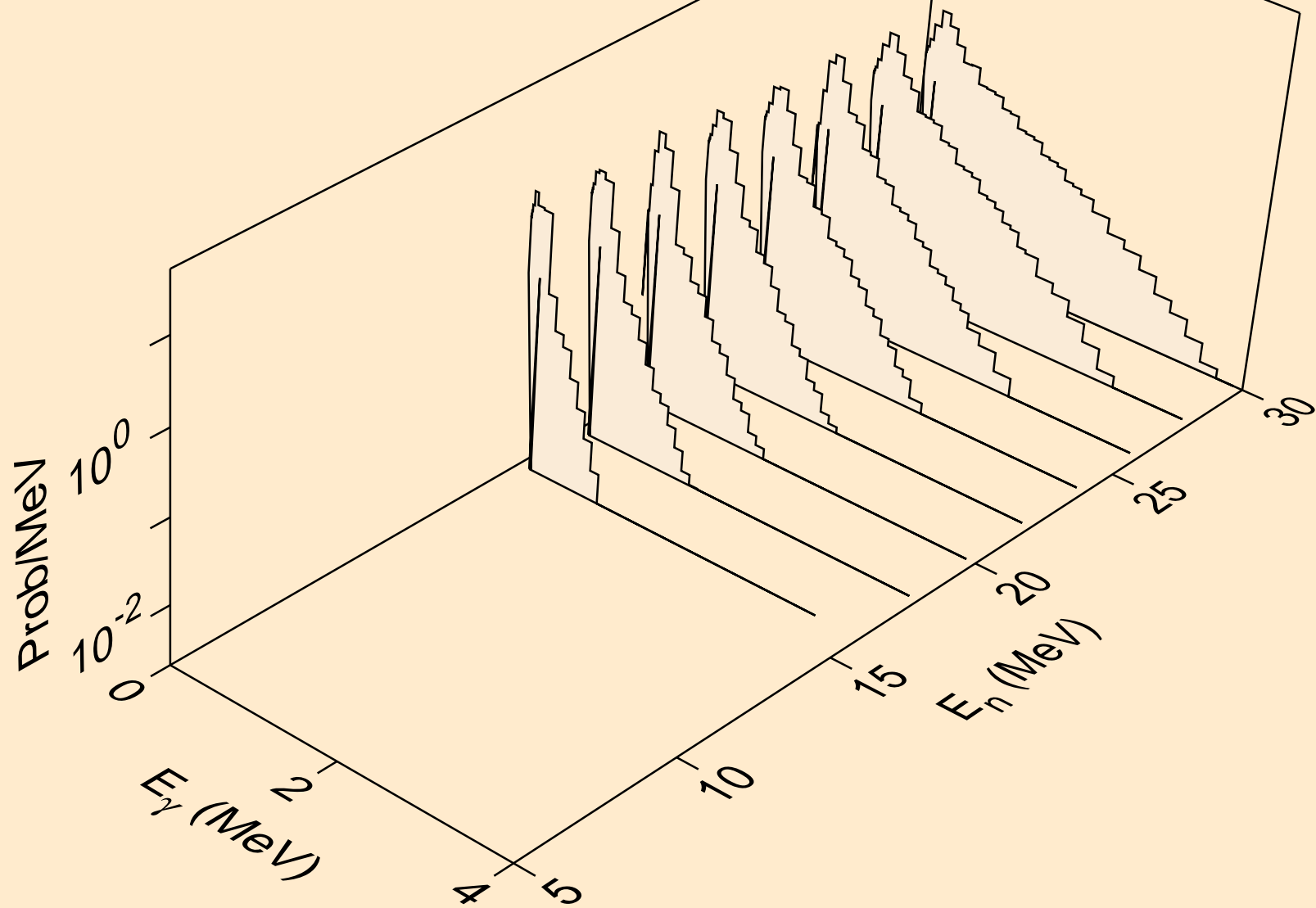

W197 NEUTRON ACER TENDL-2024 LIBRARY; T=0.K  
Photon emission for (n,3n)a

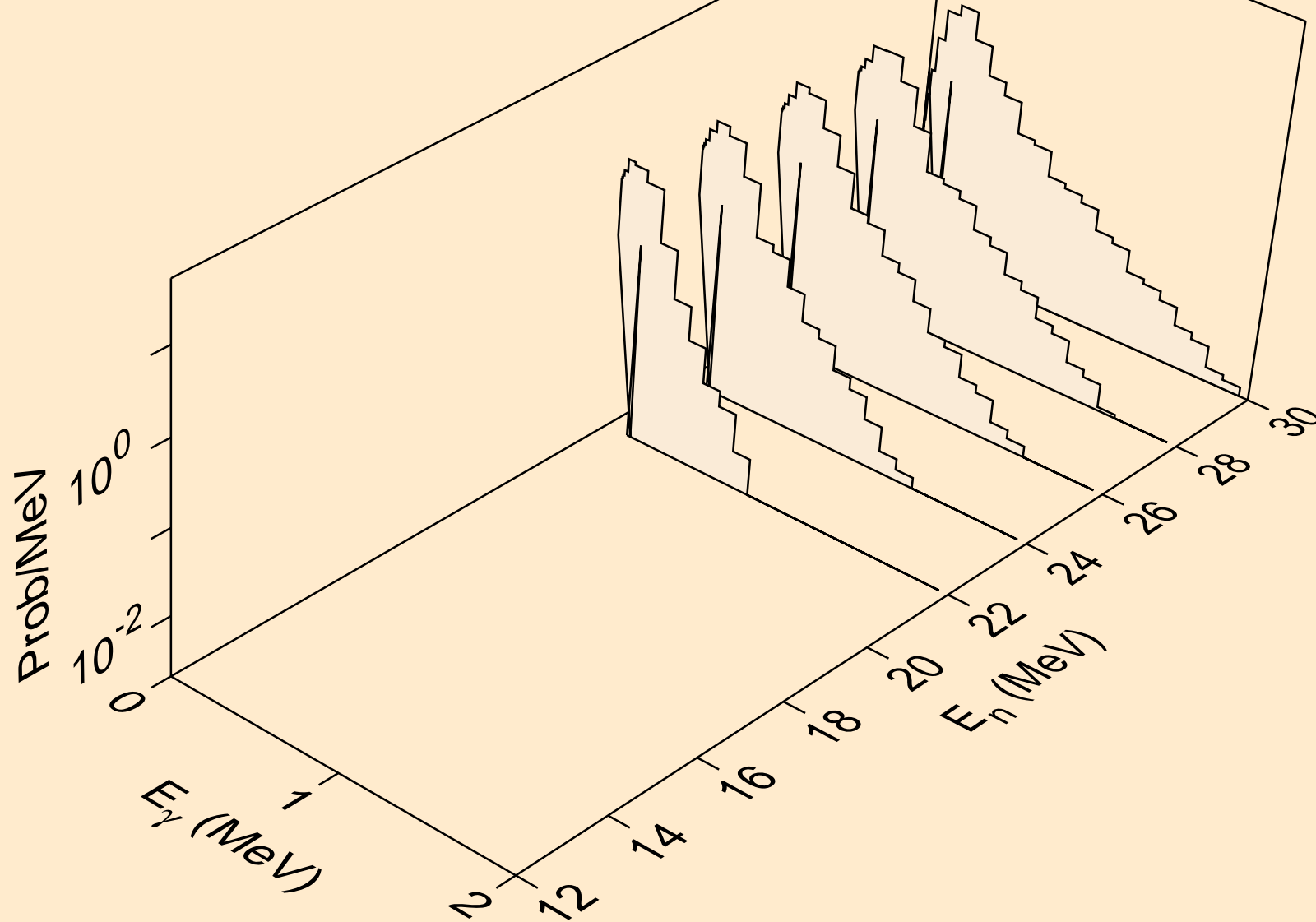

W197 NEUTRON ACER TENDL-2024 LIBRARY; T=0.K  
Photon emission for (n,n\*)p

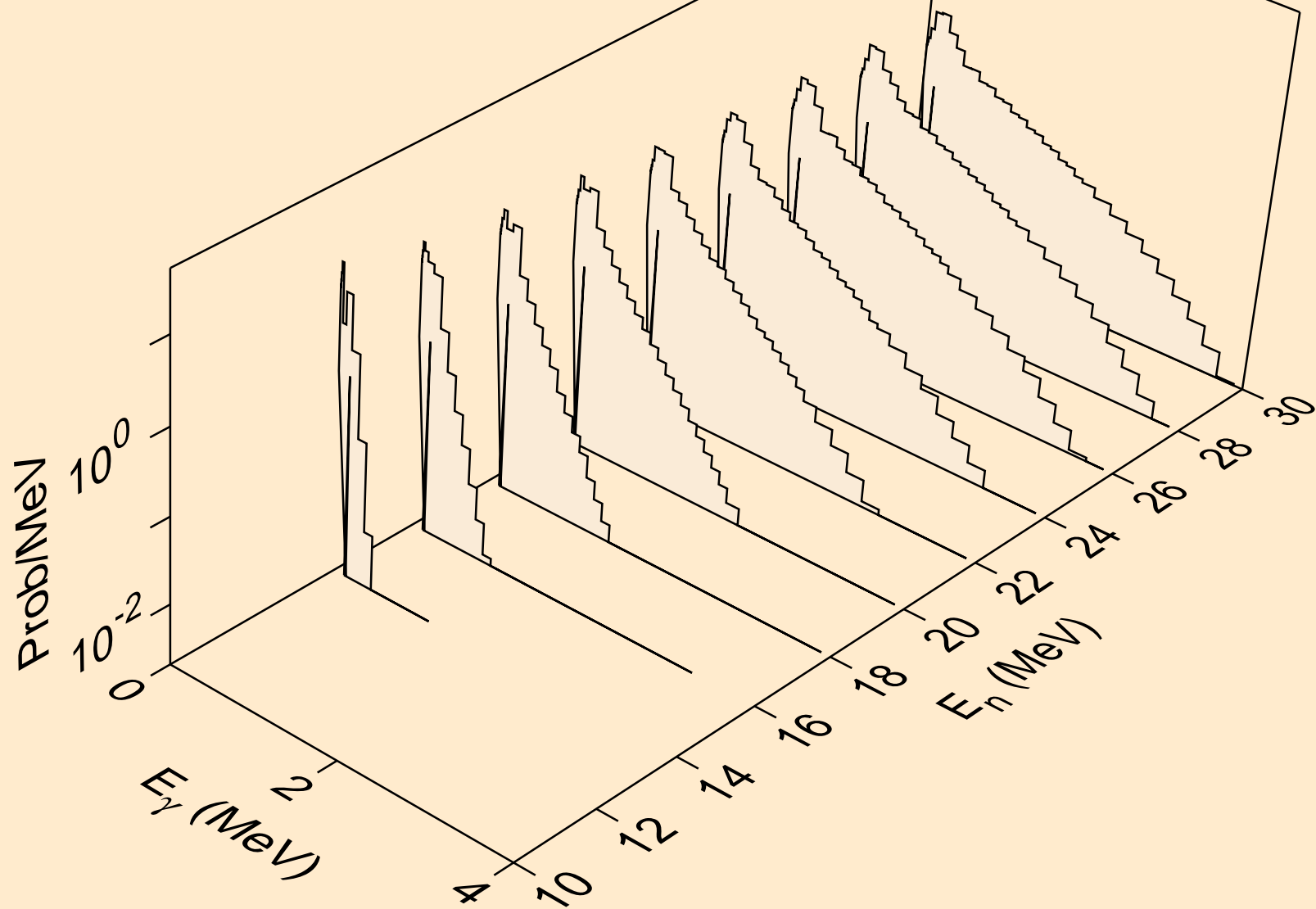

W197 NEUTRON ACER TENDL-2024 LIBRARY; T=0.K  
Photon emission for (n,n\*)d

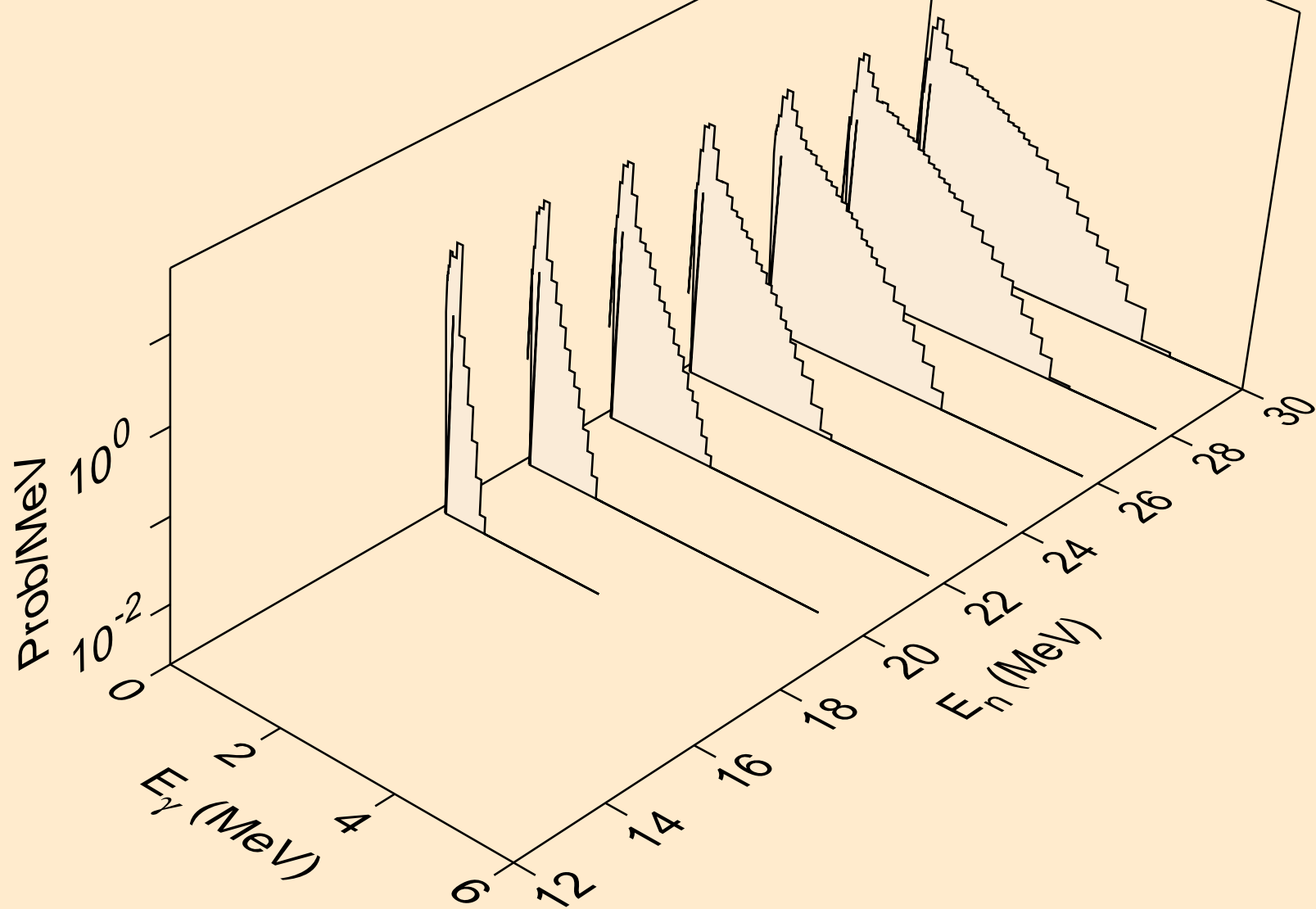

W197 NEUTRON ACER TENDL-2024 LIBRARY; T=0.K  
Photon emission for (n,n\*)t

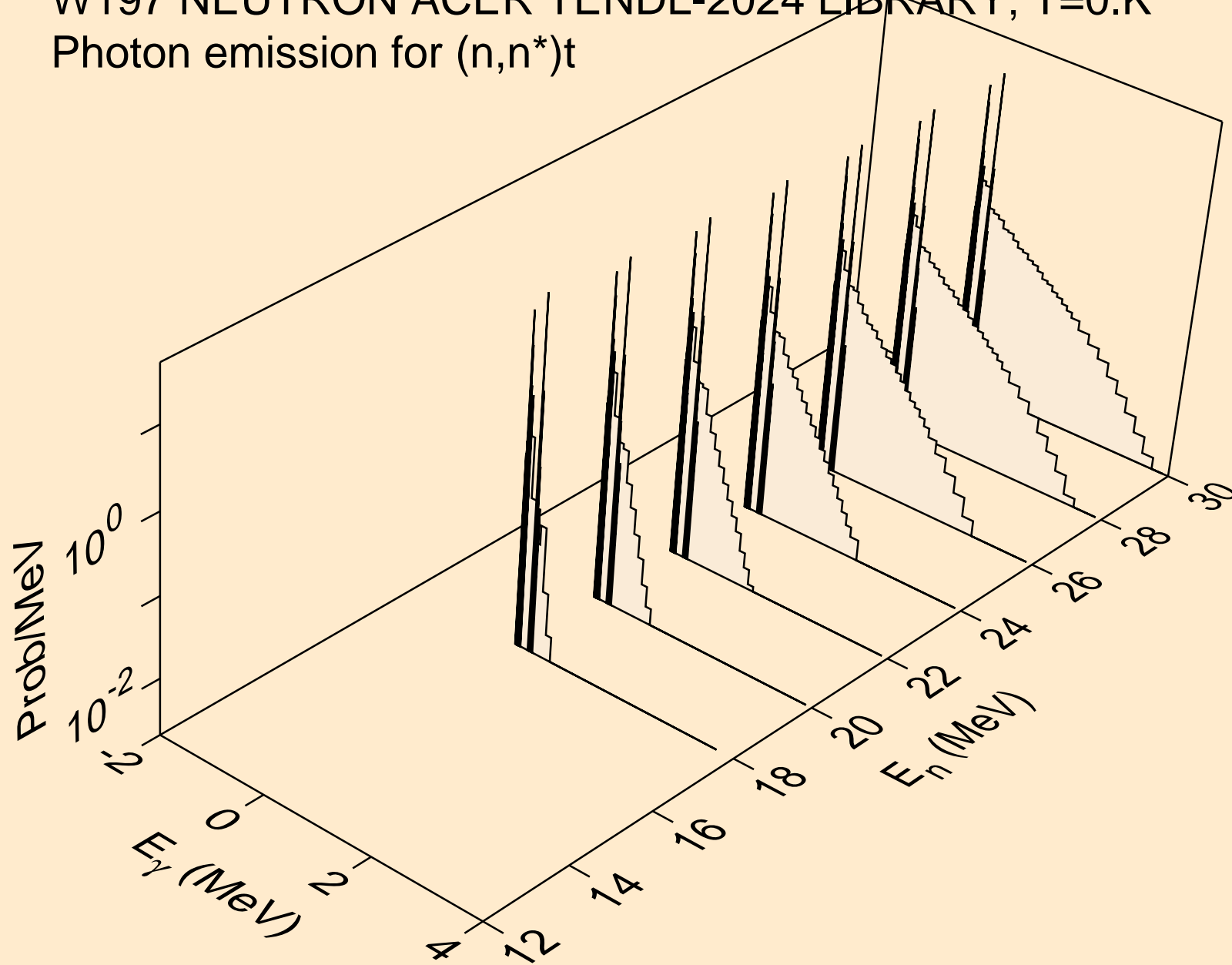

W197 NEUTRON ACER TENDL-2024 LIBRARY; T=0.K  
Photon emission for (n,4n)

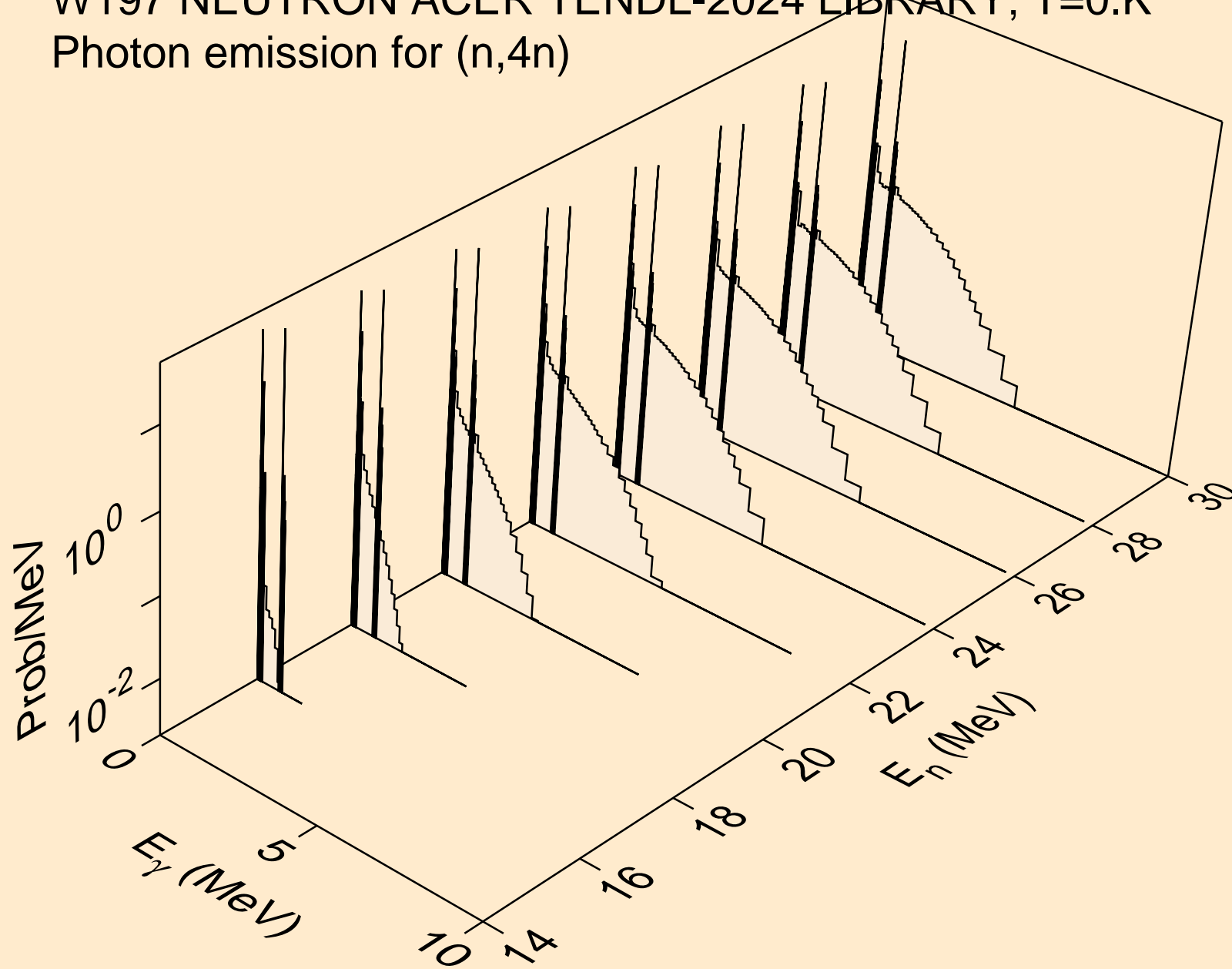

W197 NEUTRON ACER TENDL-2024 LIBRARY; T=0.K  
Photon emission for (n,2np)

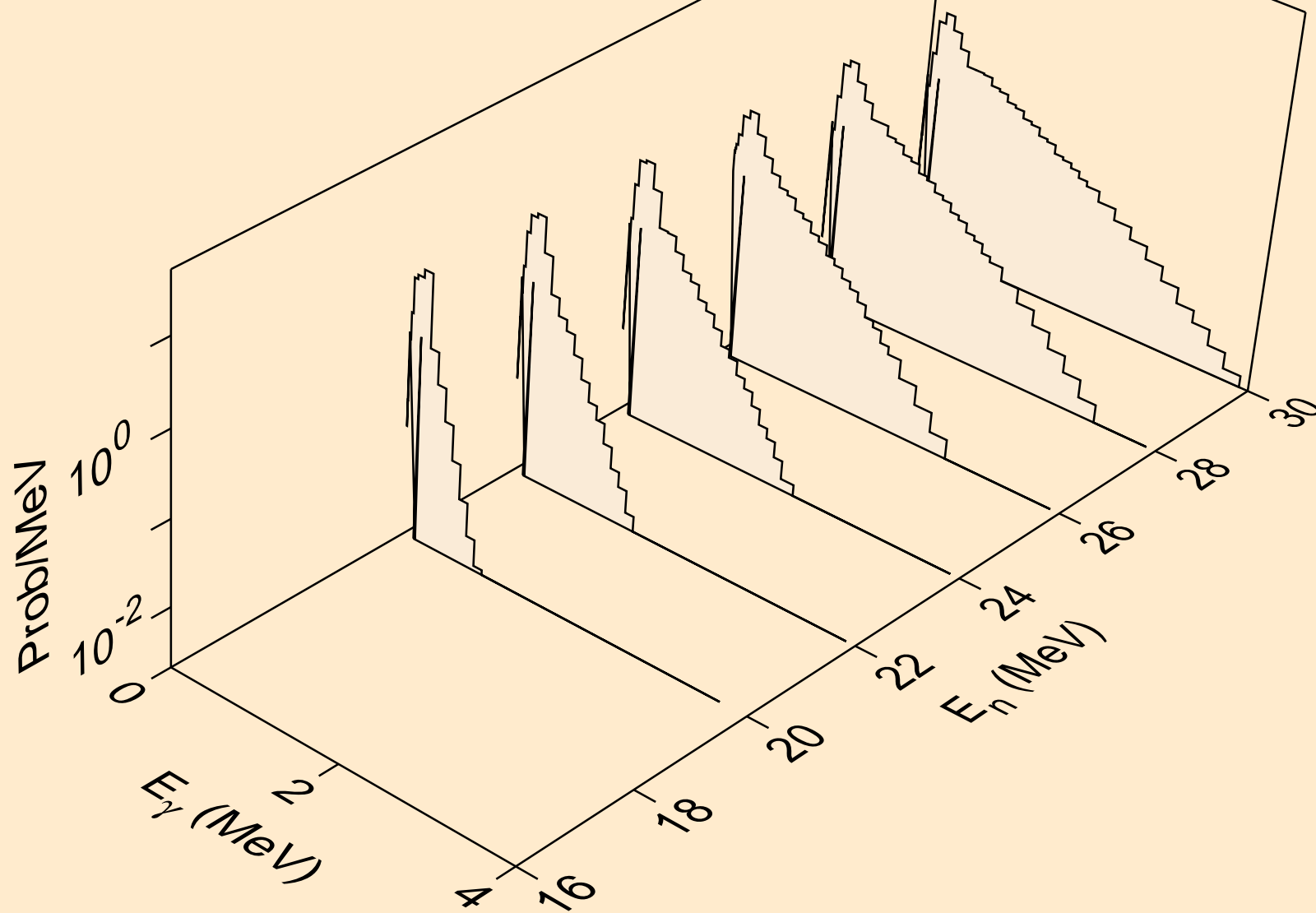

W197 NEUTRON ACER TENDL-2024 LIBRARY; T=0.K  
Photon emission for (n,3np)

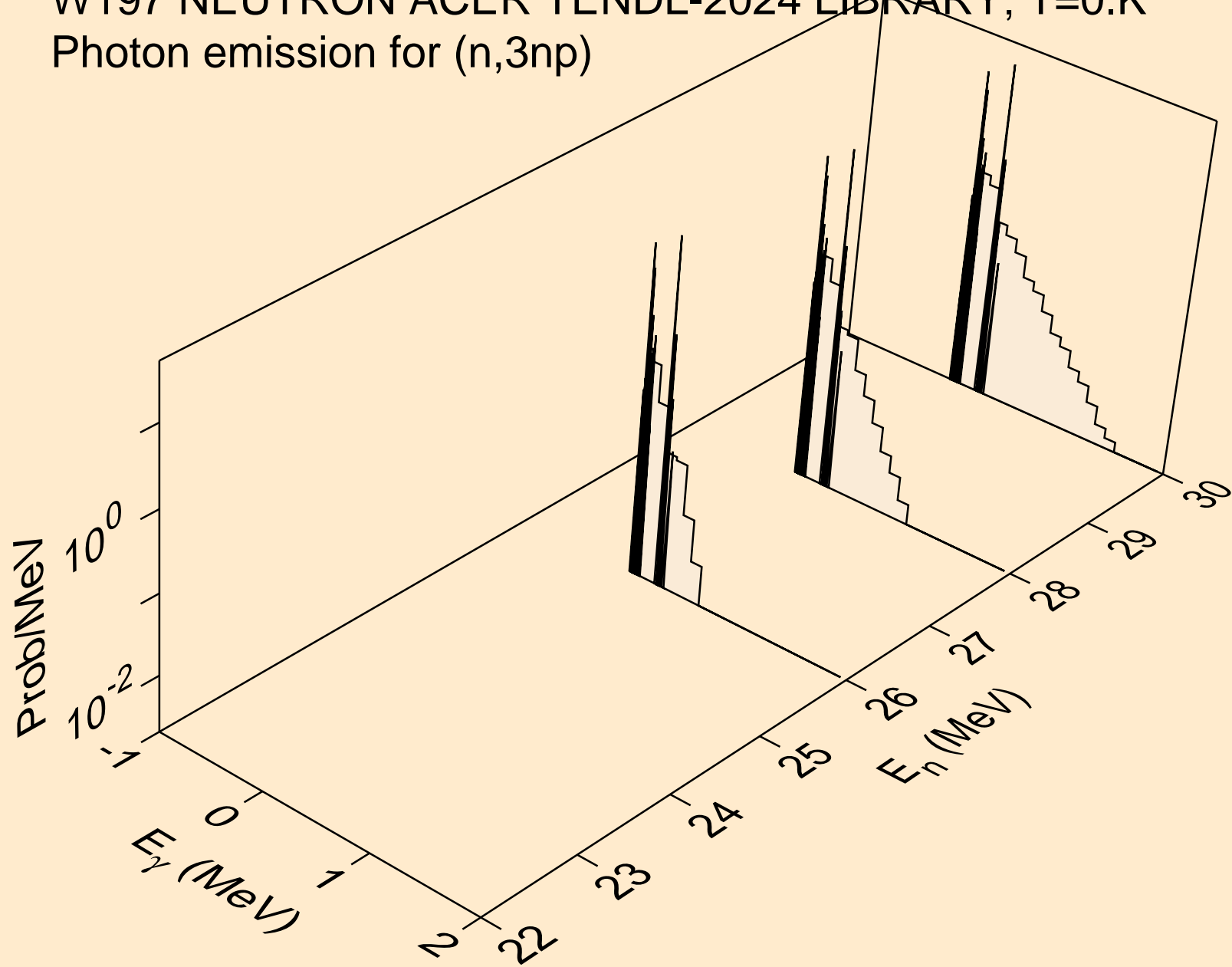

W197 NEUTRON ACER TENDL-2024 LIBRARY; T=0.K  
Photon emission for (n,n\*c)

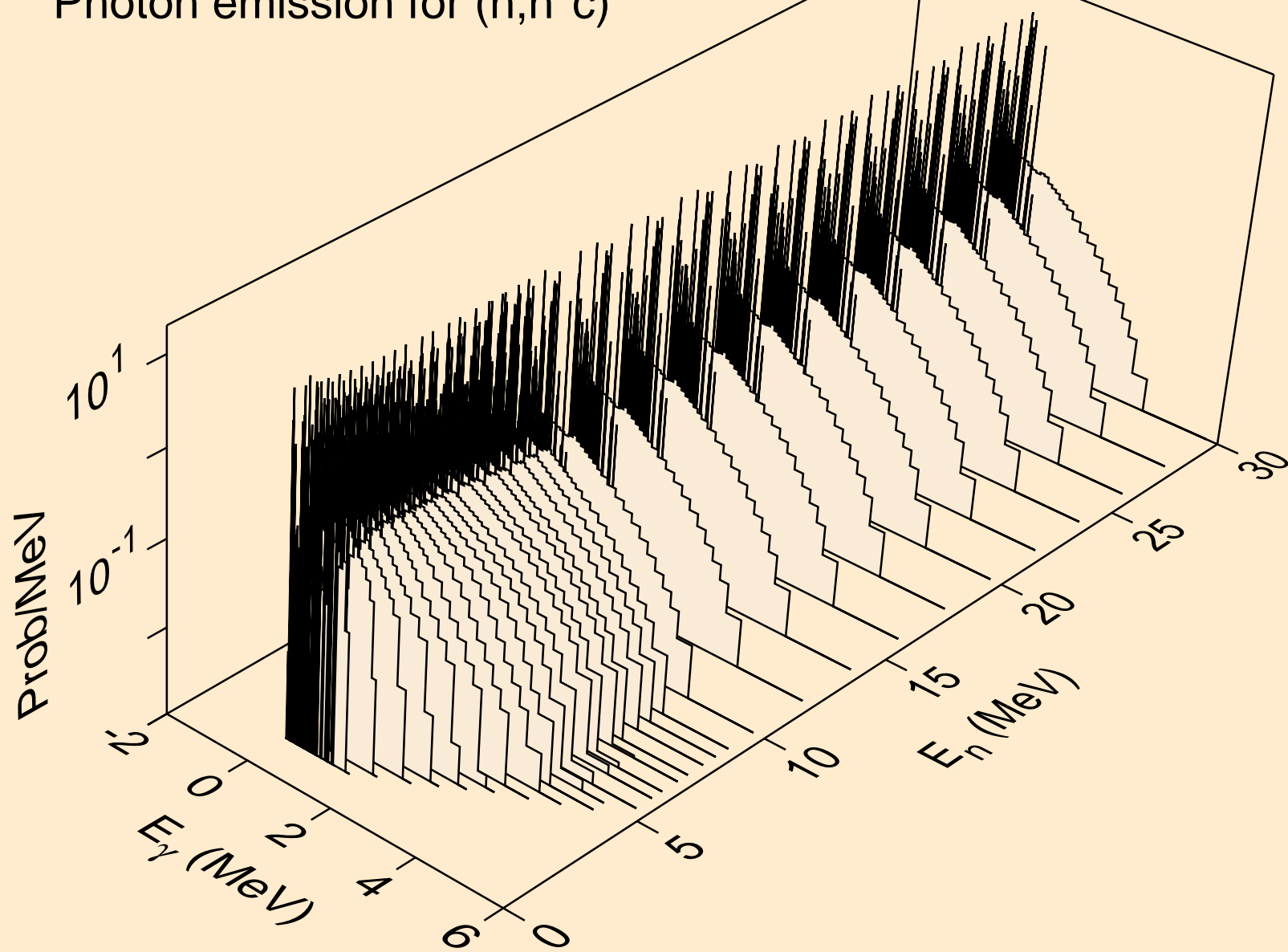

W197 NEUTRON ACER TENDL-2024 LIBRARY; T=0.K  
Photon emission for (n,gma)

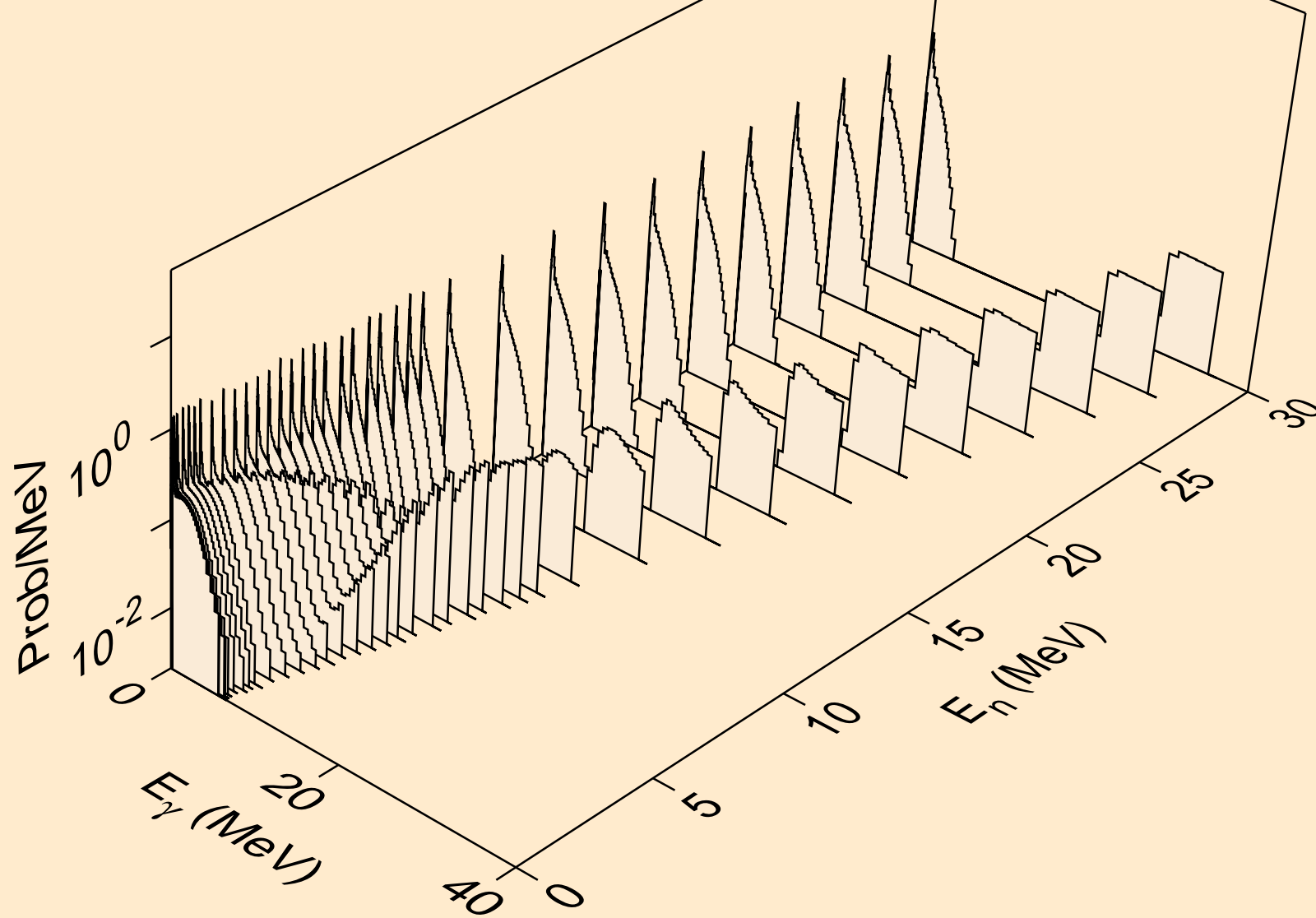

W197 NEUTRON ACER TENDL-2024 LIBRARY; T=0.K  
Photon emission for (n,p)

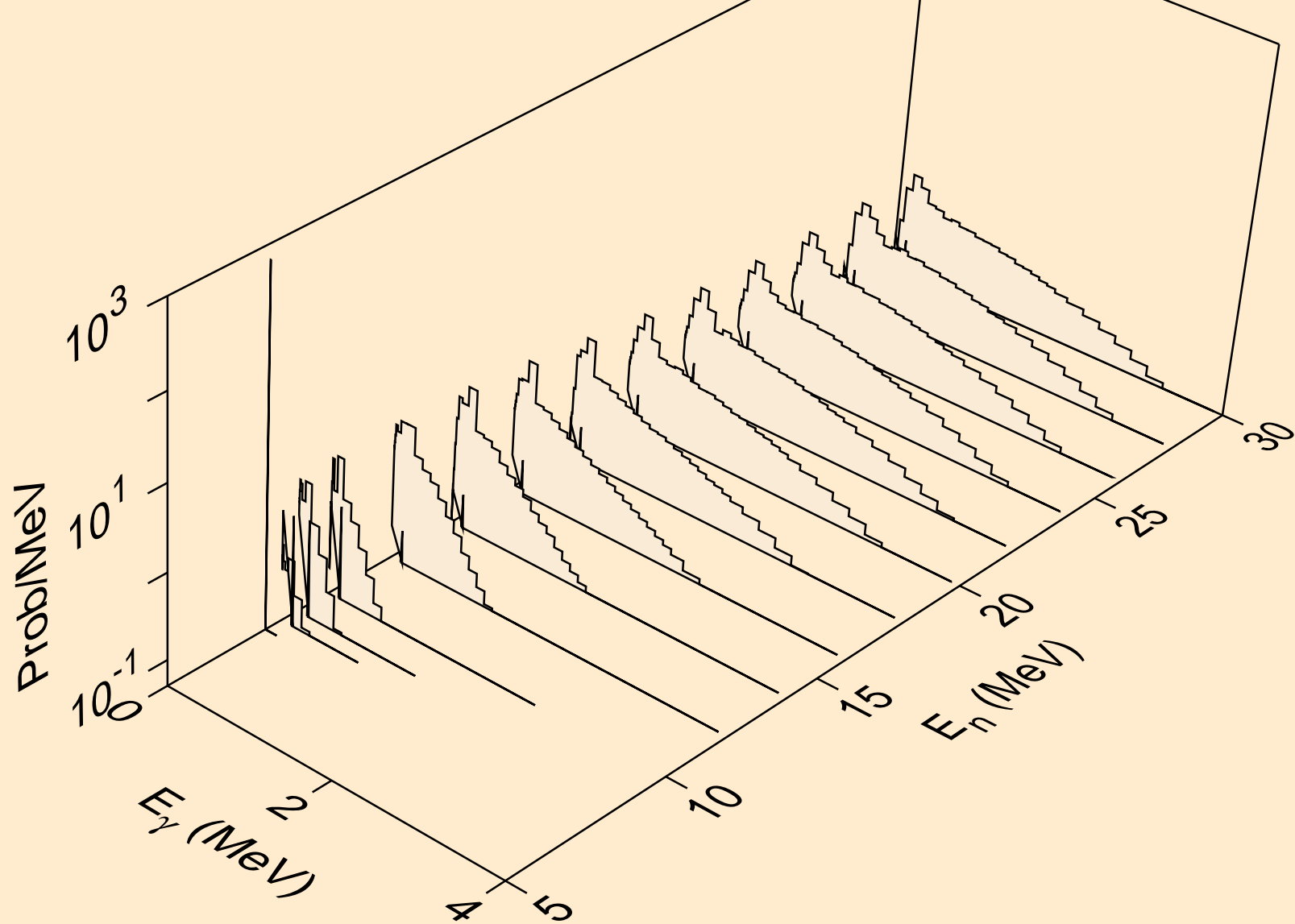

W197 NEUTRON ACER TENDL-2024 LIBRARY; T=0.K  
Photon emission for (n,d)

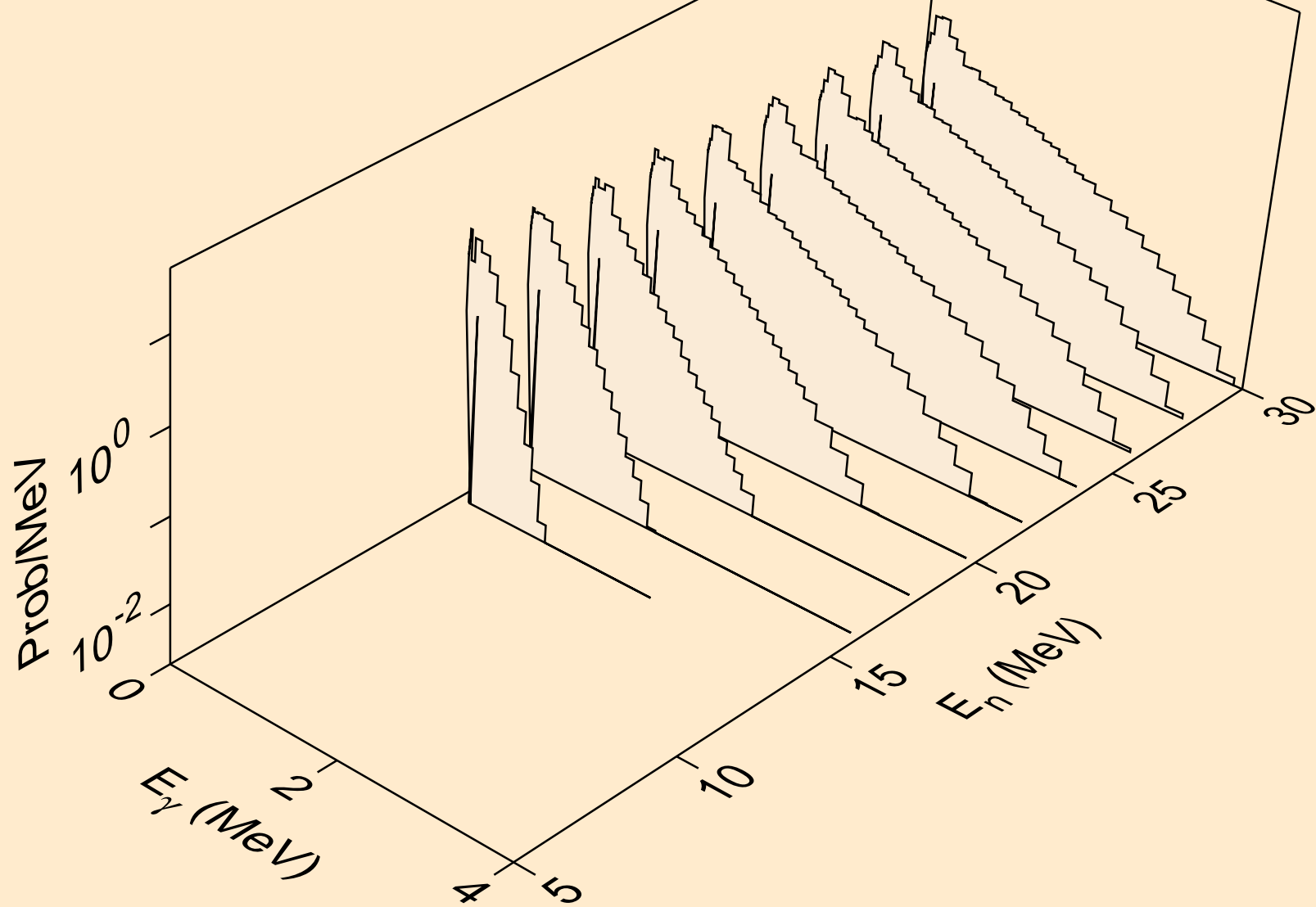

W197 NEUTRON ACER TENDL-2024 LIBRARY; T=0.K  
Photon emission for (n,t)

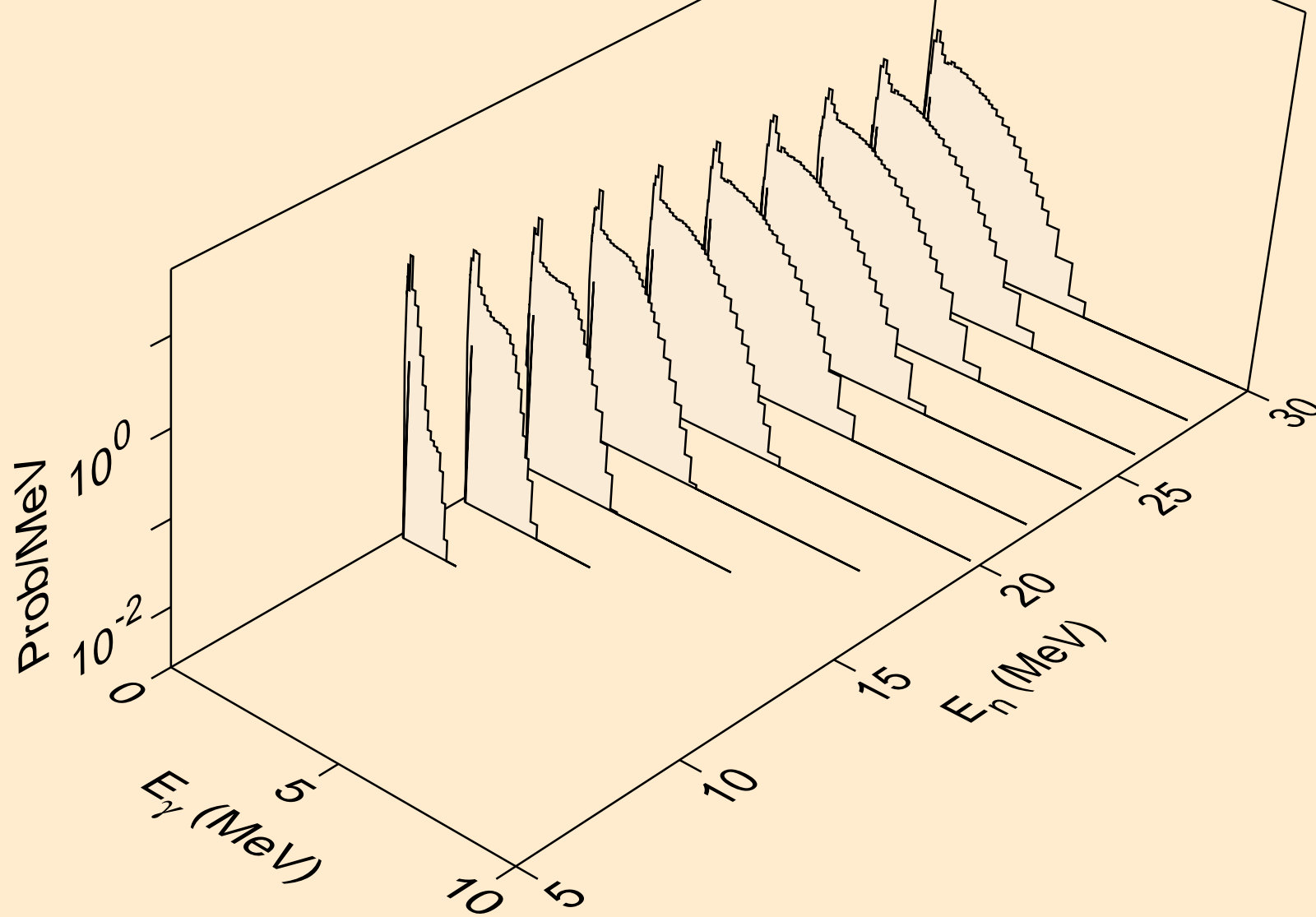

W197 NEUTRON ACER TENDL-2024 LIBRARY; T=0.K  
Photon emission for (n,he3)

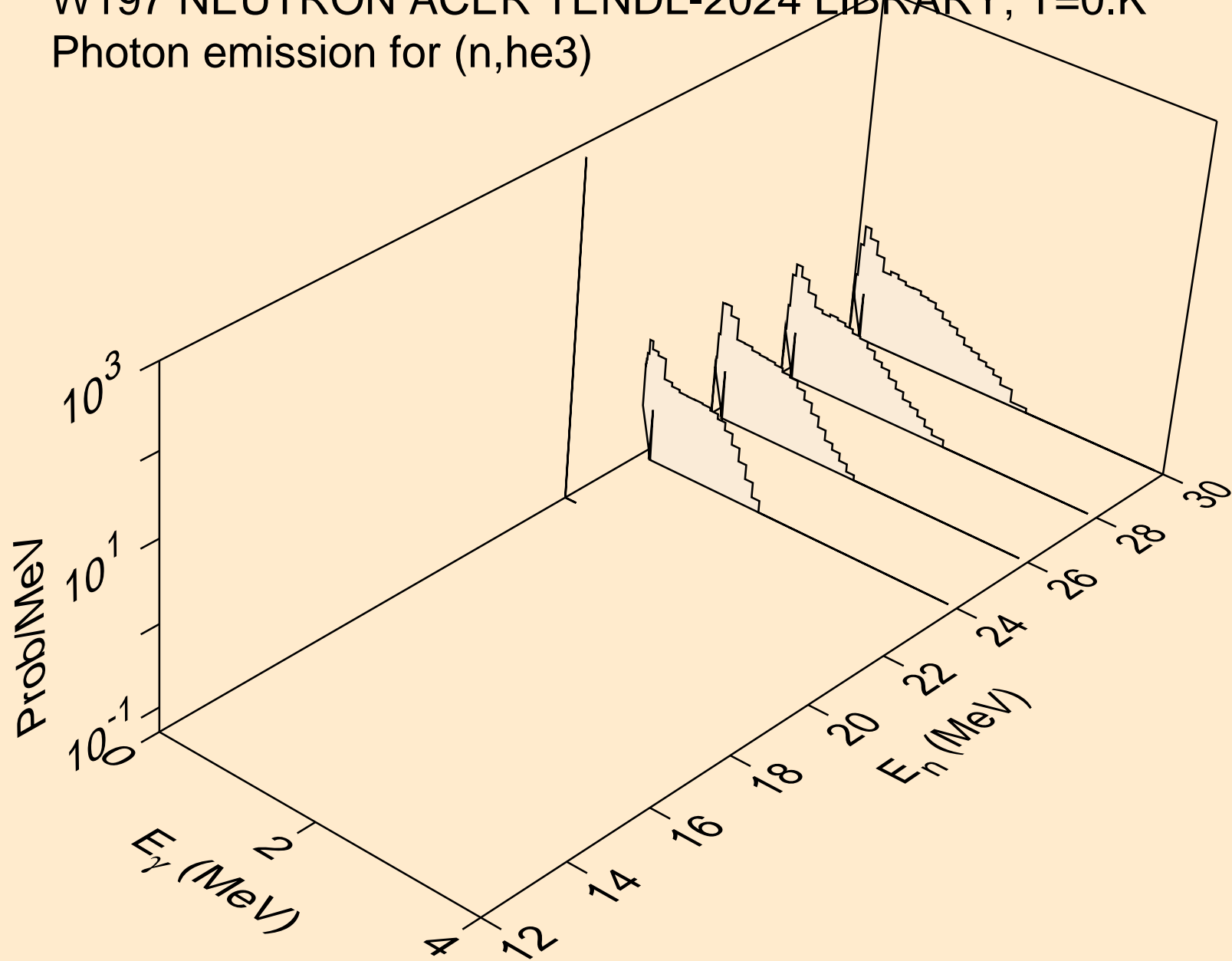

W197 NEUTRON ACER TENDL-2024 LIBRARY; T=0.K  
Photon emission for (n,a)

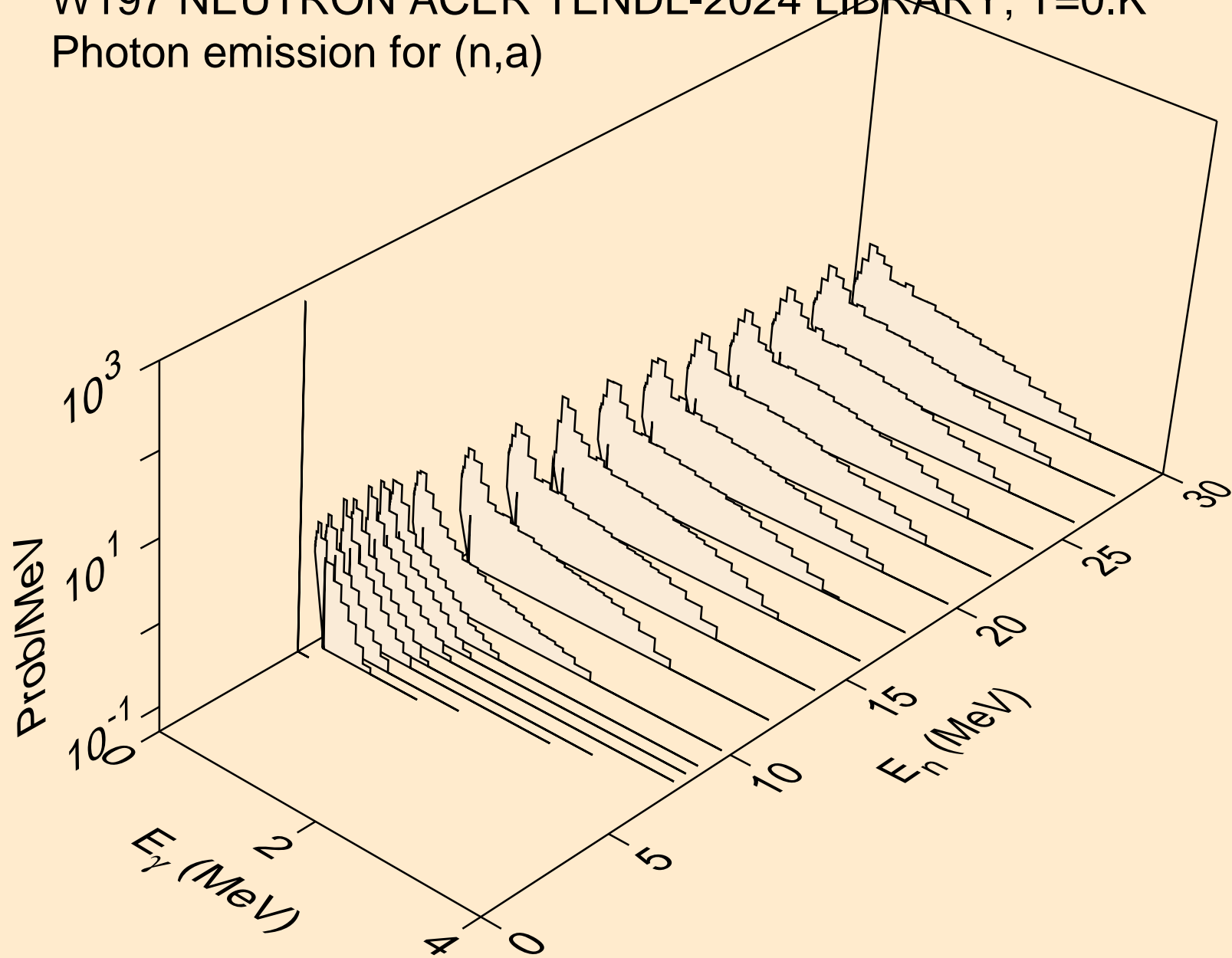

W197 NEUTRON ACER TENDL-2024 LIBRARY; T=0.K  
thermal capture photon spectrum

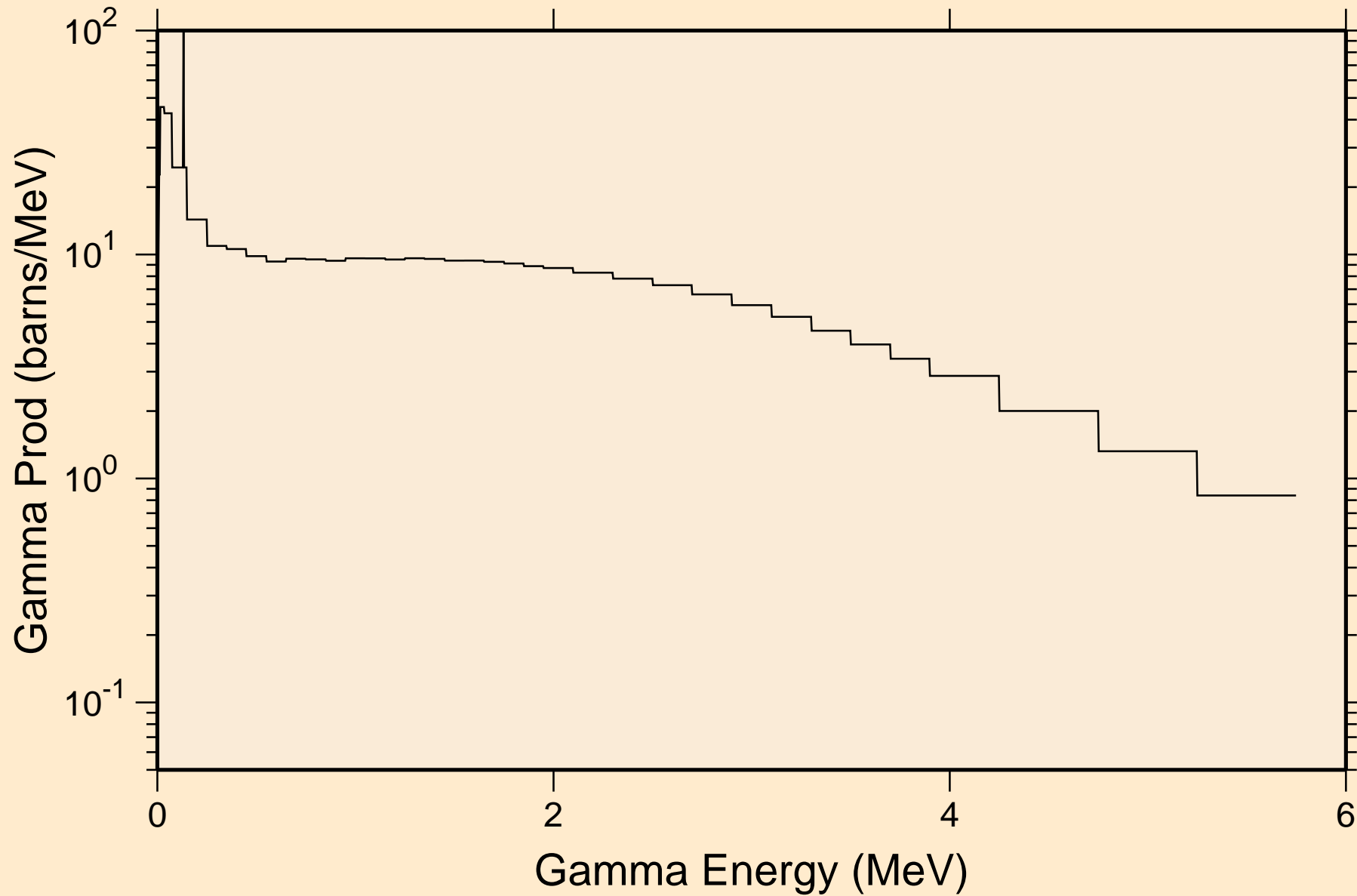

W197 NEUTRON ACER TENDL-2024 LIBRARY; T=0.K  
14 MeV photon spectrum

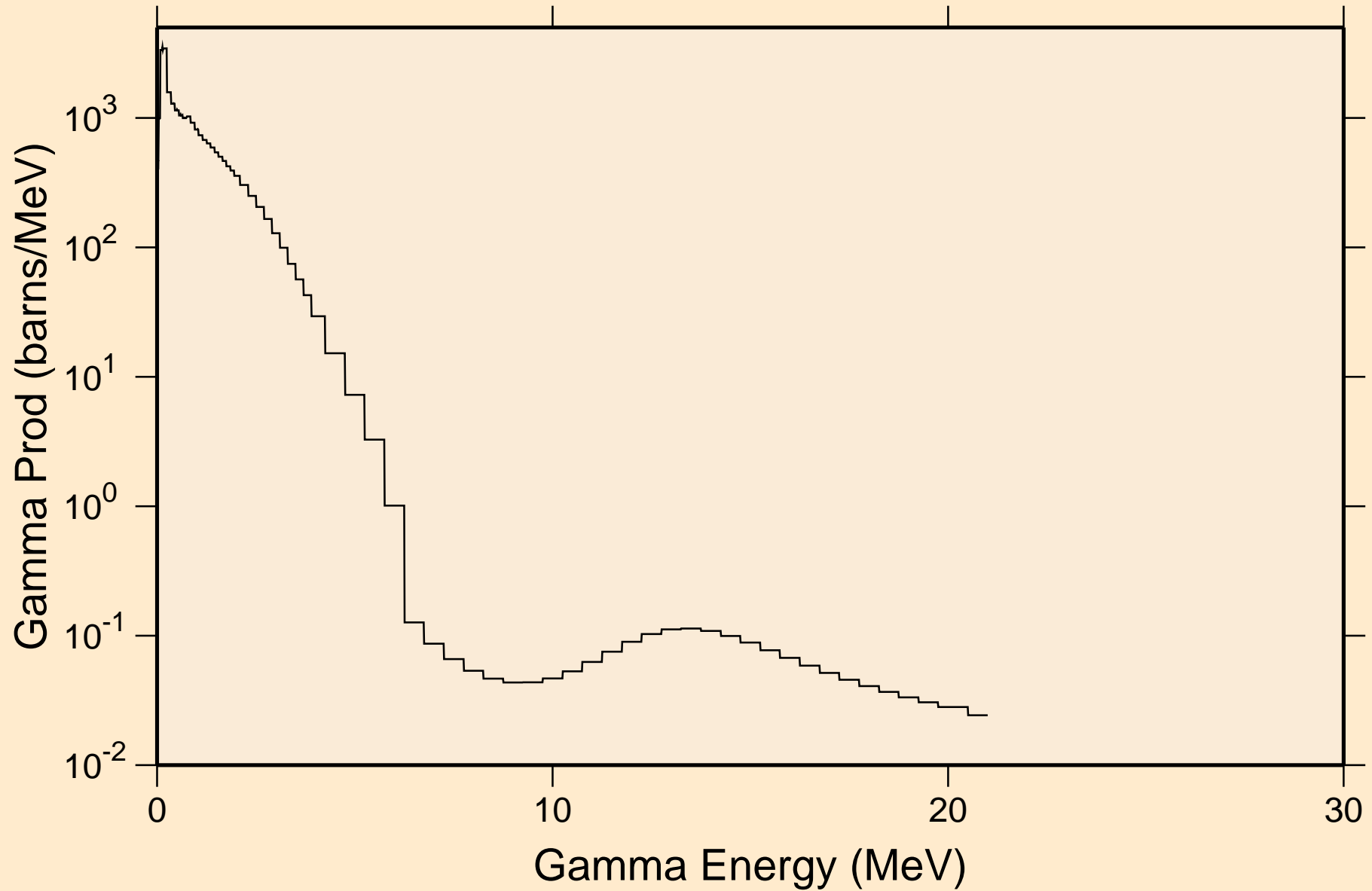

# W197 NEUTRON ACER TENDL-2024 LIBRARY; T=0.K

## Particle heating contributions

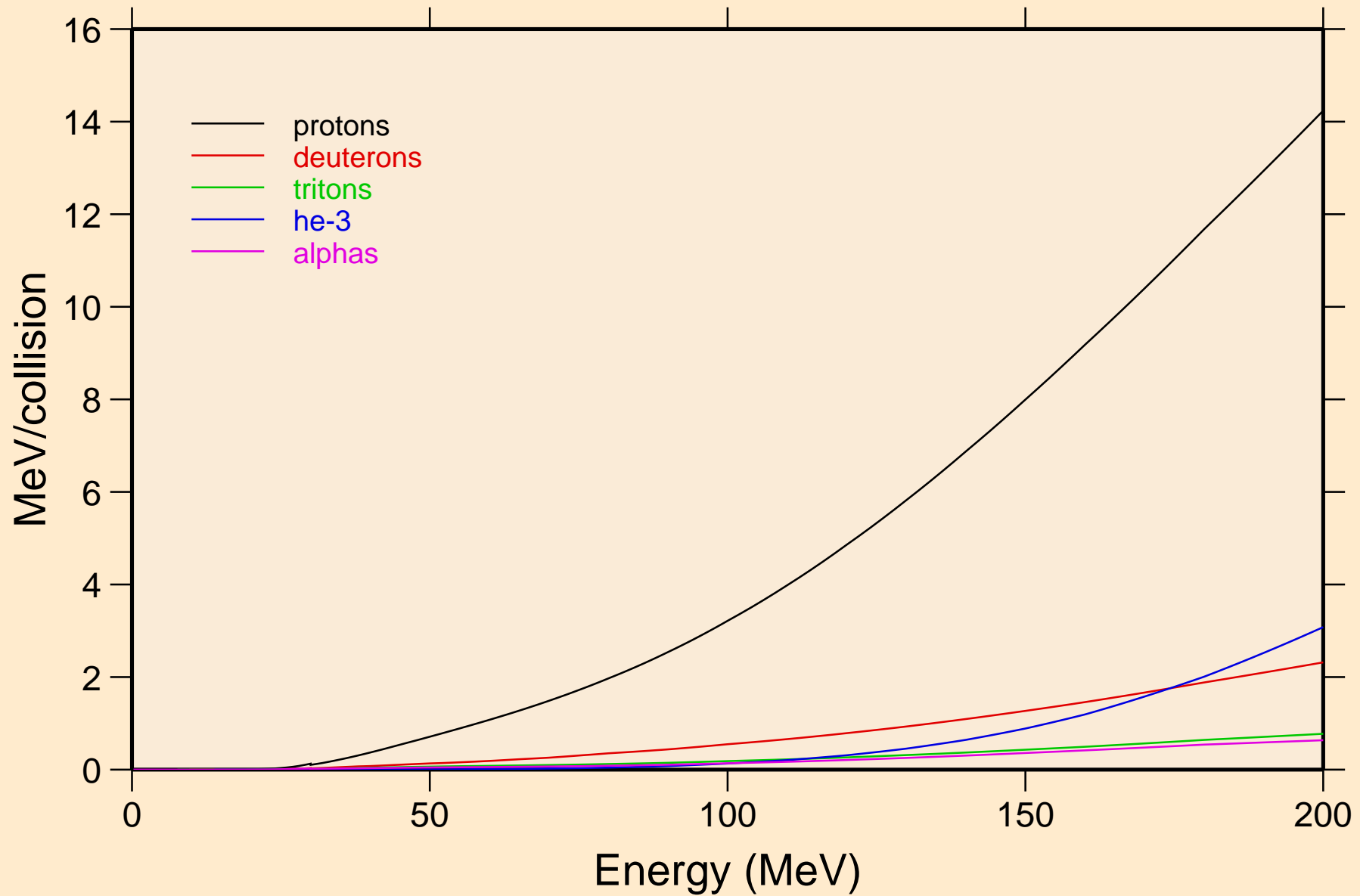

W197 NEUTRON ACER TENDL-2024 LIBRARY; T=0.K  
Recoil Heating

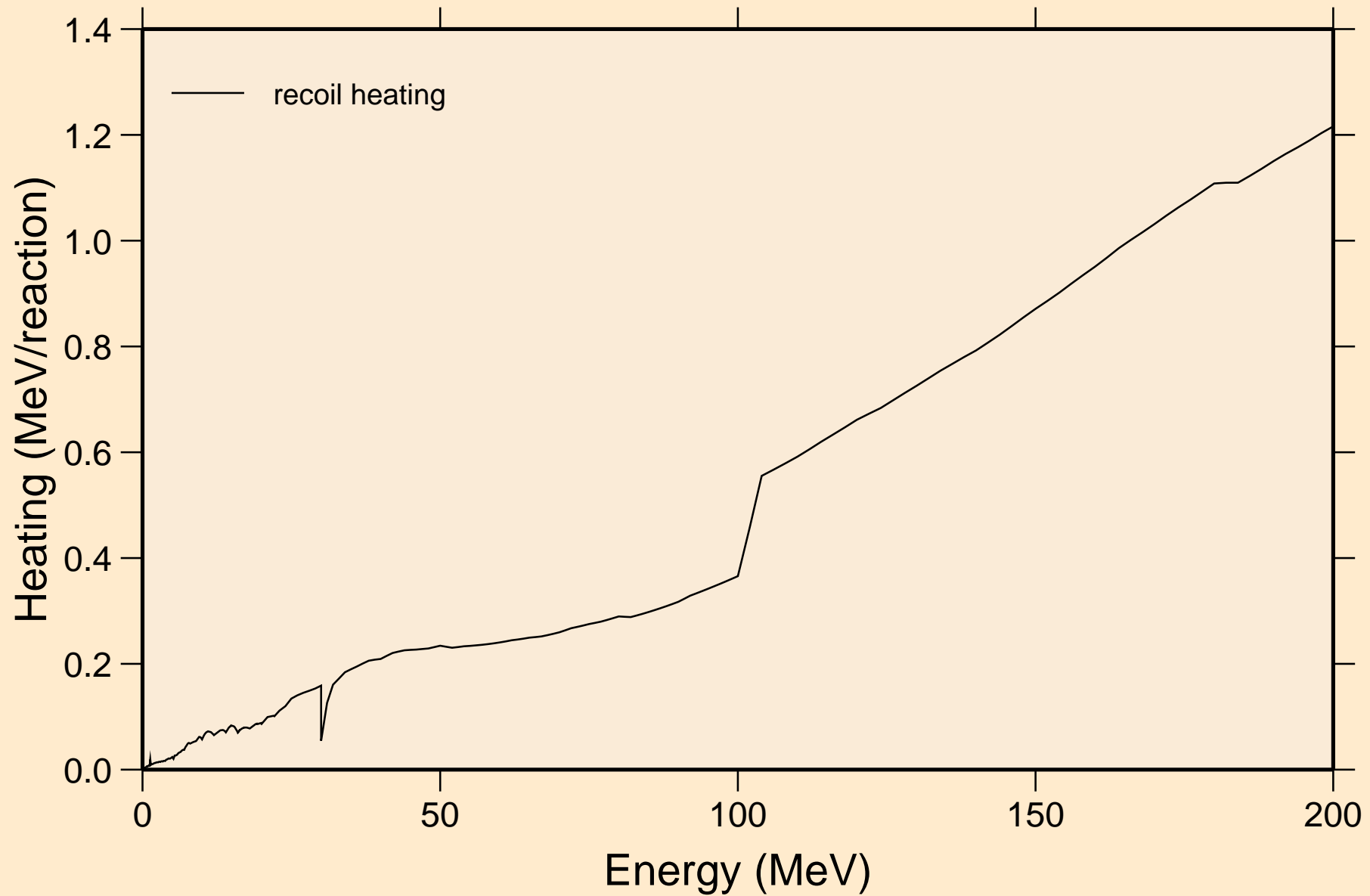

W197 NEUTRON ACER TENDL-2024 LIBRARY; T=0.K  
Particle production cross sections

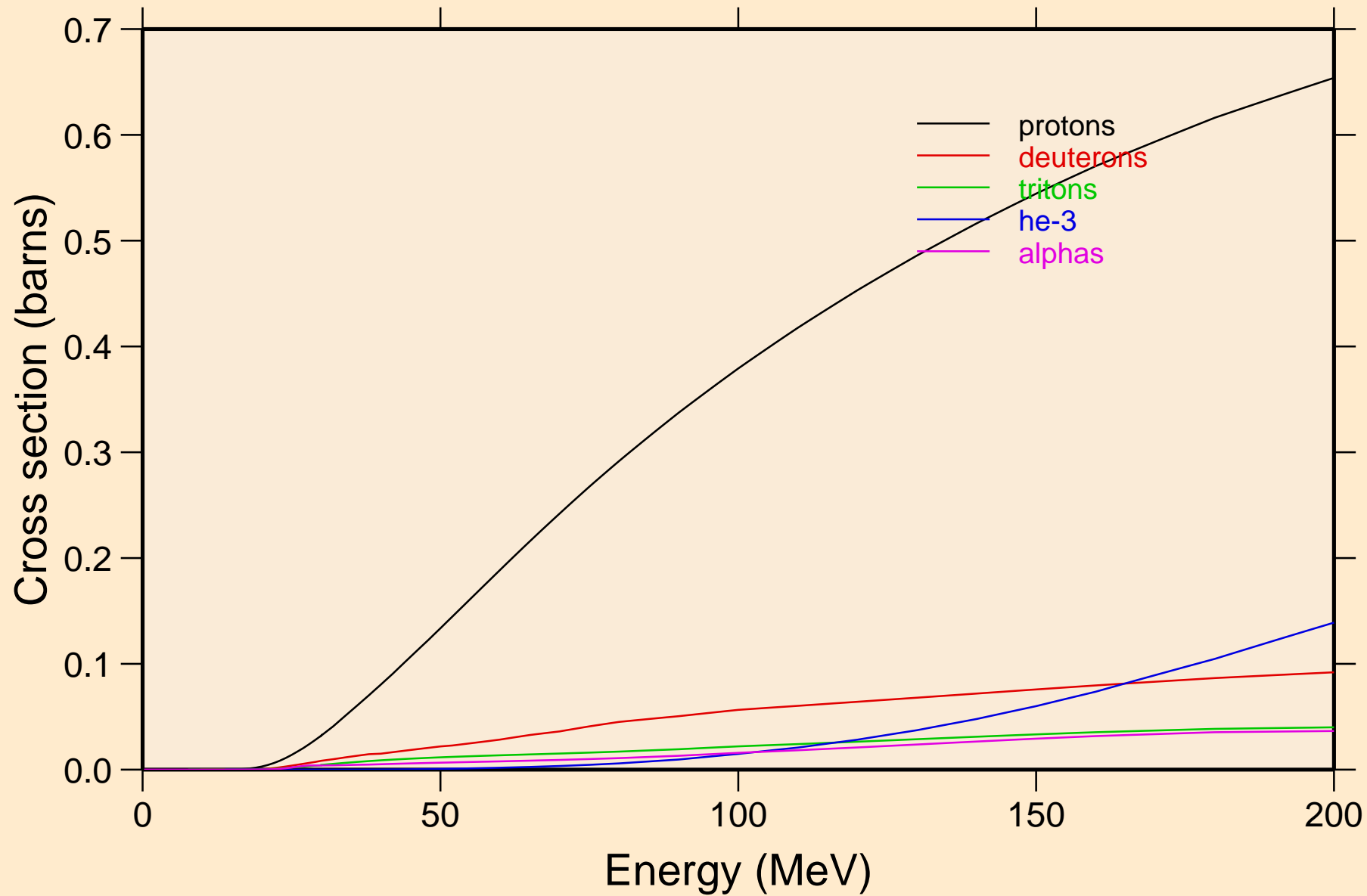

W197 NEUTRON ACER TENDL-2024 LIBRARY; T=0.K  
protons from (n,x)

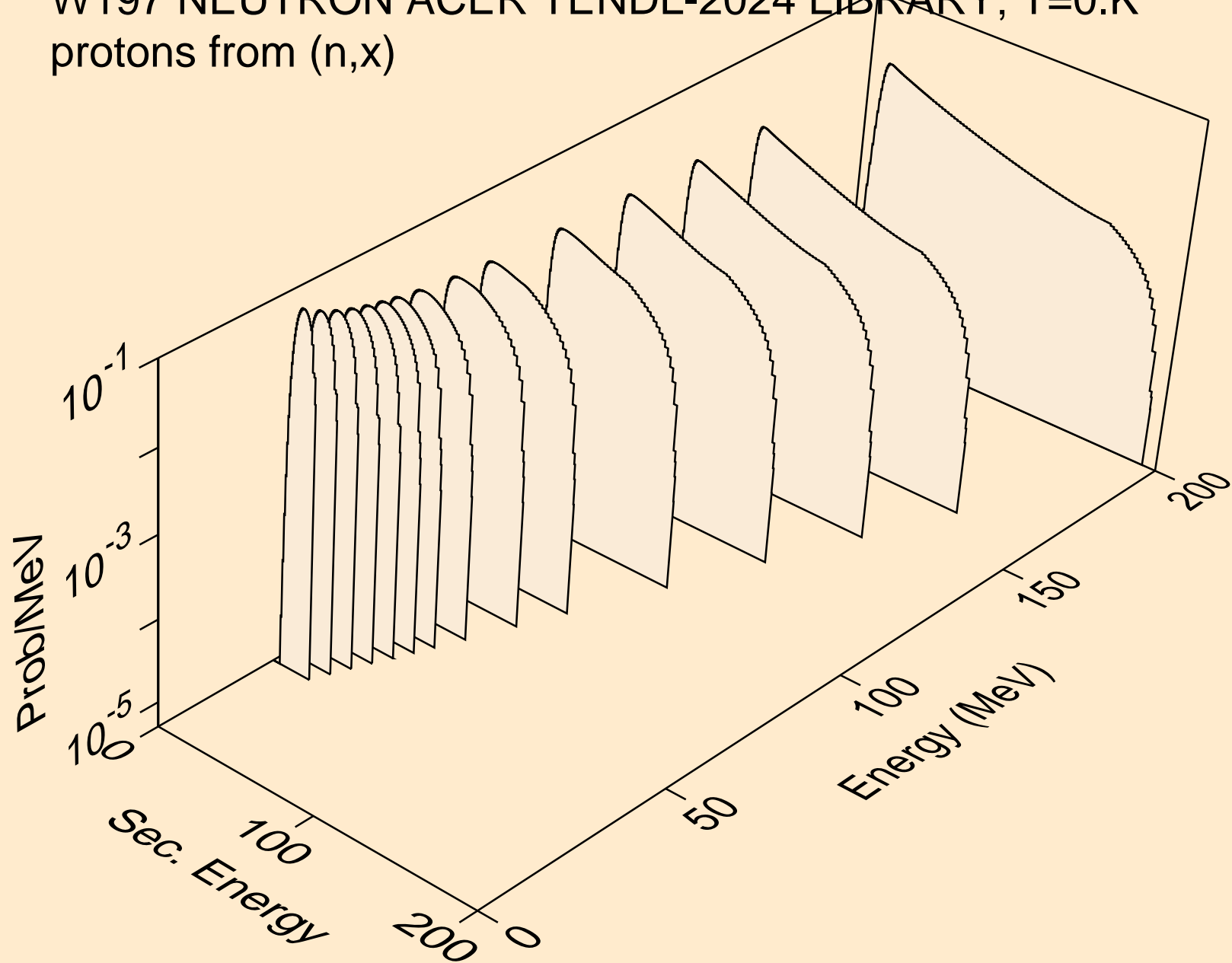



W197 NEUTRON ACER TENDL-2024 LIBRARY; T=0.K  
protons from (n,2np)

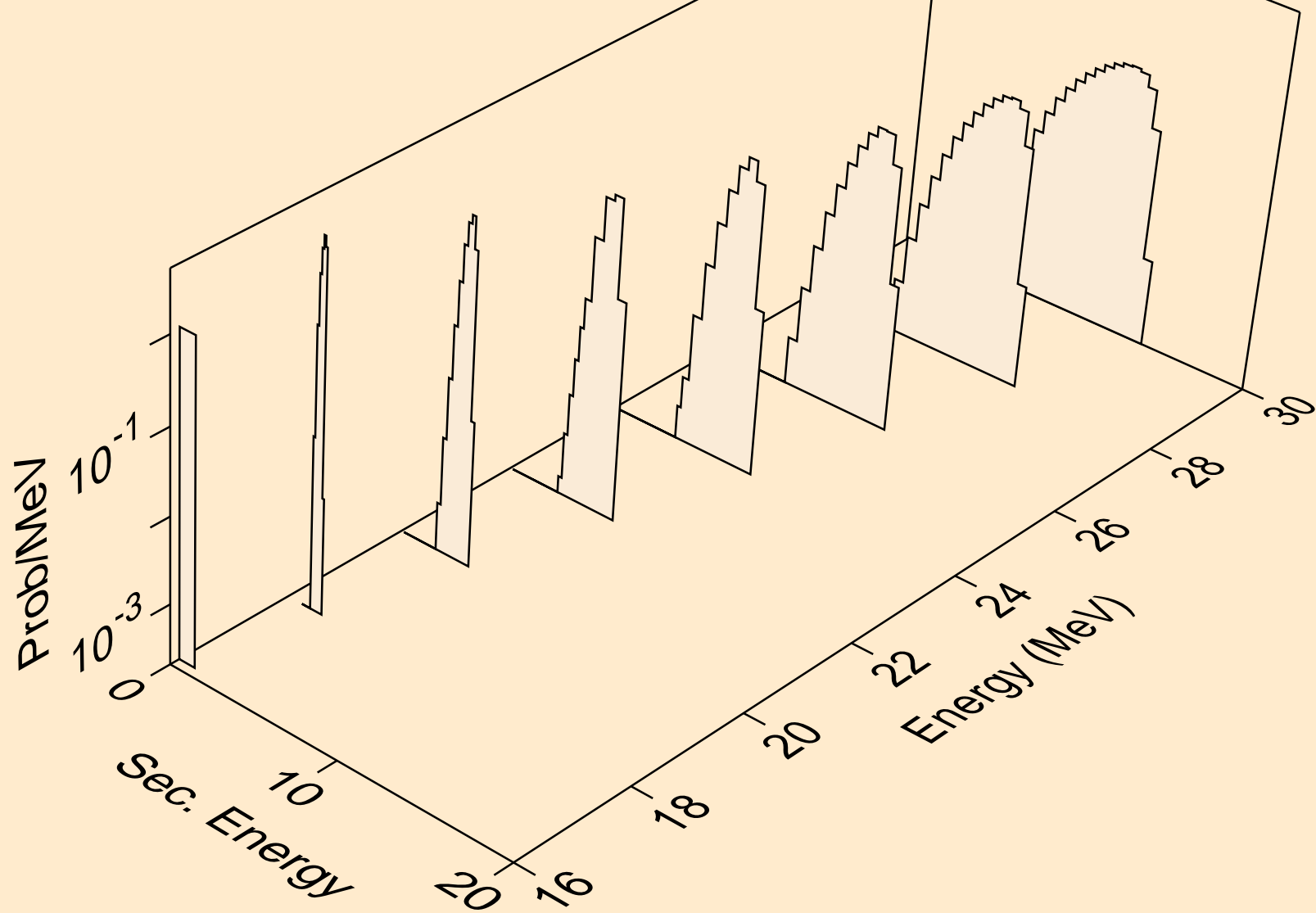

W197 NEUTRON ACER TENDL-2024 LIBRARY; T=0.K  
protons from (n,3np)

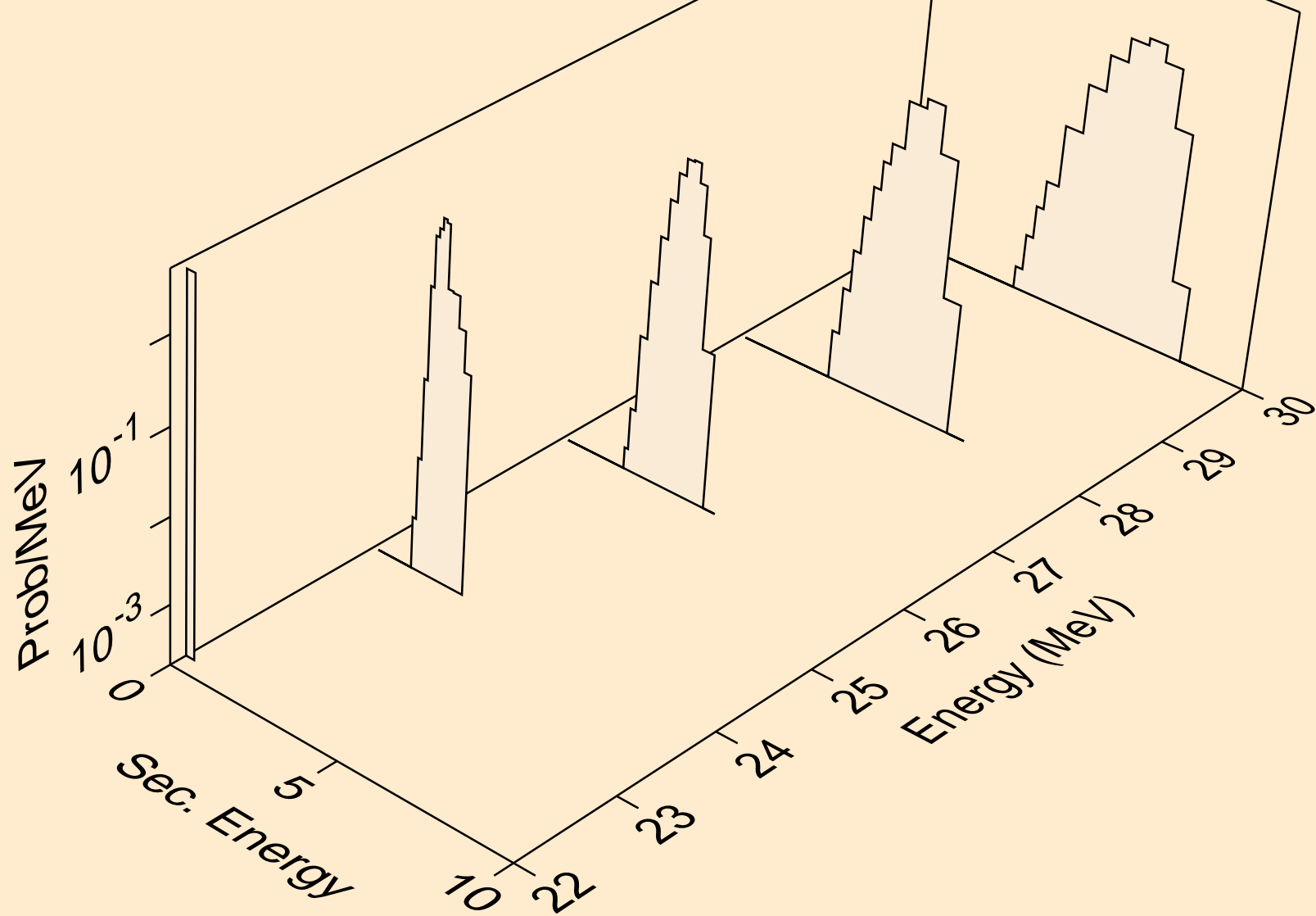

W197 NEUTRON ACER TENDL-2024 LIBRARY; T=0.K  
protons from (n,p)

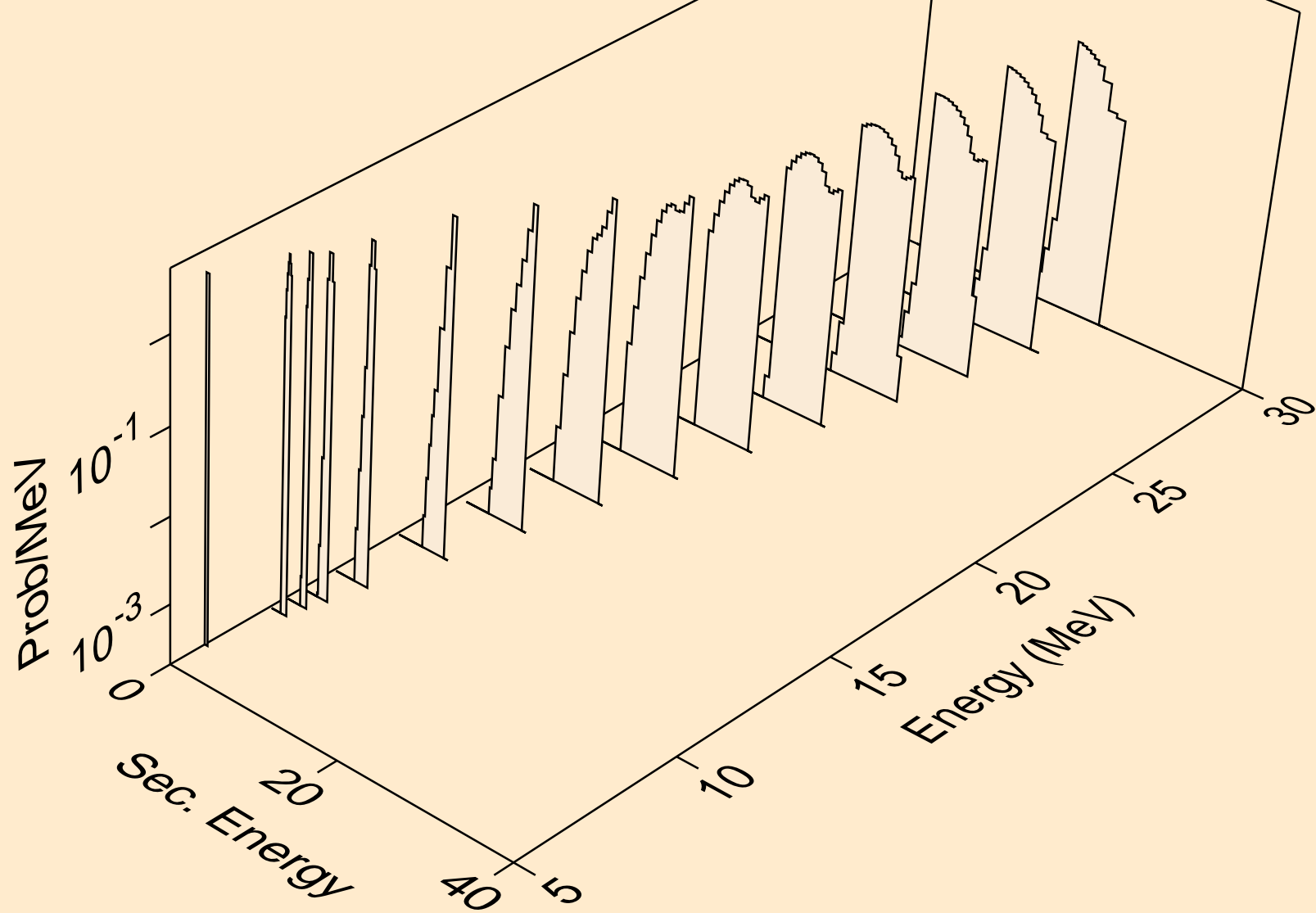

W197 NEUTRON ACER TENDL-2024 LIBRARY; T=0.K  
deuterons from (n,x)

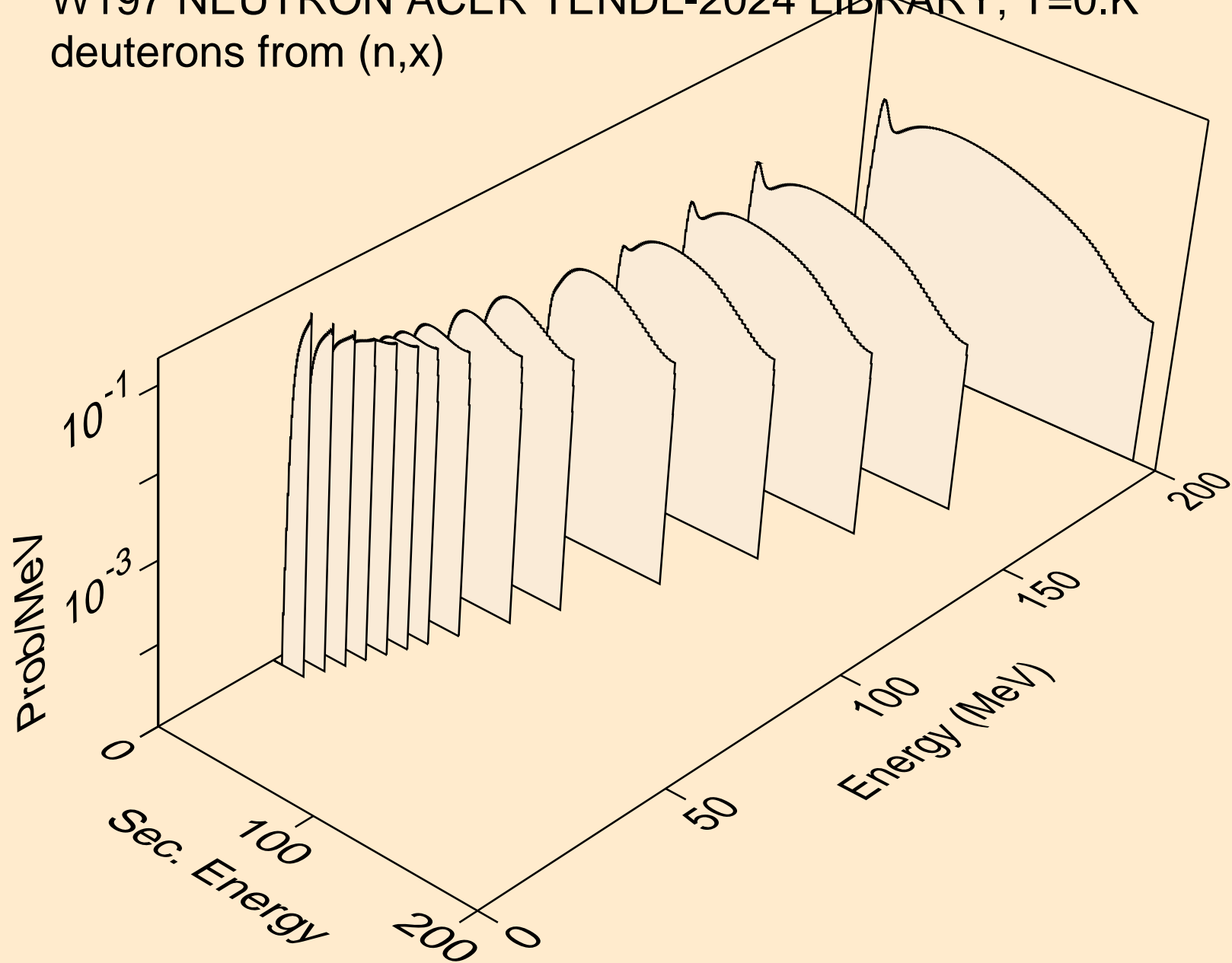

W197 NEUTRON ACER TENDL-2024 LIBRARY; T=0.K  
deuterons from (n,2nd)

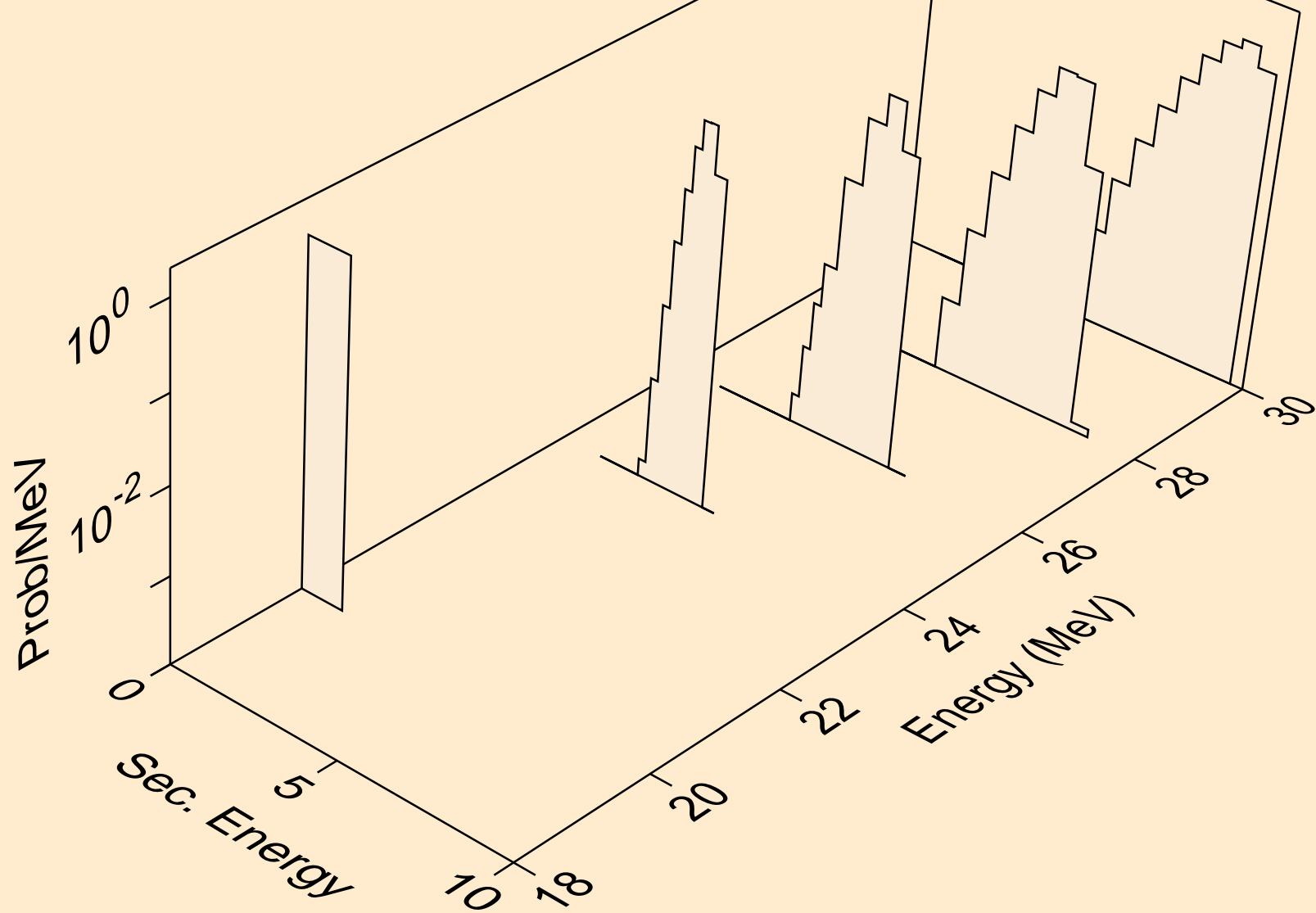

W197 NEUTRON ACER TENDL-2024 LIBRARY; T=0.K  
deuterons from (n,n\*)d

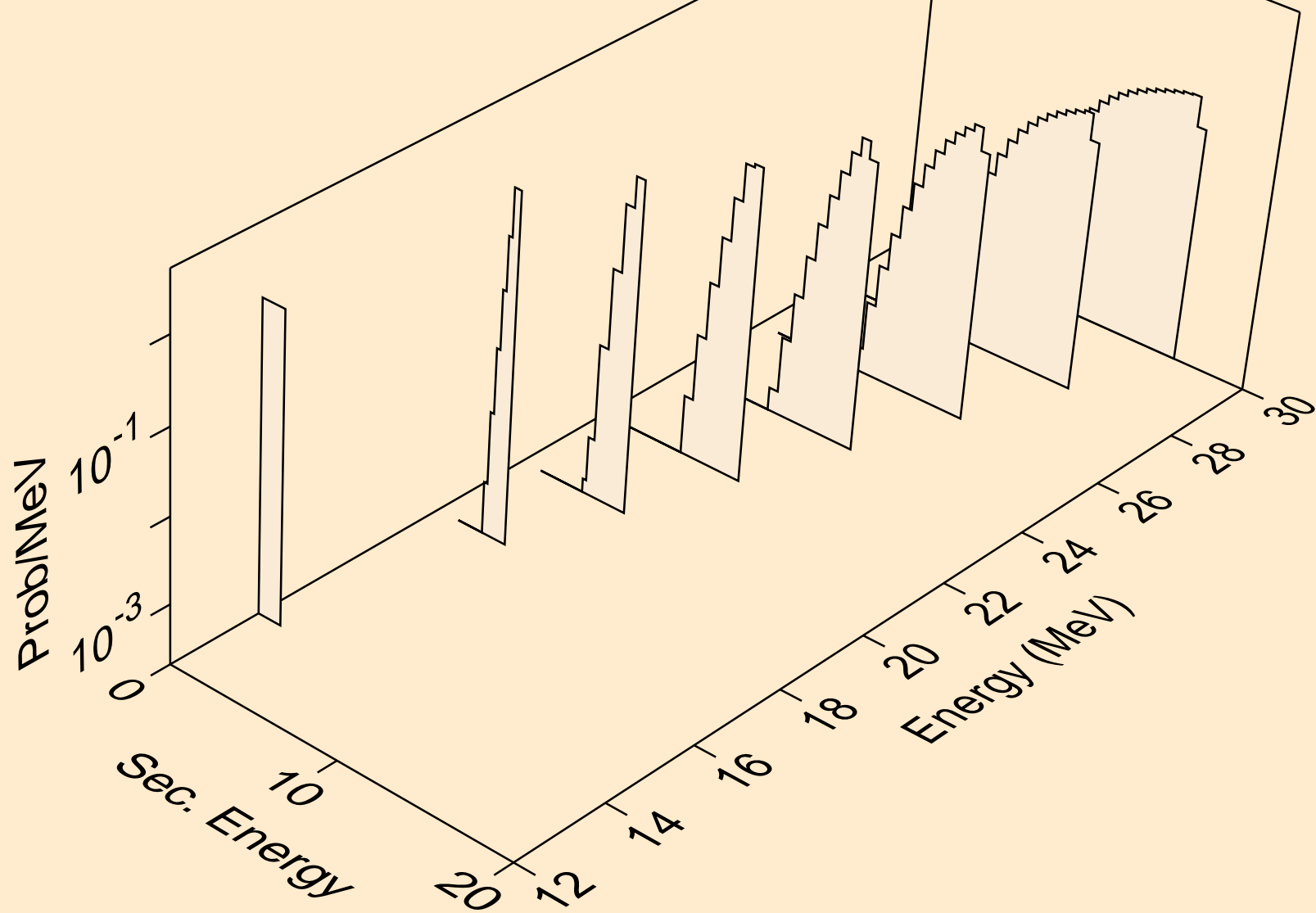

W197 NEUTRON ACER TENDL-2024 LIBRARY; T=0.K  
deuterons from (n,d)

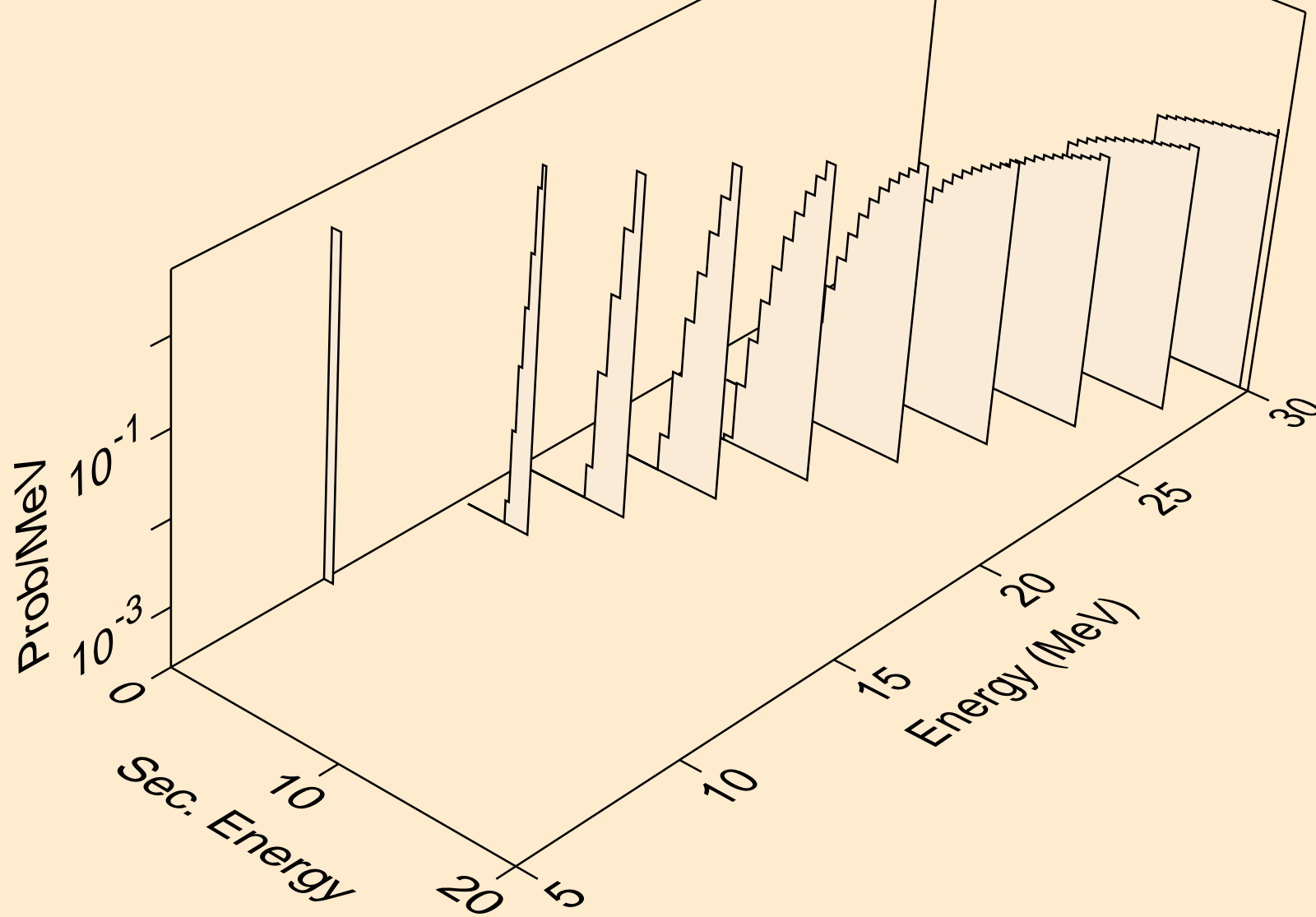

W197 NEUTRON ACER TENDL-2024 LIBRARY; T=0.K  
tritons from (n,x)

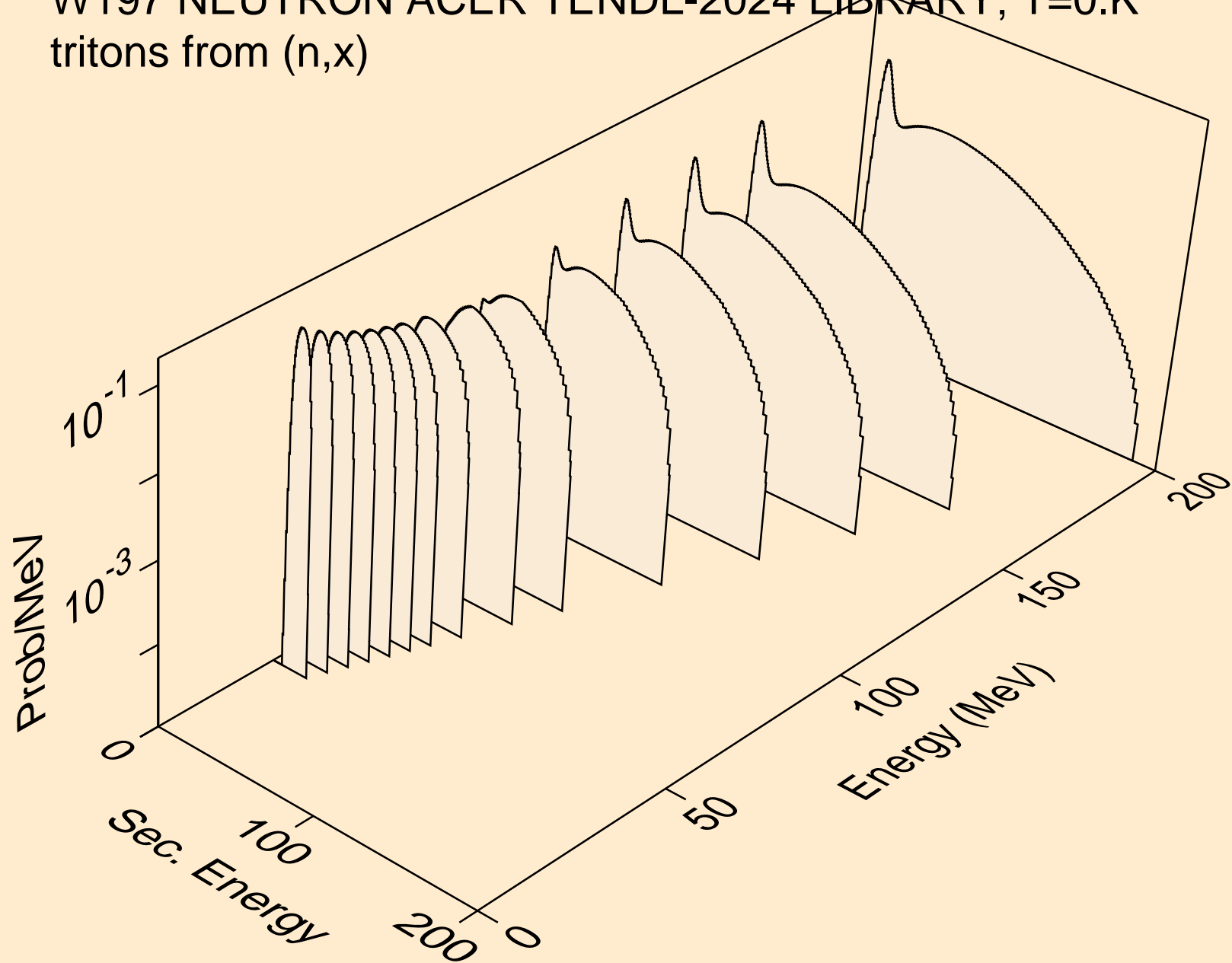

W197 NEUTRON ACER TENDL-2024 LIBRARY; T=0.K  
tritons from (n,n\*)t

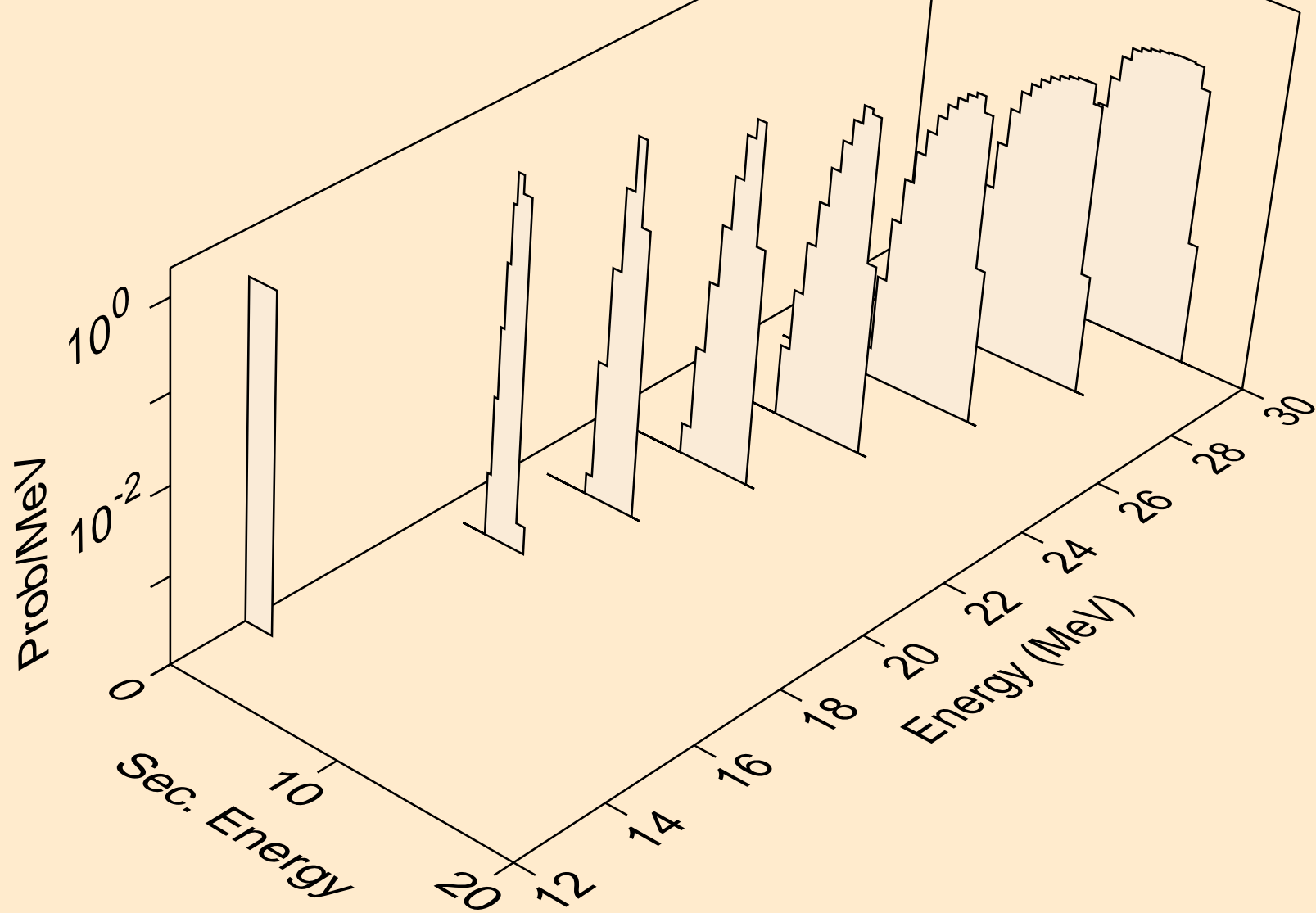

W197 NEUTRON ACER TENDL-2024 LIBRARY; T=0.K  
tritons from (n,t)

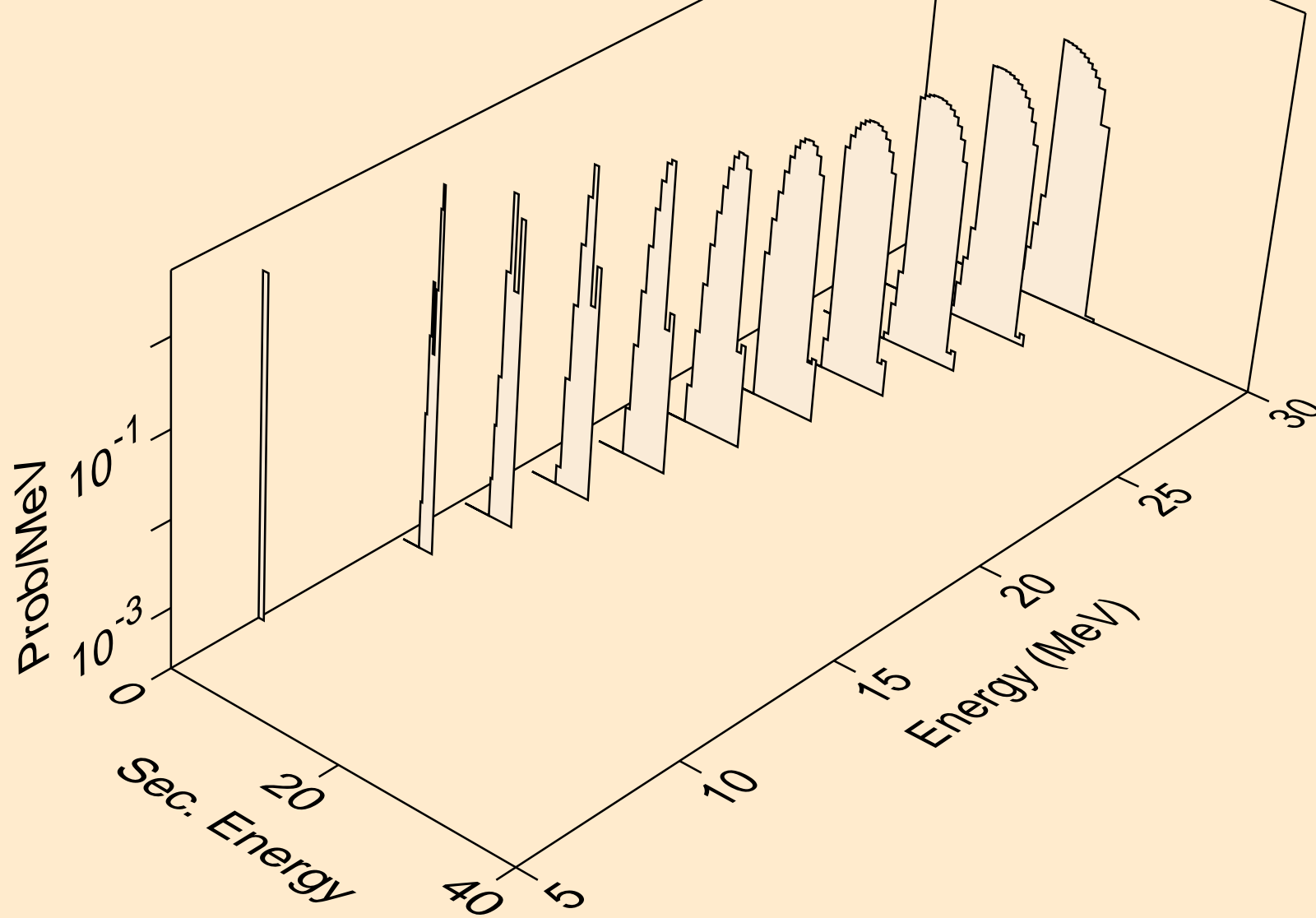

W197 NEUTRON ACER TENDL-2024 LIBRARY; T=0.K  
he3s from (n,x)

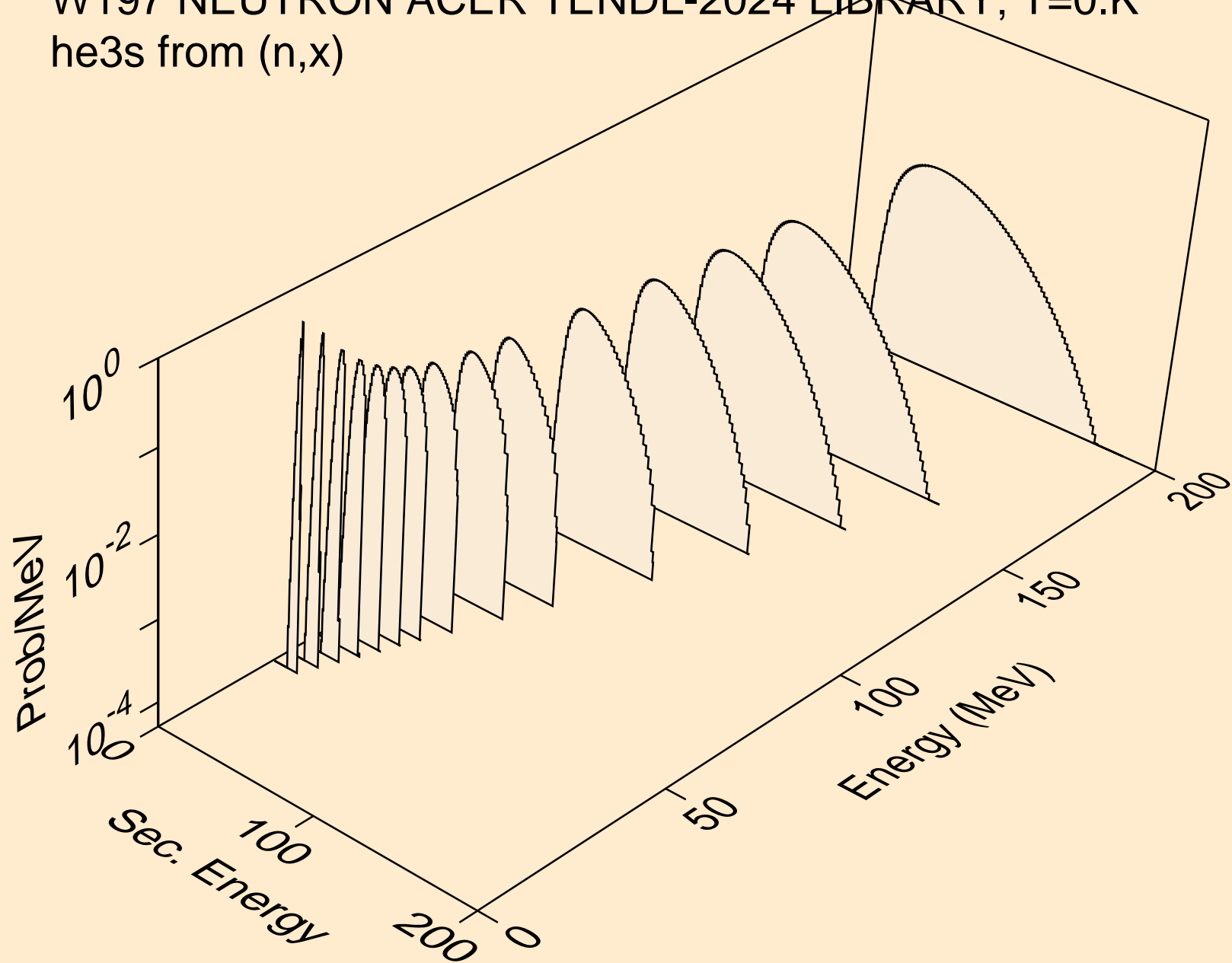

W197 NEUTRON ACER TENDL-2024 LIBRARY; T=0.K  
he3s from (n,he3)

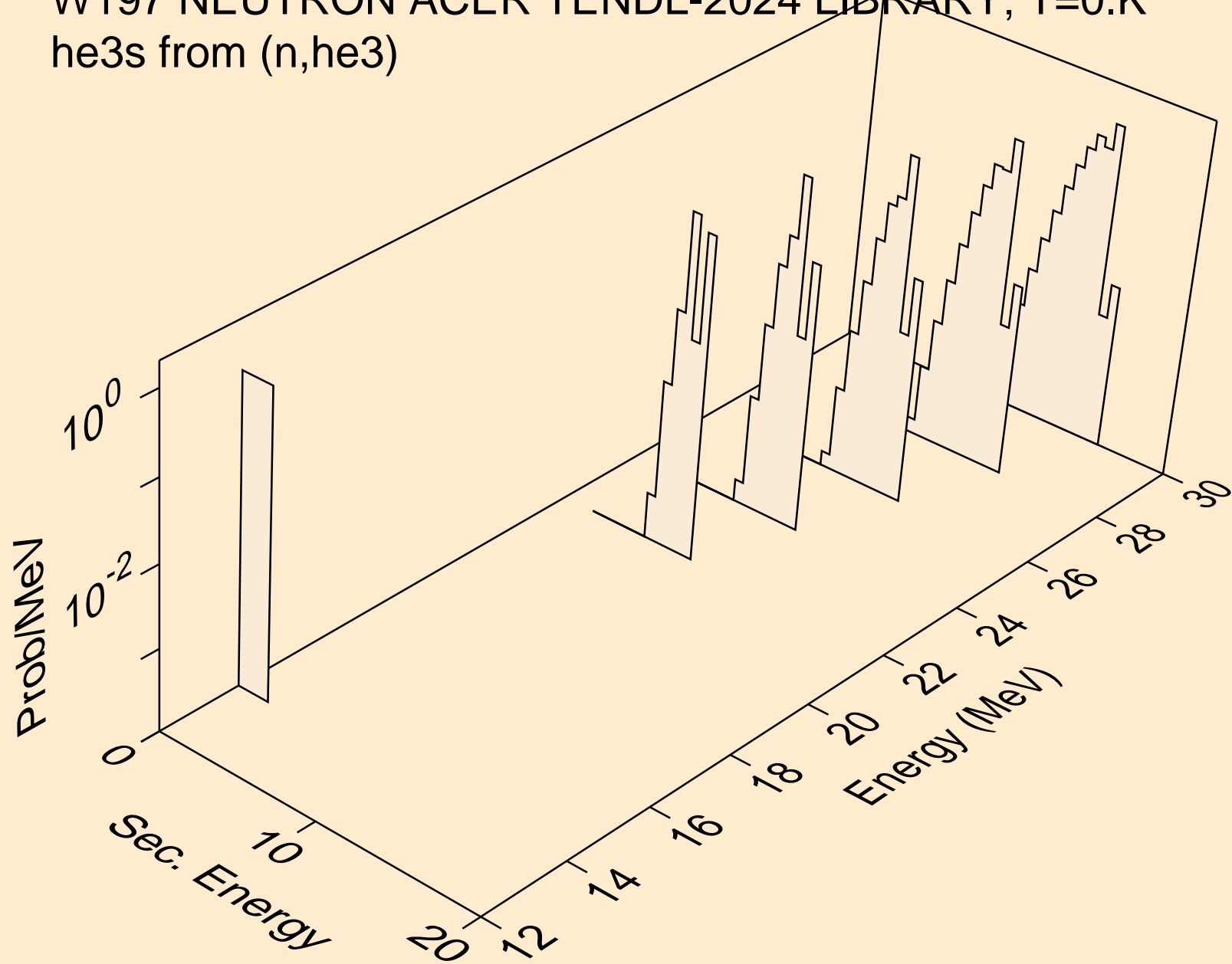

W197 NEUTRON ACER TENDL-2024 LIBRARY; T=0.K  
alphas from (n,x)

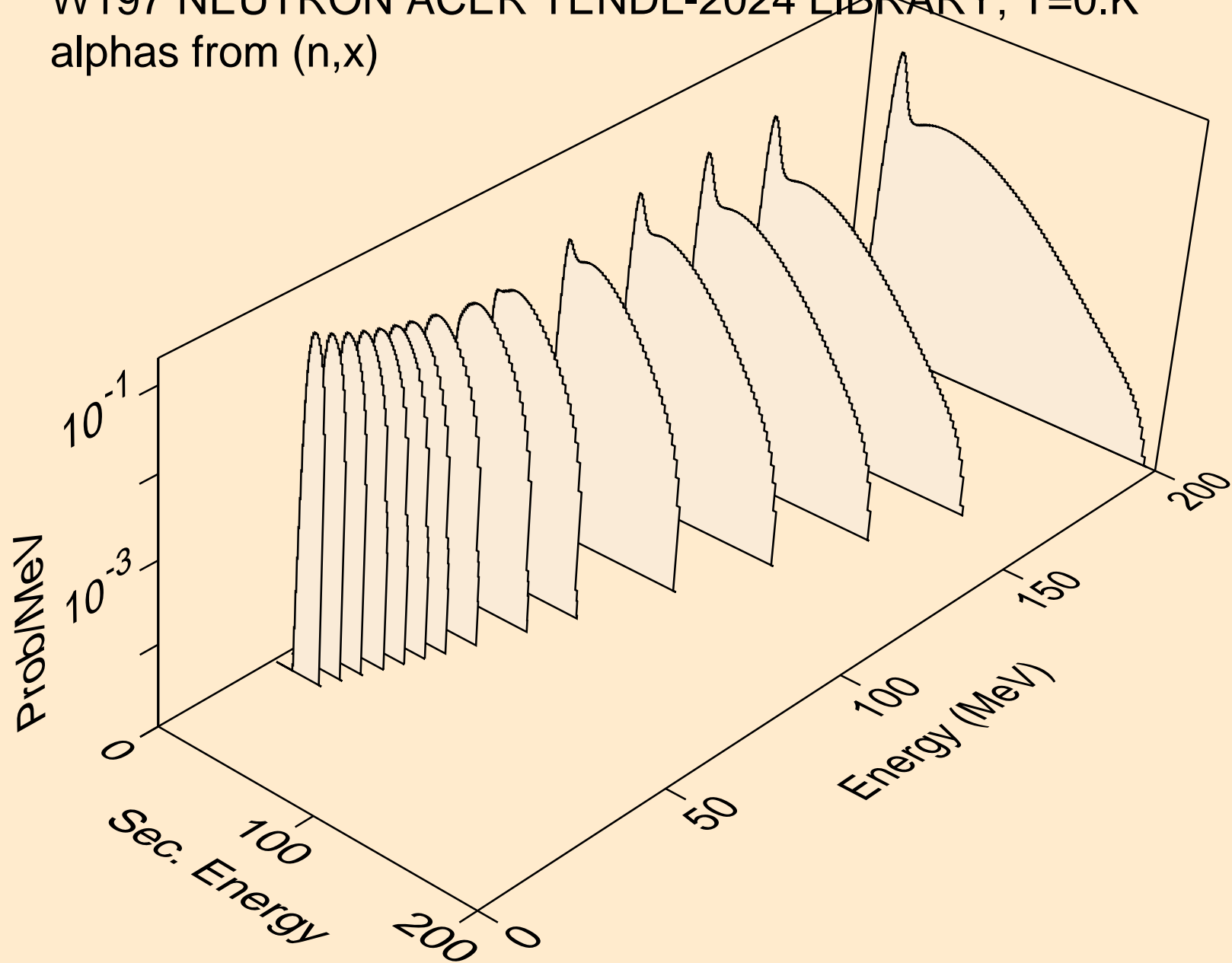

W197 NEUTRON ACER TENDL-2024 LIBRARY; T=0.K  
alphas from (n,n\*)a

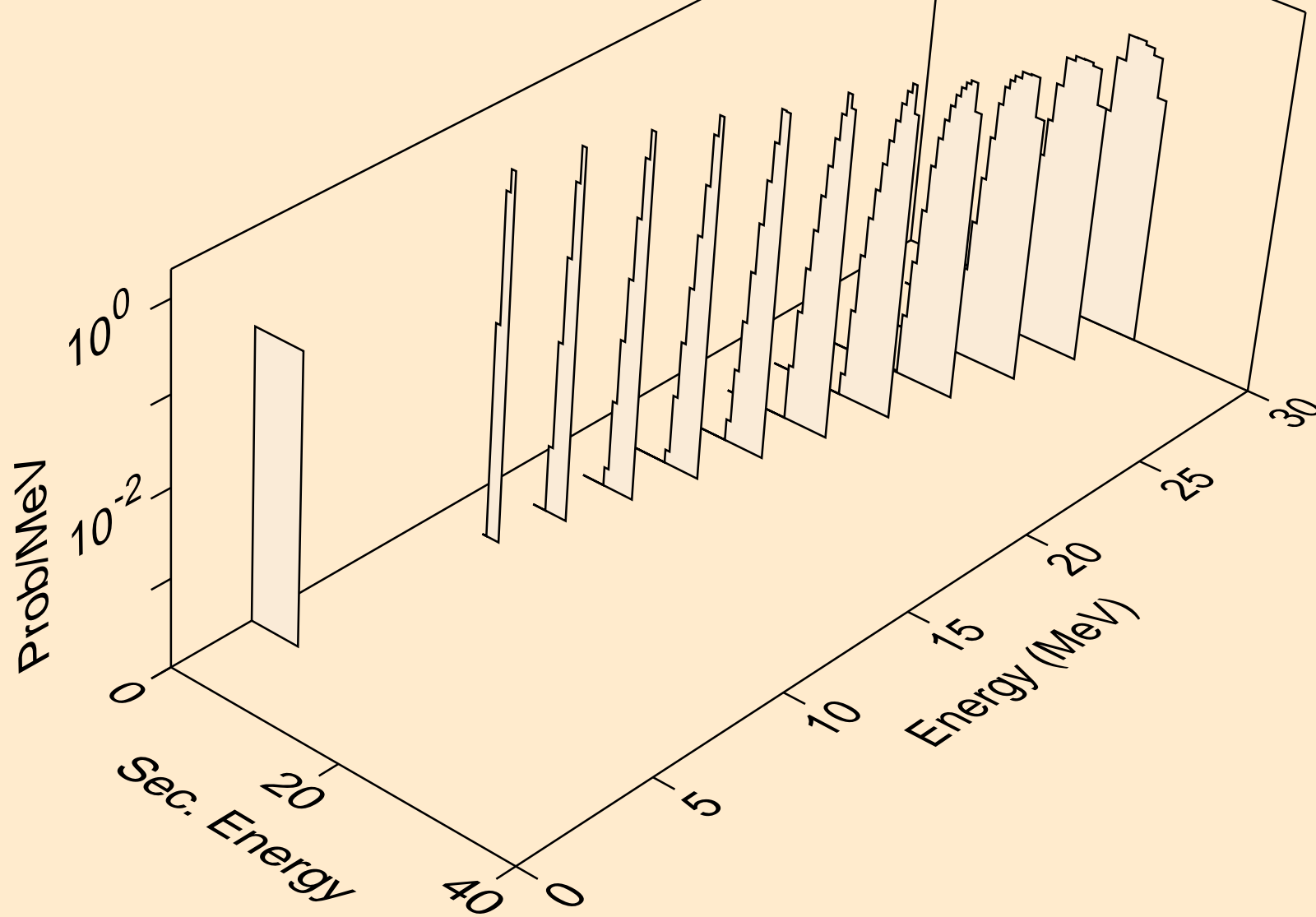

W197 NEUTRON ACER TENDL-2024 LIBRARY; T=0.K  
alphas from (n,2n)a

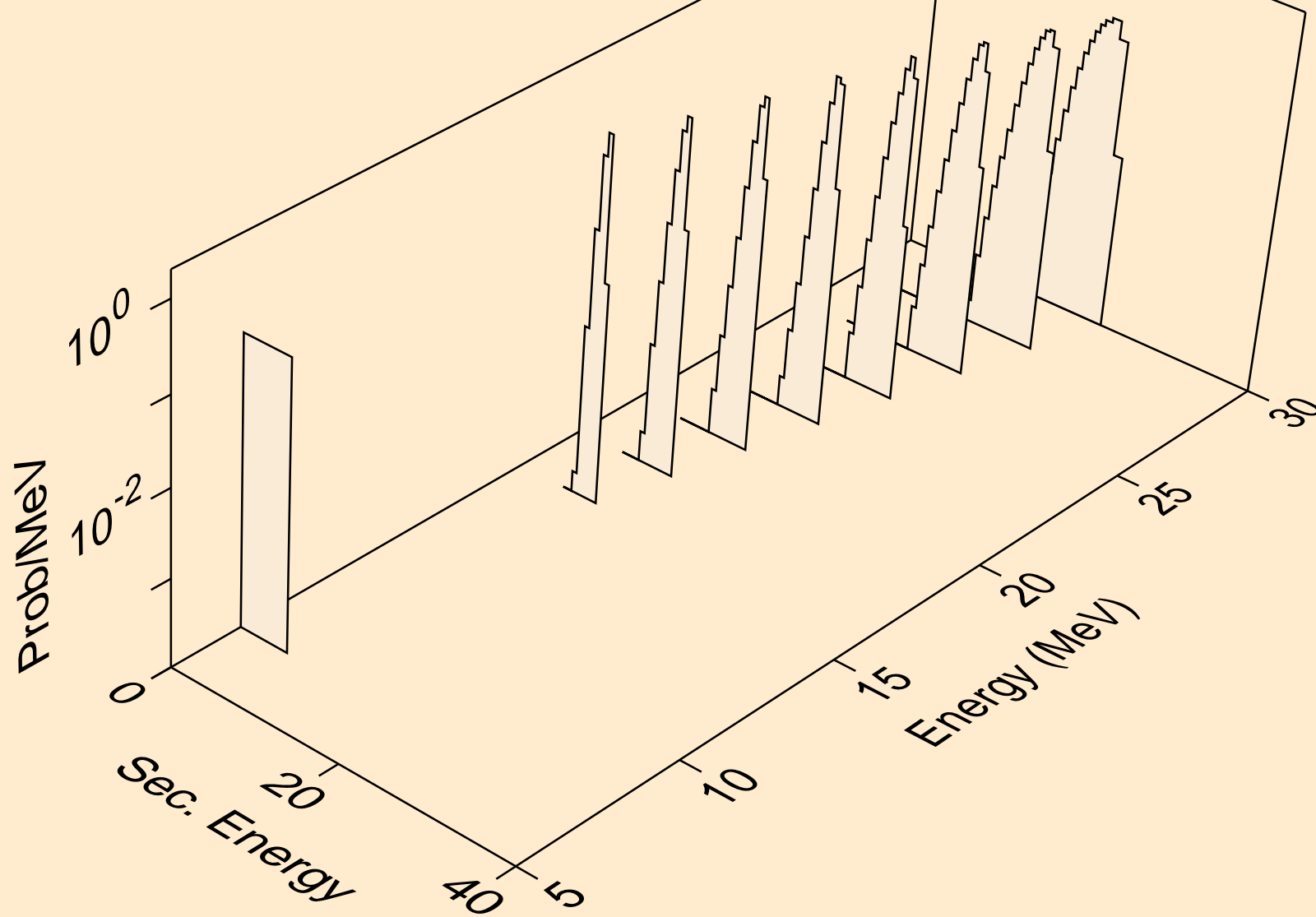

W197 NEUTRON ACER TENDL-2024 LIBRARY; T=0.K  
alphas from (n,3n)a

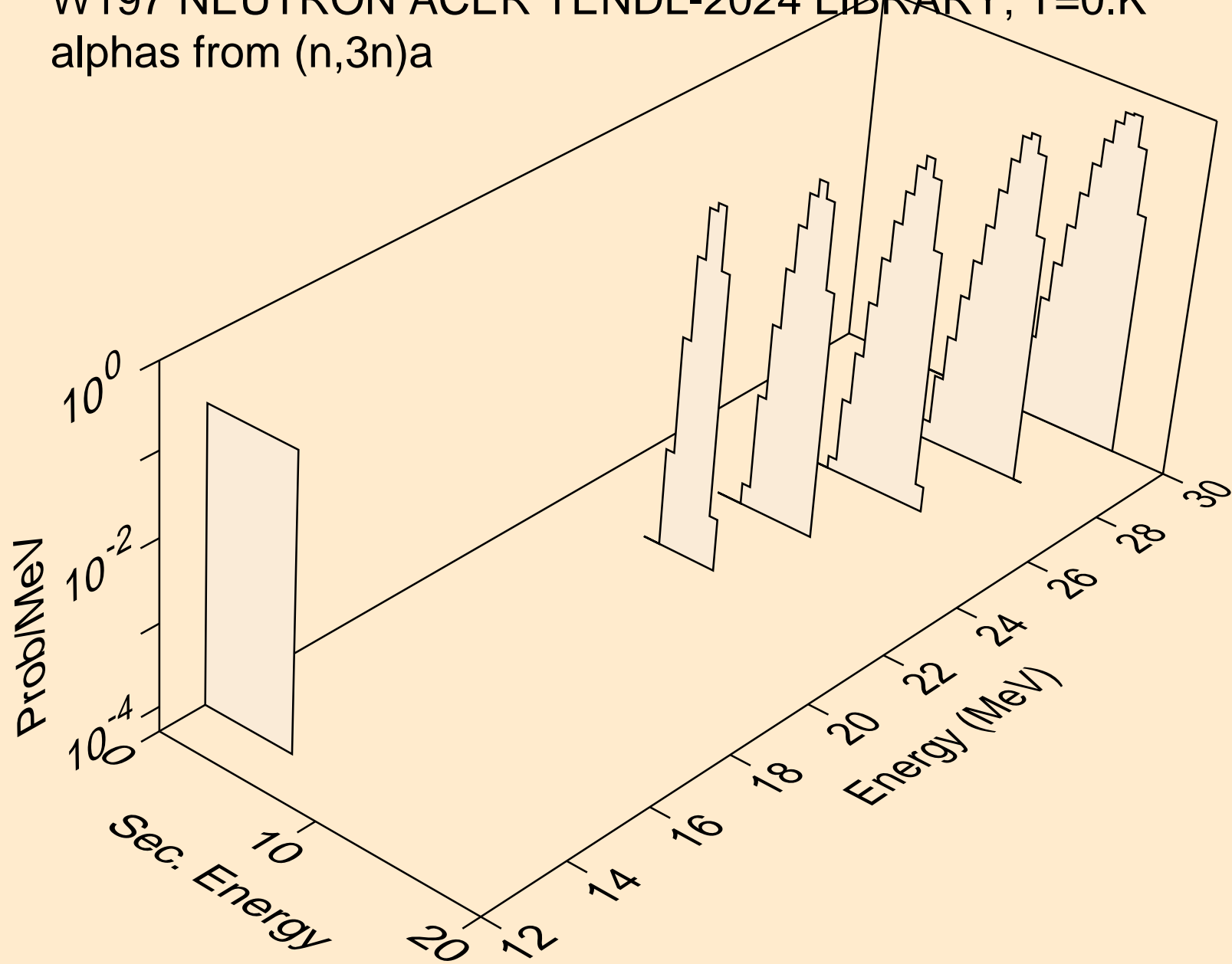

W197 NEUTRON ACER TENDL-2024 LIBRARY; T=0.K  
alphas from (n,a)

