

# HG201 PROTON ACER TENDL-2023 LIBRARY; T=0.K

## Principal cross sections

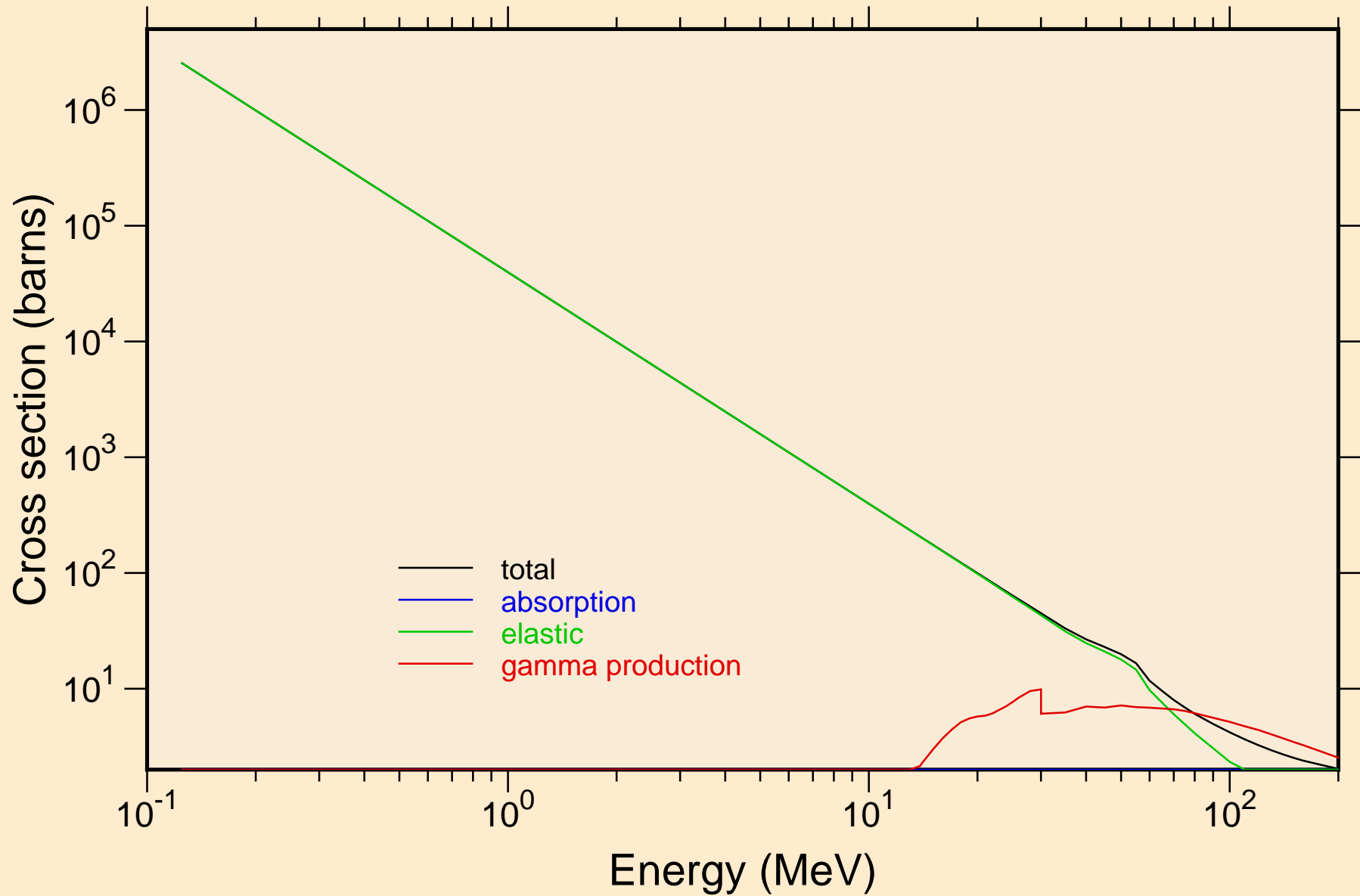

# HG201 PROTON ACER TENDL-2023 LIBRARY; T=0.K

## Heating

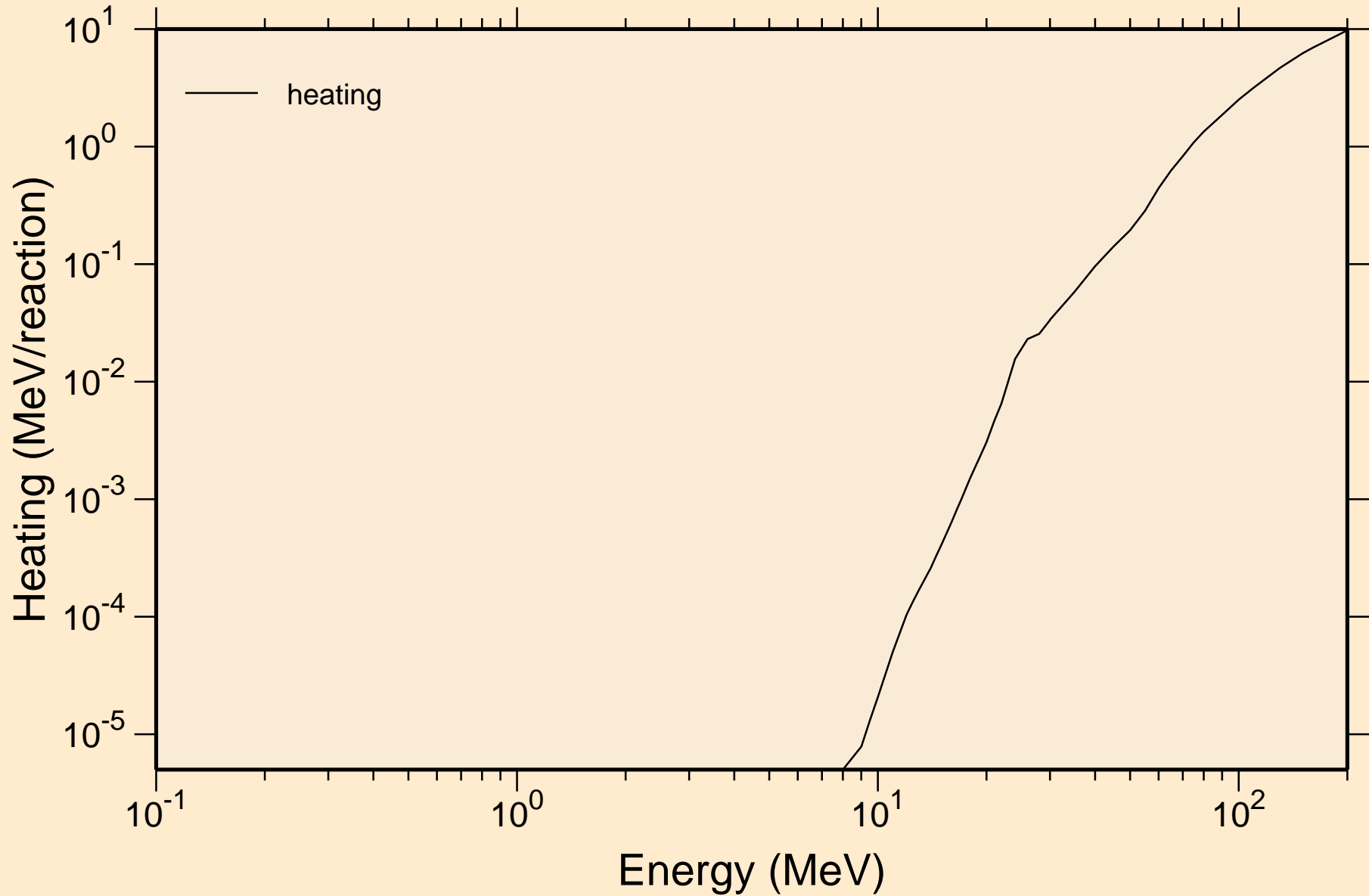

# HG201 PROTON ACER TENDL-2023 LIBRARY; T=0.K

## Principal cross sections

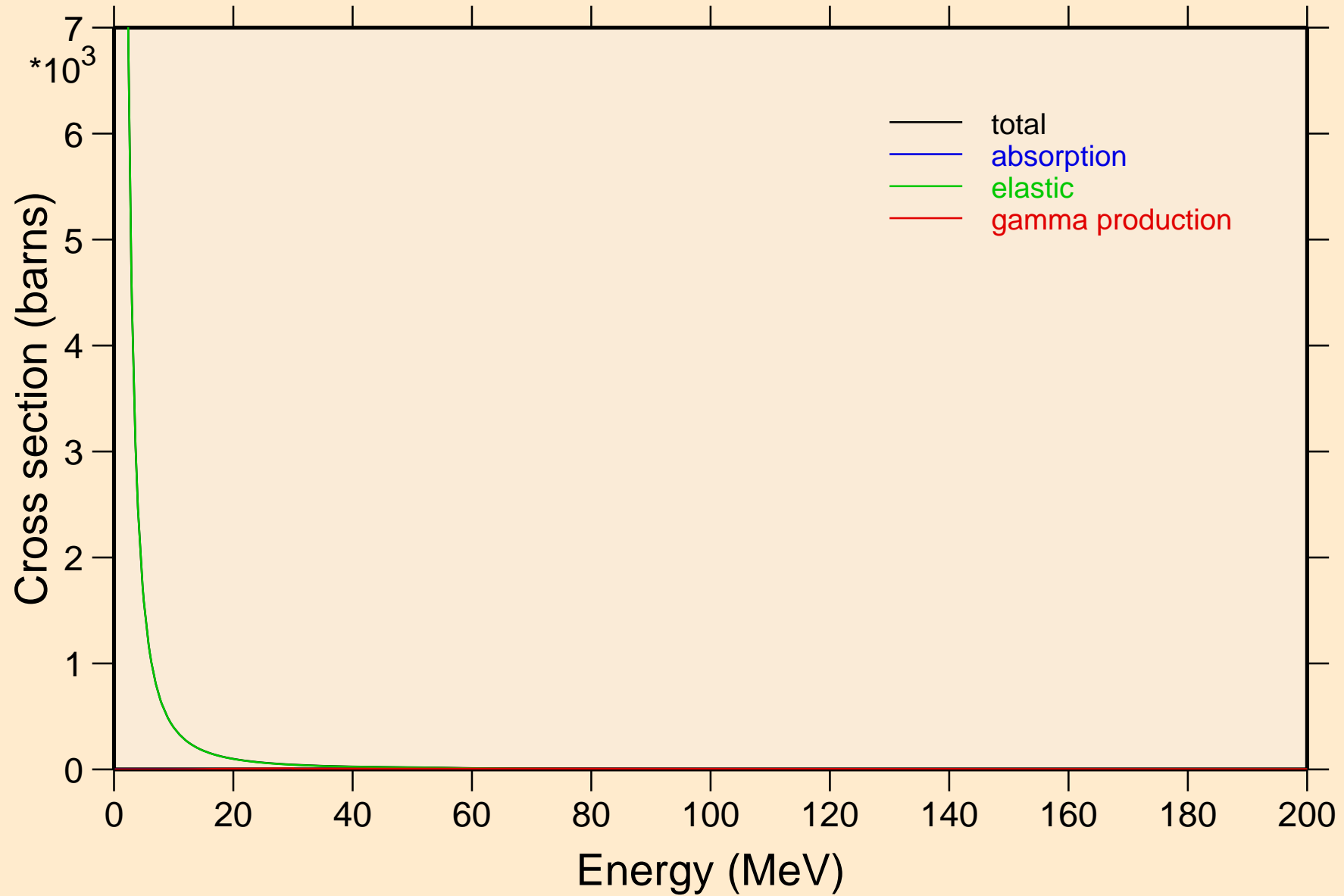

HG201 PROTON ACER TENDL-2023 LIBRARY; T=0.K

Heating

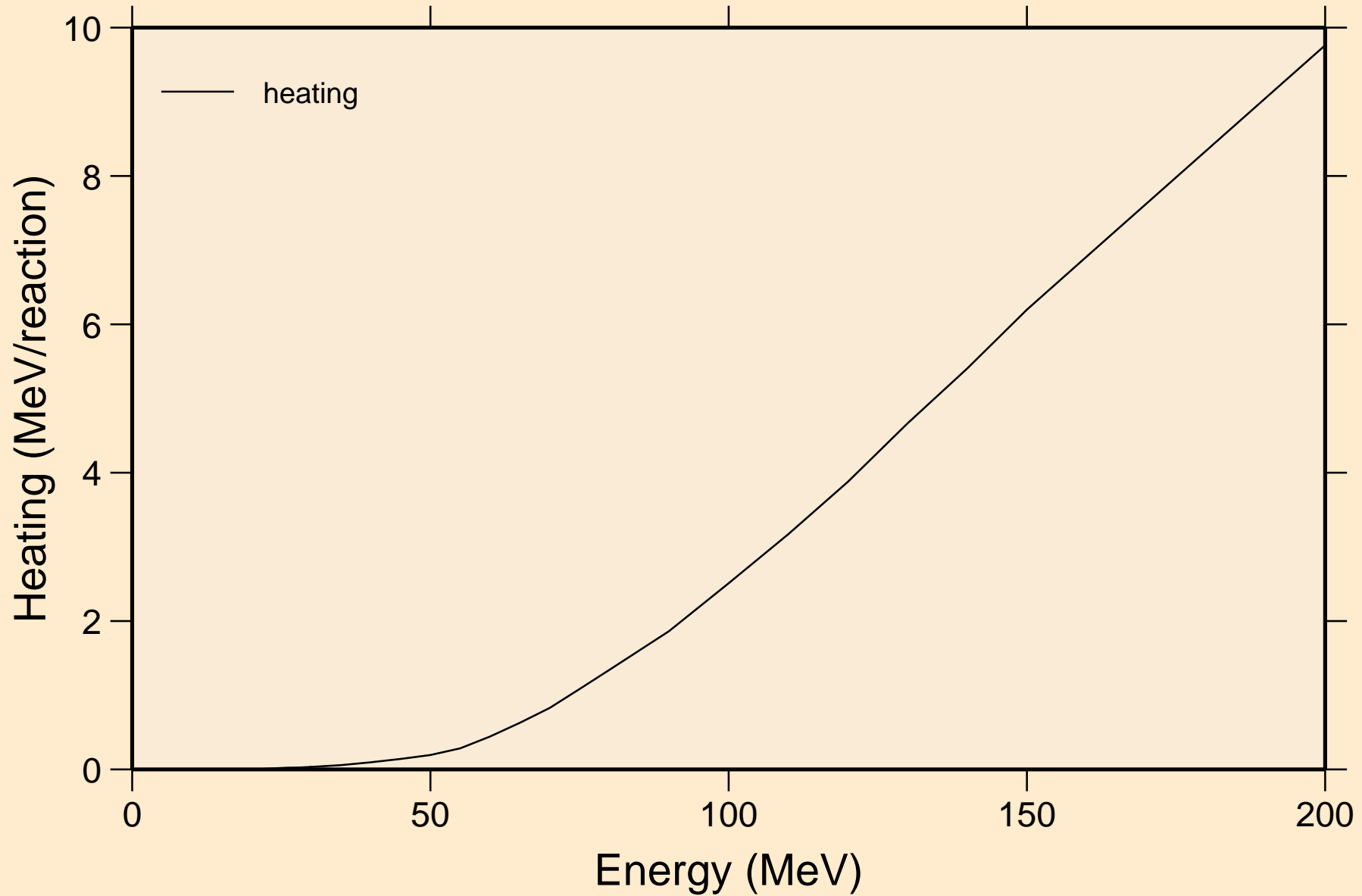

# HG201 PROTON ACER TENDL-2023 LIBRARY; T=0.K

## Threshold reactions

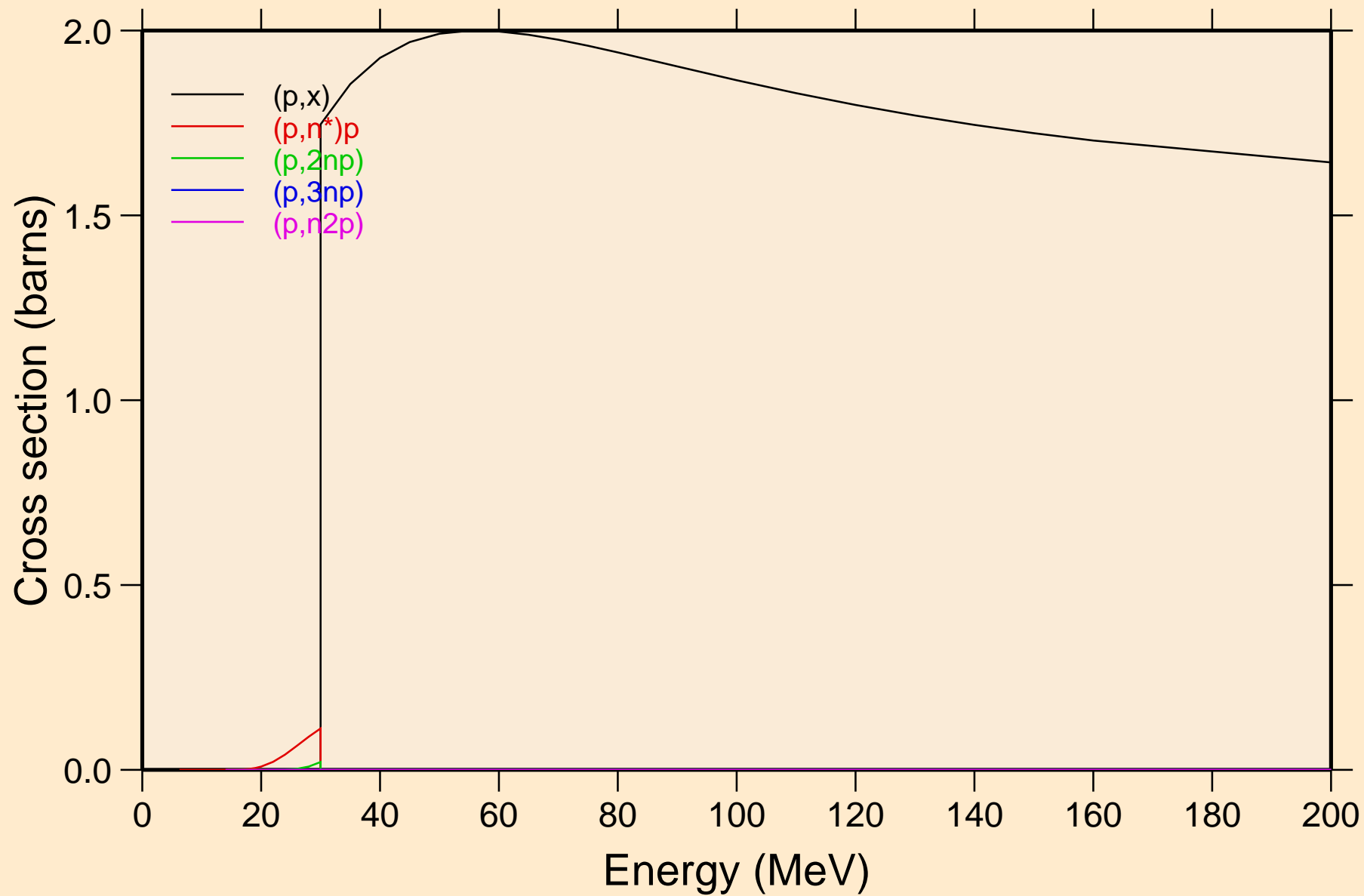

# HG201 PROTON ACER TENDL-2023 LIBRARY; T=0.K

## Threshold reactions

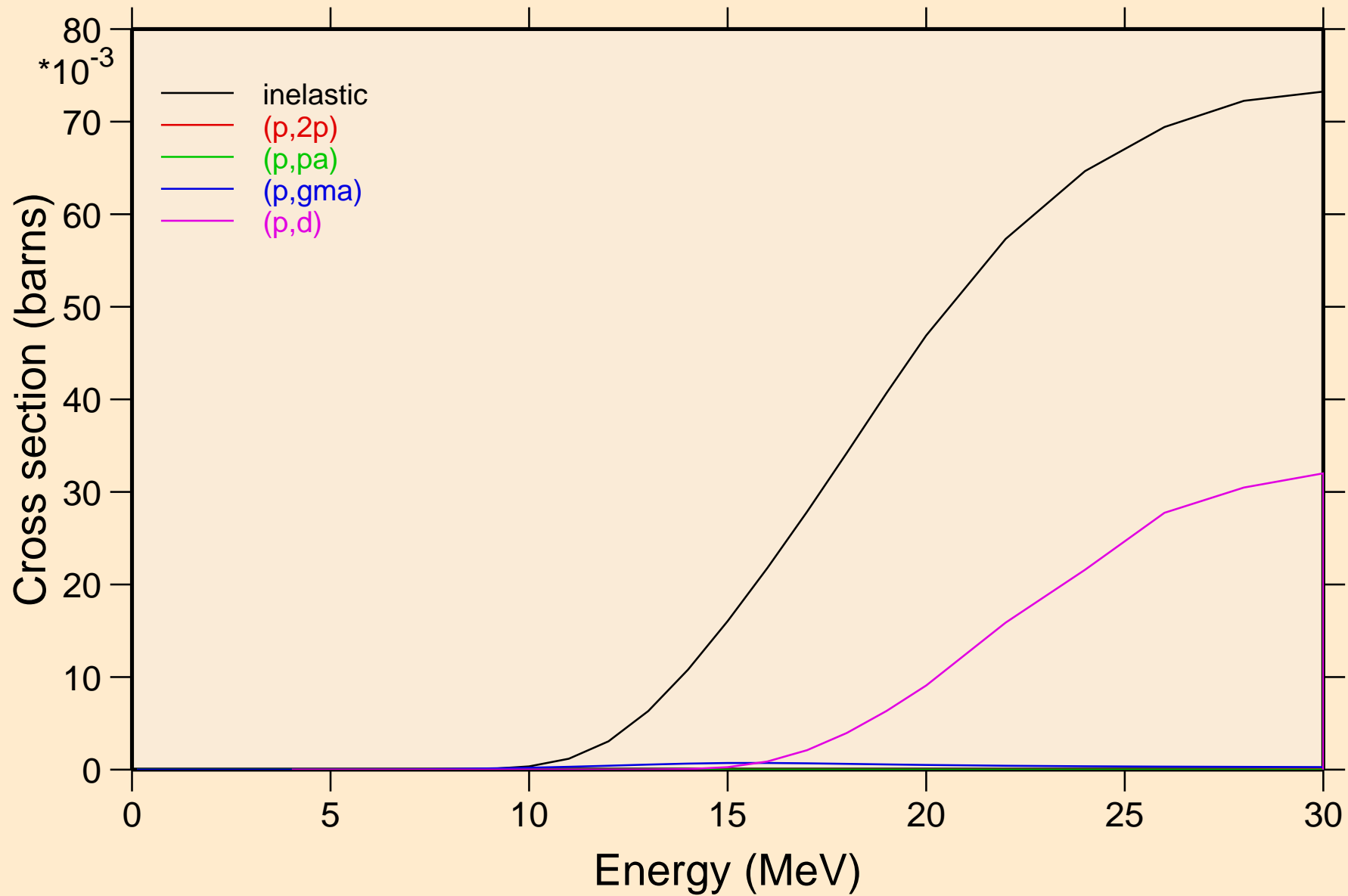

# HG201 PROTON ACER TENDL-2023 LIBRARY; T=0.K

## Threshold reactions

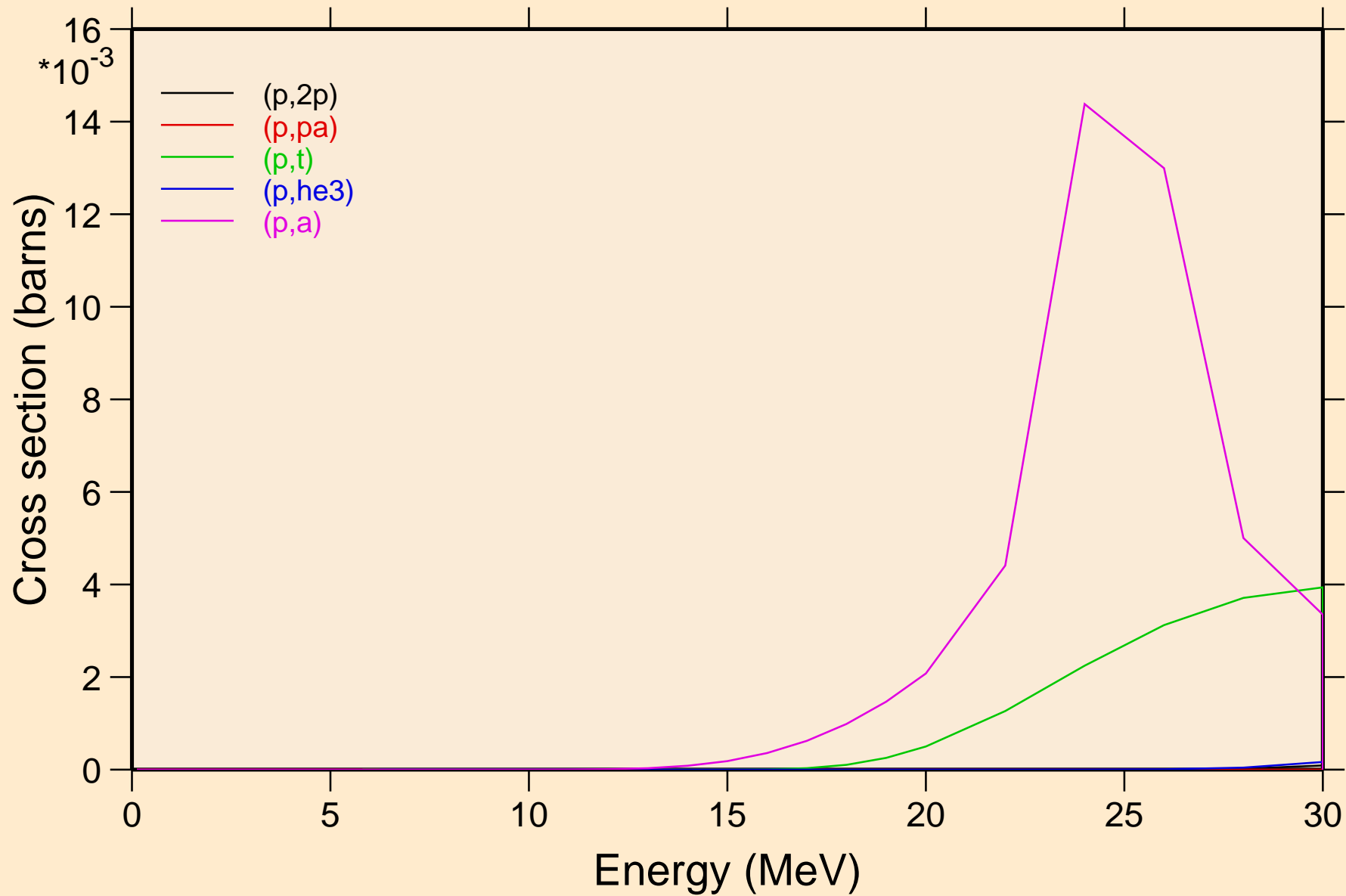

HG201 PROTON ACER TENDL-2023 LIBRARY; T=0.K  
Threshold reactions

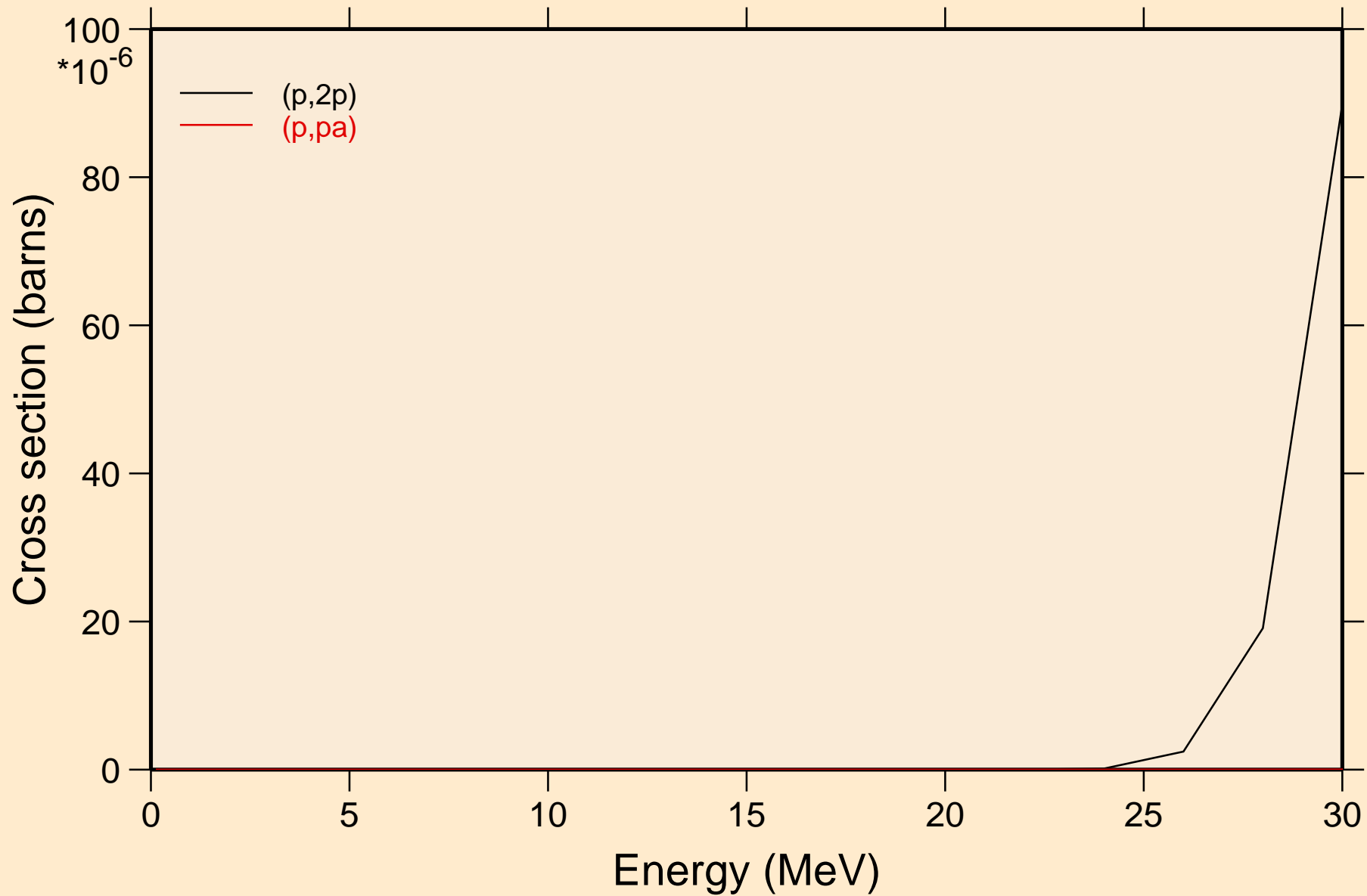

HG201 PROTON ACER TENDL-2023 LIBRARY; T=0.K  
angular distribution for elastic

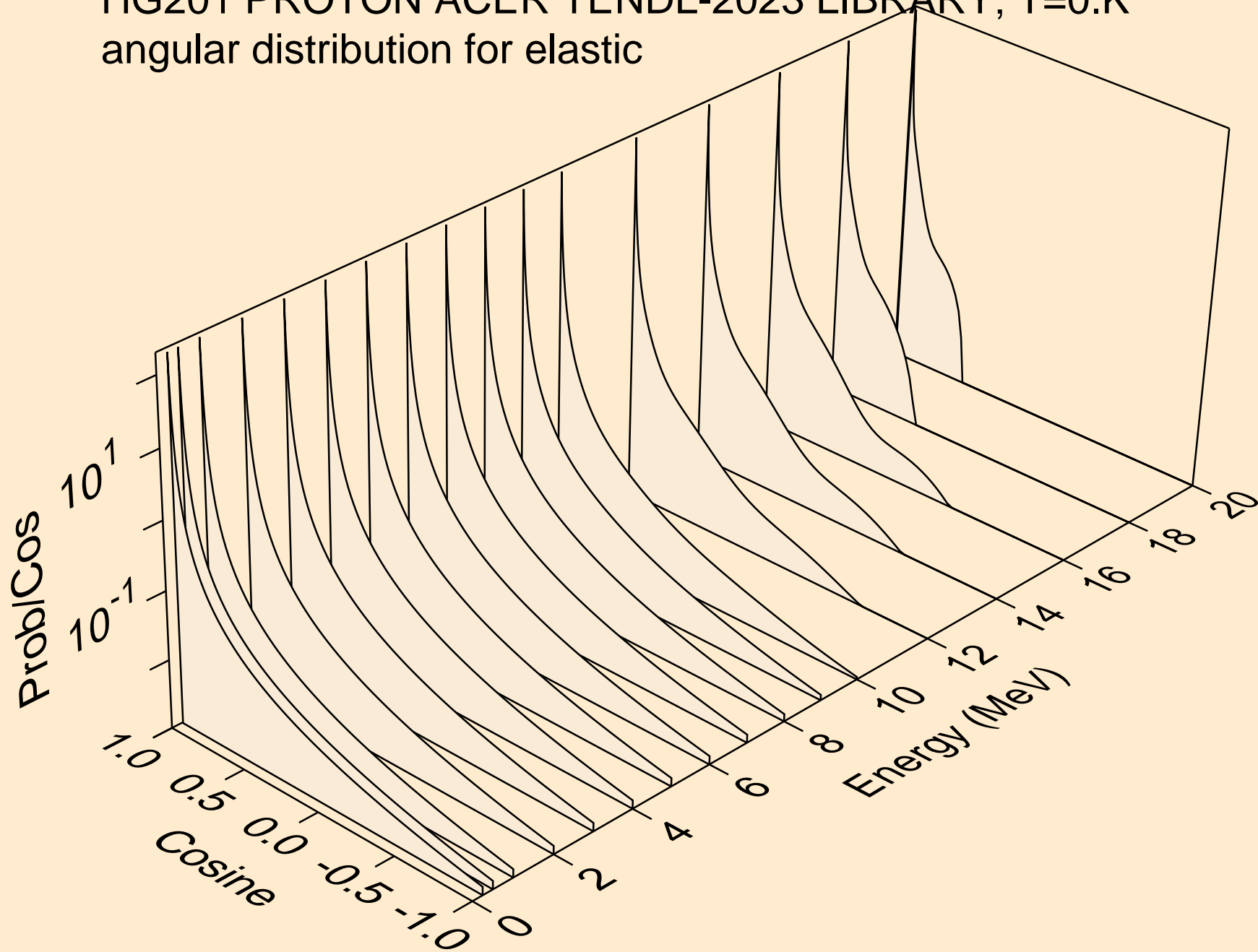

HG201 PROTON ACER TENDL-2023 LIBRARY; T=0.K  
angular distribution for elastic

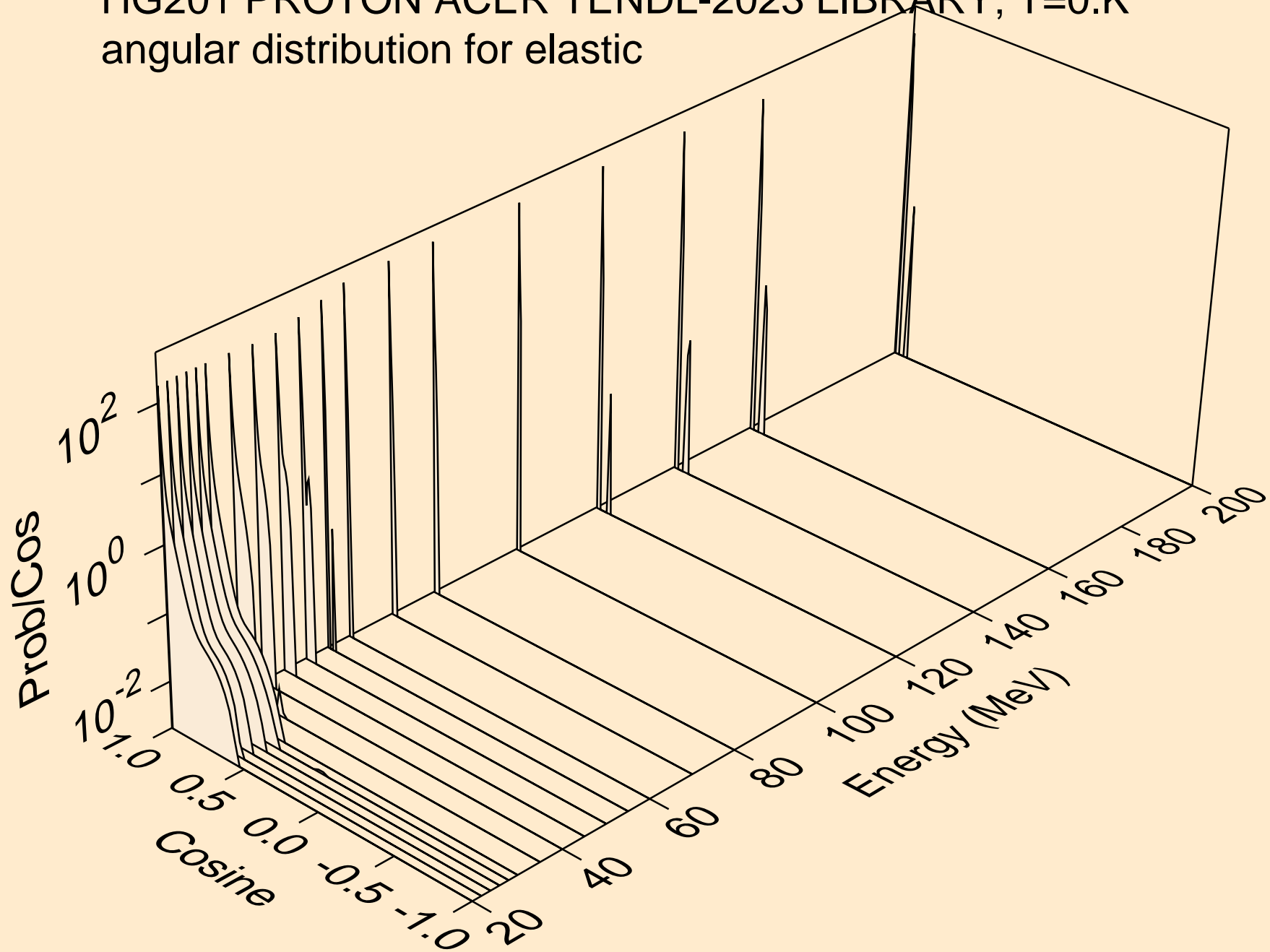

HG201 PROTON ACER TENDL-2023 LIBRARY; T=0.K  
Proton emission for (p,x)

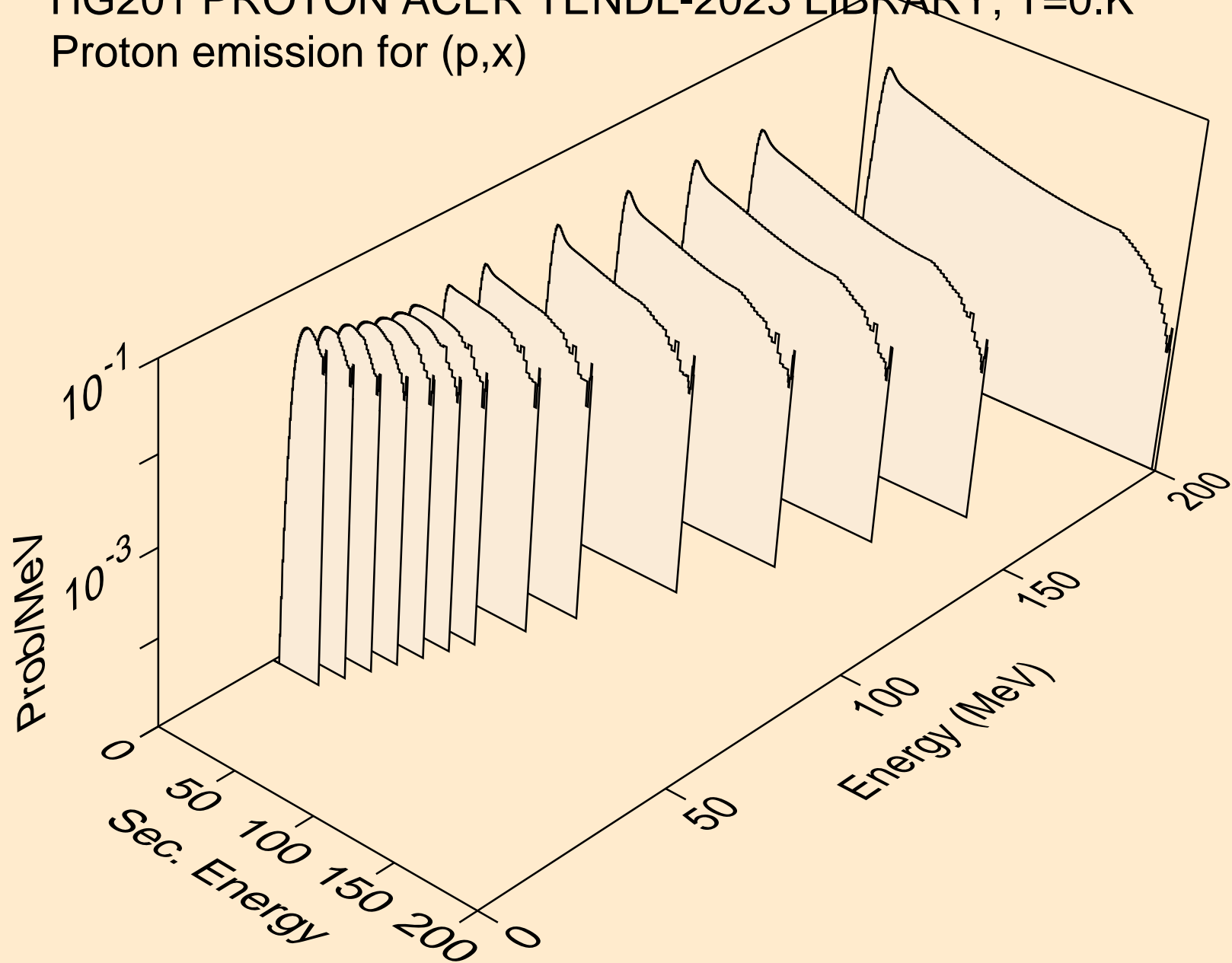

HG201 PROTON ACER TENDL-2023 LIBRARY; T=0.K  
Proton emission for (p,n\*)p

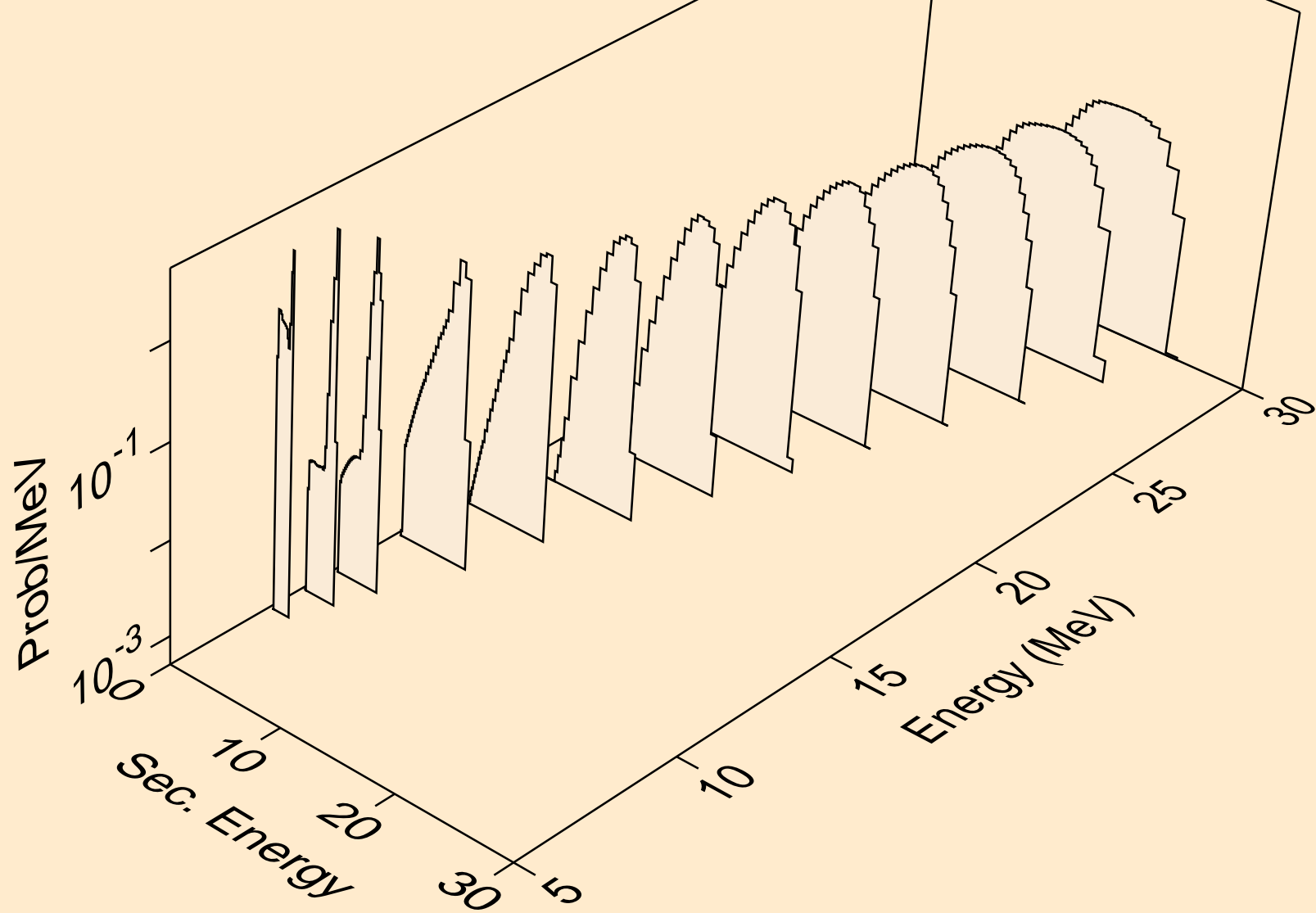

HG201 PROTON ACER TENDL-2023 LIBRARY; T=0.K  
Proton emission for (p,2np)

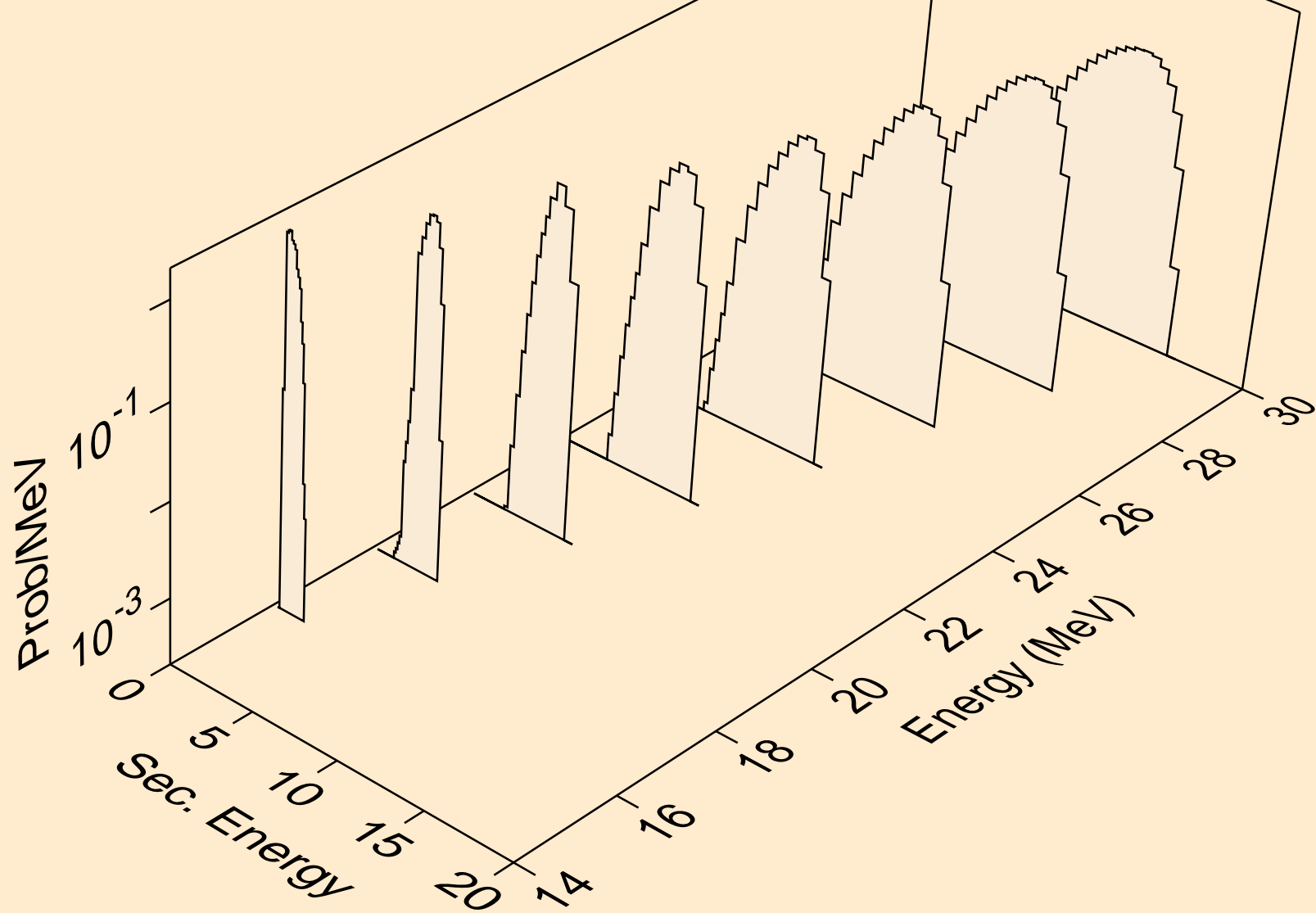

HG201 PROTON ACER TENDL-2023 LIBRARY; T=0.K  
Proton emission for (p,3np)

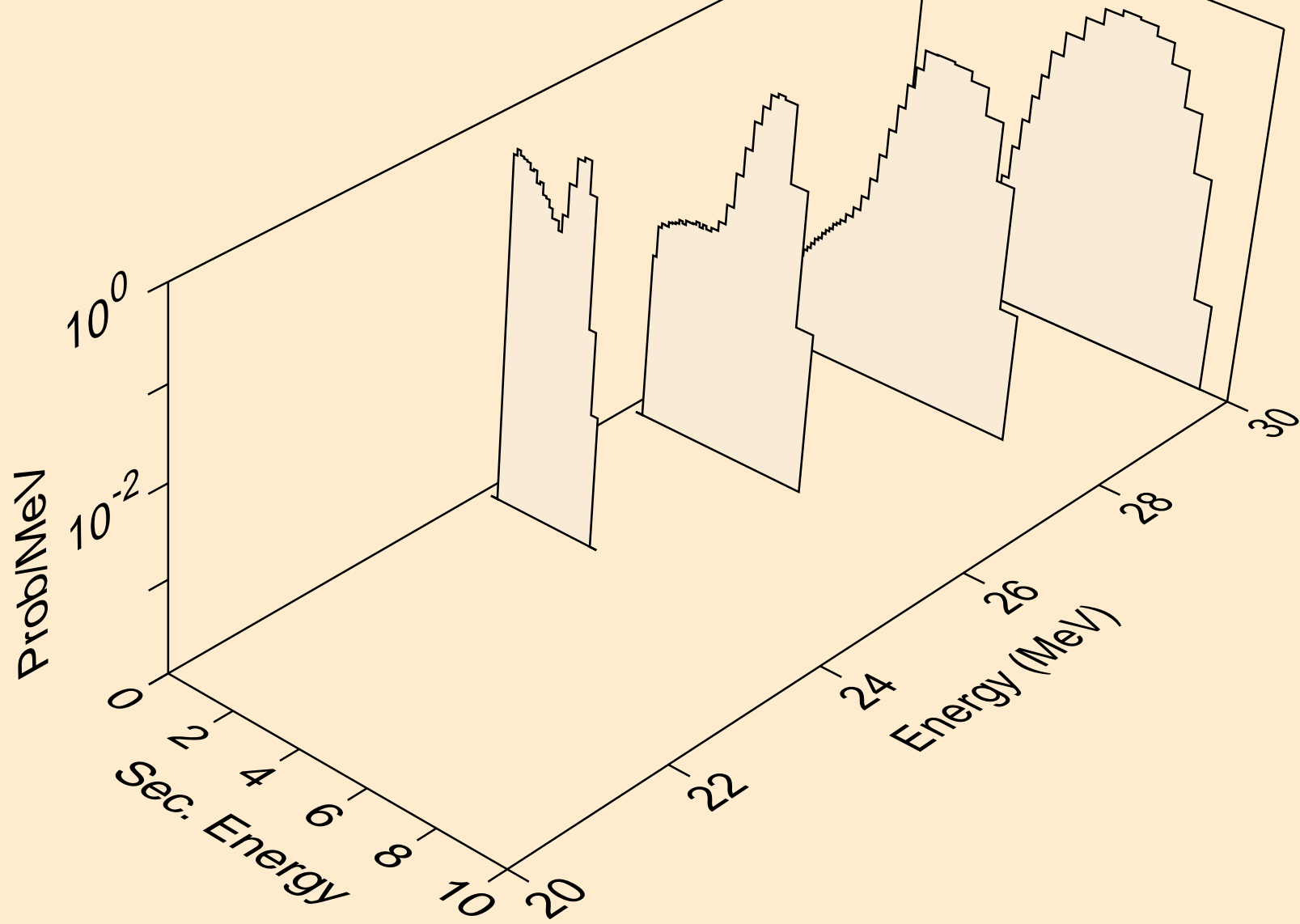

HG201 PROTON ACER TENDL-2023 LIBRARY; T=0.K  
Proton emission for (p,n2p)

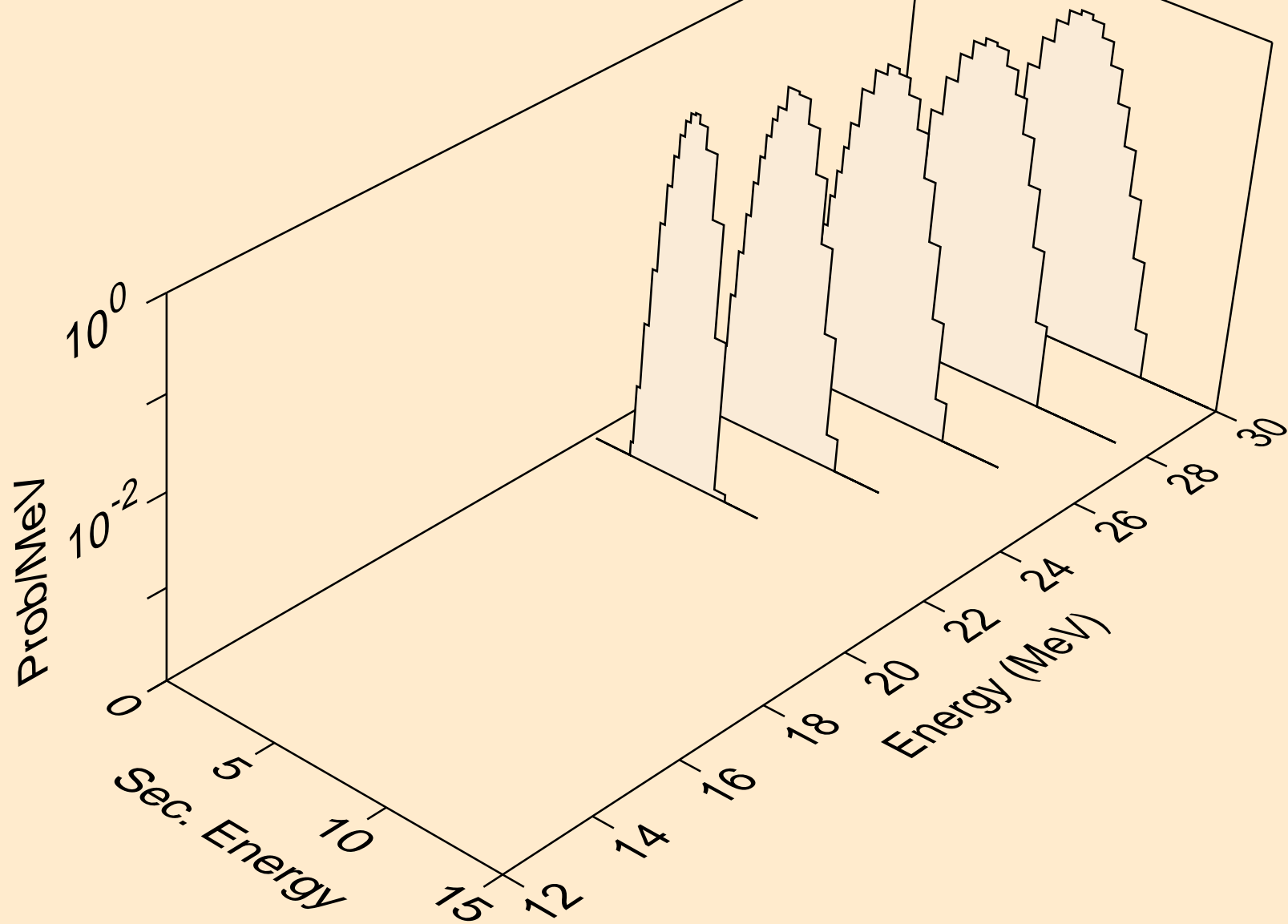

HG201 PROTON ACER TENDL-2023 LIBRARY; T=0.K  
Proton emission for inelastic

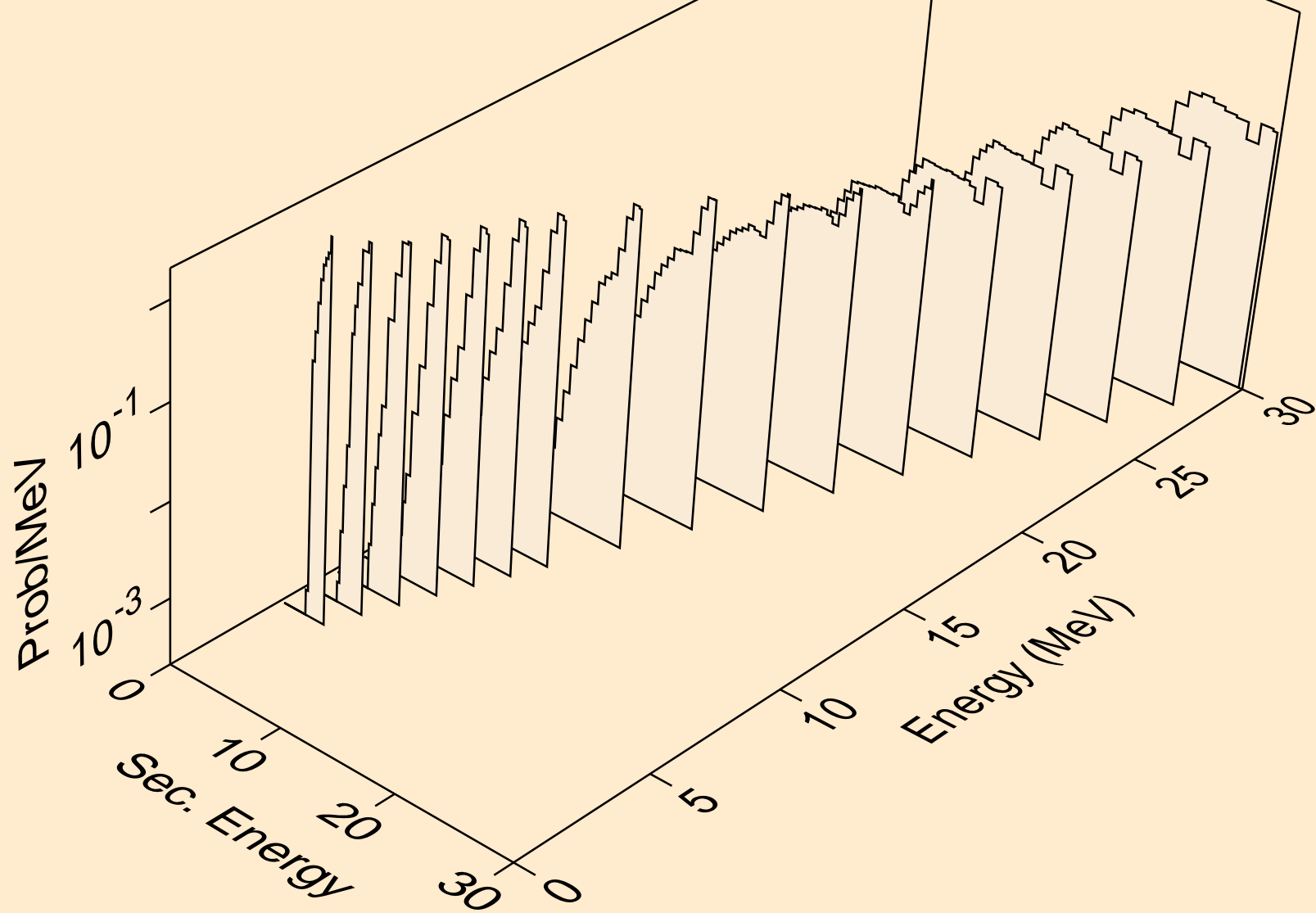

HG201 PROTON ACER TENDL-2023 LIBRARY; T=0.K  
Proton emission for (p,2p)

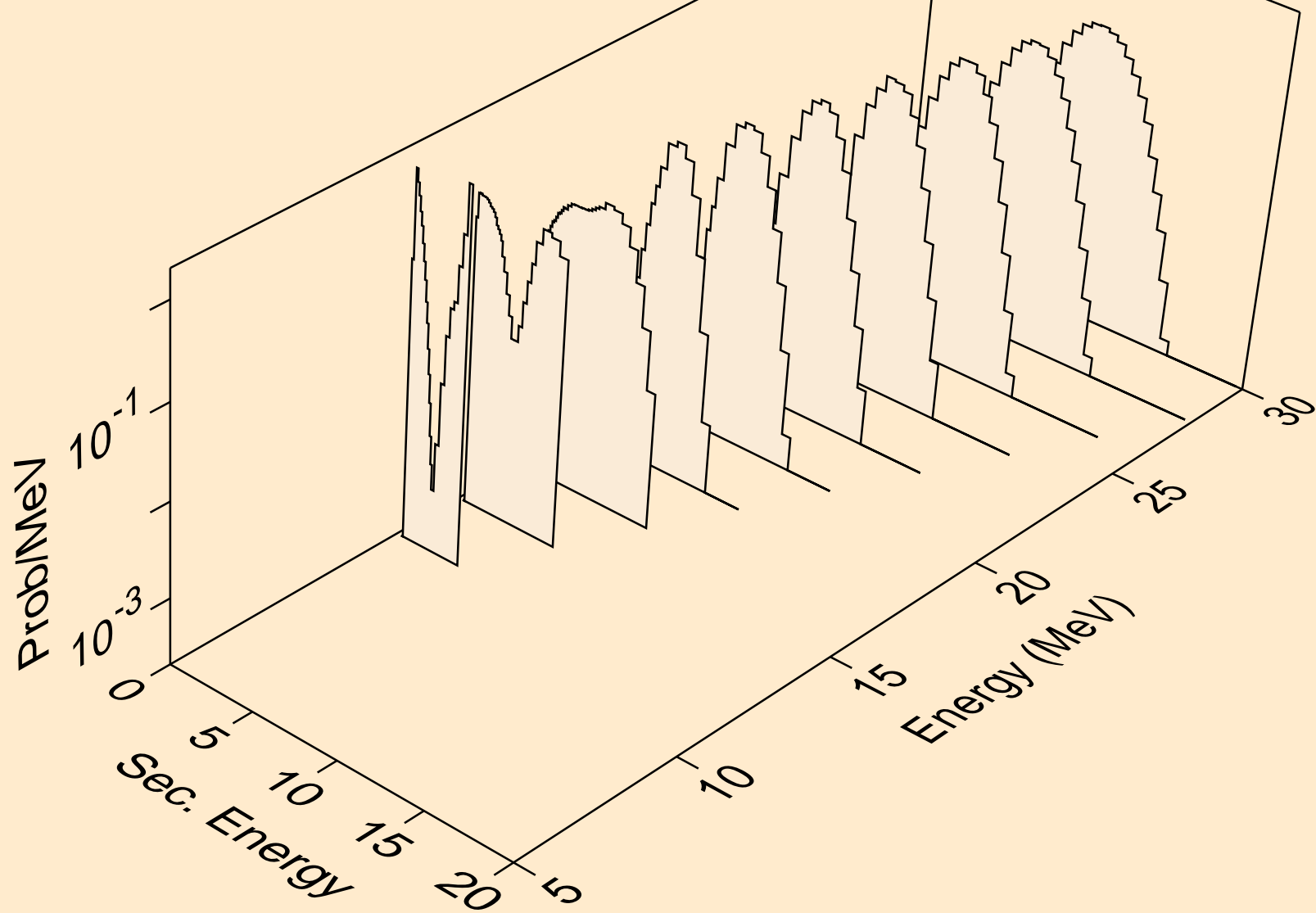

HG201 PROTON ACER TENDL-2023 LIBRARY; T=0.K  
Proton emission for (p,pa)

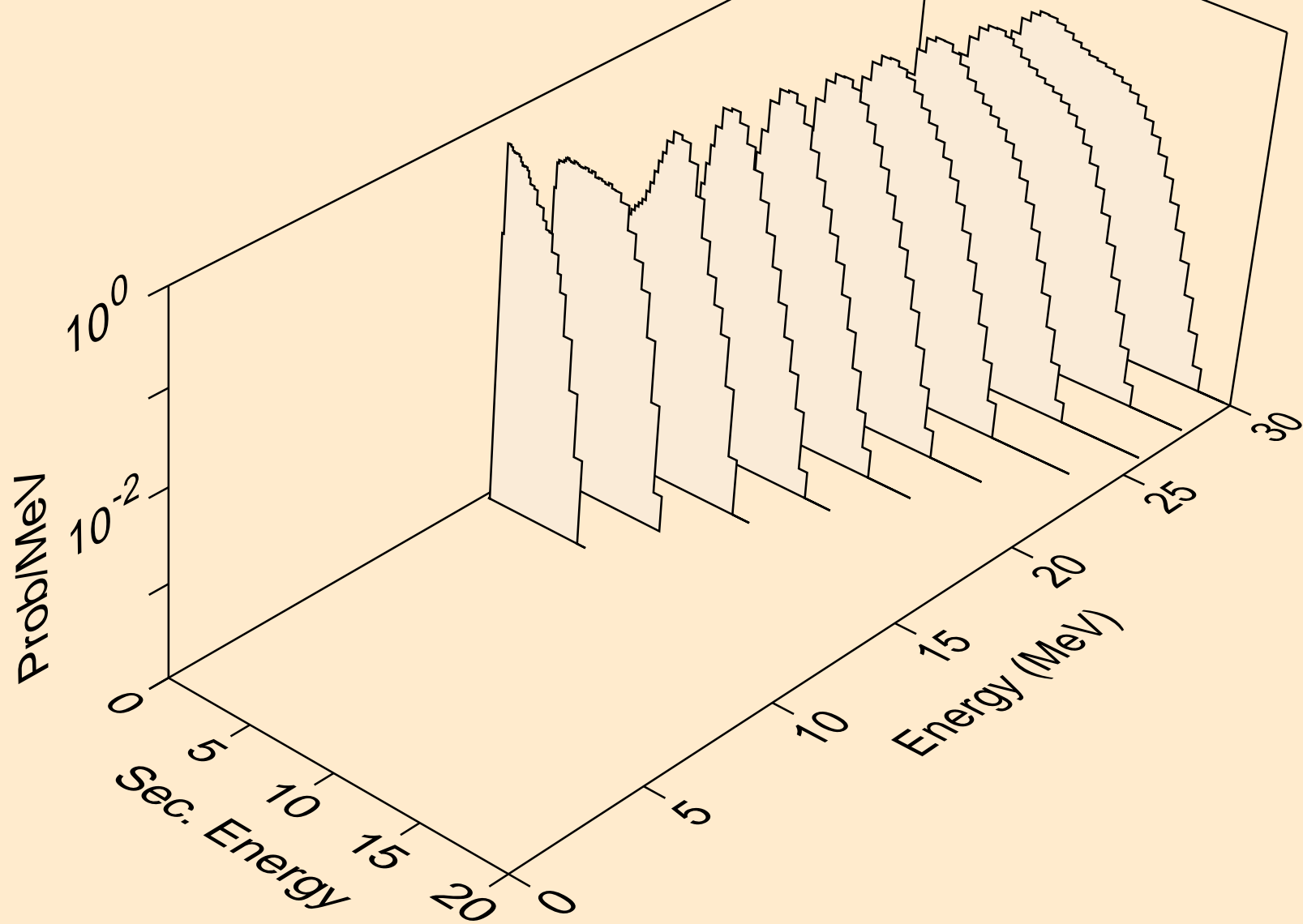

HG201 PROTON ACER TENDL-2023 LIBRARY; T=0.K  
Photon emission for (z,n)

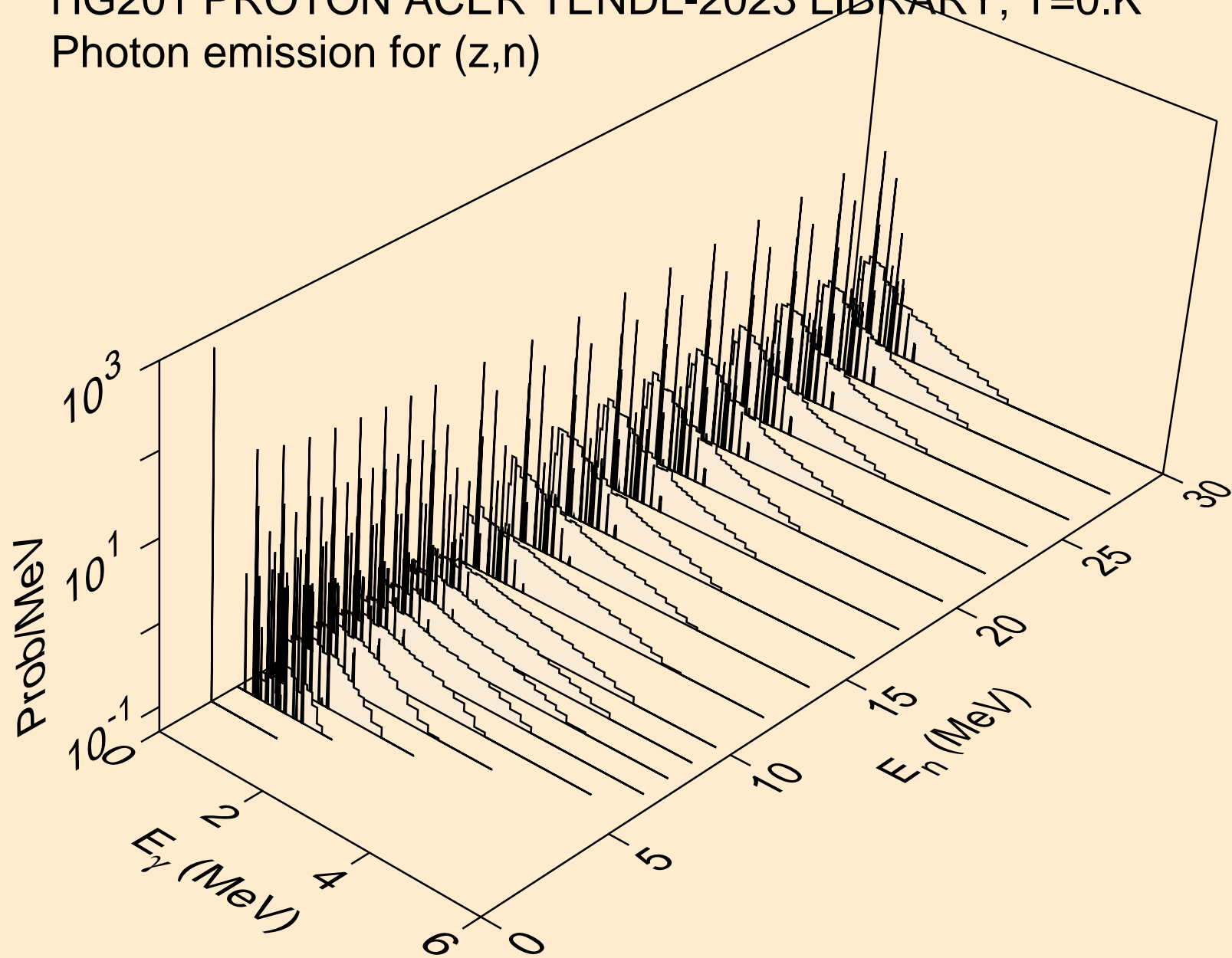

HG201 PROTON ACER TENDL-2023 LIBRARY; T=0.K  
Photon emission for (z,x)

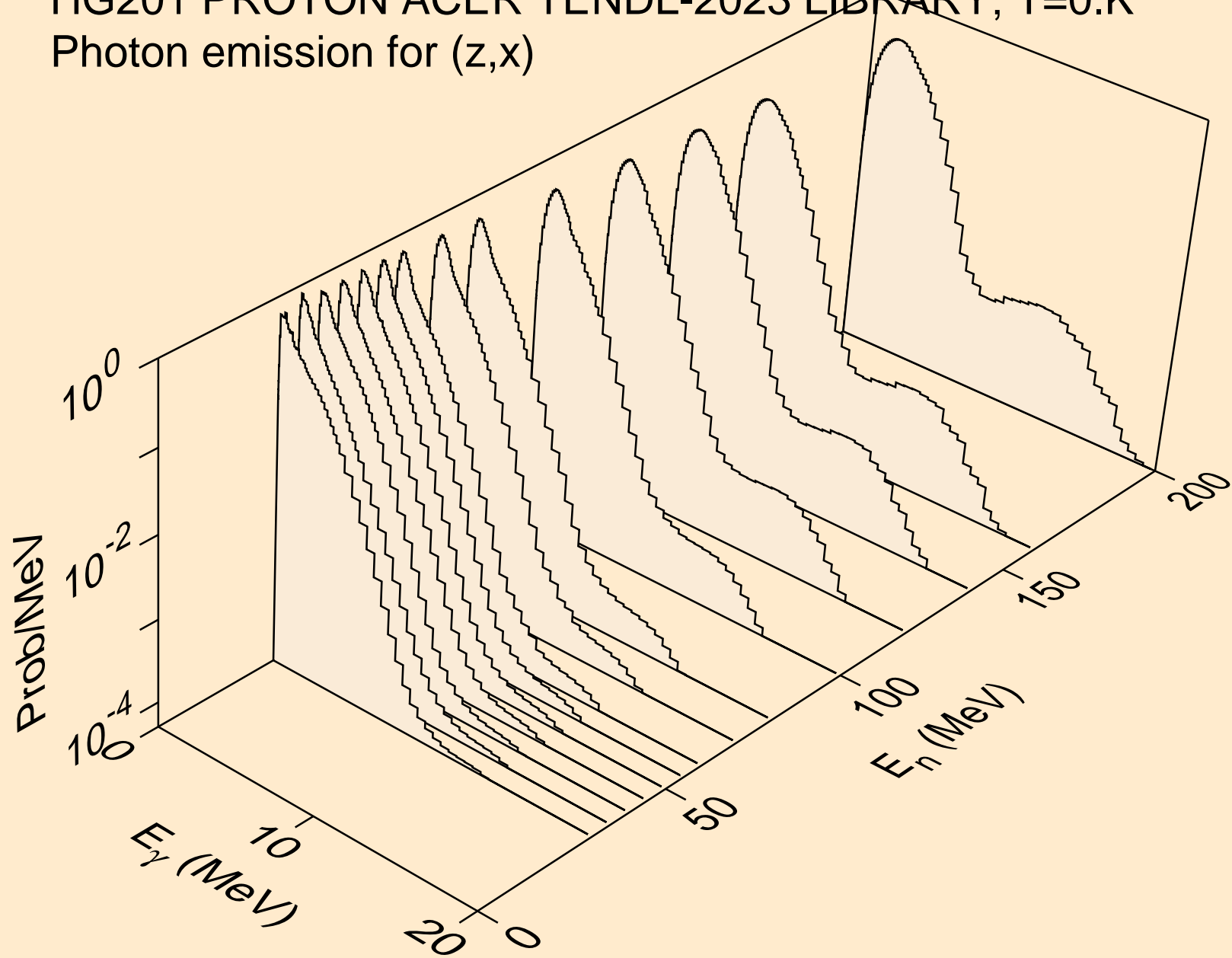

HG201 PROTON ACER TENDL-2023 LIBRARY; T=0.K  
Photon emission for (n,2nd)

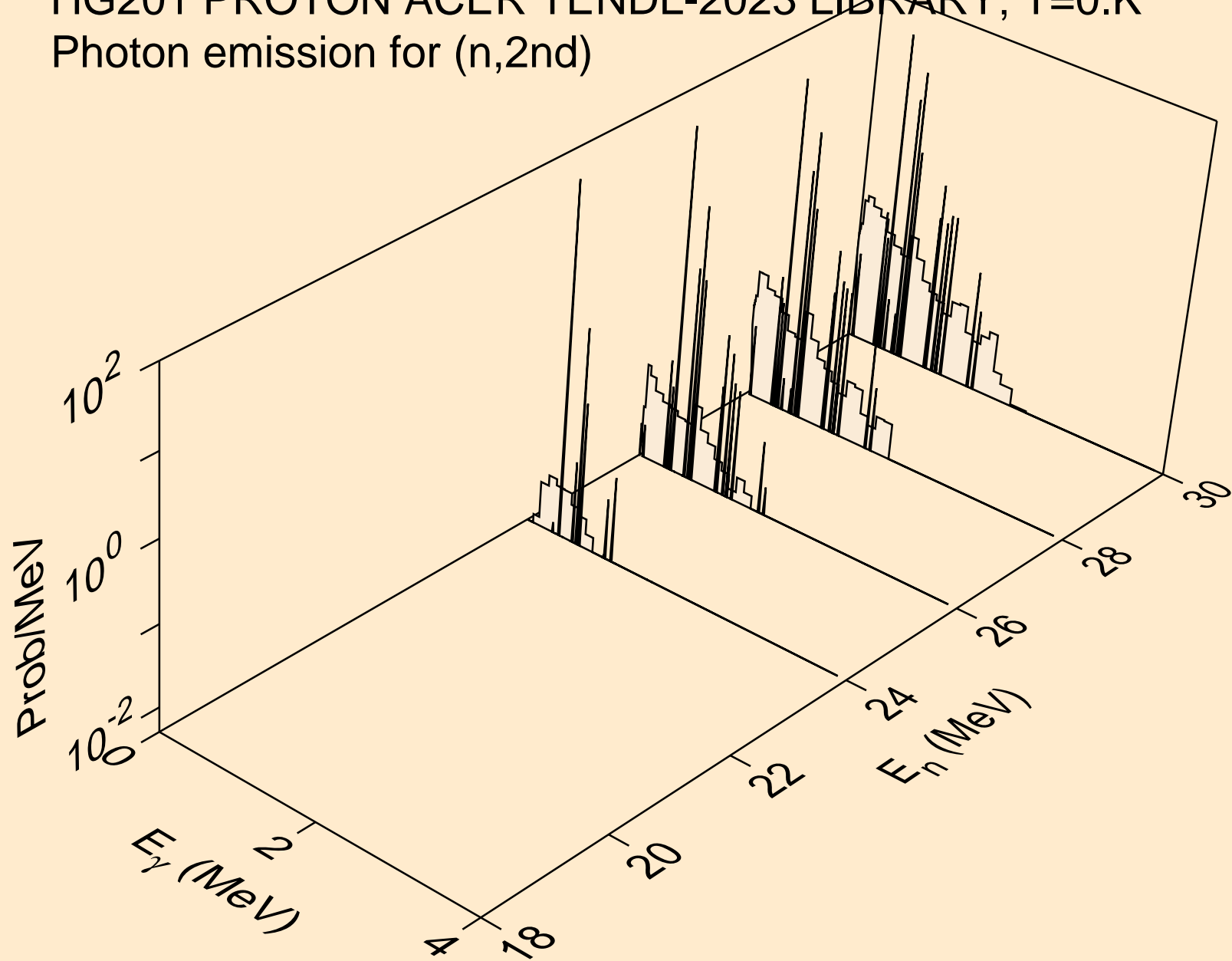

HG201 PROTON ACER TENDL-2023 LIBRARY; T=0.K  
Photon emission for (n,2n)

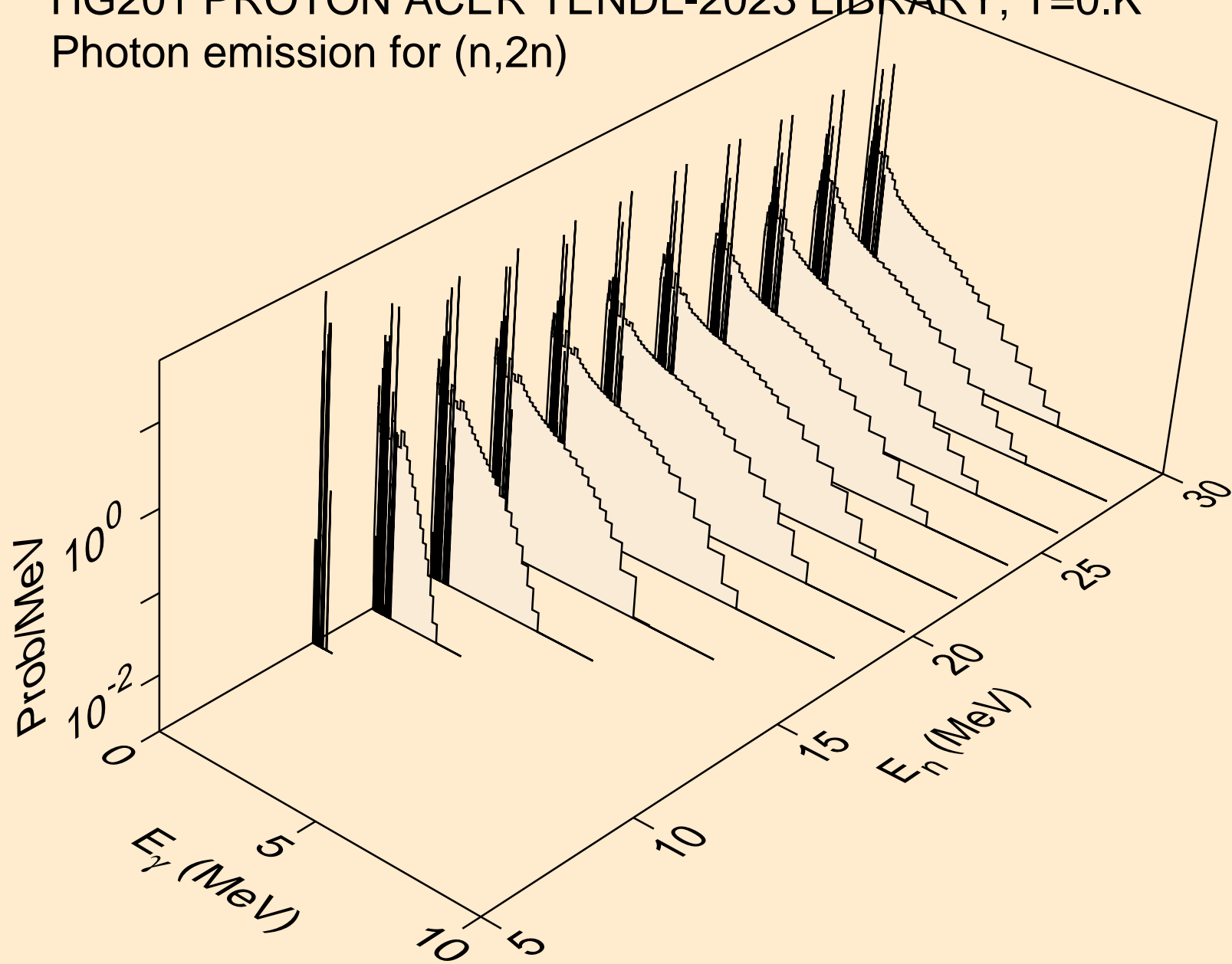

HG201 PROTON ACER TENDL-2023 LIBRARY; T=0.K  
Photon emission for (n,3n)

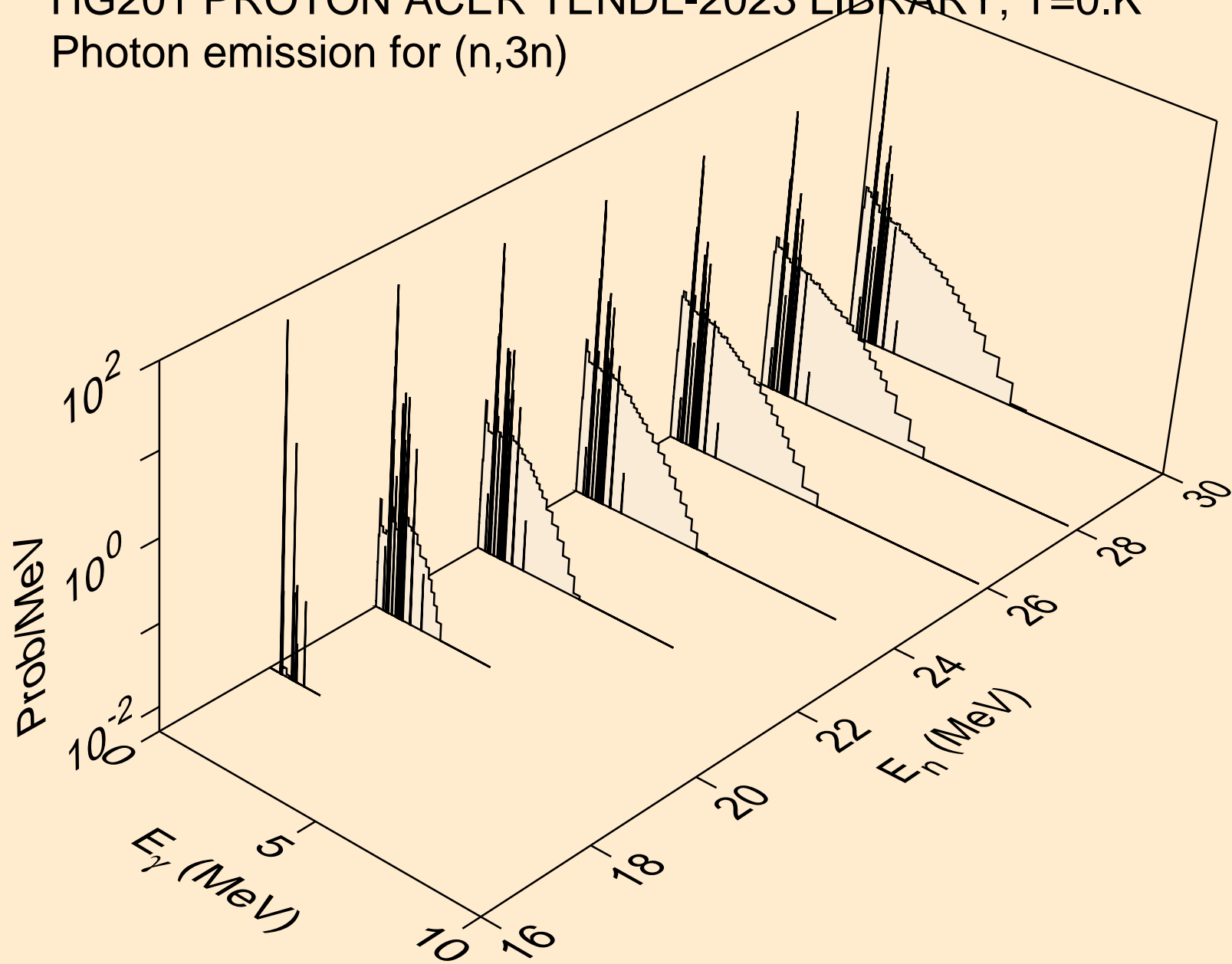

HG201 PROTON ACER TENDL-2023 LIBRARY; T=0.K  
Photon emission for (n,n\*)a

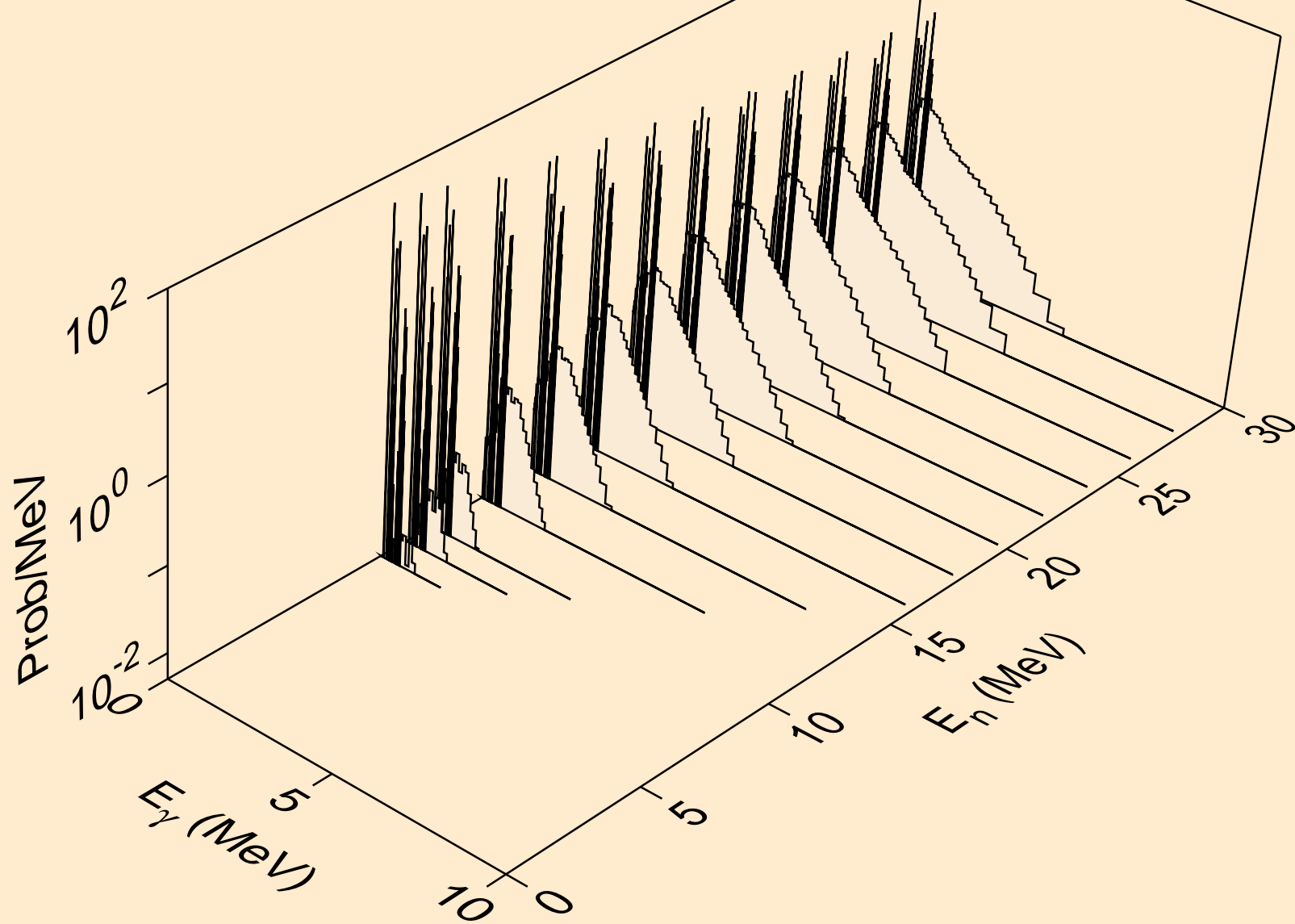

HG201 PROTON ACER TENDL-2023 LIBRARY; T=0.K  
Photon emission for (n,2n) $\alpha$

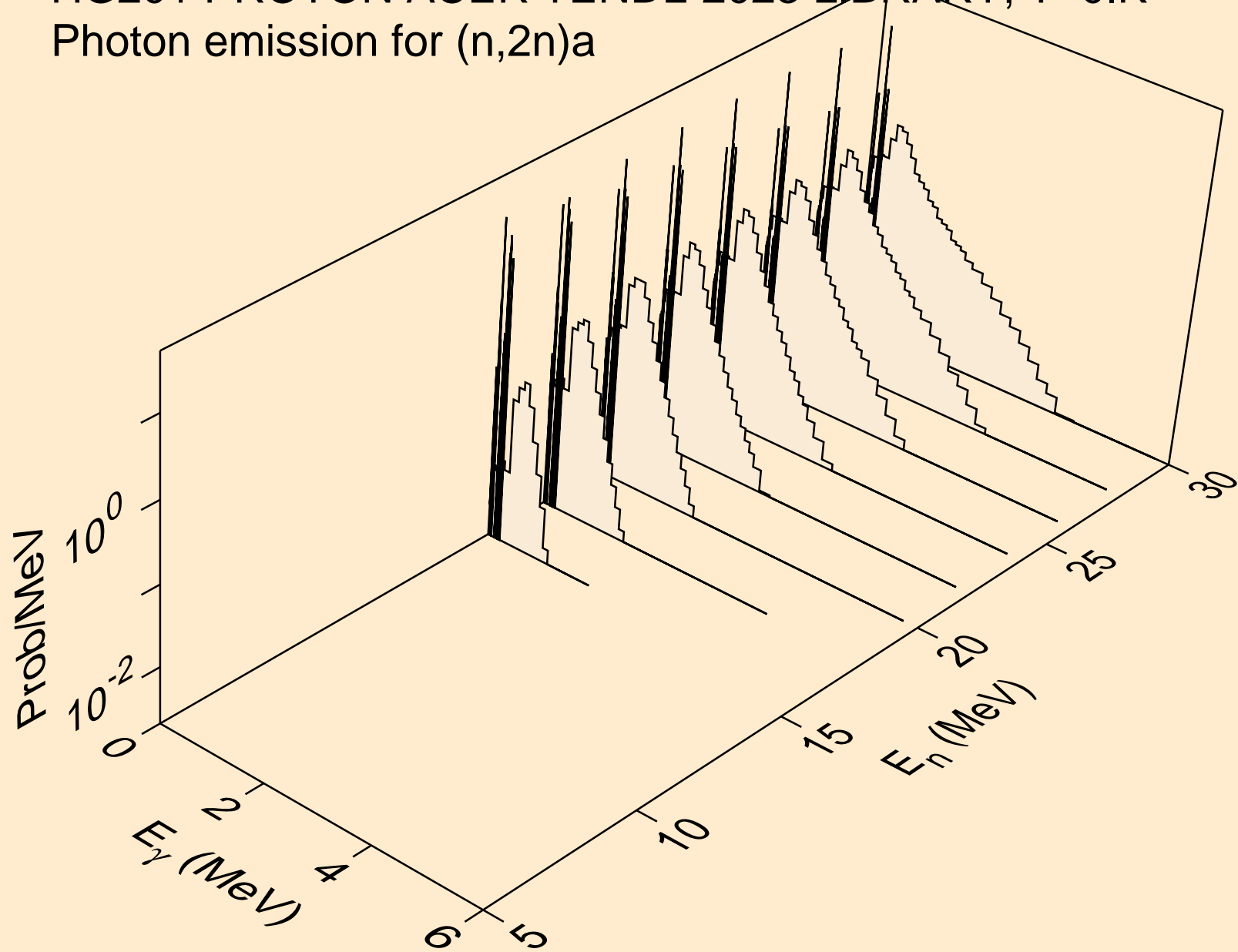

HG201 PROTON ACER TENDL-2023 LIBRARY; T=0.K  
Photon emission for (n,3n)a

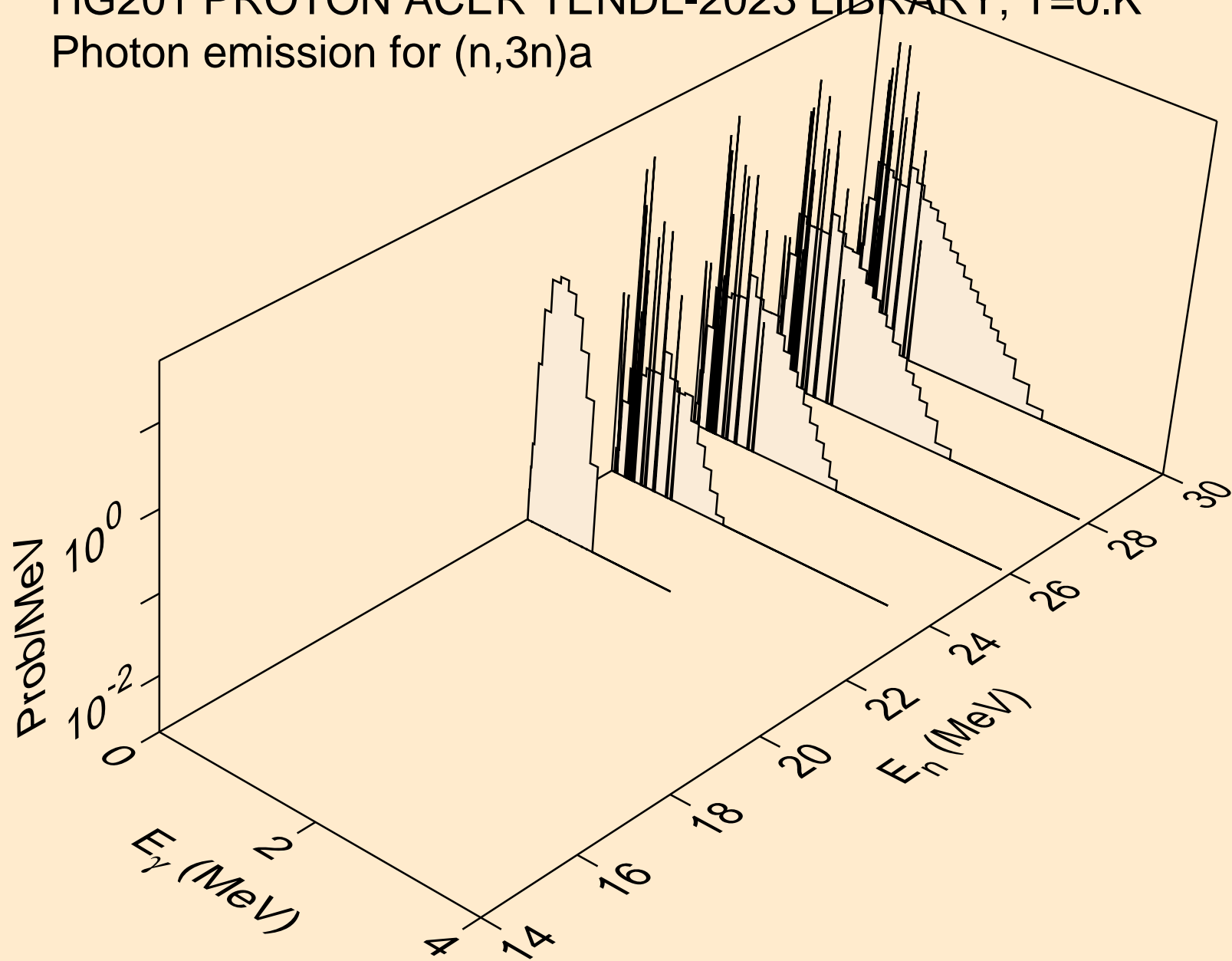

HG201 PROTON ACER TENDL-2023 LIBRARY; T=0.K  
Photon emission for (n,n\*)p

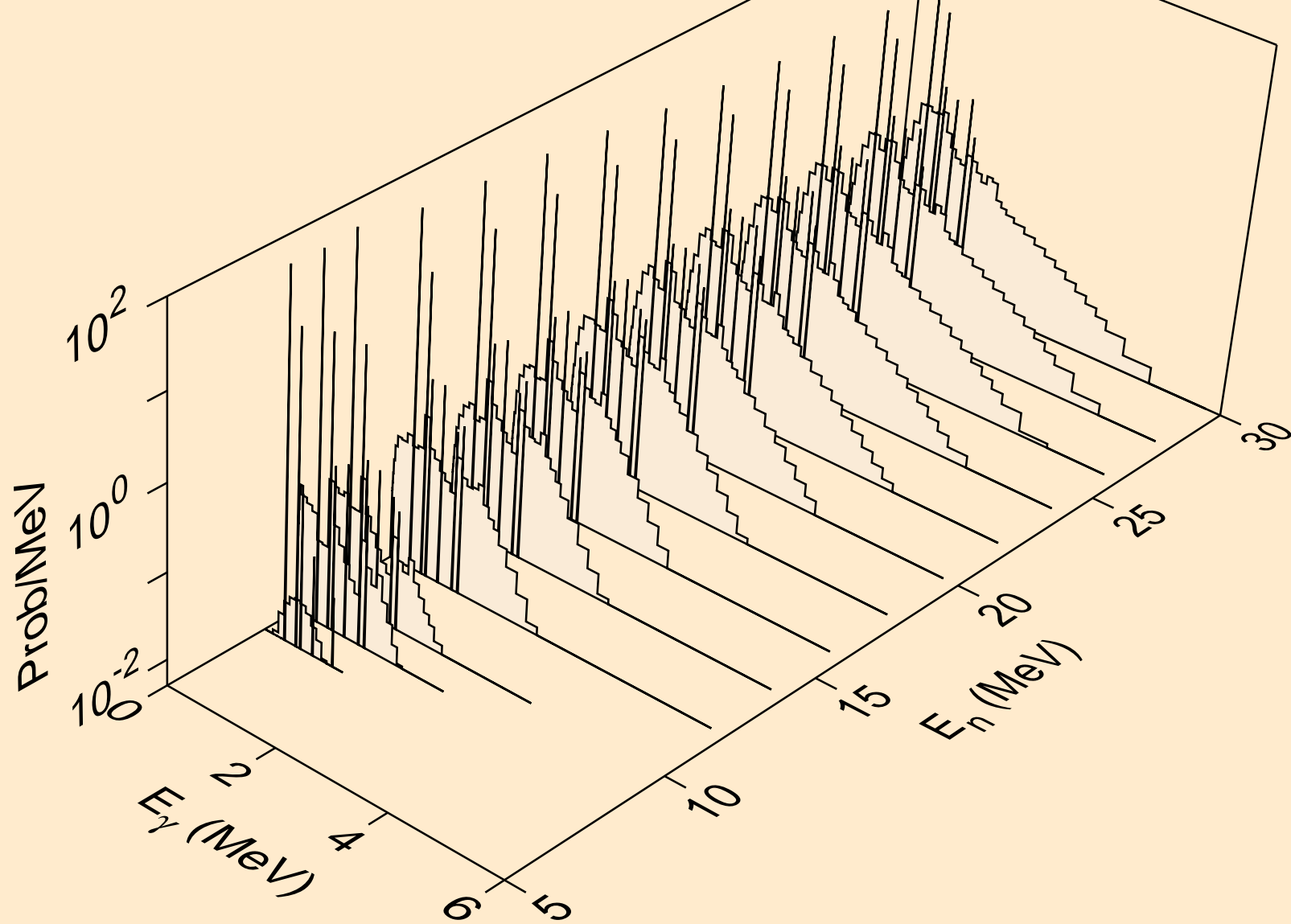

HG201 PROTON ACER TENDL-2023 LIBRARY; T=0.K  
Photon emission for (n,n\*)d

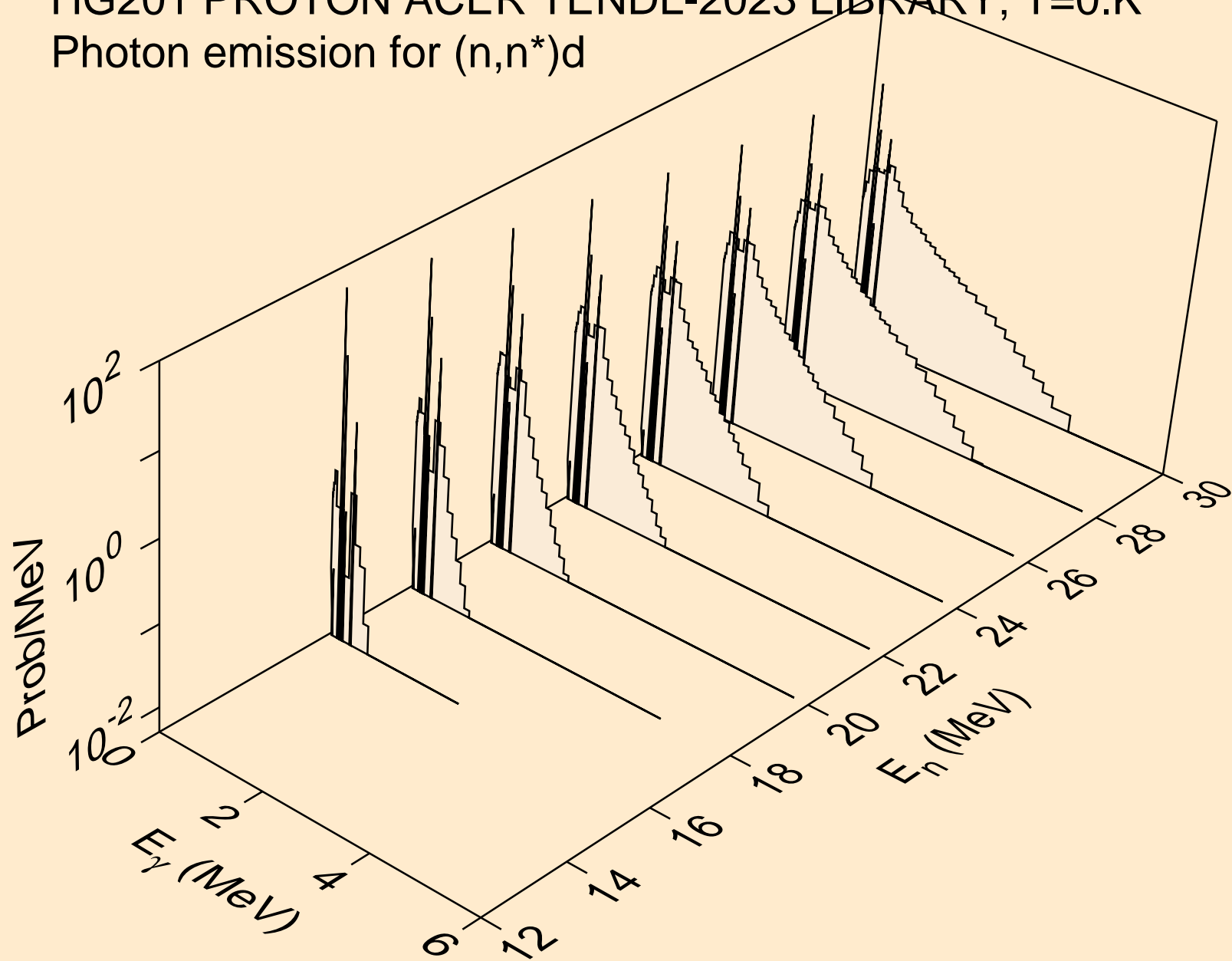

HG201 PROTON ACER TENDL-2023 LIBRARY; T=0.K  
Photon emission for (n,n\*)t

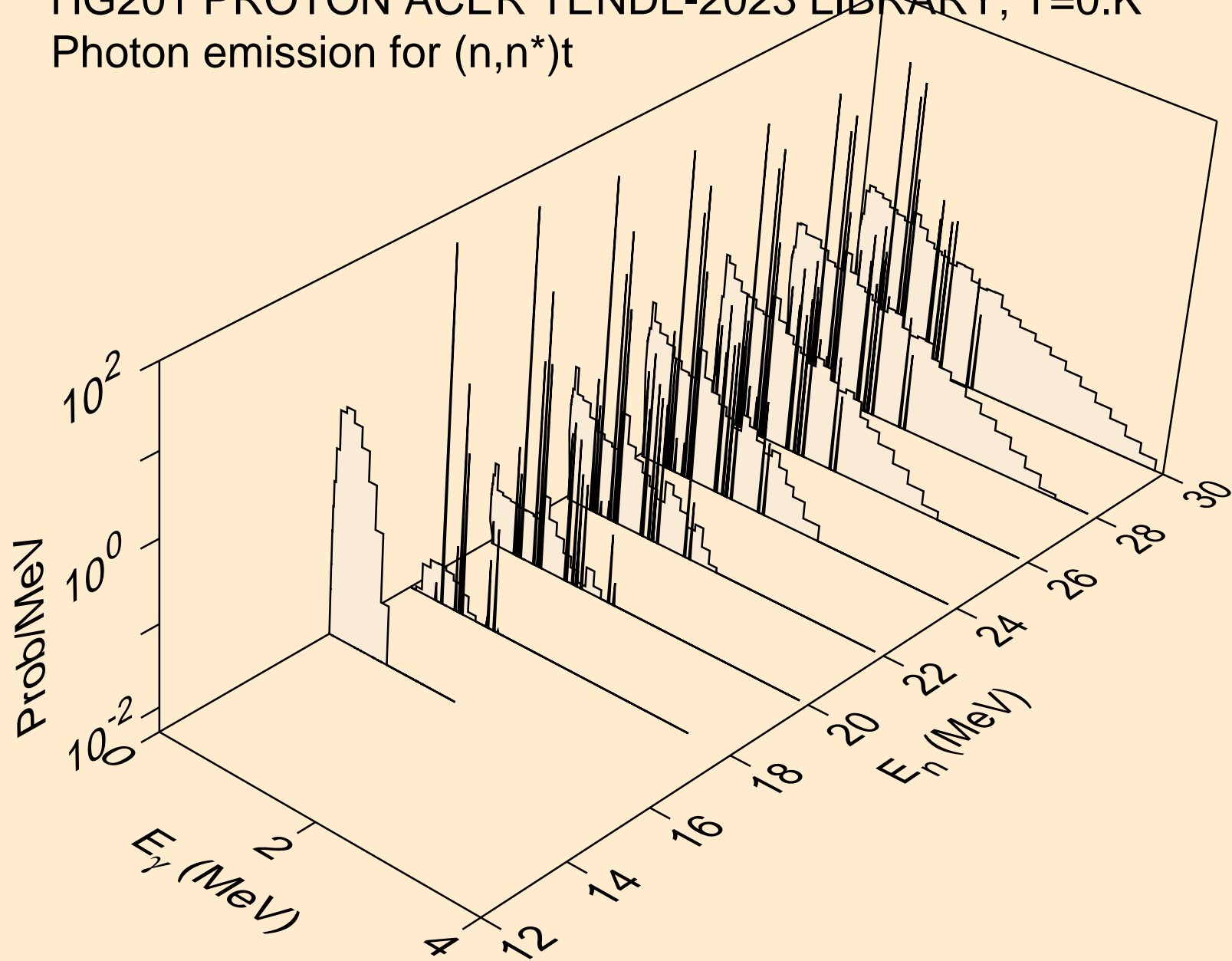

HG201 PROTON ACER TENDL-2023 LIBRARY; T=0.K  
Photon emission for (n,n\*)he3

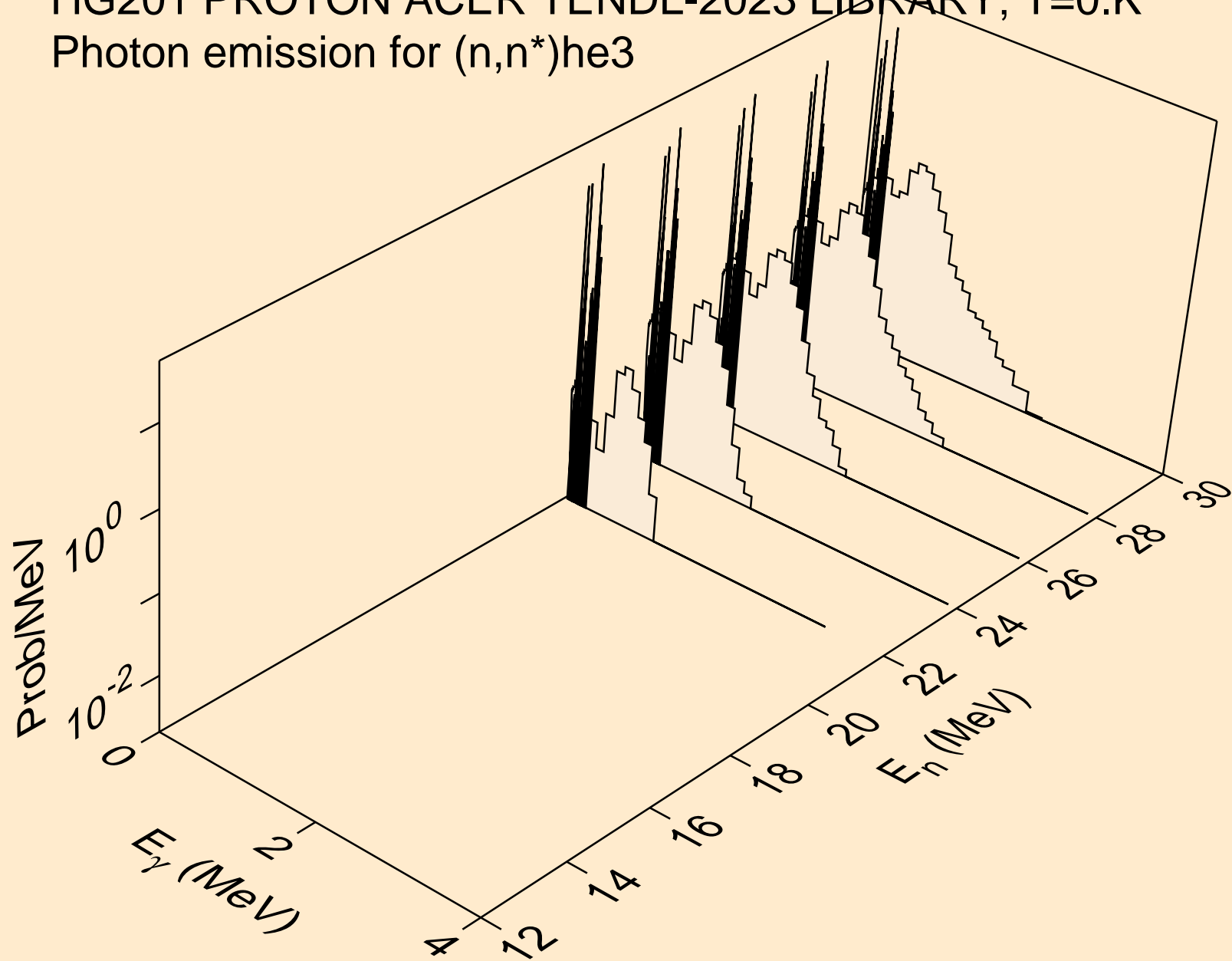

HG201 PROTON ACER TENDL-2023 LIBRARY; T=0.K  
Photon emission for (n,4n)

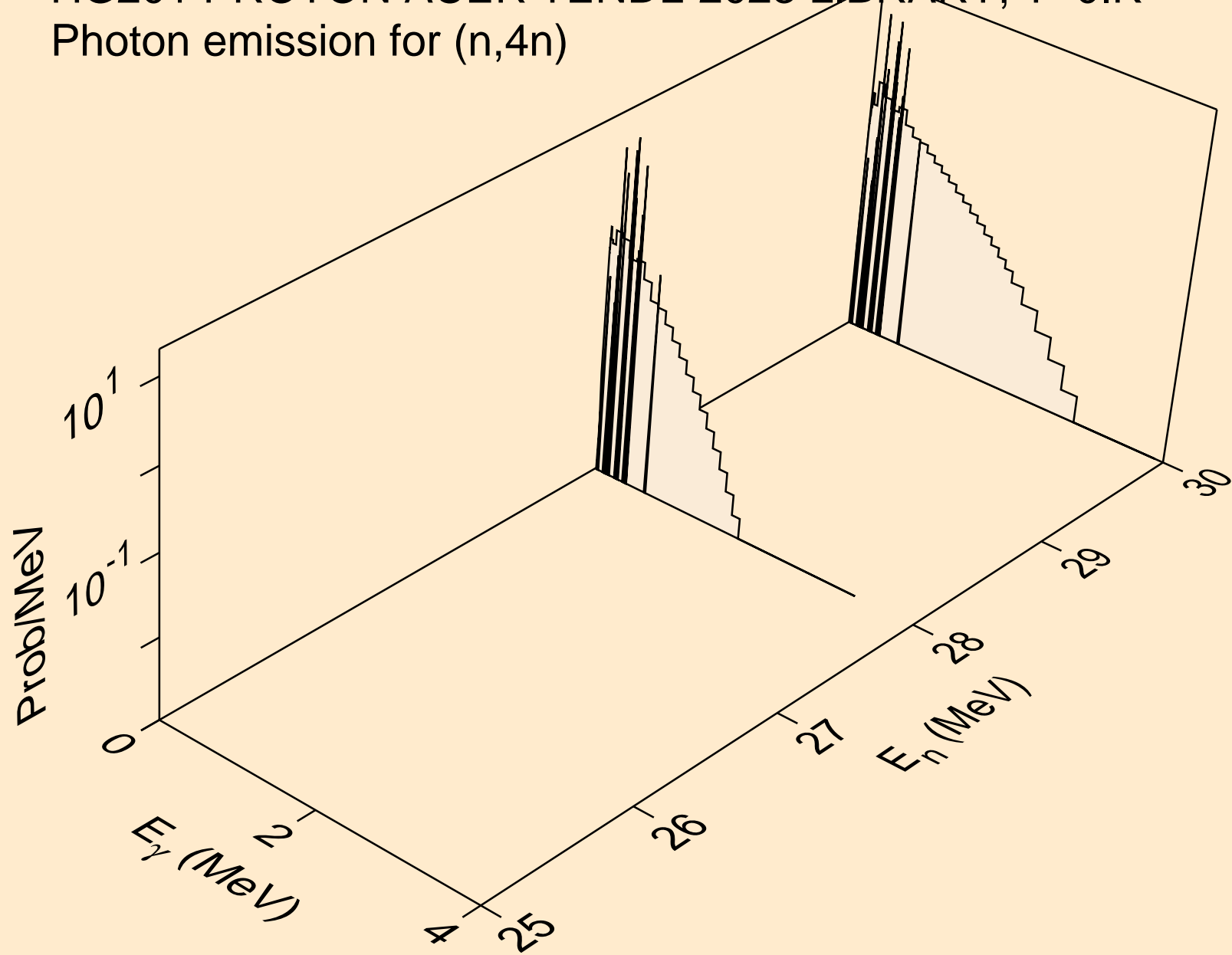

HG201 PROTON ACER TENDL-2023 LIBRARY; T=0.K  
Photon emission for (n,2np)

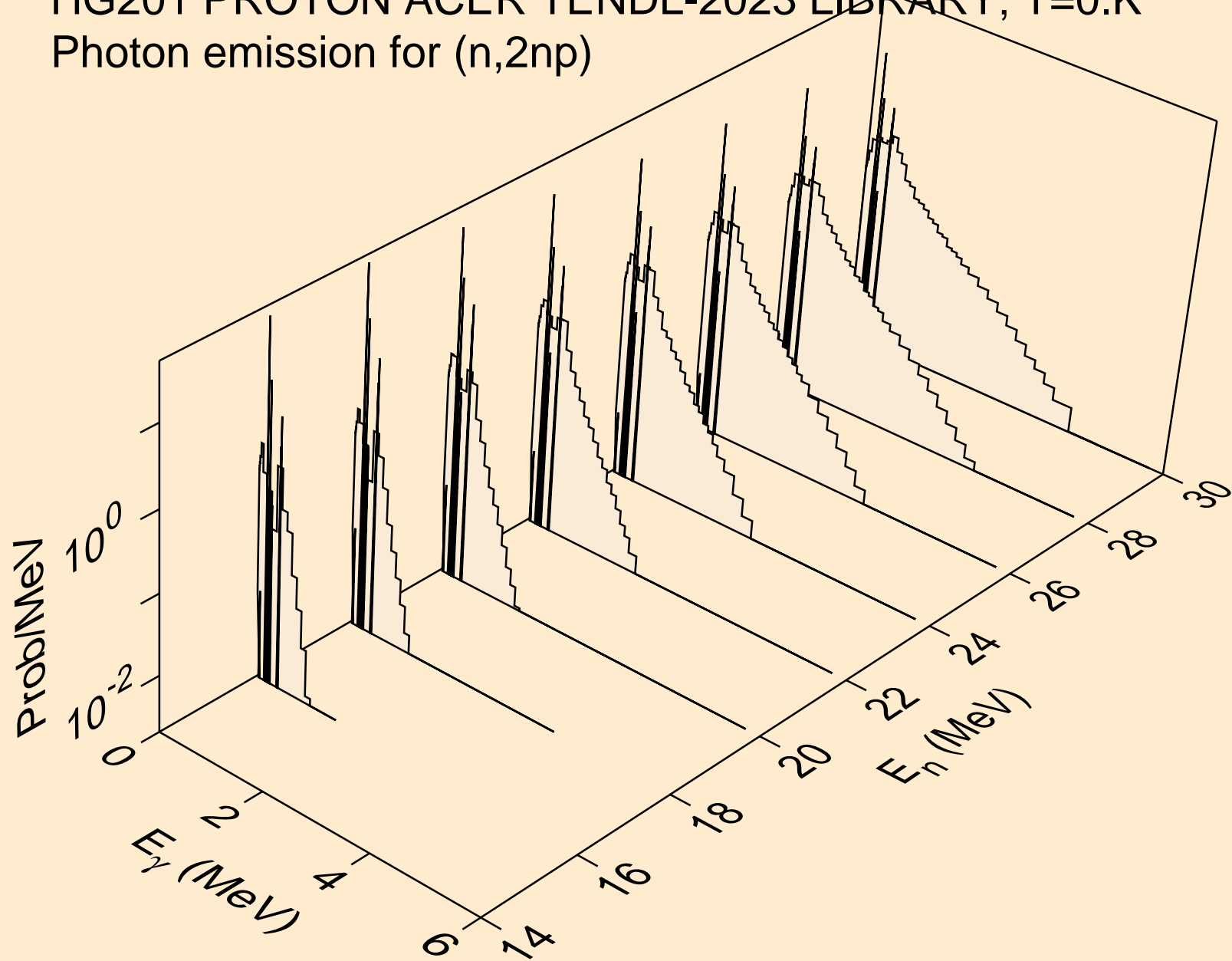

HG201 PROTON ACER TENDL-2023 LIBRARY; T=0.K  
Photon emission for (n,3np)

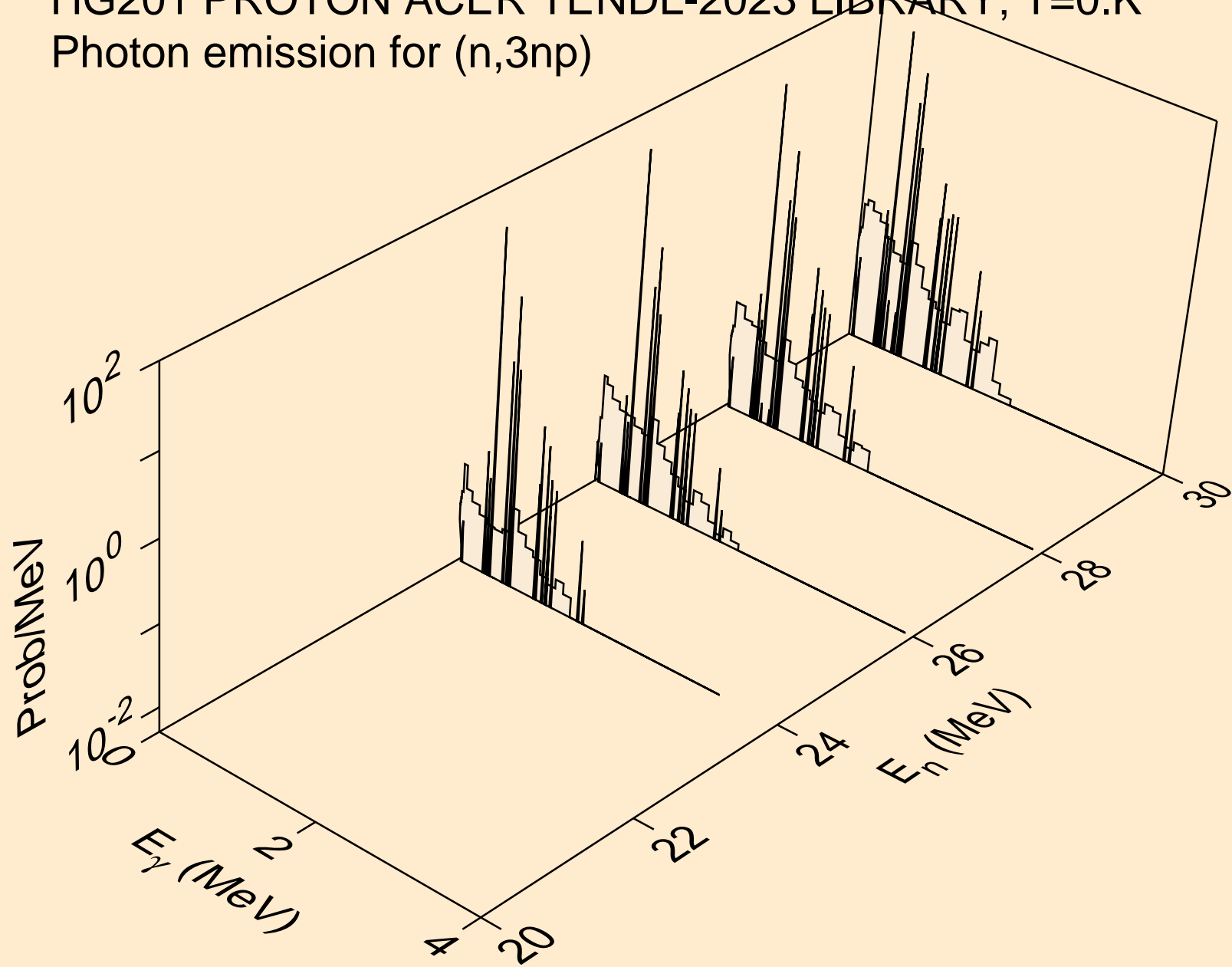

HG201 PROTON ACER TENDL-2023 LIBRARY; T=0.K  
Photon emission for (n,n2p)

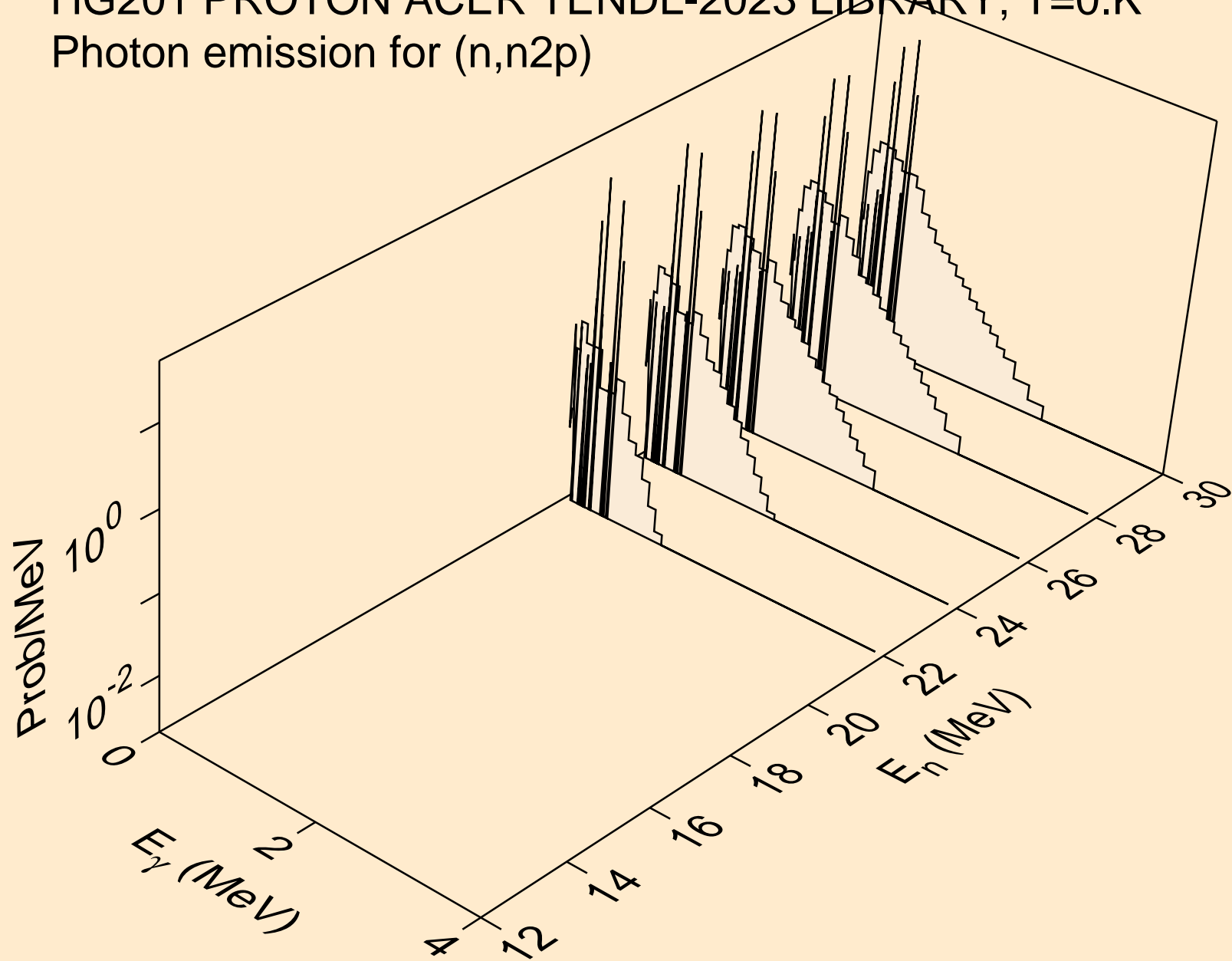

HG201 PROTON ACER TENDL-2023 LIBRARY; T=0.K  
Photon emission for (n,gma)

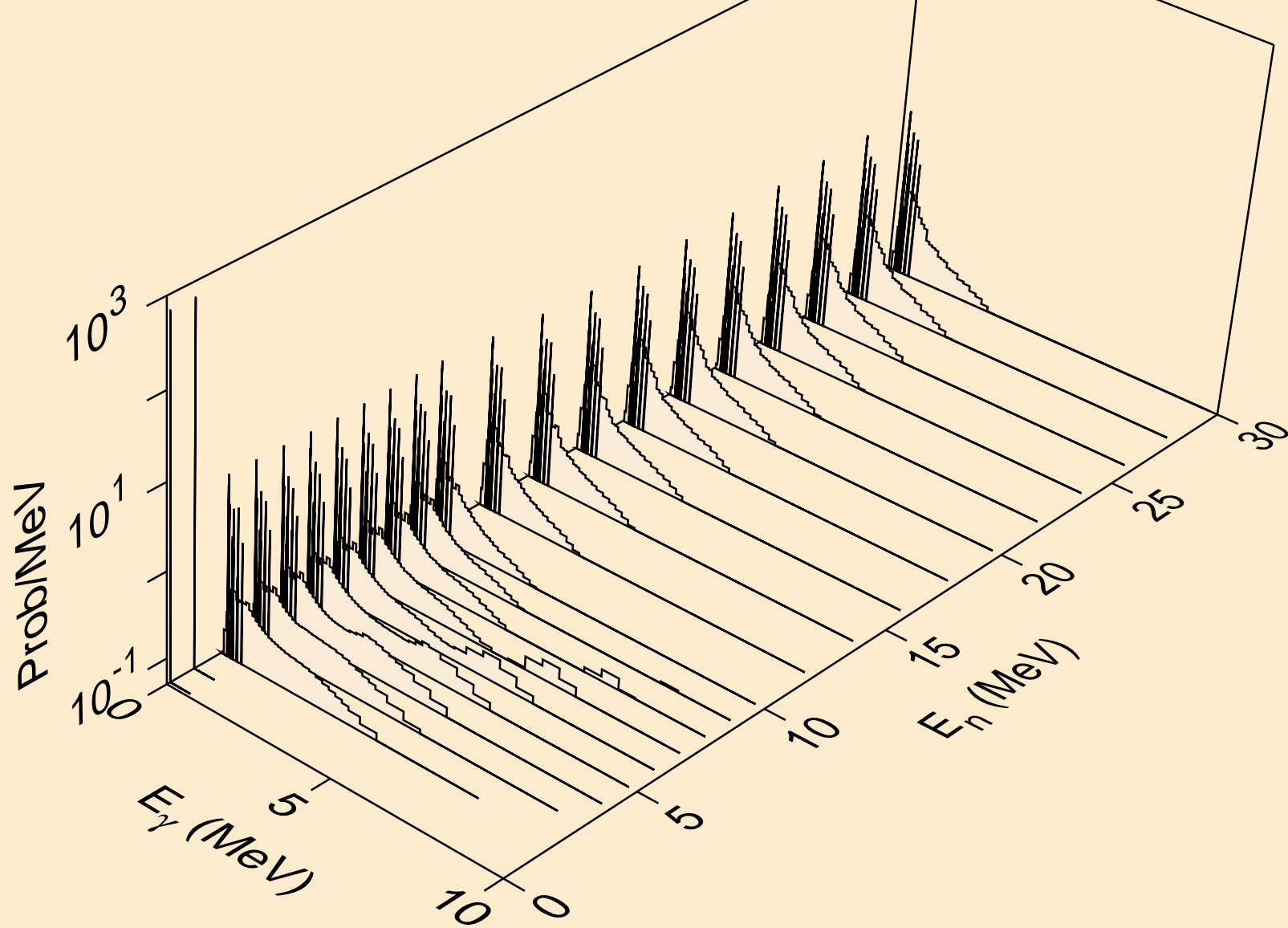

HG201 PROTON ACER TENDL-2023 LIBRARY; T=0.K  
Photon emission for inelastic

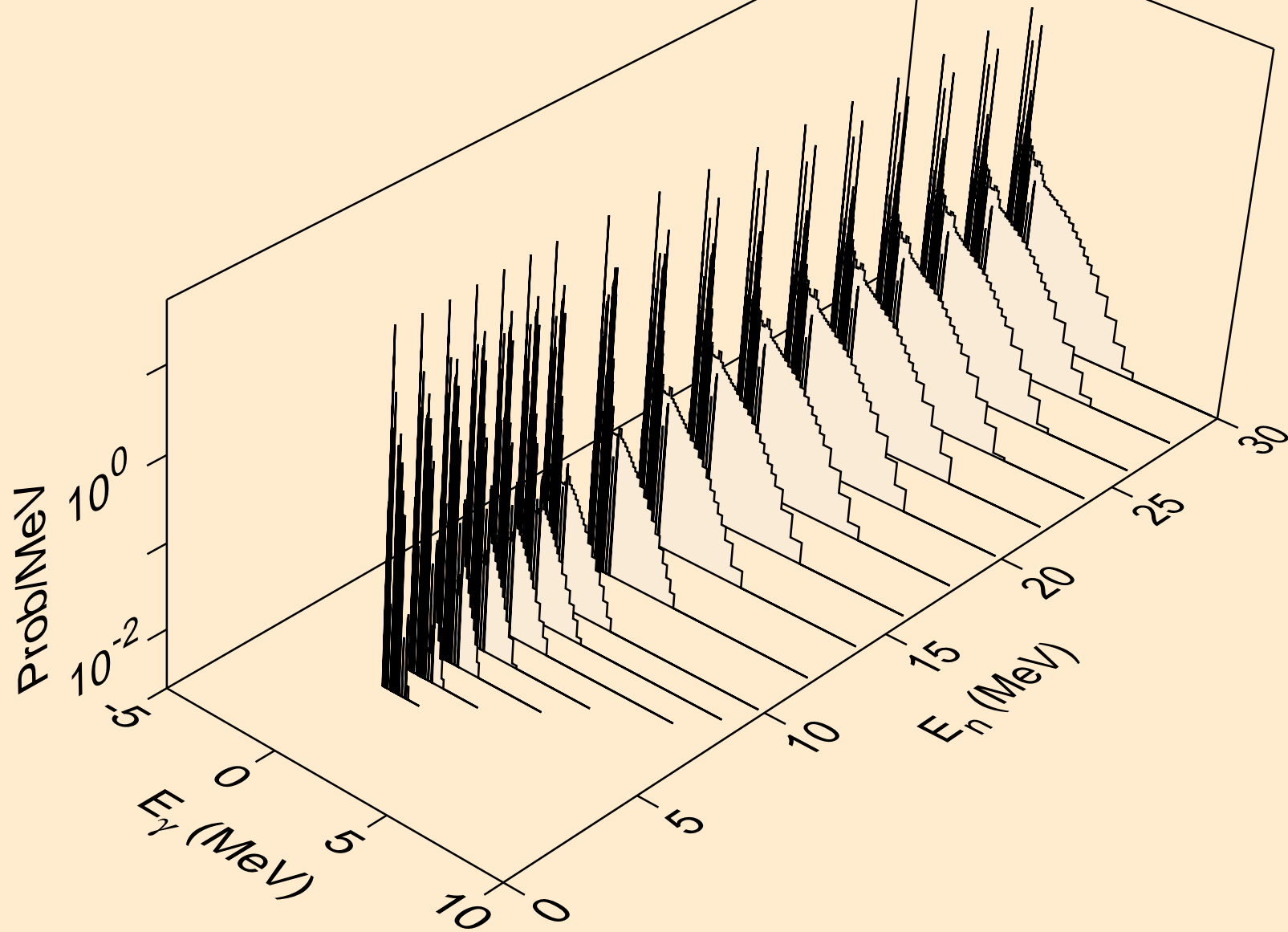

HG201 PROTON ACER TENDL-2023 LIBRARY; T=0.K  
Photon emission for (n,d)

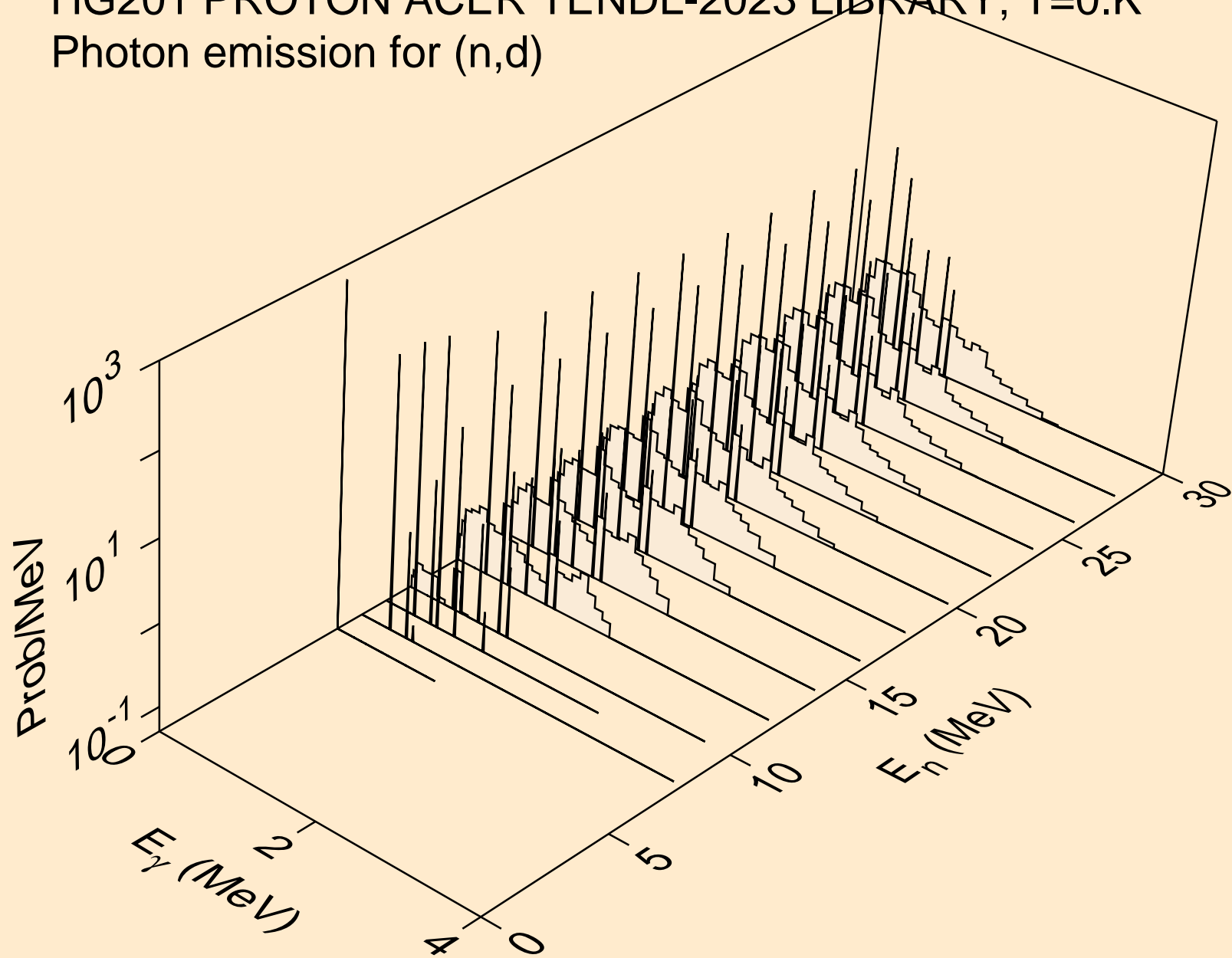

HG201 PROTON ACER TENDL-2023 LIBRARY; T=0.K  
Photon emission for (n,t)

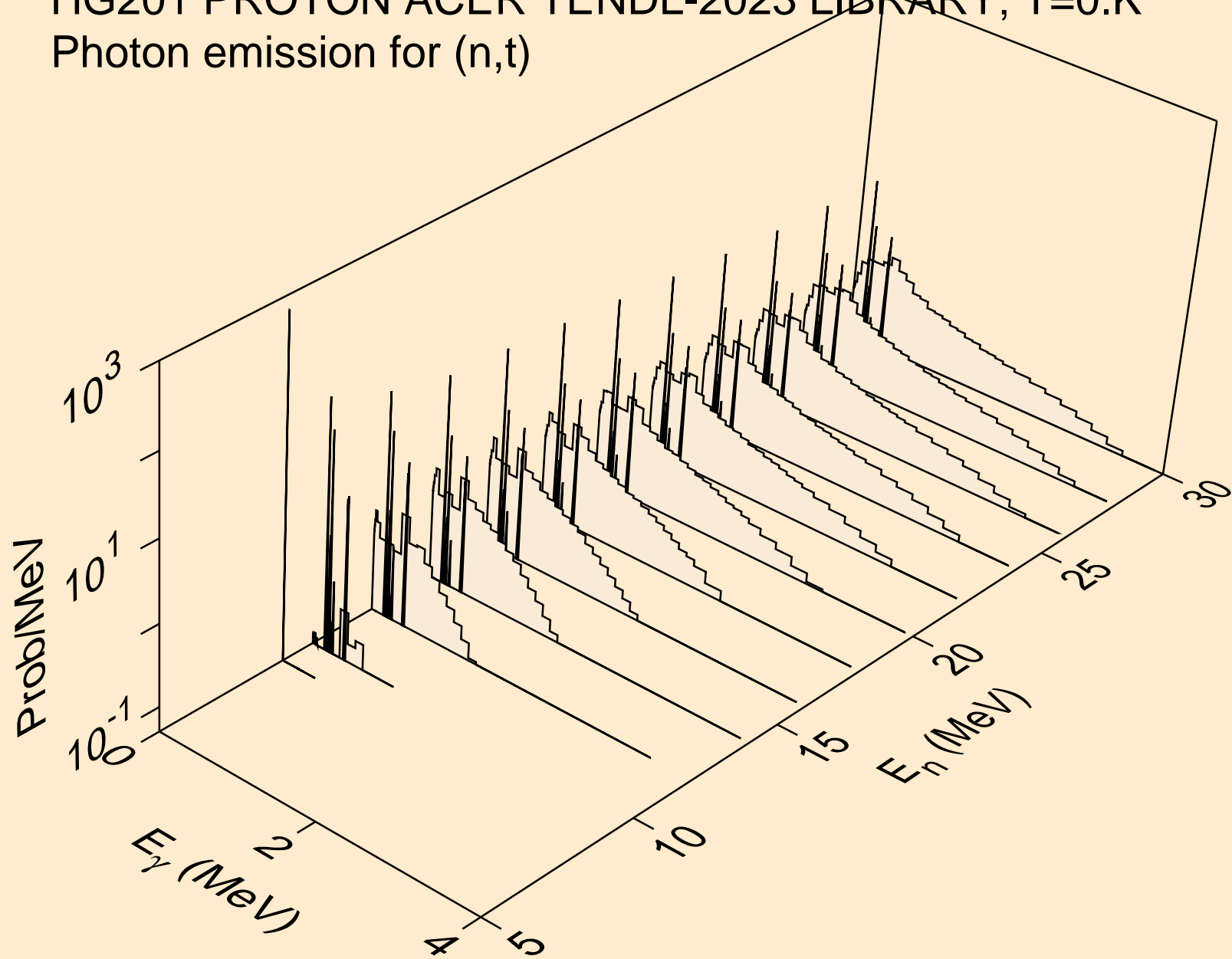

HG201 PROTON ACER TENDL-2023 LIBRARY; T=0.K  
Photon emission for (n,he3)

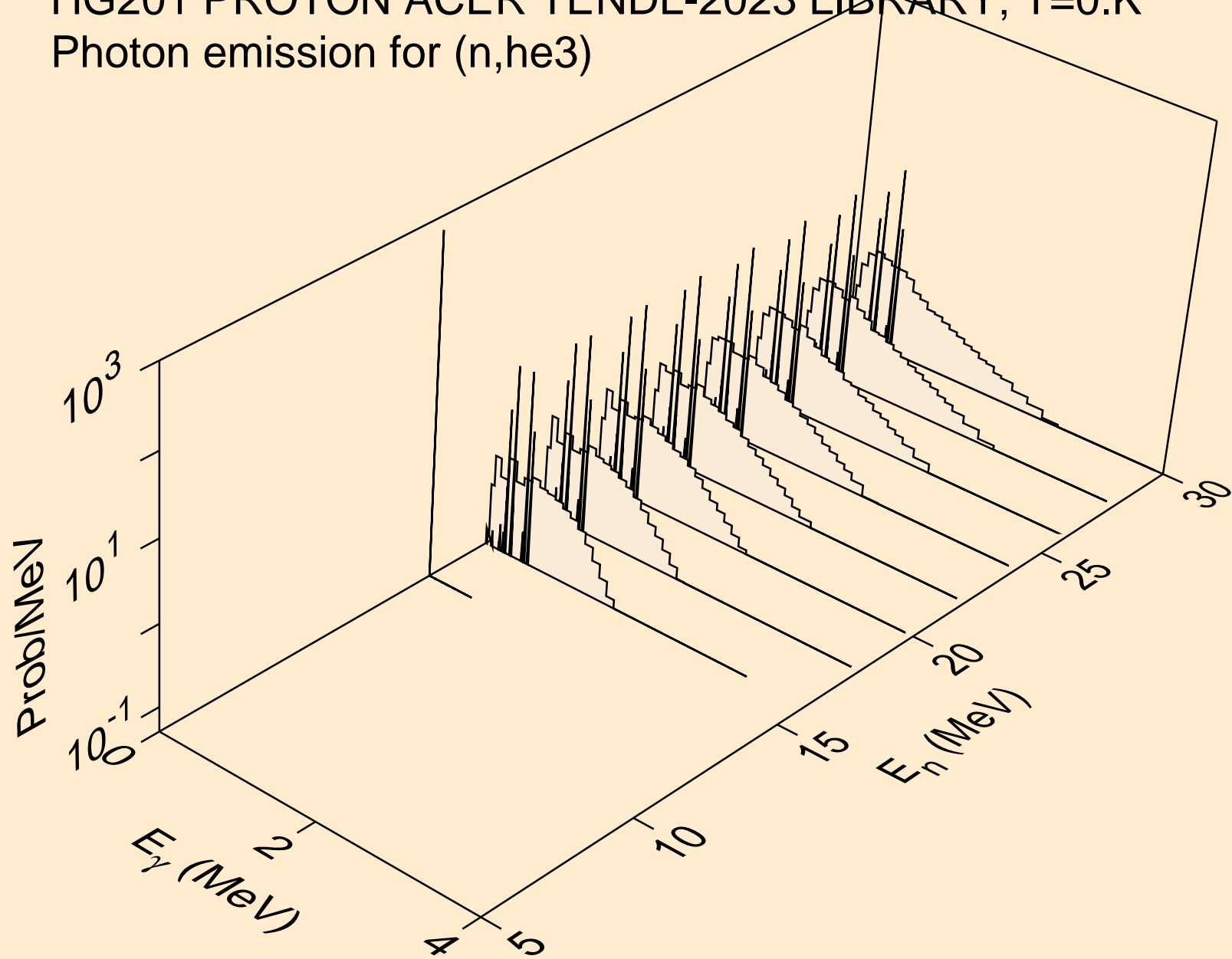

HG201 PROTON ACER TENDL-2023 LIBRARY; T=0.K  
Photon emission for (n,a)

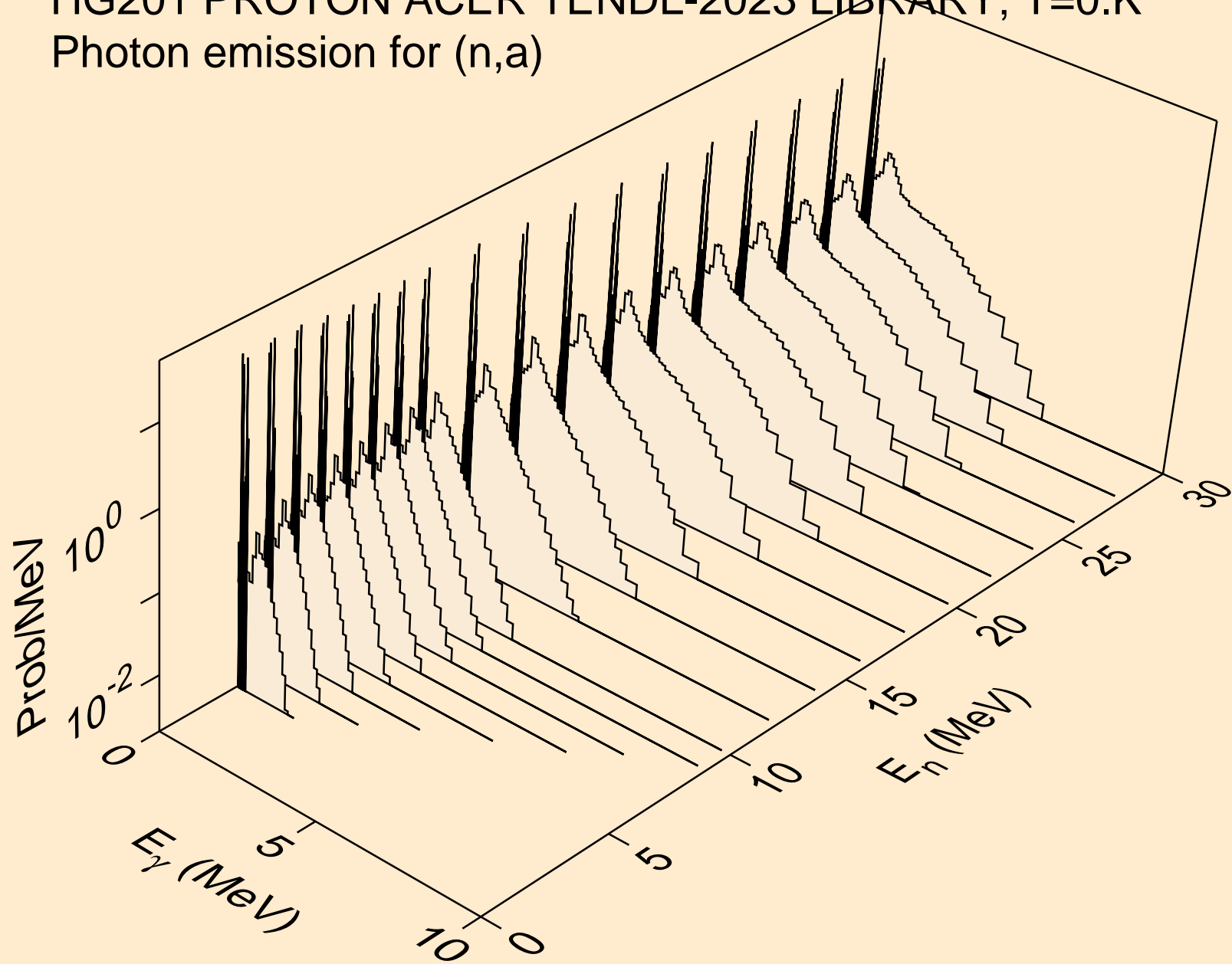

HG201 PROTON ACER TENDL-2023 LIBRARY; T=0.K  
Photon emission for (n,2p)

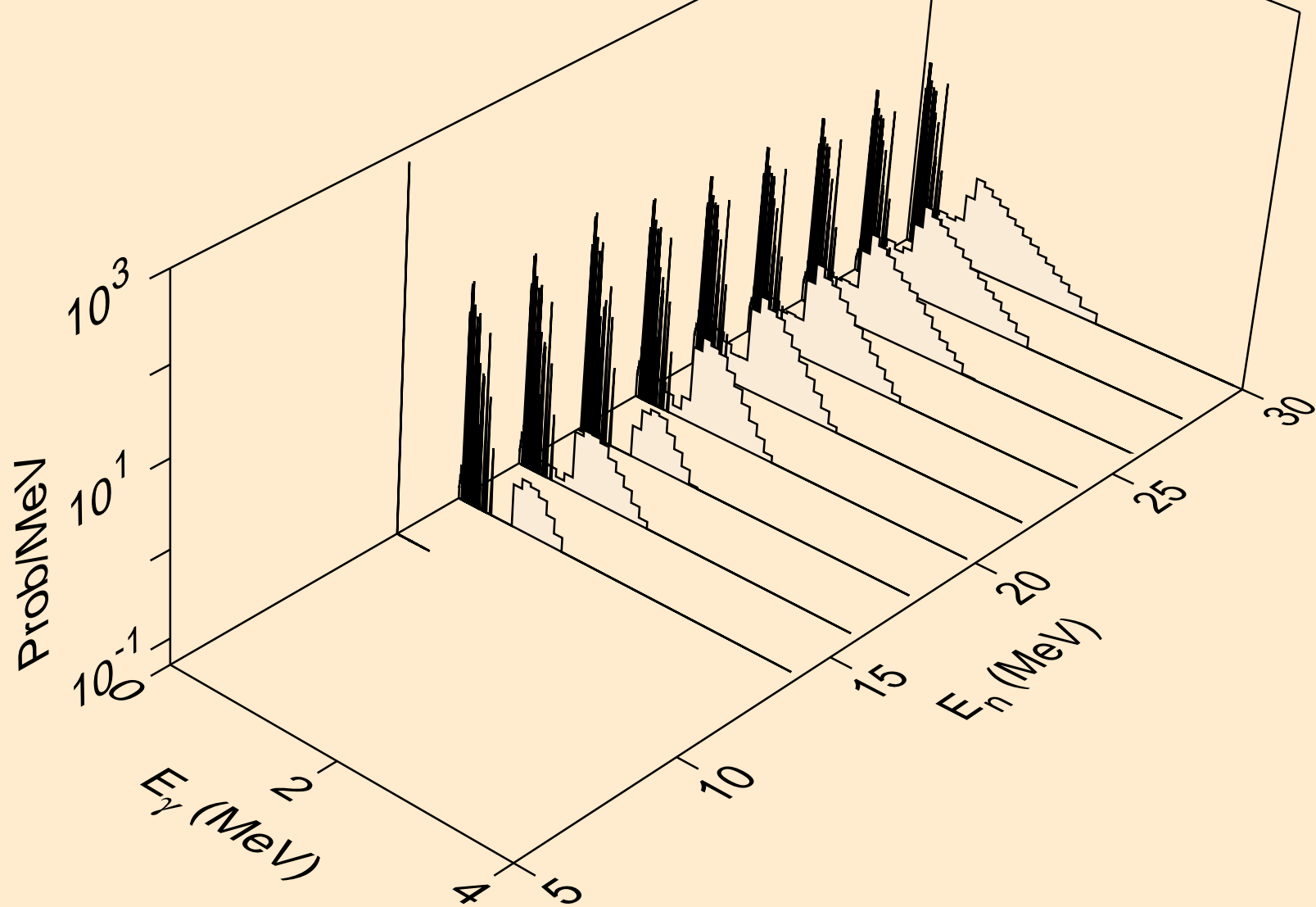

HG201 PROTON ACER TENDL-2023 LIBRARY; T=0.K  
Photon emission for (n,pa)

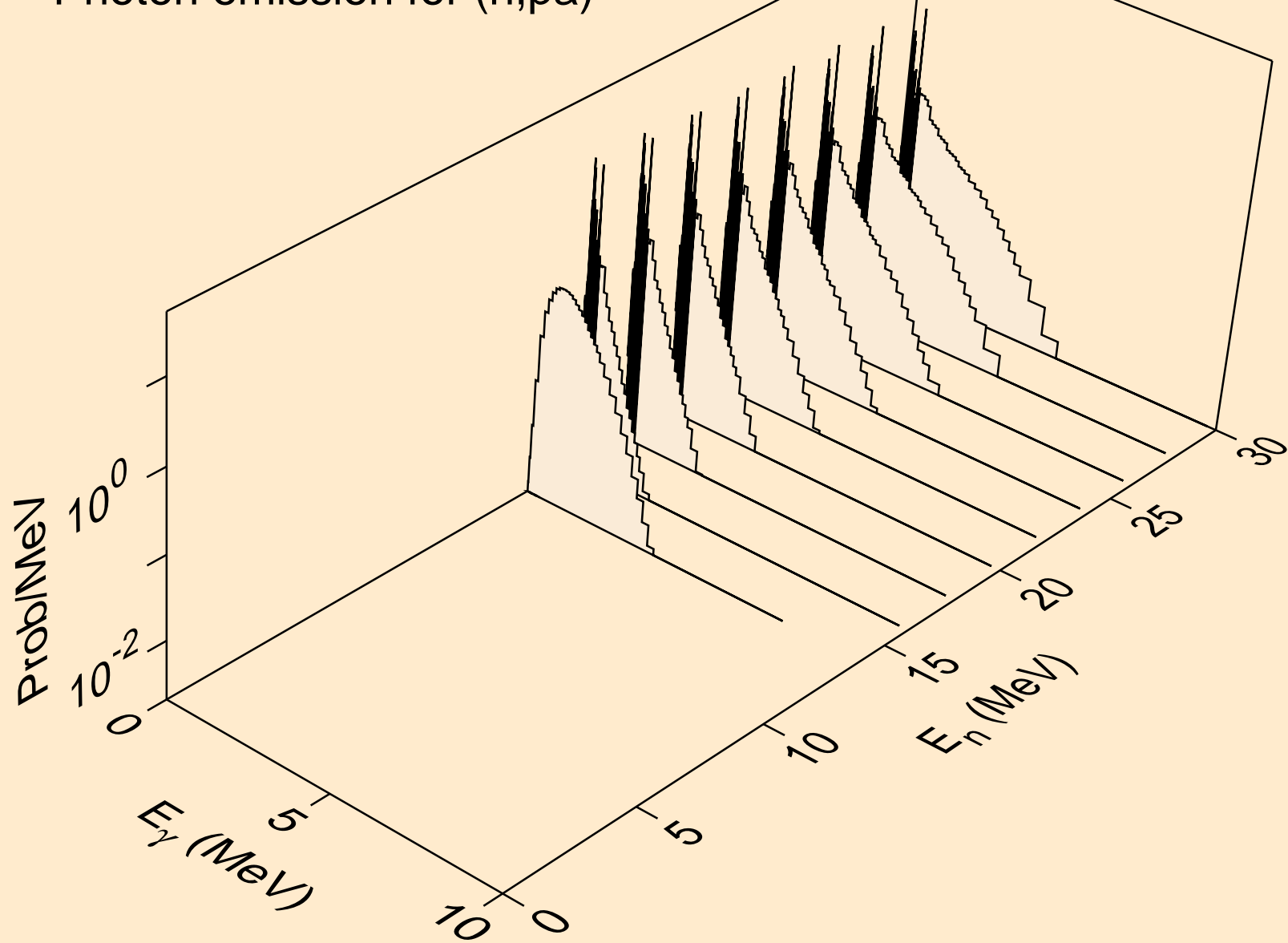

# HG201 PROTON ACER TENDL-2023 LIBRARY; T=0.K

## Particle heating contributions

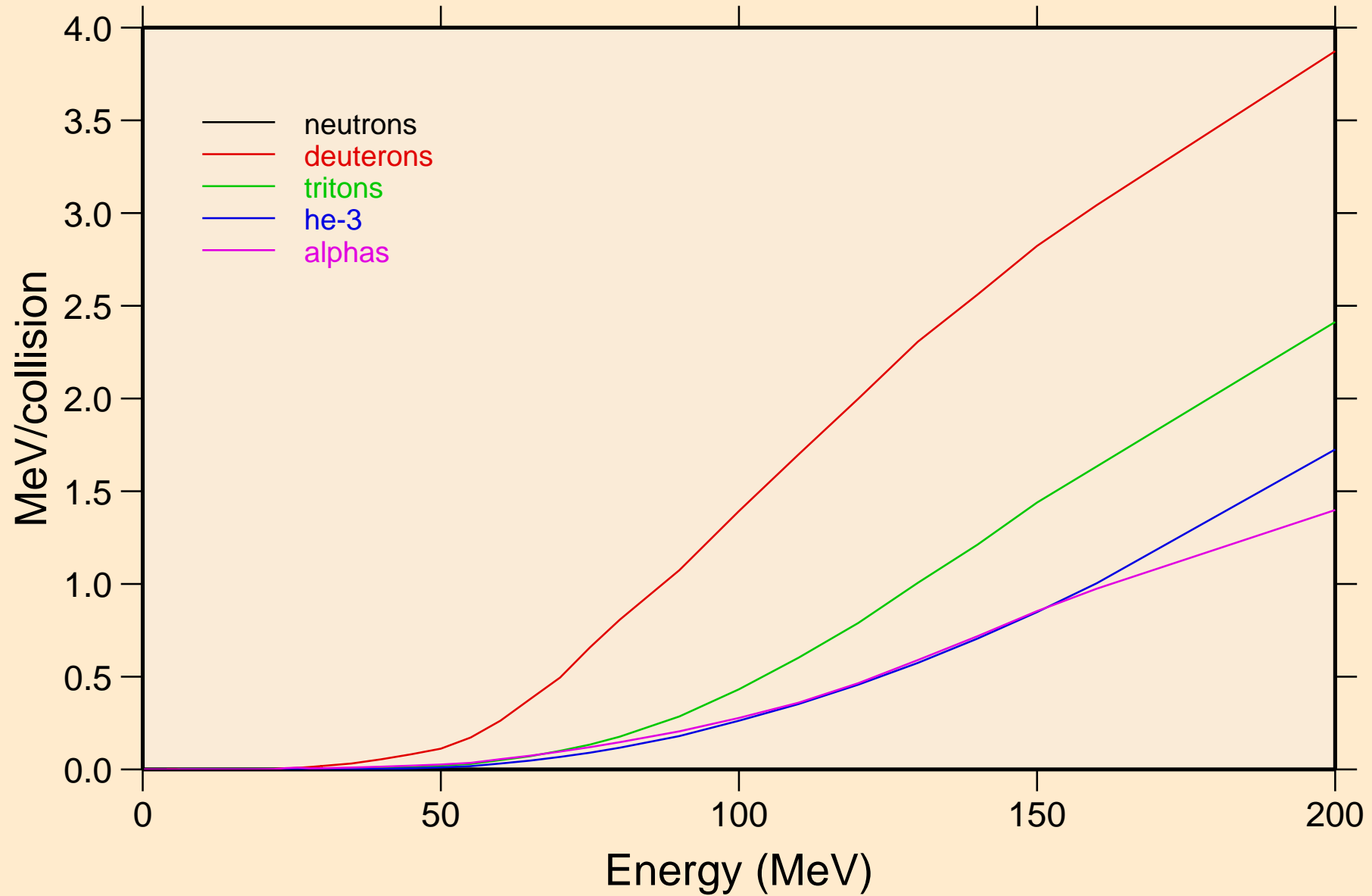

HG201 PROTON ACER TENDL-2023 LIBRARY; T=0.K  
Recoil Heating

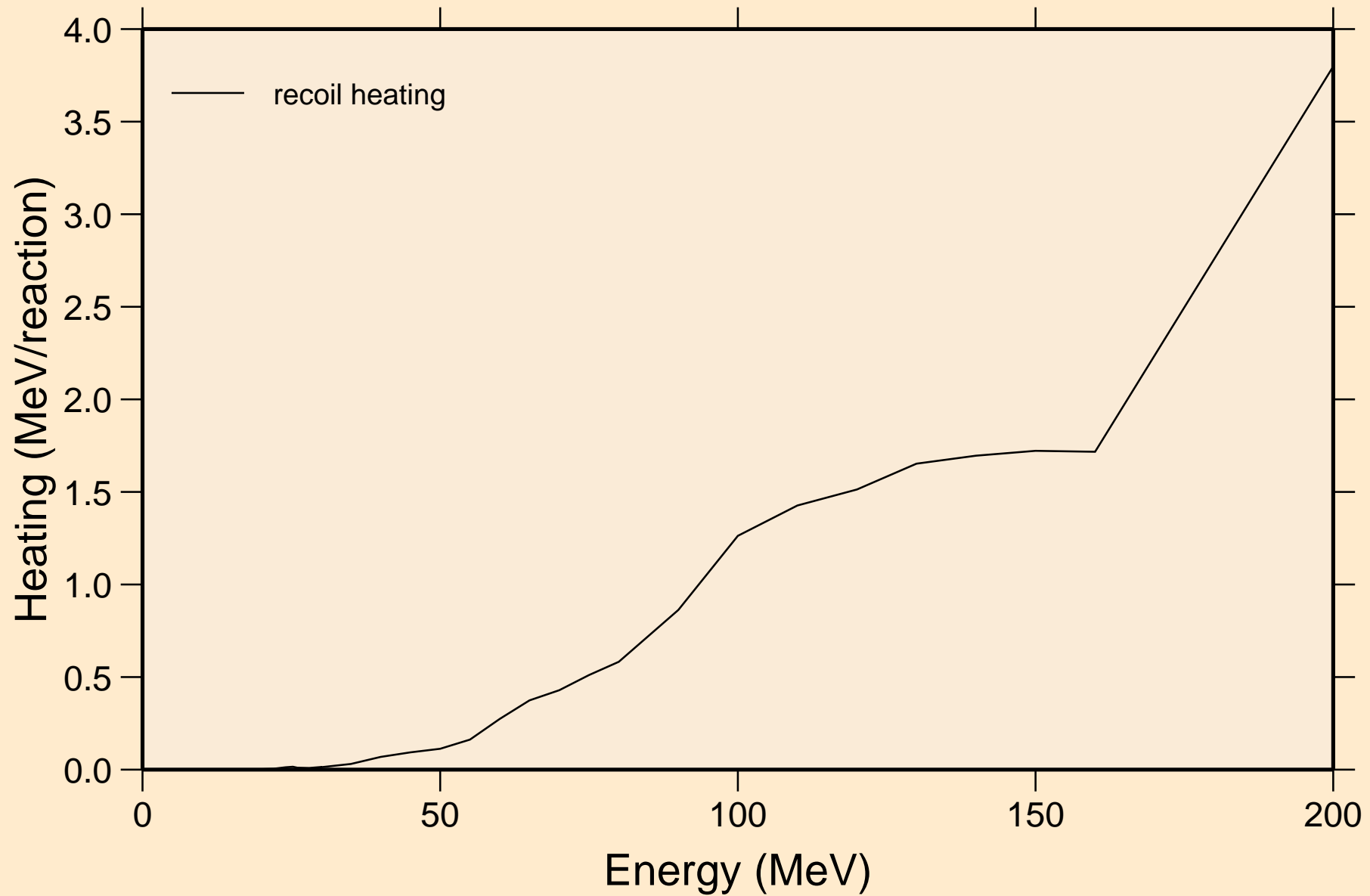

# HG201 PROTON ACER TENDL-2023 LIBRARY; T=0.K

## Particle production cross sections

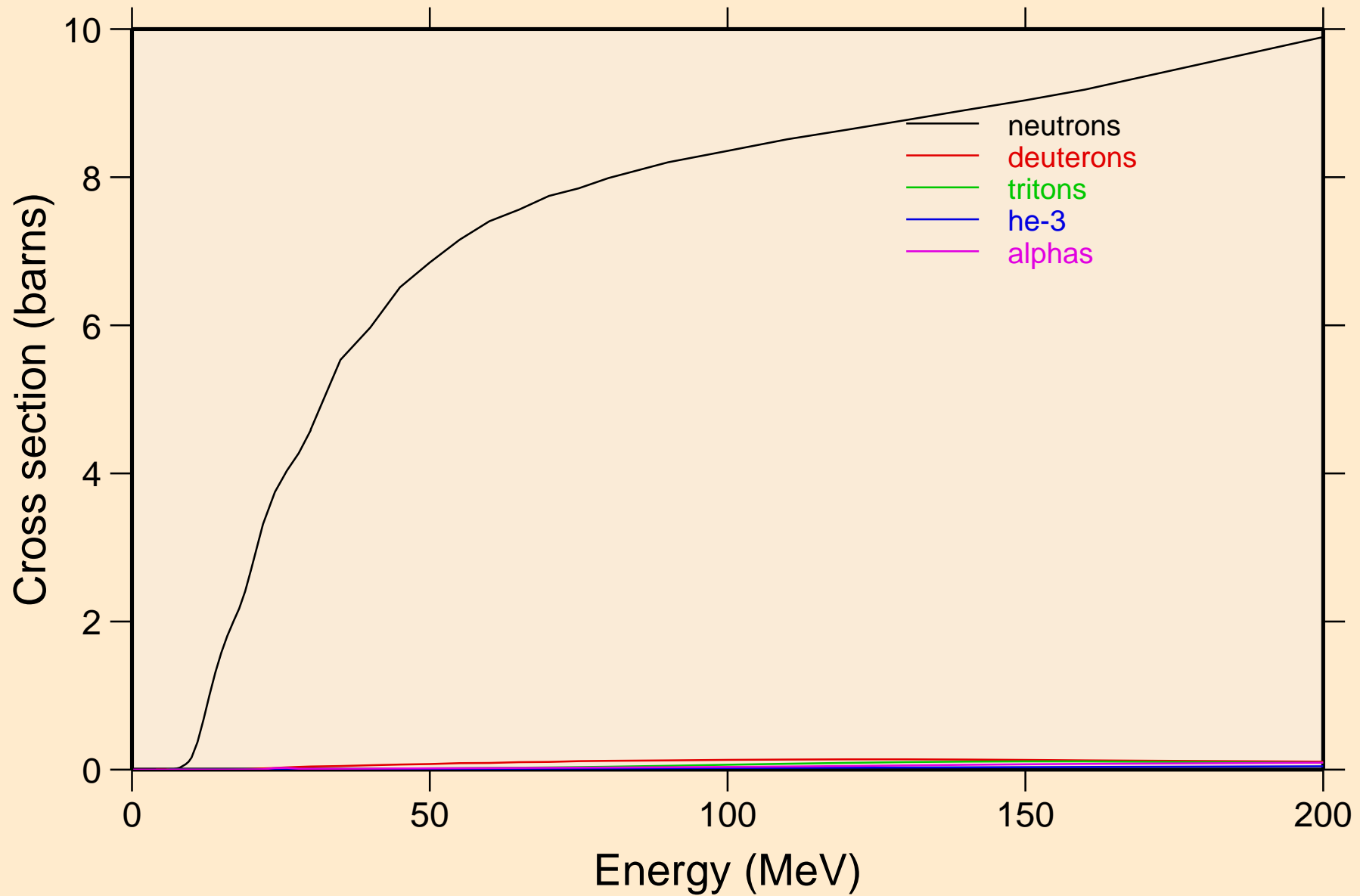

HG201 PROTON ACER TENDL-2023 LIBRARY; T=0.K  
neutrons from (p,n)

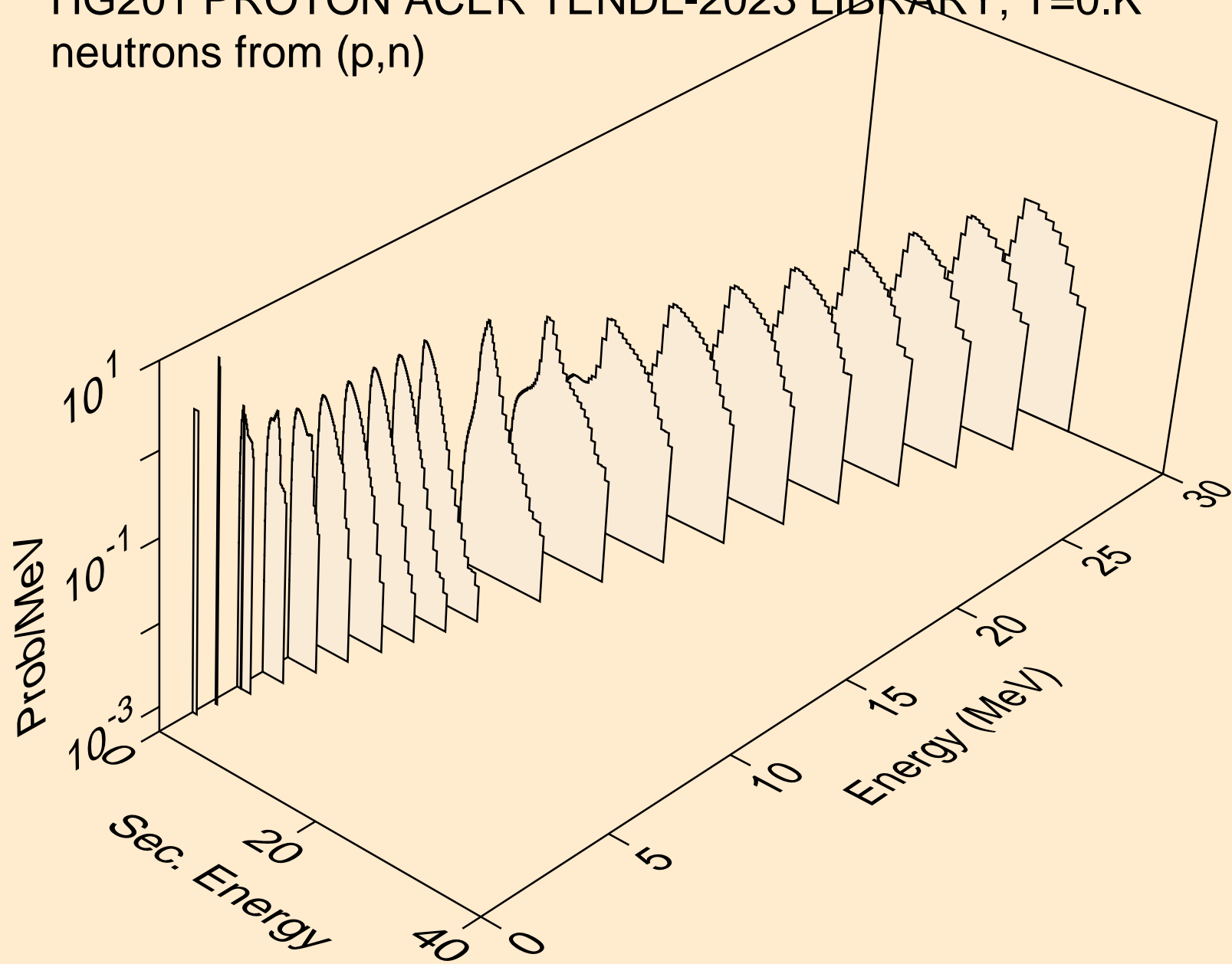

HG201 PROTON ACER TENDL-2023 LIBRARY; T=0.K  
neutrons from (p,x)

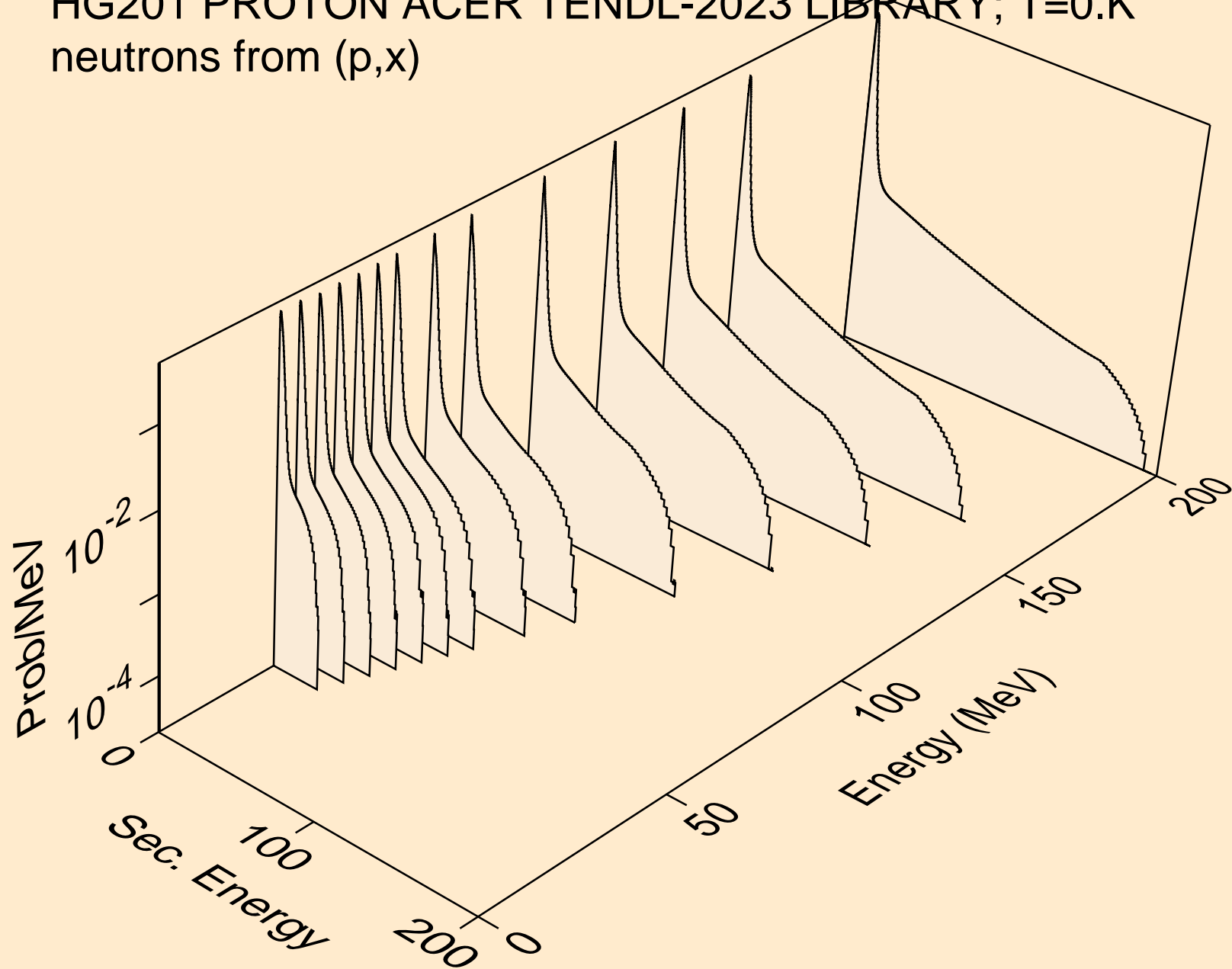

HG201 PROTON ACER TENDL-2023 LIBRARY; T=0.K  
neutrons from (p,2nd)

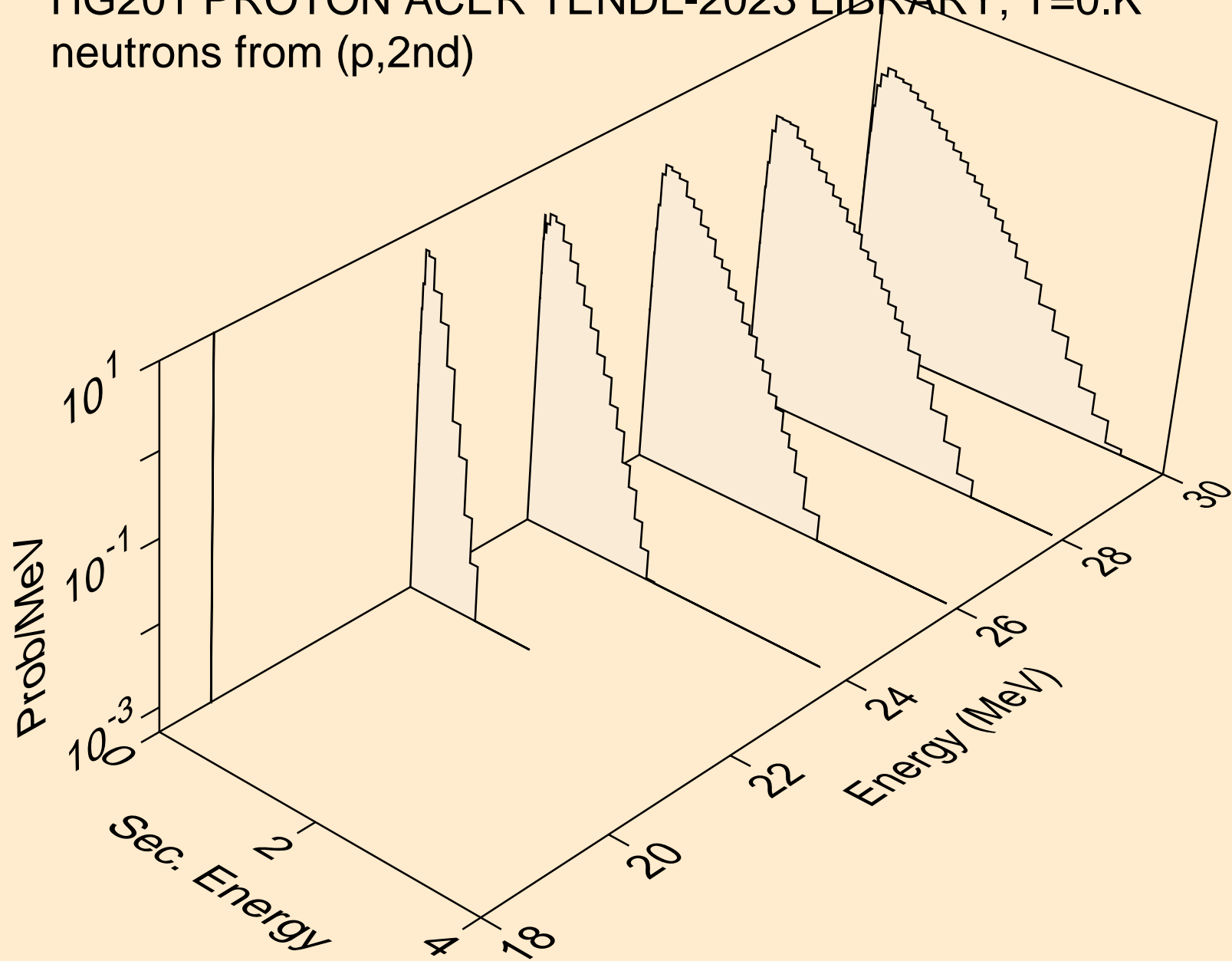

HG201 PROTON ACER TENDL-2023 LIBRARY; T=0.K  
neutrons from (p,2n)

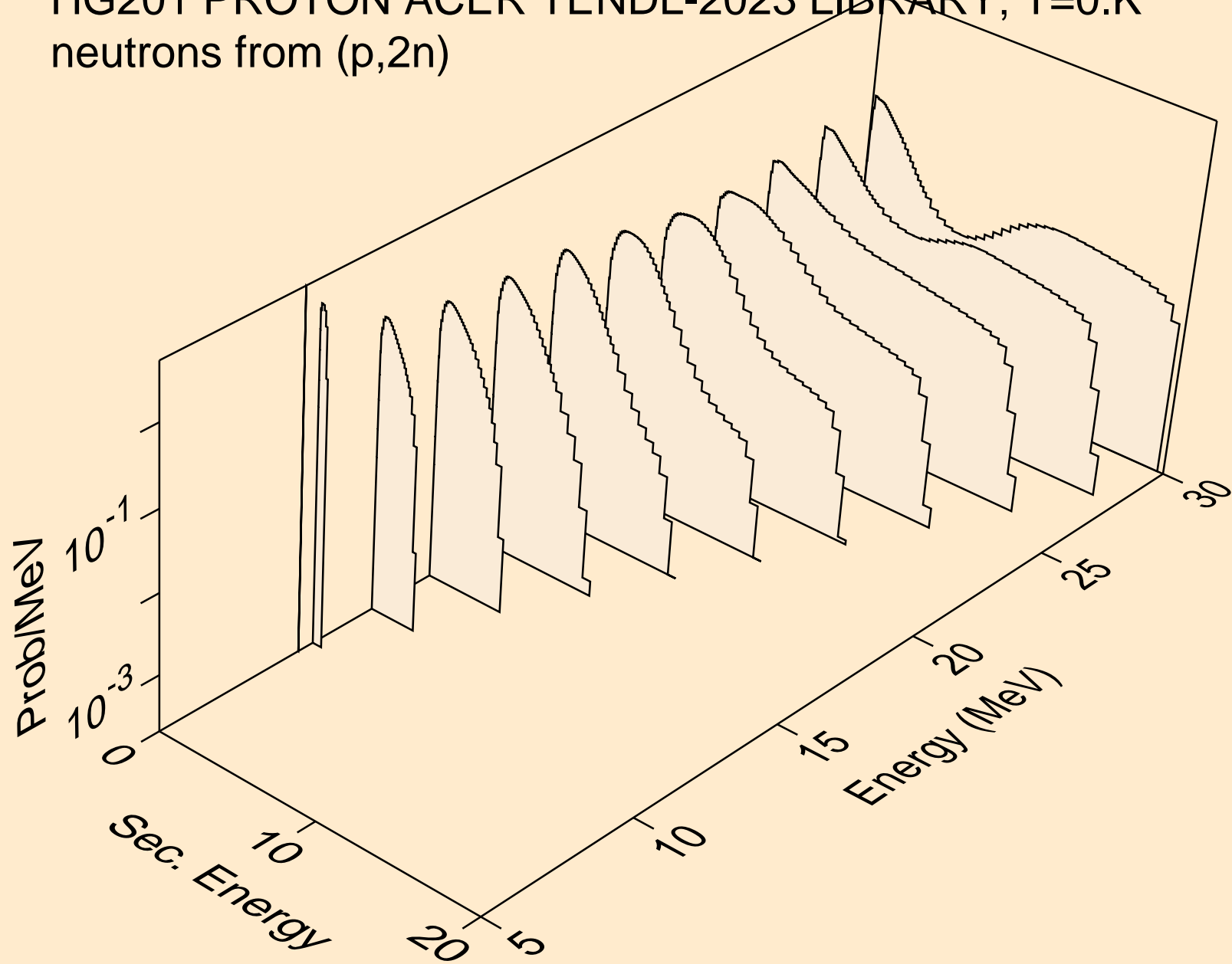

HG201 PROTON ACER TENDL-2023 LIBRARY; T=0.K  
neutrons from (p,3n)

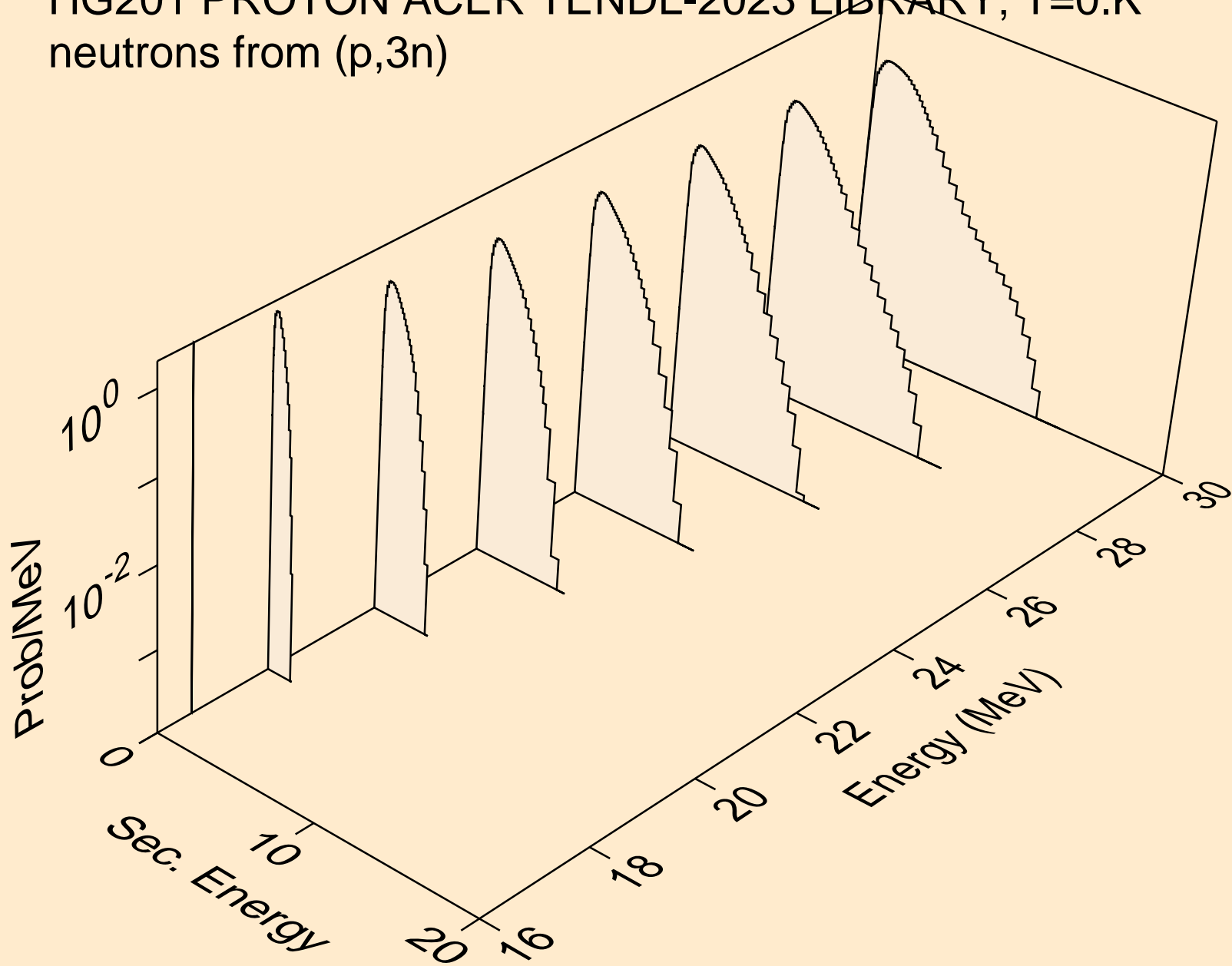

HG201 PROTON ACER TENDL-2023 LIBRARY; T=0.K  
neutrons from (p,n\*)a

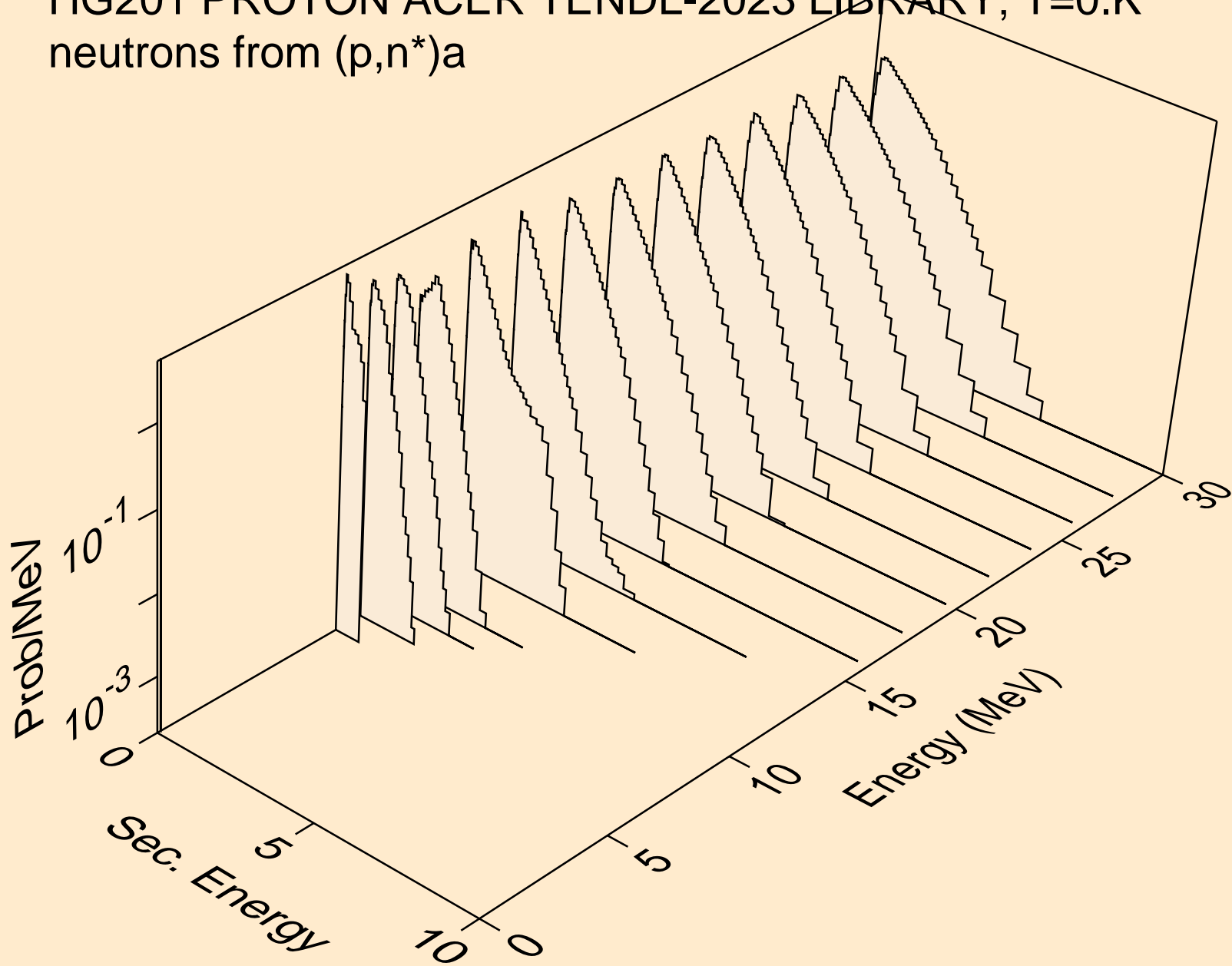

HG201 PROTON ACER TENDL-2023 LIBRARY; T=0.K  
neutrons from (p,2n)a

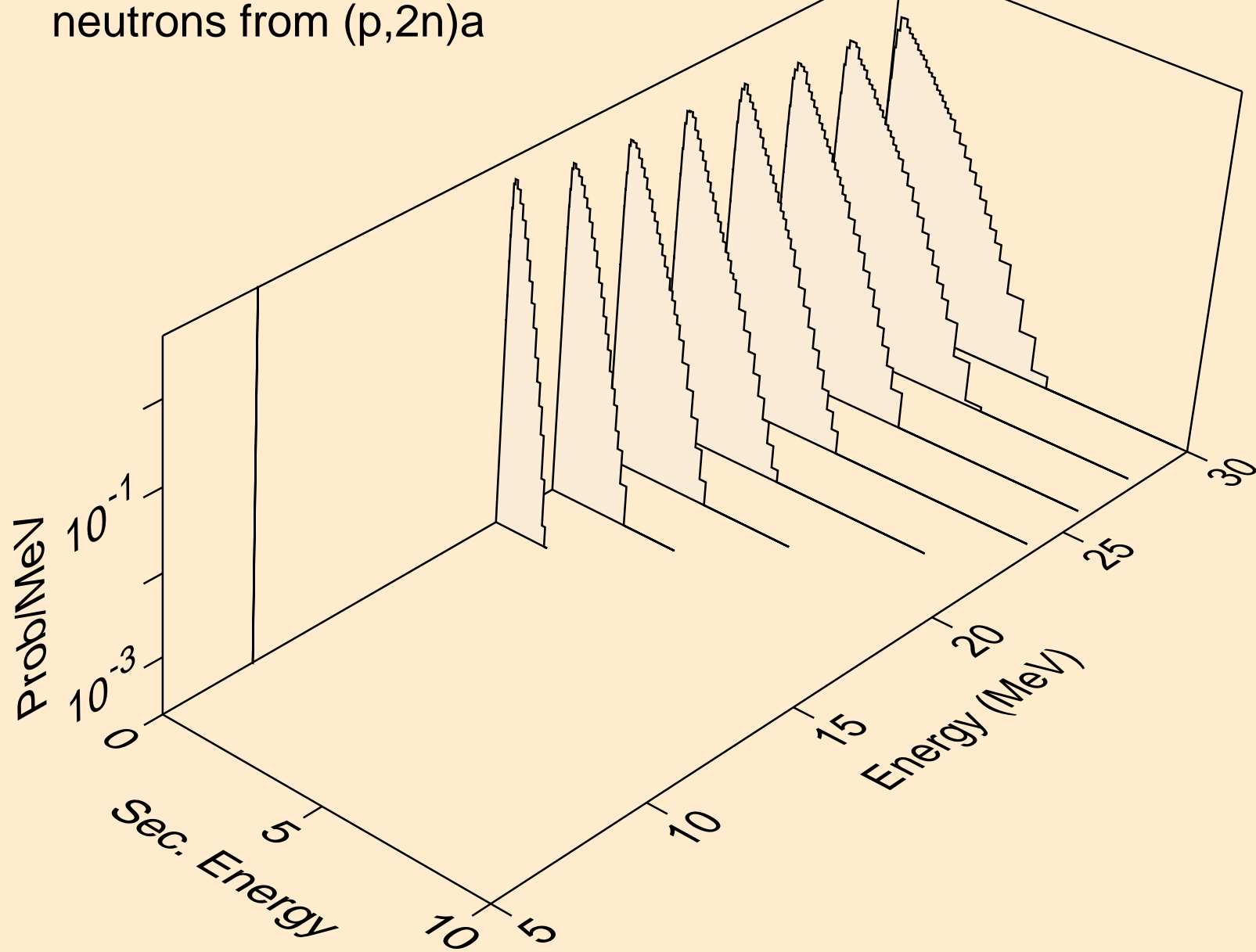

HG201 PROTON ACER TENDL-2023 LIBRARY; T=0.K  
neutrons from (p,3n)a

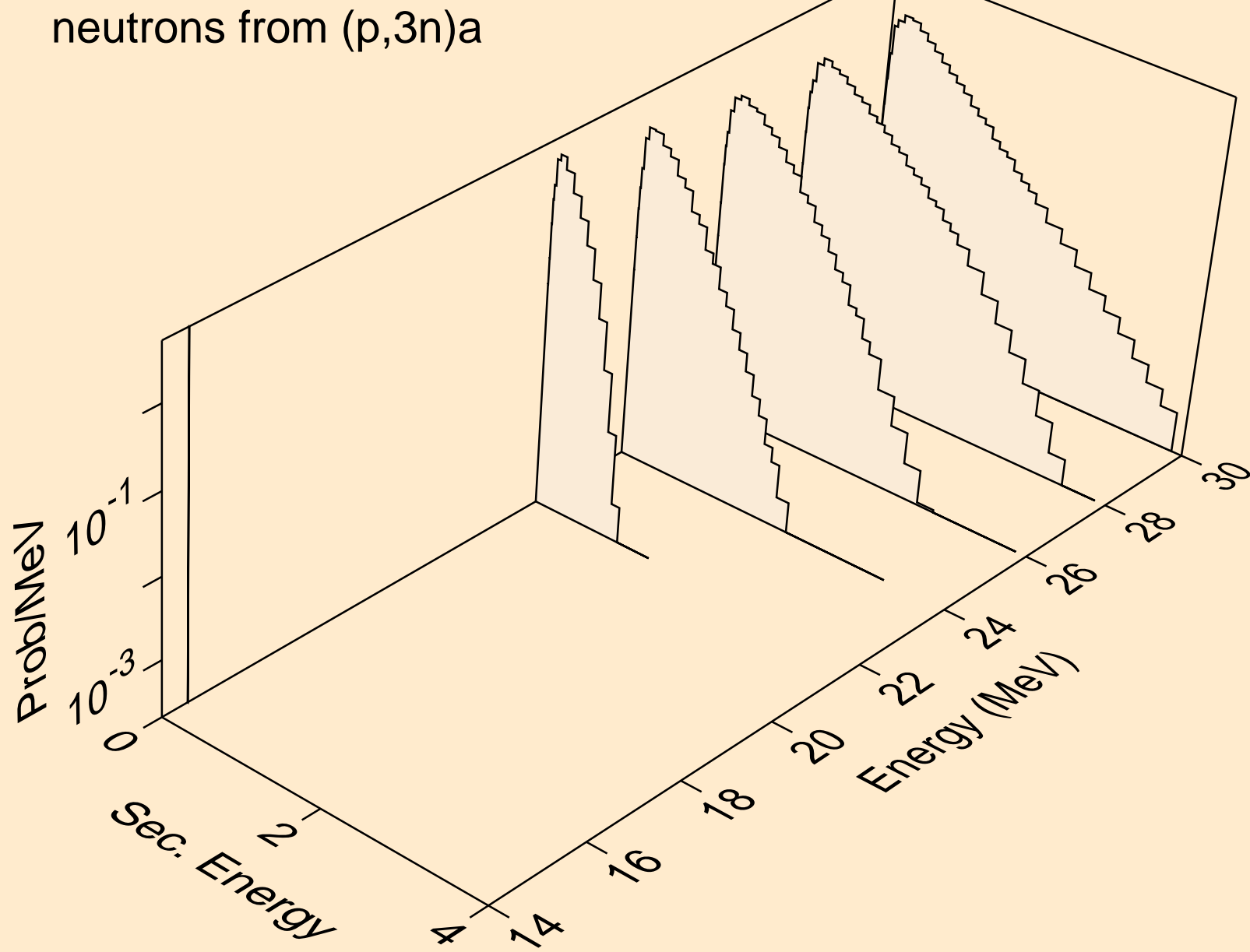

HG201 PROTON ACER TENDL-2023 LIBRARY; T=0.K  
neutrons from (p,n\*)p

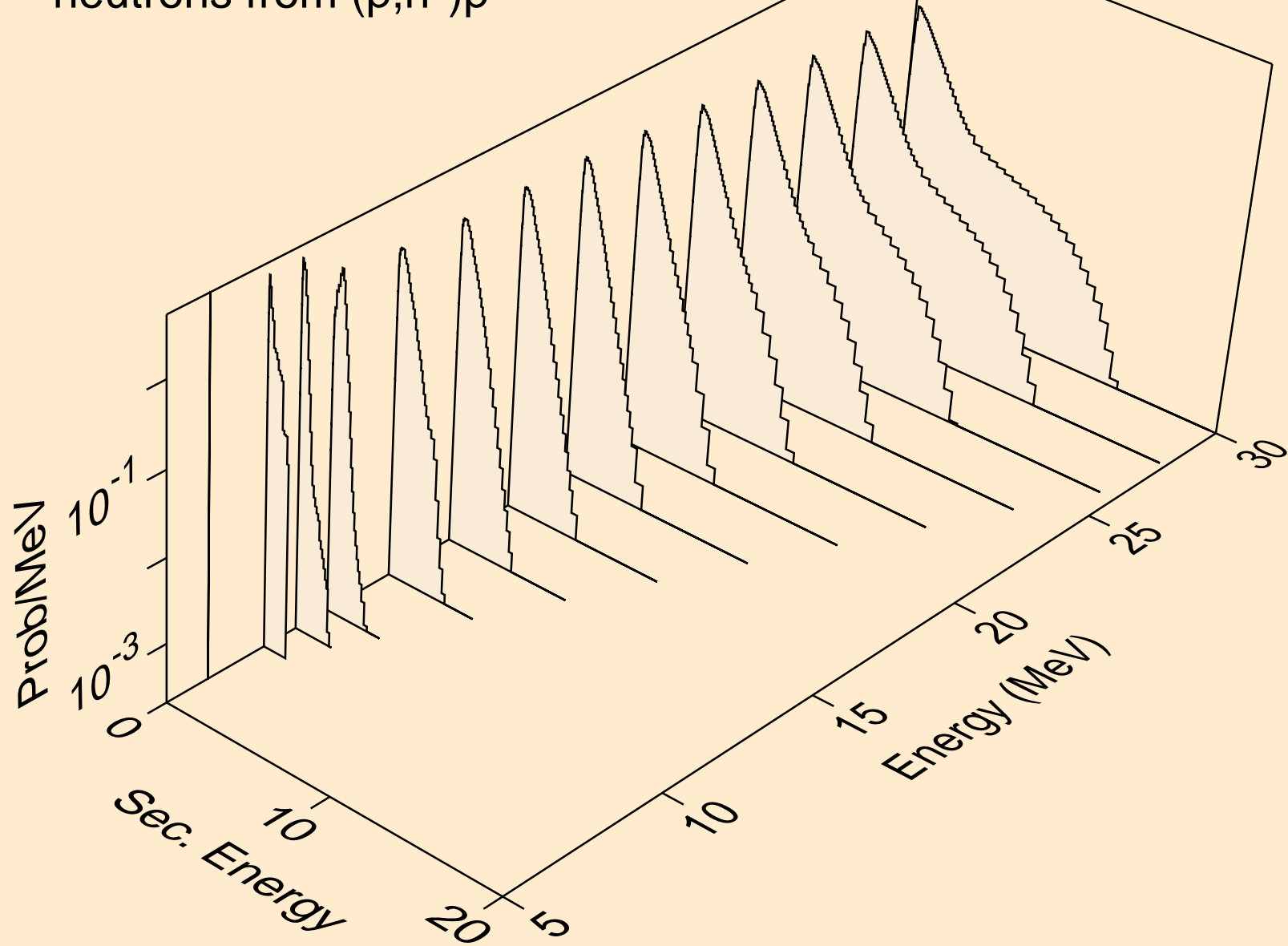

HG201 PROTON ACER TENDL-2023 LIBRARY; T=0.K  
neutrons from (p,n\*)d

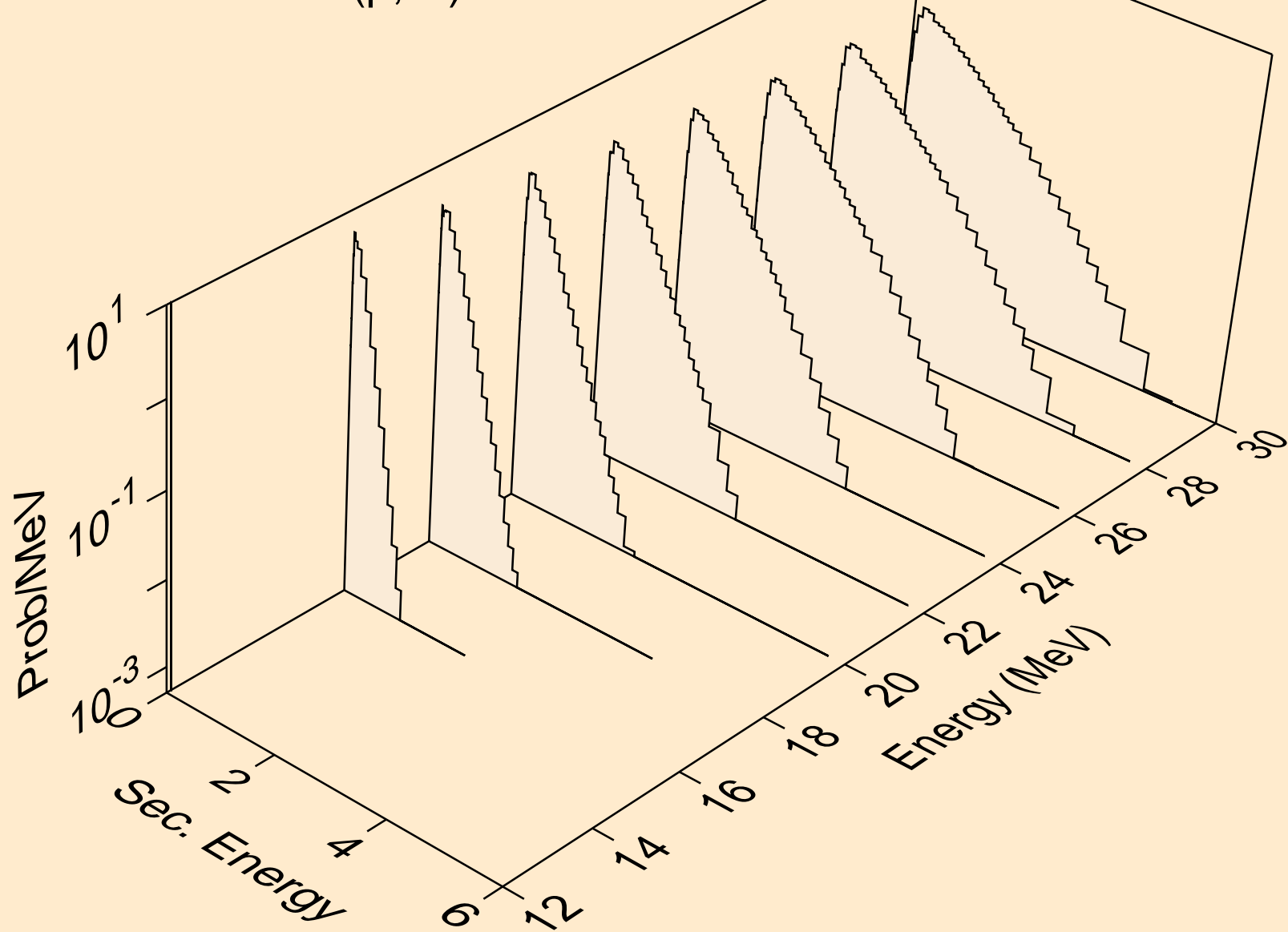

HG201 PROTON ACER TENDL-2023 LIBRARY; T=0.K  
neutrons from (p,n\*)t

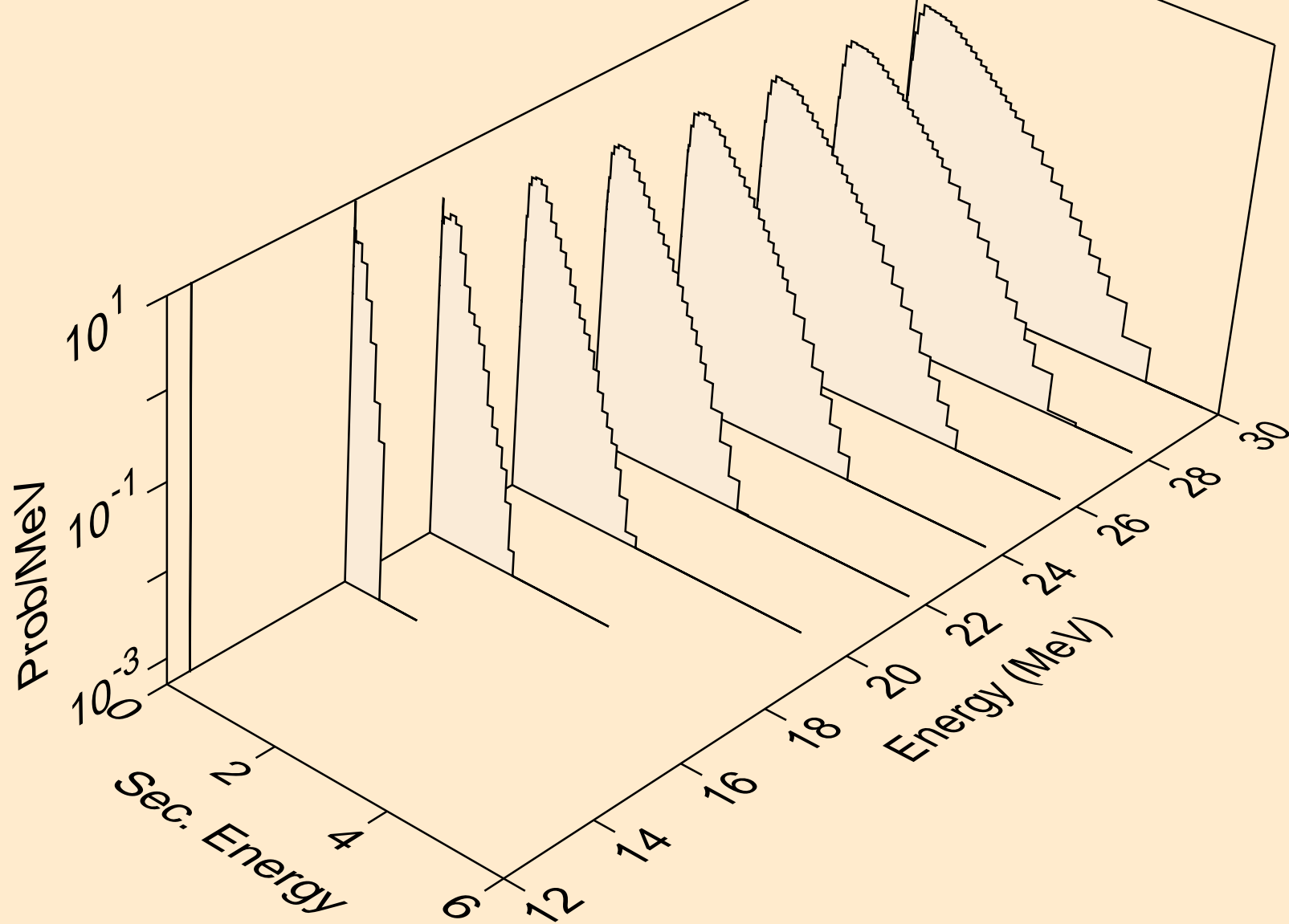

HG201 PROTON ACER TENDL-2023 LIBRARY; T=0.K  
neutrons from (p,n\*)he3

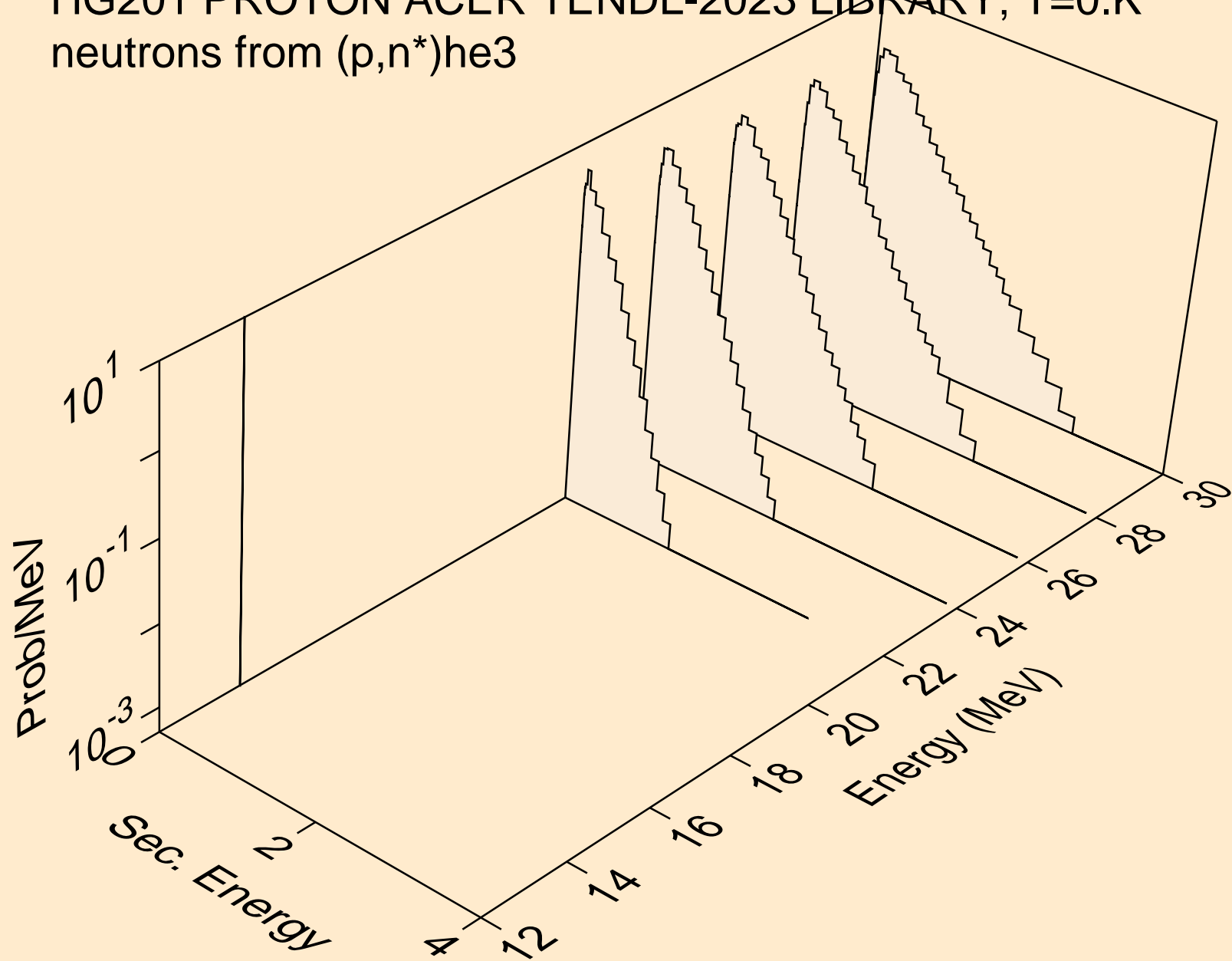

HG201 PROTON ACER TENDL-2023 LIBRARY; T=0.K  
neutrons from (p,4n)

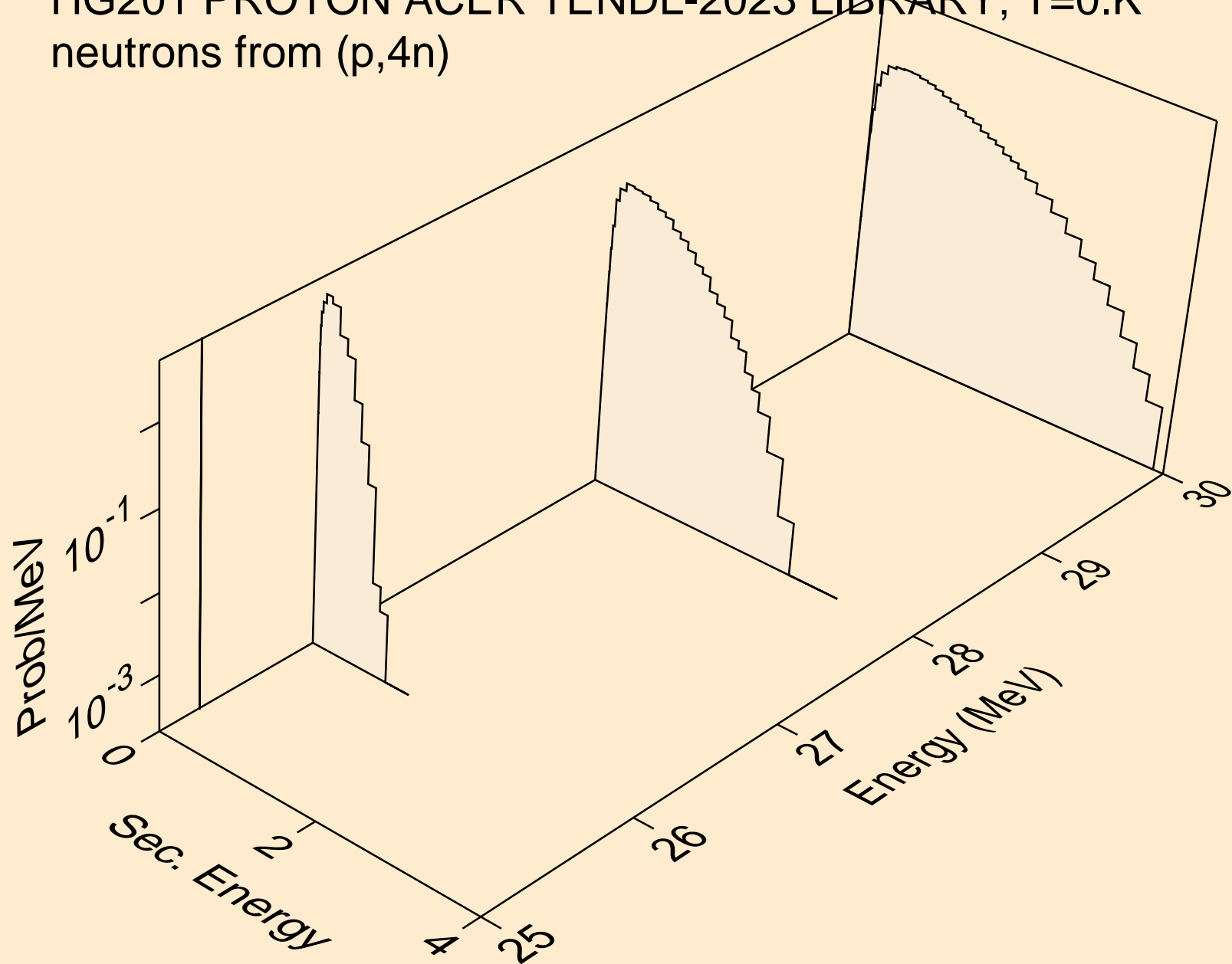

HG201 PROTON ACER TENDL-2023 LIBRARY; T=0.K  
neutrons from (p,2np)

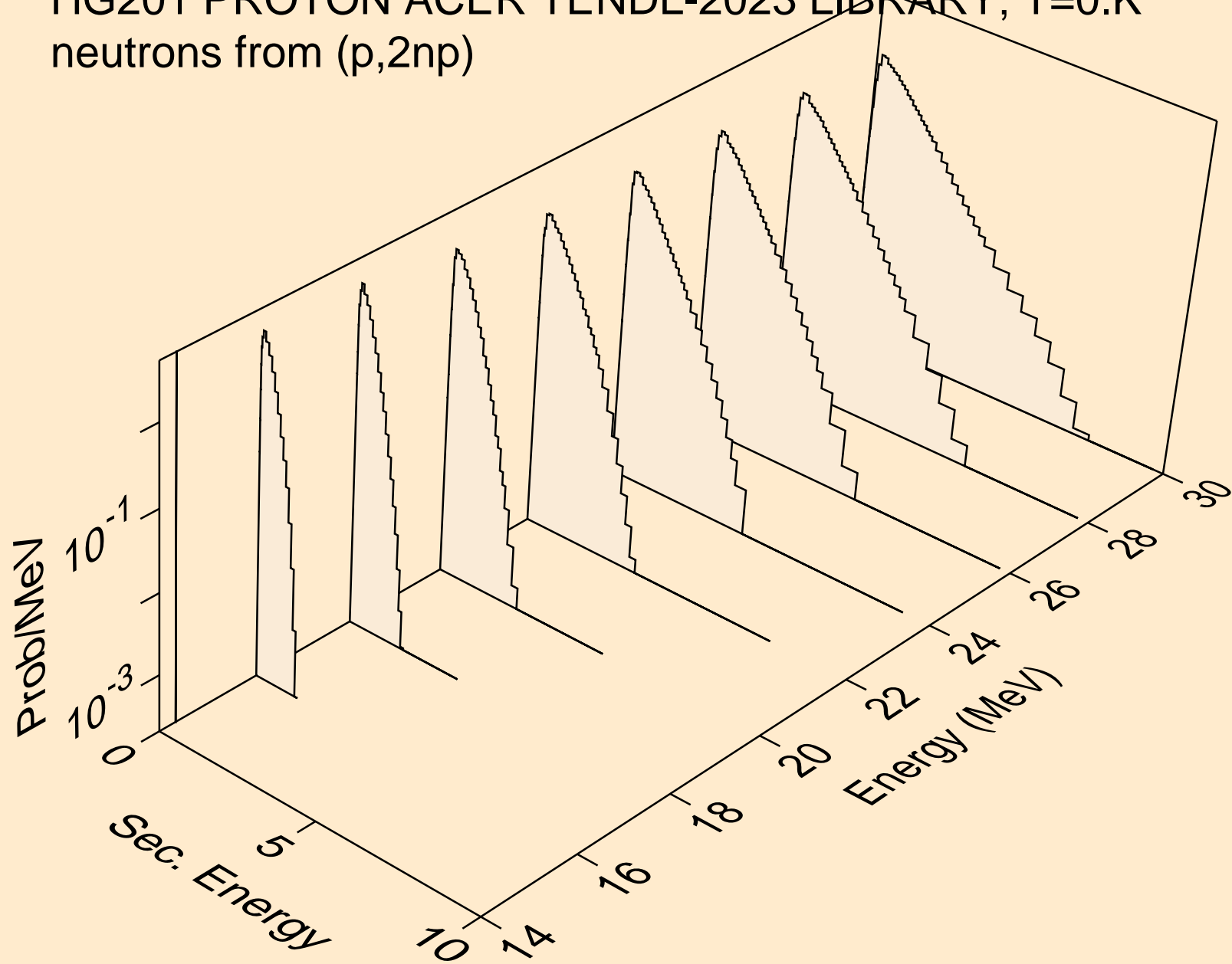

HG201 PROTON ACER TENDL-2023 LIBRARY; T=0.K  
neutrons from (p,3np)

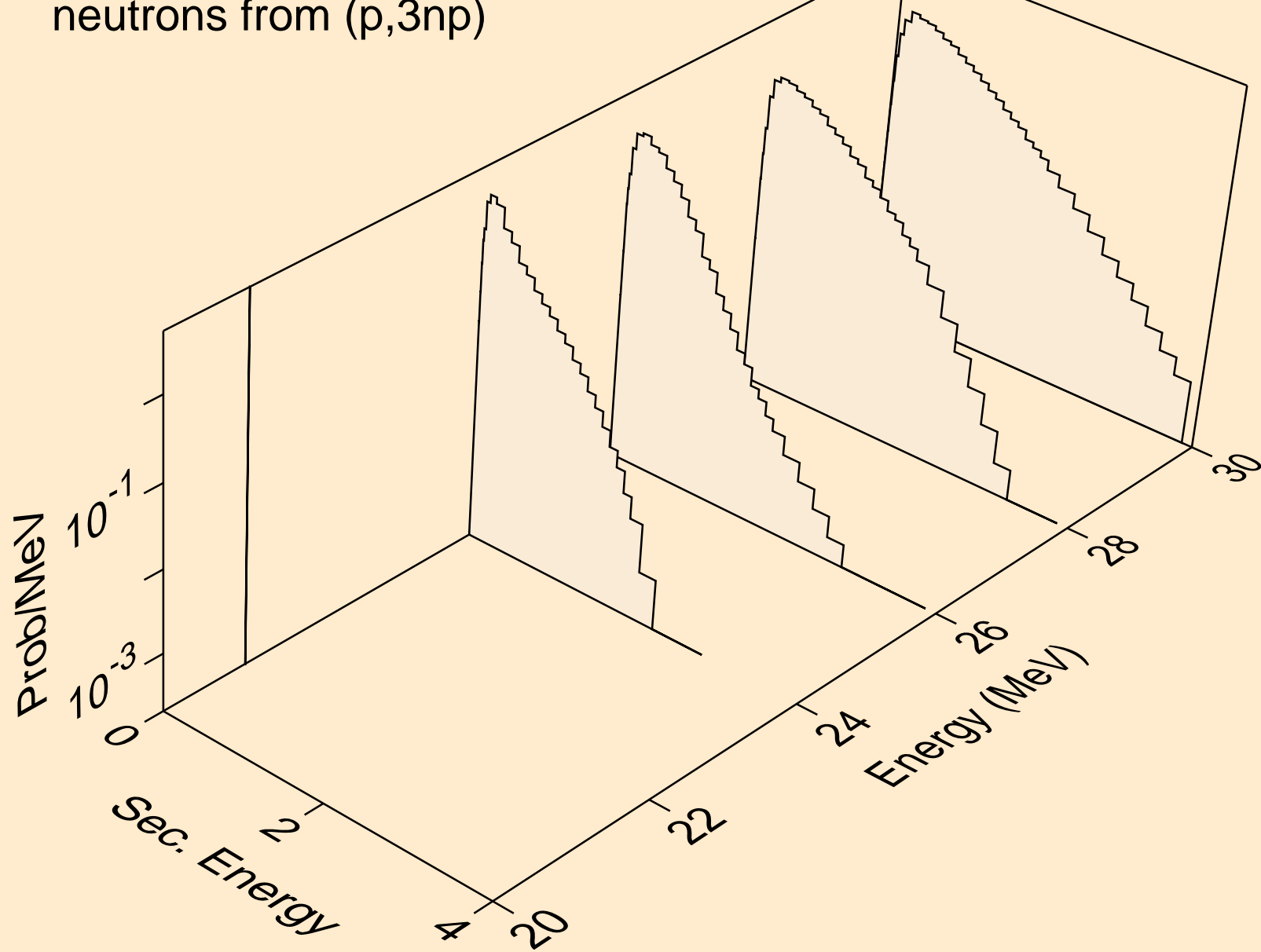

HG201 PROTON ACER TENDL-2023 LIBRARY; T=0.K  
neutrons from (p,n2p)

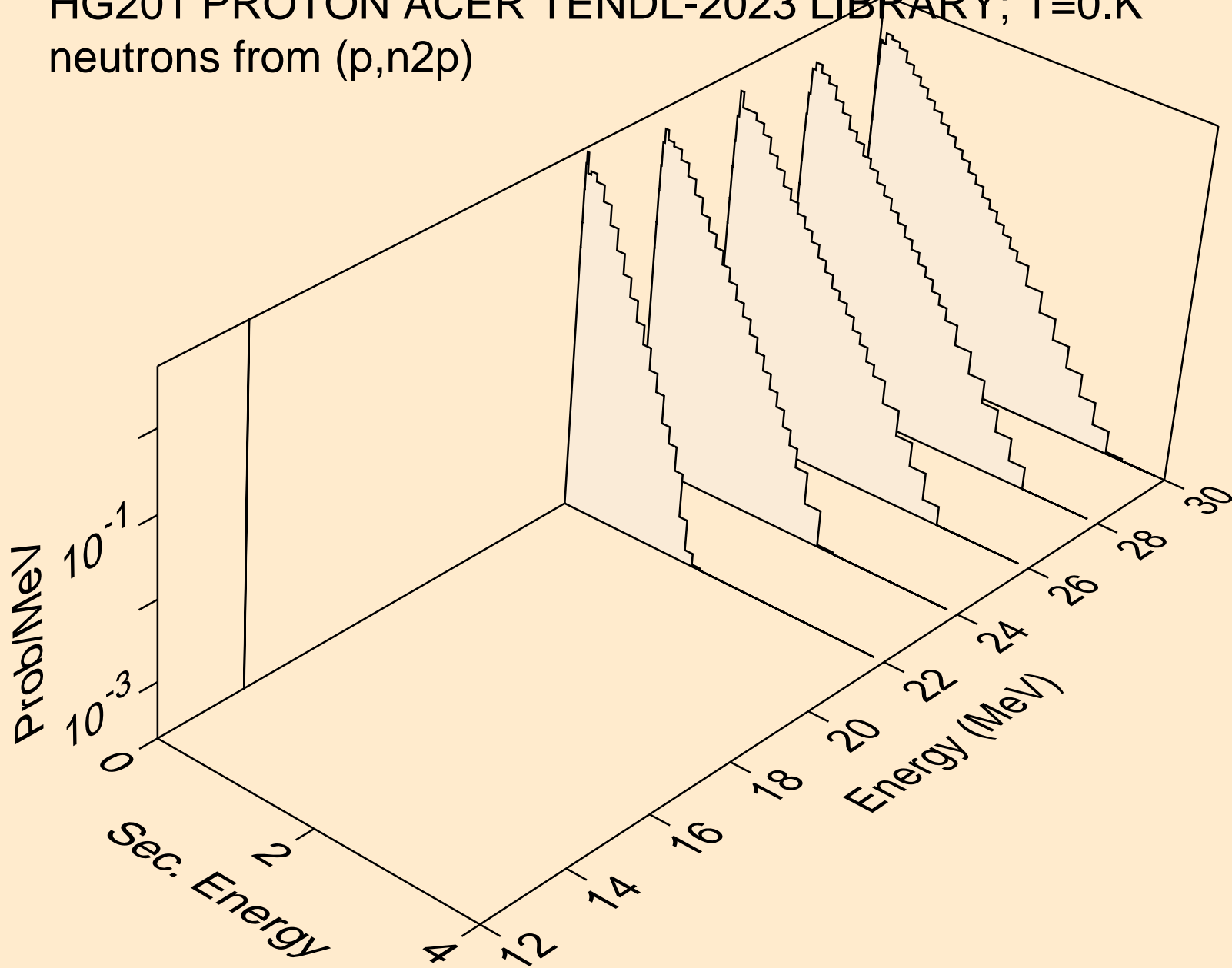

HG201 PROTON ACER TENDL-2023 LIBRARY; T=0.K  
deuterons from (p,x)

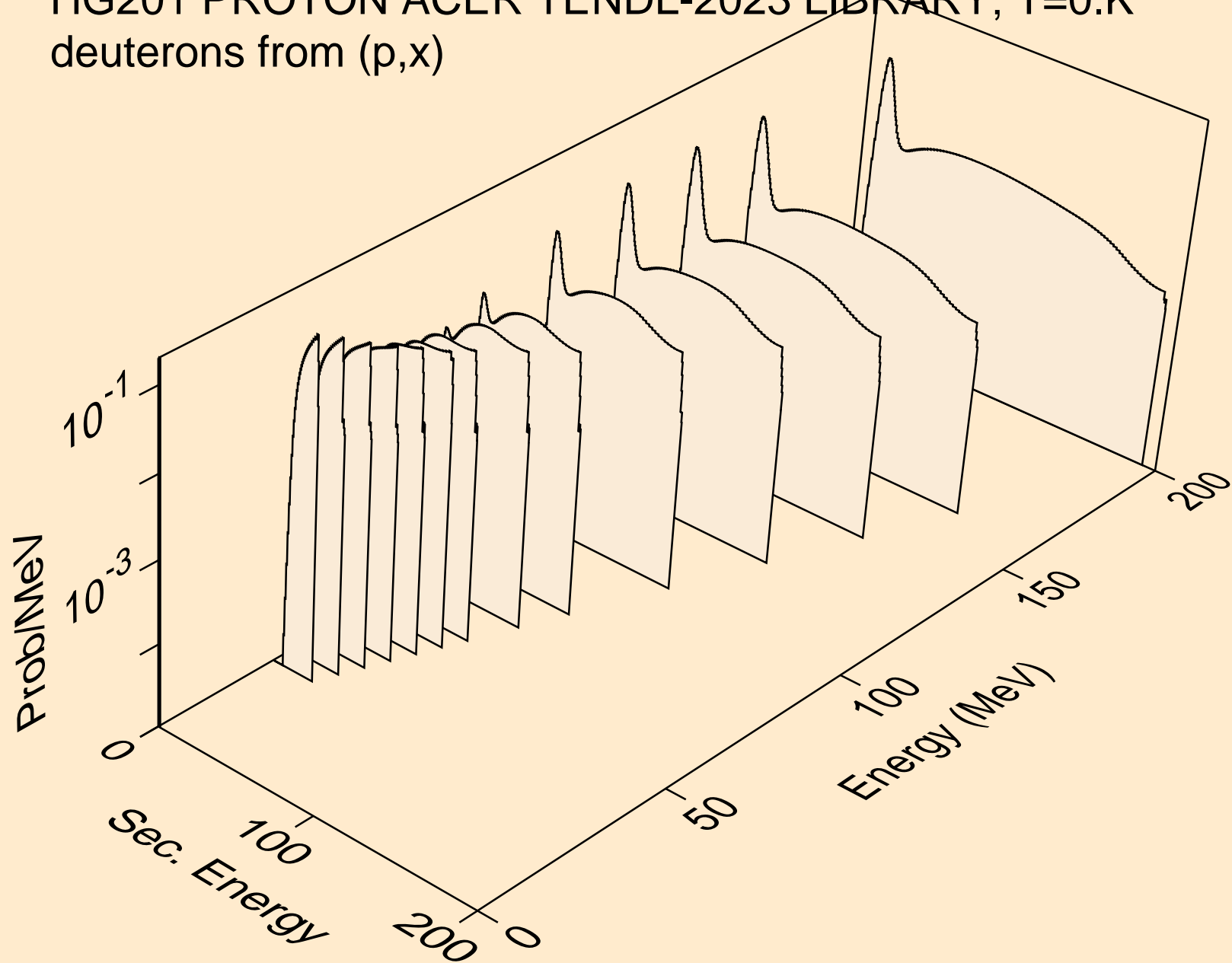

HG201 PROTON ACER TENDL-2023 LIBRARY; T=0.K  
deuterons from (p,2nd)

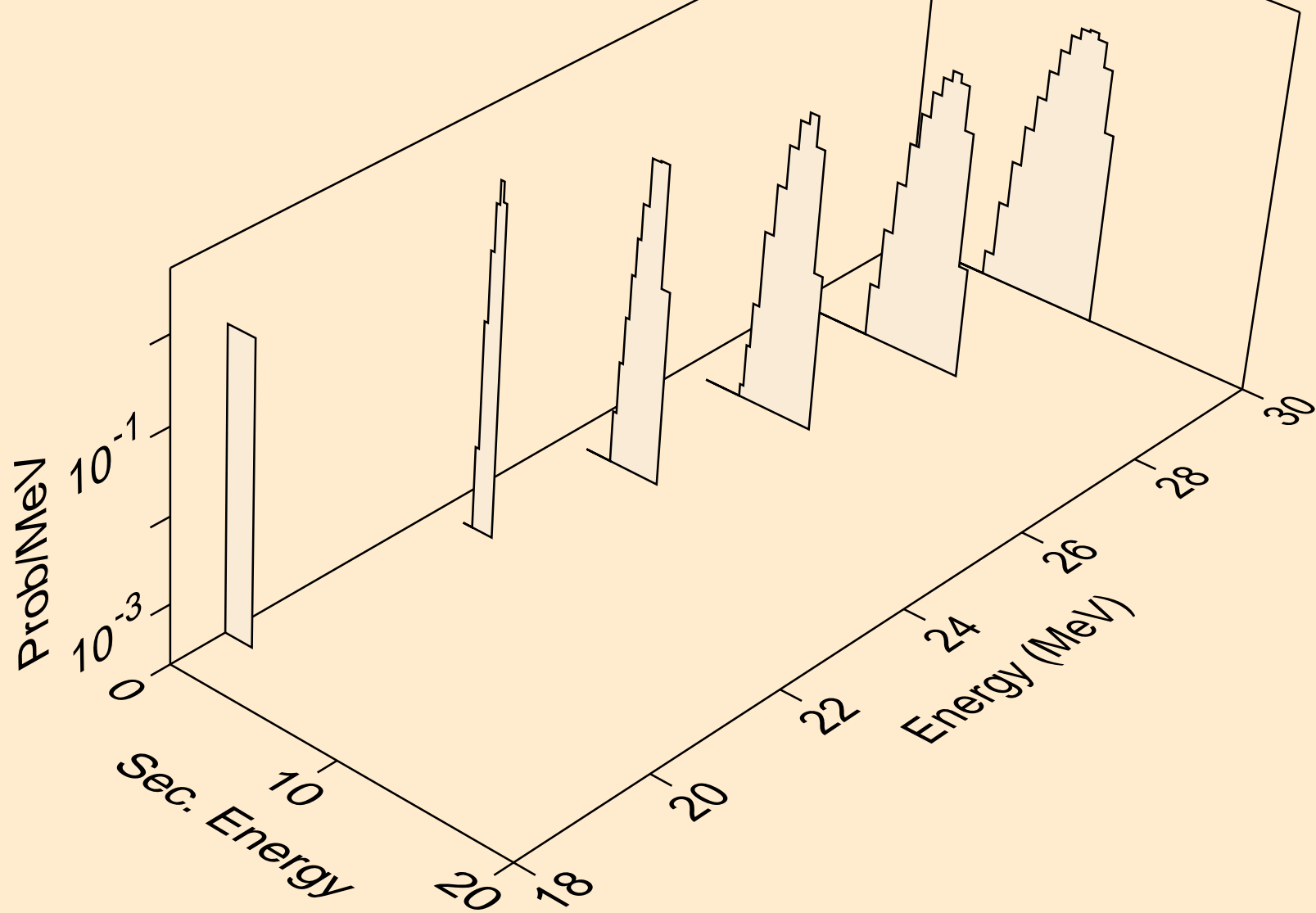

HG201 PROTON ACER TENDL-2023 LIBRARY; T=0.K  
deuterons from (p,n\*)d

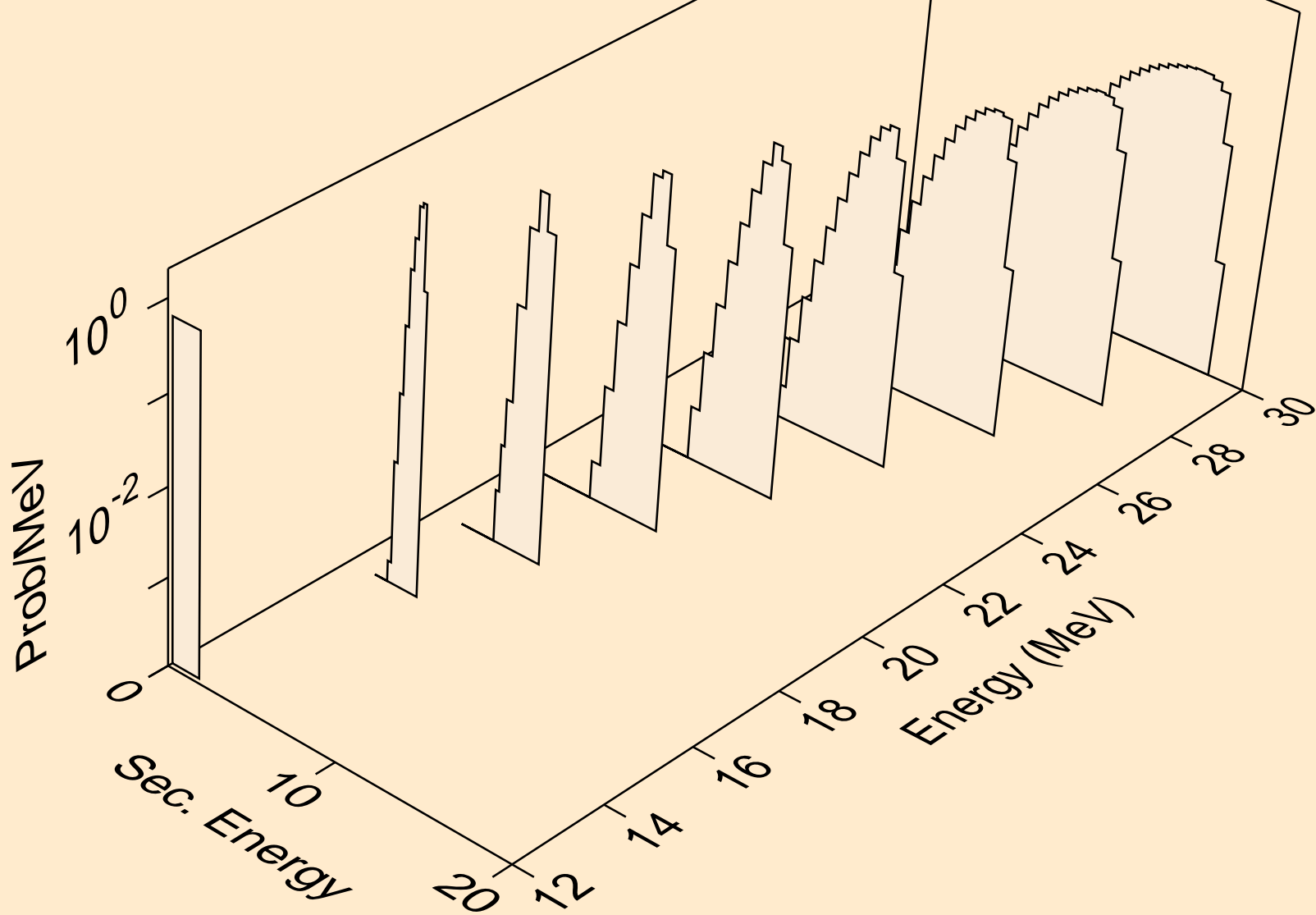

HG201 PROTON ACER TENDL-2023 LIBRARY; T=0.K  
deuterons from (p,d)

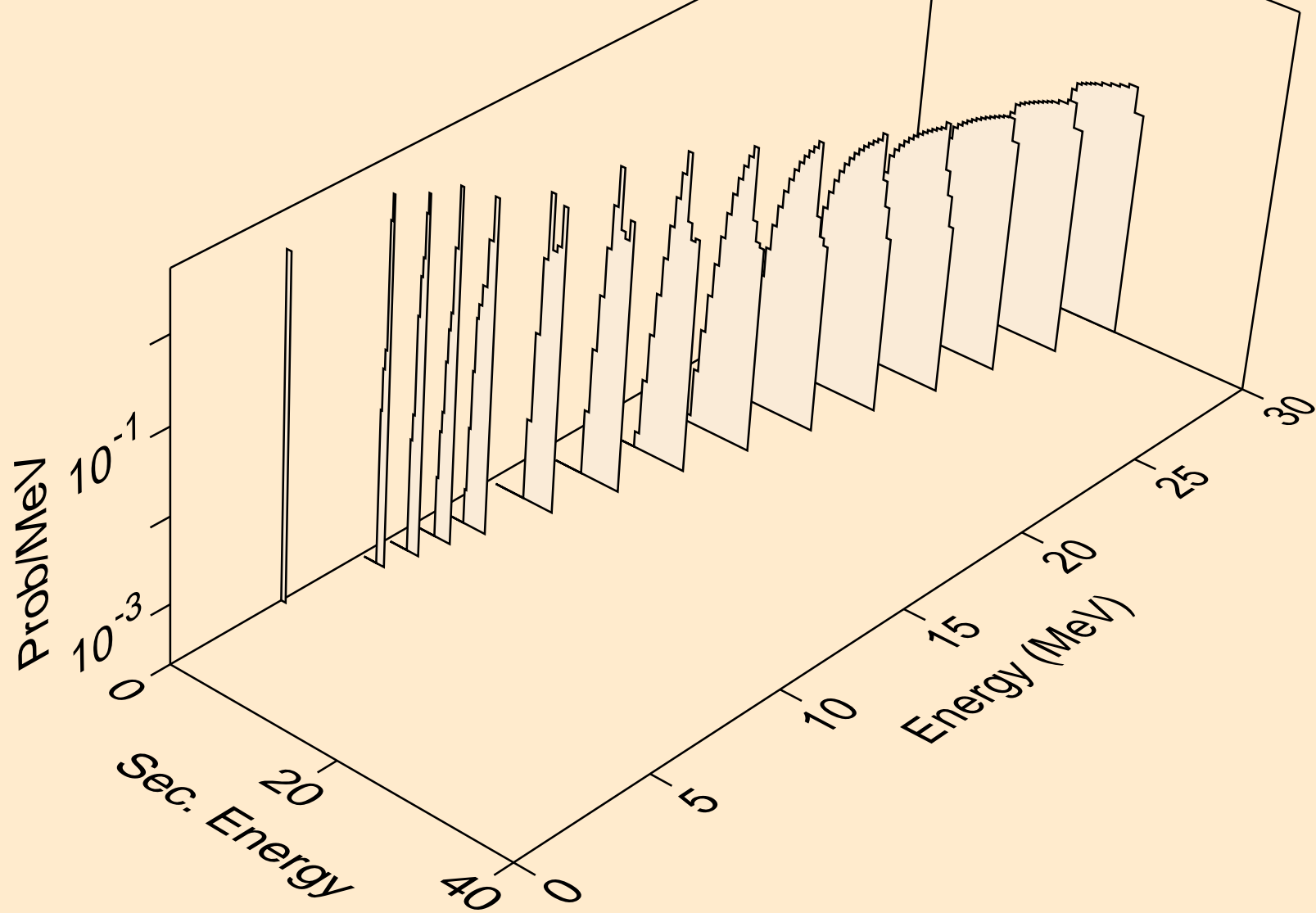

HG201 PROTON ACER TENDL-2023 LIBRARY; T=0.K  
tritons from (p,x)

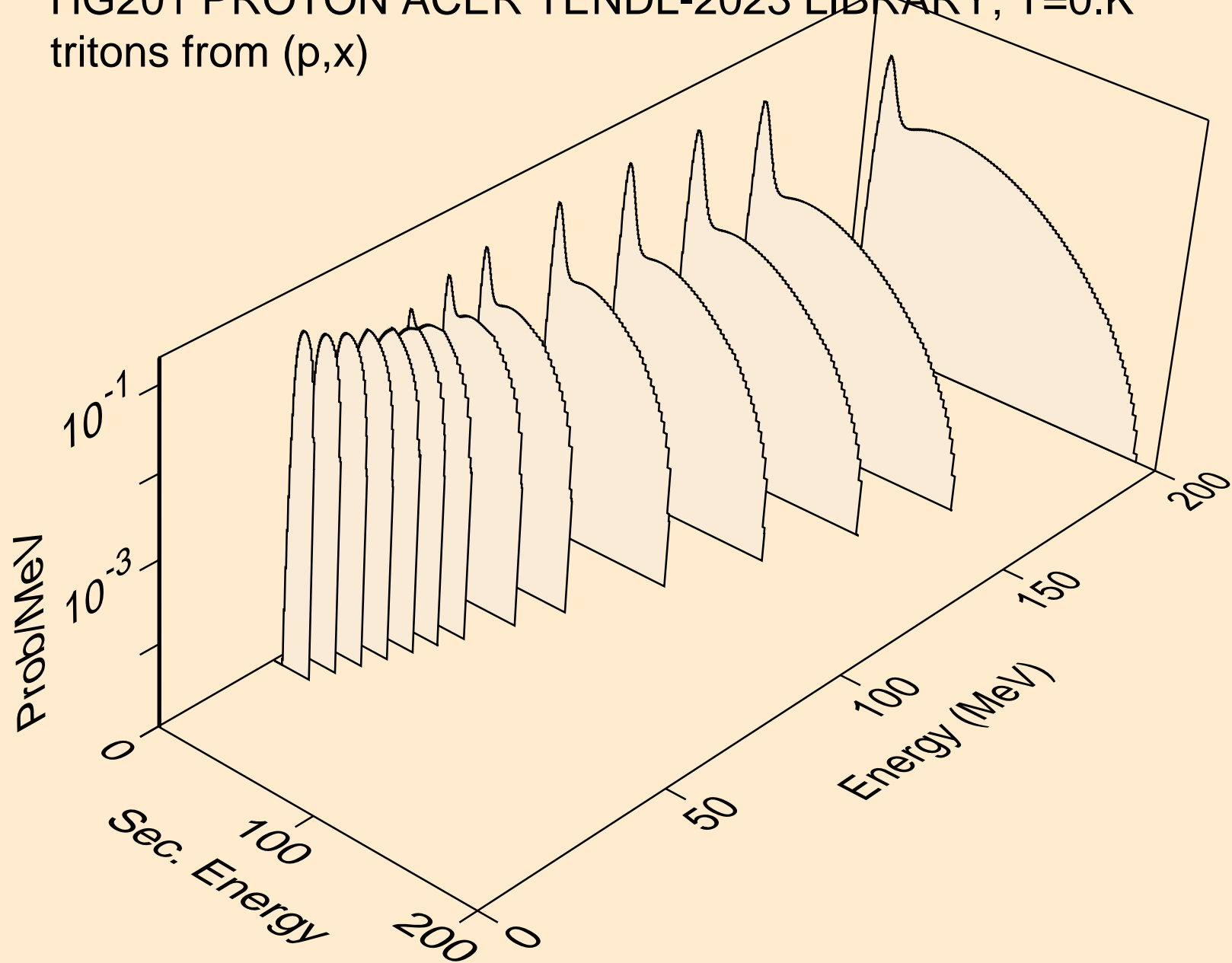

HG201 PROTON ACER TENDL-2023 LIBRARY; T=0.K  
tritons from (p,n\*)t

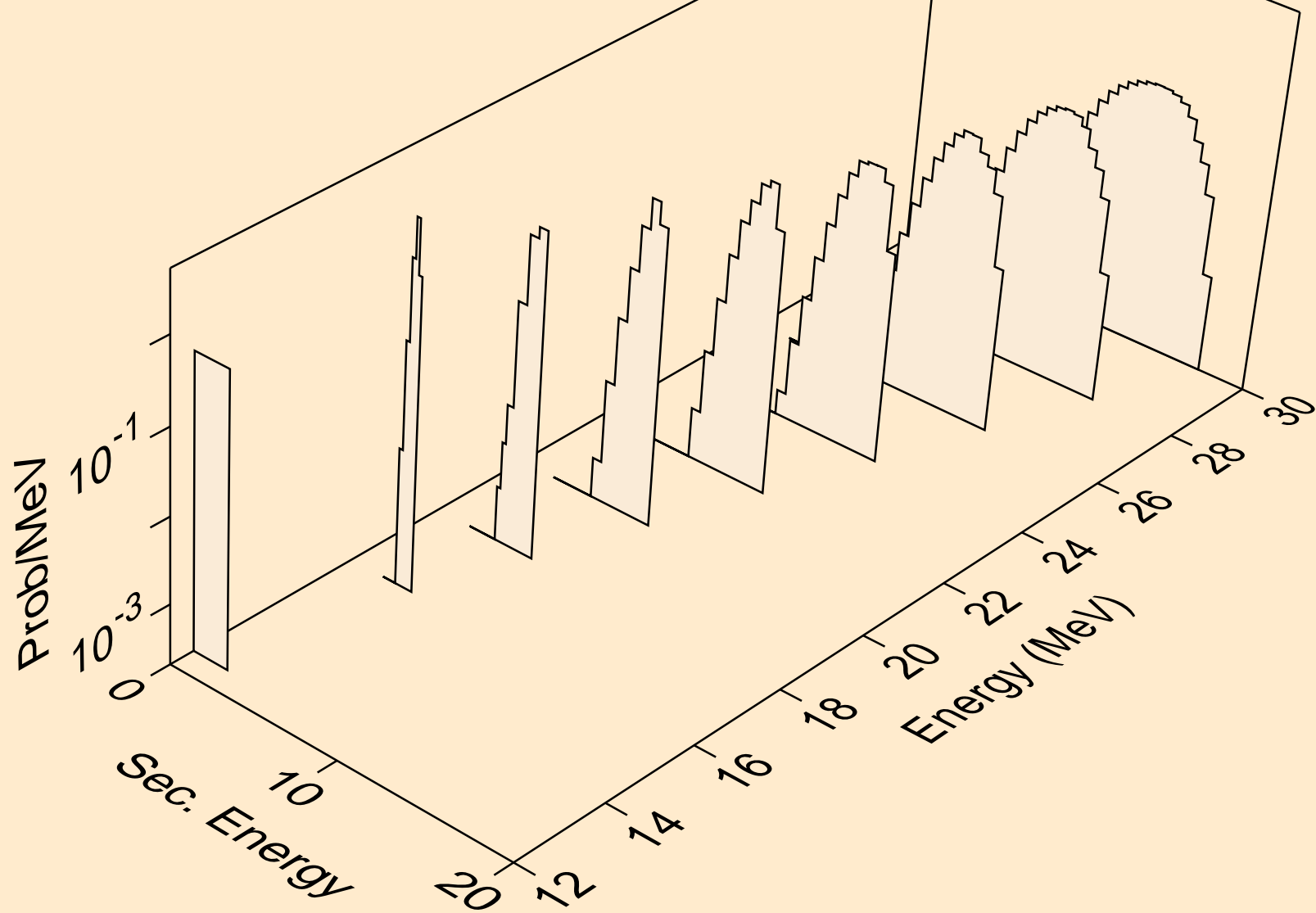

HG201 PROTON ACER TENDL-2023 LIBRARY; T=0.K  
tritons from (p,t)

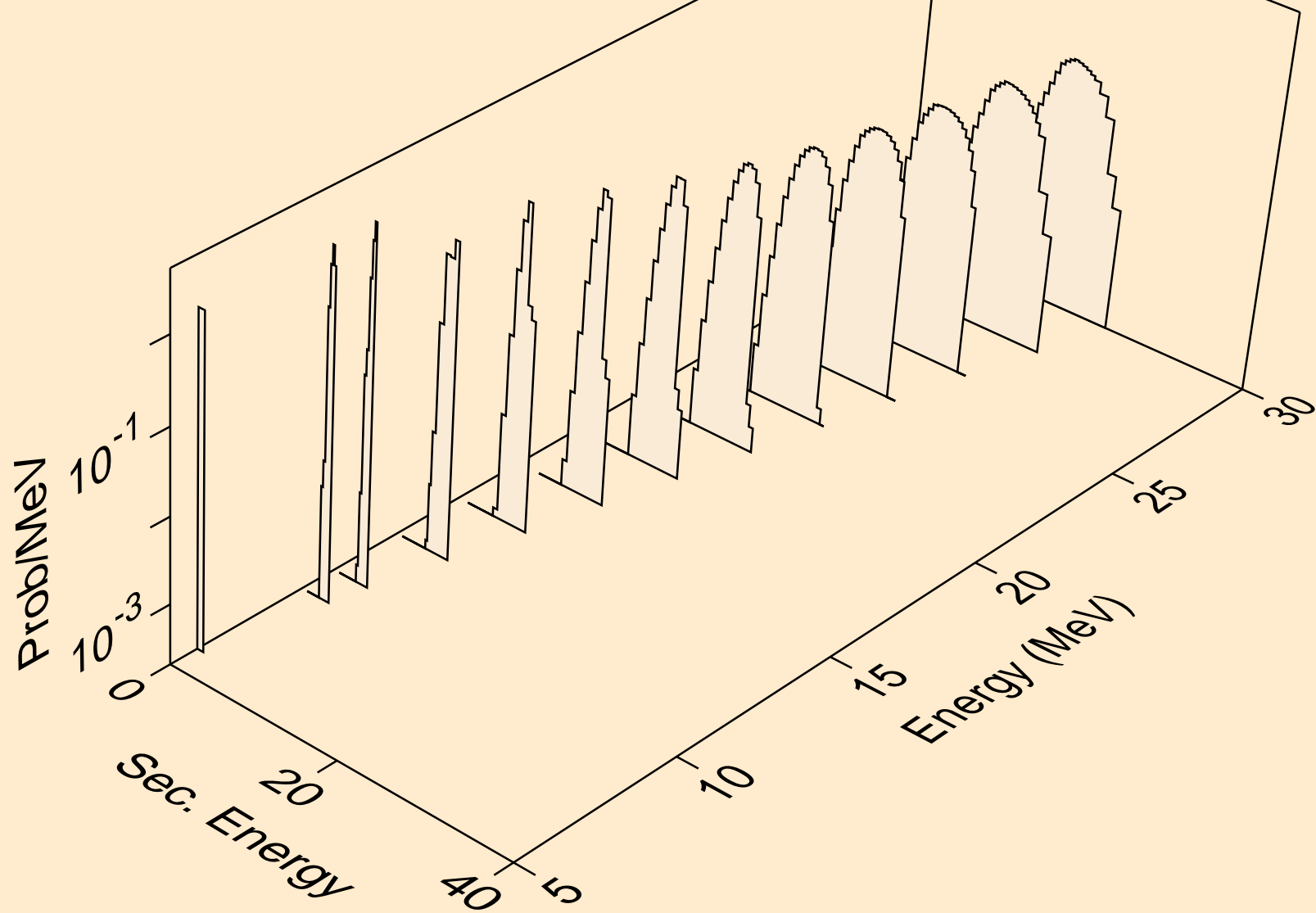

HG201 PROTON ACER TENDL-2023 LIBRARY; T=0.K  
he3s from (p,x)

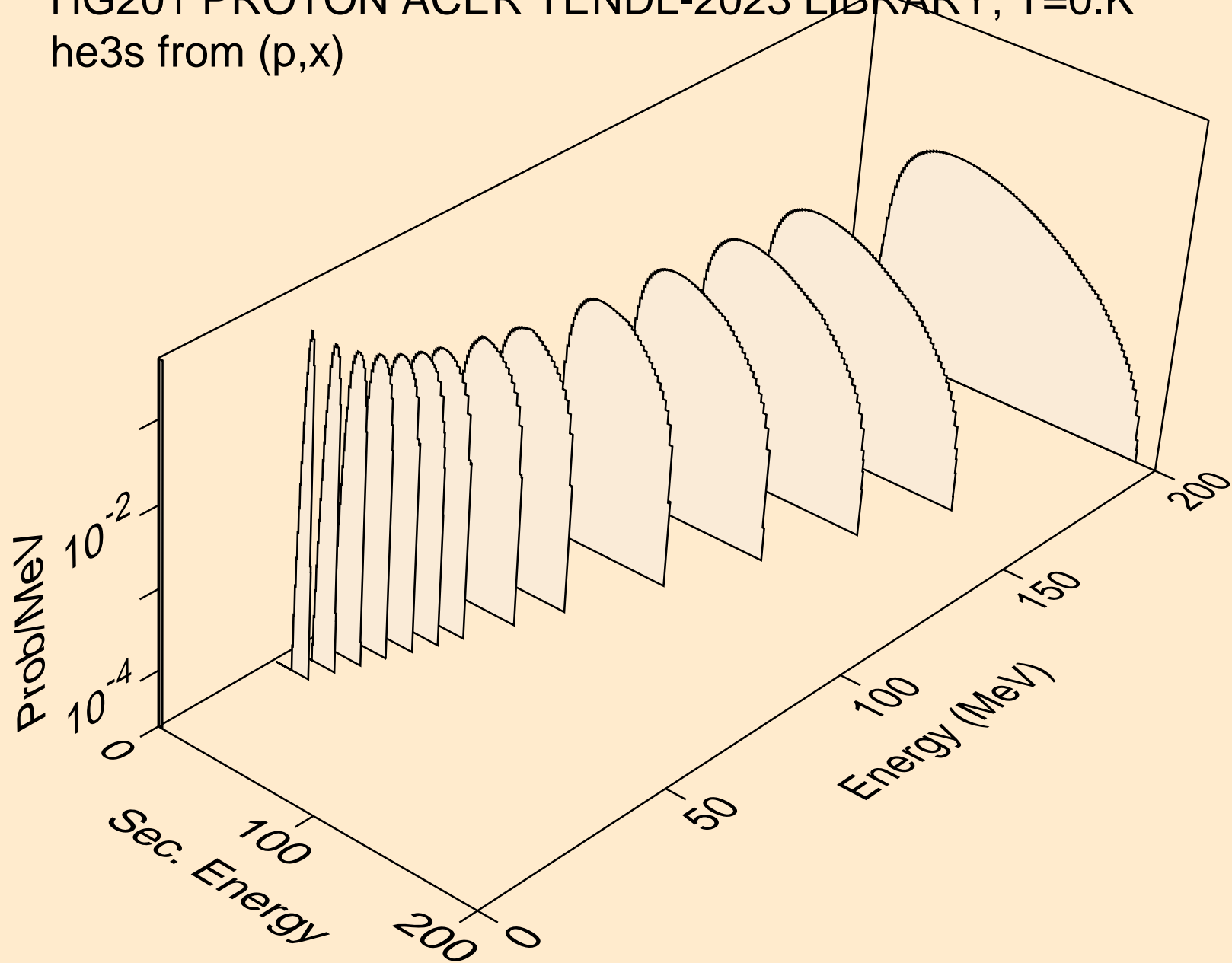

HG201 PROTON ACER TENDL-2023 LIBRARY; T=0.K  
he3s from (p,n\*)he3

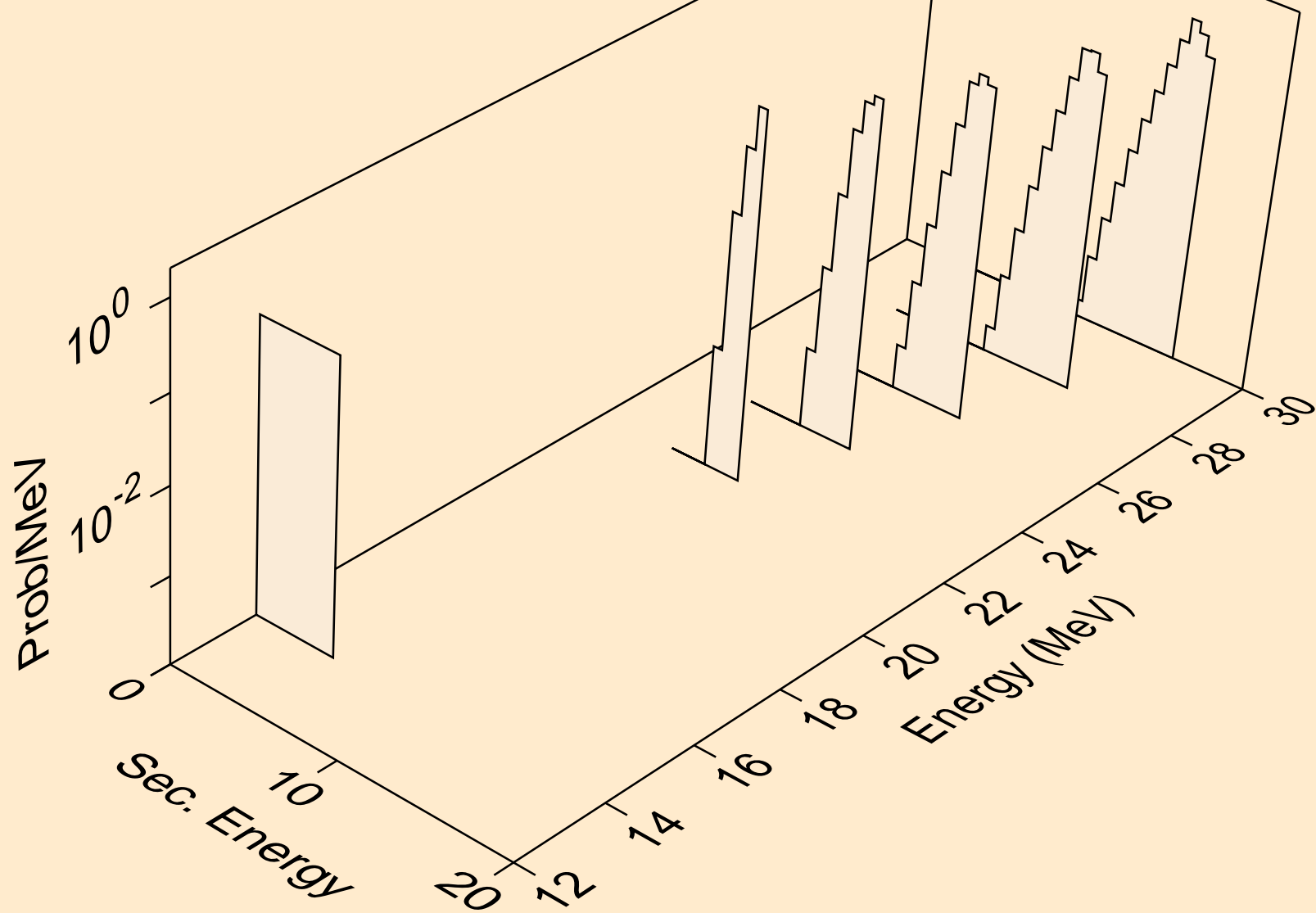

HG201 PROTON ACER TENDL-2023 LIBRARY; T=0.K  
he3s from (p,he3)

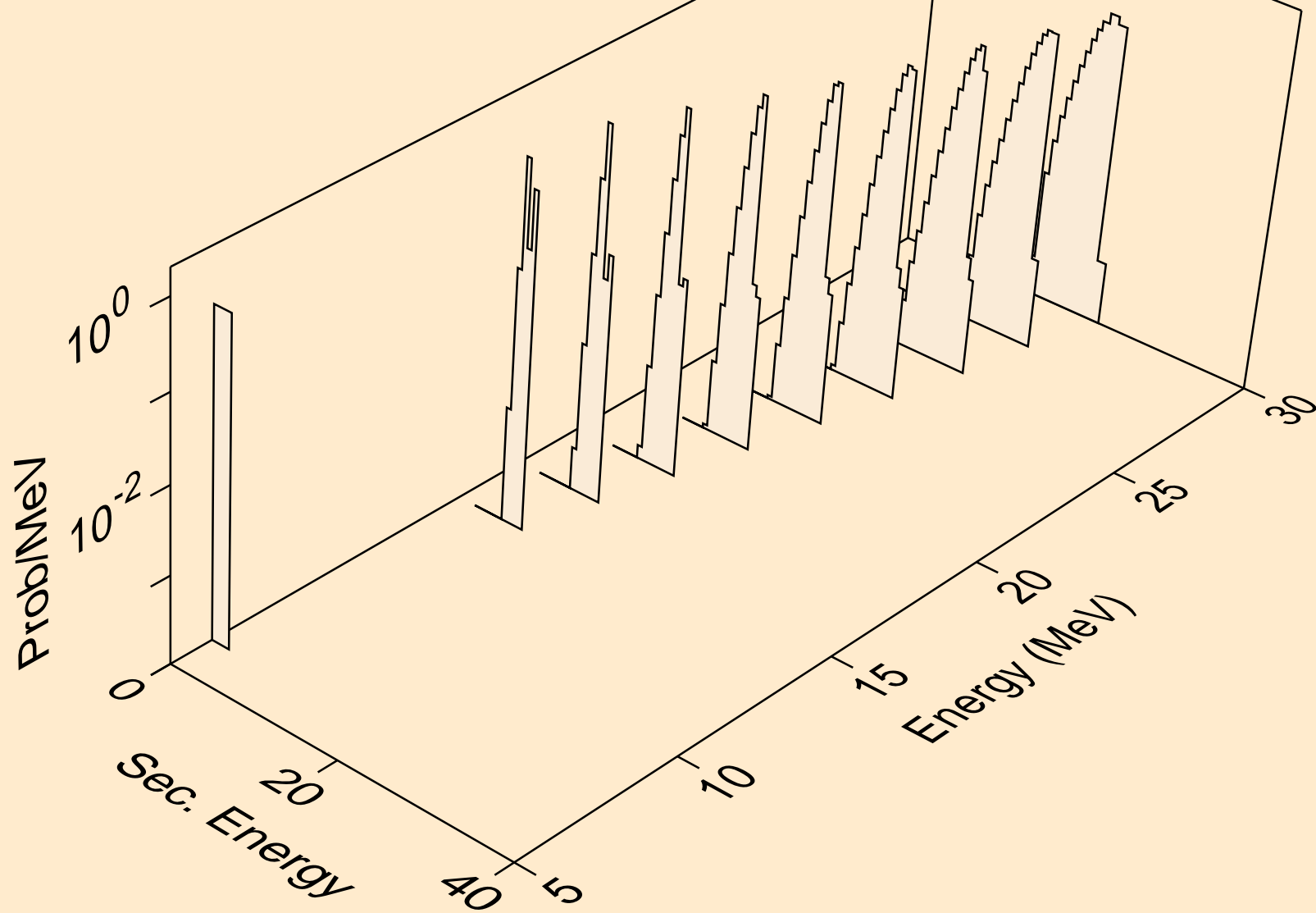

HG201 PROTON ACER TENDL-2023 LIBRARY; T=0.K  
alphas from (p,x)

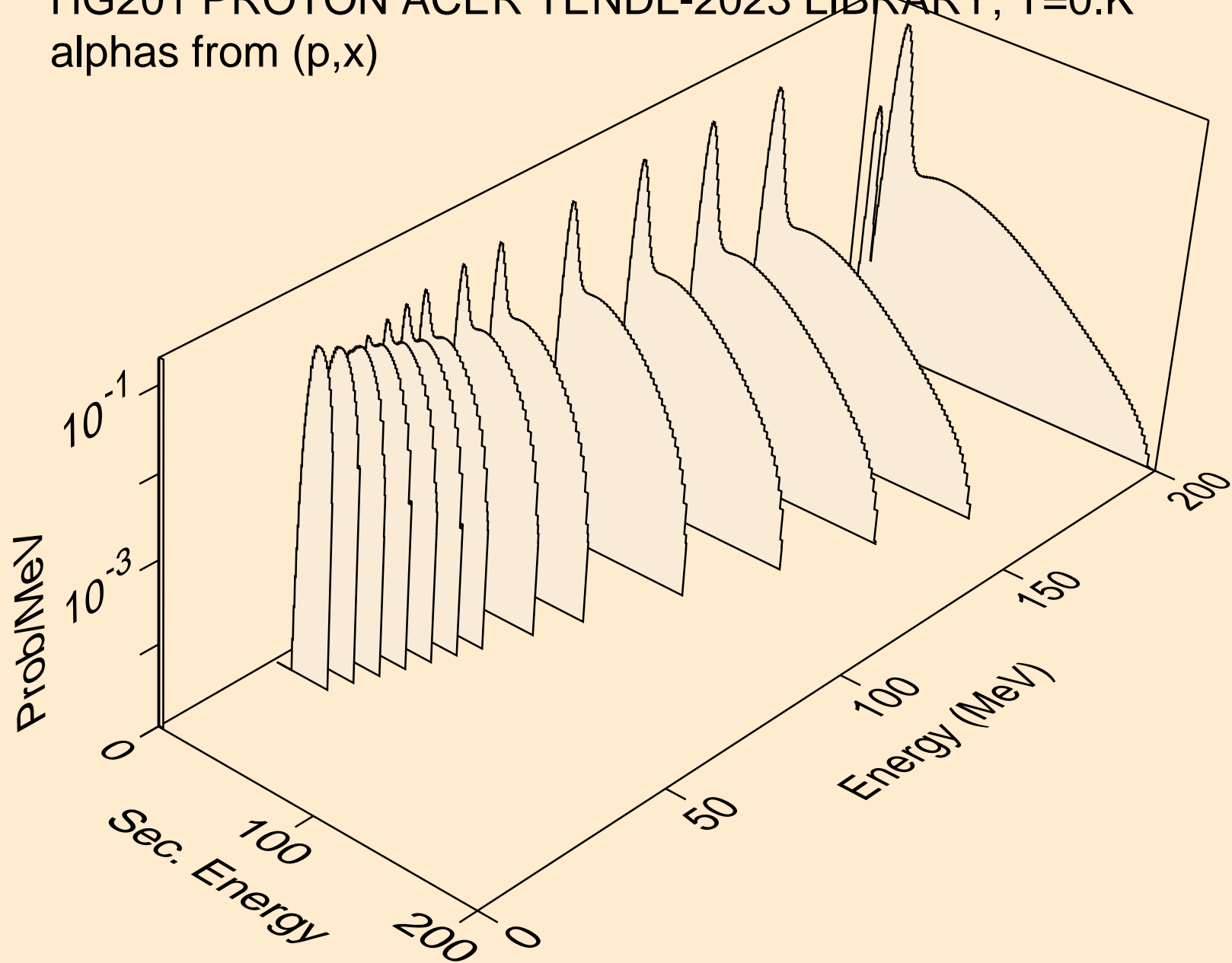

HG201 PROTON ACER TENDL-2023 LIBRARY; T=0.K  
alphas from (p,n\*)a

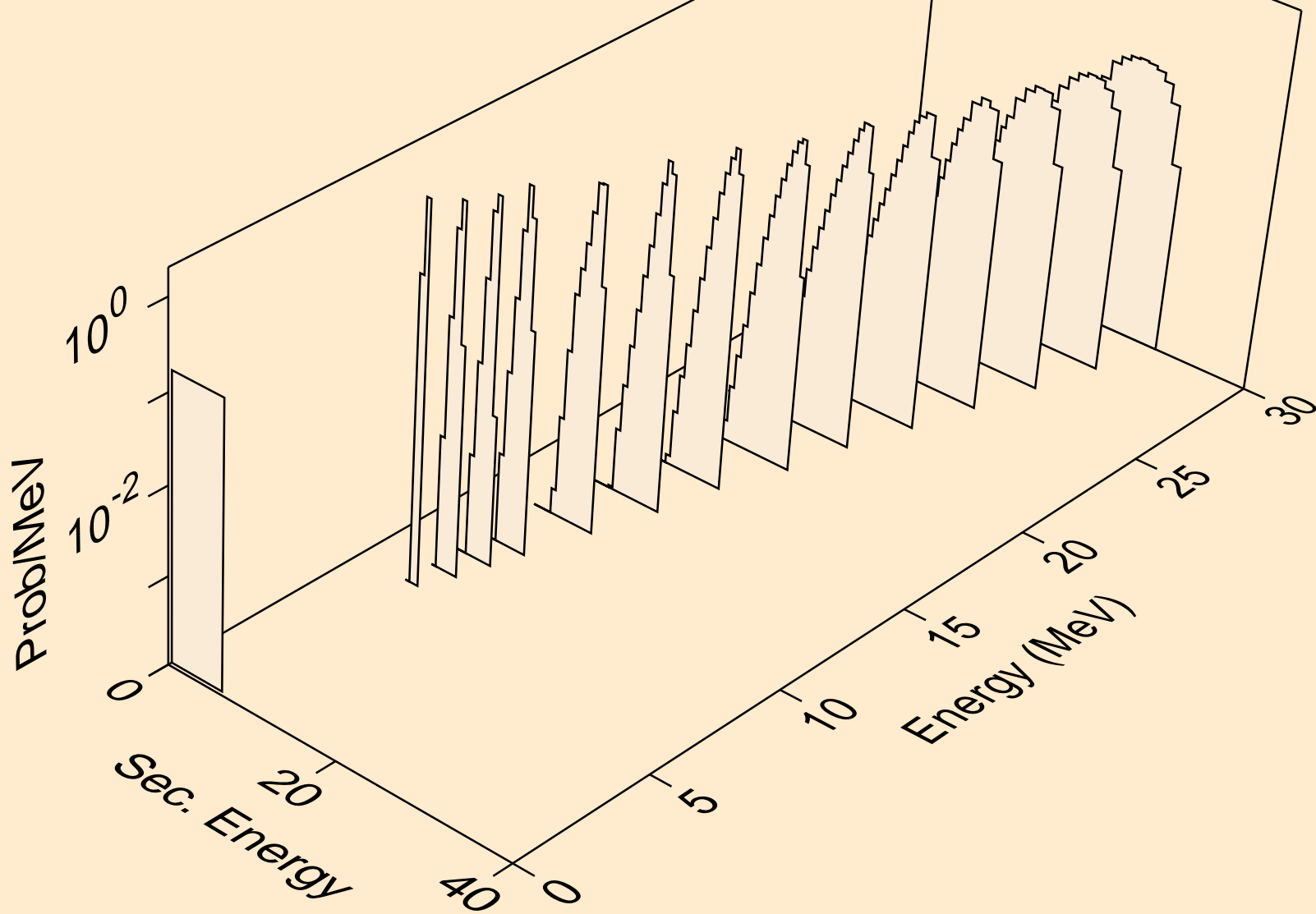

HG201 PROTON ACER TENDL-2023 LIBRARY; T=0.K  
alphas from (p,2n)a

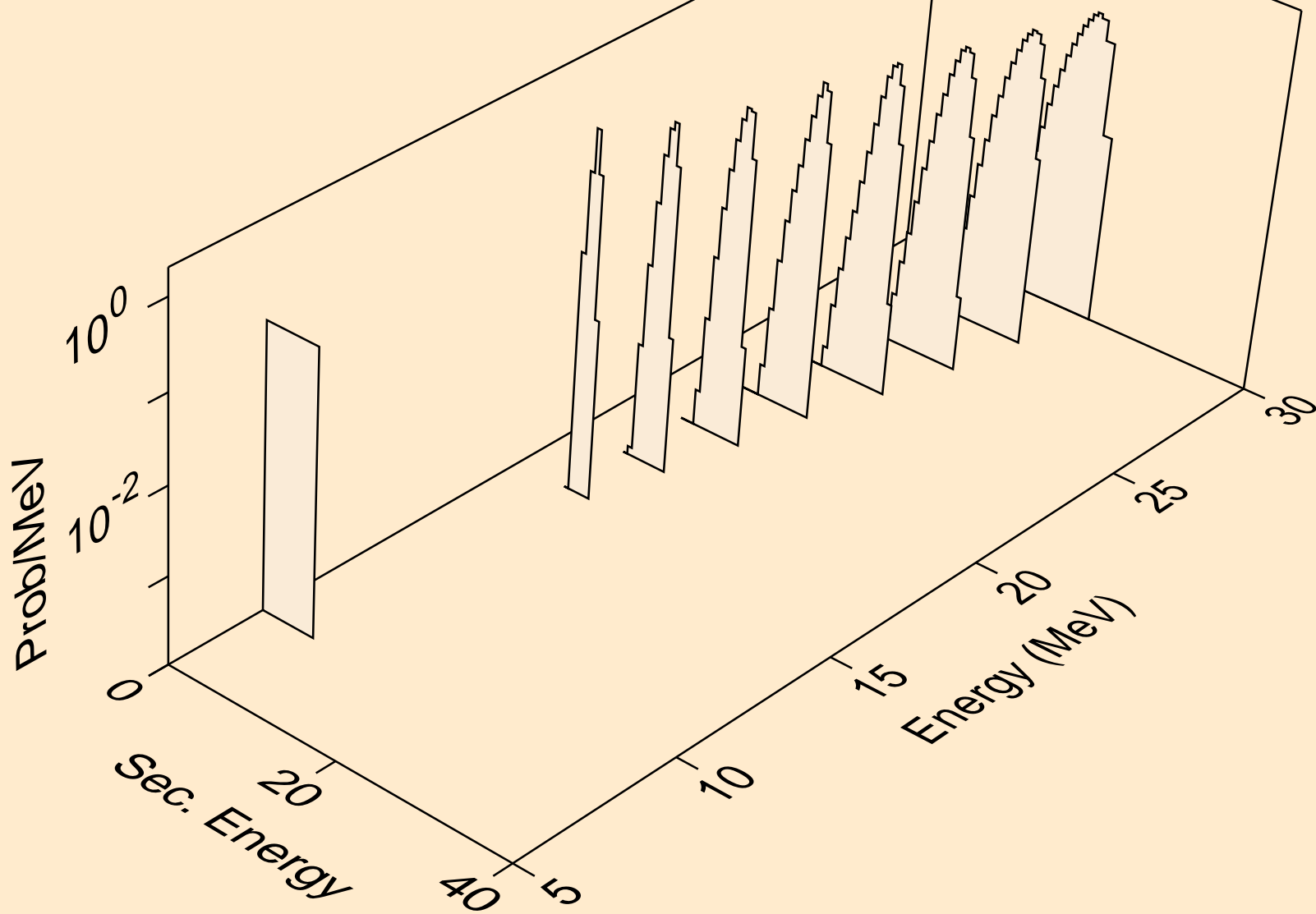

HG201 PROTON ACER TENDL-2023 LIBRARY; T=0.K  
alphas from (p,3n)a

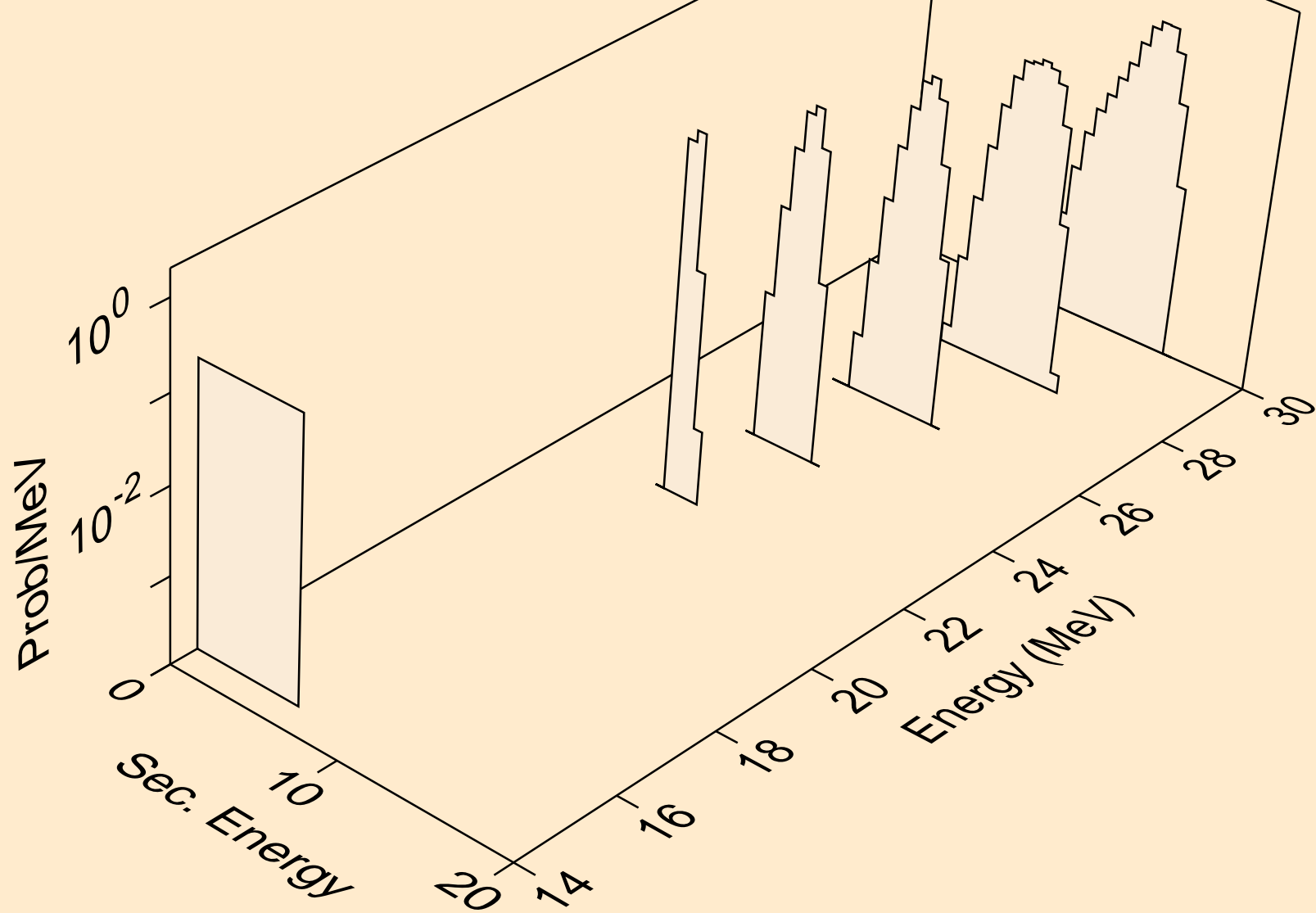

HG201 PROTON ACER TENDL-2023 LIBRARY; T=0.K  
alphas from (p,a)

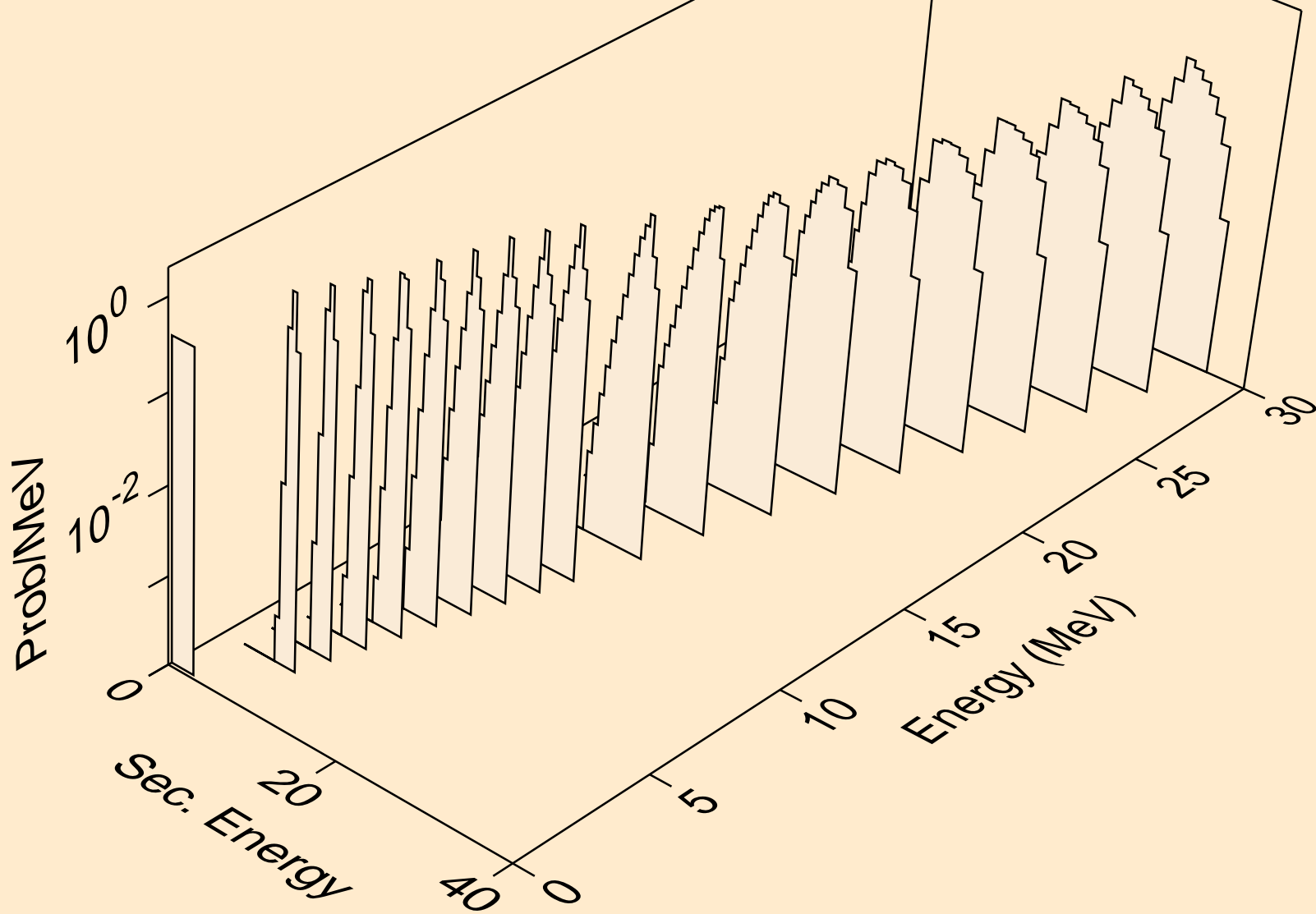

HG201 PROTON ACER TENDL-2023 LIBRARY; T=0.K  
alphas from (p,pa)

