

PU227 TRITON ACER TENDL-2023 LIBRARY; T=0.K
Principal cross sections

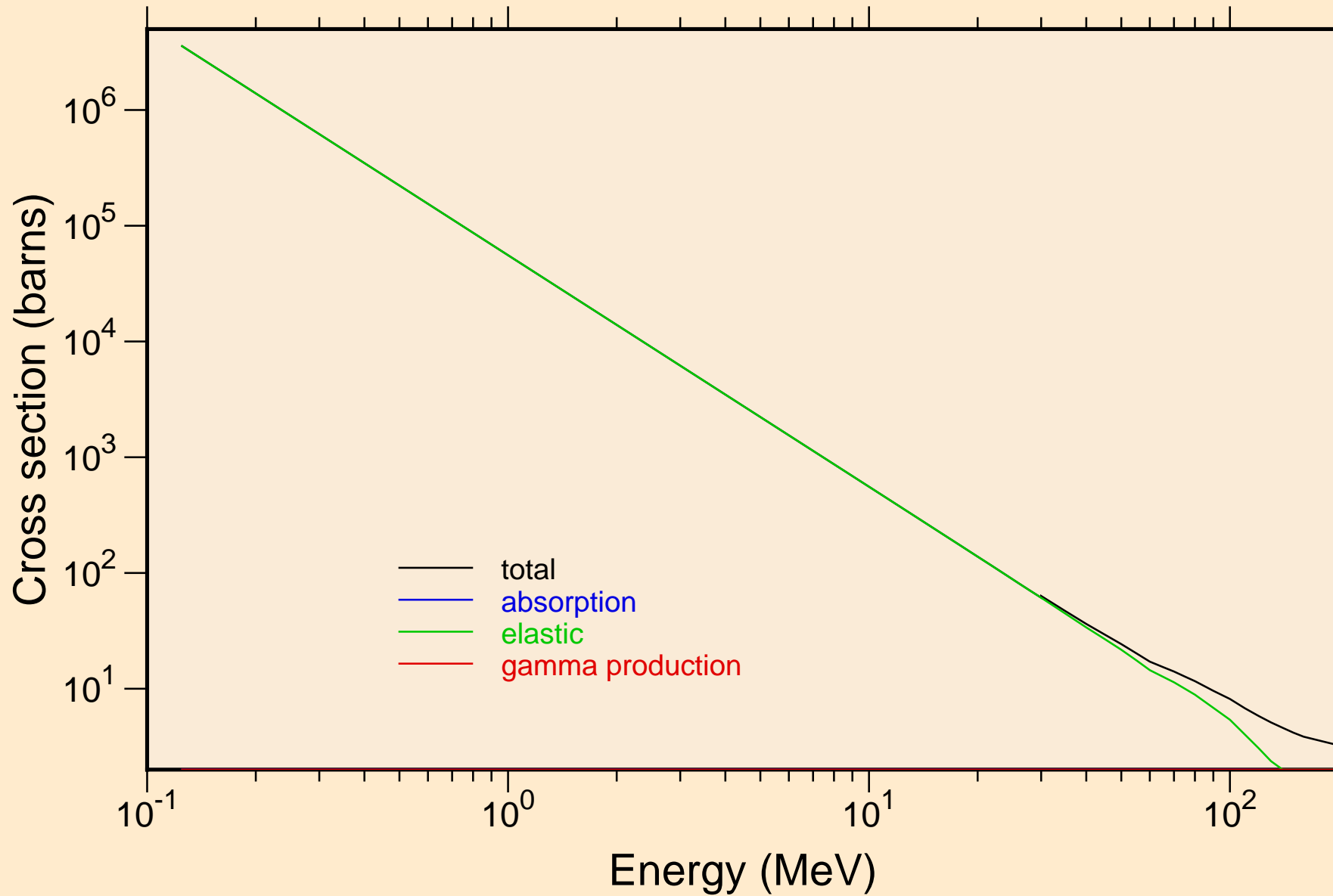

PU227 TRITON ACER TENDL-2023 LIBRARY; T=0.K

Heating

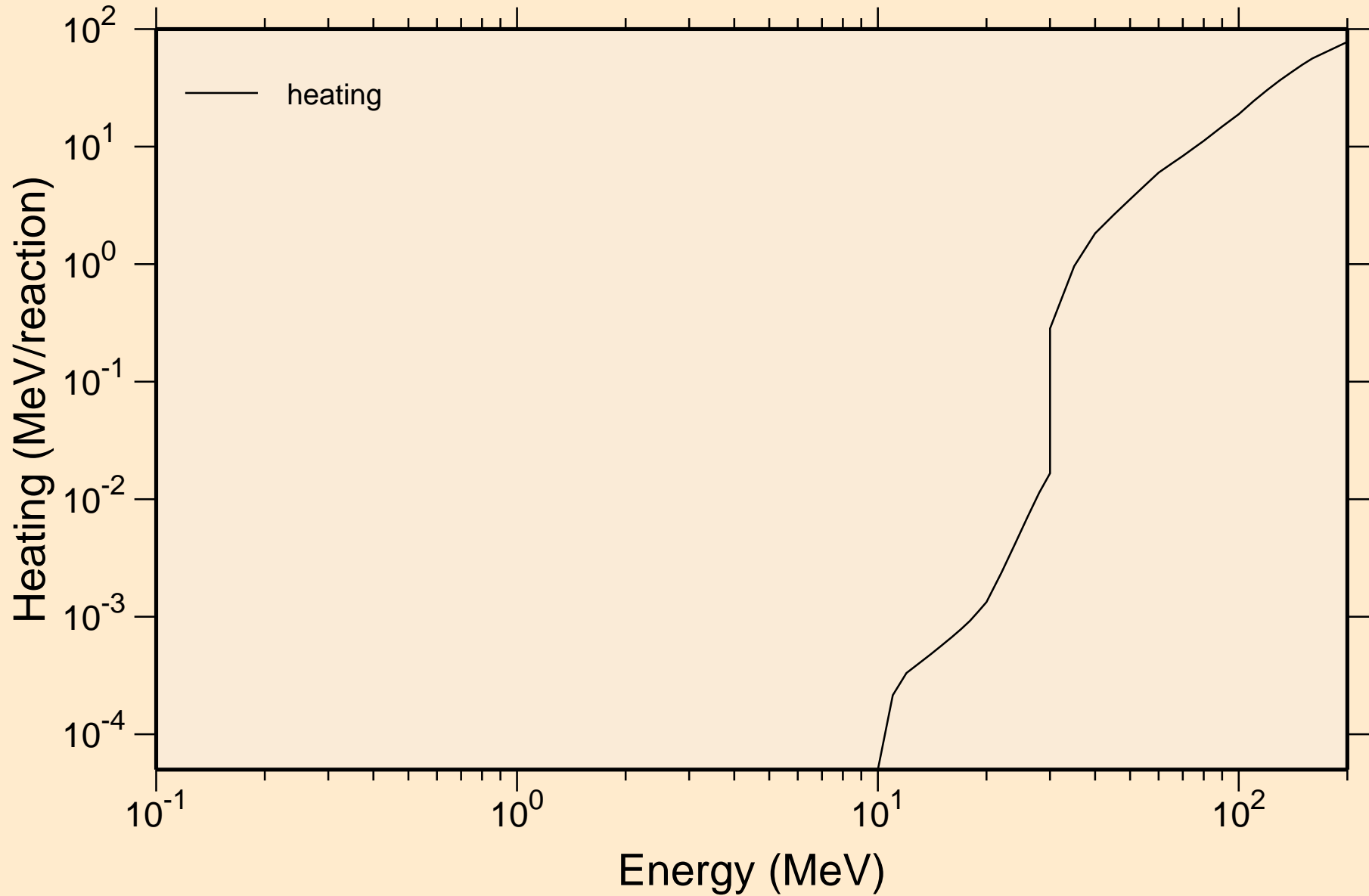

PU227 TRITON ACER TENDL-2023 LIBRARY; T=0.K
Principal cross sections

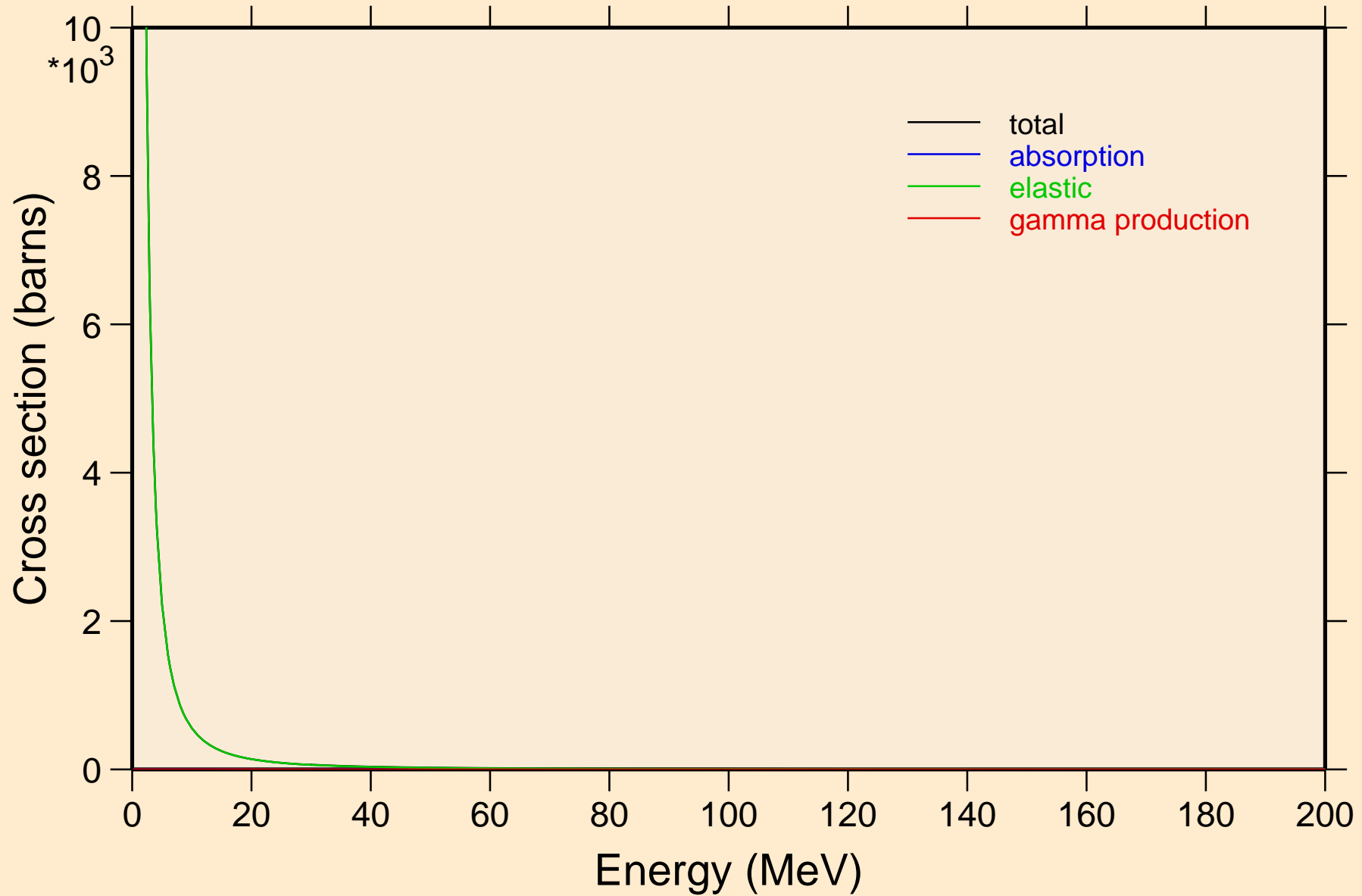

PU227 TRITON ACER TENDL-2023 LIBRARY; T=0.K

Heating

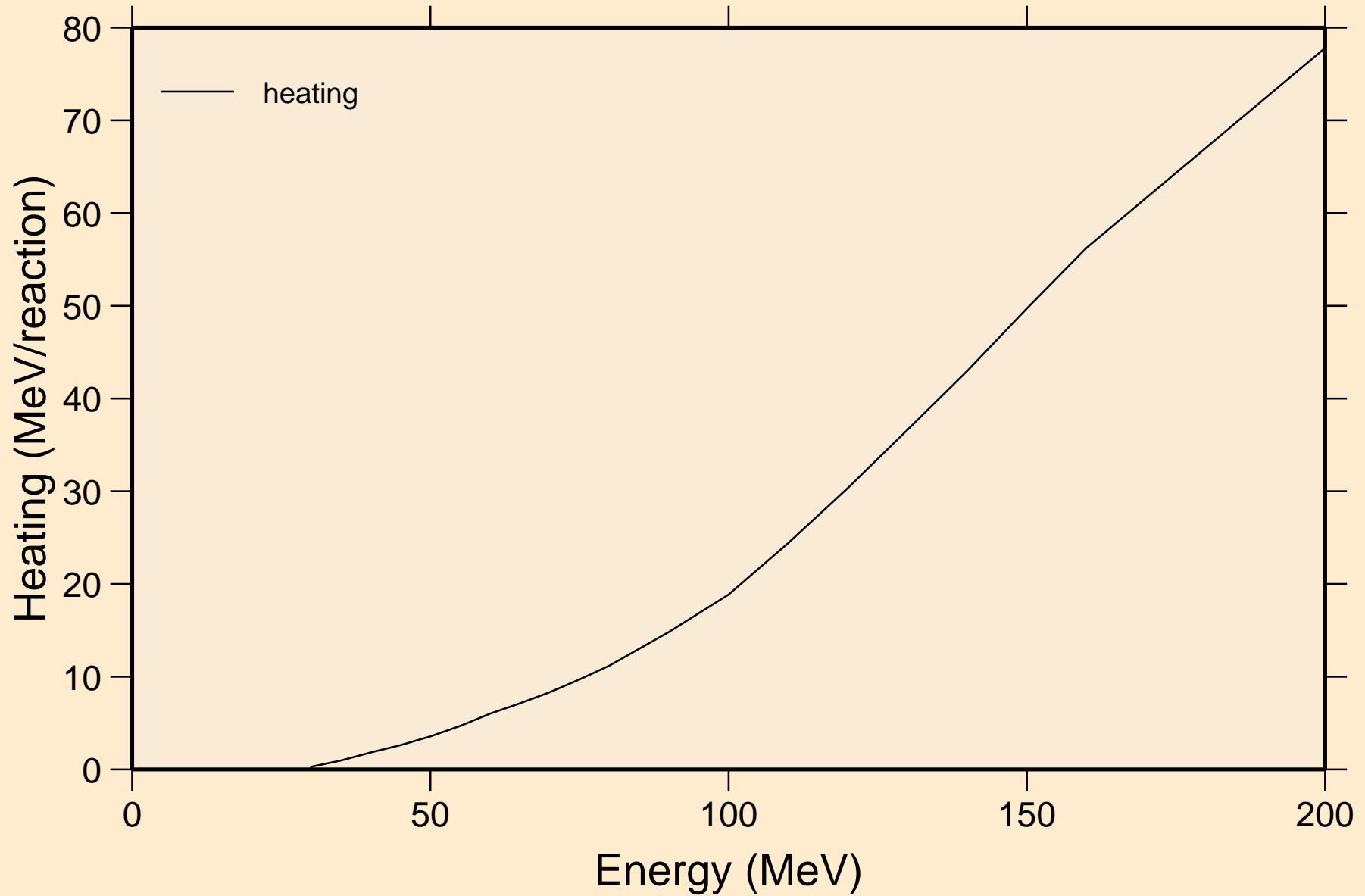

PU227 TRITON ACER TENDL-2023 LIBRARY; T=0.K
Threshold reactions

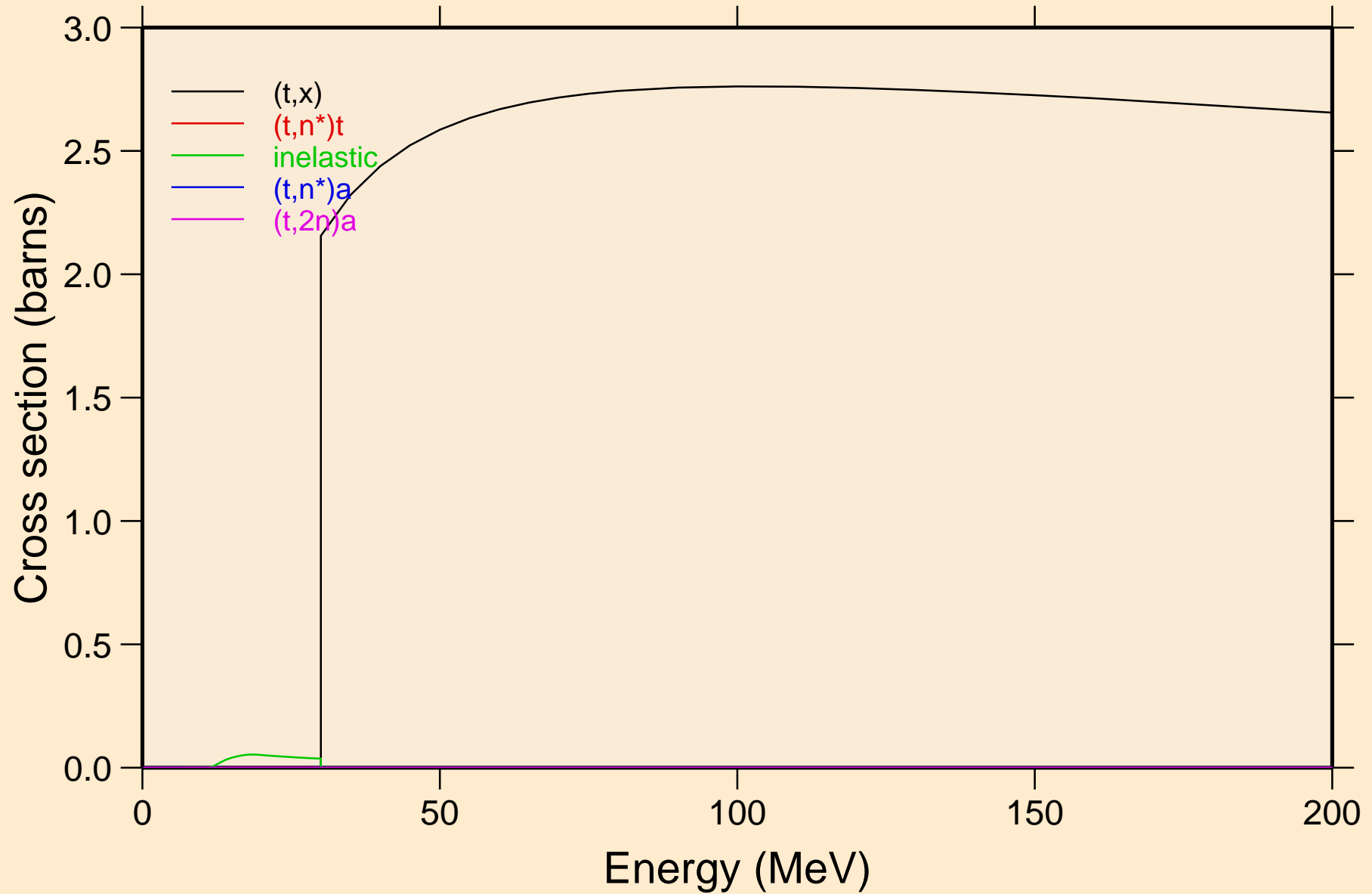

PU227 TRITON ACER TENDL-2023 LIBRARY; T=0.K
Threshold reactions

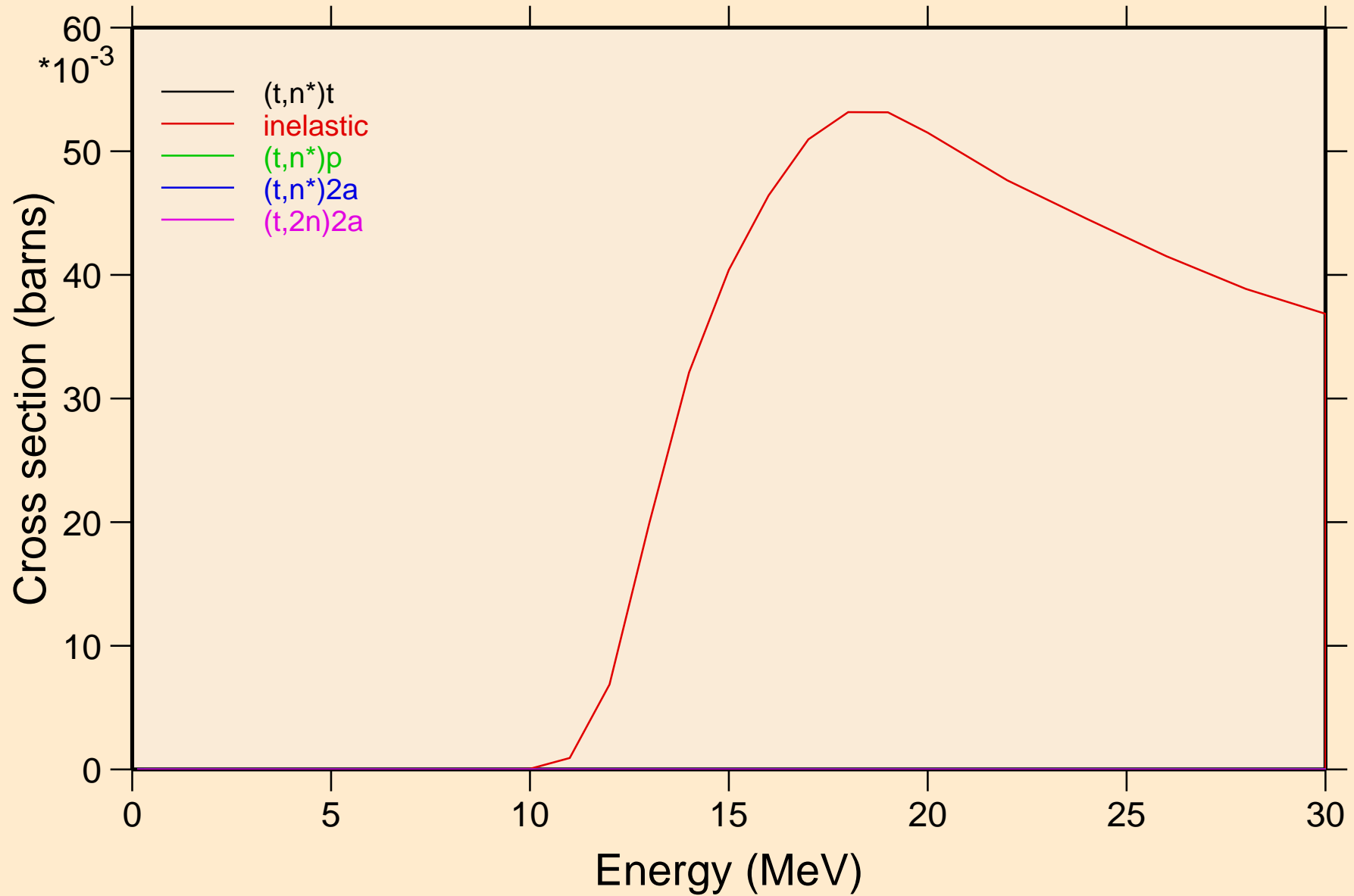

PU227 TRITON ACER TENDL-2023 LIBRARY; T=0.K
Threshold reactions

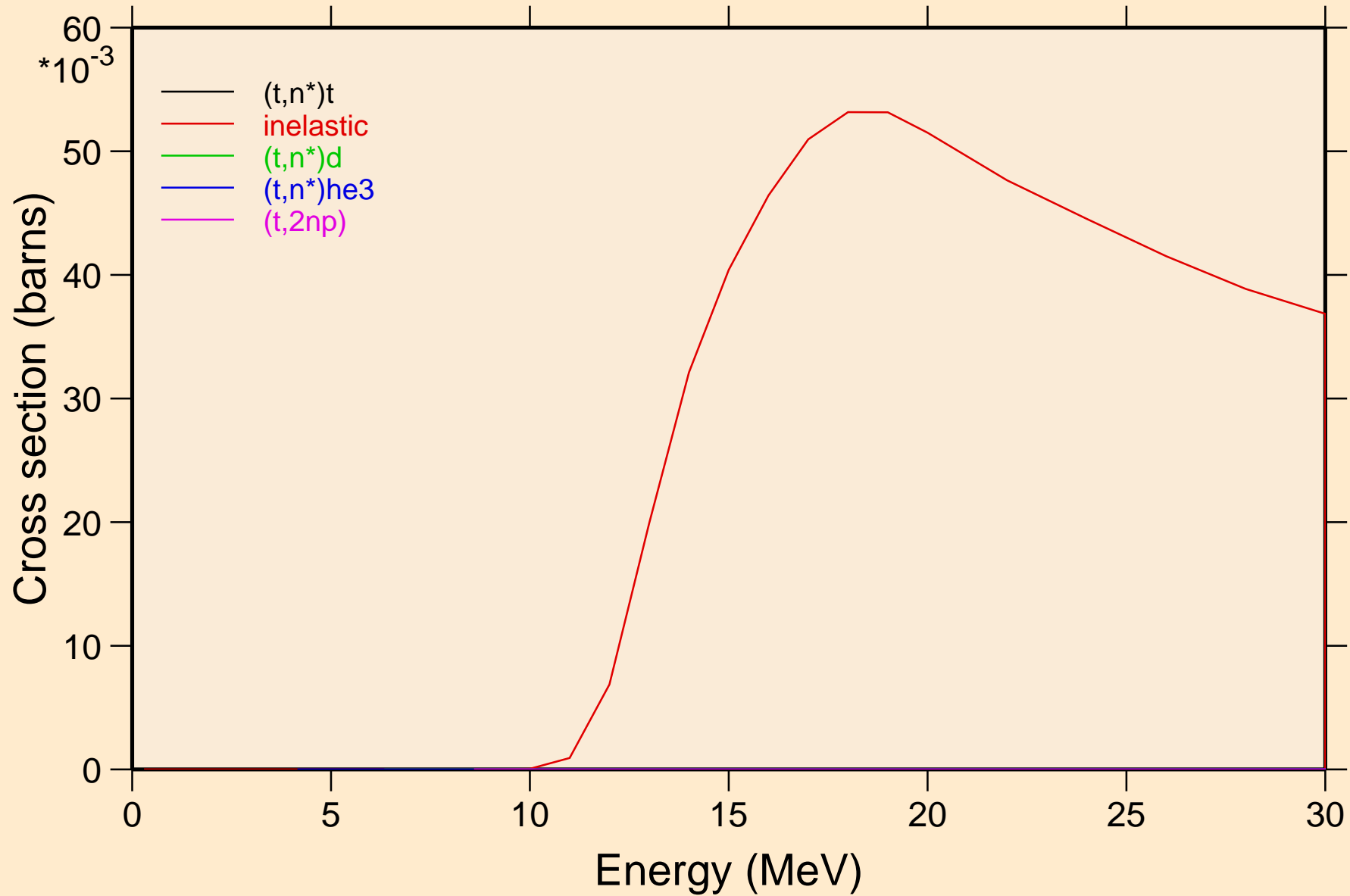

PU227 TRITON ACER TENDL-2023 LIBRARY; T=0.K
Threshold reactions

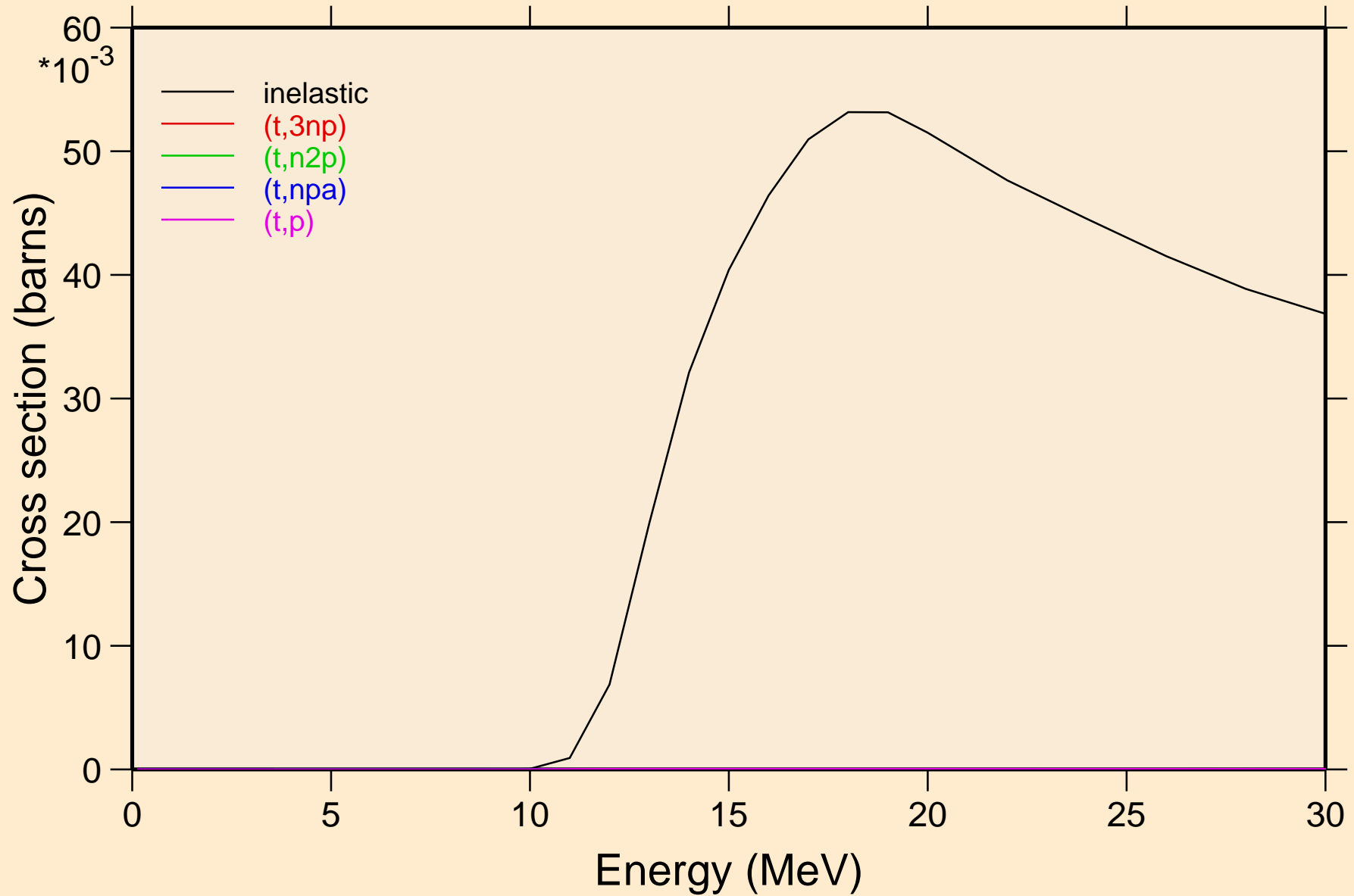

PU227 TRITON ACER TENDL-2023 LIBRARY; T=0.K
Threshold reactions

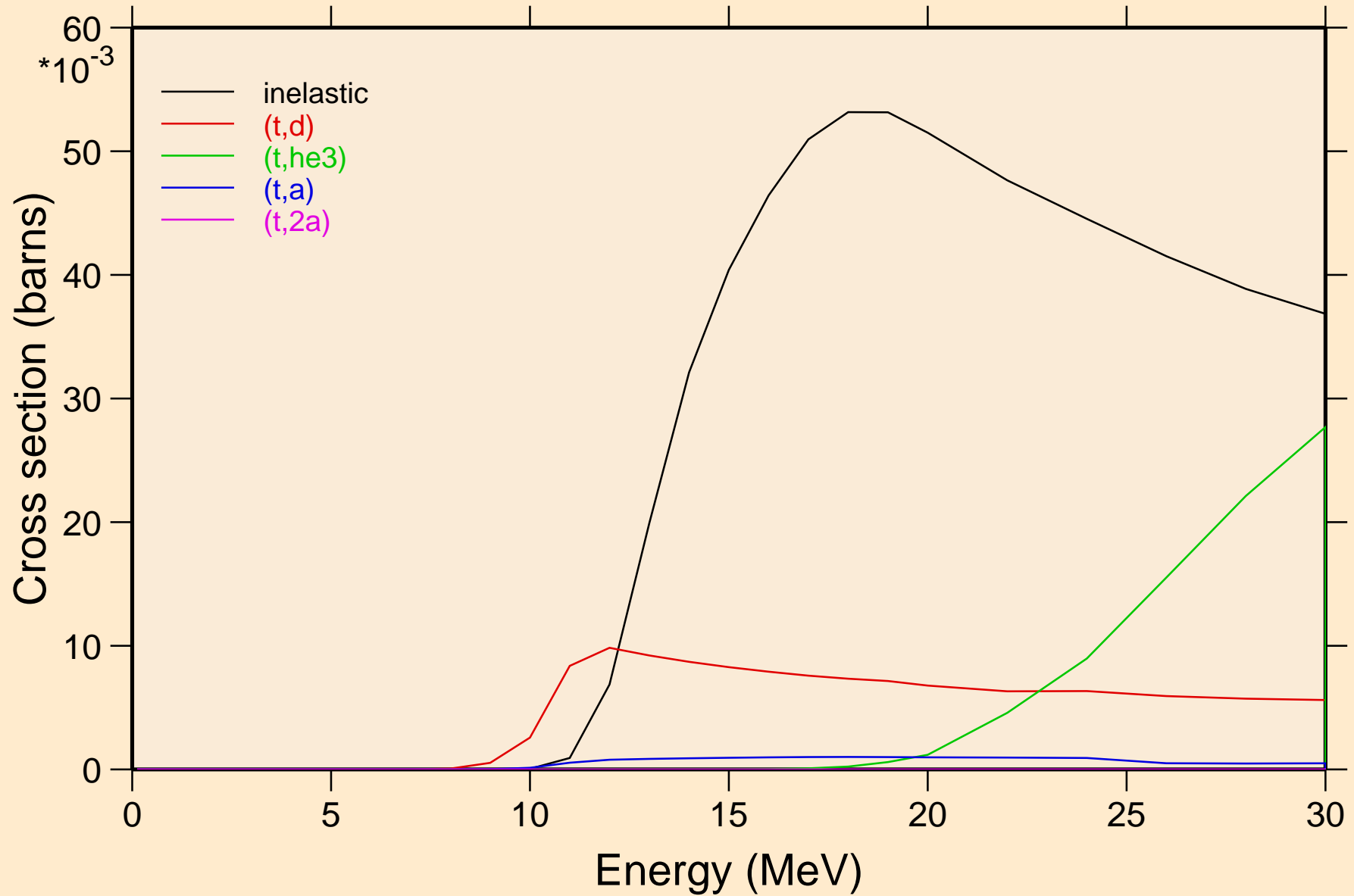

PU227 TRITON ACER TENDL-2023 LIBRARY; T=0.K
Threshold reactions

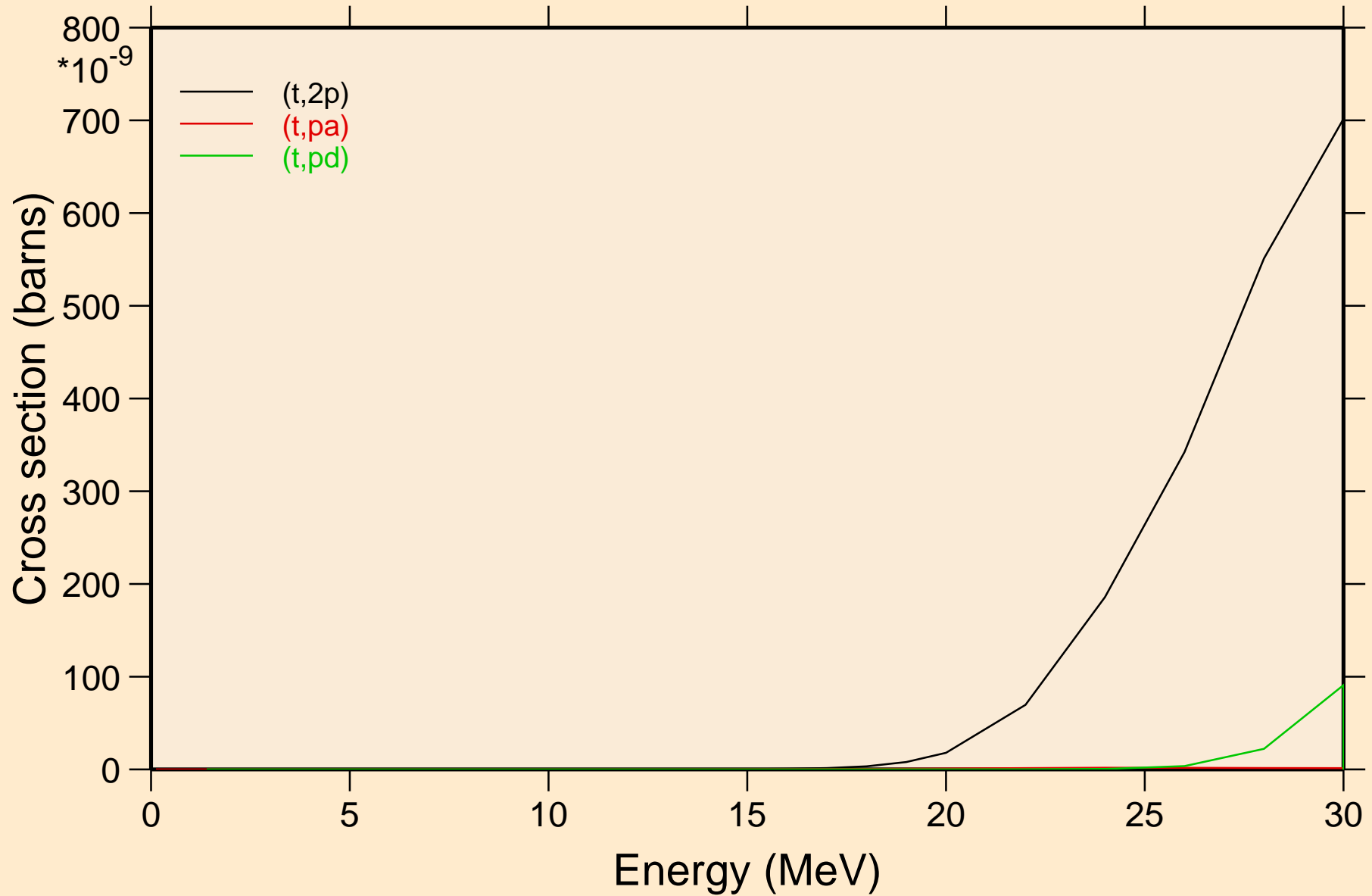

PU227 TRITON ACER TENDL-2023 LIBRARY; T=0.K
angular distribution for elastic

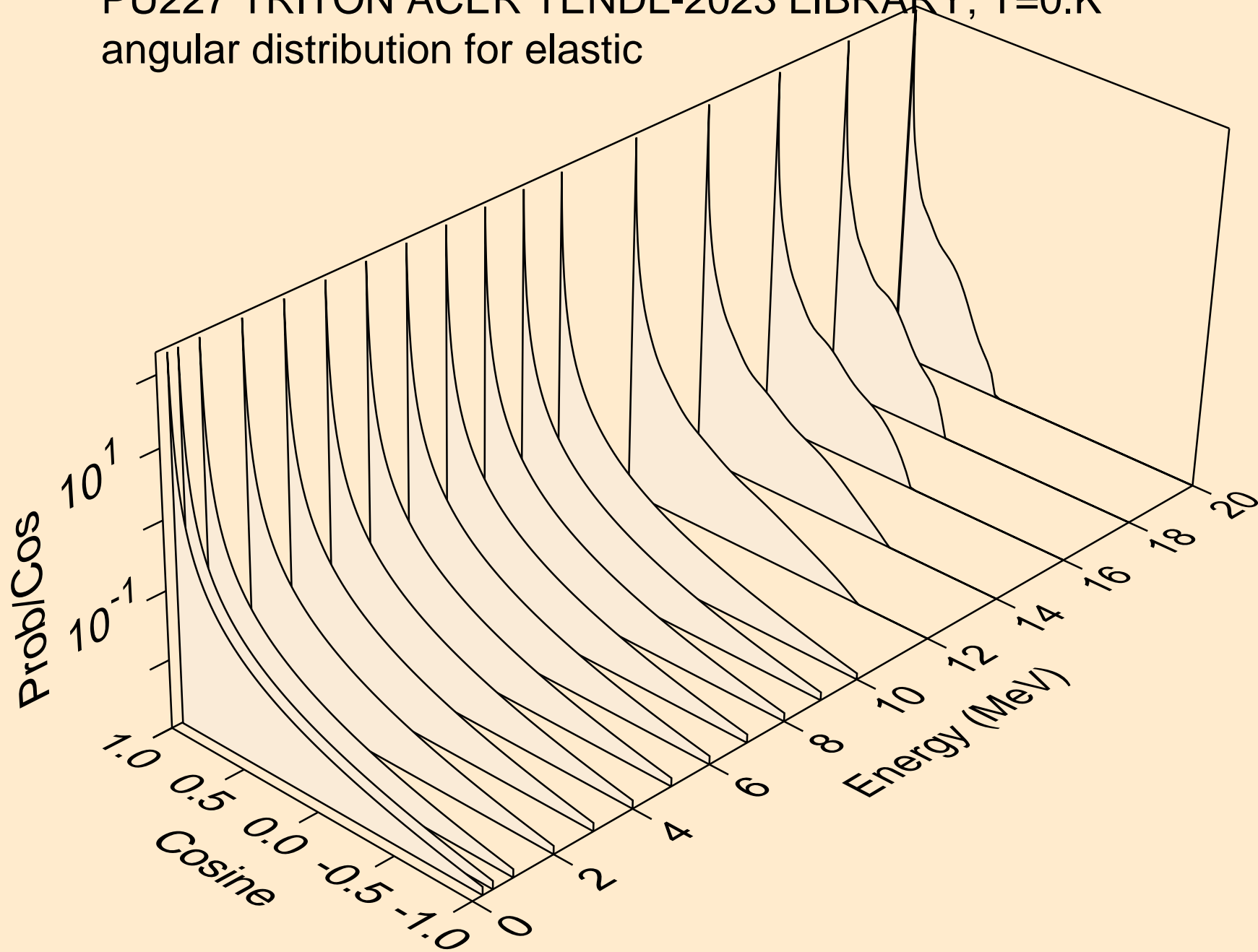

PU227 TRITON ACER TENDL-2023 LIBRARY; T=0.K
angular distribution for elastic

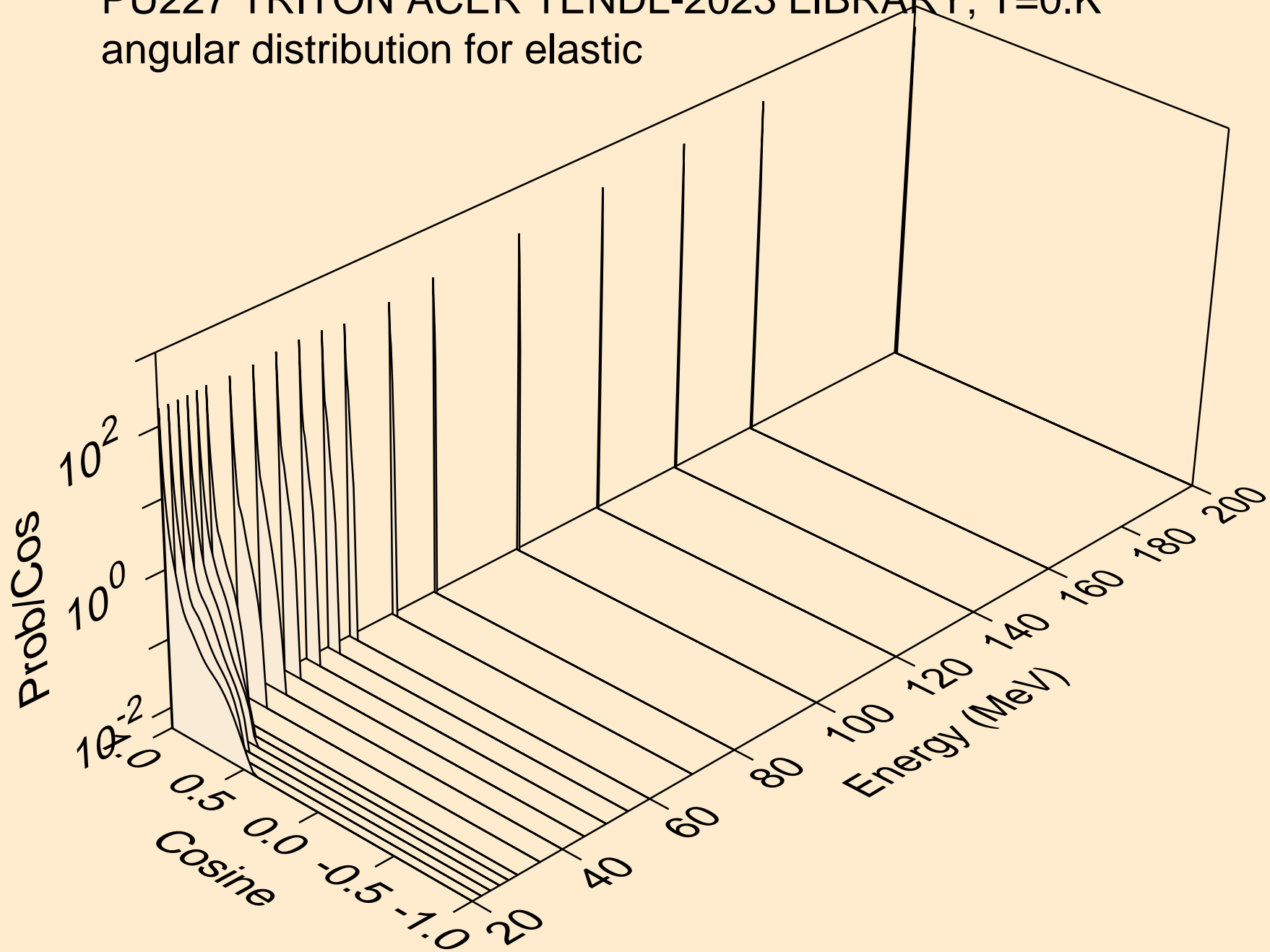

PU227 TRITON ACER TENDL-2023 LIBRARY; T=0.K
Triton emission for (t,x)

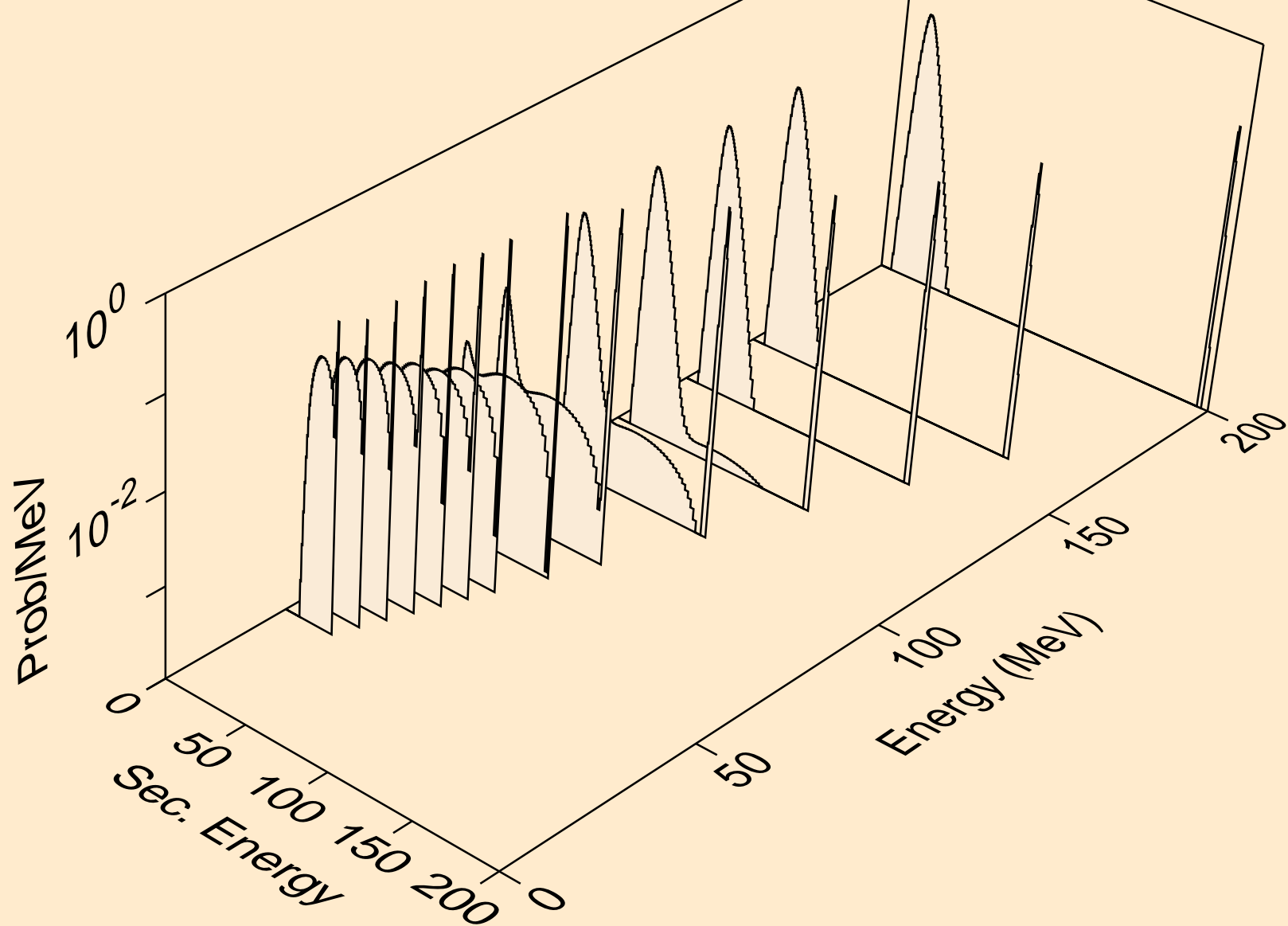

PU227 TRITON ACER TENDL-2023 LIBRARY; T=0.K
Triton emission for (t,n*)t

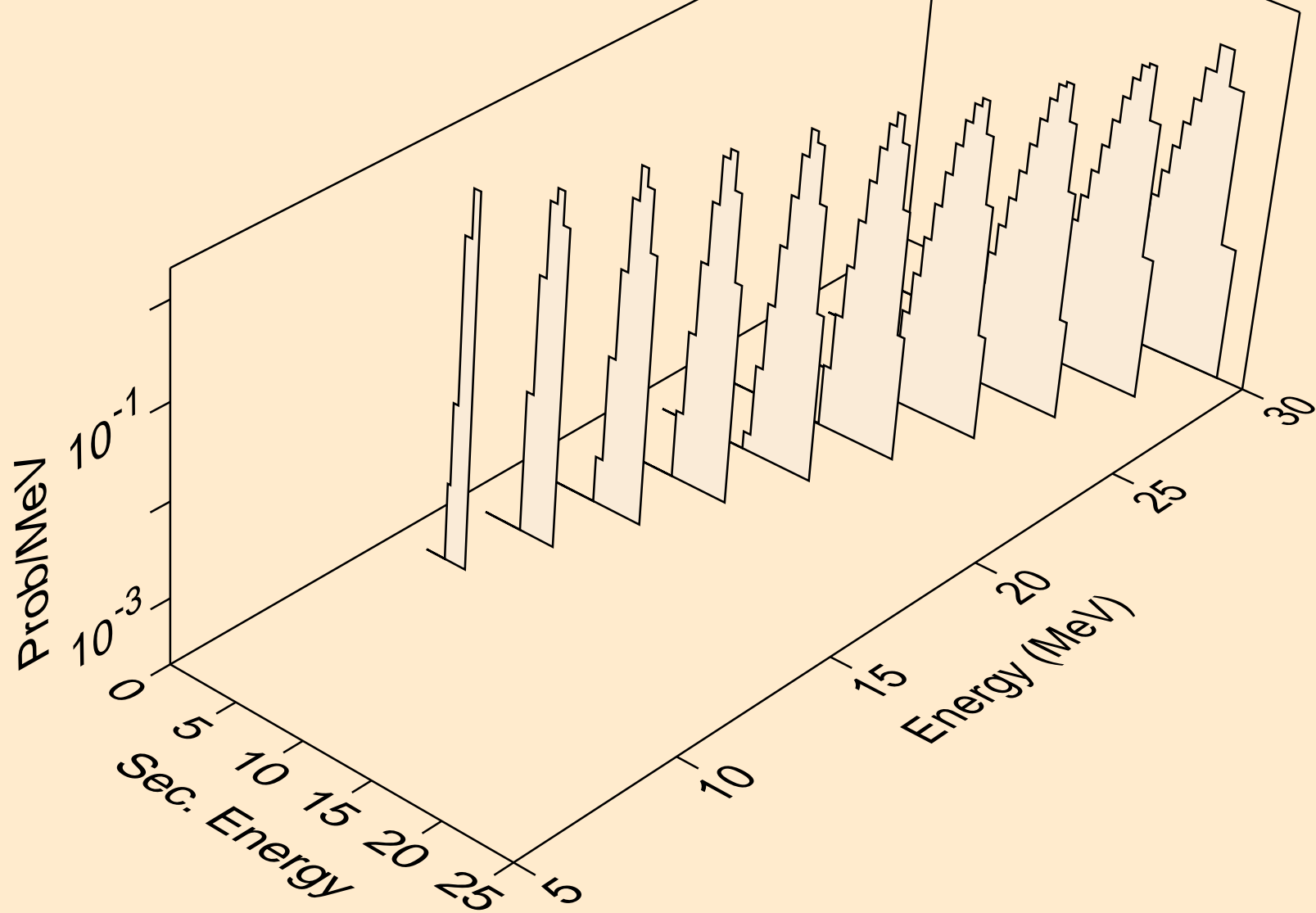

PU227 TRITON ACER TENDL-2023 LIBRARY; T=0.K
Triton emission for inelastic

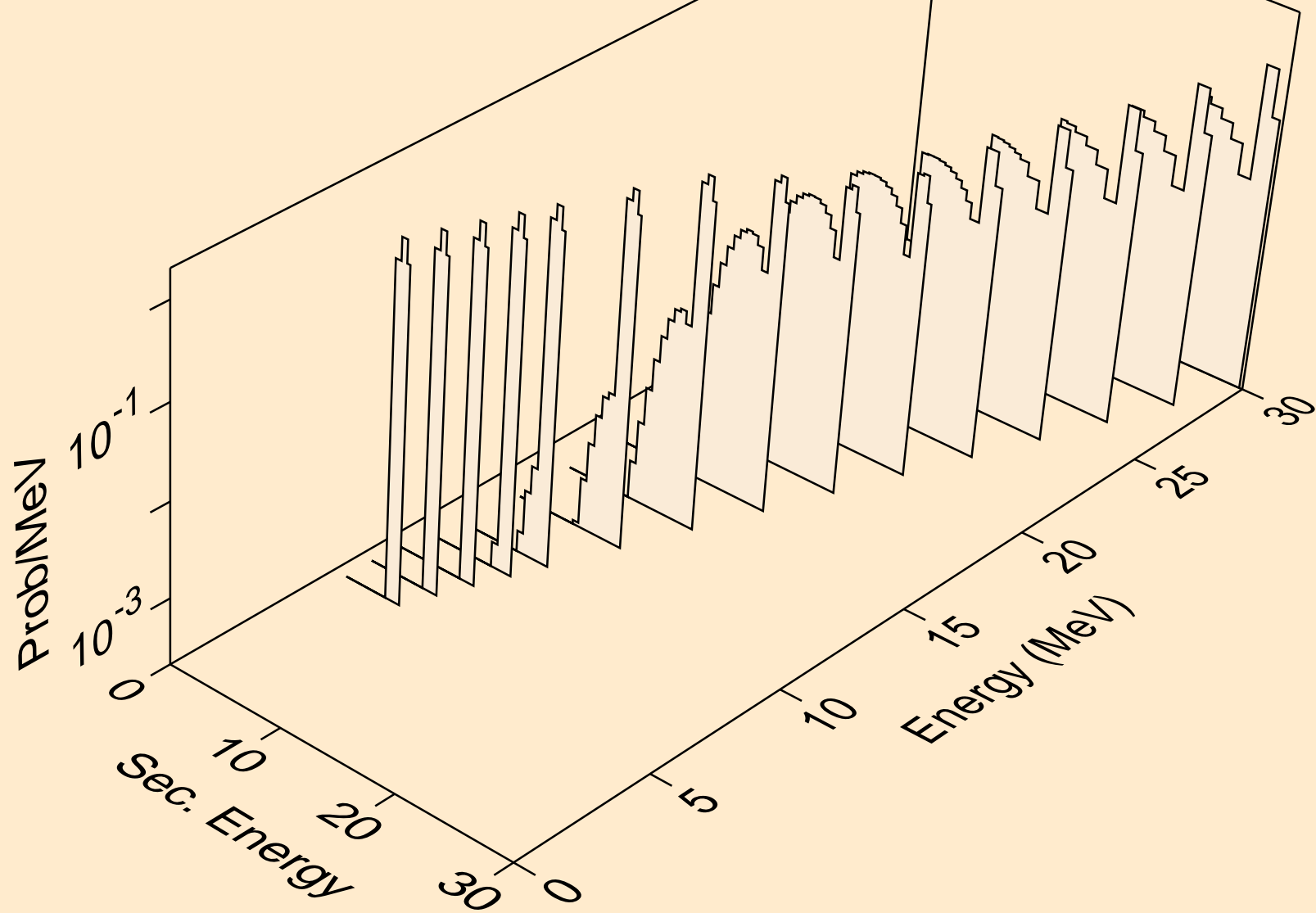

PU227 TRITON ACER TENDL-2023 LIBRARY; T=0.K
Photon emission for (z,n)

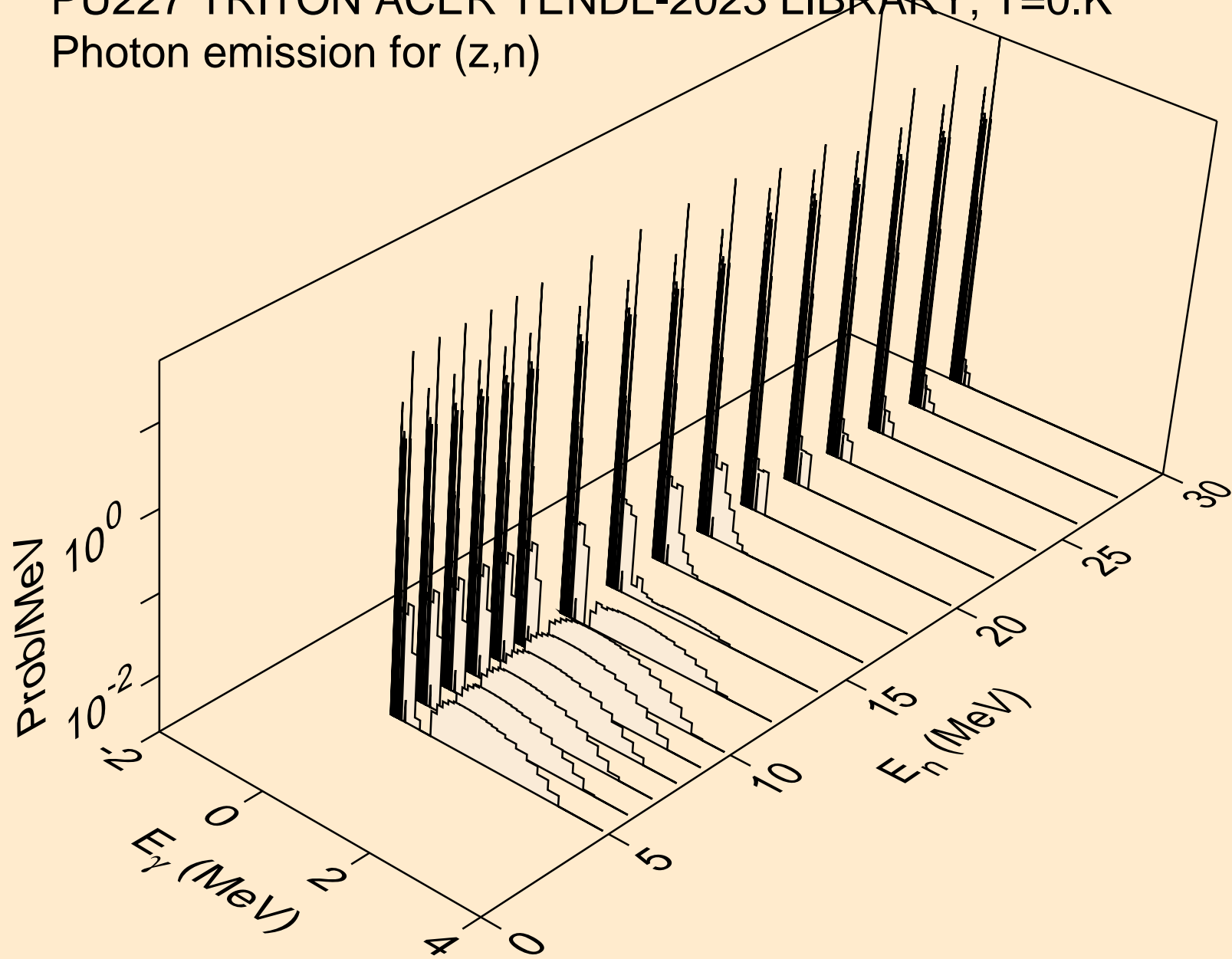

PU227 TRITON ACER TENDL-2023 LIBRARY; T=0.K
Photon emission for (z,x)

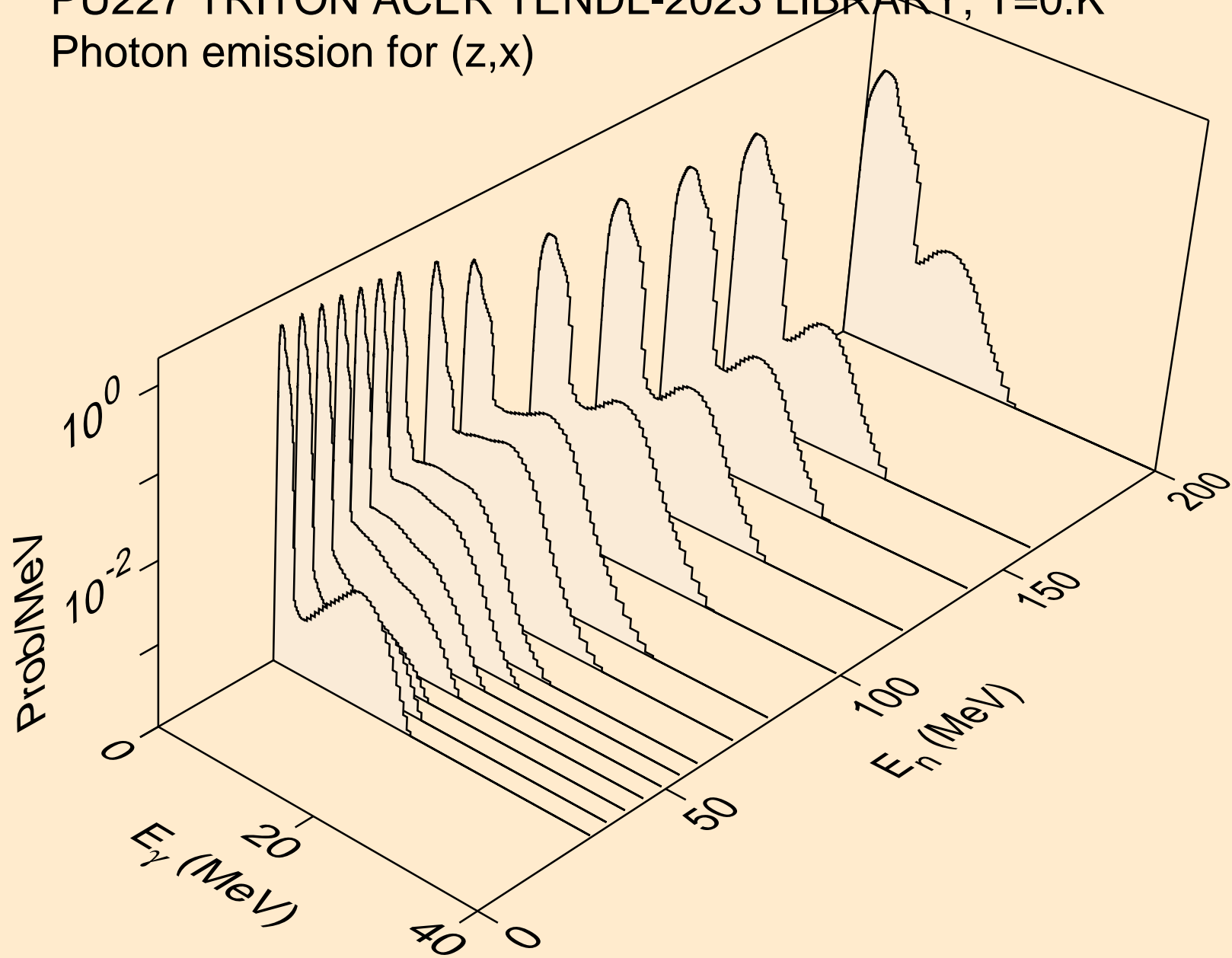

PU227 TRITON ACER TENDL-2023 LIBRARY; T=0.K
Photon emission for (n,n*)a

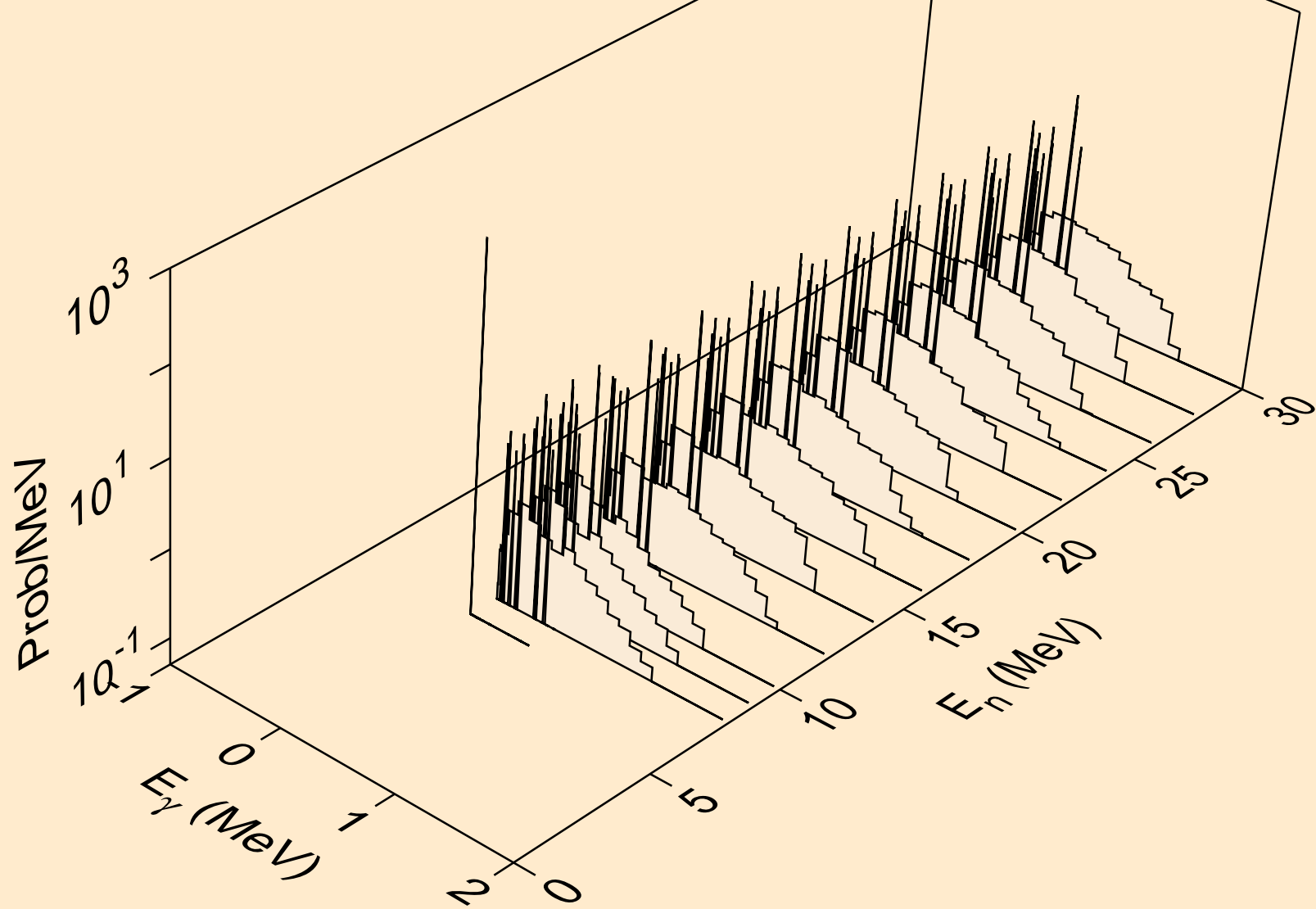

PU227 TRITON ACER TENDL-2023 LIBRARY; T=0.K
Photon emission for (n,2n)a

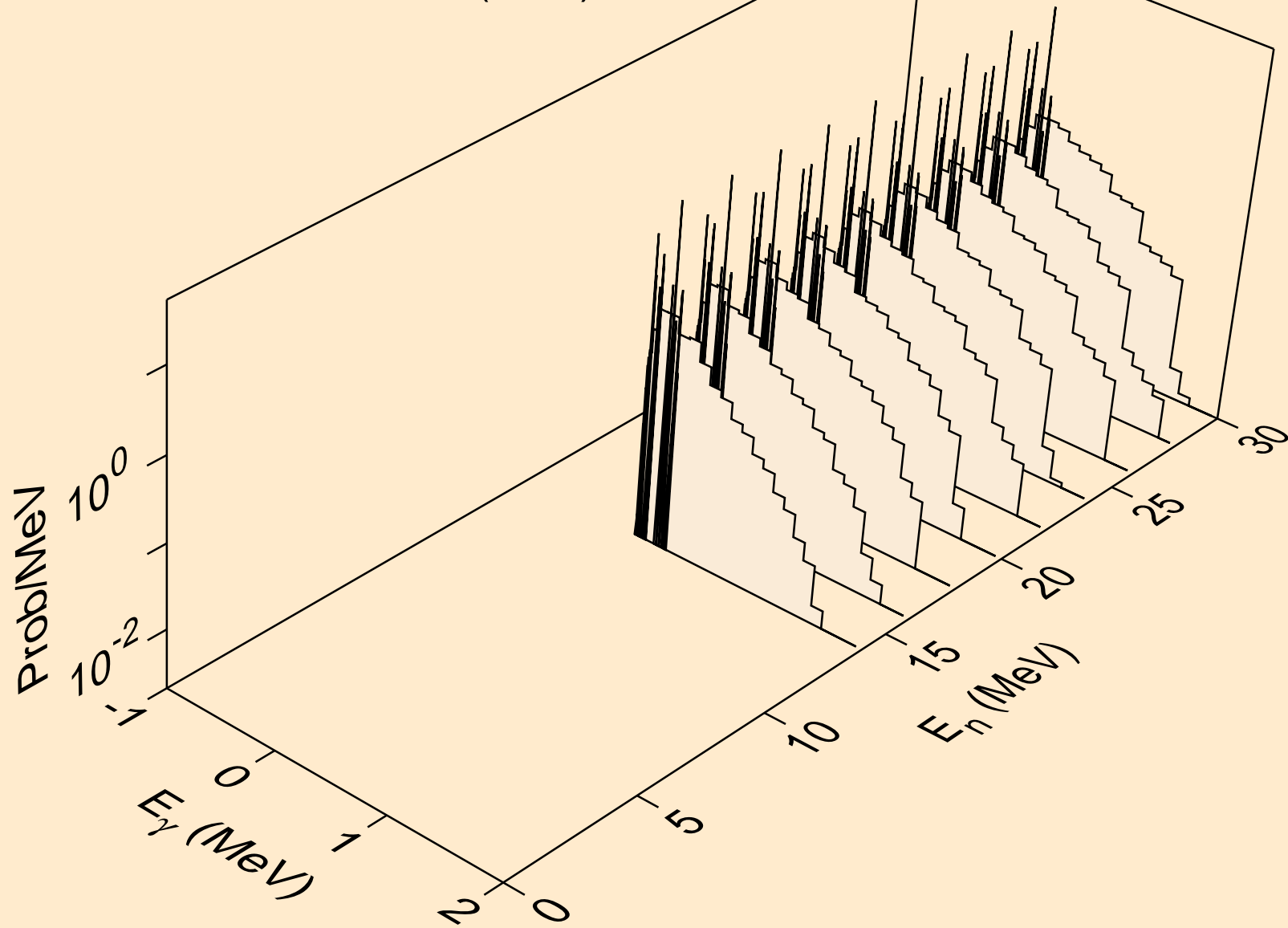

PU227 TRITON ACER TENDL-2023 LIBRARY; T=0.K
Photon emission for (n,n*)p

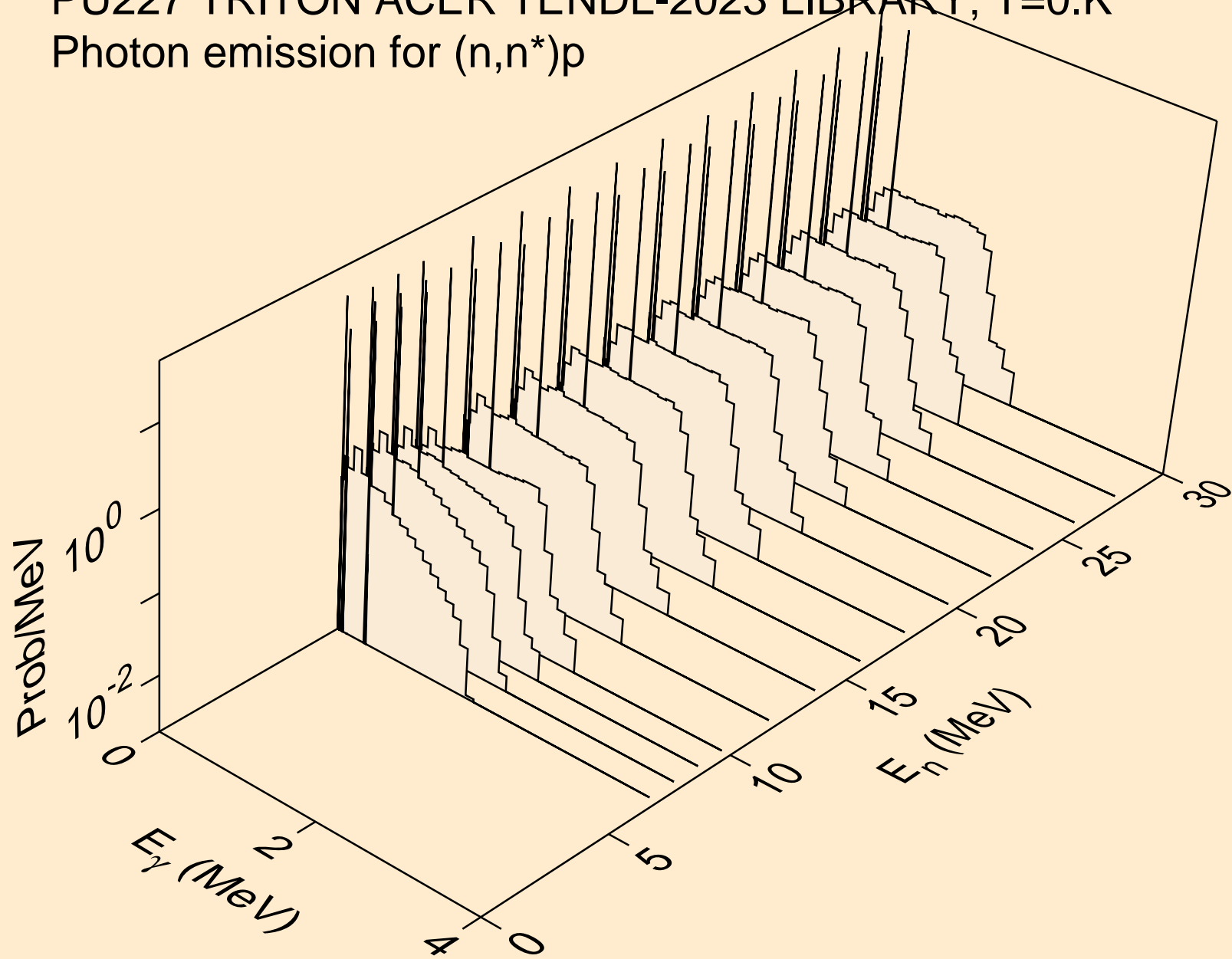

PU227 TRITON ACER TENDL-2023 LIBRARY; T=0.K
Photon emission for (n,n*)2a

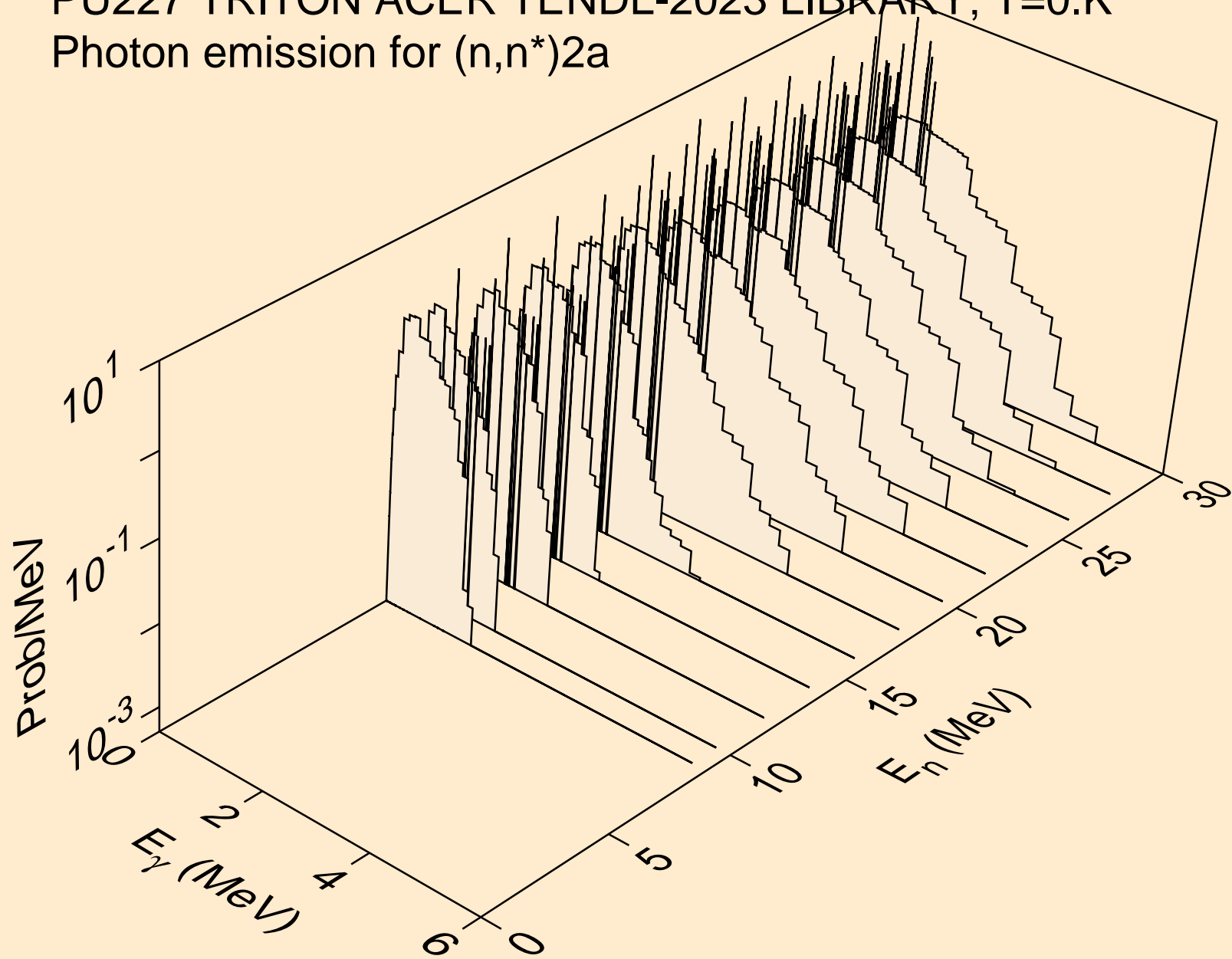

PU227 TRITON ACER TENDL-2023 LIBRARY; T=0.K
Photon emission for (n,2n)2a

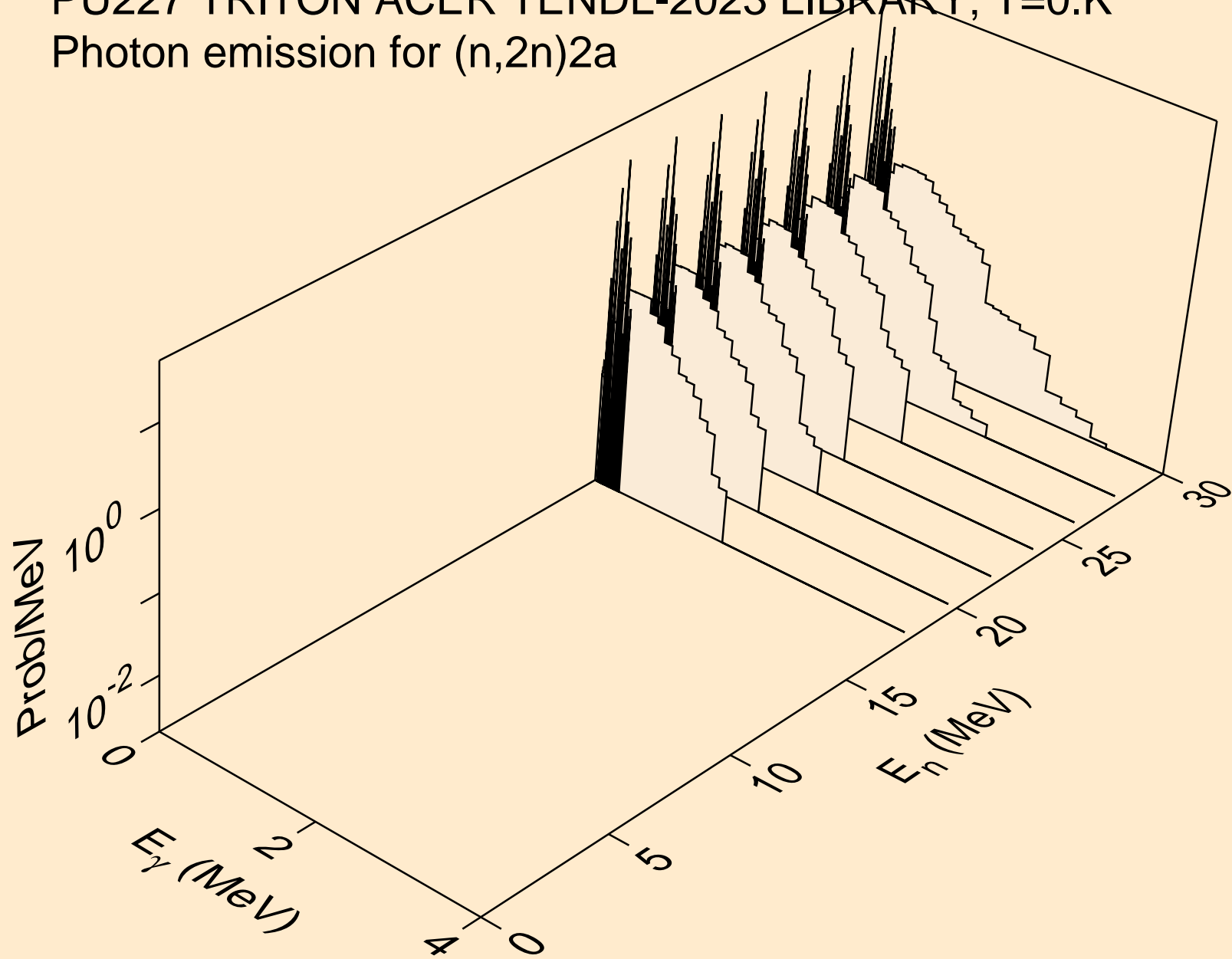

PU227 TRITON ACER TENDL-2023 LIBRARY; T=0.K
Photon emission for (n,n*)d

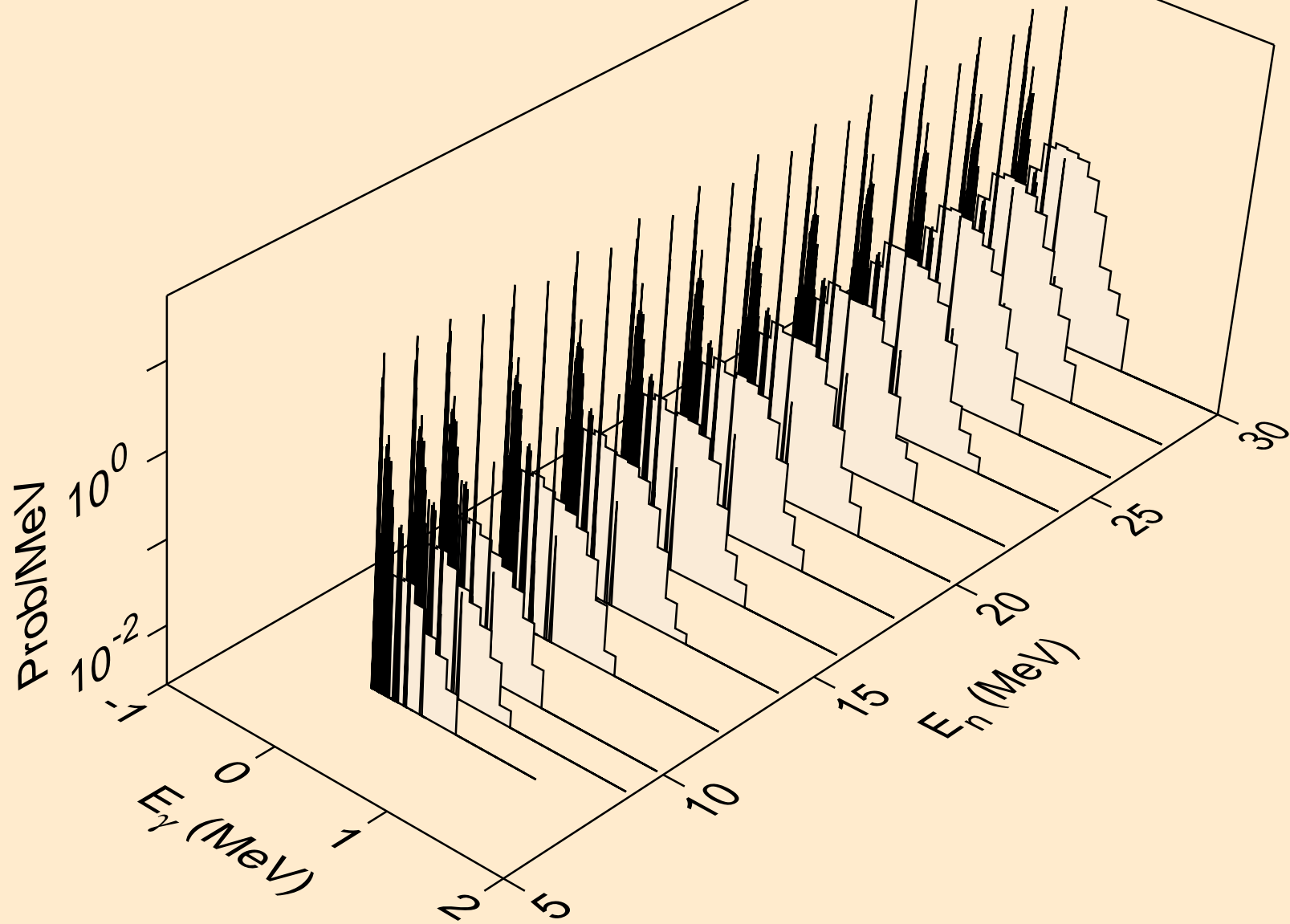

PU227 TRITON ACER TENDL-2023 LIBRARY; T=0.K
Photon emission for (n,n*)t

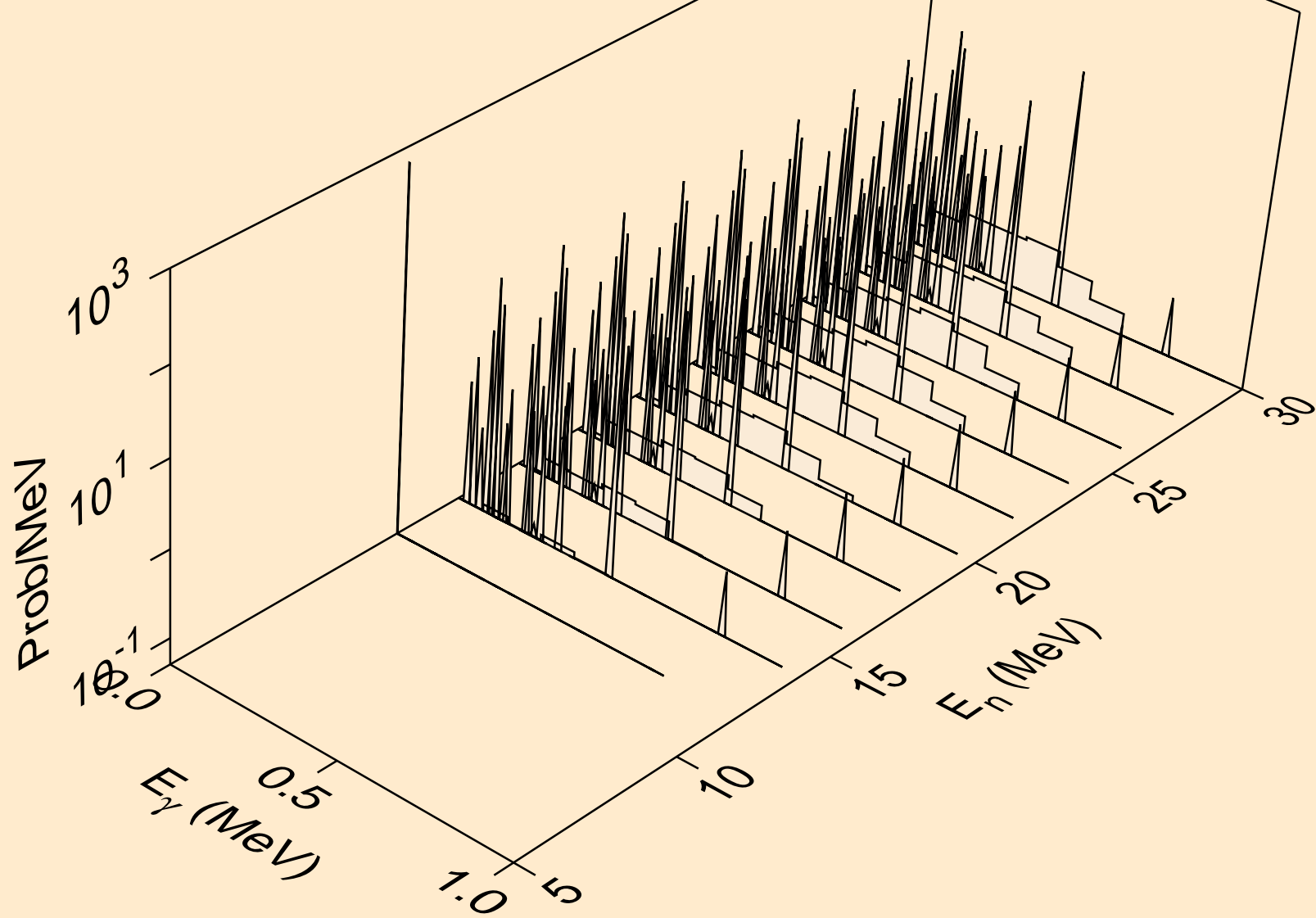

PU227 TRITON ACER TENDL-2023 LIBRARY; T=0.K
Photon emission for (n,n*)he3

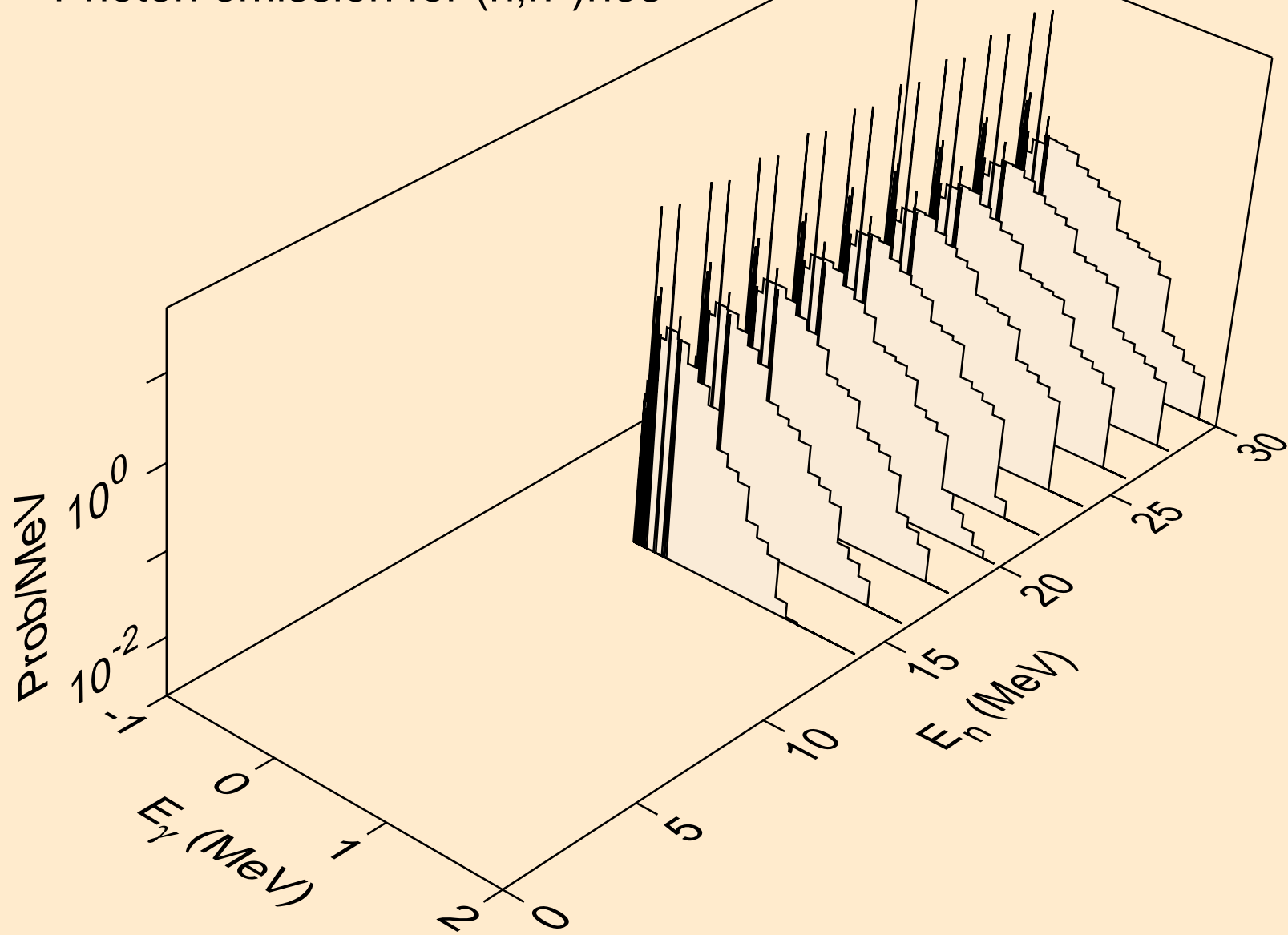

PU227 TRITON ACER TENDL-2023 LIBRARY; T=0.K
Photon emission for (n,2np)

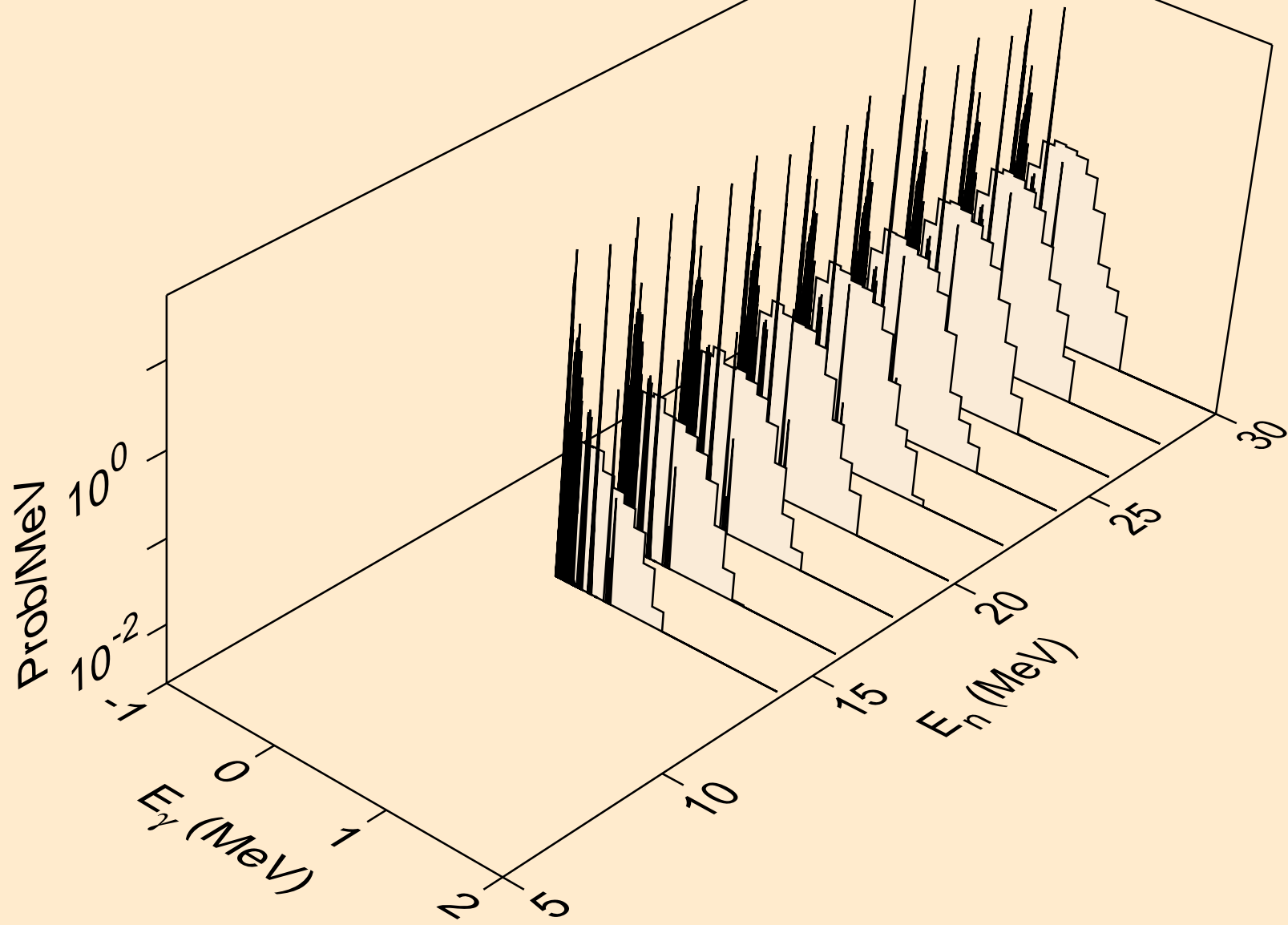

PU227 TRITON ACER TENDL-2023 LIBRARY; T=0.K
Photon emission for (n,3np)

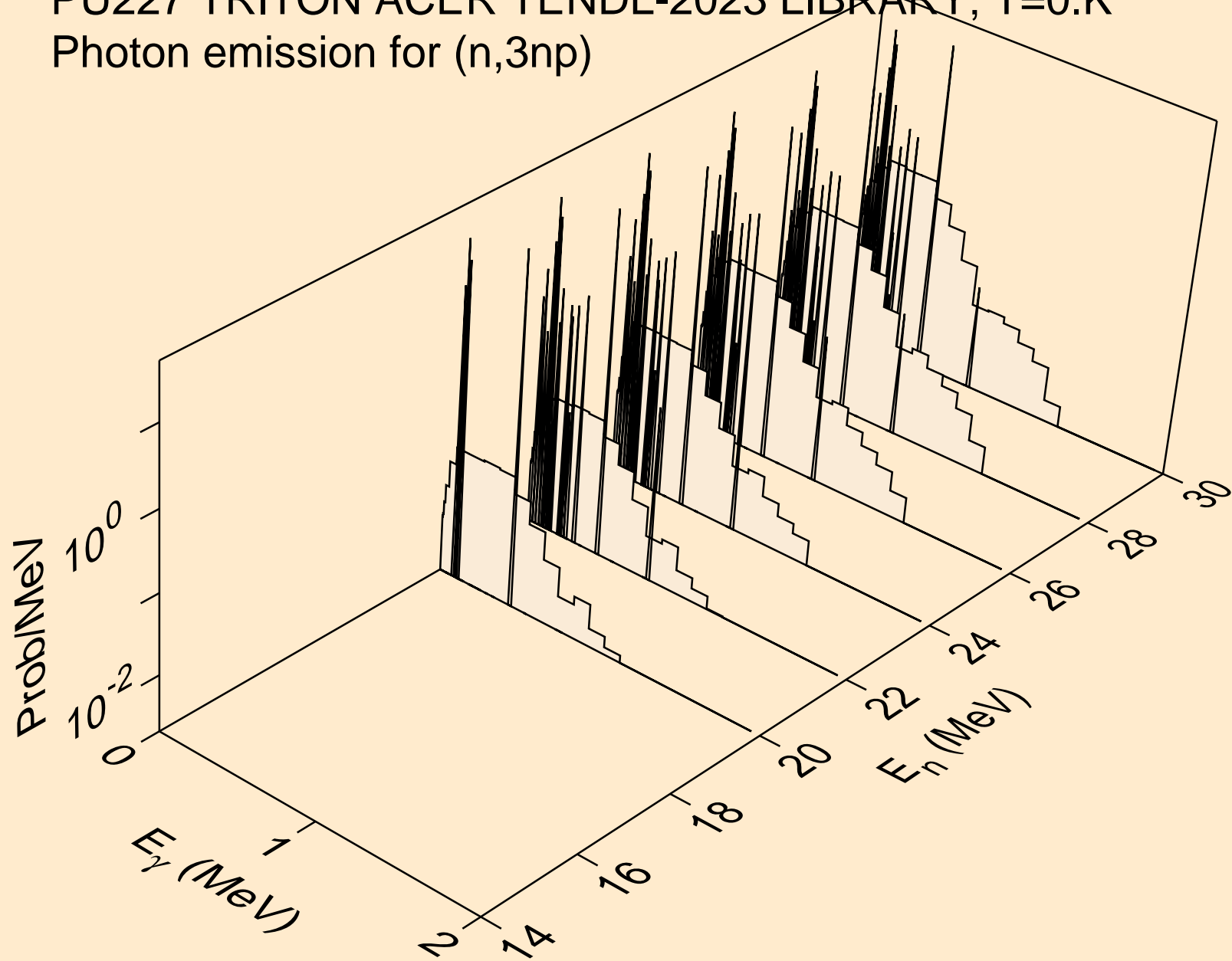

PU227 TRITON ACER TENDL-2023 LIBRARY; T=0.K
Photon emission for (n,n2p)

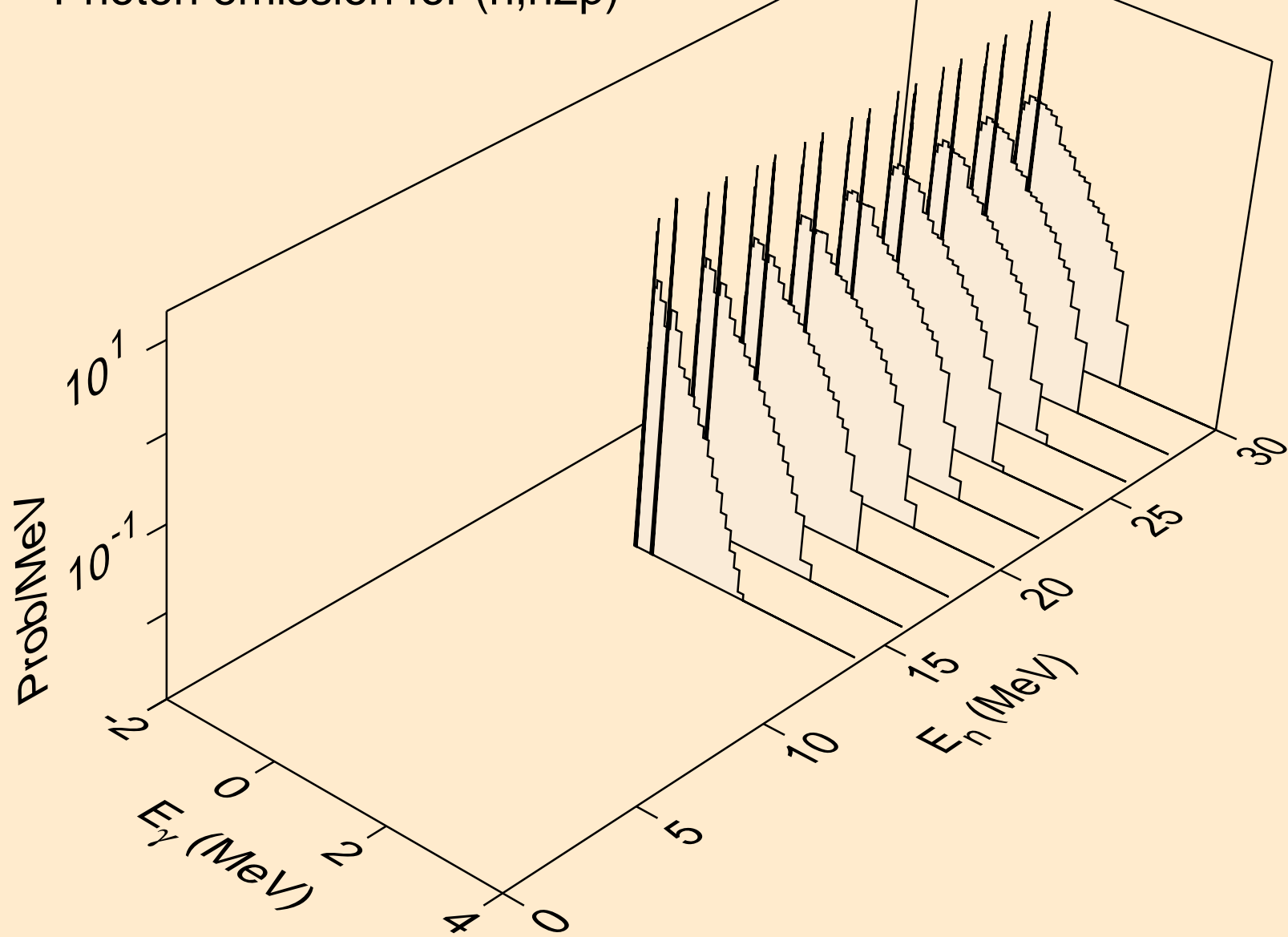

PU227 TRITON ACER TENDL-2023 LIBRARY; T=0.K
Photon emission for (n,npa)

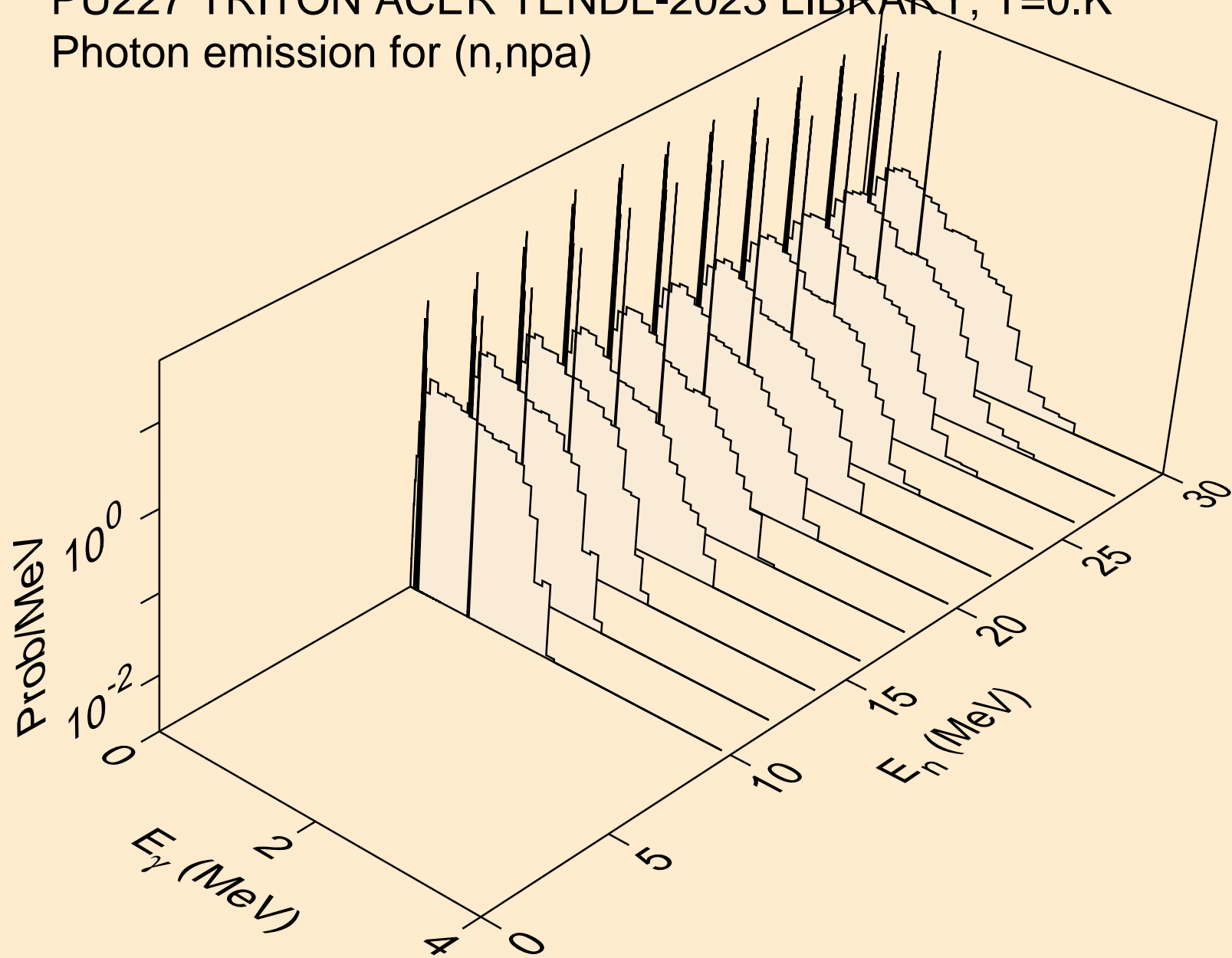

PU227 TRITON ACER TENDL-2023 LIBRARY; T=0.K
Photon emission for (n,p)

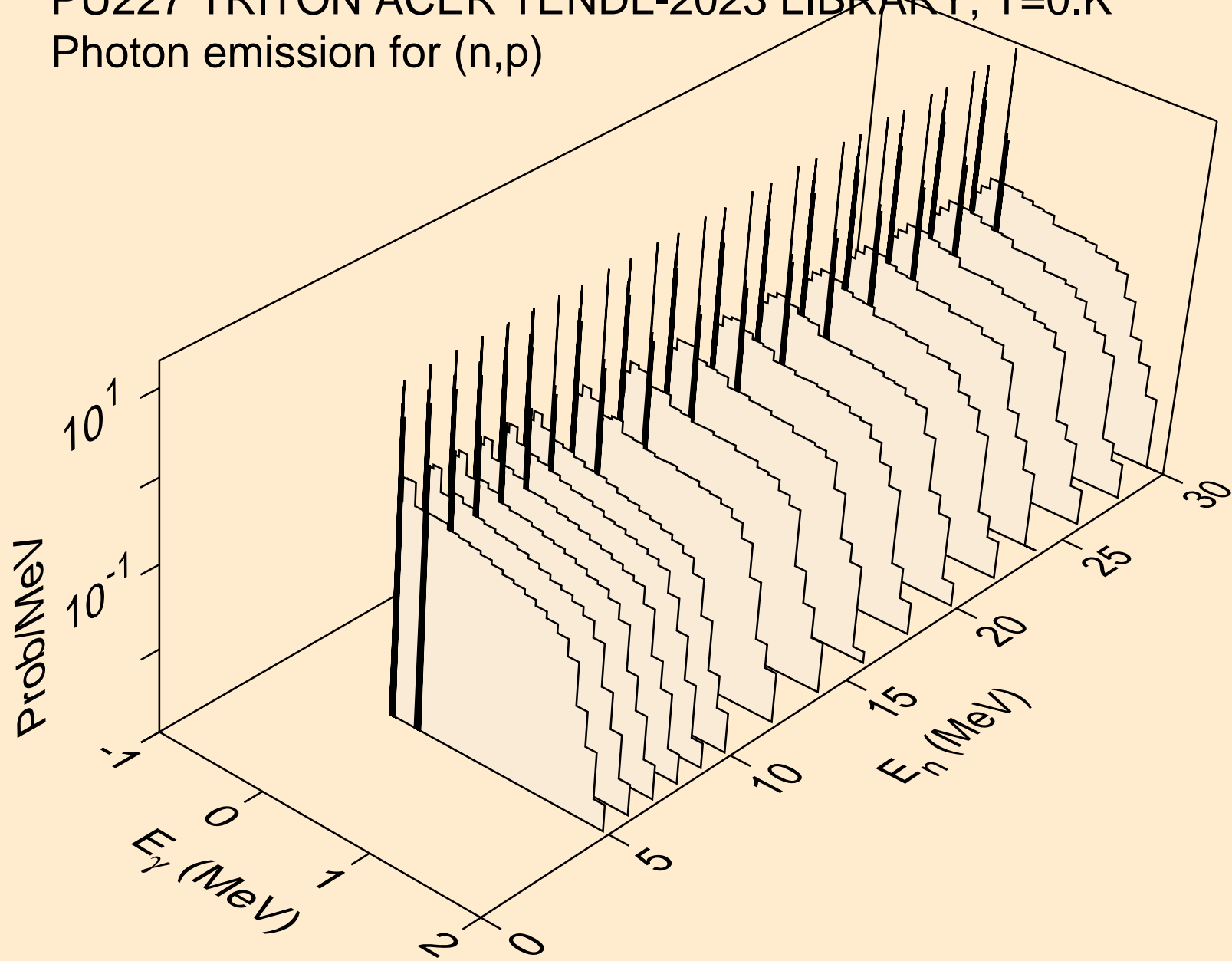

PU227 TRITON ACER TENDL-2023 LIBRARY; T=0.K
Photon emission for (n,d)

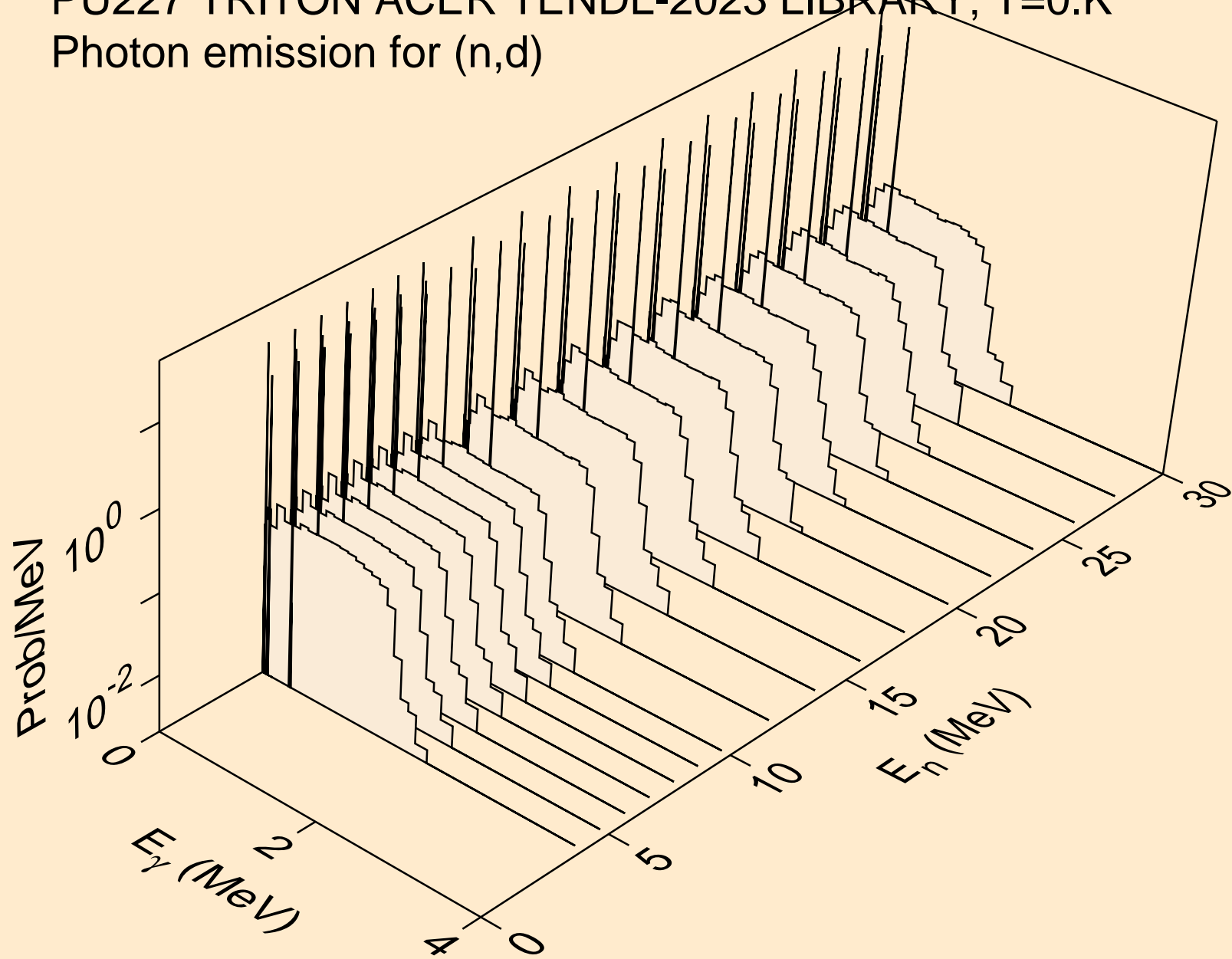

PU227 TRITON ACER TENDL-2023 LIBRARY; T=0.K
Photon emission for inelastic

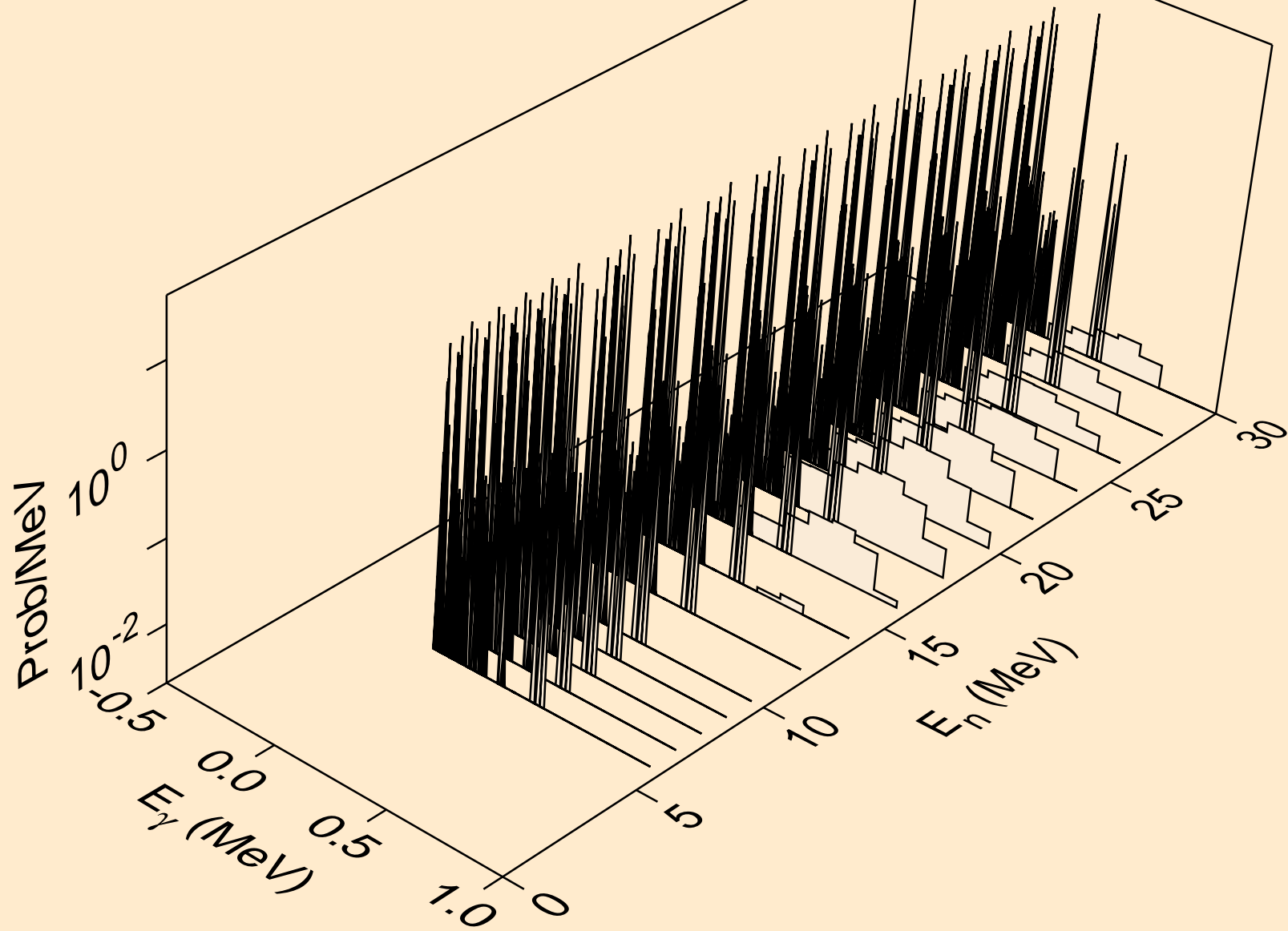

PU227 TRITON ACER TENDL-2023 LIBRARY; T=0.K
Photon emission for (n,he3)

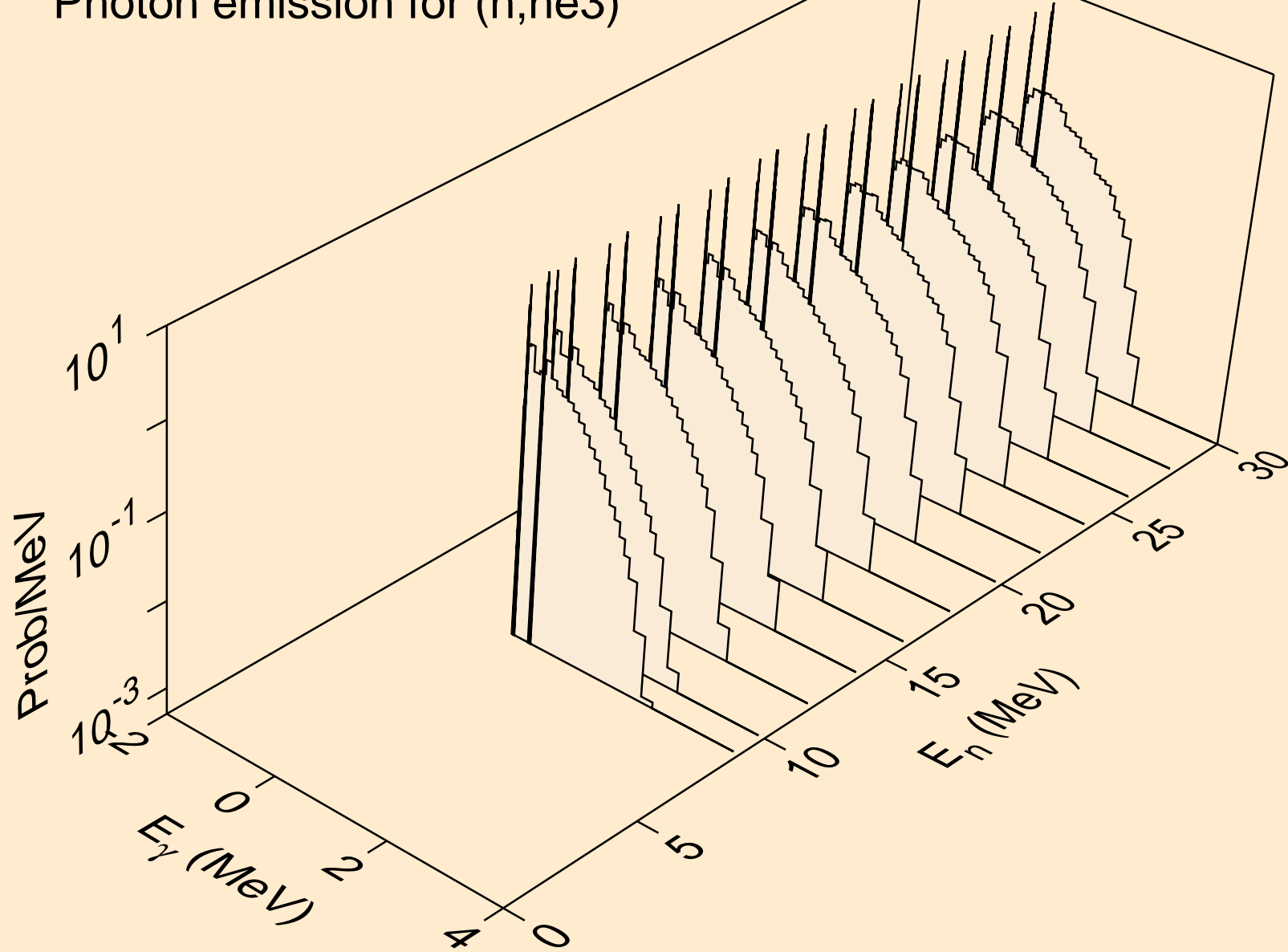

PU227 TRITON ACER TENDL-2023 LIBRARY; T=0.K
Photon emission for (n,a)

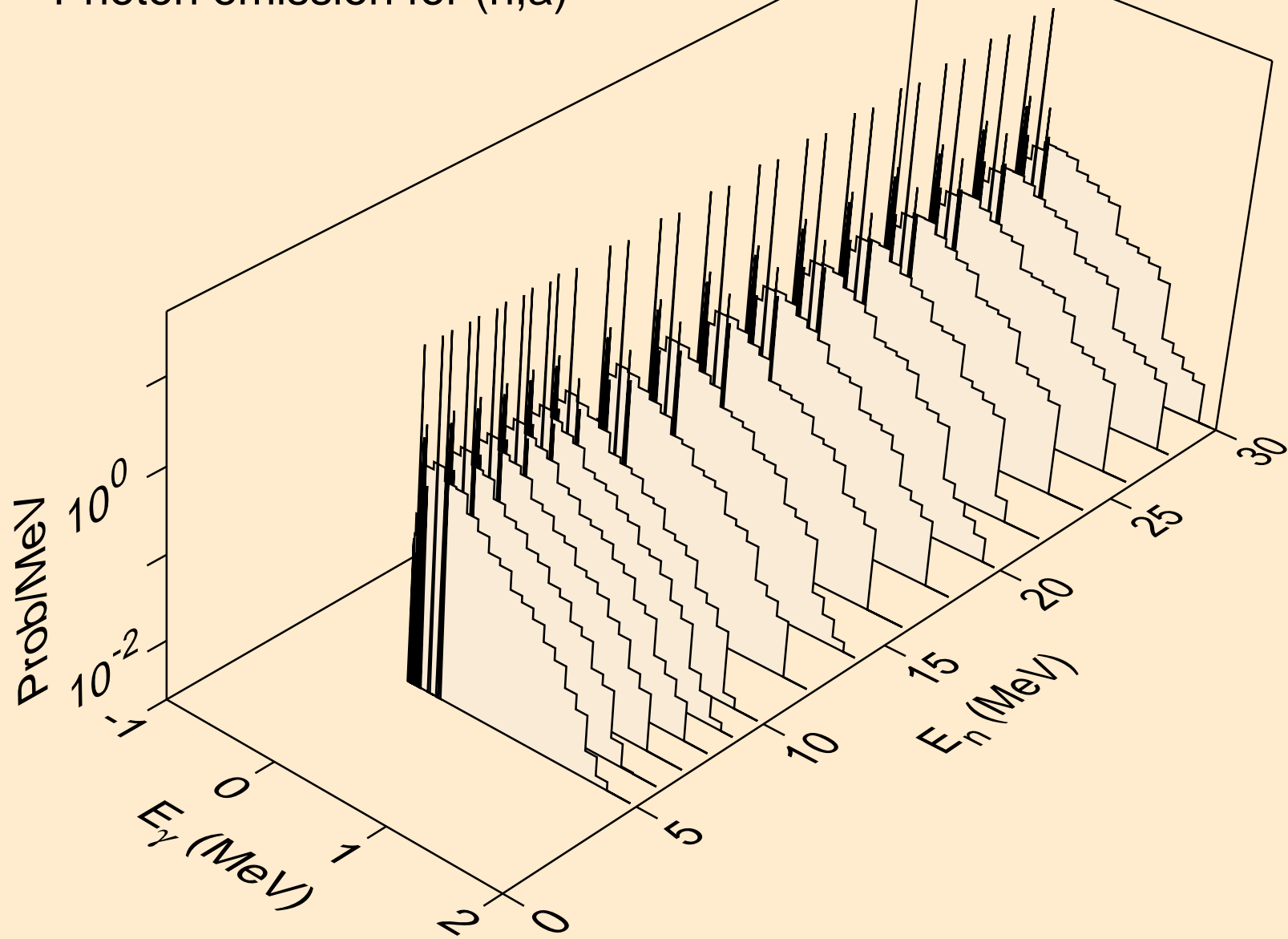

PU227 TRITON ACER TENDL-2023 LIBRARY; T=0.K
Photon emission for (n,2a)

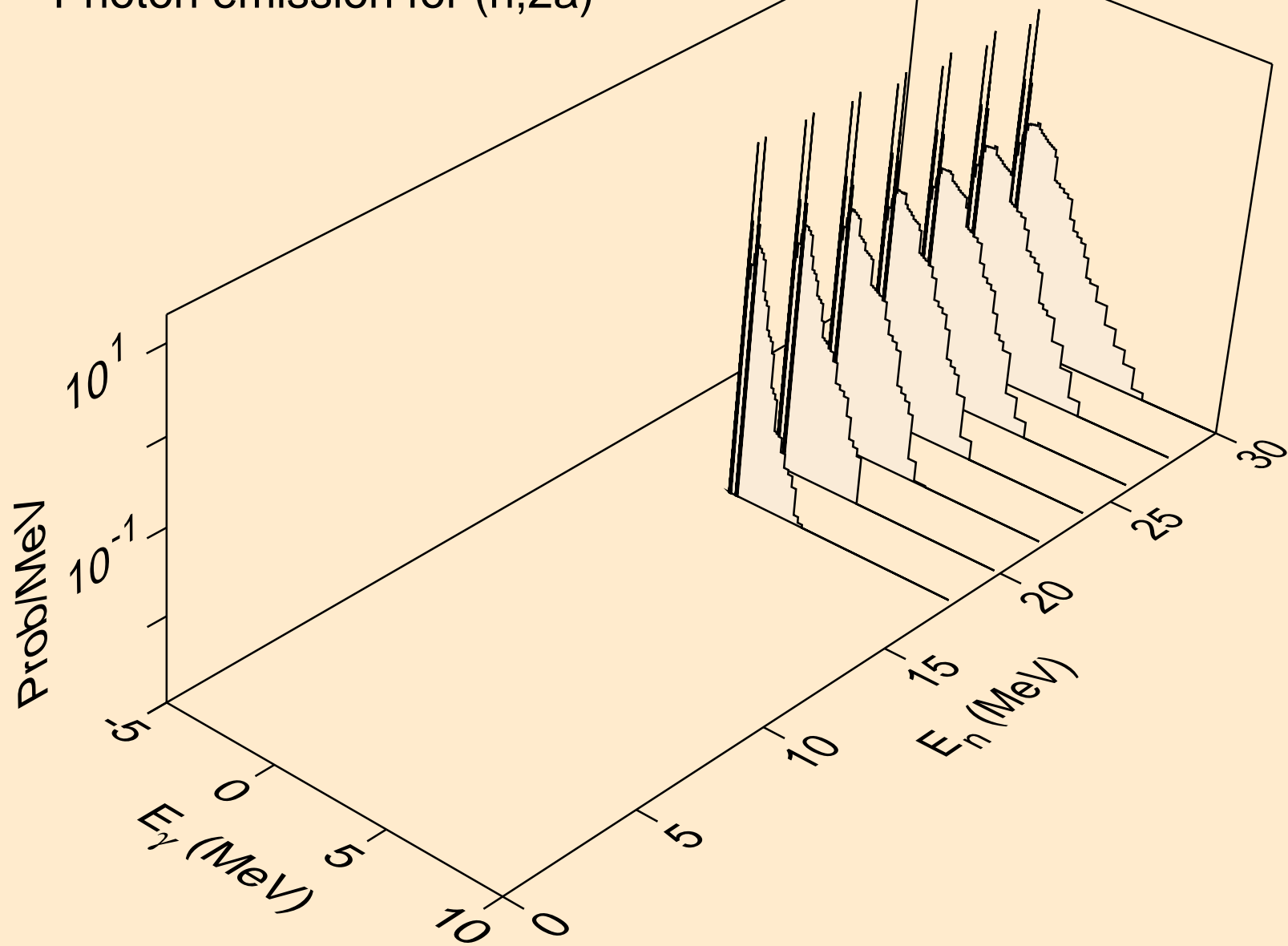

PU227 TRITON ACER TENDL-2023 LIBRARY; T=0.K
Photon emission for (n,2p)

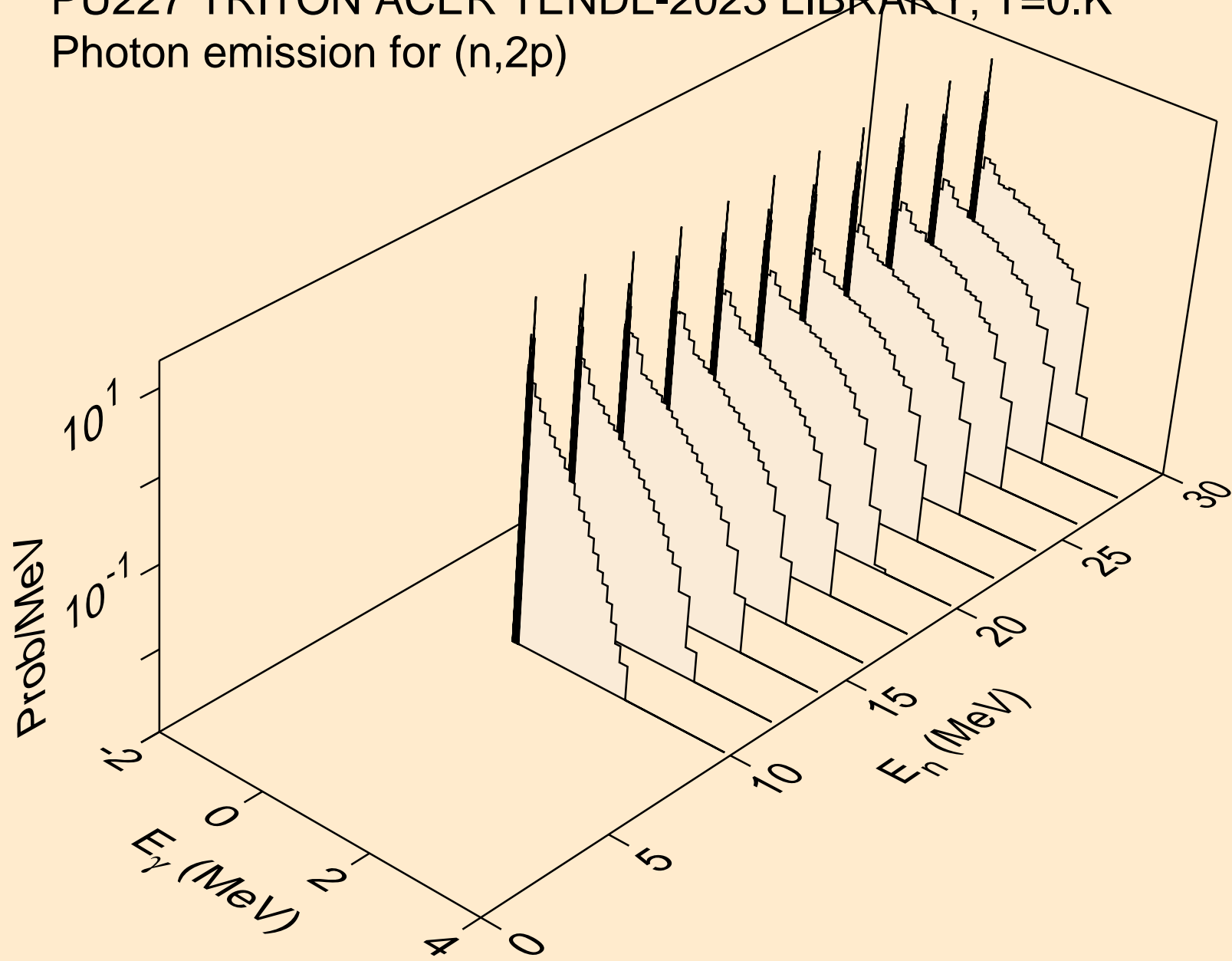

PU227 TRITON ACER TENDL-2023 LIBRARY; T=0.K
Photon emission for (n,pa)

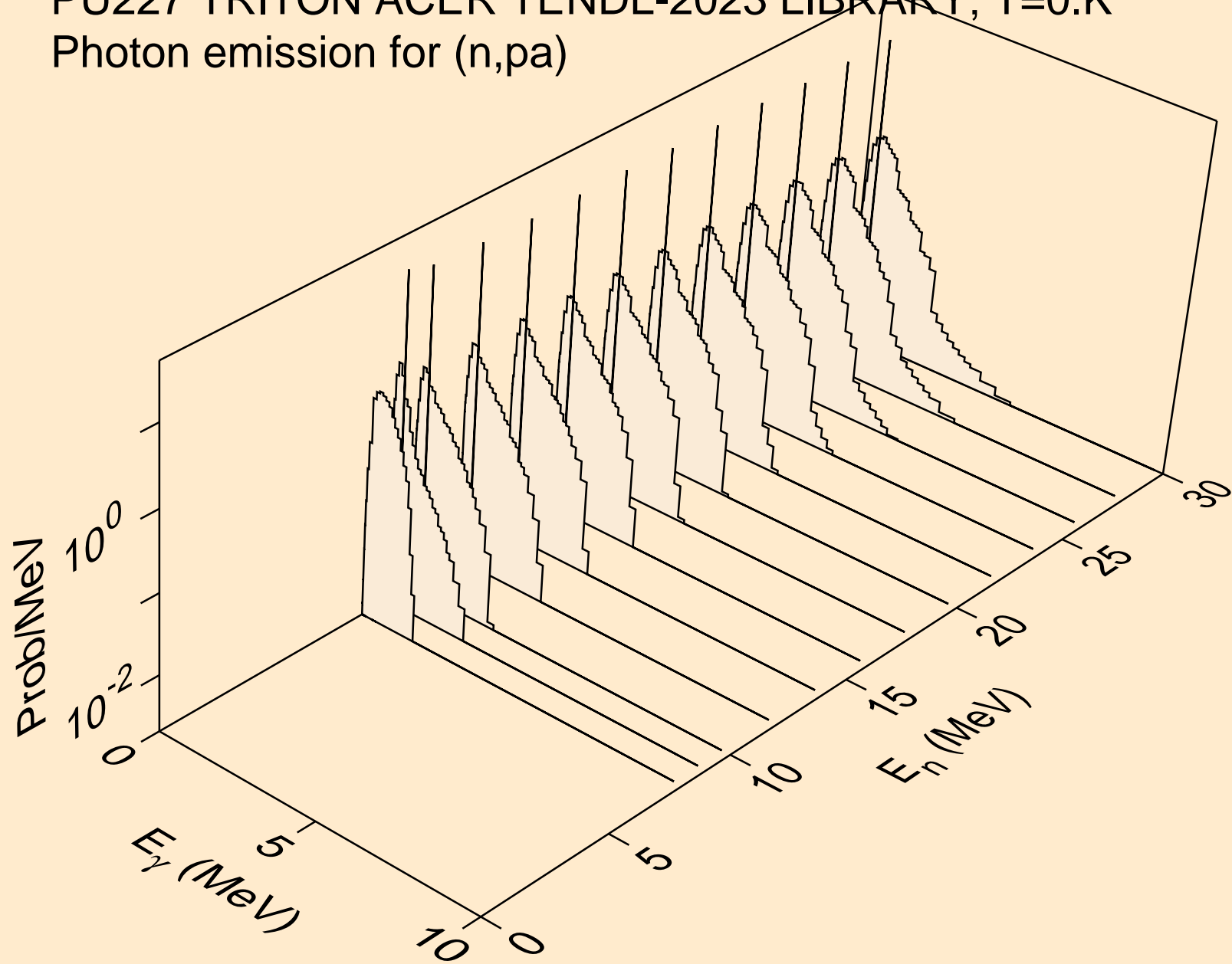

PU227 TRITON ACER TENDL-2023 LIBRARY; T=0.K
Photon emission for (n,pd)

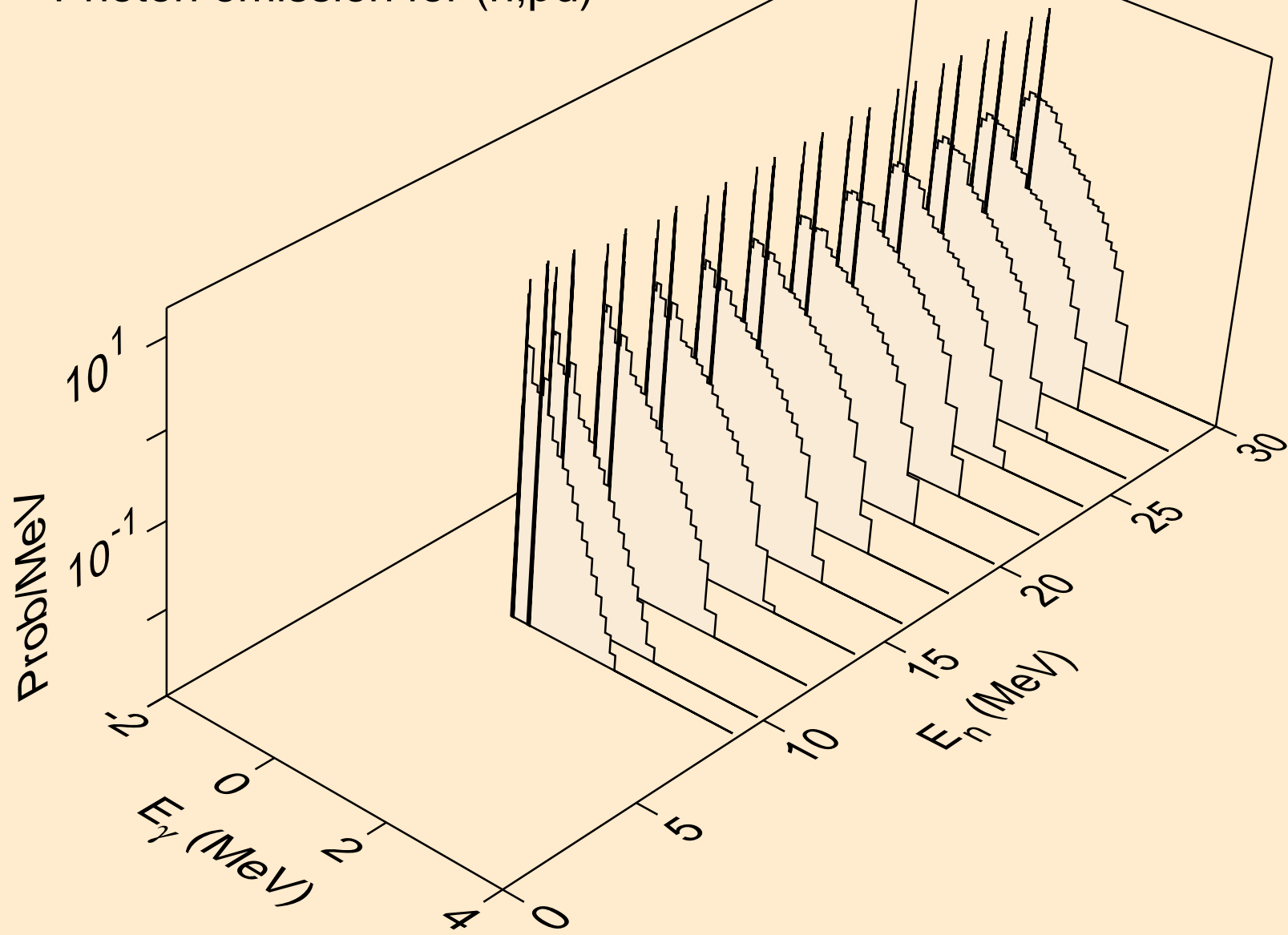

PU227 TRITON ACER TENDL-2023 LIBRARY; T=0.K
Particle heating contributions

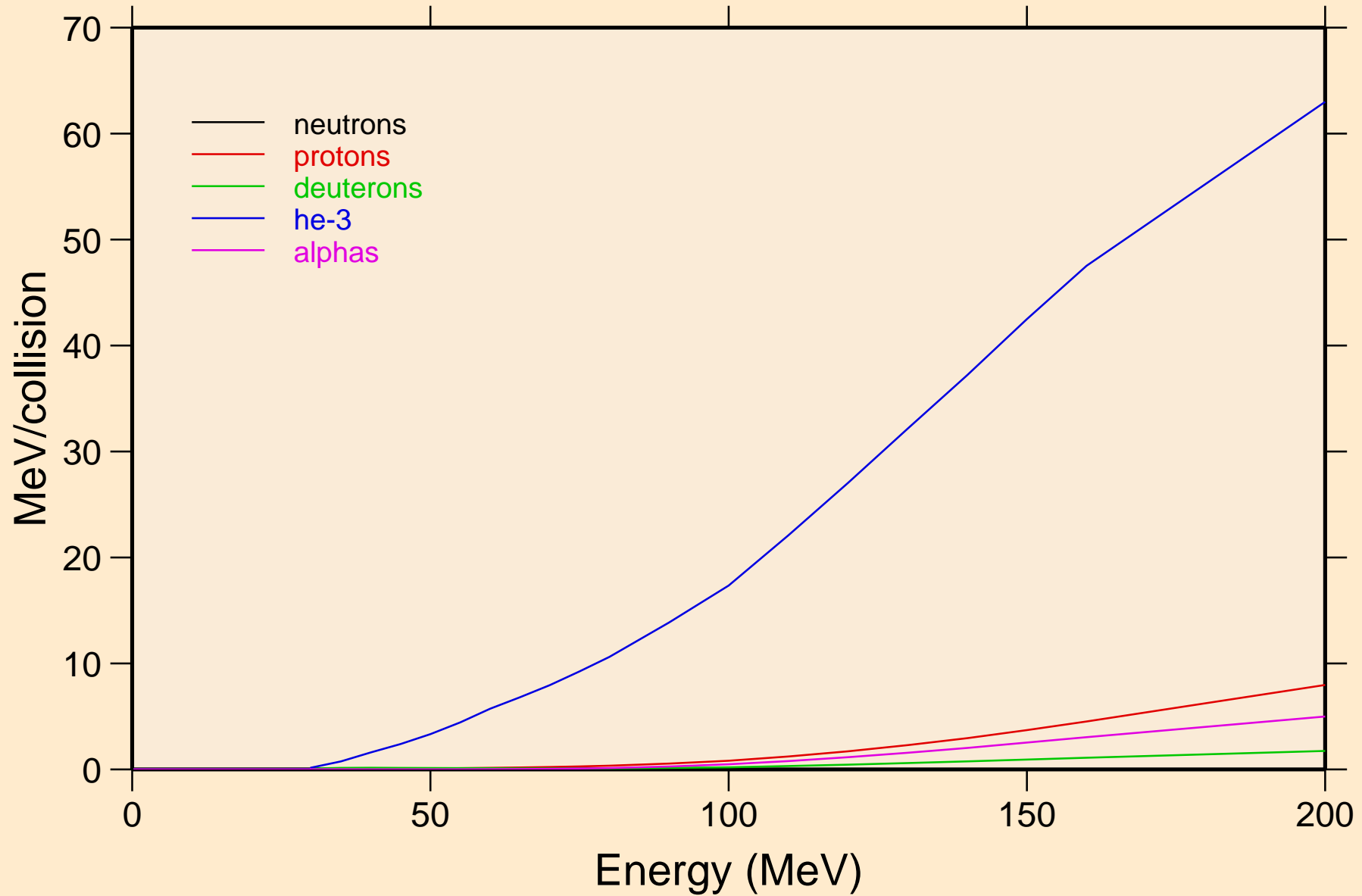

PU227 TRITON ACER TENDL-2023 LIBRARY; T=0.K
Recoil Heating

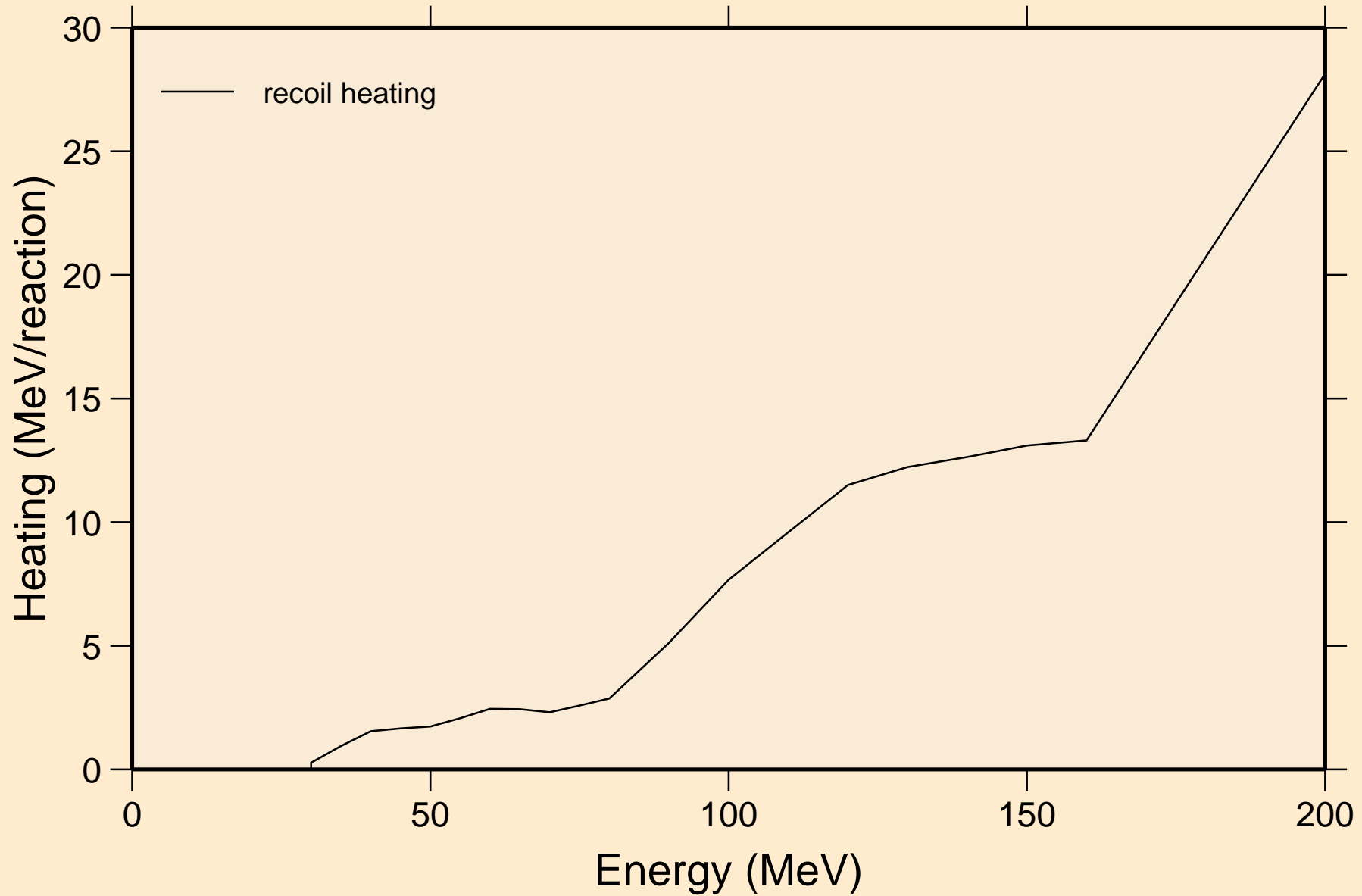

PU227 TRITON ACER TENDL-2023 LIBRARY; T=0.K
Particle production cross sections

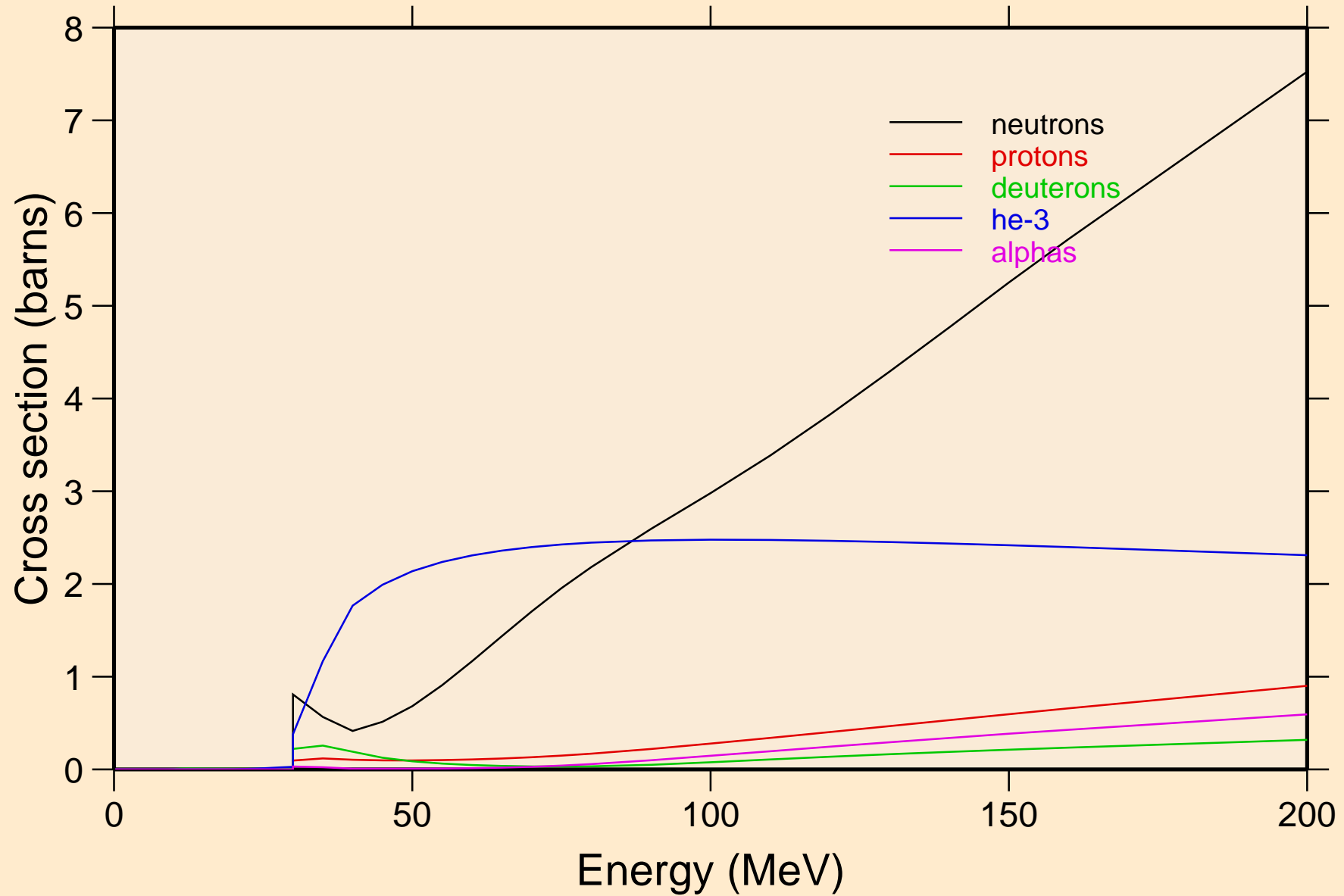

PU227 TRITON ACER TENDL-2023 LIBRARY; T=0.K
neutrons from (t,n)

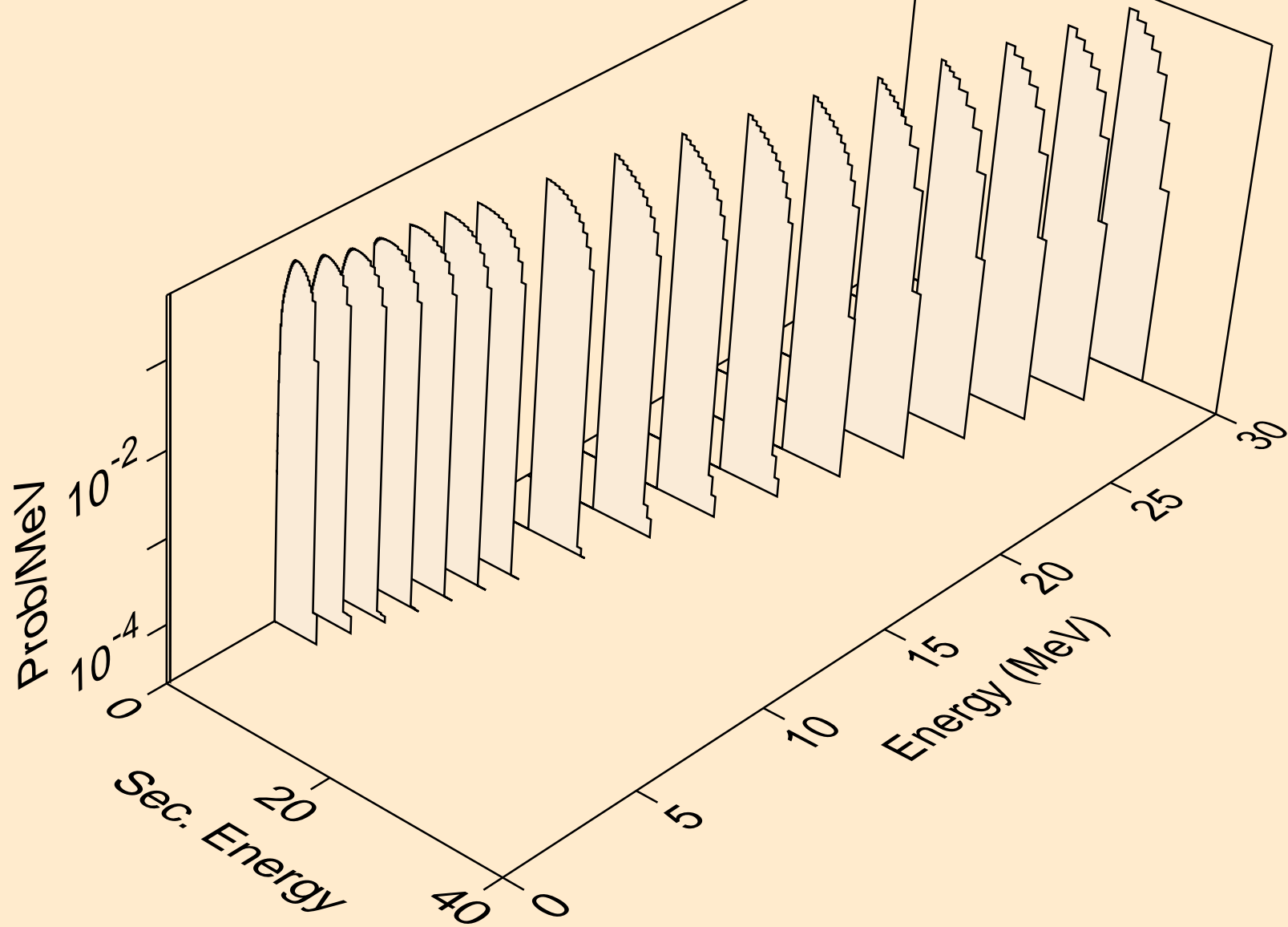

PU227 TRITON ACER TENDL-2023 LIBRARY; T=0.K
neutrons from (t,x)

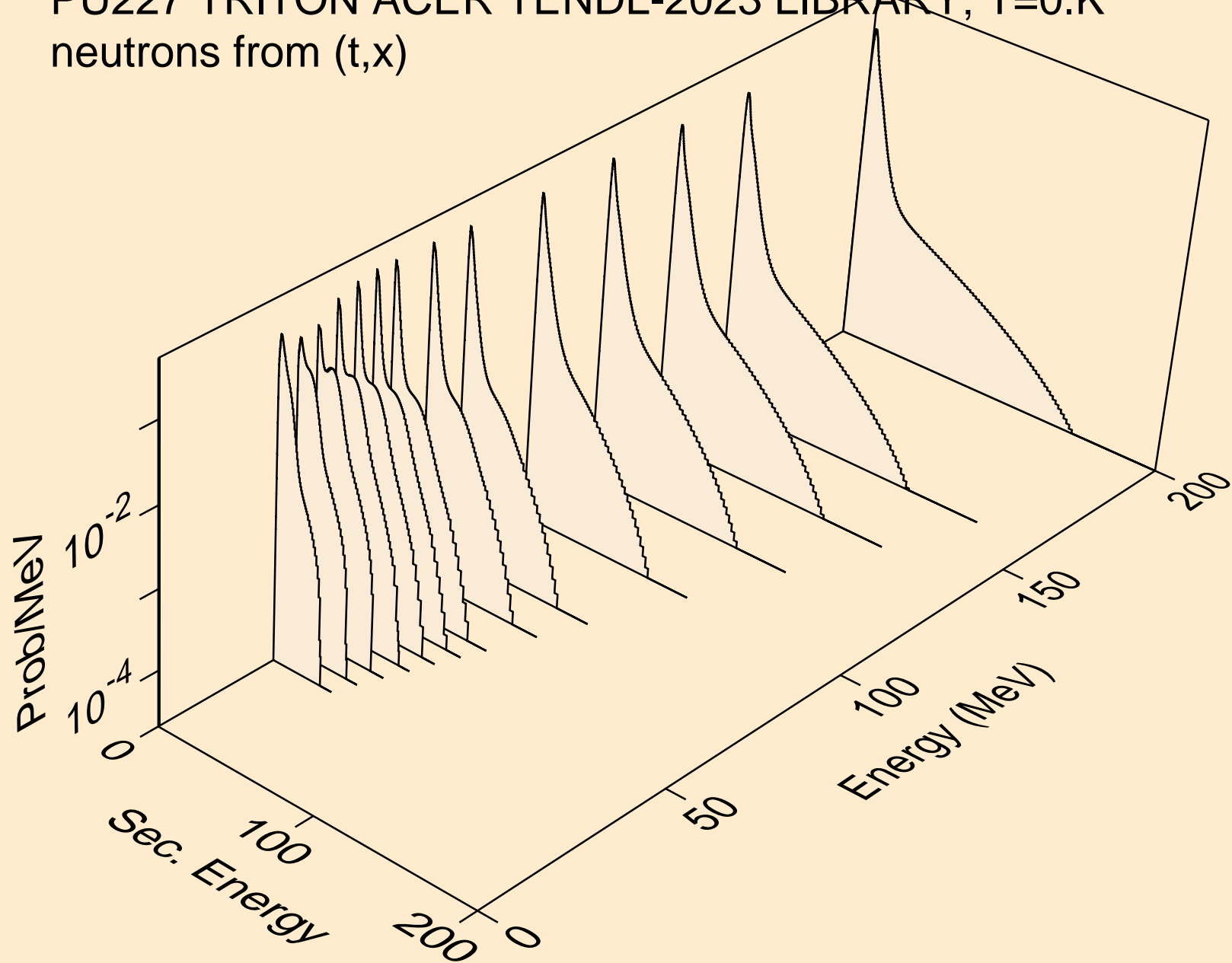

PU227 TRITON ACER TENDL-2023 LIBRARY; T=0.K
neutrons from (t,n*)a

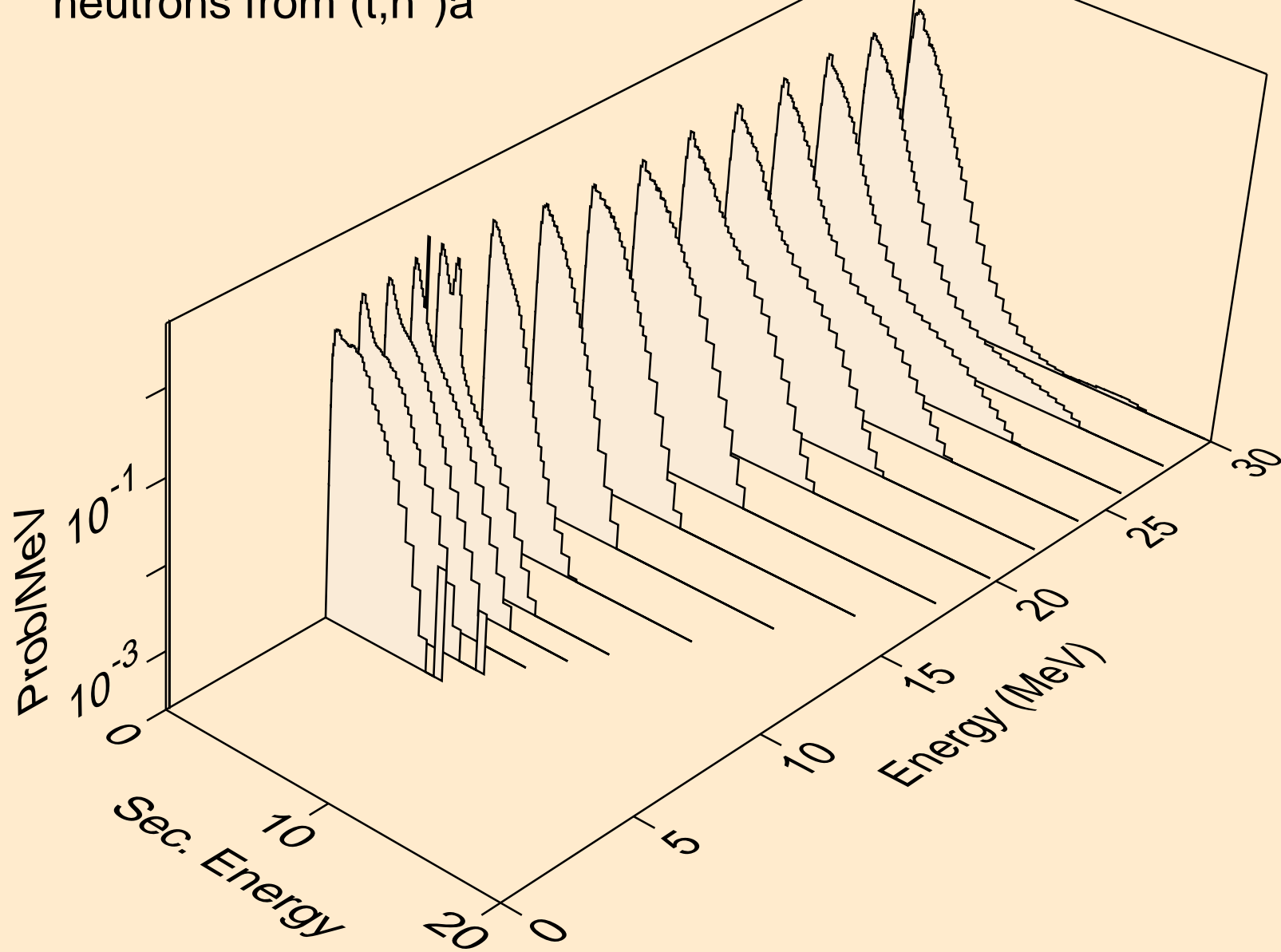

PU227 TRITON ACER TENDL-2023 LIBRARY; T=0.K
neutrons from (t,2n)a

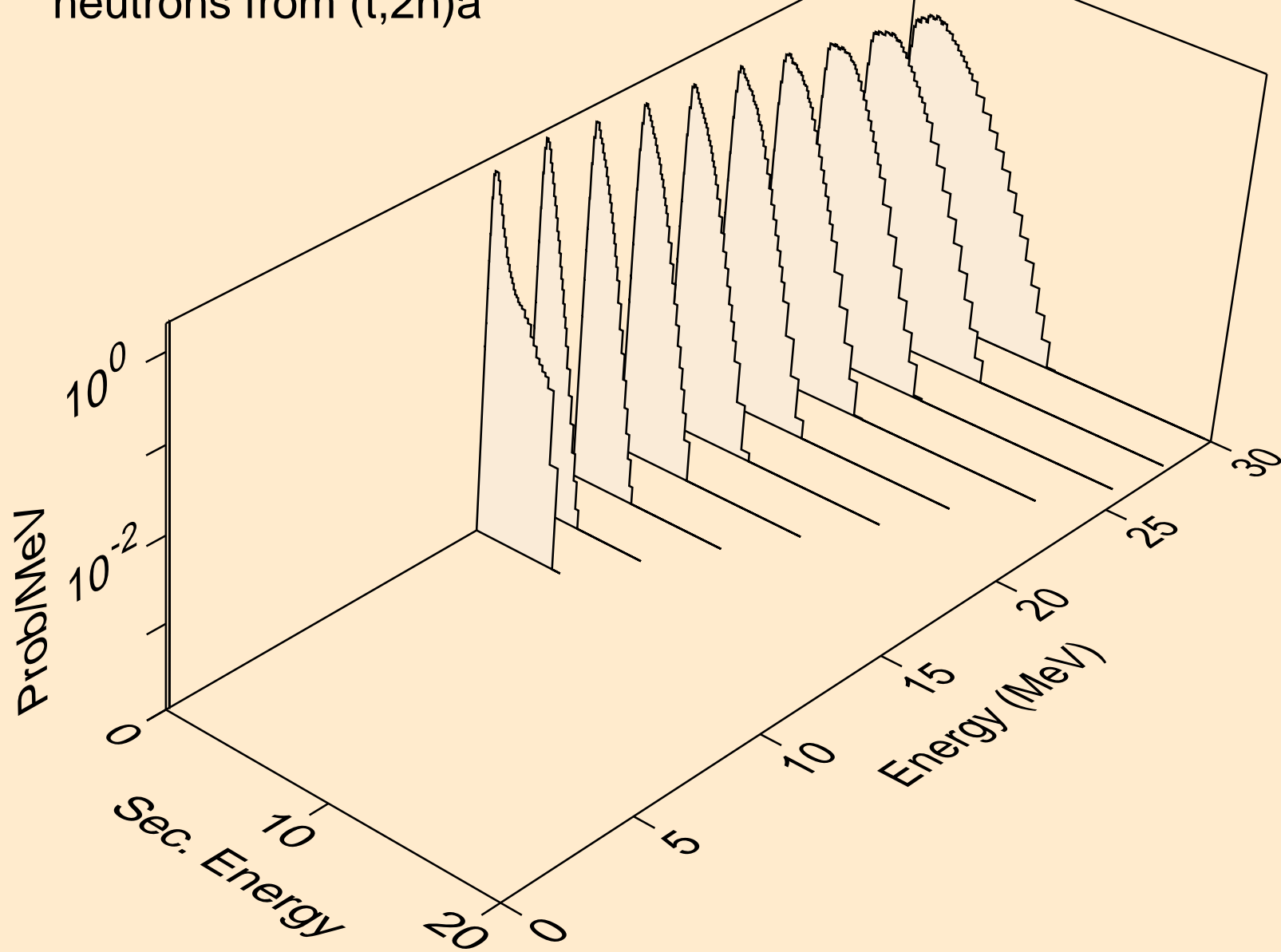

PU227 TRITON ACER TENDL-2023 LIBRARY; T=0.K
neutrons from (t,n*)p

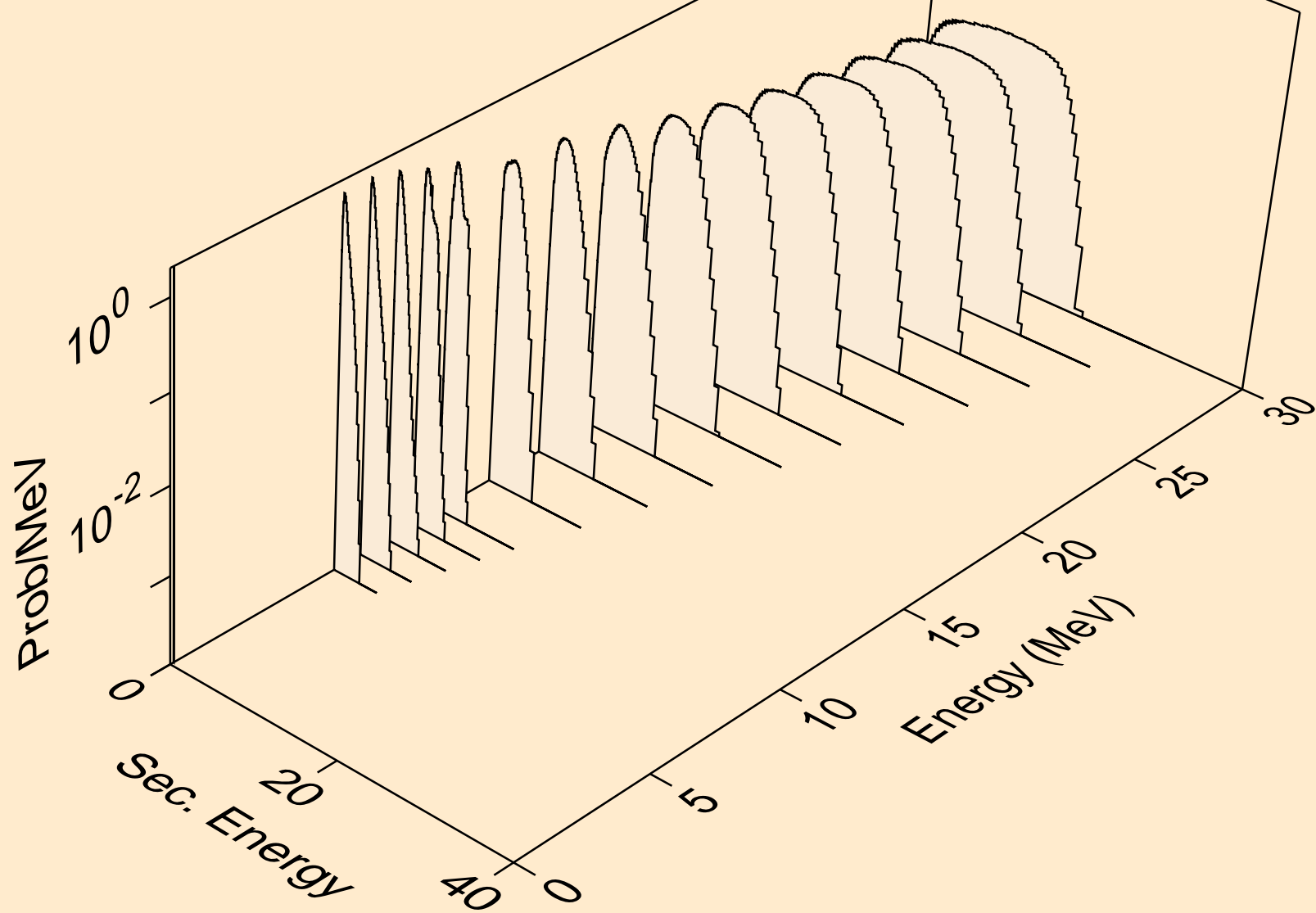

PU227 TRITON ACER TENDL-2023 LIBRARY; T=0.K
neutrons from (t,n*)2a

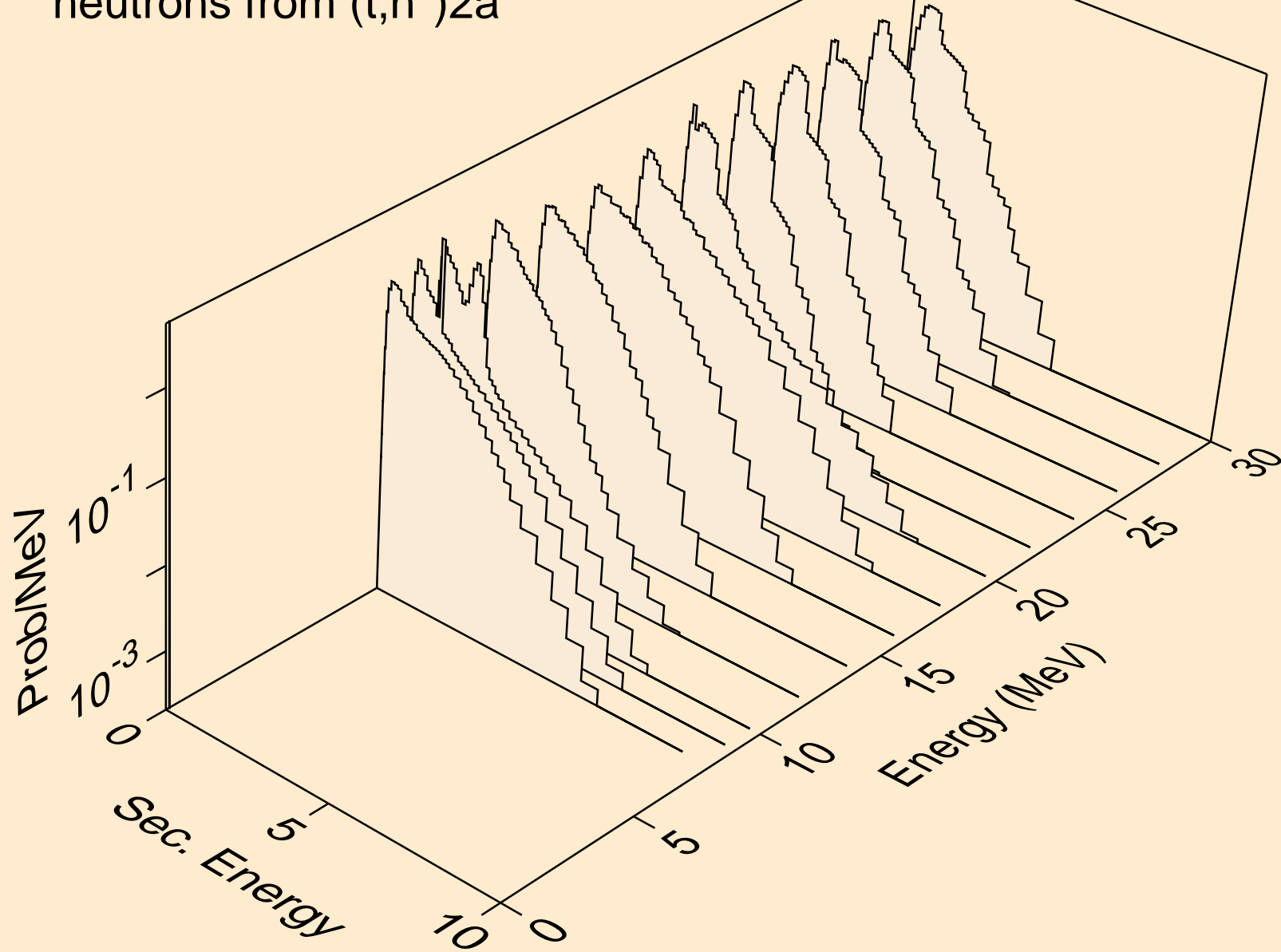

PU227 TRITON ACER TENDL-2023 LIBRARY; T=0.K
neutrons from (t,2n)2a

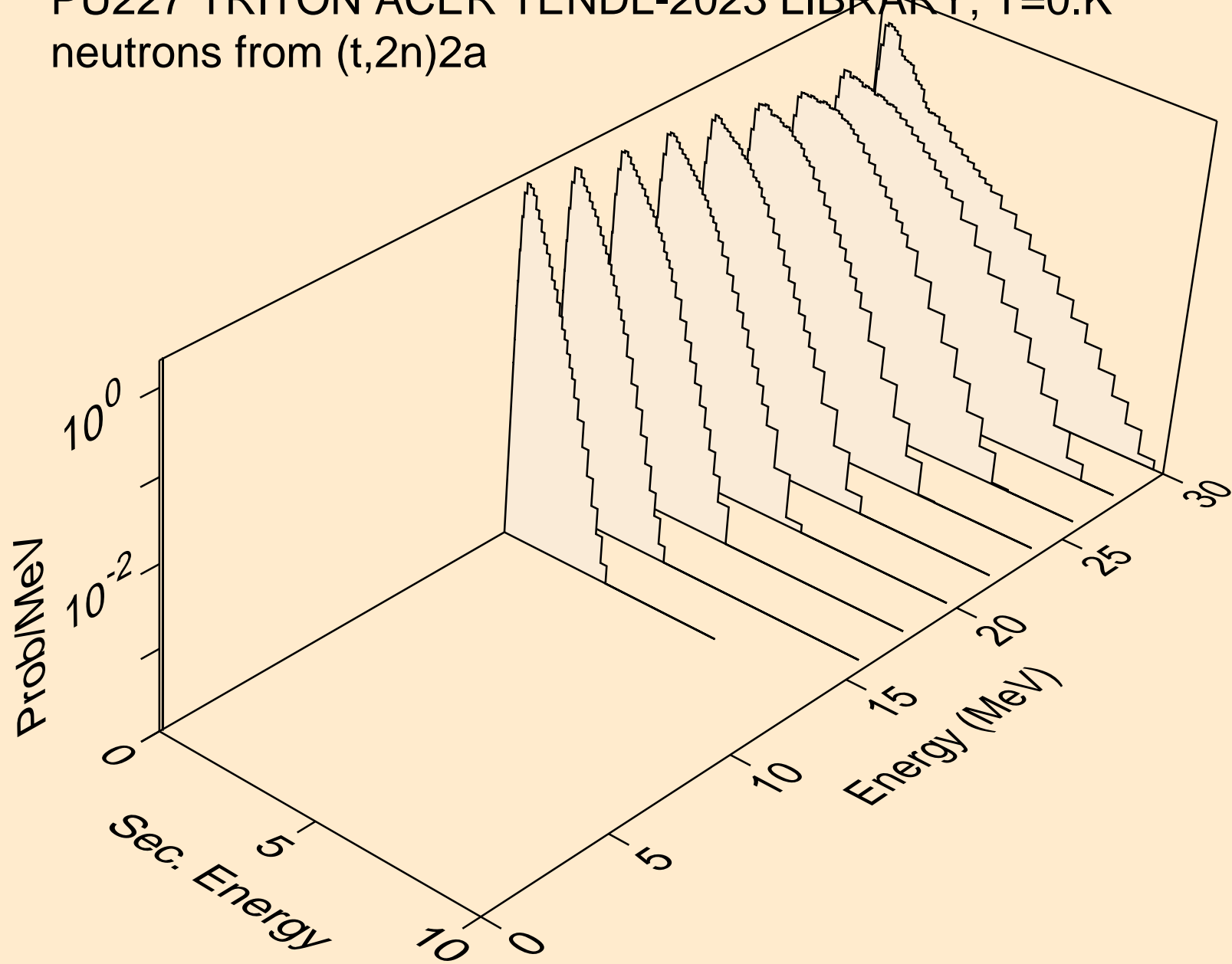

PU227 TRITON ACER TENDL-2023 LIBRARY; T=0.K
neutrons from (t,n*)d

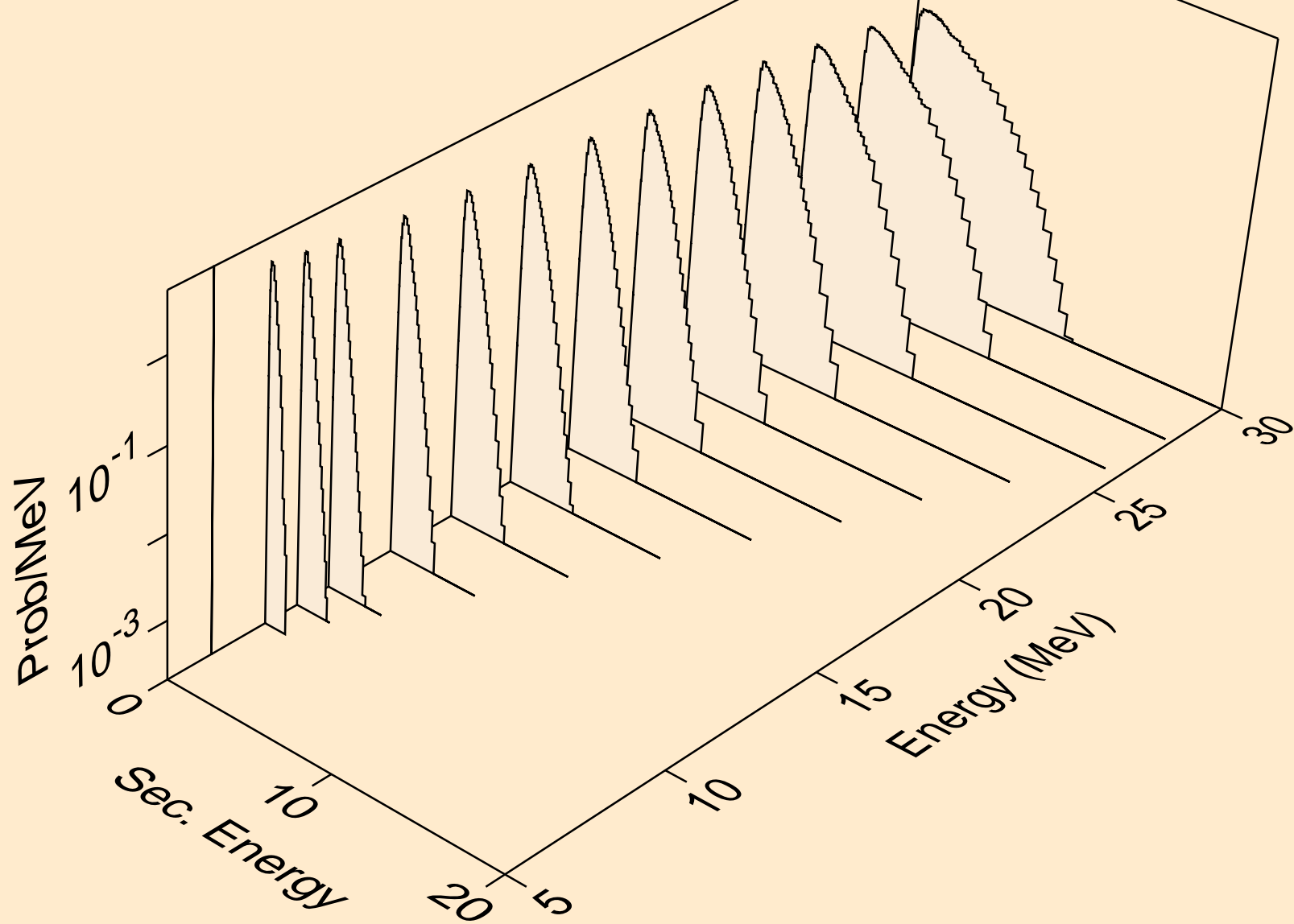

PU227 TRITON ACER TENDL-2023 LIBRARY; T=0.K
neutrons from (t,n*)t

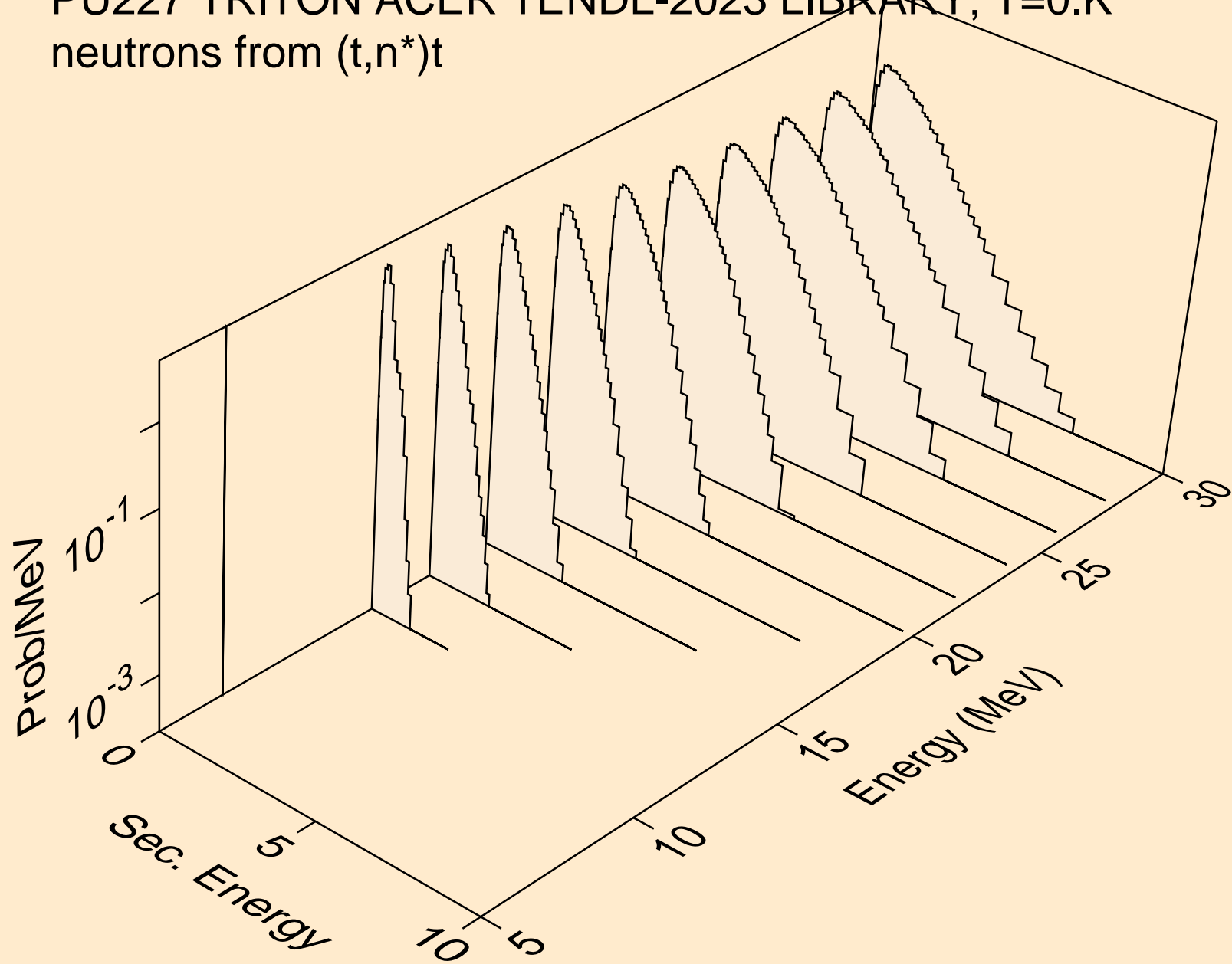

PU227 TRITON ACER TENDL-2023 LIBRARY; T=0.K
neutrons from (t,n*)he3

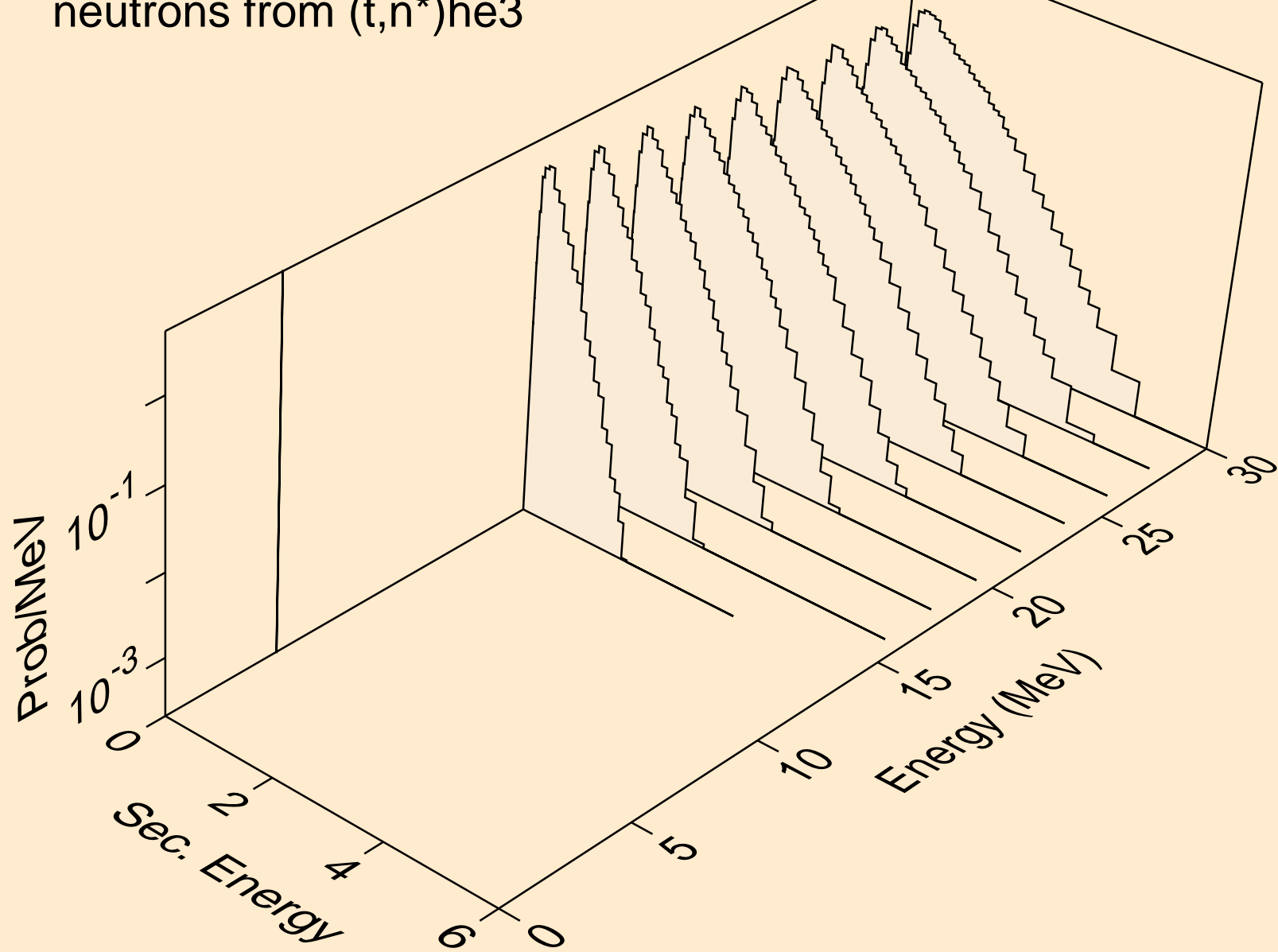

PU227 TRITON ACER TENDL-2023 LIBRARY; T=0.K
neutrons from (t,2np)

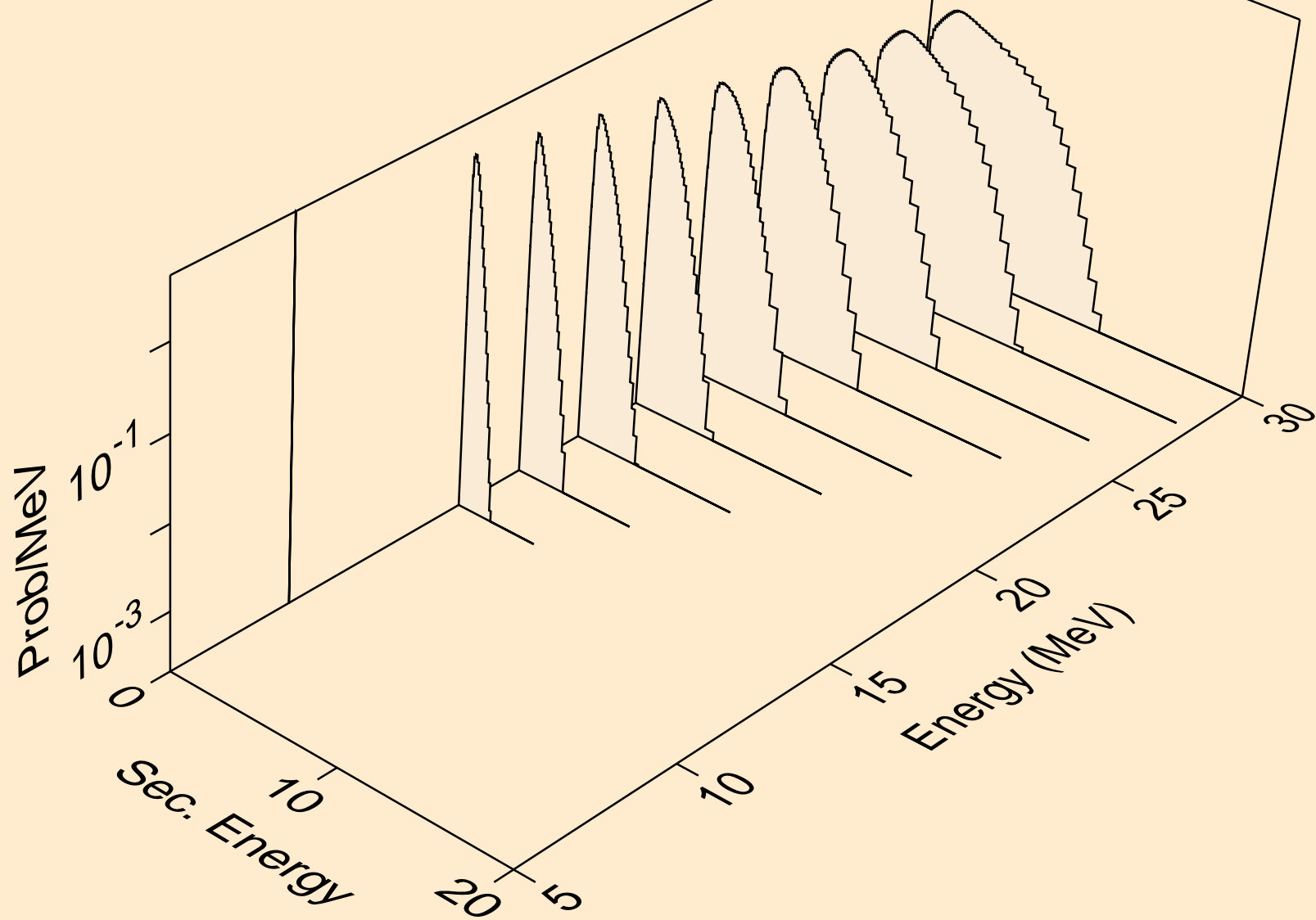

PU227 TRITON ACER TENDL-2023 LIBRARY; T=0.K
neutrons from (t,3np)

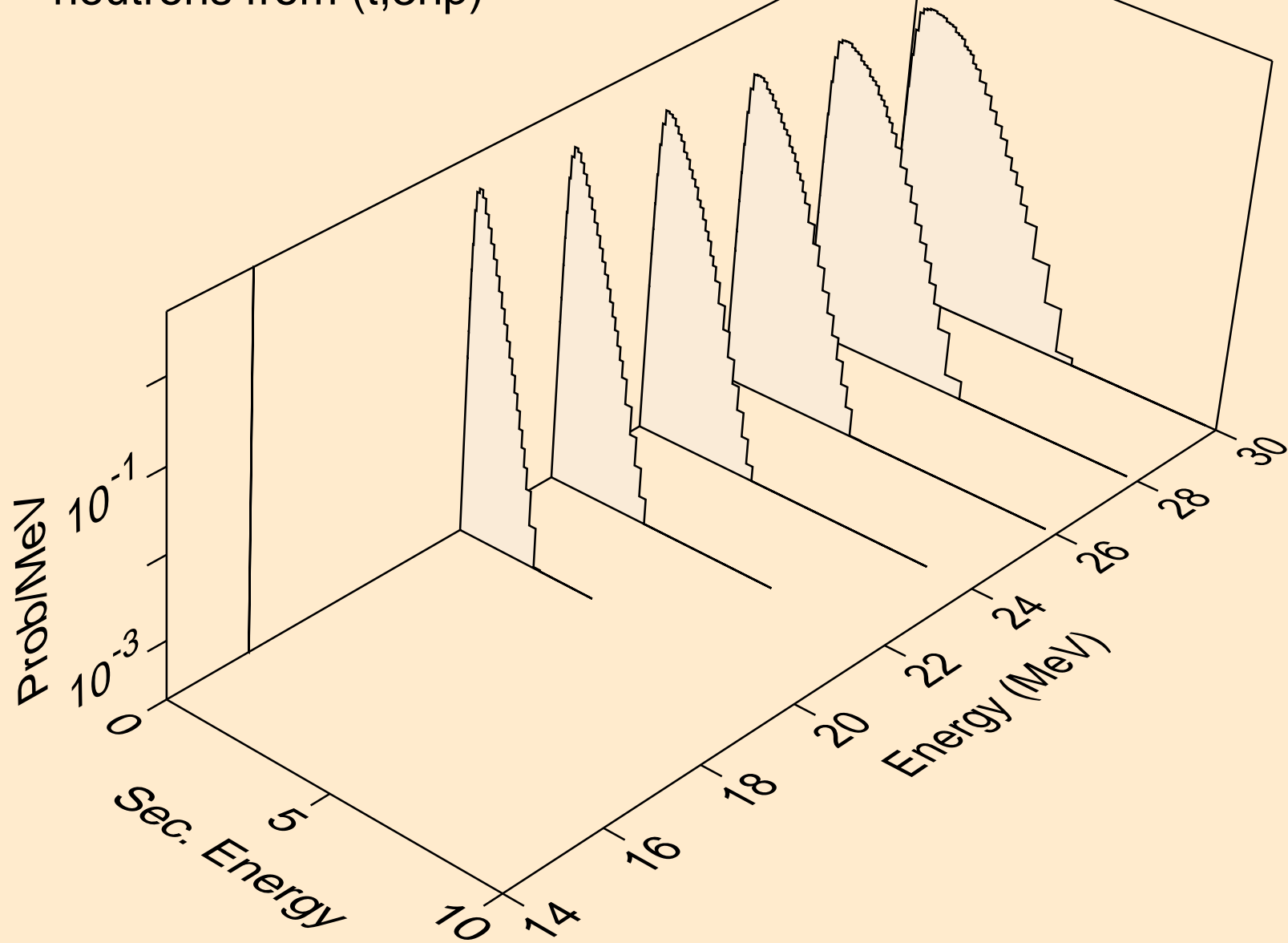

PU227 TRITON ACER TENDL-2023 LIBRARY; T=0.K
neutrons from (t,n2p)

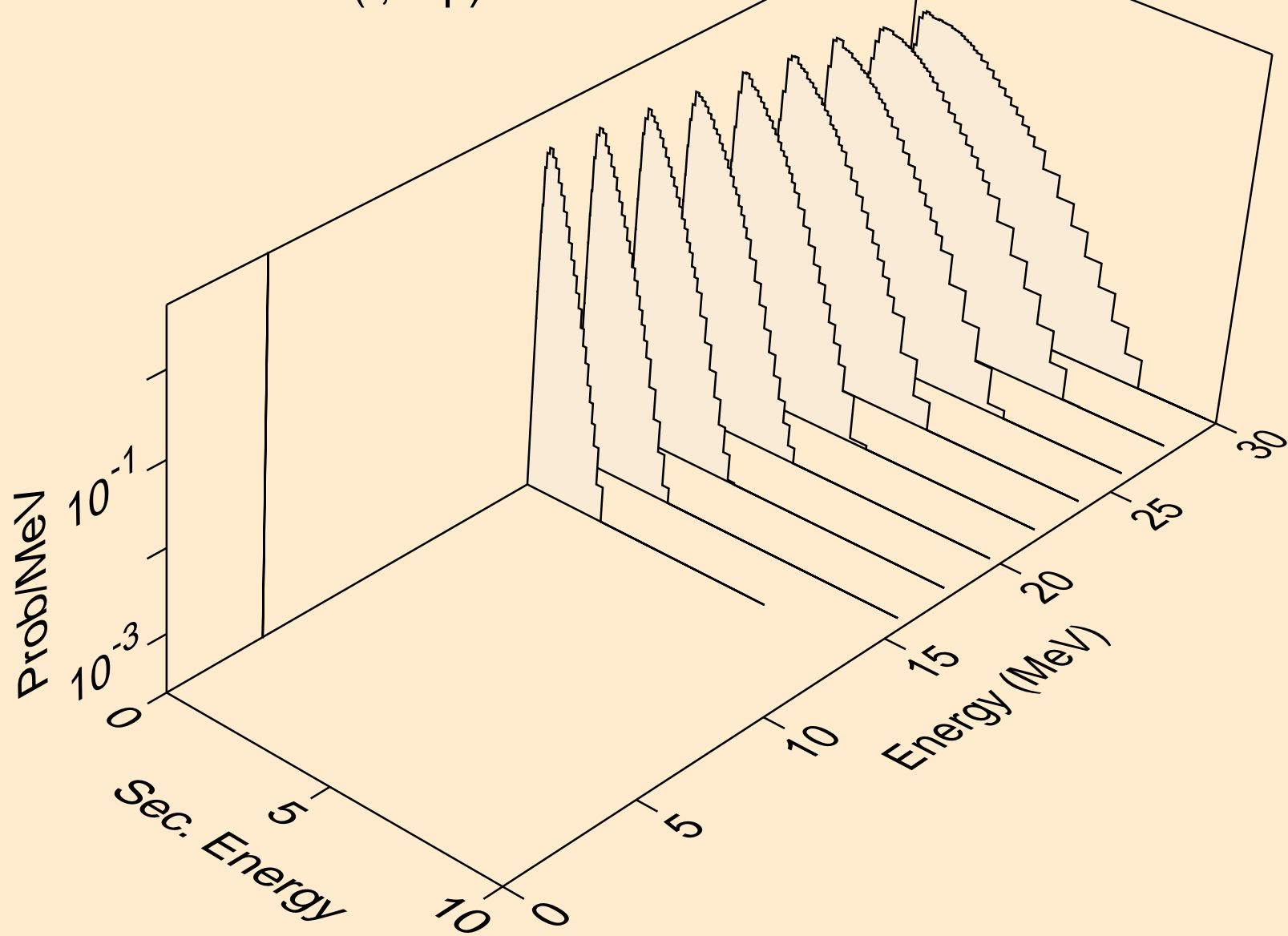

PU227 TRITON ACER TENDL-2023 LIBRARY; T=0.K
neutrons from (t,npa)

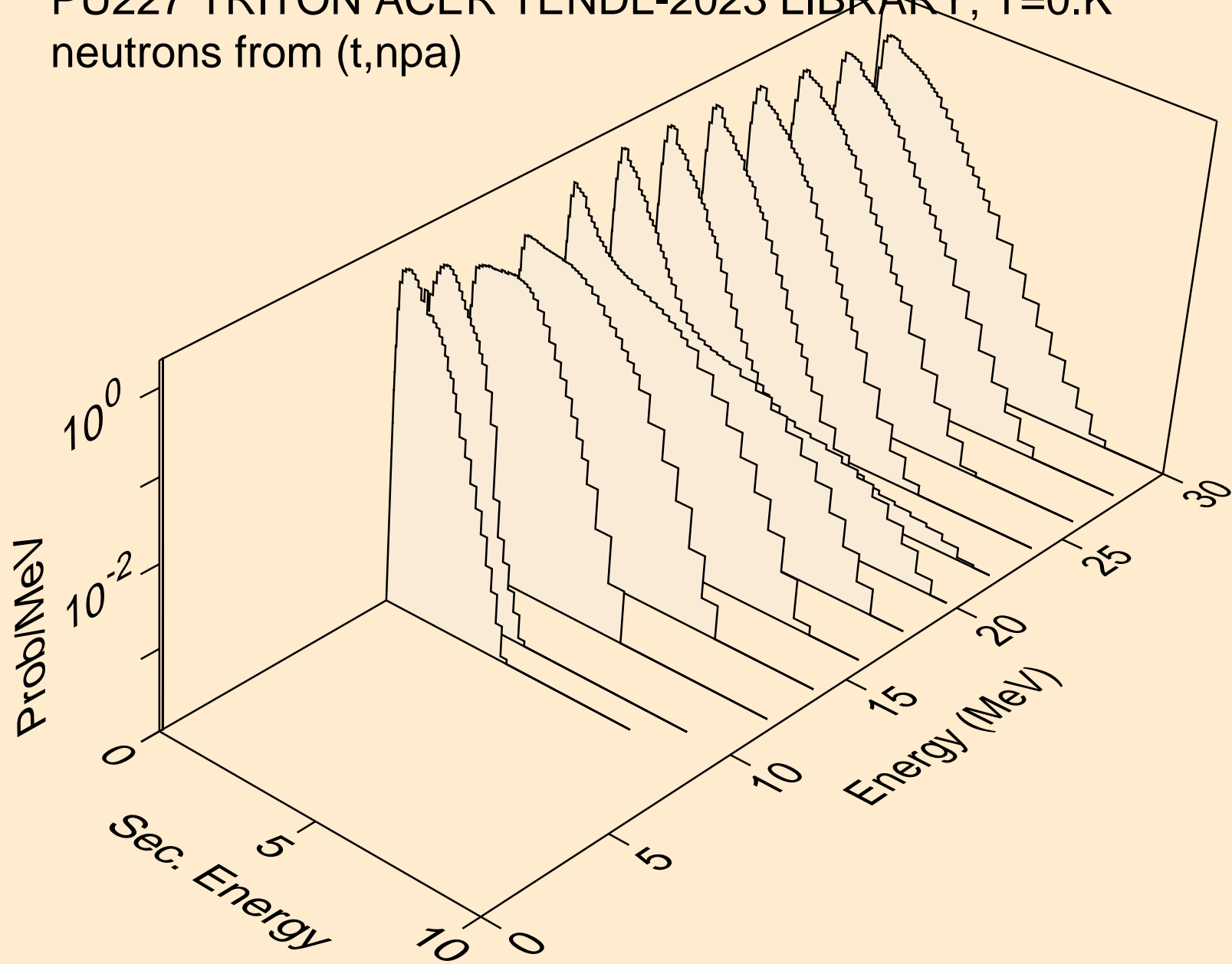

PU227 TRITON ACER TENDL-2023 LIBRARY; T=0.K
protons from (t,x)

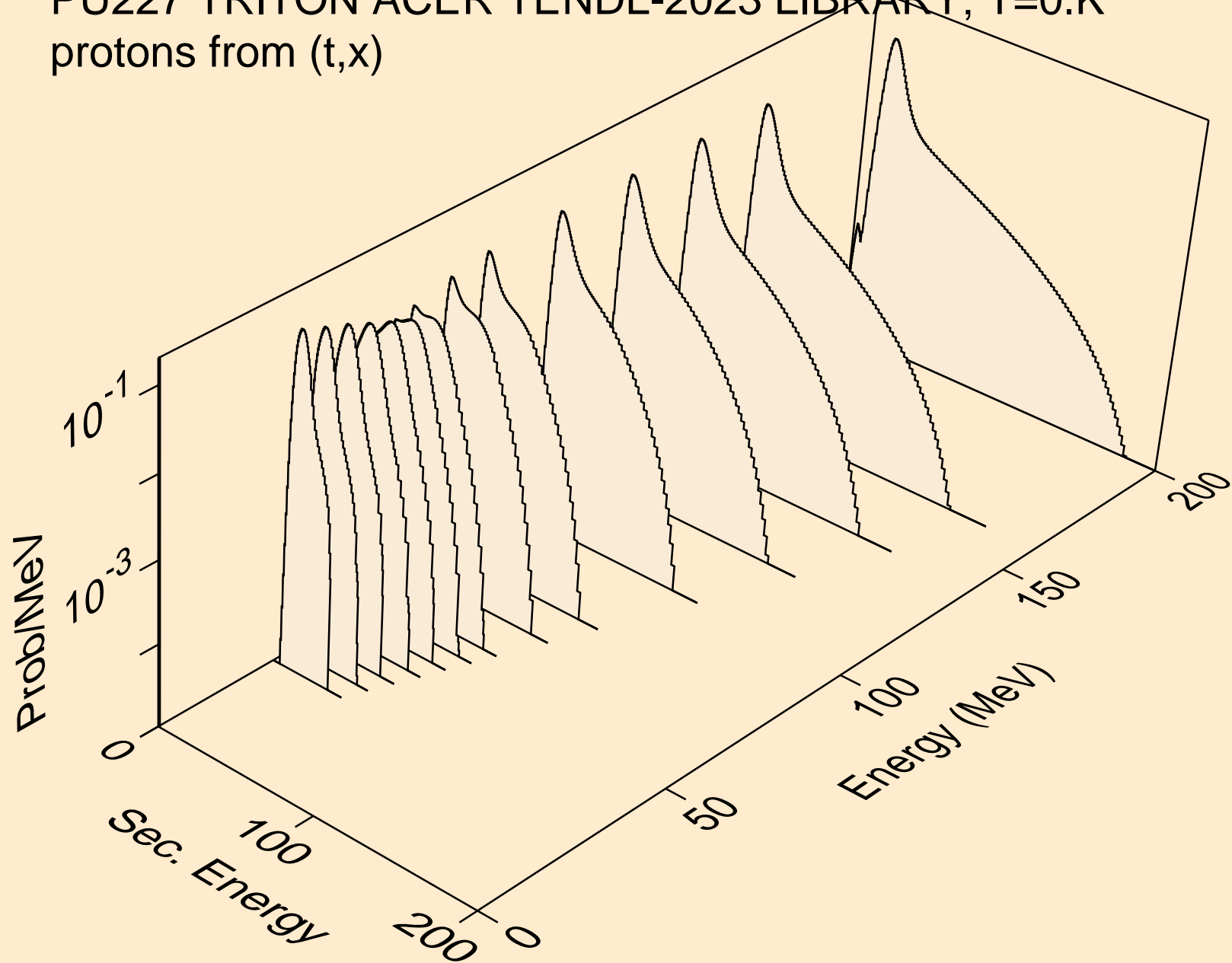

PU227 TRITON ACER TENDL-2023 LIBRARY; T=0.K
protons from (t,n*)p

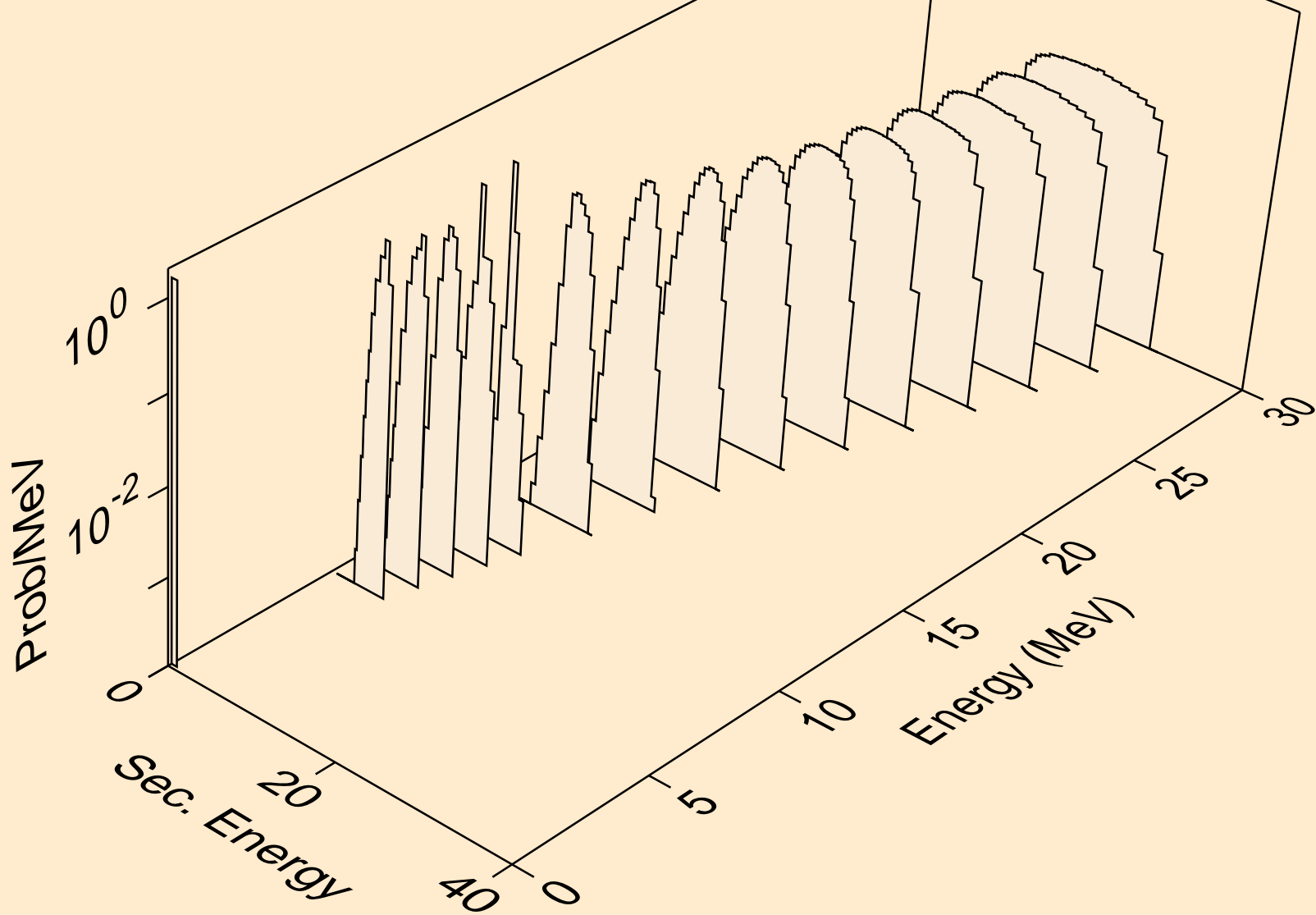

PU227 TRITON ACER TENDL-2023 LIBRARY; T=0.K
protons from (t,2np)

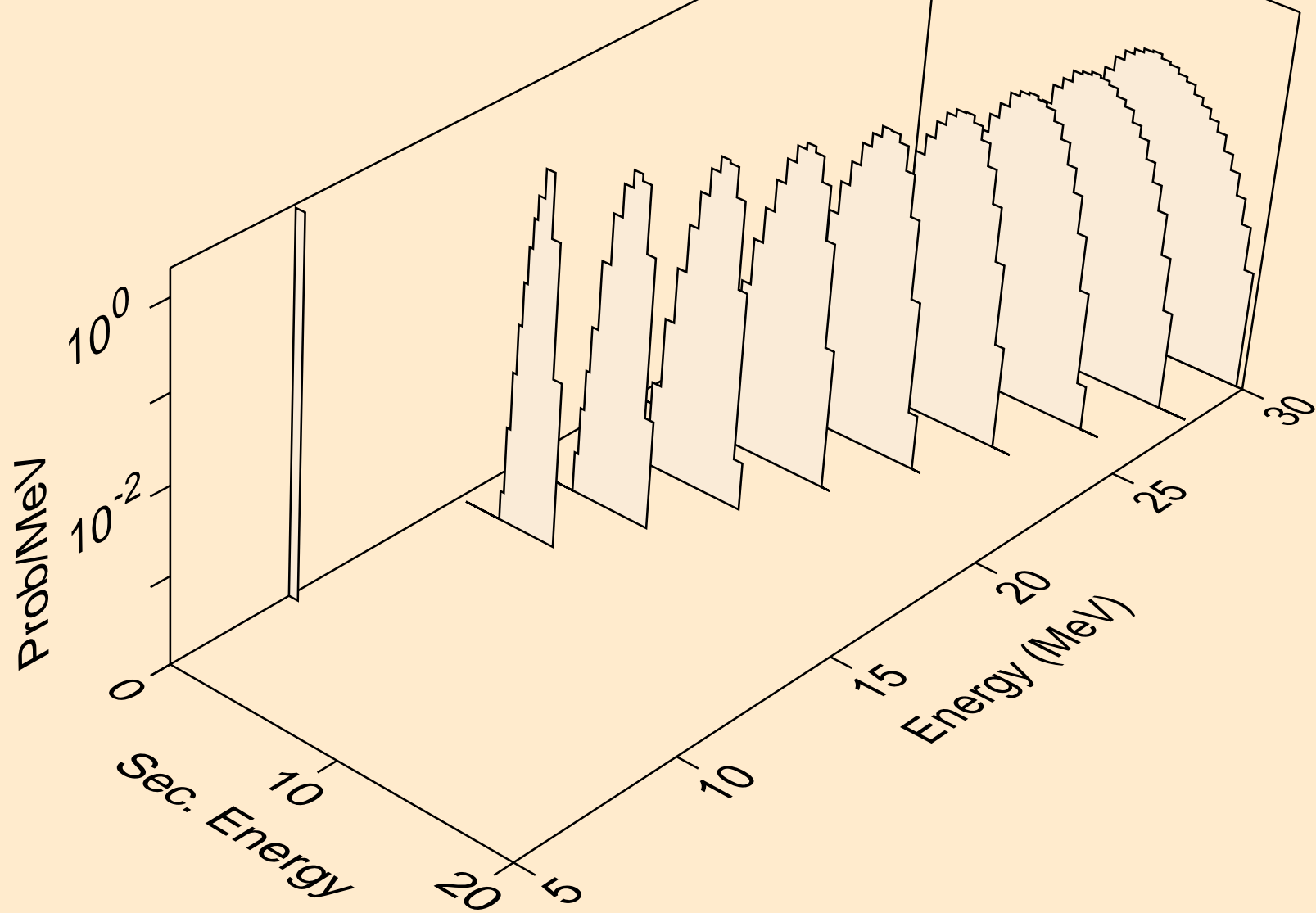

PU227 TRITON ACER TENDL-2023 LIBRARY; T=0.K
protons from (t,3np)

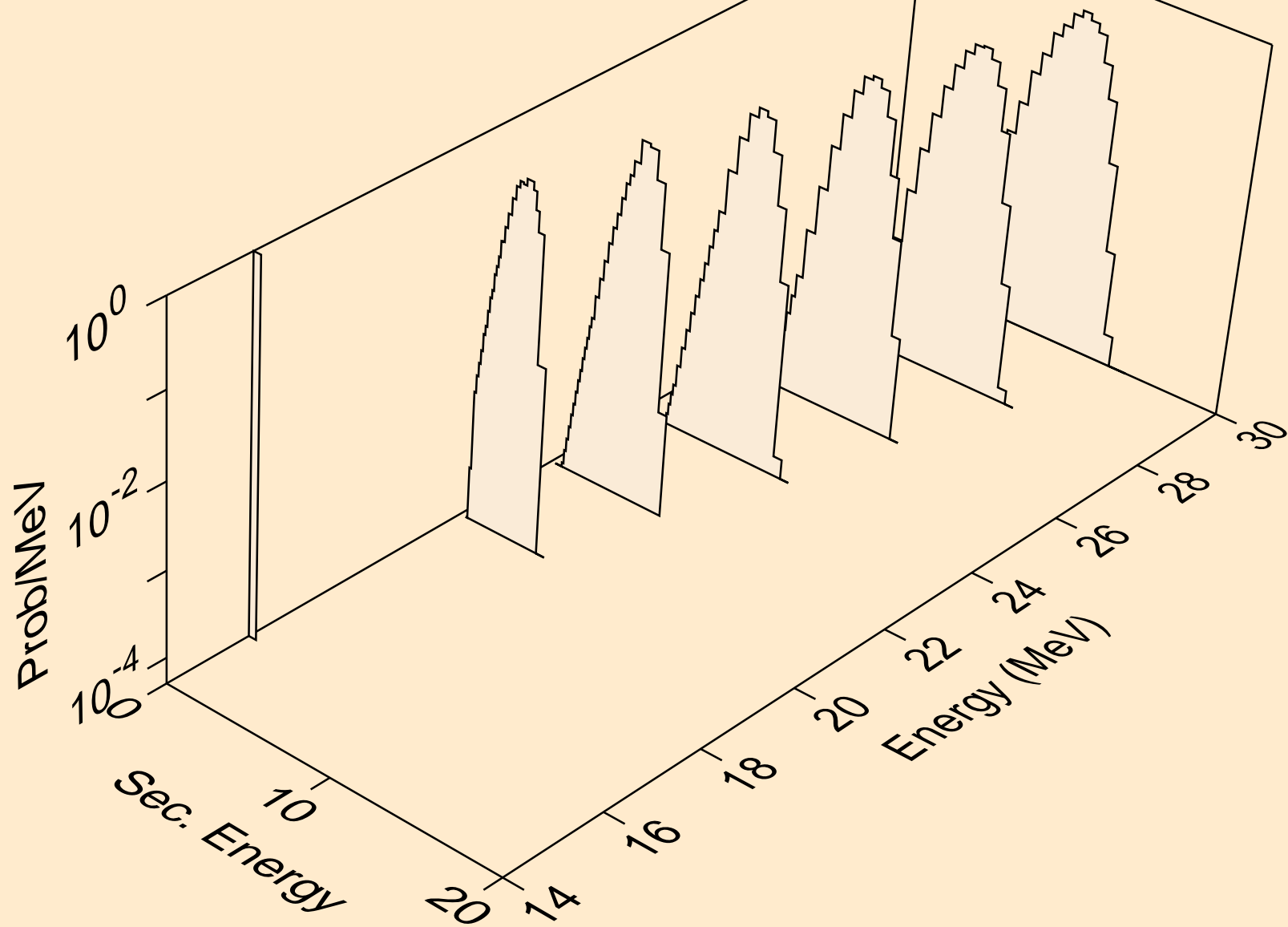

PU227 TRITON ACER TENDL-2023 LIBRARY; T=0.K
protons from (t,n2p)

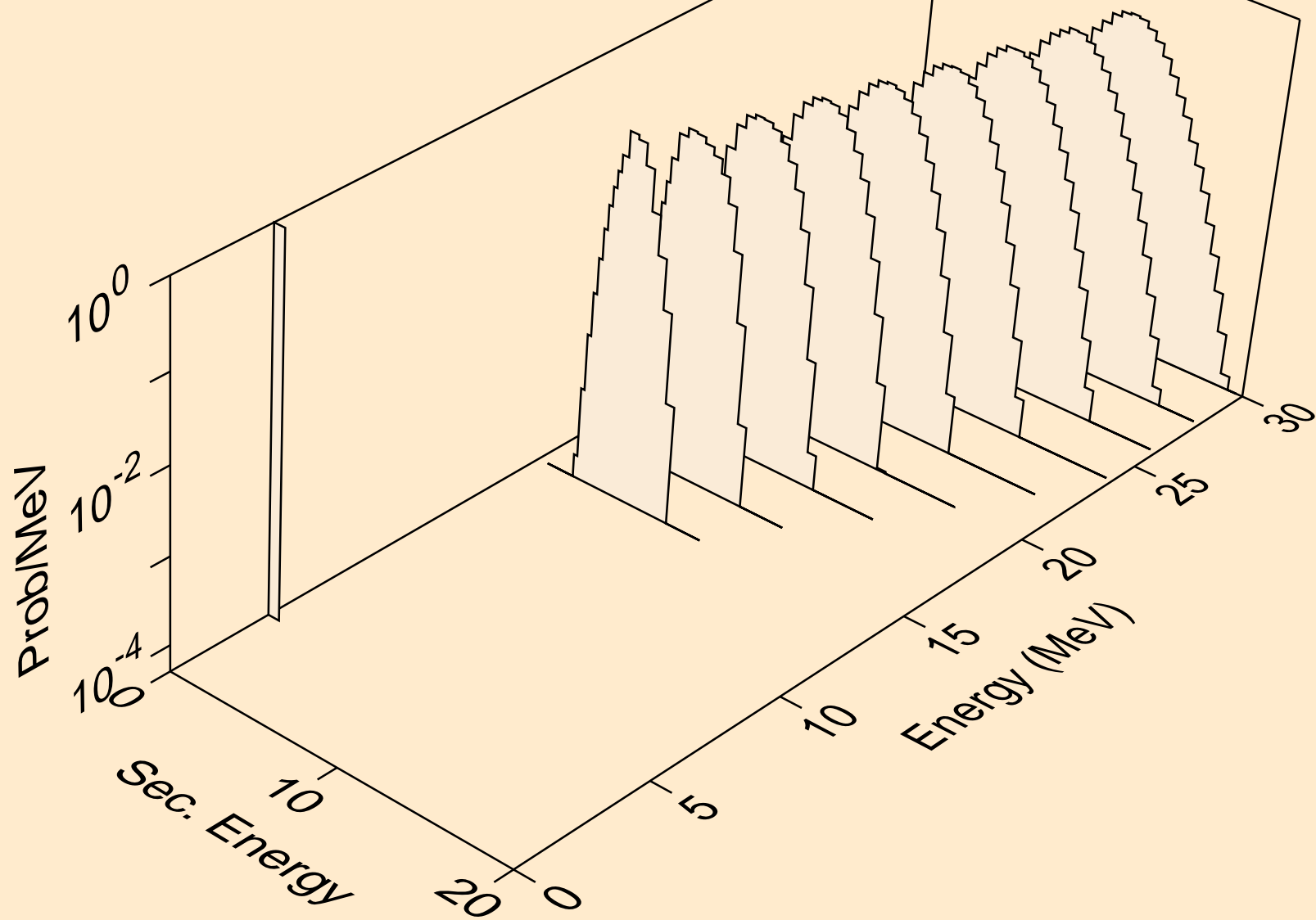

PU227 TRITON ACER TENDL-2023 LIBRARY; T=0.K
protons from (t,npa)

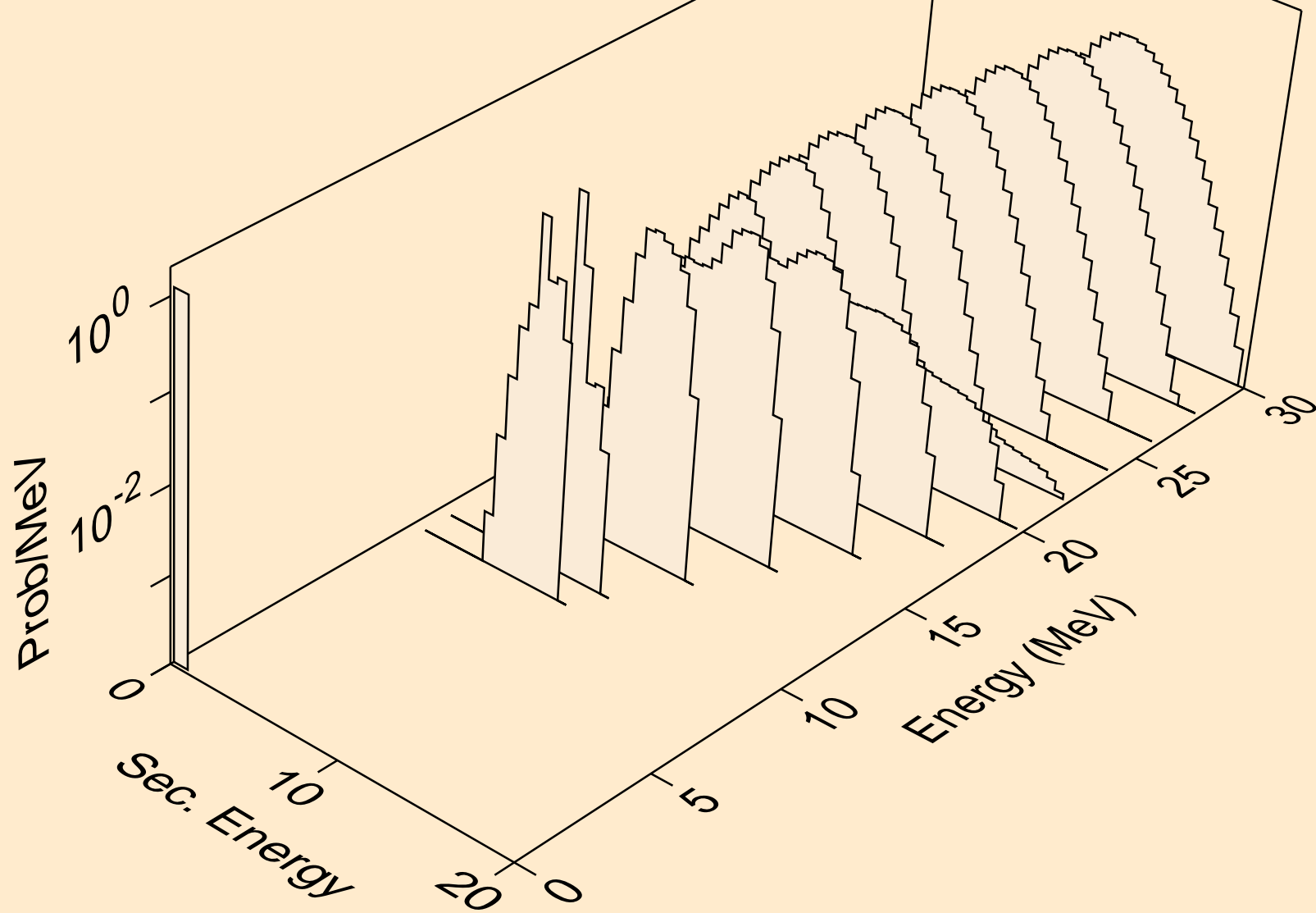

PU227 TRITON ACER TENDL-2023 LIBRARY; T=0.K
protons from (t,p)

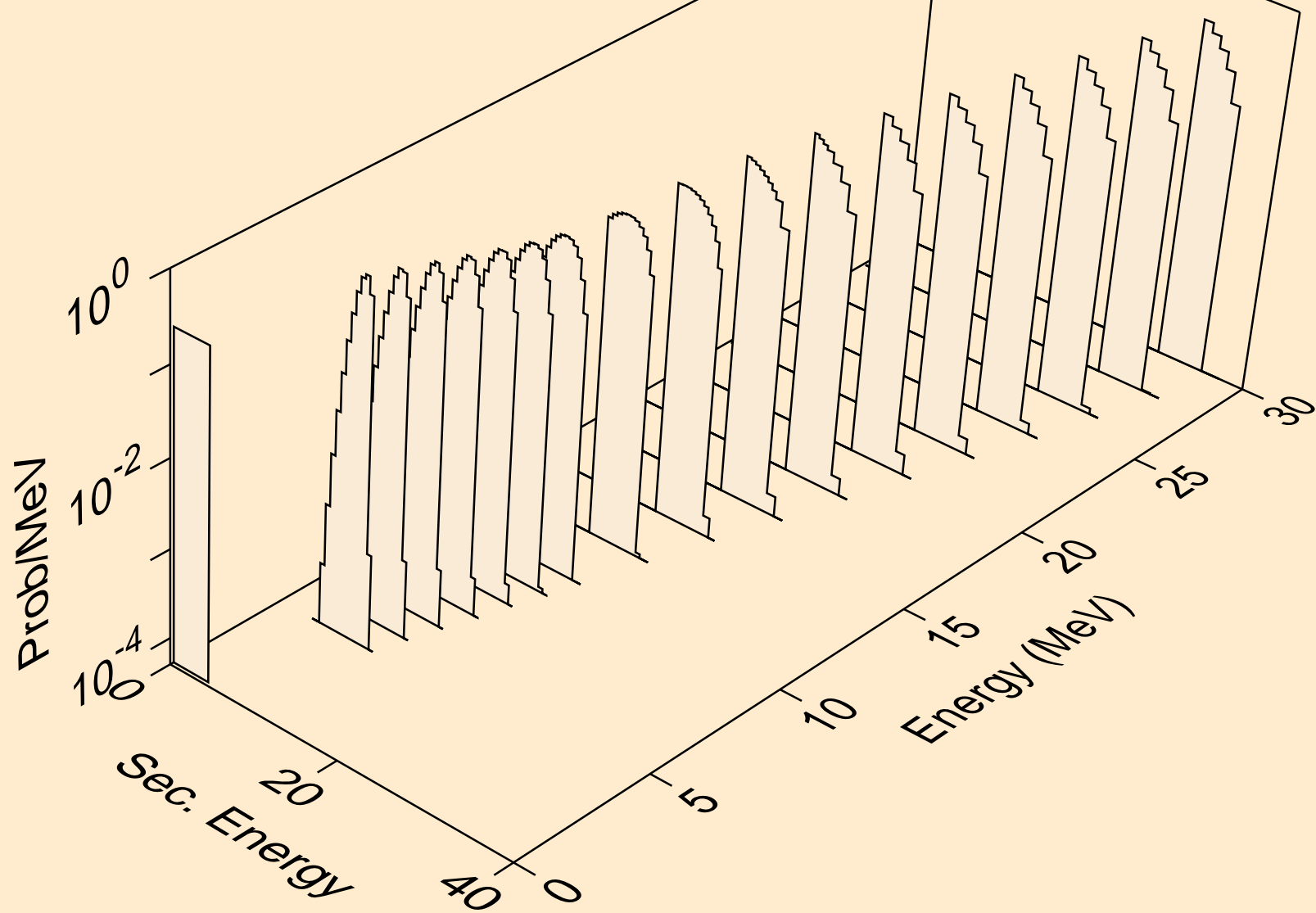

PU227 TRITON ACER TENDL-2023 LIBRARY; T=0.K
protons from (t,2p)

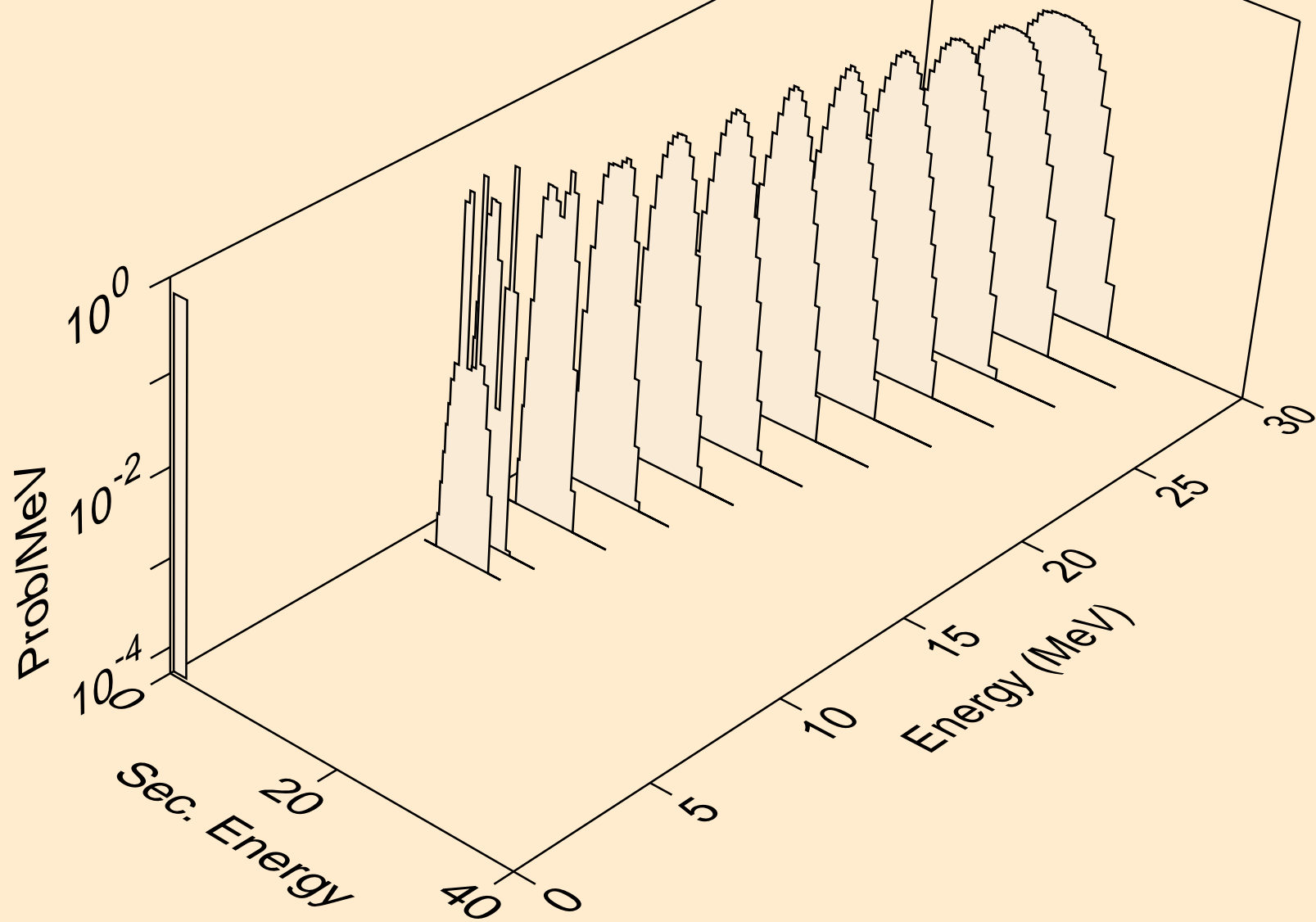

PU227 TRITON ACER TENDL-2023 LIBRARY; T=0.K
protons from (t,pa)

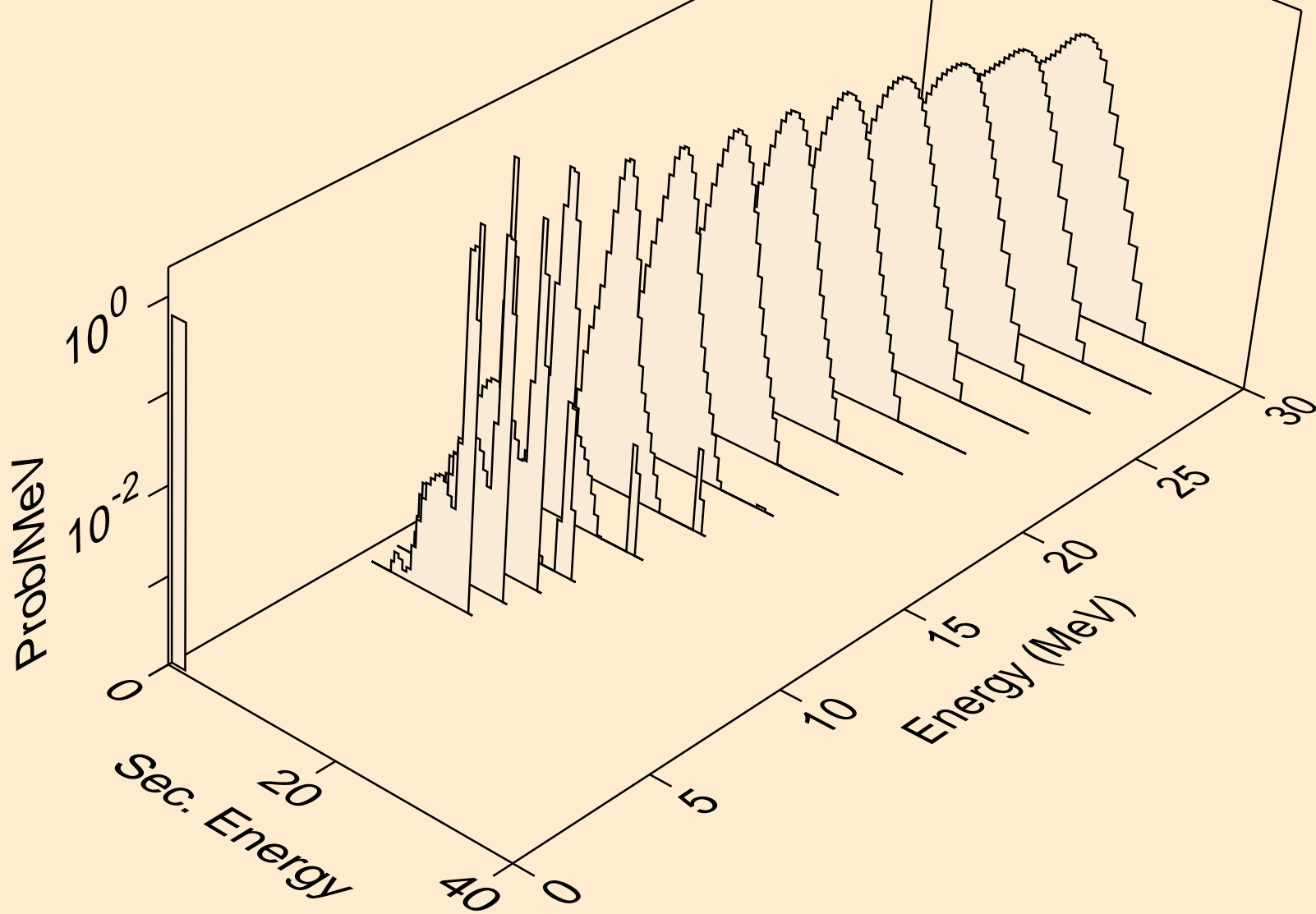

PU227 TRITON ACER TENDL-2023 LIBRARY; T=0.K
protons from (t,pd)

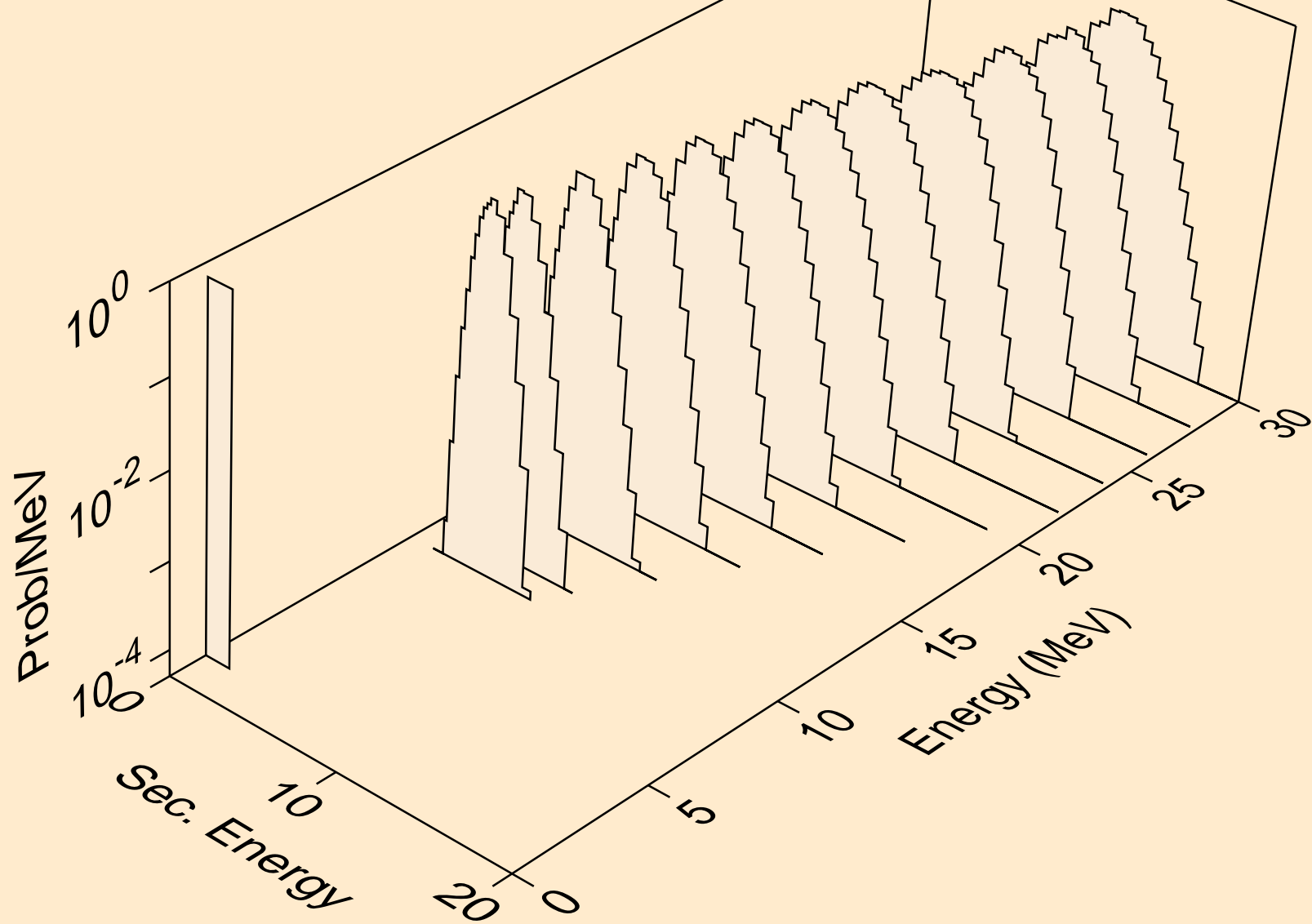

PU227 TRITON ACER TENDL-2023 LIBRARY; T=0.K
deuterons from (t,x)

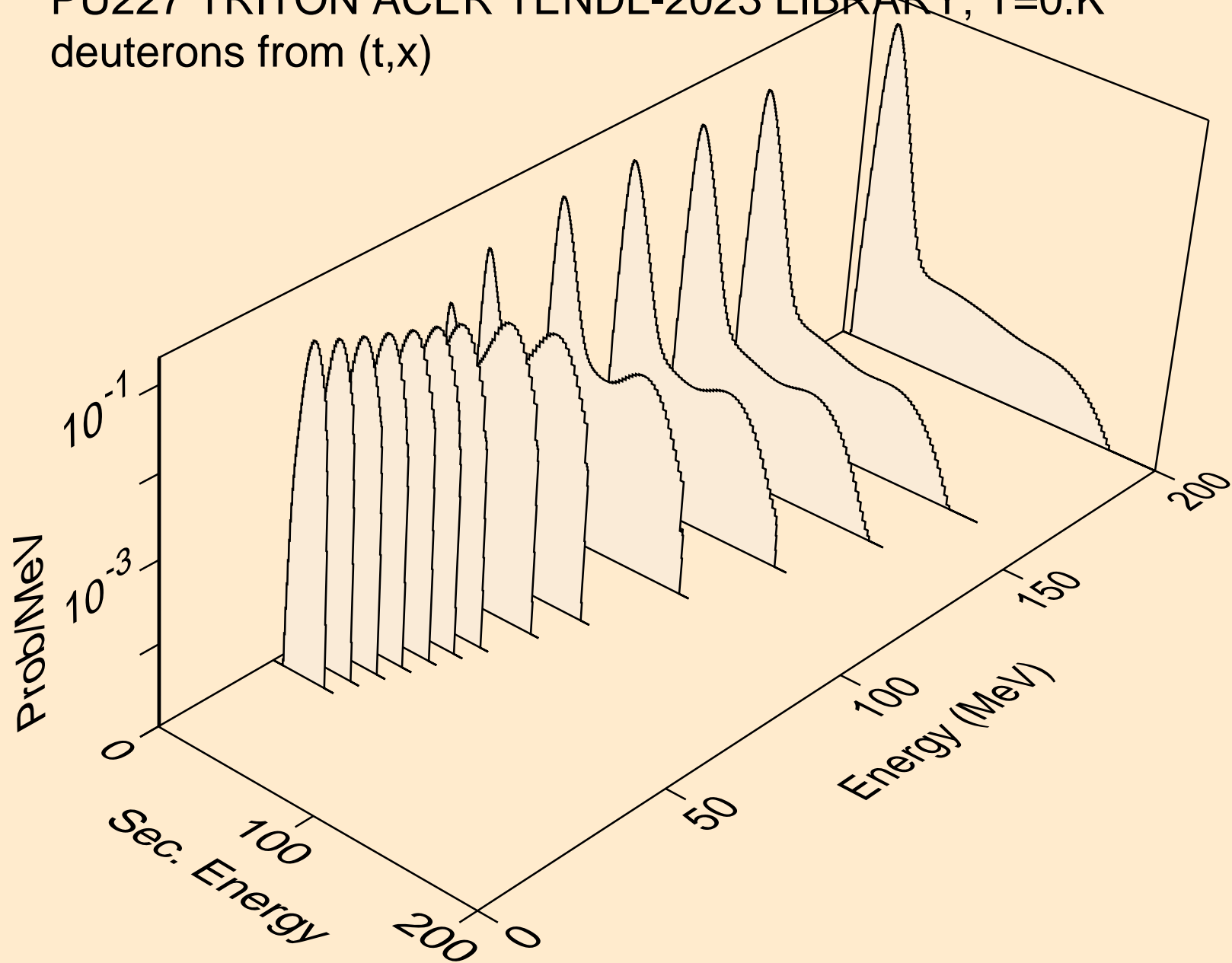

PU227 TRITON ACER TENDL-2023 LIBRARY; T=0.K
deuterons from (t,n*)d

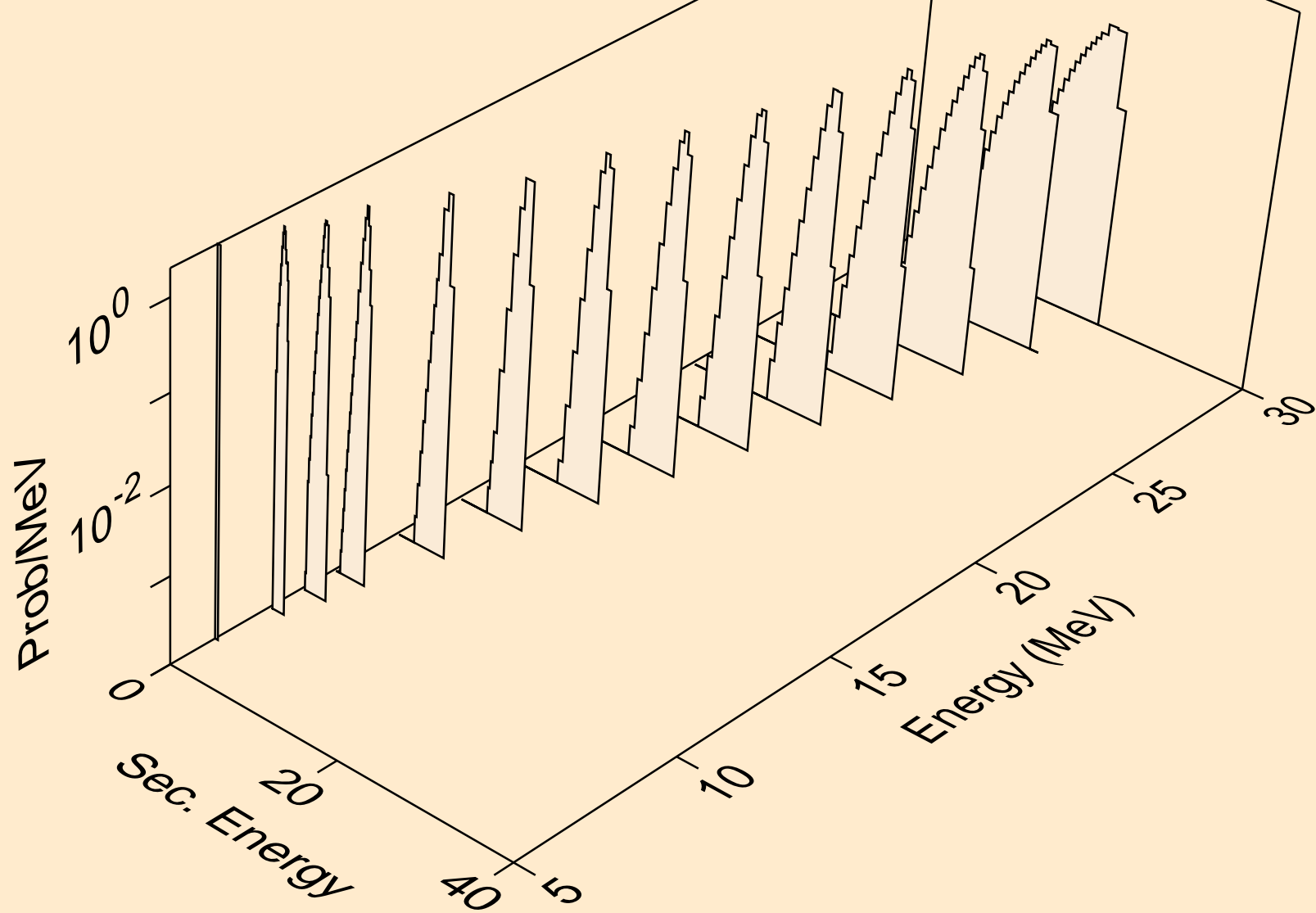

PU227 TRITON ACER TENDL-2023 LIBRARY; T=0.K
deuterons from (t,d)

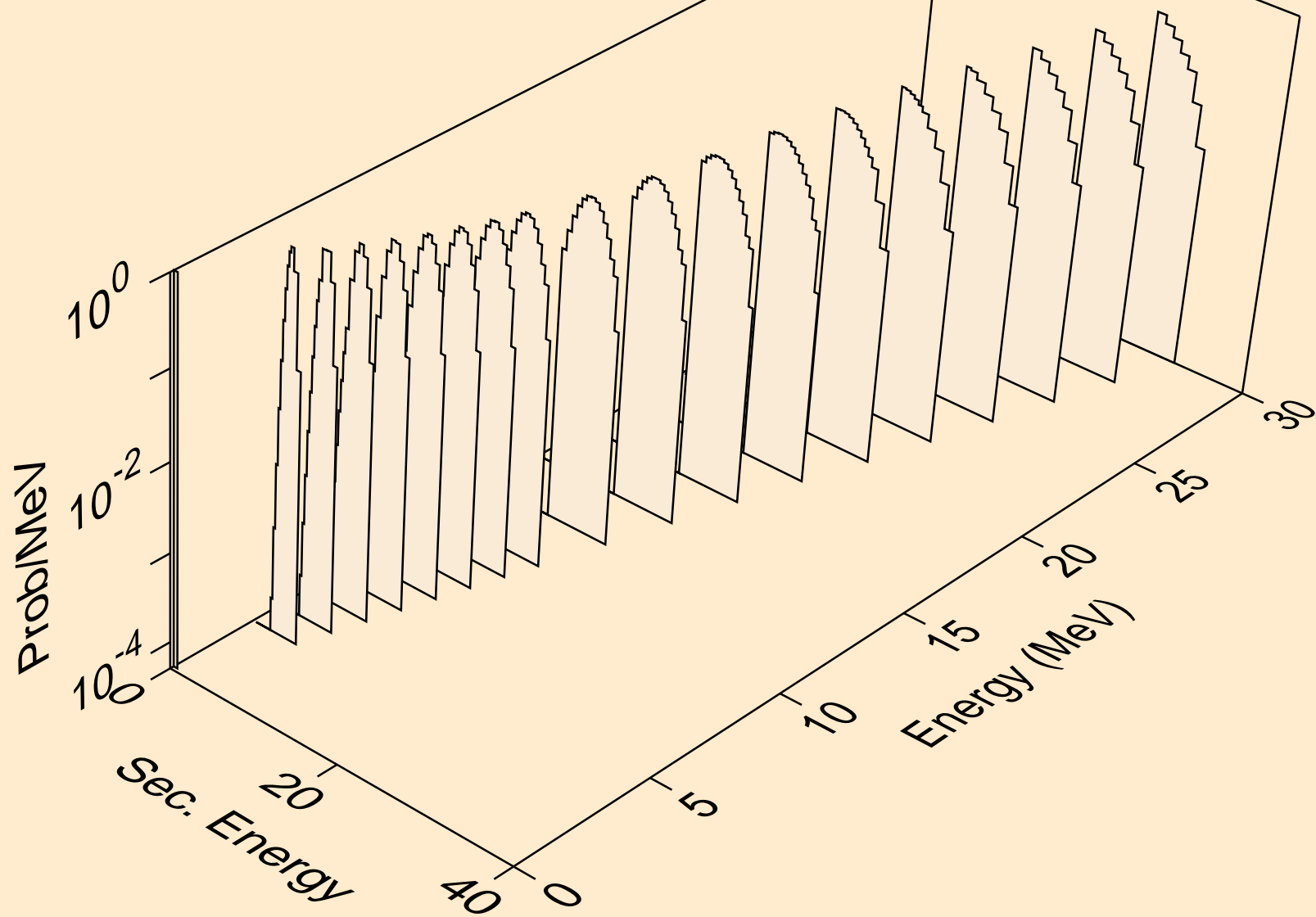

PU227 TRITON ACER TENDL-2023 LIBRARY; T=0.K
deuterons from (t,pd)

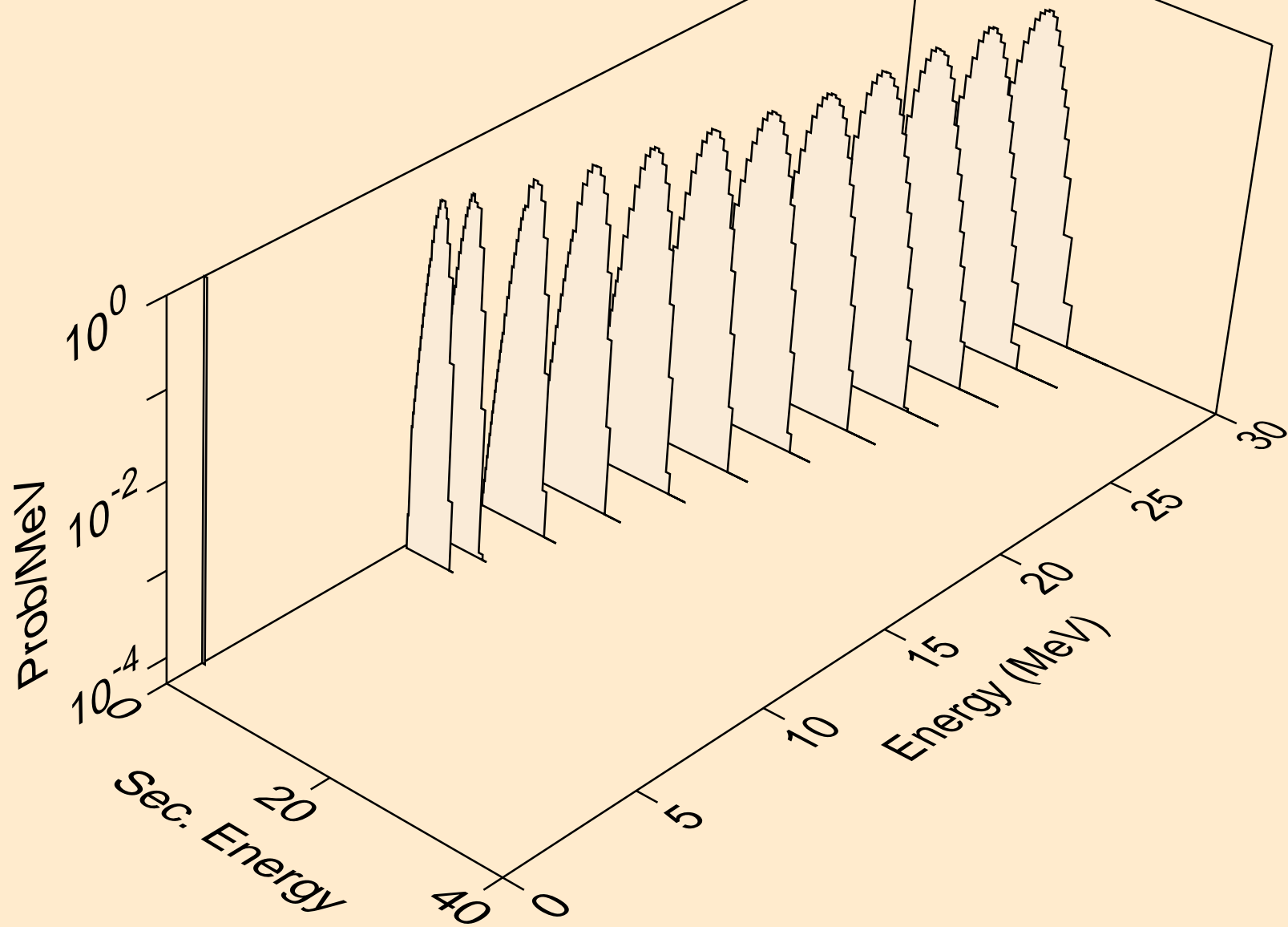

PU227 TRITON ACER TENDL-2023 LIBRARY; T=0.K
he3s from (t,x)

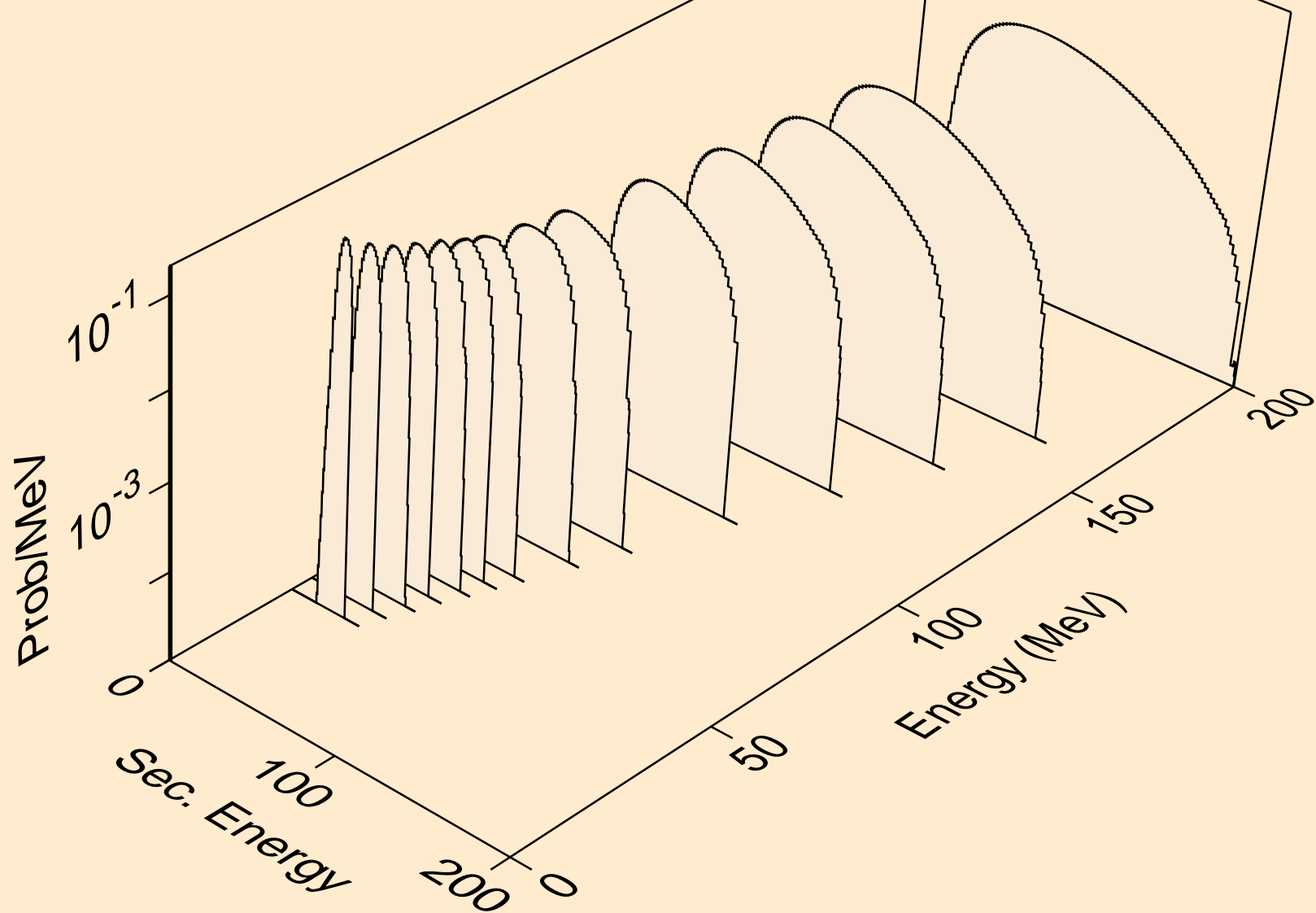

PU227 TRITON ACER TENDL-2023 LIBRARY; T=0.K
he3s from (t,n*)he3

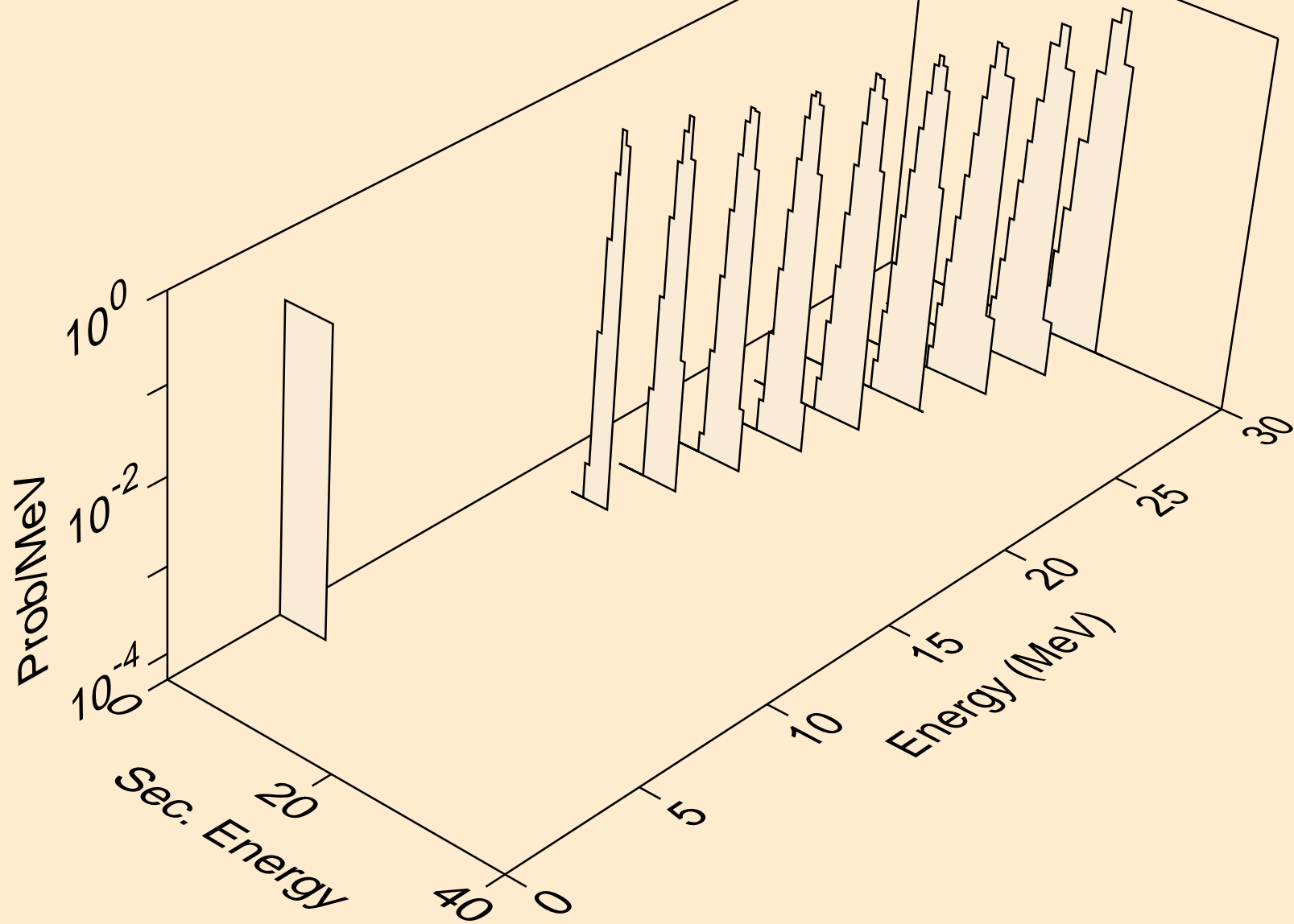

PU227 TRITON ACER TENDL-2023 LIBRARY; T=0.K
he3s from (t,he3)

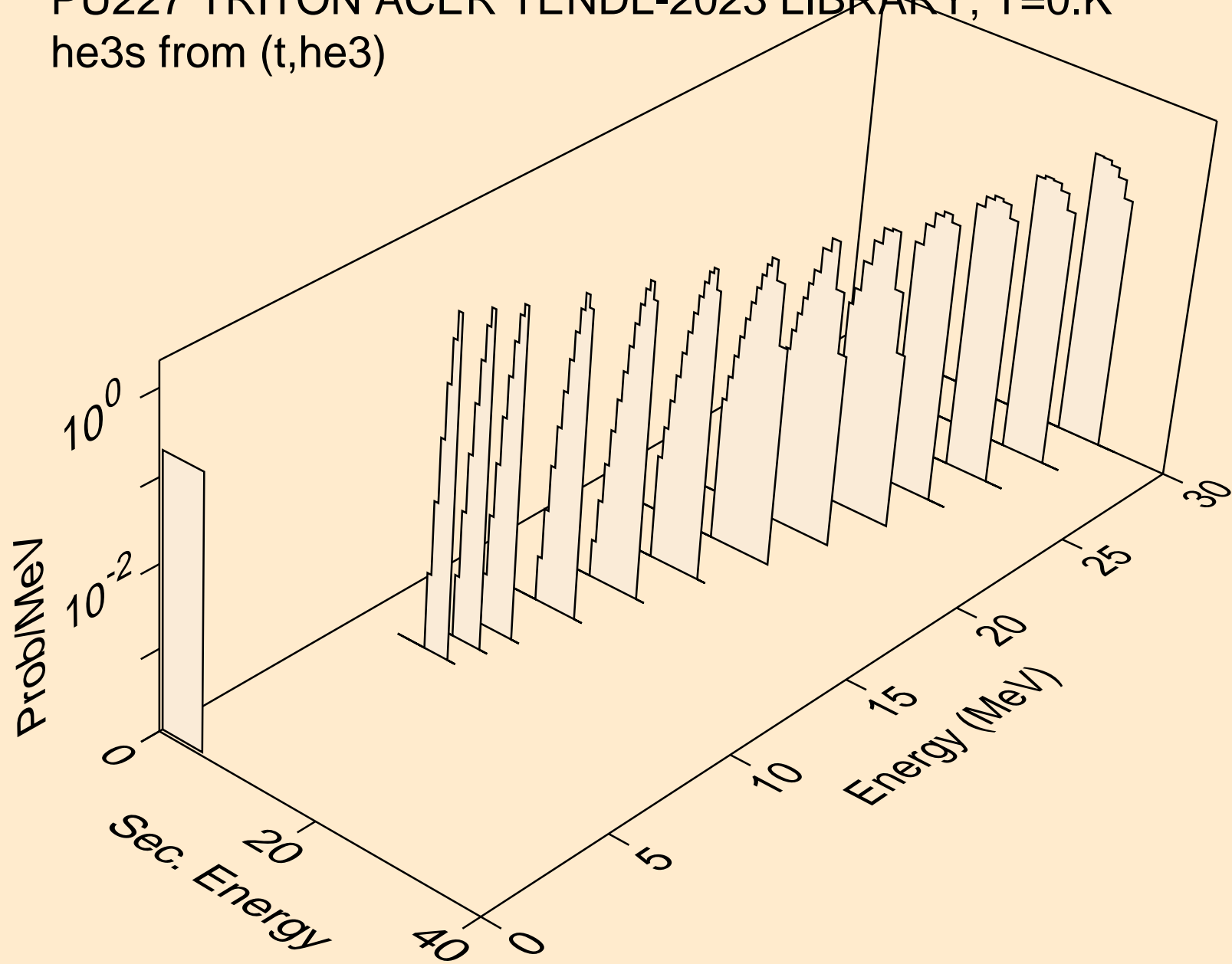

PU227 TRITON ACER TENDL-2023 LIBRARY; T=0.K
alphas from (t,x)

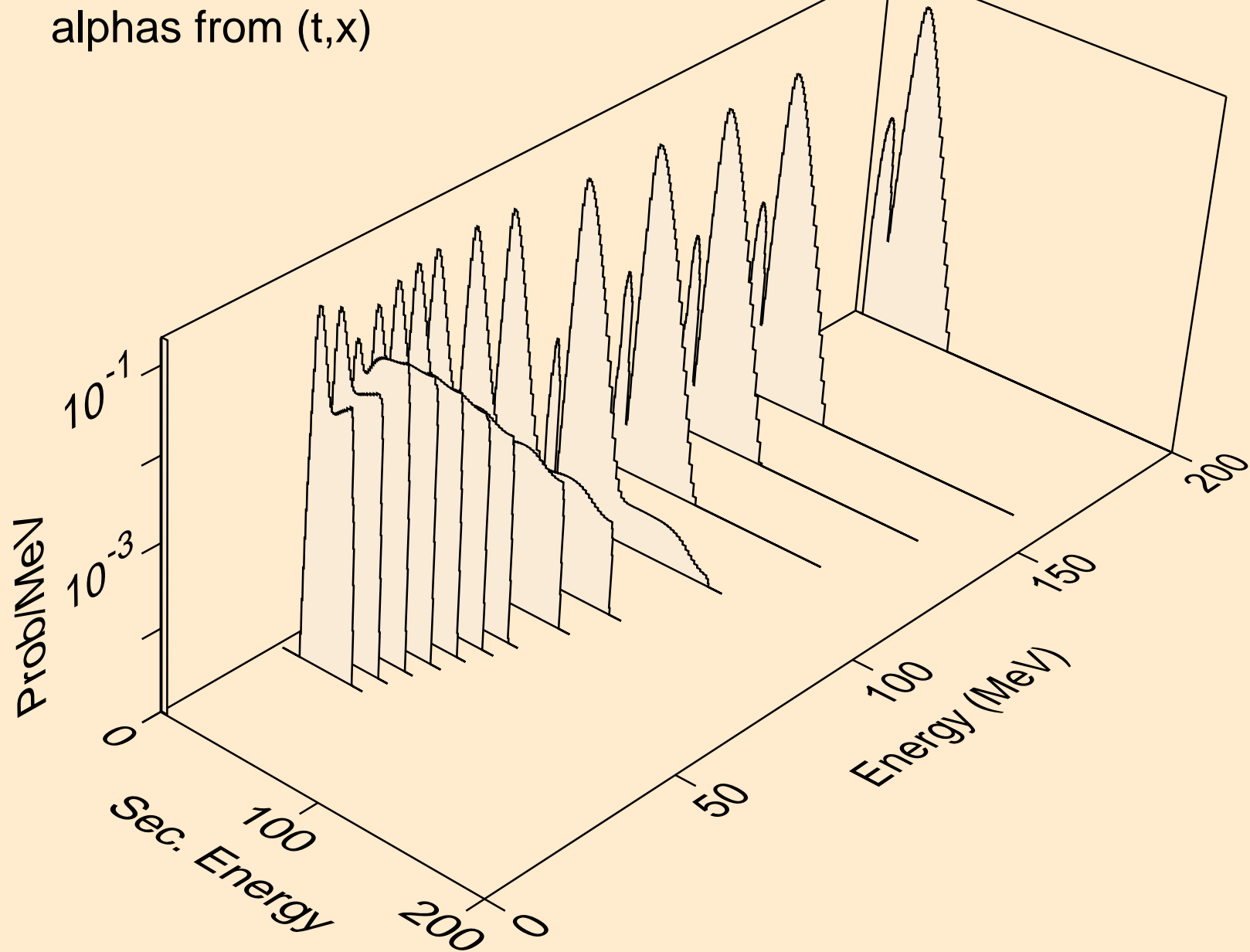

PU227 TRITON ACER TENDL-2023 LIBRARY; T=0.K
alphas from (t,n*)a

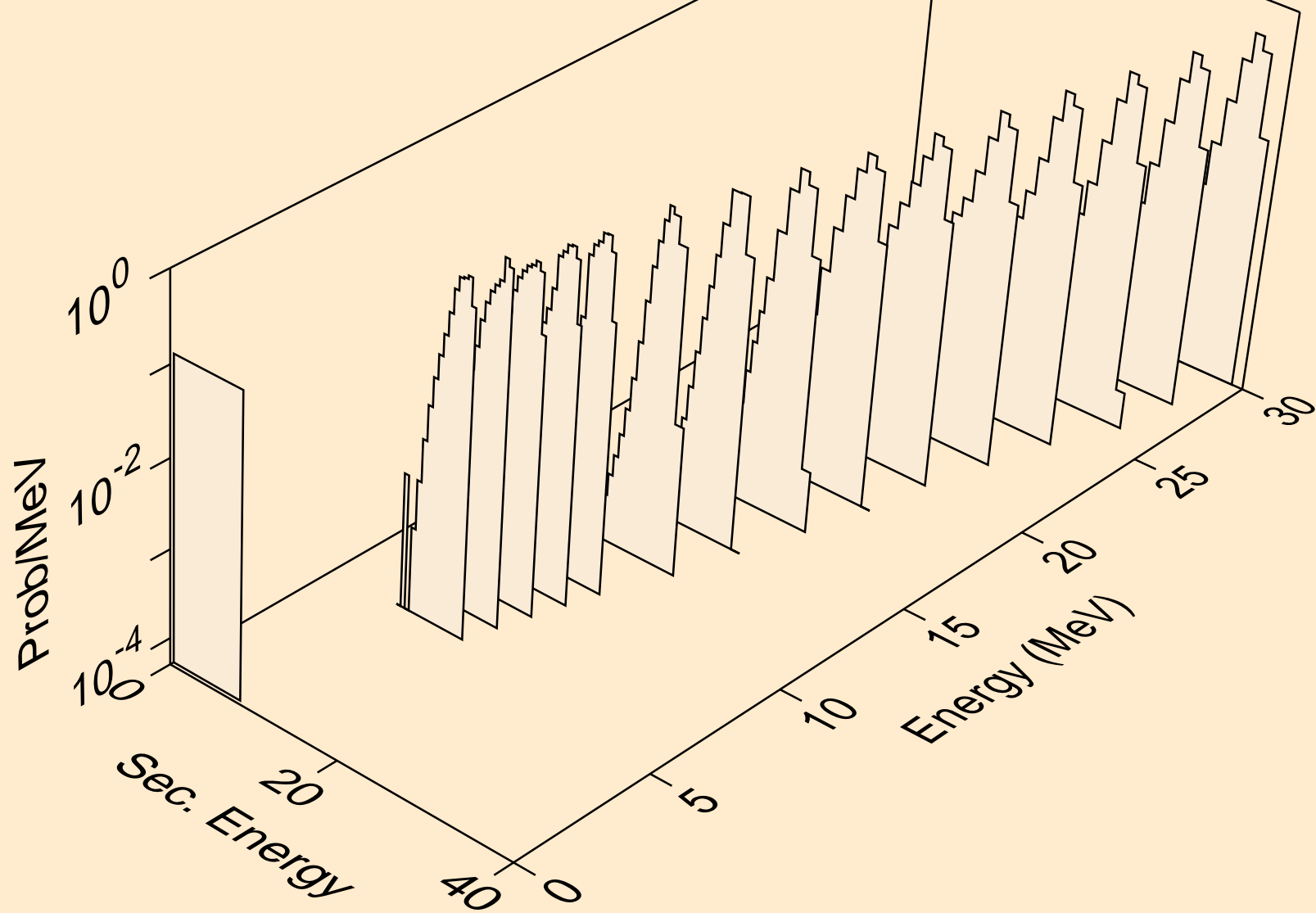

PU227 TRITON ACER TENDL-2023 LIBRARY; T=0.K
alphas from (t,2n)a

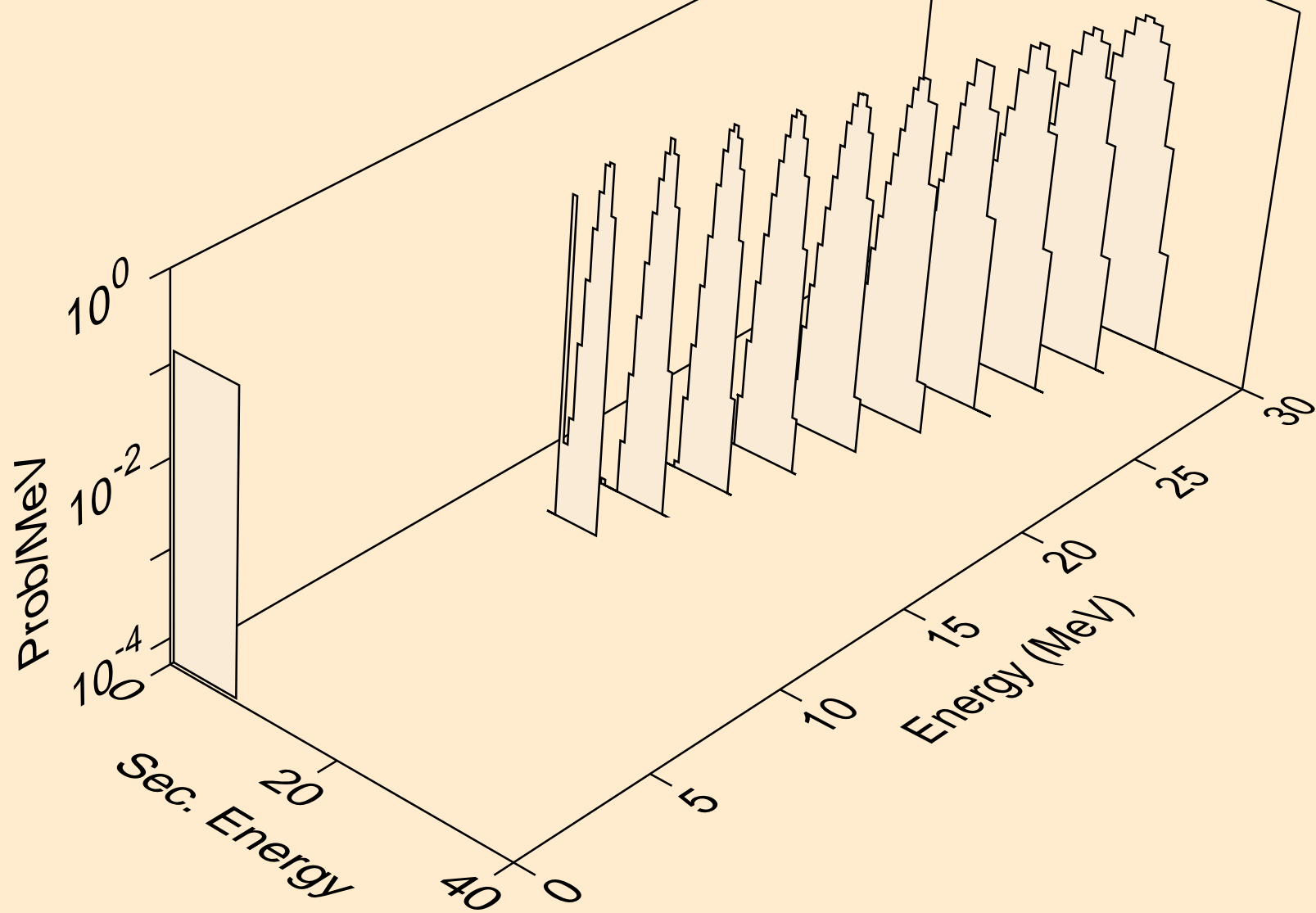

PU227 TRITON ACER TENDL-2023 LIBRARY; T=0.K
alphas from (t,n*)2a

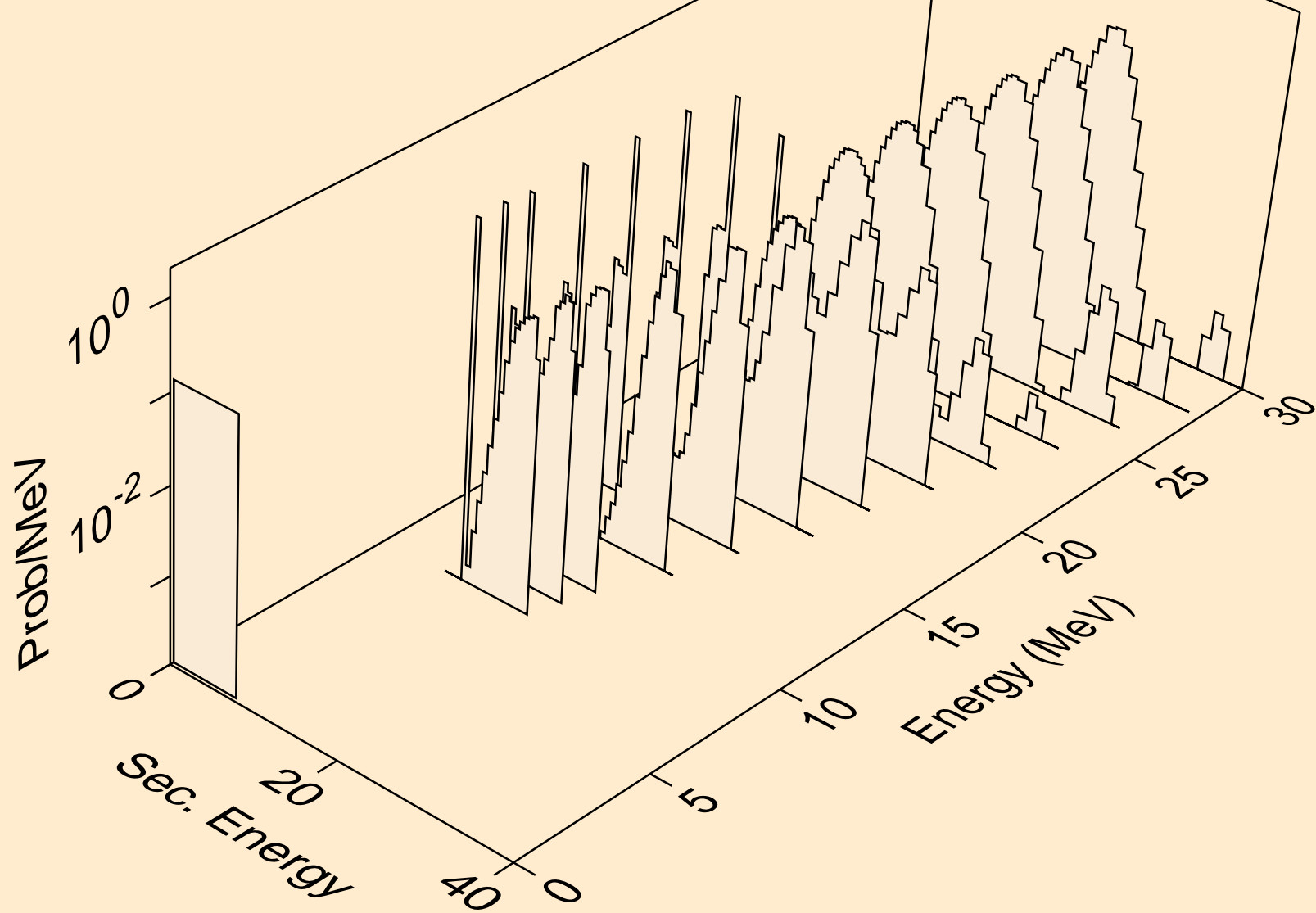

PU227 TRITON ACER TENDL-2023 LIBRARY; T=0.K
alphas from (t,2n)2a

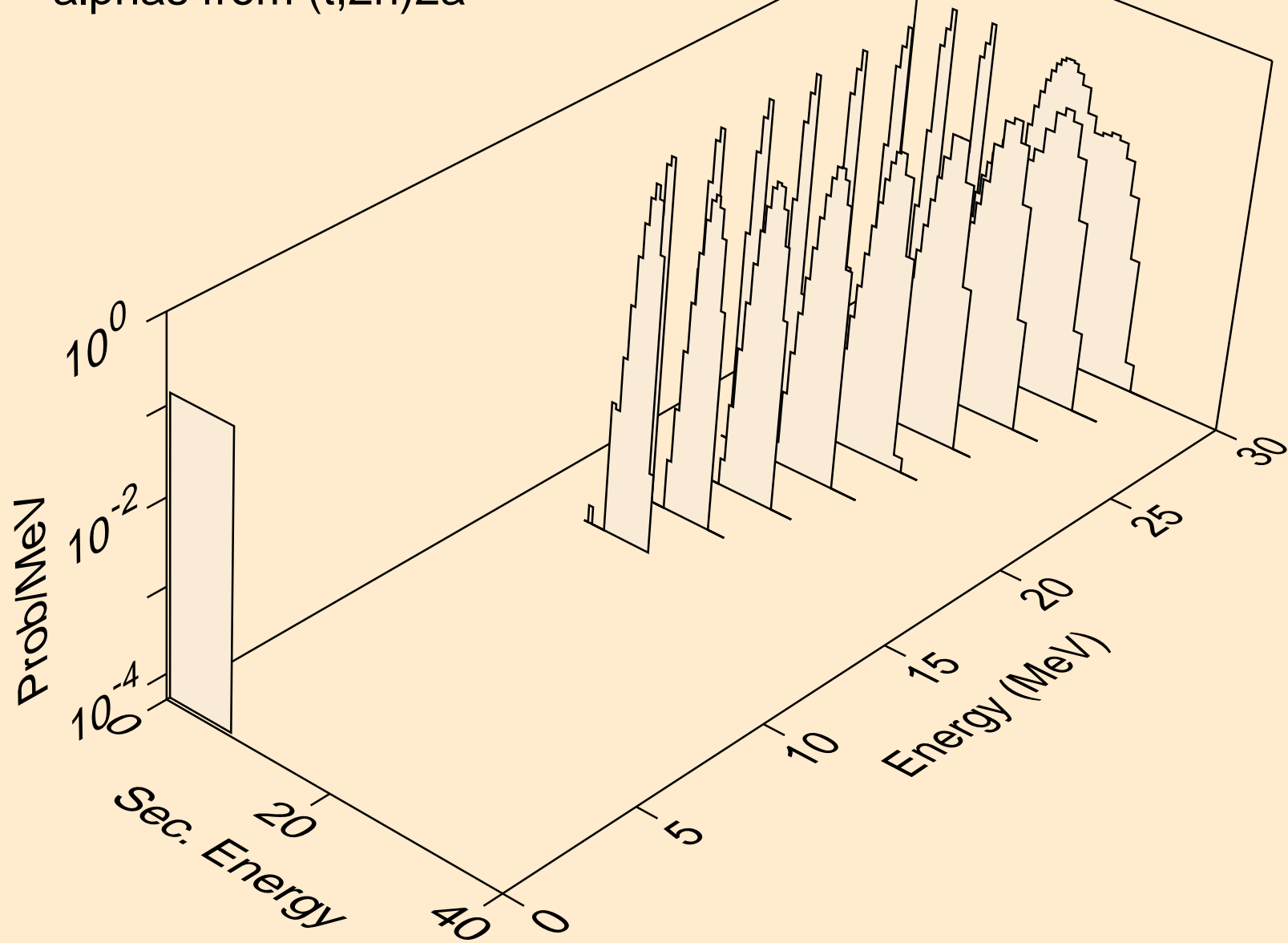

PU227 TRITON ACER TENDL-2023 LIBRARY; T=0.K
alphas from (t,npa)

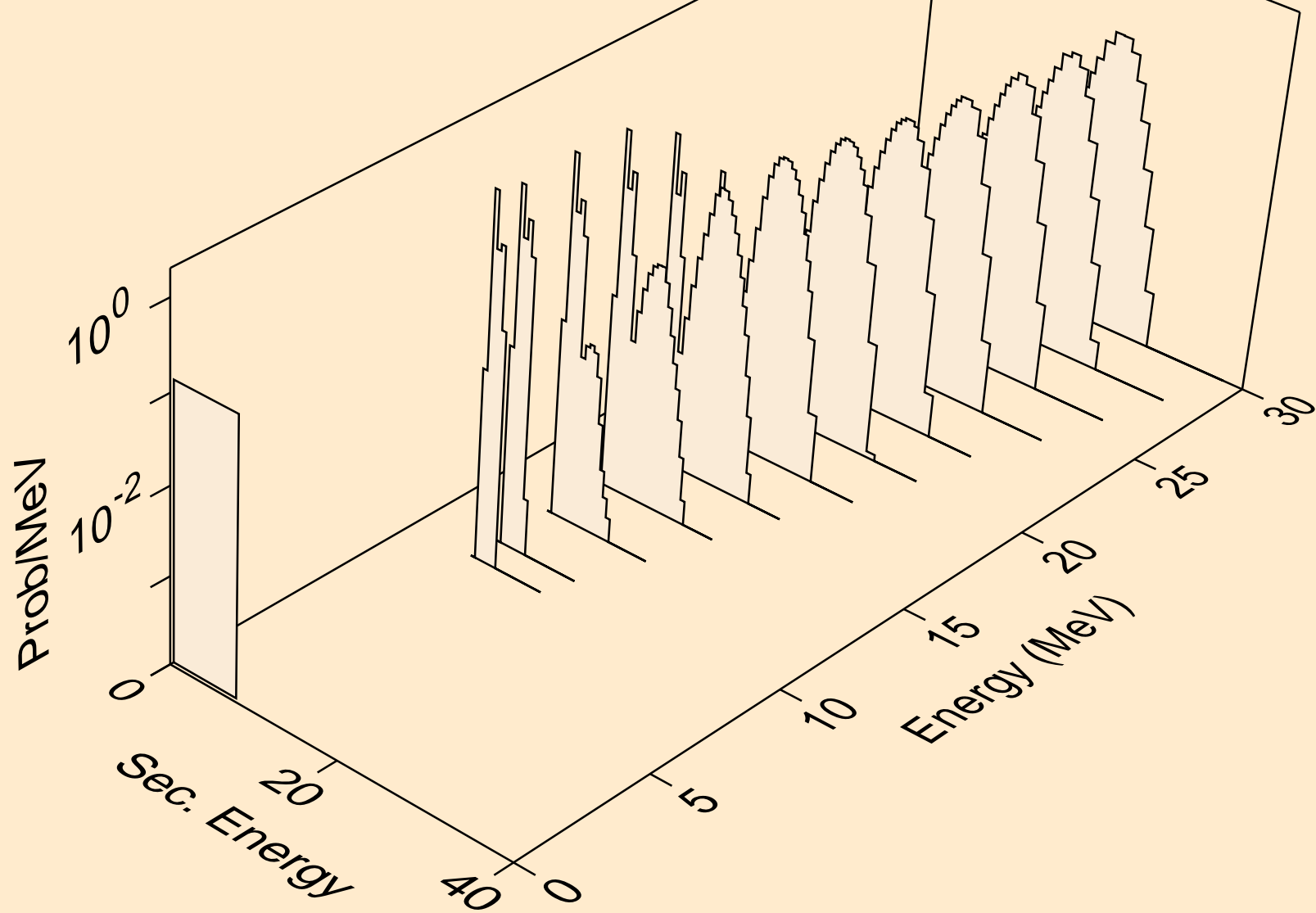

PU227 TRITON ACER TENDL-2023 LIBRARY; T=0.K
alphas from (t,a)

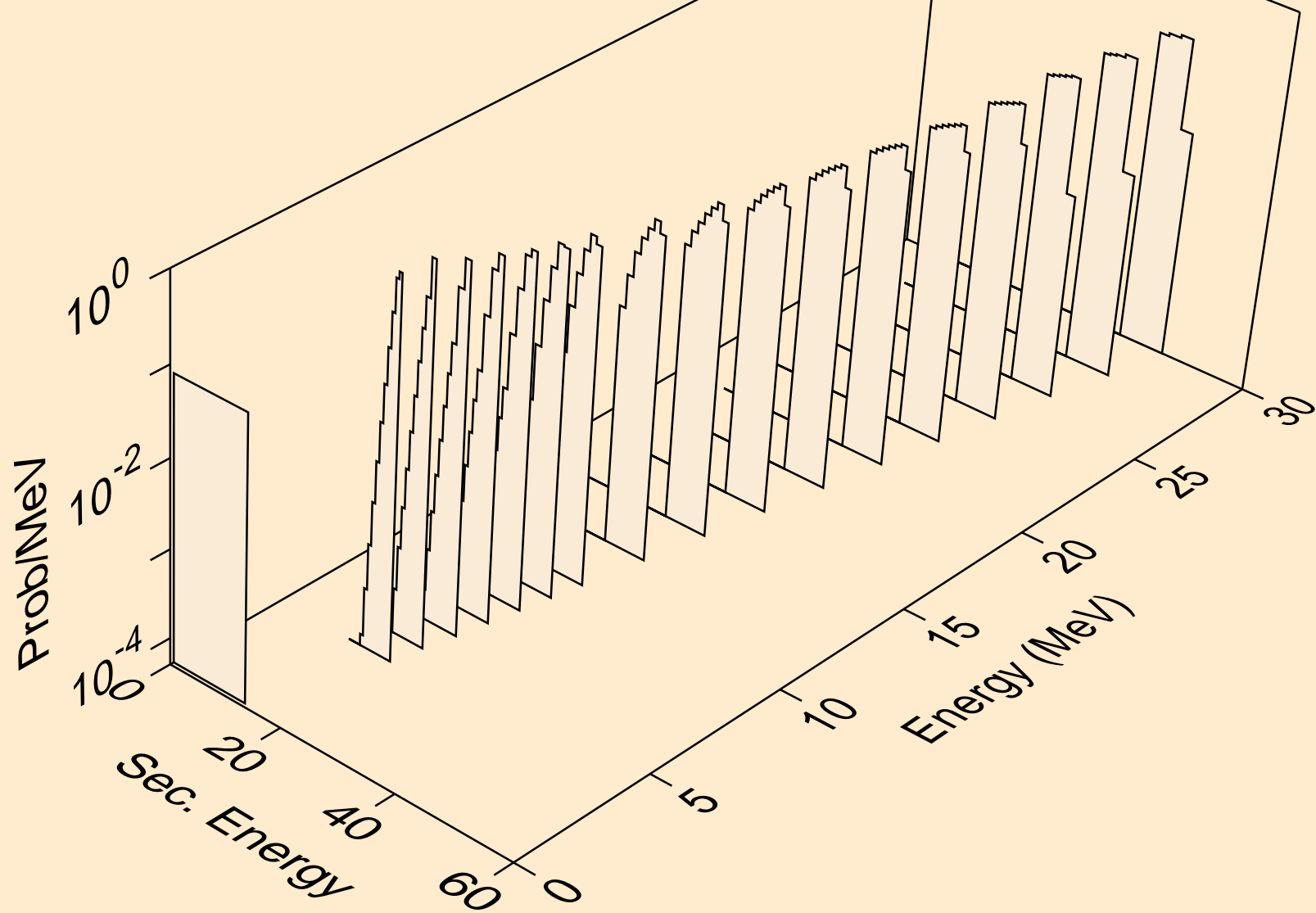

PU227 TRITON ACER TENDL-2023 LIBRARY; T=0.K
alphas from (t,2a)

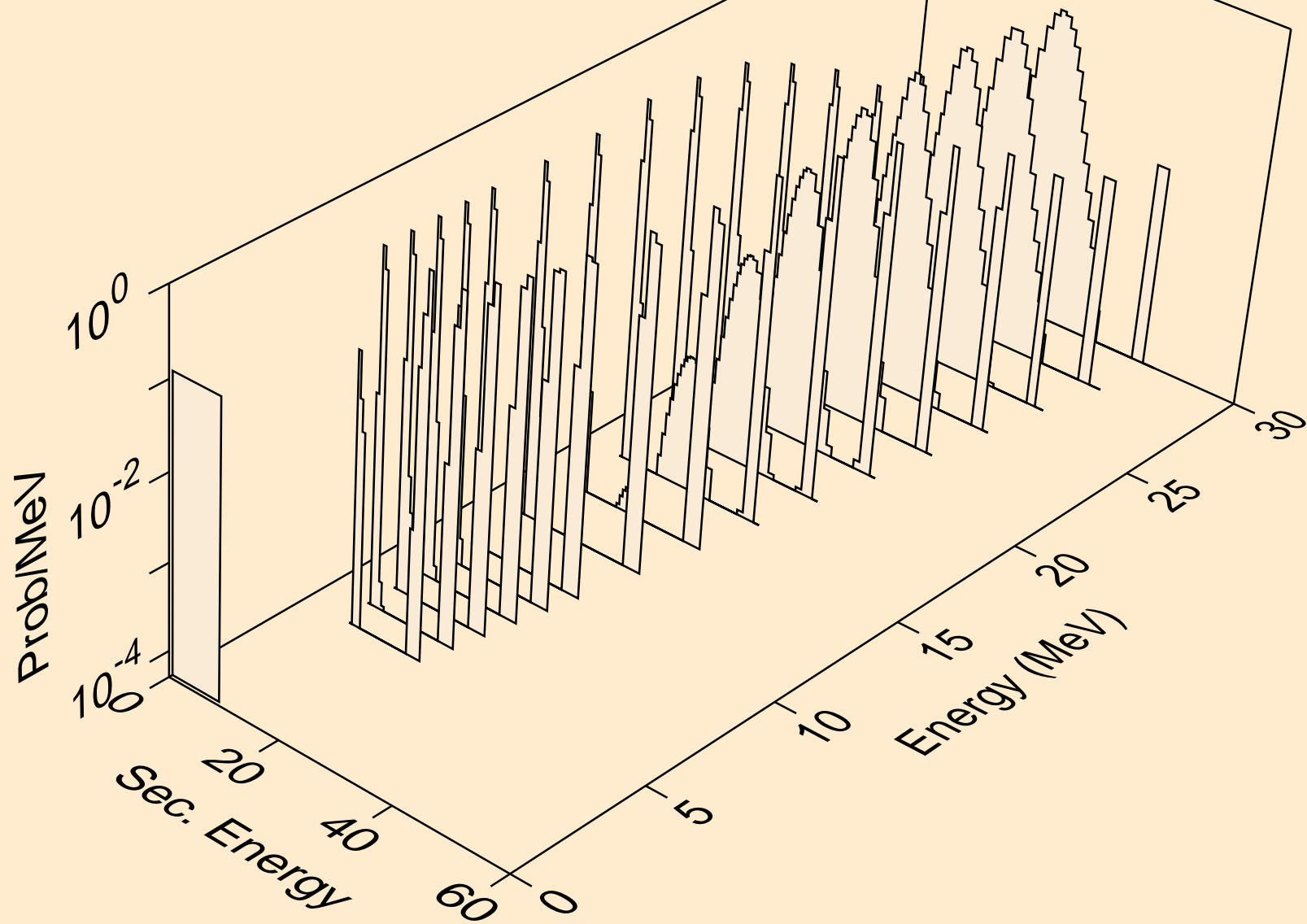

PU227 TRITON ACER TENDL-2023 LIBRARY; T=0.K
alphas from (t,pa)

