

# SM146 TRITON ACER TENDL-2023 LIBRARY; T=0.K

## Principal cross sections

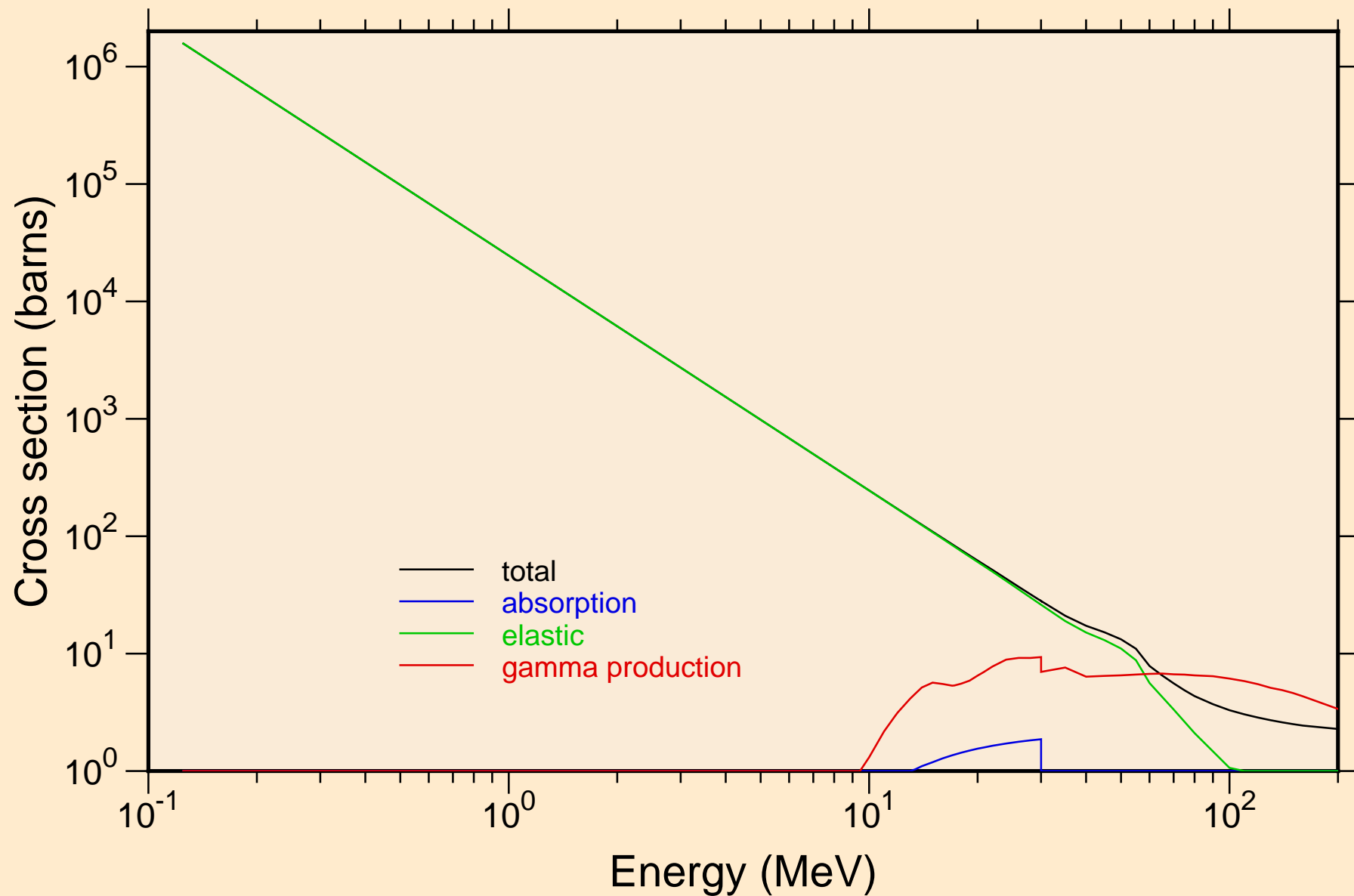

SM146 TRITON ACER TENDL-2023 LIBRARY; T=0.K  
Heating

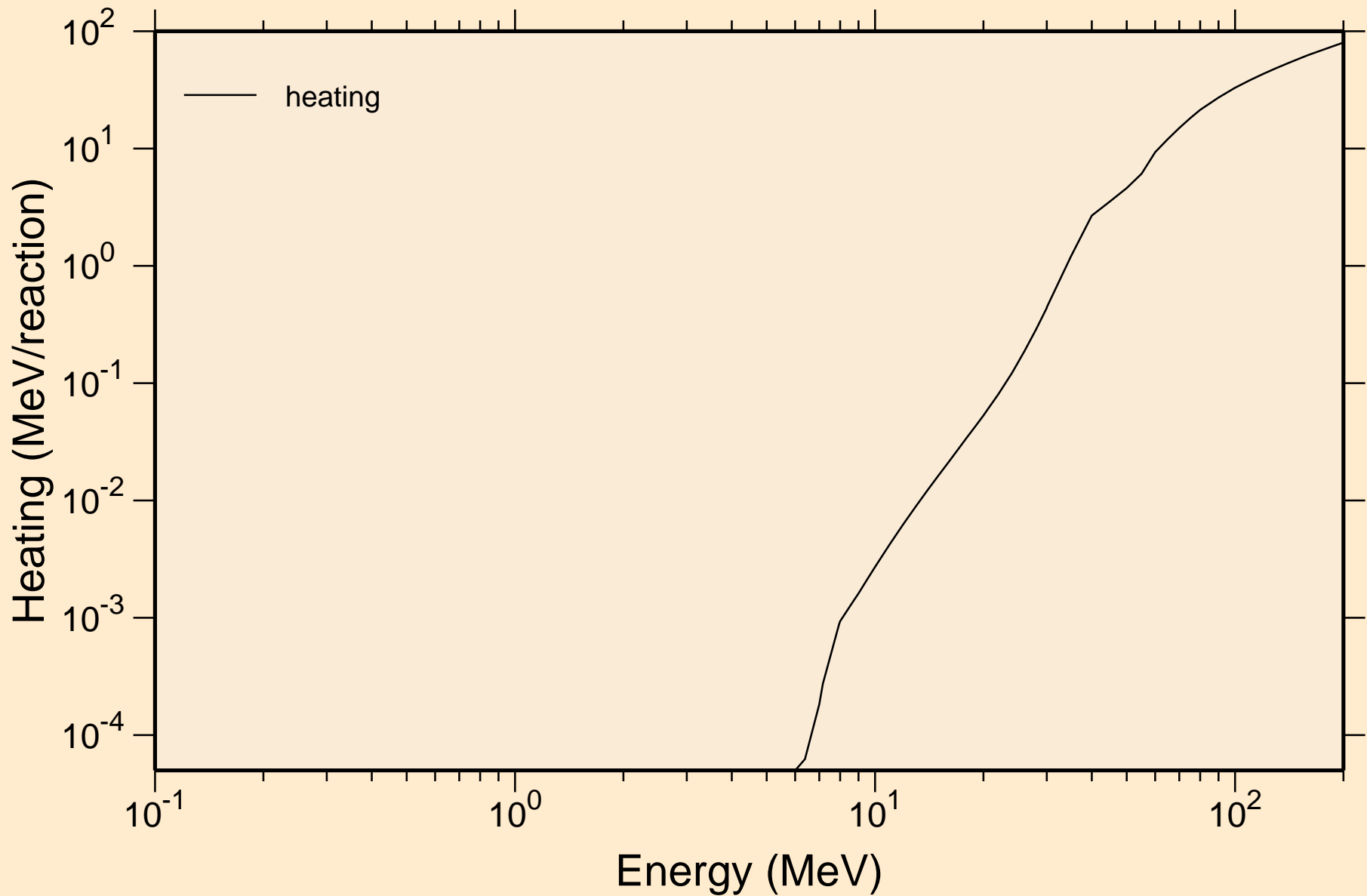

# SM146 TRITON ACER TENDL-2023 LIBRARY; T=0.K

## Principal cross sections

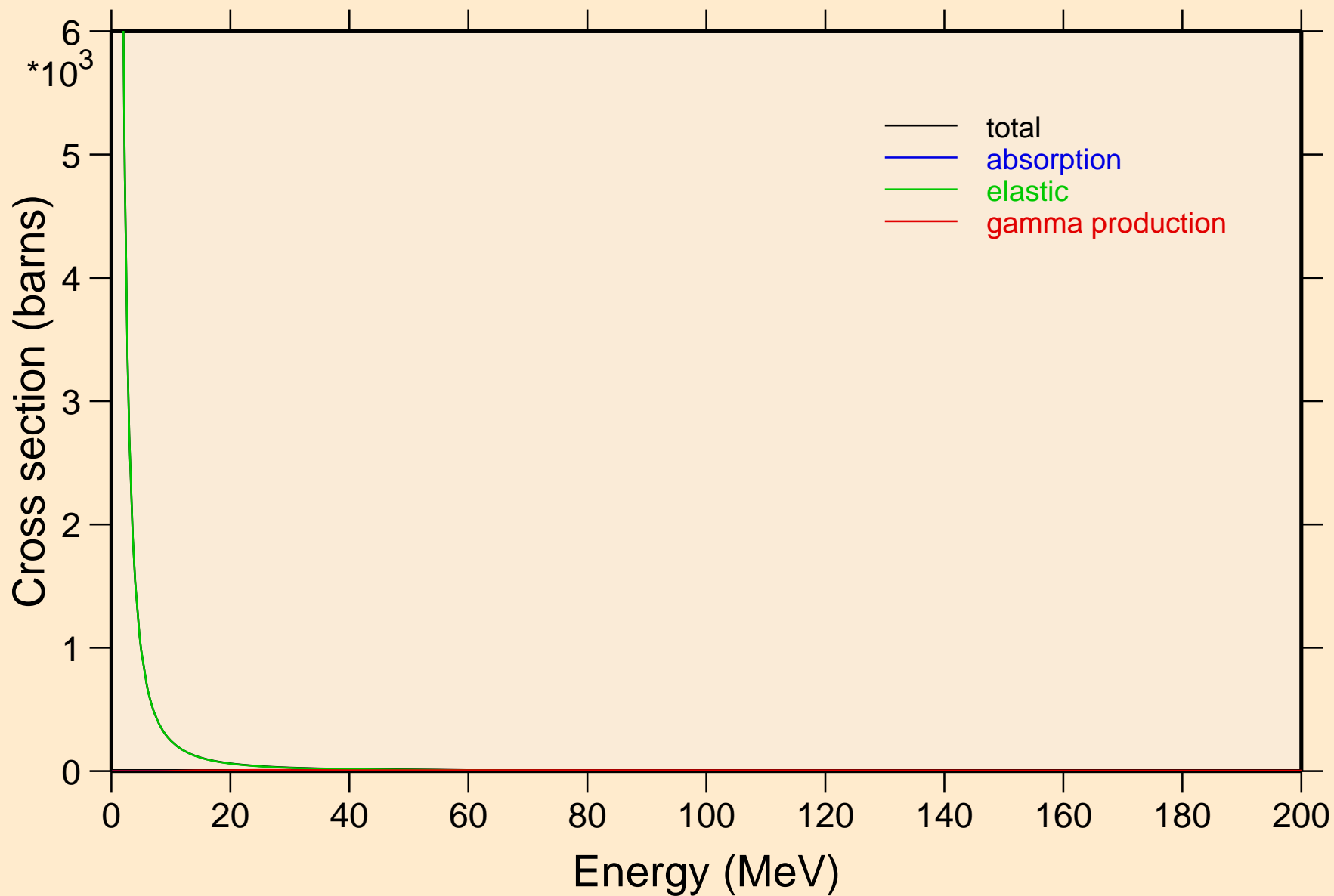

SM146 TRITON ACER TENDL-2023 LIBRARY; T=0.K  
Heating

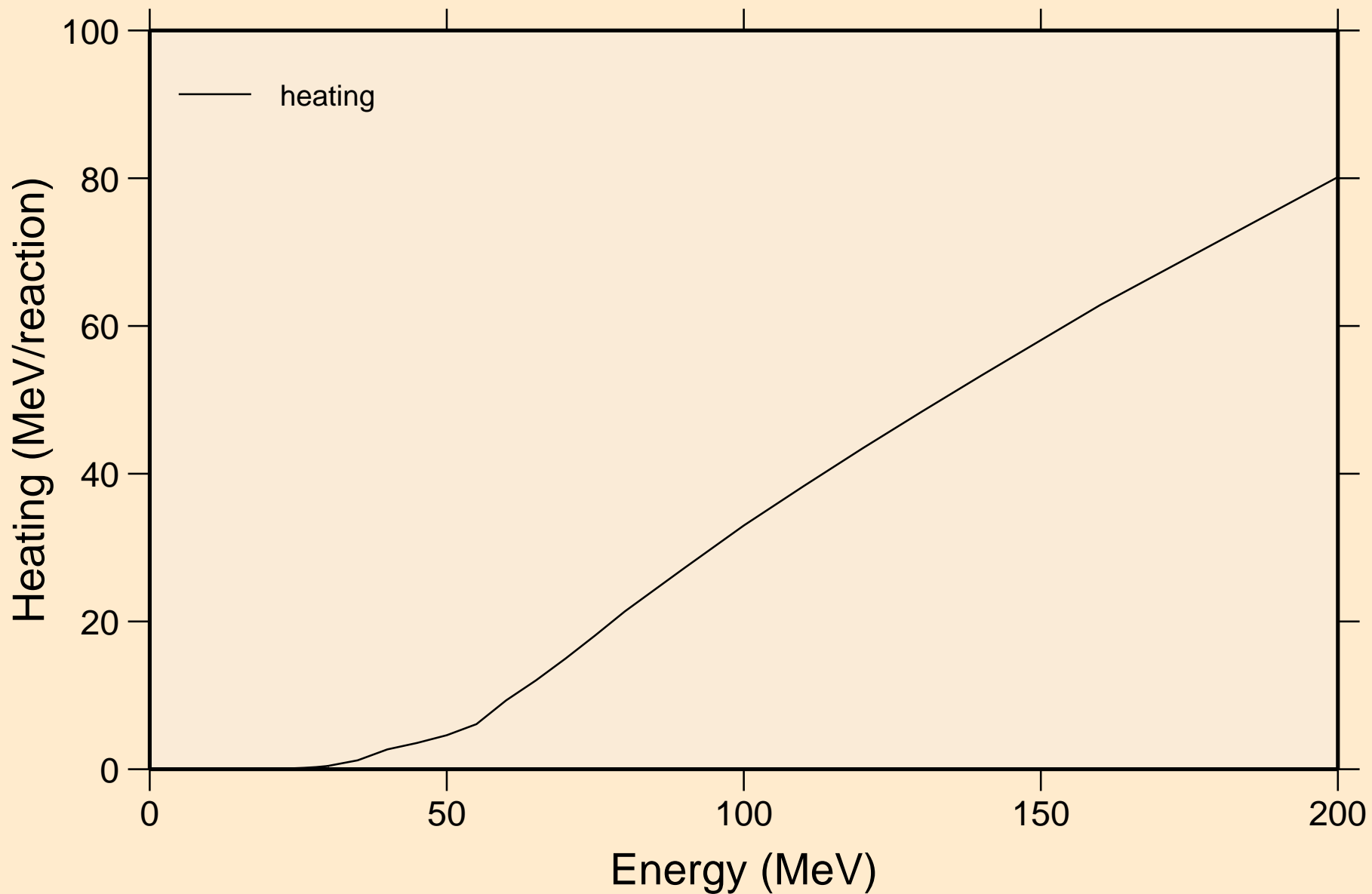

SM146 TRITON ACER TENDL-2023 LIBRARY; T=0.K  
Threshold reactions

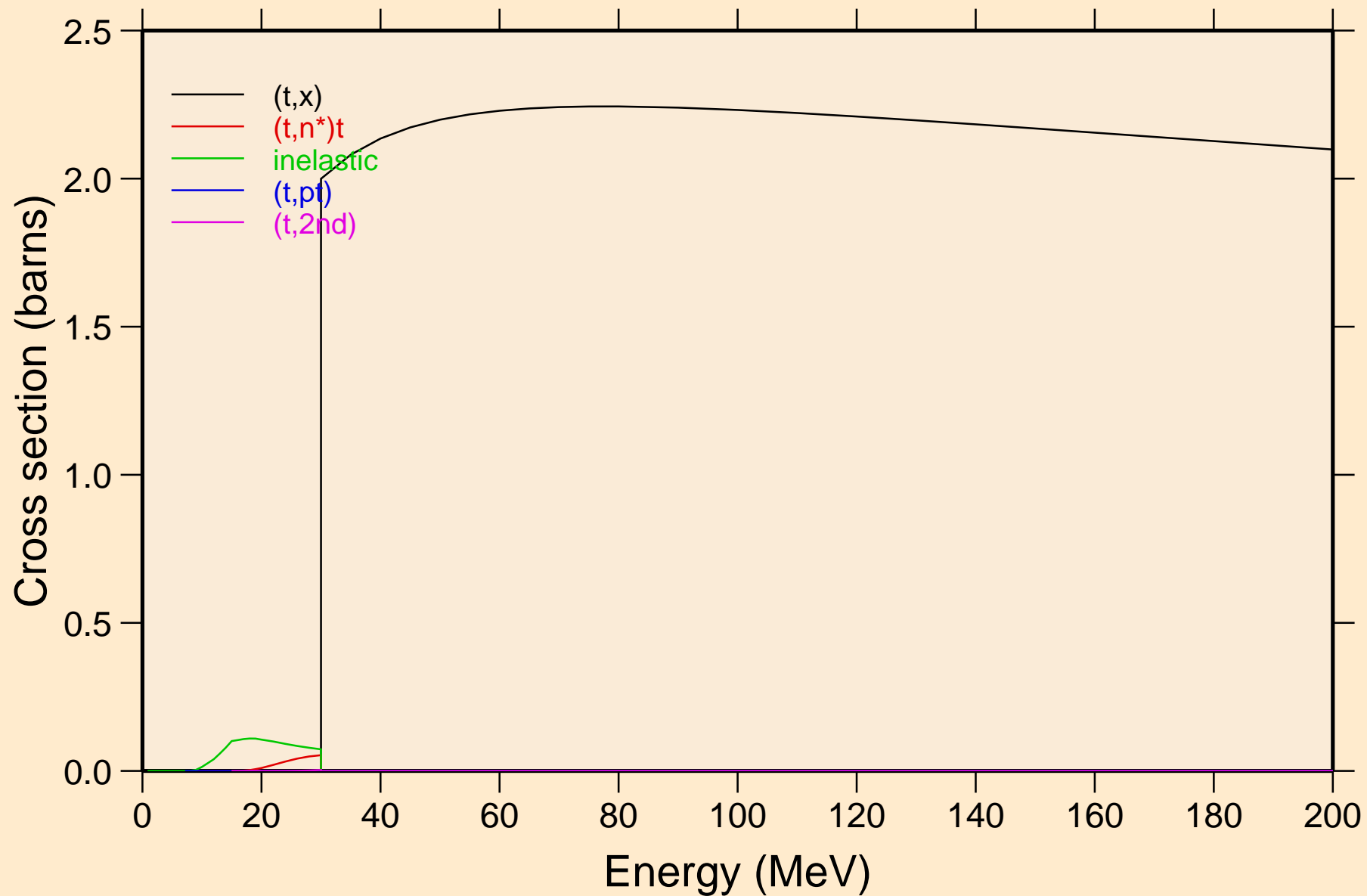

SM146 TRITON ACER TENDL-2023 LIBRARY; T=0.K  
Threshold reactions

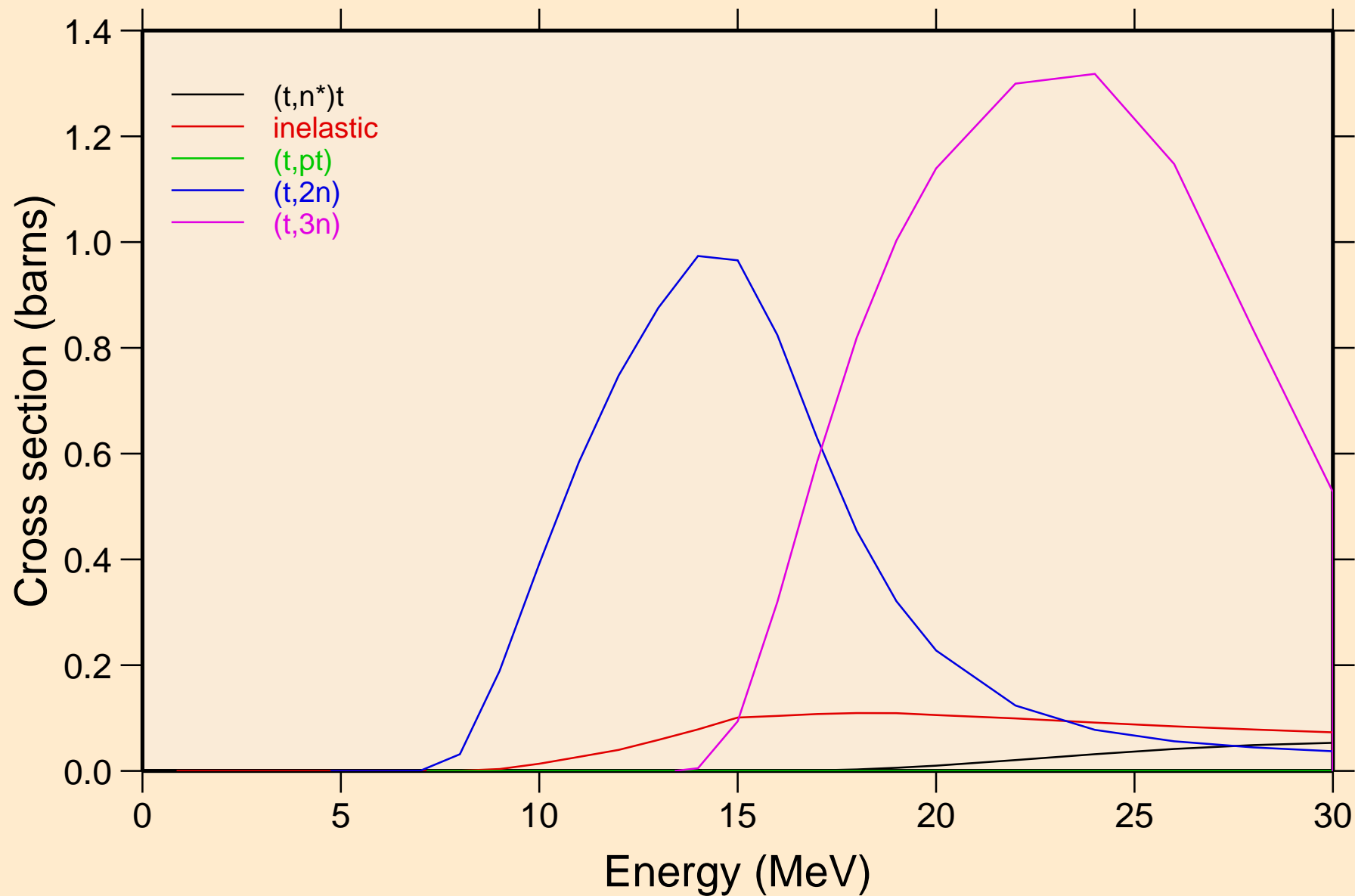

SM146 TRITON ACER TENDL-2023 LIBRARY; T=0.K  
Threshold reactions

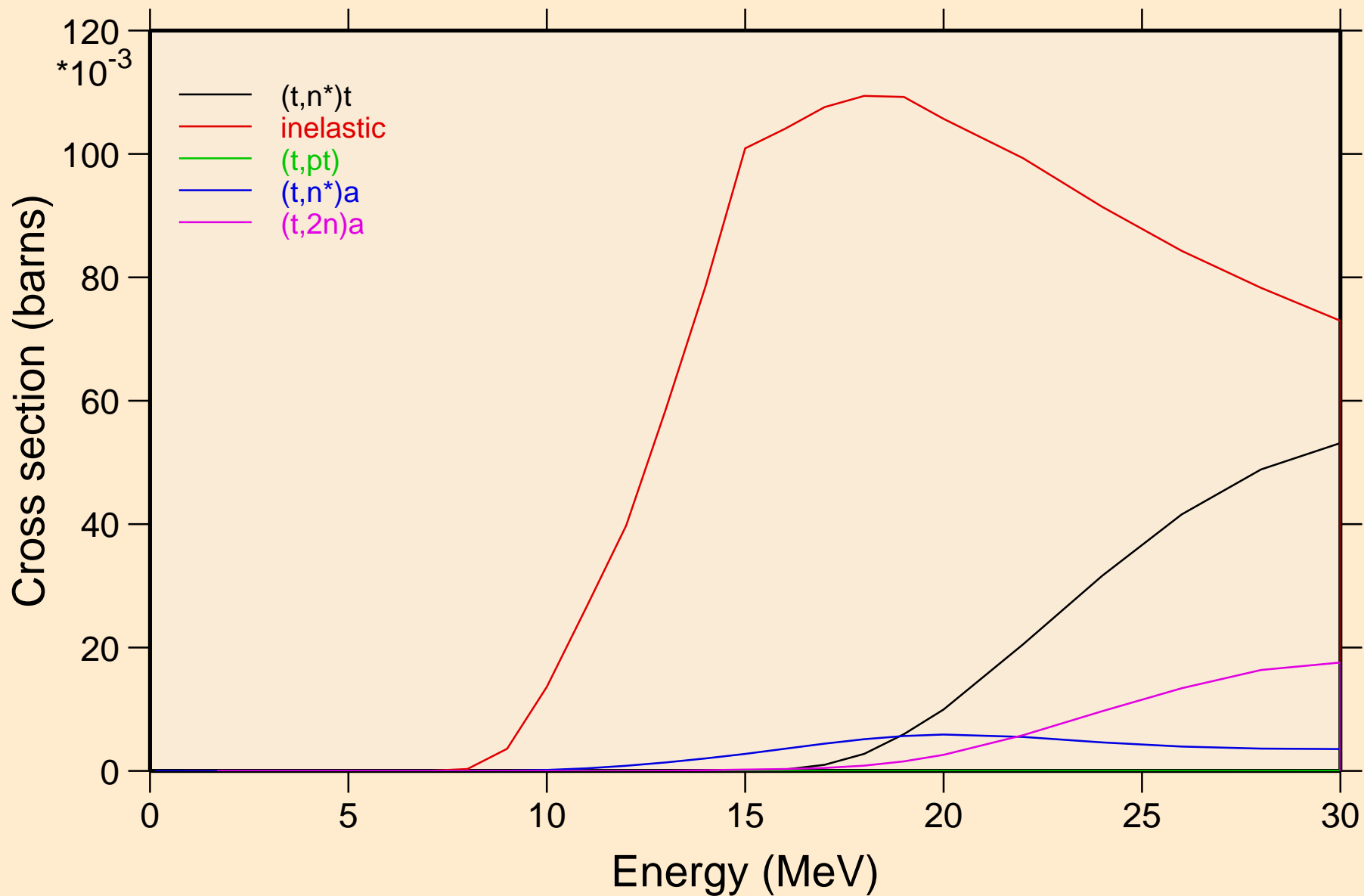

SM146 TRITON ACER TENDL-2023 LIBRARY; T=0.K  
Threshold reactions

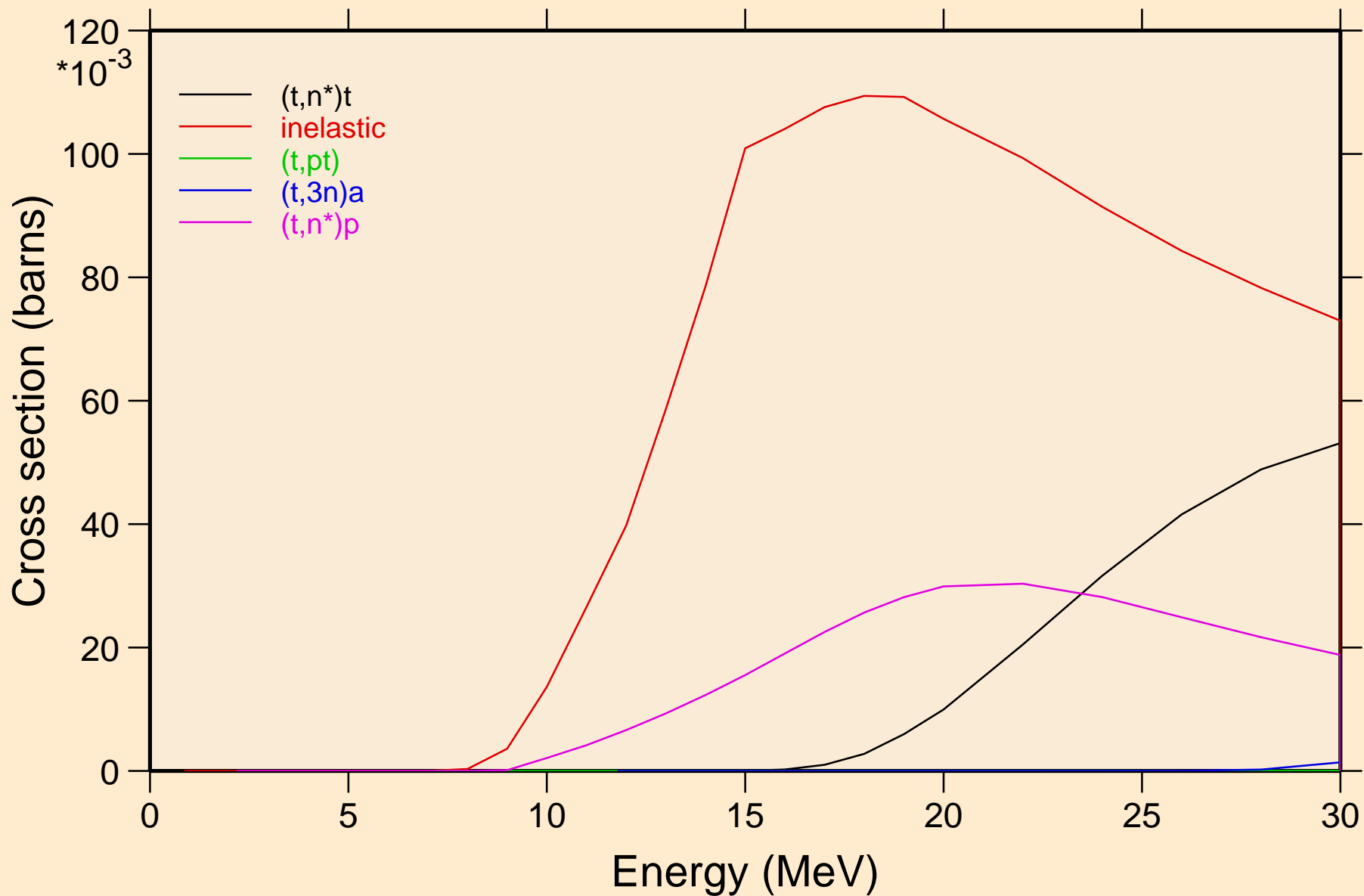

SM146 TRITON ACER TENDL-2023 LIBRARY; T=0.K  
Threshold reactions

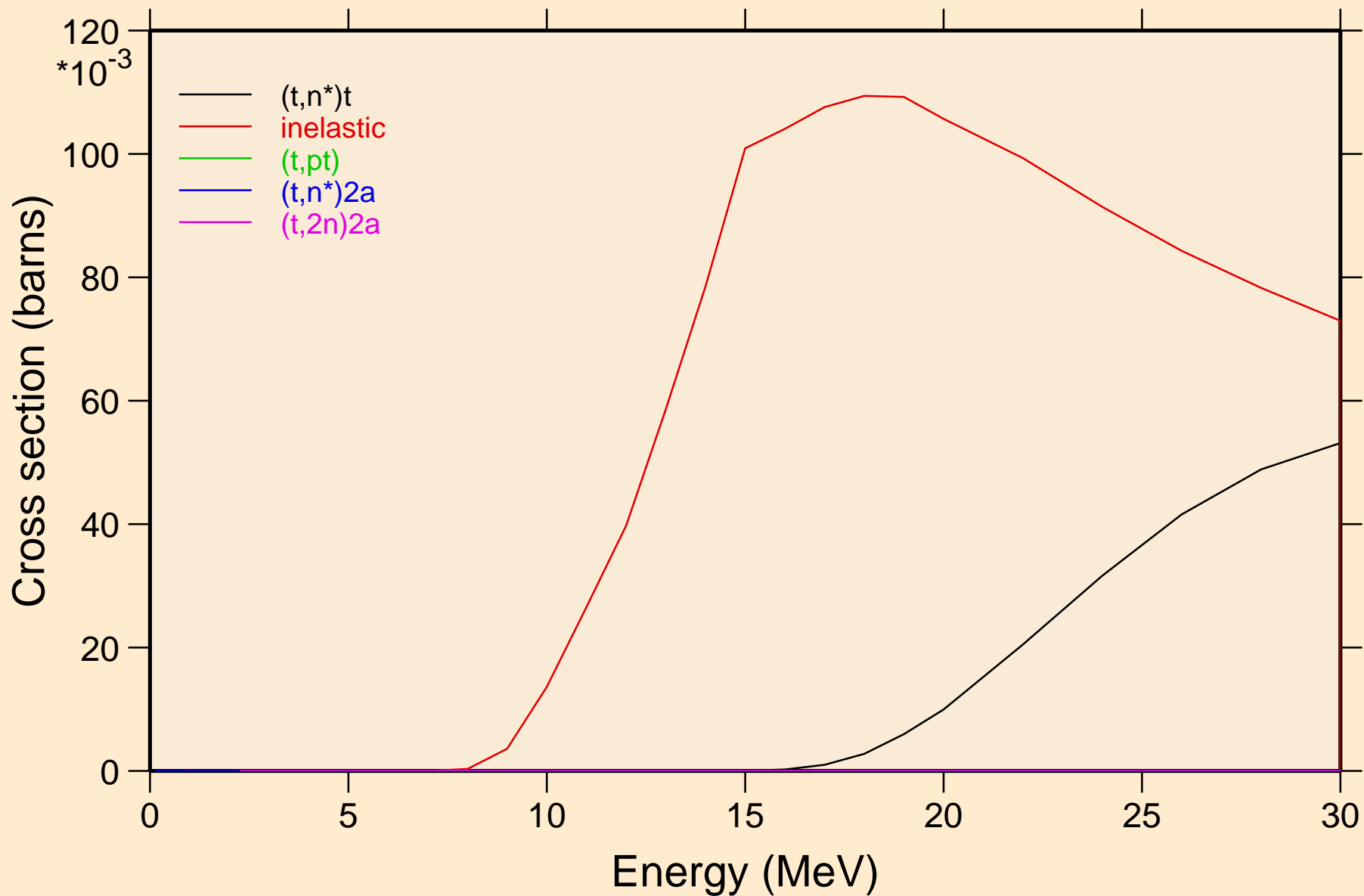

SM146 TRITON ACER TENDL-2023 LIBRARY; T=0.K  
Threshold reactions

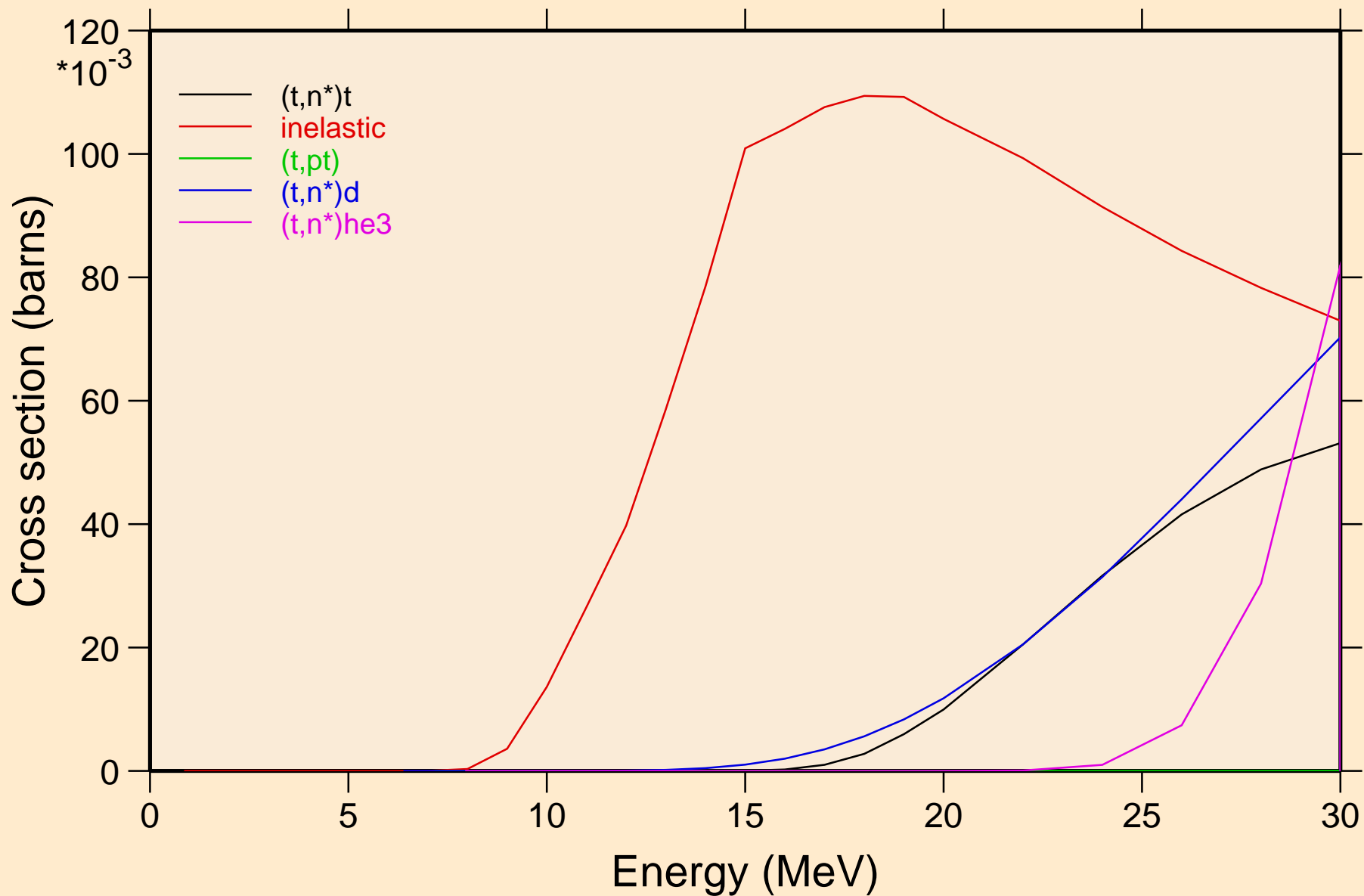

SM146 TRITON ACER TENDL-2023 LIBRARY; T=0.K  
Threshold reactions

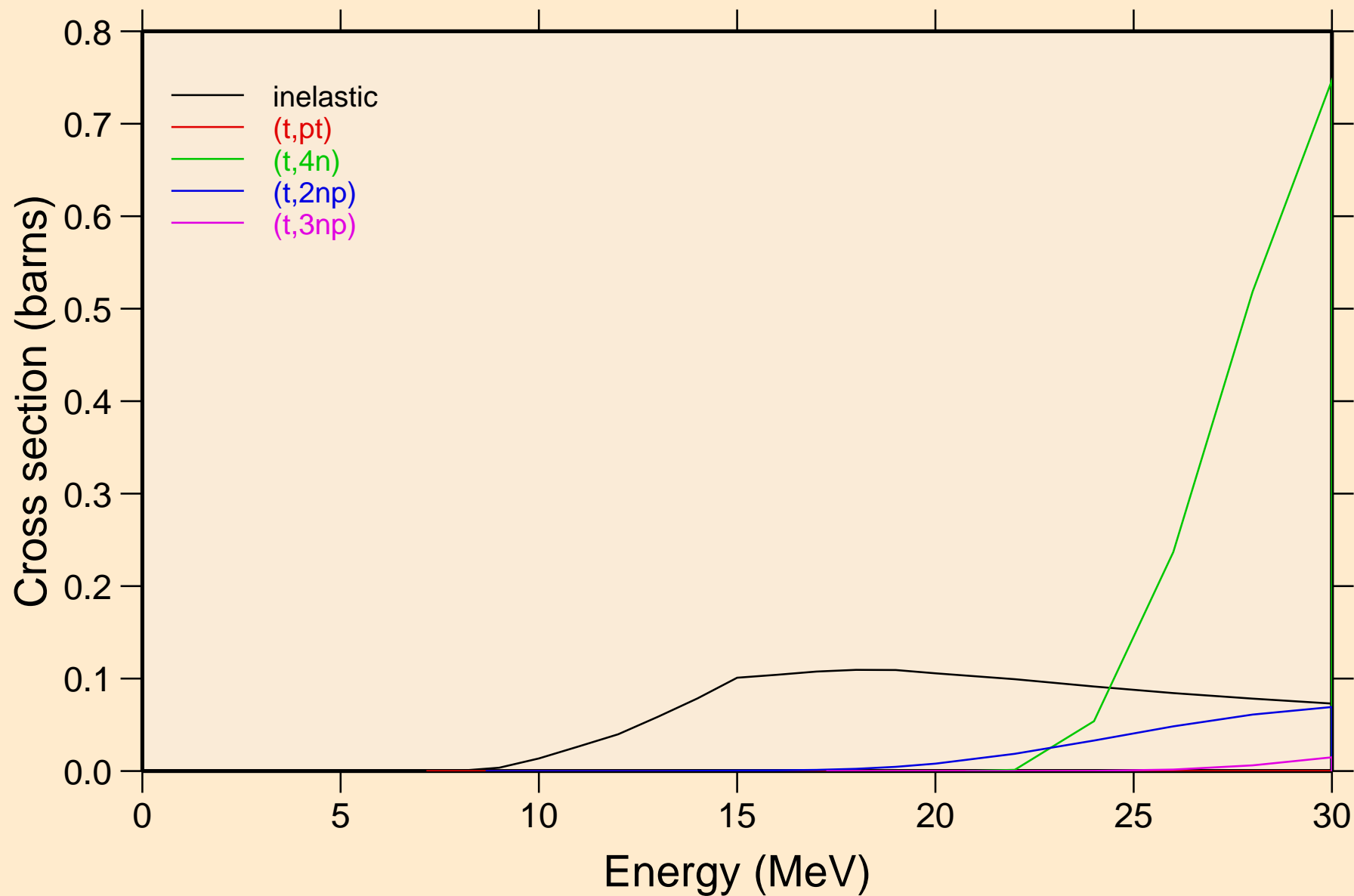

SM146 TRITON ACER TENDL-2023 LIBRARY; T=0.K  
Threshold reactions

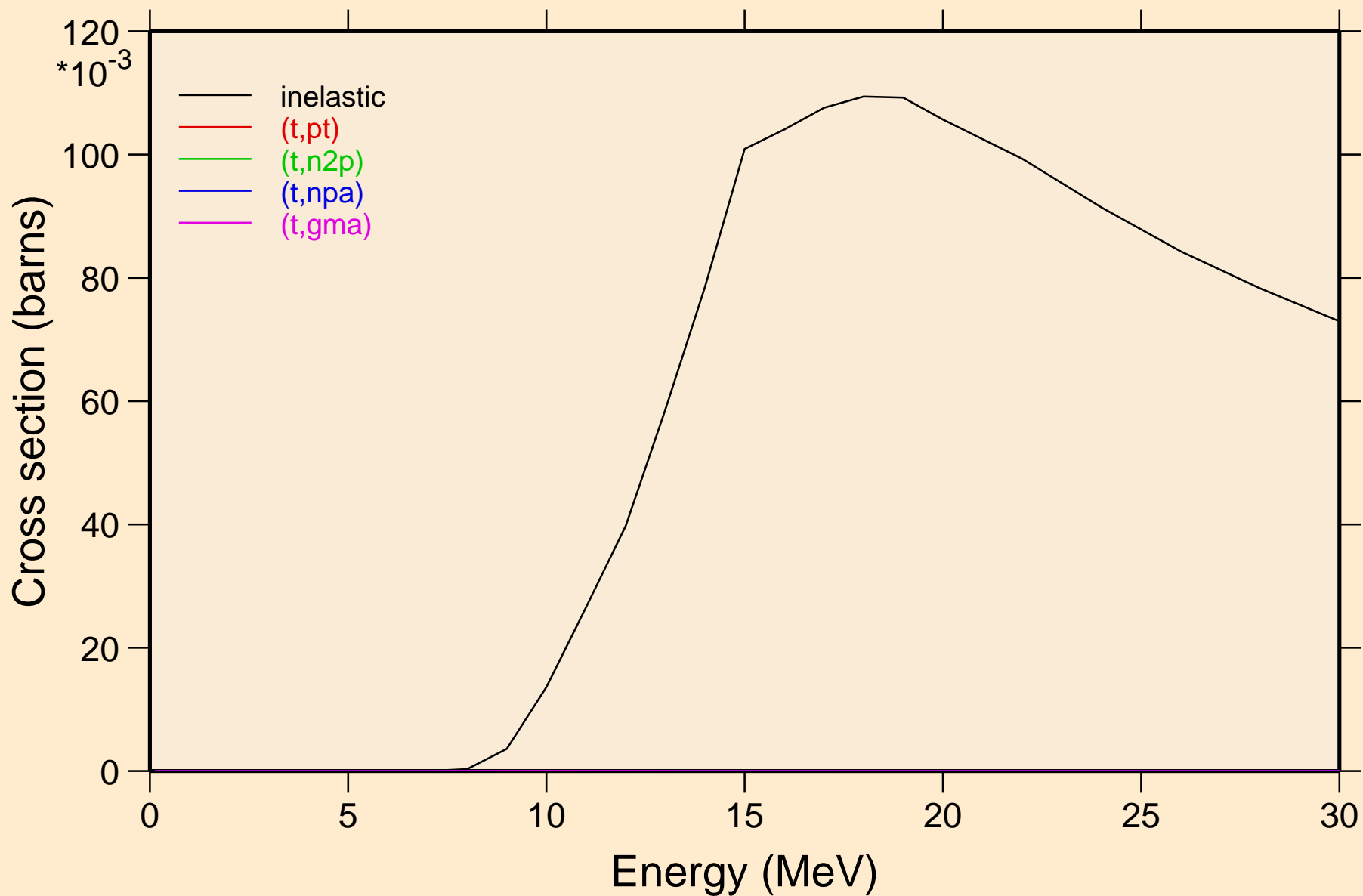

SM146 TRITON ACER TENDL-2023 LIBRARY; T=0.K  
Threshold reactions

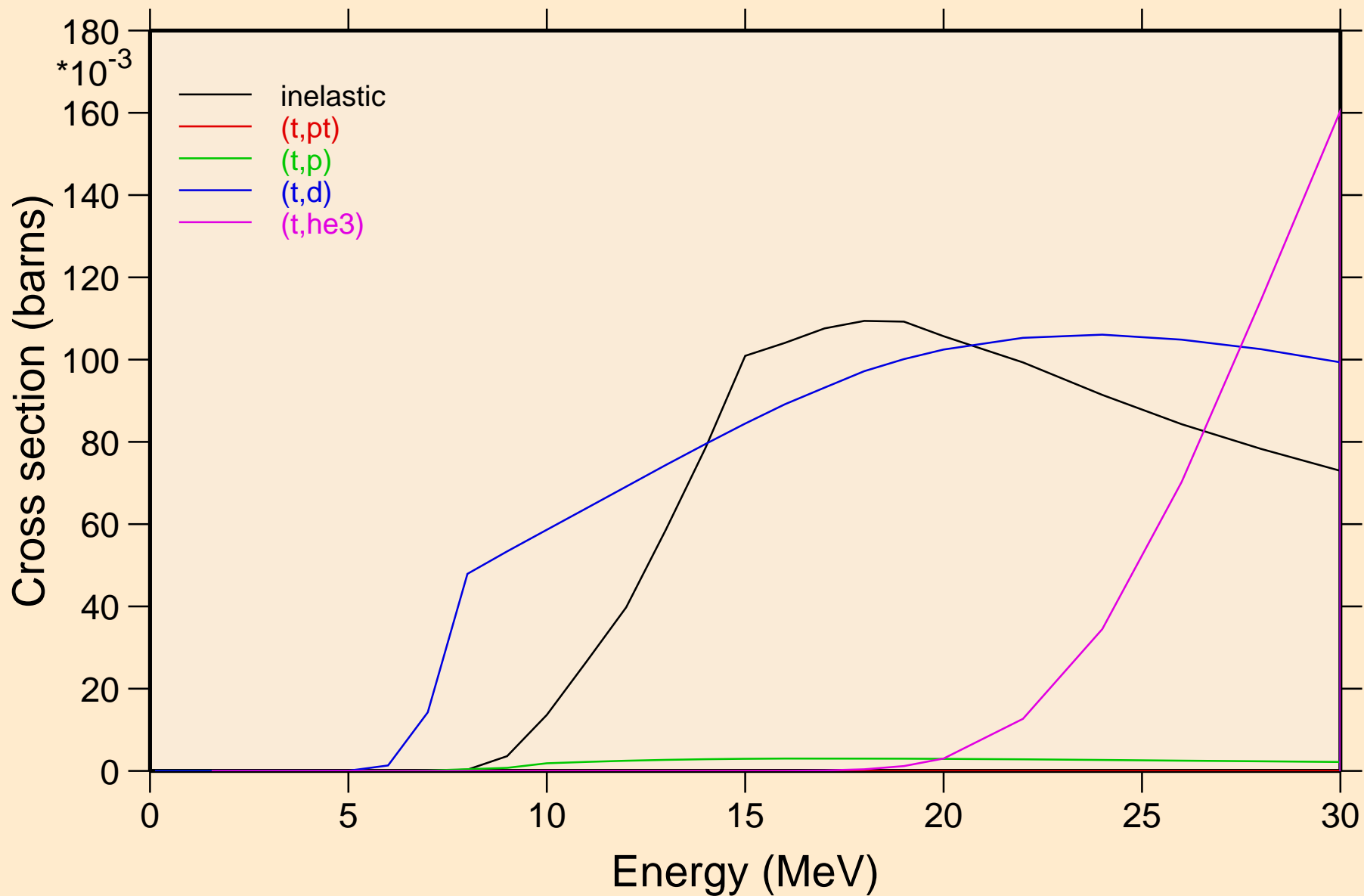

SM146 TRITON ACER TENDL-2023 LIBRARY; T=0.K  
Threshold reactions

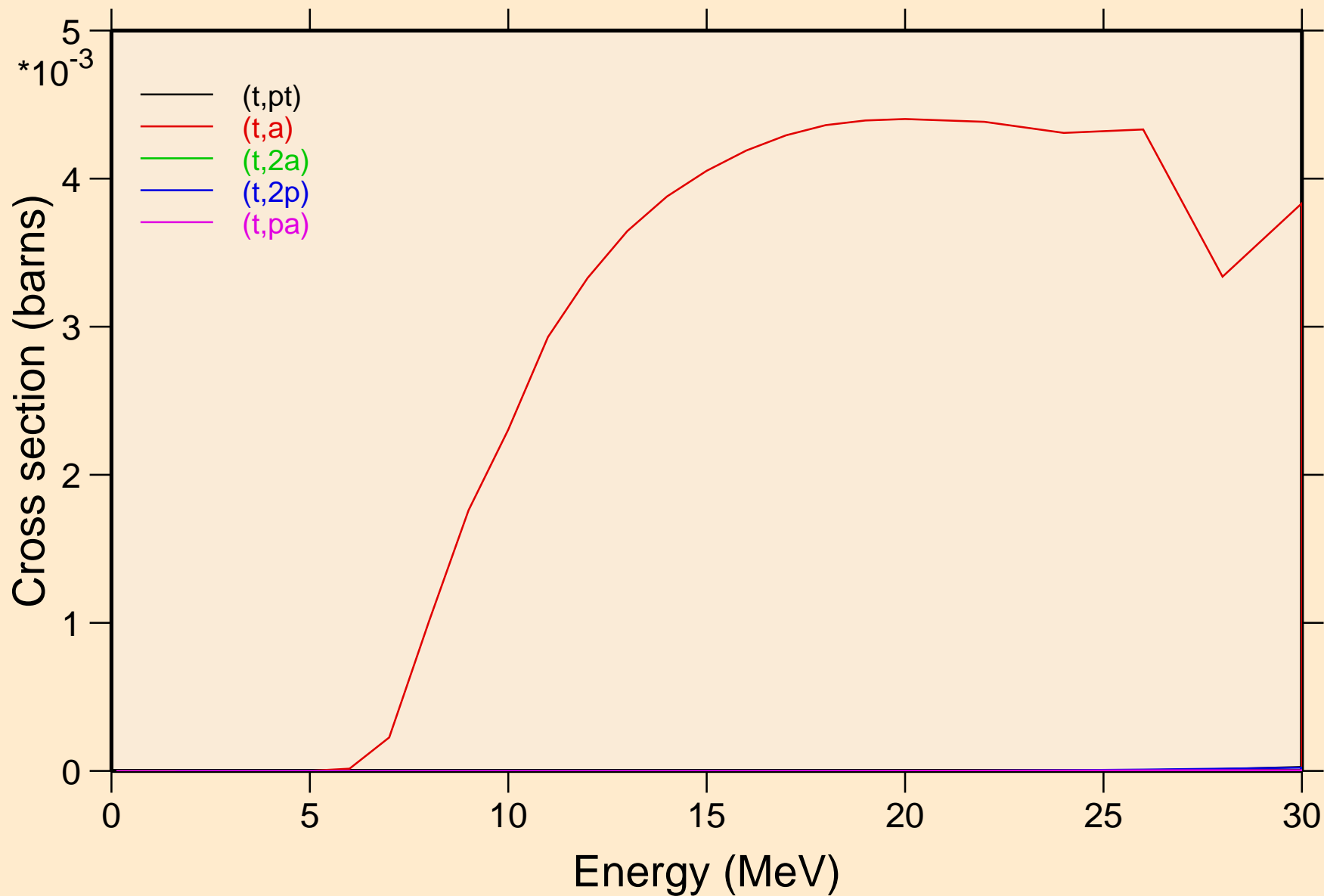

SM146 TRITON ACER TENDL-2023 LIBRARY; T=0.K  
Threshold reactions

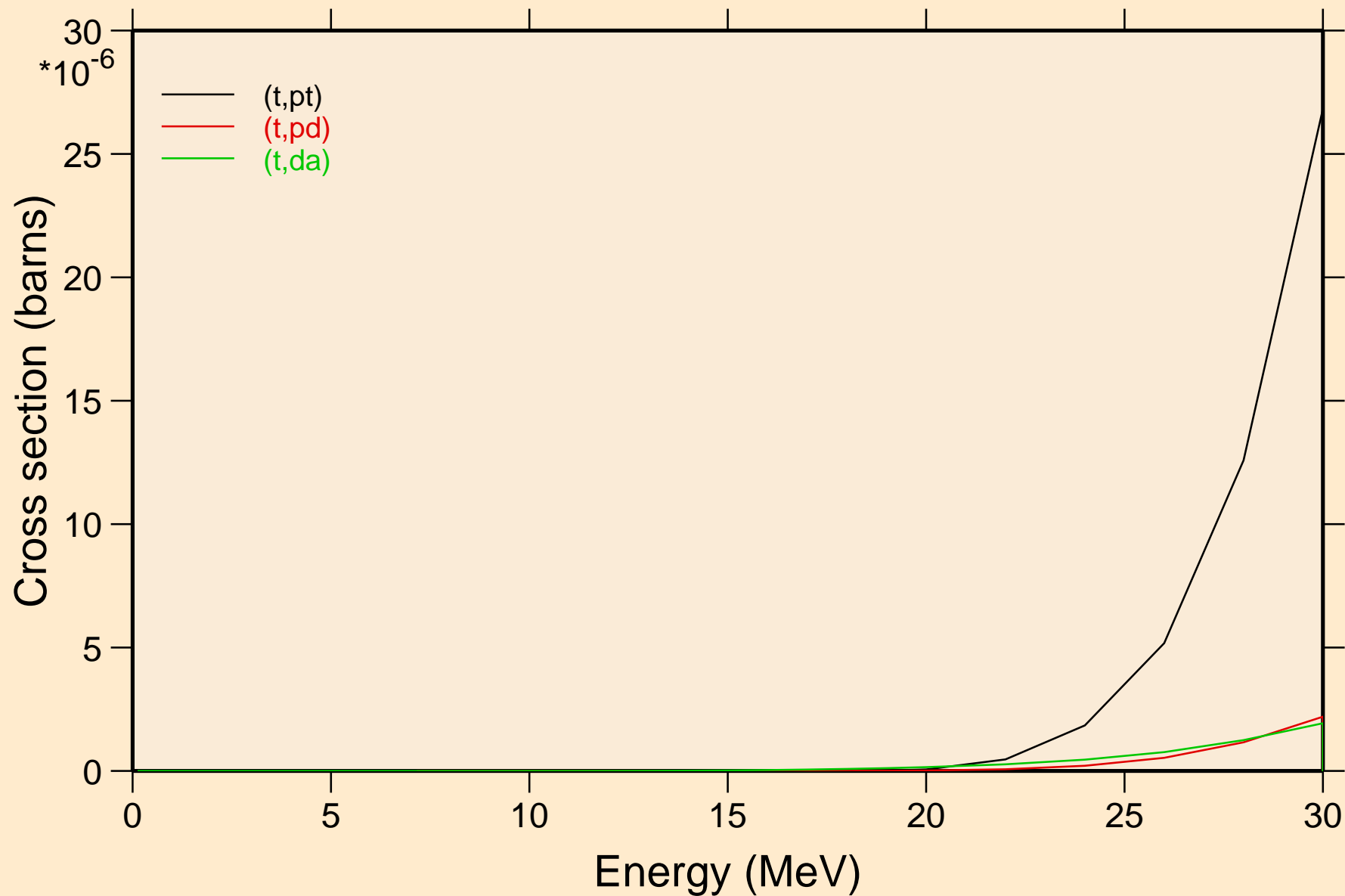

SM146 TRITON ACER TENDL-2023 LIBRARY; T=0.K  
angular distribution for elastic

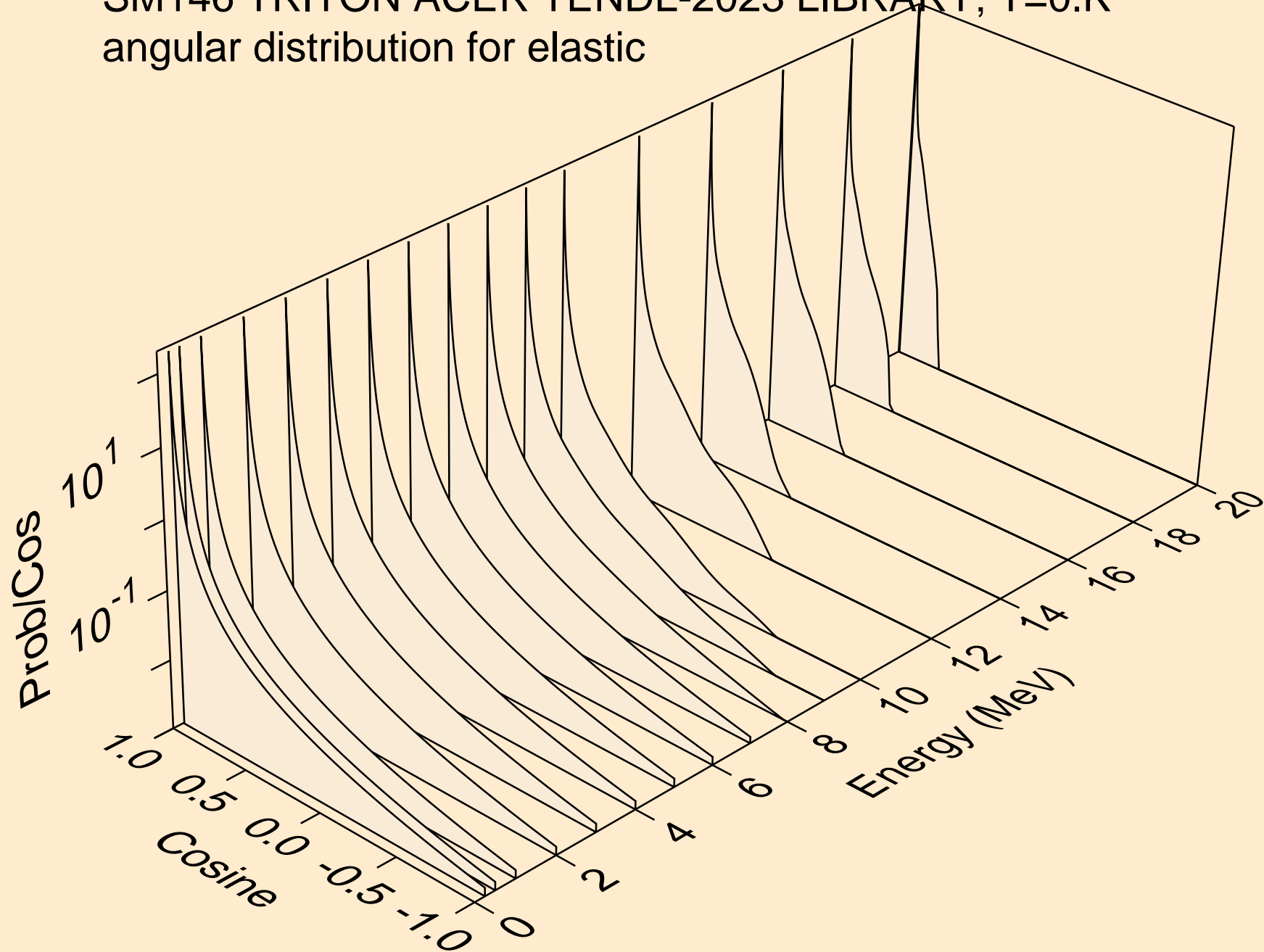

SM146 TRITON ACER TENDL-2023 LIBRARY; T=0.K  
angular distribution for elastic

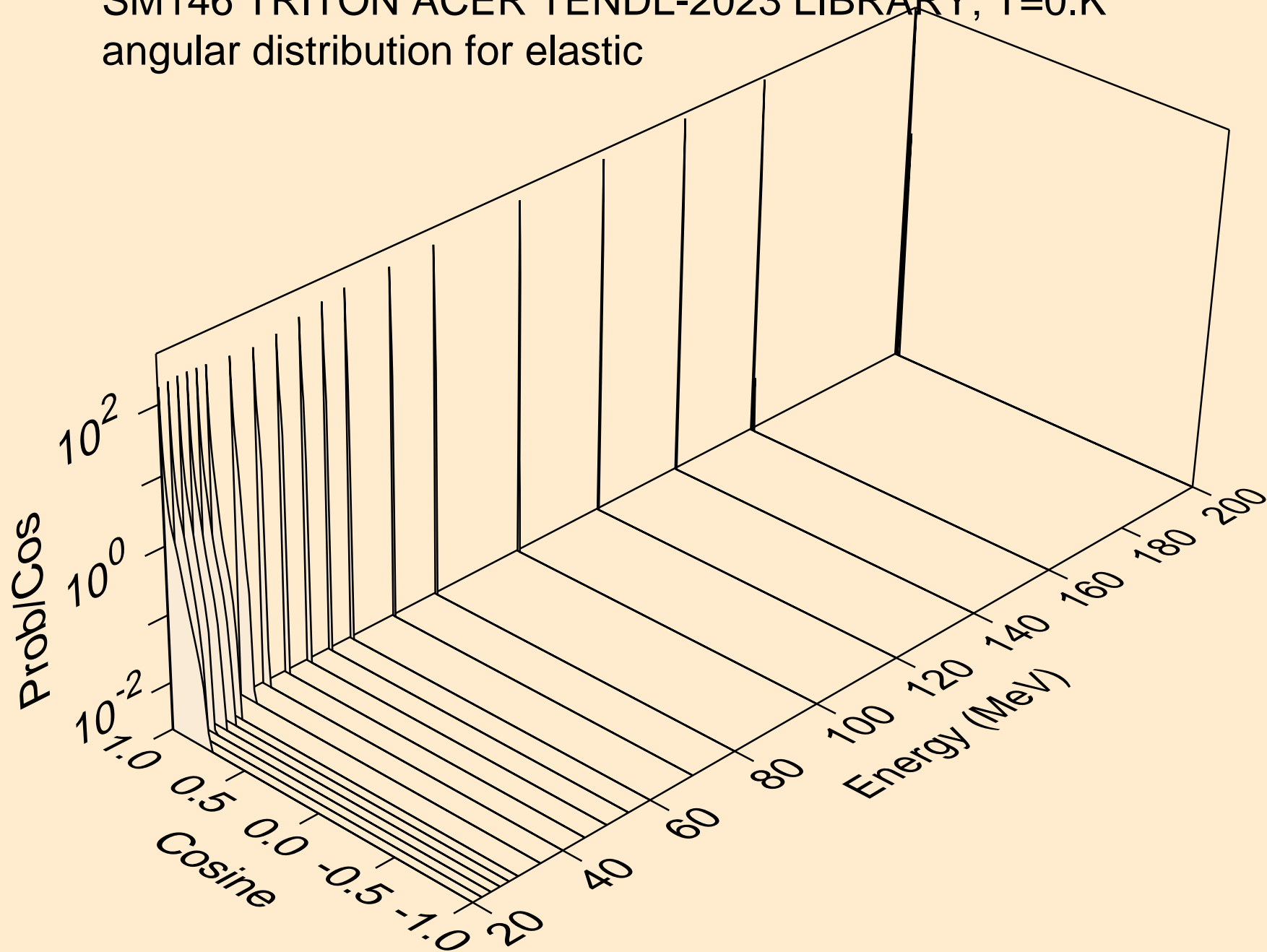

SM146 TRITON ACER TENDL-2023 LIBRARY; T=0.K  
Triton emission for (t,x)

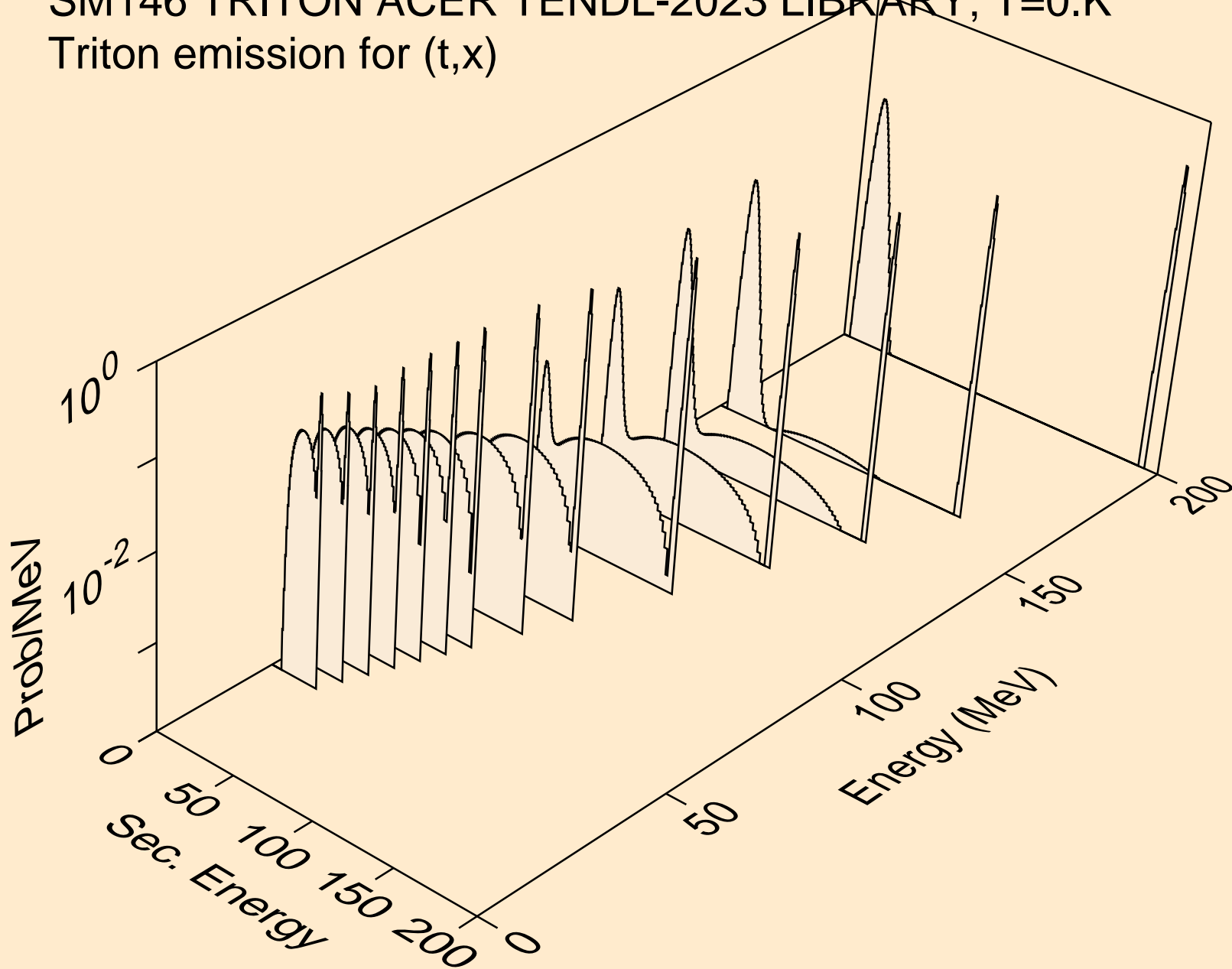

SM146 TRITON ACER TENDL-2023 LIBRARY; T=0.K  
Triton emission for (t,n\*)t

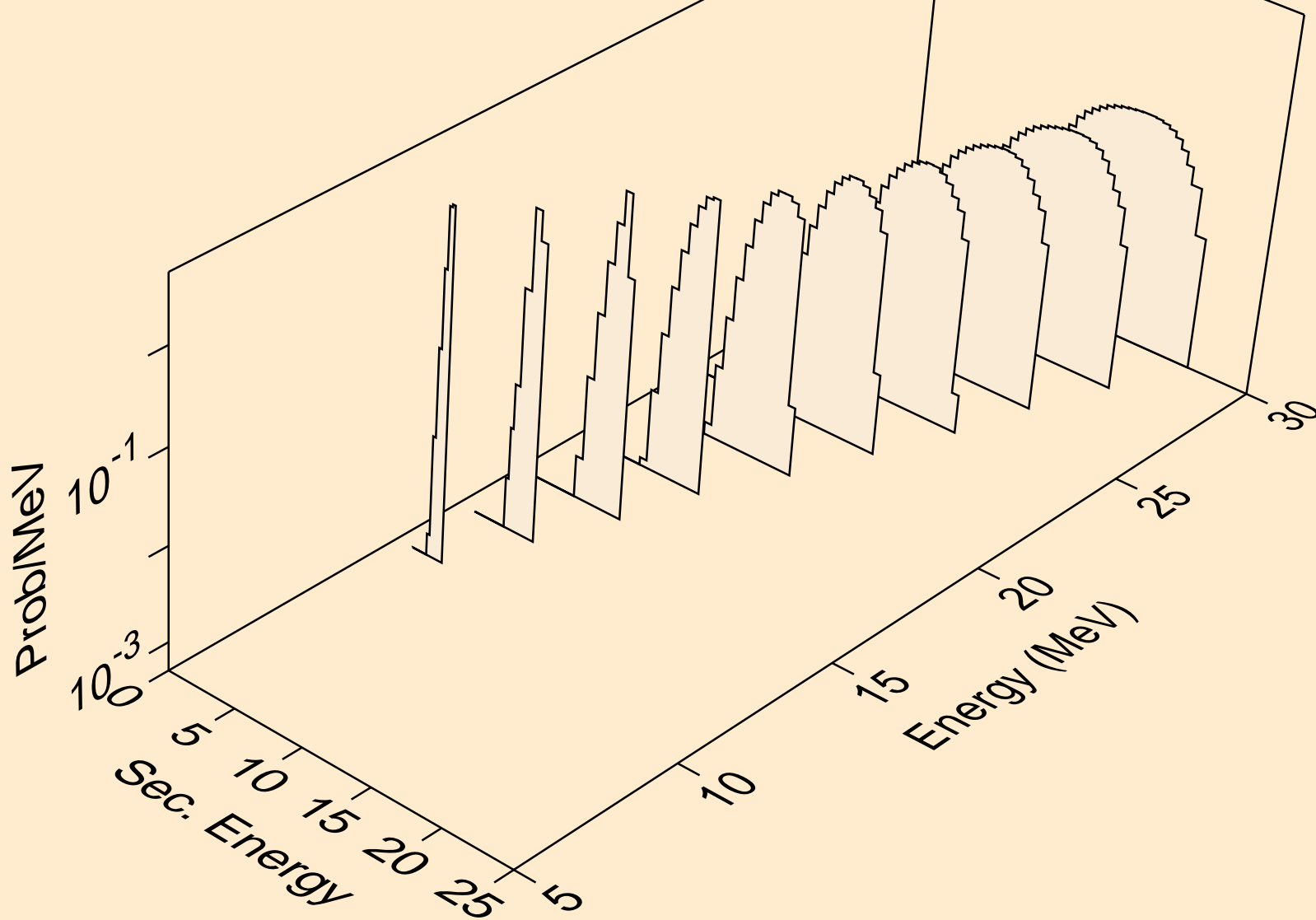

SM146 TRITON ACER TENDL-2023 LIBRARY; T=0.K  
Triton emission for inelastic

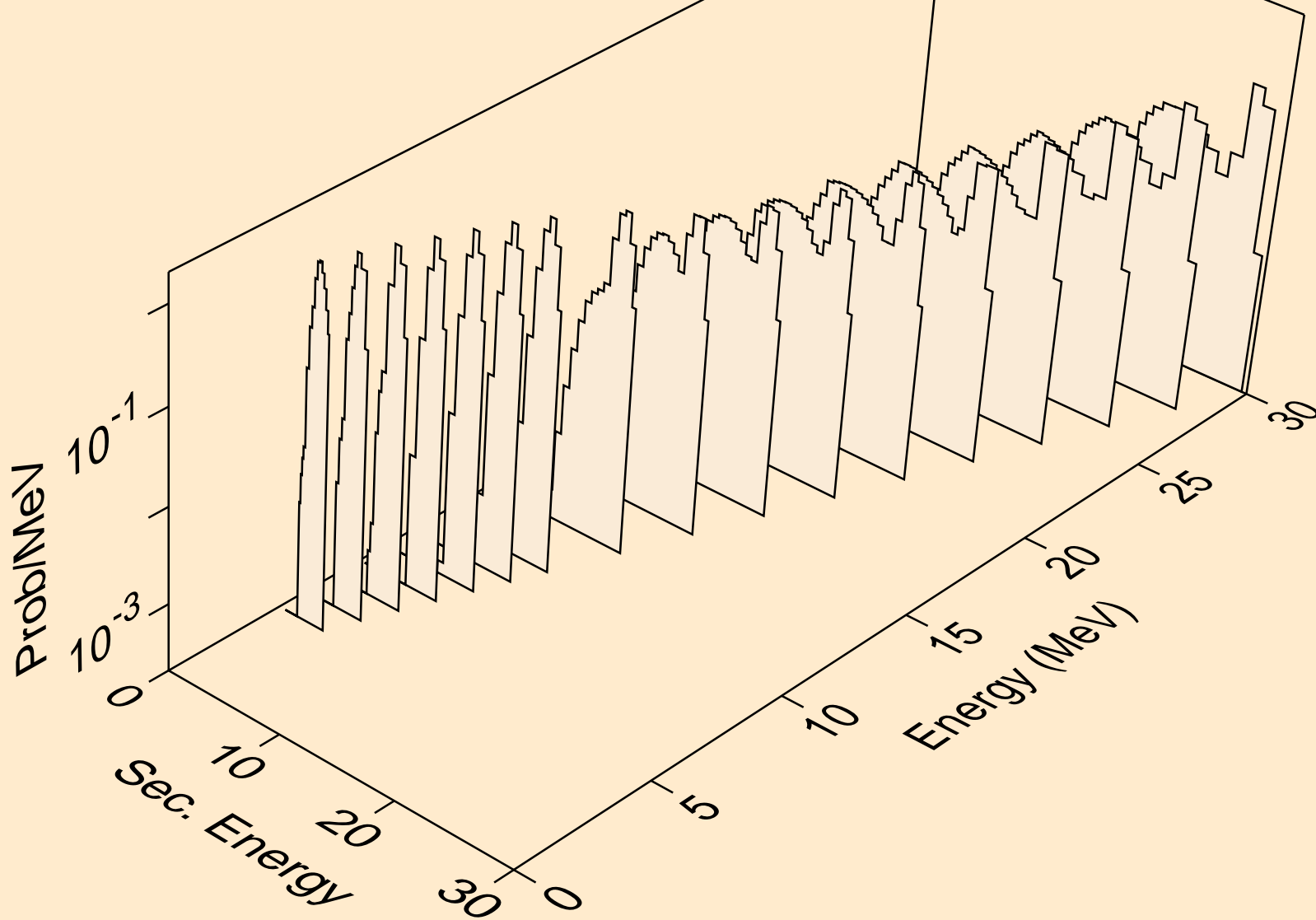

SM146 TRITON ACER TENDL-2023 LIBRARY; T=0.K  
Triton emission for (t,pt)

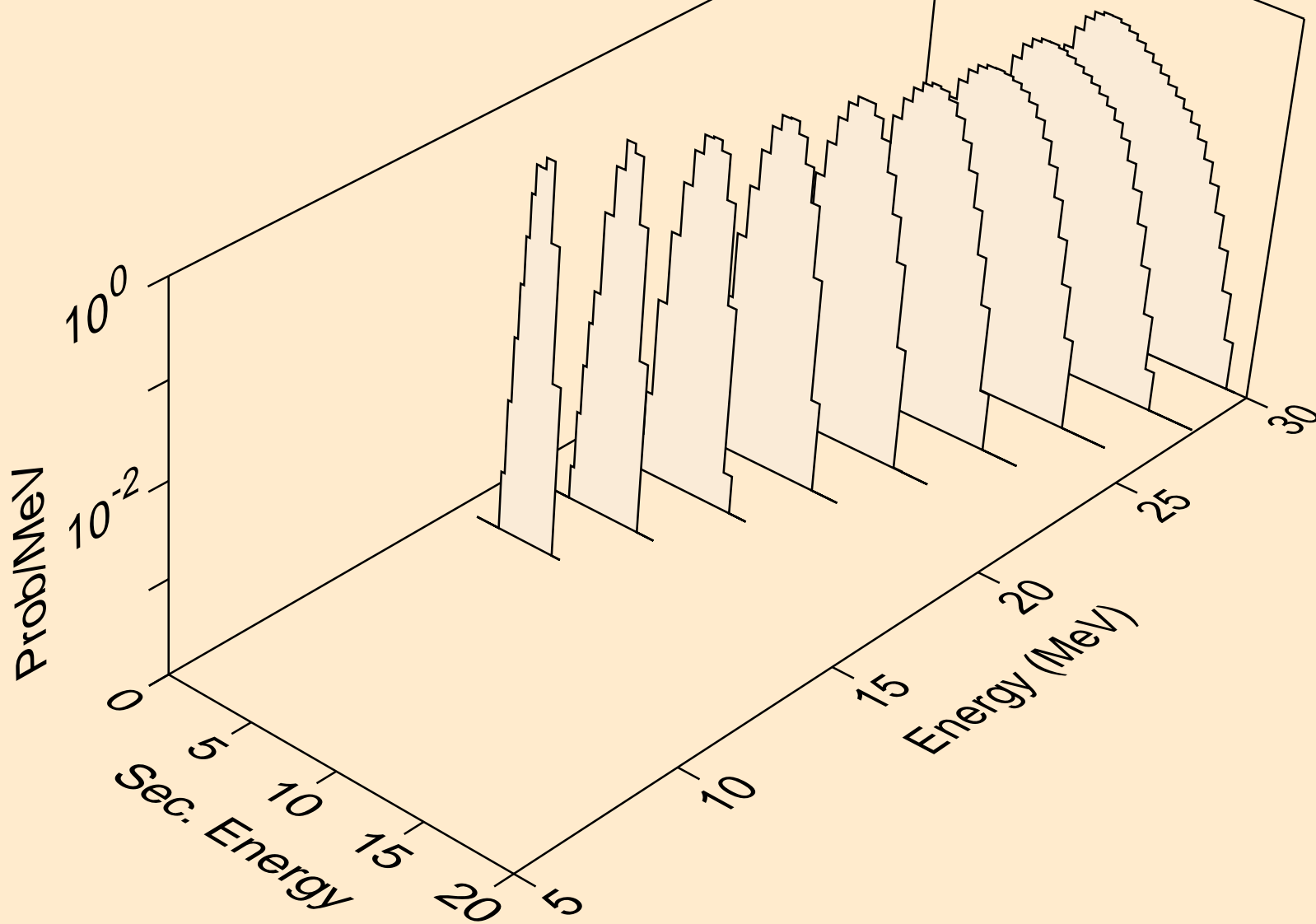

SM146 TRITON ACER TENDL-2023 LIBRARY; T=0.K  
Photon emission for (z,n)

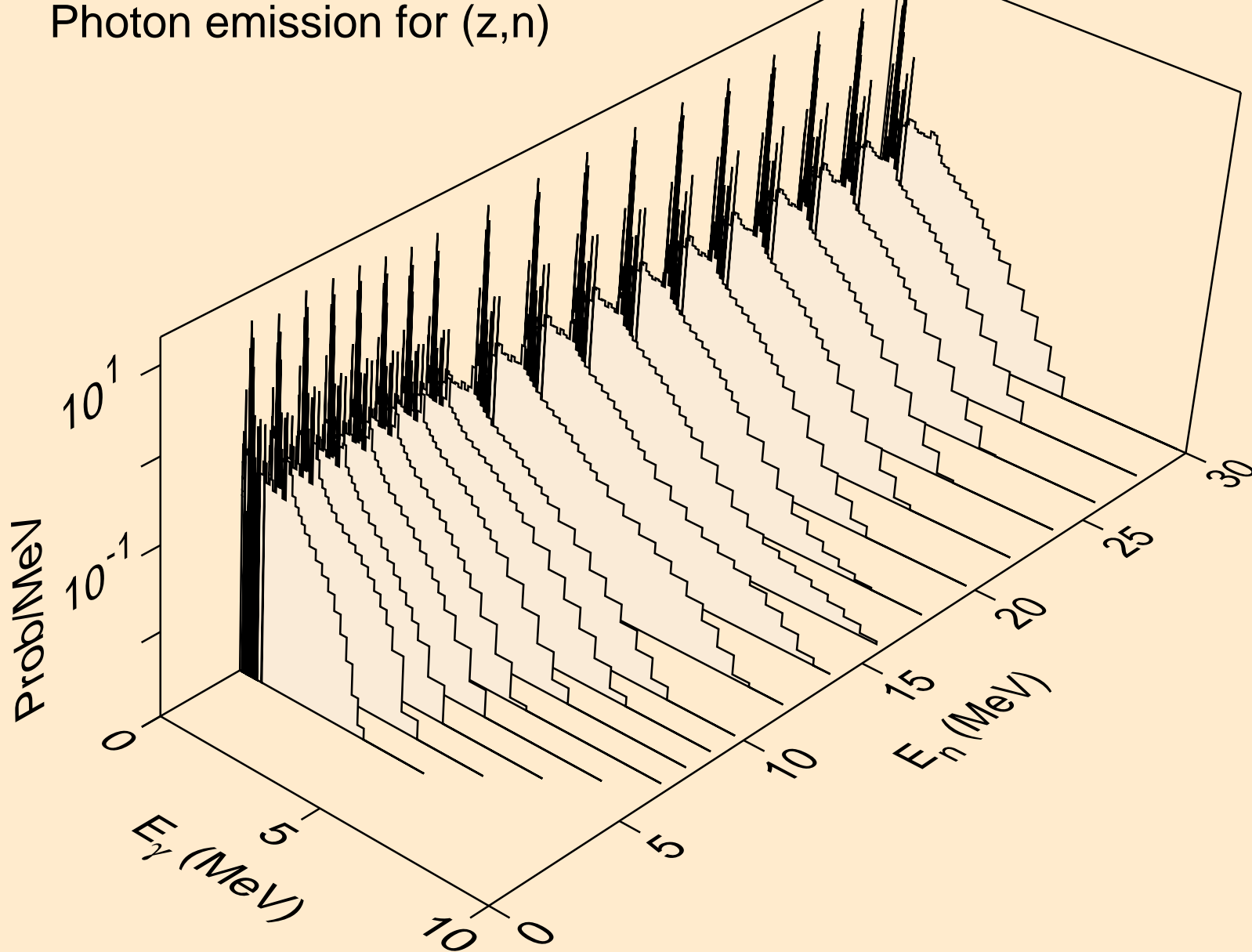

SM146 TRITON ACER TENDL-2023 LIBRARY; T=0.K  
Photon emission for (z,x)

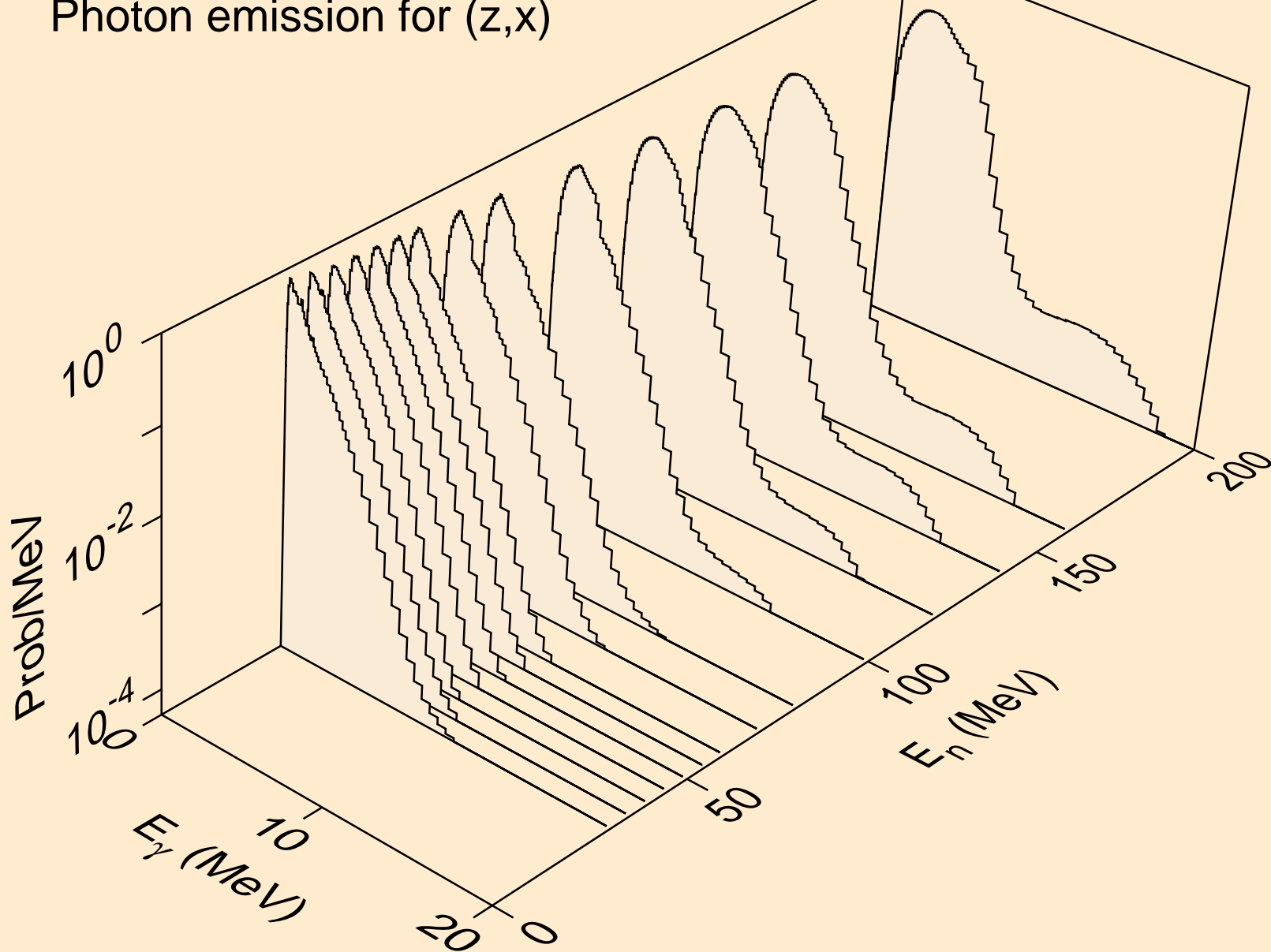

SM146 TRITON ACER TENDL-2023 LIBRARY; T=0.K  
Photon emission for (n,2nd)

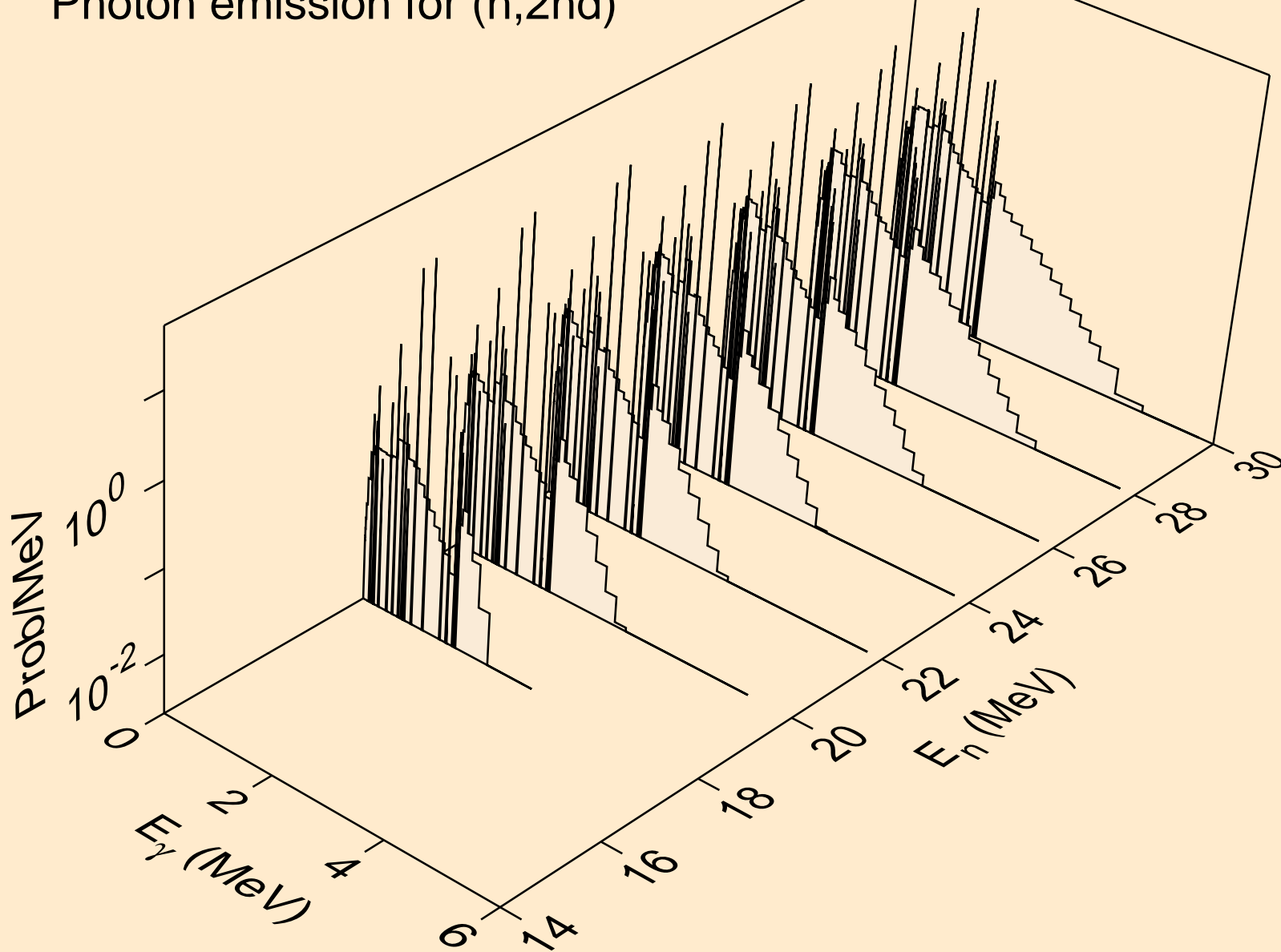

SM146 TRITON ACER TENDL-2023 LIBRARY; T=0.K  
Photon emission for (n,2n)

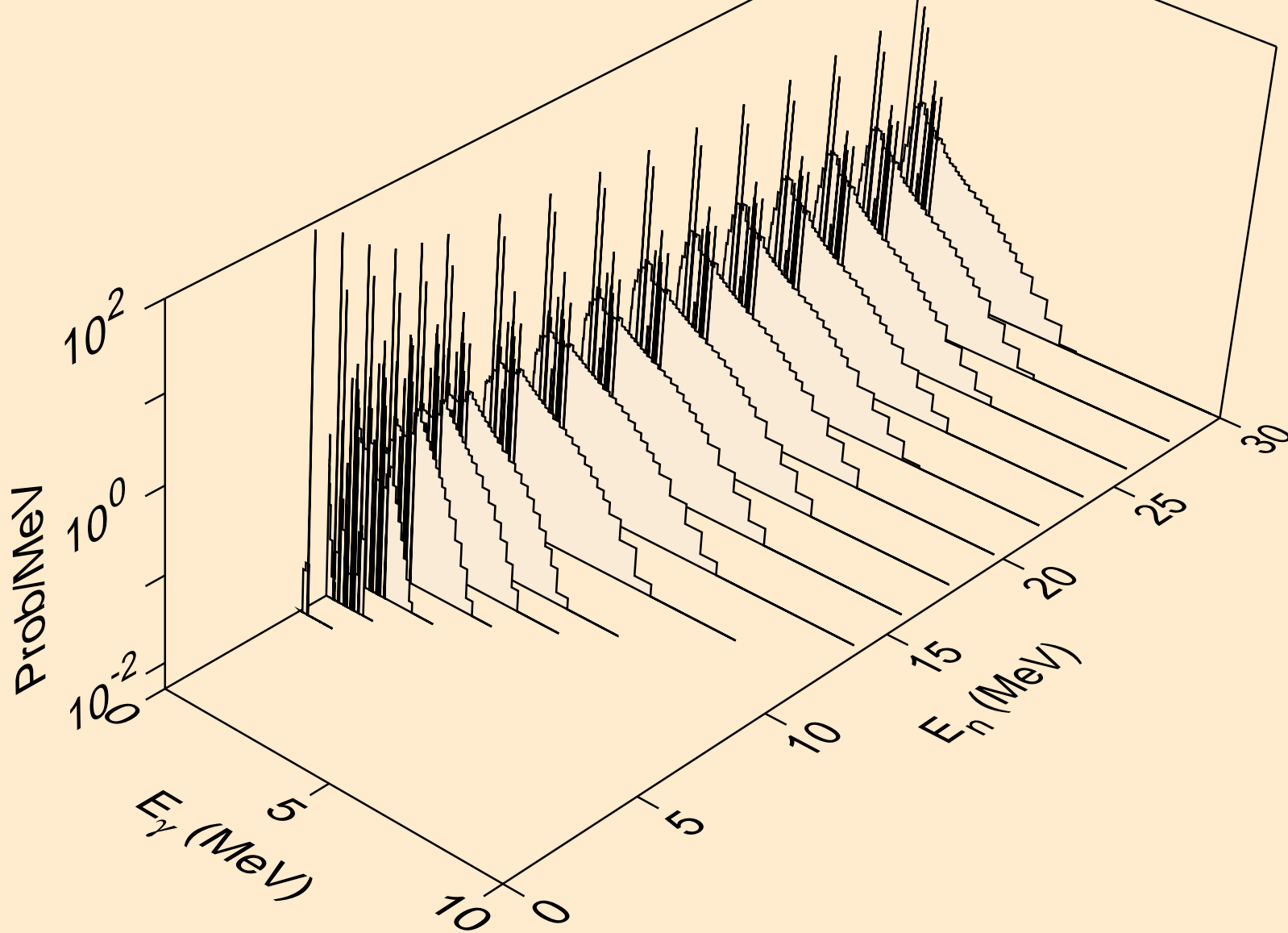

SM146 TRITON ACER TENDL-2023 LIBRARY; T=0.K  
Photon emission for (n,3n)

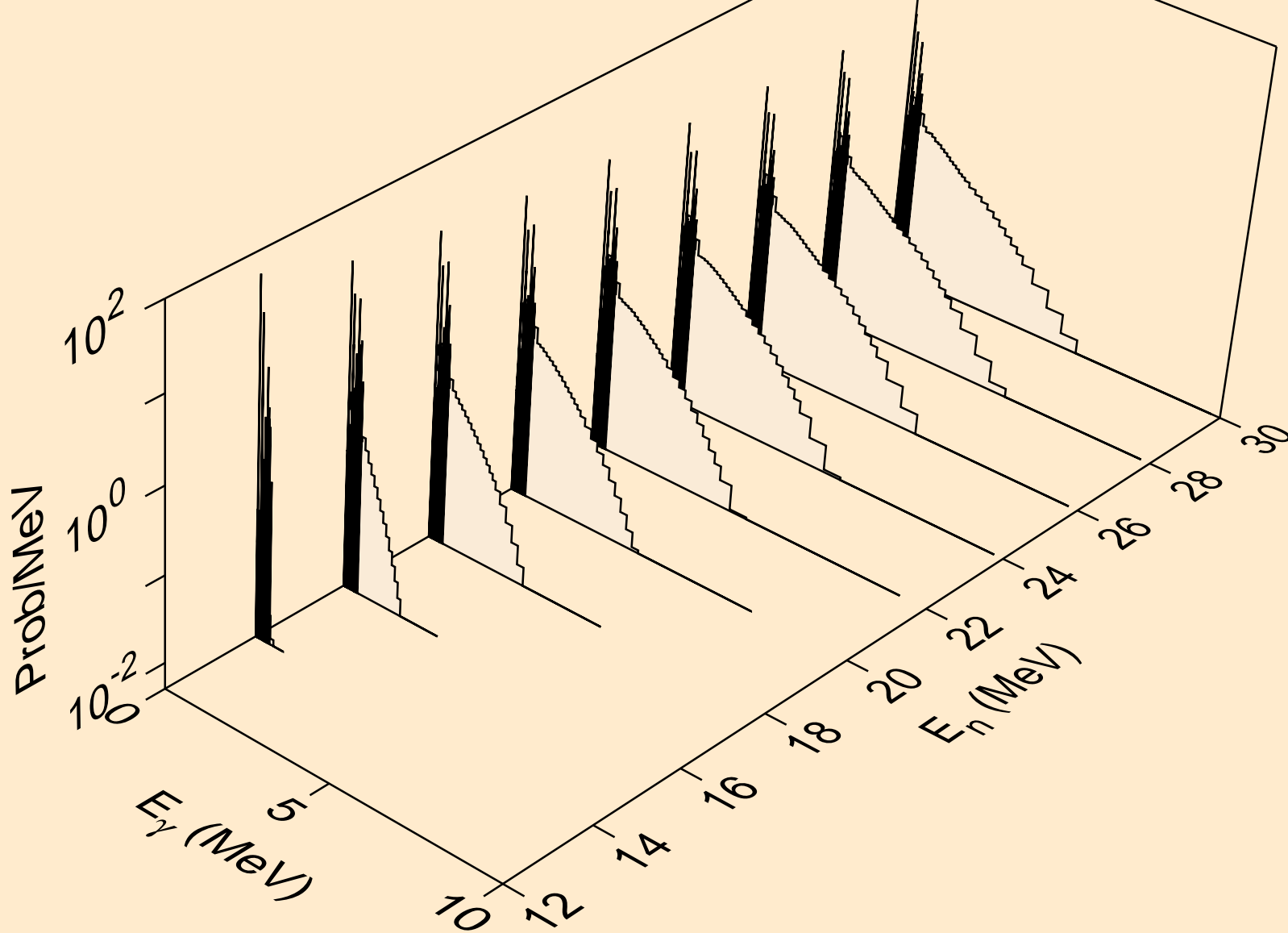

SM146 TRITON ACER TENDL-2023 LIBRARY; T=0.K  
Photon emission for (n,n\*)a

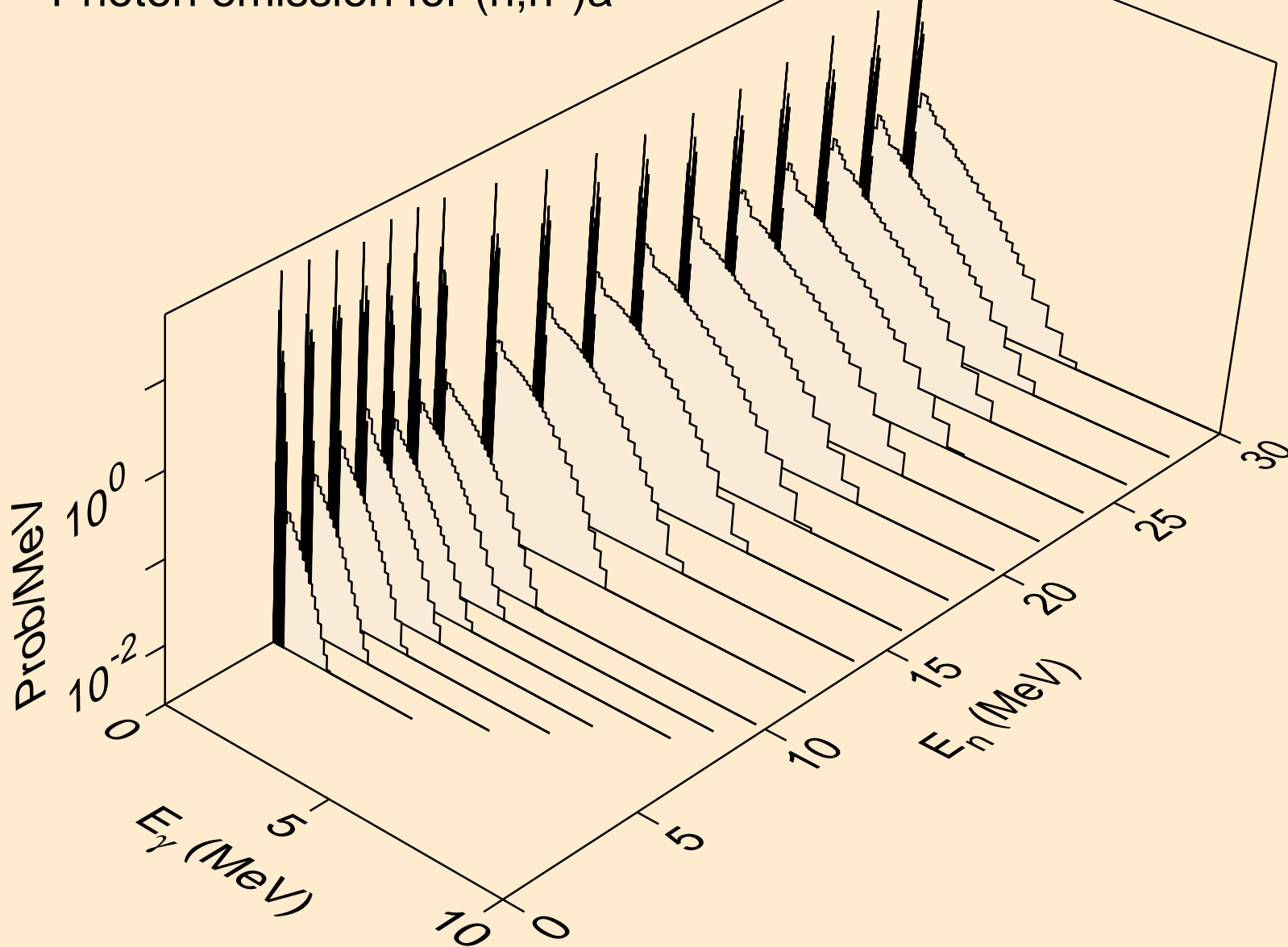

SM146 TRITON ACER TENDL-2023 LIBRARY; T=0.K  
Photon emission for (n,2n)a

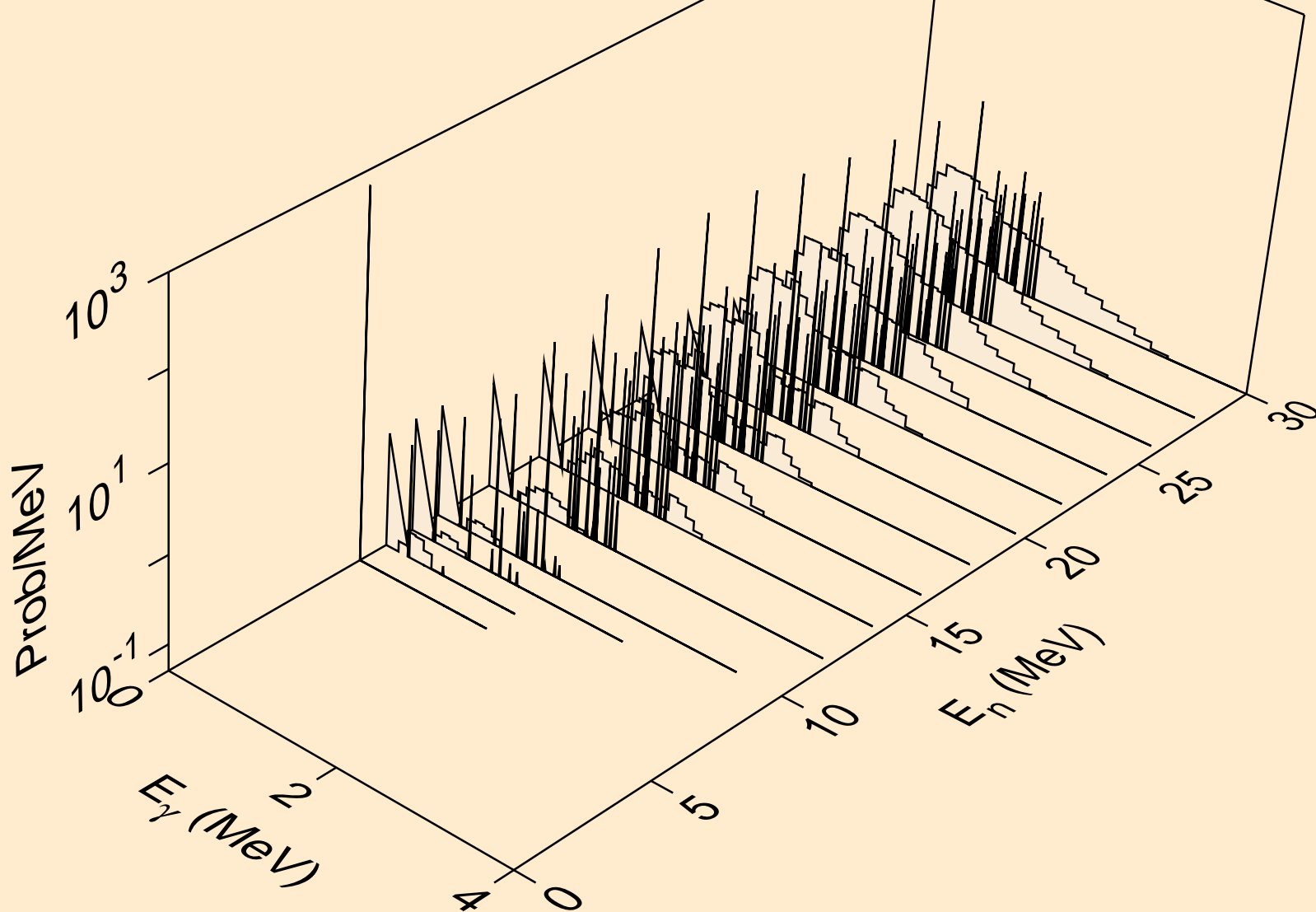

SM146 TRITON ACER TENDL-2023 LIBRARY; T=0.K  
Photon emission for (n,3n)a

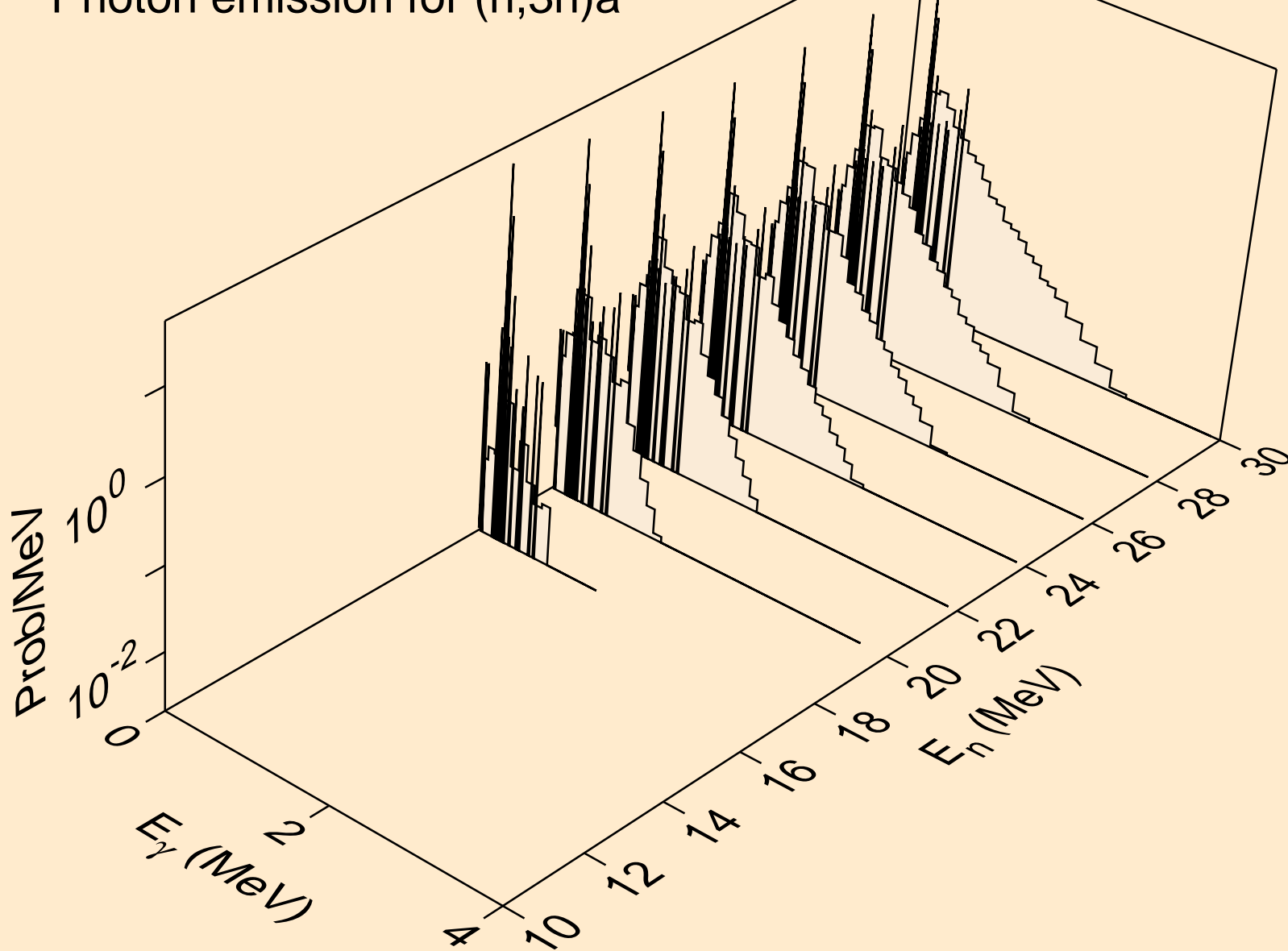

SM146 TRITON ACER TENDL-2023 LIBRARY; T=0.K  
Photon emission for (n,n\*)p

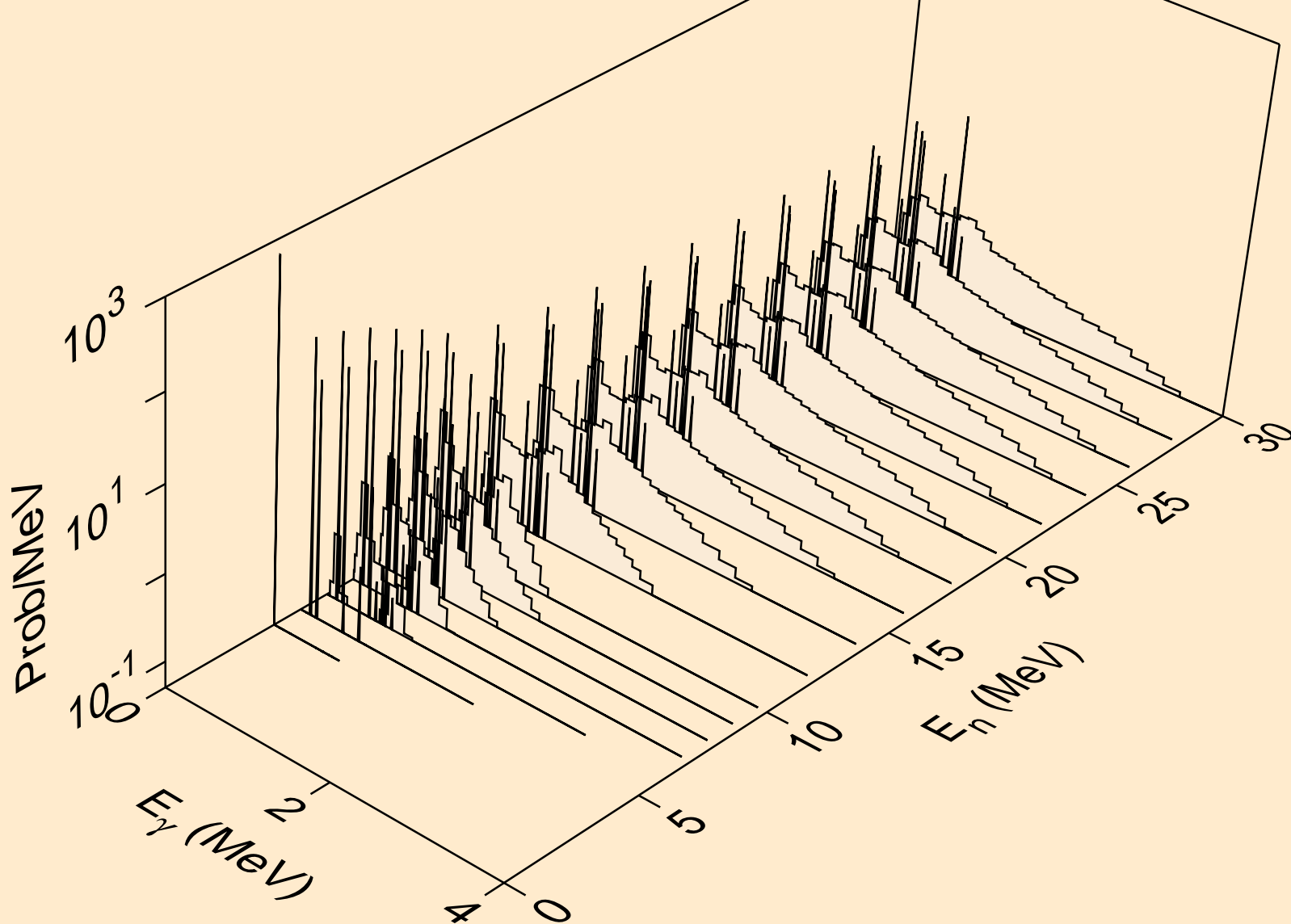

SM146 TRITON ACER TENDL-2023 LIBRARY; T=0.K  
Photon emission for (n,n\*)2a

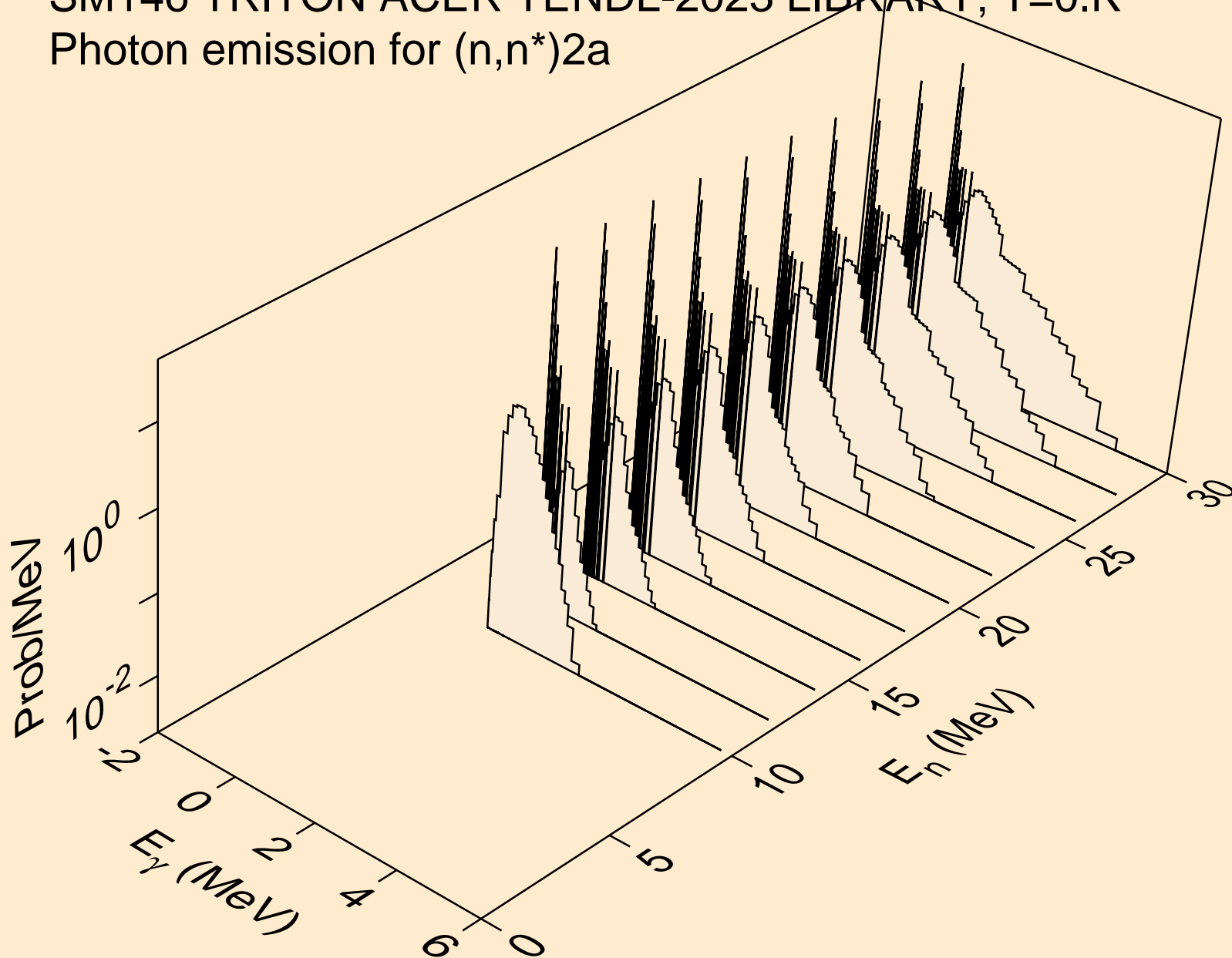

SM146 TRITON ACER TENDL-2023 LIBRARY; T=0.K  
Photon emission for (n,2n)2a

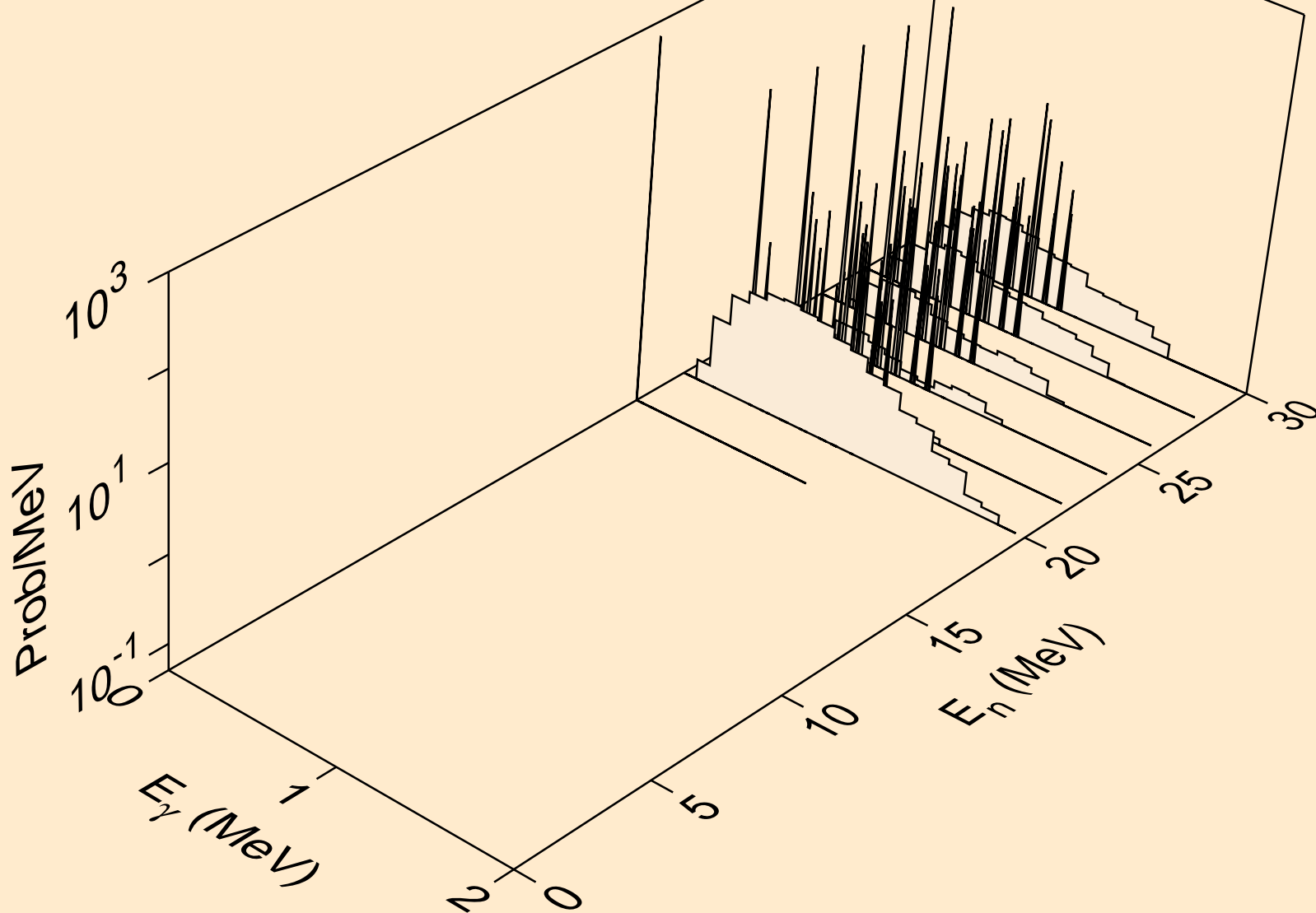

SM146 TRITON ACER TENDL-2023 LIBRARY; T=0.K  
Photon emission for (n,n\*)d

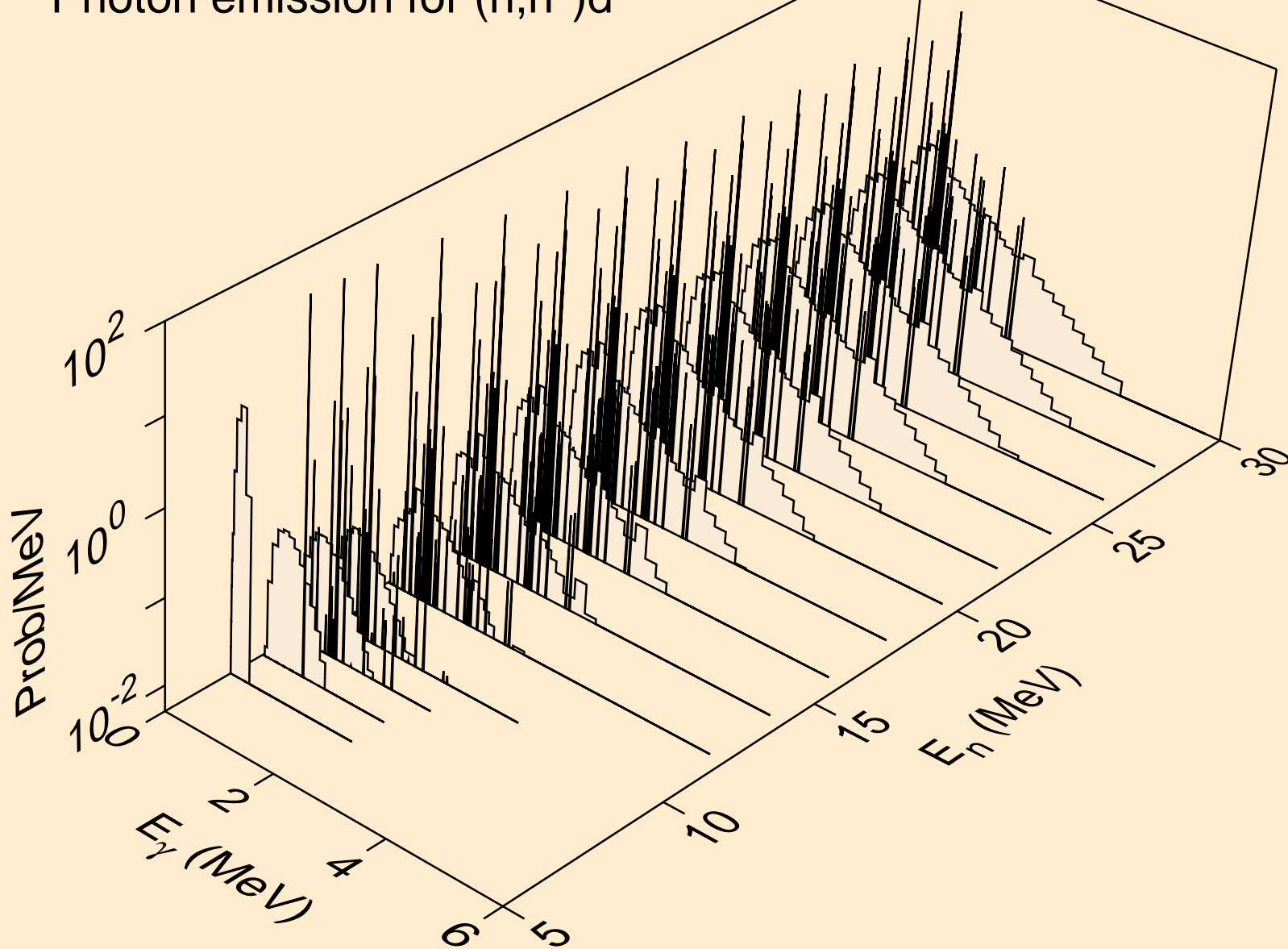

SM146 TRITON ACER TENDL-2023 LIBRARY; T=0.K  
Photon emission for (n,n\*)t

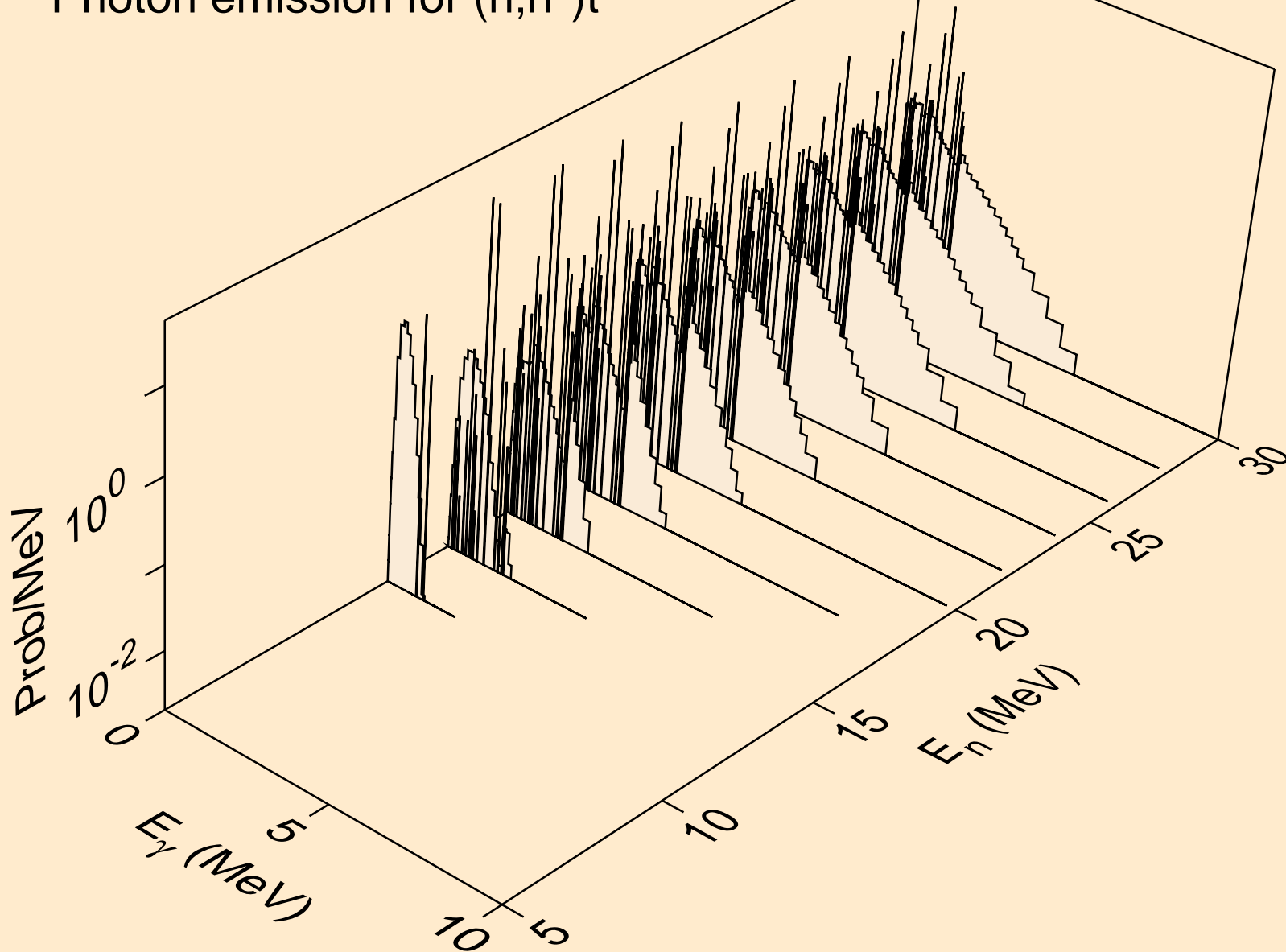

SM146 TRITON ACER TENDL-2023 LIBRARY; T=0.K  
Photon emission for (n,n\*)he3

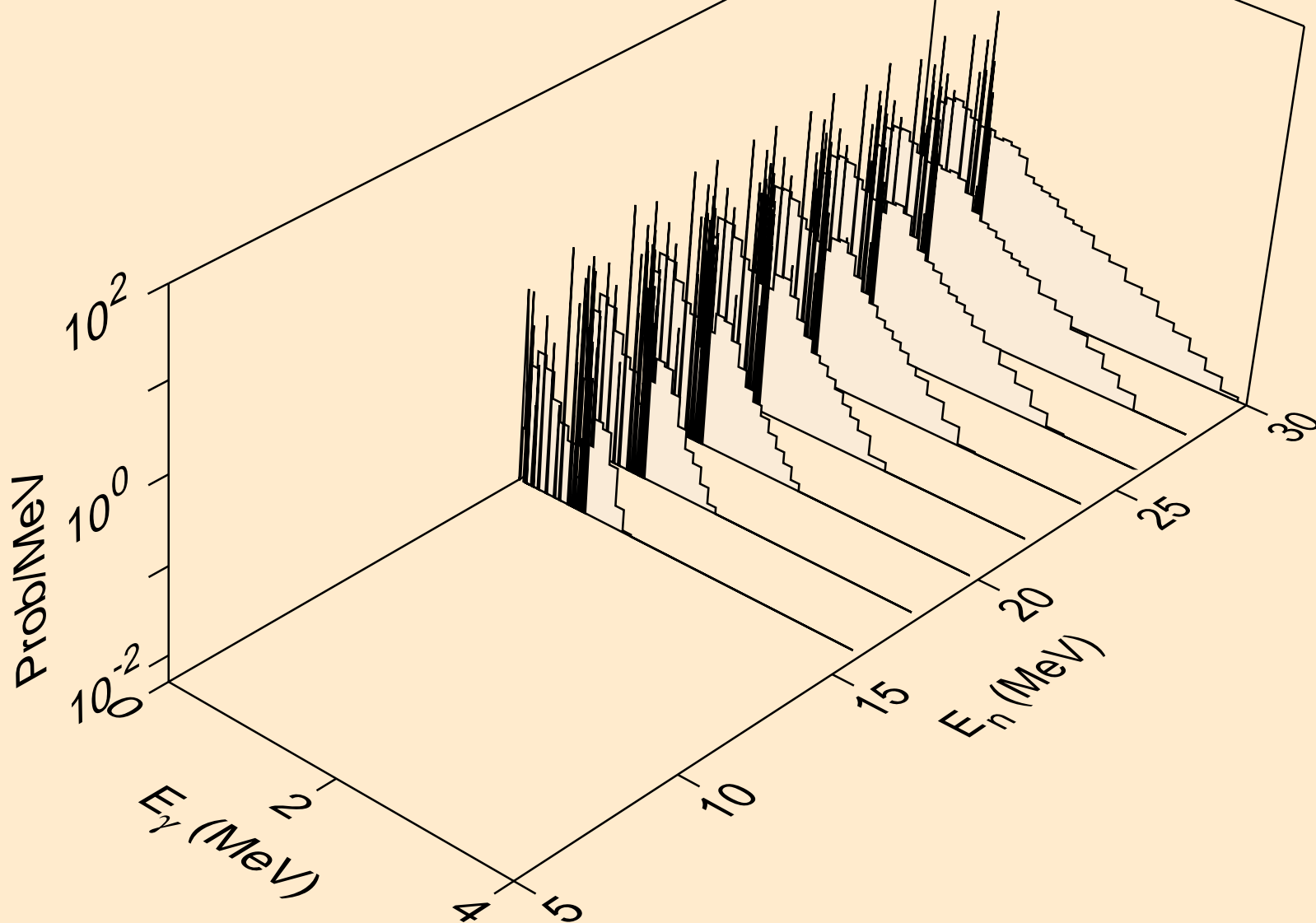

SM146 TRITON ACER TENDL-2023 LIBRARY; T=0.K  
Photon emission for (n,4n)

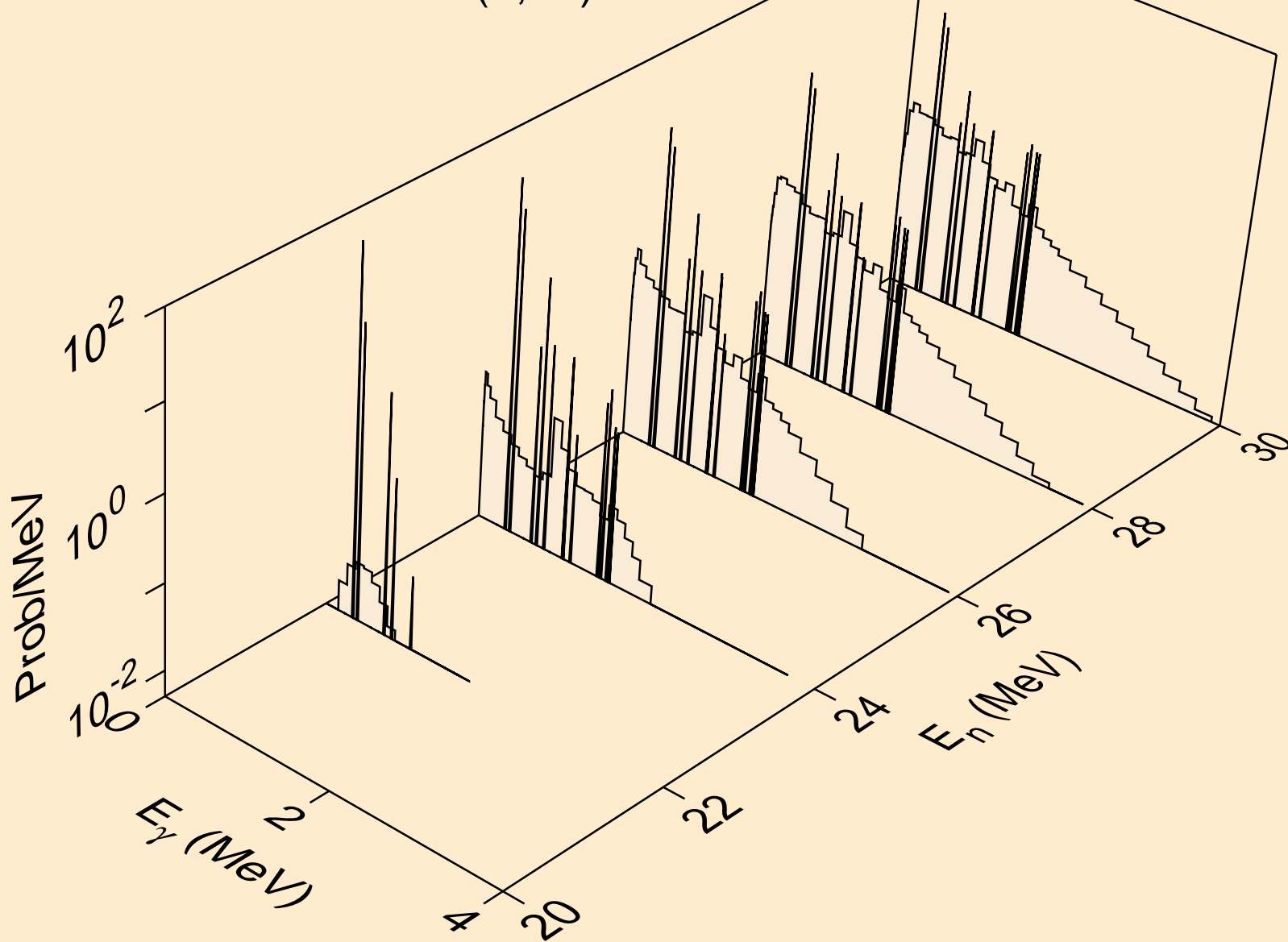

SM146 TRITON ACER TENDL-2023 LIBRARY; T=0.K  
Photon emission for (n,2np)

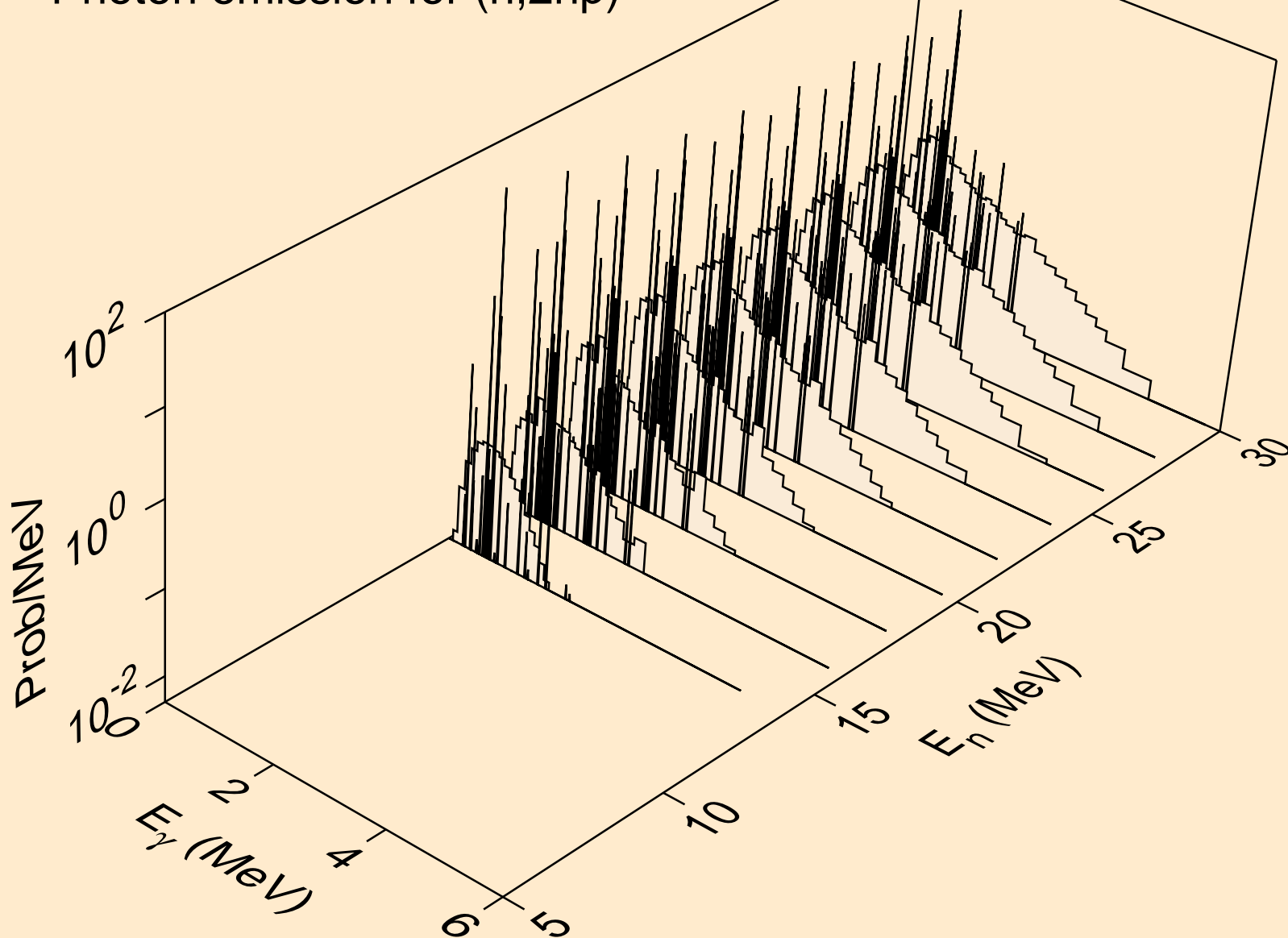

SM146 TRITON ACER TENDL-2023 LIBRARY; T=0.K  
Photon emission for (n,3np)

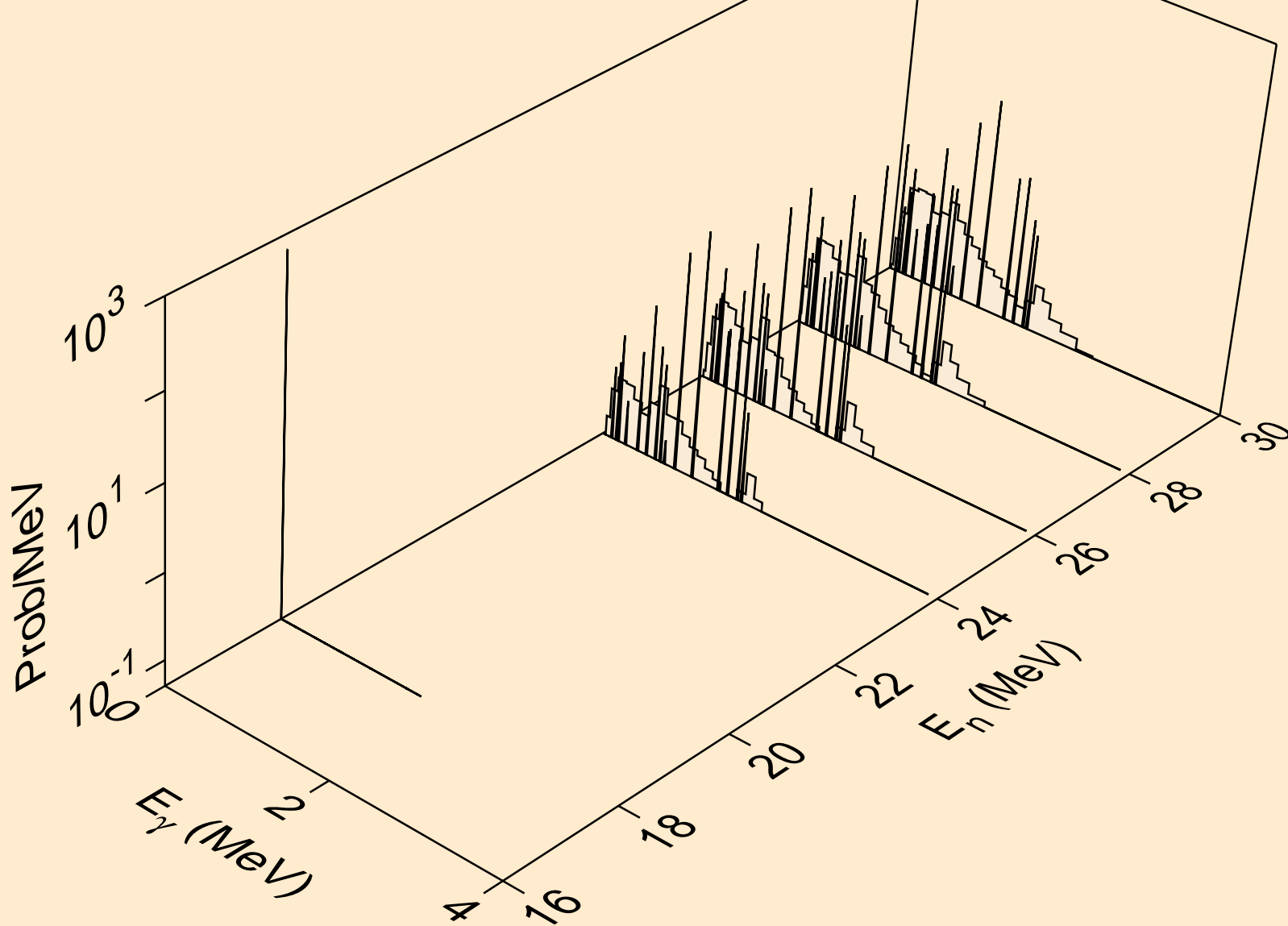

SM146 TRITON ACER TENDL-2023 LIBRARY; T=0.K  
Photon emission for (n,n2p)

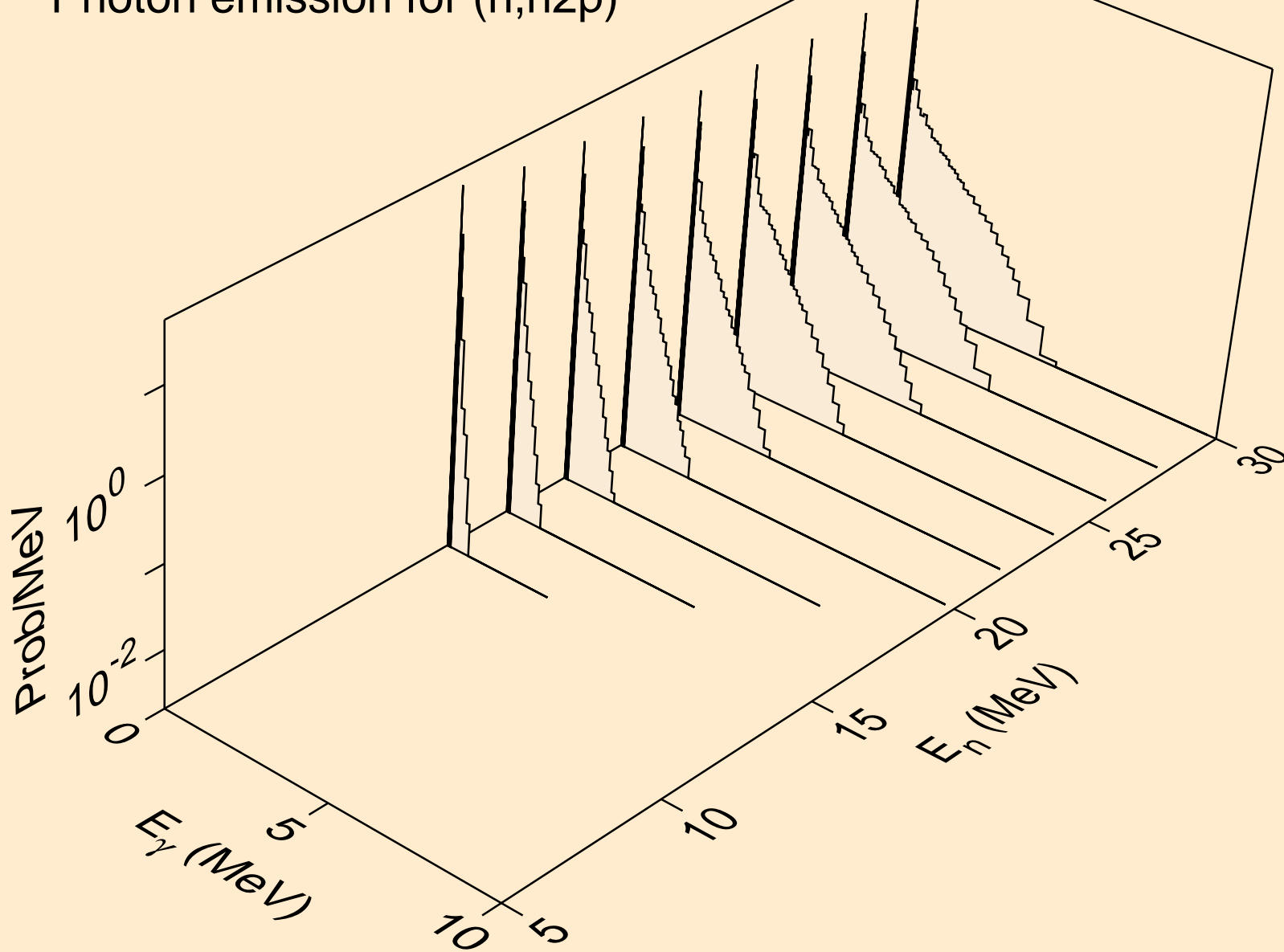

SM146 TRITON ACER TENDL-2023 LIBRARY; T=0.K  
Photon emission for (n,npa)

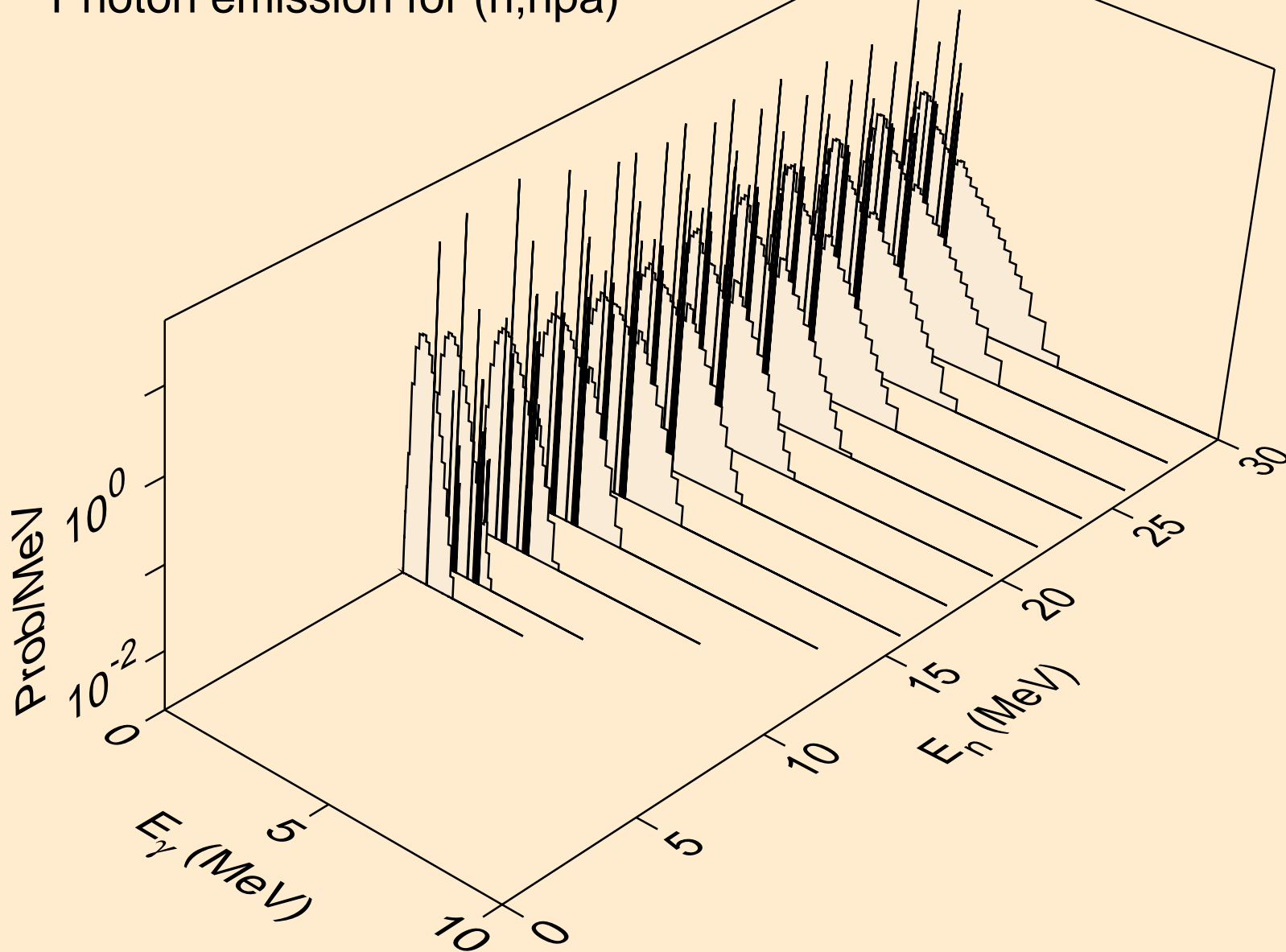

SM146 TRITON ACER TENDL-2023 LIBRARY; T=0.K  
Photon emission for (n,gma)

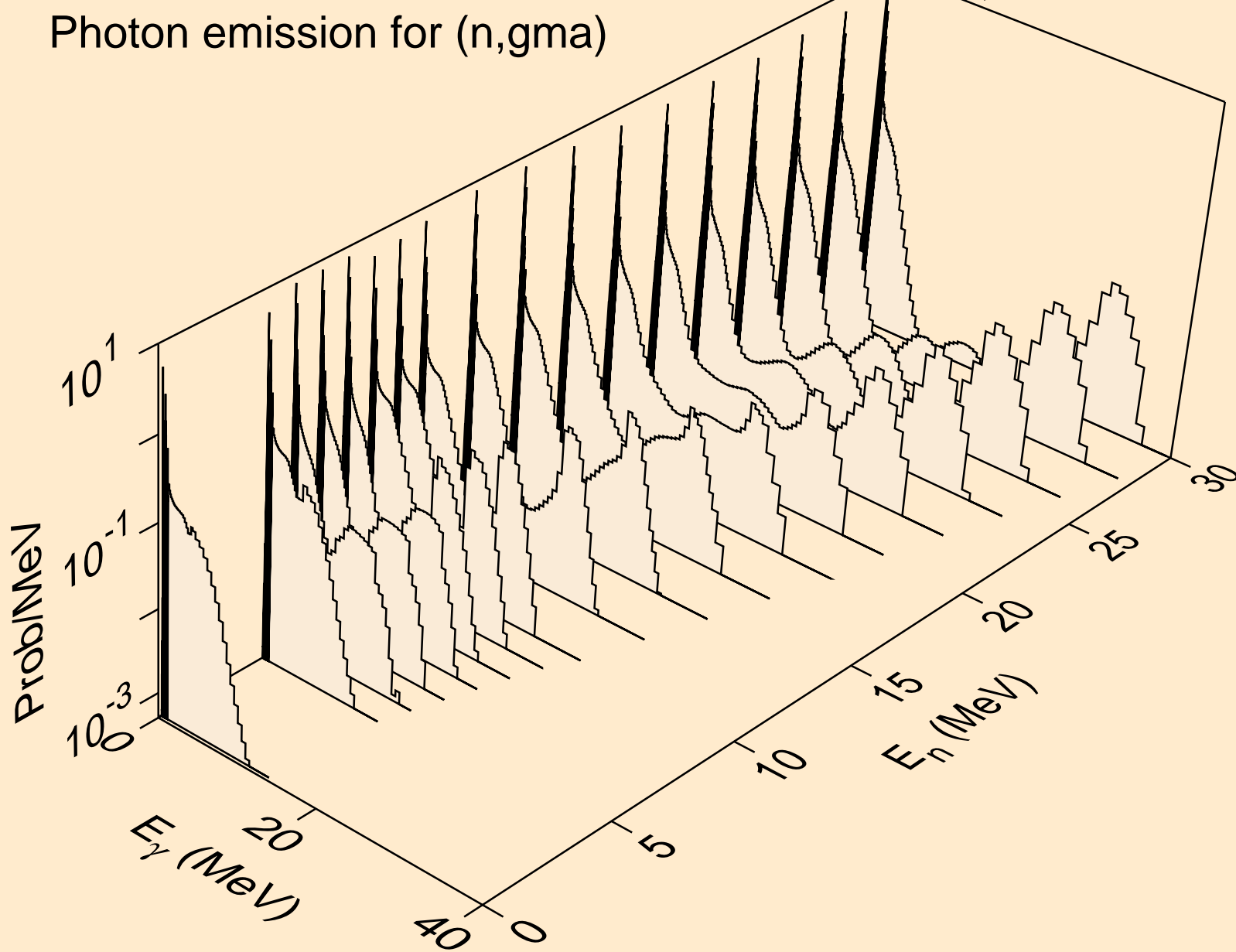

SM146 TRITON ACER TENDL-2023 LIBRARY; T=0.K  
Photon emission for (n,p)

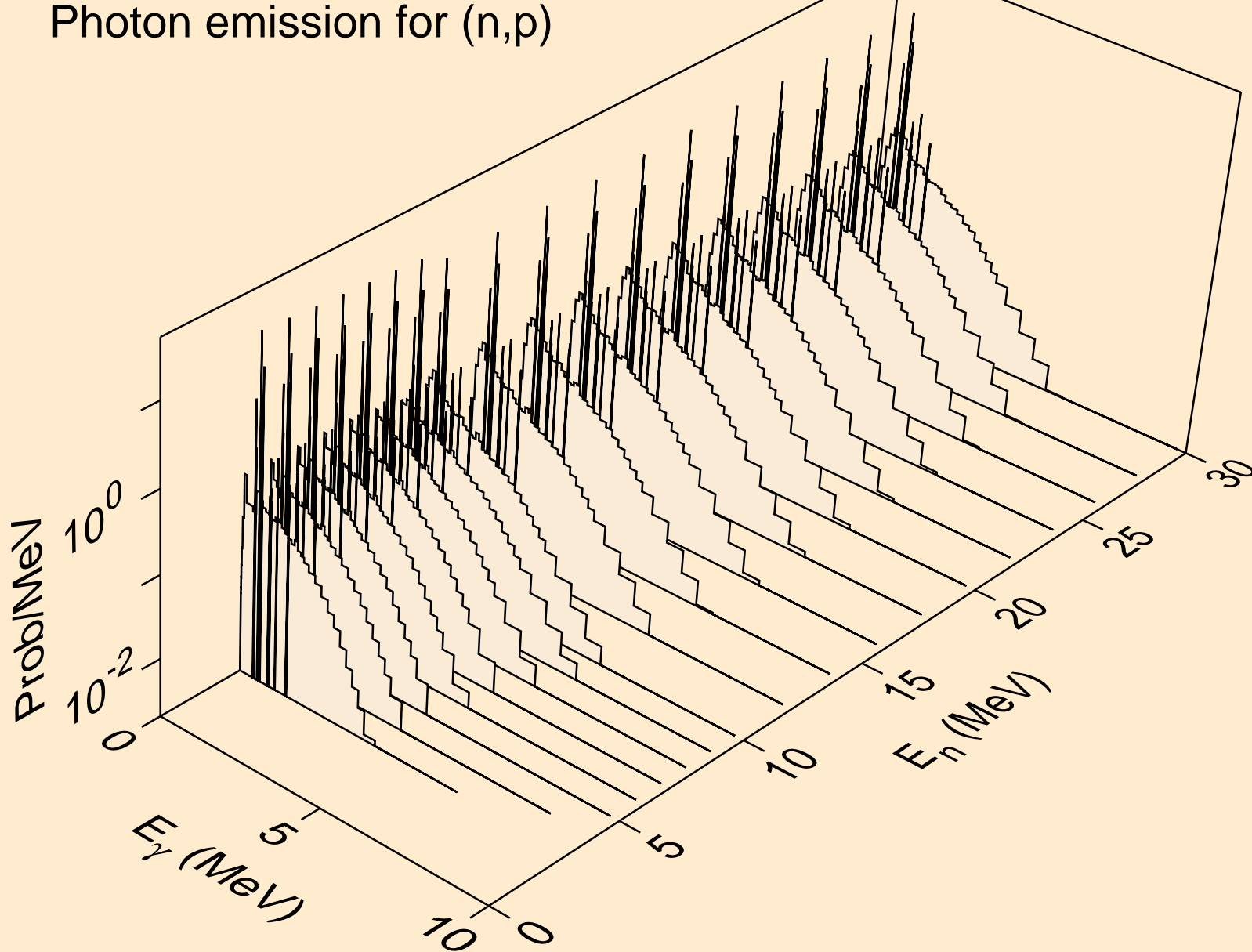

SM146 TRITON ACER TENDL-2023 LIBRARY; T=0.K  
Photon emission for (n,d)

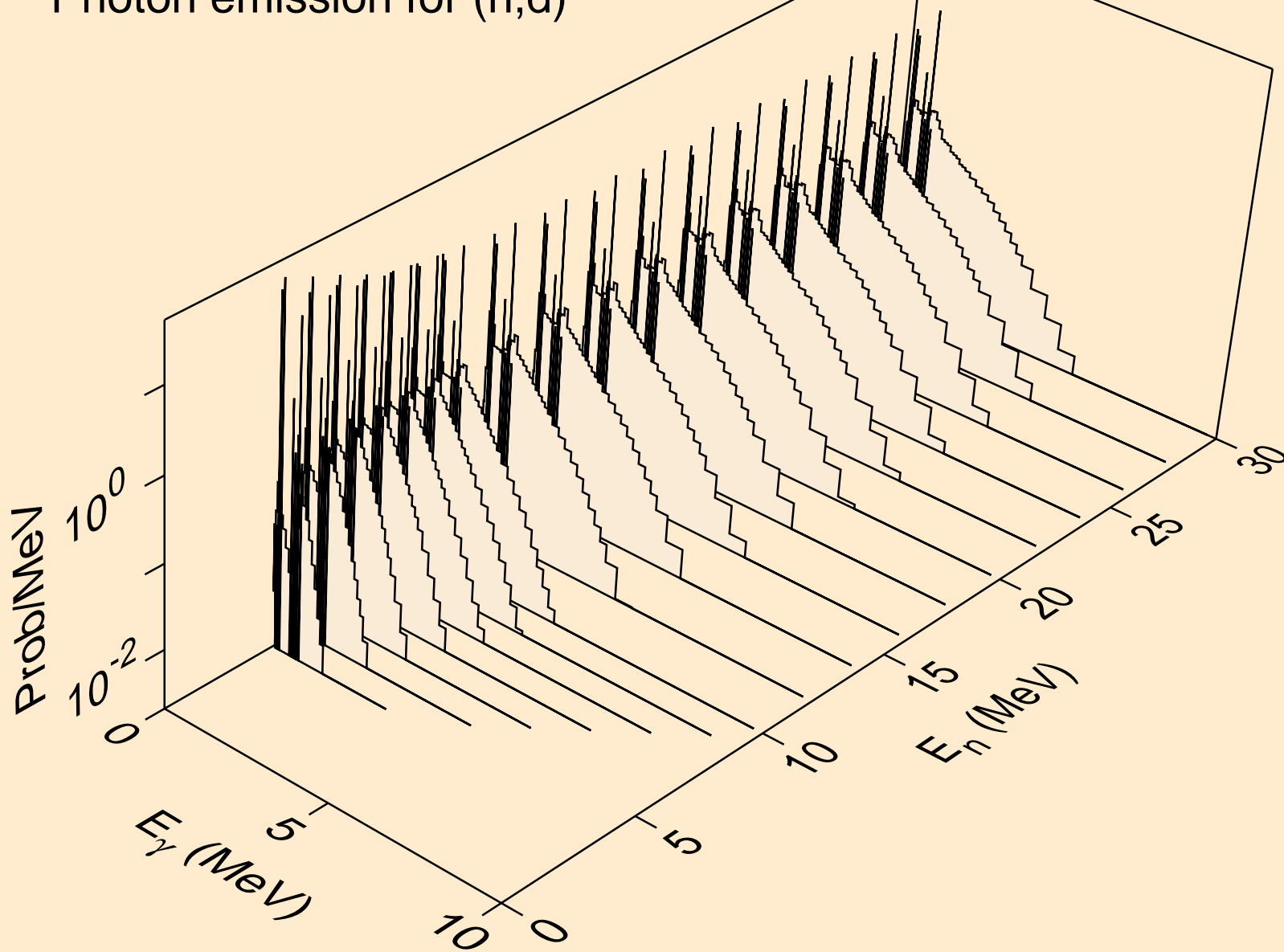

SM146 TRITON ACER TENDL-2023 LIBRARY; T=0.K  
Photon emission for inelastic

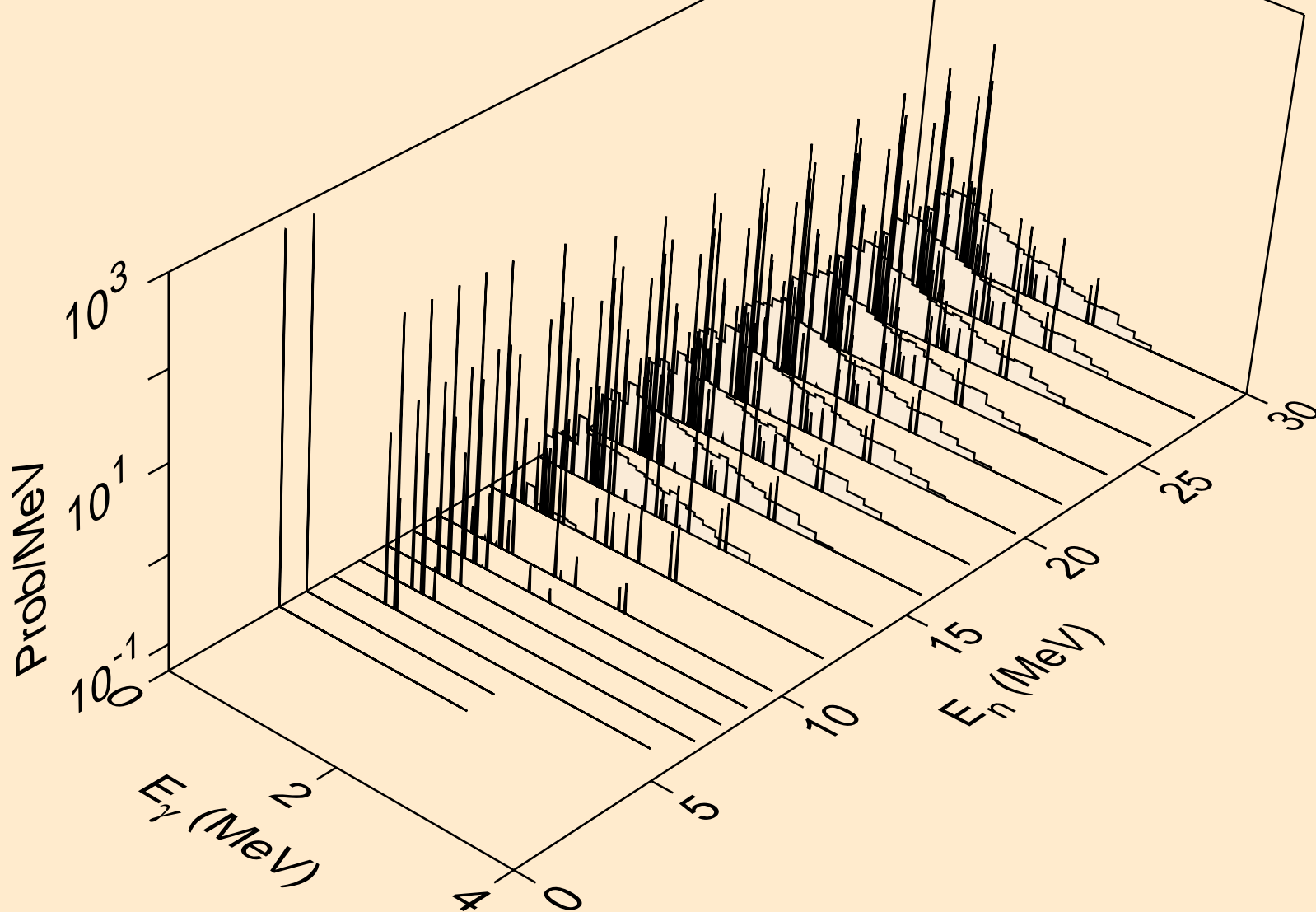

SM146 TRITON ACER TENDL-2023 LIBRARY; T=0.K  
Photon emission for (n,he3)

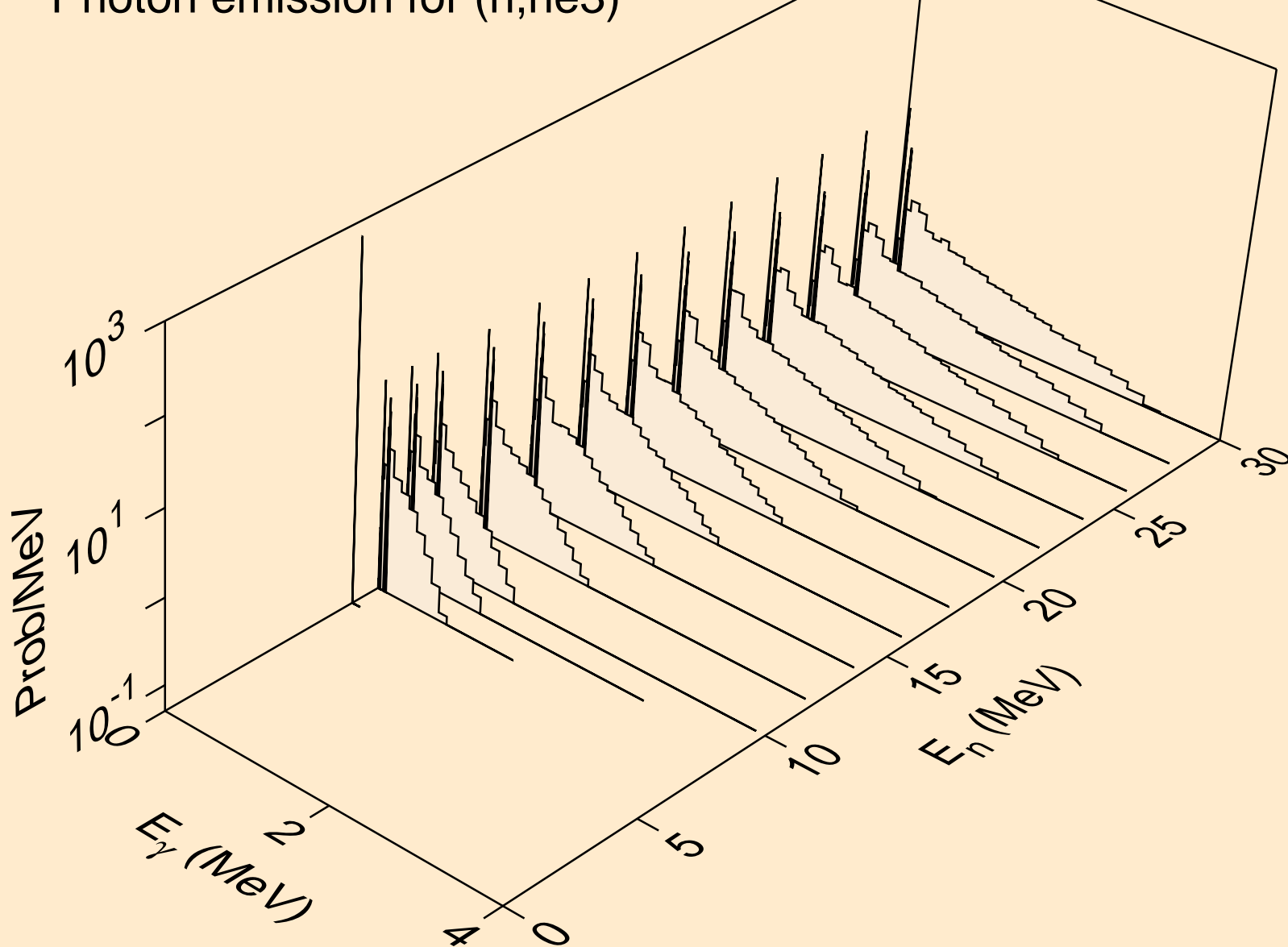

SM146 TRITON ACER TENDL-2023 LIBRARY; T=0.K  
Photon emission for (n,a)

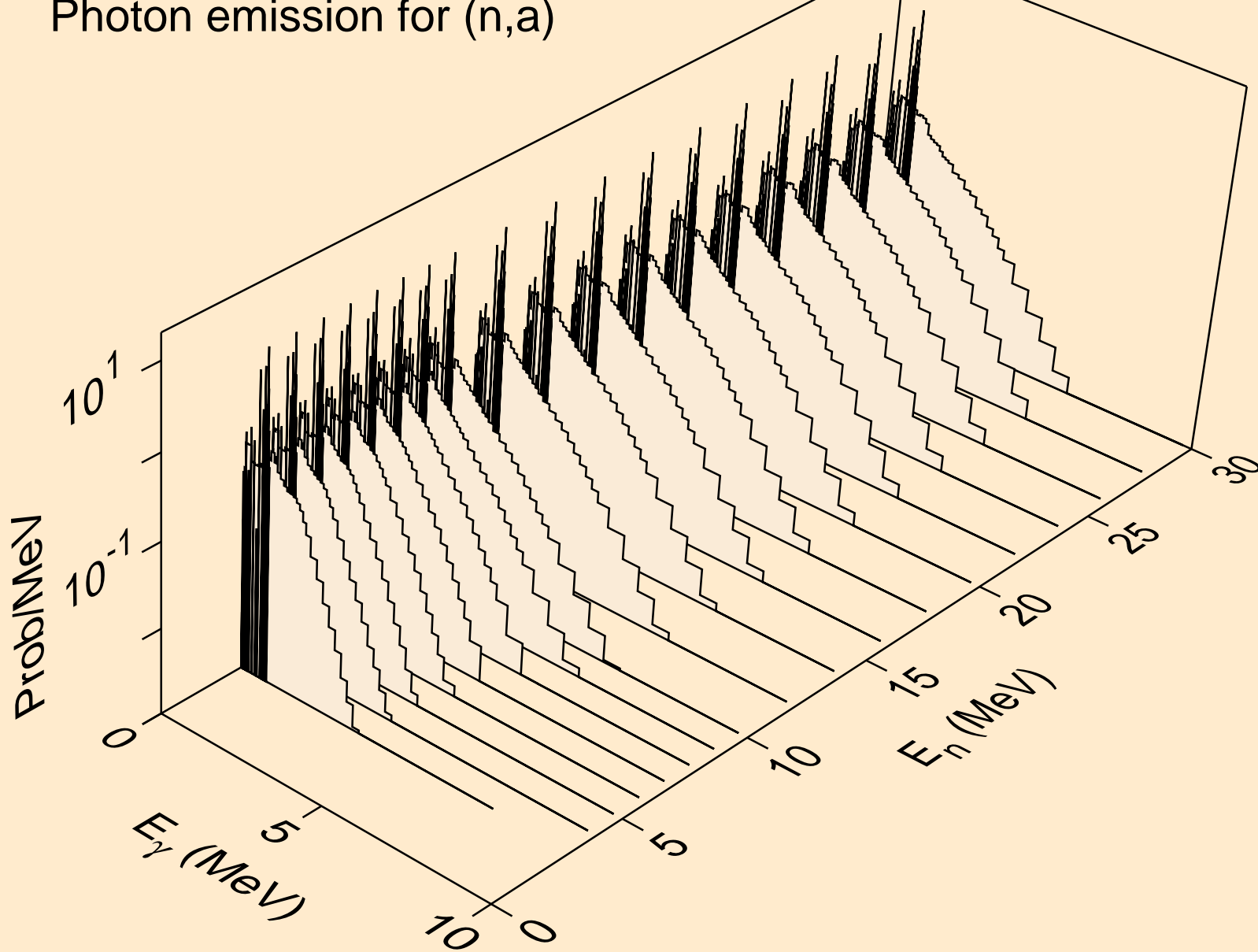

SM146 TRITON ACER TENDL-2023 LIBRARY; T=0.K  
Photon emission for (n,2a)

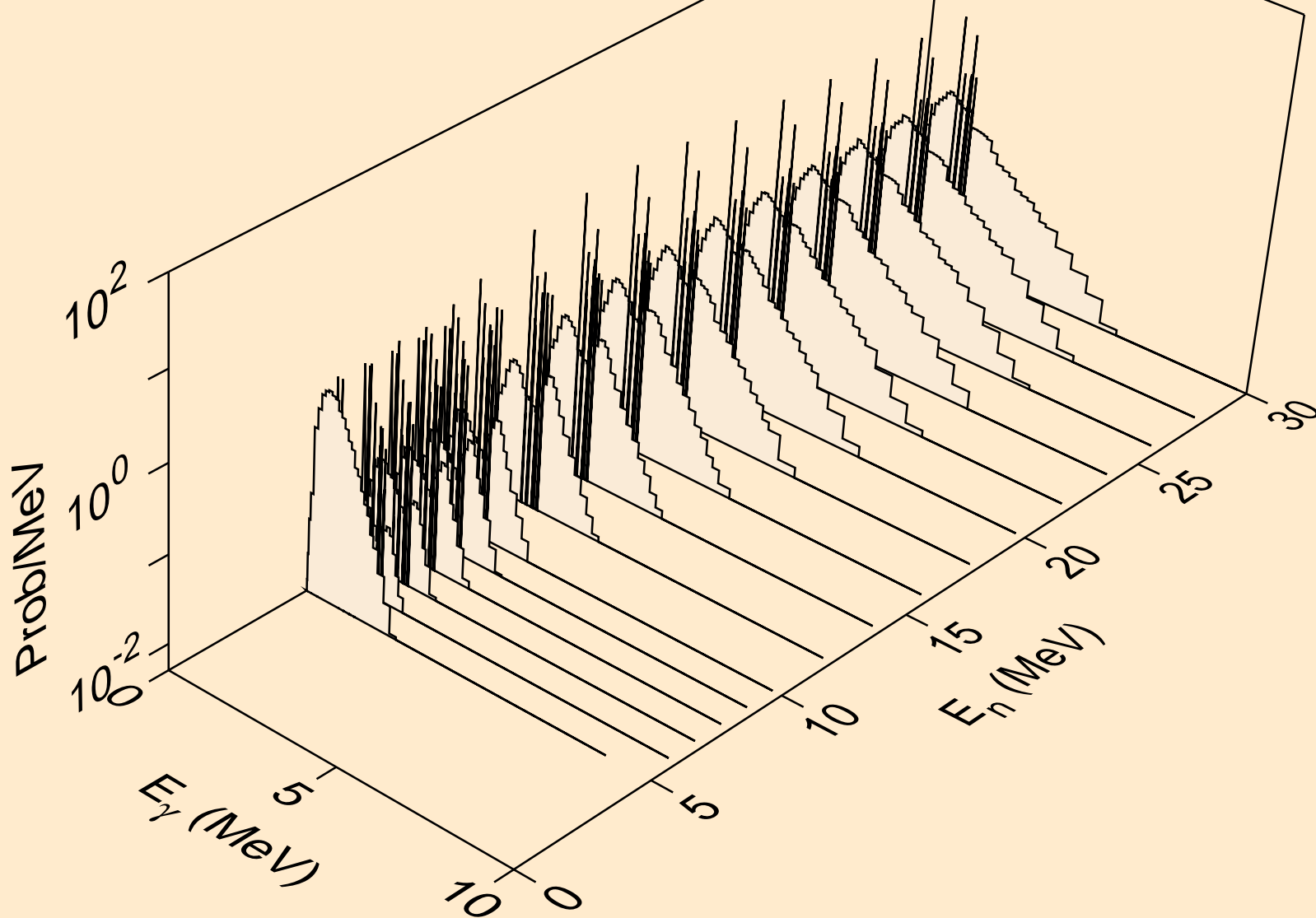

SM146 TRITON ACER TENDL-2023 LIBRARY; T=0.K  
Photon emission for (n,2p)

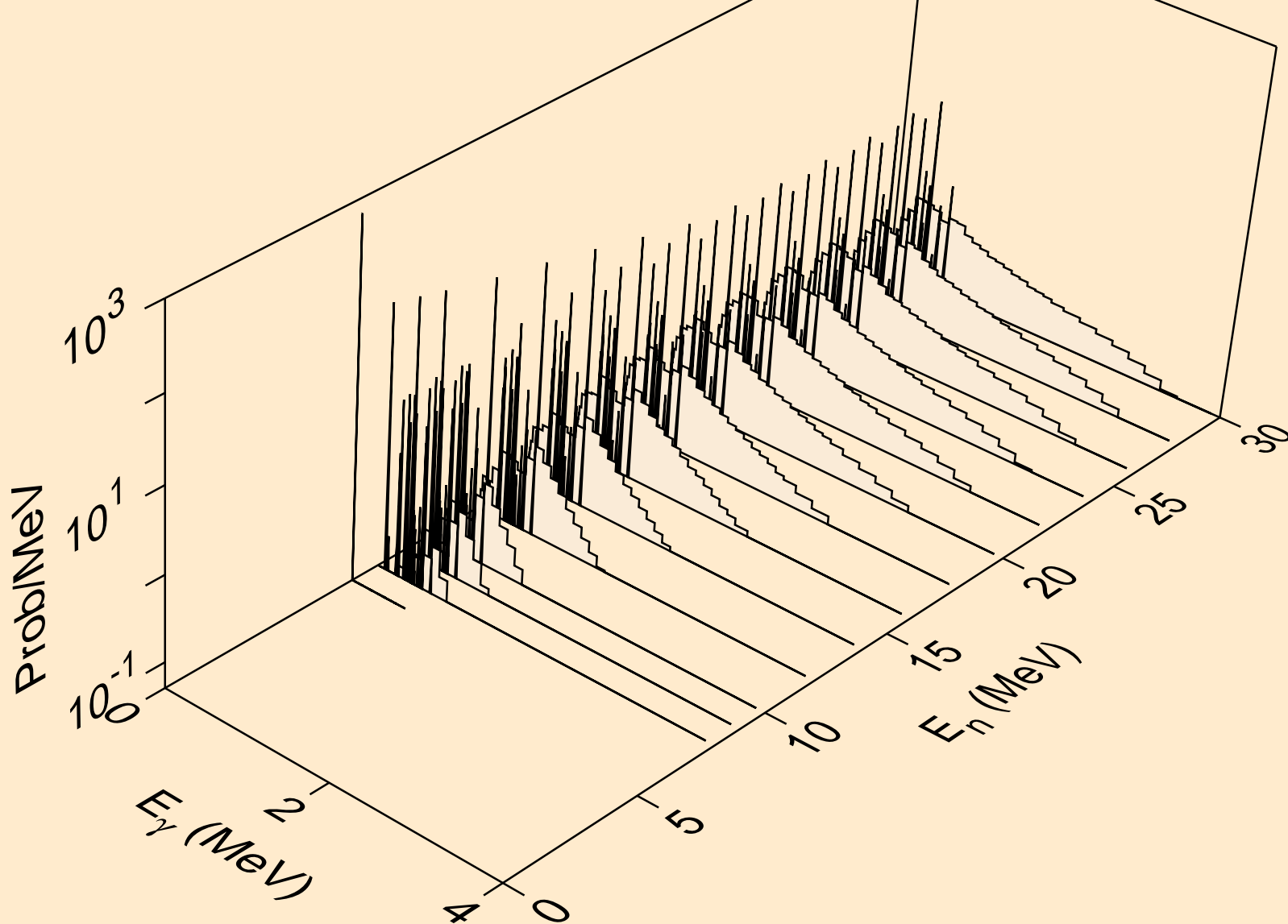

SM146 TRITON ACER TENDL-2023 LIBRARY; T=0.K  
Photon emission for (n,pa)

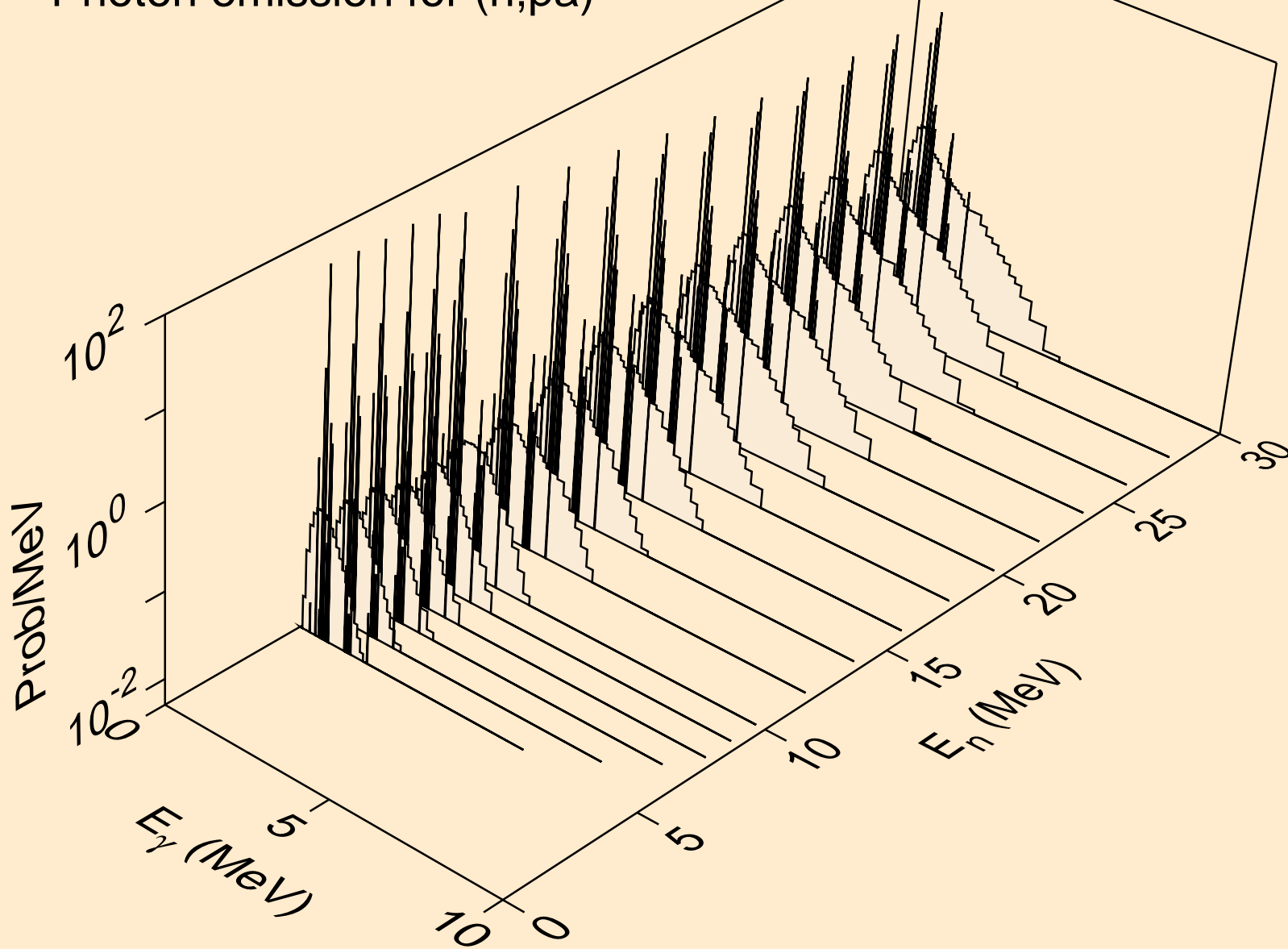

SM146 TRITON ACER TENDL-2023 LIBRARY; T=0.K  
Photon emission for (n,pd)

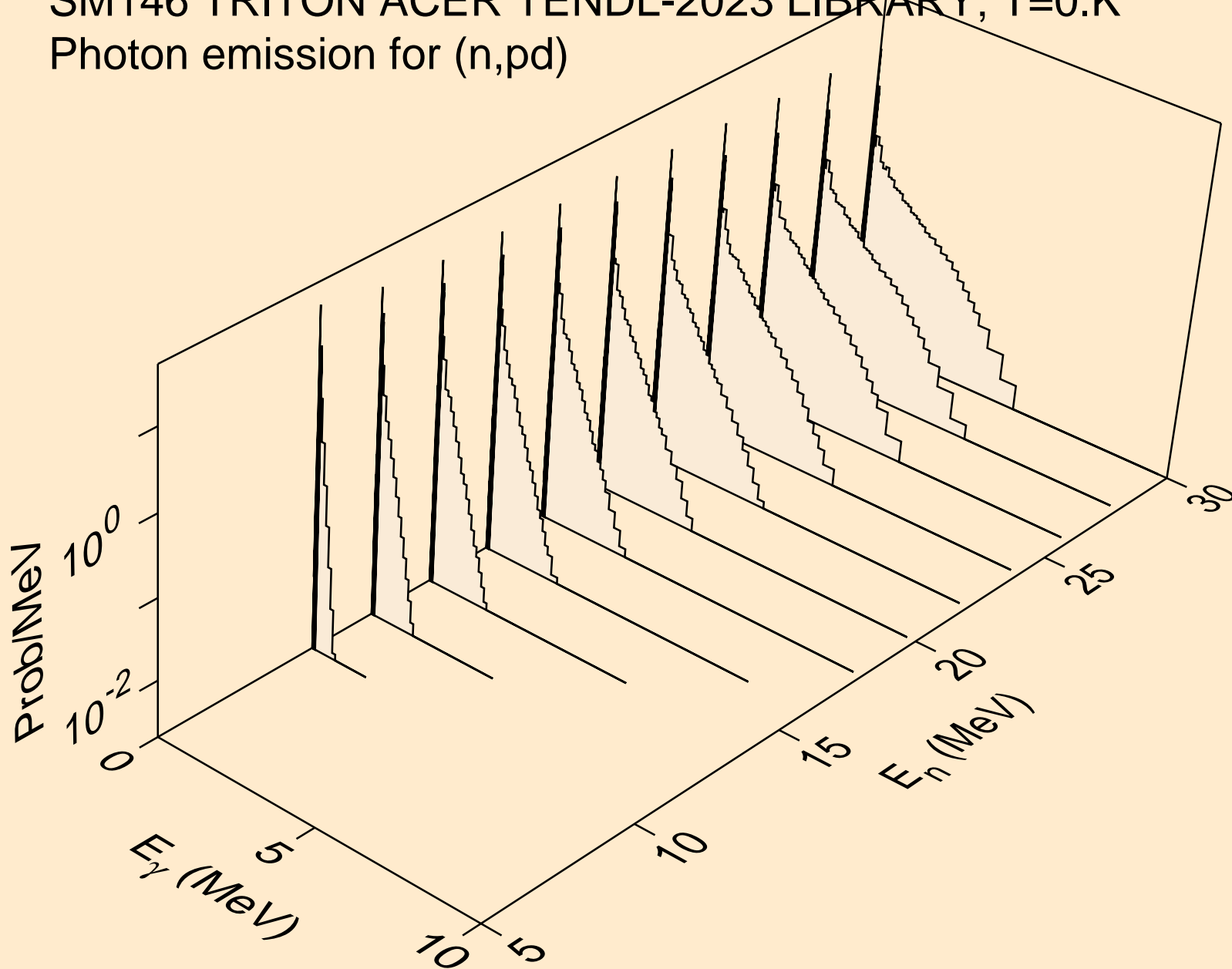

SM146 TRITON ACER TENDL-2023 LIBRARY; T=0.K  
Photon emission for (n,pt)

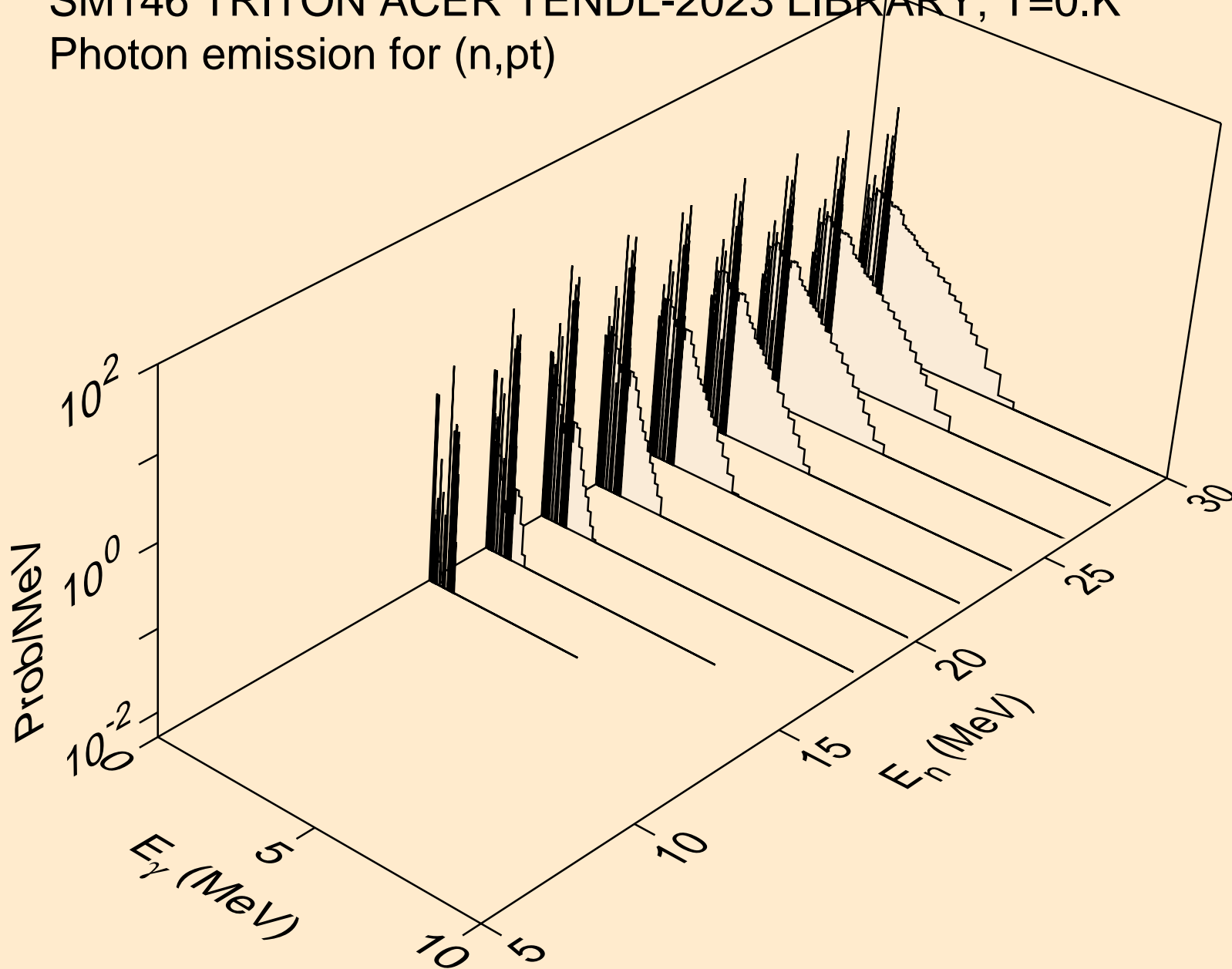

SM146 TRITON ACER TENDL-2023 LIBRARY; T=0.K  
Photon emission for (n,da)

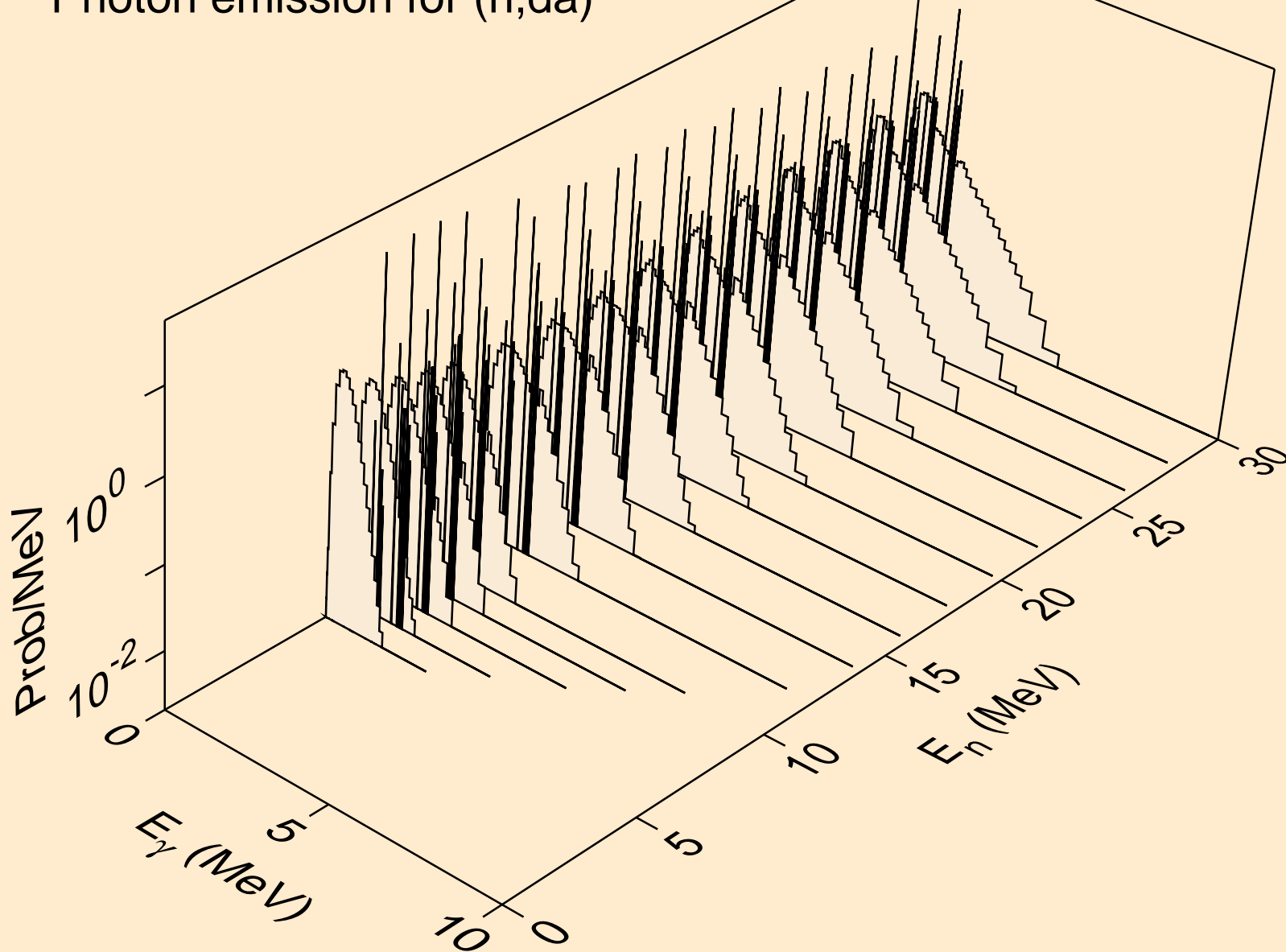

# SM146 TRITON ACER TENDL-2023 LIBRARY; T=0.K

## Particle heating contributions

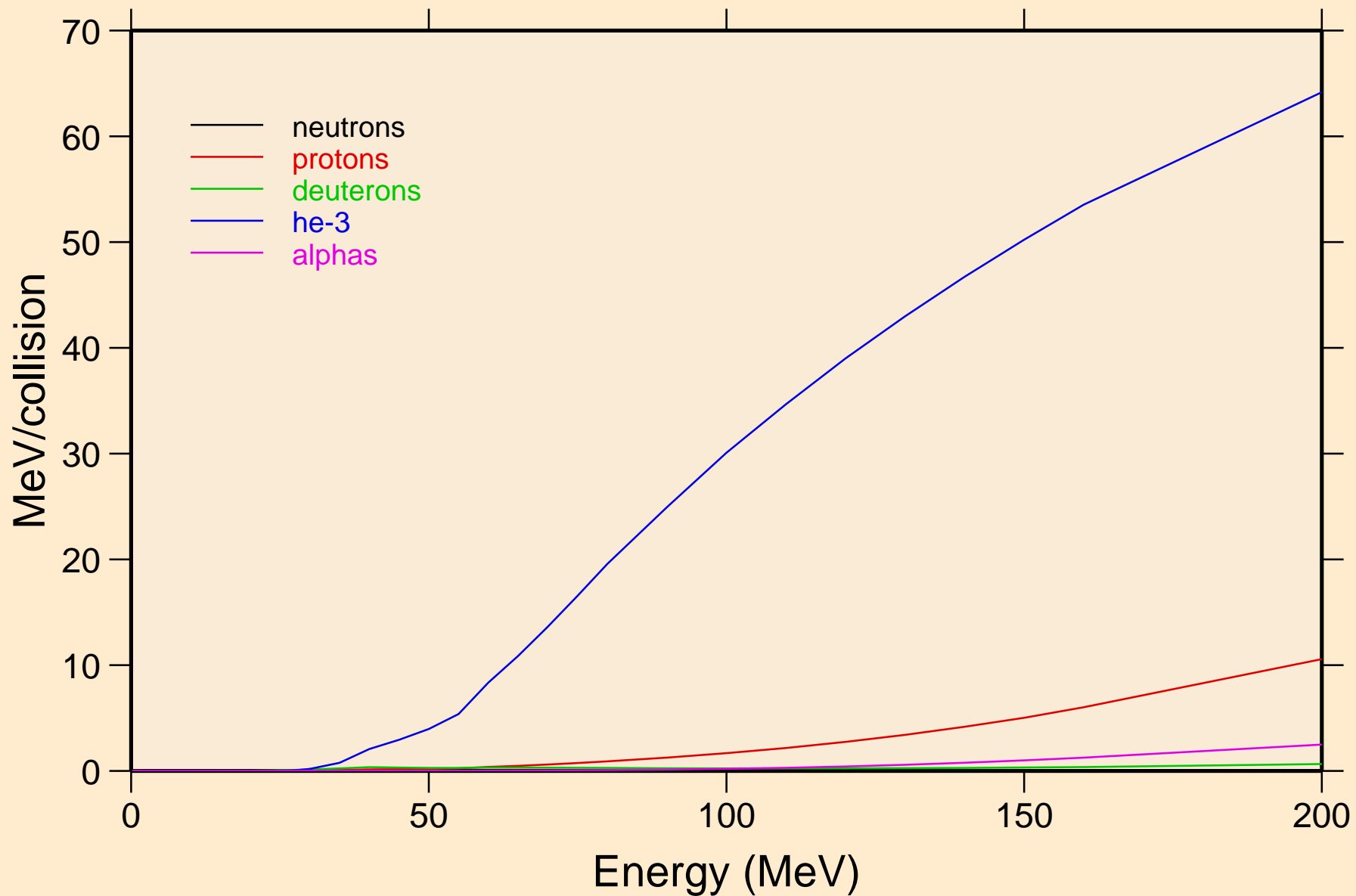

SM146 TRITON ACER TENDL-2023 LIBRARY; T=0.K  
Recoil Heating

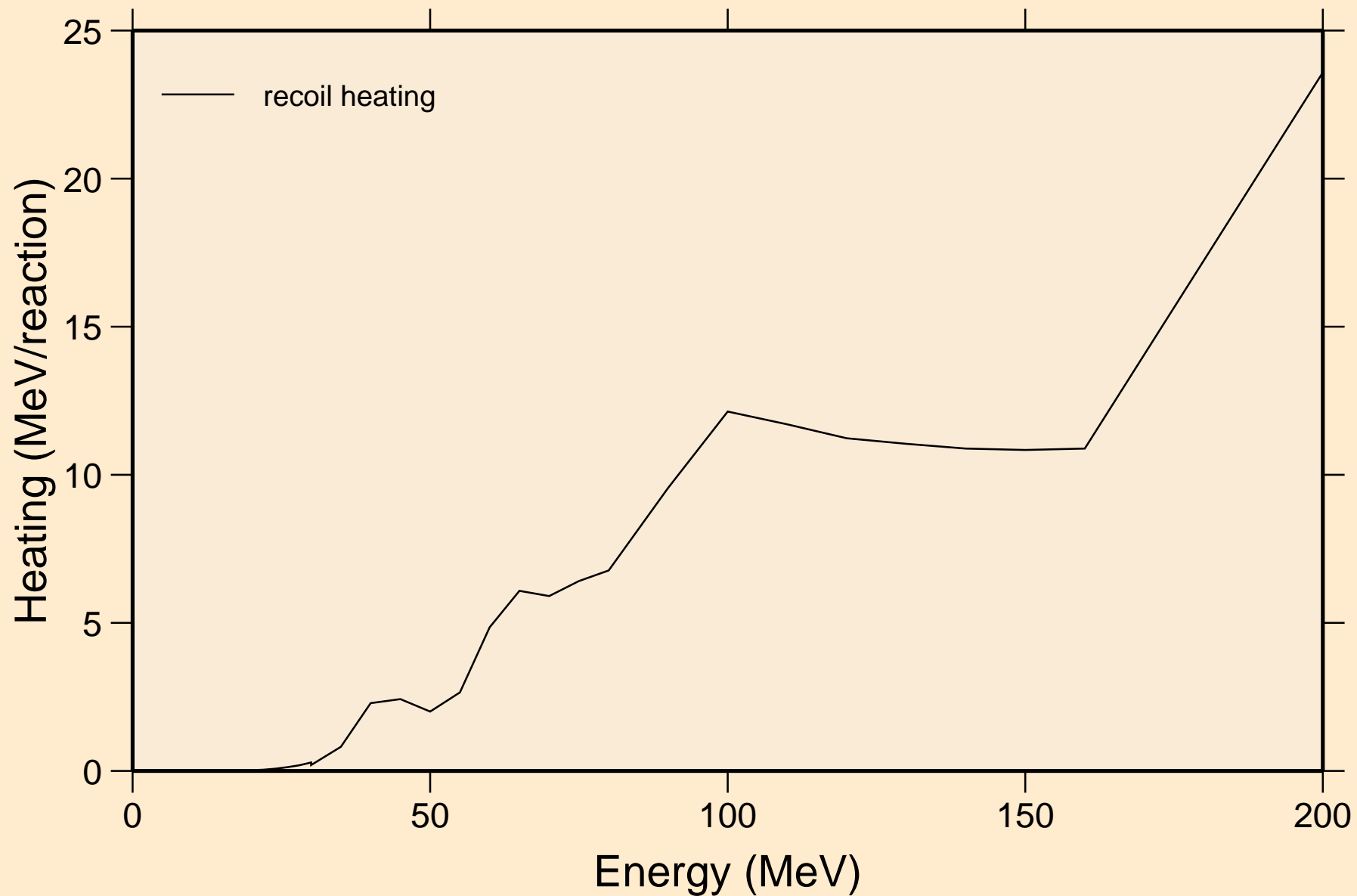

SM146 TRITON ACER TENDL-2023 LIBRARY; T=0.K  
Particle production cross sections

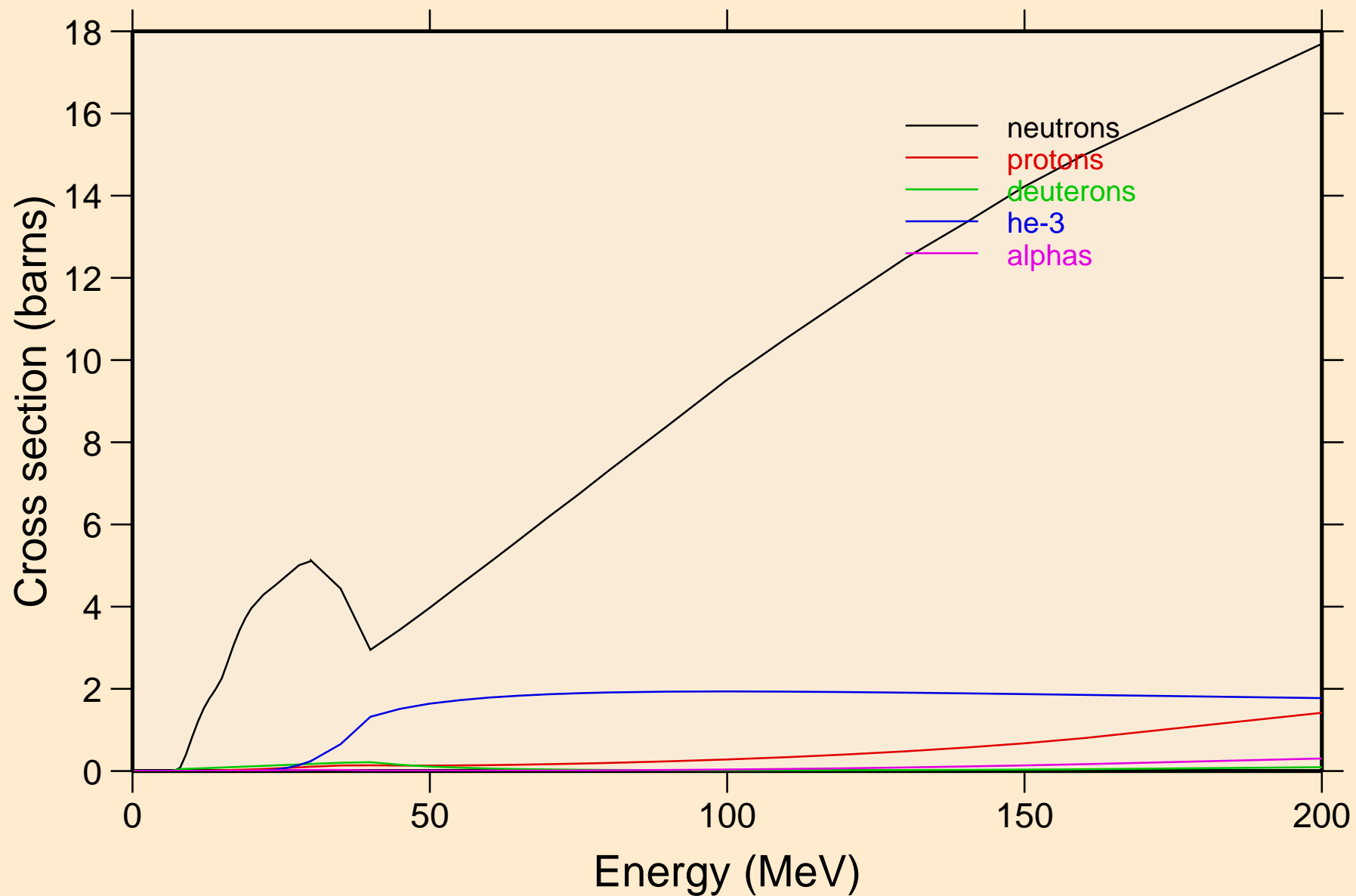

SM146 TRITON ACER TENDL-2023 LIBRARY; T=0.K  
neutrons from (t,n)

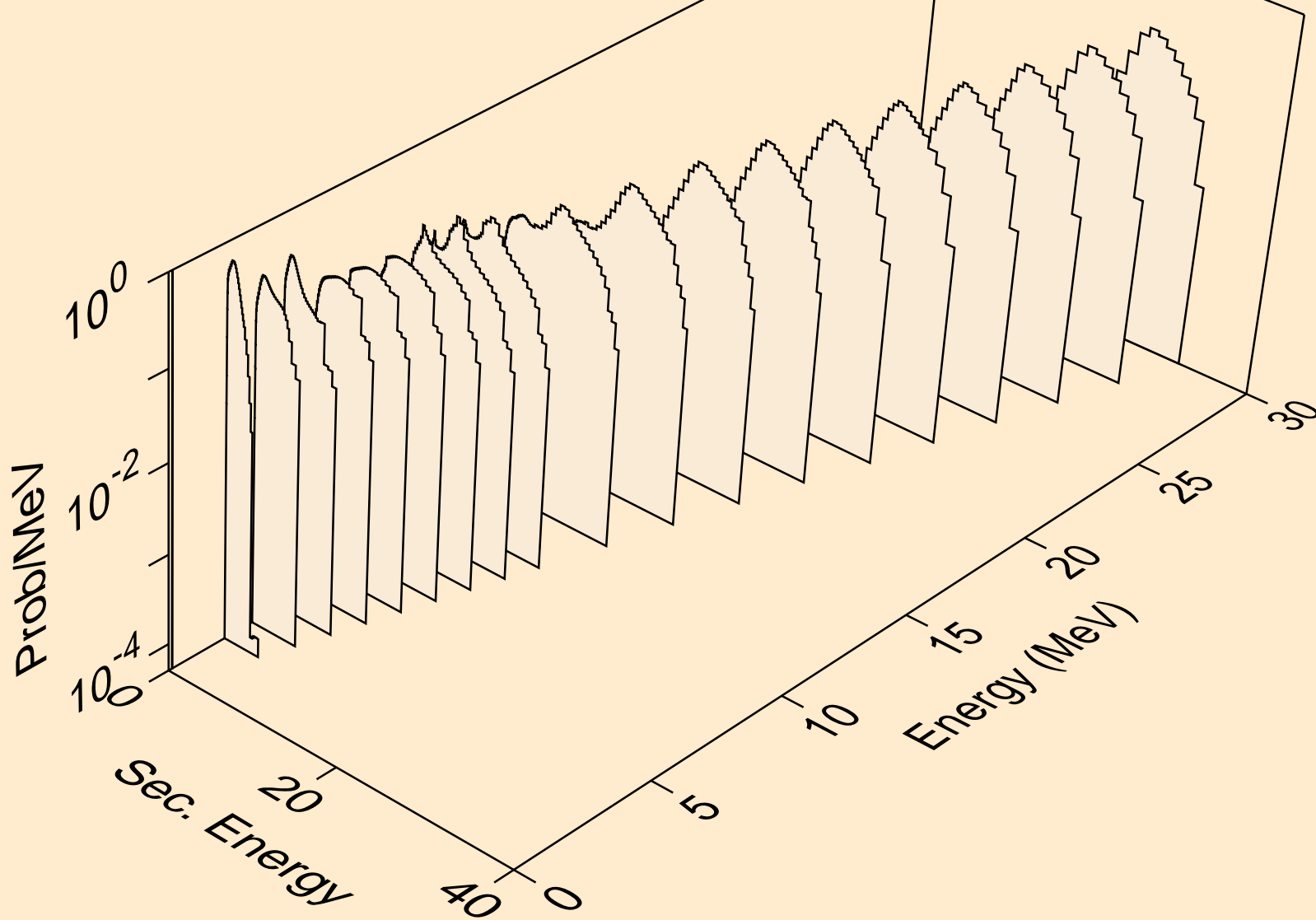

SM146 TRITON ACER TENDL-2023 LIBRARY; T=0.K  
neutrons from (t,x)

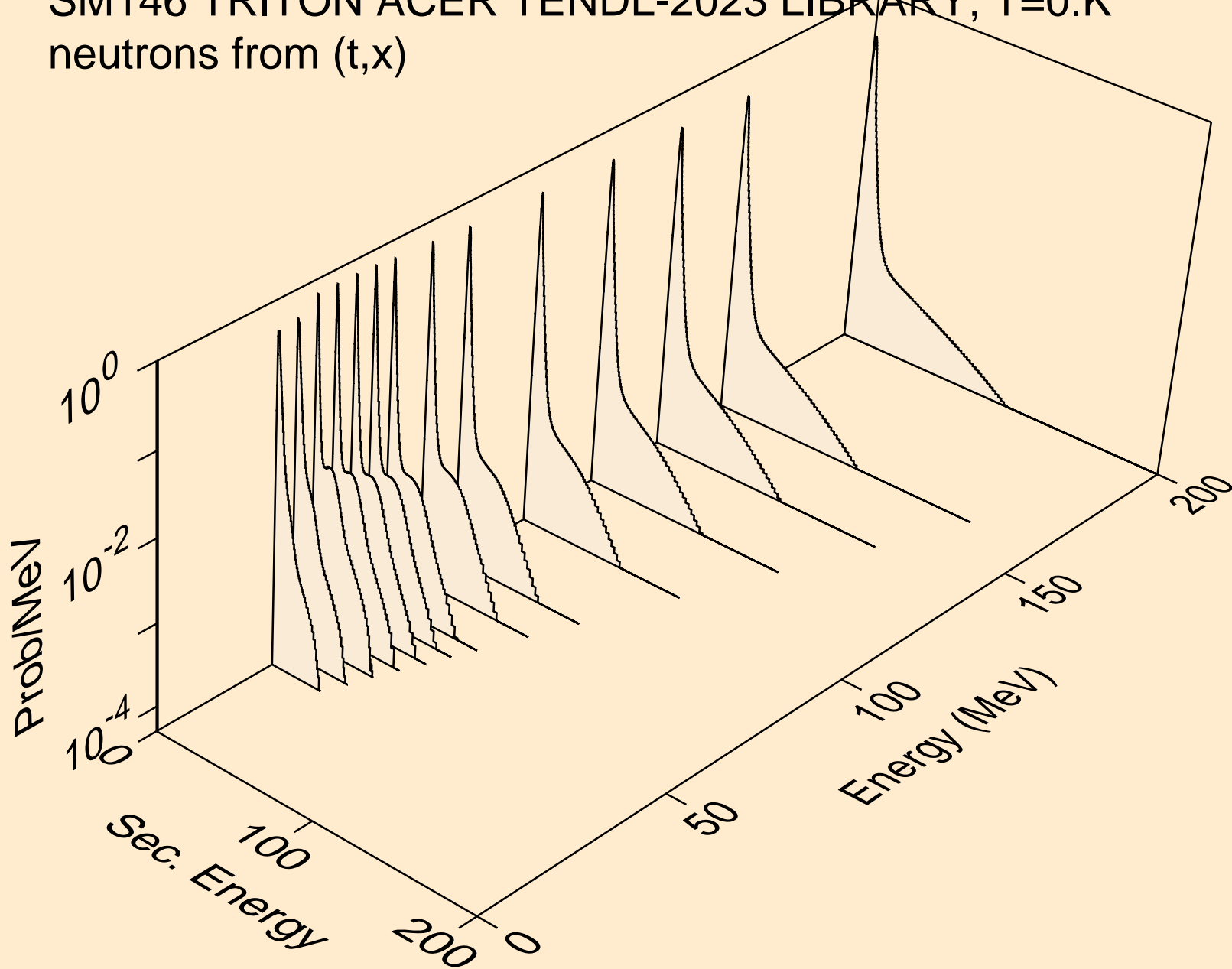

SM146 TRITON ACER TENDL-2023 LIBRARY; T=0.K  
neutrons from (t,2nd)

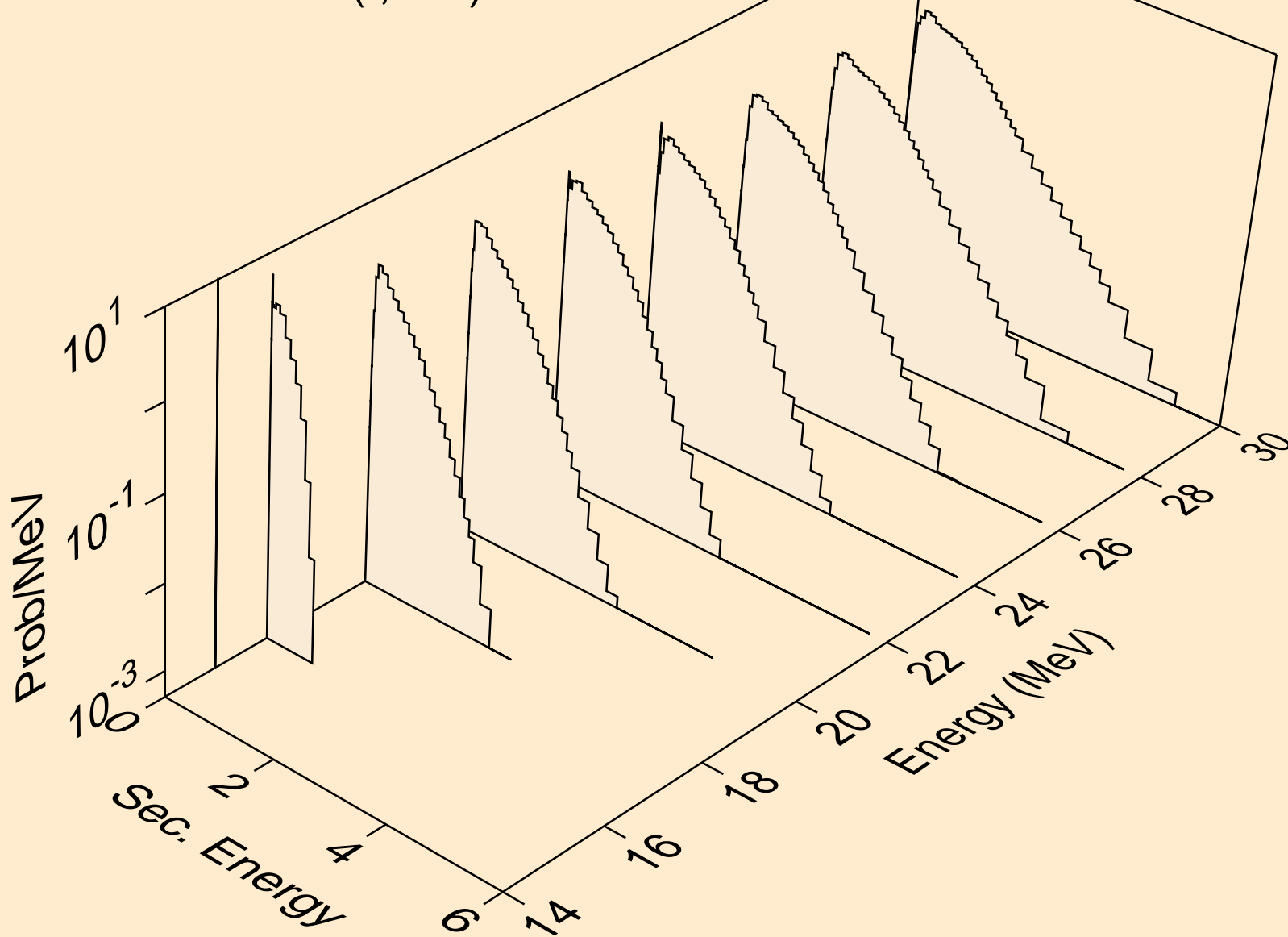

SM146 TRITON ACER TENDL-2023 LIBRARY; T=0.K  
neutrons from (t,2n)

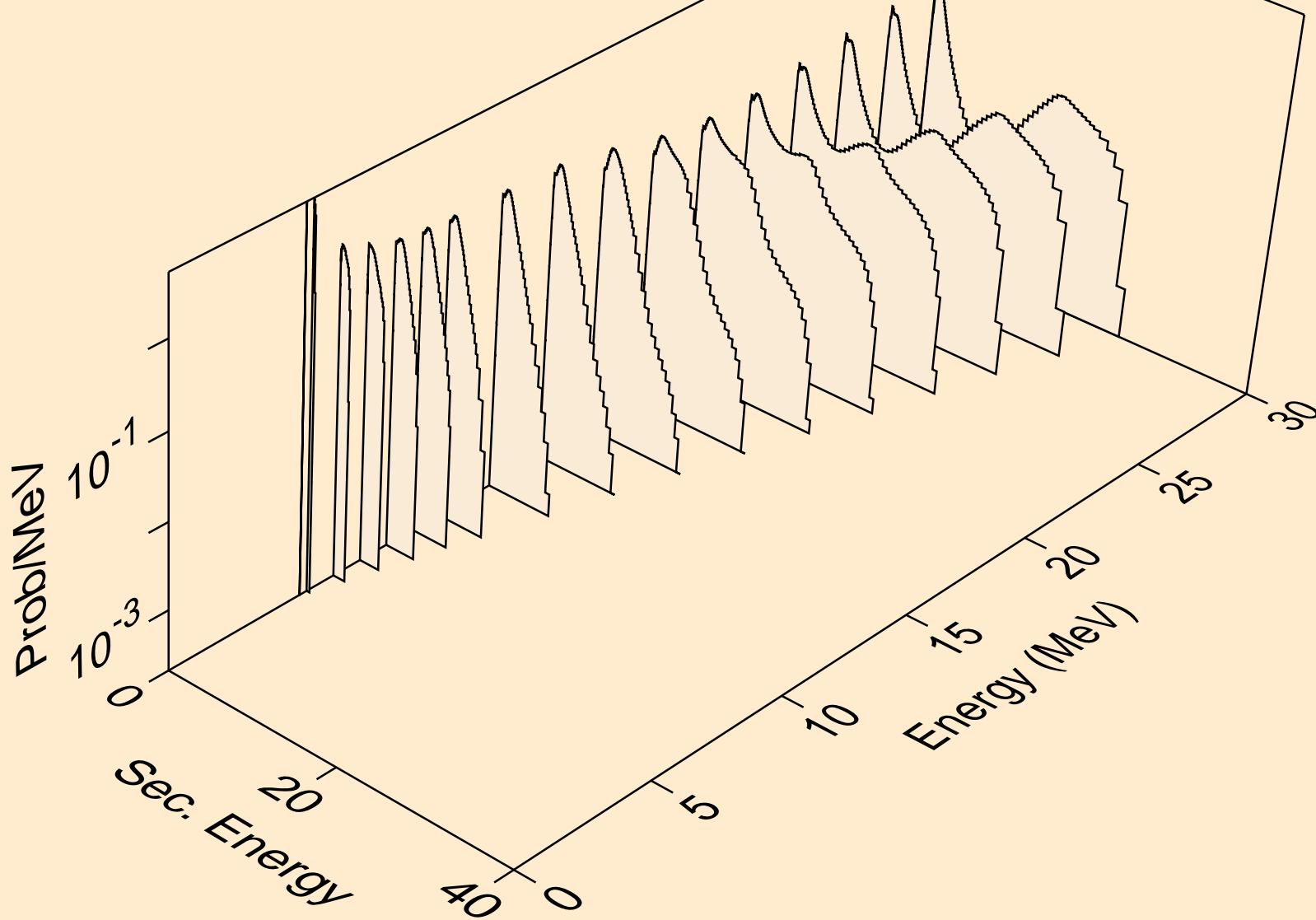

SM146 TRITON ACER TENDL-2023 LIBRARY; T=0.K  
neutrons from (t,3n)

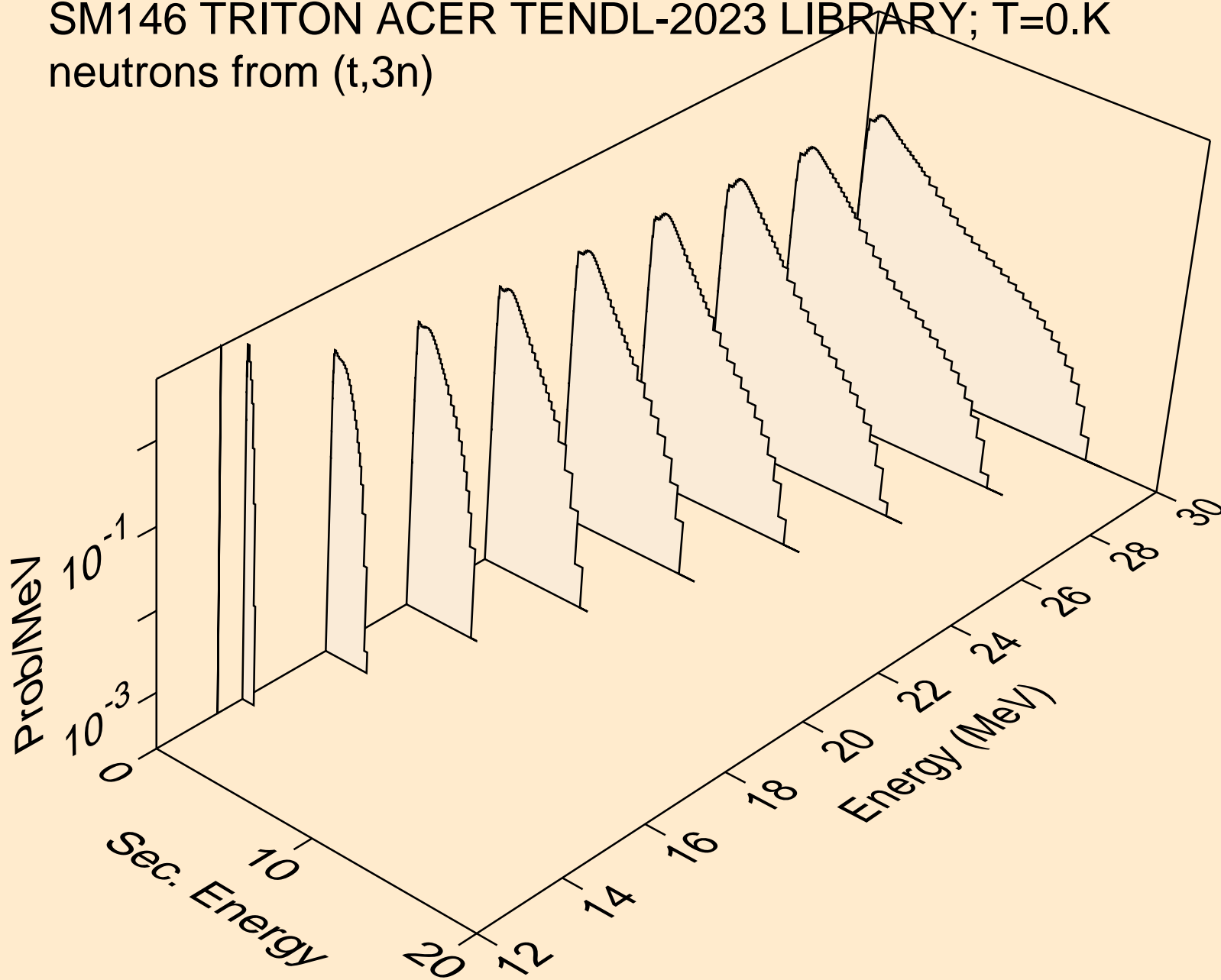

SM146 TRITON ACER TENDL-2023 LIBRARY; T=0.K  
neutrons from (t,n\*)a

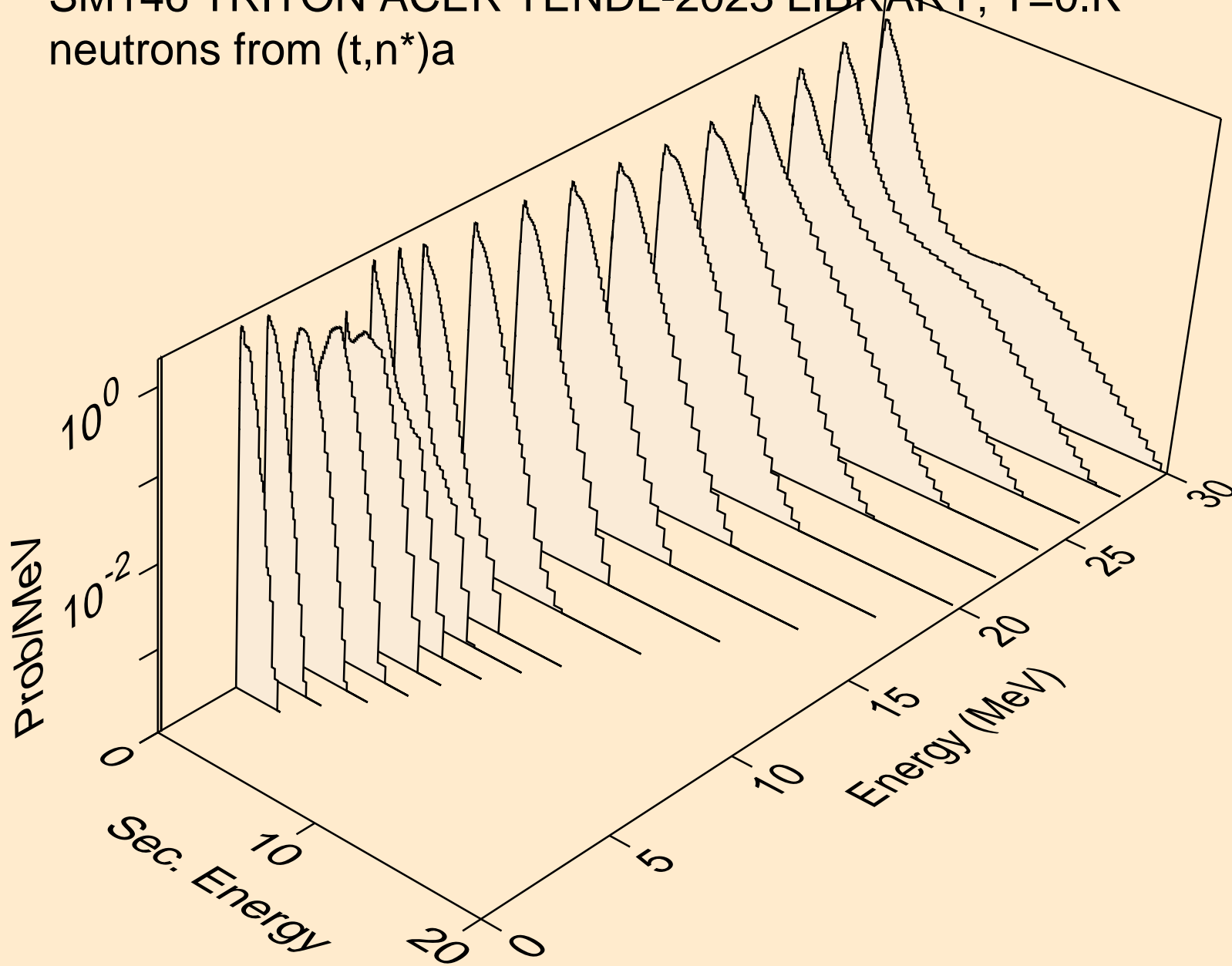

SM146 TRITON ACER TENDL-2023 LIBRARY; T=0.K  
neutrons from (t,2n)a

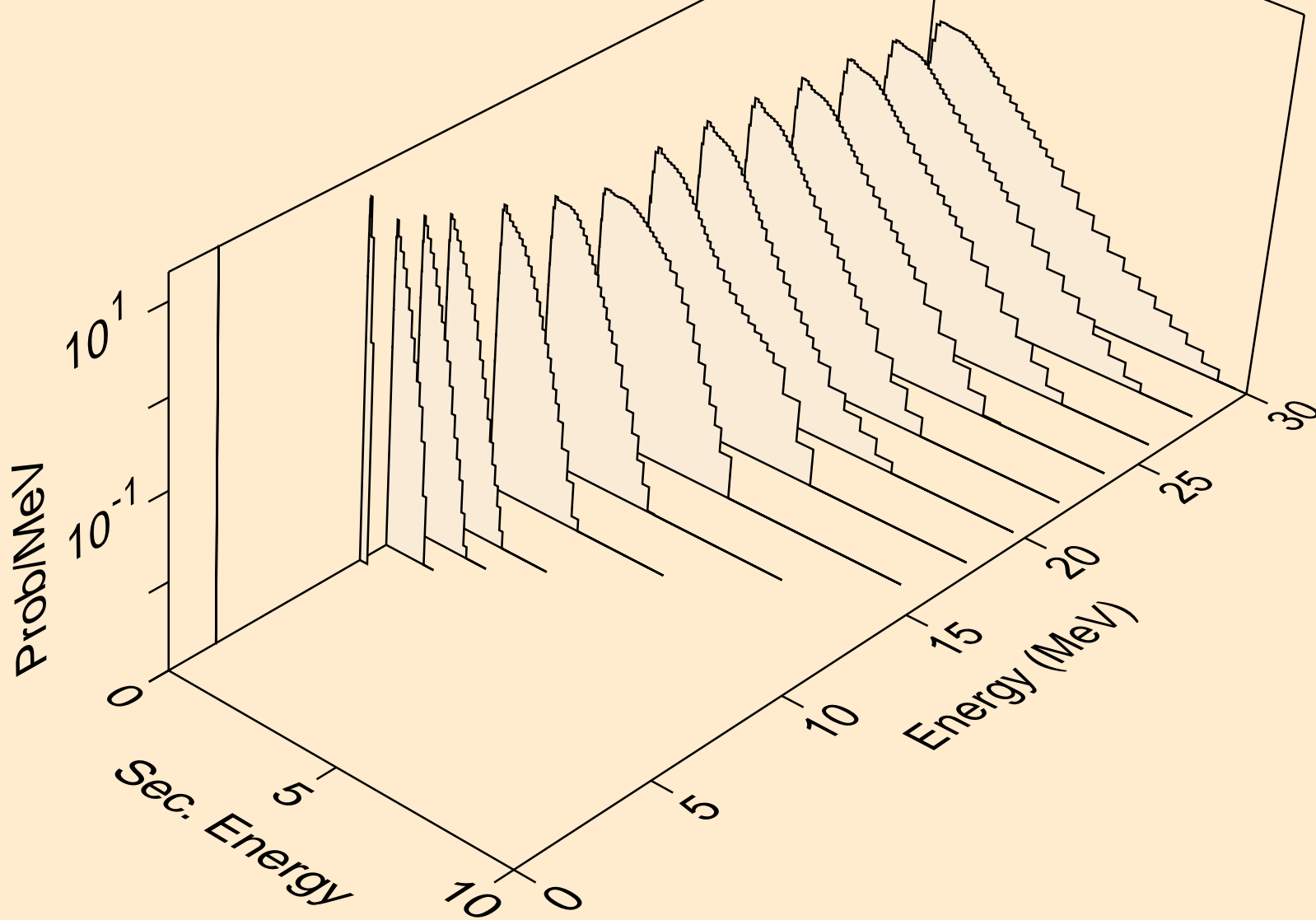

SM146 TRITON ACER TENDL-2023 LIBRARY; T=0.K  
neutrons from (t,3n)a

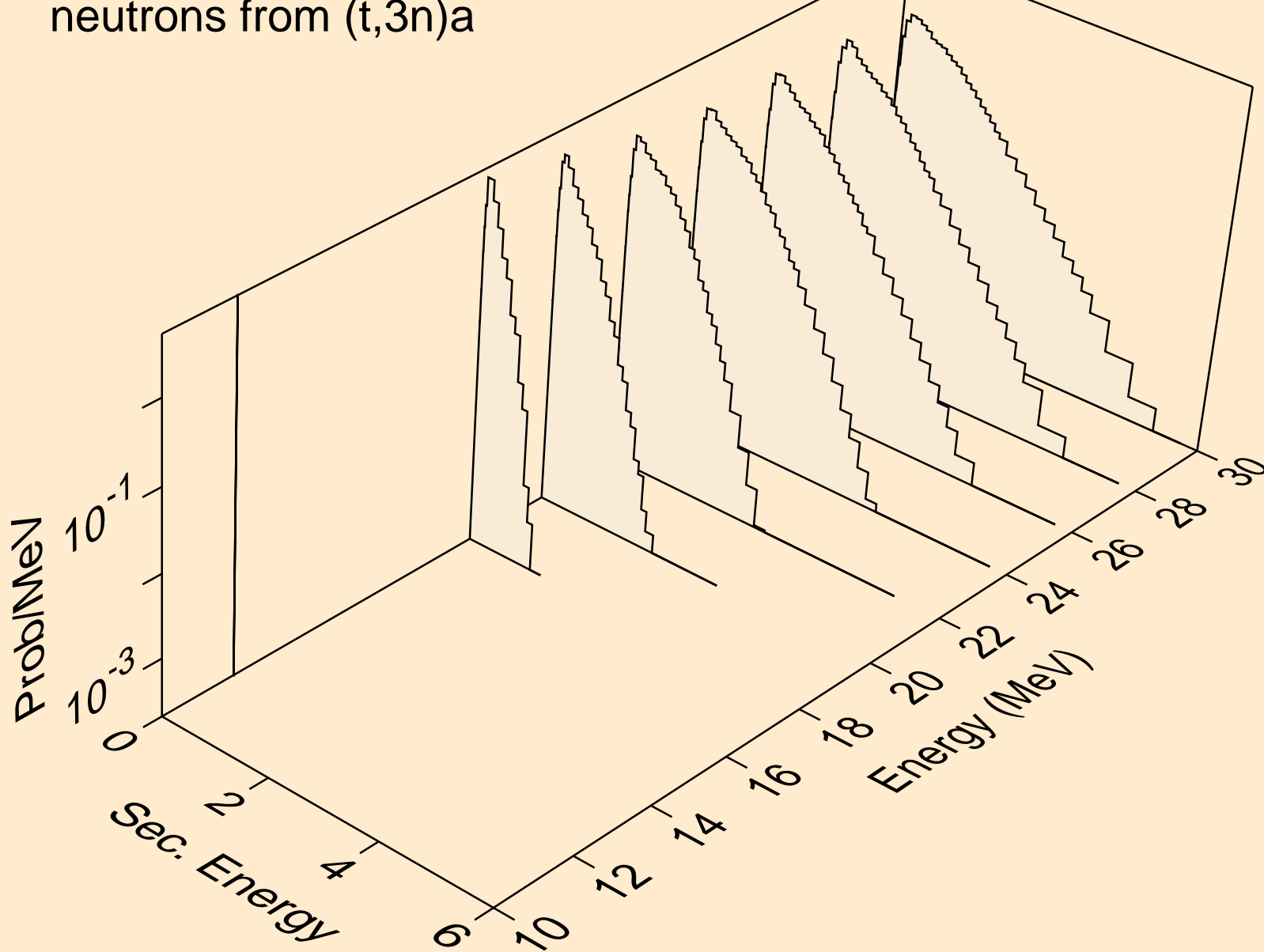

SM146 TRITON ACER TENDL-2023 LIBRARY; T=0.K  
neutrons from (t,n\*)p

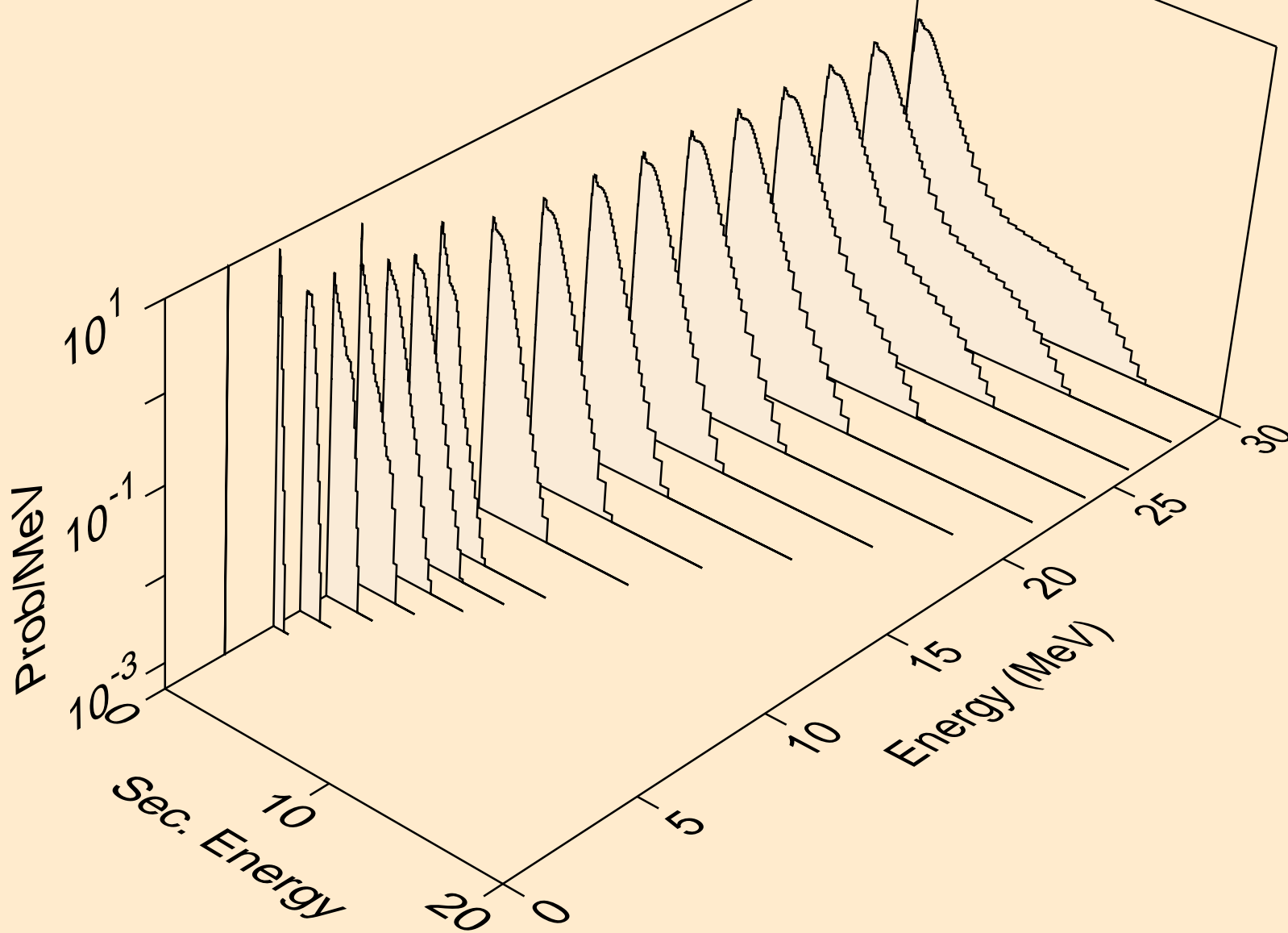

SM146 TRITON ACER TENDL-2023 LIBRARY; T=0.K  
neutrons from (t,n\*)2a

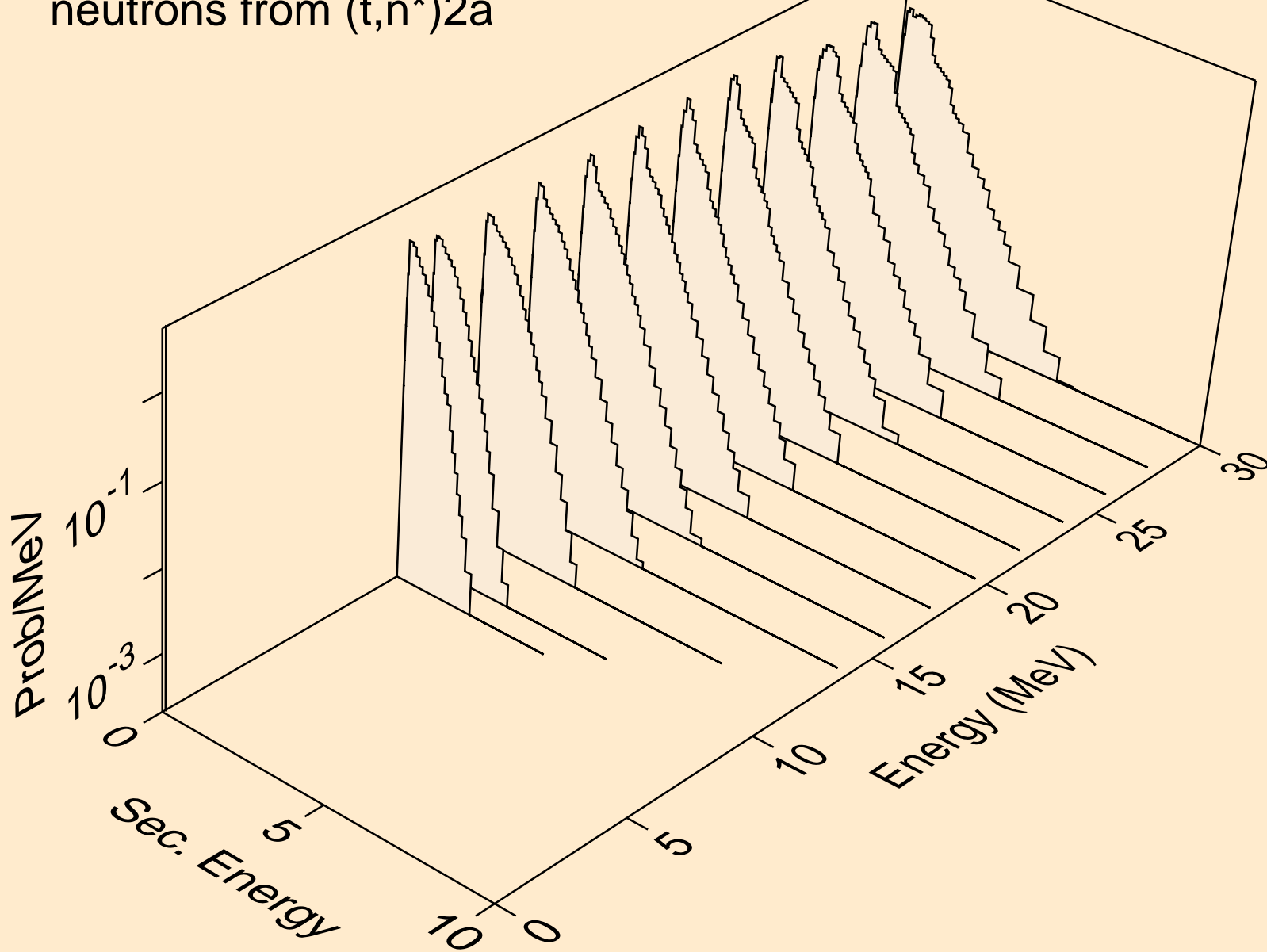

SM146 TRITON ACER TENDL-2023 LIBRARY; T=0.K  
neutrons from (t,2n)2a

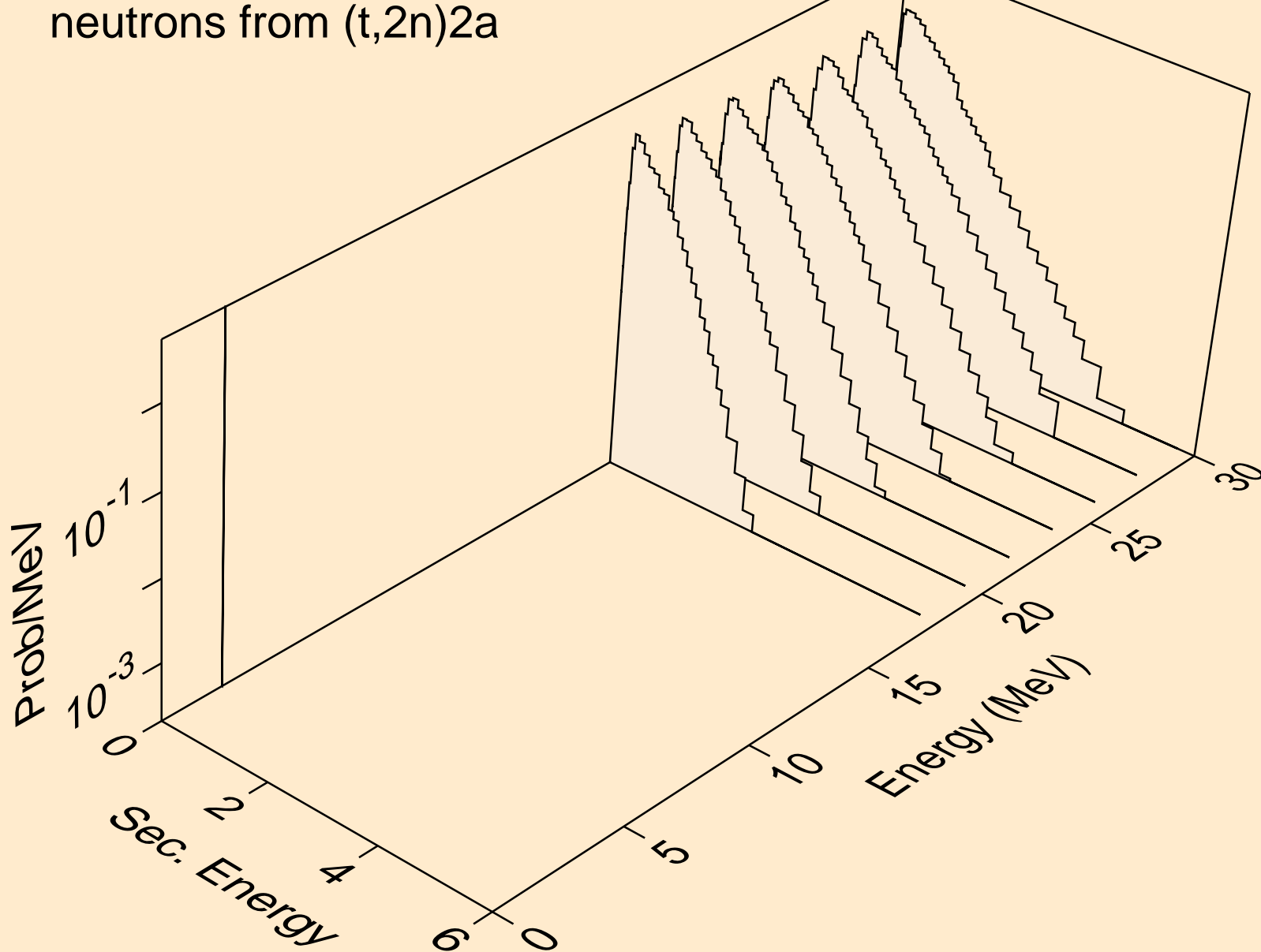

SM146 TRITON ACER TENDL-2023 LIBRARY; T=0.K  
neutrons from (t,n\*)d

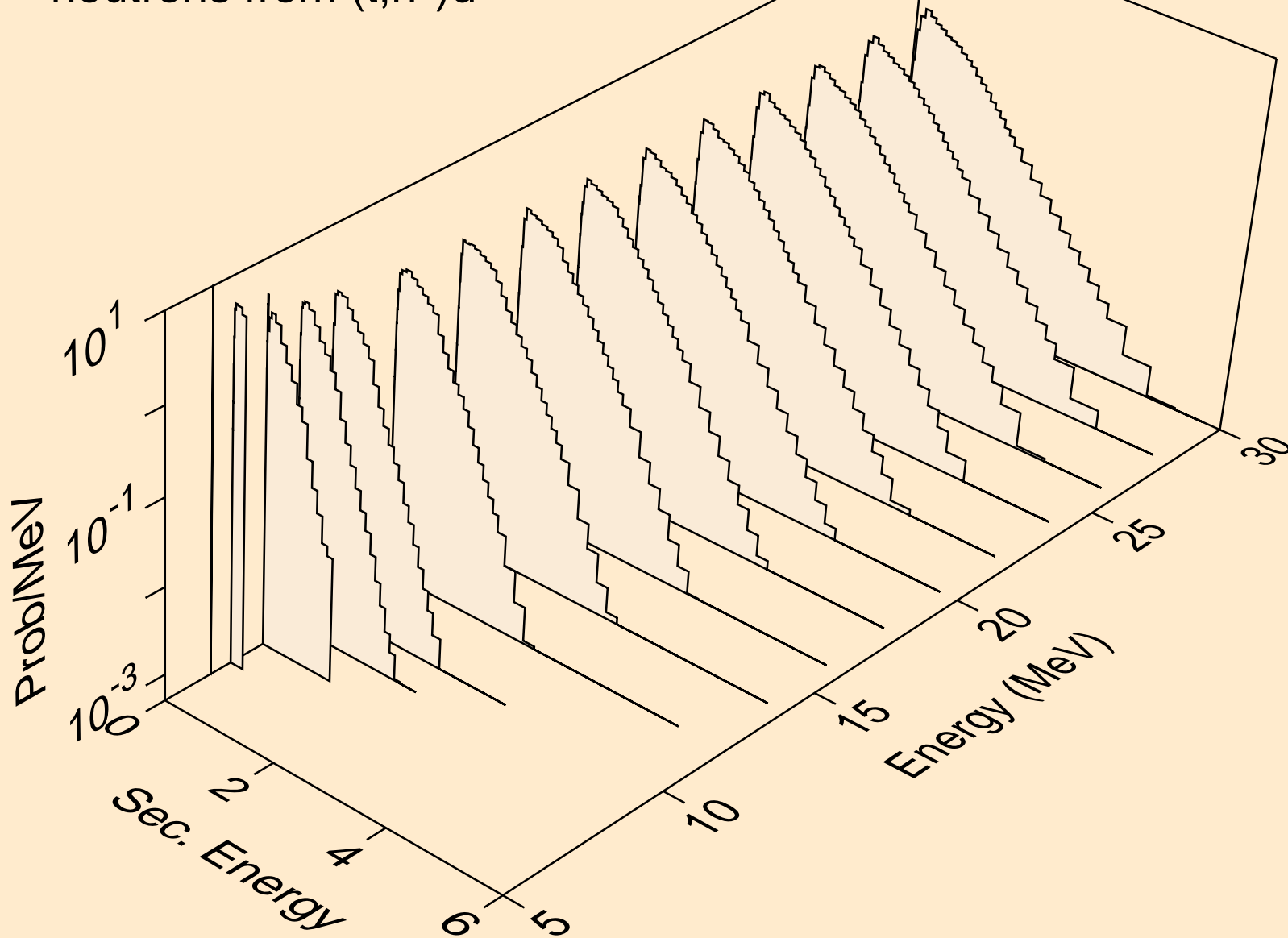

SM146 TRITON ACER TENDL-2023 LIBRARY; T=0.K  
neutrons from (t,n\*)t

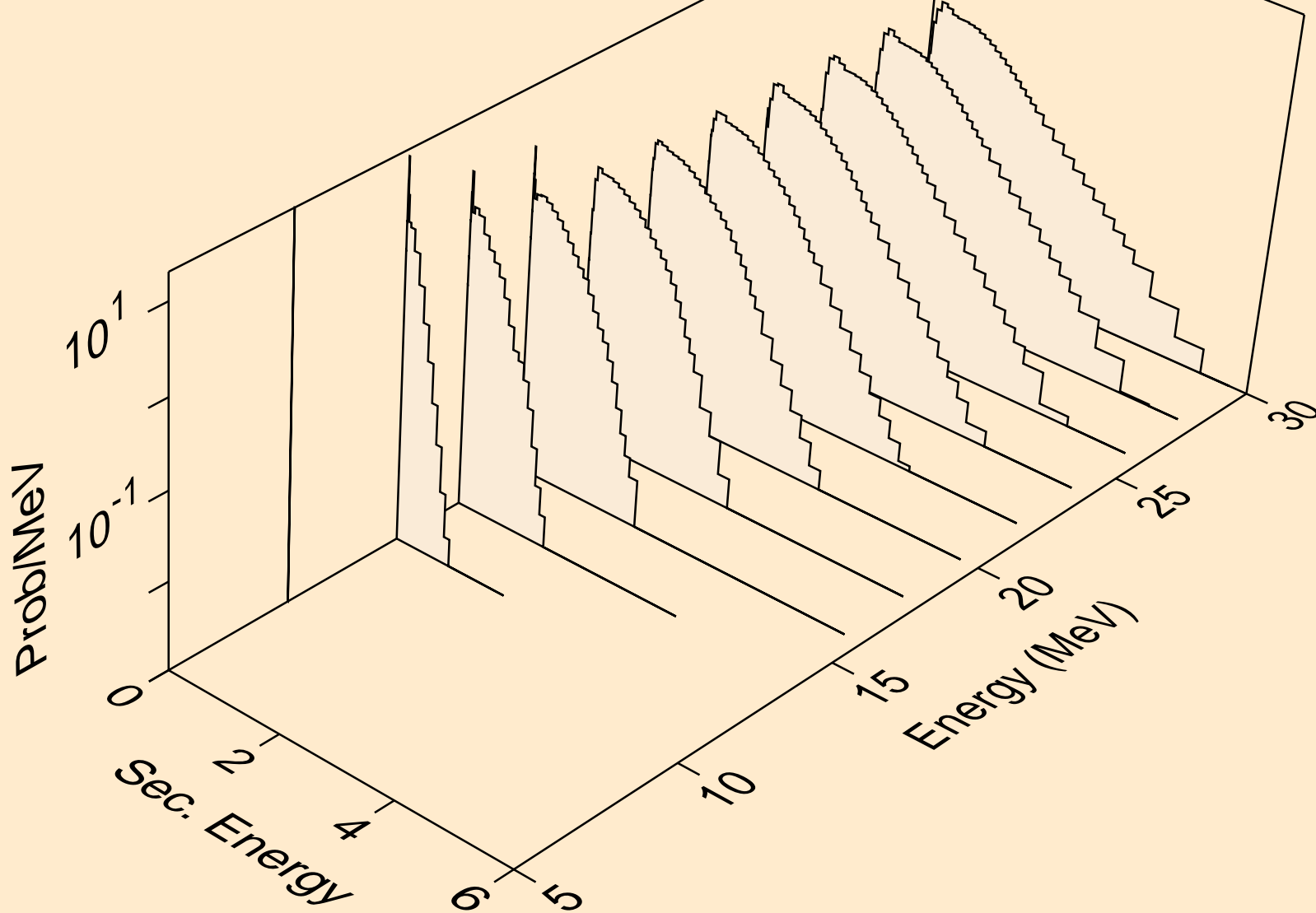

SM146 TRITON ACER TENDL-2023 LIBRARY; T=0.K  
neutrons from (t,n\*)he3

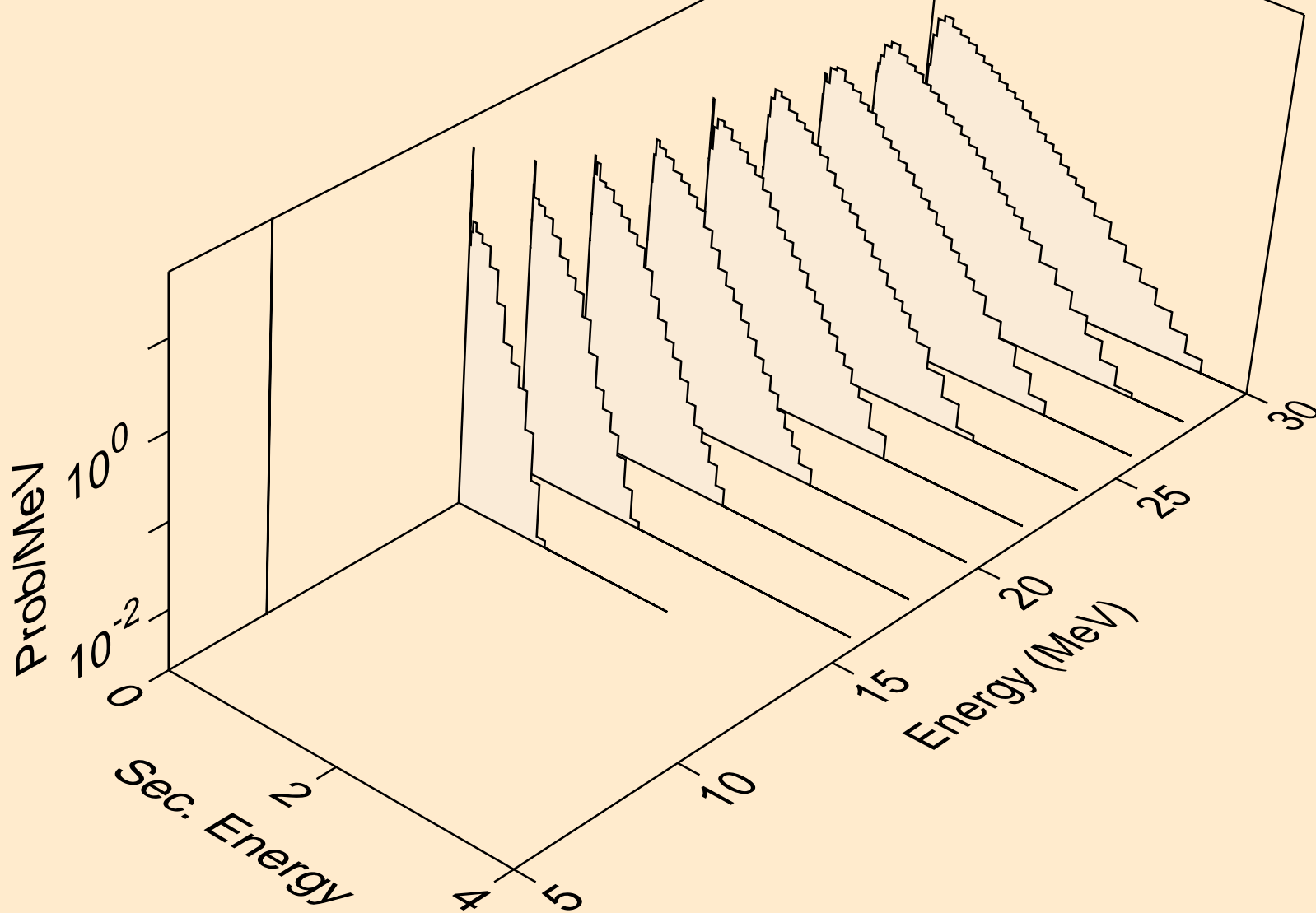

SM146 TRITON ACER TENDL-2023 LIBRARY; T=0.K  
neutrons from (t,4n)

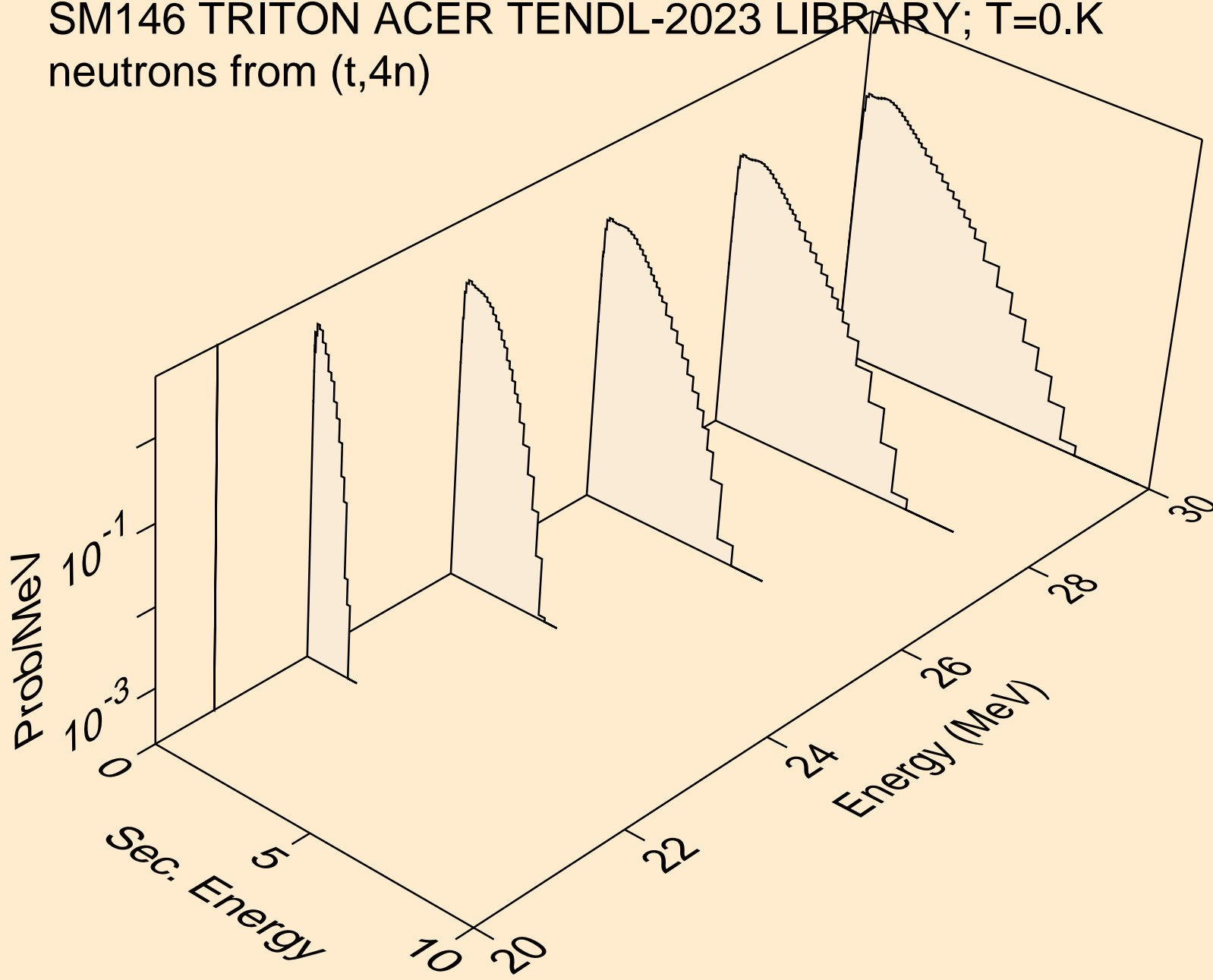

SM146 TRITON ACER TENDL-2023 LIBRARY; T=0.K  
neutrons from (t,2np)

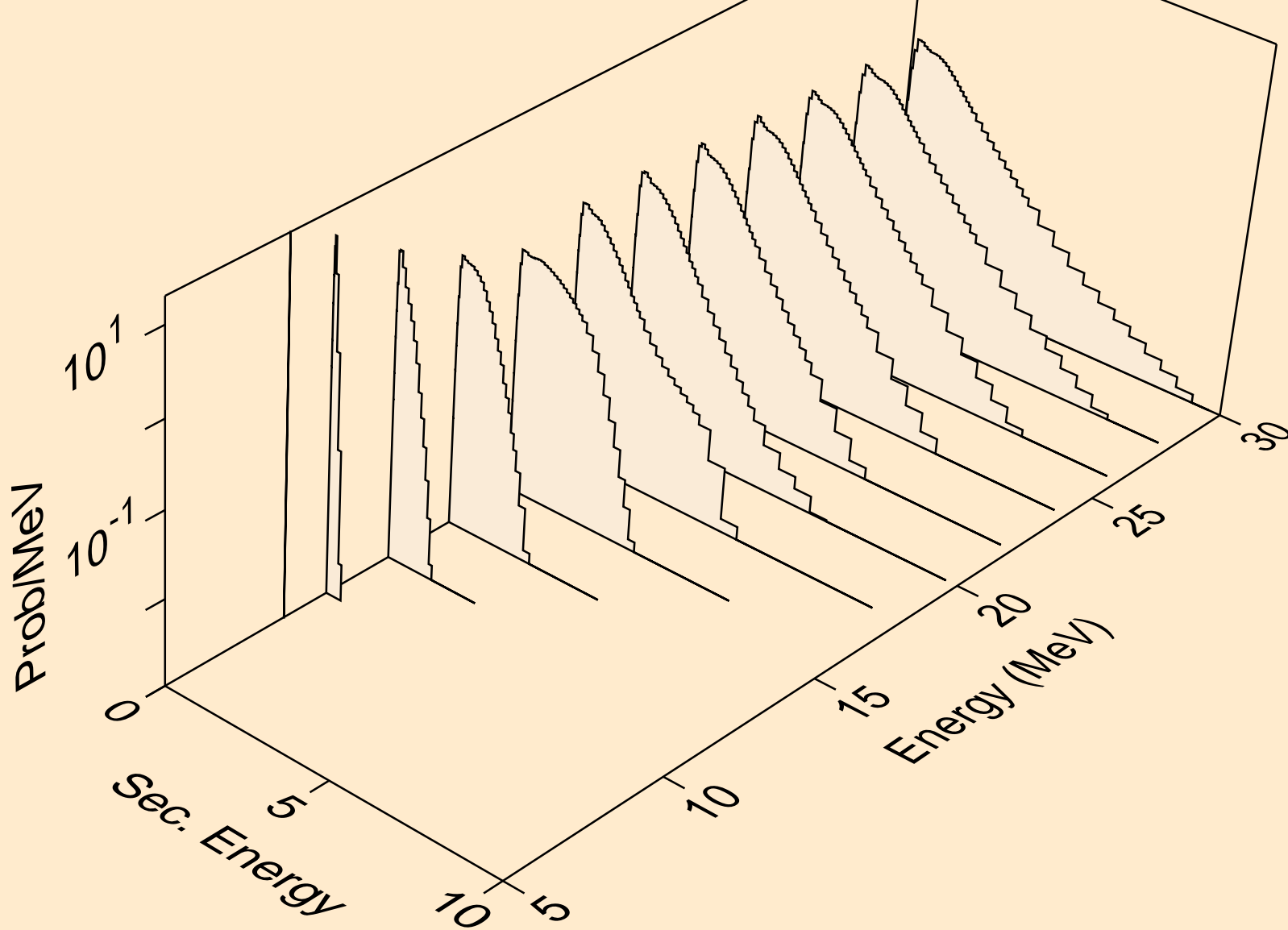

SM146 TRITON ACER TENDL-2023 LIBRARY; T=0.K  
neutrons from (t,3np)

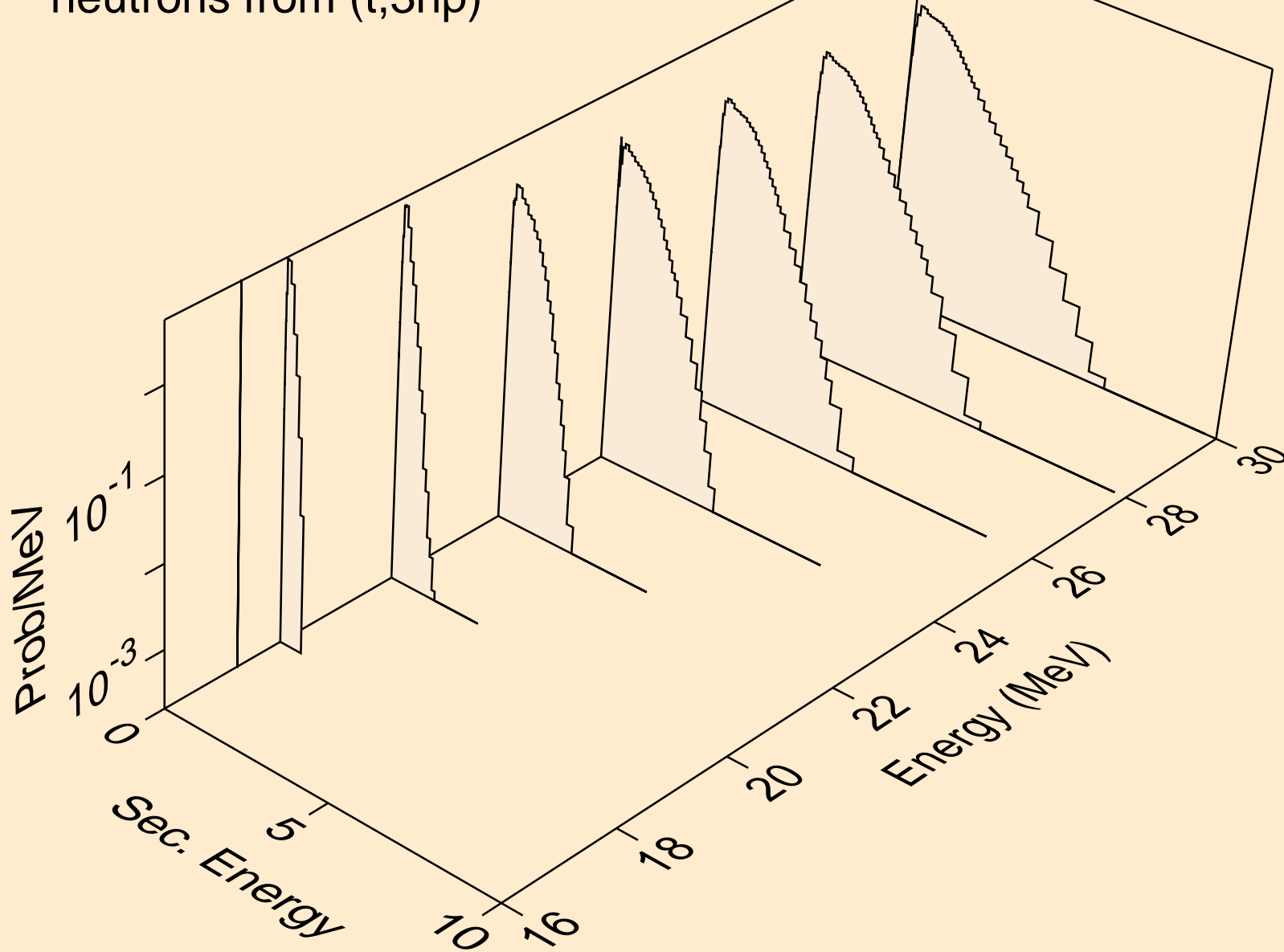

SM146 TRITON ACER TENDL-2023 LIBRARY; T=0.K  
neutrons from (t,n2p)

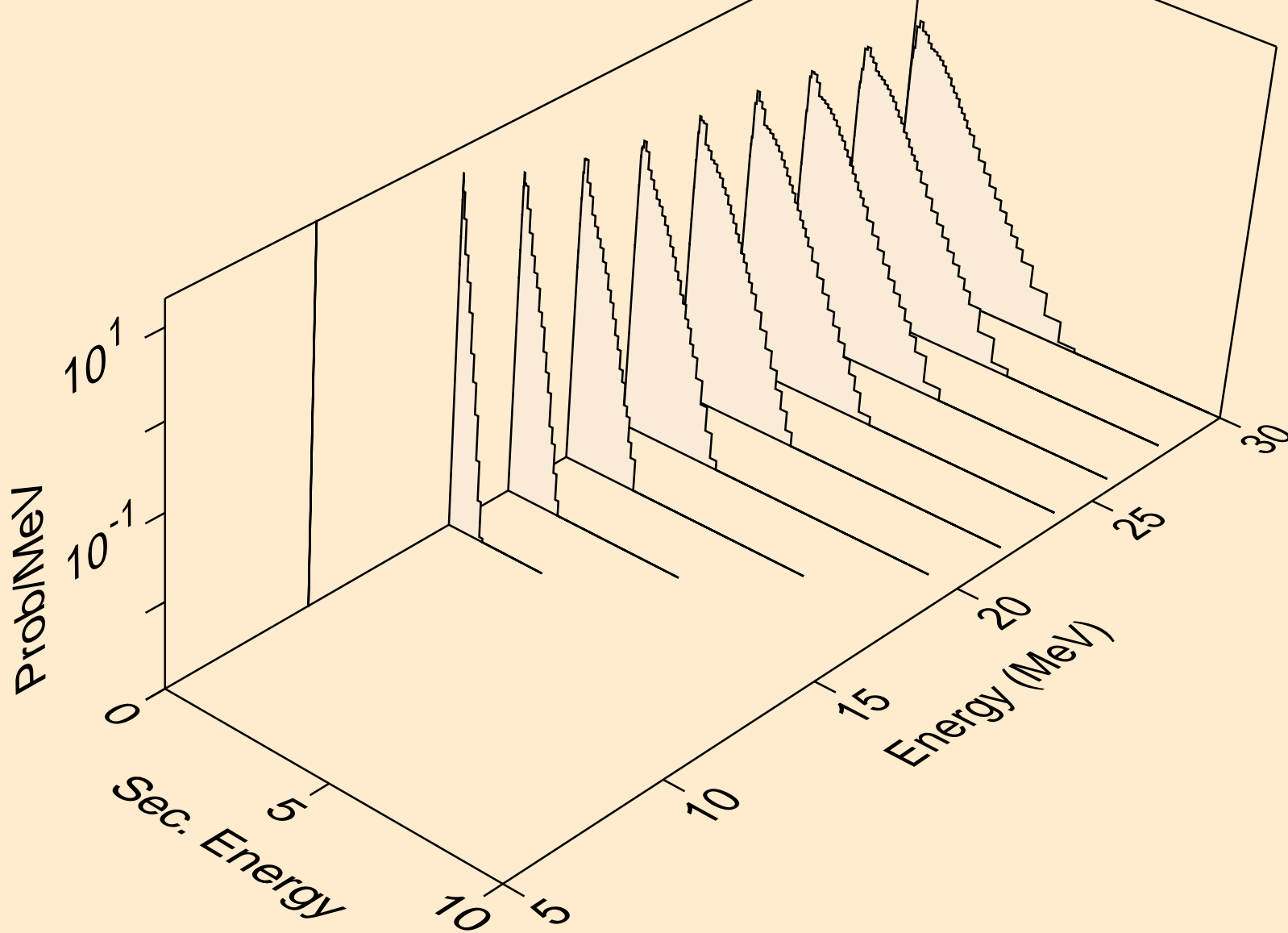

SM146 TRITON ACER TENDL-2023 LIBRARY; T=0.K  
neutrons from (t,npa)

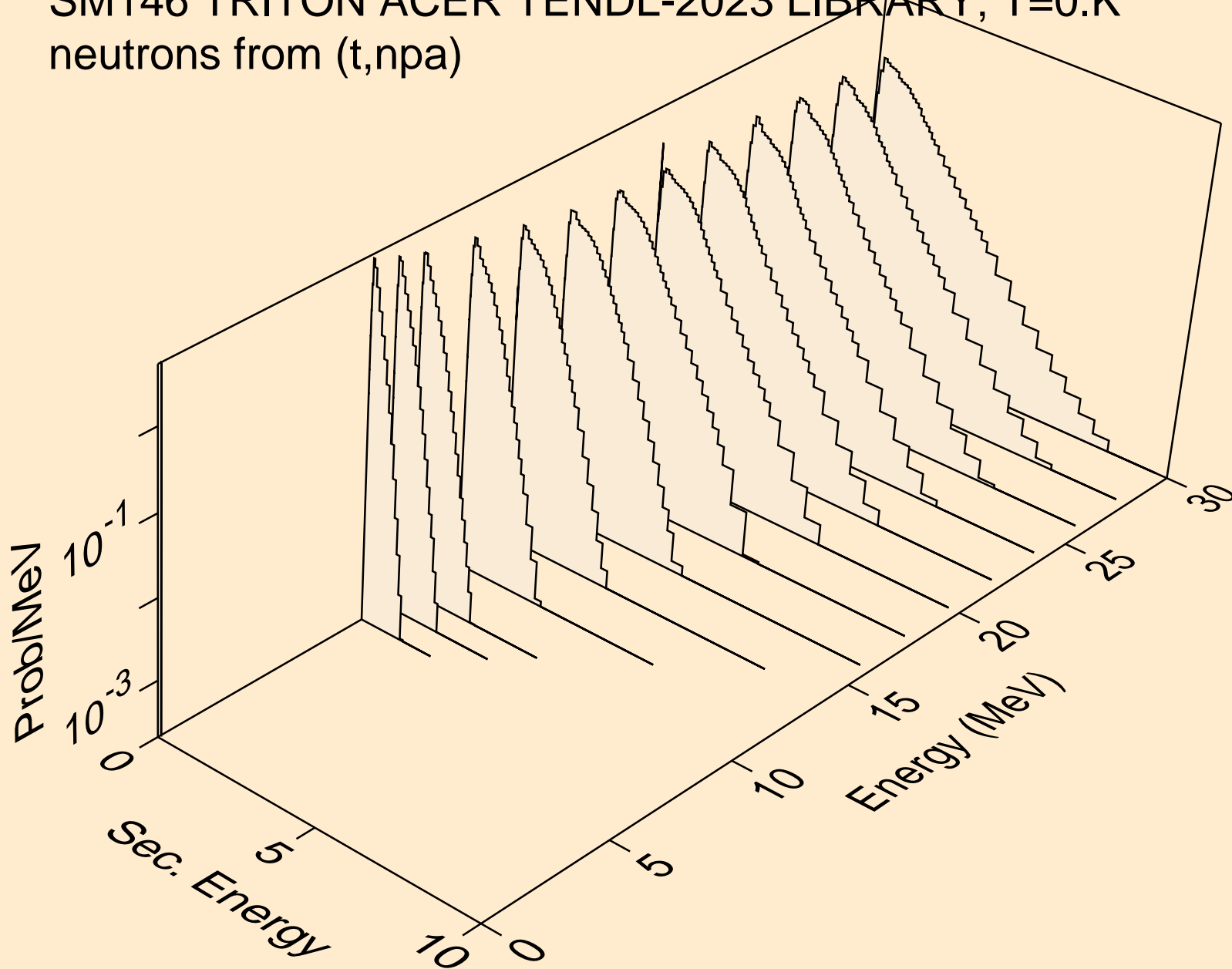

SM146 TRITON ACER TENDL-2023 LIBRARY; T=0.K  
protons from (t,x)

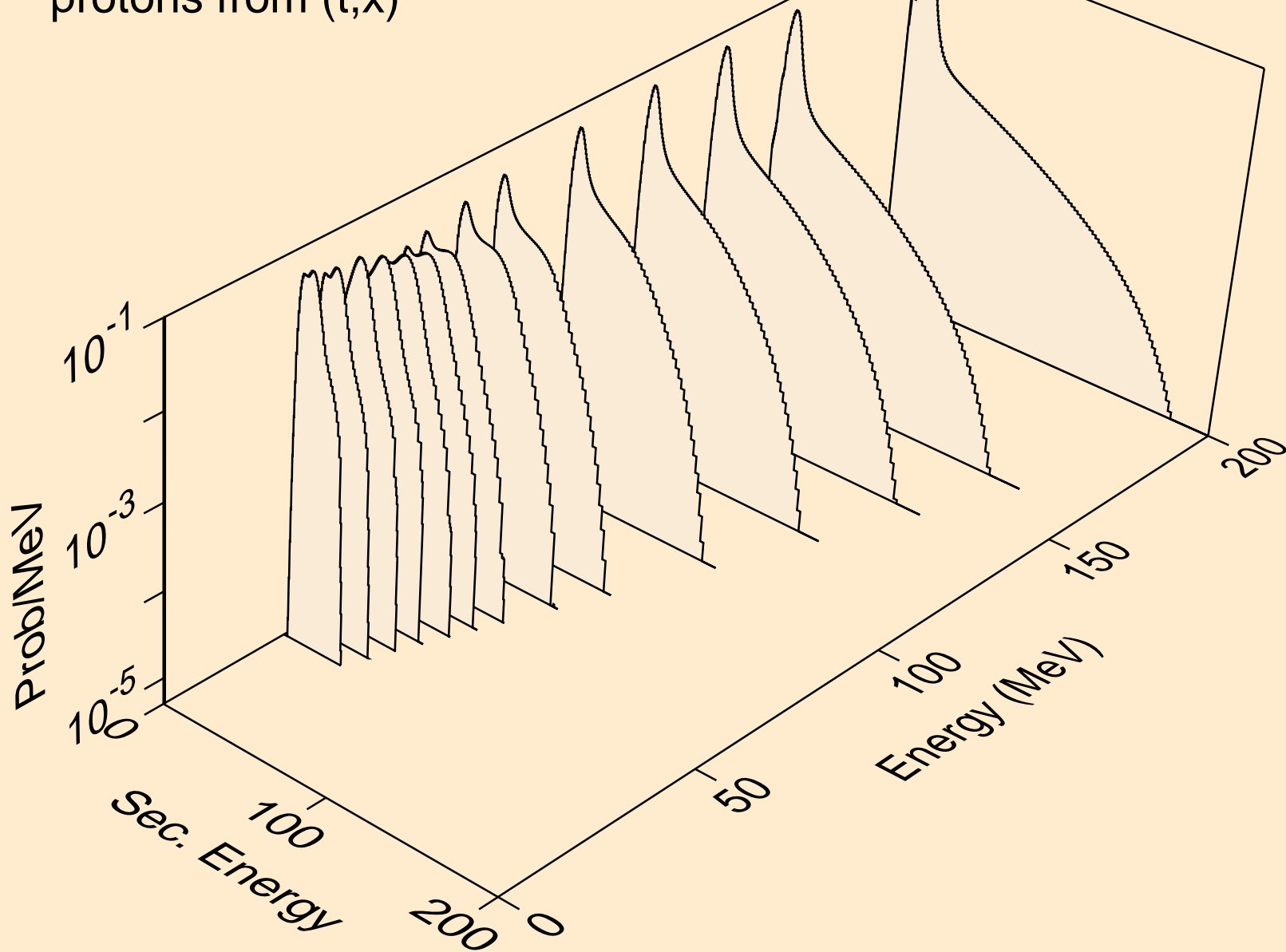

SM146 TRITON ACER TENDL-2023 LIBRARY; T=0.K  
protons from (t,n\*)p

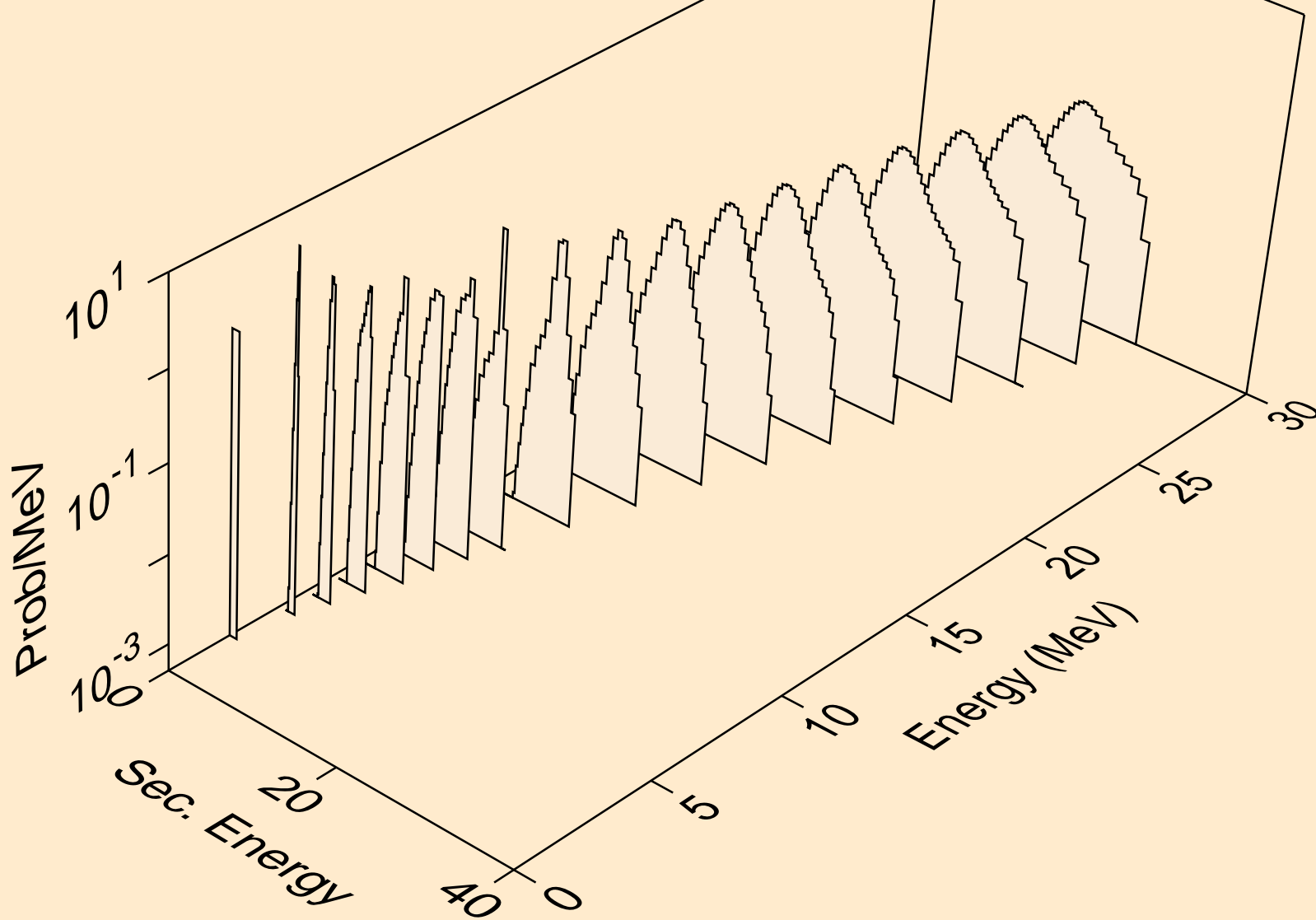

SM146 TRITON ACER TENDL-2023 LIBRARY; T=0.K  
protons from (t,2np)

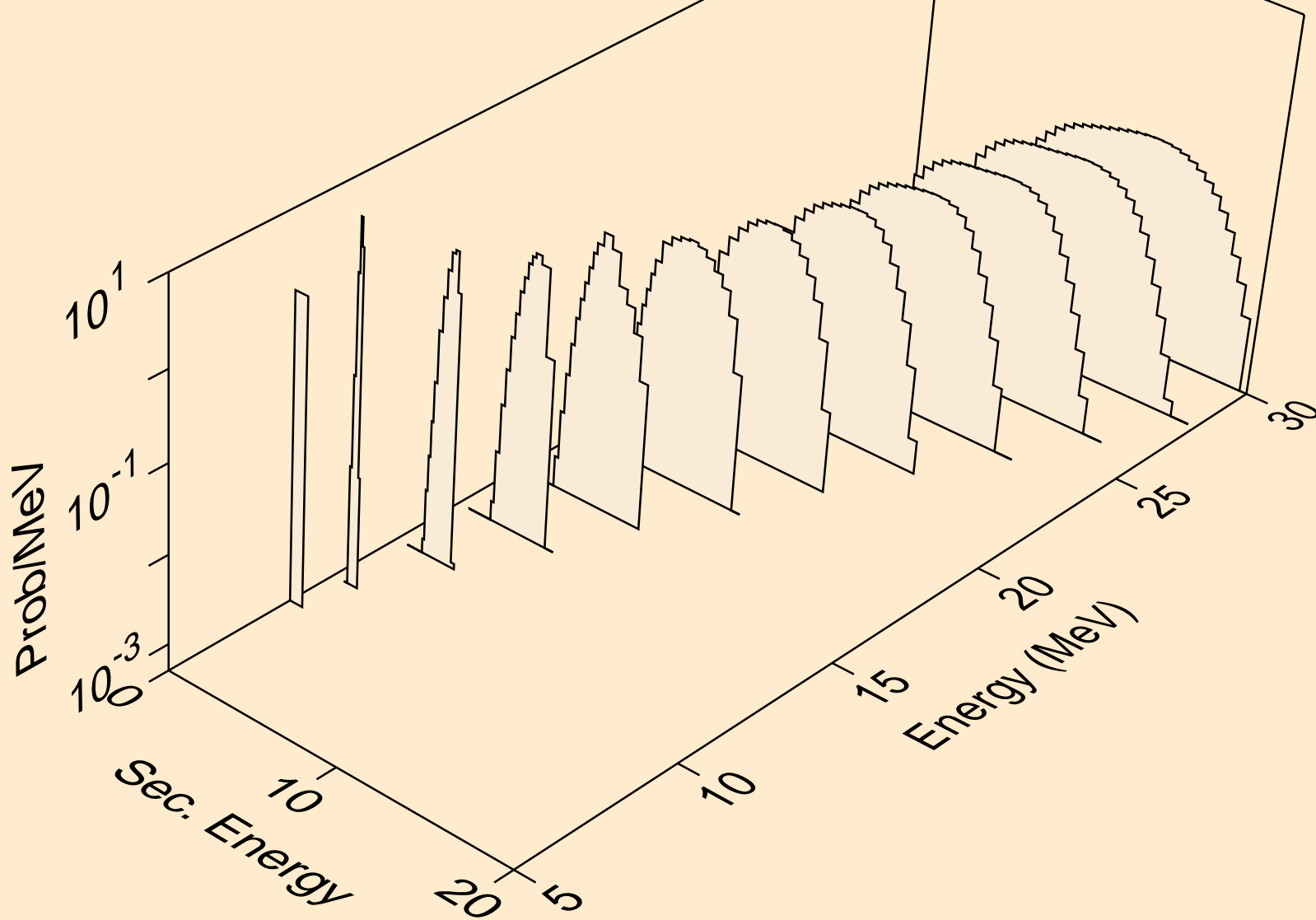

SM146 TRITON ACER TENDL-2023 LIBRARY; T=0.K  
protons from (t,3np)

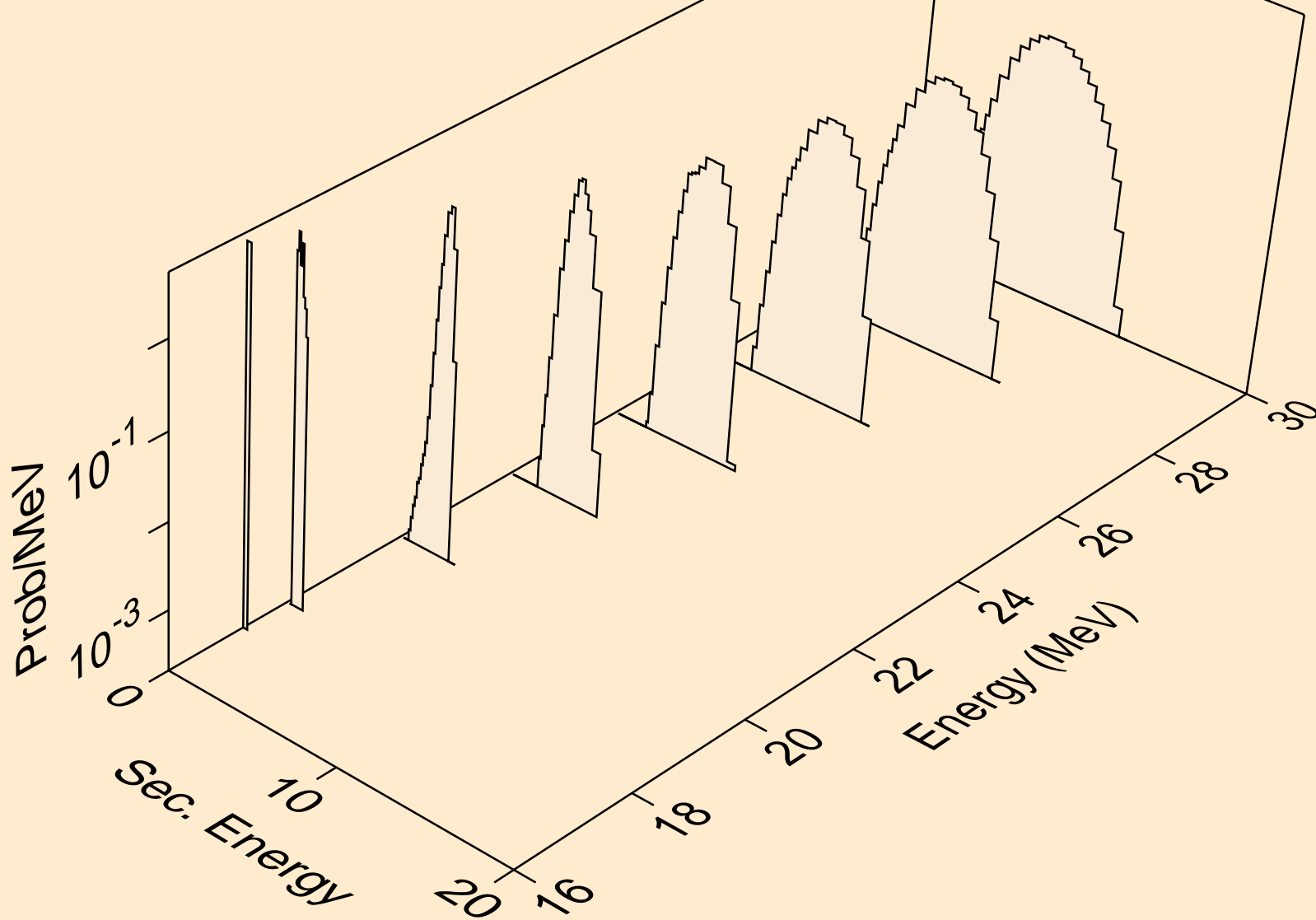

SM146 TRITON ACER TENDL-2023 LIBRARY; T=0.K  
protons from (t,n2p)

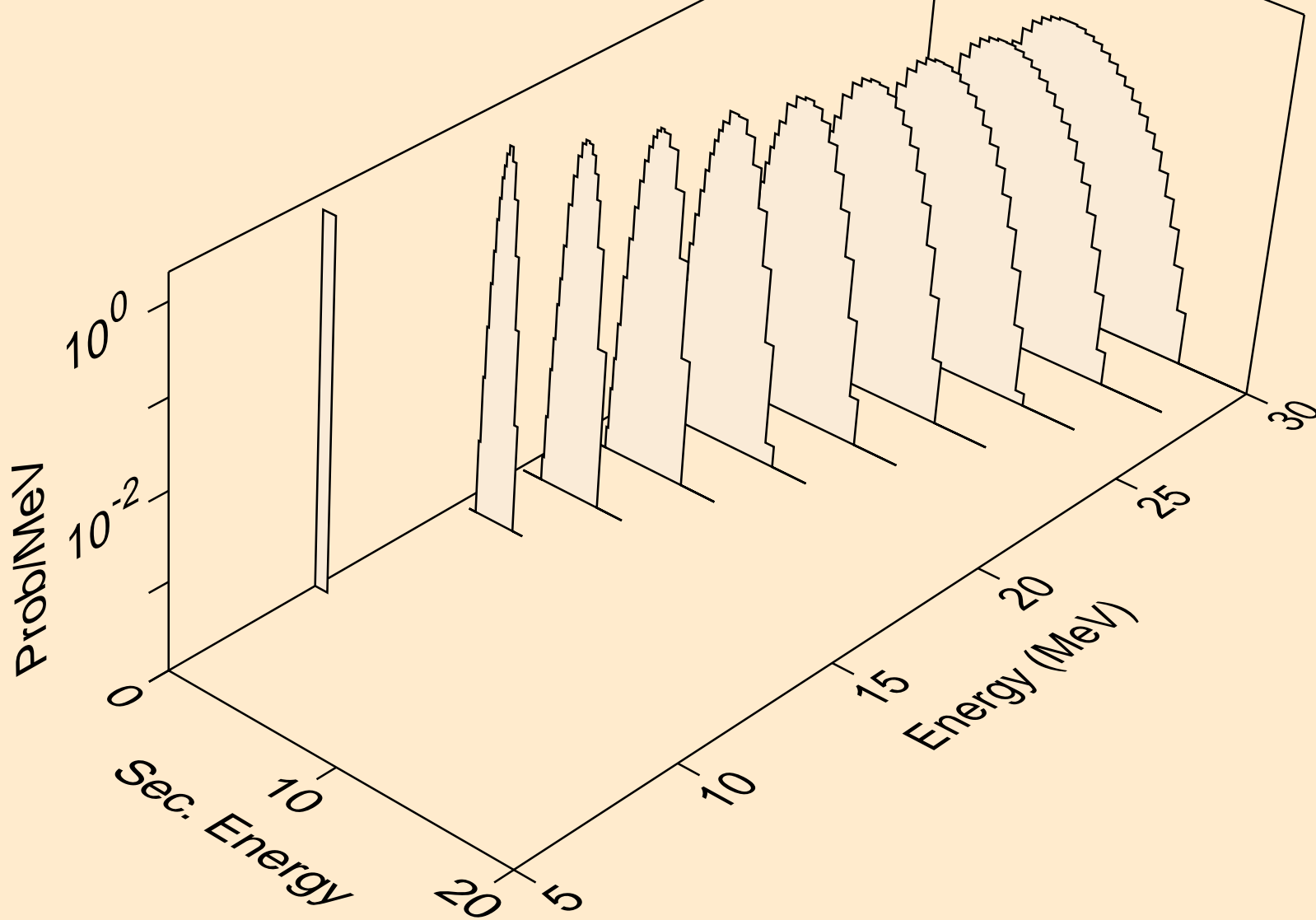

SM146 TRITON ACER TENDL-2023 LIBRARY; T=0.K  
protons from (t,npa)

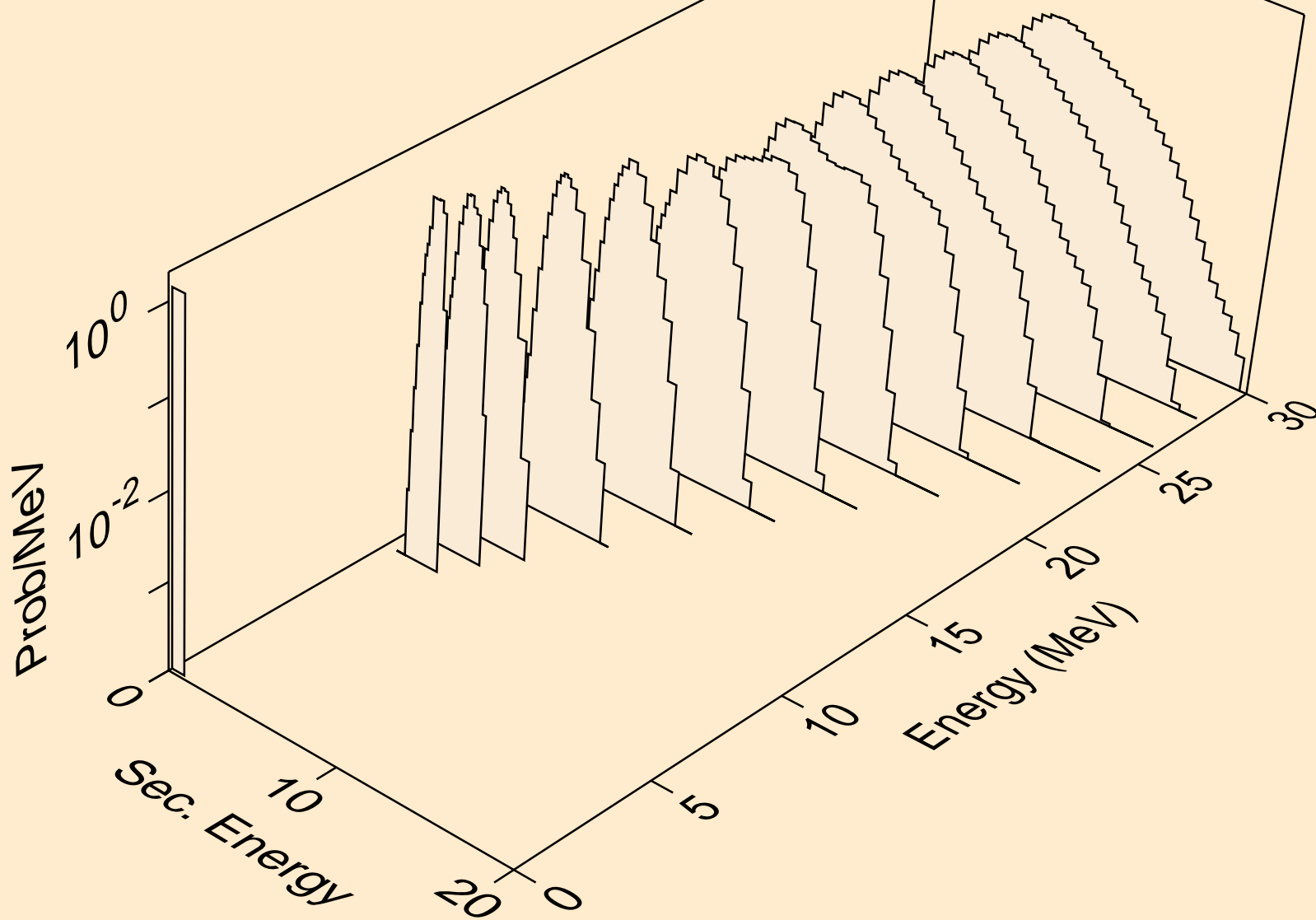

SM146 TRITON ACER TENDL-2023 LIBRARY; T=0.K  
protons from (t,p)

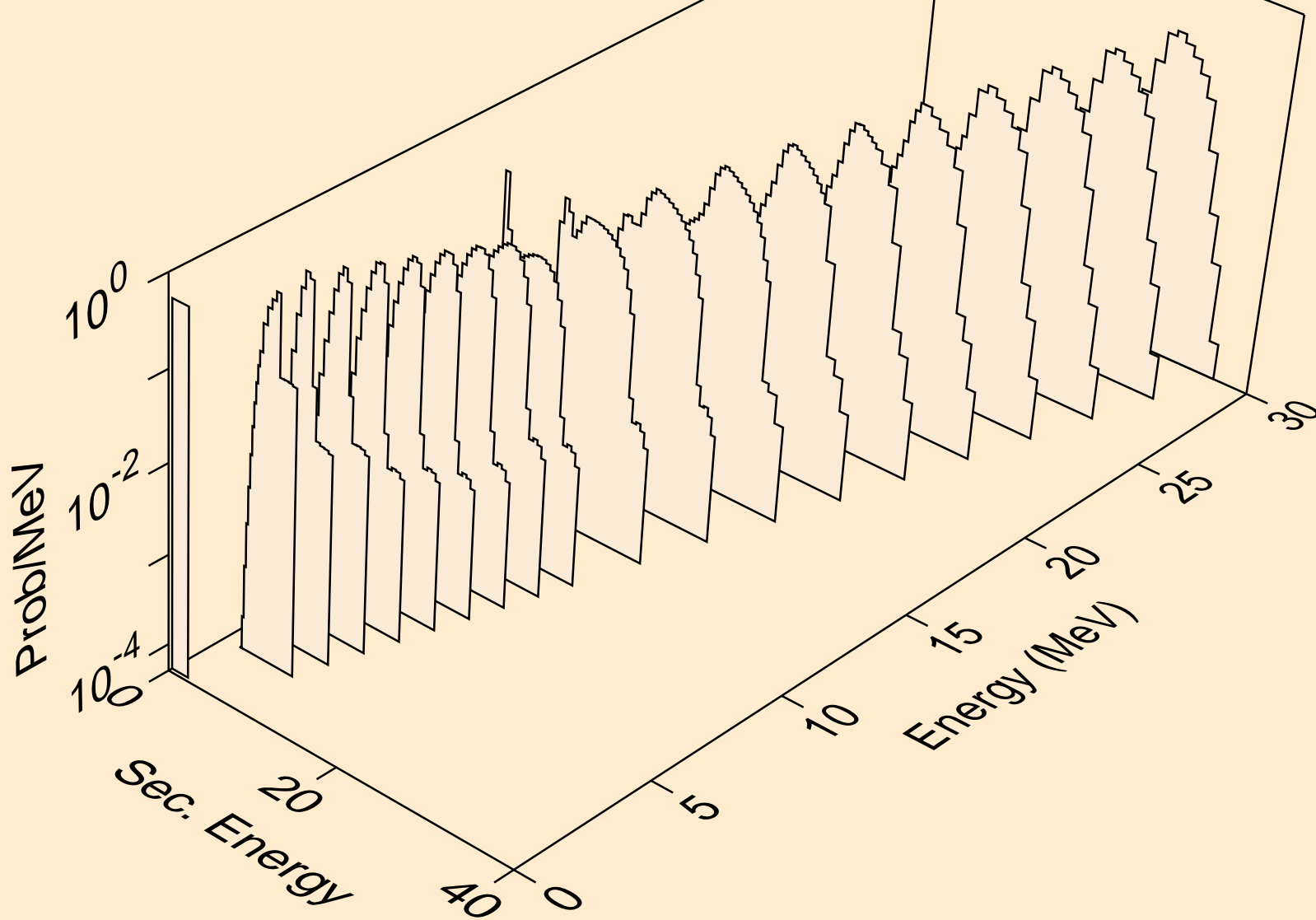

SM146 TRITON ACER TENDL-2023 LIBRARY; T=0.K  
protons from (t,2p)

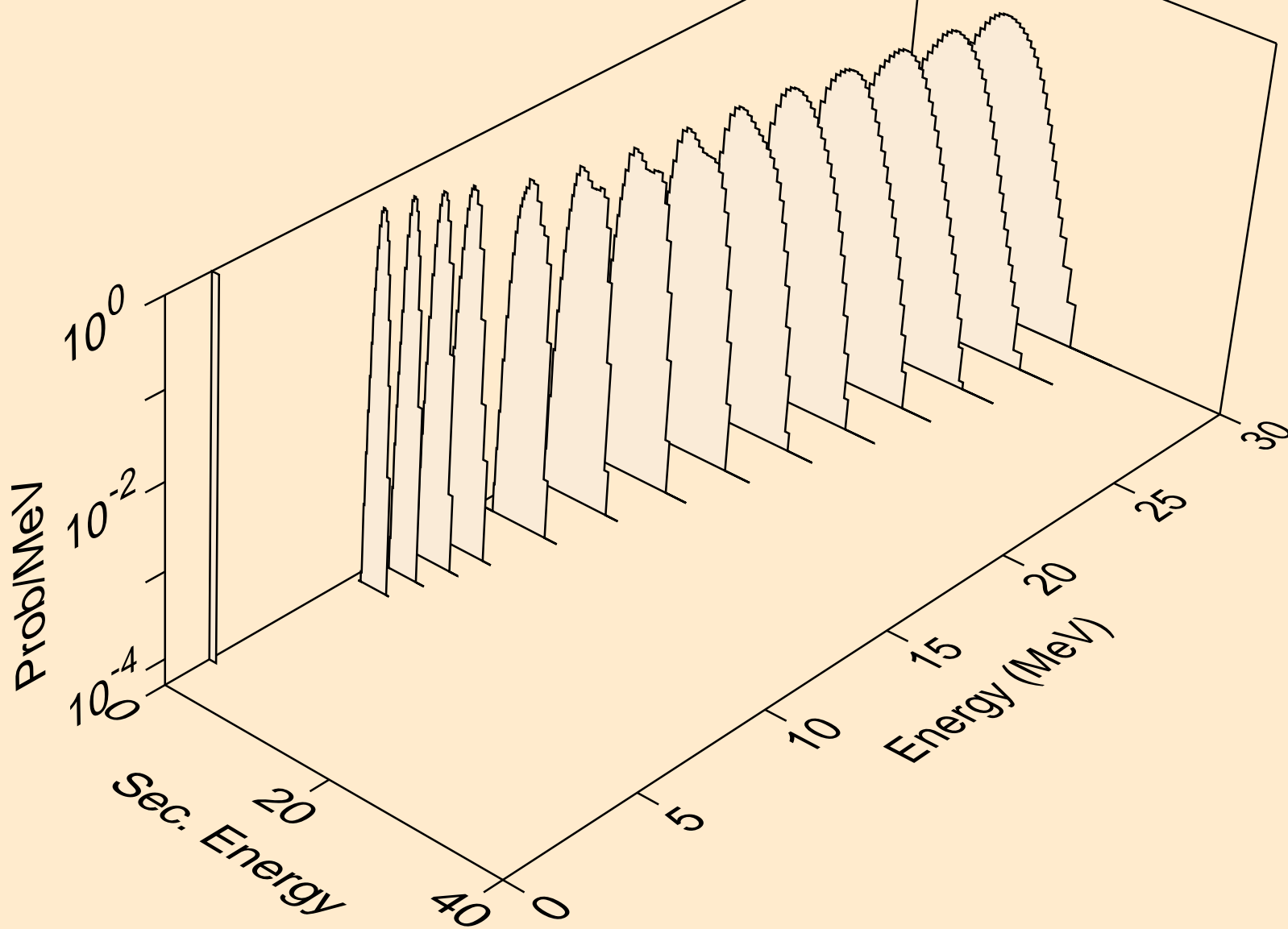

SM146 TRITON ACER TENDL-2023 LIBRARY; T=0.K  
protons from (t,pa)

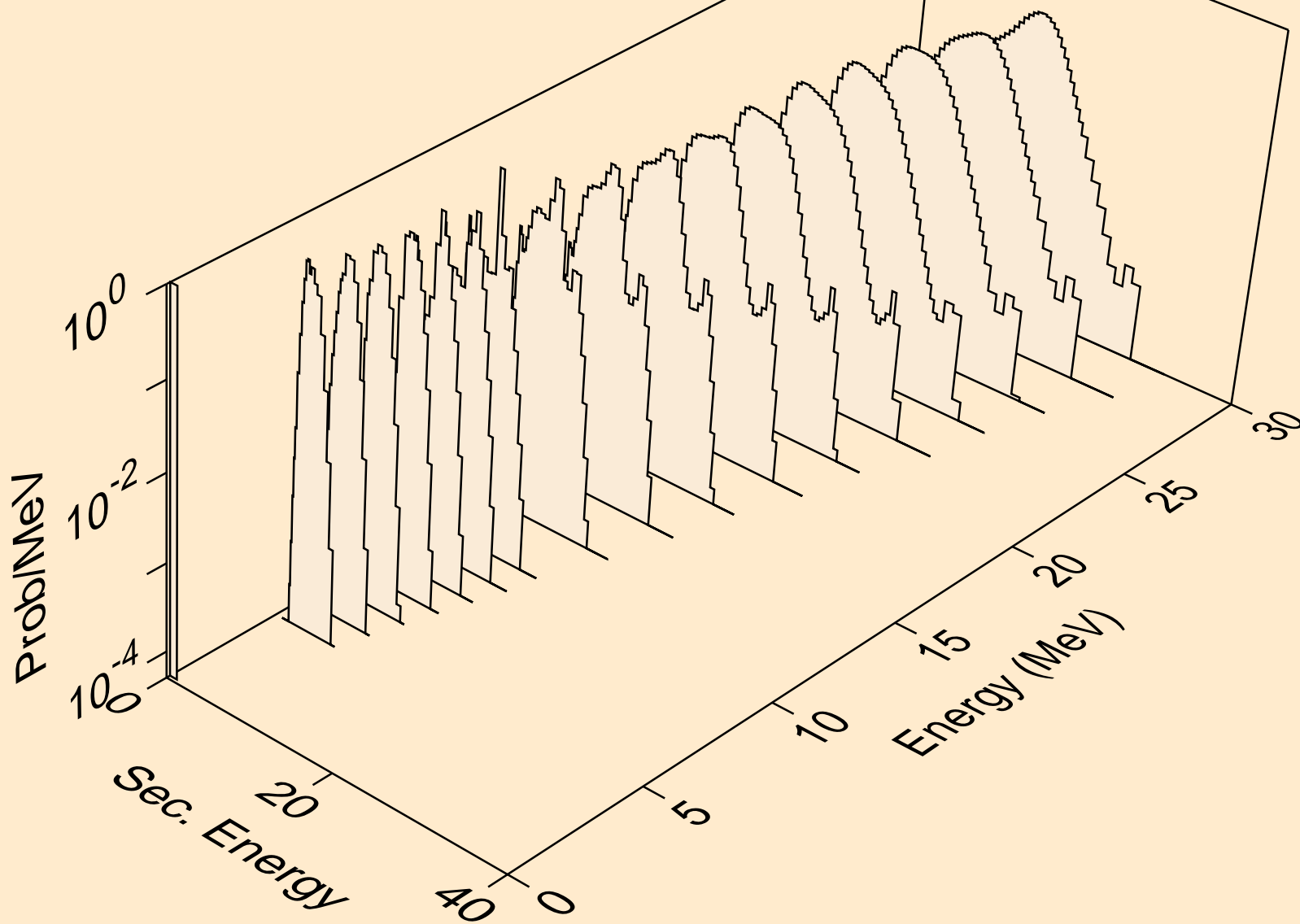

SM146 TRITON ACER TENDL-2023 LIBRARY; T=0.K  
protons from (t,pd)

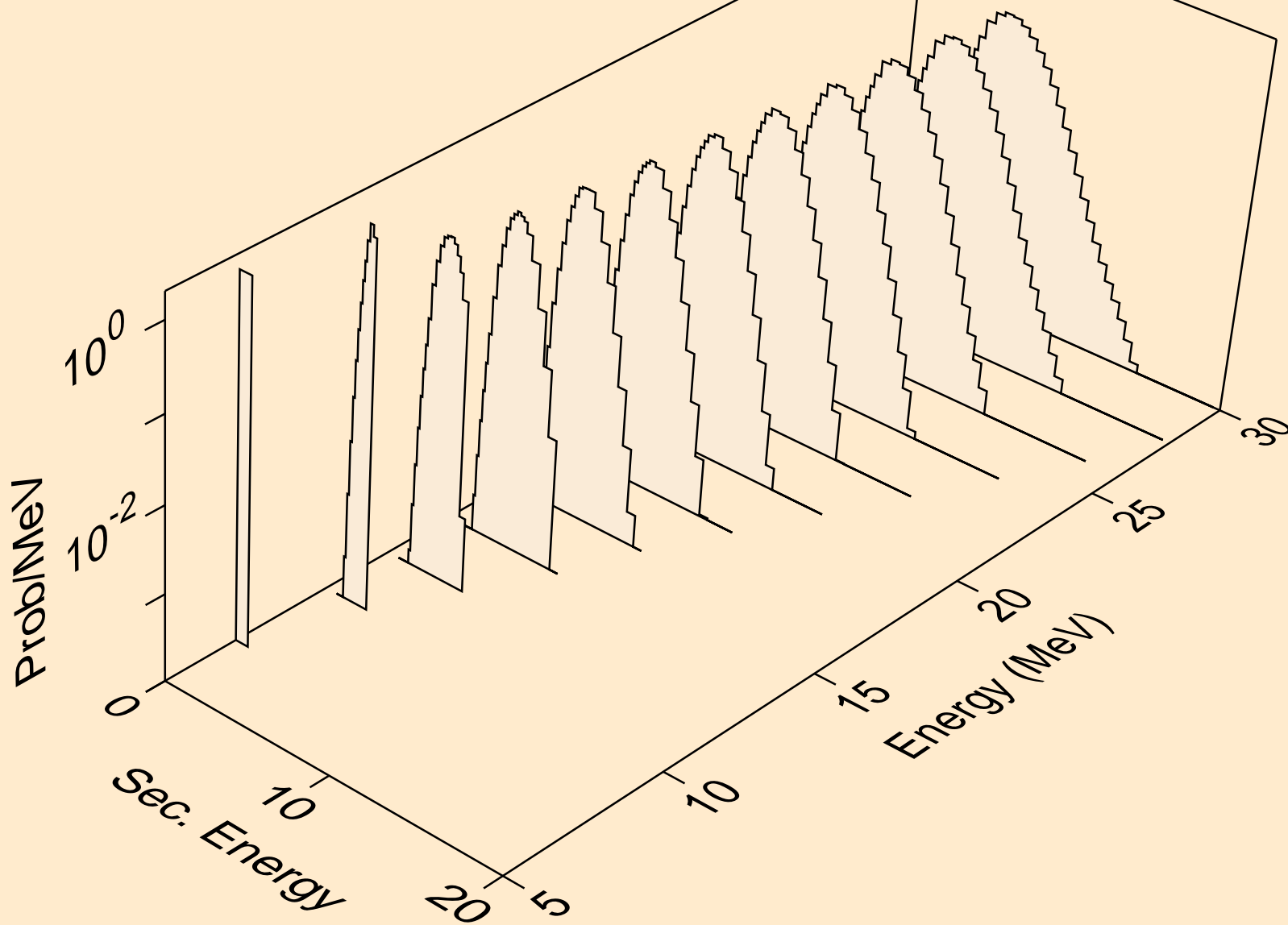

SM146 TRITON ACER TENDL-2023 LIBRARY; T=0.K  
protons from (t,pt)

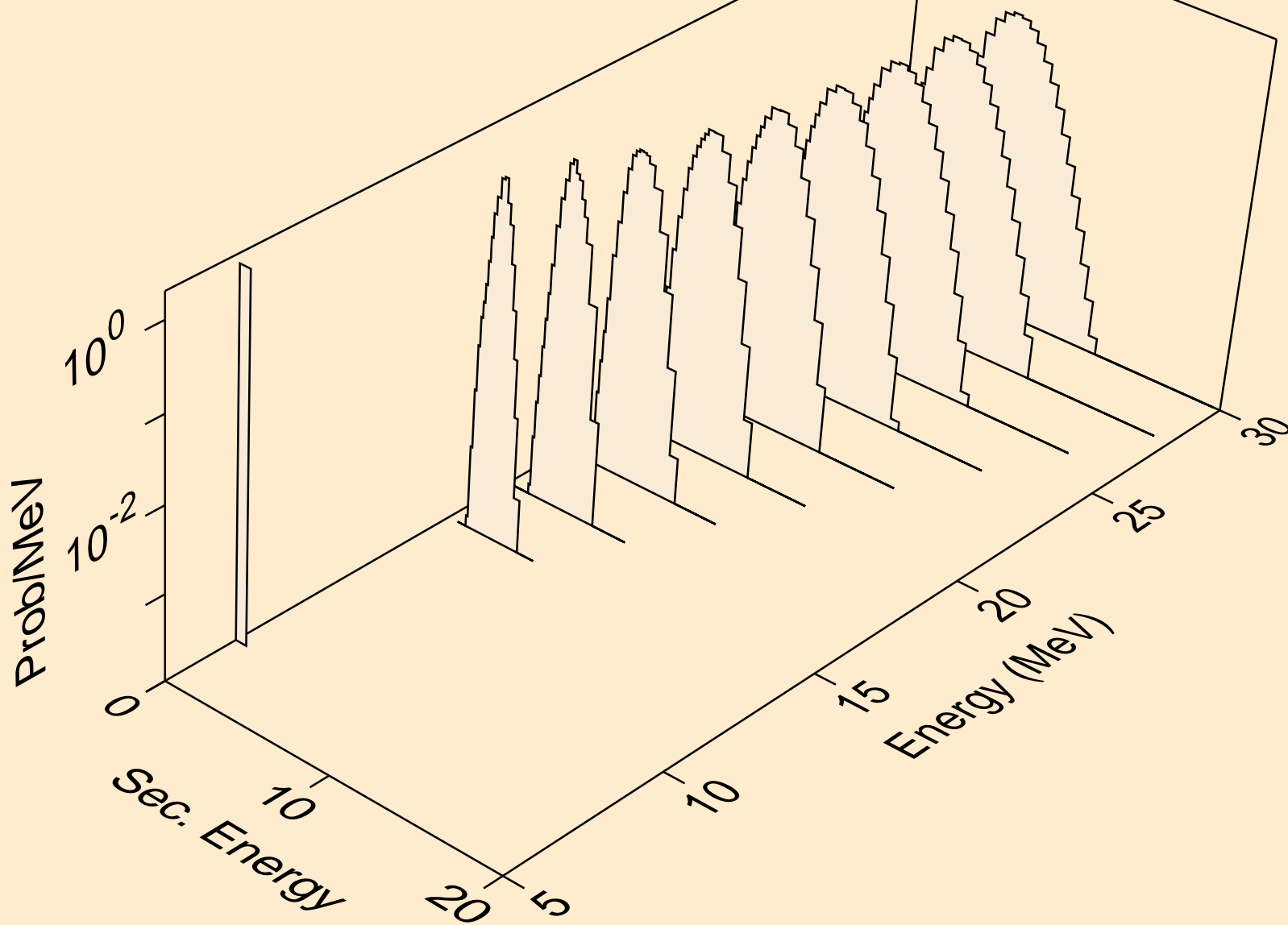

SM146 TRITON ACER TENDL-2023 LIBRARY; T=0.K  
deuterons from (t,x)

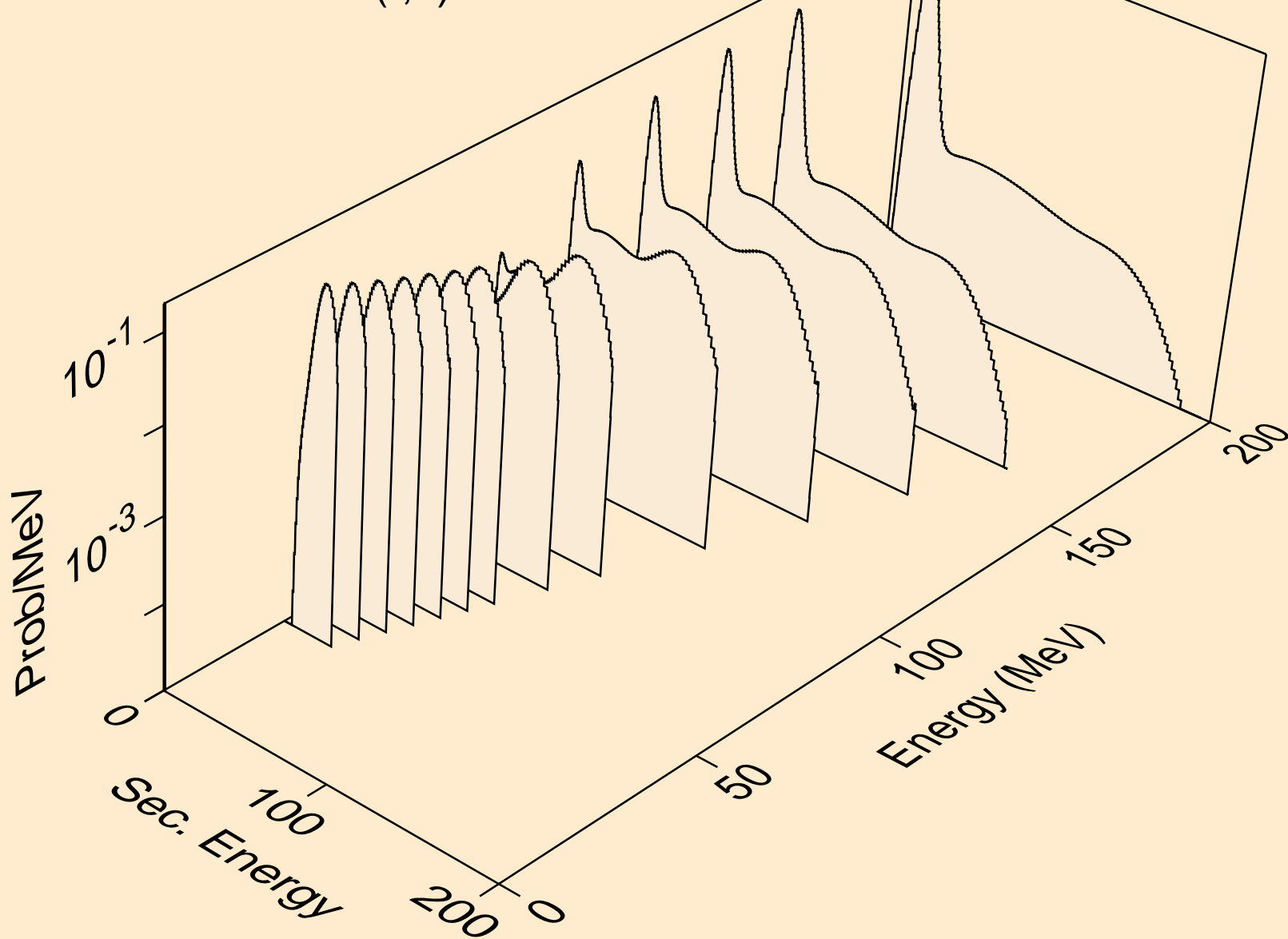

SM146 TRITON ACER TENDL-2023 LIBRARY; T=0.K  
deuterons from (t,2nd)

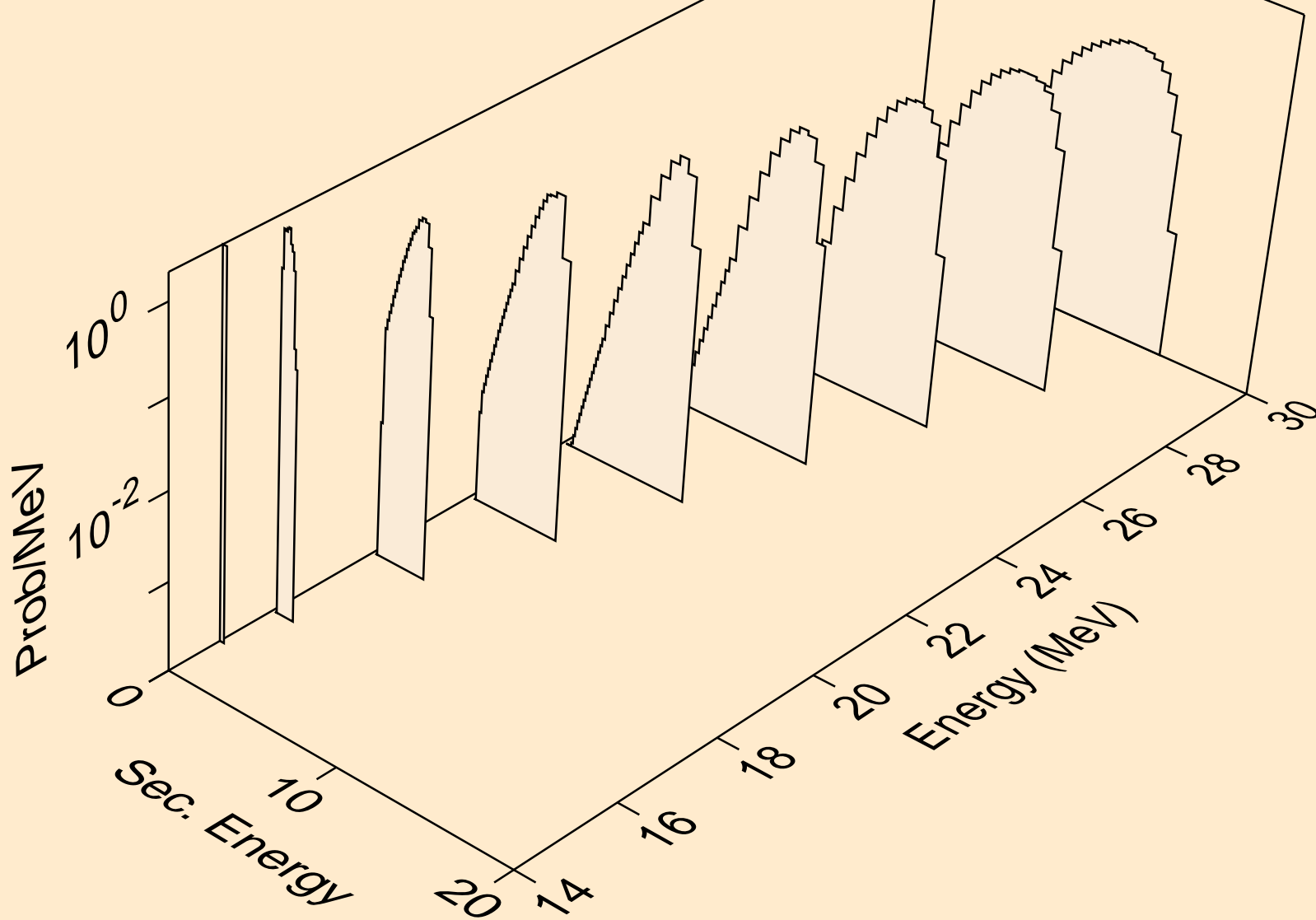

SM146 TRITON ACER TENDL-2023 LIBRARY; T=0.K  
deuterons from (t,n\*)d

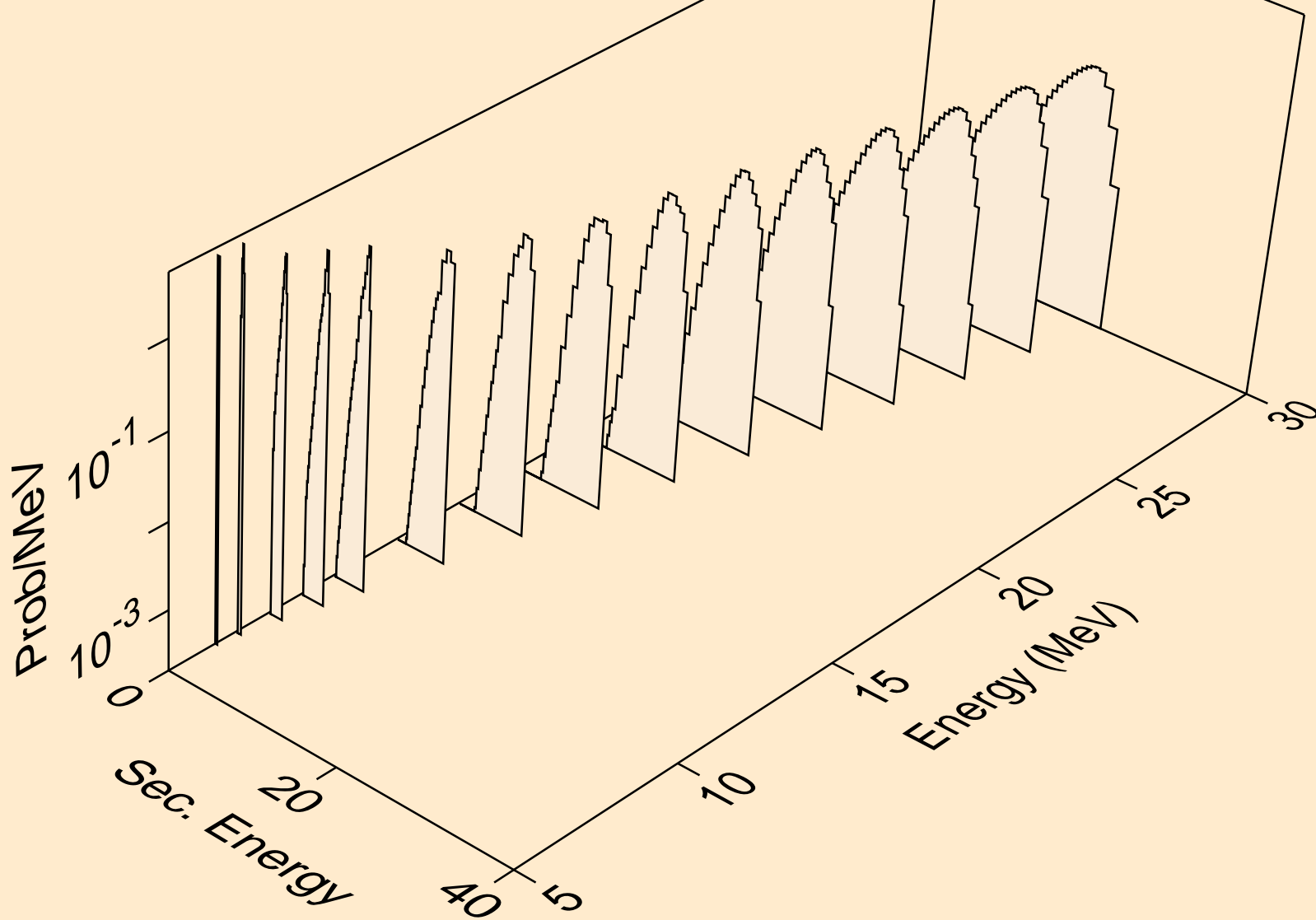

SM146 TRITON ACER TENDL-2023 LIBRARY; T=0.K  
deuterons from (t,d)

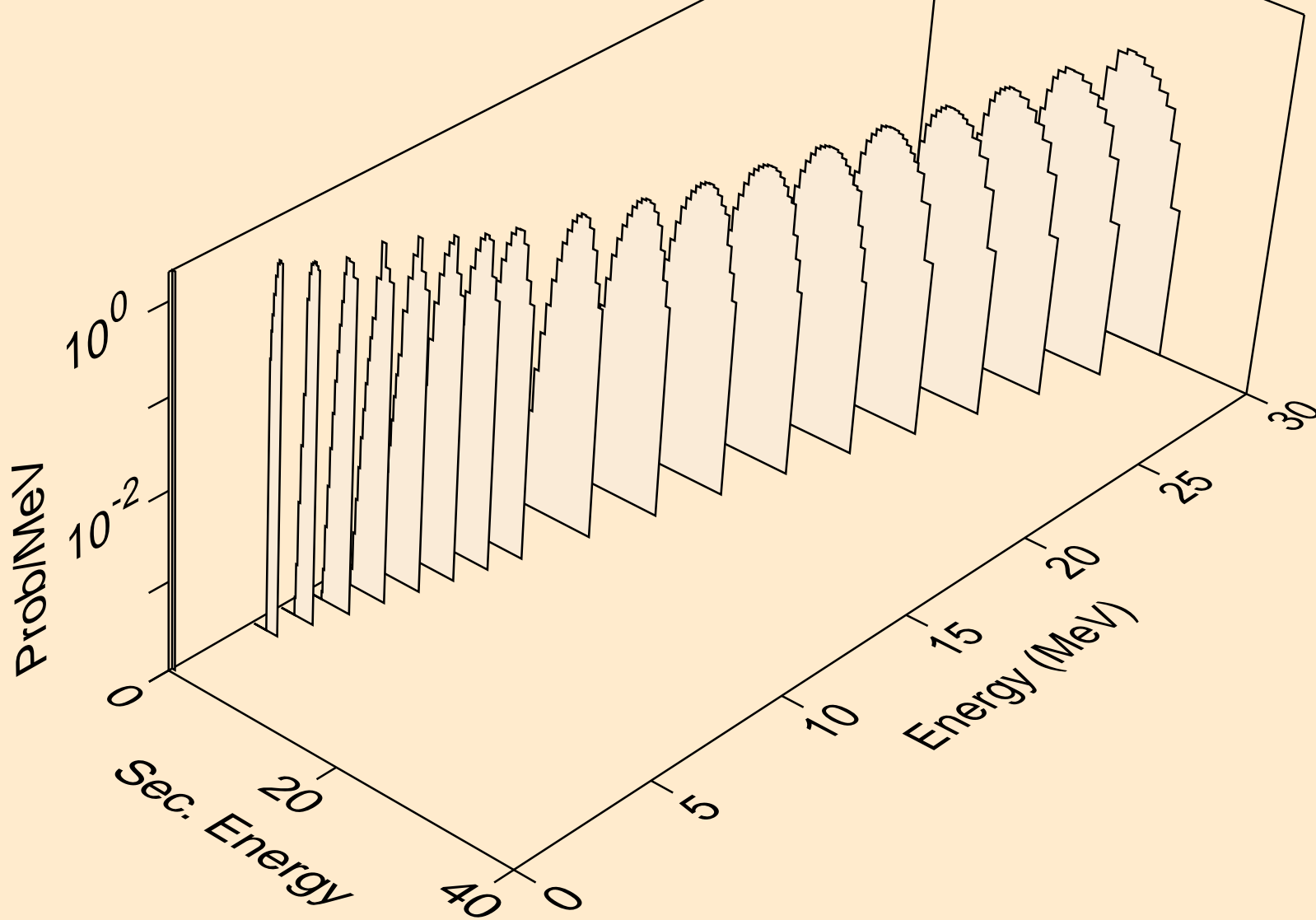

SM146 TRITON ACER TENDL-2023 LIBRARY; T=0.K  
deuterons from (t,pd)

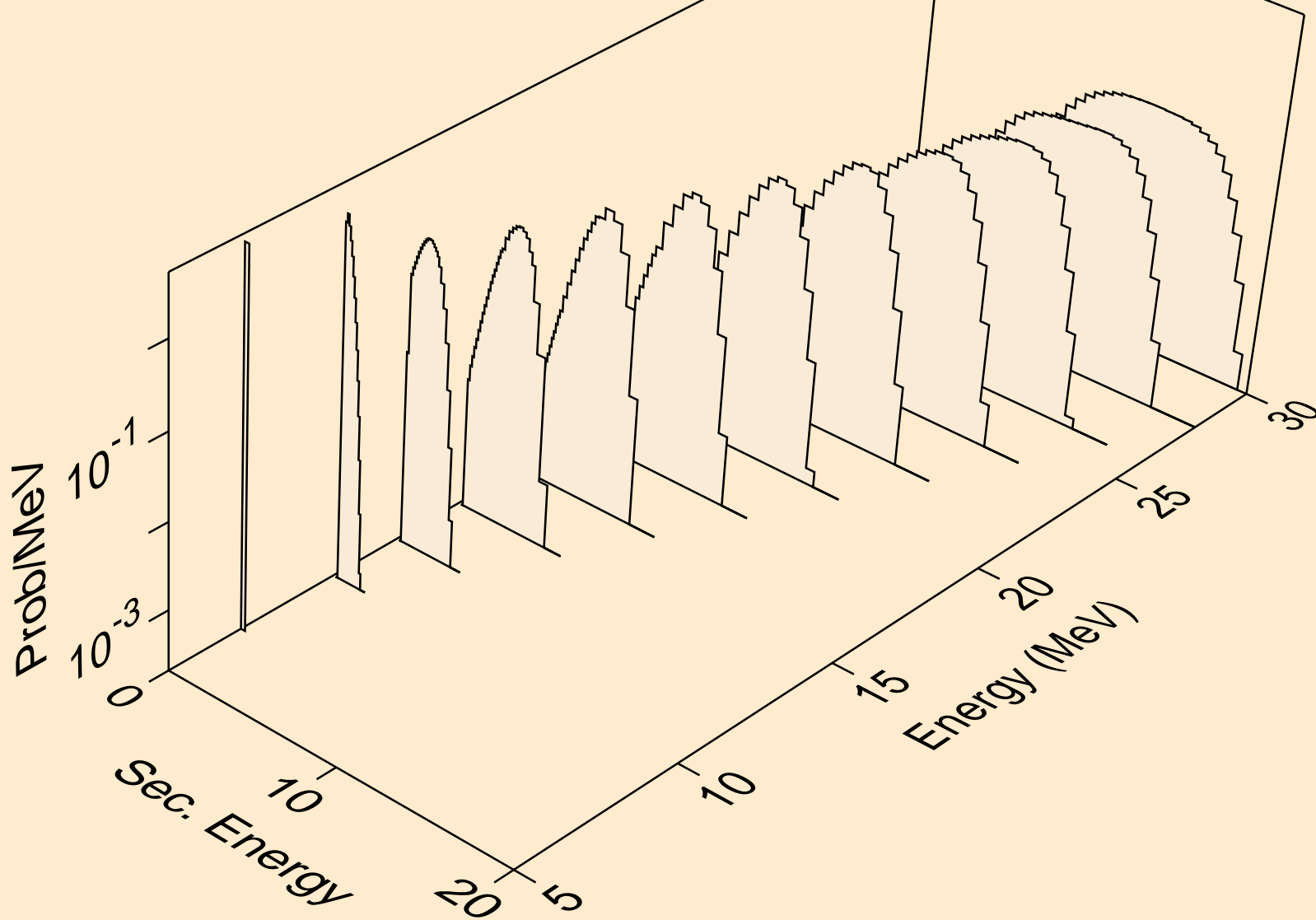

SM146 TRITON ACER TENDL-2023 LIBRARY; T=0.K  
deuterons from (t,da)

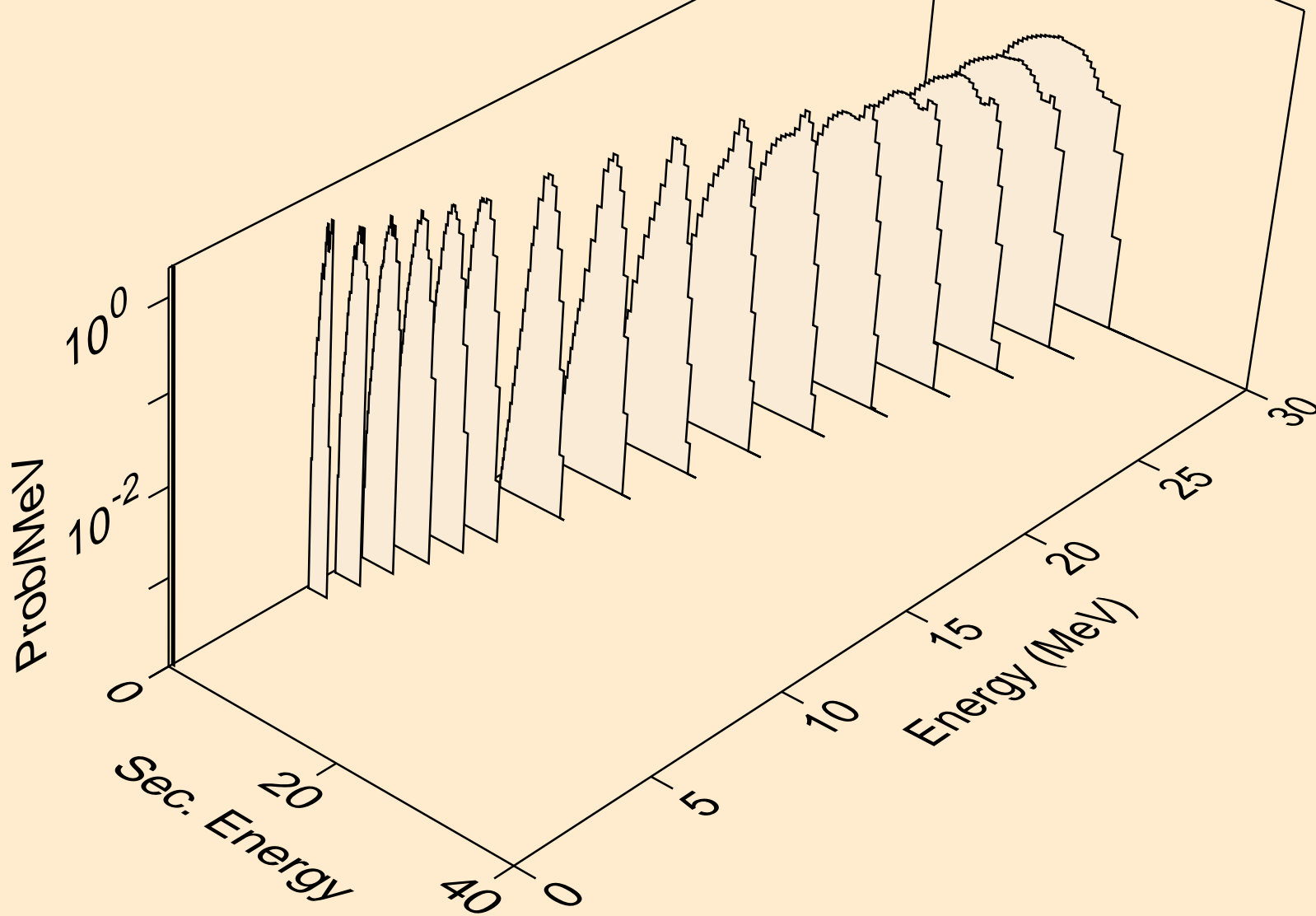

SM146 TRITON ACER TENDL-2023 LIBRARY; T=0.K  
he3s from (t,x)

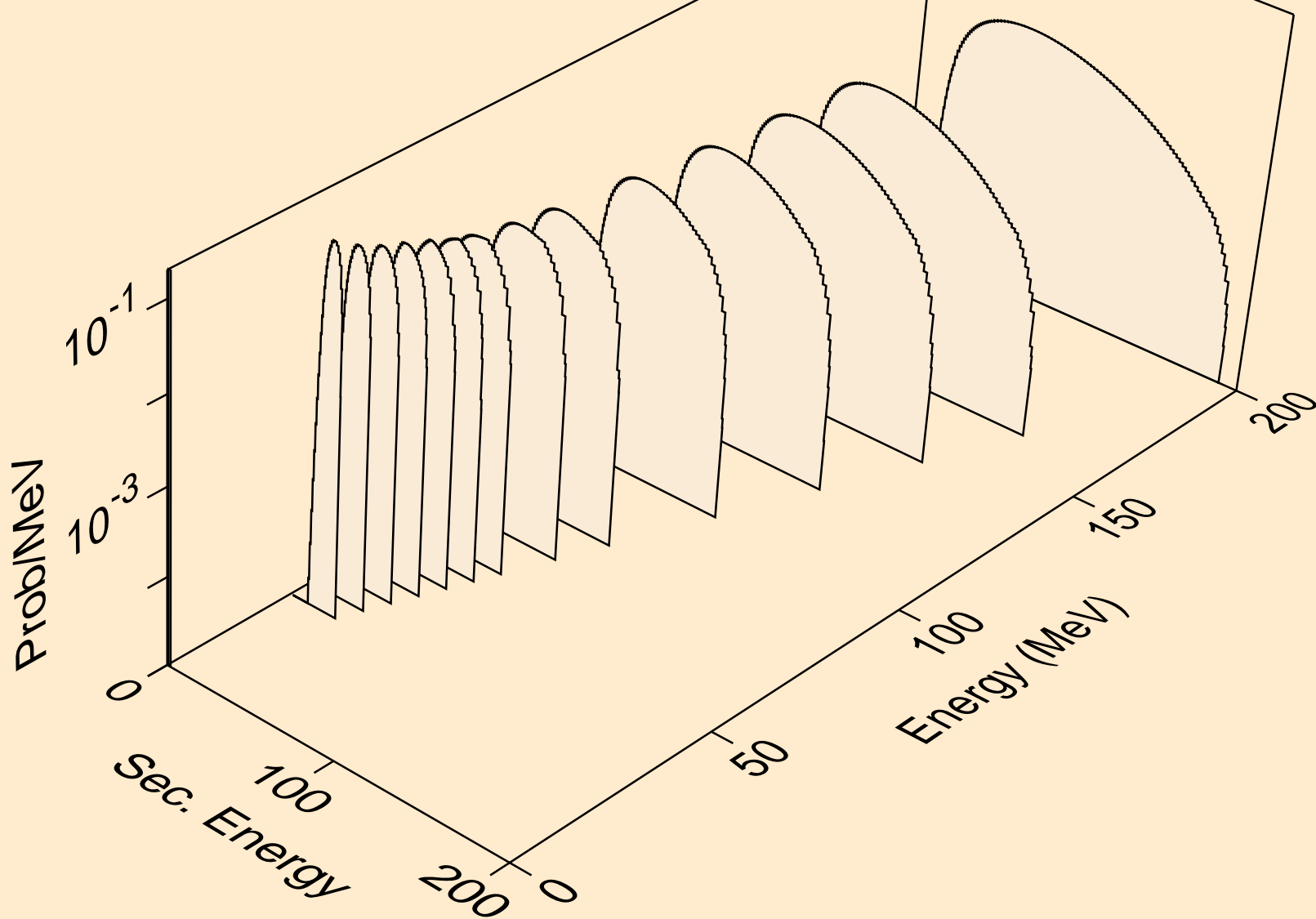

SM146 TRITON ACER TENDL-2023 LIBRARY; T=0.K  
he3s from (t,n\*)he3

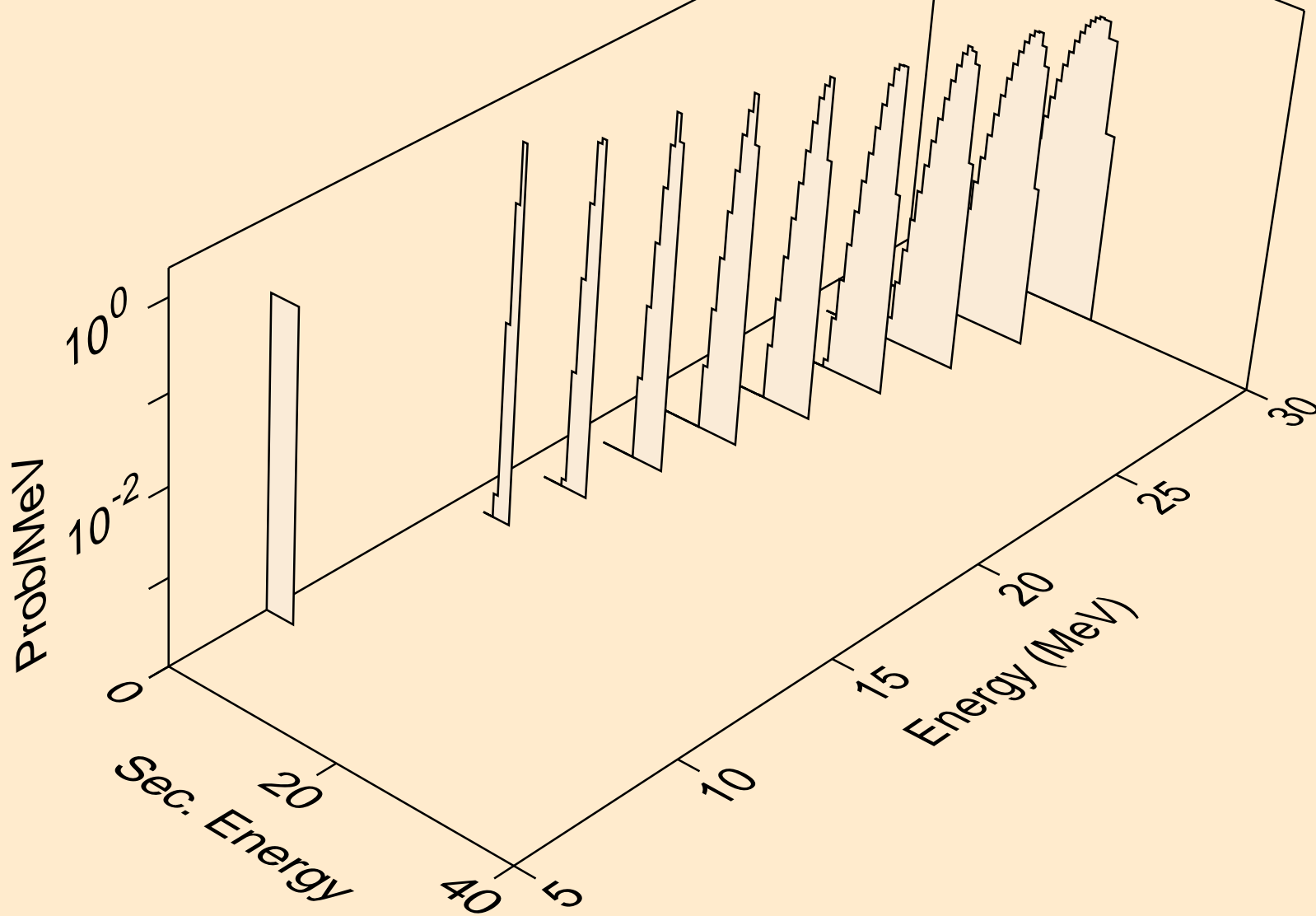

SM146 TRITON ACER TENDL-2023 LIBRARY; T=0.K  
he3s from (t,he3)

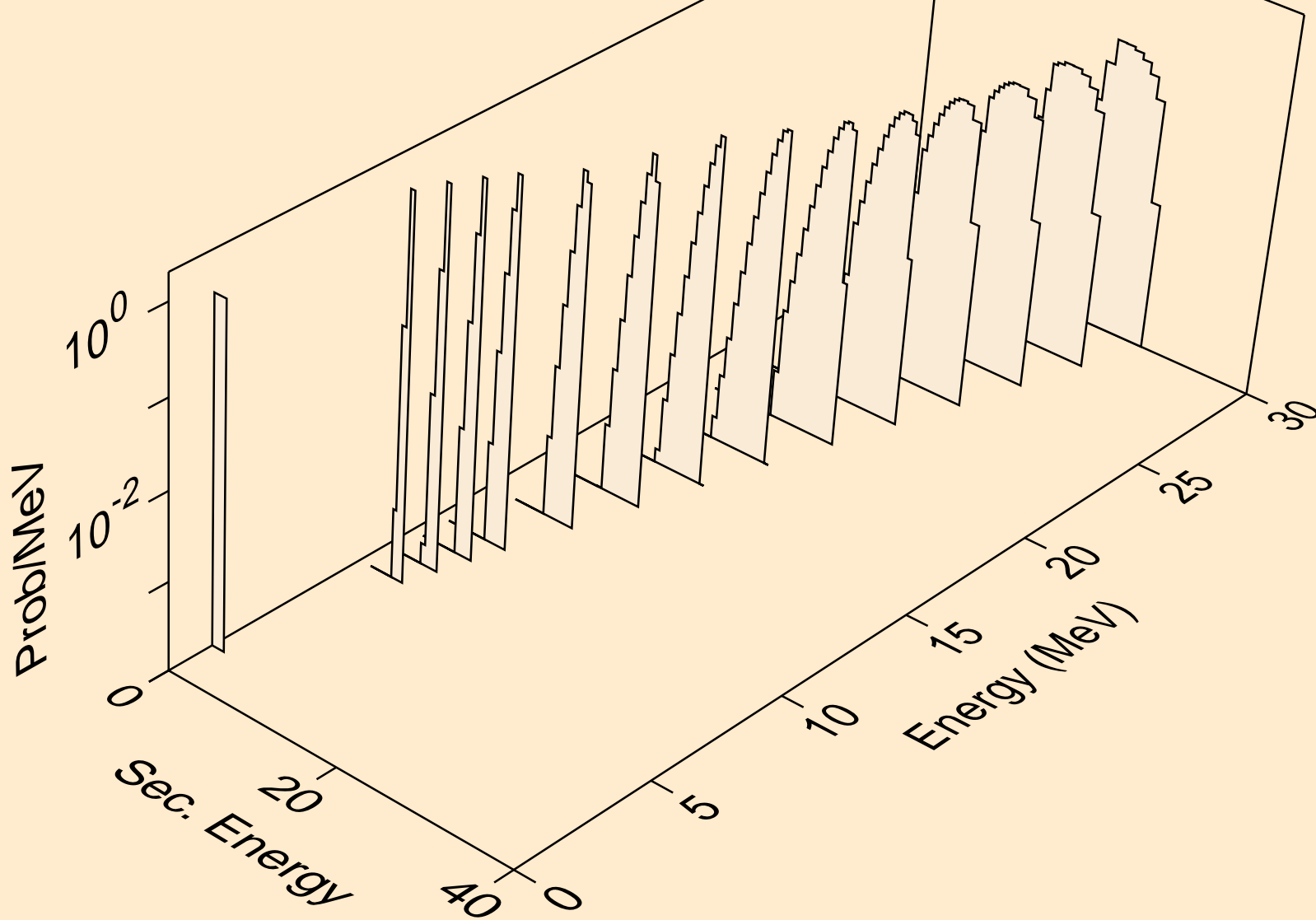

SM146 TRITON ACER TENDL-2023 LIBRARY; T=0.K  
alphas from (t,x)

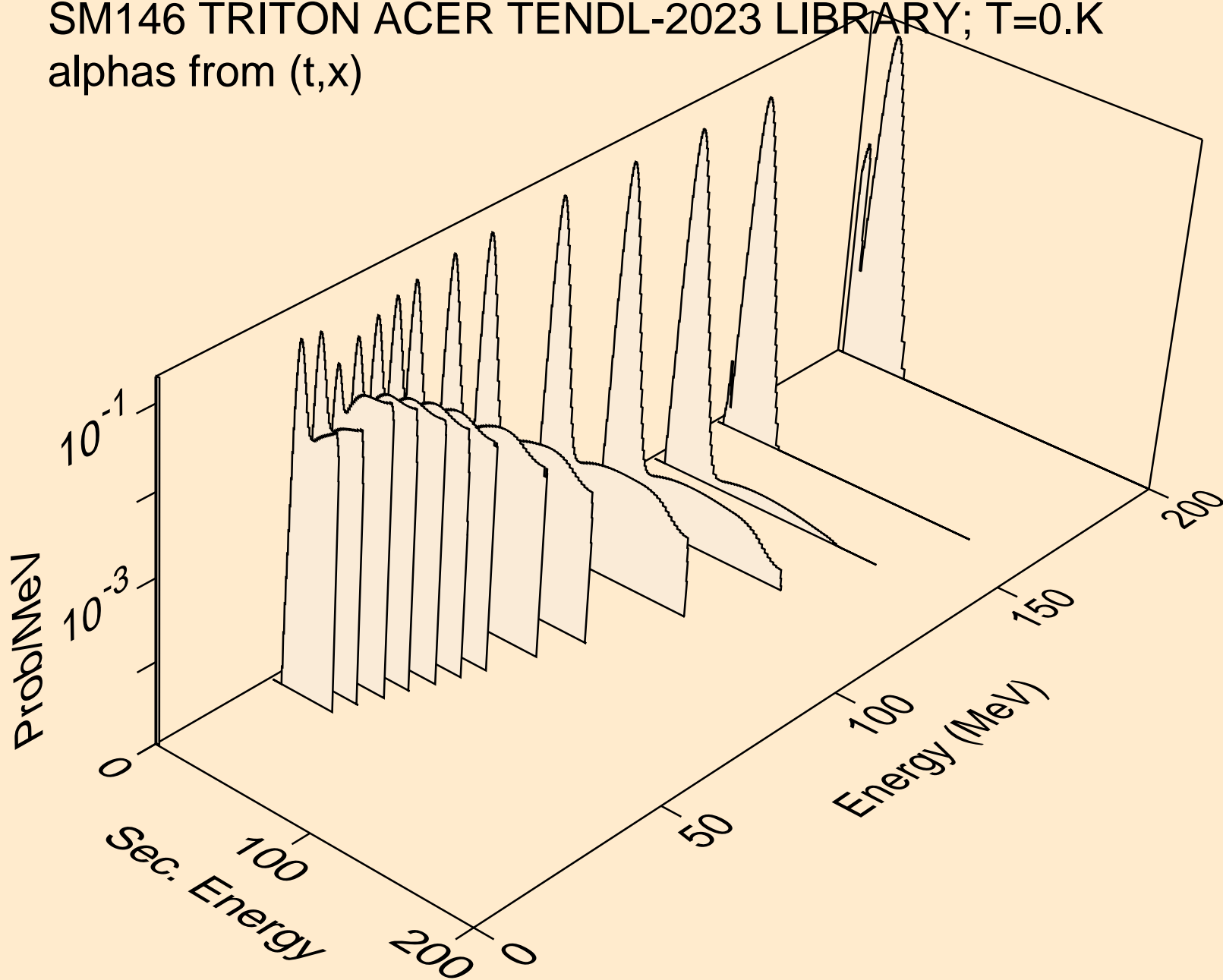

SM146 TRITON ACER TENDL-2023 LIBRARY; T=0.K  
alphas from (t,n\*)a

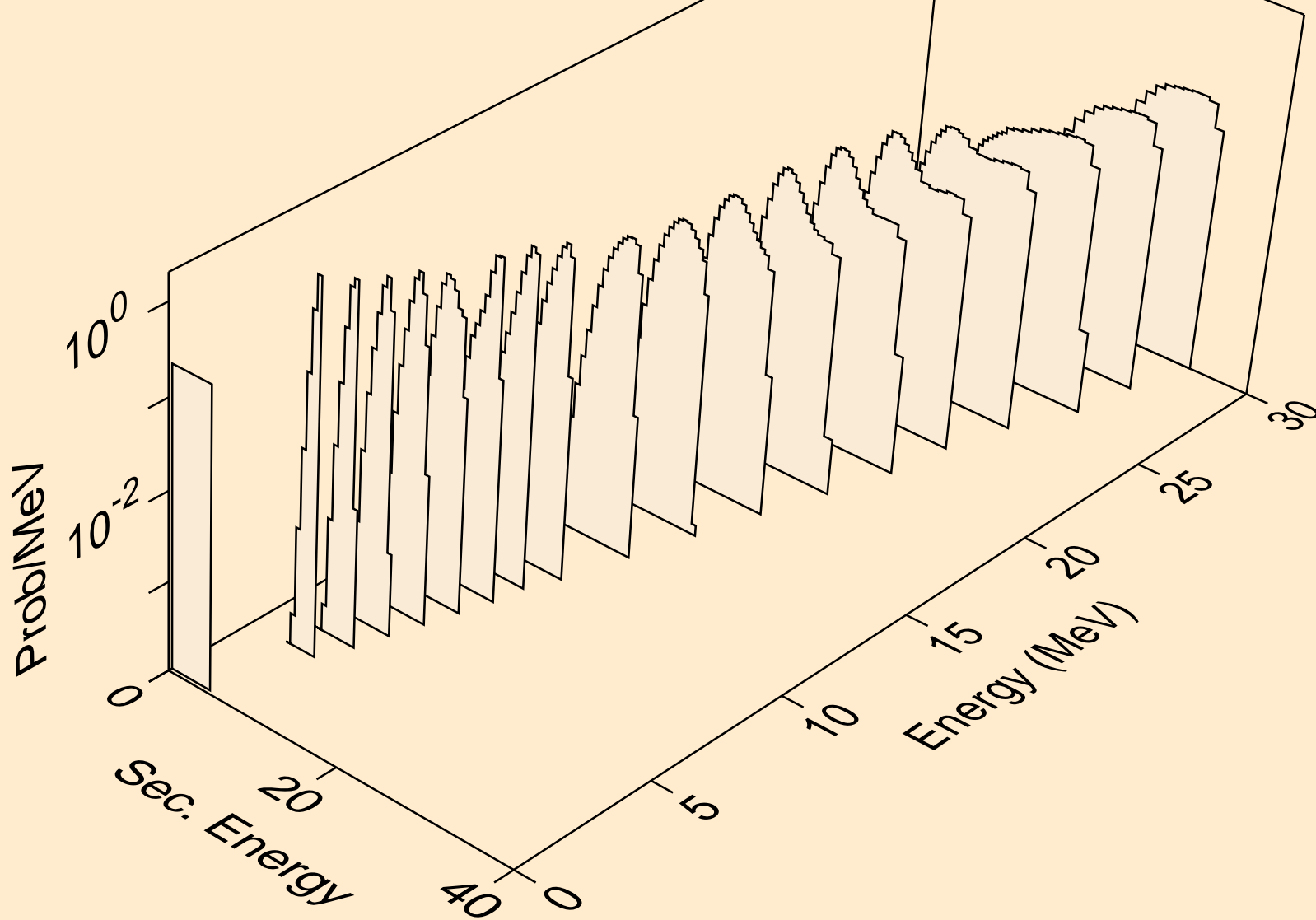

SM146 TRITON ACER TENDL-2023 LIBRARY; T=0.K  
alphas from (t,2n)a

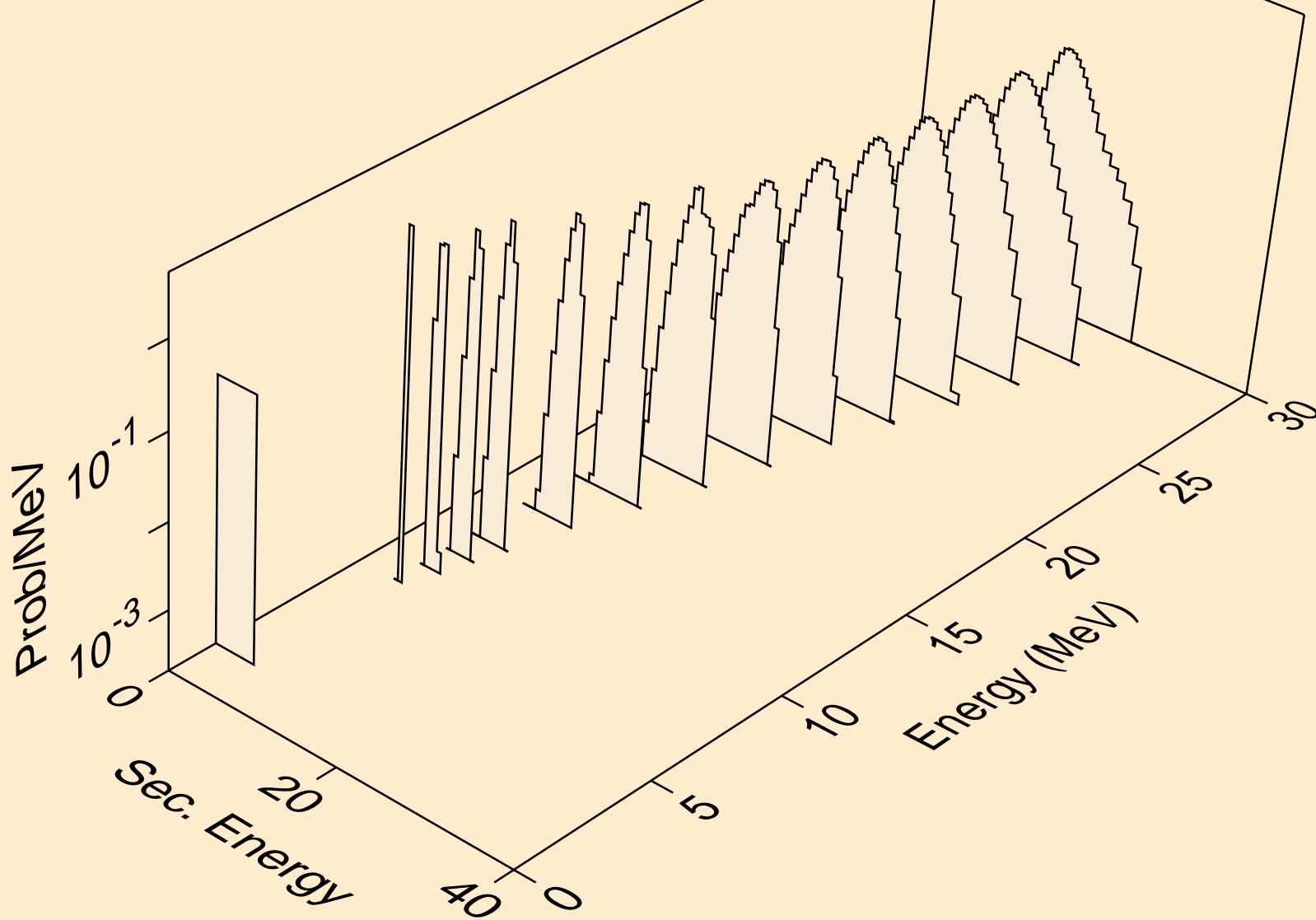

SM146 TRITON ACER TENDL-2023 LIBRARY; T=0.K  
alphas from (t,3n)a

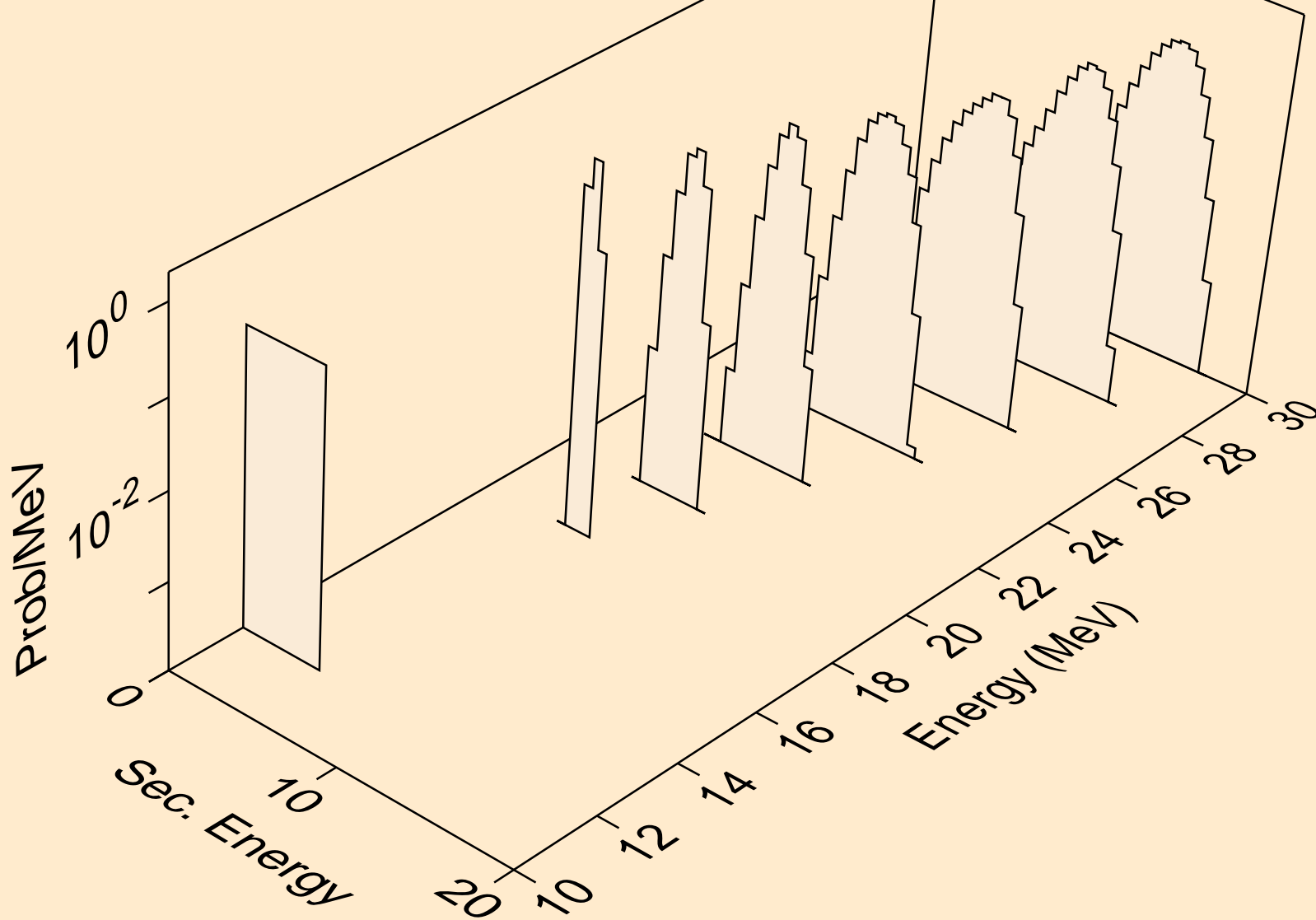

SM146 TRITON ACER TENDL-2023 LIBRARY; T=0.K  
alphas from (t,n\*)2a

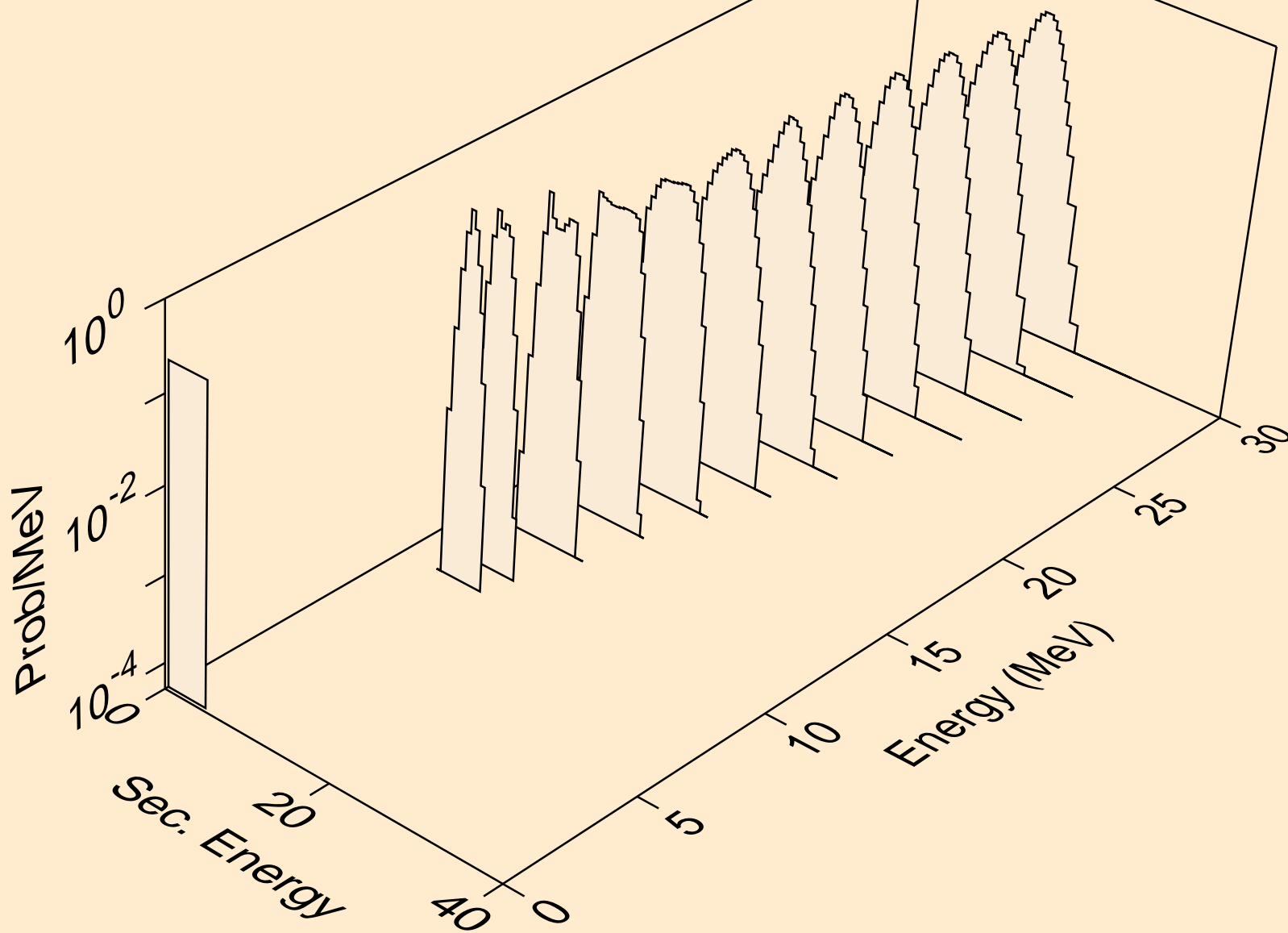

SM146 TRITON ACER TENDL-2023 LIBRARY; T=0.K  
alphas from (t,2n)2a

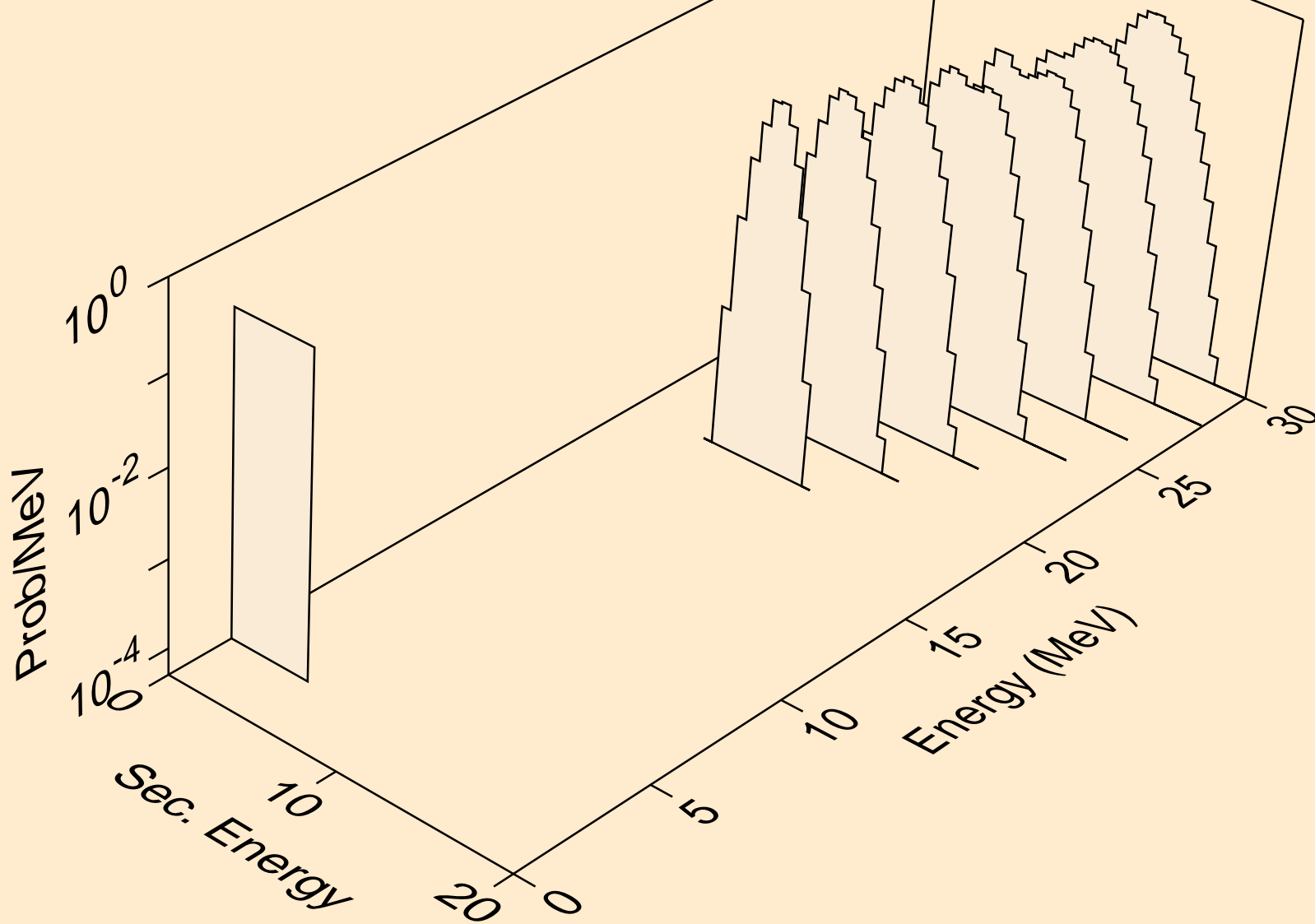

SM146 TRITON ACER TENDL-2023 LIBRARY; T=0.K  
alphas from (t,npa)

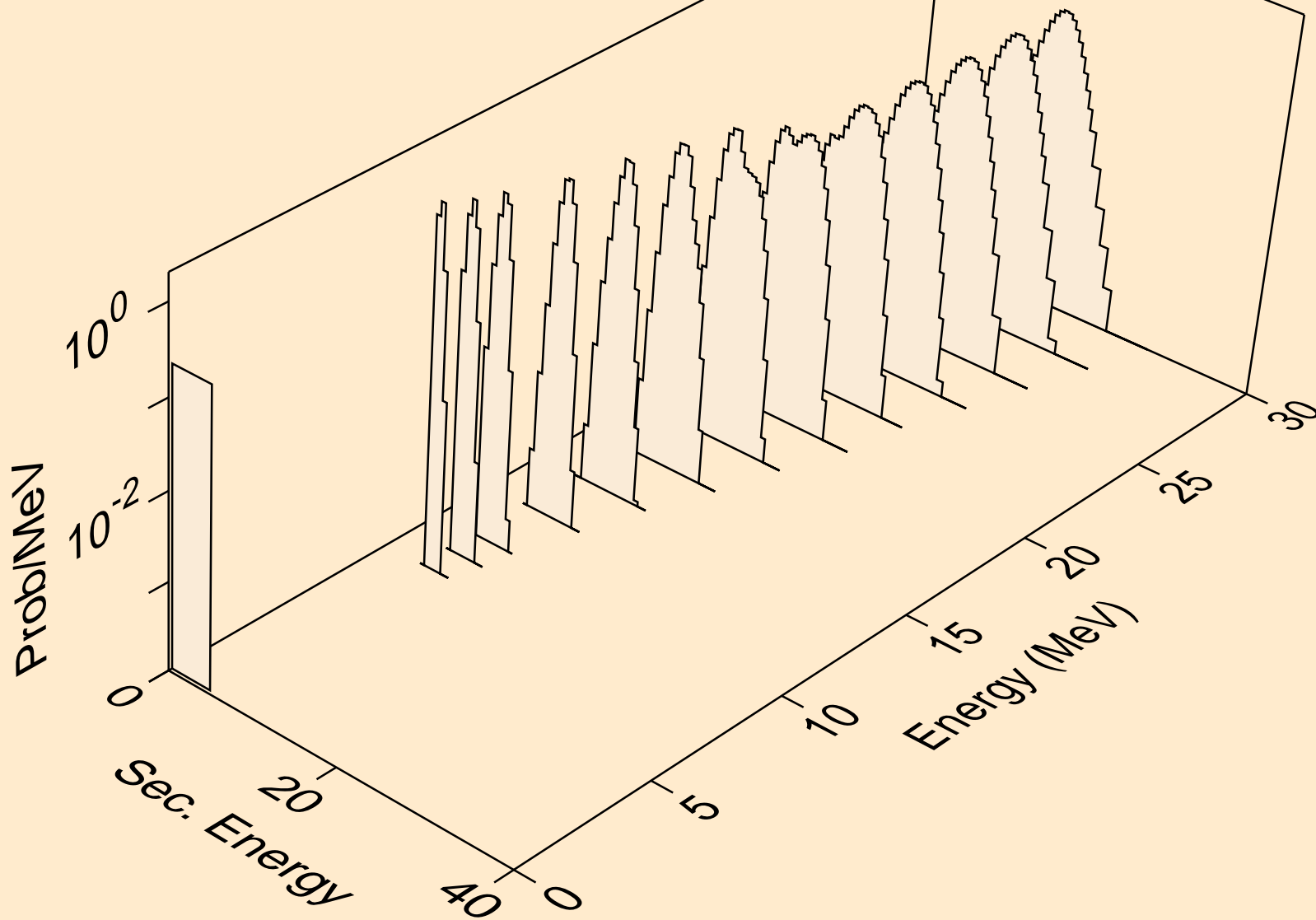

SM146 TRITON ACER TENDL-2023 LIBRARY; T=0.K  
alphas from (t,a)

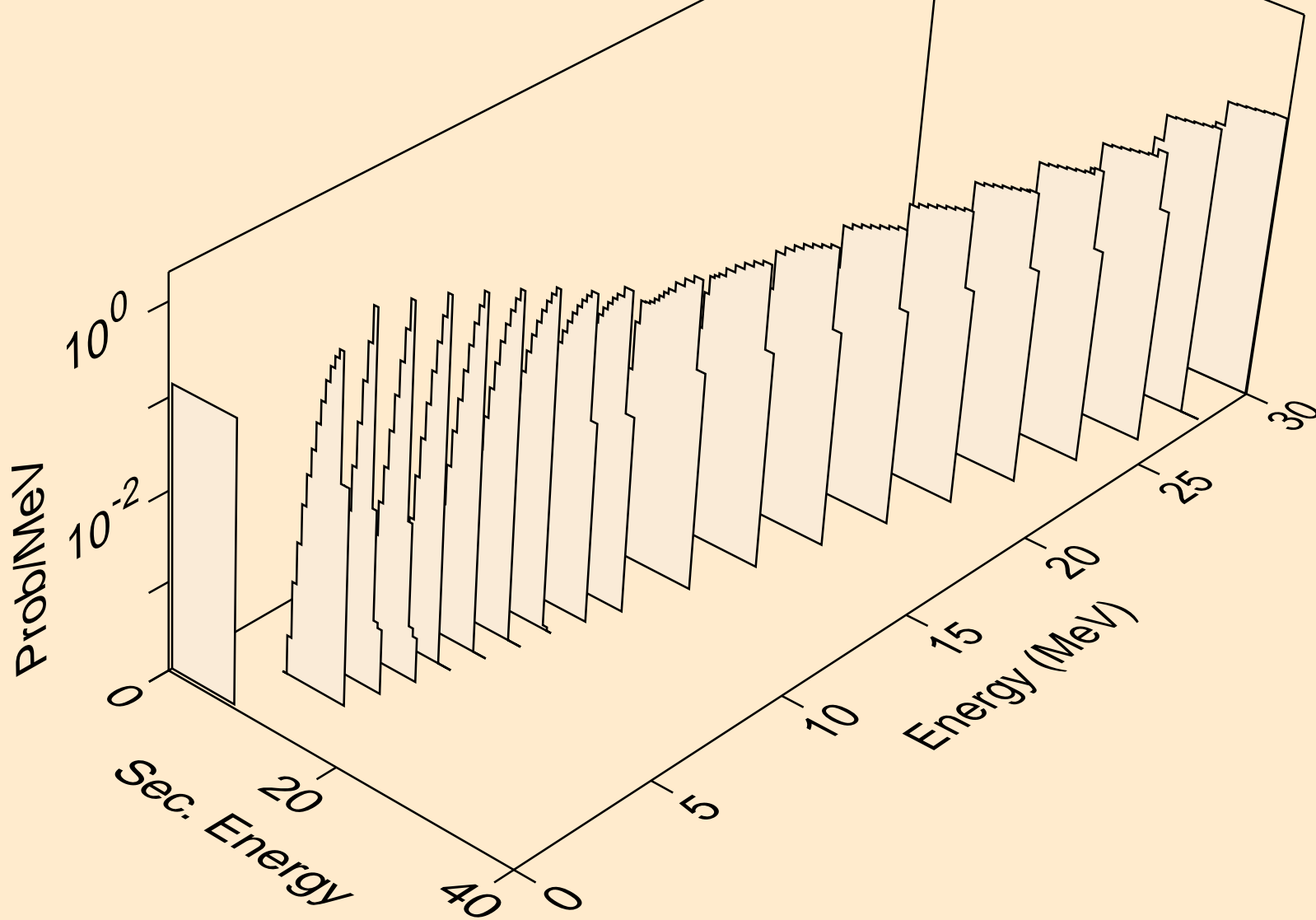

SM146 TRITON ACER TENDL-2023 LIBRARY; T=0.K  
alphas from (t,2a)

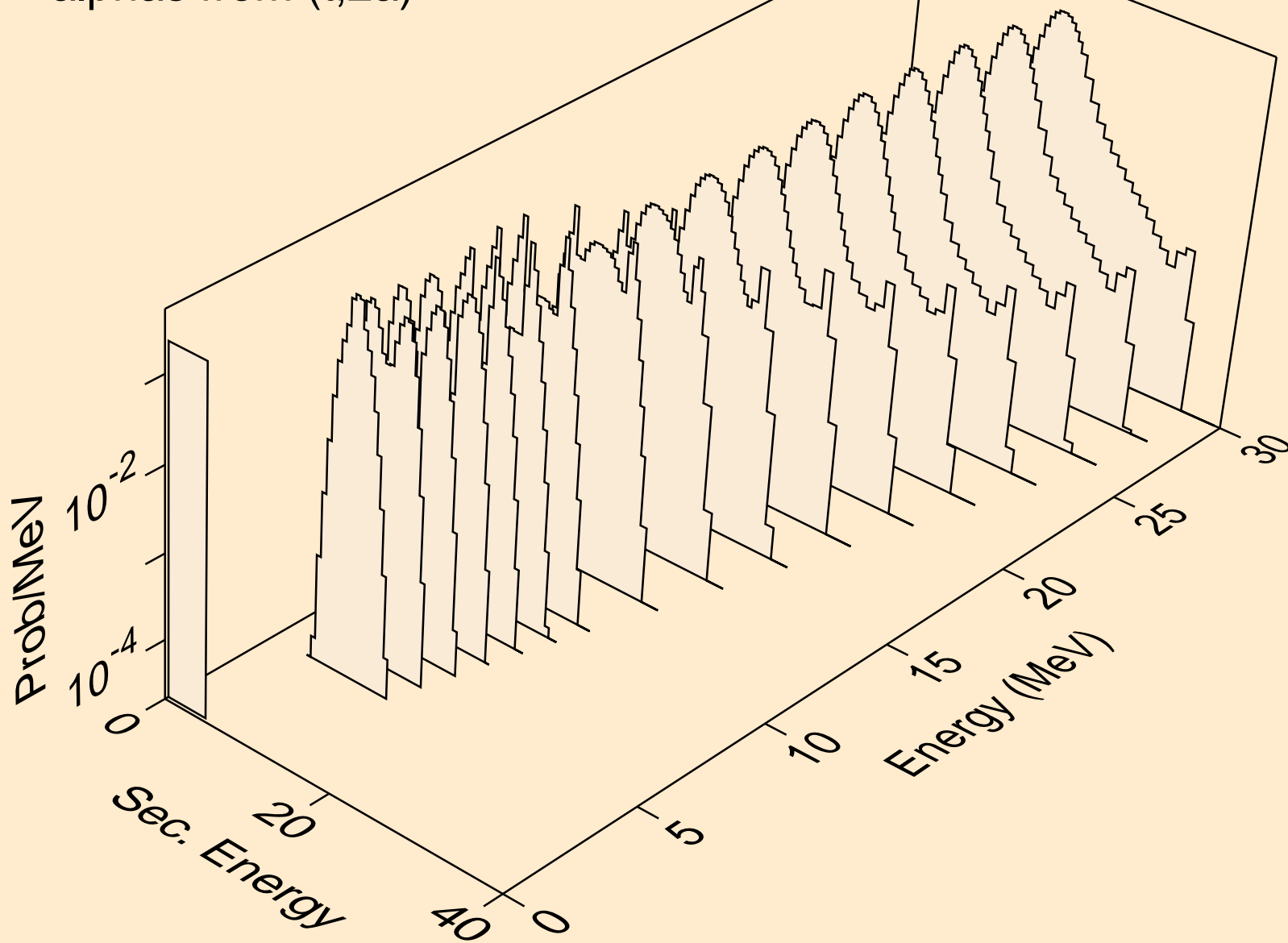

SM146 TRITON ACER TENDL-2023 LIBRARY; T=0.K  
alphas from (t,pa)

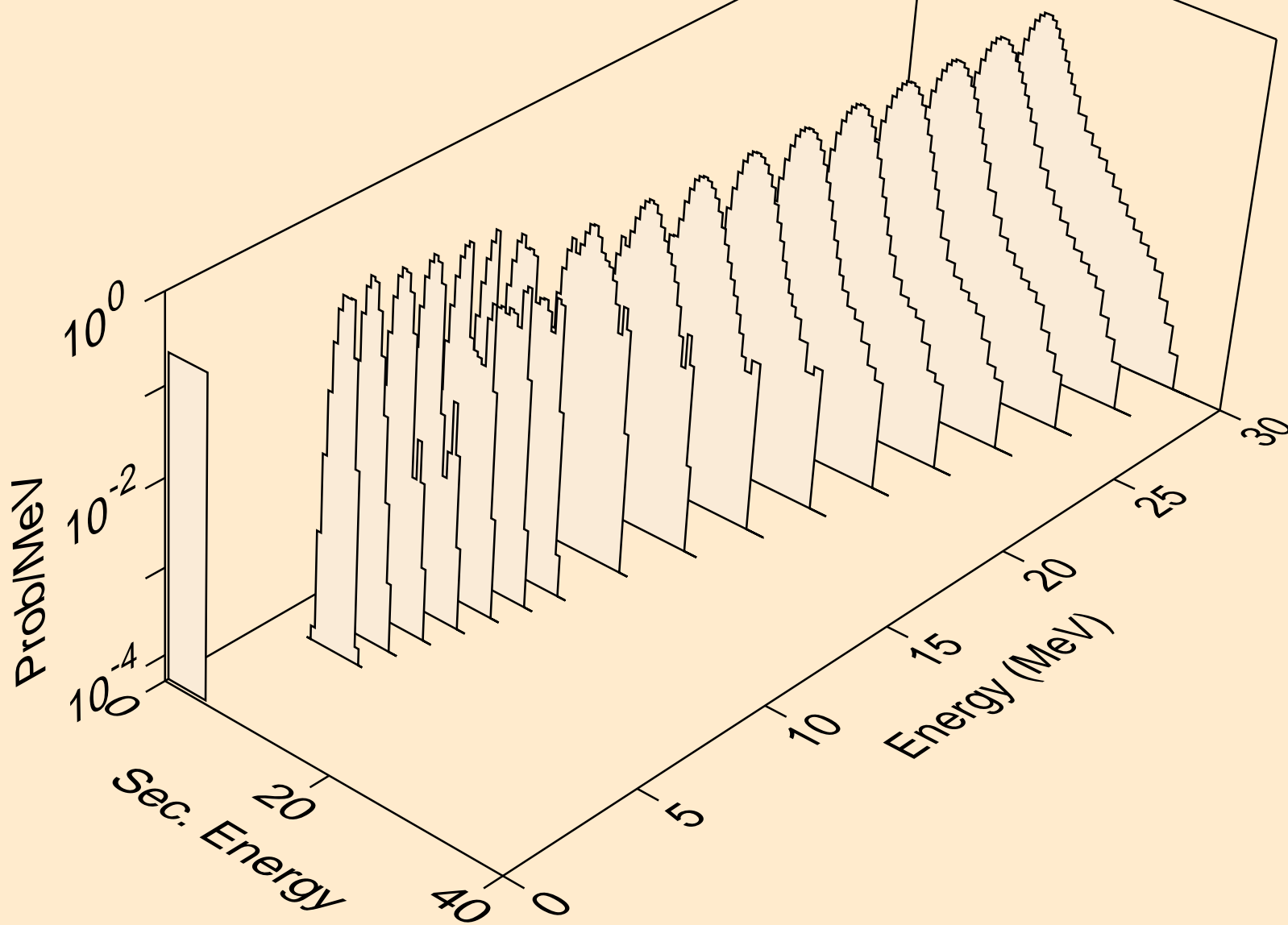

SM146 TRITON ACER TENDL-2023 LIBRARY; T=0.K  
alphas from (t,da)

