

AR037 ALPHA ACER TENDL-2024 LIBRARY; T=0.K  
Principal cross sections

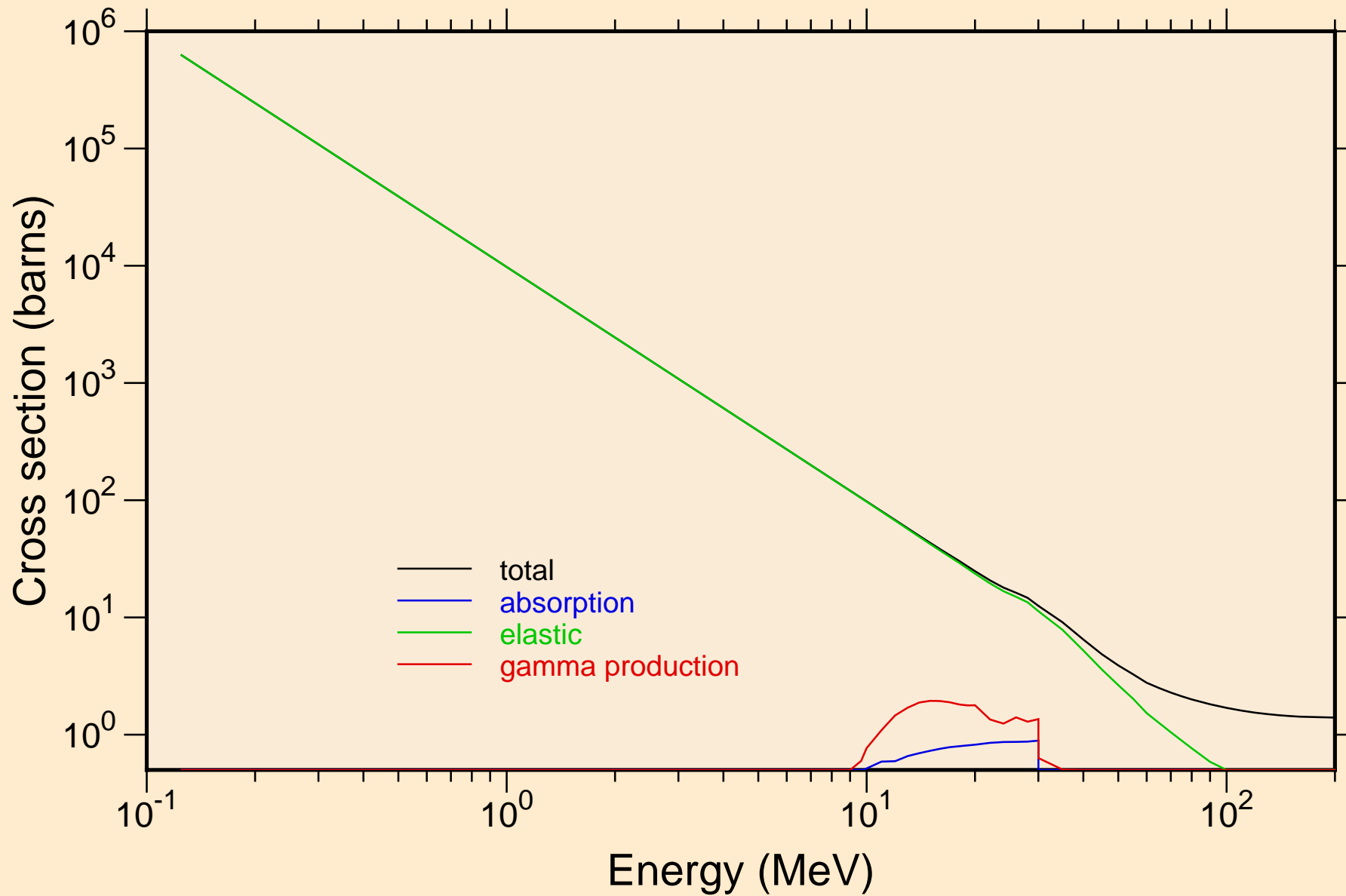

AR037 ALPHA ACER TENDL-2024 LIBRARY; T=0.K

Heating

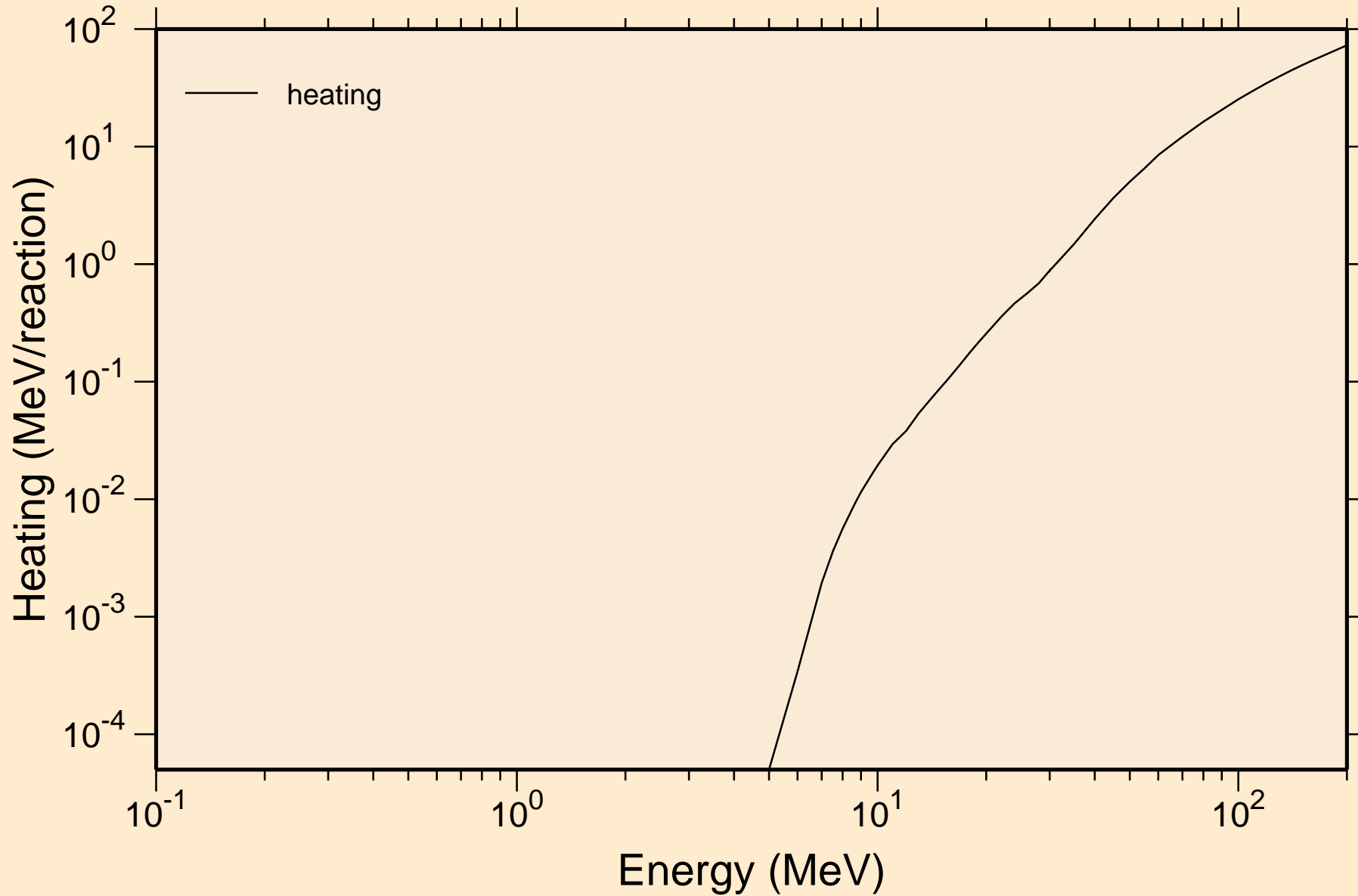

# AR037 ALPHA ACER TENDL-2024 LIBRARY; T=0.K

## Principal cross sections

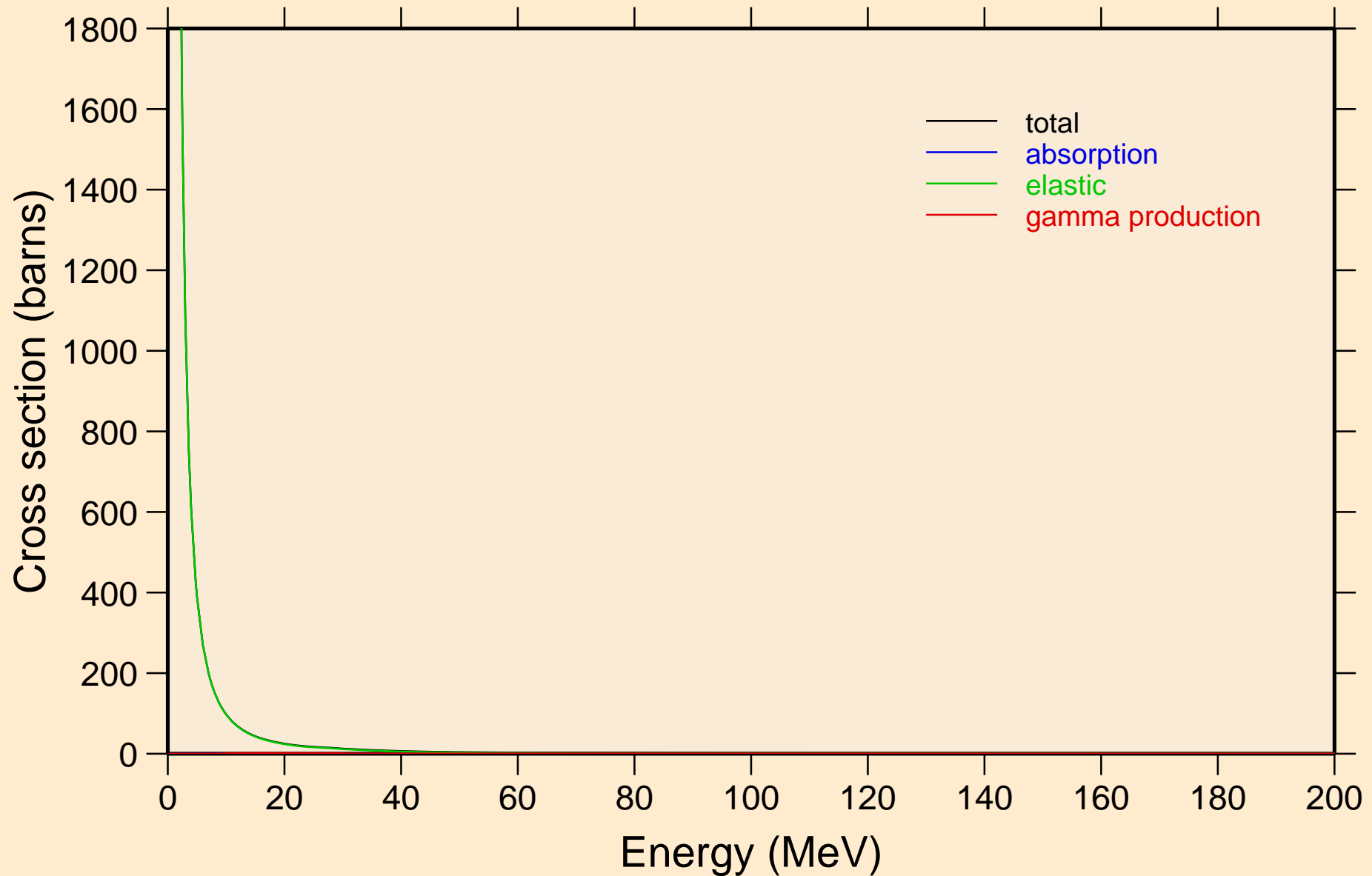

AR037 ALPHA ACER TENDL-2024 LIBRARY; T=0.K

Heating

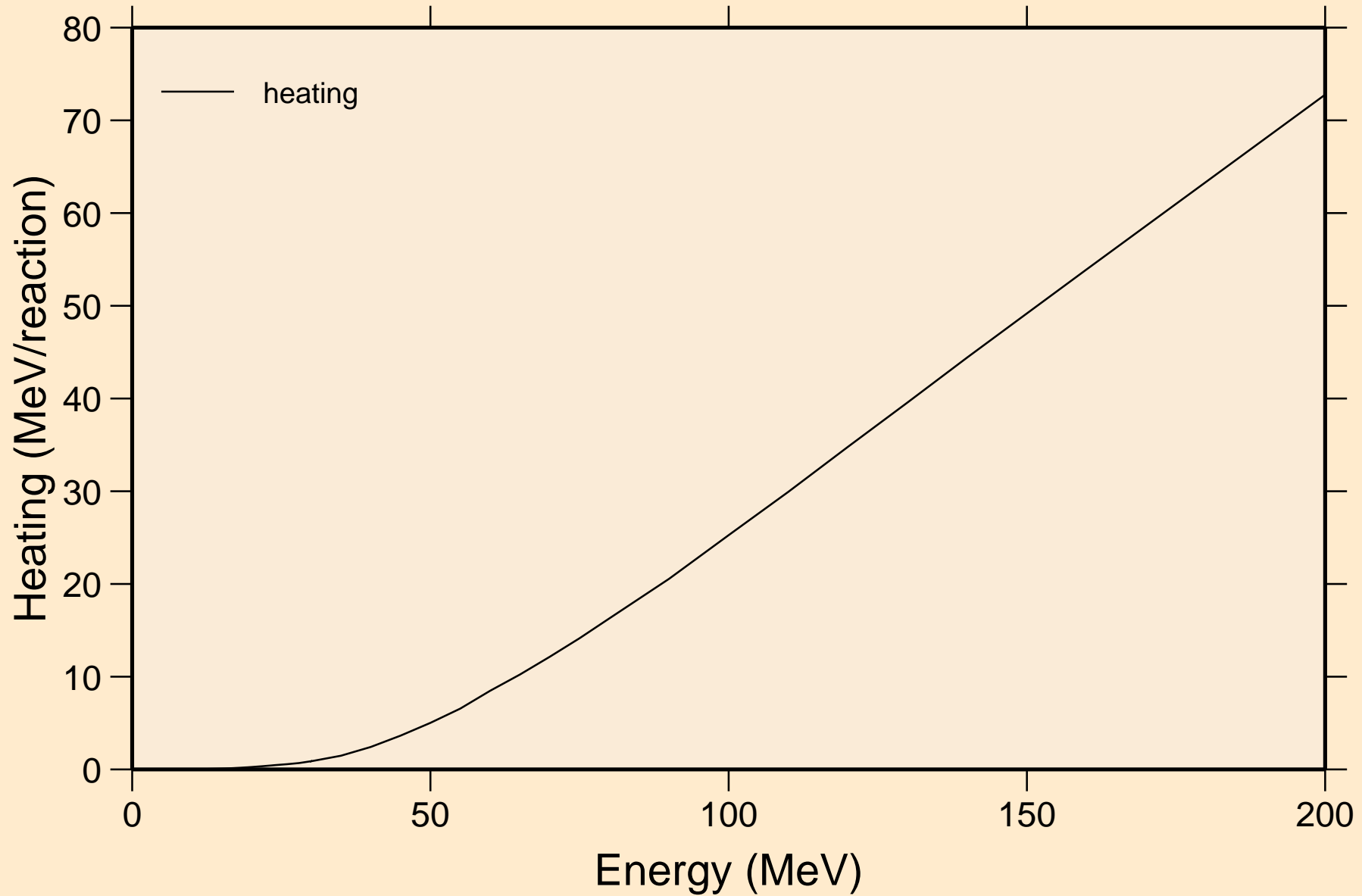

AR037 ALPHA ACER TENDL-2024 LIBRARY; T=0.K  
Threshold reactions

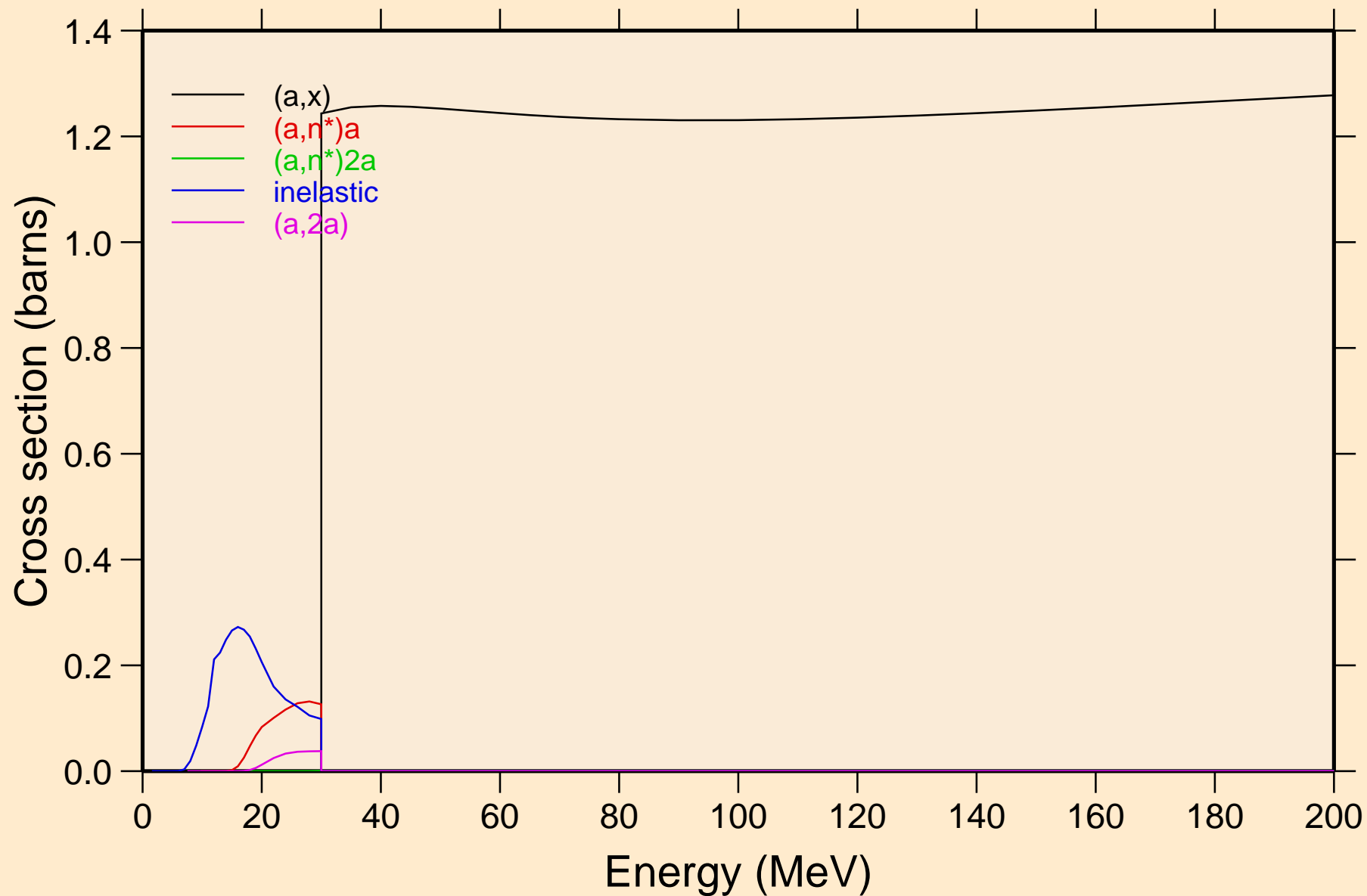

AR037 ALPHA ACER TENDL-2024 LIBRARY; T=0.K  
Threshold reactions

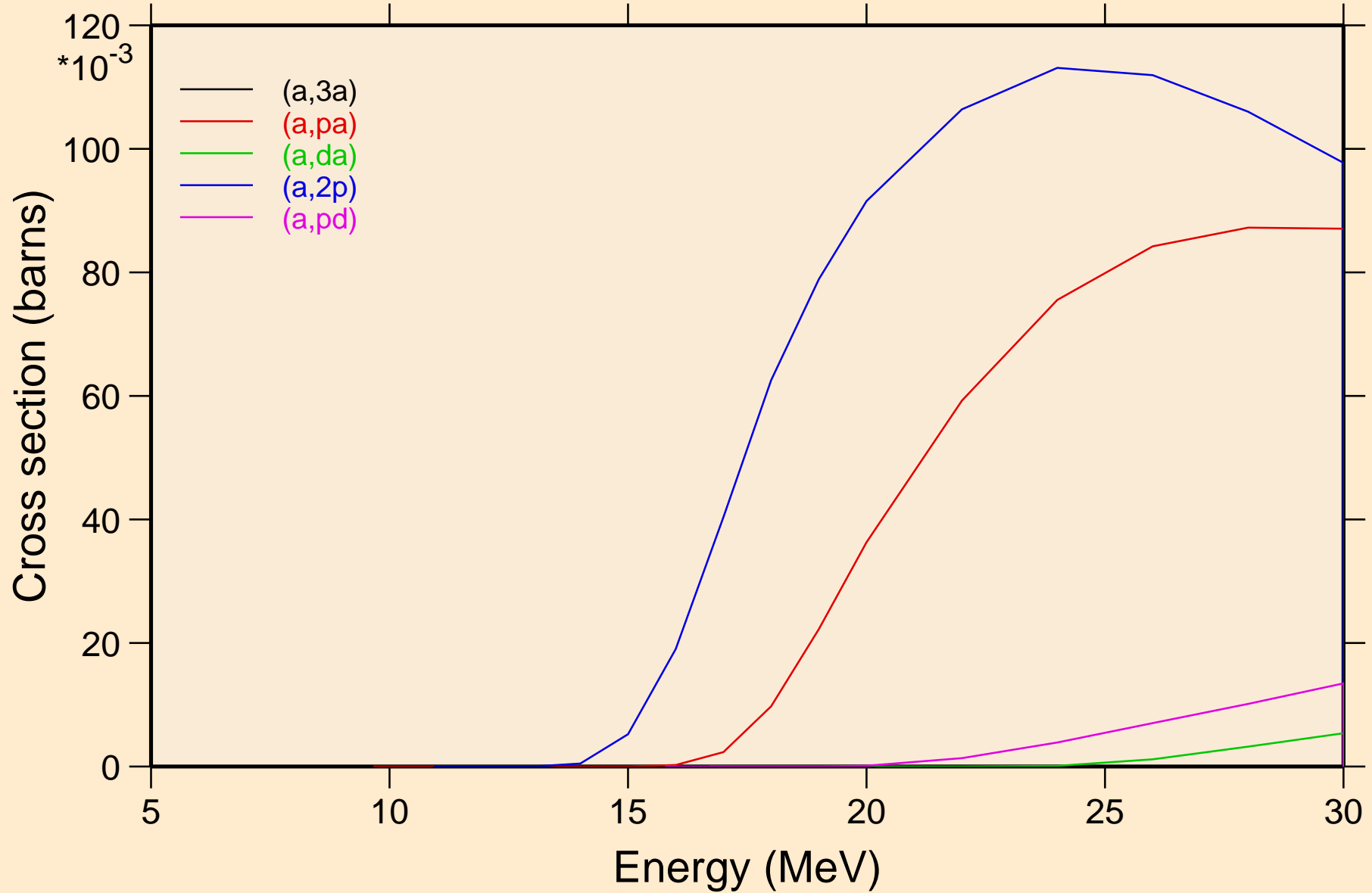

AR037 ALPHA ACER TENDL-2024 LIBRARY; T=0.K  
Threshold reactions

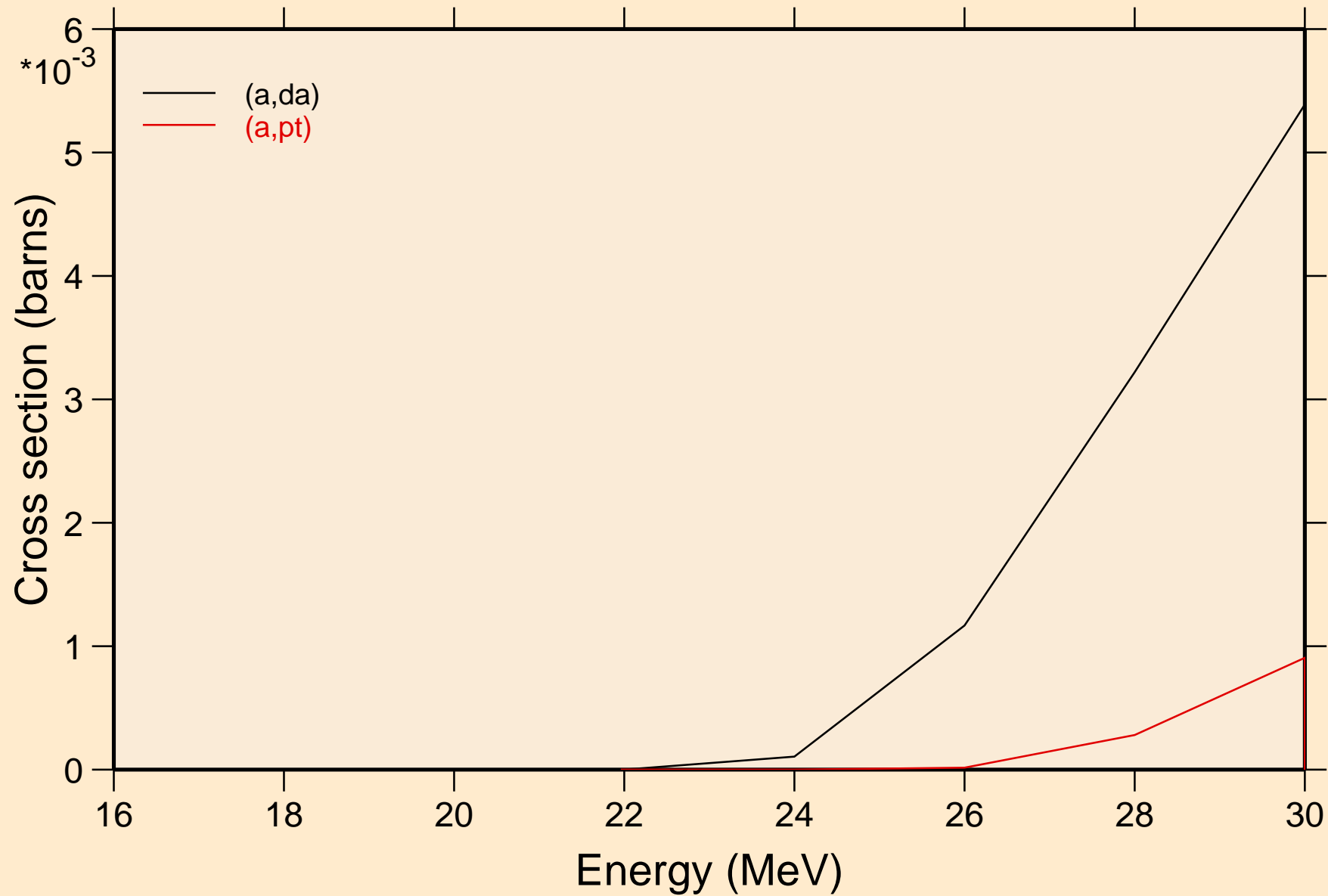

AR037 ALPHA ACER TENDL-2024 LIBRARY; T=0.K  
Threshold reactions

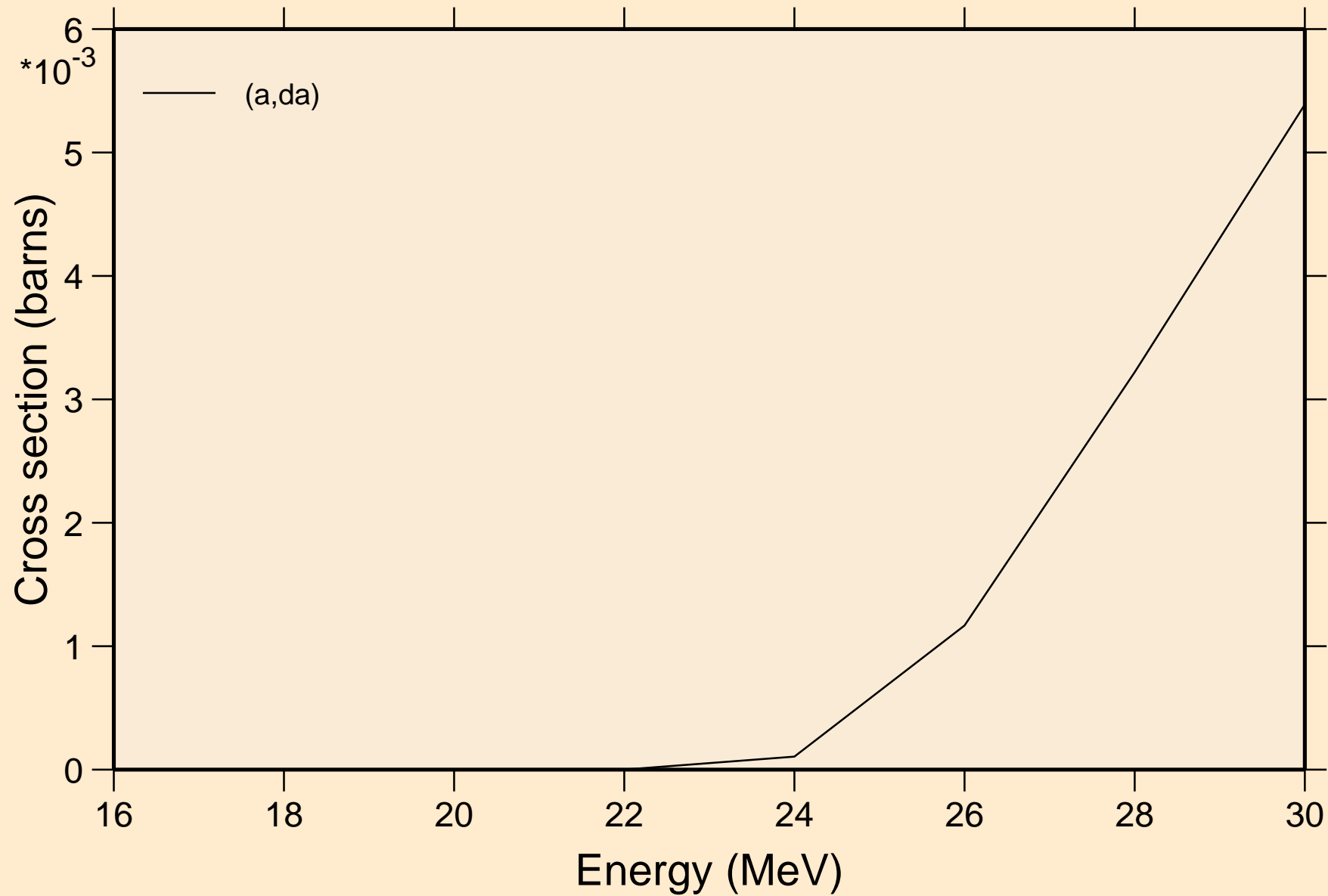

AR037 ALPHA ACER TENDL-2024 LIBRARY; T=0.K  
angular distribution for elastic

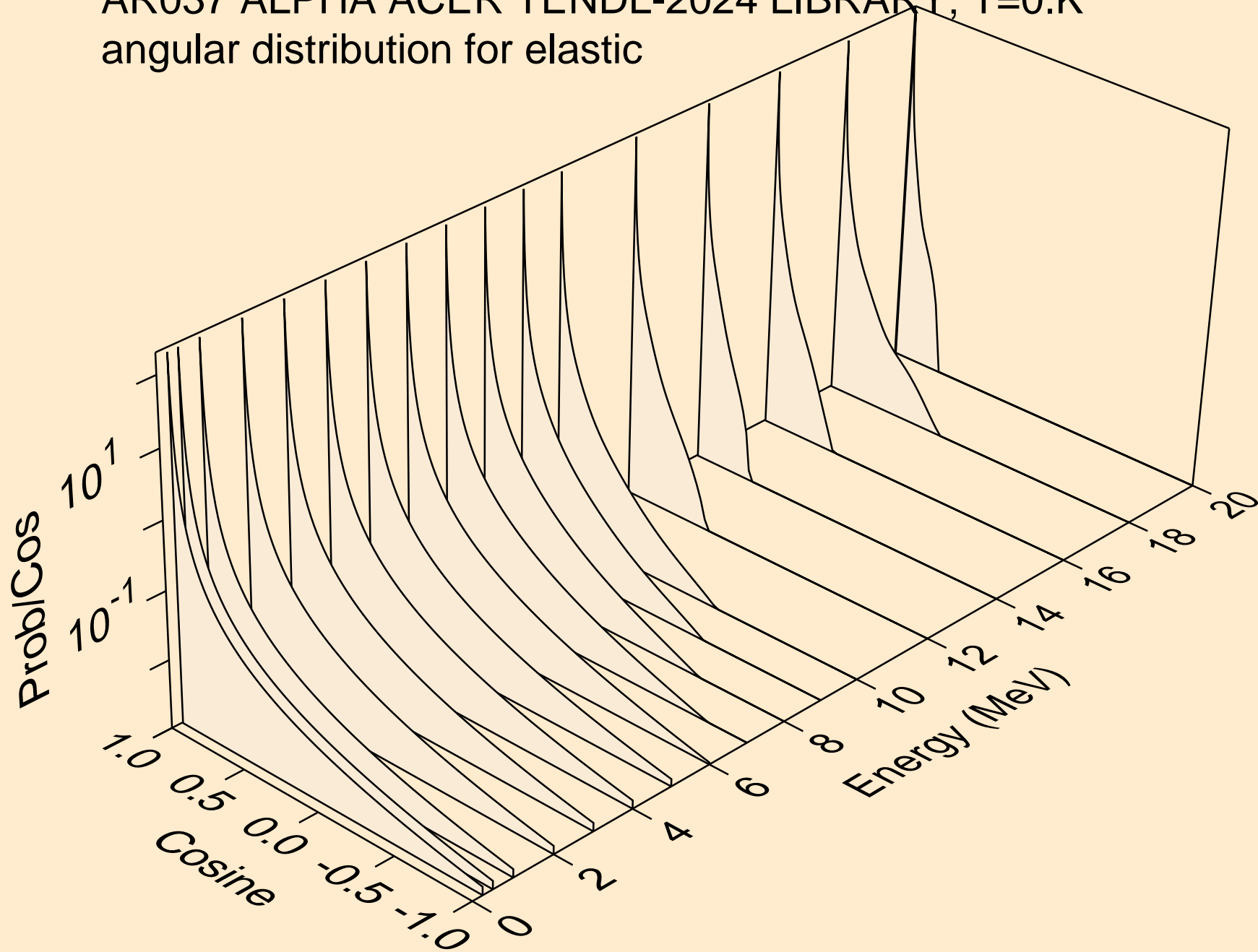

AR037 ALPHA ACER TENDL-2024 LIBRARY; T=0.K  
angular distribution for elastic

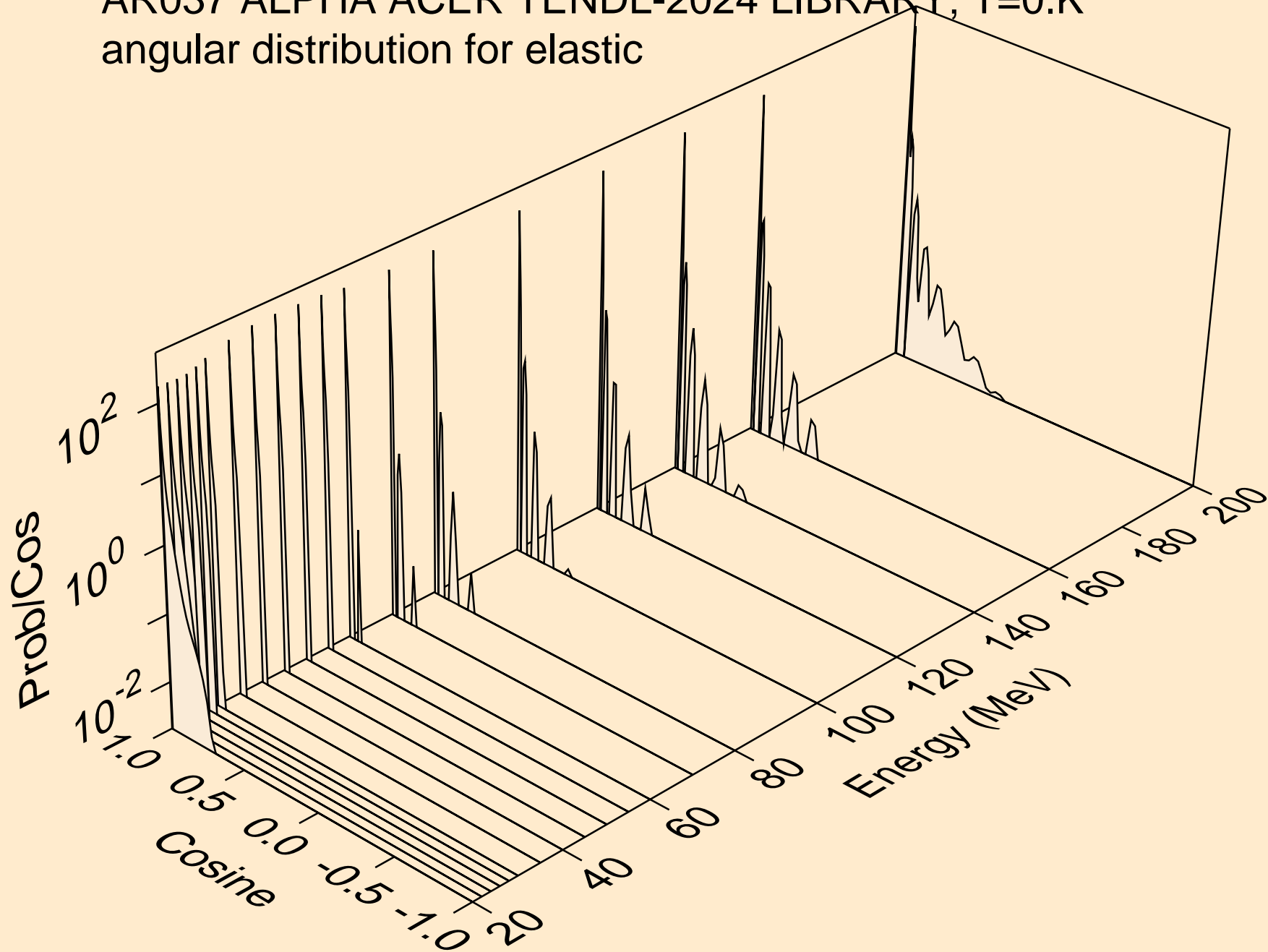

AR037 ALPHA ACER TENDL-2024 LIBRARY; T=0.K  
Alpha emission for (a,x)

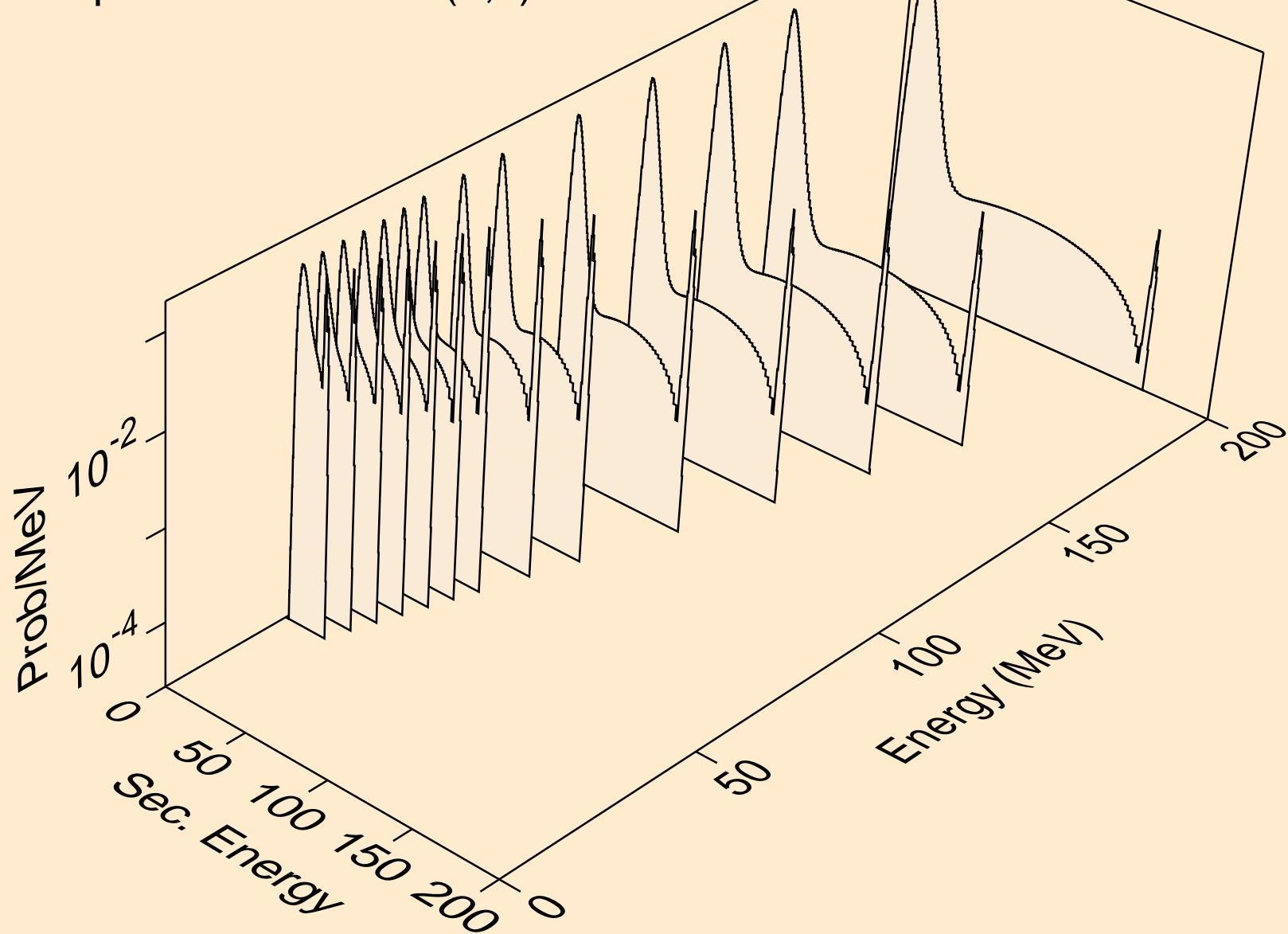

AR037 ALPHA ACER TENDL-2024 LIBRARY; T=0.K  
Alpha emission for (a,n\*)a

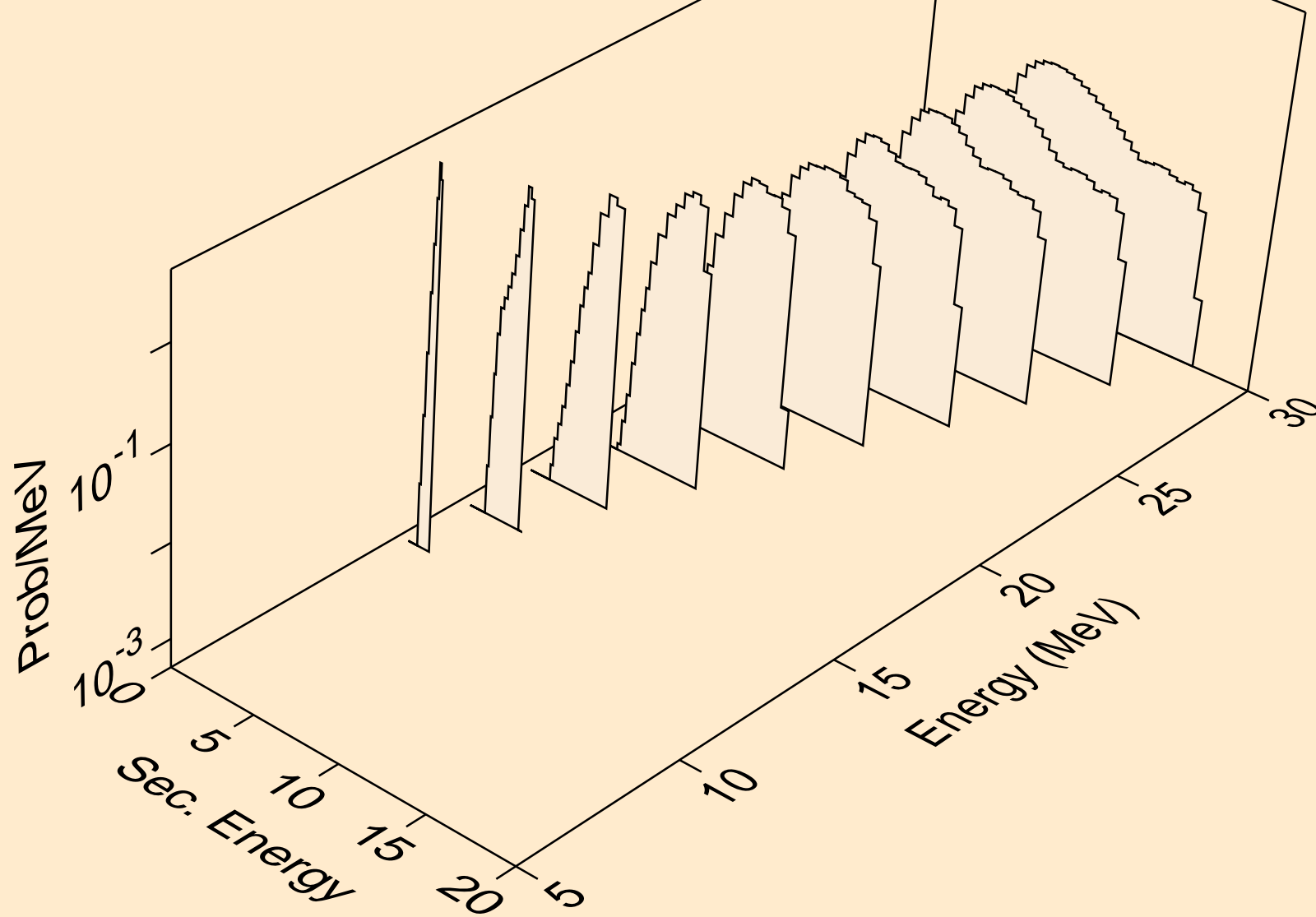

AR037 ALPHA ACER TENDL-2024 LIBRARY; T=0.K  
Alpha emission for (a,n\*)2a

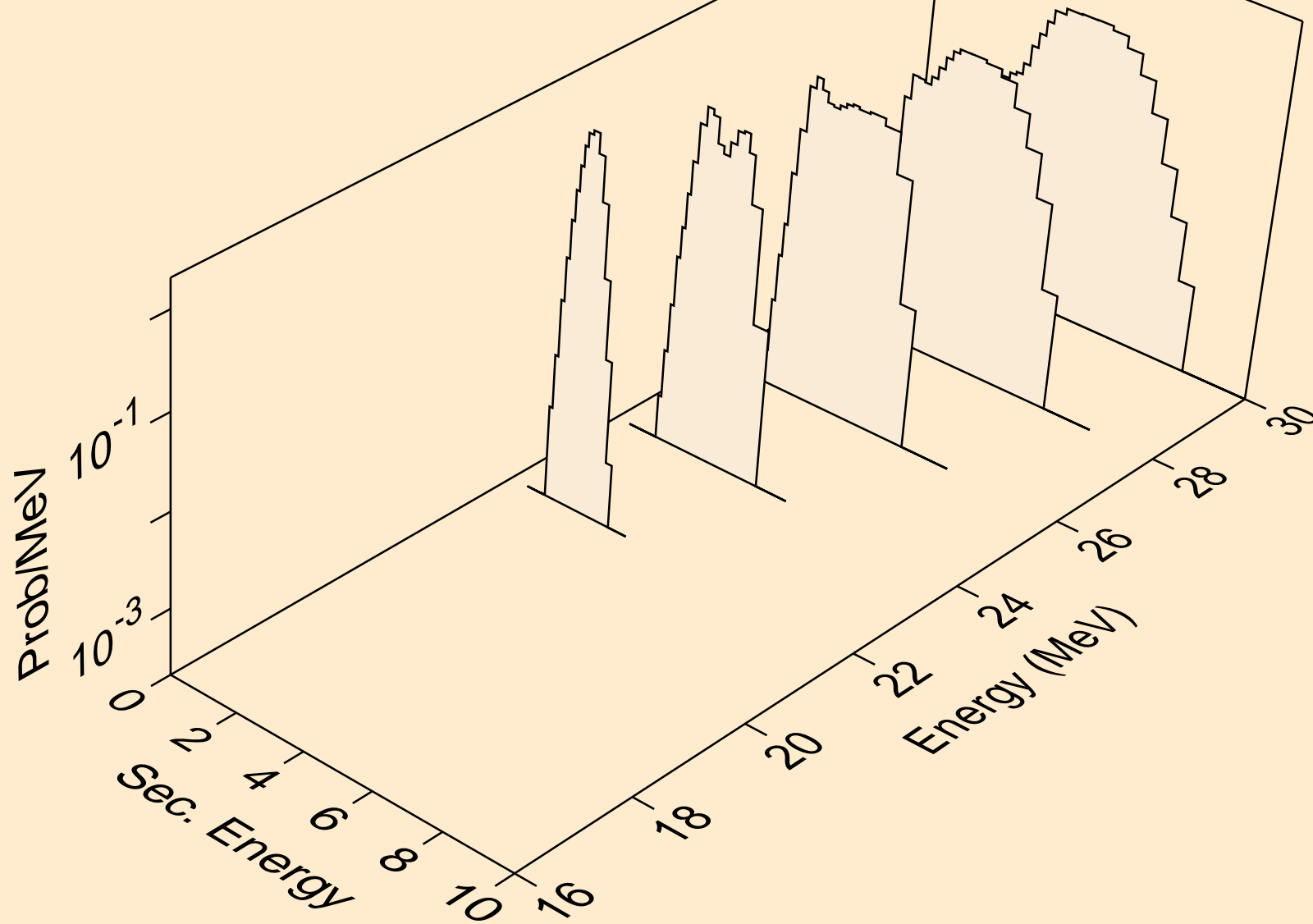

AR037 ALPHA ACER TENDL-2024 LIBRARY; T=0.K  
Alpha emission for inelastic

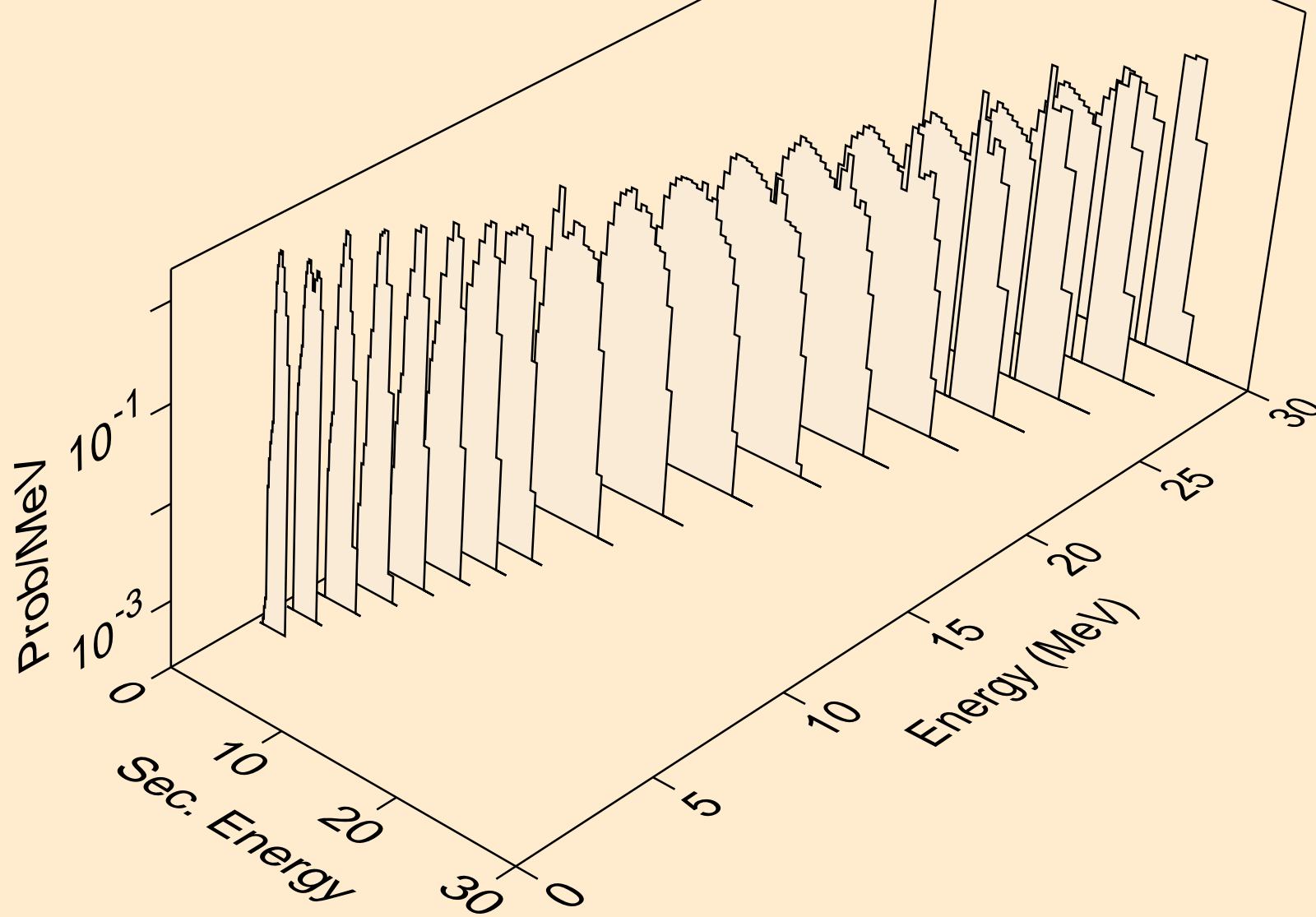

AR037 ALPHA ACER TENDL-2024 LIBRARY; T=0.K  
Alpha emission for (a,2a)

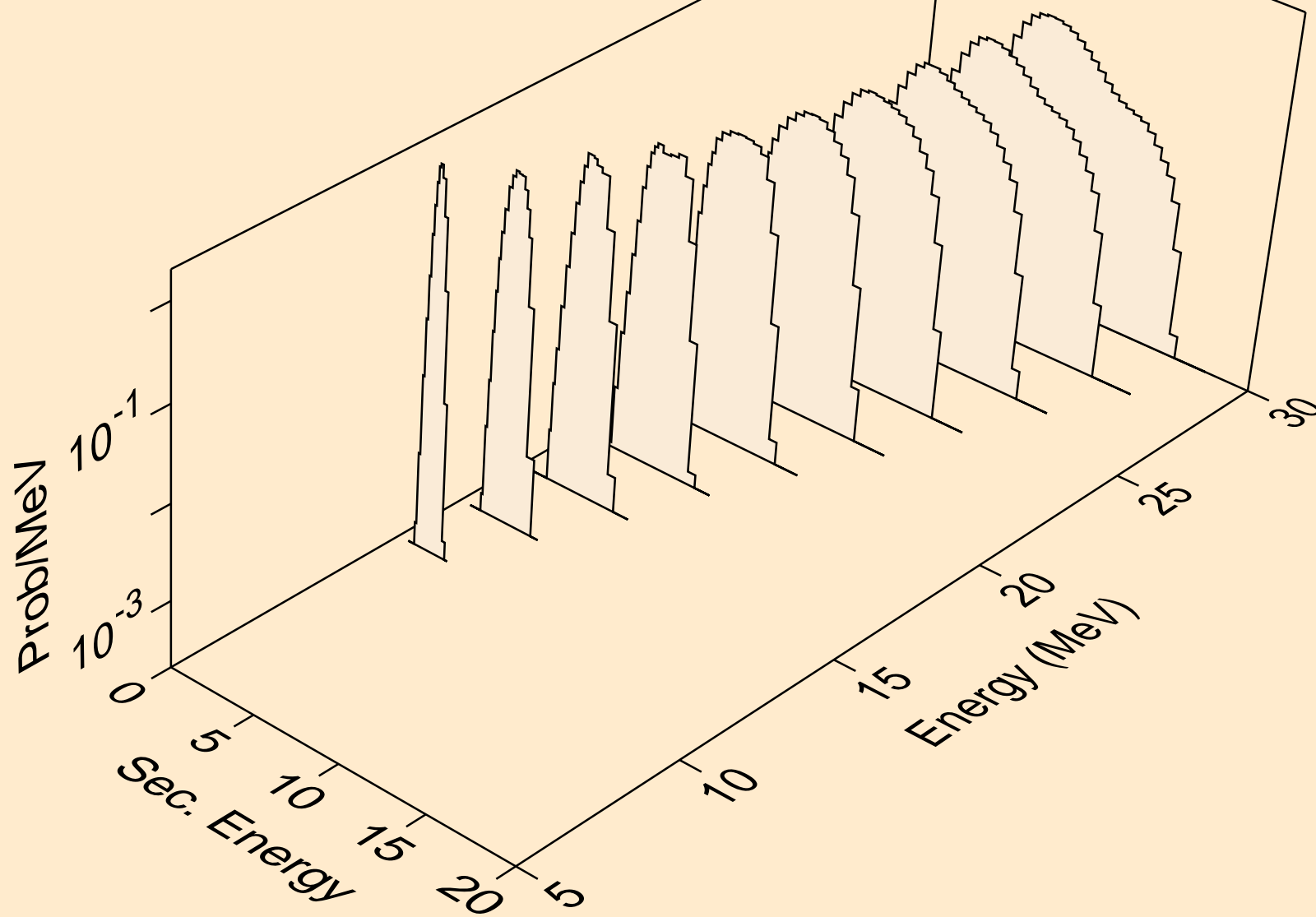

AR037 ALPHA ACER TENDL-2024 LIBRARY; T=0.K  
Alpha emission for (a,3a)

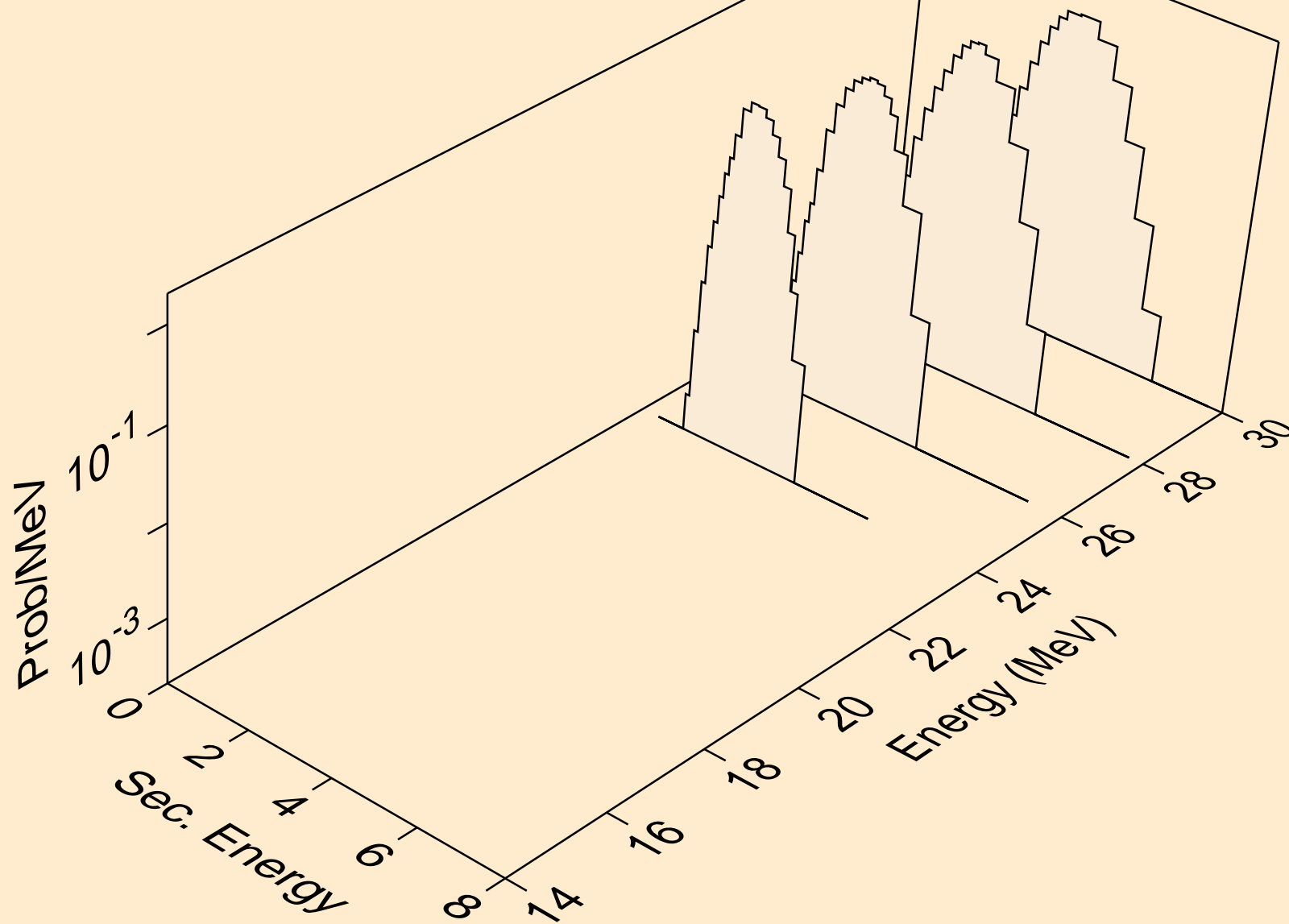

AR037 ALPHA ACER TENDL-2024 LIBRARY; T=0.K  
Alpha emission for (a,pa)

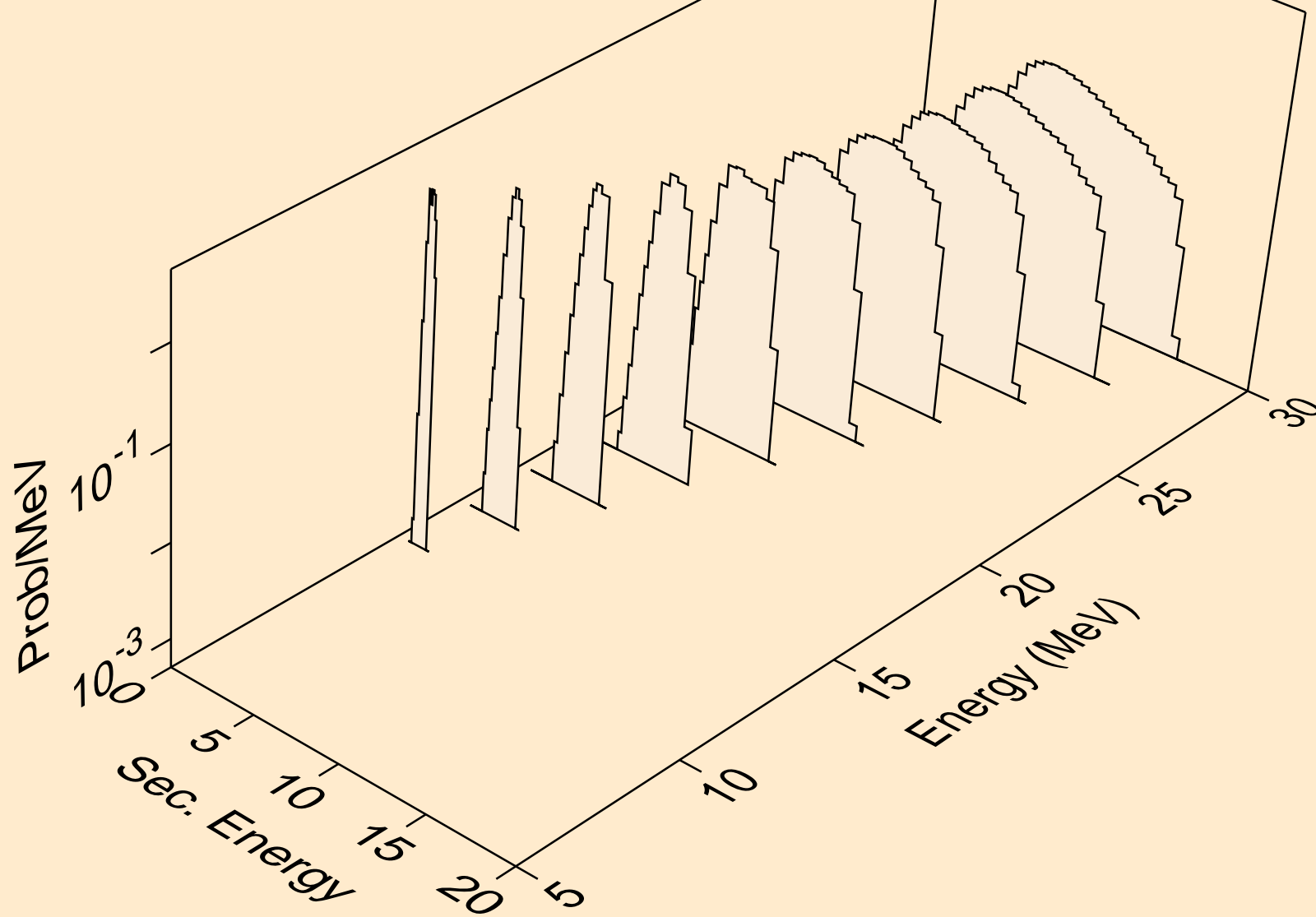

AR037 ALPHA ACER TENDL-2024 LIBRARY; T=0.K  
Alpha emission for (a,da)

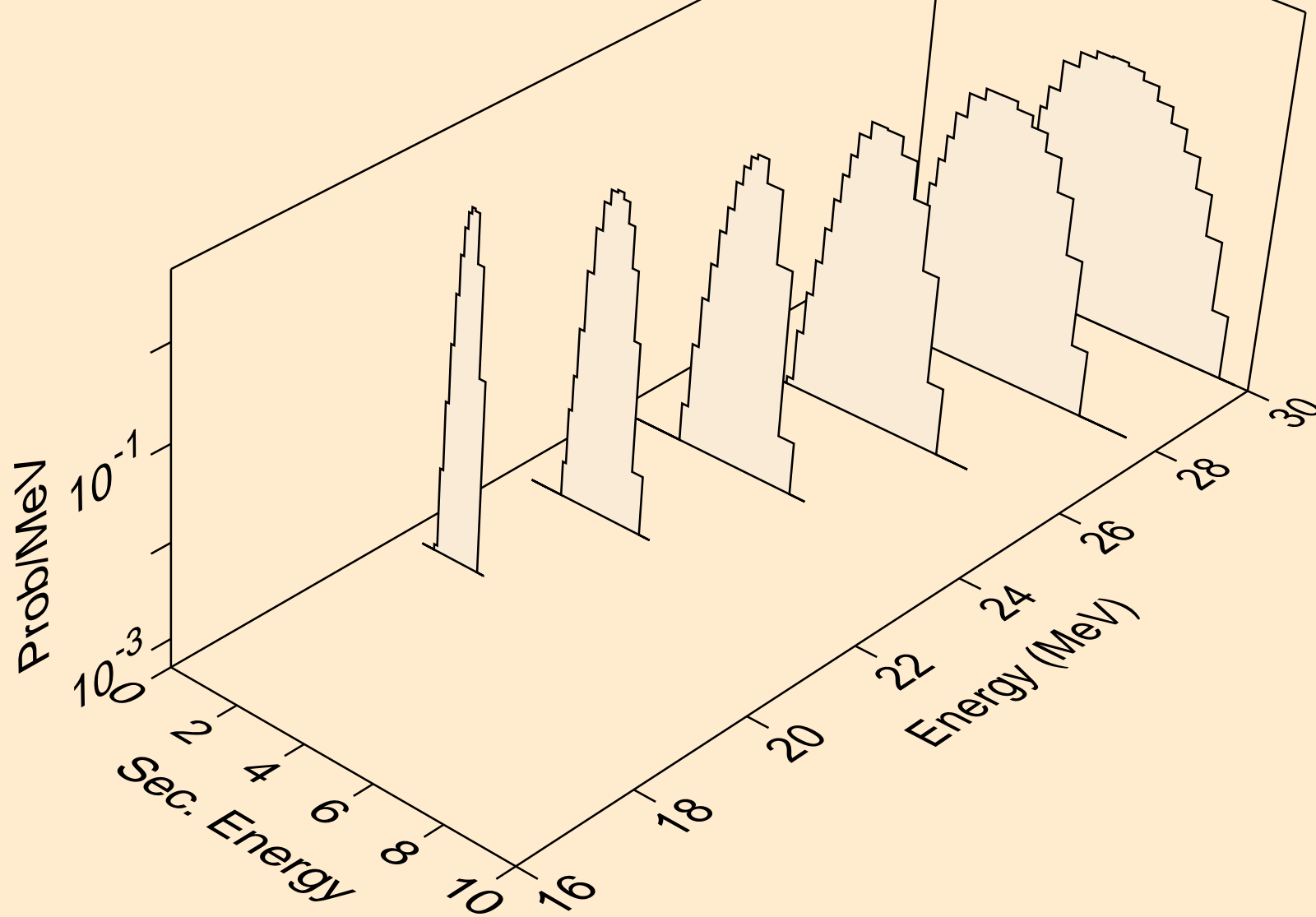

AR037 ALPHA ACER TENDL-2024 LIBRARY; T=0.K  
Photon emission for (z,n)

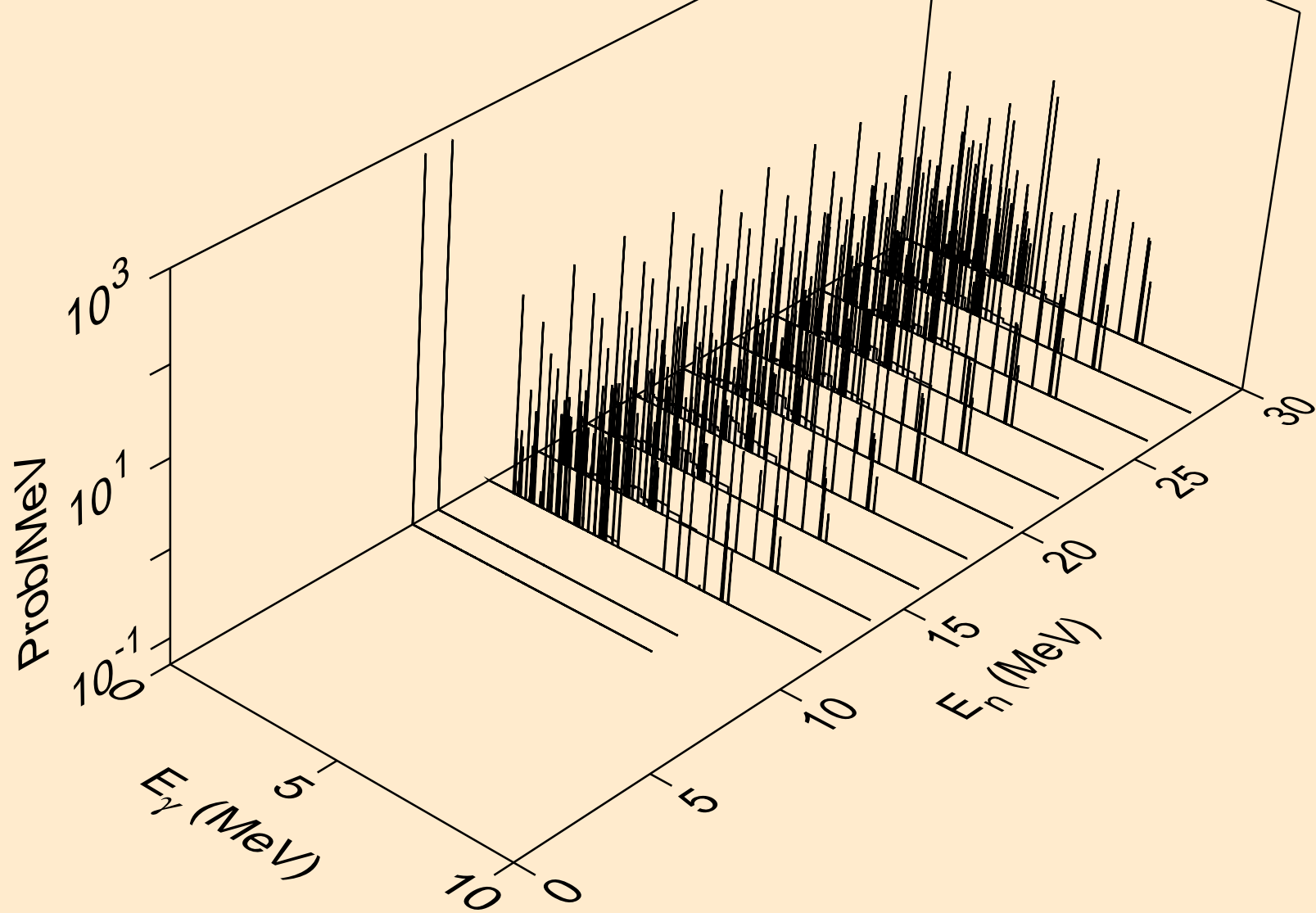

AR037 ALPHA ACER TENDL-2024 LIBRARY; T=0.K  
Photon emission for (z,x)

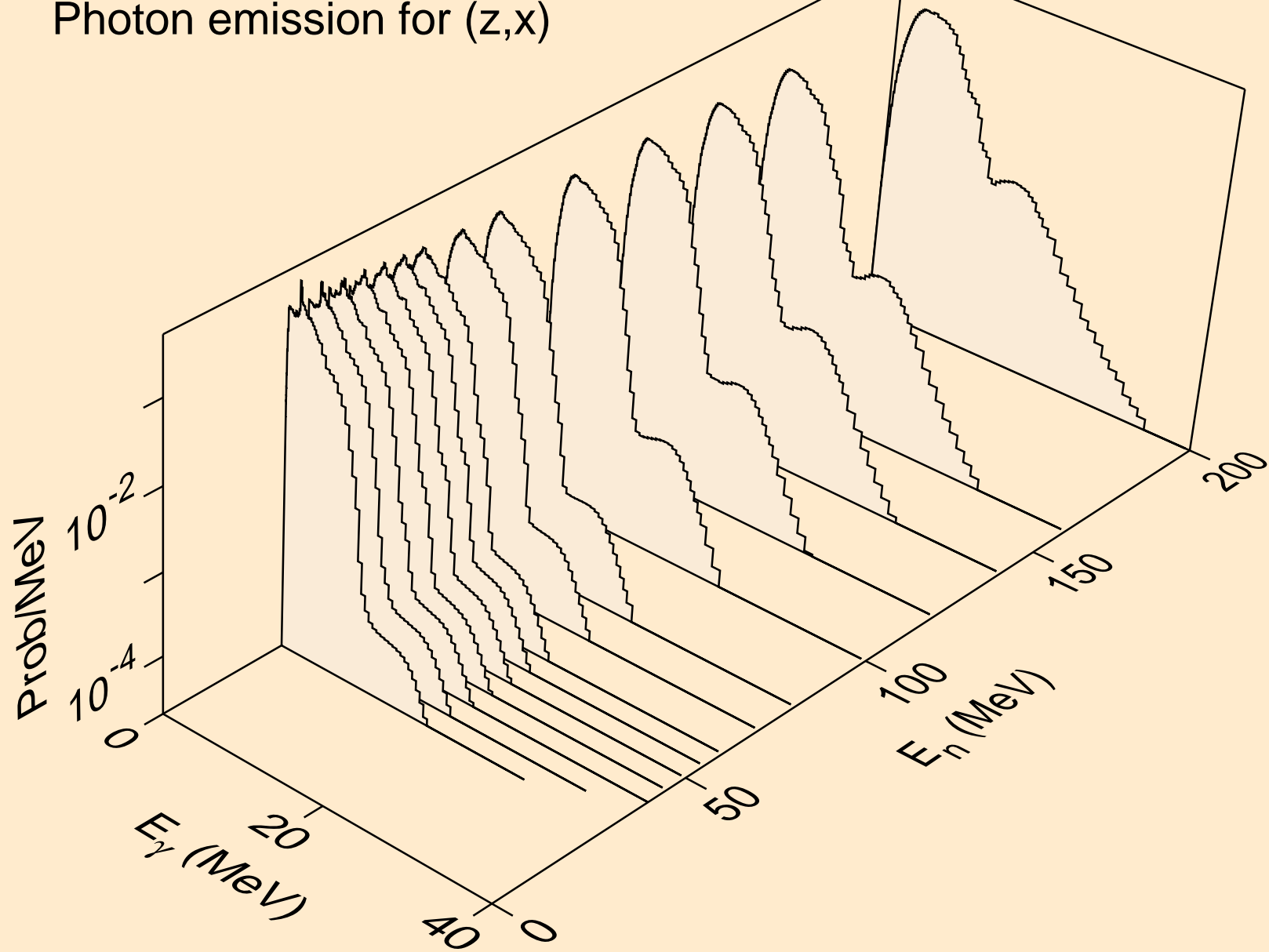

AR037 ALPHA ACER TENDL-2024 LIBRARY; T=0.K  
Photon emission for (n,2n)

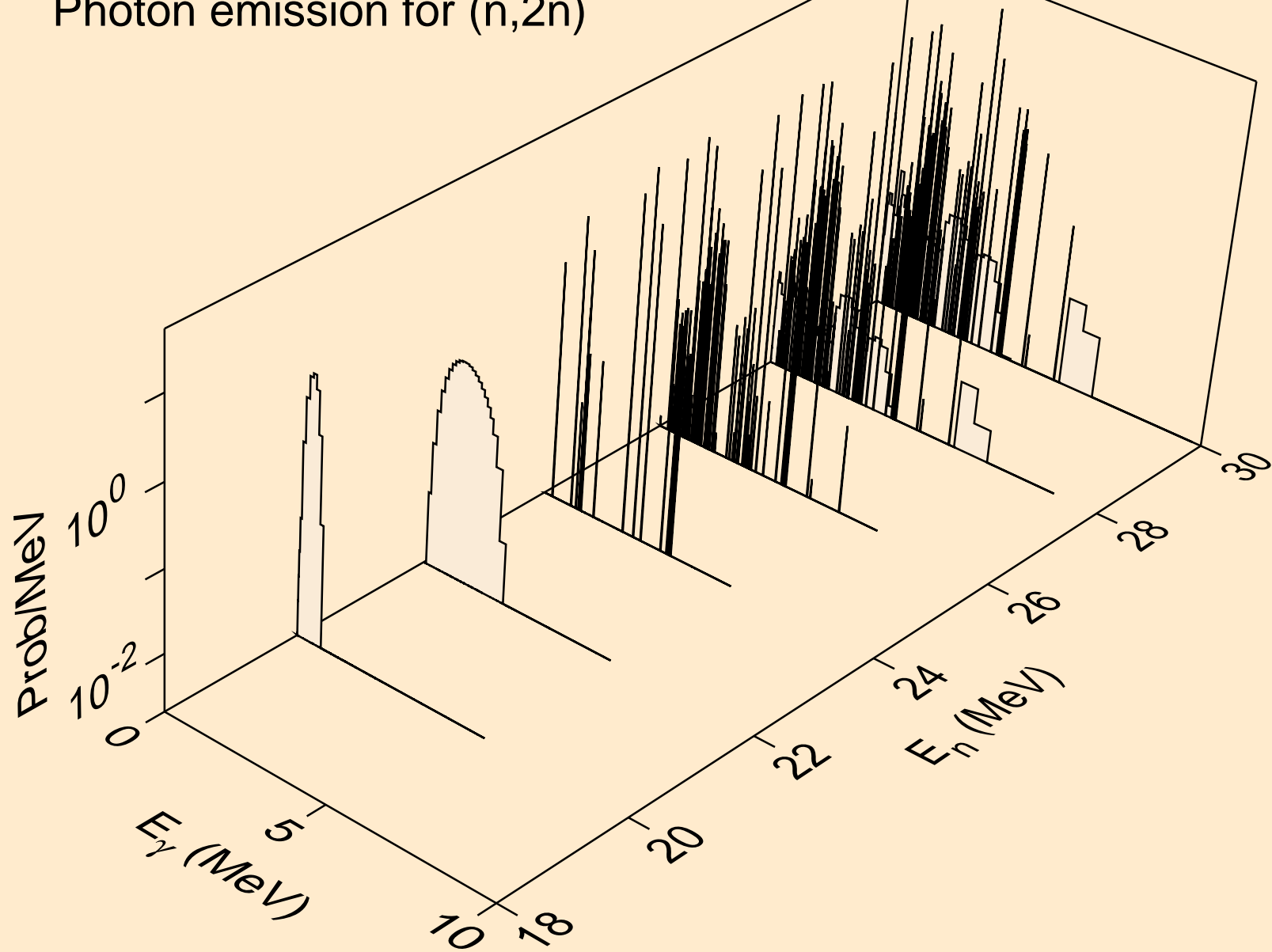

AR037 ALPHA ACER TENDL-2024 LIBRARY; T=0.K  
Photon emission for (n,n\*)a

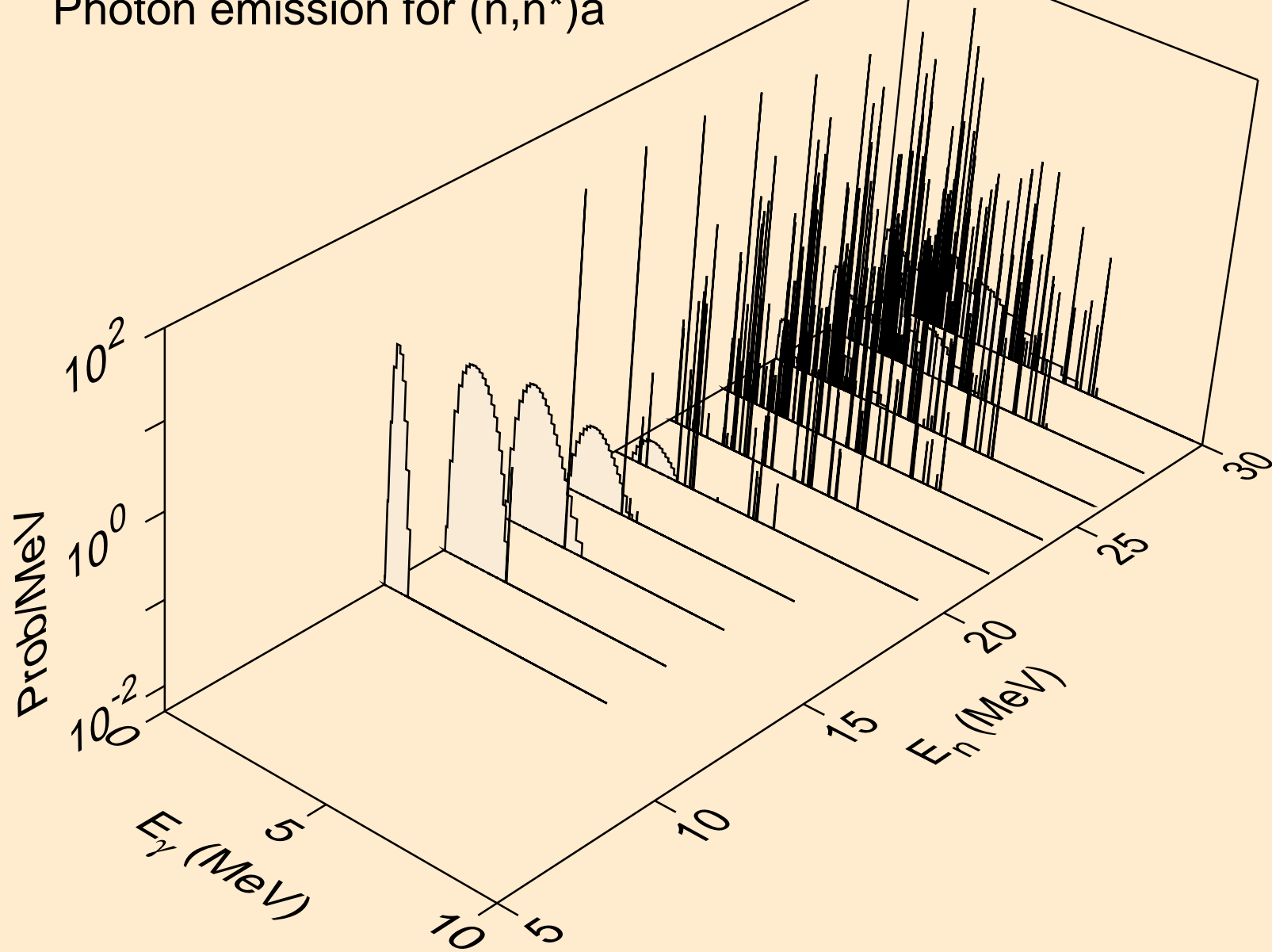

AR037 ALPHA ACER TENDL-2024 LIBRARY; T=0.K  
Photon emission for (n,n\*)p

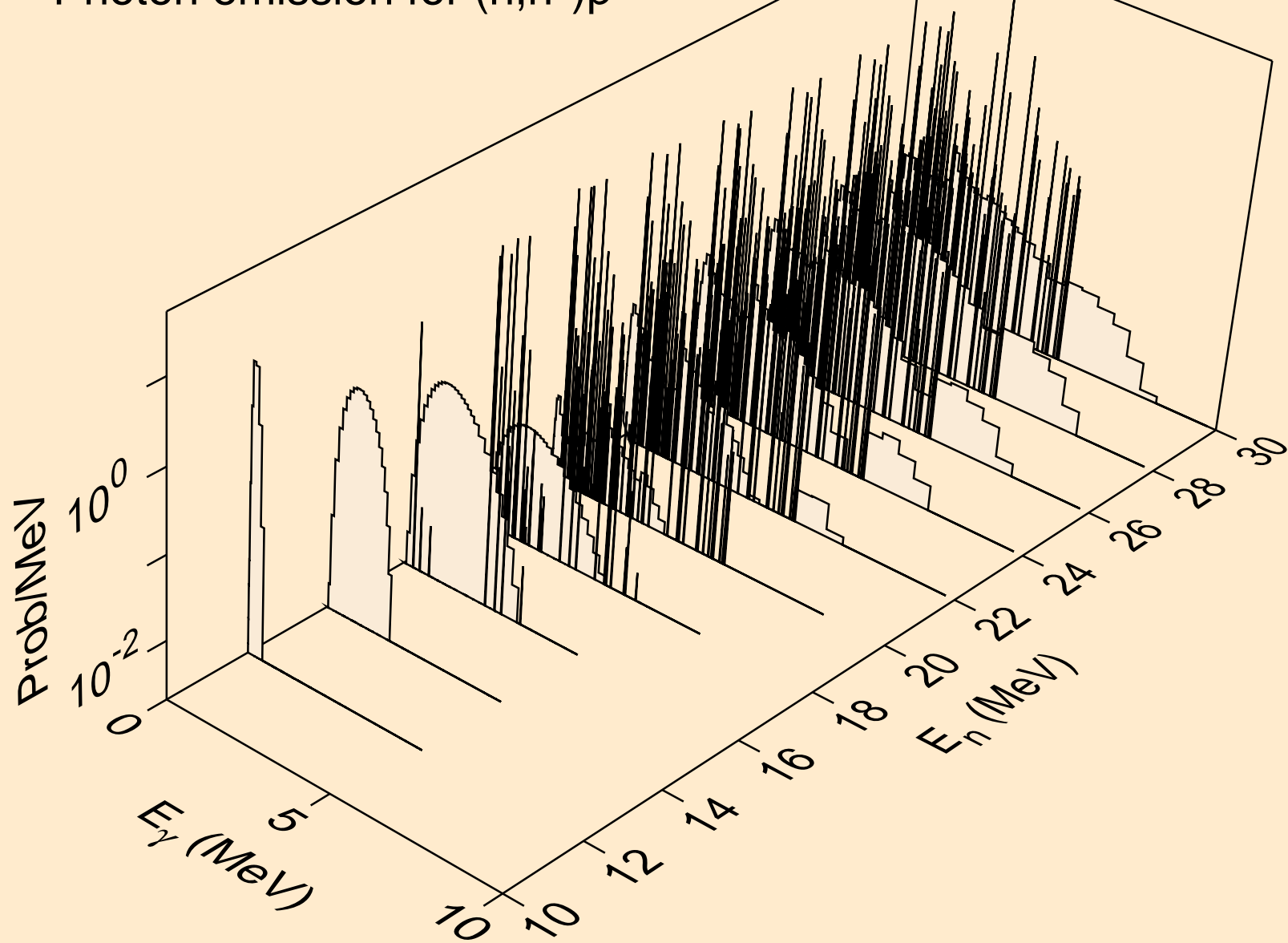

AR037 ALPHA ACER TENDL-2024 LIBRARY; T=0.K  
Photon emission for (n,n\*)2a

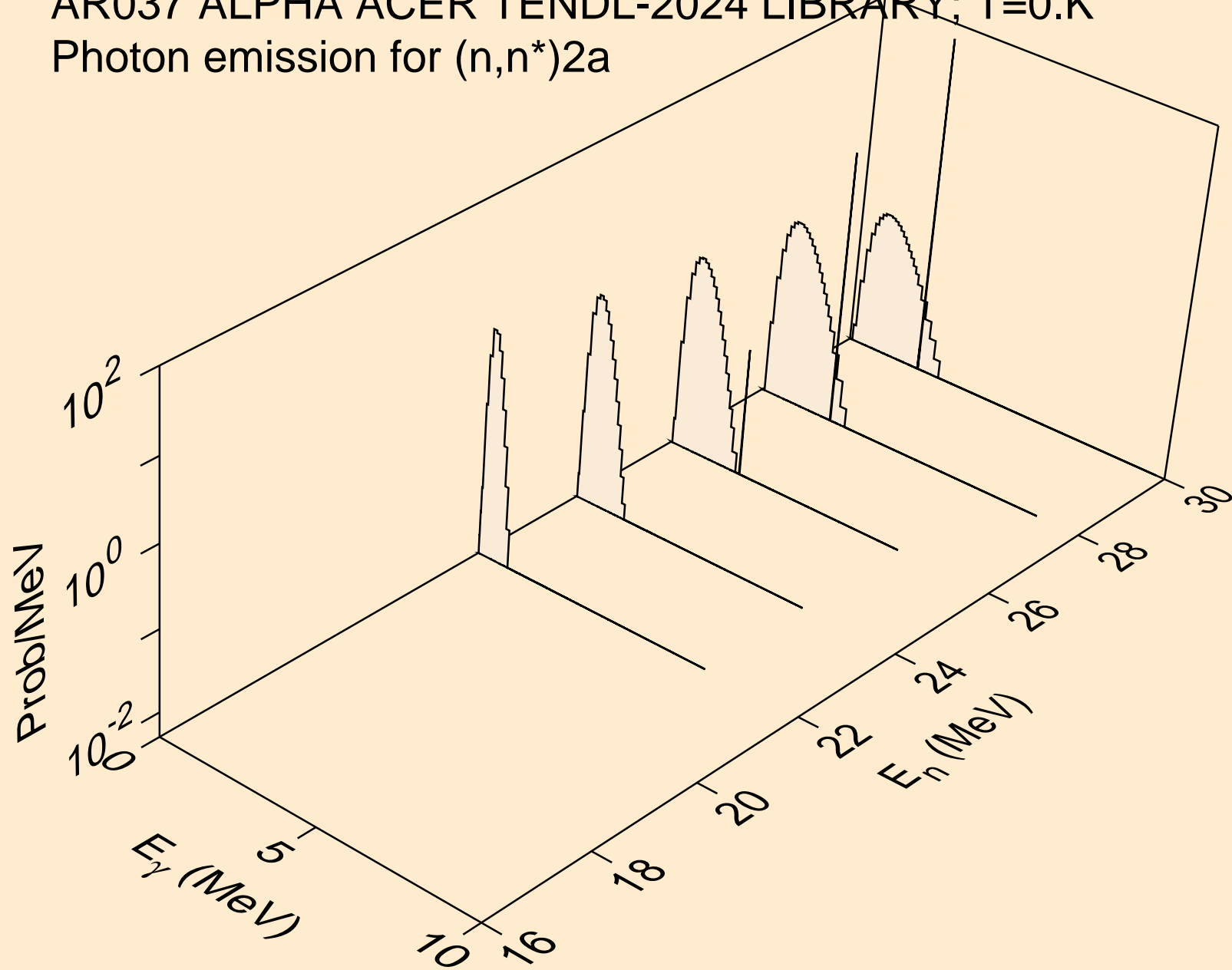

AR037 ALPHA ACER TENDL-2024 LIBRARY; T=0.K  
Photon emission for (n,n\*)d

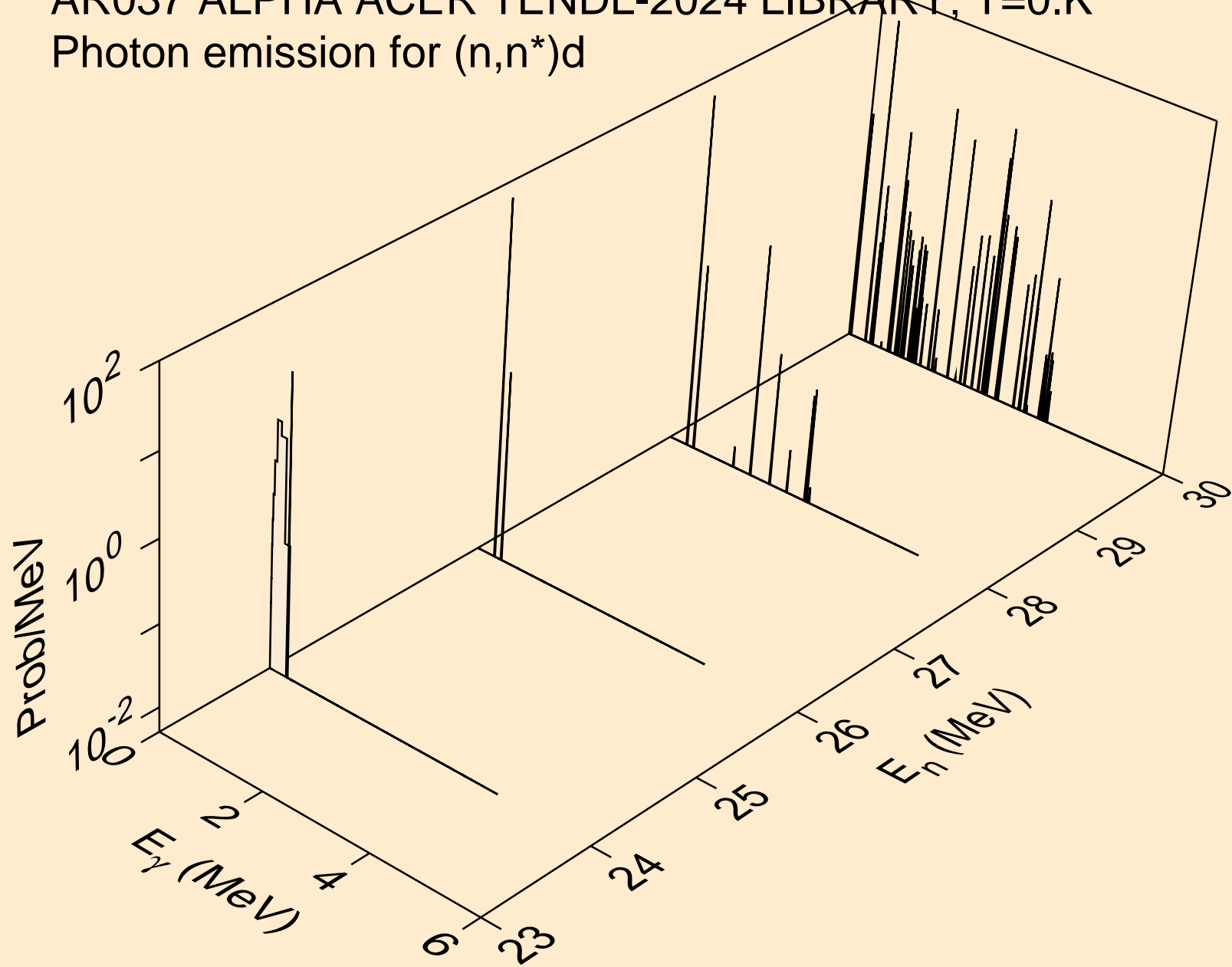

AR037 ALPHA ACER TENDL-2024 LIBRARY; T=0.K  
Photon emission for (n,n\*)he3

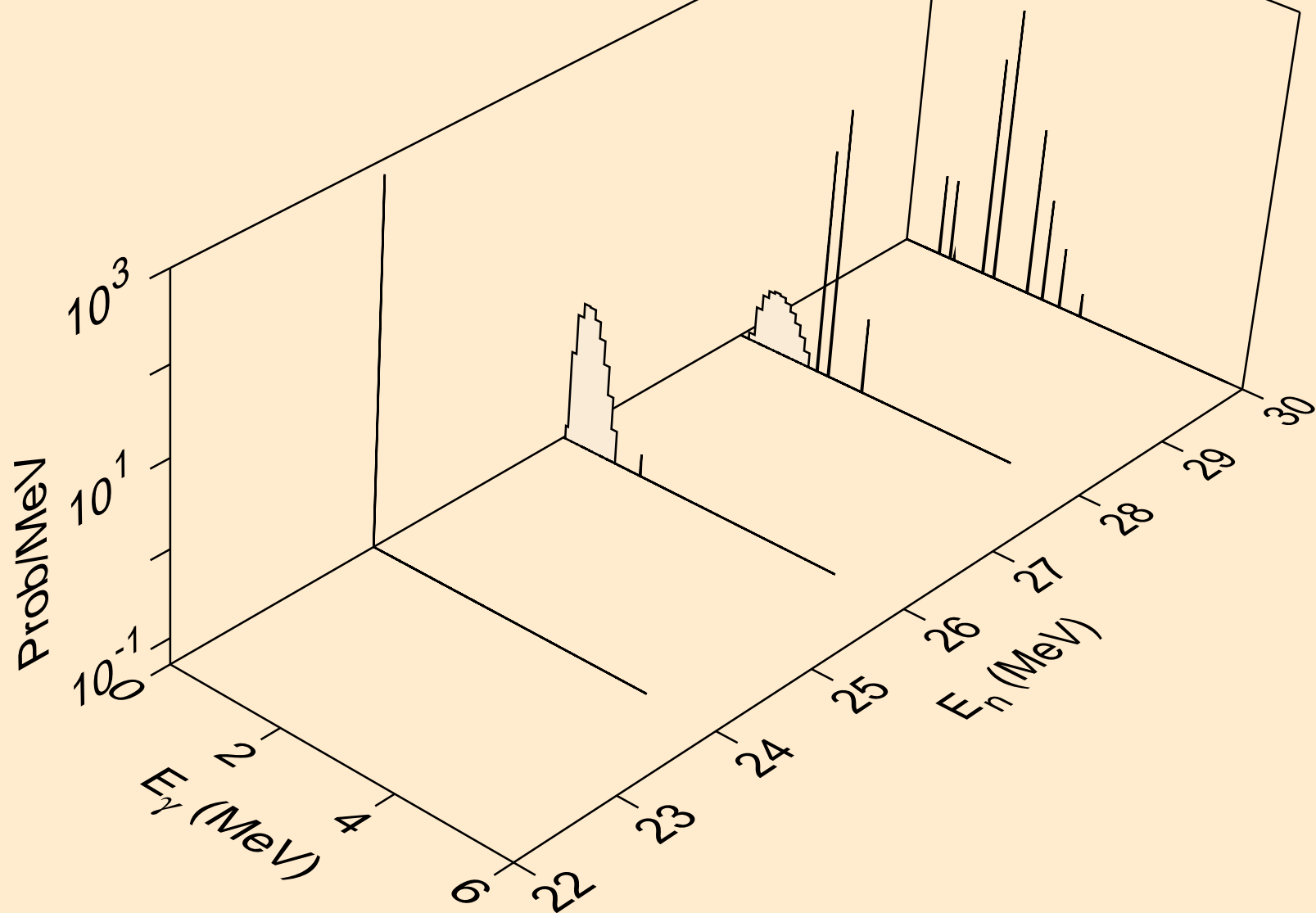

AR037 ALPHA ACER TENDL-2024 LIBRARY; T=0.K  
Photon emission for (n,2np)

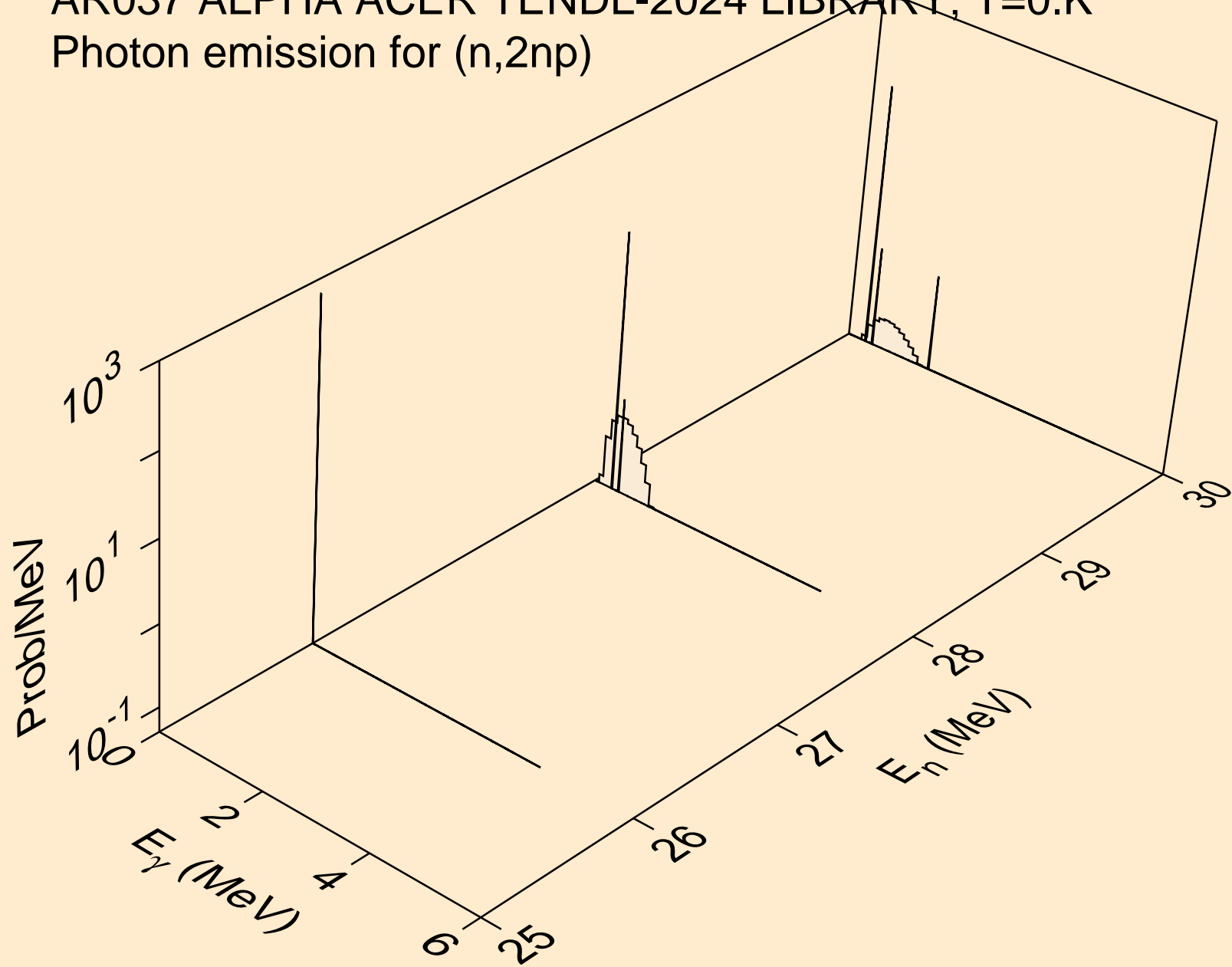

AR037 ALPHA ACER TENDL-2024 LIBRARY; T=0.K  
Photon emission for (n,n2p)

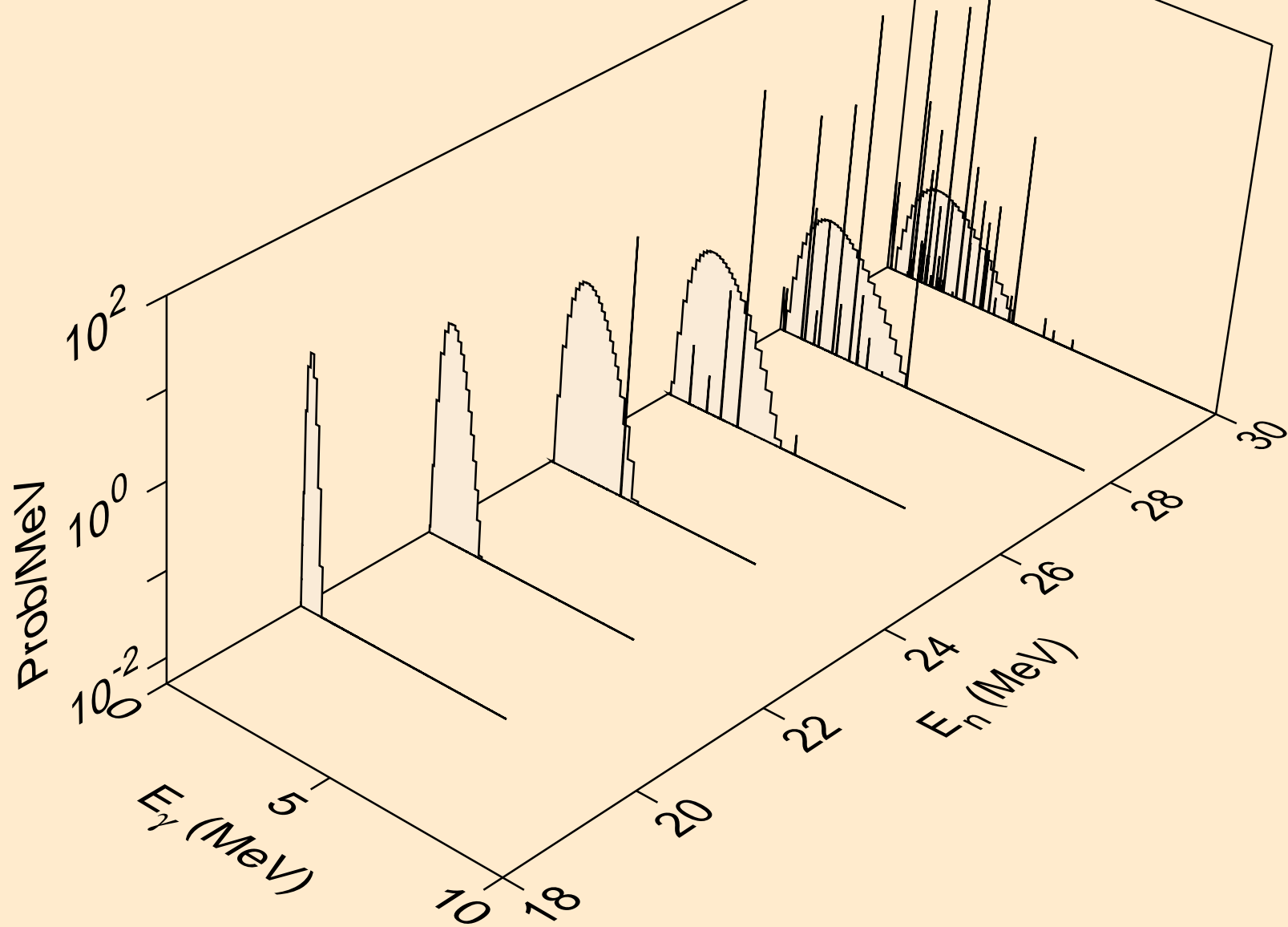

AR037 ALPHA ACER TENDL-2024 LIBRARY; T=0.K  
Photon emission for (n,npa)

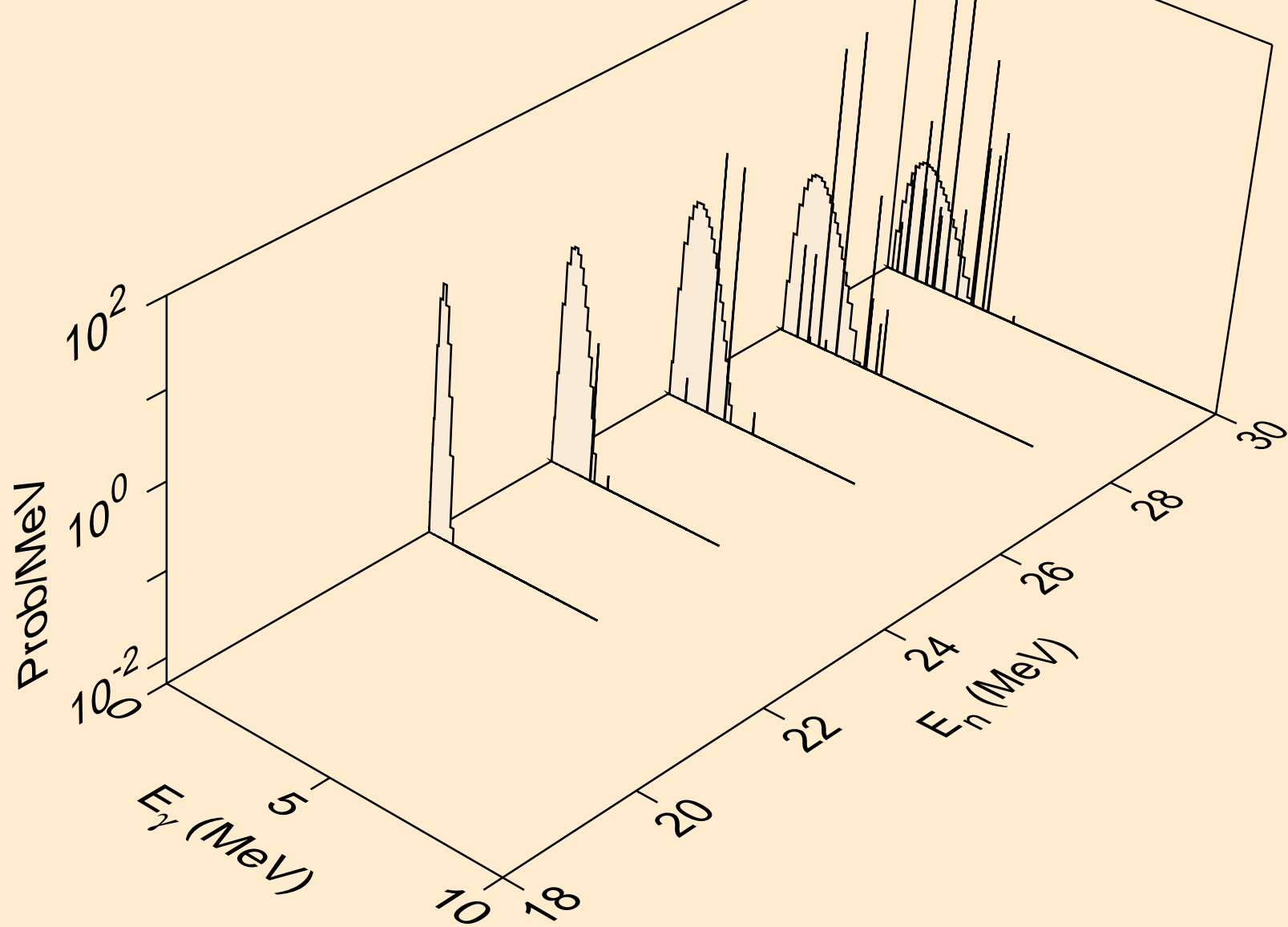

AR037 ALPHA ACER TENDL-2024 LIBRARY; T=0.K  
Photon emission for (n,gma)

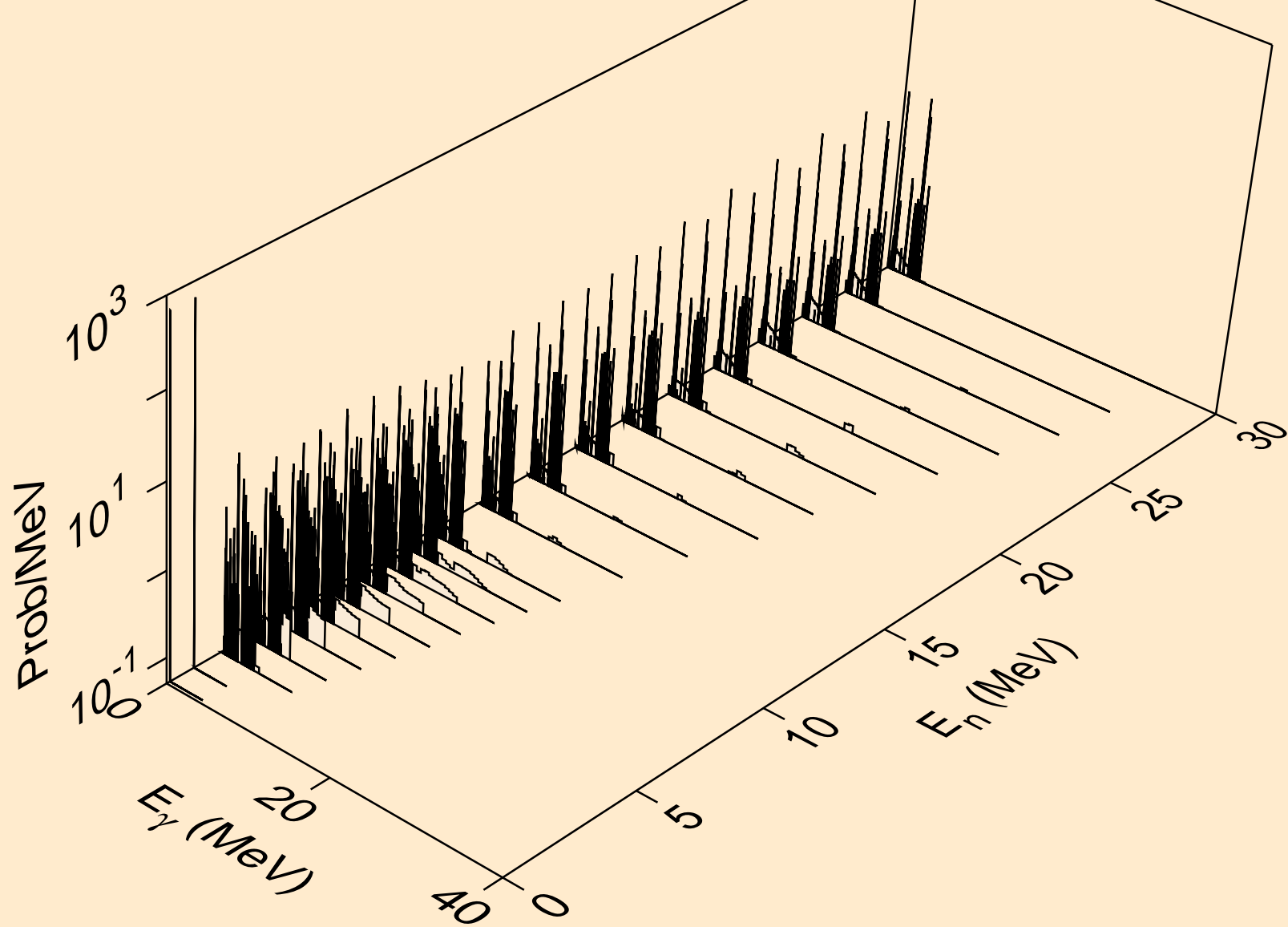

AR037 ALPHA ACER TENDL-2024 LIBRARY; T=0.K  
Photon emission for (n,p)

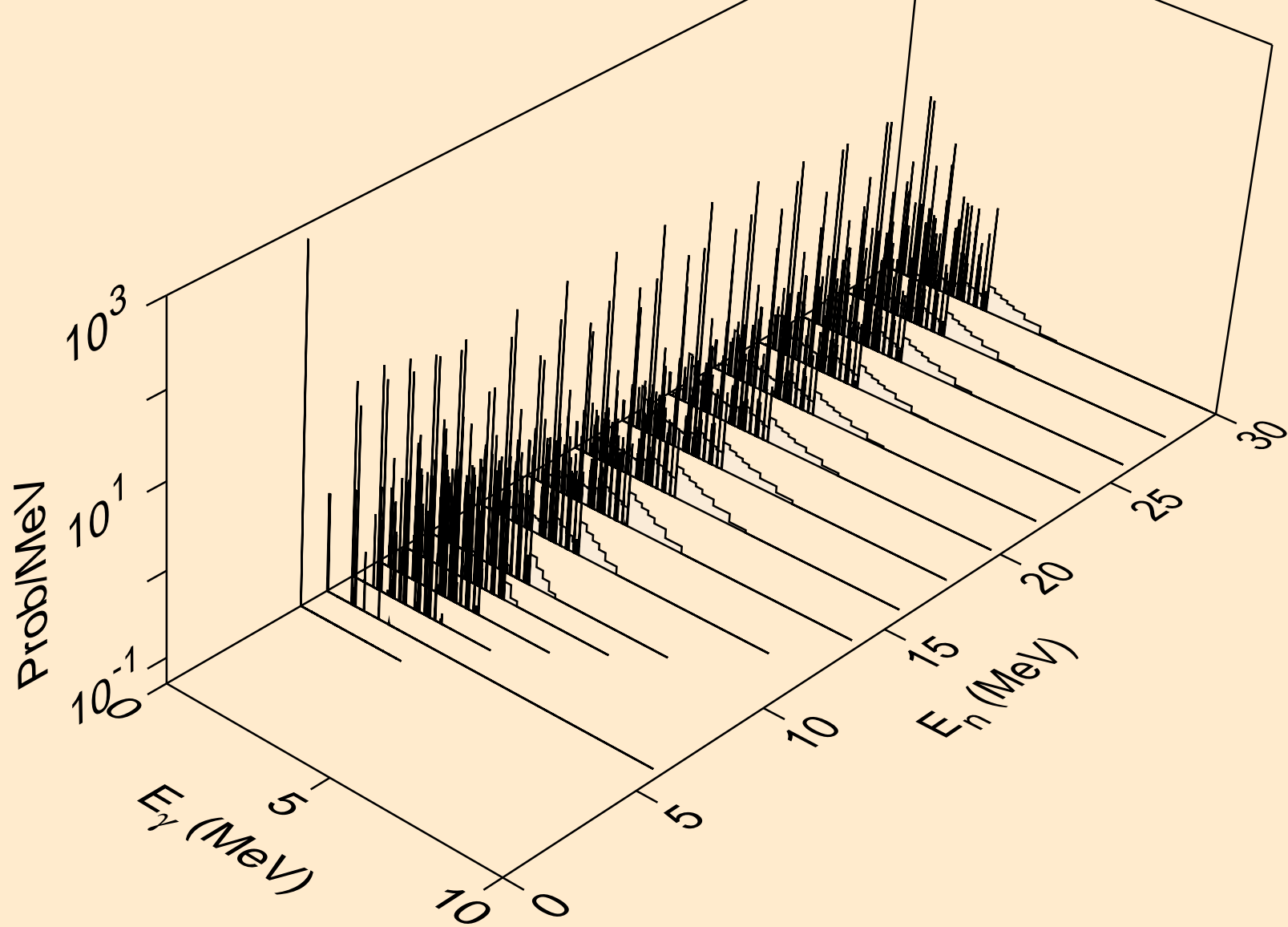

AR037 ALPHA ACER TENDL-2024 LIBRARY; T=0.K  
Photon emission for (n,d)

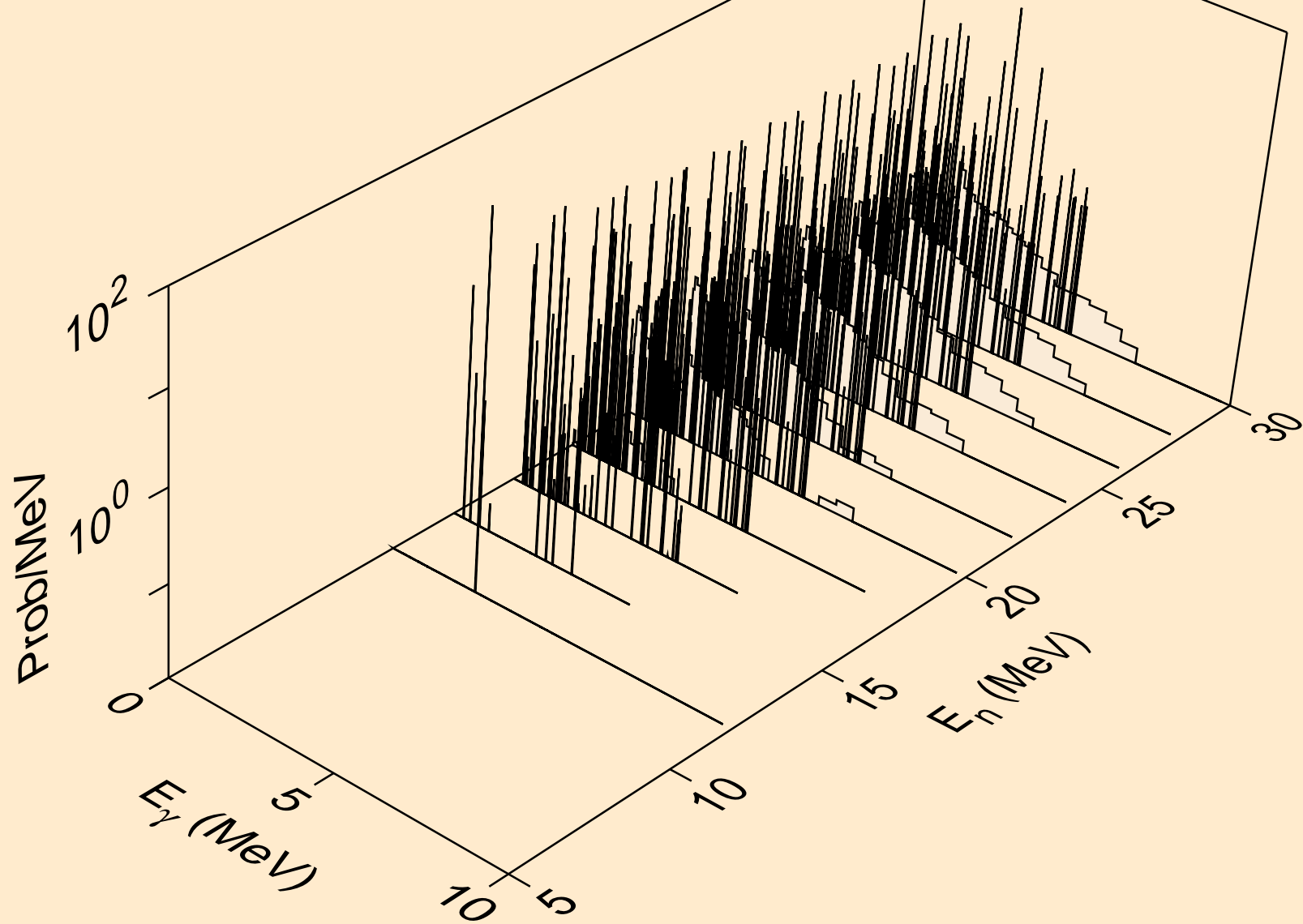

AR037 ALPHA ACER TENDL-2024 LIBRARY; T=0.K  
Photon emission for (n,t)

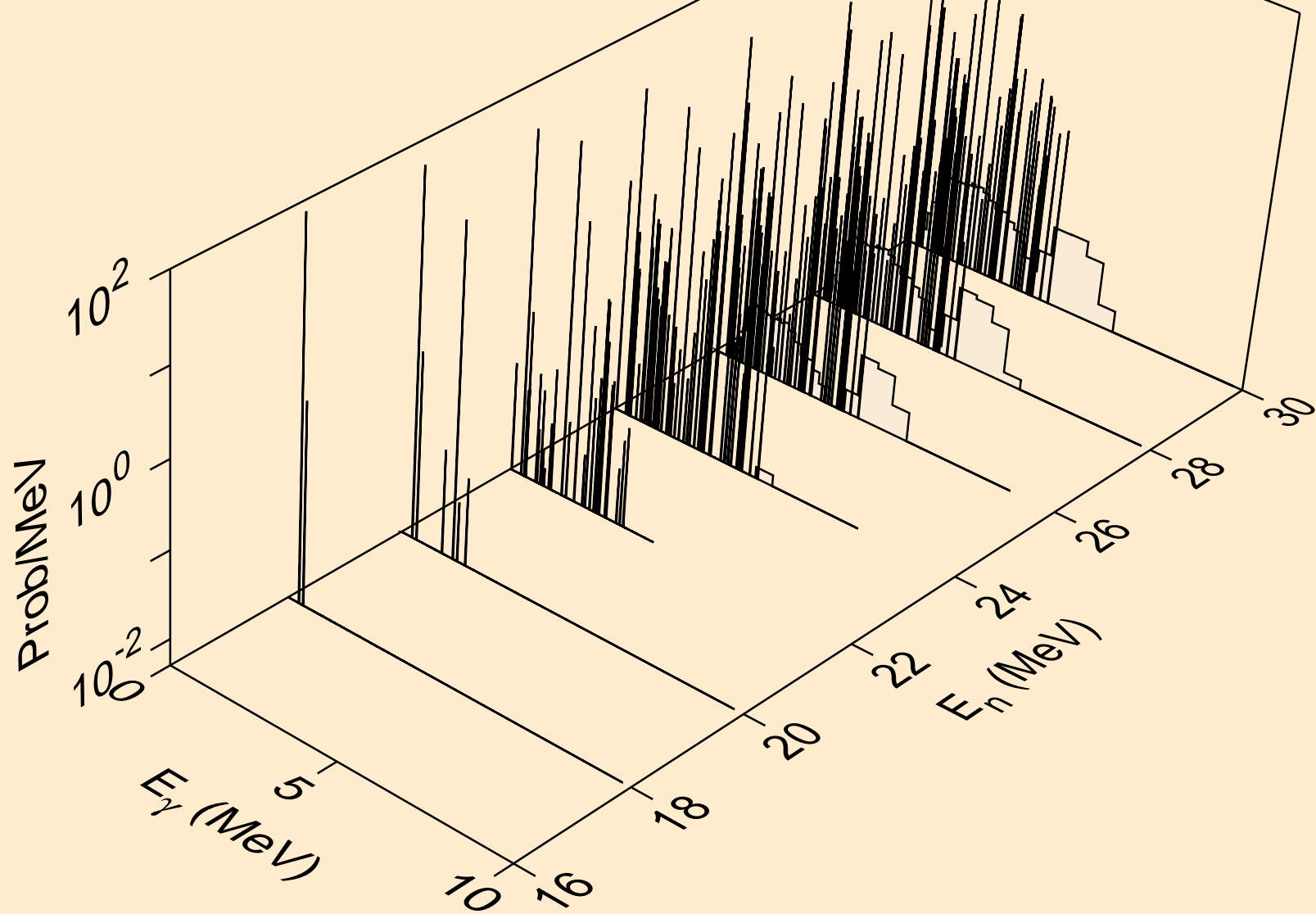

AR037 ALPHA ACER TENDL-2024 LIBRARY; T=0.K  
Photon emission for (n,he3)

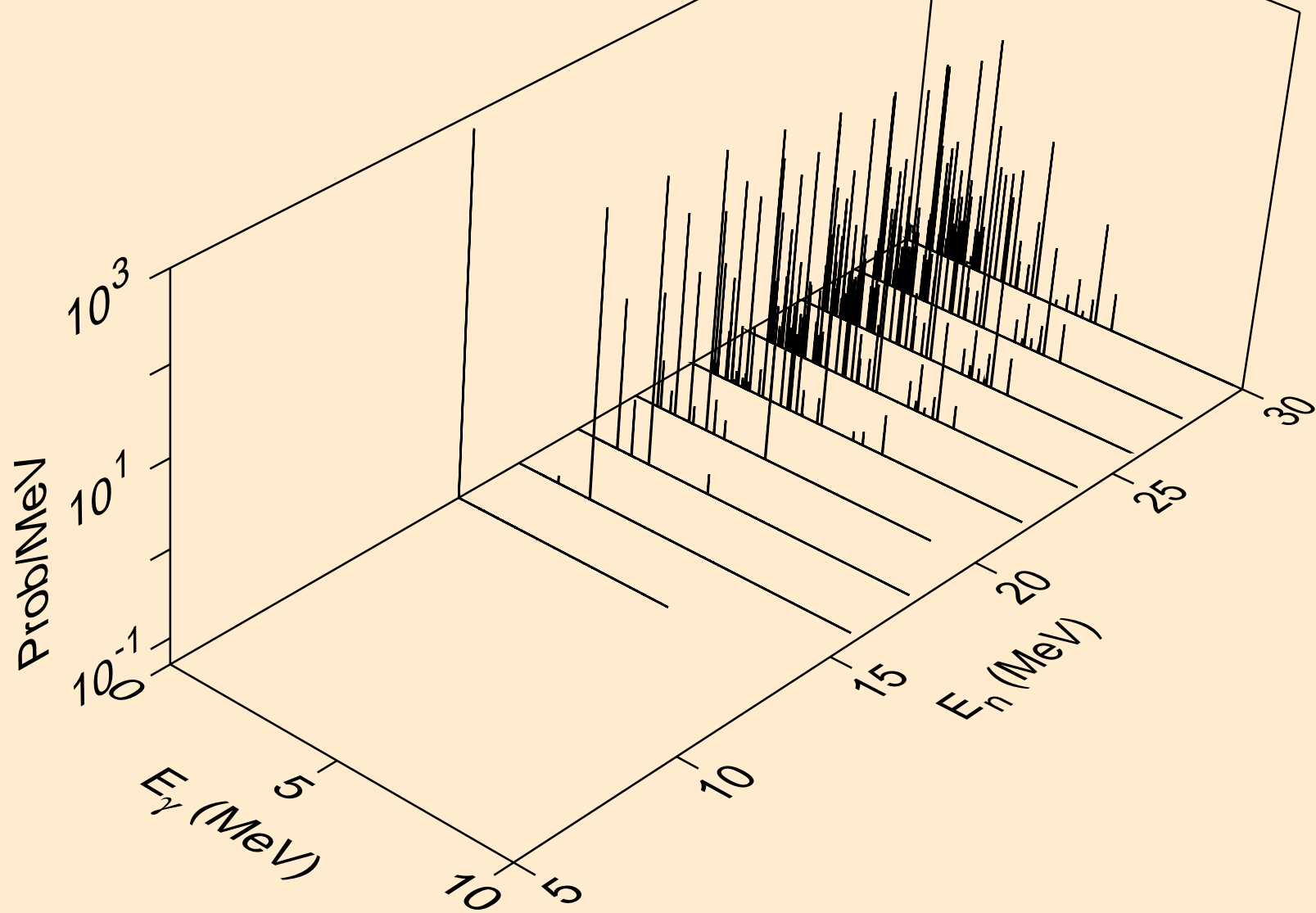

AR037 ALPHA ACER TENDL-2024 LIBRARY; T=0.K  
Photon emission for inelastic

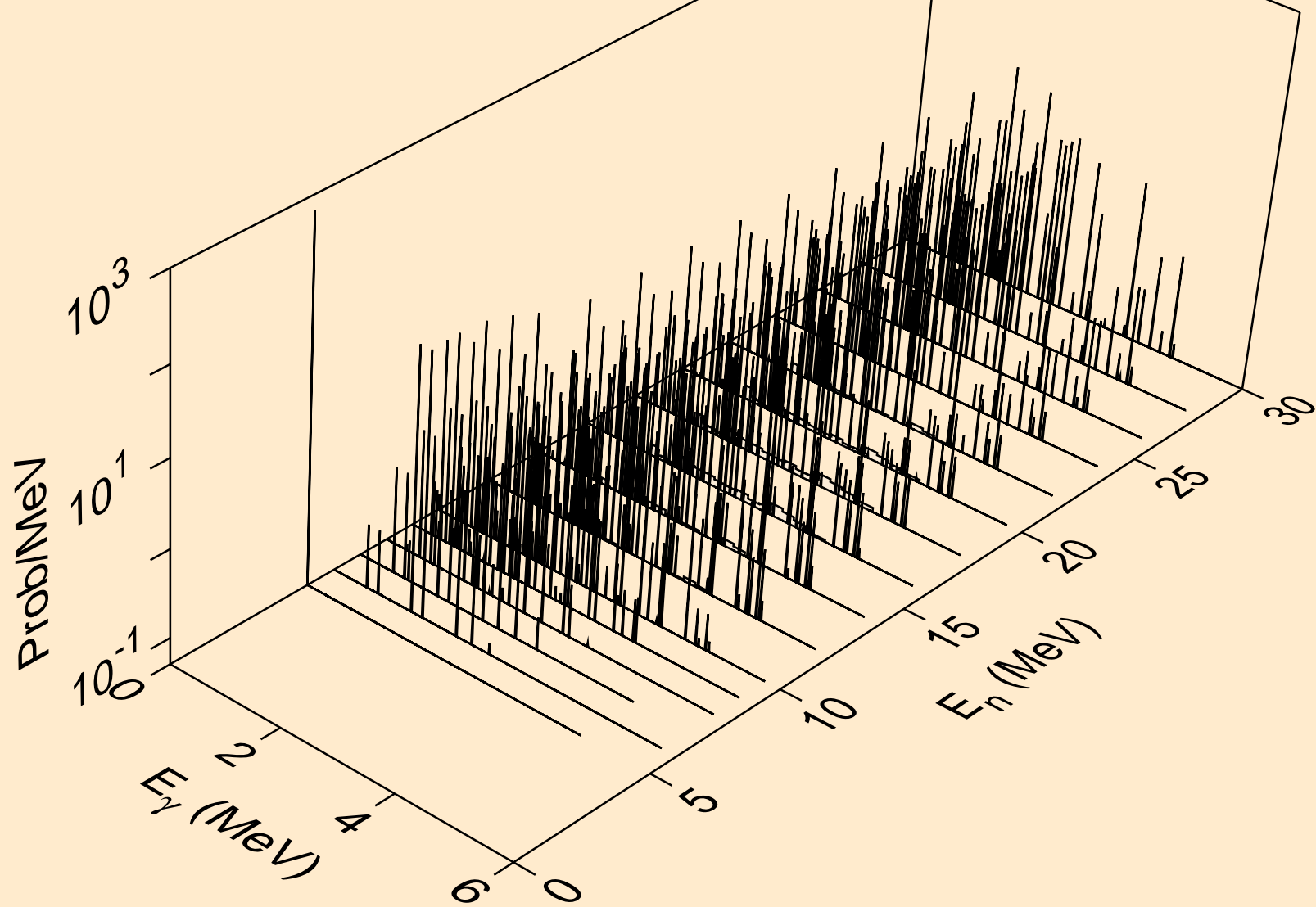

AR037 ALPHA ACER TENDL-2024 LIBRARY; T=0.K  
Photon emission for (n,2a)

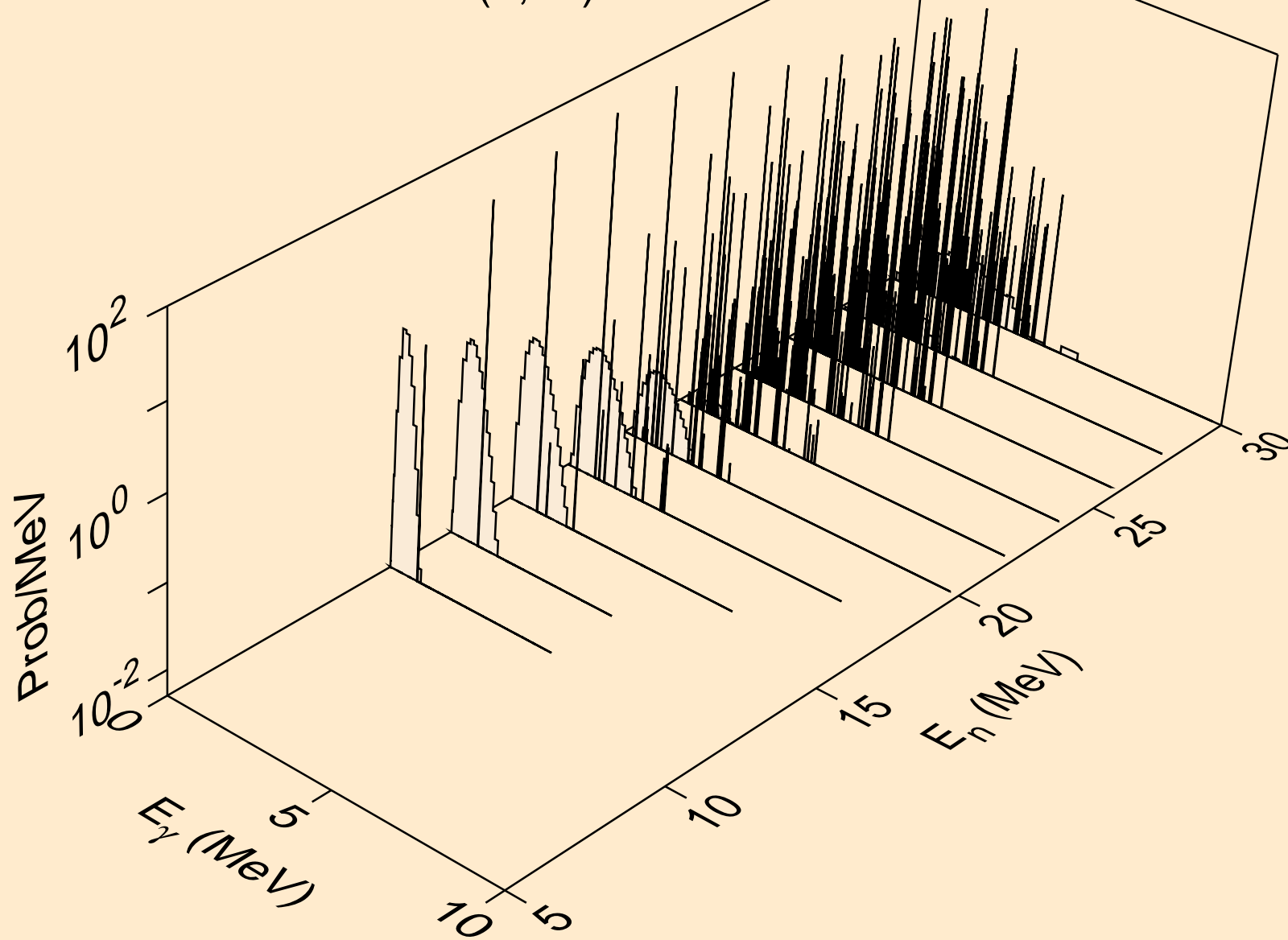

AR037 ALPHA ACER TENDL-2024 LIBRARY; T=0.K  
Photon emission for (n,3a)

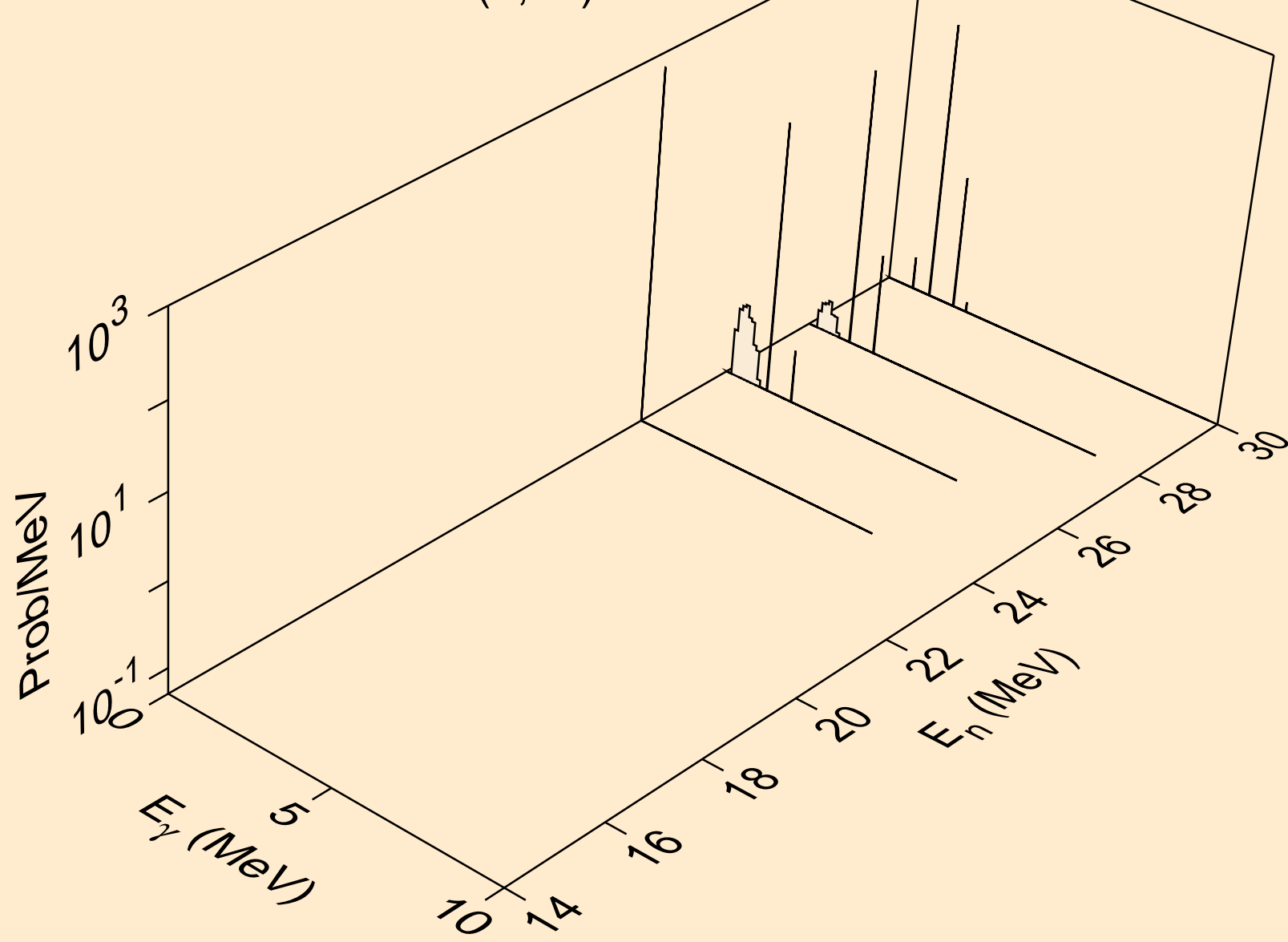

AR037 ALPHA ACER TENDL-2024 LIBRARY; T=0.K  
Photon emission for (n,2p)

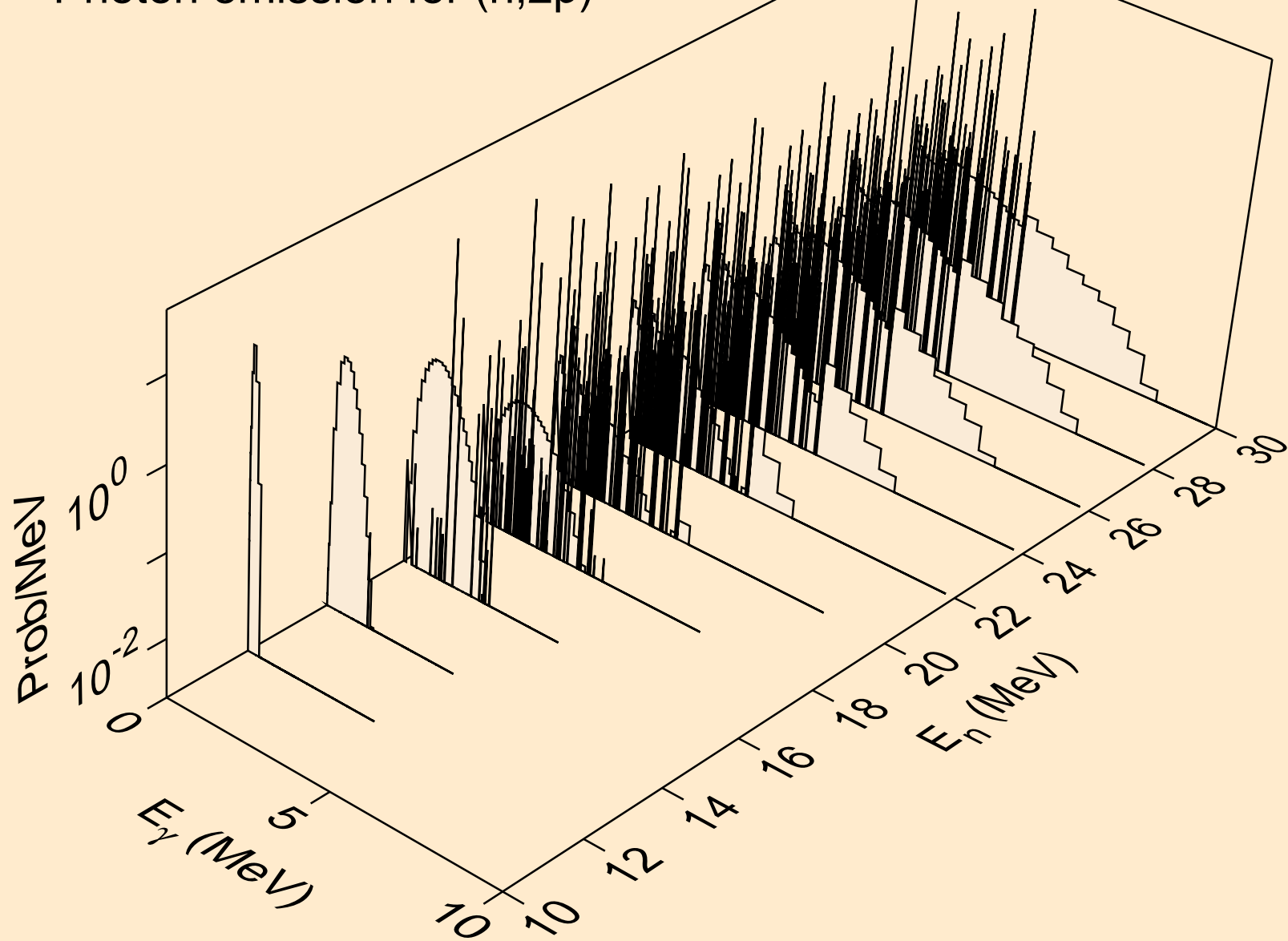

AR037 ALPHA ACER TENDL-2024 LIBRARY; T=0.K  
Photon emission for (n,pa)

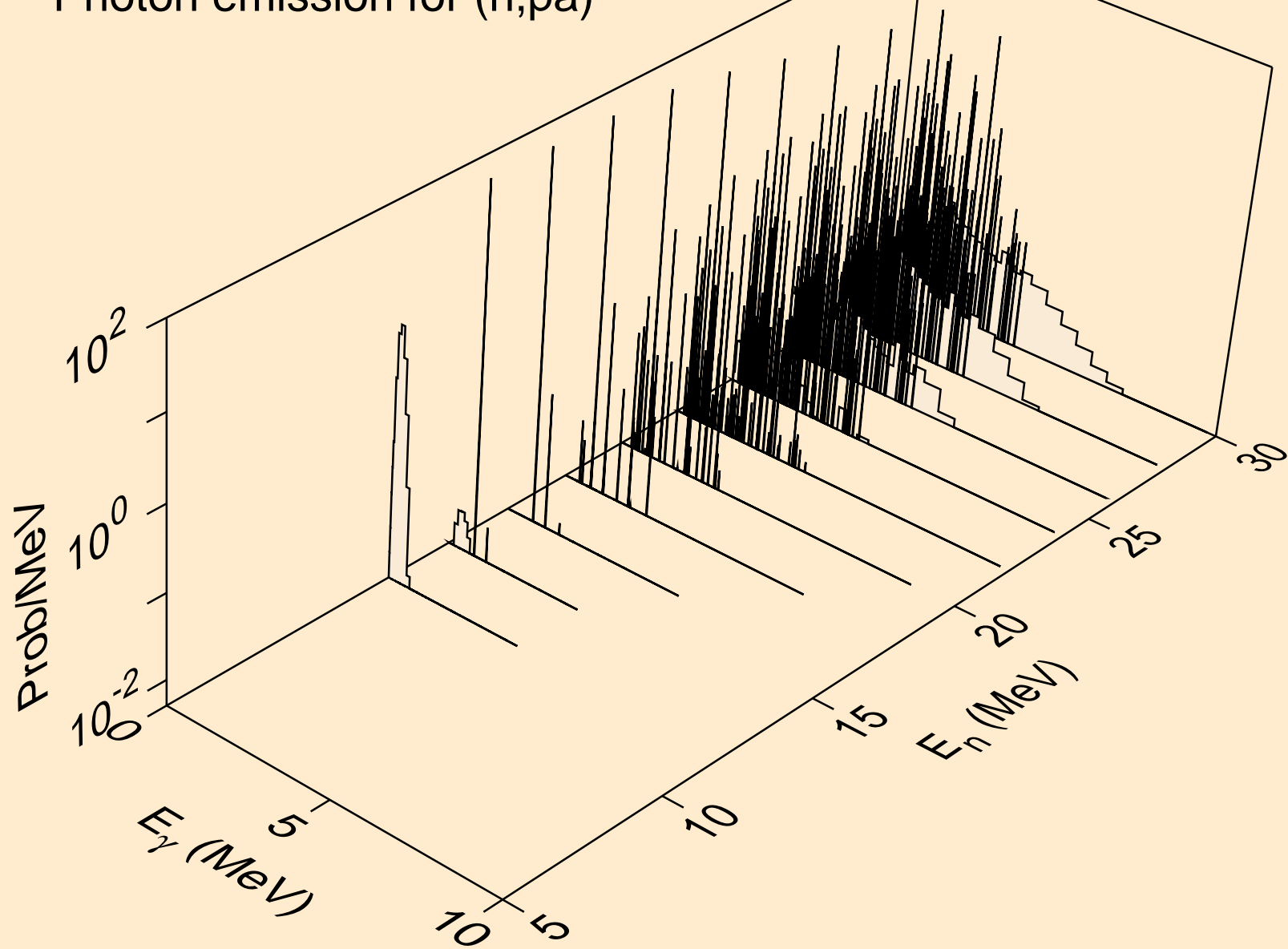

AR037 ALPHA ACER TENDL-2024 LIBRARY; T=0.K  
Photon emission for (n,pd)

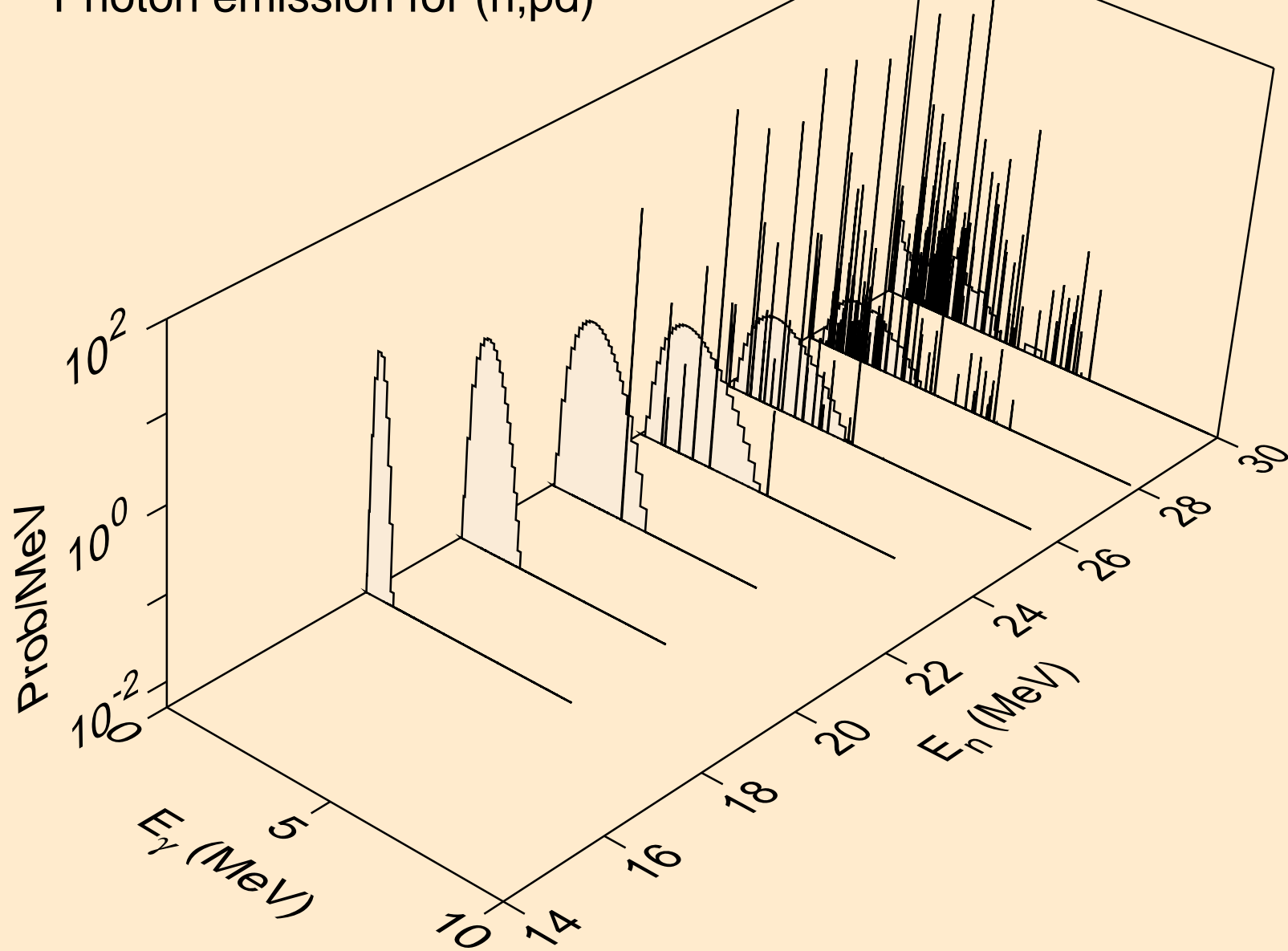

AR037 ALPHA ACER TENDL-2024 LIBRARY; T=0.K  
Photon emission for (n,pt)

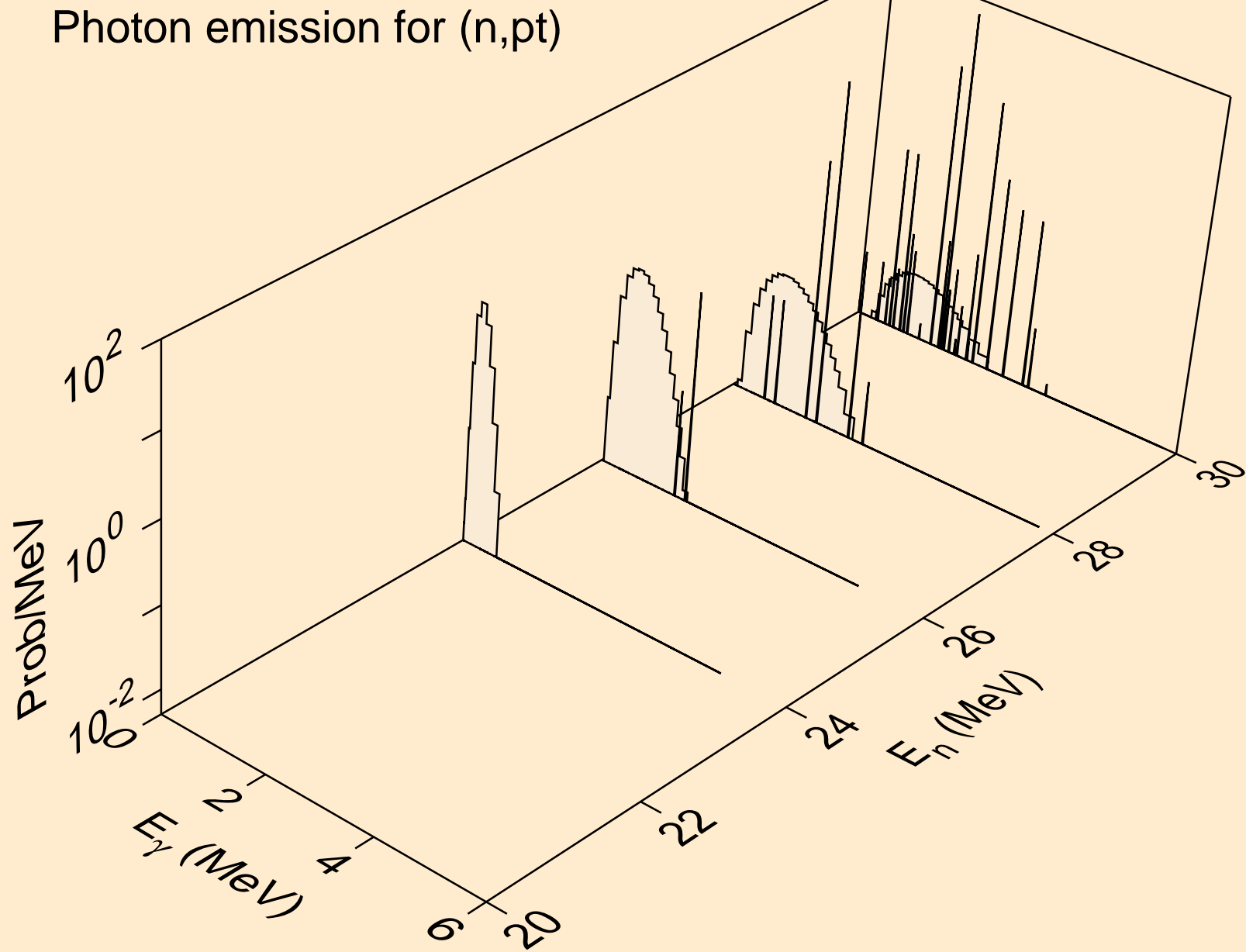

AR037 ALPHA ACER TENDL-2024 LIBRARY; T=0.K  
Photon emission for (n,da)

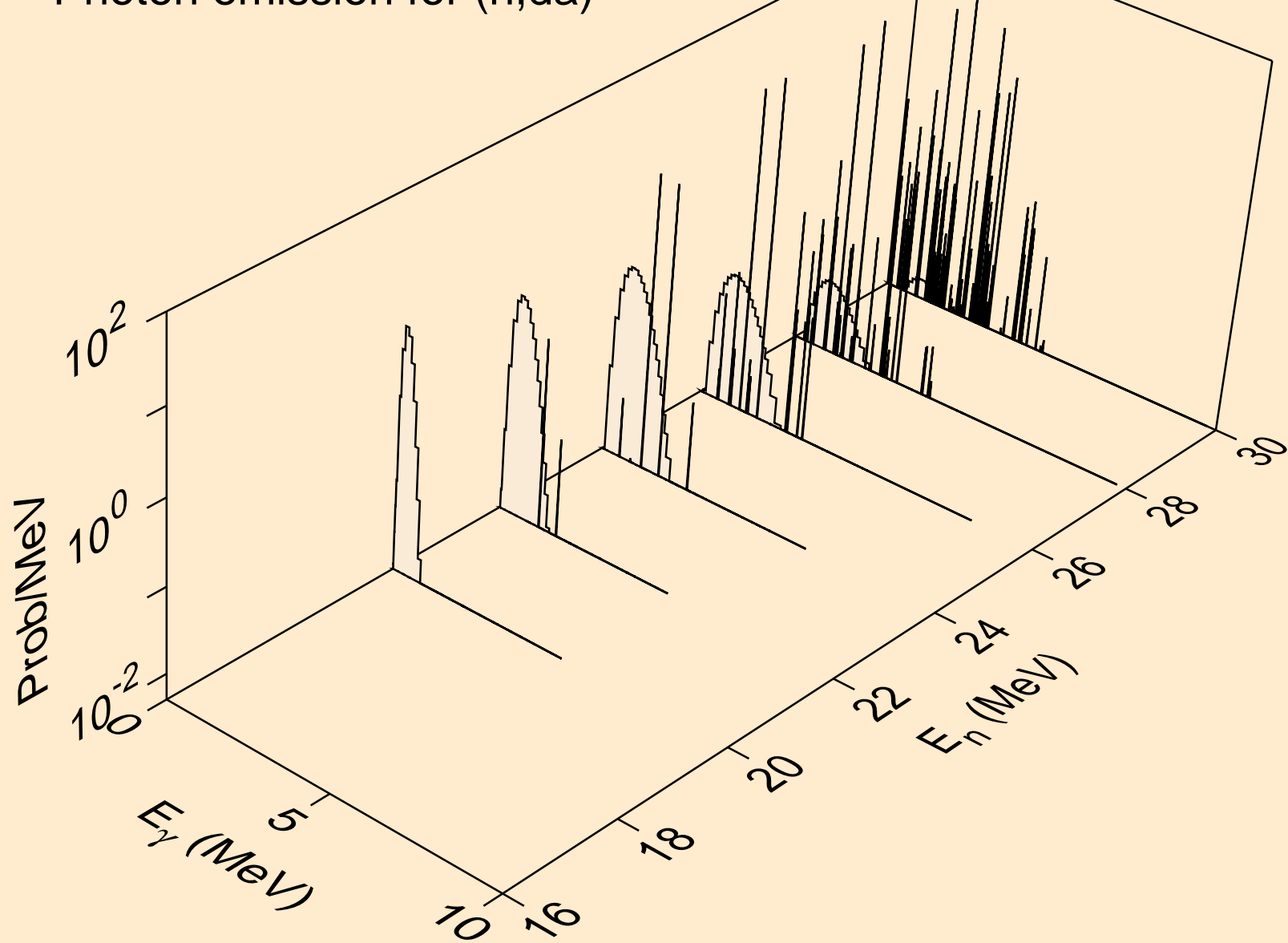

# AR037 ALPHA ACER TENDL-2024 LIBRARY; T=0.K

## Particle heating contributions

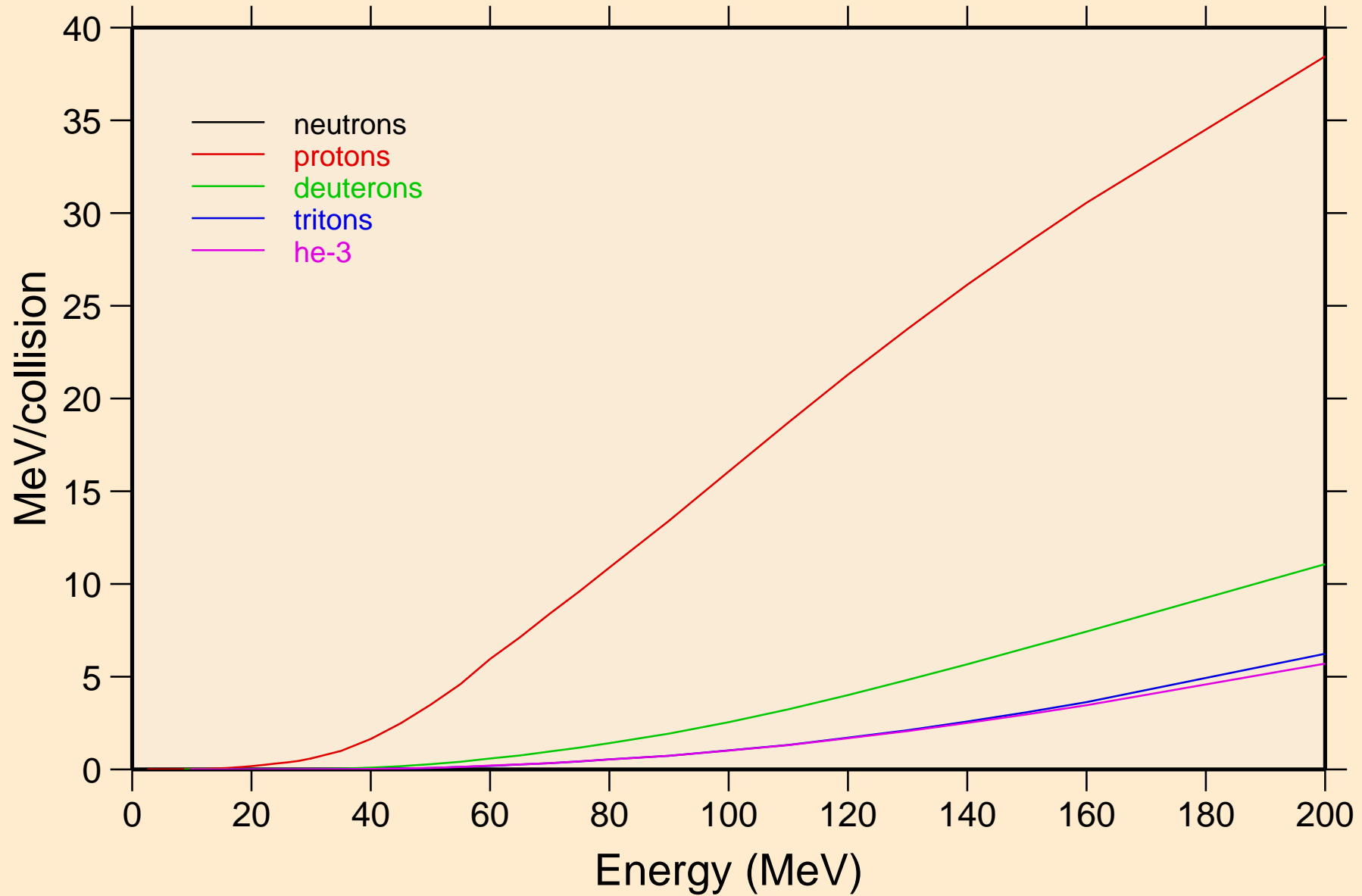

AR037 ALPHA ACER TENDL-2024 LIBRARY; T=0.K  
Recoil Heating

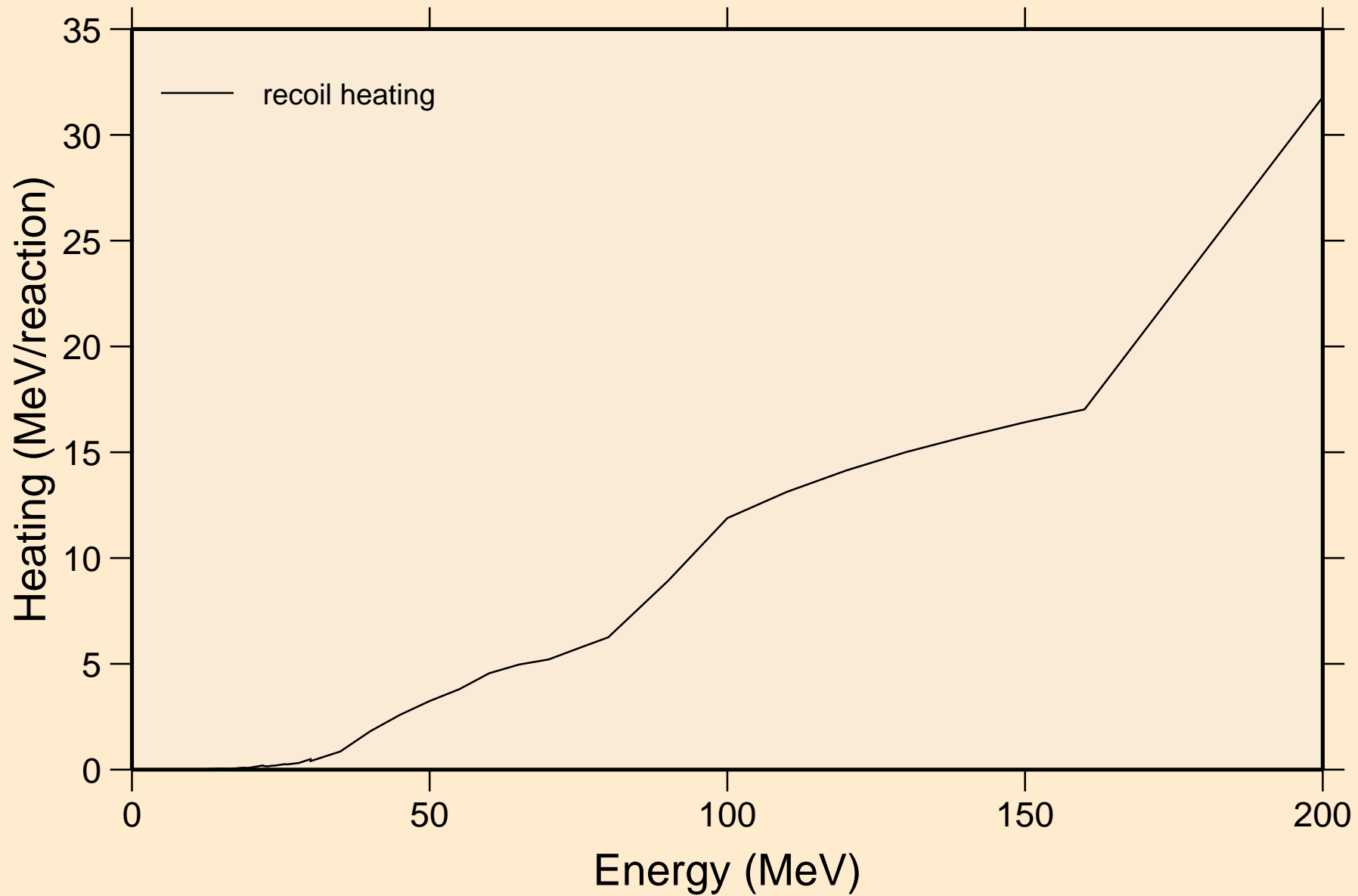

AR037 ALPHA ACER TENDL-2024 LIBRARY; T=0.K  
Particle production cross sections

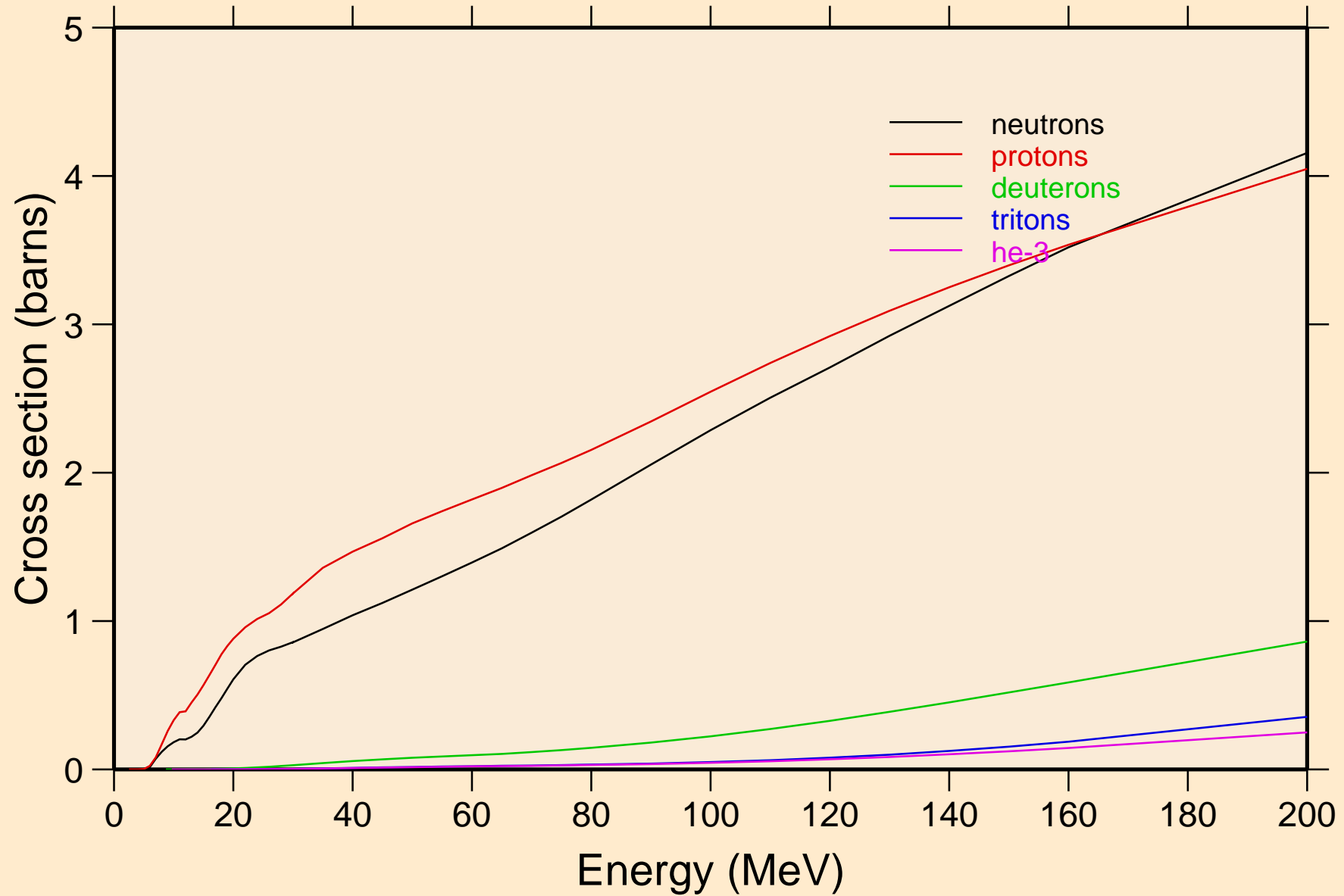

AR037 ALPHA ACER TENDL-2024 LIBRARY; T=0.K  
neutrons from (a,n)

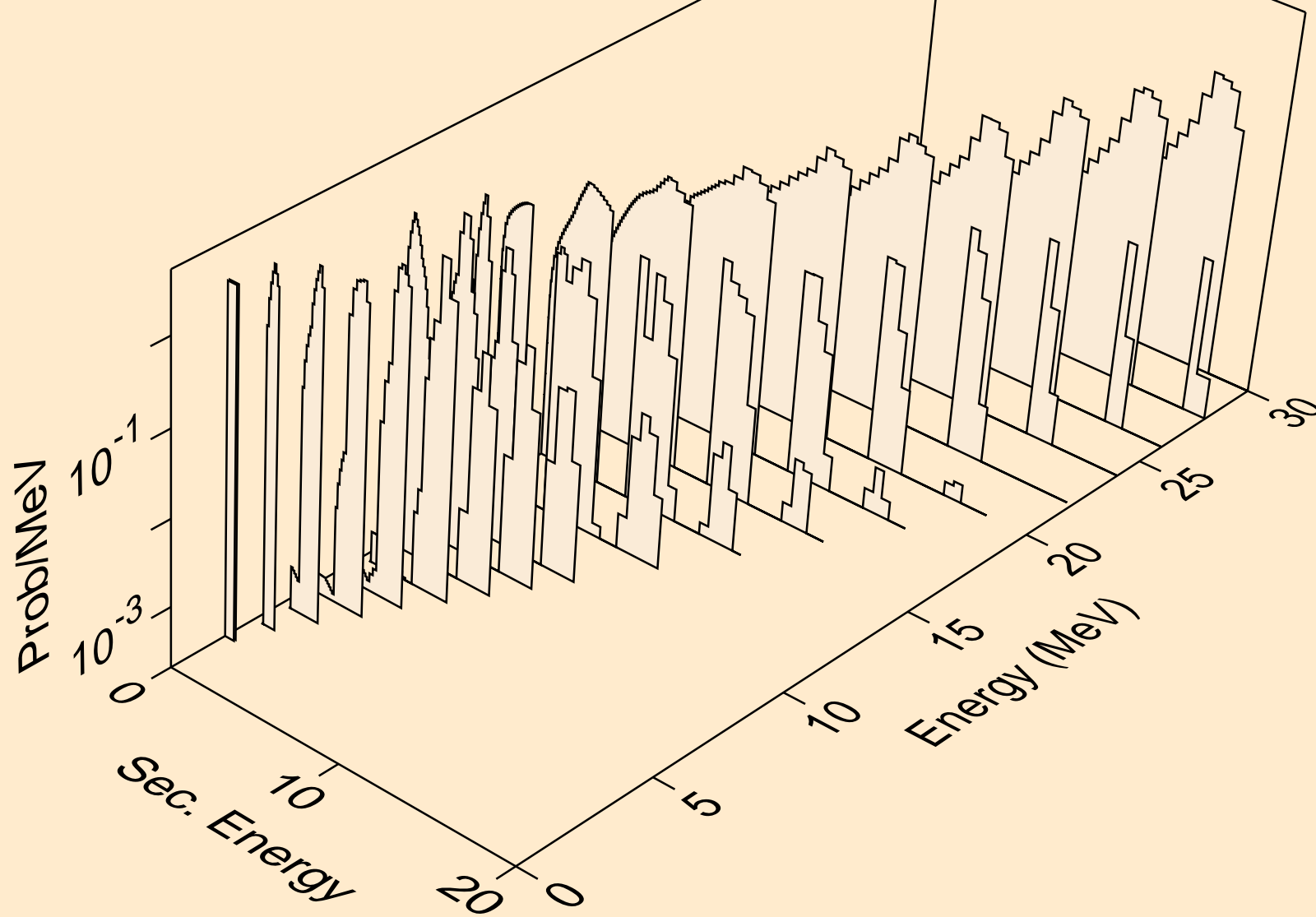

AR037 ALPHA ACER TENDL-2024 LIBRARY; T=0.K  
neutrons from (a,x)

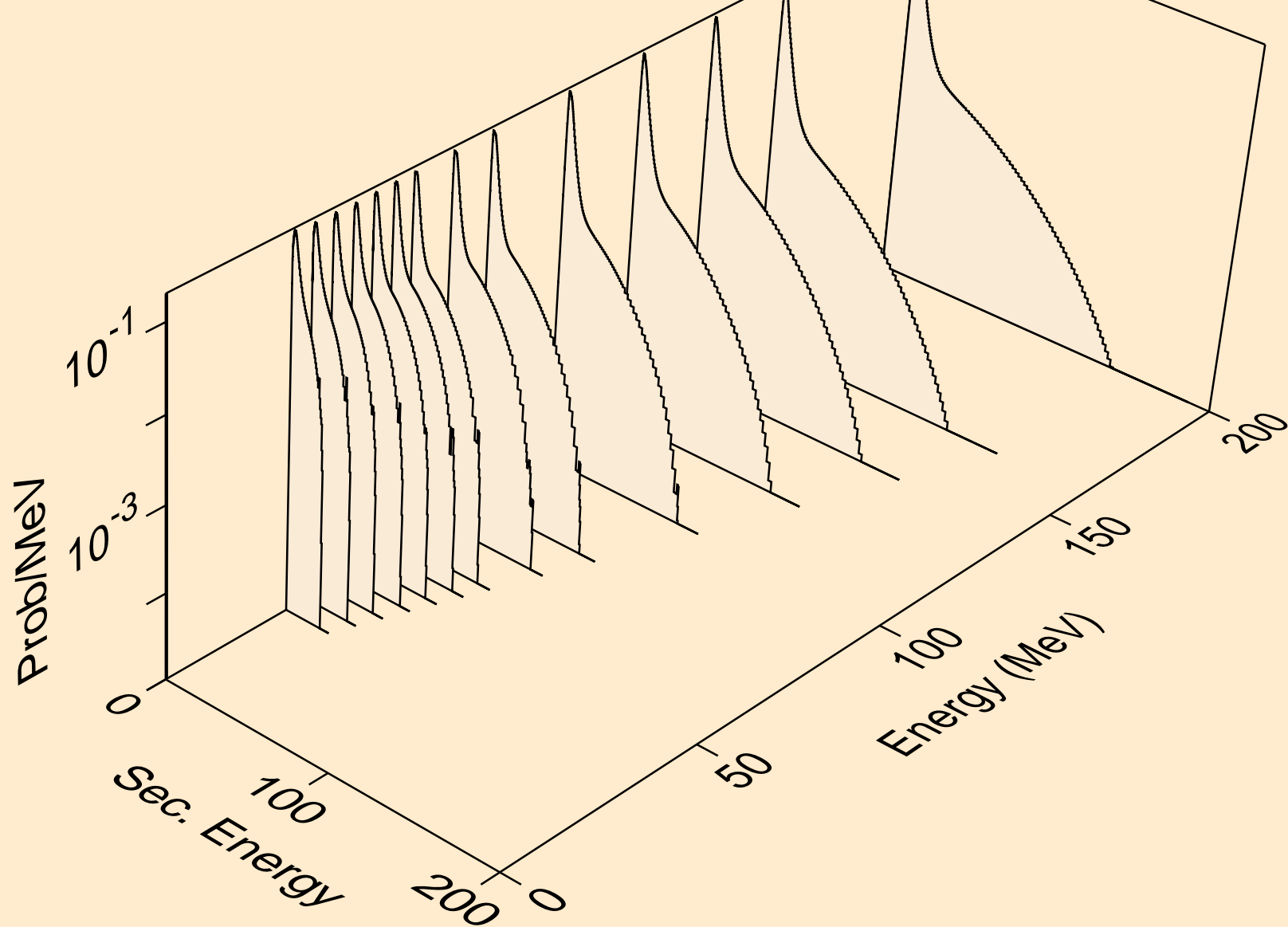

AR037 ALPHA ACER TENDL-2024 LIBRARY; T=0.K  
neutrons from (a,2n)

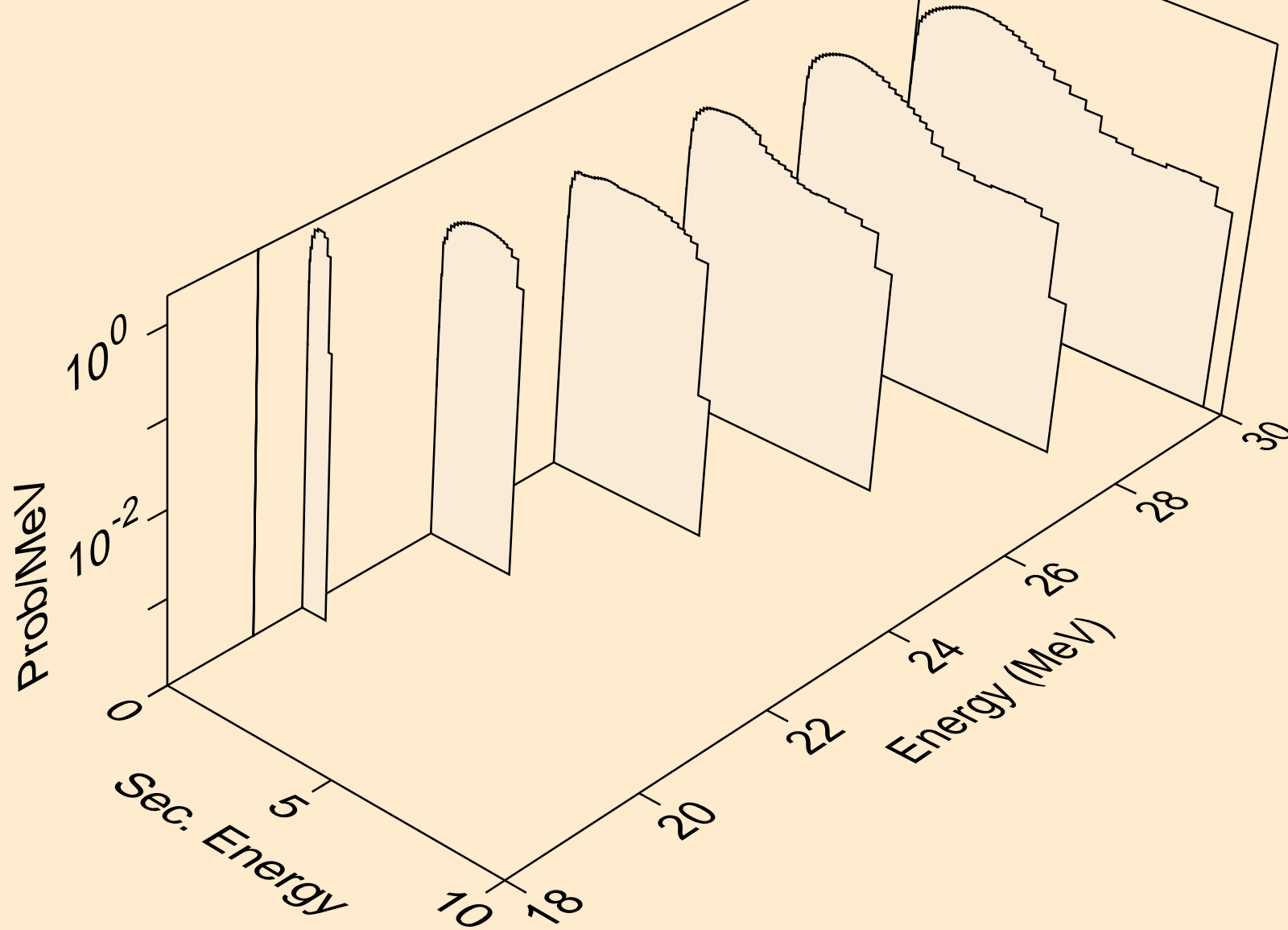

AR037 ALPHA ACER TENDL-2024 LIBRARY; T=0.K  
neutrons from (a,n\*)a

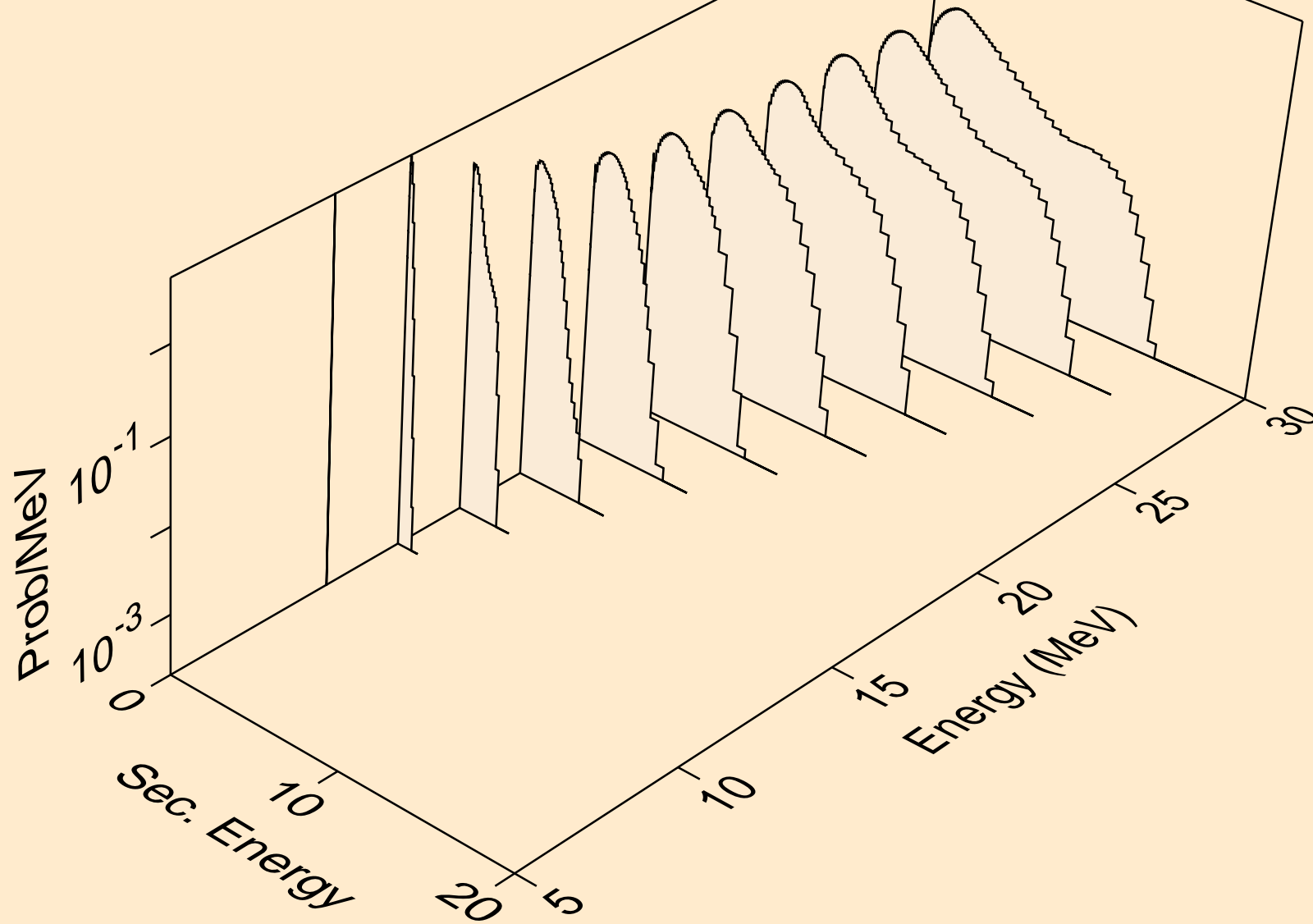

AR037 ALPHA ACER TENDL-2024 LIBRARY; T=0.K  
neutrons from (a,n\*)p

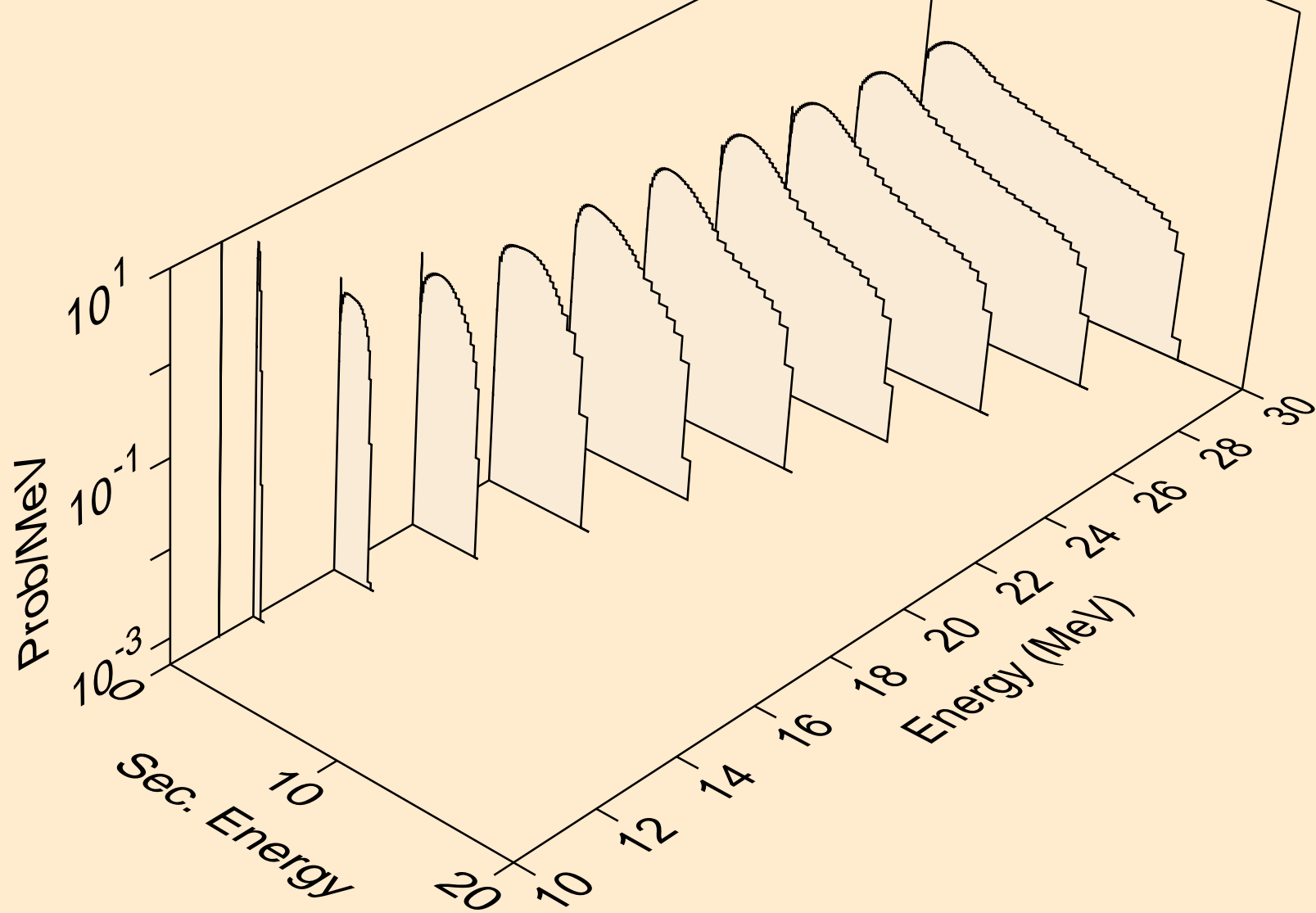

AR037 ALPHA ACER TENDL-2024 LIBRARY; T=0.K  
neutrons from (a,n\*)2a

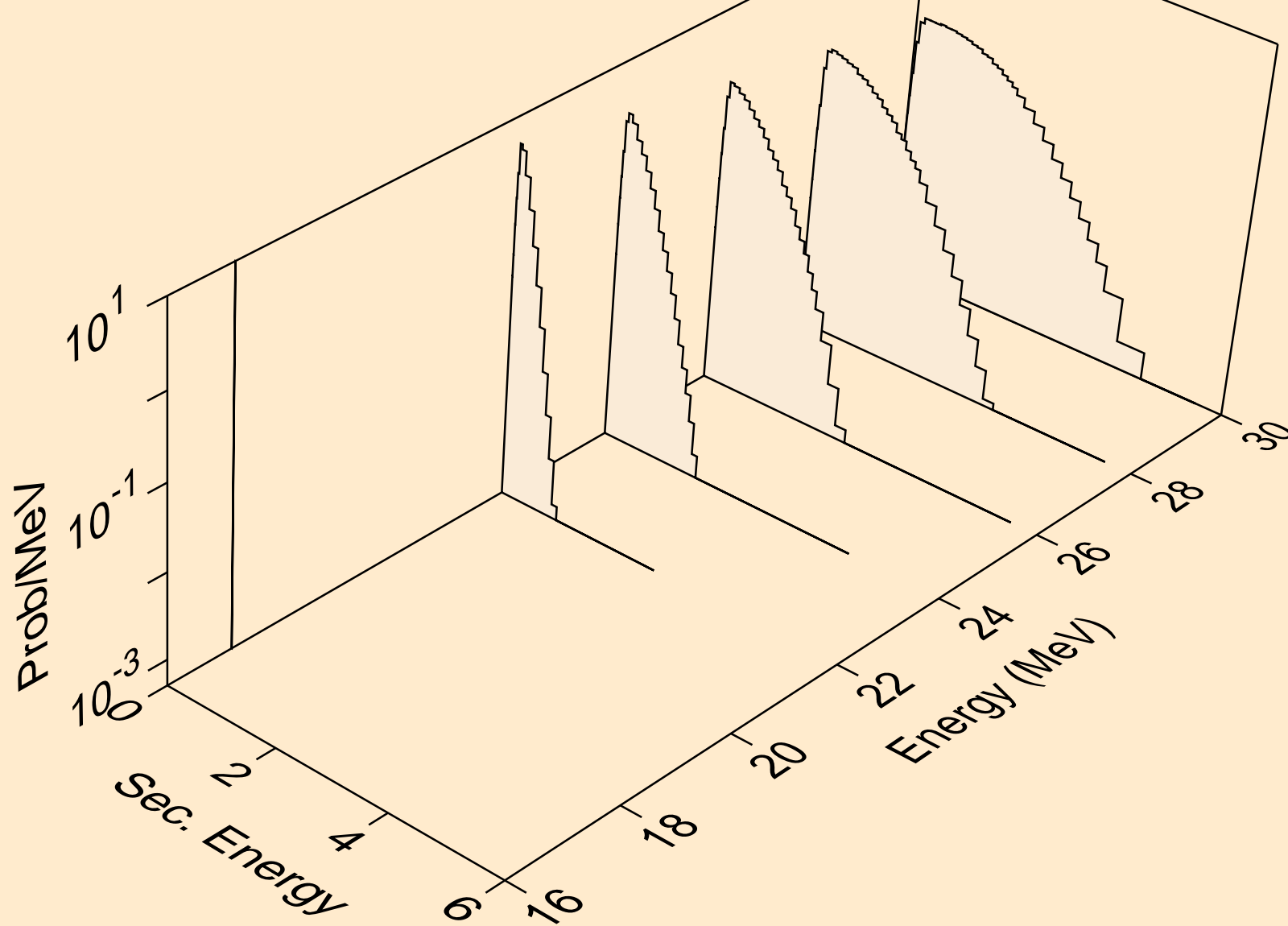

AR037 ALPHA ACER TENDL-2024 LIBRARY; T=0.K  
neutrons from (a,n\*)d

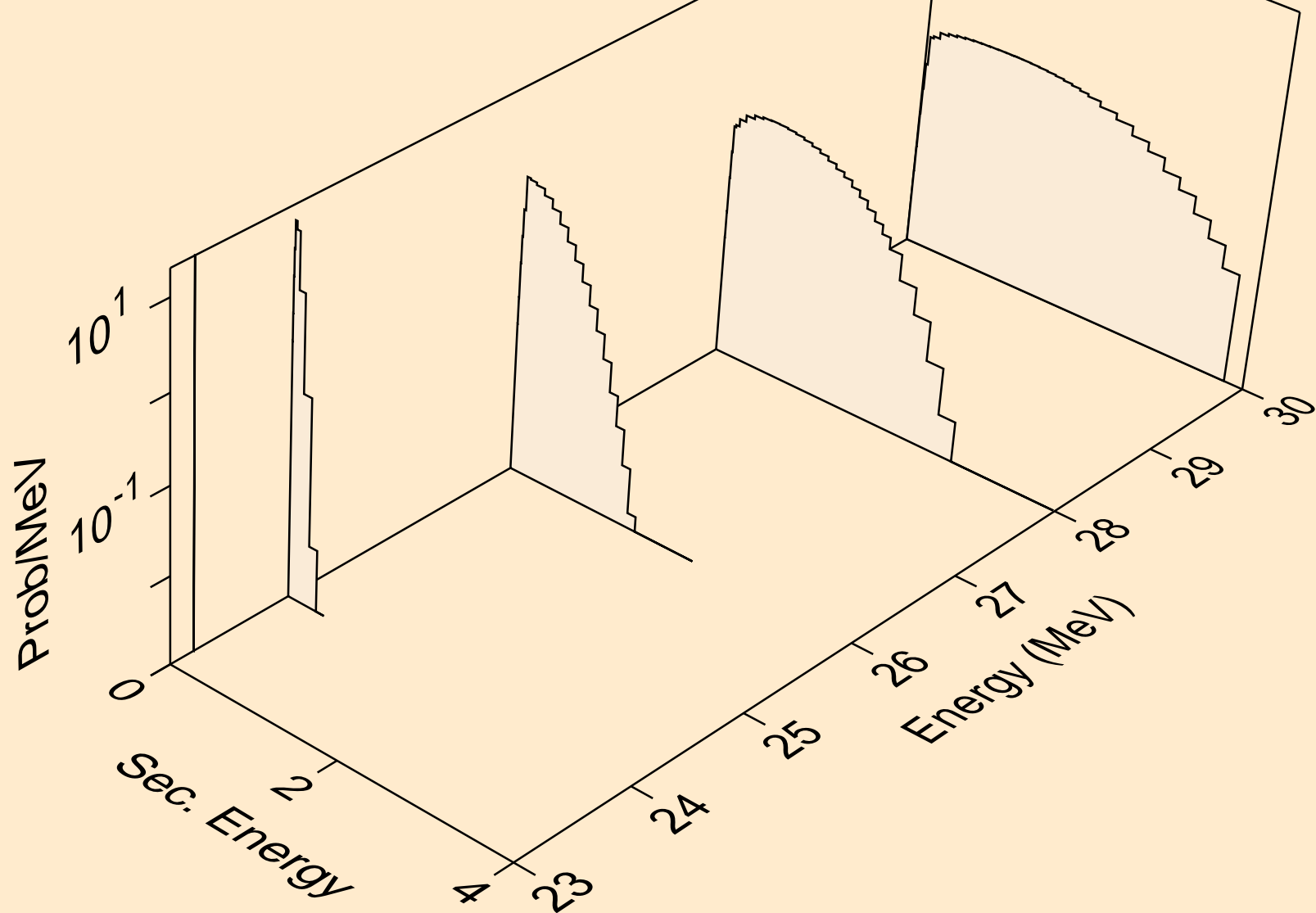

AR037 ALPHA ACER TENDL-2024 LIBRARY; T=0.K  
neutrons from (a,n\*)he3

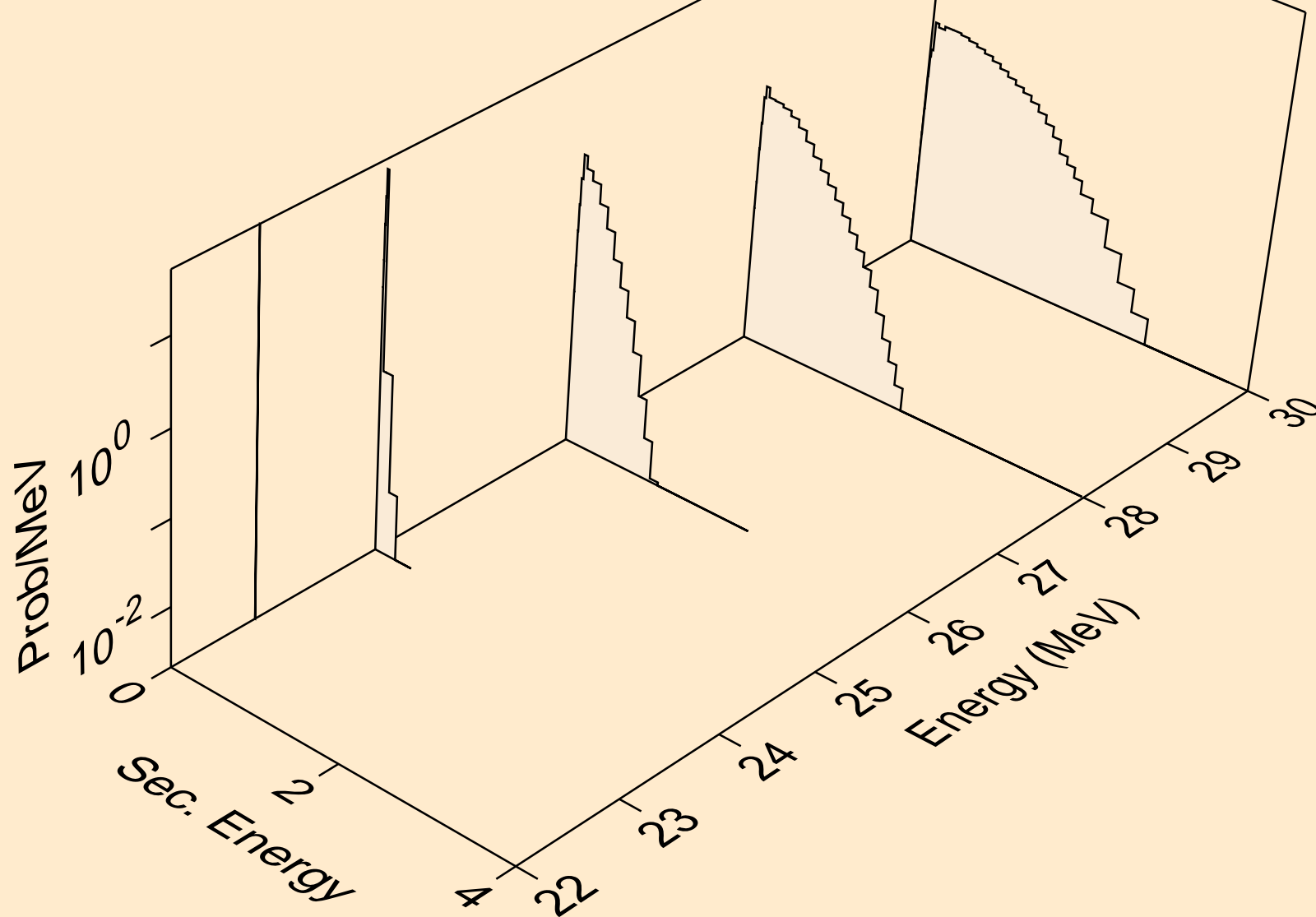

AR037 ALPHA ACER TENDL-2024 LIBRARY; T=0.K  
neutrons from (a,2np)

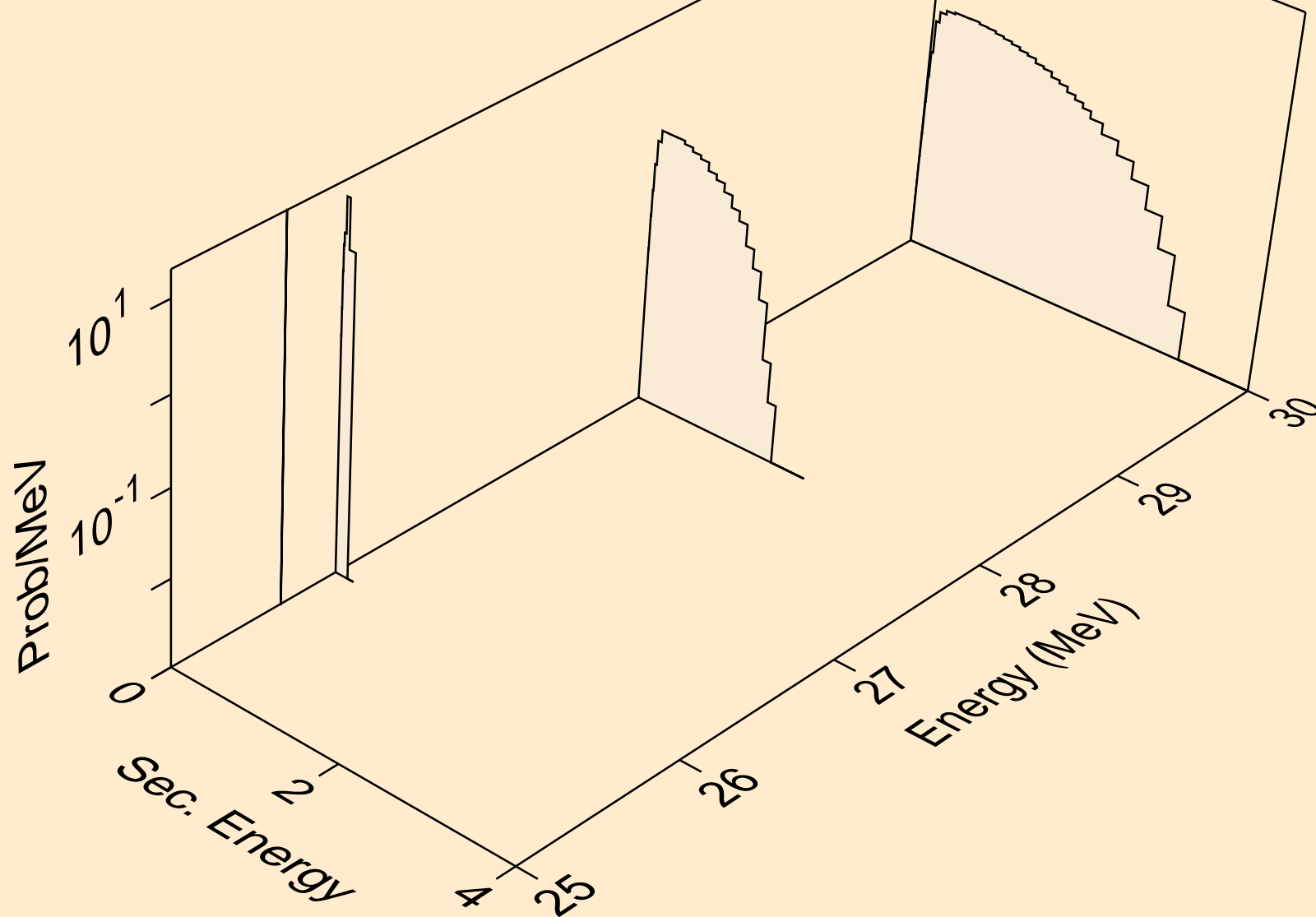

AR037 ALPHA ACER TENDL-2024 LIBRARY; T=0.K  
neutrons from (a,n2p)

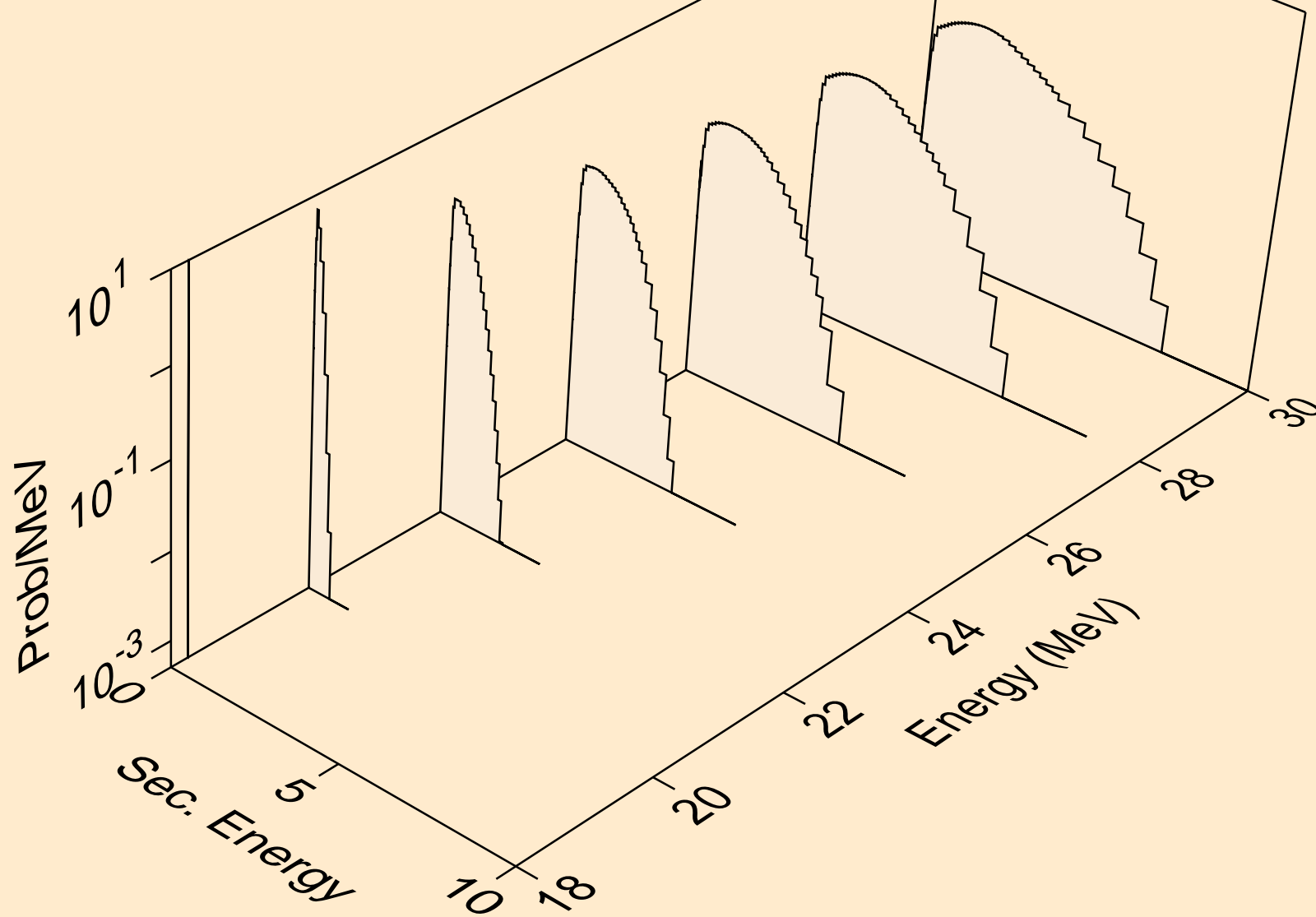

AR037 ALPHA ACER TENDL-2024 LIBRARY; T=0.K  
neutrons from (a,npa)

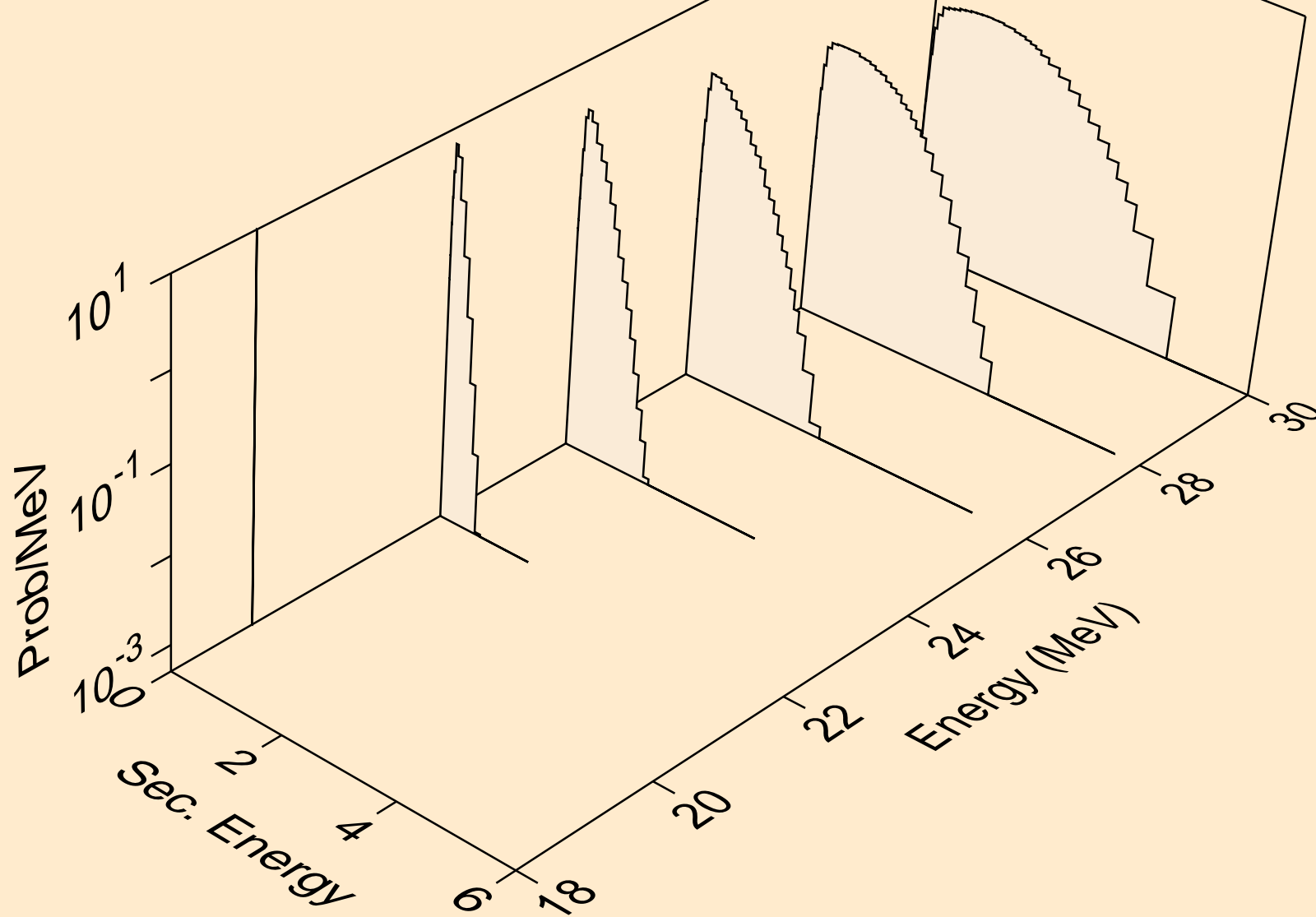

AR037 ALPHA ACER TENDL-2024 LIBRARY; T=0.K  
protons from (a,x)

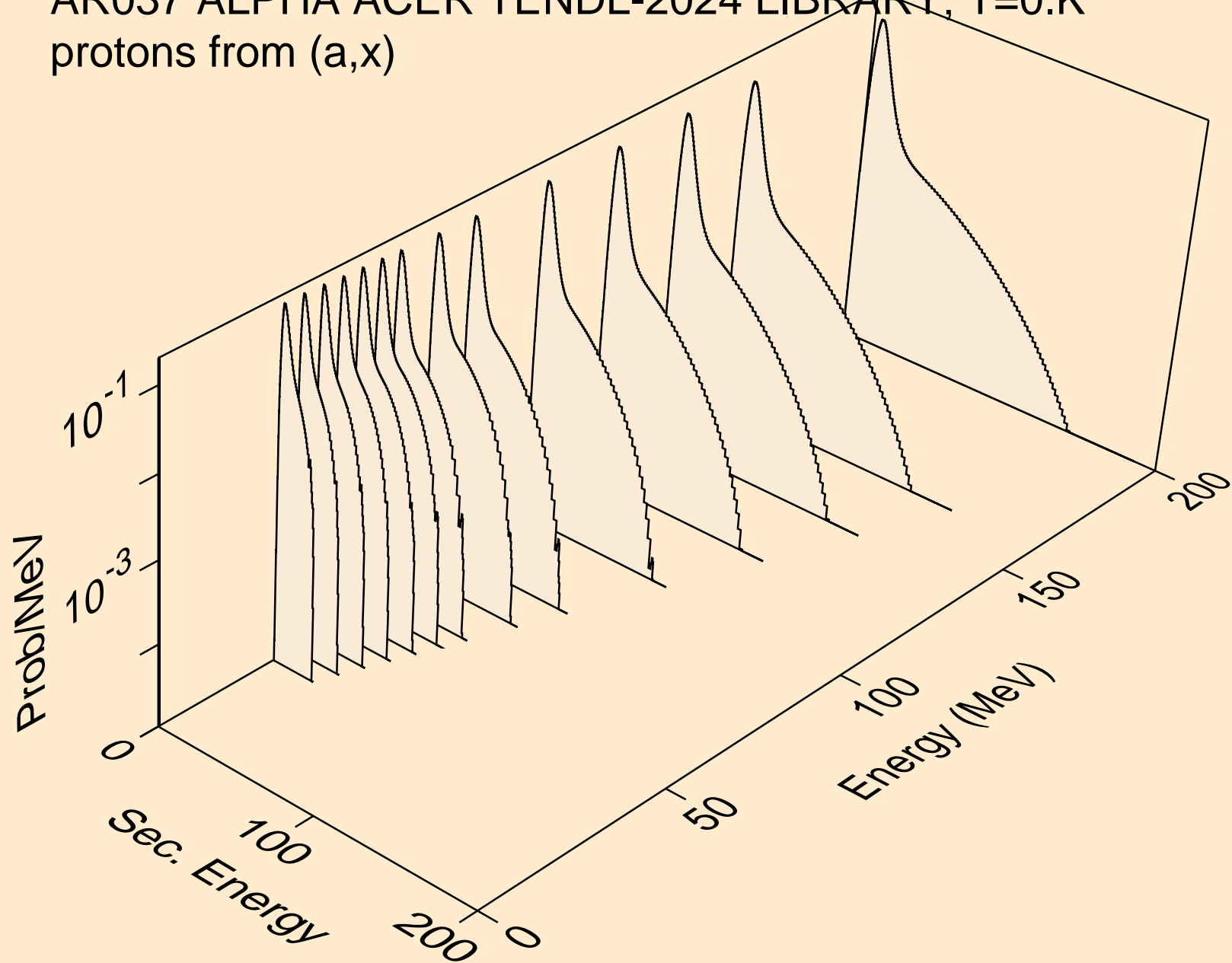

AR037 ALPHA ACER TENDL-2024 LIBRARY; T=0.K  
protons from (a,n\*)p

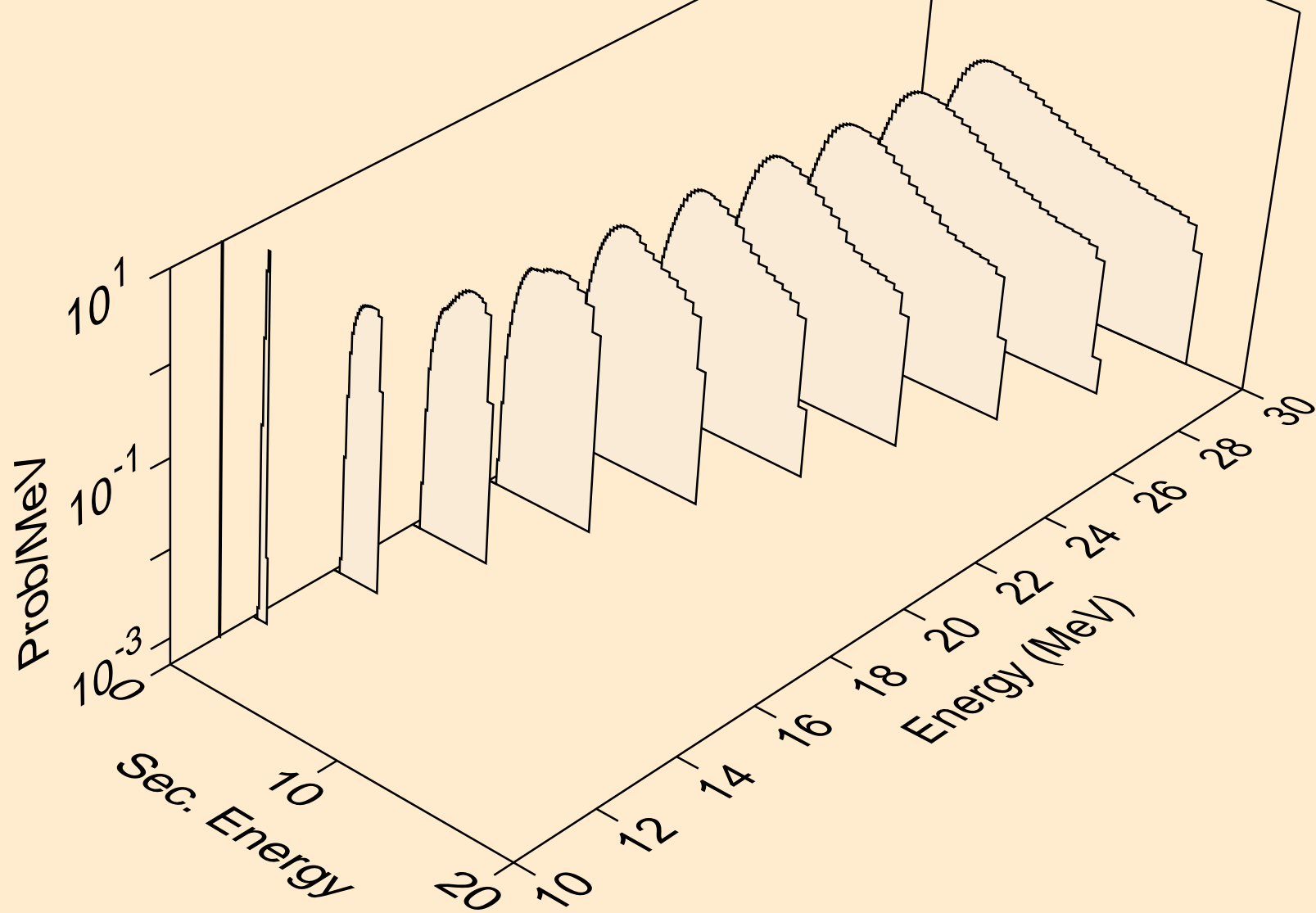

AR037 ALPHA ACER TENDL-2024 LIBRARY; T=0.K  
protons from (a,2np)

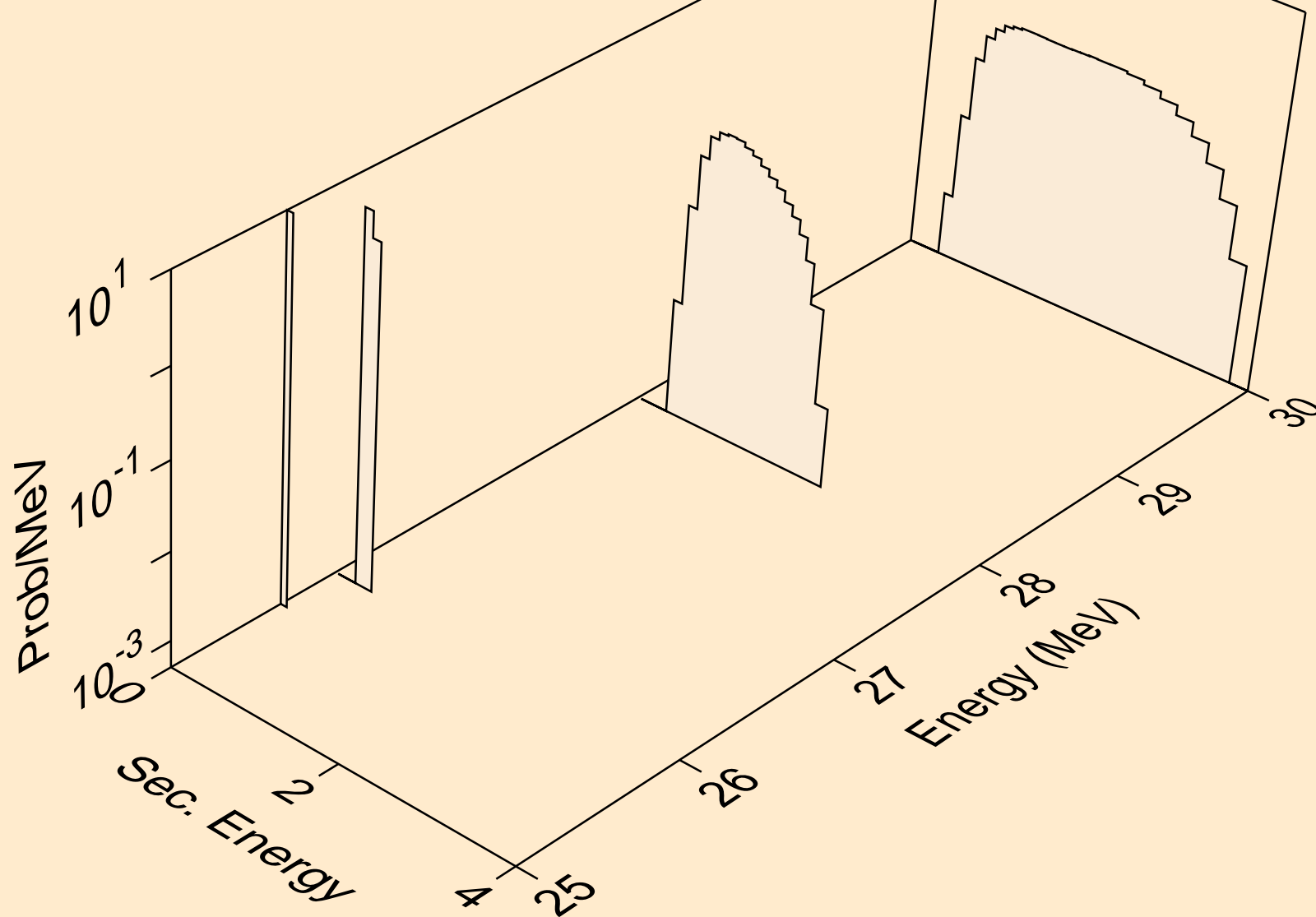

AR037 ALPHA ACER TENDL-2024 LIBRARY; T=0.K  
protons from (a,n2p)

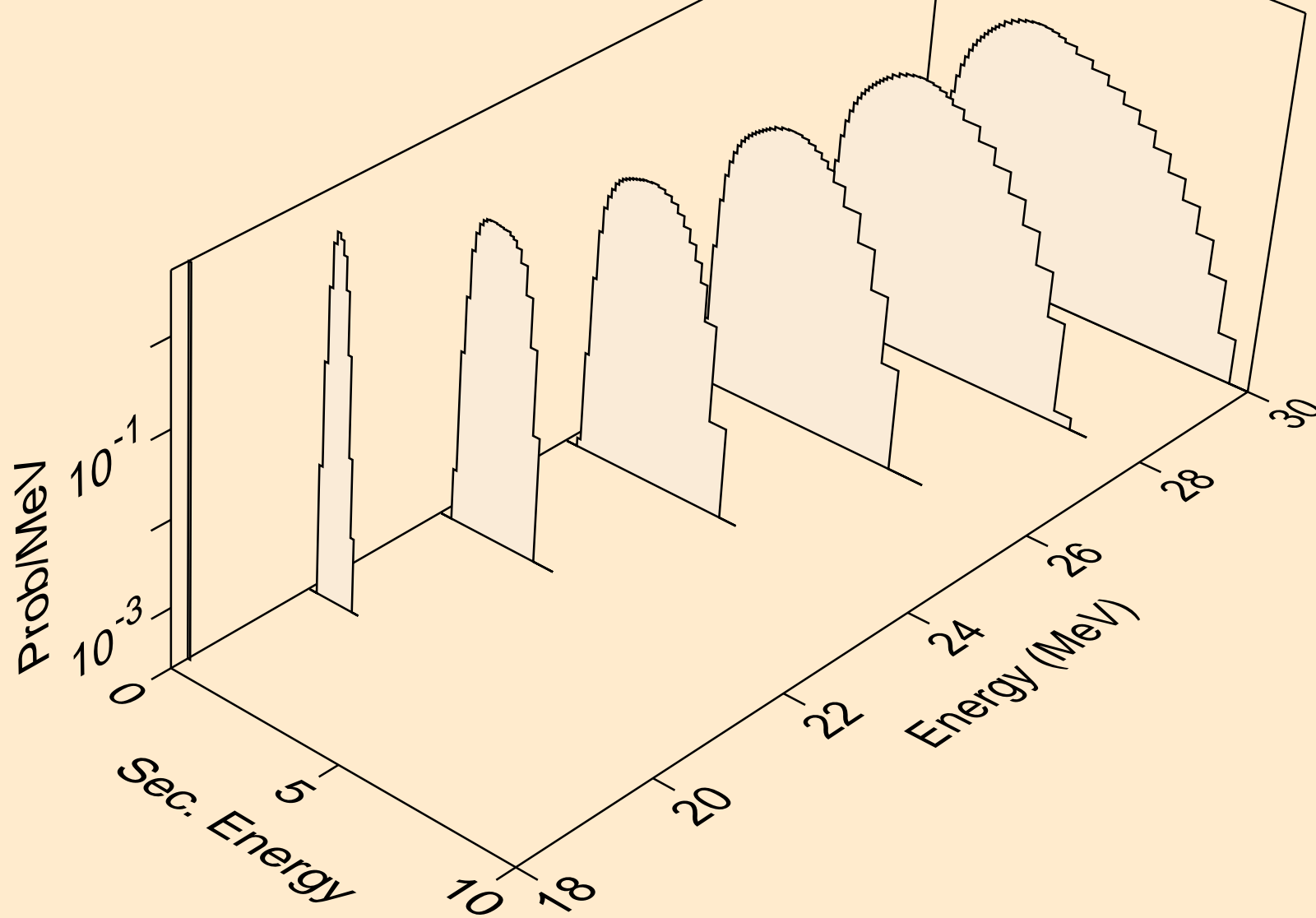

AR037 ALPHA ACER TENDL-2024 LIBRARY; T=0.K  
protons from (a,npa)

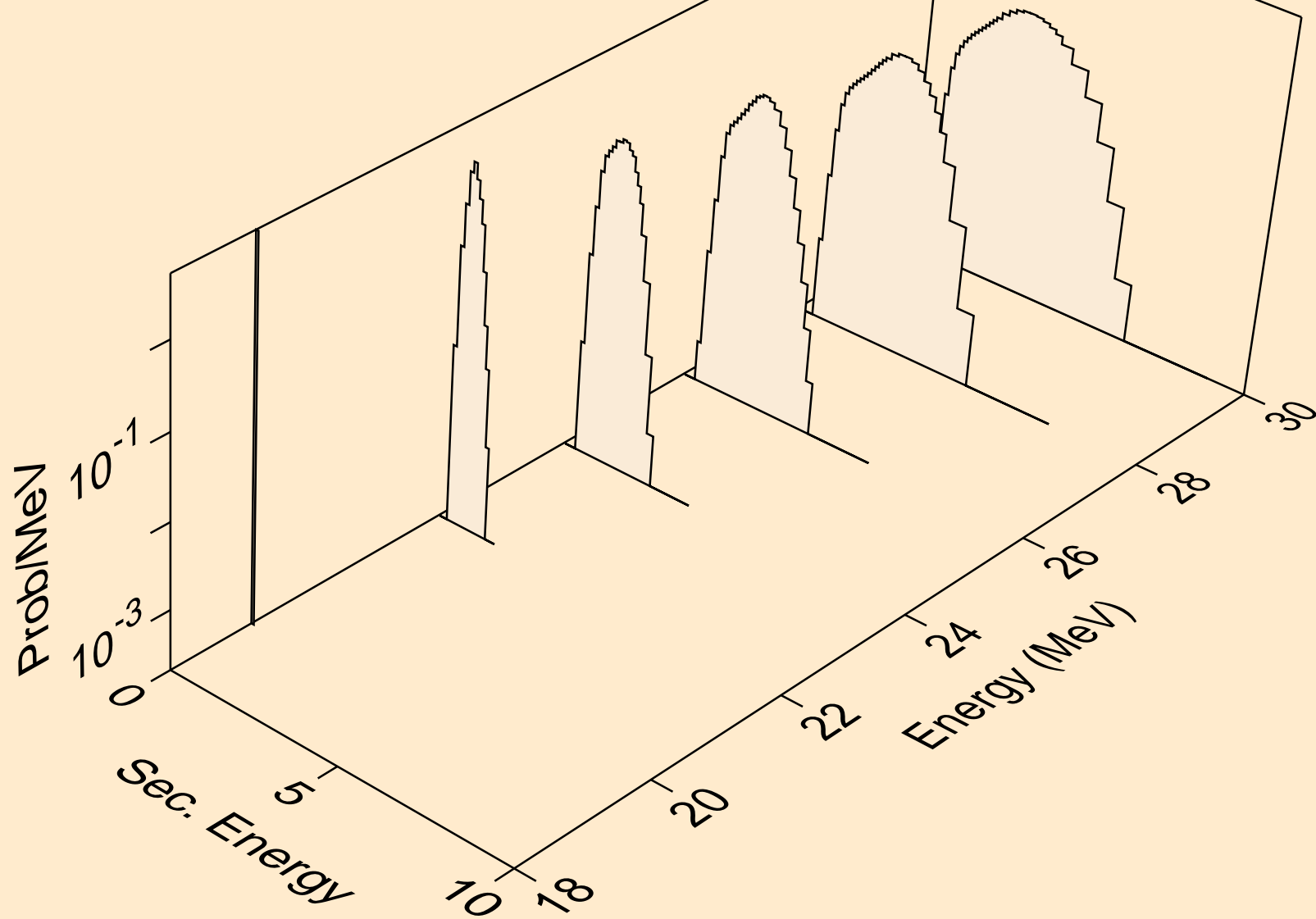

AR037 ALPHA ACER TENDL-2024 LIBRARY; T=0.K  
protons from (a,p)

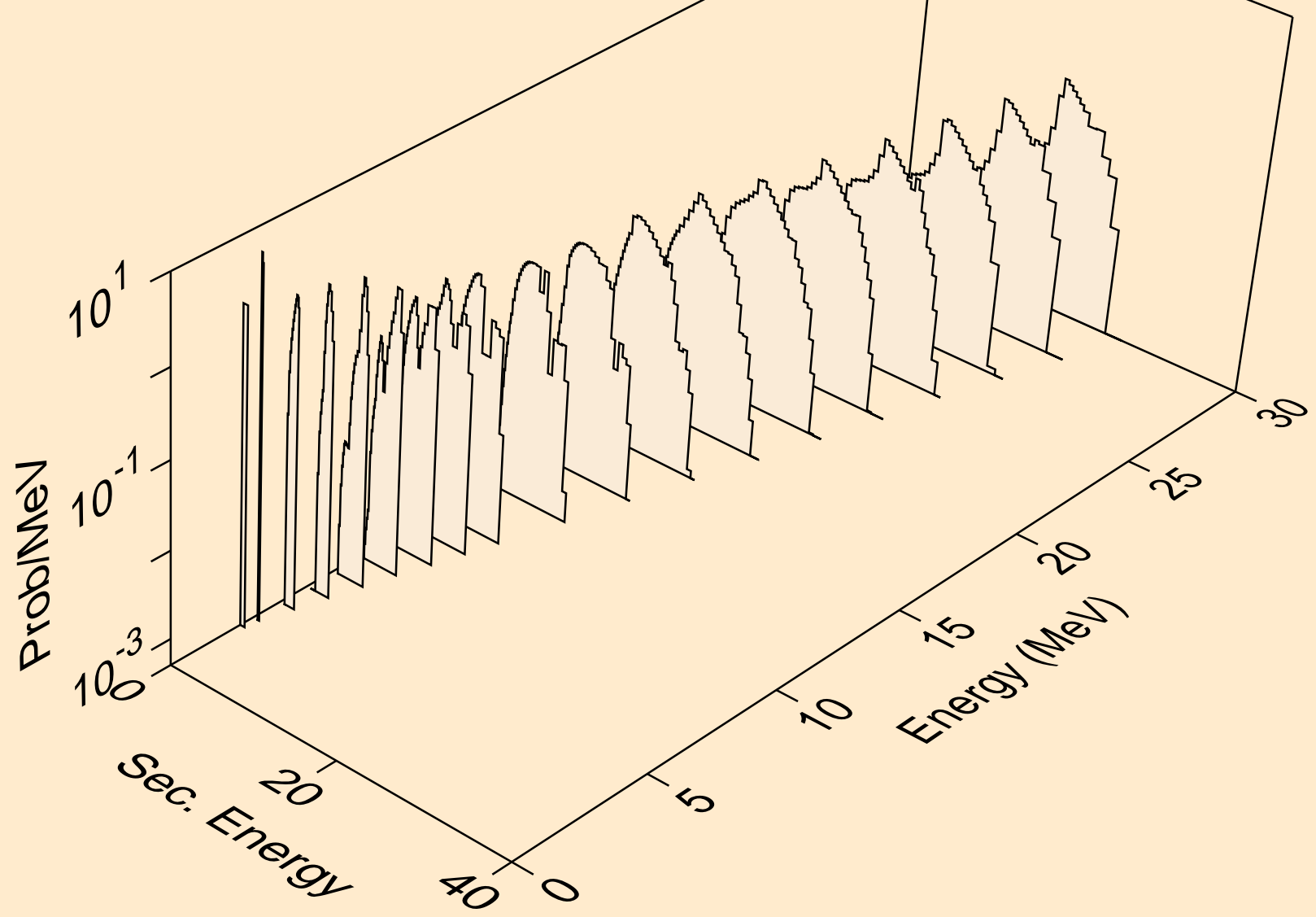

AR037 ALPHA ACER TENDL-2024 LIBRARY; T=0.K  
protons from (a,2p)

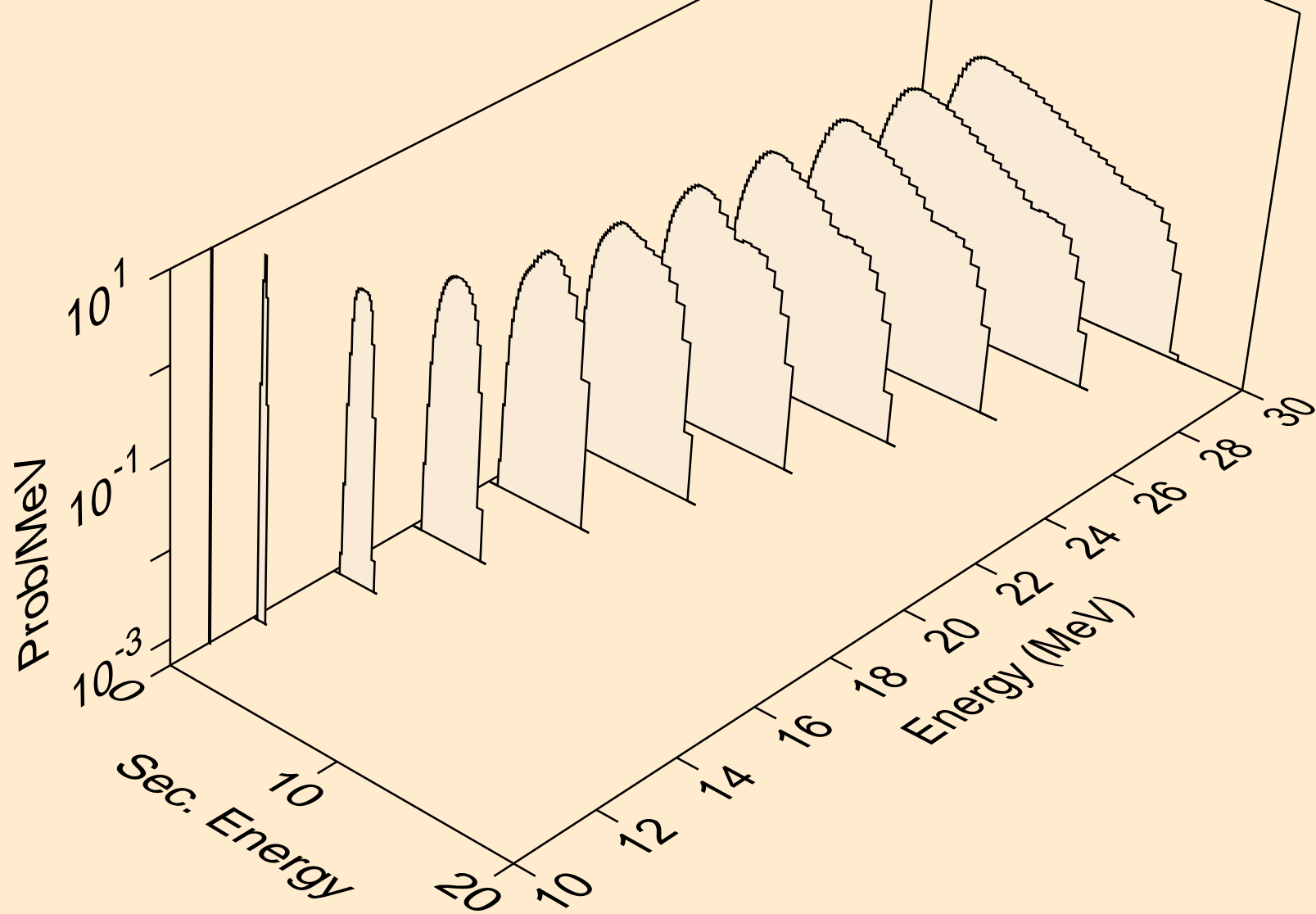

AR037 ALPHA ACER TENDL-2024 LIBRARY; T=0.K  
protons from (a,pa)

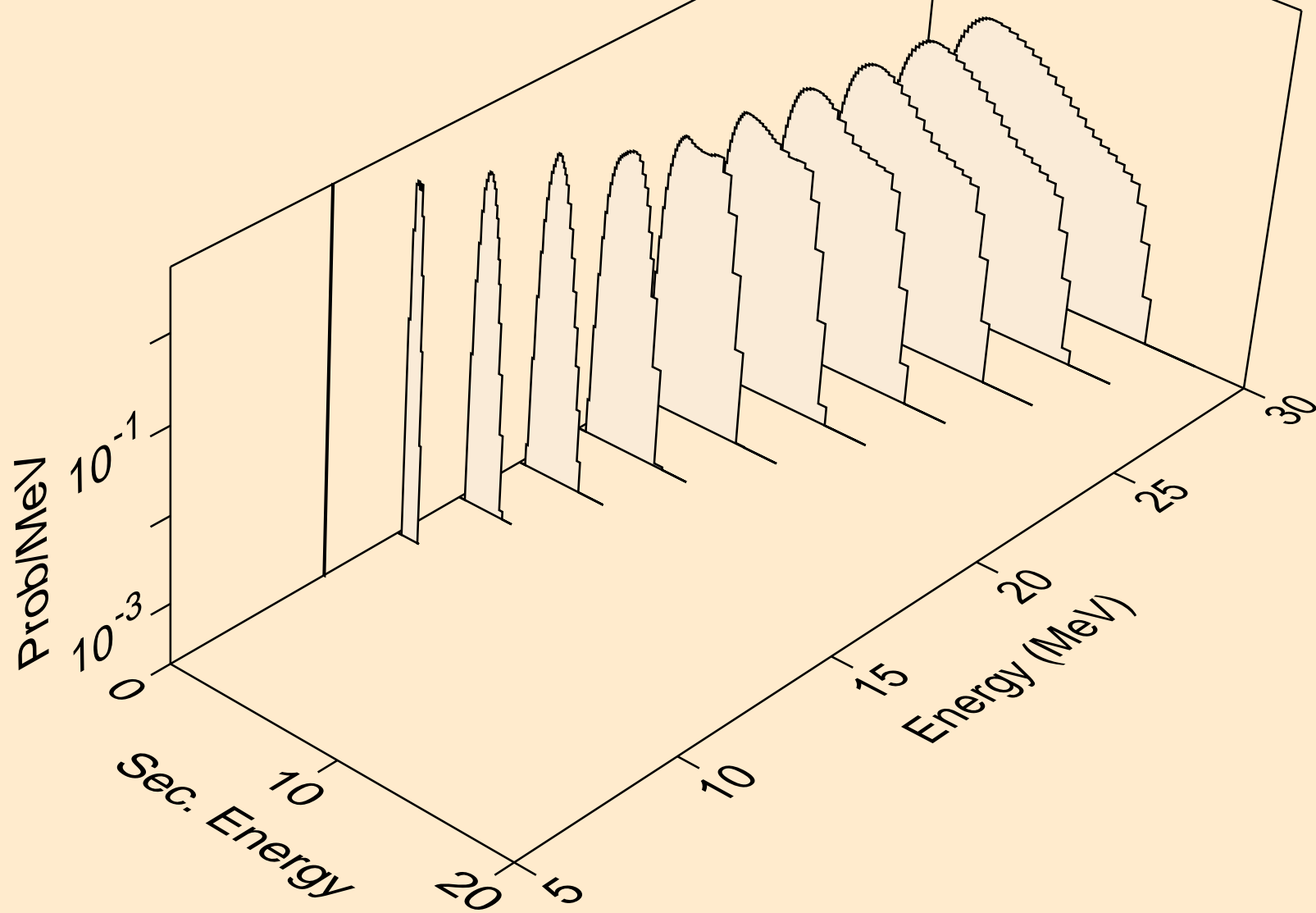

AR037 ALPHA ACER TENDL-2024 LIBRARY; T=0.K  
protons from (a,pd)

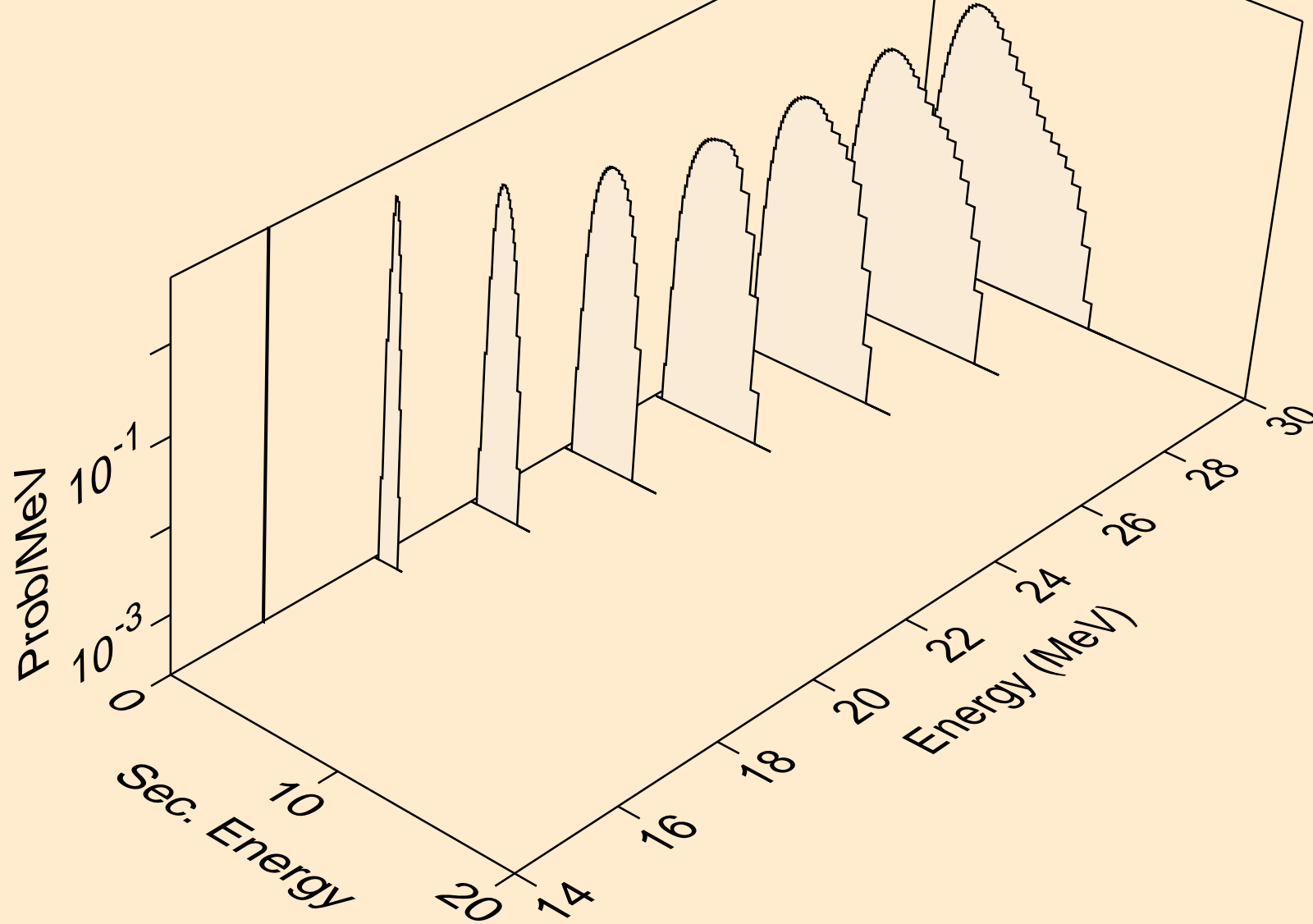

AR037 ALPHA ACER TENDL-2024 LIBRARY; T=0.K  
protons from (a,pt)

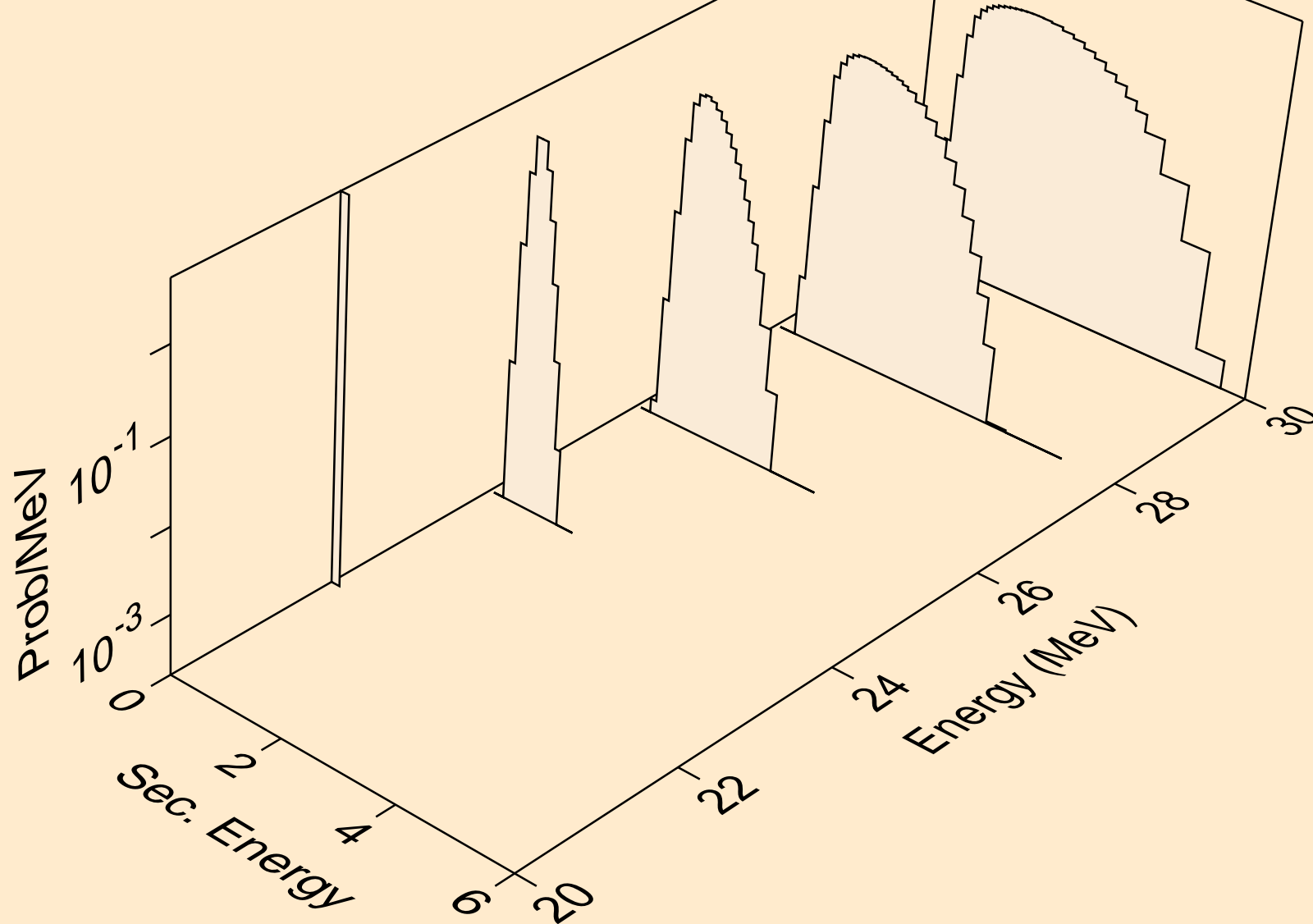

AR037 ALPHA ACER TENDL-2024 LIBRARY; T=0.K  
deuterons from (a,x)

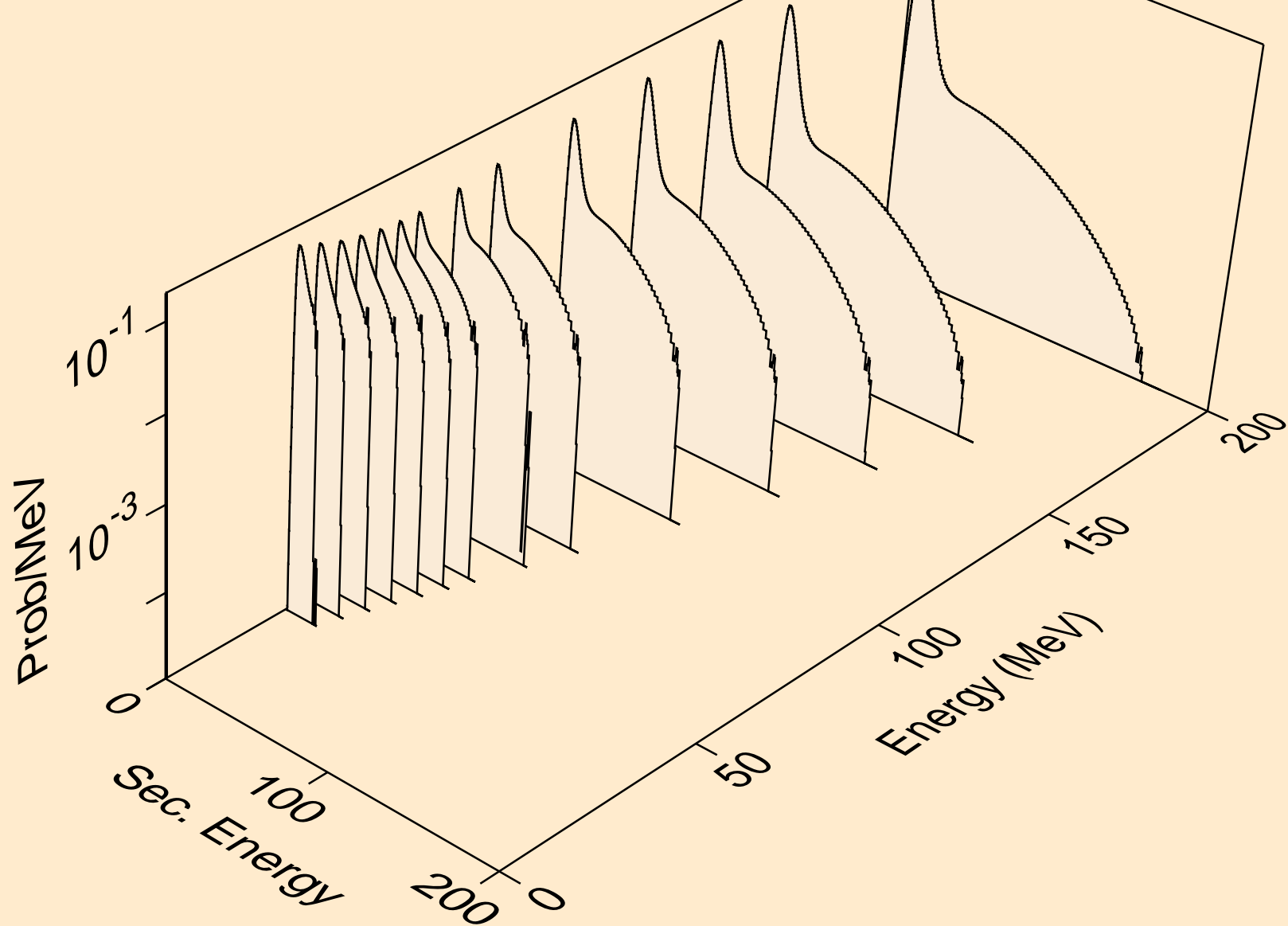

AR037 ALPHA ACER TENDL-2024 LIBRARY; T=0.K  
deuterons from (a,n\*)d

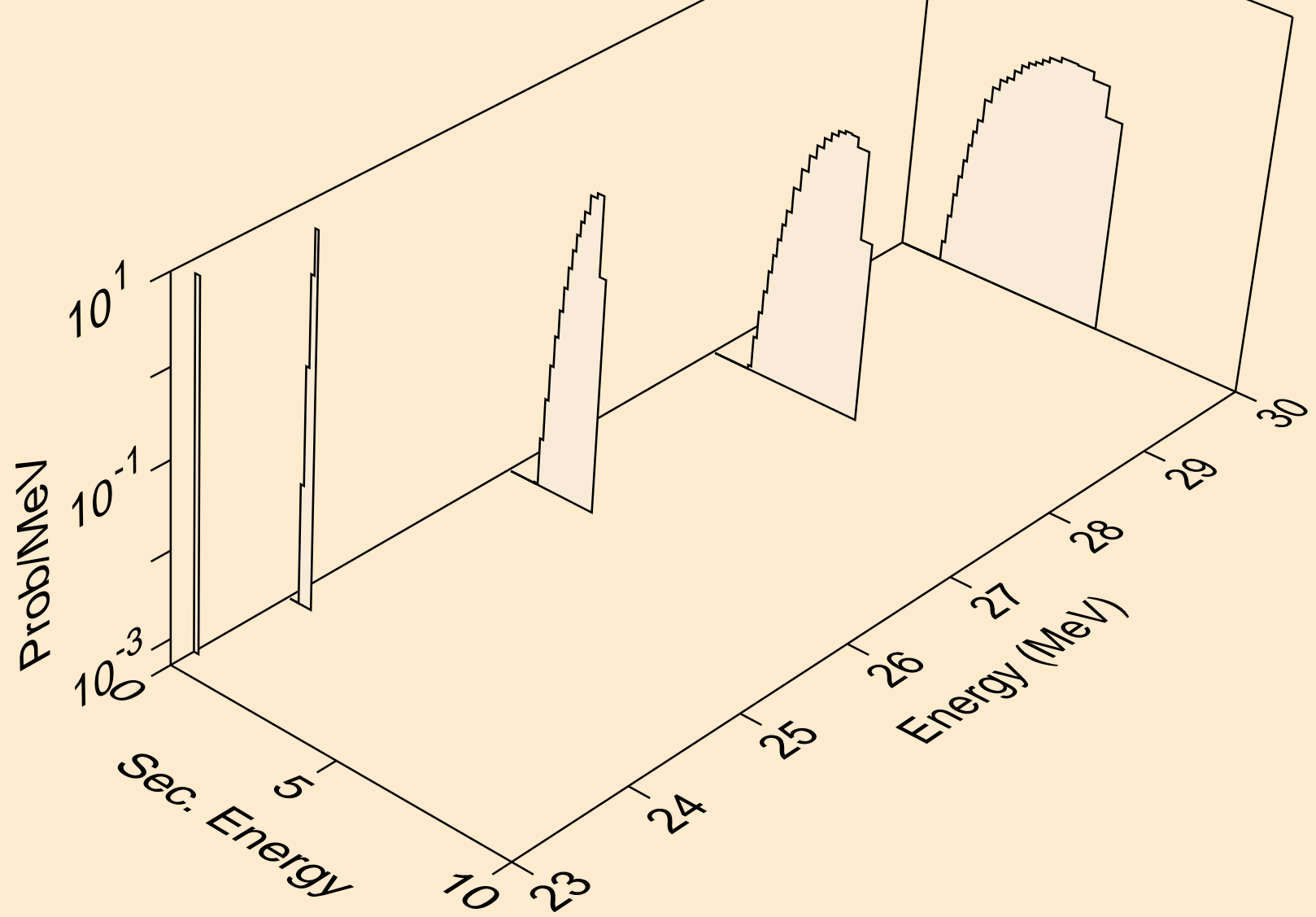

AR037 ALPHA ACER TENDL-2024 LIBRARY; T=0.K  
deuterons from (a,d)

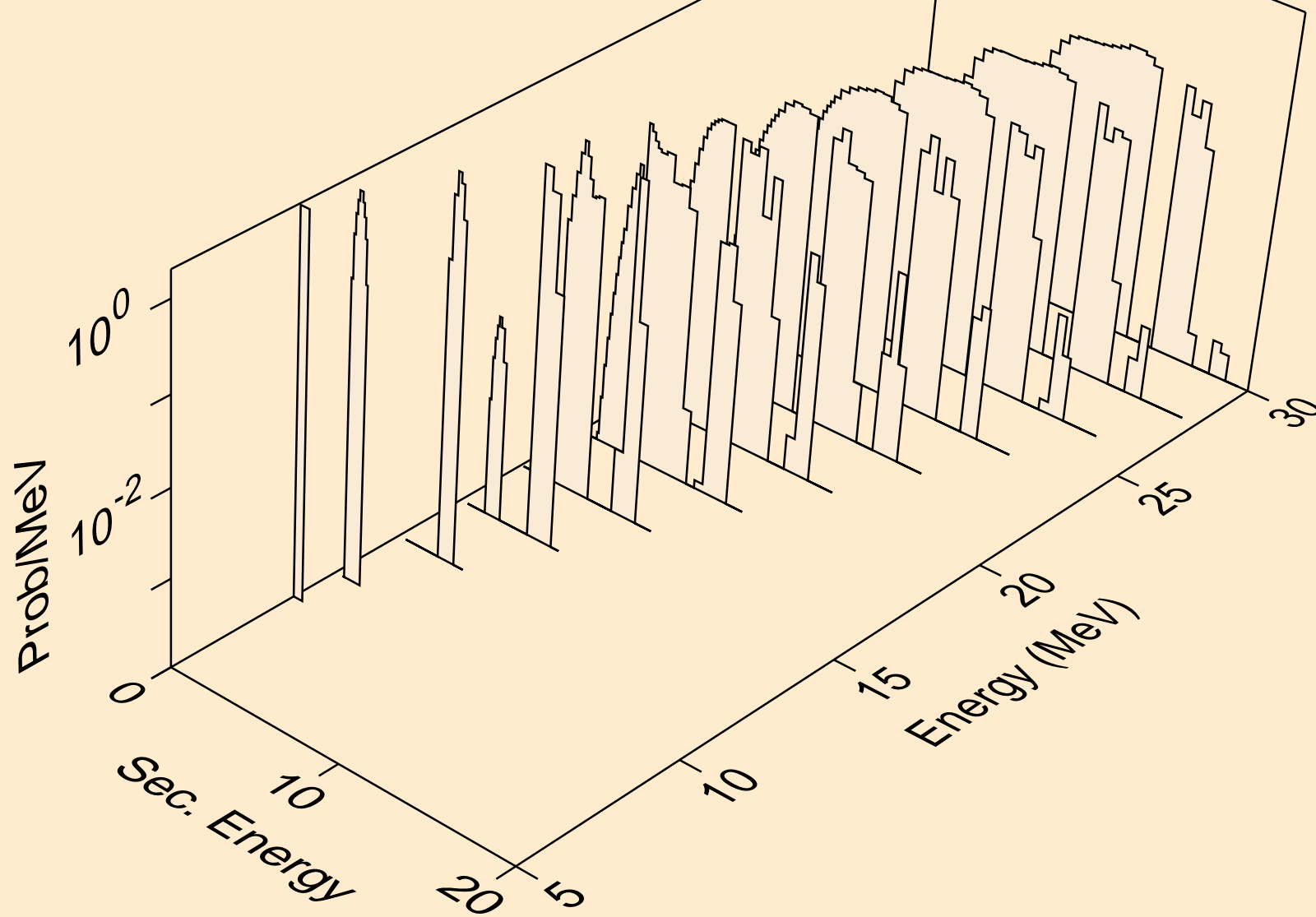

AR037 ALPHA ACER TENDL-2024 LIBRARY; T=0.K  
deuterons from (a,pd)

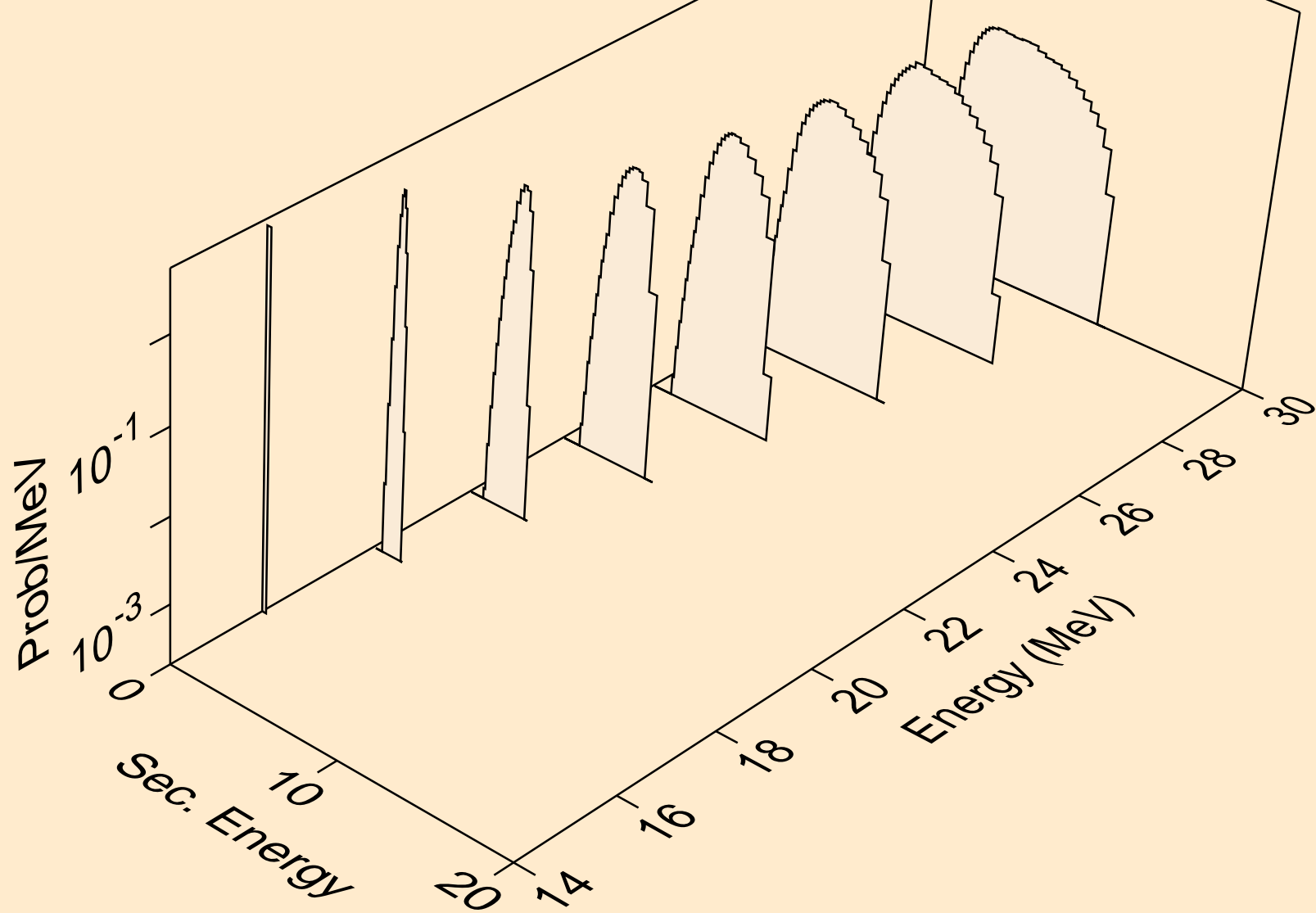

AR037 ALPHA ACER TENDL-2024 LIBRARY; T=0.K  
deuterons from (a,da)

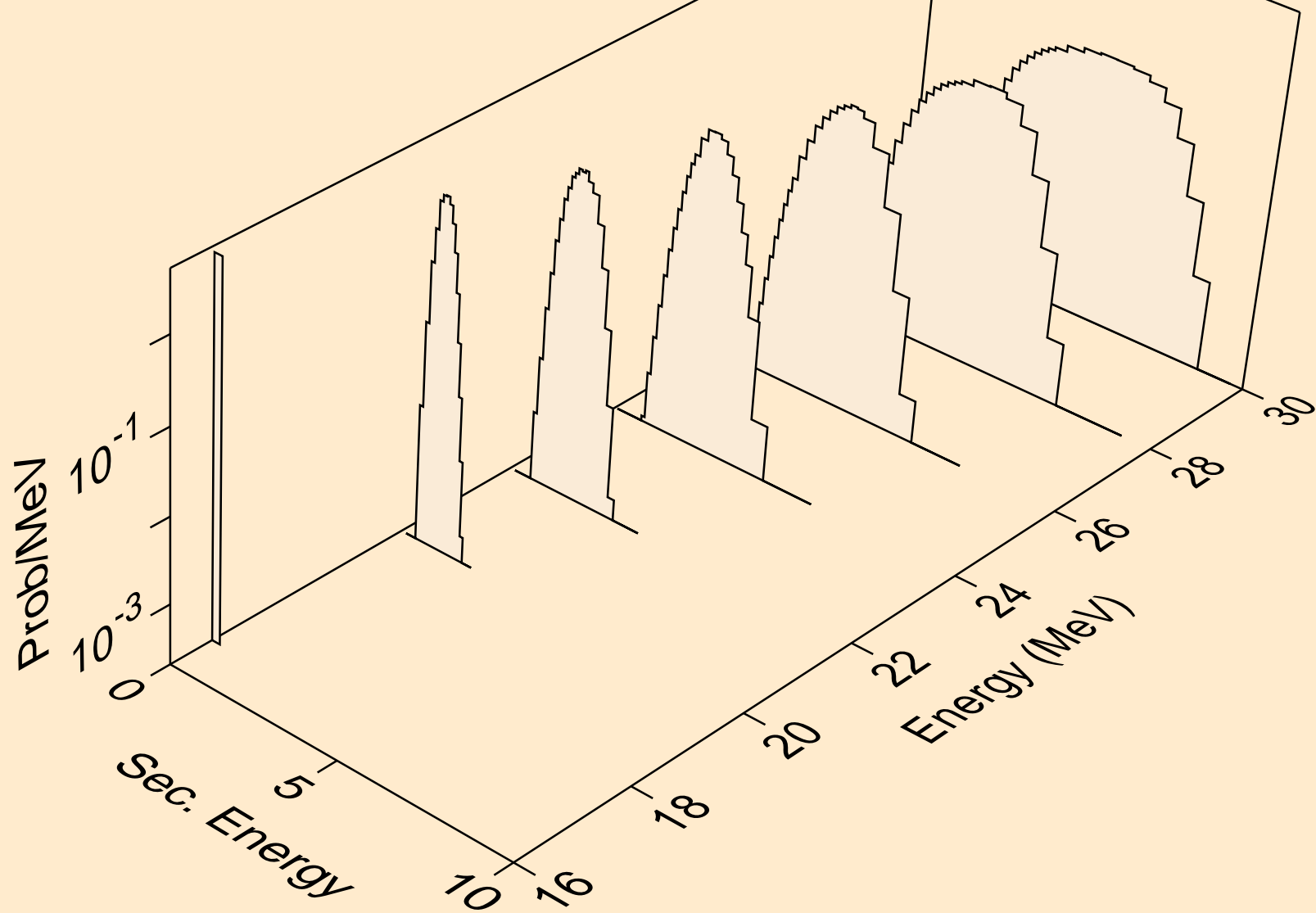

AR037 ALPHA ACER TENDL-2024 LIBRARY; T=0.K  
tritons from (a,x)

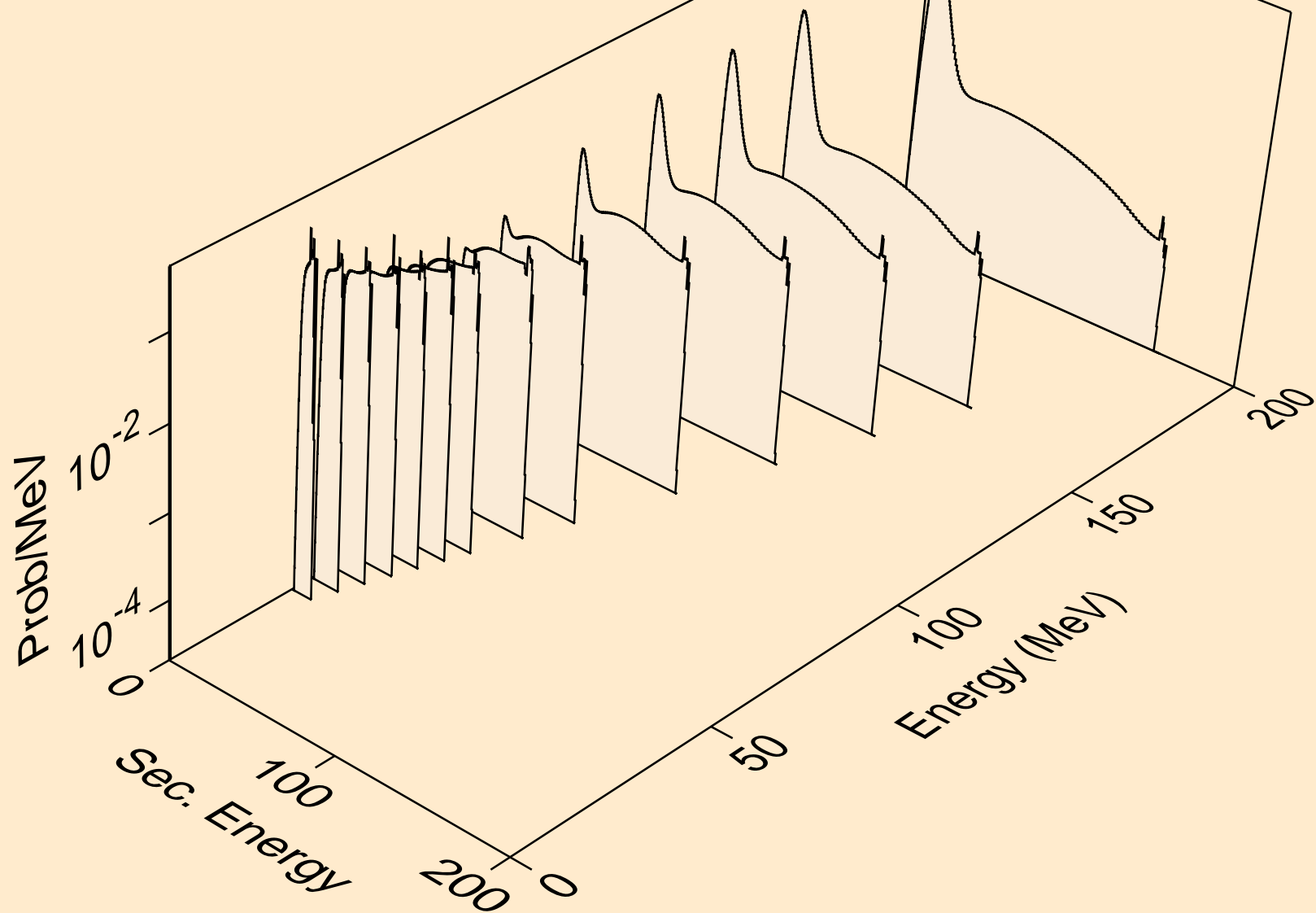

AR037 ALPHA ACER TENDL-2024 LIBRARY; T=0.K  
tritons from (a,t)

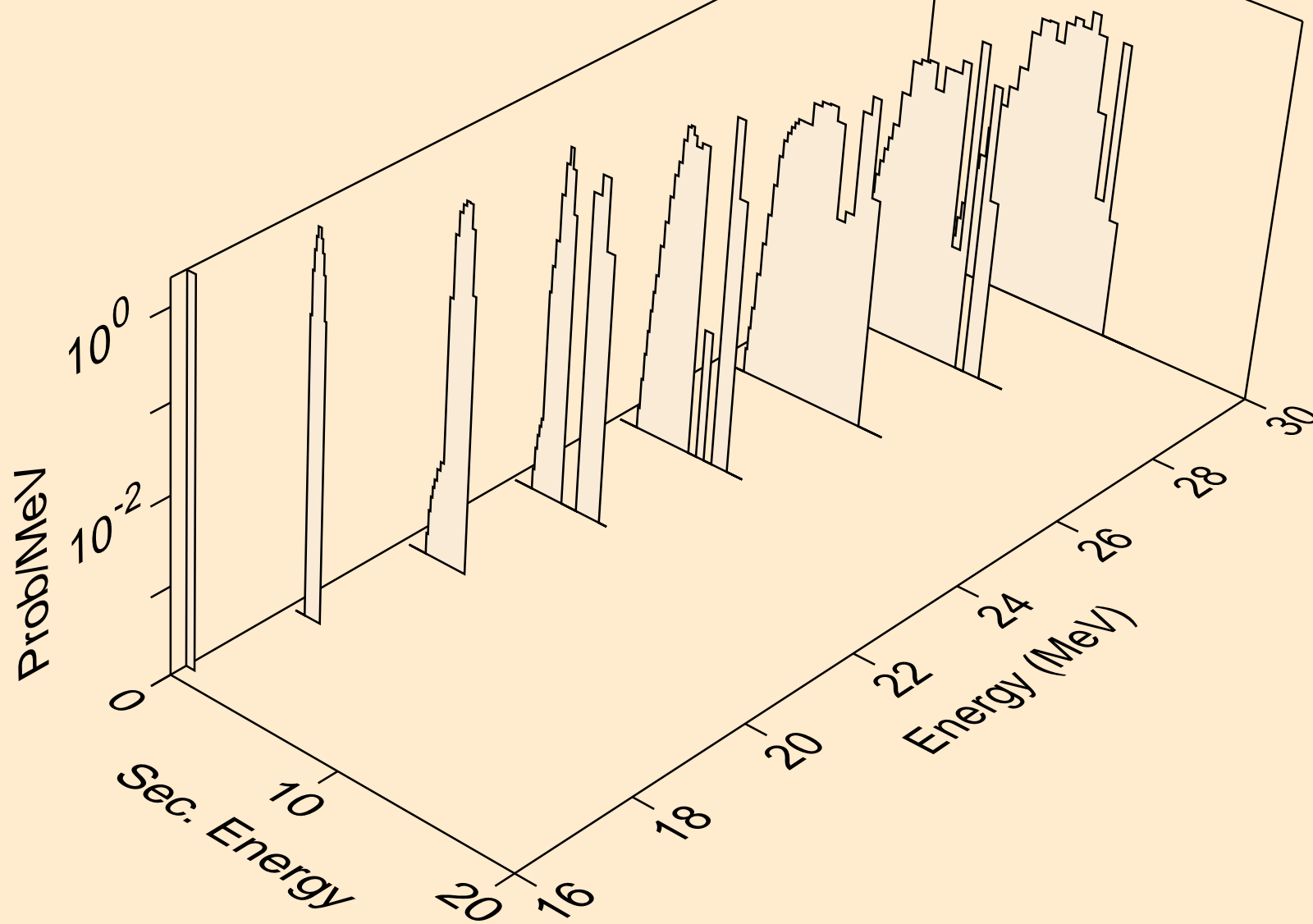

AR037 ALPHA ACER TENDL-2024 LIBRARY; T=0.K  
tritons from (a,pt)

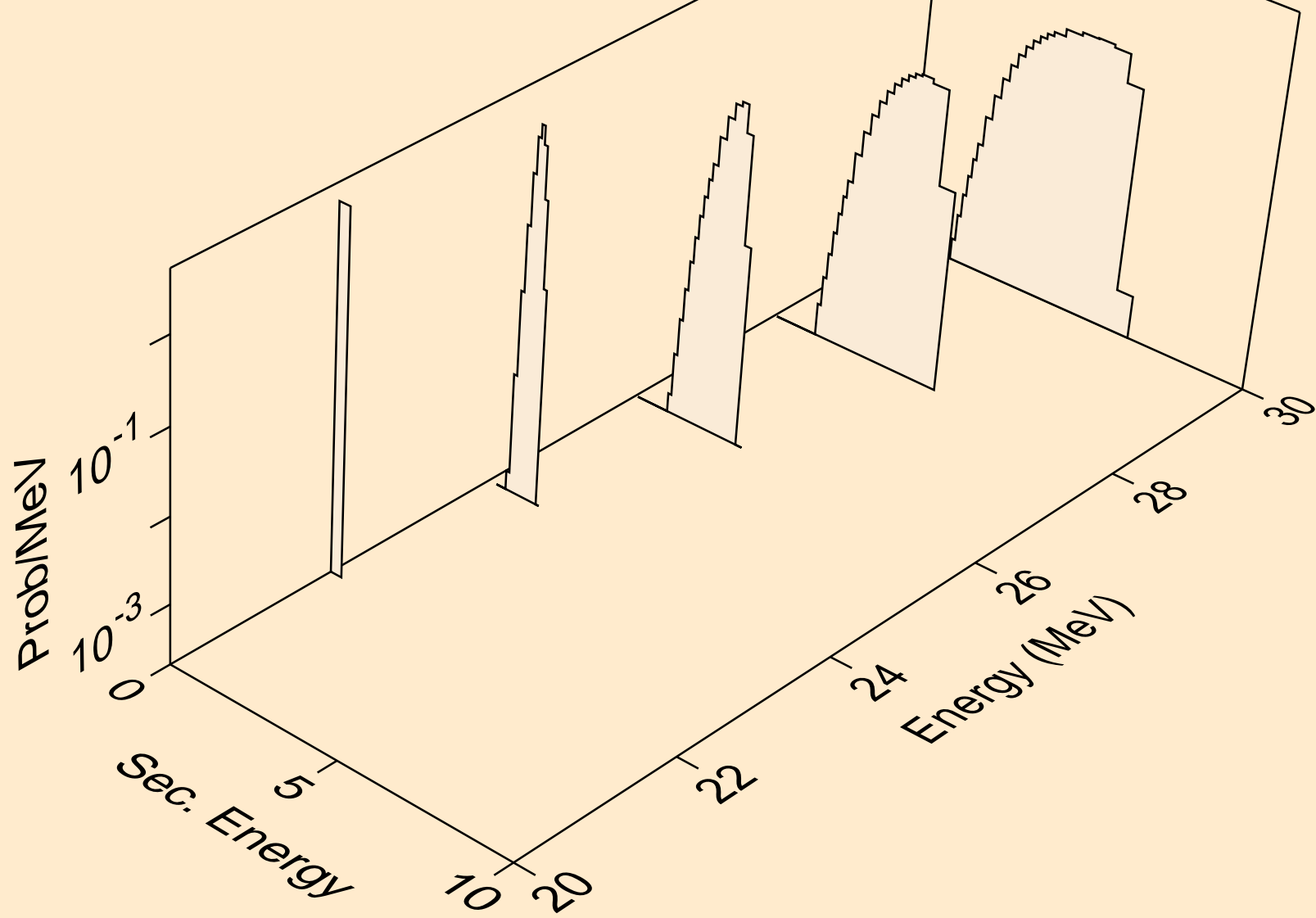

AR037 ALPHA ACER TENDL-2024 LIBRARY; T=0.K  
he3s from (a,x)

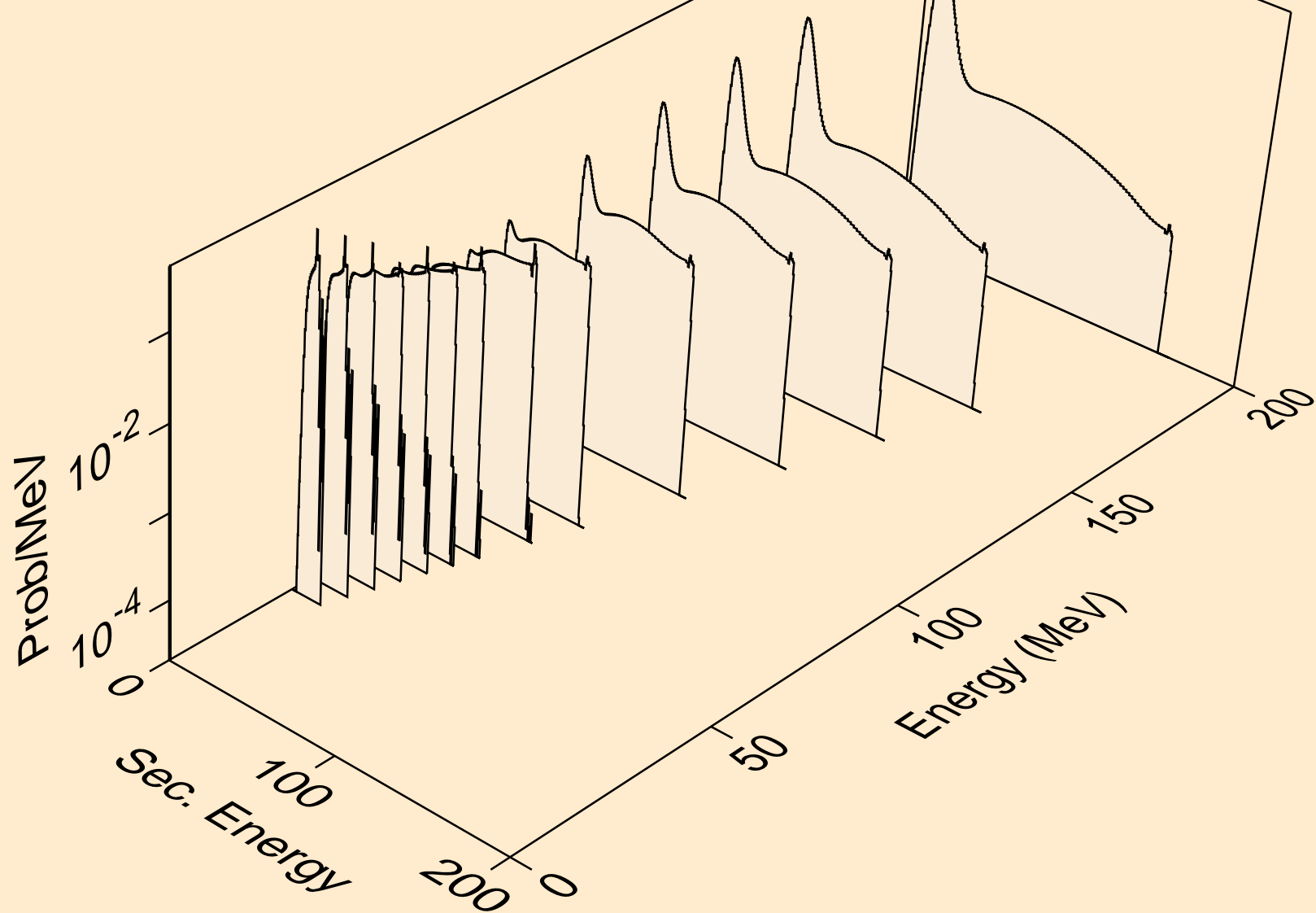

AR037 ALPHA ACER TENDL-2024 LIBRARY; T=0.K  
he3s from (a,n\*)he3

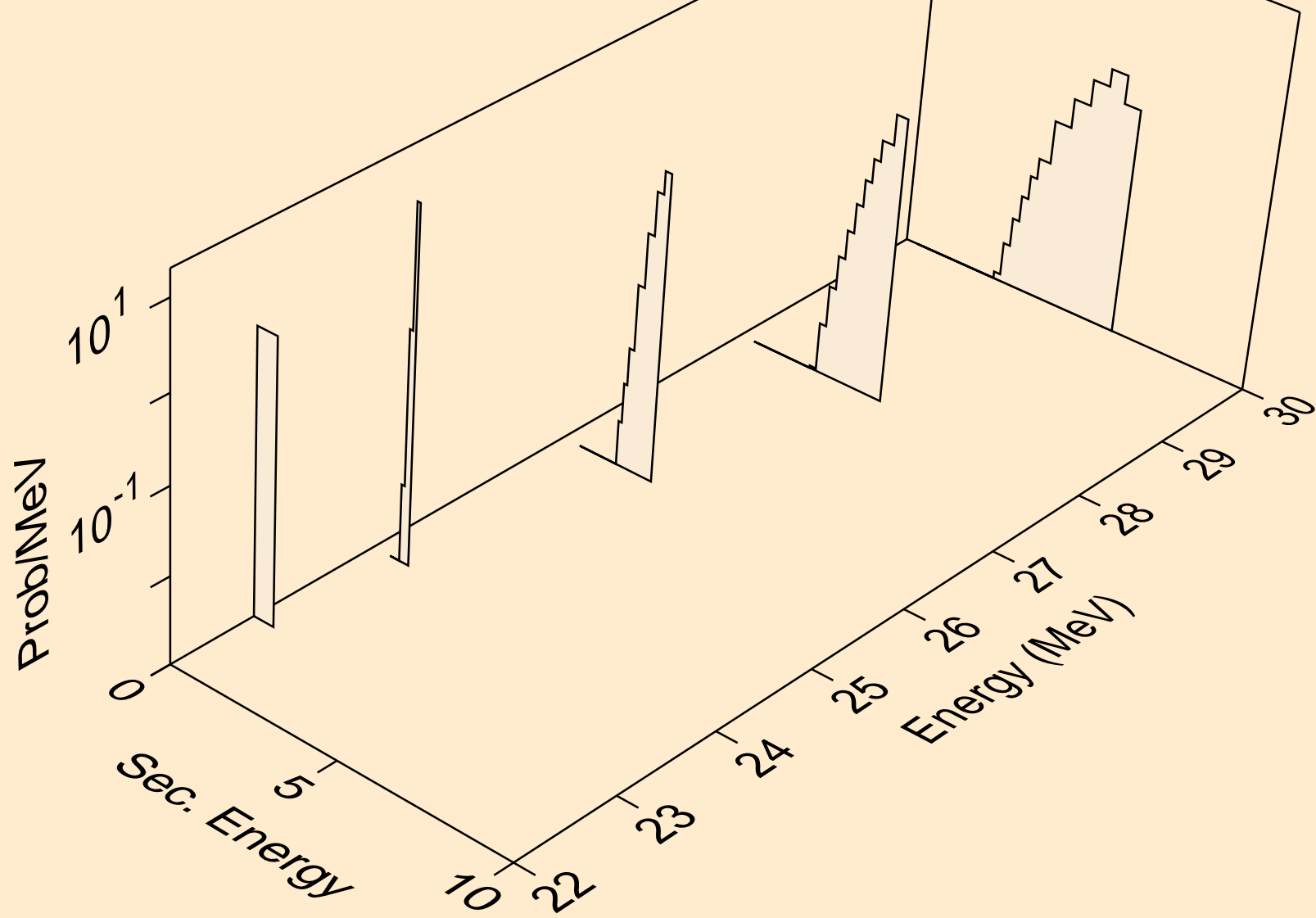

AR037 ALPHA ACER TENDL-2024 LIBRARY; T=0.K  
he3s from (a,he3)

