

AT200N ALPHA ACER TENDL-2024 LIBRARY; T=0.K  
Principal cross sections

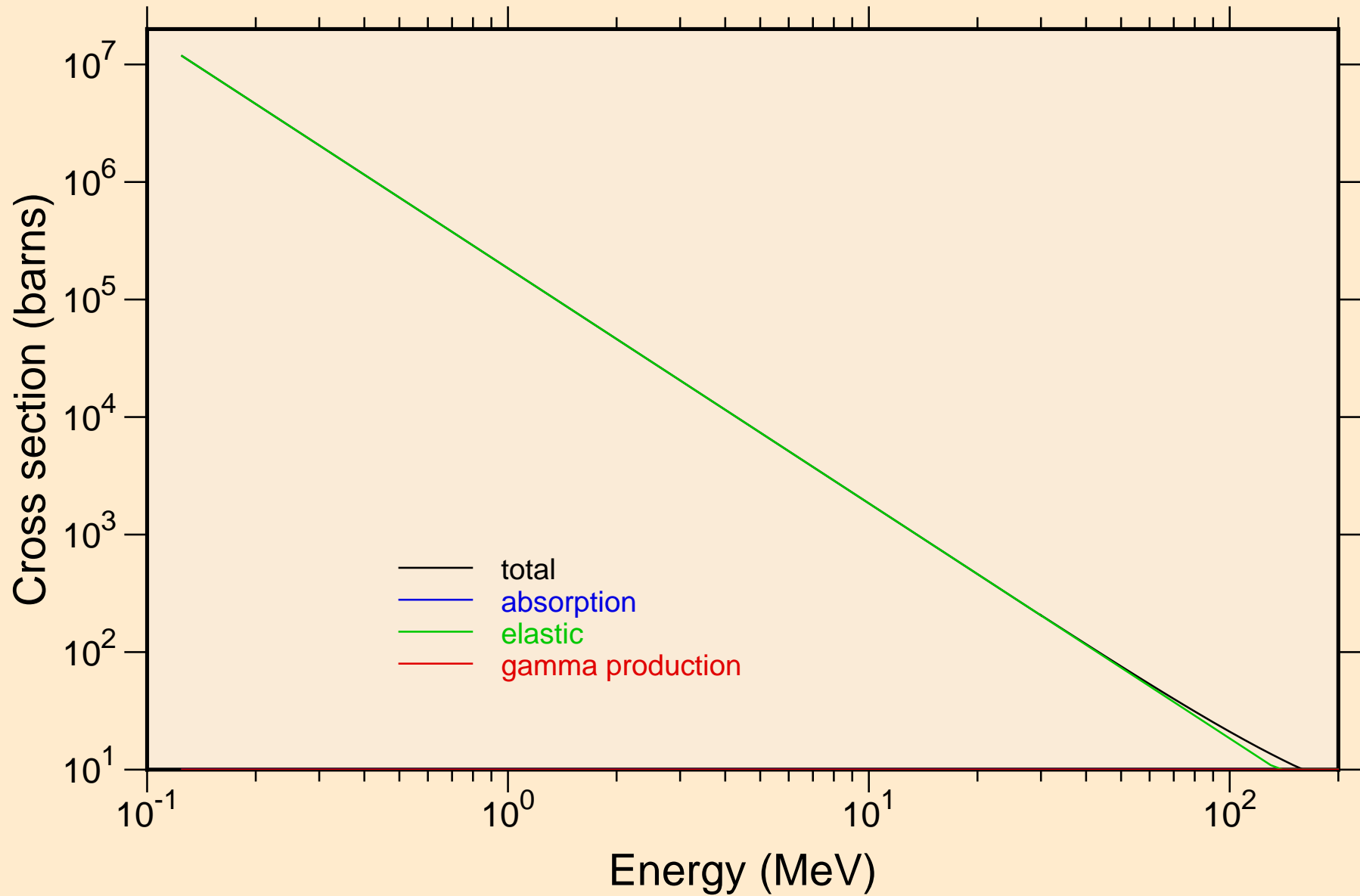

AT200N ALPHA ACER TENDL-2024 LIBRARY; T=0.K

Heating

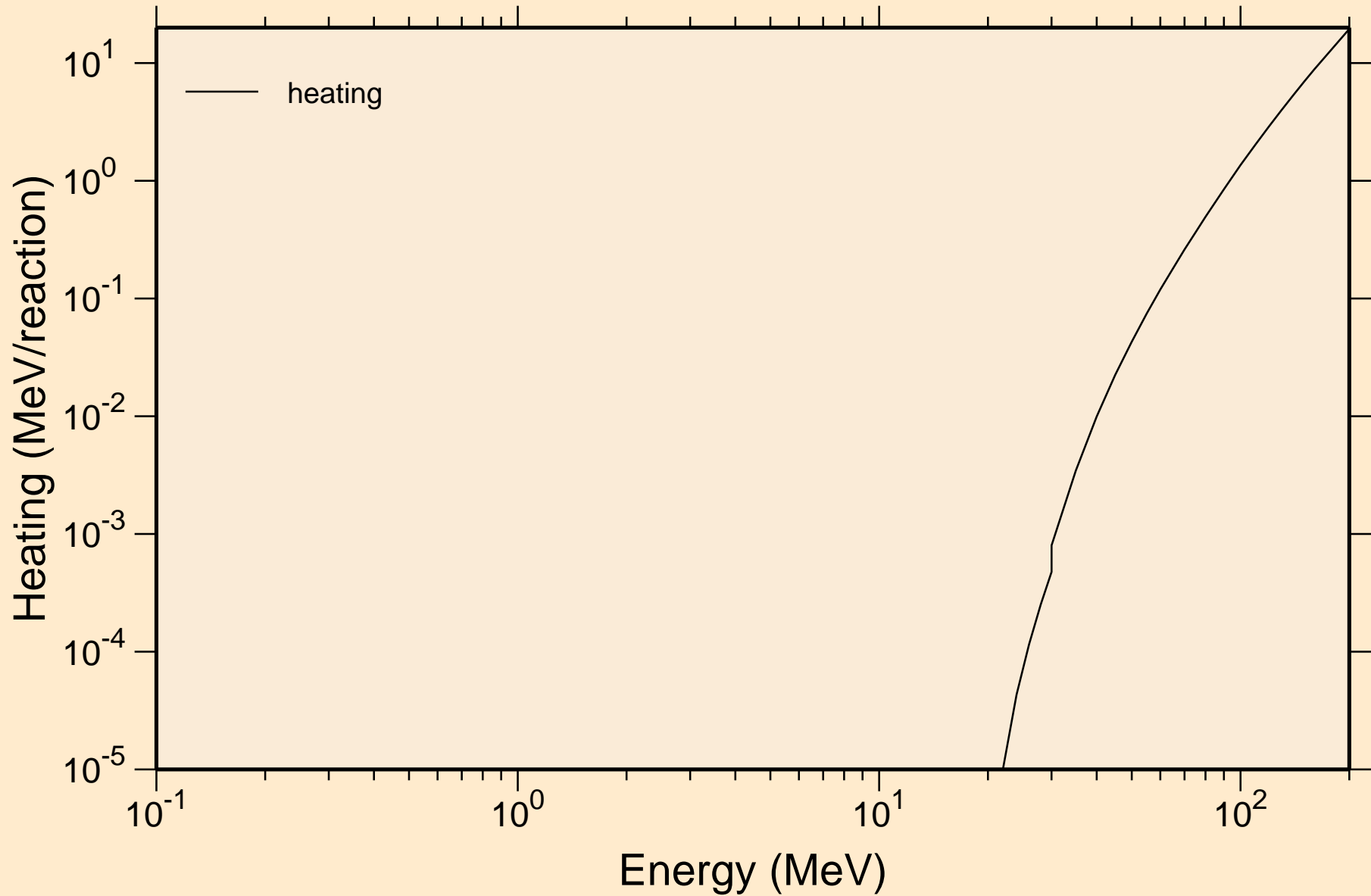

# AT200N ALPHA ACER TENDL-2024 LIBRARY; T=0.K

## Principal cross sections

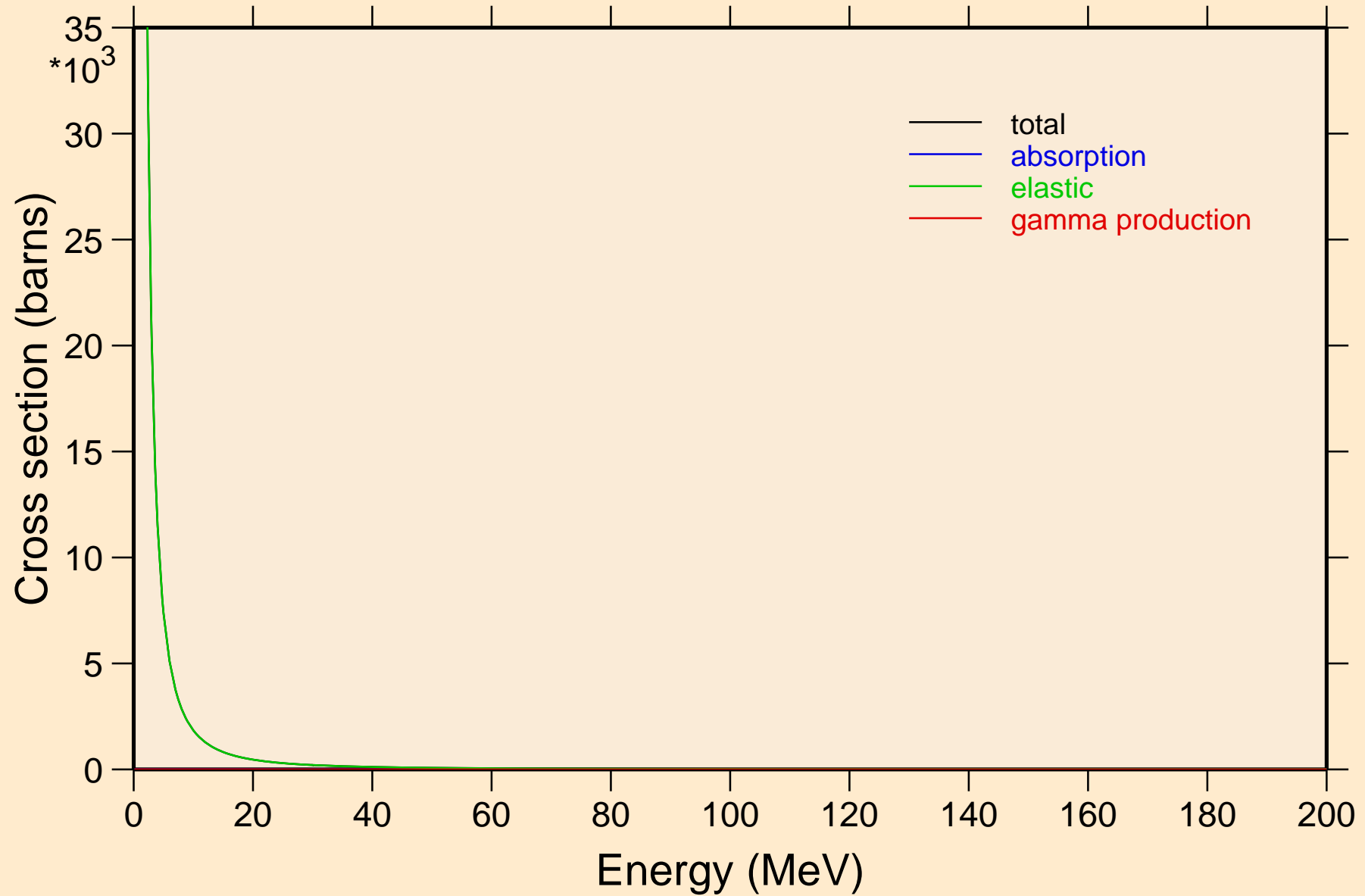

AT200N ALPHA ACER TENDL-2024 LIBRARY; T=0.K

Heating

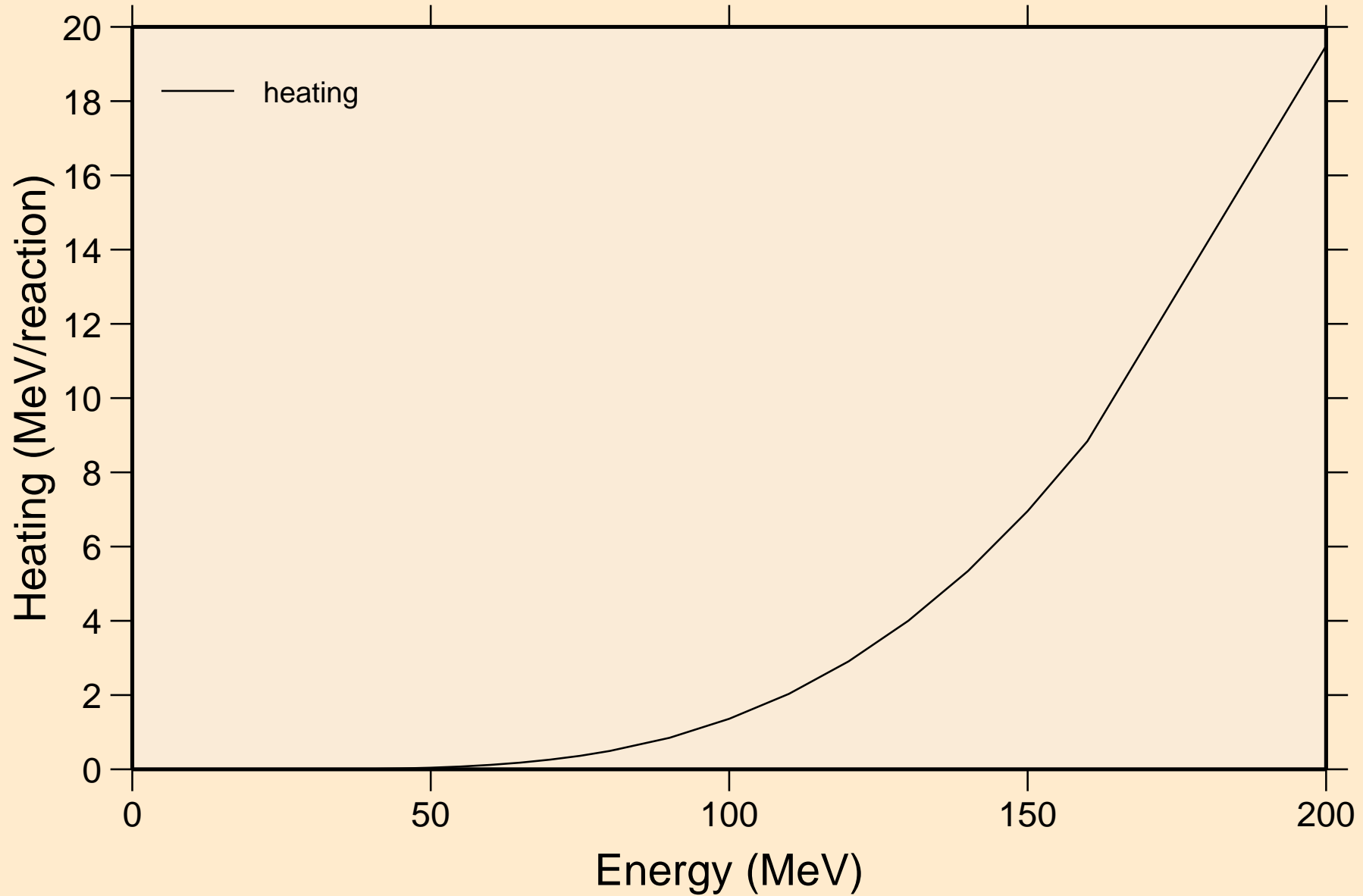

AT200N ALPHA ACER TENDL-2024 LIBRARY; T=0.K  
Threshold reactions

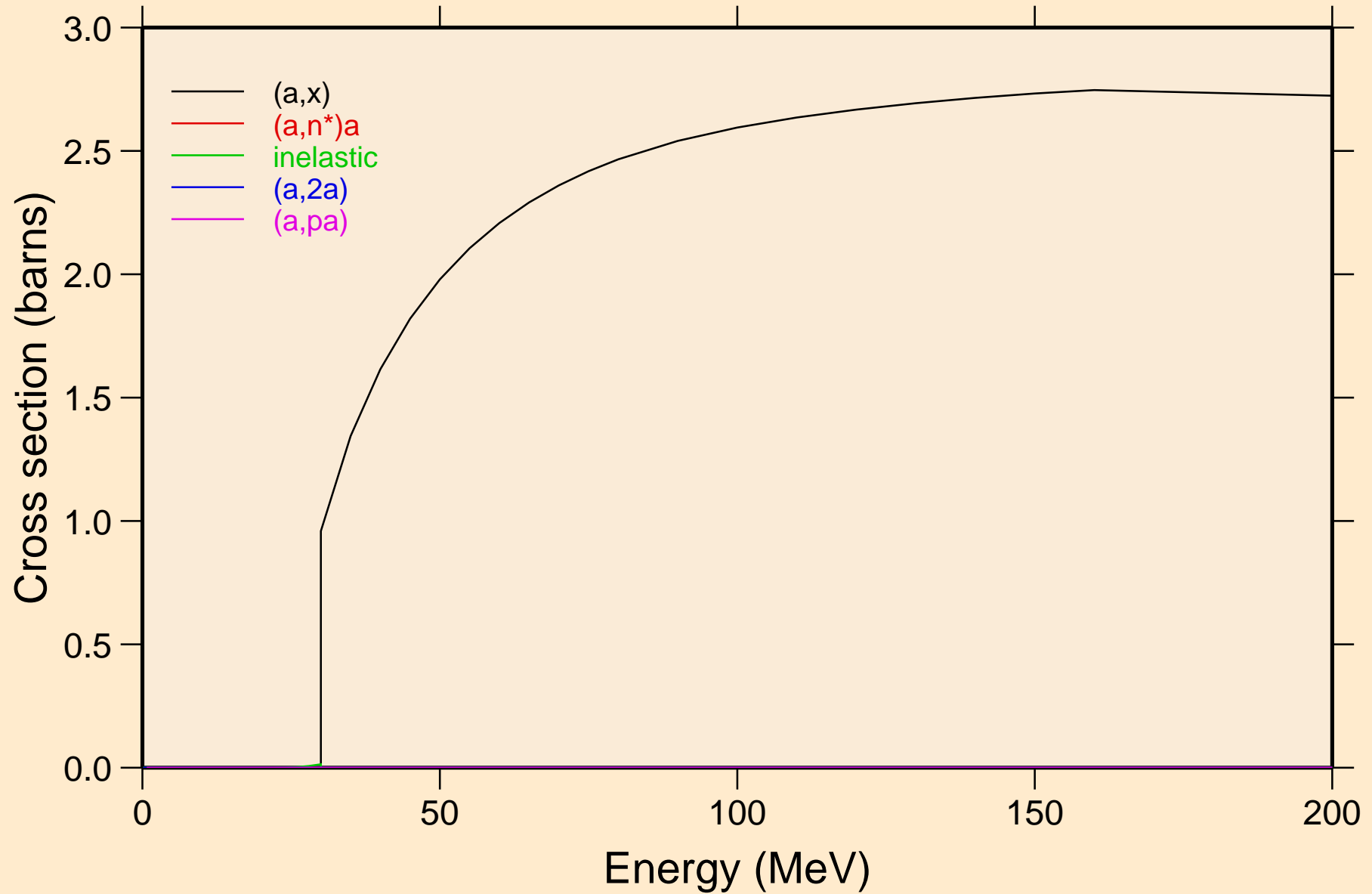

AT200N ALPHA ACER TENDL-2024 LIBRARY; T=0.K  
angular distribution for elastic

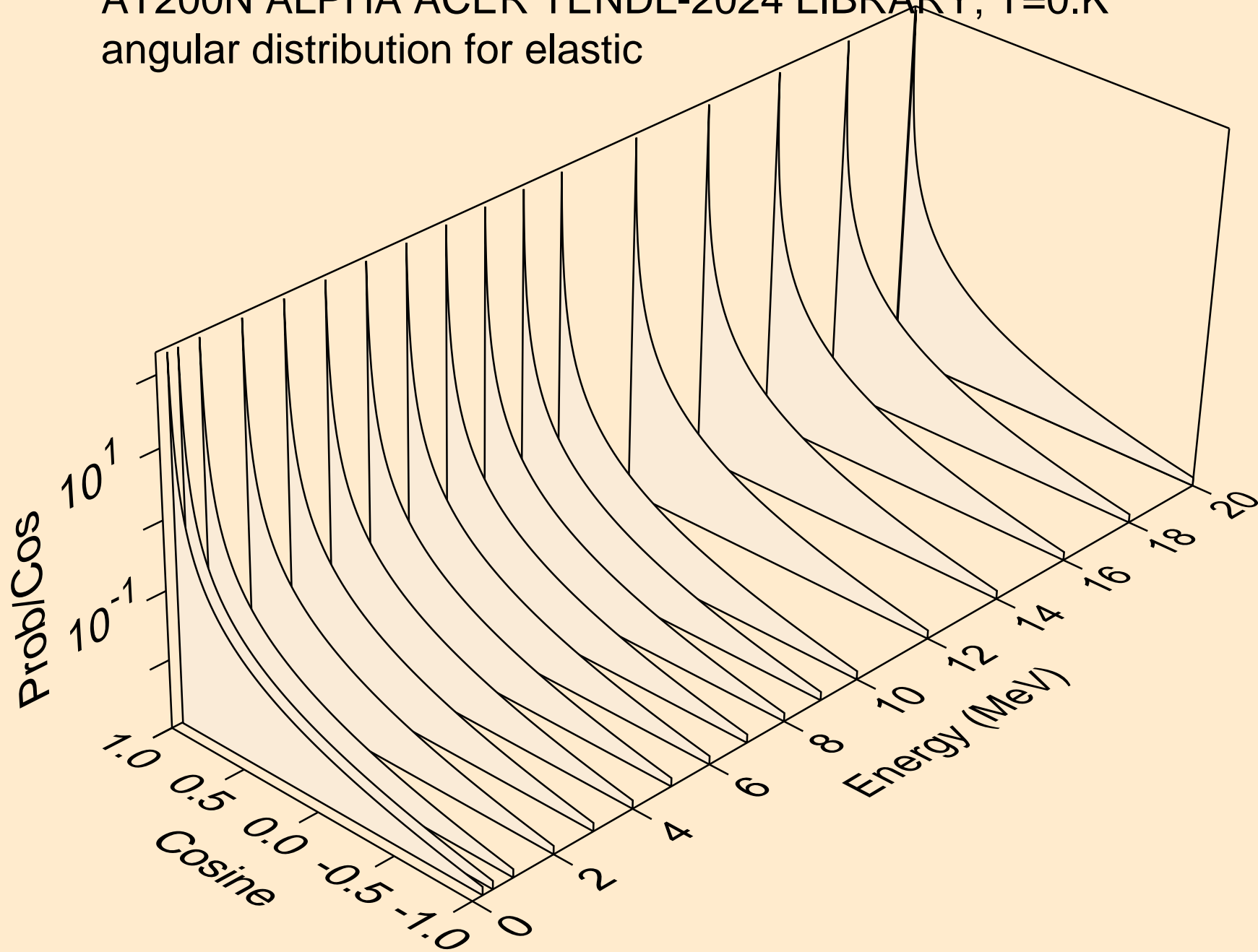

AT200N ALPHA ACER TENDL-2024 LIBRARY; T=0.K  
angular distribution for elastic

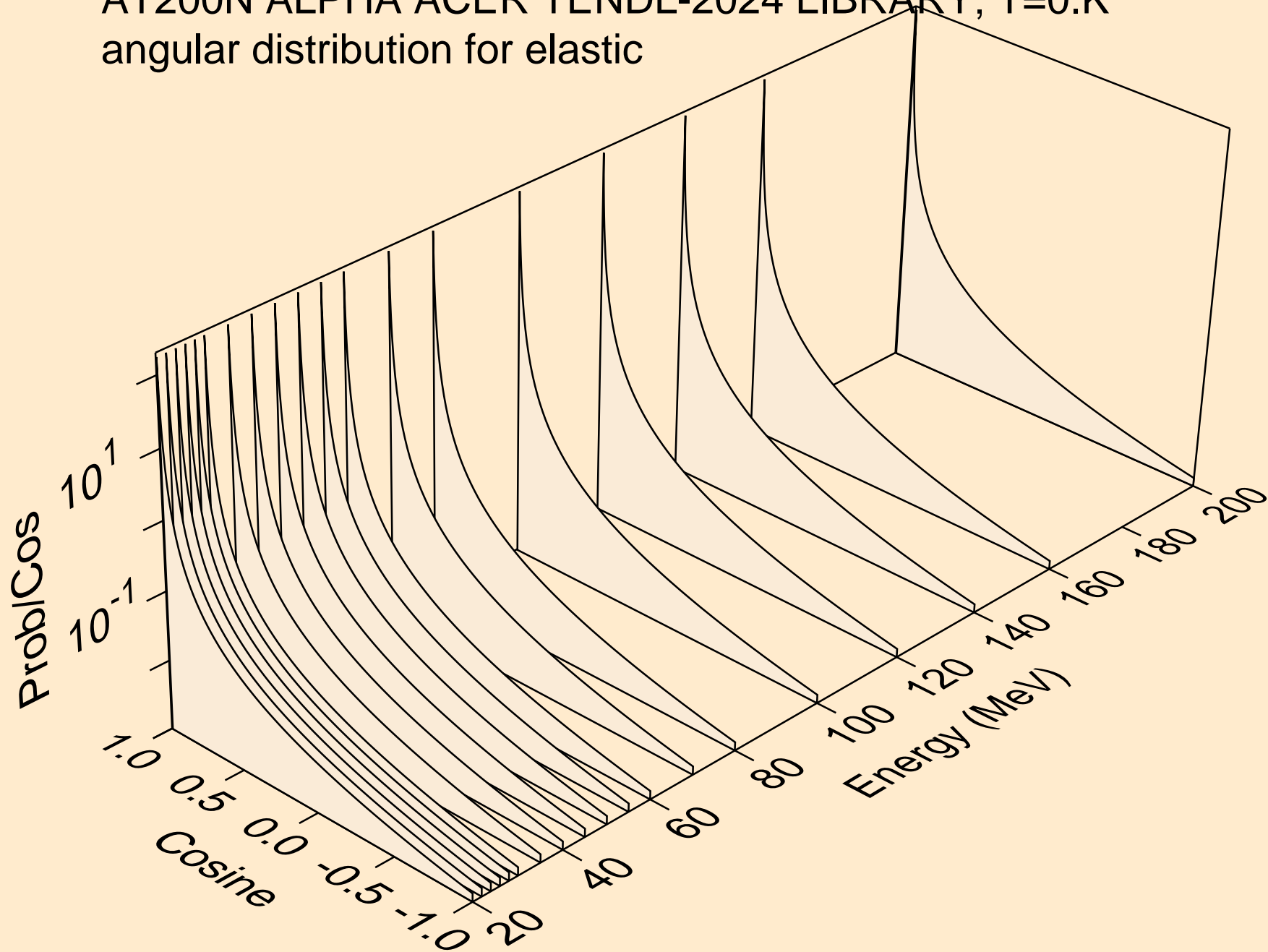

AT200N ALPHA ACER TENDL-2024 LIBRARY; T=0.K  
Alpha emission for (a,x)

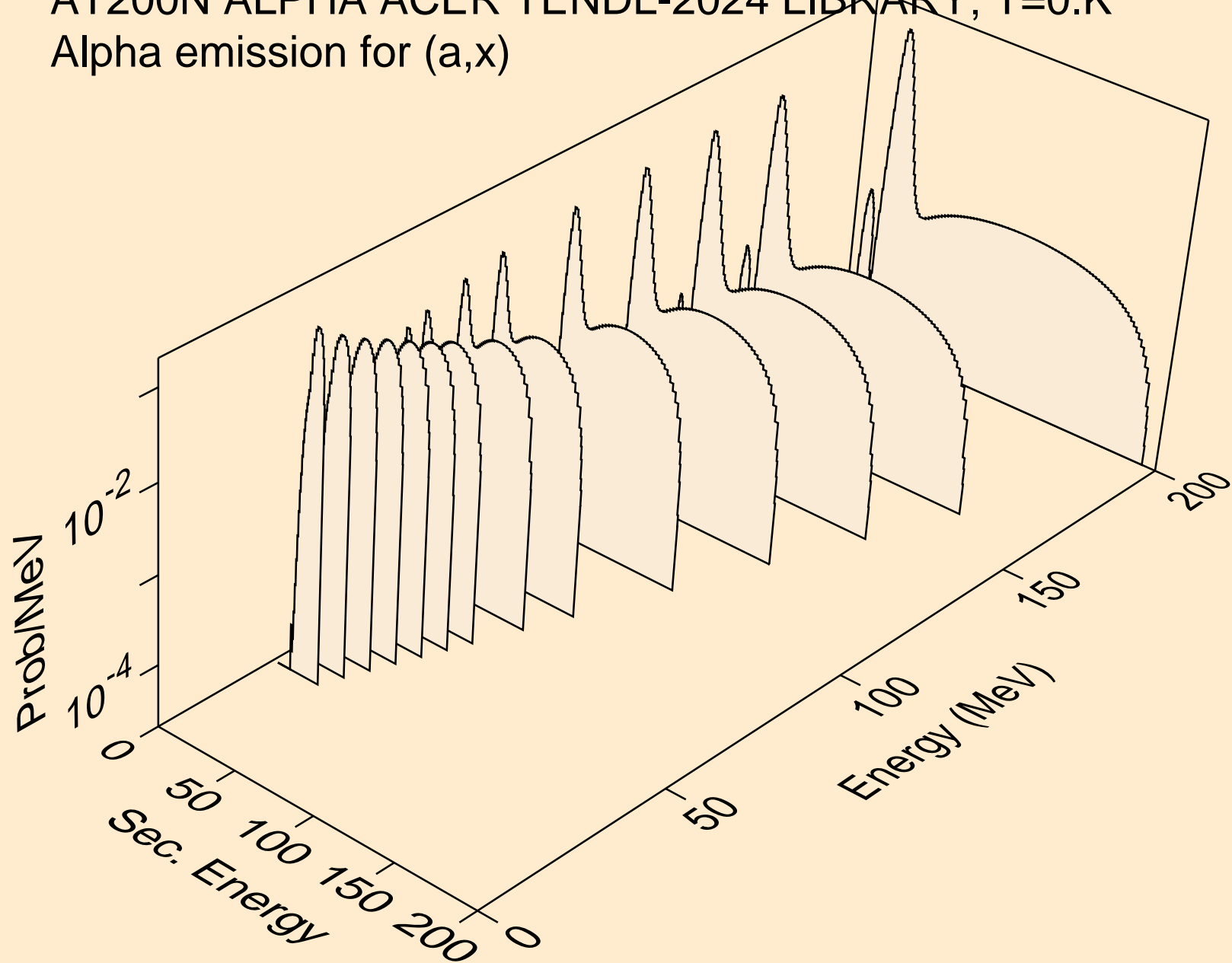

AT200N ALPHA ACER TENDL-2024 LIBRARY; T=0.K  
Alpha emission for (a,n\*)a

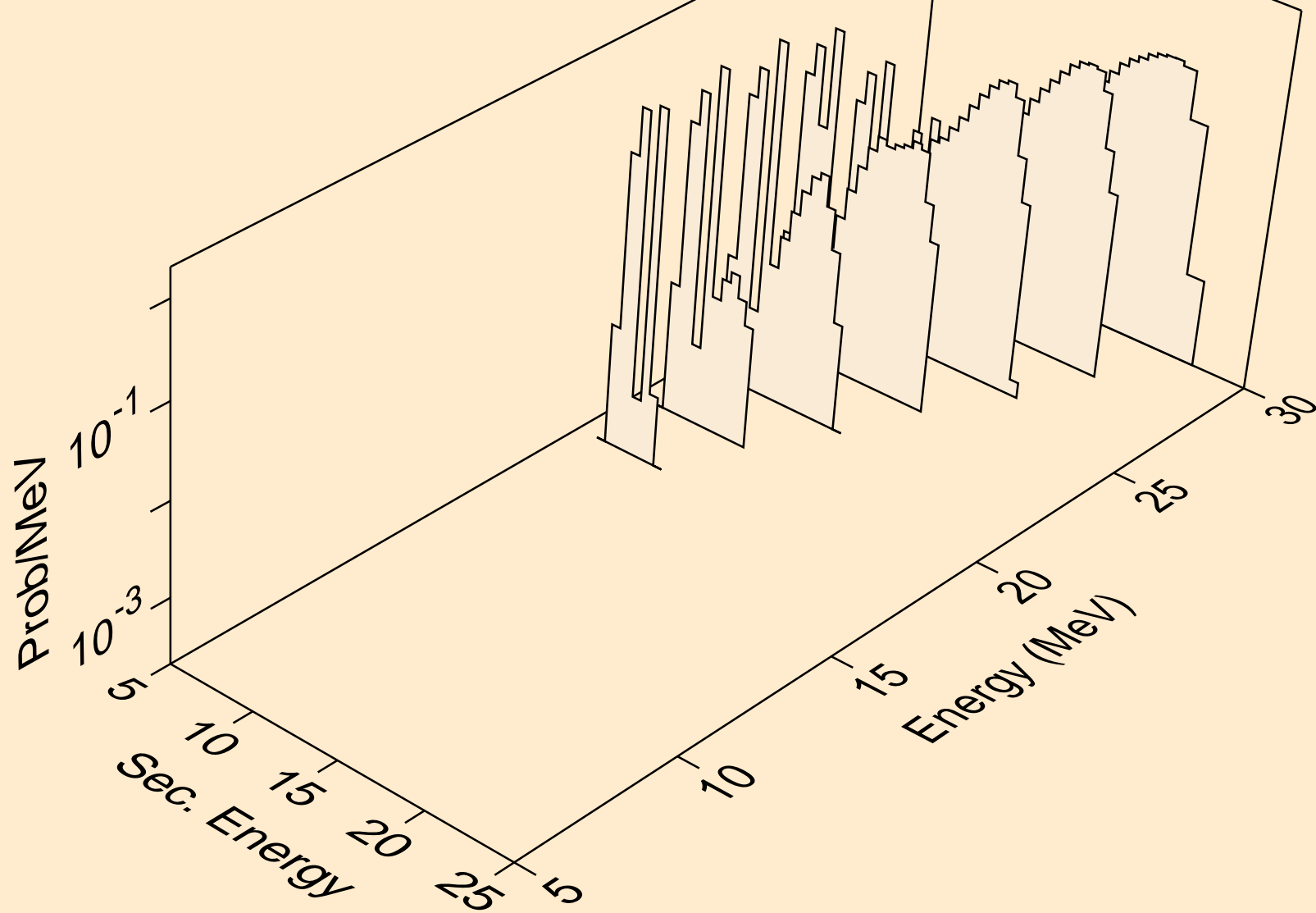

AT200N ALPHA ACER TENDL-2024 LIBRARY; T=0.K  
Alpha emission for inelastic

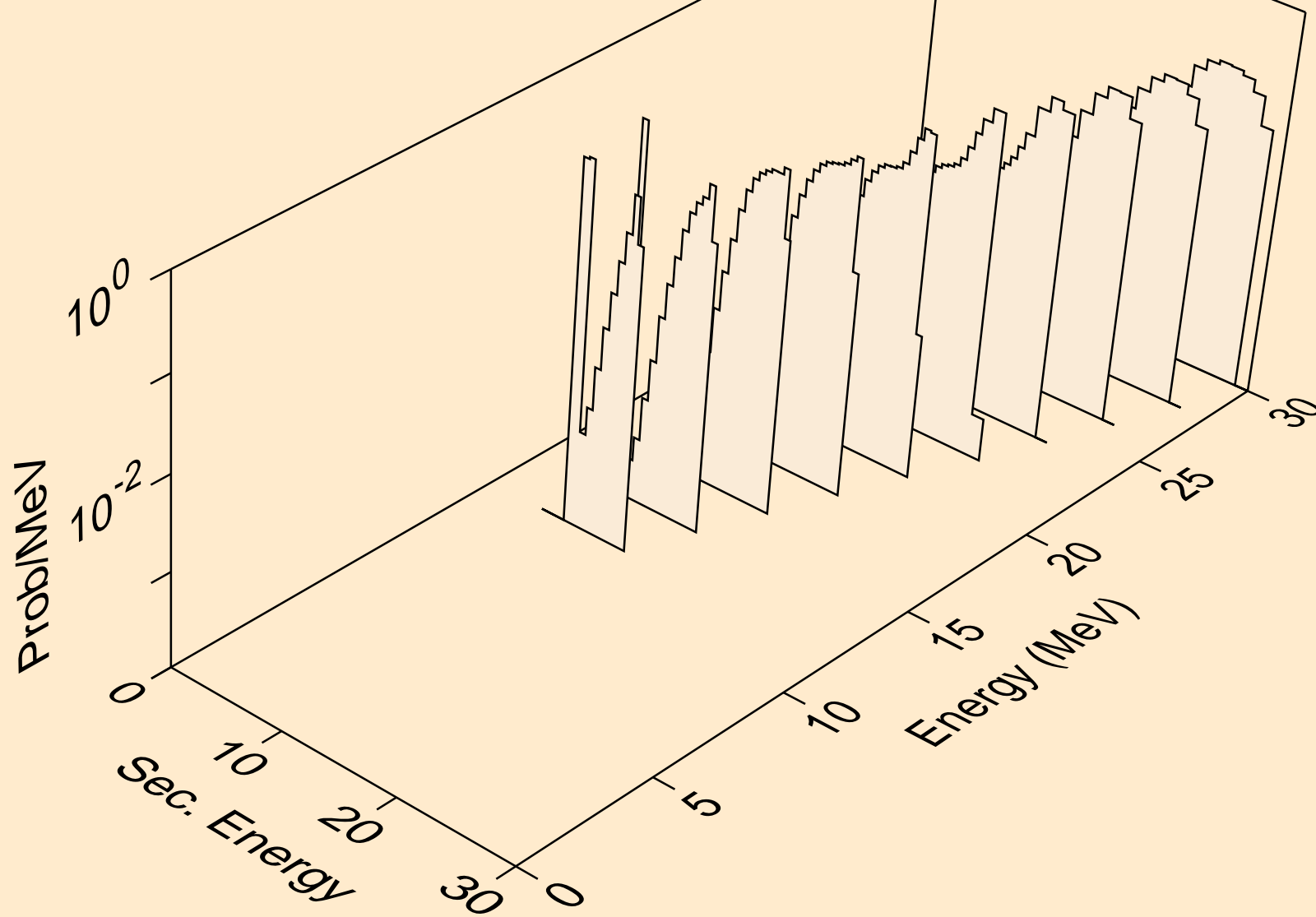

AT200N ALPHA ACER TENDL-2024 LIBRARY; T=0.K  
Alpha emission for (a,2a)

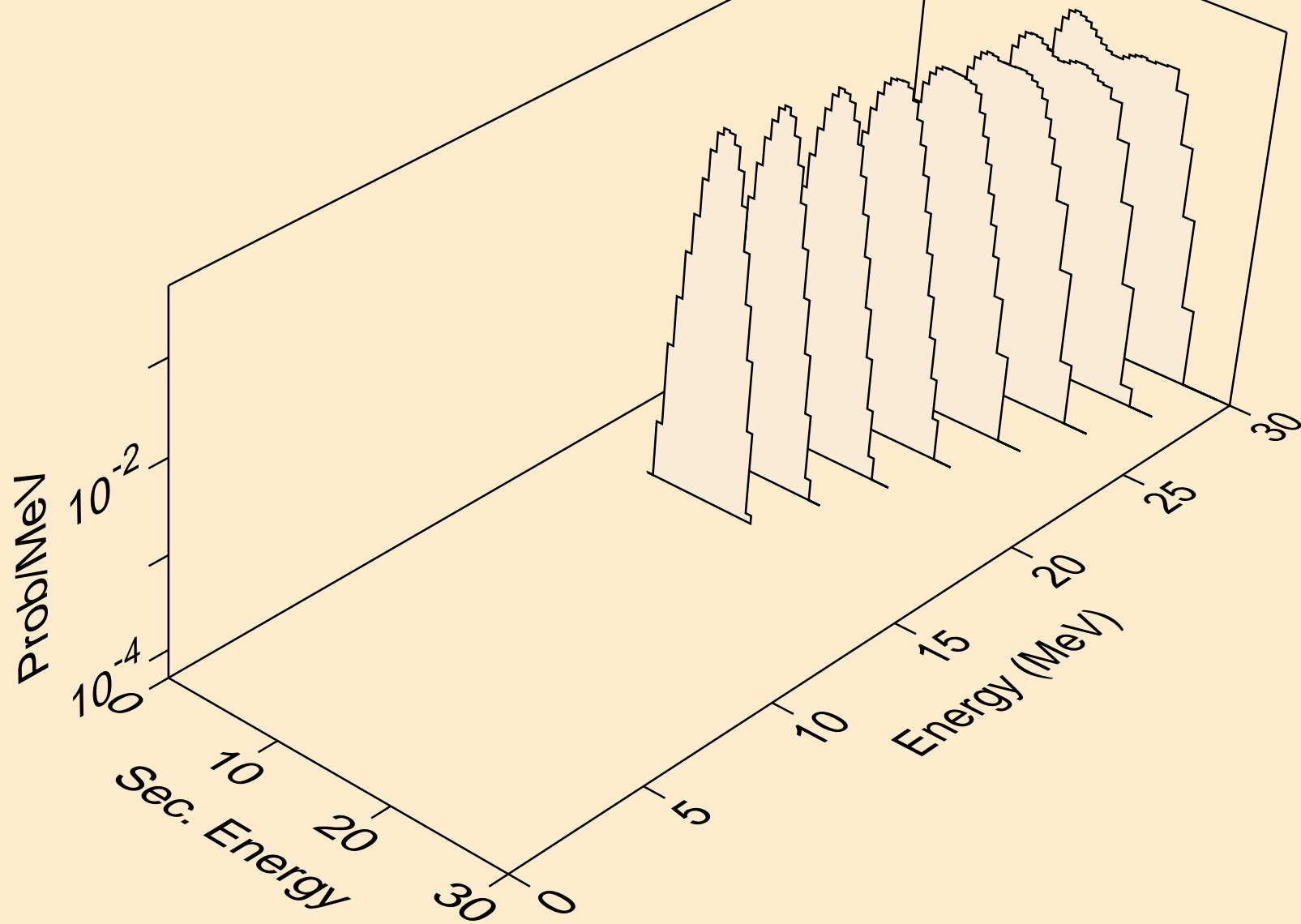

AT200N ALPHA ACER TENDL-2024 LIBRARY; T=0.K  
Alpha emission for (a,pa)

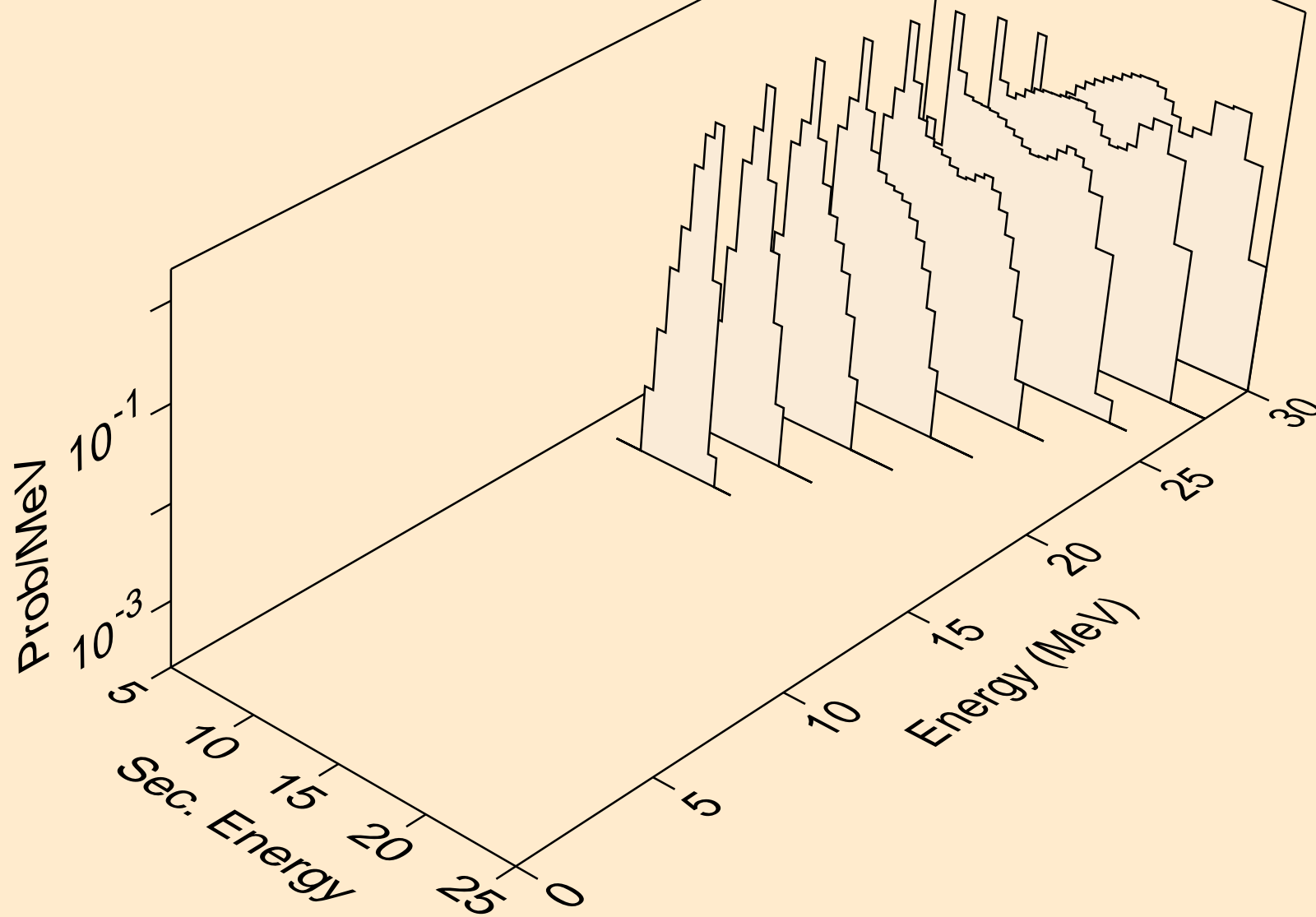

AT200N ALPHA ACER TENDL-2024 LIBRARY; T=0.K  
Photon emission for (z,n)

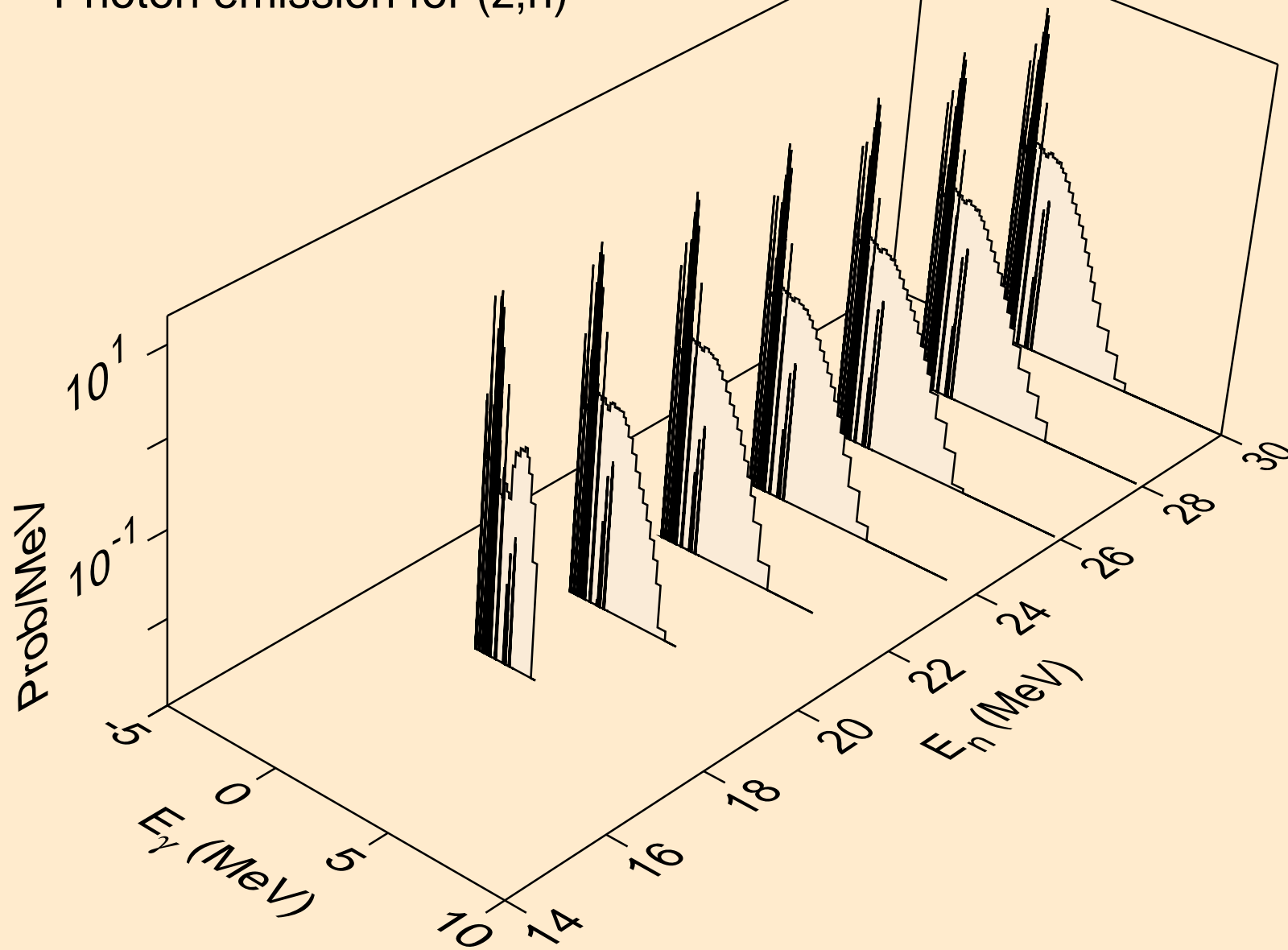

AT200N ALPHA ACER TENDL-2024 LIBRARY; T=0.K  
Photon emission for (z,x)

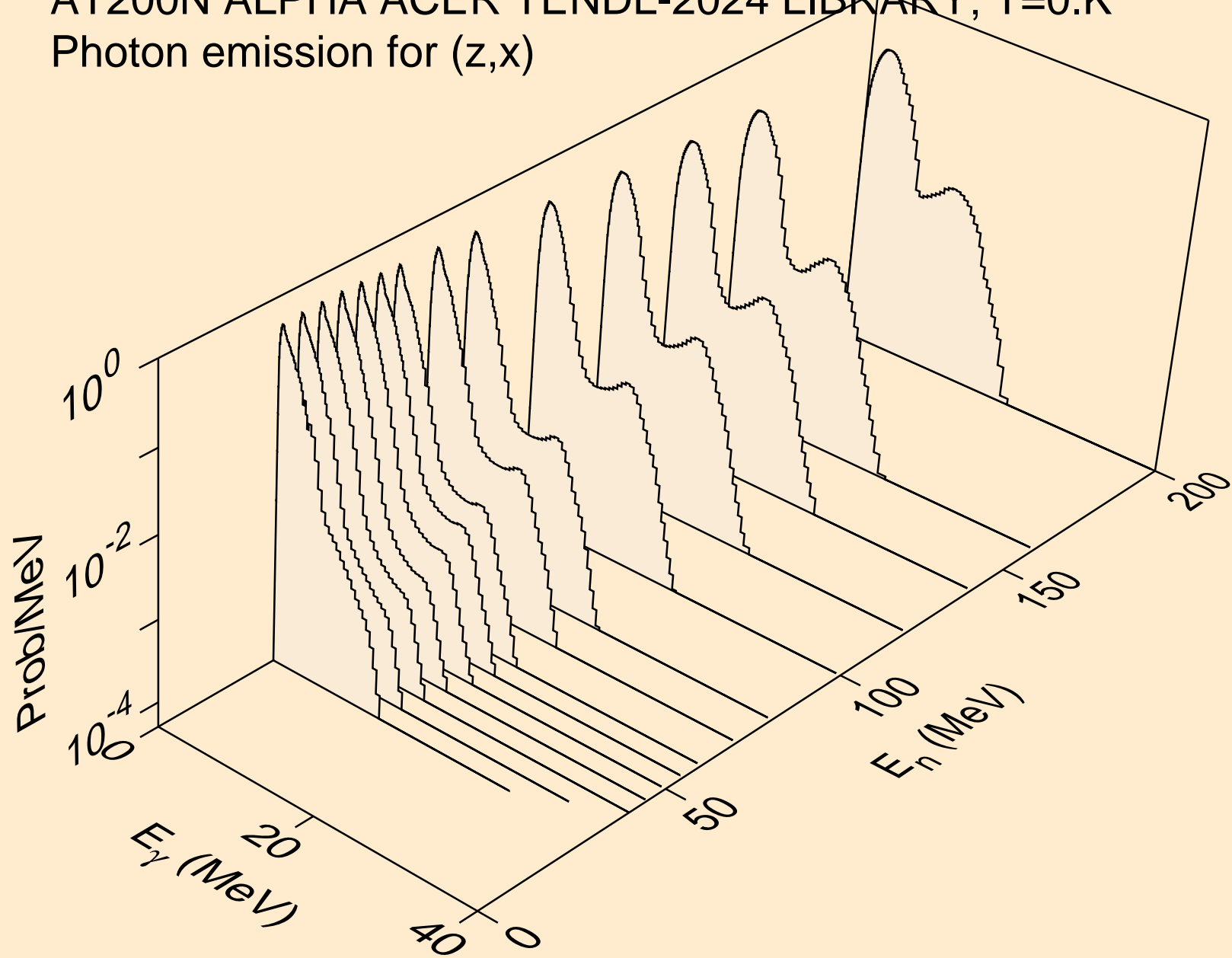

AT200N ALPHA ACER TENDL-2024 LIBRARY; T=0.K  
Photon emission for (n,2n)

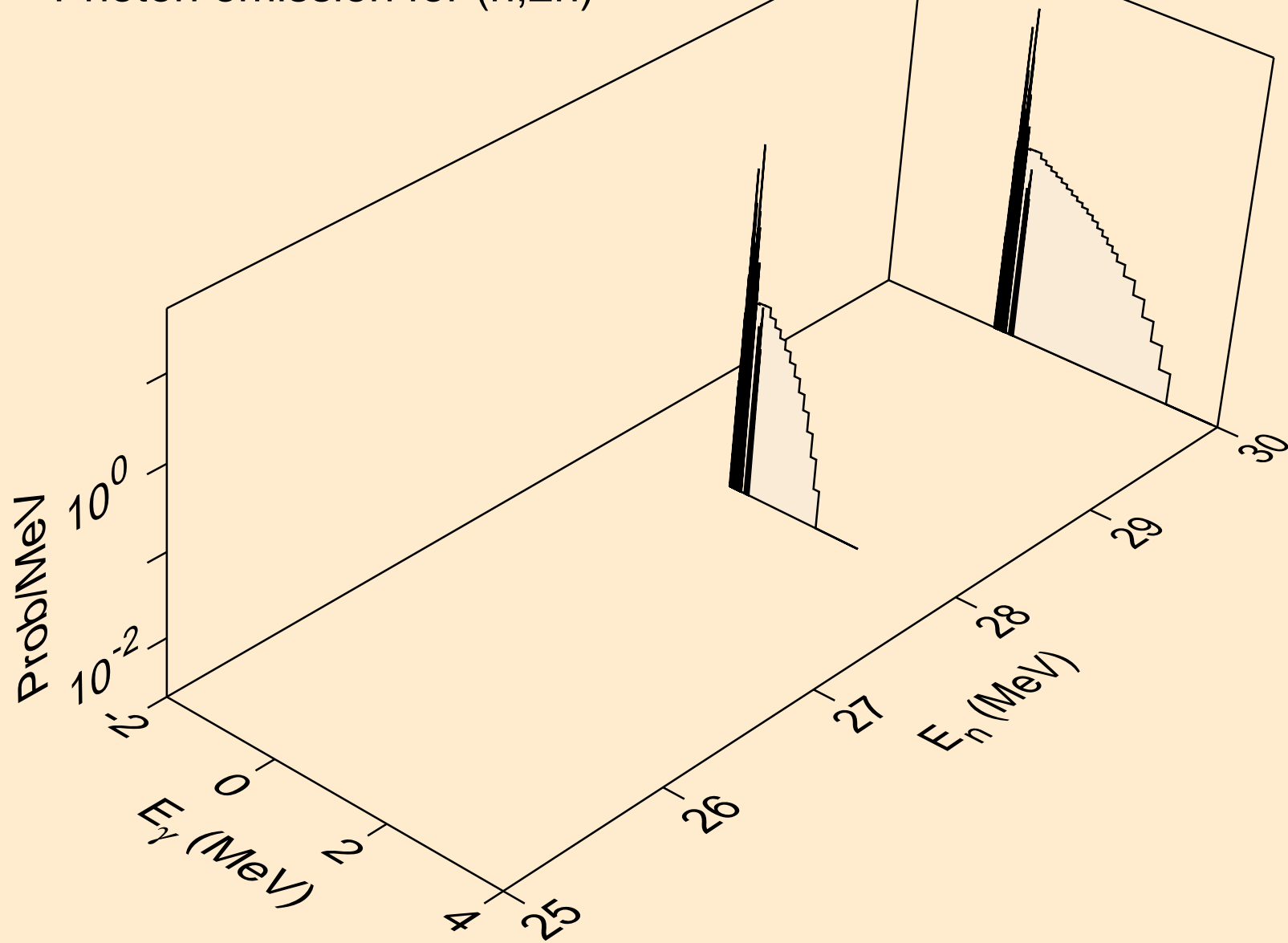

AT200N ALPHA ACER TENDL-2024 LIBRARY; T=0.K  
Photon emission for (n,n\*)a

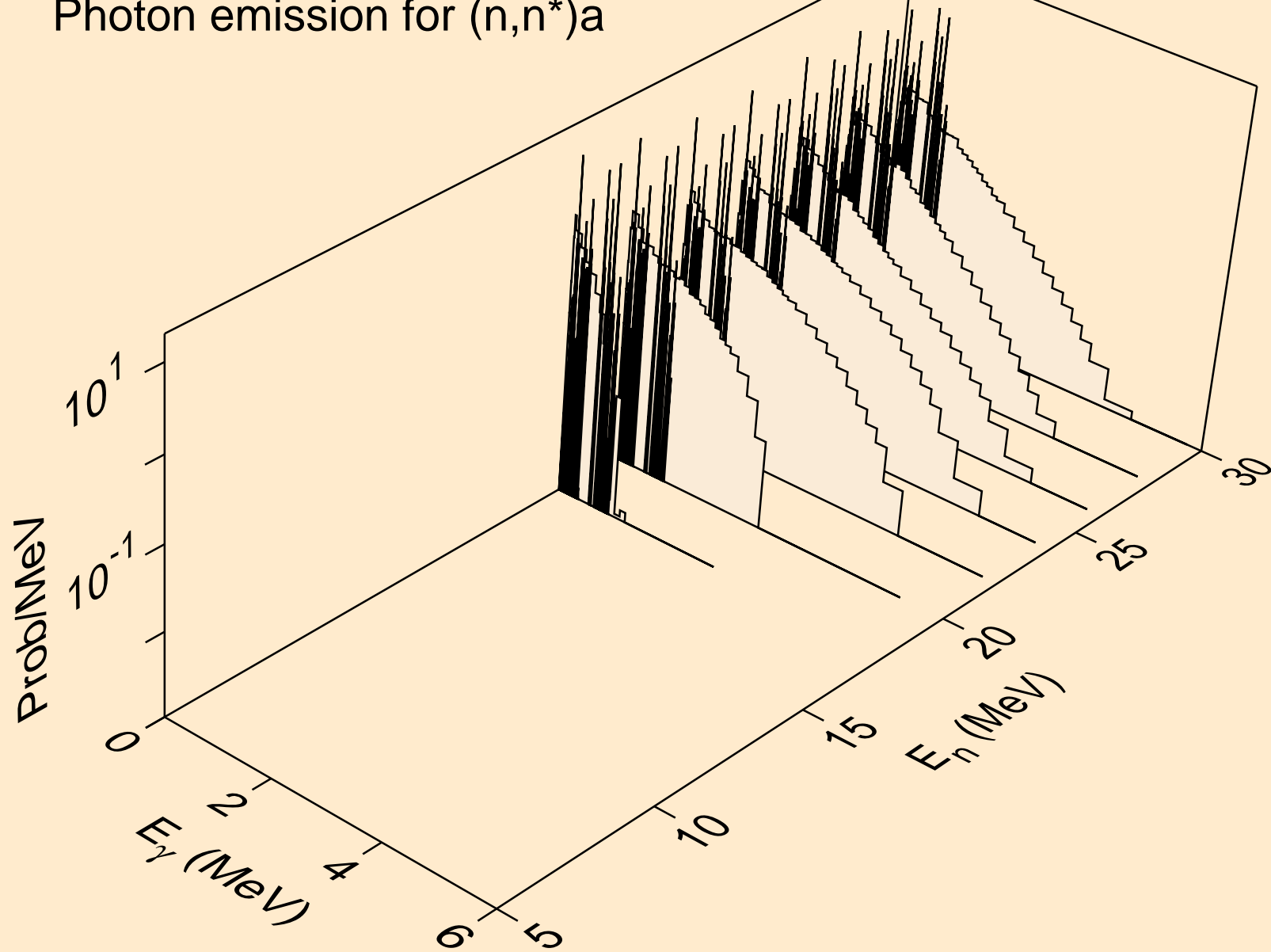

AT200N ALPHA ACER TENDL-2024 LIBRARY; T=0.K  
Photon emission for (n,n\*)p

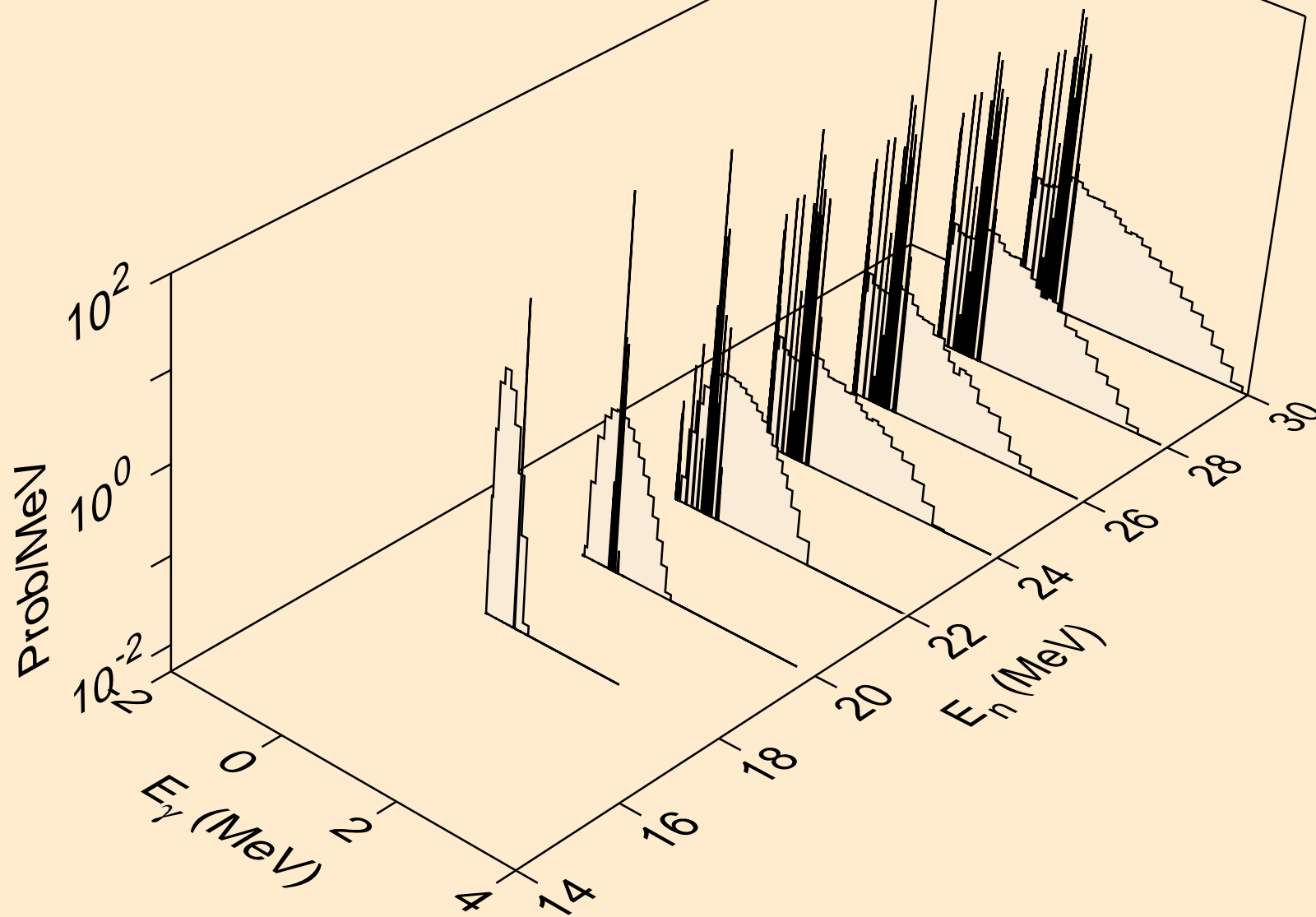

AT200N ALPHA ACER TENDL-2024 LIBRARY; T=0.K  
Photon emission for (n,n2p)

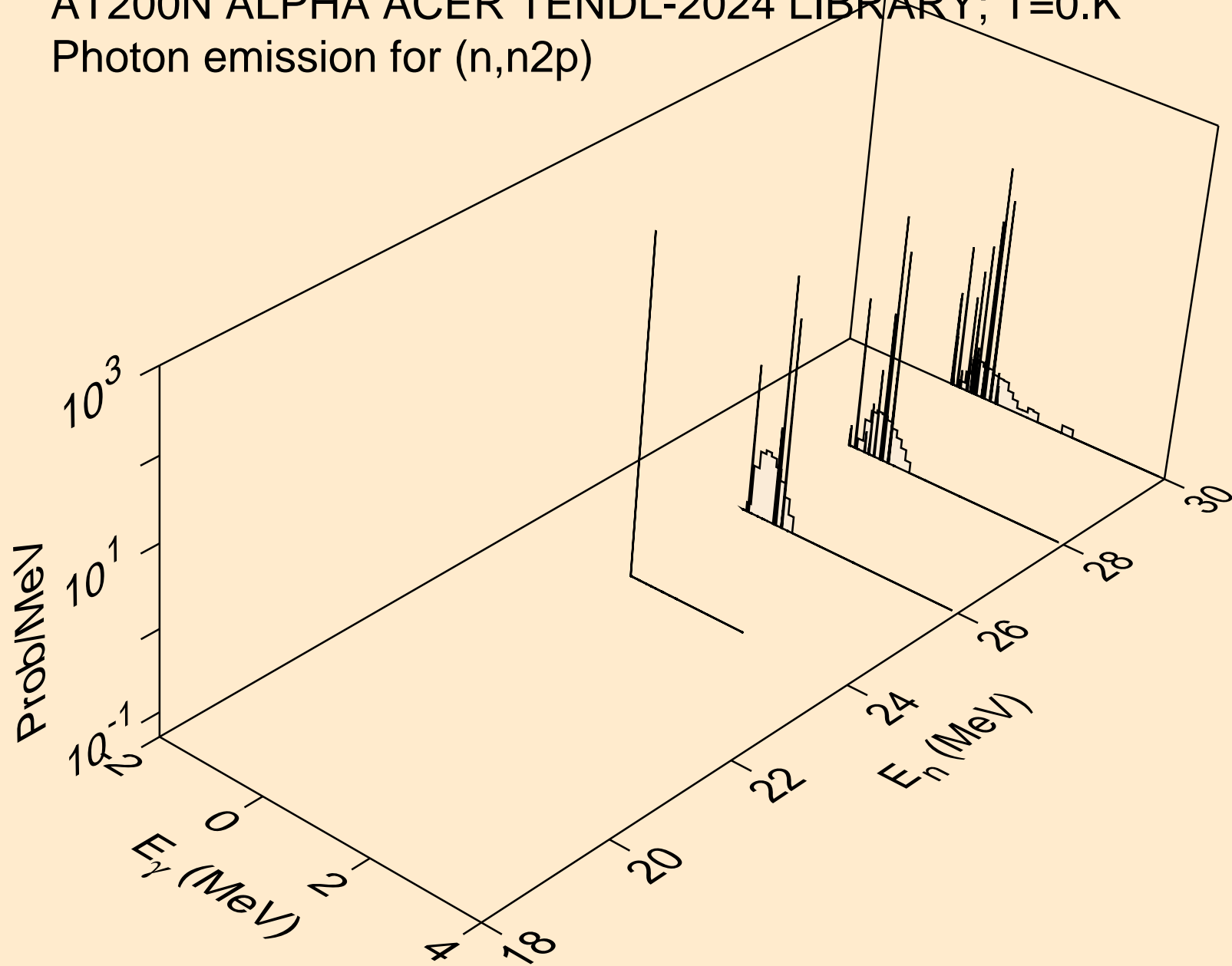

AT200N ALPHA ACER TENDL-2024 LIBRARY; T=0.K  
Photon emission for (n,npa)

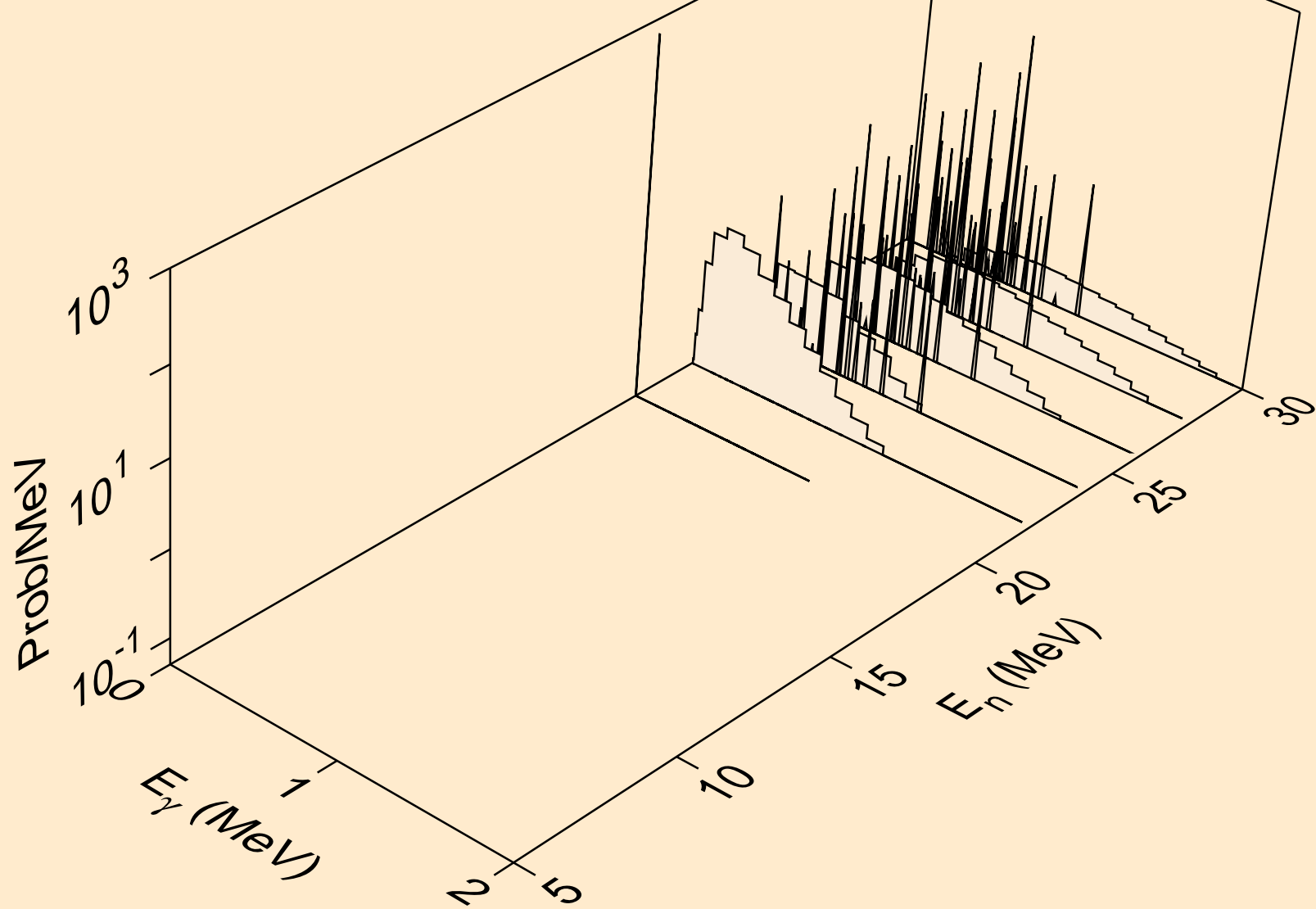

AT200N ALPHA ACER TENDL-2024 LIBRARY; T=0.K  
Photon emission for (n,gma)

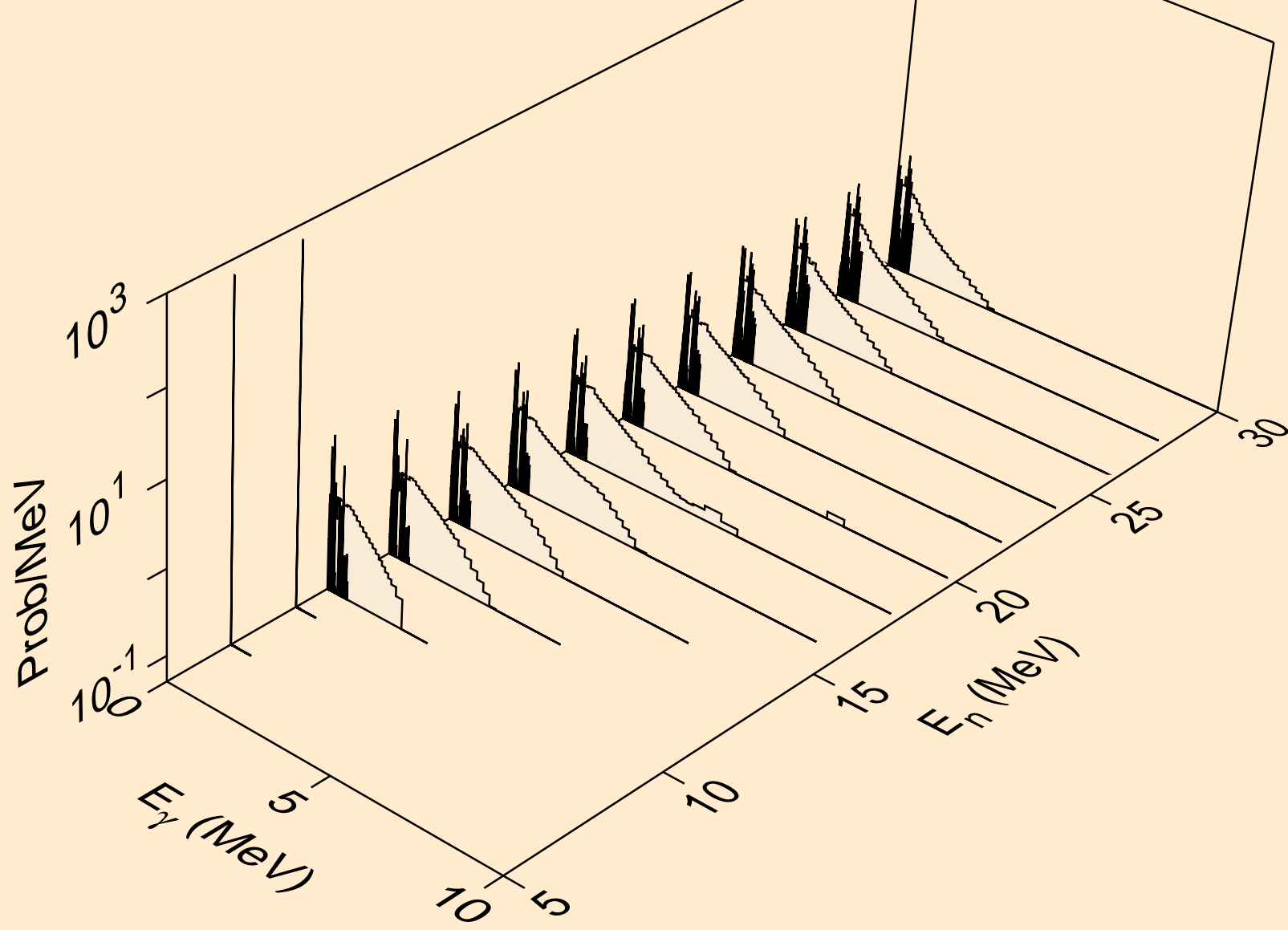

AT200N ALPHA ACER TENDL-2024 LIBRARY; T=0.K  
Photon emission for (n,p)

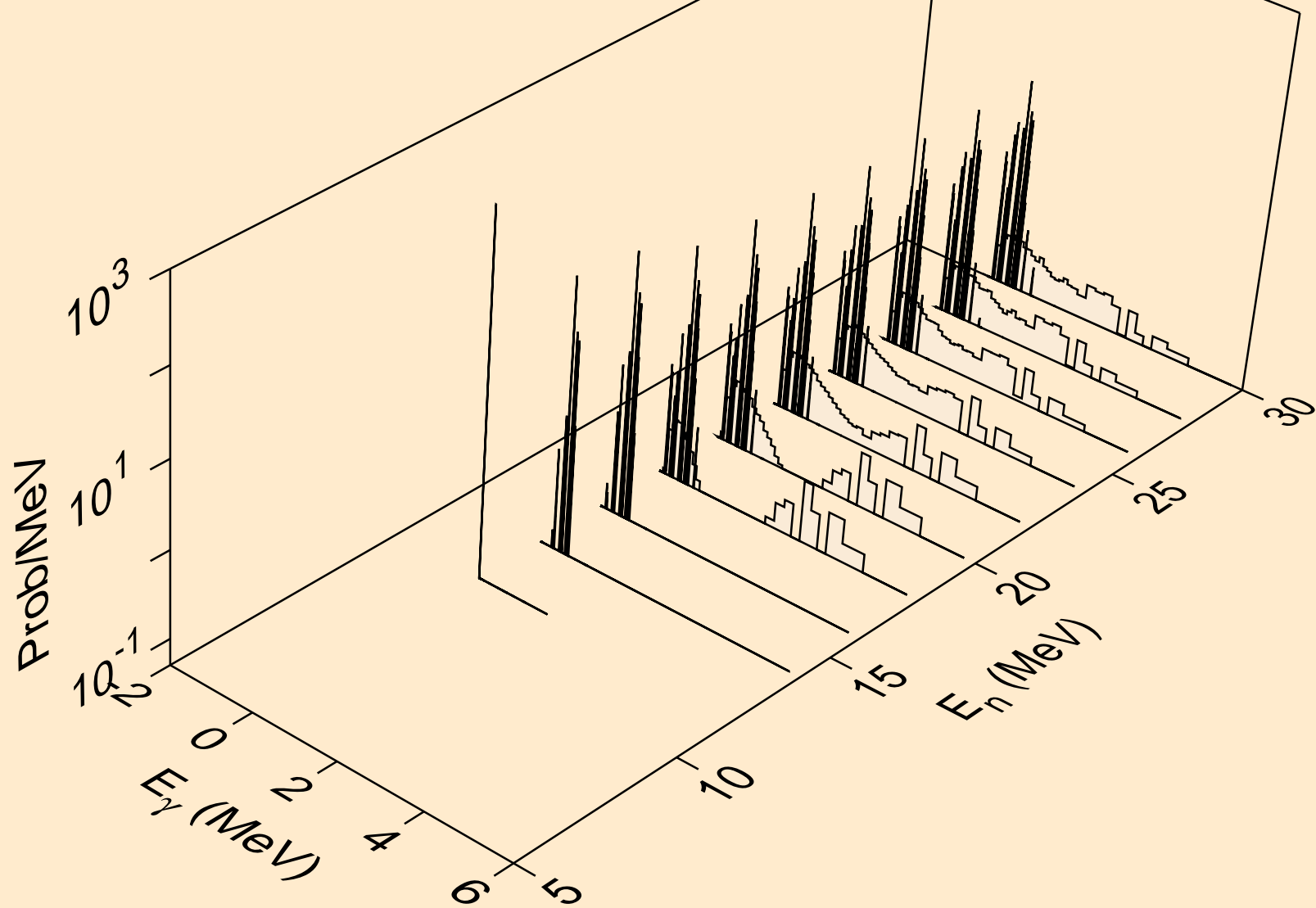

AT200N ALPHA ACER TENDL-2024 LIBRARY; T=0.K  
Photon emission for (n,d)

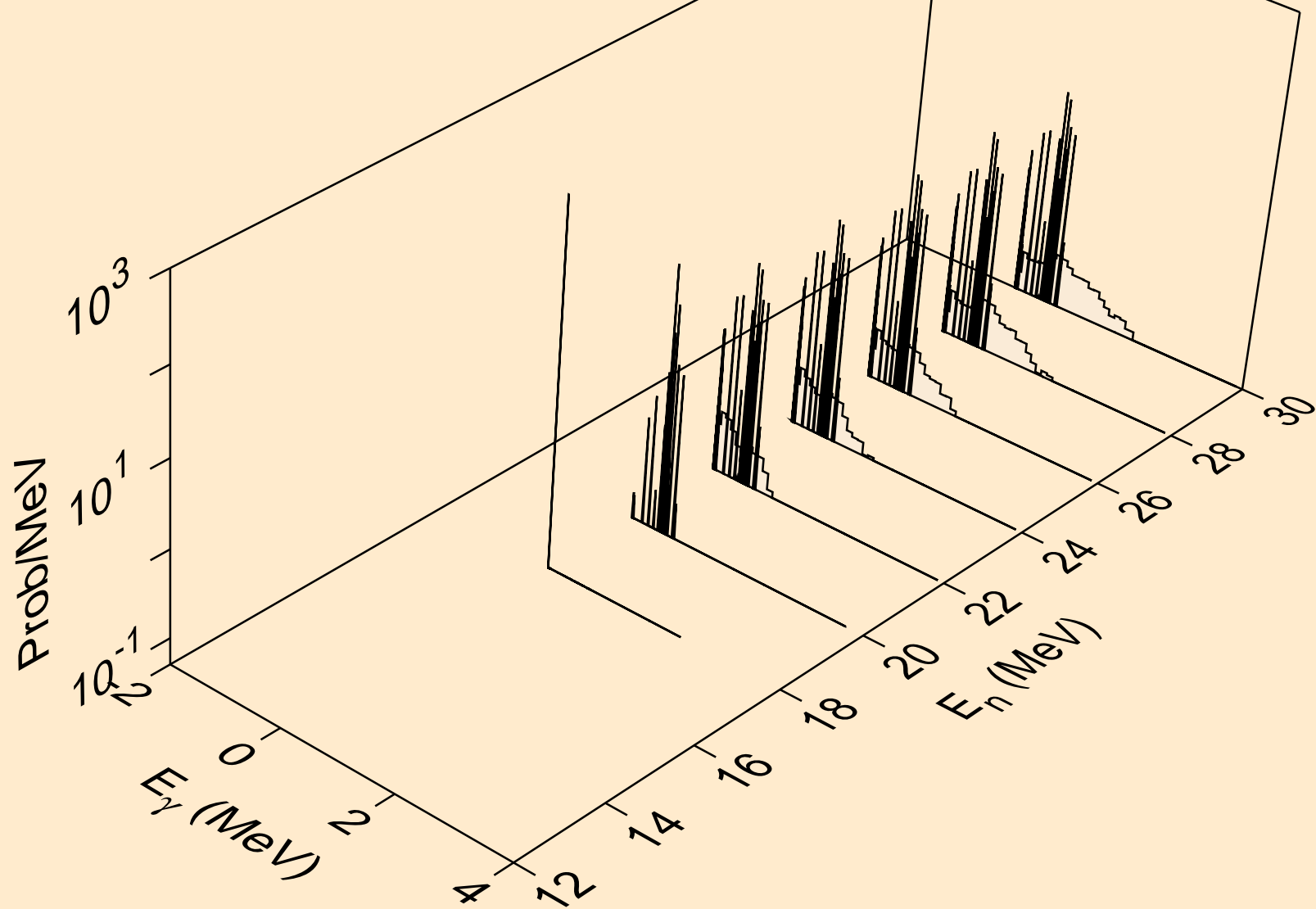

AT200N ALPHA ACER TENDL-2024 LIBRARY; T=0.K  
Photon emission for (n,t)

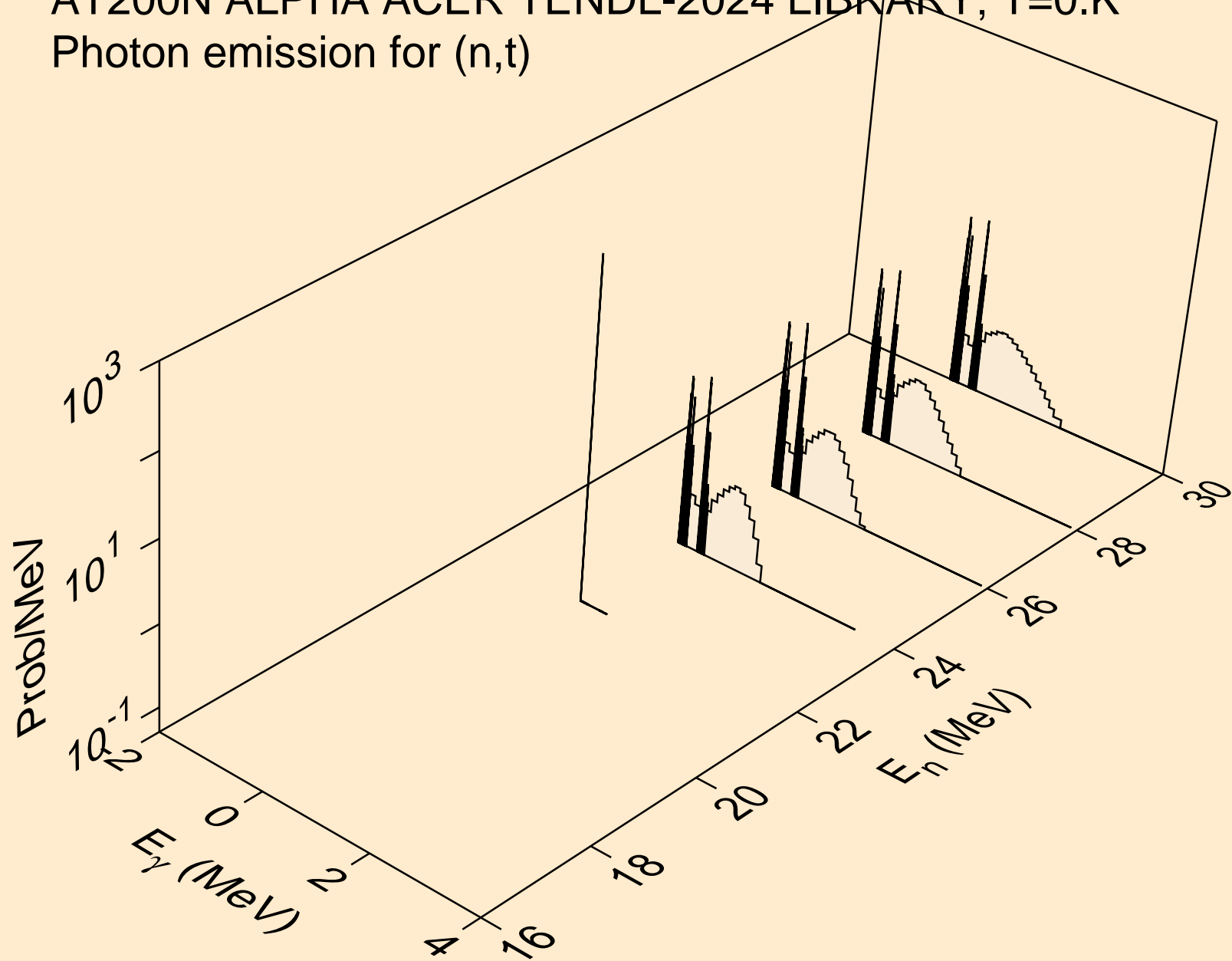

AT200N ALPHA ACER TENDL-2024 LIBRARY; T=0.K  
Photon emission for (n,he3)

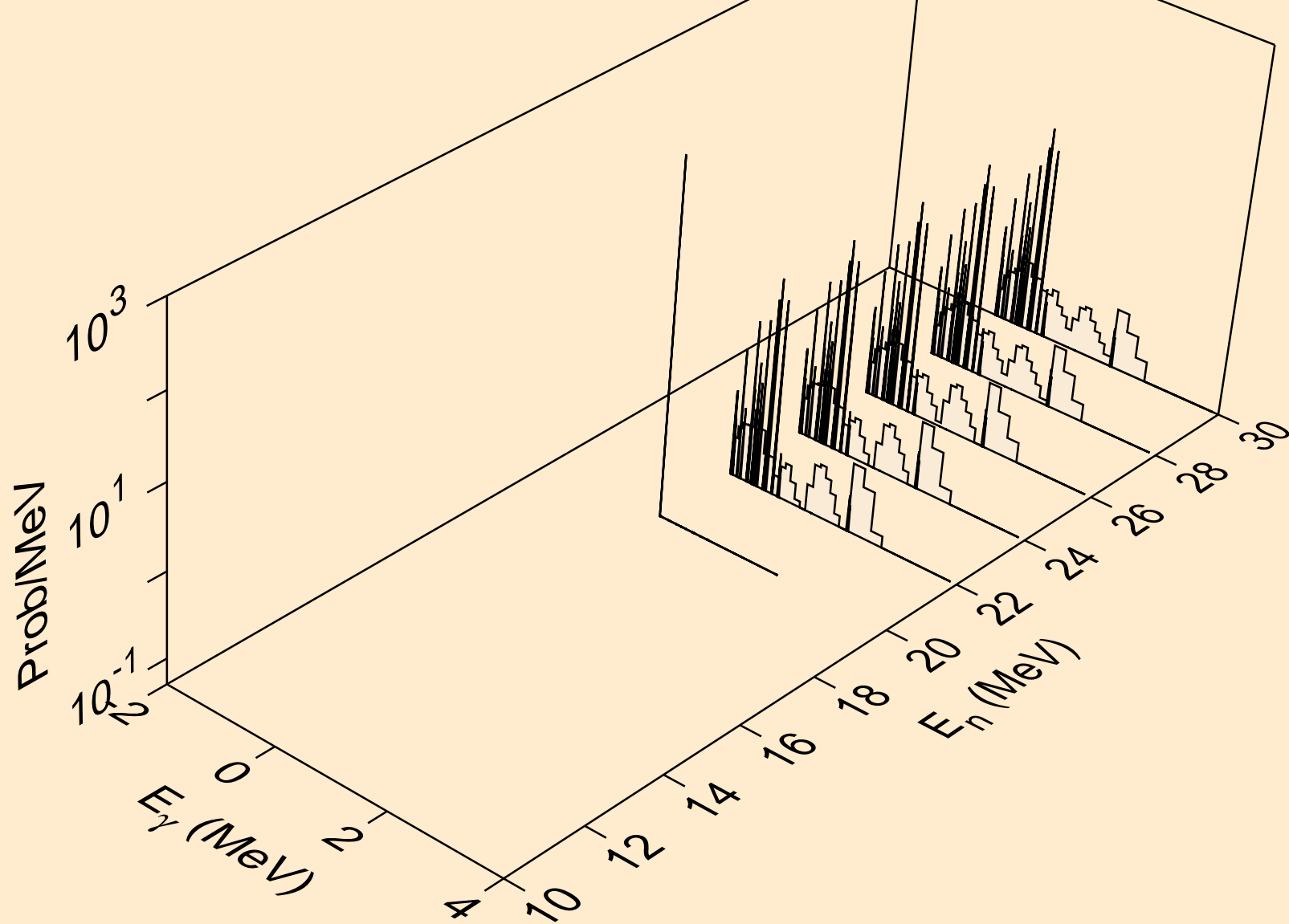

AT200N ALPHA ACER TENDL-2024 LIBRARY; T=0.K  
Photon emission for inelastic

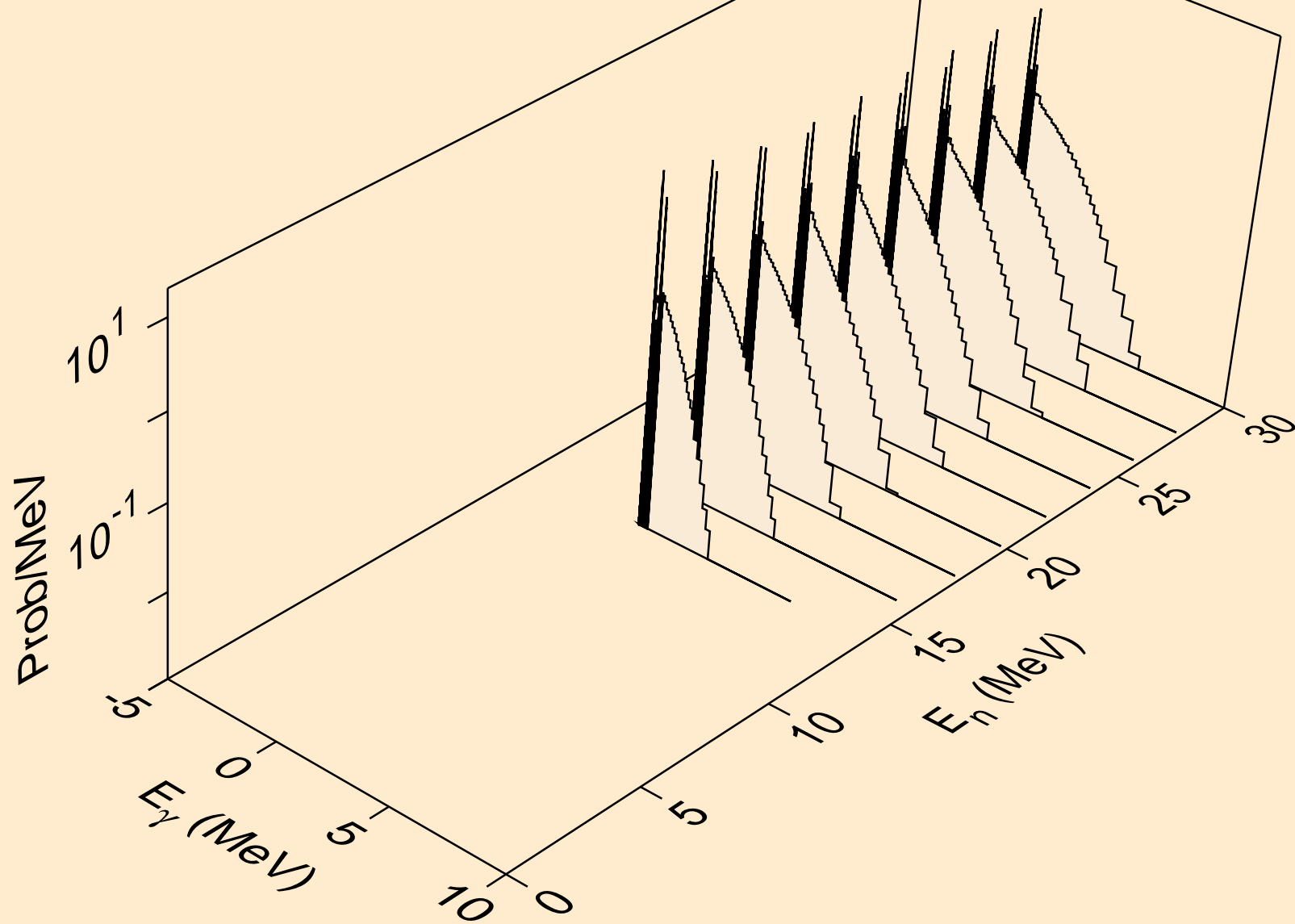

AT200N ALPHA ACER TENDL-2024 LIBRARY; T=0.K  
Photon emission for (n,2a)

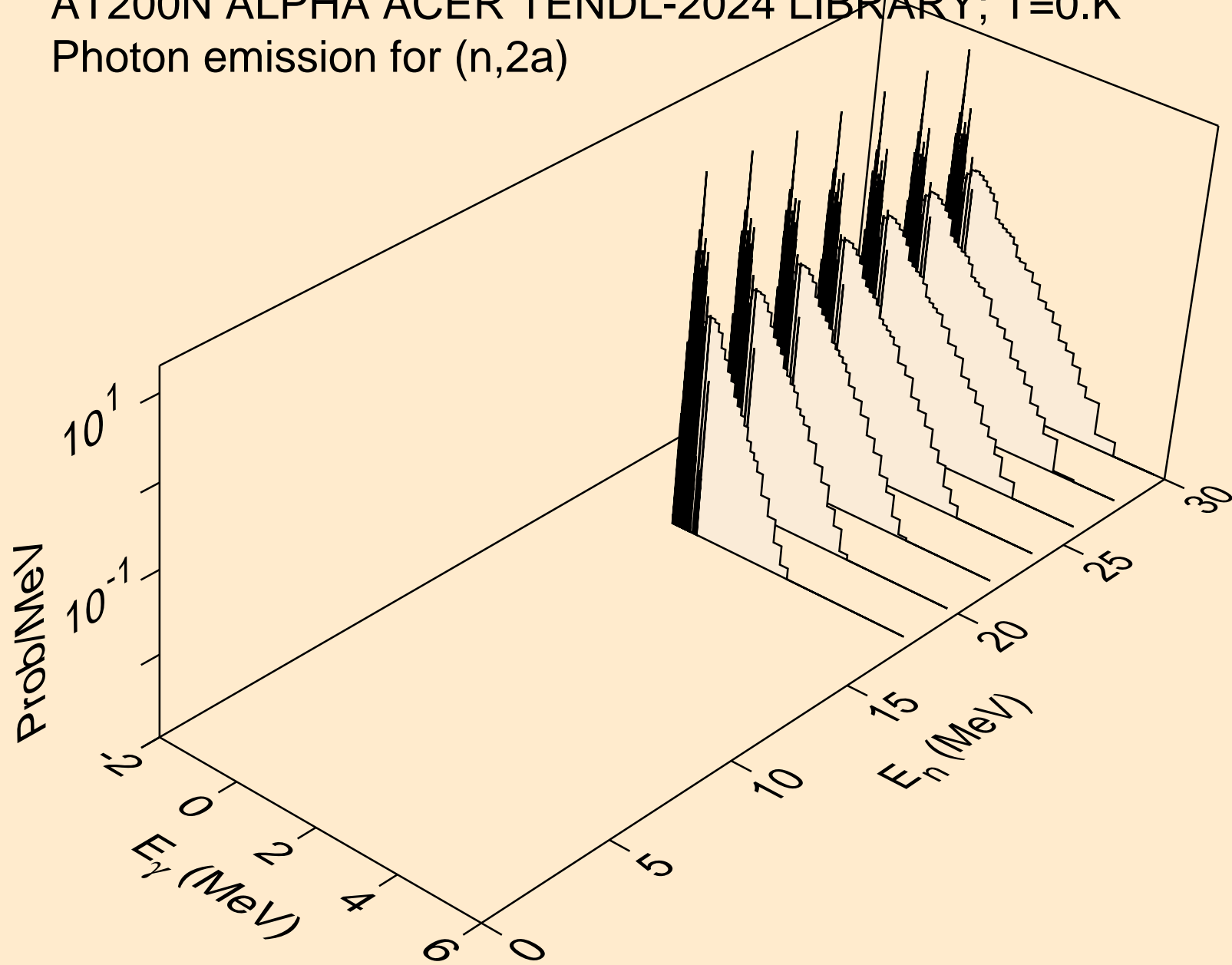

AT200N ALPHA ACER TENDL-2024 LIBRARY; T=0.K  
Photon emission for (n,2p)

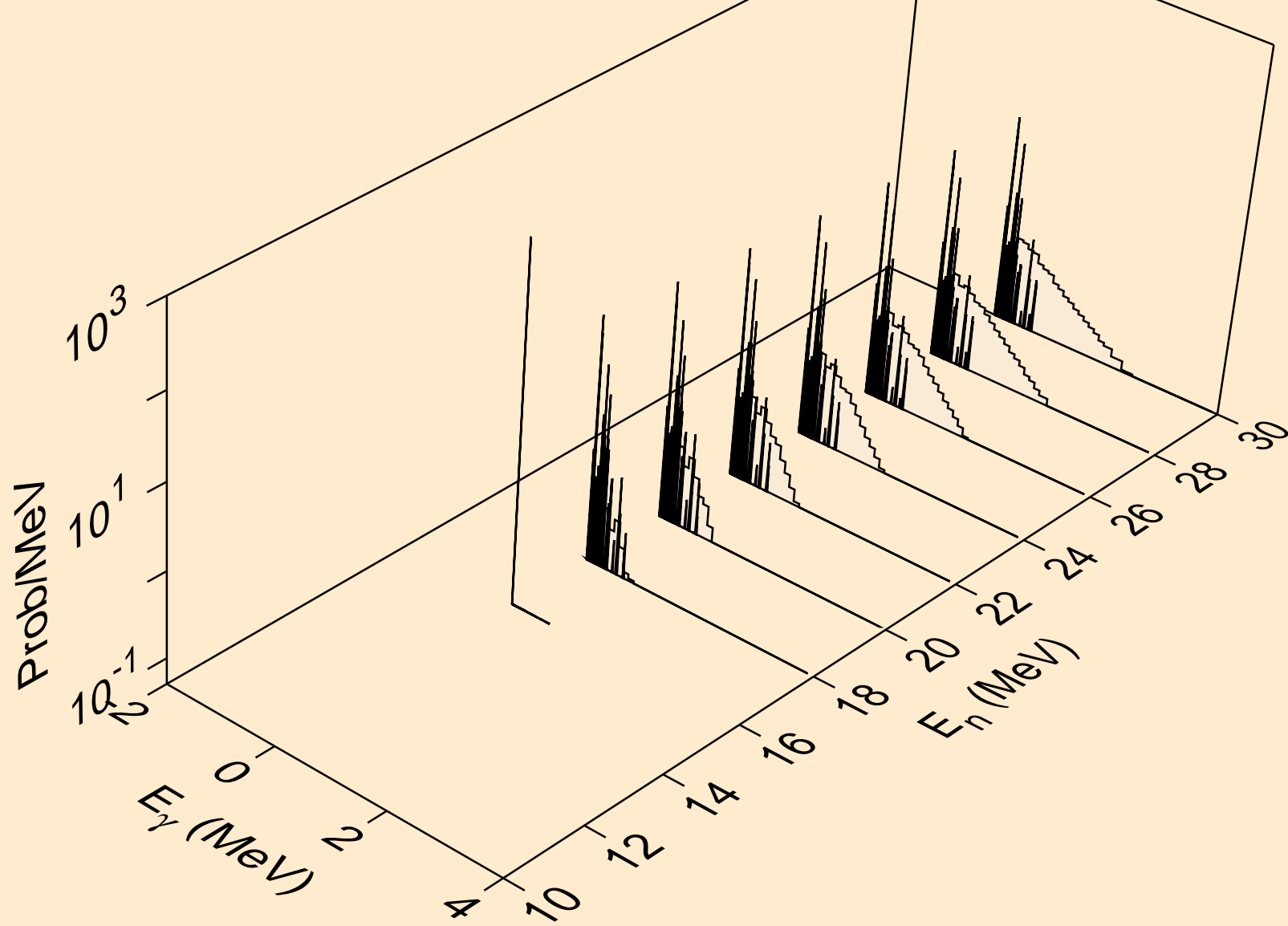

AT200N ALPHA ACER TENDL-2024 LIBRARY; T=0.K  
Photon emission for (n,p $\alpha$ )

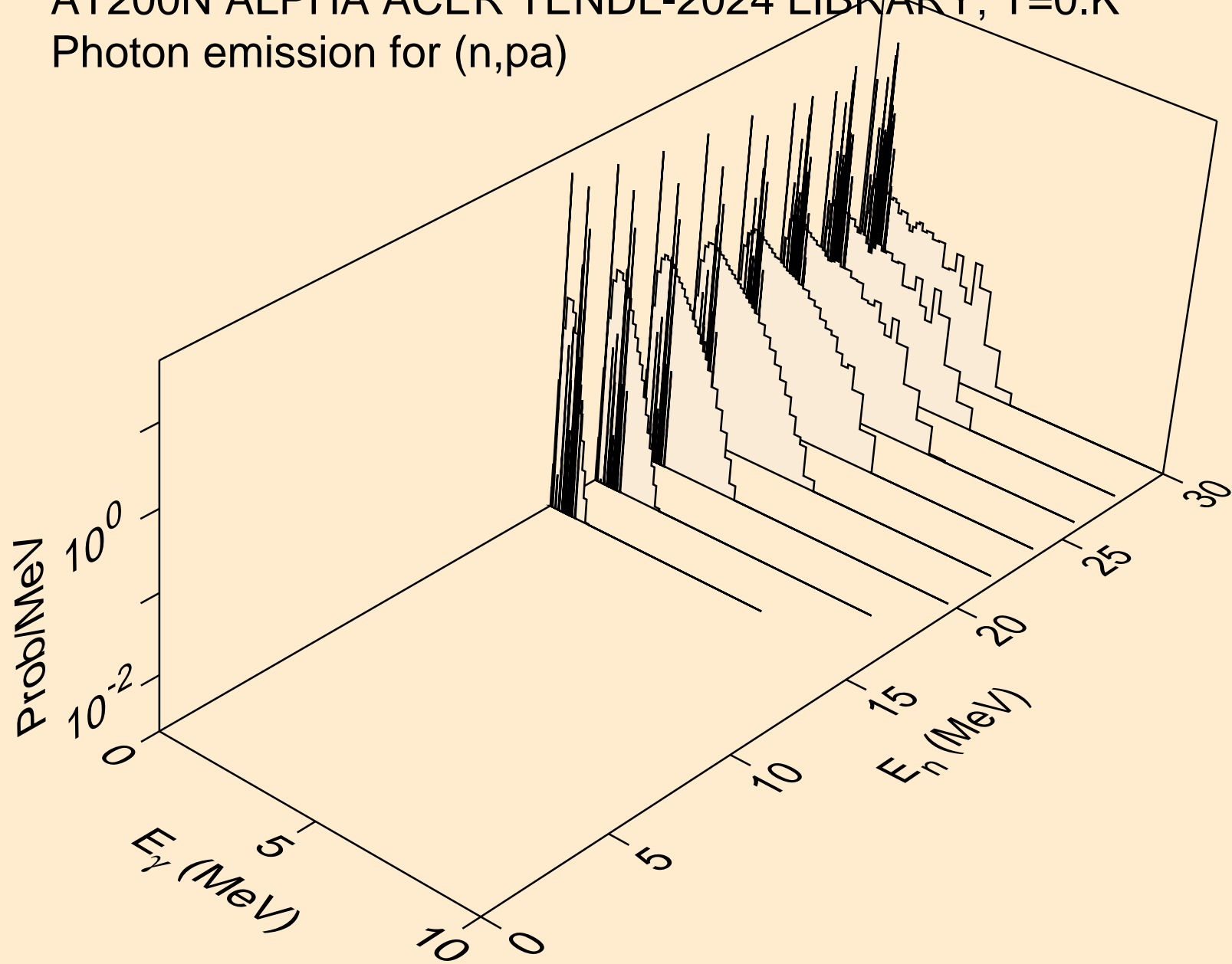

AT200N ALPHA ACER TENDL-2024 LIBRARY; T=0.K  
Particle heating contributions

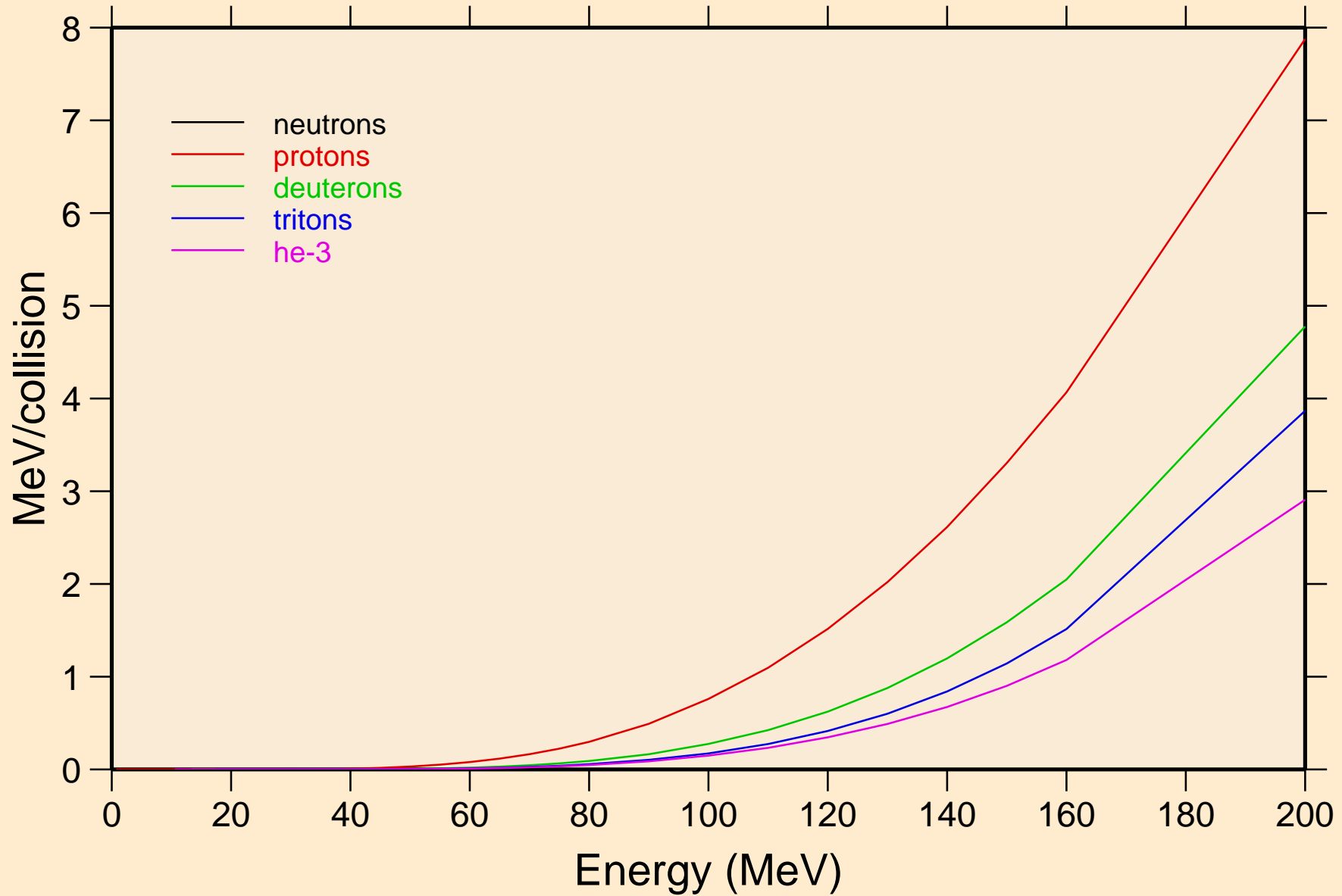

AT200N ALPHA ACER TENDL-2024 LIBRARY; T=0.K  
Recoil Heating

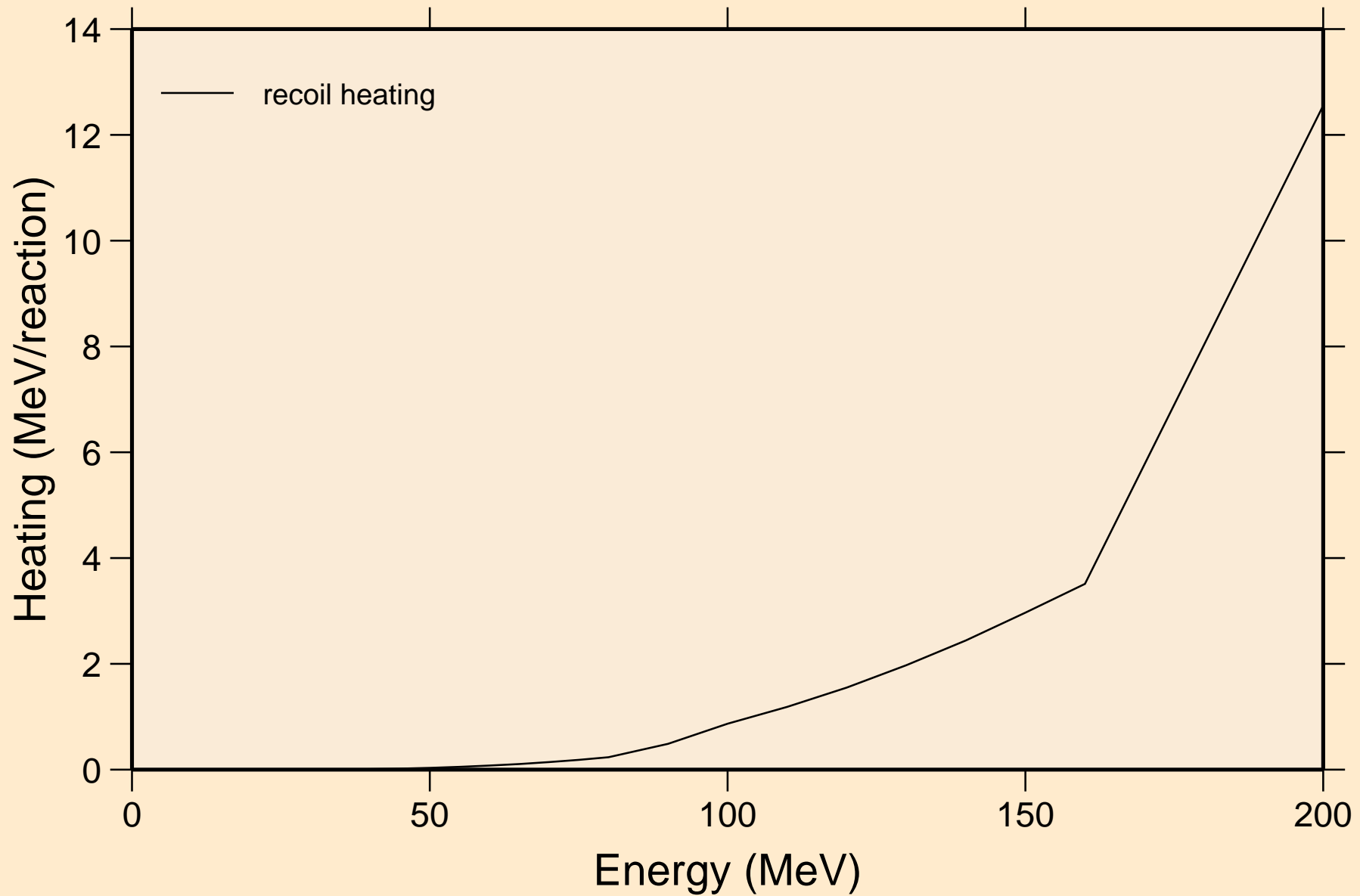

AT200N ALPHA ACER TENDL-2024 LIBRARY; T=0.K  
Particle production cross sections

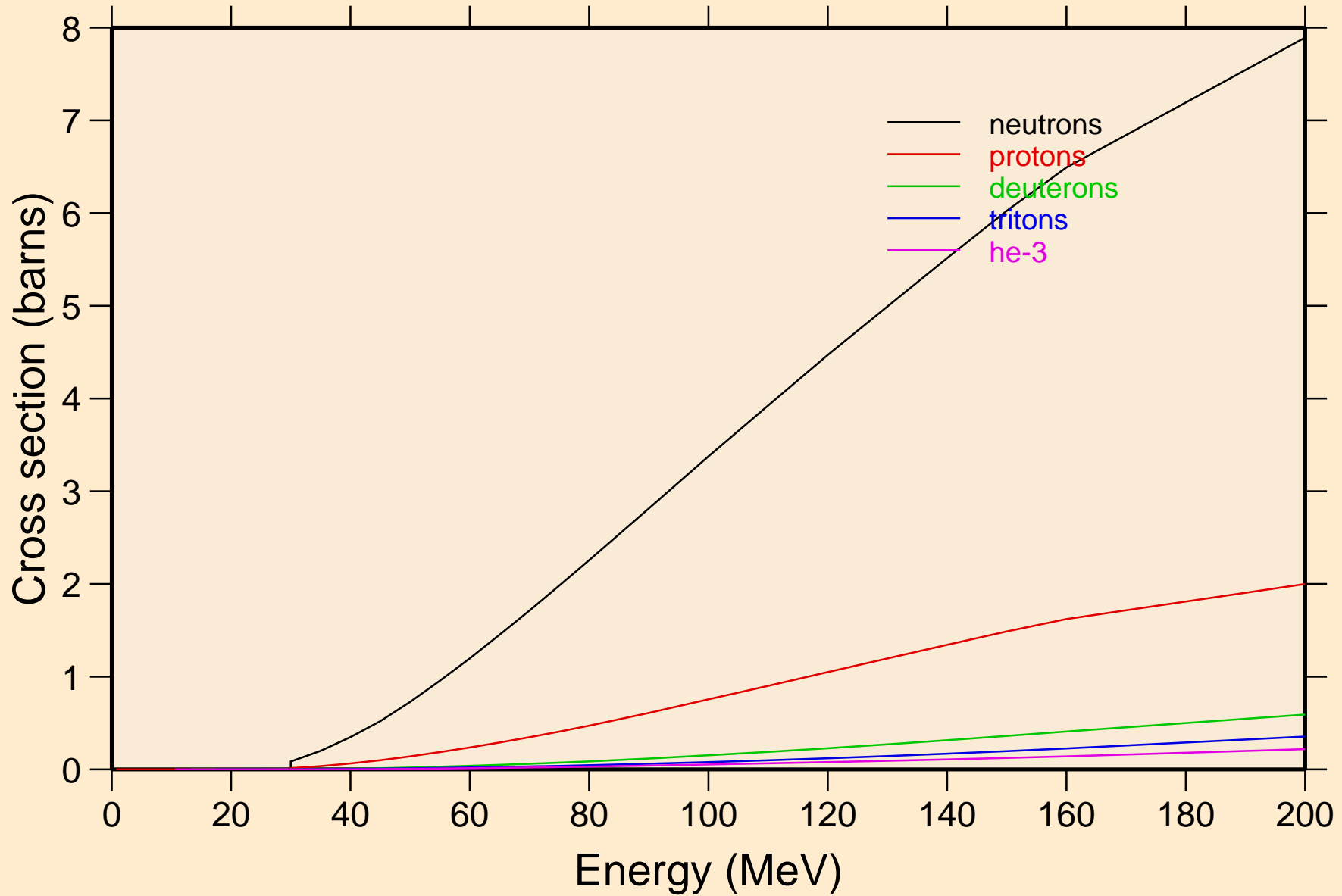

AT200N ALPHA ACER TENDL-2024 LIBRARY; T=0.K  
neutrons from (a,n)

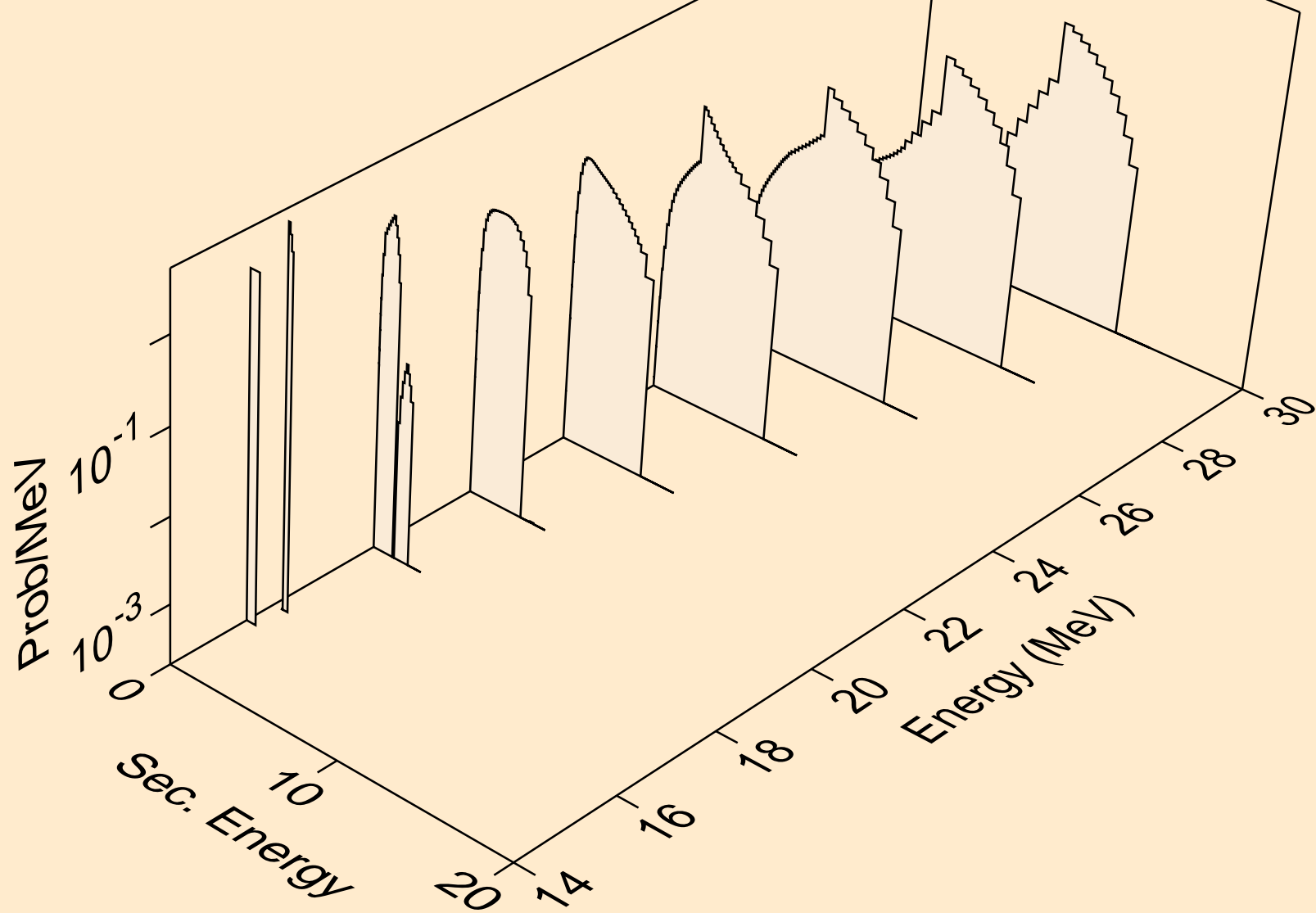

AT200N ALPHA ACER TENDL-2024 LIBRARY; T=0.K  
neutrons from (a,x)

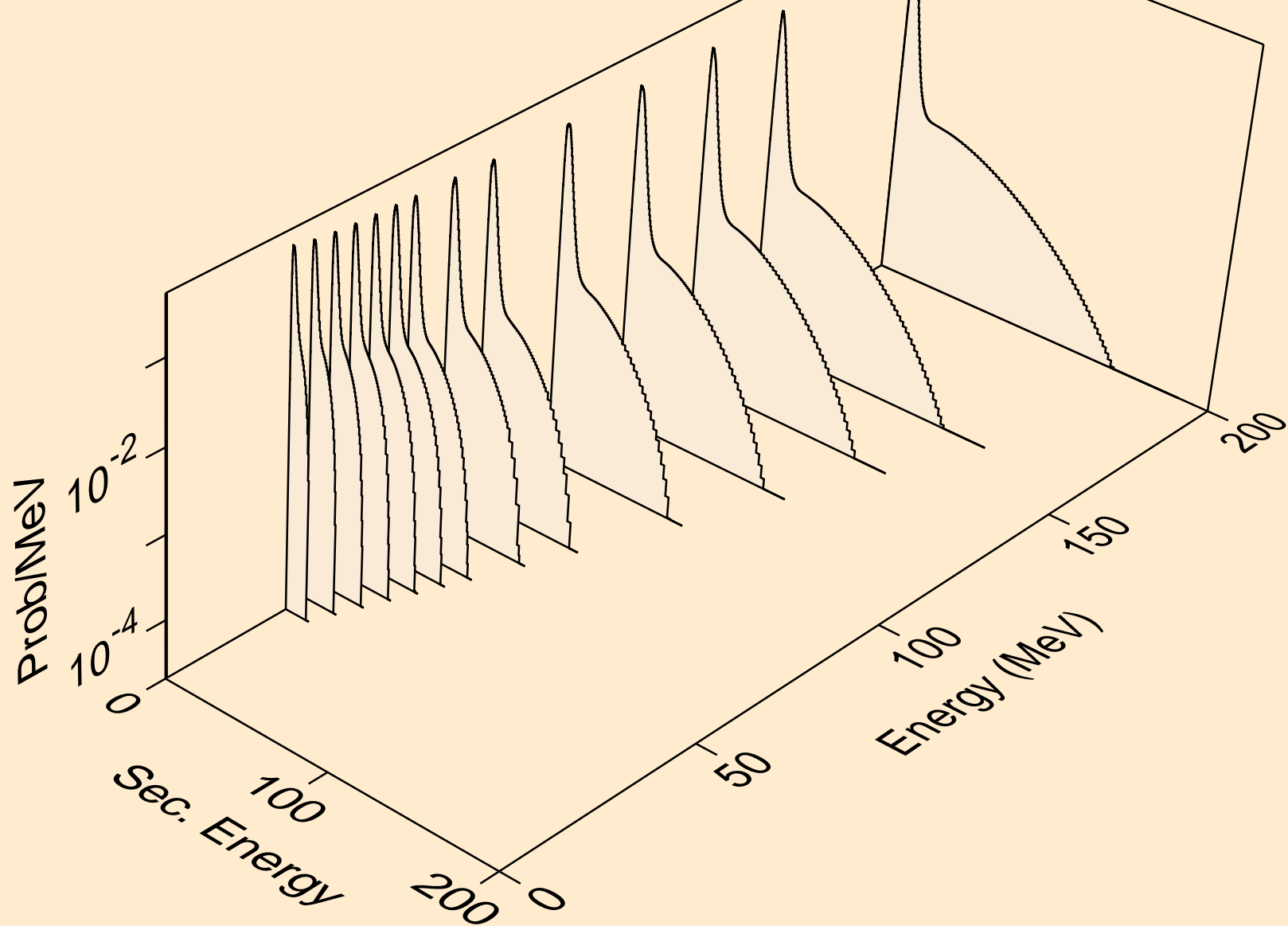

AT200N ALPHA ACER TENDL-2024 LIBRARY; T=0.K  
neutrons from (a,2n)

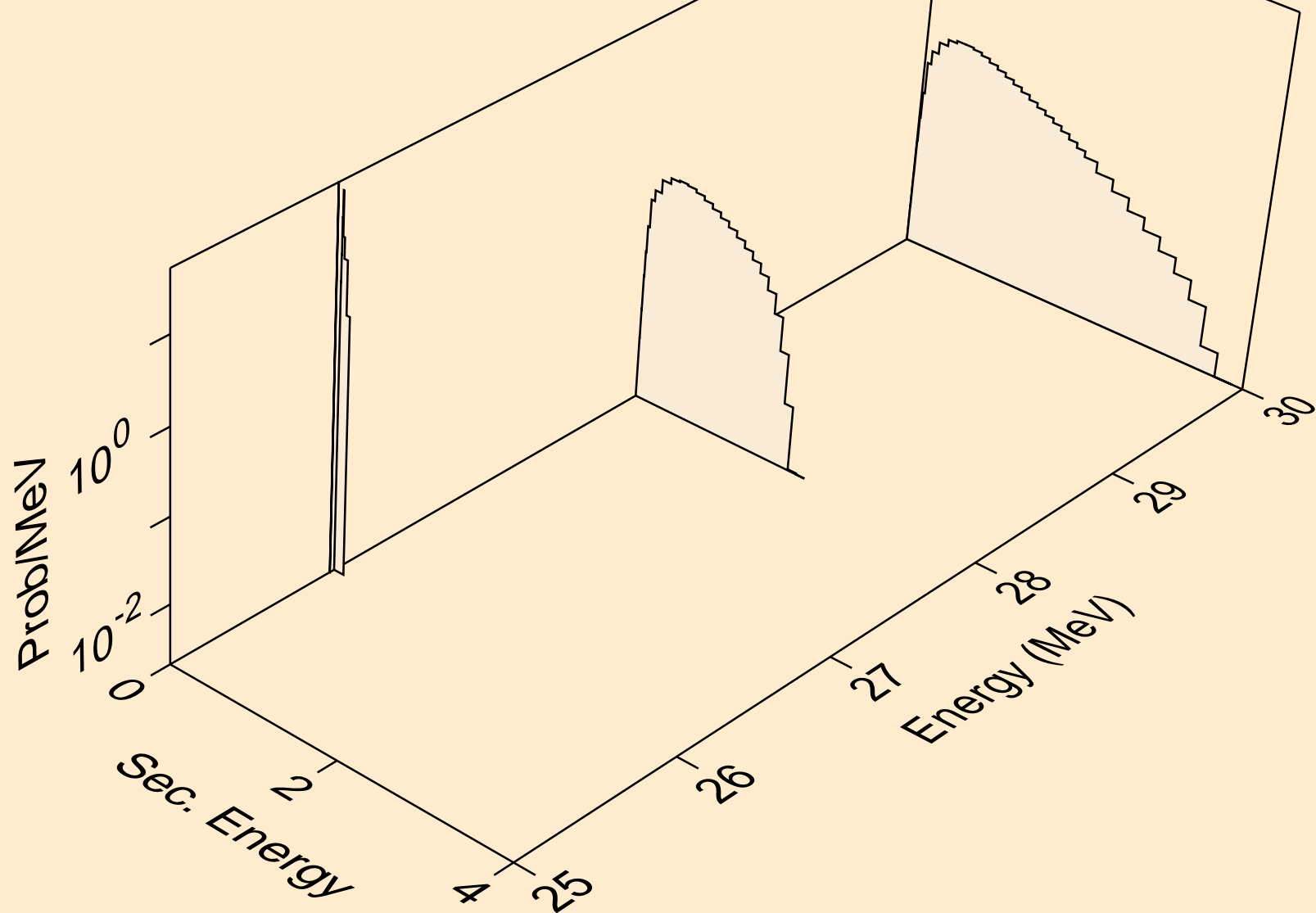

AT200N ALPHA ACER TENDL-2024 LIBRARY; T=0.K  
neutrons from (a,n\*)a

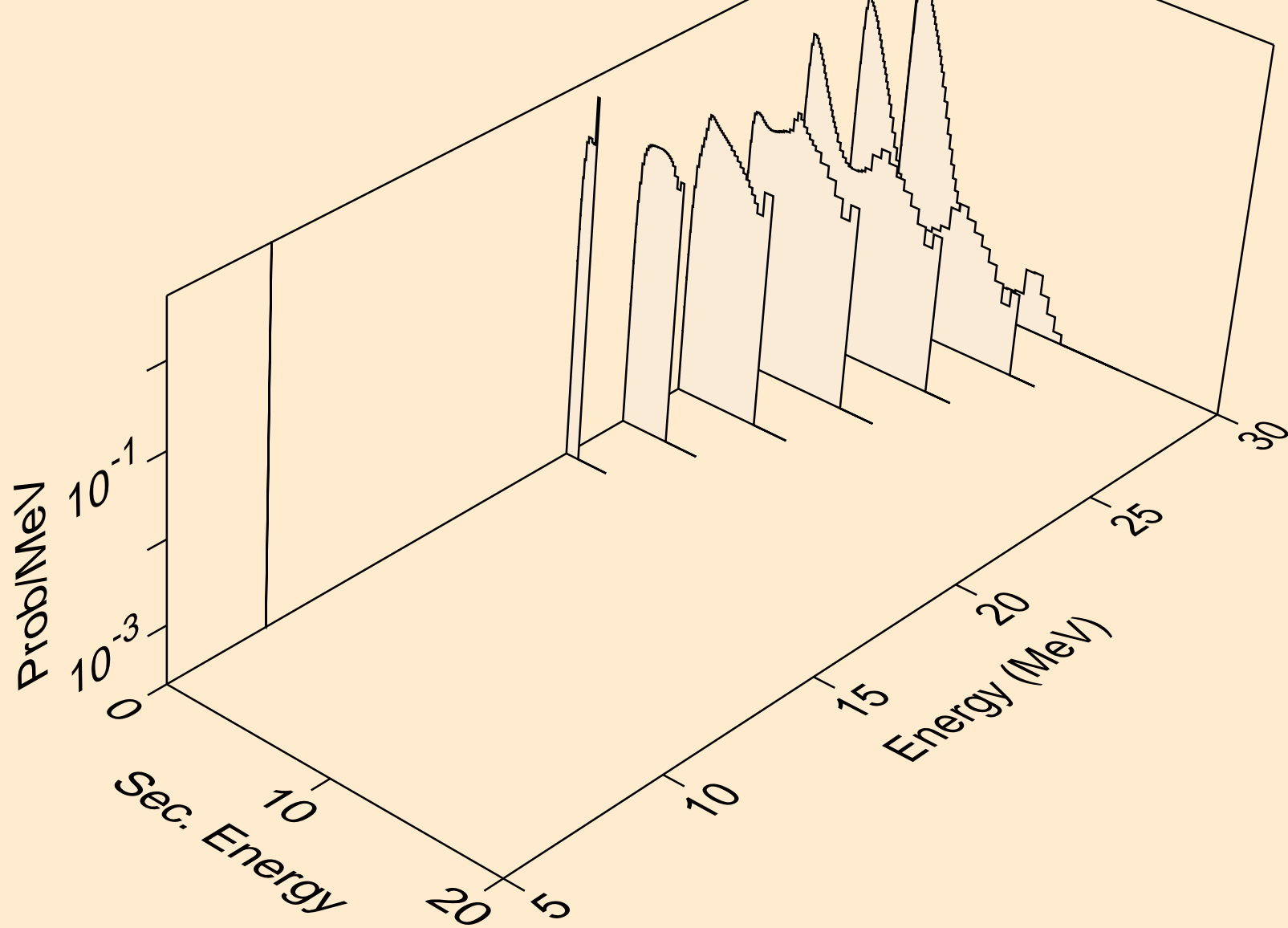

AT200N ALPHA ACER TENDL-2024 LIBRARY; T=0.K  
neutrons from (a,n\*)p

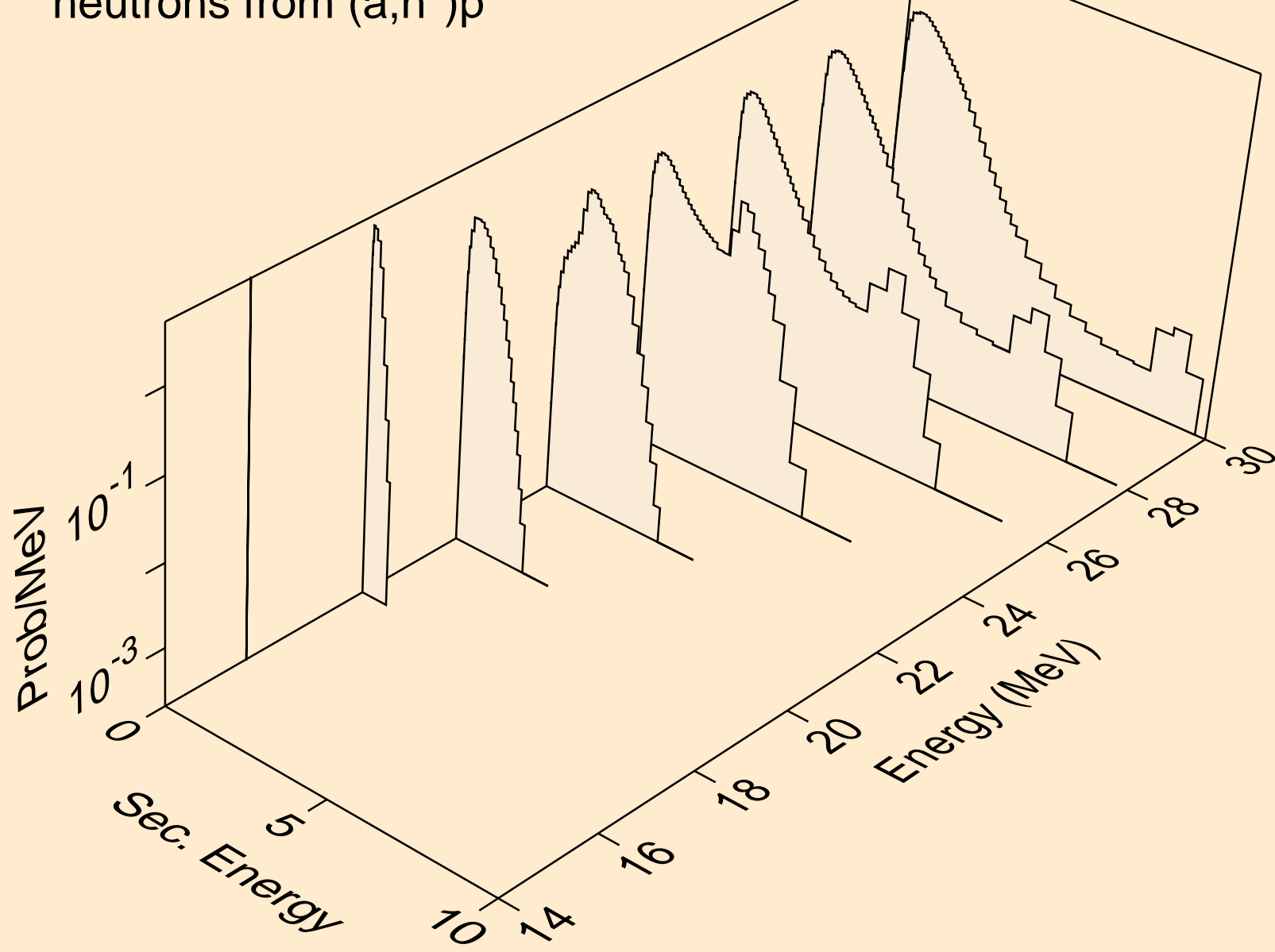

AT200N ALPHA ACER TENDL-2024 LIBRARY; T=0.K  
neutrons from (a,n2p)

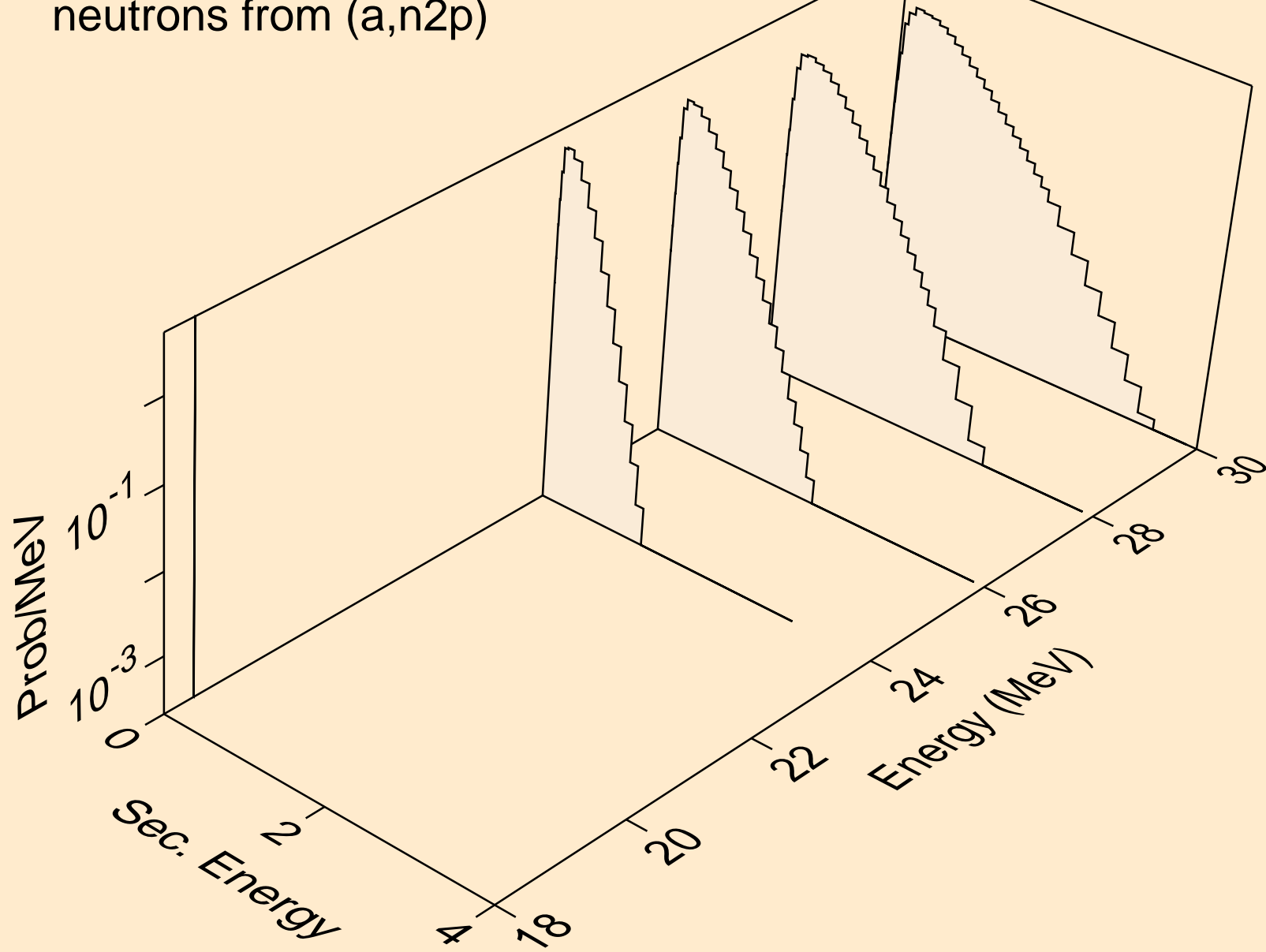

AT200N ALPHA ACER TENDL-2024 LIBRARY; T=0.K  
neutrons from (a,npa)

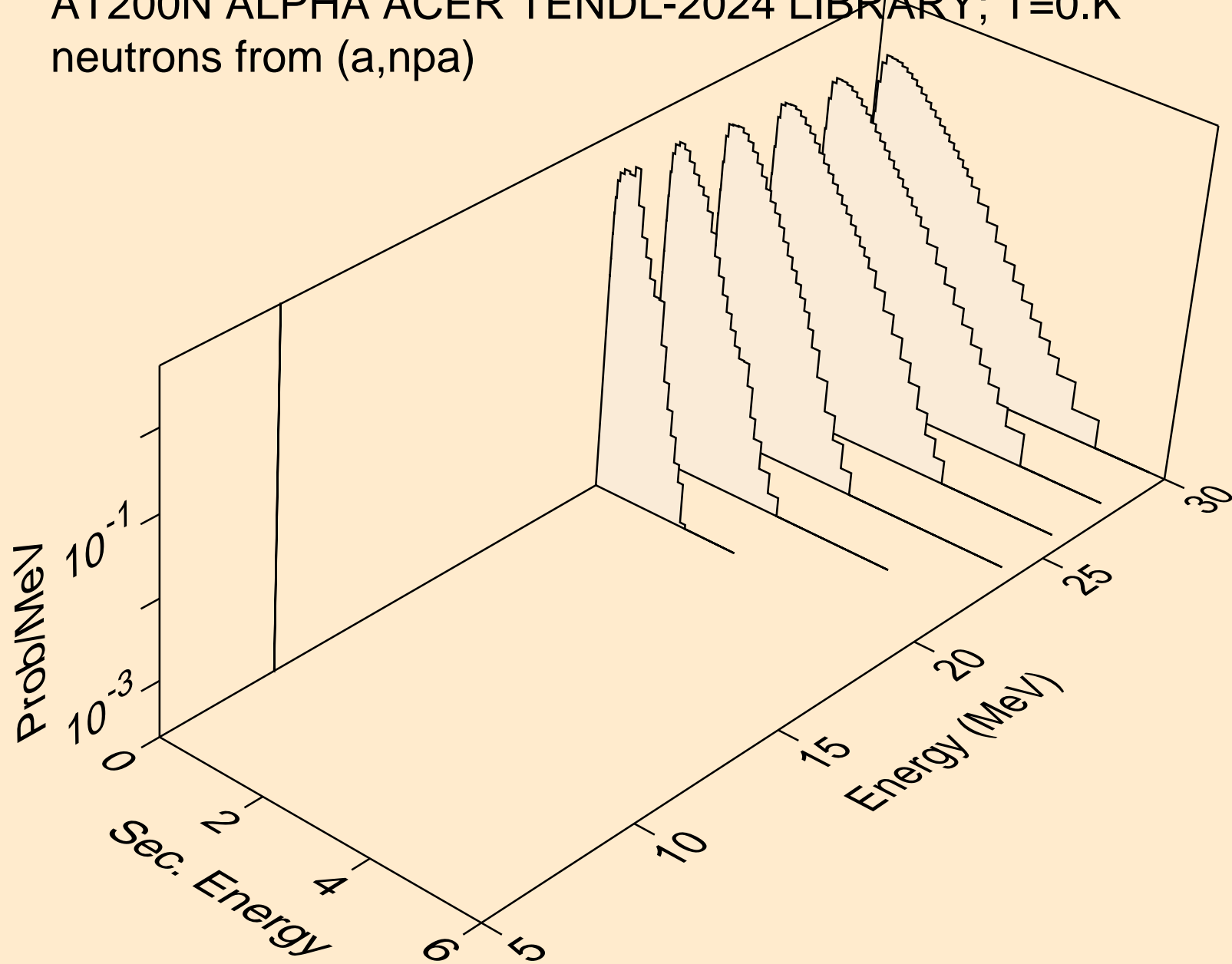

AT200N ALPHA ACER TENDL-2024 LIBRARY; T=0.K  
protons from (a,x)

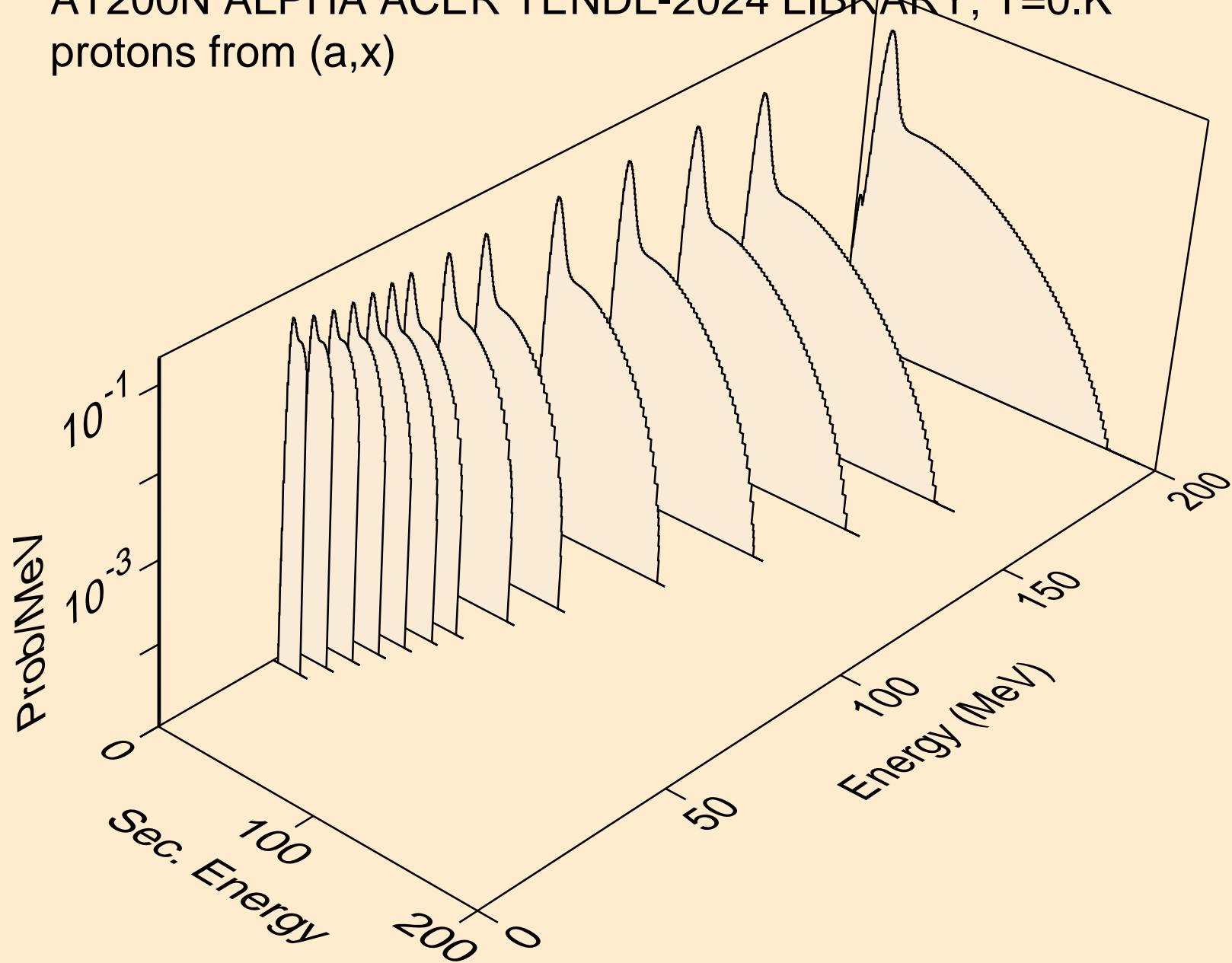

AT200N ALPHA ACER TENDL-2024 LIBRARY; T=0.K  
protons from (a,n\*)p

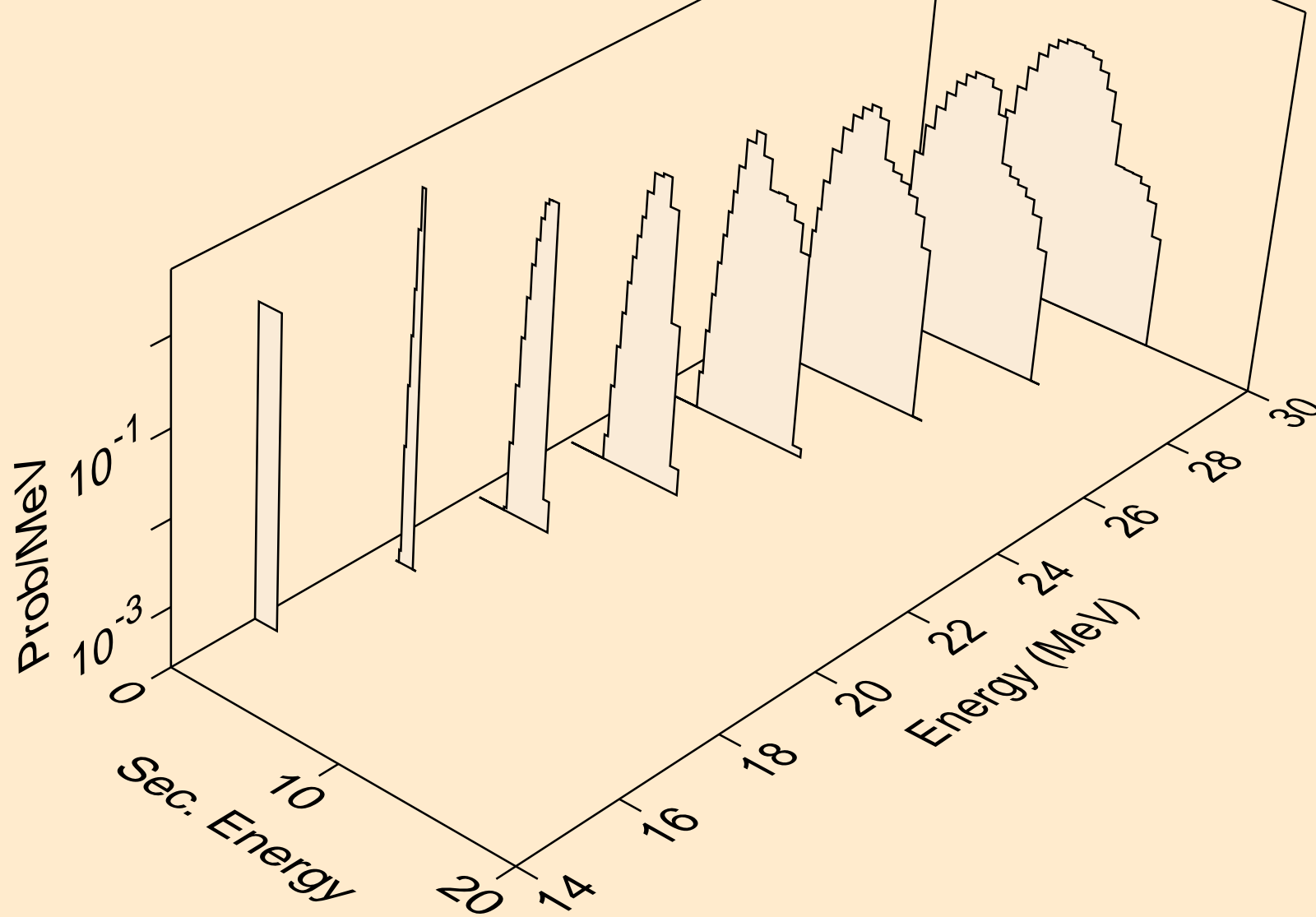

AT200N ALPHA ACER TENDL-2024 LIBRARY; T=0.K  
protons from (a,n2p)

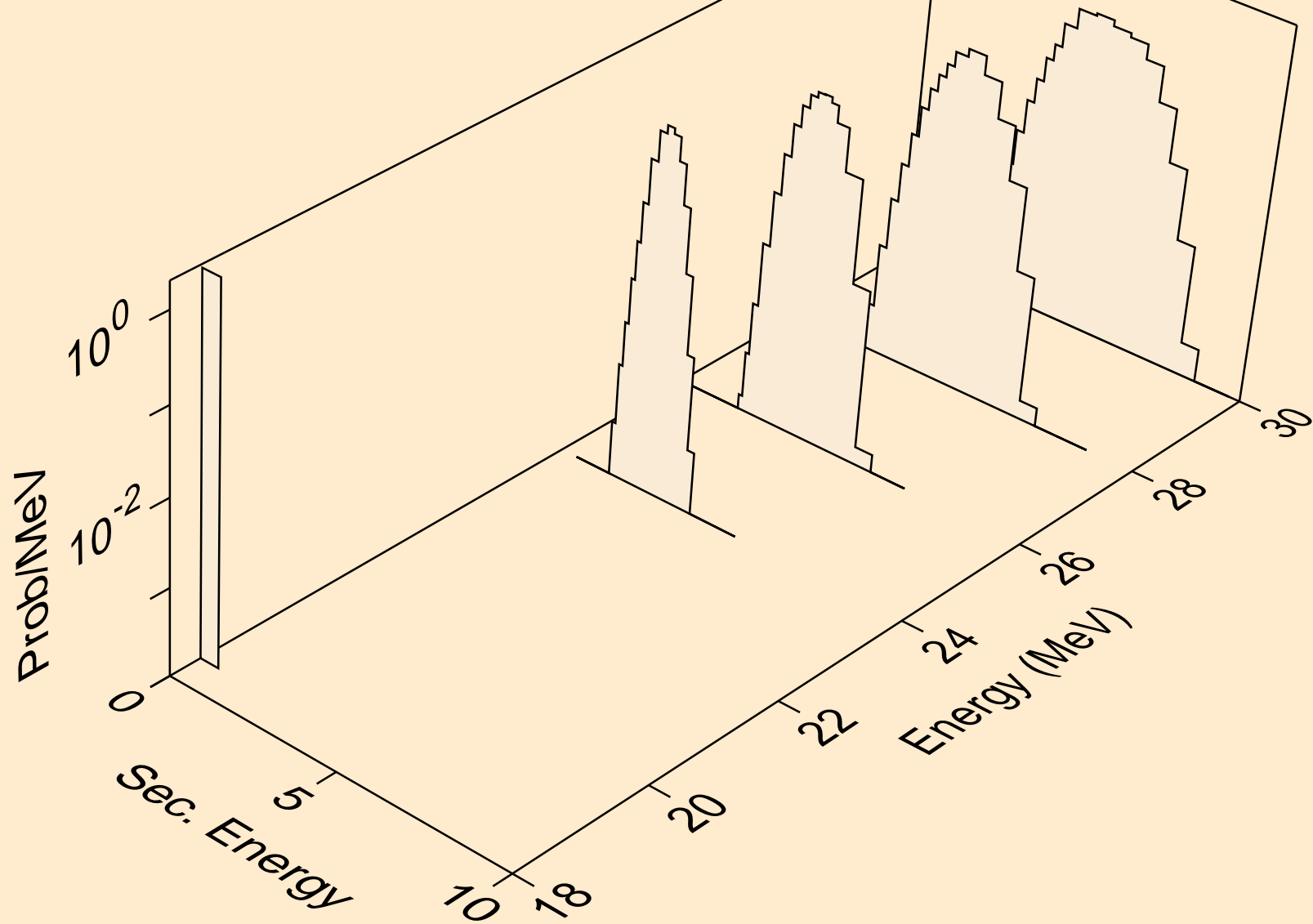

AT200N ALPHA ACER TENDL-2024 LIBRARY; T=0.K  
protons from (a,npa)

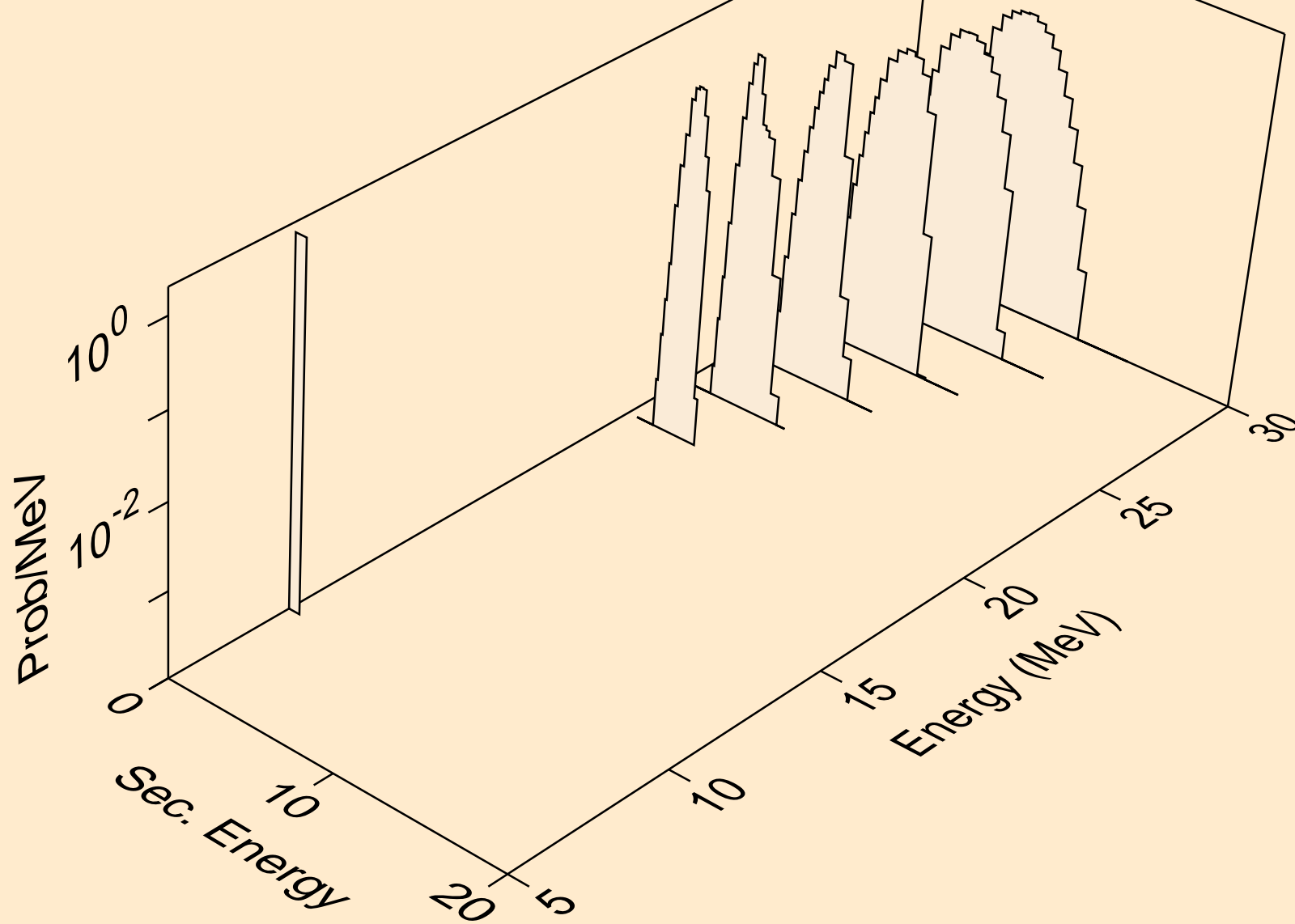

AT200N ALPHA ACER TENDL-2024 LIBRARY; T=0.K  
protons from (a,p)

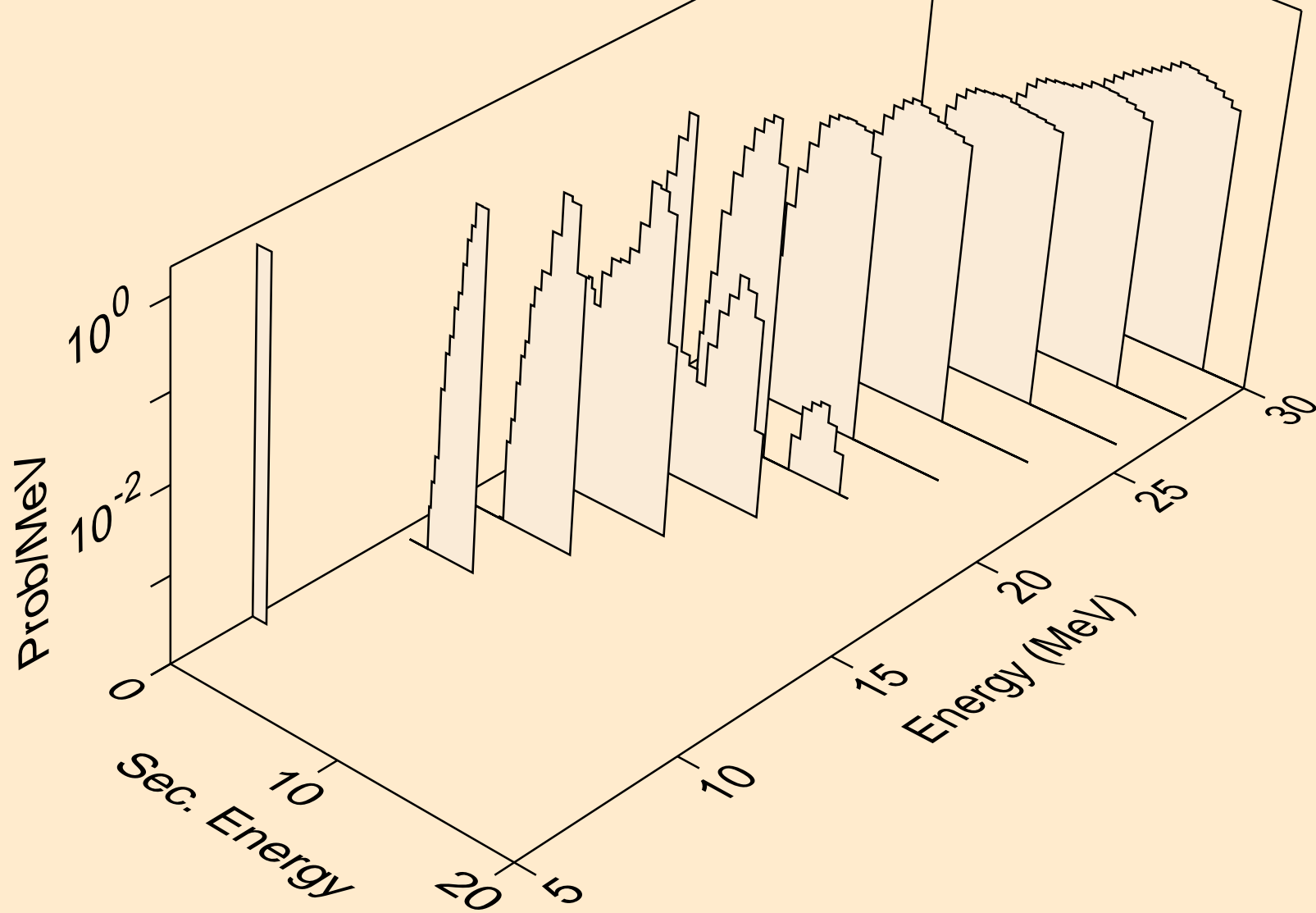

AT200N ALPHA ACER TENDL-2024 LIBRARY; T=0.K  
protons from (a,2p)

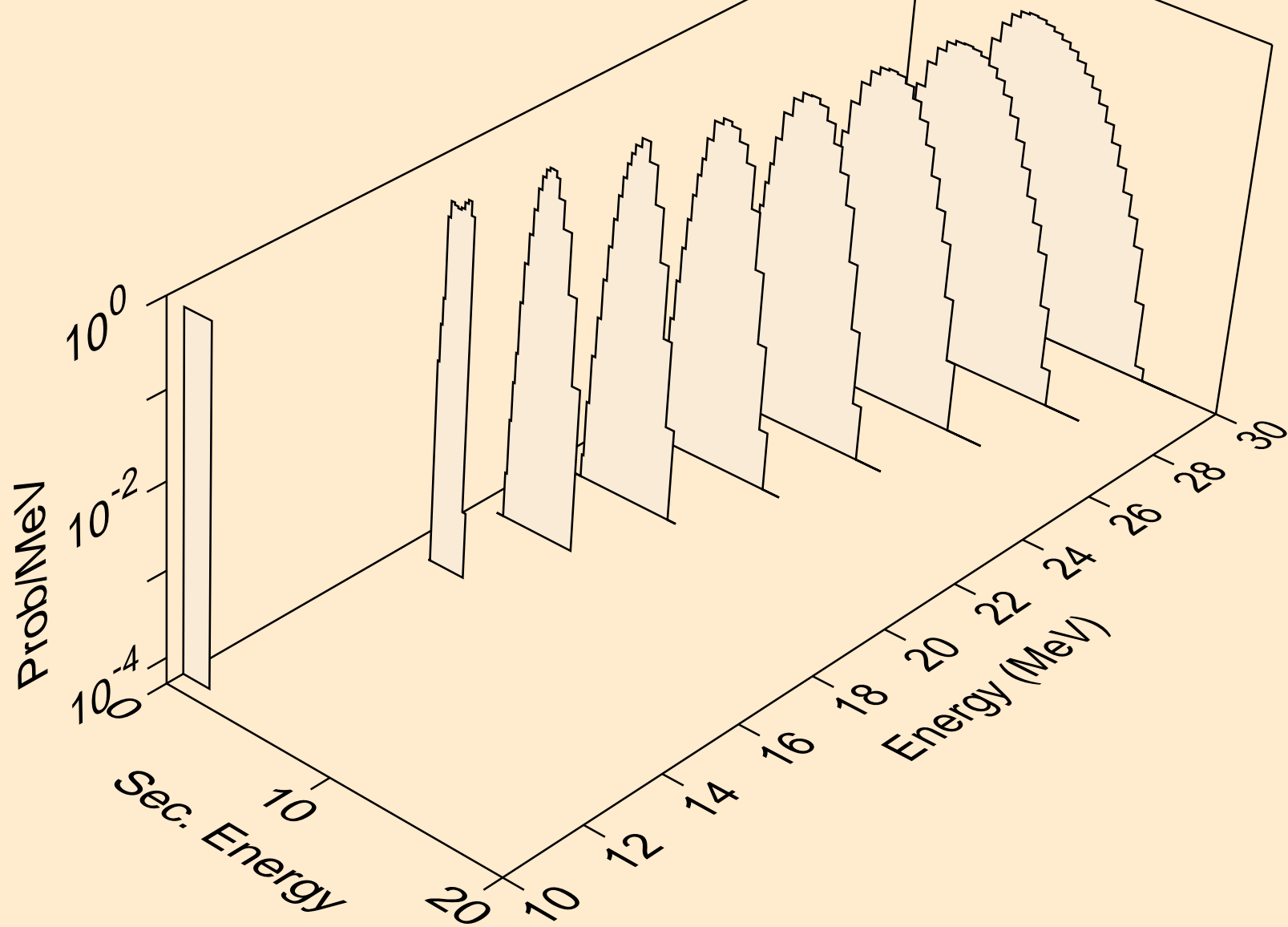

AT200N ALPHA ACER TENDL-2024 LIBRARY; T=0.K  
protons from (a,pa)

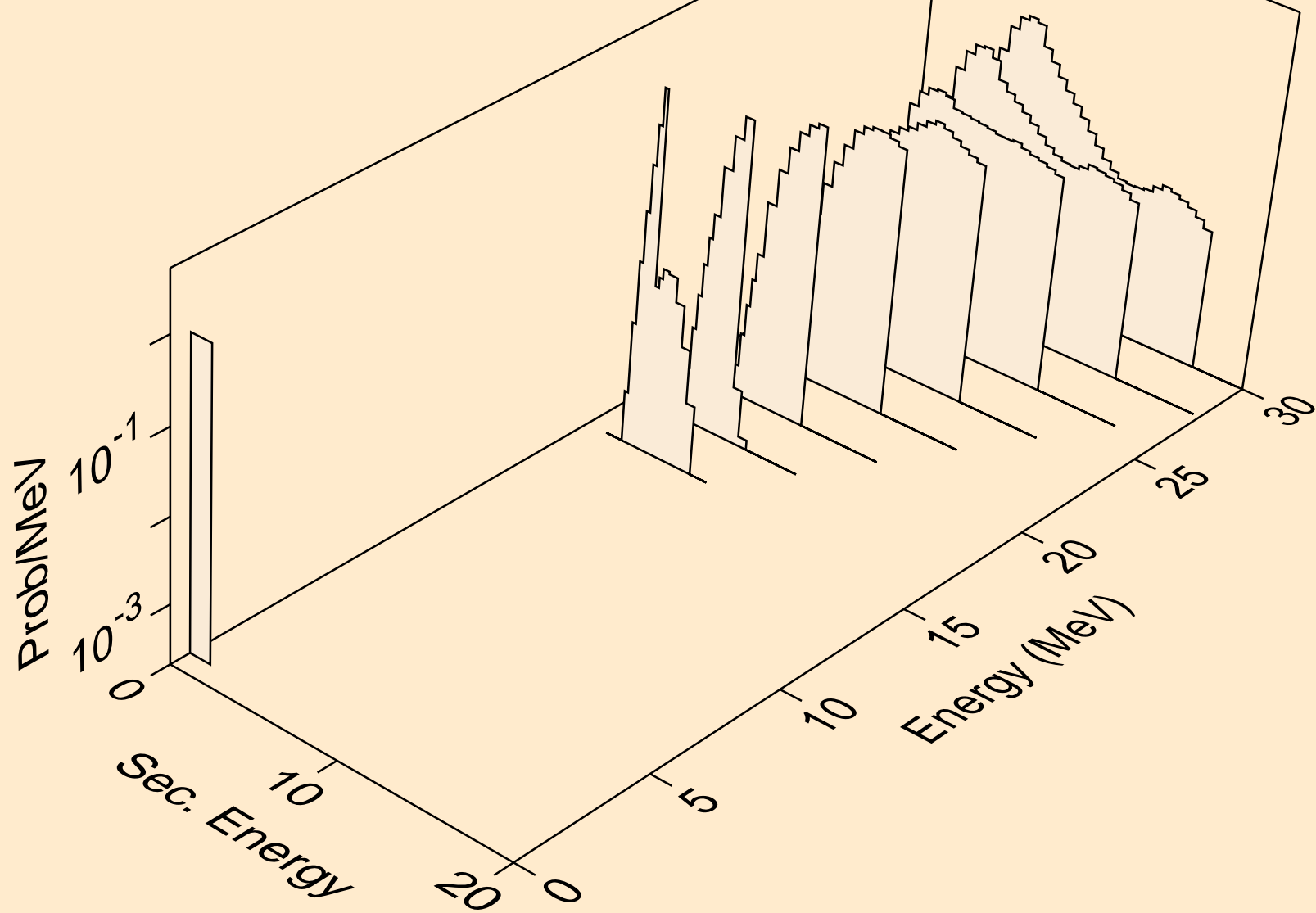

AT200N ALPHA ACER TENDL-2024 LIBRARY; T=0.K  
deuterons from (a,x)

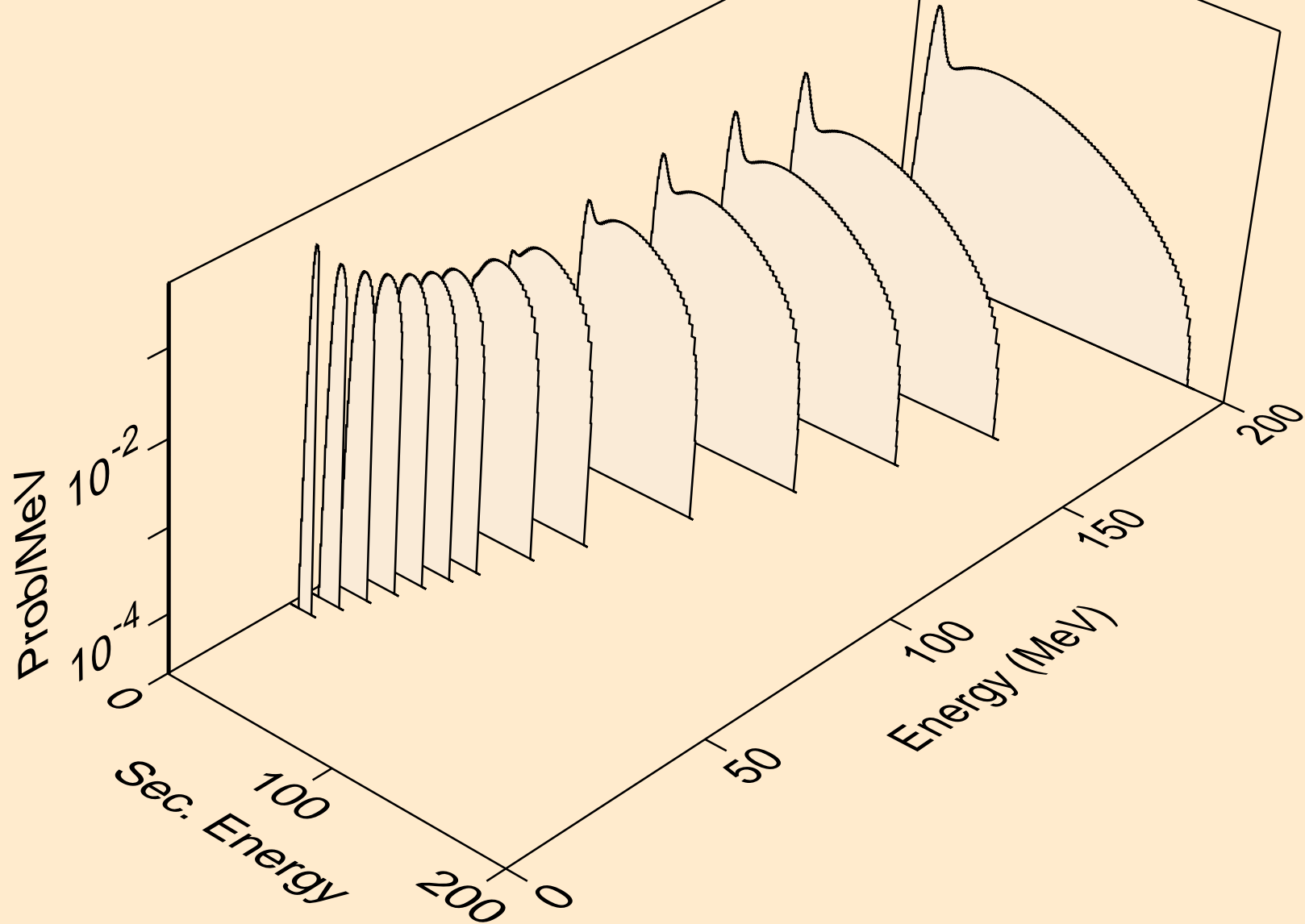

AT200N ALPHA ACER TENDL-2024 LIBRARY; T=0.K  
deuterons from (a,d)

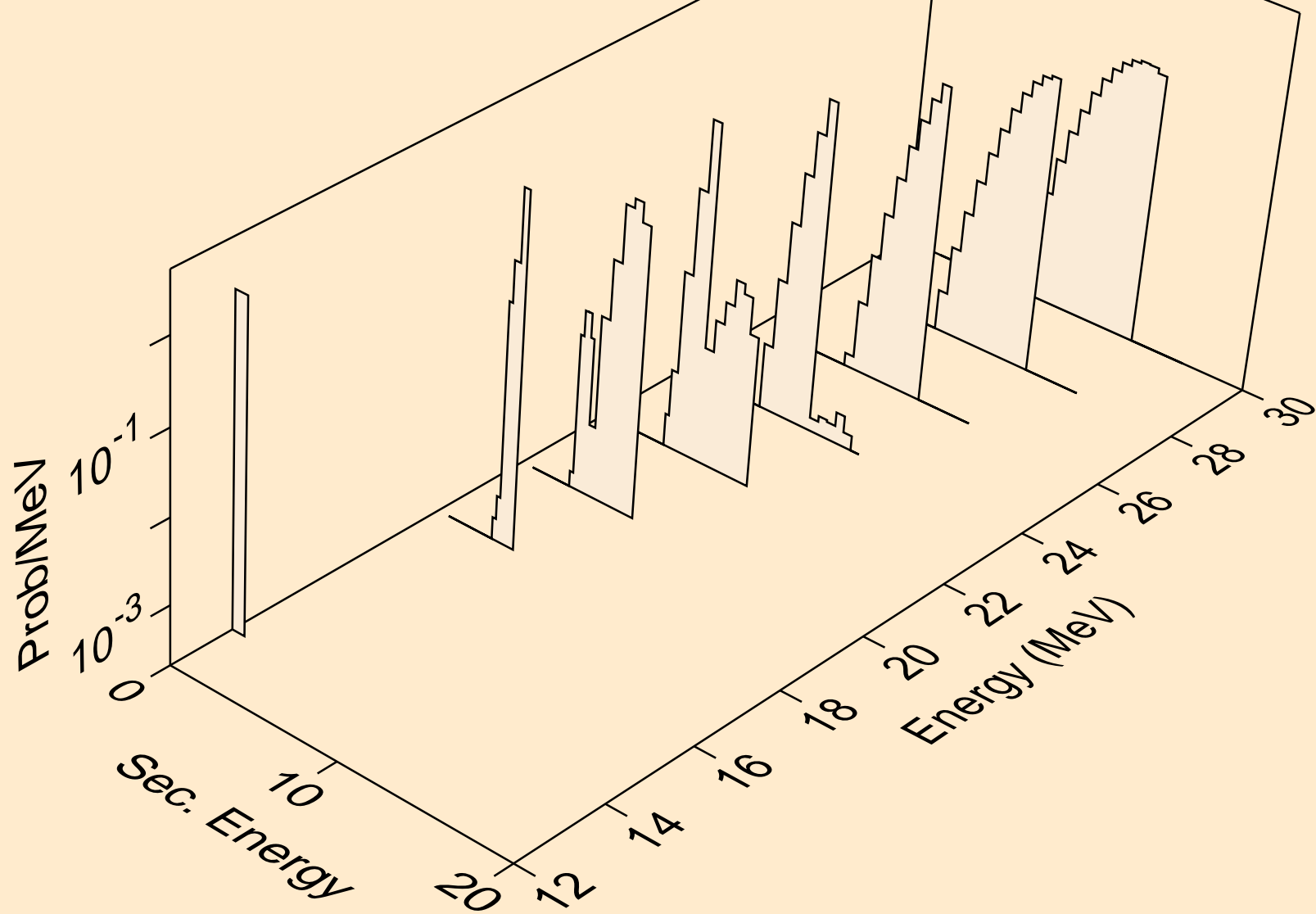

AT200N ALPHA ACER TENDL-2024 LIBRARY; T=0.K  
tritons from (a,x)

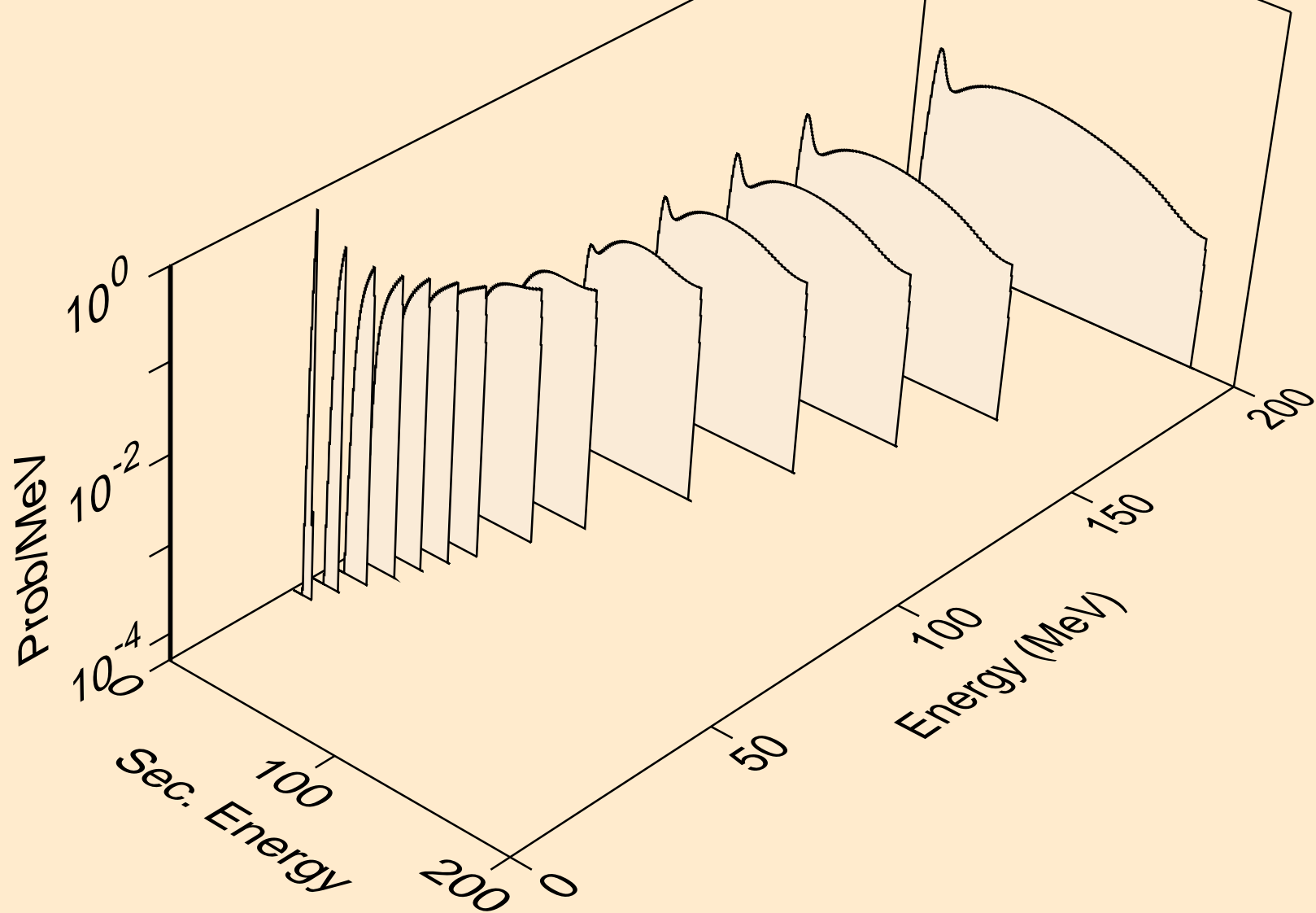

AT200N ALPHA ACER TENDL-2024 LIBRARY; T=0.K  
tritons from (a,t)

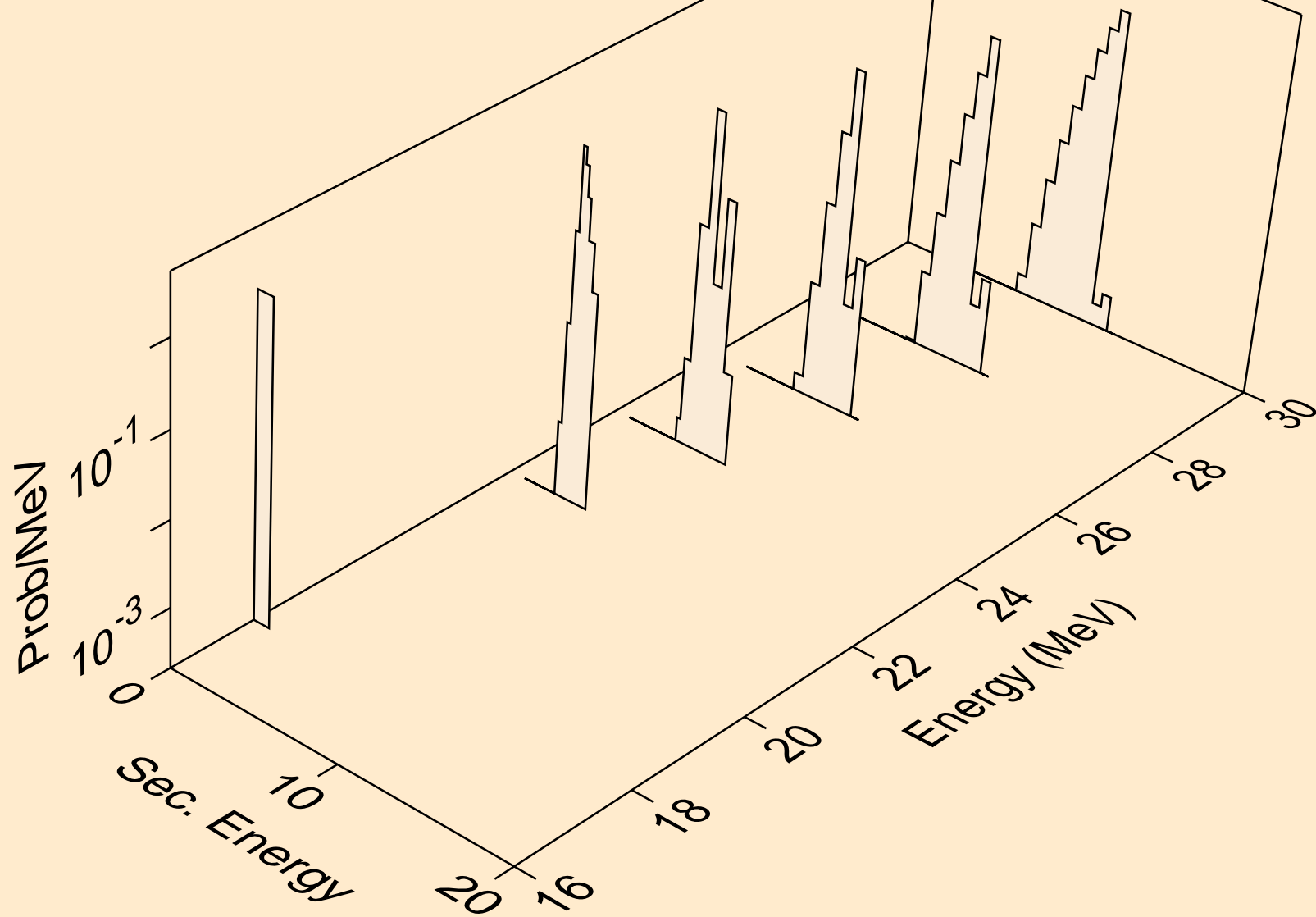

AT200N ALPHA ACER TENDL-2024 LIBRARY; T=0.K  
he3s from (a,x)

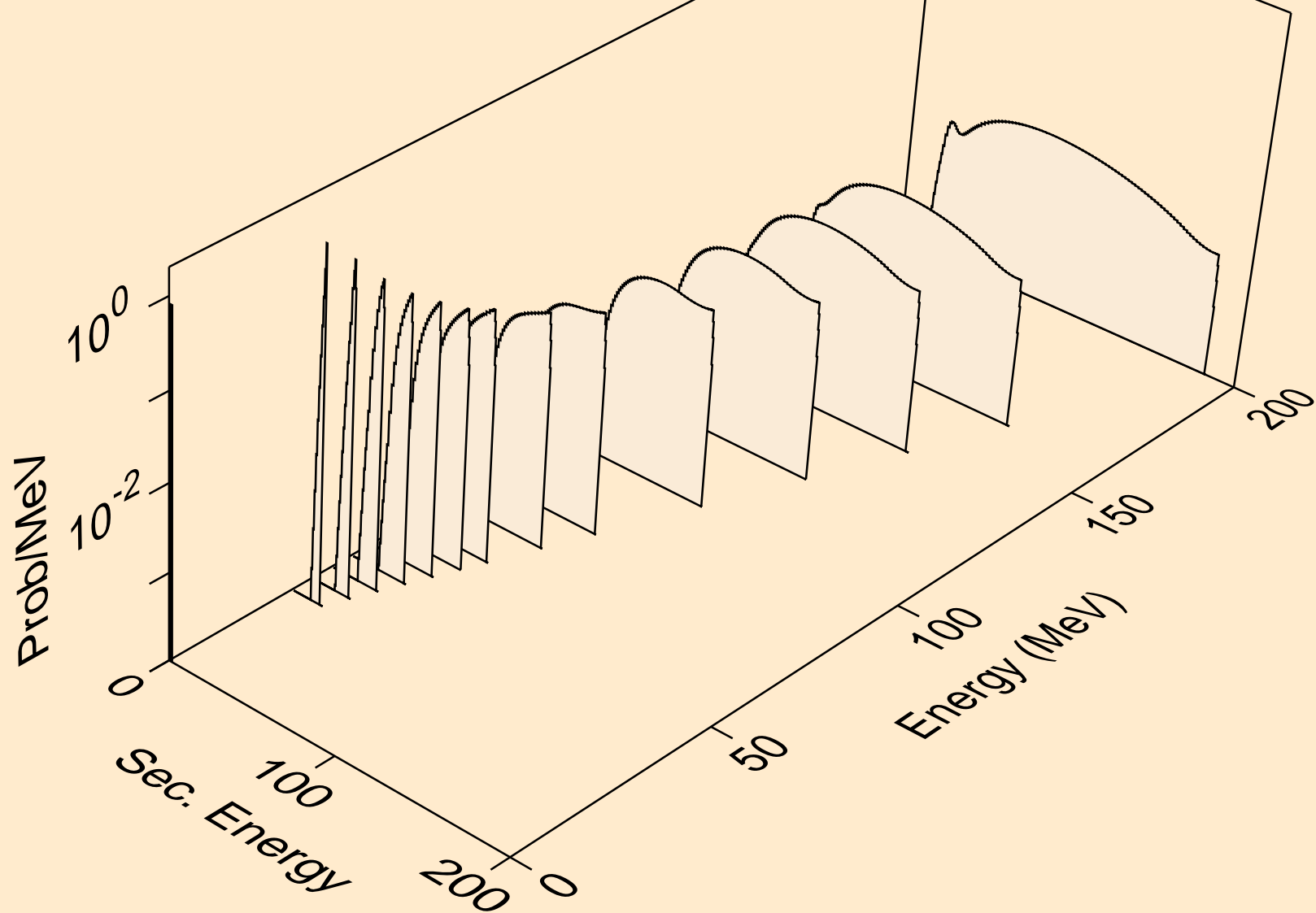

AT200N ALPHA ACER TENDL-2024 LIBRARY; T=0.K  
he3s from (a,he3)

