

# CD107 ALPHA ACER TENDL-2024 LIBRARY; T=0.K

## Principal cross sections

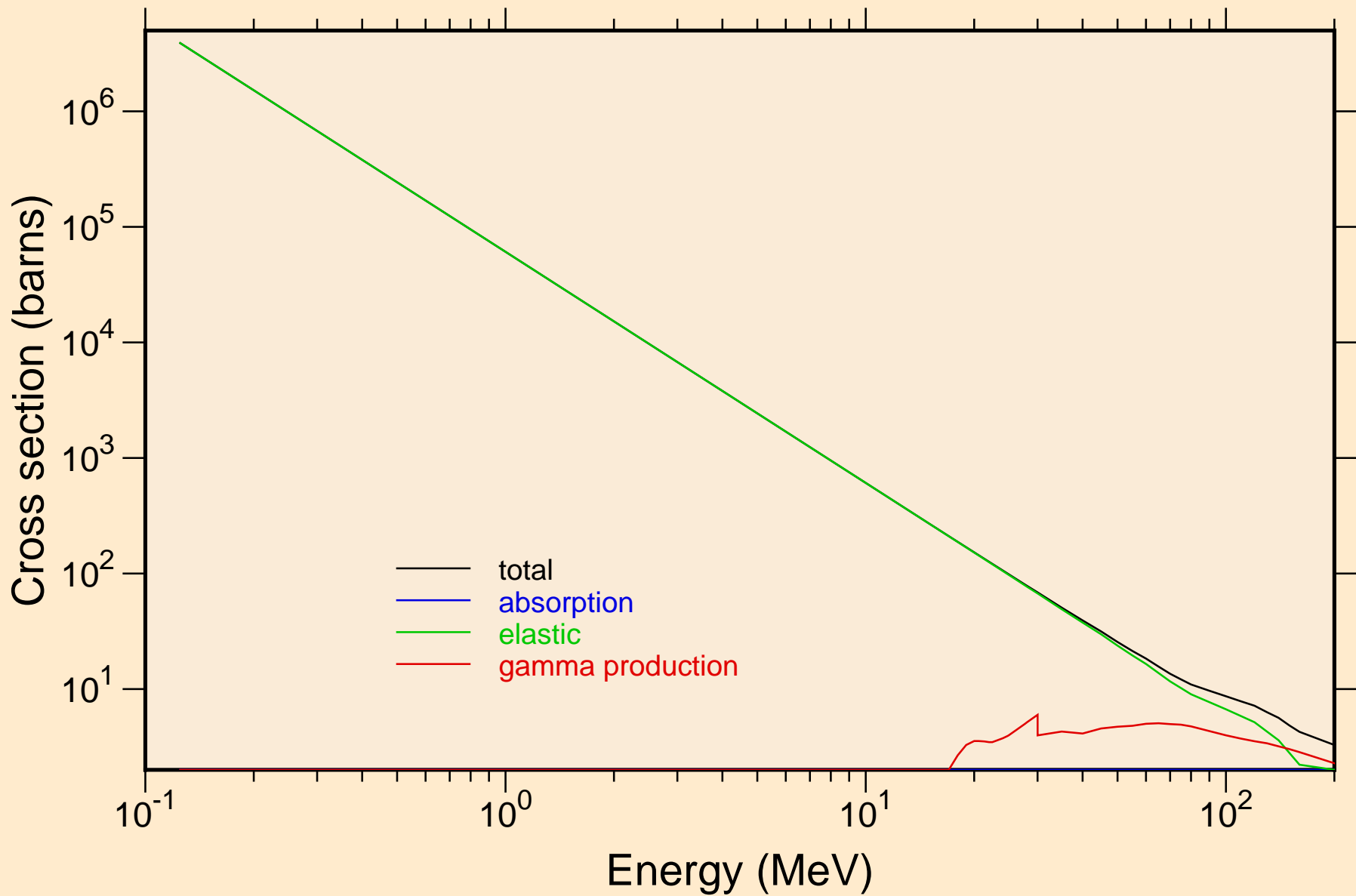

# CD107 ALPHA ACER TENDL-2024 LIBRARY; T=0.K

## Heating

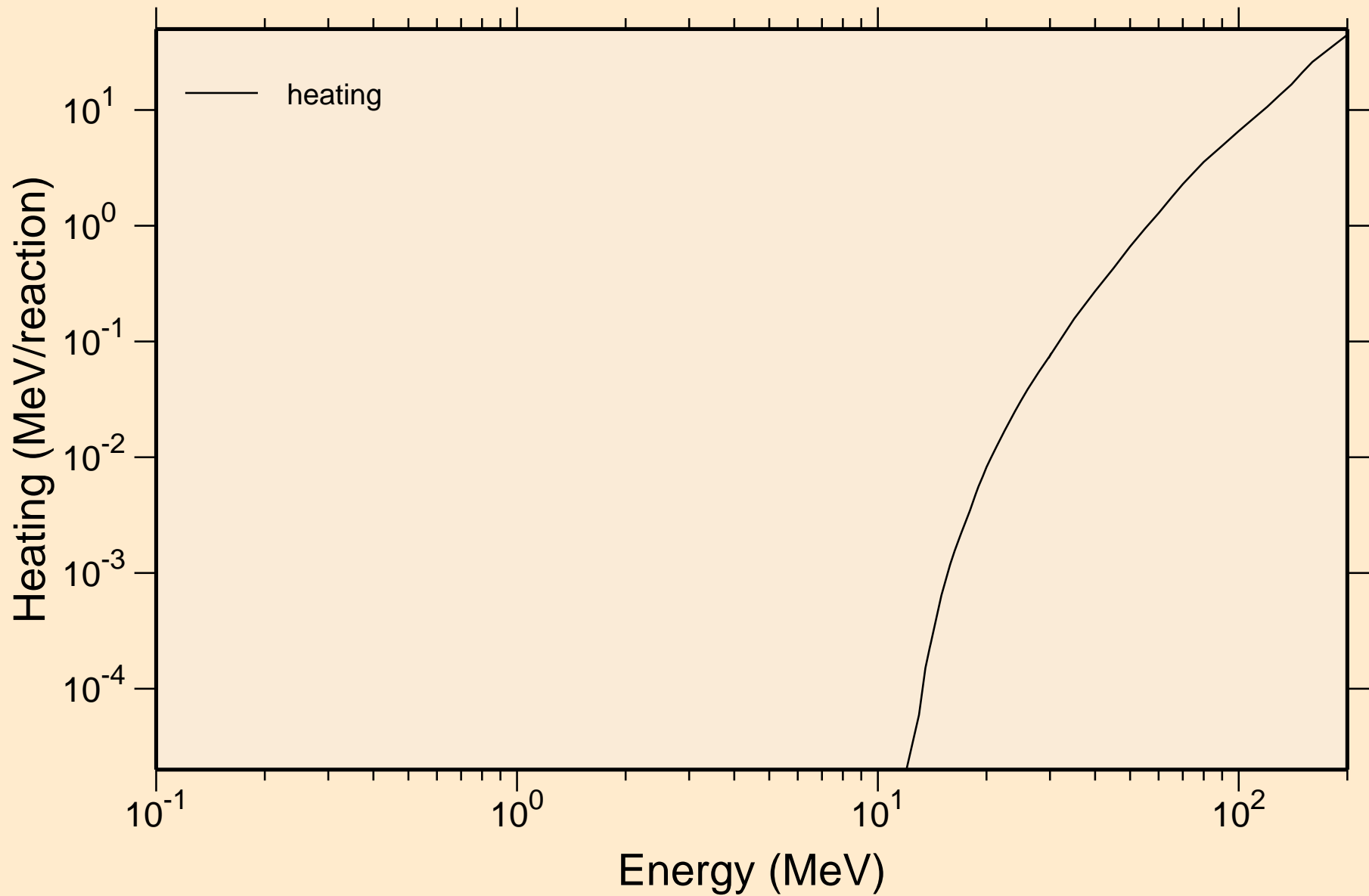

# CD107 ALPHA ACER TENDL-2024 LIBRARY; T=0.K

## Principal cross sections

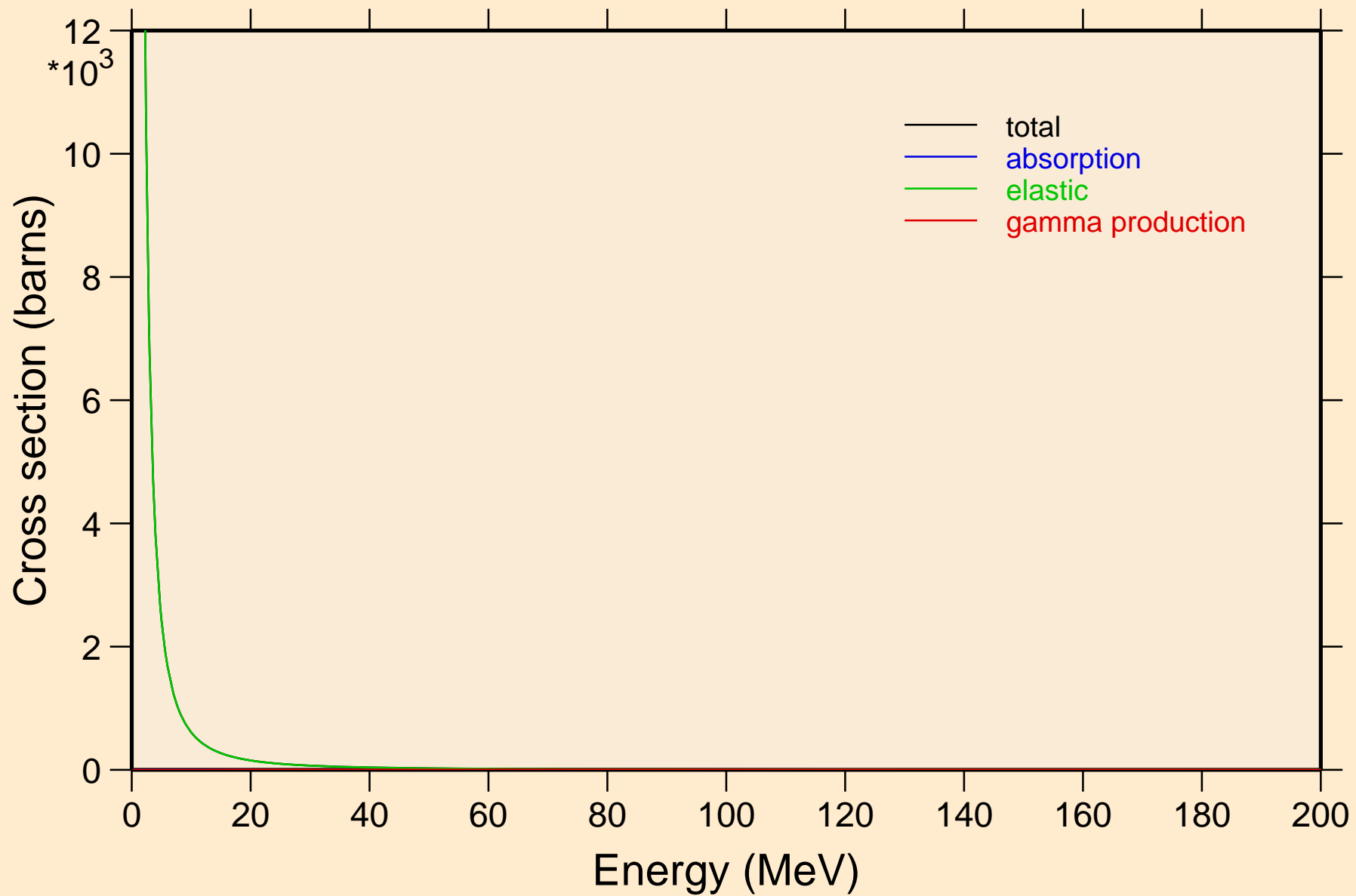

# CD107 ALPHA ACER TENDL-2024 LIBRARY; T=0.K

## Heating

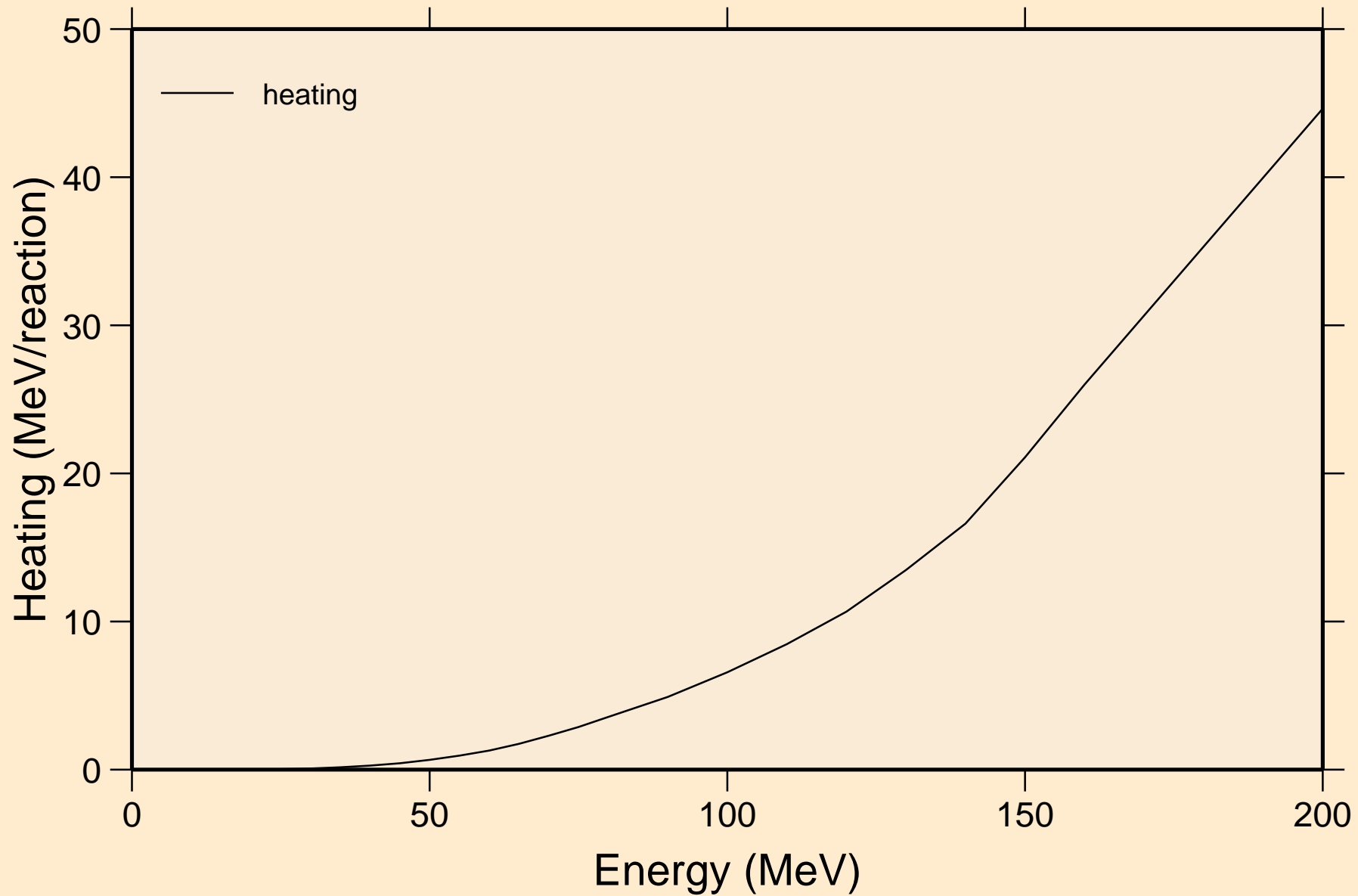

# CD107 ALPHA ACER TENDL-2024 LIBRARY; T=0.K

## Threshold reactions

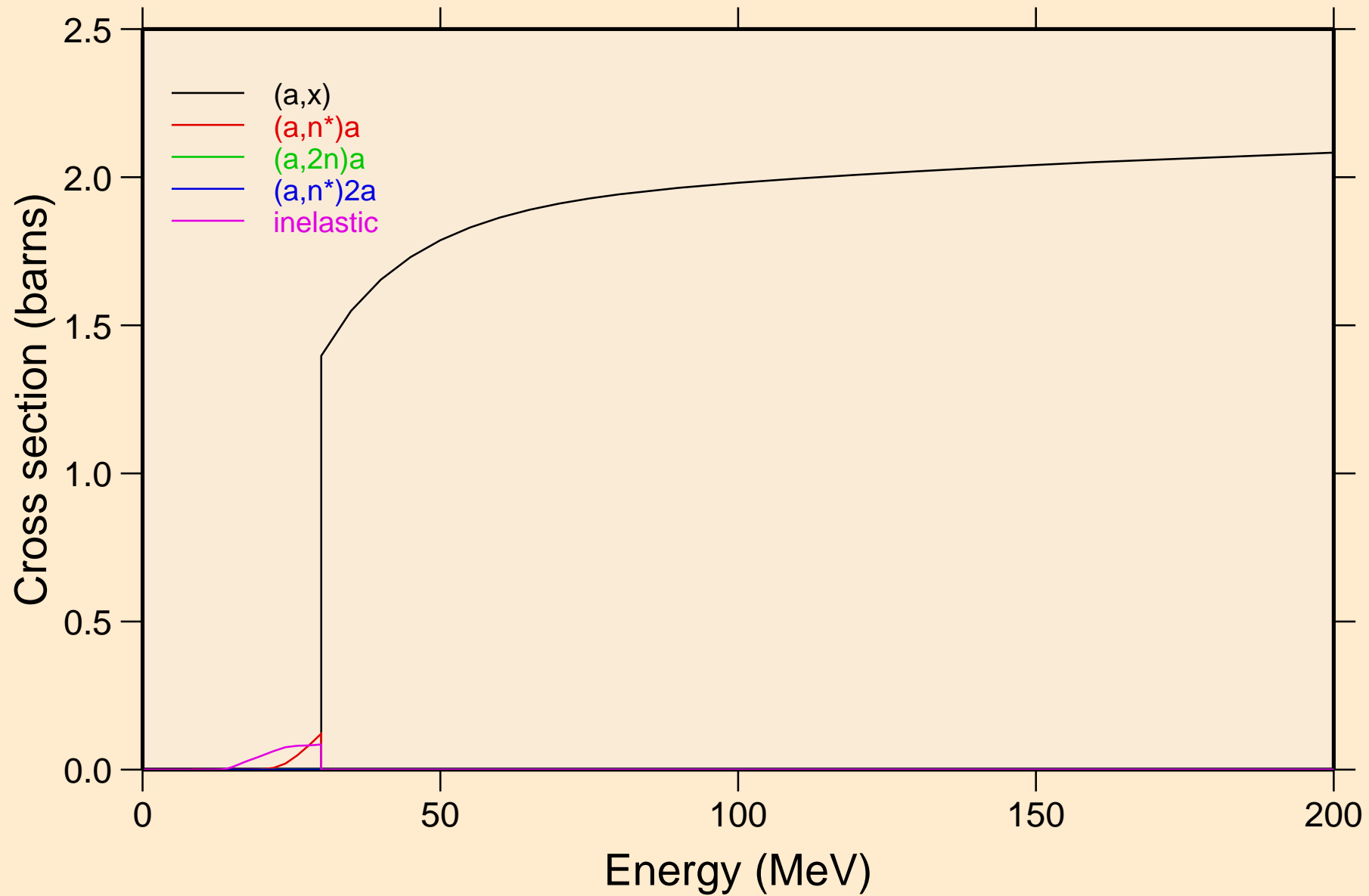

CD107 ALPHA ACER TENDL-2024 LIBRARY; T=0.K  
Threshold reactions

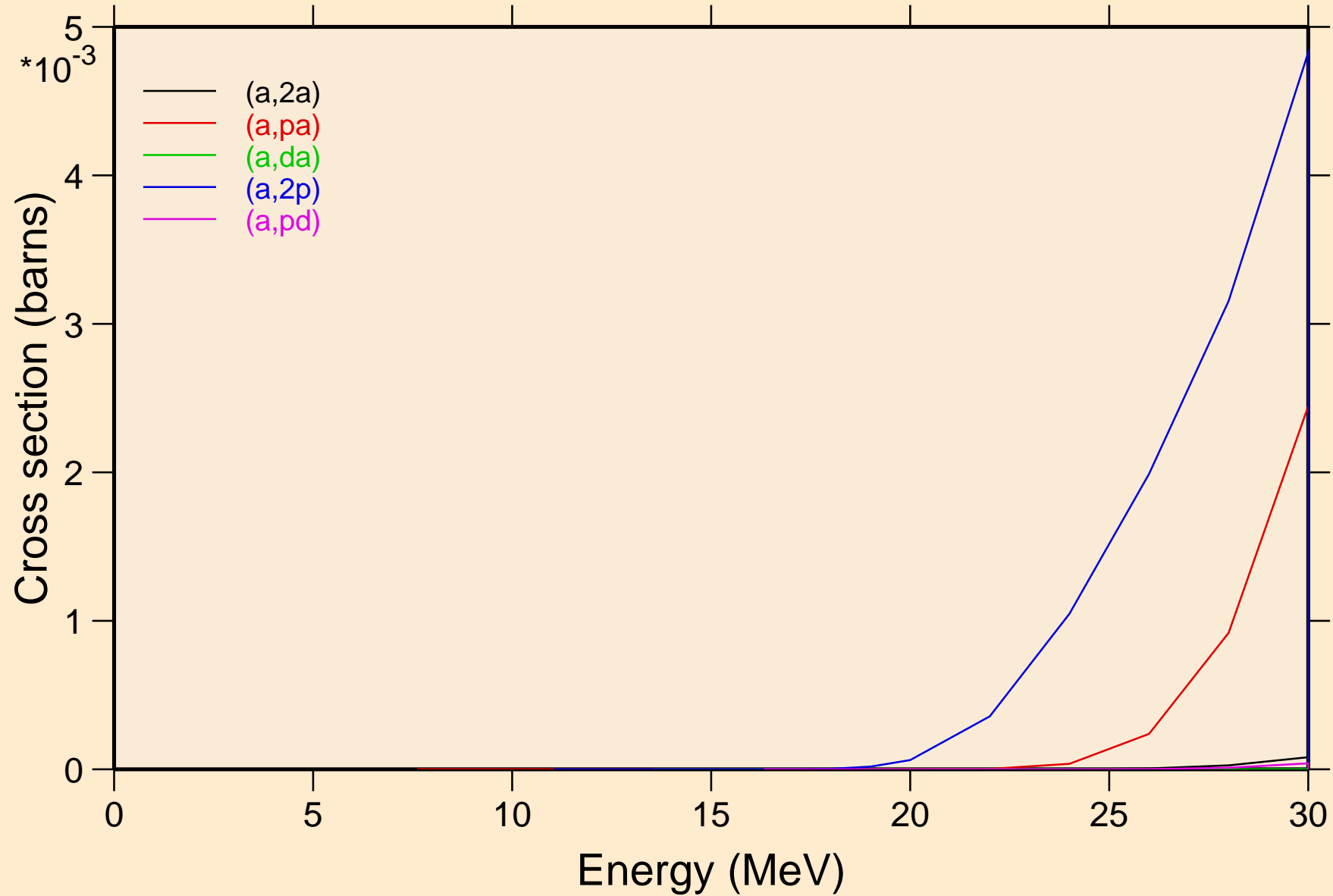

# CD107 ALPHA ACER TENDL-2024 LIBRARY; T=0.K

## Threshold reactions

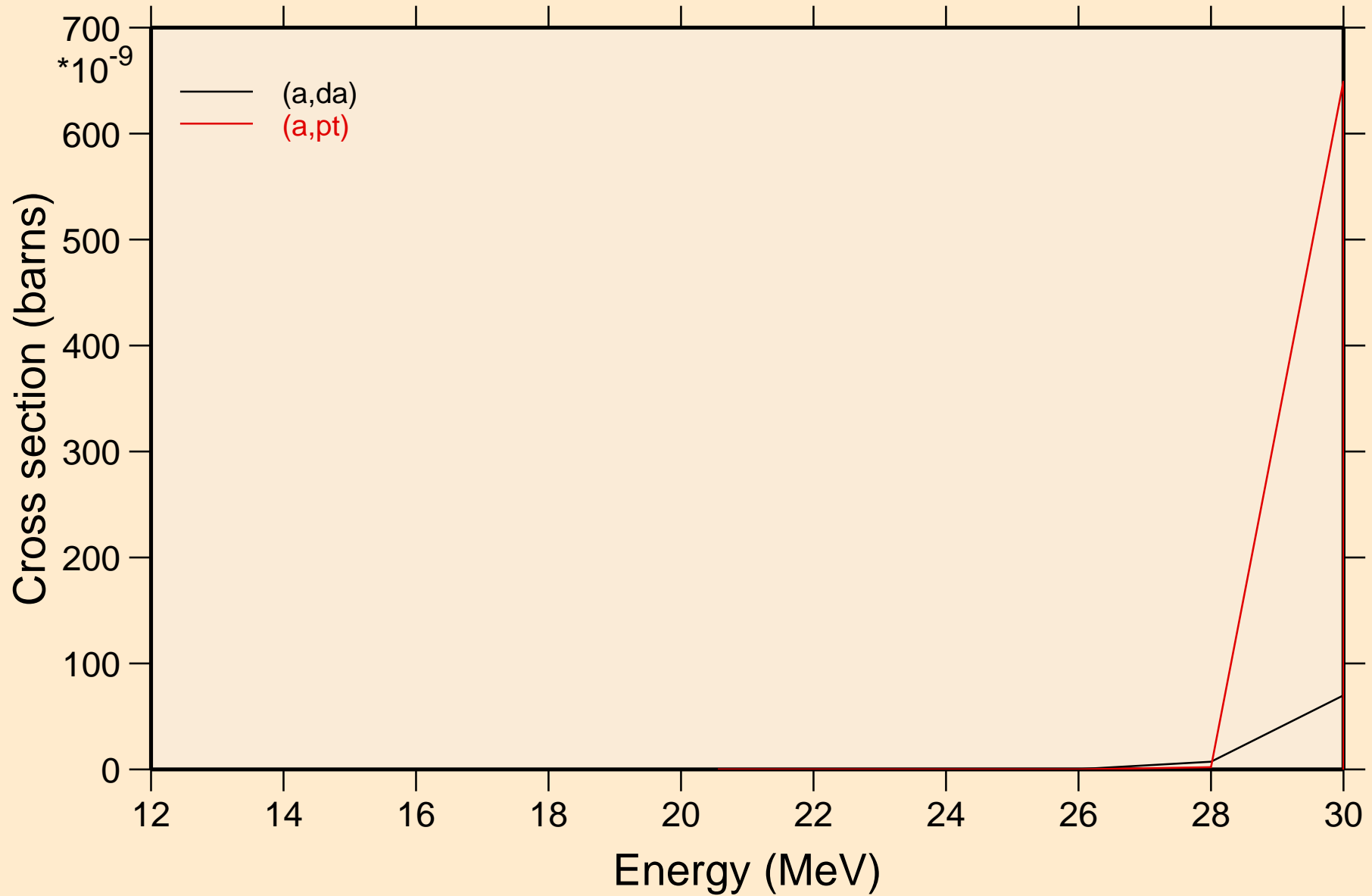

CD107 ALPHA ACER TENDL-2024 LIBRARY; T=0.K  
Threshold reactions

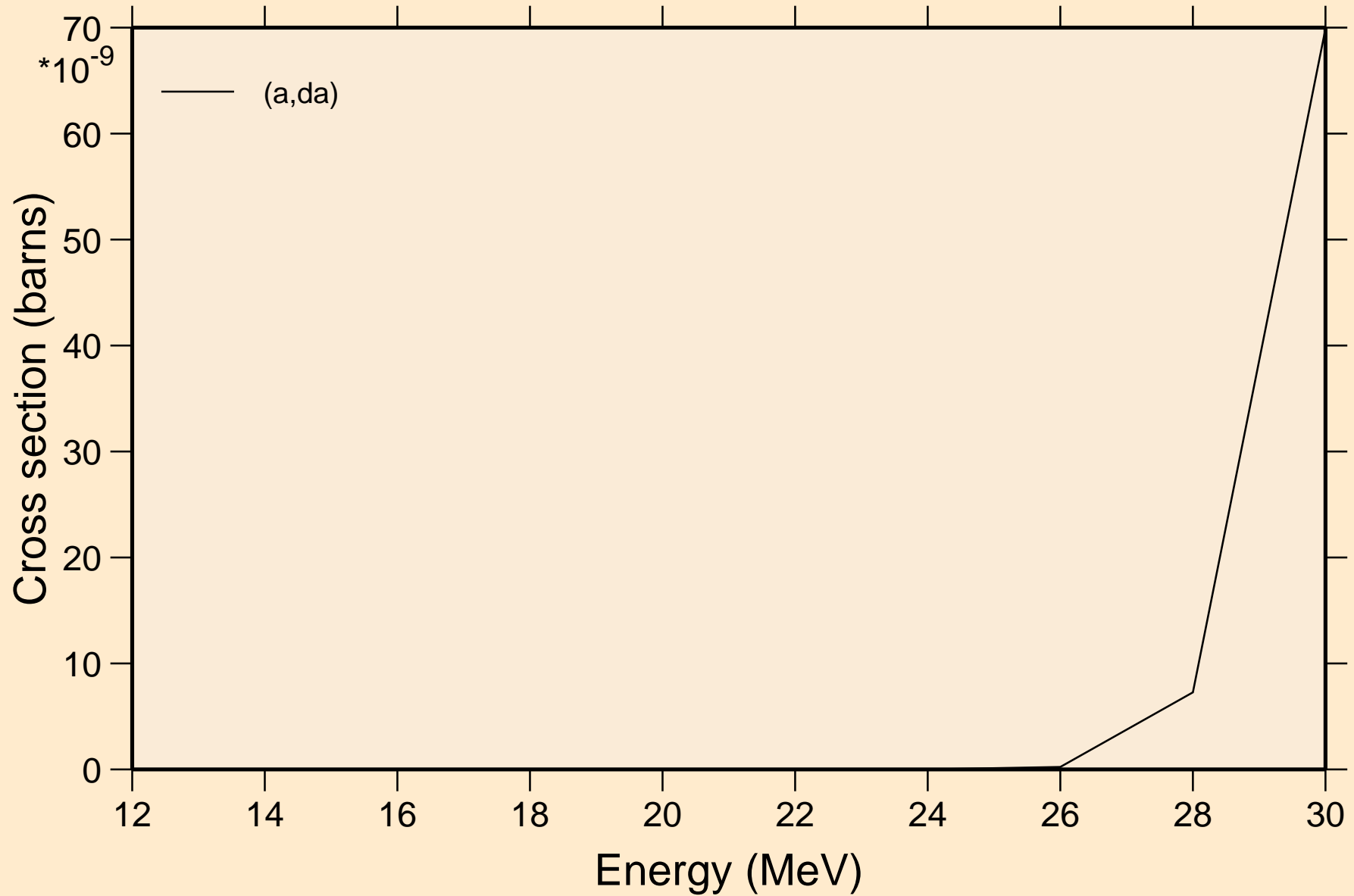

CD107 ALPHA ACER TENDL-2024 LIBRARY; T=0.K  
angular distribution for elastic

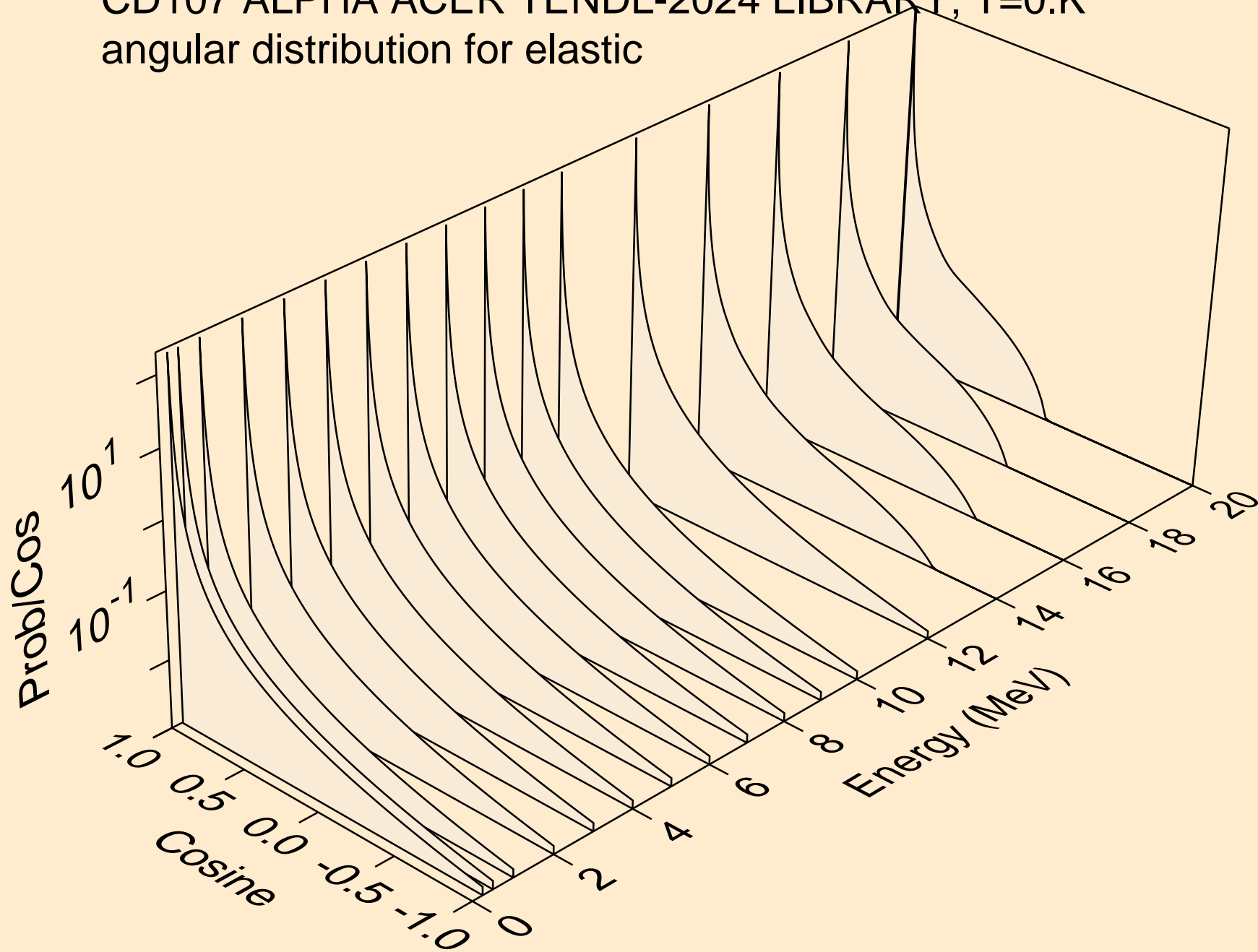

CD107 ALPHA ACER TENDL-2024 LIBRARY; T=0.K  
angular distribution for elastic

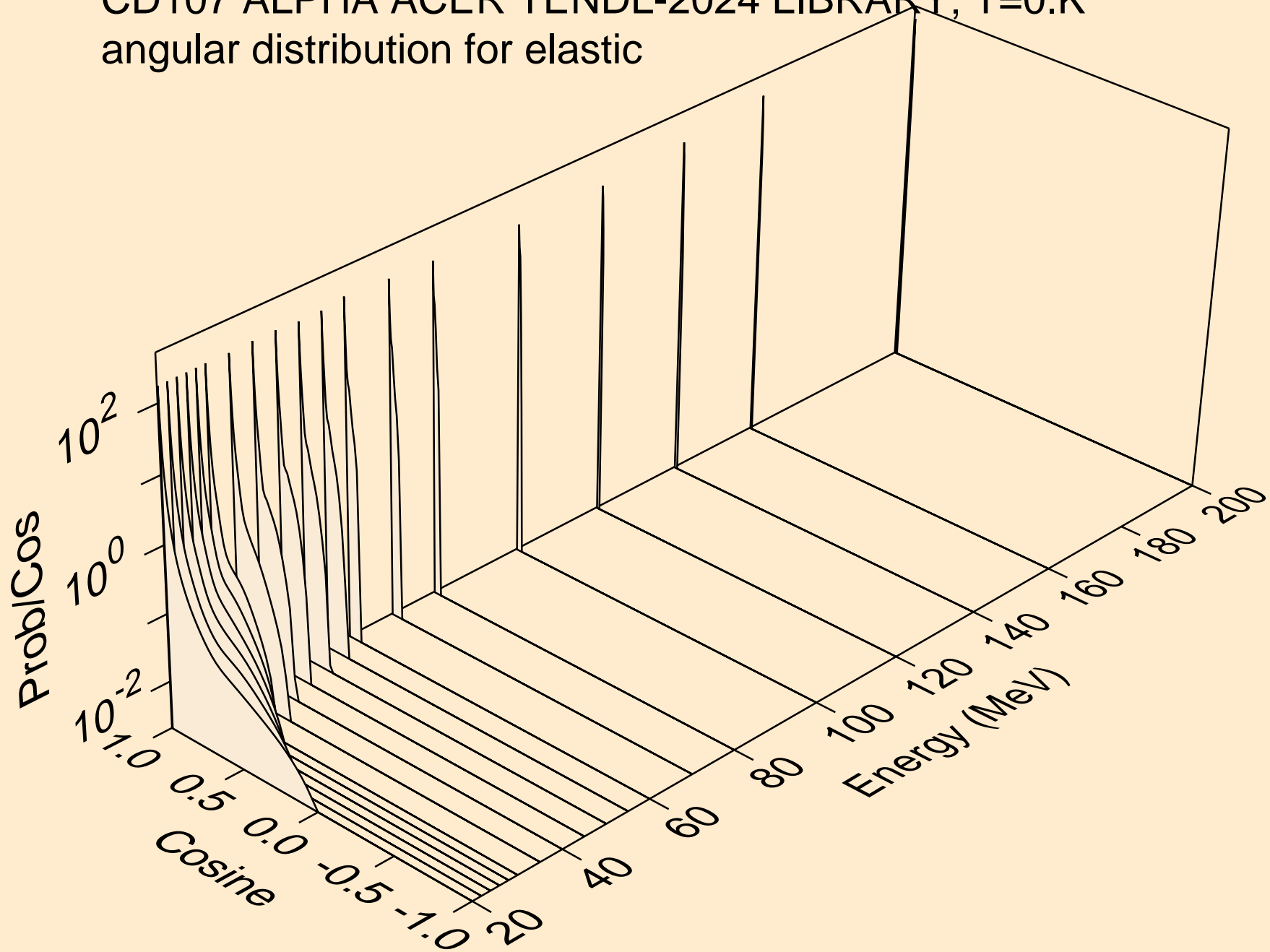

CD107 ALPHA ACER TENDL-2024 LIBRARY; T=0.K  
Alpha emission for (a,x)

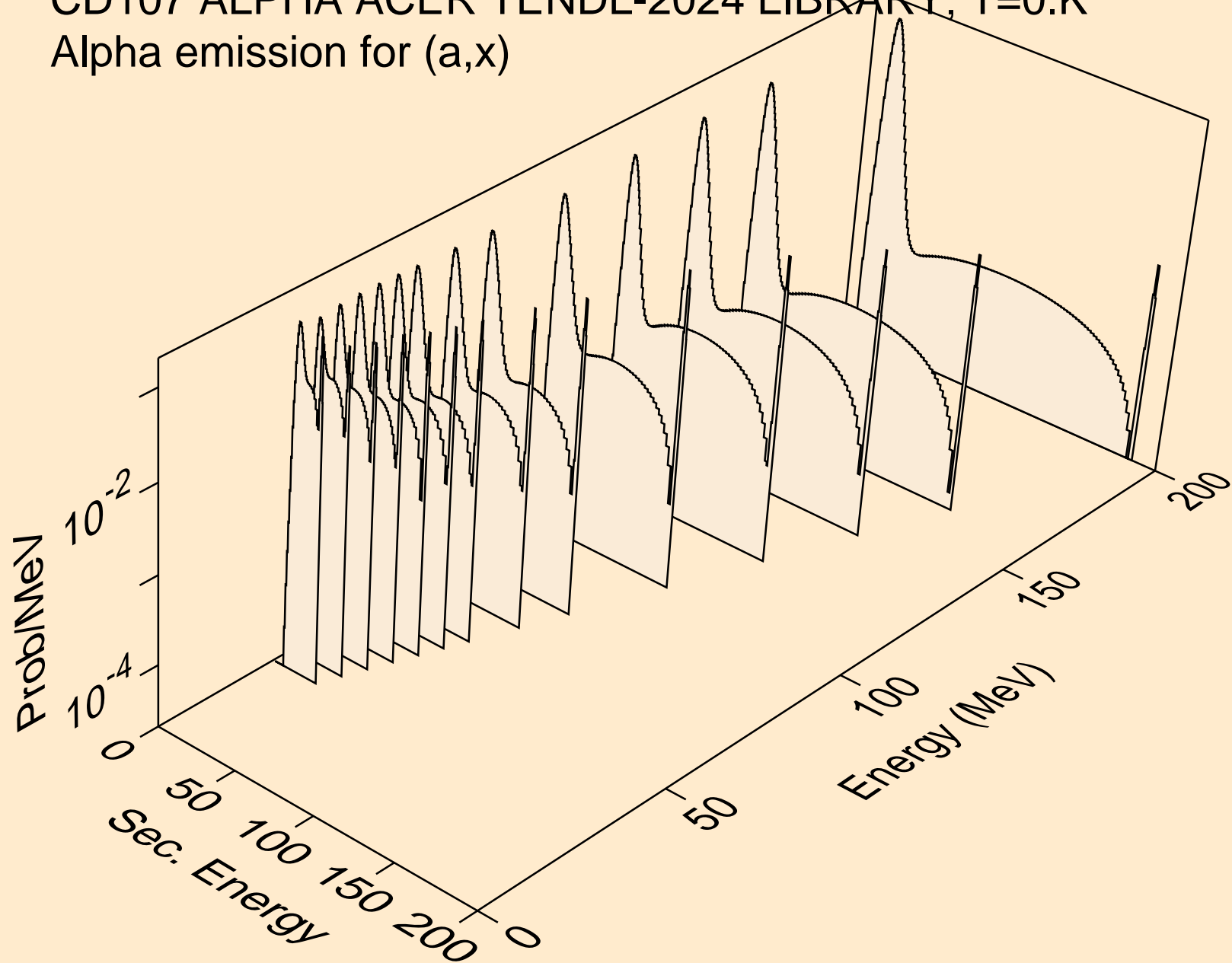

CD107 ALPHA ACER TENDL-2024 LIBRARY; T=0.K  
Alpha emission for (a,n\*)a

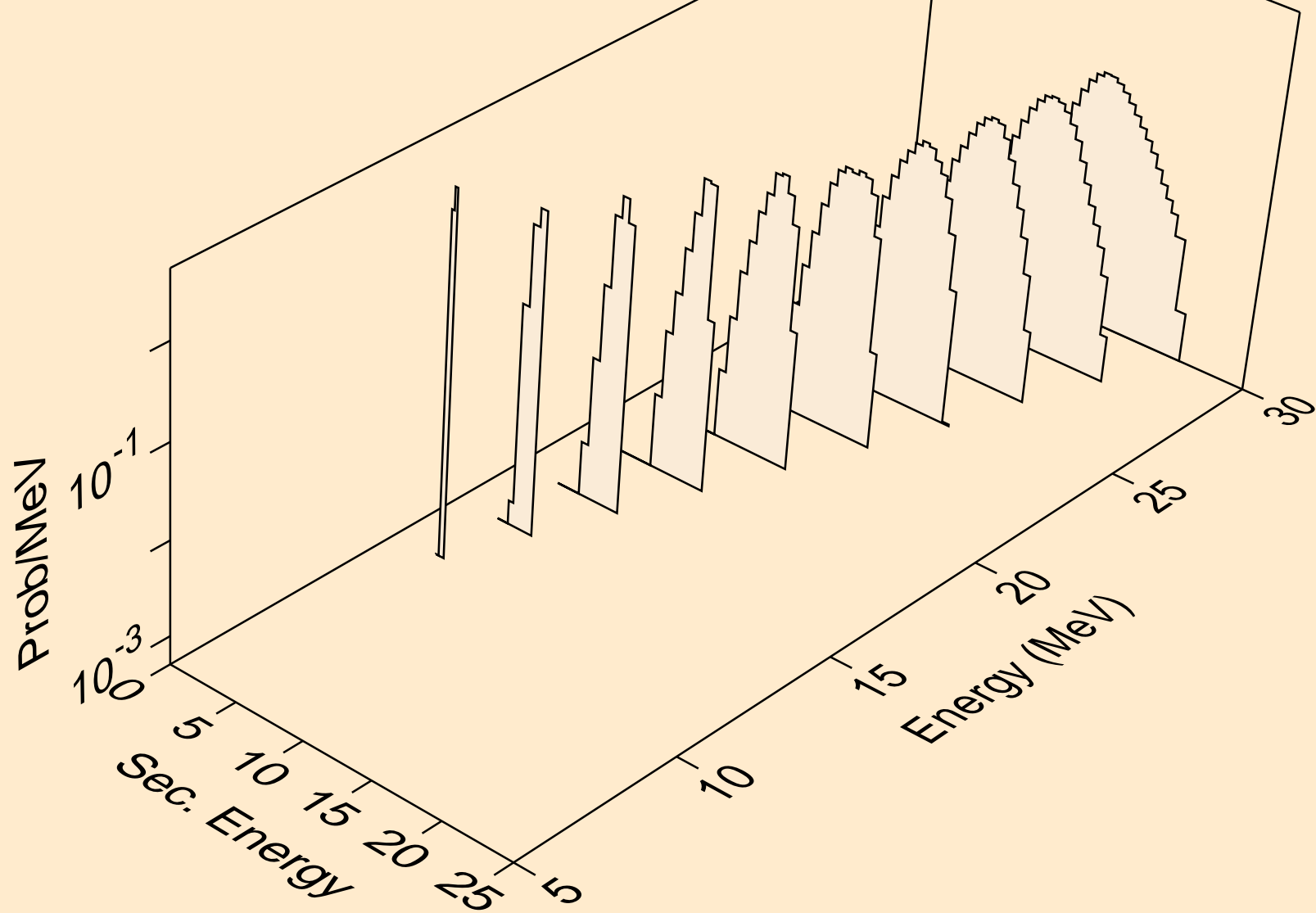

CD107 ALPHA ACER TENDL-2024 LIBRARY; T=0.K  
Alpha emission for (a,2n)a

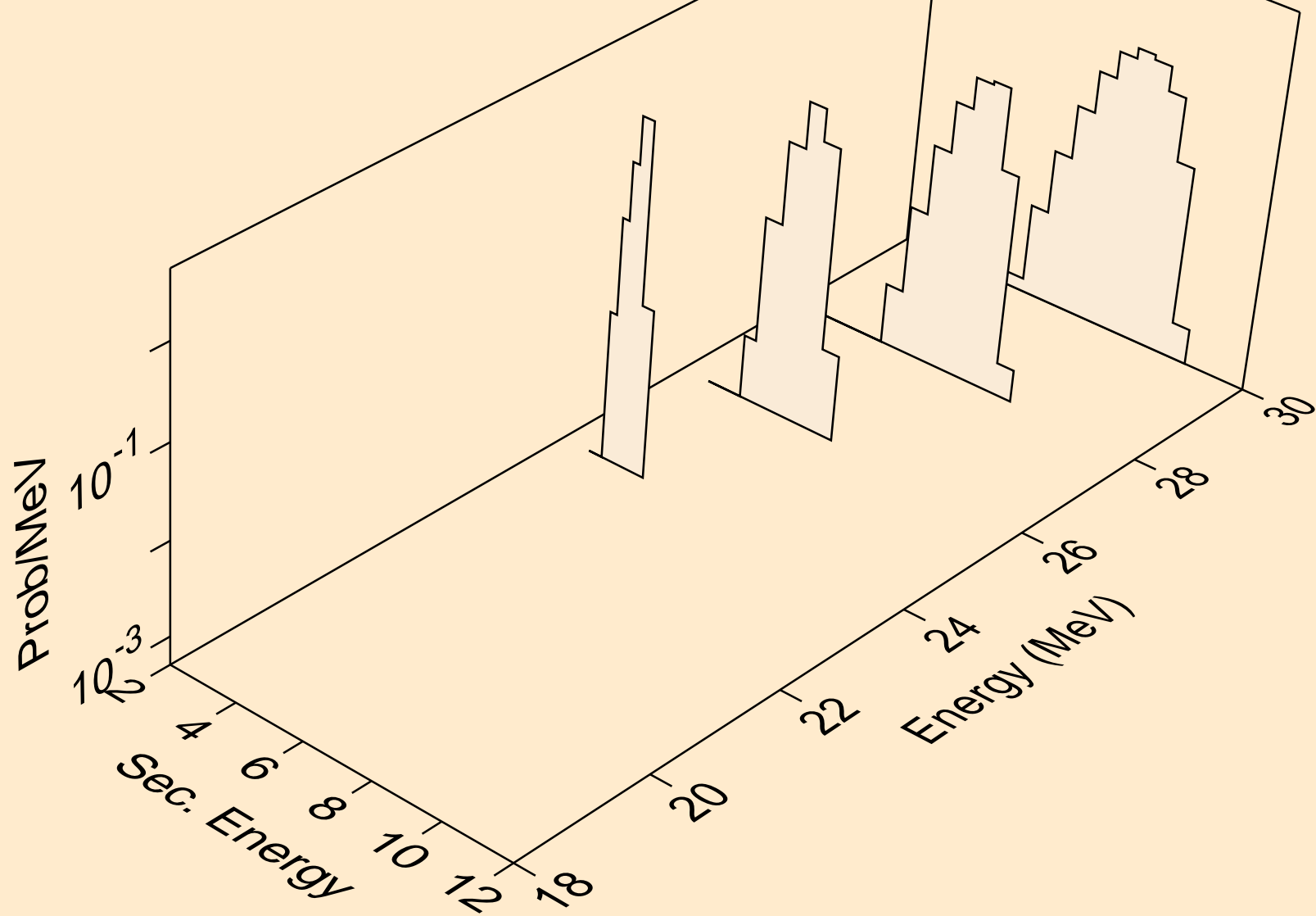

CD107 ALPHA ACER TENDL-2024 LIBRARY; T=0.K  
Alpha emission for (a,n\*)2a

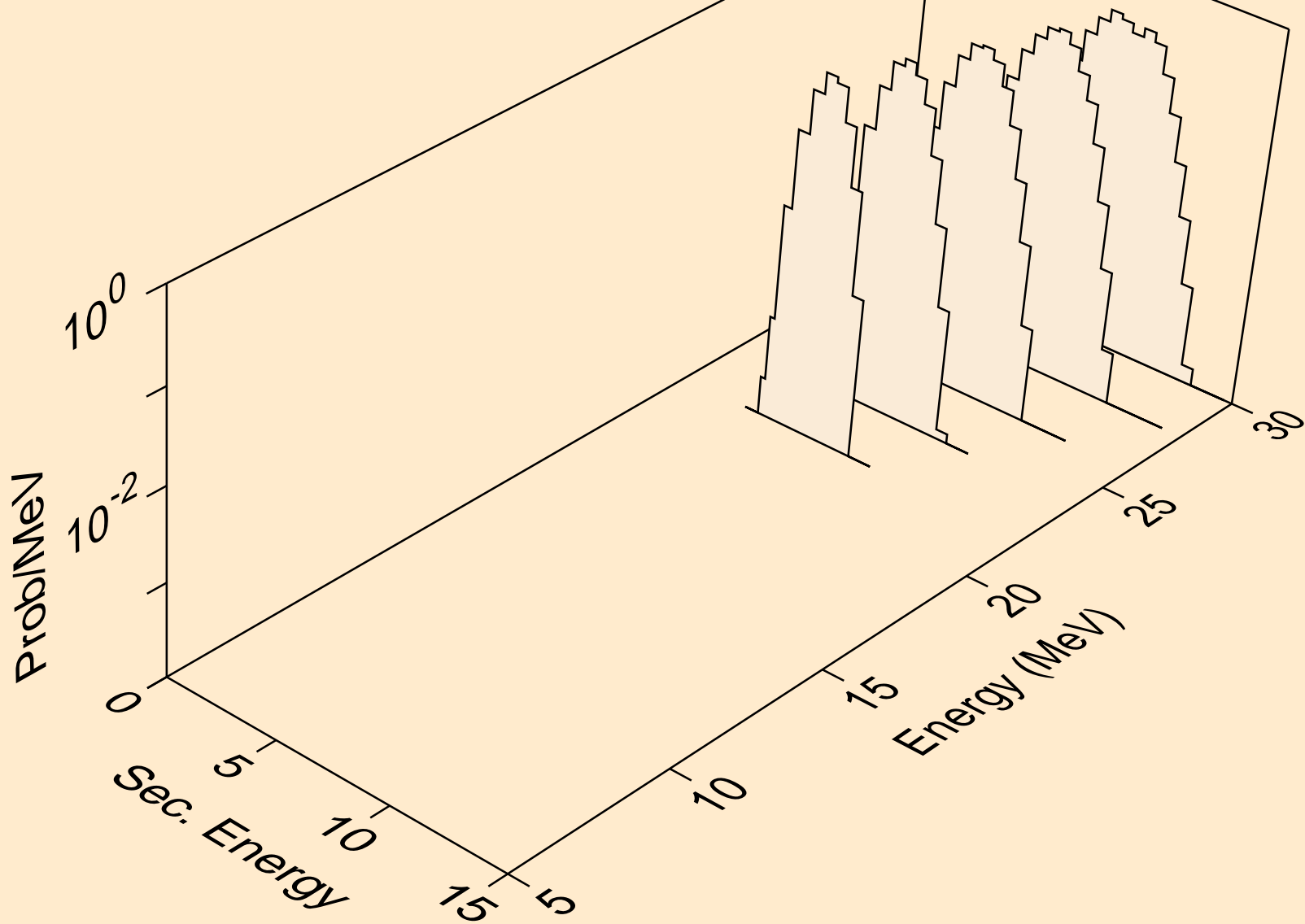

CD107 ALPHA ACER TENDL-2024 LIBRARY; T=0.K  
Alpha emission for inelastic

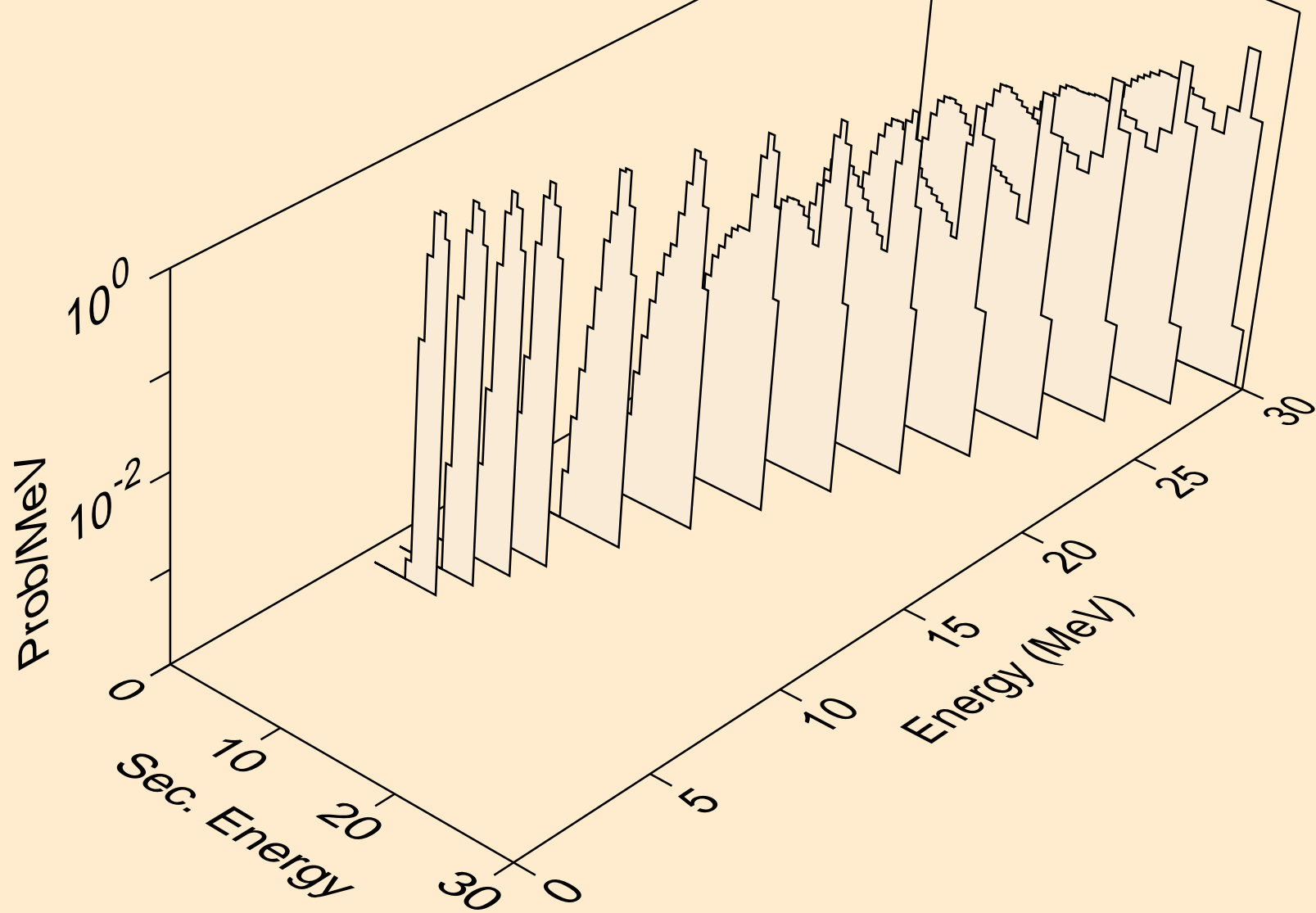

CD107 ALPHA ACER TENDL-2024 LIBRARY; T=0.K  
Alpha emission for (a,2a)

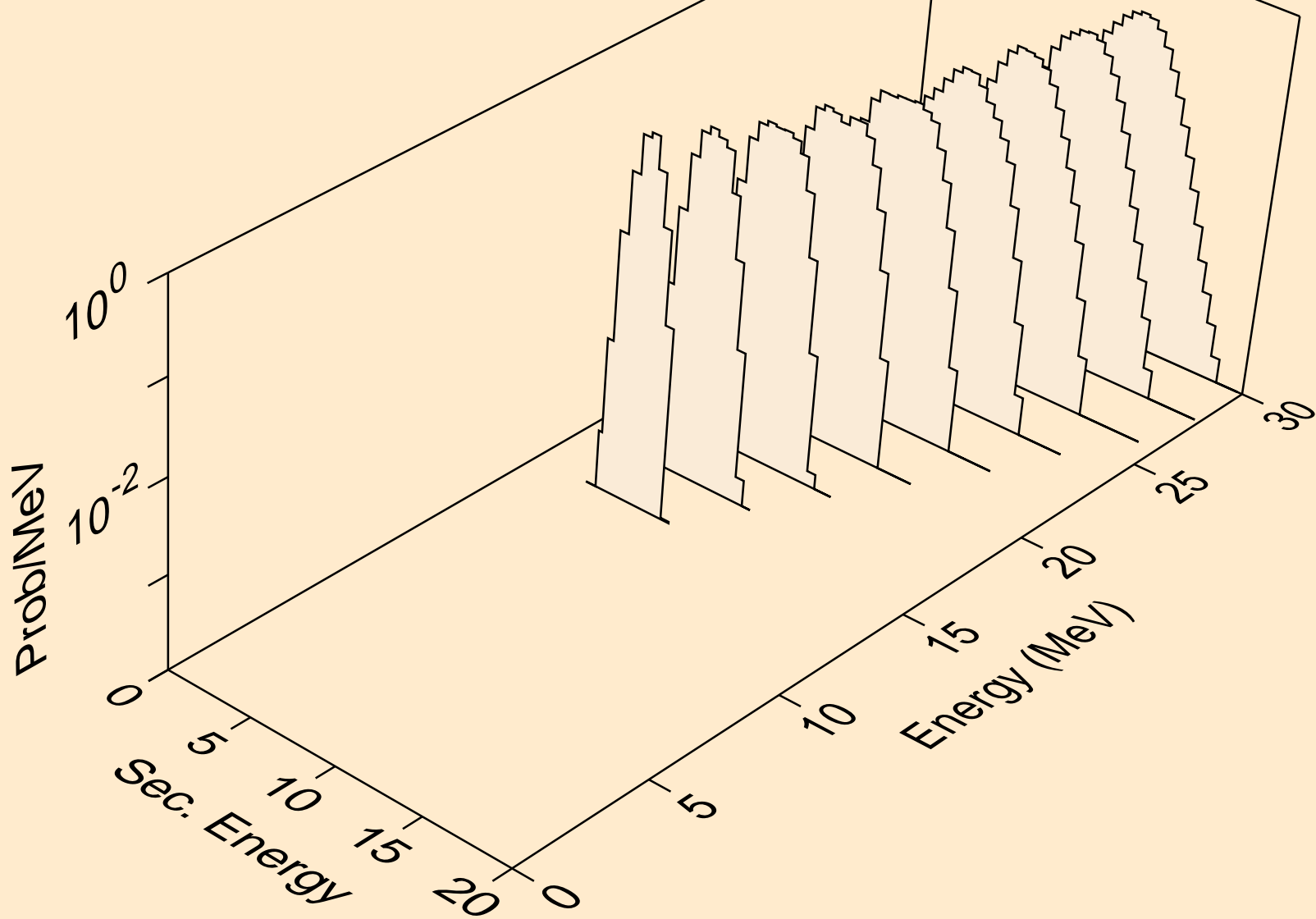

CD107 ALPHA ACER TENDL-2024 LIBRARY; T=0.K  
Alpha emission for (a,pa)

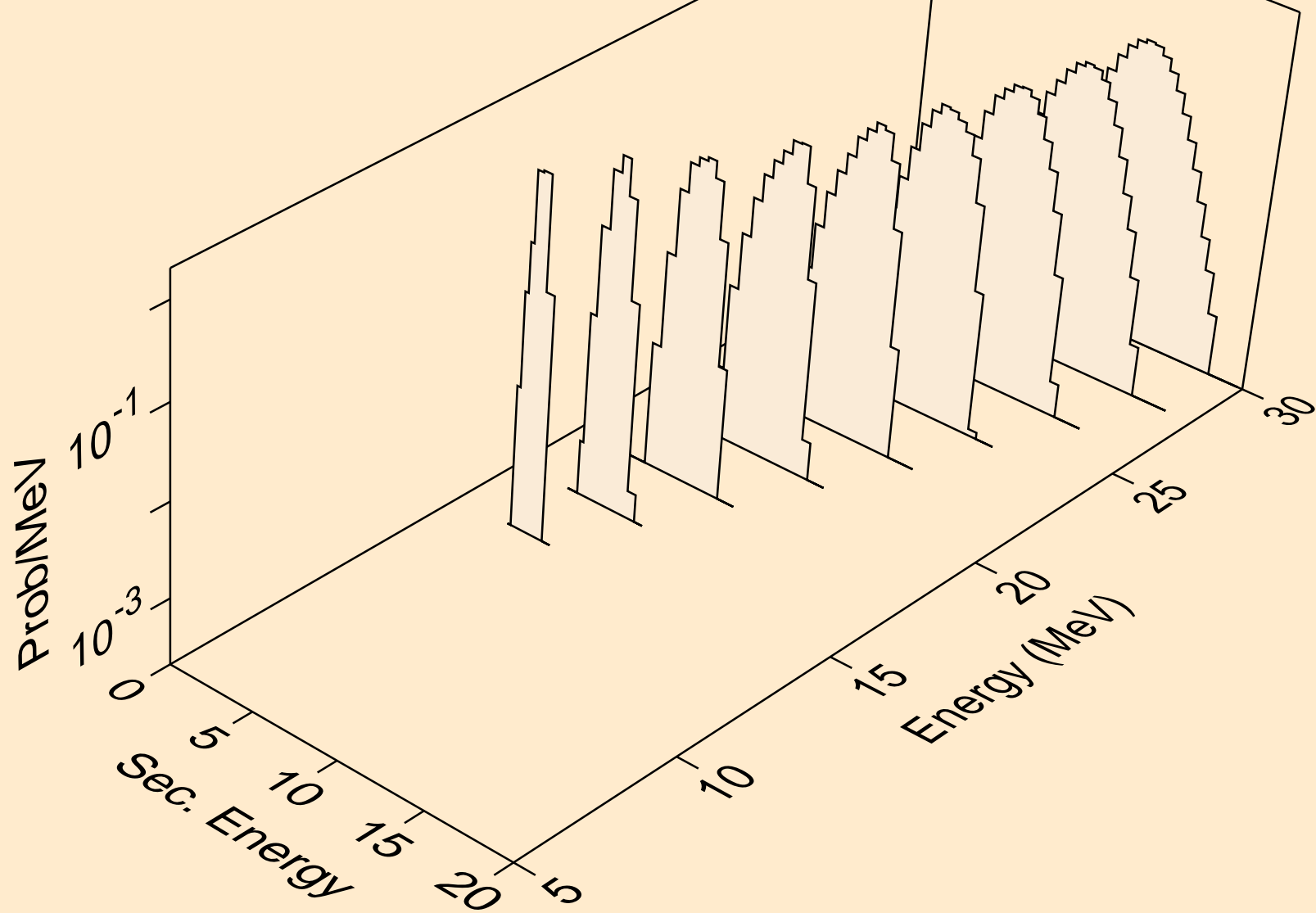

CD107 ALPHA ACER TENDL-2024 LIBRARY; T=0.K  
Alpha emission for (a,da)

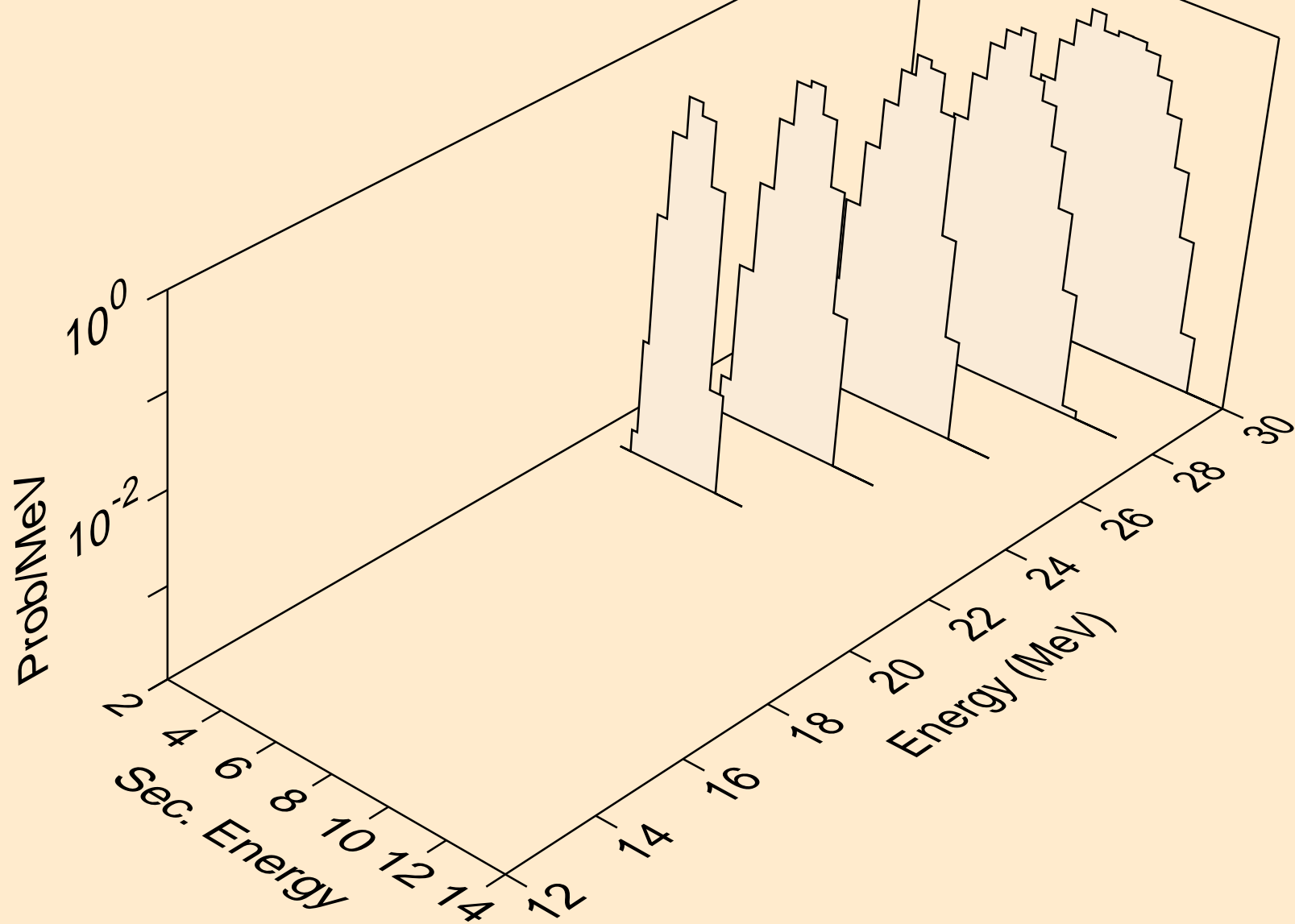

CD107 ALPHA ACER TENDL-2024 LIBRARY; T=0.K  
Photon emission for (z,n)

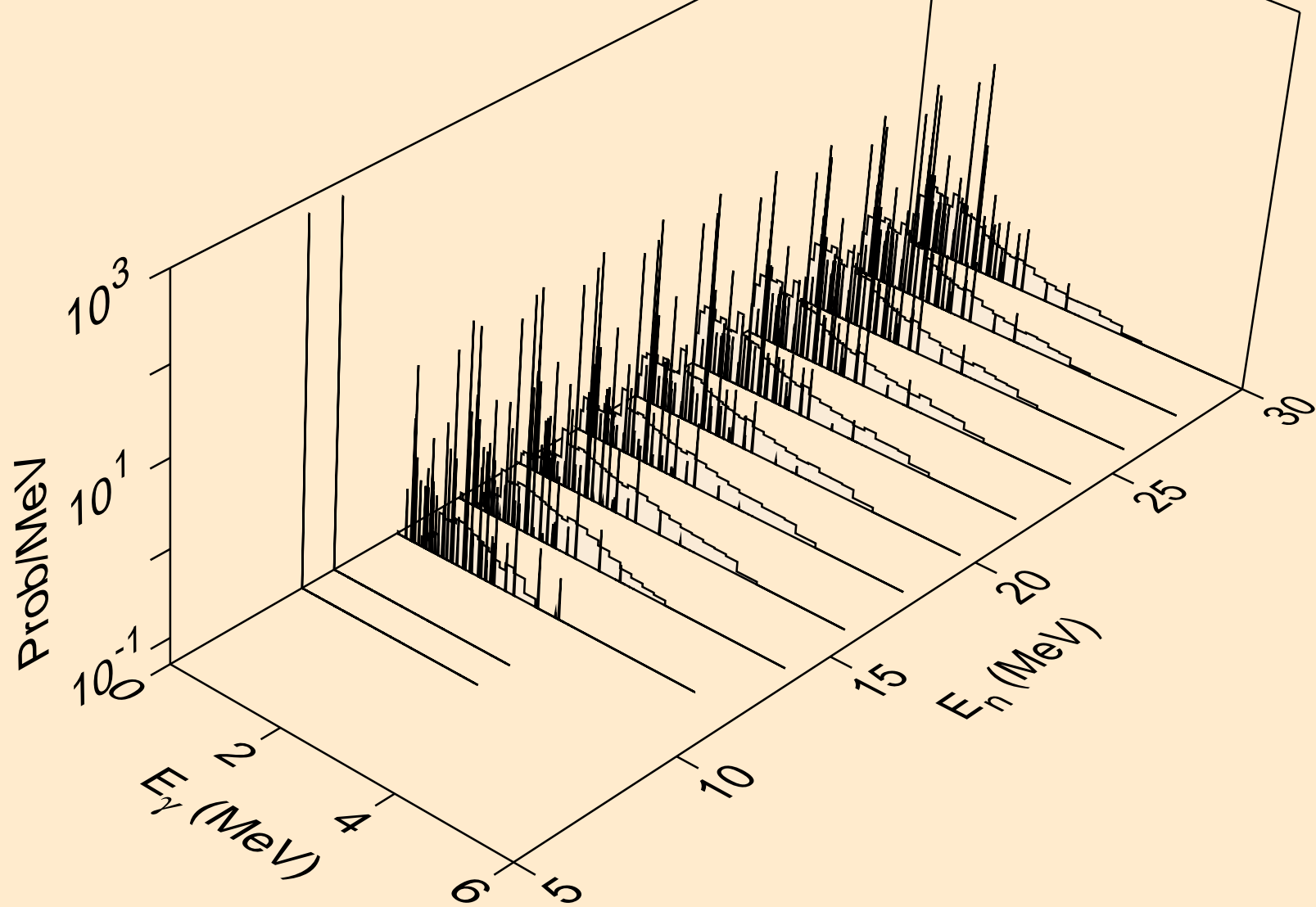

CD107 ALPHA ACER TENDL-2024 LIBRARY; T=0.K  
Photon emission for (z,x)

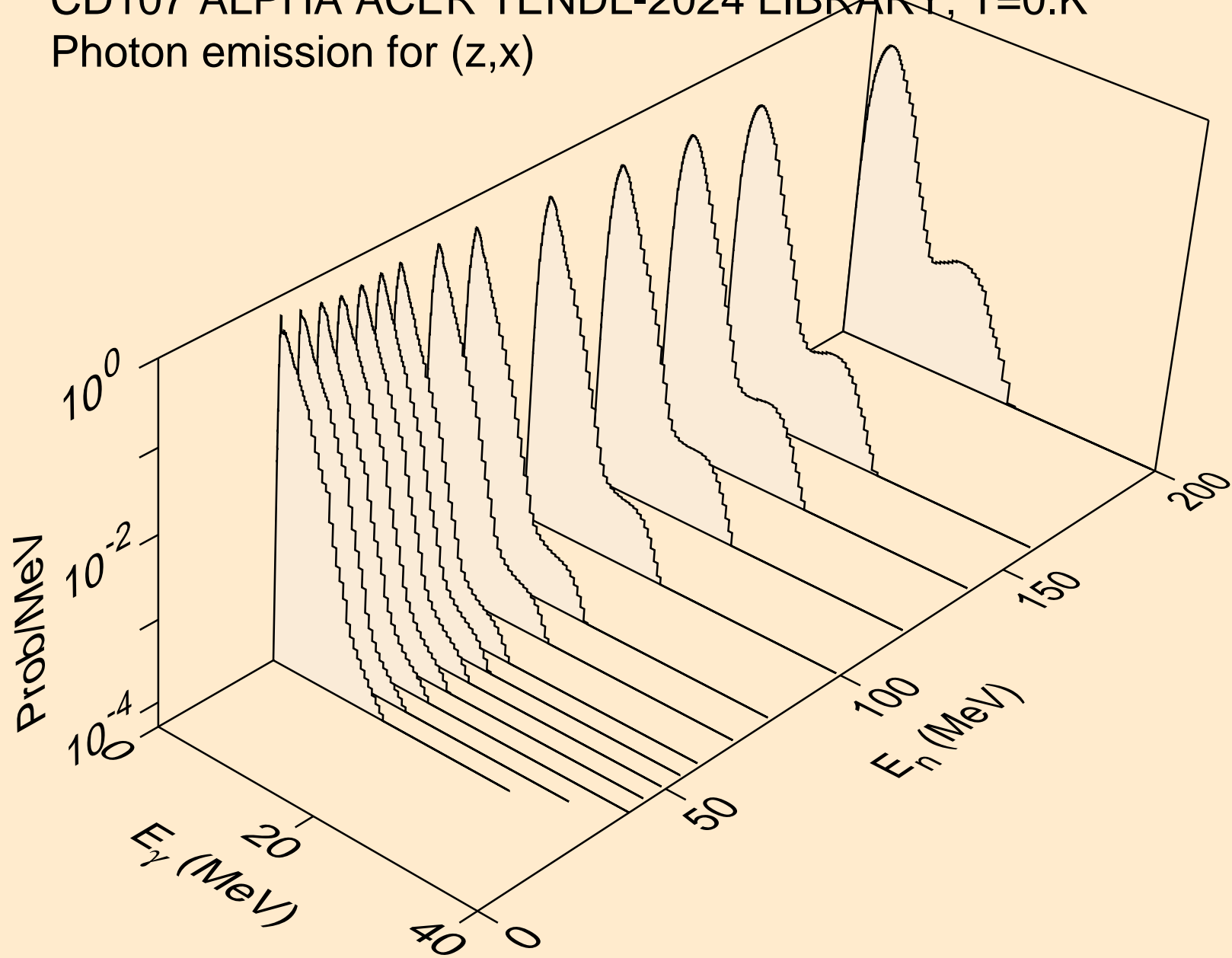

CD107 ALPHA ACER TENDL-2024 LIBRARY; T=0.K  
Photon emission for (n,2n)

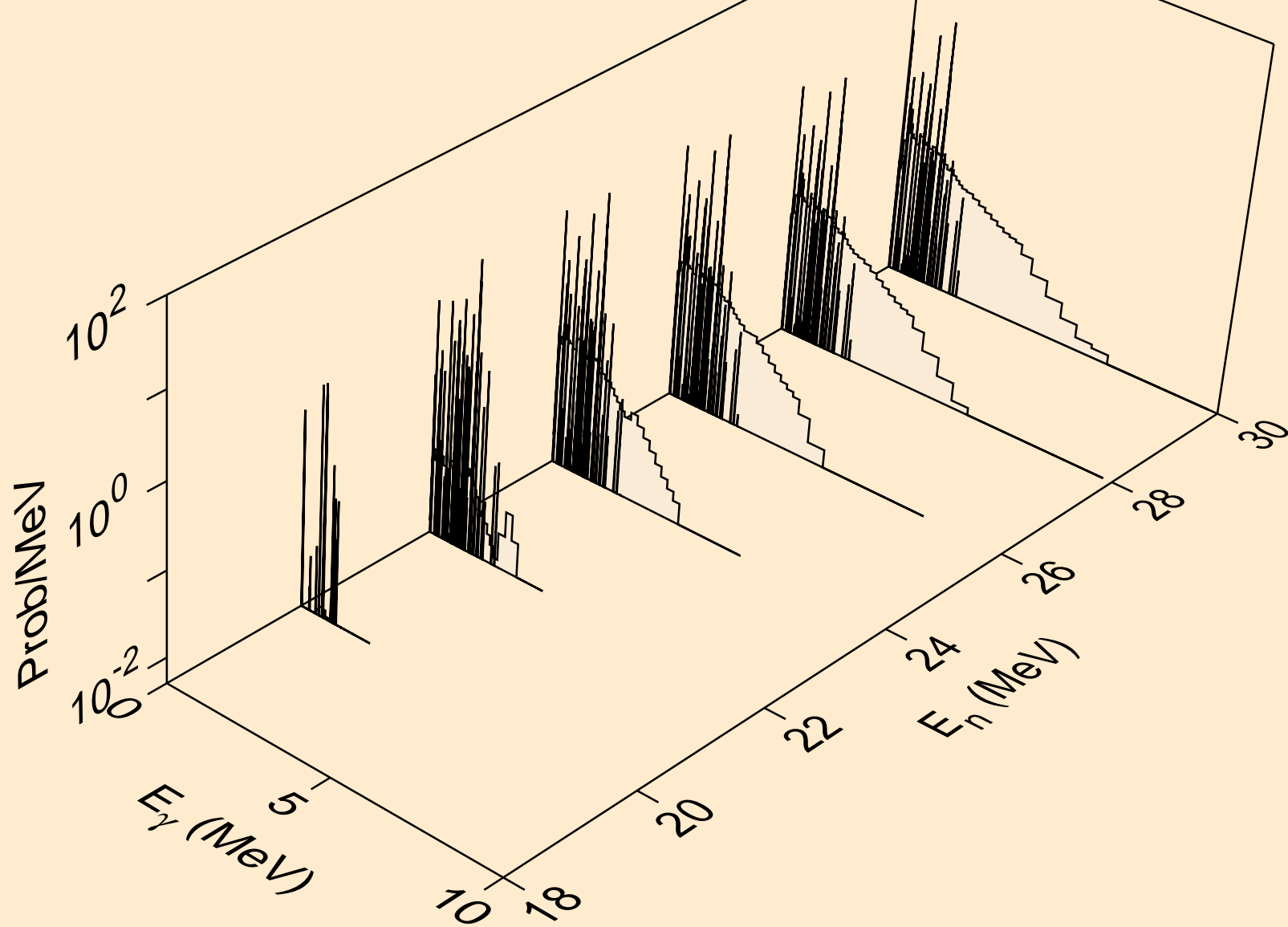

CD107 ALPHA ACER TENDL-2024 LIBRARY; T=0.K  
Photon emission for (n,3n)

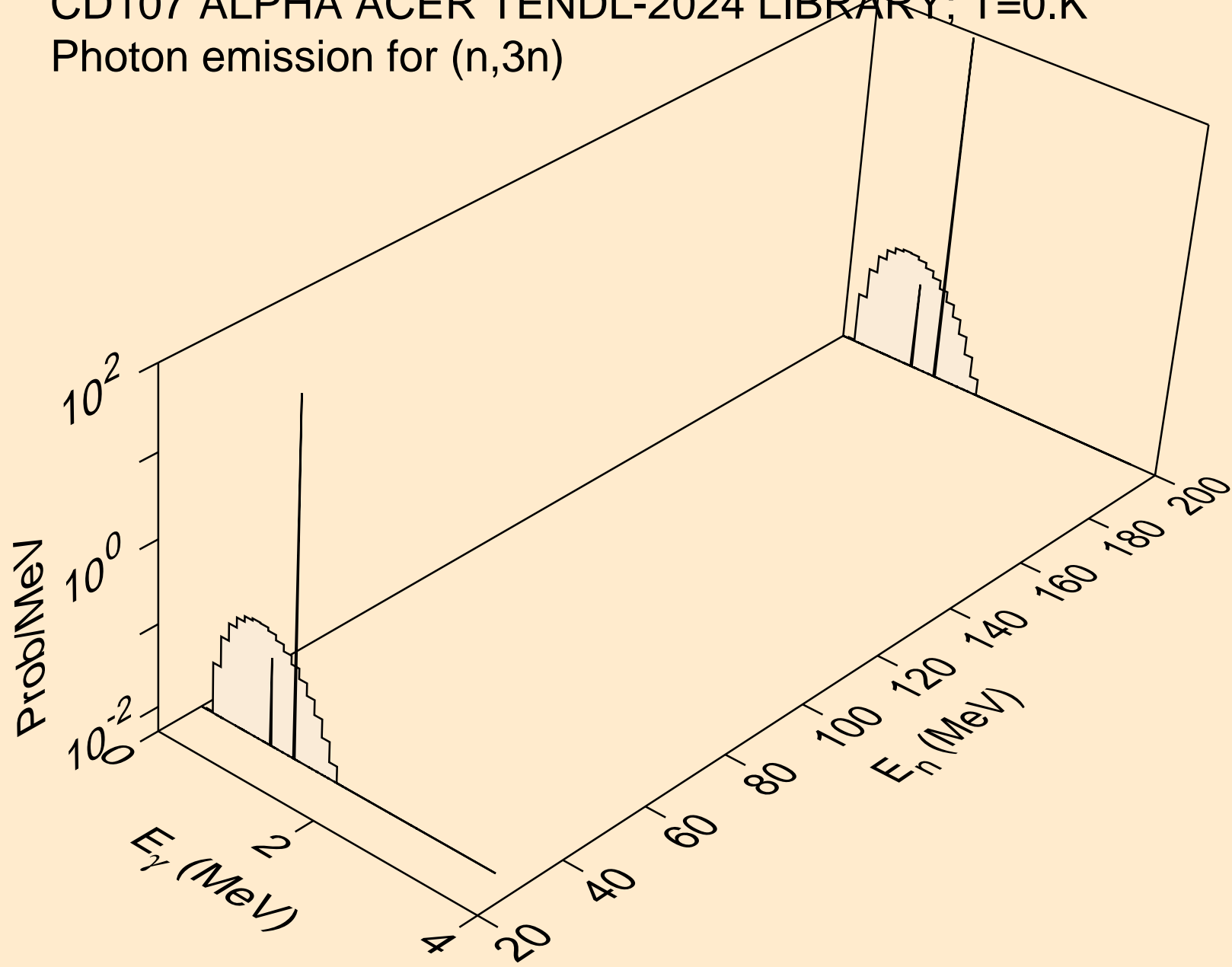

CD107 ALPHA ACER TENDL-2024 LIBRARY; T=0.K  
Photon emission for (n,n\*)a

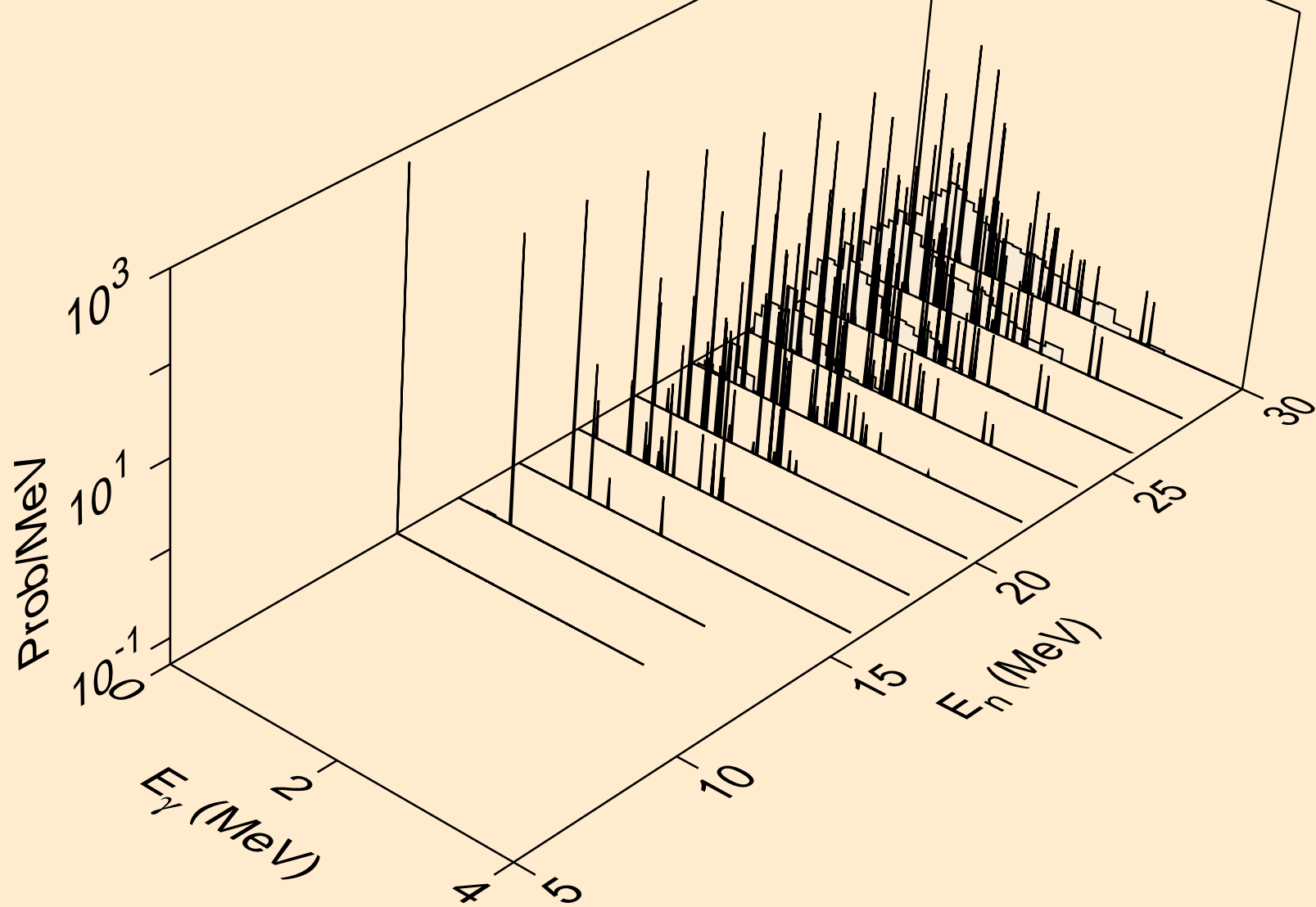

CD107 ALPHA ACER TENDL-2024 LIBRARY; T=0.K  
Photon emission for (n,2n)a

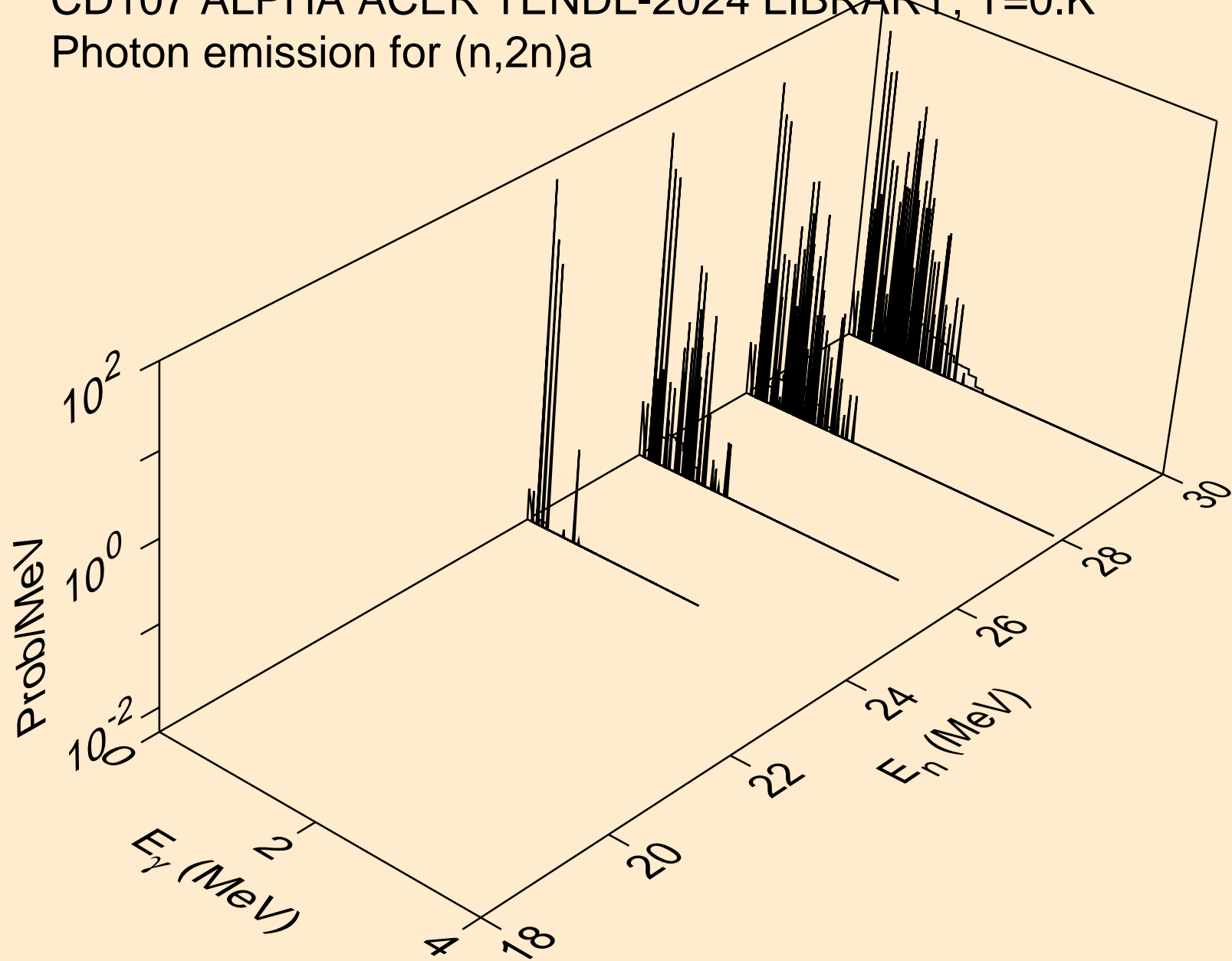

CD107 ALPHA ACER TENDL-2024 LIBRARY; T=0.K  
Photon emission for (n,n\*)p

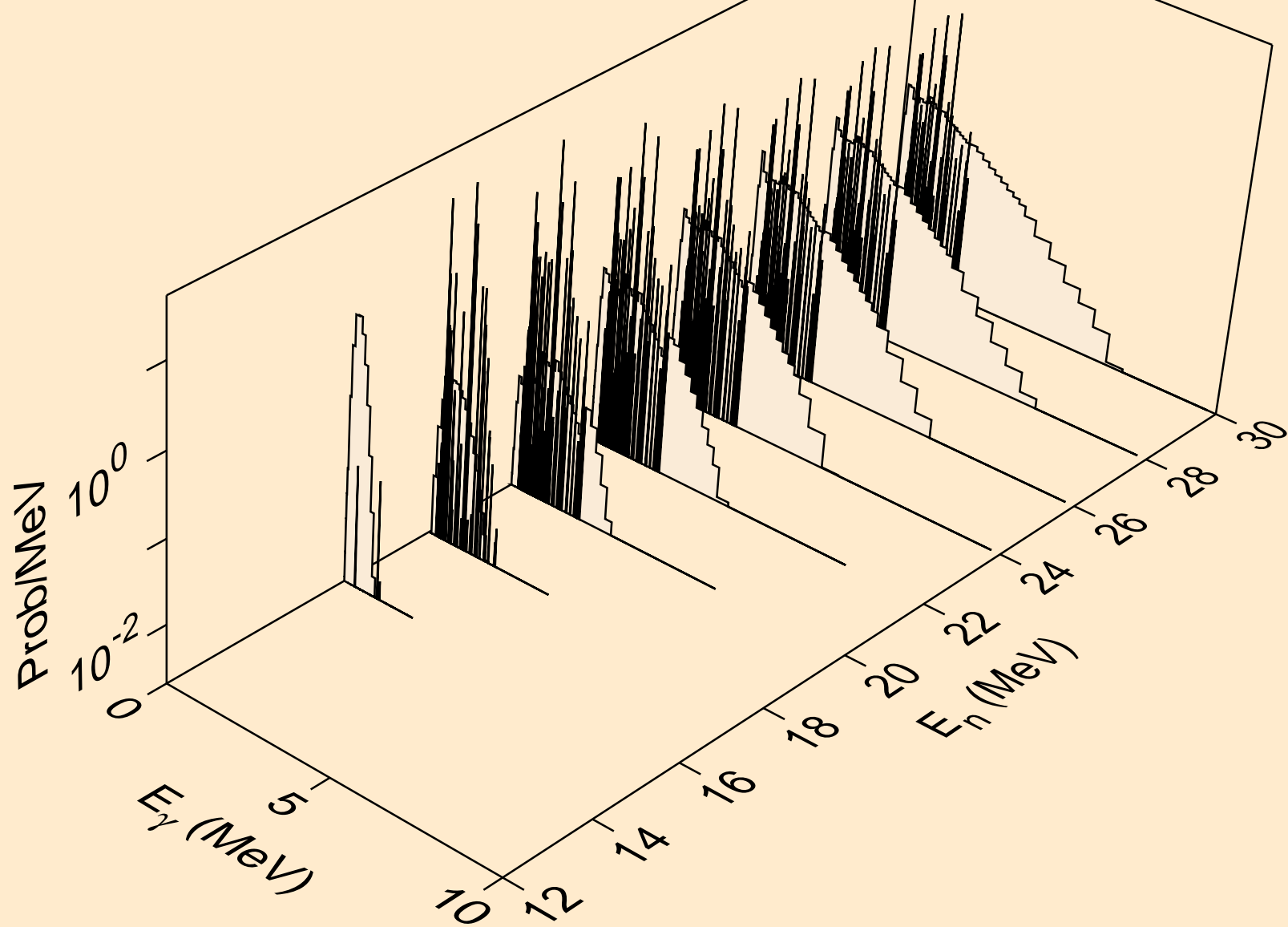

CD107 ALPHA ACER TENDL-2024 LIBRARY; T=0.K  
Photon emission for (n,n\*)2a

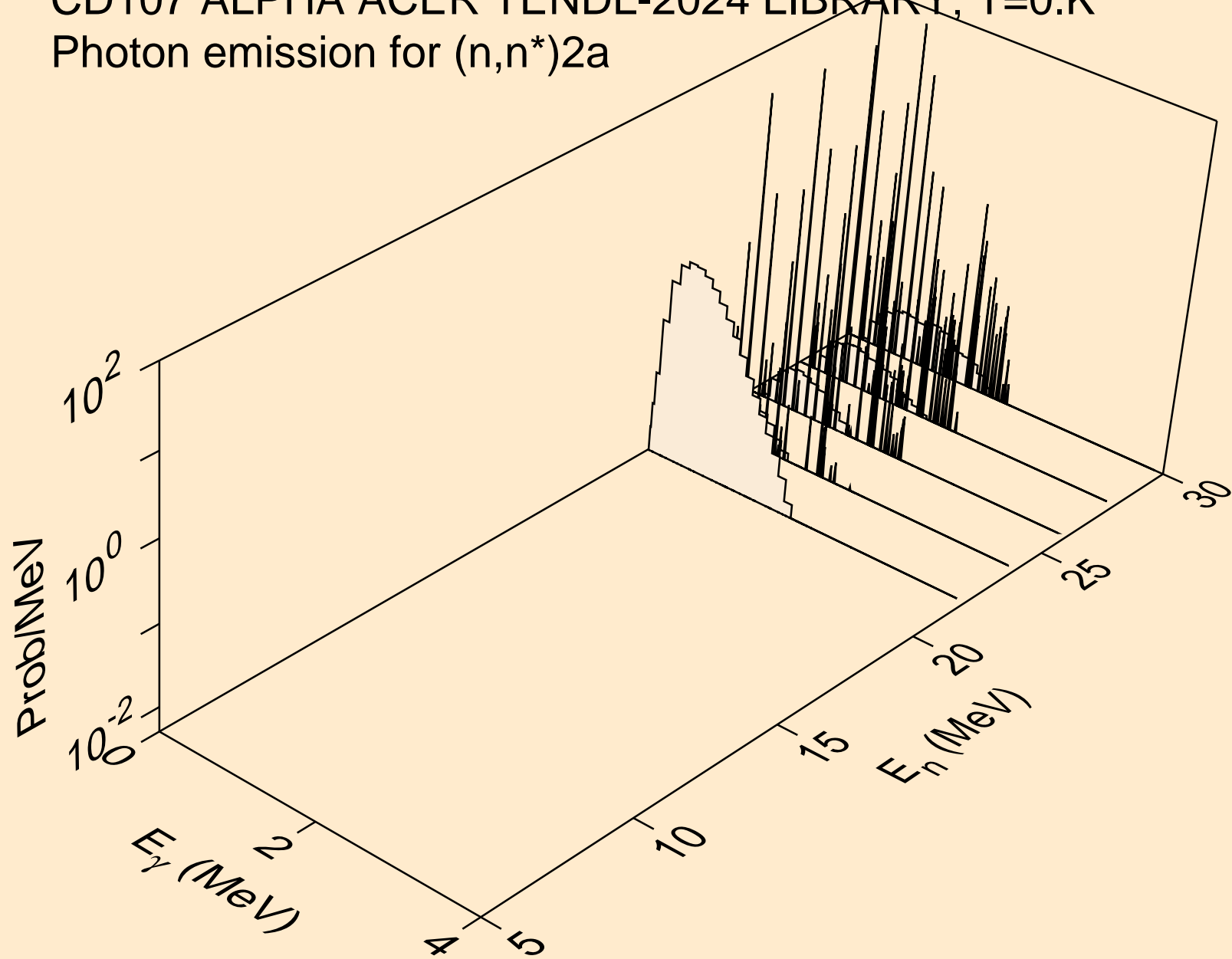

CD107 ALPHA ACER TENDL-2024 LIBRARY; T=0.K  
Photon emission for (n,n\*)d

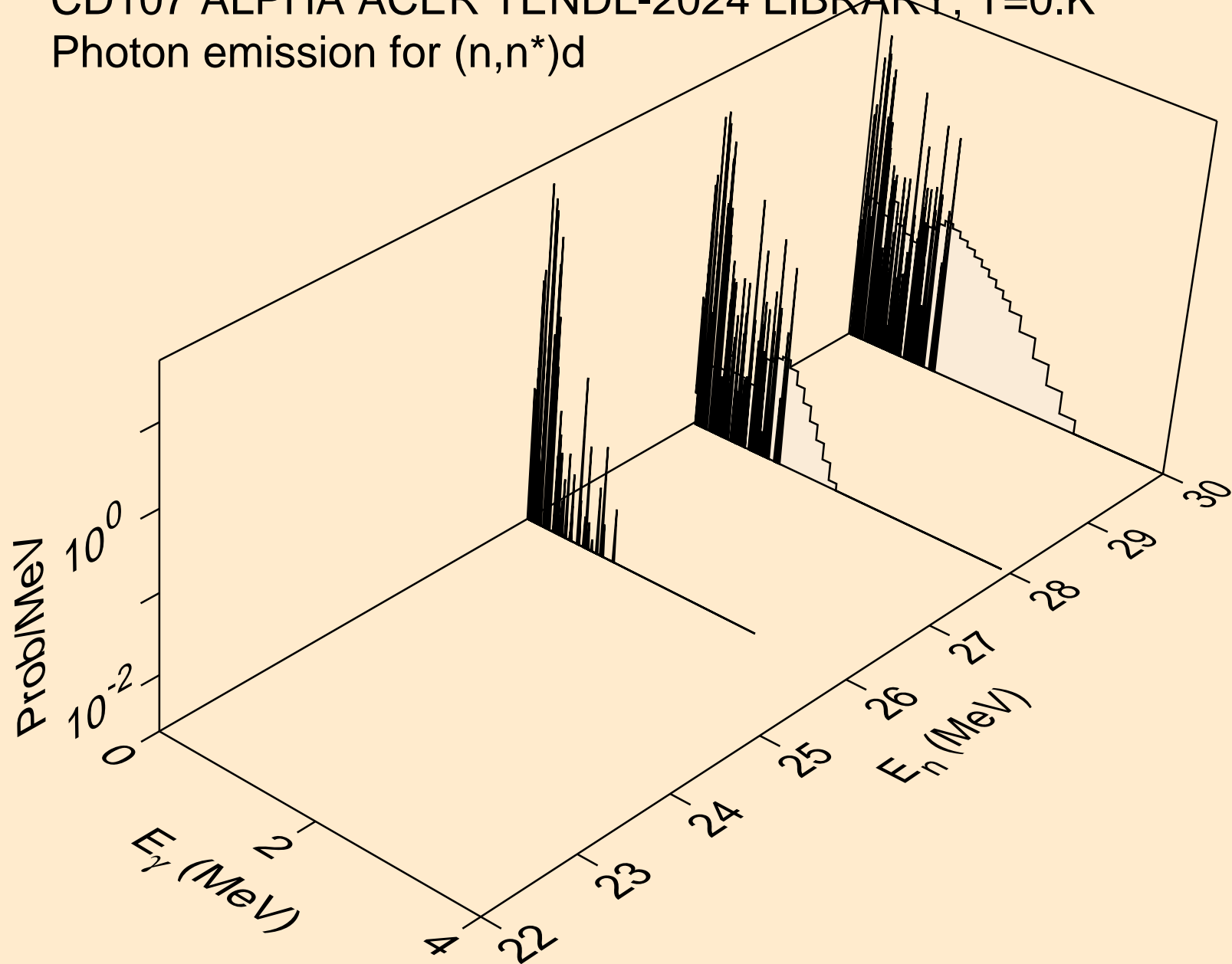

CD107 ALPHA ACER TENDL-2024 LIBRARY; T=0.K  
Photon emission for (n,n\*)t

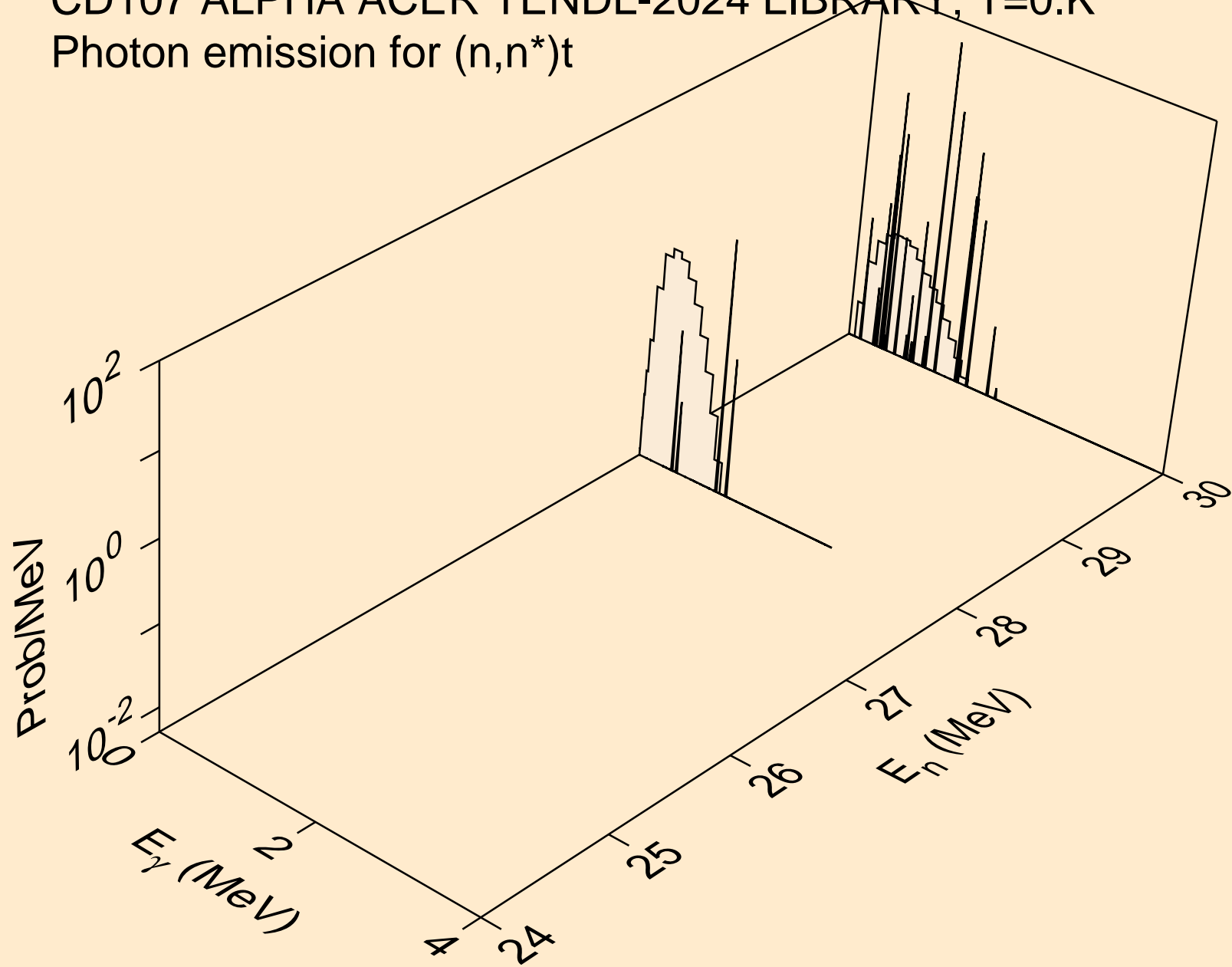

CD107 ALPHA ACER TENDL-2024 LIBRARY; T=0.K  
Photon emission for (n,n\*)he3

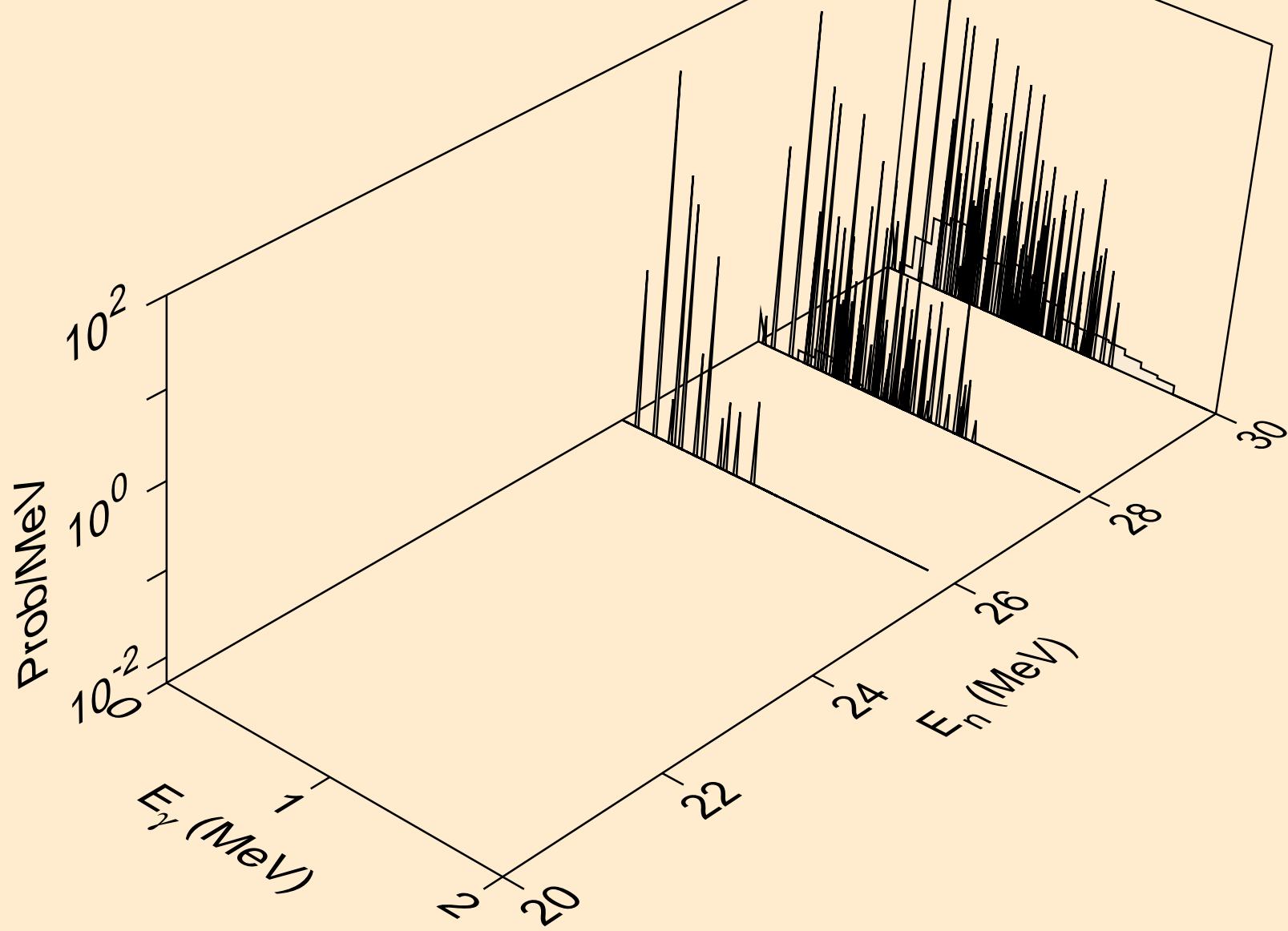

CD107 ALPHA ACER TENDL-2024 LIBRARY; T=0.K  
Photon emission for (n,2np)

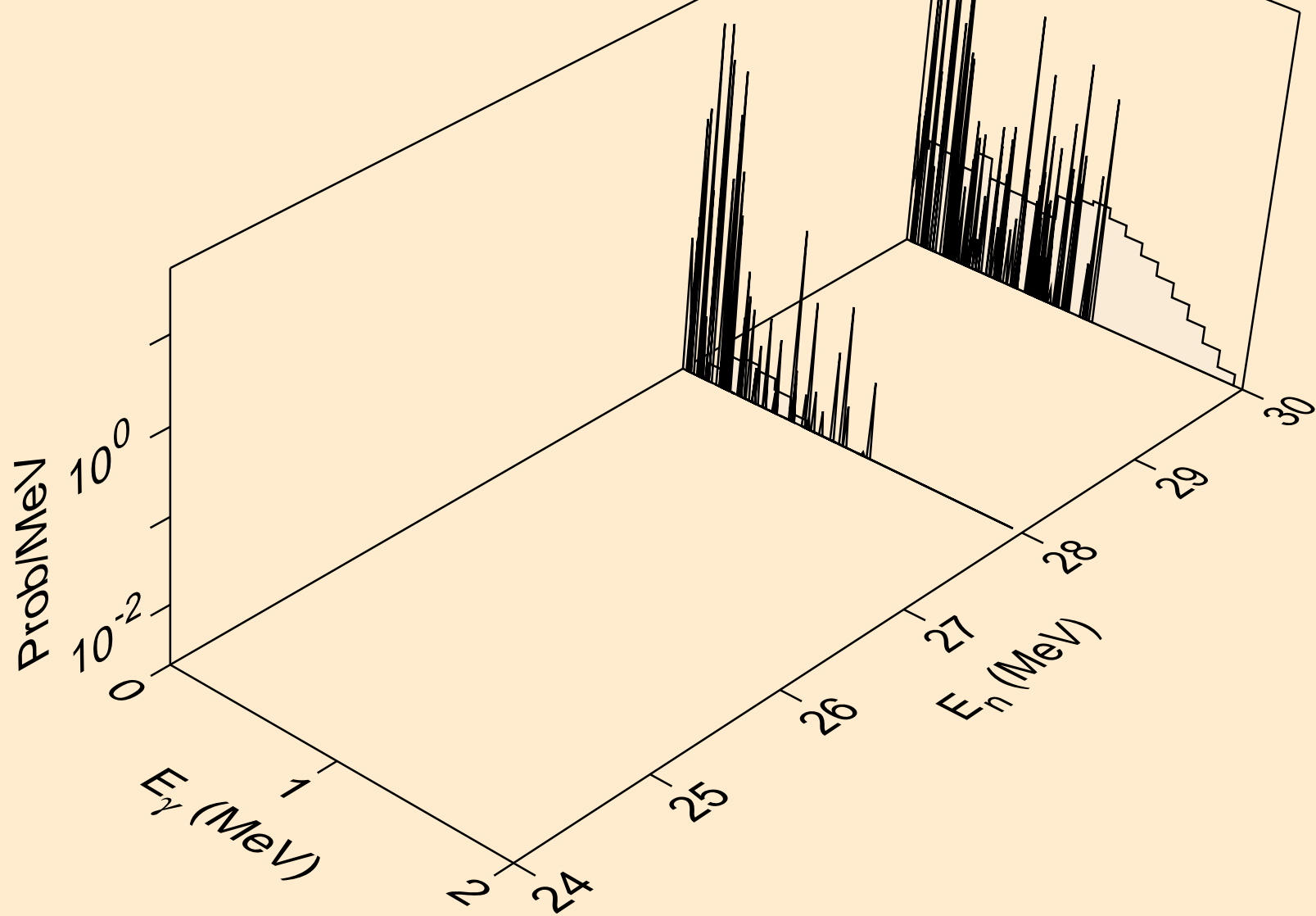

CD107 ALPHA ACER TENDL-2024 LIBRARY; T=0.K  
Photon emission for (n,n2p)

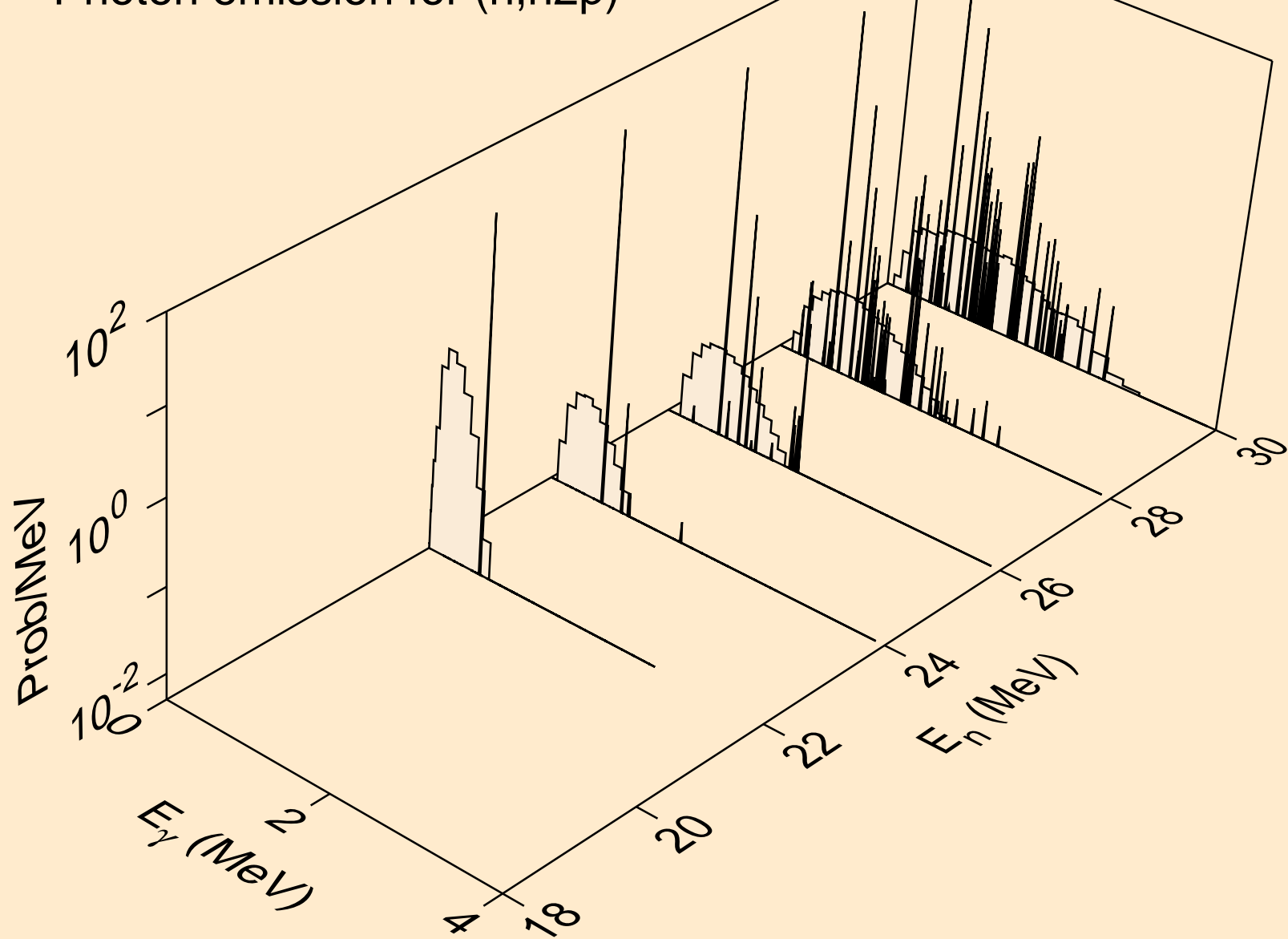

CD107 ALPHA ACER TENDL-2024 LIBRARY; T=0.K  
Photon emission for (n,npa)

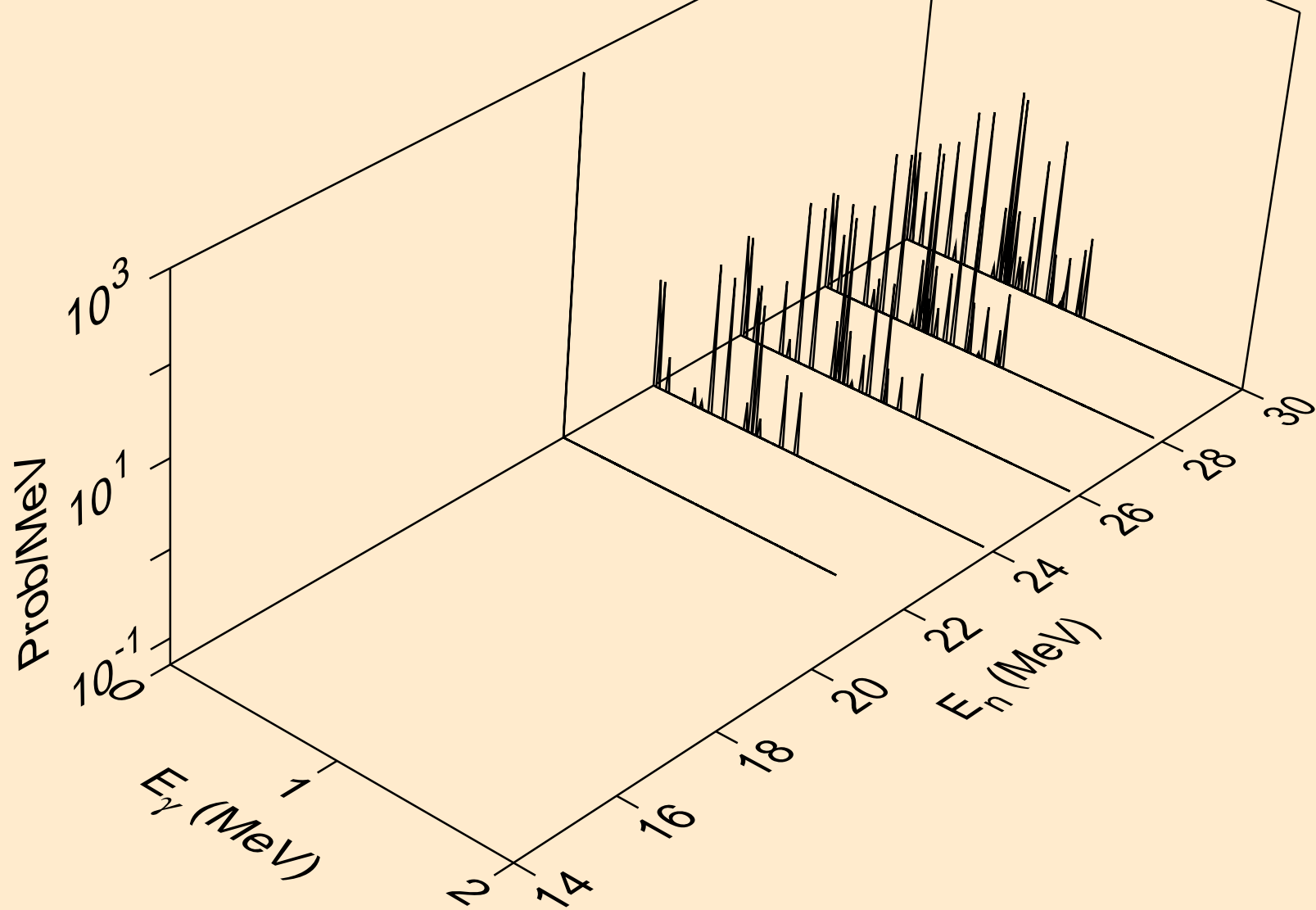

CD107 ALPHA ACER TENDL-2024 LIBRARY; T=0.K  
Photon emission for (n,gma)

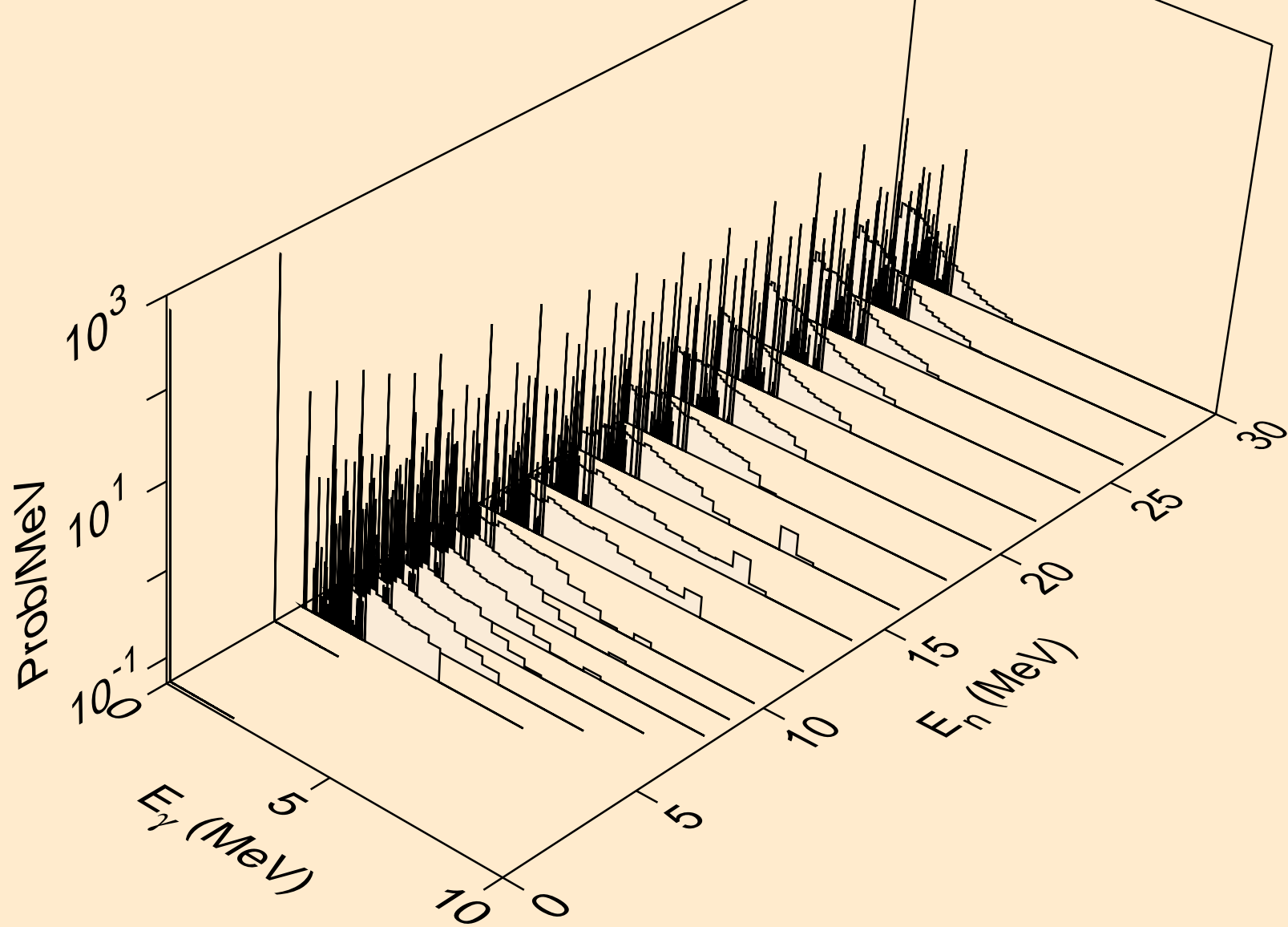

CD107 ALPHA ACER TENDL-2024 LIBRARY; T=0.K  
Photon emission for (n,p)

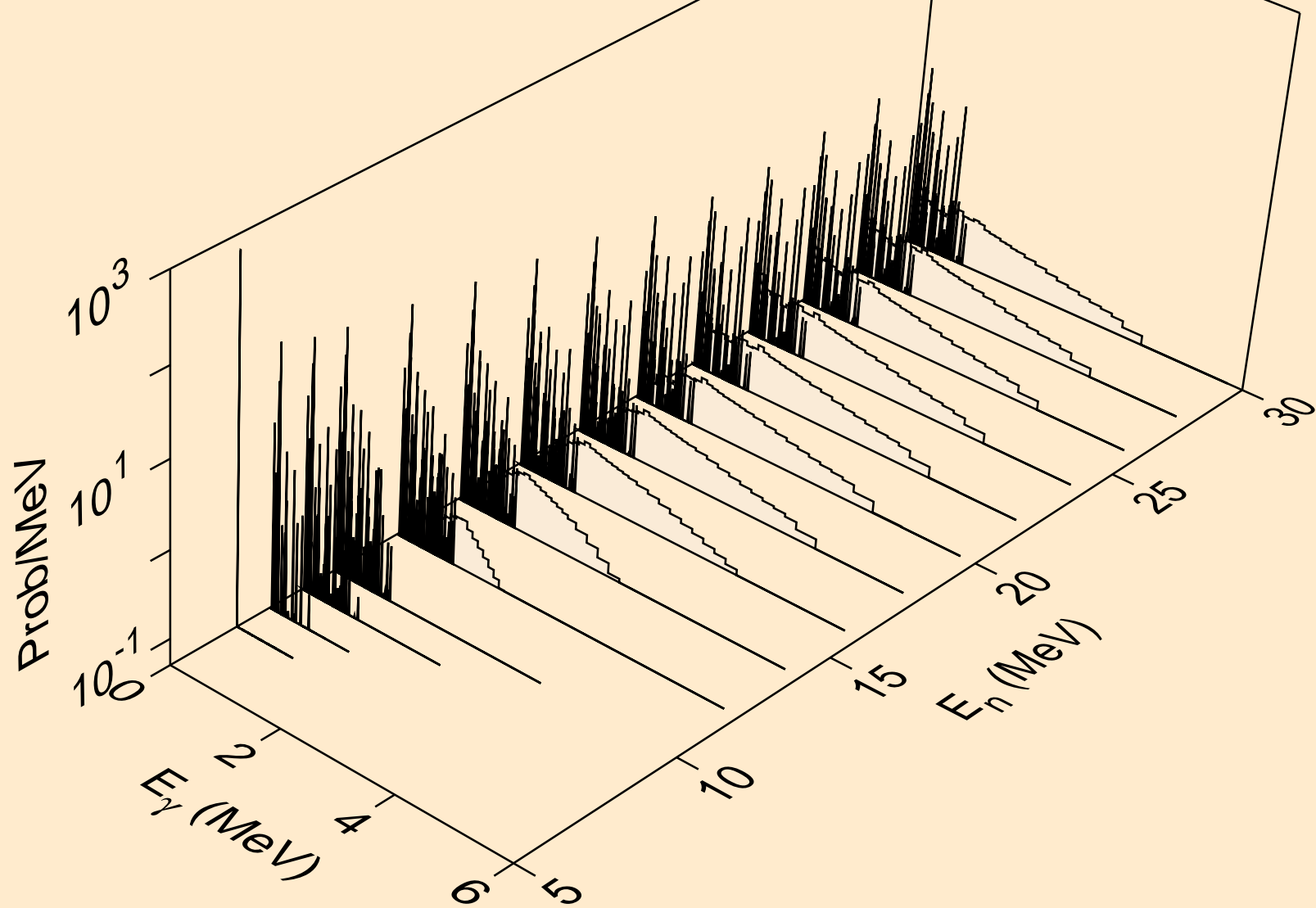

CD107 ALPHA ACER TENDL-2024 LIBRARY; T=0.K  
Photon emission for (n,d)

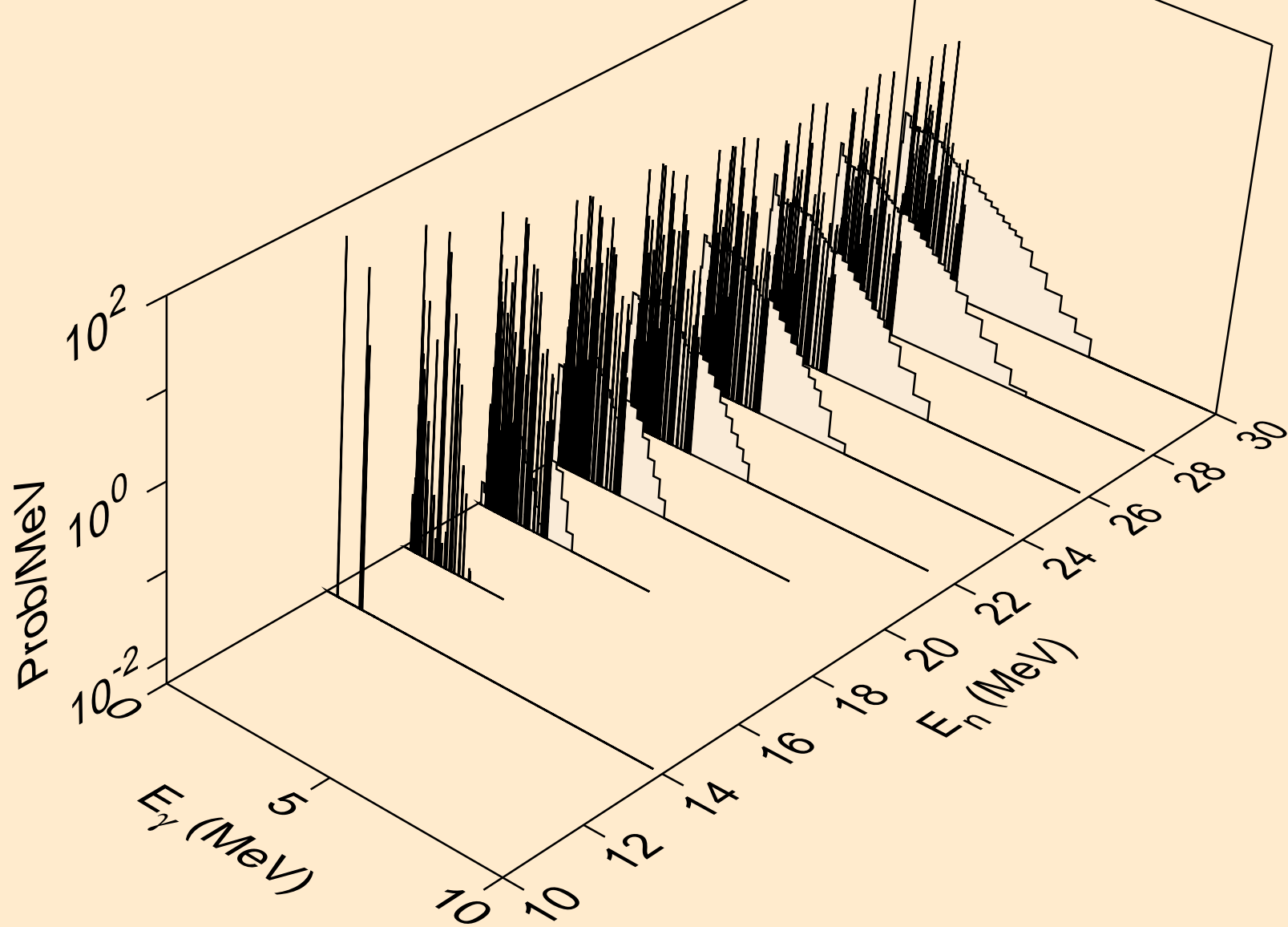

CD107 ALPHA ACER TENDL-2024 LIBRARY; T=0.K  
Photon emission for (n,t)

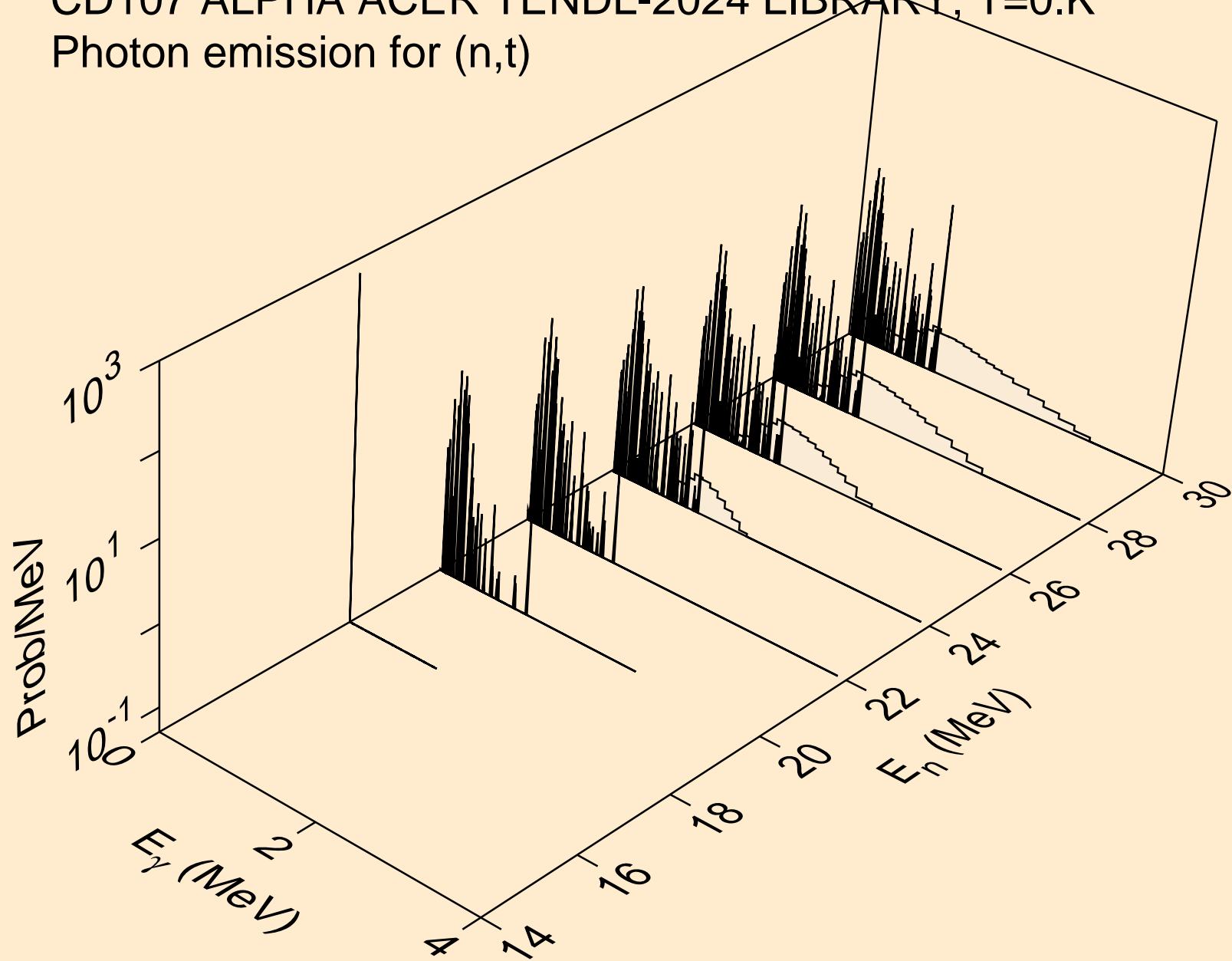

CD107 ALPHA ACER TENDL-2024 LIBRARY; T=0.K  
Photon emission for (n,he3)

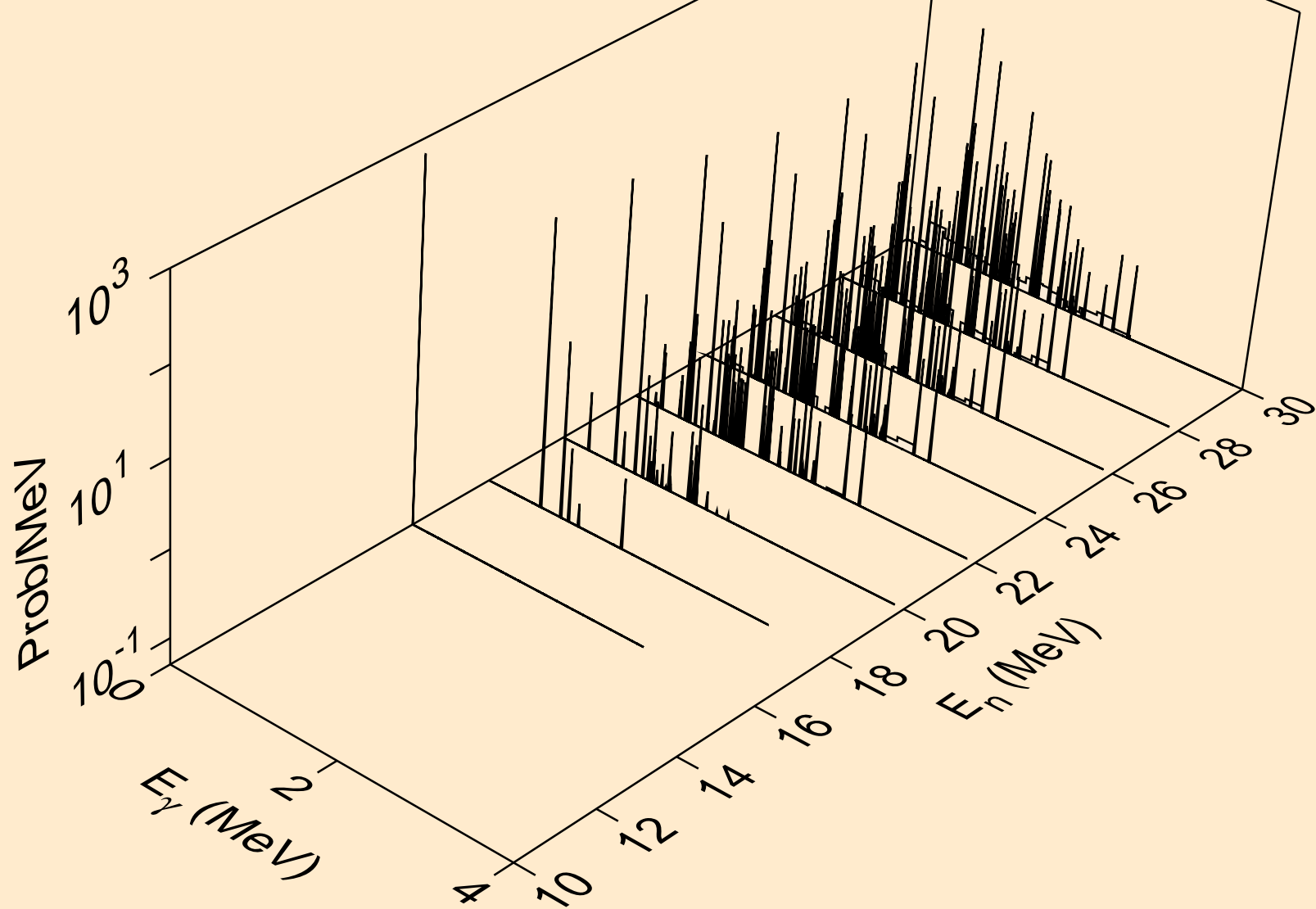

CD107 ALPHA ACER TENDL-2024 LIBRARY; T=0.K  
Photon emission for inelastic

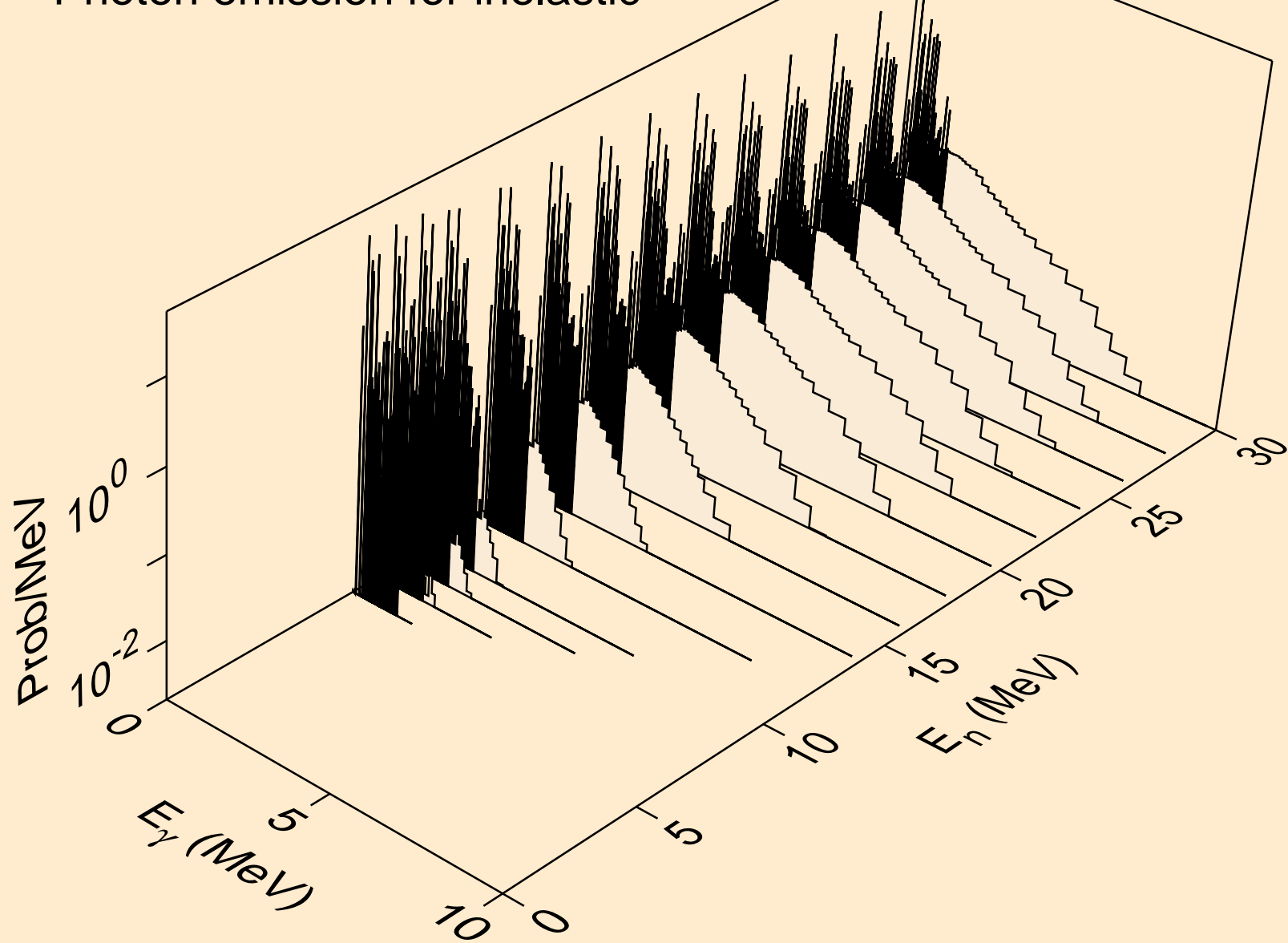

CD107 ALPHA ACER TENDL-2024 LIBRARY; T=0.K  
Photon emission for (n,2a)

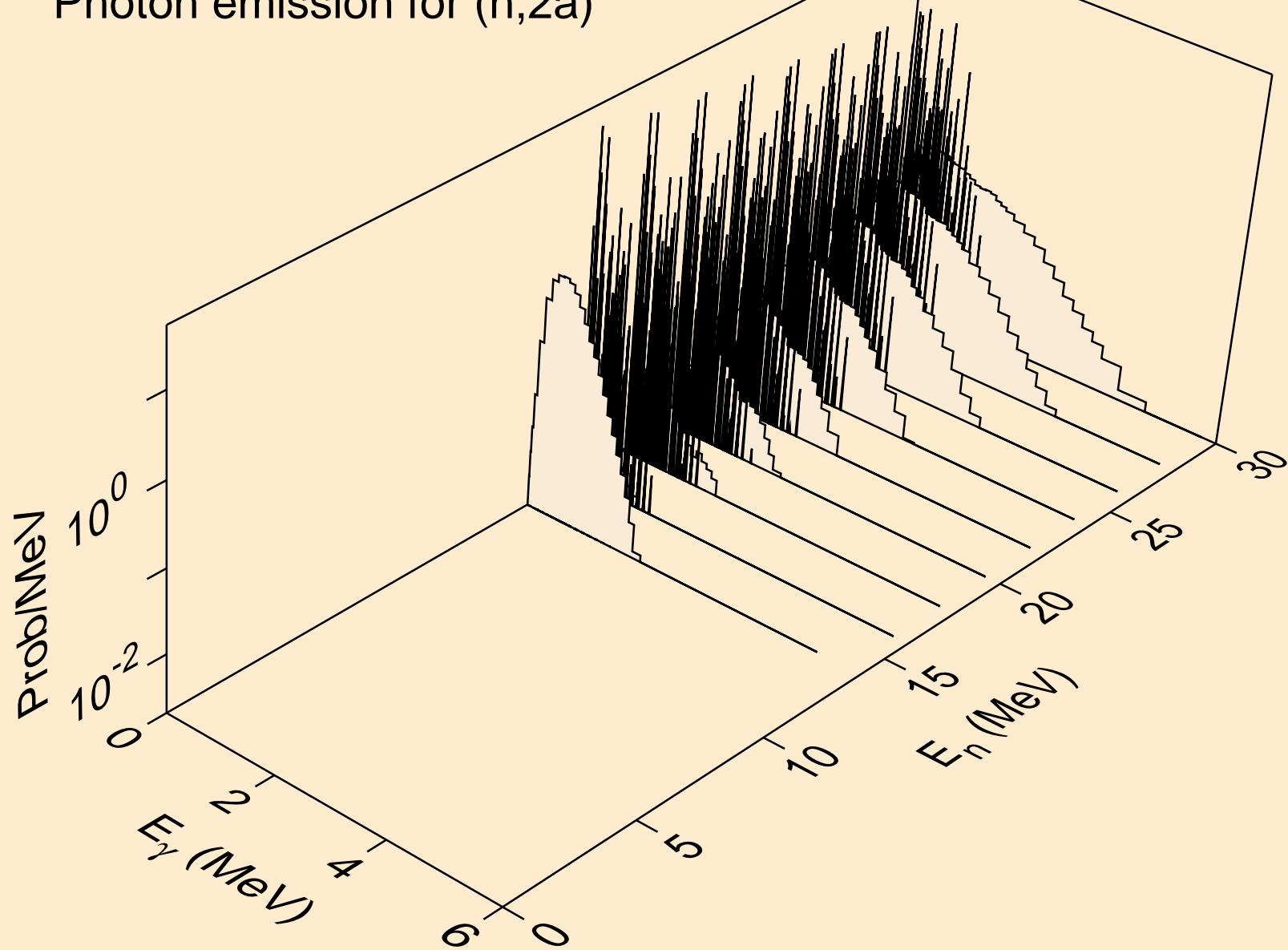

CD107 ALPHA ACER TENDL-2024 LIBRARY; T=0.K  
Photon emission for (n,2p)

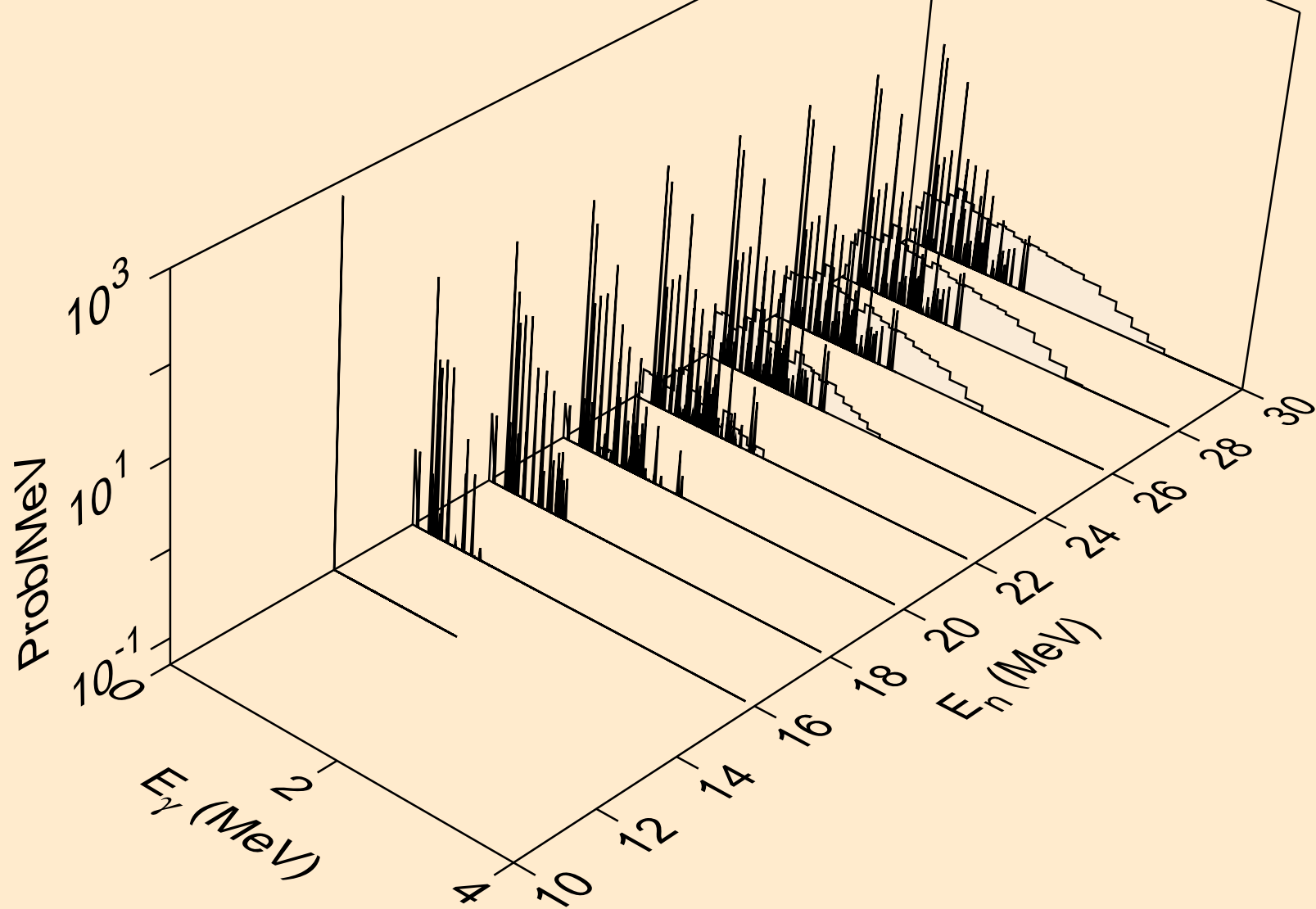

CD107 ALPHA ACER TENDL-2024 LIBRARY; T=0.K  
Photon emission for (n,pa)

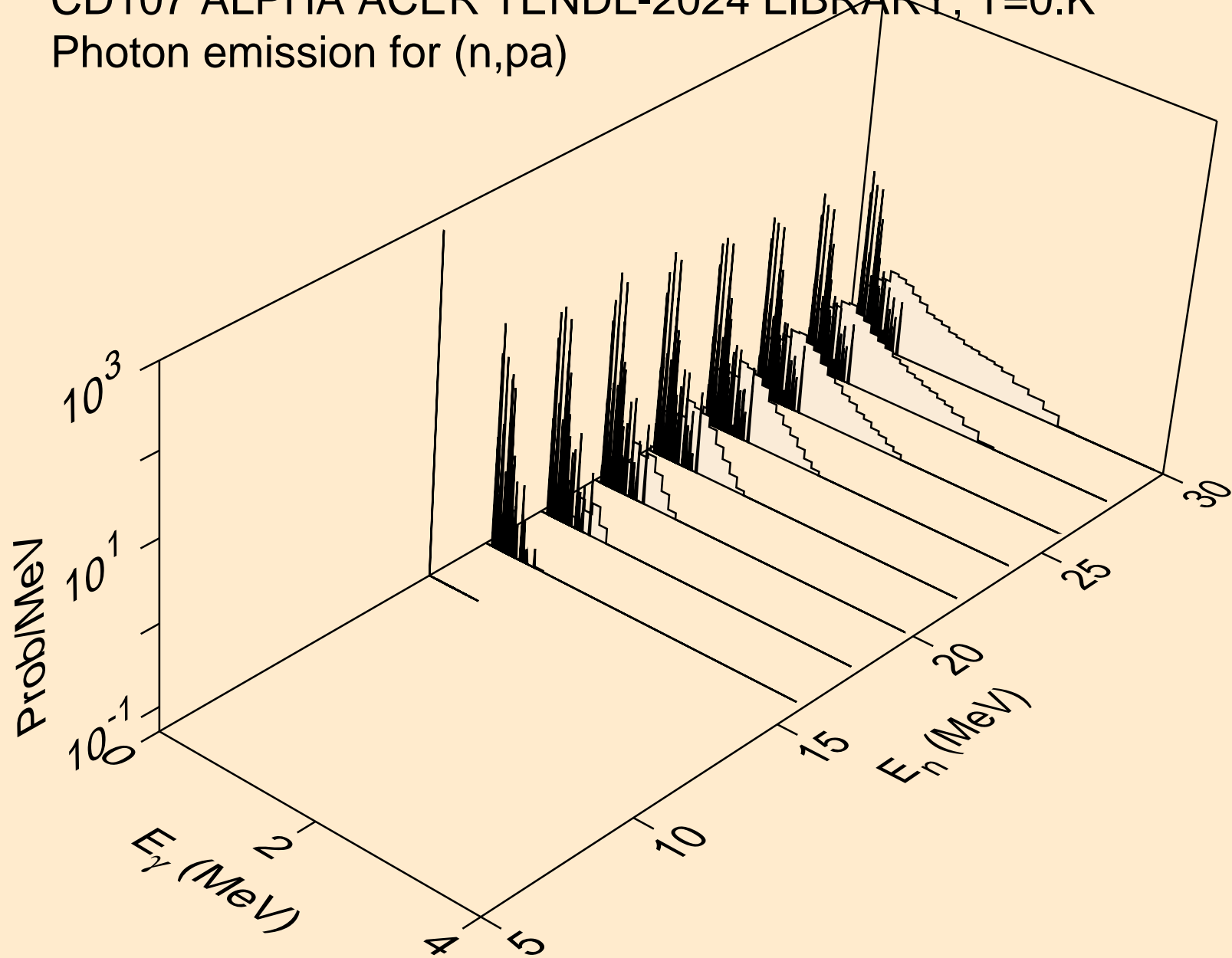

CD107 ALPHA ACER TENDL-2024 LIBRARY; T=0.K  
Photon emission for (n,pd)

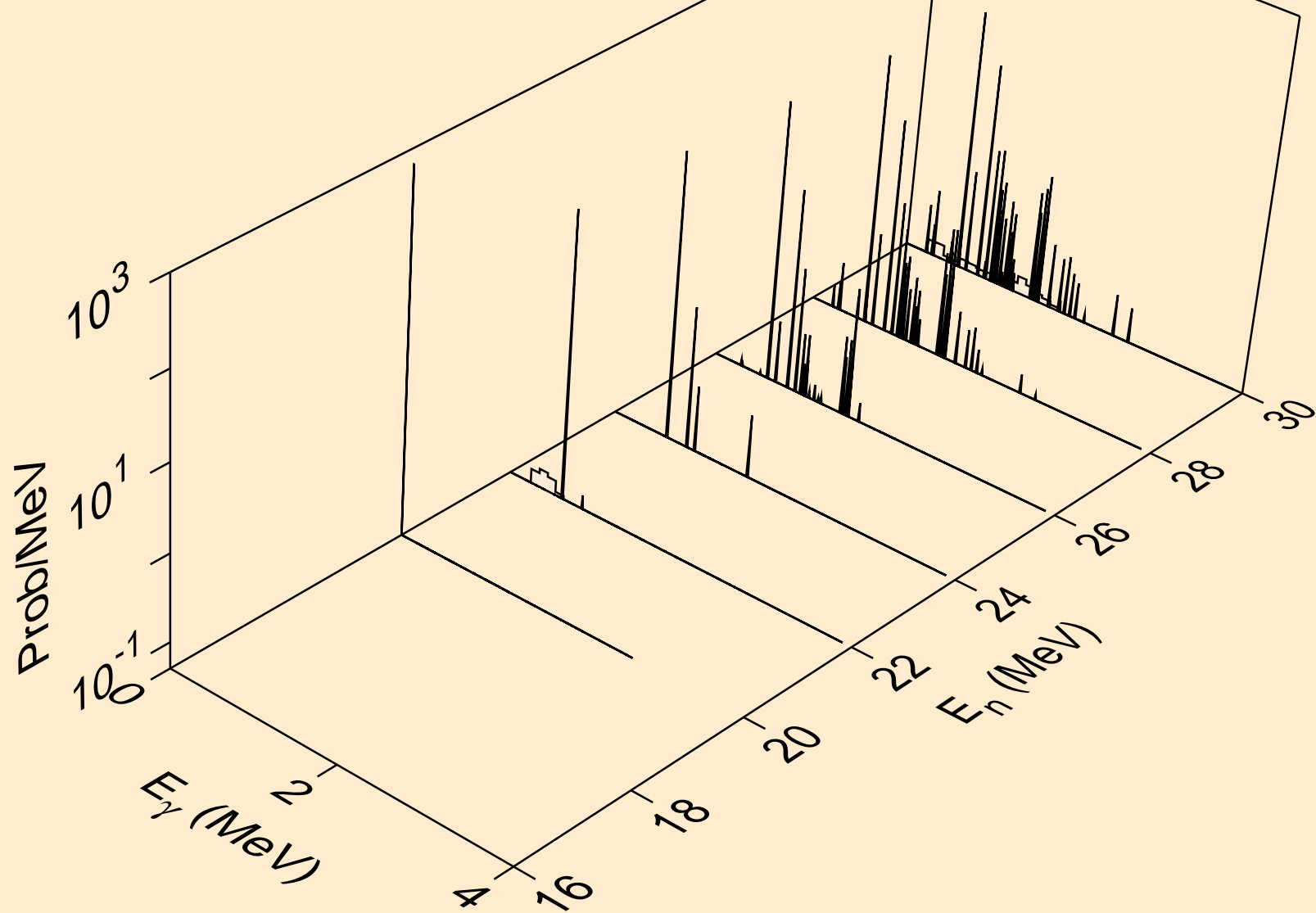

CD107 ALPHA ACER TENDL-2024 LIBRARY; T=0.K  
Photon emission for (n,pt)

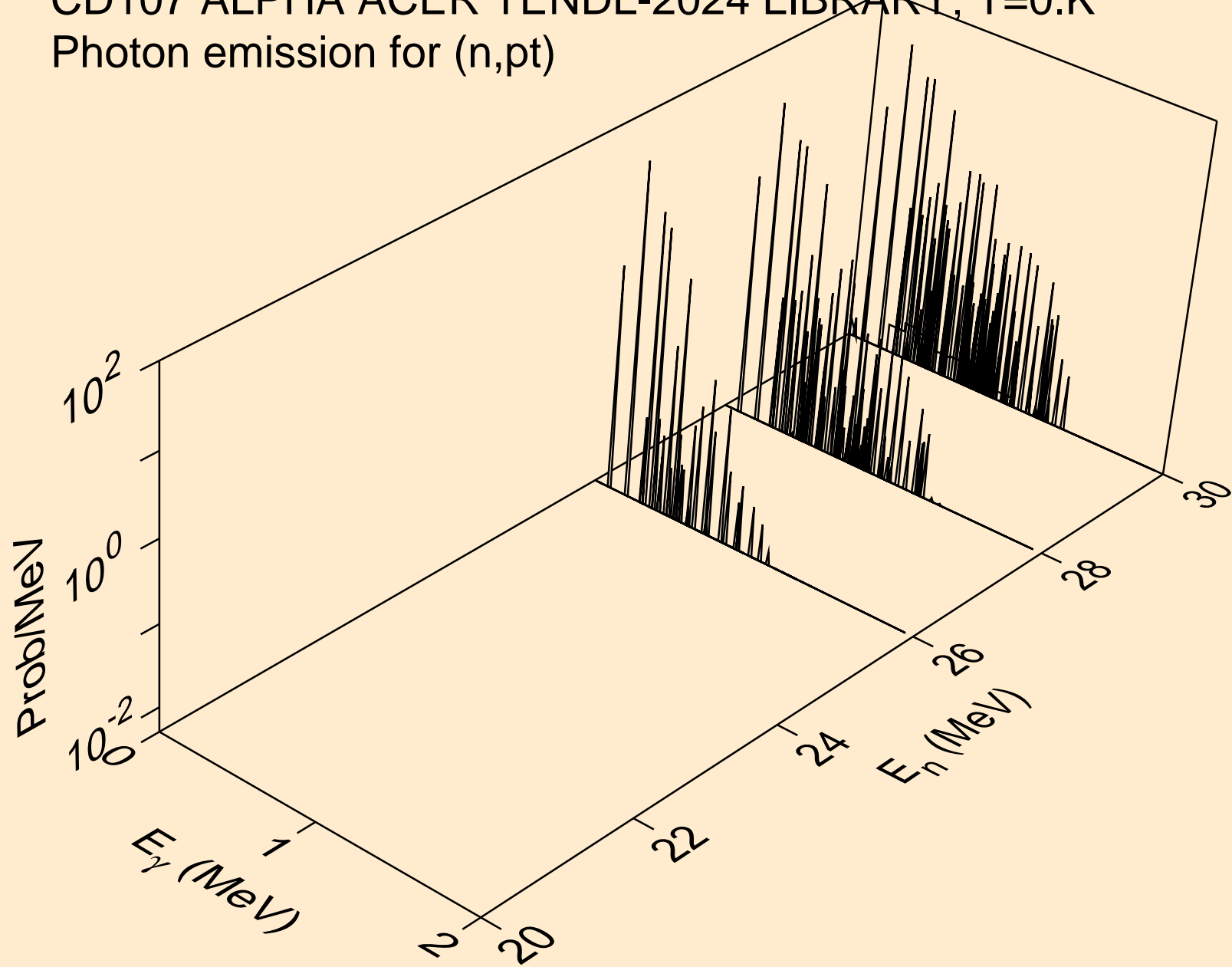

CD107 ALPHA ACER TENDL-2024 LIBRARY; T=0.K  
Photon emission for (n,da)

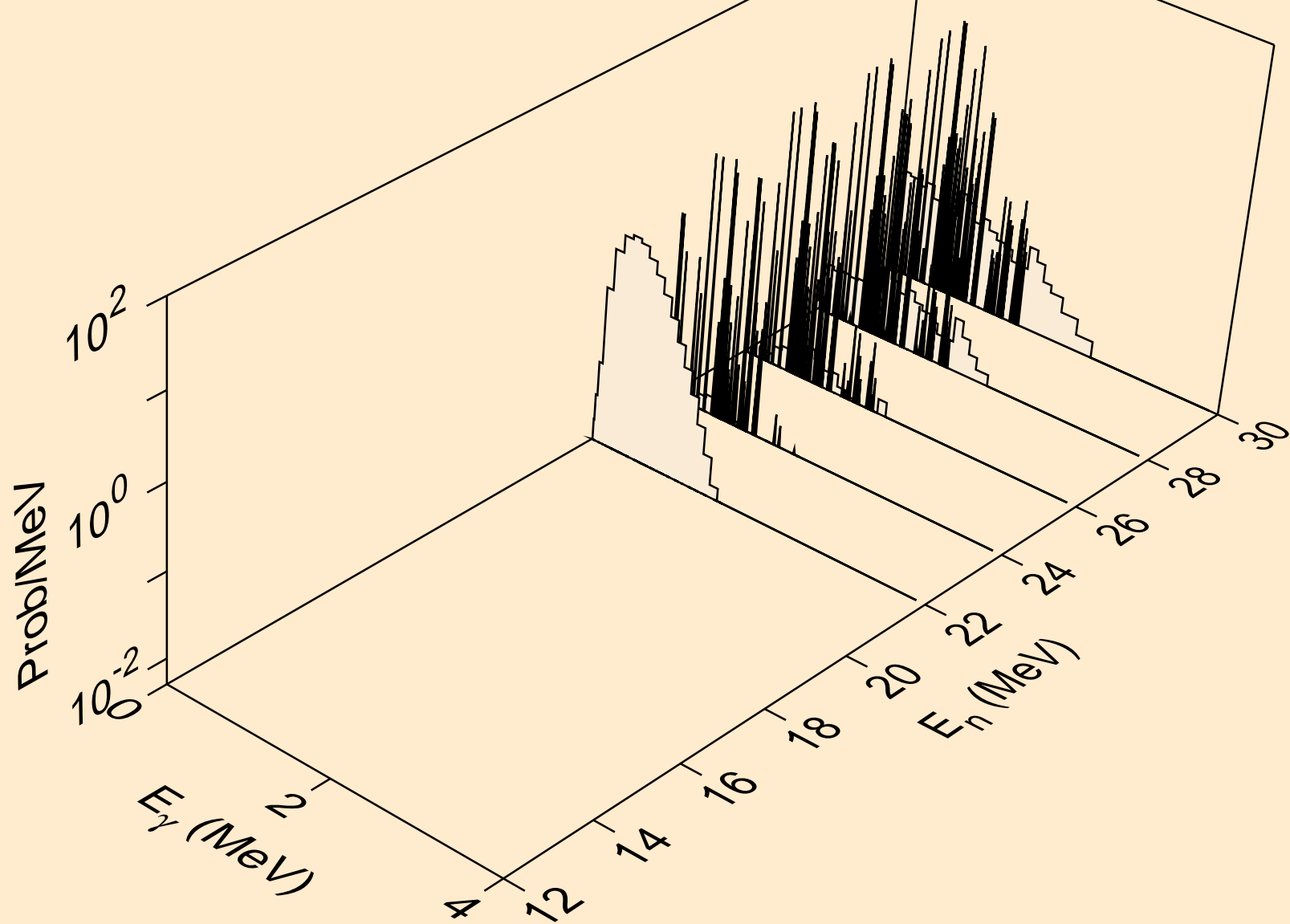

# CD107 ALPHA ACER TENDL-2024 LIBRARY; T=0.K

## Particle heating contributions

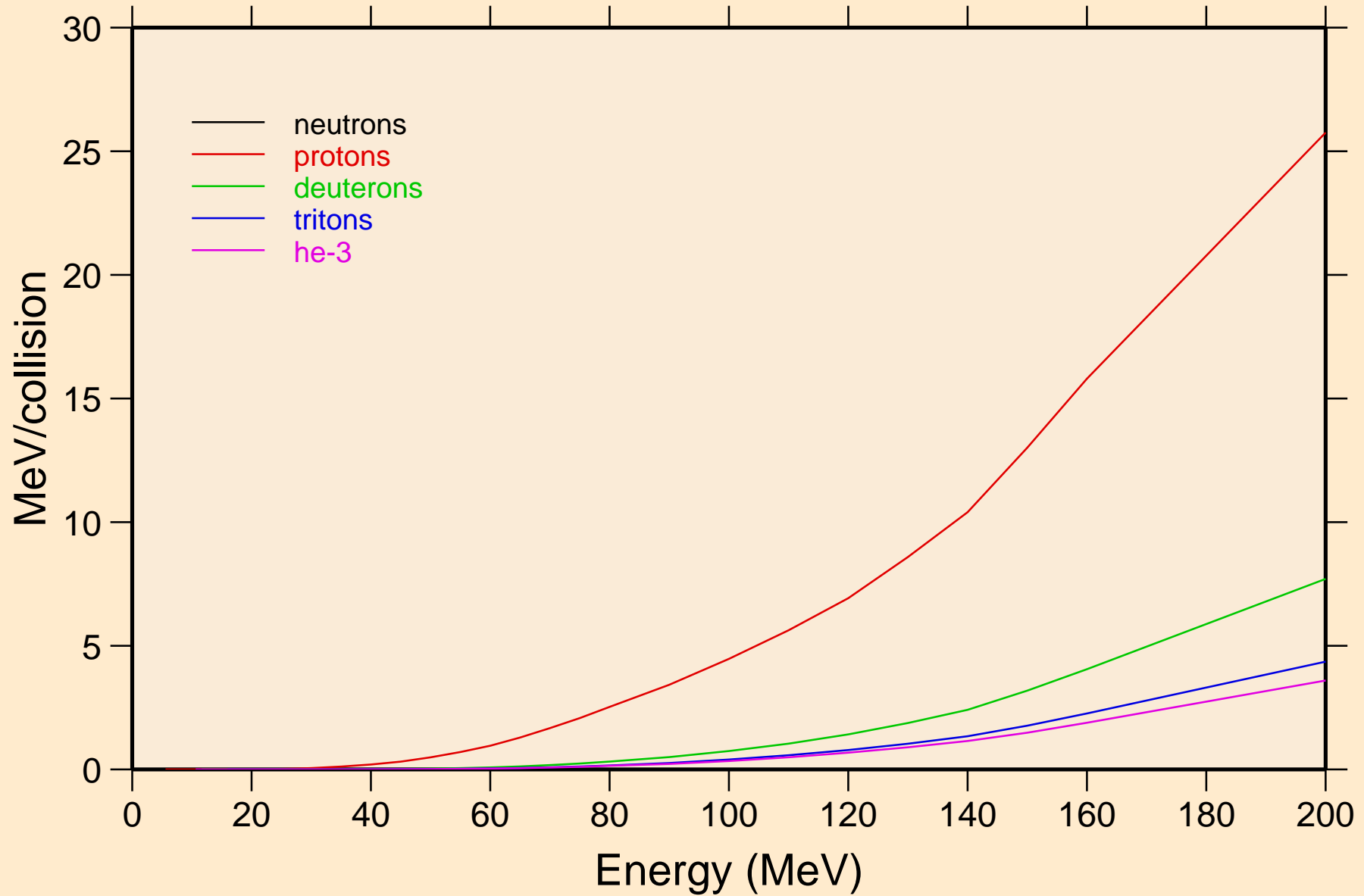

CD107 ALPHA ACER TENDL-2024 LIBRARY; T=0.K  
Recoil Heating

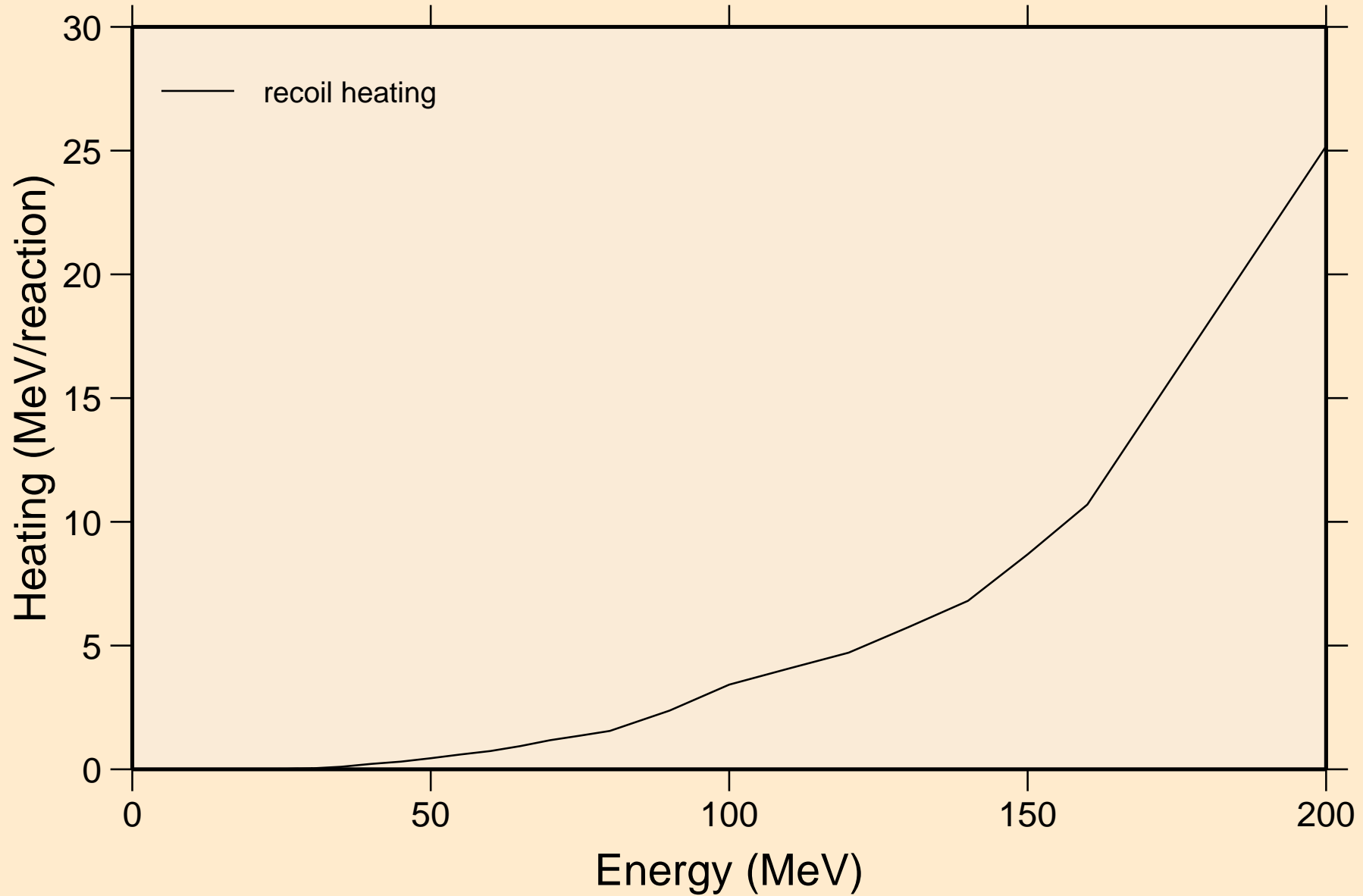

CD107 ALPHA ACER TENDL-2024 LIBRARY; T=0.K  
Particle production cross sections

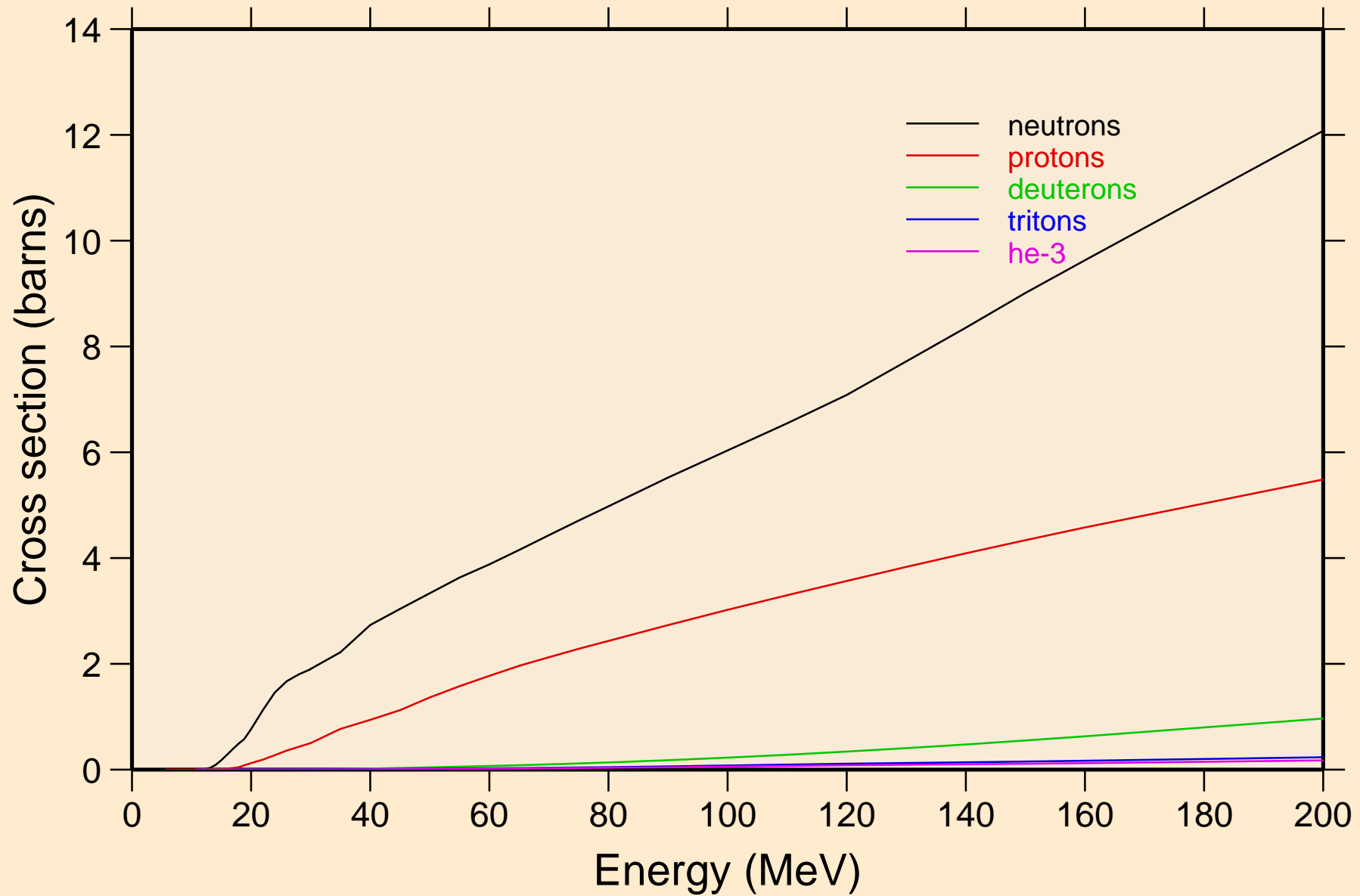

CD107 ALPHA ACER TENDL-2024 LIBRARY; T=0.K  
neutrons from (a,n)

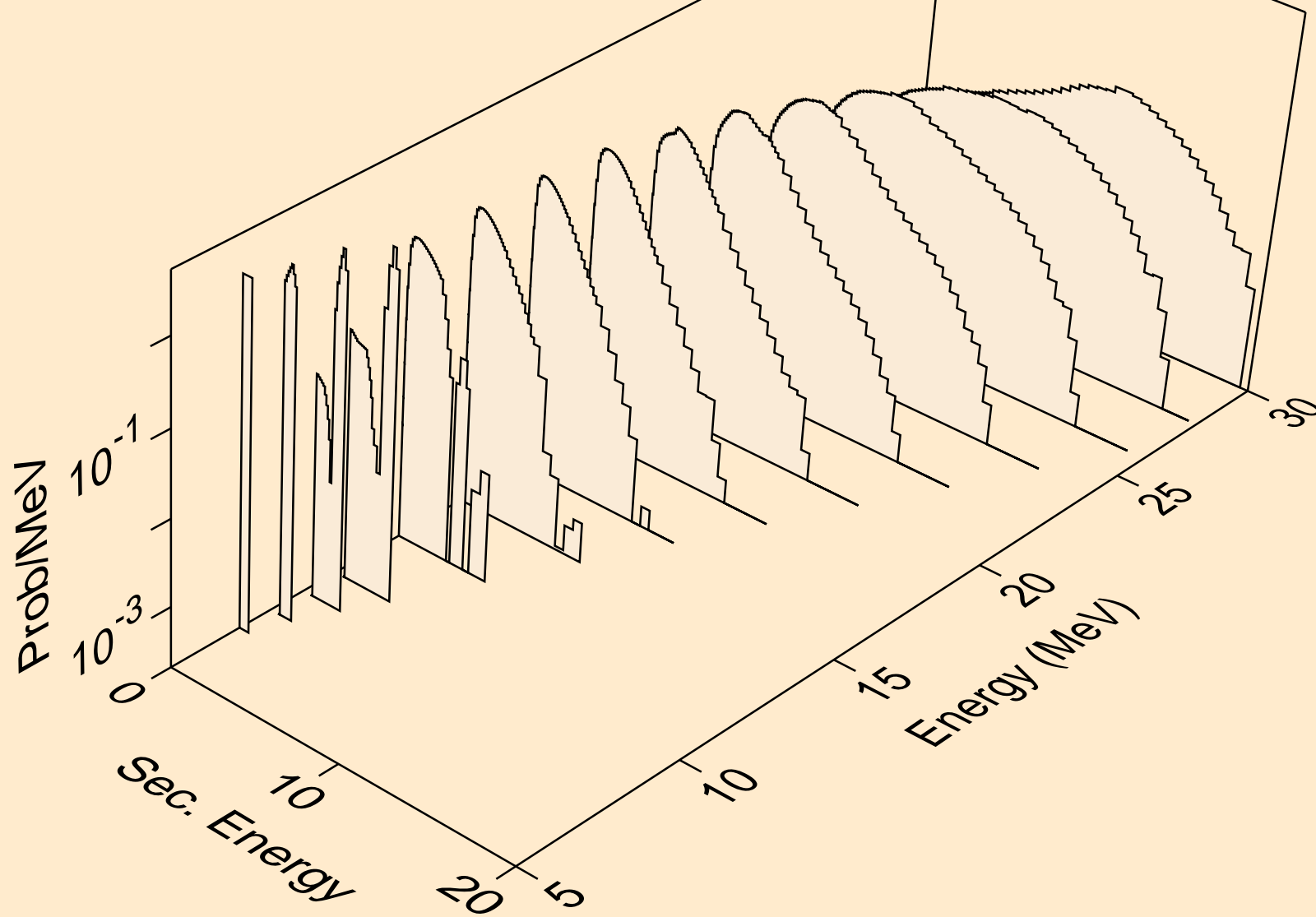

CD107 ALPHA ACER TENDL-2024 LIBRARY; T=0.K  
neutrons from (a,x)

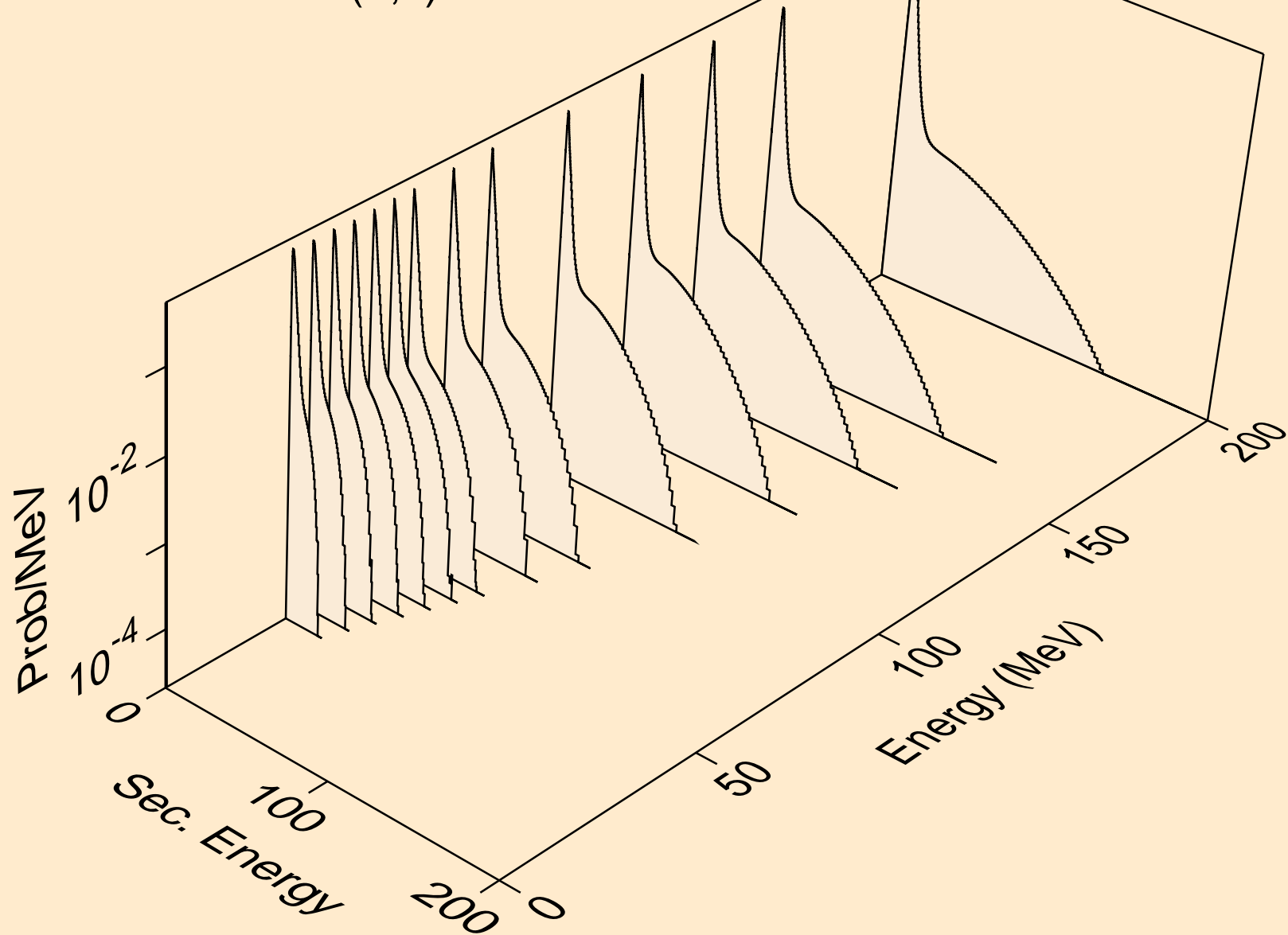

CD107 ALPHA ACER TENDL-2024 LIBRARY; T=0.K  
neutrons from (a,2n)

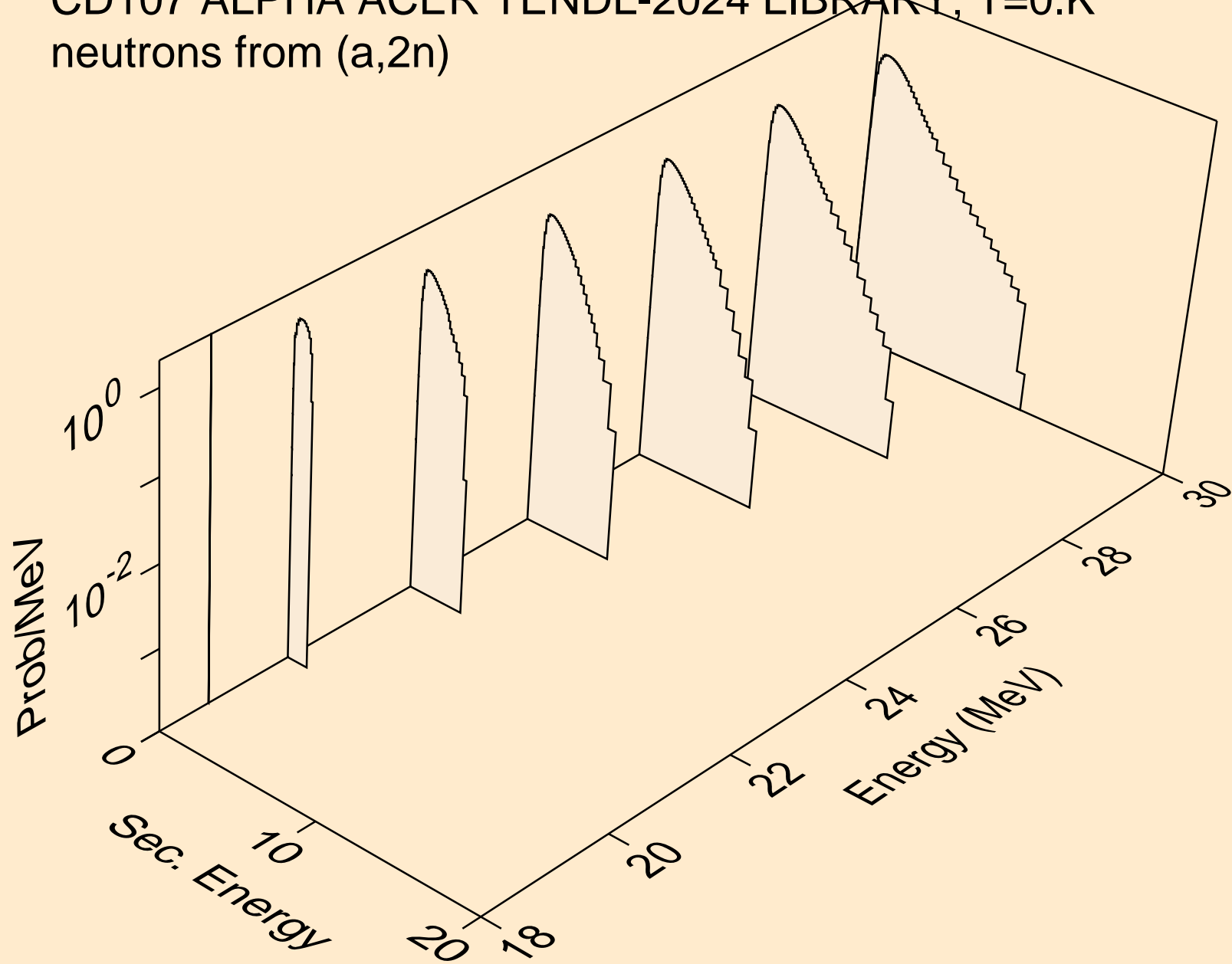

CD107 ALPHA ACER TENDL-2024 LIBRARY; T=0.K  
neutrons from (a,3n)

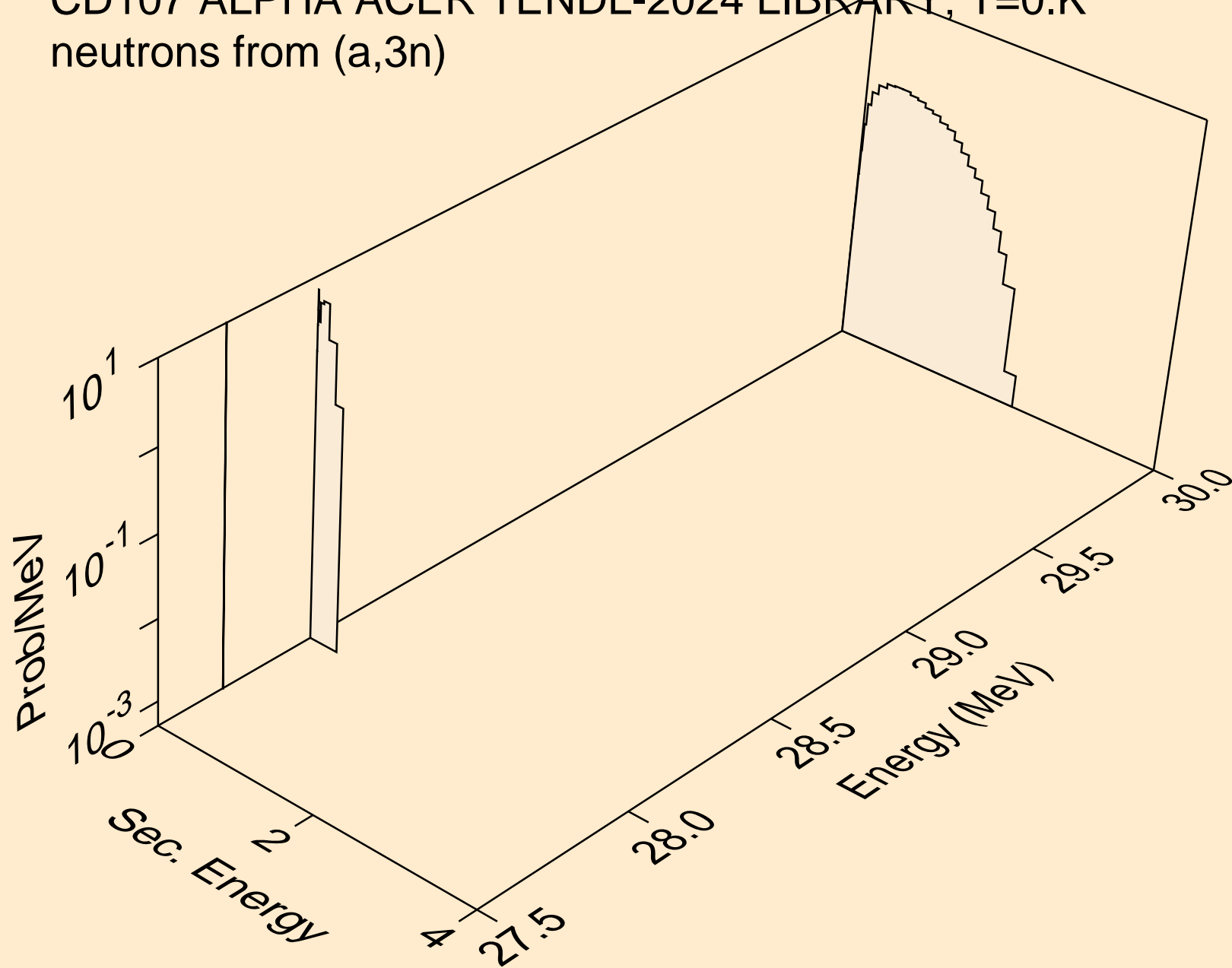

CD107 ALPHA ACER TENDL-2024 LIBRARY; T=0.K  
neutrons from (a,n\*)a

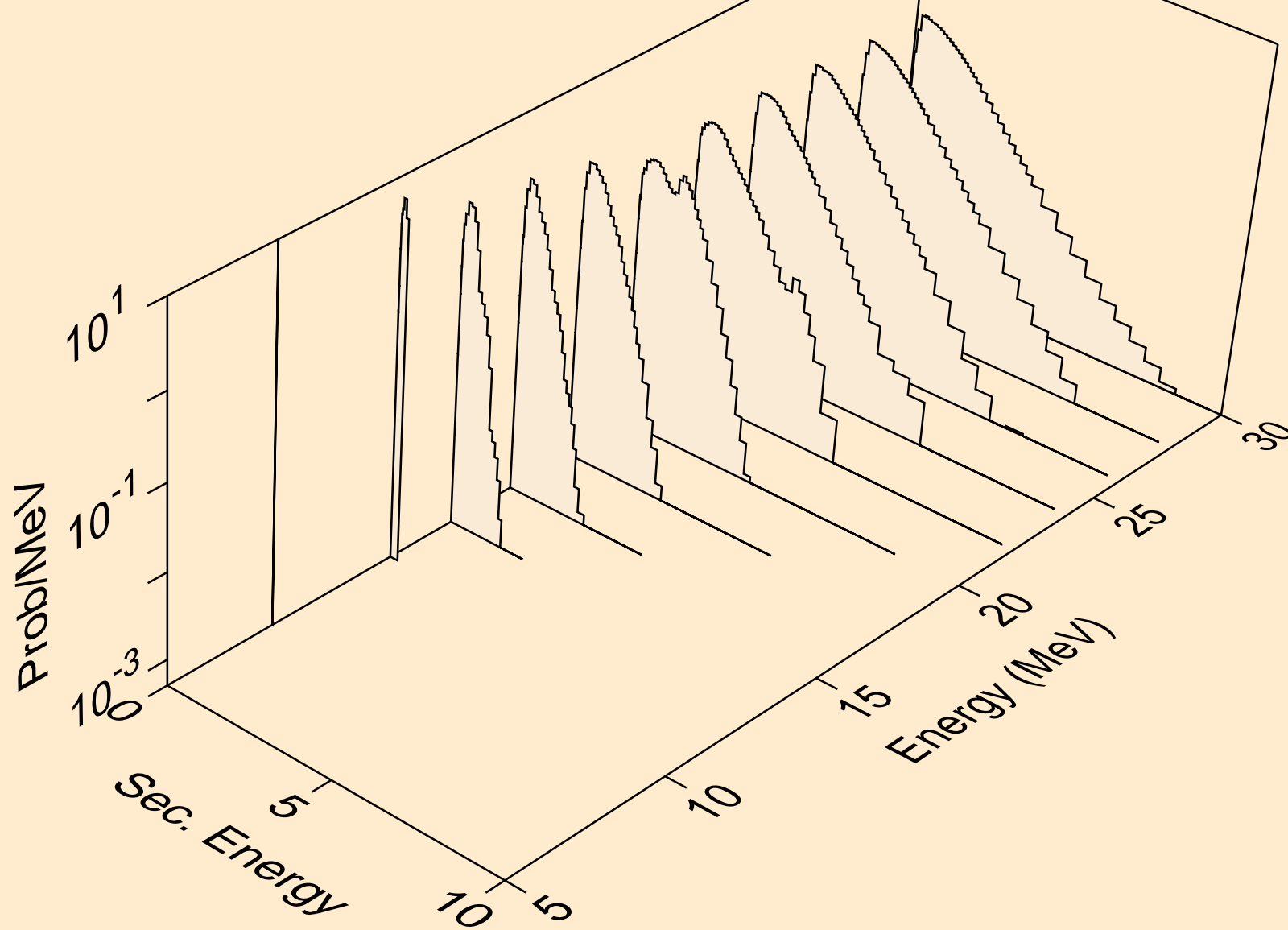

CD107 ALPHA ACER TENDL-2024 LIBRARY; T=0.K  
neutrons from (a,2n)a

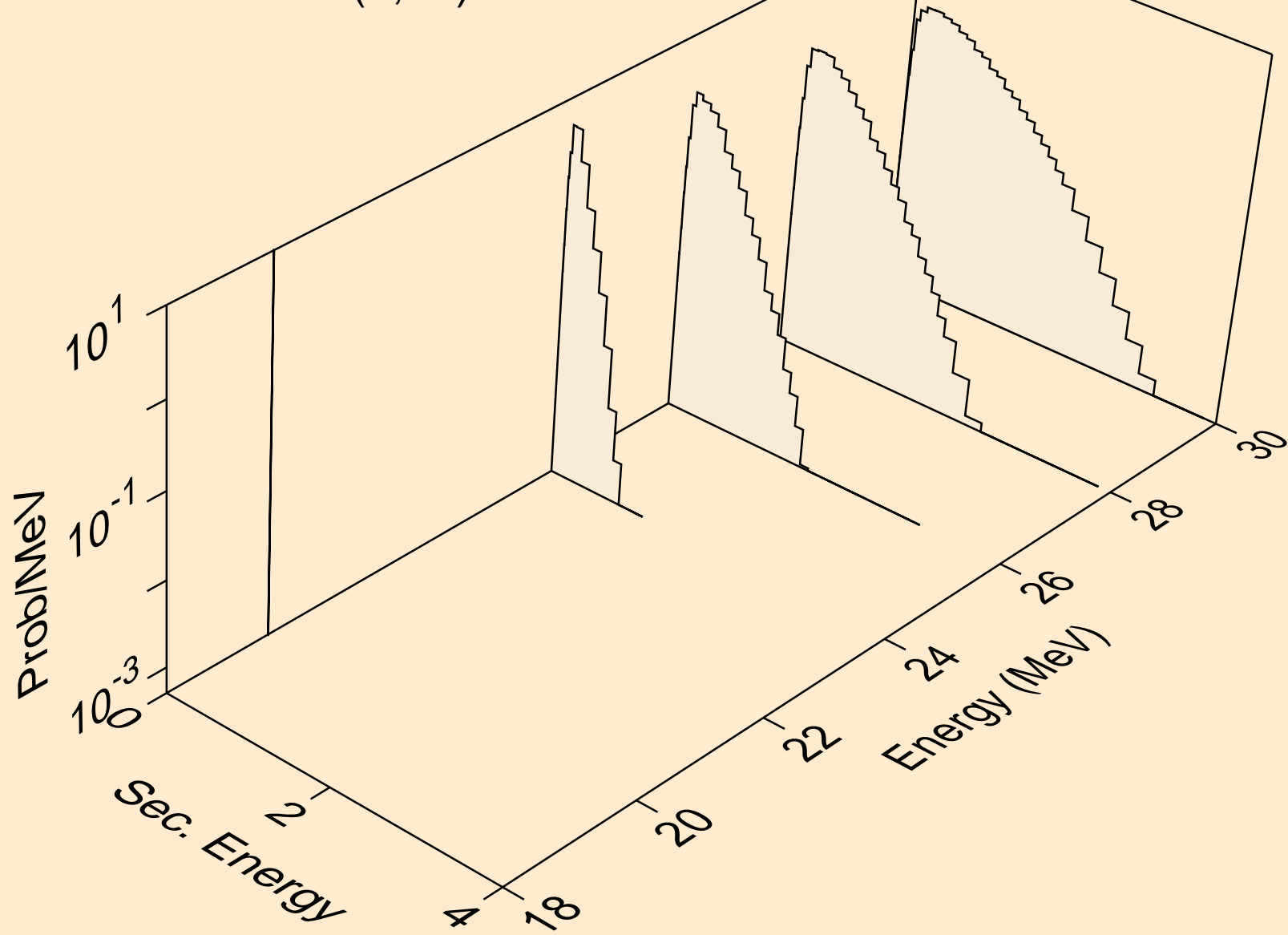

CD107 ALPHA ACER TENDL-2024 LIBRARY; T=0.K  
neutrons from (a,n\*)p

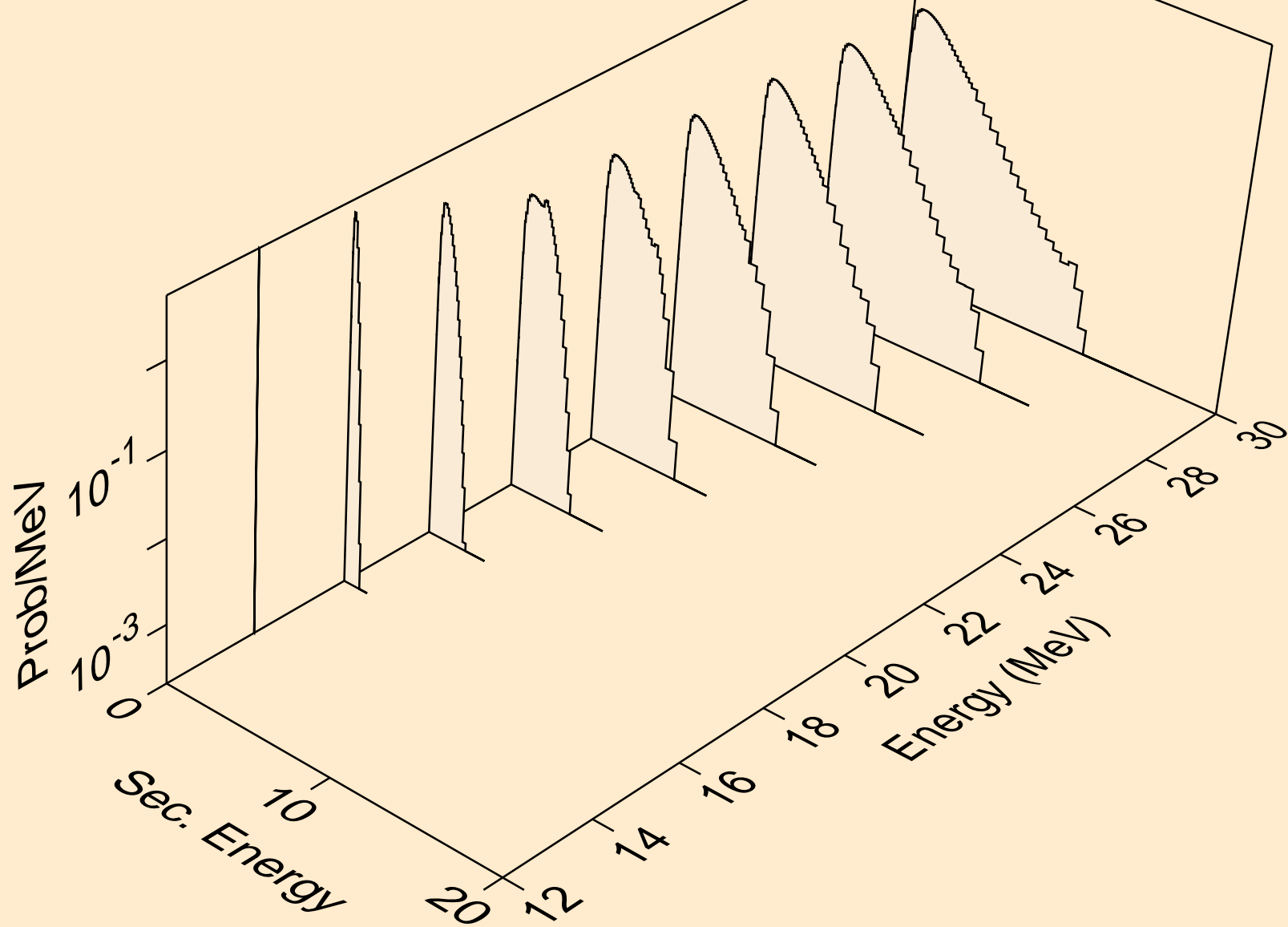

CD107 ALPHA ACER TENDL-2024 LIBRARY; T=0.K  
neutrons from (a,n\*)2a

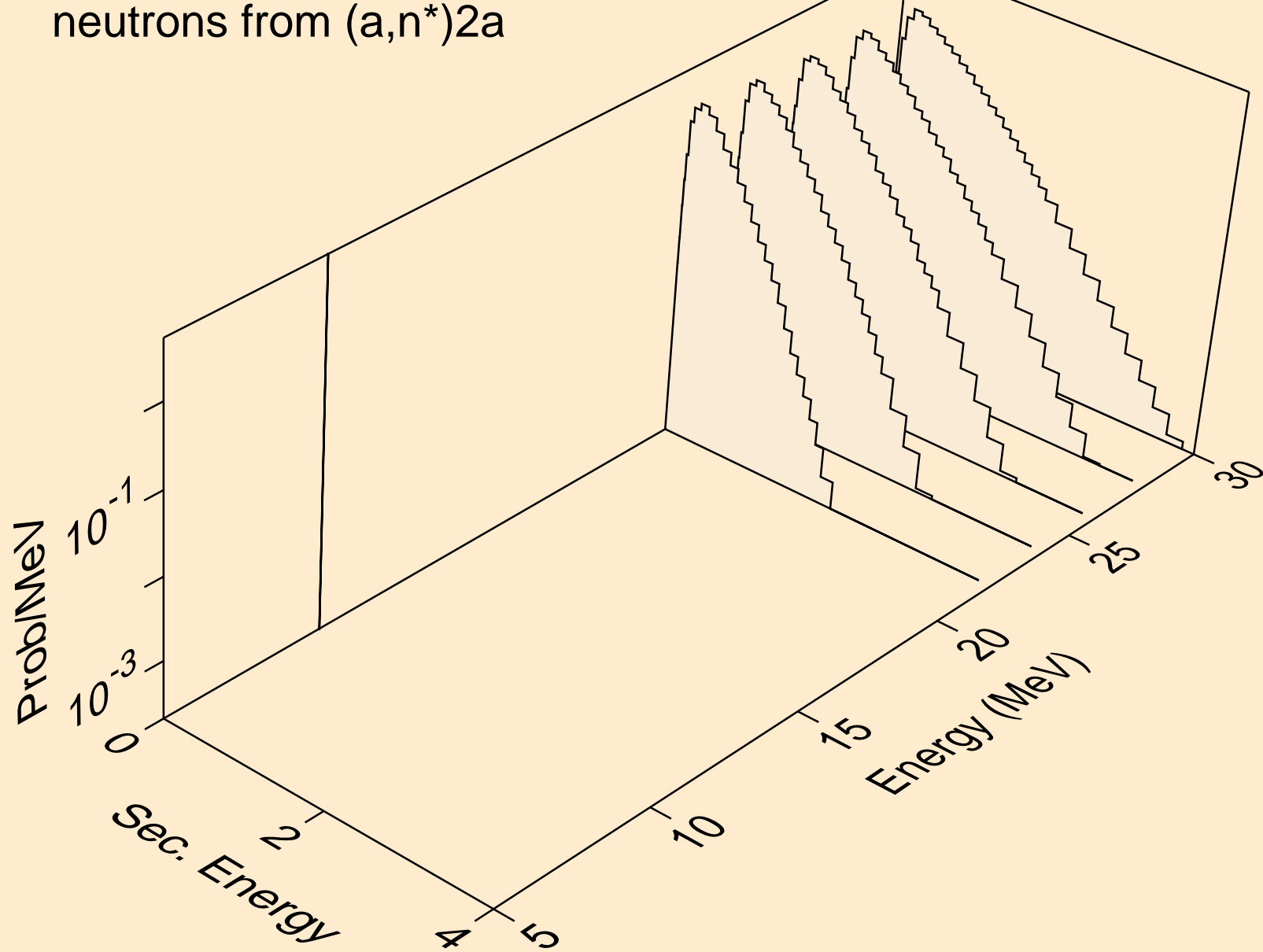

CD107 ALPHA ACER TENDL-2024 LIBRARY; T=0.K  
neutrons from (a,n\*)d

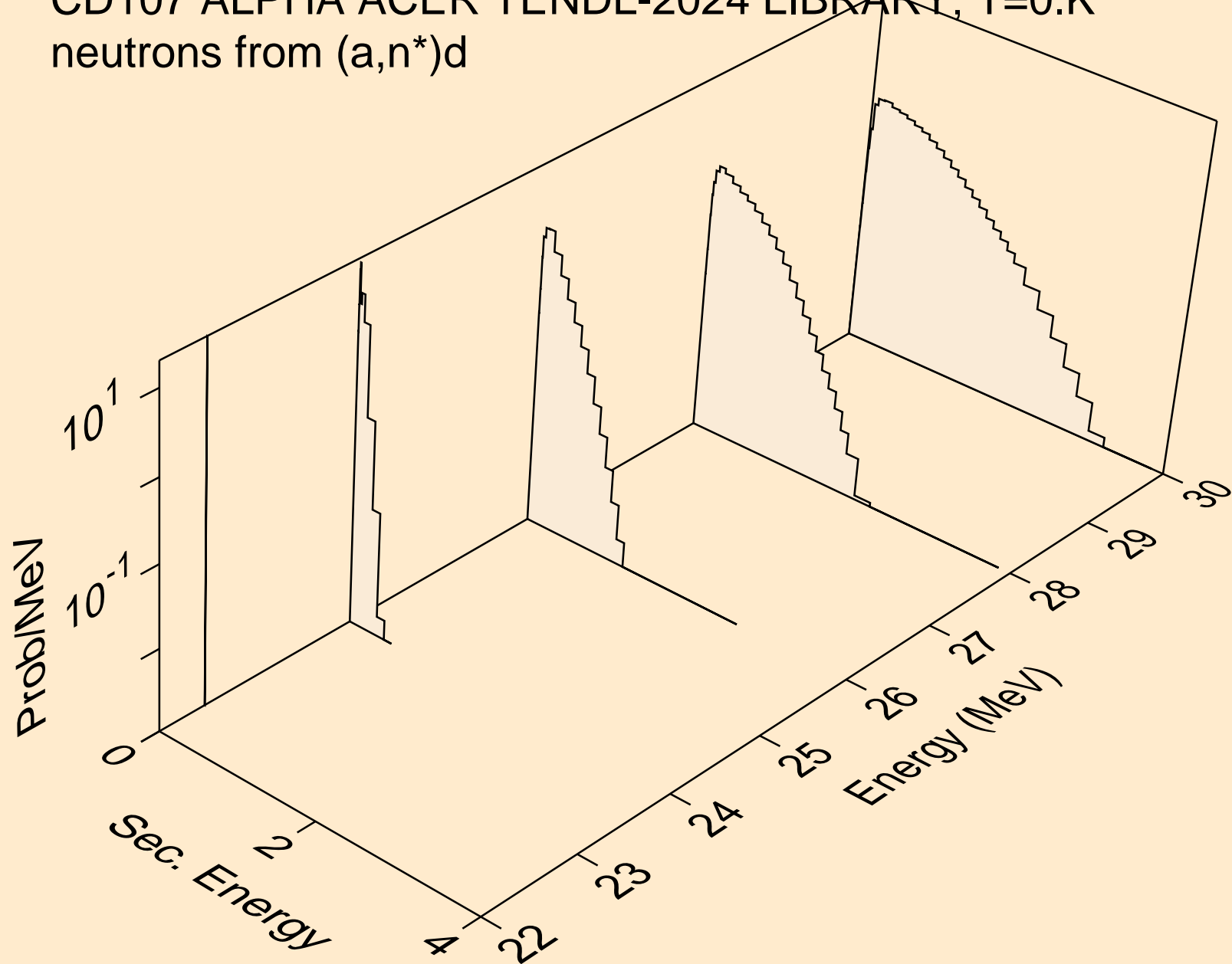

CD107 ALPHA ACER TENDL-2024 LIBRARY; T=0.K  
neutrons from (a,n\*)t

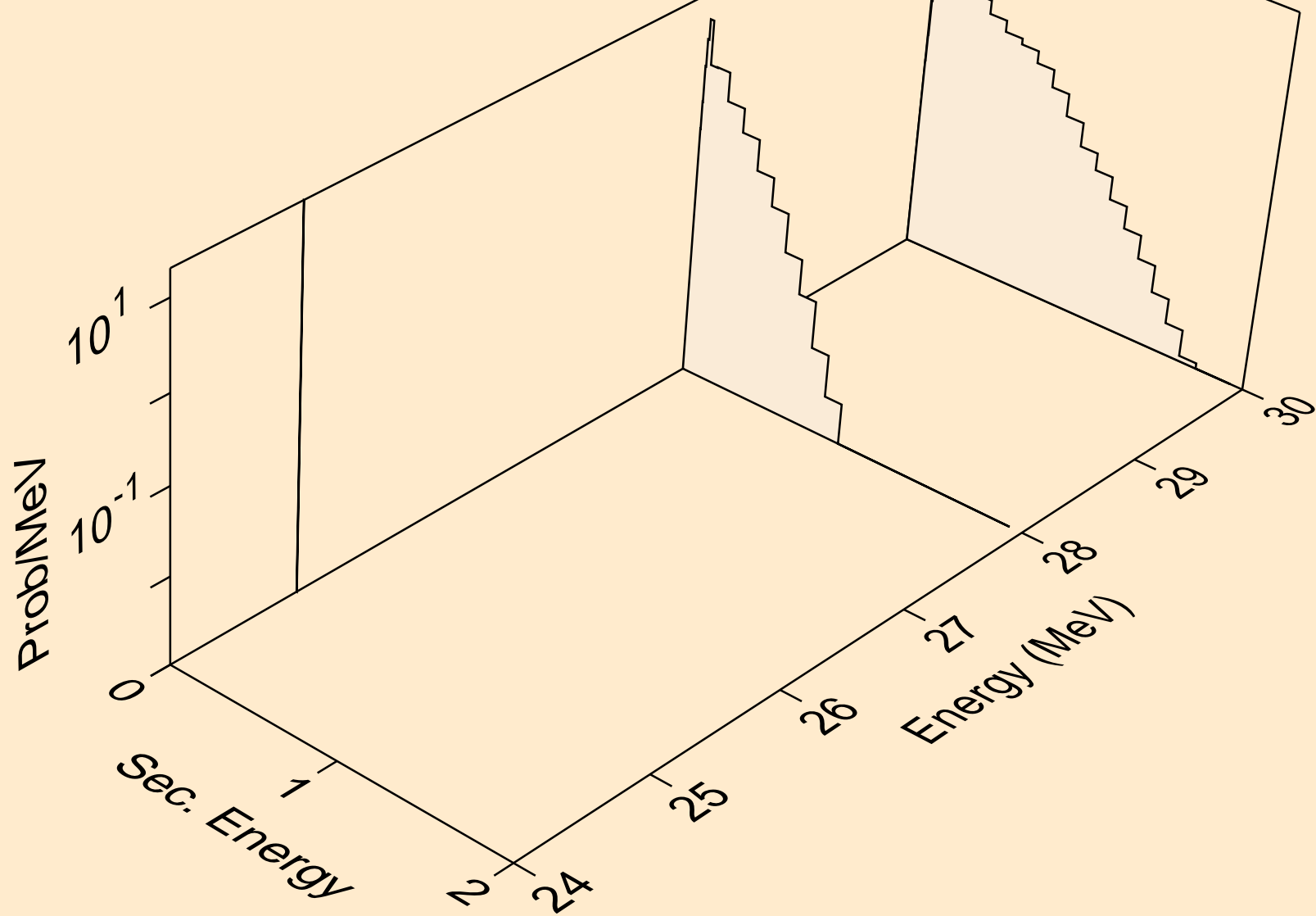

CD107 ALPHA ACER TENDL-2024 LIBRARY; T=0.K  
neutrons from (a,n\*)he3

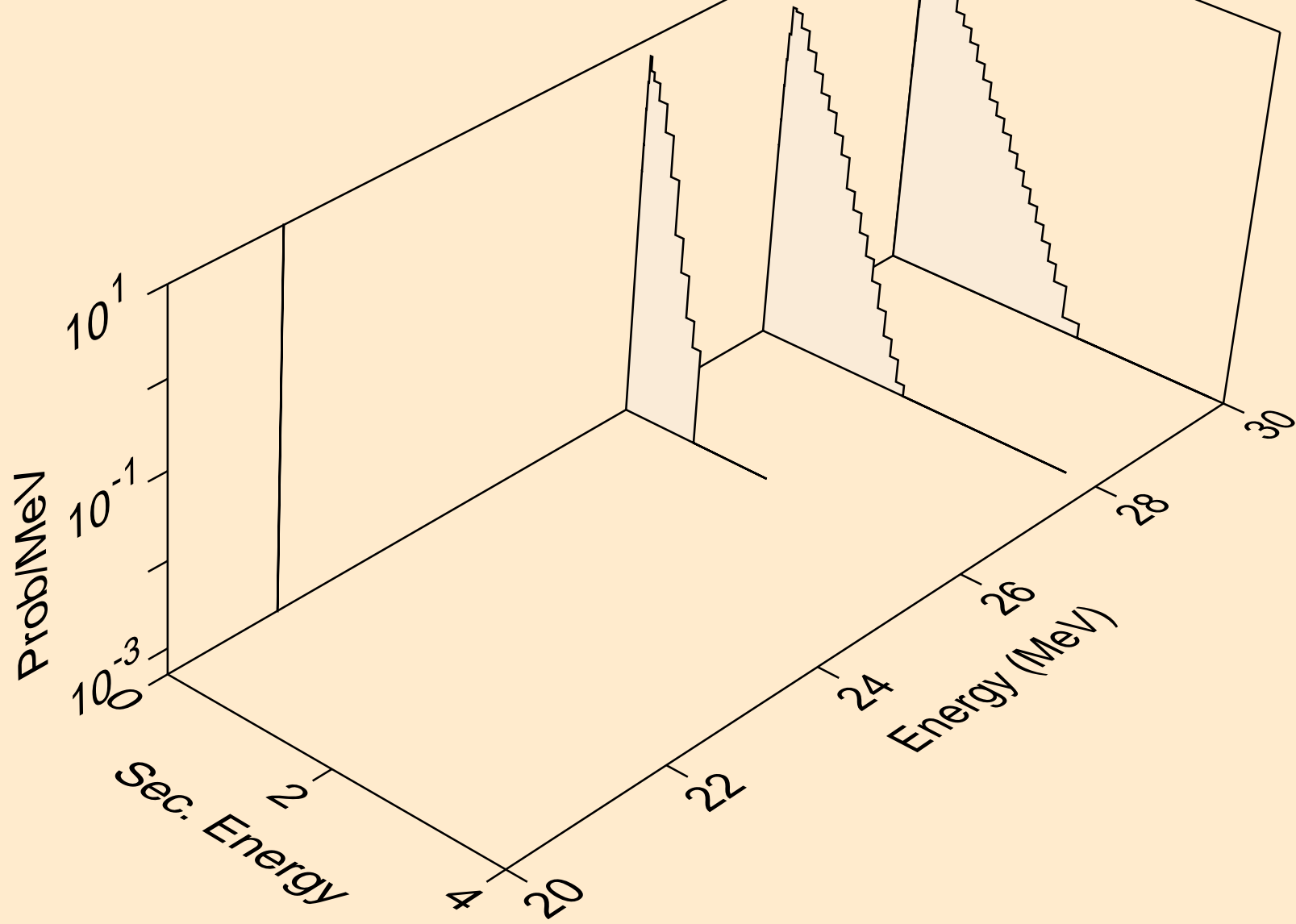

CD107 ALPHA ACER TENDL-2024 LIBRARY; T=0.K  
neutrons from (a,2np)

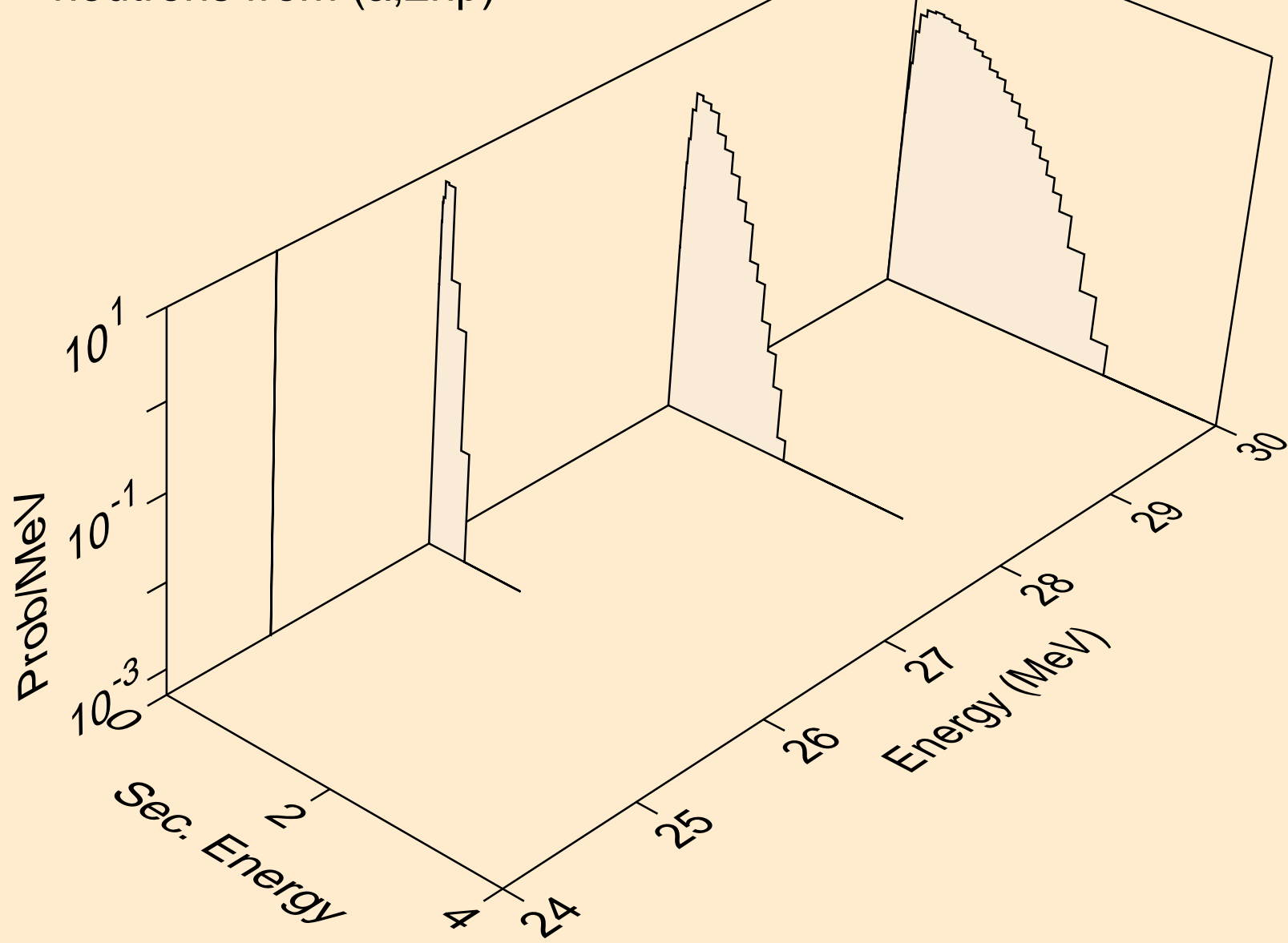

CD107 ALPHA ACER TENDL-2024 LIBRARY; T=0.K  
neutrons from (a,n2p)

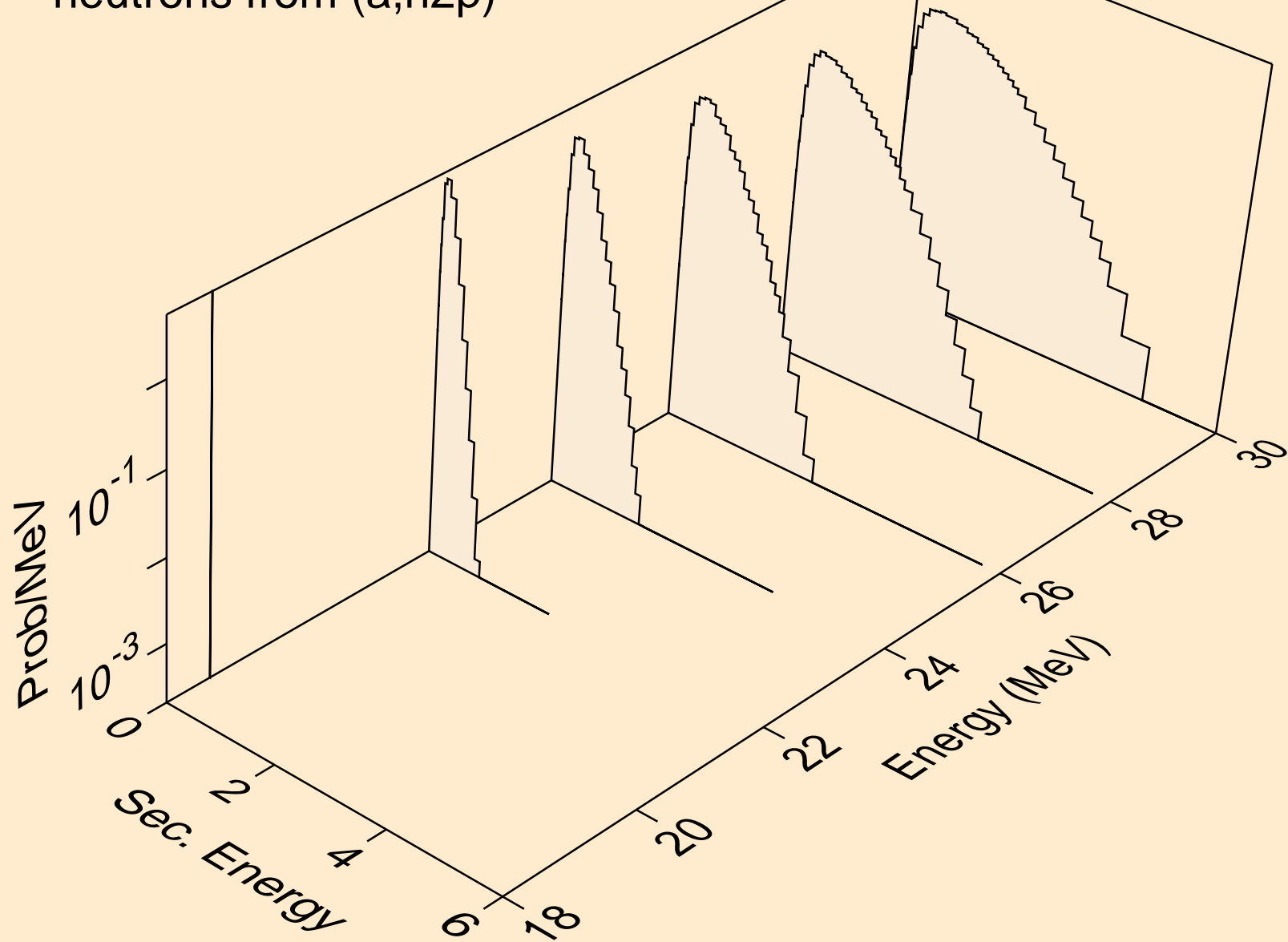

CD107 ALPHA ACER TENDL-2024 LIBRARY; T=0.K  
neutrons from (a,npa)

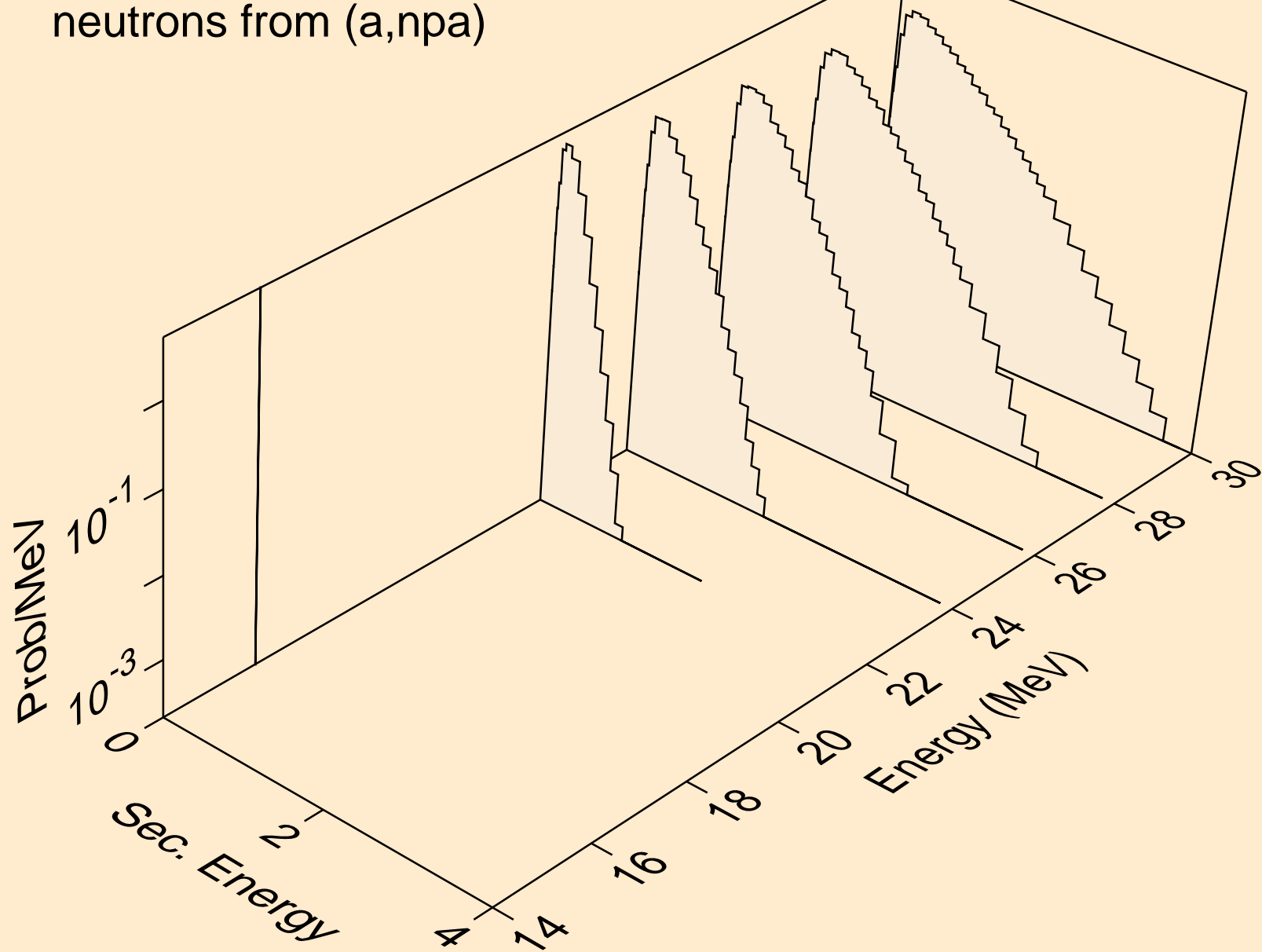

CD107 ALPHA ACER TENDL-2024 LIBRARY; T=0.K  
protons from (a,x)

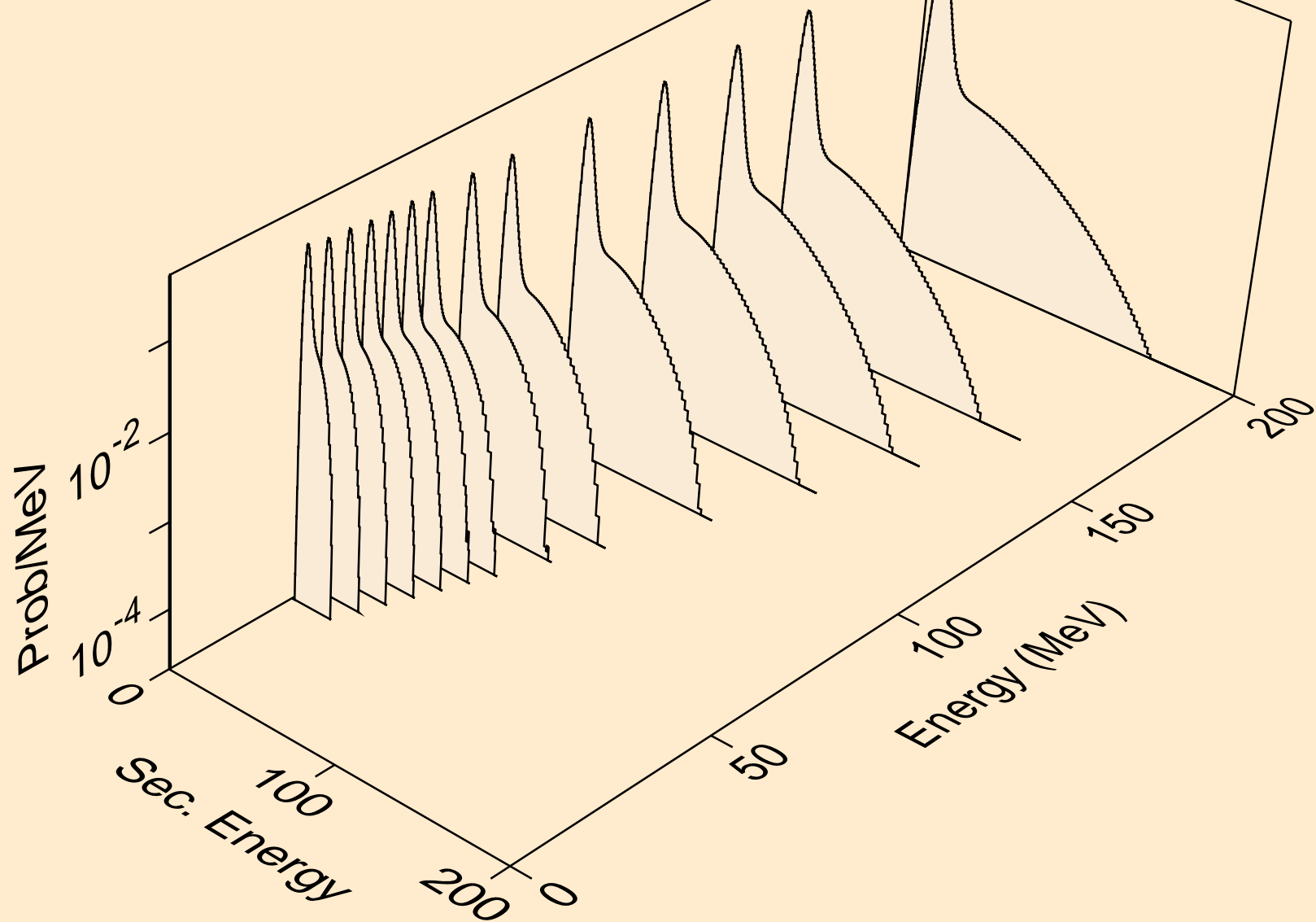

CD107 ALPHA ACER TENDL-2024 LIBRARY; T=0.K  
protons from (a,n\*)p

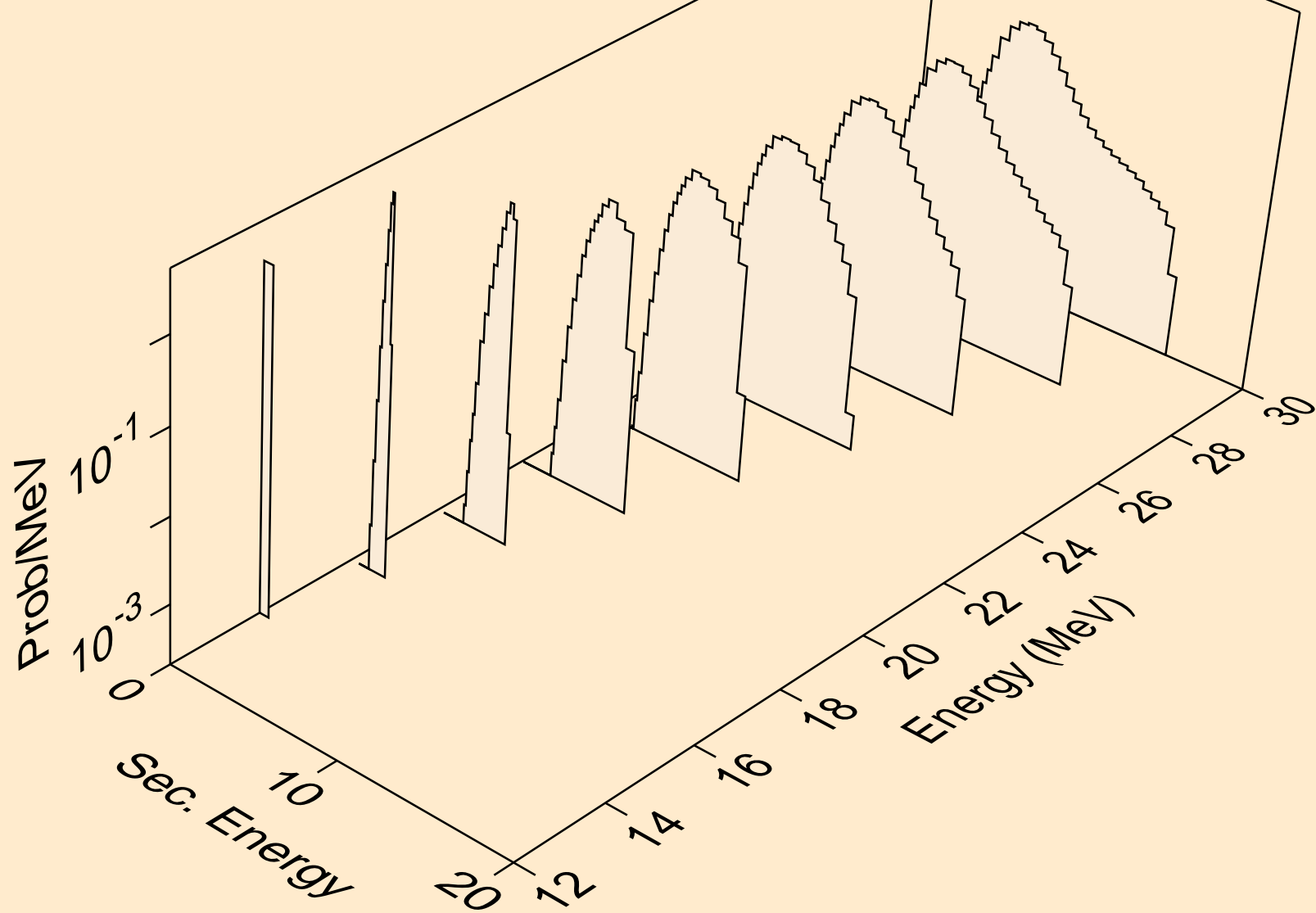

CD107 ALPHA ACER TENDL-2024 LIBRARY; T=0.K  
protons from (a,2np)

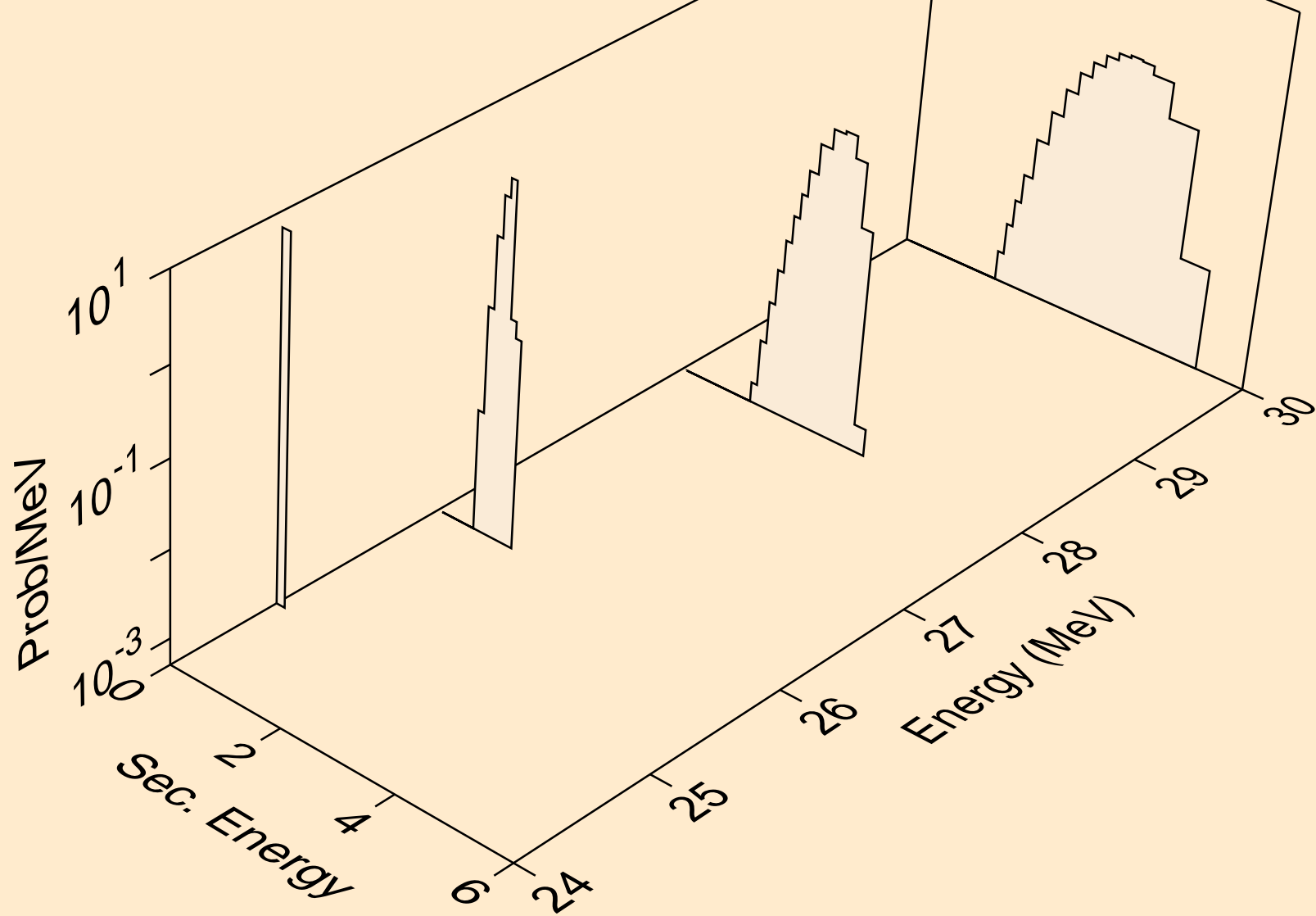

CD107 ALPHA ACER TENDL-2024 LIBRARY; T=0.K  
protons from (a,n2p)

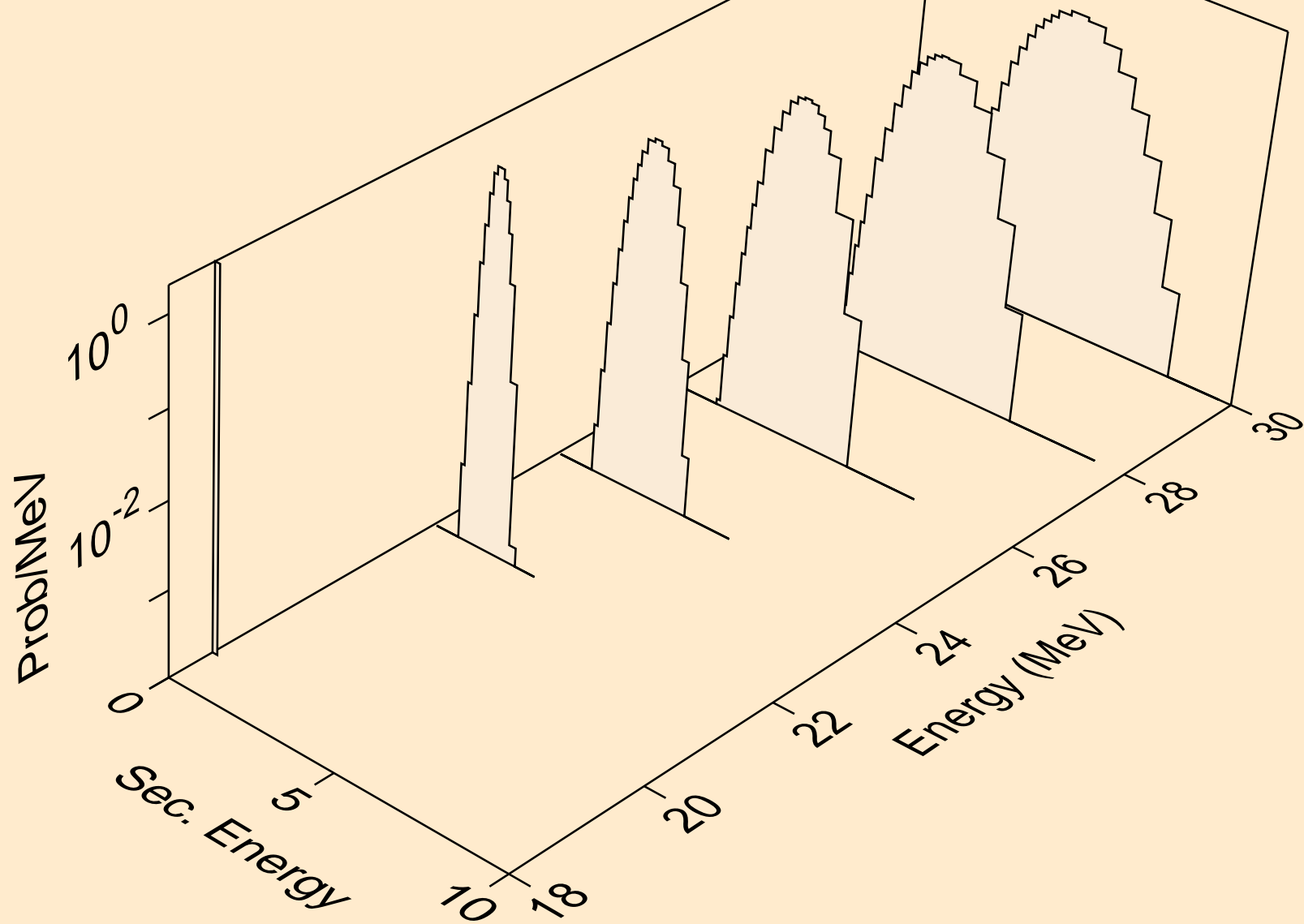

CD107 ALPHA ACER TENDL-2024 LIBRARY; T=0.K  
protons from (a,npa)

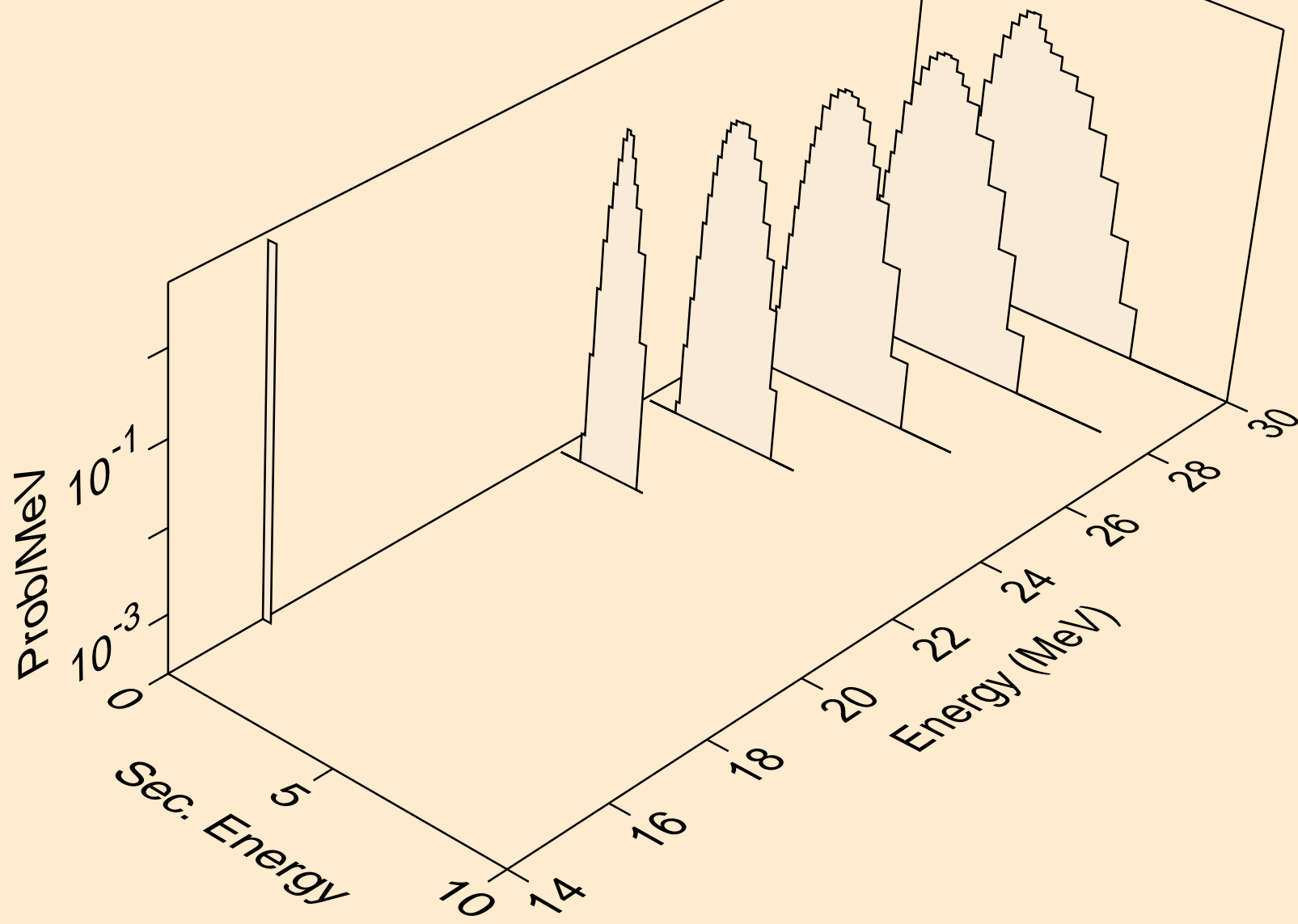

CD107 ALPHA ACER TENDL-2024 LIBRARY; T=0.K  
protons from (a,p)

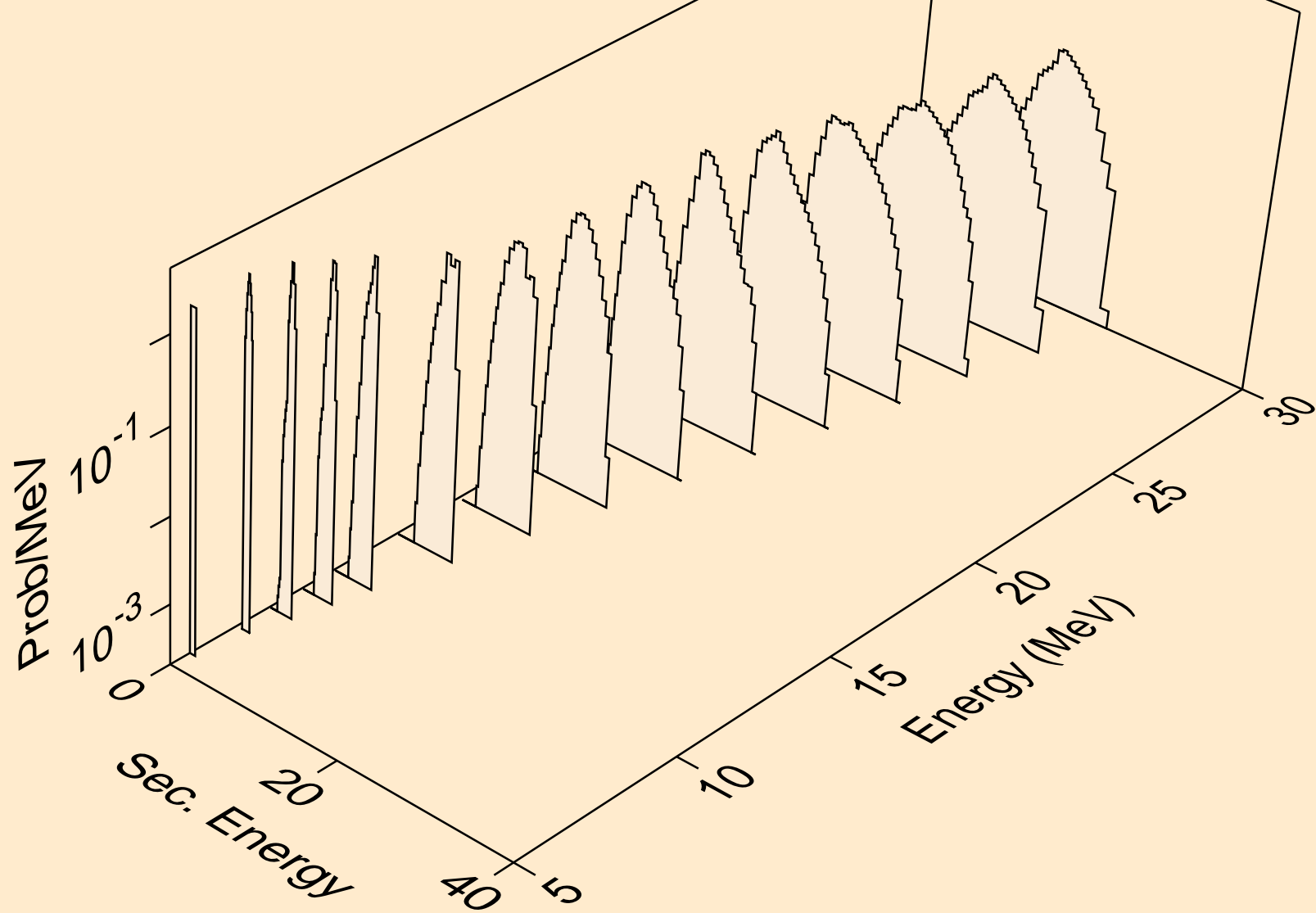

CD107 ALPHA ACER TENDL-2024 LIBRARY; T=0.K  
protons from (a,2p)

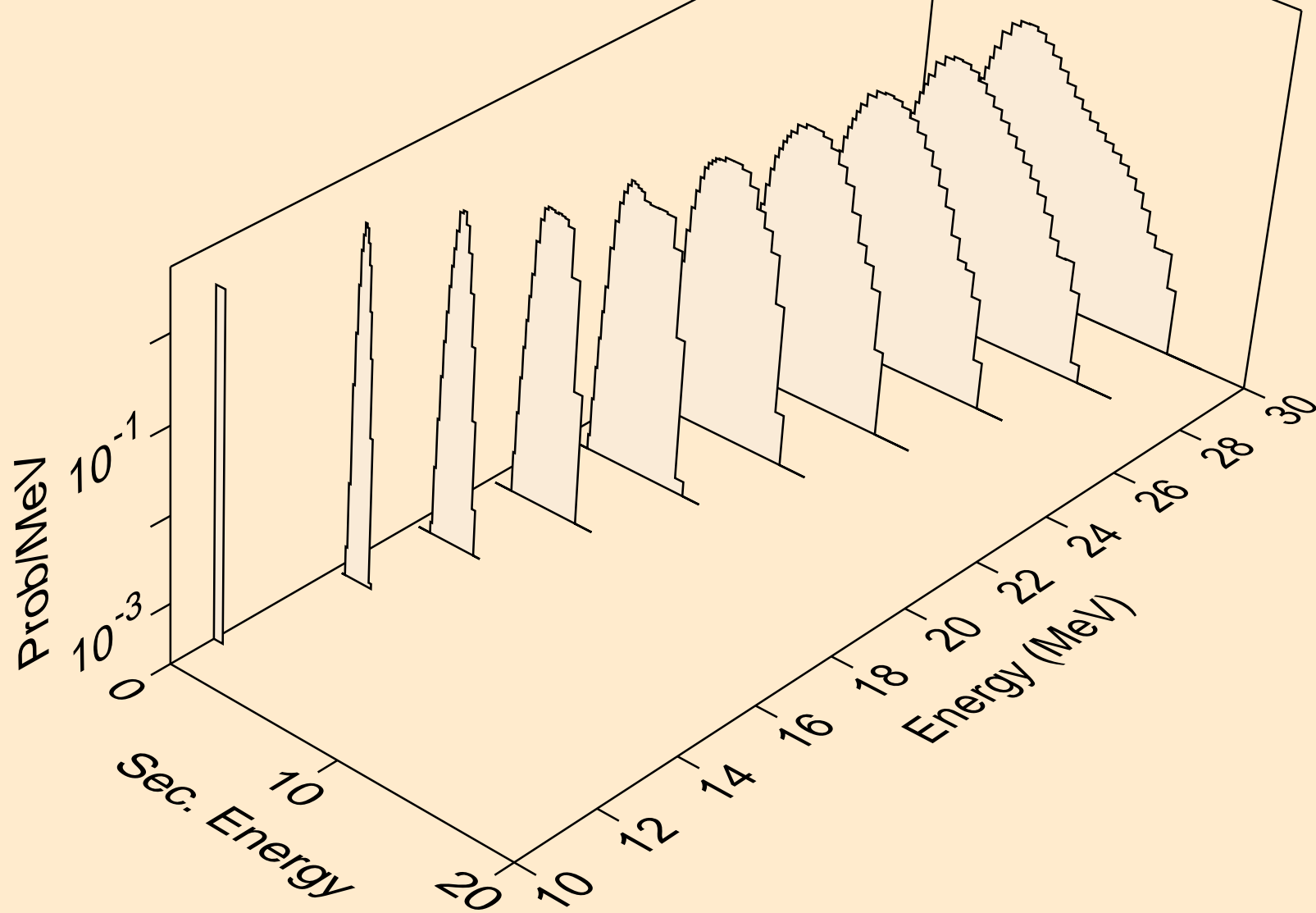

CD107 ALPHA ACER TENDL-2024 LIBRARY; T=0.K  
protons from (a,pa)

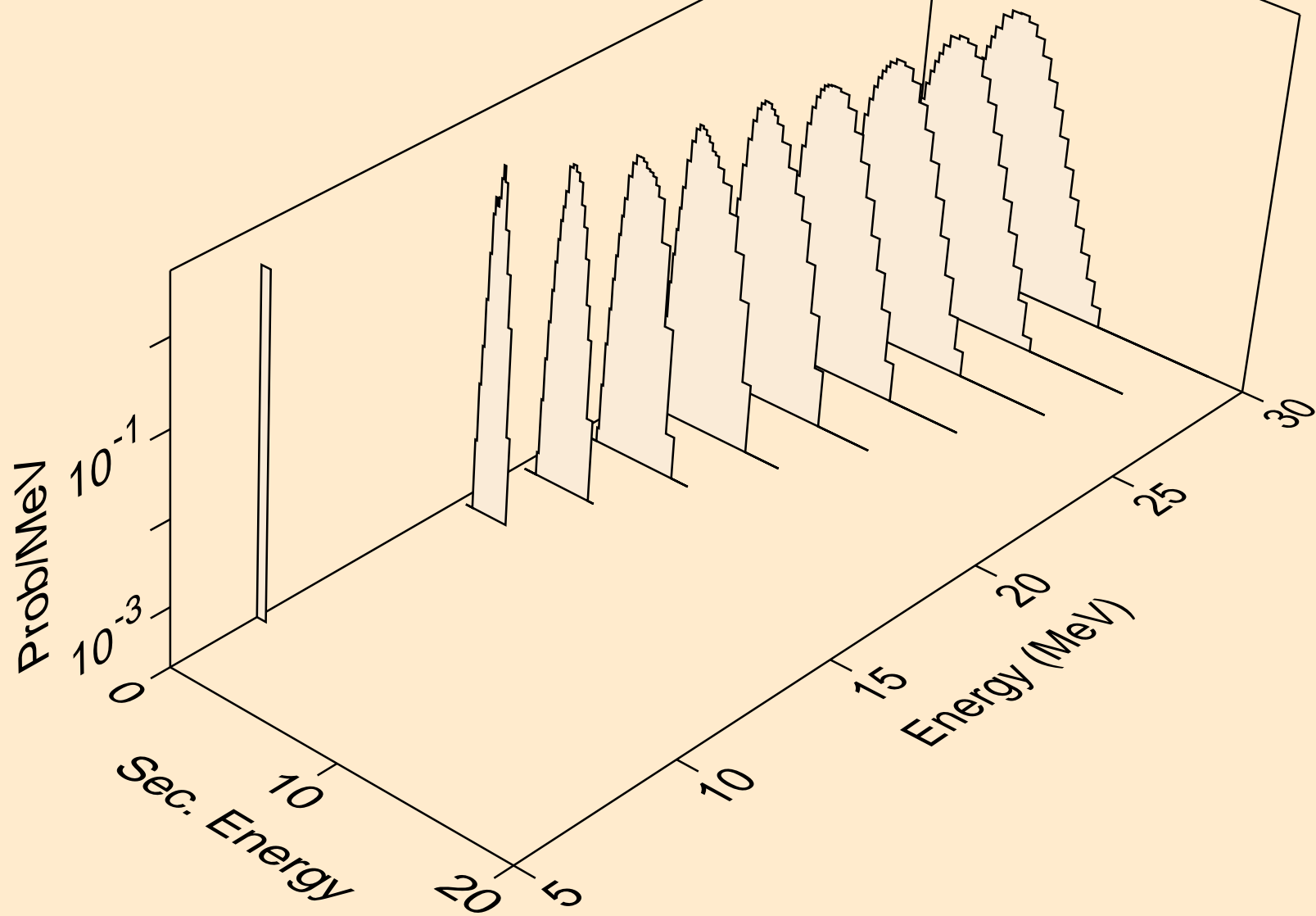

CD107 ALPHA ACER TENDL-2024 LIBRARY; T=0.K  
protons from (a,pd)

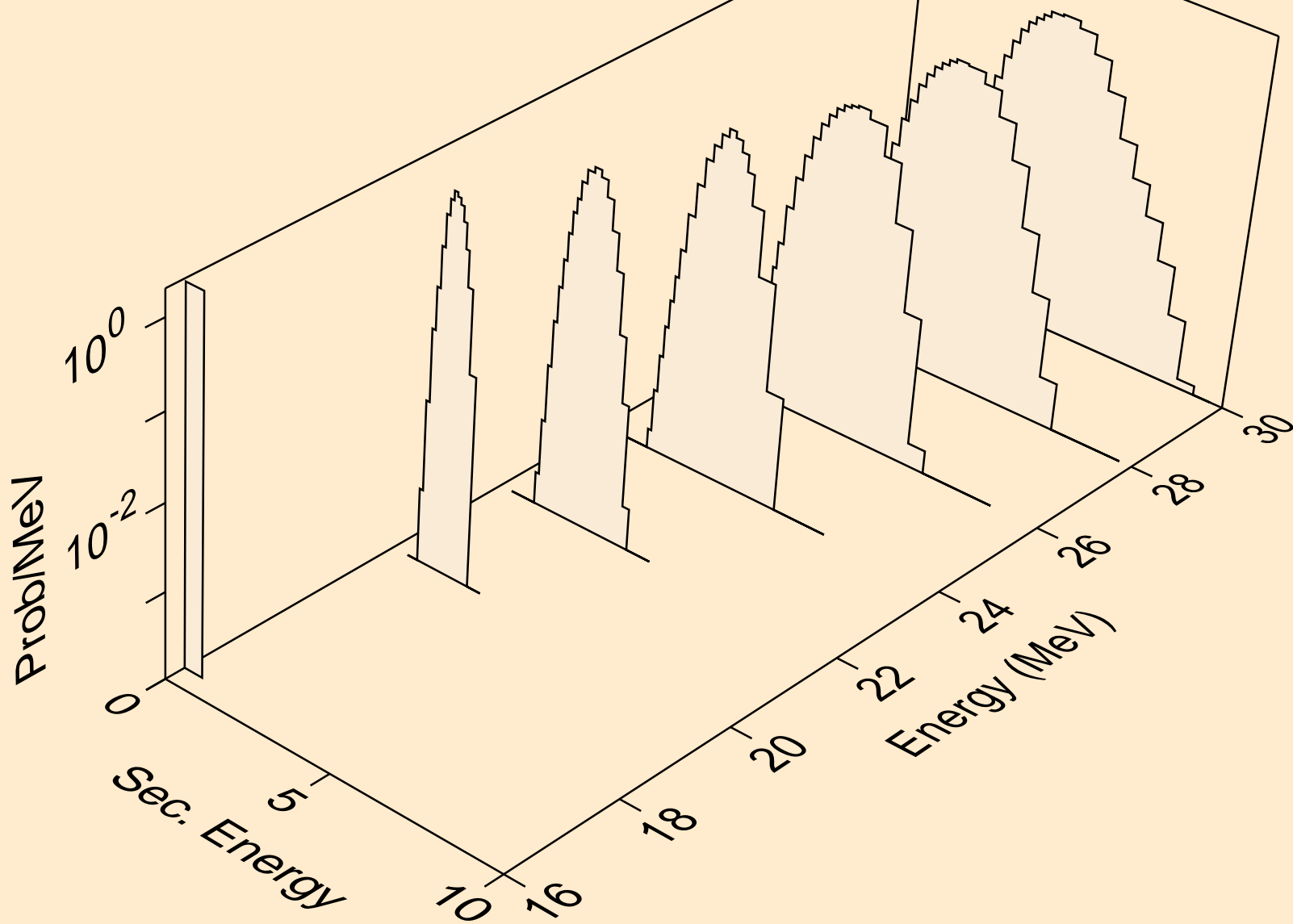

CD107 ALPHA ACER TENDL-2024 LIBRARY; T=0.K  
protons from (a,pt)

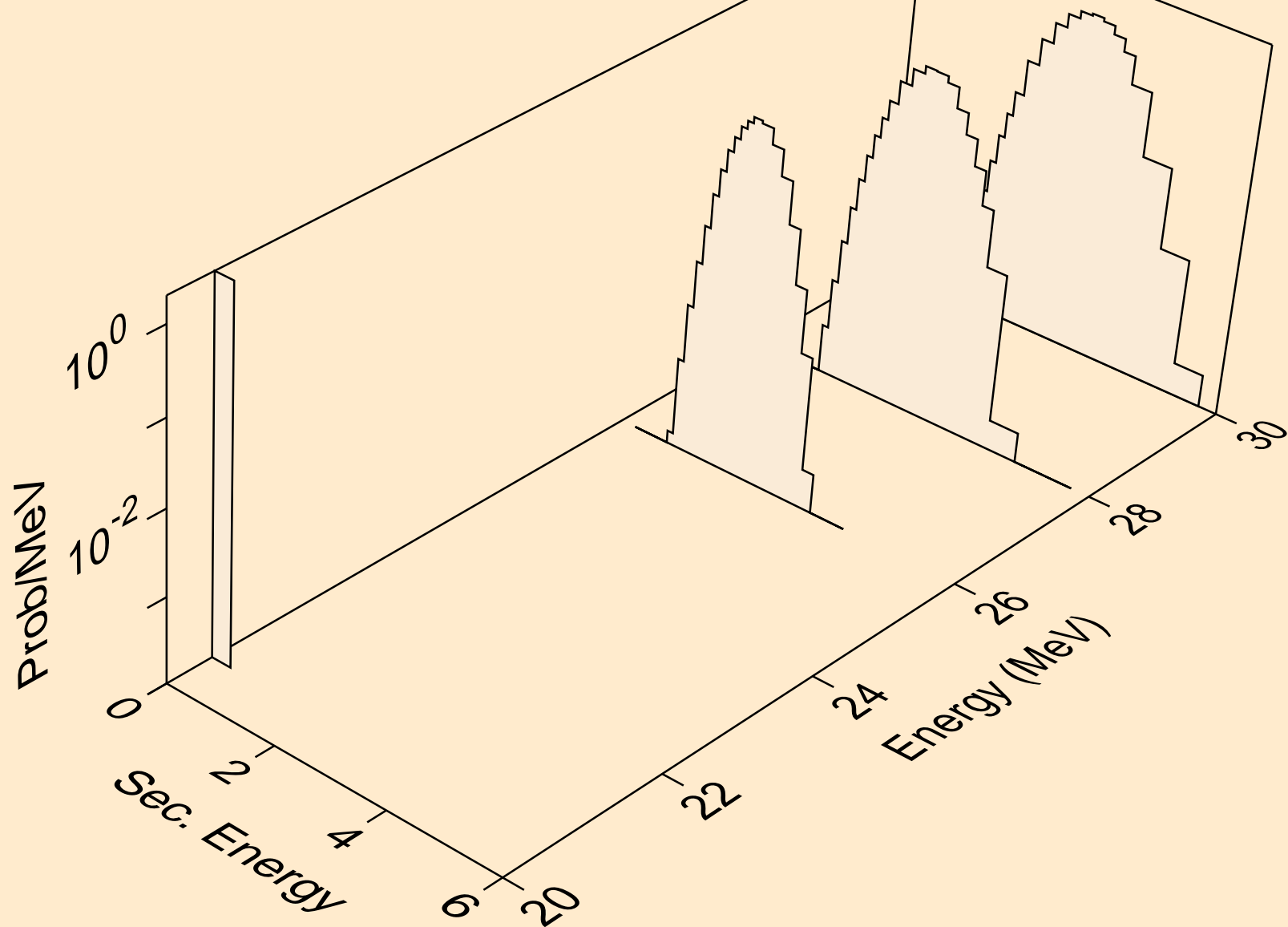

CD107 ALPHA ACER TENDL-2024 LIBRARY; T=0.K  
deuterons from (a,x)

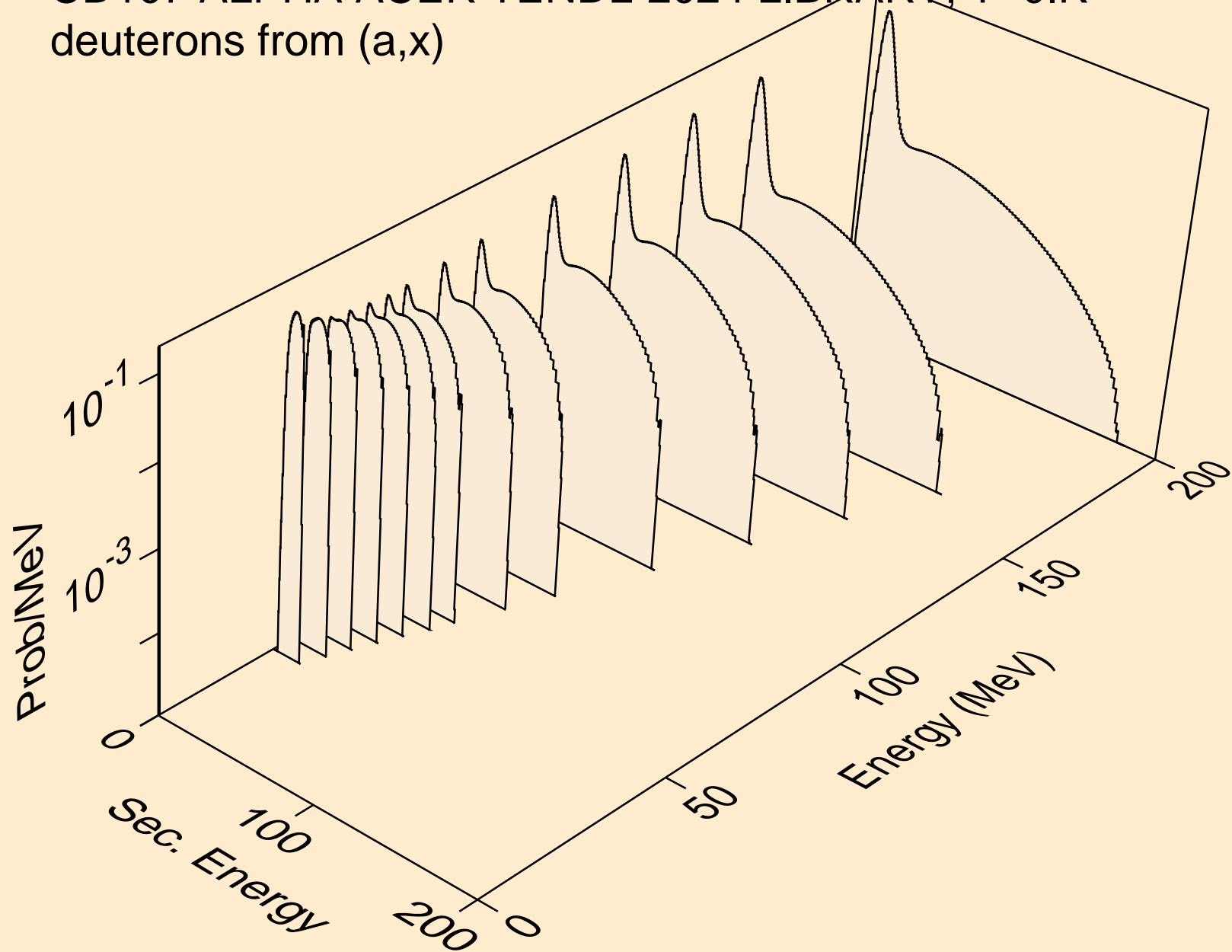

CD107 ALPHA ACER TENDL-2024 LIBRARY; T=0.K  
deuterons from (a,n\*)d

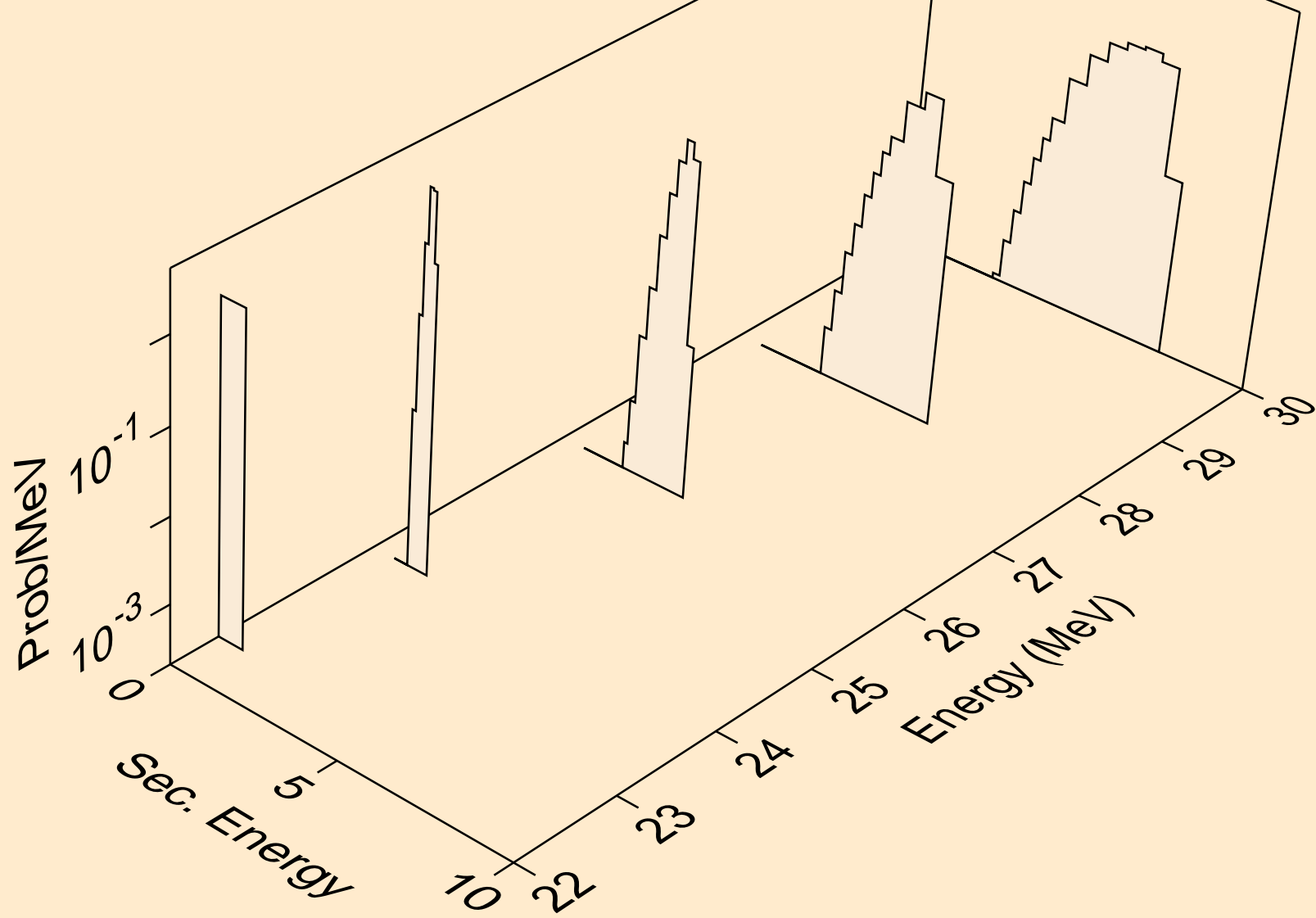

CD107 ALPHA ACER TENDL-2024 LIBRARY; T=0.K  
deuterons from (a,d)

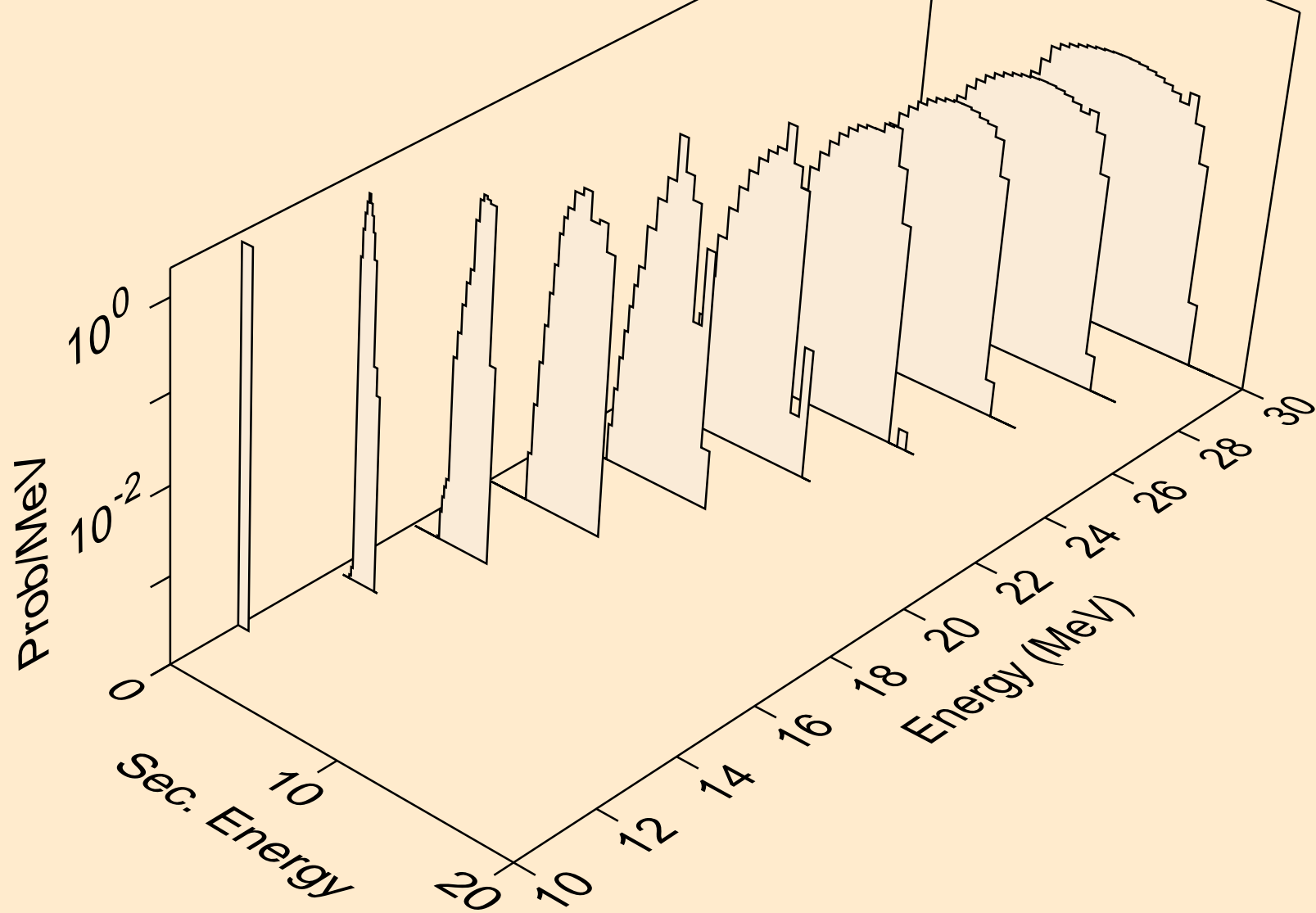

CD107 ALPHA ACER TENDL-2024 LIBRARY; T=0.K  
deuterons from (a,pd)

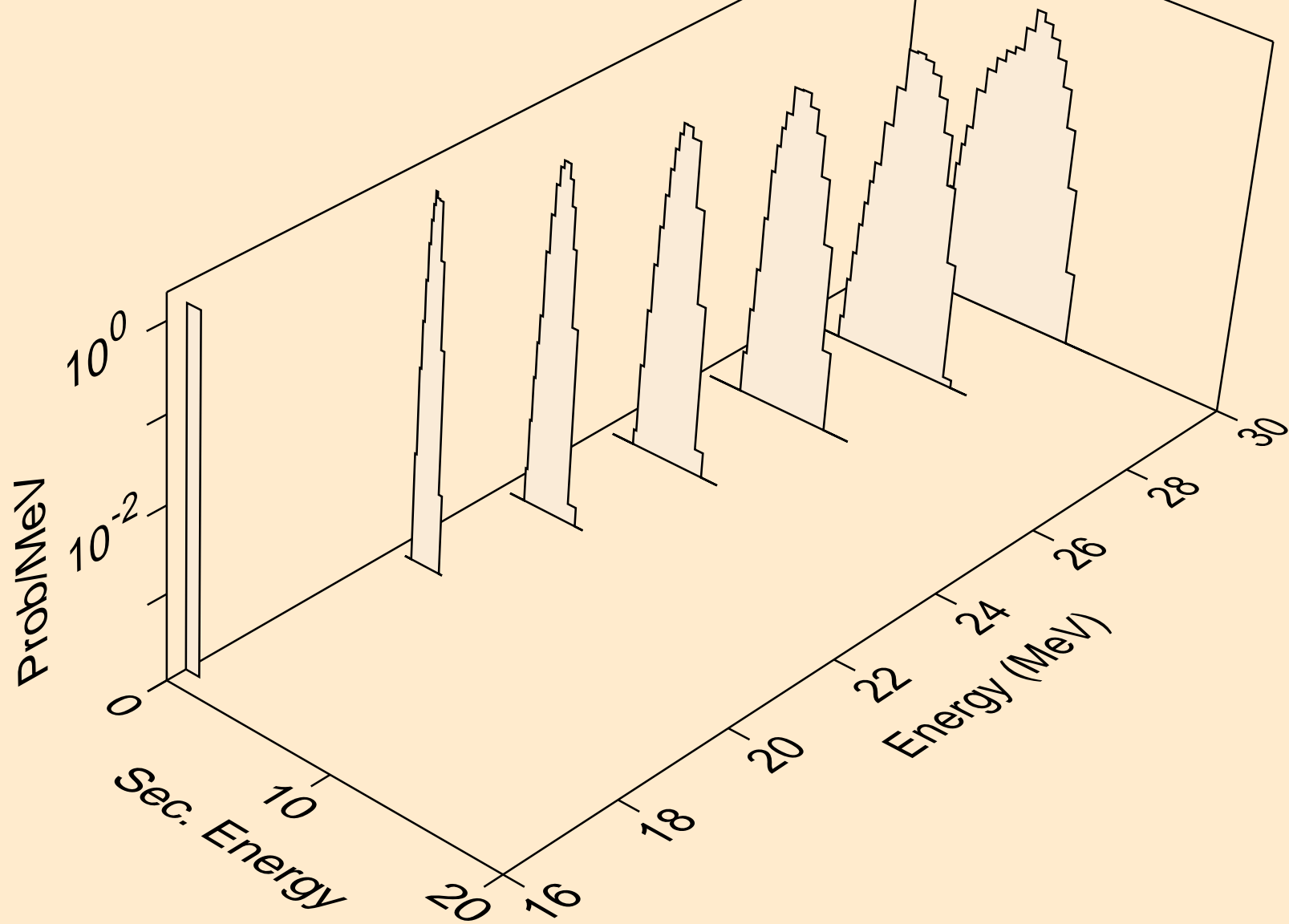

CD107 ALPHA ACER TENDL-2024 LIBRARY; T=0.K  
deuterons from (a,da)

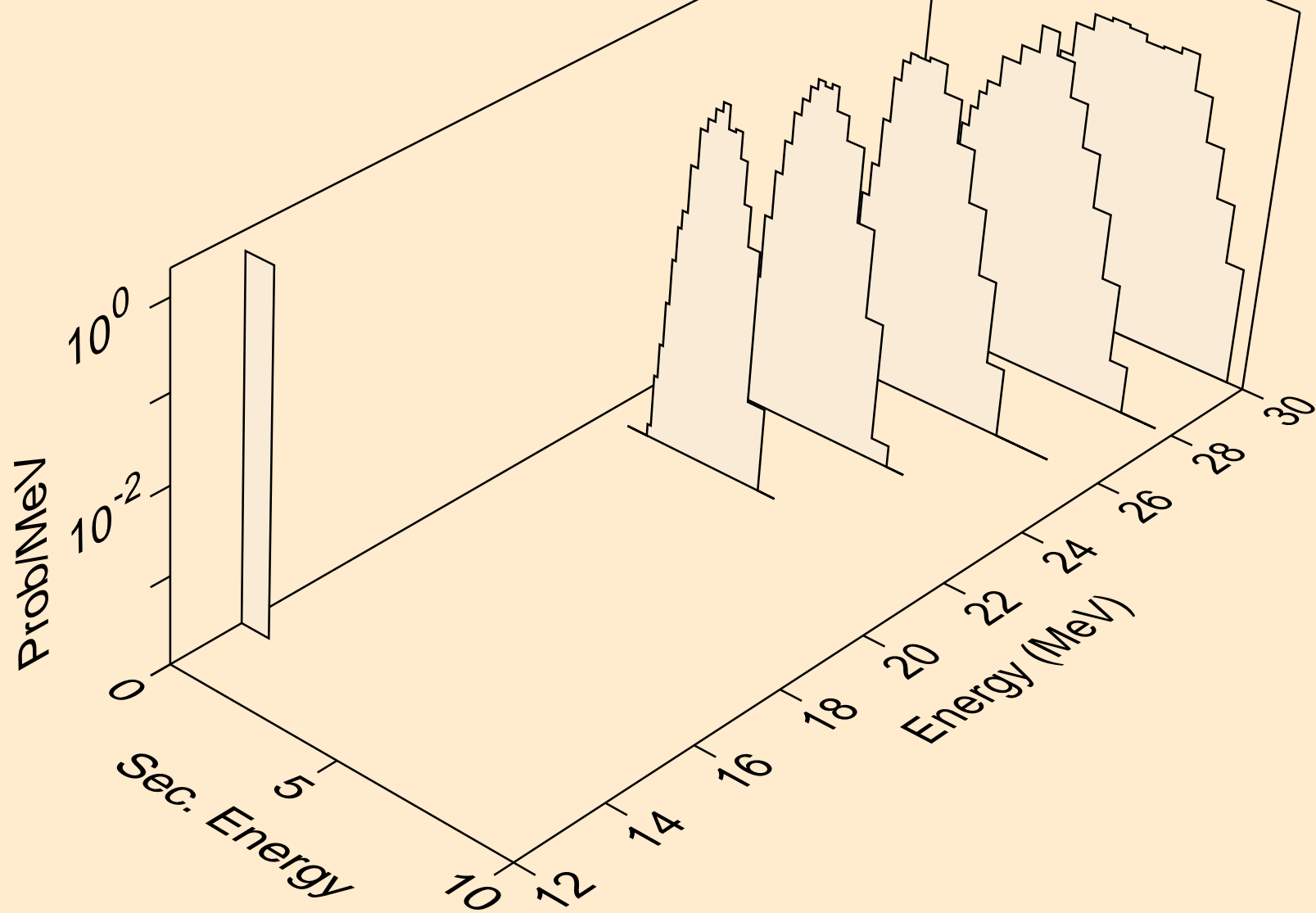

CD107 ALPHA ACER TENDL-2024 LIBRARY; T=0.K  
tritons from (a,x)

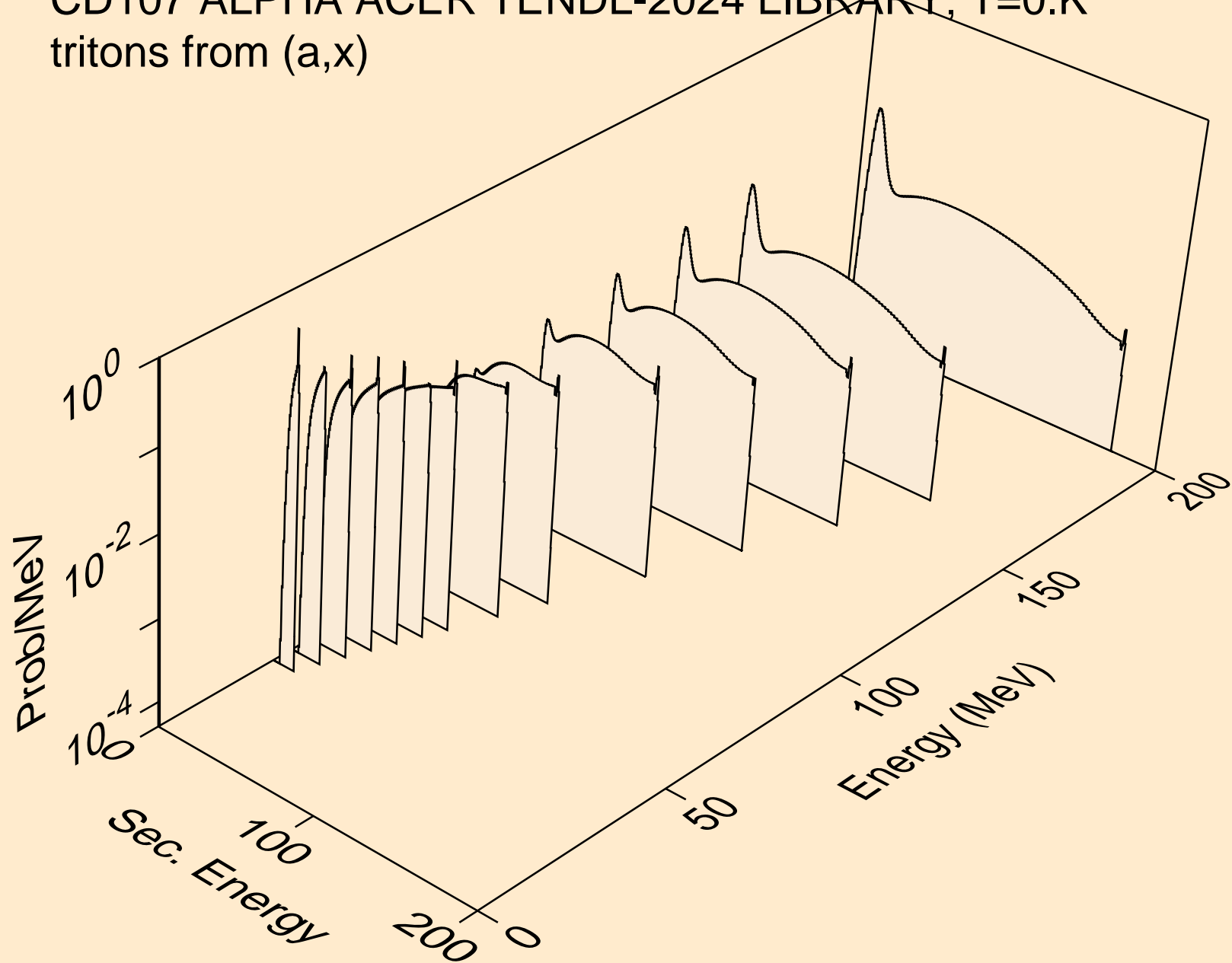

CD107 ALPHA ACER TENDL-2024 LIBRARY; T=0.K  
tritons from (a,n\*)t

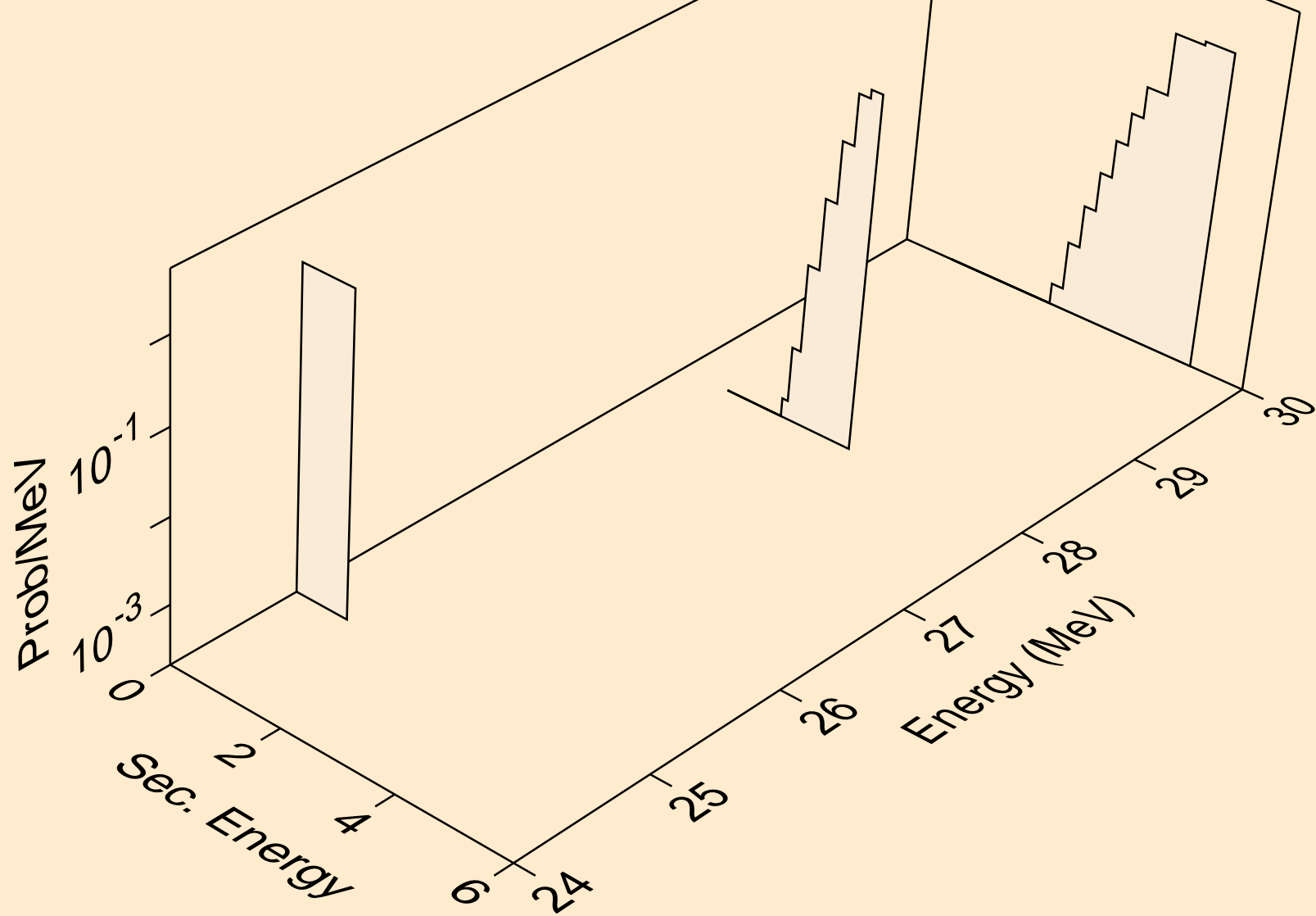

CD107 ALPHA ACER TENDL-2024 LIBRARY; T=0.K  
tritons from (a,t)

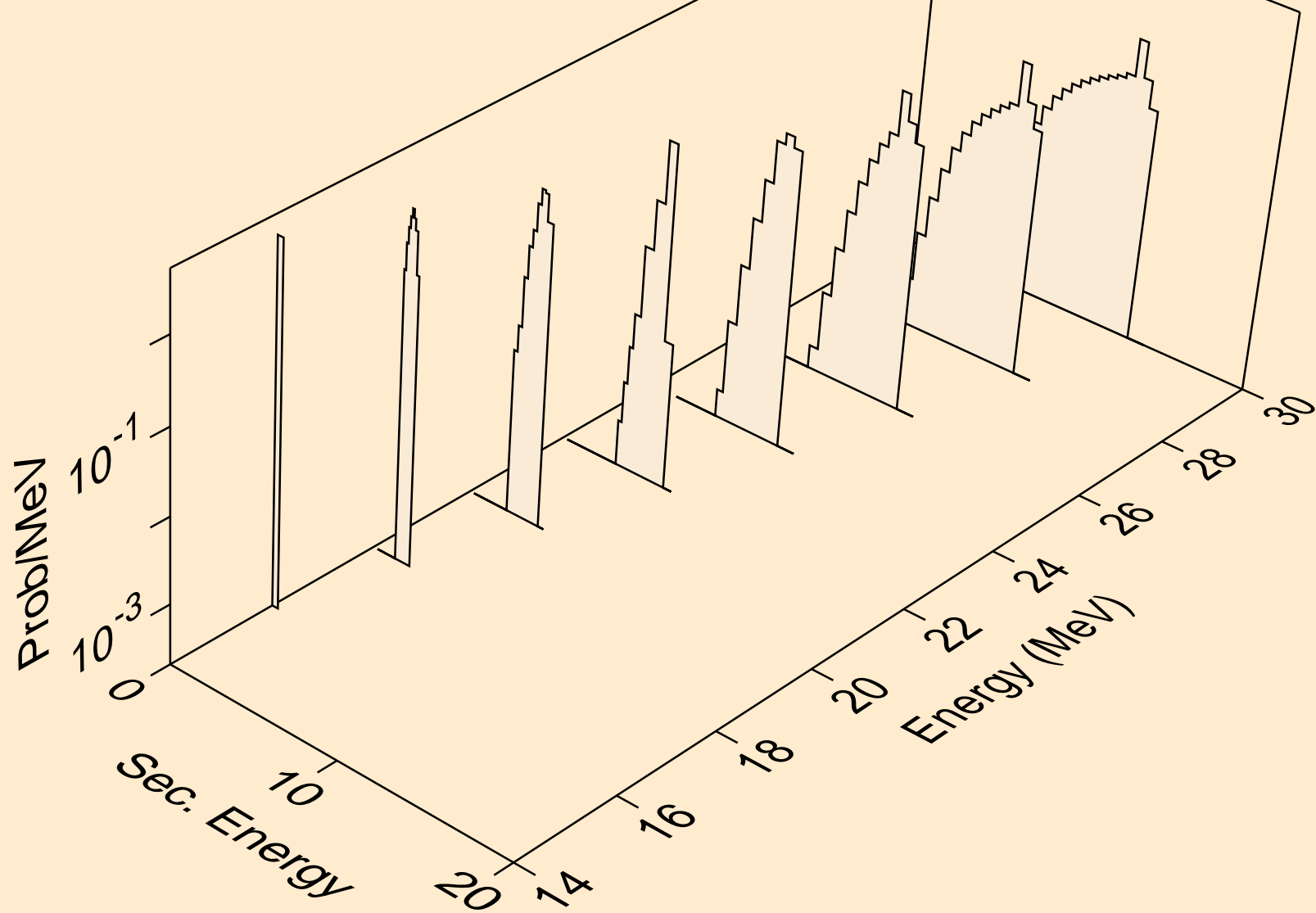

CD107 ALPHA ACER TENDL-2024 LIBRARY; T=0.K  
tritons from (a,pt)

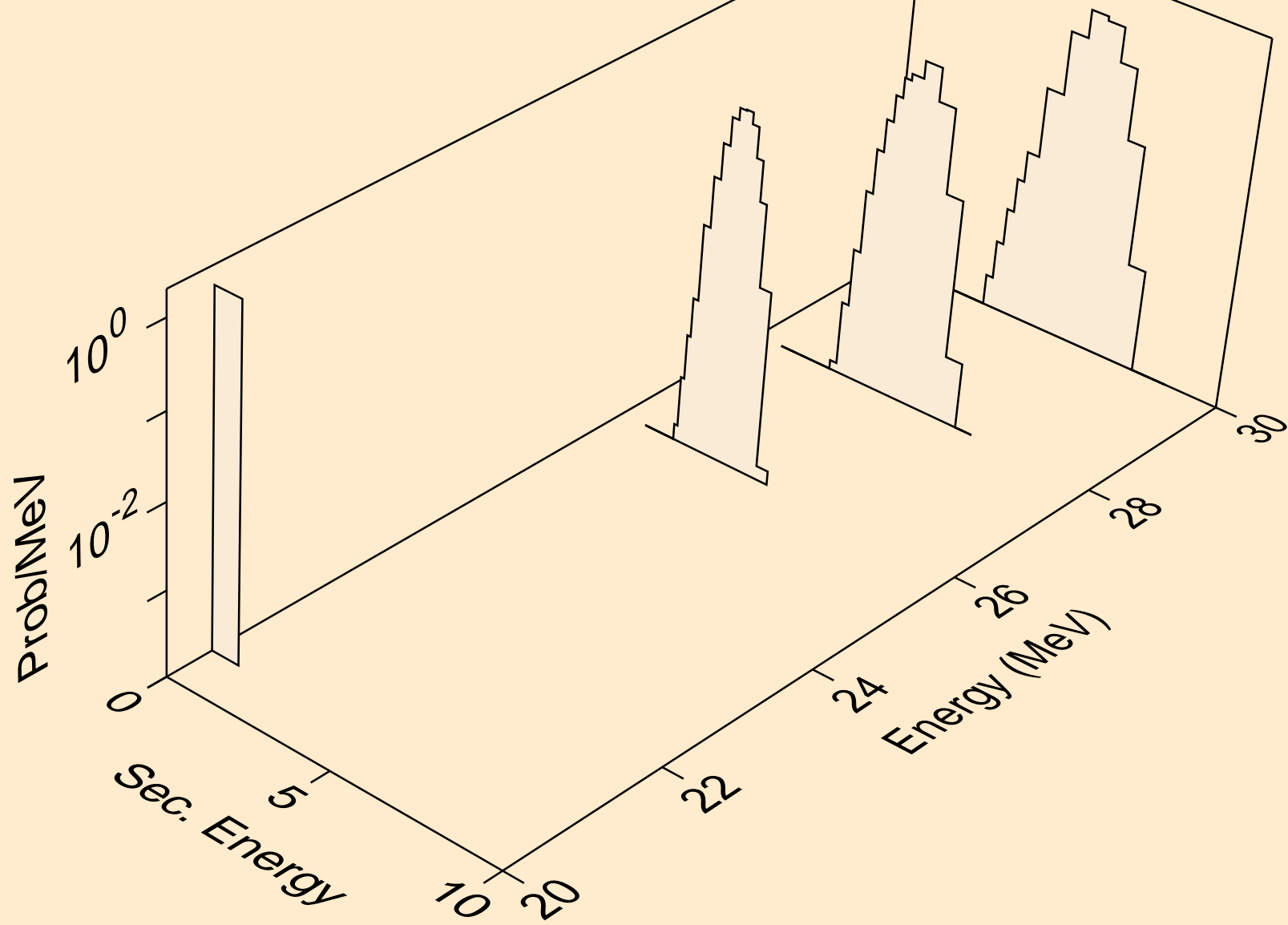

CD107 ALPHA ACER TENDL-2024 LIBRARY; T=0.K  
he3s from (a,x)

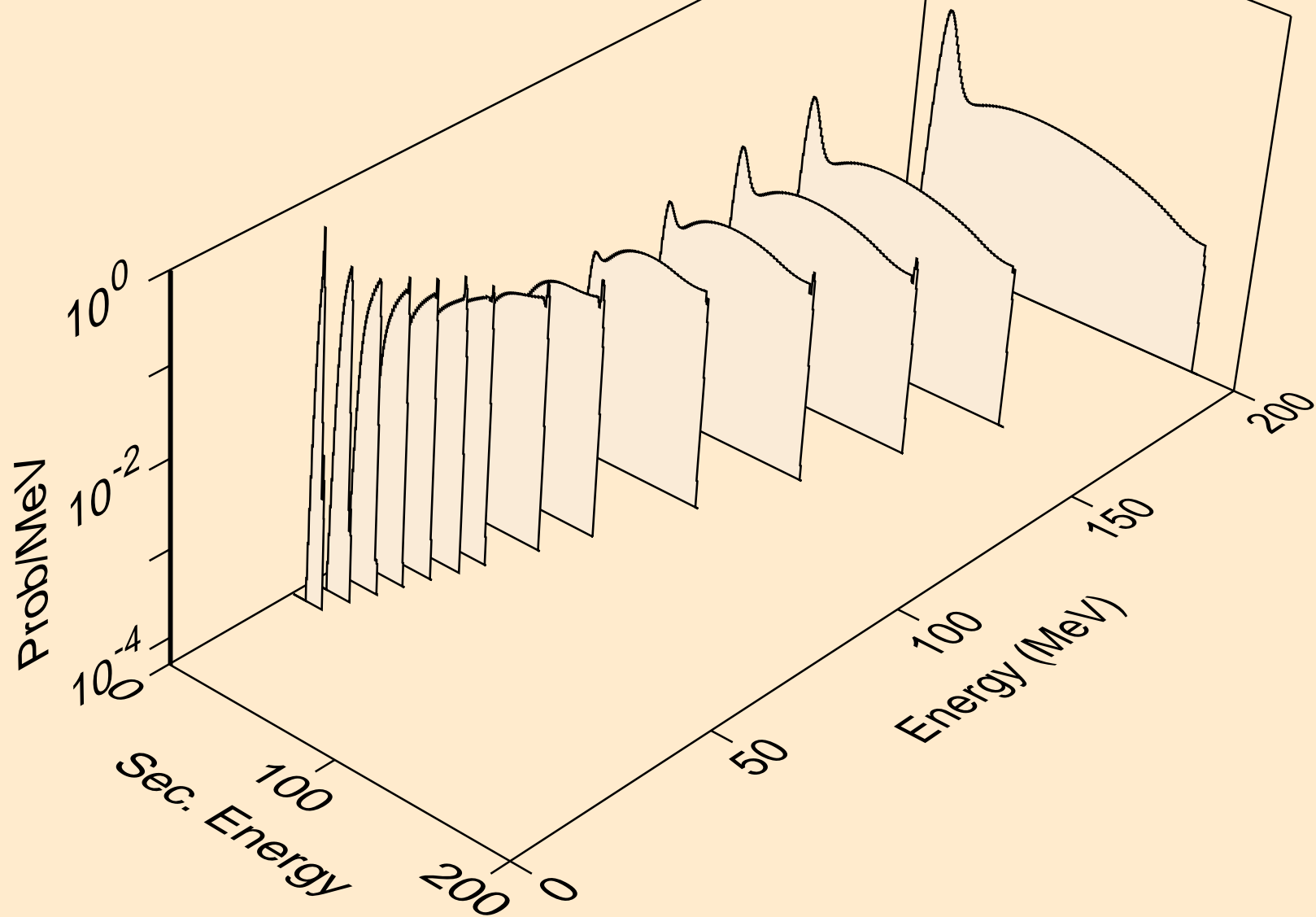

CD107 ALPHA ACER TENDL-2024 LIBRARY; T=0.K  
he3s from (a,n\*)he3

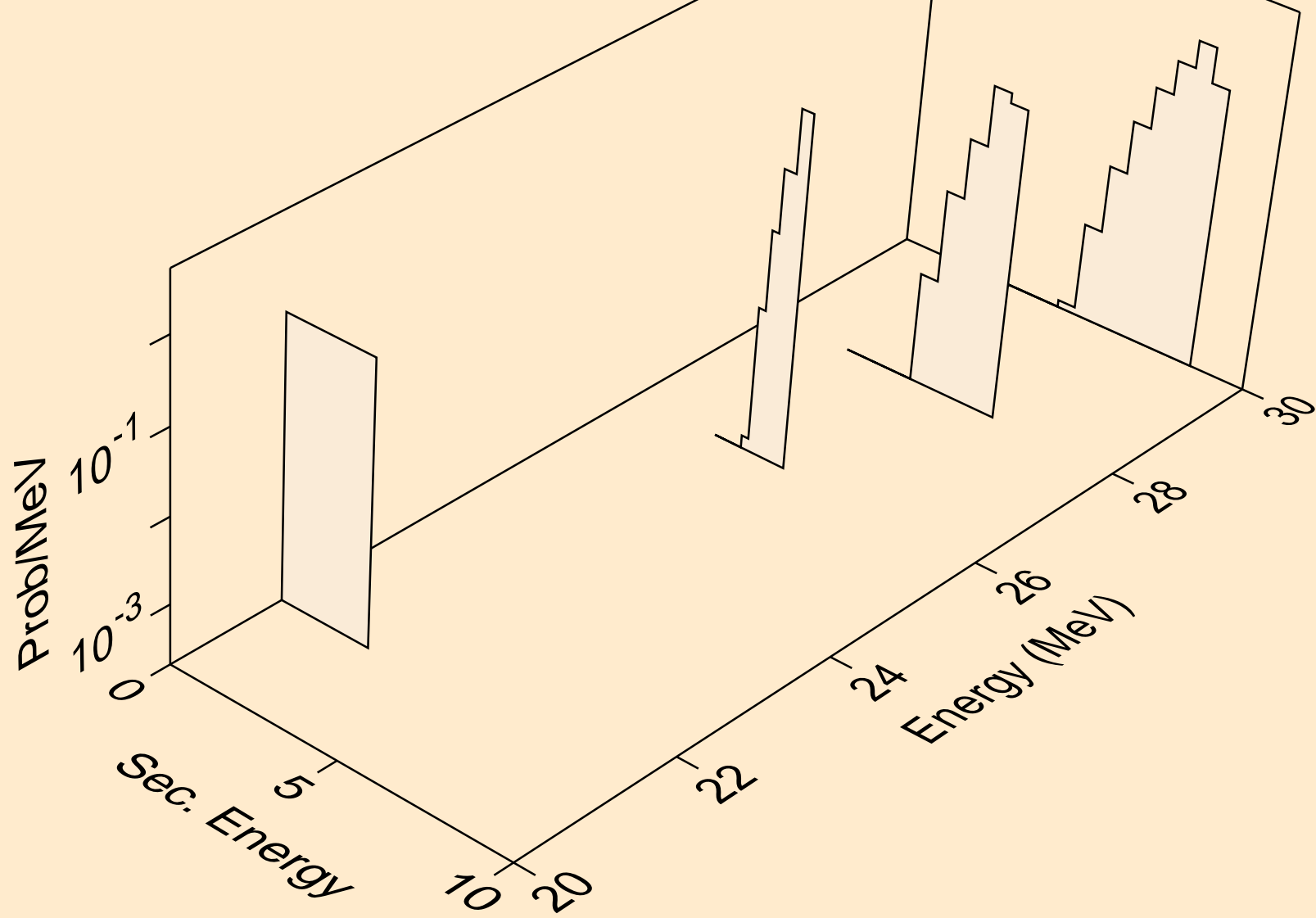

CD107 ALPHA ACER TENDL-2024 LIBRARY; T=0.K  
he3s from (a,he3)

