

CD124 ALPHA ACER TENDL-2024 LIBRARY; T=0.K

Principal cross sections

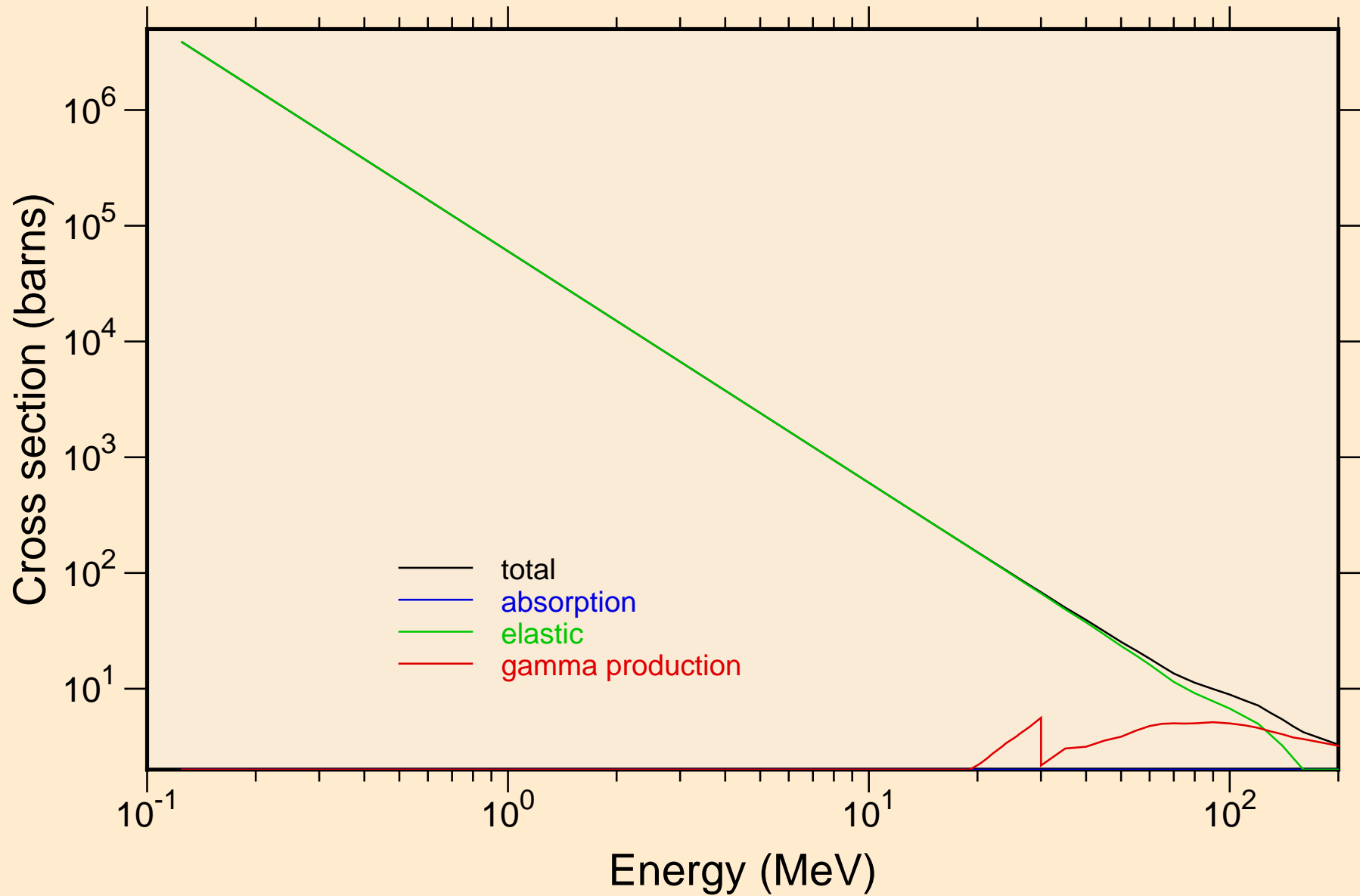

CD124 ALPHA ACER TENDL-2024 LIBRARY; T=0.K

Heating

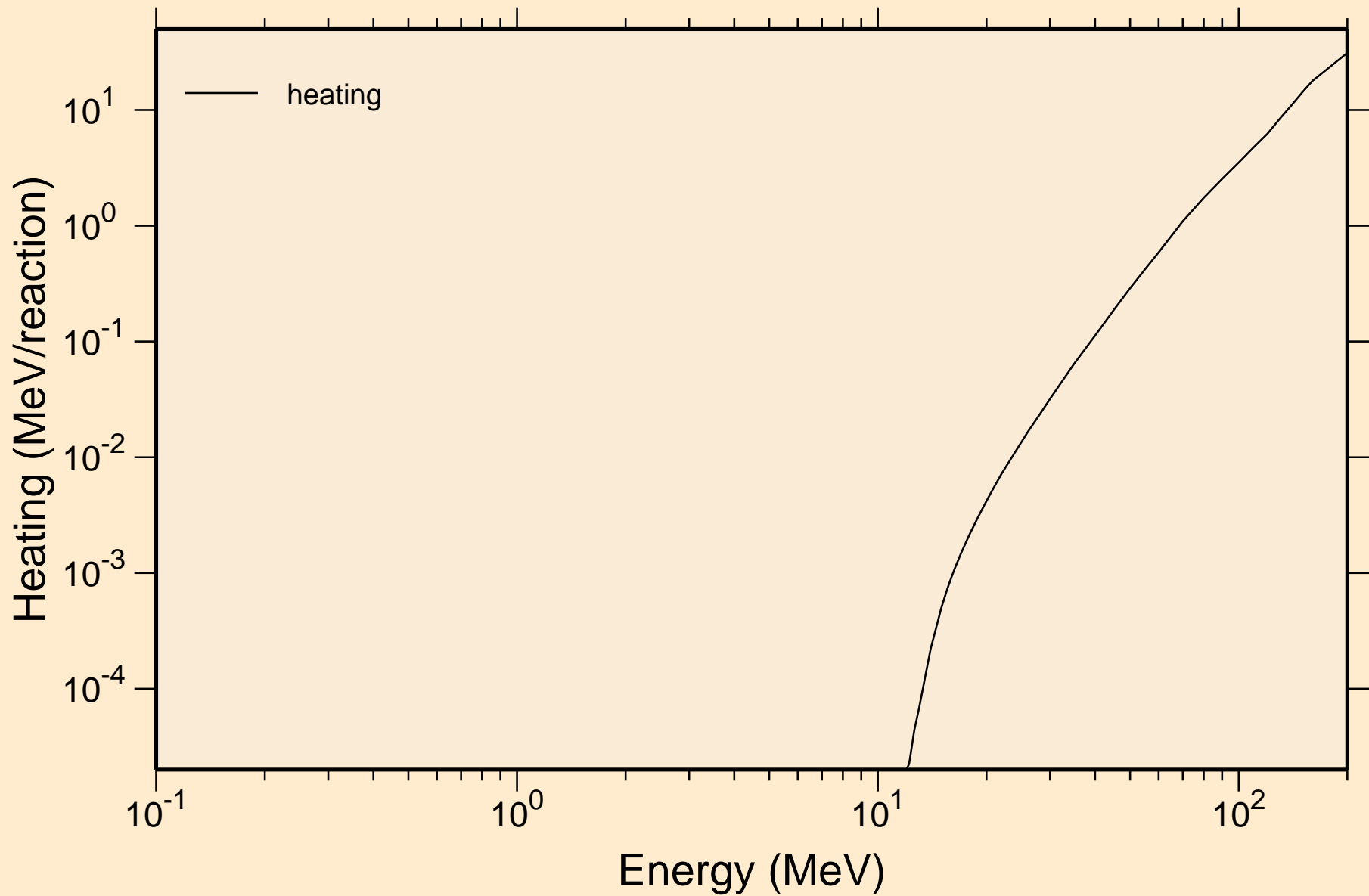

CD124 ALPHA ACER TENDL-2024 LIBRARY; T=0.K

Principal cross sections

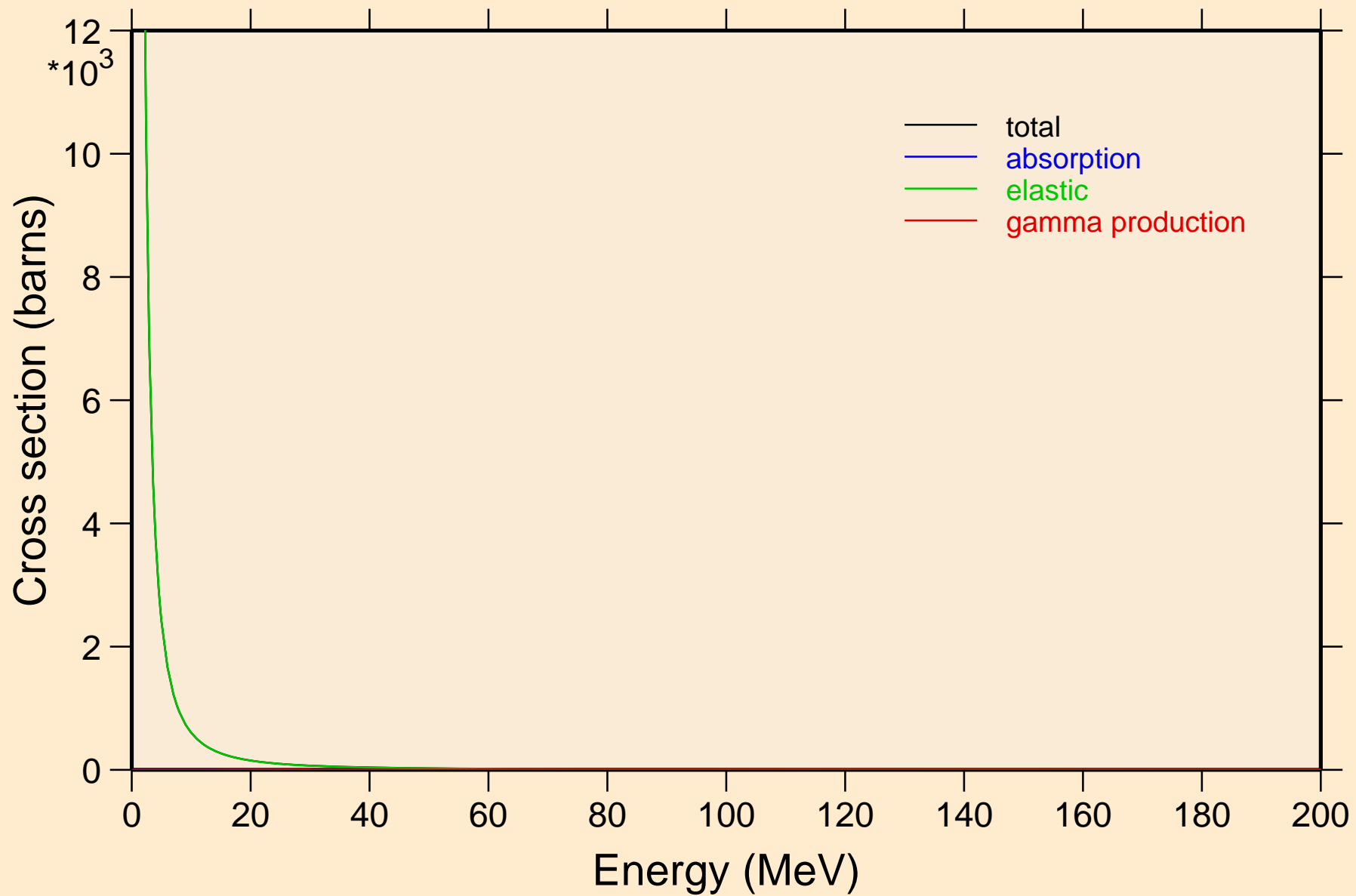

CD124 ALPHA ACER TENDL-2024 LIBRARY; T=0.K

Heating

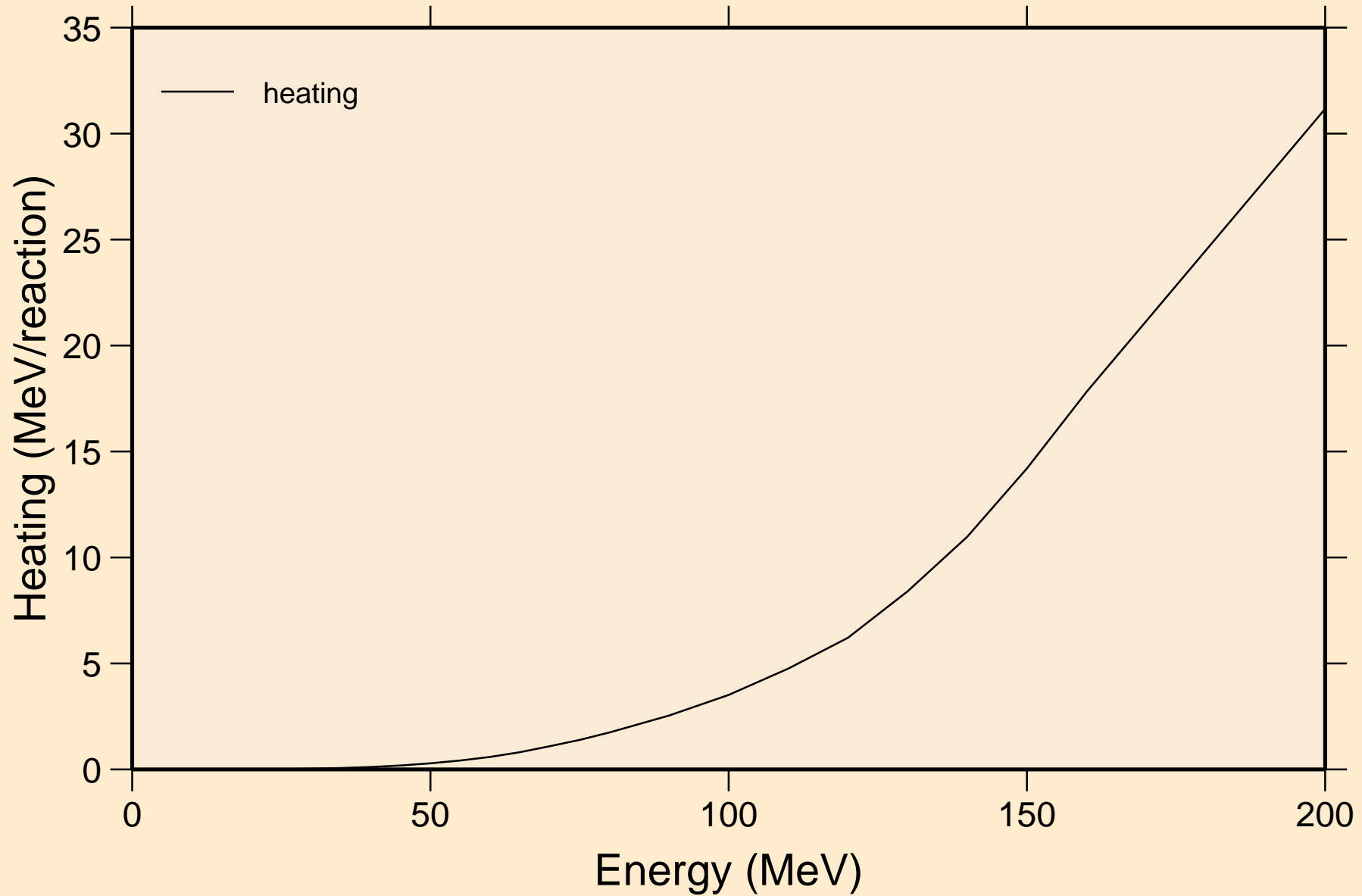

CD124 ALPHA ACER TENDL-2024 LIBRARY; T=0.K

Threshold reactions

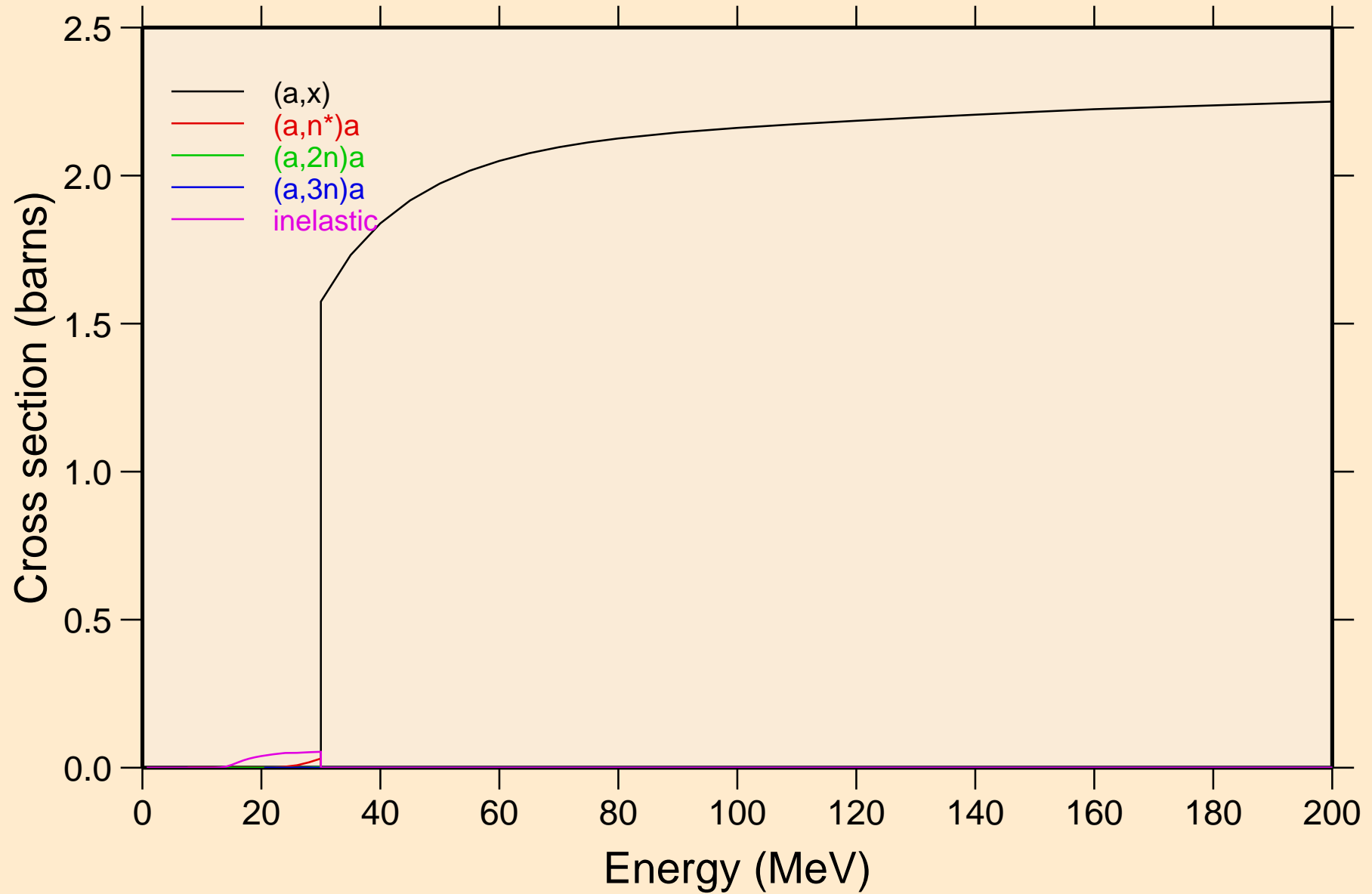

CD124 ALPHA ACER TENDL-2024 LIBRARY; T=0.K
angular distribution for elastic

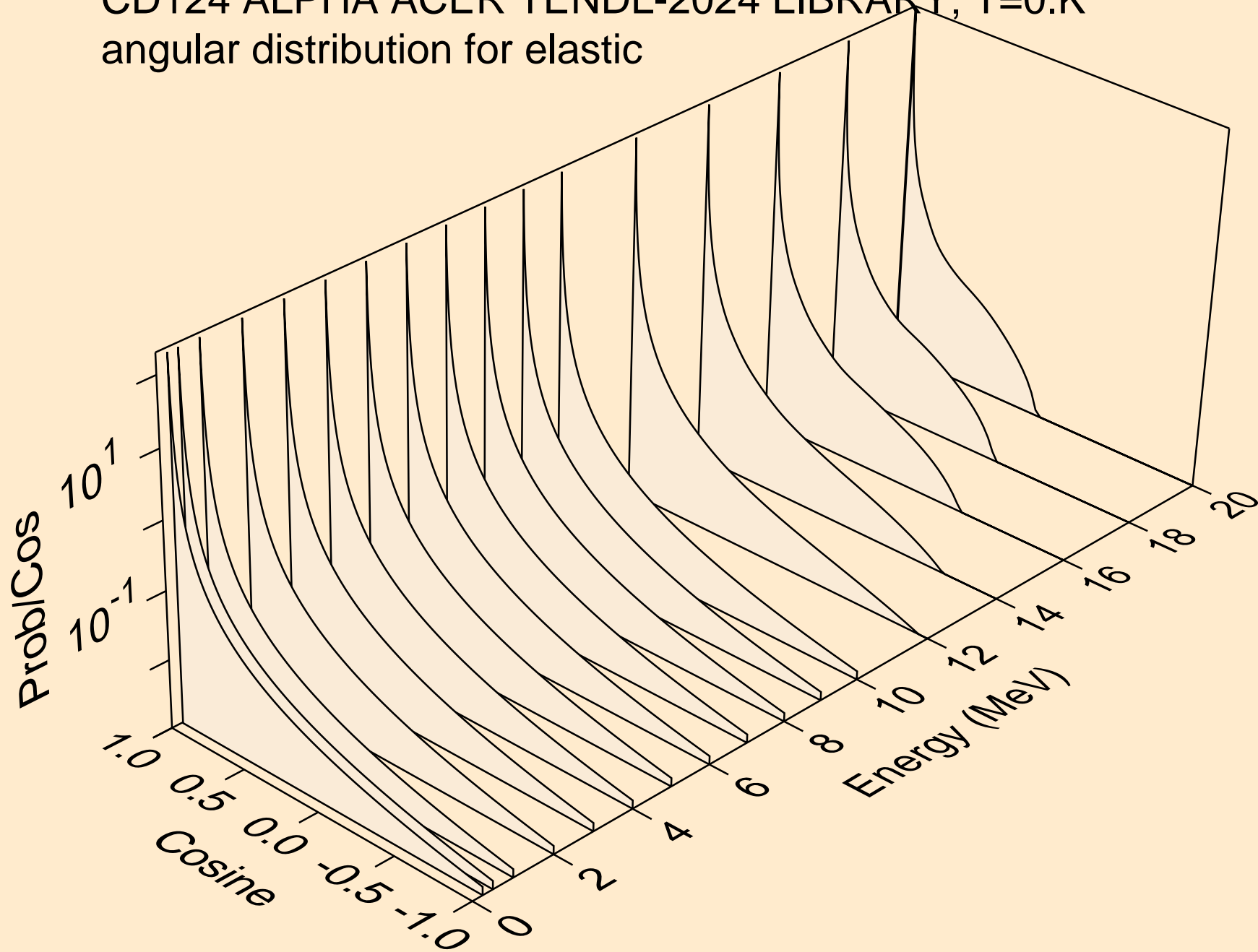

CD124 ALPHA ACER TENDL-2024 LIBRARY; T=0.K
angular distribution for elastic

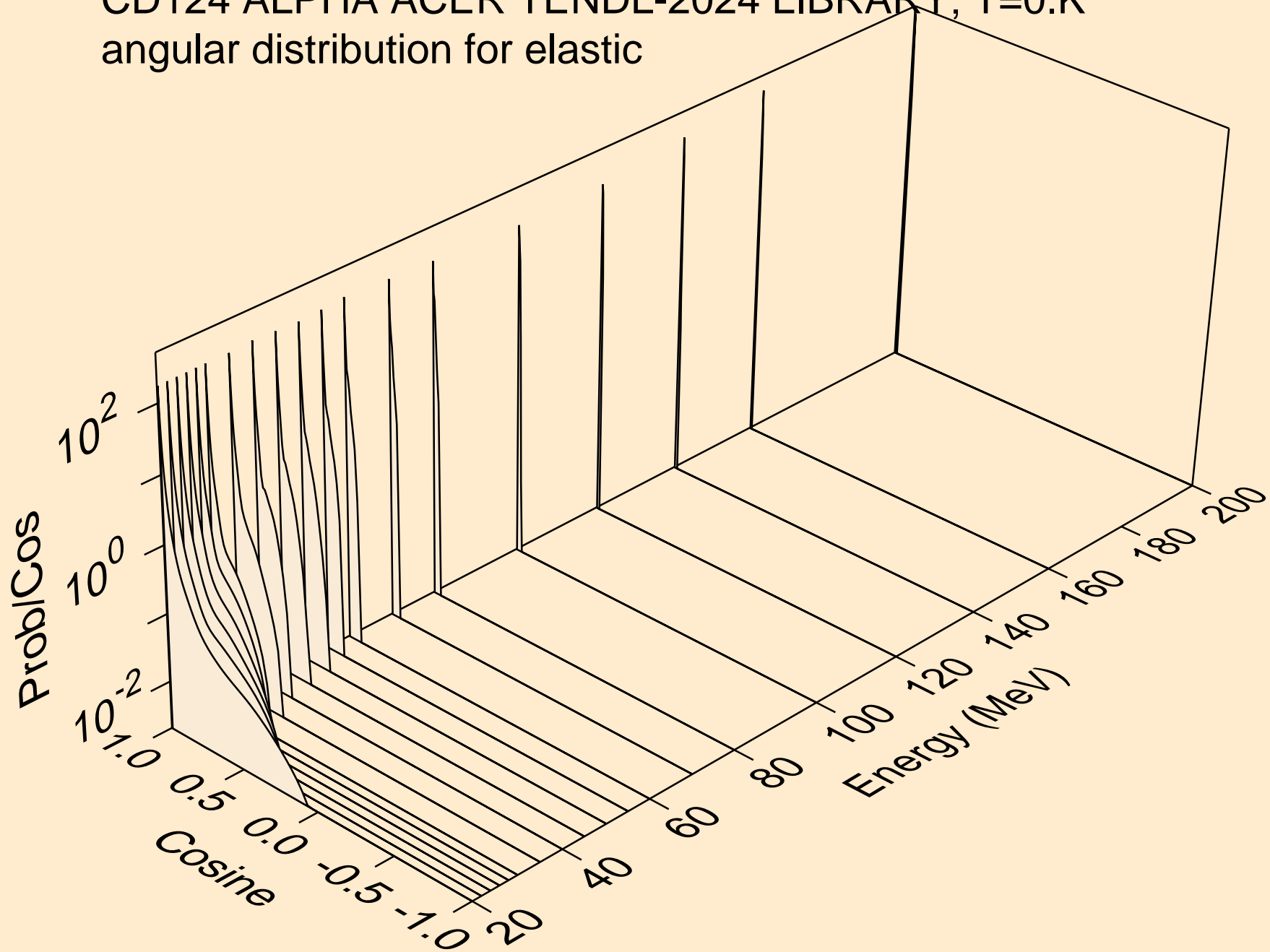

CD124 ALPHA ACER TENDL-2024 LIBRARY; T=0.K
Alpha emission for (a,x)

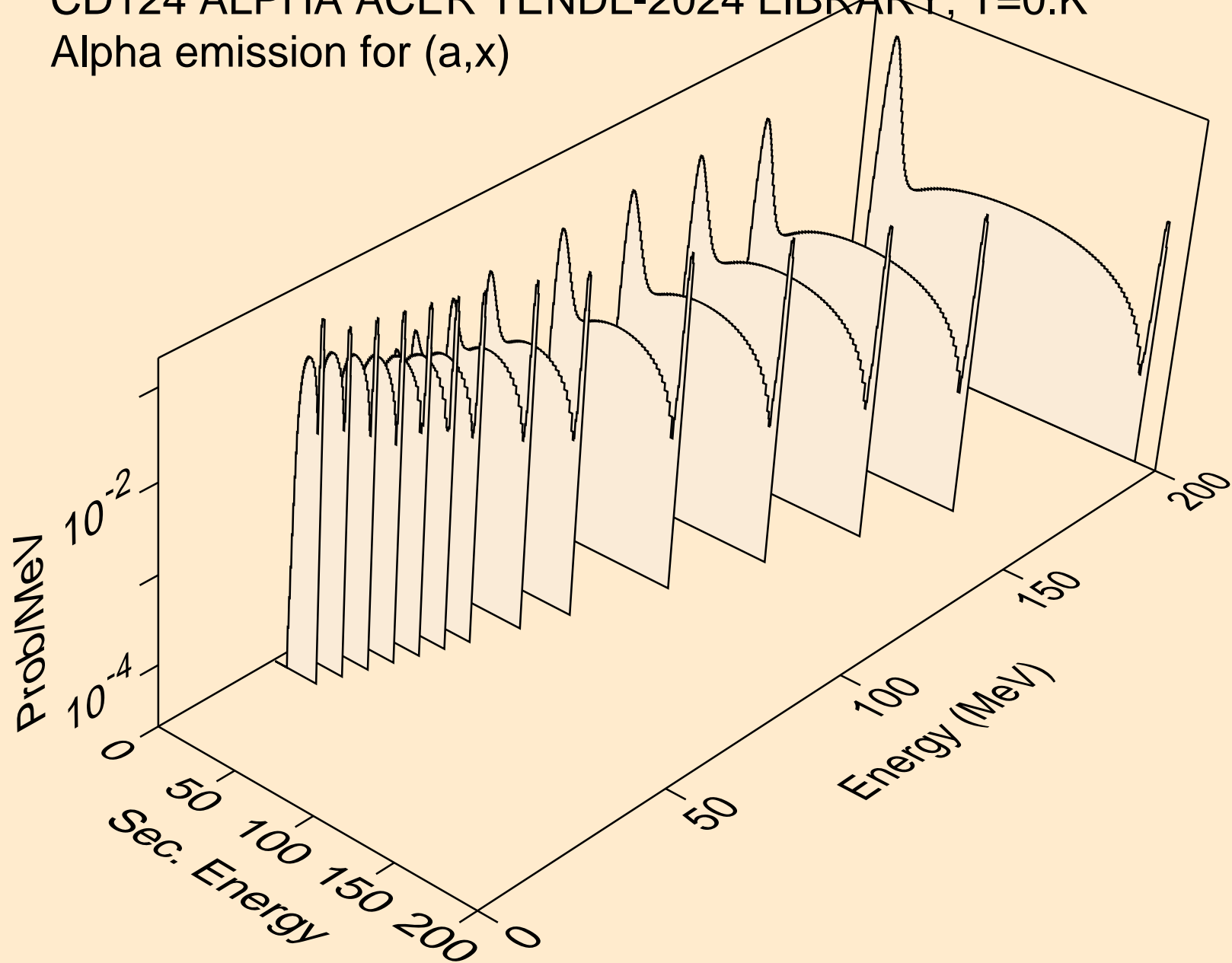

CD124 ALPHA ACER TENDL-2024 LIBRARY; T=0.K
Alpha emission for (a,n*)a

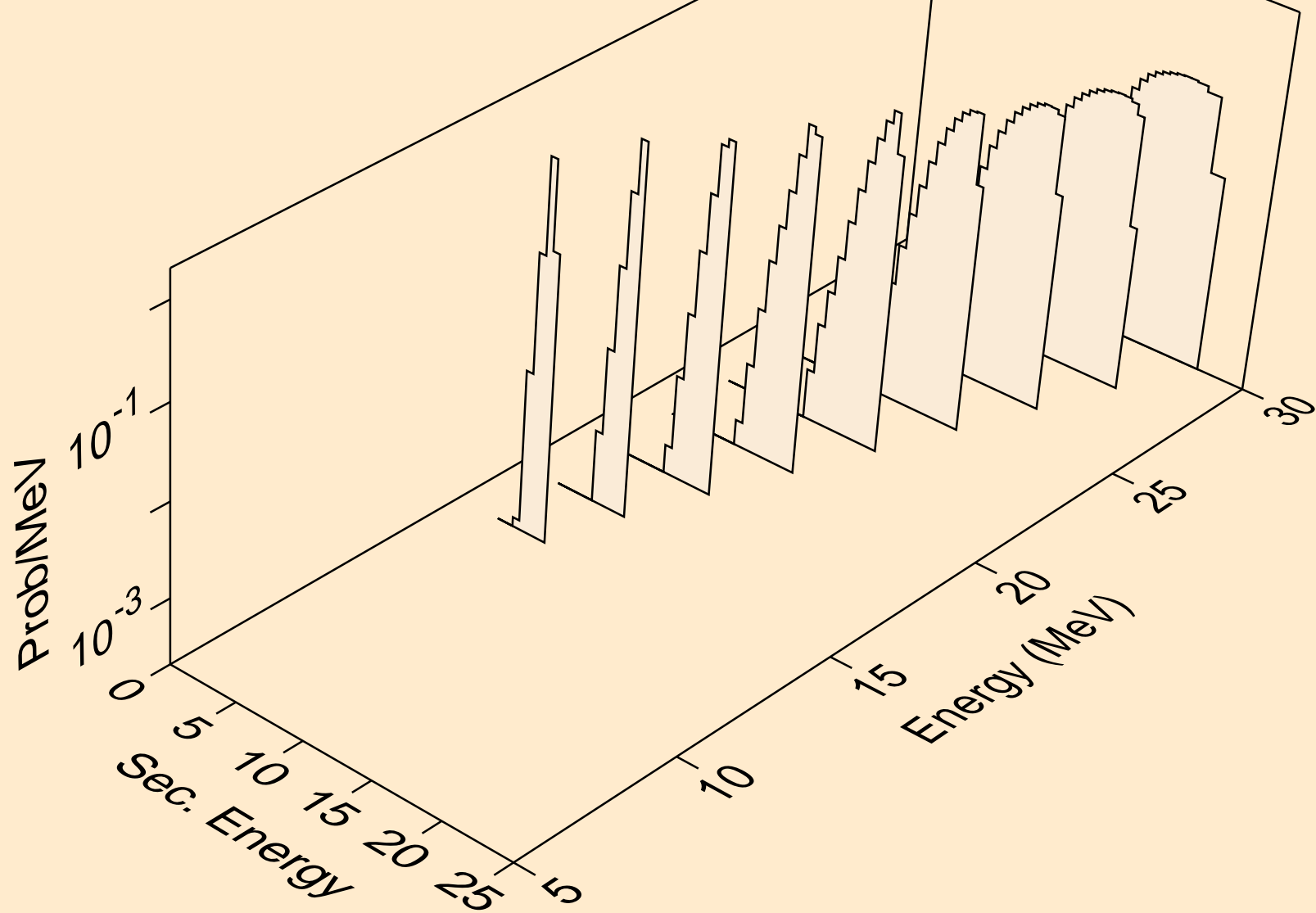

CD124 ALPHA ACER TENDL-2024 LIBRARY; T=0.K
Alpha emission for (a,2n)a

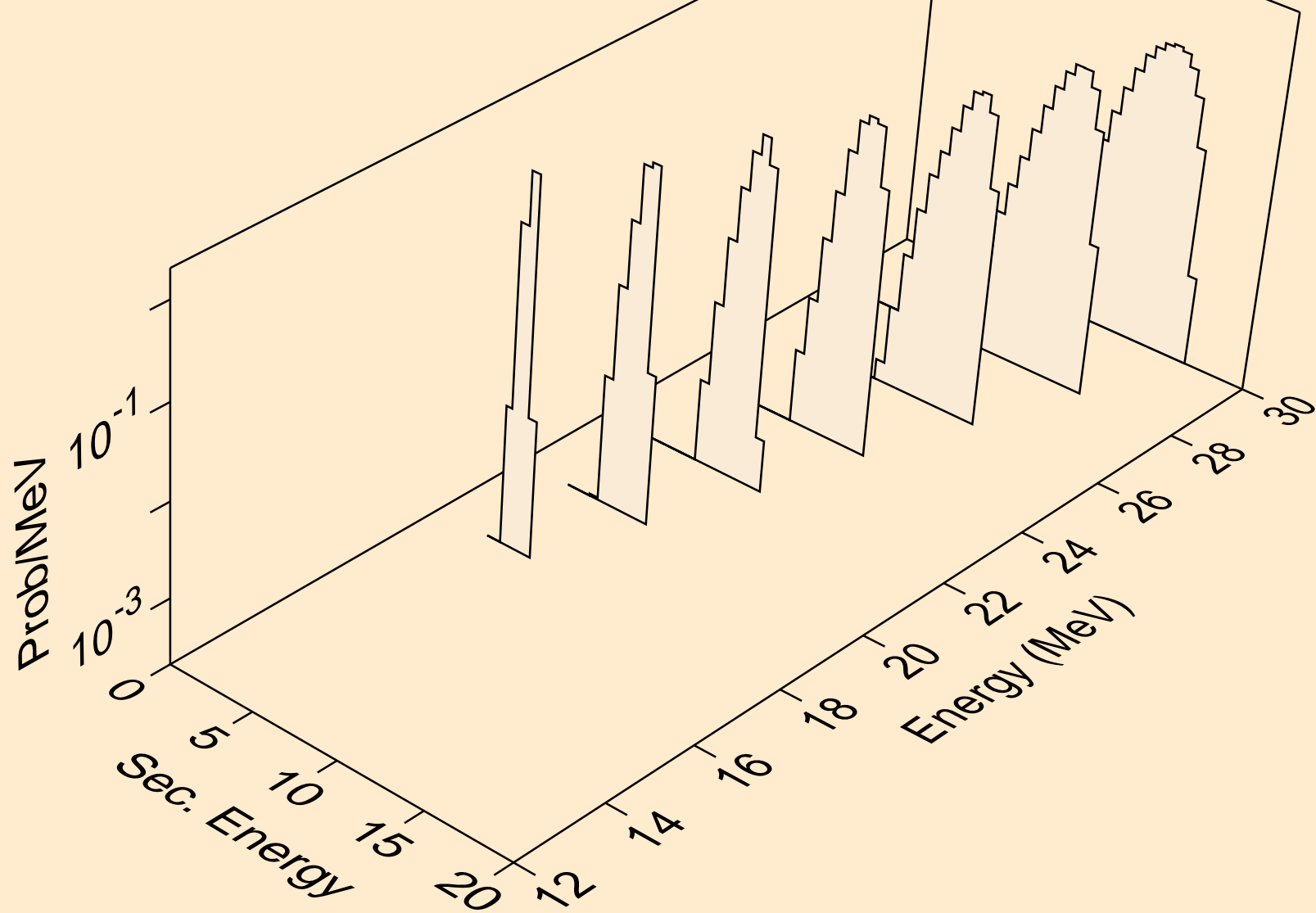

CD124 ALPHA ACER TENDL-2024 LIBRARY; T=0.K
Alpha emission for (a,3n)a

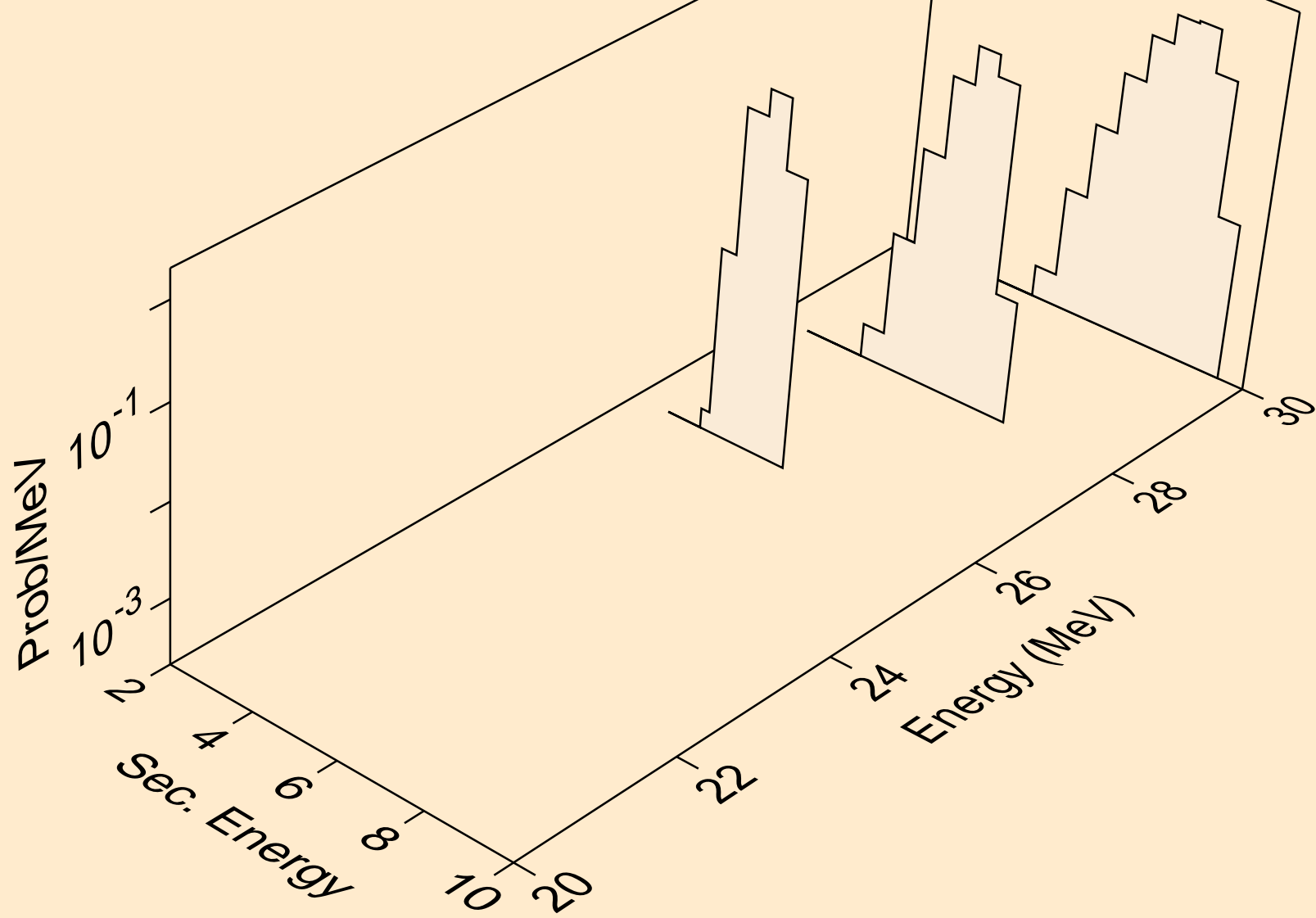

CD124 ALPHA ACER TENDL-2024 LIBRARY; T=0.K
Alpha emission for inelastic

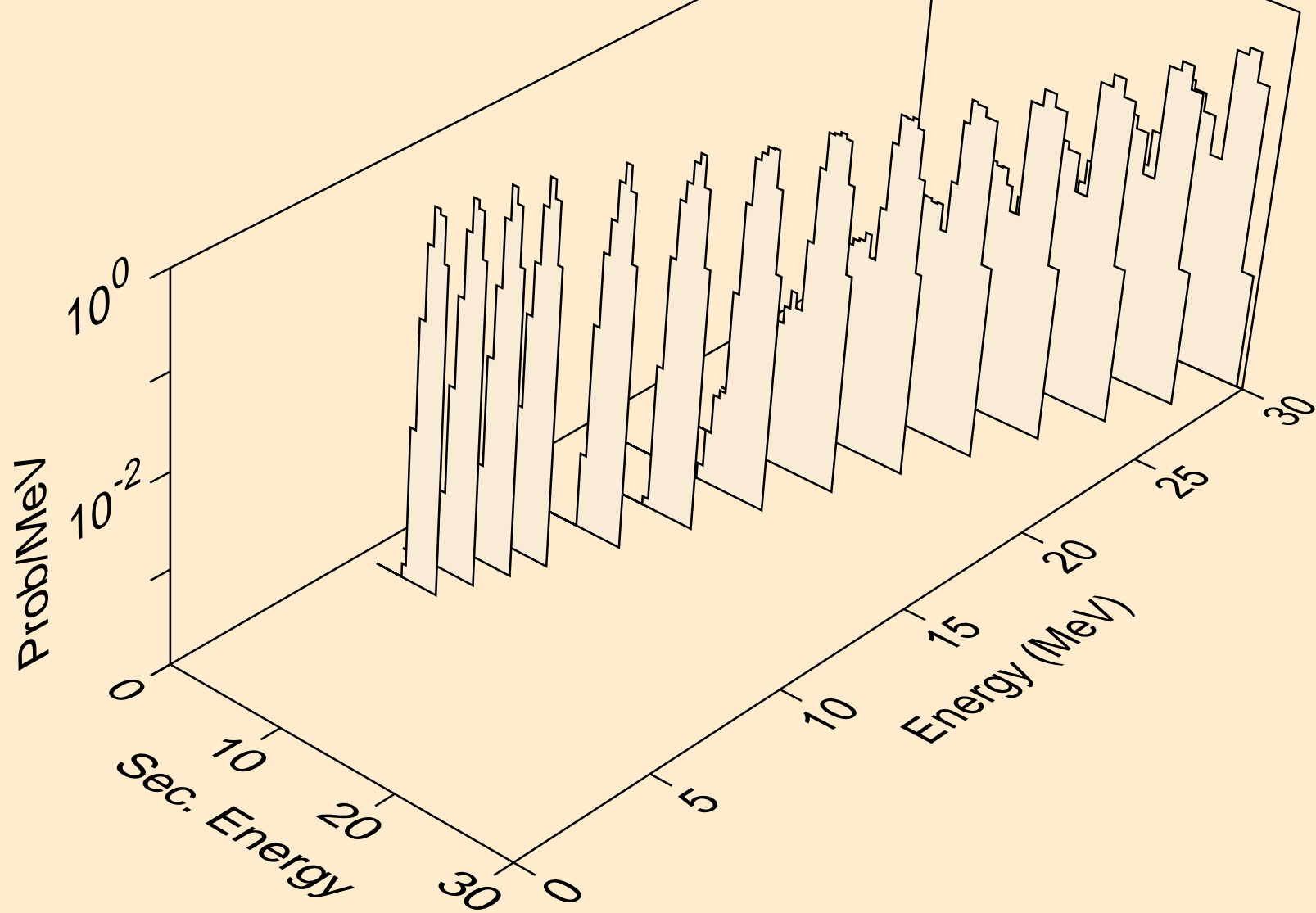

CD124 ALPHA ACER TENDL-2024 LIBRARY; T=0.K
Photon emission for (z,n)

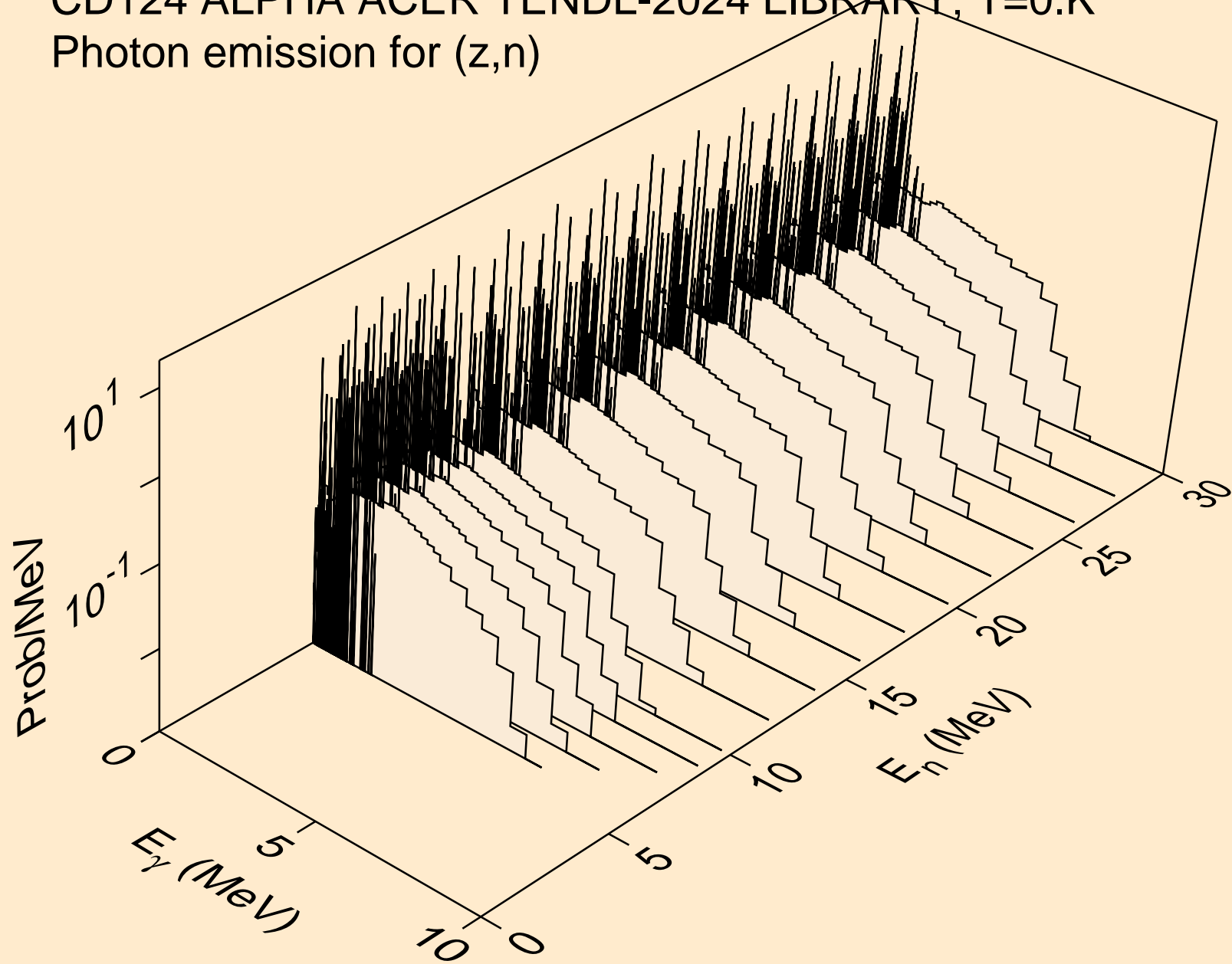

CD124 ALPHA ACER TENDL-2024 LIBRARY; T=0.K
Photon emission for (z,x)

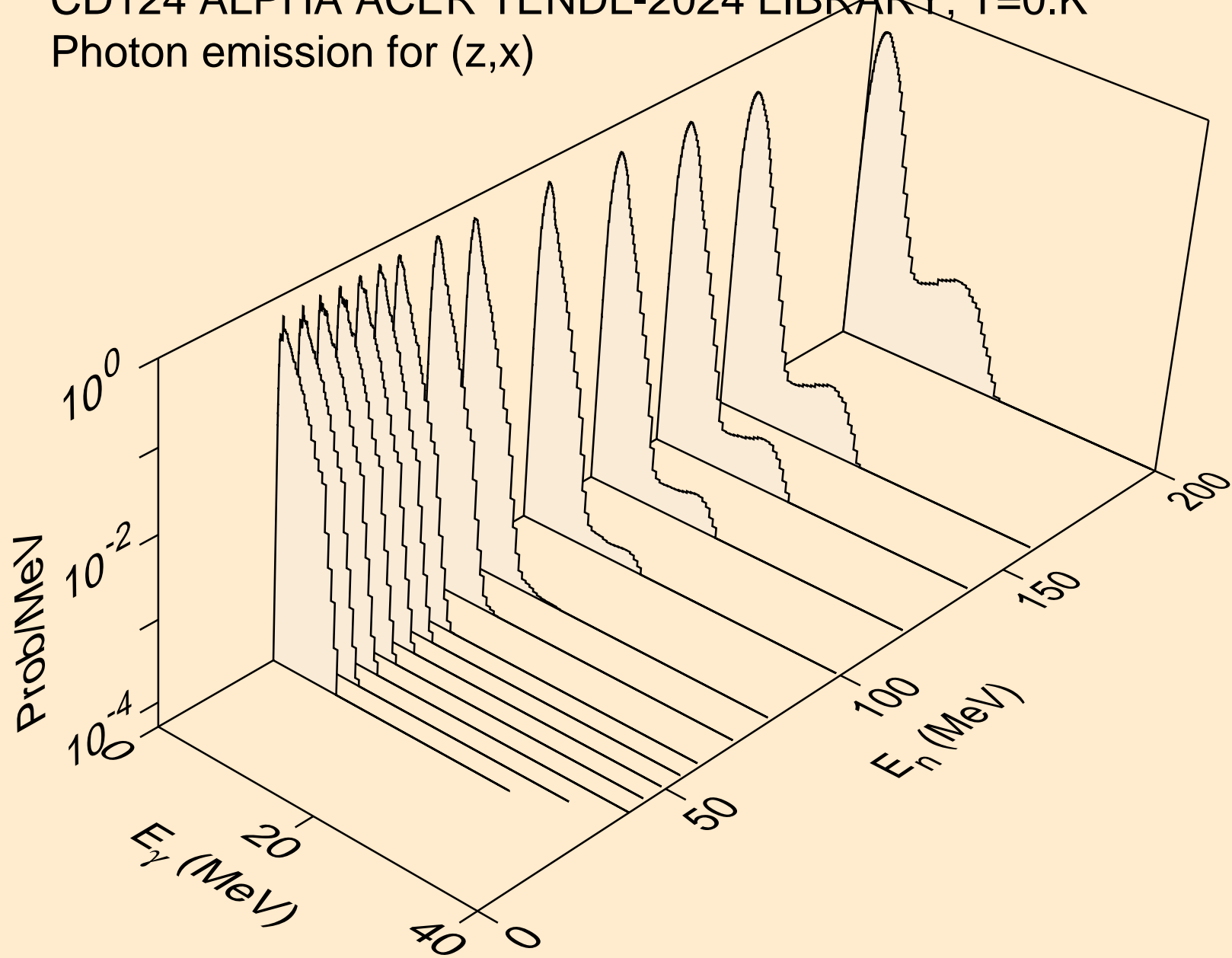

CD124 ALPHA ACER TENDL-2024 LIBRARY; T=0.K
Photon emission for (n,2nd)

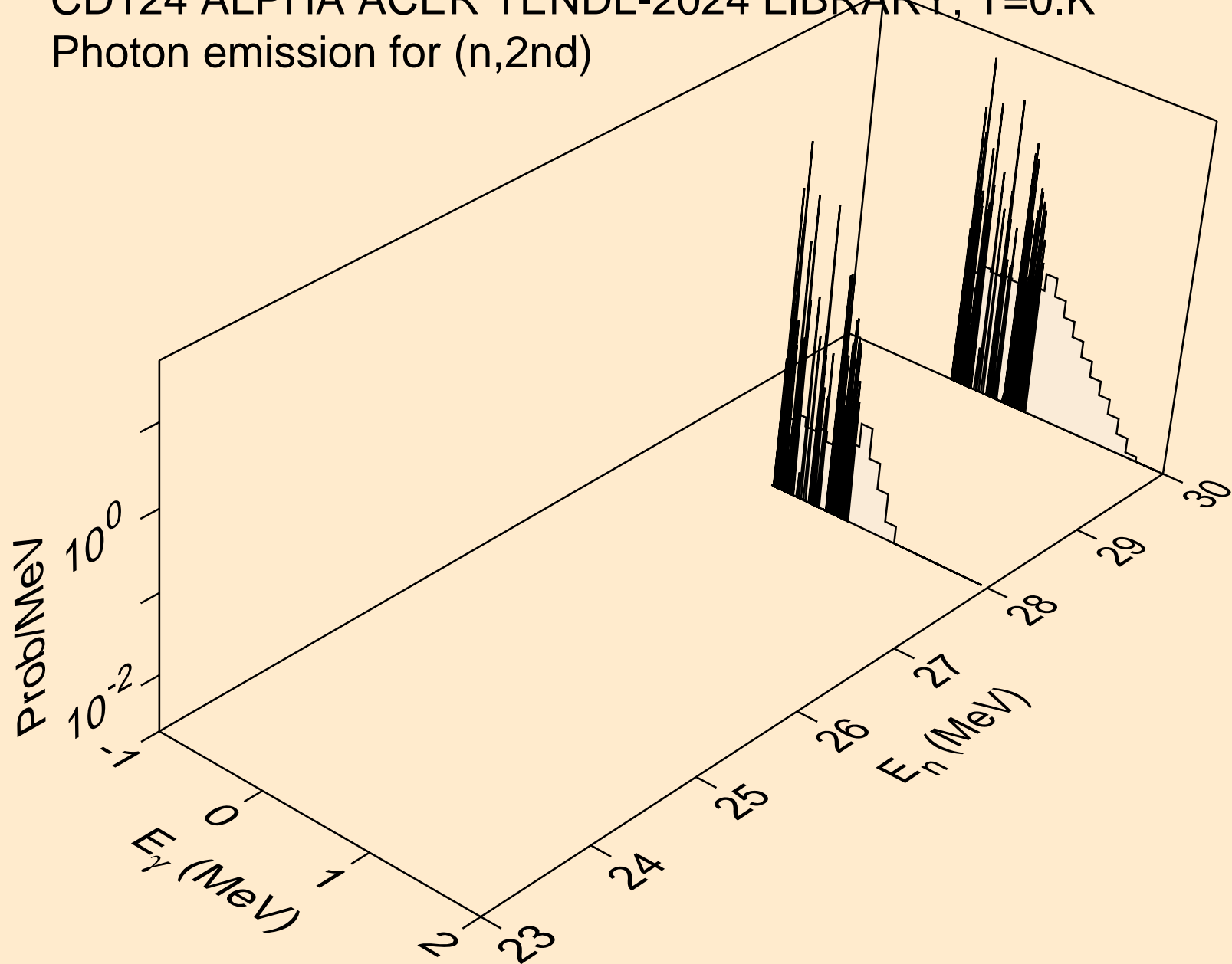

CD124 ALPHA ACER TENDL-2024 LIBRARY; T=0.K
Photon emission for (n,2n)

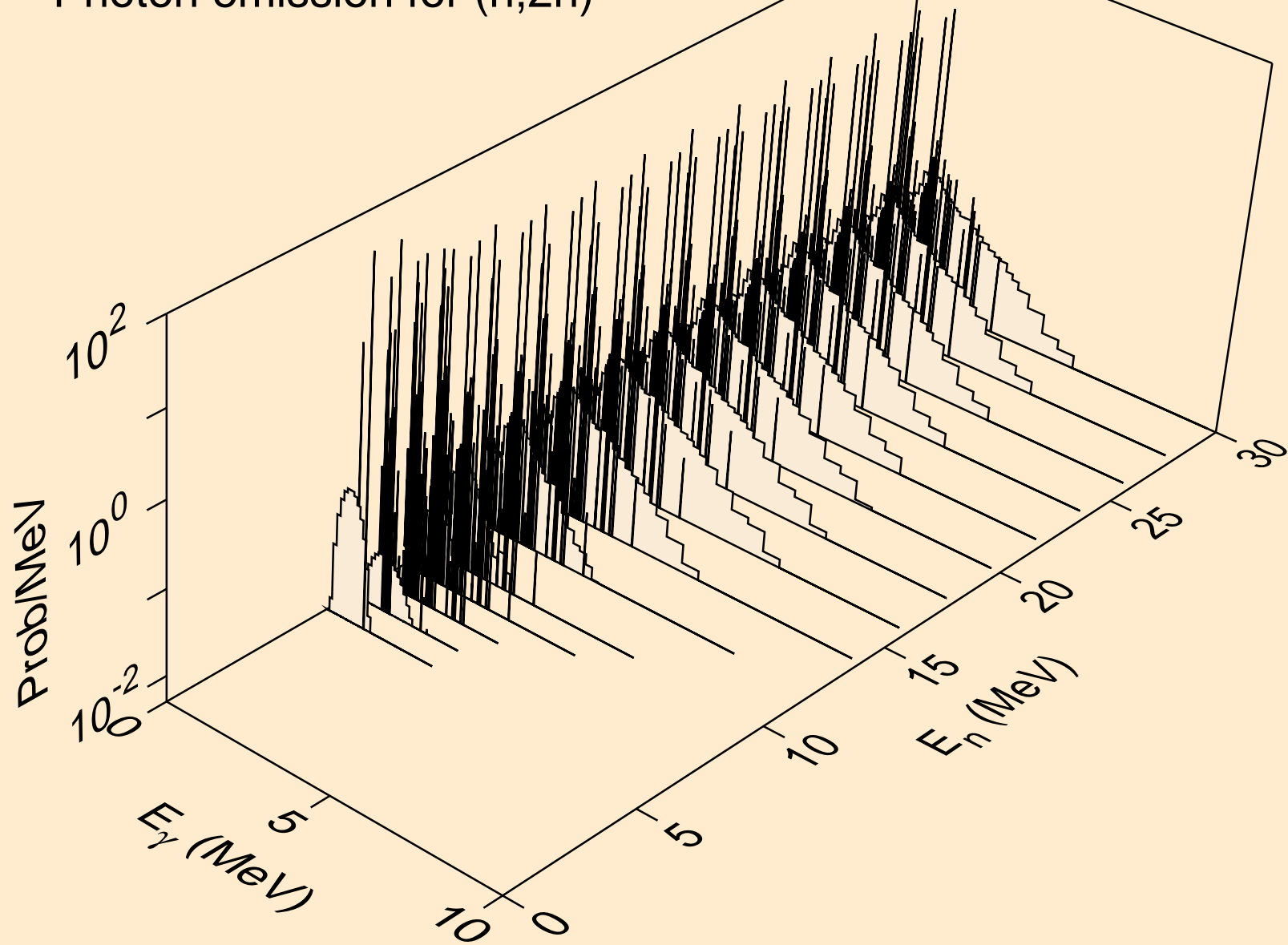

CD124 ALPHA ACER TENDL-2024 LIBRARY; T=0.K
Photon emission for (n,3n)

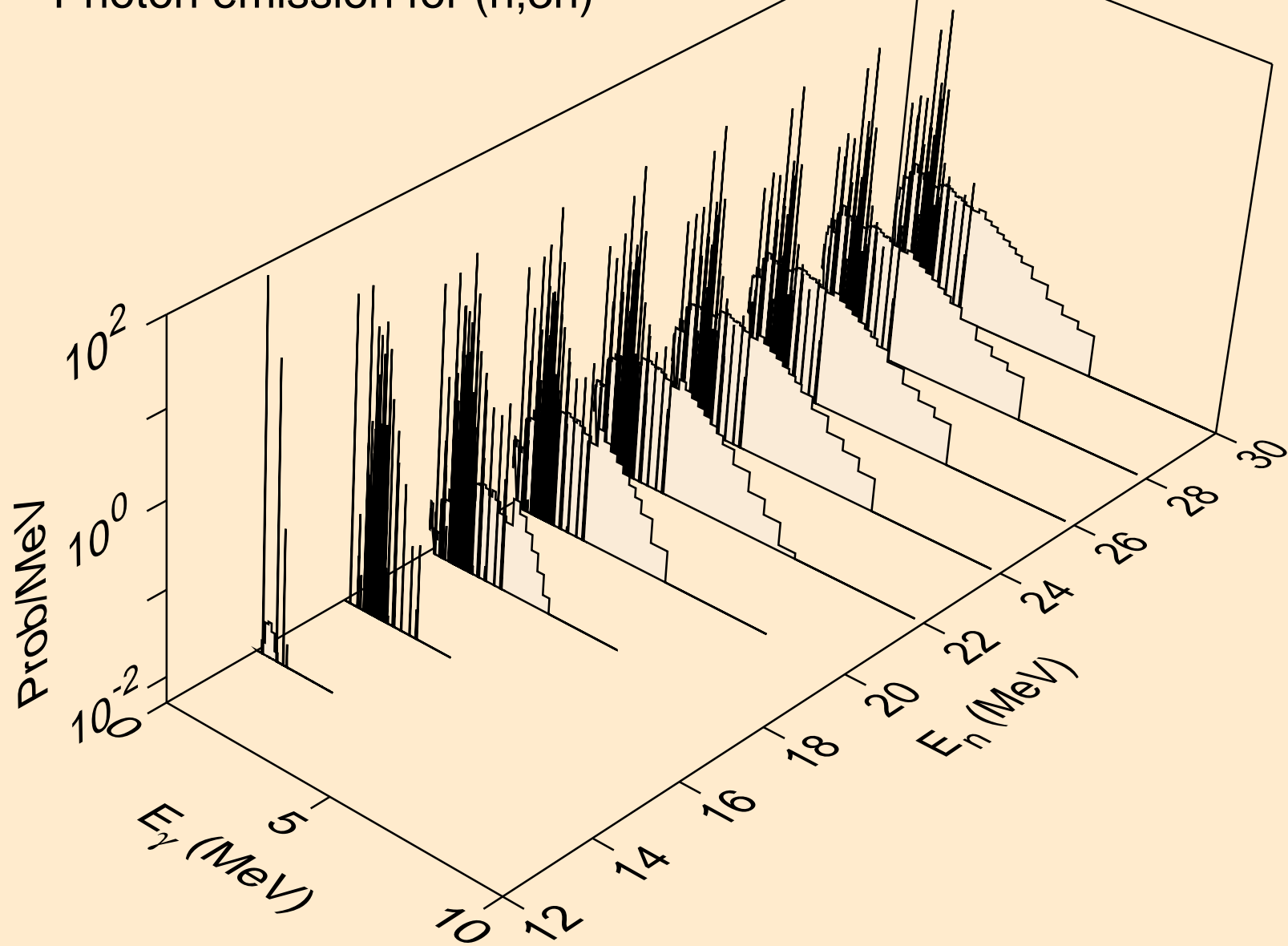

CD124 ALPHA ACER TENDL-2024 LIBRARY; T=0.K
Photon emission for (n,n*)a

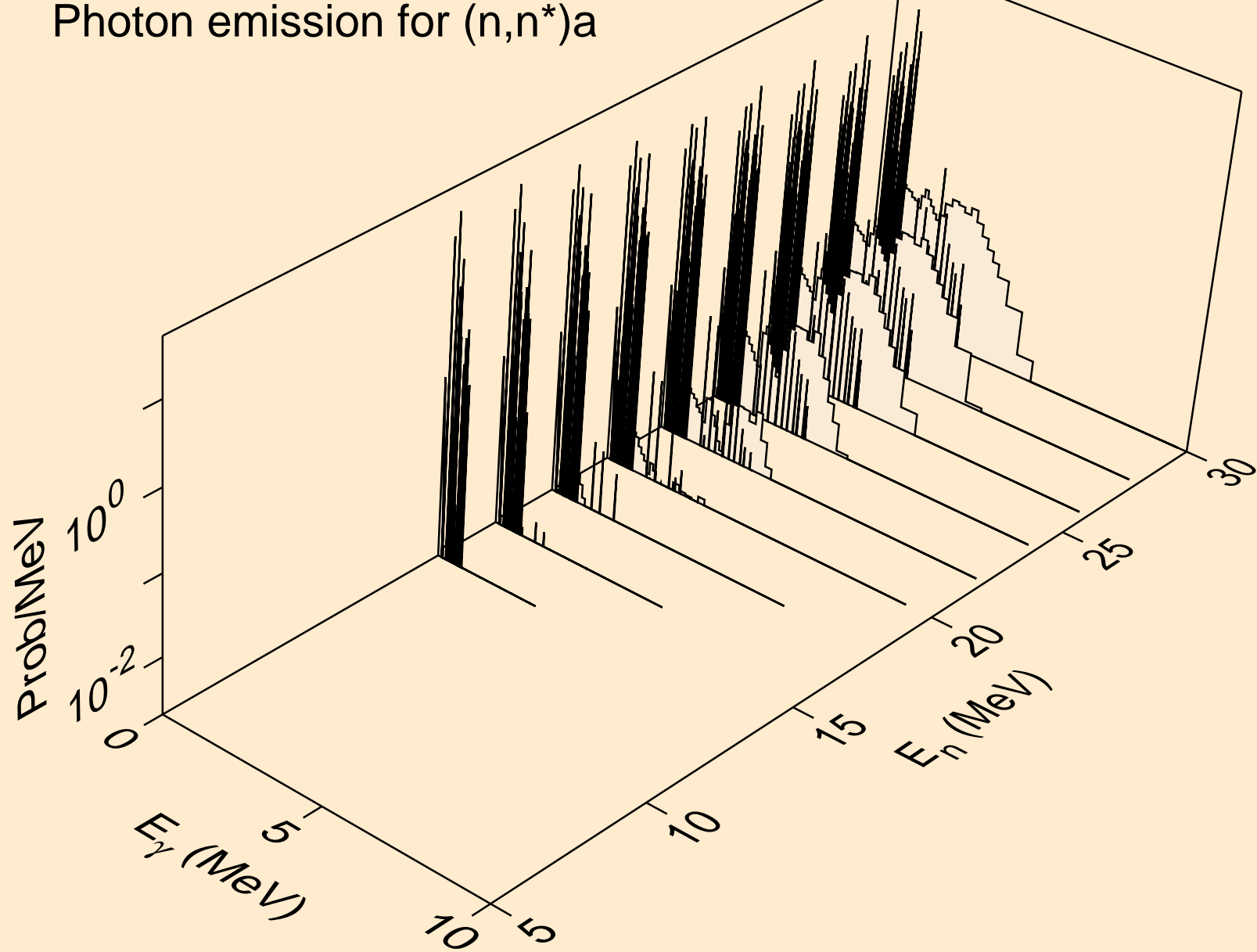

CD124 ALPHA ACER TENDL-2024 LIBRARY; T=0.K
Photon emission for (n,2n)a

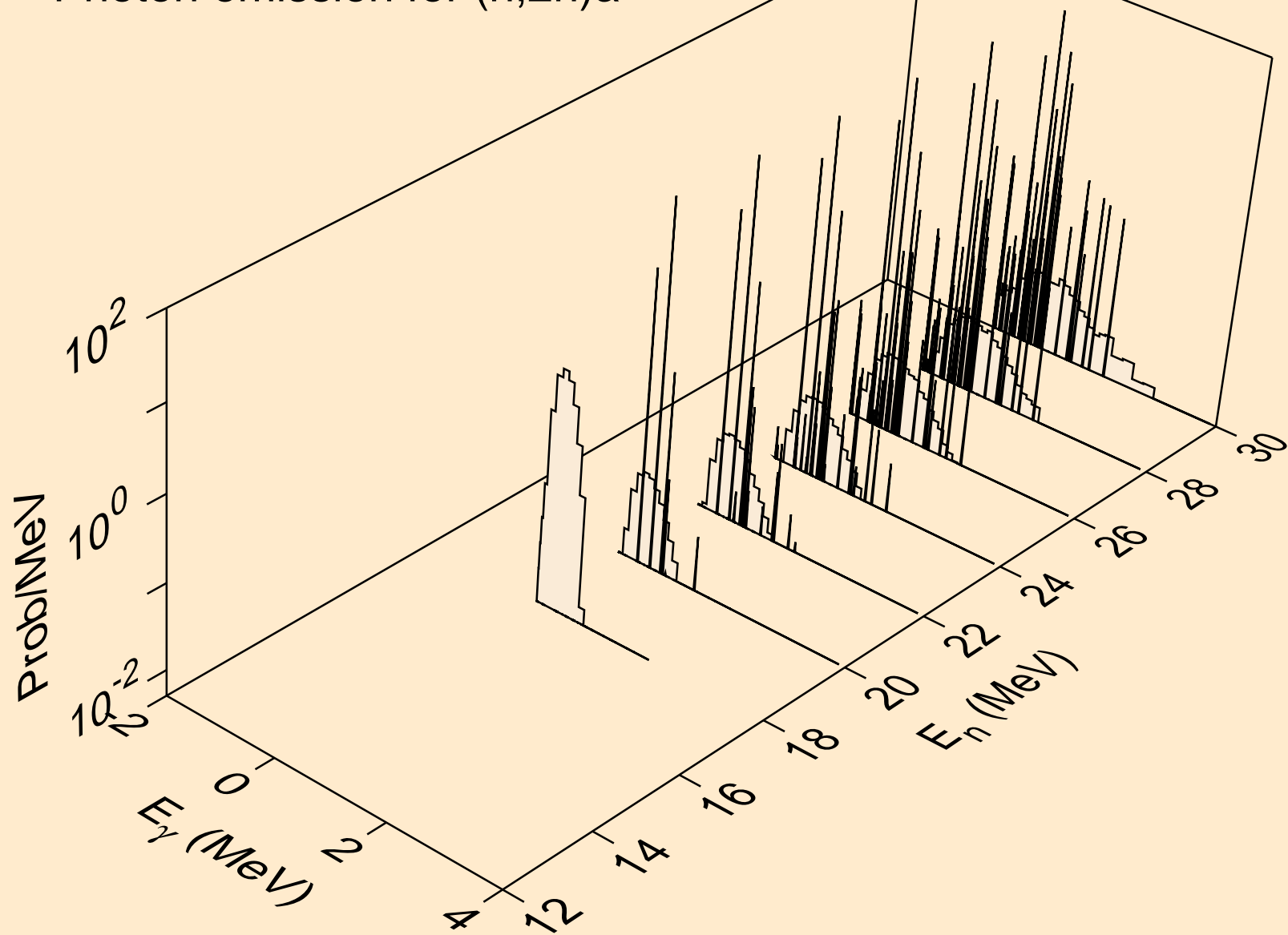

CD124 ALPHA ACER TENDL-2024 LIBRARY; T=0.K
Photon emission for (n,3n)a

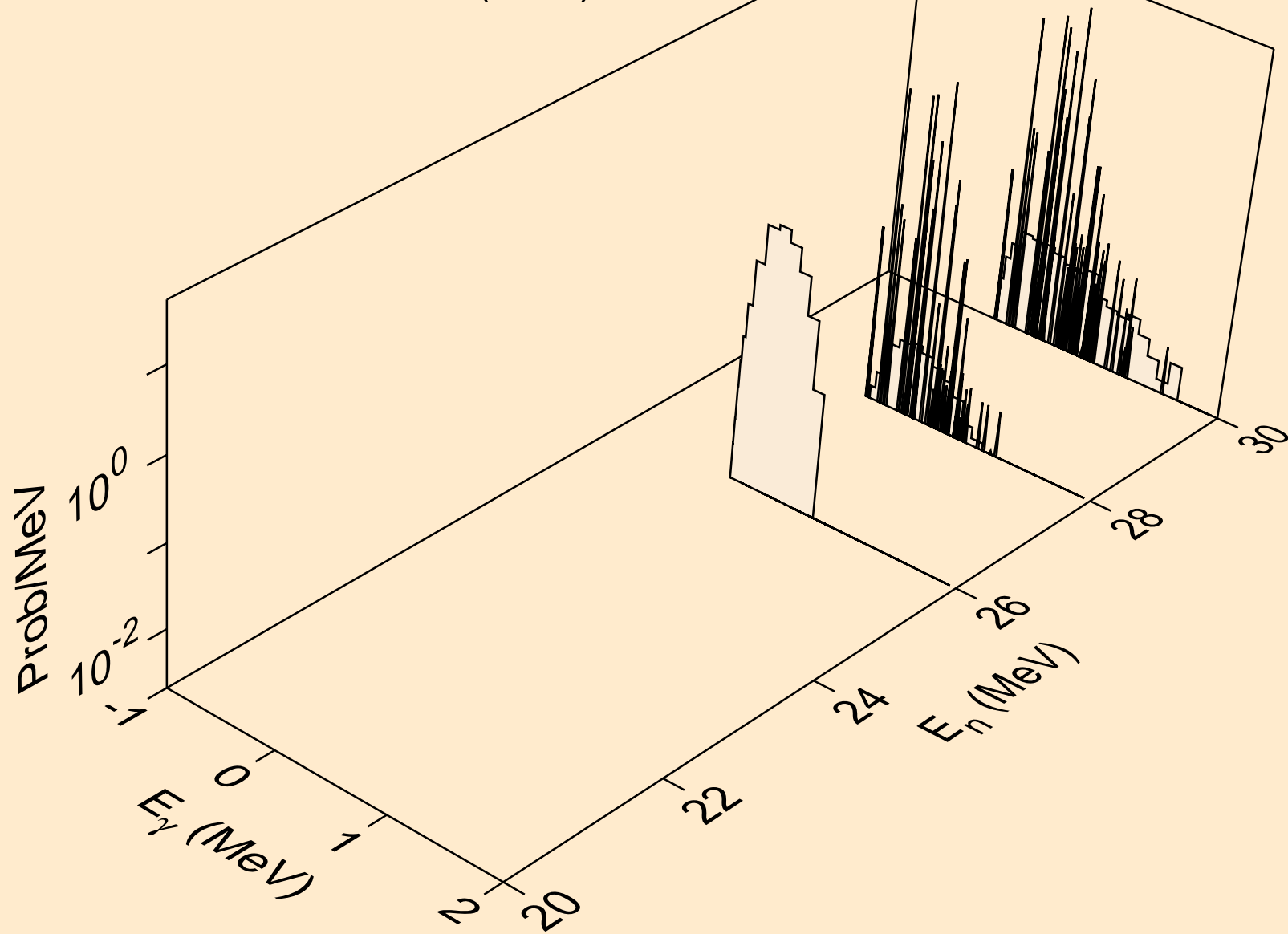

CD124 ALPHA ACER TENDL-2024 LIBRARY; T=0.K
Photon emission for (n,n*)p

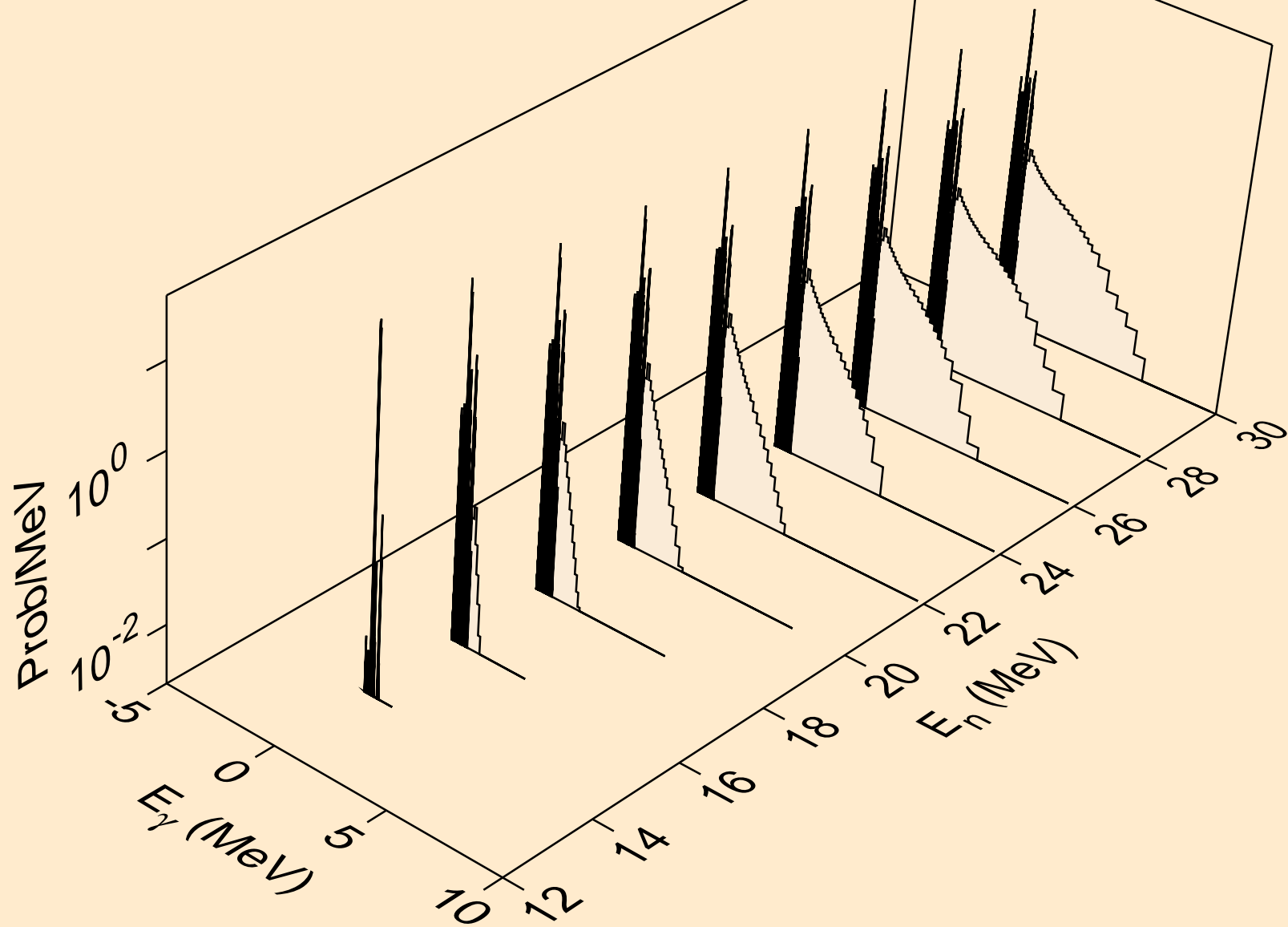

CD124 ALPHA ACER TENDL-2024 LIBRARY; T=0.K
Photon emission for (n,n*)d

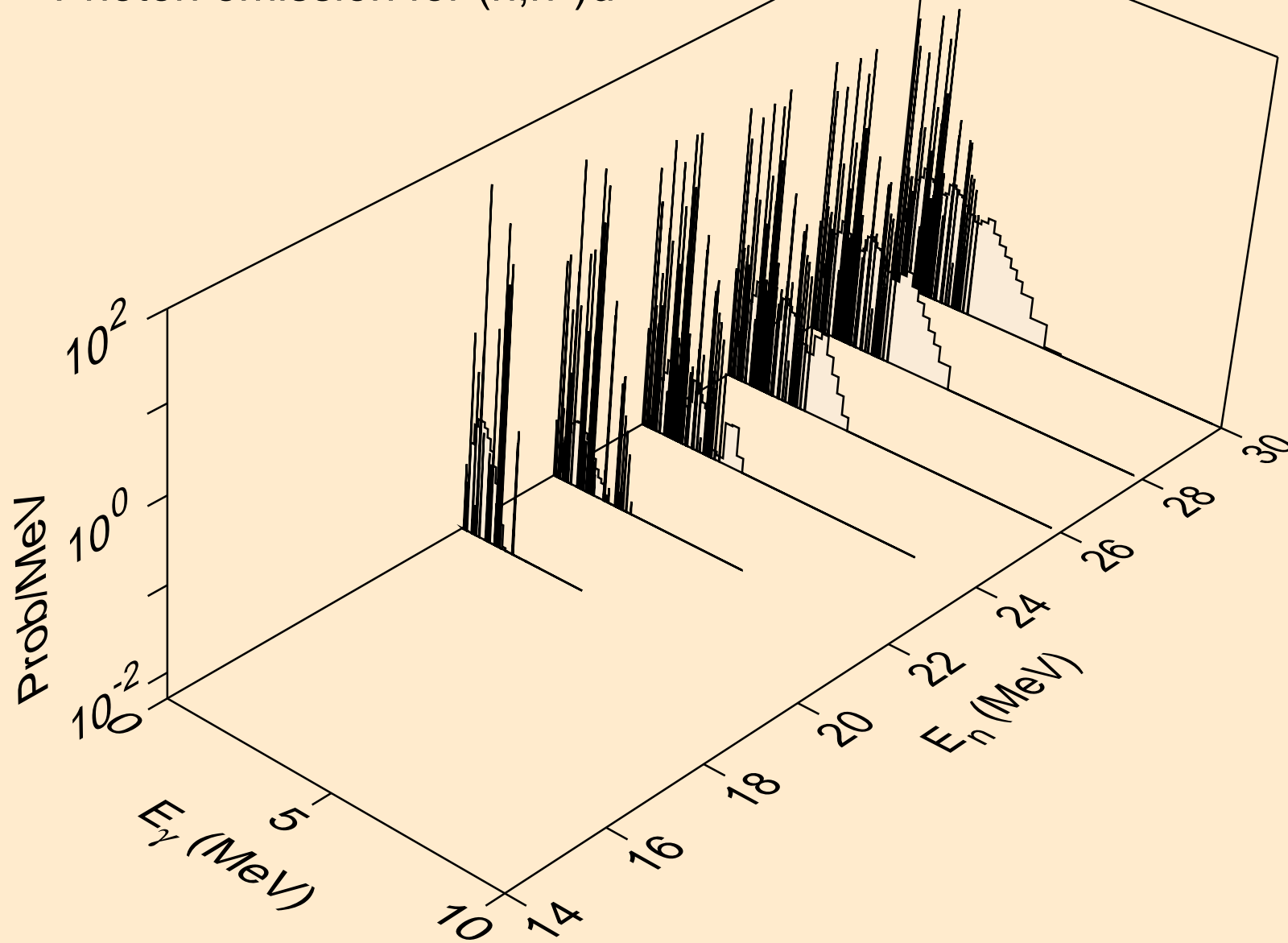

CD124 ALPHA ACER TENDL-2024 LIBRARY; T=0.K
Photon emission for (n,n*)t

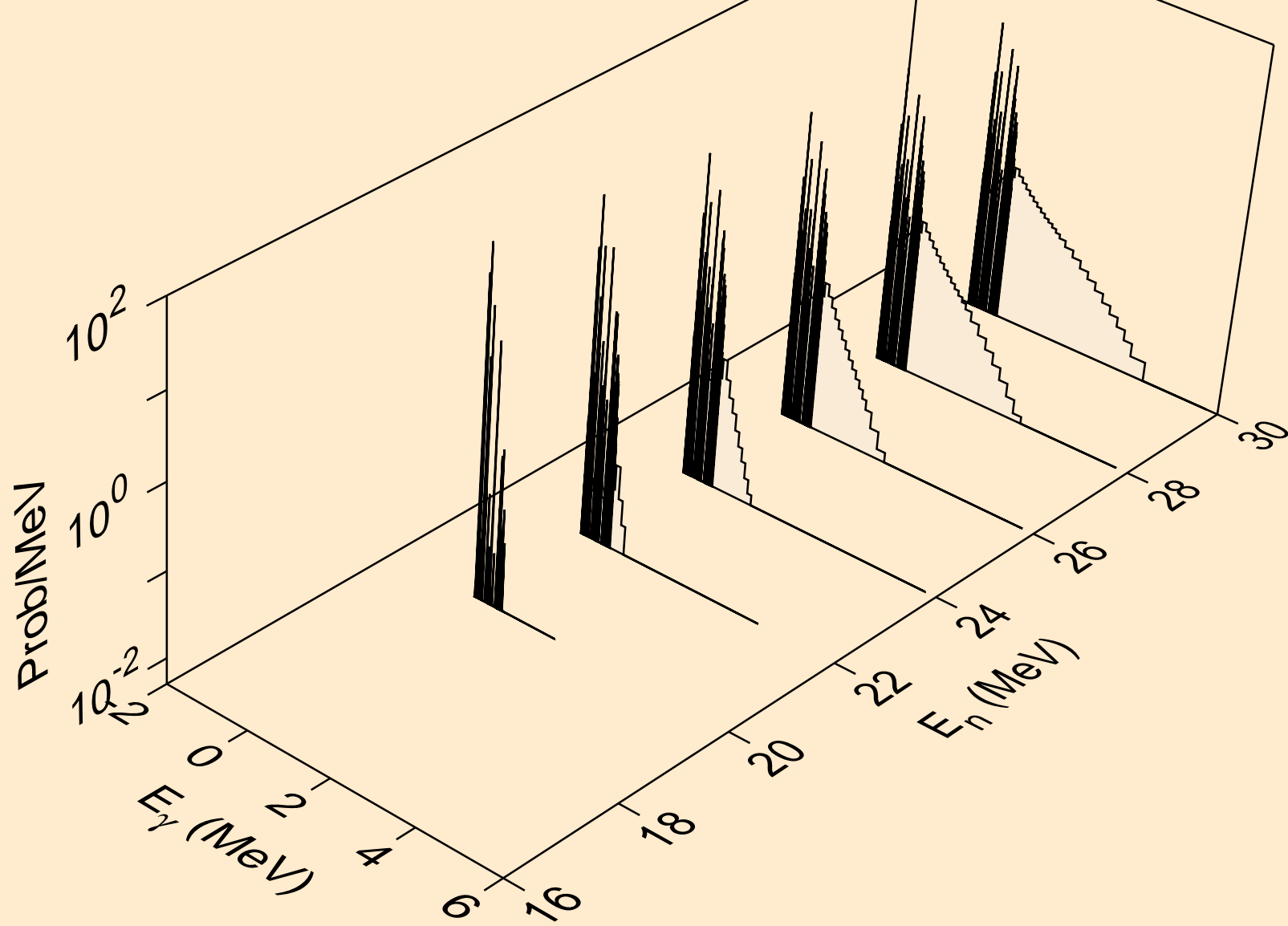

CD124 ALPHA ACER TENDL-2024 LIBRARY; T=0.K
Photon emission for (n,n*)he3

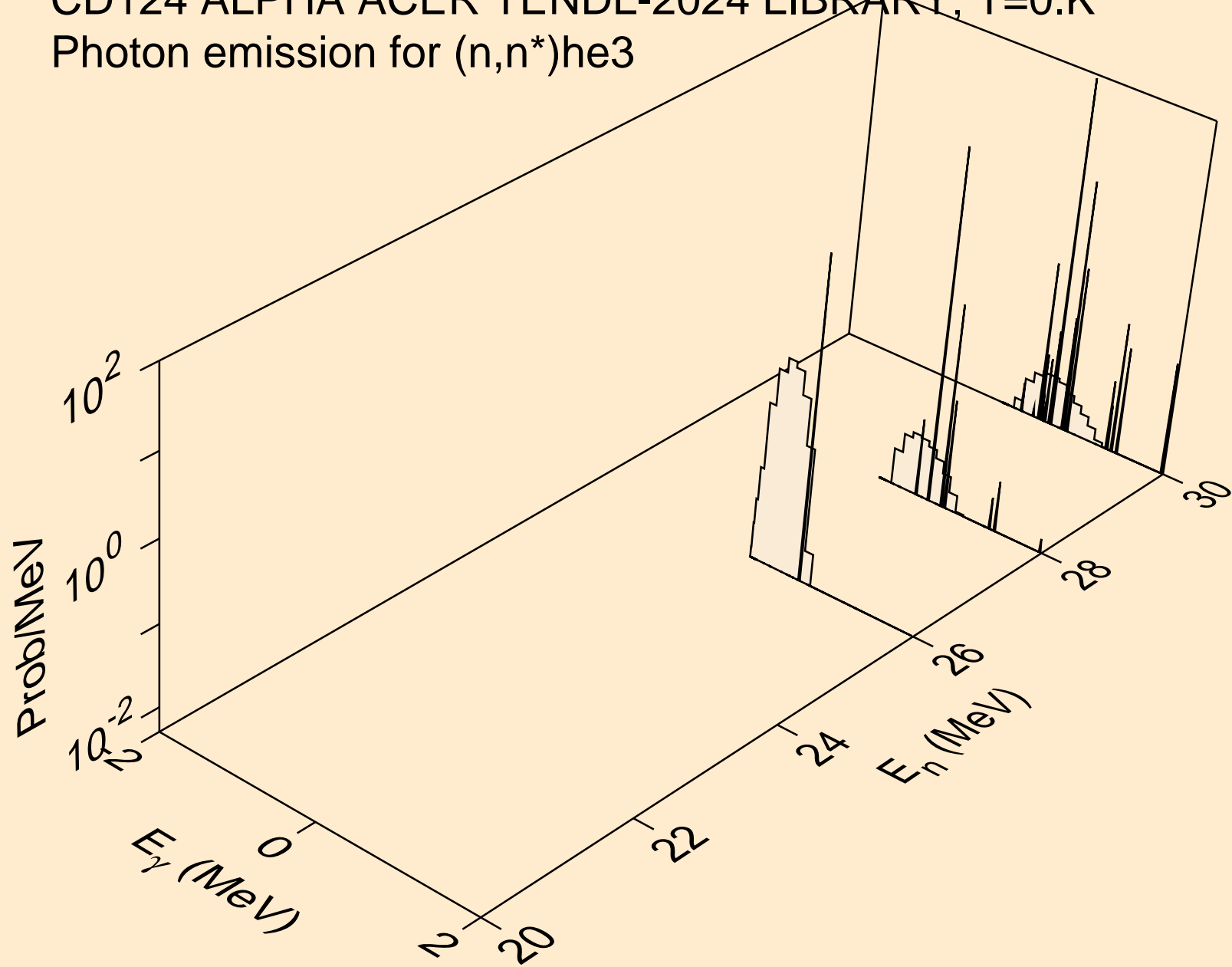

CD124 ALPHA ACER TENDL-2024 LIBRARY; T=0.K
Photon emission for (n,4n)

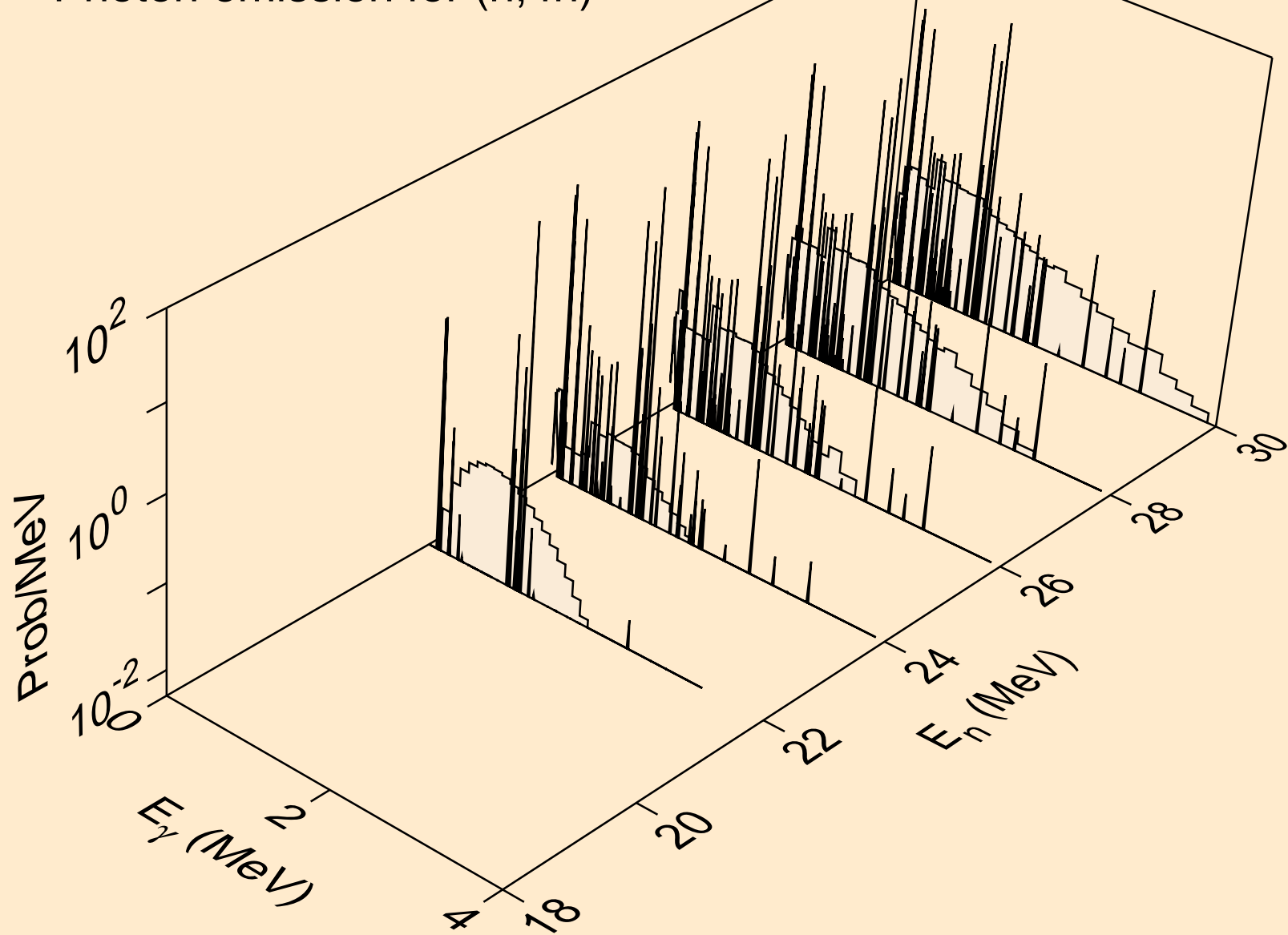

CD124 ALPHA ACER TENDL-2024 LIBRARY; T=0.K
Photon emission for (n,2np)

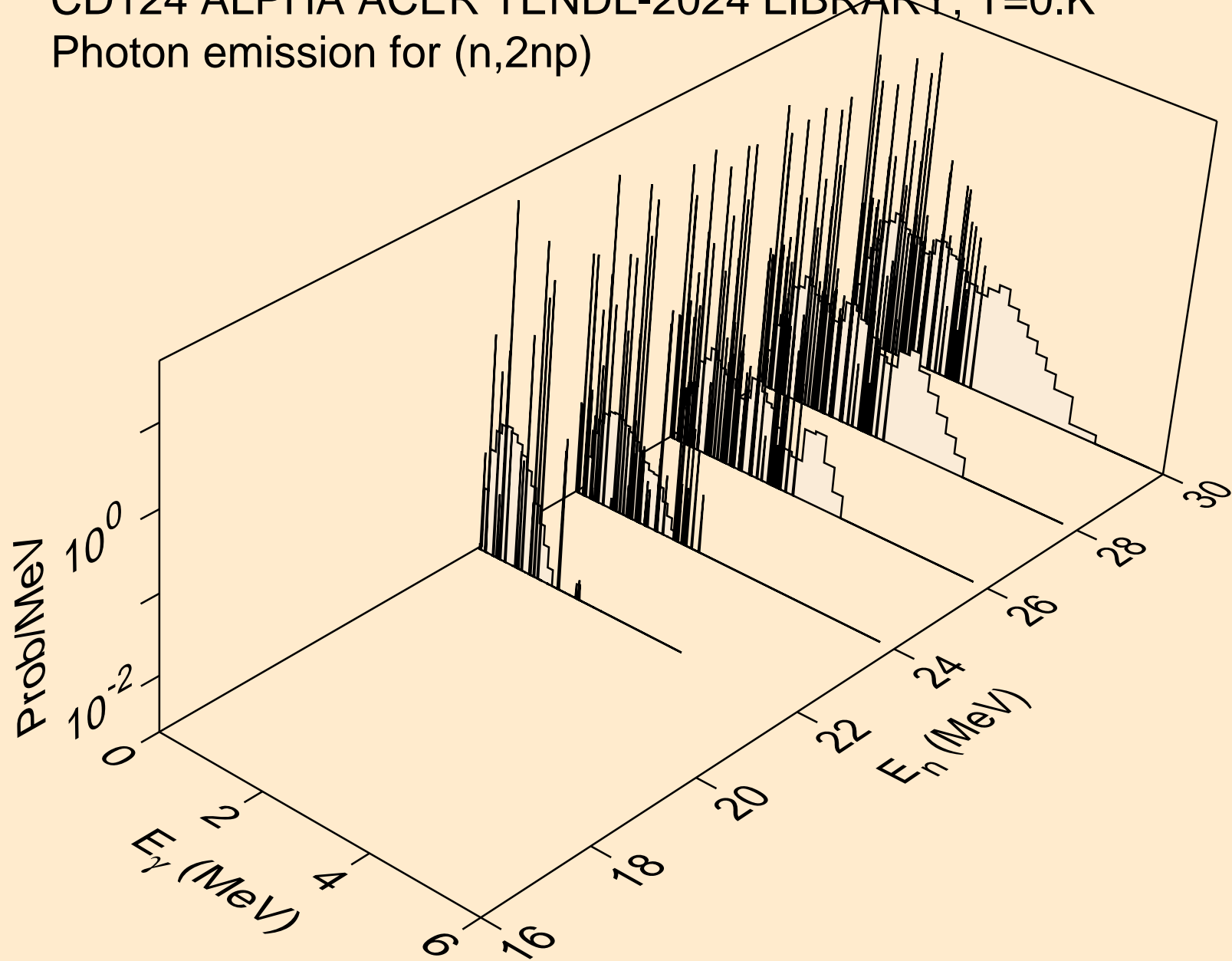

CD124 ALPHA ACER TENDL-2024 LIBRARY; T=0.K
Photon emission for (n,3np)

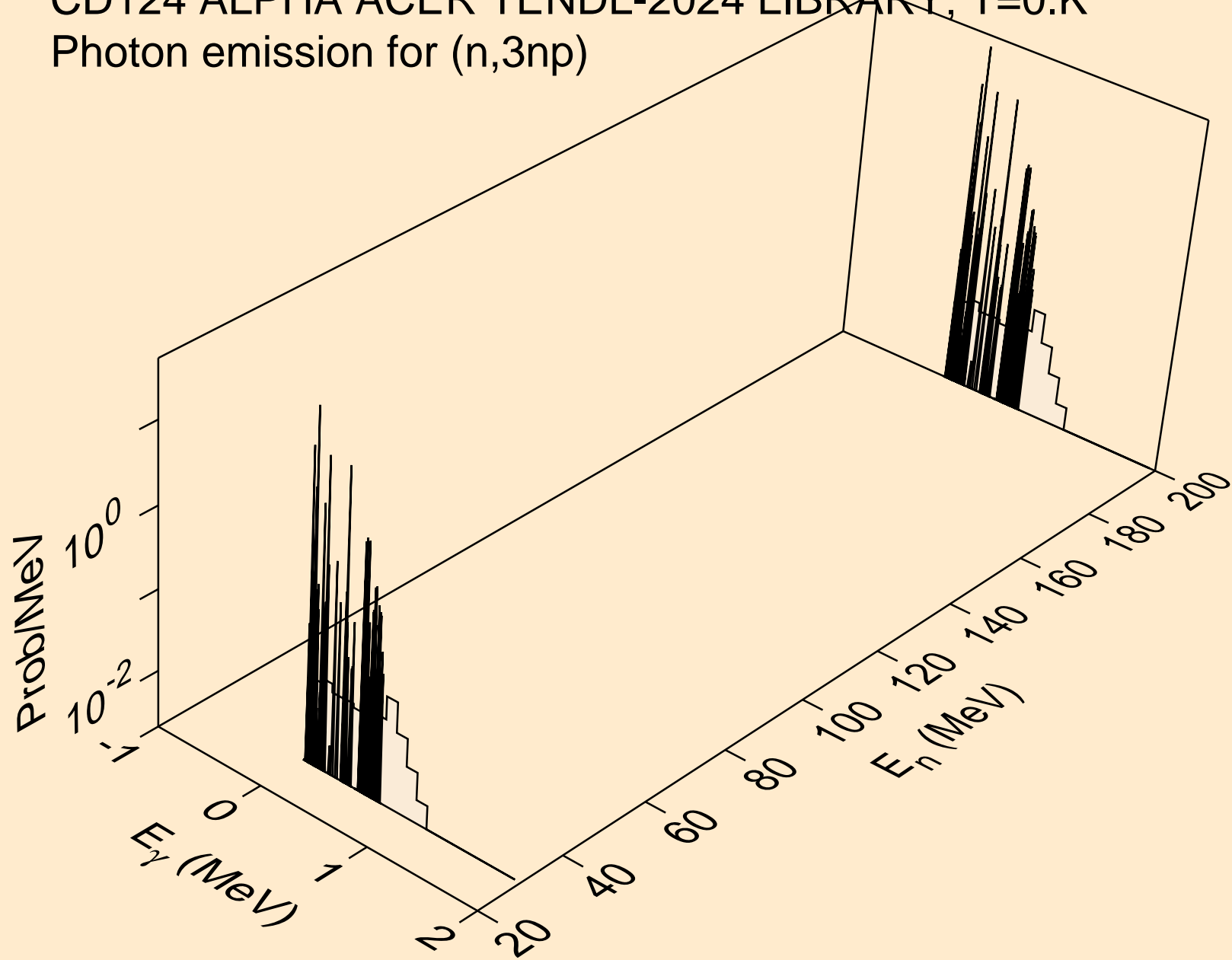

CD124 ALPHA ACER TENDL-2024 LIBRARY; T=0.K
Photon emission for (n,gma)

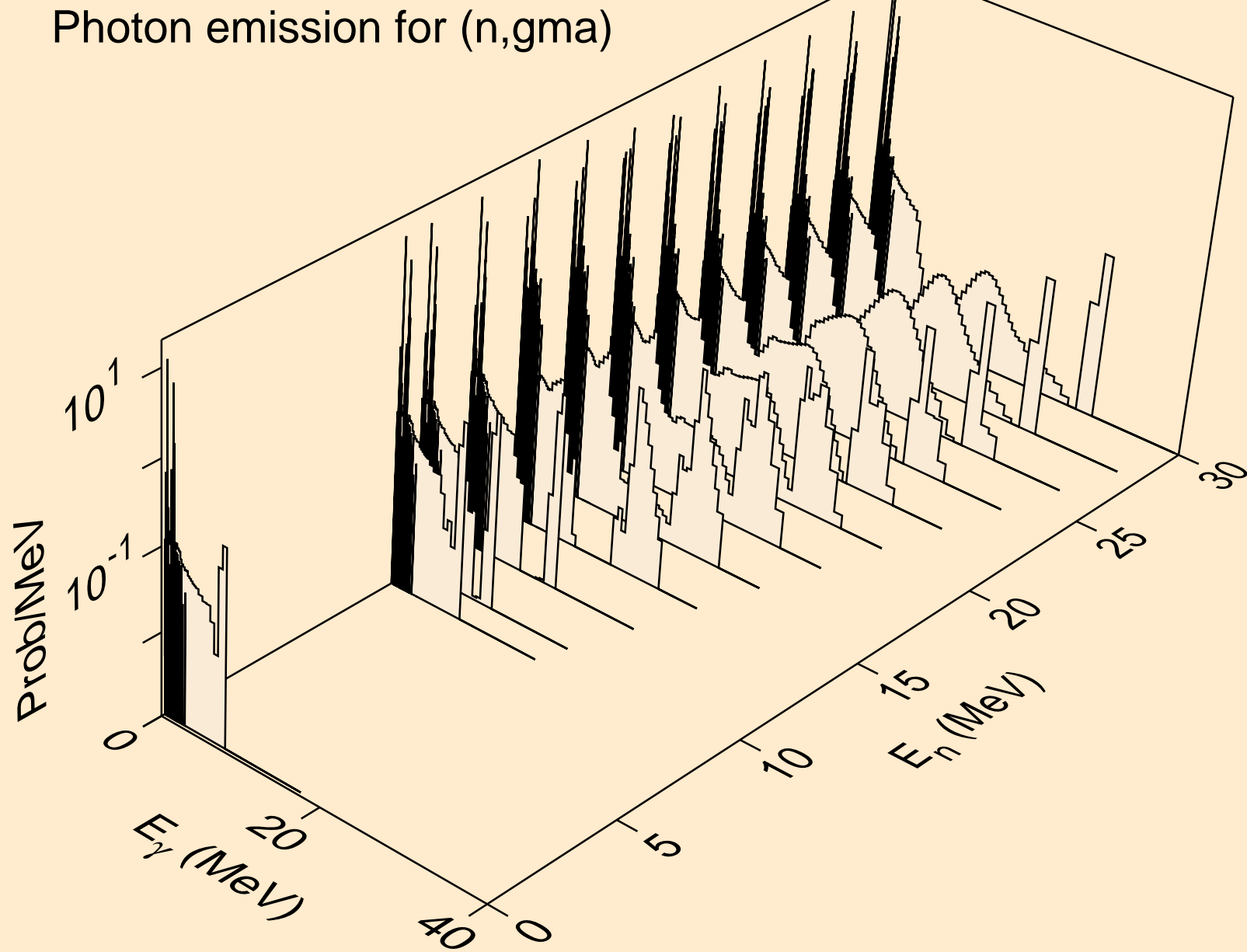

CD124 ALPHA ACER TENDL-2024 LIBRARY; T=0.K
Photon emission for (n,p)

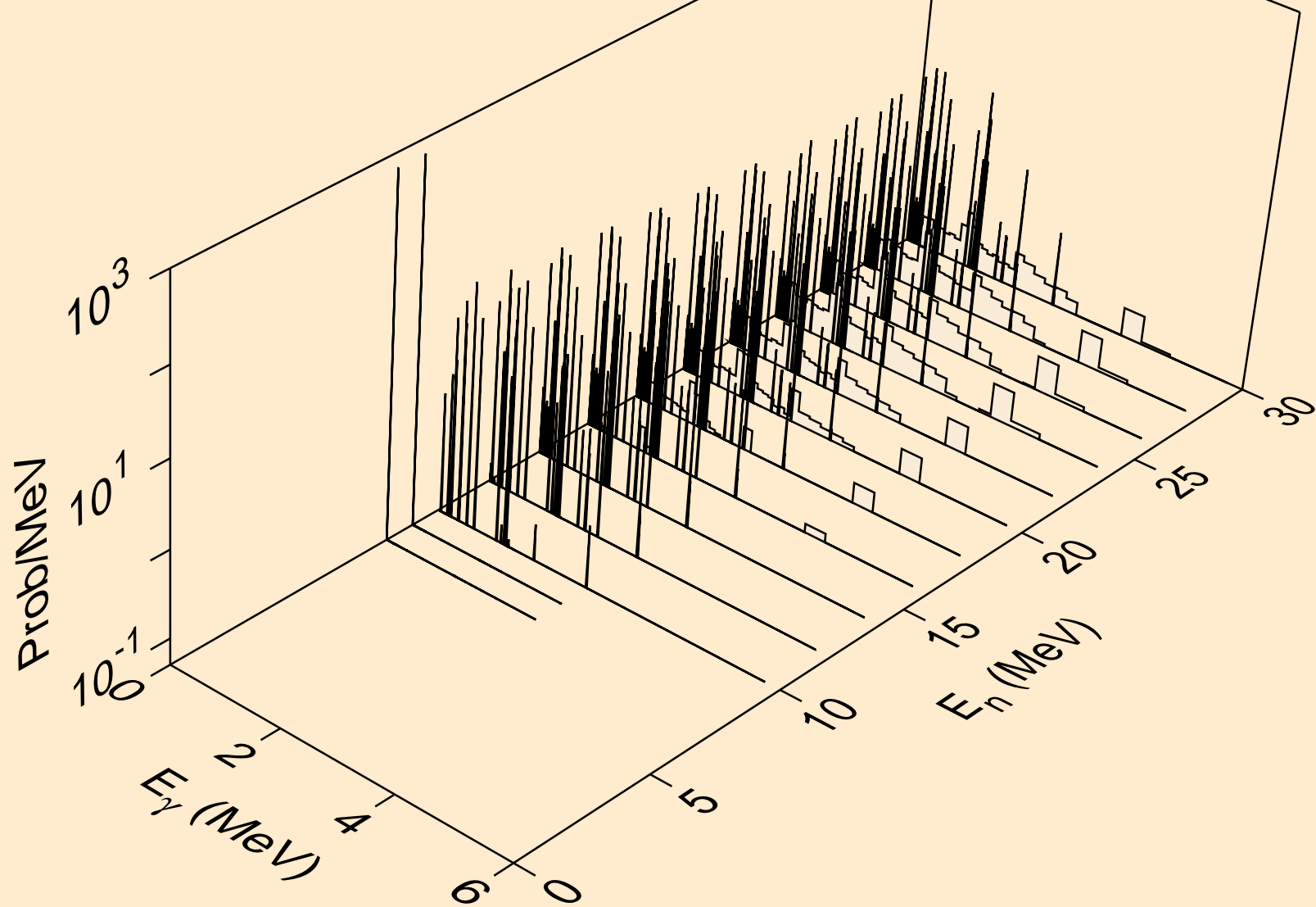

CD124 ALPHA ACER TENDL-2024 LIBRARY; T=0.K
Photon emission for (n,d)

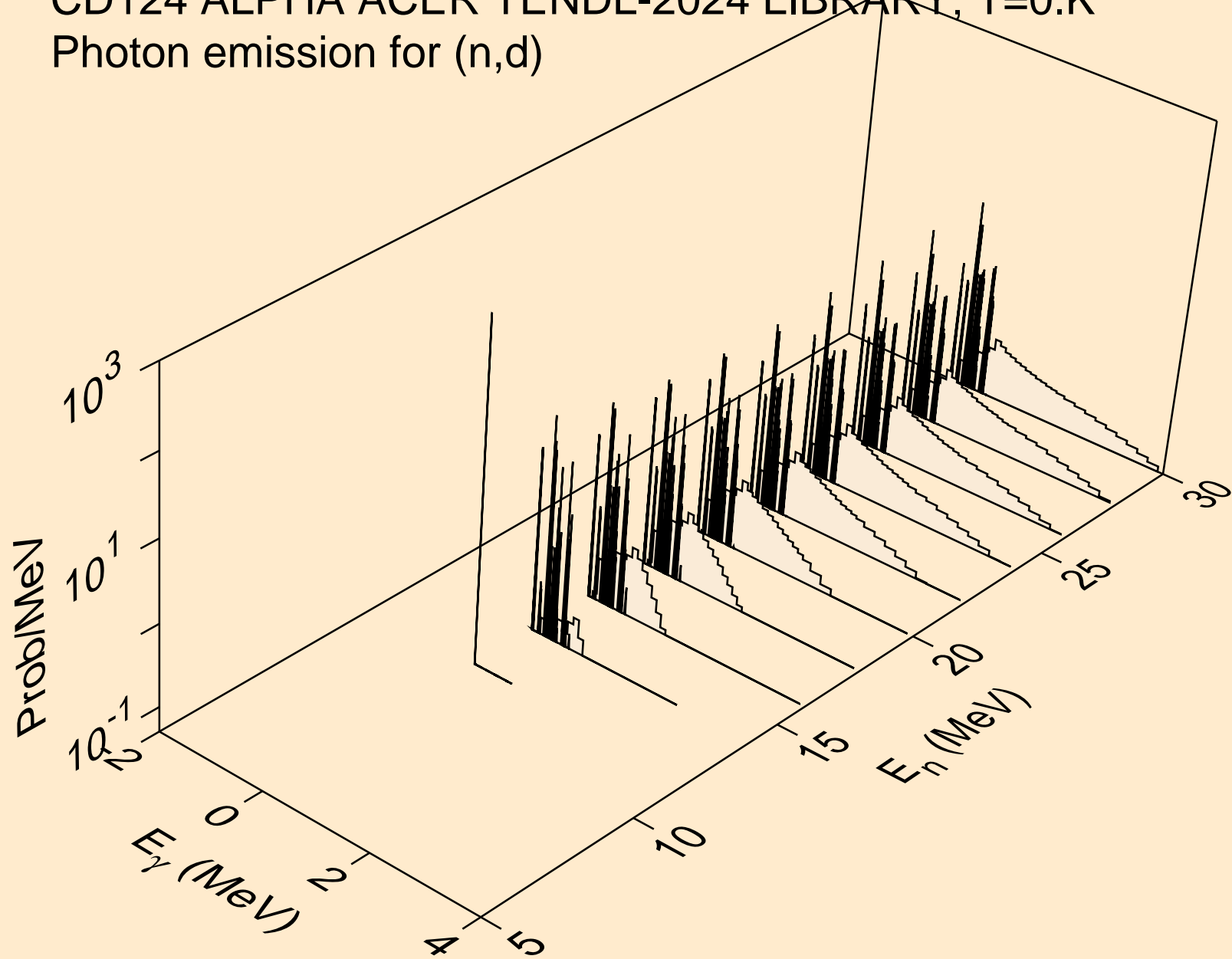

CD124 ALPHA ACER TENDL-2024 LIBRARY; T=0.K
Photon emission for (n,t)

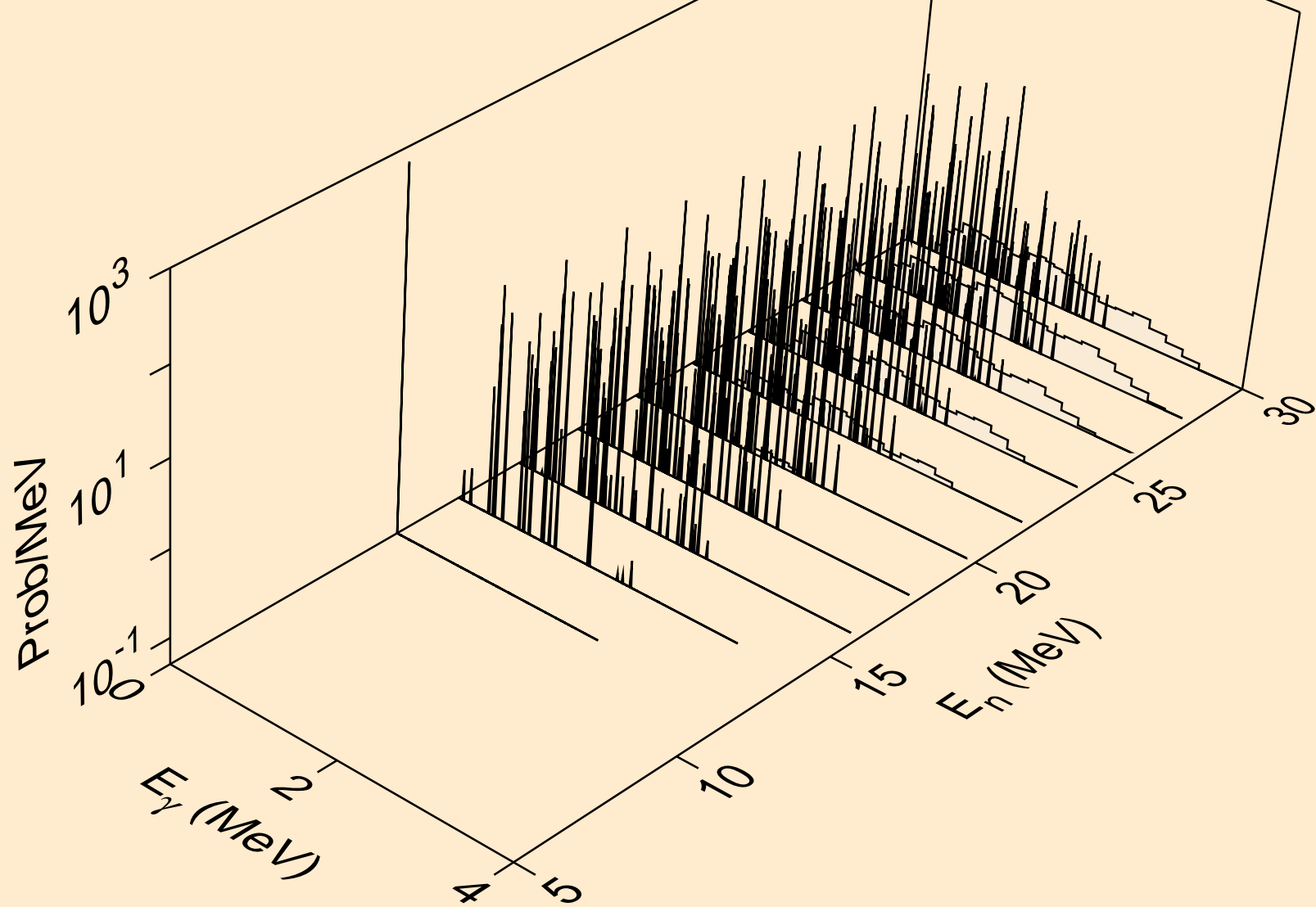

CD124 ALPHA ACER TENDL-2024 LIBRARY; T=0.K
Photon emission for (n,he3)

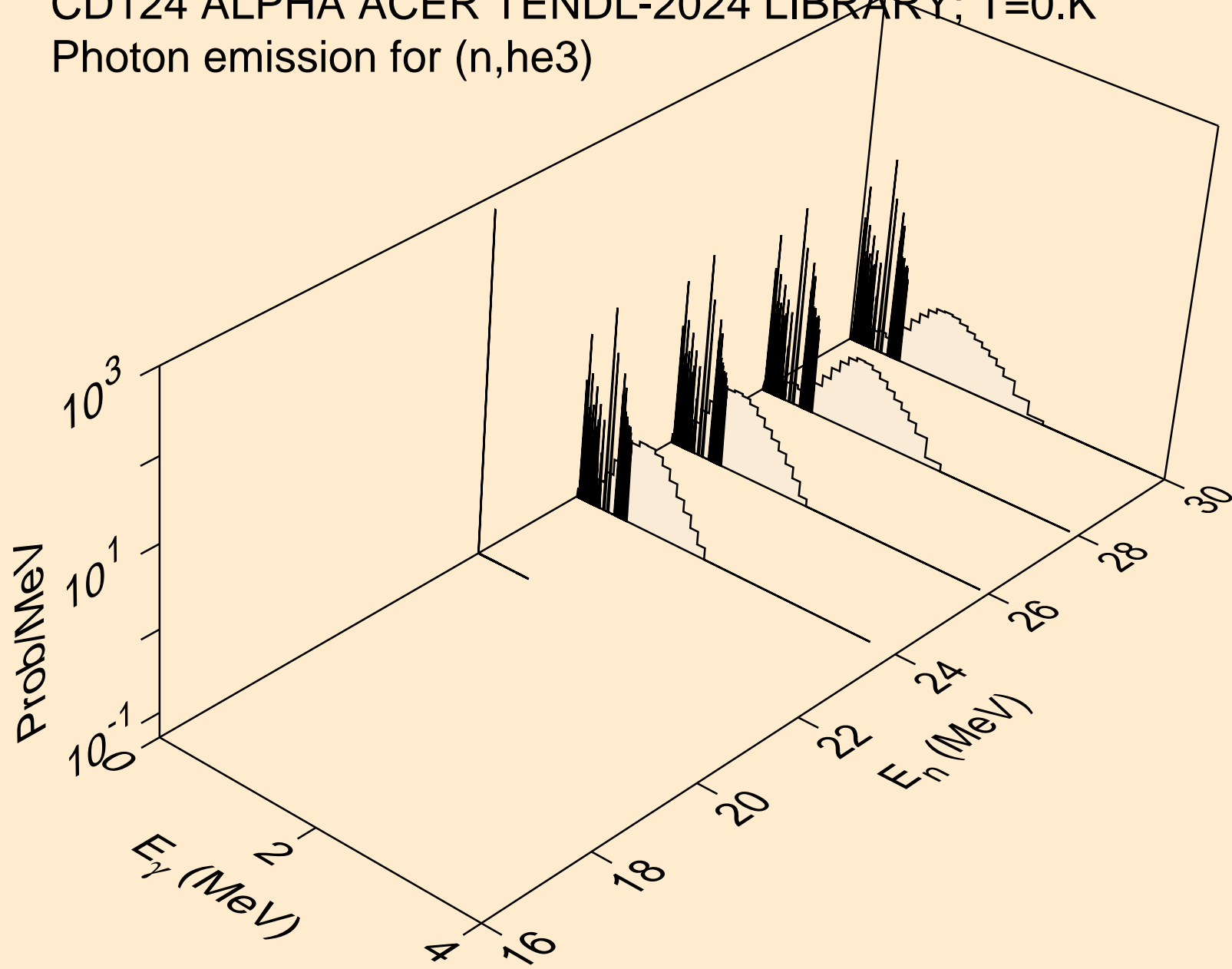

CD124 ALPHA ACER TENDL-2024 LIBRARY; T=0.K
Photon emission for inelastic

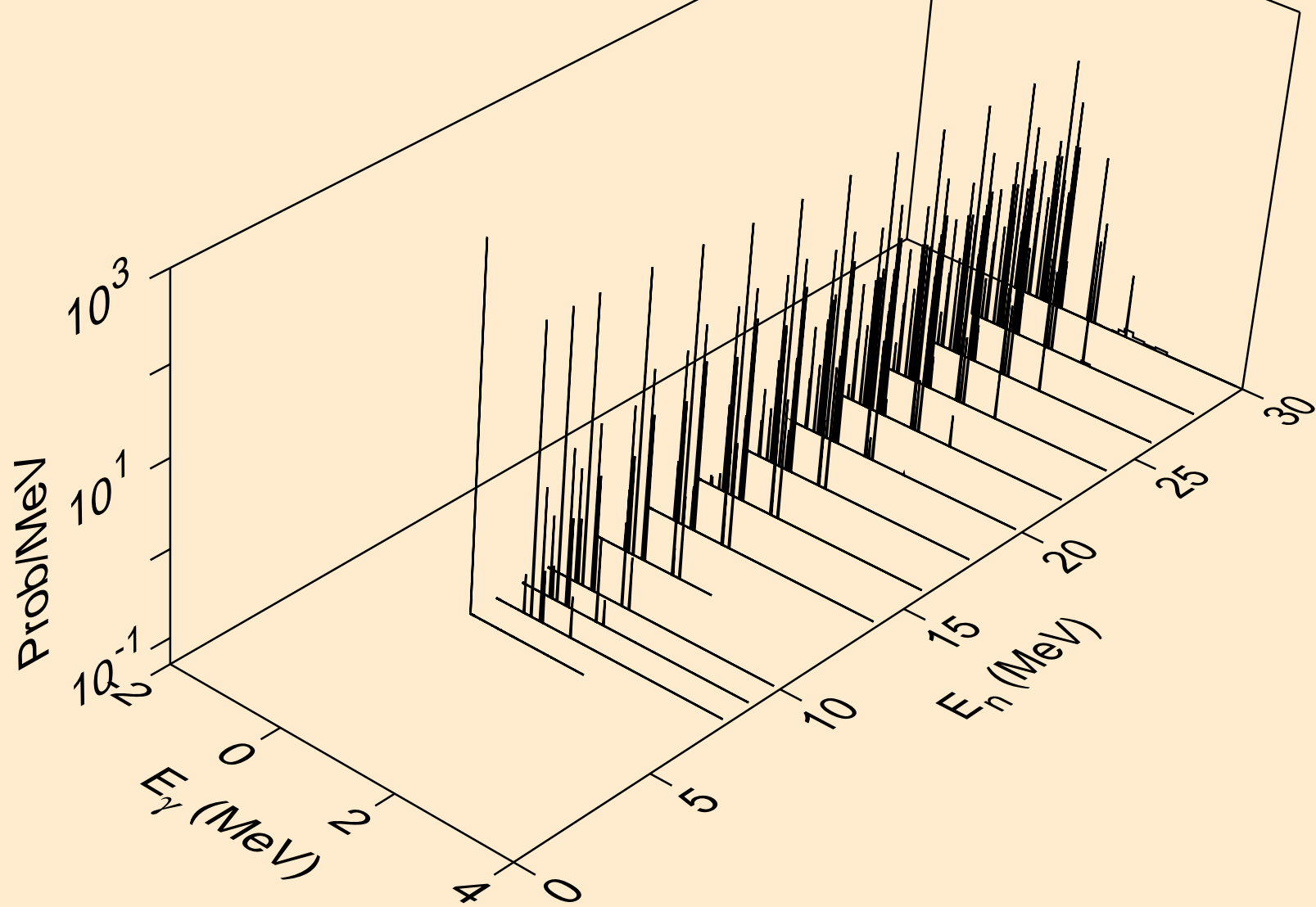

CD124 ALPHA ACER TENDL-2024 LIBRARY; T=0.K
Particle heating contributions

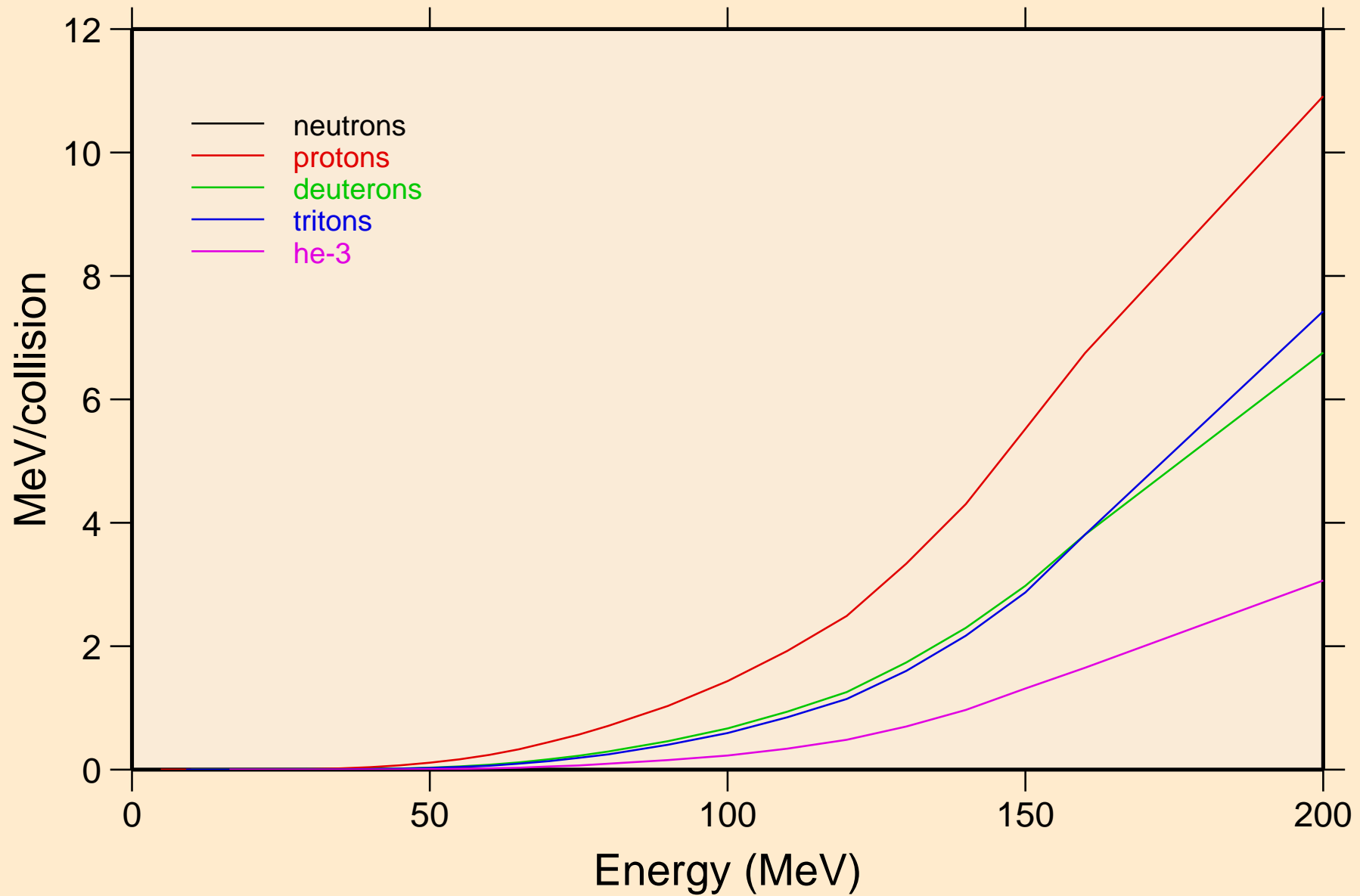

CD124 ALPHA ACER TENDL-2024 LIBRARY; T=0.K
Recoil Heating

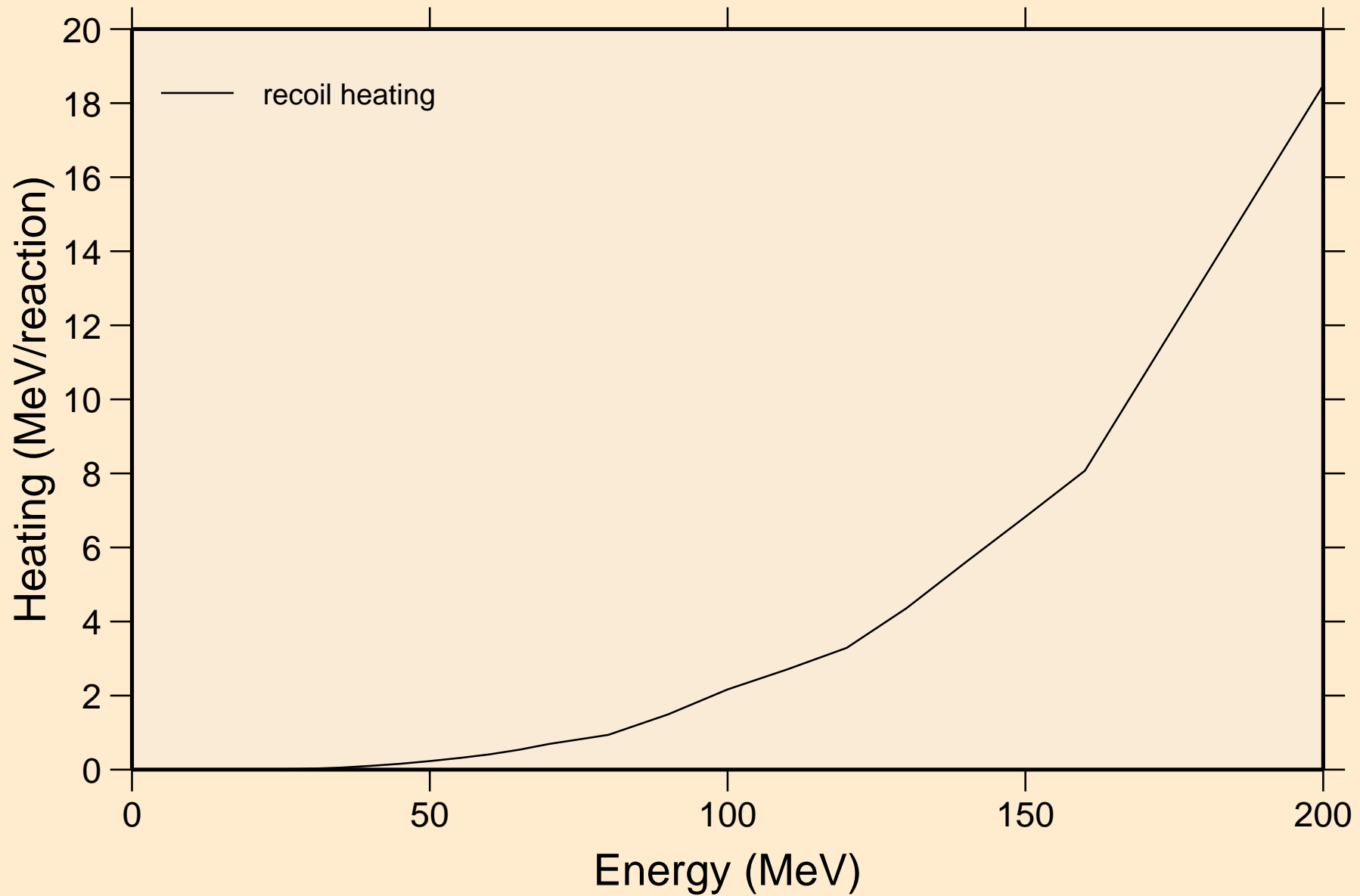

CD124 ALPHA ACER TENDL-2024 LIBRARY; T=0.K
Particle production cross sections

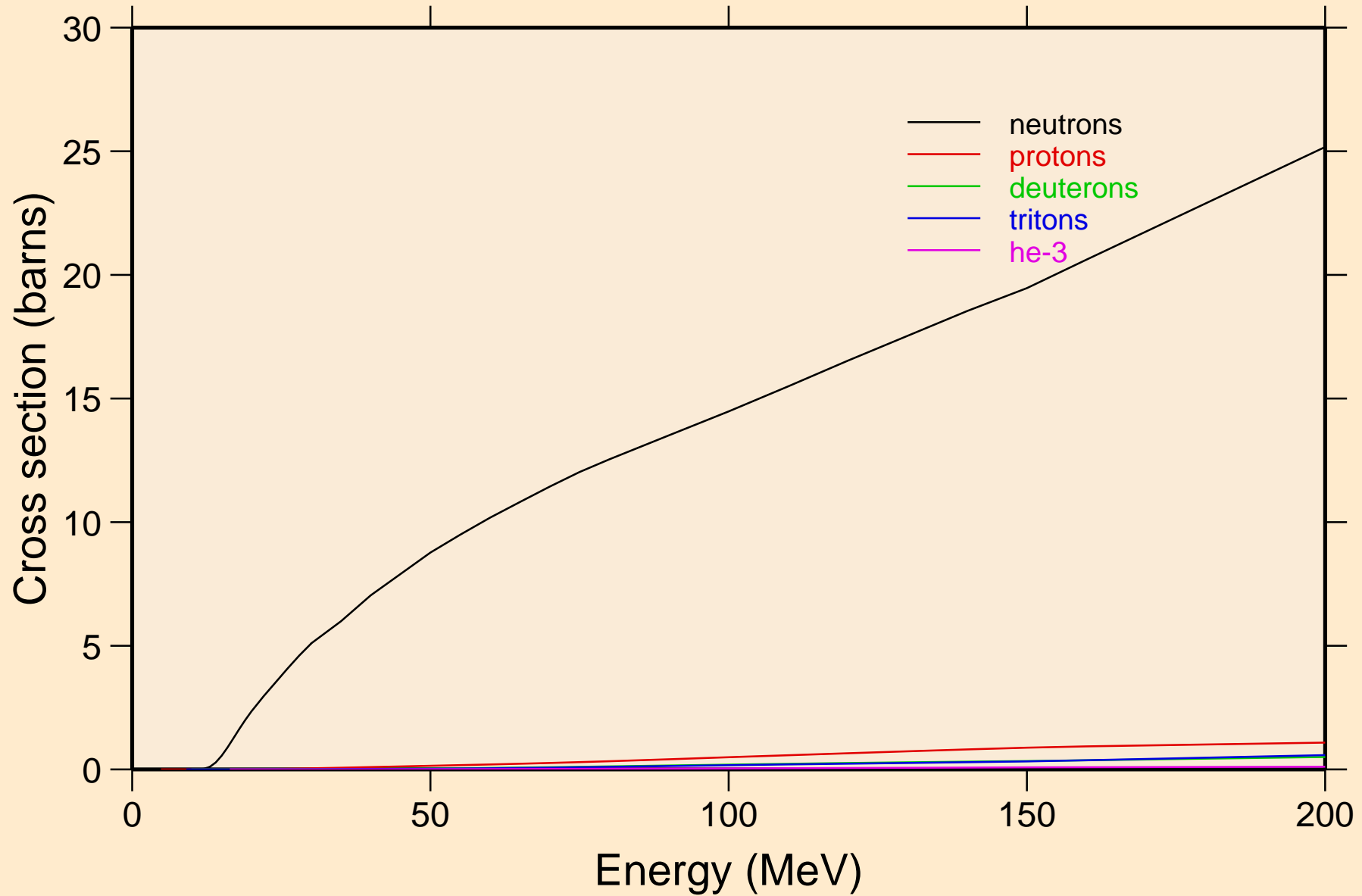

CD124 ALPHA ACER TENDL-2024 LIBRARY; T=0.K
neutrons from (a,n)

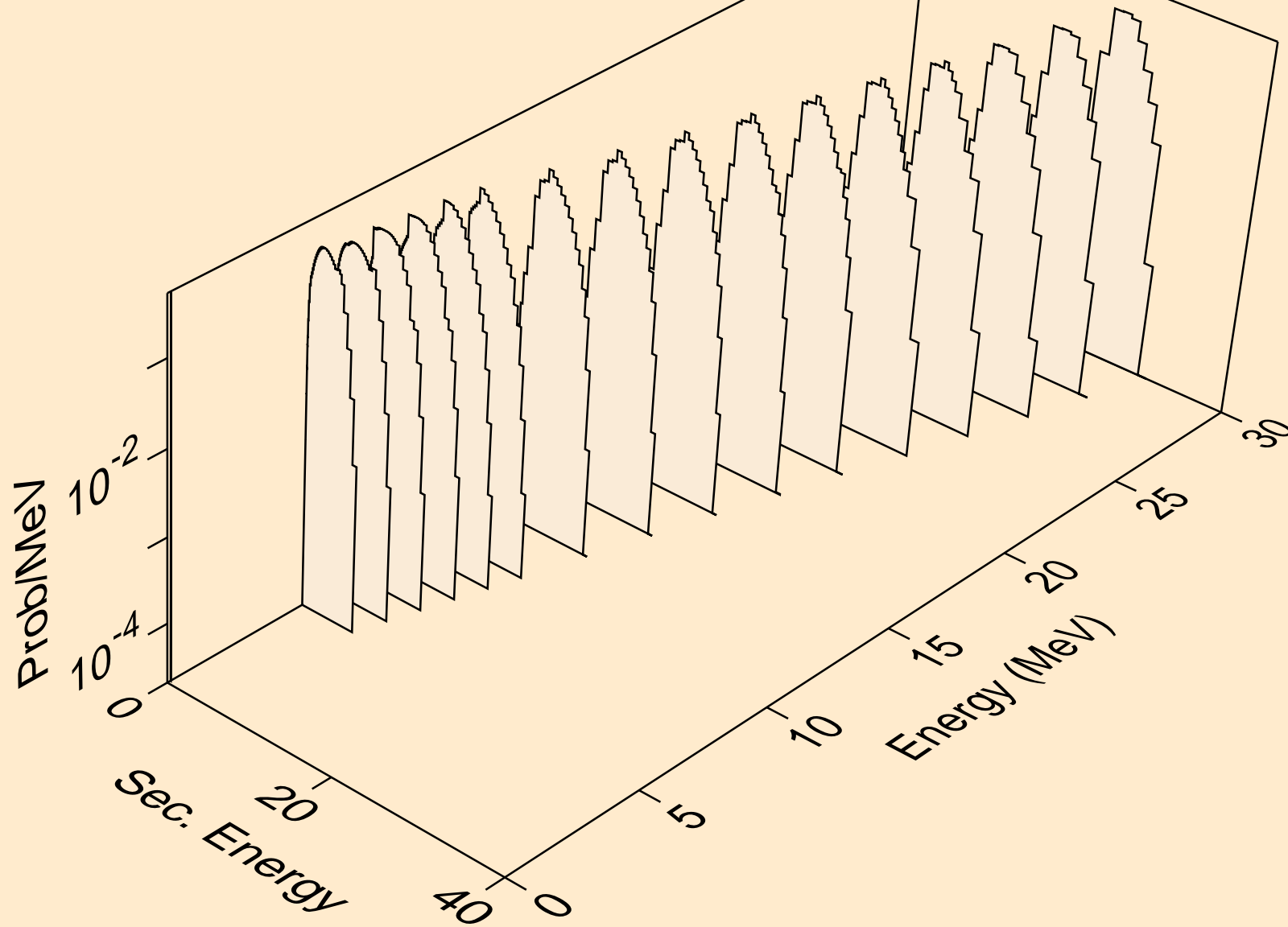

CD124 ALPHA ACER TENDL-2024 LIBRARY; T=0.K
neutrons from (a,x)

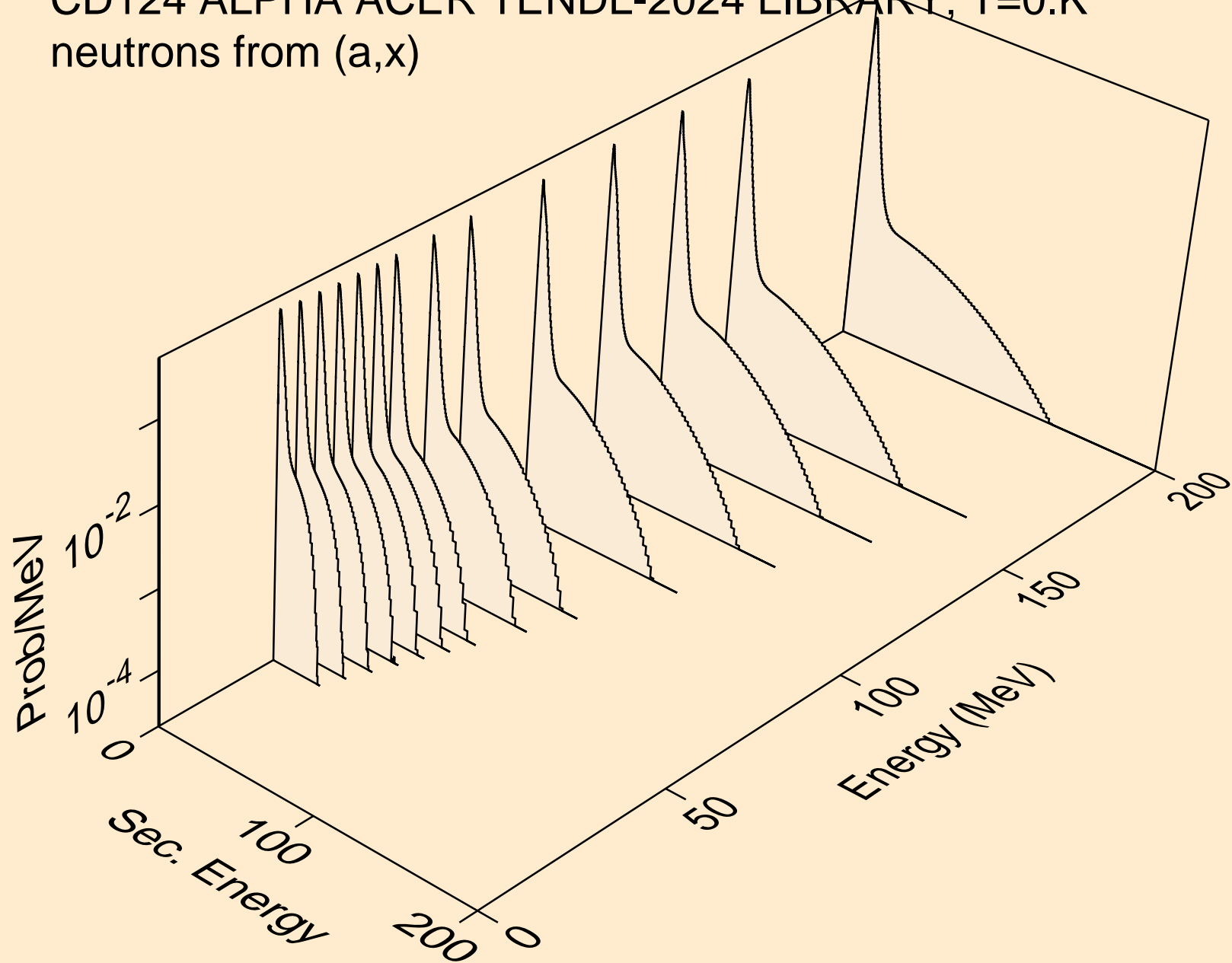

CD124 ALPHA ACER TENDL-2024 LIBRARY; T=0.K
neutrons from (a,2nd)

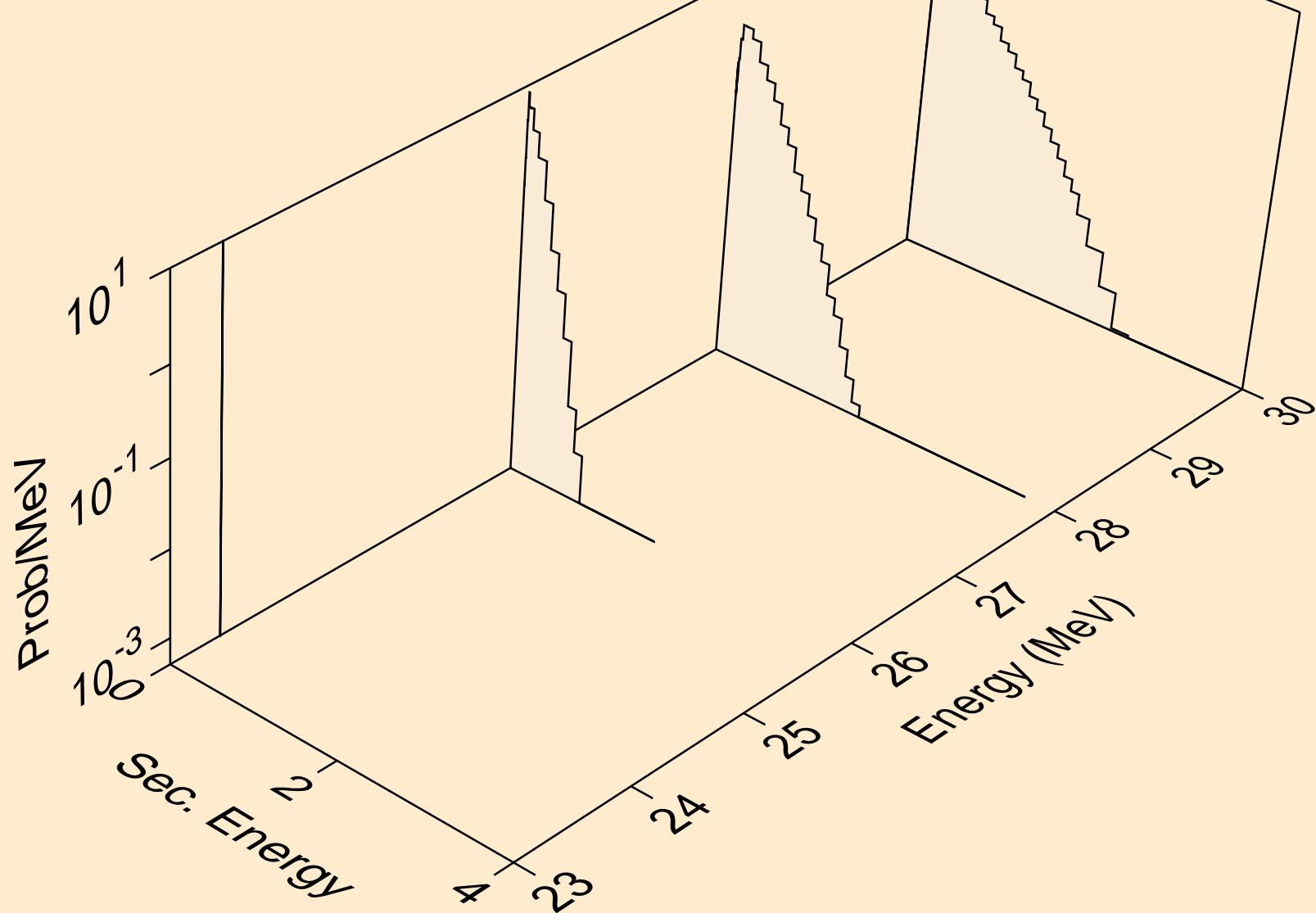

CD124 ALPHA ACER TENDL-2024 LIBRARY; T=0.K
neutrons from (a,2n)

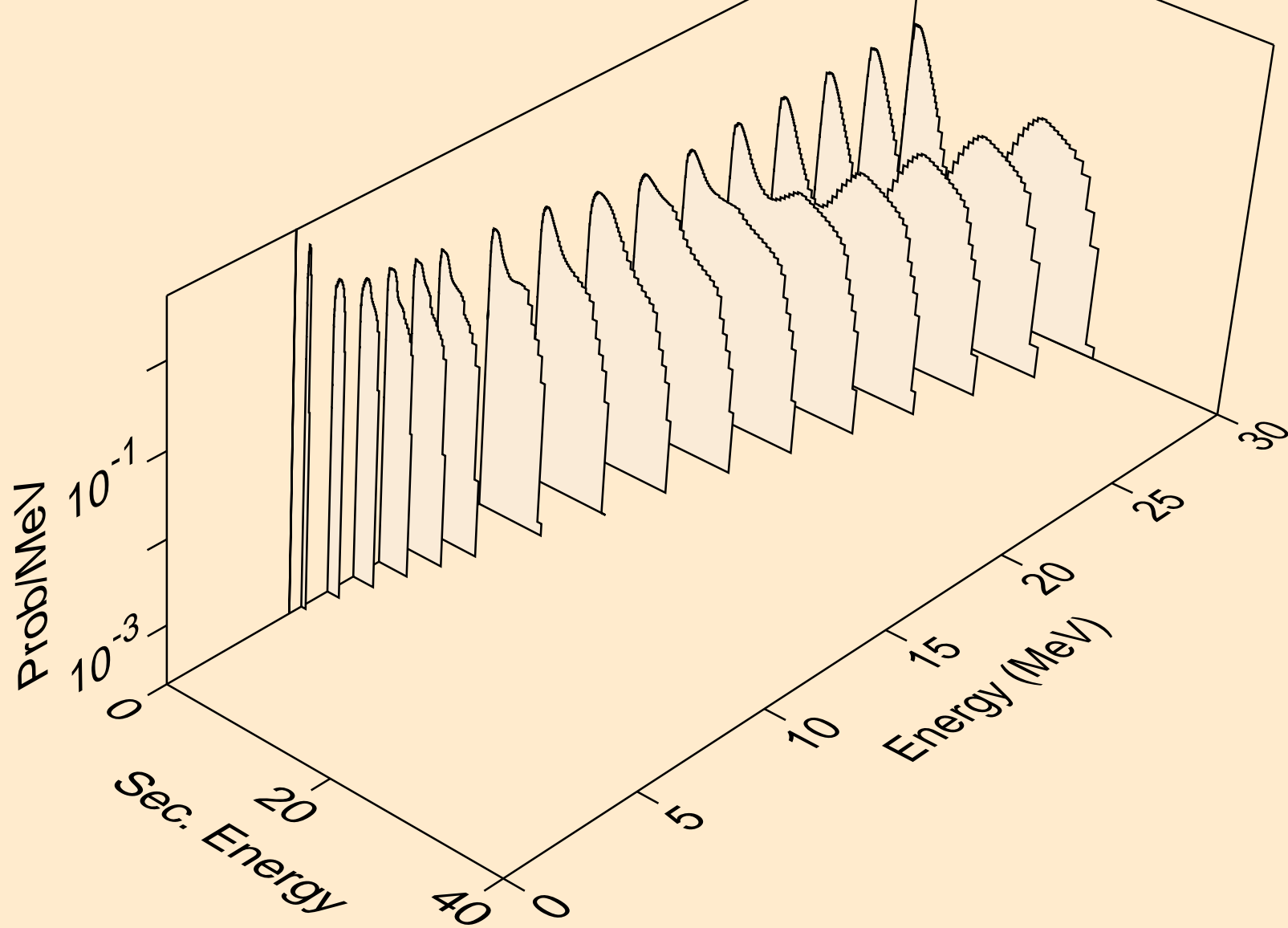

CD124 ALPHA ACER TENDL-2024 LIBRARY; T=0.K
neutrons from (a,3n)

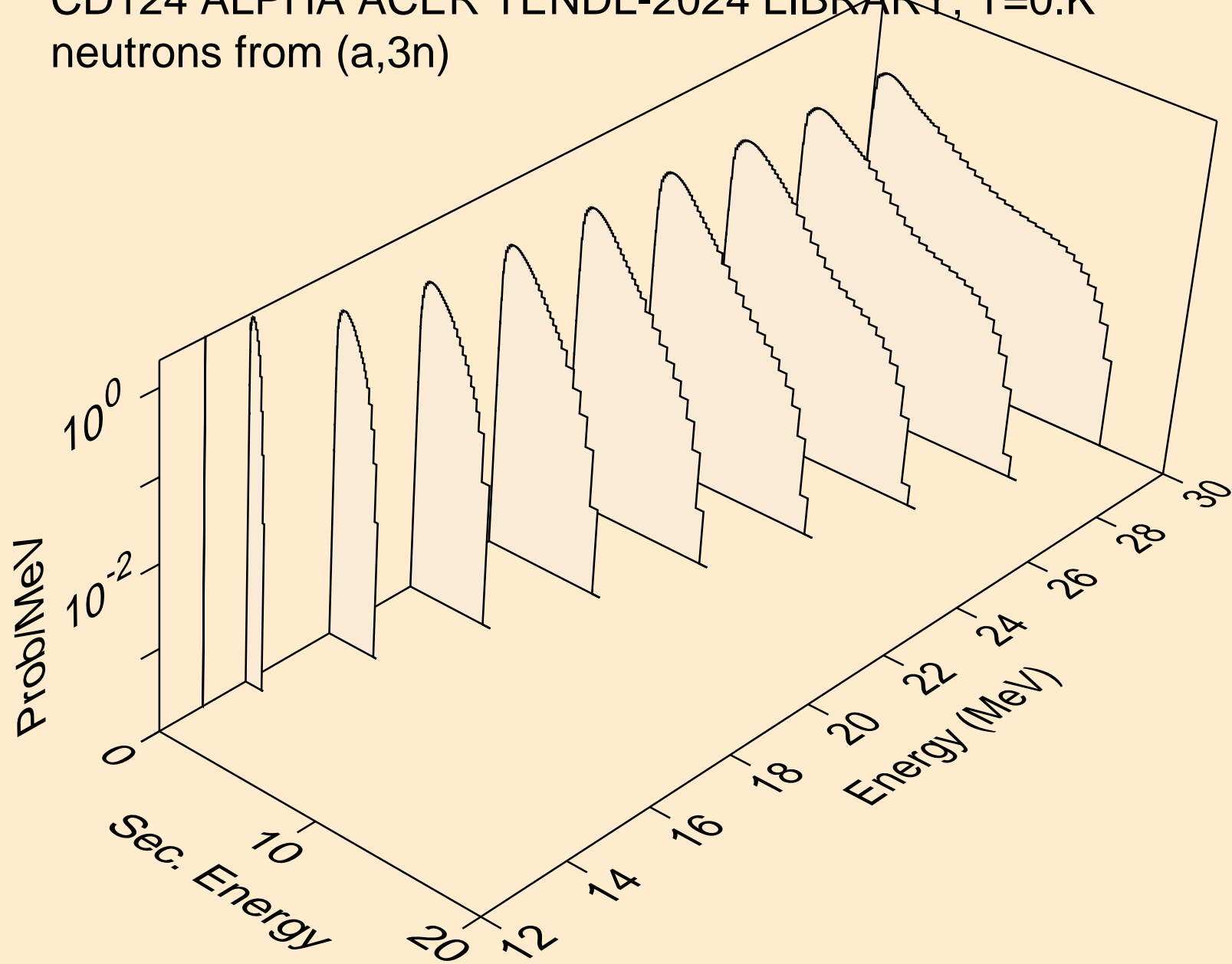

CD124 ALPHA ACER TENDL-2024 LIBRARY; T=0.K
neutrons from (a,n*)a

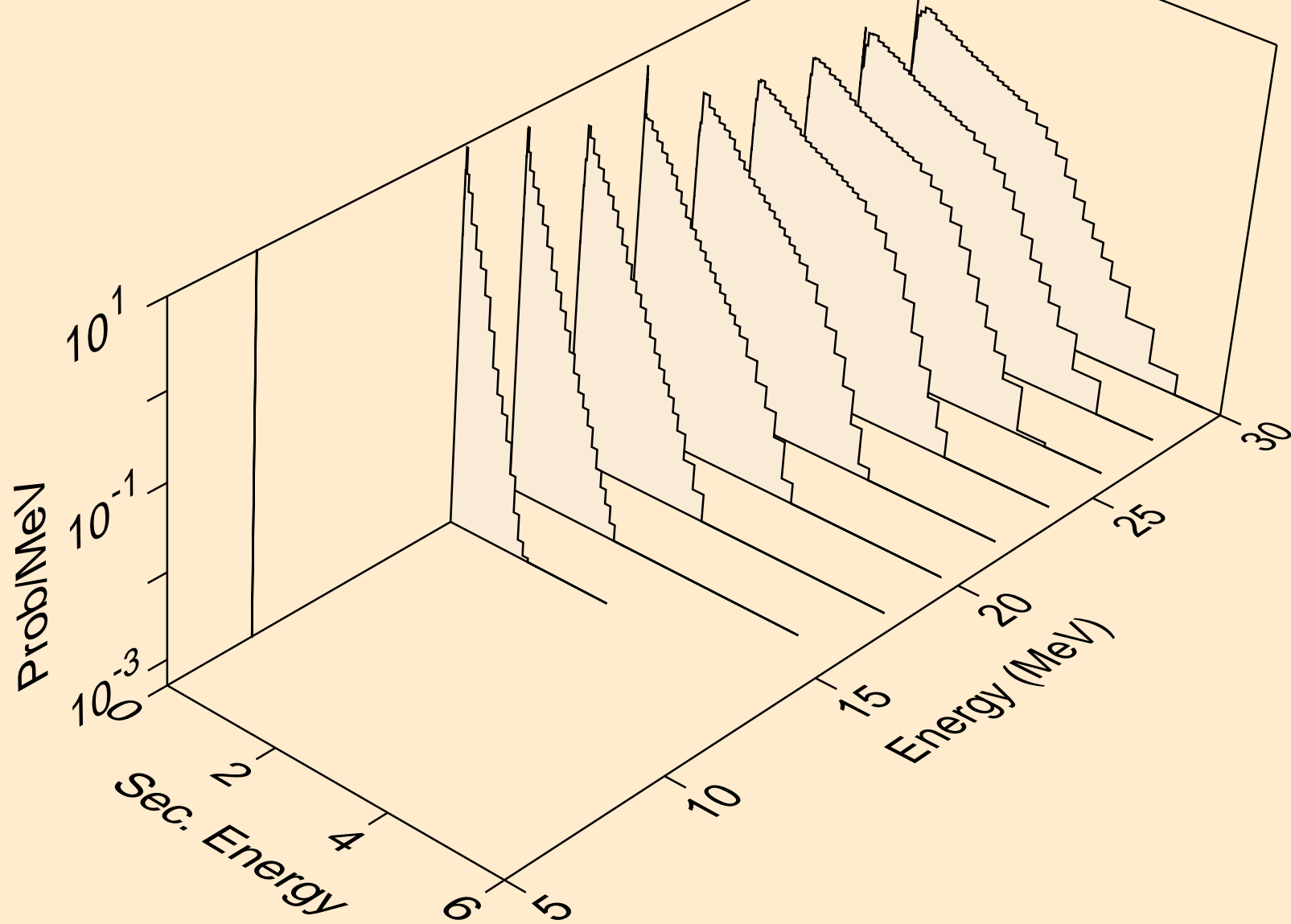

CD124 ALPHA ACER TENDL-2024 LIBRARY; T=0.K
neutrons from (a,2n)a

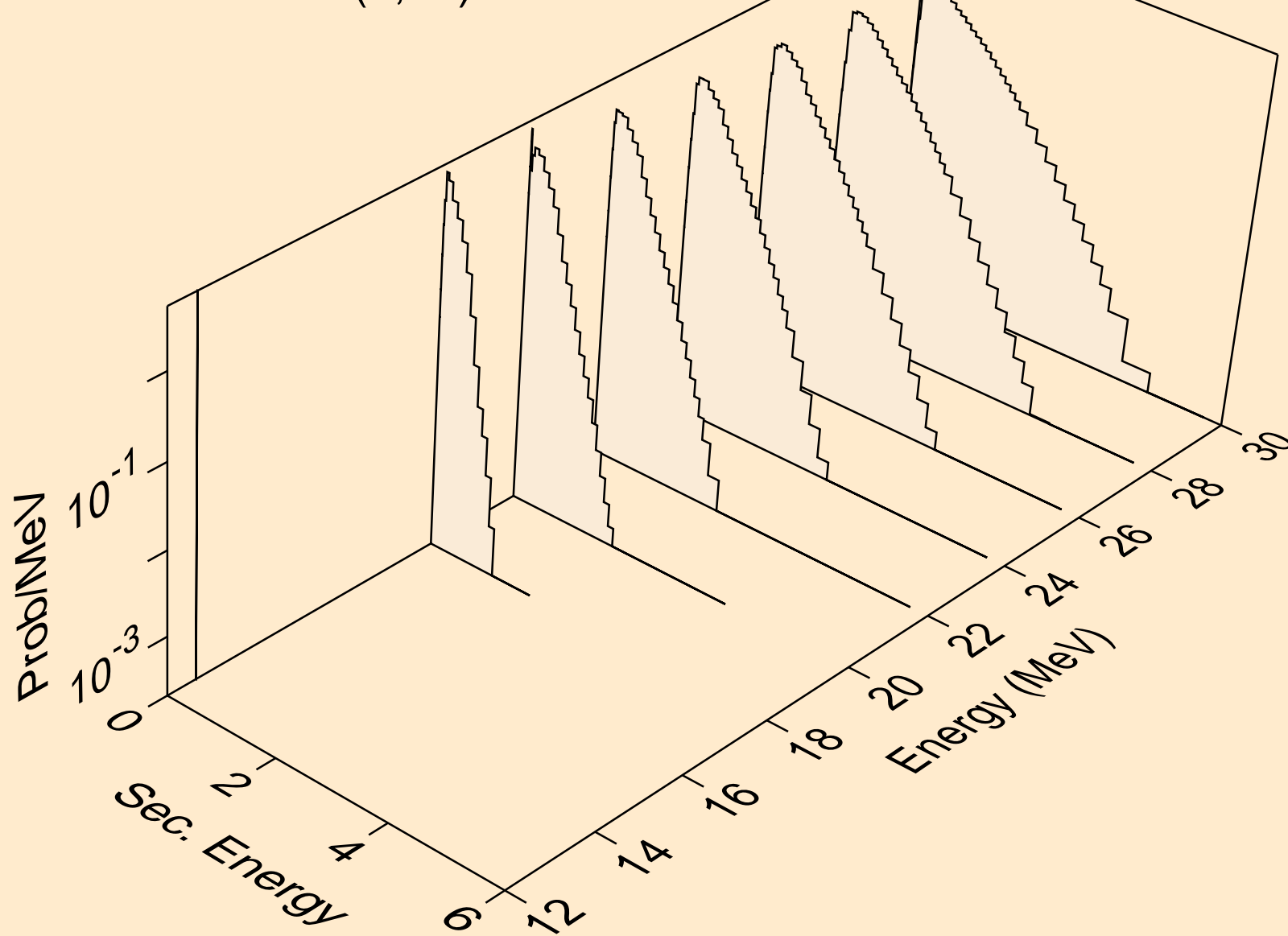

CD124 ALPHA ACER TENDL-2024 LIBRARY; T=0.K
neutrons from (a,3n)a

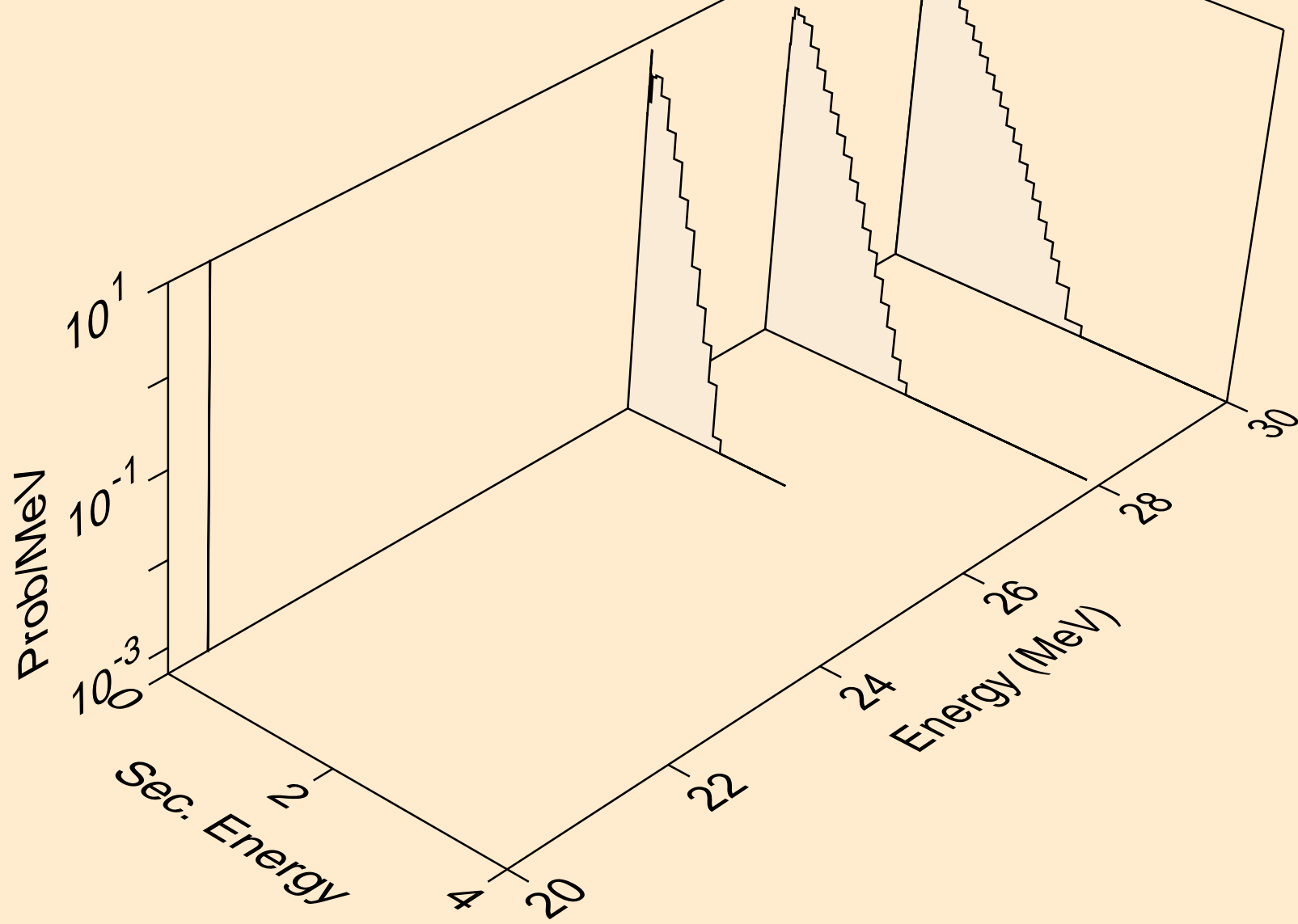

CD124 ALPHA ACER TENDL-2024 LIBRARY; T=0.K
neutrons from (a,n*)p

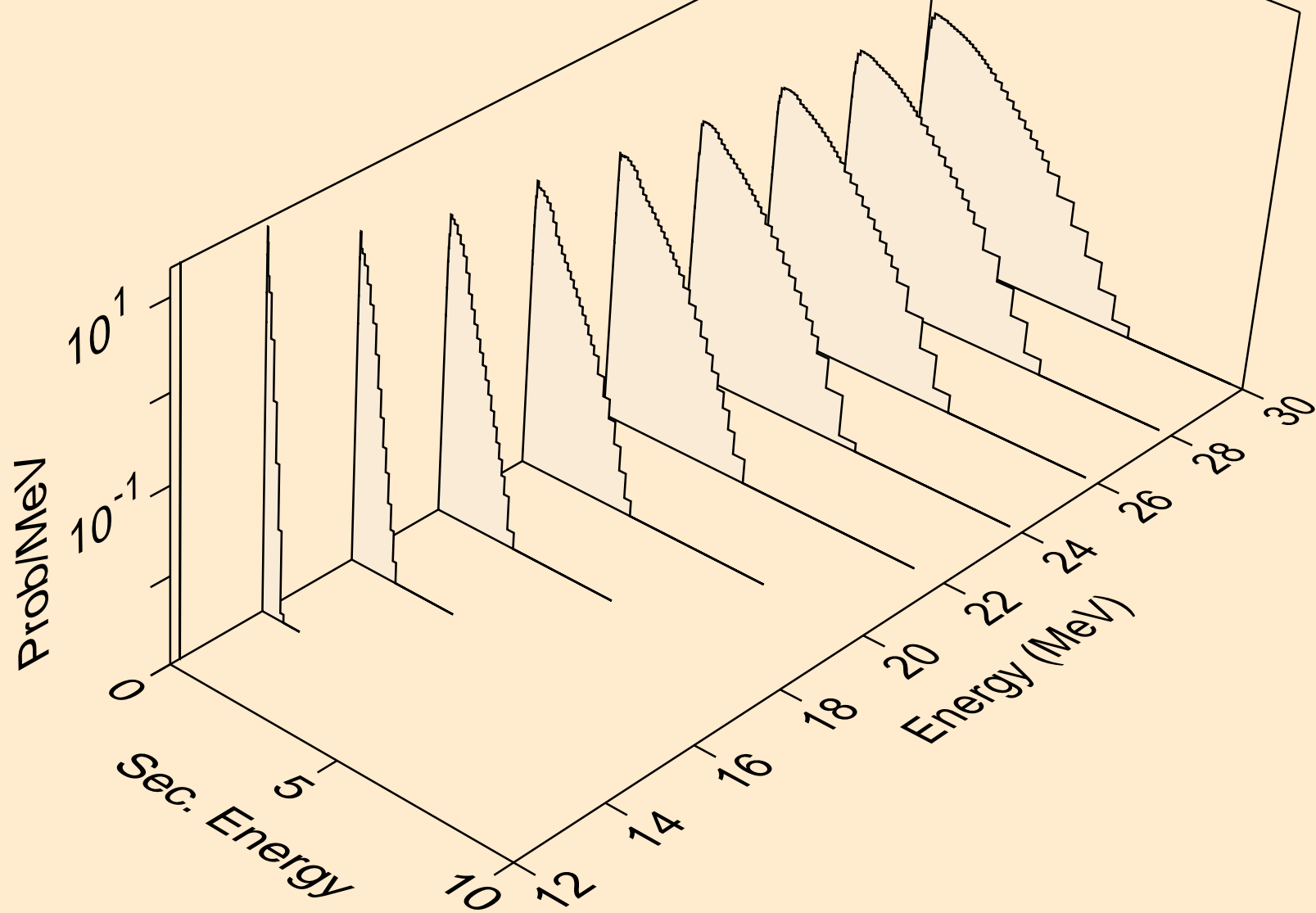

CD124 ALPHA ACER TENDL-2024 LIBRARY; T=0.K
neutrons from (a,n*)d

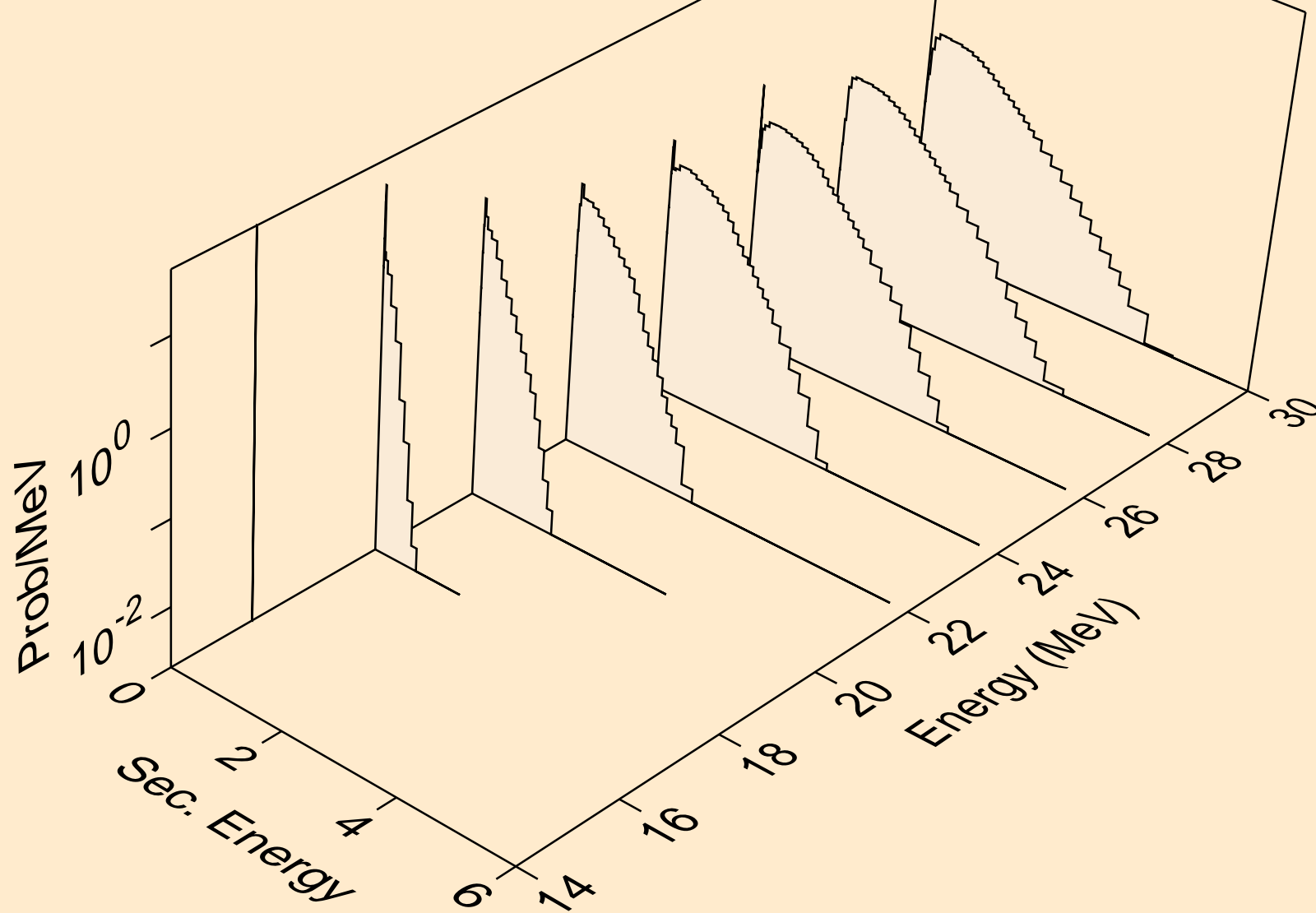

CD124 ALPHA ACER TENDL-2024 LIBRARY; T=0.K
neutrons from (a,n*)t

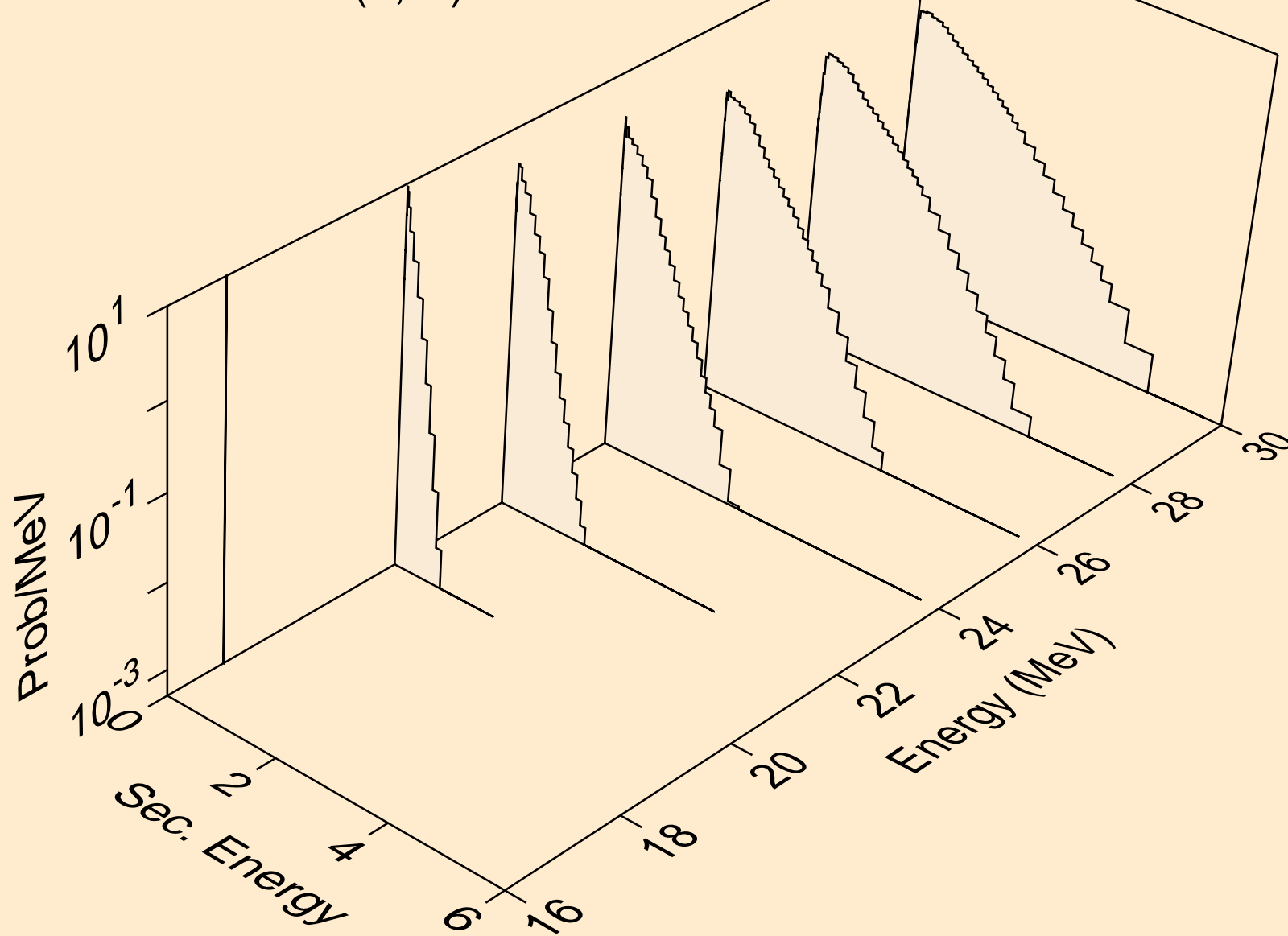

CD124 ALPHA ACER TENDL-2024 LIBRARY; T=0.K
neutrons from (a,n*)he3

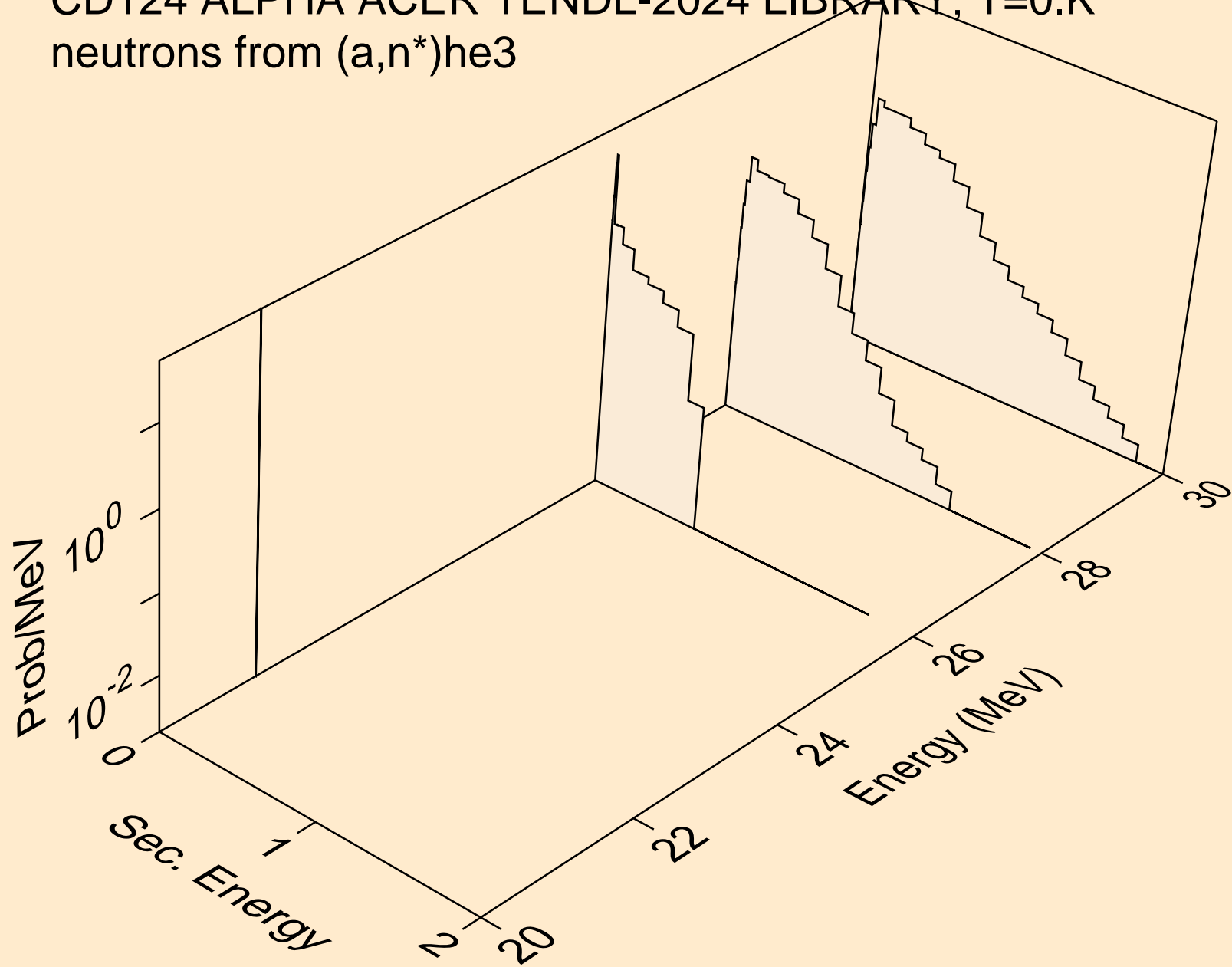

CD124 ALPHA ACER TENDL-2024 LIBRARY; T=0.K
neutrons from (a,4n)

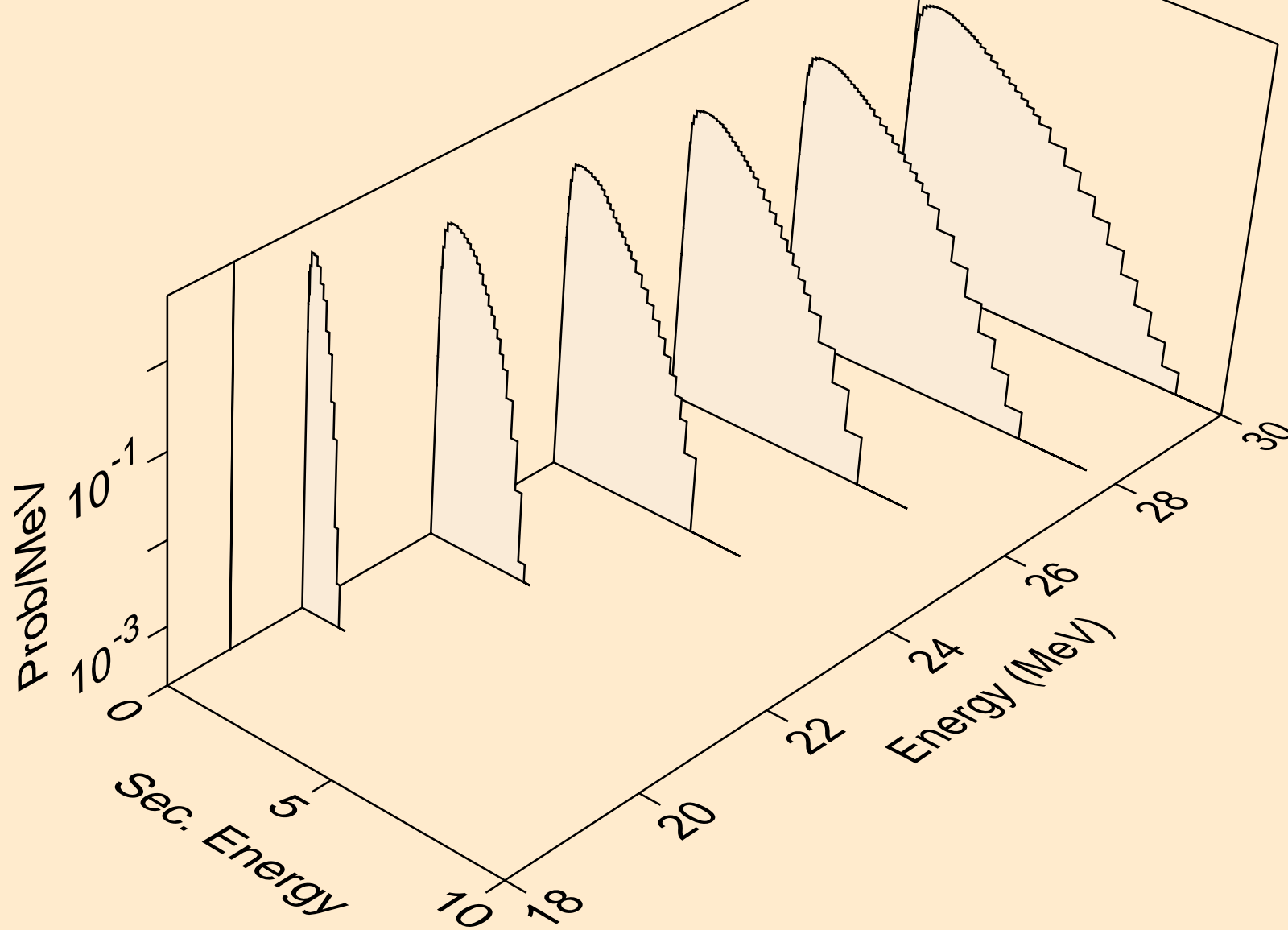

CD124 ALPHA ACER TENDL-2024 LIBRARY; T=0.K
neutrons from (a,2np)

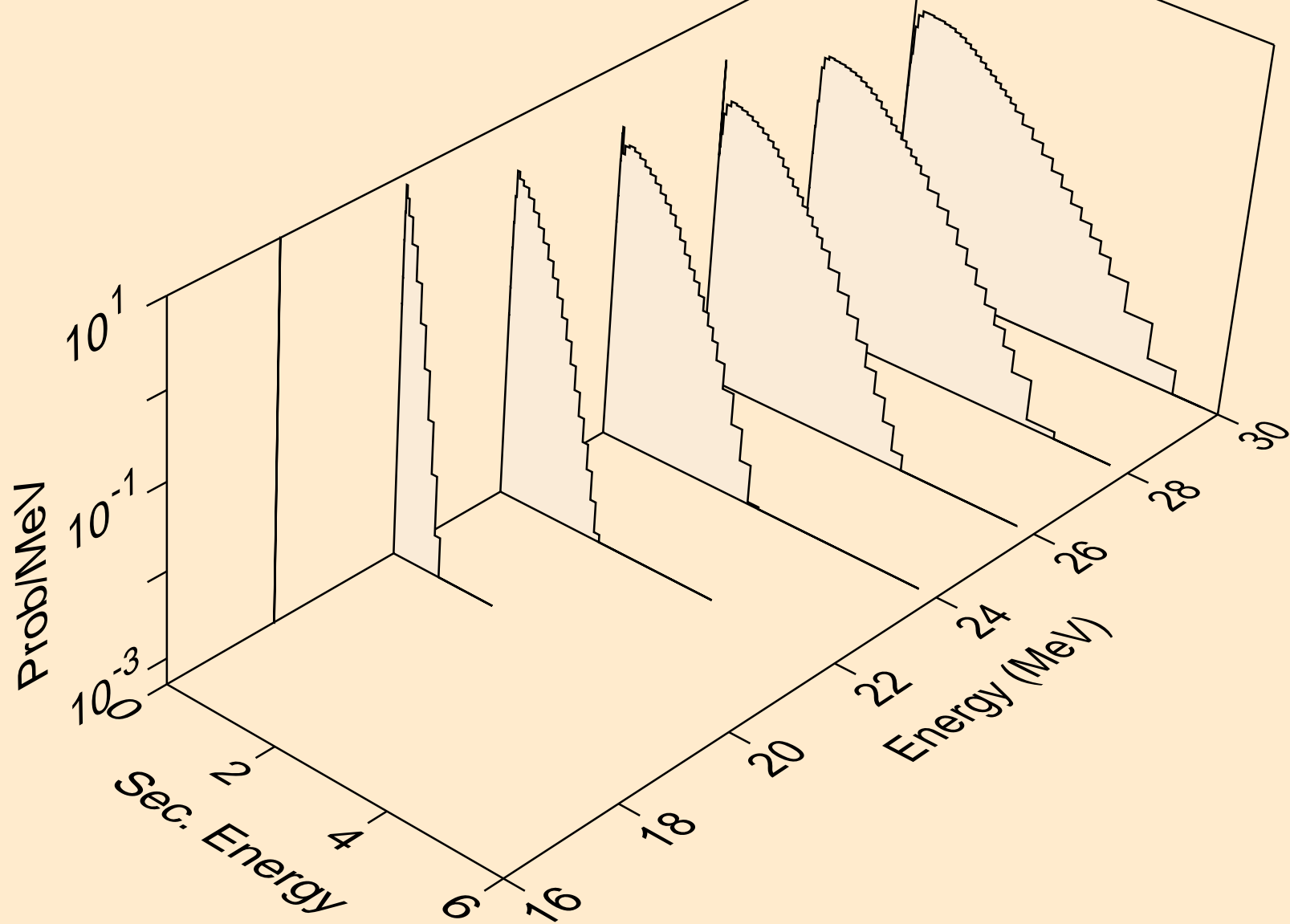

CD124 ALPHA ACER TENDL-2024 LIBRARY; T=0.K
neutrons from (a,3np)

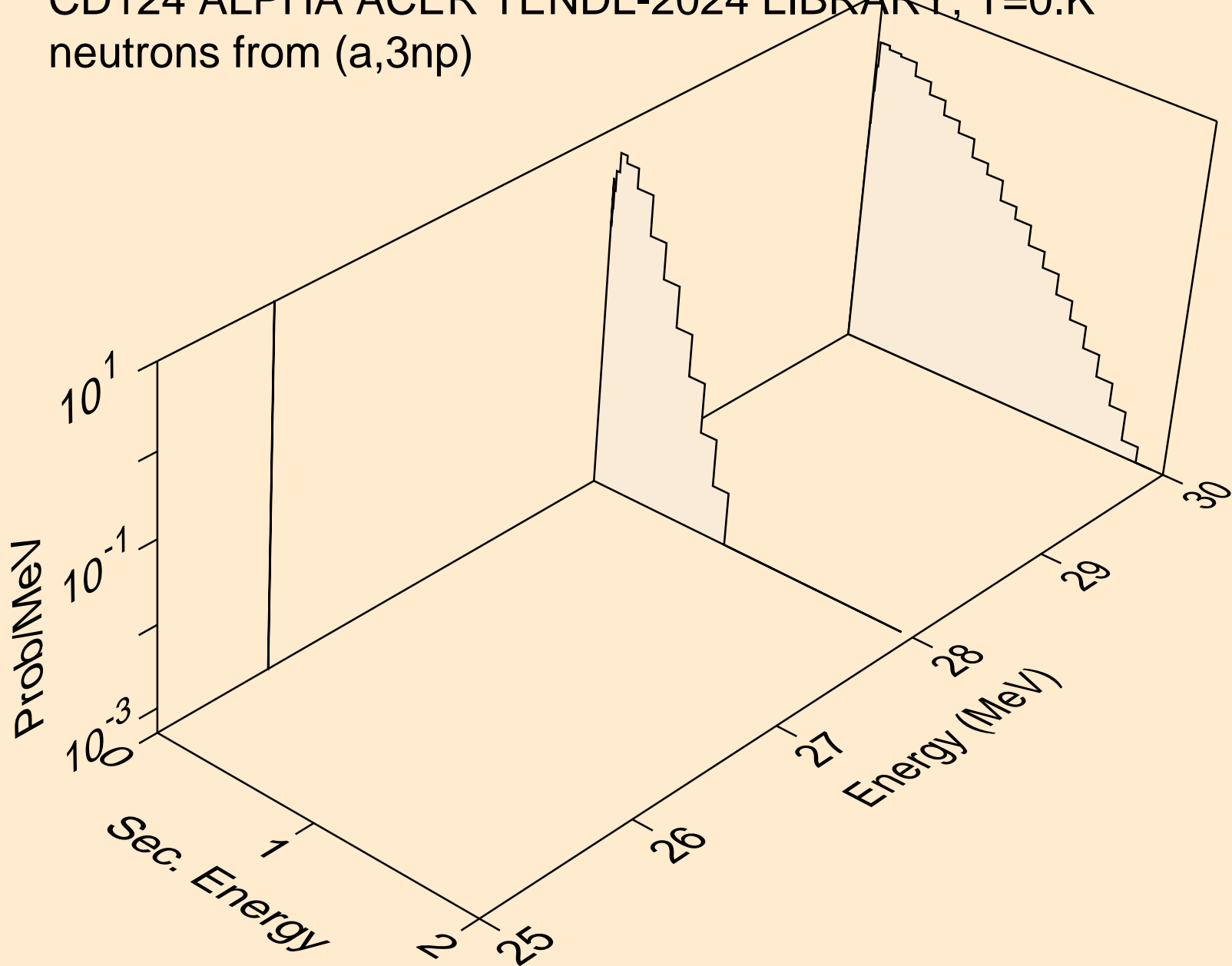

CD124 ALPHA ACER TENDL-2024 LIBRARY; T=0.K
protons from (a,x)

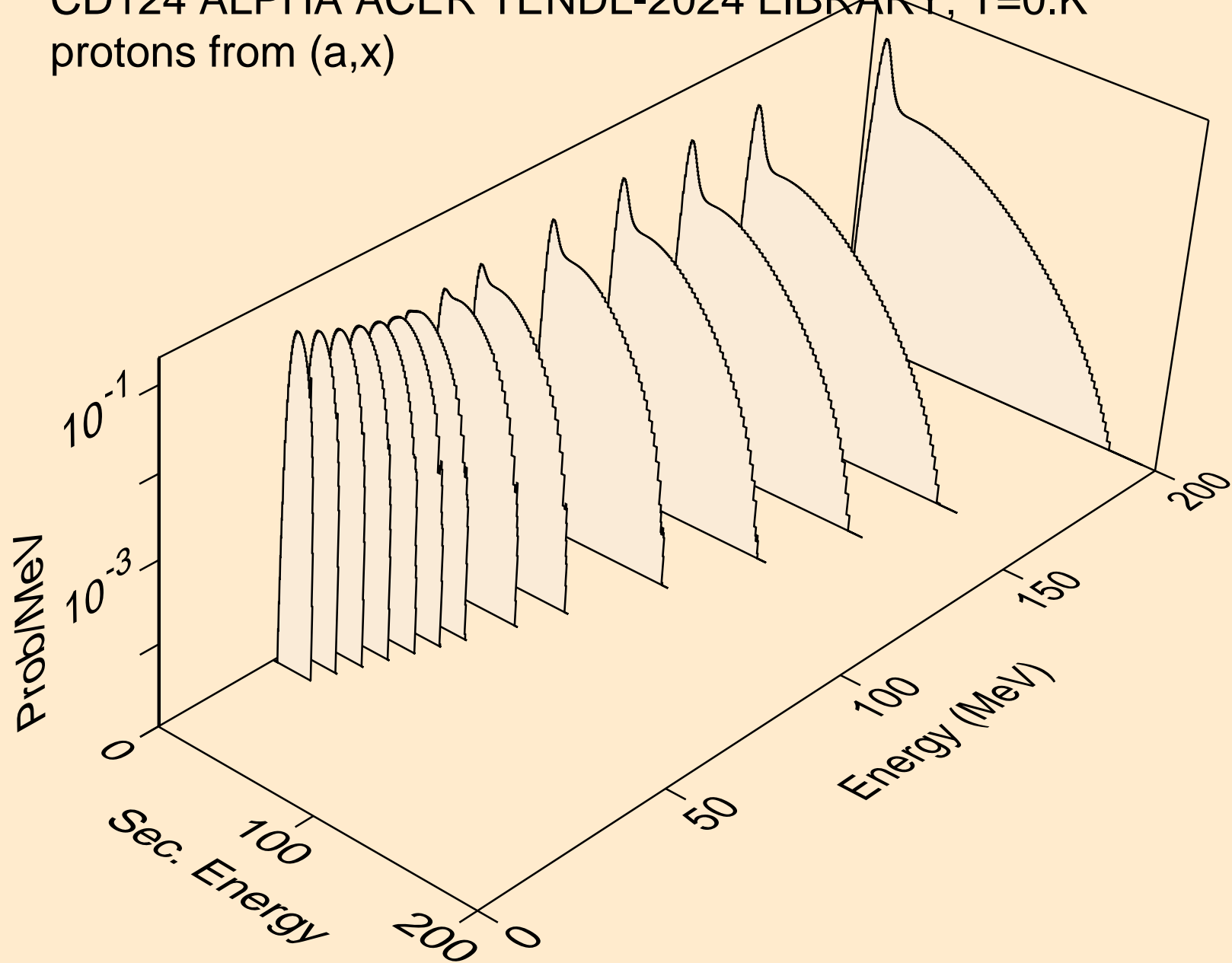

CD124 ALPHA ACER TENDL-2024 LIBRARY; T=0.K
protons from (a,n*)p

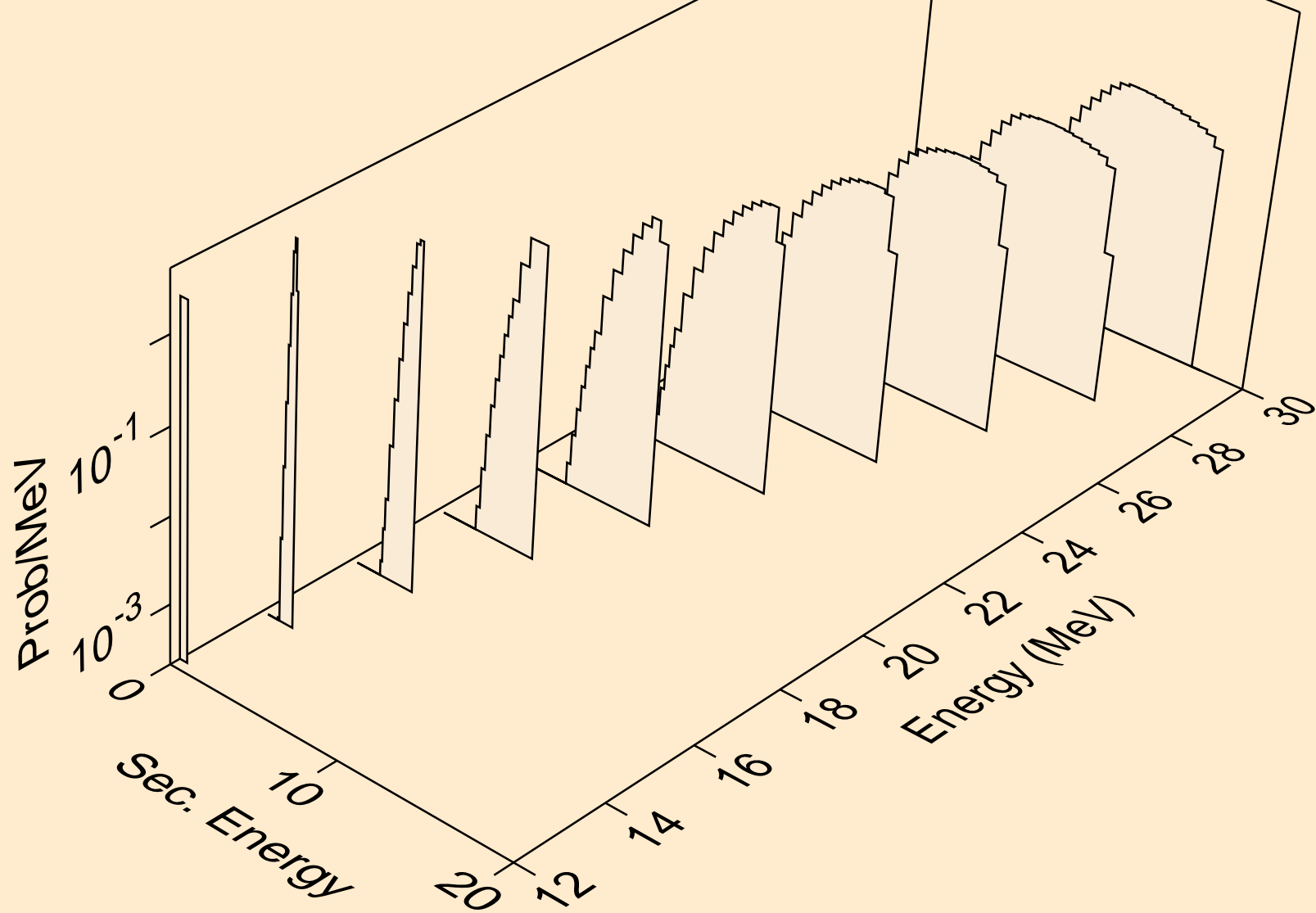

CD124 ALPHA ACER TENDL-2024 LIBRARY; T=0.K
protons from (a,2np)

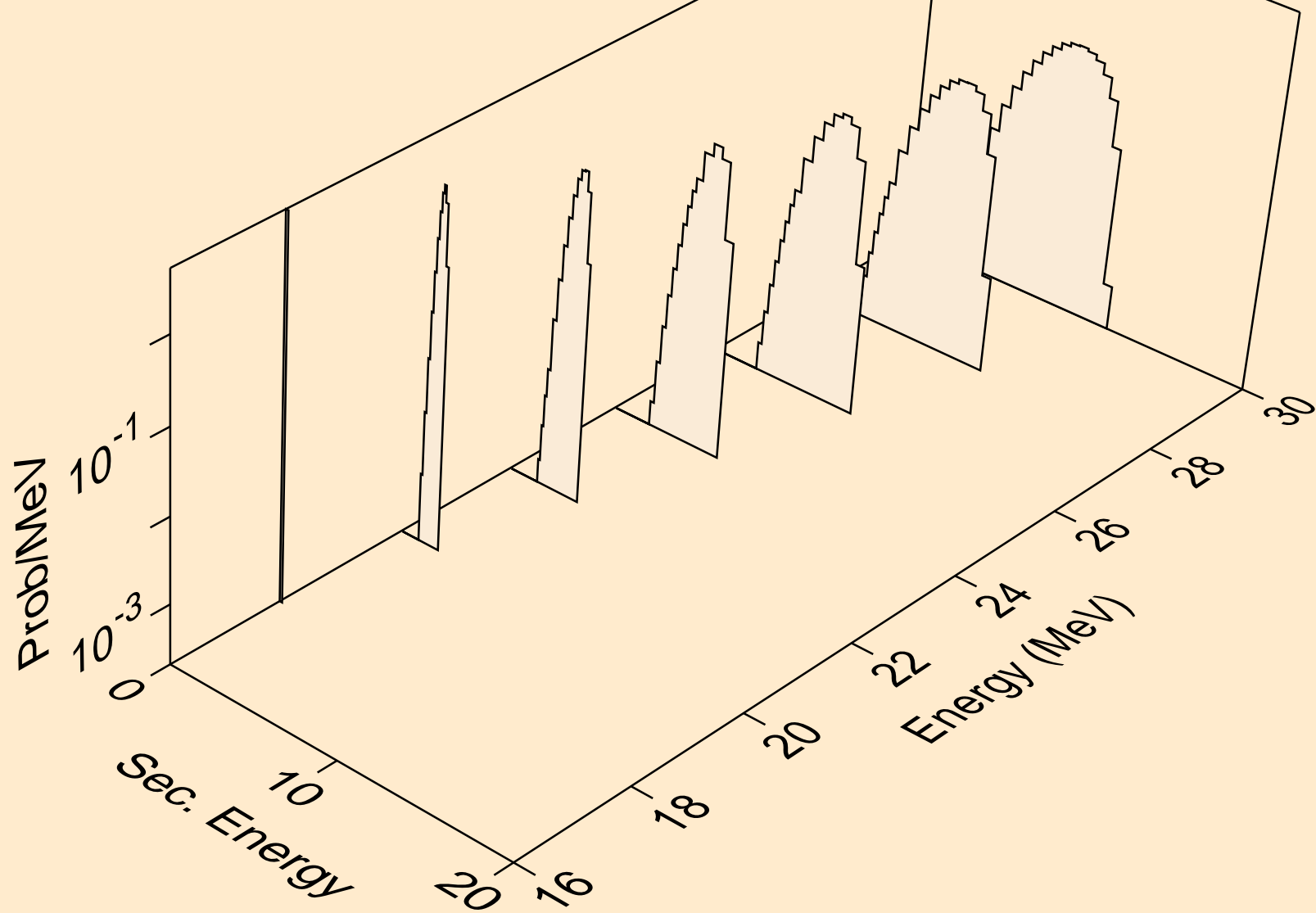

CD124 ALPHA ACER TENDL-2024 LIBRARY; T=0.K
protons from (a,3np)

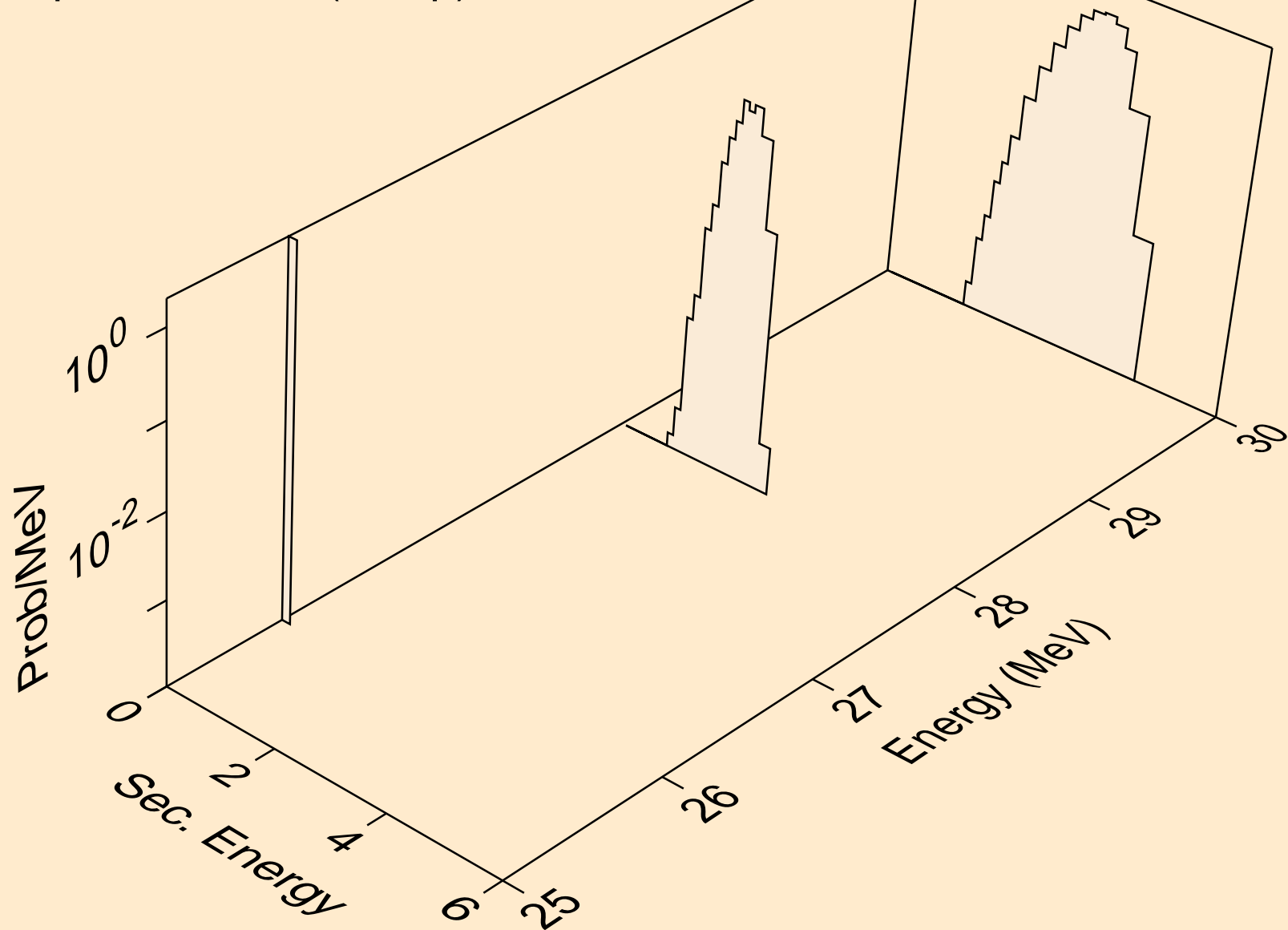

CD124 ALPHA ACER TENDL-2024 LIBRARY; T=0.K
protons from (a,p)

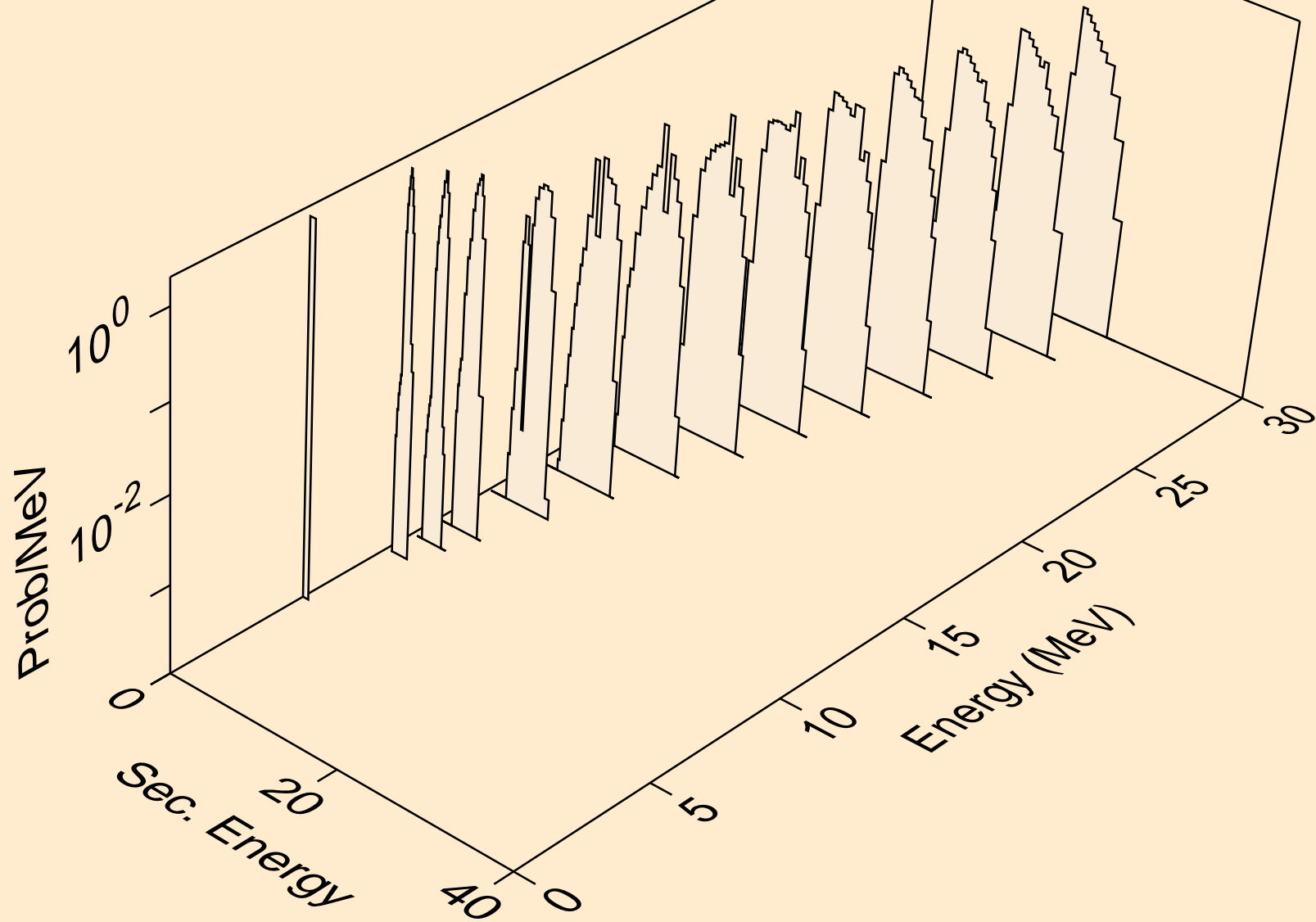

CD124 ALPHA ACER TENDL-2024 LIBRARY; T=0.K
deuterons from (a,x)

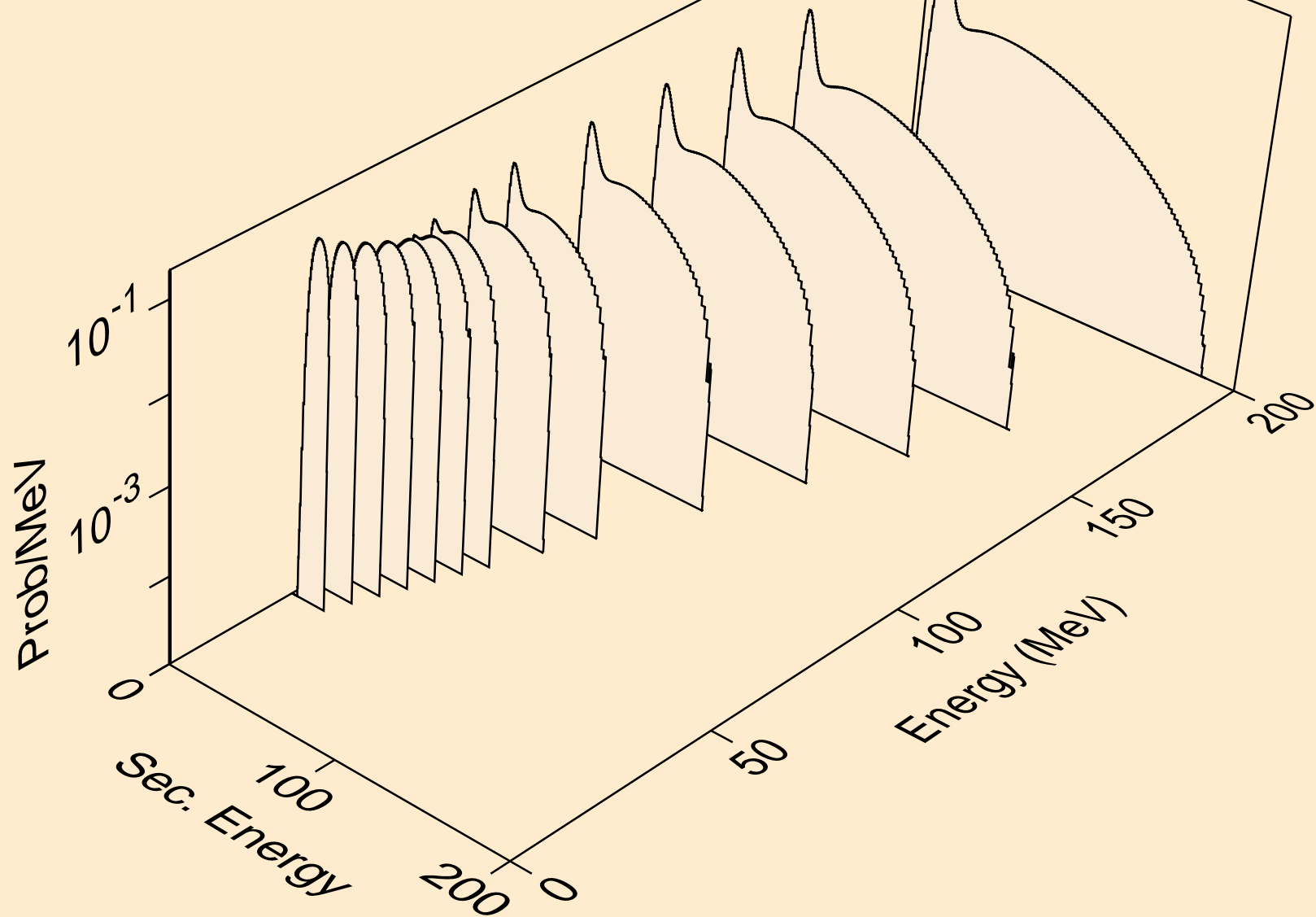

CD124 ALPHA ACER TENDL-2024 LIBRARY; T=0.K
deuterons from (a,2nd)

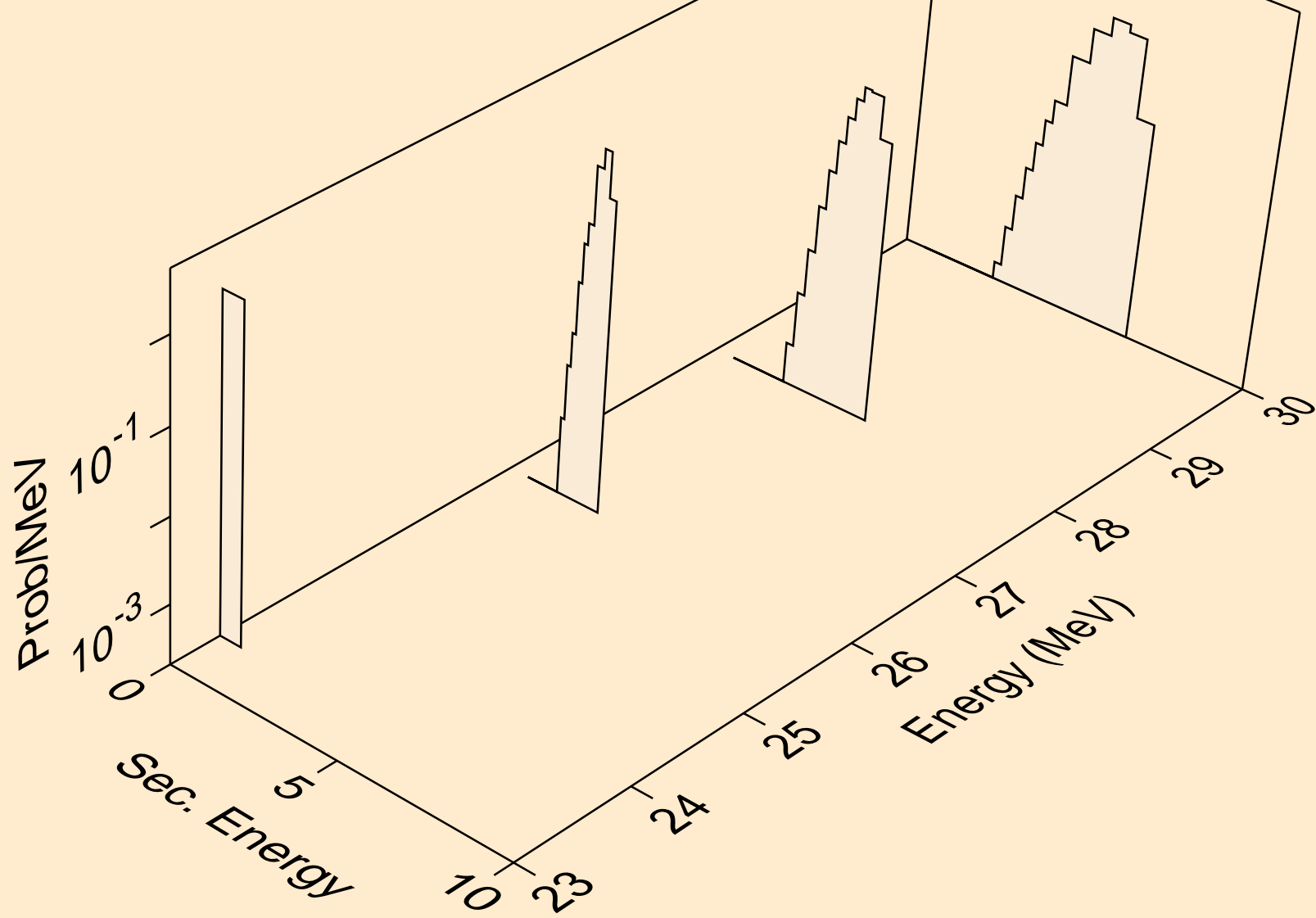

CD124 ALPHA ACER TENDL-2024 LIBRARY; T=0.K
deuterons from (a,n*)d

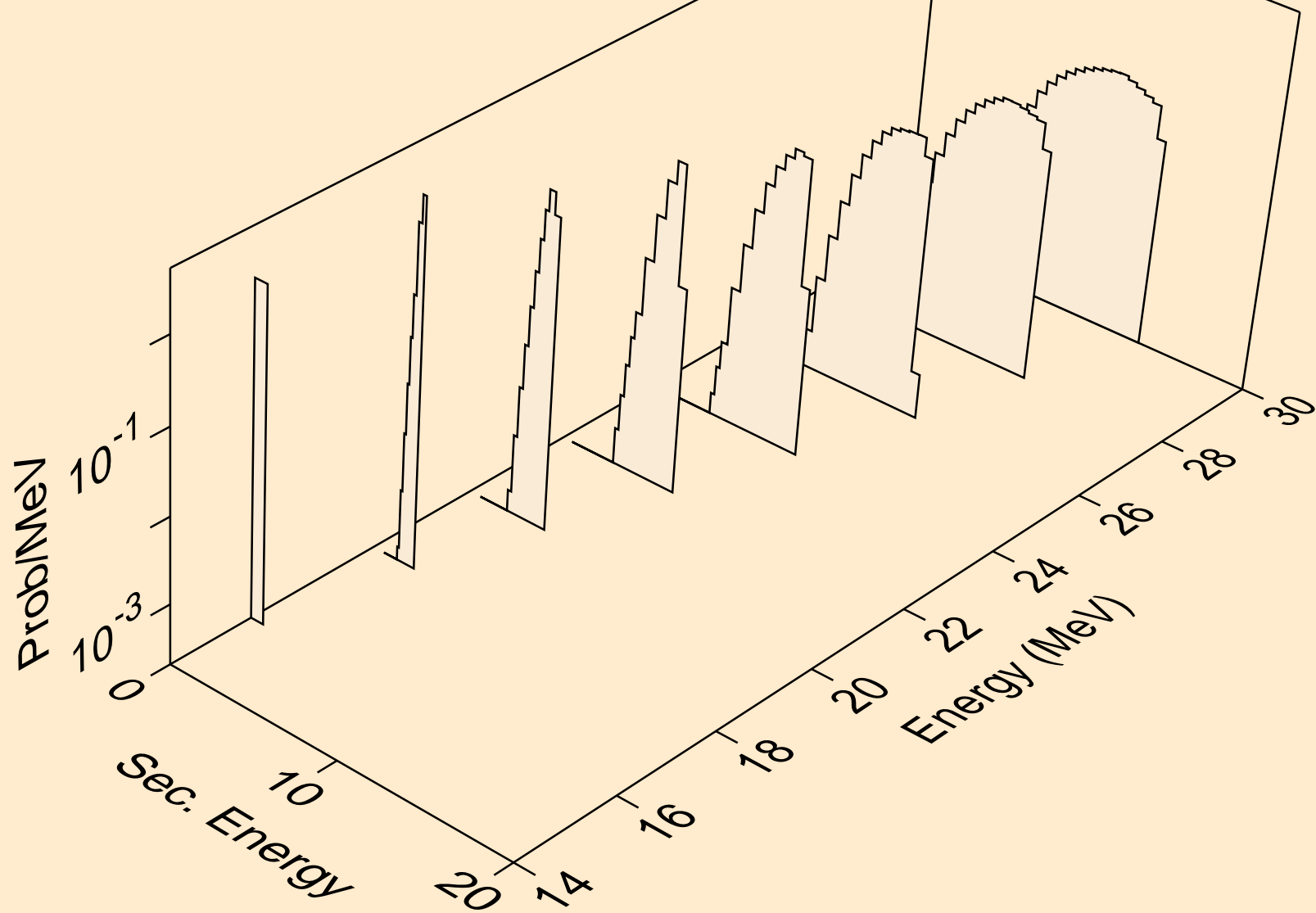

CD124 ALPHA ACER TENDL-2024 LIBRARY; T=0.K
deuterons from (a,d)

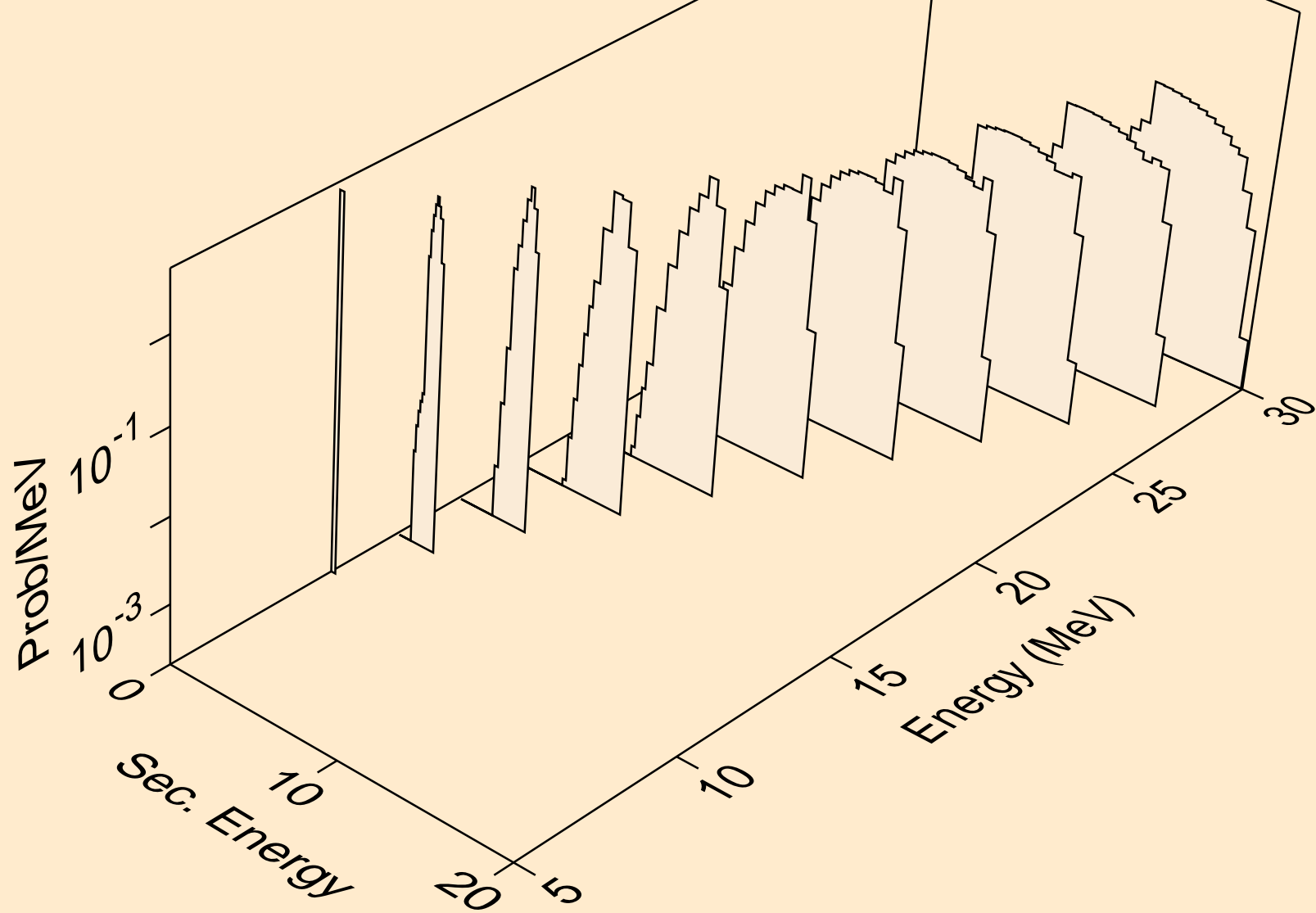

CD124 ALPHA ACER TENDL-2024 LIBRARY; T=0.K
tritons from (a,x)

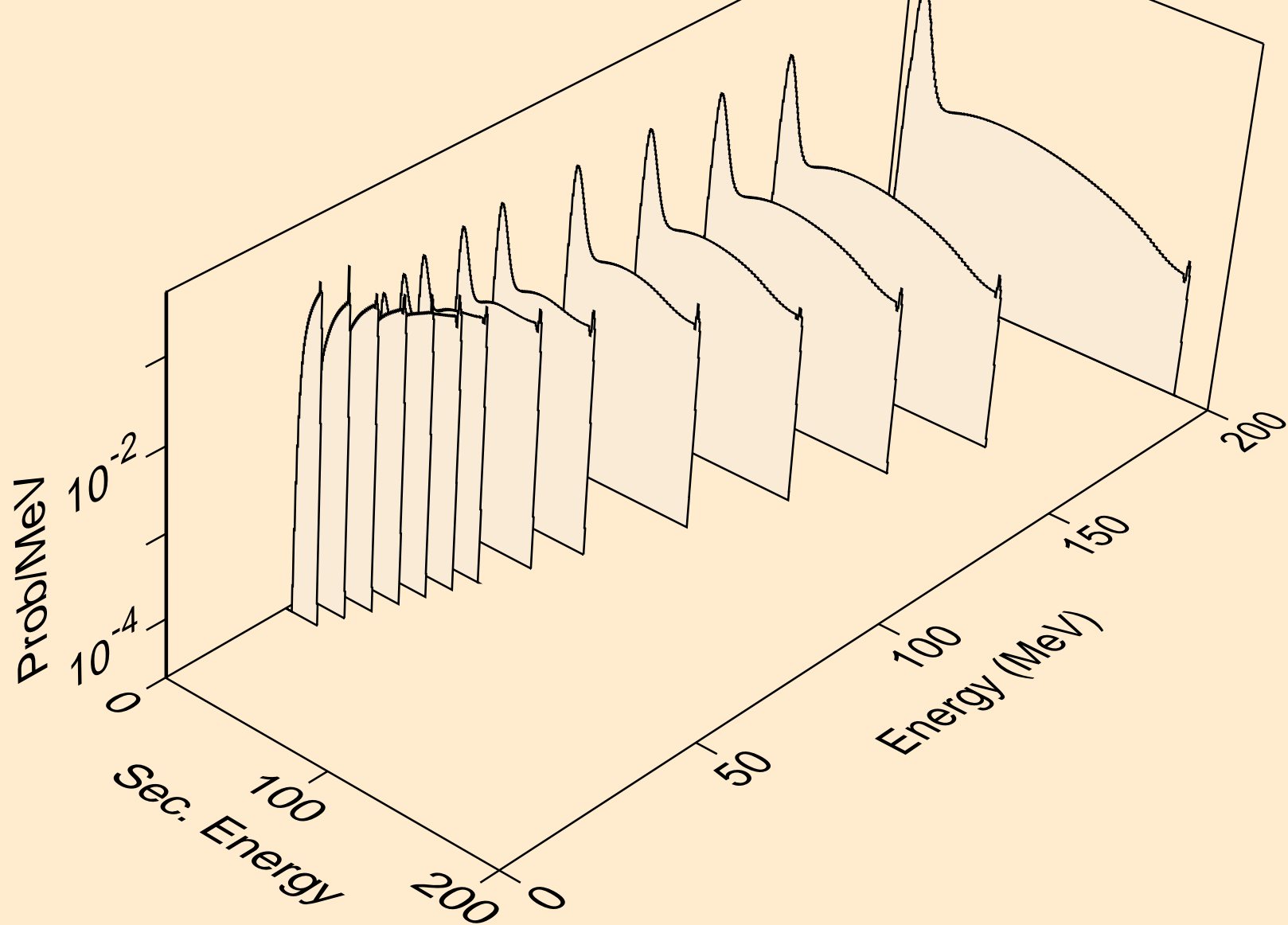

CD124 ALPHA ACER TENDL-2024 LIBRARY; T=0.K
tritons from (a,n*)t

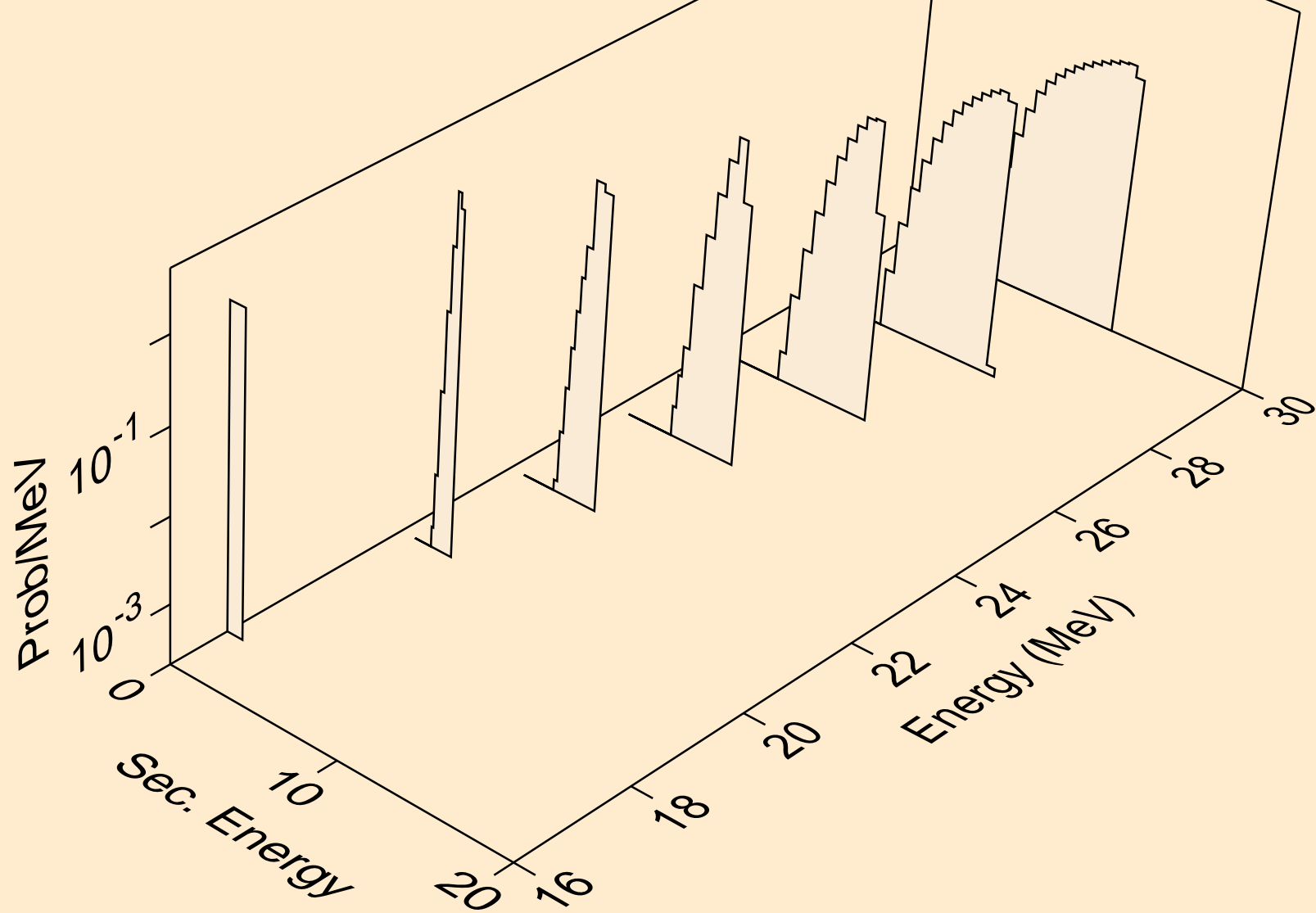

CD124 ALPHA ACER TENDL-2024 LIBRARY; T=0.K
tritons from (a,t)

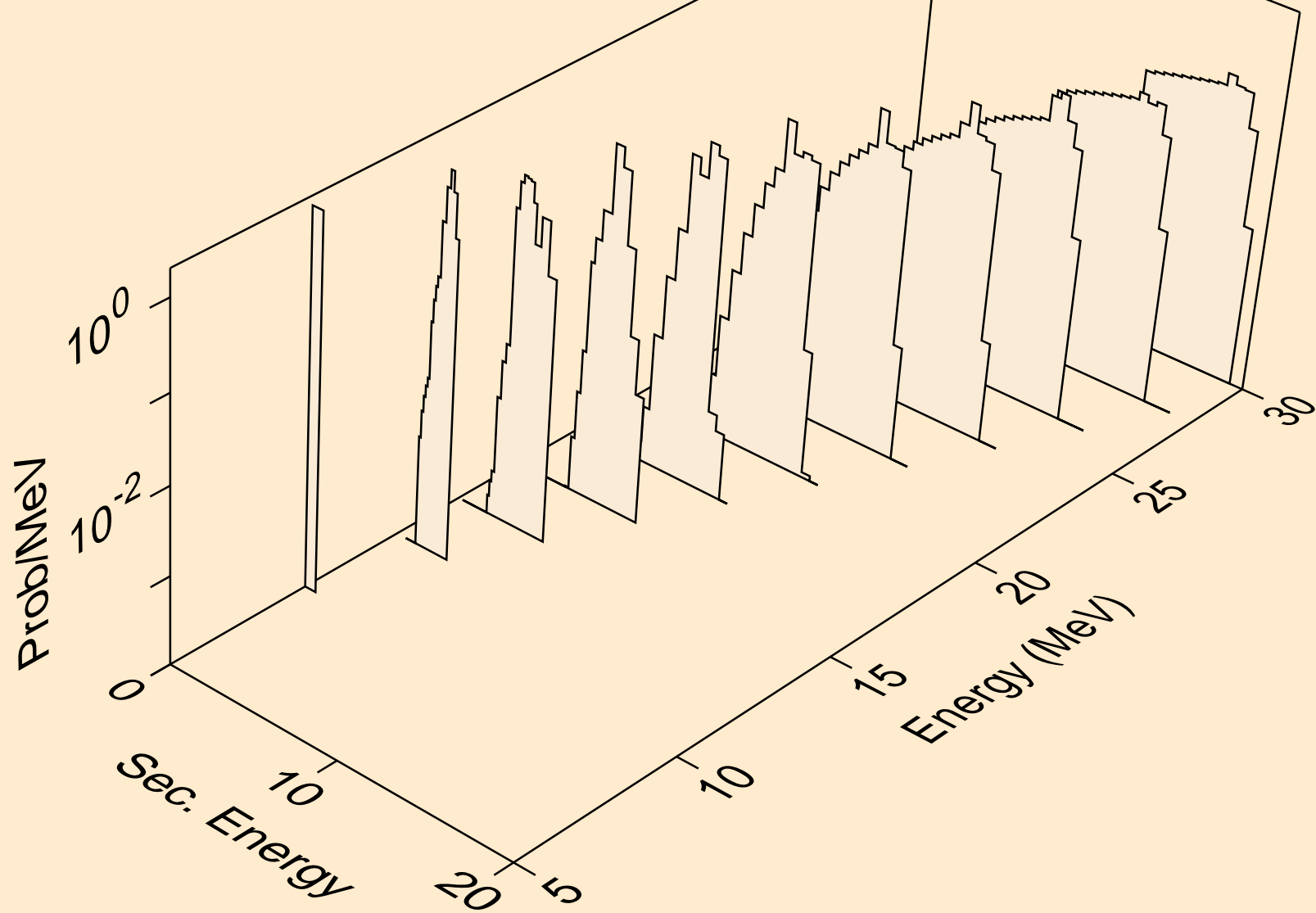

CD124 ALPHA ACER TENDL-2024 LIBRARY; T=0.K
he3s from (a,x)

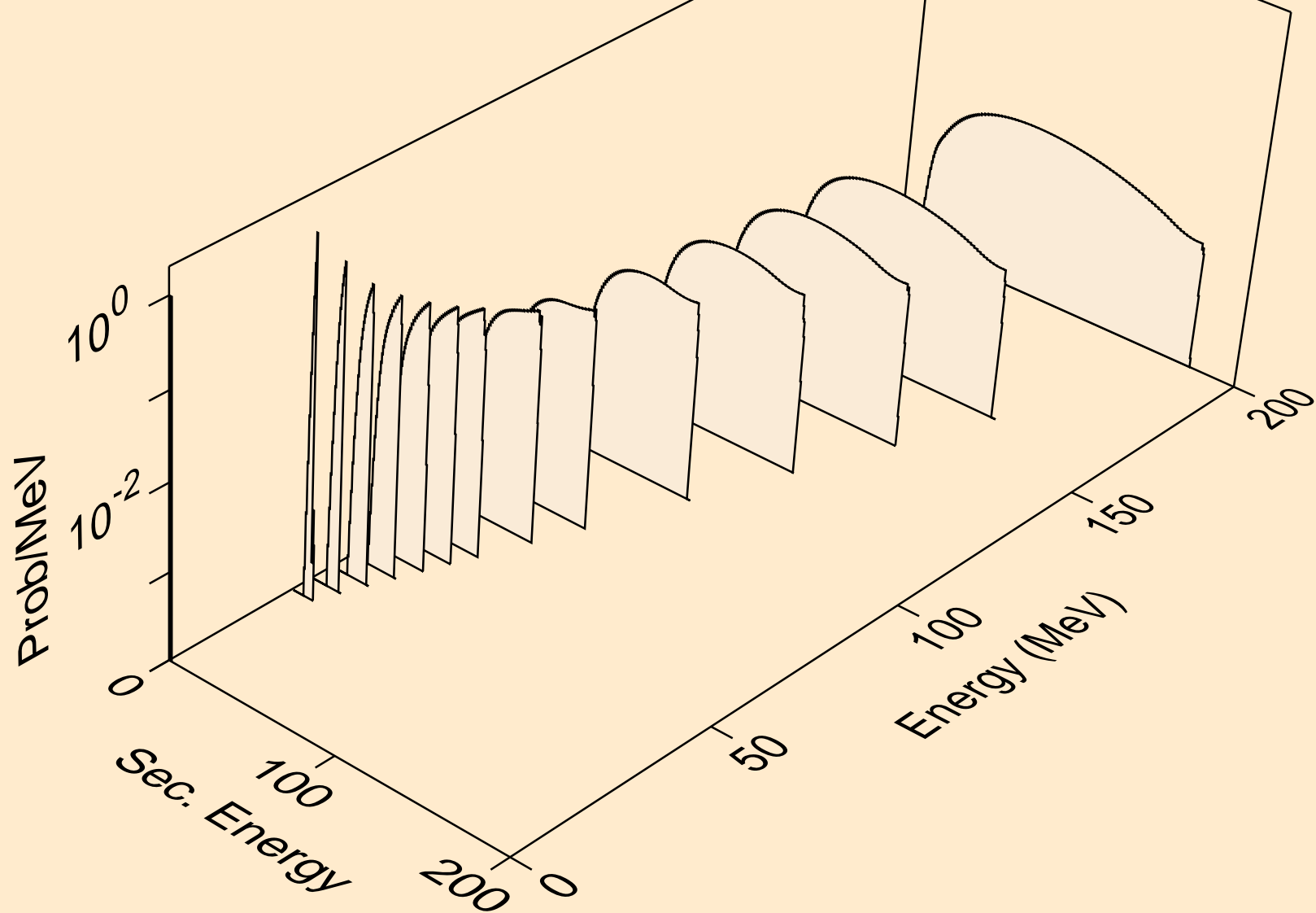

CD124 ALPHA ACER TENDL-2024 LIBRARY; T=0.K
he3s from (a,n*)he3

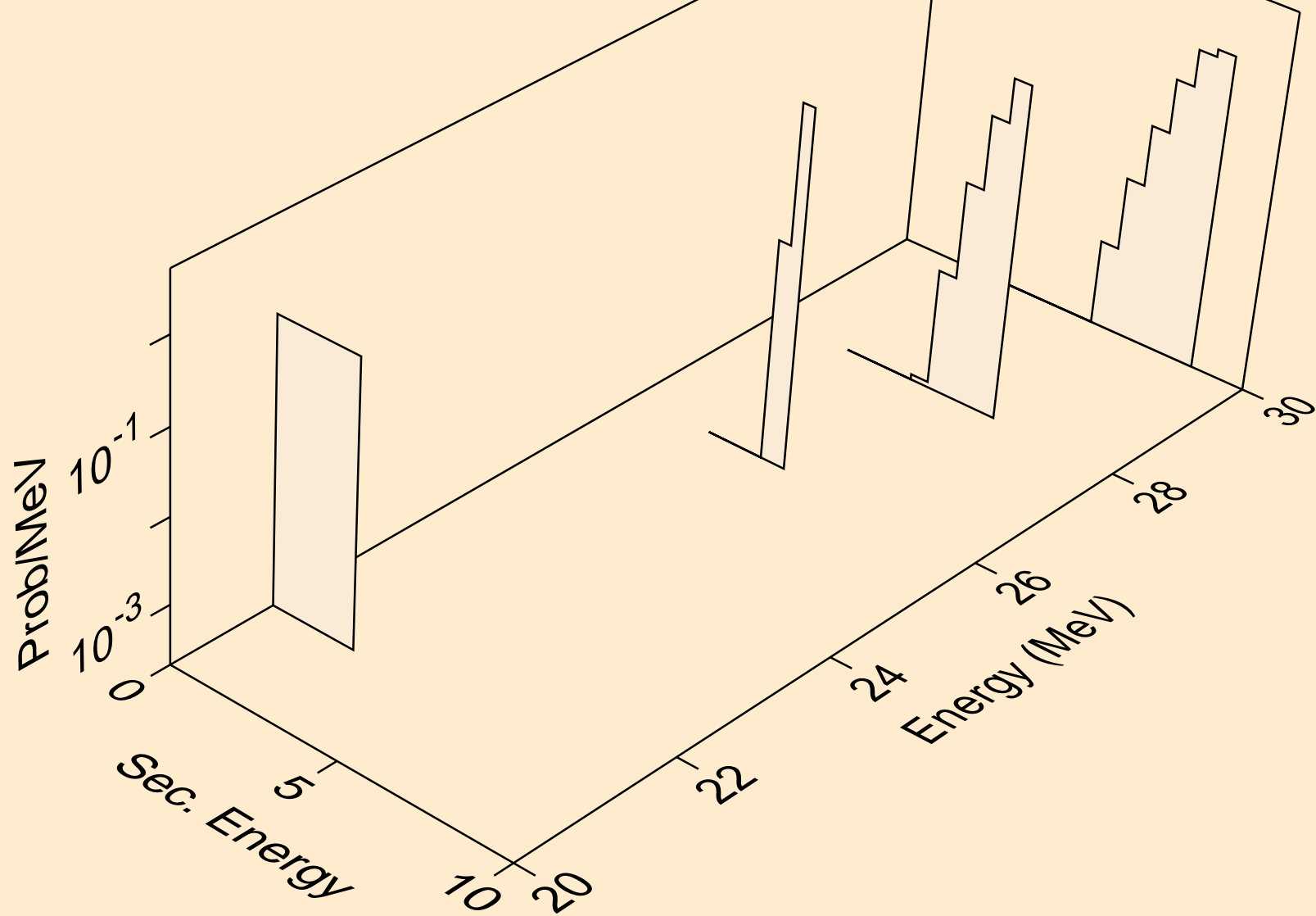

CD124 ALPHA ACER TENDL-2024 LIBRARY; T=0.K
he3s from (a,he3)

