

# EU141 ALPHA ACER TENDL-2024 LIBRARY; T=0.K

## Principal cross sections

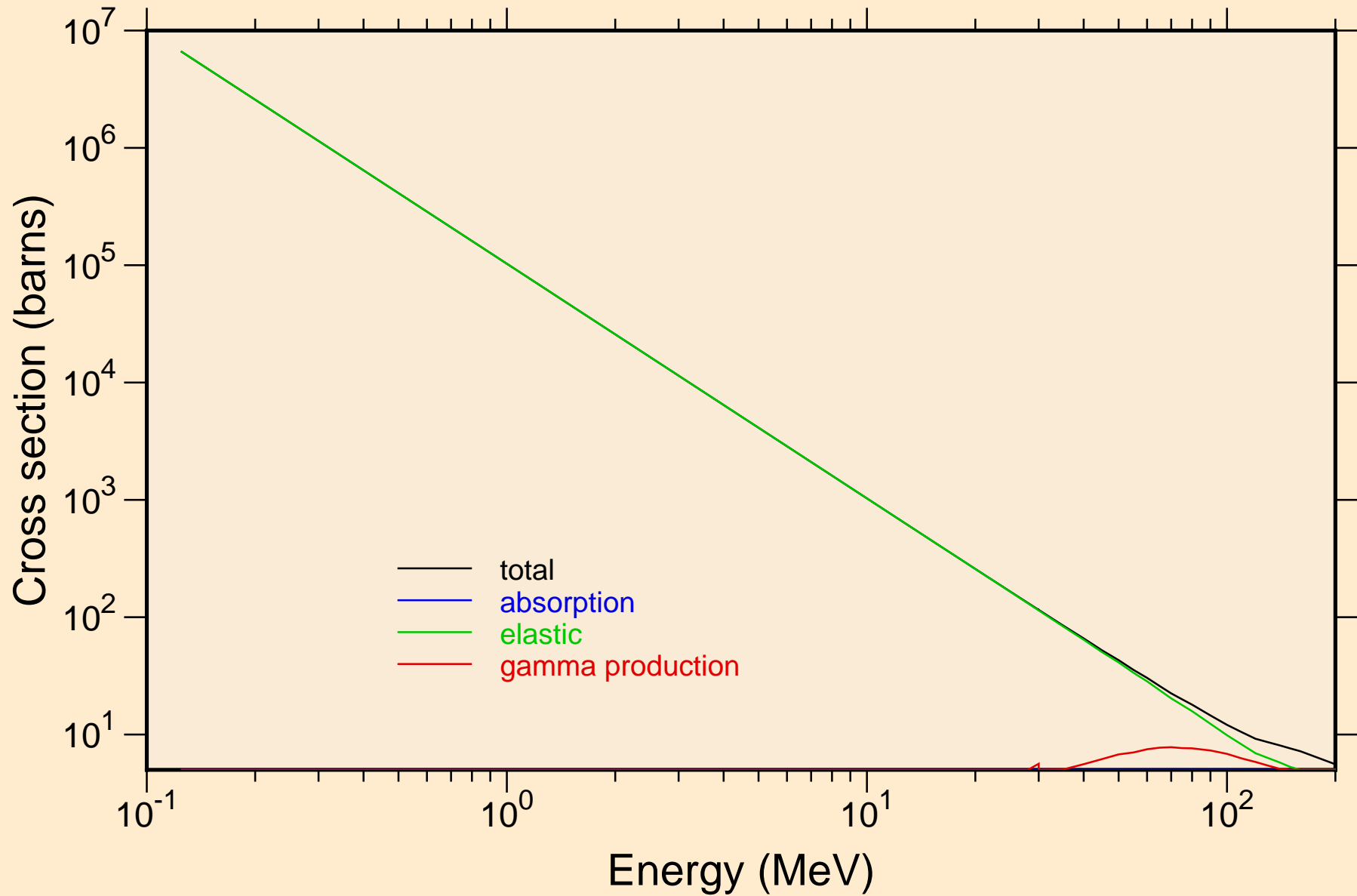

# EU141 ALPHA ACER TENDL-2024 LIBRARY; T=0.K

## Heating

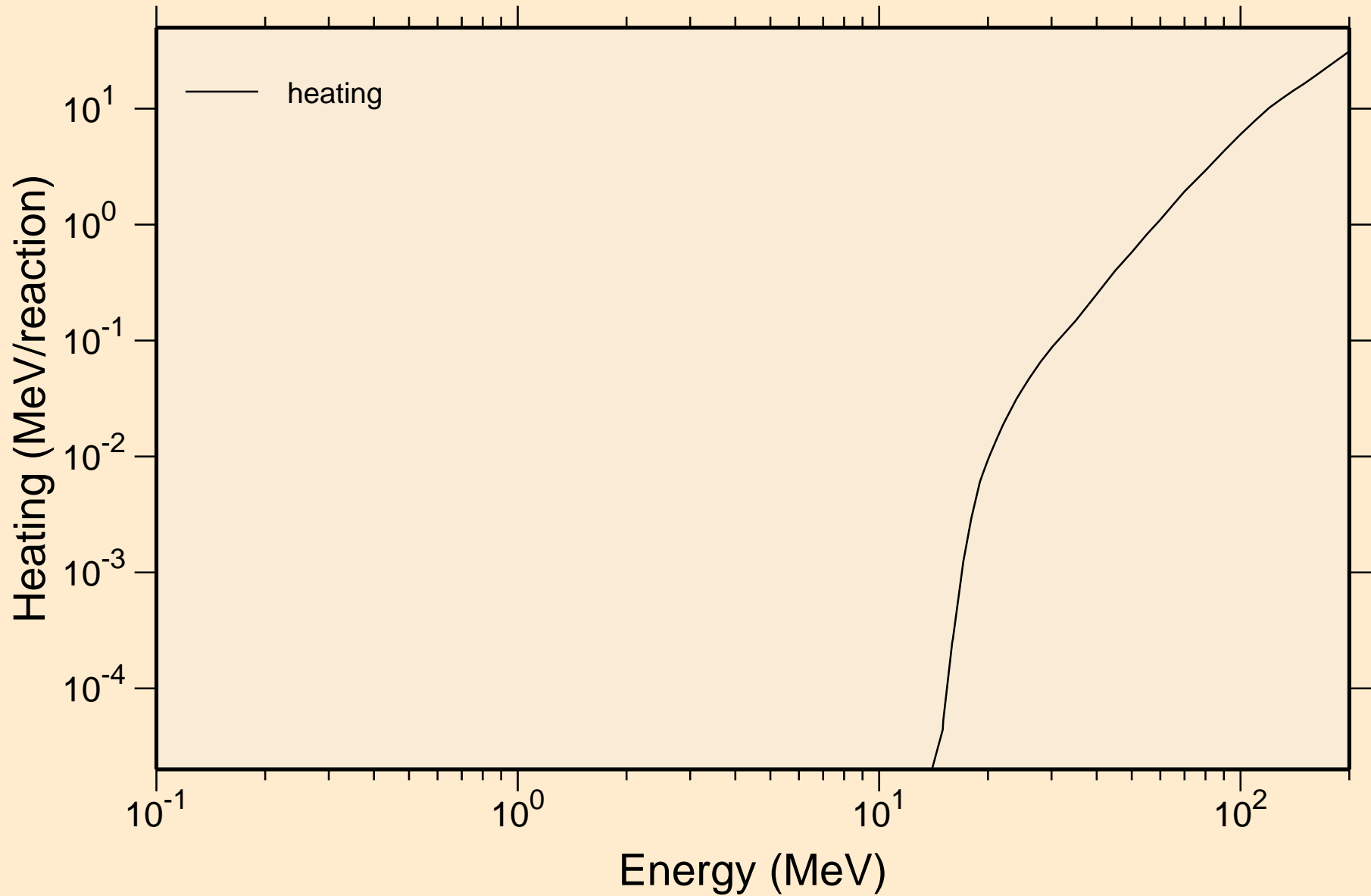

# EU141 ALPHA ACER TENDL-2024 LIBRARY; T=0.K

## Principal cross sections

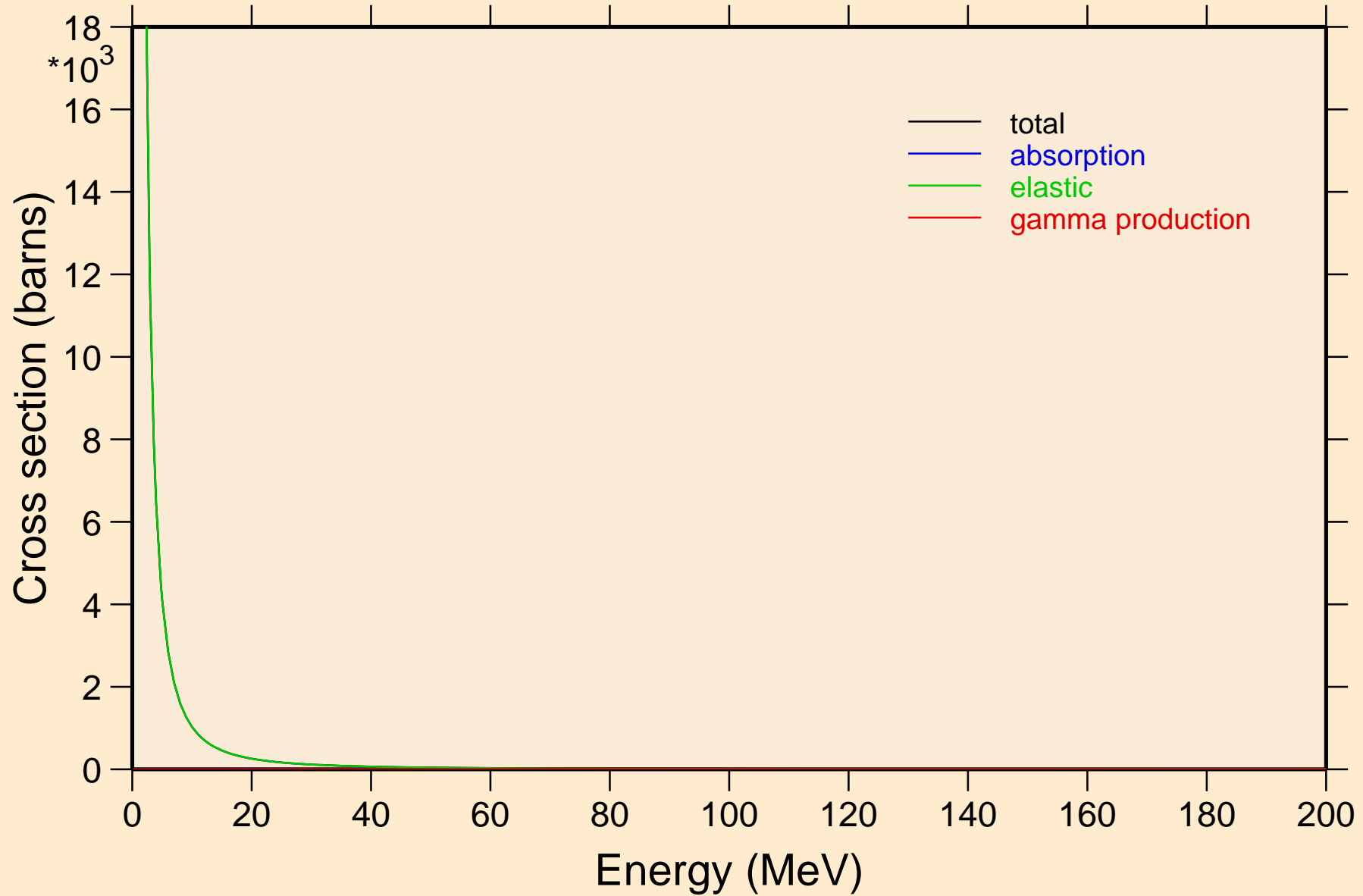

# EU141 ALPHA ACER TENDL-2024 LIBRARY; T=0.K

## Heating

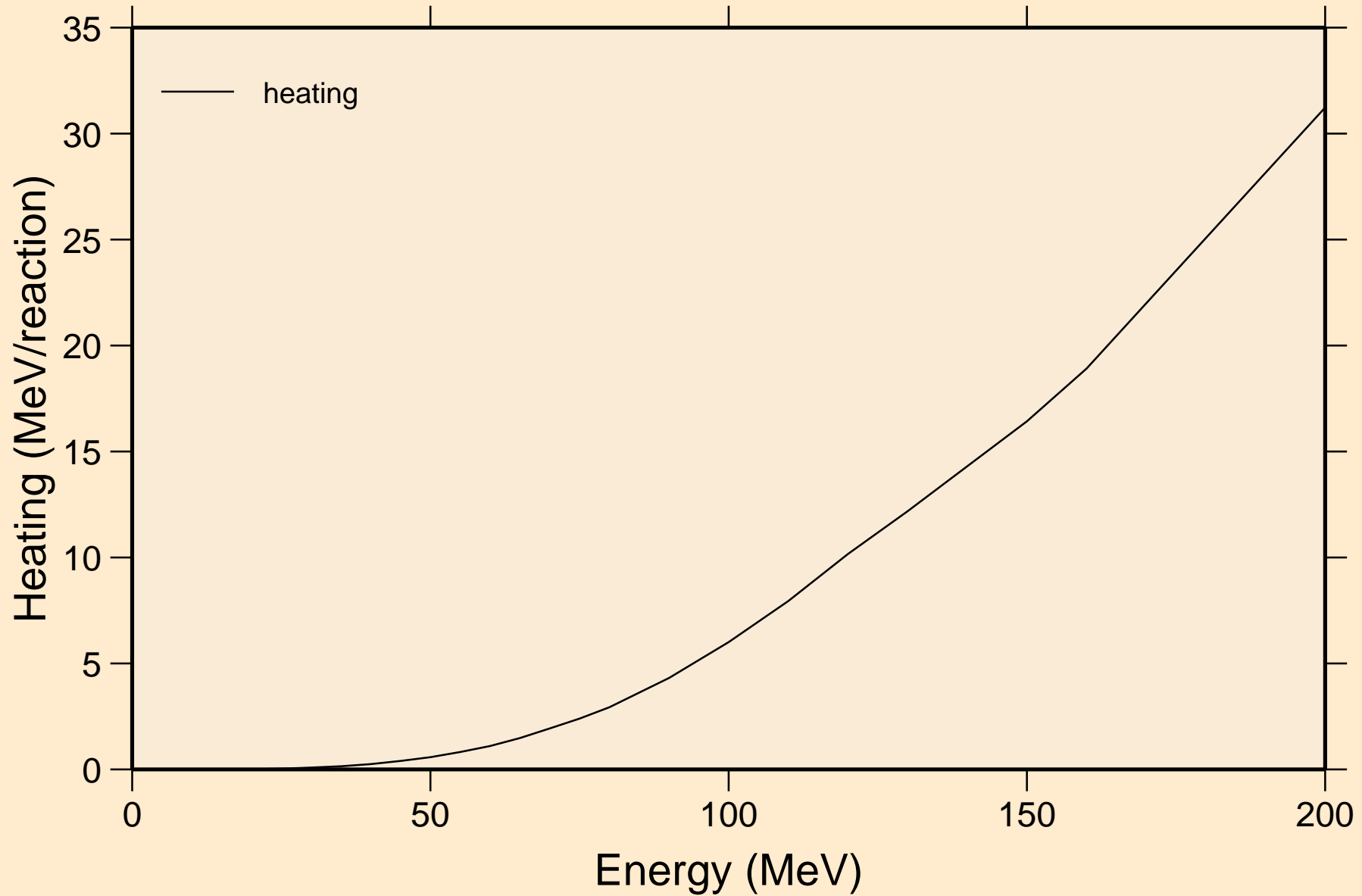

EU141 ALPHA ACER TENDL-2024 LIBRARY; T=0.K  
Threshold reactions

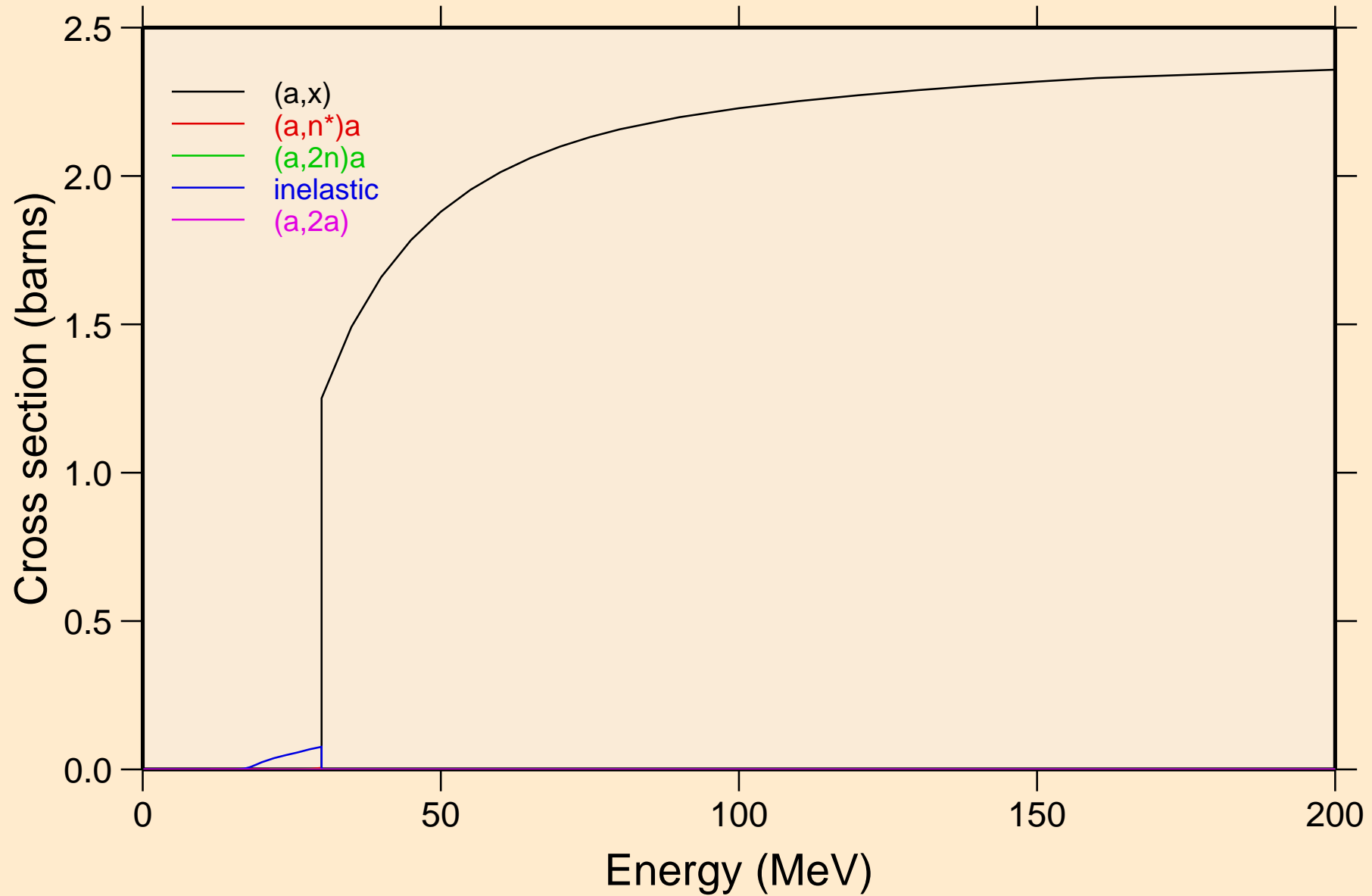

EU141 ALPHA ACER TENDL-2024 LIBRARY; T=0.K  
Threshold reactions

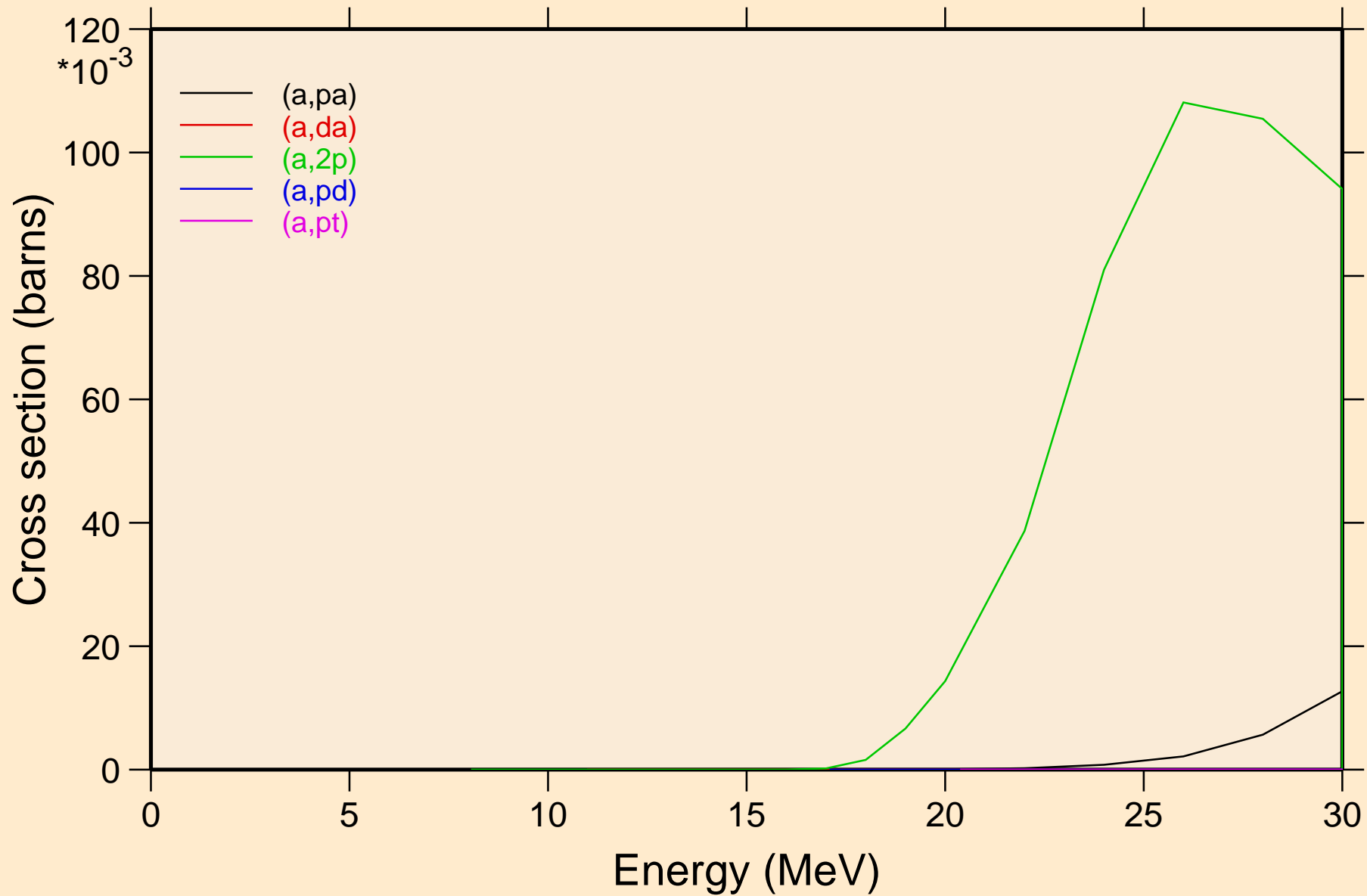

EU141 ALPHA ACER TENDL-2024 LIBRARY; T=0.K  
Threshold reactions

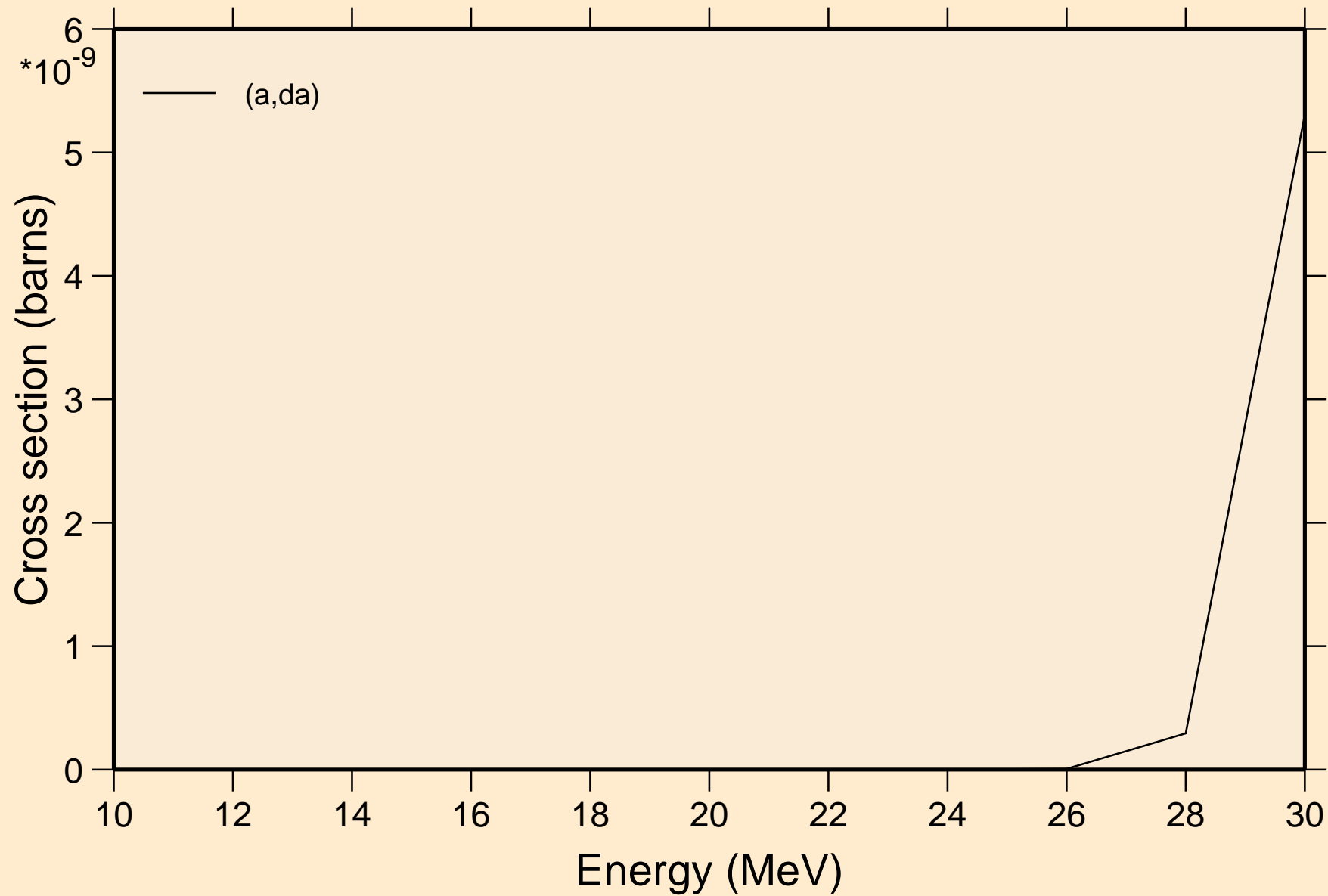

EU141 ALPHA ACER TENDL-2024 LIBRARY; T=0.K  
angular distribution for elastic

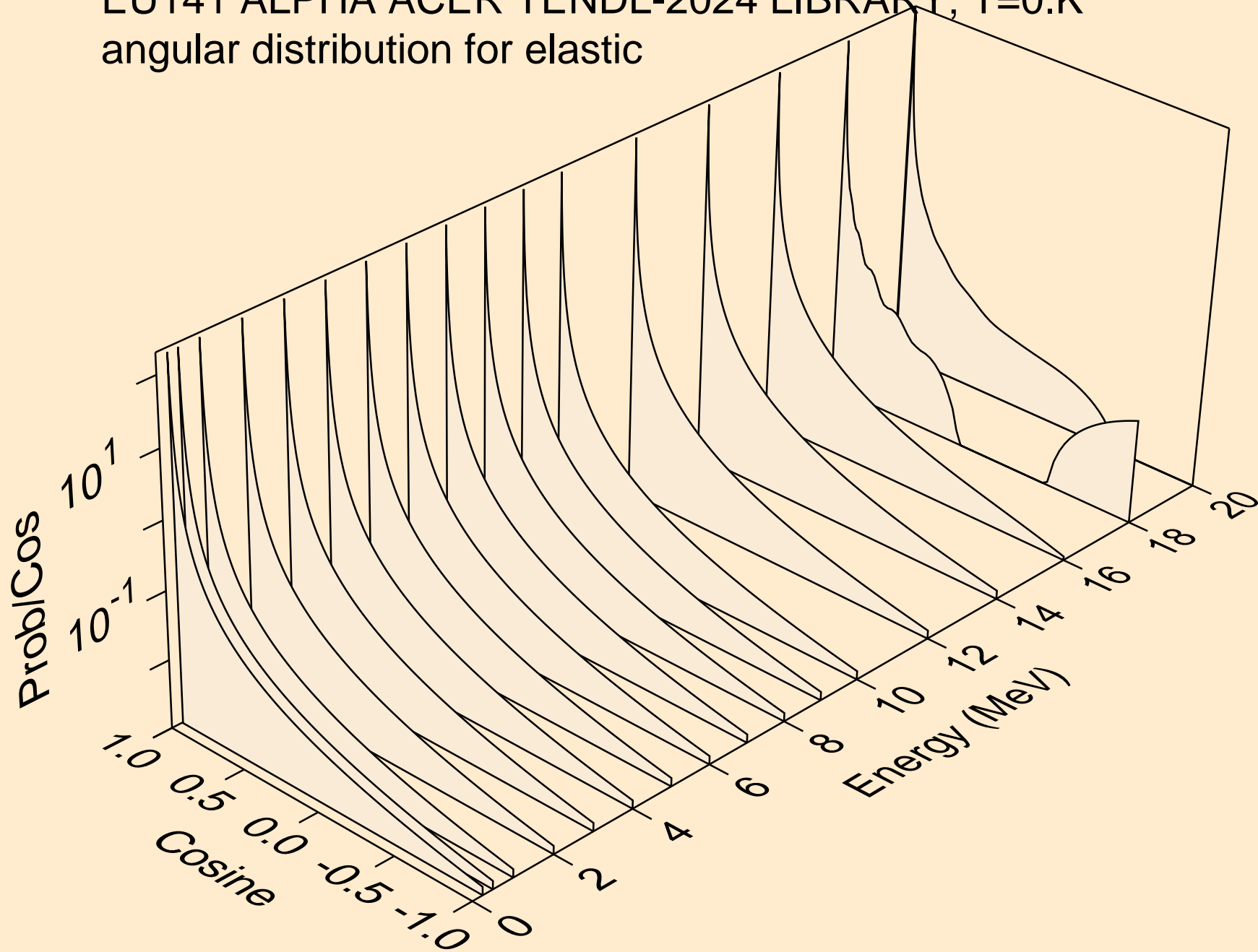

EU141 ALPHA ACER TENDL-2024 LIBRARY; T=0.K  
angular distribution for elastic

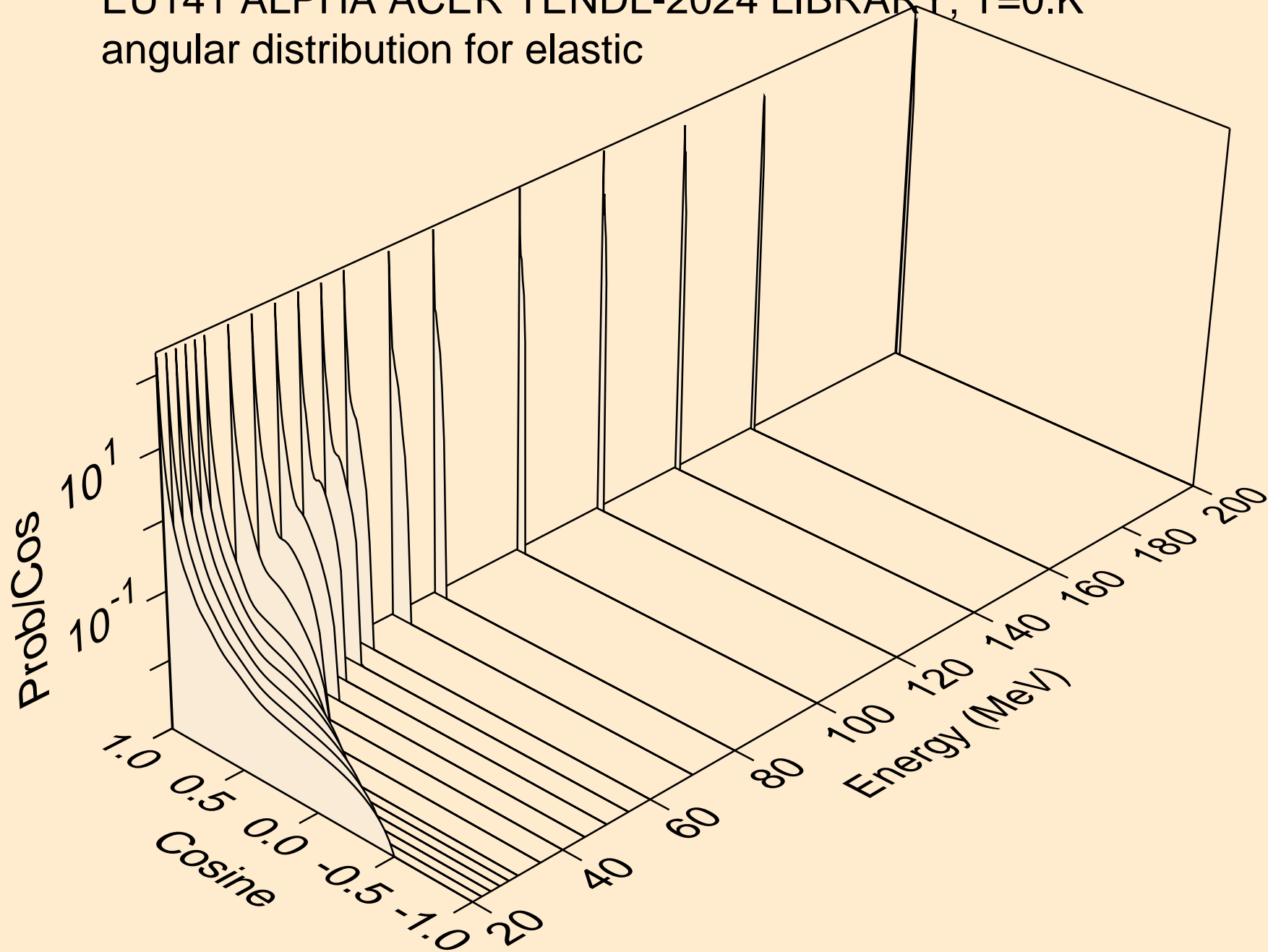

EU141 ALPHA ACER TENDL-2024 LIBRARY; T=0.K  
Alpha emission for (a,x)

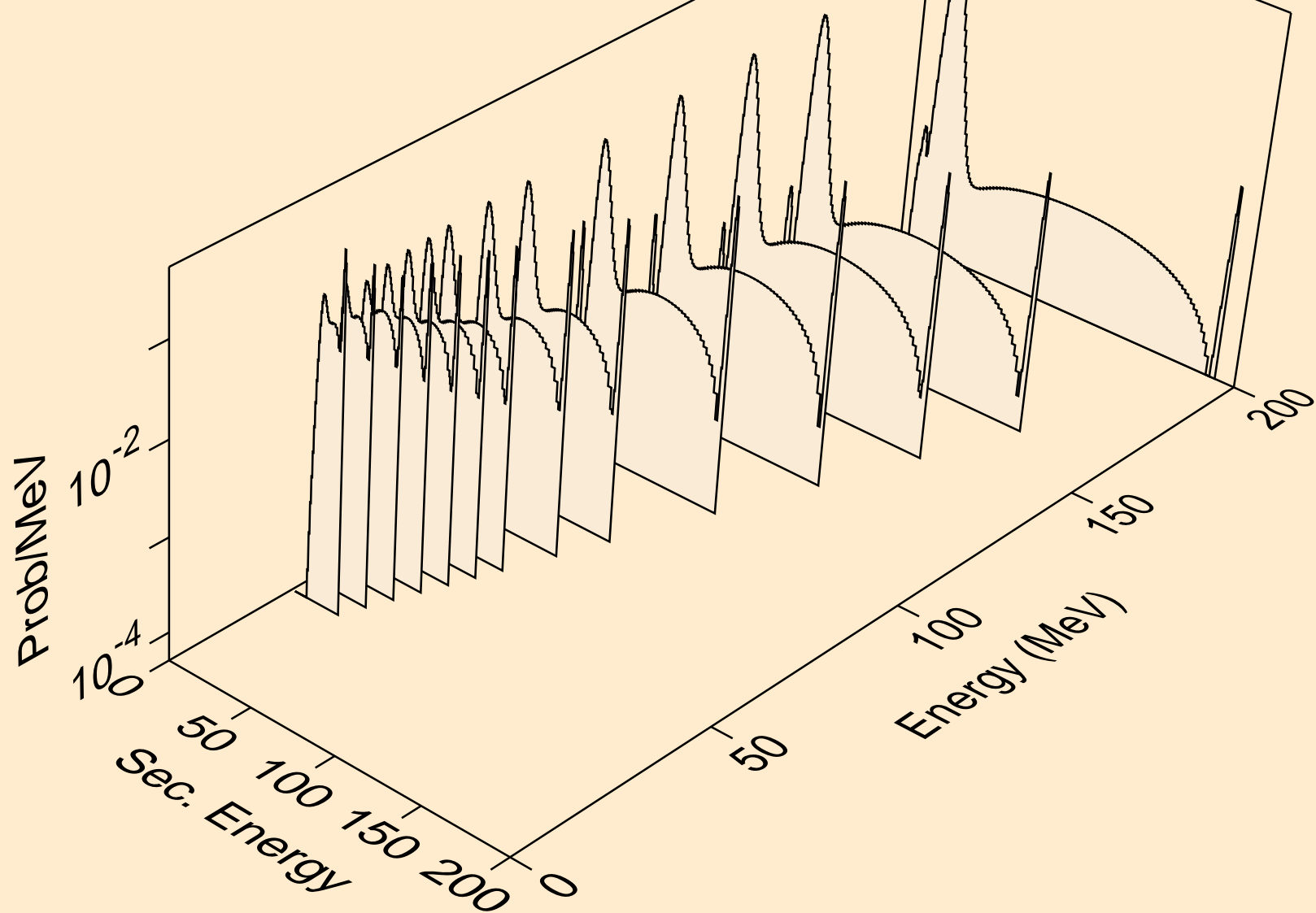

EU141 ALPHA ACER TENDL-2024 LIBRARY; T=0.K  
Alpha emission for (a,n\*)a

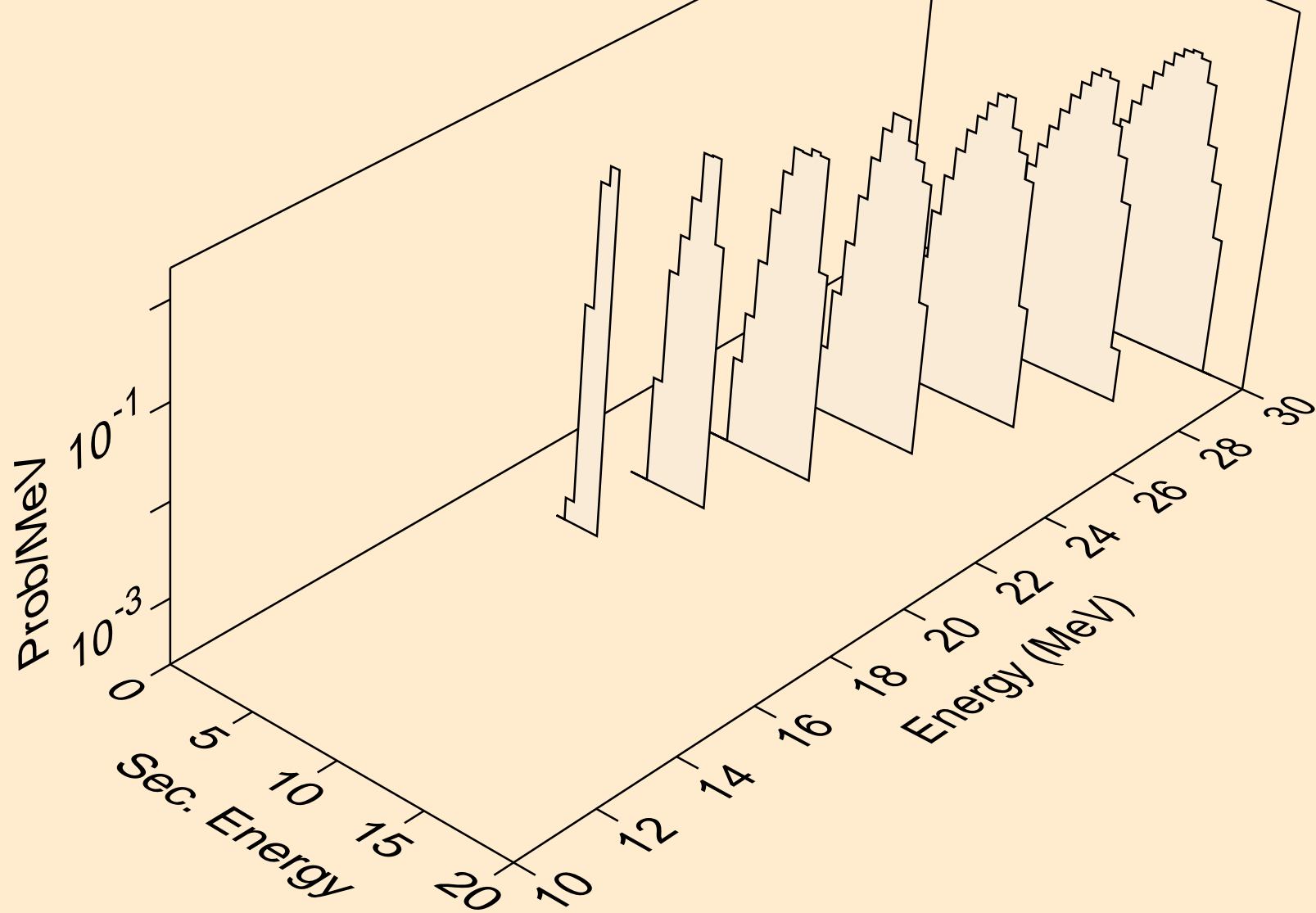

EU141 ALPHA ACER TENDL-2024 LIBRARY; T=0.K  
Alpha emission for (a,2n)a

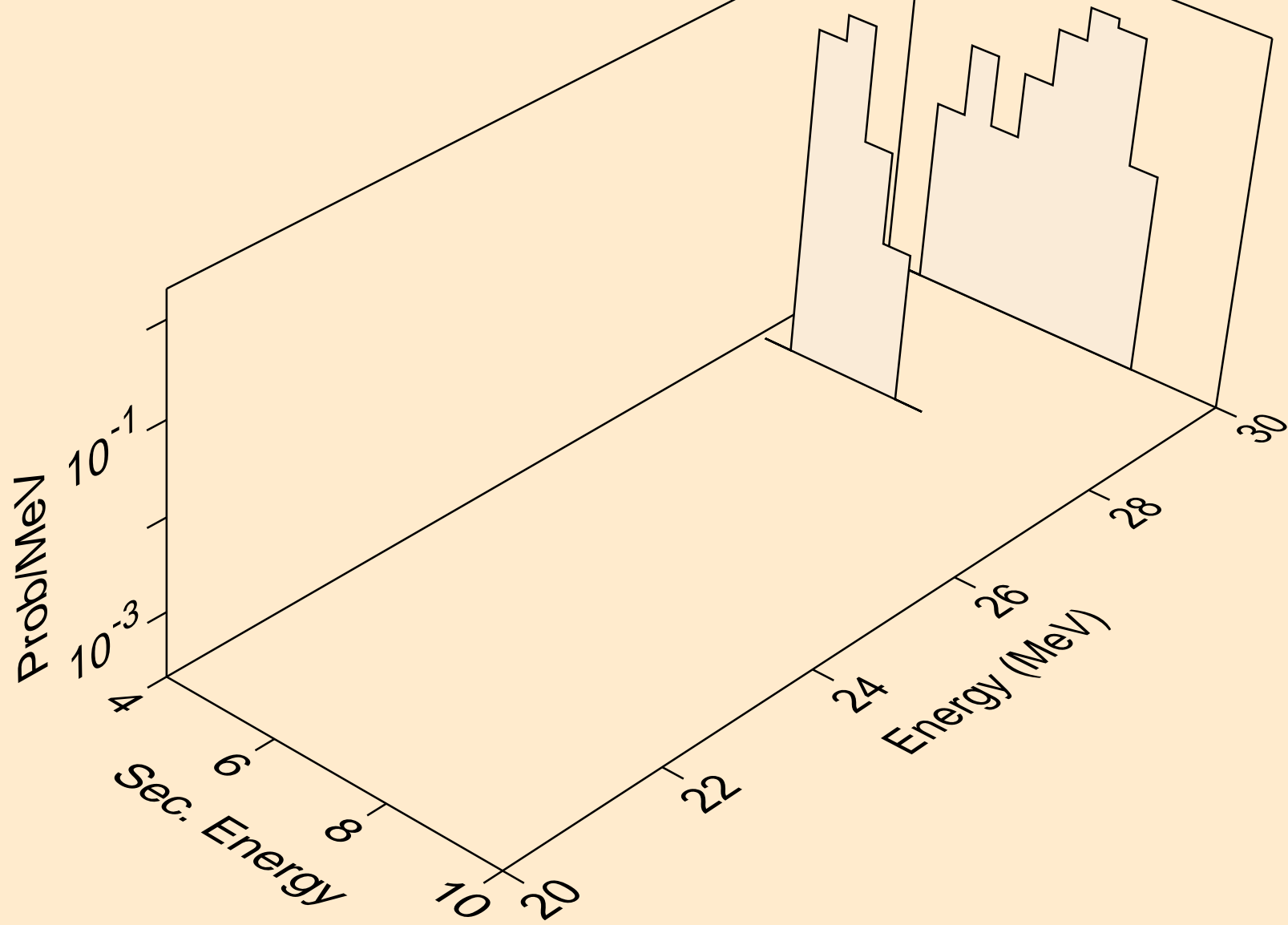

EU141 ALPHA ACER TENDL-2024 LIBRARY; T=0.K  
Alpha emission for inelastic

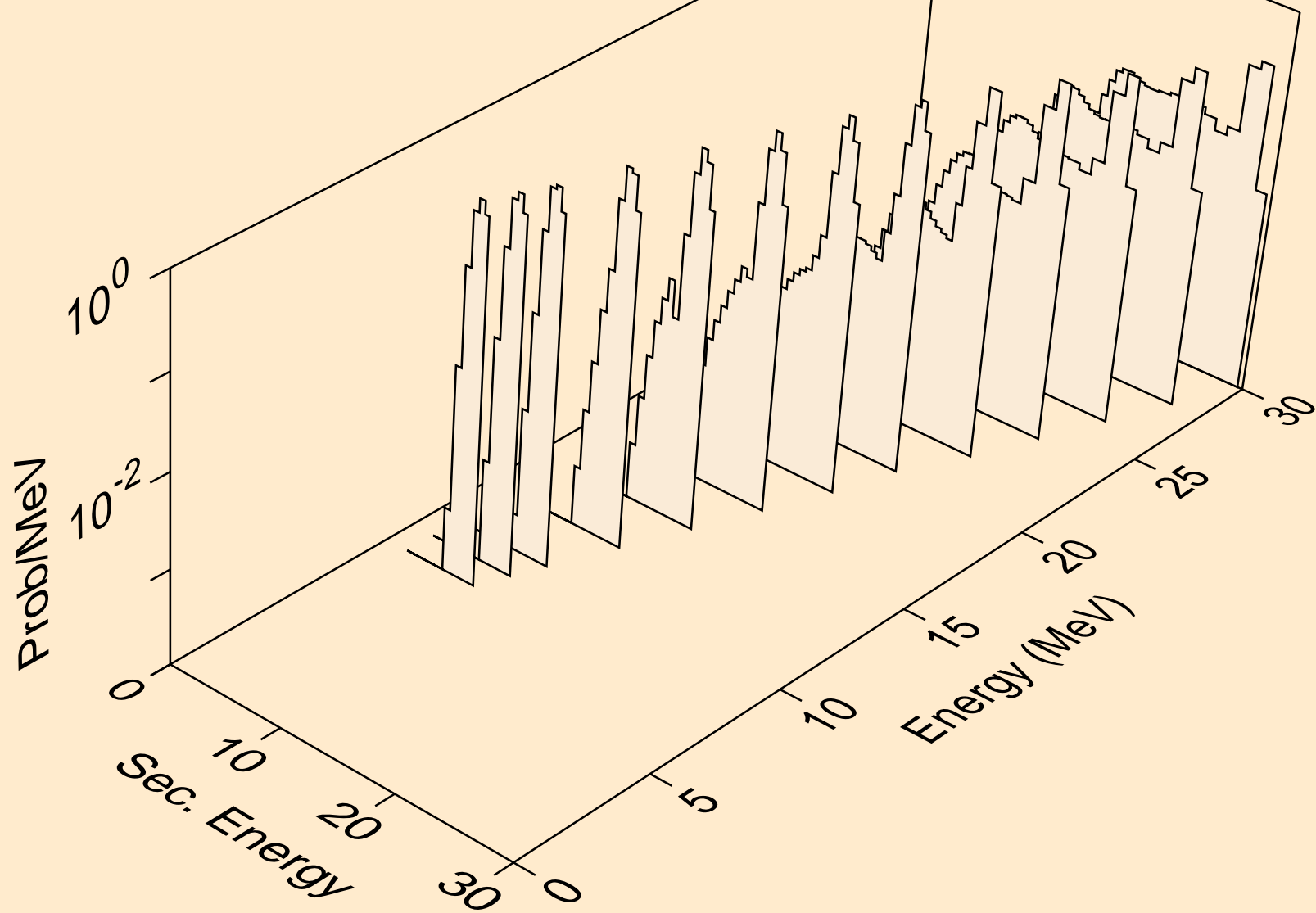

EU141 ALPHA ACER TENDL-2024 LIBRARY; T=0.K  
Alpha emission for (a,2a)

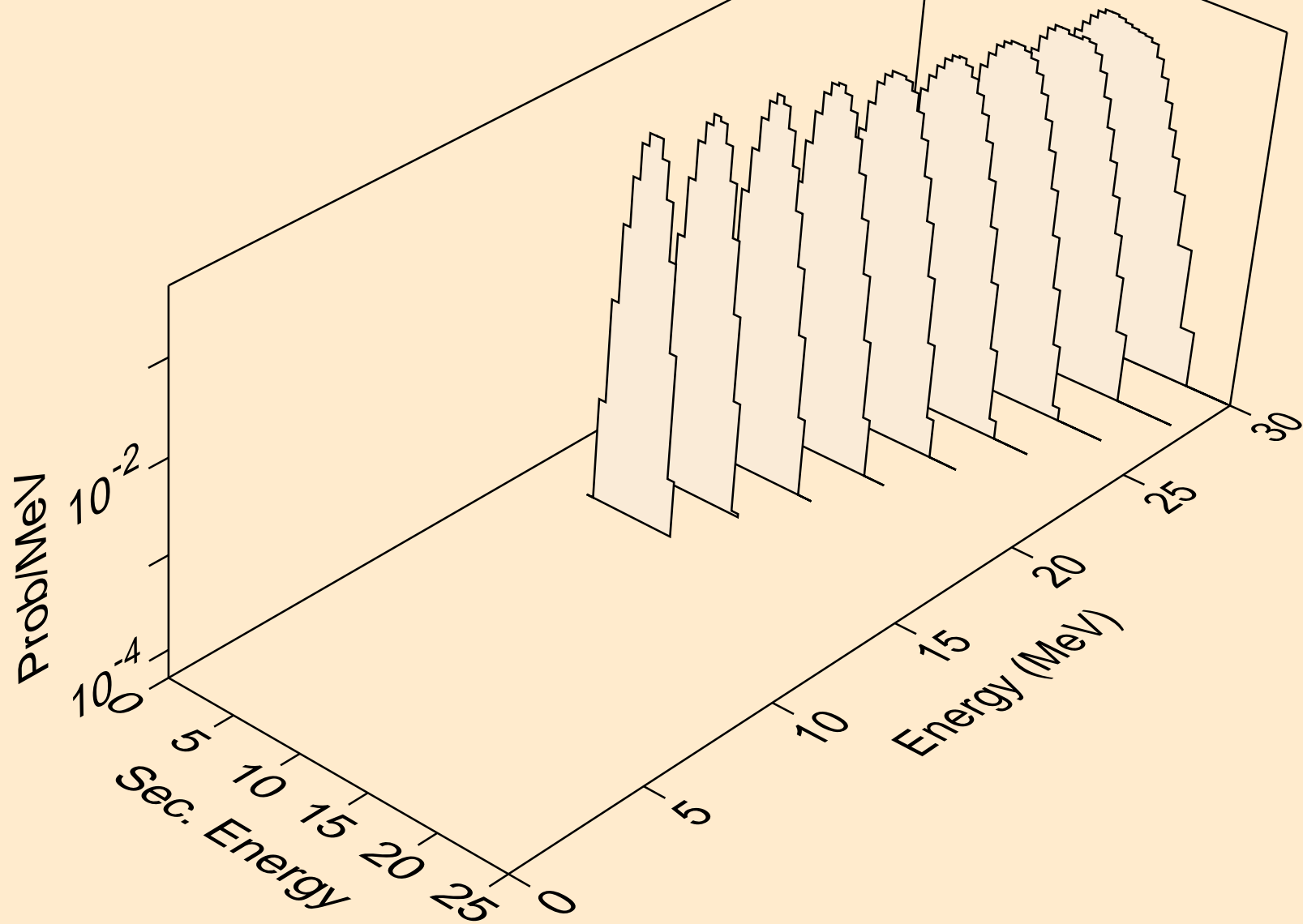

EU141 ALPHA ACER TENDL-2024 LIBRARY; T=0.K  
Alpha emission for (a,pa)

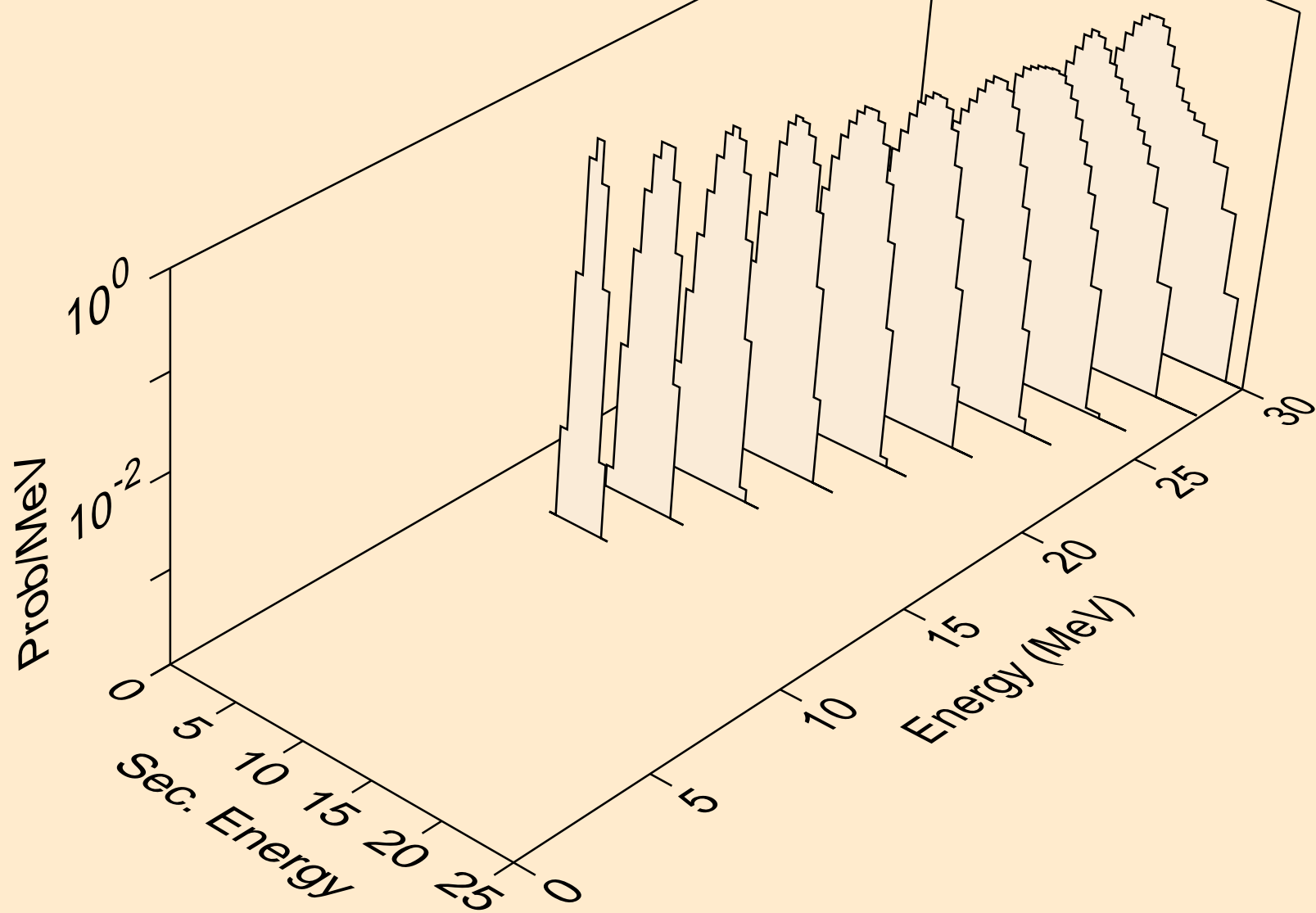

EU141 ALPHA ACER TENDL-2024 LIBRARY; T=0.K  
Alpha emission for (a,da)

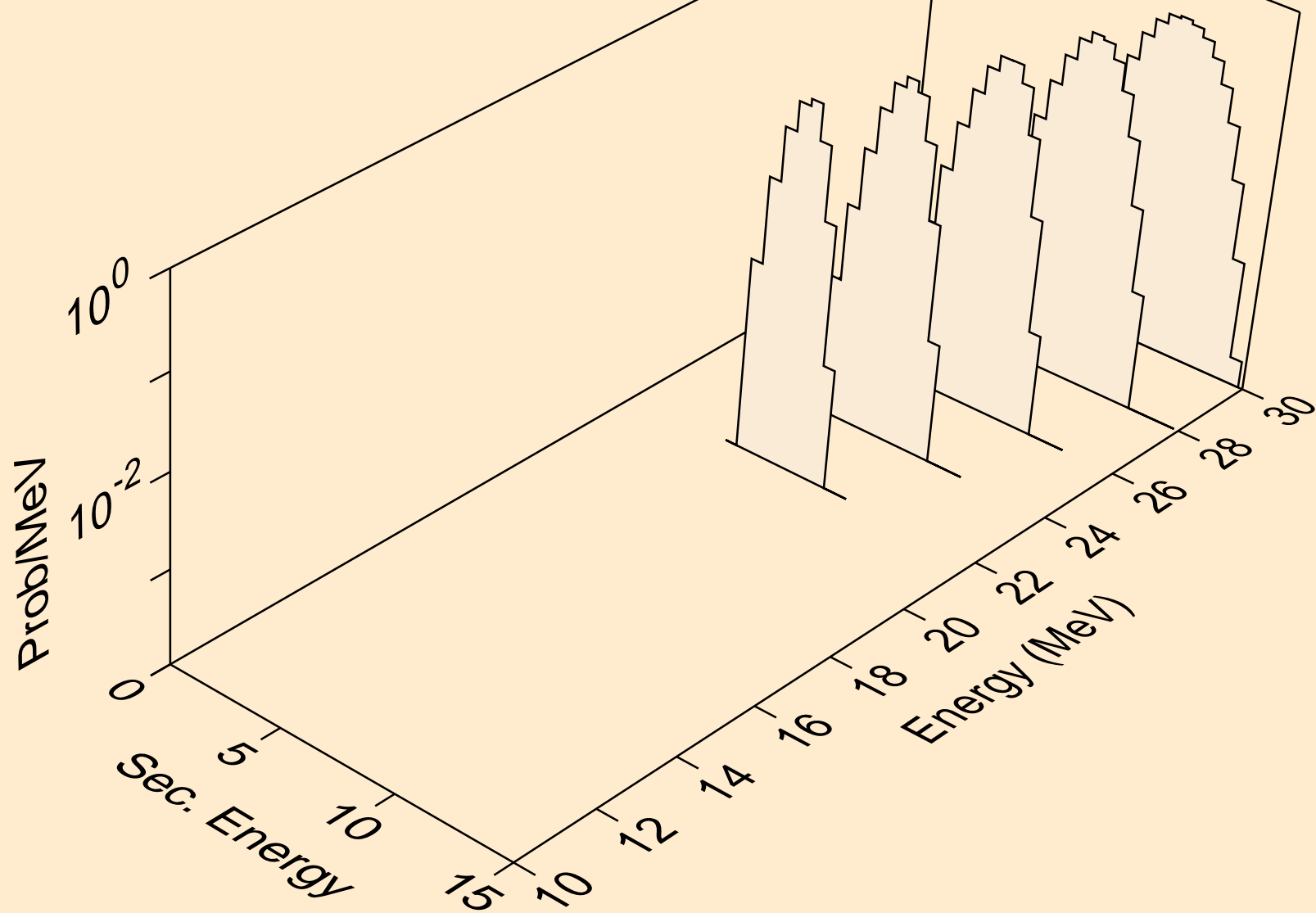

EU141 ALPHA ACER TENDL-2024 LIBRARY; T=0.K  
Photon emission for (z,n)

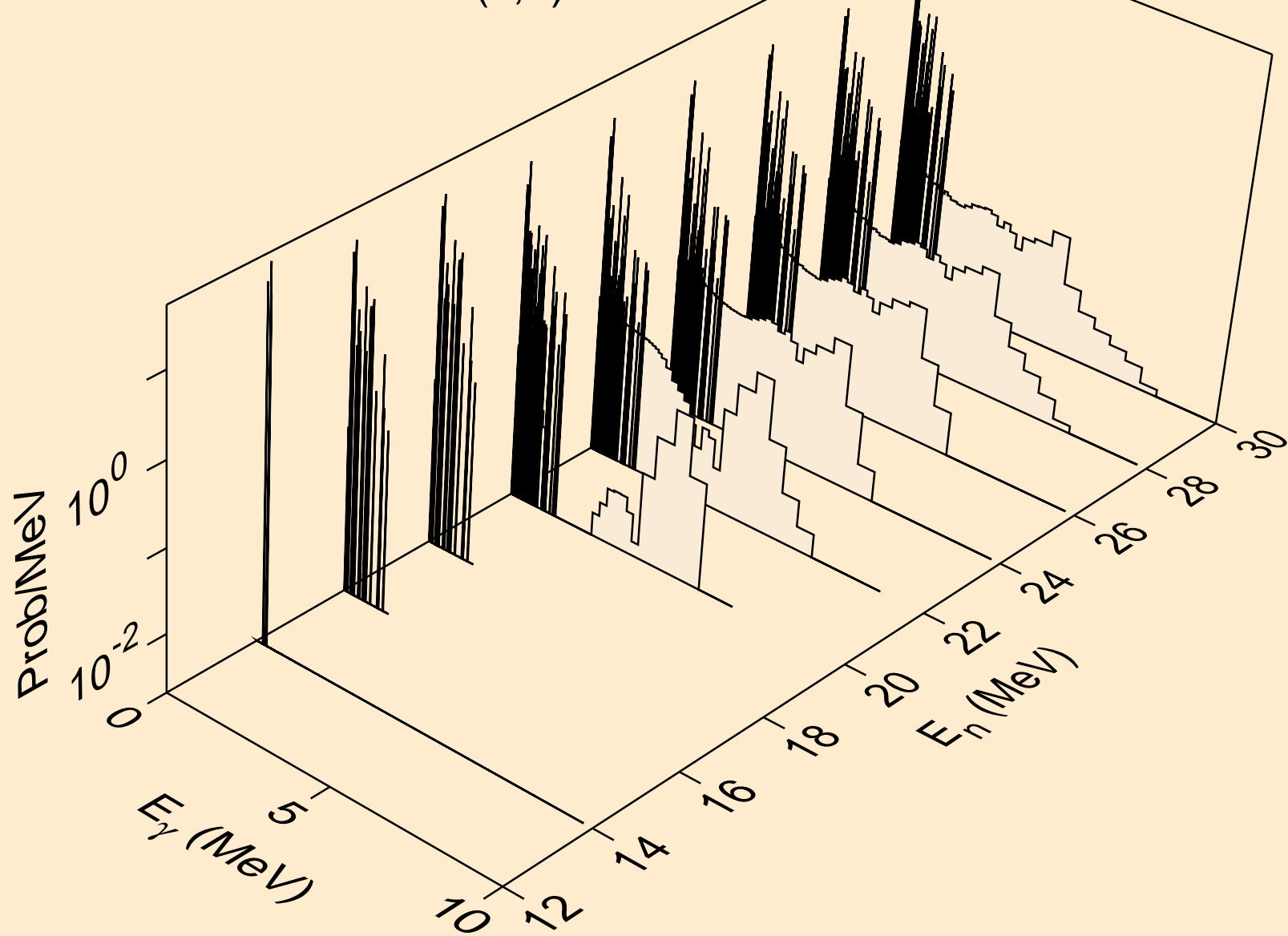

EU141 ALPHA ACER TENDL-2024 LIBRARY; T=0.K  
Photon emission for (z,x)

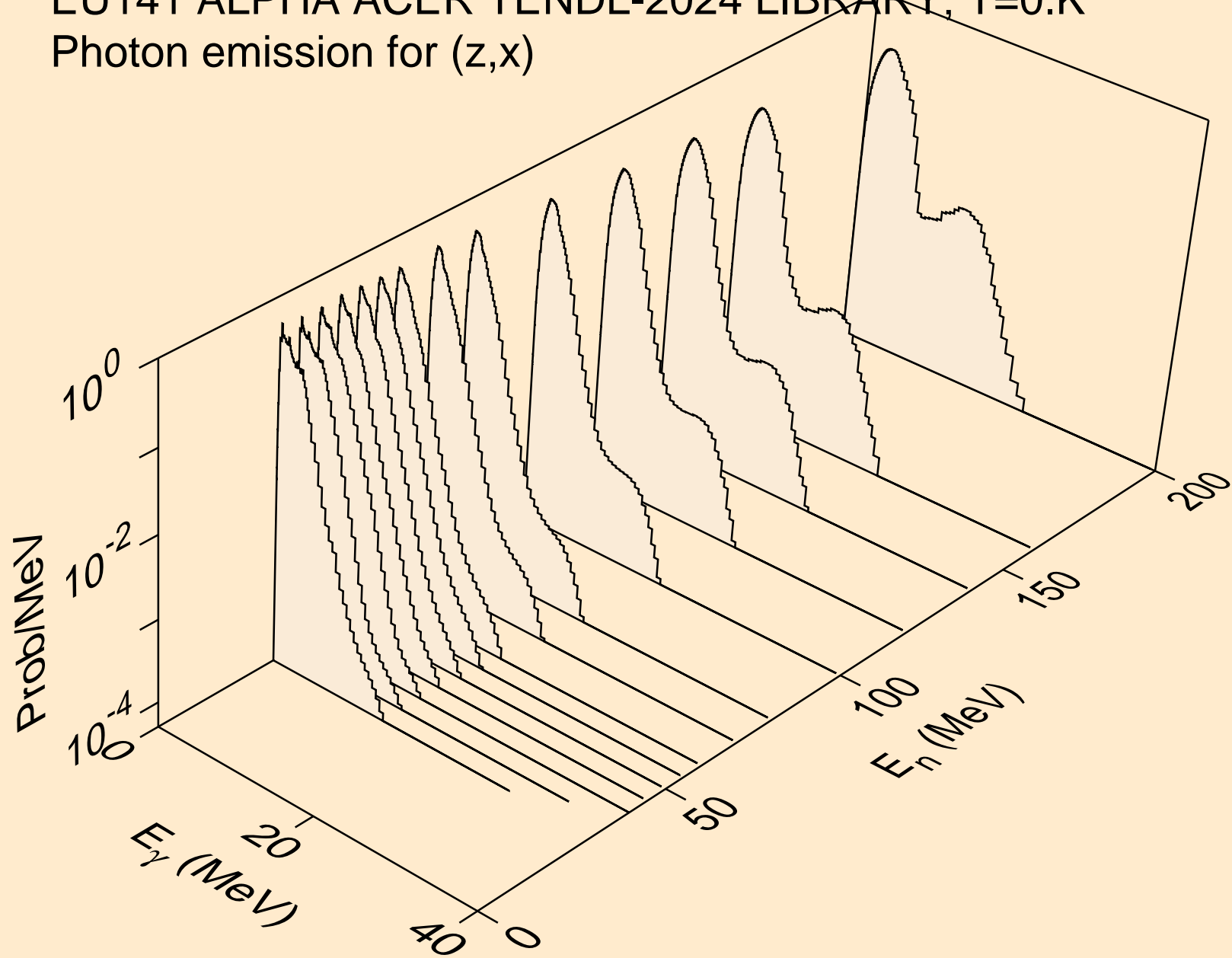

EU141 ALPHA ACER TENDL-2024 LIBRARY; T=0.K  
Photon emission for (n,2n)

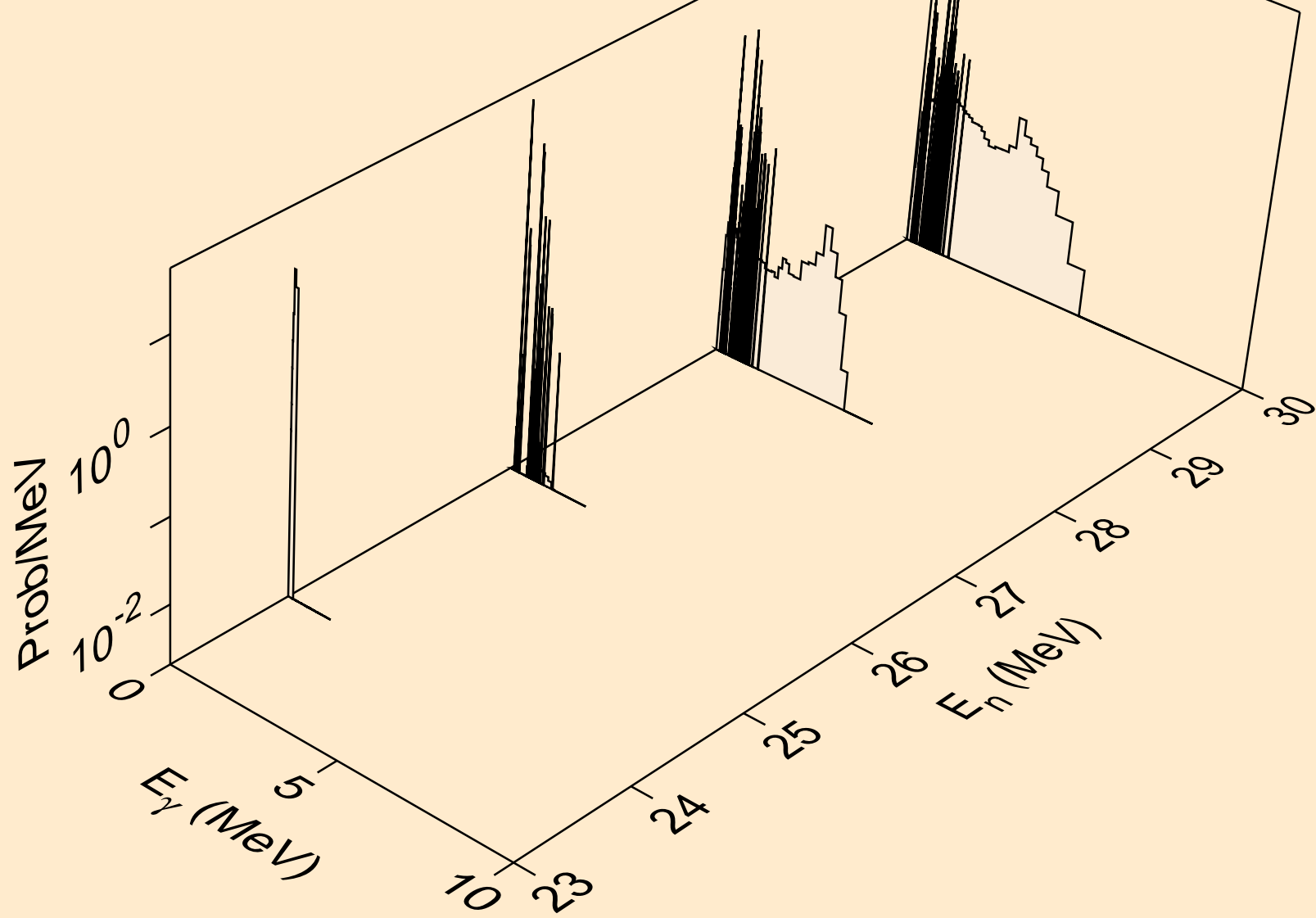

EU141 ALPHA ACER TENDL-2024 LIBRARY; T=0.K  
Photon emission for (n,n\*)a

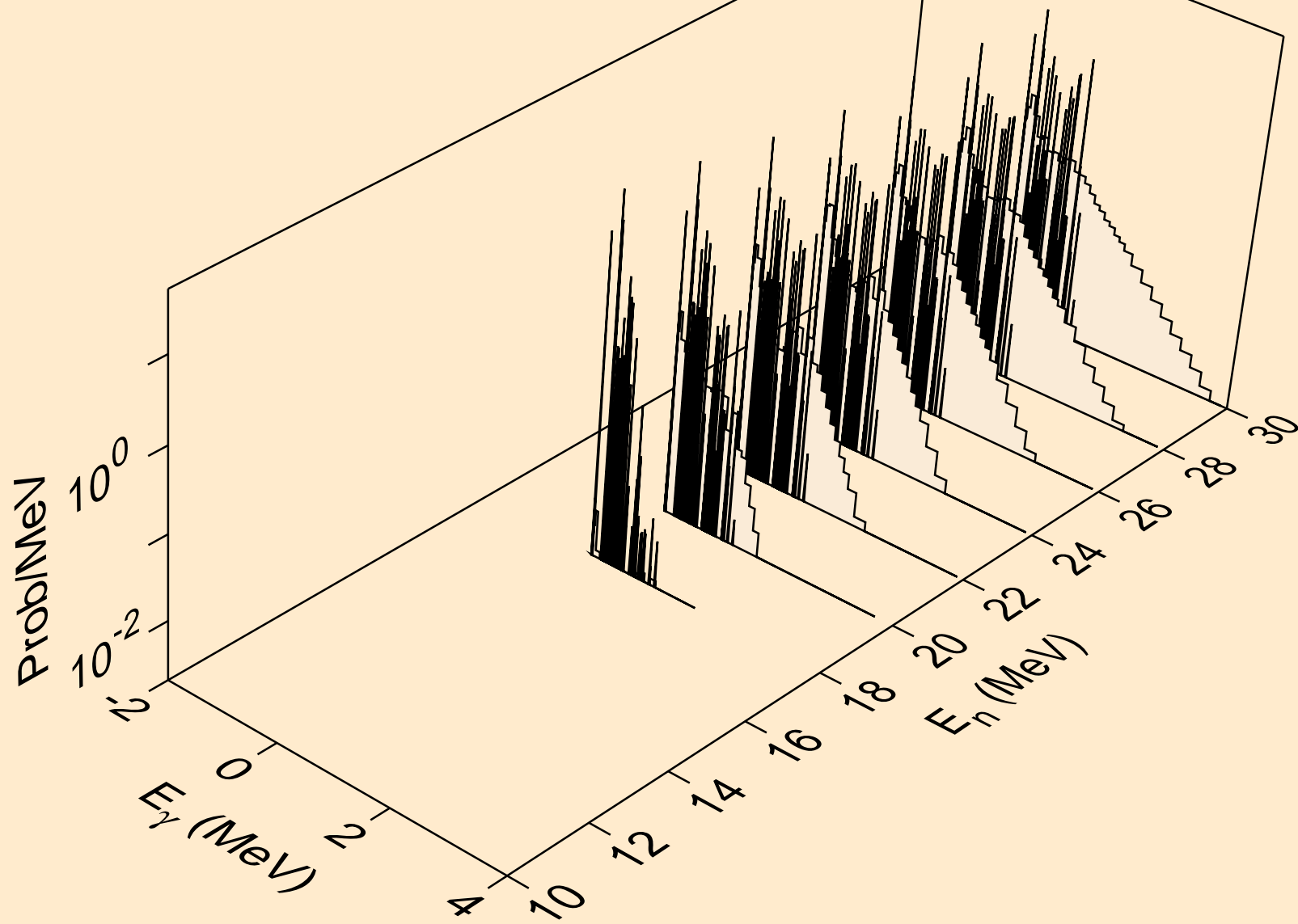

EU141 ALPHA ACER TENDL-2024 LIBRARY; T=0.K  
Photon emission for (n,2n)a

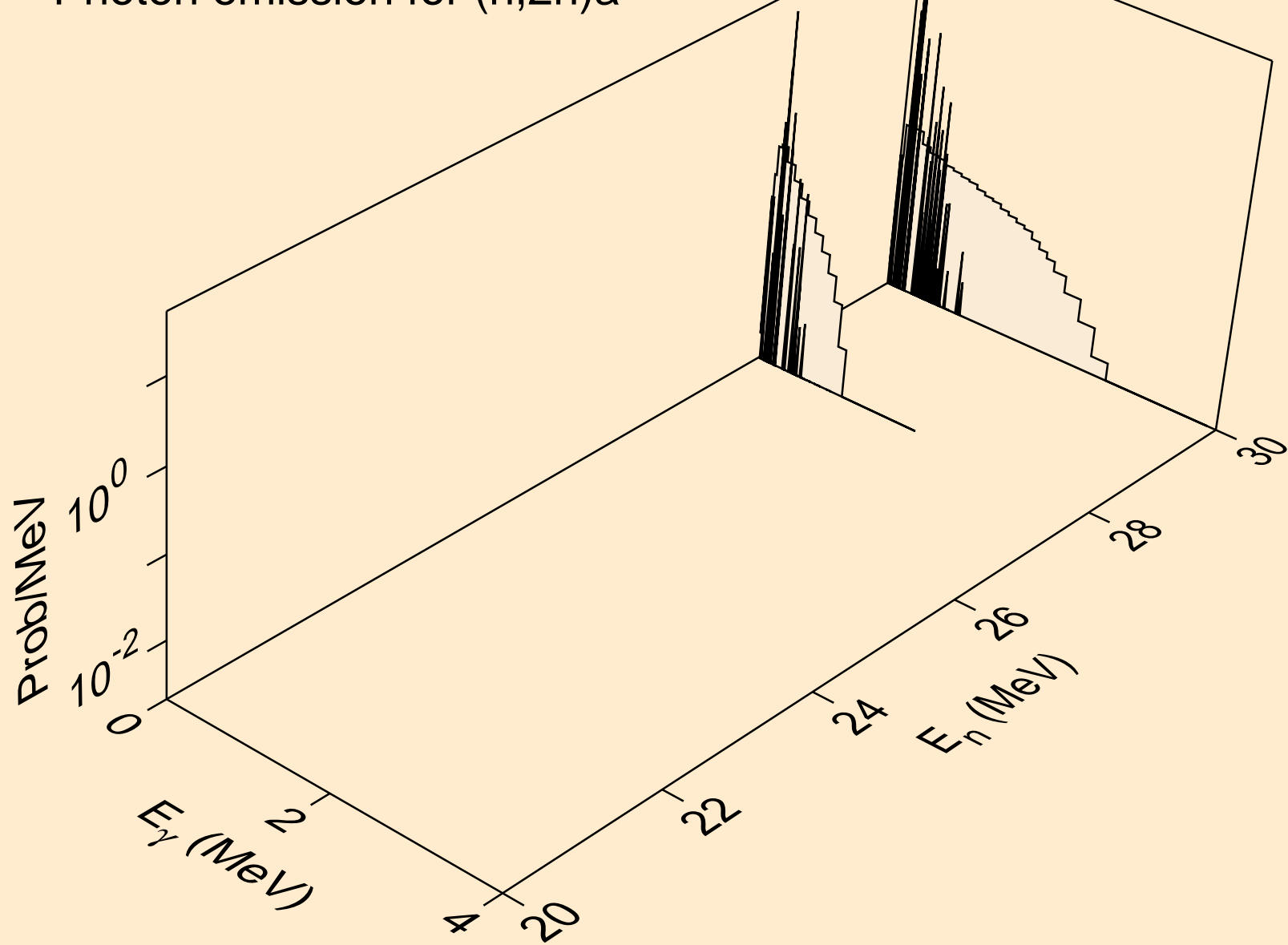

EU141 ALPHA ACER TENDL-2024 LIBRARY; T=0.K  
Photon emission for (n,n\*)p

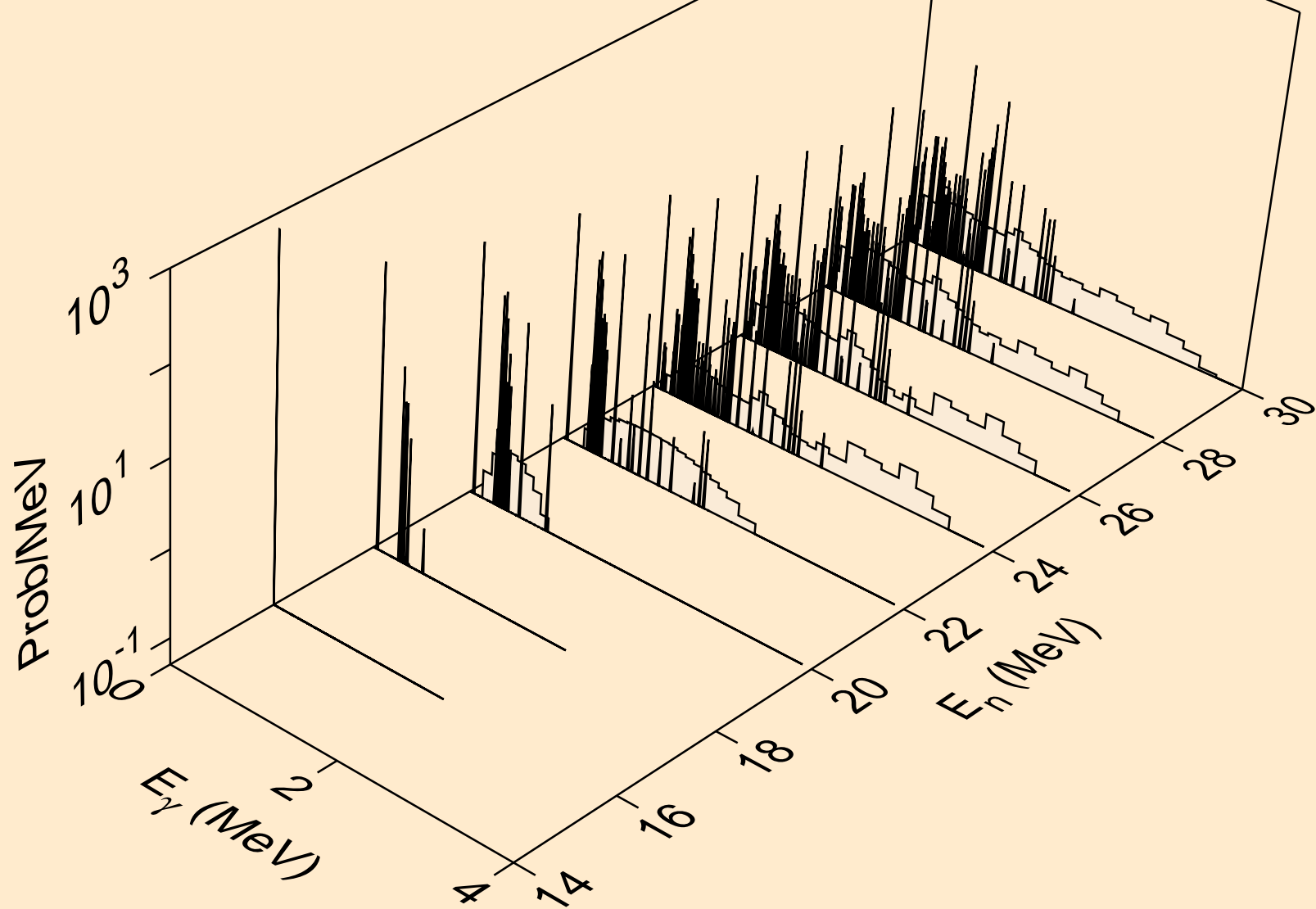

EU141 ALPHA ACER TENDL-2024 LIBRARY; T=0.K  
Photon emission for (n,n\*)d

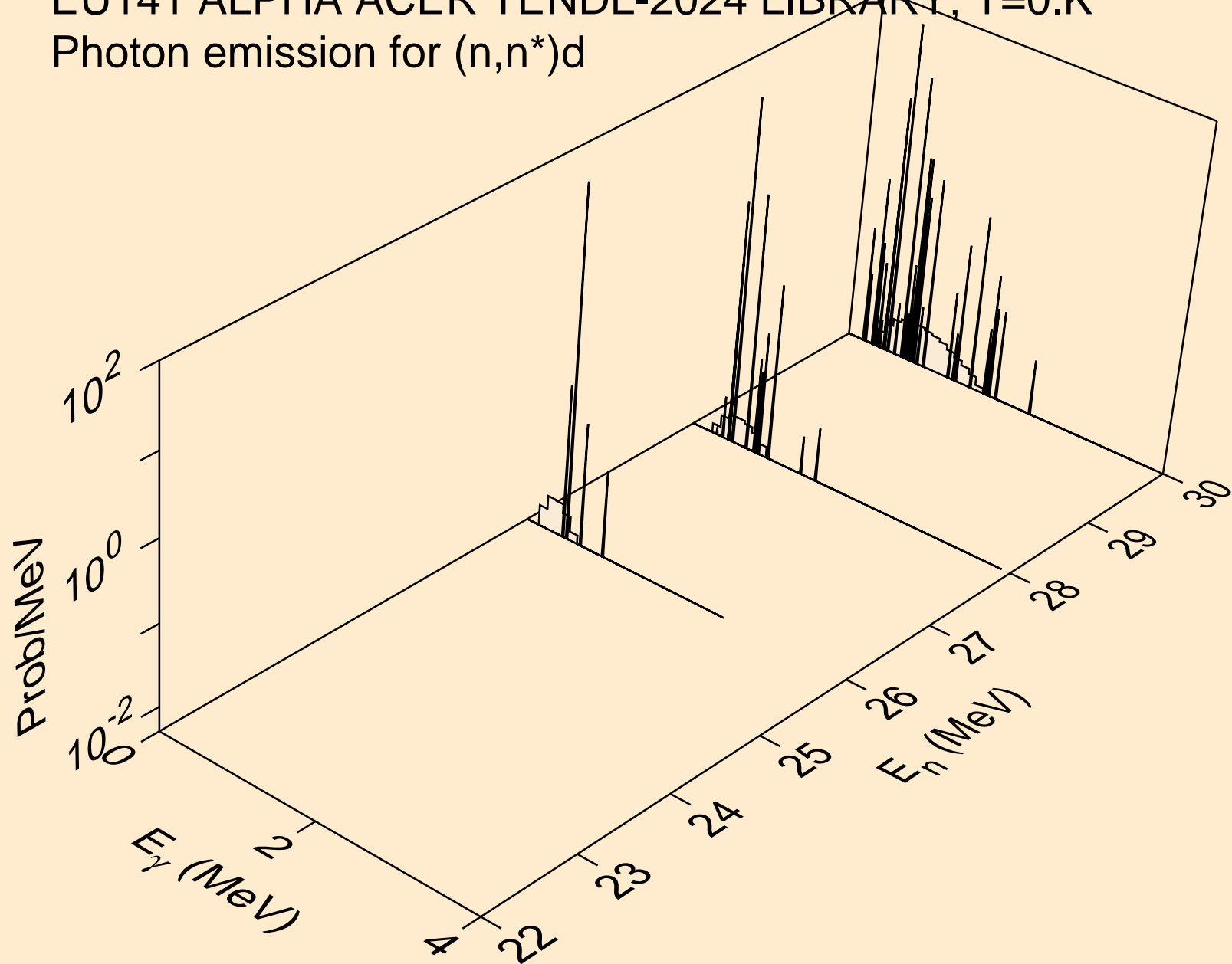

EU141 ALPHA ACER TENDL-2024 LIBRARY; T=0.K  
Photon emission for (n,2np)

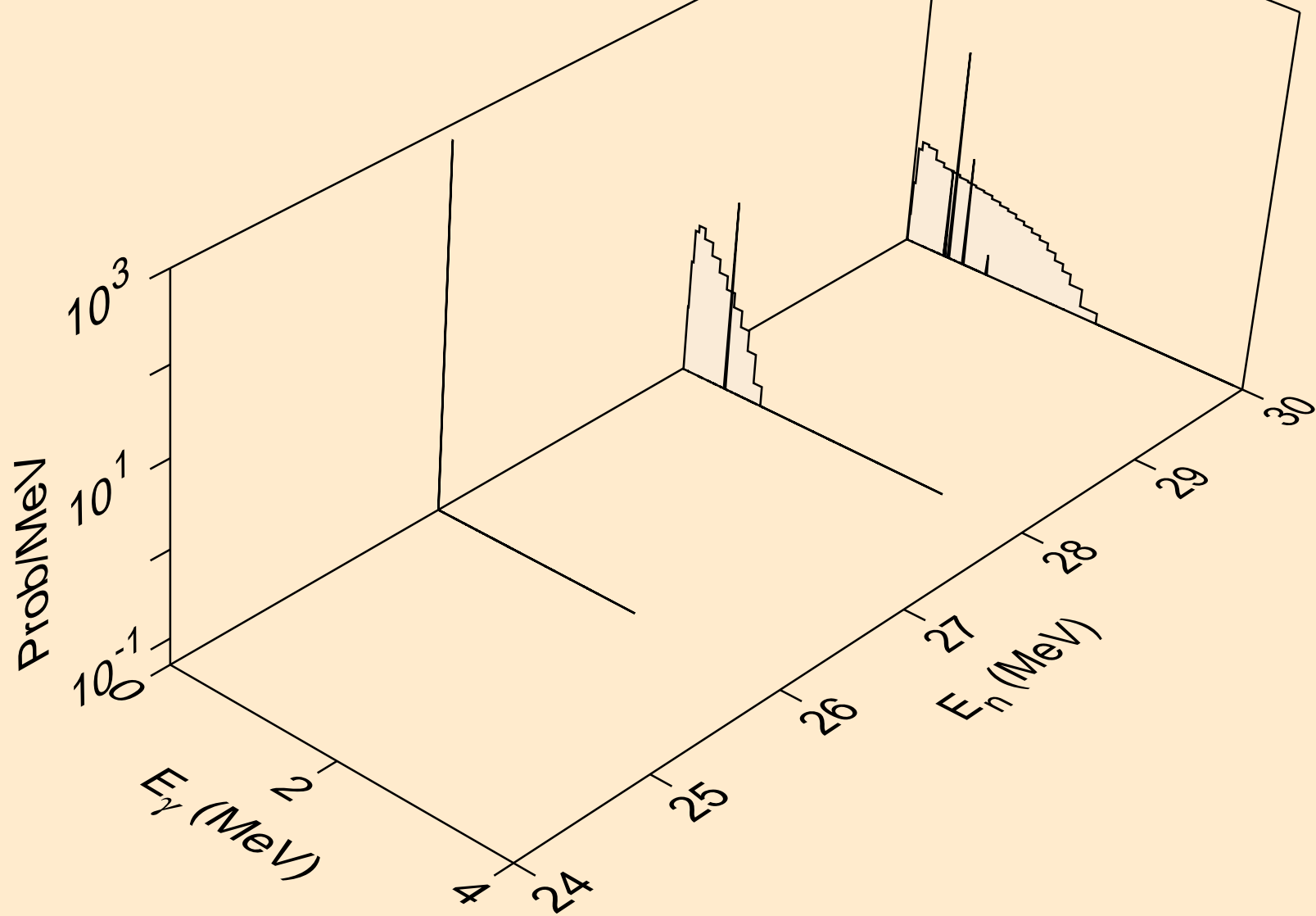

EU141 ALPHA ACER TENDL-2024 LIBRARY; T=0.K  
Photon emission for (n,n2p)

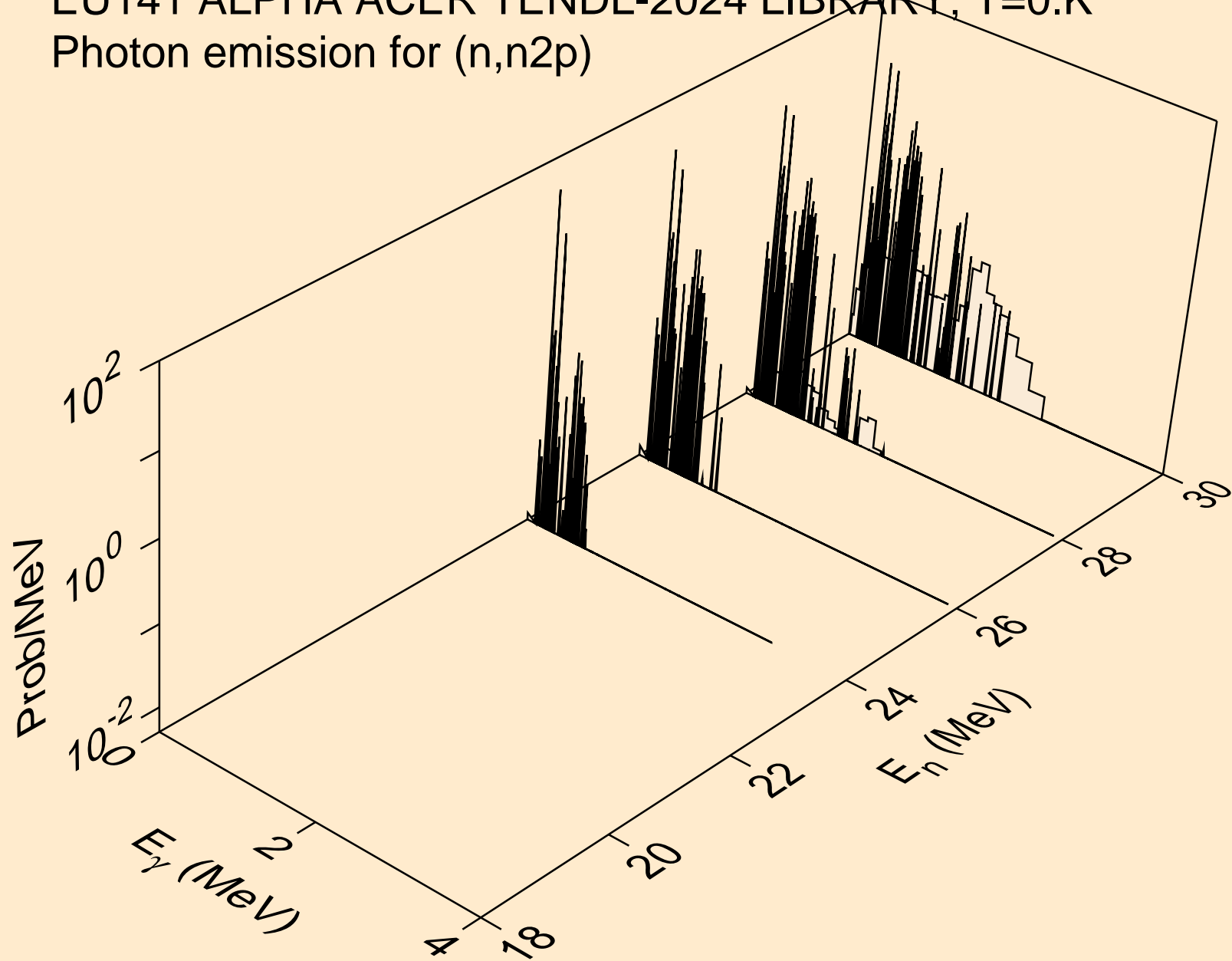

EU141 ALPHA ACER TENDL-2024 LIBRARY; T=0.K  
Photon emission for (n,npa)

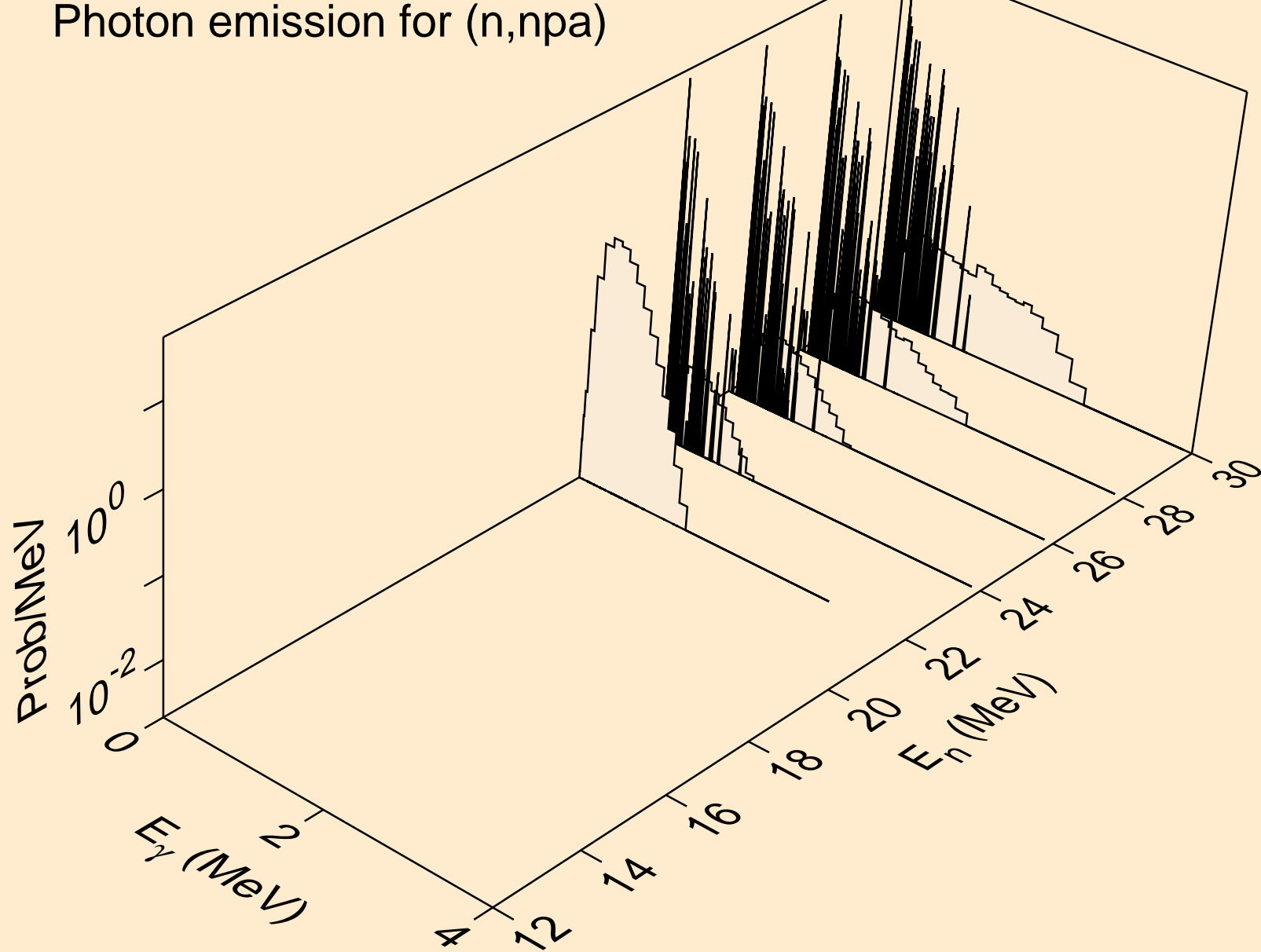

EU141 ALPHA ACER TENDL-2024 LIBRARY; T=0.K  
Photon emission for (n,gma)

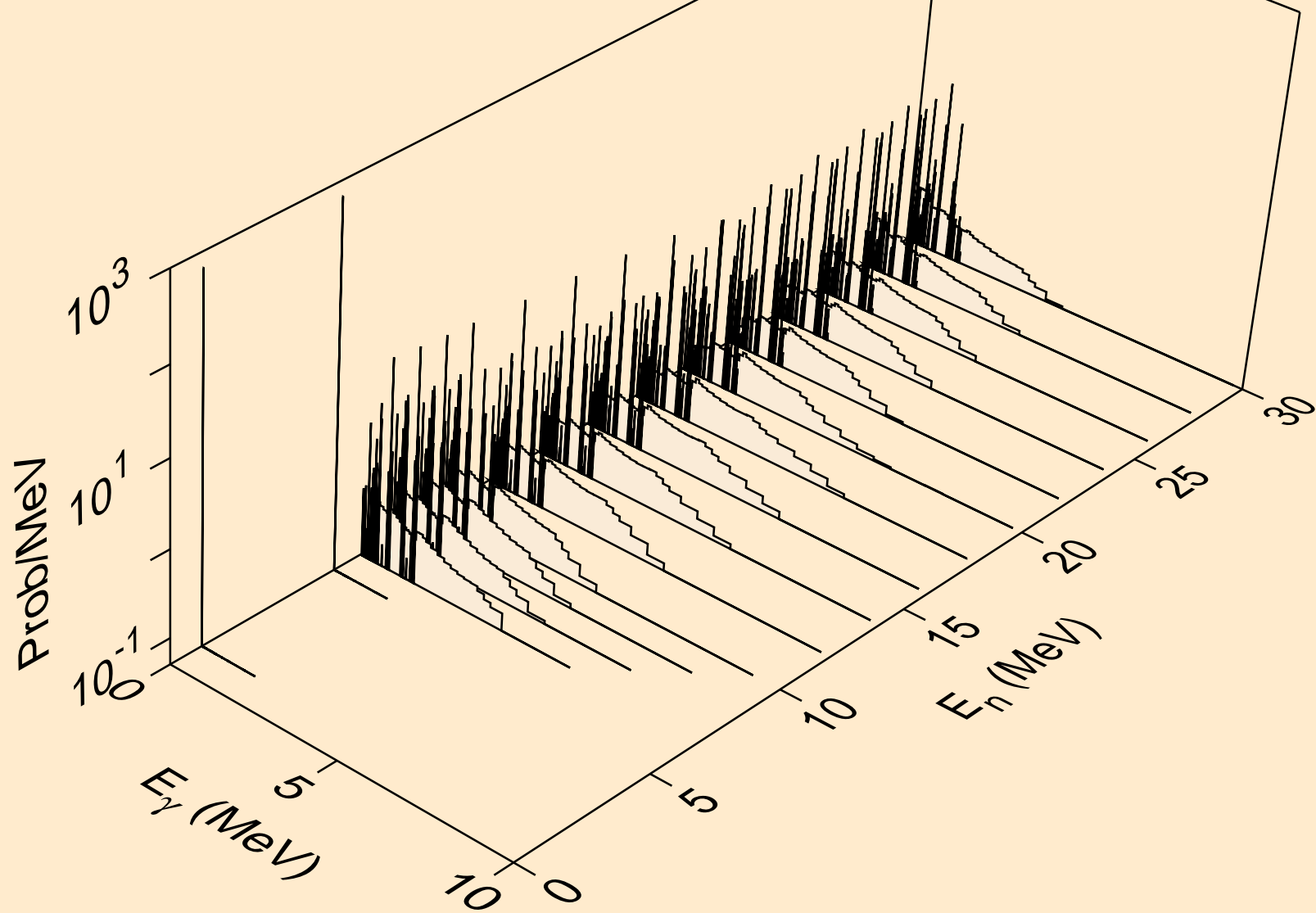

EU141 ALPHA ACER TENDL-2024 LIBRARY; T=0.K  
Photon emission for (n,p)

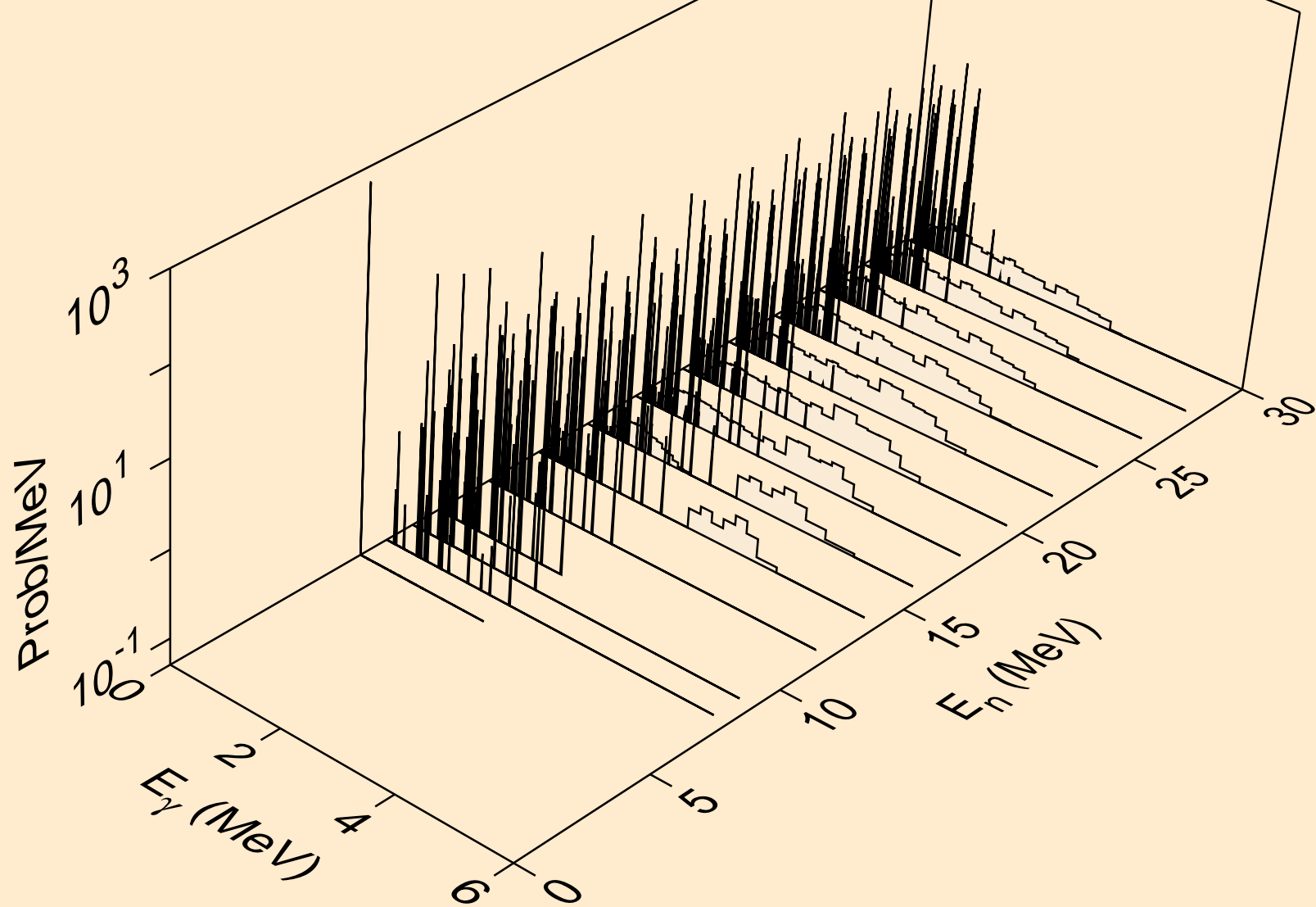

EU141 ALPHA ACER TENDL-2024 LIBRARY; T=0.K  
Photon emission for (n,d)

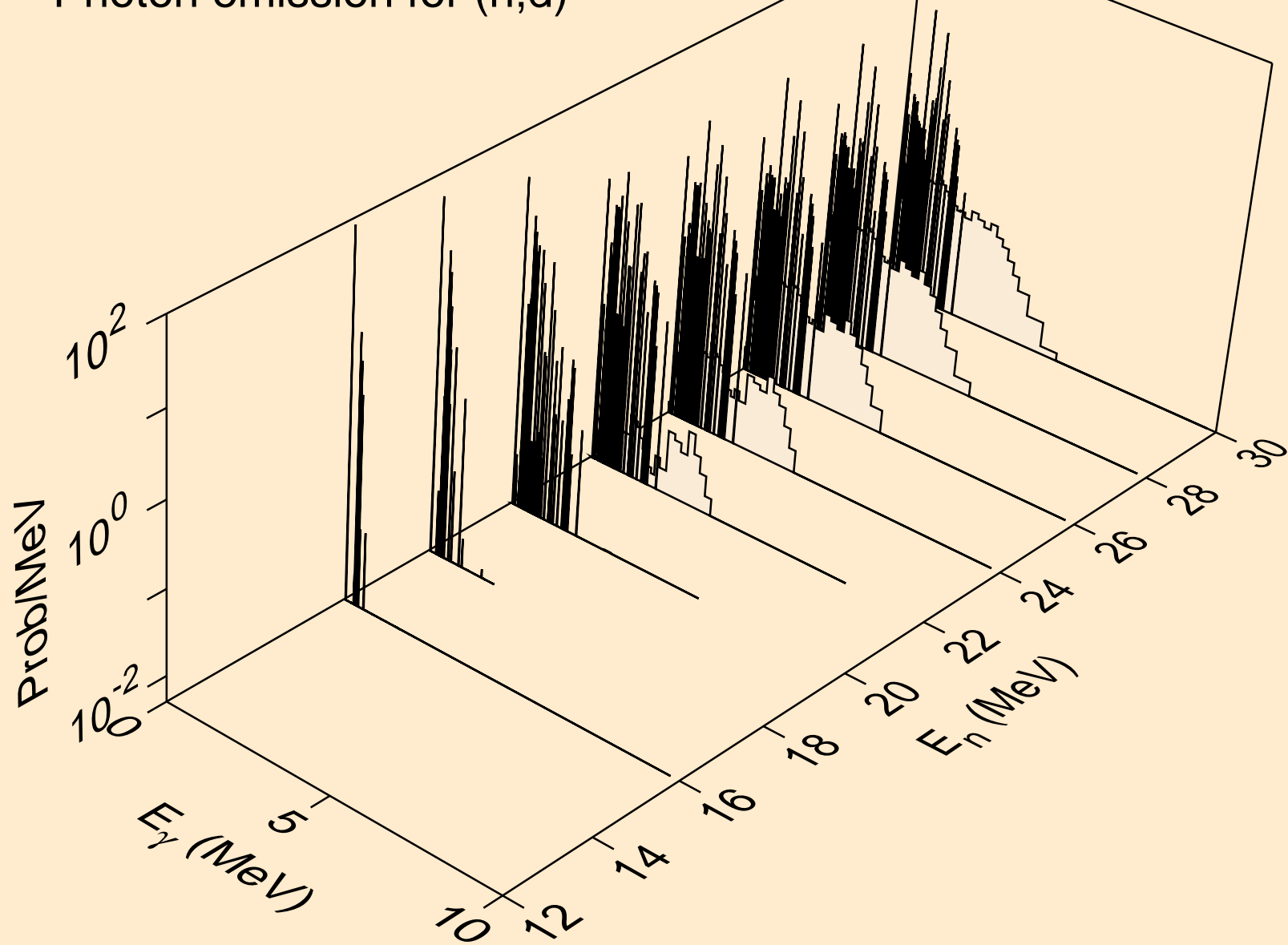

EU141 ALPHA ACER TENDL-2024 LIBRARY; T=0.K  
Photon emission for (n,t)

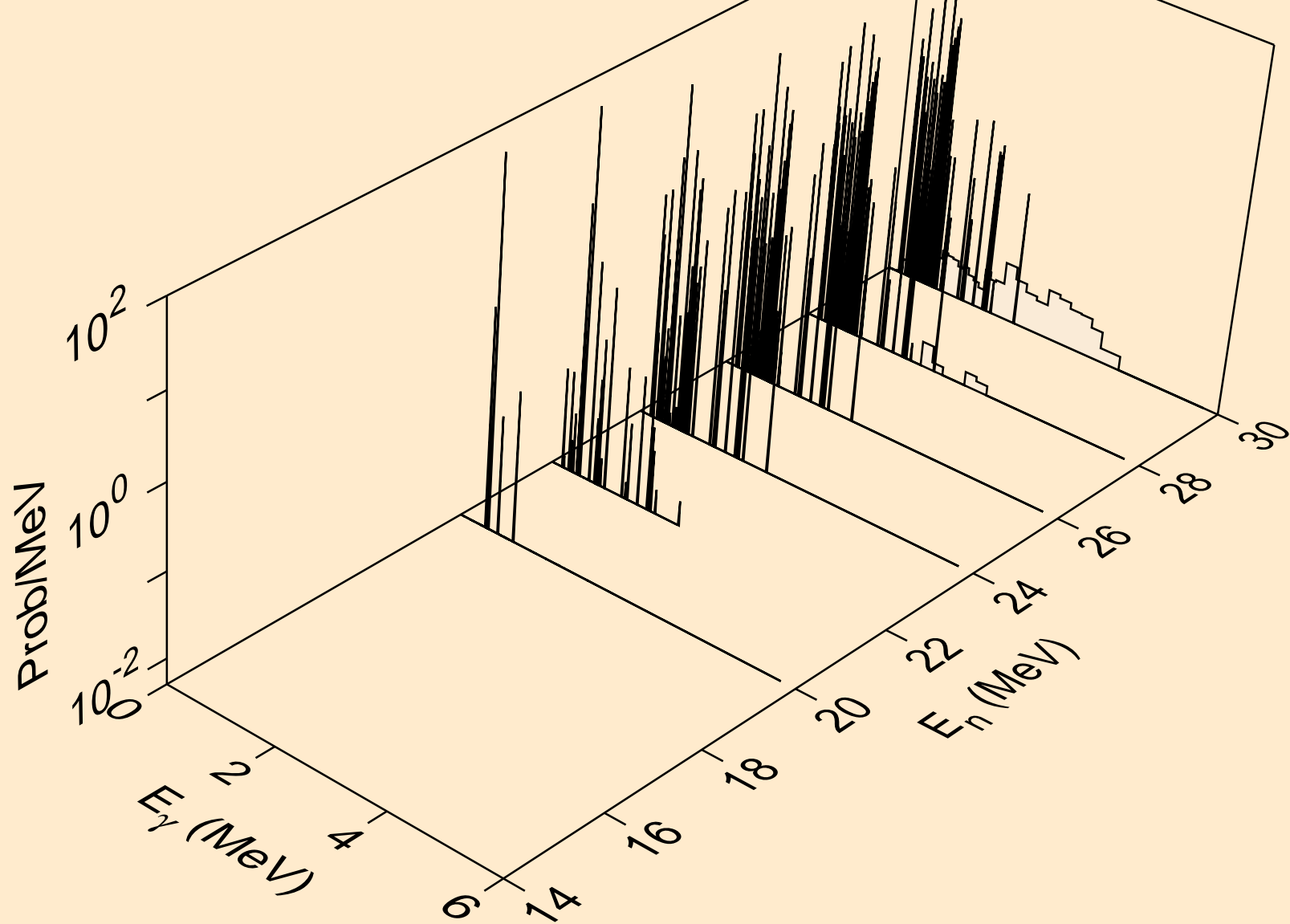

EU141 ALPHA ACER TENDL-2024 LIBRARY; T=0.K  
Photon emission for (n,he3)

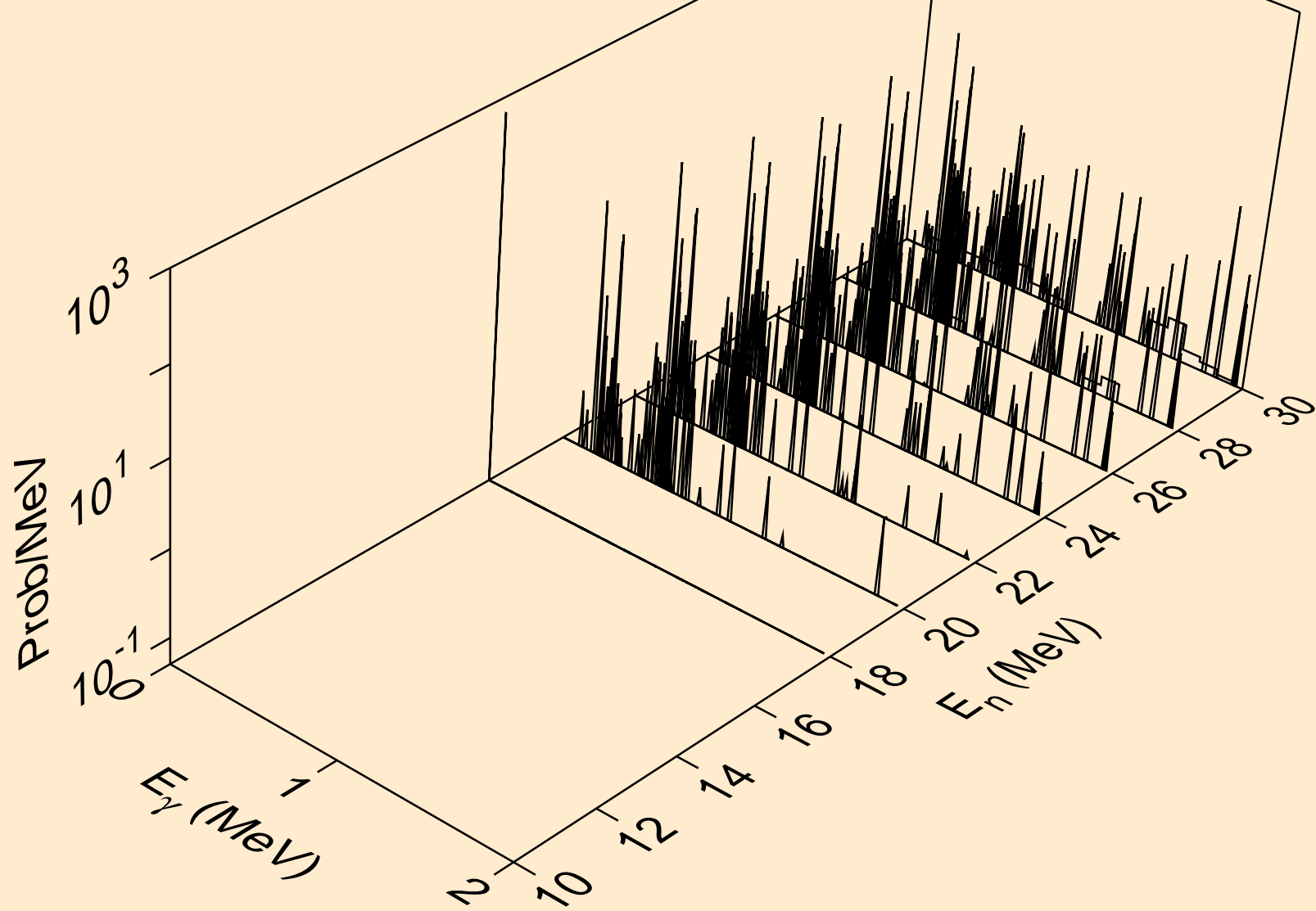

EU141 ALPHA ACER TENDL-2024 LIBRARY; T=0.K  
Photon emission for inelastic

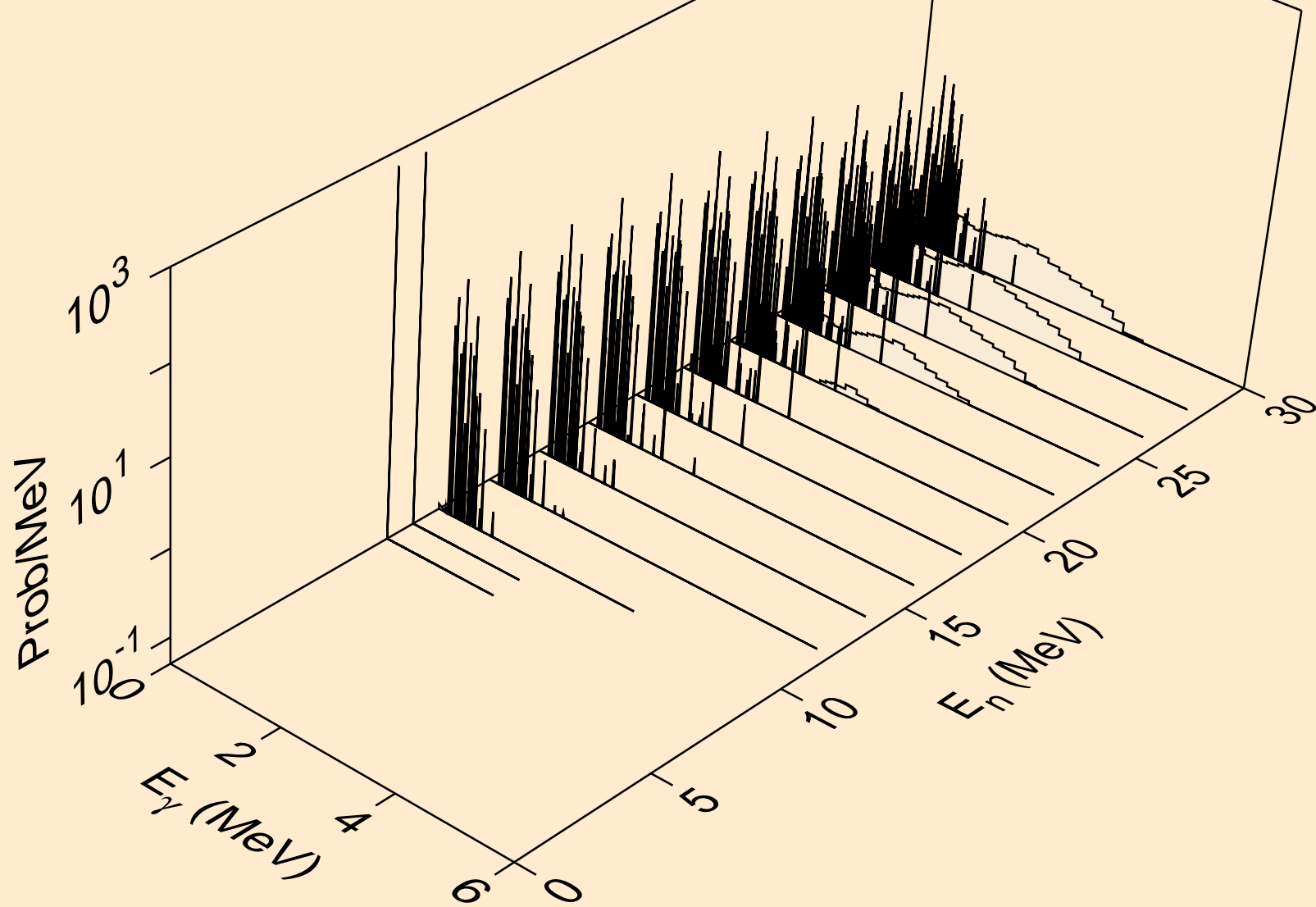

EU141 ALPHA ACER TENDL-2024 LIBRARY; T=0.K  
Photon emission for (n,2a)

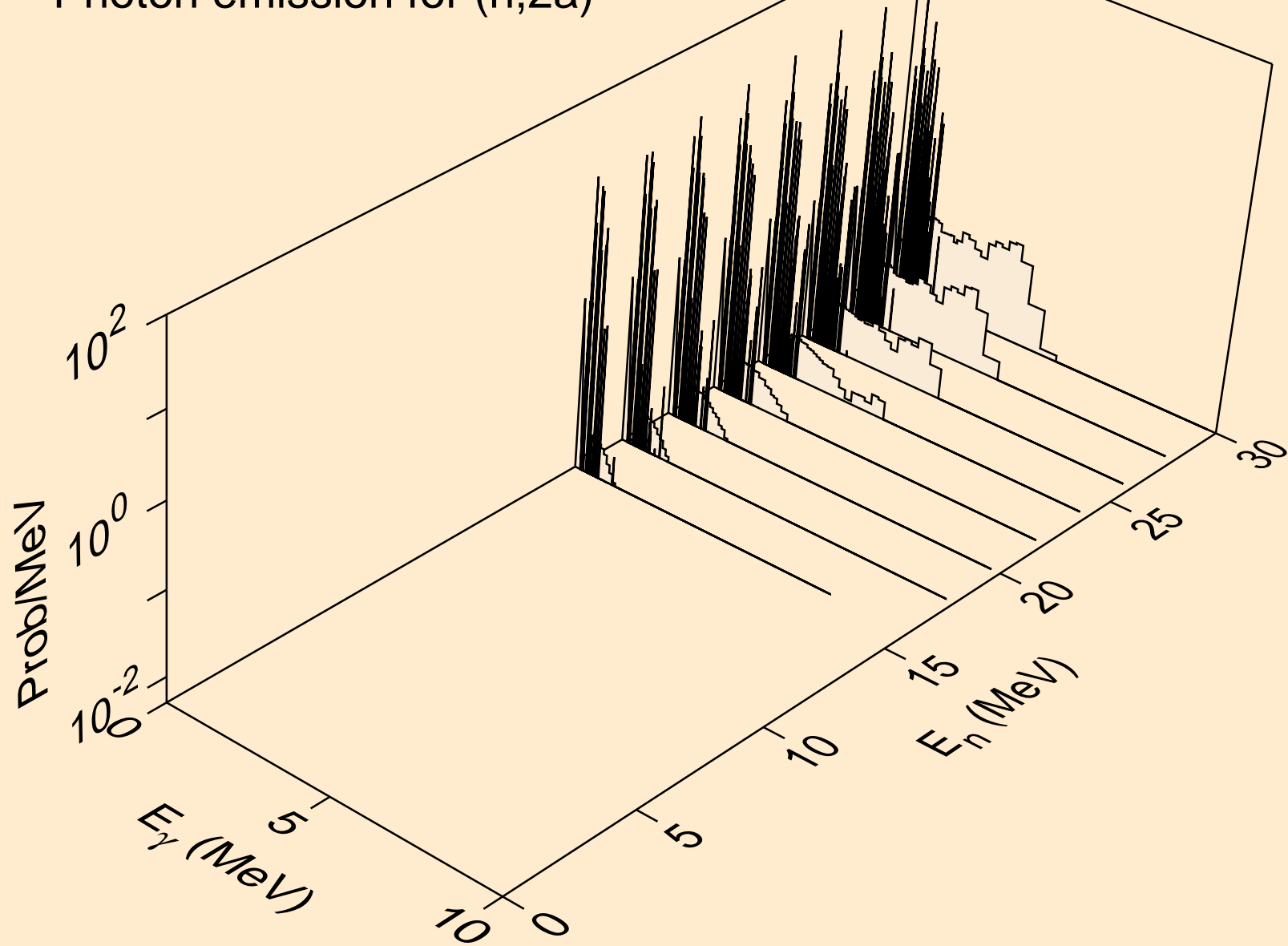

EU141 ALPHA ACER TENDL-2024 LIBRARY; T=0.K  
Photon emission for (n,2p)

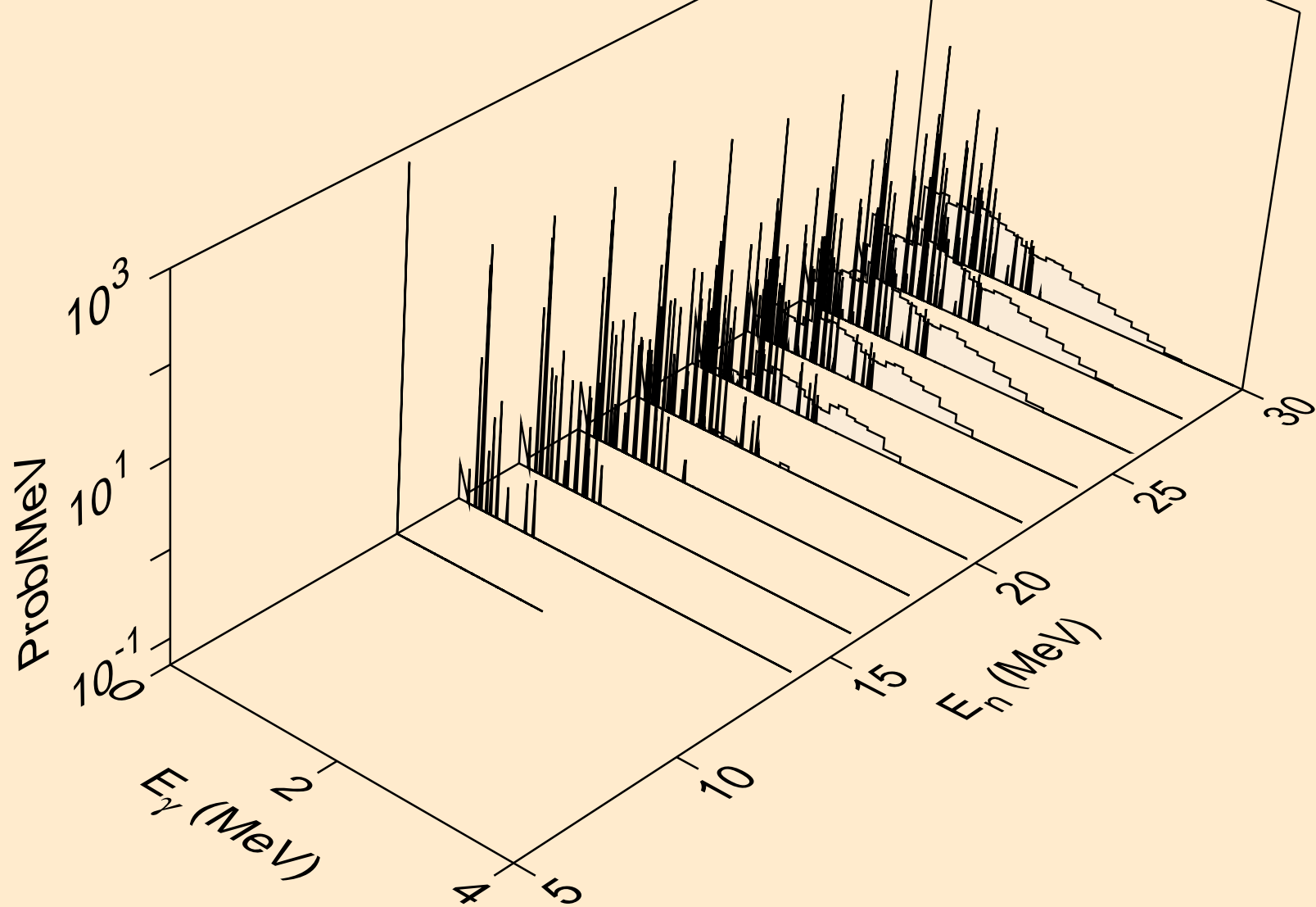

EU141 ALPHA ACER TENDL-2024 LIBRARY; T=0.K  
Photon emission for (n,p $\alpha$ )

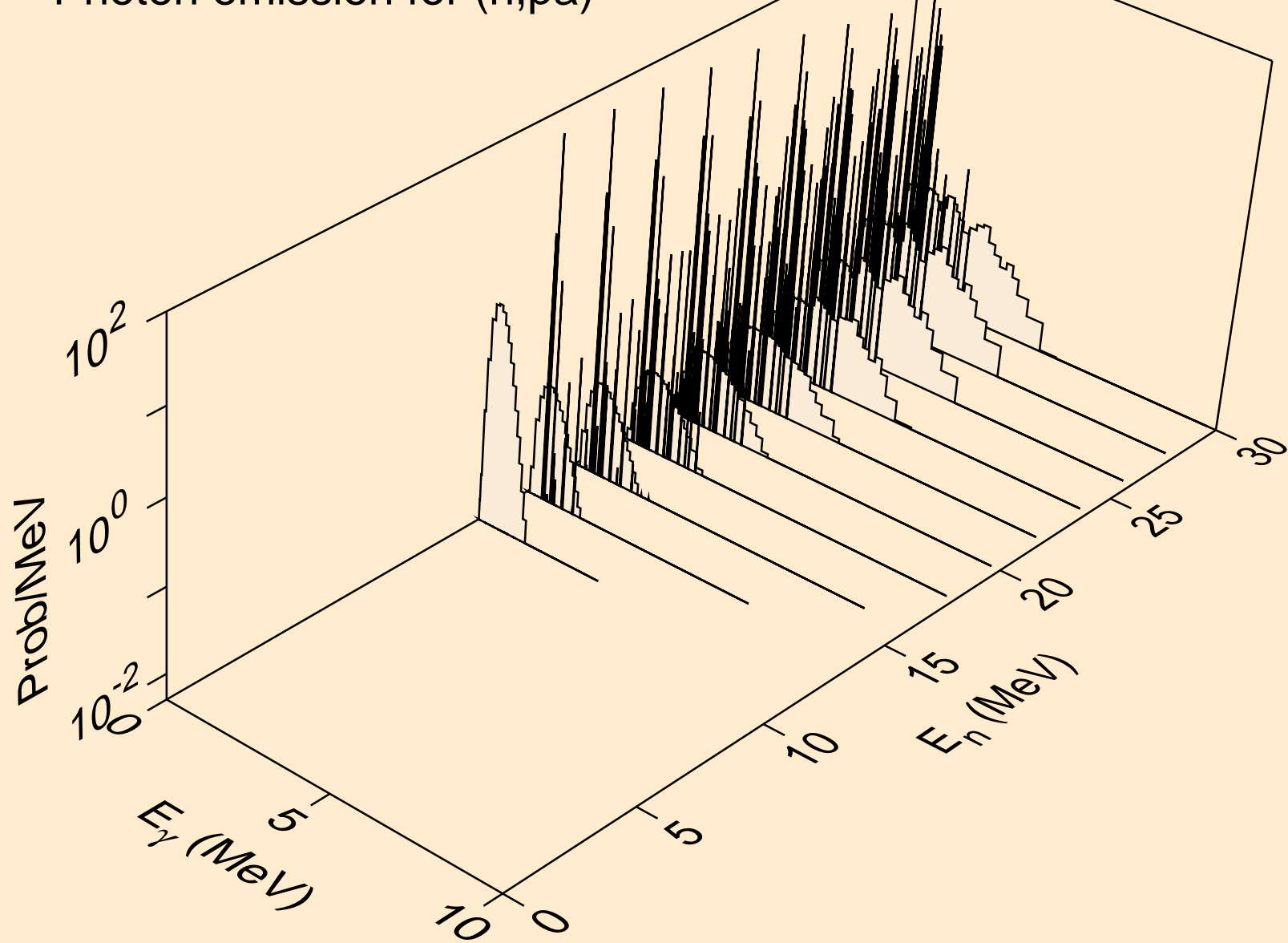

EU141 ALPHA ACER TENDL-2024 LIBRARY; T=0.K  
Photon emission for (n,pd)

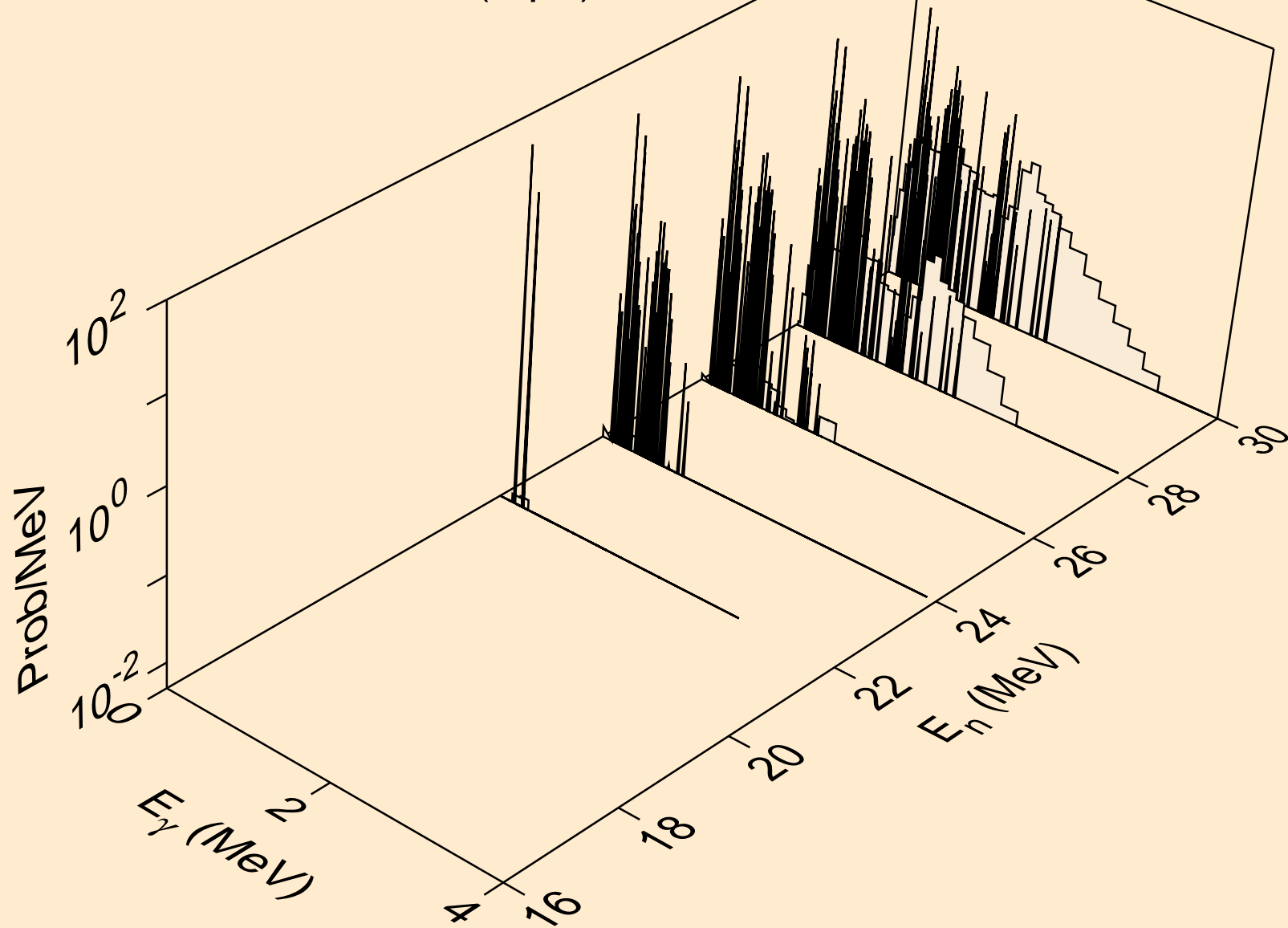

EU141 ALPHA ACER TENDL-2024 LIBRARY; T=0.K  
Photon emission for (n,pt)

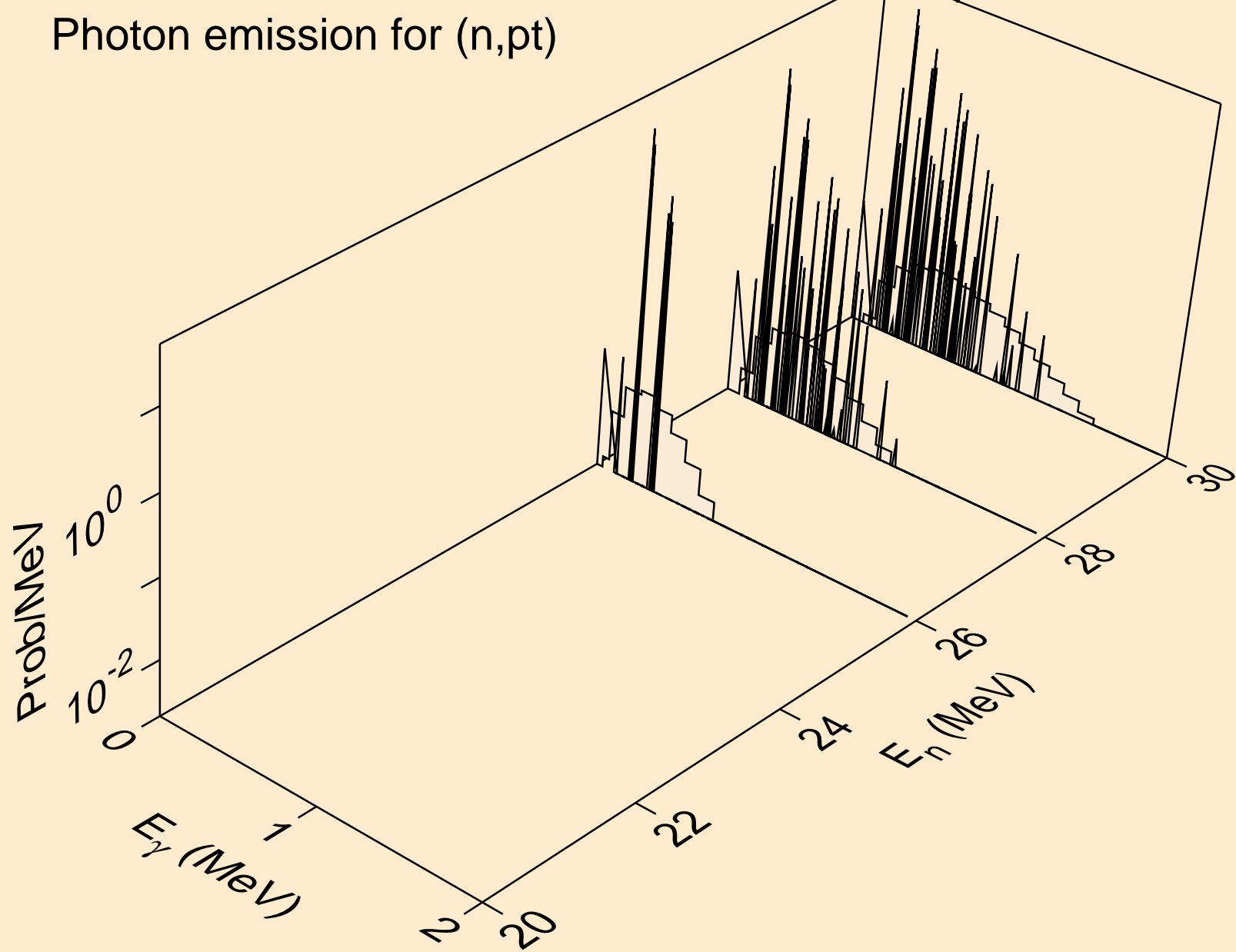

EU141 ALPHA ACER TENDL-2024 LIBRARY; T=0.K  
Photon emission for (n,da)

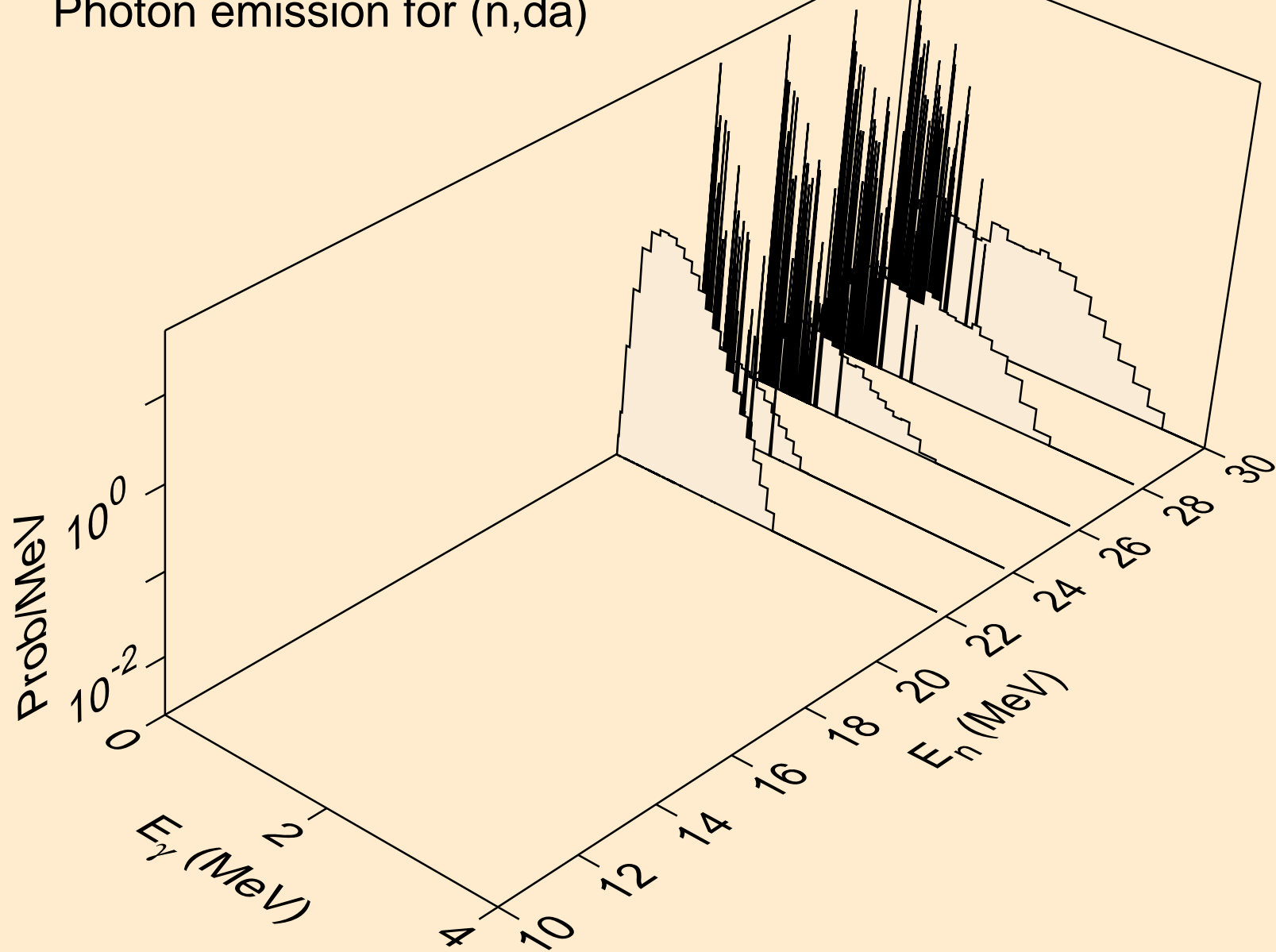

# EU141 ALPHA ACER TENDL-2024 LIBRARY; T=0.K

## Particle heating contributions

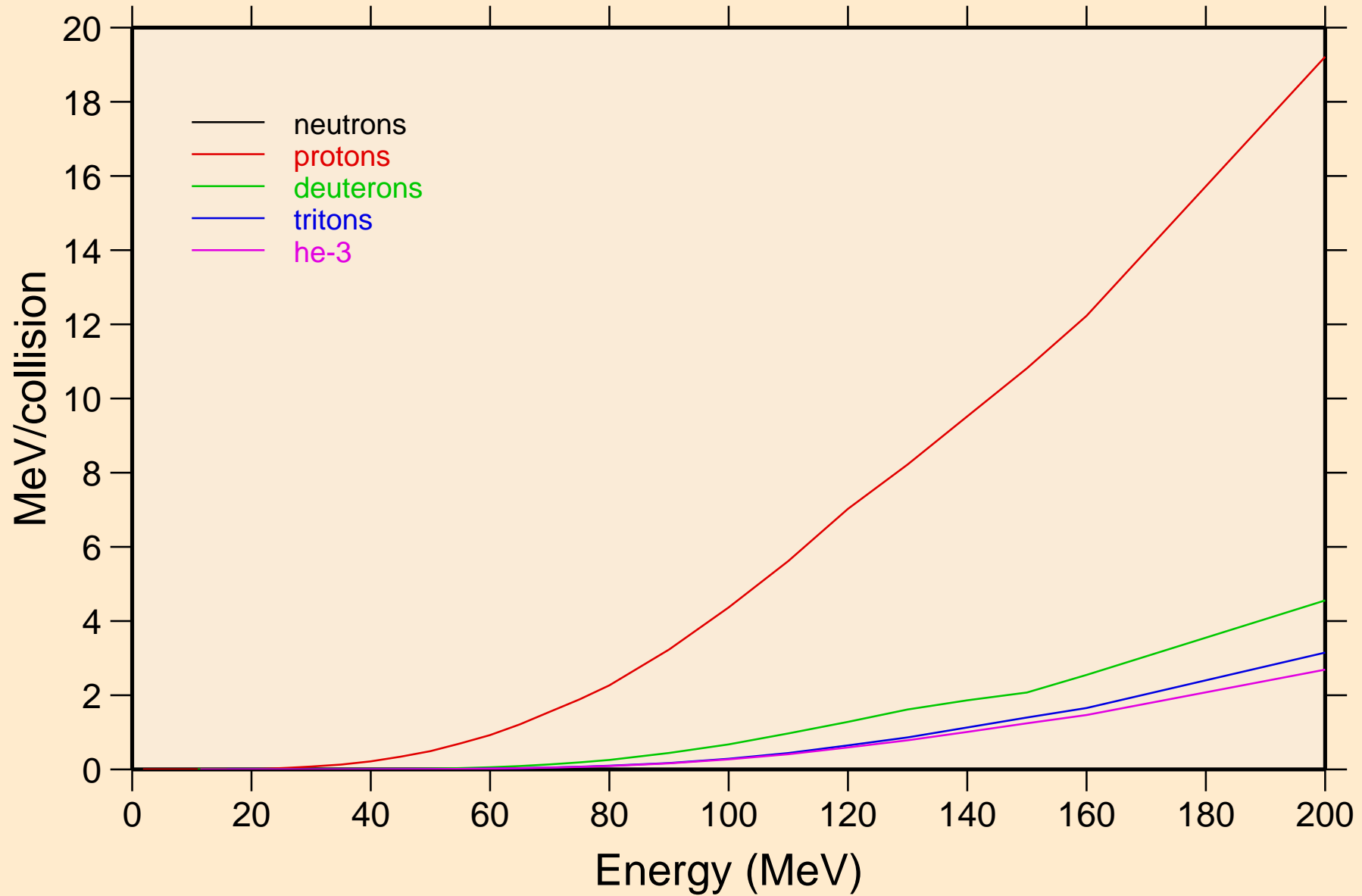

EU141 ALPHA ACER TENDL-2024 LIBRARY; T=0.K  
Recoil Heating

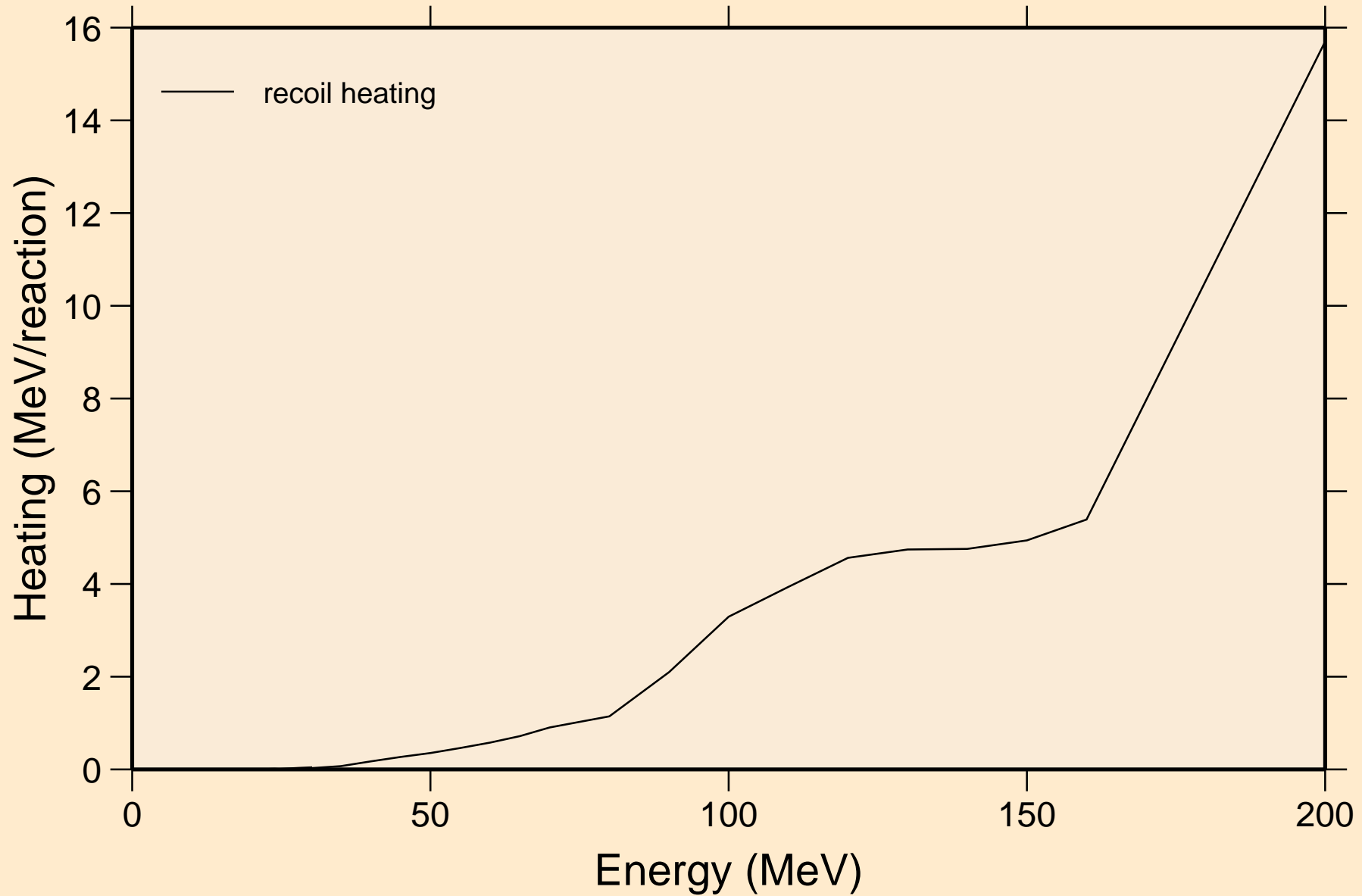

EU141 ALPHA ACER TENDL-2024 LIBRARY; T=0.K  
Particle production cross sections

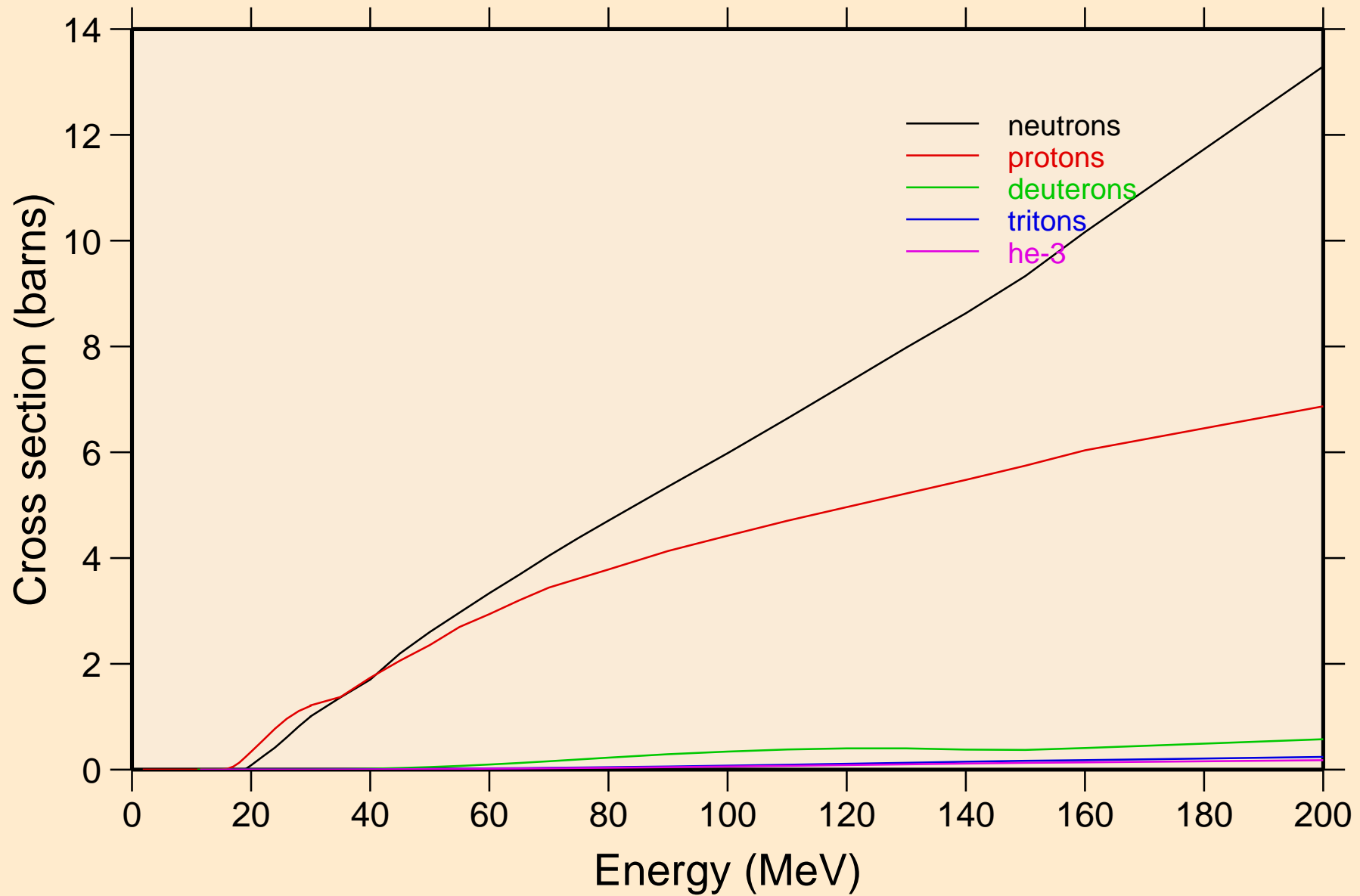

EU141 ALPHA ACER TENDL-2024 LIBRARY; T=0.K  
neutrons from (a,n)

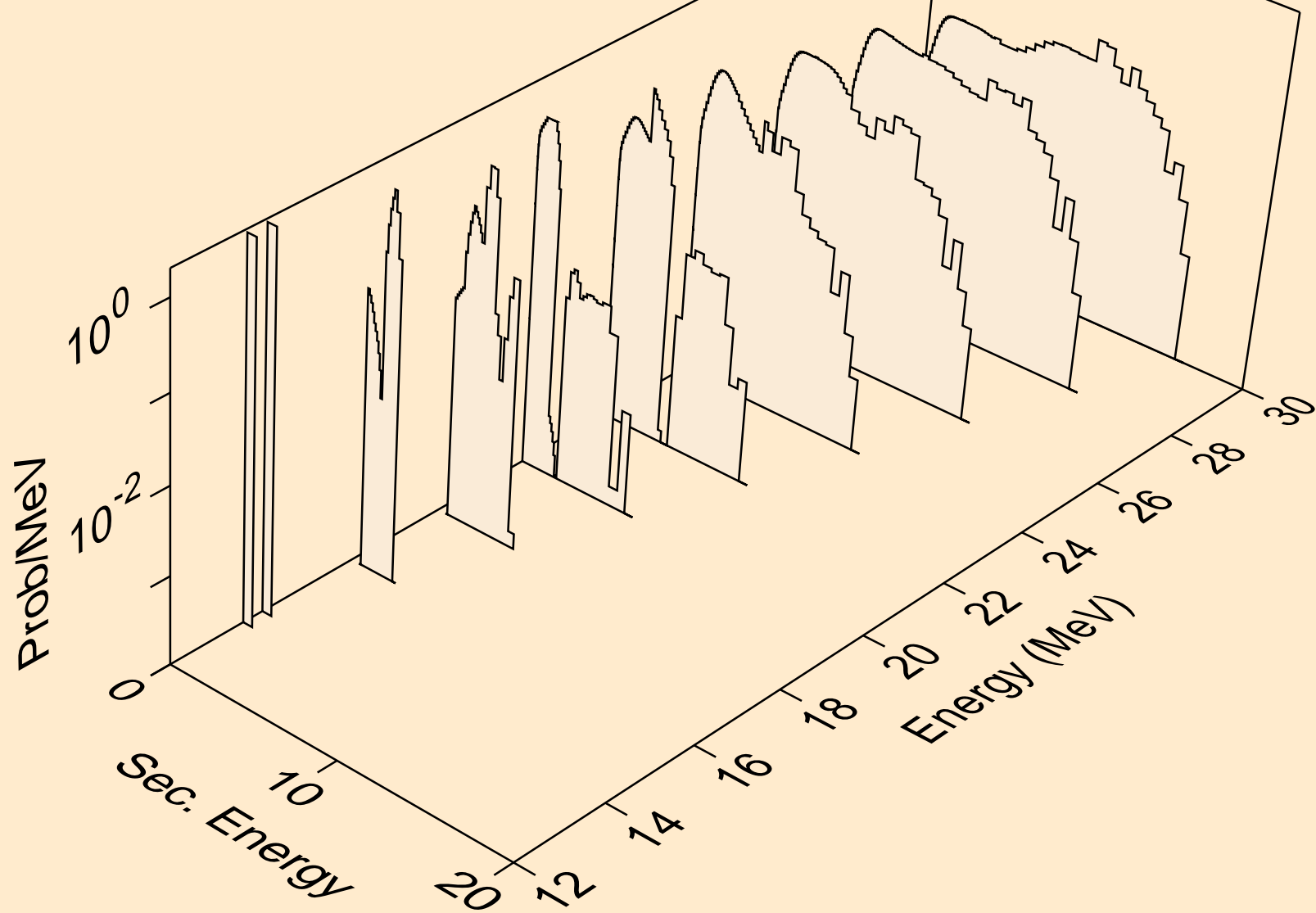

EU141 ALPHA ACER TENDL-2024 LIBRARY; T=0.K  
neutrons from (a,x)

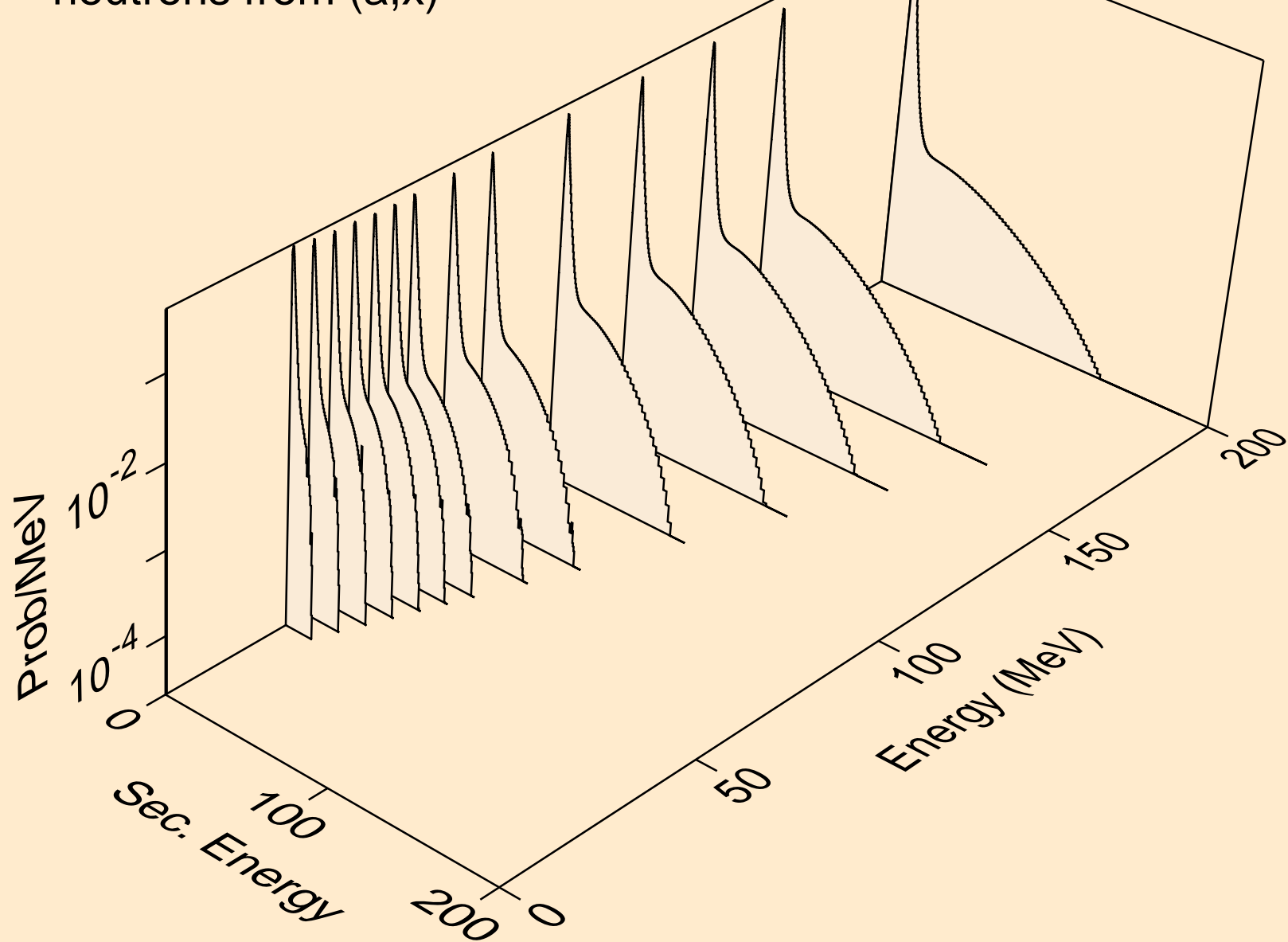

EU141 ALPHA ACER TENDL-2024 LIBRARY; T=0.K  
neutrons from (a,2n)

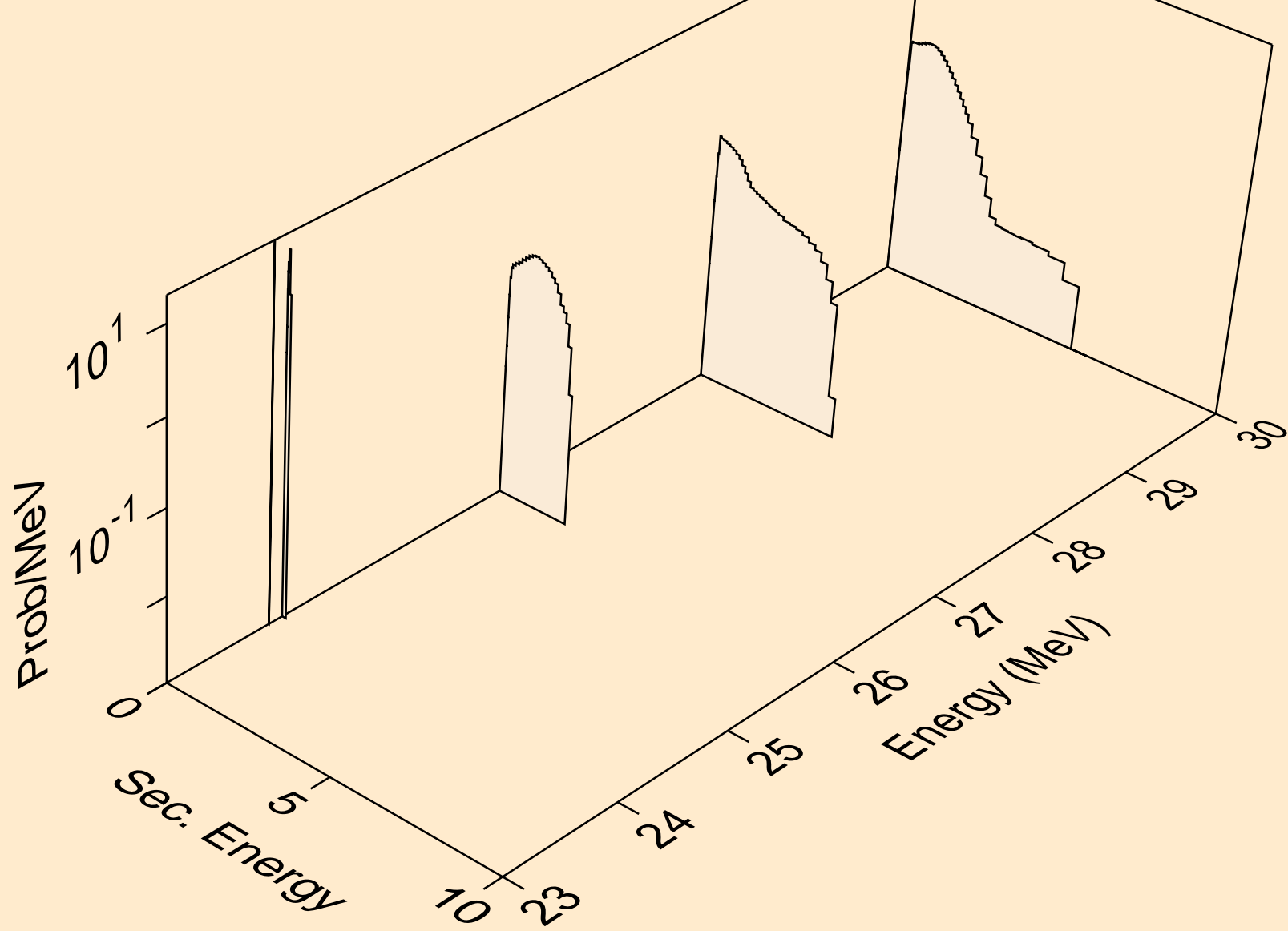

EU141 ALPHA ACER TENDL-2024 LIBRARY; T=0.K  
neutrons from (a,n\*)a

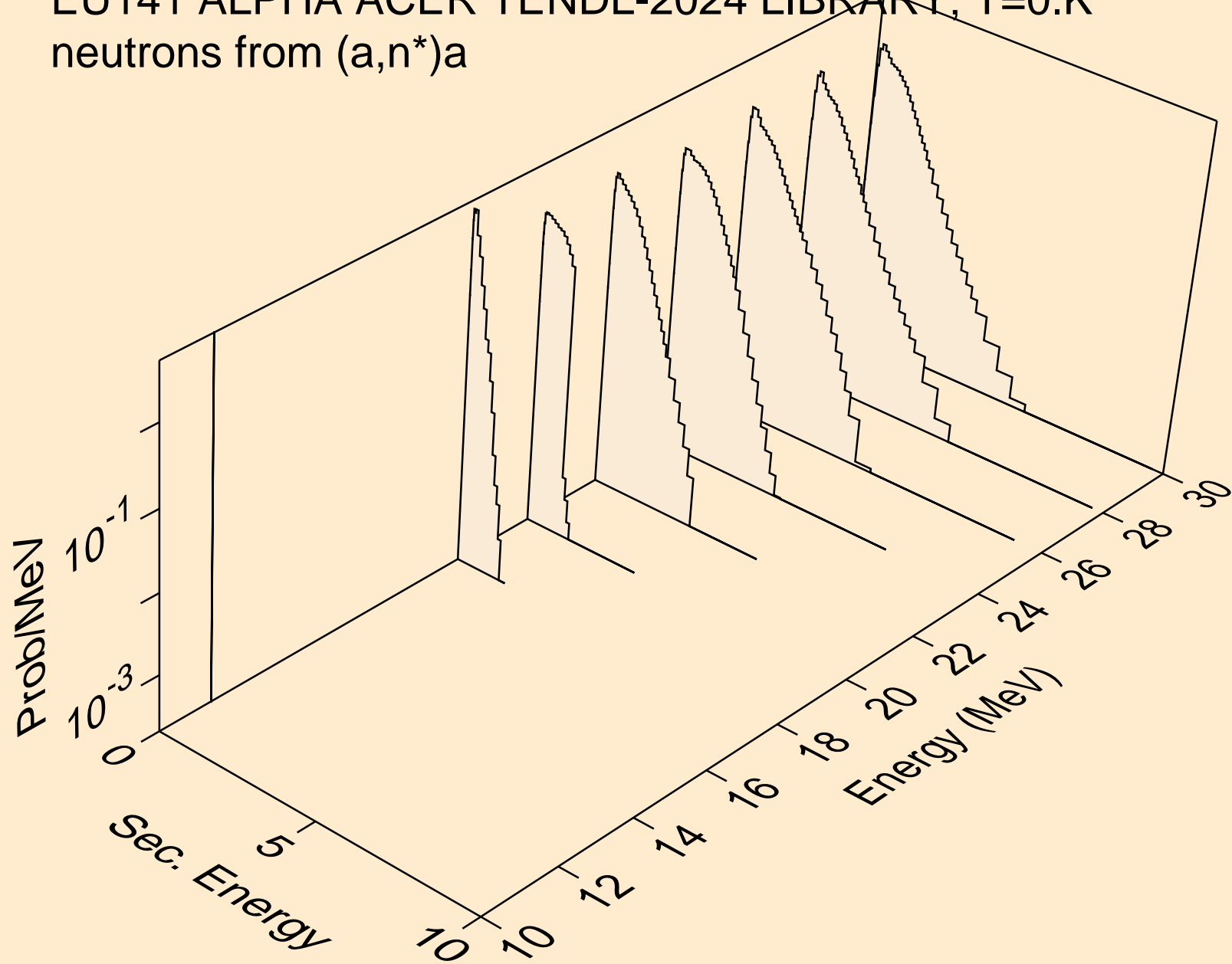

EU141 ALPHA ACER TENDL-2024 LIBRARY; T=0.K  
neutrons from (a,2n)a

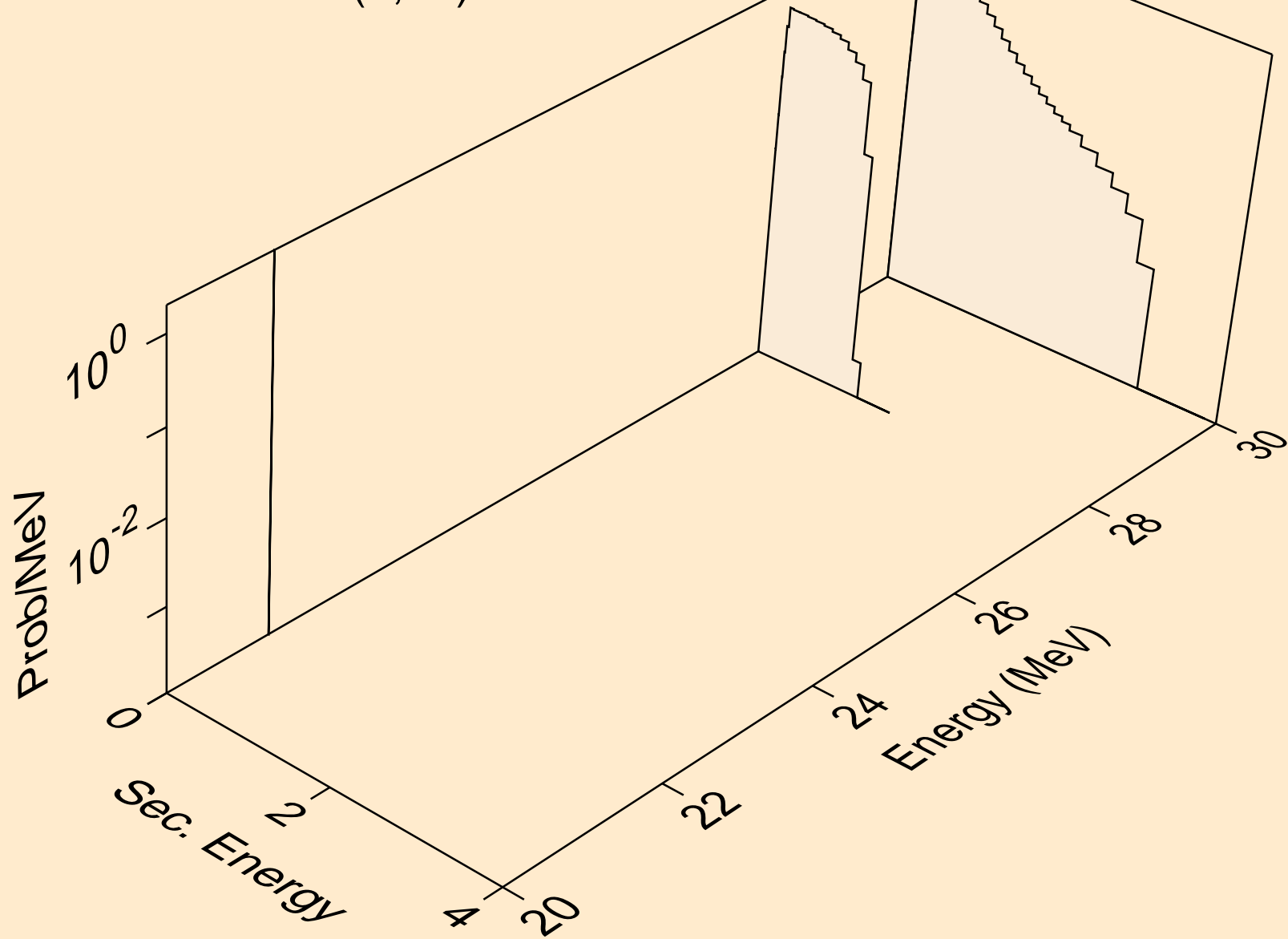

EU141 ALPHA ACER TENDL-2024 LIBRARY; T=0.K  
neutrons from (a,n\*)p

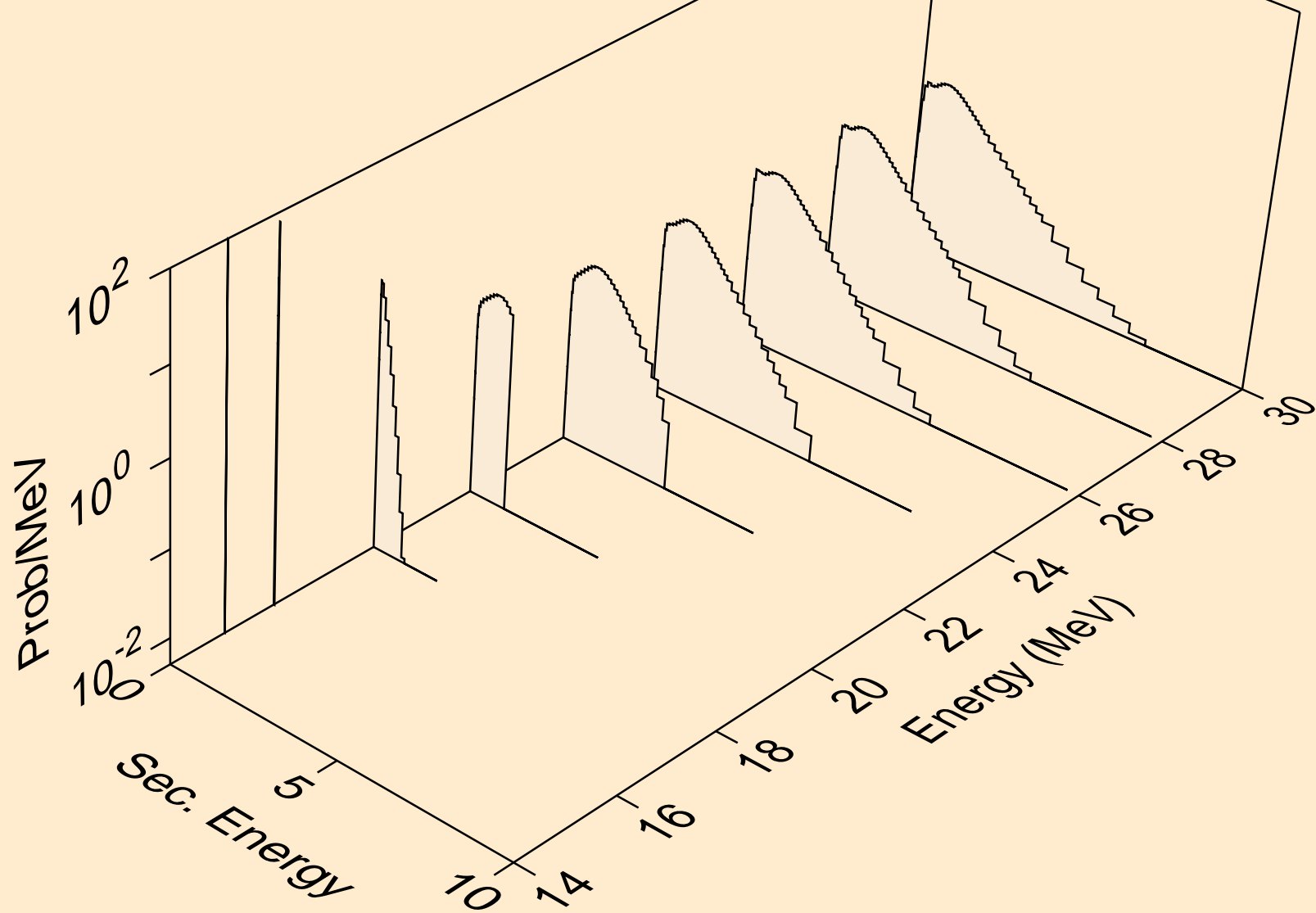

EU141 ALPHA ACER TENDL-2024 LIBRARY; T=0.K  
neutrons from (a,n\*)d

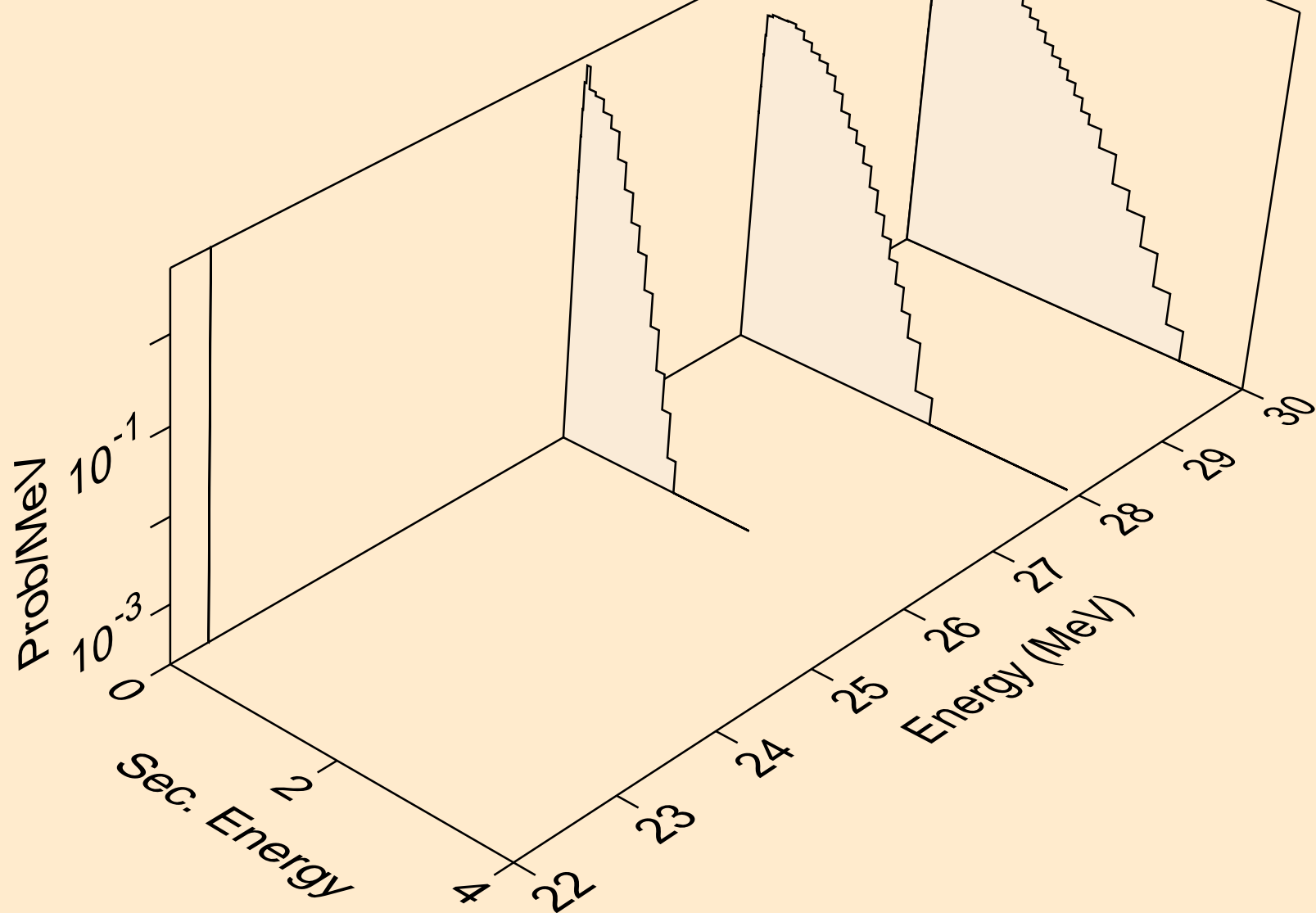

EU141 ALPHA ACER TENDL-2024 LIBRARY; T=0.K  
neutrons from (a,2np)

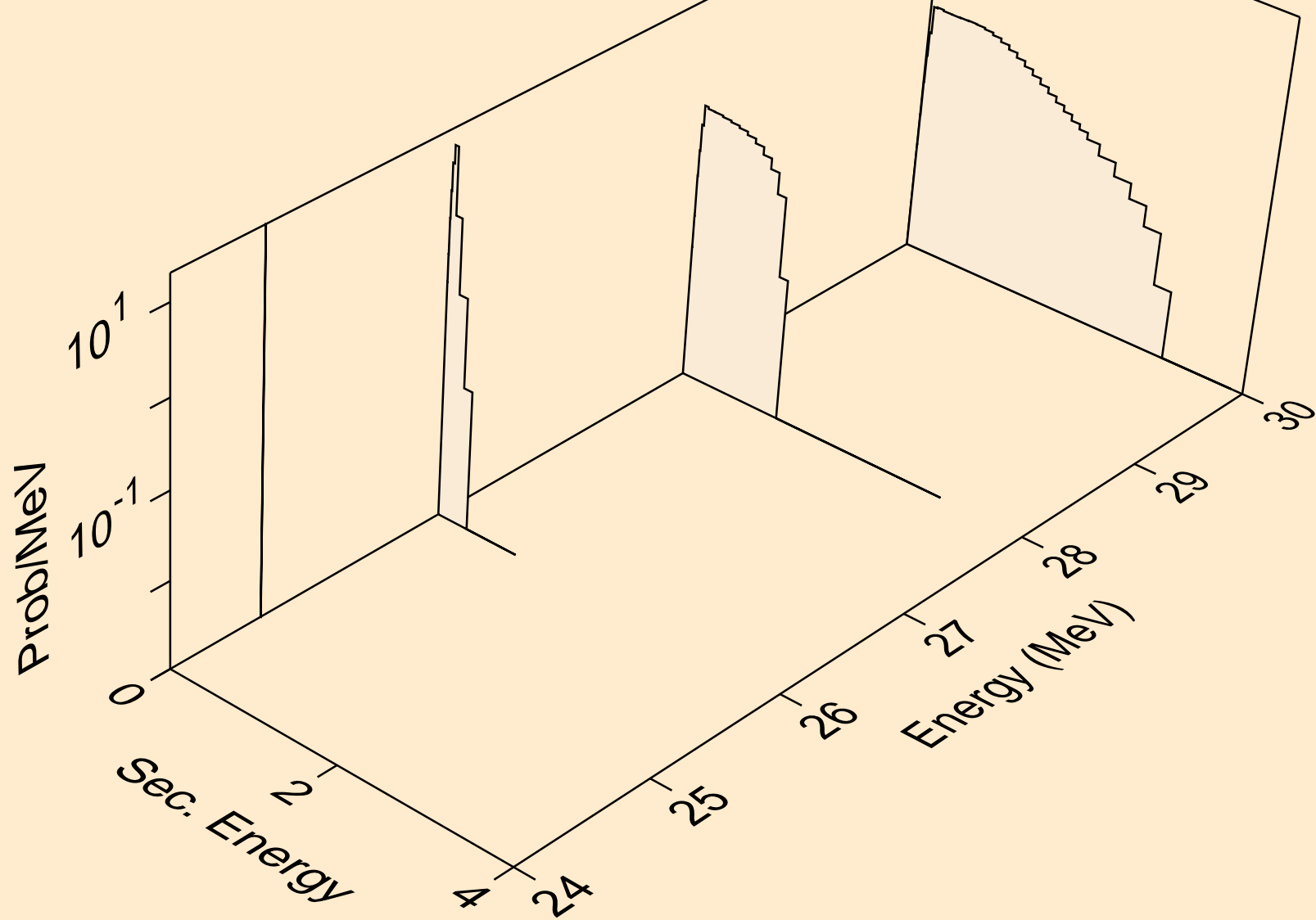

EU141 ALPHA ACER TENDL-2024 LIBRARY; T=0.K  
neutrons from (a,n2p)

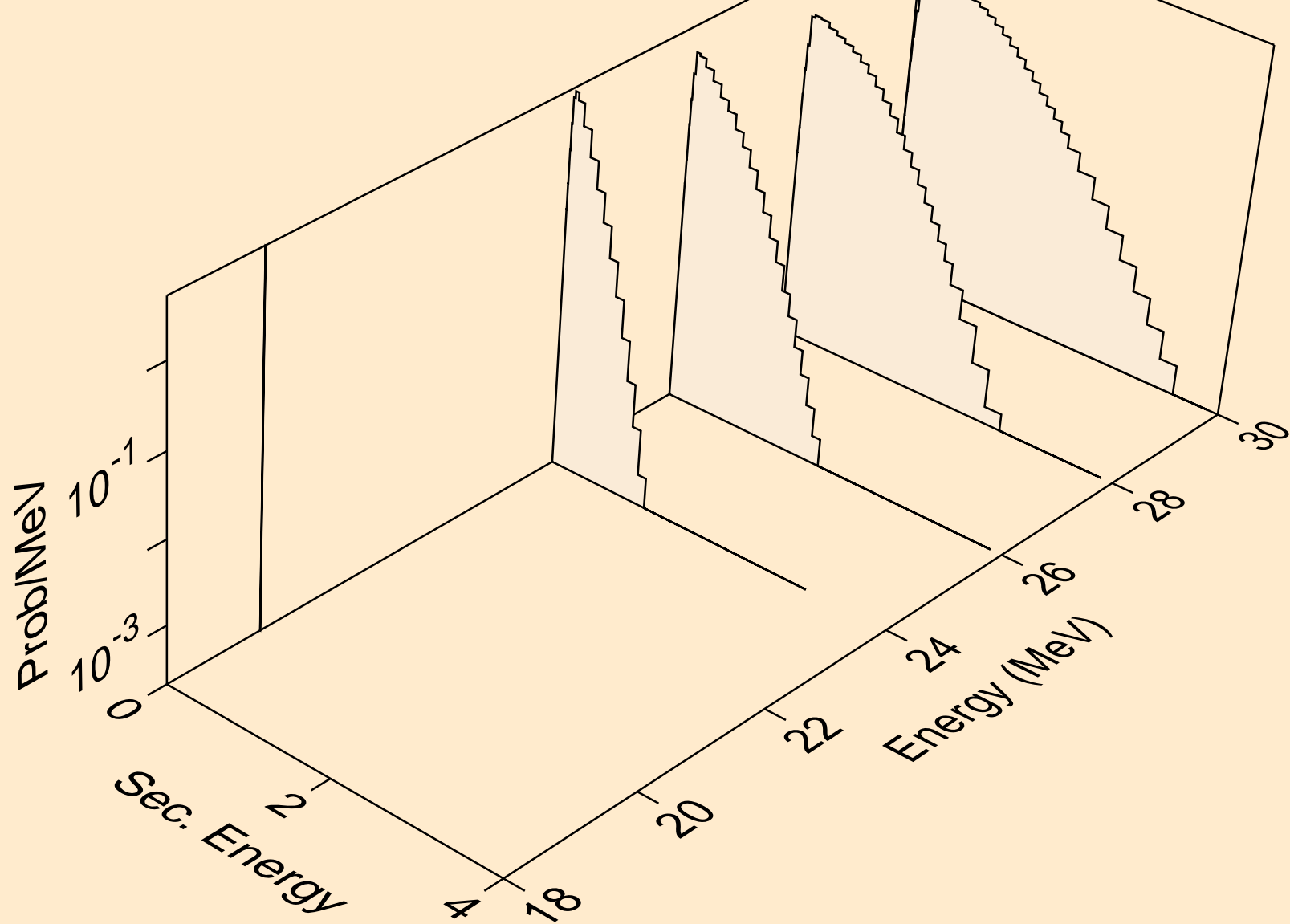

EU141 ALPHA ACER TENDL-2024 LIBRARY; T=0.K  
neutrons from (a,npa)

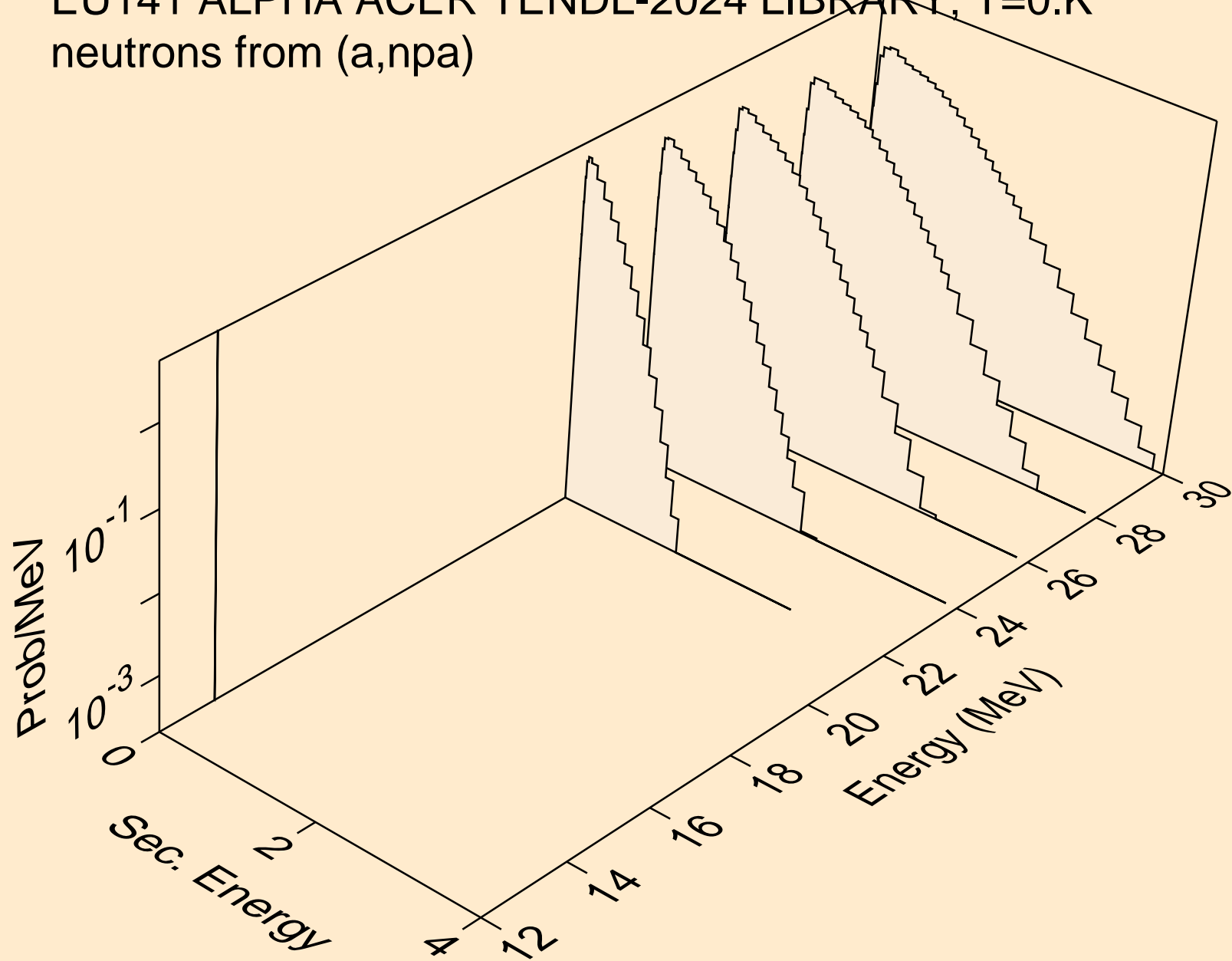

EU141 ALPHA ACER TENDL-2024 LIBRARY; T=0.K  
protons from (a,x)

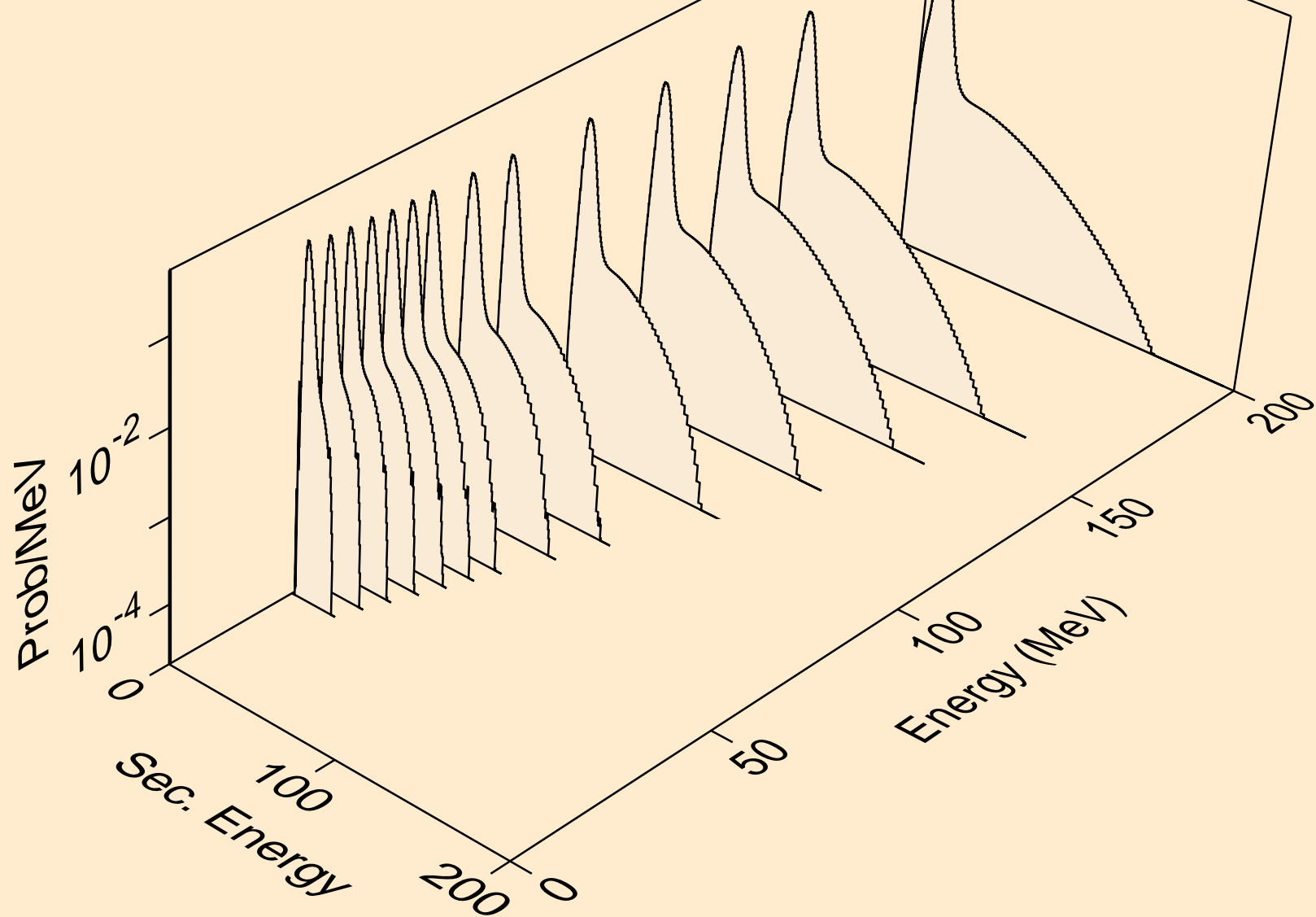

EU141 ALPHA ACER TENDL-2024 LIBRARY; T=0.K  
protons from (a,n\*)p

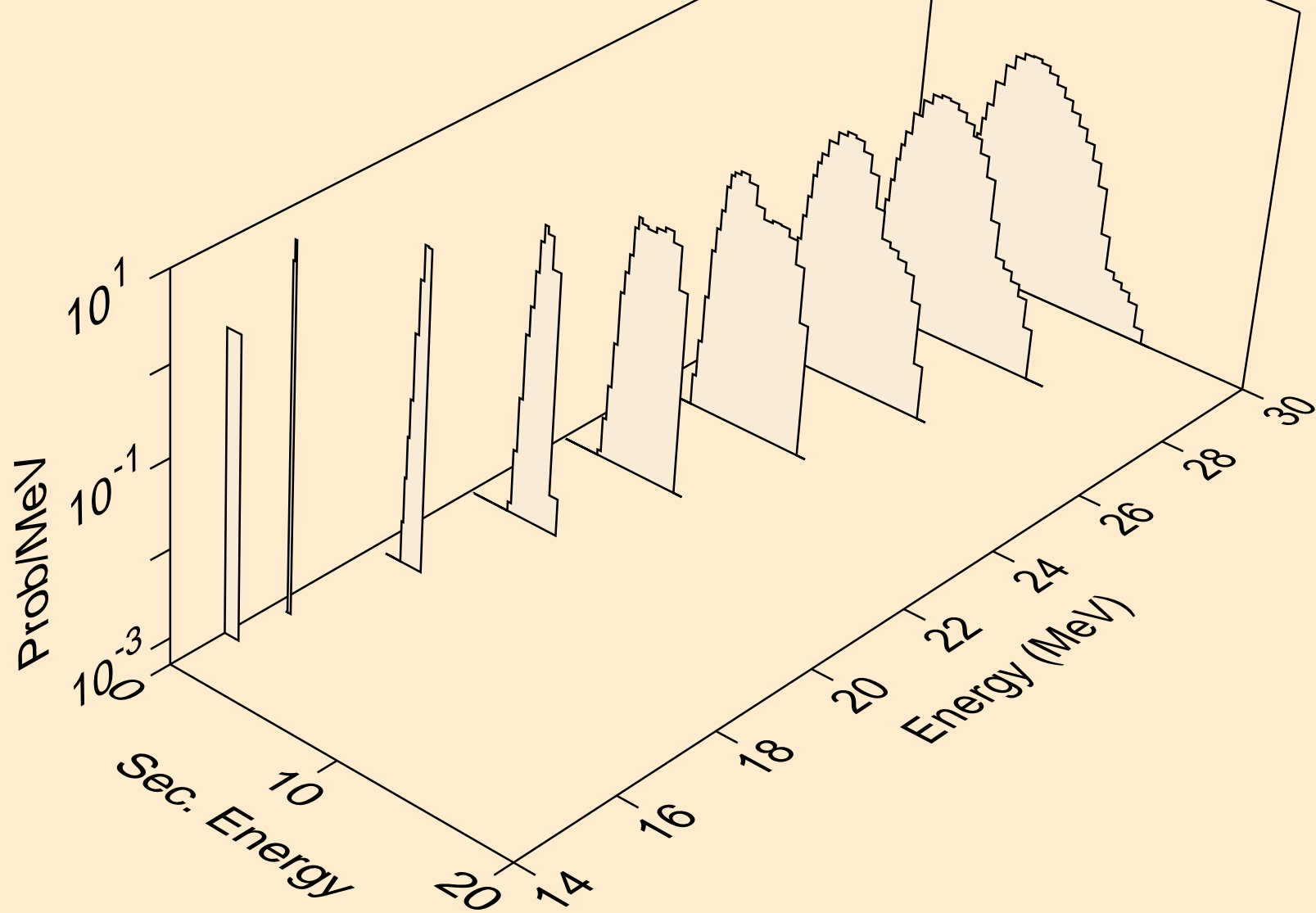

EU141 ALPHA ACER TENDL-2024 LIBRARY; T=0.K  
protons from (a,2np)

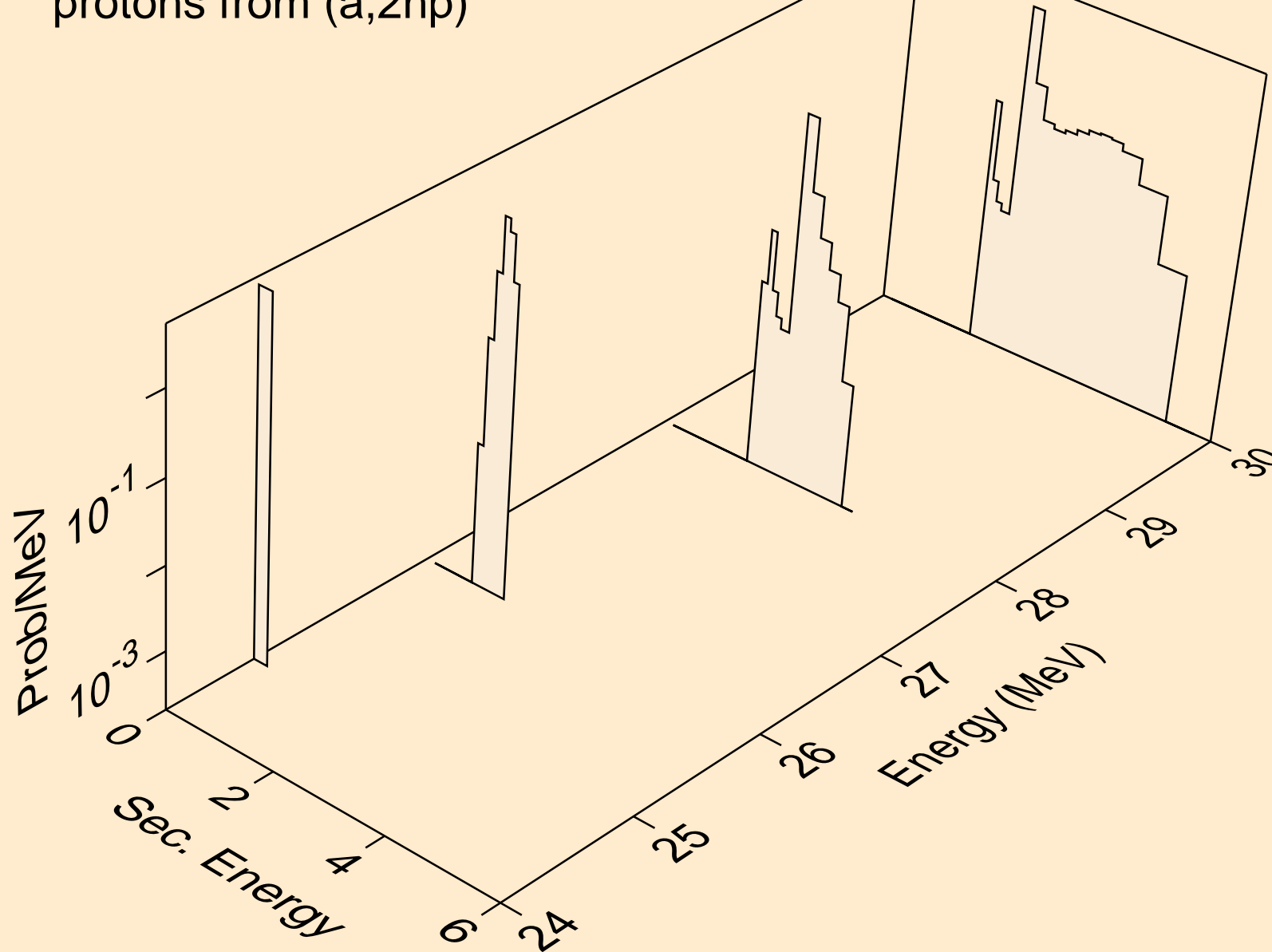

EU141 ALPHA ACER TENDL-2024 LIBRARY; T=0.K  
protons from (a,n2p)

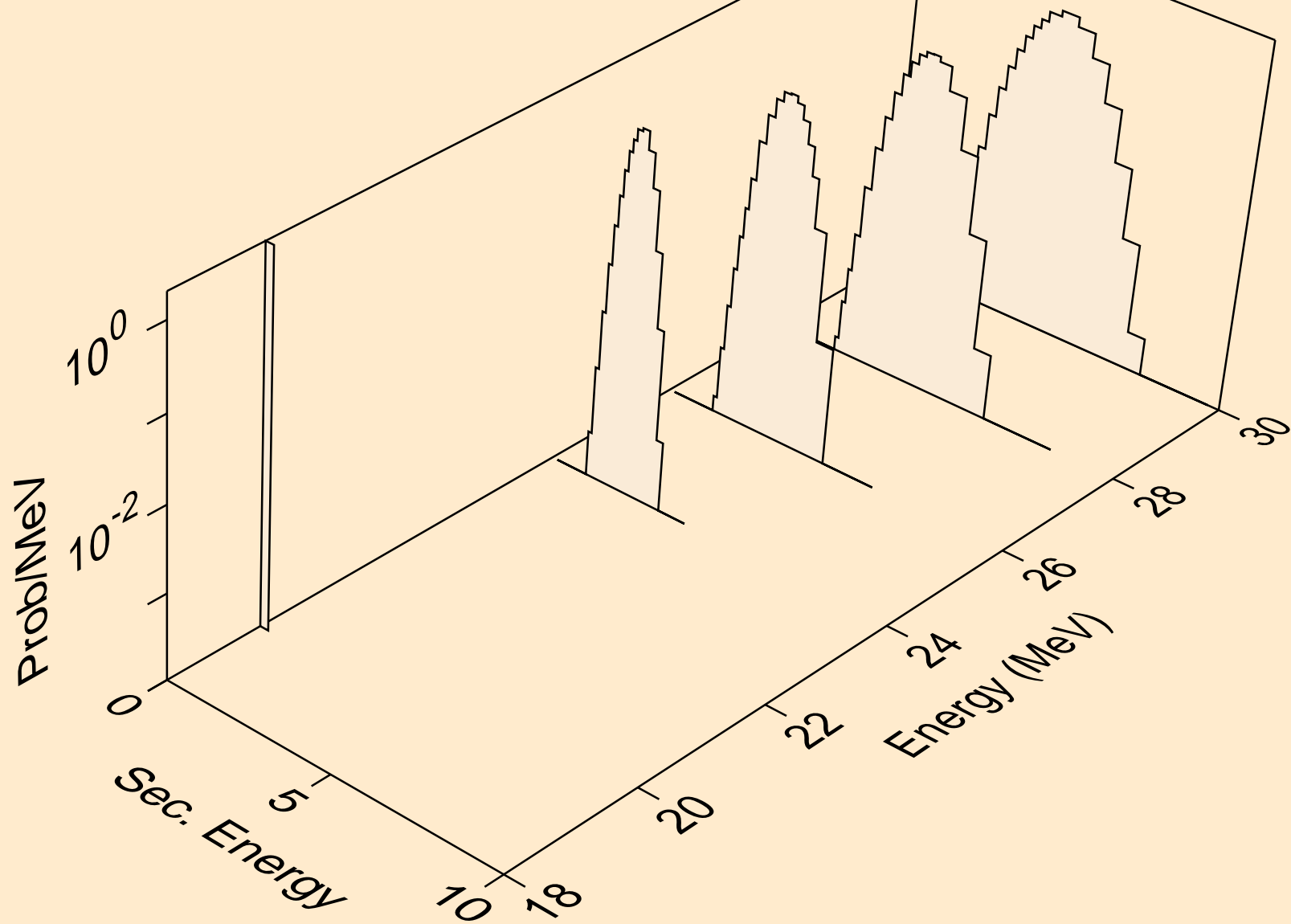

EU141 ALPHA ACER TENDL-2024 LIBRARY; T=0.K  
protons from (a,npa)

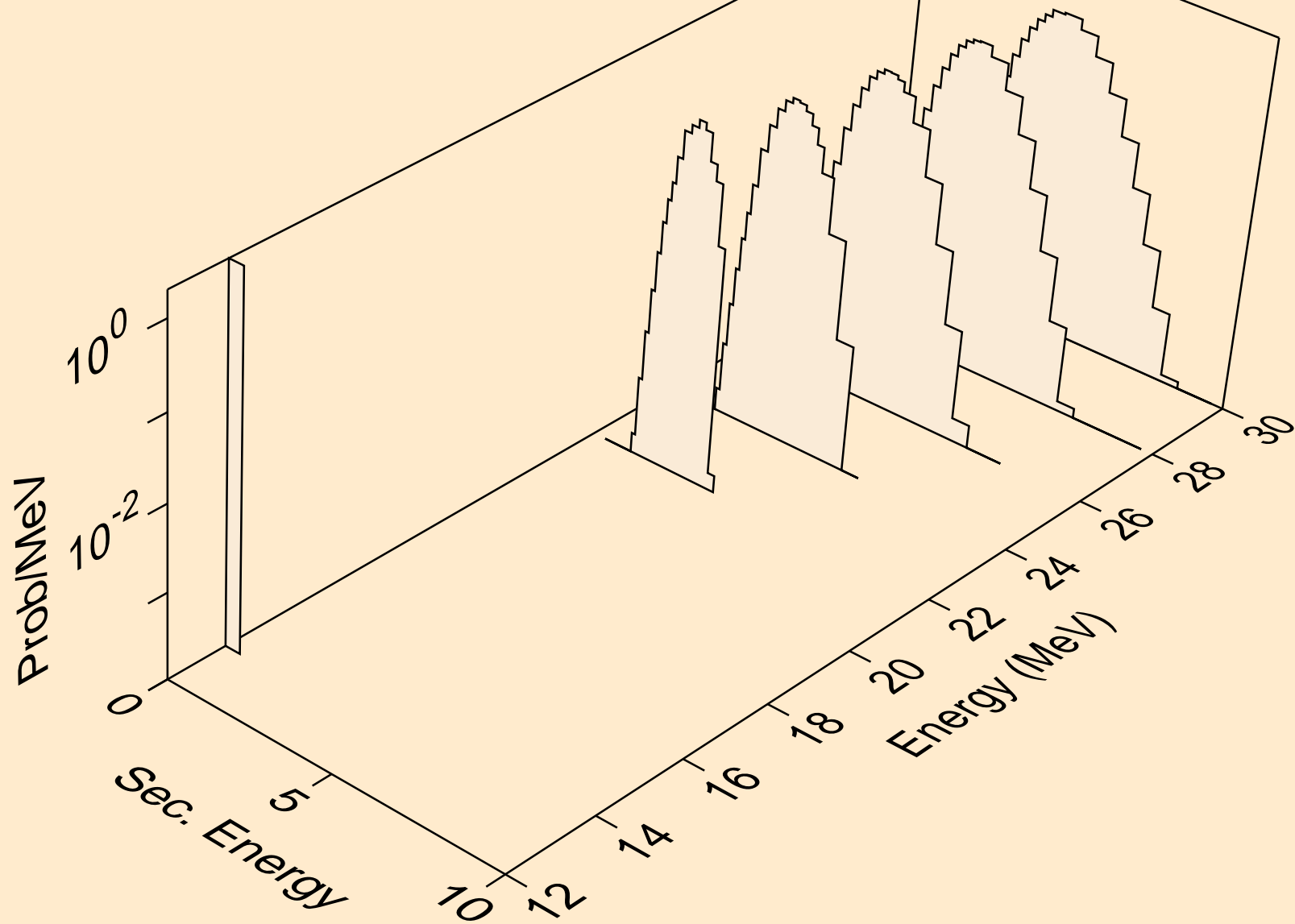

EU141 ALPHA ACER TENDL-2024 LIBRARY; T=0.K  
protons from (a,p)

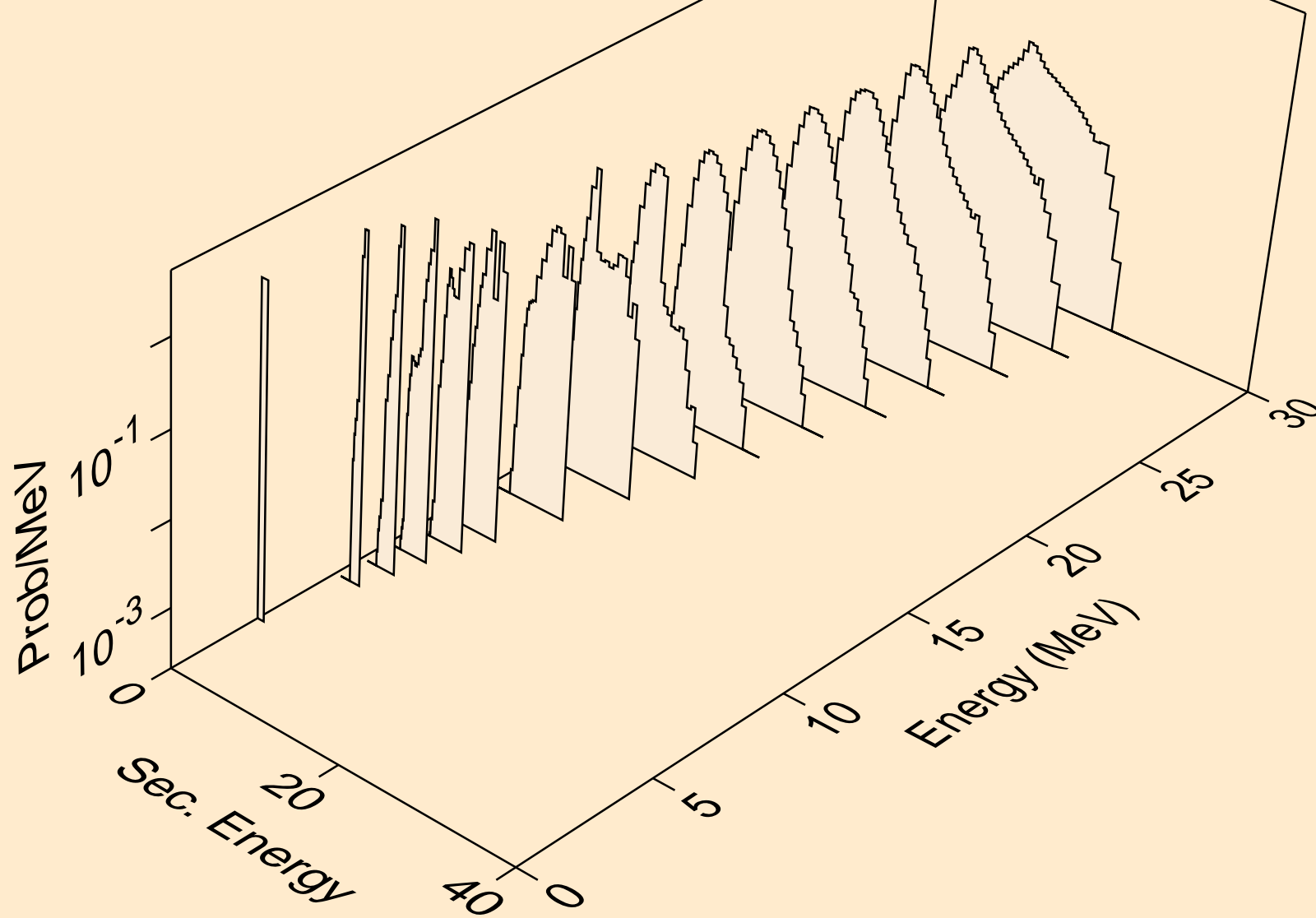

EU141 ALPHA ACER TENDL-2024 LIBRARY; T=0.K  
protons from (a,2p)

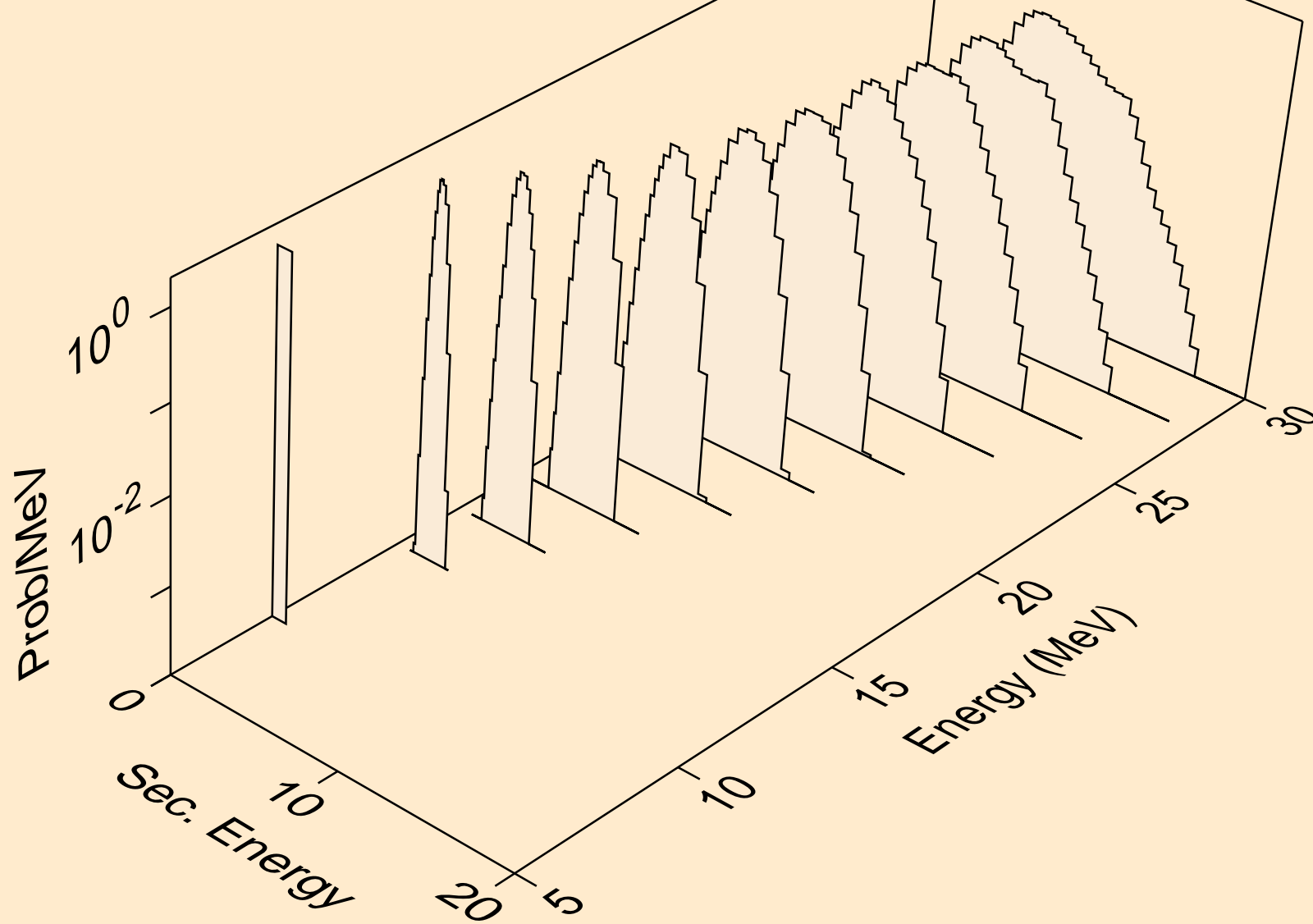

EU141 ALPHA ACER TENDL-2024 LIBRARY; T=0.K  
protons from (a,pa)

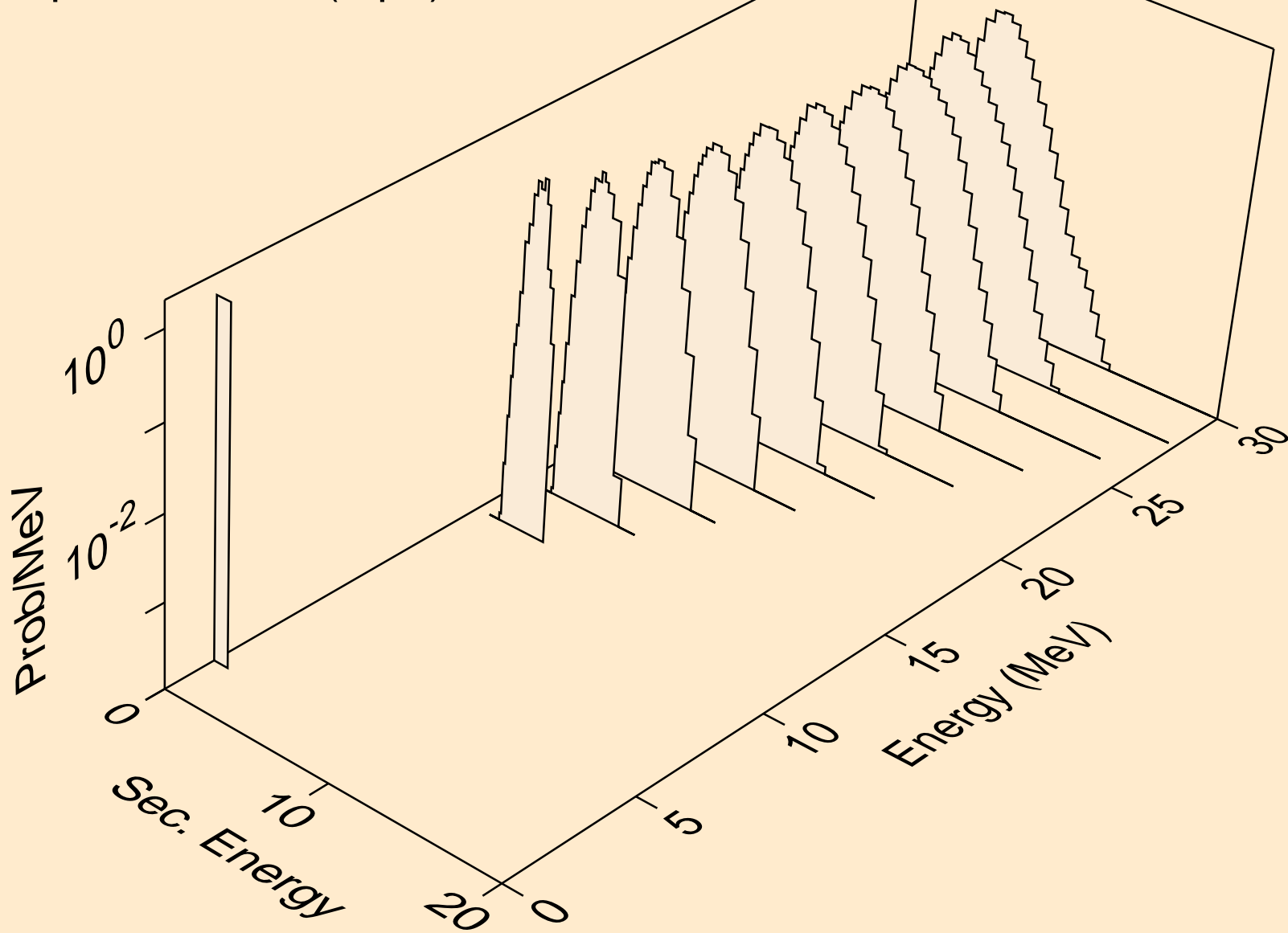

EU141 ALPHA ACER TENDL-2024 LIBRARY; T=0.K  
protons from (a,pd)

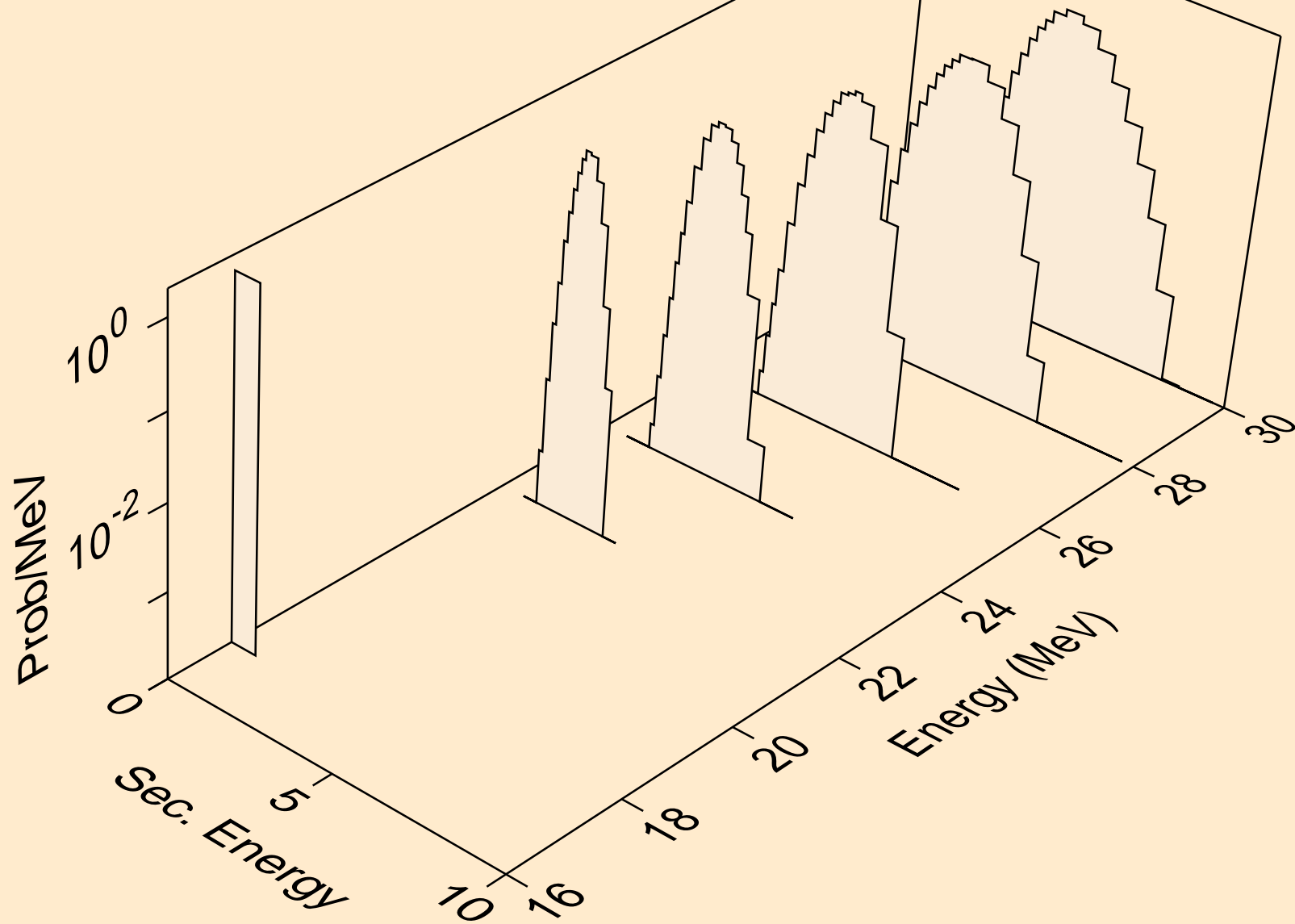

EU141 ALPHA ACER TENDL-2024 LIBRARY; T=0.K  
protons from (a,pt)

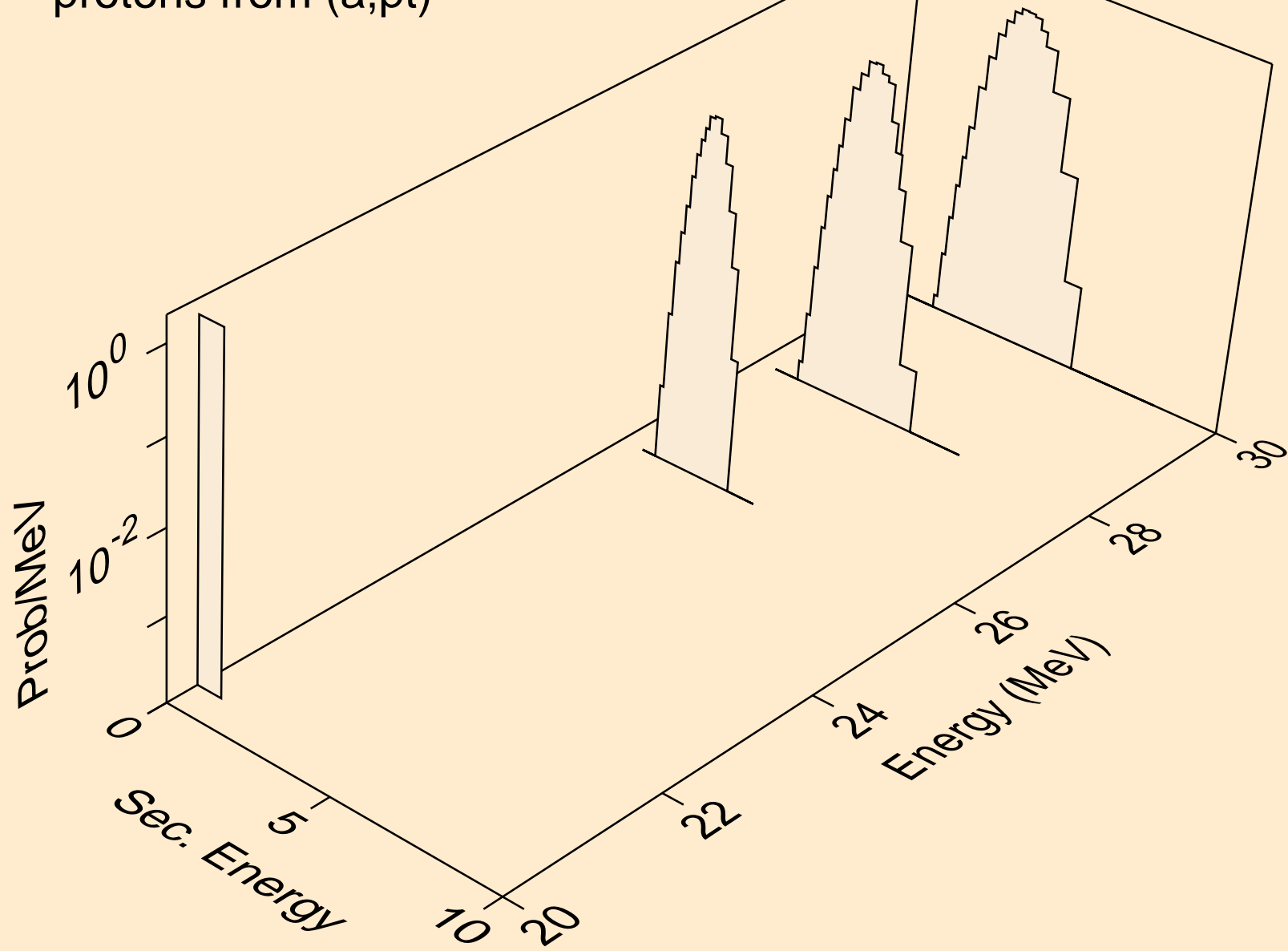

EU141 ALPHA ACER TENDL-2024 LIBRARY; T=0.K  
deuterons from (a,x)

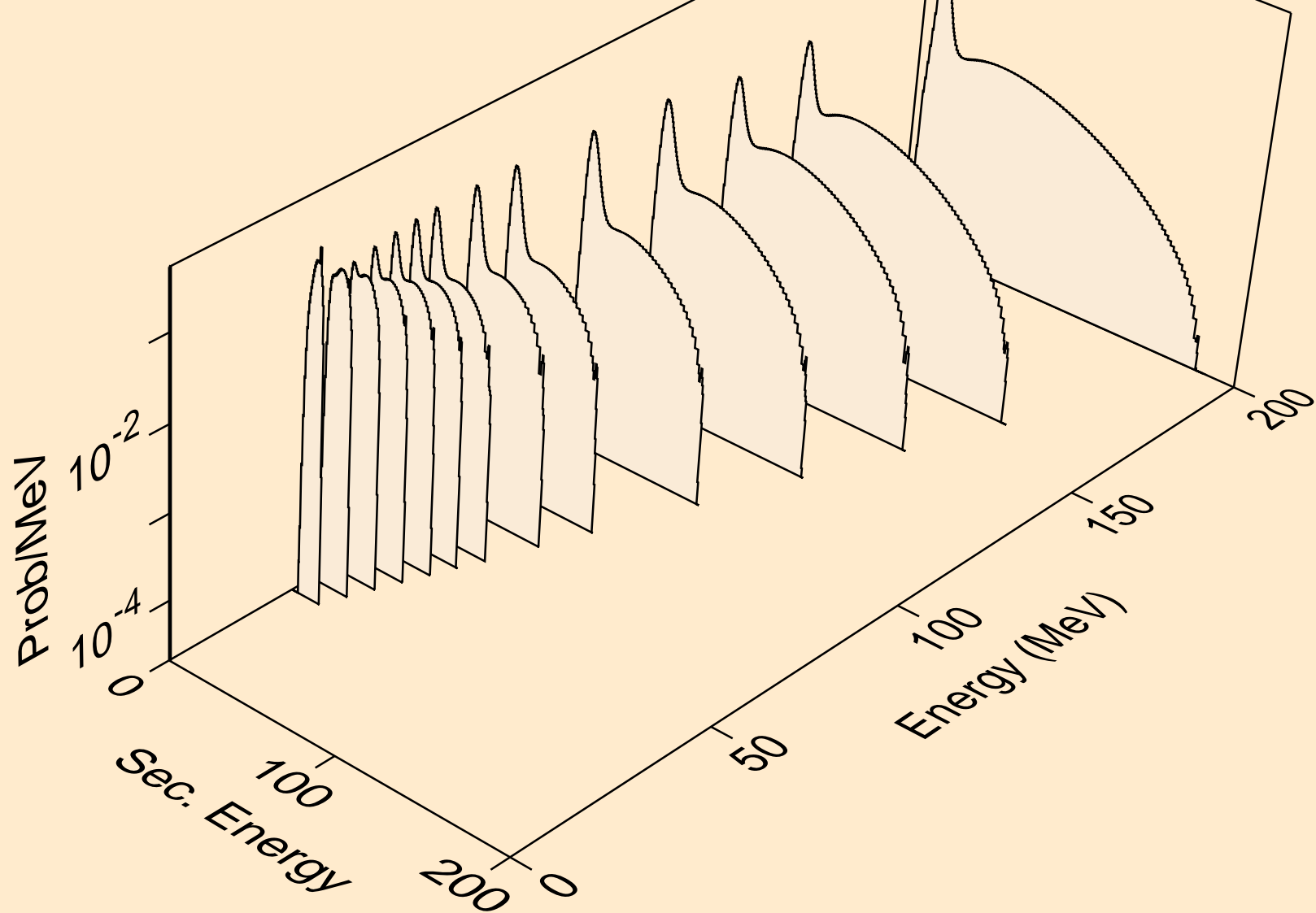

EU141 ALPHA ACER TENDL-2024 LIBRARY; T=0.K  
deuterons from (a,n\*)d

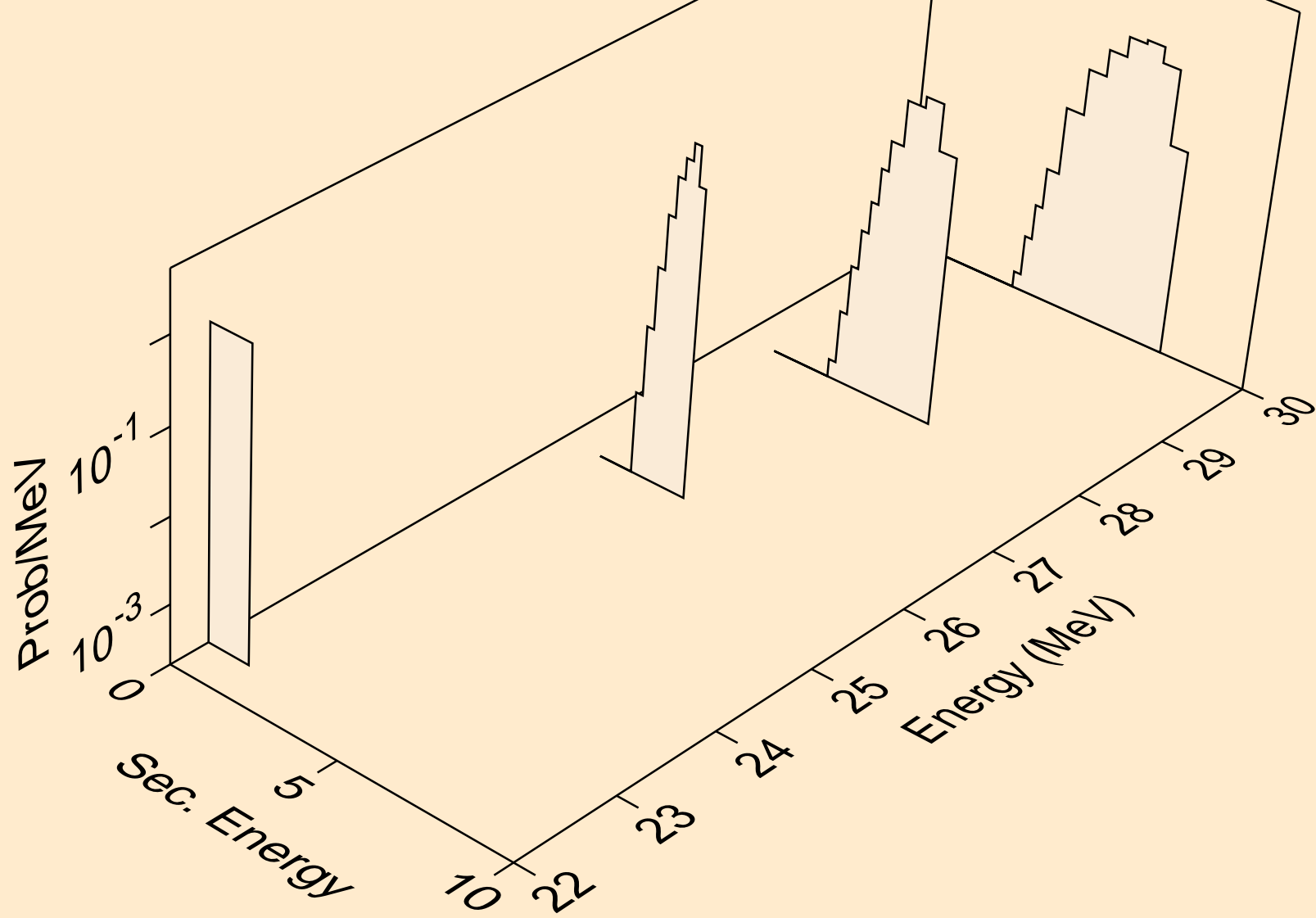

EU141 ALPHA ACER TENDL-2024 LIBRARY; T=0.K  
deuterons from (a,d)

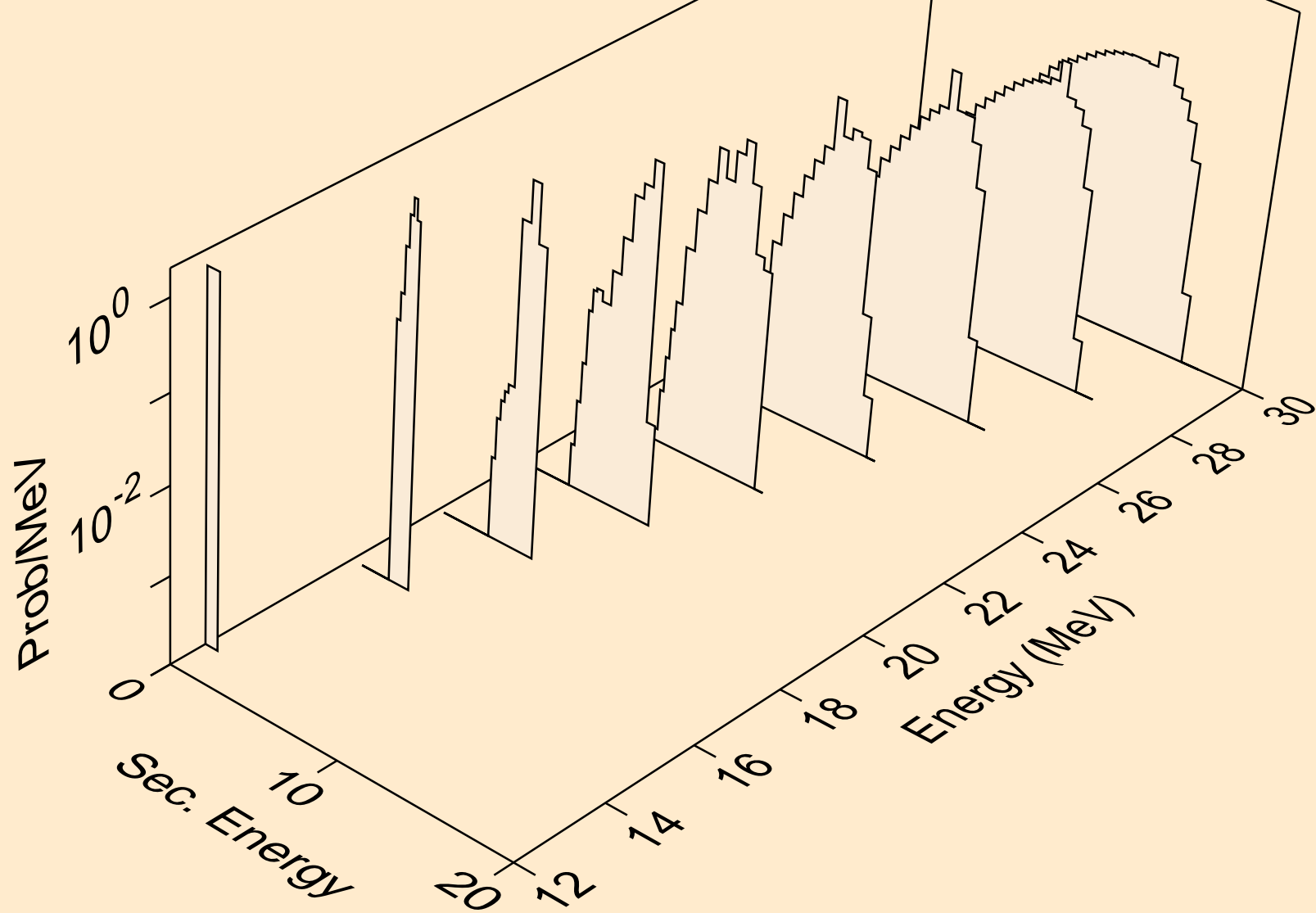

EU141 ALPHA ACER TENDL-2024 LIBRARY; T=0.K  
deuterons from (a,pd)

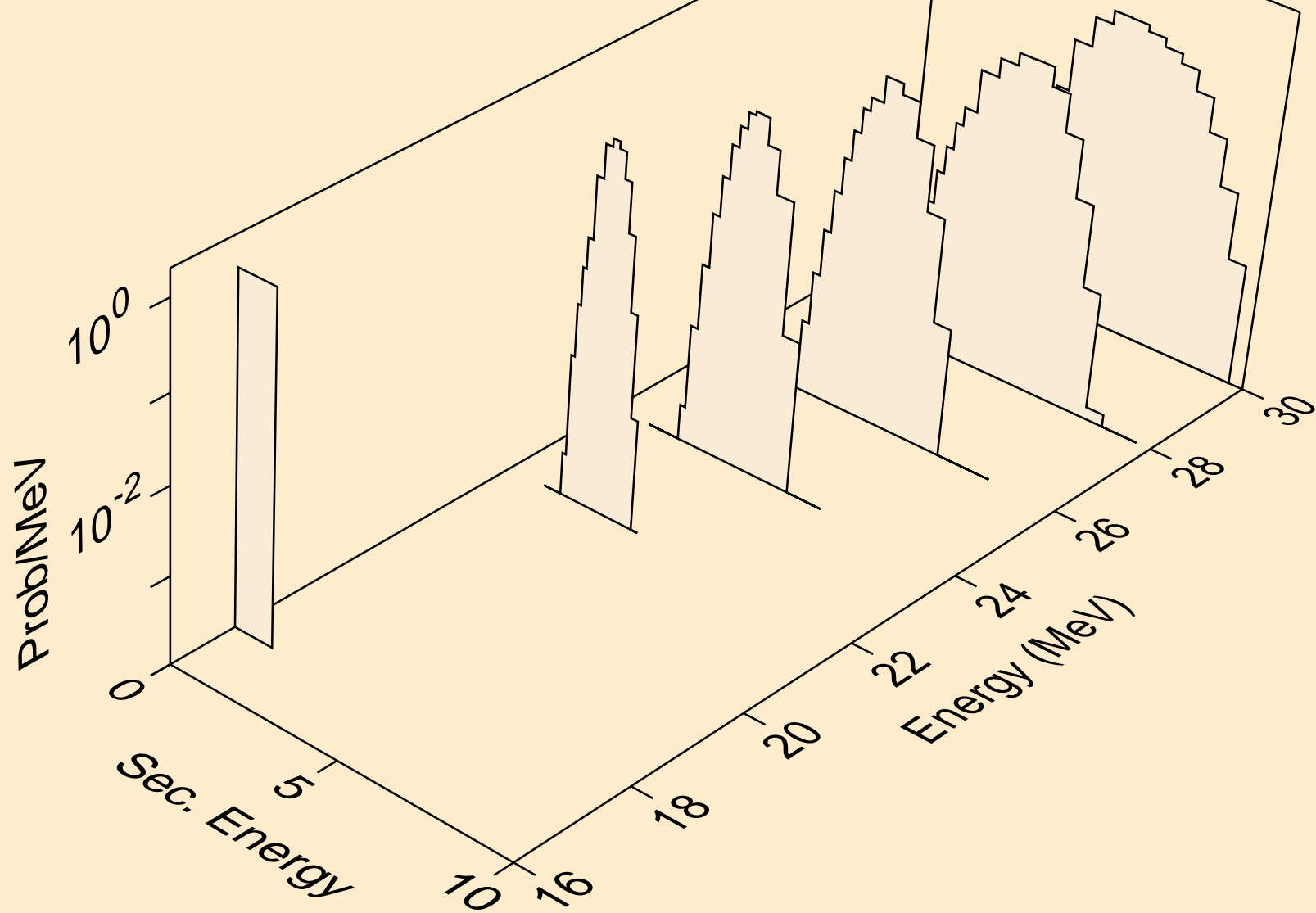

EU141 ALPHA ACER TENDL-2024 LIBRARY; T=0.K  
deuterons from (a,da)

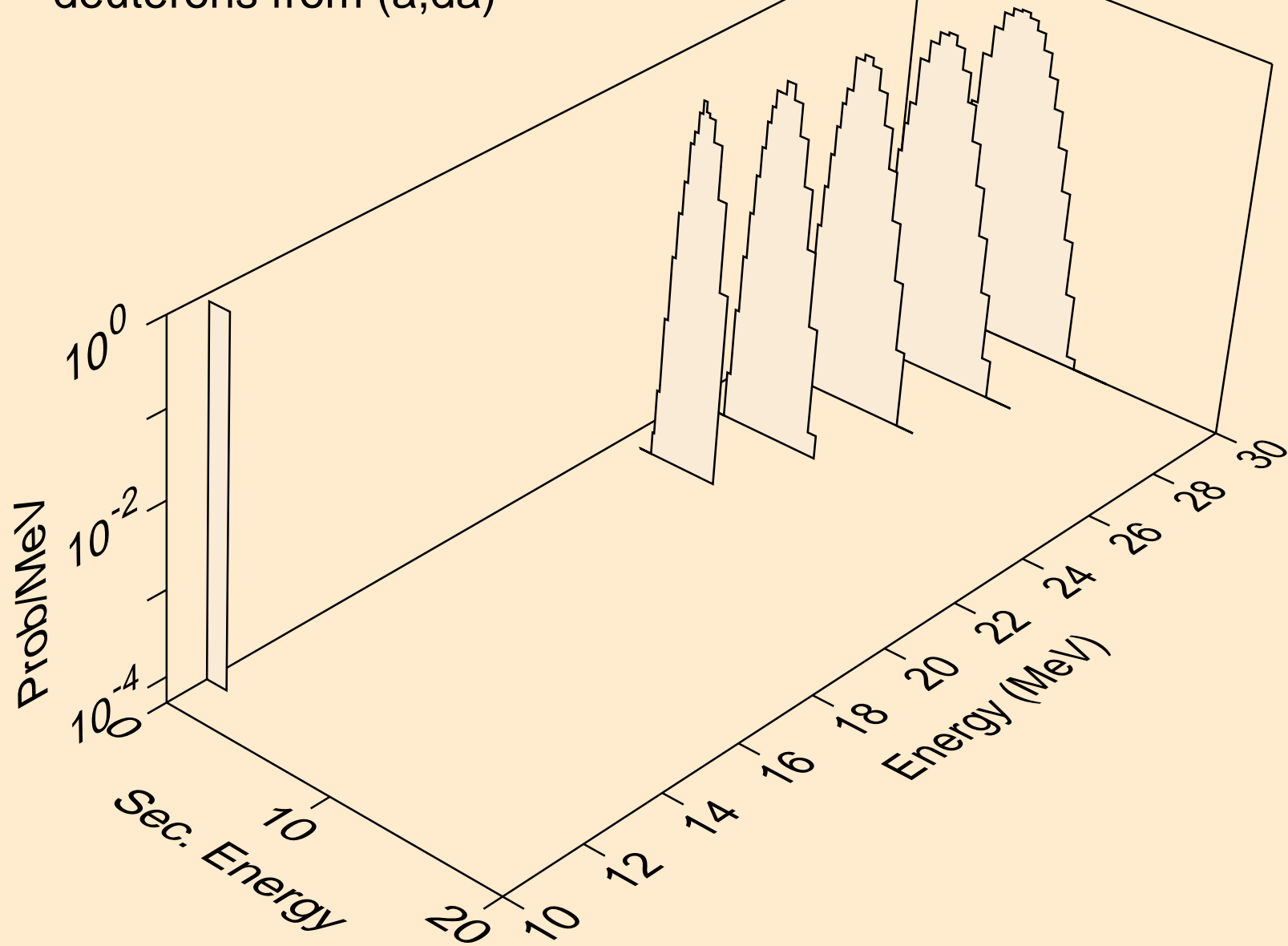

EU141 ALPHA ACER TENDL-2024 LIBRARY; T=0.K  
tritons from (a,x)

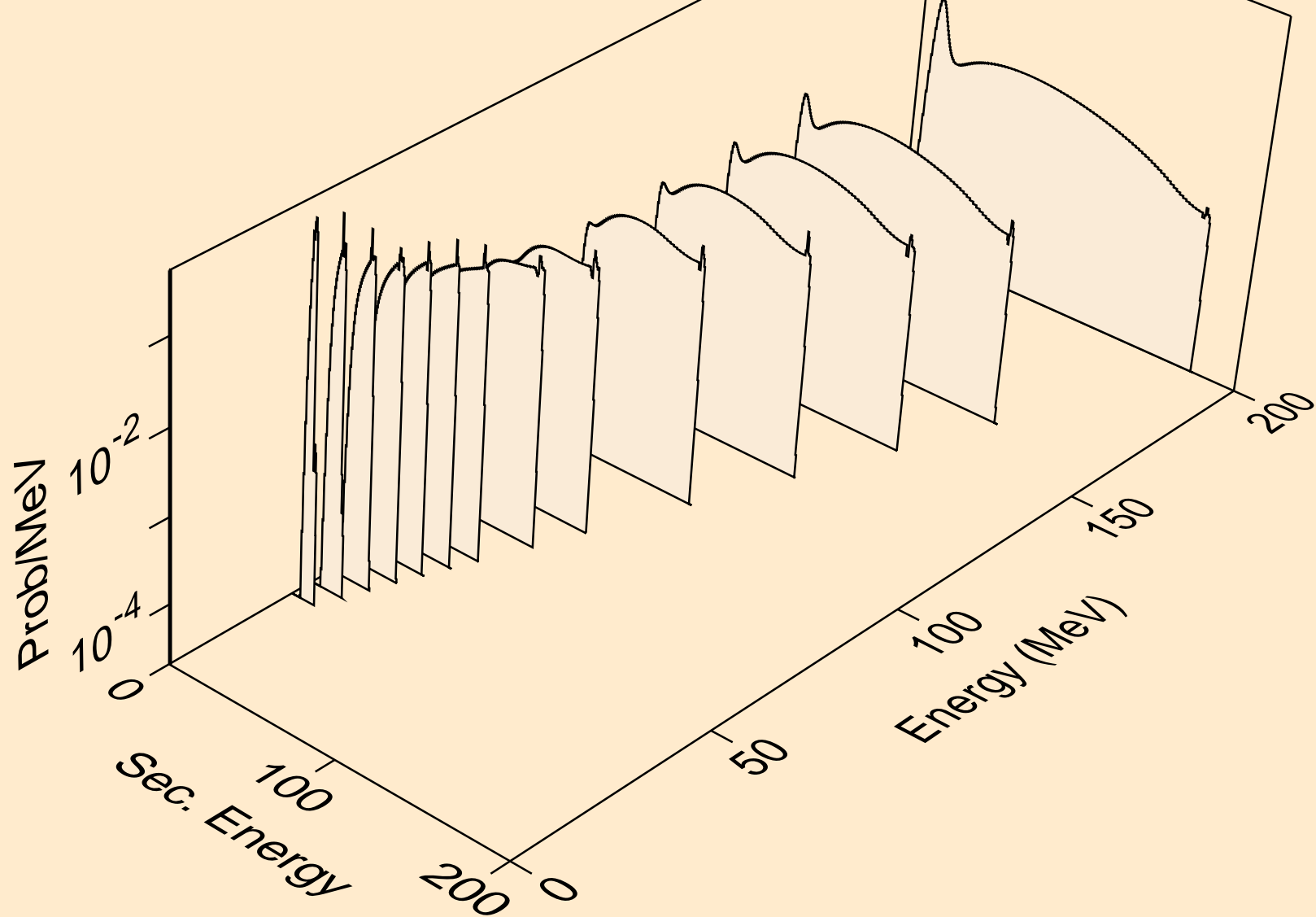

EU141 ALPHA ACER TENDL-2024 LIBRARY; T=0.K  
tritons from (a,t)

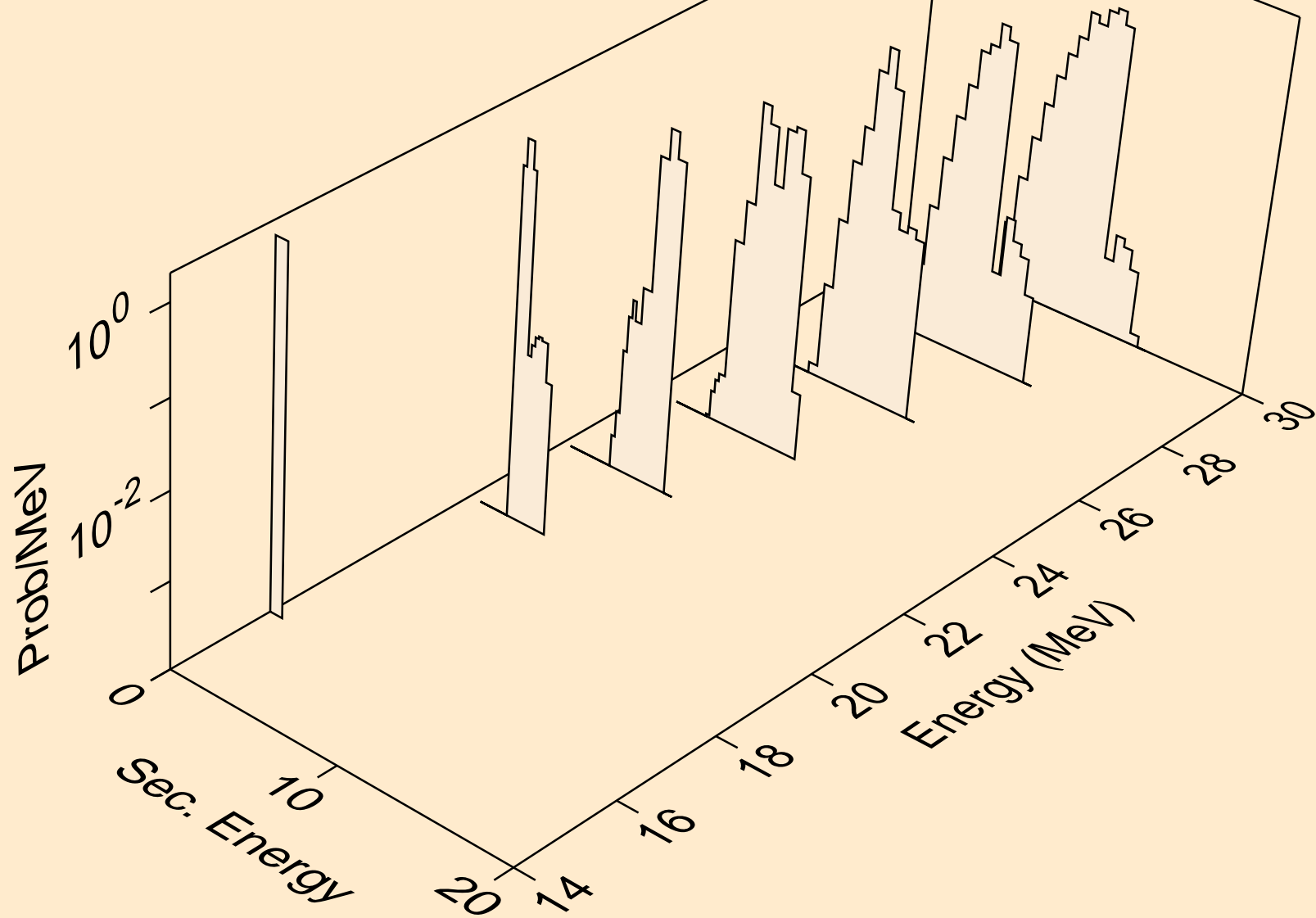

EU141 ALPHA ACER TENDL-2024 LIBRARY; T=0.K  
tritons from (a,pt)

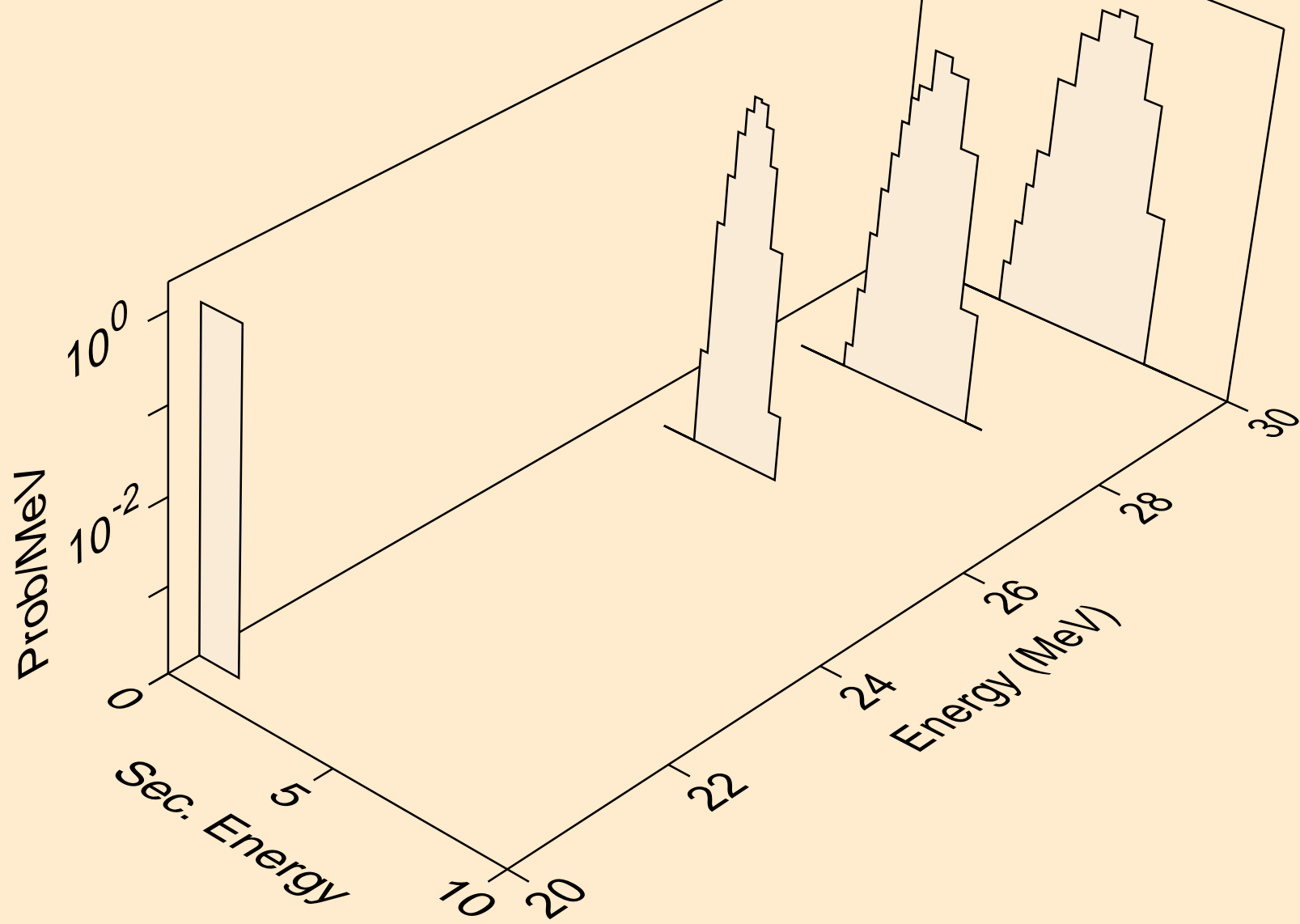

EU141 ALPHA ACER TENDL-2024 LIBRARY; T=0.K  
he3s from (a,x)

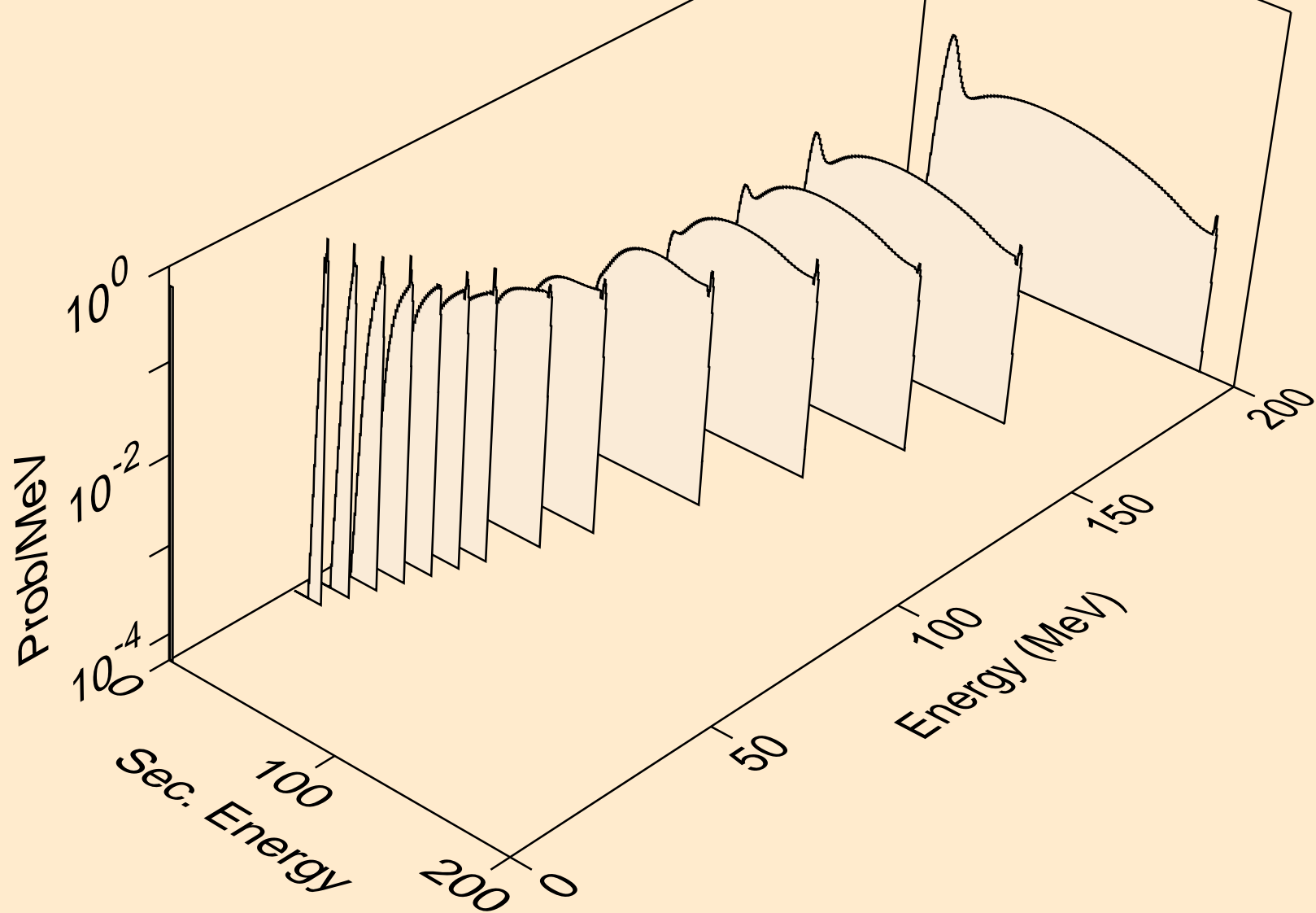

EU141 ALPHA ACER TENDL-2024 LIBRARY; T=0.K  
he3s from (a,he3)

